

AV RECEIVER

RX-V665/HTR-6260

SERVICE MANUAL

RX-V665/HTR-6260

IMPORTANT NOTICE

This manual has been provided for the use of authorized YAMAHA Retailers and their service personnel.

It has been assumed that basic service procedures inherent to the industry, and more specifically YAMAHA Products, are already known and understood by the users, and have therefore not been restated.

WARNING: Failure to follow appropriate service and safety procedures when servicing this product may result in personal injury, destruction of expensive components, and failure of the product to perform as specified. For these reasons, we advise all YAMAHA product owners that any service required should be performed by an authorized YAMAHA Retailer or the appointed service representative.

IMPORTANT: The presentation or sale of this manual to any individual or firm does not constitute authorization, certification or recognition of any applicable technical capabilities, or establish a principle-agent relationship of any form.

The data provided is believed to be accurate and applicable to the unit(s) indicated on the cover. The research, engineering, and service departments of YAMAHA are continually striving to improve YAMAHA products. Modifications are, therefore, inevitable and specifications are subject to change without notice or obligation to retrofit. Should any discrepancy appear to exist, please contact the distributor's Service Division.

WARNING: Static discharges can destroy expensive components. Discharge any static electricity your body may have accumulated by grounding yourself to the ground buss in the unit (heavy gauge black wires connect to this buss).

IMPORTANT: Turn the unit OFF during disassembly and part replacement. Recheck all work before you apply power to the unit.

■ CONTENTS

TO SERVICE PERSONNEL	2	DISPLAY DATA	63-64
FRONT PANELS	3-4	IC DATA	65-83
REAR PANELS	5-7	PIN CONNECTION DIAGRAMS	84-85
REMOTE CONTROL PANELS	8	BLOCK DIAGRAMS	86-89
SPECIFICATIONS	9-15	PRINTED CIRCUIT BOARDS	90-107
INTERNAL VIEW	16	SCHEMATIC DIAGRAMS	109-120
SERVICE PRECAUTIONS	16	REPLACEMENT PARTS LIST	121-133
DISASSEMBLY PROCEDURES	17-19	REMOTE CONTROL	134-136
UPDATING FIRMWARE	20-30	ADVANCED SETUP	137
SELF-DIAGNOSTIC FUNCTION	31-62		



このサービスマニュアルは、エコマーク認定の再生紙を使用しています。
This Service Manual uses recycled paper.

■ TO SERVICE PERSONNEL

1. Critical Components Information

Components having special characteristics are marked Δ and must be replaced with parts having specifications equal to those originally installed.

2. Leakage Current Measurement (For 120V Models Only)

When service has been completed, it is imperative to verify that all exposed conductive surfaces are properly insulated from supply circuits.

- Meter impedance should be equivalent to 1500 ohms shunted by 0.15 μ F.

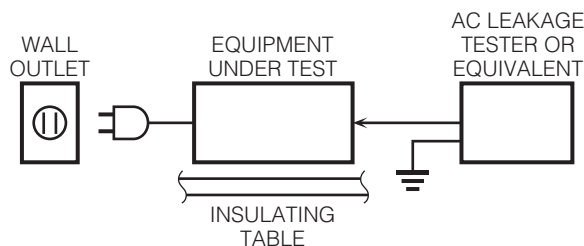

- Leakage current must not exceed 0.5mA.
- Be sure to test for leakage with the AC plug in both polarities.



For U model

“CAUTION”

“F3701: FOR CONTINUED PROTECTION AGAINST RISK OF FIRE, REPLACE ONLY WITH SAME TYPE 6A, 125V FUSE.”

For C model

CAUTION

F3701: REPLACE WITH SAME TYPE 6A, 125V FUSE.

ATTENTION

F3701: UTILISER UN FUSIBLE DE RECHANGE DE MÊME TYPE DE 6A, 125V.

WARNING: CHEMICAL CONTENT NOTICE!

This product contains chemicals known to the State of California to cause cancer, or birth defects or other reproductive harm.

DO NOT PLACE SOLDER, ELECTRICAL/ELECTRONIC OR PLASTIC COMPONENTS IN YOUR MOUTH FOR ANY REASON WHATSOEVER!

Avoid prolonged, unprotected contact between solder and your skin! When soldering, do not inhale solder fumes or expose eyes to solder/flux vapor!

If you come in contact with solder or components located inside the enclosure of this product, wash your hands before handling food.

About lead free solder

All of the P.C.B.s installed in this unit and solder joints are soldered using the lead free solder.

Among some types of lead free solder currently available, it is recommended to use one of the following types for the repair work.

- Sn + Ag + Cu (tin + silver + copper)
- Sn + Cu (tin + copper)
- Sn + Zn + Bi (tin + zinc + bismuth)

Caution:

As the melting point temperature of the lead free solder is about 30°C to 40°C (50°F to 70°F) higher than that of the lead solder, be sure to use a soldering iron suitable to each solder.

FRONT PANELS

Top view

U model

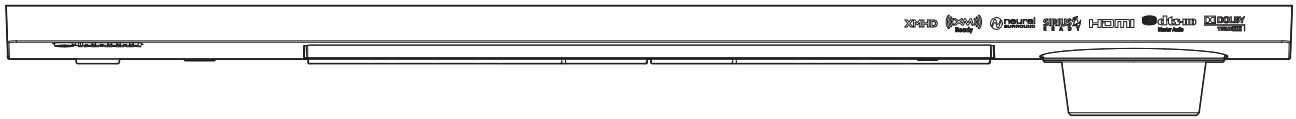

C, R, A, F, L models

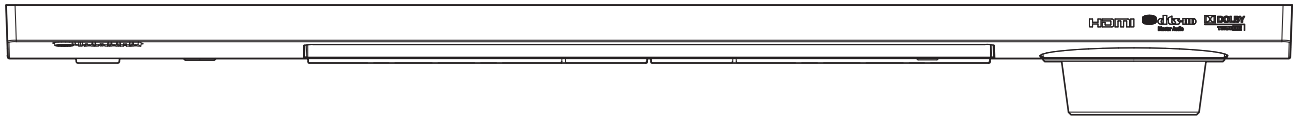

Front view

RX-V665 (U model)

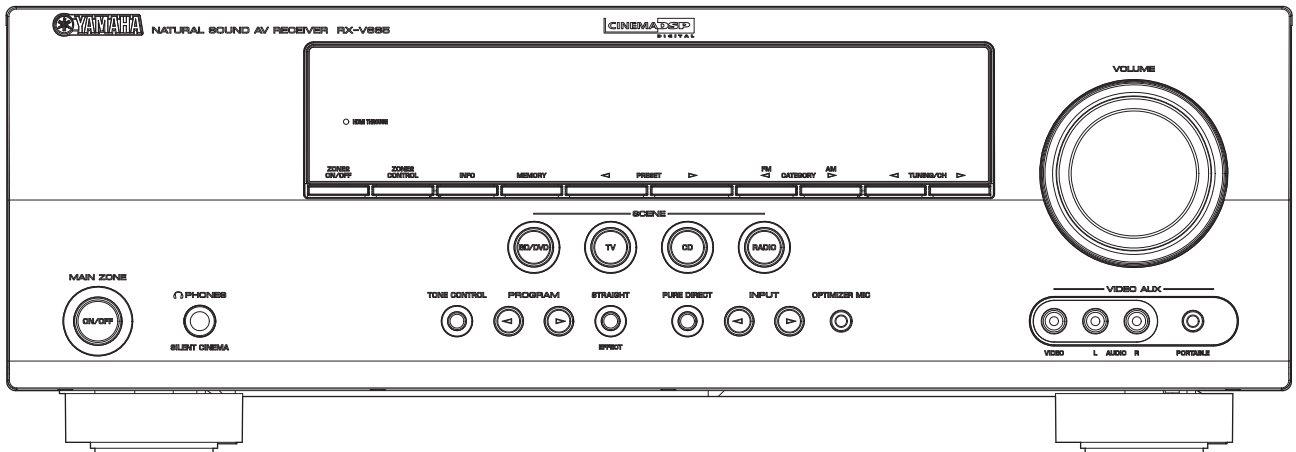

RX-V665 (C, R, A, F, L models)

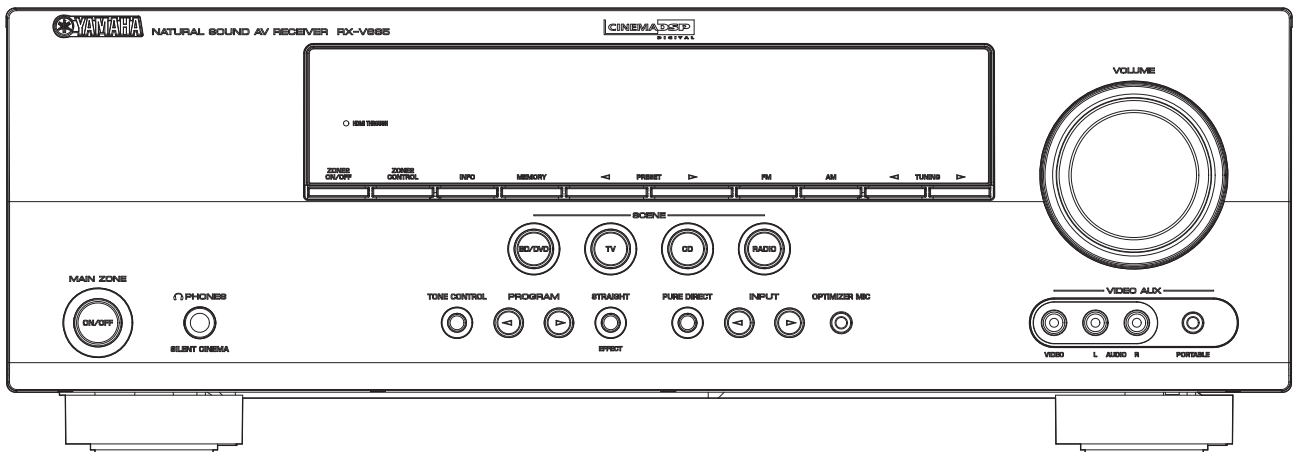

RX-V665/HTR-6260

HTR-6260 (U model)

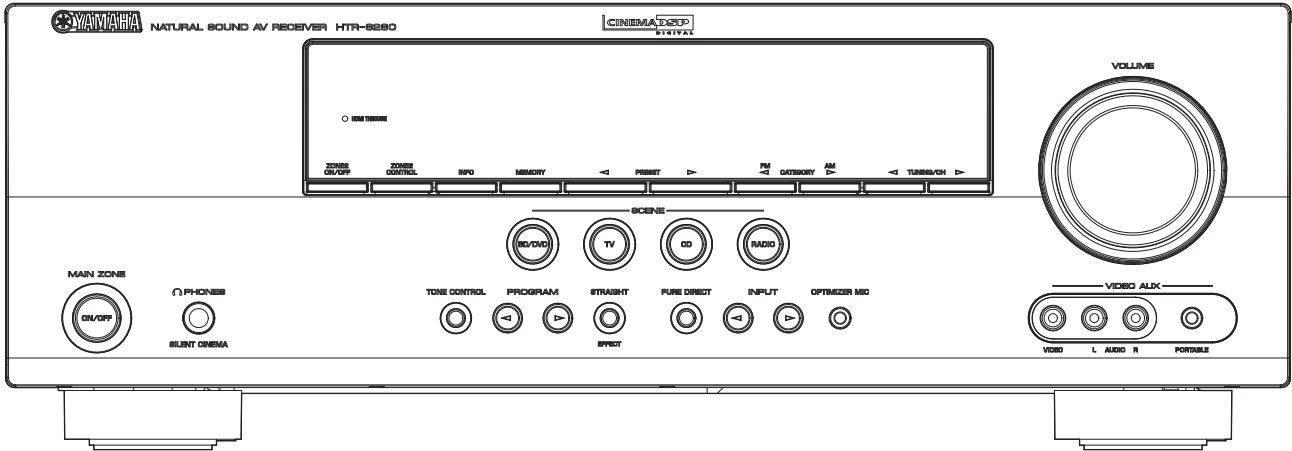

HTR-6260 (C model)

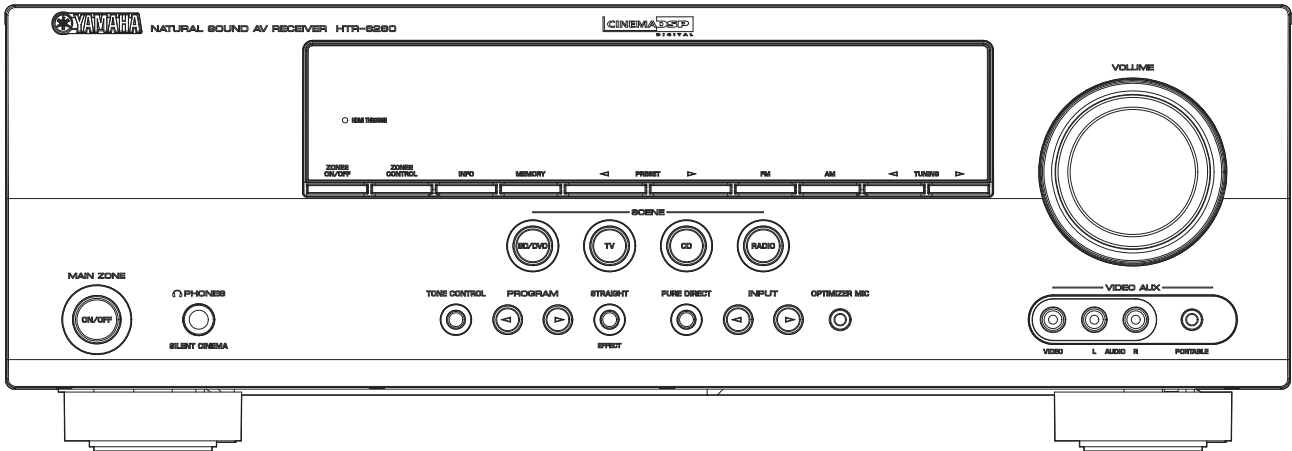

REAR PANELS

RX-V665 (U model)

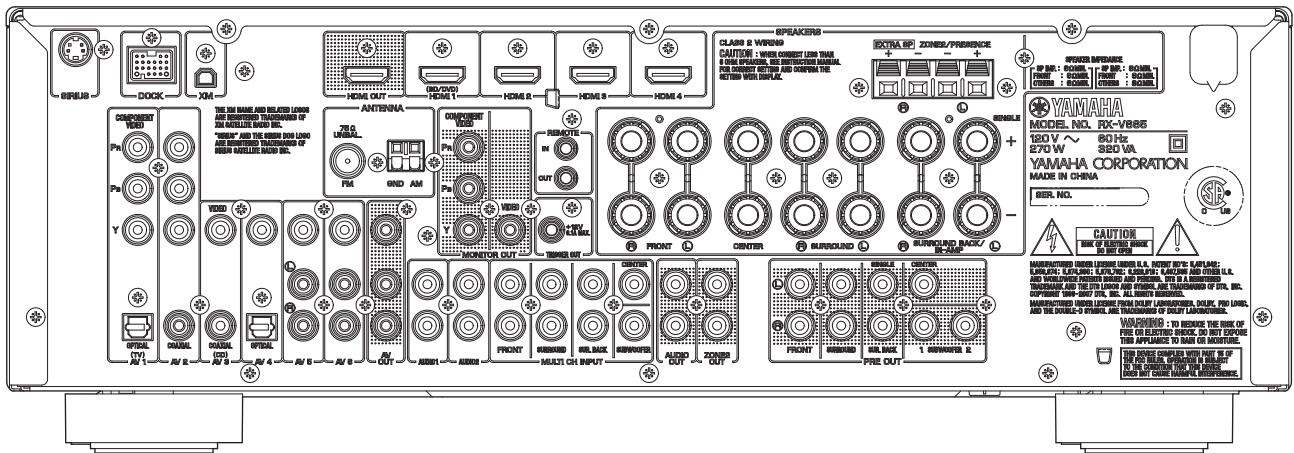

RX-V665 (C model)

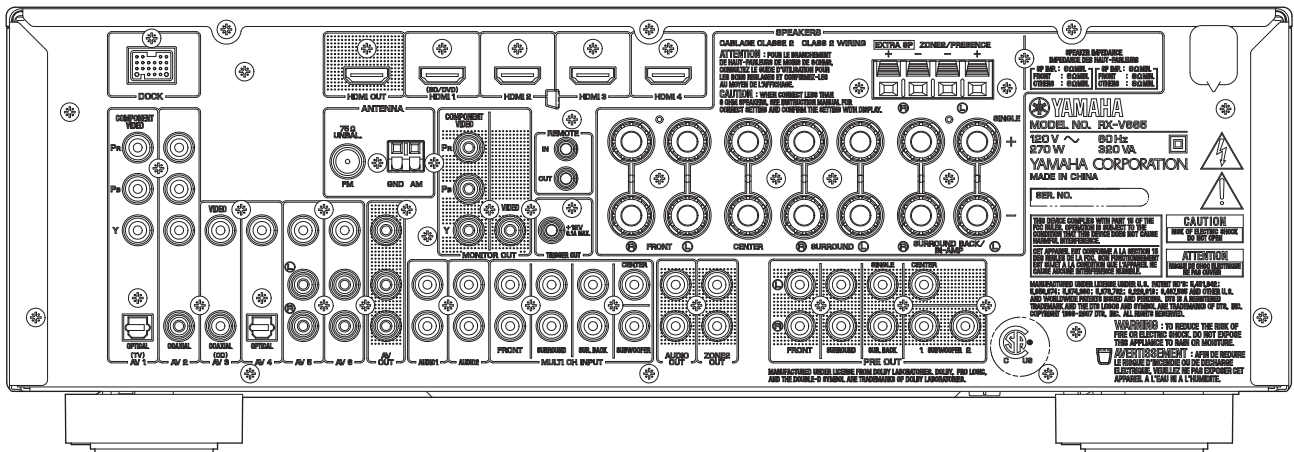

RX-V665 (R model)

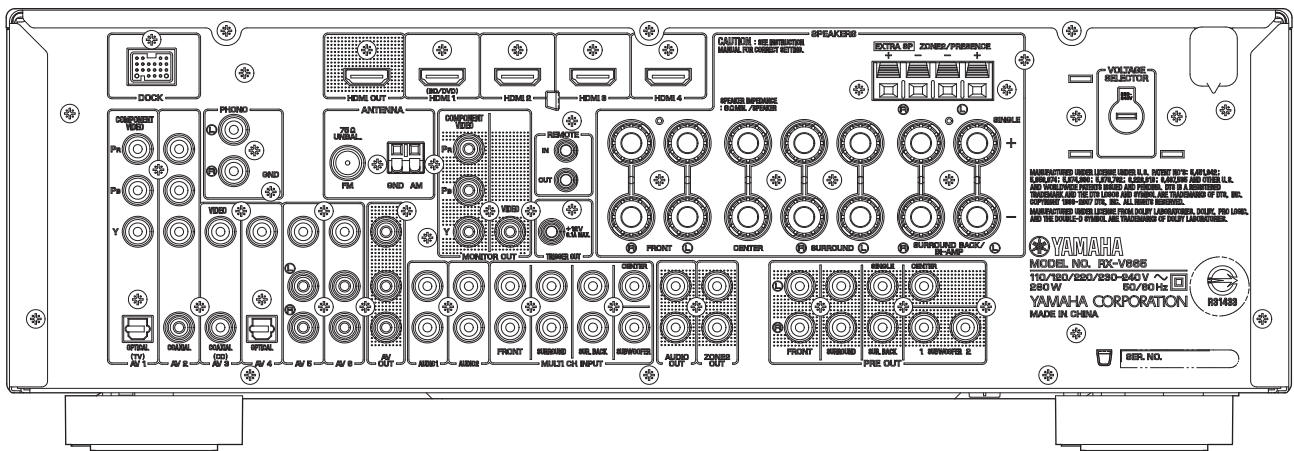

RX-V665/HTR-6260

RX-V665 (A model)

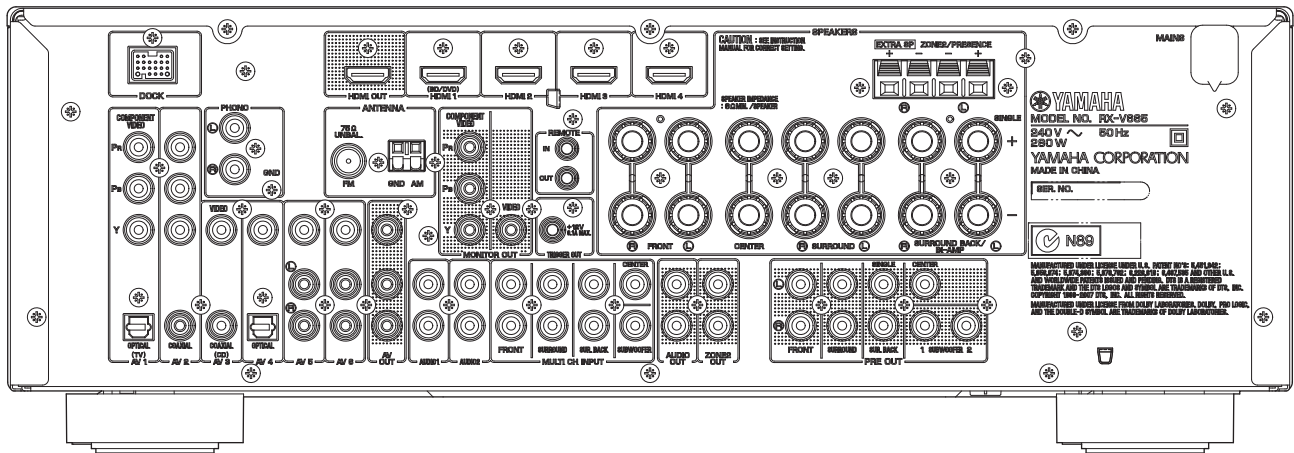

RX-V665 (F model)

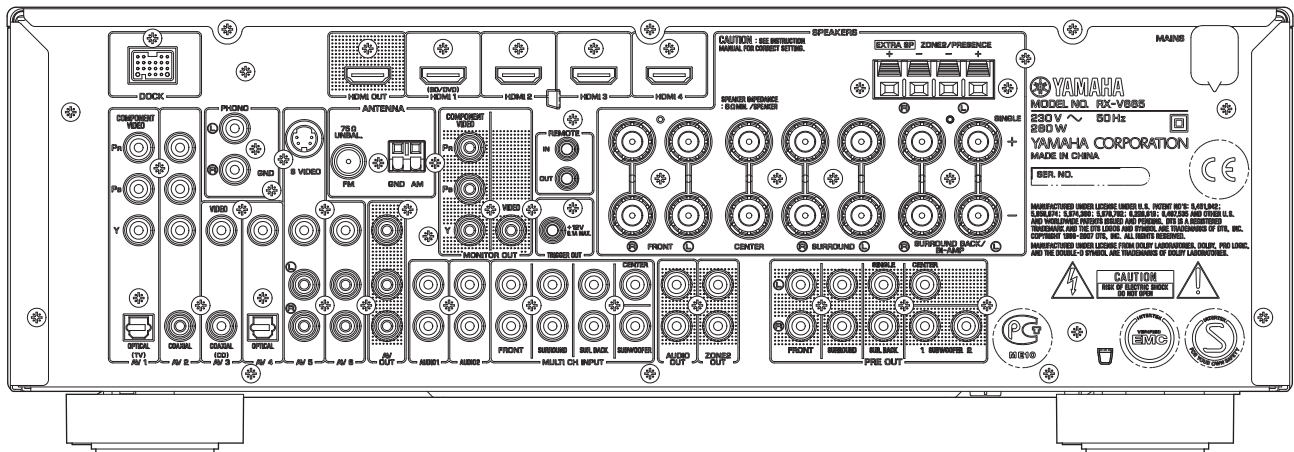

RX-V665 (L model)

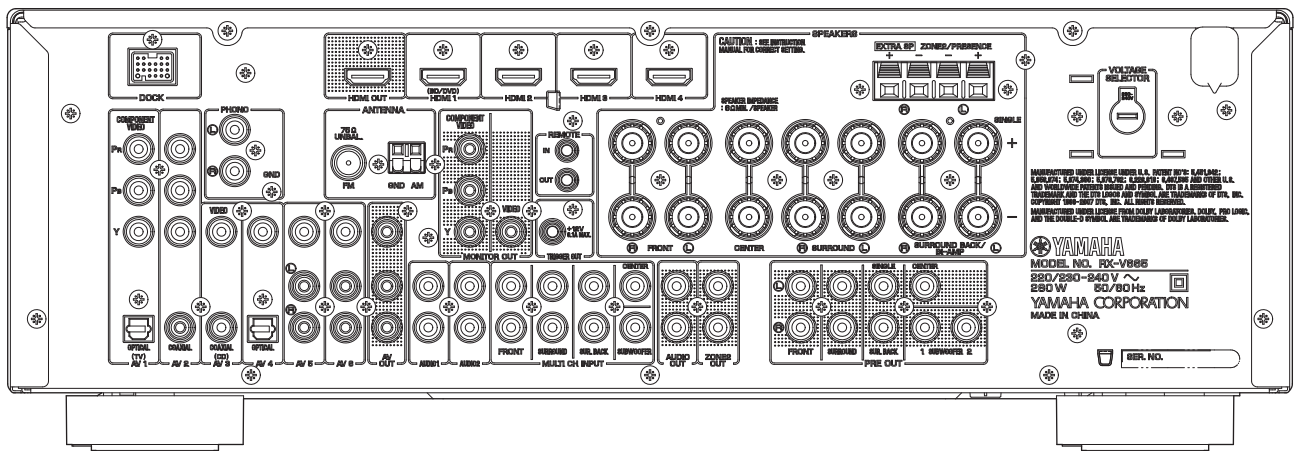

HTR-6260 (U model)

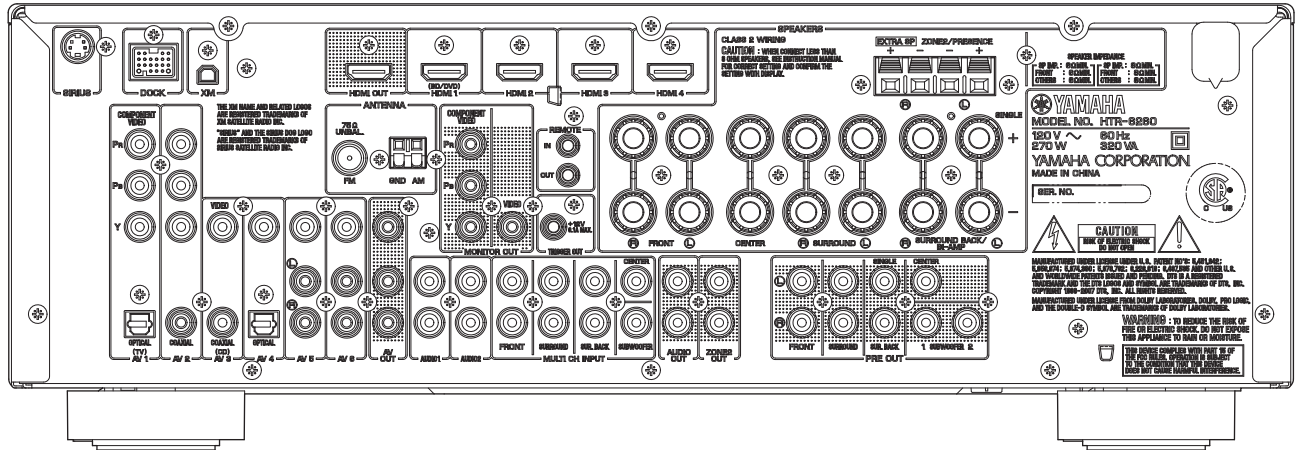

HTR-6260 (C model)

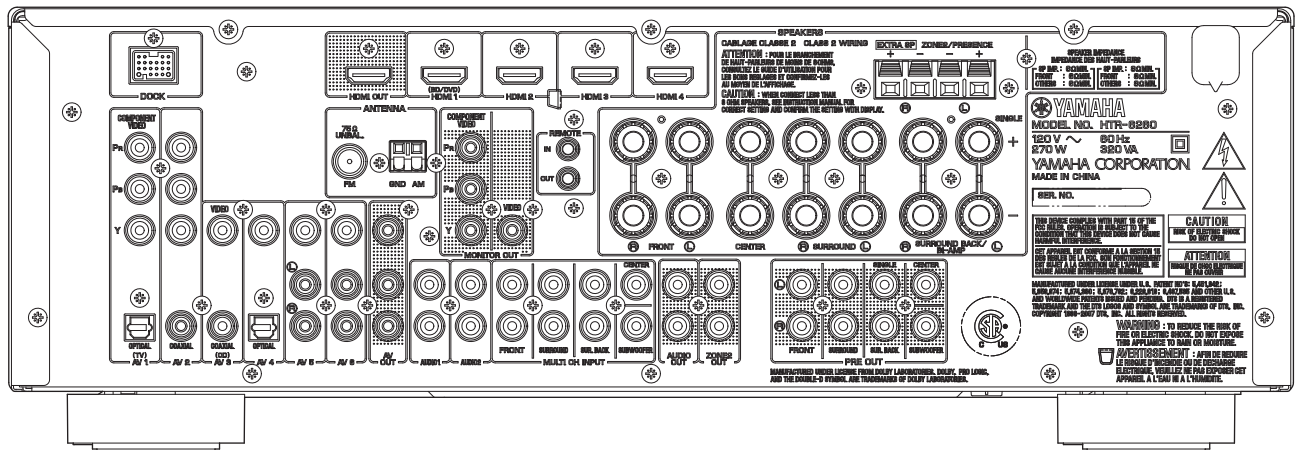

REMOTE CONTROL PANELS

RAV290

(U model)

RAV291

(C model)

RAV292

(R, A, L models)

RAV295

(F model)

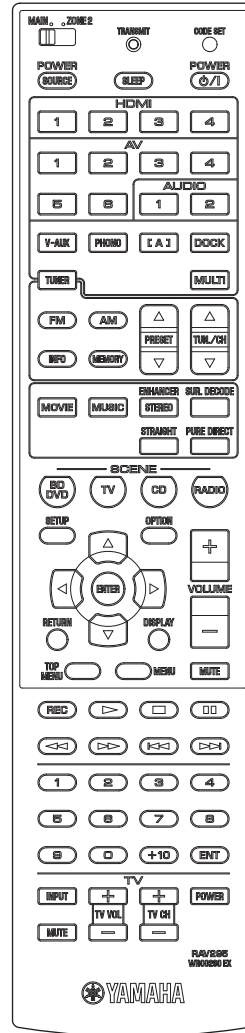
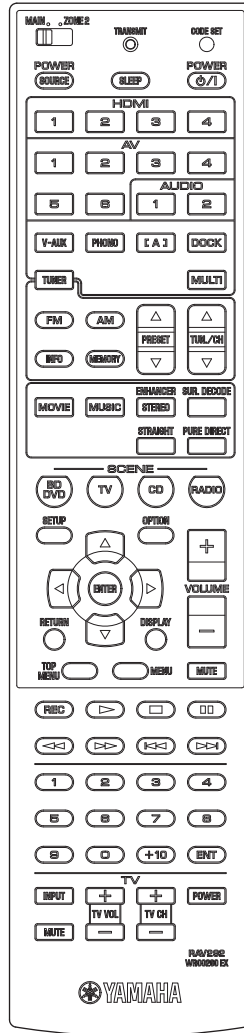
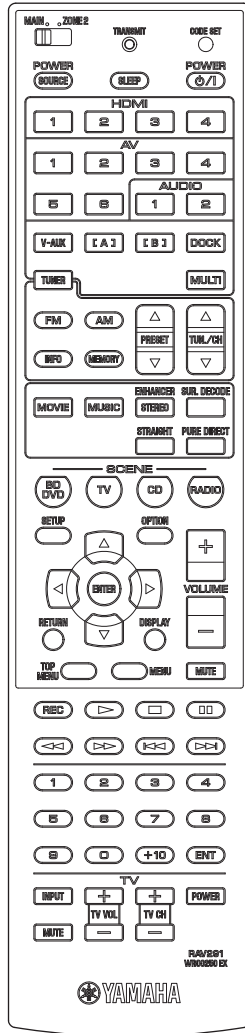
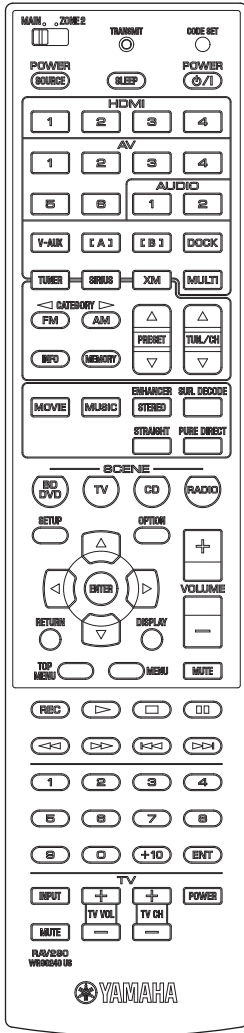

RX-V665/HTR-6260

■ SPECIFICATIONS

■ Audio Section

Minimum RMS Output Power (Power Amp. Section)

(1 kHz, 0.9 % THD)

FRONT L/R, CENTER, SURROUND L/R, SURROUND BACK L/R	
U, C models (8 ohms)	90 W/ch
R, A, F, L models (6 ohms)	90 W/ch

Maximum Power (JEITA) (1 kHz, 10 % THD, 6 ohms) [R, A, L models]

FRONT L/R, CENTER, SURROUND L/R, SURROUND BACK L/R	
	115 W/ch

MAX. Power Per Channel (1 kHz, 0.7 % THD, 4 ohms) [F, L models]

FRONT L/R, CENTER, SURROUND L/R, SURROUND BACK L/R	
	105 W/ch

IEC Power (1 kHz, 0.9 % THD, 6 ohms) [F, L models]

FRONT L/R	90 W/ch
-----------	---------

Dynamic Power Per Channel (IHF)

FRONT L/R drive	
U, C models (8 / 6 / 4 / 2 ohms)	95 / 110 / 130 / 150 W
R, A, F, L models (- / 6 / 4 / 2 ohms)	- / 100 / 110 / 125 W

Dynamic Headroom [U, C models]

8 ohms	0.23 dB
--------	---------

Input Sensitivity/Input Impedance (1 kHz, 100 W/6 ohms)

PHONO (MM) (R, A, F, L models)	3.5 mV / 47 k-ohms
AV5 etc.	200 mV / 47 k-ohms
MULTI CH INPUT	
FRONT L/R, CENTER, SURROUND L/R, SURROUND BACK L/R, SUBWOOFER	
	200 mV / 47 k-ohms

Maximum Input Signal (1 kHz)

PHONO (MM) (0.1 % THD) (R, A, F, L models)	60 mV or more
AV5 etc. (effect ON) (0.5 % THD)	2.0 V or more

Output Level/Output Impedance

REC OUT	200 mV/1.2 k-ohms
PRE OUT	1 V/1.2 k-ohms
SUBWOOFER (2 ch stereo and FRONT SP: small)	
	1 V/1.2 k-ohms
ZONE2 OUT	200 mV/1.2 k-ohms

Headphone Jack Rated Output/Output Impedance

AV5 etc. input (1 kHz, 50 mV, 8 ohms)	100 mV/470 ohms
---------------------------------------	-----------------

Frequency Response

AV5 etc., FRONT (10 Hz to 100 kHz)	0/-3 dB
------------------------------------	---------

RIAA Equalization Deviation [R, A, F, L models]

PHONO (MM)	0 ±0.5 dB
------------	-----------

Total Harmonic Distortion

PHONO (MM) to REC OUT (20 Hz to 20 kHz, 1 V) (R, A, F, L models)	0.02 % or less
AV5 etc. (Pure Direct) to FRONT SP OUT (1 kHz, 50 W)	
8 ohms (U, C models)	0.06 % or less
6 ohms (R, A, F, L models)	0.06 % or less

Signal to Noise Ratio (IHF-A network)

PHONO (MM) to REC OUT (Input shorted 2.5 mV)	
R model	86 dB or more
A, F, L models	81 dB or more
AV5, etc. (effect OFF) to SP OUT (Input shorted 250 mV)	
	100 dB or more

Residual Noise (IHF-A Network)

FRONT L/R to SP OUT	150 µV or less
---------------------	----------------

Channel Separation (1 kHz / 10 kHz)

PHONO (Input shorted)	60 dB or more / 55 dB or more
AV5, etc. (Input 5.1 k-ohms shorted)	
	60 dB or more / 45 dB or more

Volume Control

	MUTE / -80 dB to +16.5 dB / 0.5 dB step
--	---

Tone Control Characteristics

Bass	
Boost/Cut	±10 dB/2 dB, step 50 Hz
Turnover frequency	350 Hz
Treble	
Boost/Cut	±10 dB/2 dB, step 20 kHz
Turnover frequency	3.5 kHz

Filter Characteristics

FRONT, CENTER, SURROUND, SURROUND BACK small (H.P.F.)	
	fc=40/60/80/90/100/110/120/160/200 Hz, 12 dB/oct.
SUBWOOFER small (L.P.F.)	
	fc=40/60/80/90/100/110/120/160/200 Hz, 24 dB/oct.

■ Video Section

Video Signal Type

Gray back	
U, C, R models	NTSC
A, F, L models	PAL
Video conversion	
	NTSC/PAL

Composite Video Signal Level

	1 Vp-p / 75 ohms
--	------------------

S-Video Signal Level [F model]

Y	1 Vp-p / 75 ohms
C	0.286 Vp-p / 75 ohms

Component Video Signal Level

Y	1 Vp-p / 75 ohms
Cb/Cr	0.7 Vp-p / 75 ohms

Video Maximum Input Level

	1.5 Vp-p or more
--	------------------

Video Signal to Noise Ratio

	50 dB or more
--	---------------

Monitor Out Frequency Response (VIDEO CONV. OFF)

Component video signal level	5 Hz to 60 MHz, -3 dB
------------------------------	-----------------------

■ FM Section

Tuning Range

U, C models	87.5 to 107.9 MHz
R, L models	87.5 to 108.0 MHz / 87.50 to 108.00 MHz
A, F models	87.50 to 108.00 MHz

50 dB Quietening Sensitivity (IHF) (1 kHz, 100 % MOD.)

MONO/STEREO	3 µV (20.8 dBf)
-------------	-----------------

Signal to Noise Ratio (IHF)

Mono	74 dB
Stereo	69 dB

Harmonic Distortion (1 kHz)

Mono	0.3 %
Stereo	0.3 %

Antenna Input

	75 ohms unbalanced
--	--------------------

■ AM Section

Tuning Range

U, C models	530 to 1,710 kHz
R, L models	530 to 1,710 kHz / 531 to 1,611 kHz
A, F models	531 to 1,611 kHz

Antenna

	Loop antenna
--	--------------

General

Power Supply

U, C models	AC 120 V, 60 Hz
R model	AC 110/120/220/230–240 V, 50/60 Hz
A model	AC 240 V, 50 Hz
F model	AC 230 V, 50 Hz
L model	AC 220/230–240 V, 50/60 Hz

Power Consumption

U, C models	270 W / 320 VA
R, A, F, L models	280 W

Standby Power Consumption (reference data)

HDMI control: OFF / Standby through: OFF	0.2 W or less
HDMI control: ON / Standby through: ON / Repeat	3 W or less
HDMI control: ON / Standby through: ON	1.2 W or less

Maximum Power Consumption [R, L models]

(7 ch drive, 10 % THD) 490 W

Dimensions (W x H x D)

435 x 151 x 364 mm (17-1/8" x 5-7/8" x 14-3/8")

Weight

8.5 kg (18.7 lbs.)

Finish

[RX-V665]	
Black color	U, C, R, A, F, L models
Titanium color	F, L models
[HTR-6260]	
Black color	U, C models

Accessories

Remote control	x 1
Battery (R03, AAA, UM-4)	x 2
Indoor FM antenna (1.4 m)	x 1
AM loop antenna (1.0 m)	x 1
Optimizer microphone (6.0 m)	x 1

* Specifications are subject to change without notice due to product improvements.

U	U.S.A. model	A	Australian model
C	Canadian model	F	Russian model
R	General model	L	Singapore model



Manufactured under license from Dolby Laboratories. Dolby, Pro Logic and the double-D symbol are trademarks of Dolby Laboratories.



DTS is a registered trademark and the DTS logos, Symbol, DTS-HD and DTSHD Master Audio are trademark of DTS, Inc. © 1996-2007 DTS, Inc. All Rights Reserved.



Neural Surround™ name and related logos are trademarks owned by Neural Audio Corporation.

iPod™

"iPod" is a trademark of Apple Inc., registered in the U.S. and other countries.

Bluetooth™

Bluetooth is a registered trademark of Bluetooth SIG and is used by Yamaha in accordance with a license agreement.



"HDMI," the "HDMI" logo and "High-Definition Multimedia Interface" are trademarks, or registered trademarks of HDMI Licensing LLC.

x.v.Color™

"x.v.Color" is a trademark of Sony Corporation. "SILENT CINEMA" is a trademark of Yamaha Corporation.



"SILENT CINEMA" is a trademark of Yamaha Corporation.



SIRIUS, XM and all related marks and logos are trademarks of Sirius XM Radio Inc. and its subsidiaries. All rights reserved. **Service not available in Alaska and Hawaii.**

• DIMENSIONS

Top view

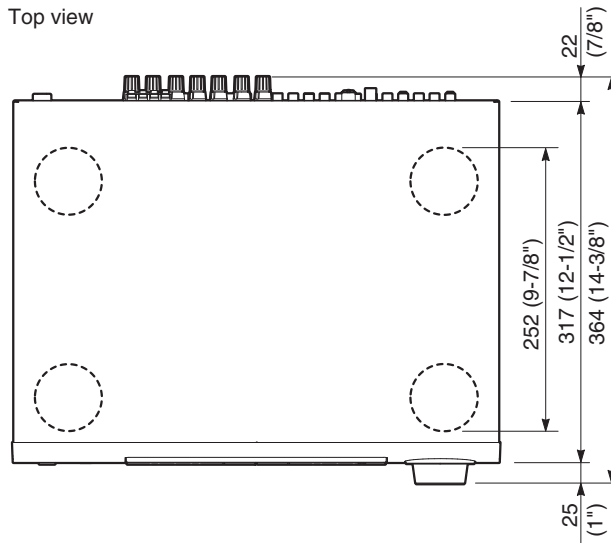

Front view

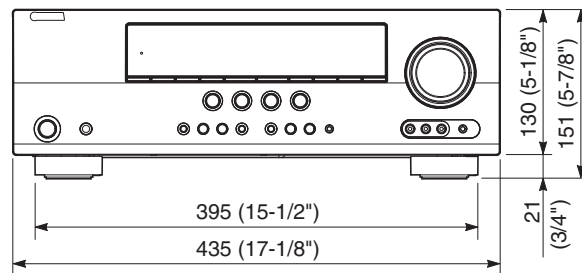

Unit: mm (inch)

• SCENE TEMPLATE

Name	BD/DVD	TV	CD	RADIO
INPUT	HDMI 1	AV-1 (Component / Optical)	AV-3 (Video / Coaxial)	TUNER
Sound field mode	STRAIGHT	STRAIGHT	STRAIGHT	MUSIC ENHANCER 7ch Enhancer
IR code output	DVD Play	None	CD Power On / Play	None

• SOUND FIELD PARAMETERS

Category	Program	Parameter																														
		Decode Type	3D DSP: ON/OFF	DSP Level: -6dB to +3dB	Init. Delay: 1 to 99ms	Room Size: 0.1 to 2.0	Liveness: 0 to 10	Sur. Init. Delay: 1 to 49ms	Sur. Room Size: 0.1 to 2.0	Sur. Liveness: 0 to 10	SB. Init. Delay: 1 to 49ms	SB. Room Size: 0.1 to 2.0	SB. Liveness: 0 to 10	Rev. Time: 1.0 to 5.0s	Rev. Delay: 0 to 250ms	Rev. Level: 0 to 100%	Dialogue Lift: 0 to 5	Center Level: 0 to 100%	Surround L Level: 0 to 100%	Surround R Level: 0 to 100%	Sur.Back Level: 0 to 100%	Presence L Level: 0 to 100%	Presence R Level: 0 to 100%	Direct: Auto/Off	Effect Level: High/Low	Panorama: On/Off	Center Width: 0 to 7	Dimension: -3 to +3	Center Image: 0.0 to 1.0	FOCUS: 0 to 8	TruBass: 0 to 8	Initialize
MOVIE	Standard	●	●	●			●	●	●	●	●	●					●															●
	Spectacle	*1	●	●	●	●	●	●		●	●						●														●	
	Sci-Fi	*1	●	●	●	●	●	●		●	●						●														●	
	Adventure	*1	●	●	●	●	●	●		●	●						●														●	
	Drama	*1	●	●	●	●	●	●		●	●						●														●	
	Mono Movie		●	●	●	●	●							●	●	●	●														●	
	Sports		●	●	●	●	●	●		●	●						●														●	
	Action Game		●	●	●	●	●	●		●	●						●														●	
	Roleplaying Game		●	●	●	●	●	●		●	●						●														●	
MUSIC	Hall in Munich		●	●	●	●	●									●														●		
	Hall in Vienna		●	●	●	●	●									●														●		
	Chamber		●	●	●	●	●						●	●	●	●														●		
	Cellar Club		●	●	●	●	●									●														●		
	The Roxy Theatre		●	●	●	●	●						●	●	●	●														●		
	The Bottom Line		●	●	●	●	●									●														●		
	Music Video		●	●	●	●	●	●	●		●	●					●													●		
STEREO	2ch Stereo																							●						●		
	7ch Stereo																●	●	●	○	●	●								●		
MUSIC ENHANCER	Straight Enhancer																							●						●		
	7ch Enhancer																							●						●		
SUR. DECODE	Surround Decoder	●																								△	△	△	▲	■	●	
STRAIGHT		*2																														

○ : The parameter to be used varies between when there is one surround pack and when there are two. On the display, the parameter value varies accordingly while the same parameter name appears.
 △ : Setting is possible only when Pro Logic II x Music (Pro Logic II Music) is selected using decode type.
 ▲ : Setting is possible only when Neo:6 Music is selected using decode type.
 ■ : Setting is possible only when CS II Cinema/Music is selected using decode type.

*1 Decode Type

Decode Type	PL II x Movie	PL II when Surround Back is None.
	Neo:6 Cinema	

*2 Decode Type

Decode Type	Pro Logic	(U model)
	PL II x Movie	
	PL II x Music	
	PL II x Game	
	Pro Logic II z	
	Neo:6 Cinema	
	Neo:6 Music	
	Neural Sur.	

• SET MENU TABLE

MAIN MENU	SUB MENU	PARAMETER	VALUE [INITIAL VALUE]	
1 • Speaker Setup				
1 Auto Setup (YPAO)	Extra SP Assign		[Zone2] / Presence / None	
	EQ Type		[Natural] / Flat / Front	
Start			[ENTER]: Start	
2 Manual Setup	A) Config	Extra SP Assign	Zone2 / Presence / [None]	
		LFE/Bass Out	SWFR / Front / [Both]	
		Front SP	Small / [Large]	
		Center SP	None / [Small] / Large	
		Sur. L/R SP	None / SMLx1 / [SMLx2] / LRGx1 / LRGx2	
		Sur. B L/R SP	None / SMLx1 / [SMLx2] / LRGx1 / LRGx2	
		Crossover Freq. Freq.	40 / 60 / [80] / 90 / 100 / 110 / 120 / 160 / 200 Hz	
		Subwoofer Phase	[Normal] / Reverse	
		Zone2 Menu	Not Available	
	B) Level	FR. L	-10.0 to +10.0 dB, [0 dB], 0.5 dB step	
		FR. R		
		CNTR		
		SUR. L		
		SUR. R		-10.0 to +10.0 dB, [-1.0 dB], 0.5 dB step
		SBL		
		SBR		
	C) Distance	SWFR	-10.0 to +10.0 dB, [0 dB], 0.5 dB step	
		Unit	meters (m) / [feet (ft)]	
		Front L	0.30 to 24.00 m, [3.00 m]	
		Front R		
		Center	0.30 to 24.00 m, [2.60 m]	
		Sur. L	0.30 to 24.00 m, [2.40 m]	
		Sur. R		
		Sur. B L		
		Sur. B R		
		SWFR	0.30 to 24.00 m, [3.00 m]	
		PRNS L	0.30 to 24.00 m, [2.40 m]	
PRNS R				
Front L		1.0 to 80.0 ft, [10.0 ft]		
Front R				
Center		1.0 to 80.0 ft, [8.5 ft]		
Sur. L		1.0 to 80.0 ft, [8.0 ft]		
Sur. R				
Sur. B L				
Sur. B R				
SWFR	1.0 to 80.0 ft, [10.0 ft]			
PRNS L	1.0 to 80.0 ft, [8.0 ft]			
PRNS R				
D) Equalizer	EQ Type Select	Auto PEQ / [GEQ] / Off		
	GEQ		* "GEQ" is available only when "EQ Type Select" is set to "GEQ."	
	Front L	63 Hz 0 dB	-6.0 to +6.0 dB, [0 dB], 0.5 dB step	
	Front R	160 Hz 0 dB		
	Center	400 Hz 0 dB		
	Sur. L	1 kHz 0 dB		
	Sur. R	2.5 kHz 0 dB		
	SBL	6.3 kHz 0 dB		
	SBR	16 kHz 0 dB		
	E) Test Tone			[Off] / On
2 • Sound Setup				
1 Dynamic Range				Min/Auto / STD / [Max]
2 Lipsync	HDMI Auto	[Off] / On		
	Auto Delay	0 to 240 ms, [0 ms], 1 ms step		
	Manual Delay			
3 • Function Setup				
1 HDMI	Control	On / [Off]		
	Standby Through	On / [Off] (* This menu is available only when "Control" is set to "Off.")		
	Audio Output	[Amp] / TV / Amp+TV (* This menu is available only when "Control" is set to "Off.")		

MAIN MENU	SUB MENU	PARAMETER	VALUE [INITIAL VALUE]		
2 Display	Resolution		[*Through] / *480p / *720p / *1080i / *1080p		
	Aspect		[Thrhg] / 16:9 / Smart		
	Dimmer		-4 to 0, [0]		
	FL Scroll		[Continue] / Once		
	OSD Shift		-5 to +5, [0]		
3 Volume	Adaptive DRC		Auto / [Off]		
	Max Volume		-30.0 dB to +15.0 dB / [+16.5 dB], 5.0 dB step		
	Init. Volume		[Off] / Mute / -80.0 to +16.5 dB, 0.5 dB step		
4 Input Rename			Input is possible to 9 characters Input possible Character type Capital : A to Z Small : a to z Figure : 0 to 9 Space Marks : # * + , - . / : < > ? etc.		
5 Zone2	Max Volume		-30.0 dB to +15.0 dB / [+16.5 dB], 5.0 dB step		
	Init. Volume		[Off] / Mute / -30.0 to +16.5 dB, 0.5 dB step		
4 • DSP Parameter					
STEREO	7ch Stereo	CT Level	0 to 100 %		
		SL Level			
		SR Level			
		SB Level			
		Initialize			
MUSIC ENHANCER	Straight Enhancer	Effect Level · High	[High] / Low		
		Initialize			
	7ch Enhancer	Effect Level · High	[High] / Low		
		Initialize			
SUR. DECODE	Sur. Decoder	SUR. Pro Logic	Pro Logic / PL Ilx Movie / PL Ilx Music / PL Ilx Game / Neo:6 Cinema / Neo:6 Music / Neural Sur. (U model)		
		Pro Logic Initialize			
		PL Ilx Movie Initialize			
		PL Ilx Music Panorama	[Off] / On		
		Center Width	0 to 7, [3]		
		Dimension	-3 to [STD] to +3		
		Initialize			
		PL Ilx Game Initialize			
		Neo:6 Cinema Initialize			
		Neo:6 Music C. Image	0.0 to 1.0, [0.3]		
		Initialize			
		Neural Sur. Initialize			
		MOVIE	Standard	SUR. PL Ilx Movie	PL Ilx Movie / Neo:6 Cinema
				PL Ilx Movie [1], [4], [8], [11], [16]	
Neo:6 Cinema [1], [4], [8], [11], [16]					
Spectacle	SUR. PL Ilx Movie		PL Ilx Movie / Neo:6 Cinema		
	PL Ilx Movie [1], [3], [4], [7], [8], [16]				
	Neo:6 Cinema [1], [4], [8], [11], [16]				
Sci-Fi	SUR. PL Ilx Movie		PL Ilx Movie / Neo:6 Cinema		
	PL Ilx Movie [1], [3], [4], [7], [8], [16]				
	Neo:6 Cinema [1], [3], [4], [7], [8], [16]				
Adventure	SUR. PL Ilx Movie		PL Ilx Movie / Neo:6 Cinema		
	PL Ilx Movie [1], [3], [4], [7], [8], [16]				
	Neo:6 Cinema [1], [3], [4], [7], [8], [16]				
Drama	SUR. PL Ilx Movie		PL Ilx Movie / Neo:6 Cinema		
	PL Ilx Movie [1], [3], [4], [7], [8], [16]				
	Neo:6 Cinema [1], [3], [4], [7], [8], [16]				
Mono Movie	[1], [2], [6], [10], [13], [14], [15], [16]				
Sports	[1], [3], [4], [7], [8], [16]				
Action Game	[1], [3], [4], [7], [8], [16]				
Roleplaying Game	[1], [3], [4], [7], [8], [16]				

MAIN MENU	SUB MENU	PARAMETER	VALUE [INITIAL VALUE]
MUSIC	Hall in Munich	[1], [2], [6], [10], [16]	
	Hall in Vienna	[1], [2], [6], [10], [16]	
	Chamber	[1], [2], [10], [13], [14], [15], [16]	
	Cellar Club	[1], [2], [6], [10], [16]	
	The Roxy Theatre	[1], [2], [6], [10], [13], [14], [15], [16]	
	The Bottom Line	[1], [2], [6], [10], [16]	
	Music Video	[1], [3], [4], [7], [8], [16]	
STEREO	2ch Stereo	Direct	[Auto] / Off
		Initialize	
	[1]	DSP Level	-6 to +3 dB, [0 dB]
	[2]	Init. Delay	1 to 99 ms
	[3]	P. Init. Dly	
	[4]	S. Init. Dly	1 to 49 ms
	[6]	Room Size	
	[7]	P. Room Size	0.1 to 2.0
	[8]	S. Room Size	
	[10]	Liveness	0 to 10
	[11]	S. Liveness	
	[13]	Rev. Time	1.0 to 5.0 s
	[14]	Rev. Delay	0 to 250 ms
	[15]	Rev. Level	0 to 100 %
	[16]	Initialize	
5 • Memory Guard			[Off] / On

INTERNAL VIEW

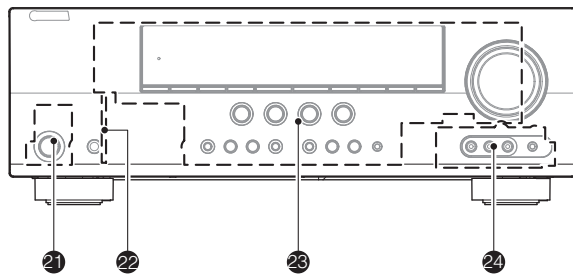
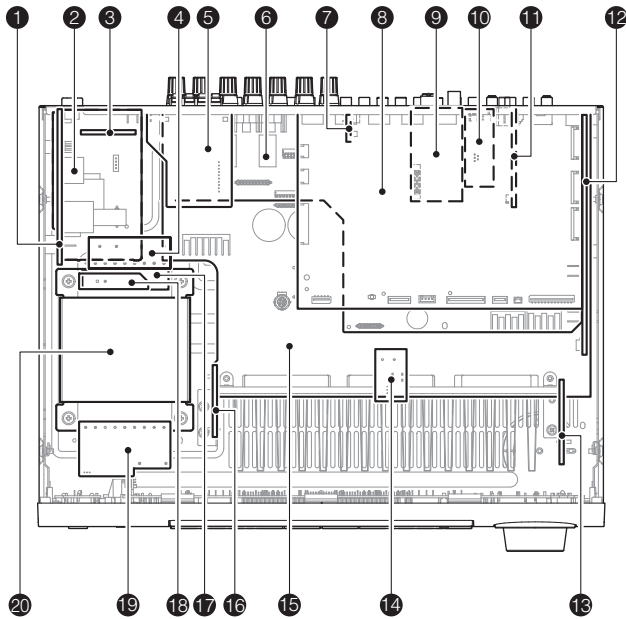

- ① VIDEO (2) P.C.B.
- ② VIDEO (3) P.C.B.
- ③ MAIN (3) P.C.B. (R, L models)
- ④ MAIN (2) P.C.B.
- ⑤ OPERATION (8) P.C.B.
- ⑥ VIDEO (1) P.C.B.
- ⑦ VIDEO (4) P.C.B.
- ⑧ DIGITAL P.C.B.
- ⑨ AM/FM TUNER
- ⑩ VIDEO (9) P.C.B. (F model)
- ⑪ OPERATION (9) P.C.B. (R, A, F, L models)
- ⑫ OPERATION (2) P.C.B.
- ⑬ OPERATION (10) P.C.B.
- ⑭ MAIN (5) P.C.B.
- ⑮ MAIN (1) P.C.B.
- ⑯ MAIN (6) P.C.B.
- ⑰ MAIN (4) P.C.B. (R, L models)
- ⑱ VIDEO (7) P.C.B. (U, C, A, F models)
- ⑲ VIDEO (6) P.C.B.
- ⑳ POWER TRANSFORMER
- ㉑ OPERATION (6) P.C.B.
- ㉒ OPERATION (3) P.C.B.
- ㉓ OPERATION (1) P.C.B.
- ㉔ OPERATION (7) P.C.B.

SERVICE PRECAUTIONS

Safety measures

- Some internal parts in this product contain high voltages and are dangerous. Be sure to take safety measures during servicing, such as wearing insulating gloves.
- Note that positions indicated below are dangerous even after the power is turned off because an electric charge remains and a high voltage continues to exist there. Before starting any repair work, perform discharge by connecting a discharge resistor (5k-ohms/10W) between terminals at following positions.
The time required for discharging is about 30 seconds.
C3703 on VIDEO (2) P.C.B.
Refer to PRINTED CIRCUIT BOARDS: VIDEO (2) P.C.B..

■ DISASSEMBLY PROCEDURES

(Remove parts in the order as numbered.)
Disconnect the power cable from the AC outlet.

1. Removal of Top Cover

- Remove 4 screws (①) and 5 screws (②). (Fig. 1)
- Slide the top cover rearward to remove it. (Fig. 1)

2. Removal of Front Panel Unit

- Remove screw (③), and remove W4001. (Fig. 1)
- Remove 2 screws (④), and remove W4002 and W4403. (Fig. 1)
- Remove 4 screws (⑤). (Fig. 1)
- Remove CB20, CB461 and CB477. (Fig. 1)
- Unlock and remove CB333. (Fig. 1)
- Release 2 hooks, and remove the front panel unit. (Fig. 1)

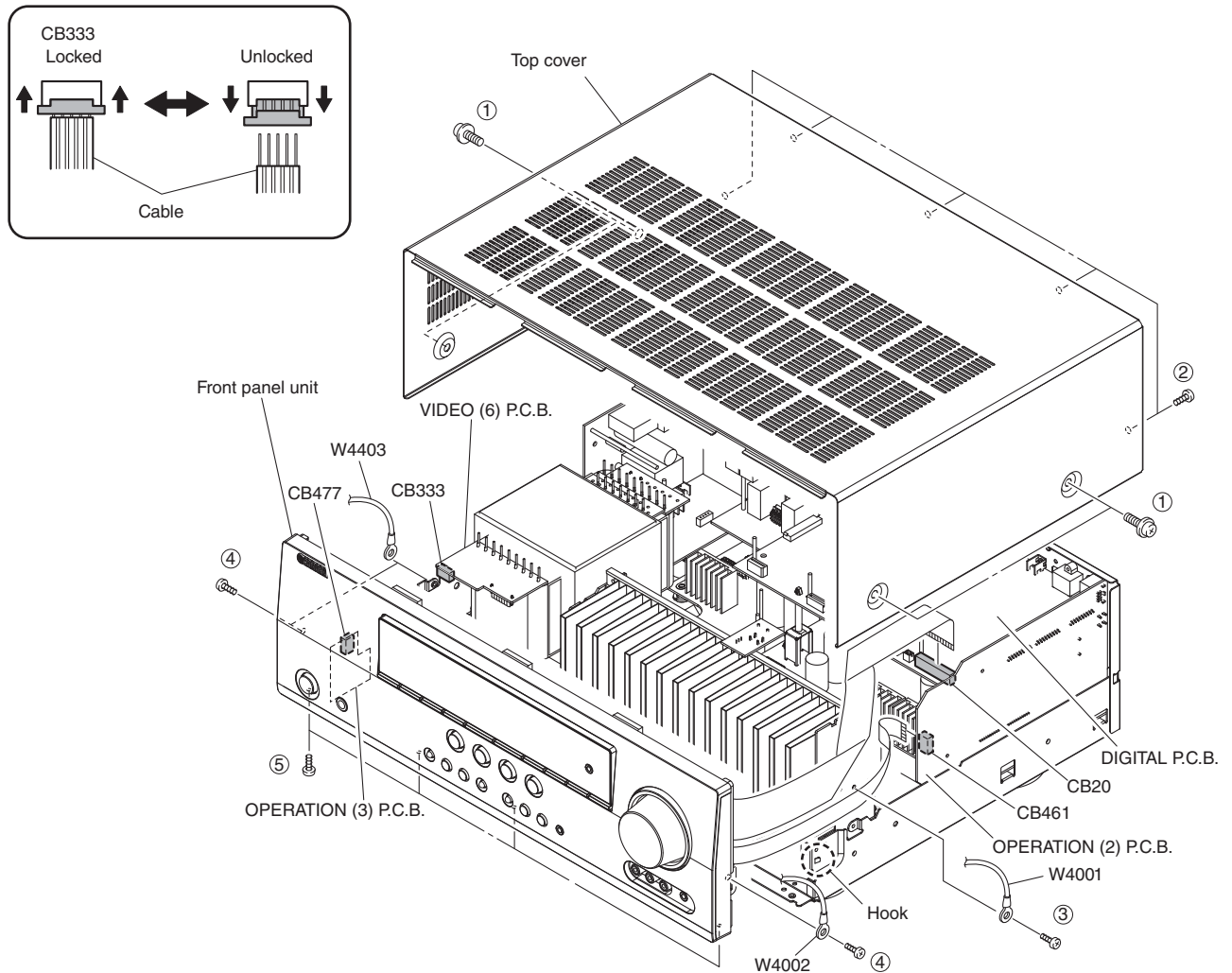

Fig. 1

3. Removal of DIGITAL P.C.B.

- a. Remove 3 screws (U model) / 2 screws (C, R, A, F, L models) (⑥) and 5 screws (⑦). (Fig. 2)
- b. Remove screw (⑧). (Fig. 2)
- c. Remove CB7, CB21, CB25, CB27, CB72 and CB73 (F model). (Fig. 2)
- d. Unlock and remove CB22-24. (Fig. 2)
- e. Release hook. (Fig. 2)
- f. Remove the DIGITAL P.C.B. which is connected directly to the OPERATION (2) P.C.B. with board-to-board connectors. (Fig. 2)

4. Removal of AMP Unit

- a. Remove 3 screws (⑨) and 4 screws (⑩). (Fig. 2)
- b. Remove 3 screws (⑪). (Fig. 2)
- c. Remove the amp unit. (Fig. 2)

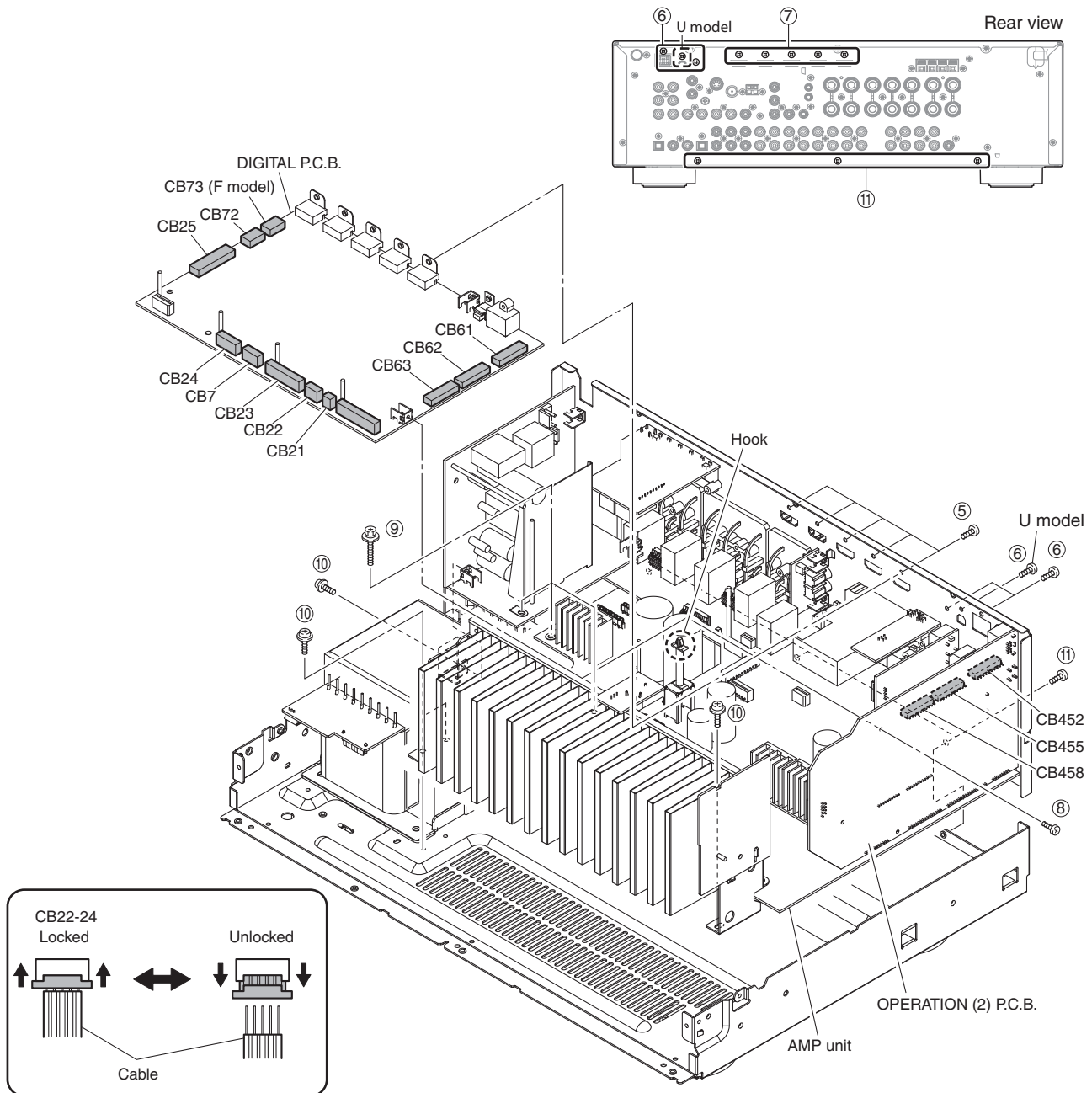

Fig. 2

When checking the P.C.B.s:

- Place the P.C.B.s (with rear panel) upright. (Fig. 3)
 - Connect the ground points of the heat sink, rear panel and MAIN (1) P.C.B. (G1000) to the chassis with a ground lead or the like. (Fig. 3)
 - When connecting the flexible flat cable, be careful with polarity.
 - Reconnect all cables (connectors) that have been disconnected.
- Be sure to use the extension cable for servicing for the following section.

DIGITAL P.C.B. CB20 to OPERATION (1) P.C.B. CB401:

MF125400 (25P, 400mm, P=1.25)

OPERATION (1) P.C.B. CB402 to OPERATION (2) P.C.B. CB461:

MF109400 (9P, 400mm, P=1.25)

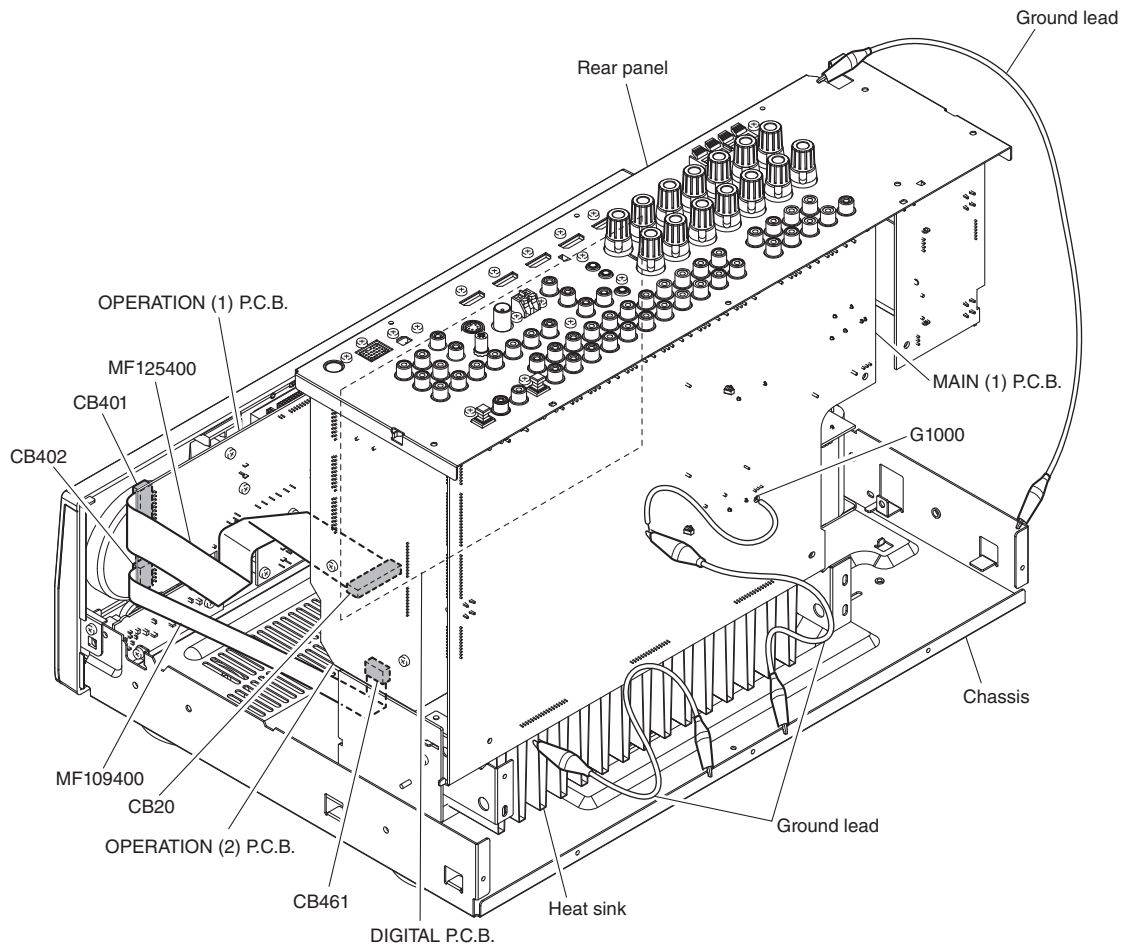

Fig. 3

■ UPDATING FIRMWARE

Note) The user memories (sound field parameters, system memory, tuner presetting, etc.) are kept stored even when you write the firmware.

When replacing the following parts, be sure to write the latest firmware.

Replaced parts	Writing method using the CD	Writing method using PC (RS232C)
DIGITAL P.C.B.	yes	yes
IC20 (Main microprocessor) of DIGITAL P.C.B.	no	yes
IC49 (TI (DSP) flash ROM) of DIGITAL P.C.B.	yes	yes

● Confirmation of firmware version and checksum

Before and after writing firmware, check the firmware version and checksum by using the self-diagnostic function menu.

Start up the self-diagnostic function and select "25. ROM VER/SUM/PORT" menu. (See "SELF DIAGNOSTIC FUNCTION")

Using the sub-menu, have the firmware version and checksum displayed, and note down them.

25. ROM VER/SUM/PORT

Firmware version

Ver: B022

The firmware version of microprocessor (IC20 DIGITAL P.C.B.) is displayed.

All checksum

Sum: 162E

The checksum value of microprocessor (IC20 DIGITAL P.C.B.) is displayed.

TI (DSP) FLASH ROM version

TiVer:02.04r1

The firmware version of TI (DSP) FLASH ROM (IC49 DIGITAL P.C.B.) is displayed.

TI (DSP) FLASH ROM checksum

TiSum:2F3C6C1A

The checksum value of TI (DSP) FLASH ROM (IC49 DIGITAL P.C.B.) is displayed.

XM version (U model)

XM VER. A009

The firmware version of XM is displayed.

SIRIUS version (U model)

SR VER. A002

The firmware version of SIRIUS is displayed.

MODEL/DESTINATION

V6 092 U 027

The model name and destination are displayed.

VERIFY error

Verify 000

Not applied to these models.

Writing method using the CD

● Required Tools

- DVD or CD player (with DIGITAL OUTPUT (OPTICAL or COAXIAL) jack)
- Optical cable (when OPTICAL jack is used)
- Digital audio pin cable (when COAXIAL jack is used)
- Firmware CD
 - * To make the firmware CD, download the latest firmware from the specified download source.

● **Connection**

Connect this unit and DVD/CD player as shown below. (Fig. 1)

Example of OPTICAL jack

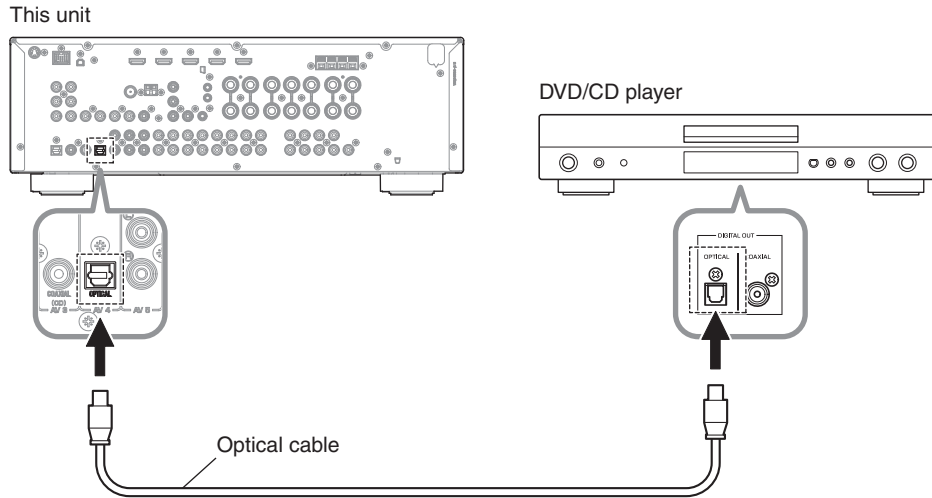

Example of COAXIAL jack

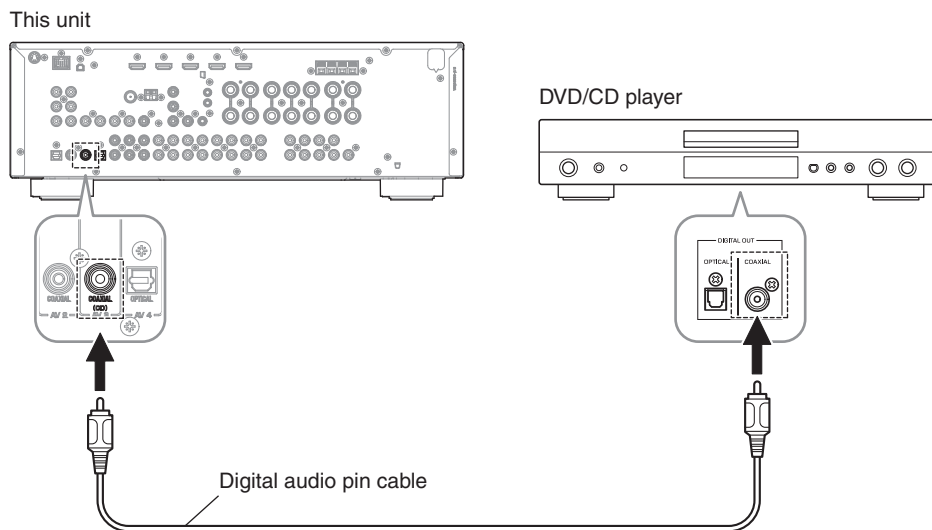

Fig. 1

● **Operation Procedures**

1. While pressing the “STRAIGHT” key of this unit, connect the power cable of this unit to the AC outlet. (Fig. 2)
The FIRMWARE UPDATE mode is activated and “CDDA Upgrader” is displayed. (Fig. 2)

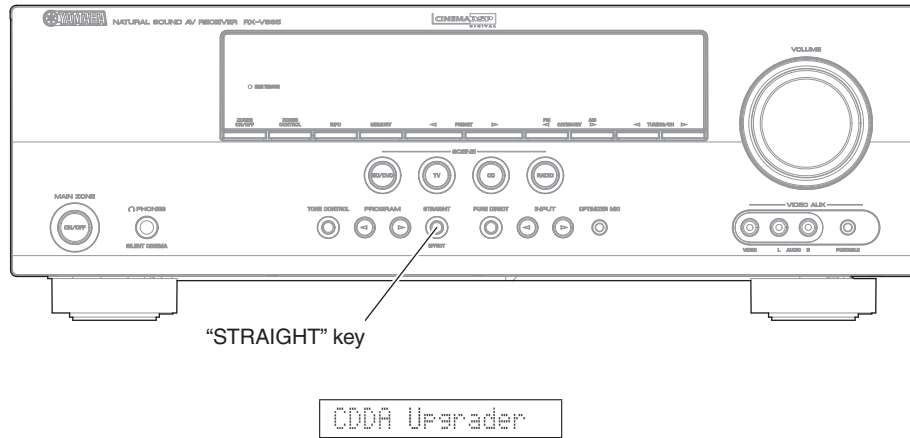

Fig. 2

2. Connect the power cable of DVD/CD player to the AC outlet.
3. Press the “STANDBY/ON” key of the DVD/CD player to turn on the power.
4. Press the “EJECT” key of the DVD/CD player to open the disc tray.
5. Put the firmware CD on the disc tray and close the disc tray.
6. Press the “PLAY” key of the DVD/CD player.
Then writing of the firmware is started. (Fig. 3)
7. When writing of the firmware is completed, “Update Success”, “Please...” and “Power off!!” are displayed repeatedly. (Fig. 3)

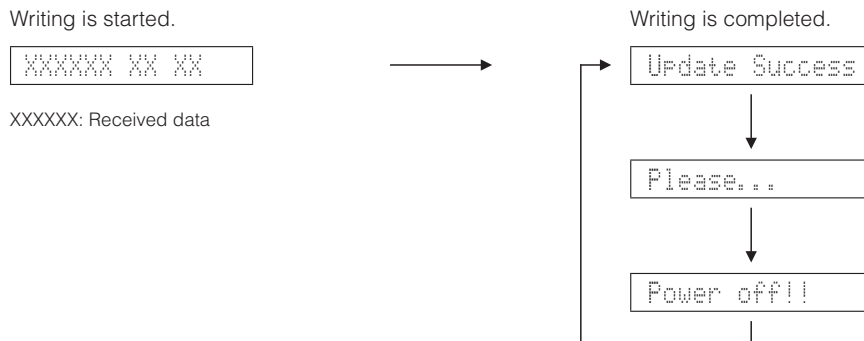

Fig. 3

- * When the version of the firmware to be written is the same as the one existing in this unit, "Same Version", "Please..." and "Power off!!" are displayed repeatedly. (Upgrading is not necessary.)

If the display remains unchanged for longer than 10 seconds after starting the firmware CD play procedure, perform the firmware CD play procedure again from the beginning.

If "FILE CORRUPTED" is displayed after "XXXXXX", make sure that the written data is not corrupted and perform Steps 1 to 7 of "Writing method using the CD" again.

If "Upgrade Failed" is displayed, perform Steps 1 to 7 of "Operation Procedures" again.

8. Press the "STOP" key of the DVD/CD player.
9. Press the "EJECT" key of the DVD/CD player to open the disc tray.
10. Remove the firmware CD from the disc tray and close the disc tray.
11. Press the "STANDBY/ON" key of the DVD/CD player to turn off the power.
12. Press the "MAIN ZONE ON/OFF" key of this unit to turn off the power.
13. Start up the self-diagnostic function and select "25. ROM VER/SUM/PORT" menu.
Using the sub-menu, have the firmware version and checksum displayed, and then check that they are the same as written ones.
 - * When the displayed firmware version and checksum are different from written ones, perform the "Writing method using the CD" all over again.
14. Press the "MAIN ZONE ON/OFF" key of this unit to turn off the power.

Writing method using PC (RS232C)

● **Required Tools**

- Firmware downloader program
 For microprocessor: DSP_FLASHER_v3.0.exe
 For DSP (TI flash ROM): DSP_FLASHER Ver2.7.exe
- Firmware
 For microprocessor: VX65xxxx.mot
 For DSP (TI flash ROM): Vx65_data1_verxxxxr.hex
- RS232C cross cable "D-sub 9 pin female"
 (Specifications)

Pin No.2 RxD	-----	Pin No.2 RxD
Pin No.3 TxD	-----	Pin No.3 TxD
Pin No.5 GND	-----	Pin No.5 GND
Pin No.7 RTS	-----	Pin No.7 RTS
Pin No.8 CTS	-----	Pin No.8 CTS
- RS232C conversion adaptor (Part No.: WR492800)

● **Preparation and precautions**

- Download firmware downloader program and the firmware from the specified source to the same folder of the PC.
- Prepare the above specified RS232C cross cable.
- While writing the firmware, keep the other application software on the PC closed.
 It is also recommended to keep the software on the task tray closed as well.

● **Connection**

1. Remove the top cover. (See "DISASSEMBLY PROCEDURES")
2. Connect the writing port (CB27 of DIGITAL P.C.B.) of this unit to the serial port (RS232C) of the PC with RS232C cross cable, RS232C conversion adaptor and flexible flat cable as shown below. (Fig. 1)
3. Set the switch (SW7) of RS232C conversion adaptor as shown below. (Fig. 1)

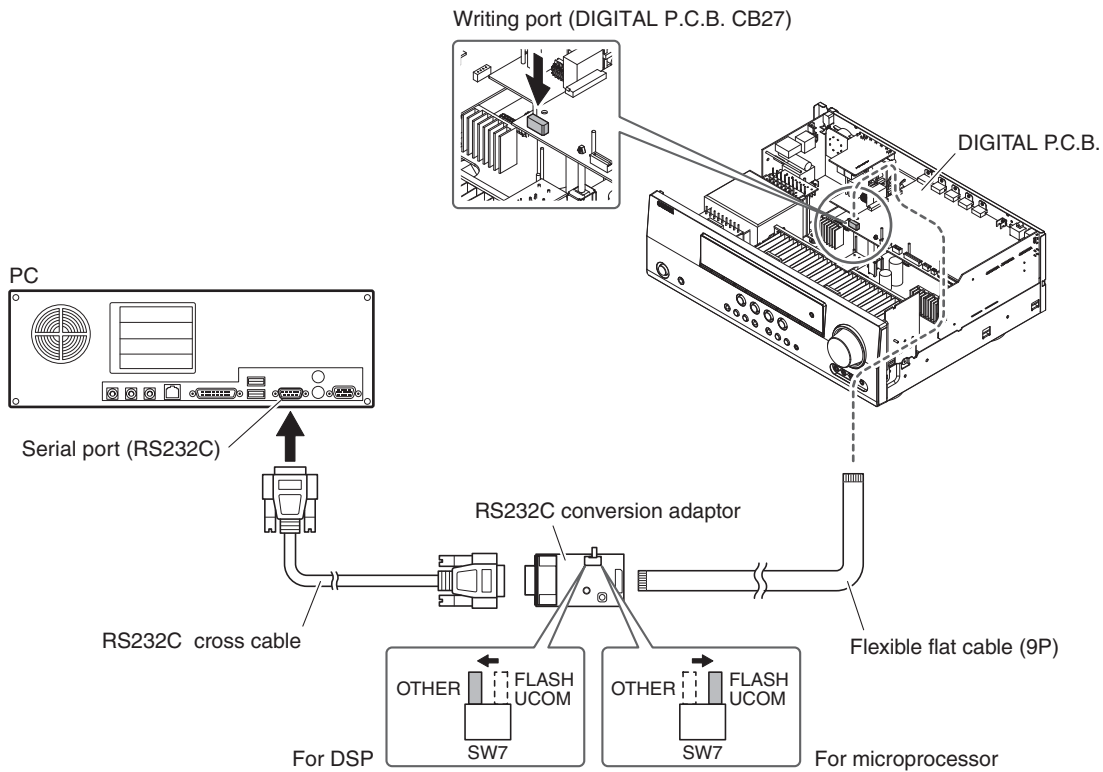

Fig. 1

● Operation Procedures

Writing to the microprocessor

1. With the power cable of this unit unconnected to the AC outlet, start up DSP_FLASHER_v3.0.exe.
The screen appears as shown below. (Fig. 2)
2. Click [...] and select the firmware name. (Fig. 2)

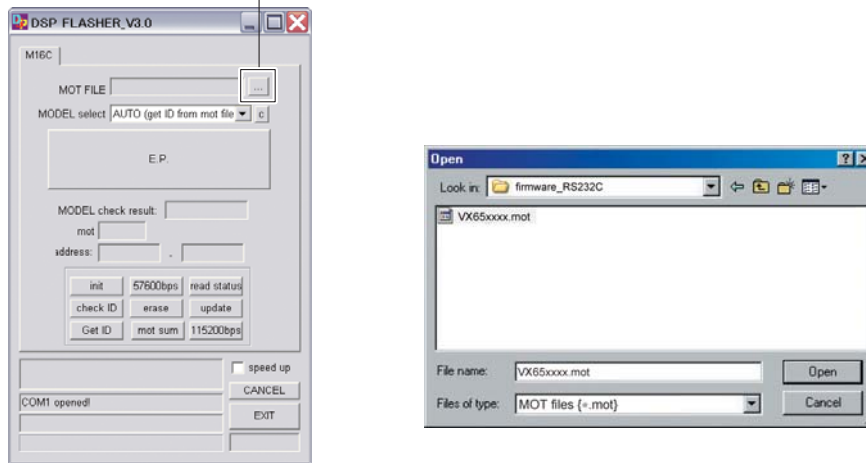
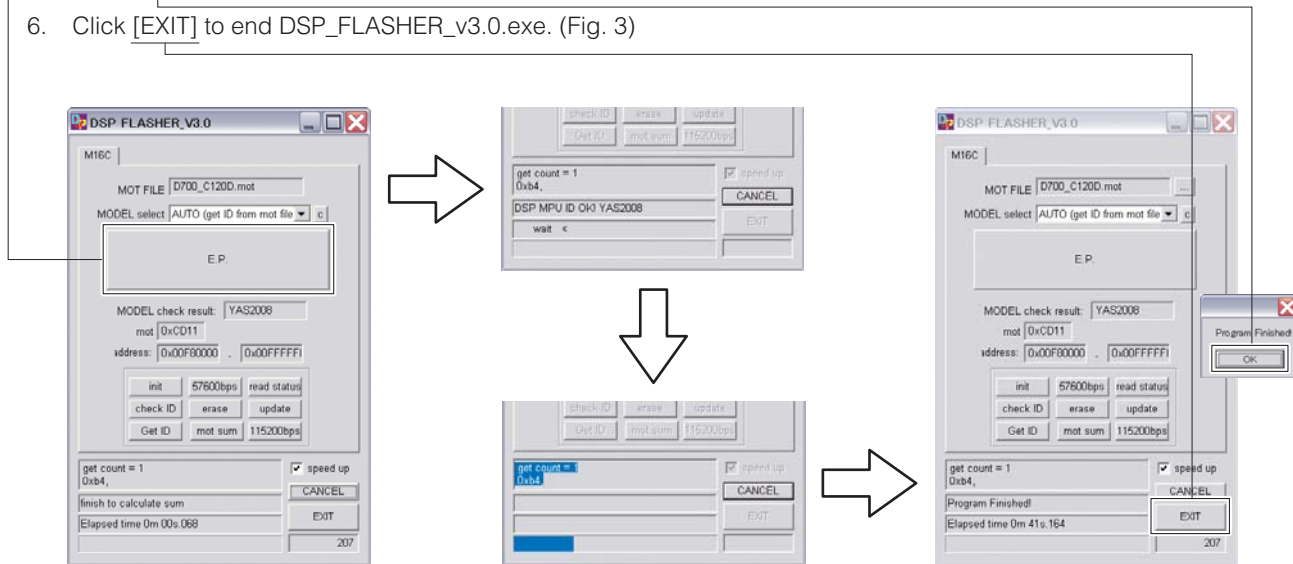

Fig. 2

3. Connect the power cable of this unit to the AC outlet.
4. Click [E.P.] to start writing. (Fig. 3)
5. When writing of the firmware is completed, "Program Finished!" is displayed. (Fig. 3)
Click [OK]. (Fig. 3)
6. Click [EXIT] to end DSP_FLASHER_v3.0.exe. (Fig. 3)



Writing being executed.

Writing completed.

Fig. 3

7. Start up the self-diagnostic function and select "25.ROM VER/SUM/PORT" menu.
Using the sub-menu, have the firmware version and checksum displayed, and then check that they are the same as written ones.
 - * When the firmware version and checksum are different from written ones, perform the "Writing to the microprocessor" all over again.
8. Disconnect the power cable of this unit from the AC outlet.

Writing to DSP

1. With the power cable of this unit unconnected to the AC outlet, start up DSP_FLASHER Ver2.7.exe. The screen appears as shown below. (Fig. 4)
2. Click [Vx61 DSP]. (Fig. 4)

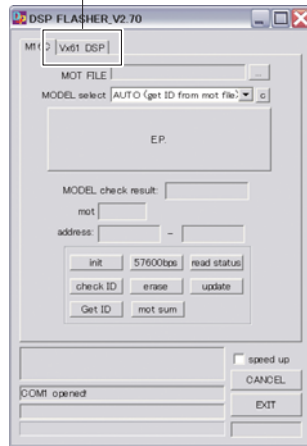

Fig. 4

3. Click [...] and select the firmware name. (Fig. 5)

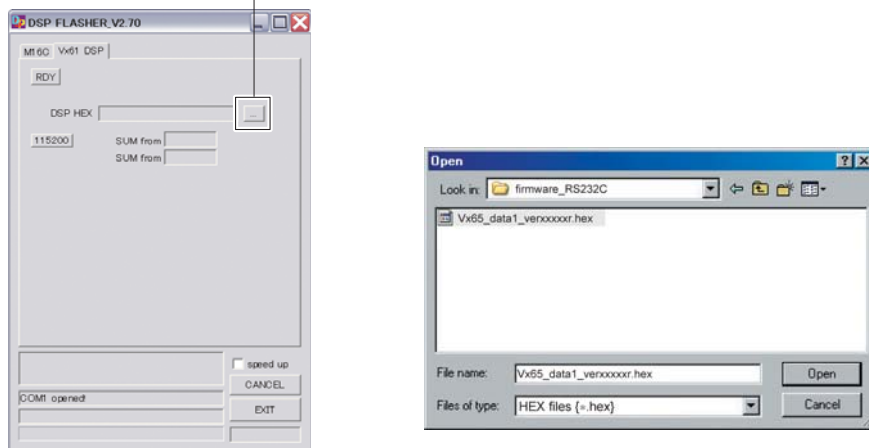

Fig. 5

- Click [RDY]. (Fig. 6)



Fig. 6

- While pressing the “PURE DIRECT” key of this unit, connect the power cable of this unit to the AC outlet. (Fig. 7)
Writing is started automatically. (Fig. 7)

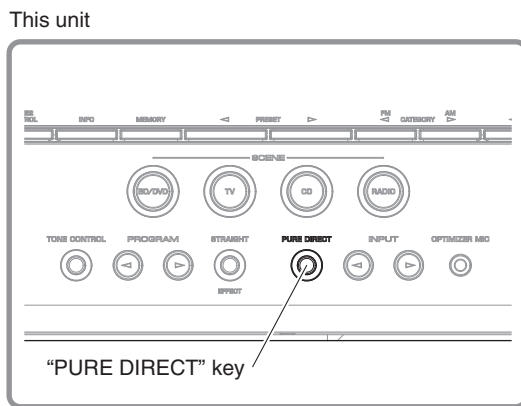

Writing being executed.

Fig. 7

6. When writing of the firmware is completed, "Vx61 DSP Flash finished!" is displayed. (Fig. 3)
7. Click [EXIT] to end DSP_FLASHER_v2.7.exe. (Fig. 8)



Fig. 8

8. Start up the self-diagnostic function and select "25.ROM VER/SUM/PORT" menu.
Using the sub-menu, have the firmware version and checksum displayed, and then check that they are the same as written ones.
 - * When the firmware version and checksum are different from written ones, perform the "Writing to DSP" all over again.
9. Disconnect the power cable of this unit from the AC outlet.

■ SELF-DIAGNOSTIC FUNCTION

This unit has self-diagnostic functions that are intended for inspection, measurement and location of faulty point.

There are 25 main menu items, each of which has sub-menu items.

Listed in the table below are main menu items and sub-menu items.

Note that not all menu items listed will apply to the models covered in this service manual.

No.	Main menu	Sub-menu
1	BYPASS	1 ANALOG BYPASS
		2 DSP BYPASS
2	RAM THROUGH	1 RAM MARGIN
		2 RAM FULL ALL
		3 RAM FULL CENTER
		4 RAM FULL SURROUND
		5 RAM FULL SURROUND BACK
3	HDMI AUDIO	1 SPDIF
		2 Multi
		3 DSD
4	SPEAKERS SET	1 FRNT: SML 0dB
		2 CENTER: NONE
		3 LFE/B: FRNT
		4 Zone2 Amp ON
		5 Bi-AMP
		6 TONE: MAX
		7 TONE: MIN
		8 SPEAKER 6 ohms
5	XCH-INPUT	1 8ch INPUT 6 ohms
		2 8ch INPUT 8 ohms
		3 LIM/PLDET/THM
6	MIC CHECK	1 MIC CHECK
7	FL/OSD CHECK	1 VFD CHECK
		2 VFD DISP OFF / MONITOR MUTE
		3 VFD DISP ALL / COMPONENT MUTE
		4 VFD DIMMER / OSD CHARACTER PATTERN
		5 CHECK PATTERN / OSD CHARACTER PATTERN
8	MANUAL TEST	1 TEST ALL
9	A/D DATA CHECK	1 PS1/PS2
		2 DC/TH
		3 IMP/PL
		4 DST/DK
		5 KO/K1
10	VIDEO CHECK	1 I2C
		2 DIGITAL COMPONENT
		3 DIGITAL CVBS
		4 DIGITAL Y/C (F model)
		5 ANALOG BYPASS
		6 TEST PATTERN
		7 VIDEO INFORMATION
11	XM STATUS (U model)	1 1k -1dB /44kHz
		2 1k -61dB /44kHz
		3 Mute /44kHz
		4 XM Tone /44kHz
		5 ISO Tone /44kHz

No.	Main menu	Sub-menu
11	XM STATUS (U model)	6 1k -1dB /32kHz
		7 1k -61dB /32kHz
		8 Mute /32kHz
		9 XM Tone /32 kHz
		10 ISO Tone /32 kHz
		11 Bus Power: OFF
12	SIRIUS (U model)	1 SIRIUS: OK (NG)
		2 SR
		3 SSP (SIRIUS #0 VERSION)
		4 MAC (SIRIUS #1 VERSION)
		5 ADP (SIRIUS #2 VERSION)
		6 PRDID
		7 SEQID
13	HD RADIO (Not applied to these models.)	1 HD CPU VERSION
		2 D: xxxxxxxxxxxx
14	DOCK	1 DOCK
		2 BT VERSION
15	HDMI INFO	1 HMN
		2 HPI
		3 HVN
16	HDMI SELECT	1 HDMI NONE
		2 HDMI IN 1
		3 HDMI IN 2
		4 HDMI IN 3
		5 HDMI IN 4
		6 HDMI UP CONVERSION
		7 HDMI UP THROUGH
17	USB (Not applied to these models.)	1 USB File 1
		2 USB File 2
18	IF STATUS (Not applied to these models.)	1 DSP STATUS
19	BUS CHECK	1 TI BUS
		2 BF LOOP (Not applied to these models.)
20	NO MENU	Invalidity
21	PROTECTION HISTORY	1 HISTORY 1
		2 HISTORY 2
		3 HISTORY 3
		4 HISTORY 4
22	NO MENU	Invalidity
23	UPDATE	1 TI FLASH BOOT (Not applied to these models.)
24	FACTORY PRESET	1 PRESET INHI
		2 PRESET RSRV
25	ROM VER/SUM/PORT	1 VERSION
		2 ALL SUM
		3 TI (DSP) FLASH VERSION
		4 TI (DSP) FLASH SUM
		5 XM VERSION (U model)
		6 SIRIUS VERSION (U model)
		7 MODEL/DESTINATION
		8 Verify (Not applied to these models.)

● Starting Self-Diagnostic Function

While pressing those 2 keys of this unit as shown in the figure below, press the “MAIN ZONE ON/OFF” key to turn on the power.

The self-diagnostic function mode is activated.

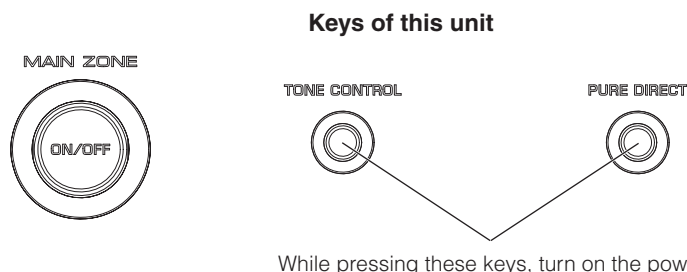

● Starting Self-Diagnostic Function in the protection cancel mode

If the protection function works and causes hindrance to trouble shoot, cancel the protection function as described below, and it will be possible to enter the self-diagnostic function mode.

(The protection functions other than the excess current detect function will be disabled.)

While pressing those 2 keys as shown in the figure above, press the “MAIN ZONE ON/OFF” key to turn on the power and keep pressing those 2 keys and “MAIN ZONE ON/OFF” key for 3 seconds or longer.

The self-diagnostic function mode is activated with the protection functions disabled.

In this mode, the SLEEP segment of the FL display of this unit flashes to indicate that the mode is self-diagnostic function mode with the protection functions disabled.

CAUTION!

Using this product with the protection function disabled may cause damage to itself. Use special care when using this mode.

● Canceling Self-Diagnostic Function

1. Before canceling self-diagnostic function, execute setting for FACTORY PRESET of main menu No. 24 (Memory initialization inhibited or Memory initialized).
 - * In order to keep the user memory stored, be sure to select PRESET INHIBITED (Memory initialization inhibited).
2. Press the “MAIN ZONE ON/OFF” key of this unit to turn off the power.

● Display provided when Self-Diagnostic Function started

The FL display of this unit displays the protection function history data then the main menu (sub-menu “1. ANALOG BYPAS” of main menu No. 1 BYPASS) a few seconds later.

When there is no history of protection function:

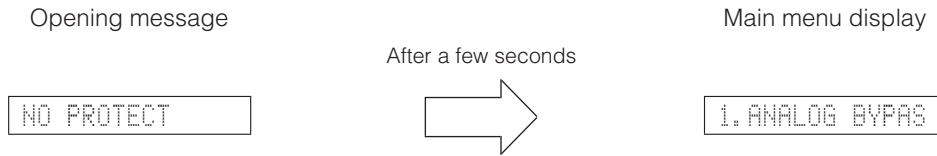

When there is a history of protection function:

When there is a history of protection function due to excess current

PRI PRT:xxx

AD value when the protection function is working

Cause: An excessive current flowed through the power amplifier.

Supplementary information: As current of the power amplifier is detected, the abnormal channel can be identified by checking the current detect transistor.

Turning on the power without correcting the abnormality will cause the protection function to work immediately and the power supply will instantly be shut off.

Note)

- Applying the power to this unit without correcting the abnormality can be dangerous and cause additional circuit damage. To avoid this, if protection function has been activated 3 times continuously, the power will not turn on even when the “MAIN ZONE ON/OFF” key is pressed. In order to turn on the power again, disconnect the power cable of this unit from the AC outlet once and then reconnect it again.
- The output transistors in each amplifier channel should be checked for damage before applying power of this unit.
- Amplifier current should be monitored by measuring DC voltage across the emitter resistors for each channel.

When there is a history of protection function due to abnormal DC output

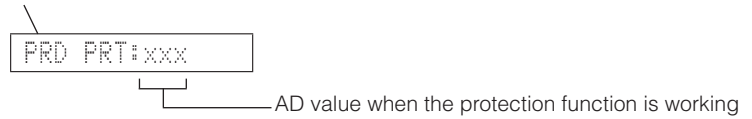

Cause: DC output from the power amplifier is abnormal.

Supplementary information: The protection function worked due to a DC voltage appearing at the speaker terminal.

A cause could be a defect in the amplifier.

If the power is turned on with the abnormality unsolved, the protection function works in about 3 seconds to turn off the power.

When there is a history of protection function due to abnormal voltage in the power supply section

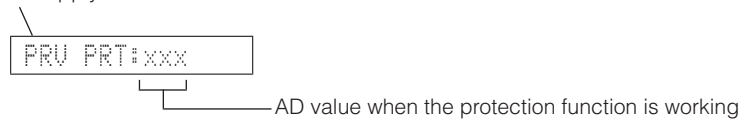

Cause: The voltage in the power supply section is abnormal.

Supplementary information: The protection function worked due to a defect or overload in the power supply.

If the power is turned on with the abnormality unsolved, the protection function works in about 1 second to turn off the power.

When there is a history of protection function due to excessive heat sink temperature



THM PRT:xxx

AD value when the protection function is working

Cause: The temperature on the heat sink is excessive.

Supplementary information: The protection function worked due to the temperature limit being exceeded.

Causes could be poor ventilation or a defect related to the thermal sensor.

If the power is turned on with the abnormality unsolved, the protection function works in about 1 second to turn off the power.

* For detection of each protection function, refer to main menu described later.

● History of protection function

When the protection function has worked, its history is stored in memory with a backup.

Even if no abnormality is noted while servicing the unit, an abnormality which has occurred previously can be defined as long as the backup data has been stored.

The history of the protection function is cleared when self-diagnostic function is cancelled by selecting PRESET RESERVED (Memory initialized) of main menu No. 24 or when the backup data is erased.

● Operation procedure of Main menu and Sub-menu

There are 25 main menu items, each of them having sub-menu items.

Main menu selection

Select the main menu using "SCENE TV" (forward) and "SCENE BD/DVD" (reverse) keys.

Sub-menu selection

Select the sub-menu using "SCENE RADIO" (forward) and "SCENE CD" (reverse) keys.

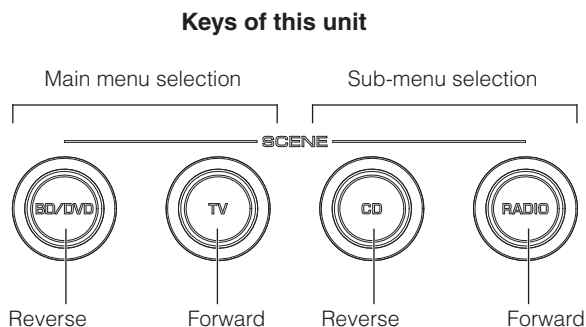

● Functions in Self-Diagnostic Function mode

In addition to the self-diagnostic function menu items, functions as listed below are available.

- Power ON/OFF
- Master volume
- Muting
- Input select
- Audio select
- PROGRAM select
- Tone control
- PURE DIRECT ON/OFF
- ZONE2 ON/OFF

* Functions related to the tuner and the set menu are not available.

● Initial settings used to start Self-Diagnostic Function

The following initial settings are used when starting self-diagnostic function.

When self-diagnostic function is canceled, these settings are restored to those before starting self-diagnostic function.

- Master volume: -20 dB
- Zone2 Volume: +2.5 dB
- Input: AV5 (MAIN ZONE) / AUDIO1 (ZONE2)
- Main menu: 1. ANALOG BYPASS
- Speaker setting: LARGE, Bass out to SWFR (All channels)
- Speaker impedance: 8 ohms position
- OSD: ON
- XM Power: ON (U model)

● Details of Self-Diagnostic Function menu

1. BYPASS

Using the sub-menu, it is possible to select ANALOG BYPASS output or DSP BYPASS output.

ANALOG BYPASS

The analog input audio signal is output to FRONT L/R in PURE DIRECT.

1. ANALOG BYPASS

INPUT: AV5 ANALOG

SPEAKER OUT: 1 kHz, SUBWOOFER OUTPUT: 50 Hz

Input level	Volume	SPEAKER OUT						SUB-WOOFER
		FRONT	CENTER	SURROUND	SURROUND BACK	PRESENCE	ZONE2	
Both ch, -20 dBm	+6.5 dB	+11.5 dBm	-∞	-∞	-∞	-∞	-∞	-∞

DSP BYPASS

The digital input audio signal is output to FRONT L/R in PURE DIRECT.

1. DSP BYPASS

INPUT: AV5 ANALOG

SPEAKER OUT: 1 kHz, SUBWOOFER OUTPUT: 50 Hz

Input level	Volume	SPEAKER OUT						SUB-WOOFER
		FRONT	CENTER	SURROUND	SURROUND BACK	PRESENCE	ZONE2	
Both ch, -20 dBm	+6.5 dB	-∞	-∞	-∞	-∞	-∞	-∞	-∞

ANALOG BYPASS

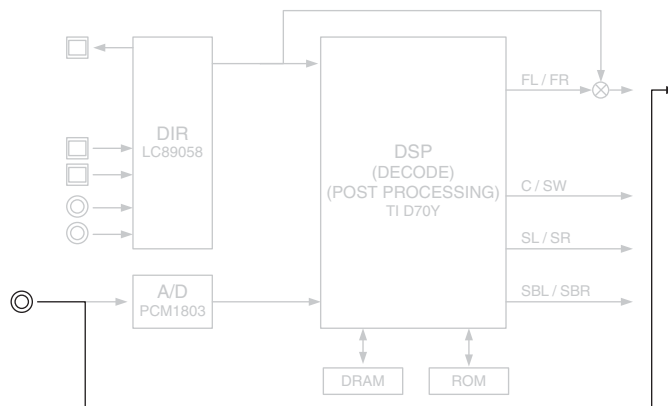

(Shaded items not used in this example)

DSP BYPASS

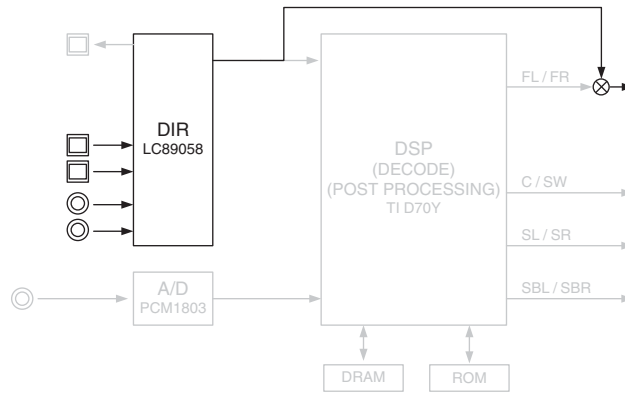

(Shaded items not used in this example)

2. RAM THROUGH

Using the sub-menu, it is possible to select MARGIN output or FULL BIT output.

RAM MARGIN

The audio signal is output including the head margin.

2. RAM MARGIN

INPUT: AV5 ANALOG

SPEAKER OUT: 1 kHz, SUBWOOFER OUTPUT: 50 Hz

Input level	Volume	SPEAKER OUT						SUB-WOOFER
		FRONT	CENTER	SURROUND	SURROUND BACK	PRESENCE	ZONE2	
Both ch, -20 dBm	+6.5 dB	+11.5 dBm	+11.5 dBm	+11.5 dBm	+11.5 dBm	-∞	-∞	-7.0 dBm

RAM FULL BIT

The audio signal is output in digital full bit without including the head margin.
 The SUBWOOFER signal is output but not in digital full bit.

2. RAM FULL ALL

INPUT: AV5 ANALOG
 SPEAKER OUT: 1 kHz, SUBWOOFER OUTPUT: 50 Hz

Input level	Volume	SPEAKER OUT						SUB-WOOFER
		FRONT	CENTER	SURROUND	SURROUND BACK	PRESENCE	ZONE2	
Both ch, -20 dBm	+6.5 dB	+11.5 dBm	+11.5 dBm	+11.5 dBm	+11.5 dBm	-∞	-∞	-7.0 dBm

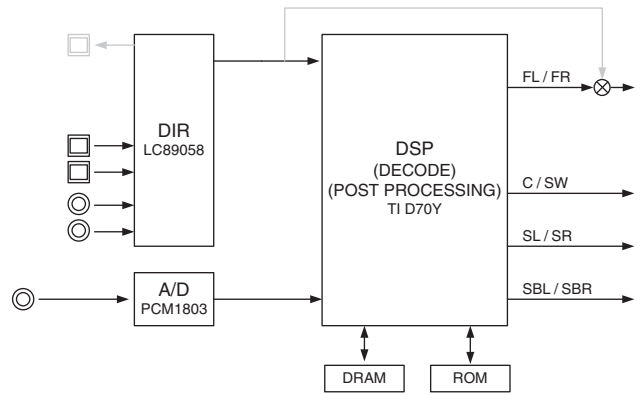

(Shaded items not used in this example)

When input source is stereo, signal is assigned as below.

- Front L → Front L / Center / Surround L / Surround Back L, R
- Front R → Front R / Surround R
- Front L +10 dB → SWFR

RAM FULL CENTER

The audio signal is output to only CENTER in digital full bit without including the head margin.

2. RAM FULL C

INPUT: AV5 ANALOG

SPEAKER OUT: 1 kHz, SUBWOOFER OUTPUT: 50 Hz

Input level	Volume	SPEAKER OUT						SUB- WOOFER
		FRONT	CENTER	SURROUND	SURROUND BACK	PRESENCE	ZONE2	
Both ch, -20 dBm	+6.5 dB	-∞	+11.5 dBm	-∞	-∞	-∞	-∞	-∞

RAM FULL SURROUND

The audio signal is output to only SURROUND L/R in digital full bit without including the head margin.

2. RAM FULL SUR

INPUT: AV5 ANALOG

SPEAKER OUT: 1 kHz, SUBWOOFER OUTPUT: 50 Hz

Input level	Volume	SPEAKER OUT						SUB- WOOFER
		FRONT	CENTER	SURROUND	SURROUND BACK	PRESENCE	ZONE2	
Both ch, -20 dBm	+6.5 dB	-∞	-∞	+11.5 dBm	-∞	-∞	-∞	-∞

RAM FULL SURROUND BACK

The audio signal is output to only SURROUND BACK L/R in digital full bit without including the head margin.

2. RAM FULL SB

INPUT: AV5 ANALOG

SPEAKER OUT: 1 kHz, SUBWOOFER OUTPUT: 50 Hz

Input level	Volume	SPEAKER OUT						SUB- WOOFER
		FRONT	CENTER	SURROUND	SURROUND BACK	PRESENCE	ZONE2	
Both ch, -20 dBm	+6.5 dB	-∞	-∞	-∞	+11.5 dBm	-∞	-∞	-∞

3. HDMI AUDIO

Using the sub-menu, the audio signals input to HDMI IN are selected and output.

* When selecting "DSD", be sure to connect an HDMI unit equipped with DSD output function to this unit.

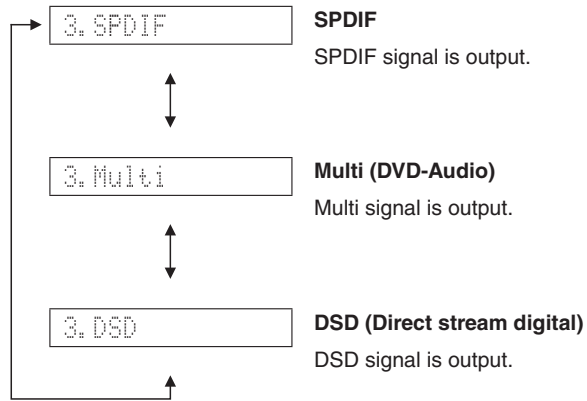

4. SPEAKER SET

The analog switch settings for each sub-menu are as shown in the table below.

	FRONT	CENTER	SURROUND	SURROUND BACK	SUBWOOFER
FRNT : SML 0dB	SMALL	LARGE	LARGE	LARGE	SWFR
CENTER : NONE	LARGE	NONE	LARGE	LARGE	SWFR
LFE/B : FRNT	LARGE	SMALL	SMALL	SMALL	FRONT
Zone2 Amp ON	LARGE	LARGE	LARGE	– (*1)	SWFR
Bi-AMP	LARGE	LARGE	LARGE	LARGE (*2)	SWFR
TONE : MAX	LARGE	LARGE	LARGE	LARGE	SWFR
TONE : MIN	LARGE	LARGE	LARGE	LARGE	SWFR
SPEAKER 6 ohms	LARGE	LARGE	LARGE	LARGE	SWFR

(*1) ZONE2 L/R (EXTRA SP L/R): LARGE

(*2) Bi-AMP: LARGE

LARGE: This mode is used for a speaker with high bass reproduction performance (a large unit). Full bandwidth signals are output.

SMALL: This mode is used for a speaker with low bass reproduction performance (a small unit). The signals of 90 Hz or less are mixed into the channel specified by LFE/BASS.

NONE: This mode is used for no center speaker. The center content is reduced by 3 dB and distributed to FRONT L/R.

SWFR: LFE of 5.1 ch signal or LFE/BASS lower than 90 Hz is output through SUBWOOFER OUT.

FRONT: LFE of 5.1 ch signal or LFE/BASS lower than 90 Hz is distributed to FRONT L/R.

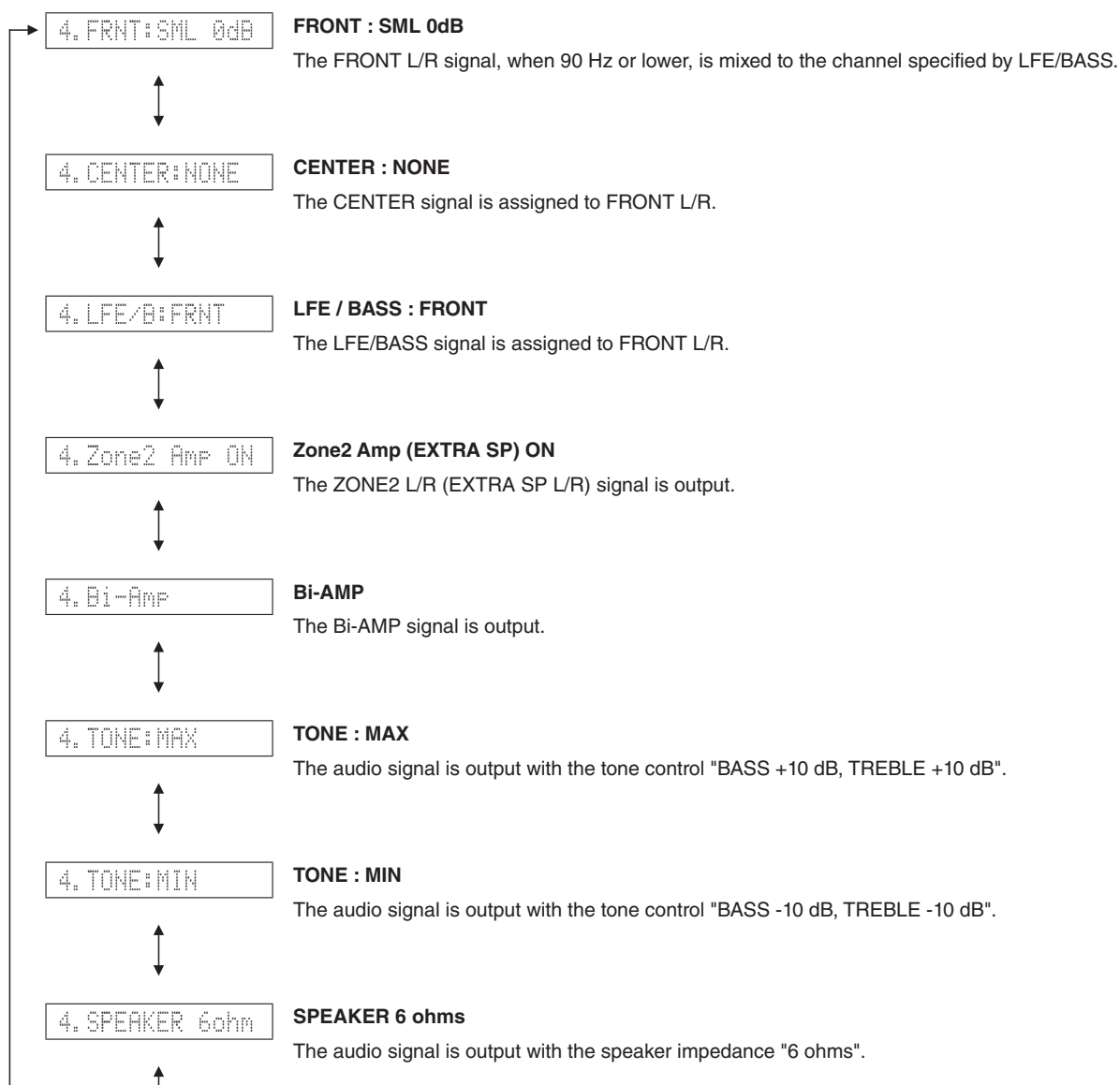

INPUT: AV5 ANALOG
SPEAKER OUT: 1 kHz, SUBWOOFER OUTPUT: 50 Hz

Sub-menu	Input level	Volume	SPEAKER OUT				SUBWOOFER OUTPUT
			FRONT L/R	CENTER	SURROUND L/R	SURROUND BACK L/R	
FRNT : SML 0dB	Both ch, -20 dBm	+6.5 dB	+11.5 dBm	+11.5 dBm	+11.5 dBm	+11.5 dBm	-4.0 dBm
CENTER : NONE	Both ch, -20 dBm	+6.5 dB	+16.5 dBm	-∞	+11.5 dBm	+11.5 dBm	-7.0 dBm
LFE/B : FRNT (50 Hz)	Both ch, -20 dBm	+6.5 dB	-∞	+11.5 dBm	+11.5 dBm	+11.5 dBm	-∞
Zone2 Amp ON	Both ch, -20 dBm	+6.5 dB	+11.5 dBm	+11.5 dBm	+11.5 dBm	-∞ (*)	-7.0 dBm
Bi-AMP	Both ch, -20 dBm	+6.5 dB	+11.5 dBm	+11.5 dBm	+17.5 dBm	+11.5 dBm	-7.0 dBm
TONE : MAX	Both ch, -20 dBm	+6.5 dB	+12.5 dBm	+11.5 dBm	+11.5 dBm	+11.5 dBm	-7.0 dBm
TONE : MIN	Both ch, -20 dBm	+6.5 dB	+10.5 dBm	+11.5 dBm	+11.5 dBm	+11.5 dBm	-7.0 dBm
SPEAKER 6 ohms	Both ch, -20 dBm	+6.5 dB	+11.5 dBm	+11.5 dBm	+11.5 dBm	+11.5 dBm	-7.0 dBm

(*) ZONE2 L/R (EXTRA SP L/R) SPEAKER OUT: +11.5 dBm

5. MULTI CH-INPUT

The input source "MULTI CHANNEL INPUT" is selected.

Using the sub-menu, it is possible to select the 6 ohms/8 ohms.

8 ch INPUT 6 ohms

5.8ch INPUT_60

INPUT: MULTI CH INPUT

SPEAKER OUT: 1 kHz, SUBWOOFER OUTPUT: 50 Hz

Input level	Volume	SPEAKER OUT						SUB- WOOFER
		FRONT	CENTER	SURROUND	SURROUND BACK	PRESENCE	ZONE2	
Both ch, -20 dBm	+6.5 dB	+11.5 dBm	+11.5 dBm	+11.5 dBm	+11.5 dBm	-∞	-∞	-18.0 dBm

8 ch INPUT 8 ohms

5.8ch INPUT_80

INPUT: MULTI CH INPUT

SPEAKER OUT: 1 kHz, SUBWOOFER OUTPUT: 50 Hz

Input level	Volume	SPEAKER OUT						SUB- WOOFER
		FRONT	CENTER	SURROUND	SURROUND BACK	PRESENCE	ZONE2	
Both ch, -20 dBm	+6.5 dB	+11.5 dBm	+11.5 dBm	+11.5 dBm	+11.5 dBm	-∞	-∞	-18.0 dBm

LIM / PLDET / THM

LIM: Setting value of LIM (Limiter control)

* Do not change the value settings because this menu is only for the use of development staff.

PLDET: Power limiter detection

The A/D conversion value during operation is displayed.

(Reference voltage: 3.3 V=255)

THM: Temperature protection detection

The A/D conversion value during operation is displayed.

(Reference voltage: 3.3 V=255)

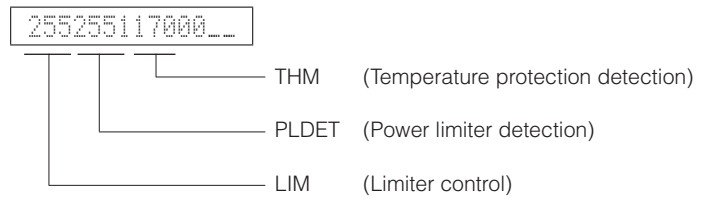
**6. MIC CHECK**

The signals input through the microphone are output to only FRONT L via A/D and D/A.

6. MIC CHK

Segment conditions of the FL driver and the FL tube are checked by turning ON and OFF all segments. Next, the operation of the FL driver is checked by using the dimmer control. Then a short between segments next to each other is checked by turning ON and OFF all segments alternately (in lattice).

(In the above example, the segments in the second row from the top are shorted.)

8. MANUAL TEST

The noise generator with a built-in DSP outputs the test noise through the channels specified by using the sub-menu.

The noise frequency for LFE is 30 to 80 Hz. Other than that, the noise frequency is 500 to 2 kHz.

TEST ALL

The test noise is output from all channels.

8. TEST ALL

9. A/D DATA CHECK

This menu is used to display the A/D conversion value of the microprocessor which detects panel keys of this unit and protection functions by using the sub-menu.

When K0/K1 menu is selected, keys become non-operable due to detection of the values of all keys.

In order to turn on the power again, disconnect the power cable of this unit from the AC outlet once and then reconnect it again.

* The figures in the diagram are given as reference only.

PS1/PS2

PSx: Power supply voltage protection detection

PS1

Voltage detects: AC_BL, AC_12, AC_5, ± 12 and +5V

Normal value: 38 to 128
(Reference voltage: 3.3 V=255)

PS2

Voltage detects: -5 and +5I

Normal value: 31 to 125
(Reference voltage: 3.3 V=255)

* If PS1 and PS2 are out of the normal value range, the protection function works to turn off the power.

PS1:089 2:078

DC/TH

DC: Power amplifier DC (DC voltage) output is detected.
 Normal value: 23 to 70
 (Reference voltage: 3.3 V=255)

TH: Temperature on the heat sink is detected.
 Normal value: 0 to 124
 (Reference voltage: 3.3 V=255)

* If DC and TH are out of the normal value range, the protection function works to turn off the power.

DC:046 TH:111

IMP/PL

IMP: 8 or 6 ohms impedance setup detection
 IMP 8: 8 ohms setting
 IMP 6: 6 ohms setting

PL: PLDET (Power amplifier output voltage detection)
 The power amplifier output voltage is detected and the power amplifier input voltage is controlled according to the detected output voltage.
 (Reference voltage: 3.3 V=255)

IMP:8 PL:255

U, C, A, F models (Reference voltage: 3.3 V=255)

	During normal operation	Value for starting limiter operation	Value for canceling limiter operation
PLDET (8 ohms/6 ohms)	255 / 255	87 / 146	125 / 171
LIM (Limiter control)	H	L	H

R, L models (Reference voltage: 3.3 V=255)

	During normal operation	Value for starting limiter operation	Value for canceling limiter operation
PLDET (8 ohms/6 ohms)	255 / 255	100 / 100	131 / 131
LIM (Limiter control)	H	L	H

DST/DK

DST: Destination detection
(Reference voltage: 3.3 V=255)

DK: DOCK type detection
(Reference voltage: 3.3 V=255)

DST:027 DK:255

Destination detection for AD port
Pull-up resistance 10 k-ohms

Ohm (R3809 VIDEO P.C.B.)	1.2 k	2.7 k	4.7 k	15.0 k	47.0 k	100.0 k
A/D value (3.3 V=255)	15 – 46	46 – 69	69 – 92	139 – 177	185 – 224	224 – 247
DEST (139 pin)	U	C	R	A	F	L

DOCK detection for AD port (IC20 Microprocessor pin no. 128)
Pull-up resistance 10 k-ohms

DOCK type (DKID 141 pin)	Bluetooth	iPod	No connect
A/D value (3.3 V=255)	5 – 25	120 – 140	255

K0/K1

K0/K1: KEY0/KEY1 (Panel key of this unit)

When the A/D conversion value of the panel key becomes out of the specified range (standard value ±4), normal operation will not be available.

In this case, check the constant of voltage dividing resistor, solder condition, etc. Refer to the table below.

(Reference voltage: 3.3 V=255)

K0:255 K1:255

Display	KEY0 (133 pin)
0 – 11	SCENE RADIO
12 – 32	SCENE CD
33 – 54	SCENE TV
55 – 75	SCENE BD/DVD
76 – 95	ZONE2 ON/OFF
96 – 118	ZONE2 CONTROL

Display	KEY0 (133 pin)
119 – 142	PROGRAM ►
143 – 162	PROGRAM ◀
181 – 197	MAIN ZONE ON/OFF
198 – 229	TONE CONTROL
255	KEY OFF

Display	KEY1 (134 pin)
0 – 11	PURE DIRECT
12 – 32	STRAIGHT
33 – 54	INFO
55 – 77	MEMORY
78 – 98	PRESET ◀
99 – 120	PRESET ►
121 – 143	CATEGORY ◀ FM

Display	KEY1 (134 pin)
144 – 165	CATEGORY ► AM
166 – 185	TUNING CH ◀
186 – 205	TUNING CH ►
206 – 225	INPUT ◀
226 – 245	INPUT ►
255	KEY OFF

10. VIDEO CHECK

I2C check

The I2C (Inter integrated circuit) bus line connection is checked.

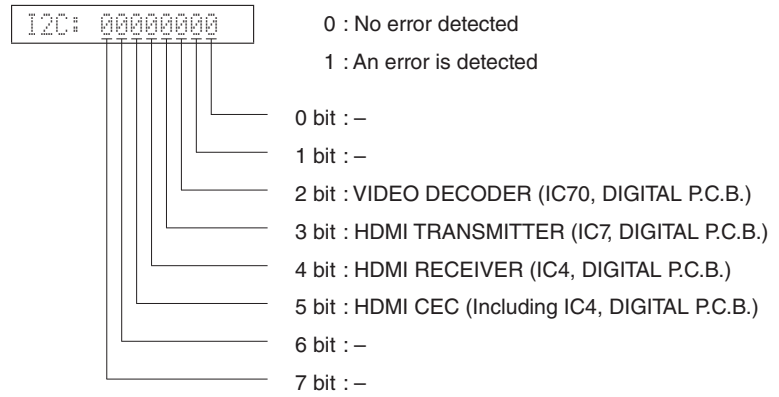

Digital component

The video signal is converted and output as shown below.

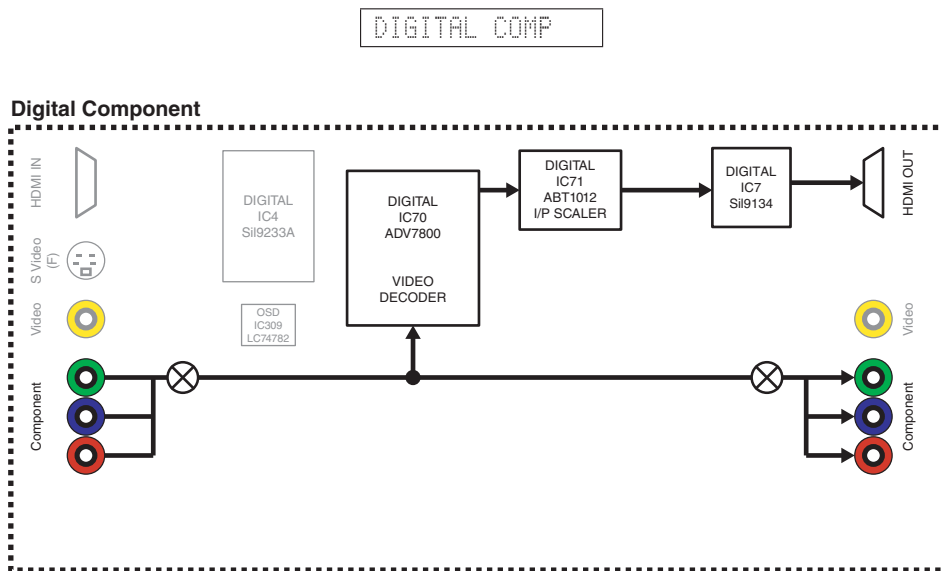

Digital CVBS (Video)

The video signal is converted and output as shown below.

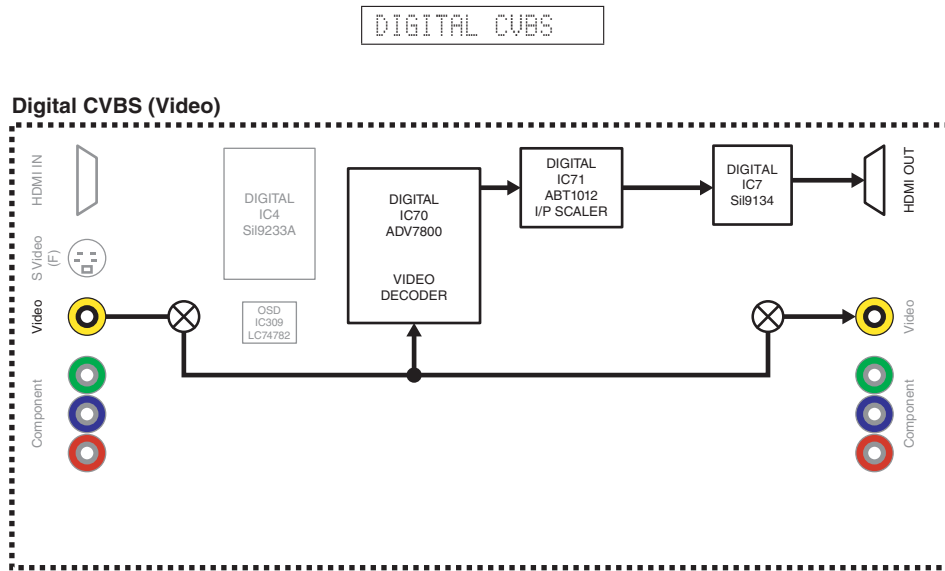

Digital Y/C (S-Video) (F model)

The video signal is converted and output as shown below.

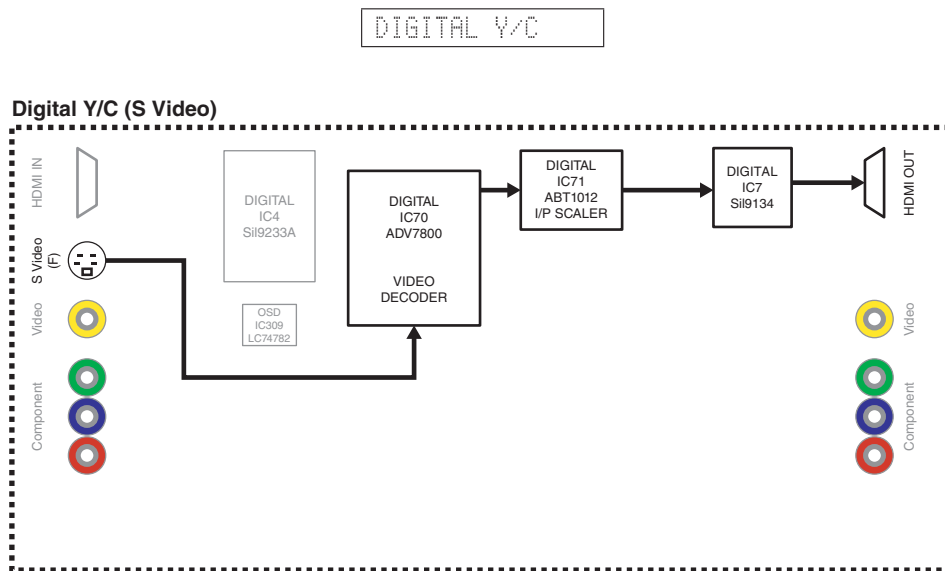

Analog bypass

The video signal is converted and output as shown below.

ANALOG BYPASS

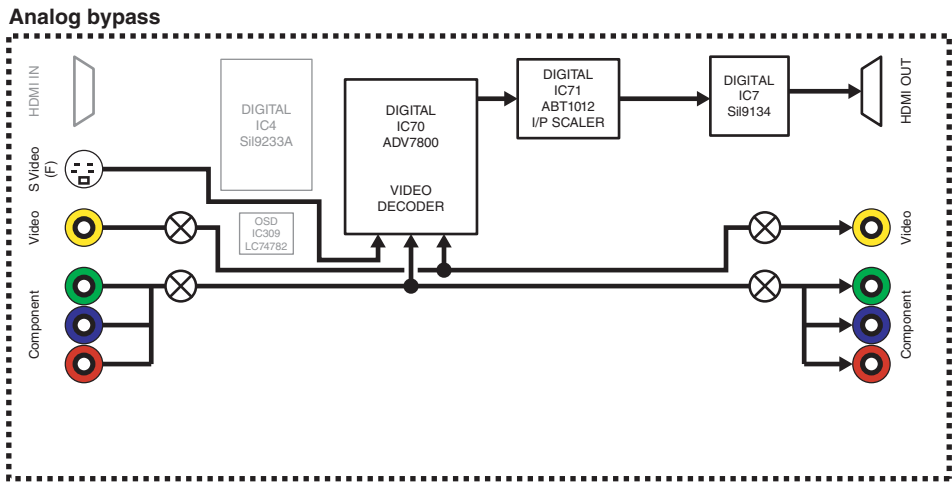

Test pattern

Not applied to these models.

TEST PATTERN

Video information

The information of input video signal is displayed.

Example

VIDEO IN 480i

11. XM STATUS (U model)

This menu is used to check the output of XM Radio Antenna.

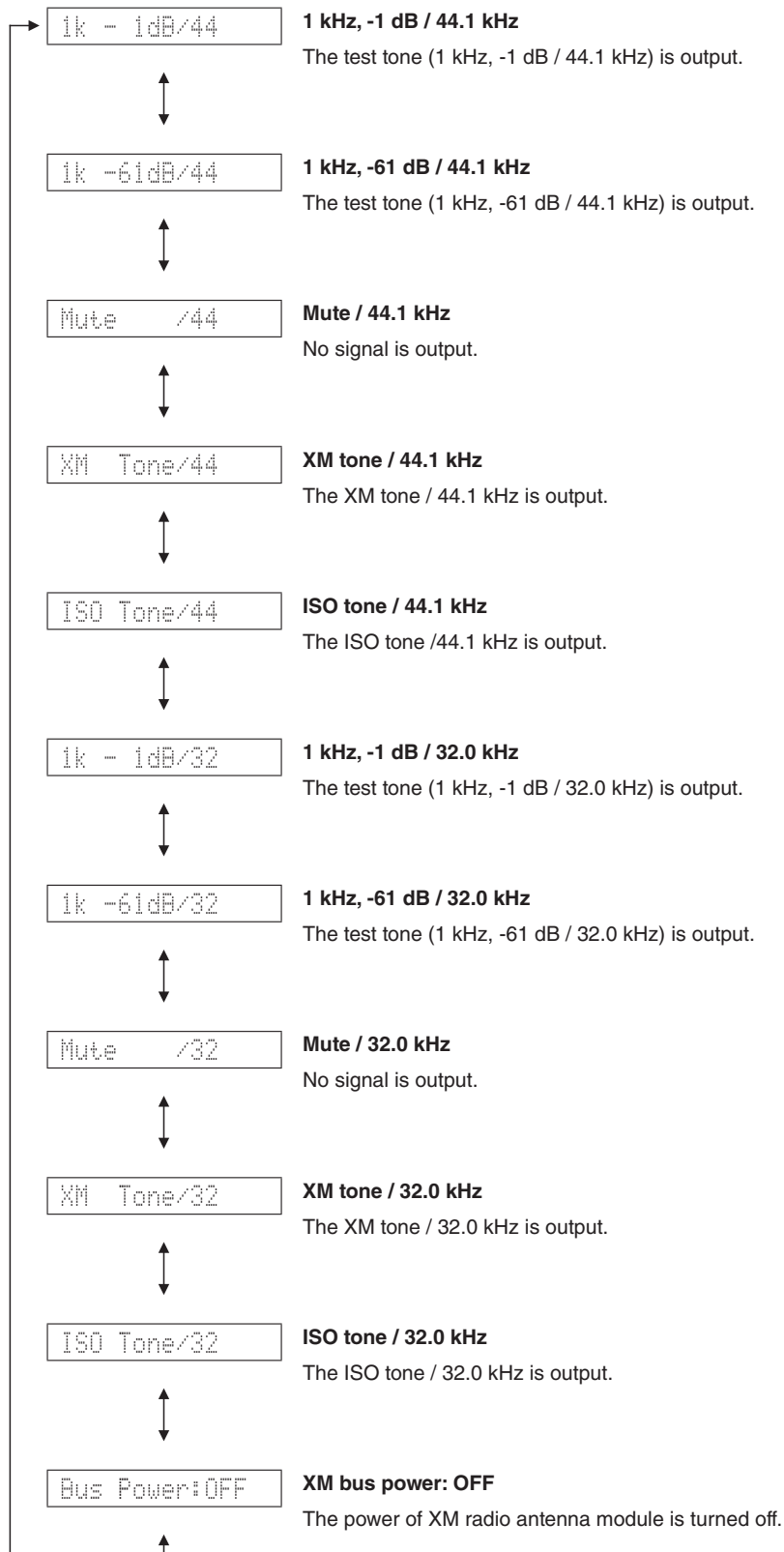

12. SIRIUS (U model)

The SIRIUS information are displayed.

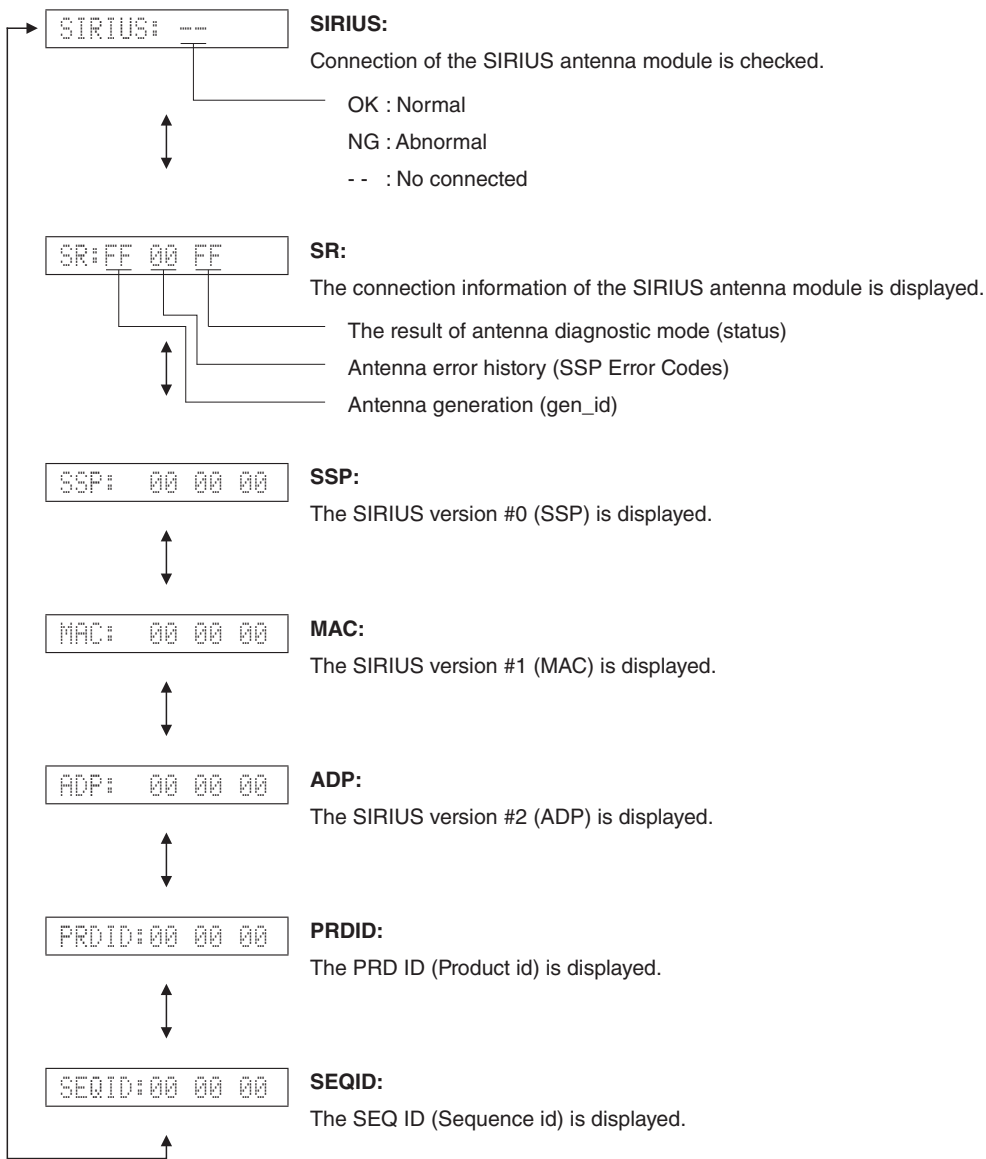

13. HD RADIO (U model)

Not applied to these models.

CPU version

HD CPU V:

DSP version

D:

14. DOCK

This menu is used to check the DOCK connector without the iPod itself.

With the power to this unit turned off, short between pins No. 14 (TX) and No. 18 (RX), between pins No. 1 (PWR) and No. 17 (ACCPOW), between pins No. 4 (iPDET) and No. 8 (DGND). Also, connect a 10 k-ohms, 1/4 W resistor between pins NO. 21 (DKID) and No. 8 (DGND). (Make sure that the power is turned off when shorting pins.)

Start up the self-diagnostic function and select this menu.

The check result is displayed according to the following display specifications.

Note) Be sure to return the shorted pins to their original condition after executing this test.

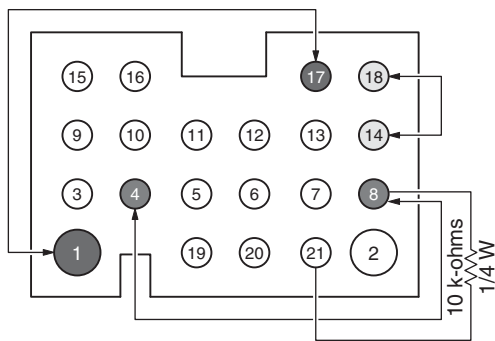

DOCK CONNECTOR

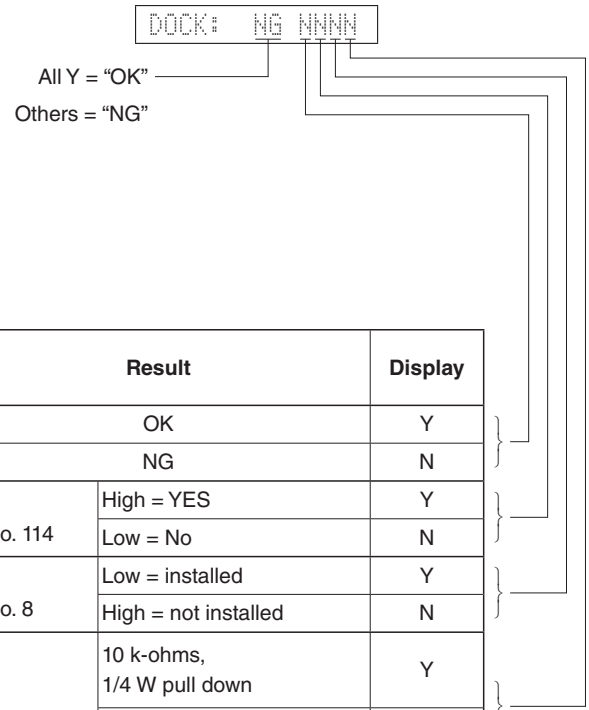

Check item	Short pins	Result	Display
UART loop back test	Pins No.14 (TX) - No.18 (RX)	OK	Y
		NG	N
iPAP (iPod accessory power) detection	Pins No.1 (PWR) - No.17 (ACCPOW)	IC20 pin No. 114 High = YES	Y
		Low = No	N
iPDET (iPod installation to DOCK) detection	Pins No.4 (iPDET) - No.8 (DGND)	IC20 pin No. 8 Low = installed	Y
		High = not installed	N
DKID (DOCK ID) detection	Pins No.21 (DKID) - No.8 (DGND) * 10 k-ohms, 1/4 W pull down	IC20 pin No. 141 10 k-ohms, 1/4 W pull down	Y
		Other	N

BT VERSION

The DOCK (Bluetooth module) version is displayed.



15. HDMI INFORMATION

The HDMI information are displayed.

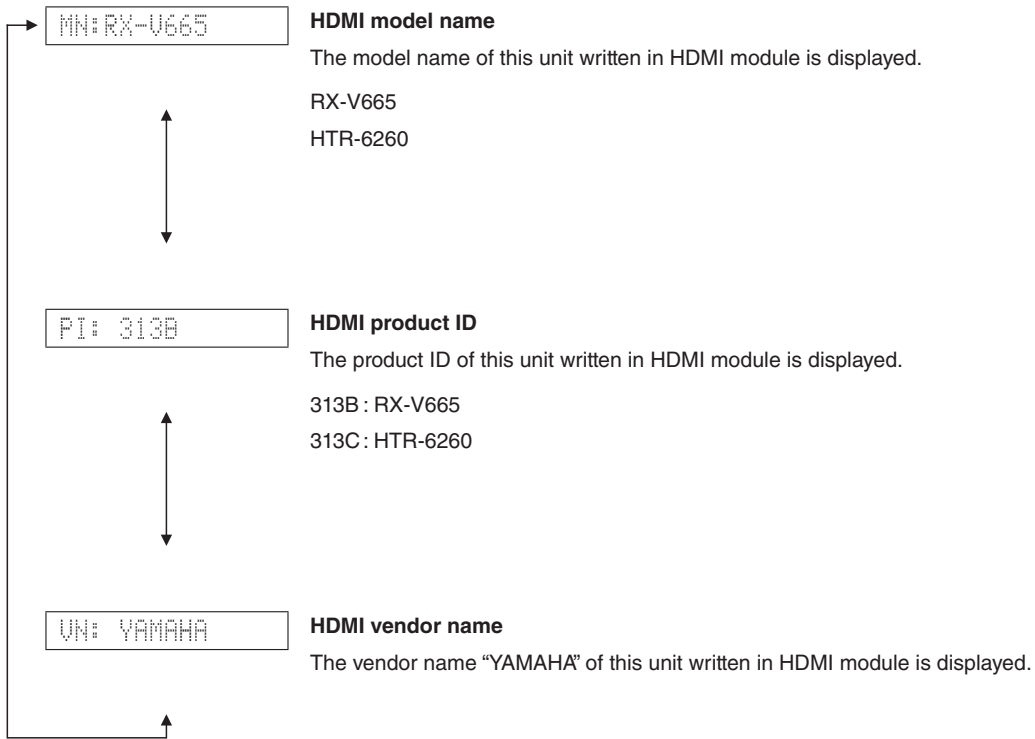

16. HDMI SELECT

Using the sub-menu, the selected input signal is output to HDMI OUT.

* Support audio is set to "OTHER".

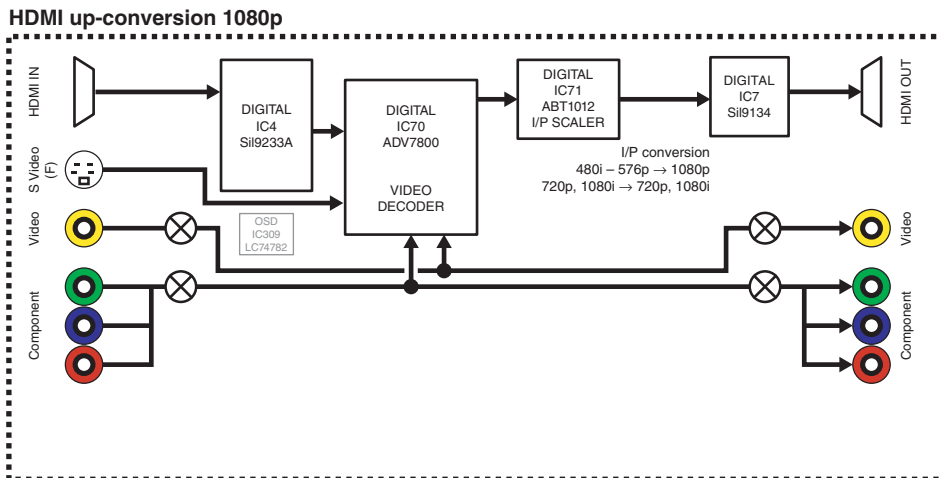
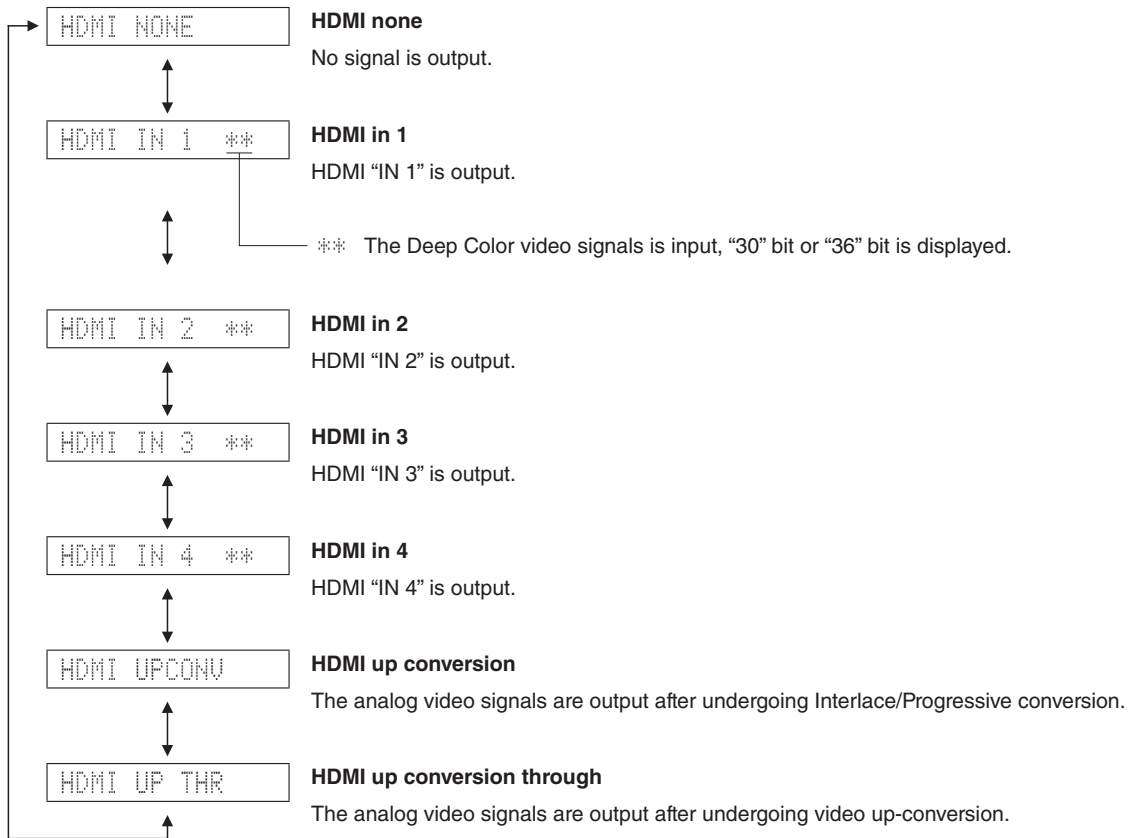

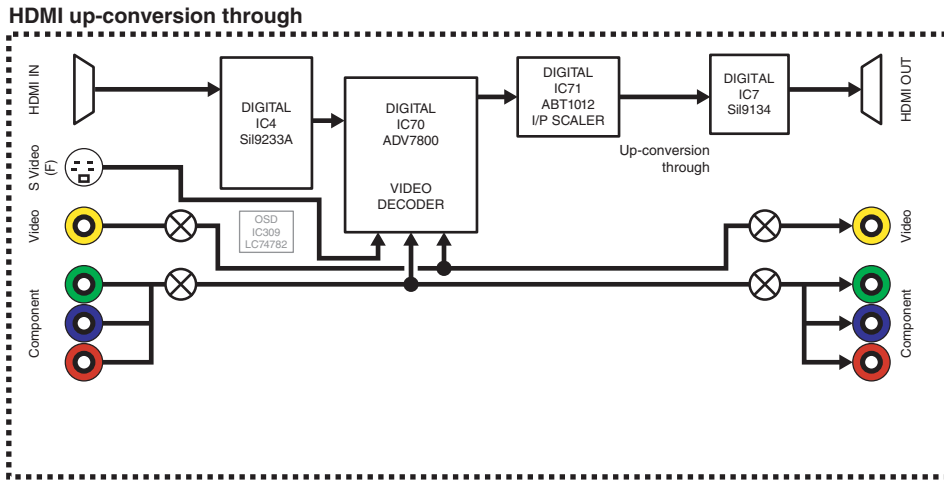

17. USB

Not applied to these models.

USB file 1

17:USB file 1

USB file 2

17:USB file 2

18. IF STATUS (Input function status)

Not applied to these models.

```
DST:7700020000
```

19. BUS CHECK

Communication and bus line connection between devices on the DSP P.C.B. are checked.

TI (DSP) BUS check

Communication and bus line connection between microprocessor (IC20) and TI (DSP, IC44) are checked.

```
TI BUS:NoEr
```

NoEr : No error detected.

Boot : When "Boot" is displayed for a few seconds or "Boot" and "NoEr" are displayed alternately, there is possibility that an error occurs.

BF LOOP :

Not applied to these models.

```
BF LOOP:
```

20. NO MENU (Invalidity)**20. NO MENU (Invalidity)**

```
Invalidity
```

21. PROTECTION HISTORY

The history of protection function is displayed.

Select this menu and press the "STRAIGHT" key, and the history will be erased.

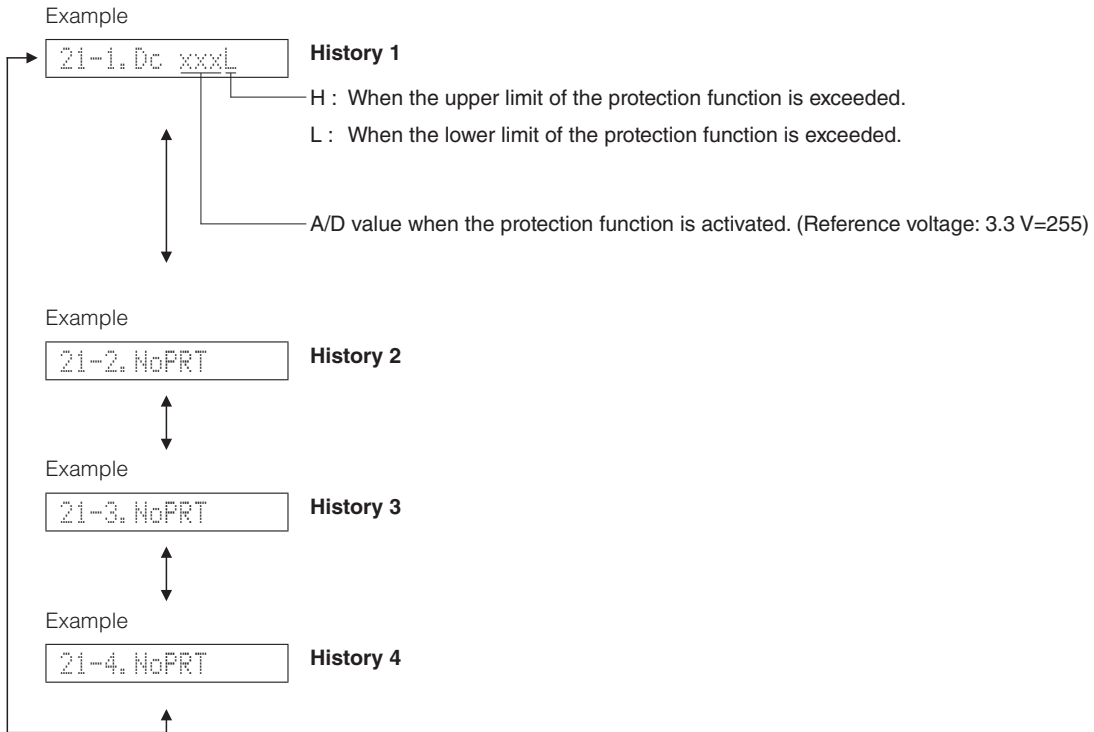

22. NO MENU (Invalidity)

Invalidity

23. UPDATE

Not applied to these models.

UPDATE TI

23. UPDATE TI

24. FACTORY PRESET

This menu is used to reserve and inhibit initialization of the back-up IC.

24. PRESET INHI



24. PRESET RSRV

PRESET INHIBIT (Initialization inhibited)

Back-up IC initialization is not executed. Select this sub-menu to protect the values set by the user.

PRESET RESERVED (Initialization reserved)

Initialization of the back-up IC is reserved. (Actually, initialization is executed the next time that the power is turned on.) Select this sub-menu to reset to the original factory settings or to reset the back-up IC. Any protection history will be cleared.

CAUTION: Before setting to the PRESET RESERVED, write down the existing preset memory content of the tuner.
(This is because setting to the PRESET RESERVED will cause the user memory content to be erased.)

25. ROM VER/SUM/PORT

The firmware version, checksum values, model name and destination are displayed.

The checksum is obtained by adding the data at every 8-bit for each program area and expressing the result as a 4-figure hexadecimal data.

* The figures in the diagram are given as reference only.

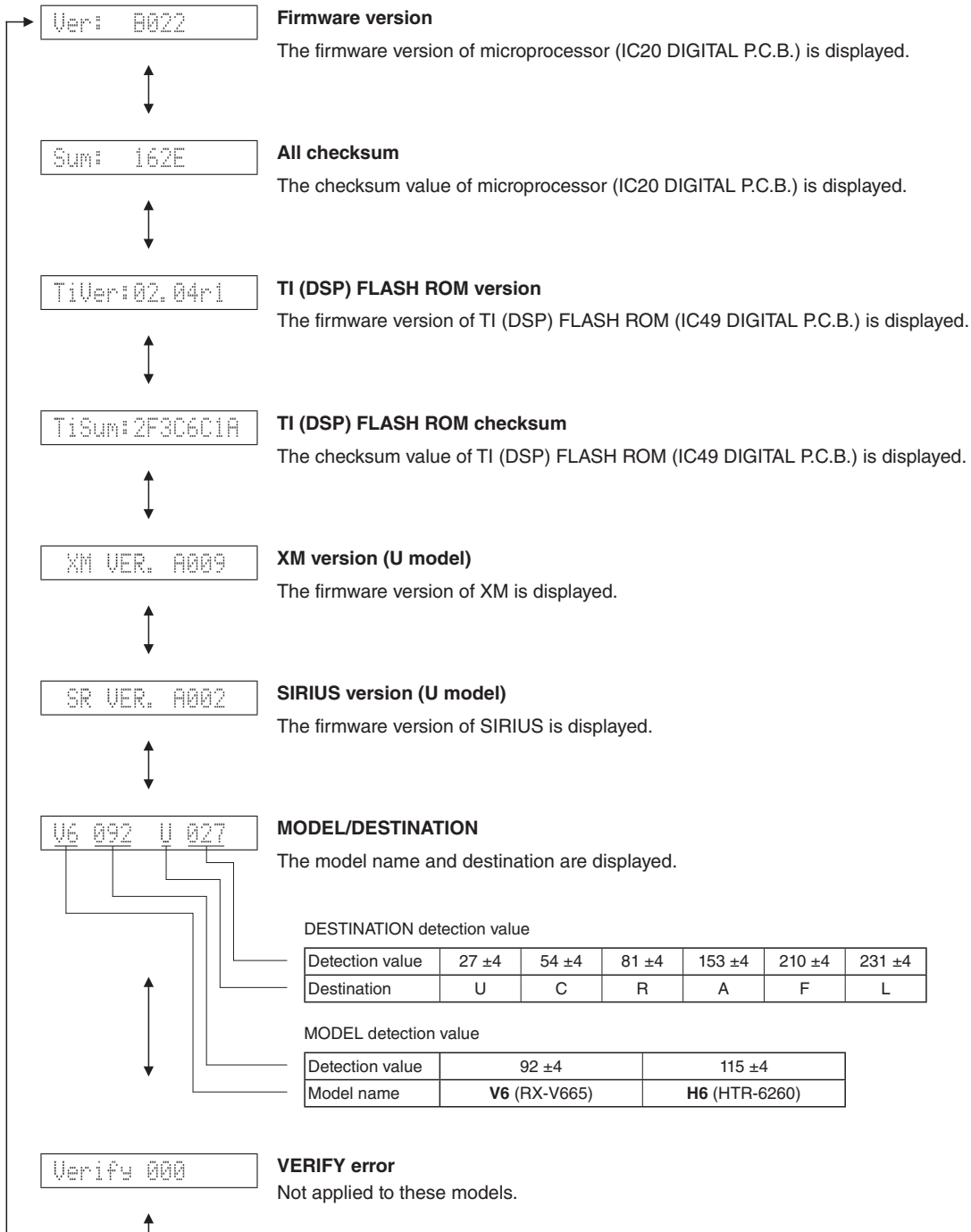

■ DISPLAY DATA

● V4001 : 18-MT-09GNK (OPERATION P.C.B.)

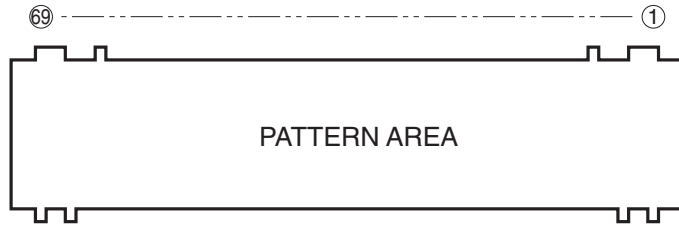

● PIN CONNECTION

Pin No.	69	68	67	66	65	64	63	62	61	60	59	58	57	56	55	54	53	52	51	50	49	48	47	46	45	44	43	42	41	40	39	38	37	36	35
Connection	F2	NX	NP	NP	P1	P2	P3	P4	P5	P6	P7	P8	P9	P10	P11	P12	P13	P14	P15	P16	P17	P18	P19	P20	P21	P22	P23	P24	P25	P26	P27	P28	P29	P30	P31

Pin No.	34	33	32	31	30	29	28	27	26	25	24	23	22	21	20	19	18	17	16	15	14	13	12	11	10	9	8	7	6	5	4	3	2	1
Connection	P32	P33	P34	P35	P36	NX	NX	NX	NX	NX	NX	NX	18G	17G	16G	15G	14G	13G	12G	11G	10G	9G	8G	7G	6G	5G	4G	3G	2G	1G	NP	NP	NX	F1

Note : 1) F1, F2 Filament pin 2) NP No pin 3) NX No extend pin 4) 1G-18G Grid pin

● GRID ASSIGNMENT

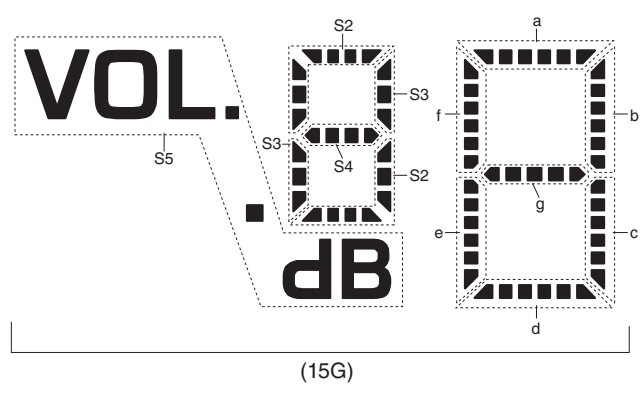
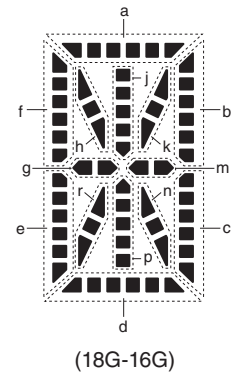
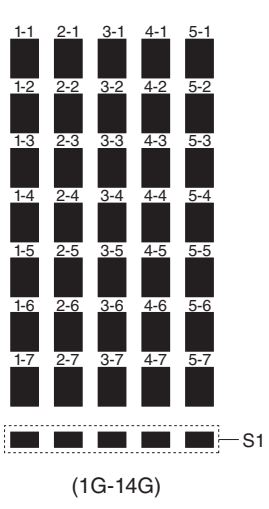
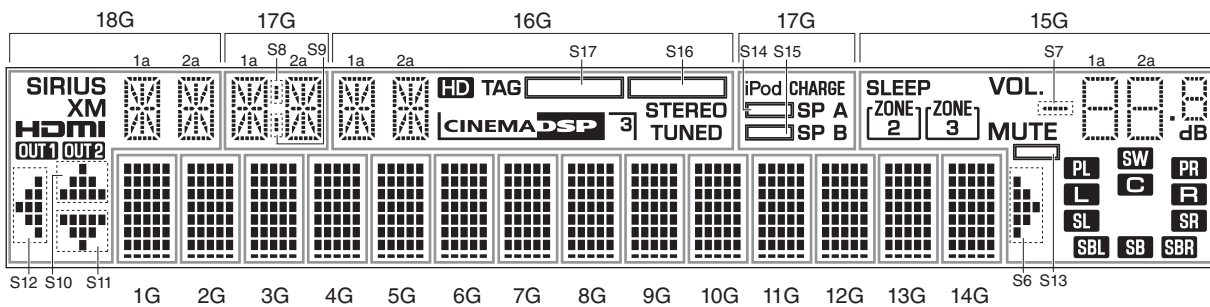

● ANODE CONNECTION

	18G	17G	16G	15G	1G-14G
P1	1a	1a	1a	S5	1-1
P2	1h	1h	1h	S7	2-1
P3	1j	1j	1j	1d	3-1
P4	1k	1k	1k	2d	4-1
P5	1b	1b	1b	S2	5-1
P6	1f	1f	1f	1e	1-2
P7	1m	1m	1m	2e	2-2
P8	1g	1g	1g	S3	3-2
P9	1c	1c	1c	1c	4-2
P10	1e	1e	1e	2c	5-2
P11	1r	1r	1r	S4	1-3
P12	1p	1p	1p	1g	2-3
P13	1n	1n	1n	2g	3-3
P14	1d	1d	1d	1f	4-3
P15	2a	2a	2a	2f	5-3
P16	2h	2h	2h	1b	1-4
P17	2j	2j	2j	2b	2-4
P18	2k	2k	2k	1a	3-4
P19	2b	2b	2b	2a	4-4
P20	2f	2f	2f	PL	5-4
P21	2m	2m	2m	SW	1-5
P22	2g	2g	2g	PR	2-5
P23	2c	2c	2c	L	3-5
P24	2e	2e	2e	C	4-5
P25	2r	2r	2r	R	5-5
P26	2p	2p	2p	SL	1-6
P27	2n	2n	2n	SR	2-6
P28	2d	2d	2d	SBL	3-6
P29	SIRIUS	S8	HD	SB	4-6
P30	XM	S9	TAG	SBR	5-6
P31	HDMI	iPod CHARGE	CINEMA DSP	S6	1-7
P32	OUT1	SP B	3	S13	2-7
P33	OUT2	S15	STEREO	MUTE	3-7
P34	S12	SP A	TUNED	ZONE 2	4-7
P35	S10	S14	S17	ZONE 3	5-7
P36	S11	—	S16	SLEEP	S1

IC DATA

IC44: D70YE101BRFP266 (DIGITAL P.C.B.)

Decoder/Post processor

* No replacement part available.

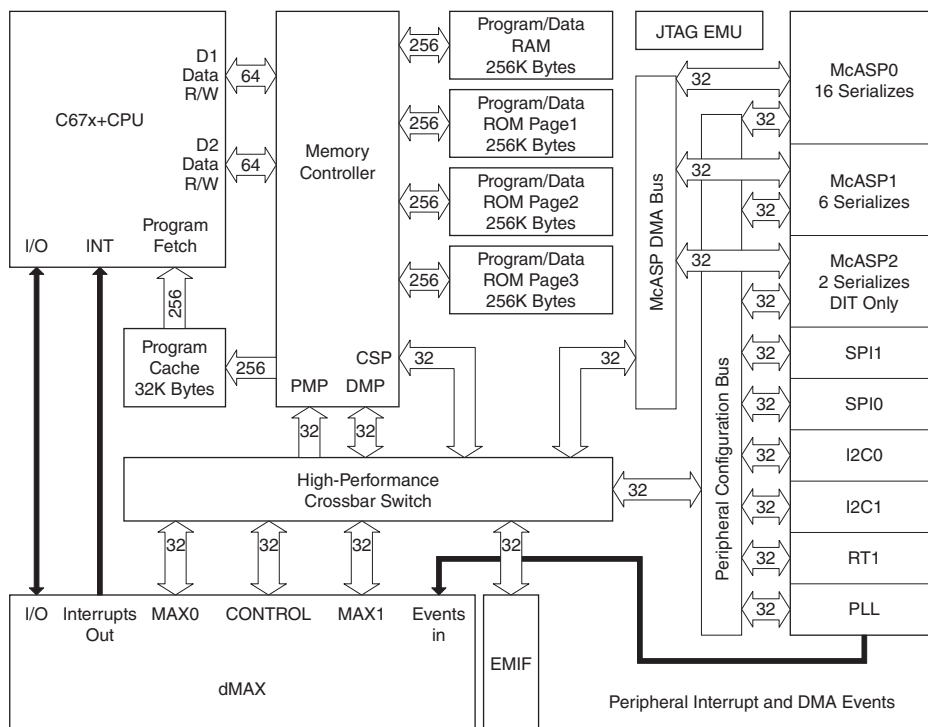
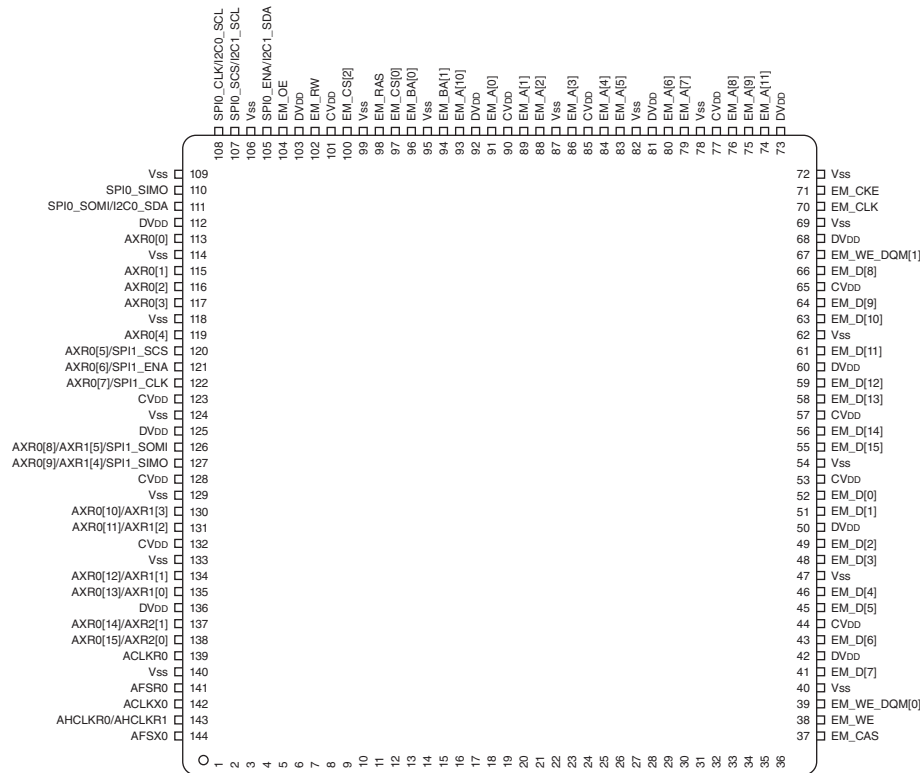

RX-V665/HTR-6260

No.	Function Name (P.C.B.)	TYPE ⁽¹⁾	PULL ⁽²⁾	GPIO ⁽³⁾	Detail of Function
1	VSS				
2	AHCLKX0/AHCLKX2	IO	–	Y	McASP0 and McASP2 transmit master clock
3	AMUTE0	IO	–	Y	McASP0 mute output
4	AMUTE1	IO	–	Y	McASP1 mute output
5	AHCLKX1	IO	–	Y	McASP1 transmit master clock
6	VSS				
7	ACLKX1	IO	–	Y	McASP1 transmit bit clock
8	CVDD				
9	ACLKR1	IO	–	Y	McASP1 receive bit clock
10	DVDD				
11	AFSX1	IO	–	Y	McASP1 transmit frame Sync (L/R clock)
12	AFSR1	IO	–	Y	McASP1 receive frame Sync (L/R clock)
13	VSS				
14	RESET	IO	–	N	Device reset pin
15	VSS				
16	CVDD				
17	CLKIN	IO	–	N	Alternate clock input (3.3-V LVCMOS input)
18	VSS				
19	TMS	IO	IPU	N	Test mode select
20	CVDD				
21	TRST	IO	IPU	N	Test reset
22	OSCVSS	PWR	–	N	Oscillator Vss tap point (for filter only)
23	OSCIN	IO	–	N	1.2-V oscillator input
24	NC	O	–	N	
25	OSCVDD	PWR	–	N	Oscillator 1.2-V Vpp tap point (for filter only)
26	VSS				
27	PLLHV	PWR	–	N	PLL 3.3-V supply input (requires external filter)
28	TDI	IO	IPU	N	Test data in
29	TDO	OZ	IPU	N	Test data out
30	VSS				
31	DVDD				
32	EMU[0]	IO	IPU	N	Emulation pin 0
33	CVDD				
34	EMU[1]	IO	IPU	N	Emulation pin 1
35	TCK	IO	IPU	N	Test clock
36	Ground(Vss)				
37	EM_CAS	O	–	N	SDRAM column address strobe
38	EM_WE	O	–	N	SDRAM write enable
39	EM_WE_DQM[0]	O	–	N	Write enable or byte enable for EM_D [7:0]
40	VSS				
41	EM_D[7]	IO	–	N	EMIF data bus [lower 16-bits]
42	DVDD				
43	EM_D[6]	IO	–	N	EMIF data bus [lower 16-bits]
44	CVDD				
45	EM_D[5]	IO	–	N	EMIF data bus [lower 16-bits]
46	EM_D[4]	IO	–	N	EMIF data bus [lower 16-bits]
47	VSS				
48	EM_D[3]	IO	–	N	EMIF data bus [lower 16-bits]
49	EM_D[2]	IO	–	N	EMIF data bus [lower 16-bits]
50	DVDD				
51	EM_D[1]	IO	–	N	EMIF data bus [lower 16-bits]
52	EM_D[0]	IO	–	N	EMIF data bus [lower 16-bits]
53	CVDD				
54	VSS				
55	EM_D[15]	IO	–	N	EMIF data bus [lower 16-bits]
56	EM_D[14]	IO	–	N	EMIF data bus [lower 16-Bits]
57	CVDD				
58	EM_D[13]	IO	–	N	EMIF data bus [lower 16-Bits]
59	EM_D[12]	IO	–	N	EMIF data bus [lower 16-Bits]
60	DVDD				
61	EM_D[11]	IO	–	N	EMIF data bus [lower 16-Bits]

No.	Function Name (P.C.B.)	TYPE ⁽¹⁾	PULL ⁽²⁾	GPIO ⁽³⁾	Detail of Function
62	VSS				
63	EM_D[10]	IO	–	N	EMIF data bus [lower 16-Bits]
64	EM_D[9]	IO	–	N	EMIF data bus [lower 16-Bits]
65	CVDD				
66	EM_D[8]	IO	–	N	EMIF data bus [lower 16-bits]
67	EM_WE_DQM[1]	O	–	N	Write enable or byte enable for EM_D [15:8]
68	DVDD				
69	VSS				
70	EM_CLK	O	–	N	SDRAM clock
71	EM_CKE	O	–	N	SDRAM clock enable
72	VSS				
73	DVDD				
74	EM_A[11]	O	–	N	EMIF address bus
75	EM_A[9]	O	–	N	EMIF address bus
76	EM_A[8]	O	–	N	EMIF address bus
77	CVDD				
78	VSS				
79	EM_A[7]	O	–	N	EMIF address bus
80	EM_A[6]	O	–	N	EMIF address bus
81	DVDD				
82	VSS				
83	EM_A[5]	O	–	N	EMIF address bus
84	EM_A[4]	O	–	N	EMIF address bus
85	CVDD				
86	EM_A[3]	O	–	N	EMIF address bus
87	VSS				
88	EM_A[2]	O	–	N	EMIF address bus
89	EM_A[1]	O	–	N	EMIF address bus
90	CVDD				
91	EM_A[0]	O	–	N	EMIF address bus
92	DVDD				
93	EM_A[10]	O	–	N	EMIF address bus
94	EM_BA[1]	O	–	N	SDRAM bank address and asynchronous memory Low-Order address
95	VSS				
96	EM_BA[0]	O	–	N	SDRAM bank address and asynchronous memory Low-Order address
97	EM_CS[0]	O	–	N	SDRAM chip select
98	EM_RAS	O	–	N	SDRAM row address strobe
99	VSS				
100	EM_CS[2]	O	–	N	Asynchronous memory chip Select
101	CVDD				
102	NC	O	–	N	Asynchronous memory read/not write
103	DVDD				
104	EM_OE	O	–	N	SDRAM output enable
105	SPI0_ENA/I2C1_SDA	IO	–	Y	SPI0 enable (ready) or I2c1 serial data
106	VSS				
107	SPI0_ENA/I2C1_SCL	IO	–	Y	SPI0 enable (ready) or I2c1 serial clock
108	SPI0_CLK/I2C0_SCL	IO	–	Y	SPI0 serial clock or I2c0 serial clock
109	VSS				
110	SPI0_SIMO	IO	–	Y	SPI0 data pin slave in master out
111	SPI0_SOMI/I2C0_SDA	IO	–	Y	SPI0 data pin slave out master in or I2C0 serial data
112	DVDD				
113	AXR0[0]	IO	–	Y	McASP0 serial data 0
114	VSS				
115	AXR0[1]	IO	–	Y	McASP0 serial data 1
116	AXR0[2]	IO	–	Y	McASP0 serial data 2
117	AXR0[3]	IO	–	Y	McASP0 serial data 3
118	VSS				
119	AXR0[4]	IO	–	Y	McASP0 serial data 4
120	SPI1_SCS	IO	–	Y	McASP0 serial data 5 or SPI1 slave chip select
121	SPI1_ENA	IO	–	Y	McASP0 serial data 6 or SPI1 enable (ready)
122	SPI1_CLK	IO	–	Y	McASP0 serial data 7 or SPI1 serial clock

No.	Function Name (P.C.B.)	TYPE ⁽¹⁾	PULL ⁽²⁾	GPIO ⁽³⁾	Detail of Function
123	CVDD				
124	VSS				
125	DVDD				
126	/SPI1_SOMI	IO	–	Y	McASP0 serial data 8 or McASP1 serial data 5 or SPI1 data pin slave out master in
127	/SPI1_SIMO	IO	–	Y	McASP0 serial data 9 or McASP1 serial data 4 or SPI1 data pin slave in master out
128	CVDD				
129	VSS				
130	AXR0[10]	IO	–	Y	McASP0 serial data 10 or McASP1 serial data 3
131	AXR0[11]	IO	–	Y	McASP0 serial data 11 or McASP1 serial data 2
132	CVDD				
133	VSS				
134	AXR0[12]	IO	–	Y	McASP0 serial data 12 or McASP1 serial data 1
135	AXR0[13]	IO	–	Y	McASP0 serial data 13 or McASP1 serial data 0
136	DVDD				
137	AXR0[14]	IO	–	Y	McASP0 serial data 14 or McASP2 serial data 1
138	AXR0[15]	IO	–	Y	McASP0 serial data 15 or McASP2 serial data 0
139	ACLKR0	IO	–	Y	McASP0 receive bit clock
140	VSS				
141	AFSR0	IO	–	Y	McASP0 receive frame Sync (L/R clock)
142	ACLKX0	IO	–	Y	McASP0 transmit bit clock
143	AHCLKR0/AHCLKR1	IO	–	Y	McASP0 and McASP1 receive master clock
144	AFSX0	IO	–	Y	McASP0 transmit frame Sync (L/R clock)

IC402: M66003-0131FP (OPERATION P.C.B.)
FL display driver

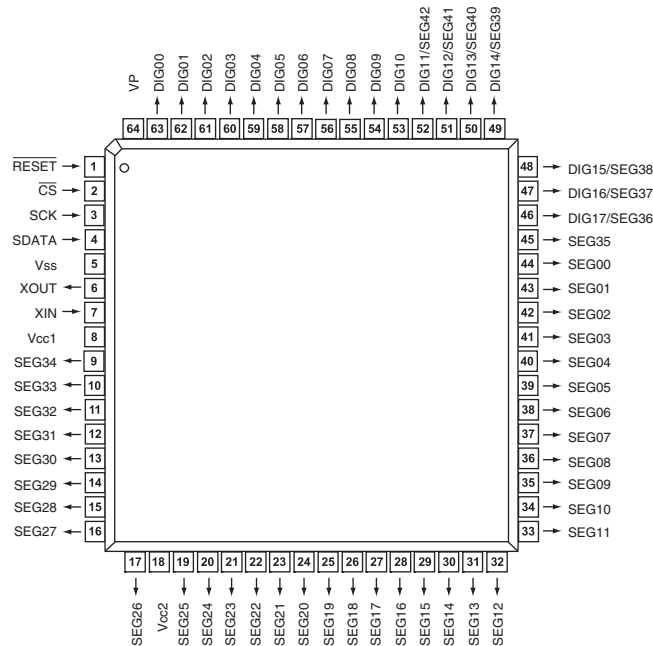
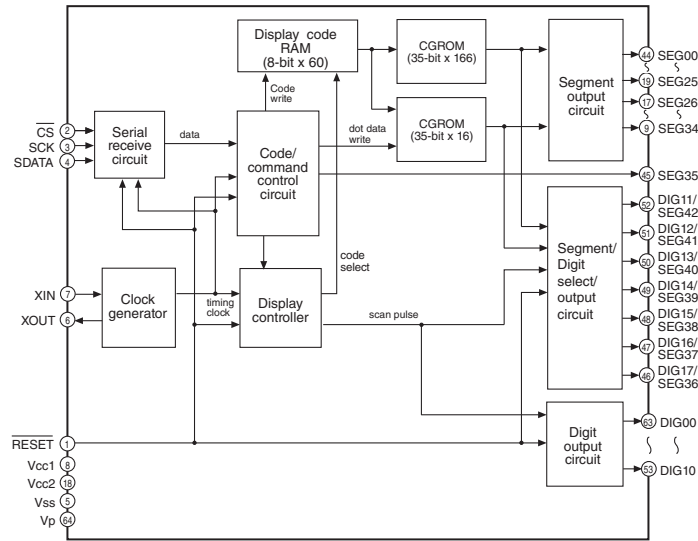

Pin No.	Port Name	Function Name	I/O	Detail of Function
1	RESET	/RESET	Reset input	When "L", M66003 is initialized.
2	CS	/CEFL	Chip select input	When "L", communication with the MCU is possible.
3	SCK	CKFL	Shift clock input	When "H", any instruction from the MCU is neglected.
4	SDATA	DTFL	Serial data input	Serial input data is taken and shifted by the positive edge of SCK.
5	Vss	VSS		GND (0V)
6	XOUT	XOUT	Clock out	When use as a CR oscillator, connect external resistor and capacitor.
7	XIN	XIN	Clock in	When use an external clock input external clock to XIN, and XOUT must be opened.

Pin No.	Port Name	Function Name	I/O	Detail of Function
8	Vcc1	VDD		Positive power supply for internal logic.
9	SEG34	P11	Segment output	Connect to segment (anode) pins of VFD.
10	SEG33	P2		
11	SEG32	P3		
12	SEG31	P4		
13	SEG30	P5		
14	SEG29	P6		
15	SEG28	P7		
16	SEG27	P8		
17	SEG26	P9		
18	Vcc2	VDD		Positive power supply for DIG and SEG outputs.
19	SEG25	P10	Segment output	Connect to segment (anode) pins of VFD.
20	SEG24	P11		
21	SEG23	P12		
22	SEG22	P13		
23	SEG21	P14		
24	SEG20	P15		
25	SEG19	P16		
26	SEG18	P17		
27	SEG17	P18I		
28	SEG16	P19		
29	SEG15	P20		
30	SEG14	P21		
31	SEG13	P22		
32	SEG12	P23		
33	SEG11	P24		
34	SEG10	P25		
35	SEG09	P26		
36	SEG08	P27		
37	SEG07	P28		
38	SEG06	P29		
39	SEG05	P30		
40	SEG04	P31		
41	SEG03	P32		
42	SEG02	P33		
43	SEG01	P34		
44	SEG00	P35		
45	SEG35	P36		
46	SEG36	P37		
47	DIG16/SEG37	G17I	Digital output	Connect to digit (grid) pins of VFD.
48	DIG15/SEG38	G16I		
49	DIG14/SEG39	G15I		
50	DIG13/SEG40	G14		
51	DIG12/SEG41	G13		
52	DIG11/SEG42	G12		
53	DIG10	G11		
54	DIG09	G10		
55	DIG08	G9		
56	DIG07	G8		
57	DIG06	G7		
58	DIG05	G6		
59	DIG04	G5		
60	DIG03	G4		
61	DIG02	G3		
62	DIG01	G2		
63	DIG00	G1		
64	VP	VP		Negative power supply to pull down.

IC41: LC89058WD-E (DIGITAL P.C.B.)
Digital audio interface receiver

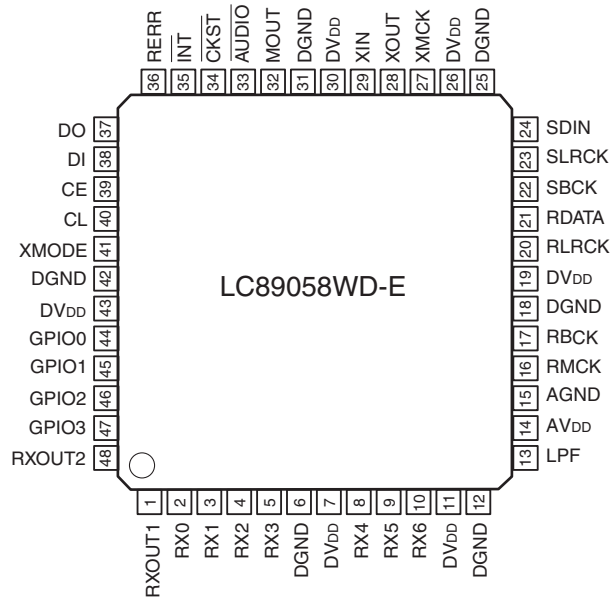
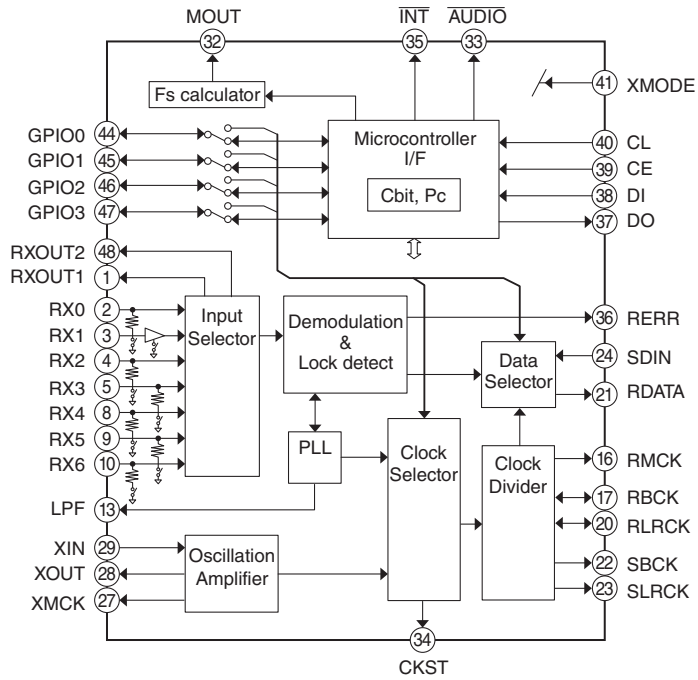

Pin No.	Function Name	I/O	Detail of Function
1	RXOUT1	O	RX0-6 input S/PDIF through output pin 1
2	RX0	I _s (pd)	5V withstand voltage TIL input level compatible S/PDIF input pin (connected to GND when RX1 is set)
3	RX1	I(pd)	Co-axial compatible S/PDIF input pin (supported demodulation sampling frequency of up to 96 kHz)
4	RX2	I _s (pd)	5V withstand voltage TIL input level compatible S/PDIF input pin (connected to GND when RX1 is set)
5	RX3	I _s (pd)	5V withstand voltage TIL input level compatible S/PDIF input pin
6	DGND		Digital GND
7	DVDD		Digital power supply (3.3V)
8	RX4	I _s (pd)	5V tolerable TIL input level compatible S/PDIF input pin
9	RX5	I _s (pd)	5V tolerable TIL input level compatible S/PDIF input pin
10	RX6	I _s (pd)	5V tolerable TIL input level compatible S/PDIF input pin
11	DVDD		Digital power supply (3.3V)
12	DGND		Digital GND
13	LPF	O	PLL loop filter connection pin
14	AVDD		Analog power supply (3.3V)
15	AGND		Analog GND
16	RMCK	O	R system clock output pin (VCO, 512fs, XIN)
17	RBCK	O/I	R system bit clock 1/0 pin (64fs)
18	DGND		Digital GND
19	DVDD		Digital power supply (3.3V)
20	RLRCK	O/I	R system LR clock 1/0 pin (fs)
21	RDATA	O	Serial audio data output pin
22	SBCK	O	S system bit clock output pin (16fs, 32fs, 64fs, 128fs)
23	SLRCK	O	S system LR clock output pin (fs/4, fs/2, fs, 2fs)
24	SDIN	I _s	External serial audio data input pin
25	DGND		Digital GND
26	DVDD		Digital power supply (3.3V)
27	XMCK	O	Oscillation amplifier clock output pin
28	XOUT	O	Output pin connected to the resonator
29	XIN	I	External clock input pin. connected to the resonator (12.288 MHz or 24.576 MHz)
30	DVDD		Digital power supply (3.3V)
31	DGND		Digital GND
32	MOUT	I/O	Emphasis information II input fs monitor output II chip address setting input pin
33	AUDIO	I/O	Channel status bit 1 output II chip address setting input pin
34	CKST	I/O	Clock switching transition period signal output II master/slave setting input pin
35	INT	I/O	Microcontroller interrupt signal output II pins 44-48 I/O setting input pin
36	RERR	O	PLL lock error and data error flag output pin
37	DO	O	CCB microcontroller I/F, read data output pin (3-state)
38	DI	I _s	CCB microcontroller I/F, write data input pin
39	CE	I _s	CCB microcontroller I/F, chip enable input pin
40	CL	I _s	CCB microcontroller I/F, clock input pin
41	XMODE	I _s	System reset input pin
42	DGND		Digital GND
43	DVDD		Digital power supply (3.3V)
44	GPI00	O/I	General-purpose I/O pin II selector input pin (output referred to RMCK pin)
45	GPI01	O/I	General-purpose I/O pin II selector input pin (output referred to RBCK pin)
46	GPI02	O/I	General-purpose I/O pin II selector input pin (output referred to RLRCK pin)
47	GPI03	O/I	General-purpose I/O pin II selector input pin (output referred to RDATA pin)
48	RXOUT2	O	RX0-6 input S/PDIF through output pin 2

* Input voltage: 1= -0.3 to 3.6V, I_s =-0.3 to 5.5V

* Output voltage: 0= -0.3 to 3.6V

* Pins 2, 4, 5, 8, 9, 10, 24, 38, 39, 40, and 41 have an internal pull-down resistor (Pd). Their level is fixed when they are unselected.

* Pins 32 and 33 are input pins for chip address setting when pin 41 is held at the low level.

* Pin 34 serves as the input pin for designating as the master or slave when pin 41 is held at the low level.

* Pin 35 serves as the input pin for configuring the I/O of pins 44 to 47 when pin 41 is held at the low level.

* The DVDD and AVDD pins must be held at the same level and turned on and off at the same timing to preclude latch-up conditions.

IC153: R2A15220FP (MAIN P.C.B.)

8-channel electronic volume with 11 input selector and tone control

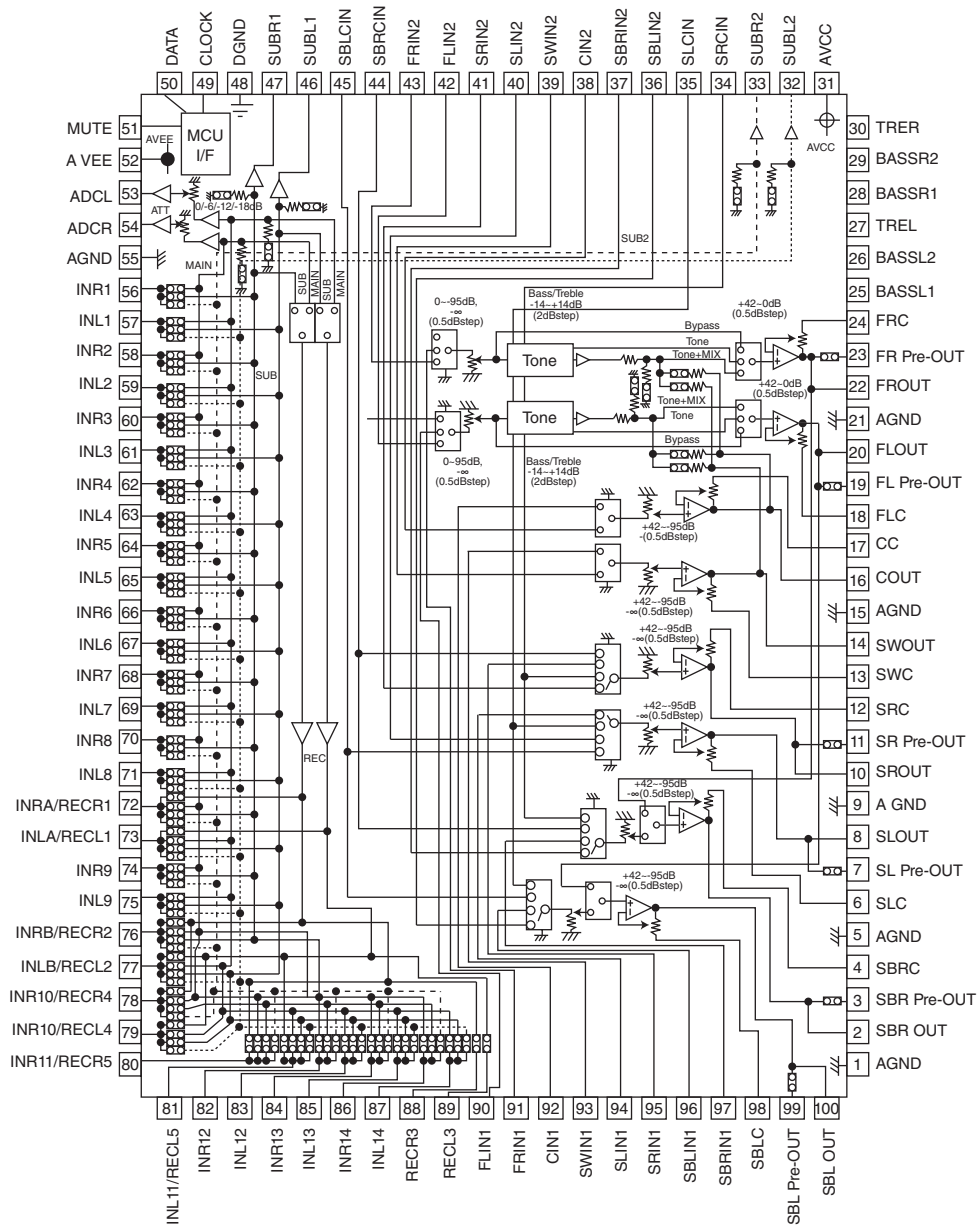

Pin No.	Port name	Function Name	Detail of Function
1	AGND	AE	Analog ground of internal circuit
2	SBROUT	VOSBL	Output pin of FL/FR/C/SW/SL/SR/SBL/SBR channel
3	SBR Pre-OUT	VOPSBL	Pre-output pin of FL/FR/SL/SR/SBL/SBR channel
4	SBRC	AE	Connects capacitor for reducing click noise of L/R/C/SW/SL/SR/SBL/SBR channel volume
5	AGND	AE	Analog ground of internal circuit
6	SLC	VOPSR	Connects capacitor for reducing click noise of L/R/C/SW/SL/SR/SBL/SBR channel volume
7	SL Pre-OUT	VOSR	Pre-output pin of FL/FR/SL/SR/SBL/SBR channel
8	SLOUT	AE	Output pin of FL/FR/C/SW/SL/SR/SBL/SBR channel
9	AGND	AE	Analog ground of internal circuit
10	SROUT	VOSL	Output pin of FL/FR/C/SW/SL/SR/SBL/SBR channel
11	SR Pre-OUT	VOPSL	Pre-output pin of FL/FR/SL/SR/SBL/SBR channel
12	SRC	AE	Connects capacitor for reducing click noise of L/R/C/SW/SL/SR/SBL/SBR channel volume
13	SWC	AE	Connects capacitor for reducing click noise of L/R/C/SW/SL/SR/SBL/SBR channel volume
14	SWOUT	VOSW	Output pin of FL/FR/C/SW/SL/SR/SBL/SBR channel
15	AGND	AE	Analog ground of internal circuit
16	COUT	VOC	Output pin of FL/FR/C/SW/SL/SR/SBL/SBR channel
17	CC	AE	Connects capacitor for reducing click noise of L/R/C/SW/SL/SR/SBL/SBR channel volume
18	FLC	AE	Connects capacitor for reducing click noise of L/R/C/SW/SL/SR/SBL/SBR channel volume
19	FL Pre-OUT	VOPFR	Pre-output pin of FL/FR/SL/SR/SBL/SBR channel
20	FLOUT	VOFR	Output pin of FL/FR/C/SW/SL/SR/SBL/SBR channel
21	AGND	POE	Analog ground of internal circuit
22	FROUT	VOFL	Output pin of FL/FR/C/SW/SL/SR/SBL/SBR channel
23	FR Pre-OUT	VOPFL	Pre-output pin of FL/FR/SL/SR/SBL/SBR channel
24	FRC	AE	Connects capacitor for reducing click noise of L/R/C/SW/SL/SR/SBL/SBR channel volume
25	BASSL1	AE	Frequency characteristic setting pin of L/R channel tone control (Bass)
26	BASSL2	AE	Frequency characteristic setting pin of L/R channel tone control (Bass)
27	TREL	AE	Frequency characteristic setting pin of L/R channel tone control (Treble)
28	BASSR1	AE	Frequency characteristic setting pin of L/R channel tone control (Bass)
29	BASSR2	AE	Frequency characteristic setting pin of L/R channel tone control (Bass)
30	TREER	AE	Frequency characteristic setting pin of L/R channel tone control (Treble)
31	AVCC	VCC	Positive power supply to internal circuit
32	SUBL1	N.C.	Output pin for L/R channel SUB1/SUB2 output
33	SUBL2	N.C.	Output pin for L/R channel SUB1/SUB2 output
34	SRCIN	N.C.	3rd multi input pin for SBL/SBR/SL/SR channel volume that is able to swap SBR/SBL with SR/SL
35	SLCIN	N.C.	3rd multi input pin for SBL/SBR/SL/SR channel volume that is able to swap SBR/SBL with SR/SL
36	SBLIN2	8SBR	Multi input pin of L/R/C/SW/SL/SR/SBL/SBR channel (Multi IN 1/2)
37	SBRIN2	8SBL	Multi input pin of L/R/C/SW/SL/SR/SBL/SBR channel (Multi IN 1/2)
38	CIN2	8C	Multi input pin of L/R/C/SW/SL/SR/SBL/SBR channel (Multi IN 1/2)
39	SWIN2	8SW	Multi input pin of L/R/C/SW/SL/SR/SBL/SBR channel (Multi IN 1/2)
40	SLIN2	8SR	Multi input pin of L/R/C/SW/SL/SR/SBL/SBR channel (Multi IN 1/2)
41	SRIN2	8SL	Multi input pin of L/R/C/SW/SL/SR/SBL/SBR channel (Multi IN 1/2)
42	FLIN2	8FR	Multi input pin of L/R/C/SW/SL/SR/SBL/SBR channel (Multi IN 1/2)
43	FRIN2	8FL	Multi input pin of L/R/C/SW/SL/SR/SBL/SBR channel (Multi IN 1/2)
44	SBRCIN	Z2L	3rd multi input pin for SBL/SBR/SL/SR channel volume that is able to swap SBR/SBL with SR/SL
45	SBLCIN	Z2R	3rd multi input pin for SBL/SBR/SL/SR channel volume that is able to swap SBR/SBL with SR/SL
46	SUBL1	Z2R	Output pin for L/R channel SUB1/SUB2 output
47	SUBR1	Z2L	Output pin for L/R channel SUB1/SUB2 output
48	DGND	MG	Digital ground of internal circuit
49	DATA	VOL_SCK	Input pin of control data
50	CLOCK	VOL_MOSI	Input pin of control clock
51	MUTE	AE	Outside mute control pin
52	AVEE	-	Negative power supply to internal circuit
53	ADCL	ADR	Output pin for L/R channel ADC
54	ADCR	ADL	Output pin for L/R channel ADC
55	AGND	AE	Analog ground of internal circuit
56	INR1	AU2L	Input pin of L/R channel (Input selector)
57	INL1	AU2R	Input pin of L/R channel (Input selector)

Pin No.	Port name	Function Name	Detail of Function
58	INR2	AU1L	Input pin of L/R channel (Input selector)
59	INL2	AU1R	Input pin of L/R channel (Input selector)
60	INR3	AV-6L	Input pin of L/R channel (Input selector)
61	INL3	AV-6R	Input pin of L/R channel (Input selector)
62	INR4	AV-5L	Input pin of L/R channel (Input selector)
63	INL4	AV-5R	Input pin of L/R channel (Input selector)
64	INR5	PHL	Input pin of L/R channel (Input selector)
65	INL5	PHR	Input pin of L/R channel (Input selector)
66	INR6	SRL	Input pin of L/R channel (Input selector)
67	INL6	SRR	Input pin of L/R channel (Input selector)
68	INR7	IPL	Input pin of L/R channel (Input selector)
69	INL7	IPR	Input pin of L/R channel (Input selector)
70	INR8	XML	Input pin of L/R channel (Input selector)
71	INL8	XMR	Input pin of L/R channel (Input selector)
72	INRA/RECR1	AV-OUT_L	Output pin for L/R channel (input selector)/Output pin for L/R channel REC output
73	INLA/RECL1	AV-OUT_R	Output pin for L/R channel (input selector)/Output pin for L/R channel REC output
74	INR9	USBL	Input pin of L/R channel (Input selector)
75	INL9	USBR	Input pin of L/R channel (Input selector)
76	INRB/RECR2	AOL	Output pin for L/R channel (input selector)/Output pin for L/R channel REC output
77	INLB/RECL2	AOR	Output pin for L/R channel (input selector)/Output pin for L/R channel REC output
78	INR10/RECR4	TUL	Output pin for L/R channel (input selector)/Output pin for L/R channel REC output
79	INL10/RECL4	TUR	Output pin for L/R channel (input selector)/Output pin for L/R channel REC output
80	INR11/RECR5	MIC	Output pin for L/R channel (input selector)/Output pin for L/R channel REC output
81	INL11/RECL5	AE	Output pin for L/R channel (input selector)/Output pin for L/R channel REC output
82	INR12	AUXL	Input pin of L/R channel (Input selector)
83	INL12	AUXR	Input pin of L/R channel (Input selector)
84	INR13	AE	Input pin of L/R channel (Input selector)
85	INL13	AE	Input pin of L/R channel (Input selector)
86	INR14	AE	Input pin of L/R channel (Input selector)
87	INL14	AE	Input pin of L/R channel (Input selector)
88	RECR3	N.C.	Output pin for L/R channel REC output
89	RECL3	N.C.	Output pin for L/R channel REC output
90	FLIN1	DAFR	Multi input pin of L/R/C/SW/SL/SR/SBL/SBR channel (Multi IN 1/2)
91	FRIN1	DAFL	Multi input pin of L/R/C/SW/SL/SR/SBL/SBR channel (Multi IN 1/2)
92	CIN1	DAC	Multi input pin of L/R/C/SW/SL/SR/SBL/SBR channel (Multi IN 1/2)
93	SWIN1	DASW	Multi input pin of L/R/C/SW/SL/SR/SBL/SBR channel (Multi IN 1/2)
94	SLIN1	DASR	Multi input pin of L/R/C/SW/SL/SR/SBL/SBR channel (Multi IN 1/2)
95	SEIN1	DASL	Multi input pin of L/R/C/SW/SL/SR/SBL/SBR channel (Multi IN 1/2)
96	SBLIN1	DASBR	Multi input pin of L/R/C/SW/SL/SR/SBL/SBR channel (Multi IN 1/2)
97	SBRIN1	DASBL	Multi input pin of L/R/C/SW/SL/SR/SBL/SBR channel (Multi IN 1/2)
98	SBLC	AE	Connects capacitor for reducing click noise of L/R/C/SW/SL/SR/SBL/SBR channel volume
99	SBL Pre-OUT	VOPSBR	Pre-output pin of FL/FR/SL/SR/SBL/SBR channel
100	SBL OUT	VOSBR	Output pin of FL/FR/C/SW/SL/SR/SBL/SBR channel

IC20: M3087BFK BGP (DIGITAL P.C.B.)
Microprocessor

RX-V665/HTR-6260

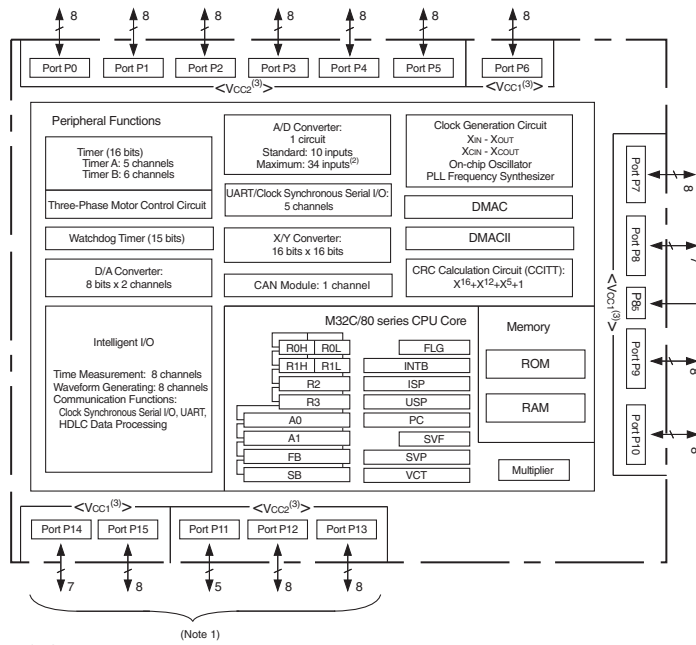

- NOTES:
1. Ports P11 to P15 are provided in the 144-pin package only.
 2. Included in the 144-pin package only.
 3. The supply voltage of M32C/84T (High-reliability version) must be Vcc1=Vcc2.

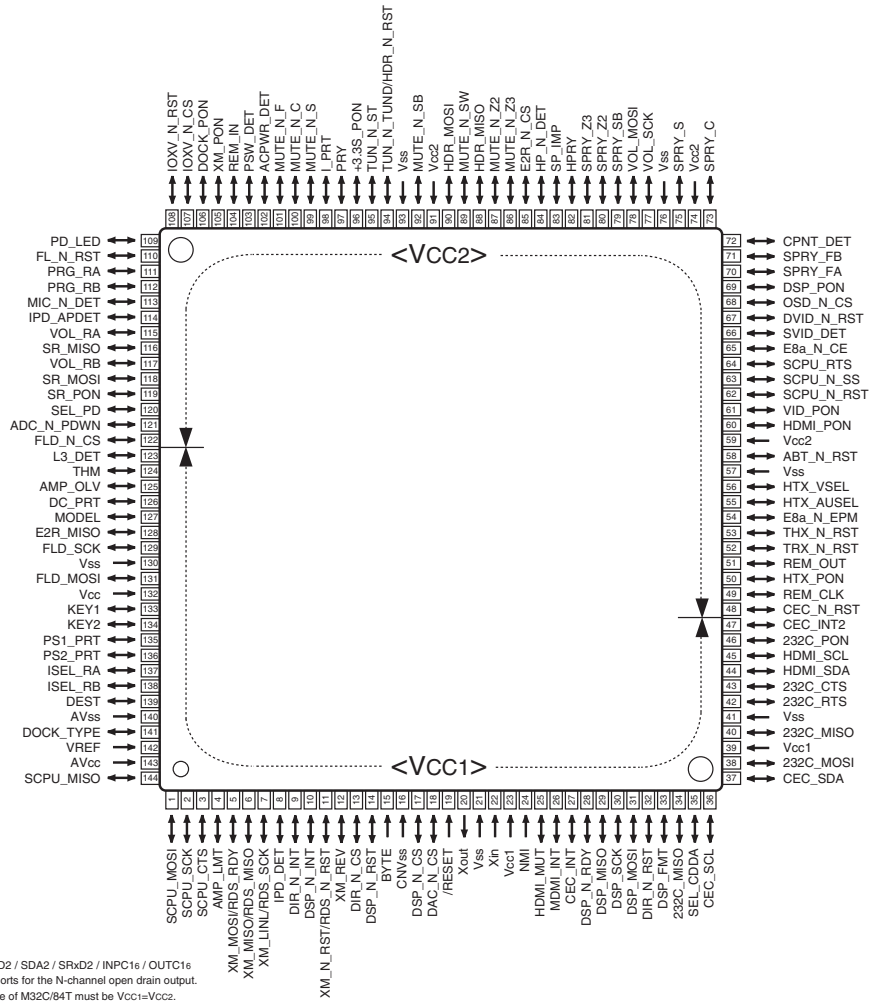

- NOTES:
1. P70 / TA0out / TxD2 / SDA2 / SRxD2 / INPC16 / OUTC16
 2. P70 and P71 are ports for the N-channel open drain output.
 3. The supply voltage of M32C/84T must be Vcc1=Vcc2.

Pin No.	Port Name	Function Name (P.C.B.)	I/O					Detail of Function
			Power On	Stby Thrh	Standby	Stby Sleep	MCU Sleep	
1	TXD4 P96/ANEX1/TXD4/ SDA4/SRXD4	IPD_MOSI	SO	O	O	O	O	Asynchronous data output for iPod
2	P95	SCPU_SCK	O	O	O	O	O	
3	P94 P94/DA1/TB4in/ CTS4/RTS4/SS4	SCPU_CTS	SI	I	I	O	O	Input for transmission control for SubCPU (clear to send)
4	DA0 P93/DA0/TB3in/ CTS3/RTS3/SS3	AMP_LMT	DA	I	I	I	I	Limiter control output
5	TXD3 P92/TB2in/TXD3/ SDA3/SRXD3/ OUTC20/IEout/ ISTXD2	XM_MOSI	SO	O	O	O	O	Asynchronous data output for XM (U model)
	P92		O	O	O	O	O	(C, R, A, F, L models)
6	RXD3 P91/TB1in/RXD3/ SCL3/STXD3/IEin/ ISRXD2	XM_MISO	SI	O	O	O	O	Asynchronous data input for XM (U model)
	P91		O	O	O	O	O	(C, R, A, F, L models)
7	P90 P90/TB0in/CLK3	XM_LINK	I	O	O	O	O	XM LINK detection (U model)
	P90		O	O	O	O	O	(C, R, A, F, L models)
8	INT8 P146/INT8	IPD_DET	IRQ	IRQ	IRQ	IRQ	O	iPod detection When inserting an iPod into the DOCK H → L Restriction of port: INT is high edge or low edge only
9	P145 P145/INT7	DIR_N_INT	IRQ	O	O	O	O	DIR interrupt Restriction of port: INT is high edge or low edge only
10	P144 P144/INT6	DSP_N_INT	IRQ	O	O	O	O	DA70Y interrupt Restriction of port: INT is high edge or low edge only
11	P143 P143/INPC17/ OUTC17	XM_N_RST	O	O	O	O	O	XM reset (U model)
	P143		O	O	O	O	O	(C, R, A, F, L models)
12	P142 P142/INPC16/OUTC16	XM_REV	I	O	O	O	O	XM antenna revision detection H: An compatibility antenna (U model)
	P142		O	O	O	O	O	(C, R, A, F, L models)
13	P141 P141/INPC15/ OUTC15	DIR_N_CS	CS	O	O	O	O	DIR chip select
14	P140 P140/INPC14/ OUTC14	DSP_N_RST	O	O	O	O	O	DA70Y reset
15	BYTE BYTE	BYTE	MCU	MCU	MCU	MCU	MCU	Switch of width of data bus input When set to single chip mode: L (16 bit)
16	CNVss CNVss	CNVss	MCU	MCU	MCU	MCU	MCU	Processor mode select Low: single chip mode High: To Flash included boot mode To boot mode with hardware resetting of P50=H, P55=L, CNVss=H
17	P87 P87/Xcin	DSP_N_CS	CS	O	O	O	O	DA70Y chip select
18	P86 P86/Xcout	DAC_N_CS	CS	O	O	O	O	DAC chip select
19	/RESET /RESET	/RESET	MCU	MCU	MCU	MCU	MCU	Reset
20	Xout Xout	Xout	MCU	MCU	MCU	MCU	MCU	20 MHz Ceramic resonator
21	Vss Vss	Vss	MCU	MCU	MCU	MCU	MCU	GND
22	Xin Xin	Xin	MCU	MCU	MCU	MCU	MCU	20 MHz ceramic resonator
23	Vcc1 Vcc1	Vcc1	MCU	MCU	MCU	MCU	MCU	Microprocessor power supply

Pin No.	Port Name	Function Name (P.C.B.)	I/O					Detail of Function
			Power On	Stby Thrh	Standby	Stby Sleep	MCU Sleep	
24	/NMI P85/NMI	/NMI	MCU	MCU	MCU	MCU	MCU	Unused, pull up to Vcc
25	INT2 P84/INT2	HDMI_MUT	IRQ	IRQ	O	O	O	HDMI mute input Act H: Mute
26	INT1 P83/INT1	HDMI_INT	IRQ	IRQ	O	O	O	Interrupt from HDMI RX
27	INT0 P82/INT0	CEC_N_INT	IRQ	IRQ	O	O	O	CEC microprocessor interrupt
28	P81 P81/TA4in/U/INPC15/ OUTC15/CTS5/ RTS5/RTP23	DSP_N_RDY	I	O	O	O	O	DA70Y RDY
	P81	DIR_WCK	I	O	O	O	O	CDDA writing DIR_WCK input
29	RXD5 P80/TA4out/U/ ISRXD0/RXD5	DSP_MISO	SI	O	O	O	O	Synchronous data input for DIR, DA70Y, DAC
30	CLK5 P77/TA3in/INPC14/ OUTC14/ISCLK0/ CLK5/RTP22	DSP_SCK	SO	O	O	O	O	Synchronous clock output for DIR, DA70Y, DAC
31	TXD5 P76/TA3out/INPC13/ OUTC13/ISTXD0/ TXD5	DSP_MOSI	SO	O	O	O	O	Synchronous data output for DIR, DA70Y, DAC
32	P75 P75/TA2in/W/ INPC12/OUTC12/ ISRXD1/RTP21	DIR_N_RST	O	O	O	O	O	DIR reset
33	P74 P74/TA2out/W/ INPC11/OUTC11/ ISCLK1/RTP20	DSP_FMT	O	O	O	O	O	DA70Y full mute output H: Mute
34	P73	232C_MISO	O	O	O	O	O	
35	P72 P72/TA1out/V/CLK2	SEL_CDDA	O	O	O	O	O	CDDA writing route select H: CDDA writing mode, L: Operational mode usually
36	SCL2 P71/TA0in/TB5in/ RXD2/SCL2/STXD2/ INPC17/OUTC17/ OUTC22/ISRXD2/ IEin/RTP03	CEC_SCL	SO	SO	O	O	O	CEC microprocessor, Tuner, HDMI_EQ (SiI9185A) I2C SCL output (100 kHz device) U-com block then +3.3S, 3.3k then pull up
37	SDA2 P70/TA0out/TXD2/ SDA2/SRXD2/ INPC16/OUTC16/ OUTC20/ISTXD2/ IEout/RTP02	CEC_SDA	SIO	SIO	O	O	O	CEC microprocessor, Tuner, HDMI_EQ (SiI9185A) I2C SDA input (100 kHz device) U-com block then +3.3S, 3.3k then pull up
38	TxD1 P67/TXD1/SDA1/ SRXD1	232C_MOSI	SO	SO	SO	O	O	RS232C data output Pull up at 100 k-ohms
	TxD1	TXD	SO					E8a, ICP (In-circuit programmer) data output
39	Vcc1 Vcc1	Vcc1	MCU	MCU	MCU	MCU	MCU	Microprocessor power supply
40	RxD1 P66/RXD1/SCL1/ STXD1	232C_MISO	SI	SI	SI	I	I	RS232C data input Pull up at 100 k-ohms
	RxD1	RXD	SI					E8a, ICP (In-circuit programmer) data input
41	Vss Vss	Vss	MCU	MCU	MCU	MCU	MCU	Microprocessor GND
42	P65 P65/CLK1	232C_RTS	SO	SO	SO	O	O	RS232C RTS output
	CLK1	E8a_SCLK	SI					E8a, ICP (In-circuit programmer) clock input Pull up at 100 k-ohms

Pin No.	Port Name	Function Name (P.C.B.)	I/O					Detail of Function
			Power On	Stby Thrh	Standby	Stby Sleep	MCU Sleep	
43	CTS1 P64/CTS1/RTS1/ SS1/OUTC21/ ISCLK2	232C_CTS	SI	SI	SI	I	I	RS232C CTS input Pull down at 100 k-ohms
	RTS1	E8a_BUSY	SO					E8a, ICP (In-circuit programmer) BUSY output
44	SDA0 P63/TXD0/SDA0/ SRXD0/IrDAout	HDMI_SDA	SIO	SIO	O	O	O	HDMI RX/TX, Video Enc/Dec I2C SCL output (400 kHz device) Pull up at HDMI block HDMI RX/TX: 5V tolerant
45	SCL0 P62/RXD0/SCL0/ STXD0/IrDAin	HDMI_SCL	SIO	SIO	O	O	O	HDMI RX/TX, Video Enc/Dec I2C SDA input/output (400 kHz device) Pull up at HDMI block HDMI RX/TX: 5V tolerant
46	P61	232C_PON	O	O	O	O	O	H: ON, L: OFF
47	P60 P60/CTS0/RTS0/ SS0/RTP00	CEC_INT2	I	I	O	O	O	CEC microprocessor interrupt
48	P137 P137/OUTC27	CEC_N_RST	O	O	O	O	O	CEC microprocessor reset
49	ISCLK2 P136/OUTC21/ ISCLK2	REM_CLK	SO	O	O	O	O	Clock output for remote control code generation No connection
50	P135 P135/OUTC22/ ISRXD2/IEin	HTX_PON	O	O	O	O	O	No use (HDMI_PON common)
51	P134 P134/OUTC20/ ISTXD0/Ieout	REM_OUT						
52	P57 P57/RDY	HRX_N_RST	O	O	O	O	O	HDMI TX reset output L: Reset Pull down at HDMI block
53	P56 P56/ALE	HTX_N_RST	O	O	O	O	O	HDMI TX reset output L: Reset Pull down at HDMI block
54	P55 P55/HOLD	E8a_N_EPM	I	I	I	I	I	E8a writing mode enable input 10 k-ohms pull down
55	P54 P54/HLDA/ALE	HTX_AUSEL	O	O	O	O	O	No use (HDMI Rx GPIO use)
56	P133 P133/OUTC23	HTX_VSEL	O	O	O	O	O	No use (HDMI Rx GPIO use)
57	Vss Vss	Vss	MCU	MCU	MCU	MCU	MCU	Microprocessor GND
58	P132 P132/OUTC26	ABT_N_RST	O	O	O	O	O	Video I/P & Scaler IC reset L: reset VID_PON=L: Low fix
59	Vcc2 Vcc2	Vcc2	MCU	MCU	MCU	MCU	MCU	Microprocessor power supply
60	P131 P131/OUTC25	HDMI_PON	O	O	O	O	O	HDMI power supply ON/OFF control H: ON, L: OFF When V2065 uses CEC microprocessor, HDMI EQ (CXB1442, Si9185A) reset may be used
61	P130 P130/OUTC24	VID_PON	O	O	O	O	O	Video power supply ON/OFF control H: ON, L: OFF Configured based on the Pure Direct specification
62	P53	SCPU_N_RST	O	O	O	O	O	
63	P52	SCPU_N_SS	O	O	O	O	O	
64	P51	SCPU_RTS	O	O	O	O	O	
65	P50 P50/WRL/WR	E8a_N_CE	I	I	I	I	I	E8a enable input 10 k-ohms pull up
66	P127 P127	SVID_DET	I	O	O	O	O	S video detection VID_PON=L: Low fix
67	P126 P126	DVID_N_RST	O	O	O	O	O	Video Enc/Dec reset VID_PON=L: Low fix
68	P125 P125	OSD_N_CS	CS	O	O	O	O	OSD chip select VID_PON=L: Low fix

Pin No.	Port Name	Function Name (P.C.B.)	I/O					Detail of Function
			Power On	Stby Thrh	Standby	Stby Sleep	MCU Sleep	
69	P47 P47/SC0/A23	DSP_PON	O	O	O	O	O	DSP power supply ON/OFF control H: ON, L: OFF
70	P46 P46/SC1/A22	SPRY_FA	O	O	O	O	O	Front A speaker relay control H: ON, L: OFF
71	P45 P45/SC2/A21	SPRY_FB	O	O	O	O	O	Front B speaker relay control H: ON, L: OFF
72	P44 P44/SC3/A20	CPNT_DET	O	O	O	O	O	No use
73	P43 P43/A19	SPRY_C	O	O	O	O	O	Center speaker relay control
74	Vcc2 Vcc2	Vcc2	MCU	MCU	MCU	MCU	MCU	Microprocessor power supply
75	P42 P42/A18	SPRY_S	O	O	O	O	O	Surround speaker relay control
76	Vss Vss	Vss	MCU	MCU	MCU	MCU	MCU	Microprocessor GND
77	P41 P41/A17	VOL_SCK	O	O	O	O	O	Electronic volume Flip-flop synchronous clock output
78	P40 P40/A16	VOL_MOSI	O	O	O	O	O	Electronic volume Flip-flop synchronous data output
79	P37 P37/A15/(D15)	SPRY_SB	O	O	O	O	O	Surround back/Bi-AMP relay control
80	P36 P36/A14/(D14)	SPRY_Z2	O	O	O	O	O	Zone2/Presence Speaker relay control SPRY_Z and SPRY_FB do not become High at the same time
81	P35 P35/A13/(D13)	SPRY_Z3	O	O	O	O	O	Zone3 speaker relay control
82	P34 P34/A12/(D12)	HPRY	O	O	O	O	O	Head phone relay control
83	P33 P33/A11/(D11)	SP_IMP	O	O	O	O	O	Speaker impedance relay control Set to 8 ohms: Low (Relay OFF, B voltage High) Set to 6 ohms plus during rising temperature: High (Relay ON, B voltage Low)
84	P32 P32/A10/(D10)	HP_N_DET	I	O	O	O	O	Headphone detection L: Headphone +3.3S pull up
85	P31 P31/A9/(D9)	E2R_N_CS	CS	CS	CS	I	I	EEPROM chip select At 10 k-ohms pull up to EEPROM power
86	P124 P124	MUTE_N_Z3	O	O	O	O	O	Zone3 line out mute control L: Mute
87	P123 P123/CTS6/RTS6	MUTE_N_Z2	O	O	O	O	O	Zone2 line out mute control L: Mute
88	P122	HDR_MISO	O	O	O	O	O	
89	P121 P121/CLK6	MUTE_N_SW	O	O	O	O	O	Subwoofer mute control L: Mute
90	P120	HDR_MOSI	O	O	O	O	O	
91	Vcc2 Vcc2	Vcc2	MCU	MCU	MCU	MCU	MCU	Microprocessor power supply
92	P30 P30/A8/(D8)	MUTE_N_SB	O	O	O	O	O	Surround back/Bi-AMP/Zone2 mute control L: Mute
93	Vss Vss	Vss	MCU	MCU	MCU	MCU	MCU	Microprocessor GND
94	P27 P27/A7/(D7)/AN27	TUN_N_TUND	I	O	O	O	O	FM/AM tuner TUNED input +3.3S to 47k then pull up
95	P26 P26/A6/(D6)/AN26	TUN_N_ST	I	O	O	O	O	FM/AM tuner STEREO detection input +3.3S to 47k then pull up
96	P25 P25/A5/(D5)/AN25	+3.3S_PON	O	O	O	O	I	+3.3S power supply ON/OFF control H: ON, L: OFF At standby sleep, becomes L [to avoid unnecessary power consumption (Mute, pull Up)] Input (HiZ) then mechanically +3.3S power switches on (to function Mute, when power down is detected)
97	P24 P24/A4/(D4)/AN24	PRY	O	O	O	O	O	Power relay ON/OFF control H: ON, L: OFF
98	P23 P23/A3/(D3)/AN23	I_PRT	I	I	O	O	O	Overcurrent protection detection

Pin No.	Port Name	Function Name (P.C.B.)	I/O					Detail of Function
			Power On	Stby Thrh	Standby	Stby Sleep	MCU Sleep	
99	P22 P22/A2/(D2)/AN22	MUTE_N_S	O	O	O	O	O	Surround mute control L: Mute
100	P21 P21/A1/(D1)/AN21	MUTE_N_C	O	O	O	O	O	Center mute control L: Mute
101	P20 P20/A0/(D0)/AN20	MUTE_N_F	O	O	O	O	O	Front (Headphone is contained) mute control L: Mute
102	INT5 P17/D15/INT5	ACPWR_DET	IRQ	IRQ	IRQ	IRQ	O	AC power detection L: Power down
103	INT4 P16/D14/INT4	PSW_DET	IRQ	IRQ	IRQ	IRQ	O	Main/Zone/Input key interrupt KEY1 port distinguishes the pressed keys
104	INT3 P15/D13/INT3	REM_IN	IRQ	IRQ	IRQ	IRQ	O	Remote control pulse input
105	P14 P14/D12	XM_PON	O	O	O	O	O	XM power supply ON/OFF control H: ON, L: OFF
106	P13 P13/D11	DOCK_PON	O	O	O	O	O	DOCK power supply ON/OFF control H: ON, L: OFF
107	P12 P12/D10	IOXV_N_CS	CS	O	O	O	O	IO extended IC (for video) chip select
108	P11 P11/D9	IOXV_N_RST	O	O	O	O	O	IO extended IC (for video) reset
109	P10 P10/D8	PD_LED	O	O	O	O	O	Pure Direct LED ON/OFF control H: ON, L: OFF
110	P07 P07/D7/AN07	FLD_N_RST	O	O	O	O	O	FL driver reset
111	P06	PRG_RA	O	O	O	O	O	
112	P05	PRG_RB	O	O	O	O	O	
113	P04 P04/D4/AN04	MIC_N_DET	I	O	O	O	O	MIC detection L: MIC
114	P114 P114	IPD_APDET	I	I	I	I	I	iPod accessory power detection While iPod boots up (about two seconds) it is set at Low after the boot, it identifies To prevent pulling of iPod High output and microprocessor Low Fix output, switch to constant input
115	P113	VOL_RA	I	O	O	O	O	Volume rotary A
116	P112 P112/INPC12/ OUTC12/ISRXS1	SR_MISO	SI	I	I	I	I	Asynchronous data input for HD SIRIUS Serial communication is 5v TTL/CMOS logic level Pull up at 100 k-ohms To prevent pulling of SIRIUS tuner's High output and microcomputer's Low Fix output, switch to constant input (U model)
	P112		O	O	O	O	O	
117	P111 P111/INPC11/ OUTC11/ISCLK1	VOL_RB	I	O	O	O	O	Volume rotary B
118	ISTXD1 P110/INPC10/ OUTC10/ISTXD1	SR_MOSI	SO	O	O	O	O	Asynchronous data output for SIRIUS Serial communication is 5V TTL/CMOS logic level (U model)
	P110		O	O	O	O	O	(C, R, A, F, L models)
119	P03 P03/D3/AN03	SR_PON	O	O	O	O	O	SIRIUS radio power supply ON/OFF control H: Power ON L: Power OFF (U model)
	P03		O	O	O	O	O	(C, R, A, F, L models)
120	P02 P02/D2/AN02	SEL_PD	O	O	O	O	O	DSP Pure Direct route select H: Pure Direct ON
121	P01 P01/D1/AN01	ADC_N_PDWN	O	O	O	O	O	ADC power down L: Power down
122	P00 P00/D0/AN00	FLD_N_CS	CS	O	O	O	O	FL driver chip select
123	AN157 P157/AN157/CTS6/ RTS6	L3_DET	AD	O	O	O	O	Component video aspect detection
124	AN156 P156/AN156/CLK6	THM	AD	AD	O	O	O	Temperature detection
125	AN155 P155/AN155/RXD6	AMP_OLV	AD	AD	O	O	O	Power AMP output level detection

Pin No.	Port Name	Function Name (P.C.B.)	I/O					Detail of Function
			Power On	Stby Thrh	Standby	Stby Sleep	MCU Sleep	
126	AN154 P154/AN154/TXD6	DC_PRT	AD	AD	O	O	O	Power AMP DC detection
127	AN153 P153/AN153/CTS5/ RTS5	MODEL	AD	AD	O	O	O	Destination discrimination by AD value When AD is taken in at power on, there is 1m sec waiting time after AD input port setting
128	ISRXD0 P152/AN152/ ISRXD0/RXD5	E2R_MISO	SI	SI	SI	O	O	Synchronous data input for EEPROM
129	ISCLK0 P151/AN151/ISCLK0/ CLK5	FLD_SCK	SO	SO	SO	O	O	FL driver, OSD, IO extended IC (Video), series 1 k-ohms go into synchronous clock output for EEPROM FL driver
130	Vss Vss	Vss	MCU	MCU	MCU	MCU	MCU	Microprocessor GND
131	ISTXD0 P150/AN150/ISTXD0/ TXD5	FLD_MOSI	SO	SO	SO	O	O	FL driver, OSD, IO extended IC (Video), series 1 k-ohms go into synchronous data output for EEPROM FL driver
132	Vcc1 Vcc1	Vcc1	MCU	MCU	MCU	MCU	MCU	Microprocessor power supply
133	AN7 P107/AN7/KI3/RTP33	KEY1	AD	AD	AD	I	O	KEY1 AD value taken in During PSW_DET interruption, distinguishes the used keys which are switched to AD
134	AN6 P106/AN6/KI2/RTP32	KEY2	AD	AD	AD	I	O	KEY2 AD value taken in During PSW_DET interruption, distinguishes the used keys which are switched to AD
135	AN5 P105/AN5/KI1/RTP31	PS1_PRT	AD	AD	O	O	O	PS protection detection 1
136	AN4 P104/AN4/KI0/RTP30	PS2_PRT	AD	AD	O	O	O	PS protection detection 2
137	P103	ISEL_RA	O	O	O	O	O	
138	P102	ISEL_RB	O	O	O	O	O	
139	AN1 P101/AN1/RTP11	DEST	AD	AD	AD	O	O	AD destination discrimination Data is taken in when resetting is cancelled
140	AVss AVss	AVss	MCU	MCU	MCU	MCU	MCU	Microprocessor GND
141	AN0 P100/AN0/RTP10	DOCK_TYPE	AD	AD	AD	I	O	DOCK discriminate Identifies the connected DOCK type, then switches the action During IPD_DET interruption, switches to AD, make a distinction based on post-10 ms A/D value Make a distinction from IPD_DET Low edge through post-10ms A/D value
142	Vref Vref	VREF	MCU	MCU	MCU	MCU	MCU	Microprocessor power supply
143	AVcc AVcc	AVcc	MCU	MCU	MCU	MCU	MCU	Microprocessor power supply
144	RXD4 P97/ADTRG/RXD4/ SCL4/STXD4	IPD_MISO	SI	I	I	I	O	Asynchronous data input for iPod To prevent pulling of iPod High output and microprocessor Low Fix output, input setup

Key detection for A/D port

Key input (A/D) pull-up resistance 10 k-ohms

Ohm	0	+ 1.0k	+ 1.0k	+ 1.5k	+ 1.5k	+ 2.2k	+ 3.3k	+ 4.7k	+ 22.0k	+ 33.0k
V	0 – 0.15	0.15 – 0.42	0.43 – 0.70	0.71 – 0.97	0.98 – 1.24	1.25 – 1.53	1.54 – 1.84	1.84 – 2.1	2.34 – 2.55	2.55 – 2.97
A/D value (3.3 V=255)	0 – 11	12 – 32	33-54	55 – 75	76 – 95	96 – 118	119 – 142	143 – 162	181 – 197	198 – 229
KEY1 (133 pin)	SCENE RADIO	SCENE CD	SCENE TV	SCENE BD/DVD	ZONE2 ON/OFF	ZONE2 CONTROL	PROGRAM >	PROGRAM <	MAIN ZONE ON/OFF	TONE CONTROL

Ohm	0	+ 1.0k	+ 1.0k	+ 1.5k	+ 1.8k	+ 2.2k	+ 3.3k	+ 4.7k	+ 6.8k	+ 10.0k	+ 22.0k	+ 68.0k
V	0 – 0.15	0.15 – 0.42	0.43 – 0.70	0.71 – 0.99	1.0 – 1.27	1.28 – 1.56	1.57 – 1.86	1.86 – 2.14	2.14 – 2.4	2.4 – 2.65	2.66 – 2.91	2.92 – 3.17
A/D value (3.3 V=255)	0 – 11	12 – 32	33 – 54	55 – 77	78 – 98	99 – 120	121 – 143	144 – 165	166 – 185	186 – 205	206 – 225	226 – 245
KEY2 (134 pin)	PURE DIRECT	STRAIGHT	INFO	MEMORY	PRESET <	PRESET >	CATEGORY < FM	CATEGORY > AM	TUNING CH <	TUNING CH >	INPUT <	INPUT >

Destination detection for A/D port

Destination input (A/D) pull-up resistance 10 k-ohms

Ohm (R3809 VIDEO P.C.B.)	1.2k	2.7k	4.7k	15.0k	47.0k	100.0k
V	0.2 – 0.6	0.6 – 0.9	0.9 – 1.2	1.8 – 2.3	2.4 – 2.9	2.9 – 3.2
A/D value (3.3 V=255)	15 – 46	46 – 69	69 – 92	139 – 177	185 – 224	224 – 247
DEST (139 pin)	U	C	R	A	F	L

Model detection for A/D port

Model input (A/D) pull-up resistance 10 k-ohms

Ohm (R201 DIGITAL P.C.B.)	5.6k	8.2k
V	1.1 – 1.3	1.3 – 1.6
A/D value (3.3 V=255)	85 – 95	110 – 120
MODEL (127 pin)	RX-V665	HTR-6260



PIN CONNECTION DIAGRAMS

• ICs

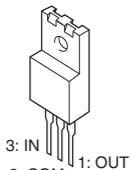
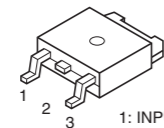
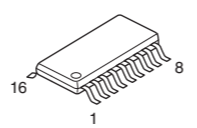
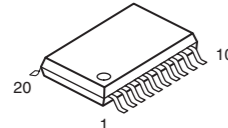
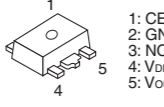
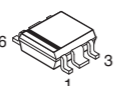
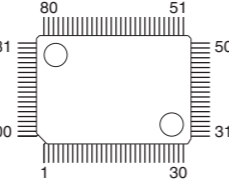
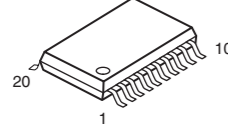
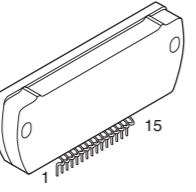
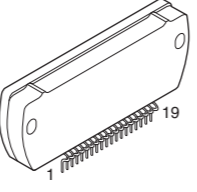
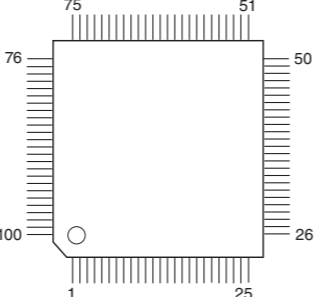
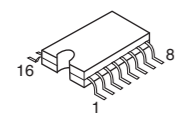
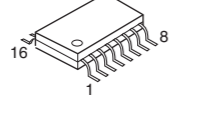

RX-V665/HTR-6260

<p>ABT1012Q100</p>	<p>ADV7800BSTZ-80</p>	<p>BA00JC5WT-V5</p>	<p>BD9323EFJ-E2</p>		
<p>D70YE101BRFP266 M30878JBG P SiI9233ACTU</p>		<p>FHP3350IM14X</p>	<p>K4S641632N-LC60000</p>		
<p>KIA7912PI</p>	<p>LA73050-TLM-E</p>	<p>LC709004A-TLM-E LC74782JM-8A16-TLMC</p>	<p>LC72725KM-UY-TLM-E</p>		
<p>LC89058WD-E</p>	<p>LE25LA322M-TLM-E</p>	<p>LM19CIZ/LF</p>	<p>M66003-0131FP-R</p>	<p>MX29LV160DBTI-70G</p>	
<p>NJM2068MD-TE2</p>	<p>NJM2388F05</p> <ol style="list-style-type: none"> 1. V_{IN} 2. V_{OUT} 3. GND 4. ON/OFF CONTROL 	<p>NJM2396F05</p> <ol style="list-style-type: none"> 1. IN 2. V_{OUT} 3. GND 4. ON/OFF CONTROL 	<p>NJM2581M</p>	<p>NJM2867F3-05</p>	<p>NJM4565M NJM4565M (TE1)</p>

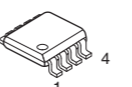
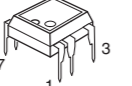



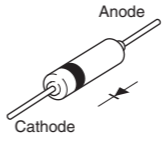
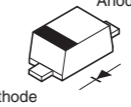
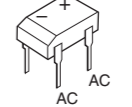
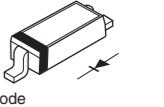
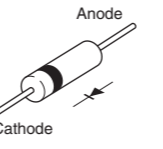
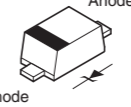
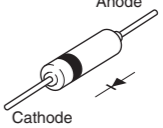
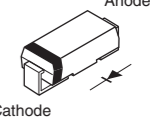
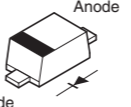

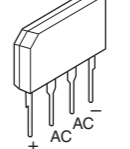
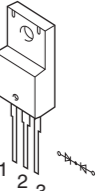
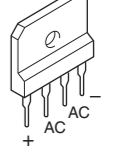

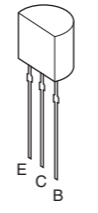
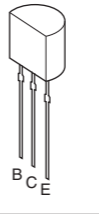

• ICs

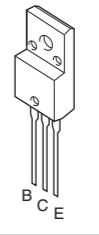
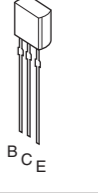
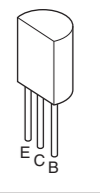
NJM7812FA  3: IN 2: COM 1: OUT	NJM78M05DL1A (TE1)  1: INPUT 2: GND 3: OUTPUT	PCM1680DBQR  28 14 1	PCM1781DBQR  16 8 1
PCM1803DBR  20 1	R1172H181B-T1-F R1172H331D-T1-F R1172H501D-T1-F  1: CE 2: GND 3: NC 4: V _{DD} 5: V _{OUT}	R1172S121D-E2-F  6 1	R2A15220FP  80 51 81 50 100 31 1 30
SN74LVTH245APW  20 1	STK433-130-E  15	STK433-330-E  19	SiI9134CTU  75 51 76 50 100 26 1 25
TC74HC4051AFEL  16 1	TC74VHC157FT  16 1	TC74VHCT08AFT TC74VHCU04FT  14 7 1	TC7SH04FU-TE85L TC7SH08FU  5 4 3 1
TC7WZ32FK (TE85L, F)  8 4 1	TL431ACLPR  1: CATHODE 2: ANODE 3: REF	TOP254PN  7 1	

• Diodes

1N4002S 1SS133 1SS176 1SS270A  Anode Cathode	1SS355  Anode Cathode	DB105  AC AC	KDS160-RTK  Anode Cathode
HT18G P6KE200ARL  Anode Cathode	MAZ8033GHL 3.4V MAZ8043GHL 4.4V MAZ8091GML 9.1V  Anode Cathode	MTZJ10B MTZJ15B MTZJ22C MTZJ3.3B MTZJ39D MTZJ5.1B MTZJ6.8C  Anode Cathode	RB051L-40 UDZ5.1B  Anode Cathode
RB501V-40  Anode Cathode	RLZ7.5B 7.5V  Anode Cathode	RS203M-B-C-J80  + AC AC	SG10SC4M  1 2 3
TS6P03G 6.0A 200V  + AC AC			

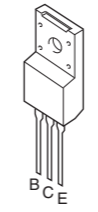
• Transistors

2N5401C-AT/P 2SA1015-Y  E C B	2N5551C-AT  B C E	2SA1576A  C B E	2SB1274  B C E	2SC1740S  B C E	2SC1815 Y 2SC1815 Y TP  E C B
2SC2412K  C B E	2SC4081 T106  C B E	2SD1938F  C B E	DTA114EKA DTA143EKA DTA144EKA DTC114EKA DTC144EKA  3 1 2	1: GND 2: IN 3: OUT	KRA104S-RTK KRC102S-RTK  OUT COMMON IN
KTA1046-Y-U/P  B C E	KTC3875S  C B E	MCH6336-TL-E  4 6 3 1 5 2 1: Drain 2: Drain 3: Gate 4: Source 5: Drain 6: Drain			

BLOCK DIAGRAMS

ANALOG AUDIO Section Block Diagram

MAIN • See page 116, 117 → SCHEMATIC DIAGRAM

VIDEO • See page 118-120 → SCHEMATIC DIAGRAM

OPERATION • See page 114, 115 → SCHEMATIC DIAGRAM

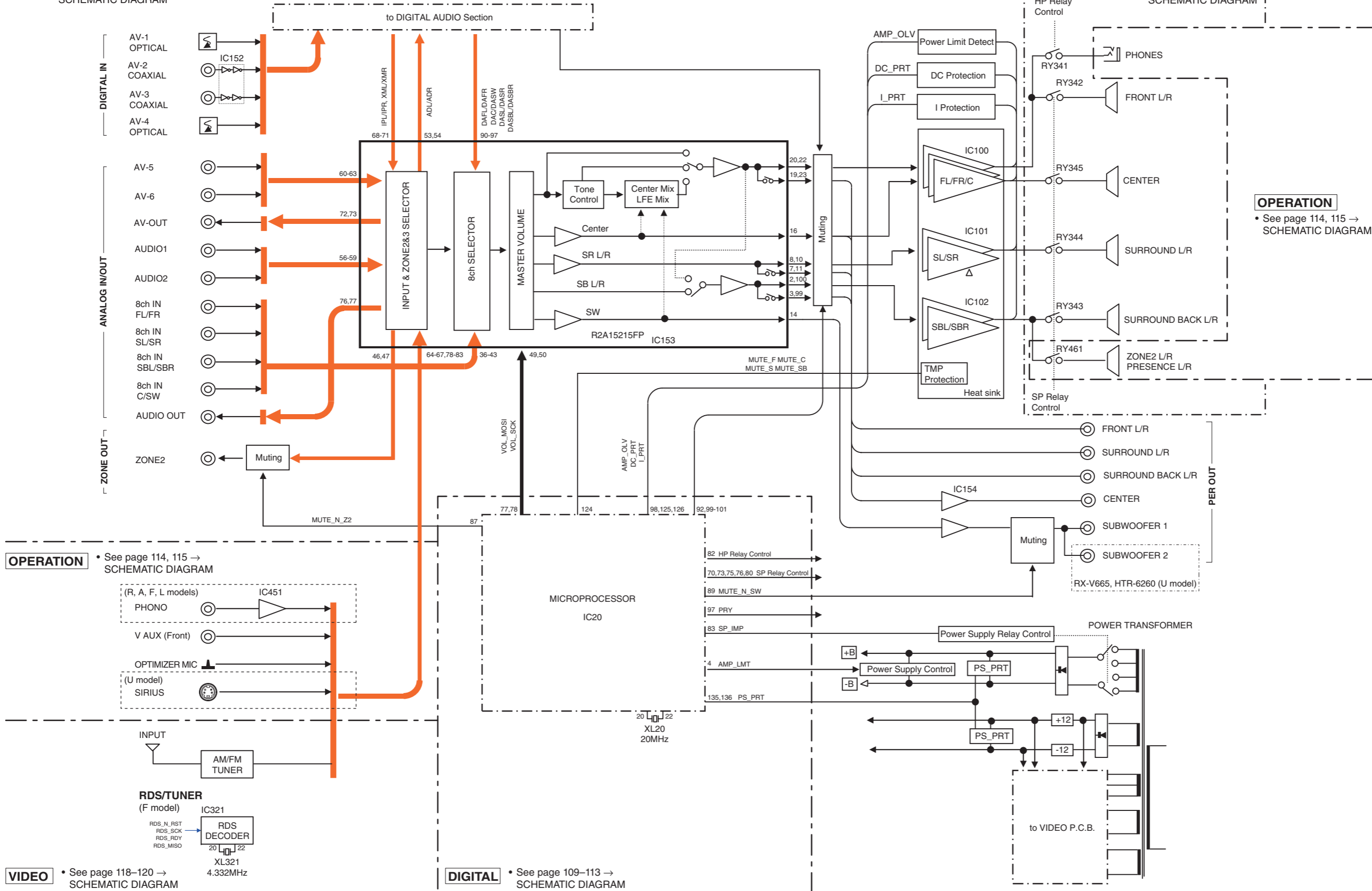

VIDEO • See page 118-120 → SCHEMATIC DIAGRAM

DIGITAL • See page 109-113 → SCHEMATIC DIAGRAM

DIGITAL AUDIO Section Block Diagram

DIGITAL • See page 109–113 → SCHEMATIC DIAGRAM

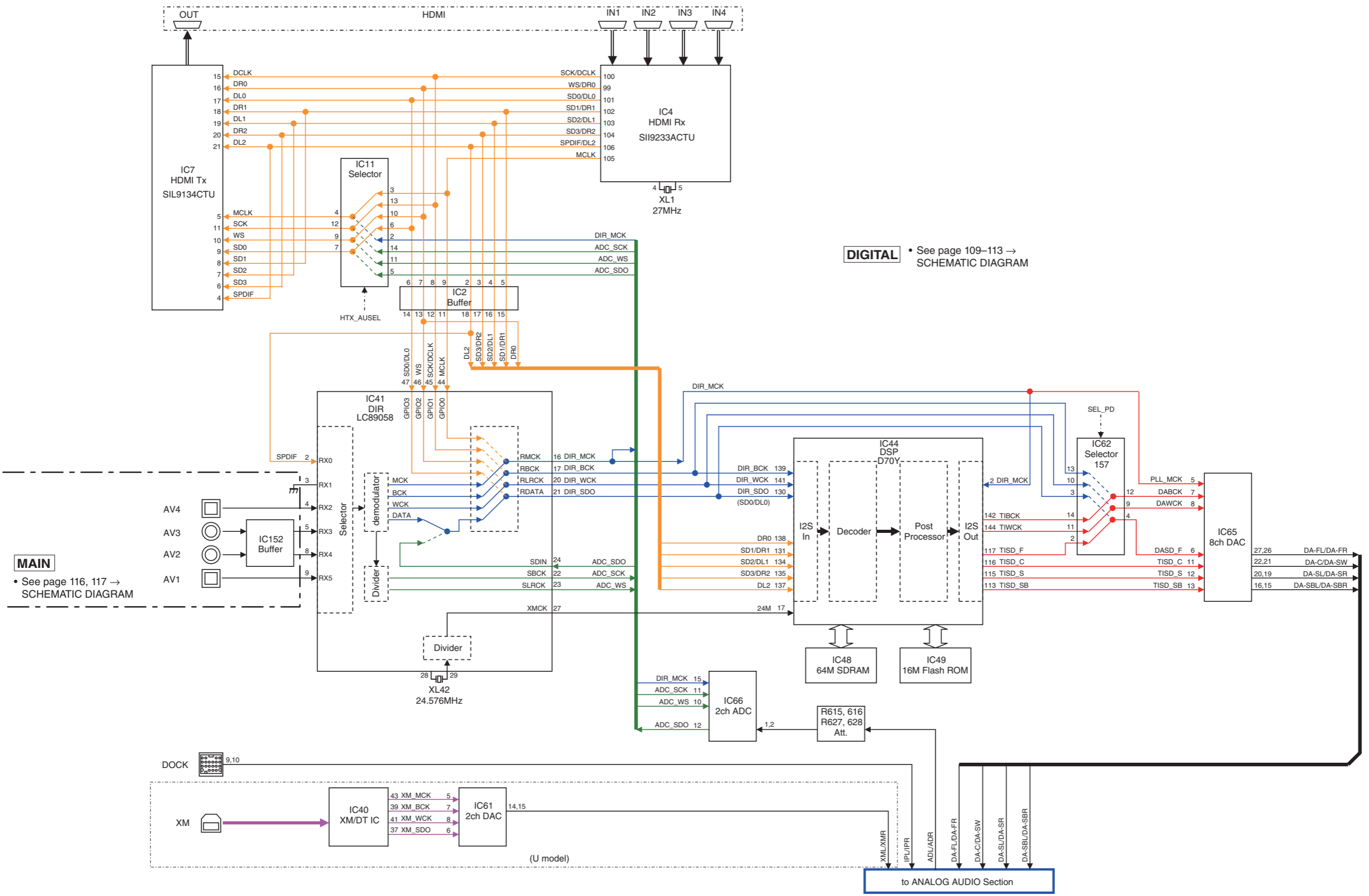

VIDEO Section Block Diagram

DIGITAL VIDEO section

ANALOG VIDEO section

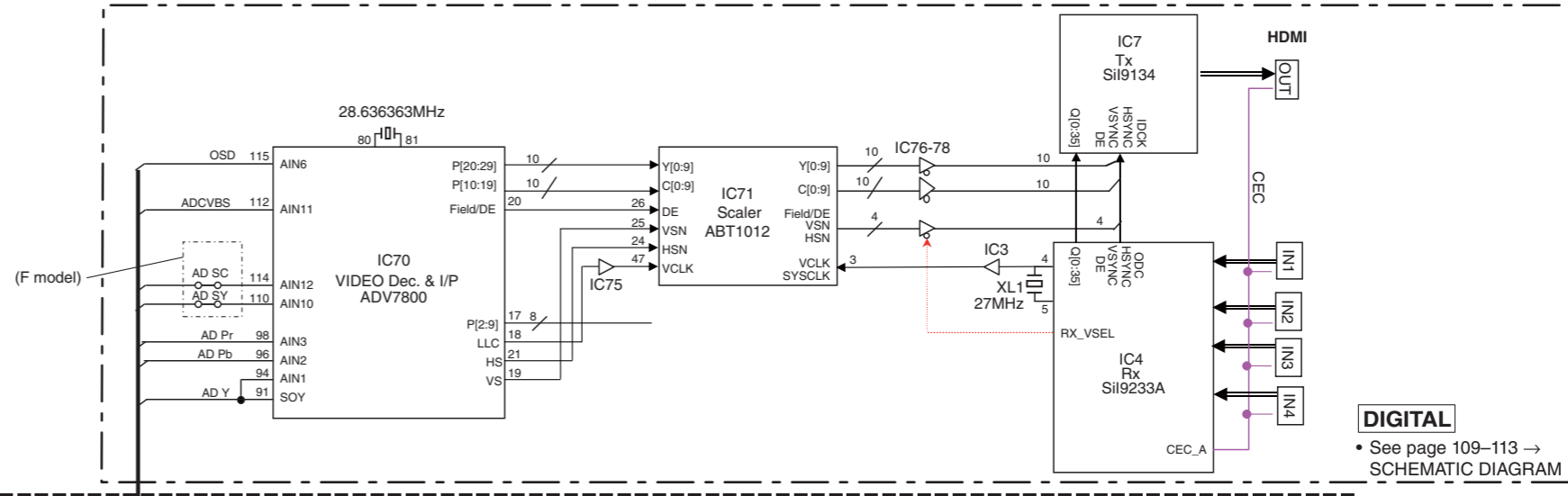
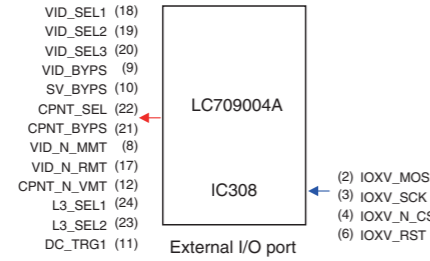

DIGITAL
 • See page 109–113 →
 SCHEMATIC DIAGRAM

OPERATION • See page 114, 115 →
 SCHEMATIC DIAGRAM

DIGITAL • See page 109–113 →
 SCHEMATIC DIAGRAM

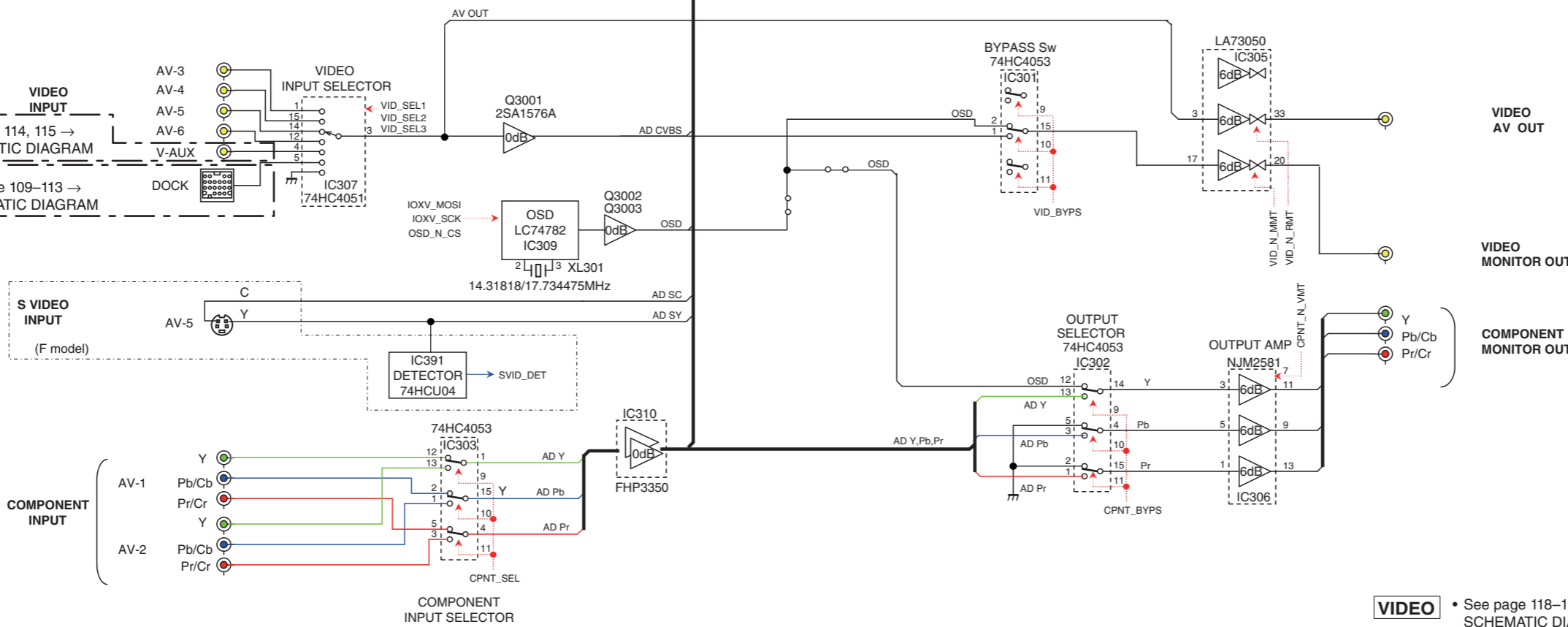

VIDEO • See page 118–120 →
 SCHEMATIC DIAGRAM

Power Supply Section Block Diagram

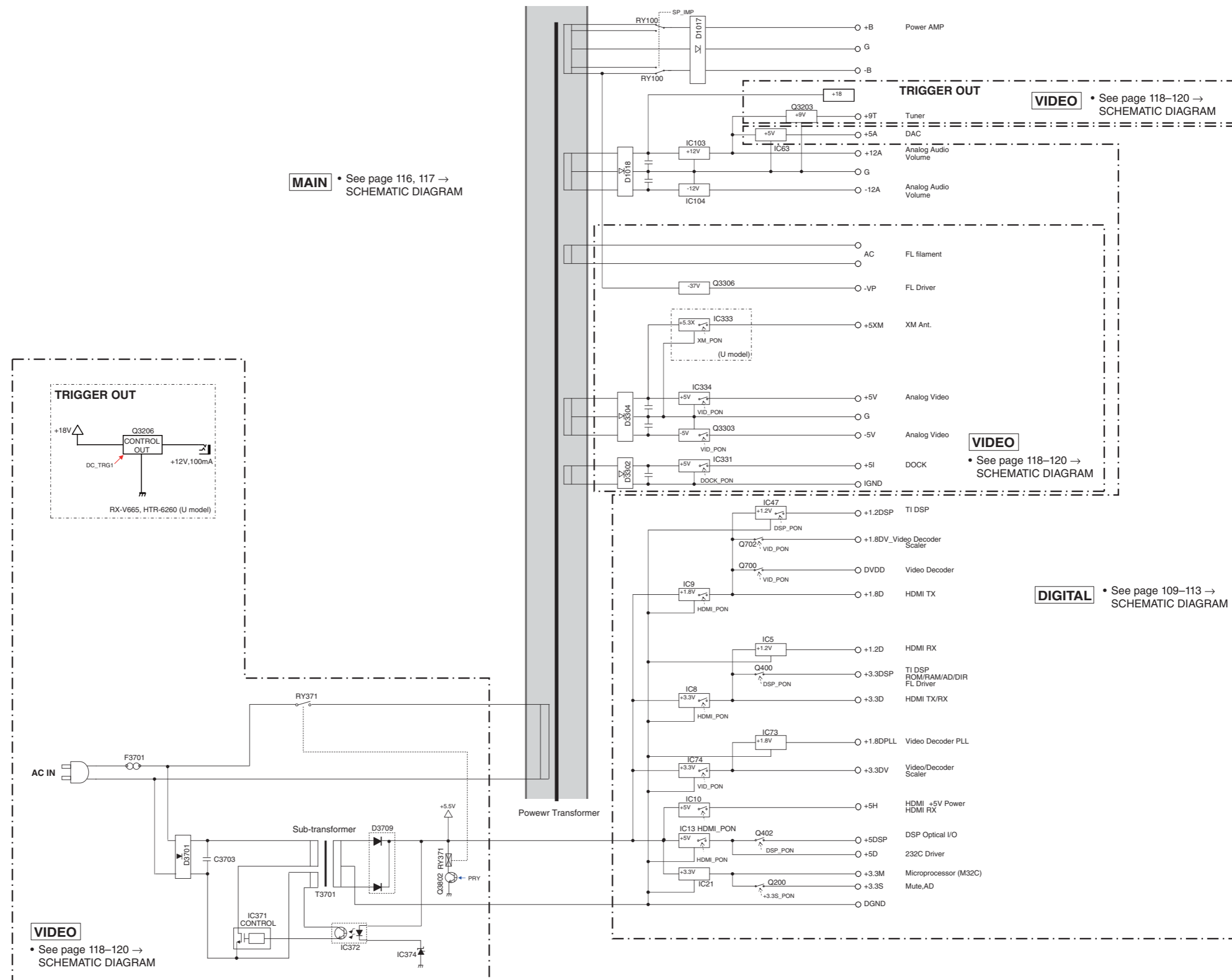

MAIN • See page 116, 117 → SCHEMATIC DIAGRAM

VIDEO • See page 118–120 → SCHEMATIC DIAGRAM

VIDEO • See page 118–120 → SCHEMATIC DIAGRAM

DIGITAL • See page 109–113 → SCHEMATIC DIAGRAM

VIDEO • See page 118–120 → SCHEMATIC DIAGRAM

PRINTED CIRCUIT BOARDS

DIGITAL P.C.B. (Side A)

POINT (A) XL1 (Pin 5 of IC4)

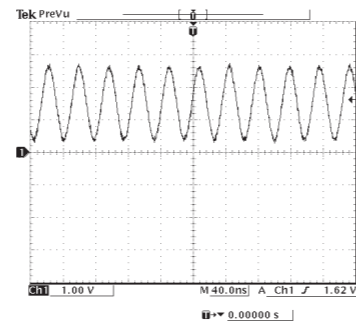

POINT (B) XL20 (Pin 20 of IC20)

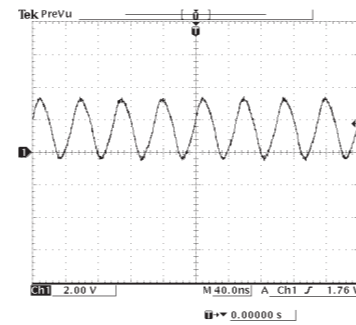

POINT (C) XL41 (Pin 28 of IC40)

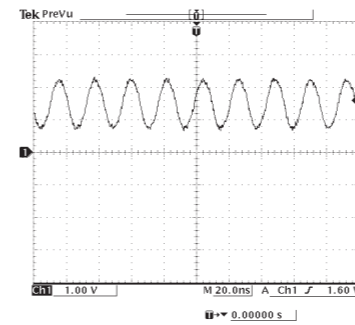

POINT (D) XL42 (Pin 29 of IC41)

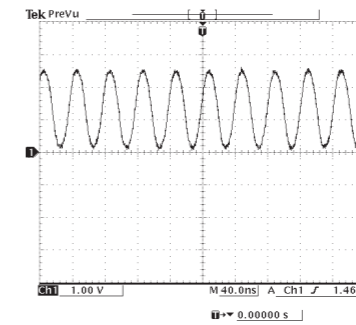

POINT (E) XL70 (Pin 81 of IC70)

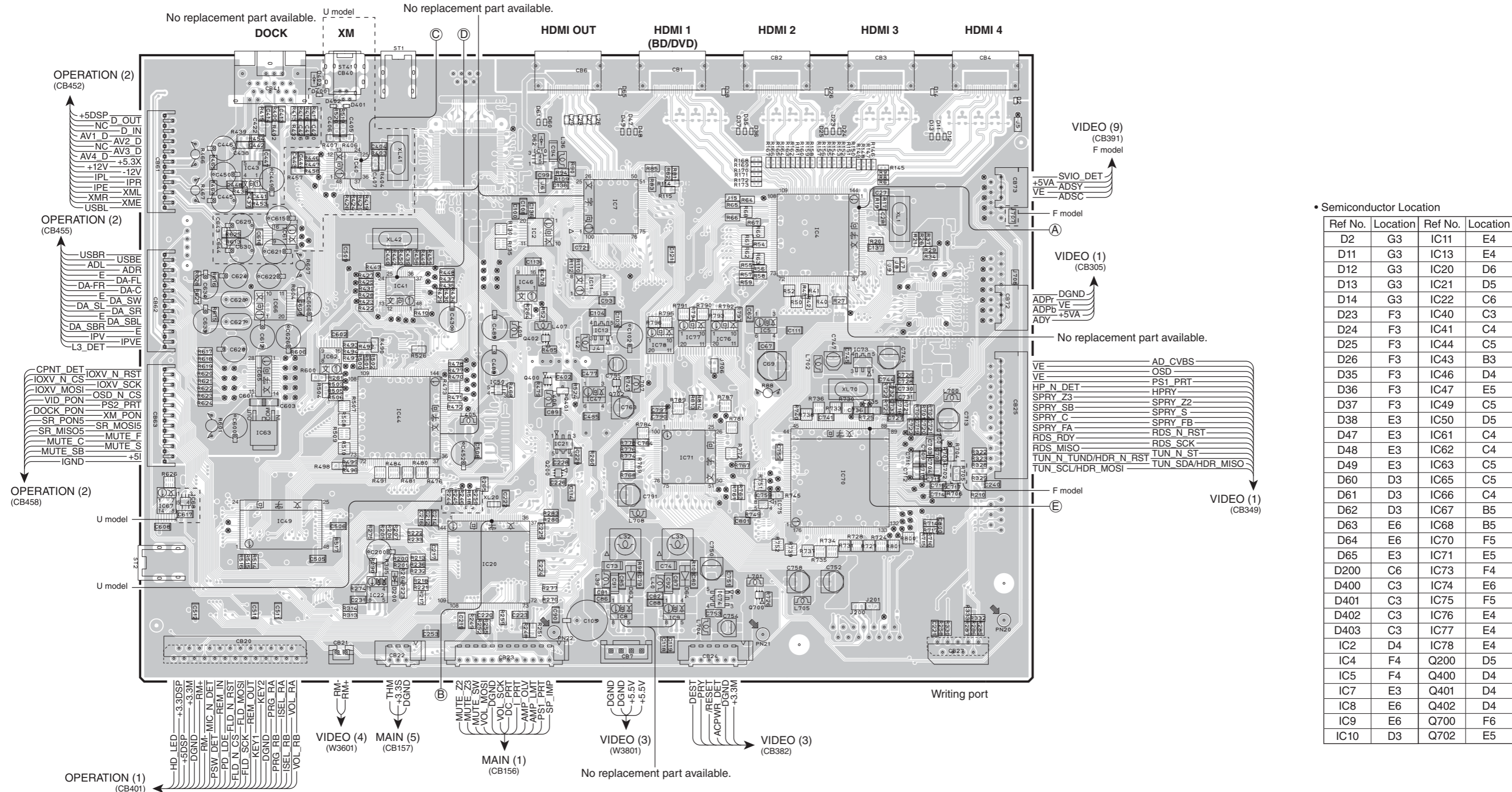
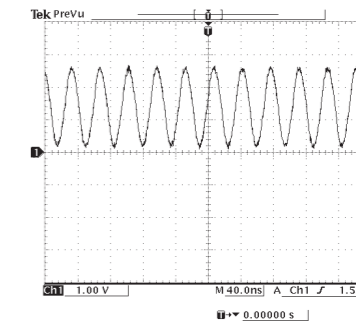

• Semiconductor Location

Ref No.	Location	Ref No.	Location
D2	G3	IC11	E4
D11	G3	IC13	E4
D12	G3	IC20	D6
D13	G3	IC21	D5
D14	G3	IC22	C6
D23	F3	IC40	C3
D24	F3	IC41	C4
D25	F3	IC44	C5
D26	F3	IC43	B3
D35	F3	IC46	D4
D36	F3	IC47	E5
D37	F3	IC49	C5
D38	E3	IC50	D5
D47	E3	IC61	C4
D48	E3	IC62	C4
D49	E3	IC63	C5
D60	D3	IC65	C5
D61	D3	IC66	C4
D62	D3	IC67	B5
D63	E6	IC68	B5
D64	E6	IC70	F5
D65	E3	IC71	E5
D200	C6	IC73	F4
D400	C3	IC74	E6
D401	C3	IC75	F5
D402	C3	IC76	E4
D403	C3	IC77	E4
IC2	D4	IC78	E4
IC4	F4	Q200	D5
IC5	F4	Q400	D4
IC7	E3	Q401	D4
IC8	E6	Q402	D4
IC9	E6	Q700	F6
IC10	D3	Q702	E5

DIGITAL P.C.B. (Side B)

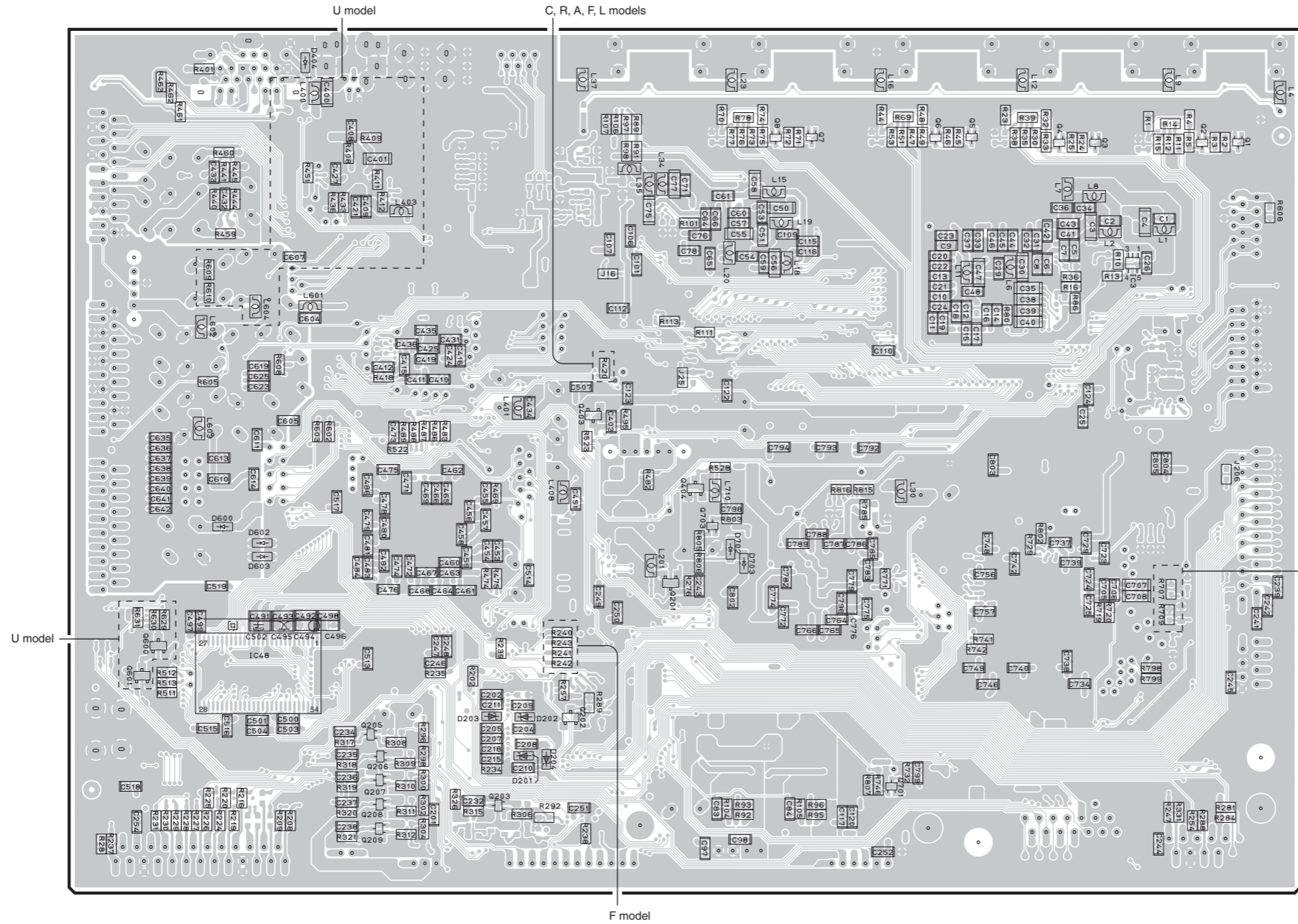

• Semiconductor Location

Ref No.	Location
D201	D6
D202	D6
D203	D6
D204	D6
D404	C3
D600	C5
D602	C5
D603	C5
D702	E5
D703	E5
IC3	G4
IC48	C5
Q1	G3
Q2	G3
Q3	G3
Q4	F3
Q5	F3
Q6	F3
Q7	E3
Q8	E3
Q201	E5
Q202	D6
Q203	D6
Q205	C6
Q206	C6
Q207	C6
Q208	C6
Q209	C6
Q403	D4
Q404	E5
Q600	B5
Q601	B5
Q701	F6
Q703	E5

OPERATION (1) P.C.B. (Side A)

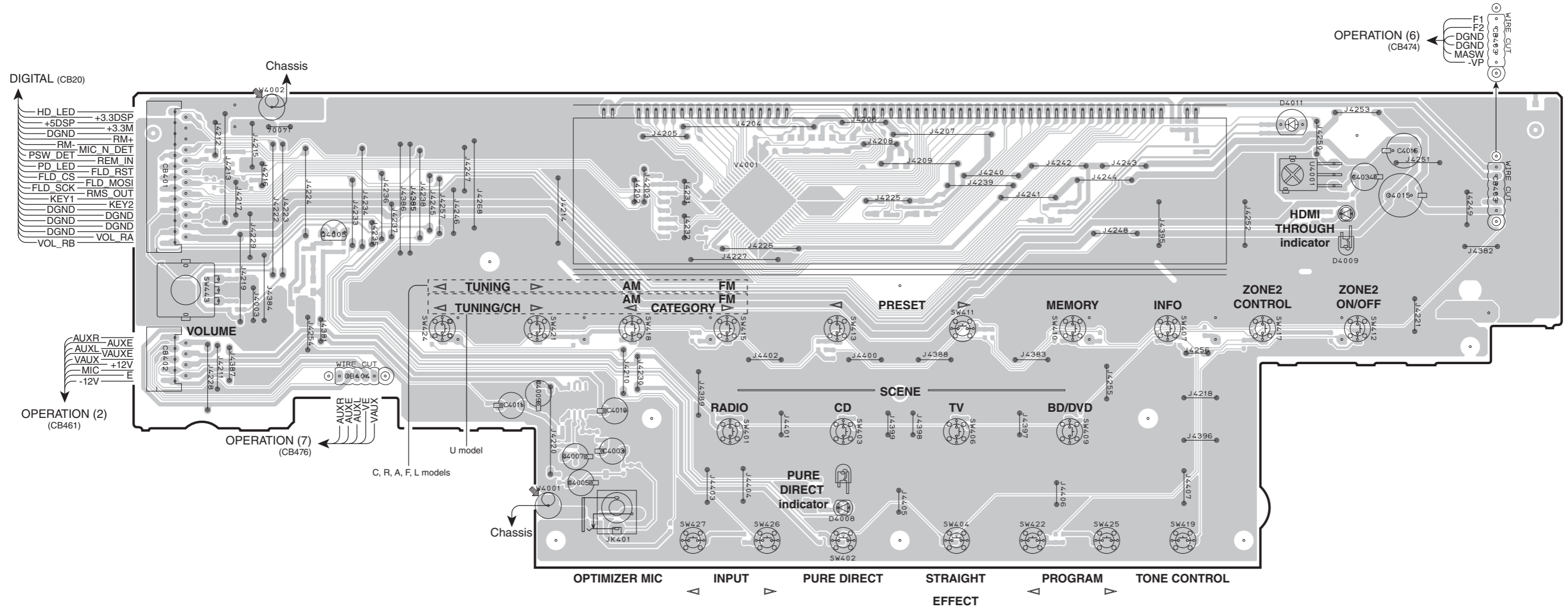

• Semiconductor Location

Ref No.	Location
D4008	F5
D4009	I3
D4011	I3
Q4005	C3

OPERATION (1) P.C.B. (Side B)

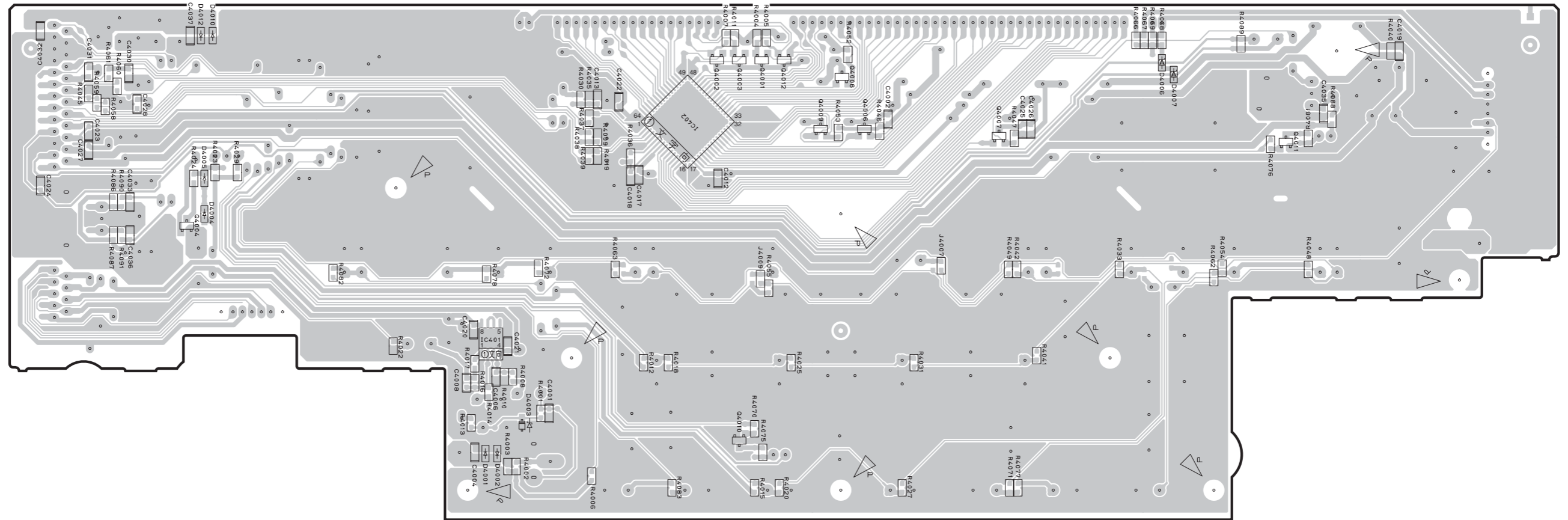

• Semiconductor Location

Ref No.	Location	Ref No.	Location
D4001	D5	Q4001	F3
D4002	D5	Q4002	E3
D4003	D5	Q4003	F3
D4004	C4	Q4004	C4
D4005	C3	Q4006	F3
D4006	H3	Q4007	G3
D4007	H3	Q4008	F3
D4010	C3	Q4009	F3
D4012	C3	Q4010	F5
IC401	D4	Q4011	I3
IC402	E3	Q4012	F3

OPERATION (2) P.C.B. (Side B)

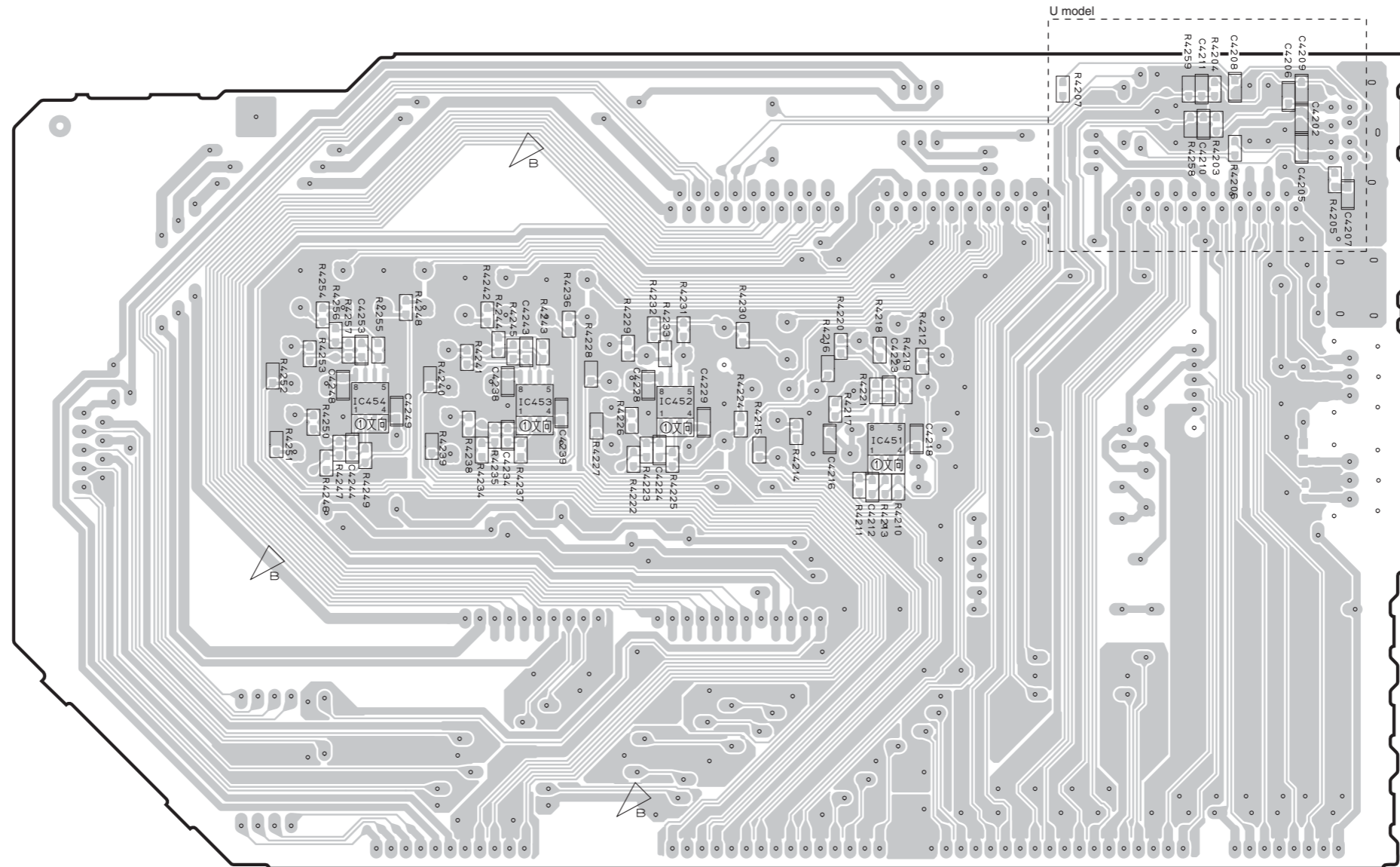

• Semiconductor Location

Ref No.	Location
IC451	F4
IC452	E4
IC453	E4
IC454	D4

OPERATION (3) P.C.B. (Side A)

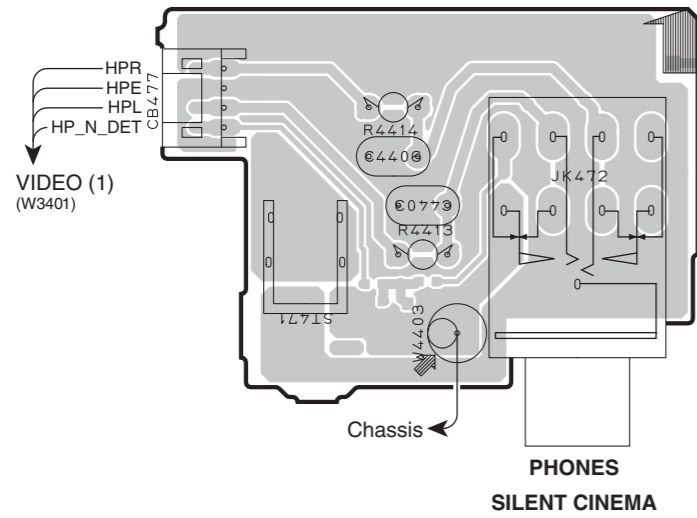

OPERATION (6) P.C.B. (Side A)

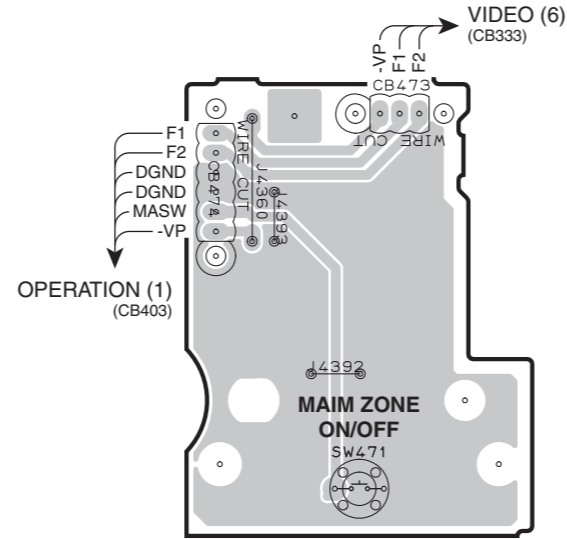

OPERATION (7) P.C.B. (Side A)

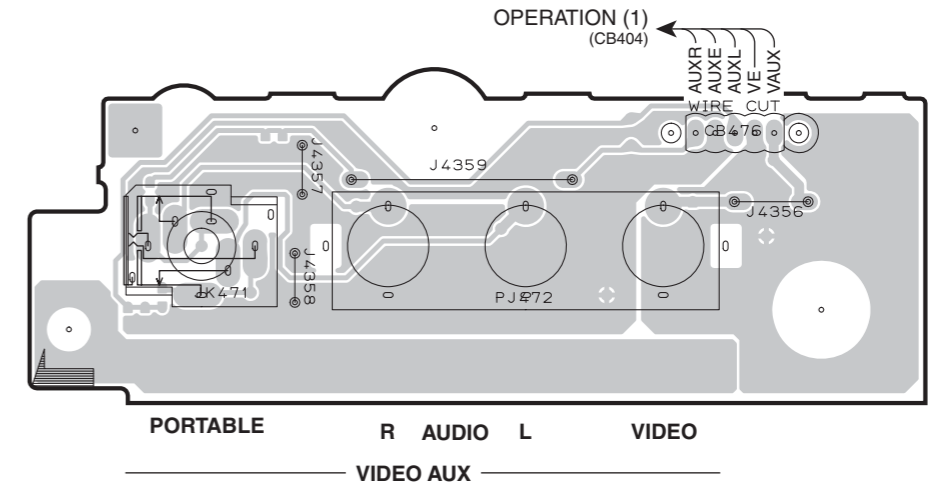

OPERATION (8) P.C.B. (Side A)

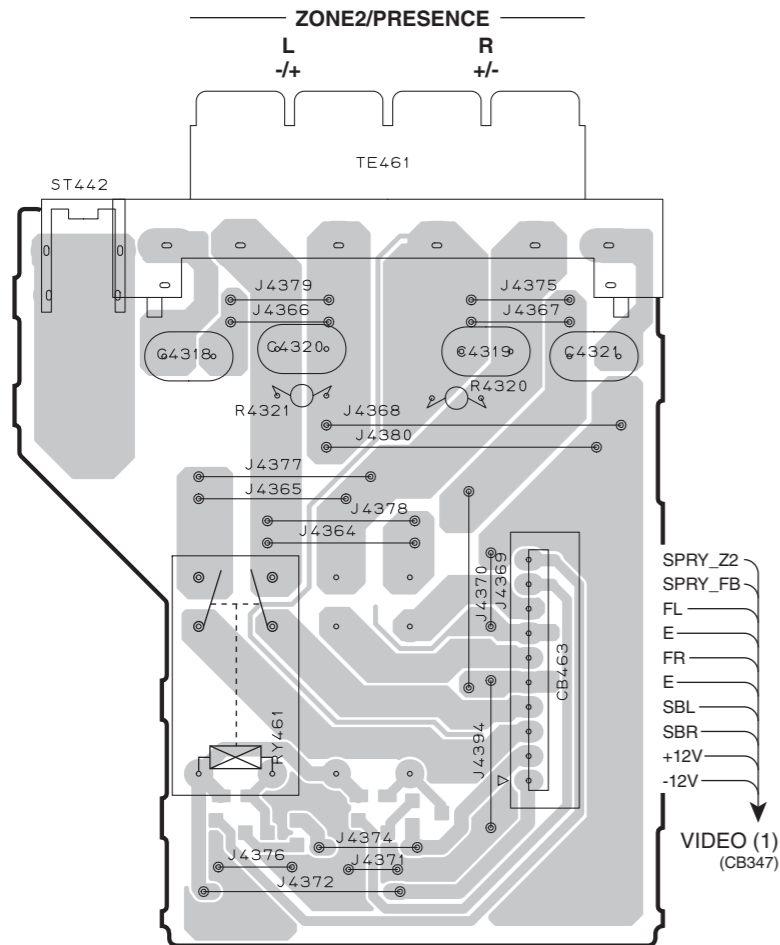

OPERATION (9) P.C.B. (Side A)

R, A, F, L models

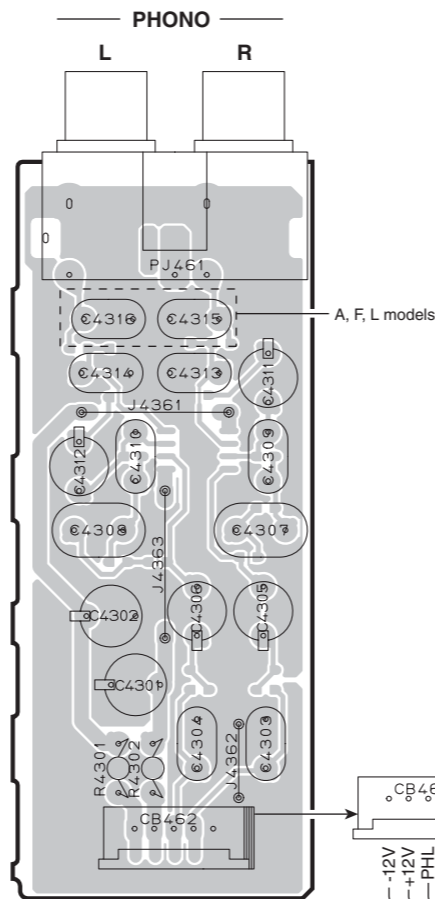

OPERATION (10) P.C.B. (Side A)

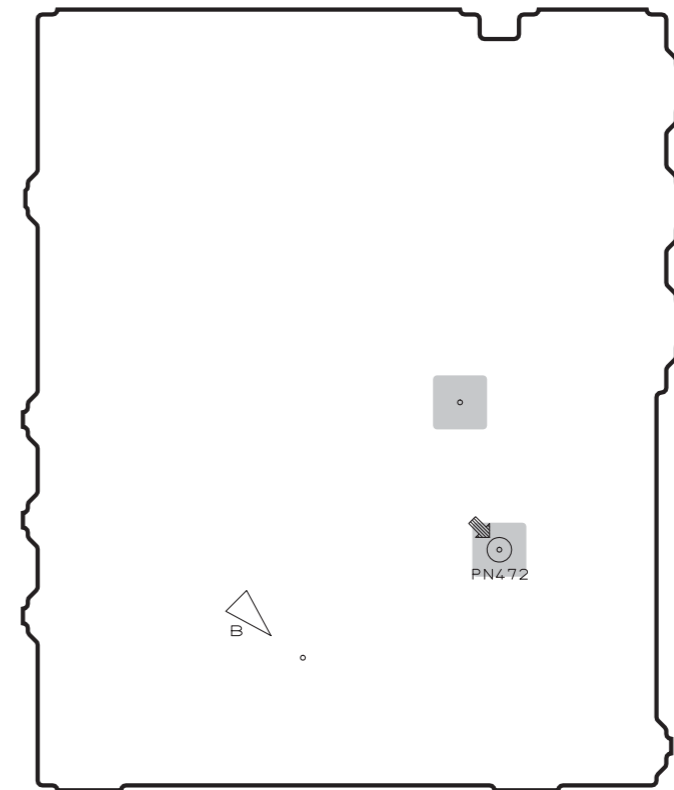

OPERATION (3) P.C.B. (Side B)

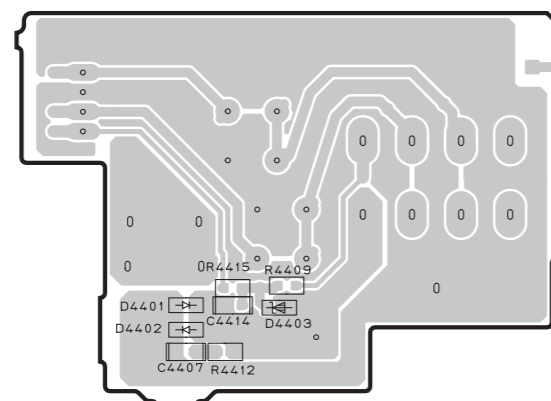

OPERATION (6) P.C.B. (Side B)

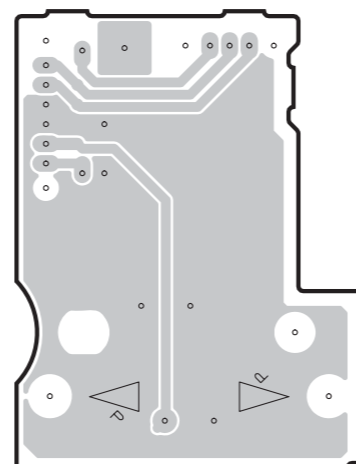

OPERATION (7) P.C.B. (Side B)

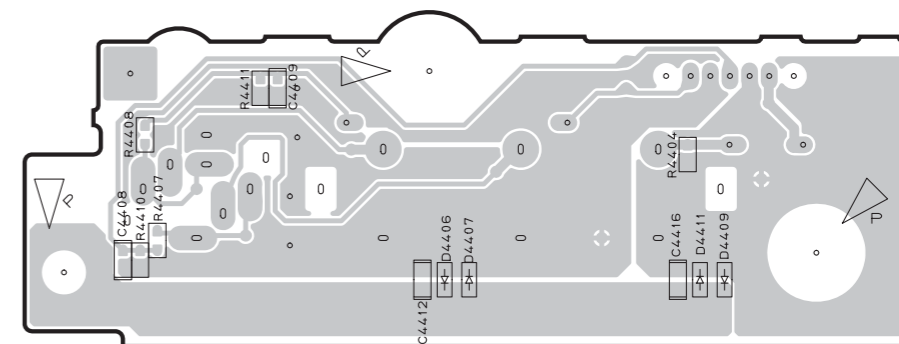

OPERATION (8) P.C.B. (Side B)

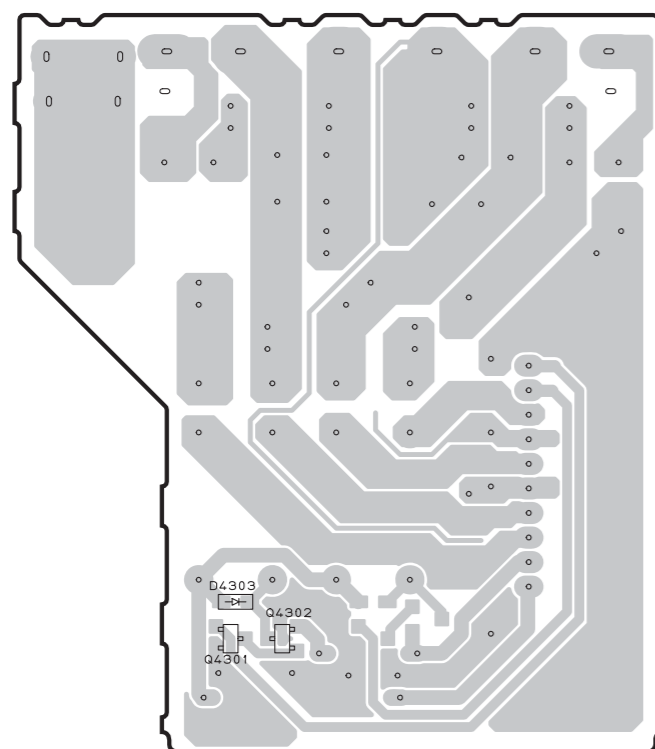

OPERATION (9) P.C.B. (Side B)

R, A, F, L models

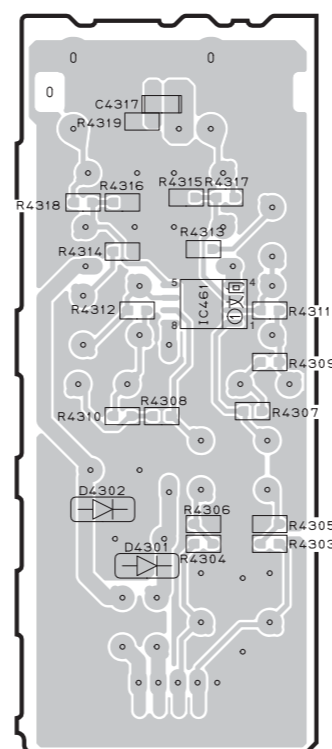

OPERATION (10) P.C.B. (Side B)

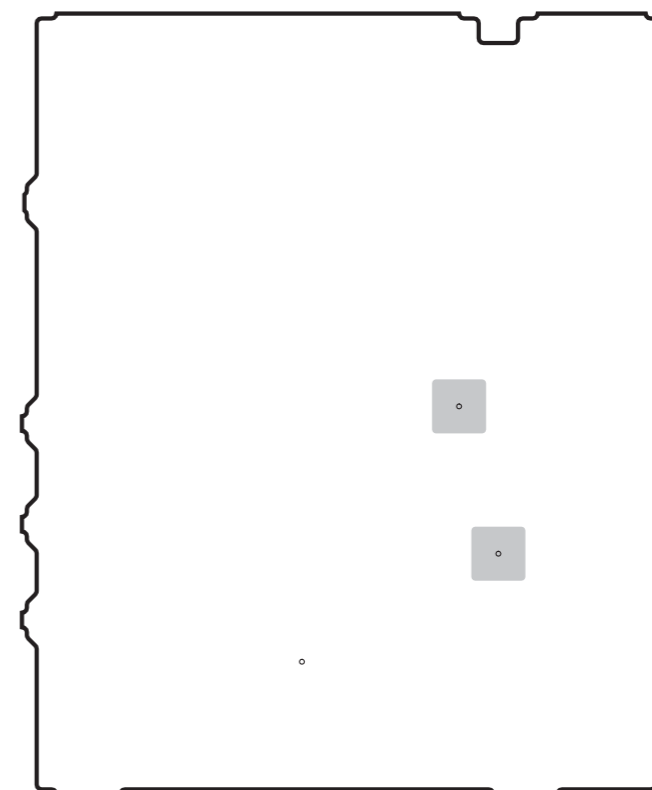

• Semiconductor Location

Ref No.	Location
D4301	E6
D4302	E6
D4303	B7
D4401	B3
D4402	B3
D4403	B3
D4406	H3
D4407	H3
D4409	I3
D4411	I3
IC461	E6
Q4301	B7
Q4302	B7

MAIN (1) P.C.B. (Side A)

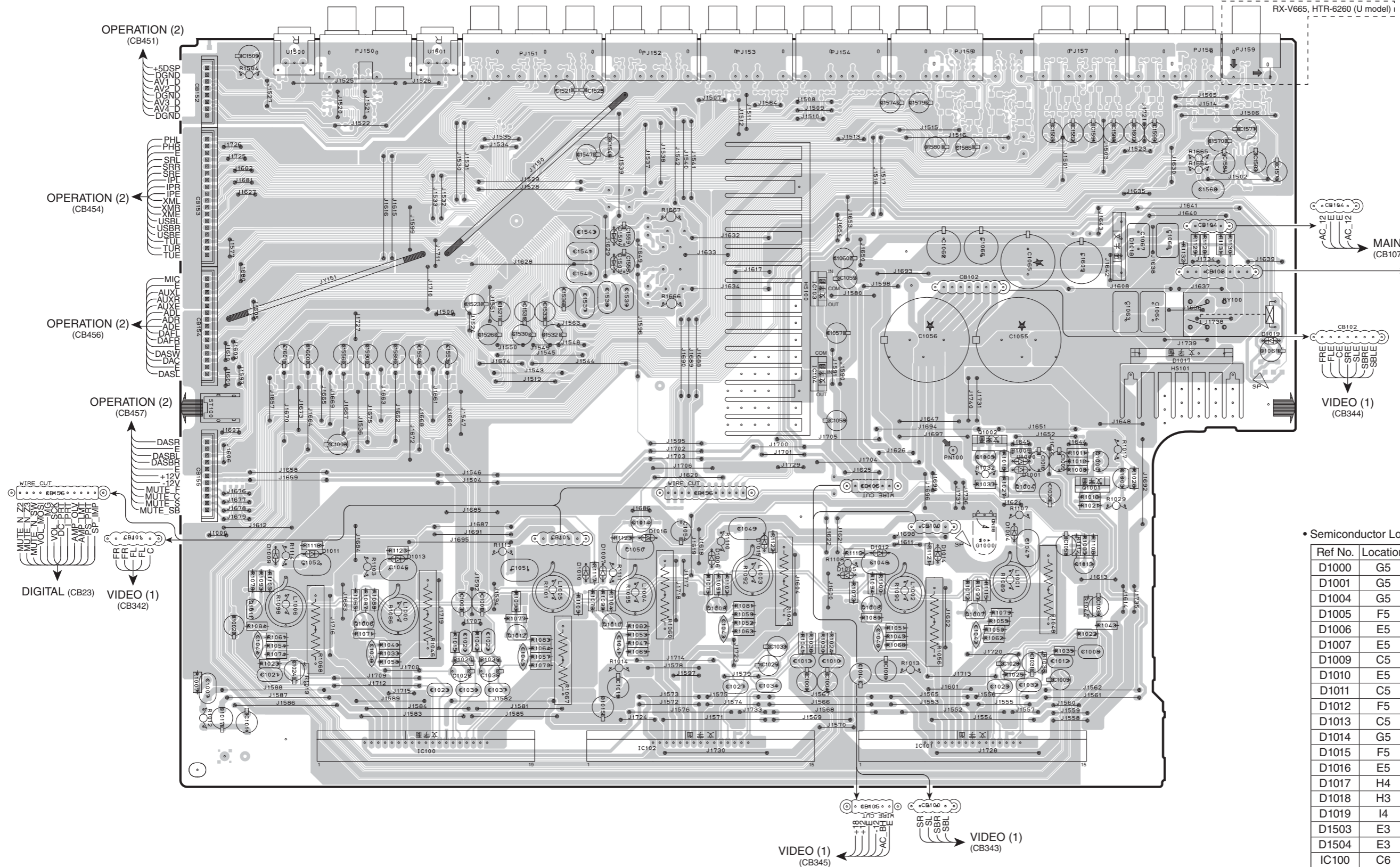
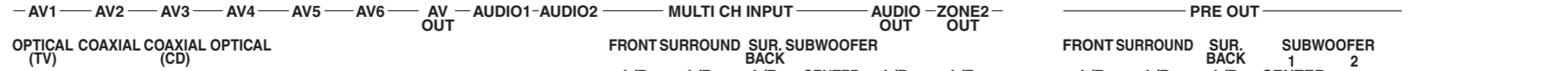

• Semiconductor Location

Ref No.	Location	Ref No.	Location
D1000	G5	IC101	G6
D1001	G5	IC102	E6
D1004	G5	IC103	F4
D1005	F5	IC104	F4
D1006	E5	Q1000	H5
D1007	E5	Q1001	H5
D1009	C5	Q1002	G5
D1010	E5	Q1003	H5
D1011	C5	Q1004	G5
D1012	F5	Q1005	G5
D1013	C5	Q1006	C6
D1014	G5	Q1007	G6
D1015	F5	Q1008	F6
D1016	E5	Q1009	E6
D1017	H4	Q1010	E6
D1018	H3	Q1011	B6
D1019	I4	Q1012	D6
D1503	E3	Q1013	H5
D1504	E3	Q1014	E5
IC100	C6		

MAIN (1) P.C.B. (Side B)

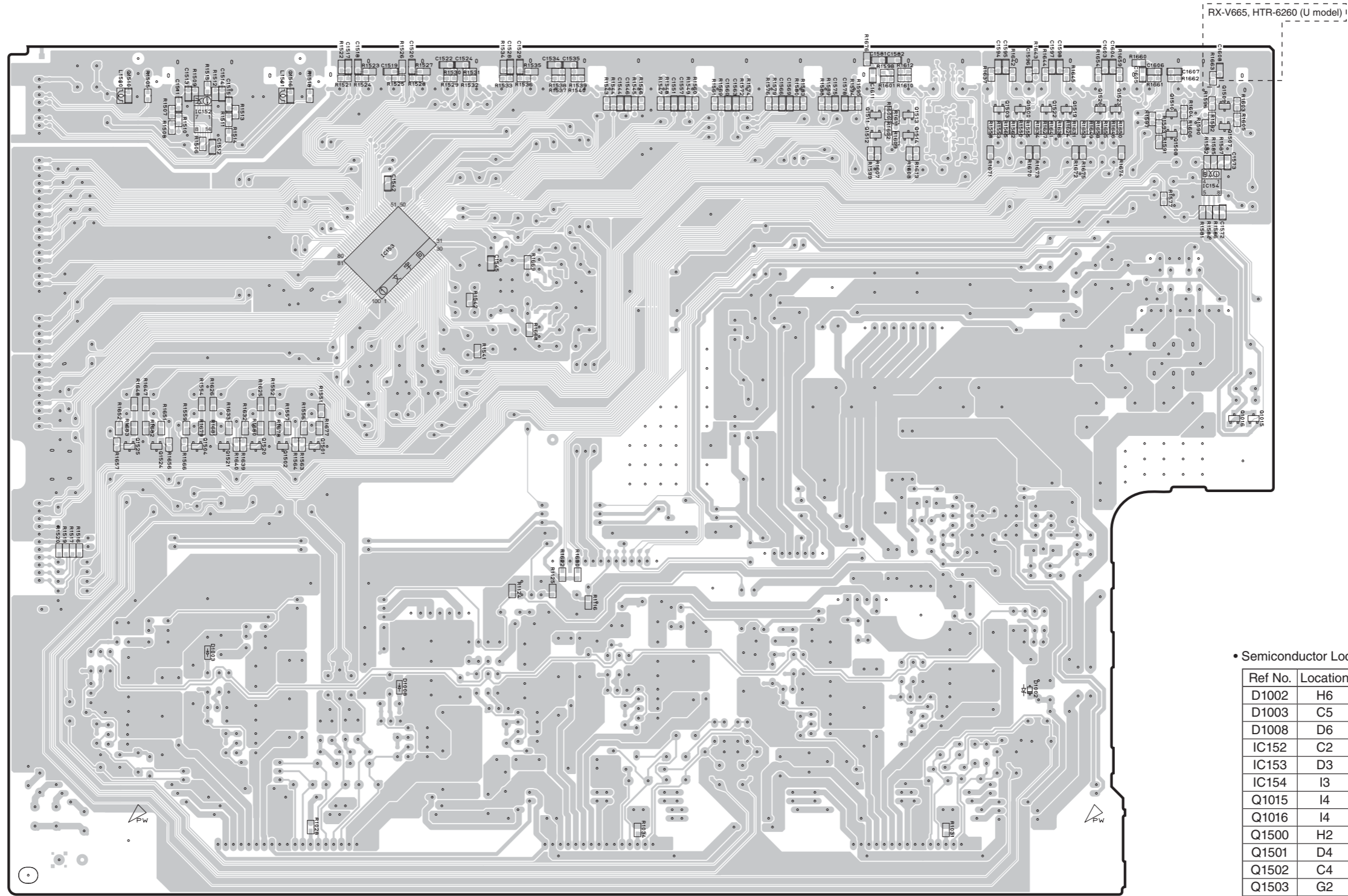

• Semiconductor Location

Ref No.	Location	Ref No.	Location
D1002	H6	Q1509	I2
D1003	C5	Q1510	H2
D1008	D6	Q1511	G2
IC152	C2	Q1512	G3
IC153	D3	Q1513	G2
IC154	I3	Q1514	G3
Q1015	I4	Q1519	H2
Q1016	I4	Q1520	C4
Q1500	H2	Q1521	C4
Q1501	D4	Q1522	H2
Q1502	C4	Q1523	H2
Q1503	G2	Q1524	C4
Q1504	C4	Q1525	C4
Q1507	I2	Q1526	H2
Q1508	H3		

MAIN (2) P.C.B. (Side A)

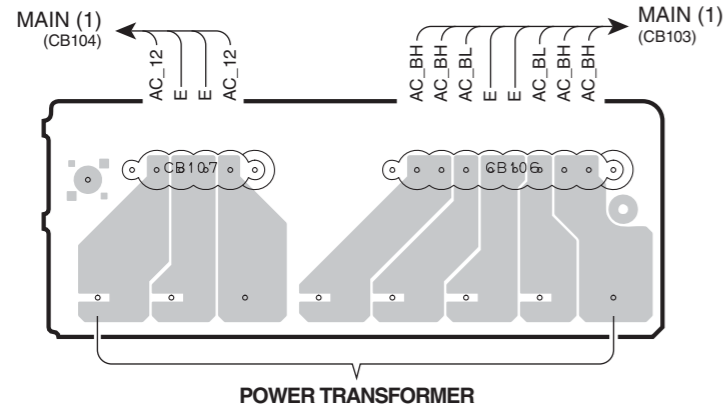

MAIN (3) P.C.B. (Side A)

R, L models

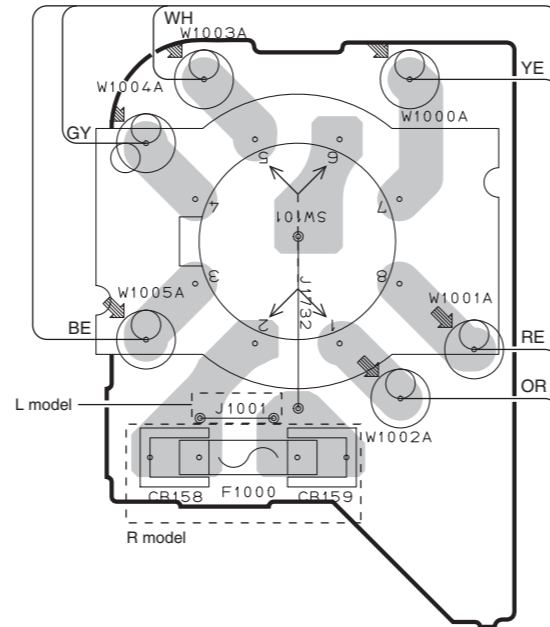

VOLTAGE SELECTOR

VOLTAGE SELECTOR	
230-240V	1-2/5-6
220V	2-3/6-7
110V	3-4/7-8
120V	4-5/8-1

MAIN (4) P.C.B. (Side A)

R, L models

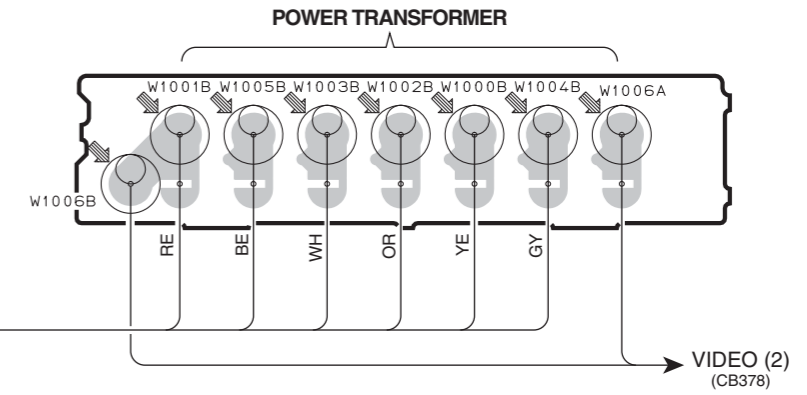

MAIN (5) P.C.B. (Side A)

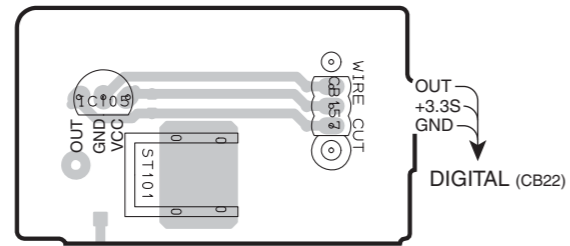

MAIN (6) P.C.B. (Side A)

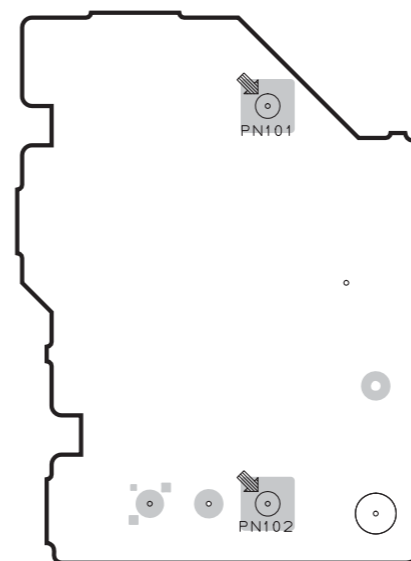

• Semiconductor Location

Ref No.	Location
IC105	C5

1
2
3
4
5
6
7

MAIN (2) P.C.B. (Side B)

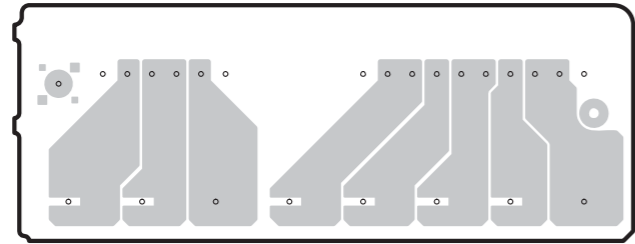

MAIN (3) P.C.B. (Side B)

R, L models

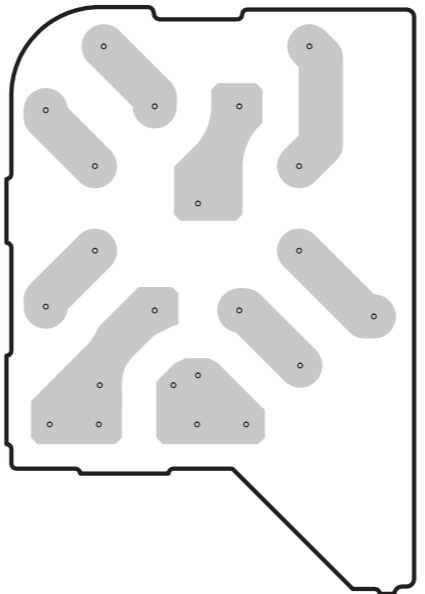

MAIN (4) P.C.B. (Side B)

R, L models

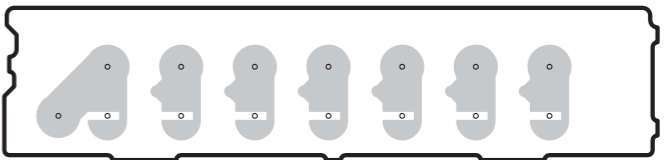

MAIN (5) P.C.B. (Side B)

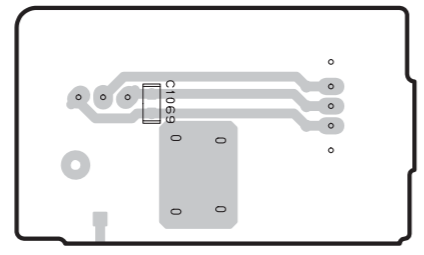

MAIN (6) P.C.B. (Side B)

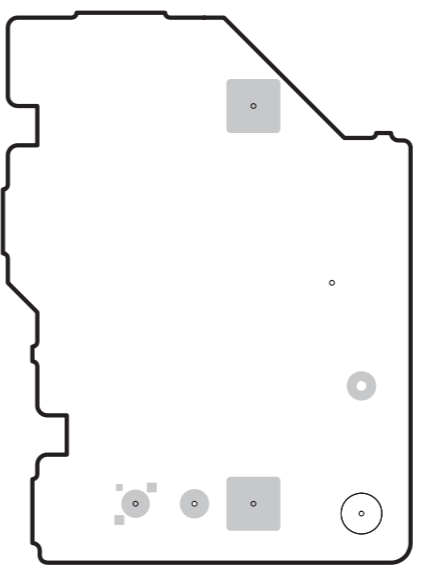

VIDEO (1) P.C.B. (Side A)

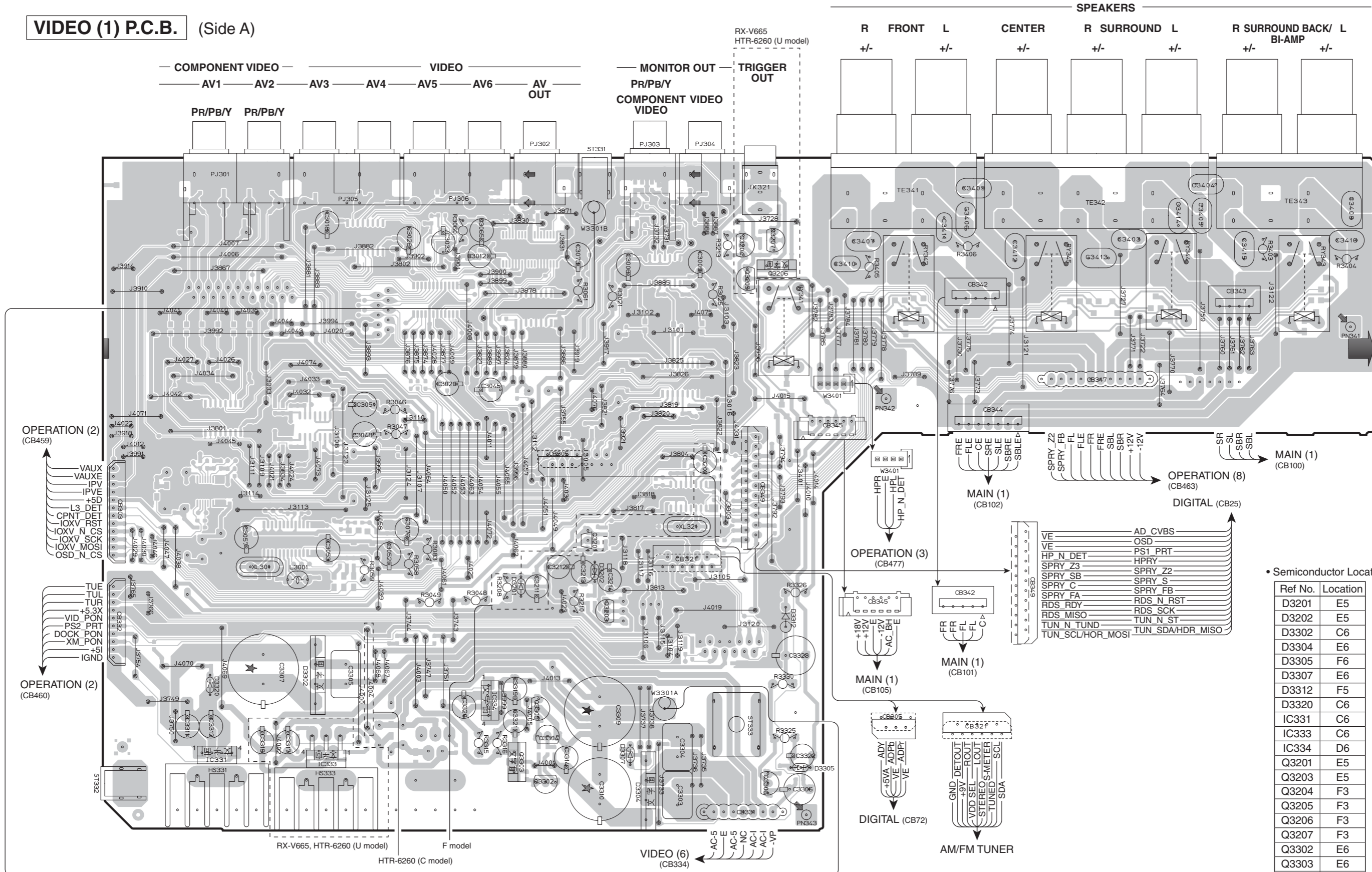

• Semiconductor Location

Ref No.	Location
D3201	E5
D3202	E5
D3302	C6
D3304	E6
D3305	F6
D3307	E6
D3312	F5
D3320	C6
IC331	C6
IC333	C6
IC334	D6
Q3201	E5
Q3203	E5
Q3204	F3
Q3205	F3
Q3206	F3
Q3207	F3
Q3302	E6
Q3303	E6
Q3304	E6
Q3305	E6
Q3306	F6

- VAUX
- VAUXE
- IPV
- IPVE
- +5D
- L3
- CPNT DET
- IOXV_RST
- IOXV_N_CS
- IOXV_SCK
- IOXV_MOSI
- OSD_N_CS
- TUE
- TUL
- TUR
- +5.3X
- VID_PON
- PS2_PRT
- DOCK_PON
- XM_PON
- +5I
- IGND
- AD_CVBS
- OSD
- VE
- HP_N_DET
- SPRY_Z3
- SPRY_SB
- SPRY_C
- SPRY_FA
- RDS_RDY
- RDS_MISO
- TUN_N_TUND
- TUN_SCL/HOR_MOSI
- PS1_PRT
- HPRY
- SPRY_Z2
- SPRY_S
- SPRY_FB
- RDS_N_RST
- RDS_SCK
- TUN_N_ST
- TUN_SDA/HDR_MISO
- VE
- OSD
- HP_N_DET
- SPRY_Z3
- SPRY_SB
- SPRY_C
- SPRY_FA
- RDS_RDY
- RDS_MISO
- TUN_N_TUND
- TUN_SCL/HOR_MOSI
- AD_CVBS
- OSD
- VE
- HP_N_DET
- SPRY_Z3
- SPRY_SB
- SPRY_C
- SPRY_FA
- RDS_RDY
- RDS_MISO
- TUN_N_TUND
- TUN_SCL/HOR_MOSI

VIDEO (1) P.C.B. (Side B)

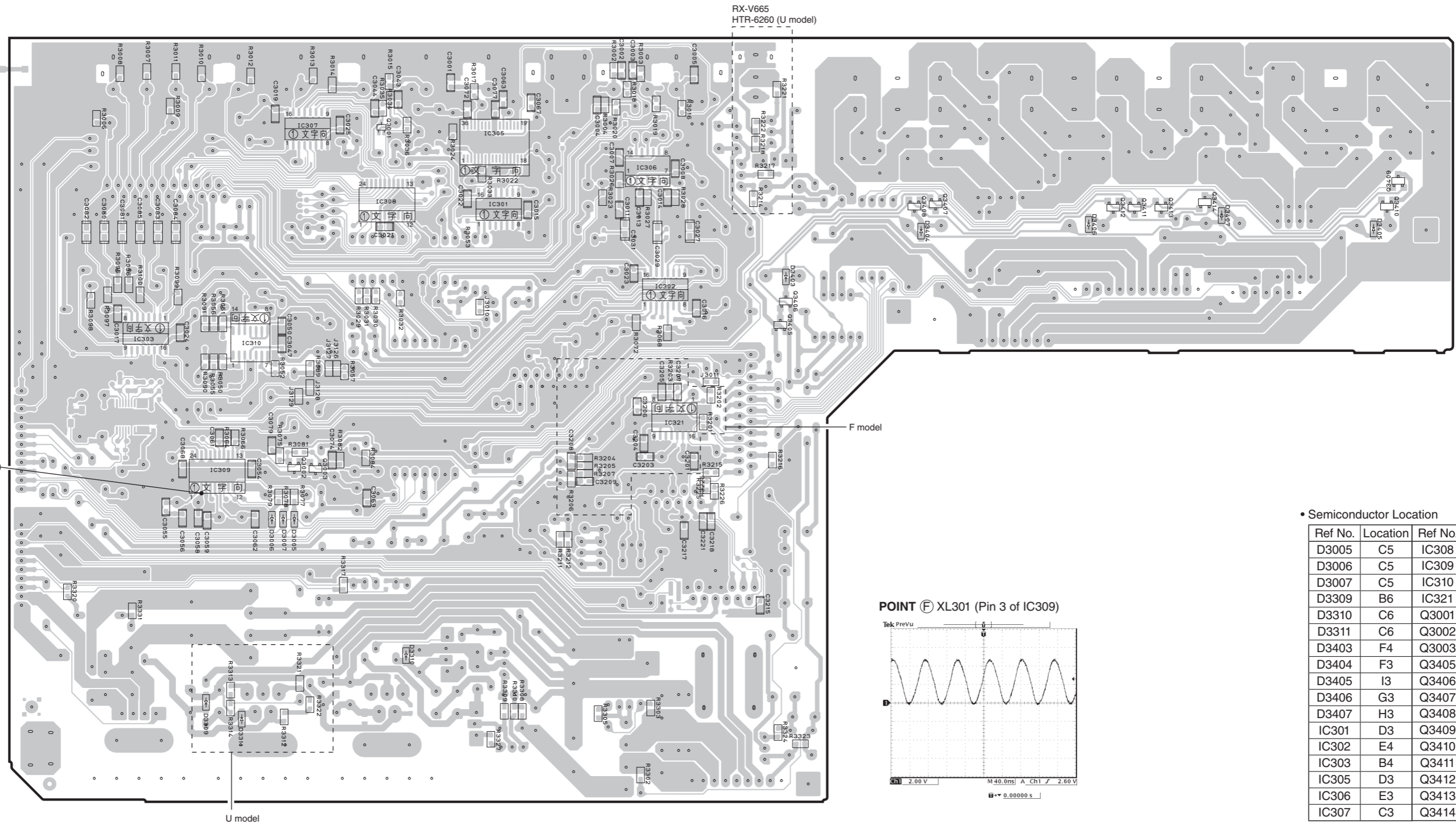

• Semiconductor Location

Ref No.	Location	Ref No.	Location
D3005	C5	IC308	C3
D3006	C5	IC309	B5
D3007	C5	IC310	C4
D3309	B6	IC321	E4
D3310	C6	Q3001	C3
D3311	C6	Q3002	C5
D3403	F4	Q3003	C5
D3404	F3	Q3405	F4
D3405	I3	Q3406	F4
D3406	G3	Q3407	G3
D3407	H3	Q3408	F3
IC301	D3	Q3409	I3
IC302	E4	Q3410	I3
IC303	B4	Q3411	H3
IC305	D3	Q3412	H3
IC306	E3	Q3413	H3
IC307	C3	Q3414	H3

POINT F XL301 (Pin 3 of IC309)

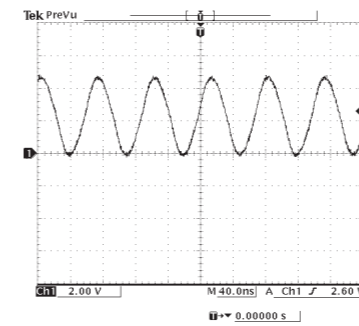

VIDEO (2) P.C.B. (Side A)

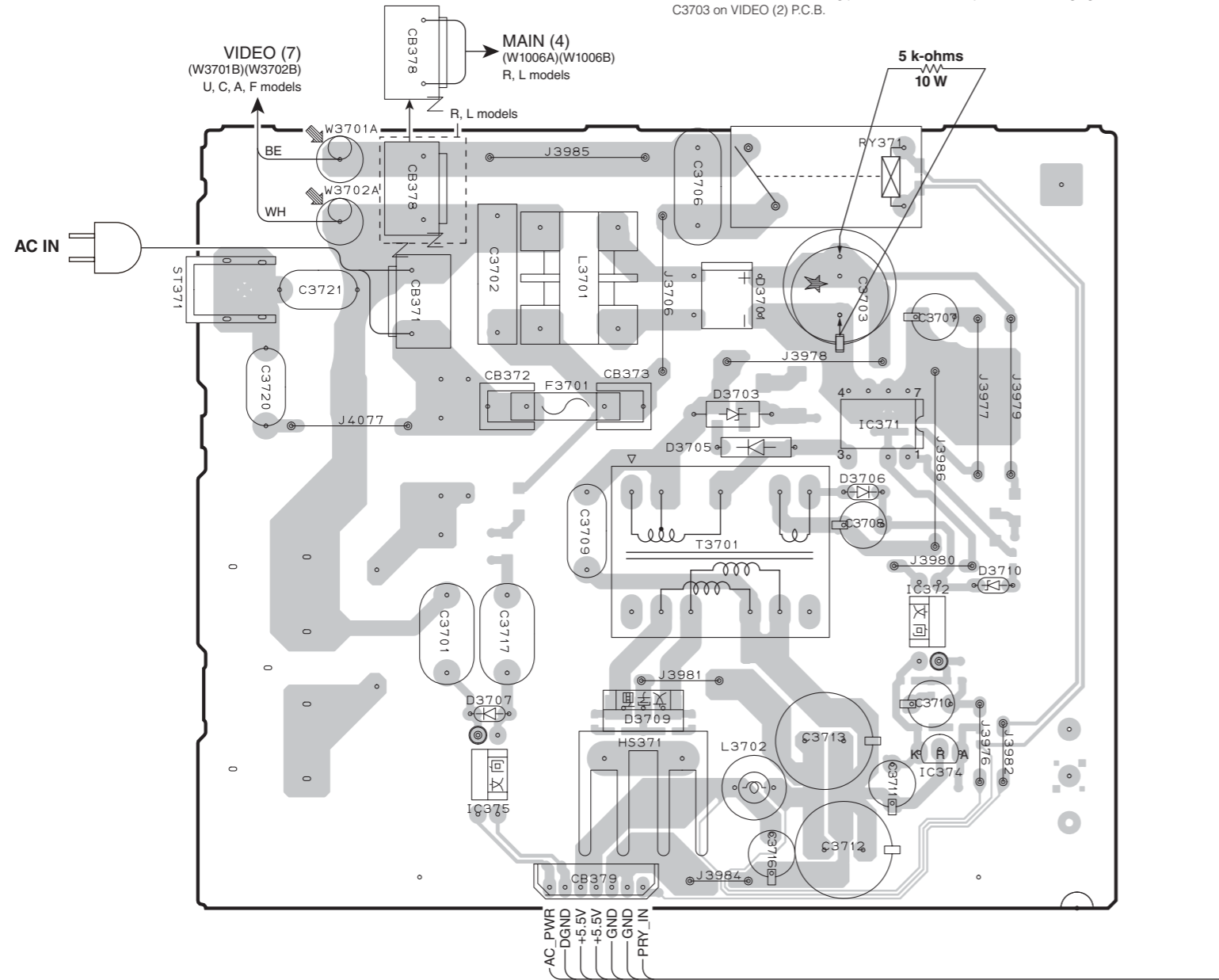

CAUTION !
Safety measures

- Some internal parts in this product contain high voltages and are dangerous. Be sure to take safety measures during servicing, such as wearing insulating gloves.
- Note that positions indicated below are dangerous even after the power is turned off because an electric charge remains and a high voltage continues to exist there. Before starting any repair work, perform discharge by connecting a discharge resistor (5k-ohms/10W) between terminals at following positions. The time required for discharging is about 30 seconds. C3703 on VIDEO (2) P.C.B.

VIDEO (3) P.C.B. (Side A)

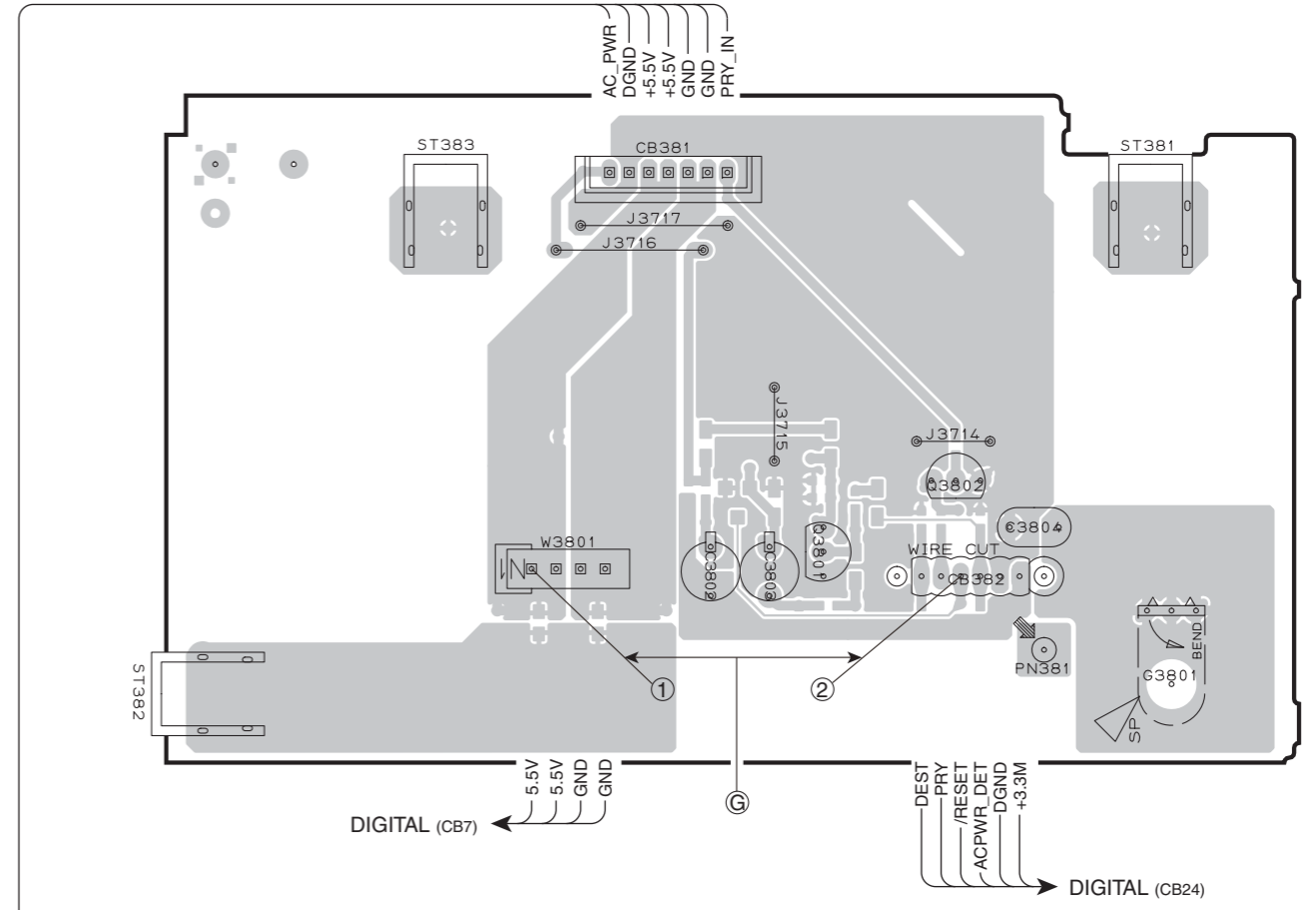

• Semiconductor Location

Ref No.	Location	Ref No.	Location
D3701	D3	IC371	E3
D3703	D3	IC372	E4
D3705	D3	IC374	E5
D3706	E4	IC375	C5
D3707	C4	Q3801	I4
D3709	D4	Q3802	I4
D3710	E4		

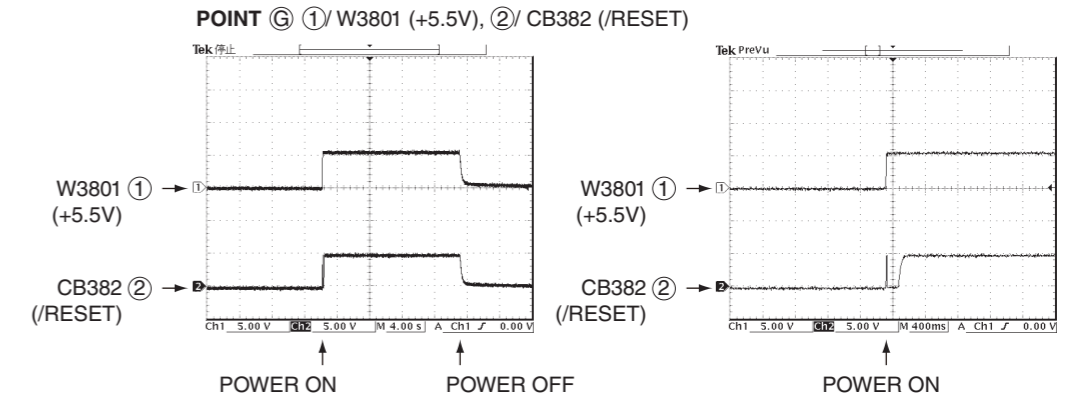

VIDEO (2) P.C.B. (Side B)

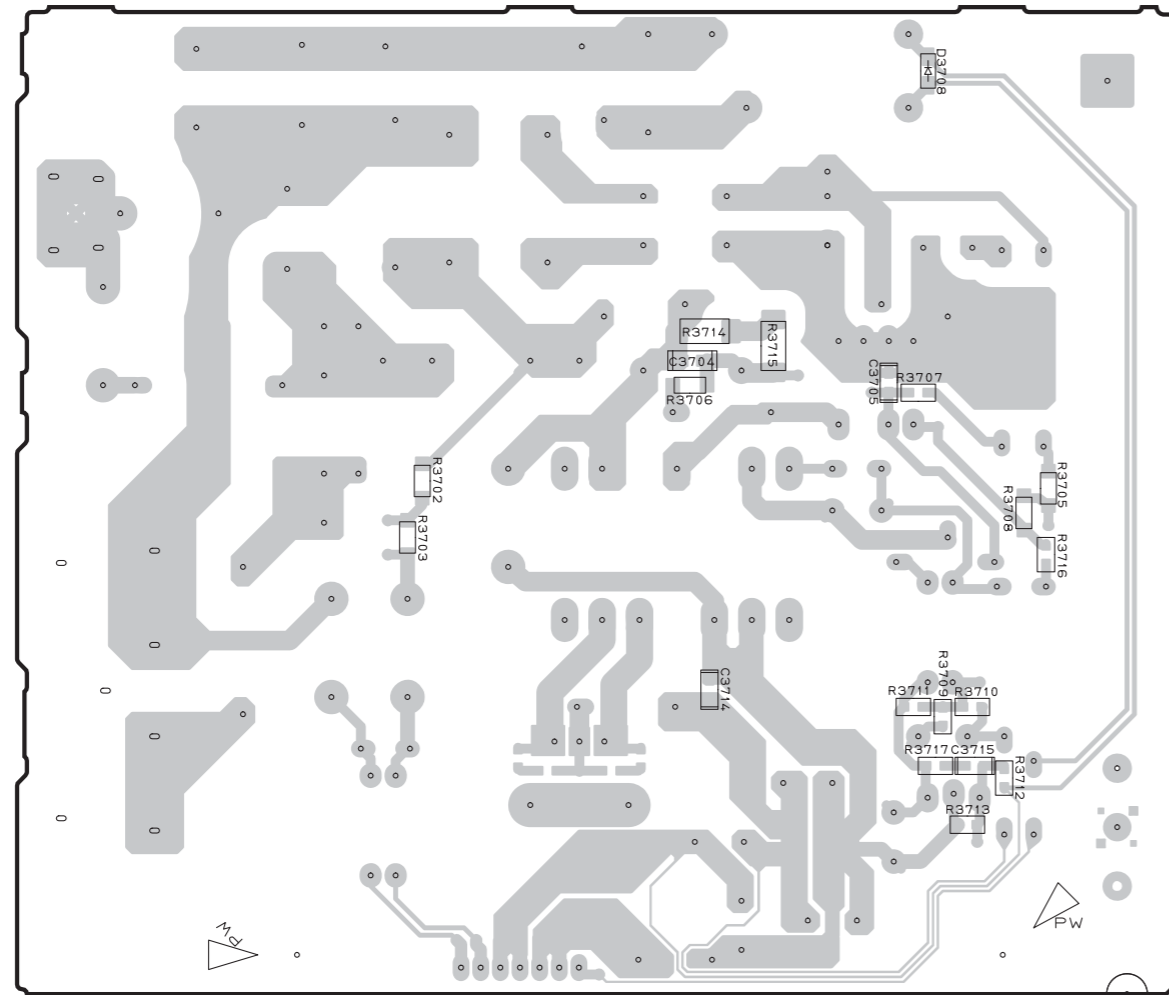

VIDEO (3) P.C.B. (Side B)

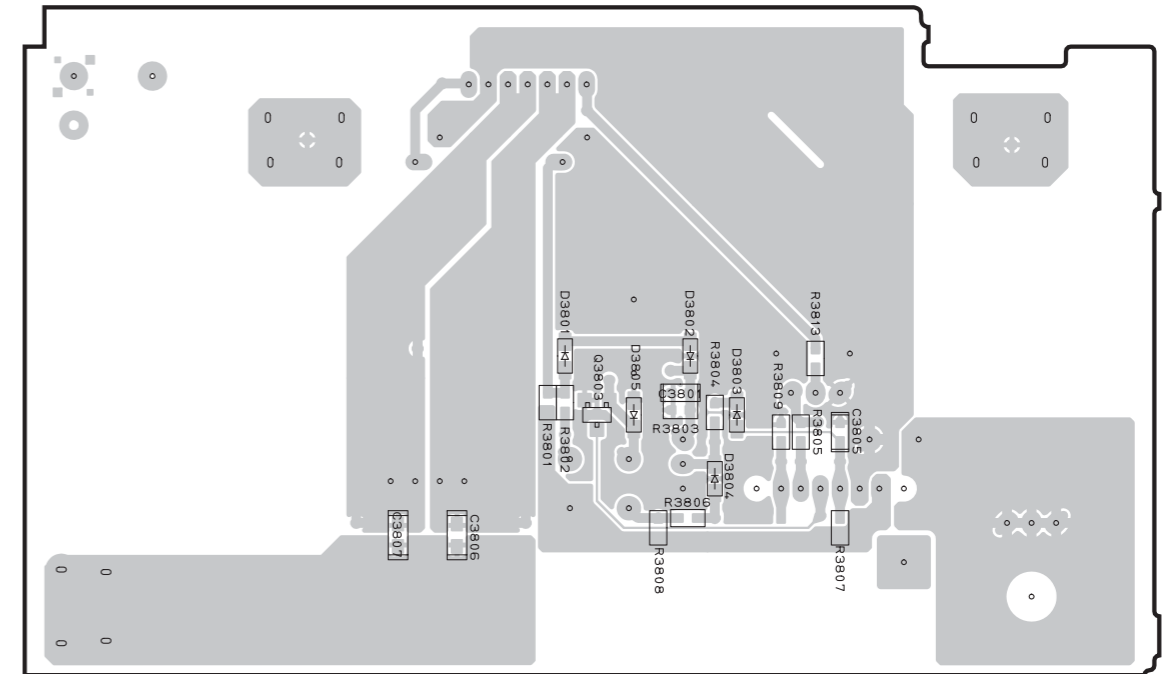

• Semiconductor Location

Ref No.	Location
D3708	D2
D3801	H4
D3802	H4
D3803	H4
D3804	H4
D3805	H4
Q3803	H4

VIDEO (4) P.C.B. (Side A)

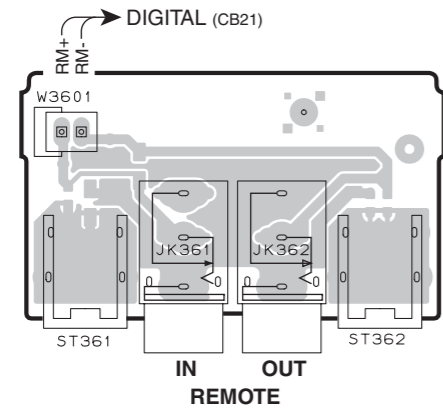

VIDEO (6) P.C.B. (Side A)

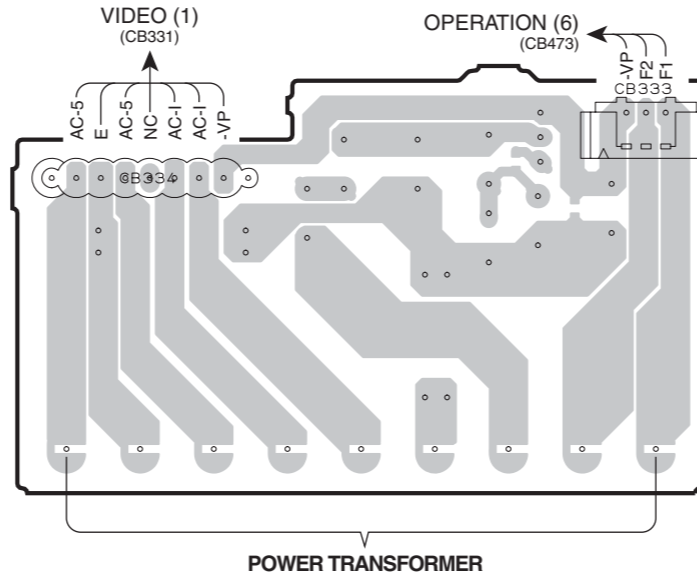

VIDEO (7) P.C.B. (Side A)

U, C, A, F models

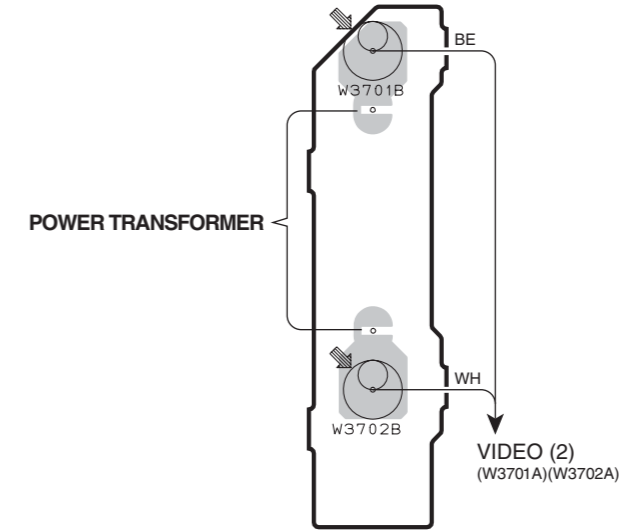

VIDEO (9) P.C.B. (Side A)

F model

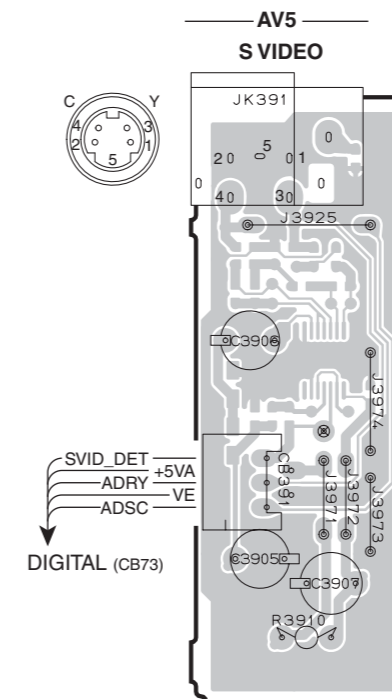

VIDEO (4) P.C.B. (Side B)

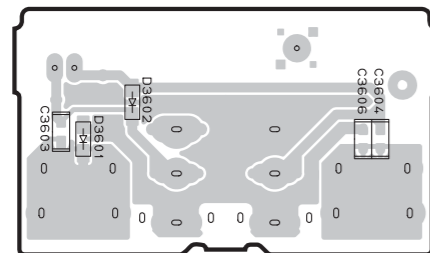

VIDEO (6) P.C.B. (Side B)

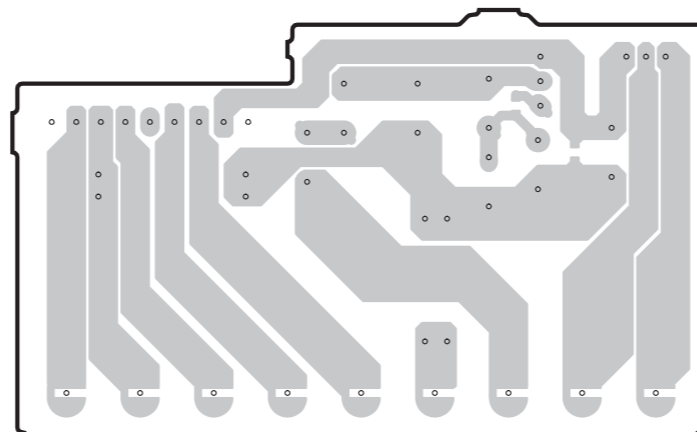

VIDEO (7) P.C.B. (Side B)

U, C, A, F models

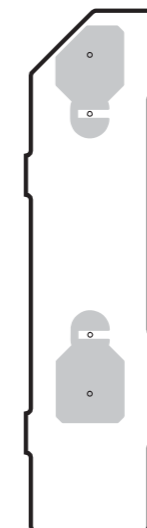

VIDEO (9) P.C.B. (Side B)

F model

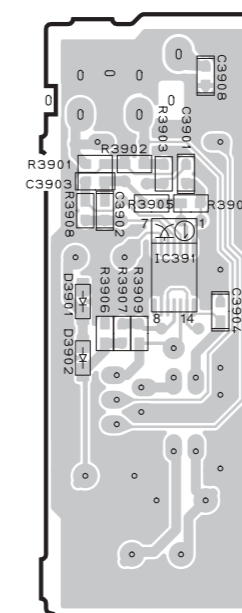

• Semiconductor Location

Ref No.	Location
D3601	A3
D3602	B3
D3901	G6
D3902	G6
IC391	H6

1
2
3
4
5
6
7

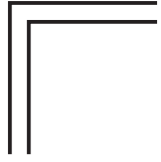

MEMO

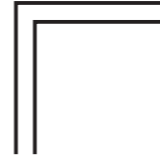
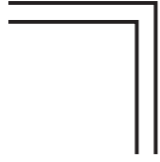

MEMO

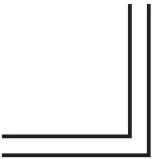
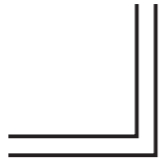
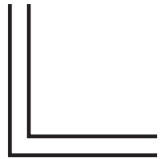
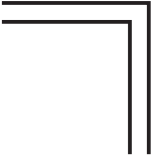

SCHEMATIC DIAGRAMS
DIGITAL 1/5

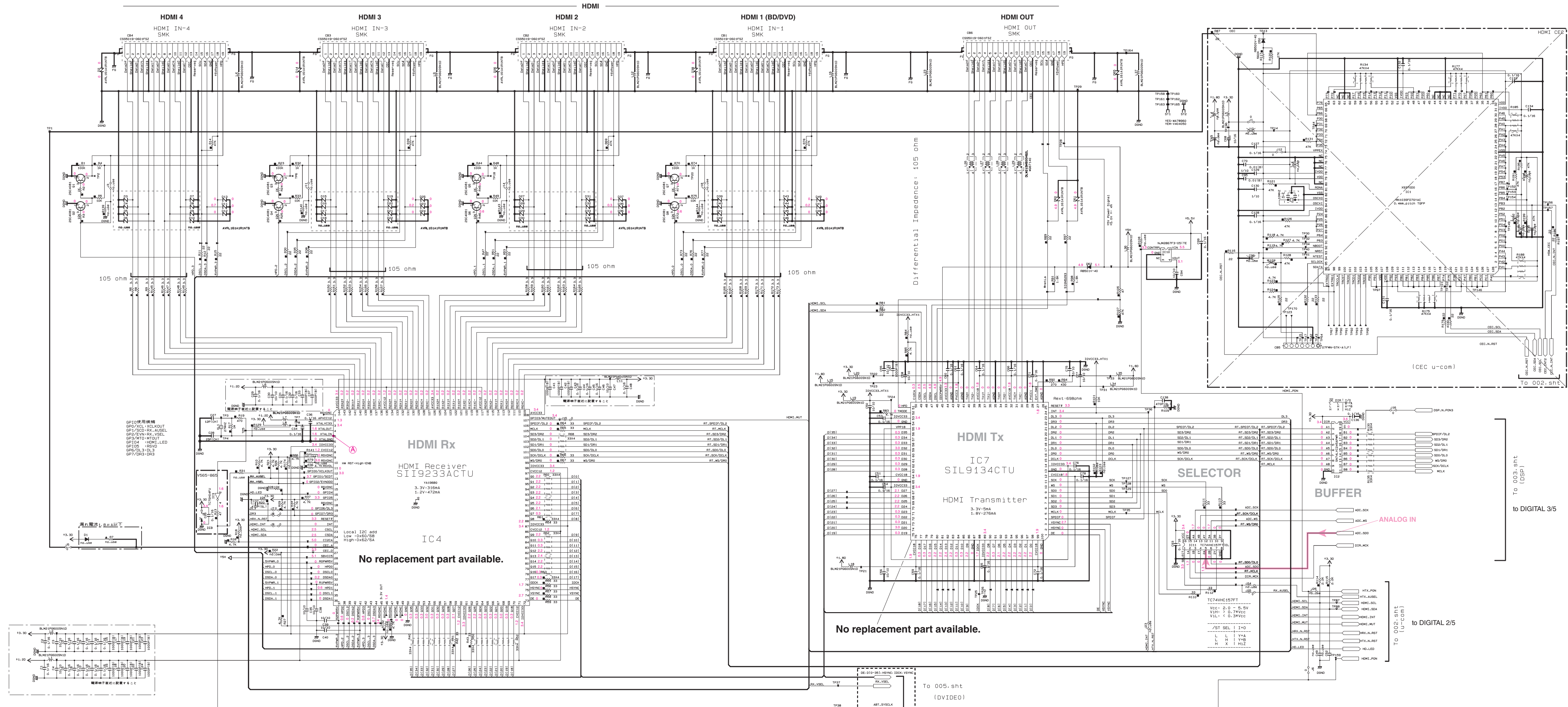

Interchangeable Parts at Manufacture Stage

Part No.	Reference Parts Number	Parts Name
41	0403-000-000-003	RESISTOR
42	0001-000-401	DT14404A PHOTODIODE
43	9801	DT14404A PHOTODIODE
44	D40P-402	AVL-031030108 SERVO MOTOR
45	IC48	448641020-100000 V54C3001041E10

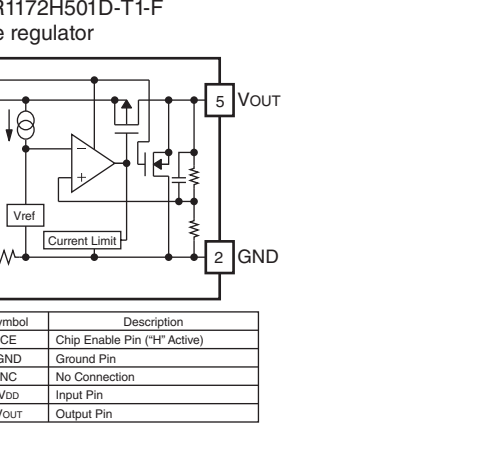
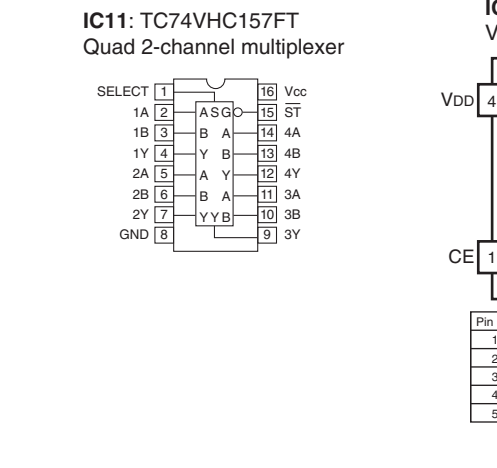
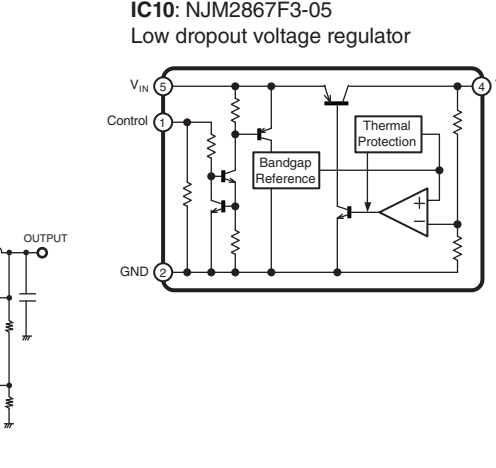
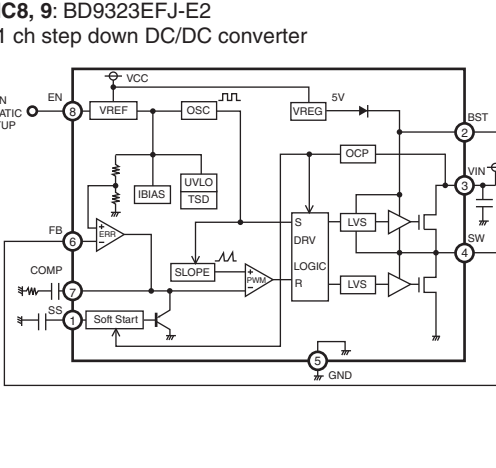
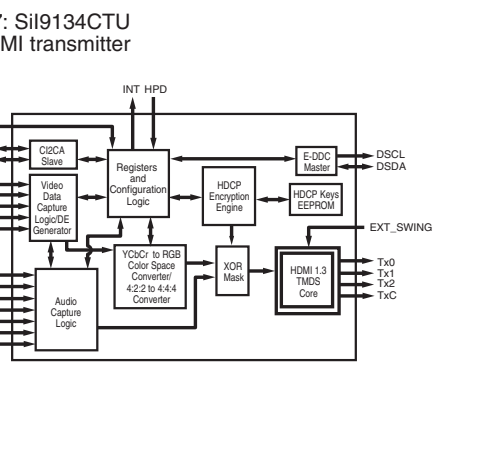
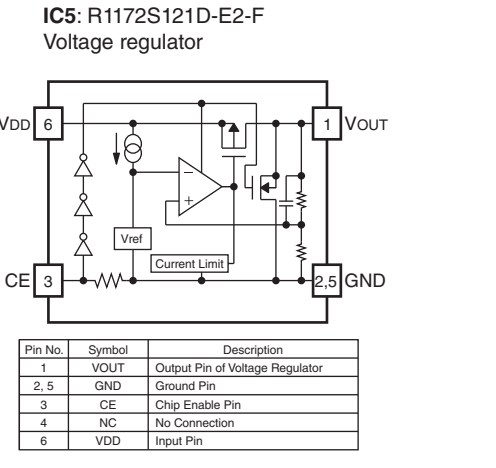
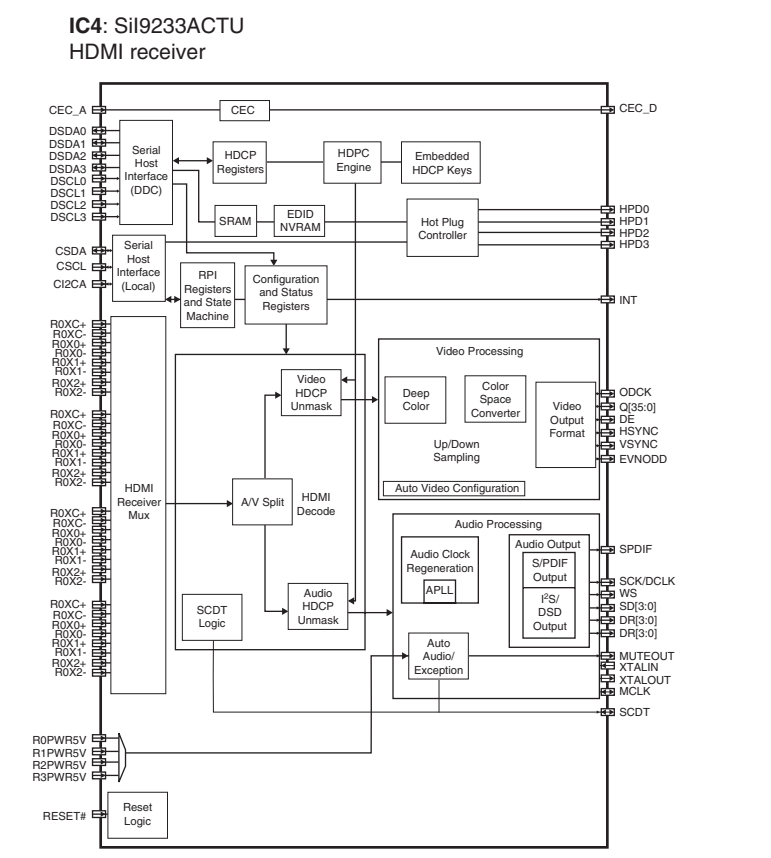
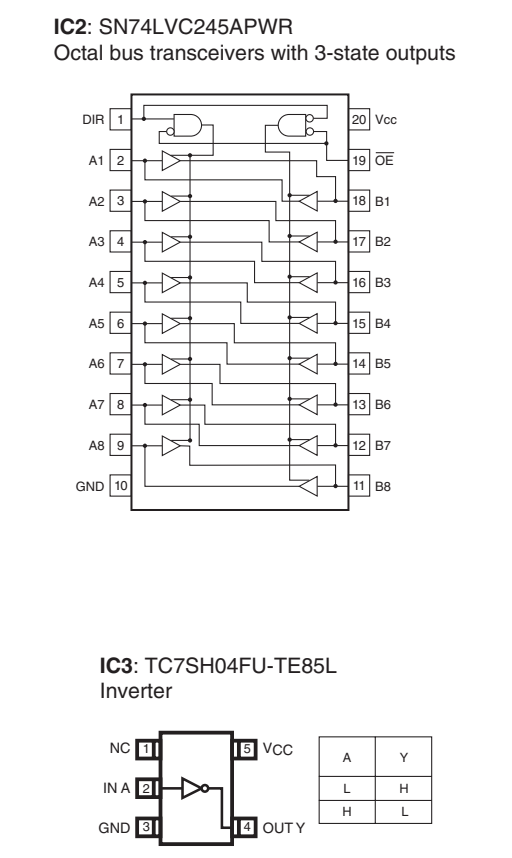
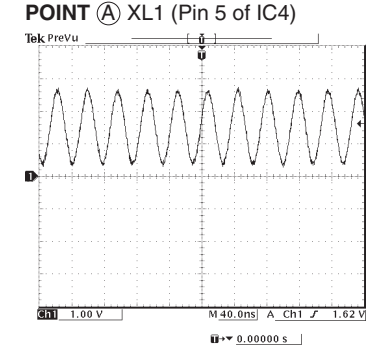

REMARKS	PARTS NAME	REMARKS	PARTS NAME
NO MARK	ELECTROL. YTC. CAPACITOR	NO MARK	TANTALUM CAPACITOR
NO MARK	CERAMIC CAPACITOR	NO MARK	CARBON FILM RESISTOR (P=5)
⊙	POLYESTER TUBULAR CAPACITOR	⊙	CERAMIC TUBULAR CAPACITOR
⊙	POLYESTER FILM CAPACITOR	⊙	METAL FILM RESISTOR (P=10)
⊙	POLYPROPYLENE FILM CAPACITOR	⊙	METAL OXIDE FILM RESISTOR
⊙	MICA CAPACITOR	⊙	METAL PLATE RESISTOR
⊙	POLYPROPYLENE FILM CAPACITOR	⊙	FIRE PROOF CARBON FILM RESISTOR
⊙	SEMICONDUCTIVE CERAMIC CAPACITOR	⊙	CEMENT MOLDED RESISTOR
⊙	POLYPHENYLENE SULFIDE FILM CAPACITOR	⊙	SEMI VARIABLE RESISTOR
		⊙	CHIP RESISTOR

NOTICE (mode1)

(J) JAPAN
(U) U.S.A.
(C) CANADA
(G) GENERAL
(T) CHINA
(K) KOREA
(A) AUSTRALIA
(B) BRITISH
(O) EUROPE
(L) SINGAPORE
(E) SOUTH EUROPE
(V) TAIWAN
(F) RUSSIAN

* All voltages are measured with a 10MΩ/V DC electronic voltmeter.
* Components having special characteristics are marked Δ and must be replaced with parts having specifications equal to those originally installed.
* Schematic diagram is subject to change without notice.

Page 114 [E10] to OPERATION (1)_CB401

Page 120 [B2] to VIDEO (4)_V3601

Page 116 [K7] to MAIN (5)_CB157

Page 117 [K8] to MAIN (1)_CB156

Page 120 [I9] to VIDEO (3)_CB382

Page 119 [G8] to VIDEO (1)_CB349

REMARKS	PARTS NAME
NO MARK	ELECTROLYTIC CAPACITOR
NO MARK	TANTALUM CAPACITOR
NO MARK	CERAMIC CAPACITOR
⊙	CERAMIC TUBULAR CAPACITOR
⊗	POLYESTER FILM CAPACITOR
○	POLYSTYRENE FILM CAPACITOR
⊖	MICA CAPACITOR
⊕	POLYPROPYLENE FILM CAPACITOR
⊗	SEMICONDUCTIVE CERAMIC CAPACITOR
⊕	POLYPHENYLENE SULFIDE FILM CAPACITOR

REMARKS	PARTS NAME
NO MARK	CARBON FILM RESISTOR (P=5)
□	CARBON FILM RESISTOR (P=10)
△	METAL OXIDE FILM RESISTOR
⊗	METAL FILM RESISTOR
⊕	METAL PLATE RESISTOR
⊖	FIRE PROOF CARBON FILM RESISTOR
⊗	CEMENT MOLDED RESISTOR
⊕	SEMI VARIABLE RESISTOR
⊖	CHIP RESISTOR

NOTICE (mode1)

(J)..... JAPAN
 (U)..... U.S.A
 (C)..... CANADA
 (R)..... GENERAL
 (T)..... CHINA
 (K)..... KOREA
 (A)..... AUSTRALIA
 (B)..... BRITISH
 (G)..... EUROPE
 (L)..... SINGAPORE
 (E)..... SOUTH EUROPE
 (V)..... TAIWAN
 (F)..... RUSSIAN

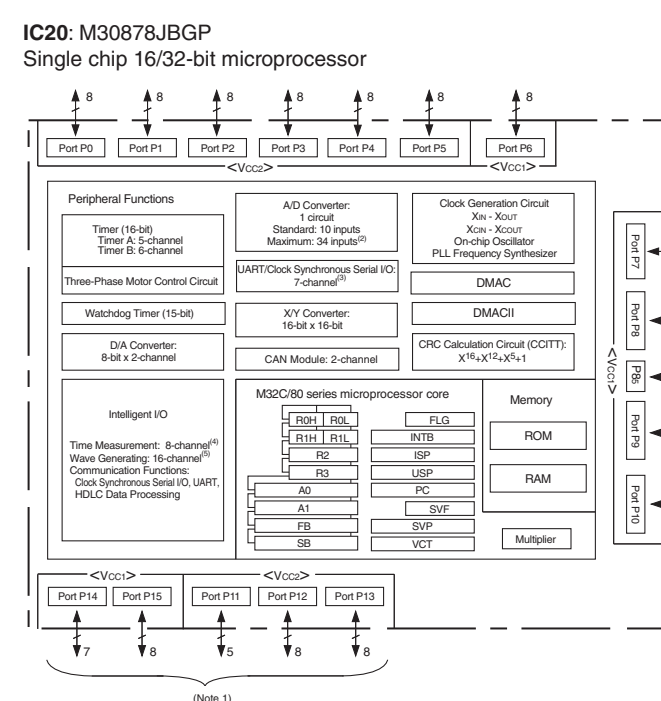
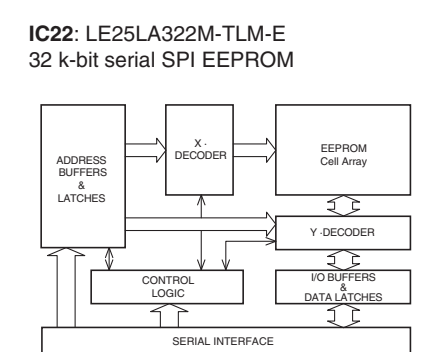
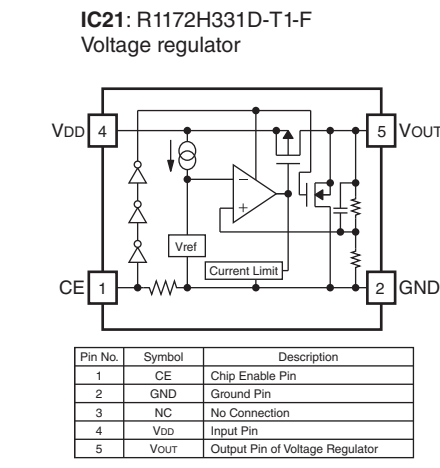
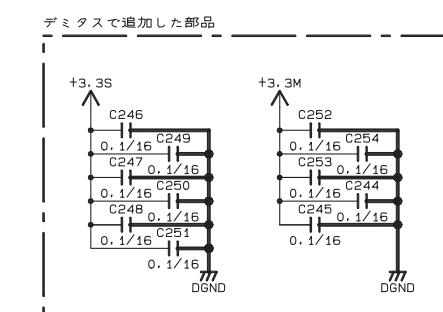
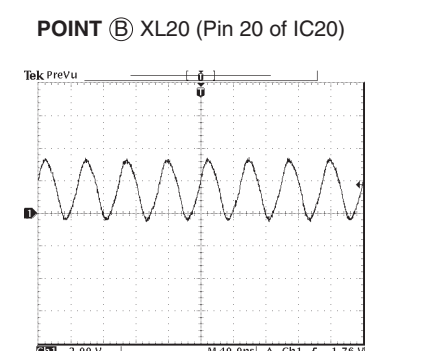
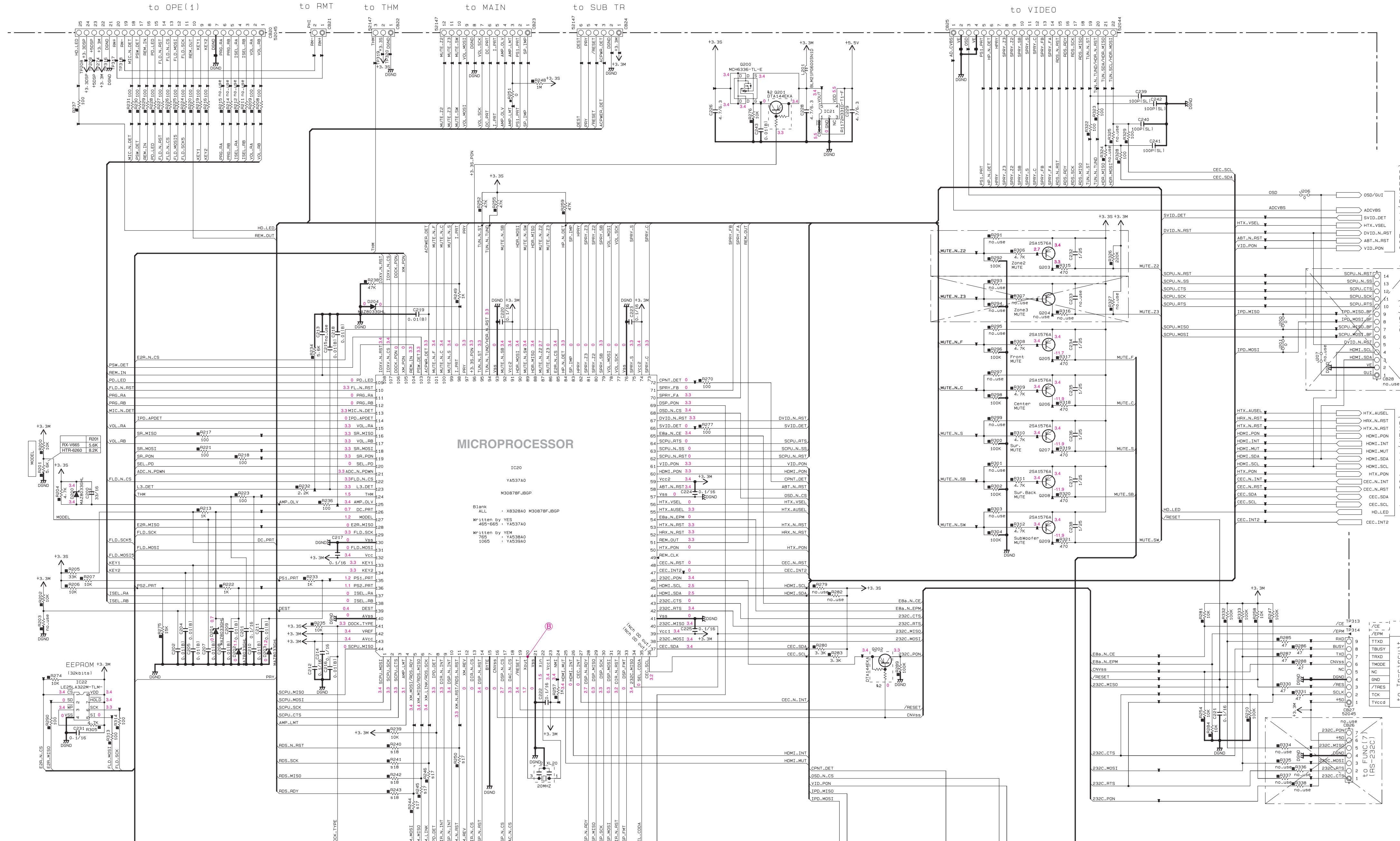

NOTES:
 1. Pin P11 to P15 are provided for the 144-pin package only.
 2. Pin P16 to P18 are provided for the 144-pin package only.
 3. Pin P19 to P21 are provided for the 144-pin package only.
 4. Pin P22 to P24 are provided for the 144-pin package only.
 5. Pin P25 to P27 are provided for the 144-pin package only.

Key detection for A/D port

Key input (A/D) pull-up resistance 10 k-ohms

Ohm	0	+1.0k	+1.0k	+1.5k	+1.5k	+2.2k	+3.3k	+4.7k	+22.0k	+33.0k
V	0-0.15	0.15-0.42	0.43-0.70	0.71-0.97	0.98-1.24	1.25-1.53	1.54-1.84	1.84-2.1	2.34-2.55	2.55-2.97
A/D value (3.3 V=255)	0-11	12-32	33-54	55-75	76-95	96-118	119-142	143-162	181-197	198-229
KEY1 (133 pin)	SCENE RADIO	SCENE CD	SCENE TV	ZONE2 BD/DVD	ZONE2 ON/OFF	PROGRAM >	PROGRAM <	MAIN ZONE ON/OFF	TONES	CONTROL

Ohm	0	+1.0k	+1.0k	+1.5k	+1.5k	+2.2k	+3.3k	+4.7k	+6.8k	+10.0k	+22.0k	+68.0k
V	0-0.15	0.15-0.42	0.43-0.70	0.71-0.99	1.0-1.27	1.28-1.56	1.57-1.86	1.86-2.14	2.14-2.4	2.4-2.65	2.66-2.91	2.92-3.17
A/D value (3.3 V=255)	0-11	12-32	33-54	55-77	78-98	99-120	121-143	144-165	166-185	186-205	206-225	226-245
KEY2 (134 pin)	PURE DIRECT	STRAIGHT	INFO	MEMORY	PRESET <	PRESET >	CATEGORY FM	CATEGORY AM	TUNING CH	TUNING CH	INPUT <	INPUT >

* All voltages are measured with a 10MΩ/V DC electronic voltmeter.
 * Components having special characteristics are marked Δ and must be replaced with parts having specifications equal to those originally installed.
 * Schematic diagram is subject to change without notice.

DIGITAL 3/5

No replacement part available.

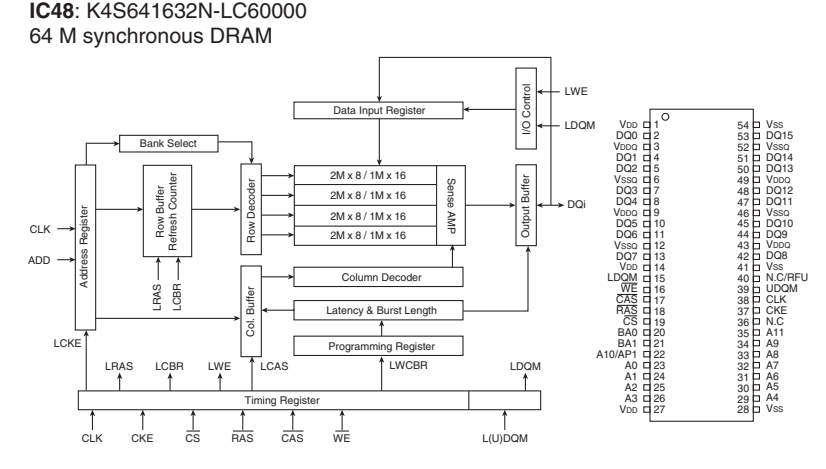
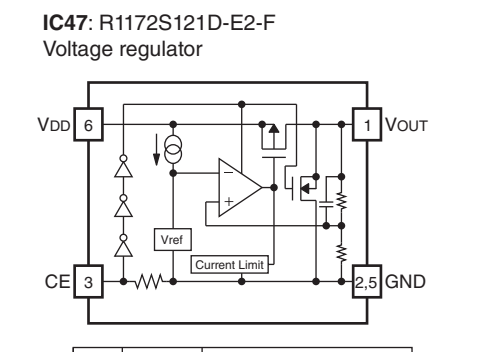
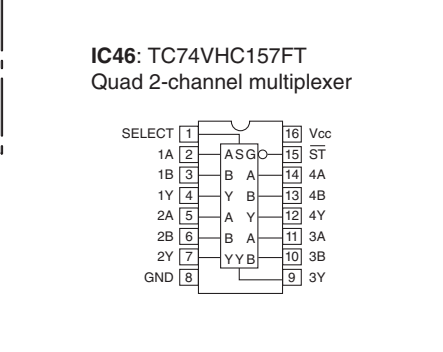
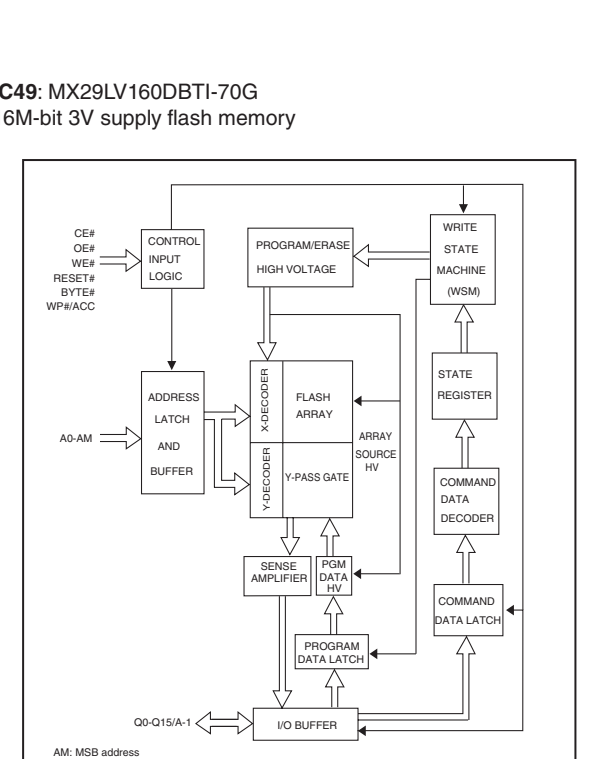
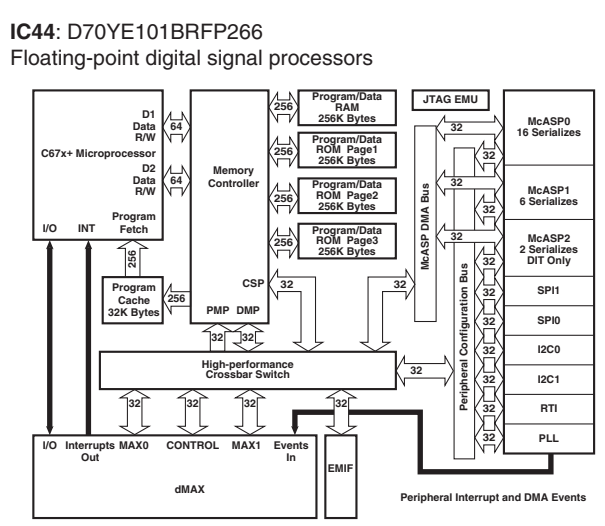
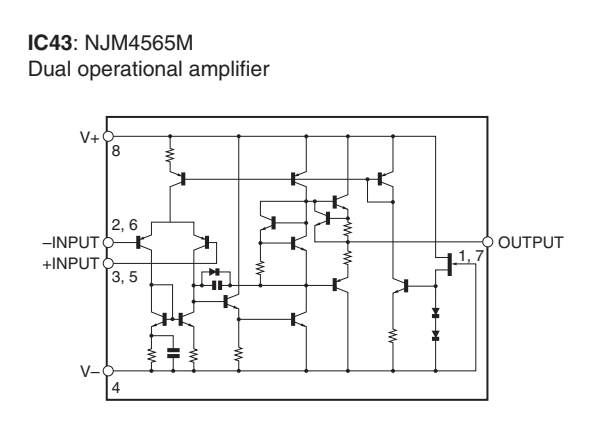
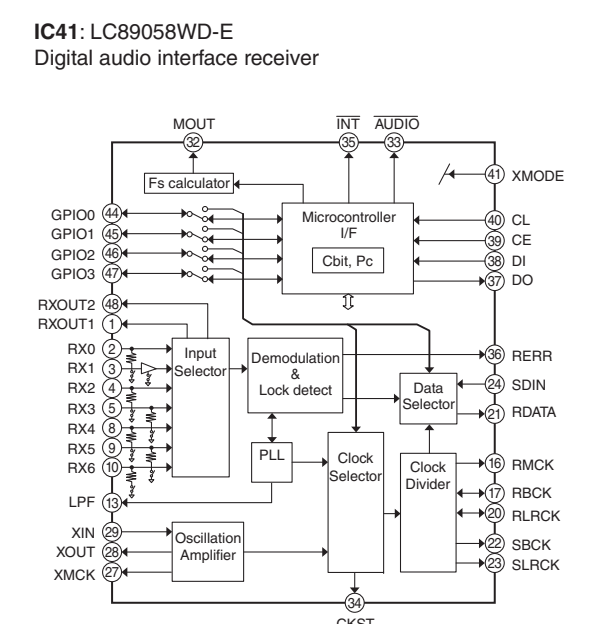
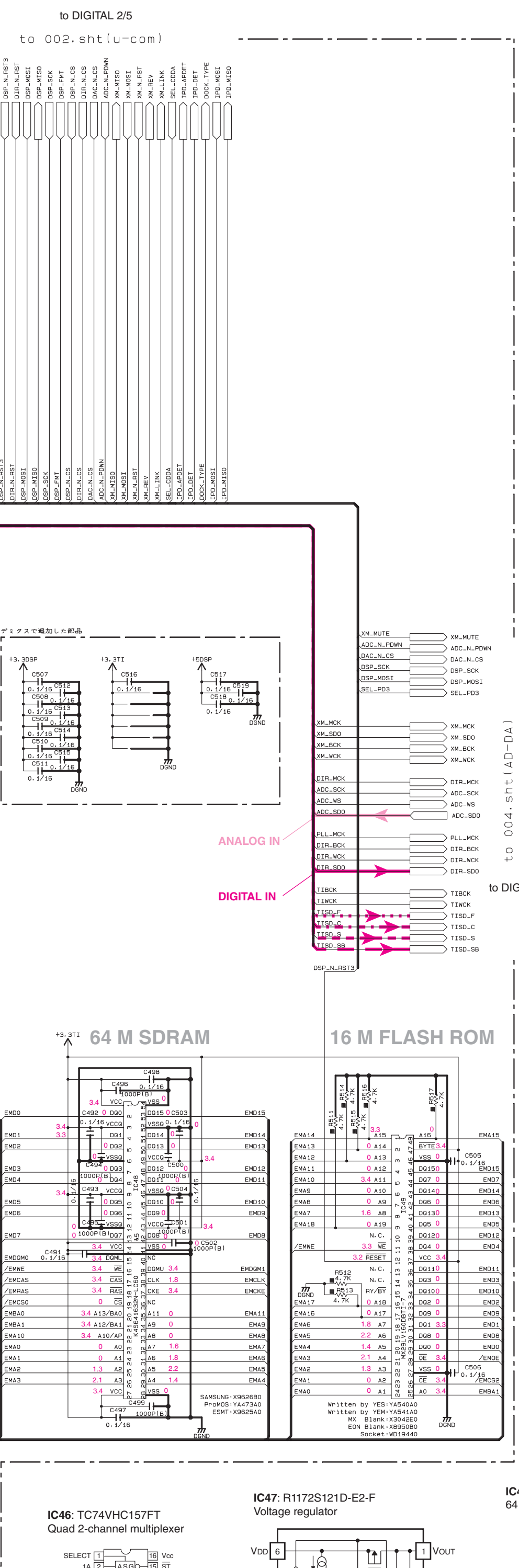
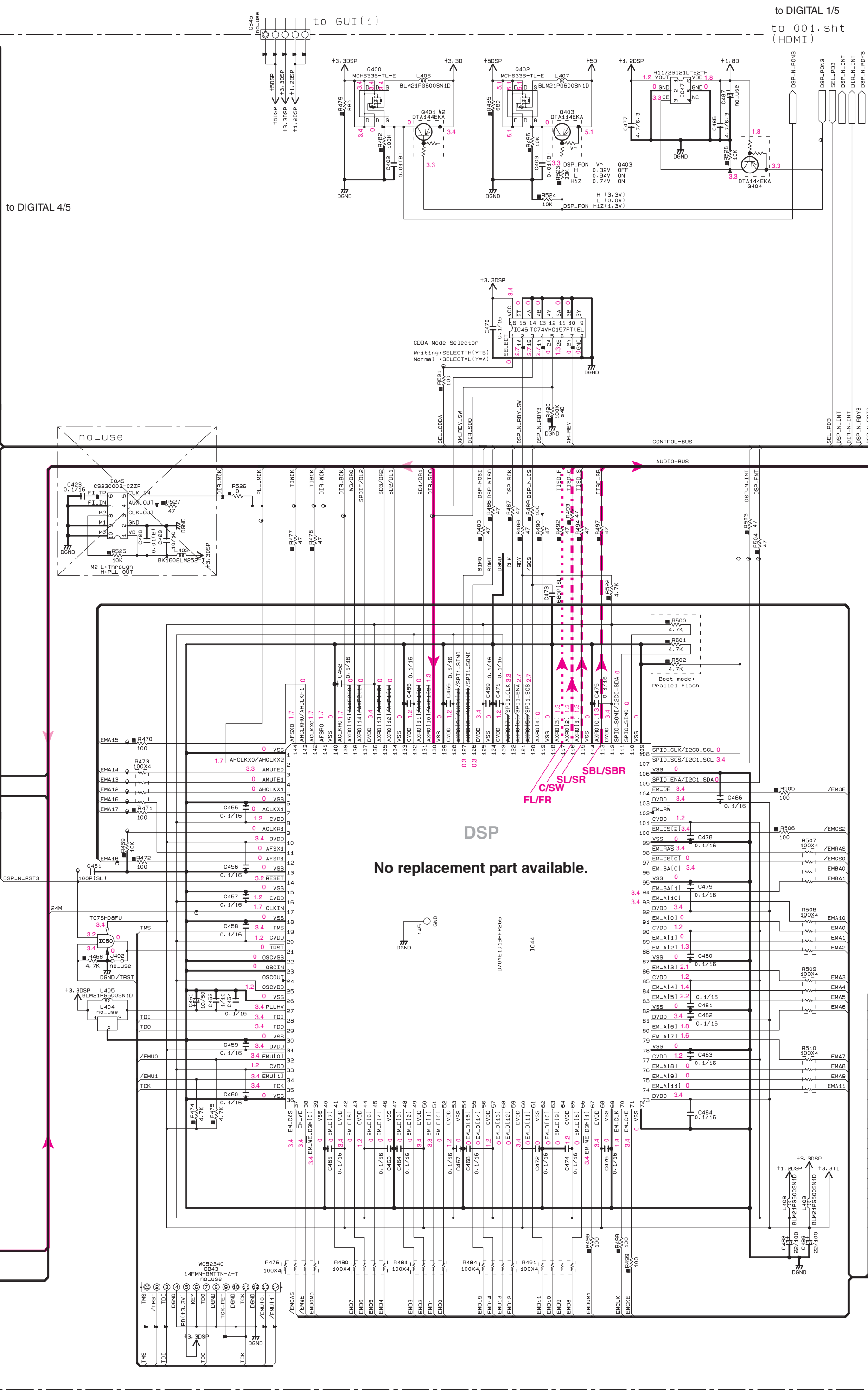
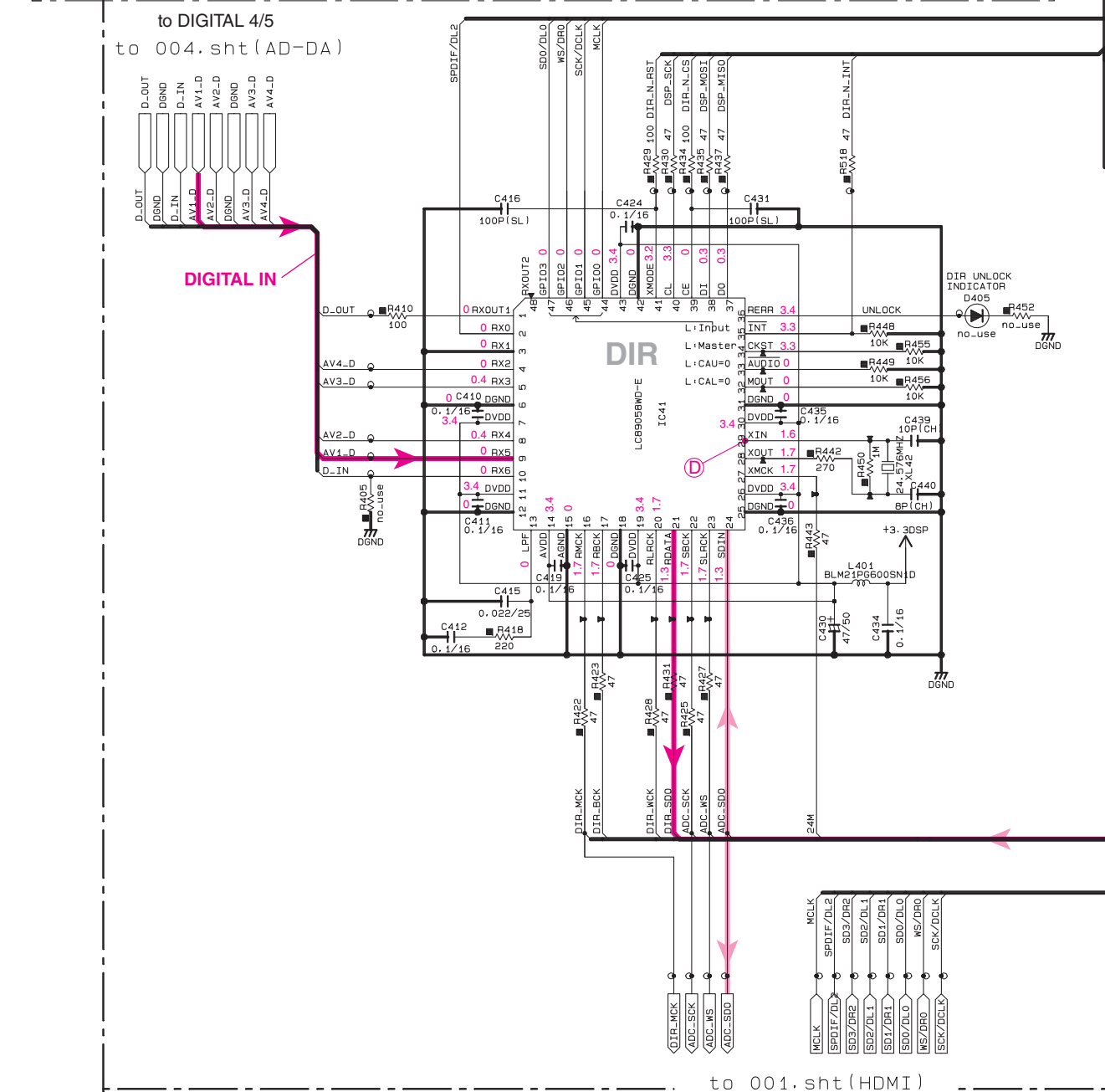
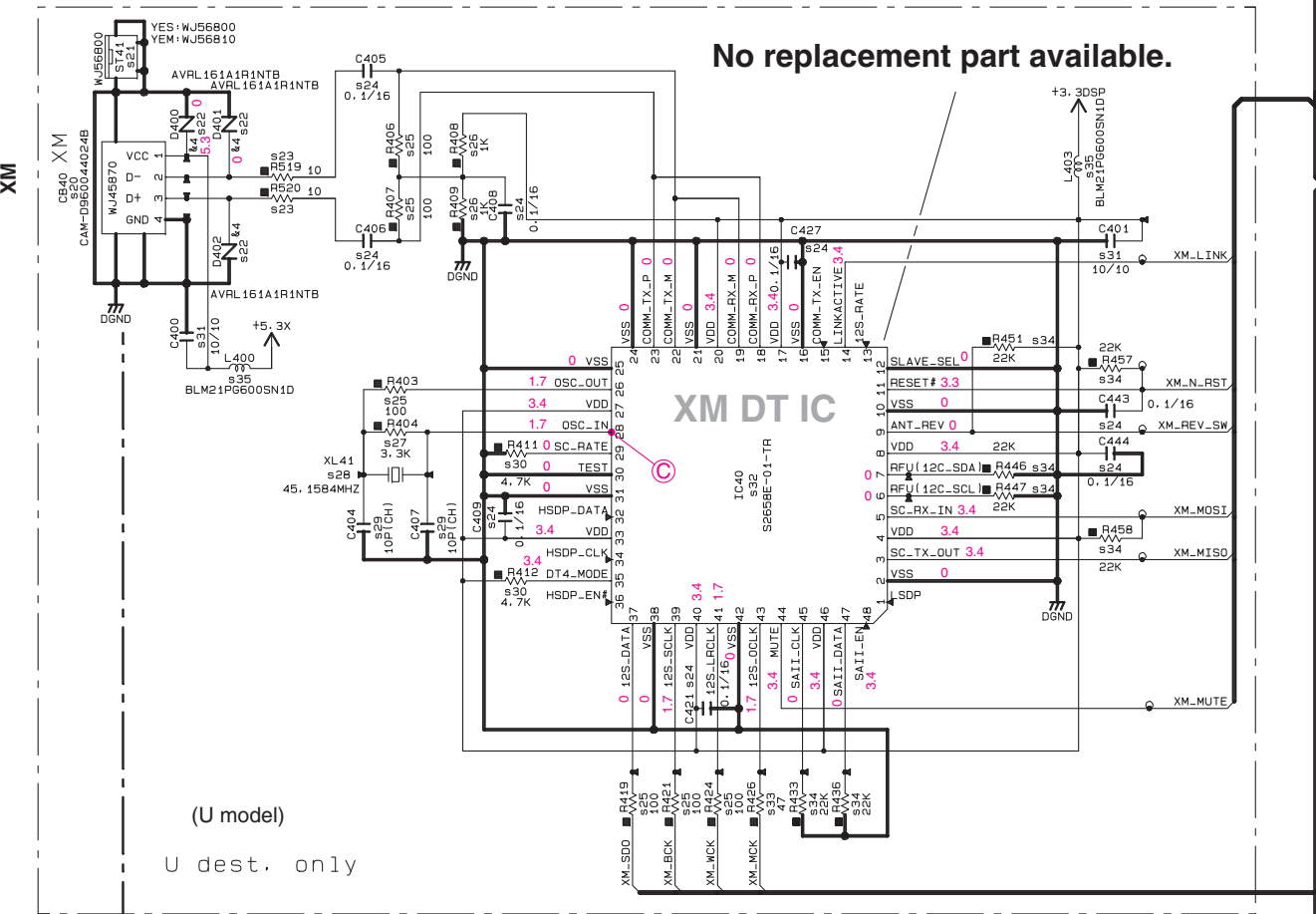
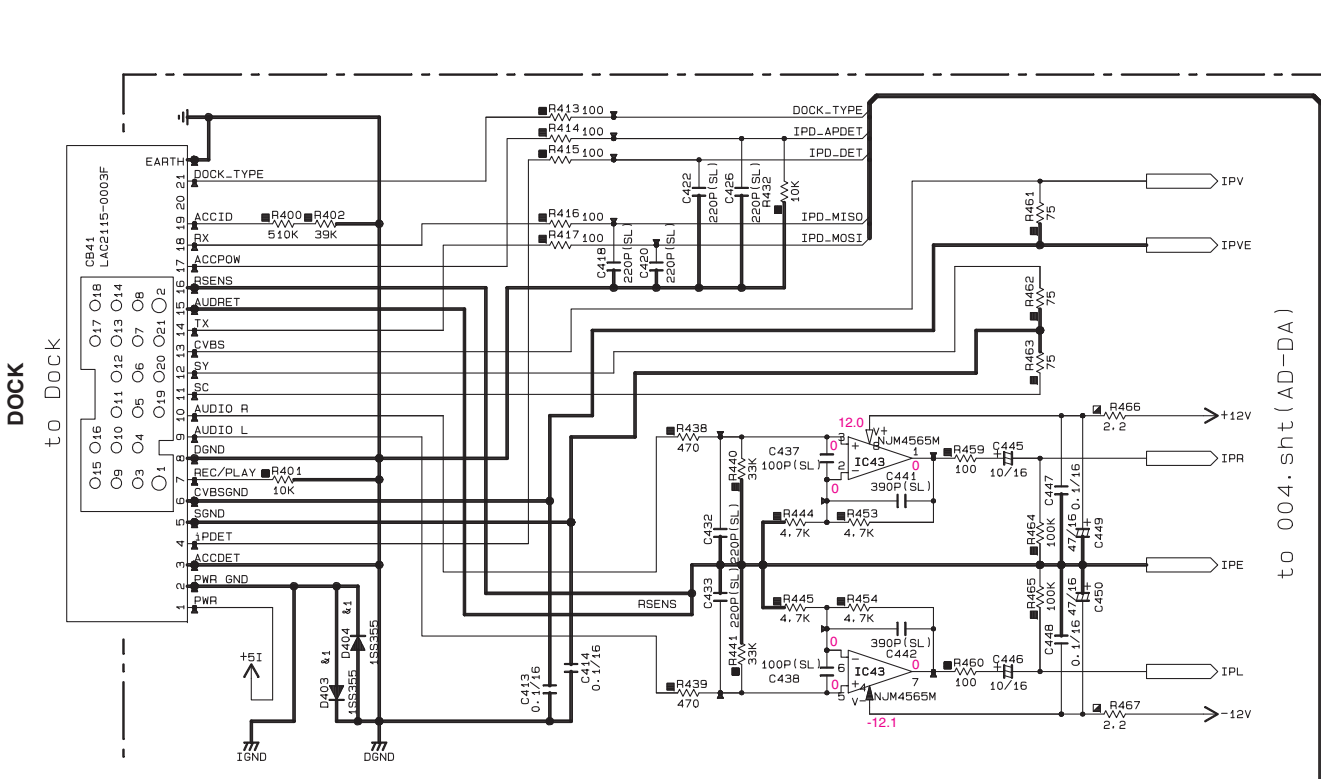
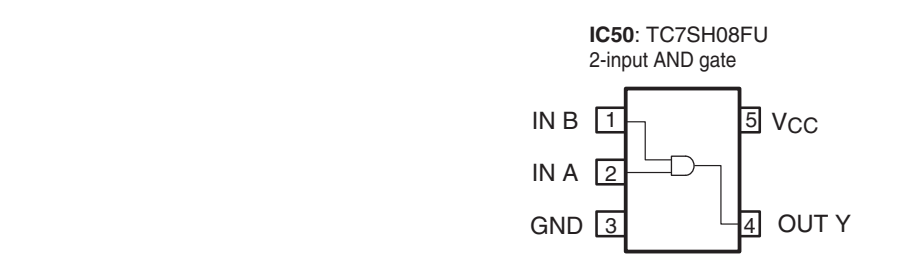
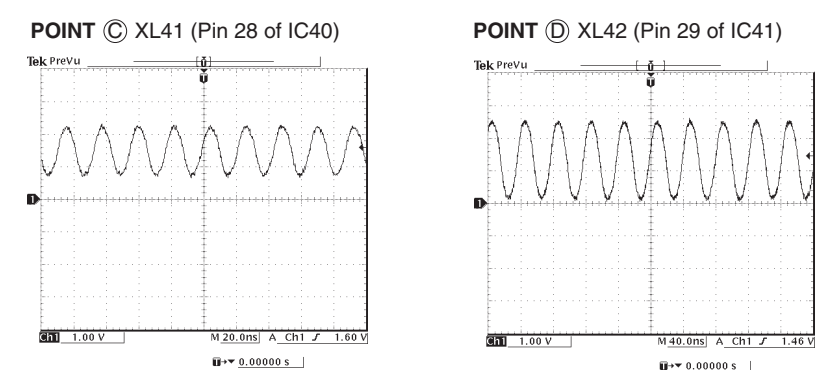
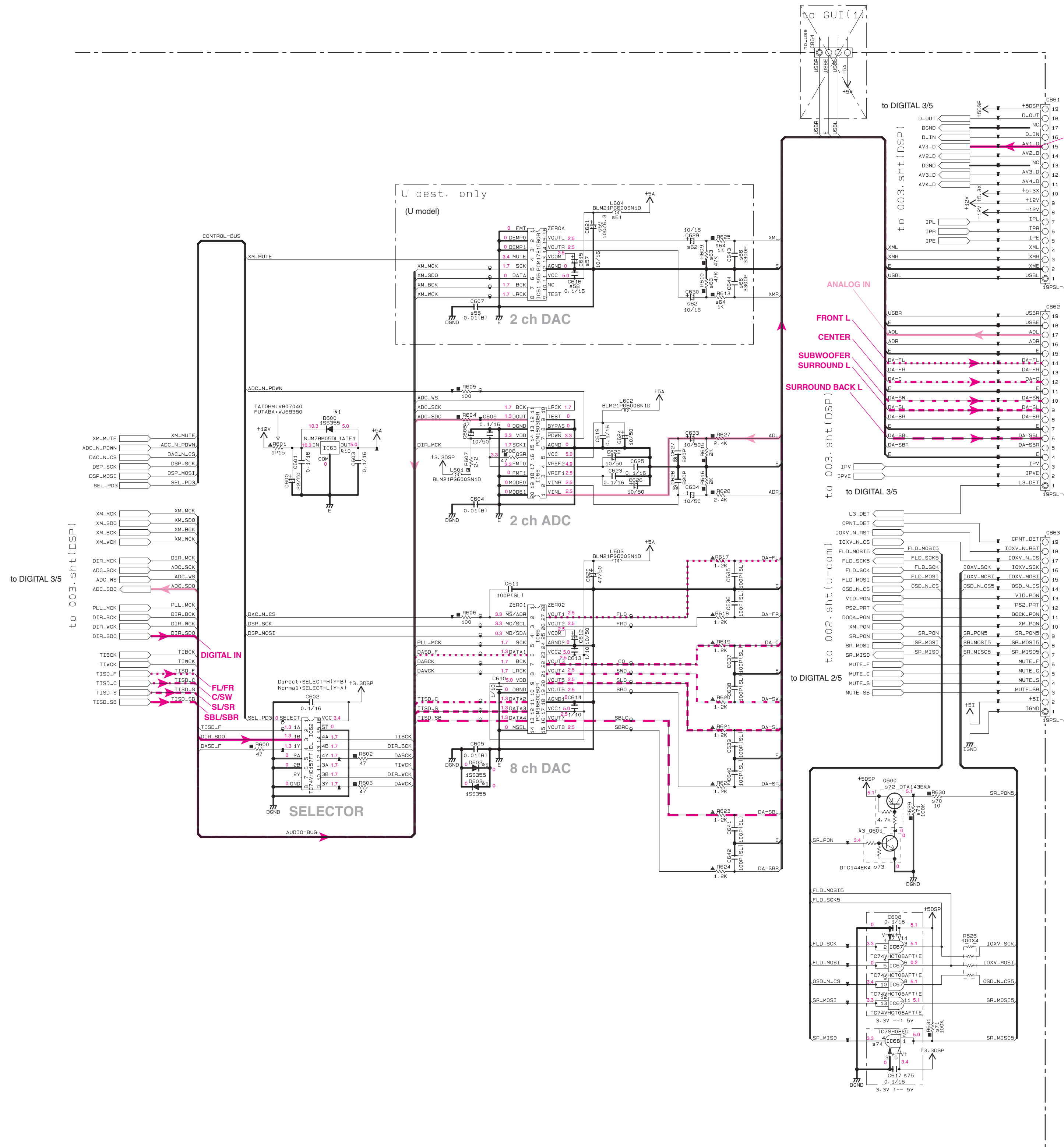

Table with columns for CAPACITOR, RESISTOR, and PARTS_NAME. Includes a NOTICE section for component origins.



* All voltages are measured with a 10MΩ/V DC electronic voltmeter. * Components having special characteristics are marked Δ and must be replaced with parts having specifications equal to those originally installed. * Schematic diagram is subject to change without notice.

DIGITAL 4/5



s1 ~19:002.sht(u-com)
 s20~54:003.sht(DSP)
 s55~89:004.sht(AD-DA)
 s90~99:005.sht(DVIDEO)

Destination Part List

sXX	LOC	U	CRAL	SEF
s17	R246 R245 R250 R244	RD35510 100	X	X
s18	R247 R241 R243 R240	X X X X	X	X
s20	CB40	MJ45870	X	X
s21	ST41	MJ56800	X	X
s22	D400 D401 D402	HE67480 AVR165425RNTB1 RD35410 10	X X X	X X X
s23	R202 R203 R204	RD35410 10	X	X
s24	C421 C443 C408 C407 C406 C405 C409	US03510 0.1/16	X	X
s25	R424 R421 R403 R406 R419	RD35510 100	X	X
s26	R409 R408	RD35610 1K	X	X
s27	R404	RD35633	X	X
s28	XL41	MH45530 45.1584MHz	X	X
s29	C404 C407	US01110 100P/CH1	X	X
s30	R412	RD35647	X	X
s31	C411 C400	M075630 10/10	X	X
s32	IC40	V407040 S05650-01-1TR	X	X
s33	R426	RD35477 47	X	X
s34	R446 R436 R458 R457 R451	RD37522 22K	X	X
s35	L403 L400	V244950 BLM21P0600SN1D	X	X
s48	R420	RD35610 100K	X	X
s55	C607	US06410 0.1/16	X	X
s56	IC61	PCM1781DBOR	X	X
s57	C615	UR03710 100/0.3	X	X
s58	C616	US13510 0.1/16	X	X
s59	C621	UR01810 100/0.3	X	X
s62	C620	UR03710 100/0.3	X	X
s63	R609 R610	RD35747 47K	X	X
s64	R629 R613	RD35610 1K	X	X
s66	CB43 CB44	US06333 3300P	X	X
s70	R630	RD35410 10	X	X
s71	R629 R631	RD35810 1K	X	X
s72	0600	V65650 DT1438KA	X	X
s73	0601	V656570 DT1448KA	X	X
s74	IC68	V088040 TC7SH08FU	X	X
s75	C617	US13510 0.1/16	X	X
s80	C673	X	X	V004410 52044 0
s91	R703 R707 R705	X	X	RD35000 0
s92	R709 R707	RD35000 0	X	RD35000 0
s93	R808	RD35610 100K	X	RD35610 100K

IC61: PCM1781DBOR

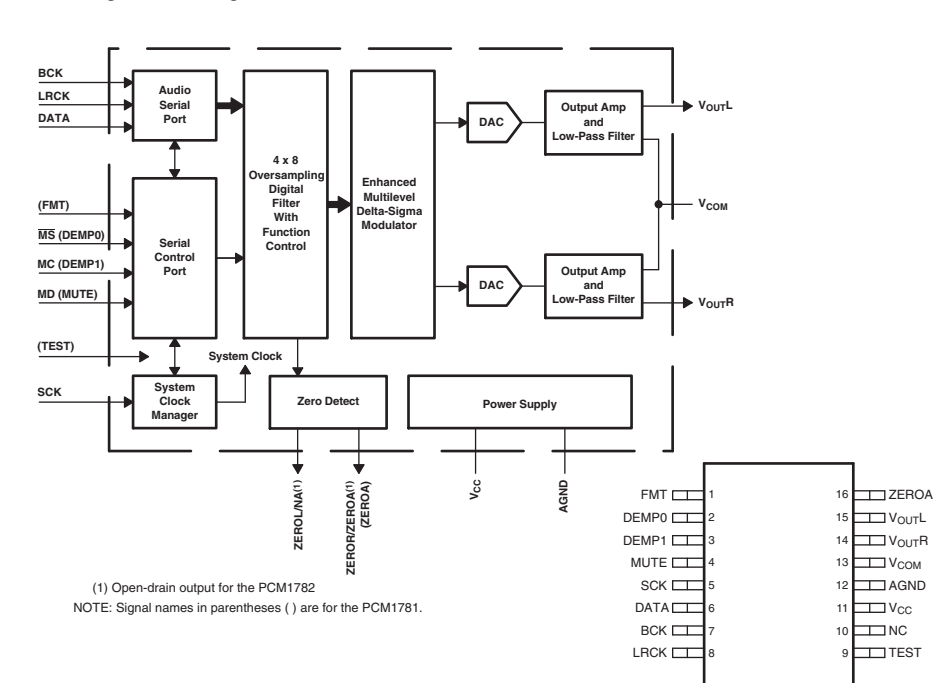

(1) Open-drain output for the PCM1782
 NOTE: Signal names in parentheses () are for the PCM1781.

IC62: TC74VHC157FT

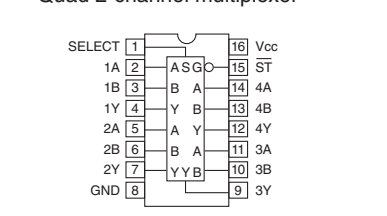

IC63: NJM78M05DL1A (TE1)

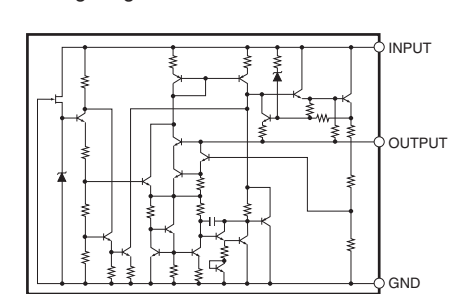

IC65: PCM1680DBOR

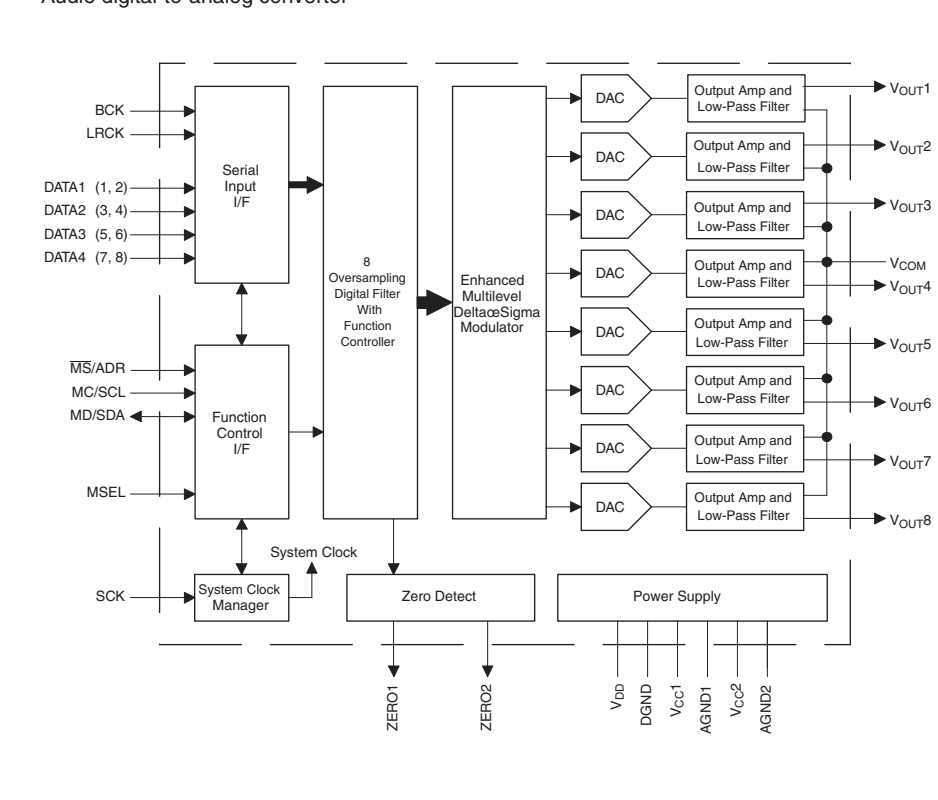

IC66: PCM1803DBR

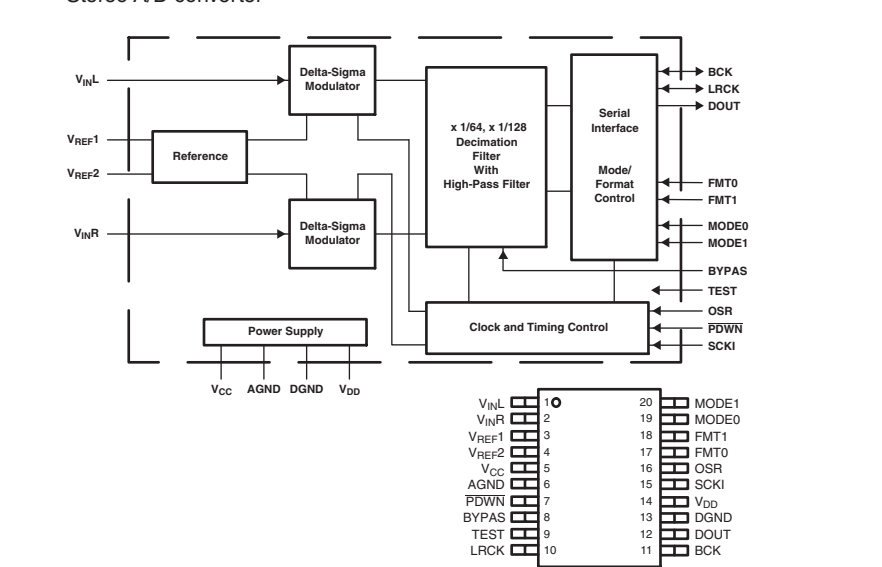

IC67: TC74VHC08AFT

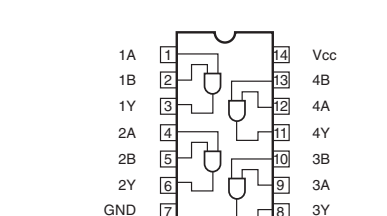

IC68: TC7SH08FU

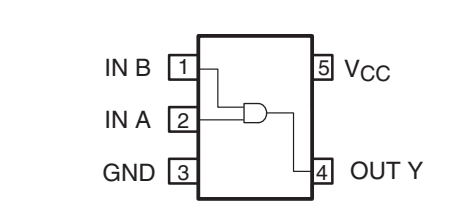

Page 115 B3 to OPERATION (2)_CB452

Page 115 D3 to OPERATION (2)_CB455

Page 115 E3 to OPERATION (2)_CB458

CAPACITOR

REMARKS	PARTS NAME
NO MARK	ELECTROLYTIC CAPACITOR
⊗	TANTALUM CAPACITOR
NO MARK	CERAMIC CAPACITOR
⊙	CERAMIC TUBULAR CAPACITOR
⊖	POLYESTER FILM CAPACITOR
○	MICA CAPACITOR
⊕	POLYPROPYLENE FILM CAPACITOR
⊖	SEMICONDUCTIVE CERAMIC CAPACITOR
⊕	POLYPHENYLENE SULFIDE FILM CAPACITOR

RESISTOR

REMARKS	PARTS NAME
NO MARK	CARBON FILM RESISTOR (P=5)
⊗	CARBON FILM RESISTOR (P=10)
△	METAL OXIDE FILM RESISTOR
⊖	METAL FILM RESISTOR
⊕	METAL PLATE RESISTOR
⊖	FIRE PROOF CARBON FILM RESISTOR
⊖	CEMENT MOLDED RESISTOR
⊖	SEMI VARIABLE RESISTOR
⊖	CHIP RESISTOR

NOTICE (mode1)
 (J)..... JAPAN
 (U)..... U.S.A
 (C)..... CANADA
 (R)..... GENERAL
 (T)..... CHINA
 (K)..... KOREA
 (A)..... AUSTRALIA
 (B)..... BRITISH
 (E)..... EUROPE
 (L)..... SINGAPORE
 (S)..... SOUTH EUROPE
 (V)..... TAIWAN
 (F)..... RUSSIAN

* All voltages are measured with a 10MΩ/V DC electronic voltmeter.
 * Components having special characteristics are marked Δ and must be replaced with parts having specifications equal to those originally installed.
 * Schematic diagram is subject to change without notice.

DIGITAL 5/5

Page 120 [B3] to VIDEO (9)_CB391 (F model)

Page 118 [K9] to VIDEO (1)_CB305

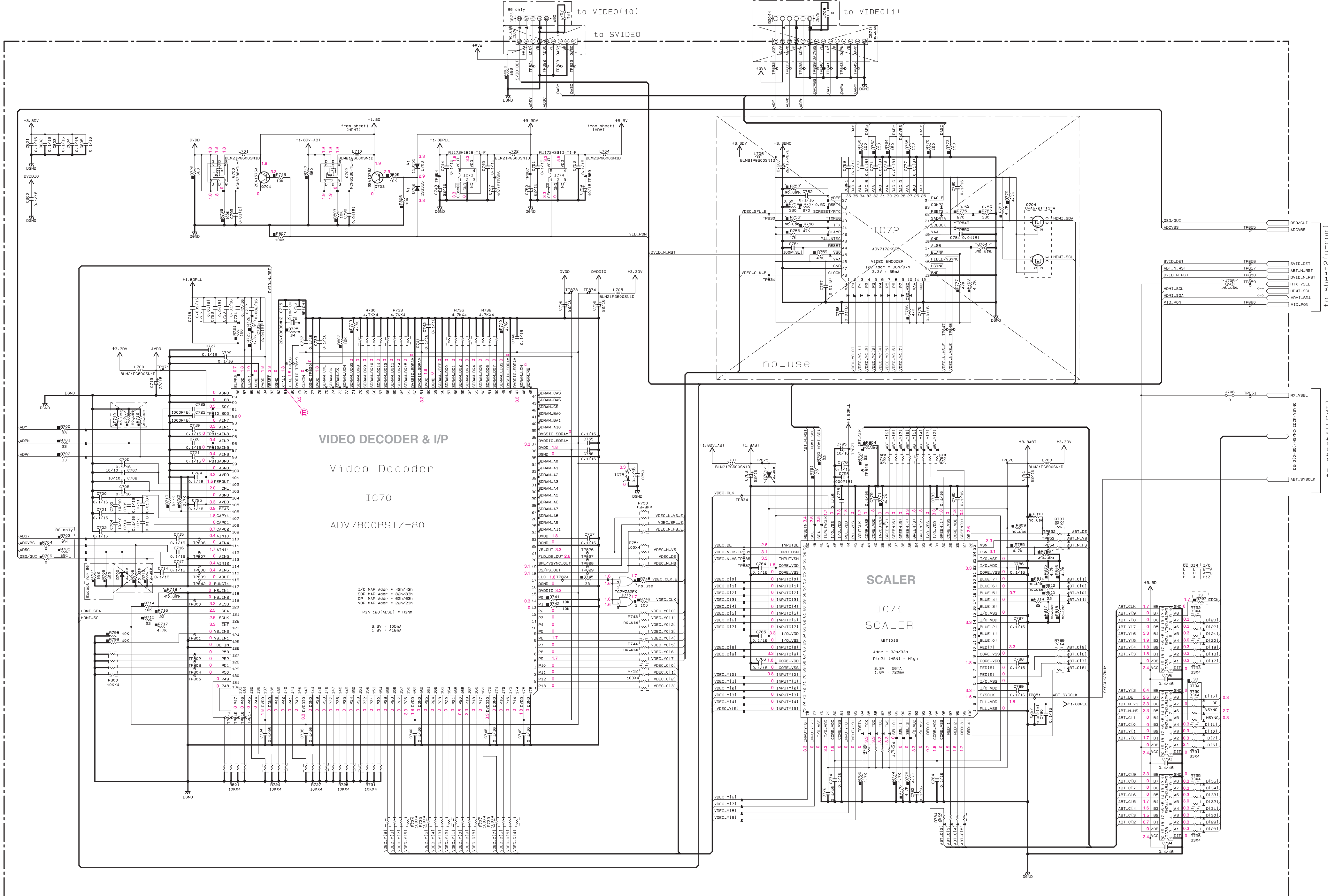

IC76-78: SN74LVTH245APW 3.3 V ABT octal bus transceivers with 3-state outputs

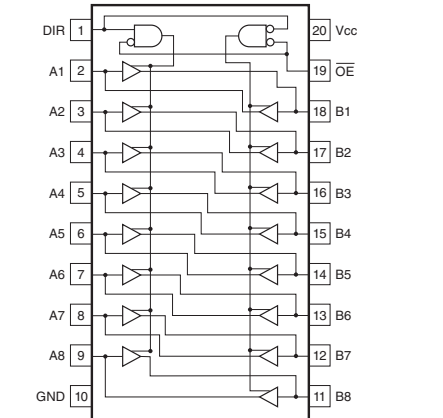

IC75: TC7W32FK (TE8SL, F) Dual 2-input OR gate

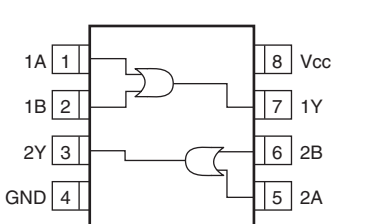

IC74: R1172H31D-T1-F Voltage regulator

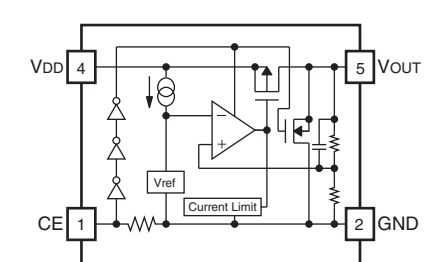

IC73: R1172H181B-T1-F Voltage regulator

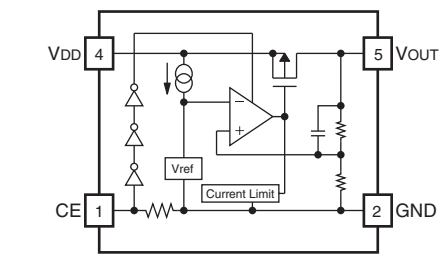

IC71: ABT1012Q100 Advanced video processor device

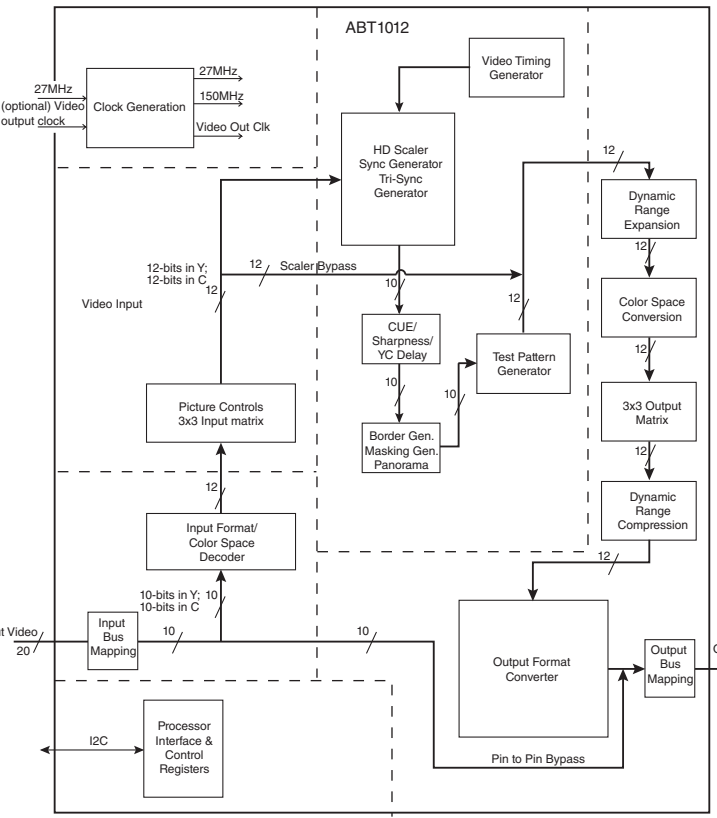

VIDEO DECODER & I/P
Video Decoder
IC70
ADV7800BSTZ-80

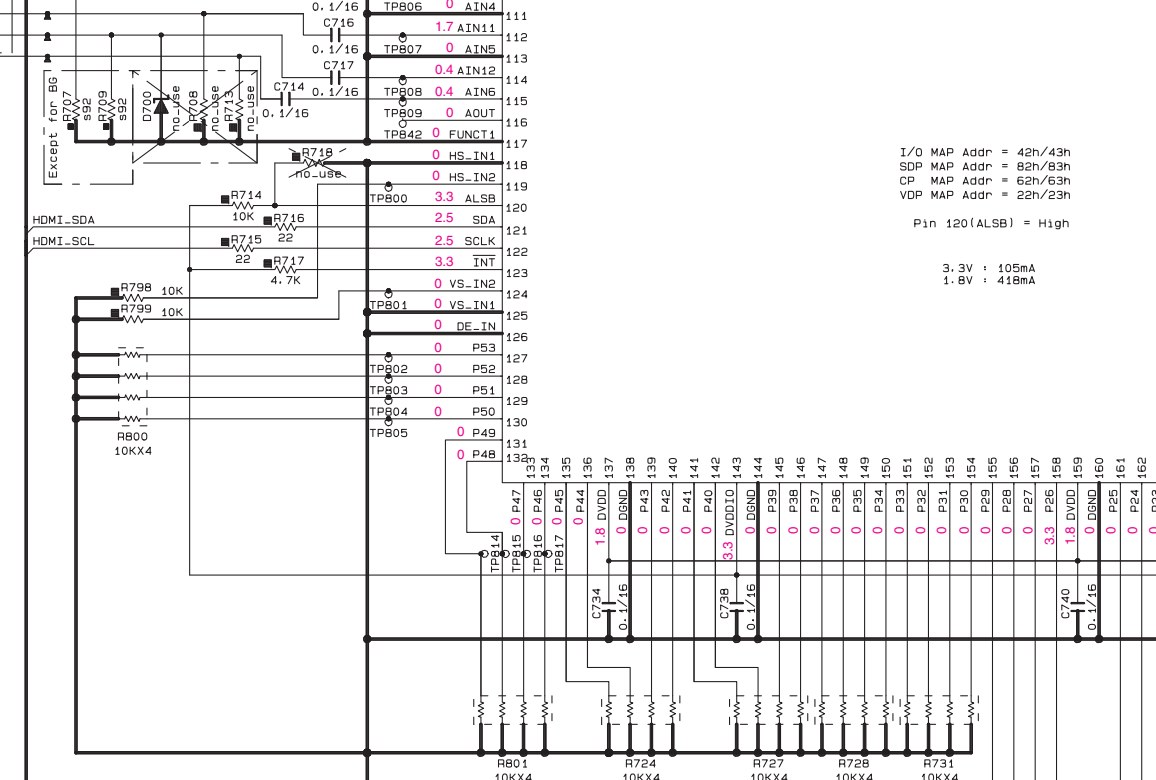

SCALER
IC71
SCALER

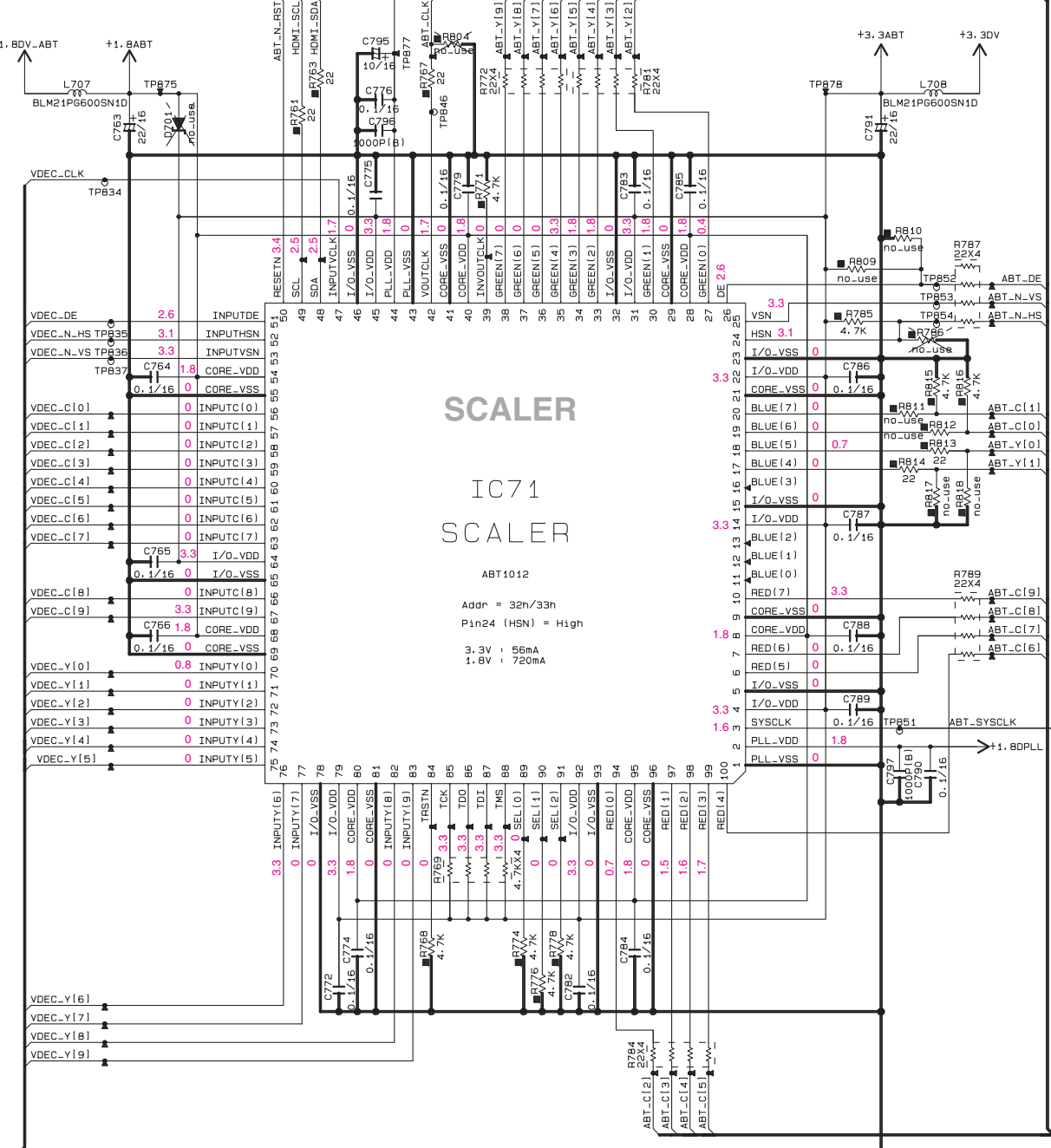

IC70: ADV7800BSTZ-80 10-bit, SDTV/HDTV 3D comb filter, video decoder and graphics digitizer

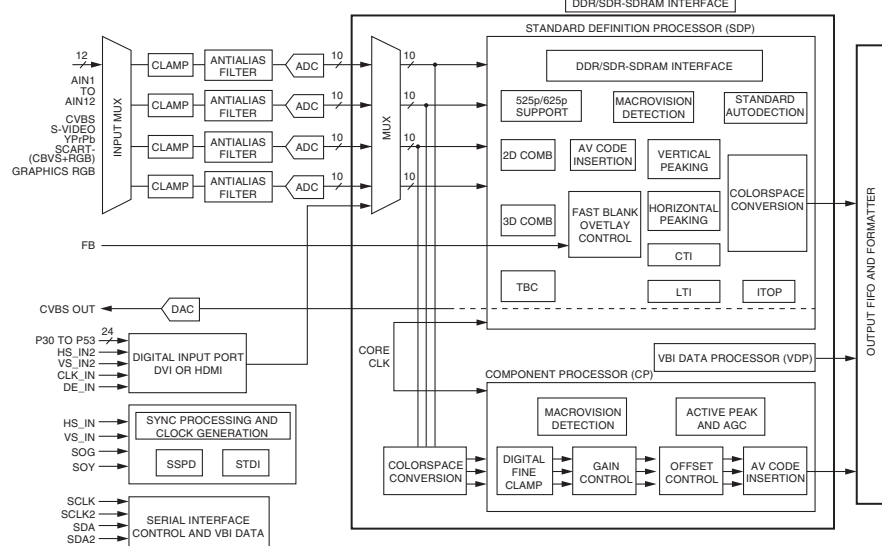

DVIDEO CB/1C/XL: 70 -84 OTHER : 700-849

DIGITAL (5)

POINT (XL70 (Pin #1 of IC70))

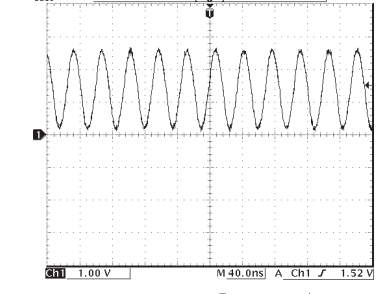

REMARKS	PARTS NAME
NO MARK	ELECTROLYTIC CAPACITOR
⊗	TANTALUM CAPACITOR
⊙	CERAMIC CAPACITOR
⊕	CERAMIC TUBULAR CAPACITOR
⊖	POLYESTER FILM CAPACITOR
⊗	POLYSTYRENE FILM CAPACITOR
⊕	POLYPROPYLENE FILM CAPACITOR
⊖	SEMICONDUCTIVE CERAMIC CAPACITOR
⊗	POLYPHENYLENE SULFIDE FILM CAPACITOR

REMARKS	PARTS NAME
NO MARK	CARBON FILM RESISTOR (P=5)
⊗	CARBON FILM RESISTOR (P=10)
⊕	METAL OXIDE FILM RESISTOR
⊖	METAL FILM RESISTOR
⊗	FIRE PROOF CARBON FILM RESISTOR
⊕	CEMENT MOLDED RESISTOR
⊖	SEMI VARIABLE RESISTOR
⊗	CHIP RESISTOR

NOTICE (model)
(J)..... JAPAN
(U)..... U.S.A
(C)..... CANADA
(R)..... GENERAL
(T)..... CHINA
(K)..... KOREA
(A)..... AUSTRALIA
(B)..... BRITISH
(G)..... EUROPE
(L)..... SINGAPORE
(E)..... SOUTH EUROPE
(V)..... TAIWAN
(F)..... RUSSIAN

* All voltages are measured with a 10MΩ/V DC electronic voltmeter.
* Components having special characteristics are marked Δ, and must be replaced with parts having specifications equal to those originally installed.
* Schematic diagram is subject to change without notice.

OPERATION 1/2

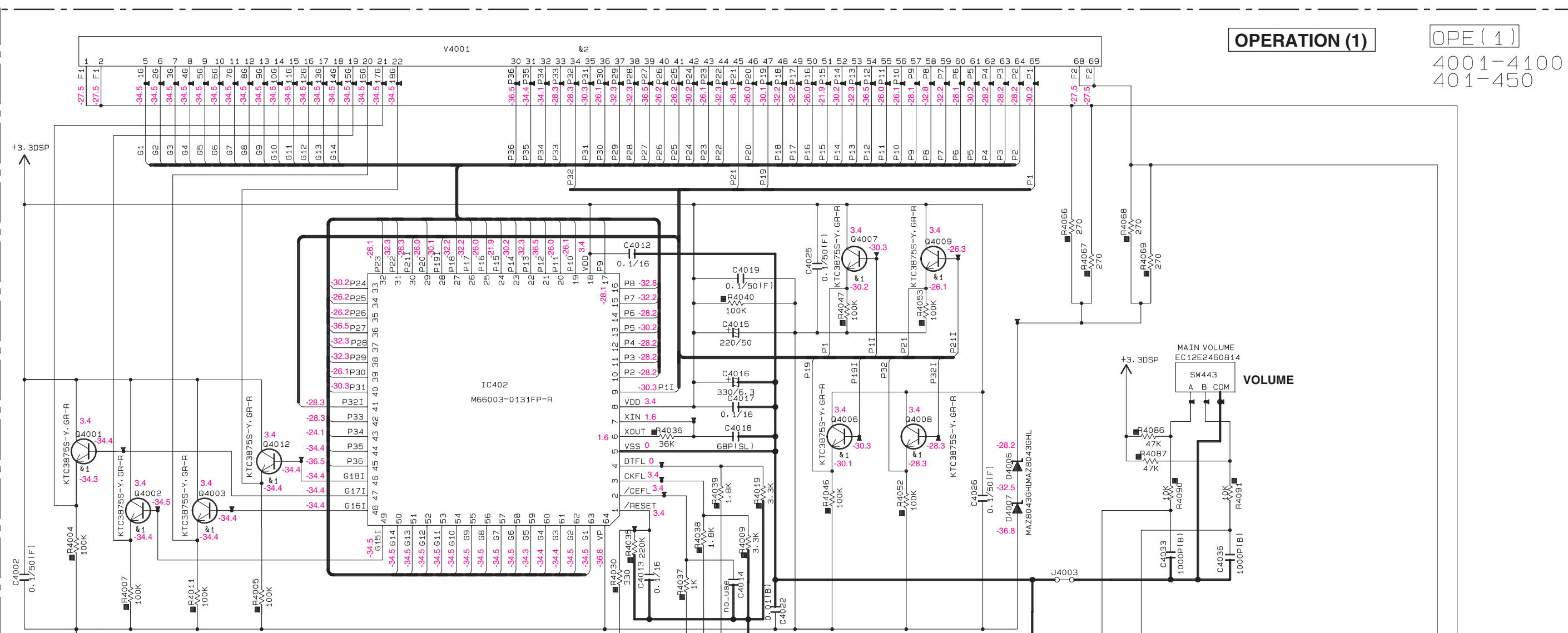

OPERATION (1) OPE (1)
4001-4100
401-450

Interchangeable Parts at Manufacture-Stage

Mark	Reference Parts Number	Parts Name
K1	04001-4003, 4006-4012	KTC3875S-Y, GR-RTK/P C2412K10/R/S1
K2	V4001	1B-WT-0909K IMA-15B0011
K3	G4004-4301	DT114EKA KRC102S-RTK/P
K4	D4001-4002, 4004-4005, 4010-4013, 4303-4401, 4402-4406, 4407-4409, 4411	1S5395 MAZJ1110GL
K5	G4302	DT114EKA KRA102S-RTK/P
K6	U4001	SM3385VHM6 RRM7238-09

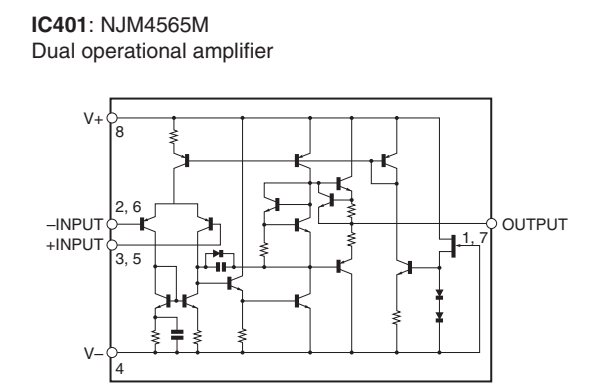

RESISTOR

REMARKS	PARTS NAME
NO MARK	CARBON FILM RESISTOR (P=5)
□	CARBON FILM RESISTOR (P=10)
△	METAL OXIDE FILM RESISTOR
▲	METAL FILM RESISTOR
⊠	METAL PLATE RESISTOR
⊞	FIRE PROOF CARBON FILM RESISTOR
⊞	CEMENT MOLDED RESISTOR
⊞	SEMI VARIABLE RESISTOR
⊞	CHIP RESISTOR

CAPACITOR

REMARKS	PARTS NAME
NO MARK	ELECTROLYTIC CAPACITOR
⊗	TANTALUM CAPACITOR
NO MARK	CERAMIC CAPACITOR
⊙	CERAMIC TUBULAR CAPACITOR
⊙	POLYESTER FILM CAPACITOR
⊙	POLYSTYRENE FILM CAPACITOR
⊙	MICA CAPACITOR
⊙	POLYPROPYLENE FILM CAPACITOR
⊙	SEMICONDUCTIVE CERAMIC CAPACITOR
⊙	POLYPHENYLENE SULFIDE FILM CAPACITOR

NOTICE (model)
(J)..... JAPAN
(U)..... U.S.A
(C)..... CANADA
(R)..... GENERAL
(T)..... CHINA
(K)..... KOREA
(A)..... AUSTRALIA
(B)..... BRITISH
(G)..... EUROPE
(L)..... SINGAPORE
(V)..... SOUTH EUROPE
(V)..... TAIWAN
(F)..... RUSSIAN

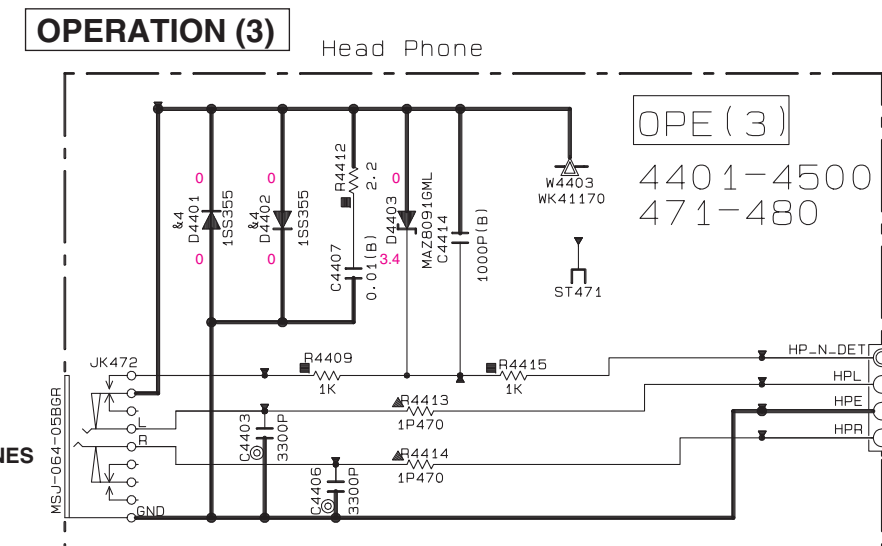
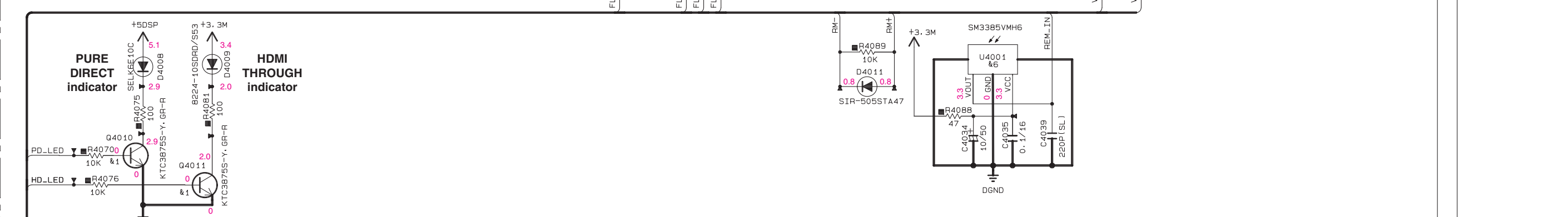
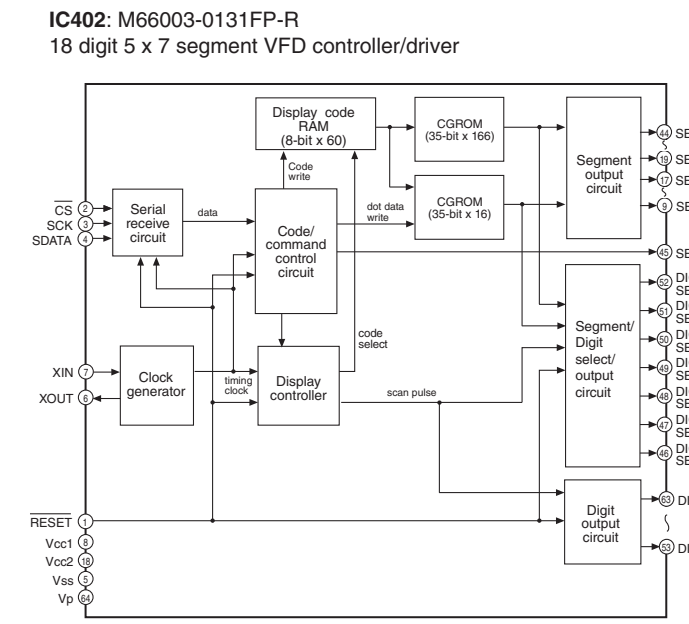

Page 119 [B4]
to VIDEO (1)_W3401

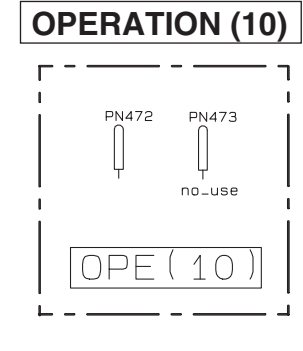
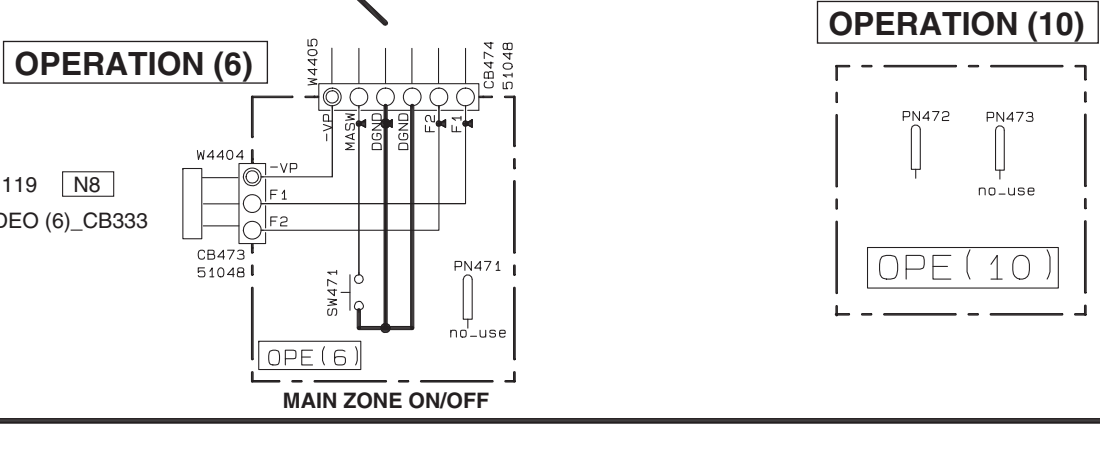
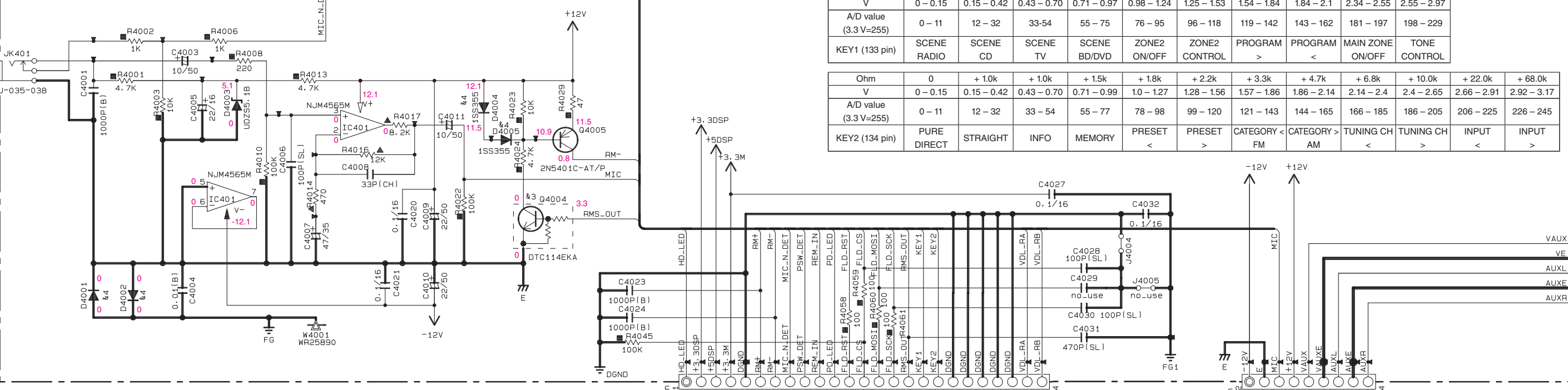
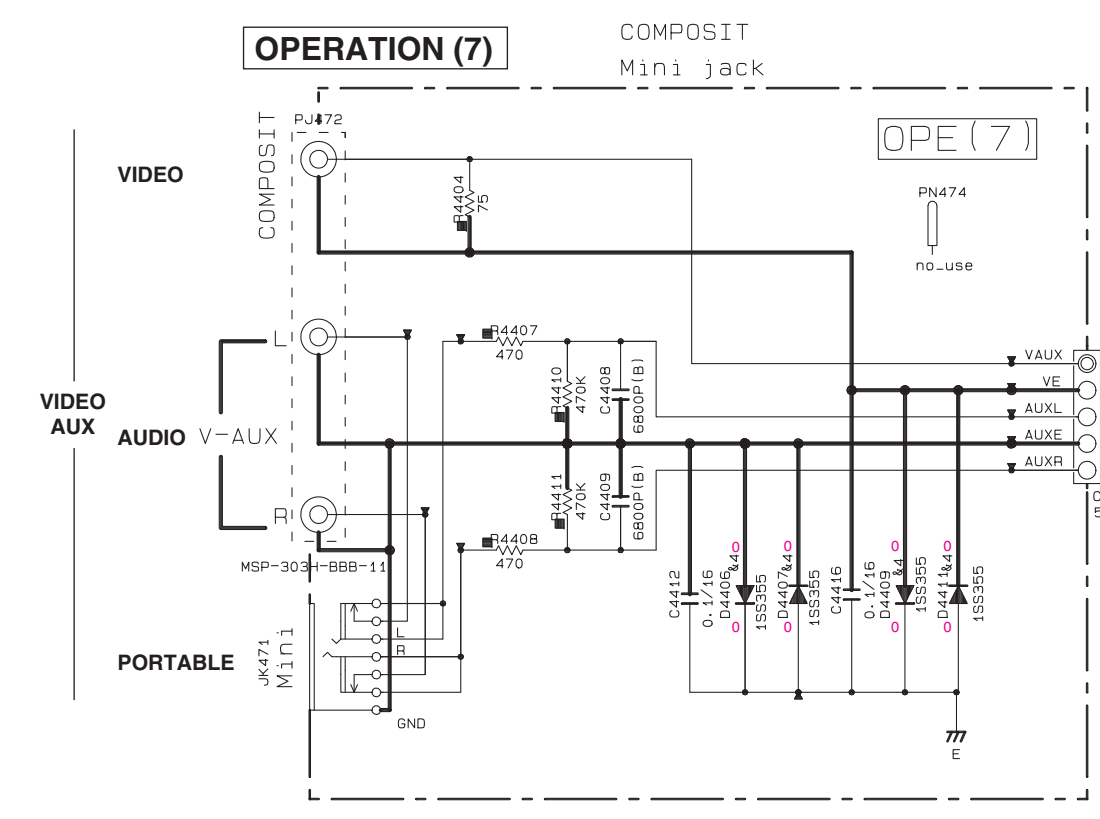
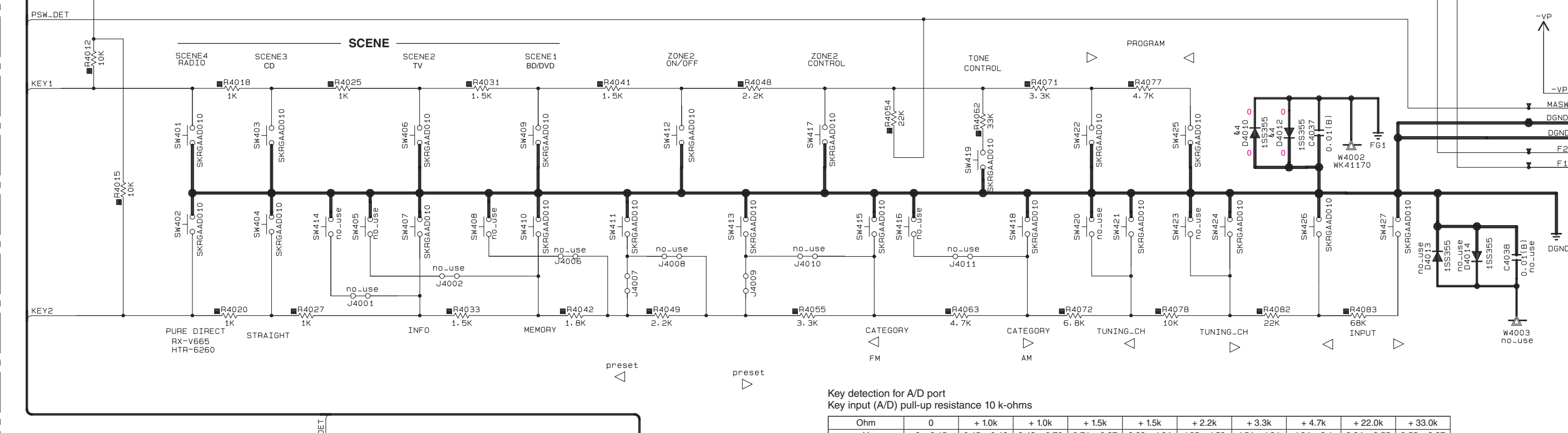

Key detection for A/D port
Key input (A/D) pull-up resistance 10 k-ohms

Ohm	0	+1.0k	+1.0k	+1.5k	+1.5k	+2.2k	+3.3k	+4.7k	+22.0k	+33.0k
V	0-0.15	0.15-0.42	0.43-0.70	0.71-0.97	0.98-1.24	1.25-1.53	1.54-1.84	1.84-2.21	2.24-2.55	2.55-2.97
A/D value (3.3 V±25%)	0-11	12-32	33-54	55-77	76-95	96-118	119-142	143-162	181-197	198-229
KEY1 (133 pin)	SCENE RADIO	SCENE CD	SCENE TV	SCENE BD/DVD	ZONE2 CONTROL	PROGRAM >	PROGRAM <	MAIN ZONE ON/OFF	TONE CONTROL	

Ohm	0	+1.0k	+1.0k	+1.5k	+1.5k	+2.2k	+3.3k	+4.7k	+6.8k	+10.0k	+22.0k	+68.0k
V	0-0.15	0.15-0.42	0.43-0.70	0.71-0.99	1.0-1.27	1.28-1.56	1.57-1.86	1.86-2.14	2.14-2.4	2.4-2.65	2.66-2.91	2.92-3.17
A/D value (3.3 V±25%)	0-11	12-32	33-54	55-77	78-98	99-120	121-143	144-165	166-185	186-205	206-225	226-245
KEY2 (134 pin)	PURE DIRECT	STRAIGHT	INFO	MEMORY	PRESET >	PRESET <	CATEGORY >	CATEGORY <	TUNING CH >	TUNING CH <	INPUT >	INPUT <

Page 110 [B2] to DIGITAL_CB20
Page 115 [I5] to OPERATION (2)_CB461

* All voltages are measured with a 10MΩ/V DC electronic voltmeter.
* Components having special characteristics are marked Δ and must be replaced with parts having specifications equal to those originally installed.
* Schematic diagram is subject to change without notice.

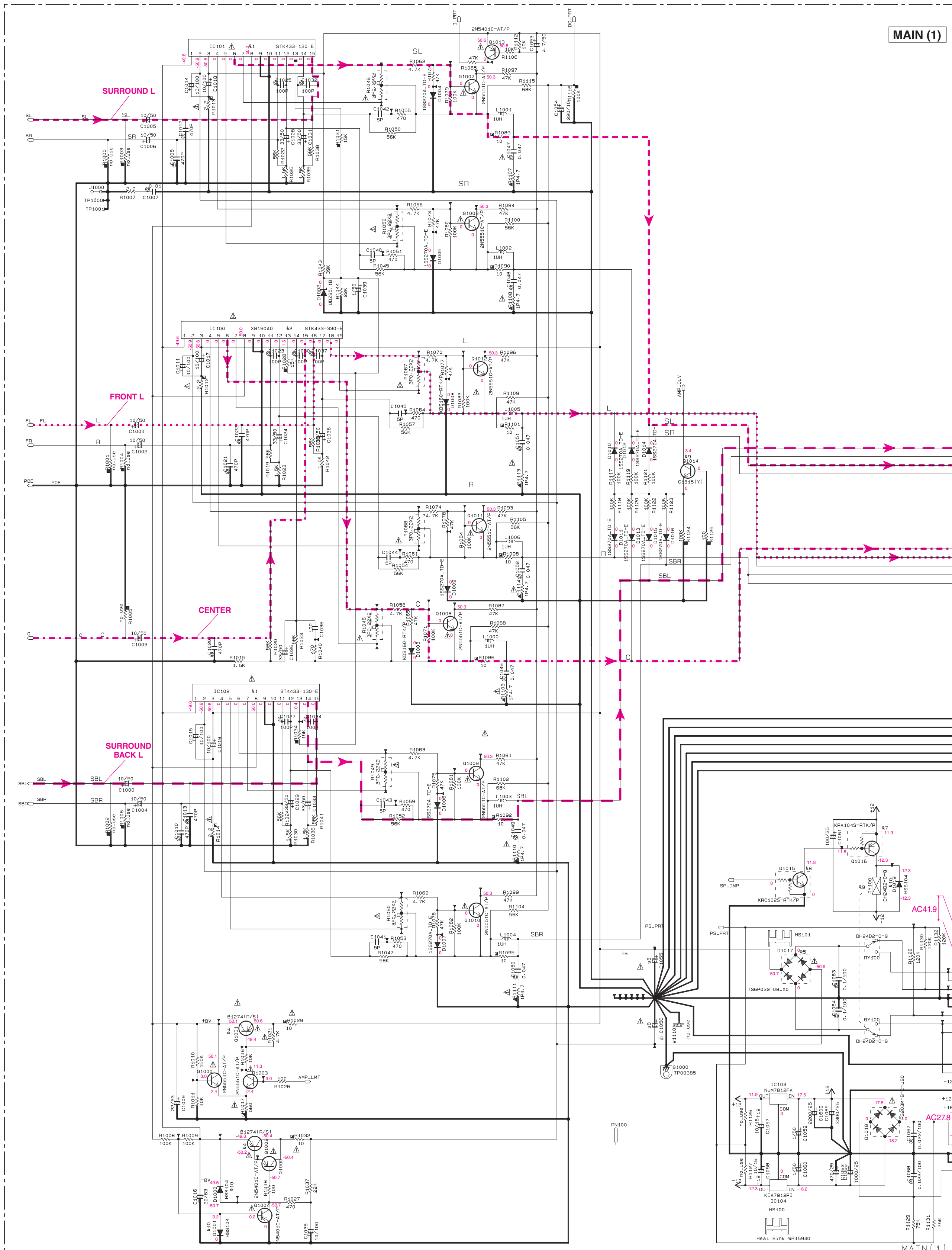

RESISTOR

REMARKS	PARTS NAME
NO MARK	CARBON FILM RESISTOR (P=5)
△	CARBON FILM RESISTOR (P=10)
▲	METAL OXIDE FILM RESISTOR
□	METAL FILM RESISTOR
⊠	METAL PLATE RESISTOR
■	FIRE PROOF CARBON FILM RESISTOR
⊙	CEMENT MOLDED RESISTOR
⊚	SEMI VARIABLE RESISTOR
⊛	CHIP RESISTOR

CAPACITOR

REMARKS	PARTS NAME
NO MARK	ELECTROLYTIC CAPACITOR
⊗	TANTALUM CAPACITOR
NO MARK	CERAMIC CAPACITOR
⊙	CERAMIC TUBULAR CAPACITOR
⊚	POLYESTER FILM CAPACITOR
○	POLYSTYRENE FILM CAPACITOR
⊖	MICA CAPACITOR
⊕	POLYPROPYLENE FILM CAPACITOR
⊙	SEMICONDUCTIVE CERAMIC CAPACITOR
⊚	POLYPHENYLENE SULFIDE FILM CAPACITOR

NOTICE (mode1)
 (J)..... JAPAN
 (U)..... U.S.A.
 (C)..... CANADA
 (R)..... GENERAL
 (T)..... CHINA
 (K)..... KOREA
 (A)..... AUSTRALIA
 (B)..... BRITISH
 (G)..... EUROPE
 (L)..... SINGAPORE
 (E)..... SOUTH EUROPE
 (V)..... TAIWAN
 (F)..... RUSSIAN

Interchangeable Parts at Manufacture Stage

Mark	Reference Parts Number	Parts Name
41	IC101, 102	STK433-130-E STK433-330-E
42	IC100	STK433-330-E STK433-330-E
43	U1500-1501	J8R165 GF1FV515K0F
44	G1001, 1002	28B12741N/S1 28B15051E/P1 KTA1048-V-U/P
45	D1017	T86P030-08_X0 R5603M-B-C-U80
46	G1500-1504, 1507-1514 1519-1526	28D19381F1 28C99381A1F1 28D2741E1
47	G1016	KRA1048-RTK/P DTA148KA
48	G1015	K8C1028-RTK/P DTC1148KA
49	G1014	28C18151V1 KTC3189Y-AT
410	G1000, 1001-1019	H8S104 15S133 15S176

Destination Part List

xxx	LC	UC	R	AF
41	W1006A	X	W47540	X
42	W1006B	X	VH-5298T	X
43	W1004B	X	MH06030	X
44	W1004A	X	MH06030	X
45	W1003B	X	MH06030	X
46	W1005A	X	MH06030	X
47	W1005B	X	MH06030	X
48	W1005C	X	MH06030	X
49	W1005D	X	MH06030	X
50	W1005E	X	MH06030	X
51	W1005F	X	MH06030	X
52	W1005G	X	MH06030	X
53	W1005H	X	MH06030	X
54	W1005I	X	MH06030	X
55	W1005J	X	MH06030	X
56	W1005K	X	MH06030	X
57	W1005L	X	MH06030	X
58	W1005M	X	MH06030	X
59	W1005N	X	MH06030	X
60	W1005O	X	MH06030	X
61	W1005P	X	MH06030	X
62	W1005Q	X	MH06030	X
63	W1005R	X	MH06030	X
64	W1005S	X	MH06030	X
65	W1005T	X	MH06030	X
66	W1005U	X	MH06030	X
67	W1005V	X	MH06030	X
68	W1005W	X	MH06030	X
69	W1005X	X	MH06030	X
70	W1005Y	X	MH06030	X
71	W1005Z	X	MH06030	X
72	W1006A	X	MH06030	X
73	W1006B	X	MH06030	X
74	W1006C	X	MH06030	X
75	W1006D	X	MH06030	X
76	W1006E	X	MH06030	X
77	W1006F	X	MH06030	X
78	W1006G	X	MH06030	X
79	W1006H	X	MH06030	X
80	W1006I	X	MH06030	X
81	W1006J	X	MH06030	X
82	W1006K	X	MH06030	X
83	W1006L	X	MH06030	X
84	W1006M	X	MH06030	X
85	W1006N	X	MH06030	X
86	W1006O	X	MH06030	X
87	W1006P	X	MH06030	X
88	W1006Q	X	MH06030	X
89	W1006R	X	MH06030	X
90	W1006S	X	MH06030	X
91	W1006T	X	MH06030	X
92	W1006U	X	MH06030	X
93	W1006V	X	MH06030	X
94	W1006W	X	MH06030	X
95	W1006X	X	MH06030	X
96	W1006Y	X	MH06030	X
97	W1006Z	X	MH06030	X
98	W1007A	X	MH06030	X
99	W1007B	X	MH06030	X
100	W1007C	X	MH06030	X
101	W1007D	X	MH06030	X
102	W1007E	X	MH06030	X
103	W1007F	X	MH06030	X
104	W1007G	X	MH06030	X
105	W1007H	X	MH06030	X
106	W1007I	X	MH06030	X
107	W1007J	X	MH06030	X
108	W1007K	X	MH06030	X
109	W1007L	X	MH06030	X
110	W1007M	X	MH06030	X
111	W1007N	X	MH06030	X
112	W1007O	X	MH06030	X
113	W1007P	X	MH06030	X
114	W1007Q	X	MH06030	X
115	W1007R	X	MH06030	X
116	W1007S	X	MH06030	X
117	W1007T	X	MH06030	X
118	W1007U	X	MH06030	X
119	W1007V	X	MH06030	X
120	W1007W	X	MH06030	X
121	W1007X	X	MH06030	X
122	W1007Y	X	MH06030	X
123	W1007Z	X	MH06030	X
124	W1008A	X	MH06030	X
125	W1008B	X	MH06030	X
126	W1008C	X	MH06030	X
127	W1008D	X	MH06030	X
128	W1008E	X	MH06030	X
129	W1008F	X	MH06030	X
130	W1008G	X	MH06030	X
131	W1008H	X	MH06030	X
132	W1008I	X	MH06030	X
133	W1008J	X	MH06030	X
134	W1008K	X	MH06030	X
135	W1008L	X	MH06030	X
136	W1008M	X	MH06030	X
137	W1008N	X	MH06030	X
138	W1008O	X	MH06030	X
139	W1008P	X	MH06030	X
140	W1008Q	X	MH06030	X
141	W1008R	X	MH06030	X
142	W1008S	X	MH06030	X
143	W1008T	X	MH06030	X
144	W1008U	X	MH06030	X
145	W1008V	X	MH06030	X
146	W1008W	X	MH06030	X
147	W1008X	X	MH06030	X
148	W1008Y	X	MH06030	X
149	W1008Z	X	MH06030	X
150	W1009A	X	MH06030	X
151	W1009B	X	MH06030	X
152	W1009C	X	MH06030	X
153	W1009D	X	MH06030	X
154	W1009E	X	MH06030	X
155	W1009F	X	MH06030	X
156	W1009G	X	MH06030	X
157	W1009H	X	MH06030	X
158	W1009I	X	MH06030	X
159	W1009J	X	MH06030	X
160	W1009K	X	MH06030	X
161	W1009L	X	MH06030	X
162	W1009M	X	MH06030	X
163	W1009N	X	MH06030	X
164	W1009O	X	MH06030	X
165	W1009P	X	MH06030	X
166	W1009Q	X	MH06030	X
167	W1009R	X	MH06030	X
168	W1009S	X	MH06030	X
169	W1009T	X	MH06030	X
170	W1009U	X	MH06030	X
171	W1009V	X	MH06030	X
172	W1009W	X	MH06030	X
173	W1009X	X	MH06030	X
174	W1009Y	X	MH06030	X
175	W1009Z	X	MH06030	X
176	W1010A	X	MH06030	X
177	W1010B	X	MH06030	X
178	W1010C	X	MH06030	X
179	W1010D	X	MH06030	X
180	W1010E	X	MH06030	X
181	W1010F	X	MH06030	X
182	W1010G	X	MH06030	X
183	W1010H	X	MH06030	X
184	W1010I	X	MH06030	X
185	W1010J	X	MH06030	X
186	W1010K	X	MH06030	X
187	W1010L	X	MH06030	X
188	W1010M	X	MH06030	X
189	W1010N	X	MH06030	X
190	W1010O	X	MH06030	X
191	W1010P	X	MH06030	X
192	W1010Q	X	MH06030	X
193	W1010R	X	MH06030	X
194	W1010S	X	MH06030	X
195	W1010T	X	MH06030	X
196	W1010U	X	MH06030	X
197	W1010V	X	MH06030	X
198	W1010W	X	MH06030	X
199	W1010X	X	MH06030	X
200	W1010Y	X	MH06030	X
201	W1010Z	X	MH06030	X

Page 119 [B6]
to VIDEO (1)_CB343

Page 119 [B5]
to VIDEO (1)_CB342

Page 119 [B7]
to VIDEO (1)_CB344

Page 119 [B7]
to VIDEO (1)_CB345

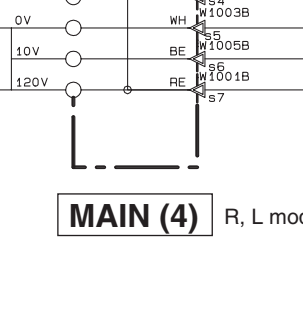
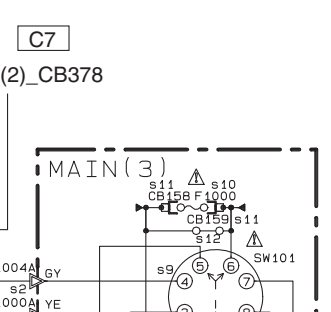
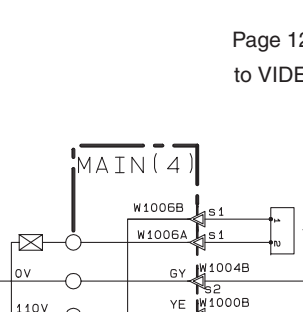
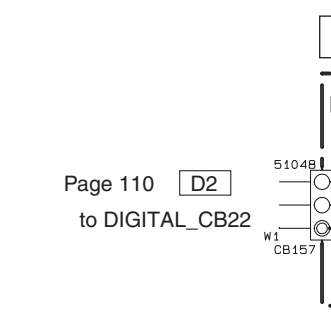
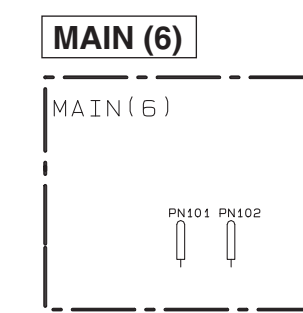

VOLTAGE SELECTOR

230-240V	1-2/5-6
220V	2-3/6-7
110V	3-4/7-8
120V	4-5/8-1

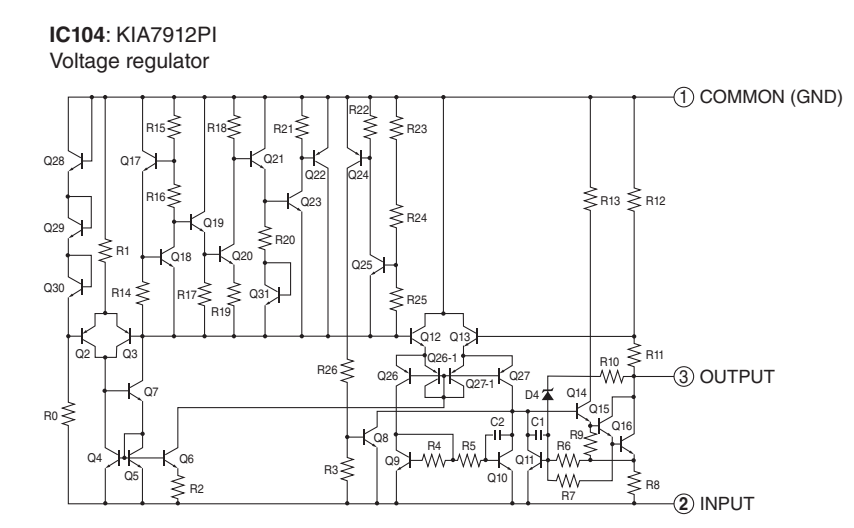
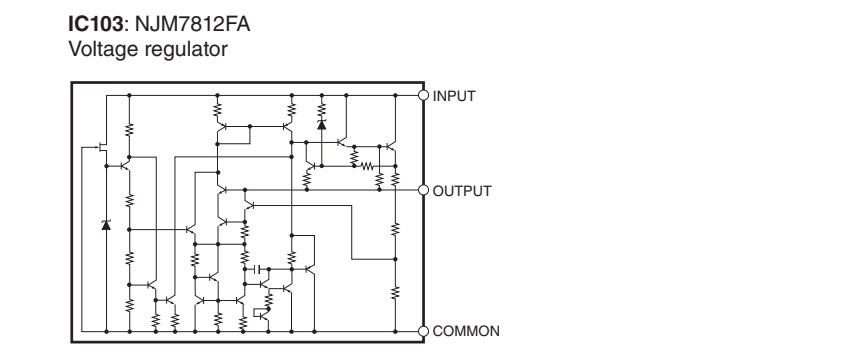
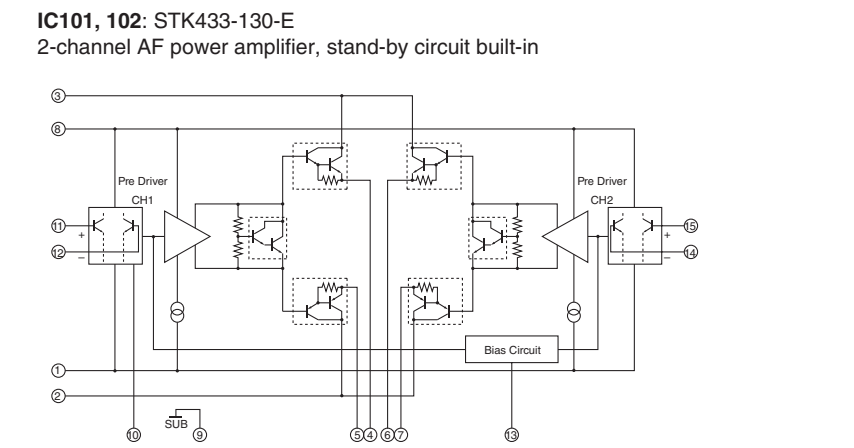
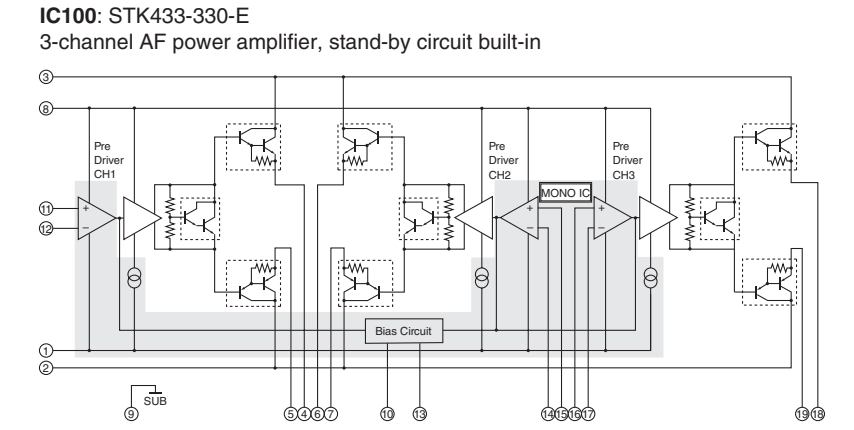

* All voltages are measured with a 10MΩ/DC electronic voltmeter.
 * Components having special characteristics are marked Δ and must be replaced with parts having specifications equal to those originally installed.
 * Schematic diagram is subject to change without notice.

MAIN 2/2

Page 115 [BB] to OPERATION (2)_CB451

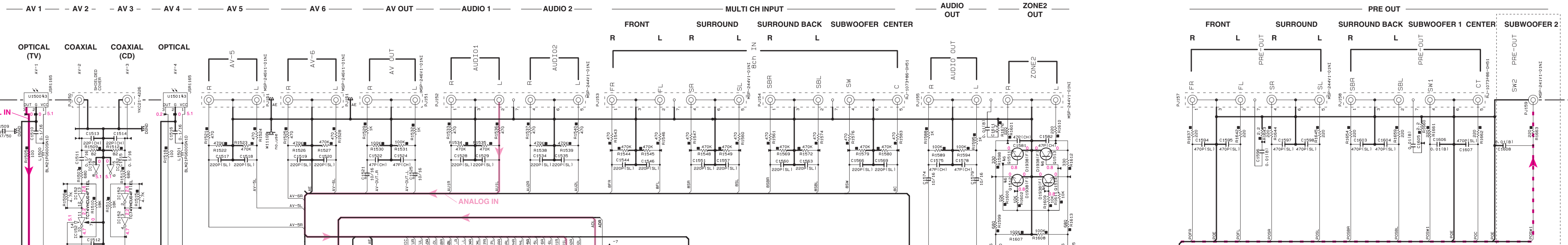

RX-V665, HTR-6260 (U model)

Page 115 [C8] to OPERATION (2)_CB454

Page 115 [D8] to OPERATION (2)_CB456

Page 115 [E8] to OPERATION (2)_CB457

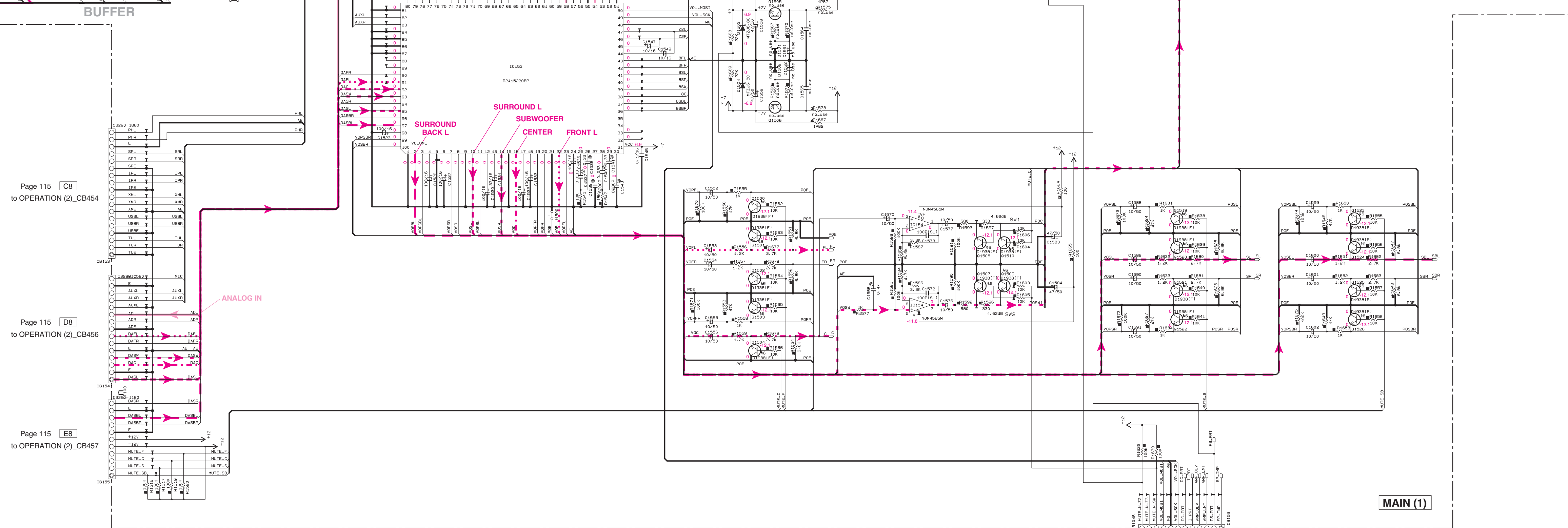

MAIN (1)

IC152: TC74VHC04FT Hex inverters

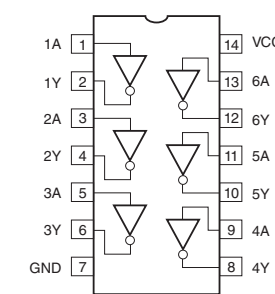

IC153: R2A15220FP 8-channel electronic volume with 11 input selector and tone control

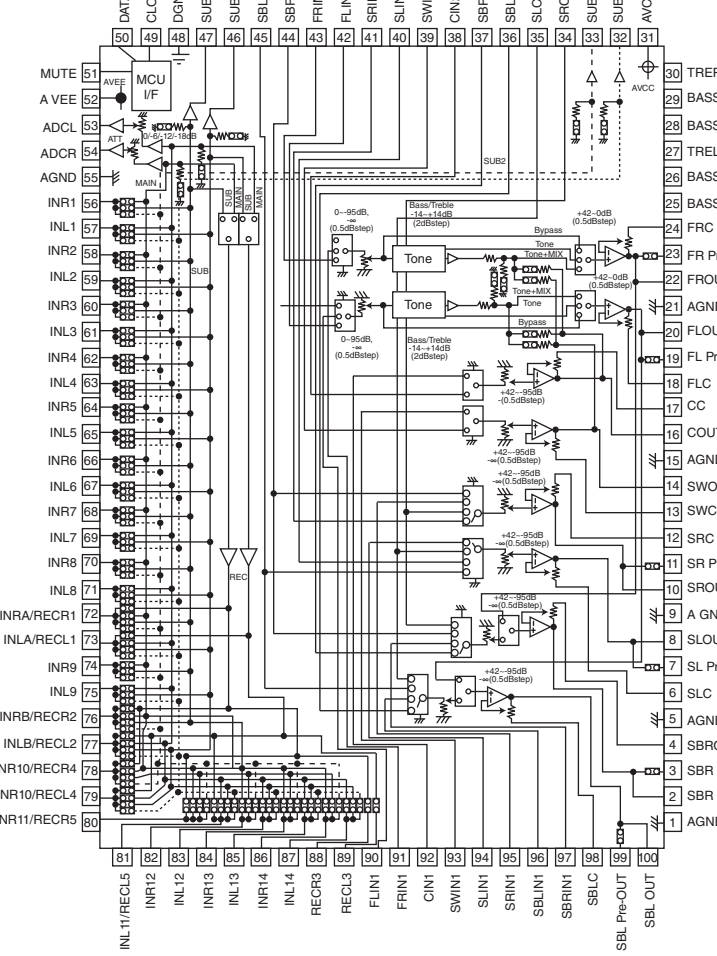

IC154: NJM4565M Dual operational amplifier

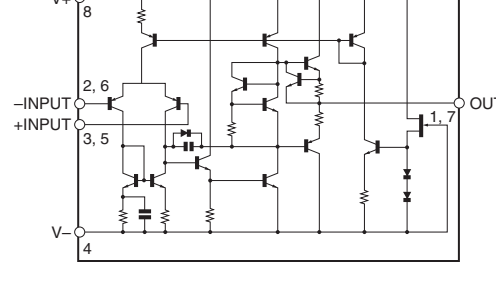

NOTICE (model)

- (J) JAPAN
(U) U.S.A
(C) CANADA
(R) GENERAL
(T) CHINA
(K) KOREA
(A) AUSTRALIA
(B) BRITISH
(G) EUROPE
(L) SINGAPORE
(E) SOUTH EUROPE
(V) TAIWAN
(F) RUSSIAN

Table with columns: REMARKS, PARTS NAME. Lists resistor types: CARBON FILM RESISTOR, CARBON FILM RESISTOR (P=5), METAL OXIDE FILM RESISTOR, METAL FILM RESISTOR, METAL PLATE RESISTOR, FIRE-PROOF CARBON FILM RESISTOR, CEMENT MOLDED RESISTOR, SEMI-VARIABLE RESISTOR, CHIP RESISTOR.

Table with columns: REMARKS, PARTS NAME. Lists capacitor types: ELECTROLYTIC CAPACITOR, TANTALUM CAPACITOR, CERAMIC CAPACITOR, CERAMIC TUBULAR CAPACITOR, POLYESTER FILM CAPACITOR, POLYETHYLENE FILM CAPACITOR, MICA CAPACITOR, POLYPROPYLENE FILM CAPACITOR, SEMICONDUCTIVE CERAMIC CAPACITOR.

Interchangeable Parts at Manufacture-Stage

Table with columns: Mark, Reference Parts Number, Parts Name.

Page 110 [E2] to DIGITAL_CB23

All voltages are measured with a 10MΩ/V DC electronic voltmeter. Components having special characteristics are marked Δ and must be replaced with parts having specifications equal to those originally installed. Schematic diagram is subject to change without notice.

1
2
3
4
5
6
7
8
9
10

COMPONENT VIDEO IN

AV 1 AV1
AV 2 AV2
AV 3 AV3
AV 4 AV4
AV 5 AV5
AV 6 AV6

VIDEO IN

AV OUT

COMPONENT VIDEO

MONITOR VIDEO

MON OUT

VIDEO

Destination Part List

REV.	LOC.	U	C	R	A	S.E.P.	L
0101	AL301	VY9490	VY9490	VY9490	W11965	W11965	W11965
0102	C3055	U090118	U090118	U090118	U090118	U090118	U090118
0103	C3056	U090118	U090118	U090118	U090118	U090118	U090118
0104	C3058	U090118	U090118	U090118	U090118	U090118	U090118

Interchangeable Parts at Manufacture-Stage

Mark	Reference Parts Number	Part's Name
51	D3700-3707	H5514 15513 15516
52	D3000-3003	KT1045-V-LUP 200014R/16.16/R/1 200014R/16.16/R/1
53	IC301-303	TC74HC4053AF M74HC4053JL-NL
54	D3000-3003	200014R/16.16/R/1 200014R/16.16/R/1 200014R/16.16/R/1
55	D3000-3007-3009-3011-3013-3017-3021-3025-3031-3032	155099 M4201100L
56	D3400-3408-3410-3412-3414	DT144EXA M4202-RTX/P
57	D3400-3407-3409-3411-3413	DT144EXA M4202-RTX/P
58	D3001	DT144EXA M4202-RTX/P
59	D3001	DT144EXA/16.16/R/1 RSC3114M16.16/R/1

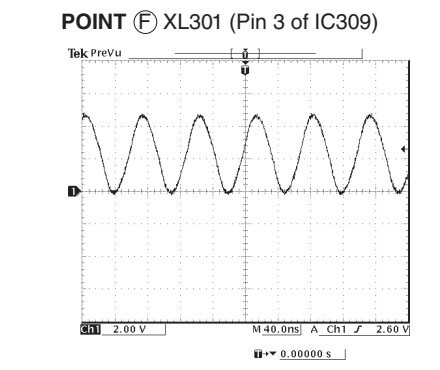
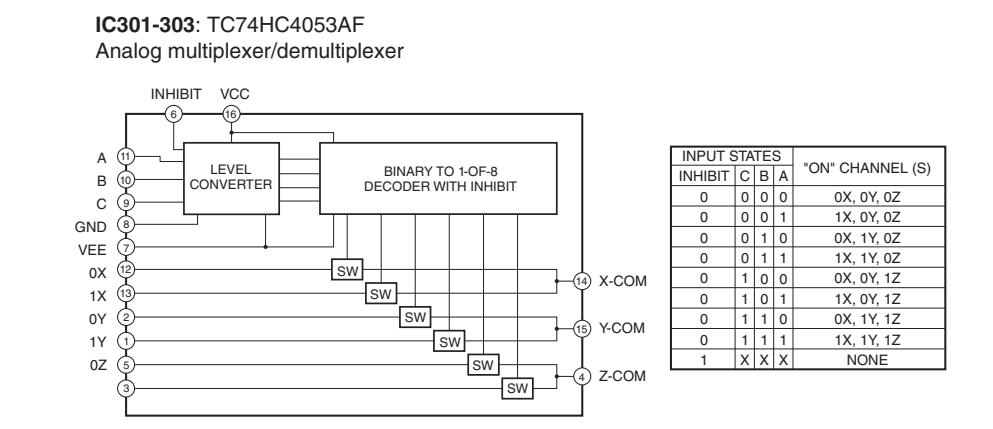

Page 115 [G7]
to OPERATION (2)_CB459

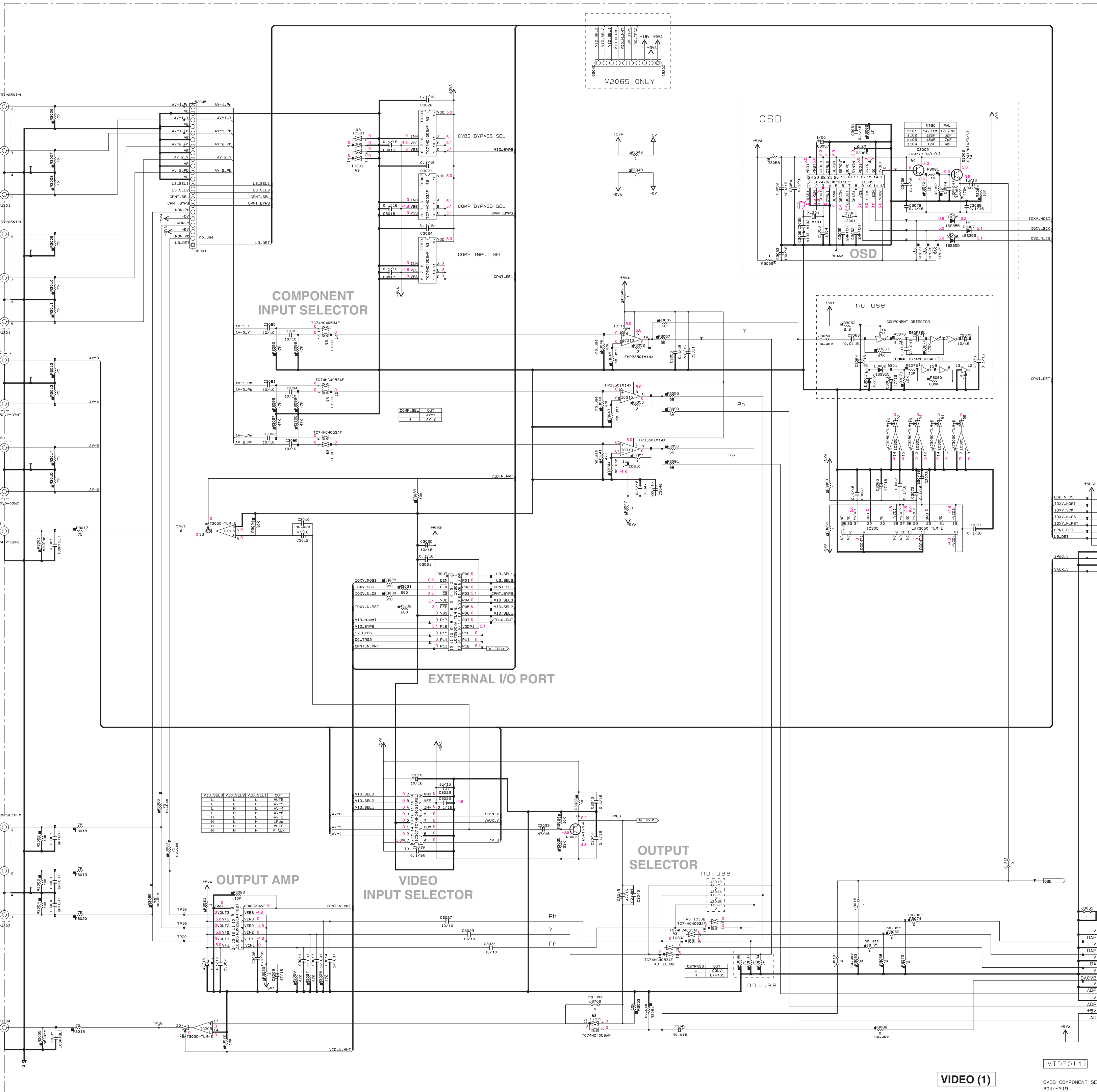
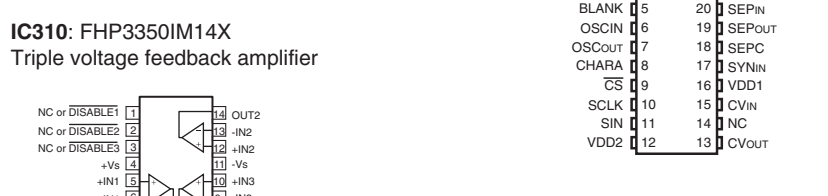
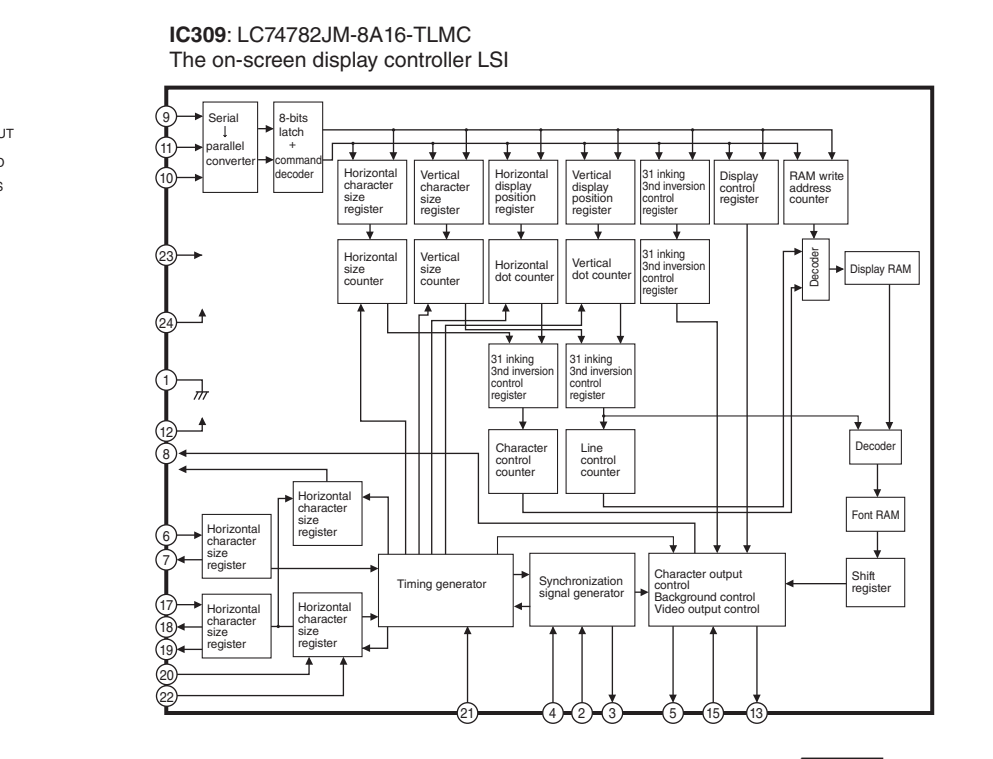
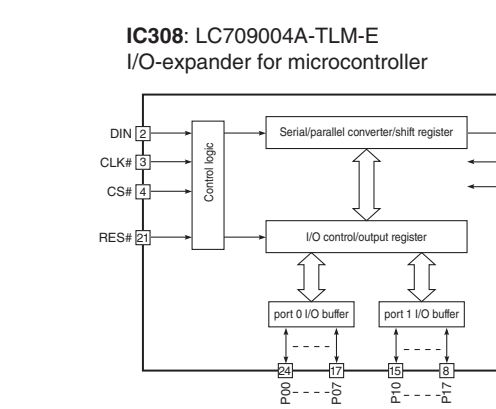
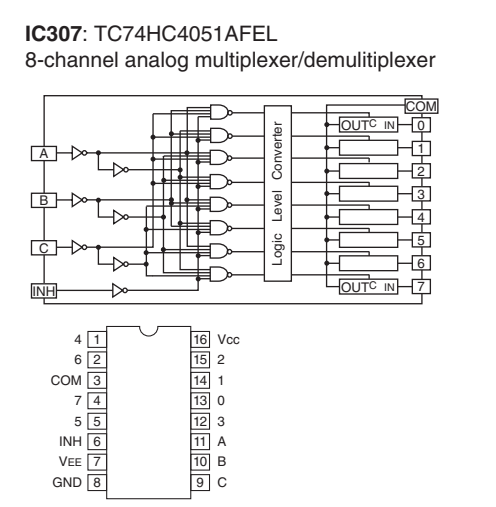
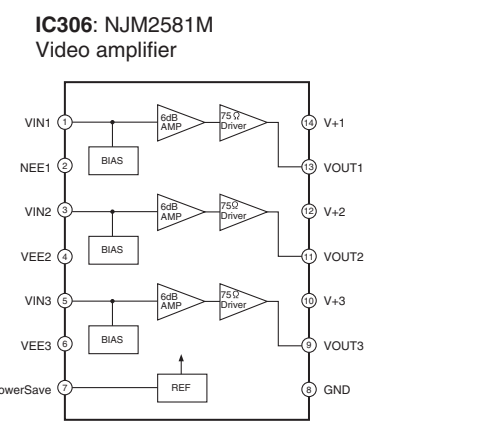
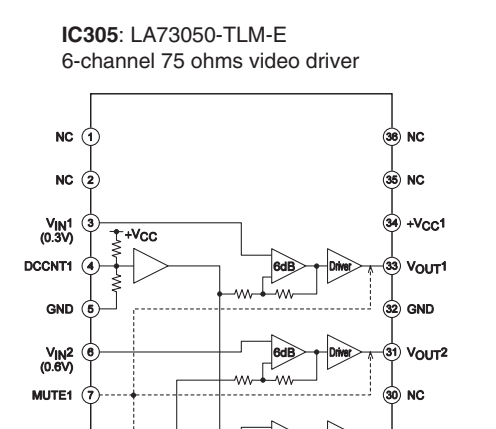

RESISTOR

REMARKS	PARTS NAME
NO MARK	CARBON FILM RESISTOR (P+5)
□	CARBON FILM RESISTOR (P-10)
△	METAL OXIDE FILM RESISTOR
▲	METAL FILM RESISTOR
■	METAL PLATE RESISTOR
□	FIRE PROOF CARBON FILM RESISTOR
■	CEMENT MOLDED RESISTOR
□	THICK VARIABLE RESISTOR
■	THIN RESISTOR

CAPACITOR

REMARKS	PARTS NAME
NO MARK	ELECTROLYTIC CAPACITOR
□	TANTALUM CAPACITOR
NO MARK	CERAMIC CAPACITOR
●	CERAMIC TUBULAR CAPACITOR
○	DIENESTER FILM CAPACITOR
○	POLYSTYRENE FILM CAPACITOR
○	MICA CAPACITOR
○	POLYPROPYLENE FILM CAPACITOR
●	SEMICONDUCTIVE CERAMIC CAPACITOR

NOTICE [mode1]

(J)..... JAPAN
(U)..... U.S.A.
(C)..... CANADA
(R)..... GENERAL
(T)..... CHINA
(K)..... KOREA
(A)..... AUSTRALIA
(B)..... BRITISH
(G)..... EUROPE
(L)..... SINGAPORE
(E)..... SOUTH EUROPE
(V)..... TAIWAN
(F)..... RUSSIAN

* All voltages are measured with a 10MΩ/V DC electronic voltmeter.
* Components having special characteristics are marked Δ and must be replaced with parts having specifications equal to those originally installed.
* Schematic diagram is subject to change without notice.

VIDEO 2/3

Destination Part List	RDS	U	C	B	A	S-E-F	L
R201	IC301	X	X	X	X	X825A0	X
R202	NL301	X	X	X	X	LC2725000-17L	X
R203	C303	X	X	X	X	US08127	X
R204	C304	X	X	X	X	US13510	X
R205	R301	X	X	X	X	RD3510	X
R206	R302	X	X	X	X	RD3510	X
R207	R303	X	X	X	X	RD3510	X
R208	R304	X	X	X	X	RD3510	X
R209	R305	X	X	X	X	RD3510	X
R210	R306	X	X	X	X	RD3510	X
R211	R307	X	X	X	X	RD3510	X
R212	R308	X	X	X	X	RD3510	X
R213	R309	X	X	X	X	RD3510	X
R214	R310	X	X	X	X	RD3510	X
R215	R311	X	X	X	X	RD3510	X
R216	R312	X	X	X	X	RD3510	X
R217	R313	X	X	X	X	RD3510	X

Destination Part List	U	C	B	A	S-E-F	L	
R245	IC317	X	X	X	X	UR6610	X
R246	D311	X	X	X	X	V13390	X
R247	D312	X	X	X	X	V13395	X
R248	R320	X	X	X	X	RF45768	X
R249	R321	X	X	X	X	RF45822	X
R250	R322	X	X	X	X	RF45822	X
R251	R323	X	X	X	X	RF45822	X
R252	R324	X	X	X	X	RF45822	X
R253	R325	X	X	X	X	RF45822	X
R254	IC333	X	X	X	X	BA00JC5W1-V5	X
R255	IC333	X	X	X	X	BA00JC5W1-V5	X
R256	TE342	X	X	X	X	W56100	X
R257	TE342	X	X	X	X	W56100	X
R258	TE342	X	X	X	X	W56100	X
R259	TE342	X	X	X	X	W56100	X
R260	TE342	X	X	X	X	W56100	X
R261	TE342	X	X	X	X	W56100	X
R262	TE342	X	X	X	X	W56100	X
R263	TE342	X	X	X	X	W56100	X
R264	TE342	X	X	X	X	W56100	X

RESISTOR	PARTS NAME
NO MARK	CARBON FILM RESISTOR (P=5)
□	CARBON FILM RESISTOR (P=10)
△	METAL OXIDE FILM RESISTOR
◇	METAL FILM RESISTOR
○	FINE-PROOF CARBON FILM RESISTOR
◎	CEMENT MOUNTED RESISTOR
⊙	SEMI-VARIABLE RESISTOR
⊚	CHIP RESISTOR

CAPACITOR	PARTS NAME
NO MARK	ELECTROLYTIC CAPACITOR
□	TANTALUM CAPACITOR
◇	NO MARK CERAMIC CAPACITOR
○	CERAMIC TUBULAR CAPACITOR
◎	POLYESTER FILM CAPACITOR
⊙	POLYETHYLENE FILM CAPACITOR
⊚	MICA CAPACITOR
⊛	POLYPROPYLENE FILM CAPACITOR
⊜	SEMICONDUCTIVE CERAMIC CAPACITOR

NOTICE (model)
 (J)..... JAPAN
 (U)..... U.S.A.
 (C)..... CANADA
 (G)..... GENERAL
 (T)..... CHINA
 (K)..... KOREA
 (A)..... AUSTRALIA
 (B)..... BRITISH
 (E)..... EUROPE
 (L)..... SINGAPORE
 (S)..... SOUTH EUROPE
 (V)..... TAIWAN
 (F)..... RUSSIAN

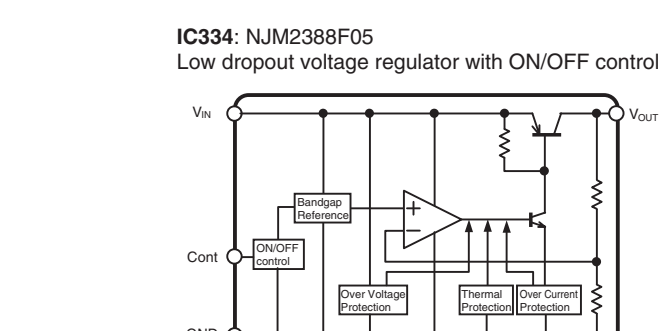
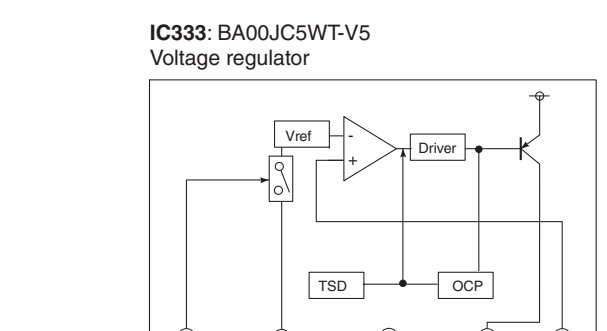
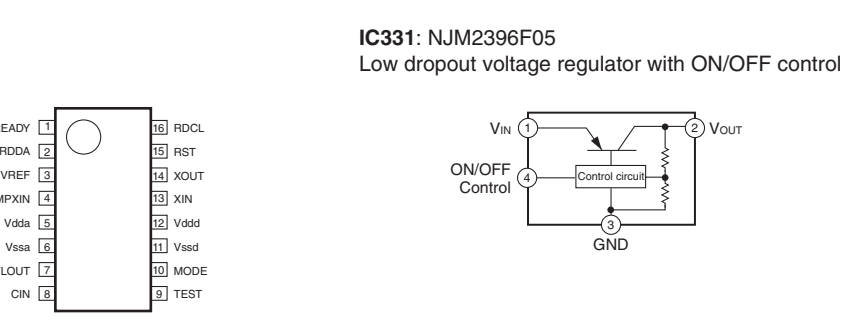
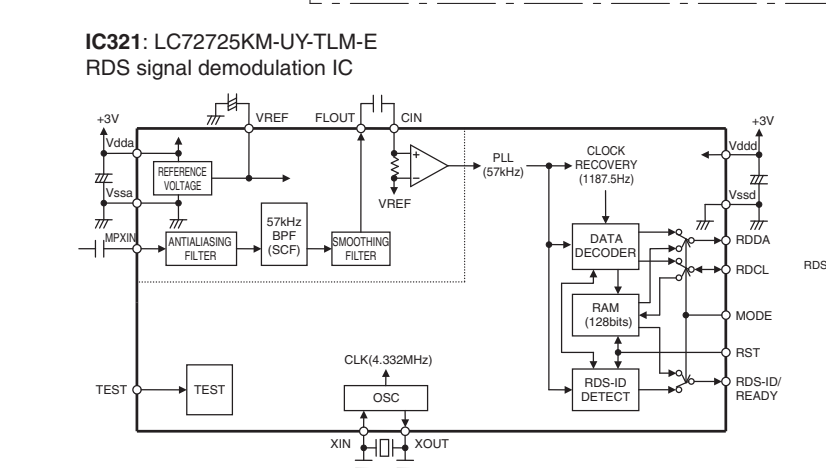
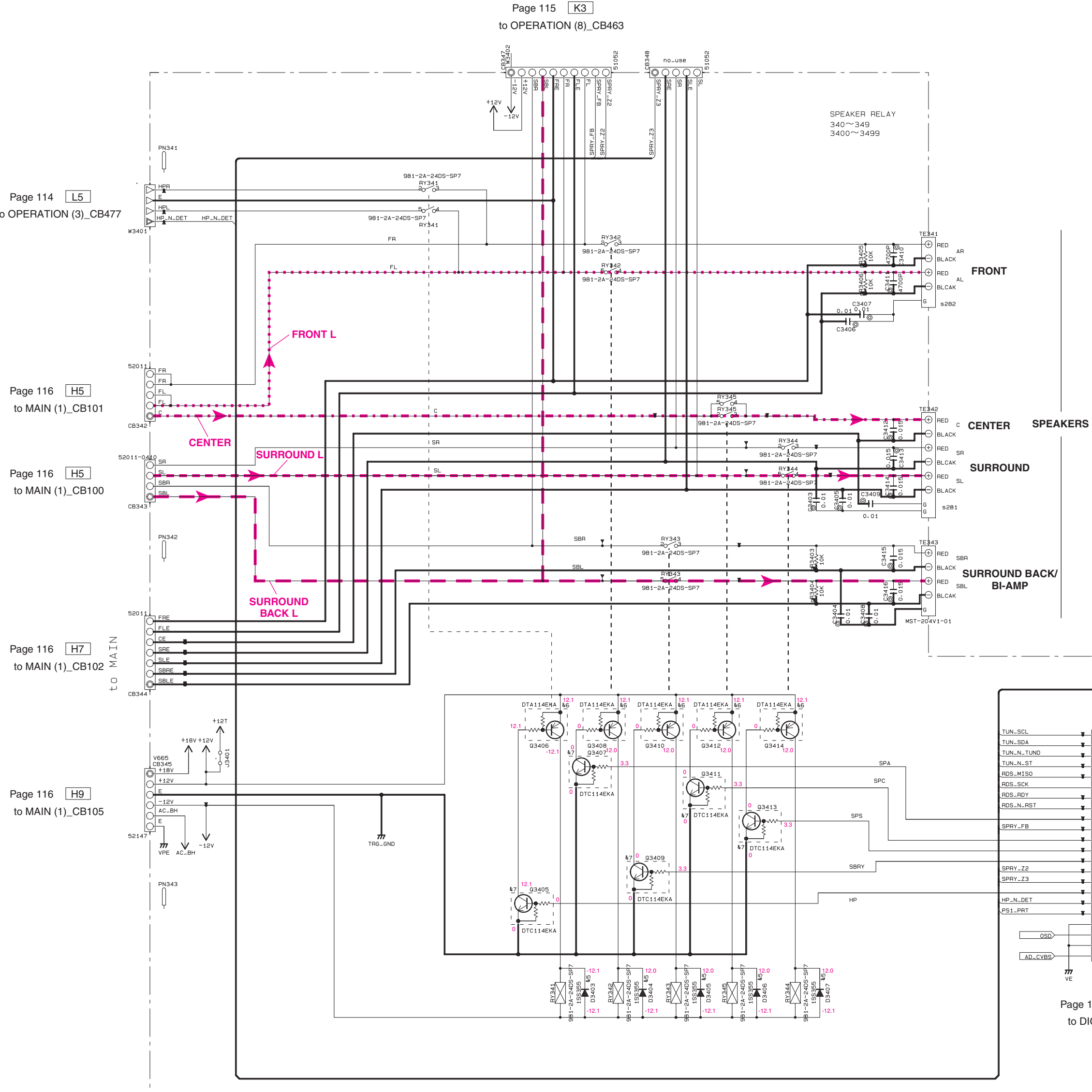
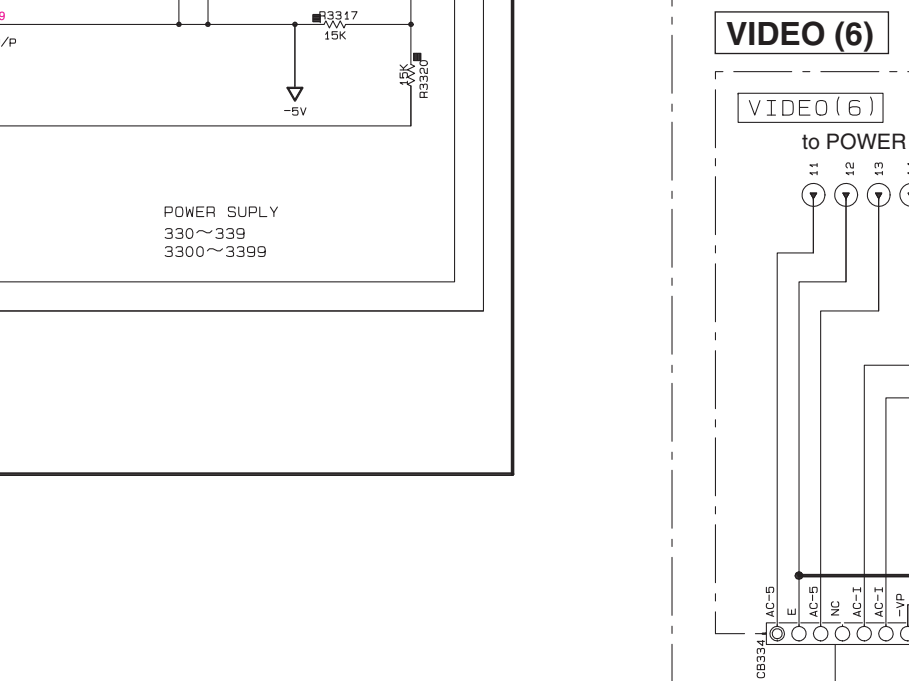
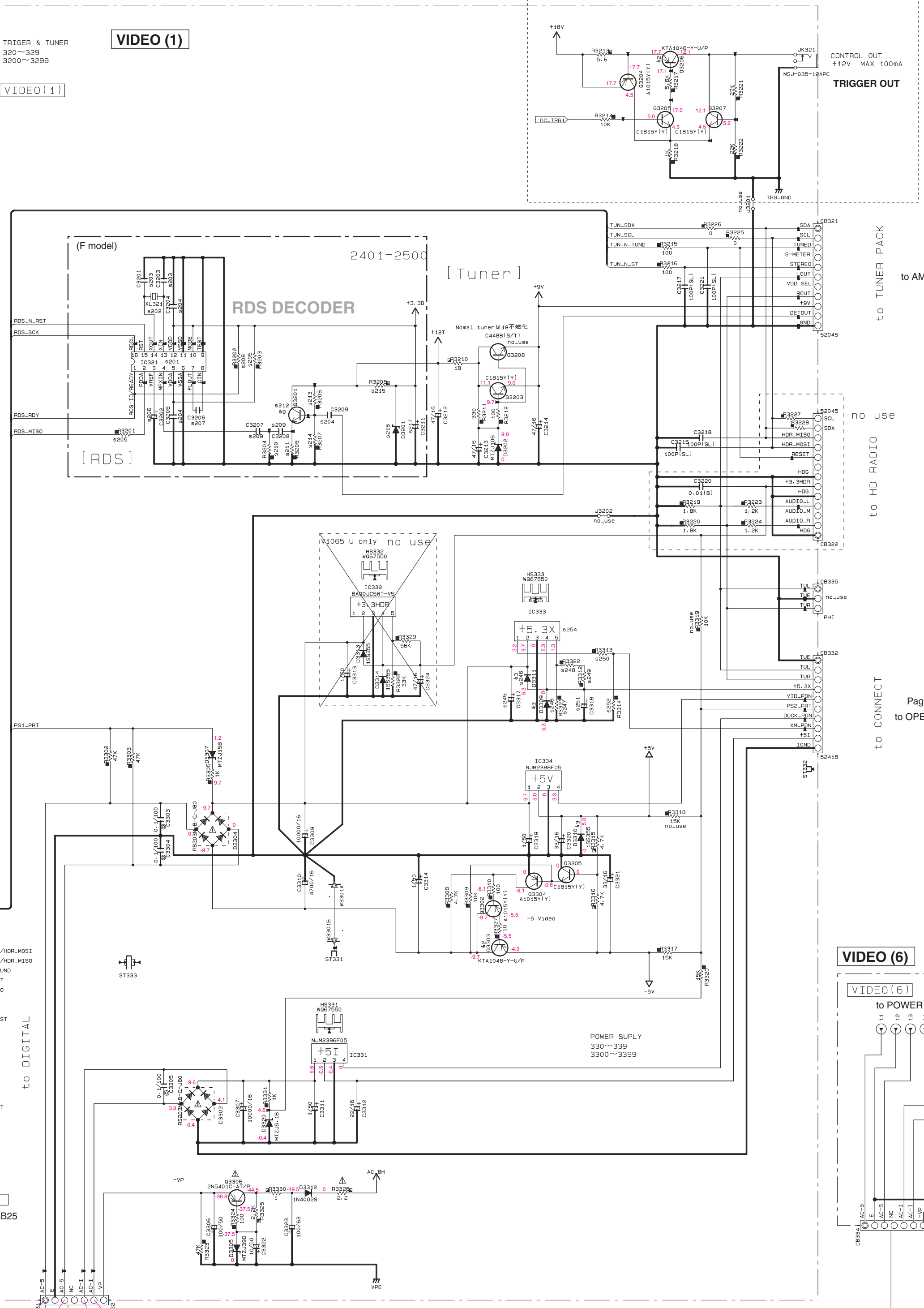
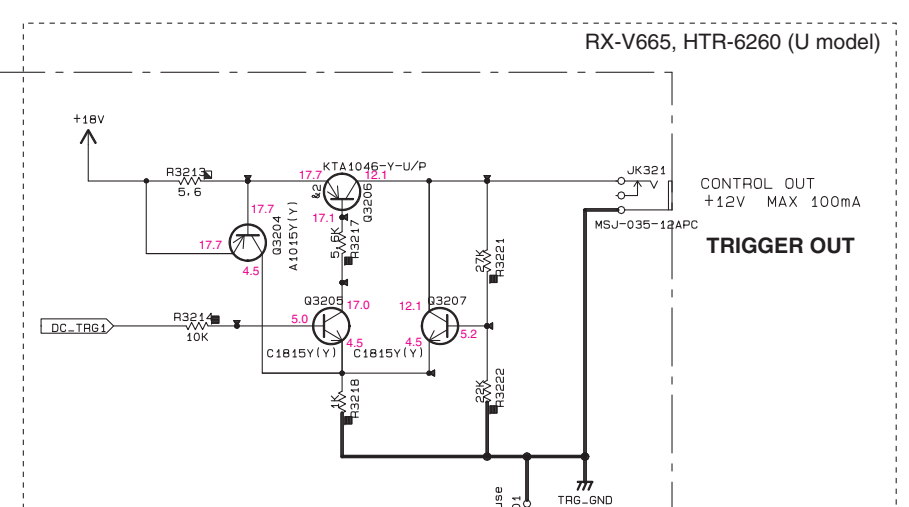

* All voltages are measured with a 10MΩ/V DC electronic voltmeter.
 * Components having special characteristics are marked △ and must be replaced with parts having specifications equal to those originally installed.
 * Schematic diagram is subject to change without notice.

■ REPLACEMENT PARTS LIST

• ELECTRICAL COMPONENT PARTS

WARNING

- Components having special characteristics are marked Δ and must be replaced with parts having specifications equal to those originally installed.

ABBREVIATIONS IN THIS LIST ARE AS FOLLOWS:

C.A.EL.CHP	: CHIP ALUMI.ELECTROLYTIC CAP	L.EMIT	: LIGHT EMITTING MODULE
C.CE	: CERAMIC CAP	LED.DSPLY	: LED DISPLAY
C.CE.ARRAY	: CERAMIC CAP ARRAY	LED.INFRD	: LED,INFRARED
C.CE.CHP	: CHIP CERAMIC CAP	MODUL.RF	: MODULATOR,RF
C.CE.ML	: MULTILAYER CERAMIC CAP	PHOT.CPL	: PHOTO COUPLER
C.CE.M.CHP	: CHIP MULTILAYER CERAMIC CAP	PHOT.INTR	: PHOTO INTERRUPTER
C.CE.SAFTY	: RECOGNIZED CERAMIC CAP	PHOT.RFLCT	: PHOTO REFLECTOR
C.CE.TUBLR	: CERAMIC TUBULAR CAP	PIN.TEST	: PIN,TEST POINT
C.CE.SMI	: SEMI CONDUCTIVE CERAMIC CAP	PLST.RIVET	: PLASTIC RIVET
C.EL	: ELECTROLYTIC CAP	R.ARRAY	: RESISTOR ARRAY
C.MICA	: MICA CAP	R.CAR.	: CARBON RESISTOR
C.ML.FLM	: MULTILAYER FILM CAP	R.CAR.CHP	: CHIP RESISTOR
C.MP	: METALLIZED PAPER CAP	R.CAR.FP	: FLAME PROOF CARBON RESISTOR
C.MYLAR	: MYLAR FILM CAP	R.FUS	: FUSABLE RESISTOR
C.MYLAR.ML	: MULTILAYER MYLAR FILM CAP	R.MTL.CHP	: CHIP METAL FILM RESISTOR
C.PAPER	: PAPER CAPACITOR	R.MTL.FLM	: METAL FILM RESISTOR
C.PLS	: POLYSTYRENE FILM CAP	R.MTL.OXD	: METAL OXIDE FILM RESISTOR
C.POL	: POLYESTER FILM CAP	R.MTL.PLAT	: METAL PLATE RESISTOR
C.POLY	: POLYETHYLENE FILM CAP	RSNR.CE	: CERAMIC RESONATOR
C.PP	: POLYPROPYLENE FILM CAP	RSNR.CRYS	: CRYSTAL RESONATOR
C.TNTL	: TANTALUM CAP	R.TW.CEM	: TWIN CEMENT FIXED RESISTOR
C.TNTL.CHP	: CHIP TANTALUM CAP	R.CEMENT	: CEMENT RESISTOR
C.TRIM	: TRIMMER CAP	SCR.BND.HD	: BIND HEAD B-TIGHT SCREW
CN	: CONNECTOR	SCR.BW.HD	: BW HEAD TAPPING SCREW
CN.BS.PIN	: CONNECTOR,BASE PIN	SCR.CUP	: CUP TIGHT SCREW
CN.CANNON	: CONNECTOR,CANNON	SCR.TERM	: SCREW TERMINAL
CN.DIN	: CONNECTOR,DIN	SCR.TR	: SCREW,TRANSISTOR
CN.FLAT	: CONNECTOR,FLAT CABLE	SUPRT.PCB	: SUPPORT,P.C.B.
CN.POST	: CONNECTOR,BASE POST	SURG.PRTCT	: SURGE PROTECTOR
COIL.MX.AM	: COIL,AM MIX	SW.TACT	: TACT SWITCH
COIL.AT.FM	: COIL,FM ANTENNA	SW.LEAF	: LEAF SWITCH
COIL.DT.FM	: COIL,FM DETECT	SW.LEVER	: LEVER SWITCH
COIL.MX.FM	: COIL,FM MIX	SW.MICRO	: MICRO SWITCH
COIL.OUTPT	: OUTPUT COIL	SW.PUSH	: PUSH SWITCH
DIOD.ARRAY	: DIODE ARRAY	SW.RT.ENC	: ROTARY ENCODER
DIODE.BRG	: DIODE BRIDGE	SW.RT.MTR	: ROTARY SWITCH WITH MOTOR
DIODE.CHP	: CHIP DIODE	SW.RT	: ROTARY SWITCH
DIODE.VAR	: VARACTOR DIODE	SW.SLIDE	: SLIDE SWITCH
DIOD.Z.CHP	: CHIP ZENER DIODE	TERM.SP	: SPEAKER TERMINAL
DIODE.ZENR	: ZENER DIODE	TERM.WRAP	: WRAPPING TERMINAL
DSCR.CE	: CERAMIC DISCRIMINATOR	THRMST.CHP	: CHIP THERMISTOR
FER.BEAD	: FERRITE BEADS	TR.CHP	: CHIP TRANSISTOR
FER.CORE	: FERRITE CORE	TR.DGT	: DIGITAL TRANSISTOR
FET.CHP	: CHIP FET	TR.DGT.CHP	: CHIP DIGITAL TRANSISTOR
FL.DSPLY	: FLUORESCENT DISPLAY	TRANS	: TRANSFORMER
FLTR.CE	: CERAMIC FILTER	TRANS.PULS	: PULSE TRANSFORMER
FLTR.COMB	: COMB FILTER MODULE	TRANS.PWR	: POWER TRANSFORMER ASS'Y
FLTR.LC.RF	: LC FILTER,EMI	TUNER.AM	: TUNER PACK,AM
GND.MTL	: GROUND PLATE	TUNER.FM	: TUNER PACK,FM
GND.TERM	: GROUND TERMINAL	TUNER.PK	: FRONT-ENDTUNER PACK
HOLDER.FUS	: FUSE HOLDER	VR	: ROTARY POTENTIOMETER
IC.PRTCT	: IC PROTECTOR	VR.MTR	: POTENTIOMETER WITH MOTOR
JUMPER.CN	: JUMPER CONNECTOR	VR.SW	: POTENTIOMETER WITH ROTARY SW
JUMPER.TST	: JUMPER,TEST POINT	VR.SLIDE	: SLIDE POTENTIOMETER
L.DTCT	: LIGHT DETECTING MODULE	VR.TRIM	: TRIMMER POTENTIOMETER

P.C.B. DIGITAL

RX-V665/HTR-6260

Ref No.	Part No.	Description	Markets
*	WQ923900	P. C. B. DIGITAL	U (V665)
*	WQ925100	P. C. B. DIGITAL	U (6260)
*	WQ924000	P. C. B. DIGITAL	CRAL (V665)
*	WQ925200	P. C. B. DIGITAL	C (6260)
*	WQ924100	P. C. B. DIGITAL	F (V665)
CB1-4	WM462600	CN. HDMI 19P SE	
CB6	WM462600	CN. HDMI 19P SE	
CB7	LB918040	CN. BS. PIN 4P	
CB20	VPO82900	CN. BS. PIN 25P	
CB21	VB389800	CN. BS. PIN 2P	
CB22	VK024700	CN. BS. PIN 3P	
CB23	VK025600	CN. BS. PIN 12P	
CB24	VF728300	CN 6P	
CB25	VQ045200	CN. BS. PIN 22P	
CB27	VQ047200	CN. BS. PIN 9P	
* CB40	WJ458700	CN. XM 4P, CAM-D96	U
CB61-63	V9356900	CN. JE 19P SE	
CB72	VQ044200	CN. BS. PIN 6P	
CB73	VQ044100	CN. BS. PIN 5P	F
C1-2	US135100	C. CE. CHP 0.1uF 16V	
C3-4	WD758300	C. CE. CHP 10uF 10V	
C5-14	US135100	C. CE. CHP 0.1uF 16V	
C15-24	US063100	C. CE. CHP 1000pF 50V B	
C25-26	US135100	C. CE. CHP 0.1uF 16V	
C27	US061120	C. CE. CHP 12pF 50V B	
C28	US061150	C. CE. CHP 15pF 50V B	
C29	US135100	C. CE. CHP 0.1uF 16V	
C30	WD758300	C. CE. CHP 10uF 10V	
C31-32	US135100	C. CE. CHP 0.1uF 16V	
C33	US063100	C. CE. CHP 1000pF 50V B	
C34	US135100	C. CE. CHP 0.1uF 16V	
C35	WD758300	C. CE. CHP 10uF 10V	
C36	US135100	C. CE. CHP 0.1uF 16V	
C37	US063100	C. CE. CHP 1000pF 50V B	
C38-40	WD758300	C. CE. CHP 10uF 10V	
C41-43	US063100	C. CE. CHP 1000pF 50V B	
C44-46	US135100	C. CE. CHP 0.1uF 16V	
C47	WD758300	C. CE. CHP 10uF 10V	
C48	US135100	C. CE. CHP 0.1uF 16V	
C50	WD758300	C. CE. CHP 10uF 10V	
C51	US135100	C. CE. CHP 0.1uF 16V	
C53-54	US135100	C. CE. CHP 0.1uF 16V	
C55-56	WD758300	C. CE. CHP 10uF 10V	
C57	US063100	C. CE. CHP 1000pF 50V B	
C58	WD758300	C. CE. CHP 10uF 10V	
C59-61	US135100	C. CE. CHP 0.1uF 16V	
C62	WG251600	C. CE. CHP 4.7uF 6.3V	
C64-66	US135100	C. CE. CHP 0.1uF 16V	
C67	WG251600	C. CE. CHP 4.7uF 6.3V	
C69	UF027470	C. EL. CHP 47uF 10V	
C71-72	US135100	C. CE. CHP 0.1uF 16V	
C73-74	WJ344400	C. CE. CHP 22uF 6.3V	
C75	WD758300	C. CE. CHP 10uF 10V	
C76	US135100	C. CE. CHP 0.1uF 16V	
C77	WD758300	C. CE. CHP 10uF 10V	
C78	US135100	C. CE. CHP 0.1uF 16V	
C79-80	US062220	C. CE. CHP 220pF 50V B	

* New Parts

Ref No.	Part No.	Description	Markets
C81-82	US135100	C. CE. CHP 0.1uF 16V	
C83	US063330	C. CE. CHP 3300pF 50V B	
C84	US063470	C. CE. CHP 4700pF 50V B	
C85	US063120	C. CE. CHP 1200pF 50V B	
C86	US135100	C. CE. CHP 0.1uF 16V	
C87	US063120	C. CE. CHP 1200pF 50V B	
C88-90	US135100	C. CE. CHP 0.1uF 16V	
C91-92	WD758300	C. CE. CHP 10uF 10V	
C93	US135100	C. CE. CHP 0.1uF 16V	
C94	WD758300	C. CE. CHP 10uF 10V	
C97-101	US135100	C. CE. CHP 0.1uF 16V	
C102	UR267470	C. EL 47uF 50V	
C103	WG251600	C. CE. CHP 4.7uF 6.3V	
C104	US135100	C. CE. CHP 0.1uF 16V	
C105	WH772100	C. EL 1000uF 10V	
C106-124	US135100	C. CE. CHP 0.1uF 16V	
C136	US135100	C. CE. CHP 0.1uF 16V	
C137-138	US062470	C. CE. CHP 470pF 50V B	
C200	UR837330	C. EL 33uF 16V	
C201	US135100	C. CE. CHP 0.1uF 16V	
C202	US064100	C. CE. CHP 0.01uF 50V B	
C204-205	US064100	C. CE. CHP 0.01uF 50V B	
C207-211	US064100	C. CE. CHP 0.01uF 50V B	
C212	US135100	C. CE. CHP 0.1uF 16V	
C214	US135100	C. CE. CHP 0.1uF 16V	
C215-216	US064100	C. CE. CHP 0.01uF 50V B	
C217	US135100	C. CE. CHP 0.1uF 16V	
C218-219	US064100	C. CE. CHP 0.01uF 50V B	
C220-225	US135100	C. CE. CHP 0.1uF 16V	
C226	WG251600	C. CE. CHP 4.7uF 6.3V	
C228-229	WG251600	C. CE. CHP 4.7uF 6.3V	
C231	US135100	C. CE. CHP 0.1uF 16V	
C232	US046100	C. CE. CHP 1uF 25V	
C234-238	US046100	C. CE. CHP 1uF 25V	
C239-242	US062100	C. CE. CHP 100pF 50V B	
C243	US064100	C. CE. CHP 0.01uF 50V B	
C244-254	US135100	C. CE. CHP 0.1uF 16V	
C400-401	WD758300	C. CE. CHP 10uF 10V	U
C402-403	US064100	C. CE. CHP 0.01uF 50V B	
C404	US061100	C. CE. CHP 10pF 50V B	U
C405-406	US035100	C. CE. CHP 0.1uF 16V B	U
C407	US061100	C. CE. CHP 10pF 50V B	U
C408-409	US035100	C. CE. CHP 0.1uF 16V B	U
C410-411	US135100	C. CE. CHP 0.1uF 16V	
C412	US035100	C. CE. CHP 0.1uF 16V B	
C413-414	US135100	C. CE. CHP 0.1uF 16V	
C415	US044220	C. CE. CHP 0.022uF 25V B	
C416	US062100	C. CE. CHP 100pF 50V B	
C418	US062220	C. CE. CHP 220pF 50V B	
C419	US135100	C. CE. CHP 0.1uF 16V	
C420	US062220	C. CE. CHP 220pF 50V B	
C421	US035100	C. CE. CHP 0.1uF 16V B	U
C422	US062220	C. CE. CHP 220pF 50V B	
C424-425	US135100	C. CE. CHP 0.1uF 16V	
C426	US062220	C. CE. CHP 220pF 50V B	
C427	US035100	C. CE. CHP 0.1uF 16V B	U
C430	UR067470	C. EL 47uF 50V	

* New Parts

P.C.B. DIGITAL

RX-V665/HTR-6260

Ref No.	Part No.	Description	Markets
C431	US062100	C. CE. CHP 100pF 50V B	
C432-433	US062220	C. CE. CHP 220pF 50V B	
C434-436	US135100	C. CE. CHP 0. 1uF 16V	
C437-438	US062100	C. CE. CHP 100pF 50V B	
C439	US061100	C. CE. CHP 10pF 50V B	
C440	US060800	C. CE. CHP 8pF 50V B	
C441-442	US062390	C. CE. CHP 390pF 50V B	
C443-444	US035100	C. CE. CHP 0. 1uF 16V B	U
C445-446	UR837100	C. EL 10uF 16V	
C447-448	US135100	C. CE. CHP 0. 1uF 16V	
C449-450	UR237470	C. EL 47uF 16V	
C451	US062100	C. CE. CHP 100pF 50V B	
C452	URO67100	C. EL 10uF 50V	
C453	US126100	C. CE. CHP 1uF 10V	
C454-472	US135100	C. CE. CHP 0. 1uF 16V	
C473	US062680	C. CE. CHP 680pF 50V B	
C474-476	US135100	C. CE. CHP 0. 1uF 16V	
C477	WG251600	C. CE. CHP 4. 7uF 6. 3V	
C478-484	US135100	C. CE. CHP 0. 1uF 16V	
C485	WG251600	C. CE. CHP 4. 7uF 6. 3V	
C486	US135100	C. CE. CHP 0. 1uF 16V	
C488-489	UU297220	C. EL 22uF 100V	
C491-493	US135100	C. CE. CHP 0. 1uF 16V	
C494-496	US063100	C. CE. CHP 1000pF 50V B	
C497-498	US135100	C. CE. CHP 0. 1uF 16V	
C499-502	US063100	C. CE. CHP 1000pF 50V B	
C503-519	US135100	C. CE. CHP 0. 1uF 16V	
C600	UU267220	C. EL 22uF 50V	
C601-603	US135100	C. CE. CHP 0. 1uF 16V	
C604-605	US064100	C. CE. CHP 0. 01uF 50V B	
C606	URO67100	C. EL 10uF 50V	
C607	US064100	C. CE. CHP 0. 01uF 50V B	U
C608-609	US135100	C. CE. CHP 0. 1uF 16V	
C610	US126100	C. CE. CHP 1uF 10V	
C611	US062100	C. CE. CHP 100pF 50V B	
C612	URO67100	C. EL 10uF 50V	
C613-614	US126100	C. CE. CHP 1uF 10V	
C615	UR237100	C. EL 10uF 16V	U
C616-617	US135100	C. CE. CHP 0. 1uF 16V	U
C619	US135100	C. CE. CHP 0. 1uF 16V	
C620	URO67470	C. EL 47uF 50V	
C621	UR218100	C. EL 100uF 6. 3V	U
C622	URO67100	C. EL 10uF 50V	
C623	US135100	C. CE. CHP 0. 1uF 16V	
C624	UU267100	C. EL 10uF 50V	
C625	US135100	C. CE. CHP 0. 1uF 16V	
C626	URO67100	C. EL 10uF 50V	
C627-628	WJ603600	C. MYLAR 820pF 50V J	
C629-630	UR837100	C. EL 10uF 16V	U
C633-634	URO67100	C. EL 10uF 50V	
C635-642	US062100	C. CE. CHP 100pF 50V B	
C643-644	US663330	C. CE. CHP 3300pF 50V	U
C700-702	US135100	C. CE. CHP 0. 1uF 16V	
C703-704	WD758300	C. CE. CHP 10uF 10V	
C705-706	US135100	C. CE. CHP 0. 1uF 16V	
C707-708	WD758300	C. CE. CHP 10uF 10V	
C709-710	US135100	C. CE. CHP 0. 1uF 16V	

* New Parts

Ref No.	Part No.	Description	Markets
C711-712	US064100	C. CE. CHP 0. 01uF 50V B	
C713	UF037220	C. EL. CHP 22uF 16V	
C714-717	US135100	C. CE. CHP 0. 1uF 16V	
C718	US034390	C. CE. CHP 0. 039uF 16V B	
C719-721	US135100	C. CE. CHP 0. 1uF 16V	
C722-723	US063100	C. CE. CHP 1000pF 50V B	
C724-725	US135100	C. CE. CHP 0. 1uF 16V	
C726	US064100	C. CE. CHP 0. 01uF 50V B	
C727	US135100	C. CE. CHP 0. 1uF 16V	
C728	US064100	C. CE. CHP 0. 01uF 50V B	
C729	US135100	C. CE. CHP 0. 1uF 16V	
C730	VZ243400	C. CE. CHP 0. 33uF 16V	
C731	VZ281900	C. CE. CHP 0. 47uF 16V K	
C732	US034820	C. CE. CHP 0. 082uF 16V K	
C733	US064100	C. CE. CHP 0. 01uF 50V B	
C734	US135100	C. CE. CHP 0. 1uF 16V	
C735	US061100	C. CE. CHP 10pF 50V B	
C736	US060800	C. CE. CHP 8pF 50V B	
C737-742	US135100	C. CE. CHP 0. 1uF 16V	
C743	UF037220	C. EL. CHP 22uF 16V	
C744-746	US135100	C. CE. CHP 0. 1uF 16V	
C747	UF037100	C. EL. CHP 10uF 16V	
C748-749	US135100	C. CE. CHP 0. 1uF 16V	
C750	UF037220	C. EL. CHP 22uF 16V	
C751	US135100	C. CE. CHP 0. 1uF 16V	
C752	UF037220	C. EL. CHP 22uF 16V	
C753	US135100	C. CE. CHP 0. 1uF 16V	
C754	UF037100	C. EL. CHP 10uF 16V	
C755-757	US135100	C. CE. CHP 0. 1uF 16V	
C758	UF037220	C. EL. CHP 22uF 16V	
C759	US135100	C. CE. CHP 0. 1uF 16V	
C763	UF037220	C. EL. CHP 22uF 16V	
C764-766	US135100	C. CE. CHP 0. 1uF 16V	
C772	US135100	C. CE. CHP 0. 1uF 16V	
C774-776	US135100	C. CE. CHP 0. 1uF 16V	
C779	US135100	C. CE. CHP 0. 1uF 16V	
C782-790	US135100	C. CE. CHP 0. 1uF 16V	
C791	UF037220	C. EL. CHP 22uF 16V	
C792-794	US135100	C. CE. CHP 0. 1uF 16V	
C795	UF037100	C. EL. CHP 10uF 16V	
C796-797	US063100	C. CE. CHP 1000pF 50V B	
C798-799	US064100	C. CE. CHP 0. 01uF 50V B	
C800-805	US135100	C. CE. CHP 0. 1uF 16V	
D2	WE674800	D1ODE AVRL161A1R1NTB	
D11-14	WE674800	D1ODE AVRL161A1R1NTB	
D23-26	WE674800	D1ODE AVRL161A1R1NTB	
D35-38	WE674800	D1ODE AVRL161A1R1NTB	
D47-49	WE674800	D1ODE AVRL161A1R1NTB	
D60-61	WE674800	D1ODE AVRL161A1R1NTB	
D62	VV220700	D1ODE. SHOT RB051V-40	
D63-64	V6267600	D1ODE RB051L-40	
D65	WE674800	D1ODE AVRL161A1R1NTB	
D200-204	YU990900	D1ODE. ZENR MAZ8033GHL 3. 4V	
D400-402	WE674800	D1ODE AVRL161A1R1NTB	U
D403-404	VT332900	D1ODE 1SS355	
D600	VT332900	D1ODE 1SS355	
D602-603	VT332900	D1ODE 1SS355	

* New Parts

P.C.B. DIGITAL and P.C.B. OPERATION

RX-V665/HTR-6260

Ref No.	Part No.	Description	Markets
D702-703	VT332900	DIODE	1SS355
IC2	XZ287A00	IC	SN74LVC245APWR
IC3	XS775A00	IC	TC7SH04FU
IC5	X7195A00	IC	R1172S121D-E2-F
IC10	X7741A00	IC	NJM2867F3-05 (TE1)
IC11	X0199B00	IC	TC74VHC157FT (EL, K)
* IC13	YA255A00	IC	R1172H501D-T1-F
IC20	X8328A00	IC. CPU	M30878FJGBP (unwritten)
IC21	X8194A00	IC	R1172H331D-T1-F
* IC22	YA398A00	IC. MEMORY	LE25LA322M-TLM-E
* IC41	YA399A00	IC	LC89058WD-E
IC43	X7378A00	IC	NJM4565M (TE1)
IC46	X0199B00	IC	TC74VHC157FT (EL, K)
IC47	X7195A00	IC	R1172S121D-E2-F
* IC48	X9626B00	IC. MEMORY	K45641632N-LC60000
* IC49	YA540C00	IC. MEMORY	MX29LV160DBT1-70G (written)
IC50	XR680A00	IC	TC7SH08FU (TE85L, JF)
IC61	X7375A00	IC	PCM1781DBQR
IC62	X0199B00	IC	TC74VHC157FT (EL, K)
IC63	XS534A00	IC	NJM78M05DL1A
IC65	X7355A00	IC	PCM1680DBQR
IC66	X7357A00	IC	PCM1803DBR
IC67	X3586B00	IC	TC74VHCT08AFT EL, K
IC68	XR680A00	IC	TC7SH08FU (TE85L, JF)
IC70	X9393A00	IC	ADV7800BSTZ-80
* IC71	YA215A00	IC	ABT1012
IC73	X9460A00	IC	R1172H181B-T1-F
IC74	X8194A00	IC	R1172H331D-T1-F
IC75	X8531A00	IC	TC7WZ32FK
IC76-78	XZ283A00	IC	SN74LVTH245APW BUS
PN20-22	V9637500	PIN	L=70 #18
Q1-8	VQ986700	TR	2SC4081 T106
Q200	WQ381000	FET	MCH6336-TL-E
Q201-202	VV655300	TR. DGT	DTA144EKA
Q203	VR936300	TR	2SA1576A T106
Q205-209	VR936300	TR	2SA1576A T106
Q400	WQ381000	FET	MCH6336-TL-E
Q401	VV655300	TR. DGT	DTA144EKA
Q402	WQ381000	FET	MCH6336-TL-E
Q403	VV655000	TR. DGT	DTA114EKA
Q404	VV655300	TR. DGT	DTA144EKA
Q600	VV655200	TR. DGT	DTA143EKA
Q601	VV655700	TR. DGT	DTC144EKA
Q700	WQ381000	FET	MCH6336-TL-E
Q701	VR936300	TR	2SA1576A T106
Q702	WQ381000	FET	MCH6336-TL-E
Q703	VR936300	TR	2SA1576A T106
R88	WJ682800	R. MTL. FLM	2. 2Ω 1W
R201		R. CHP	5. 6KΩ 1/16W J (V665)
R201		R. CHP	8. 2KΩ 1/16W J (6260)
R466-467	HV753220	R. CAR. FP	2. 2Ω 1/4W
R601	WJ683800	R. MTL. FLM	15Ω 1W
R607	HV753220	R. CAR. FP	2. 2Ω 1/4W
* ST1	WR364700	SCR. TERM	M3
* ST2	WR364800	SCR. TERM	3. 5
* XL1	WR725300	RSNR. CRYST	27MHz
XL20	WF997400	RSNR. CE	20MHz

* New Parts

Ref No.	Part No.	Description	Markets
* XL41	WH455300	RSNR. CRYST	45. 1584MHz
XL42	V3625700	RSNR. CRYST	24. 576MHz
XL70	VZ772700	RSNR. CRYST	28. 63636MHz
*	WQ923400	P. C. B.	OPERATION
*	WQ923500	P. C. B.	OPERATION
*	WQ923600	P. C. B.	OPERATION
*	WQ923700	P. C. B.	OPERATION
CB401	VQ045400	CN. BS. PIN	25P
CB402	VQ044400	CN. BS. PIN	9P
CB451	VQ961100	CN. BS. PIN	8P
CB452	V9357000	CN	19P TE
CB454	VQ962100	CN. BS. PIN	18P
CB455	V9357000	CN	19P TE
CB456	VQ961800	CN. BS. PIN	15P
CB457	VQ961400	CN. BS. PIN	11P
CB458	V9357000	CN	19P TE
CB459	VQ963300	CN. BS. PIN	12P
CB460	VQ963100	CN. BS. PIN	10P
CB461	VQ044400	CN. BS. PIN	9P
CB462	VK026400	CN. BS. PIN	5P
* CB463	VQ586000	CN. JUMPER	52011 10P TE
CB477	VB858300	CN. BS. PIN	4P
C4001	US063100	C. CE. CHP	1000pF 50V B
C4002	US065100	C. CE. CHP	0. 1uF 50V B
C4003	UR067100	C. EL	10uF 50V
C4004	US064100	C. CE. CHP	0. 01uF 50V B
C4005	UR837220	C. EL	22uF 16V
C4006	US062100	C. CE. CHP	100pF 50V B
C4007	UR257470	C. EL	47uF 35V
C4008	US061330	C. CE. CHP	33pF 50V B
C4009-4010	UR267220	C. EL	22uF 50V
C4011	UR067100	C. EL	10uF 50V
C4012-4013	US135100	C. CE. CHP	0. 1uF 16V
C4015	UR268220	C. EL	220uF 50V
C4016	UM388330	C. EL	330uF 6. 3V
C4017	US135100	C. CE. CHP	0. 1uF 16V
C4018	US061680	C. CE. CHP	68pF 50V B
C4019	US065100	C. CE. CHP	0. 1uF 50V B
C4020-4021	US135100	C. CE. CHP	0. 1uF 16V
C4022	US064100	C. CE. CHP	0. 01uF 50V B
C4023-4024	US063100	C. CE. CHP	1000pF 50V B
C4025-4026	US065100	C. CE. CHP	0. 1uF 50V B
C4027	US135100	C. CE. CHP	0. 1uF 16V
C4028	US062100	C. CE. CHP	100pF 50V B
C4030	US062100	C. CE. CHP	100pF 50V B
C4031	US062470	C. CE. CHP	470pF 50V B
C4032	US135100	C. CE. CHP	0. 1uF 16V
C4033	US063100	C. CE. CHP	1000pF 50V B
C4034	UM417100	C. EL	10uF 50V
C4035	US135100	C. CE. CHP	0. 1uF 16V
C4036	US063100	C. CE. CHP	1000pF 50V B
C4037	US064100	C. CE. CHP	0. 01uF 50V B
C4202	US063100	C. CE. CHP	1000pF 50V B
C4205-4211	US062220	C. CE. CHP	220pF 50V B

* New Parts

P.C.B. OPERATION

RX-V665/HTR-6260

Ref No.	Part No.	Description	Markets
C4212	US062100	C. CE. CHP 100pF 50V B	
C4213	UR067100	C. EL 10uF 50V	
C4214	UR037100	C. EL 10uF 16V	
C4215	WJ603500	C. MYLAR 680pF 50V	
C4216	US135100	C. CE. CHP 0. 1uF 16V	
C4217	UR267470	C. EL 47uF 50V	
C4218	US135100	C. CE. CHP 0. 1uF 16V	
C4219	UR267470	C. EL 47uF 50V	
C4220	WJ603500	C. MYLAR 680pF 50V	
C4221	UR037100	C. EL 10uF 16V	
C4222	UR067100	C. EL 10uF 50V	
C4223-4224	US062100	C. CE. CHP 100pF 50V B	
C4225	UR067100	C. EL 10uF 50V	
C4226	UR037100	C. EL 10uF 16V	
C4227	WJ603500	C. MYLAR 680pF 50V	
C4228-4229	US135100	C. CE. CHP 0. 1uF 16V	
C4230	WJ605800	C. MYLAR 0. 047uF 50V J	
C4231-4232	UR067100	C. EL 10uF 50V	
C4233	WJ604700	C. MYLAR 6800pF 50V	
C4234	US062100	C. CE. CHP 100pF 50V B	
C4235	UR067100	C. EL 10uF 50V	
C4236	UR037100	C. EL 10uF 16V	
C4237	WJ603500	C. MYLAR 680pF 50V	
C4238-4239	US135100	C. CE. CHP 0. 1uF 16V	
C4240	WJ603500	C. MYLAR 680pF 50V	
C4241	UR037100	C. EL 10uF 16V	
C4242	UR067100	C. EL 10uF 50V	
C4243-4244	US062100	C. CE. CHP 100pF 50V B	
C4245	UR067100	C. EL 10uF 50V	
C4246	UR037100	C. EL 10uF 16V	
C4247	WJ603500	C. MYLAR 680pF 50V	
C4248-4249	US135100	C. CE. CHP 0. 1uF 16V	
C4250	WJ603500	C. MYLAR 680pF 50V	
C4251	UR037100	C. EL 10uF 16V	
C4252	UR067100	C. EL 10uF 50V	
C4253	US062100	C. CE. CHP 100pF 50V B	
C4301	UR267470	C. EL 47uF 50V	RAGEFL
C4302	UR267470	C. EL 47uF 50V	RAGEFL
C4303	WJ603700	C. MYLAR 1000pF 50V	RAGEFL
C4304	WJ603700	C. MYLAR 1000pF 50V	RAGEFL
C4305	UR267100	C. EL 10uF 50V	RAGEFL
C4306	UR267100	C. EL 10uF 50V	RAGEFL
C4307	WJ605600	C. MYLAR 0. 033uF 50V	RAGEFL
C4308	WJ605600	C. MYLAR 0. 033uF 50V	RAGEFL
C4309	WJ604900	C. MYLAR 9100pF 50V	RAGEFL
C4310	WJ604900	C. MYLAR 9100pF 50V	RAGEFL
C4311	UR218220	C. EL 220uF 6. 3V	RAGEFL
C4312	UR218220	C. EL 220uF 6. 3V	RAGEFL
C4313	WJ603100	C. MYLAR 220pF 50V	RAGEFL
C4314	WJ603100	C. MYLAR 220pF 50V	RAGEFL
C4315-4316	WJ603100	C. MYLAR 220pF 50V	RAGEFL
C4317	US064100	C. CE. CHP 0. 01uF 50V B	RAGEFL
C4318-4321	WJ605000	C. MYLAR 0. 01uF 50V J	
C4403	WJ604300	C. MYLAR 3300pF 50V	
C4406	WJ604300	C. MYLAR 3300pF 50V	
C4407	US064100	C. CE. CHP 0. 01uF 50V B	
C4408-4409	US063680	C. CE. CHP 6800pF 50V B	

* New Parts

Ref No.	Part No.	Description	Markets
C4412	US135100	C. CE. CHP 0. 1uF 16V	
C4414	US063100	C. CE. CHP 1000pF 50V B	
C4416	US135100	C. CE. CHP 0. 1uF 16V	
D4001-4002	VT332900	D1ODE 1SS355	
D4003	VU171900	D1ODE. ZENR UDZ5. 1B 5. 1V	
D4004-4005	VT332900	D1ODE 1SS355	
D4006-4007	VU991900	D1ODE. ZENR MAZ8043GHL 4. 4V	
D4008	WG760400	LED SELK6E10C BLUE	
D4009	WR095700	LED 8224-10SDRD/S530A3	
D4010	VT332900	D1ODE 1SS355	
D4011	V2598200	LED SIR-505ST	
D4012	VT332900	D1ODE 1SS355	
D4301	VV659300	D1ODE. ZENR RLZ7. 5B 7. 5V	RAGEFL
D4302	VV659300	D1ODE. ZENR RLZ7. 5B 7. 5V	RAGEFL
D4303	VT332900	D1ODE 1SS355	
D4401-4402	VT332900	D1ODE 1SS355	
D4403	VU995000	D1ODE. ZENR MAZ8091GML 9. 1V	
D4406-4407	VT332900	D1ODE 1SS355	
D4409	VT332900	D1ODE 1SS355	
D4411	VT332900	D1ODE 1SS355	
IC401	X7378A00	IC NJM4565M	
IC402	X6386A00	IC M66003-0131FP	
IC451-454	X7378A00	IC NJM4565M	
IC461	X3505A00	IC NJM2068MD-TE2	RAGEFL
JK401	WC814400	JACK. MNI JY-3554-01-130	
JK451	VV269500	CN 8P DIN	U
JK471	WJ117400	JACK. MINI OPTIMIZER MIC	
JK472	V9408200	JACK. PHONE MSJ-064-05B GR	
PJ461	WD599600	JACK. PIN 2P MSP-252V2-06 NI	RAGEFL
PJ472	WJ117500	JACK. PIN 3P	
PN451	V9637500	PIN L=70 #18	
PN472	V9637500	PIN L=70 #18	
Q4001-4003	WC529400	TR KTC3875S Y GR RTK	
Q4004	VV655400	TR. DGT DTC114EKA	
Q4005	WC397700	TR 2N5401C-AT	
Q4006-4012	WC529400	TR KTC3875S Y GR RTK	
Q4301	VV655400	TR. DGT DTC114EKA	
Q4302	VV655000	TR. DGT DTA114EKA	
R4208-4209	HV753220	R. CAR. FP 2. 2Ω 1/4W	
R4301	HV755470	R. CAR. FP 470Ω 1/4W	RAGEFL
R4302	HV755470	R. CAR. FP 470Ω 1/4W	RAGEFL
R4320-4321	HV757100	R. CAR. FP 10KΩ 1/4W	
R4413-4414	WJ685600	R. MTL. FLM 470Ω 1W J	
RY461	WJ122400	RELAY 981-2A-24DS-SP7	
ST442	WA789600	SCR. TERM M3	
ST451	WA789600	SCR. TERM M3	CRAGEFL
ST471	WA789700	SCR. TERM D3. 5	
SW401-404	WD483100	SW. TACT SKRGAAD010	
SW406-407	WD483100	SW. TACT SKRGAAD010	
SW409-413	WD483100	SW. TACT SKRGAAD010	
SW415	WD483100	SW. TACT SKRGAAD010	
SW417-419	WD483100	SW. TACT SKRGAAD010	
SW421-422	WD483100	SW. TACT SKRGAAD010	
SW424-427	WD483100	SW. TACT SKRGAAD010	
SW443	V9597100	SW. RT. ENC EC12E2460802	
SW471	WD483100	SW. TACT SKRGAAD010	
* TE461	WQ380000	TERM. PUSH MSP-154V1 4P PUSH	

* New Parts

P.C.B. OPERATION and P.C.B. MAIN

RX-V665/HTR-6260

Ref No.	Part No.	Description	Markets
* U4001	WQ600700	L. DTCT	SM3385VMH6
V4001	WQ842100	FL. DSPLY	18-MT-09GNK
	WA790900	SPACER	4. 6/10/32
*	WQ918900	P. C. B.	MAIN
	WQ918900	P. C. B.	MAIN
*	WQ919400	P. C. B.	MAIN
*	WQ919000	P. C. B.	MAIN
*	WQ919100	P. C. B.	MAIN
*	WQ919200	P. C. B.	MAIN
CB152	VQ962900	CN. BS. PIN	8P
CB153	VQ963900	CN. BS. PIN	18P
CB154	VQ963600	CN. BS. PIN	15P
CB155	VQ963200	CN. BS. PIN	11P
CB158	WNO77700	CL.IP. FUSE	CLIP PFC5000-0202F
CB159	WNO77700	CL.IP. FUSE	CLIP PFC5000-0202F
C1000-1006	URO67100	C. EL	10uF 50V
C1007	WJ605000	C. MYLAR	0. 01uF 50V J
C1008	WJ603300	C. MYLAR	470pF 50V J
C1009	UR277220	C. EL	22uF 63V
C1010	WJ603300	C. MYLAR	470pF 50V J
C1011	UR297100	C. EL	10uF 100V
C1012-1013	WJ603300	C. MYLAR	470pF 50V J
C1014-1015	UR297100	C. EL	10uF 100V
C1016	UR277220	C. EL	22uF 63V
C1017-1019	UR297100	C. EL	10uF 100V
C1020-1022	WJ603300	C. MYLAR	470pF 50V J
C1023	WJ602900	C. MYLAR	100pF 50V K
C1024	URO67330	C. EL	33uF 50V
C1025	WJ602900	C. MYLAR	100pF 50V K
C1026	URO67330	C. EL	33uF 50V
C1027	WJ602900	C. MYLAR	100pF 50V K
C1028-1029	URO67330	C. EL	33uF 50V
C1030	WJ602900	C. MYLAR	100pF 50V K
C1031	URO67330	C. EL	33uF 50V
C1032	WJ602900	C. MYLAR	100pF 50V K
C1033	URO67330	C. EL	33uF 50V
C1034	WJ602900	C. MYLAR	100pF 50V K
C1035	UR897100	C. EL	10uF 100V
C1036	FG651100	C. CE	10pF 50V
C1037	WJ602900	C. MYLAR	100pF 50V K
C1038	URO67330	C. EL	33uF 50V
C1039	UR866100	C. EL	1uF 50V
C1040-1045	FG650500	C. CE	5pF 50V
C1046-1052	WJ605800	C. MYLAR	0. 047uF 50V J
C1053	UR866470	C. EL	4. 7uF 50V
C1054	UR828220	C. EL	220uF 10V
△ C1055-1056	WN524400	C. EL	6800uF 63V
C1057-1058	WK041800	C. EL	10uF 16V
C1059-1060	UR266100	C. EL	1uF 50V
C1061	UR858100	C. EL	100uF 35V
C1062	URO48470	C. EL	470uF 25V
C1063-1064	WJ611400	C. MYLAR	0. 1uF 100V J
C1065	URO49330	C. EL	3300uF 25V
C1066	URO49100	C. EL	1000uF 25V

* New Parts

Ref No.	Part No.	Description	Markets
C1067-1068	WN165500	C. PP	0. 022uF 100V
C1069	US135100	C. CE. CHP	0. 1uF 16V
C1509	URO67470	C. EL	47uF 50V
C1510-1512	US135100	C. CE. CHP	0. 1uF 16V
C1513-1514	US061220	C. CE. CHP	22pF 50V B
C1515-1516	US135100	C. CE. CHP	0. 1uF 16V
C1517-1520	US062220	C. CE. CHP	220pF 50V B
C1521	UR837100	C. EL	10uF 16V
C1522	US061470	C. CE. CHP	47pF 50V B
C1523	UR838100	C. EL	100uF 16V
C1524	US061470	C. CE. CHP	47pF 50V B
C1525	UR837100	C. EL	10uF 16V
C1526-1527	UR838100	C. EL	100uF 16V
C1528-1529	US062220	C. CE. CHP	220pF 50V B
C1530	UR838100	C. EL	100uF 16V
C1531	UR837330	C. EL	33uF 16V
C1532-1533	UR838100	C. EL	100uF 16V
C1534-1535	US062220	C. CE. CHP	220pF 50V B
C1536	UR838100	C. EL	100uF 16V
C1537	WJ605600	C. MYLAR	0. 033uF 50V
C1538	VR169000	C. MYLAR	0. 33uF 50V
C1539	WJ604800	C. MYLAR	8200pF 50V
C1540	WJ605600	C. MYLAR	0. 033uF 50V
C1541	VR169000	C. MYLAR	0. 33uF 50V
C1542	US135100	C. CE. CHP	0. 1uF 16V
C1543	WJ604800	C. MYLAR	8200pF 50V
C1544	US062220	C. CE. CHP	220pF 50V B
C1545	US135100	C. CE. CHP	0. 1uF 16V
C1546	US062220	C. CE. CHP	220pF 50V B
C1547	UR837100	C. EL	10uF 16V
C1549	UR837100	C. EL	10uF 16V
C1551	US062220	C. CE. CHP	220pF 50V B
C1552-1556	UR267100	C. EL	10uF 50V
C1557	US062220	C. CE. CHP	220pF 50V B
C1558-1559	UR267470	C. EL	47uF 50V
C1560	US062220	C. CE. CHP	220pF 50V B
C1563	US062220	C. CE. CHP	220pF 50V B
C1566	US062220	C. CE. CHP	220pF 50V B
C1568	VR169200	C. MYLAR	0. 47uF 50V
C1569	US062220	C. CE. CHP	220pF 50V B
C1570	UR267100	C. EL	10uF 50V
C1572-1573	US062100	C. CE. CHP	100pF 50V B
C1574	UR837100	C. EL	10uF 16V
C1575	US061470	C. CE. CHP	47pF 50V B
C1576-1577	UR267100	C. EL	10uF 50V
C1578	US061470	C. CE. CHP	47pF 50V B
C1579-1580	UR837100	C. EL	10uF 16V
C1581-1582	US061470	C. CE. CHP	47pF 50V B
C1583-1584	UR267470	C. EL	47uF 50V
C1585	UR837100	C. EL	10uF 16V
C1588-1591	UR267100	C. EL	10uF 50V
C1594-1595	US062470	C. CE. CHP	470pF 50V B
C1596	US064100	C. CE. CHP	0. 01uF 50V B
C1597-1598	US062470	C. CE. CHP	470pF 50V B
C1599-1602	UR267100	C. EL	10uF 50V
C1603-1604	US062470	C. CE. CHP	470pF 50V B
C1605-1606	US064100	C. CE. CHP	0. 01uF 50V B

* New Parts

P.C.B. MAIN and P.C.B. VIDEO

RX-V665/HTR-6260

Ref No.	Part No.	Description	Markets
C1607	US062470	C. CE. CHP 470pF 50V B	
C1608	US064100	C. CE. CHP 0. 01uF 50V B	URAFL
C1608	US064100	C. CE. CHP 0. 01uF 50V B	C (V665)
C1609	UR049220	C. EL 2200uF 25V	
C1611	US064100	C. CE. CHP 0. 01uF 50V B	
D1000-1001	VD631600	DIODE 1SS133, 176	
D1002	VU171900	DIODE. ZENR UDZ5. 1B 5. 1V	
D1003	WC398800	DIODE KDS160-RTK	
D1004-1007	VN008700	DIODE 1SS270A	
D1008	WC398800	DIODE KDS160-RTK	
D1009-1016	VN008700	DIODE 1SS270A	
△ D1017	WA653200	DIODE. BRG TS6P03G 6A 200V	
△ D1018	WH487300	DIODE. BRG RS203M 2. 0A 200V	
D1019	VD631600	DIODE 1SS133, 176	
D1503-1504	VG438400	DIODE. ZENR MTZJ6. 8C 6. 8V	
△ F1000	VV071700	FUSE 3. 15A 250V	R
△ IC100	X8190A00	IC STK433-330-E	
△ IC101-102	X7427A00	IC STK433-130-E	
IC103	XJ608A00	IC NJM7812FA	
IC104	X4154A00	IC K1A7912P1	
IC105	YA381A00	IC LM19C1Z/LF THERMAL	
IC152	XZ509A00	IC TC74VHCU04FT INVER	
IC153	YA361A00	IC R2A15220FP	
IC154	X7378A00	IC NJM4565M (TE1)	
PJ150	V5715300	JACK. PIN 2P OR/OR	
PJ151	V7046800	JACK. PIN 6P MSP-246V1-01N1	
PJ152-153	V7046700	JACK. PIN 4P MSP-244V1-01N1	
PJ154	WG674900	JACK. PIN 4P	
PJ155	V7046700	JACK. PIN 4P MSP-244V1-01N1	
PJ157	V7046700	JACK. PIN 4P MSP-244V1-01N1	
PJ158	WG674900	JACK. PIN 4P	
PJ159	V7189700	JACK. PIN 1P	URAFL
PJ159	V7189700	JACK. PIN 1P	C (V665)
PN101-102	V8637500	PIN L=50 #18	
△ Q1000	WC398400	TR 2N5551C-AT	
△ Q1001-1002	VC614000	TR 2SB1274 Q, R, S	
△ Q1003	WC398400	TR 2N5551C-AT	
△ Q1004-1005	WC397700	TR 2N5401C-AT	
△ Q1006-1012	WC398400	TR 2N5551C-AT	
△ Q1013	WC397700	TR 2N5401C-AT	
Q1014	iC181510	TR 2SC1815 Y	
Q1015	WC435000	TR. DGT KRC102S-RTK	
Q1016	WC434900	TR. DGT KRA104S-RTK	
Q1500-1504	VZ725900	TR 2SD1938F S, T	
Q1507-1514	VZ725900	TR 2SD1938F S, T	
Q1519-1526	VZ725900	TR 2SD1938F S, T	
△ R1012-1014	HV753220	R. CAR. FP 2. 2Ω 1/4W	
△ R1017	HV755560	R. CAR. FP 560Ω 1/4W	
△ R1029	HV754100	R. CAR. FP 10Ω 1/4W	
△ R1032	HV754100	R. CAR. FP 10Ω 1/4W	
△ * R1046	WP839400	R. WW 0. 22+0. 22 3W	
△ * R1048-1049	WP839400	R. WW 0. 22+0. 22 3W	
△ * R1056	WP839400	R. WW 0. 22+0. 22 3W	
△ * R1060	WP839400	R. WW 0. 22+0. 22 3W	
△ * R1067-1068	WP839400	R. WW 0. 22+0. 22 3W	
R1086	HV754100	R. CAR. FP 10Ω 1/4W	
R1089-1090	HV754100	R. CAR. FP 10Ω 1/4W	

* New Parts

Ref No.	Part No.	Description	Markets
R1092	HV754100	R. CAR. FP 10Ω 1/4W	
R1095	HV754100	R. CAR. FP 10Ω 1/4W	
R1098	HV754100	R. CAR. FP 10Ω 1/4W	
R1101	HV754100	R. CAR. FP 10Ω 1/4W	
△ R1103	WJ683200	R. MTL. FLM 4. 7Ω 1W	
△ R1107-1108	WJ683200	R. MTL. FLM 4. 7Ω 1W	
△ R1110-1111	WJ683200	R. MTL. FLM 4. 7Ω 1W	
△ R1113-1114	WJ683200	R. MTL. FLM 4. 7Ω 1W	
R1504	HV753100	R. CAR. FP 1Ω 1/4W	
R1664-1665	HV755100	R. CAR. FP 100Ω 1/4W	
R1666-1667	WJ684700	R. MTL. FLM 82Ω 1W	
RY100	WE648700	RELAY DC DH24D2-0-Q	
* ST100	WR364700	SCR. TERM M3	
ST101	WA789700	SCR. TERM D3. 5	
△ SW101	WB493700	VOLT. SELCT R8140246	R
△ SW101	WD073700	VOLT. SELCT R8140254	L
U1500-1501	WN333200	CN. PHOTO. R 1P JSR1165	
	WE774200	SCR. BND. HD 3x10 MFZN2W3	
*	WQ920800	P. C. B. VIDEO	U
*	WQ920900	P. C. B. VIDEO	C (V665)
*	WQ921400	P. C. B. VIDEO	C (6260)
*	WQ921000	P. C. B. VIDEO	R
*	WQ921100	P. C. B. VIDEO	A
*	WQ921200	P. C. B. VIDEO	F
*	WQ921300	P. C. B. VIDEO	L
CB303	VQ961500	CN. BS. PIN 12P	
CB305	VQ047000	CN. BS. PIN 6P	
CB321	VM859500	CN. BS. PIN 11P	
CB332	VQ961300	CN. BS. PIN 10P	
CB333	VK024700	CN. BS. PIN 3P	
CB342	VQ585500	CN. JUMPER 5P	
CB343	VZ130900	CN. JUMPER 4P	
CB344	VQ585700	CN. JUMPER 7P	
CB345	VF728300	CN 6P	
CB349	VQ047700	CN. BS. PIN 22P	
CB371	VG879900	CN. BS. PIN 2P	
CB372-373	WN103000	CLIP. FUSE TP00351-31	
CB378	VG879900	CN. BS. PIN 2P	RL
CB379	VQ961000	CN. BS. PIN 7P	
CB381	VQ962800	CN. BS. PIN 7P	
CB391	VQ044100	CN. BS. PIN 5P	F
C3001	US062100	C. CE. CHP 100pF 50V B	
C3002-3004	US060800	C. CE. CHP 8pF 50V B	
C3005	US062100	C. CE. CHP 100pF 50V B	
C3006	UR837470	C. EL 47uF 16V	
C3007-3008	US135100	C. CE. CHP 0. 1uF 16V	
C3009	UR837470	C. EL 47uF 16V	
C3011	US060300	C. CE. CHP 3pF 50V B	
C3012	UR837470	C. EL 47uF 16V	
C3013-3014	US060300	C. CE. CHP 3pF 50V B	
C3015-3017	US135100	C. CE. CHP 0. 1uF 16V	
C3018	UR837100	C. EL 10uF 16V	
C3019	US135100	C. CE. CHP 0. 1uF 16V	
C3020	UR837100	C. EL 10uF 16V	

* New Parts

P.C.B. VIDEO

RX-V665/HTR-6260

Ref No.	Part No.	Description	Markets
C3021-3025	US135100	C. CE. CHP	0. 1uF 16V
C3026	UR837100	C. EL	10uF 16V
C3027	WD758300	C. CE. CHP	10uF 10V
C3029	WD758300	C. CE. CHP	10uF 10V
C3031	WD758300	C. CE. CHP	10uF 10V
C3033	UR837470	C. EL	47uF 16V
C3043-3044	US135100	C. CE. CHP	0. 1uF 16V
C3045	UR837470	C. EL	47uF 16V
C3047	US135100	C. CE. CHP	0. 1uF 16V
C3048	UR838220	C. EL	220uF 16V
C3050	US135100	C. CE. CHP	0. 1uF 16V
C3051	UR838220	C. EL	220uF 16V
C3052-3053	UR838100	C. EL	100uF 16V
C3054	US135100	C. CE. CHP	0. 1uF 16V
C3055	US061120	C. CE. CHP	12pF 50V B
C3055	US060500	C. CE. CHP	5pF 50V B
C3056	US061180	C. CE. CHP	18pF 50V B
C3056	US060700	C. CE. CHP	7pF 50V B
C3057	UR866100	C. EL	1uF 50V
C3058	US060600	C. CE. CHP	6pF 50V B
C3058	US060400	C. CE. CHP	4pF 50V B
C3059	US061240	C. CE. CHP	24pF 50V B
C3061	US135100	C. CE. CHP	0. 1uF 16V
C3062	US061240	C. CE. CHP	24pF 50V B
C3063	US135100	C. CE. CHP	0. 1uF 16V
C3065	UR837470	C. EL	47uF 16V
C3067-3069	US135100	C. CE. CHP	0. 1uF 16V
C3072	US135100	C. CE. CHP	0. 1uF 16V
C3073	UR838220	C. EL	220uF 16V
C3074	US061100	C. CE. CHP	10pF 50V B
C3076	UR837100	C. EL	10uF 16V
C3077	US135100	C. CE. CHP	0. 1uF 16V
C3079	US135100	C. CE. CHP	0. 1uF 16V
C3080-3085	WD758300	C. CE. CHP	10uF 10V
C3201	US061270	C. CE. CHP	27pF 50V B
C3202	UR837100	C. EL	10uF 16V
C3203	US061270	C. CE. CHP	27pF 50V B
C3204-3205	US135100	C. CE. CHP	0. 1uF 16V
C3206	US062560	C. CE. CHP	560pF 50V B
C3207-3208	US062330	C. CE. CHP	330pF 50V B
C3209	US135100	C. CE. CHP	0. 1uF 16V
C3211	UR837470	C. EL	47uF 16V
C3212-3214	UR837470	C. EL	47uF 16V
C3215	US062100	C. CE. CHP	100pF 50V B
C3217-3218	US062100	C. CE. CHP	100pF 50V B
C3221	US062100	C. CE. CHP	100pF 50V B
C3303-3305	WJ611400	C. MYLAR	0. 1uF 100V J
C3306	UR868100	C. EL	100uF 50V
C3307	WG601900	C. EL	10000uF 16V
C3309	WG601900	C. EL	10000uF 16V
C3310	URO39470	C. EL	4700uF 16V
C3311	UR866100	C. EL	1uF 50V
C3312	UR837220	C. EL	22uF 16V
C3314	UR866100	C. EL	1uF 50V
C3317	UR866100	C. EL	1uF 50V
C3317	UR866100	C. EL	1uF 50V
C3318	UR837470	C. EL	47uF 16V

* New Parts

Ref No.	Part No.	Description	Markets
C3318	UR837470	C. EL	47uF 16V
C3319	UR866100	C. EL	1uF 50V
C3320-3321	UR837330	C. EL	33uF 16V
C3322	UR867100	C. EL	10uF 50V
C3323	UR878100	C. EL	100uF 63V
C3403-3409	WJ605000	C. MYLAR	0. 01uF 50V J
C3410-3411	WJ604500	C. MYLAR	4700pF 50V
C3412-3416	WJ605200	C. MYLAR	0. 015uF 50V
C3603-3604	US063100	C. CE. CHP	1000pF 50V B
C3606	US064100	C. CE. CHP	0. 01uF 50V B
C3701	WQ852400	C. POL. MTL	0. 022uF 630V
△ C3702	WK005000	C. CE. SAFTY	0. 047uF 275V
* C3703	WR082000	C. EL	100uF 220V
* C3703	WR082100	C. EL	100uF 400V
* C3703	WQ852500	C. EL	68uF 400V
* C3704	WR182800	C. CE. CHP	2200pF 250V
C3705	US065100	C. CE. CHP	0. 1uF 50V B
△ * C3706	WQ939400	C. CE. SAFTY	0. 01uF 250V
C3707	UR837470	C. EL	47uF 16V
C3708	UR867100	C. EL	10uF 50V
△ * C3709	WQ902200	C. CE. SAFTY	2200pF 250V
C3710-3711	UR866100	C. EL	1uF 50V
C3712-3713	WH777900	C. EL	1000uF 35V
C3714	US046100	C. CE. CHP	1uF 25V
C3715	US135100	C. CE. CHP	0. 1uF 16V
C3716	WH771300	C. EL	100uF 10V
* C3717	WQ852400	C. POL. MTL	0. 022uF 630V
△ * C3720-3721	WQ902300	C. CE. SAFTY	1000pF 250V
C3801	US064100	C. CE. CHP	0. 01uF 50V B
C3802	V7887800	C. EL	1uF 50V
C3803	WJ335500	C. EL	2. 2uF 50V
C3804	WJ603700	C. MYLAR	1000pF 50V
C3805	US064100	C. CE. CHP	0. 01uF 50V B
C3806-3807	WD758300	C. CE. CHP	10uF 10V
C3901	US064100	C. CE. CHP	0. 01uF 50V B
C3902	US062120	C. CE. CHP	120pF 50V B
C3903	US062220	C. CE. CHP	220pF 50V B
C3904	US135100	C. CE. CHP	0. 1uF 16V
C3905	UR837470	C. EL	47uF 16V
C3906	UR837100	C. EL	10uF 16V
C3907	UR818470	C. EL	470uF 6. 3V
C3908	US064100	C. CE. CHP	0. 01uF 50V B
D3005-3007	VT332900	DIODE	1SS355
D3201	VG436100	DIODE. ZENR	MTZJ3. 3B 3. 3V
D3202	VG439500	DIODE. ZENR	MTZJ10B 10V
D3302	WH487300	DIODE. BRG	RS203M 2. 0A 200V
D3304	WH487300	DIODE. BRG	RS203M 2. 0A 200V
D3305	VG444700	DIODE. ZENR	MTZ J 39D 39. 0V TP
D3307	VG440800	DIODE. ZENR	MTZJ15B 15V
D3309	VT332900	DIODE	1SS355
D3309	VT332900	DIODE	1SS355
D3310-3311	VT332900	DIODE	1SS355
D3311	VT332900	DIODE	1SS355
D3312	VV307700	DIODE	1N4002S
D3320	VG437400	DIODE. ZENR	MTZJ5. 1B 5. 1V
D3403-3407	VT332900	DIODE	1SS355
D3601-3602	VT332900	DIODE	1SS355

* New Parts

P.C.B. VIDEO

Carbon Resistors

Ref No.	Part No.	Description	Markets
Δ D3701	WH471700	DIODE.BRG DB105 1A 600V	
D3703	WN672400	DIODE.ZENR P6KE200A 200V	
D3705	WQ647500	DIODE HT18G	
D3706-3707	VD631600	DIODE 1SS133, 176	
D3708	VT332900	DIODE 1SS355	
D3709	WR007000	DIODE.SCHO 10A 40V SG10SC4M	
D3710	VG442200	DIODE.ZENR MTZJ22C 22V	
D3801-3805	VT332900	DIODE 1SS355	
D3901-3902	VT332900	DIODE 1SS355	F
F3701	WB221200	FUSE T6A 125V	UC
F3701	WB760600	FUSE T6.3A 250V	R
F3701	VV071700	FUSE 3.15A 250V	AFL
IC301-303	XY879A00	IC TC74HC4053AF(EL)	
IC305	X6742A00	IC LA73050-TLM-E	
IC306	X2904A00	IC NJM2581M VIDEO AMP	
IC307	XY549A00	IC TC74HC4051AFEL	
IC308	X7779A00	IC LC709004A-TLM-E	
IC309	X7818A00	IC LC74782JM-8A16-TLM	
IC310	X8875A00	IC FHP33501M14X	
* IC321	X8235A00	IC LC72725KM	F
IC331	X8276A00	IC NJM2396F05	
IC333	X8035A00	IC BA00JC5WT-V5	U
IC334	X6143A00	IC NJM2388F05 5.0V	
* IC371	YA565A00	IC TOP254PN SW	
Δ * IC372	WQ867100	PHOT.CPL EL816(M)(C)	
* IC374	YA276A00	IC TL431AC 2.5-36V	
Δ * IC375	WQ867100	PHOT.CPL EL816(M)(C)	
IC391	XZ509A00	IC TC74VHC04FT INVER	F
JK321	V9435700	JACK.MNI MSJ-035-12APC	URAF
JK321	V9435700	JACK.MNI MSJ-035-12APC	C (V665)
JK361-362	V9435700	JACK.MNI MSJ-035-12APC	
JK391	V6931000	GN.DIN 1P YKF51-5506	F
PJ301	WG505100	JACK.PIN 6P	
PJ302	V7189800	JACK.PIN 1P	
PJ303	WH381400	JACK.PIN 3P JACK G,B,R	
PJ304	V7189800	JACK.PIN 1P	
PJ305-306	V7190000	JACK.PIN 2P	
PN341-343	V9637500	PIN L=70 #18	
PN381	V9637500	PIN L=70 #18	
Q3001	VR936300	TR 2SA1576A T106	
Q3002-3003	VV556400	TR 2SC2412K Q,R,S	
Q3201	iC174020	TR 2SC1740S QRS	F
Q3203	WJ173600	TR 2SC1815Y TP	
Q3204	WJ173500	TR 2SA1015Y Y TP	URAF
Q3204	WJ173500	TR 2SA1015Y Y TP	C (V665)
Q3205	WJ173600	TR 2SC1815Y TP	URAF
Q3205	WJ173600	TR 2SC1815Y TP	C (V665)
Q3206	WG538600	TR KTA1046-Y-U/P	URAF
Q3206	WG538600	TR KTA1046-Y-U/P	C (V665)
Q3207	WJ173600	TR 2SC1815Y TP	URAF
Q3207	WJ173600	TR 2SC1815Y TP	C (V665)
Q3302	WJ173500	TR 2SA1015Y Y TP	
Q3303	WG538600	TR KTA1046-Y-U/P	
Q3304	WJ173500	TR 2SA1015Y Y TP	
Q3305	WJ173600	TR 2SC1815Y TP	
Q3306	WC397700	TR 2N5401C-AT	
Q3405	VV655400	TR.DGT DTC114EKA	

* New Parts

Ref No.	Part No.	Description	Markets
Q3406	VV655000	TR.DGT DTA114EKA	
Q3407	VV655400	TR.DGT DTC114EKA	
Q3408	VV655000	TR.DGT DTA114EKA	
Q3409	VV655400	TR.DGT DTC114EKA	
Q3410	VV655000	TR.DGT DTA114EKA	
Q3411	VV655400	TR.DGT DTC114EKA	
Q3412	VV655000	TR.DGT DTA114EKA	
Q3413	VV655400	TR.DGT DTC114EKA	
Q3414	VV655000	TR.DGT DTA114EKA	
Q3801-3802	WJ173600	TR 2SC1815Y TP	
Q3803	VV655700	TR.DGT DTC144EKA	
R3021	HV753100	R.CAR.FP 1Ω 1/4W	
R3025	HV753100	R.CAR.FP 1Ω 1/4W	
R3046-3049	HV753100	R.CAR.FP 1Ω 1/4W	
R3058-3061	HV753100	R.CAR.FP 1Ω 1/4W	
R3083	HV755470	R.CAR.FP 470Ω 1/4W	
R3208	HV755680	R.CAR.FP 680Ω 1/4W	F
R3210	HV754180	R.CAR.FP 18Ω 1/4W	
R3213	HV753560	R.CAR.FP 5.6Ω 1/4W	URAF
R3213	HV753560	R.CAR.FP 5.6Ω 1/4W	C (V665)
R3315-3316	HV756470	R.CAR.FP 4.7KΩ 1/4W	
R3325	HV756220	R.CAR.FP 2.2KΩ 1/4W	
R3326	HV753220	R.CAR.FP 2.2Ω 1/4W	
R3330	HV753100	R.CAR.FP 1Ω 1/4W	
R3403-3406	HV757100	R.CAR.FP 10KΩ 1/4W	
R3910	HV753220	R.CAR.FP 2.2Ω 1/4W	F
RY341-345	WJ122400	RELAY 981-2A-24DS-SP7	
Δ RY371	WQ804100	RELAY DC DLS5D1-0(M)0.25	
ST331-332	WA789700	SCR.TERM D3.5	
ST361-362	WA789700	SCR.TERM D3.5	
ST371	WA789700	SCR.TERM D3.5	
ST381-383	WA789700	SCR.TERM D3.5	
Δ * T3701	YA507A00	TRANS.PWR	
TE341	WK560800	TERM.SP 4P MST-204V1-01 NC	UCRA
TE341	WK560900	TERM.SP 4P MST-204V1-01 WC	FL
TE342	WK561000	TERM.SP 6P MST-207V1-01 NC	UCRA
TE342	WK561100	TERM.SP 6P MST-207V1-01 WC	FL
TE343	WK560800	TERM.SP 4P MST-204V1-01 NC	UCRA
TE343	WK560900	TERM.SP 4P MST-204V1-01 WC	FL
XL301	VV949800	RSNR.CRYS 14.31818MHz	UCR
XL301	WK196100	RSNR.CRYS 17.734475MHz	AFL
XL321	V2731100	RSNR.CRYS 4.332M HC-49/U	F
	WE774200	SCR.BND.HD 3x10 MFZN2W3	

* New Parts

Value	1/4W Type Part No.	1/6W Type Part No.	Value	1/4W Type Part No.	1/6W Type Part No.
1.0 Ω	HJ35 3100	HF85 3100	11 kΩ	HF45 7110	HF45 7110
1.8 Ω	HJ35 3180	*	12 kΩ	HJ35 7120	HF85 7120
2.2 Ω	HJ35 3220	HF85 3220	13 kΩ	HF45 7130	HF45 7130
3.3 Ω	HJ35 3330	HF85 3330	15 kΩ	HF45 7150	HF45 7150
4.7 Ω	HJ35 3470	HF85 3470	18 kΩ	HF45 7180	HF45 7180
5.6 Ω	HJ35 3560	HF85 3560	22 kΩ	HF45 7220	HF45 7220
10 Ω	HF45 4100	HF45 4100	24 kΩ	HF45 7240	HF45 7240
15 Ω	HJ35 4150	HF85 4150	27 kΩ	HJ35 7270	HF85 7270
22 Ω	HF45 4220	HF45 4220	30 kΩ	HF45 7300	HF45 7300
27 Ω	HJ35 4270	HF85 4270	33 kΩ	HF45 7330	HF45 7330
33 Ω	HF45 4330	HF45 4330	36 kΩ	HF45 7360	HF45 7360
39 Ω	HJ35 4470	HF85 4390	39 kΩ	HF45 7390	HF45 7390
47 Ω	HF45 4470	HF45 4470	47 kΩ	HF45 7470	HF45 7470
56 Ω	HF45 4560	HF45 4560	51 kΩ	HF45 7510	HF45 7510
68 Ω	HF45 4680	HF45 4680	56 kΩ	HF45 7560	HF45 7560
75 Ω	HF45 4750	HF45 4750	62 kΩ	HF45 7620	HF45 7620
82 Ω	HF45 4820	HF45 4820	68 kΩ	HF45 7680	HF45 7680
91 Ω	HF45 4910	HF45 4910	82 kΩ	HF45 7820	HF45 7820
100 Ω	HF45 5100	HF45 5100	91 kΩ	HF45 7910	HF45 7910
110 Ω	HJ35 5110	HF85 5110	100 kΩ	HF45 8100	HF45 8100
120 Ω	HF45 5120	HF45 5120	110 kΩ	HF45 8110	HF45 8110
150 Ω	HF45 5150	HF45 5150	120 kΩ	HF45 8120	HF45 8120
160 Ω	HJ35 5160	*	150 kΩ	HF45 8150	HF45 8150
180 Ω	HF45 5180	HF45 5180	180 kΩ	HF45 8180	HF45 8180
200 Ω	HF45 5200	HF45 5200	220 kΩ	HJ35 8220	HF85 8220
220 Ω	HF45 5220	HF45 5220	270 kΩ	HF45 8270	HF45 8270
270 Ω	HF45 5270	HF45 5270	300 kΩ	HF45 8300	HF45 8300
330 Ω	HF45 5330	HF45 5330	330 kΩ	HF45 8330	HF45 8330
390 Ω	HF45 5390	HF45 5390	390 kΩ	HJ35 8390	HF85 8390
430 Ω	HF45 5430	HF45 5430	470 kΩ	HF45 8470	HF45 8470
470 Ω	HF45 5470	HF45 5470	560 kΩ	HJ35 8560	HF85 8560
510 Ω	HF45 5510	HF45 5510	680 kΩ	HJ35 8680	HF85 8680
560 Ω	HF45 5560	HF45 5560	820 kΩ	HJ35 8820	HF85 8820
680 Ω	HF45 5680	HF45 5680	1.0 MΩ	HF45 9100	HF45 9100
820 Ω	HF45 5820	HF45 5820	1.2 MΩ	HJ35 9120	*
910 Ω	HF45 5910	HF45 5910	1.5 MΩ	HJ35 9150	HF85 9150
1.0 kΩ	HF45 6100	HF45 6100	1.8 MΩ	HJ35 9180	HF85 9180
1.2 kΩ	HF45 6120	HF45 6120	2.2 MΩ	HJ35 9220	HF85 9220
1.5 kΩ	HF45 6150	HF45 6150	3.3 MΩ	HJ35 9330	HF85 9330
1.8 kΩ	HF45 6180	HF45 6180	3.9 MΩ	HJ35 9390	*
2.0 kΩ	HJ35 6200	HF85 6200	4.7 MΩ	HJ35 9470	HF85 9470
2.2 kΩ	HF45 6220	HF45 6220			
2.4 kΩ	HJ35 6240	HF85 6240			
2.7 kΩ	HF45 6270	HF45 6270			
3.0 kΩ	HF45 6300	HF45 6300			
3.3 kΩ	HF45 6330	HF45 6330			
3.6 kΩ	HJ35 6360	HF85 6360			
3.9 kΩ	HF45 6390	HF45 6390			
4.7 kΩ	HF45 6470	HF45 6470			
5.1 kΩ	HF45 6510	HF45 6510			
5.6 kΩ	HF45 6560	HF45 6560			
6.8 kΩ	HF45 6680	HF45 6680			
8.2 kΩ	HF45 6820	HF45 6820			
9.1 kΩ	HF45 6910	HF45 6910			
10 kΩ	HF45 7100	HF45 7100			

* : Not available

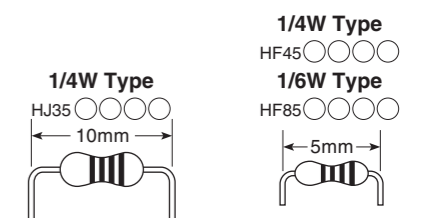

• OVERALL ASS'Y

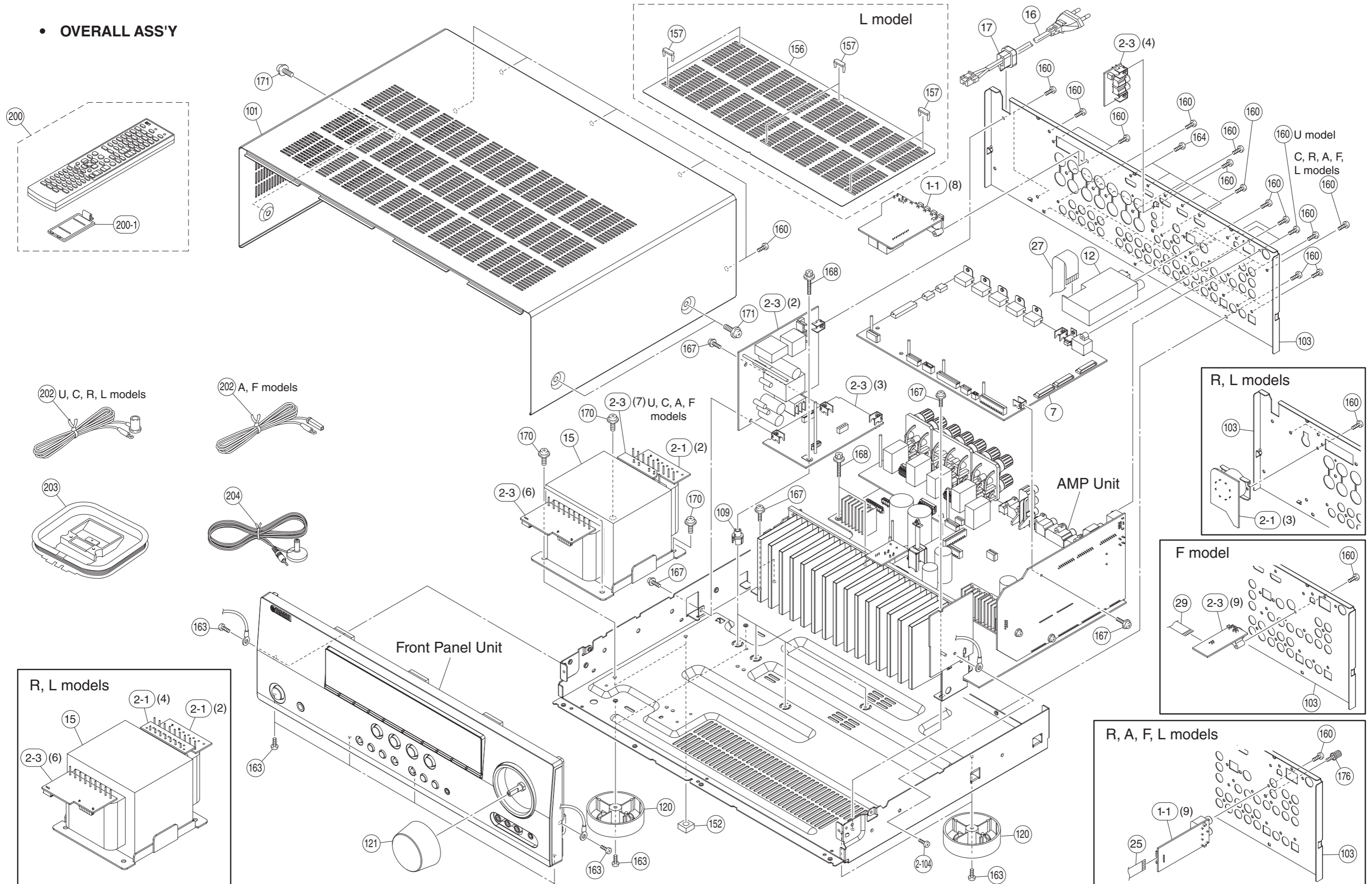

Ref No.	Part No.	Description	Remarks	Markets
* 1-1	WQ923400	P. C. B. ASS' Y	OPERATION	U
* 1-1	WQ923500	P. C. B. ASS' Y	OPERATION	C
* 1-1	WQ923600	P. C. B. ASS' Y	OPERATION	R
* 1-1	WQ923700	P. C. B. ASS' Y	OPERATION	AFL
* 2-1	WQ918900	P. C. B. ASS' Y	MAIN	U
* 2-1	WQ918900	P. C. B. ASS' Y	MAIN	V665 C
* 2-1	WQ919400	P. C. B. ASS' Y	MAIN	6260 C
* 2-1	WQ919000	P. C. B. ASS' Y	MAIN	R
* 2-1	WQ919100	P. C. B. ASS' Y	MAIN	AF
* 2-1	WQ919200	P. C. B. ASS' Y	MAIN	L
* 2-3	WQ920800	P. C. B. ASS' Y	VIDEO	U
* 2-3	WQ920900	P. C. B. ASS' Y	VIDEO	V665 C
* 2-3	WQ921400	P. C. B. ASS' Y	VIDEO	6260 C
* 2-3	WQ921000	P. C. B. ASS' Y	VIDEO	R
* 2-3	WQ921100	P. C. B. ASS' Y	VIDEO	A
* 2-3	WQ921200	P. C. B. ASS' Y	VIDEO	F
* 2-3	WQ921300	P. C. B. ASS' Y	VIDEO	L
2-104	WF002600	PW HEAD B-TIGHT SCREW	3x8 MFZN2W3	
* 7	WQ923900	P. C. B. ASS' Y	DIGITAL	V665 U
* 7	WQ925100	P. C. B. ASS' Y	DIGITAL	6260 U
* 7	WQ924000	P. C. B. ASS' Y	DIGITAL	V665 GRAL
* 7	WQ925200	P. C. B. ASS' Y	DIGITAL	6260 C
* 7	WQ924100	P. C. B. ASS' Y	DIGITAL	V665 F
* 12	WQ756600	AM/FM TUNER	FAEH06-A	UCRL
* 12	WQ756700	AM/FM TUNER	FAEH06-E	AGEF
* 12	WB877300	AM/FM TUNER	FAE381-A07F	
△ * 15	YA520A00	POWER TRANSFORMER		UC
△ * 15	YA521A00	POWER TRANSFORMER		RL
△ * 15	YA523A00	POWER TRANSFORMER		A
△ * 15	YA524A00	POWER TRANSFORMER		F
△ * 16	WB120500	POWER CABLE	2m	UC
△ * 16	WC992700	POWER CABLE	2m	R
△ * 16	WC743700	POWER CABLE	2m	A
△ * 16	WB212300	POWER CABLE	2m	FL
17	V2438700	CORD STOPPER	10P1	
25	MF113100	FLEXIBLE FLAT CABLE	13P 100mm P=1.25	
26	MF121120	FLEXIBLE FLAT CABLE	21P 120mm P=1.25	
* 27	WR384700	FLEXIBLE FLAT CABLE	11P 100mm P=1.25	
* 29	WR378500	FLEXIBLE FLAT CABLE	5P 180mm P=1.25	F
* 101	WQ665800	TOP COVER		BL
* 101	WQ666000	TOP COVER		TI
* 103	WQ685300	REAR PANEL		V665 U
* 103	WQ685500	REAR PANEL		6260 U
* 103	WQ685400	REAR PANEL		V665 C
* 103	WQ685600	REAR PANEL		6260 C
* 103	WQ841200	REAR PANEL		V665 R
* 103	WQ841300	REAR PANEL		V665 A
* 103	WQ841400	REAR PANEL		V665 F
* 103	WQ841500	REAR PANEL		V665 L
109	WH242000	SUPPORT H8		
120	WA790500	LEG	D60/H21 HS	
* 121	WQ822700	KNOB D50		BL
* 121	WQ823000	KNOB D50		TI

* New Parts

Ref No.	Part No.	Description	Remarks	Markets
152	WP126800	DAMPER	SCREW MASK	
* 156	WR306100	SHEET TOP		L
157	WJ323900	RIVET TOP		L
160	WE774100	BIND HEAD BONDING B-T. SCREW	3x8 MFZN2B3	
163	WE774300	BIND HEAD B-TIGHT SCREW	3x8 MFZN2W3	
164	WE877900	BIND HEAD S-TIGHT SCREW	3x6 MFZN2W3	
167	WF002600	PW HEAD B-TIGHT SCREW	3x8 MFZN2W3	
168	WE774600	SCREW IC	3x18 MFZN2W3	
170	WE774700	BIND HEAD S-TIGHT SCREW	4x10 MFZN2W3	
171	VH313200	PW HEAD S-TIGHT SCREW	4x8-10 MFN13BL	BL
171	VD069600	PW HEAD S-TIGHT SCREW	4x8-10 MFN133	TI
176	AA627310	GROUND TERMINAL		RAGEFL
		ACCESSORIES		
* 200	WRO02400	REMOTE CONTROL	RAV290	U
* 200	WRO02500	REMOTE CONTROL	RAV291	C
* 200	WRO02600	REMOTE CONTROL	RAV292	RAL
* 200	WRO02900	REMOTE CONTROL	RAV295	F
200-1	AAX82380	BATTERY COVER		CG-2209
202	WB212500	INDOOR FM ANTENNA	1.4m 1pc	UCRL
202	WB212400	INDOOR FM ANTENNA	1.4m 1pc	AF
203	WB212600	AM LOOP ANTENNA	1.0m 1pc	
204	WN649600	OPTIMIZER MICROPHONE BATTERY	6.0m 1pc R03, AAA, UM-4 2pcs	EM6022L-HN1700
		SERVICE TOOLS		
	WR492800	RS232C CONVERSION ADAPTOR	3.3Vtype withFFC9P	
	MF125400	FLEXIBLE FLAT CABLE	25P 200mm P=1.25	
	MF109400	FLEXIBLE FLAT CABLE	9P 160mm P=1.25	

* New Parts

• FRONT PANEL UNIT

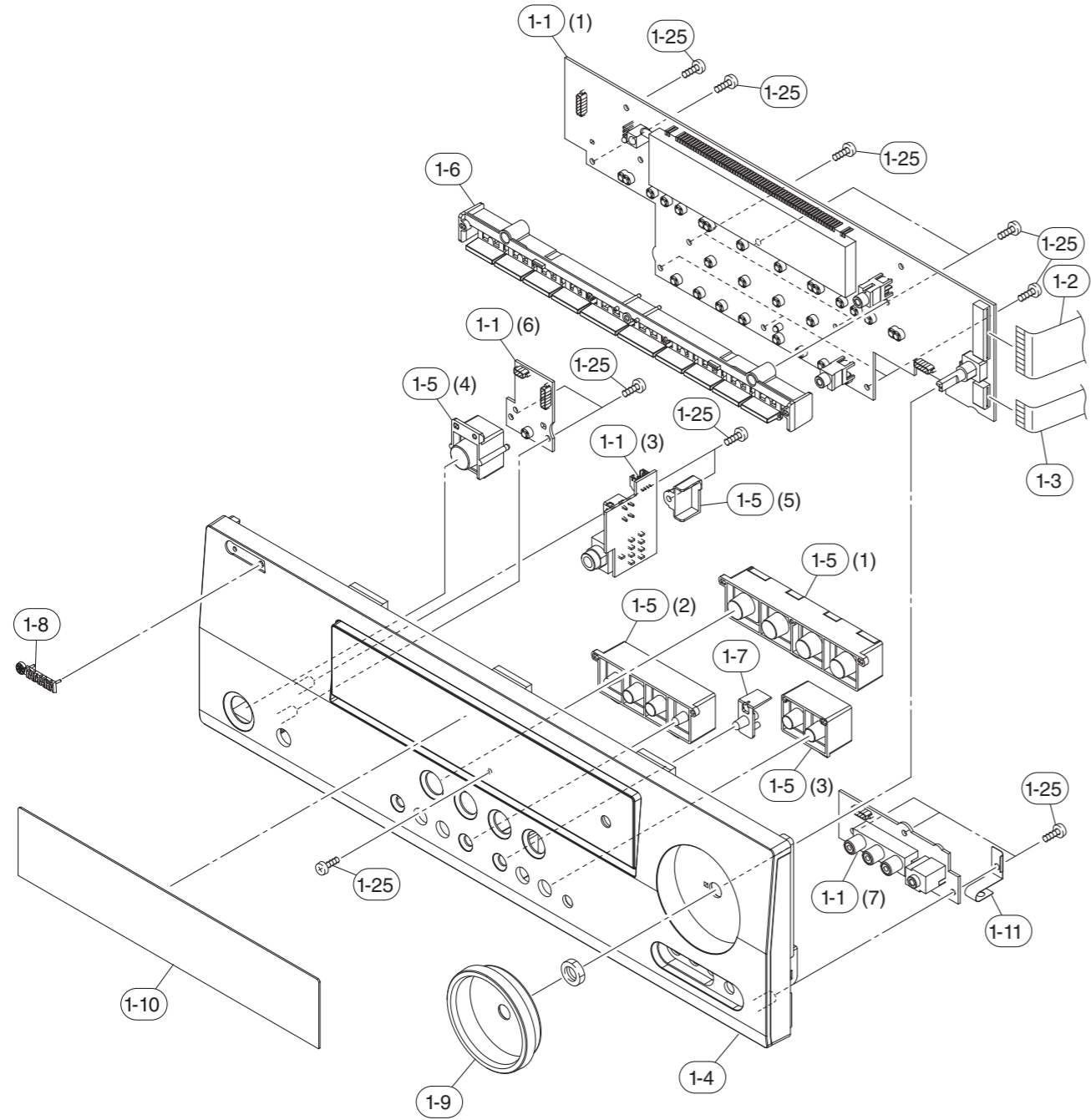

Ref No.	Part No.	Description	Remarks	Markets
* 1-1	WQ923400	P. C. B. ASS'Y	OPERATION	U
* 1-1	WQ923500	P. C. B. ASS'Y	OPERATION	C
* 1-1	WQ923600	P. C. B. ASS'Y	OPERATION	R
* 1-1	WQ923700	P. C. B. ASS'Y	OPERATION	AFL
* 1-2	WR400600	FLEXIBLE FLAT CABLE	25P 200mm P=1.25	
* 1-3	WR382800	FLEXIBLE FLAT CABLE	9P 160mm P=1.25	
* 1-4	WR0901A0	FRONT PANEL ASS'Y		V665BL
* 1-4	WR0873A0	FRONT PANEL ASS'Y		6260BL
* 1-4	WR0902A0	FRONT PANEL ASS'Y		V665BL
* 1-4	WR0874A0	FRONT PANEL ASS'Y		6260BL
* 1-4	WR0885A0	FRONT PANEL ASS'Y		V665TI
* 1-5	WQ831900	BUTTON CASE		BL
* 1-5	WQ832100	BUTTON CASE		TI
* 1-6	WQ822100	BUTTON TUNER		
* 1-7	WQ833100	BUTTON PD		
1-8	WJ193300	EMBLEM BL		
* 1-9	WQ822300	ESCUTCHEON VOL		BL
* 1-9	WQ822600	ESCUTCHEON VOL		TI
* 1-10	WQ833400	SHEET WINDOW		U
* 1-10	WQ833500	SHEET WINDOW		CRAFL
* 1-11	WR248300	EARTH PLATE		
1-25	WE774800	BIND HEAD P-TIGHT SCREW	3x8 MFZN2W3	

* New Parts

• AMP UNIT

1
2
3
4
5
6
7

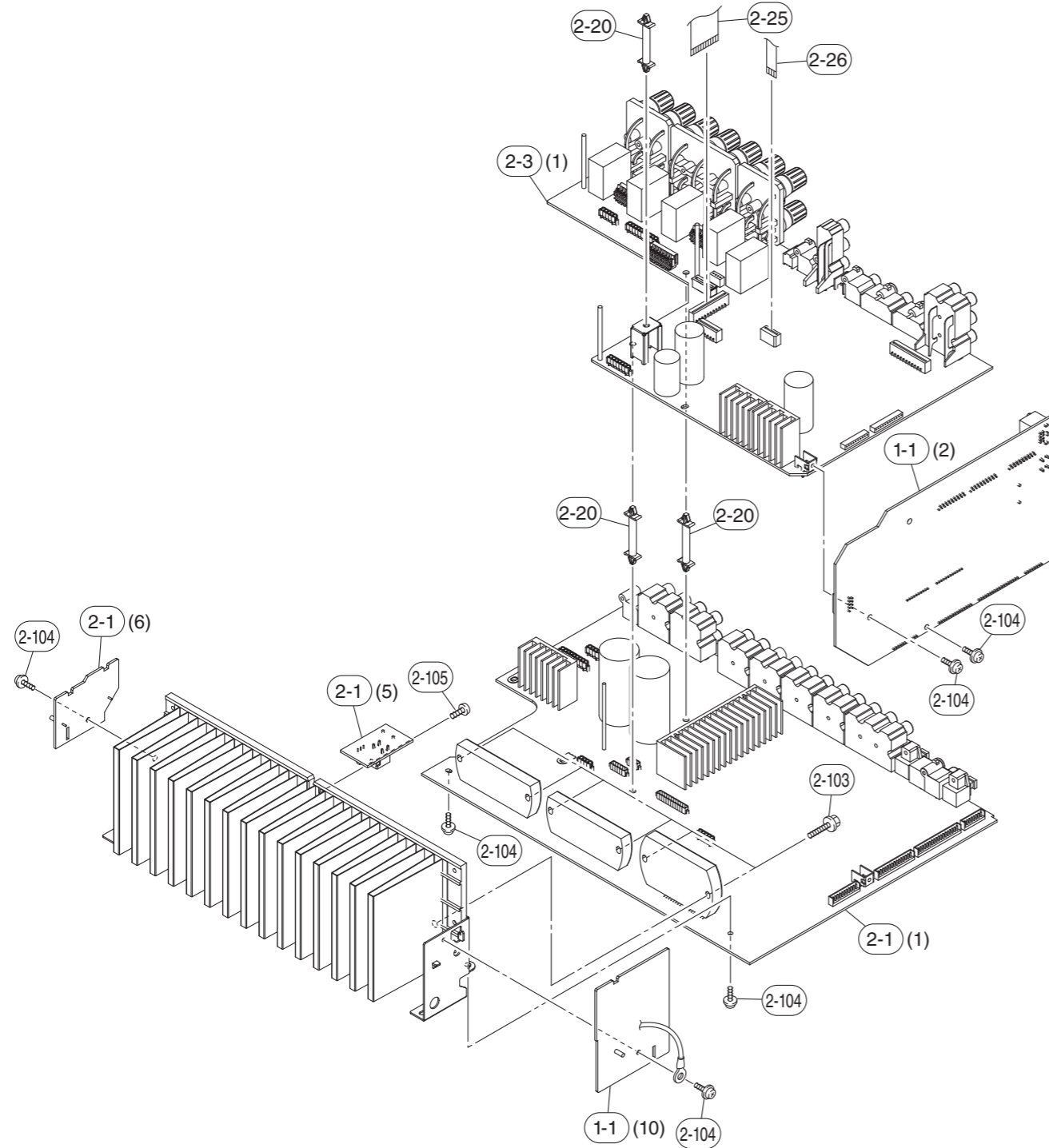

Ref No.	Part No.	Description	Remarks	Markets
* 1-1	WQ923400	P. C. B. ASS' Y	OPERATION	U
* 1-1	WQ923500	P. C. B. ASS' Y	OPERATION	C
* 1-1	WQ923600	P. C. B. ASS' Y	OPERATION	R
* 1-1	WQ923700	P. C. B. ASS' Y	OPERATION	AFL
* 2-1	WQ918900	P. C. B. ASS' Y	MAIN	U
* 2-1	WQ918900	P. C. B. ASS' Y	MAIN	C
* 2-1	WQ919400	P. C. B. ASS' Y	MAIN	C
* 2-1	WQ919000	P. C. B. ASS' Y	MAIN	R
* 2-1	WQ919100	P. C. B. ASS' Y	MAIN	AF
* 2-1	WQ919200	P. C. B. ASS' Y	MAIN	L
* 2-3	WQ920800	P. C. B. ASS' Y	VIDEO	U
* 2-3	WQ920900	P. C. B. ASS' Y	VIDEO	C
* 2-3	WQ921400	P. C. B. ASS' Y	VIDEO	C
* 2-3	WQ921000	P. C. B. ASS' Y	VIDEO	R
* 2-3	WQ921100	P. C. B. ASS' Y	VIDEO	A
* 2-3	WQ921200	P. C. B. ASS' Y	VIDEO	F
* 2-3	WQ921300	P. C. B. ASS' Y	VIDEO	L
* 2-20	WS000800	SPACER SUPPORT	LCA4-29M	
* 2-25	WR397000	FLEXIBLE FLAT CABLE	22P 140mm P=1.25	
* 2-26	WR379700	FLEXIBLE FLAT CABLE	6P 200mm P=1.25	
2-103	WE774600	SCREW IC	3x18 MFZN2W3	
2-104	WF002600	PW HEAD B-TIGHT SCREW	3x8 MFZN2W3	
2-105	WE774300	BIND HEAD B-TIGHT SCREW	3x8 MFZN2W3	

* New Parts

REMOTE CONTROL

● RAV290: U model / RAV291: C model / RAV292: R, A, L models / RAV295: F model

SCHEMATIC DIAGRAMS

RAV290/RAV291/RAV292

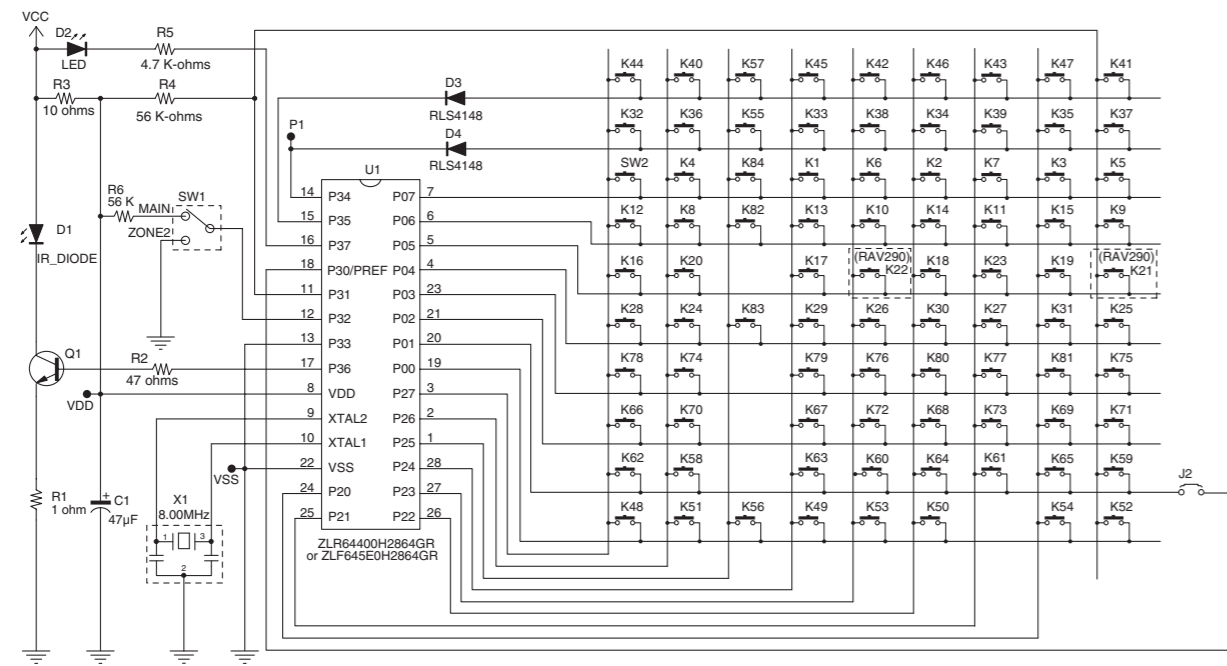

RAV295

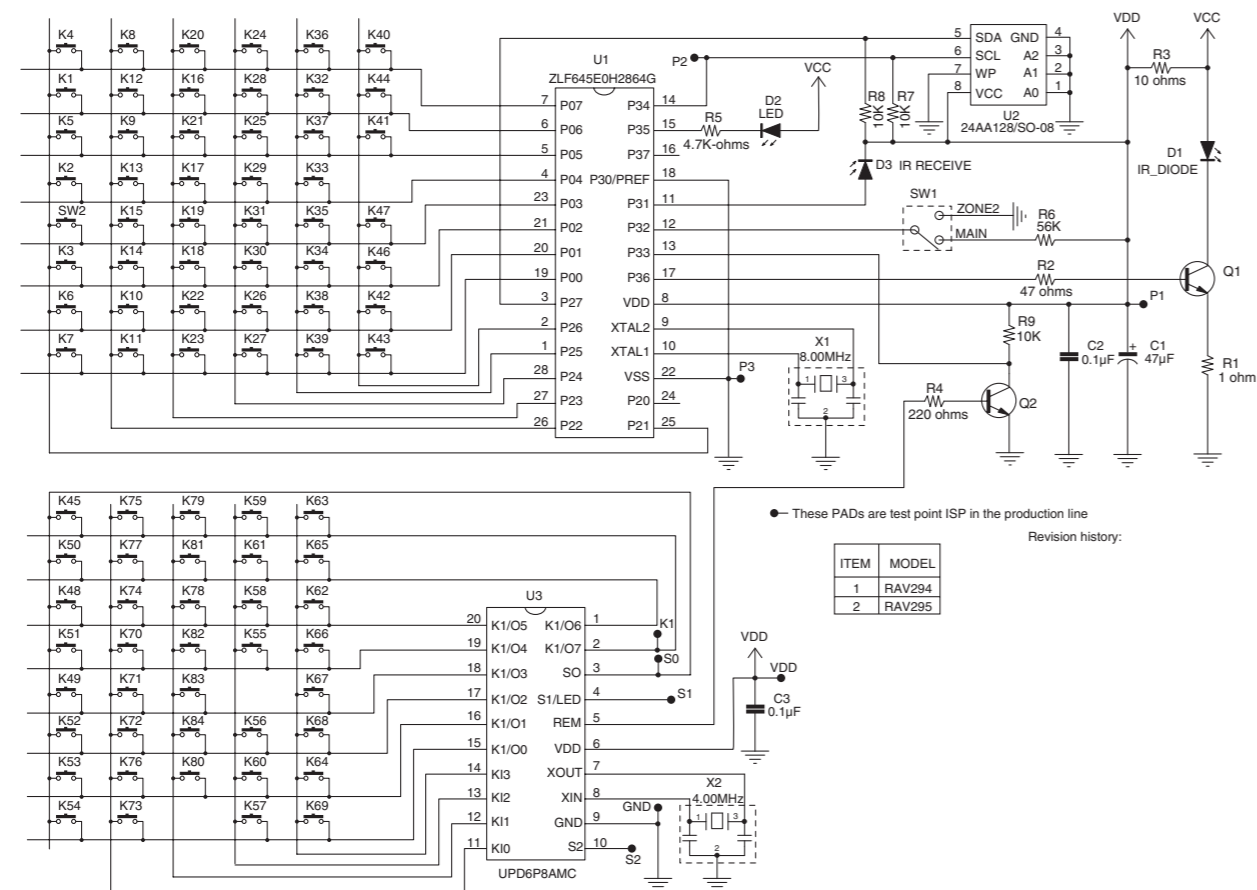

PANELS

RAV290
U model

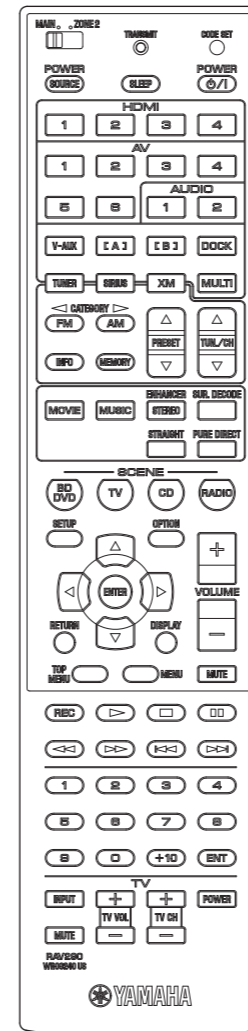

RAV291
C model

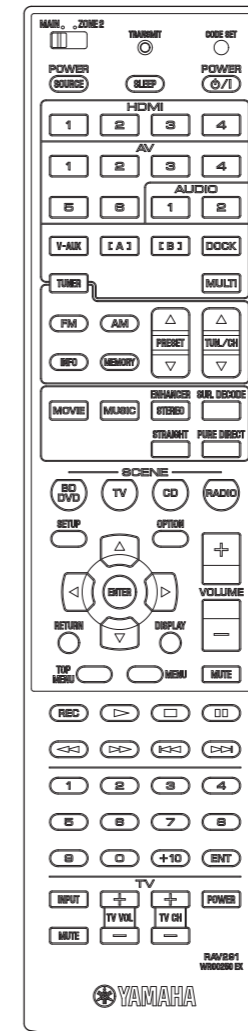

RAV292
R, A, L models

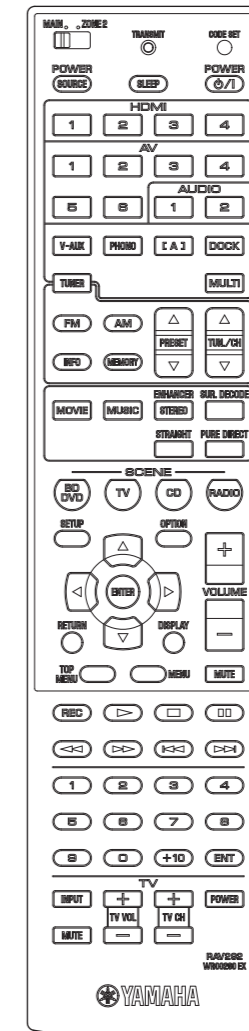

RAV295
F model

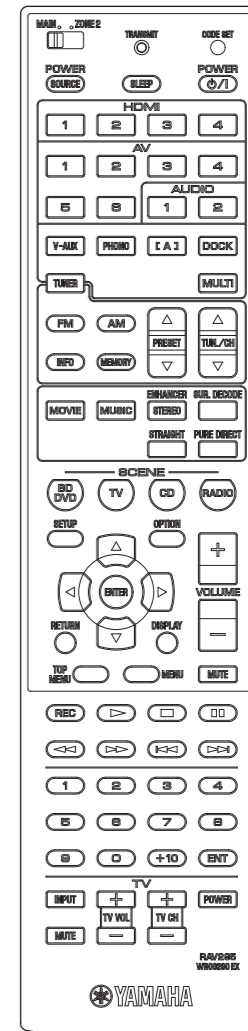

KEY NO. LAYOUT

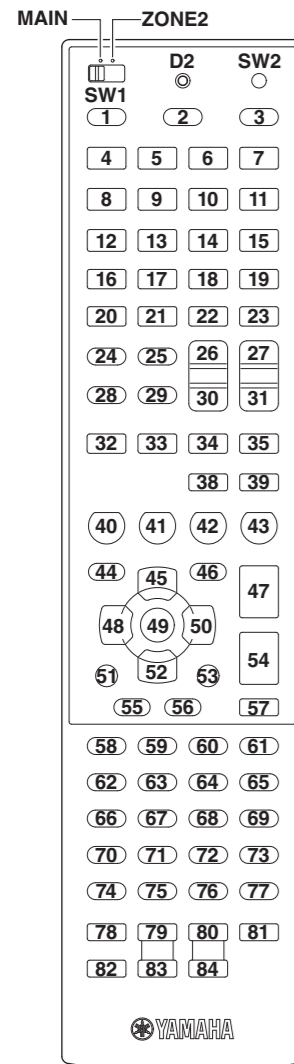

KEY CODE

GROUP	PRE SET	Key No.	FUNCTION	COM	ID1		ID2	
					MAIN	ZONE2	MAIN	ZONE2
	-	SW1	MAIN/ZONE 2	-	[MAIN]	[ZONE2]	[MAIN]	[ZONE2]
	-	D2	TRANSMIT	-	-	-	-	-
	-	SW2	CODE SET	-	-	-	-	-
POWER	-	K2	SLEEP	O	7A-30	7A-31	7A-30CE	7A-31CF
	-	K3	POWER	O	7E-2A	7A-453A	7E-2AD4	7A-453B
INPUT 1	O	K4	HDMI-1	O	7A-4738	7A-4837	7A-4739	7A-4836
	O	K5	HDMI-2	O	7A-4A35	7A-4B34	7A-4A34	7A-4B35
	O	K6	HDMI-3	O	7A-4D32	7A-4E31	7A-4D33	7A-4E30
	O	K7	HDMI-4	O	7A-502F	7A-512E	7A-502E	7A-512F
	O	K8	AV-1	O	7A-532C	7A-542B	7A-532D	7A-542A
	O	K9	AV-2	O	7A-5629	7A-5728	7A-5628	7A-5729
	O	K10	AV-3	O	7A-5926	7A-5A25	7A-5927	7A-5A24
	O	K11	AV-4	O	7A-5C23	7A-5D22	7A-5C22	7A-5D23
	O	K12	AV-5	O	7A-5F20	7A-601F	7A-5F21	7A-601E
	O	K13	AV-6	O	7A-621D	7A-631C	7A-621C	7A-631D
	O	K14	AUDIO-1	O	7A-651A	7A-6619	7A-651B	7A-6618
	O	K15	AUDIO-2	O	7A-6817	7A-6916	7A-6816	7A-6917
	O	K16	V-AUX	O	7A-55	7A-D8	7A-55AB	7A-D826
	O	K17	[A] (RAV290, 291) [PHONO] (RAV292, 295)	O	7A-14	7A-D0	7A-14EA	7A-D02E
	O	K23	MULTI CH	O	7A-87	-	7A-8779	-
INPUT 2	-	K18	[B] (RAV290, 291) [A] (RAV292, 295)	O	7F01-3F	7F01-40	7F01-3FC1	7F01-40BE
	-	K19	DOCK	O	7F01-4A	7F01-4B	7F01-4AB4	7F01-4BB5
	-	K20	TUNER	O	7A-16	7A-D2	7A-16E8	7A-D22C
	-	K21	SIRIUS (RAV290) U model	O	7A-39	7A-3A	7A-39C7	7A-3AC4
	-	K22	XM (RAV290) U model	O	7A-B4	7A-B8	7A-B44A	7A-B846
RADIO	-	K24	CATEGORY (-) FM	O	7F01-5827	7F01-5926	7F01-5826	7F01-5927
	-	K25	CATEGORY (+) AM	O	7F01-552A	7F01-5629	7F01-552B	7F01-5628
	-	K26	PRESET (+)	O	7F01-5B24	7F01-5C23	7F01-5B25	7F01-5C22
	-	K27	TUNING/CH (+)	O	7F01-611E	7F01-621D	7F01-611F	7F01-621C
	-	K28	INFO	O	7A-2758	7A-2857	7A-2759	7A-2856
	-	K29	MEMORY	O	7F01-6718	7F01-6817	7F01-6719	7F01-6816
	-	K30	PRESET (-)	O	7F01-5E21	7F01-5F20	7F01-5E20	7F01-5F21
	-	K31	TUNING/CH (-)	O	7F01-641B	7F01-651A	7F01-641A	7F01-651B
DSP	-	K32	MOVIE	O	7A-88	-	7A-8876	-
	-	K33	MUSIC	O	7A-89	-	7A-8977	-
	-	K34	STEREO/ENHANCER	O	7A-94	-	7A-946A	-
	-	K35	SUR. DECODE	O	7A-8D	-	7A-8D73	-
	-	K38	STRAIGHT	O	7A-56	-	7A-56A8	-
	-	K39	PURE DIRECT	O	7A-DD	-	7A-DD23	-
SCENE	-	K40	BD/DVD	O	7A-007F	7A-017E	7A-007E	7A-017F
	-	K41	TV	O	7A-037C	7A-047B	7A-037D	7A-047A
	-	K42	CD	O	7A-0679	7A-0778	7A-0678	7A-0779
	-	K43	RADIO or GAME	O	7A-0976	7A-0A75	7A-0977	7A-0A74

GROUP	PRE SET	Key No.	FUNCTION	COM	ID1		ID2	
					MAIN	ZONE2	MAIN	ZONE2
MENU	-	K44	SETUP	O	7A-84	-	7A-847A	-
	-	K46	SUBMENU	O	7A-6B14	-	7A-6B15	-
CURSOR	-	K45	UP	-	7A-9D	-	7A-9D63	-
	-	K48	LEFT	-	7A-9F	-	7A-9F61	-
	-	K49	ENTER	-	7A-DE	-	7A-DE20	-
	-	K50	RIGHT	-	7A-9E	-	7A-9E60	-
	-	K51	RETURN	-	7A-AA	-	7A-AA54	-
	-	K52	DOWN	-	7A-9C	-	7A-9C62	-
	-	K53	(DISPLAY)	-	7F01-60	7F01-80	7F01-609E	7F01-807E
VOLUME	-	K47	VOLUME (+)	O	7A-1A	7A-DA	7A-1AE4	7A-DA24
	-	K54	VOLUME (-)	O	7A-1B	7A-DB	7A-1BE5	7A-DB25
	-	K57	MUTE	O	7A-1C	7A-DC	7A-1CE2	7A-DC22
SOURCE	-	K1	POWER (SOURCE)	-	* Function code			
	-	K55	TOP MENU	-				
	-	K56	MENU	-				
	-	K58	REC	-				
	-	K59	PLAY	-				
	-	K60	STOP	-				
	-	K61	PAUSE	-				
	-	K62	REW	-				
	-	K63	FF	-				
	-	K64	SKIP (-)	-				
	-	K65	SKIP (+)	-				
10 key	-	K66	1	-	* Function code			
	-	K67	2	-				
	-	K68	3	-				
	-	K69	4	-				
	-	K70	5	-				
	-	K71	6	-				
	-	K72	7	-				
	-	K73	8	-				
	-	K74	9	-				
	-	K75	0	-				
	-	K76	+10	-				
	-	K77	ENT	-				
TV	-	K78	TV INPUT	-	* TV mode			
	-	K79	TV VOL (+)	-				
	-	K80	TV CH (+)	-				
	-	K81	TV POWER	-				
	-	K82	TV MUTE	-				
	-	K83	TV VOL (-)	-				
	-	K84	TV CH (-)	-				

FUNCTION CODE

Key No.	BD			DVD				DVR		LD		CD		CD-R		MD				
	Brand	Yamaha-1	Yamaha-2	Brand	Yamaha-1	Yamaha-2	Yamaha-3	T	Brand	Yamaha	Brand	Yamaha	Brand	Yamaha-1	Yamaha-2	Brand	Yamaha-1	Yamaha-2	Yamaha-3	
	Preset Number	2018	Preset Number	2000	2003	2001	2136	Preset Number	2011	Preset Number	2002	Preset Number	5013	5000	Preset Number	5001	Preset Number	5002	5003	5004
Function	Code	Function	Code	Code	Code	Code	Code	Function	Code	Function	Code	Function	Code	Code	Function	Code	Function	Code	Code	Code
K45	UP	7C-B4	UP	7C-B4	2002 B0 00 85 35	004.088	45B5 80	MENU UP	048.088	-	-	-	-	-	-	-	-	-	-	-
K48	LEFT	7C-B5	LEFT	7C-B5	2002 B0 00 87 37	004.090	45B5 51	MENU LEFT	048.090	-	-	-	-	-	-	-	-	-	-	-
K49	ENTER	7C-B8	ENTER	7C-B8	2002 B0 00 82 32	004.092	45B5 21	MENU ENTER	048.092	-	-	-	-	-	-	-	-	-	-	-
K50	RIGHT	7C-B6	RIGHT	7C-B6	2002 B0 00 88 38	004.091	45B5 4D	MENU RIGHT	048.091	-	-	-	-	-	-	-	-	-	-	-
K51	RETURN	7C-B7	RETURN	7C-B7	2002 B0 00 81 31	004.131	45B5 22	RETURN	048.131	-	-	-	-	-	-	-	-	-	-	-
K52	DOWN	7C-B3	DOWN	7C-B3	2002 B0 00 86 36	004.089	45B5 81	MENU DOWN	048.089	-	-	-	-	-	-	-	-	-	-	-
K53	DISPLAY	7C-A6	DISPLAY	7C-A6	2002 B0 00 92 22	004.015	45B5 26	DISPLAY	048.015	DISPLAY	7C-13	DISPLAY	79-0A	79-0A	DISPLAY	7F-9E	DISPLAY	79-A5	79-A5	180F
K1	SOURCE POWER	7C-80	SOURCE POWER	7C-80	2002 B0 00 3D 8D	004.012	45B5 12	AV POWER	048.012	AV POWER	-	AV POWER	79-60	79-60	AV POWER	7F-80	AV POWER	-	79-B5	150F
K55	TOP MENU	7C-B1	TOP MENU	7C-B1	2002 B0 00 9B 2B	004.113	45B5 DE	TITLE	048.200	-	-	-	-	-	-	-	-	-	-	-
K56	MENU	7C-D0	MENU	7C-B2	2002 B0 00 80 30	004.084	45B5 84	MENU	048.084	-	-	-	-	-	-	-	-	-	-	-
K58	DISC SKIP	7C-8B	DISC SKIP	7C-8B	-	004.127	??	REC	048.055	-	-	DISC SKIP	7A-4F	79-4F	REC	-	REC	79-AF	79-B1	2D0F
K59	PLAY	7C-82	PLAY	7C-82	2002 B0 00 0A BA	004.044	45B5 15	PLAY	048.044	PLAY	7C-05	PLAY	7A-08	79-02	PLAY	7F-82	PLAY	79-A8	79-A8	2A0F
K60	STOP	7C-85	STOP	7C-85	2002 B0 00 00 B0	004.049	45B5 14	STOP	048.049	STOP	7C-5B	STOP	7A-09	79-56	STOP	7F-84	STOP	79-AA	79-AA	280F
K61	PAUSE	7C-83	PAUSE	7C-83	2002 B0 00 06 B6	004.048	45B5 00	PAUSE	048.048	PAUSE	7C-5A	PAUSE	7A-09	79-55	PAUSE	7F-83	PAUSE	79-A9	79-A9	290F
K62	REW	7C-86	REW	7C-86	2002 B0 00 04 B4	004.041	45B5 19	REW	048.041	REW	7C-06	REW	7A-0D	79-05	REW	7F-88	REW	79-AC	79-AC	2B0F
K63	FF	7C-87	FF	7C-87	2002 B0 00 05 B5	004.040	45B5 13	FF	048.040	FF	7C-07	FF	7A-0C	79-06	FF	7F-89	FF	79-AD	79-AD	2C0F
K64	SKIP (-)	7C-B9	SKIP (-)	7C-B9	2002 B0 00 49 F9	004.033	45B5 23	SKIP (-)	048.033	CHAP/SKIP (-)	7C-02	SKIP (-)	7A-0B	79-04	SKIP (-)	7F-86	SKIP (-)	79-AB	79-AB	200F
K65	SKIP (+)	7C-BA	SKIP (+)	7C-BA	2002 B0 00 4A FA	004.032	45B5 24	SKIP (+)	048.032	CHAP/SKIP (+)	7C-03	SKIP (+)	7A-0A	79-07	SKIP (+)	7F-87	SKIP (+)	79-AE	79-AE	210F
K66	1	7C-94	1	7C-94	2002 B0 00 10 A0	004.001	45B5 01	1	048.001	1	7C-17	1	79-11	79-11	1	7F-91	1	79-85	79-87	000F
K67	2	7C-95	2	7C-95	2002 B0 00 11 A1	004.002	45B5 02	2	048.002	2	7C-18	2	79-12	79-12	2	7F-92	2	79-86	79-88	010F
K68	3	7C-96	3	7C-96	2002 B0 00 12 A2	004.003	45B5 03	3	048.003	3	7C-19	3	79-13	79-13	3	7F-93	3	79-87	79-89	020F
K69	4	7C-97	4	7C-97	2002 B0 00 13 A3	004.004	45B5 04	4	048.004	4	7C-1A	4	79-14	79-14	4	7F-94	4	79-88	79-BA	030F
K70	5	7C-98	5	7C-98	2002 B0 00 14 A4	004.005	45B5 05	5	048.005	5	7C-1B	5	79-15	79-15	5	7F-95	5	79-89	79-BB	040F
K71	6	7C-99	6	7C-99	2002 B0 00 15 A5	004.006	45B5 06	6	048.006	6	7C-1C	6	79-16	79-16	6	7F-96	6	79-8A	79-BC	050F
K72	7	7C-9A	7	7C-9A	2002 B0 00 16 A6	004.007	45B5 07	7	048.007	7	7C-1D	7	79-17	79-17	7	7F-97	7	79-8B	79-BD	060F
K73	8	7C-9B	8	7C-9B	2002 B0 00 17 A7	004.008	45B5 08	8	048.008	8	7C-1E	8	79-18	79-18	8	7F-98	8	79-8C	79-BE	070F
K74	9	7C-9C	9	7C-9C	2002 B0 00 18 A8	004.009	45B5 09	9	048.009	9	7C-1F	9	79-19	79-19	9	7F-99	9	79-8D	79-BF	080F
K75	0	7C-93	0	7C-93	2002 B0 00 19 A9	004.000	45B5 0A	0	048.000	0	7C-10	0/10	79-10	79-10	0	7F-90	0	79-8E	79-C0	090F
K76	+10	7C-9D	+10	7C-9D	2002 B0 00 89 39	004.120	45B5 25	+10	-	+10	7C-5D	+10	79-1A	79-1A	+10	7F-9A	+10	79-8F	79-8F	0A0F
K77	TITLE/INDEX	7C-9E	TITLE/INDEX	7C-9E	-	-	45B5 20	TITLE/INDEX	-	CHAP/TIME	7C-15	INDEX	79-0B	79-0B	INDEX	7F-8A	INDEX	-	-	-
K78	TV INPUT	(TV INPUT)	TV INPUT	(TV INPUT)	(TV INPUT)	(TV INPUT)	(TV INPUT)	TV INPUT	(TV INPUT)	TV INPUT	(TV INPUT)	TV INPUT	(TV INPUT)	(TV INPUT)	TV INPUT	(TV INPUT)	TV INPUT	(TV INPUT)	(TV INPUT)	(TV INPUT)
K79	TV VOL (+)	(TV VOL +)	TV VOL (+)	(TV VOL +)	(TV VOL +)	(TV VOL +)	(TV VOL +)	TV VOL (+)	(TV VOL +)	TV VOL (+)	(TV VOL +)	TV VOL (+)	(TV VOL +)	(TV VOL +)	TV VOL (+)	(TV VOL +)	TV VOL (+)	(TV VOL +)	(TV VOL +)	(TV VOL +)
K80	TV CH (+)	(TV CH +)	TV CH (+)	(TV CH +)	(TV CH +)	(TV CH +)	(TV CH +)	TV CH (+)	(TV CH +)	TV CH (+)	(TV CH +)	TV CH (+)	(TV CH +)	(TV CH +)	TV CH (+)	(TV CH +)	TV CH (+)	(TV CH +)	(TV CH +)	(TV CH +)
K81	TV POWER	(TV POWER)	TV POWER	(TV POWER)	(TV POWER)	(TV POWER)	(TV POWER)	TV POWER	(TV POWER)	TV POWER	(TV POWER)	TV POWER	(TV POWER)	(TV POWER)	TV POWER	(TV POWER)	TV POWER	(TV POWER)	(TV POWER)	(TV POWER)
K82	TV MUTE	(TV MUTE)	TV MUTE	(TV MUTE)	(TV MUTE)	(TV MUTE)	(TV MUTE)	TV MUTE	(TV MUTE)	TV MUTE	(TV MUTE)	TV MUTE	(TV MUTE)	(TV MUTE)	TV MUTE	(TV MUTE)	TV MUTE	(TV MUTE)	(TV MUTE)	(TV MUTE)
K83	TV VOL (-)	(TV VOL -)	TV VOL (-)	(TV VOL -)	(TV VOL -)	(TV VOL -)	(TV VOL -)	TV VOL (-)	(TV VOL -)	TV VOL (-)	(TV VOL -)	TV VOL (-)	(TV VOL -)	(TV VOL -)	TV VOL (-)	(TV VOL -)	TV VOL (-)	(TV VOL -)	(TV VOL -)	(TV VOL -)
K84	TV CH (-)	(TV CH -)	TV CH (-)	(TV CH -)	(TV CH -)	(TV CH -)	(TV CH -)	TV CH (-)	(TV CH -)	TV CH (-)	(TV CH -)	TV CH (-)	(TV CH -)	(TV CH -)	TV CH (-)	(TV CH -)	TV CH (-)	(TV CH -)	(TV CH -)	(TV CH -)

Key No.	TUNER											TAPE					TV								
	Brand	Yamaha-2	Yamaha-3	Yamaha-4	Yamaha-5	Yamaha-6	Yamaha-7	Yamaha-*	Yamaha-11	Yamaha-12	Brand	Yamaha-8	Yamaha-*	Brand	Yamaha-9	Yamaha-10	Brand	Yamaha-1	Yamaha-2	Brand	Yamaha-1	Yamaha-2	Yamaha-3	Yamaha-4	Yamaha-5
	Preset Number	5014	5007	5008	5009	5010	5011	****	5015	5016	Preset Number	5012	****	Preset Number	5017	5018	Preset Number	5005	5006	Preset Number	0000	0001	0002	0003	0004
Function	Code	Code	Code	Code	Code	Code	Code	Code	Code	Function	Code	Code	Function	Code	Code	Function	Code	Code	Function	Code	Code	Code	Code	Code	Code
K45	PRESET (+)	7A-10	7A-10	7D-F5	7A-6A	7D-31	7F01-0E	7F01-0EF0	7A-6A94	7A-10EE	UP	7F01-2E	7F01-2ED0	UP	7F01-E1	7F01-E11F	-	-	-	MENU UP	D1CC	D16C	5070	01 111 0 01 0EE 1	F082
K48	A-E/CAT. (-)	-	7A-AC	7D-BB	7A-6E	7D-35	7F01-10	7F01-10EE	7A-6E90	7A-AC52	LEFT	7F01-30	7F01-30CE	LEFT	7F01-E2	7F01-E21C	-	-	-	MENU LEFT	D1CE	D16E	5073	01 115 0 01 0EA 1	F080
K49	ENTER	-	7A-AD	7D-BC	7A-6F	7D-36	7F01-11	7F01-11EF	7A-6F91	7A-AD53	ENTER	7F01-31	7F01-31CF	ENTER	7F01-E3	7F01-E31D	-	-	-	MENU ENTER	D1D0	D170	5033	01 15F 0 01 0A0 1	F087
K50	A-E/CAT. (+)	D1-0D	7A-12	7D-F7	7A-6C	7D-33	7F01-12	7F01-12EC	7A-6C92	7A-12EC	RIGHT	7F01-32	7F01-32CC	RIGHT	7F01-E4	7F01-E41A	A/B	7A-06	7F-06	MENU RIGHT	D1CF	D16F	5072	01 114 0 01 0EB 1	F081
K51	MEMORY	-	7A-AF	7D-BE	7A-71	7D-38	7F01-13	7F01-13ED	7A-718F	7A-AF51	RETURN	7F01-33	7F01-33CD	MEMORY	7F01-DF	7F01-DF21	-	-	-	RETURN	D1D5	D175	500A	01 12F 0 01 0D0 1	-
K52	PRESET (-)	7A-11	7A-11	7D-F6	7A-6B	7D-32	7F01-14	7F01-14EA	7A-6B95	7A-11EF	DOWN	7F01-34	7F01-34CA	DOWN	7F01-E5	7F01-E51B	-	-	-	MENU DOWN	D1CD	D16D	5071	01 112 0 01 0ED 1	F083
K53	DISPLAY	-	7A-B0	7D-BF	7A-72	7D-39	7F01-15	7F01-15EB	7A-728C	7A-B04E	DISPLAY	7F01-35	7F01-35CB	DISPLAY	7F01-E0	7F01-E01E	-	-	-	DISPLAY	-	-	5010	01 11B 0 01 0E4 1	-
K1	AV POWER	D1-1B	D1-1B	-	-	-	7F01-00	7F01-00FE	-	-	AV POWER	7F01-20	7F01-20DE	AV POWER	7F01-D0	7F01-D02E	AV POWER	-	-	AV POWER	-	-	-	-	-
K55	BAND	-	7A-AE	7D-BD	7A-70	7D-37	7F01-0D	7F01-0DF3	7A-708E	7A-AE50	TITLE	7F01-2D	7F01-2DD3	TITLE	7F01-DD	7F01-DD23	-	-	-	TITLE	-	-	-	-	-
K56	SRCH MODE	-	7A-AB	7D-BA	7A-6D	7D-34	7F01-0F	7F01-0FF1	7A-6D93	7A-AB55	MENU	7F01-2F	7F01-2FD1	SRCH MODE	7F01-DE	7F01-DE20	-	-	-	MENU	D1D3	D173	5053	01 120 0 01 0DF 1	F086
K58	-	-	-	-	-	-	7F01-16	7F01-16E8	-	-	PC/MCX	7F01-36	7F01-36C8	REC	7F01-E6	7F01-E618	REC	7A-04	7F-04	REC	-	-	-	-	-
K59	-	-	-	-	-	-	7F01-1E	7F01-1EE0	-	-	PLAY	7F01-3E	7F01-3EC0	PLAY	7F01-E8	7F01-E816	PLAY	7A-00	7F-00	PLAY	-	-	-	-	-
K60	-	-	-	-	-	-	7F01-1D	7F01-1DE3	-	-	STOP	7F01-3D	7F01-3DC3	STOP	7F01-E9	7F01-E917	STOP	7A-03	7F-03	STOP	-	-	-	-	-
K61	-	-	-	-	-	-	7F01-1A	7F01-1AE4	-	-	PAUSE	7F01-3A	7F01-3AC4	PAUSE	7F01-E7	7F01-E719	PAUSE	-	-	PAUSE	-	-	-	-	-
K62	FREQ	7A-A4	7A-A4	7D-23	7A-3D	-	7F01-17	7F01-17E9	7A-3DC3	7A-A45A	NET RADIO	7F01-37	7F01-37C9	REW	7F01-EA	7F01-EA14	REW	7A-01	7F-01	REW	-	-	-	-	-
K63	EON	7A-A5	7A-A5	7D-24	7A-3E	-	7F01-18	7F01-18E6	7A-3EC0	7A-A55B	USB	7F01-38	7F01-38C6	FF	7F01-EB	7F01-EB15	FF	7A-02	7F-02	FF	-	-	-	-	-
K64	PTY MODE	7A-A6	7A-A6	7D-25	7A-3F	-	7F01-1B	7F01-1BE5	7A-3FC1	7A-A658	SKIP (-)	7F01-3B	7F01-3BC5	SKIP (+)	7F01-EC	7F01-EC12	DIR A	7A-07	7F-07	SKIP (-)	-	-	-	-	-
K65	PTY START	7A-A7	7A-A7	7D-26	7A-EF	-	7F01-1C	7F01-1CE2	7A-EF11	7A-A759	SKIP (+)	7F01-3C	7F01-3CC2	SKIP (+)	7F01-ED	7F01-ED13	DIR B	7A-00	7F-08	SKIP (+)	-	-	-	-	-
K66	P1	D1-0E	7A-E5	7D-F8																					

Advanced setup

In the advanced setup, you can set basic operations of this unit, such as on and off of a bi-amp connection, or initialize user settings. Perform the following steps to change settings.

- 1 Set this unit to the standby mode.**
- 2 Press **Ⓐ**MAIN ZONE ON/OFF while pressing and holding **Ⓜ**STRAIGHT on the front panel.**
The advanced setup menu appears on the front panel display.

ADVANCED SETUP

- 3 Press **Ⓛ**PROGRAM **</>** repeatedly to select the parameter you want to change.**
The default setting are marked with “*.”

• Set values are placed in XXX of the following parameters on an actual display screen.
- SP IMP. -XXX**
Choices: 6ΩMIN/8ΩMIN*
Selects output impedance of this unit according to connected speakers.
- REMOTE ID -XXX**
Choices: ID1*/ID2
Sets a remote control ID. When using multiple Yamaha AV receivers, you can operate them with a single remote control by setting the receiver IDs to the same setting.
- SR PIN -XXX**
Choices: RESET/CANCEL
Resets Parental lock cord when using SIRIUS Satellite tuner.
- BI AMP - XXX**
Choices: ON/OFF*
Switches on and off of bi-amp connection of main speakers.
- SCENE IR -XXX**
Choices: ON*/OFF
Selects whether or not to transmit the control signals to an external component connected to the REMOTE jacks on this unit when BD/DVD or CD SCENE function is selected.
- MON. CHK - XXXX**
Choices: YES*/SKIP
Adds upscaling limitation on output signals to a video monitor connected to this unit via the HDMI OUT jack.

INIT-XXXXXXXXXX

Choices: DSP PARAM/VIDEO/ALL/CANCEL

Initializes various settings stored in this unit. You can select an initialization method from the following.

DSP PARAM: All parameters of sound field programs

VIDEO: Video conversion settings (resolution/aspect) in the setup menu and the OSD display position

ALL: Reset this unit to initial factory settings

CANCEL: Cancellation of initialization

- 4 Press **Ⓜ**STRAIGHT a few times to select the value you want to change.**

The value selected here becomes effective when this unit is turned on the next time. You can change multiple settings by repeating steps 3 and 4.

- 5 Press **Ⓐ**MAIN ZONE ON/OFF, turns off this system, and press **Ⓐ**MAIN ZONE ON/OFF again.**

The value set in step 3 becomes effective, and this unit turns on. When you select initialization in step 3, the initialization is performed.

Setting a remote control ID

Two IDs are provided for the remote control of this unit. If another Yamaha amplifier is in the same room, setting a different remote control ID to this unit prevents unwanted operation of the other amplifier.

ID1 is set for both remote control and amplifier by default. When you change the remote control ID, display “Advance Setup” (see the previous section) and change the ID for the amplifier too.

- 1 Press **Ⓛ**CODE SET on the remote control using a pointed object such as the tip of a ballpoint pen.**

ⓁTRANSMIT blinks twice.

- 2 Press **Ⓛ**SETUP on the remote control.**

- 3 Enter the desired remote control ID code.**

To switch to ID1:

Enter “5019” using **Ⓛ**Numeric keys.

To switch to ID2:

Enter “5020” using **Ⓛ**Numeric keys.

Once the remote control code is registered,

ⓁTRANSMIT blinks twice.

If it fails, **Ⓛ**TRANSMIT blinks six times. Repeat from step 1.



- Initializing the remote control code returns it to ID1.

RX-V665/HTR-6260

