

AV RECEIVER/AV AMPLIFIER RX-V1065/HTR-6280/ AX-V1065 SERVICE MANUAL

RX-V1065/HTR-6280/
AX-V1065

IMPORTANT NOTICE

This manual has been provided for the use of authorized YAMAHA Retailers and their service personnel. It has been assumed that basic service procedures inherent to the industry, and more specifically YAMAHA Products, are already known and understood by the users, and have therefore not been restated.

WARNING: Failure to follow appropriate service and safety procedures when servicing this product may result in personal injury, destruction of expensive components, and failure of the product to perform as specified. For these reasons, we advise all YAMAHA product owners that any service required should be performed by an authorized YAMAHA Retailer or the appointed service representative.

IMPORTANT: The presentation or sale of this manual to any individual or firm does not constitute authorization, certification or recognition of any applicable technical capabilities, or establish a principle-agent relationship of any form.

The data provided is believed to be accurate and applicable to the unit(s) indicated on the cover. The research, engineering, and service departments of YAMAHA are continually striving to improve YAMAHA products. Modifications are, therefore, inevitable and specifications are subject to change without notice or obligation to retrofit. Should any discrepancy appear to exist, please contact the distributor's Service Division.

WARNING: Static discharges can destroy expensive components. Discharge any static electricity your body may have accumulated by grounding yourself to the ground buss in the unit (heavy gauge black wires connect to this buss).

IMPORTANT: Turn the unit OFF during disassembly and part replacement. Recheck all work before you apply power to the unit.

CONTENTS

TO SERVICE PERSONNEL	2	CONFIRMATION OF IDLING CURRENT OF AMP UNIT / アンプユニットのアイドリング電流の確認	67
FRONT PANELS	3-5	DISPLAY DATA	68-69
REAR PANELS	6-9	IC DATA	70-92
REMOTE CONTROL PANELS	10	PIN CONNECTION DIAGRAMS	93-95
SPECIFICATIONS / 参考仕様	11-17	BLOCK DIAGRAMS	96-99
INTERNAL VIEW	18	PRINTED CIRCUIT BOARDS	100-118
SERVICE PRECAUTIONS / サービス時の注意事項	18	SCHEMATIC DIAGRAMS	119-132
DISASSEMBLY PROCEDURES / 分解手順	19-21	REPLACEMENT PARTS LIST	133-158
UPDATING FIRMWARE / ファームウェアの書き込み	22-32	REMOTE CONTROL	159-161
SELF-DIAGNOSTIC FUNCTION / ダイアグ (自己診断機能)	33-66	ADVANCED SETUP	162
		本機の基本設定 / 初期化を行う	163-164



このサービスマニュアルは、エコマーク認定の再生紙を使用しています。
This Service Manual uses recycled paper.

101142

Copyright © 2009 YAMAHA CORPORATION All rights reserved.
This manual is copyrighted by YAMAHA and may not be copied or
redistributed either in print or electronically without permission.



YAMAHA

YAMAHA CORPORATION
P.O.Box 1, Hamamatsu, Japan

animate '09.06

■ TO SERVICE PERSONNEL

1. Critical Components Information

Components having special characteristics are marked Δ and must be replaced with parts having specifications equal to those originally installed.

2. Leakage Current Measurement (For 120V Models Only)

When service has been completed, it is imperative to verify that all exposed conductive surfaces are properly insulated from supply circuits.

- Meter impedance should be equivalent to 1500 ohms shunted by 0.15 μ F.

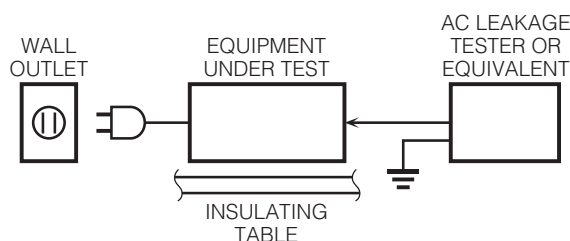

- Leakage current must not exceed 0.5mA.
- Be sure to test for leakage with the AC plug in both polarities.



For U model

“CAUTION”

“F3701: FOR CONTINUED PROTECTION AGAINST RISK OF FIRE, REPLACE ONLY WITH SAME TYPE 10A, 125V FUSE.”

For C model

CAUTION

F3701: REPLACE WITH SAME TYPE 10A, 125V FUSE.

ATTENTION

F3701: UTILISER UN FUSIBLE DE RECHANGE DE MÊME TYPE DE 10A, 125V.

WARNING: CHEMICAL CONTENT NOTICE!

This product contains chemicals known to the State of California to cause cancer, or birth defects or other reproductive harm.

DO NOT PLACE SOLDER, ELECTRICAL/ELECTRONIC OR PLASTIC COMPONENTS IN YOUR MOUTH FOR ANY REASON WHATSOEVER!

Avoid prolonged, unprotected contact between solder and your skin! When soldering, do not inhale solder fumes or expose eyes to solder/flux vapor!

If you come in contact with solder or components located inside the enclosure of this product, wash your hands before handling food.

About lead free solder / 無鉛ハンダについて

All of the P.C.B.s installed in this unit and solder joints are soldered using the lead free solder.

Among some types of lead free solder currently available, it is recommended to use one of the following types for the repair work.

- Sn + Ag + Cu (tin + silver + copper)
- Sn + Cu (tin + copper)
- Sn + Zn + Bi (tin + zinc + bismuth)

Caution:

As the melting point temperature of the lead free solder is about 30°C to 40°C (50°F to 70°F) higher than that of the lead solder, be sure to use a soldering iron suitable to each solder.

本機に搭載されているすべての基板およびハンダ付けによる接合部は無鉛ハンダでハンダ付けされています。

無鉛ハンダにはいくつかの種類がありますが、修理時には下記のような無鉛ハンダの使用を推奨します。

- Sn+Ag+Cu (錫 + 銀 + 銅)
- Sn+Cu (錫 + 銅)
- Sn+Zn+Bi (錫 + 亜鉛 + ビスマス)

注意：

無鉛ハンダの融点温度は通常の鉛入りハンダに比べ 30 ～ 40°C 程度高くなっていますので、それぞれのハンダに合ったハンダごてをご使用ください。

FRONT PANELS

Top view

U model



C, R, T, K, A, B, G, E, F, L models

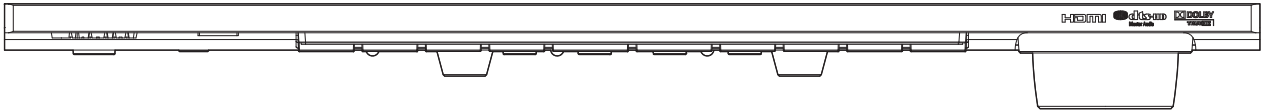

J model

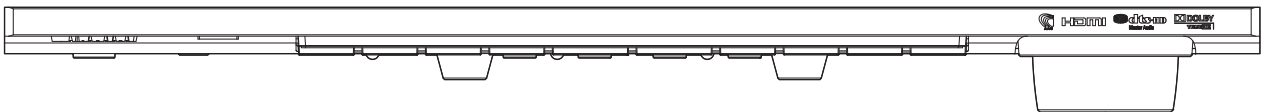

Front view

RX-V1065 (U model)

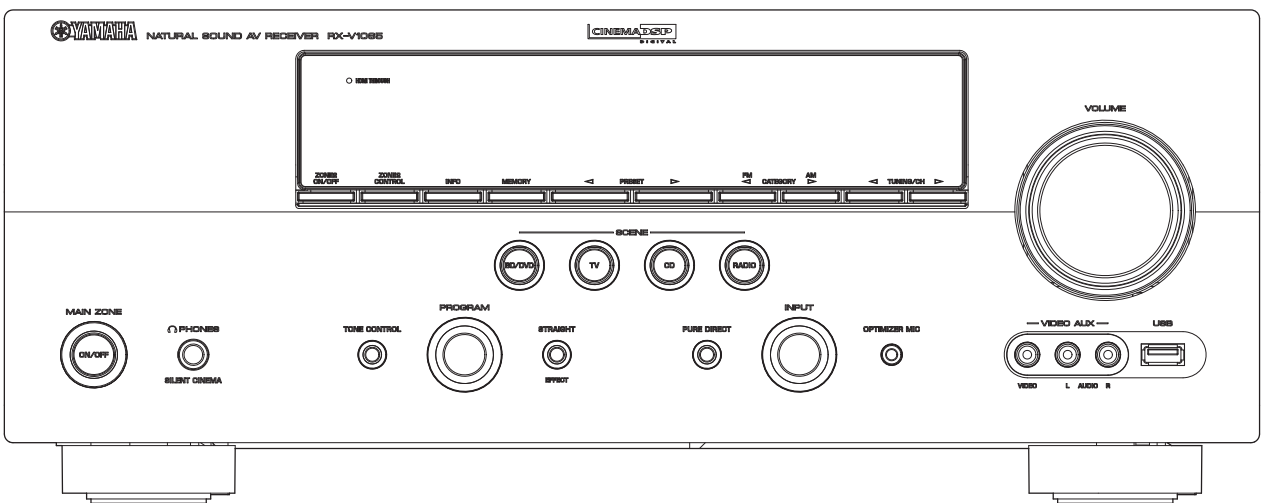

RX-V1065 (C, R, K, A, B, G, E, F, L models)

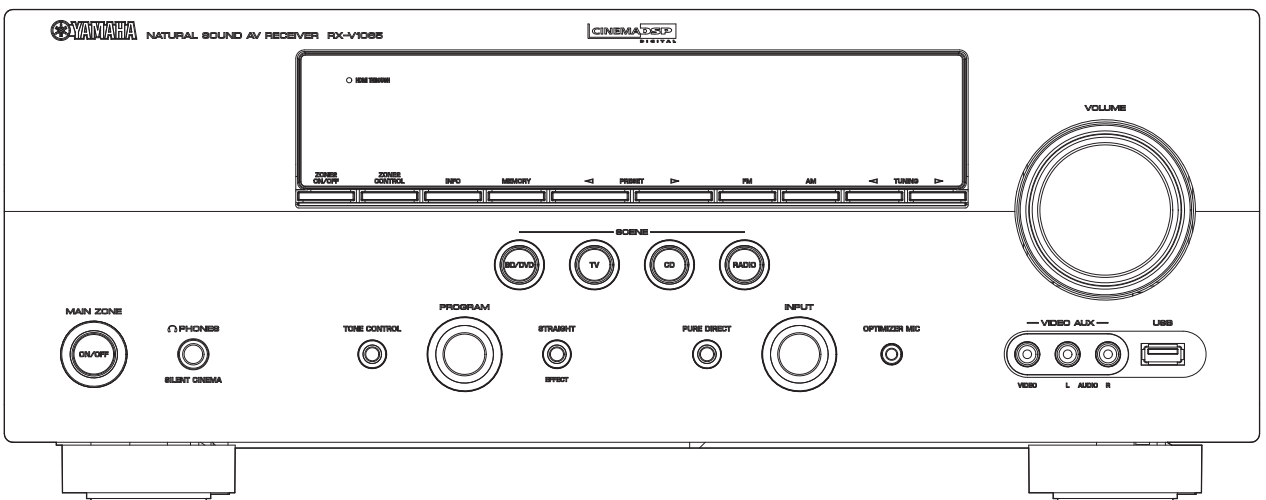

RX-V1065/HTR-6280/
AX-V1065

RX-V1065 (T model)

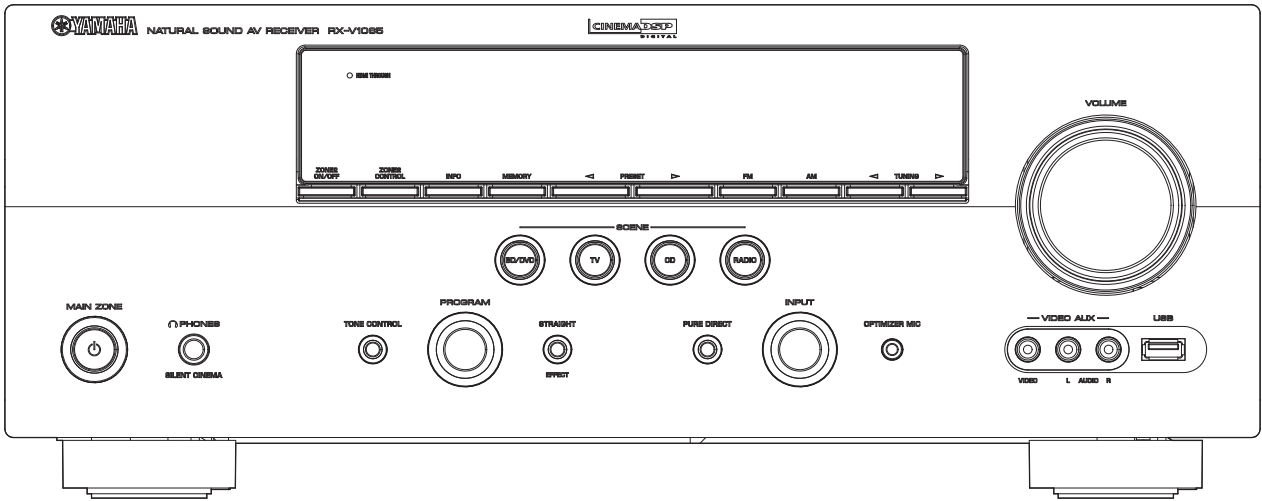

HTR-6280 (U model)

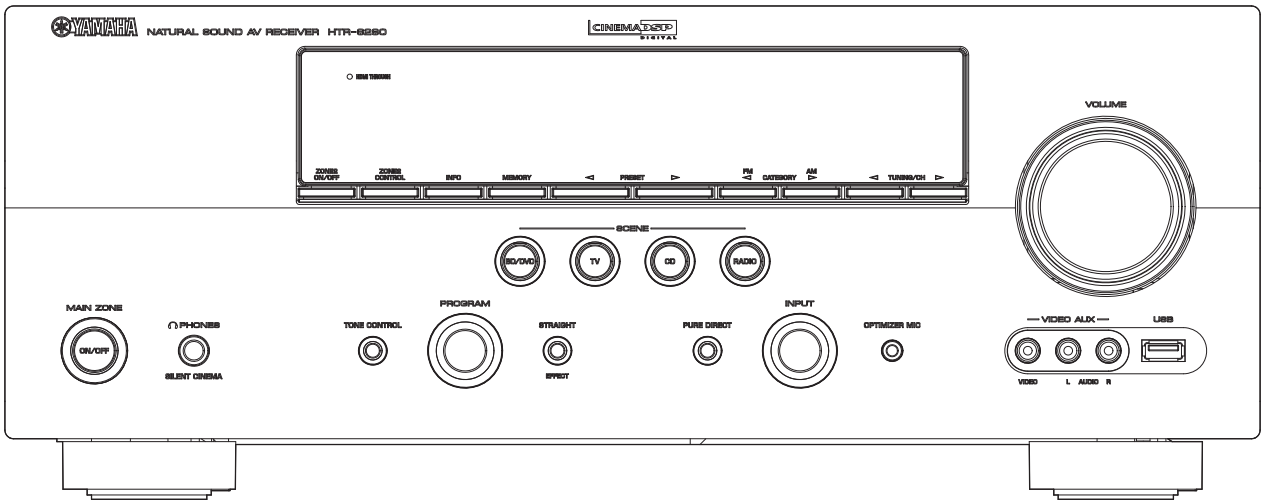

HTR-6280 (C model)

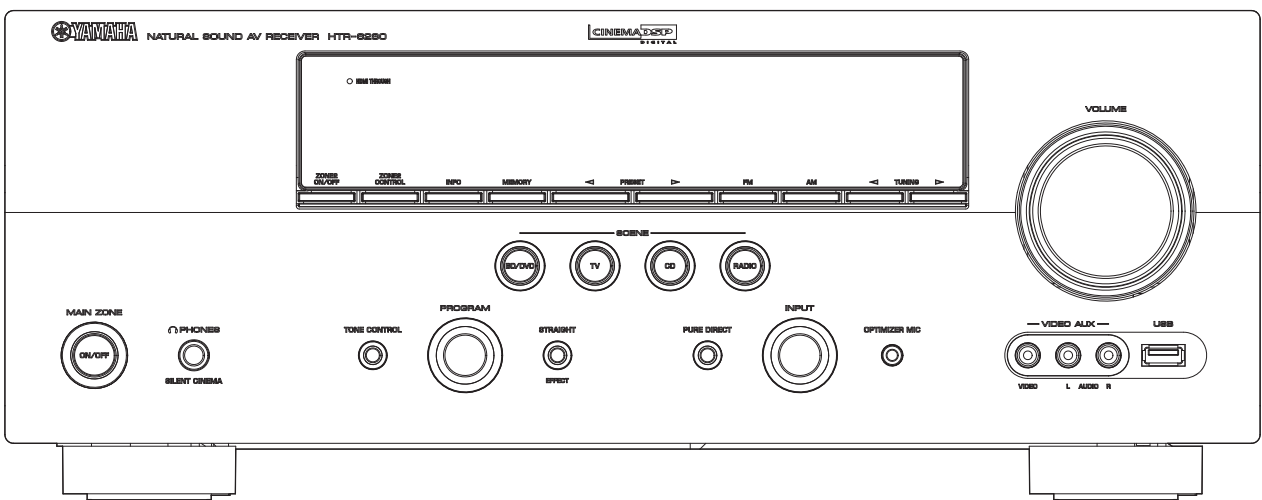

AX-V1065 (J model)

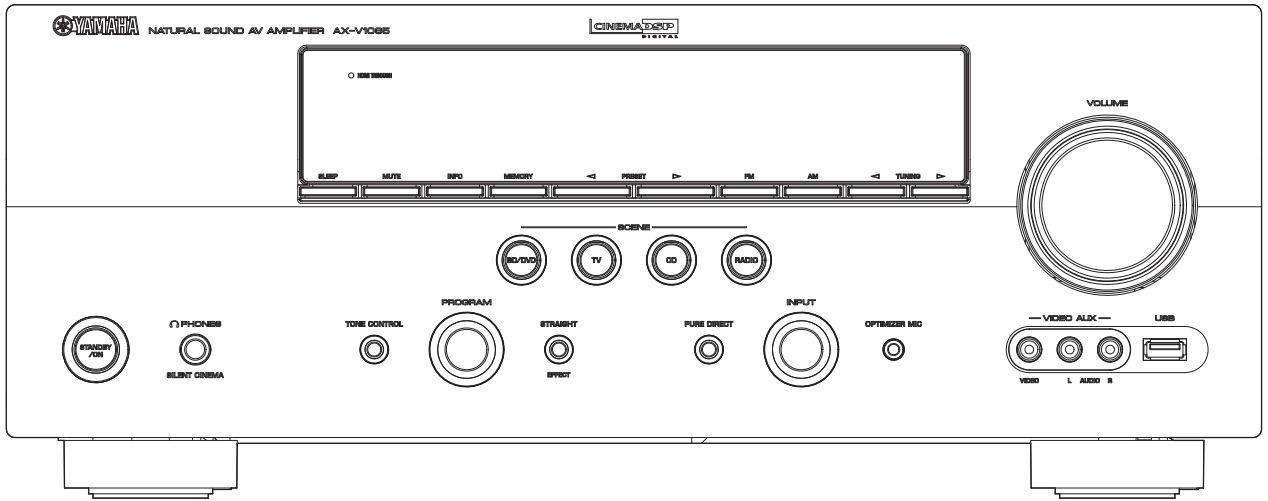

RX-V1065/HTR-6280/
AX-V1065

REAR PANELS

RX-V1065 (U model)

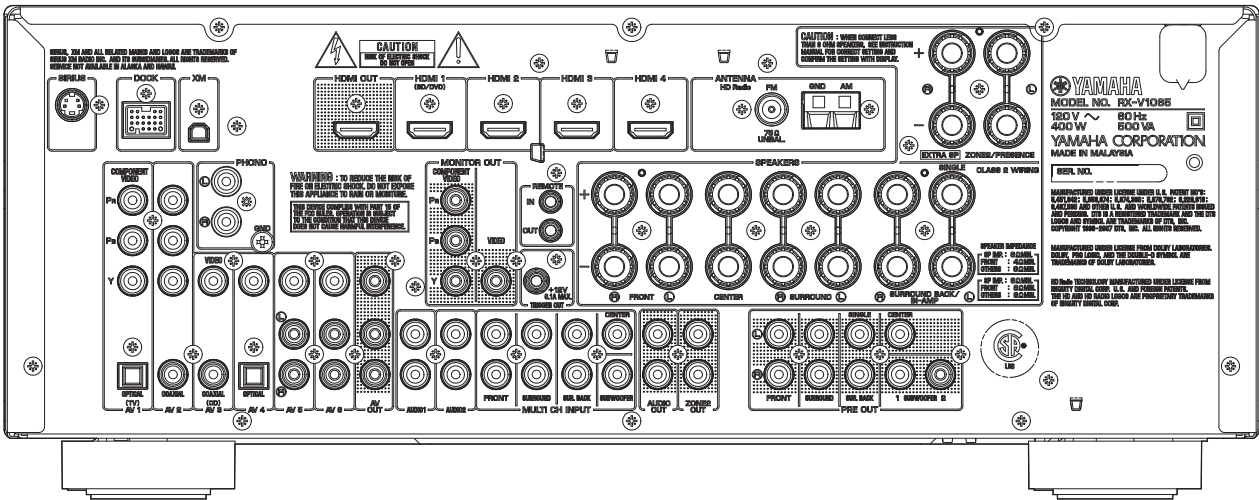

RX-V1065 (C model)

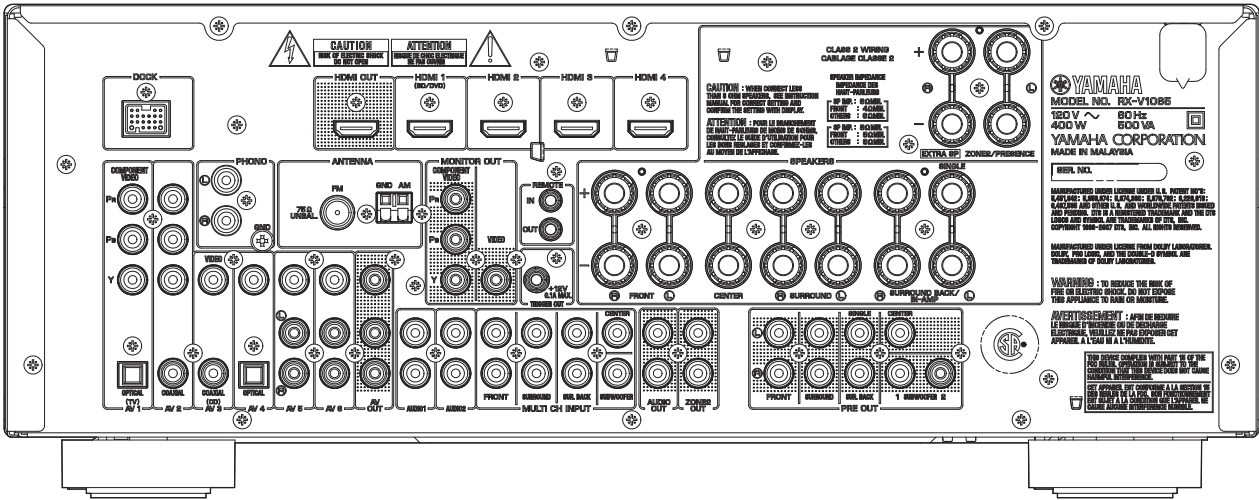

RX-V1065 (R model)

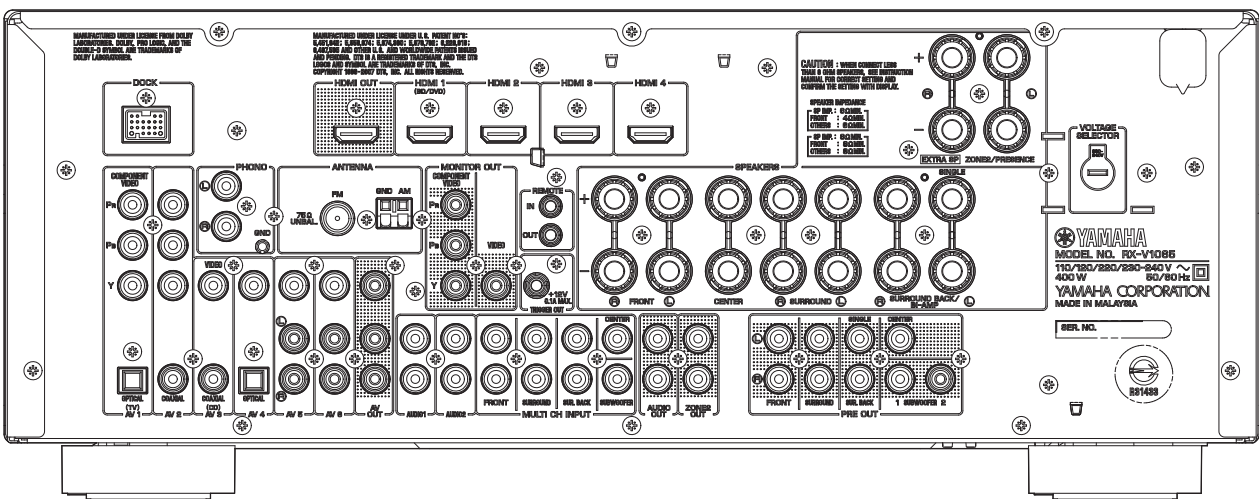

RX-V1065/HTR-6280/AX-V1065

RX-V1065 (T model)

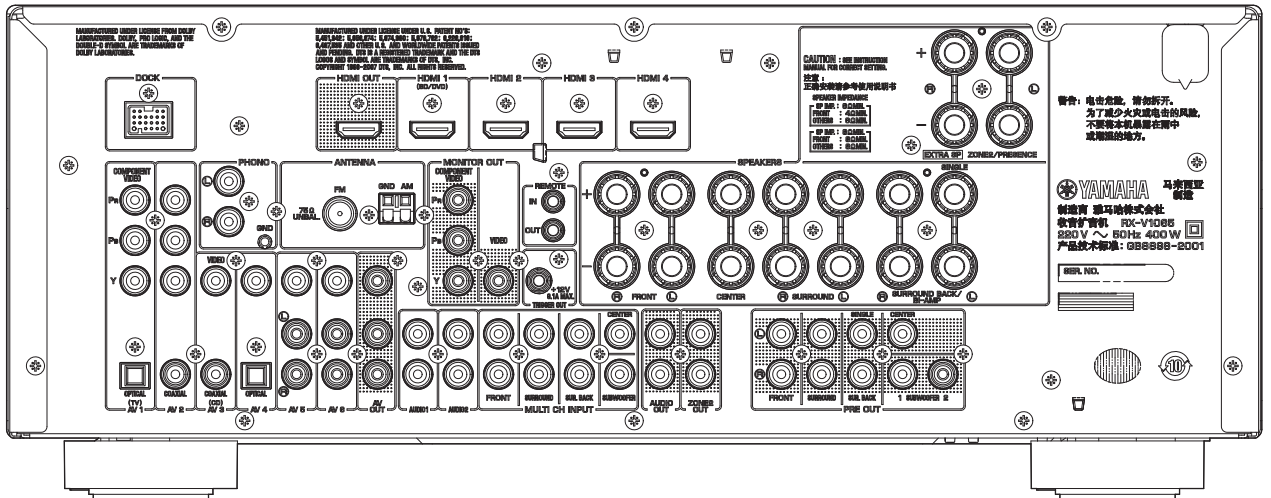

RX-V1065 (K model)

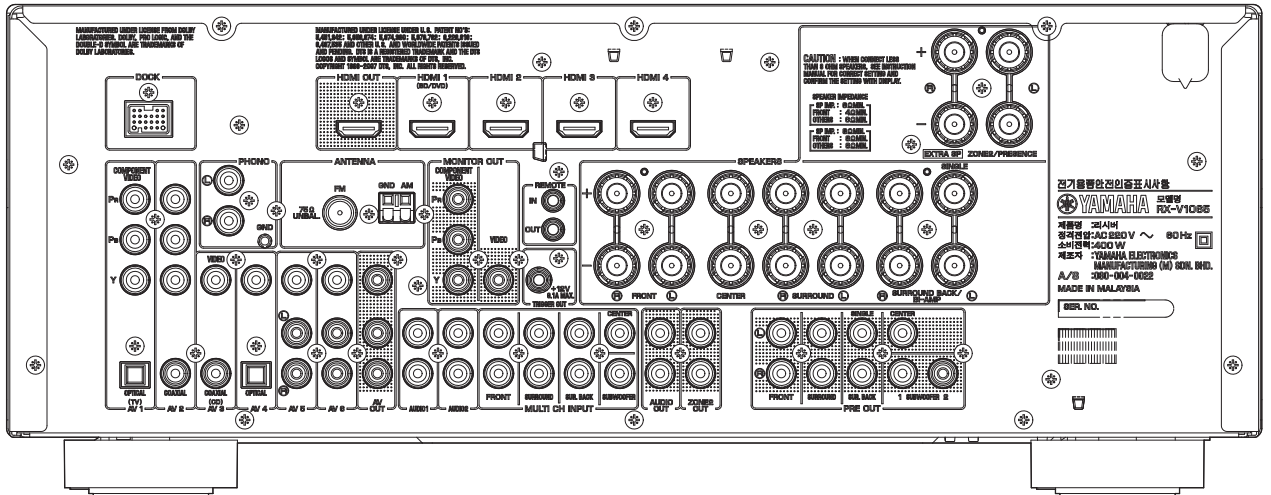

RX-V1065 (A model)

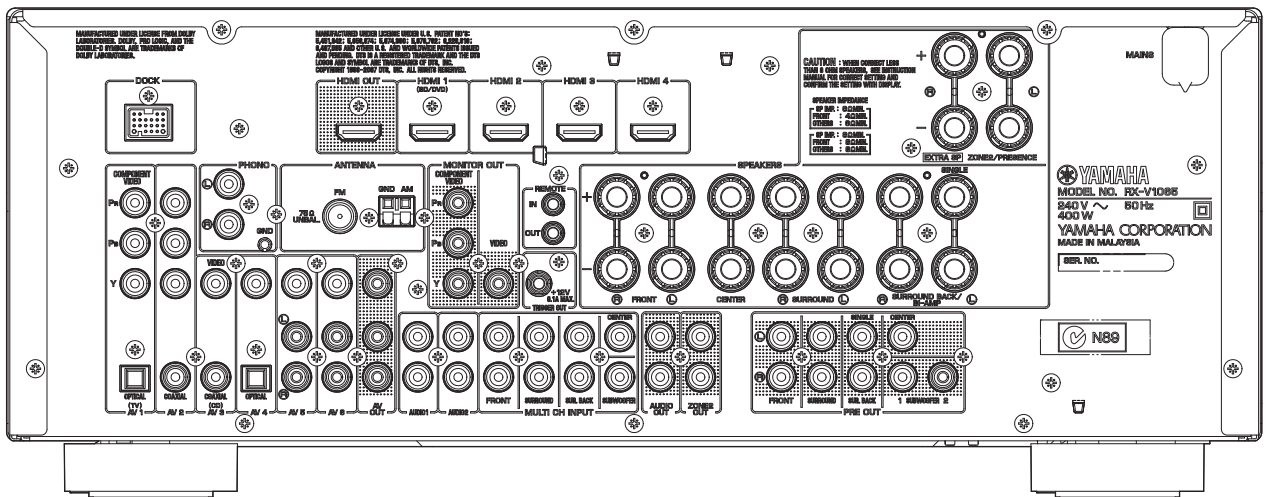

RX-V1065 (B, G, E, F models)

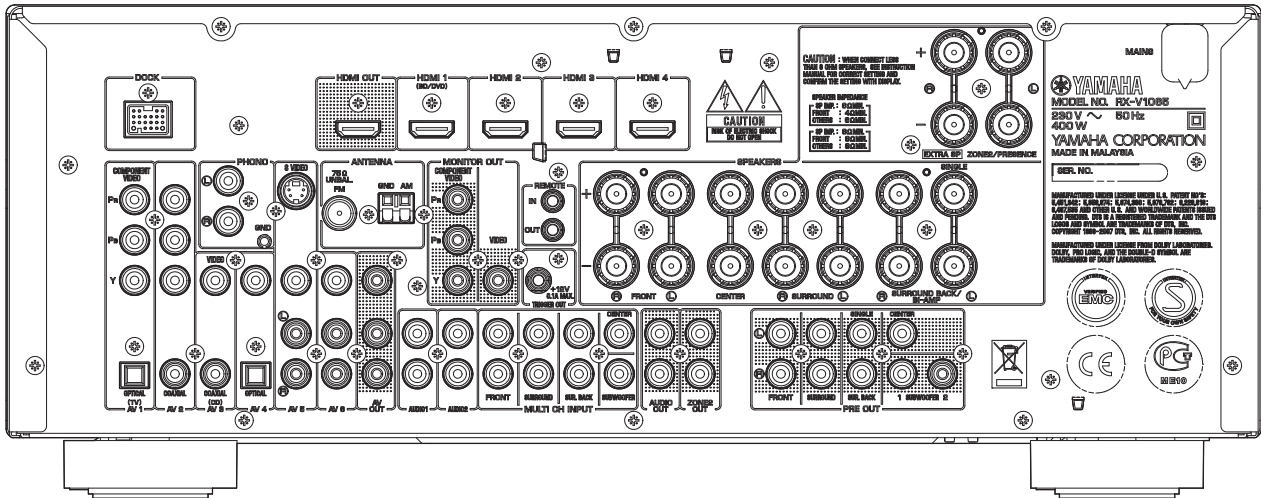

RX-V1065 (L model)

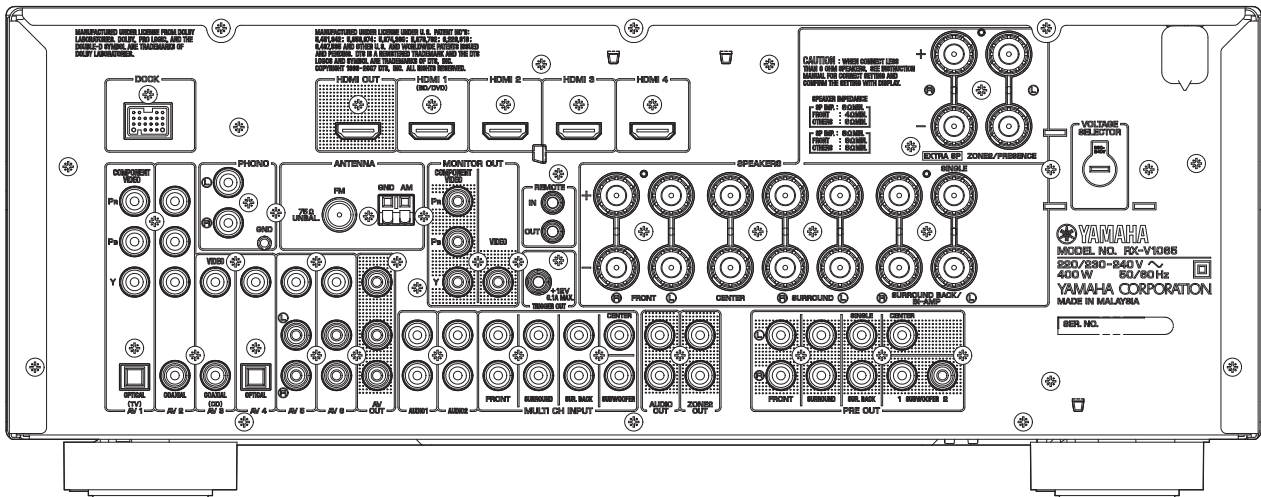

HTR-6280 (U model)

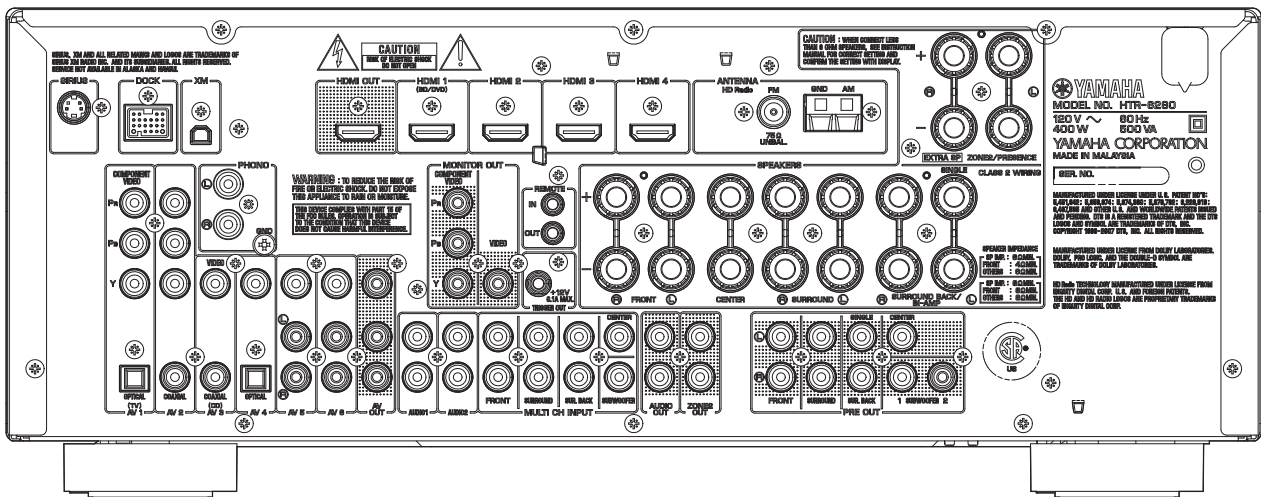

HTR-6280 (C model)

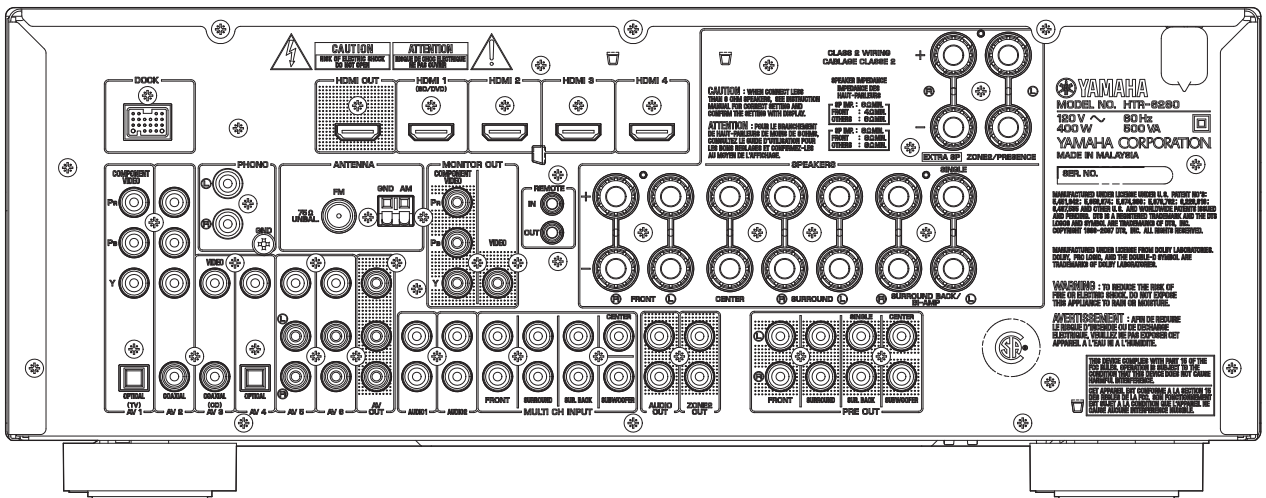

AX-V1065 (J model)

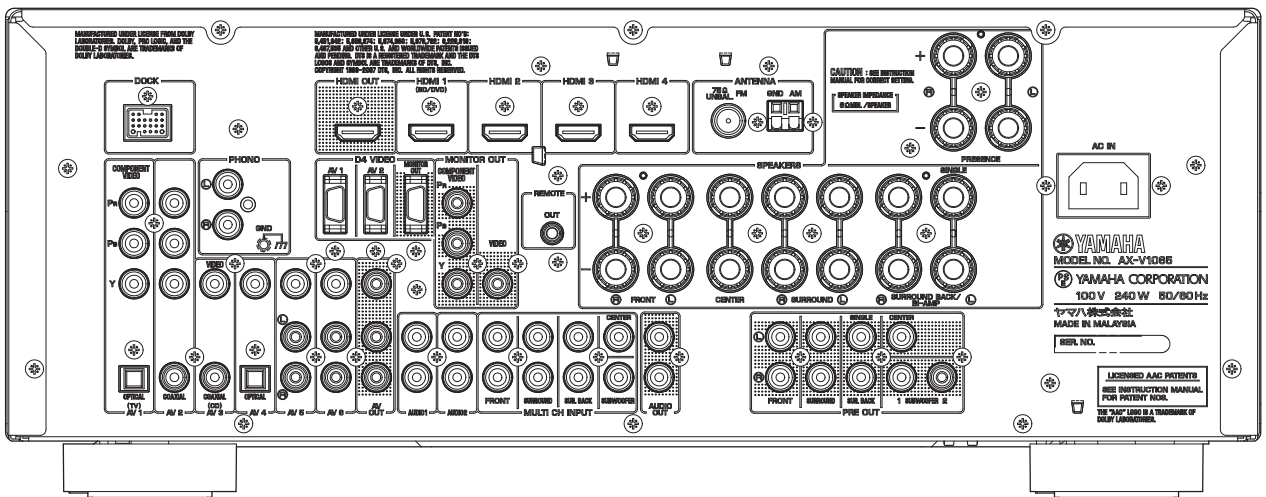

RX-V1065/HTR-6280/
AX-V1065

REMOTE CONTROL PANELS

RAV287

(U model)

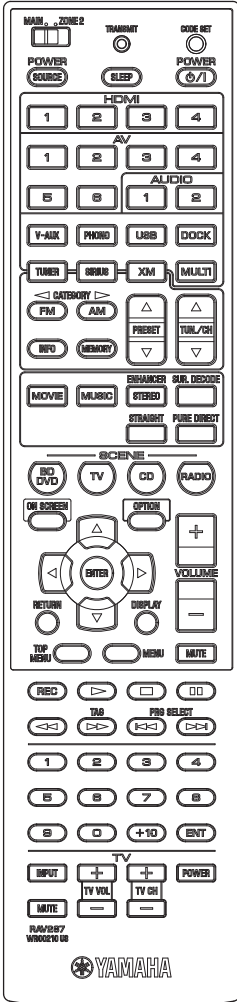

RAV288

(C, R, A, L models)

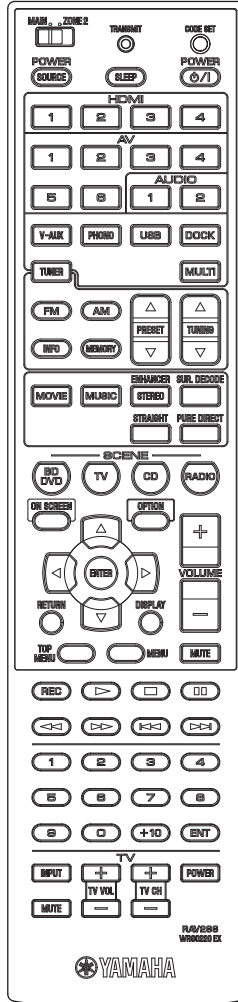

RAV294

(T, K, B, G, E, F models)

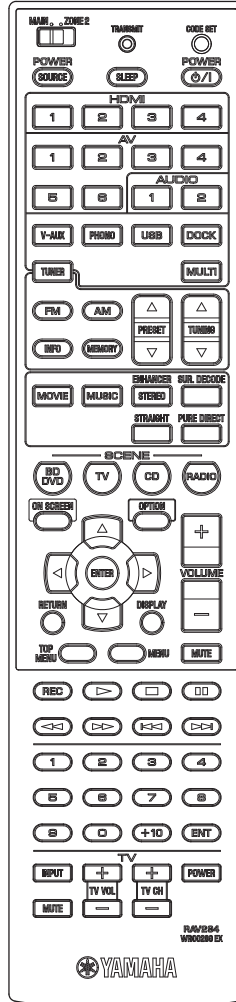

RAV286

(J model)

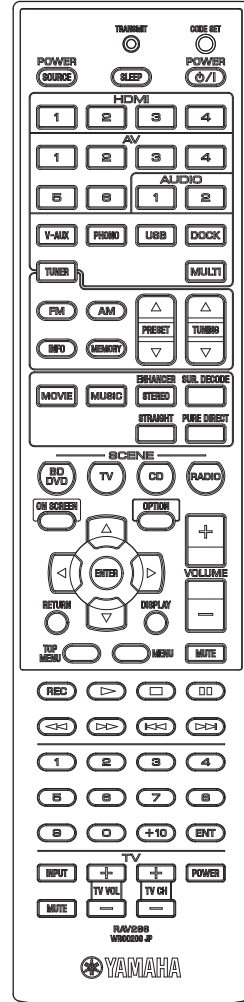

RX-V1065/HTR-6280/AX-V1065

■ SPECIFICATIONS / 参考仕様

■ Audio Section / オーディオ部

Minimum RMS Output Power (Power Amp. Section) / 定格出力 (パワーアンプ部)

[RX-V1065] (20 Hz to 20 kHz, 0.08 % THD, 8 ohms)	
FRONT L/R	105 W + 105 W
CENTER	105 W
SURROUND L/R	105 W + 105 W
SURROUND BACK L/R	105 W + 105 W

[HTR-6280] (1 kHz, 0.7 % THD, 8 ohms)	
FRONT L/R	120 W + 120 W
CENTER	120 W
SURROUND L/R	120 W + 120 W
SURROUND BACK L/R	120 W + 120 W

[AX-V1065] (20 Hz to 20 kHz, 0.09 % THD, 6 ohms)	
FRONT L/R	105 W + 105 W
CENTER	105 W
SURROUND L/R	105 W + 105 W
SURROUND BACK L/R	105 W + 105 W

Maximum Power / 実用最大出力 (JEITA) (1 kHz, 10 % THD) [R, T, K, L, J models]

FRONT L/R	
R, T, K, L models (8 ohms)	145 W + 145 W
J model (6 ohms)	145 W + 145 W

CENTER	
R, T, K, L models (8 ohms)	145 W
J model (6 ohms)	145 W

SURROUND L/R	
R, T, K, L models (8 ohms)	145 W + 145 W
J model (6 ohms)	145 W + 145 W

SURROUND BACK L/R	
R, T, K, L models (8 ohms)	145 W + 145 W
J model (6 ohms)	145 W + 145 W

MAX. Power Per Channel (1 kHz, 0.7 % THD, 4 ohms) [G, E, F, L models]

FRONT L/R	155 W + 155 W
CENTER	155 W
SURROUND L/R	155 W + 155 W
SURROUND BACK L/R	155 W + 155 W

IEC Power (1 kHz, 0.08 % THD, 8 ohms) [G, E, F, L models]

FRONT L/R	115 W + 115 W
-----------	---------------

Dynamic Power Per Channel / ダイナミックパワー (IHF)

FRONT L/R drive	
U, C, R, T, K, A, B, G, E, F, L models (8 / 6 / 4 / 2 ohms)	140 / 175 / 205 / 250 W
J model (6 / 4 / 2 ohms)	145 / 175 / 220 W

Dynamic Headroom [U, C models]

8 ohms	1.25 dB
--------	---------

Damping Factor / ダンピングファクタ

(20 Hz to 20 kHz, 8 ohms, SPEAKER-A)

FRONT L/R	100 or more
-----------	-------------

Input Sensitivity/Input Impedance / 入力感度/入力インピーダンス (1 kHz, 100 W/8 ohms)

PHONO (MM)	3.5 mV / 47 k-ohms
AV5 etc.	200 mV / 47 k-ohms
MULTI CH INPUT	
FRONT L/R, CENTER, SURROUND L/R, SURROUND BACK L/R, SUBWOOFER	200 mV / 47 k-ohms

Maximum Input Signal / 最大許容入力 (1 kHz)

PHONO (MM) (0.1 % THD)	60 mV or more
AV5 etc. (Effect ON) (0.5 % THD)	2.3 V or more

Output Level/Output Impedance / 出力電圧/出力インピーダンス

REC OUT	200 mV/1.2 k-ohms
PRE OUT	1 V/1.2 k-ohms
SUBWOOFER (2 ch stereo and FRONT SP: small)	
	1 V/1.2 k-ohms
ZONE2 OUT	
U, C, R, T, K, A, B, G, E, F, L models	200 mV/1.2 k-ohms

Headphone Jack Rated Output/Output Impedance /

ヘッドホン出力/出力インピーダンス

AV5 etc. input (1 kHz, 50 mV, 8 ohms)	100 mV/470 ohms
---------------------------------------	-----------------

Frequency Response / 周波数特性

AV5 etc., FRONT (10 Hz to 100 kHz)	+0/-3 dB
------------------------------------	----------

RIAA Equalization Deviation / RIAA 偏差

PHONO (MM)	0 ±0.5 dB
------------	-----------

Total Harmonic Distortion / 全高調波歪率

PHONO (MM) to REC OUT (20 Hz to 20 kHz, 1 V)	0.02 % or less
AV5 etc. (PURE DIRECT) to FRONT SP OUT (20 Hz to 20 kHz, 50 W)	
U, C, R, T, K, A, B, G, E, F, L models (8 ohms)	0.06 % or less
J model (6 ohms)	0.06 % or less

Signal to Noise Ratio / 信号対雑音比 (IHF-A network)

PHONO (MM) to REC OUT (Input shorted 5 mV)	
U, C, R, T models	86 dB or more
K, A, B, G, E, F, L models	81 dB or more
PHONO (MM) to REC OUT (Input shorted 2.5 mV)	
J model	80 dB or more
AV5, etc. (PURE DIRECT) to SP OUT (Input shorted 250 mV)	
	100 dB or more

Residual Noise / 残留ノイズ (IHF-A Network)

FRONT L/R to SP OUT	150 µV or less
---------------------	----------------

Channel Separation / チャンネルセパレーション (1 kHz / 10 kHz)

PHONO (Input shorted)	
	60 dB or more / 55 dB or more
AV5, etc. (Input 5.1 k-ohms shorted)	
	60 dB or more / 45 dB or more

Volume Control / 可変範囲/ステップ

	MUTE / -80 dB to +16.5 dB / 0.5 dB step
--	---

Tone Control Characteristics / トーンコントロール特性

FRONT L/R	
Bass	
Boost/Cut	±10 dB/2 dB, step 50 Hz
Turnover frequency	350 Hz
Treble	
Boost/Cut	±10 dB/2 dB, step 20 kHz
Turnover frequency	3.5 kHz

Filter Characteristics / フィルタ特性

FRONT, CENTER, SURROUND, SURROUND BACK small (H.P.F.)	
	fc=40/60/80/90/100/110/120/160/200 Hz, 12 dB/oct.
SUBWOOFER small (L.P.F.)	
	fc=40/60/80/90/100/110/120/160/200 Hz, 24 dB/oct.

■ Video Section / ビデオ部

Video Signal Type (Gray back) / ビデオ信号方式 (グレーバック)

Gray back / グレーバック	
U, C, R, K, J models	NTSC
T, A, B, G, E, F, L models	PAL
Video conversion / ビデオコンバージョン	
	NTSC/PAL

Composite Video Signal Level / コンポジットビデオ信号

	1 Vp-p / 75 ohms
--	------------------

S-Video Signal Level [B, G, E, F models]
 Y 1 Vp-p / 75 ohms
 C 0.286 Vp-p / 75 ohms

Component Video Signal Level / コンポーネントビデオ信号
 Y 1 Vp-p / 75 ohms
 Cb/Cr 0.7 Vp-p / 75 ohms

D4 Video Signal / D4 ビデオ信号 [J model]
 Y 1 Vp-p / 75 ohms
 Cb/Cr 0.7 Vp-p / 75 ohms

Video Maximum Input Level / ビデオ最大許容入力
 VIDEO CONVERSION OFF 1.5 Vp-p or more

Video Signal to Noise Ratio / ビデオ信号対雑音比
 50 dB or more

Monitor Out Frequency Response / モニター出力周波数帯域
 (VIDEO CONVERSION OFF)
 Component video signal level 5 Hz to 60 MHz, -3 dB
 D4 video signal / D4 ビデオ信号 [J model]
 5 Hz to 60 MHz, -3 dB

■ **FM Section / FM 部**

Tuning Range / 受信周波数範囲
 U, C models 87.5 to 107.9 MHz
 R, L models 87.5 to 108.0 MHz / 87.50 to 108.00 MHz
 T, K, A, B, G, E, F models 87.50 to 108.00 MHz
 J model 76.0 to 90.0 MHz

50 dB Quietening Sensitivity (IHF) (1 kHz, 100 % MOD.)
 Mono/Stereo 3 µV (20.8 dBf)

Signal to Noise Ratio / 信号対雑音比 (IHF)
 Mono 74 dB
 Stereo 70 dB

Harmonic Distortion / 歪率 (1 kHz)
 Mono 0.3 %
 Stereo 0.3 %

Antenna Input / アンテナ入力
 75 ohms unbalanced

■ **AM Section / AM 部**

Tuning Range / 受信周波数範囲
 U, C models 530 to 1,710 kHz
 R, L models 530 to 1,710 kHz / 531 to 1,611 kHz
 T, K, A, B, G, E, F, J models 531 to 1,611 kHz

Antenna / アンテナ Loop antenna

■ **General / 総合**

Power Supply / 電源電圧
 U, C models AC 120 V, 60 Hz
 R model AC 110/120/220/230-240 V, 50/60 Hz
 T model AC 220 V, 50 Hz
 K model AC 220 V, 60 Hz
 A model AC 240 V, 50 Hz
 B, G, E, F models AC 230 V, 50 Hz
 L model AC 220/230-240 V, 50/60 Hz
 J model AC 100 V, 50/60 Hz

Power Consumption / 消費電力
 U, C models 400 W / 500 VA
 R, T, K, A, B, G, E, F, L models 400 W
 J model 240 W

Standby Power Consumption (reference data) / 待機時消費電力 (参考値)
 HDMI control: OFF / Standby through: OFF 0.2 W or less
 HDMI control: ON / Standby through: ON 1.2 W or less
 HDMI control: ON / Standby through: ON / Repeat 3.0 W or less

Maximum Power Consumption [R, L models] 590 W

Dimensions (W x H x D) / 寸法 (幅 × 高さ × 奥行き)
 435 x 171 x 365 mm (17-1/8" x 6-3/4" x 14-3/8")

Weight / 質量 11.1 kg (24.5 lbs.)

Finish / 仕上げ
 [RX-V1065]
 Gold color R, T model
 Black color U, C, R, T, A, B, G, E, F, L models
 Titanium color K, G, E, F, L models
 [HTR-6280]
 Black color U, C models
 [AX-V1065]
 Black color J model

Accessories / 付属品

Remote control x 1
 Battery (R03, AAA, UM-4) x 2
 Indoor FM antenna (1.4 m) x 1
 AM loop antenna
 (1.2 m) (U model) x 1
 (1.0 m) (C, R, T, K, A, B, G, E, F, L, J models) x 1
 Optimizer microphone (6.0 m) x 1
 Power cable (2.0 m) (J model) x 1

* **Specifications are subject to change without notice due to product improvements.**

※ 参考仕様および外観は予告なく変更されることがあります。

U <i>U.S.A. model</i>	B <i>British model</i>
C <i>Canadian model</i>	G <i>European model</i>
R <i>General model</i>	E <i>South European model</i>
T <i>Chinese model</i>	F <i>Russian model</i>
K <i>Korean model</i>	L <i>Singapore model</i>
A <i>Australian model</i>	J <i>Japanese model</i>



Manufactured under license from Dolby Laboratories. Dolby, Pro Logic and the double-D symbol are trademarks of Dolby Laboratories.

ドルビーラボラトリーズからの実施権に基づき製造されています。「ドルビー」、「PRO LOGIC」、「Surround EX」およびダブルD記号  は、ドルビーラボラトリーズの商標です。



DTS is a registered trademark and the DTS logos, Symbol, DTS-HD and DTS-HD Master Audio are trademark of DTS, Inc. © 1996-2007 DTS, Inc. All Rights Reserved.

DTS は DTS 社の登録商標です。また、DTS ロゴ、記号、および DTS-HD、DTS-HD Master Audio は DTS 社の商標です。著作権 1996-2007 年 DTS 社。不許複製。



Neural Surround™ name and related logos are trademarks owned by Neural Audio Corporation.

iPod™

“iPod” is a trademark of Apple Inc., registered in the U.S. and other countries.

iPod は、米国およびその他の国々で登録された Apple Inc. の商標または登録商標です。

Bluetooth™

Bluetooth is a registered trademark of Bluetooth SIG and is used by Yamaha in accordance with a license agreement.

Bluetoothは、Bluetooth SIGの登録商標でありヤマハはライセンスに基づき使用しています。

HDMI

“HDMI,” the “HDMI” logo and “High-Definition Multimedia Interface” are trademarks, or registered trademarks of HDMI Licensing LLC.

HDMI、HDMI ロゴ、および High-Definition Multimedia Interface は、HDMI Licensing, LLC の商標または登録商標です。

x.v.Color

“x.v.Color” is a trademark of Sony Corporation.

「x.v.Color」は、ソニー株式会社の商標です。

SILENT™ CINEMA

“SILENT CINEMA” is a trademark of Yamaha Corporation.

「サイレントシネマ™ SILENT CINEMA™」はヤマハ株式会社の登録商標です。



SIRIUS, XM and all related marks and logos are trademarks of Sirius XM Radio Inc. and its subsidiaries. All rights reserved. **Service not available in Alaska and Hawaii.**

HD Radio

HD Radio™ Technology Manufactured Under License From iBiquity Digital Corp. U.S. and Foreign Patents. HD Radio™ and the HD Radio logo are proprietary trademarks of iBiquity Digital Corp.



AAC ロゴマークはドルビーラボラトリーズの商標です。

• **DIMENSIONS**

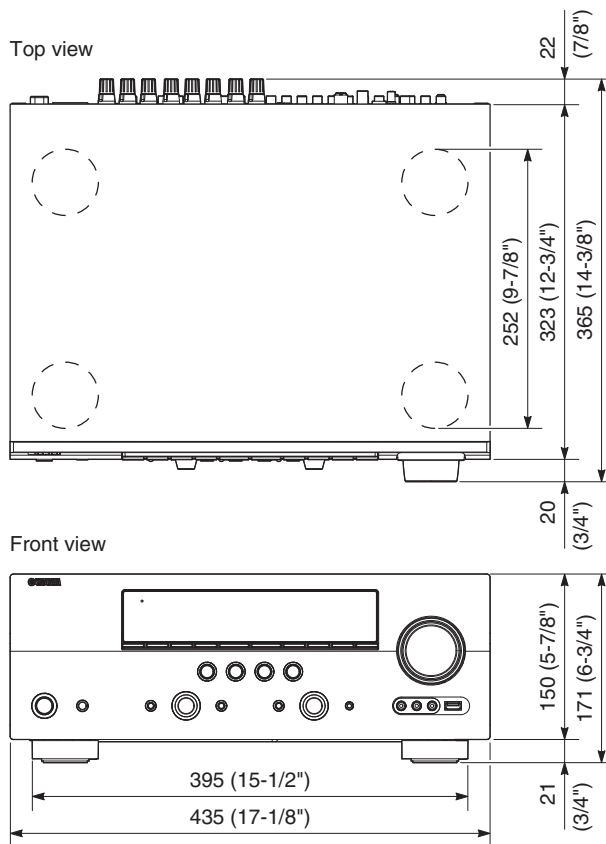

Unit: mm (inch)
単位: mm (インチ)

• **SCENE TEMPLATE**

Name	BD/DVD	TV	CD	RADIO
INPUT	HDMI1	AV-1 (Component / Optical)	AV-3 (Video / Coaxial)	TUNER
Sound field mode	STRAIGHT	STRAIGHT	STRAIGHT	MUSIC ENHANCER 7ch Enhancer
IR code output	DVD Play	None	CD Power On / Play	None

• SOUND FIELD PARAMETERS

Category	Program	Parameter																																
		Decode Type	3D DSP: ON/OFF	DSP Level: -6dB to +3dB	Init. Delay: 1 to 99ms	Room Size: 0.1 to 2.0	Liveness: 0 to 10	Sur. Init. Delay: 1 to 49ms	Sur. Room Size: 0.1 to 2.0	Sur. Liveness: 0 to 10	SB. Init. Delay: 1 to 49ms	SB. Room Size: 0.1 to 2.0	SB. Liveness: 0 to 10	Rev. Time: 1.0 to 5.0s	Rev. Delay: 0 to 250ms	Rev. Level: 0 to 100%	Dialogue Lift: 0 to 5	Center Level: 0 to 100%	Surround L Level: 0 to 100%	Surround R Level: 0 to 100%	Sur.Back Level: 0 to 100%	Presence L Level: 0 to 100%	Presence R Level: 0 to 100%	Direct: Auto/Off	Effect Level: High/Low	Panorama: On/Off	Center Width: 0 to 7	Dimension: -3 to +3	Center Image: 0.0 to 1.0	FOCUS: 0 to 8	TruBass: 0 to 8	Initialize		
MOVIE	Standard	● *1	●	●			●	●	●	●	●	●					●																	●
	Spectacle	● *1	●	●	●	●	●	●	●	●	●	●					●																	●
	Sci-Fi	● *1	●	●	●	●	●	●	●	●	●	●					●																	●
	Adventure	● *1	●	●	●	●	●	●	●	●	●	●					●																	●
	Drama	● *1	●	●	●	●	●	●	●	●	●	●					●																	●
	Mono Movie		●	●	●	●	●							●	●	●																		●
	Sports		●	●	●	●	●	●	●	●	●	●					●	●	●															●
	Action Game		●	●	●	●	●	●	●	●	●	●					●																	●
Roleplaying Game		●	●	●	●	●	●	●	●	●	●					●																	●	
MUSIC	Hall in Munich		●	●	●	●	●									●																	●	
	Hall in Vienna		●	●	●	●	●									●																	●	
	Chamber		●	●	●	●	●							●	●	●																	●	
	Cellar Club		●	●	●	●	●									●																	●	
	The Roxy Theatre		●	●	●	●	●							●	●	●																	●	
	The Bottom Line		●	●	●	●	●									●																	●	
	Music Video		●	●	●	●	●	●	●	●	●	●					●																●	
STEREO	2ch Stereo																		●	●	●	○	●	●								●		
	7ch Stereo																		●	●	●	○	●	●								●		
MUSIC ENHANCER	Straight Enhancer																								●							●		
	7ch Enhancer																							●							●			
SUR. DECODE	Surround Decoder	● *2																								△	△	△	▲	■	■	●		
STRAIGHT																																		

○ : The parameter to be used varies between when there is one surround pack and when there are two. On the display, the parameter value varies accordingly while the same parameter name appears. / サラウンドパックの数が1つの場合と2つの場合で使用するパラメータは変わるが、パラメータ名は同じ表示でパラメータ値のみを切換えて表示

△ : Setting is possible only when Pro Logic II x Music (Pro Logic II Music) is selected using decode type. / Decode Type で Pro Logic II x Music (Pro Logic II Music) を選択時のみ設定可

▲ : Setting is possible only when Neo:6 Music is selected using decode type. / Decode Type で Neo:6 Music を選択時のみ設定可

■ : Setting is possible only when CS II Cinema/Music is selected using decode type. / Decode Type で CS II Cinema/Music を選択時のみ選択可

*1 Decode Type

Decode Type	PL II x Movie	PL II when Surround Back is None. / Surround Back が None の場合は PL II
	Neo:6 Cinema	

*2 Decode Type

Decode Type	Pro Logic	PL II when Surround Back is None. / Surround Back が None の場合は PL II
	PL II x Movie	
	PL II x Music	
	PL II x Game	
	Pro Logic II z	
	Neo:6 Cinema	
	Neo:6 Music	
	Neural Sur.	

• SET MENU TABLE / セットメニュー

MAIN MENU	SUB-MENU	PARAMETER	VALUE [INITIAL VALUE]	
1 • Speaker Setup				
1 Auto Setup (YPAO)	Extra SP Assign		[Zone2] / Presence / None	
	EQ Type		[Natural] / Flat / Front	
	Start		[ENTER]: Start	
2 Manual Setup	A) Speaker Configuration	Extra Speaker Assignment	Zone2 / Presence / [None]	
		LFE/Bass Out	Subwoofer / Front / [Both]	
		Front Speaker	Small / [Large]	
		Center Speaker	None / [Small] / Large	
		Surround L/R Speaker	None / Large x 1 / Small x 1 / Large x 2 / [Small x 2]	
		Surround Back L/R Speaker	None / Large x 1 / Small x 1 / Large x 2 / [Small x 2]	
		Bass Crossover Frequency	40 / 60 / [80] / 90 / 100 / 110 / 120 / 160 / 200 Hz	
		Subwoofer Phase	[Normal] / Reverse	
	B) Speaker Level	Front L	-10.0 to +10.0 dB, [0 dB], 0.5 dB step	
		Front R		
		Center		
		Surround L		
		Surround R		-10.0 to +10.0 dB, [-1.0 dB], 0.5 dB step
		Surround Back L		
		Surround Back R		
	C) Speaker Distance	Subwoofer	-10.0 to +10.0 dB, [0 dB], 0.5 dB step	
		Unit	meters (m) / [feet (ft)]	
		Front L	0.30 to 24.00 m, [3.00 m]	
		Front R		
		Center		
		Surround L	0.30 to 24.00 m, [2.40 m]	
		Surround R		
		Surround Back L		
		Surround Back R		
		Subwoofer	0.30 to 24.00 m, [3.00 m]	
		Presence L		
		Presence R	1.0 to 80.0 ft, [10.0 ft]	
Front L				
Front R				
Center				
Surround L				
Surround R	1.0 to 80.0 ft, [8.0 ft]			
Surround Back L				
Surround Back R				
Subwoofer	1.0 to 80.0 ft, [10.0 ft]			
Presence L				
Presence R				
D) Equalizer	EQ Type Select		Auto PEQ / [GEQ] / Off	
	GEQ		* "GEQ" is available only when "EQ Type Select" is set to "GEQ". / "GEQ" 選択時のみ設定可能	
	Front L	63 Hz 0 dB	-6.0 to +6.0 dB, [0 dB], 0.5 dB step	
	Front R	160 Hz 0 dB		
	Center	400 Hz 0 dB		
	Sur. L	1 kHz 0 dB		
	Sur. R	2.5 kHz 0 dB		
	SBL	6.3 kHz 0 dB		
	SBR	16 kHz 0 dB		
	E) Test Tone			[Off] / On
2 • Sound Setup				
1 Dynamic Range				Min/Auto / STD / [Max.]
2 Lipsync	HDMI Auto Lipsync		[Off] / On	
	Auto Delay		0 to 240 ms, [0 ms], 1 ms step	
	Manual Delay			
3 • Function Setup				
1 HDMI	HDMI Control		On / [Off]	
	Standby Through		On / [Off] (* This menu is available only when "Control" is set to "Off". / "Control : Off" 選択時のみ設定可能)	
	Audio Output		[Amplifier] / TV / Amplifier + TV (* This menu is available only when "Control" is set to "Off". / "Control : Off" 選択時のみ設定可能)	
	Resolution		[*Through] / *480p / *720p / *1080i / *1080p	
	Aspect		[Through] / 16:9 / Smart Zoom	

RX-V1065/HTR-6280/AX-V1065

MAIN MENU	SUB-MENU	PARAMETER	VALUE [INITIAL VALUE]		
2 Display	Dimmer		-4 to 0, [0]		
	Front Panel Display Scroll		[Continuous] / Once		
	GUI Position		-5 to +5, [0]		
3 Volume	Adaptive DRC		Auto / [Off]		
	Max Volume		-30.0 dB to +15.0 dB / [+16.5 dB], 5.0 dB step		
	Initial Volume		[Off] / Mute / -80.0 to +16.5 dB, 0.5 dB step		
4 Input Rename			Input is possible to 9 characters / 9文字まで入力可能 Input possible Character type / 入力可能文字 Capital / 英大文字 : A to Z Small / 英小文字 : a to z Figure / 数字 : 0 to 9 Space / 空白 Marks / 記号 : # * + , - . / : < > ? etc.		
5 Zone2	Zone2 Max. Volume		-30.0 dB to +15.0 dB / [+16.5 dB], 5.0 dB step		
	Zone2 Initial Volume		[Off] / Mute / -80.0 to +16.5 dB, 0.5 dB step		
4 • DSP Parameter					
STEREO	7ch Stereo	CT Level	0 to 100 %		
		SL Level			
		SR Level			
		SB Level			
		Initialize			
MUSIC ENHANCER	Straight Enhancer	Effect Level - High	[High] / Low		
		Initialize			
	7ch Enhancer	Effect Level - High	[High] / Low		
		Initialize			
SUR. DECODE	Sur. Decoder	SUR. Pro Logic	Pro Logic / PL Ilx Movie / PL Ilx Music / PL Ilx Game / Neo:6 Cinema / Neo:6 Music / Neural Sur. (U model)		
		Pro Logic Initialize			
		PL Ilx Movie Initialize			
		PL Ilx Music	Panorama	[Off] / On	
			Center Width	0 to 7, [3]	
			Dimension	-3 to [STD] to +3	
		Initialize			
		PL Ilx Game Initialize			
		Neo:6 Cinema Initialize			
		Neo:6 Music	C. Image	0.0 to 1.0, [0.3]	
			Initialize		
		Neural Sur. Initialize			
		MOVIE	Standard	SUR. PL Ilx Movie	PL Ilx Movie / Neo:6 Cinema
				PL Ilx Movie [1], [4], [8], [11], [16]	
Neo:6 Cinema [1], [4], [8], [11], [16]					
Spectacle	SUR. PL Ilx Movie		PL Ilx Movie / Neo:6 Cinema		
	PL Ilx Movie [1], [3], [4], [7], [8], [16]				
	Neo:6 Cinema [1], [4], [8], [11], [16]				
Sci-Fi	SUR. PL Ilx Movie		PL Ilx Movie / Neo:6 Cinema		
	PL Ilx Movie [1], [3], [4], [7], [8], [16]				
	Neo:6 Cinema [1], [3], [4], [7], [8], [16]				
Adventure	SUR. PL Ilx Movie		PL Ilx Movie / Neo:6 Cinema		
	PL Ilx Movie [1], [3], [4], [7], [8], [16]				
	Neo:6 Cinema [1], [3], [4], [7], [8], [16]				
Drama	SUR. PL Ilx Movie		PL Ilx Movie / Neo:6 Cinema		
	PL Ilx Movie [1], [3], [4], [7], [8], [16]				
	Neo:6 Cinema [1], [3], [4], [7], [8], [16]				
Mono Movie			[1], [2], [6], [10], [13], [14], [15], [16]		
Sports			[1], [3], [4], [7], [8], [16]		
Action Game			[1], [3], [4], [7], [8], [16]		
Roleplaying Game			[1], [3], [4], [7], [8], [16]		

MAIN MENU	SUB-MENU	PARAMETER	VALUE [INITIAL VALUE]
MUSIC	Hall in Munich	[1], [2], [6], [10], [16]	
	Hall in Vienna	[1], [2], [6], [10], [16]	
	Chamber	[1], [2], [10], [13], [14], [15], [16]	
	Cellar Club	[1], [2], [6], [10], [16]	
	The Roxy Theatre	[1], [2], [6], [10], [13], [14], [15], [16]	
	The Bottom Line	[1], [2], [6], [10], [16]	
	Music Video	[1], [3], [4], [7], [8], [16]	
STEREO	2ch Stereo	Direct	[Auto] / Off
		Initialize	
	[1]	DSP Level	-6 to +3 dB, [0 dB]
	[2]	Init. Delay	
	[3]	P. Init. Dly	1 to 99 ms
	[4]	S. Init. Dly	1 to 49 ms
	[6]	Room Size	
	[7]	P. Room Size	0.1 to 2.0
	[8]	S. Room Size	
	[10]	Liveness	
	[11]	S. Liveness	0 to 10
	[13]	Rev. Time	1.0 to 5.0 s
	[14]	Rev. Delay	0 to 250 ms
	[15]	Rev. Level	0 to 100 %
	[16]	Initialize	
5 • Memory Guard			[Off] / On

INTERNAL VIEW

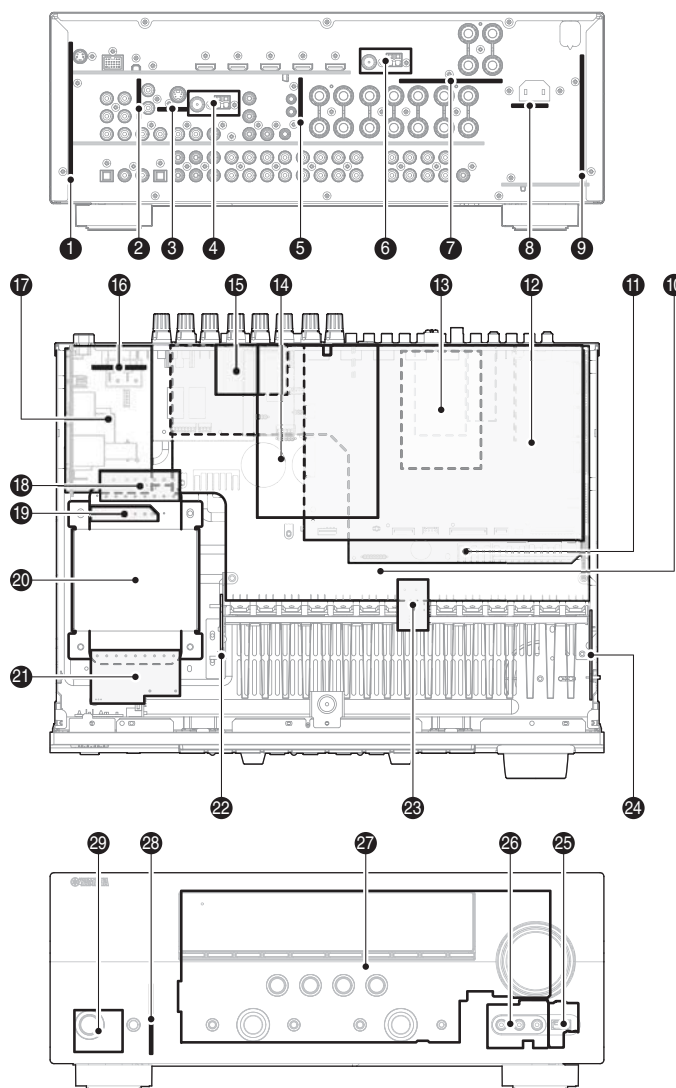

- ① OPERATION (2) P.C.B.
- ② OPERATION (9) P.C.B.
(R, T, K, A, B, G, E, F, L, J models)
- ③ VIDEO (9) P.C.B. (B, G, E, F models)
- ④ AM/FM TUNER
(C, R, T, K, A, B, G, E, F, L models)
- ⑤ VIDEO (4) P.C.B.
- ⑥ AM/FM TUNER (J model)
- ⑦ OPERATION (8) P.C.B.
- ⑧ OPERATION (11) P.C.B. (J model)
- ⑨ VIDEO (2) P.C.B.
- ⑩ MAIN (1) P.C.B.
- ⑪ VIDEO (1) P.C.B.
- ⑫ DIGITAL P.C.B.
- ⑬ VIDEO (8) P.C.B. (J model)
- ⑭ GUI P.C.B.
- ⑮ HD RADIO TUNER (U model)
- ⑯ MAIN (3) P.C.B. (R, L models)
- ⑰ VIDEO (3) P.C.B.
- ⑱ MAIN (2) P.C.B.
- ⑲ VIDEO (7) P.C.B.
(U, C, T, K, A, B, G, E, F, J models)
MAIN (4) P.C.B. (R, L models)
- ⑳ POWER TRANSFORMER
- ㉑ VIDEO (6) P.C.B.
- ㉒ MAIN (6) P.C.B.
- ㉓ MAIN (5) P.C.B.
- ㉔ OPERATION (10) P.C.B.
- ㉕ OPERATION (5) P.C.B.
- ㉖ OPERATION (4) P.C.B.
- ㉗ OPERATION (1) P.C.B.
- ㉘ OPERATION (3) P.C.B.
- ㉙ OPERATION (6) P.C.B.

SERVICE PRECAUTIONS / サービス時の注意事項

Safety measures

- Some internal parts in this product contain high voltages and are dangerous.
Be sure to take safety measures during servicing, such as wearing insulating gloves.
- Note that positions indicated below are dangerous even after the power is turned off because an electric charge remains and a high voltage continues to exist there.
Before starting any repair work, perform discharge by connecting a discharge resistor (5k-ohms/10W) between terminals at following positions.
The time required for discharging is about 30 seconds.
C3703 on VIDEO (2) P.C.B.
Refer to "PRINTED CIRCUIT BOARDS: VIDEO (2) P.C.B."

安全対策

- この製品の内部には高電圧部分があり危険です。修理の際は、絶縁性の手袋を使用するなどの安全対策を行ってください。
- 下記箇所には電源を OFF にした後も電荷が残り、高電圧が維持されており危険です。
修理作業前に放電用抵抗 (5 kΩ / 10 W) を下記箇所の端子間に接続して放電してください。
放電所用時間は約 30 秒間です。
VIDEO (2) P.C.B. の C3703
"PRINTED CIRCUIT BOARDS : VIDEO (2) P.C.B." を参照してください。

DISASSEMBLY PROCEDURES / 分解手順

(Remove parts in the order as numbered.)
Disconnect the power cable from the AC outlet.

(番号順に部品を取り外してください。)
AC 電源コンセントから、電源コードを抜いてください。

1. Removal of Top Cover

- a. Remove 4 screws (①), 5 screws (②) and screw (③). (Fig. 1)
- b. Slide the top cover rearward to remove it. (Fig. 1)

1. トップカバーの外し方

- a. ①のネジ4本、②のネジ5本、③のネジ1本を外します。(Fig. 1)
- b. トップカバーを後方へスライドさせ、取り外します。(Fig. 1)

2. Removal of Front Panel and Sub Chassis Unit

- a. Remove screw (④) and then remove the support top. (Fig. 1)
- b. Remove 2 knobs. (Fig. 1)
- c. Remove 6 screws (⑤) and then remove the front panel. (Fig. 1)
- d. Remove 2 push rivets and then remove the plate side (L) and (R). (Fig. 1)
- e. Remove CB20, CB461, CB477 and CB550. (Fig. 1)
- f. Remove 2 screws (⑥) and then pull out the sub-chassis unit. (Fig. 1)
- g. Unlock and remove CB333. (Fig. 1)
- h. Remove the sub-chassis unit. (Fig. 1)

2. フロントパネル、サブシャーシユニットの外し方

- a. ④のネジ1本を外し、サポートトップを取り外します。(Fig. 1)
- b. ノブ2個を取り外します。(Fig. 1)
- c. ⑤のネジ6本を外し、フロントパネルを取り外します。(Fig. 1)
- d. プッシュリベット2個を外し、プレートサイド(L)、(R)を取り外します。(Fig. 1)
- e. CB20、CB461、CB477、CB550を外します。(Fig. 1)
- f. ⑥のネジ2本を外し、サブシャーシユニットを引き出します。(Fig. 1)
- g. ロックを外し、CB333を外します。(Fig. 1)
- h. サブシャーシユニットを取り外します。(Fig. 1)

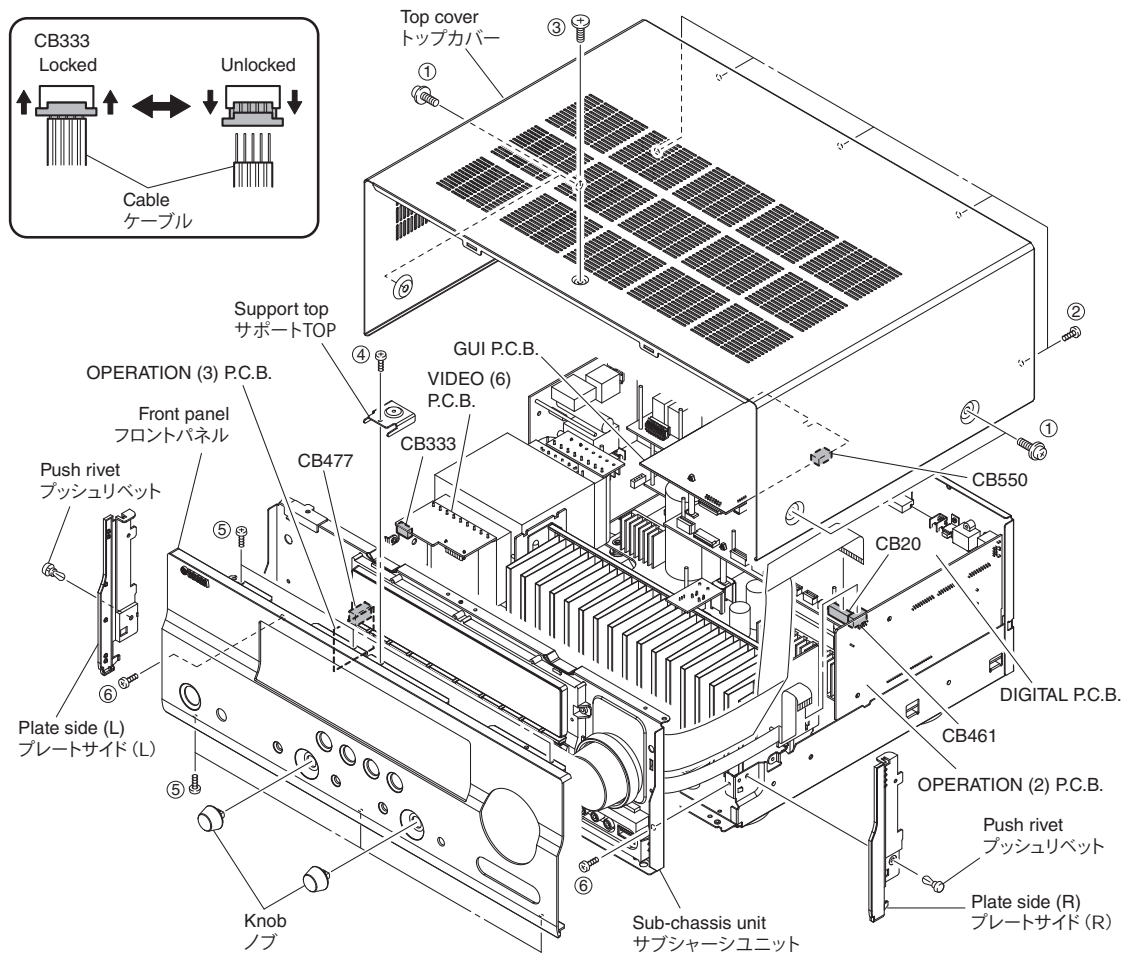

Fig. 1

3. Removal of GUI and DIGITAL P.C.B.s

- Remove 2 screws (7). (Fig. 2)
- Remove CB501. (Fig. 2)
- Unlock and remove CB500, CB503. (Fig. 2)
- Release hook, and remove the GUI P.C.B.. (Fig. 2)
- Remove 3 screws (U model) / 2 screws (C, R, T, K, A, B, G, E, F, L models) (8) and 5 screws (9). (Fig. 2)
- Remove screw (10). (Fig. 2)
- Remove 2 screws (U model) (11). (Fig. 2)
- Remove CB322 (U model). (Fig. 2)
- Remove the HD radio tuner (U model). (Fig. 2)
- Remove CB7, CB21, CB25, CB72 and CB73 (B, G, E, F models). (Fig. 2)
- Unlock and remove CB22~24. (Fig. 2)
- Release hook. (Fig. 2)
- Remove the DIGITAL P.C.B. which is connected directly to the OPERATION (2) P.C.B. with board-to-board connectors. (Fig. 2)

4. Removal of AMP Unit

- Remove 3 screws (12) and 4 screws (13). (Fig. 2)
- Remove 3 screws (14). (Fig. 2)
- Remove the amp unit. (Fig. 2)

3. GUI P.C.B.、DIGITAL P.C.B. の外し方

- 7のネジ2本を外します。(Fig. 2)
- CB501を外します。(Fig. 2)
- ロックを外し、CB500、CB503を外します。(Fig. 2)
- フック1箇所を外し、GUI P.C.B.を取り外します。(Fig. 2)
- 8のネジ2本、9のネジ5本を外します。(Fig. 2)
- 10のネジ1本を外します。(Fig. 2)
- 11のネジ2本を外します。(Fig. 2)
- CB321を外します。(Fig. 2)
- AM/FMチューナーを取り外します。(Fig. 2)
- CB7、CB21、CB25、CB72を外します。(Fig. 2)
- ロックを外し、CB22～24を外します。(Fig. 2)
- フック1箇所を外します。(Fig. 2)
- DIGITAL P.C.B.を取り外します。ただし、DIGITAL P.C.B.はOPERATION (2) P.C.B.に基板対基板コネクタで直接接続されています。(Fig. 2)

4. アンプユニットの外し方

- 12のネジ3本、13のネジ4本を外します。(Fig. 2)
- 14のネジ3本を外します。(Fig. 2)
- アンプユニットを取り外します。(Fig. 2)

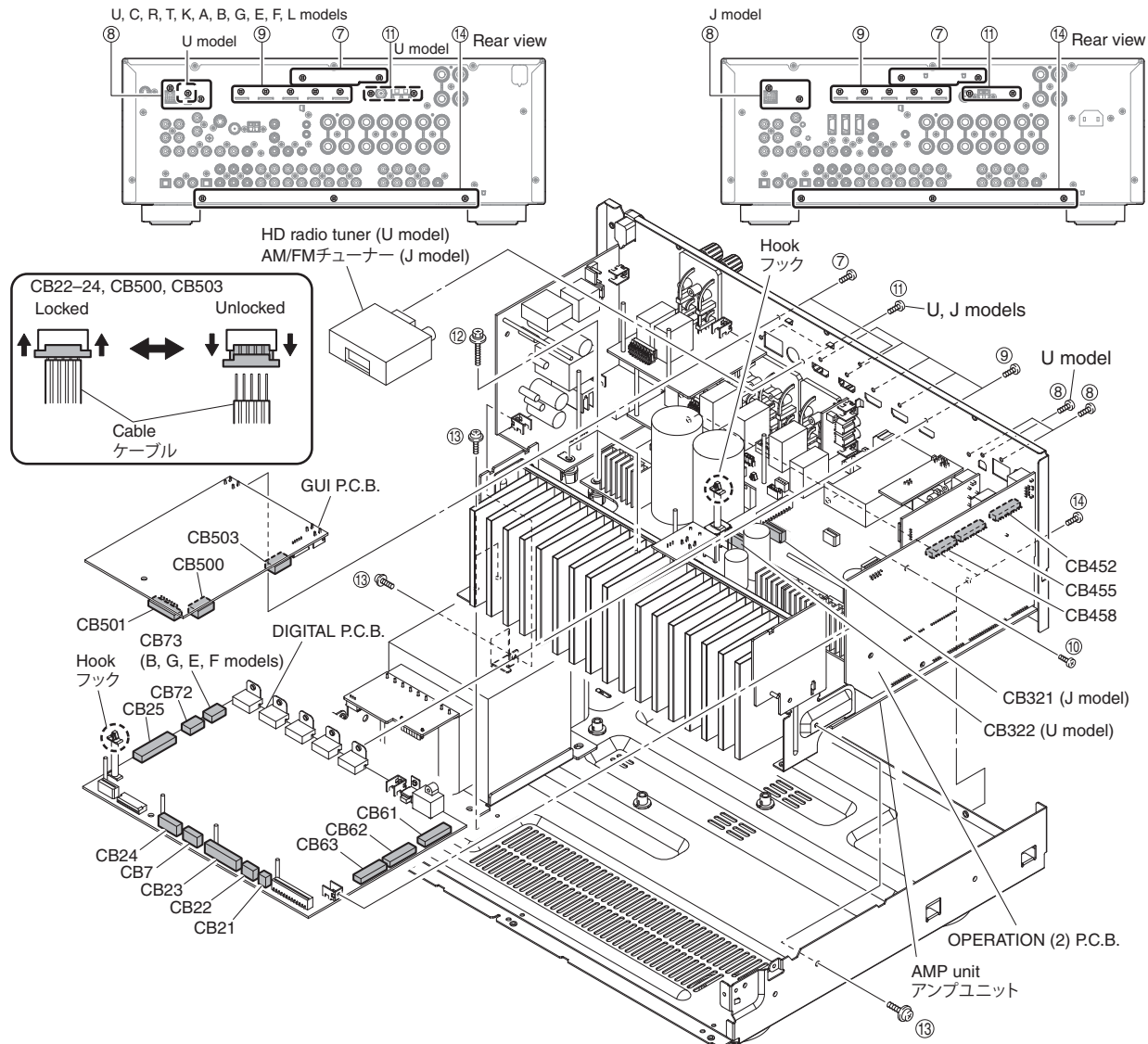

Fig. 2

When checking the P.C.B.s:

- Place the P.C.B.s (with rear panel) upright. (Fig. 3)
 - Connect the ground points of the heatsink, rear panel and MAIN (1) P.C.B. (G1000) to the chassis with a ground lead or the like. (Fig. 3)
 - When connecting the flexible flat cable, be careful with polarity.
 - Reconnect all cables (connectors) that have been disconnected.
- Be sure to use the extension cable for servicing for the following section.

DIGITAL P.C.B. CB20 to OPERATION (1) P.C.B. CB401:
MF125400 (25P, 400mm, P=1.25)

OPERATION (1) P.C.B. CB402 to OPERATION (2) P.C.B. CB461:
MF109400 (9P, 400mm, P=1.25)

P.C.B. をチェックする場合には：

- リアパネルと一緒に P.C.B. を立ち上げて置きます。(Fig. 3)
- ヒートシンク、リアパネル、MAIN (1) P.C.B. の G1000 のアースをリード線等でシャーシに接続してください。(Fig. 3)
- フラットケーブルを接続する際、極性に注意してください。
- 外したケーブル (コネクター) をすべて接続します。ただし次の区間は、サービス用延長ケーブルを使用してください。

DIGITAL P.C.B. CB20 ~ OPERATION (1) P.C.B. CB401 :
MF125400 (25P、400mm、P=1.25)

OPERATION (1) P.C.B. CB402 ~ OPERATION (2) P.C.B. CB461 :
MF109400 (9P、400mm、P=1.25)

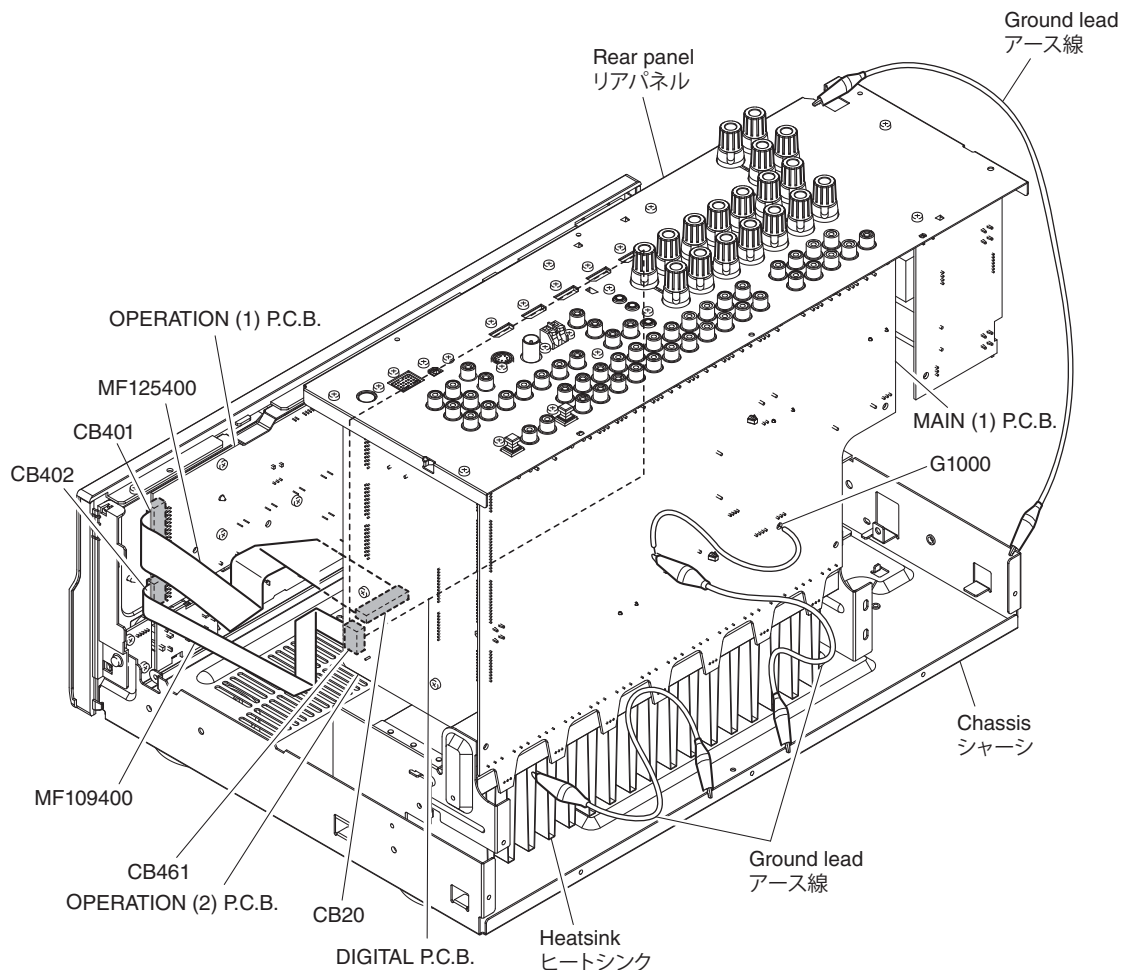

Fig. 3

■ UPDATING FIRMWARE / ファームウェアの書き込み

Note) The user memories (sound field parameters, system memory, tuner presetting, etc.) are kept stored even when you write the firmware.

注意) ファームウェアの書き込みを行っても、ユーザーメモリー（音場プログラムのパラメーターやシステムメモリー、チューナープリセット等）は保持されます。

When replacing the following parts, be sure to write the latest firmware.

下記の部品をサービス部品に交換した場合、最新のファームウェアの書き込みを行ってください。

Replaced parts	Writing method using the USB / USB を使用して書き込む方法	Writing method using PC (RS232C) / PC (RS232C) を使用して書き込む方法
DIGITAL P.C.B.	yes	yes
IC20 (Main microprocessor) of DIGITAL P.C.B.	no	yes
IC49 (TI (DSP) flash ROM) of DIGITAL P.C.B.	yes	yes
IC513 (BF (Sub-microprocessor) flash ROM) of GUI P.C.B.	yes	no

● Confirmation of firmware version and checksum

Before and after writing firmware, check the firmware version and checksum by using the self-diagnostic function menu.

Start up the self-diagnostic function and select "25. ROM VER/SUM/PORT" menu. (See "SELF DIAGNOSTIC FUNCTION")

Using the sub-menu, have the firmware version and checksum displayed, and note down them.

● ファームウェアのバージョンとチェックサムの確認

ファームウェアの書き込みの前後に、ファームウェアのバージョンとチェックサムをダイアグメニューで確認します。

ダイアグを起動し、「25. ROM VER/SUM/PORT」メニューを選択します。（ダイアグ（自己診断機能）参照）

サブメニューでファームウェアのバージョンとチェックサムを表示し、それらを書きとめます。

25. ROM VER/SUM/PORT

Firmware version

Ver: C045E

The firmware version of main microprocessor (IC20 DIGITAL P.C.B.) is displayed.
メインマイコン (IC20 DIGITAL P.C.B.) のファームウェアバージョンが表示されます。

All checksum

Sum: 6E5E

The checksum value of main microprocessor (IC20 DIGITAL P.C.B.) is displayed.
メインマイコン (IC20 DIGITAL P.C.B.) のチェックサムが表示されます。

TI (DSP) FLASH ROM version

TiVer: 02.06r1

The firmware version of TI (DSP) FLASH ROM (IC49 DIGITAL P.C.B.) is displayed.
TI (DSP) FLASH ROM (IC49 DIGITAL P.C.B.) のファームウェアバージョンが表示されます。

TI (DSP) FLASH ROM checksum

TiSum: 46C49F69

The checksum value of TI (DSP) FLASH ROM (IC49 DIGITAL P.C.B.) is displayed.
TI (DSP) FLASH ROM (IC49 DIGITAL P.C.B.) のチェックサムが表示されます。

BF version

BF Ver: B023

The firmware version of BF (sub-microprocessor, IC505 GUI P.C.B.) is displayed.
BF (サブマイコン、IC505 GUI P.C.B.) のファームウェアバージョンが表示されます。

BF checksum 1 (All/Main)

All: D7FAMa: 079F

The checksum value (All/Main) of BF (sub-microprocessor, IC505 GUI P.C.B.) is displayed.
BF (サブマイコン、IC505 GUI P.C.B.) のチェックサム (All / Main) が表示されます。

BF checksum 2 (Application/USB)

Ap: 612DUa: 5A0A

The checksum value (Application/USB) of BF (sub-microprocessor, IC505 GUI P.C.B.) is displayed.
BF (サブマイコン、IC505 GUI P.C.B.) のチェックサム (Application / USB) が表示されます。

Supplementary information:

In this unit, it is possible to check the firmware version by using the ADVANCED SETUP menu as well as the self-diagnostic function menu. Follow the procedures below.

1. While pressing the "STRAIGHT" key of this unit, press the "MAIN ZONE ON/OFF" key of this unit to turn on the power. The ADVANCED SETUP mode is activated, and "ADVANCED SETUP" is displayed. (Fig. 1)
2. Rotate the "PROGRAM" knob and select the "VER---.---.---". (Fig. 1)
After a few seconds, each firmware version is displayed.

補足：本機では、ダイアグメニューと同様に、アドバンスドセットアップメニューを使ってファームウェアのバージョンを確認することができます。下記の手順に従って操作してください。

1. 本機の "STRAIGHT" キーを押しながら "STANDBY/ON" キーを押して電源を入れます。アドバンスドセットアップモードが起動し、"ADVANCED SETUP" が表示されます。(Fig. 1)
2. 本機の "PROGRAM" ツマミを回し、"VER---.---.---" を選択します。(Fig. 1)
数秒後、各ファームウェアバージョンが表示されます。

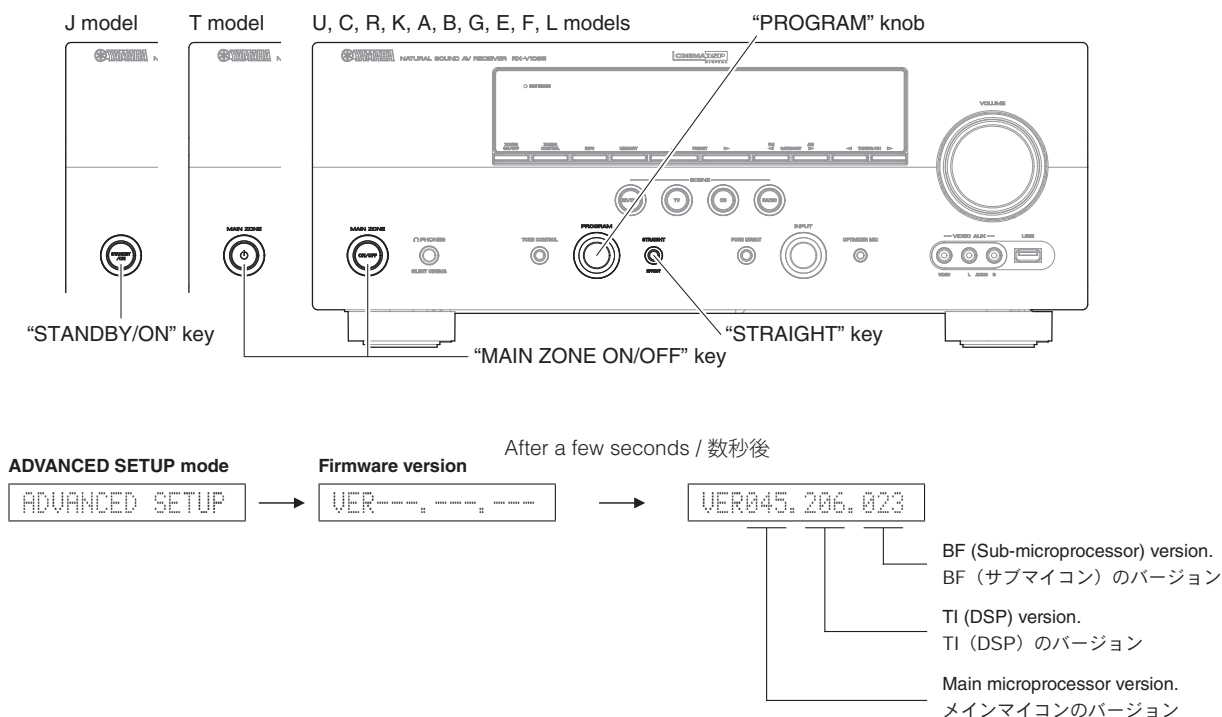

Note) The checksum is not displayed.
注意) チェックサムは表示されません。

Fig. 1

3. Press the "MAIN ZONE ON/OFF" key of this unit to turn off the power.

3. 本機の "STANDBY/ON" キーを押して電源を切ります。

Writing method using the USB

- **Required Tools**
 - USB storage device
 - Firmware (RX-Vx065_xxxx_SP.bin)

- **Preparation**
 1. Download the latest firmware from the specified download source to the folder of the PC.
 2. Copy the latest firmware from the PC to the root folder of the USB storage device.

Note) When the firmware is copied to the subfolder, it is impossible to update firmware.

- **Operation procedures**
 1. Insert the USB storage device to the USB terminal of this unit. (Fig. 2)
 2. While pressing the "TONE CONTROL" key of this unit, connect the power cable to the AC outlet. (Fig. 2)
Writing of the firmware is started and the screen is displayed as shown below. (Fig. 3).

USB を使用して書き込む方法

- **必要なツール**
 - USB フラッシュメモリー
 - ファームウェア (RX-Vx065_xxxx_SP.bin)

- **準備**
 1. 指定のダウンロード先から、最新のファームウェアを、PCのフォルダにダウンロードしてください。
 2. 最新のファームウェアをPCからUSBフラッシュメモリーのルートフォルダにコピーします。
注意) ファームウェアをPCからサブフォルダにコピーした場合、書き込みできません。

- **操作方法**
 1. 本機のUSB端子にUSBフラッシュメモリーを差し込みます。(Fig. 2)
 2. 本機の "TONE CONTROL" キーを押しながら、電源コードをACコンセントに接続します。(Fig. 2)
ファームウェアの書き込みが開始され、下記のように表示されます。(Fig. 3)

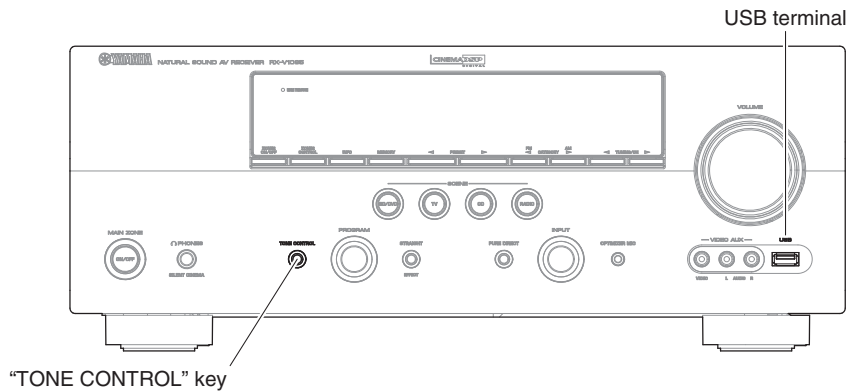

Fig. 2

Writing is started. / 書き込み開始

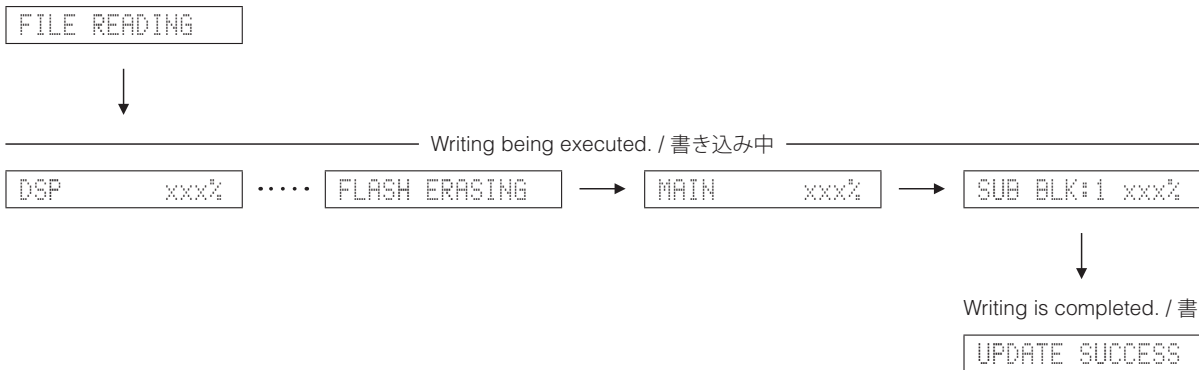

Fig. 3

3. When writing of the firmware is completed, "UPDATE SUCCESS" is displayed.
 - * "UPDATE FAIL" is displayed before writing is completed, perform the operation procedures from step 1 to 2 again.
 4. Press the "MAIN ZONE ON/OFF" key of this unit to turn off the power.
 5. Remove the USB storage device from the USB terminal of this unit.
 6. Start up the self-diagnostic function and select "25. ROM VER/SUM/PORT" menu.

Using the sub-menu, have the firmware version and checksum displayed, and then check that they are the same as written ones.

 - * When the displayed firmware version and checksum are different from written ones, perform the "Writing the Firmware" procedure all over again.
 7. Press the "MAIN ZONE ON/OFF" key to turn off the power.
3. ファームウェアの書き込みが完了すると、「UPDATE SUCCESS」が表示されます。
 - ※ 途中で「UPDATE FAIL」が表示された場合は、操作手順の1から2までをもう一度やり直してください。
 4. 本機の「STANDBY/ON」キーを押して電源を切ります。
 5. 本機のUSB端子からUSBフラッシュメモリーを取り外します。
 6. ダイアグを起動し、「25. ROM VER/SUM/PORT」メニューを選択します。

サブメニューでファームウェアのバージョンとチェックサムを表示し、それらが書き込んだものと同じであることを確認します。

 - ※ 表示されたファームウェアのバージョンとチェックサムが、書き込まれたものと異なる場合、「ファームウェアの書き込み」をもう一度やり直してください。
 7. 本機の「STANDBY/ON」キーを押して電源を切ります。

Writing method using PC (RS232C)

● Required Tools

- Firmware downloader program
For main microprocessor:
DSP_FLASHER_v3.0.exe
For DSP (TI flash ROM):
DSP_FLASHER Ver2.7.exe
- Firmware
For main microprocessor:
U model...U165xxxx.mot
C,R,T,K,A,B,G,E,F,L models...E165xxxx.mot
For DSP (TI flash ROM):
Vx65_data1_verxxxxr.hex
- RS232C cross cable "D-sub 9 pin female"
(Specifications)

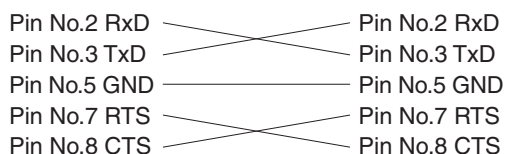

- RS232C conversion adaptor (Part No.: WR492800)

● Preparation and precautions

- Download the firmware downloader program and the firmware from the specified source to the same folder of the PC.
- Prepare the above specified RS232C cross cable.
- While writing the firmware, keep the other application software on the PC closed.
It is also recommended to keep the software on the task tray closed as well.

PC (RS232C) を使用して書き込む方法

● 必要なツール

- ファームウェア書き込み用プログラム
メインマイコン用：
DSP_FLASHER_v3.0.exe
DSP (TI flash ROM) 用：
DSP_FLASHER Ver2.7.exe
- ファームウェア
メインマイコン用：
E165xxxx.mot
DSP (TI flash ROM) 用：
Vx65_data1_verxxxxr.hex
- RS232C クロスケーブル "D-sub 9pin メス"
(仕様)

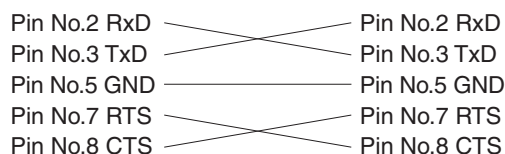

- RS232C 変換アダプター (部品番号：WR492800)

● 準備と注意

- 指定のダウンロード先から、ファームウェア書き込み用プログラムとファームウェアを、PCの同じフォルダへダウンロードしてください。
- RS232C クロスケーブルは必ず上記仕様のもを用意してください。
- 書き込み時は、PC上の他のアプリケーションソフトは閉じてください。
さらに、タスクトレイ上にあるソフトも閉じておくことを推奨します。

● **Connection**

1. Remove the top cover. (See “DISASSEMBLY PROCEDURES”)
2. Connect the writing port (CB27 of DIGITAL P.C.B.) of this unit to the serial port (RS232C) of the PC with RS232C cross cable, RS232C conversion adaptor and flexible flat cable as shown below. (Fig. 1)
3. Set the switch (SW7) of RS232C conversion adaptor as shown below. (Fig. 1)

● **接続**

1. トップカバーを取り外します。(“分解手順” 参照)
2. 本機の書き込み用ポート (DIGITAL P.C.B. CB27) と PC のシリアルポート (RS232C) を下記のように接続します。(Fig. 1)
3. RS232C 変換アダプターのスイッチ (SW7) を下記のように設定します。(Fig. 1)

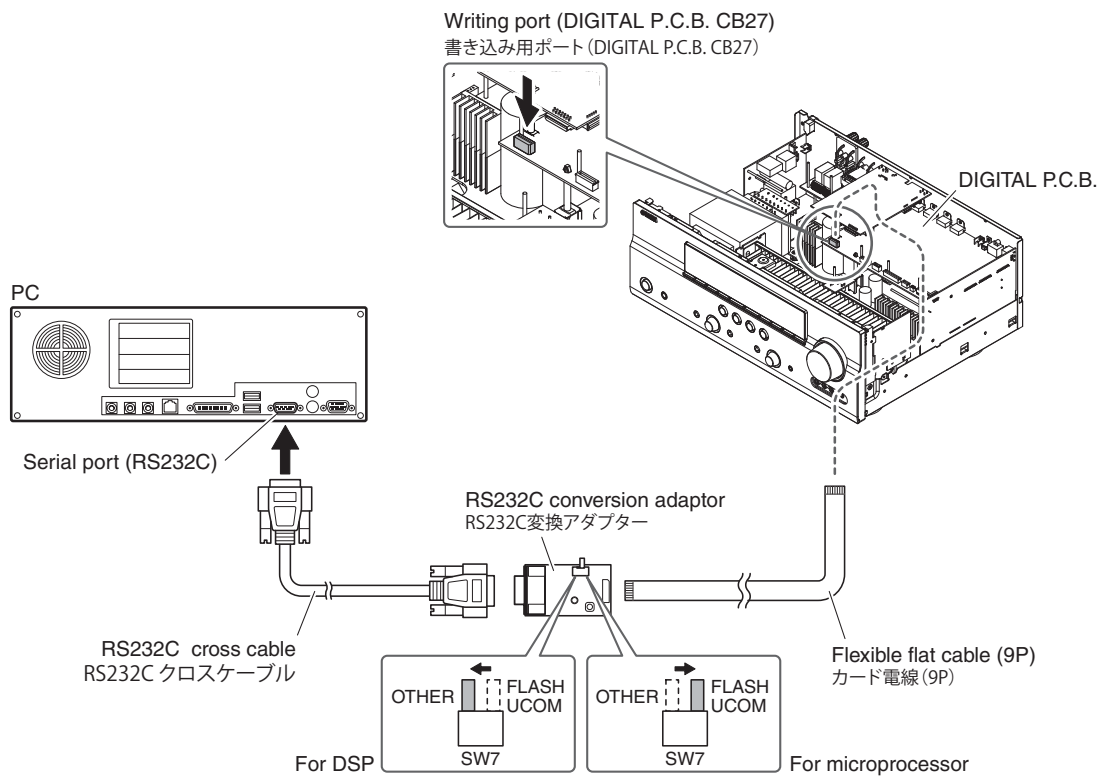

Fig. 1

● Operation Procedures

Writing to the main microprocessor

1. With the power cable of this unit unconnected to the AC outlet, start up DSP_FLASHER_v3.0.exe. The screen appears as shown below. (Fig. 2)
2. Click [...] and select the firmware name. (Fig. 2)

● 操作手順

メインマイコンへの書き込み

1. 本機の電源コードを AC コンセントに接続していない状態で、DSP_FLASHER_v3.0.exe を起動します。下記の画面が表示されます。(Fig. 2)
2. [...] をクリックし、書き込むファームウェアを選択します。(Fig. 2)

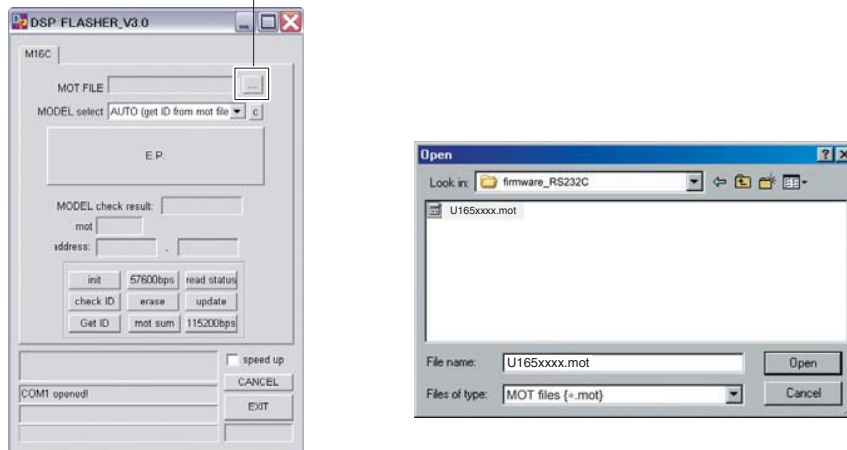

Fig. 2

- | | |
|--|--|
| <p>3. Connect the power cable of this unit to the AC outlet.</p> <p>4. Click [E.P.] to start writing. (Fig. 3)</p> | <p>3. 本機の電源コードを AC コンセントに接続します。</p> <p>4. [E.P.] をクリックして書き込みを開始します。(Fig. 3)</p> |
| <p>5. When writing of the firmware is completed, "Program Finished!" is displayed. (Fig. 3)
Click [OK]. (Fig. 3)</p> | <p>5. ファームウェアの書き込みが完了すると、"Program Finished!" が表示されます。(Fig. 3)
[OK] をクリックします。(Fig. 3)</p> |
| <p>6. Click [EXIT] to end DSP_FLASHER_v3.0.exe. (Fig. 3)</p> | <p>6. [EXIT] をクリックして DSP_FLASHER_v3.0.exe を終了します。(Fig. 3)</p> |

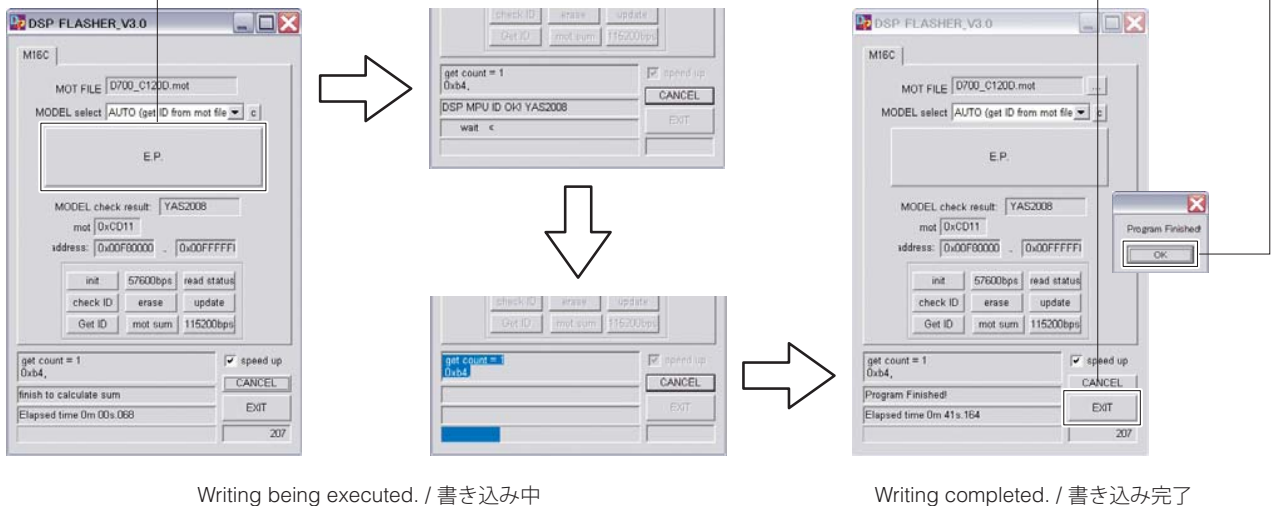

Fig. 3

- | | |
|---|--|
| <p>7. Disconnect the power cable of this unit from the AC outlet.</p> <p>8. Remove the RS232C conversion adaptor and flexible flat cable from the writing port (CB27, DIGITAL P.C.B.) of this unit.</p> <p>9. Start up the self-diagnostic function and select "25. ROM VER/SUM/PORT" menu.</p> <p>Using the sub-menu, have the firmware version and checksum displayed, and then check that they are the same as written ones.</p> <p>* When the firmware version and checksum are different from written ones, perform the "Writing to the microprocessor" all over again.</p> <p>10. Disconnect the power cable of this unit from the AC outlet.</p> | <p>7. 本機の電源コードを AC コンセントから抜きます。</p> <p>8. 本機の書き込み用ポート (DIGITAL P.C.B. CB27) から RS232C 変換アダプターとカード電線を取り外します。</p> <p>9. ダイアグを起動し、"25. ROM VER/SUM/PORT"メニューを選択します。</p> <p>サブメニューでファームウェアのバージョンとチェックサムを表示し、それらが書き込んだものと同じであることを確認します。</p> <p>※ ファームウェアのバージョンとチェックサムが、書き込まれたものと異なる場合、"マイコンへの書き込み" をもう一度やり直してください。</p> <p>10. 本機の電源コードを AC コンセントから抜きます。</p> |
|---|--|

Writing to DSP

1. With the power cable of this unit unconnected to the AC outlet, start up DSP_FLASHER Ver2.7.exe.
The screen appears as shown below. (Fig. 4)
2. Click [Vx61 DSP]. (Fig. 4)

DSP への書き込み

1. 本機の電源コードを AC コンセントに接続していない状態で、DSP_FLASHER Ver2.7.exe を起動します。
下記の画面が表示されます。(Fig. 4)
2. [Vx61 DSP] をクリックします。(Fig. 4)



Fig. 4

3. Click [...] and select the firmware name. (Fig. 5)

3. [...] をクリックし、書き込むファームウェアを選択します。(Fig. 5)

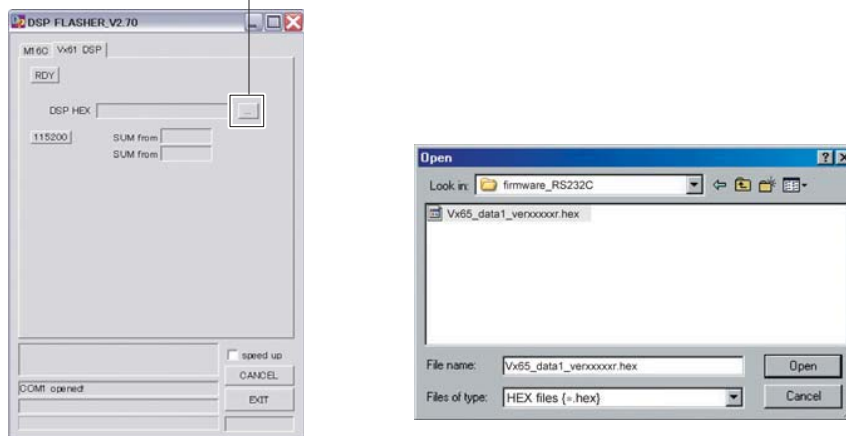

Fig. 5

4. Click [RDY]. (Fig. 6)

4. [RDY] をクリックします。(Fig. 6)



Fig. 6

5. While pressing the “PURE DIRECT” key of this unit, connect the power cable of this unit to the AC outlet. (Fig. 7)

5. 本機の“PURE DIRECT”キーを押しながら、本機の電源コードをACコンセントに接続します。(Fig. 7)
自動的に書き込みが開始されます。(Fig. 7)

Writing is started automatically. (Fig. 7)

This unit / 本機

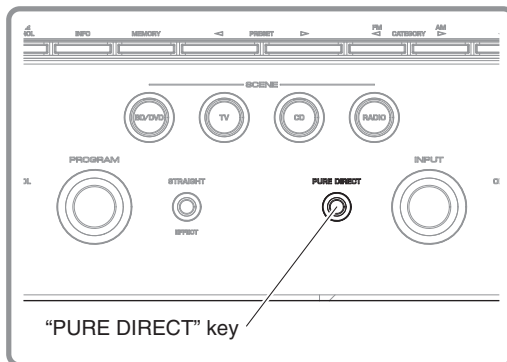

Writing being executed. /
書き込み中

Fig. 7

- | | |
|---|---|
| <p>6. When writing of the firmware is completed, "Vx61 DSP Flash finished!" is displayed. (Fig. 3)</p> <p>7. Click [EXIT] to end DSP_FLASHER_v2.7.exe. (Fig. 8)</p> | <p>6. ファームウェアの書き込みが完了すると、“Vx61 DSP Flash finished!”が表示されます。(Fig. 3)</p> <p>7. [EXIT] をクリックして DSP_FLASHER_v2.7.exe を終了します。(Fig. 8)</p> |
|---|---|



Fig. 8

- | | |
|---|--|
| <p>8. Start up the self-diagnostic function and select "25. ROM VER/SUM/PORT" menu.</p> <p>Using the sub-menu, have the firmware version and checksum displayed, and then check that they are the same as written ones.</p> <p>* When the firmware version and checksum are different from written ones, perform the "Writing to DSP" all over again.</p> <p>9. Disconnect the power cable of this unit from the AC outlet.</p> | <p>8. ダイアグを起動し、“25. ROM VER/SUM/PORT”メニューを選択します。</p> <p>サブメニューでファームウェアのバージョンとチェックサムを表示し、それらが書き込んだものと同じであることを確認します。</p> <p>※ ファームウェアのバージョンとチェックサムが、書き込まれたものと異なる場合、“DSP への書き込み”をもう一度やり直してください。</p> <p>9. 本機の電源コードを AC コンセントから抜きます。</p> |
|---|--|

■ SELF-DIAGNOSTIC FUNCTION / ダイアグ（自己診断機能）

CAUTION!

Do not disconnect the power cable of this unit from the AC outlet while this unit is in the self-diagnostic function mode, otherwise the user memories (input rename, sound field parameters, system memory, tuner presetting, etc.) will be initialized.

Therefore, to cancel the self-diagnostic function, be sure to press the "MAIN ZONE ON/OFF" key of this unit to turn off the power.

注意！

本機がダイアグモードのときに、電源コードを AC コンセントから抜かないでください。もしそうした場合は、ユーザーメモリー（入力ソース名、音場プログラムのパラメーター、セットメニュー、チューナープリセット等）が初期化されてしまいます。

そのために、ダイアグを解除するときは必ず本機の "STANDBY/ON" キーを押して電源を切ってください。

This unit has self-diagnostic functions that are intended for inspection, measurement and location of faulty point.

There are 25 main menu items, each of which has sub-menu items.

Listed in the table below are main menu items and sub-menu items.

Note that not all menu items listed will apply to the models covered in this service manual.

本機には、検査、測定、不良個所の発見を目的にしたダイアグ（自己診断機能）があります。

メインメニューは 25 個あり、そのそれぞれにサブメニューがあります。

下表はダイアグメニュー一覧です。

下表の全ダイアグメニュー項目が、このサービスマニュアル記載のモデルに適用されるとは限りません。

No.	Main menu	Sub-menu
1	BYPASS	1 ANALOG BYPASS
		2 DSP BYPASS
2	RAM THROUGH	1 RAM MARGIN
		2 RAM FULL ALL
		3 RAM FULL CENTER
		4 RAM FULL SURROUND
		5 RAM FULL SURROUND BACK
3	HDMI AUDIO	1 SPDIF
		2 Multi
		3 DSD
4	SPEAKERS SET	1 FRNT: SML 0dB
		2 CENTER: NONE
		3 LFE/B: FRNT
		4 Zone2 Amp ON
		5 Bi-AMP
		6 TONE: MAX
		7 TONE: MIN
		8 SPEAKER 6 ohms
5	MULTI CH-INPUT	1 8ch INPUT 6 ohms
		2 8ch INPUT 8 ohms
		3 LIM/PLDET/THM
6	MIC CHECK	1 MIC CHECK
7	FL/GUI CHECK	1 VFD CHECK
		2 VFD DISP OFF / MONITOR MUTE
		3 VFD DISP ALL / COMPONENT MUTE
		4 VFD DIMMER / OSD CHARACTER PATTERN
		5 CHECK PATTERN / OSD CHARACTER PATTERN
8	MANUAL TEST	1 TEST ALL
9	A/D DATA CHECK	1 PS1/PS2
		2 DC/TH
		3 IMP/PL
		4 DST/DK
		5 K0/K1
10	VIDEO CHECK	1 I2C
		2 DIGITAL COMPONENT
		3 DIGITAL CVBS
		4 DIGITAL Y/C (B, G, E, F models)
		5 ANALOG BYPASS
		6 TEST PATTERN
		7 VIDEO INFORMATION

No.	Main menu	Sub-menu
11	XM STATUS (U model)	1 1k -1dB /44kHz
		2 1k -61dB /44kHz
		3 Mute /44kHz
		4 XM Tone /44kHz
		5 ISO Tone /44kHz
		6 1k -1dB /32kHz
		7 1k -61dB /32kHz
		8 Mute /32kHz
		9 XM Tone /32 kHz
		10 ISO Tone /32 kHz
		11 Bus Power: OFF
12	SIRIUS (U model)	1 SIRIUS: OK (NG)
		2 SR
		3 SSP (SIRIUS #0 VERSION)
		4 MAC (SIRIUS #1 VERSION)
		5 ADP (SIRIUS #2 VERSION)
		6 PRDID
		7 SEQID
13	HD RADIO (U model)	1 HD CPU VERSION
		2 D: xxxxxxxxxxxx
14	DOCK	1 DOCK
		2 BT VERSION
15	HDMI INFO	1 HMN
		2 HPI
		3 HVN
16	HDMI SELECT	1 HDMI NONE
		2 HDMI IN 1
		3 HDMI IN 2
		4 HDMI IN 3
		5 HDMI IN 4
		6 HDMI UP CONVERSION
		7 HDMI UP THROUGH
17	USB	1 USB File 1
		2 USB File 2
18	IF STATUS (Not applied to these models. / このモデルには適用されません。)	1 DSP STATUS
19	BUS CHECK	1 TI BUS
		2 BF LOOP
20	NO MENU	Invalidity
21	PROTECTION HISTORY	1 HISTORY 1
		2 HISTORY 2
		3 HISTORY 3
		4 HISTORY 4
22	NO MENU	Invalidity
23	UPDATE	1 TI FLASH BOOT (Not applied to these models. / このモデルには適用されません。)
24	FACTORY PRESET	1 PRESET INHI
		2 PRESET RSRV
25	ROM VER/SUM/PORT	1 VERSION
		2 ALL SUM
		3 TI (DSP) FLASH VERSION
		4 TI (DSP) FLASH SUM
		5 BF VERSION
		6 BF SUM 1 (All/Main)
		7 BF SUM 2 (Application/USB)
		8 XM VERSION
		9 SIRIUS VERSION
		10 MODEL/DESTINATION
		11 Verify (Not applied to these models. / このモデルには適用されません。)

● Starting Self-Diagnostic Function

While pressing those 2 keys of this unit as shown in the figure below, press the “MAIN ZONE ON/OFF” key to turn on the power.

The self-diagnostic function mode is activated.

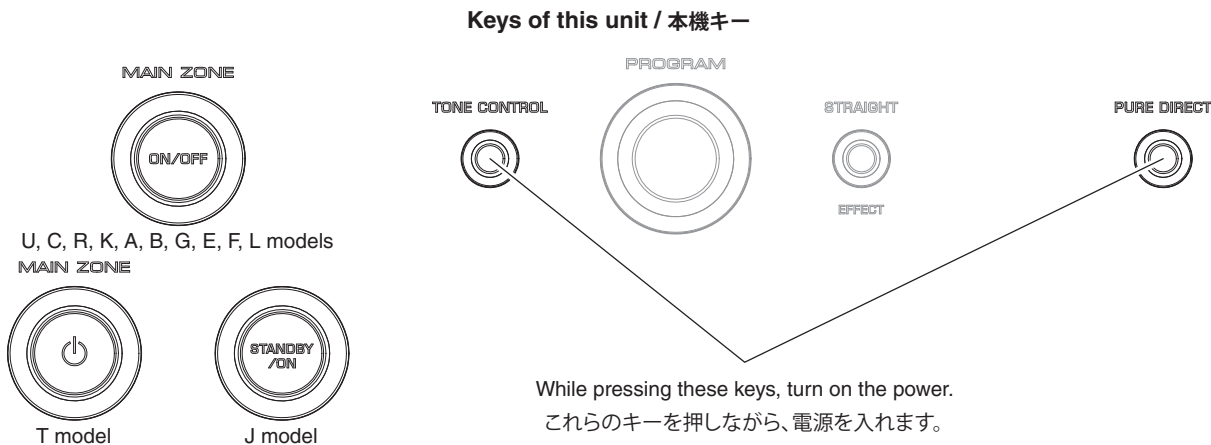

● ダイアグの起動

本機の下図に示す 2 つのキーを押しながら “STANDBY/ON” キーを押して電源を入れます。

ダイアグが起動します。

● Starting Self-Diagnostic Function in the protection cancel mode

If the protection function works and causes hindrance to trouble shoot, cancel the protection function as described below, and it will be possible to enter the self-diagnostic function mode.

(The protection functions other than the excess current detect function will be disabled.)

While pressing those 2 keys as shown in the figure above, press the “MAIN ZONE ON/OFF” key to turn on the power and keep pressing those 2 keys and “MAIN ZONE ON/OFF” key for 3 seconds or longer.

The self-diagnostic function mode is activated with the protection functions disabled.

In this mode, the SLEEP segment of the FL display of this unit flashes to indicate that the mode is self-diagnostic function mode with the protection functions disabled.

CAUTION!

Using this product with the protection function disabled may cause damage to itself. Use special care when using this mode.

● プロテクション解除モードでの起動

プロテクションが動作することにより、故障箇所の診断に支障をきたすような場合は、次の方法によりプロテクションを解除した状態でダイアグモードに入ることができます。

(過電流検出以外のプロテクション動作を解除する)

上図に示す 2 つのキーを押しながら “STANDBY/ON” キーを押して電源を入れ、2 つのキーと “STANDBY/ON” キーを 3 秒以上押し続けます。

プロテクション解除モードでダイアグが起動します。

このモードでは本機 FL の “SLEEP” セグメントが点滅し、プロテクションを解除した状態でのダイアグモードであることを知らせます。

注意!

プロテクションを解除した状態でのダイアグモードは、危険な状態でもプロテクションが作動しないため、動作させると、機器を破壊することがあります。このモードを使用する場合は十分注意してください。

● Canceling Self-Diagnostic Function

- Before canceling self-diagnostic function, execute setting for FACTORY PRESET of main menu No. 24 (Memory initialization inhibited or Memory initialized).
 - * In order to keep the user memory stored, be sure to select PRESET INHIBITED (Memory initialization inhibited).
- Press the “MAIN ZONE ON/OFF” key of this unit to turn off the power.

● ダイアグの解除

- ダイアグを解除する前に、メインメニュー No. 24 の FACTORY PRESET (メモリーの初期化禁止 / またはメモリーの初期化) の設定をします。
 - ※ ユーザーメモリーを保持したい場合は、必ず PRESET INHIBIT (メモリー初期化禁止) を選択してください。
- 本機の “STANDBY/ON” キーを押して電源を切ります。

● Display provided when Self-Diagnostic Function started

The display is as described below depending on the situation when the last time the power to this unit is turned off.

1. When the power is turned off by usual operation:

The FL display of this unit displays "NO PROTECT" then the main menu (sub-menu "1. ANALOG BYPAS" of main menu 1 BYPASS) a few seconds later.

Opening message / オープニング表示

NO PROTECT

After a few seconds / 数秒後



Main menu display / メインメニュー表示

1. ANALOG BYPAS

2. When the protection function worked to turn off the power:

The FL display of this unit displays the data of protection function which worked at that time then the main menu (sub-menu "1. ANALOG BYPAS" of main menu 1 BYPASS) a few seconds later.

Note: At that time if you reactivate the self-diagnostic function after turning off the power once by pressing the "MAIN ZONE ON/OFF" key, "NO PROTECT" will be displayed because that situation is equal to "1. When the power is turned off by usual operation:" described above.

However the protection function history is stored in memory with a backup. For details, refer to main menu 21 PROTECTION HISTORY.

2-1. When the protection function worked due to excess current.

Cause: An excessive current flowed through the power amplifier.

Supplementary information: As current of the power amplifier is detected, the abnormal channel can be identified by checking the current detect transistor.

Turning on the power without correcting the abnormality will cause the protection function to work immediately and the power supply will instantly be shut off.

PRI PRT:xxx

AD value when the protection function is working
電圧の A/D 変換値

● ダイアグ起動時の表示

最後に本機の電源が切れたときの状況により、下記のように表示されます。

1. 通常の操作で電源を切った場合：

本機の FL ディスプレイに "NO PROTECT" が表示されます。数秒後、メインメニュー 1 BYPASS のサブメニュー "1. ANALOG BYPAS" が表示されます。

2. プロテクションが働いて電源が切れた場合：

本機の FL ディスプレイにそのときに働いたプロテクションの情報が表示されます。数秒後、メインメニュー 1 BYPASS のサブメニュー "1. ANALOG BYPAS" が表示されます。

注) このときに "STANDBY/ON" キーを押して一旦電源を切った後にダイアグを再起動すると、上述の「1. 通常の操作で電源を切った場合」に相当するので、"NO PROTECT" が表示されます。

ただし、プロテクションの履歴はメモリーにバックアップして記憶されます。詳細は、メインメニュー 21 PROTECTION HISTORY を参照してください。

2-1. 過電流によりプロテクションが働いた場合

原因： パワーアンプに過電流が流れた。

補足： パワートランジスタの電流を検出していますので、電流検出トランジスタをチェックすれば異常チャンネルが特定できます。

異常状態のまま電源を入れると、瞬時にプロテクションが働き、すぐに電源が切れます。

Note)

- Applying the power to this unit without correcting the abnormality can be dangerous and cause additional circuit damage. To avoid this, if protection function has been activated 3 times continuously, the power will not turn on even when the “MAIN ZONE ON/OFF” key is pressed. In order to turn on the power again, disconnect the power cable of this unit from the AC outlet once and then reconnect it again.
- The output transistors in each amplifier channel should be checked for damage before applying power of this unit.
- Amplifier current should be monitored by measuring DC voltage across the emitter resistors for each channel.

注意！

- 異常状態のまま本機の電源を入れると、危険な状態になり、さらに回路が損傷を受ける原因になります。それを避けるために、プロテクションが連続して3回働いた場合、それ以降“STANDBY ON”キーを押しても電源が入らなくなります。再度電源を入れる場合、一度本機の電源コードをAC電源コンセントから抜いて接続し直してください。
- 本機の電源を入れる前に、各アンプのチャンネル内の出力トランジスタに損傷がないかチェックしてください。
- アンプの電流は、各チャンネルのエミッターの抵抗器間電圧を測定することによりモニターしてください。

2-2. When the protection function worked due to a short between speaker terminals.**2-2. スピーカー端子間のショートによりプロテクションが働いた場合**

I PROTECT:xxx

AD value when the protection function is working
電圧の A/D 変換値**Cause:** The line between speaker terminals is shorted.**Supplementary information:** As the excess current is detected after operation of the speaker relay, the shorted speaker terminal and the connected speaker can be identified.

Turning on the power without correcting the abnormality will cause the protection function to work immediately and the power supply will instantly be shut off.

原因：スピーカー端子間がショートしている。**補足：**スピーカーリレー動作後に過電流を検出しているため、スピーカー端子および接続しているスピーカーのショートが特定できます。

異常状態のまま電源を入れると、瞬時にプロテクションが働き、すぐに電源が切れます。

2-3. When the protection function worked due to abnormal DC output.**2-3. DC 出力異常によりプロテクションが働いた場合**

PRD PRT:xxx

AD value when the protection function is working
電圧の A/D 変換値**Cause:** DC output from the power amplifier is abnormal.**Supplementary information:** The protection function worked due to a DC voltage appearing at the speaker terminal. A cause could be a defect in the amplifier.

Turning on the power without correcting the abnormality will cause the protection function to work in 3 seconds and the power supply will be shut off.

原因：パワーアンプからの DC 出力が異常。**補足：**パワーアンプの不具合により、スピーカー端子に直流電圧が加えられたために、プロテクションが働いたことを示します。

異常状態のまま電源を入れると、3秒後にプロテクションが働き、電源が切れます。

2-4. When the protection function worked due to abnormal voltage in the power supply section.

PRV PRT:xxx

AD value when the protection function is working
電圧の A/D 変換値

Cause: The voltage in the power supply section is abnormal.
Supplementary information: The protection function worked due to a defect or overload in the power supply.

Turning on the power without correcting the abnormality will cause the protection function to work in 1 second and the power supply will be shut off.

2-5. When the protection function worked due to excessive heatsink temperature.

THM PRT:xxx

AD value when the protection function is working
電圧の A/D 変換値

Cause: The temperature on the heatsink is excessive.
Supplementary information: The protection function worked due to the temperature limit being exceeded. Causes could be poor ventilation or a defect related to the thermal sensor.

Turning on the power without correcting the abnormality will cause the protection function to work in 1 second and the power supply will be shut off.

* For detection of each protection function, refer to main menu described later.

2-4. 電源部の電圧異常によりプロテクションが働いた場合

原因: 電源部の電圧が異常。
補足: 電源部の不具合により、電源電圧が正常な範囲から外れたために、プロテクションが働いたことを示します。

異常状態のまま電源を入れると、1秒後にプロテクションが働き、電源が切れます。

2-5. ヒートシンクの異常温度によりプロテクションが働いた場合

原因: ヒートシンクの温度が異常。
補足: ヒートシンクの温度が制限値を超えたために、プロテクションが働いたことを示します。

異常状態のまま電源を入れると、1秒後にプロテクションが働き、電源が切れます。

※ 各プロテクションの検出に関しては、後述のメインメニューを参照してください。

● History of protection function

When the protection function has worked, its history is stored in memory with a backup.

Even if no abnormality is noted while servicing the unit, an abnormality which has occurred previously can be defined as long as the backup data has been stored.

For details of the history of protection function, refer to main menu 21 PROTECTION HISTORY.

The history of the protection function is cleared when self-diagnostic function is cancelled by selecting PRESET RESERVED (Memory initialized) of main menu 24 or when the backup data is erased.

● プロテクションの履歴

プロテクションが働いた場合、その履歴をバックアップして記憶しています。サービスのときに異常が認められなくても、バックアップが残っていれば、お客様のところで起きた異常を区別できます。

プロテクション履歴の詳細は、メインメニュー 21 PROTECTION HISTORY を参照してください。

メインメニュー 24 PRESET RESERVED (メモリーの初期化) を選んでダイアグを解除した場合、またはバックアップが消えた場合にプロテクションの履歴はクリアされます。

● Operation procedure of Main menu and Sub-menu

There are 25 main menu items, each of them having sub-menu items.

Main menu selection

Select the main menu using "PROGRAM" knob.

Sub-menu selection

Select the sub-menu using "SCENE RADIO" (forward) and "SCENE CD" (reverse) keys.

● メインメニューとサブメニューの操作

ダイアグには No. 1～25 のメインメニューがあり、それぞれにサブメニューがあります。

メインメニューの選択

"PROGRAM" ノブで選択します。

サブメニューの選択

"SCENE RADIO" (順送り)、"SCENE CD" (逆送り) キーで選択します。

Keys of this unit / 本機キー

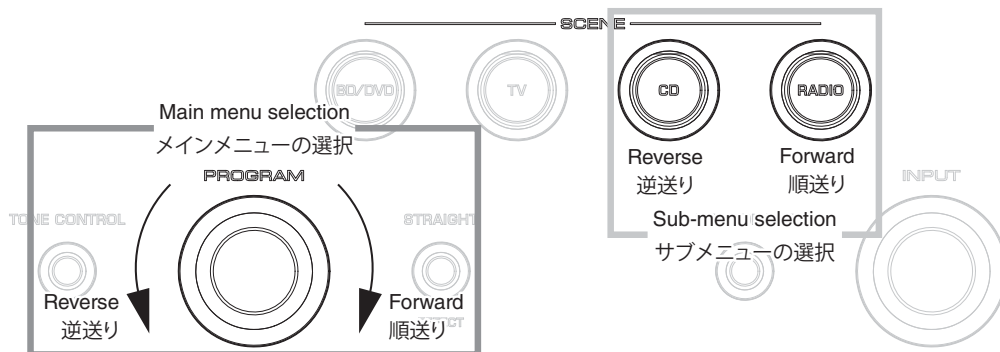

● Functions in Self-Diagnostic Function mode

In addition to the self-diagnostic function menu items, functions as listed below are available.

- Power ON/OFF
- Master volume
- Muting
- Input select
- Audio select
- PROGRAM select
- Tone control
- PURE DIRECT ON/OFF
- ZONE2 ON/OFF

* Functions related to the tuner and the set menu are not available.

● ダイアグ中の機能

ダイアグメニューの他に、以下の機能が動作します。

- 電源 オン/オフ
- マスターボリューム
- ミューティング
- インプットセレクト
- オーディオセレクト
- プログラムセレクト
- トーンコントロール
- PURE DIRECT ON/OFF

※ チューナー関連、セットメニュー関連は機能しません。

● Initial settings used to start Self-Diagnostic Function

The following initial settings are used when starting self-diagnostic function.

When self-diagnostic function is canceled, these settings are restored to those before starting self-diagnostic function.

- Master volume: -20 dB
- Zone2 Volume: +2.5 dB
- Input: AV5 (MAIN ZONE) / AUDIO1 (ZONE2)
- Main menu: 1. ANALOG BYPASS
- Speaker setting: LARGE, Bass out to SWFR (All channels)
- Speaker impedance: 8 ohms position
- OSD: ON
- XM Power: ON (U model)

● ダイアグ開始時の初期設定

ダイアグ開始時に以下のような設定になります。ダイアグ解除時にはダイアグ開始前の状態に戻ります。

- マスターボリューム：-20 dB
- インプット：AV5
- メインメニュー：1. ANALOG BYPASS
- スピーカー設定：LARGE、Bass out to SWFR (すべてのチャンネル)
- スピーカーインピーダンス：8 オーム
- OSD：オン

● Details of Self-Diagnostic Function menu

1. BYPASS

Using the sub-menu, it is possible to select ANALOG BYPASS output or DSP BYPASS output.

ANALOG BYPASS

The analog input audio signal is output to FRONT L/R in PURE DIRECT.

● ダイアグメニュー詳細

1. BYPASS

サブメニューにより、ANALOG BYPASS/DSP BYPASSが選択可能です。

ANALOG BYPASS

アナログ入力の音声信号が PURE DIRECT で FRONT L/R へ出力されます。

1. ANALOG BYPASS

INPUT: AV5 ANALOG
SPEAKER OUT: 1 kHz, SUBWOOFER OUTPUT: 50 Hz

Input level	Volume	SPEAKER OUT						SUB-WOOFER OUTPUT
		FRONT	CENTER	SURROUND	SURROUND BACK	PRESENCE	ZONE2	
Both ch, -20 dBm	+6.5 dB	+13.0 dBm	-∞	-∞	-∞	-∞	-∞	-∞

DSP BYPASS

The digital input audio signal is output to FRONT L/R in PURE DIRECT.

DSP BYPASS

デジタル入力の音声信号が PURE DIRECT で FRONT L/R へ出力されます。

1. DSP BYPASS

INPUT: AV5 ANALOG
SPEAKER OUT: 1 kHz, SUBWOOFER OUTPUT: 50 Hz

Input level	Volume	SPEAKER OUT						SUB-WOOFER OUTPUT
		FRONT	CENTER	SURROUND	SURROUND BACK	PRESENCE	ZONE2	
Both ch, -20 dBm	+6.5 dB	-∞	-∞	-∞	-∞	-∞	-∞	-∞

ANALOG BYPASS

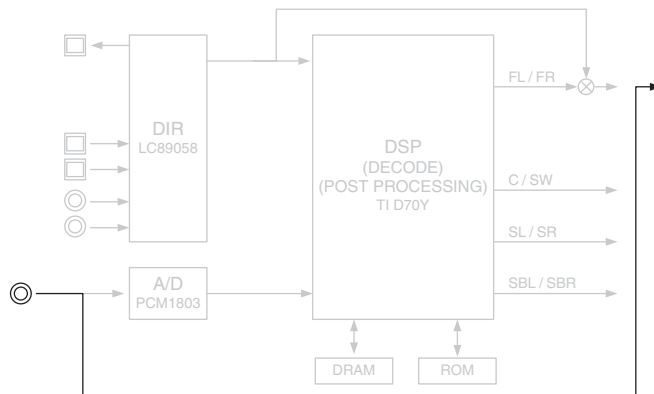

(Shaded items not used in this example)

DSP BYPASS

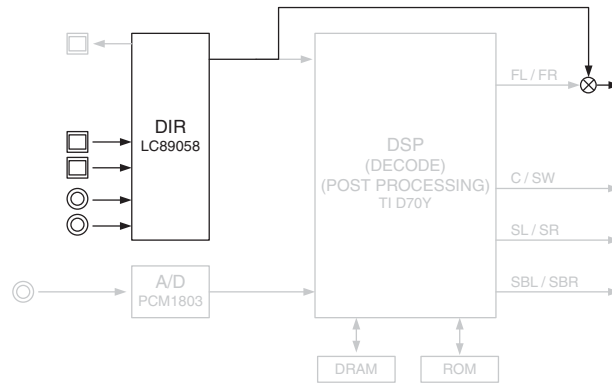

(Shaded items not used in this example)

2. RAM THROUGH

Using the sub-menu, it is possible to select MARGIN output or FULL BIT output.

RAM MARGIN

The audio signal is output including the head margin.

2. RAM THROUGH

サブメニューにより、MARGIN/FULL BIT が選択可能です。

RAM MARGIN

音声信号がヘッドマージンを含んで出力されます。

2. RAM MARGIN

INPUT: AV5 ANALOG

SPEAKER OUT: 1 kHz, SUBWOOFER OUTPUT: 50 Hz

Input level	Volume	SPEAKER OUT						SUB-WOOFER OUTPUT
		FRONT	CENTER	SURROUND	SURROUND BACK	PRESENCE	ZONE2	
Both ch, -20 dBm	+6.5 dB	+13.0 dBm	+13.0 dBm	+13.0 dBm	+13.0 dBm	-∞	-∞	-6.5 dBm

RAM FULL BIT

The audio signal is output in digital full bit without including the head margin.

The SUBWOOFER signal is output but not in digital full bit.

RAM FULL BIT

音声信号がヘッドマージンを含まず、デジタルフルビットで出力されます。

SUBWOOFERは出力されますが、デジタルフルビットではありません。

2. RAM FULL ALL

INPUT: AV5 ANALOG

SPEAKER OUT: 1 kHz, SUBWOOFER OUTPUT: 50 Hz

Input level	Volume	SPEAKER OUT						SUB-WOOFER OUTPUT
		FRONT	CENTER	SURROUND	SURROUND BACK	PRESENCE	ZONE2	
Both ch, -20 dBm	+6.5 dB	+13.0 dBm	+13.0 dBm	+13.0 dBm	+13.0 dBm	-∞	-∞	-6.5 dBm

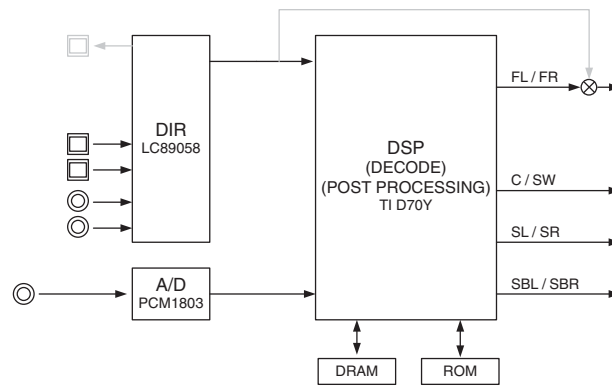

(Shaded items not used in this example)

When input source is stereo, signal is assigned as below.

2 ch 信号入力時、以下のように信号が振り分けられて出力されます。

- Front L → Front L / Center / Surround L / Surround Back L, R
- Front R → Front R / Surround R
- Front L +10 dB → SWFR

RAM FULL CENTER

The audio signal is output to only CENTER in digital full bit without including the head margin.

RAM FULL CENTER

音声信号がヘッドマージンを含まず、デジタルフルビットでCENTERのみへ出力されます。

2. RAM FULL C

INPUT: AV5 ANALOG
SPEAKER OUT: 1 kHz, SUBWOOFER OUTPUT: 50 Hz

Input level	Volume	SPEAKER OUT						SUB-WOOFER OUTPUT
		FRONT	CENTER	SURROUND	SURROUND BACK	PRESENCE	ZONE2	
Both ch, -20 dBm	+6.5 dB	-∞	+13.0 dBm	-∞	-∞	-∞	-∞	-∞

RAM FULL SURROUND

The audio signal is output to only SURROUND L/R in digital full bit without including the head margin.

RAM FULL SURROUND

音声信号がヘッドマージンを含まず、デジタルフルビットでSURROUND L/Rのみへ出力されます。

2. RAM FULL SUR

INPUT: AV5 ANALOG
SPEAKER OUT: 1 kHz, SUBWOOFER OUTPUT: 50 Hz

Input level	Volume	SPEAKER OUT						SUB-WOOFER OUTPUT
		FRONT	CENTER	SURROUND	SURROUND BACK	PRESENCE	ZONE2	
Both ch, -20 dBm	+6.5 dB	-∞	-∞	+13.0 dBm	-∞	-∞	-∞	-∞

RAM FULL SURROUND BACK

The audio signal is output to only SURROUND BACK L/R in digital full bit without including the head margin.

RAM FULL SURROUND BACK

音声信号がヘッドマージンを含まず、デジタルフルビットでSURROUND BACK L/Rのみへ出力されます。

2. RAM FULL SB

INPUT: AV5 ANALOG
SPEAKER OUT: 1 kHz, SUBWOOFER OUTPUT: 50 Hz

Input level	Volume	SPEAKER OUT						SUB-WOOFER OUTPUT
		FRONT	CENTER	SURROUND	SURROUND BACK	PRESENCE	ZONE2	
Both ch, -20 dBm	+6.5 dB	-∞	-∞	-∞	+13.0 dBm	-∞	-∞	-∞

3. HDMI AUDIO

Using the sub-menu, the audio signals input to HDMI IN are selected and output.

- * When selecting "DSD", be sure to connect an HDMI unit equipped with DSD output function to this unit.

3. HDMI AUDIO

サブメニューにより、HDMI IN に入力された音声信号が選択、出力されます。

- ※ "DSD" を選択する場合、必ず DSD 出力が可能な HDMI 機器を接続してください。

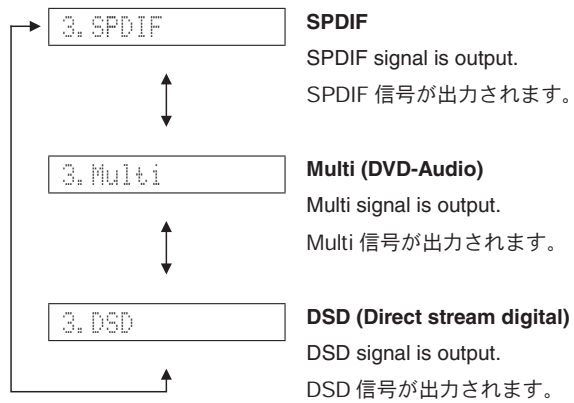

4. SPEAKER SET

The analog switch settings for each sub-menu are as shown in the table below.

	FRONT	CENTER	SURROUND	SURROUND BACK	SUBWOOFER
FRNT : SML 0dB	SMALL	LARGE	LARGE	LARGE	SWFR
CENTER : NONE	LARGE	NONE	LARGE	LARGE	SWFR
LFE/B : FRNT	LARGE	SMALL	SMALL	SMALL	FRONT
Zone2 Amp ON	LARGE	LARGE	LARGE	– (*1)	SWFR
Bi-AMP	LARGE	LARGE	LARGE	LARGE (*2)	SWFR
TONE : MAX	LARGE	LARGE	LARGE	LARGE	SWFR
TONE : MIN	LARGE	LARGE	LARGE	LARGE	SWFR
SPEAKER 6 ohms	LARGE	LARGE	LARGE	LARGE	SWFR

(*1) ZONE2 L/R (EXTRA SP L/R): LARGE

(*2) Bi-AMP: LARGE

LARGE: This mode is used for a speaker with high bass reproduction performance (a large unit).
Full bandwidth signals are output.

SMALL: This mode is used for a speaker with low bass reproduction performance (a small unit).
The signals of 90 Hz or less are mixed into the channel specified by LFE/BASS.

NONE: This mode is used for no center speaker.
The center content is reduced by 3 dB and distributed to FRONT L/R.

SWFR: LFE of 5.1 ch signal or LFE/BASS lower than 90 Hz is output through SUBWOOFER OUT.

FRONT: LFE of 5.1 ch signal or LFE/BASS lower than 90 Hz is distributed to FRONT L/R.

4. SPEAKER SET

各サブメニューにおけるアナログスイッチの設定は以下の通りです。

LARGE : 低音再生能力の高い（ユニットの大きい）スピーカーを使用するモードです。
全帯域が出力されます。

SMALL : 低音再生能力の低い（ユニットの小さい）スピーカーを使用するモードです。
90 Hz 以下が LFE/BASS で指定したチャンネルへミックスされます。

NONE : センタースピーカーを使用しないモードです。
センター成分は -3 dB されて、FRONT L/R へ振り分けられます。

SWFR : 5.1 ch 信号の LFE または 90 Hz 以下の LFE/BASS が SUBWOOFER OUT へ出力されます。

FRONT : 5.1 ch 信号の LFE または 90 Hz 以下の LFE/BASS を FRONT L/R へ振り分けます。

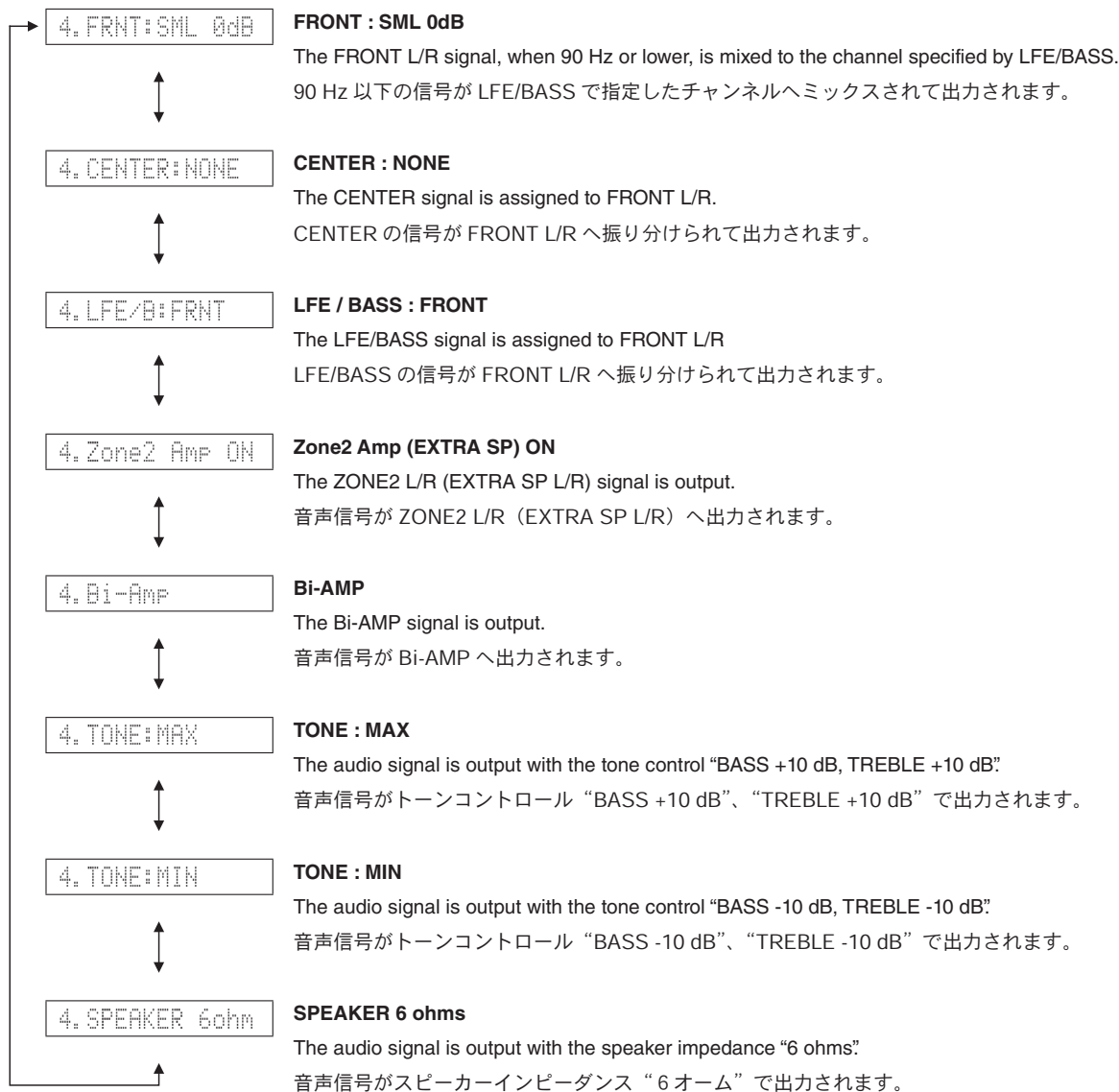

INPUT: AV5 ANALOG

SPEAKER OUT: 1 kHz, SUBWOOFER OUTPUT: 50 Hz

Sub-menu	Input level	Volume	SPEAKER OUT				SUBWOOFER OUTPUT
			FRONT L/R	CENTER	SURROUND L/R	SURROUND BACK L/R	
FRNT : SML 0dB	Both ch, -20 dBm	+6.5 dB	+13.0 dBm	+13.0 dBm	+13.0 dBm	+13.0 dBm	-3.0 dBm
CENTER : NONE	Both ch, -20 dBm	+6.5 dB	+18.0 dBm	-∞	+13.0 dBm	+13.0 dBm	-7.5 dBm
LFE/B : FRNT (50 Hz)	Both ch, -20 dBm	+6.5 dB	-∞	+13.0 dBm	+13.0 dBm	+13.0 dBm	-∞
Zone2 Amp ON	Both ch, -20 dBm	+6.5 dB	+13.0 dBm	+13.0 dBm	+13.0 dBm	-∞ (*)	-7.5 dBm
Bi-AMP	Both ch, -20 dBm	+6.5 dB	+13.0 dBm	+13.0 dBm	+13.0 dBm	+13.0 dBm	-7.5 dBm
TONE : MAX	Both ch, -20 dBm	+6.5 dB	+14.0 dBm	+13.0 dBm	+13.0 dBm	+13.0 dBm	-7.5 dBm
TONE : MIN	Both ch, -20 dBm	+6.5 dB	+12.0 dBm	+13.0 dBm	+13.0 dBm	+13.0 dBm	-7.5 dBm
SPEAKER 6 ohms	Both ch, -20 dBm	+6.5 dB	+13.0 dBm	+13.0 dBm	+13.0 dBm	+13.0 dBm	-7.5 dBm

(*) ZONE2 L/R (EXTRA SP L/R) SPEAKER OUT: +13.0 dBm

5. MULTI CH-INPUT

The input source “MULTI CHANNEL INPUT” is selected.

Using the sub-menu, it is possible to select the 6 ohms/8 ohms.

When LIM / PLDET / THM menu is selected, keys become non-operable.

However, it is possible to advance to the next main menu by turning the “PROGRAM” knob of this unit.

5. MULTI CH-INPUT

入力ソース“MULTI CHANNEL INPUT”が選択されます。サブメニューにより、6 オーム / 8 オームが選択可能です。

LIM / PLDET / THM のメニューにすると、キー操作はできなくなりますが、本機の “PROGRAM” ツマミを回すことにより、次のメインメニューに進めることができます。

8 ch INPUT 6 ohms

8 ch INPUT 6 ohms

5.8ch INPUT_60

INPUT: MULTI CH INPUT

SPEAKER OUT: 1 kHz, SUBWOOFER OUTPUT: 50 Hz

Input level	Volume	SPEAKER OUT						SUB-WOOFER OUTPUT
		FRONT	CENTER	SURROUND	SURROUND BACK	PRESENCE	ZONE2	
Both ch, -20 dBm	+6.5 dB	+13.0 dBm	+13.0 dBm	+13.0 dBm	+13.0 dBm	-∞	-∞	-16.5 dBm

8 ch INPUT 8 ohms

8 ch INPUT 8 ohms

5.8ch INPUT_80

INPUT: MULTI CH INPUT

SPEAKER OUT: 1 kHz, SUBWOOFER OUTPUT: 50 Hz

Input level	Volume	SPEAKER OUT						SUB-WOOFER OUTPUT
		FRONT	CENTER	SURROUND	SURROUND BACK	PRESENCE	ZONE2	
Both ch, -20 dBm	+6.5 dB	+13.0 dBm	+13.0 dBm	+13.0 dBm	+13.0 dBm	-∞	-∞	-16.5 dBm

LIM / PLDET / THM

LIM: Setting value of LIM (Limiter control)
 * Do not change the value settings because this menu is only for the use of development staff.

PLDET: Power limiter detection
 The A/D conversion value during operation is displayed.
 (Reference voltage: 3.3 V=255)

THM: Temperature protection detection
 The A/D conversion value during operation is displayed.
 (Reference voltage: 3.3 V=255)

LIM / PLDET / THM

LIM : LIM (リミッター制御) の設定値
 ※ 開発スタッフ専用メニューですので、設定値の変更は行わないでください。

PLDET : パワーリミッターの検出
 動作時の A/D 変換値が表示されます。
 (基準電圧 : 3.3 V = 255)

THM : 温度プロテクションの検出
 動作時の A/D 変換値が表示されます。
 (基準電圧 : 3.3 V = 255)

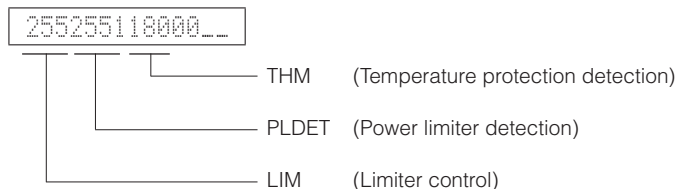

6. MIC CHECK

The signals input through the microphone are output to only FRONT L via A/D and D/A.

6. MIC CHECK

マイクから入力された信号が A/D - D/A 経由で FRONT L のみへ出力されます。



7. FL/GUI CHECK

This menu is used to check the FL display and video control sections. When checking the video control section, connect a TV monitor to this unit with a component video cable and video pin cable.

Using the sub-menu, the FL display section or video control section varies as shown below.

7. FL/GUI CHECK

FL 表示部および映像表示部のチェックプログラムです。映像制御部をチェックする場合には、TV モニターと本機をコンポーネント /D ビデオケーブル、ビデオ用ピンケーブルで接続します。

サブメニューにより、FL 表示部と映像表示部の選択が以下のように連動して変わります。

Checking FL display section / FL 表示部のチェック

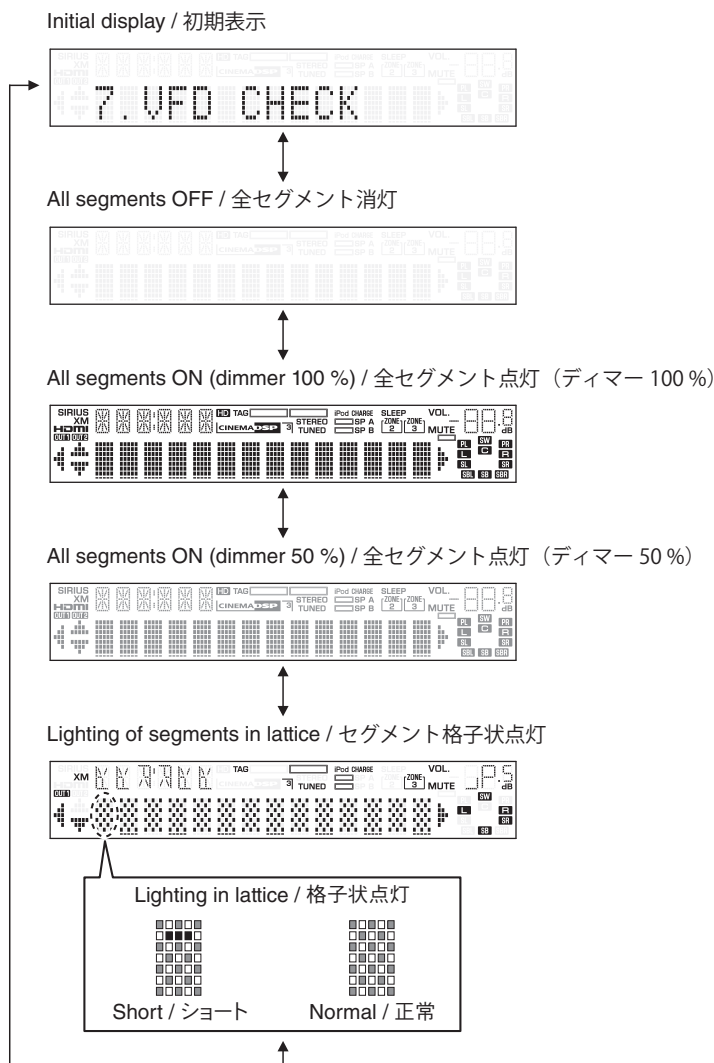

Check of the Video control section. (Monitor out) / 映像表示部のチェック (モニター出力)

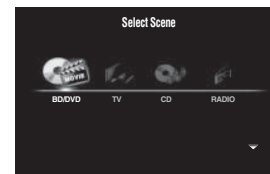
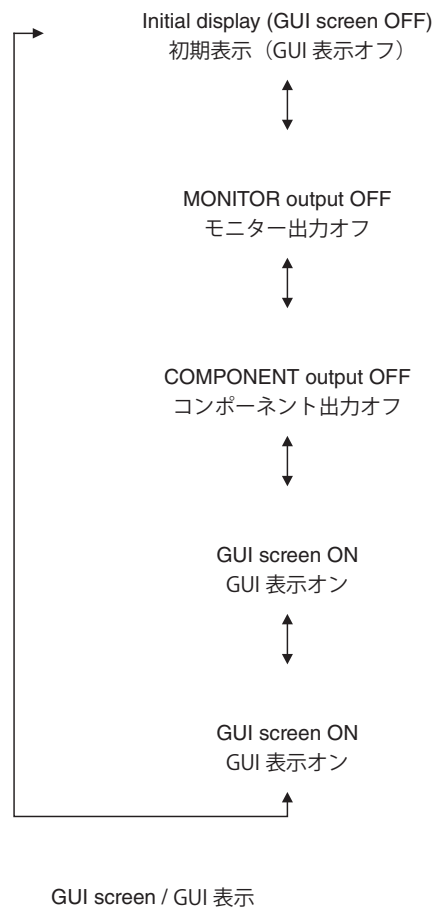

Segment conditions of the FL driver and the FL tube are checked by turning ON and OFF all segments. Next, the operation of the FL driver is checked by using the dimmer control. Then a short between segments next to each other is checked by turning ON and OFF all segments alternately (in lattice).

(In the above example, the segments in the second row from the top are shorted.)

全セグメント消灯・全セグメント点灯により FL ドライバー、FL 管のセグメントの不良を確認します。

次に、ディマーコントロールによって FL ドライバーの動作チェックを行います。

さらに全セグメントを交互（格子状）に点灯／消灯することで、隣り合うセグメントのショートをチェックします。

（前記の例は、上から 2 列目のセグメントがショートしています。）

8. MANUAL TEST

The built-in noise generator of DSP outputs the test noise through the channels specified by using the sub-menu.

The noise frequency for LFE is 30 to 80 Hz. Other than that, the noise frequency is 500 Hz to 2 kHz.

TEST ALL

The test noise is output from all channels.

8. MANUAL TEST

DSP 内蔵のノイズ発生回路によって、サブメニューで指定したチャンネルへテストノイズが出力されます。

LFE 用のノイズ周波数は 30～80 Hz、それ以外はノイズ周波数 500 Hz～2 kHz となります。

TEST ALL

全チャンネルからテストノイズが出力されます。

8. TEST ALL

9. A/D DATA CHECK

This menu is used to display the A/D conversion value of the microprocessor which detects panel keys of this unit and protection functions by using the sub-menu.

When K0/K1 menu is selected, keys become non-operable due to detection of the values of all keys.

However, it is possible to advance to the next main menu by turning the "PROGRAM" knob of this unit.

* The figures in the diagram are given as reference only.

PS1/PS2

PSx: Power supply voltage protection detection

PS1

Voltage detects: AC_BL, AC_12, AC_5, ±12 and +5V

Normal value: 38 to 128
(Reference voltage: 3.3 V=255)

PS2

Voltage detects: -5 and +5I

Normal value: 31 to 125
(Reference voltage: 3.3 V=255)

* If PS1 or PS2 becomes out of the normal value range, the protection function works to turn off the power.

PS1:089 2:077

DC/TH

DC: Power amplifier DC (DC voltage) output is detected.

Normal value: 23 to 70
(Reference voltage: 3.3 V=255)

TH: Temperature on the heatsink is detected.

Normal value: 0 to 124
(Reference voltage: 3.3 V=255)

* If DC or TH becomes out of the normal value range, the protection function works to turn off the power.

DC:049 TH:118

9. A/D DATA CHECK

本機パネルキー、プロテクションなどを検出しているマイコンの A/D 変換値を、サブメニューで表示します。

K0/K1 のメニューにすると、全キーの値を検出するためキー操作はできなくなります。本機の "PROGRAM" ツマミを回すことにより、次のメインメニューに進めることができます。

※ 図中の数値は参考例です。

PS1/PS2

PSx: 電源電圧プロテクションの検出

PS1

検出電圧: AC_BL, AC_12, AC_5, ±12, +5V

正常値: 38 ~ 128
(基準電圧: 3.3 V = 255)

PS2

検出電圧: -5V, +5I

正常値: 31 ~ 125
(基準電圧: 3.3 V = 255)

※ PS1 または PS2 が正常値を外れるとプロテクションが働き、電源が切れます。

DC/TH

DC: パワーアンプ DC (直流電圧) 出力の検出

正常値: 23 ~ 70
(基準電圧: 3.3 V = 255)

TH: ヒートシンク温度の検出

正常値: 0 ~ 124
(基準電圧: 3.3 V = 255)

※ DC または TH が正常値を外れるとプロテクションが働き、電源が切れます。

IMP/PL

IMP: 8 or 6 ohms impedance setup detection

IMP 8: 8 ohms setting

IMP 6: 6 ohms setting

PL: PLDET (Power amplifier output voltage detection)

The power amplifier output voltage is detected and the power amplifier input voltage is controlled according to the detected output voltage.

(Reference voltage: 3.3 V=255)

TH/PL

IMP: インピーダンス設定の検出

(このモデルには適用されません。)

PL: PLDET (パワーアンプ出力電圧の検出)

パワーアンプ出力電圧を検出して、パワーアンプ入力電圧を制御します。

(基準電圧: 3.3 V = 255)

IMP:8 PL:255

U, C, T, K, A, B, G, E, F models (Reference voltage: 3.3 V=255)

	During normal operation	Value for starting limiter operation	Value for canceling limiter operation
PLDET (8 ohms/6 ohms)	255 / 255	87 / 146	125 / 171
LIM (Limiter control)	H	L	H

R, L models (Reference voltage: 3.3 V=255)

	During normal operation	Value for starting limiter operation	Value for canceling limiter operation
PLDET (8 ohms/6 ohms)	255 / 255	100 / 100	131 / 131
LIM (Limiter control)	H	L	H

J model (基準電圧: 3.3 V = 255)

	通常値	リミッタ動作開始値	リミッタ動作解除値
PLDET (8 ohms/6 ohms)	255 / 255	100 / 100	131 / 131
LIM (リミッター制御)	H	L	H

DST/DK

DST: Destination detection

(Reference voltage: 3.3 V=255)

DK: DOCK type detection

(Reference voltage: 3.3 V=255)

DST/DK

DST: 仕向け先の検出

(基準電圧: 3.3 V = 255)

DK: DOCK タイプの検出

(基準電圧: 3.3 V = 255)

DST:000 DK:255

Destination detection for AD port

Pull-up resistance 10 k-ohms

Ohm (R3809 VIDEO P.C.B.)	0.0 k	1.2 k	2.7 k	4.7 k	6.8 k	10.0 k	15.0 k	47.0 k	100.0 k
A/D value (3.3 V=255)	0 – 15	15 – 46	46 – 69	69 – 92	92 – 115	115 – 139	139 – 177	185 – 224	224 – 247
DEST (139 pin)	J	U	C	R	T	K	A	B, G, E, F	L

DOCK detection for AD port (IC20 Microprocessor pin no. 128)

Pull-up resistance 10 k-ohms

DOCK type (DKID 141 pin)	Bluetooth	iPod	No connect
A/D value (3.3 V=255)	5 – 25	120 – 140	255

K0/K1

K0/K1: KEY0/KEY1 (Panel key of this unit)

When the A/D conversion value of the panel key becomes out of the specified range (standard value ± 4), normal operation will not be available.

In this case, check the constant of voltage dividing resistor, solder condition, etc. Refer to the table below.

(Reference voltage: 3.3 V=255)

K0/K1

K0/K1 : KEY0/KEY1 (本機/パネルキー)

パネルキーの A/D 値が規定範囲 (基準値 ± 4) から外れると、正常な動きをしません。

下表をご覧になり、各キーの分圧抵抗の定数、ハンダ不良等の確認をしてください。

(基準電圧 : 3.3 V = 255)

K0:255 K1:255

RX-V1065/HTR-6280

Displayed / 表示	K0
0 - 11	SCENE RADIO
12 - 32	SCENE CD
33 - 54	SCENE TV
55 - 75	SCENE BD/DVD
76 - 95	ZONE2 ON/OFF
96 - 118	ZONE2 CONTROL
119 - 142	—
143 - 162	—
181 - 197	MAIN ZONE ON/OFF
198 - 229	TONE CONTROL
255	KEY OFF

Displayed / 表示	K1
0 - 11	PURE DIRECT
12 - 32	STRAIGHT / EFFECT
33 - 54	INFO
55 - 77	MEMORY
78 - 98	PRESET ◀
99 - 120	PRESET ▶
121 - 143	CATEGORY ◀ FM
144 - 165	CATEGORY ▶ AM
166 - 185	TUNING CH ◀
186 - 205	TUNING CH ▶
206 - 225	—
226 - 245	—
255	KEY OFF

AX-V1065

Displayed / 表示	K0
0 - 11	SCENE RADIO
12 - 32	SCENE CD
33 - 54	SCENE TV
55 - 75	SCENE BD/DVD
76 - 95	SLEEP
96 - 118	MUTE
119 - 142	—
143 - 162	—
181 - 197	STANDBY/ON
198 - 229	TONE CONTROL
255	KEY OFF

Displayed / 表示	K1
0 - 11	PURE DIRECT
12 - 32	STRAIGHT / EFFECT
33 - 54	INFO
55 - 77	MEMORY
78 - 98	PRESET ◀
99 - 120	PRESET ▶
121 - 143	FM
144 - 165	AM
166 - 185	TUNING ◀
186 - 205	TUNING ▶
206 - 225	—
226 - 245	—
255	KEY OFF

10. VIDEO CHECK

I2C check

The I2C (Inter integrated circuit) bus line connection is checked.

10. VIDEO CHECK

I2C check

I2C (Inter integrated circuit) バスラインの接続をチェックします。

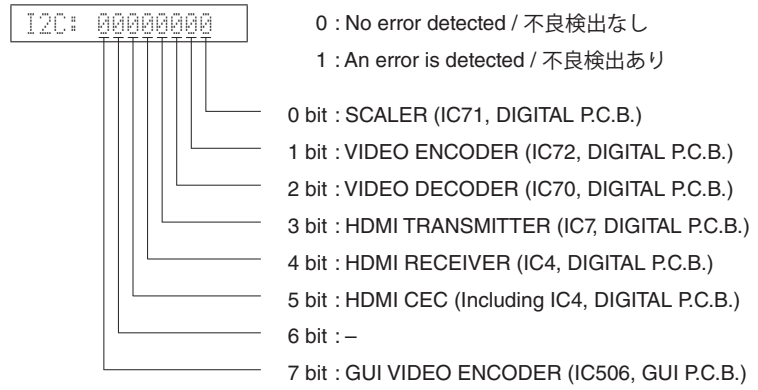

0 : No error detected / 不良検出なし
1 : An error is detected / 不良検出あり

Digital component

The video signal is converted and output as shown below.

Digital component

映像信号が以下のように変換され、出力されます。

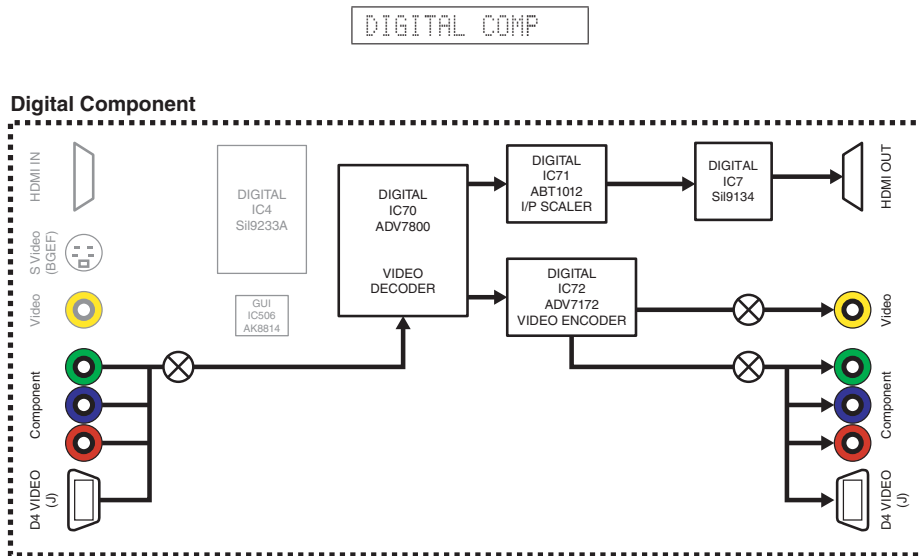

Digital CVBS (Video)

The video signal is converted and output as shown below.

Digital CVBS (Video)

映像信号が以下のように変換され、出力されます。

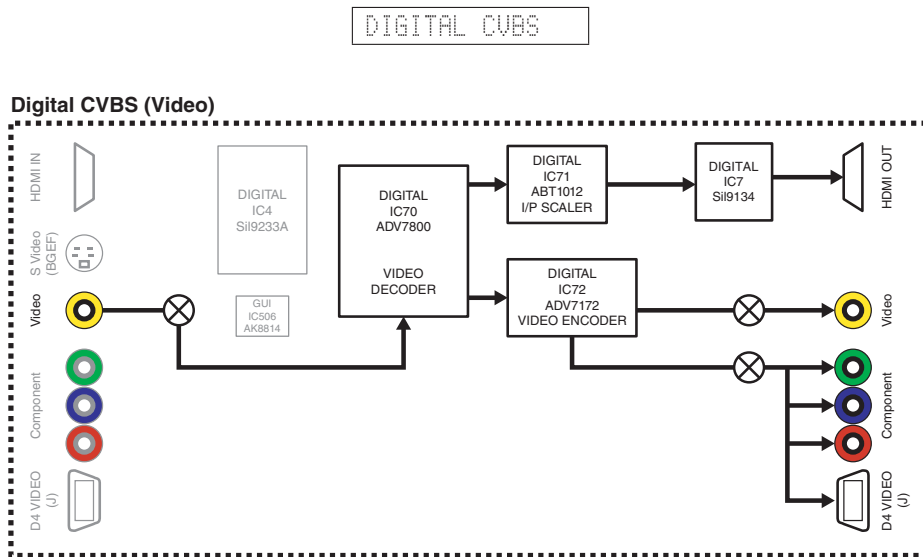

Digital Y/C (S-Video) (B, G, E, F models)

The video signal is converted and output as shown below.

Digital Y/C (S-Video) (B, G, E, F models)

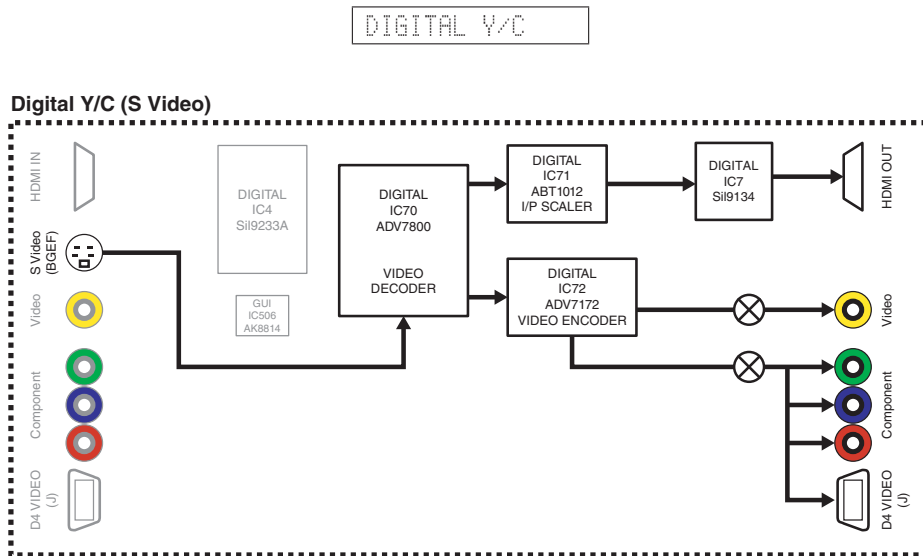

Analog bypass

The video signal is converted and output as shown below.

Analog bypass

映像信号が以下のように変換され、出力されます。

ANALOG BYPASS

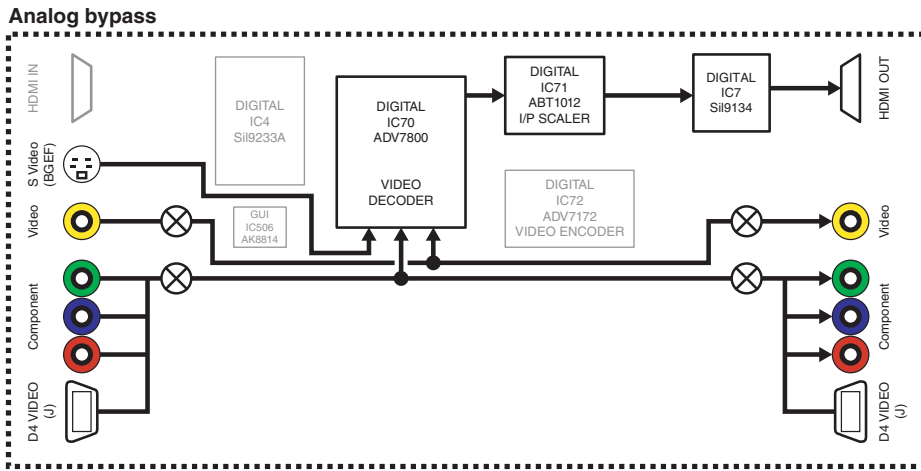

Test pattern

The test pattern is output from IC72 (DIGITAL P.C.B.).

Test pattern

IC72 (DIGITAL P.C.B.) からテストパターンが出力されます。

TEST PATTERN

Digital Component

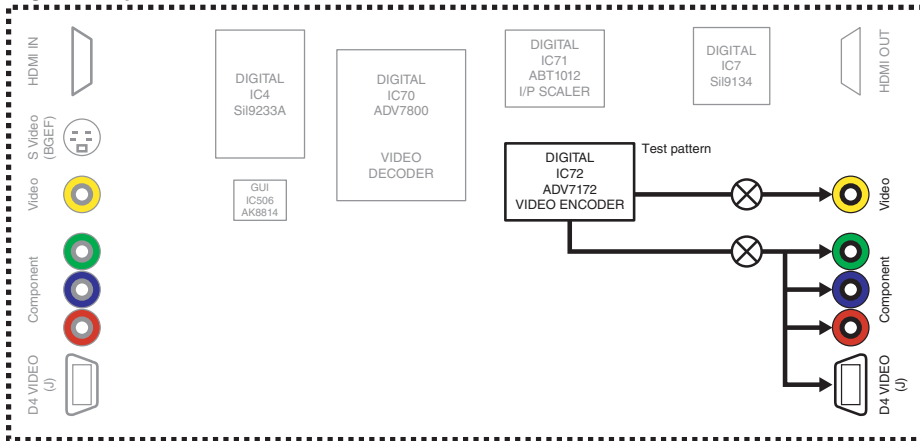

IC72 Test pattern

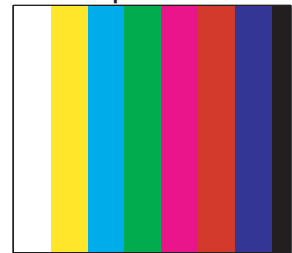

Video information

The information of input video signal is displayed.

Video information

入力されている映像信号の情報が表示されます。

Example / 例

VIDEO IN 480i

11. XM STATUS (U model)

This menu is used to check the output of XM Radio Antenna.

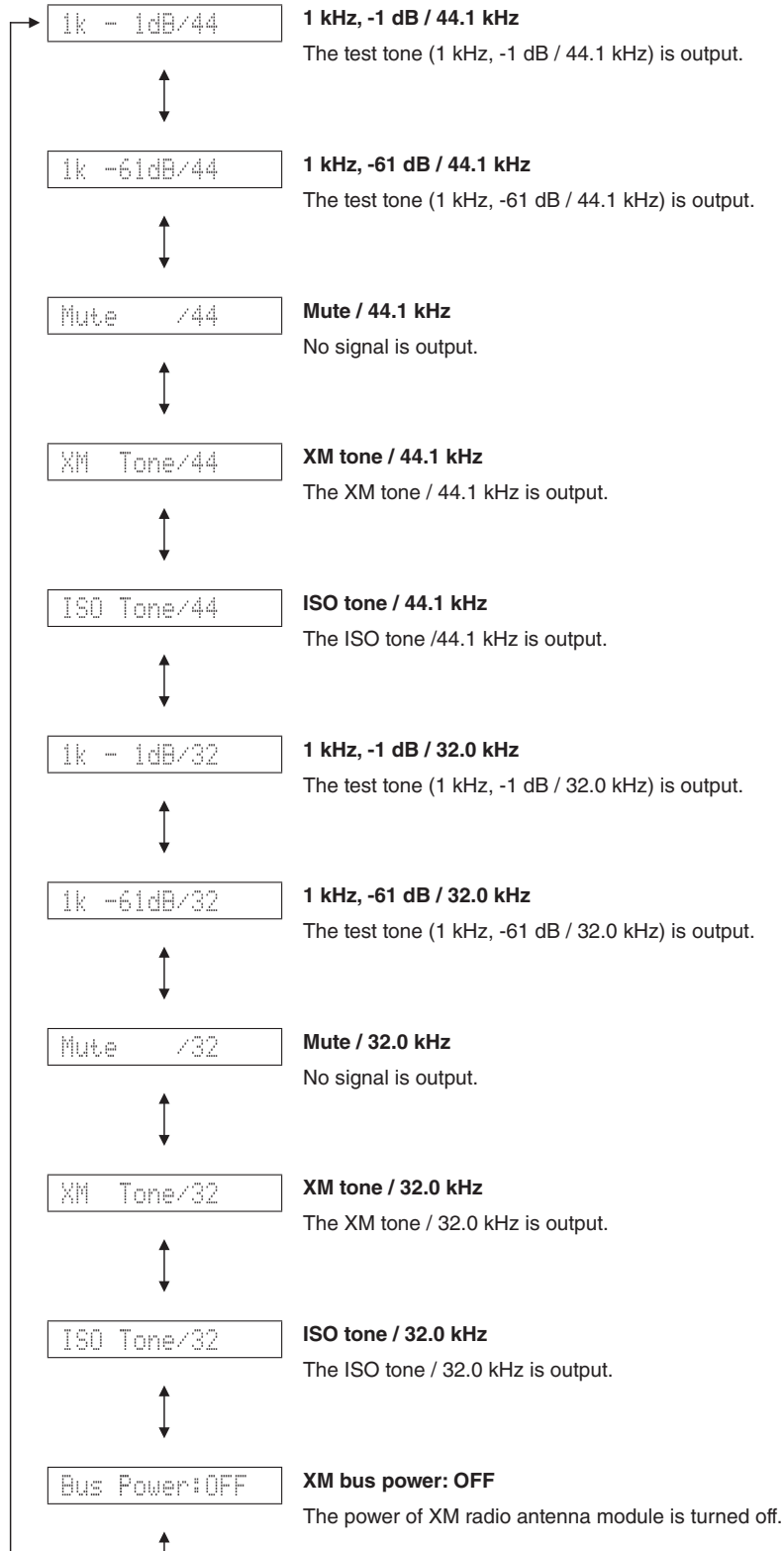

12. SIRIUS (U model)

The SIRIUS information are displayed.

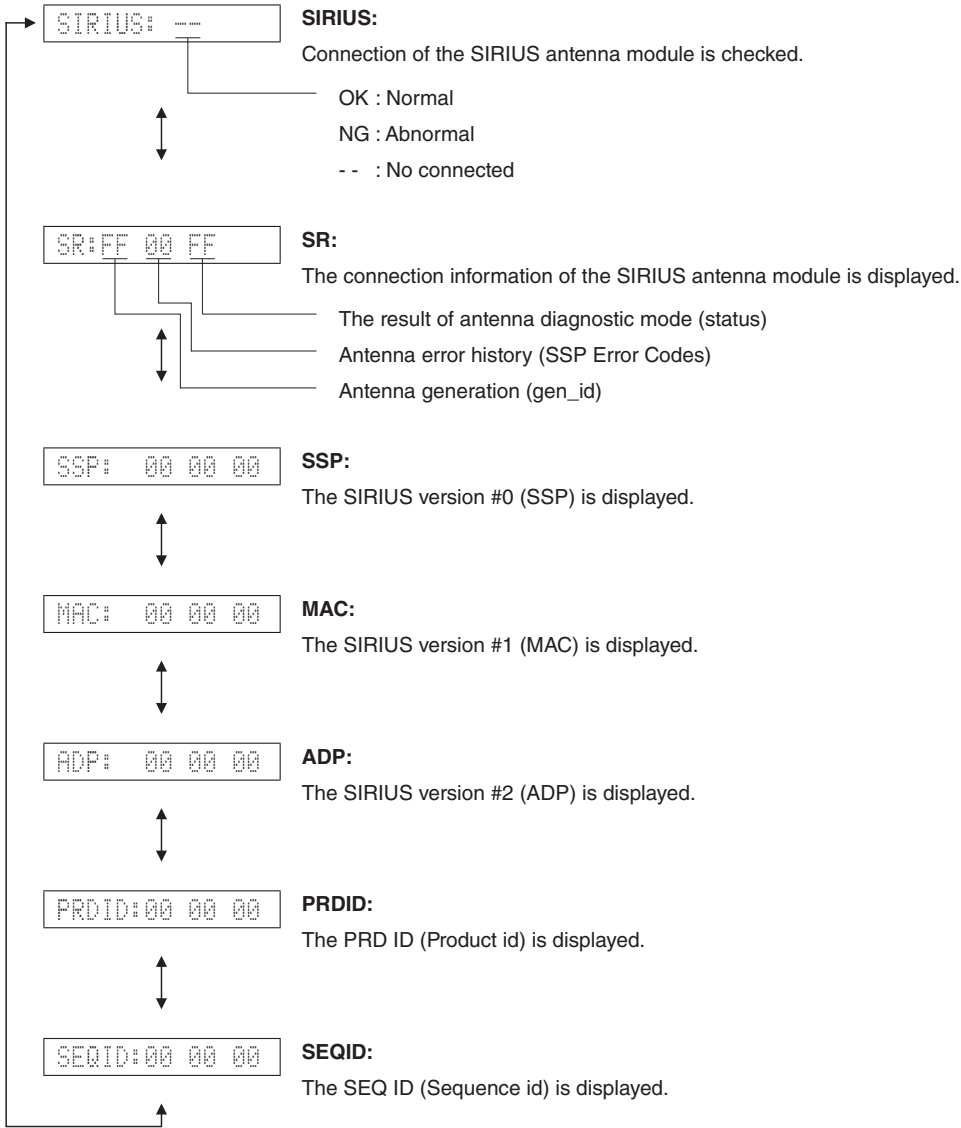

13. HD RADIO (U model)

The firmware version is displayed.

CPU version

The firmware version is displayed.

HD CPU V:03.00

DSP version

The DSP version is displayed.

D: C0003.000

14. DOCK

This menu is used to check the DOCK connector without the iPod itself.

With the power to this unit turned off, short between pins No. 14 (TX) and No. 18 (RX), between pins No. 1 (PWR) and No. 17 (ACCPOW), between pins No. 4 (iPDET) and No. 8 (DGND). Also, connect a 10 k-ohms, 1/4 W resistor between pins NO. 21 (DKID) and No. 8 (DGND). (Make sure that the power is turned off when shorting pins.)

Start up the self-diagnostic function and select this menu.

The check result is displayed according to the following display specifications.

Note) Be sure to return the shorted pins to their original condition after executing this test.

14. DOCK

iPod 本体無しで、DOCK コネクタの検査を行うメニューです。

本機の電源を切った状態で、DOCK コネクタの 14 ピン (TX) と 18 ピン (RX)、1 ピン (PWR) と 17 ピン (ACCPOW)、4 ピン (iPDET) と 8 ピン (DGND) をショートさせます。また、21 ピン (DKID) と 8 ピン (DGND) の間に 10 k Ω、1/4 W 抵抗を接続します。(ショートさせる時は、必ず電源を切ってください。)

ダイアグを起動して本メニューを選択します。

下記表示仕様に従って、チェック結果が表示されます。

注意) 検査後、ショートしたピンを必ず元の状態に戻してください。

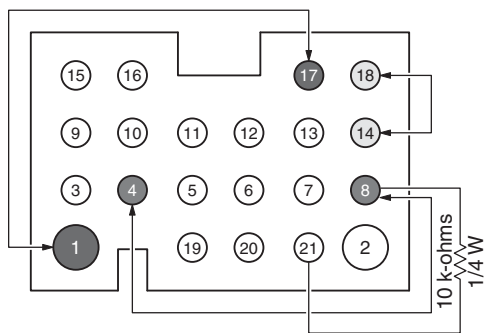

DOCK CONNECTOR

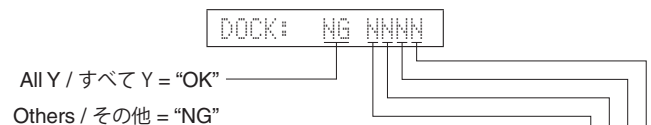

Check item / チェック項目	Short pins / ショートピン	Result / 結果	Display / 表示
UART loop back test / UART ループバックテスト	Pins No.14 (TX) - No.18 (RX)	OK	Y
		NG	N
iPAP (iPod accessory power) detection / iPAP (iPod accessory power) 検出	Pins No.1 (PWR) - No.17 (ACCPOW)	IC20 pin No. 114 High = YES	Y
		Low = No	N
iPDET (iPod installation to DOCK) detection / iPDET (iPod installation to DOCK) 検出	Pins No.4 (iPDET) - No.8 (DGND)	IC20 pin No. 8 Low = installed / 装着	Y
		High = not installed / 非装着	N
DKID (DOCK ID) detection / DKID (DOCK ID) 検出	Pins No.21 (DKID) - No.8 (DGND) * 10 k-ohms, 1/4 W pull down	IC20 pin No. 141 10 k-ohms, 1/4 W pull down	Y
		Other	N

BT VERSION

The DOCK (Bluetooth module) version is displayed.

BT VERSION

DOCK (Bluetooth module) のバージョンが表示されます。

BT V:

15. HDMI INFORMATION

The HDMI informations are displayed.

MN:RX-V1065

HDMI model name

The model name of this unit written in HDMI module is displayed.

HDMI モジュールに書き込まれている本機のモデル名が表示されます。

RX-V1065

HTR-6280

AX-V1065

PI: 3140

HDMI product ID

The product ID of this unit written in HDMI module is displayed.

HDMI モジュールに書き込まれている本機のプロダクト ID が表示されます。

3140 : RX-V1065

3141 : HTR-6280

3142 : AX-V1065

UN: YAMAHA

HDMI vendor name

The vendor name "YAMAHA" of this unit written in HDMI module is displayed.

HDMI モジュールに書き込まれている本機のベンダー名 "YAMAHA" が表示されます。

15. HDMI INFORMATION

HDMI の情報が表示されます。

16. HDMI SELECT

Using the sub-menu, the selected input signal is output to HDMI OUT.

* Support audio is set to "OTHER".

16. HDMI SELECT

サブメニューにより、選択された入力信号が HDMI OUT へ出力されます。

※ SUPPORT AUDIO は "OTHER" に設定されます。

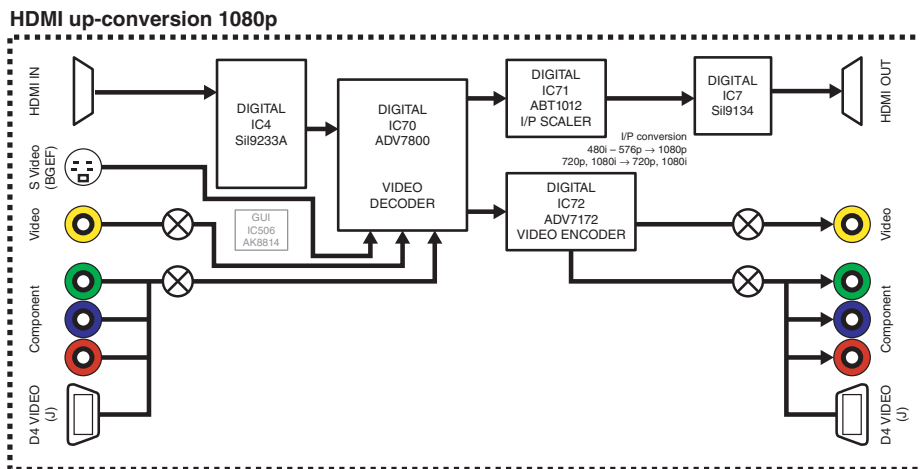
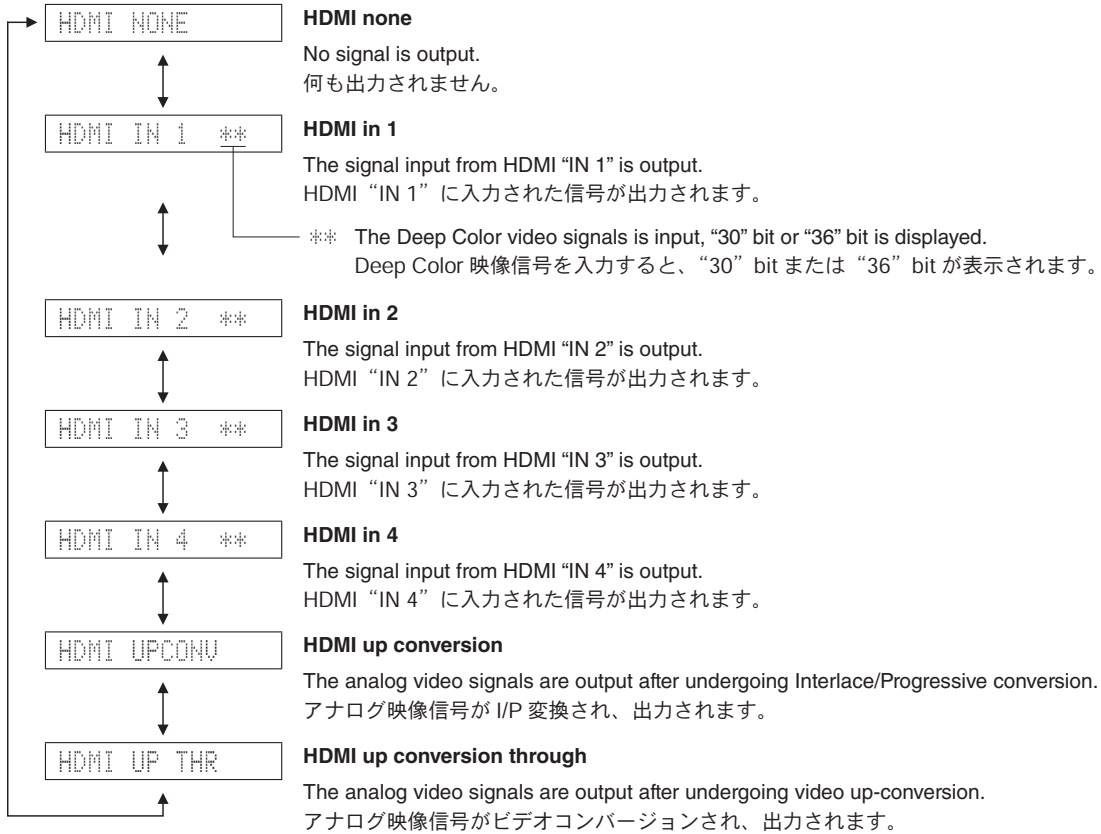

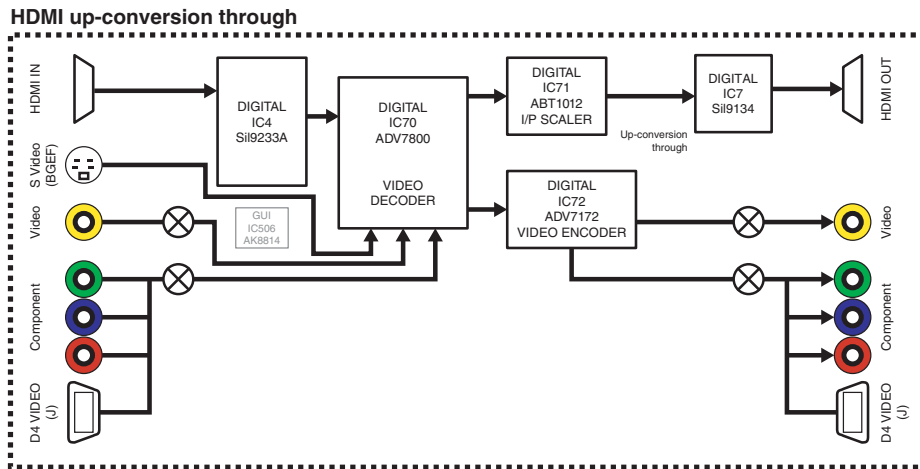

17. USB

The music file stored in the USB storage device is reproduced.

- a. Copy 2 or more music files from PC to the root folder of the USB storage device.
- b. Insert the USB storage device to the USB terminal of this unit.

USB file 1

The 1st piece of the music files stored in the USB storage device connected to the USB terminal is reproduced.



USB file 2

The 2nd piece of the music files stored in the USB storage device connected to the USB terminal is reproduced.

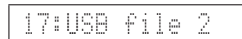

17. USB

USB フラッシュメモリーに記録された音楽ファイルが再生されます。

- a. USB フラッシュメモリーのルートフォルダに (PC から) 音楽ファイルを 2 曲以上コピーします。
- b. USB フラッシュメモリーを本機の USB 端子に接続します。

USB file 1

USB 端子に接続された USB フラッシュメモリーの音楽ファイルの 1 曲目が再生されます。

USB file 2

USB 端子に接続された USB フラッシュメモリーの音楽ファイルの 2 曲目が再生されます。

18. IF STATUS (Input function status)

Not applied to these models.

DSP status



18. IF STATUS (Input function status)

このモデルには適用されません。

DSP status

19. BUS CHECK

Communication and bus line connection between devices on the DIGITAL P.C.B. are checked.

TI (DSP) BUS check

Communication and bus line connection between microprocessor (IC20) and TI (DSP, IC44) are checked.

```
TI BUS:NoEr
```

NoEr : No error detected.

Boot : When "Boot" is displayed for a few seconds or "Boot" and "NoEr" are displayed alternately, there is possibility that an error occurs.

BF LOOP :

Communication and bus line connection between main microprocessor (IC20) and BF (sub-microprocessor, IC505) are checked.

```
BF LOOP:
```

OK : No error detected.

NG : An error is detected.

19. BUS CHECK

DIGITAL P.C.B. 内のデバイス間の通信とバスラインの接続をチェックします。

TI (DSP) BUS check

マイコン (IC20) と TI (DSP, IC44) の通信・バスラインの接続をチェックします。

NoEr : 不良検出なし

Boot : "Boot" が数秒間表示されるまたは "Boot" と "NoEr" が交互に表示される場合、異常が発生している可能性があります。

BF LOOP :

メインマイコン (IC20) と BF (サブマイコン, IC505) の通信・バスラインの接続をチェックします。

OK : 不良検出なし

NG : 不良検出あり

20. NO MENU (Invalidity)

```
Invalidity
```

20. NO MENU (Invalidity)

21. PROTECTION HISTORY

The history of protection function is displayed. Select this menu and press the "STRAIGHT" key, and the history will be erased.

21. PROTECTION HISTORY

過去のプロテクション履歴が表示されます。サブメニューを選んだ後、"STRAIGHT" キーを押すと履歴は消去されます。

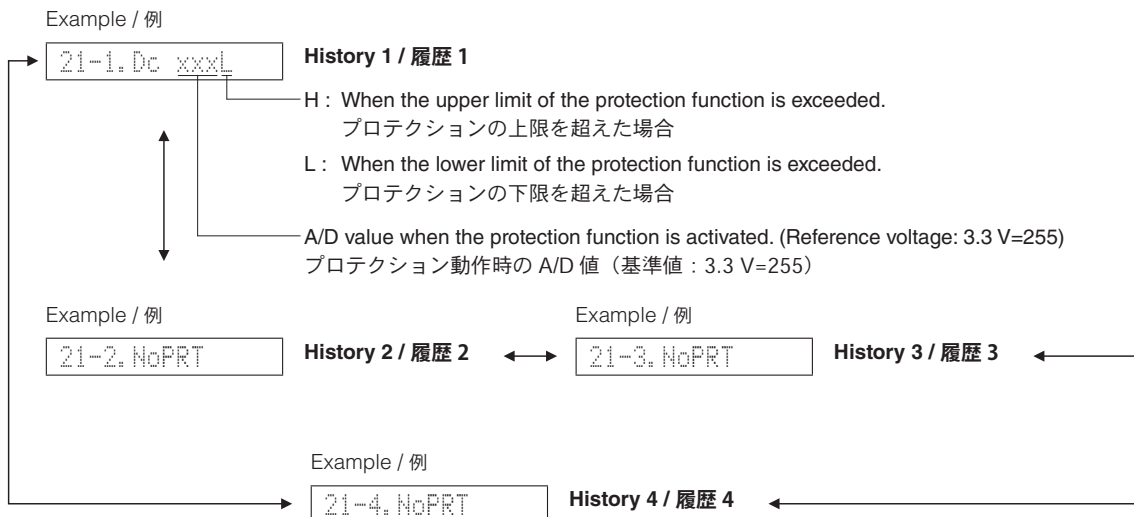

22. NO MENU (Invalidity)**22. NO MENU (Invalidity)**

Invalidity

23. UPDATE

Not applied to these models.

23. UPDATE

このモデルには適用されません。

UPDATE TI**UPDATE TI**

23. UPDATE TI

24. FACTORY PRESET

This menu is used to reserve/inhibit initialization of the back-up IC.

24. FACTORY PRESET

バックアップ用 IC（音場プログラムのパラメーターやセットメニュー内容等）の初期化を予約／禁止します。

24. PRESET INHI



24. PRESET RSRV

PRESET INHIBIT (Initialization inhibited) / PRESET INHIBIT (初期化禁止)

Back-up IC initialization is not executed. Select this sub-menu to protect the values set by the user.

バックアップ IC の初期化は行われません。ユーザーの設定値を保護するときは、こちらを選択してください。

PRESET RESERVED (Initialization reserved) / PRESET RESERVED (初期化予約)

Initialization of the back-up IC is reserved. (Actually, initialization is executed the next time that the power is turned on.) Select this sub-menu to reset to the original factory settings or to reset the back-up IC. Any protection history will be cleared.

バックアップ IC の初期化が予約されます。(実際に初期化されるのは、次回の電源投入時です。) 工場出荷時やバックアップ IC をリセットしたいときは、こちらを選択してください。このとき、プロテクション履歴も初期化されます。

CAUTION: Before setting to the PRESET RESERVED, write down the existing preset memory content of the tuner.

(This is because setting to the PRESET RESERVED will cause the user memory content to be erased.)

注意： PRESET RESERVED を選んで初期化をする前に、チューナーのユーザーメモリー内容を書き写してください。

(初期化をすると、ユーザーメモリーの内容は消えてしまいます。)

25. ROM VER/SUM/PORT

The firmware version, checksum values, model name and destination are displayed.

The checksum is obtained by adding the data at every 8-bit for each program area and expressing the result as a 4-figure hexadecimal data.

* The figures in the diagram are given as reference only.

Firmware version

The firmware version of microprocessor (IC20 DIGITAL P.C.B.) is displayed.

```
Ver: C045E
```

All checksum

The checksum value of microprocessor (IC20 DIGITAL P.C.B.) is displayed.

```
Sum: 6E5E
```

TI (DSP) FLASH ROM version

The firmware version of TI (DSP) FLASH ROM (IC49 DIGITAL P.C.B.) is displayed.

```
TiVer:02.06r1
```

TI (DSP) FLASH ROM checksum

The checksum value of TI (DSP) FLASH ROM (IC49 DIGITAL P.C.B.) is displayed.

```
TiSum:46C49F69
```

BF version

The firmware version of BF (sub-microprocessor, IC505 GUI P.C.B.) is displayed.

```
BF Ver: B023
```

BF checksum 1 (All/Main)

The checksum value (All/Main) of BF (sub-microprocessor, IC505 GUI P.C.B.) is displayed.

```
A1:D7FAMa:079F
```

25. ROM VER/SUM/PORT

ファームウェアのバージョン、チェックサム、モデル名、仕向け先が表示されます。

チェックサムは、プログラムエリア別にデータを8ビットごとに加算していき、4桁の16進データで現したものです。

※ 図中の数値は参考例です。

Firmware version

マイコン (IC20 DIGITAL P.C.B.) のファームウェアバージョンが表示されます。

All checksum

マイコン (IC20 DIGITAL P.C.B.) のチェックサムが表示されます。

TI (DSP) FLASH ROM version

TI (DSP) FLASH ROM (IC49 DIGITAL P.C.B.) のファームウェアバージョンが表示されます。

TI (DSP) FLASH ROM checksum

TI (DSP) FLASH ROM (IC49 DIGITAL P.C.B.) のチェックサムが表示されます。

BF version

BF (サブマイコン、IC505 GUI P.C.B.) のファームウェアバージョンが表示されます。

BF checksum 1 (All / Main)

BF (サブマイコン、IC505 GUI P.C.B.) のチェックサム (All / Main) が表示されます。

BF checksum 2 (Application/USB)

The checksum value (Application/USB) of BF (sub-microprocessor, IC505 GUI P.C.B.) is displayed.



BF checksum 2 (Application / USB)

BF (サブマイコン、IC505 GUI P.C.B.) のチェックサム (Application / USB) が表示されます。

XM version (U model)

The firmware version of XM is displayed.

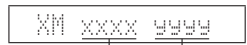

yyyy : BF (sub-microprocessor)
xxxx : Main microprocessor

XM version (U model)

SIRIUS version (U model)

The firmware version of SIRIUS is displayed.

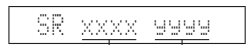

yyyy : BF (sub-microprocessor)
xxxx : Main microprocessor

SIRIUS version (U model)

MODEL/DESTINATION

The model name and destination are displayed.

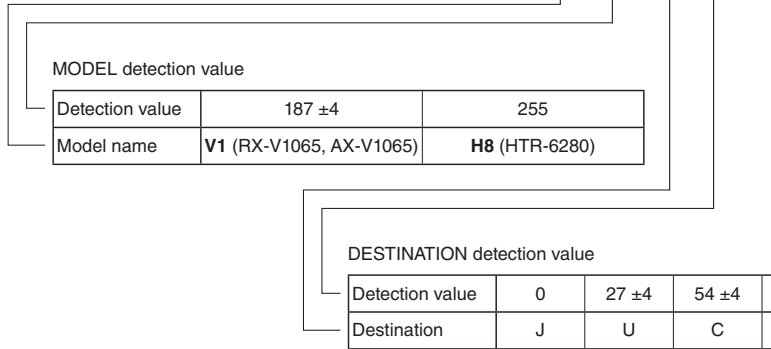

MODEL detection value

Detection value	187 ±4	255
Model name	V1 (RX-V1065, AX-V1065)	H8 (HTR-6280)

DESTINATION detection value

Detection value	0	27 ±4	54 ±4	81 ±4	93 ±4	127 ±4	153 ±4	210 ±4	231 ±4
Destination	J	U	C	R	T	K	A	B, G, E, F	L

MODEL/DESTINATION

モデル名、仕向け先が表示されます。

VERIFY error

Not applied to these models.

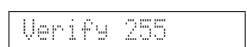

VERIFY error

このモデルには適用されません。

■ CONFIRMATION OF IDLING CURRENT OF AMP UNIT / アンプユニットのアイドリング電流の確認

- Right after power is turned on, confirm that the voltage across the terminals of R1152 (SURROUND BACK Rch), R1154 (SURROUND Rch), R1150 (FRONT Rch), R1148 (CENTER), R1149 (FRONT Lch), R1153 (SURROUND Lch), R1151 (SURROUND BACK Lch) are between 0.1mV and 10.0mV.
- If it exceeds 10.0 mV, open (cut off) R1104 (SURROUND BACK Rch), R1106 (SURROUND Rch), R1102 (FRONT Rch), R1100 (CENTER), R1101 (FRONT Lch), R1105 (SURROUND Lch), R1103 (SURROUND BACK Lch) and reconfirm the voltage.

Attention

If the measured voltage exceeds 10.0mV after an amplifier repair, first check for a defective component before cutting the bias resistor.

- Confirm that the voltage is 0.2 mV to 15.0 mV after 60 minutes.

- 電源投入直後、R1152 (SURROUND BACK Rch)、R1154 (SURROUND Rch)、R1150 (FRONT Rch)、R1148 (CENTER)、R1149 (FRONT Lch)、R1153 (SURROUND Lch)、R1151 (SURROUND BACK Lch) の端子間電圧を測定し、0.1 mV から 10.0 mV の間であることを確認してください。

- 電圧が 10 mV を超えている場合は、R1104 (SURROUND BACK Rch)、R1106 (SURROUND Rch)、R1102 (FRONT Rch)、R1100 (CENTER)、R1101 (FRONT Lch)、R1105 (SURROUND Lch)、R1103 (SURROUND BACK Lch) をカットし、電圧を再確認してください。

注意

パワーアンプ修理後に 10.0mV を超えている場合は、抵抗をカットする前に故障箇所を調べてください。

- 60 分後、電圧が 0.2 mV ~ 15.0 mV であることを確認してください。

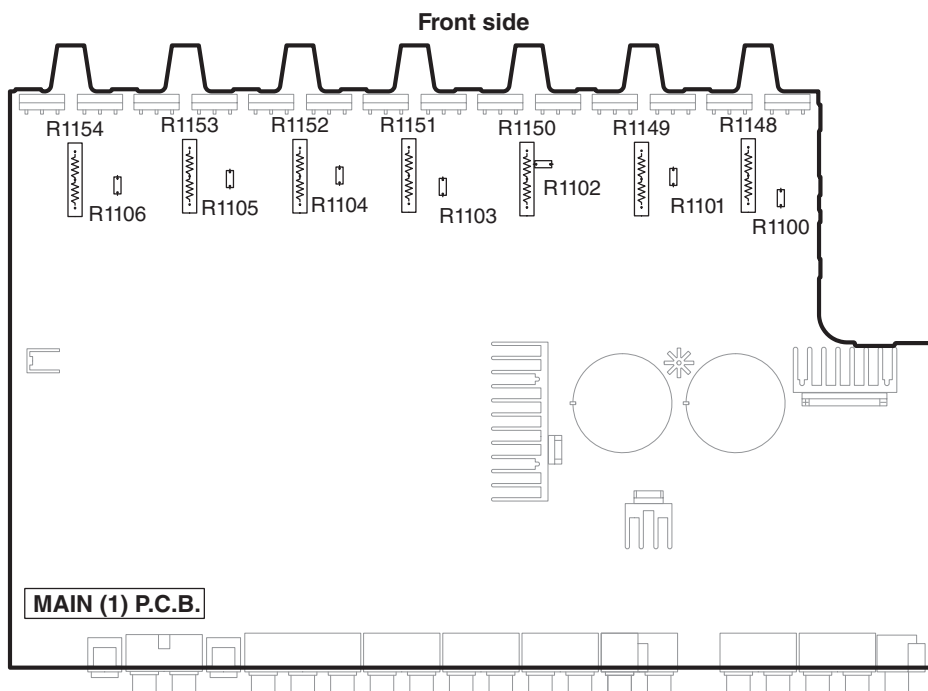
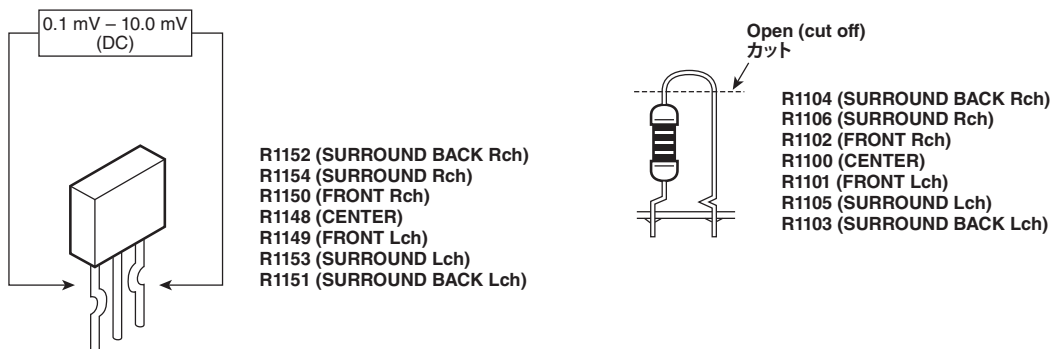

■ DISPLAY DATA

● V4001 : 18-MT-09GNK (OPERATION P.C.B.)

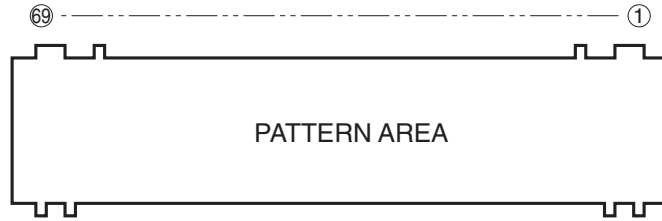

● PIN CONNECTION

Pin No.	69	68	67	66	65	64	63	62	61	60	59	58	57	56	55	54	53	52	51	50	49	48	47	46	45	44	43	42	41	40	39	38	37	36	35
Connection	F2	NX	NP	NP	P1	P2	P3	P4	P5	P6	P7	P8	P9	P10	P11	P12	P13	P14	P15	P16	P17	P18	P19	P20	P21	P22	P23	P24	P25	P26	P27	P28	P29	P30	P31

Pin No.	34	33	32	31	30	29	28	27	26	25	24	23	22	21	20	19	18	17	16	15	14	13	12	11	10	9	8	7	6	5	4	3	2	1
Connection	P32	P33	P34	P35	P36	NX	NX	NX	NX	NX	NX	NX	18G	17G	16G	15G	14G	13G	12G	11G	10G	9G	8G	7G	6G	5G	4G	3G	2G	1G	NP	NP	NX	F1

Note : 1) F1, F2 Filament pin 2) NP No pin 3) NX No extend pin 4) 1G-18G Grid pin

● GRID ASSIGNMENT

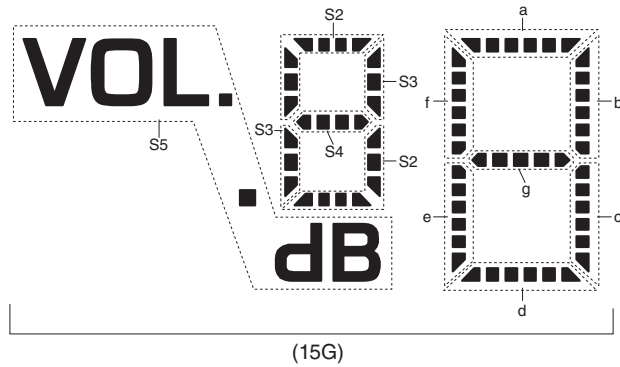
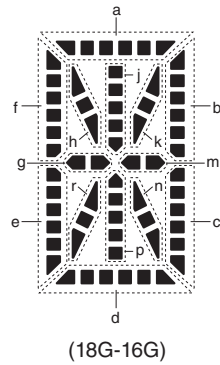
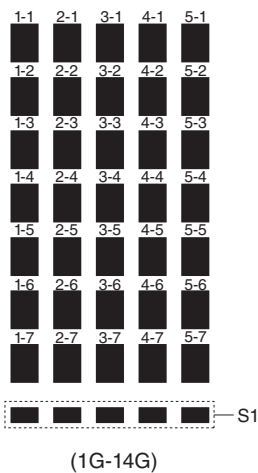
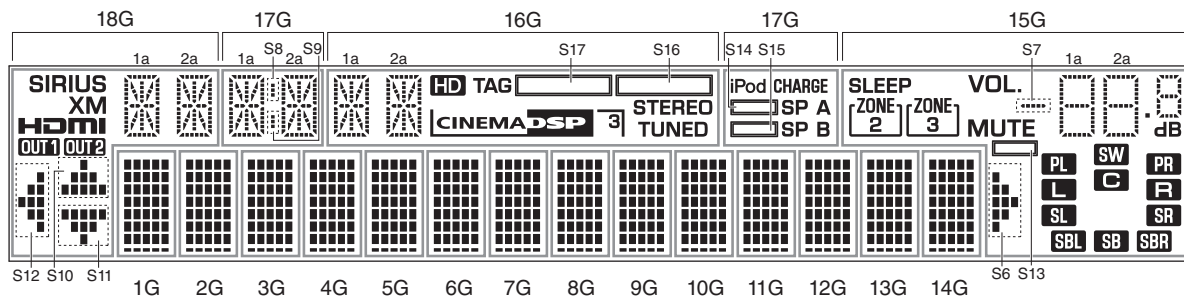

● ANODE CONNECTION

	18G	17G	16G	15G	1G-14G
P1	1a	1a	1a	S5	1-1
P2	1h	1h	1h	S7	2-1
P3	1j	1j	1j	1d	3-1
P4	1k	1k	1k	2d	4-1
P5	1b	1b	1b	S2	5-1
P6	1f	1f	1f	1e	1-2
P7	1m	1m	1m	2e	2-2
P8	1g	1g	1g	S3	3-2
P9	1c	1c	1c	1c	4-2
P10	1e	1e	1e	2c	5-2
P11	1r	1r	1r	S4	1-3
P12	1p	1p	1p	1g	2-3
P13	1n	1n	1n	2g	3-3
P14	1d	1d	1d	1f	4-3
P15	2a	2a	2a	2f	5-3
P16	2h	2h	2h	1b	1-4
P17	2j	2j	2j	2b	2-4
P18	2k	2k	2k	1a	3-4
P19	2b	2b	2b	2a	4-4
P20	2f	2f	2f	PL	5-4
P21	2m	2m	2m	SW	1-5
P22	2g	2g	2g	PR	2-5
P23	2c	2c	2c	L	3-5
P24	2e	2e	2e	C	4-5
P25	2r	2r	2r	R	5-5
P26	2p	2p	2p	SL	1-6
P27	2n	2n	2n	SR	2-6
P28	2d	2d	2d	SBL	3-6
P29	SIRIUS	S8	HD	SB	4-6
P30	XM	S9	TAG	SBR	5-6
P31	HDMI	iPod CHARGE	CINEMA DSP	S6	1-7
P32	OUT1	SP B	3	S13	2-7
P33	OUT2	S15	STEREO	MUTE	3-7
P34	S12	SP A	TUNED	ZONE 2	4-7
P35	S10	S14	S17	ZONE 3	5-7
P36	S11	—	S16	SLEEP	S1

IC DATA

IC44: D70YE101BRFP266 (DIGITAL P.C.B.)
Decoder/Post processor

* No replacement part available. / サービス部品供給なし

RX-V1065/HTR-6280/
AX-V1065

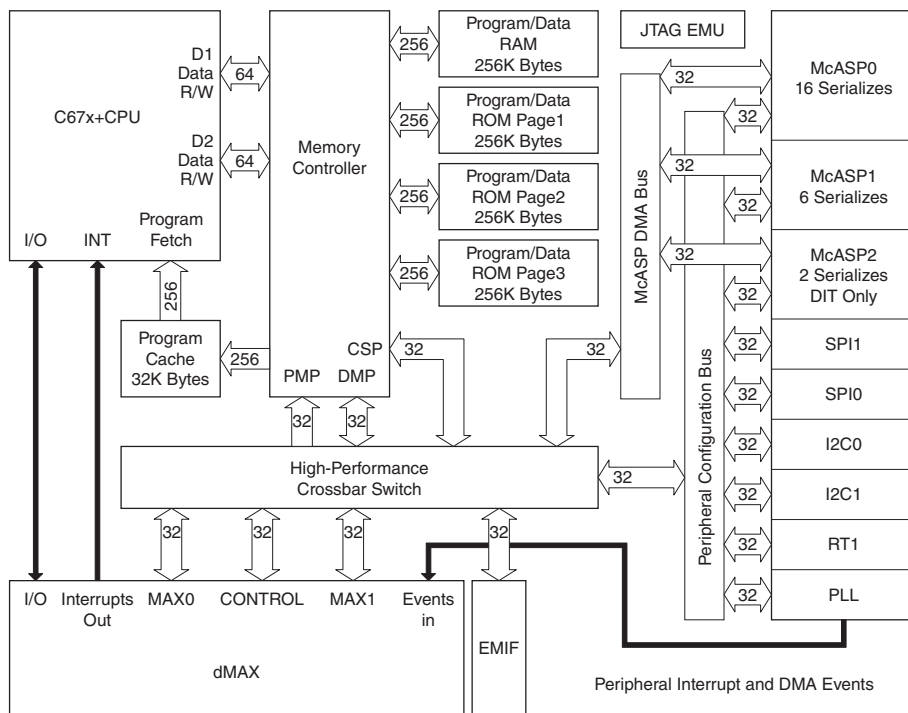
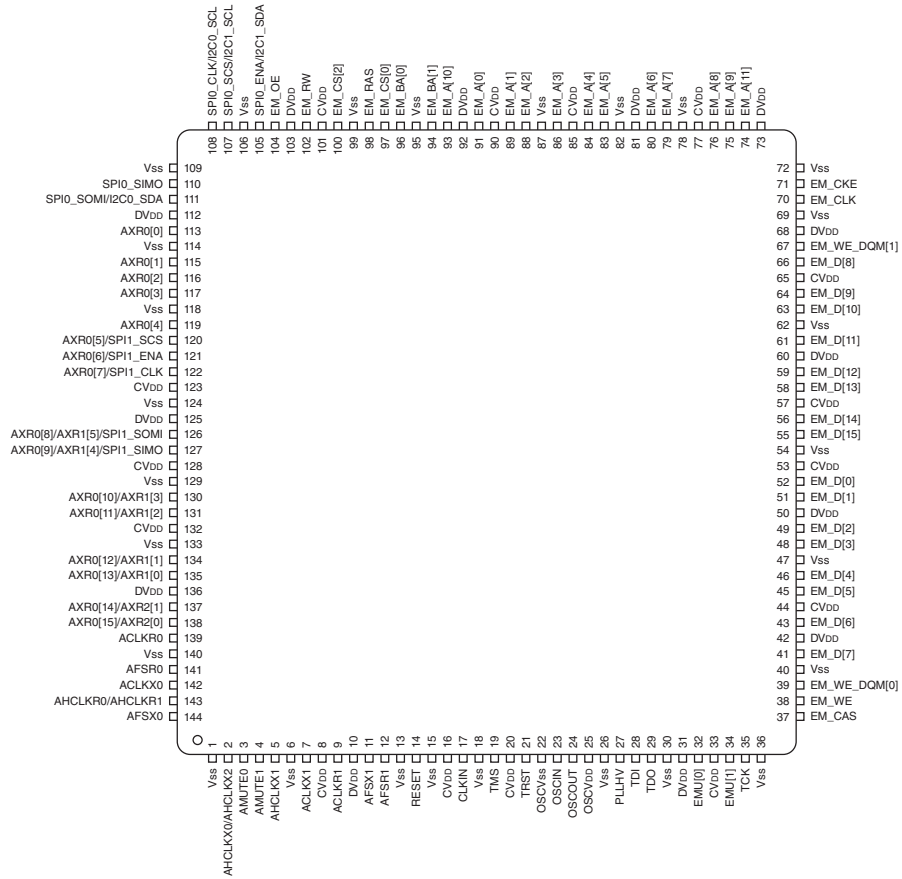

No.	Function Name (P.C.B.)	TYPE ⁽¹⁾	PULL ⁽²⁾	GPIO ⁽³⁾	Detail of Function
1	VSS				
2	AHCLKX0/AHCLKX2	IO	–	Y	McASP0 and McASP2 transmit master clock
3	AMUTE0	IO	–	Y	McASP0 mute output
4	AMUTE1	IO	–	Y	McASP1 mute output
5	AHCLKX1	IO	–	Y	McASP1 transmit master clock
6	VSS				
7	ACLKX1	IO	–	Y	McASP1 transmit bit clock
8	CVDD				
9	ACLKR1	IO	–	Y	McASP1 receive bit clock
10	DVDD				
11	AFSX1	IO	–	Y	McASP1 transmit frame Sync (L/R clock)
12	AFSR1	IO	–	Y	McASP1 receive frame Sync (L/R clock)
13	VSS				
14	RESET	IO	–	N	Device reset pin
15	VSS				
16	CVDD				
17	CLKIN	IO	–	N	Alternate clock input (3.3-V LVCMOS input)
18	VSS				
19	TMS	IO	IPU	N	Test mode select
20	CVDD				
21	TRST	IO	IPU	N	Test reset
22	OSCVSS	PWR	–	N	Oscillator Vss tap point (for filter only)
23	OSCIN	IO	–	N	1.2-V oscillator input
24	NC	O	–	N	
25	OSCVDD	PWR	–	N	Oscillator 1.2-V Vpp tap point (for filter only)
26	VSS				
27	PLLHV	PWR	–	N	PLL 3.3-V supply input (requires external filter)
28	TDI	IO	IPU	N	Test data in
29	TDO	OZ	IPU	N	Test data out
30	VSS				
31	DVDD				
32	EMU[0]	IO	IPU	N	Emulation pin 0
33	CVDD				
34	EMU[1]	IO	IPU	N	Emulation pin 1
35	TCK	IO	IPU	N	Test clock
36	Ground(Vss)				
37	EM_CAS	O	–	N	SDRAM column address strobe
38	EM_WE	O	–	N	SDRAM write enable
39	EM_WE_DQM[0]	O	–	N	Write enable or byte enable for EM_D [7:0]
40	VSS				
41	EM_D[7]	IO	–	N	EMIF data bus [lower 16-bits]
42	DVDD				
43	EM_D[6]	IO	–	N	EMIF data bus [lower 16-bits]
44	CVDD				
45	EM_D[5]	IO	–	N	EMIF data bus [lower 16-bits]
46	EM_D[4]	IO	–	N	EMIF data bus [lower 16-bits]
47	VSS				
48	EM_D[3]	IO	–	N	EMIF data bus [lower 16-bits]
49	EM_D[2]	IO	–	N	EMIF data bus [lower 16-bits]
50	DVDD				
51	EM_D[1]	IO	–	N	EMIF data bus [lower 16-bits]
52	EM_D[0]	IO	–	N	EMIF data bus [lower 16-bits]
53	CVDD				
54	VSS				
55	EM_D[15]	IO	–	N	EMIF data bus [lower 16-bits]
56	EM_D[14]	IO	–	N	EMIF data bus [lower 16-Bits]
57	CVDD				
58	EM_D[13]	IO	–	N	EMIF data bus [lower 16-Bits]
59	EM_D[12]	IO	–	N	EMIF data bus [lower 16-Bits]
60	DVDD				
61	EM_D[11]	IO	–	N	EMIF data bus [lower 16-Bits]

No.	Function Name (P.C.B.)	TYPE ⁽¹⁾	PULL ⁽²⁾	GPIO ⁽³⁾	Detail of Function
62	VSS				
63	EM_D[10]	IO	–	N	EMIF data bus [lower 16-Bits]
64	EM_D[9]	IO	–	N	EMIF data bus [lower 16-Bits]
65	CVDD				
66	EM_D[8]	IO	–	N	EMIF data bus [lower 16-bits]
67	EM_WE_DQM[1]	O	–	N	Write enable or byte enable for EM_D [15:8]
68	DVDD				
69	VSS				
70	EM_CLK	O	–	N	SDRAM clock
71	EM_CKE	O	–	N	SDRAM clock enable
72	VSS				
73	DVDD				
74	EM_A[11]	O	–	N	EMIF address bus
75	EM_A[9]	O	–	N	EMIF address bus
76	EM_A[8]	O	–	N	EMIF address bus
77	CVDD				
78	VSS				
79	EM_A[7]	O	–	N	EMIF address bus
80	EM_A[6]	O	–	N	EMIF address bus
81	DVDD				
82	VSS				
83	EM_A[5]	O	–	N	EMIF address bus
84	EM_A[4]	O	–	N	EMIF address bus
85	CVDD				
86	EM_A[3]	O	–	N	EMIF address bus
87	VSS				
88	EM_A[2]	O	–	N	EMIF address bus
89	EM_A[1]	O	–	N	EMIF address bus
90	CVDD				
91	EM_A[0]	O	–	N	EMIF address bus
92	DVDD				
93	EM_A[10]	O	–	N	EMIF address bus
94	EM_BA[1]	O	–	N	SDRAM bank address and asynchronous memory Low-Order address
95	VSS				
96	EM_BA[0]	O	–	N	SDRAM bank address and asynchronous memory Low-Order address
97	EM_CS[0]	O	–	N	SDRAM chip select
98	EM_RAS	O	–	N	SDRAM row address strobe
99	VSS				
100	EM_CS[2]	O	–	N	Asynchronous memory chip Select
101	CVDD				
102	NC	O	–	N	Asynchronous memory read/not write
103	DVDD				
104	EM_OE	O	–	N	SDRAM output enable
105	SPI0_ENA/I2C1_SDA	IO	–	Y	SPI0 enable (ready) or I2c1 serial data
106	VSS				
107	SPI0_ENA/I2C1_SCL	IO	–	Y	SPI0 enable (ready) or I2c1 serial clock
108	SPI0_CLK/I2C0_SCL	IO	–	Y	SPI0 serial clock or I2c0 serial clock
109	VSS				
110	SPI0_SIMO	IO	–	Y	SPI0 data pin slave in master out
111	SPI0_SOMI/I2C0_SDA	IO	–	Y	SPI0 data pin slave out master in or I2C0 serial data
112	DVDD				
113	AXR0[0]	IO	–	Y	McASP0 serial data 0
114	VSS				
115	AXR0[1]	IO	–	Y	McASP0 serial data 1
116	AXR0[2]	IO	–	Y	McASP0 serial data 2
117	AXR0[3]	IO	–	Y	McASP0 serial data 3
118	VSS				
119	AXR0[4]	IO	–	Y	McASP0 serial data 4
120	SPI1_SCS	IO	–	Y	McASP0 serial data 5 or SPI1 slave chip select
121	SPI1_ENA	IO	–	Y	McASP0 serial data 6 or SPI1 enable (ready)
122	SPI1_CLK	IO	–	Y	McASP0 serial data 7 or SPI1 serial clock

No.	Function Name (P.C.B.)	TYPE ⁽¹⁾	PULL ⁽²⁾	GPIO ⁽³⁾	Detail of Function
123	CVDD				
124	VSS				
125	DVDD				
126	/SPI1_SOMI	IO	–	Y	McASP0 serial data 8 or McASP1 serial data 5 or SPI1 data pin slave out master in
127	/SPI1_SIMO	IO	–	Y	McASP0 serial data 9 or McASP1 serial data 4 or SPI1 data pin slave in master out
128	CVDD				
129	VSS				
130	AXR0[10]	IO	–	Y	McASP0 serial data 10 or McASP1 serial data 3
131	AXR0[11]	IO	–	Y	McASP0 serial data 11 or McASP1 serial data 2
132	CVDD				
133	VSS				
134	AXR0[12]	IO	–	Y	McASP0 serial data 12 or McASP1 serial data 1
135	AXR0[13]	IO	–	Y	McASP0 serial data 13 or McASP1 serial data 0
136	DVDD				
137	AXR0[14]	IO	–	Y	McASP0 serial data 14 or McASP2 serial data 1
138	AXR0[15]	IO	–	Y	McASP0 serial data 15 or McASP2 serial data 0
139	ACLKR0	IO	–	Y	McASP0 receive bit clock
140	VSS				
141	AFSR0	IO	–	Y	McASP0 receive frame Sync (L/R clock)
142	ACLKX0	IO	–	Y	McASP0 transmit bit clock
143	AHCLKR0/AHCLKR1	IO	–	Y	McASP0 and McASP1 receive master clock
144	AFSX0	IO	–	Y	McASP0 transmit frame Sync (L/R clock)

IC402: M66003-0131FP (OPERATION P.C.B.)
FL display driver

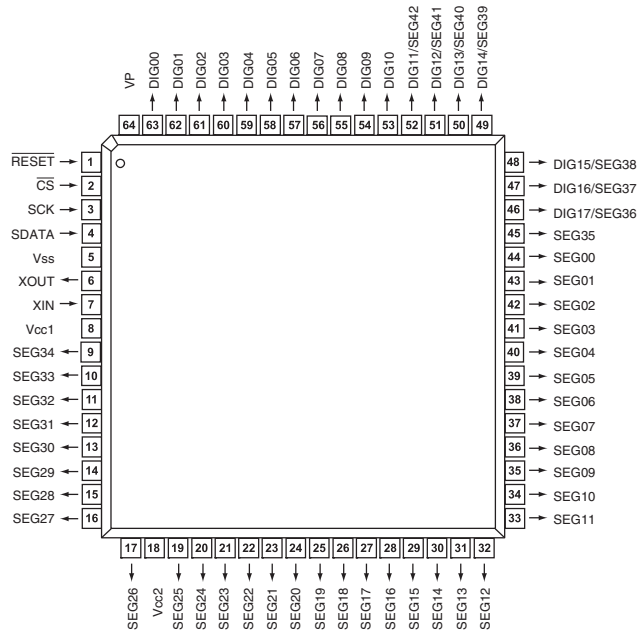
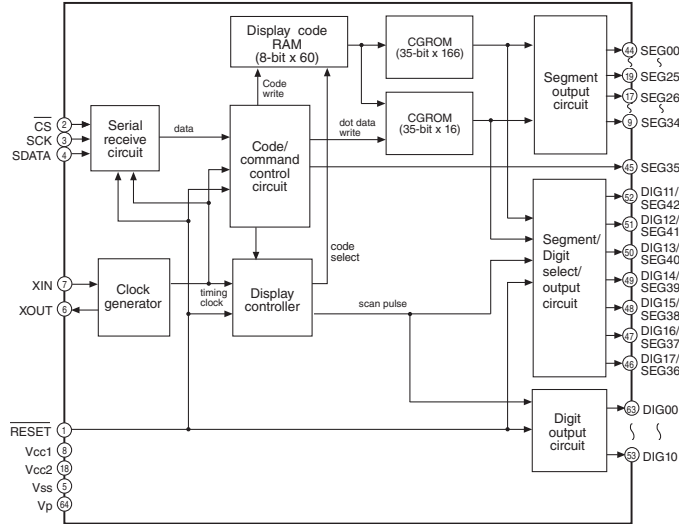

Pin No.	Port Name	Function Name	I/O	Detail of Function
1	RESET	/RESET	Reset input	When "L" M66003 is initialized.
2	CS	/CEFL	Chip select input	When "L" communication with the MCU is possible.
3	SCK	CKFL	Shift clock input	When "H", any instruction from the MCU is neglected.
4	SDATA	DTFL	Serial data input	Serial input data is taken and shifted by the positive edge of SCK.
5	Vss	VSS		GND (0V)
6	XOUT	XOUT	Clock out	When use as a CR oscillator, connect external resistor and capacitor.
7	XIN	XIN	Clock in	When use an external clock input external clock to XIN, and XOUT must be opened.

Pin No.	Port Name	Function Name	I/O	Detail of Function
8	Vcc1	VDD		Positive power supply for internal logic.
9	SEG34	P11	Segment output	Connect to segment (anode) pins of VFD.
10	SEG33	P2		
11	SEG32	P3		
12	SEG31	P4		
13	SEG30	P5		
14	SEG29	P6		
15	SEG28	P7		
16	SEG27	P8		
17	SEG26	P9		
18	Vcc2	VDD		Positive power supply for DIG and SEG outputs.
19	SEG25	P10	Segment output	Connect to segment (anode) pins of VFD.
20	SEG24	P11		
21	SEG23	P12		
22	SEG22	P13		
23	SEG21	P14		
24	SEG20	P15		
25	SEG19	P16		
26	SEG18	P17		
27	SEG17	P18I		
28	SEG16	P19		
29	SEG15	P20		
30	SEG14	P21		
31	SEG13	P22		
32	SEG12	P23		
33	SEG11	P24		
34	SEG10	P25		
35	SEG09	P26		
36	SEG08	P27		
37	SEG07	P28		
38	SEG06	P29		
39	SEG05	P30		
40	SEG04	P31		
41	SEG03	P32		
42	SEG02	P33		
43	SEG01	P34		
44	SEG00	P35		
45	SEG35	P36		
46	SEG36	P37		
47	DIG16/SEG37	G17I	Digital output	Connect to digit (grid) pins of VFD.
48	DIG15/SEG38	G16I		
49	DIG14/SEG39	G15I		
50	DIG13/SEG40	G14		
51	DIG12/SEG41	G13		
52	DIG11/SEG42	G12		
53	DIG10	G11		
54	DIG09	G10		
55	DIG08	G9		
56	DIG07	G8		
57	DIG06	G7		
58	DIG05	G6		
59	DIG04	G5		
60	DIG03	G4		
61	DIG02	G3		
62	DIG01	G2		
63	DIG00	G1		
64	VP	VP		Negative power supply to pull down.

IC41: LC89058WD-E (DIGITAL P.C.B.)
Digital audio interface receiver

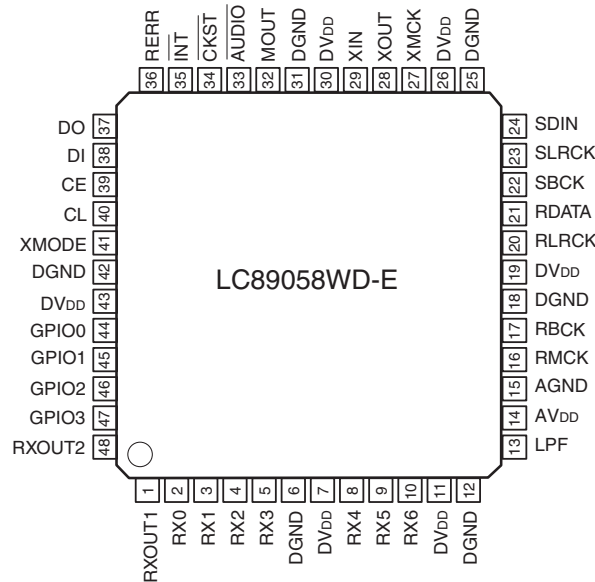
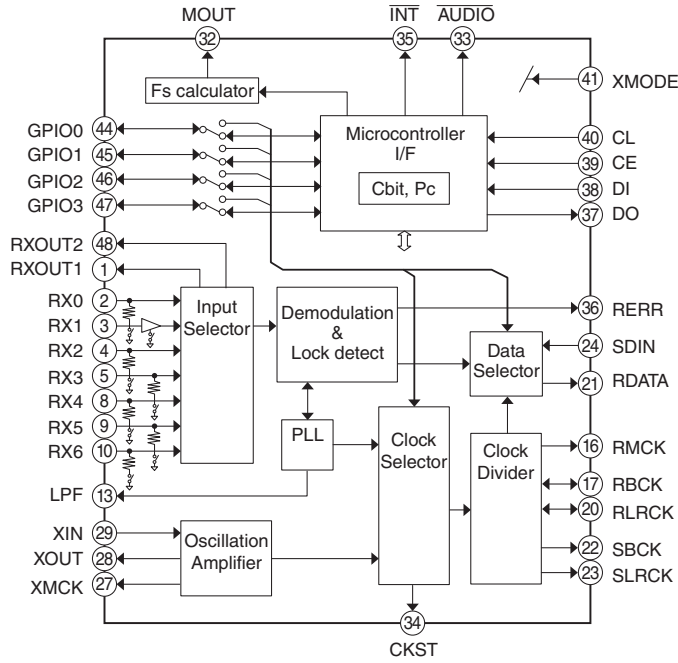

Pin No.	Function Name	I/O	Detail of Function
1	RXOUT1	O	RX0-6 input S/PDIF through output pin 1
2	RX0	I _s (pd)	5V withstand voltage TIL input level compatible S/PDIF input pin (connected to GND when RX1 is set)
3	RX1	I(pd)	Co-axial compatible S/PDIF input pin (supported demodulation sampling frequency of up to 96 kHz)
4	RX2	I _s (pd)	5V withstand voltage TIL input level compatible S/PDIF input pin (connected to GND when RX1 is set)
5	RX3	I _s (pd)	5V withstand voltage TIL input level compatible S/PDIF input pin
6	DGND		Digital GND
7	DVDD		Digital power supply (3.3V)
8	RX4	I _s (pd)	5V tolerable TIL input level compatible S/PDIF input pin
9	RX5	I _s (pd)	5V tolerable TIL input level compatible S/PDIF input pin
10	RX6	I _s (pd)	5V tolerable TIL input level compatible SIPDIF input pin
11	DVDD		Digital power supply (3.3V)
12	DGND		Digital GND
13	LPF	O	PLL loop filter connection pin
14	AVDD		Analog power supply (3.3V)
15	AGND		Analog GND
16	RMCK	O	R system clock output pin (VCO, 512fs, XIN)
17	RBCK	O/I	R system bit clock 1/0 pin (64fs)
18	DGND		Digital GND
19	DVDD		Digital power supply (3.3V)
20	RLRCK	O/I	R system LR clock 1/0 pin (fs)
21	RDATA	O	Serial audio data output pin
22	SBCK	O	S system bit clock output pin (16fs, 32fs, 64fs, 128fs)
23	SLRCK	O	S system LR clock output pin (fs/4, fs/2, fs, 2fs)
24	SDIN	I _s	External serial audio data input pin
25	DGND		Digital GND
26	DVDD		Digital power supply (3.3V)
27	XMCK	O	Oscillation amplifier clock output pin
28	XOUT	O	Output pin connected to the resonator
29	XIN	I	External clock input pin. connected to the resonator (12.288 MHz or 24.576 MHz)
30	DVDD		Digital power supply (3.3V)
31	DGND		Digital GND
32	MOUT	I/O	Emphasis information II input fs monitor output II chip address setting input pin
33	AUDIO	I/O	Channel status bit 1 output II chip address setting input pin
34	CKST	I/O	Clock switching transition period signal output II master/slave setting input pin
35	INT	I/O	Microcontroller interrupt signal output II pins 44-48 I/O setting input pin
36	RERR	O	PLL lock error and data error flag output pin
37	DO	O	CCB microcontroller I/F, read data output pin (3-state)
38	DI	I _s	CCB microcontroller I/F, write data input pin
39	CE	I _s	CCB microcontroller I/F, chip enable input pin
40	CL	I _s	CCB microcontroller I/F, clock input pin
41	XMODE	I _s	System reset input pin
42	DGND		Digital GND
43	DVDD		Digital power supply (3.3V)
44	GPIO0	O/I	General-purpose I/O pin II selector input pin (output referred to RMCK pin)
45	GPIO1	O/I	General-purpose I/O pin II selector input pin (output referred to RBCK pin)
46	GPIO2	O/I	General-purpose I/O pin II selector input pin (output referred to RLRCK pin)
47	GPIO3	O/I	General-purpose I/O pin II selector input pin (output referred to RDATA pin)
48	RXOUT2	O	RX0-6 input S/PDIF through output pin 2

* Input voltage: 1= -0.3 to 3.6V, I_s = -0.3 to 5.5V

* Output voltage: 0= -0.3 to 3.6V

* Pins 2, 4, 5, 8, 9, 10, 24, 38, 39, 40, and 41 have an internal pull-down resistor (Pd). Their level is fixed when they are unselected.

* Pins 32 and 33 are input pins for chip address setting when pin 41 is held at the low level.

* Pin 34 serves as the input pin for designating as the master or slave when pin 41 is held at the low level.

* Pin 35 serves as the input pin for configuring the I/O of pins 44 to 47 when pin 41 is held at the low level.

* The DVDD and AVDD pins must be held at the same level and turned on and off at the same timing to preclude latch-up conditions.

IC153: R2A15220FP (MAIN P.C.B.)

8-channel electronic volume with 11 input selector and tone control

RX-V1065/HTR-6280/
AX-V1065

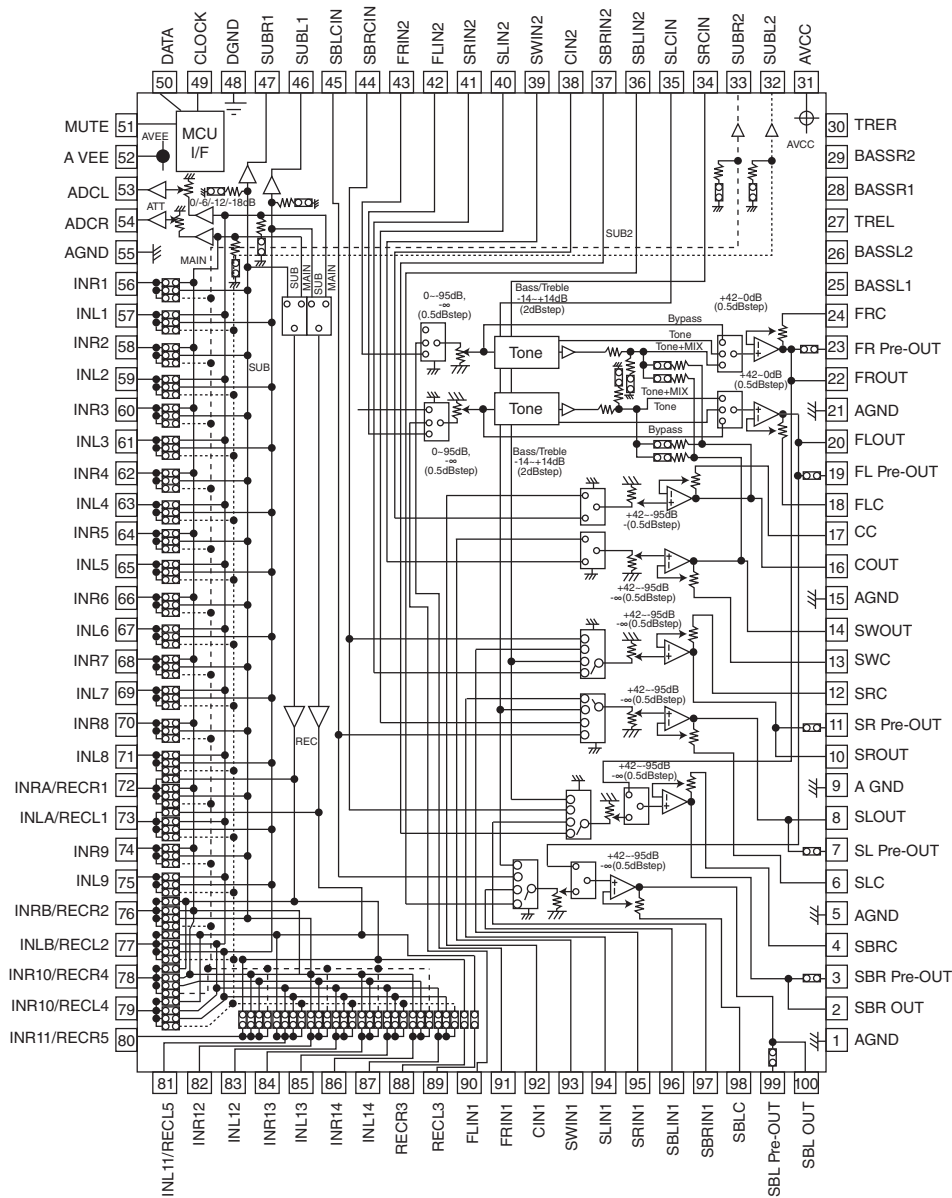

Pin No.	Port name	Function Name	Detail of Function
1	AGND	AE	Analog ground of internal circuit
2	SBROUT	VOSBL	Output pin of FL/FR/C/SW/SL/SR/SBL/SBR channel
3	SBR Pre-OUT	VOPPSBL	Pre-output pin of FL/FR/SL/SR/SBL/SBR channel
4	SBRC	AE	Connects capacitor for reducing click noise of L/R/C/SW/SL/SR/SBL/SBR channel volume
5	AGND	AE	Analog ground of internal circuit
6	SLC	VOPSR	Connects capacitor for reducing click noise of L/R/C/SW/SL/SR/SBL/SBR channel volume
7	SL Pre-OUT	VOSR	Pre-output pin of FL/FR/SL/SR/SBL/SBR channel
8	SLOUT	AE	Output pin of FL/FR/C/SW/SL/SR/SBL/SBR channel
9	AGND	AE	Analog ground of internal circuit
10	SROUT	VOSL	Output pin of FL/FR/C/SW/SL/SR/SBL/SBR channel
11	SR Pre-OUT	VOPSL	Pre-output pin of FL/FR/SL/SR/SBL/SBR channel
12	SRC	AE	Connects capacitor for reducing click noise of L/R/C/SW/SL/SR/SBL/SBR channel volume
13	SWC	AE	Connects capacitor for reducing click noise of L/R/C/SW/SL/SR/SBL/SBR channel volume
14	SWOUT	VOSW	Output pin of FL/FR/C/SW/SL/SR/SBL/SBR channel
15	AGND	AE	Analog ground of internal circuit
16	COUT	VOC	Output pin of FL/FR/C/SW/SL/SR/SBL/SBR channel
17	CC	AE	Connects capacitor for reducing click noise of L/R/C/SW/SL/SR/SBL/SBR channel volume
18	FLC	AE	Connects capacitor for reducing click noise of L/R/C/SW/SL/SR/SBL/SBR channel volume
19	FL Pre-OUT	VOPFR	Pre-output pin of FL/FR/SL/SR/SBL/SBR channel
20	FLOUT	VOFR	Output pin of FL/FR/C/SW/SL/SR/SBL/SBR channel
21	AGND	POE	Analog ground of internal circuit
22	FROUT	VOFL	Output pin of FL/FR/C/SW/SL/SR/SBL/SBR channel
23	FR Pre-OUT	VOPFL	Pre-output pin of FL/FR/SL/SR/SBL/SBR channel
24	FRC	AE	Connects capacitor for reducing click noise of L/R/C/SW/SL/SR/SBL/SBR channel volume
25	BASSL1	AE	Frequency characteristic setting pin of L/R channel tone control (Bass)
26	BASSL2	AE	Frequency characteristic setting pin of L/R channel tone control (Bass)
27	TREL	AE	Frequency characteristic setting pin of L/R channel tone control (Treble)
28	BASSR1	AE	Frequency characteristic setting pin of L/R channel tone control (Bass)
29	BASSR2	AE	Frequency characteristic setting pin of L/R channel tone control (Bass)
30	TRER	AE	Frequency characteristic setting pin of L/R channel tone control (Treble)
31	AVCC	VCC	Positive power supply to internal circuit
32	SUBL1	N.C.	Output pin for L/R channel SUB1/SUB2 output
33	SUBL2	N.C.	Output pin for L/R channel SUB1/SUB2 output
34	SRCIN	N.C.	3rd multi input pin for SBL/SBR/SL/SR channel volume that is able to swap SBR/SBL with SR/SL
35	SLCIN	N.C.	3rd multi input pin for SBL/SBR/SL/SR channel volume that is able to swap SBR/SBL with SR/SL
36	SBLIN2	8SBR	Multi input pin of L/R/C/SW/SL/SR/SBL/SBR channel (Multi IN 1/2)
37	SBRIN2	8SBL	Multi input pin of L/R/C/SW/SL/SR/SBL/SBR channel (Multi IN 1/2)
38	CIN2	8C	Multi input pin of L/R/C/SW/SL/SR/SBL/SBR channel (Multi IN 1/2)
39	SWIN2	8SW	Multi input pin of L/R/C/SW/SL/SR/SBL/SBR channel (Multi IN 1/2)
40	SLIN2	8SR	Multi input pin of L/R/C/SW/SL/SR/SBL/SBR channel (Multi IN 1/2)
41	SRIN2	8SL	Multi input pin of L/R/C/SW/SL/SR/SBL/SBR channel (Multi IN 1/2)
42	FLIN2	8FR	Multi input pin of L/R/C/SW/SL/SR/SBL/SBR channel (Multi IN 1/2)
43	FRIN2	8FL	Multi input pin of L/R/C/SW/SL/SR/SBL/SBR channel (Multi IN 1/2)
44	SBRCIN	Z2L	3rd multi input pin for SBL/SBR/SL/SR channel volume that is able to swap SBR/SBL with SR/SL
45	SBLCIN	Z2R	3rd multi input pin for SBL/SBR/SL/SR channel volume that is able to swap SBR/SBL with SR/SL
46	SUBL1	Z2R	Output pin for L/R channel SUB1/SUB2 output
47	SUBR1	Z2L	Output pin for L/R channel SUB1/SUB2 output
48	DGND	MG	Digital ground of internal circuit
49	DATA	VOL_SCK	Input pin of control data
50	CLOCK	VOL_MOSI	Input pin of control clock
51	MUTE	AE	Outside mute control pin
52	AVEE	-	Negative power supply to internal circuit
53	ADCL	ADR	Output pin for L/R channel ADC
54	ADCR	ADL	Output pin for L/R channel ADC
55	AGND	AE	Analog ground of internal circuit
56	INR1	AU2L	Input pin of L/R channel (Input selector)
57	INL1	AU2R	Input pin of L/R channel (Input selector)

Pin No.	Port name	Function Name	Detail of Function
58	INR2	AU1L	Input pin of L/R channel (Input selector)
59	INL2	AU1R	Input pin of L/R channel (Input selector)
60	INR3	AV-6L	Input pin of L/R channel (Input selector)
61	INL3	AV-6R	Input pin of L/R channel (Input selector)
62	INR4	AV-5L	Input pin of L/R channel (Input selector)
63	INL4	AV-5R	Input pin of L/R channel (Input selector)
64	INR5	PHL	Input pin of L/R channel (Input selector)
65	INL5	PHR	Input pin of L/R channel (Input selector)
66	INR6	SRL	Input pin of L/R channel (Input selector)
67	INL6	SRR	Input pin of L/R channel (Input selector)
68	INR7	IPL	Input pin of L/R channel (Input selector)
69	INL7	IPR	Input pin of L/R channel (Input selector)
70	INR8	XML	Input pin of L/R channel (Input selector)
71	INL8	XMR	Input pin of L/R channel (Input selector)
72	INRA/RECR1	AV-OUT_L	Output pin for L/R channel (input selector)/Output pin for L/R channel REC output
73	INLA/RECL1	AV-OUT_R	Output pin for L/R channel (input selector)/Output pin for L/R channel REC output
74	INR9	USBL	Input pin of L/R channel (Input selector)
75	INL9	USBR	Input pin of L/R channel (Input selector)
76	INRB/RECR2	AOL	Output pin for L/R channel (input selector)/Output pin for L/R channel REC output
77	INLB/RECL2	AOR	Output pin for L/R channel (input selector)/Output pin for L/R channel REC output
78	INR10/RECR4	TUL	Output pin for L/R channel (input selector)/Output pin for L/R channel REC output
79	INL10/RECL4	TUR	Output pin for L/R channel (input selector)/Output pin for L/R channel REC output
80	INR11/RECR5	MIC	Output pin for L/R channel (input selector)/Output pin for L/R channel REC output
81	INL11/RECL5	AE	Output pin for L/R channel (input selector)/Output pin for L/R channel REC output
82	INR12	AUXL	Input pin of L/R channel (Input selector)
83	INL12	AUXR	Input pin of L/R channel (Input selector)
84	INR13	AE	Input pin of L/R channel (Input selector)
85	INL13	AE	Input pin of L/R channel (Input selector)
86	INR14	AE	Input pin of L/R channel (Input selector)
87	INL14	AE	Input pin of L/R channel (Input selector)
88	RECR3	N.C.	Output pin for L/R channel REC output
89	RECL3	N.C.	Output pin for L/R channel REC output
90	FLIN1	DAFR	Multi input pin of L/R/C/SW/SL/SR/SBL/SBR channel (Multi IN 1/2)
91	FRIN1	DAFL	Multi input pin of L/R/C/SW/SL/SR/SBL/SBR channel (Multi IN 1/2)
92	CIN1	DAC	Multi input pin of L/R/C/SW/SL/SR/SBL/SBR channel (Multi IN 1/2)
93	SWIN1	DASW	Multi input pin of L/R/C/SW/SL/SR/SBL/SBR channel (Multi IN 1/2)
94	SLIN1	DASR	Multi input pin of L/R/C/SW/SL/SR/SBL/SBR channel (Multi IN 1/2)
95	SEIN1	DASL	Multi input pin of L/R/C/SW/SL/SR/SBL/SBR channel (Multi IN 1/2)
96	SBLIN1	DASBR	Multi input pin of L/R/C/SW/SL/SR/SBL/SBR channel (Multi IN 1/2)
97	SBRIN1	DASBL	Multi input pin of L/R/C/SW/SL/SR/SBL/SBR channel (Multi IN 1/2)
98	SBLC	AE	Connects capacitor for reducing click noise of L/R/C/SW/SL/SR/SBL/SBR channel volume
99	SBL Pre-OUT	VOPSBR	Pre-output pin of FL/FR/SL/SR/SBL/SBR channel
100	SBL OUT	VOSBR	Output pin of FL/FR/C/SW/SL/SR/SBL/SBR channel

IC20: M3087BFK BGP (DIGITAL P.C.B.)
Main microprocessor

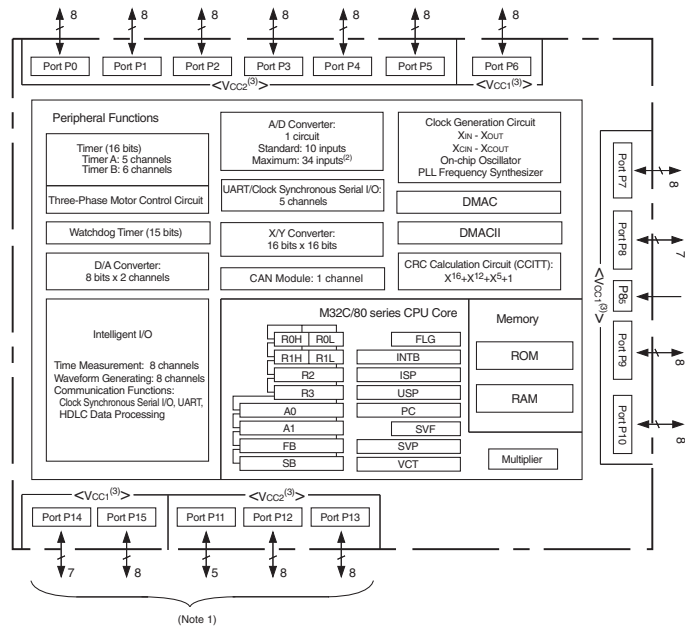

NOTES:
1. Ports P11 to P15 are provided in the 144-pin package only.
2. Included in the 144-pin package only.
3. The supply voltage of M32C/84T (High-reliability version) must be Vcc1=Vcc2.

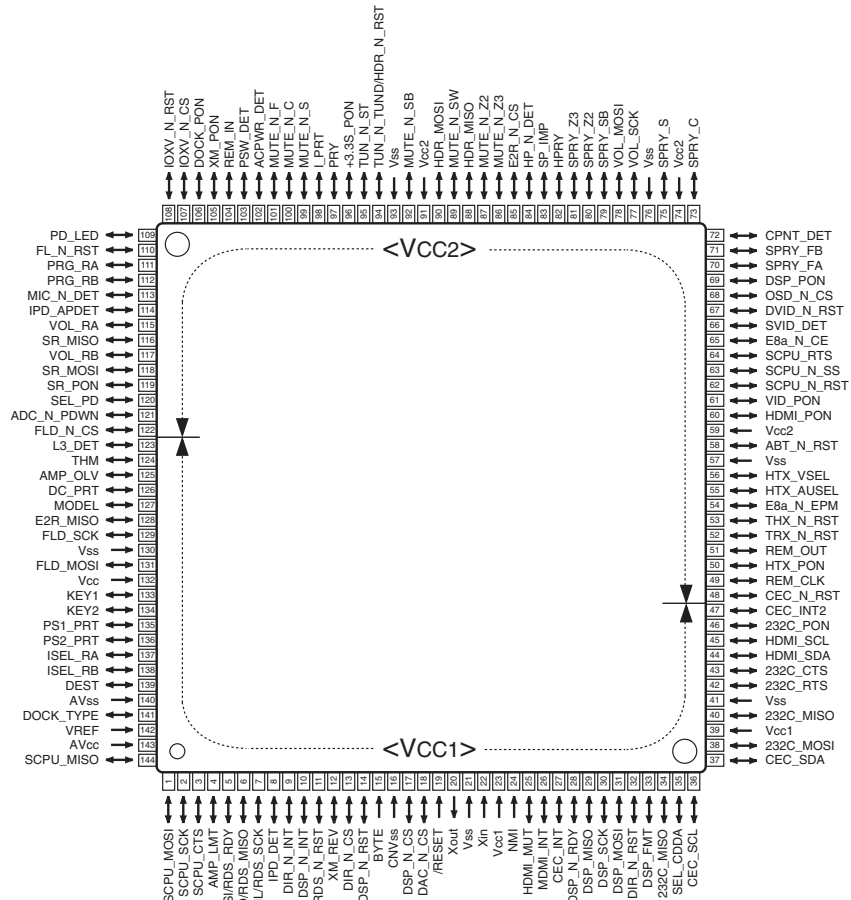

NOTES:
1. P70 / TA0OUT / Tx/D2 / SD/A2 / SRxD2 / INPC1e / OUTC1e
2. P70 and P71 are ports for the N-channel open drain output.
3. The supply voltage of M32C/84T must be Vcc1=Vcc2.

Pin No.	Port Name	Function Name (P.C.B.)	I/O						Detail of Function
			Power On	Stby Thrh	Standby	Stby Sleep	Sleep	MCU Sleep	
1	TXD4	SCPU_MOSI	SO	O	O	O		O	Synchronous data output for sub-microprocessor
2	CLK4 P95/ANEX0/CLK4	SCPU_SCK	SO	O	O	O		O	Synchronous clock output for sub-microprocessor
3	P94 P94/DA1/TB4in/ CTS4/RTS4/SS4	SCPU_CTS	SI	I	I	O		O	Input for transmission control for sub-microprocessor (clear to send)
4	DA0 P93/DA0/TB3in/ CTS3/RTS3/SS3	AMP_LMT	DA	I	I	I		I	Limiter control output
5	TXD3 P92/TB2in/TXD3/ SDA3/SRXD3/ OUTC20/IEout/ ISTXD2	XM_MOSI	SO	O	O	O	O		Asynchronous data output for XM (U model)
	P92		O	O	O	O	O		(C, R, T, K, A, B, E, F, L, J models)
	TB2in	RDS_RDY	TMR	O	O	O	O		RDS RRADY input / Pull-up (G model)
6	RXD3 P91/TB1in/RXD3/ SCL3/STXD3/IEin/ ISRXD2	XM_MISO	SI	O	O	O	O		Asynchronous data input for XM (U model)
	P91		O	O	O	O	O		(C, R, T, K, A, B, E, F, L, J models)
	RXD3	RDS_MISO	SI	O	O	O		O	Synchronous data input for RDS (G model)
7	P90 P90/TB0in/CLK3	XM_LINK	I	O	O	O		O	XM LINK detection (U model)
	P90		O	O	O	O		O	(C, R, T, K, A, B, E, F, L, J models)
	CLK3	RDS_SCK	SO	O	O	O		O	Synchronous clock output for RDS IC / Low level should stand by (G model)
8	INT8 P146/INT8	IPD_DET	IRQ	IRQ	IRQ	IRQ		O	iPod detection When inserting an iPod into the DOCK H → L Restriction of port: INT is high edge or low edge only
9	P145 P145/INT7	DIR_N_INT	IRQ	O	O	O		O	DIR interrupt Restriction of port: INT is high edge or low edge only
10	P144 P144/INT6	DSP_N_INT	IRQ	O	O	O		O	DA70Y interrupt Restriction of port: INT is high edge or low edge only
11	P143 P143/INPC17/ OUTC17	XM_N_RST	O	O	O	O	O		XM reset (U model)
	P143		O	O	O	O	O		(C, R, T, K, A, B, E, F, L, J models)
		RDS_N_RST	O	O	O	O	O		RDS reset (G model)
12	P142 P142/INPC16/ OUTC16	DIR_SDO	I	O	O	O		O	DIR DATA input at mode of CDDA writing
	P142		O	O	O	O	O		
		XM_REV	I	O	O	O		O	XM antenna revision detection (U model) H: An compatibility antenna
	P142		O	O	O	O		O	(C, R, T, K, A, B, G, E, F, L, J models)
13	P141 P141/INPC15/ OUTC15	DIR_N_CS	CS	O	O	O		O	DIR chip select
14	P140 P140/INPC14/ OUTC14	DSP_N_RST	O	O	O	O		O	DA70Y reset
15	BYTE BYTE	BYTE	MCU	MCU	MCU	MCU		MCU	Switch of width of data bus input When set to single chip mode: L (16 bit)
16	CNVss CNVss	CNVss	MCU	MCU	MCU	MCU		MCU	Processor mode select Low: single chip mode High: To Flash included boot mode To boot mode with hardware resetting of P50=H, P55=L, CNVss=H
17	P87 P87/Xcin	DSP_N_CS	CS	O	O	O		O	DA70Y chip select
18	P86 P86/Xcout	DAC_N_CS	CS	O	O	O		O	DAC chip select
19	/RESET /RESET	/RESET	MCU	MCU	MCU	MCU		MCU	Reset
20	Xout Xout	Xout	MCU	MCU	MCU	MCU		MCU	20 MHz Ceramic resonator

Pin No.	Port Name	Function Name (P.C.B.)	I/O						Detail of Function
			Power On	Stby Thrh	Standby	Stby Sleep	Sleep	MCU Sleep	
21	Vss Vss	Vss	MCU	MCU	MCU	MCU		MCU	GND
22	Xin Xin	Xin	MCU	MCU	MCU	MCU		MCU	20 MHz ceramic resonator
23	Vcc1 Vcc1	Vcc1	MCU	MCU	MCU	MCU		MCU	Microprocessor power supply
24	/NMI P85/NMI	/NMI	MCU	MCU	MCU	MCU		MCU	Unused, pull up to Vcc
25	INT2 P84/INT2	HDMI_MUT	IRQ	IRQ	O	O		O	HDMI mute input Act H: Mute
26	INT1 P83/INT1	HDMI_INT	IRQ	IRQ	O	O		O	Interrupt from HDMI RX
27	INT0 P82/INT0	CEC_N_INT	IRQ	IRQ	O	O		O	CEC microprocessor interrupt
28	P81 P81/TA4in/U/INPC15/ OUTC15/CTS5/ RTS5/RTP23	DSP_N_RDY	I	O	O	O		O	DA70Y RDY
	P81	DIR_WCK	I	O	O	O		O	CDDA writing DIR_WCK input
29	RXD5 P80/TA4out/U/ ISRXD0/RXD5	DSP_MISO	SI	O	O	O		O	Synchronous data input for DIR, DA70Y, DAC
30	CLK5 P77/TA3in/INPC14/ OUTC14/ISCLK0/ CLK5/RTP22	DSP_SCK	SO	O	O	O		O	Synchronous clock output for DIR, DA70Y, DAC
31	TXD5 P76/TA3out/INPC13/ OUTC13/ISTXD0/ TXD5	DSP_MOSI	SO	O	O	O		O	Synchronous data output for DIR, DA70Y, DAC
32	P75 P75/TA2in/W/ INPC12/OUTC12/ ISRXD1/RTP21	DIR_N_RST	O	O	O	O		O	DIR reset
33	P74 P74/TA2out/W/ INPC11/OUTC11/ ISCLK1/RTP20	DSP_FMT	O	O	O	O		O	DA70Y full mute output H: Mute
34	P73	232C_MISO	O	O	O	O		O	
35	P72 P72/TA1out/V/CLK2	SEL_CDDA	O	O	O	O		O	CDDA writing route select H: CDDA writing mode, L: Operational mode usually
36	SCL2 P71/TA0in/TB5in/ RXD2/SCL2/STXD2/ INPC17/OUTC17/ OUTC22/ISRXD2/ IEin/RTP03	CEC_SCL	SO	SO	O	O		O	CEC microprocessor, Tuner, HDMI_EQ (SiI9185A) I2C SCL output (100 kHz device) U-com block then +3.3S, 3.3k then pull up
37	SDA2 P70/TA0out/TXD2/ SDA2/SRXD2/ INPC16/OUTC16/ OUTC20/ISTXD2/ IEout/RTP02	CEC_SDA	SIO	SIO	O	O		O	CEC microprocessor, Tuner, HDMI_EQ (SiI9185A) I2C SDA input (100 kHz device) U-com block then +3.3S, 3.3k then pull up
38	TxD1 P67/TXD1/SDA1/ SRXD1	232C_MOSI	SO	SO	SO	O		O	RS232C data output Pull up at 100 k-ohms
	TxD1	TXD	SO						E8a, ICP (In-circuit programmer) data output
39	Vcc1 Vcc1	Vcc1	MCU	MCU	MCU	MCU		MCU	Microprocessor power supply
40	RxD1 P66/RXD1/SCL1/ STXD1	232C_MISO	SI	SI	SI	I		I	RS232C data input Pull up at 100 k-ohms
	RxD1	RXD	SI						E8a, ICP (In-circuit programmer) data input

Pin No.	Port Name	Function Name (P.C.B.)	I/O						Detail of Function
			Power On	Stby Thrh	Standby	Stby Sleep	Sleep	MCU Sleep	
41	Vss Vss	Vss	MCU	MCU	MCU	MCU		MCU	Microprocessor GND
42	P65 P65/CLK1	232C_RTS	SO	SO	SO	O		O	RS232C RTS output
	CLK1	E8a_SCLK	SI						E8a, ICP (In-circuit programmer) clock input / Pull up at 100 k-ohms
43	CTS1 P64/CTS1/RTS1/ SS1/OUTC21/ ISCLK2	232C_CTS	SI	SI	SI	I		I	RS232C CTS input Pull down at 100 k-ohms
	RTS1	E8a_BUSY	SO						E8a, ICP (In-circuit programmer) BUSY output
44	SDA0 P63/TXD0/SDA0/ SRXD0/IrDAout	HDMI_SDA	SIO	SIO	O	O		O	HDMI RX/TX, Video Enc/Dec I2C SCL output (400 kHz device) Pull up at HDMI block HDMI RX/TX: 5V tolerant
45	SCL0 P62/RXD0/SCL0/ STXD0/IrDAin	HDMI_SCL	SIO	SIO	O	O		O	HDMI RX/TX, Video Enc/Dec I2C SDA input/output (400 kHz device) Pull up at HDMI block HDMI RX/TX: 5V tolerant
46	P61	232C_PON	O	O	O	O		O	H: ON, L: OFF
47	P60 P60/CTS0/RTS0/ SS0/RTP00	CEC_INT2	I	I	O	O		O	CEC microprocessor interrupt
48	P137 P137/OUTC27	CEC_N_RST	O	O	O	O		O	CEC microprocessor reset
49	ISCLK2 P136/OUTC21/ ISCLK2	REM_CLK	SO	O	O	O		O	Clock output for remote control code generation No connection
50	P135 P135/OUTC22/ ISRXD2/IEin	HTX_PON	O	O	O	O		O	No use (HDMI_PON common)
51	P134 P134/OUTC20/ ISTXD0/leout	REM_OUT							
52	P57 P57/RDY	HRX_N_RST	O	O	O	O		O	HDMI TX reset output / L: Reset Pull down at HDMI block
53	P56 P56/ALE	HTX_N_RST	O	O	O	O		O	HDMI TX reset output / L: Reset Pull down at HDMI block
54	P55 P55/HOLD	E8a_N_EPM	I	I	I	I		I	E8a writing mode enable input 10 k-ohms pull down
55	P54 P54/HLDA/ALE	HTX_AUSEL	O	O	O	O		O	No use (HDMI Rx GPIO use)
56	P133 P133/OUTC23	HTX_VSEL	O	O	O	O		O	No use (HDMI Rx GPIO use)
57	Vss Vss	Vss	MCU	MCU	MCU	MCU		MCU	Microprocessor GND
58	P132 P132/OUTC26	ABT_N_RST	O	O	O	O		O	Video I/P & Scaler IC reset L: reset / VID_PON=L: Low fix
59	Vcc2 Vcc2	Vcc2	MCU	MCU	MCU	MCU		MCU	Microprocessor power supply
60	P131 P131/OUTC25	HDMI_PON	O	O	O	O		O	HDMI power supply ON/OFF control / H: ON, L: OFF When V2065 uses CEC microprocessor, HDMI EQ (CXB1442, SiI9185A) reset may be used
61	P130 P130/OUTC24	VID_PON	O	O	O	O		O	Video power supply ON/OFF control / H: ON, L: OFF Configured based on the Pure Direct specification
62	P53 P53/CLKout/BCLK/ ALE	SCPU_N_RST	O	O	O	O		O	SubCPU reset Because the delay circuit of 2 ms is passed so that it may discriminate against reset of Flash and BlackFin, it is necessary to secure the change time of 5 ms or more.
63	P52 P52/RD	SCPU_N_SS	O	O	O	O		O	SubCPU slave select
64	P51 P51/WRH/BHE	SCPU_RTS	SO	O	O	O		O	Output for SubCPU reception control (request to send)
65	P50 P50/WRL/WR	E8a_N_CE	I	I	I	I		I	E8a enable input 10 k-ohms pull up
66	P127 P127	SVID_DET	I	O	O	O		O	S video detection VID_PON=L: Low fix

Pin No.	Port Name	Function Name (P.C.B.)	I/O						Detail of Function
			Power On	Stby Thrh	Standby	Stby Sleep	Sleep	MCU Sleep	
67	P126 P126	DVID_N_RST	O	O	O	O		O	Video Enc/Dec reset VID_PON=L: Low fix
68	P125 P125	OSD_N_CS	CS	O	O	O		O	OSD chip select VID_PON=L: Low fix
69	P47 P47/SC0/A23	DSP_PON	O	O	O	O		O	DSP power supply ON/OFF control H: ON, L: OFF
70	P46 P46/SC1/A22	SPRY_FA	O	O	O	O		O	Front A speaker relay control H: ON, L: OFF
71	P45 P45/SC2/A21	SPRY_FB	O	O	O	O		O	Front B speaker relay control H: ON, L: OFF
72	P44 P44/SC3/A20	CPNT_DET	O	O	O	O		O	No use
73	P43 P43/A19	SPRY_C	O	O	O	O		O	Center speaker relay control
74	Vcc2 Vcc2	Vcc2	MCU	MCU	MCU	MCU		MCU	Microprocessor power supply
75	P42 P42/A18	SPRY_S	O	O	O	O		O	Surround speaker relay control
76	Vss Vss	Vss	MCU	MCU	MCU	MCU		MCU	Microprocessor GND
77	P41 P41/A17	VOL_SCK	O	O	O	O		O	Electronic volume Flip-flop synchronous clock output
78	P40 P40/A16	VOL_MOSI	O	O	O	O		O	Electronic volume Flip-flop synchronous data output
79	P37 P37/A15/(D15)	SPRY_SB	O	O	O	O		O	Surround back/Bi-AMP relay control
80	P36 P36/A14/(D14)	SPRY_Z2	O	O	O	O		O	Zone2/Presence Speaker relay control SPRY_Z2 and SPRY_FB do not become High at the same time (U, C, R, T, K, A, G, E, F, L models) (B, J models)
	P36		O	O	O	O		O	
81	P35		O	O	O	O		O	
82	P34 P34/A12/(D12)	HPRY	O	O	O	O		O	Head phone relay control
83	P33 P33/A11/(D11)	SP_IMP	O	O	O	O		O	Speaker impedance relay control Set to 8 ohms: Low (Relay OFF, B voltage High) Set to 6 ohms plus during rising temperature: High (Relay ON, B voltage Low)
84	P32 P32/A10/(D10)	HP_N_DET	I	O	O	O		O	Headphone detection L: Headphone +3.3S pull up
85	P31 P31/A9/(D9)	E2R_N_CS	CS	CS	CS	I		I	EEPROM chip select At 10 k-ohms pull up to EEPROM power
86	P124		O	O	O	O		O	
87	P123 P123/CTS6/RTS6	MUTE_N_Z2	O	O	O	O		O	Zone2 line out mute control L: Mute (U, C, R, T, K, A, G, E, F, L models) (B, J models)
	P123		O	O	O	O		O	
88	P122	HDR_MISO	SI	I	I	I		I	Asynchronous data input for HD Radio To prevent pulling of HD Radio's High output and microprocessor's Low Fix output, switch to constant input (U model) (C, R, T, K, A, B, G, E, F, L, J models)
	P122		O	O	O	O		O	
89	P121 P121/CLK6	MUTE_N_SW	O	O	O	O		O	Subwoofer mute control L: Mute
90	TXD6	HDR_MOSI	SO	O	O	O		O	HD Radio asynchronous data output (U model) (C, R, T, K, A, B, G, E, F, L, J models)
	P120		O	O	O	O		O	
91	Vcc2 Vcc2	Vcc2	MCU	MCU	MCU	MCU		MCU	Microprocessor power supply
92	P30 P30/A8/(D8)	MUTE_N_SB	O	O	O	O		O	Surround back/Bi-AMP/Zone2 mute control L: Mute
93	Vss Vss	Vss	MCU	MCU	MCU	MCU		MCU	Microprocessor GND
94	P27	TUN_N_TUND	O	O	O	O		O	HD Radio reset (U model) FM/AM tuner TUNED input +3.3S to 47k then pull up (C, R, T, K, A, B, G, E, F, L, J models)
	P27 P27/A7/(D7)/AN27		I	O	O	O		O	

Pin No.	Port Name	Function Name (P.C.B.)	I/O						Detail of Function
			Power On	Stby Thrh	Standby	Stby Sleep	Sleep	MCU Sleep	
95	P26		O	O	O	O	O		(U model)
	P26/A6/(/D6)/AN26	TUN_N_ST	I	O	O	O	O	O	FM/AM tuner STEREO detection input +3.3S to 47k then pull up (C, R, T, K, A, B, G, E, F, L, J models)
96	P25 P25/A5/(/D5)/AN25	+3.3S_PON	O	O	O	O		I	+3.3S power supply ON/OFF control H: ON, L: OFF At standby sleep, becomes L [to avoid unnecessary power consumption (Mute, pull Up)] Input (HiZ) then mechanically +3.3S power switches on (to function Mute, when power down is detected)
97	P24 P24/A4/(/D4)/AN24	PRY	O	O	O	O		O	Power relay ON/OFF control H: ON, L: OFF
98	P23 P23/A3/(/D3)/AN23	I_PRT	I	I	O	O		O	Overcurrent protection detection
99	P22 P22/A2/(/D2)/AN22	MUTE_N_S	O	O	O	O		O	Surround mute control L: Mute
100	P21 P21/A1/(/D1)/AN21	MUTE_N_C	O	O	O	O		O	Center mute control L: Mute
101	P20 P20/A0/(/D0)/AN20	MUTE_N_F	O	O	O	O		O	Front (Headphone is contained) mute control L: Mute
102	INT5 P17/D15/INT5	ACPWR_DET	IRQ	IRQ	IRQ	IRQ		O	AC power detection L: Power down
103	INT4 P16/D14/INT4	PSW_DET	IRQ	IRQ	IRQ	IRQ		O	Main/Zone/Input key interrupt KEY1 port distinguishes the pressed keys
104	INT3 P15/D13/INT3	REM_IN	IRQ	IRQ	IRQ	IRQ		O	Remote control pulse input
105	P14 P14/D12	XM_PON	O	O	O	O		O	XM Radio power supply ON/OFF control H: ON, L: OFF (U model)
	P14		O	O	O	O		O	(C, R, T, K, A, B, G, E, F, L, J models)
106	P13 P13/D11	DOCK_PON	O	O	O	O		O	DOCK power supply ON/OFF control H: ON, L: OFF
107	P12 P12/D10	IOXV_N_CS	CS	O	O	O		O	IO extended IC (for video) chip select
108	P11 P11/D9	IOXV_N_RST	O	O	O	O		O	IO extended IC (for video) reset
109	P10 P10/D8	PD_LED	O	O	O	O		O	Pure Direct LED ON/OFF control H: ON, L: OFF
110	P07 P07/D7/AN07	FLD_N_RST	O	O	O	O		O	FL driver reset
111	P06 P06/D6/AN06	PRG_RA	I	O	O	O		O	Program rotary A Pull-up
112	P05 P05/D5/AN05	PRG_RB	I	O	O	O		O	Program rotary B Pull-up
113	P04 P04/D4/AN04	MIC_N_DET	I	O	O	O		O	MIC detection L: MIC
114	P114 P114	IPD_APDET	I	I	I	I		I	iPod accessory power detection While iPod boots up (about two seconds) it is set at Low after the boot, it identifies To prevent pulling of iPod High output and microprocessor Low Fix output, switch to constant input
115	P113	VOL_RA	I	O	O	O		O	Volume rotary A
116	ISRXD1 P112/INPC12/ OUTC12/ISRXS1	SR_MISO	SI	I	I	I		I	Asynchronous data input for SIRIUS Serial communication is 5V TTL/CMOS logic level Pull up at 100 k-ohms (U model) To prevent pulling of SIRIUS tuner's High output and microprocessor's Low Fix output, switch to constant input
	P112		O	O	O	O		O	(C, R, T, K, A, B, G, E, F, L, J models)
117	P111 P111/INPC11/ OUTC11/ISCLK1	VOL_RB	I	O	O	O		O	Volume rotary B
118	ISTXD1 P110/INPC10/ OUTC10/ISTXD1	SR_MOSI	SO	O	O	O		O	Asynchronous data output for SIRIUS Serial communication is 5V TTL/CMOS logic level (U model)
	P110		O	O	O	O		O	(C, R, T, K, A, B, G, E, F, L, J models)

Pin No.	Port Name	Function Name (P.C.B.)	I/O						Detail of Function
			Power On	Stby Thrh	Standby	Stby Sleep	Sleep	MCU Sleep	
119	P03 P03/D3/AN03	SR_PON	O	O	O	O		O	SIRIUS radio power supply ON/OFF control (U model) H: Power ON, L: Power OFF
	P03		O	O	O	O		O	(C, R, T, K, A, B, G, E, F, L, J models)
120	P02 P02/D2/AN02	SEL_PD	O	O	O	O		O	DSP Pure Direct route select H: Pure Direct ON
121	P01 P01/D1/AN01	ADC_N_PDWN	O	O	O	O		O	ADC power down L: Power down
122	P00 P00/D0/AN00	FLD_N_CS	CS	O	O	O		O	FL driver chip select
123	AN157 P157/AN157/CTS6/ RTS6	L3_DET	AD	O	O	O		O	Component video aspect detection
124	AN156 P156/AN156/CLK6	THM	AD	AD	O	O		O	Temperature detection
125	AN155 P155/AN155/RXD6	AMP_OLV	AD	AD	O	O		O	Power AMP output level detection
126	AN154 P154/AN154/TXD6	DC_PRT	AD	AD	O	O		O	Power AMP DC detection
127	AN153 P153/AN153/CTS5/ RTS5	MODEL	AD	AD	O	O		O	Destination discrimination by AD value When AD is taken in at power on, there is 1m sec waiting time after AD input port setting
128	ISRXD0 P152/AN152/ ISRXD0/RXD5	E2R_MISO	SI	SI	SI	O		O	Synchronous data input for EEPROM
129	ISCLK0 P151/AN151/ISCLK0/ CLK5	FLD_SCK	SO	SO	SO	O		O	FL driver, OSD, IO extended IC (Video), series 1 k-ohms go into synchronous clock output for EEPROM FL driver
130	Vss Vss	Vss	MCU	MCU	MCU	MCU		MCU	Microprocessor GND
131	ISTXD0 P150/AN150/ISTXD0/ TXD5	FLD_MOSI	SO	SO	SO	O		O	FL driver, OSD, IO extended IC (Video), series 1 k-ohms go into synchronous data output for EEPROM FL driver
132	Vcc1 Vcc1	Vcc1	MCU	MCU	MCU	MCU		MCU	Microprocessor power supply
133	AN7 P107/AN7/KI3/RTP33	KEY1	AD	AD	AD	I		O	KEY1 AD value taken in During PSW_DET interruption, distinguishes the used keys which are switched to AD
134	AN6 P106/AN6/KI2/RTP32	KEY2	AD	AD	AD	I		O	KEY2 AD value taken in During PSW_DET interruption, distinguishes the used keys which are switched to AD
135	AN5 P105/AN5/KI1/RTP31	PS1_PRT	AD	AD	O	O		O	PS protection detection 1
136	AN4 P104/AN4/KI0/RTP30	PS2_PRT	AD	AD	O	O		O	PS protection detection 2
137	P103 P103/AN3/RTP13	ISEL_RA	I	O	O	O		O	Input selector rotary A
138	P102 P102/AN2/RTP12	ISEL_RB	I	O	O	O		O	Input selector rotary B
139	AN1 P101/AN1/RTP11	DEST	AD	AD	AD	O		O	AD destination discrimination Data is taken in when resetting is cancelled
140	AVss AVss	AVss	MCU	MCU	MCU	MCU		MCU	Microprocessor GND
141	AN0 P100/AN0/RTP10	DOCK_TYPE	AD	AD	AD	I		O	DOCK discriminate Identifies the connected DOCK type, then switches the action During IPD_DET interruption, switches to AD, make a distinction based on post-10 ms A/D value Make a distinction from IPD_DET Low edge through post-10ms A/D value
142	Vref Vref	VREF	MCU	MCU	MCU	MCU		MCU	Microprocessor power supply
143	AVcc AVcc	AVcc	MCU	MCU	MCU	MCU		MCU	Microprocessor power supply
144	RXD4	SCPU_MISO	SO	I	I	I		O	Synchronous data input for SubCPU

RX-V1065/HTR-6280/AX-V1065

Key detection for A/D port

Key input (A/D) pull-up resistance 10 k-ohms

RX-V1065/HTR-6280

Ohm	0	+1.0k	+1.0k	+1.5k	+1.5k	+2.2k	+3.3k	+4.7k	+22.0k	+33.0k
V	0 – 0.15	0.15 – 0.42	0.43 – 0.70	0.71 – 0.97	0.98 – 1.24	1.25 – 1.53	1.54 – 1.84	1.84 – 2.1	2.34 – 2.55	2.55 – 2.97
A/D value (3.3 V=255)	0 – 11	12 – 32	33 – 54	55 – 75	76 – 95	96 – 118	119 – 142	143 – 162	181 – 197	198 – 229
KEY1 (133 pin)	SCENE RADIO	SCENE CD	SCENE TV	SCENE BD/DVD	ZONE2 ON/OFF	ZONE2 CONTROL	—	—	MAIN ZONE ON/OFF	TONE CONTROL

Ohm	0	+1.0k	+1.0k	+1.5k	+1.8k	+2.2k	+3.3k	+4.7k	+6.8k	+10.0k	+22.0k	+68.0k
V	0 – 0.15	0.15 – 0.42	0.43 – 0.70	0.71 – 0.99	1.0 – 1.27	1.28 – 1.56	1.57 – 1.86	1.86 – 2.14	2.14 – 2.4	2.4 – 2.65	2.66 – 2.91	2.92 – 3.17
A/D value (3.3 V=255)	0 – 11	12 – 32	33 – 54	55 – 77	78 – 98	99 – 120	121 – 143	144 – 165	166 – 185	186 – 205	206 – 225	226 – 245
KEY2 (134 pin)	PURE DIRECT	STRAIGHT / EFFECT	INFO	MEMORY	PRESET <	PRESET >	CATEGORY < FM	CATEGORY > AM	TUNING CH <	TUNING CH >	—	—

AX-V1065

Ohm	0	+1.0k	+1.0k	+1.5k	+1.5k	+2.2k	+3.3k	+4.7k	+22.0k	+33.0k
V	0 – 0.15	0.15 – 0.42	0.43 – 0.70	0.71 – 0.97	0.98 – 1.24	1.25 – 1.53	1.54 – 1.84	1.84 – 2.1	2.34 – 2.55	2.55 – 2.97
A/D value (3.3 V=255)	0 – 11	12 – 32	33 – 54	55 – 75	76 – 95	96 – 118	119 – 142	143 – 162	181 – 197	198 – 229
KEY1 (133 pin)	SCENE RADIO	SCENE CD	SCENE TV	SCENE BD/DVD	SLEEP	MUTE	—	—	STANDBY/ ON	TONE CONTROL

Ohm	0	+1.0k	+1.0k	+1.5k	+1.8k	+2.2k	+3.3k	+4.7k	+6.8k	+10.0k	+22.0k	+68.0k
V	0 – 0.15	0.15 – 0.42	0.43 – 0.70	0.71 – 0.99	1.0 – 1.27	1.28 – 1.56	1.57 – 1.86	1.86 – 2.14	2.14 – 2.4	2.4 – 2.65	2.66 – 2.91	2.92 – 3.17
A/D value (3.3 V=255)	0 – 11	12 – 32	33 – 54	55 – 77	78 – 98	99 – 120	121 – 143	144 – 165	166 – 185	186 – 205	206 – 225	226 – 245
KEY2 (134 pin)	PURE DIRECT	STRAIGHT / EFFECT	INFO	MEMORY	PRESET <	PRESET >	FM	AM	TUNING <	TUNING >	—	—

Destination detection for A/D port

Destination input (A/D) pull-up resistance 10 k-ohms

Ohm (R3809 VIDEO P.C.B.)	0	1.2 k	2.7 k	4.7 k	6.8 k	10.0 k	15.0 k	47.0 k	100.0 k
V	0 – 0.2	0.2 – 0.6	0.6 – 0.9	0.9 – 1.2	1.2 – 1.5	1.5 – 1.8	1.8 – 2.3	2.4 – 2.9	2.9 – 3.2
A/D value (3.3V=255)	0 – 15	15 – 46	46 – 69	69 – 92	92 – 115	115 – 139	139 – 177	185 – 224	224 – 247
DEST (139 pin)	J	U	C	R	T	K	A	B, G, E, F	L

Model detection for A/D port

Model input (A/D) pull-up resistance 10 k-ohms

Ohm (R201 DIGITAL P.C.B.)	100.0 k	—
V	2.8 – 3.2	3.2 – 3.3
A/D value (3.3 V=255)	215 – 244	245 – 255
MODEL (127 pin)	RX-V1065/AX-V1065	HTR-6280

IC505: AD91089ZSKBC (GUI P.C.B.)

Sub-microprocessor

* No replacement part available. / サービス部品供給なし

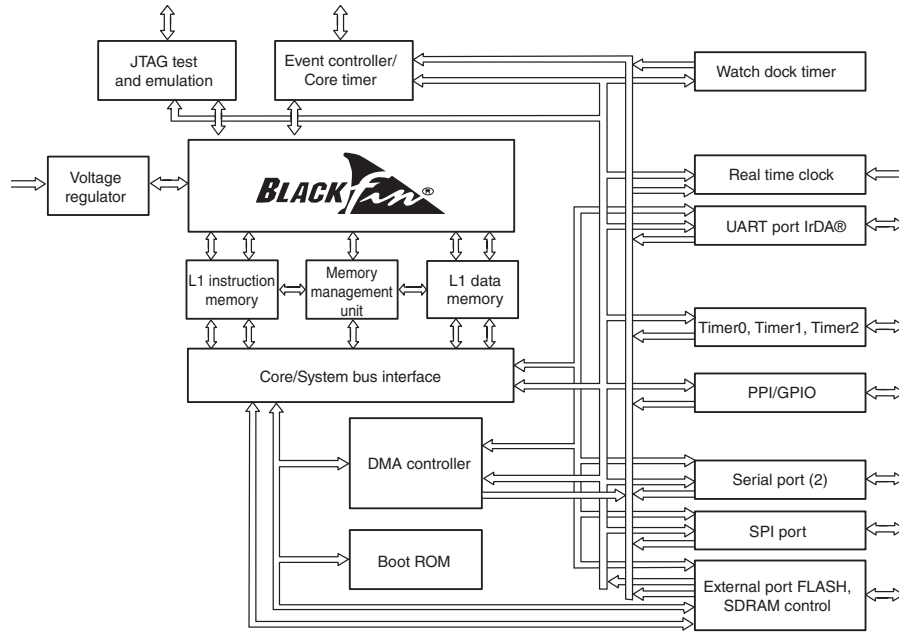

RX-V1065/HTR-6280/
AX-V1065

Memory Interface

Pin No.	Function Name	I/O	Detail of Function		
121	ADDR19	O	Address bus for async/Sync access		
122	ADDR18				
123	ADDR17				
124	ADDR16				
125	ADDR15				
126	ADDR14				
127	ADDR13				
135	ADDR12	O	Address bus for async/Sync access		
136	ADDR11				
137	ADDR10				
138	ADDR9				
139	ADDR8				
140	ADDR7				
141	ADDR6				
142	ADDR5	O	Address bus for async/Sync access		
146	ADDR4				
147	ADDR3				
148	ADDR2				
149	ADDR1				
98	DATA15			I/O	Daea bus for async access
99	DATA14				
100	DATA13				
101	DATA12				
102	DATA11				
103	DATA10				
104	DATA9				
105	DATA8	I/O	Daea bus for async access		
108	DATA7				
109	DATA6				
110	DATA5				
112	DATA4				
113	DATA3				
114	DATA2				
115	DATA1	I/O	Daea bus for async access		
116	DATA0				
150	ABE1	O	Byte enables/Data masks for async/Sync access		
151	ABE0				
163	BR	I	Bus request (This pin should be pulled HIGH if not used.)		
119	BG	O	Bus grant		
120	BGH	O	Bus grant hang		

Asynchronous memory control

Pin No.	Function Name	I/O	Detail of Function
158	AMS3	O	Banks select
159	AMS2		
160	AMS1		
161	AMS0		
162	ARDY	I	hardware ready control (This pin should be pulled HIGH if not used.)
154	AOE	O	Output enable
153	ARE	O	Read enable
152	AWE	O	Write enable

Synchronous memory control

Pin No.	Function Name	I/O	Detail of Function
167	SRAS	O	Row address strobe
166	SCAS	O	Column address strobe
165	SWE	O	Write enable
173	SCKE	O	Clock enable
169	CLKOUT	O	Clock output
164	SA10	O	A10 pin
172	SMS	O	Bank select

Timers

Pin No.	Function Name	I/O	Detail of Function
79	TMR0	I/O	Timer0
78	PPI_FS1	I/O	Timer1/PPI frame sync1
77	PPI_FS2	I/O	Timer2/PPI frame sync2

PPI port

Pin No.	Function Name	I/O	Detail of Function
22	PP10	I/O	PPI3-0
23	PP11		
24	PP12		
26	PP13		
21	PPI_CLK	I	PPI clock/External timer reference

Port F: GPIO/Parallel peripheral interface port/SPI/Timers

Pin No.	Function Name	I/O	Detail of Function
51	N_SPISS	I/O	GPIO/SPI slave select input
50	PF1	I/O	GPIO/SPI slave select enable 1/ Timer alternate clock input
49	PF2	I/O	GPIO/SPI slave select enable 2
48	PPI_PS3	I/O	GPIO/SPI slave select enable 3/ PPI frame sync 3
47	PF4	I/O	GPIO/SPI slave select enable 4/ PPI 15
46	PF5	I/O	GPIO/SPI slave select enable 5/ PPI 14
38	PF6	I/O	GPIO/SPI slave select enable 6/ PPI 13
37	PF7	I/O	GPIO/SPI slave select enable 7/ PPI 12
36	PF8	I/O	GPIO/PPI 11
35	PF9	I/O	GPIO/PPI 10
34	PF10	I/O	GPIO/PPI 9
33	PF11	I/O	GPIO/PPI 8
32	PPI7	I/O	GPIO/PPI 7
29	PPI6	I/O	GPIO/PPI 6
28	PPI5	I/O	GPIO/PPI 5
27	PPI4	I/O	GPIO/PPI 4

JTAG port

Pin No.	Function Name	I/O	Detail of Function
94	TCK	I	JTAG clock
87	TDO	O	JTAG serial data out
86	TDI	I	JTAG serial data in
85	TMS	I	JTAG mode select
84	TRST	I	JTAG reset (This pin is should be pulled LOW if JTAG is not used.)
83	EMU	O	Emulation output

SPI port

Pin No.	Function Name	I/O	Detail of Function
55	MOSI	I/O	Master out slave in
54	MISO	I/O	Master in slave out (This pin is should be pulled HIGH through a 4.7 k-ohms resistor if booting via the SPI port.)
53	SCK	I/O	SPI clock

Serial ports

Pin No.	Function Name	I/O	Detail of Function
76	RSCLK0	I/O	SPORT0 receive serial clock
75	RFS0	I/O	SPORT0 receive frame sync
74	DR0PRI	I	SPORT0 receive data primary
73	DR0SEC	I	SPORT0 receive data secondary
72	TSCLK0	I/O	SPORT0 transmit serial clock
69	TFS0	I/O	SPORT0 transmit frame sync
68	DT0PRI	O	SPORT0 transmit data primary
67	DT0SEC	O	SPORT0 transmit data secondary
65	RSCLK1	I/O	SPORT1 receive serial clock
64	RFS1	I/O	SPORT1 receive frame sync
63	DR1PRI	I	SPORT1 receive data primary
62	DR1SEC	I	SPORT1 receive data secondary
61	TSCLK1	I/O	SPORT1 transmit serial clock
60	TFS1	I/O	SPORT1 transmit frame sync
59	DT1PRI	O	SPORT1 transmit data primary
58	DT1SEC	O	SPORT1 transmit data secondary

UART port

Pin No.	Function Name	I/O	Detail of Function
82	RX	I	UART receive
81	TX	O	UART transmit

Real-time clock

Pin No.	Function Name	I/O	Detail of Function
17	RTXI	I	RTC crystal input (This pin should be pulled LOW when not used.)
16	RTXO	O	RTC crystal output

Clock

Pin No.	Function Name	I/O	Detail of Function
10	CLKIN	I	Clock/Crystal input (This pin needs to be at a level or clocking.)
11	XTAL	O	Crystal output

Mode controls

Pin No.	Function Name	I/O	Detail of Function
13	RESET	I	Reset (This pin is always active during core power-on.)
14	NMI	I	Nonmaskable interrupt (This pin should be pulled LOW when not used.)
95	BMODE1	I	Boot mode strap (These pins must be pulled to the state required for the desired boot mode.)
96	BMODE0		

Voltage regulator

Pin No.	Function Name	I/O	Detail of Function
4	VROUT1	O	External FET drive
5	VROUT0		



Supplies

Pin No.	Function Name	I/O	Detail of Function
6	VDDEXT	P	I/O power supply
12			
20			
31			
45			
57			
71			
93			
107			
118			
134			
145			
156			
171			
25	VDDINT	P	Core power supply
52			
66			
80			
111			
143			
157			
168			
18	VDDRTC	P	Real-time clock power supply





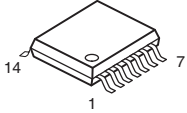
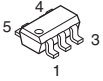
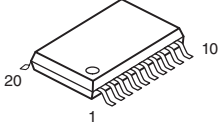
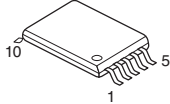
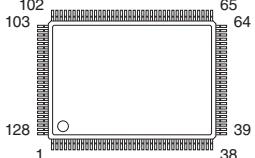
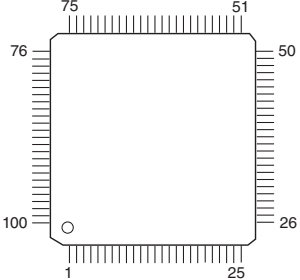
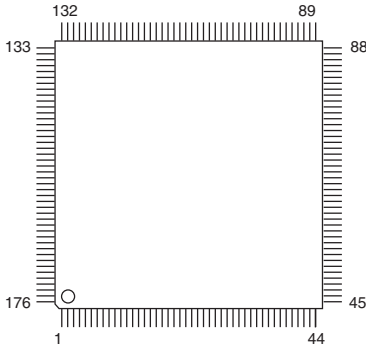
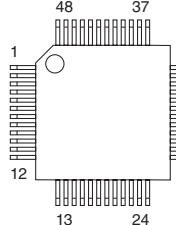
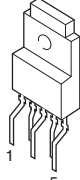
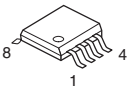
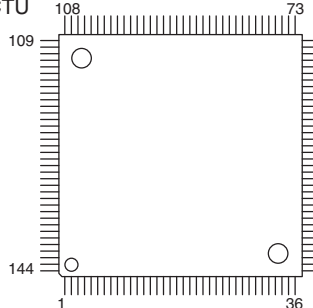
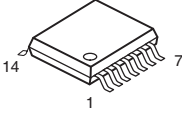
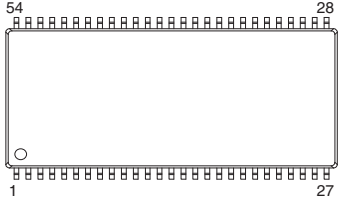
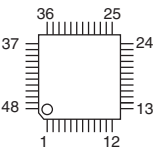
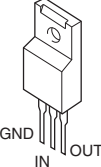
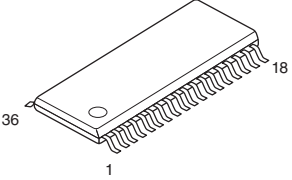
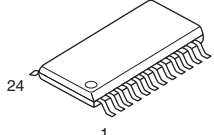
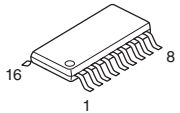
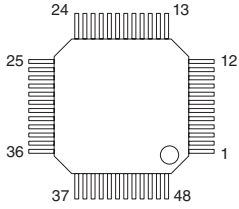
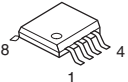
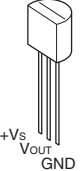
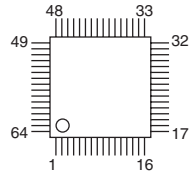



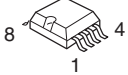
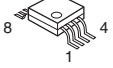
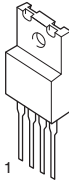
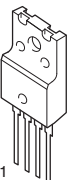
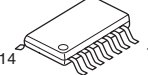

Pin No.	Function Name	I/O	Detail of Function
1	GND	G	External ground
2			
3			
7			
8			
9			
15			
19			
30			
39			
40			
41			
42			
43			
44			
56			
70			
88			
89			
90			
91			
92			
97			
106			
117			
128			
129			
130			
131			
132			
133			
144			
155			
170			
174			
175			
176			

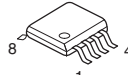
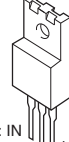
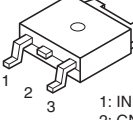
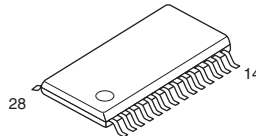
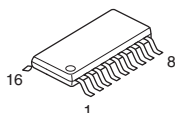
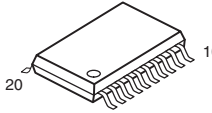
PIN CONNECTION DIAGRAMS

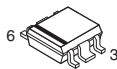
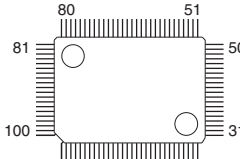
• ICs

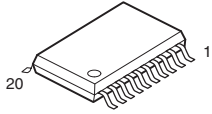
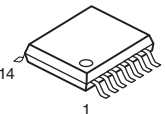
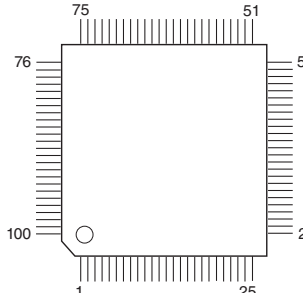
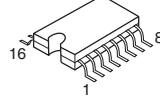
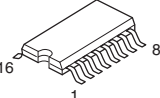
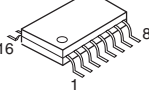
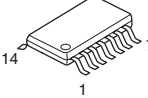
<p>74LVC08APW 74LVC32APW</p> 	<p>74LVC1G08GW</p> 	<p>74LVC245APW, 118</p> 	<p>CS230003-CZZR</p> 	<p>ISP1760BE</p> 
<p>ABT1012Q100</p> 	<p>ADV7800BSTZ-80 AD91089ZSKBC</p> 	<p>ADV7172KST AK8814VQ</p> 	<p>BA00JC5WT-V5</p> 	
<p>BD9323EFJ-E2</p> 	<p>D70YE101BRFP266 M30878JBGP SiI9233ACTU</p> 	<p>FHP3350IM14X</p> 	<p>K4S641632N-LC60000 K4S561632J-UC75000</p> 	
<p>F2621E-01-TR</p> 	<p>KIA7912PI</p> 	<p>LA73050-TLM-E</p> 	<p>LC709004A-TLM-E</p> 	<p>LC72725KM-UY-TLM-E</p> 
<p>LC89058WD-E</p> 	<p>LE25LA322M-TLM-E LE25LB2562M-TLM-E</p> 	<p>LM19CIZ/LF</p> 	<p>M66003-0131FP-R</p> 	<p>MX29LV160DBTI-70G MX29LV640DBTC-90G</p> 

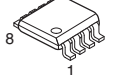
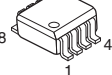
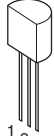
RX-V1065/HTR-6280/
AX-V1065

<p>NE5532DR</p> 	<p>NJM2068MD-TE2</p> 	<p>NJM2388F05</p>  <p>1. V_{IN} 2. V_{OUT} 3. GND 4. ON/OFF CONTROL</p>	<p>NJM2396F05</p>  <p>1. IN 2. V_{OUT} 3. GND 4. ON/OFF CONTROL</p>	<p>NJM2581M</p> 	<p>NJM2867F3-05</p> 
<p>NJM4565M (TE1)</p> 	<p>NJM7812FA</p>  <p>3: IN 2: COM 1: OUT</p>	<p>NJM78M05DL1A (TE1)</p>  <p>1: INPUT 2: GND 3: OUTPUT</p>	<p>PCM1680DBQR</p> 		
<p>PCM1781DBQR SN74LV163APWR</p> 	<p>PCM1803DBR</p> 	<p>R1172H181B-T1-F R1172H331D-T1-F R1172H501D-T1-F</p>  <p>1: CE 2: GND 3: NC 4: V_{DD} 5: V_{OUT}</p>	<p>R1173S001D-E2-F</p> 	<p>R2A15220FP</p> 	
<p>R5523N001A-TR-F</p> 	<p>SN74LVC245APWR SN74LVTH245APW</p> 	<p>SN74LV74APWR</p> 	<p>SiI9134CTU</p> 		
<p>TC74HC4051AFEL TC74HC4052AF</p> 	<p>TC74HC4053AF</p> 	<p>TC74VHC157FT</p> 	<p>TC74VHCT08AFT TC74VHCU04FT</p> 	<p>TC7SH04FU-TE85L TC7SH08FU</p> 	
<p>TC7WH14FK TC7WZ32FK (TE85L, F)</p> 	<p>TC7WHU04FU</p> 	<p>TL431ACLPR</p>  <p>1: CATHODE 2: ANODE 3: REF</p>	<p>TOP254PN</p> 		

• Diodes

1N402S 1SS133 1SS176	1SS355	D6SBN20	DB105
HT18G P6KE200ARL	MAZ8033GHL 3.4V MAZ8036GLL 3.5V	MITZJ10B MITZJ12B MITZJ13B MITZJ2.4B MITZJ22C MITZJ3.3B MITZJ39D	RB051L-40 UDZ5.1B
MA111 RB501V-40	RLZ7.5B 7.5V	RS203M-B-C-J80	SG10SC4M

• Transistors

2N5401C-AT/P 2SA1015-Y	2N5551C-AT	2SA1576A	2SA1695 O.P.Y 2SC4488 O.P.Y	2SA1708	2SA1770S/T-AN
2SA949 2SC1615 Y 2SC2229	2SC1740S	2SC2412K	2SC4081 T106	2SD1938F	2SD1915F
DTA114EKA DTA143EKA DTC114EKA DTC144EKA	KRA102M-AT/P KPC102M-AT	KTA1046-Y-U/P KTA1837-U/P	KT A1517S KTC387ES KTC3911S	MCH6336-TL-E	μPA672-T1-A

BLOCK DIAGRAMS

ANALOG AUDIO Section Block Diagram

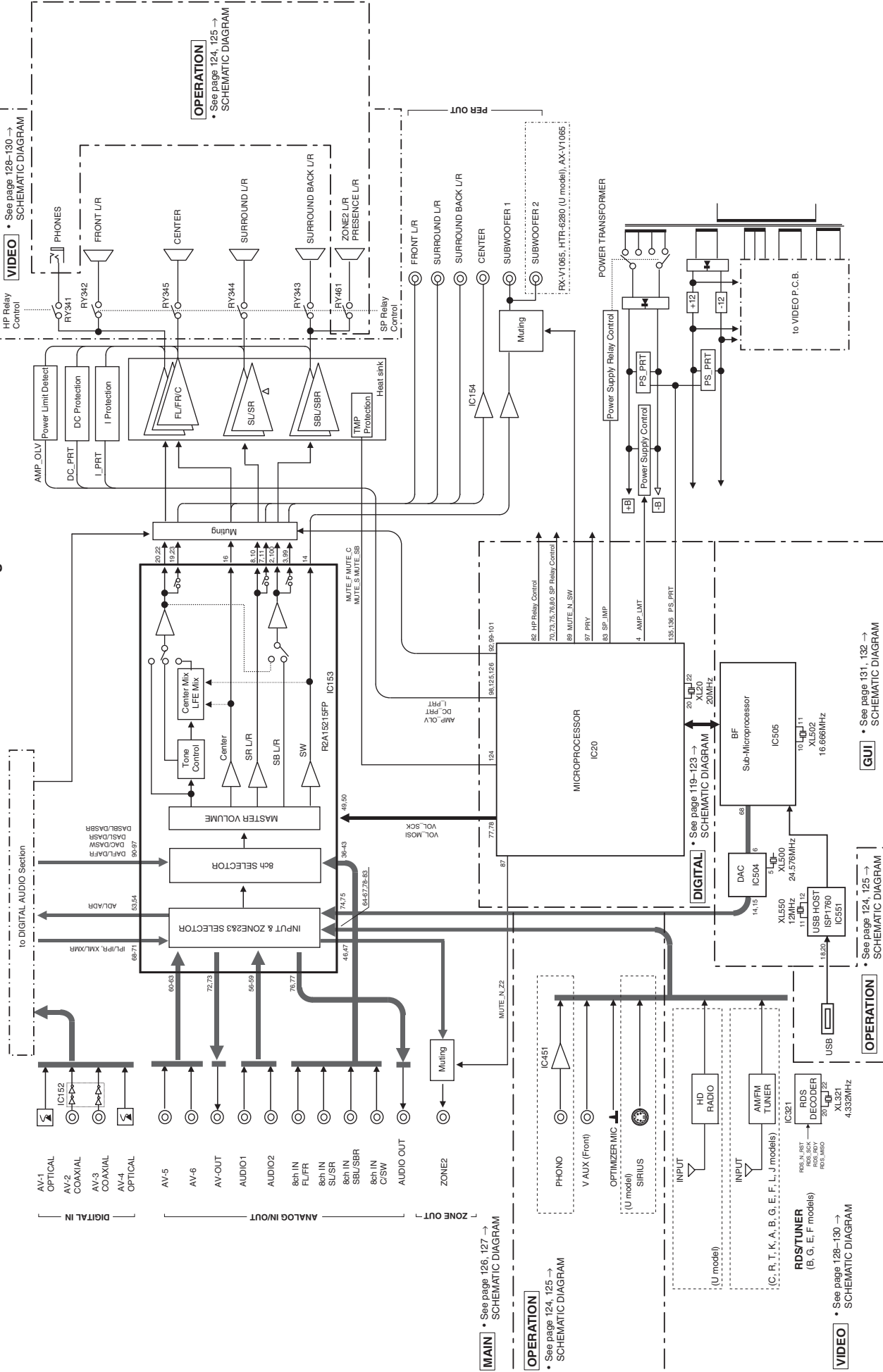

MAIN • See page 126, 127 → SCHEMATIC DIAGRAM

OPERATION • See page 124, 125 → SCHEMATIC DIAGRAM

VIDEO • See page 128-130 → SCHEMATIC DIAGRAM

OPERATION • See page 124, 125 → SCHEMATIC DIAGRAM

OPERATION • See page 124, 125 → SCHEMATIC DIAGRAM

GUI • See page 131, 132 → SCHEMATIC DIAGRAM

DIGITAL AUDIO Section Block Diagram

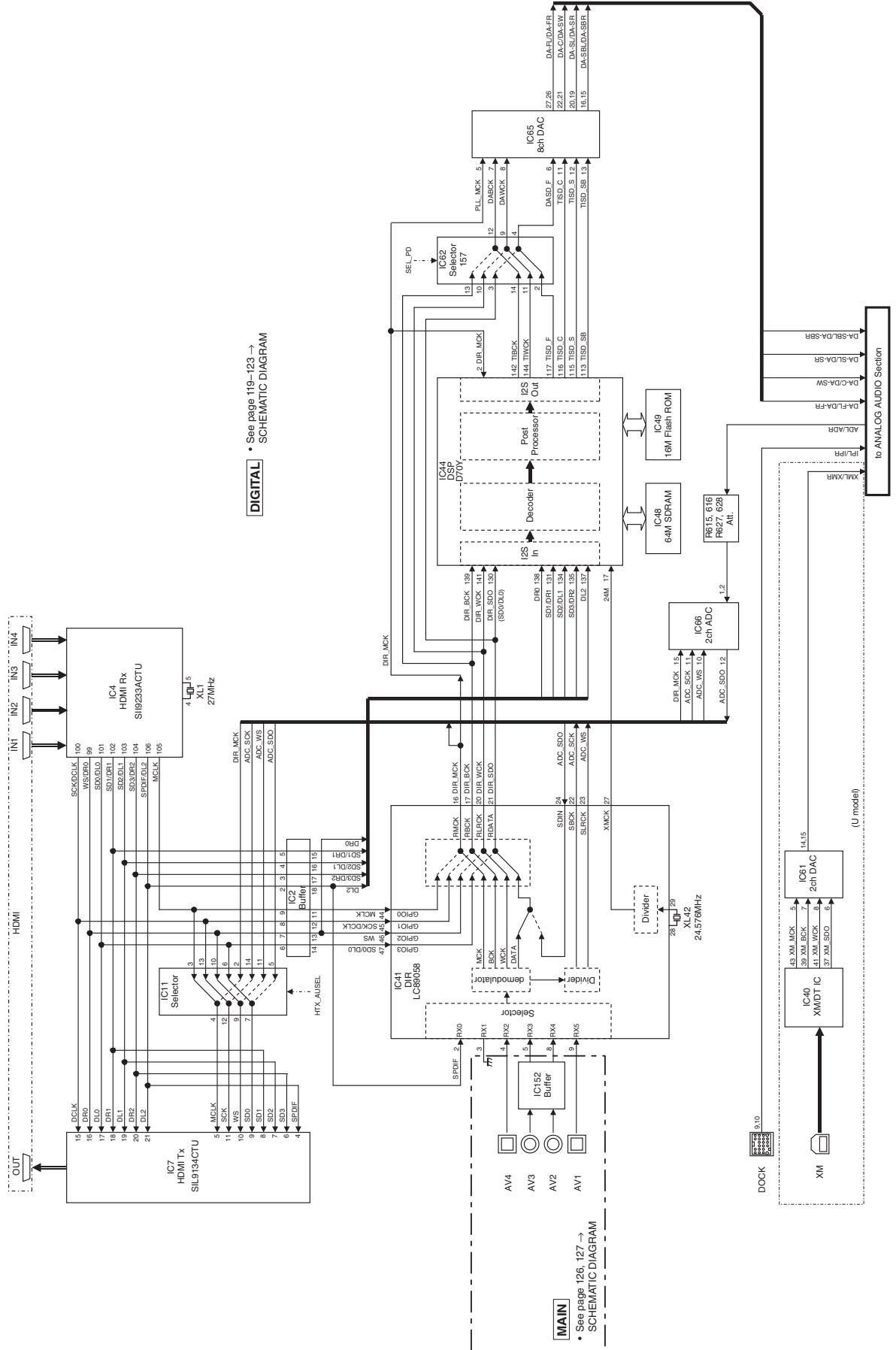

DIGITAL • See page 119-123 → SCHEMATIC DIAGRAM

MAIN • See page 126, 127 → SCHEMATIC DIAGRAM

Power Supply Section Block Diagram

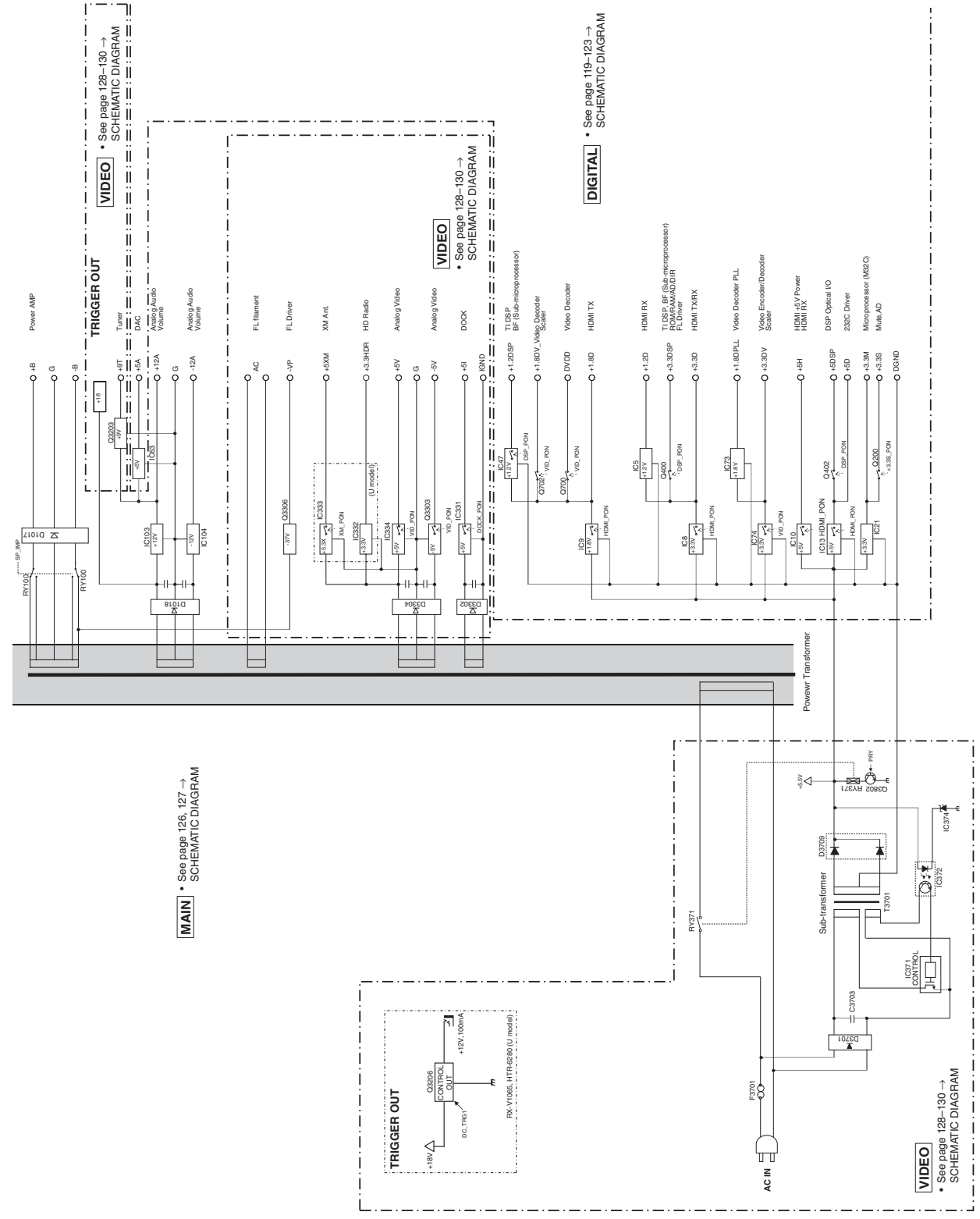

MAIN • See page 126, 127 → SCHEMATIC DIAGRAM

TRIGGER OUT
+12V, 100mA
DC, 100mA
+12V, 100mA (U model)
RX-V1065, HTR-6280 (U model)

VIDEO • See page 128-130 → SCHEMATIC DIAGRAM

DIGITAL • See page 119-123 → SCHEMATIC DIAGRAM

PRINTED CIRCUIT BOARDS

DIGITAL P.C.B. (Side A)

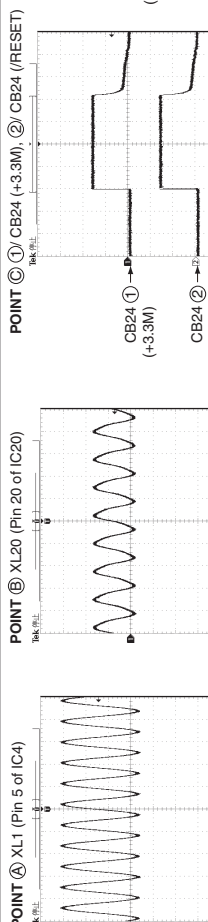
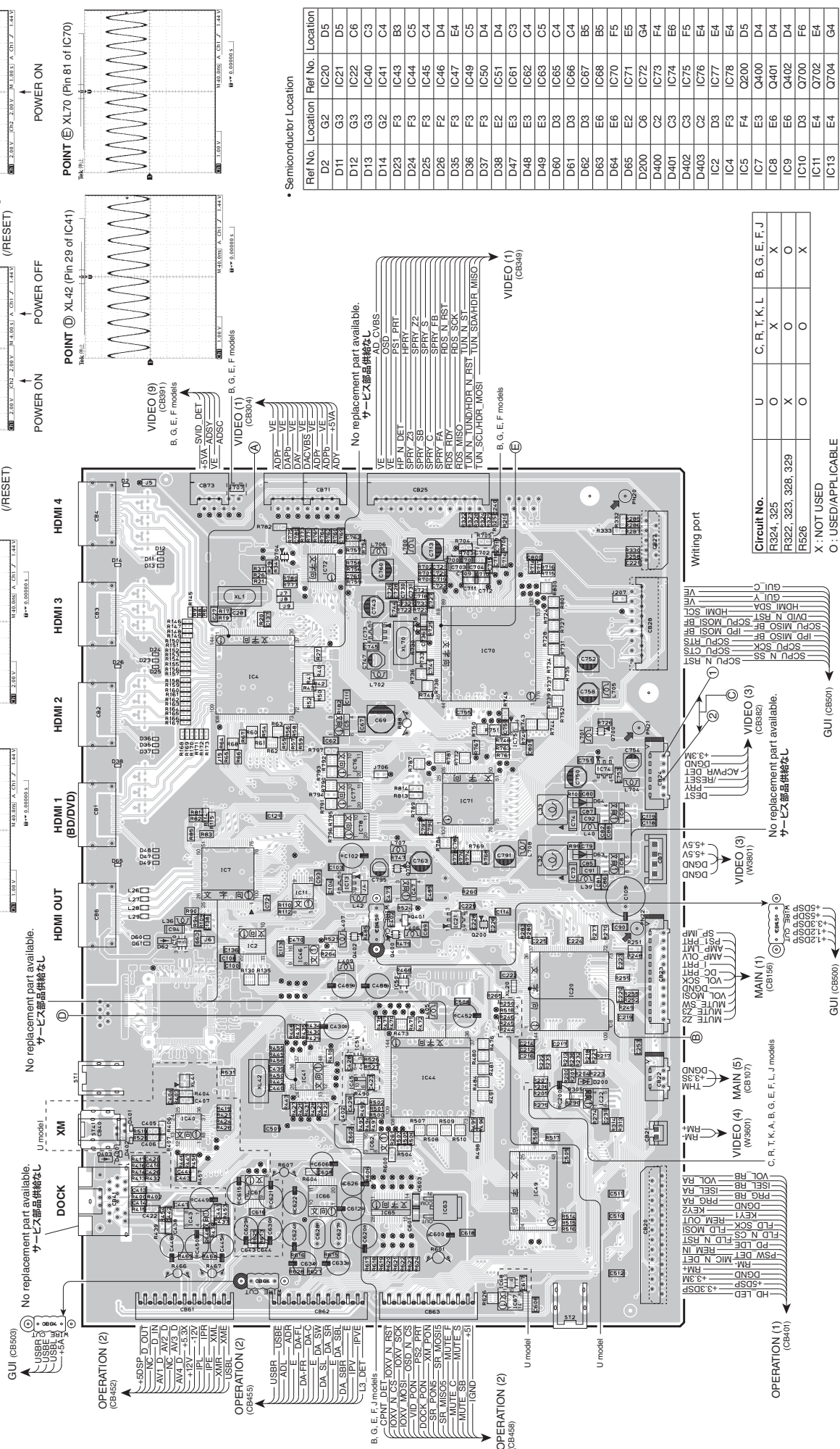

Semiconductor Location

Ref No.	Location	Ref No.	Location
D2	G2	IC20	D5
D11	G3	IC21	D6
D12	G3	IC22	C6
D13	G3	IC40	C3
D14	G2	IC41	C4
D23	F3	IC43	B3
D24	F3	IC44	C5
D25	F3	IC45	C4
D26	F2	IC46	D4
D35	F3	IC47	E4
D36	F3	IC49	E5
D37	F3	IC50	D4
D38	E2	IC51	D4
D48	E3	IC61	C3
D49	E3	IC62	C4
D60	D3	IC65	C4
D61	D3	IC66	C4
D62	D3	IC67	B5
D63	E6	IC68	B5
D64	E6	IC70	F5
D65	E2	IC71	E5
D200	C6	IC72	G4
D400	C2	IC73	F4
D401	C3	IC74	E6
D402	C3	IC75	F5
D403	C2	IC76	E4
IC2	D3	IC77	E4
IC4	F3	IC78	E4
IC5	F4	Q200	D5
IC7	E3	Q400	D4
IC8	E6	Q401	D4
IC9	E6	Q402	D4
IC10	D3	O700	F6
IC11	E4	O701	E4
IC13	E4	O702	G4

Circuit No.	U	C	R	T	K	L	B	G	E	F	J
R324, 325											X
R322, 323, 328, 329										X	O
R526										O	X

X : NOT USED
O : USED/APPLICABLE

DIGITAL P.C.B. (Side B)

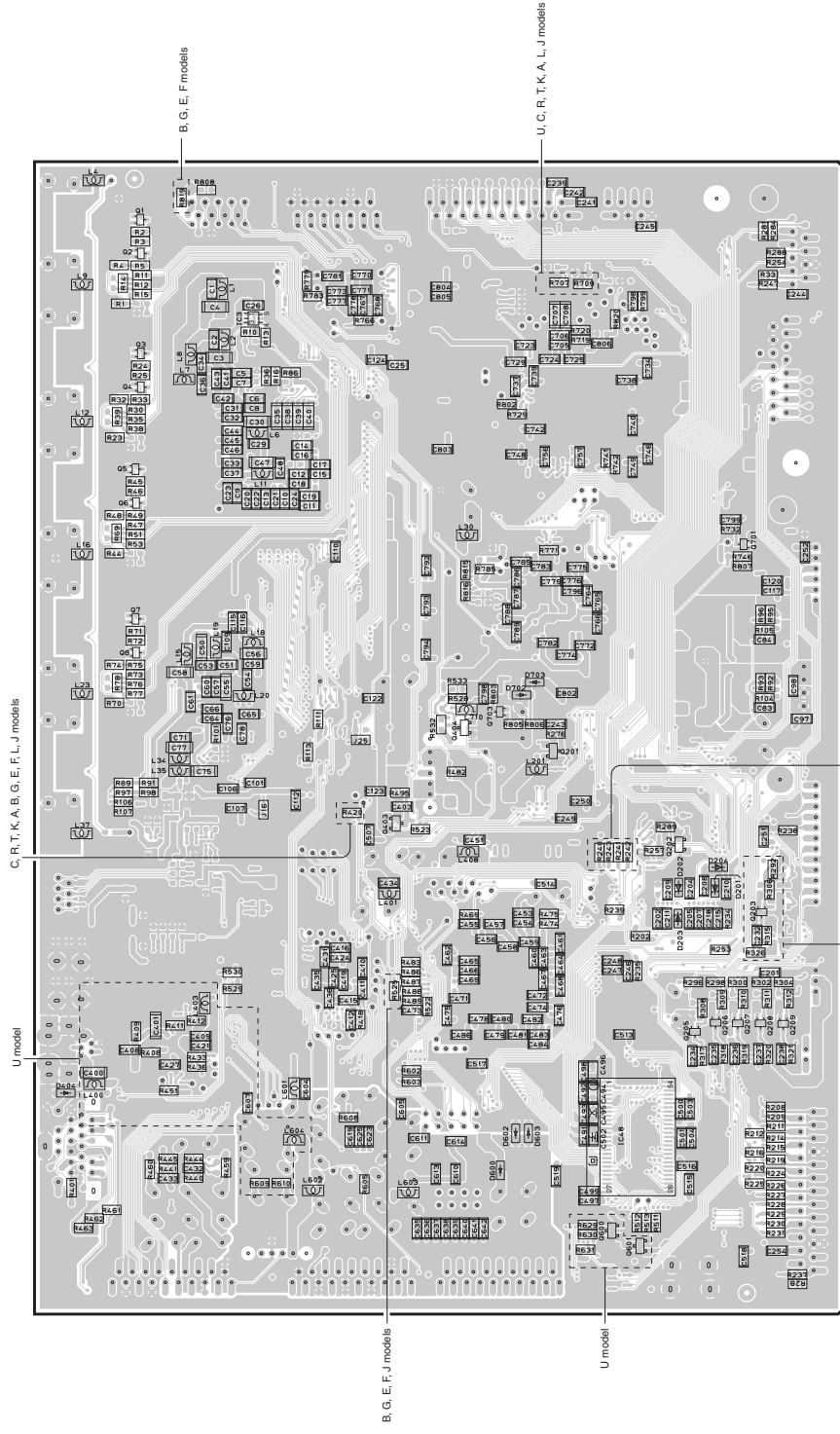

• Semiconductor Location

Ref No.	Location
D201	D6
D202	D6
D203	D6
D204	D6
D404	C3
D600	C5
D602	C5
D603	C5
D702	E5
D703	E5
IC3	G4
IC48	O5
O1	G3
O2	G3
O3	G3
O4	F3
O5	F3
O6	F3
O7	E3
O8	E3
Q201	E5
Q202	D6
Q203	D6
Q205	C6
Q206	C6
Q207	C6
Q208	C6
Q209	C6
Q403	D4
Q404	E5
Q600	B5
Q601	B5
Q701	F6
Q703	E5

OPERATION (1) P.C.B. (Side A)

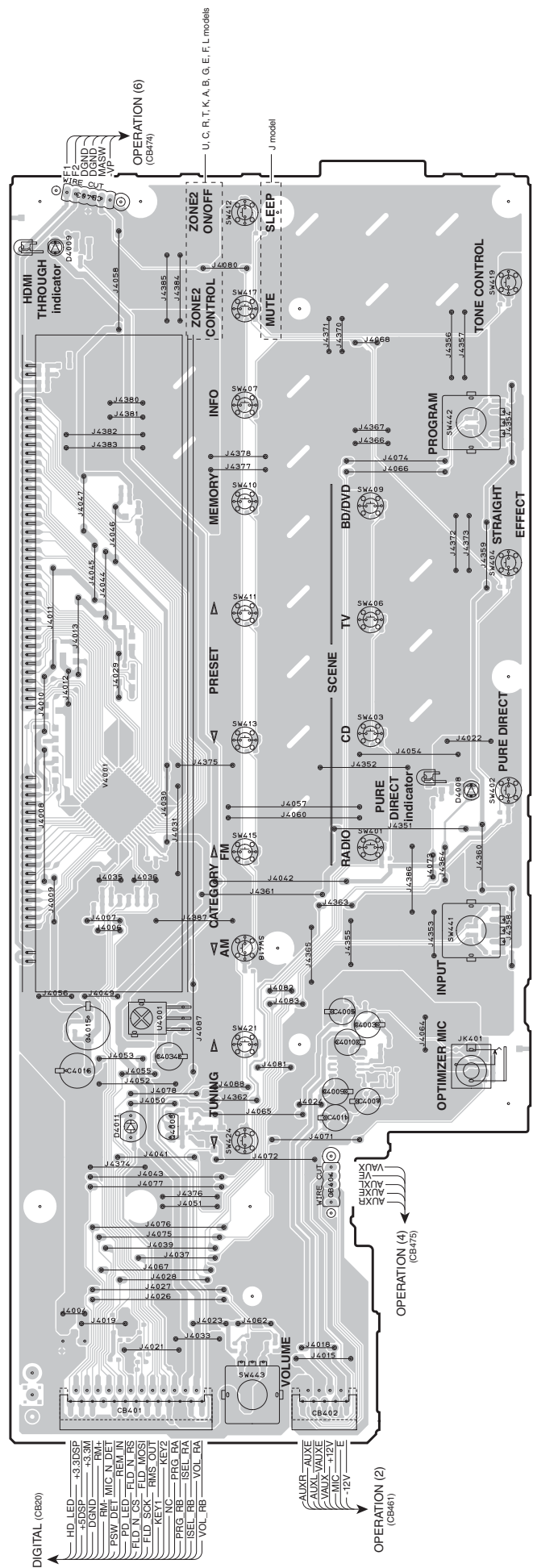

• Semiconductor Location

Ref No.	Location
D4008	F5
D4009	I3
D4011	D3
C4005	D3

OPERATION (1) P.C.B. (Side B)

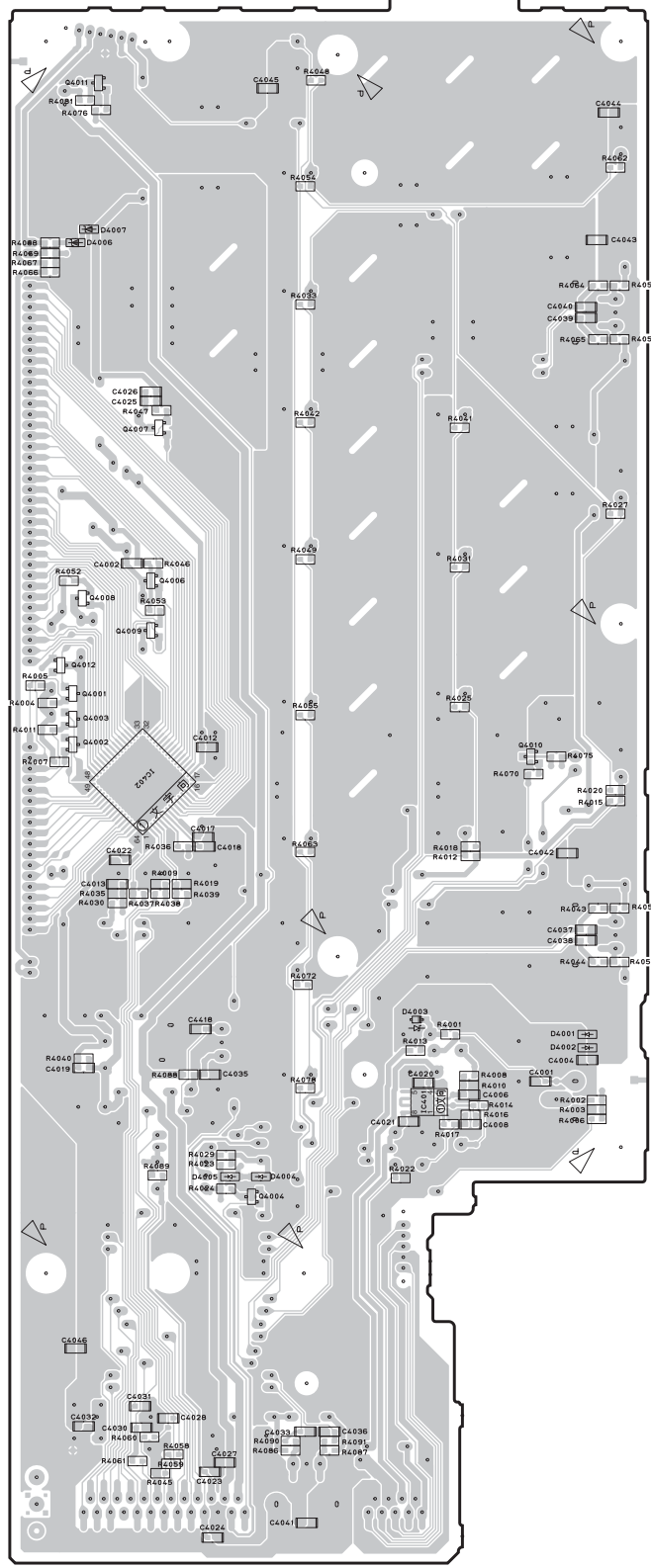

• Semiconductor Location

Ref No.	Location	Ref No.	Location	Ref No.	Location
D4001	D5	IC401	D5	Q4007	G3
D4002	D5	IC402	E3	Q4008	F3
D4003	D4	Q4001	F3	Q4009	F3
D4004	C4	Q4002	F3	Q4010	E5
D4005	C4	Q4003	F3	Q4011	I3
D4006	H3	Q4004	C4	Q4012	F3
D4007	H3	Q4006	F3		

OPERATION (2) P.C.B. (Side A)

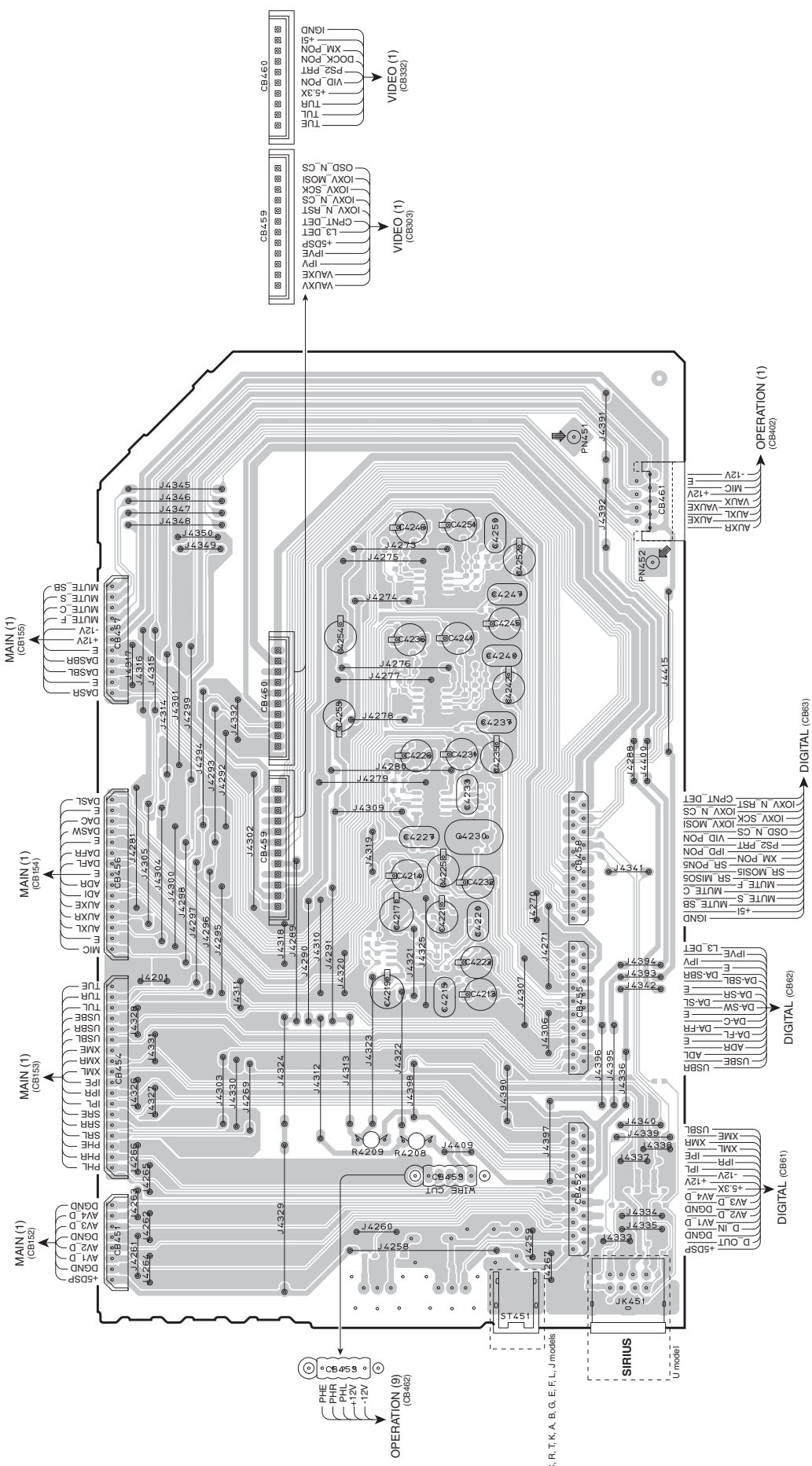

C. R. T. K. A. B. G. E. F. L. J. models

SIRIUS

U model

OPERATION (2) P.C.B. (Side B)

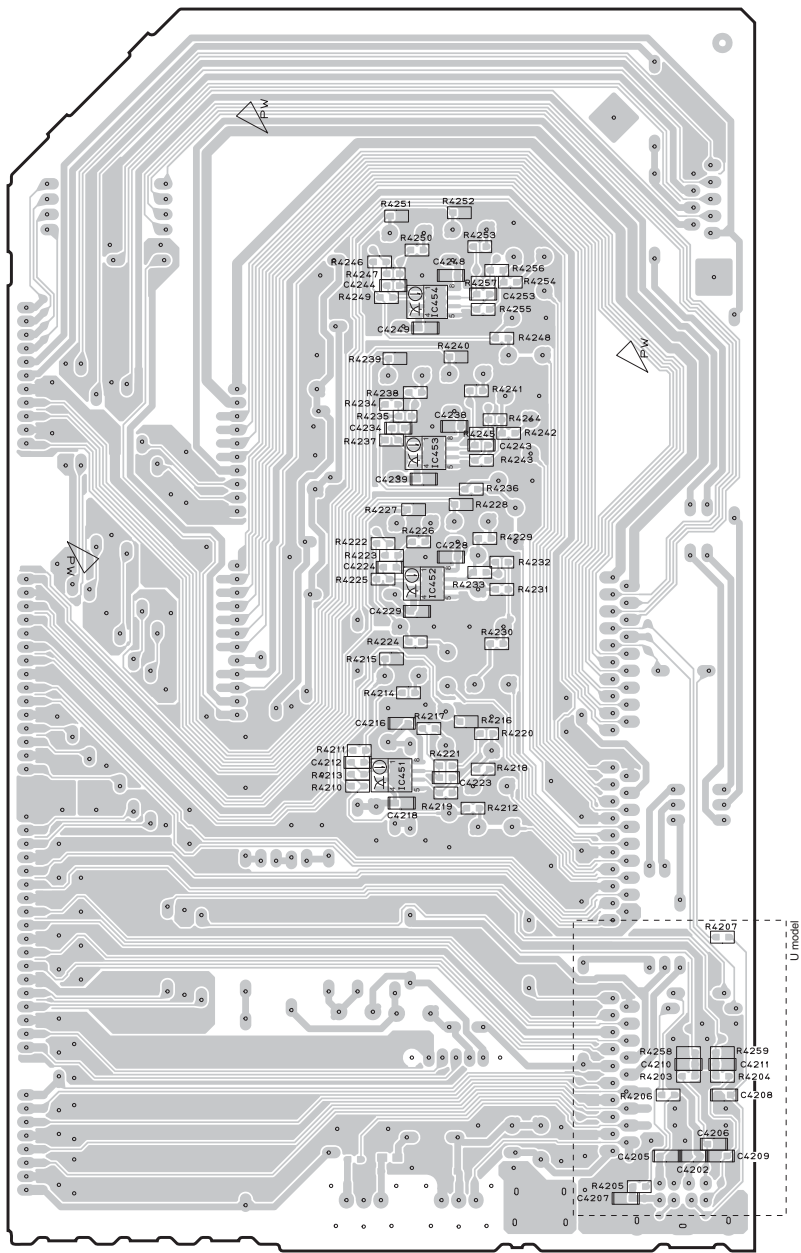

• Semiconductor Location

Ref No.	Location
IC451	D4
IC452	D4
IC453	E4
IC454	F4

1

OPERATION (3) P.C.B. (Side A)

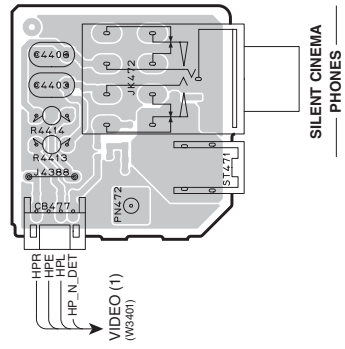

OPERATION (4) P.C.B. (Side A)

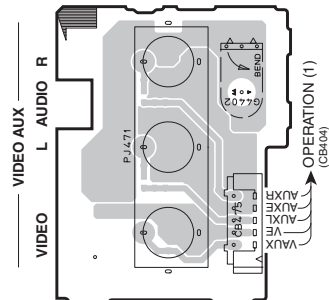

OPERATION (5) P.C.B. (Side A)

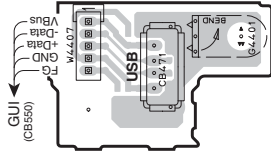

OPERATION (6) P.C.B. (Side A)

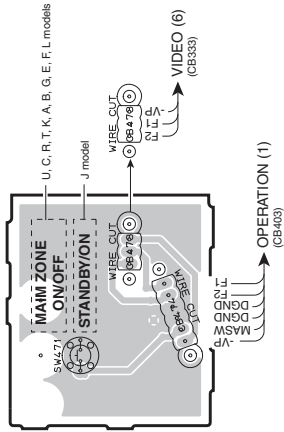

2

3

OPERATION (8) P.C.B. (Side A)

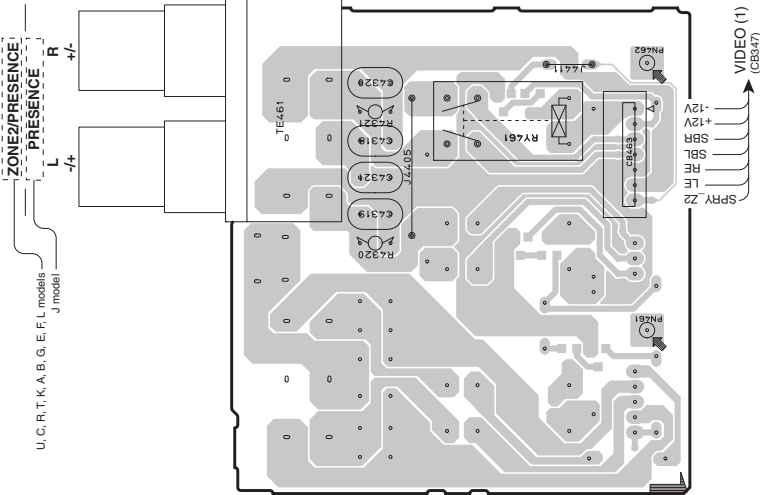

OPERATION (9) P.C.B. (Side A)

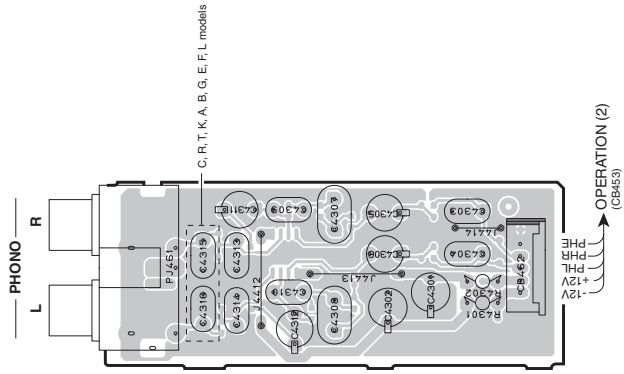

OPERATION (10) P.C.B. (Side A)

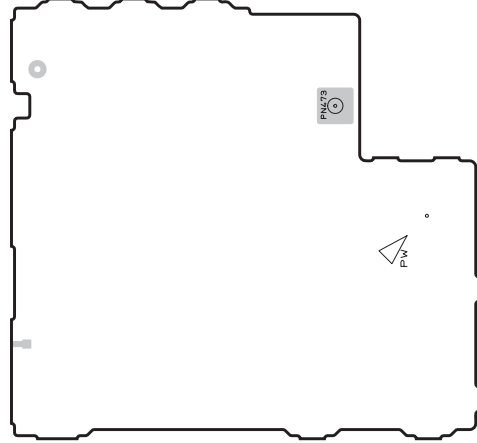

OPERATION (11) P.C.B. (Side A)

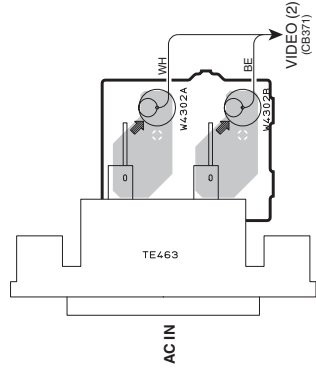

4

5

6

7

MAIN (1) P.C.B. (Side A)

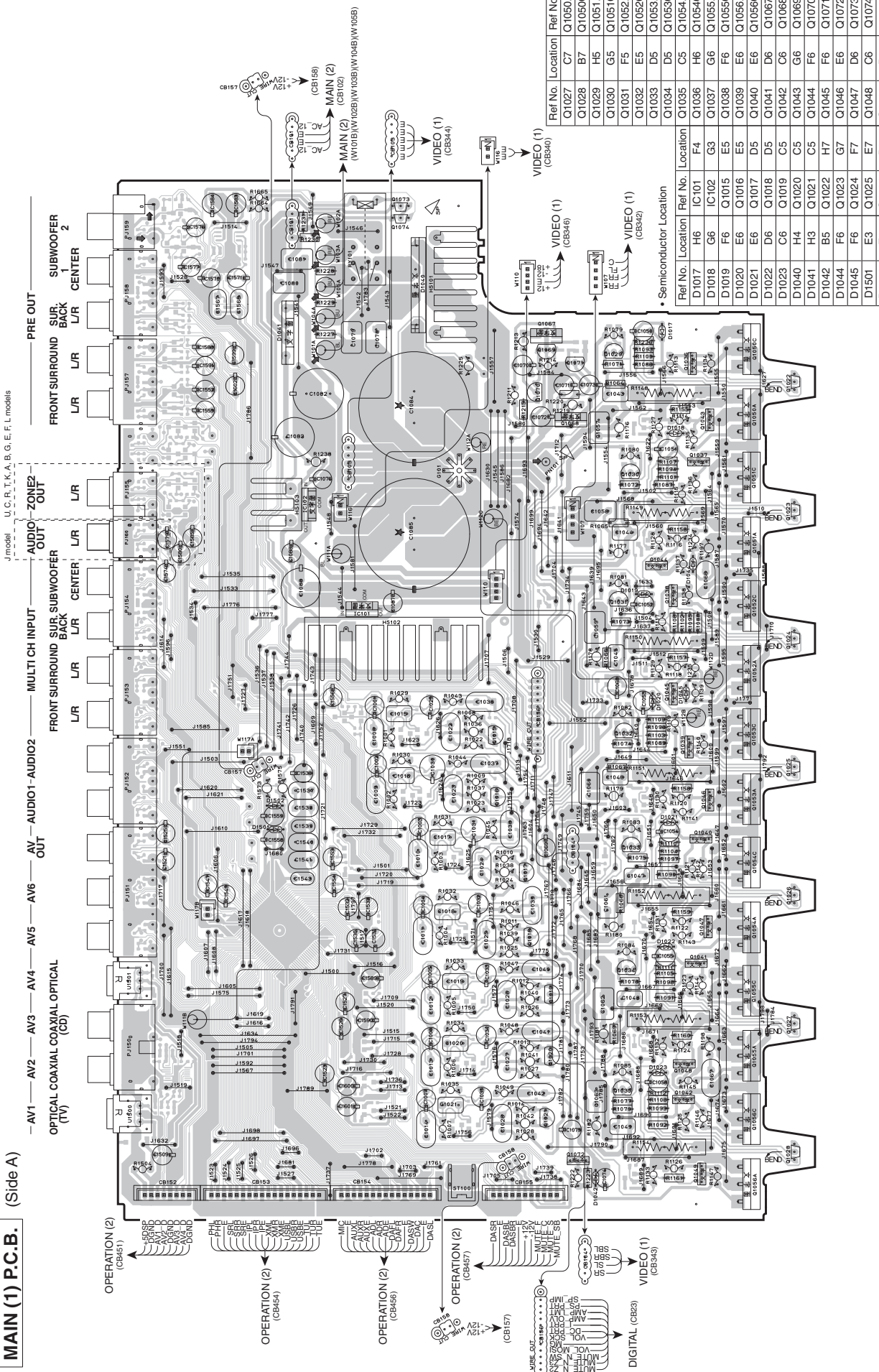

• Semiconductor Location

Ref. No.	Location	Ref. No.	Location
Q1027	C7	Q1050A	G6
Q1028	B7	Q1050C	H6
Q1029	H5	Q1051A	G6
Q1030	G5	Q1051C	G6
Q1031	F5	Q1052A	F6
Q1032	E5	Q1052C	F6
Q1033	D5	Q1053A	E6
Q1035	C5	Q1054A	D6
Q1036	H6	Q1054C	D6
Q1038	F6	Q1055A	C6
Q1039	E6	Q1056A	B6
Q1040	E6	Q1056C	C6
Q1041	D6	Q1067	H5
Q1042	C6	Q1068	G5
Q1043	G6	Q1069	H5
Q1044	F6	Q1070	H5
Q1045	F6	Q1072	B5
Q1047	D6	Q1073	I4
Q1048	C6	Q1074	I4
Q1049	B6		

MAIN (1) P.C.B. (Side B)

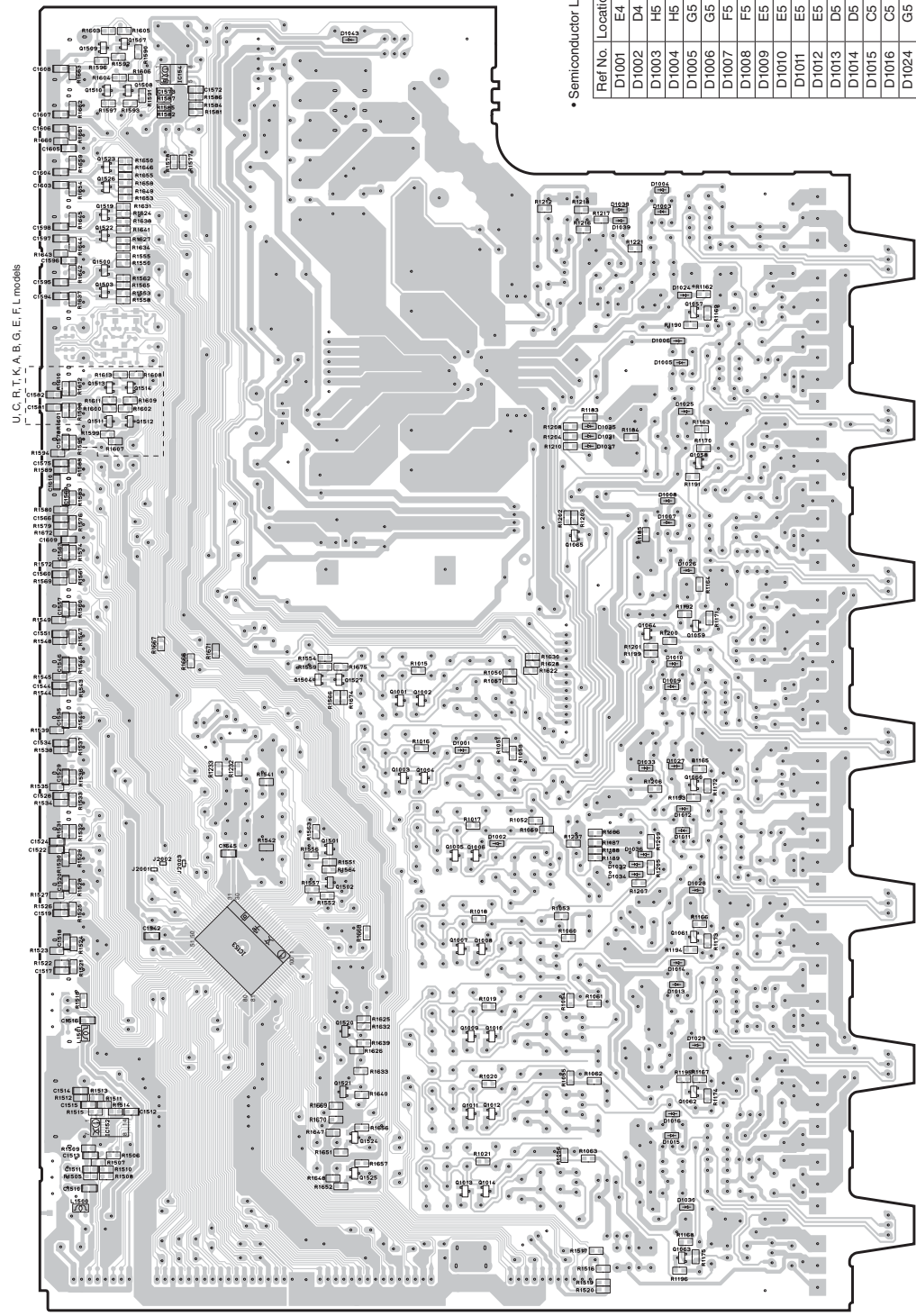

• Semiconductor Location

Ref No.	Location	Ref No.	Location
D1001	E4	D1030	C5
D1002	D4	D1031	G5
D1003	H5	D1032	D5
D1004	H5	D1033	E5
D1005	G5	D1034	D5
D1006	G5	D1035	G5
D1007	F5	D1036	D5
D1008	F5	D1037	G5
D1009	E5	D1038	H5
D1010	E5	D1039	H5
D1011	E5	D1043	I4
D1012	E5	IC152	C2
D1013	D5	IC153	D3
D1014	D5	IC154	I3
D1015	C5	Q1001	E4
D1016	C5	Q1002	E4
D1024	G5	Q1003	E4
D1025	G5	Q1004	E4
D1026	F5	Q1005	D4
D1027	E5	Q1006	D4
D1028	D6	Q1007	D4
D1029	C6	Q1008	D4
Q1009	C4	Q1065	F5
Q1010	C4	Q1500	G2
Q1011	C4	Q1501	G2
Q1012	C4	Q1502	D4
Q1013	C4	Q1503	G2
Q1014	C4	Q1504	E4
Q1057	G6	Q1507	I2
Q1058	F6	Q1508	H3
Q1059	F6	Q1509	I2
Q1060	E6	Q1510	H2
Q1061	D6	Q1511	G2
Q1062	C6	Q1512	G3
Q1063	B5	Q1513	G3
Q1064	F5	Q1514	G3

MAIN (2) P.C.B. (Side A)

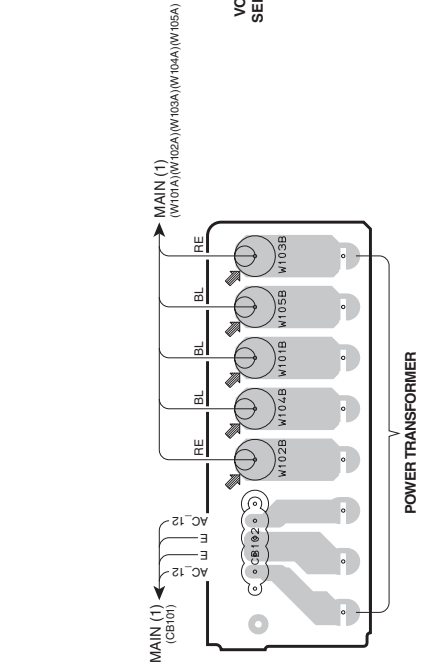

MAIN (3) P.C.B. (Side A)

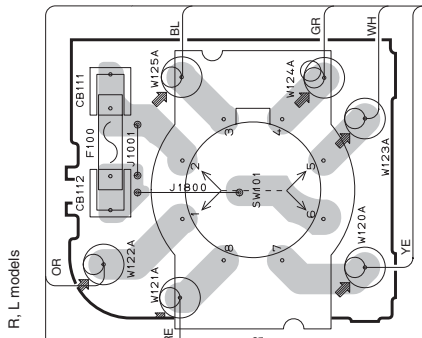

VOLTAGE SELECTOR

230V-240V	1-2/5-6
220V	2-3/6-7
110V	3-4/7-8
120V	4-5/8-1

MAIN (4) P.C.B. (Side A)

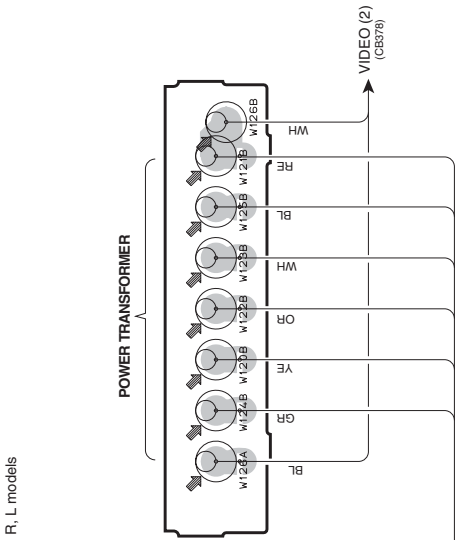

MAIN (5) P.C.B. (Side A)

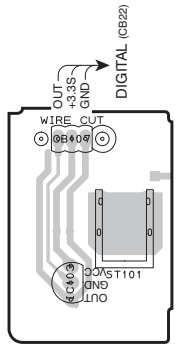

MAIN (6) P.C.B. (Side A)

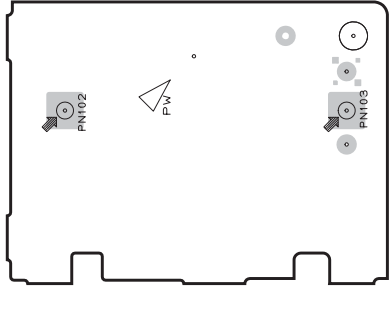

- Semiconductor Location
- | Ref No. | Location |
|---------|----------|
| IC103 | C5 |

1

MAIN (2) P.C.B. (Side B)

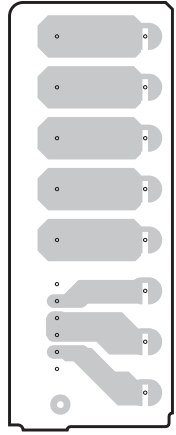

2

MAIN (3) P.C.B. (Side B)

R, L models

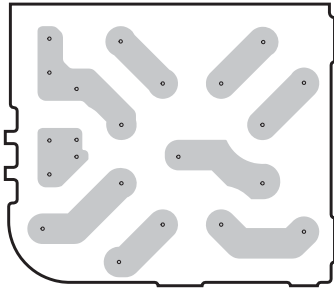

3

MAIN (4) P.C.B.

R, L models

(Side B)

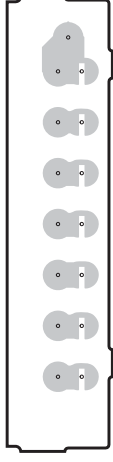

4

MAIN (5) P.C.B. (Side B)

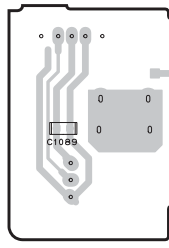

5

MAIN (6) P.C.B. (Side B)

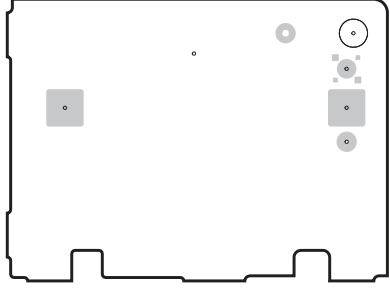

6

7

VIDEO (1) P.C.B. (Side A)

SPEAKERS

R FRONT L CENTER R SURROUND L R SURROUND BACK/ L
 +/- +/- +/- +/- +/- +/-

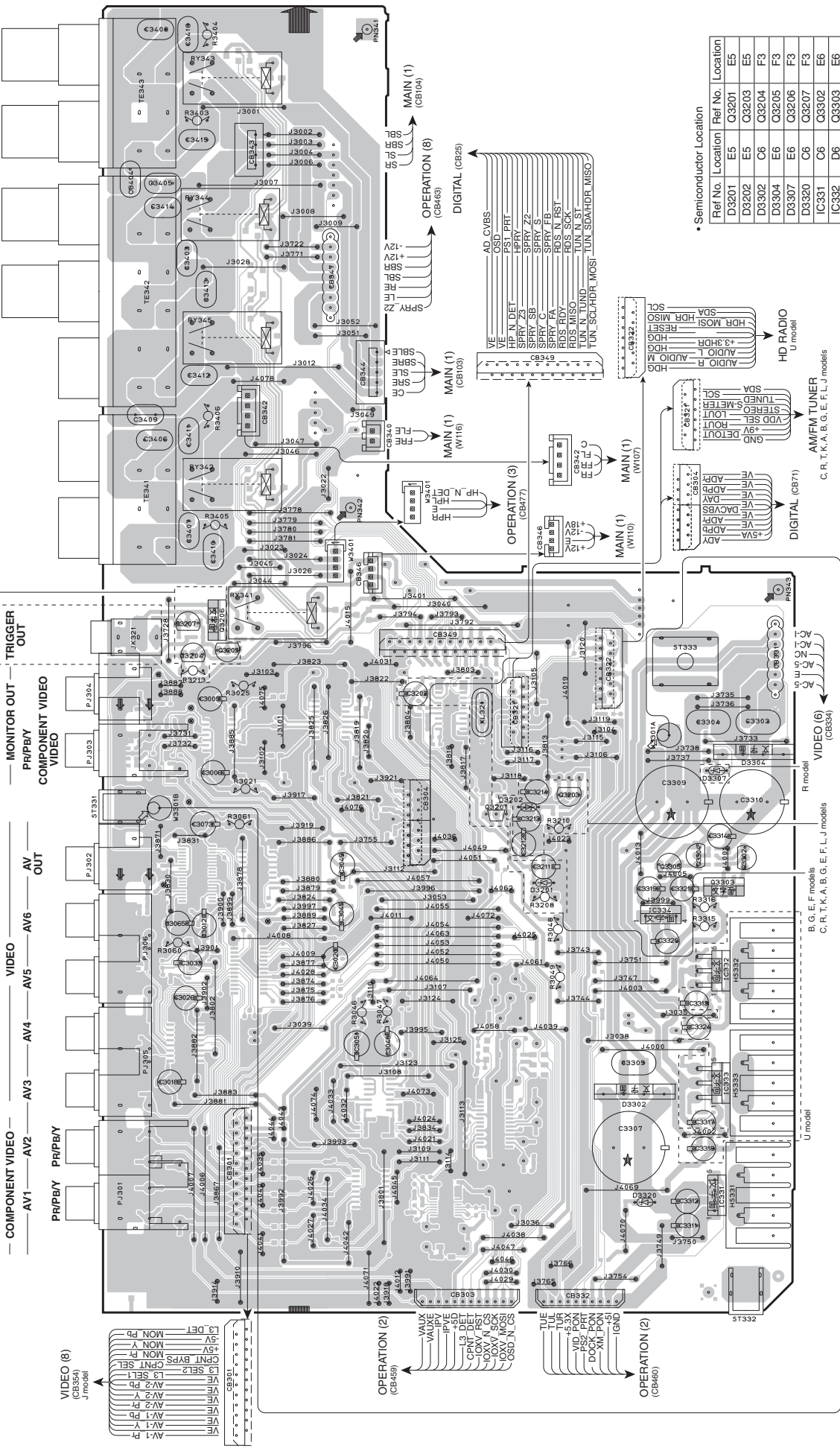

Semiconductor Location

Ref No.	Location	Ref No.	Location
D3201	E5	Q3201	E5
D3202	E5	Q3203	E5
D3302	C6	Q3204	F3
D3304	E6	Q3205	F3
D3307	E6	Q3206	F3
D3320	C6	Q3207	F3
IC331	C6	Q3302	E6
IC332	D6	Q3303	E6
IC333	C6	Q3304	E6
IC334	D6	Q3305	E6

C.R.T.K.A.B.G.E.F.L.J models

B.G.E.F models
 C.R.T.K.A.B.G.E.F.L.J models

U model

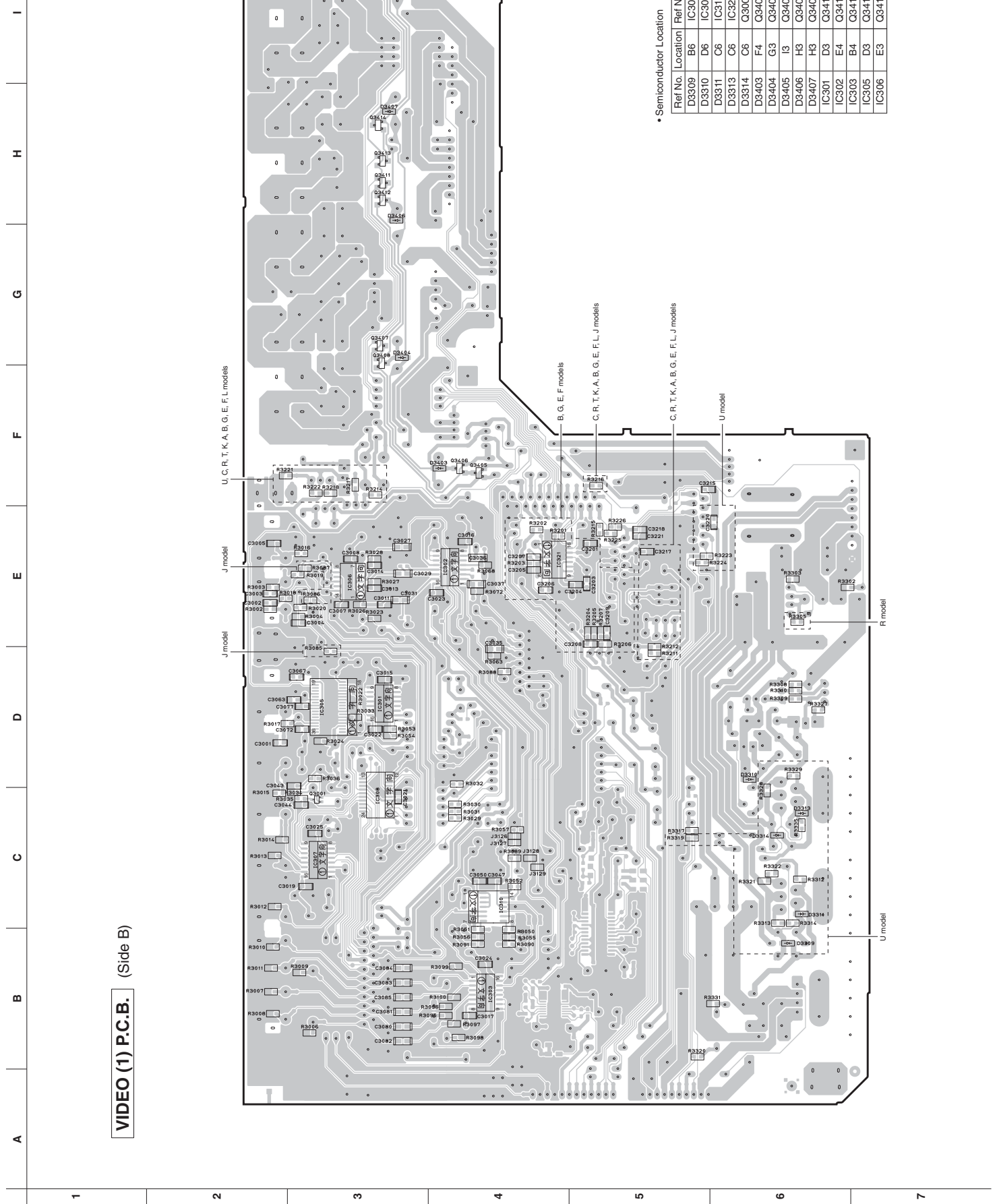

• Semiconductor Location

Ref No.	Location	Ref No.	Location
D3309	B6	IC307	C3
D3310	D6	IC308	C3
D3311	C6	IC310	C4
D3313	C6	IC321	E4
D3314	C6	Q3001	C3
D3403	F4	Q3405	F4
D3405	I3	Q3407	G3
D3406	H3	Q3408	G3
D3407	H3	Q3409	I3
IC301	D3	Q3410	I3
IC302	E4	Q3411	H3
IC303	B4	Q3412	H3
IC305	D3	Q3413	H3
IC306	E3	Q3414	H3

VIDEO (2) P.C.B. (Side A)

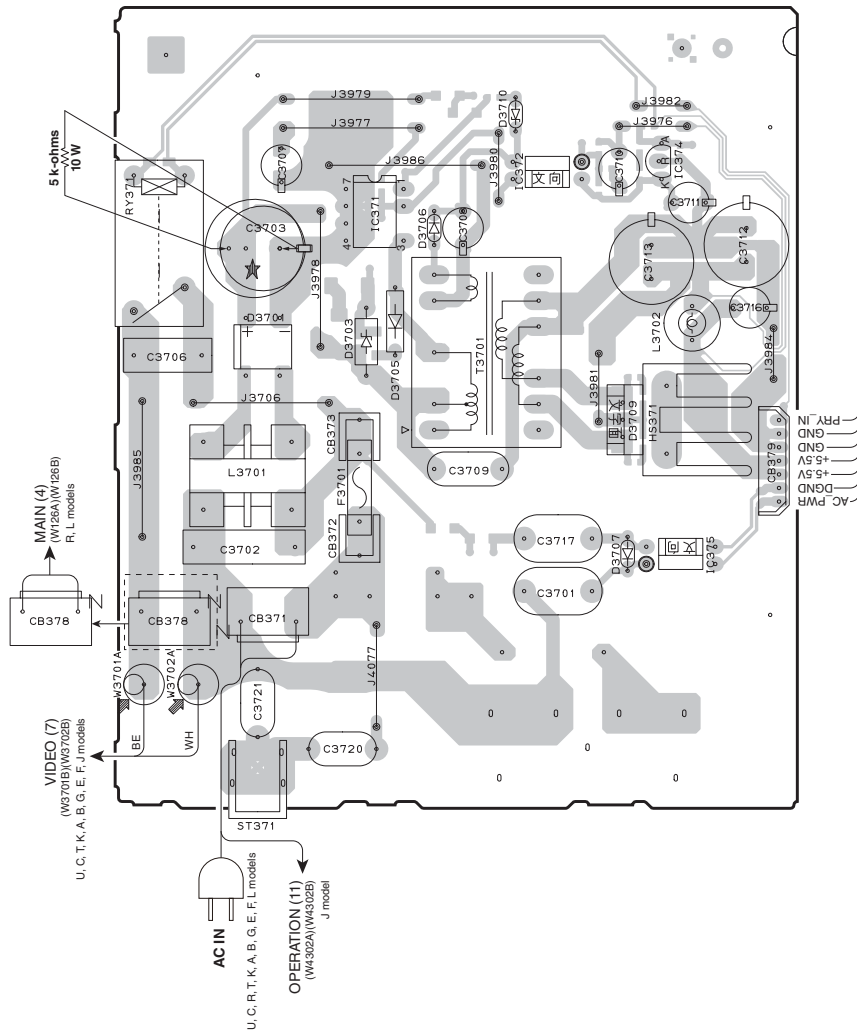

VIDEO (3) P.C.B. (Side A)

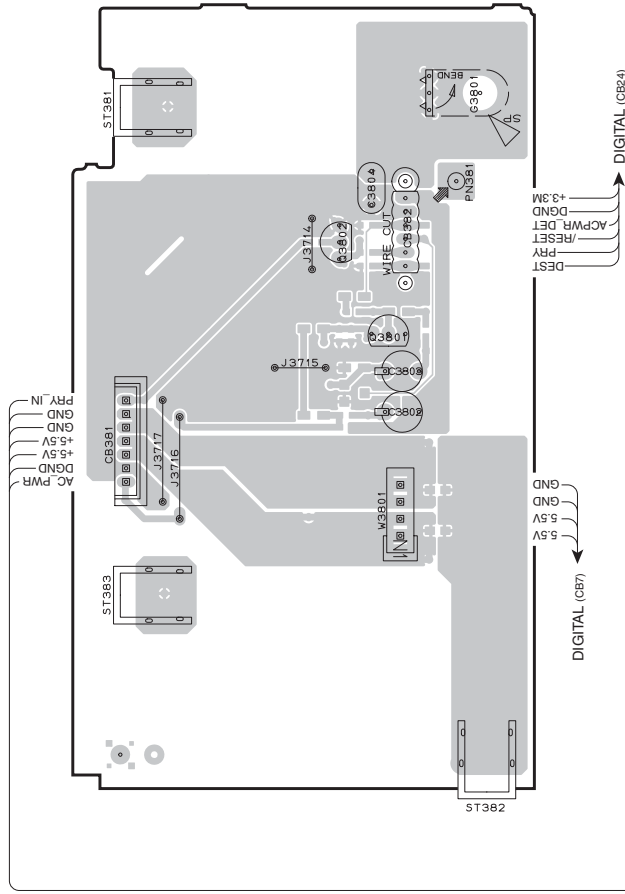

• Semiconductor Location

Ref No.	Location	Ref No.	Location	Ref No.	Location
D3701	D3	D3709	D4	IC374	E5
D3703	D3	D3710	E4	IC375	C5
D3705	D3	IC371	E3	Q3801	I4
D3706	E4	IC372	E4	Q3802	I4
D3707	C4				

Notes

Safety measures

- Some internal parts in this product contain high voltages and are dangerous. Be sure to take safety measures during servicing, such as wearing insulating gloves.
- Note that positions indicated below are dangerous even after the power is turned off because an electric charge remains and a high voltage continues to exist there. Before starting any repair work, perform discharge by connecting a discharge resistor (5k-ohms/10W) between terminals at following positions. The time required for discharging is about 30 seconds.
C3703 on VIDEO (2) P.C.B.

注意)

安全対策

- この製品の内部には高電圧部分があり危険です。修理の際は、絶縁性の手袋を使用するなどの安全対策を行ってください。下記箇所には電源を OFF にした後も電荷が残り、高電圧が維持されており危険です。修理作業前に放電用抵抗 (5kΩ/10W) を下記箇所の端子間に接続して放電してください。放電所要時間は約 30 秒間です。
VIDEO (2) P.C.B. の C3703

VIDEO (2) P.C.B. (Side B)

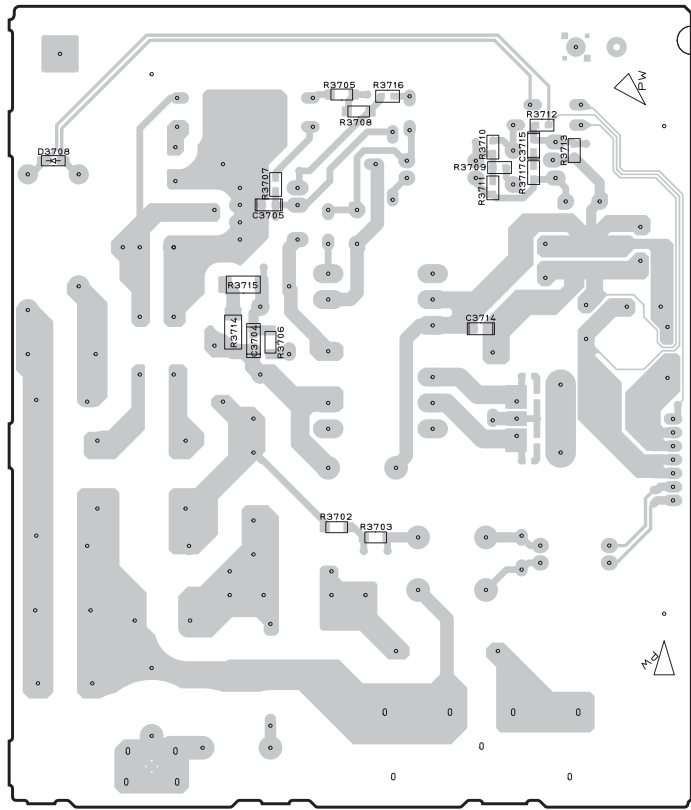

VIDEO (3) P.C.B. (Side B)

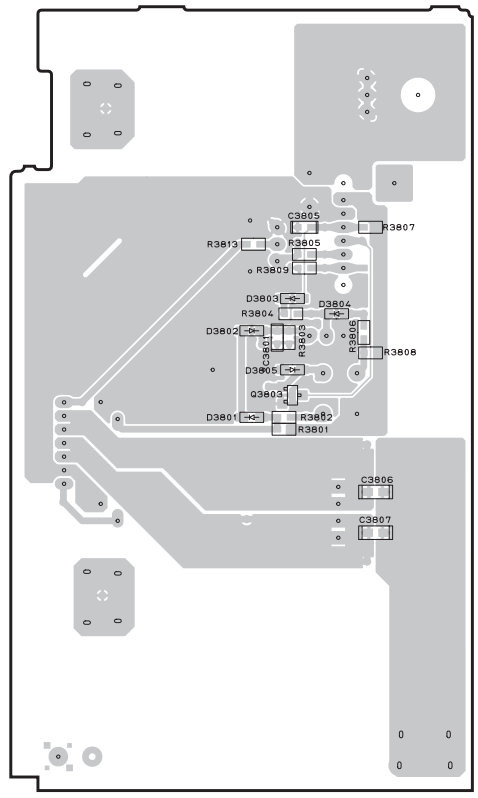

• Semiconductor Location

Ref No.	Location
D3708	D2
D3801	H4
D3802	H4
D3803	H4
D3804	H4
D3805	H4
Q3803	H4

VIDEO (4) P.C.B. (Side A)

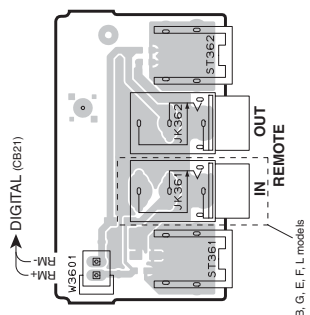

U.C.T,K,A,B,G,E,F,L models

VIDEO (6) P.C.B. (Side A)

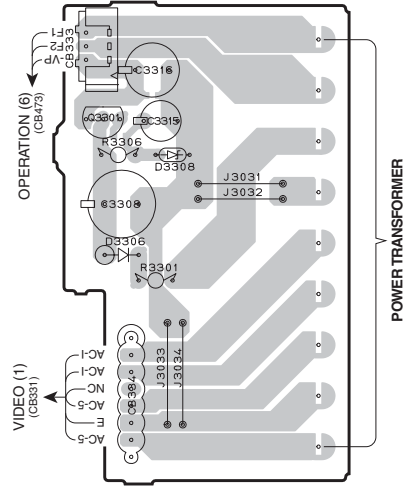

VIDEO (7) P.C.B. (Side A)

U, C, T, K, A, B, G, E, F, J models

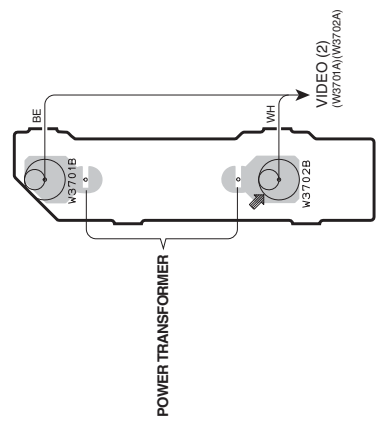

VIDEO (8) P.C.B. (Side A)

J model

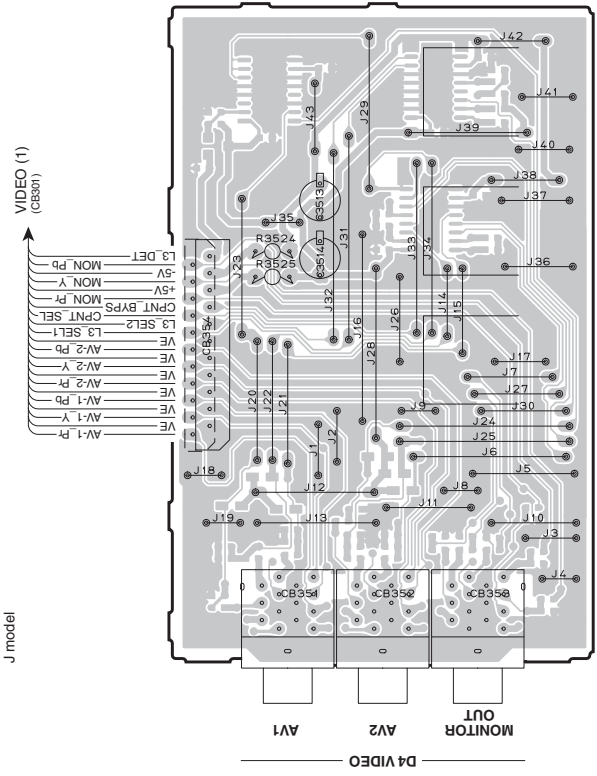

VIDEO (9) P.C.B. (Side A)

B, G, E, F models

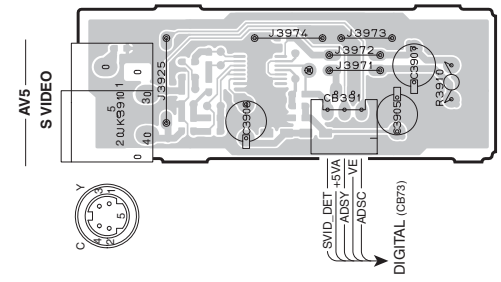

• Semiconductor Location

Ref No.	Location
D3306	E3
D3308	F3
Q3301	F3

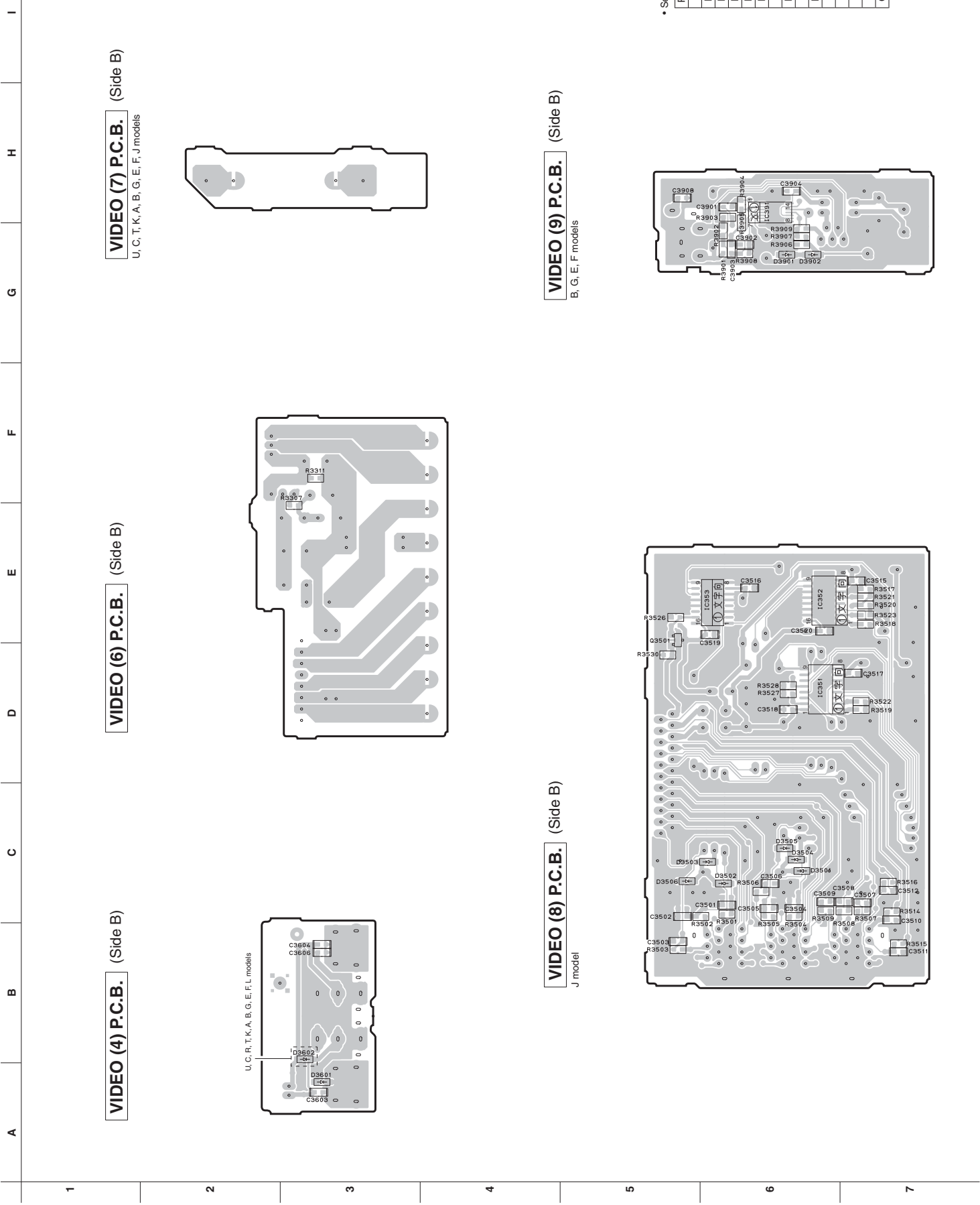

VIDEO (4) P.C.B. (Side B)

VIDEO (6) P.C.B. (Side B)

VIDEO (7) P.C.B. (Side B)

U, C, T, K, A, B, G, E, F, J models

U, C, R, T, K, A, B, G, E, F, L models

VIDEO (8) P.C.B. (Side B)

J model

VIDEO (9) P.C.B. (Side B)

B, G, E, F models

• Semiconductor Location

Ref No.	Location
D3501	C6
D3502	C6
D3503	C6
D3504	C6
D3505	C6
D3506	C5
D3601	A3
D3602	B3
D3901	G6
D3902	G6
IC351	D6
IC352	E6
IC391	H6
Q3501	E5

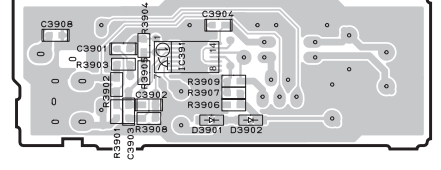
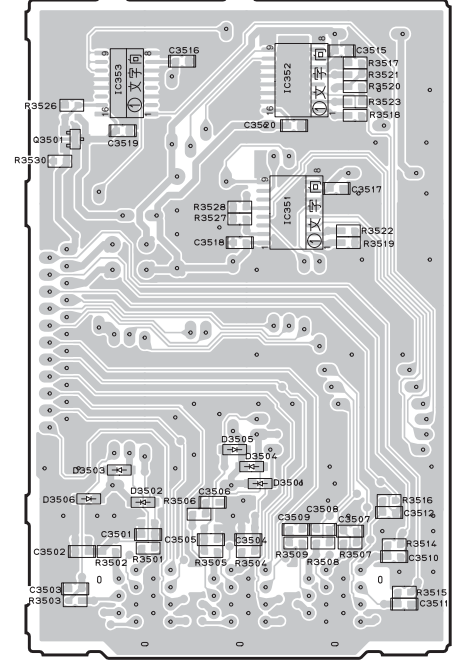

GUI P.C.B. (Side A)

No replacement part available.
 交換部品供給なし

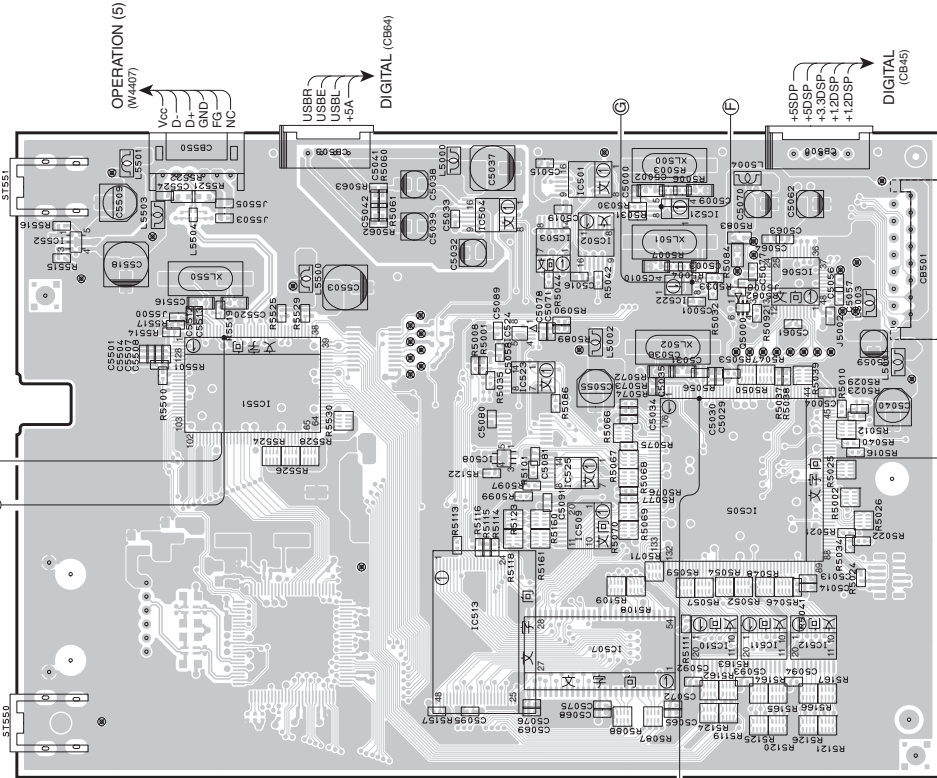

No replacement part available.
 交換部品供給なし

- SCPU N_RST
- SCPU N_SS
- SCPU SCK
- SCPU RST
- SCPU MISO_BF
- IPU MOSI_BF
- SCPU MISO_BF
- SCPU MISO_RST
- DVID N_RST
- HDMI_SCL
- HDMI_SDA
- VE GUI_CVBS_SV
- VE GUI_SC

DIGITAL (CB28)

POINT ㊦ XL500 (Pin 6 of IC521)

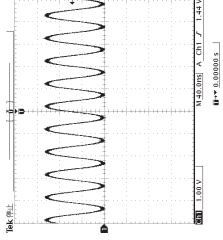

POINT ㊧ XL501 (Pin 6 of IC522)

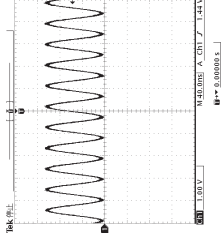

POINT ㊨ XL502 (Pin 10 of IC505)

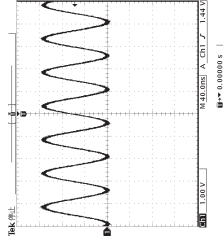

POINT ㊩ XL550 (Pin 11 of IC551)

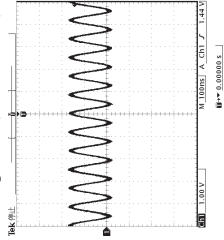

GUI P.C.B. (Side B)

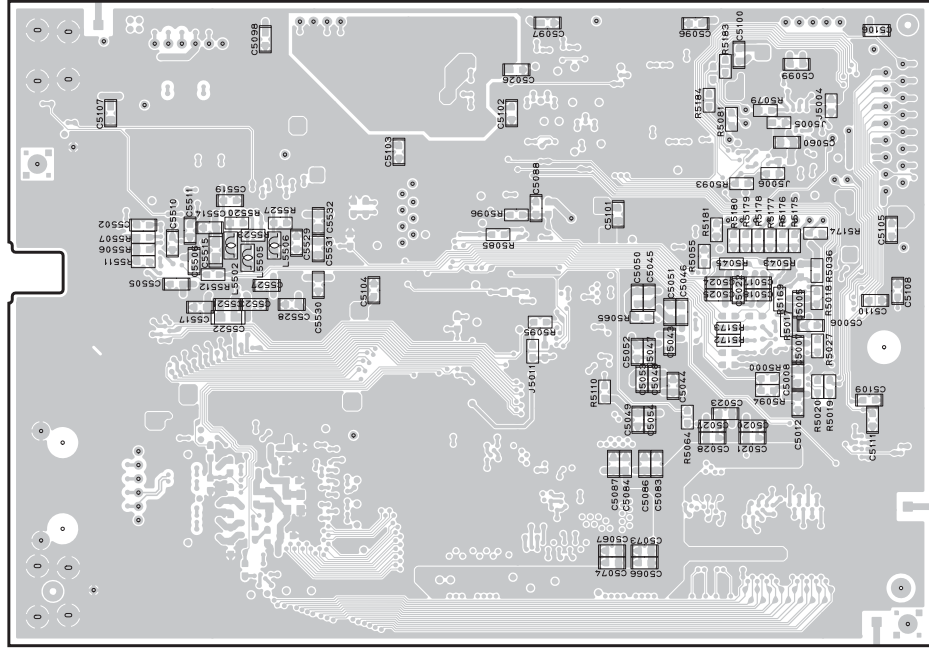

• Semiconductor Location

Ref No.	Location	Ref No.	Location	Ref No.	Location
IC501	D4	IC508	C4	IC522	D5
IC502	D4	IC509	C4	IC523	C4
IC503	D4	IC510	B5	IC524	D4
IC504	D4	IC511	B5	IC525	C4
IC505	C5	IC512	B5	IC526	D2
IC506	D5	IC513	B4	IC551	C3
IC507	B4	IC521	D5	Q5000	D5

SCHEMATIC DIAGRAMS
DIGITAL 1/5

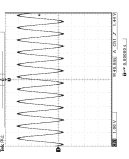
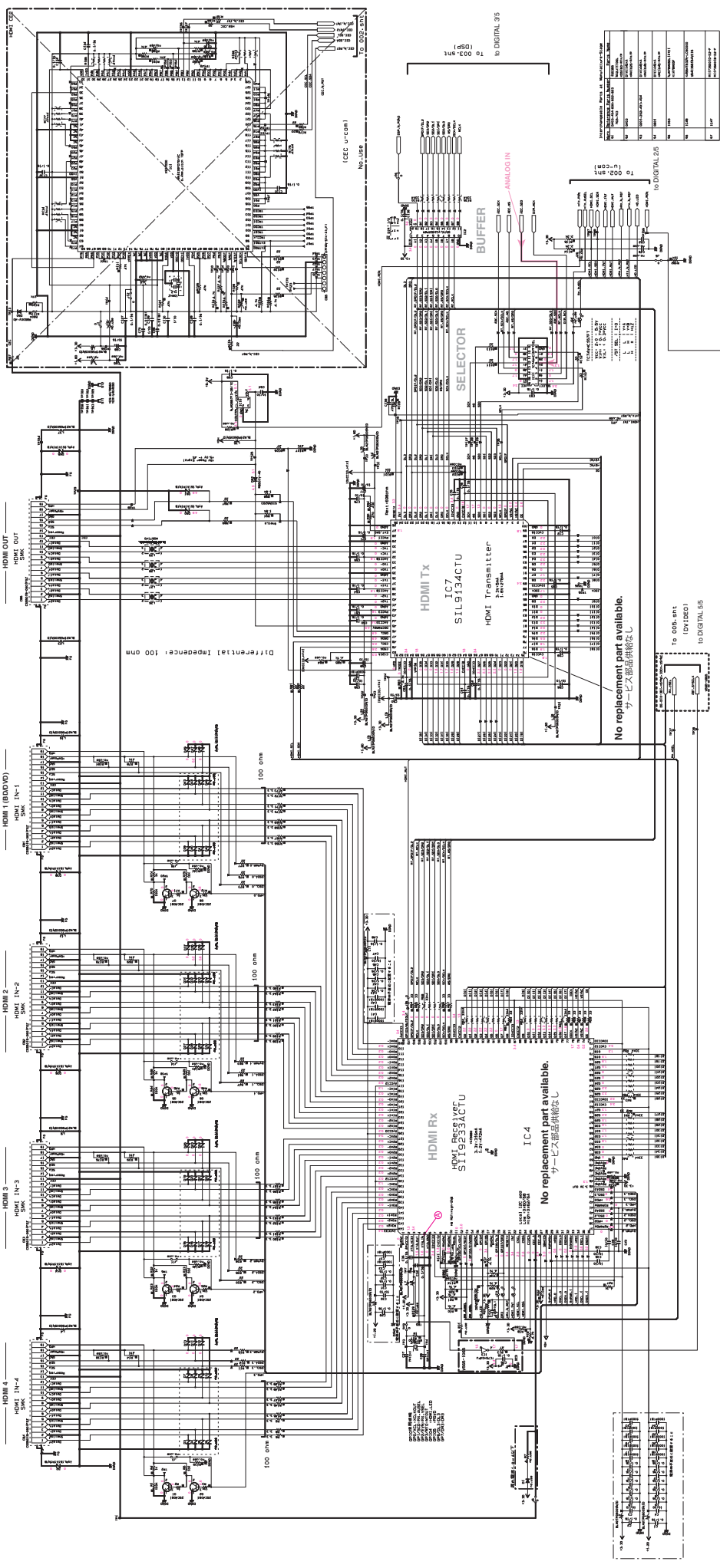

Page 130 [LB]
to VIDEO (3), VCR01

IC	Part No.	Quantity	Remarks
IC1	SI19233ACTU	1	HDMI Receiver
IC2	SN74VHC24PWR	1	3-bit serial output
IC3	TC7SH4P1TEBL	1	3-state inverter
IC4	SI19233ACTU	1	HDMI transmitter
IC5	BD0932EF-1E2	1	1.0A step-down DCDC converter
IC6	RT17251D1-E2F	1	Voltage regulator
IC7	SIL9134CTU	1	HDMI transmitter
IC8	BD0932EF-1E2	1	1.0A step-down DCDC converter
IC9	RT17251D1-E2F	1	Voltage regulator
IC10	TC7SH4P1TEBL	1	3-state inverter
IC11	TC7AH6153FT	1	Quad 2-channel multiplexer
IC12	RT17251D1-E2F	1	Voltage regulator

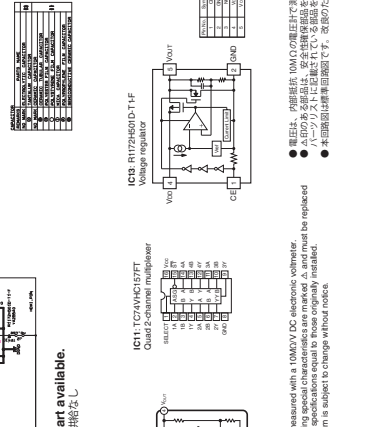
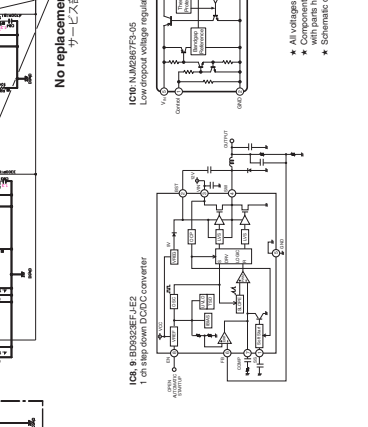
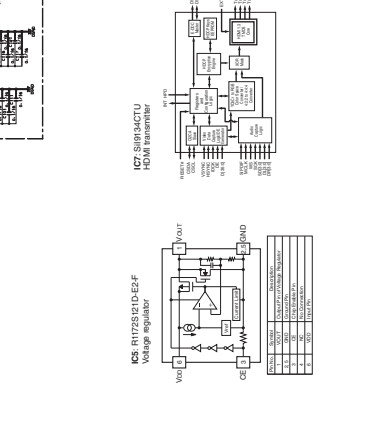
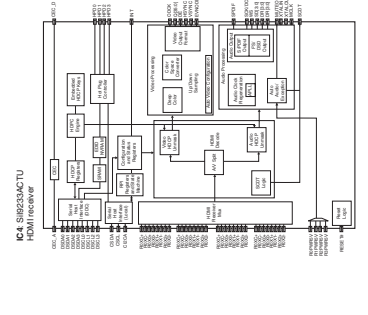
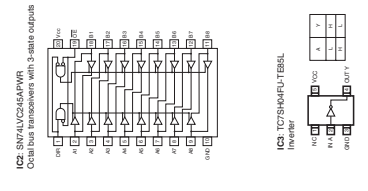

No replacement part available.
交換不能部品

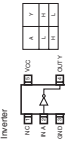

- All voltages are measured with a 10MΩV DC electronic voltmeter.
- Components having special characteristics are marked Δ and must be replaced with components having the same characteristics when replaced.
- Schematic diagrams are subject to change without notice.
- 電圧は、10MΩV DC電圧計で測定したものです。
- △印のある部品は、特殊な特性を示しています。部品の交換が必要の場合は、同様の特性を示す部品と交換する必要があります。
- 本図面は仕様変更なく変更することがあります。

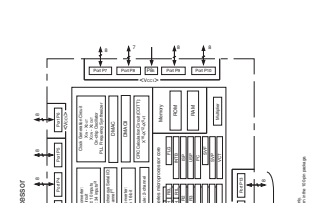
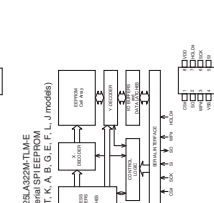
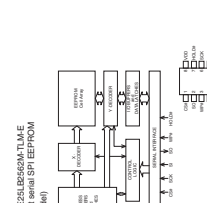
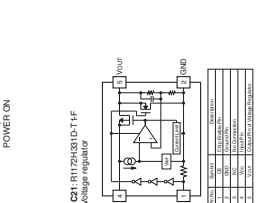
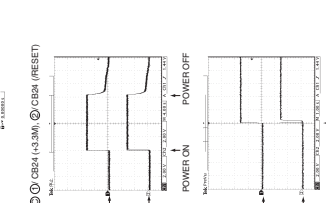
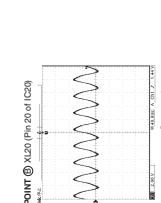

Table with 2 columns: Pin No. and Signal Name. Lists pins 1 through 100 and their corresponding signals.

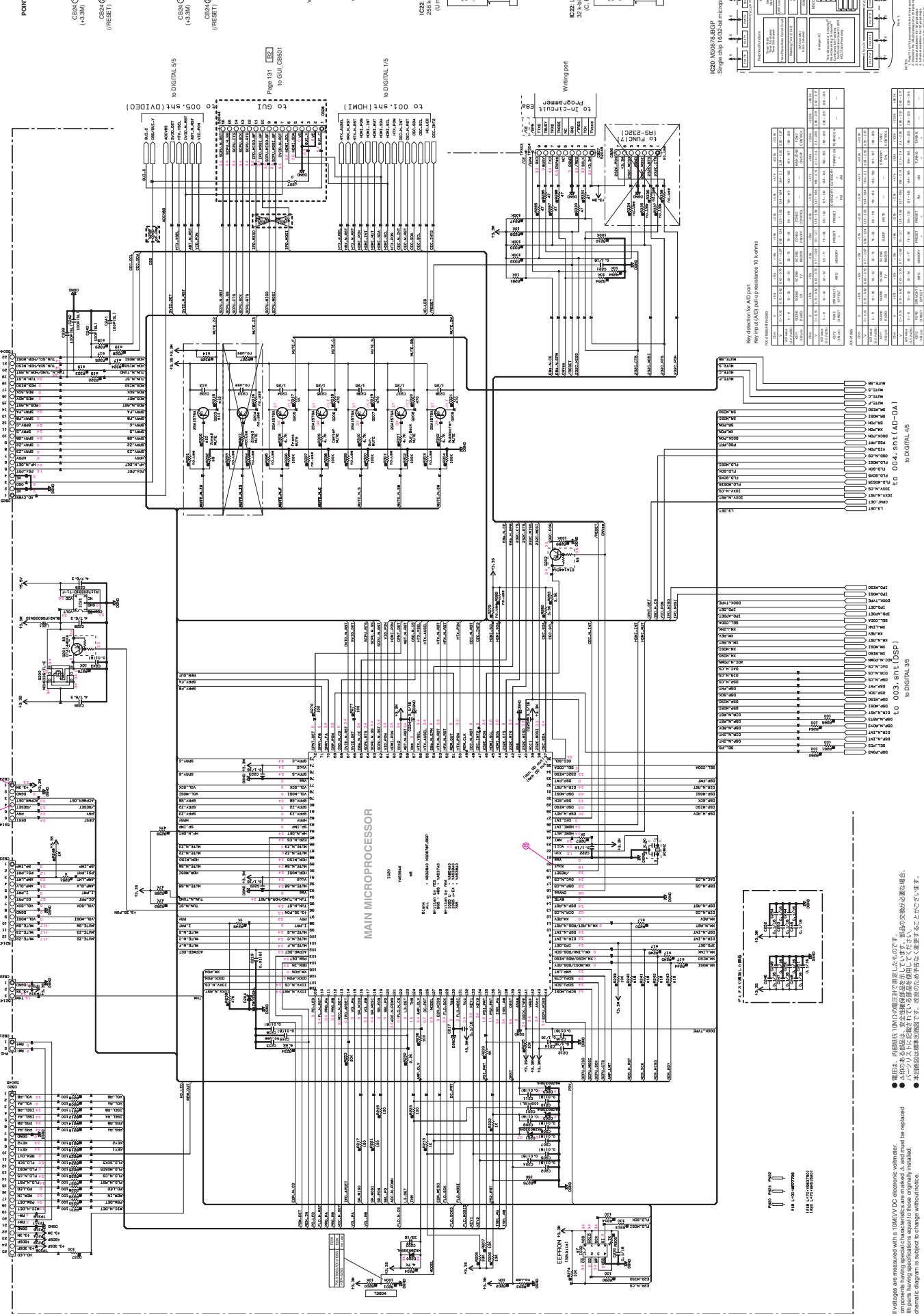

Table with 2 columns: Pin No. and Signal Name. Lists pins 101 through 200 and their corresponding signals.

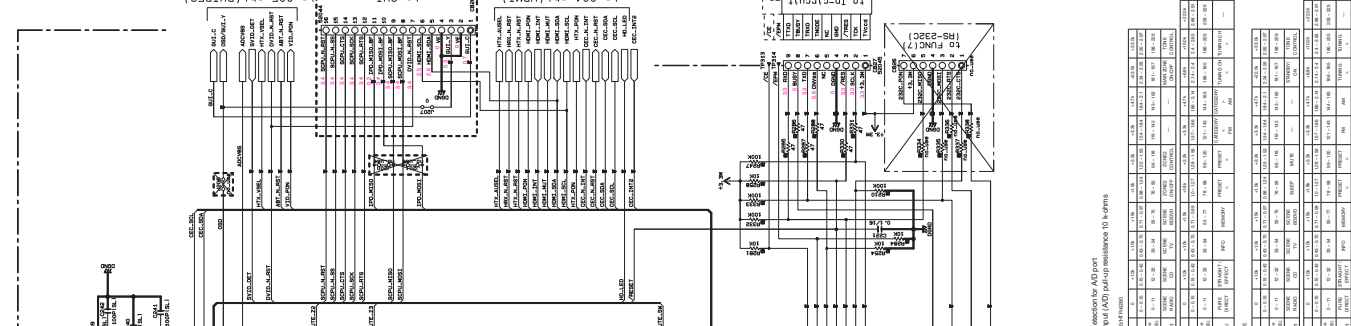

Table with 2 columns: Pin No. and Signal Name. Lists pins 201 through 300 and their corresponding signals.

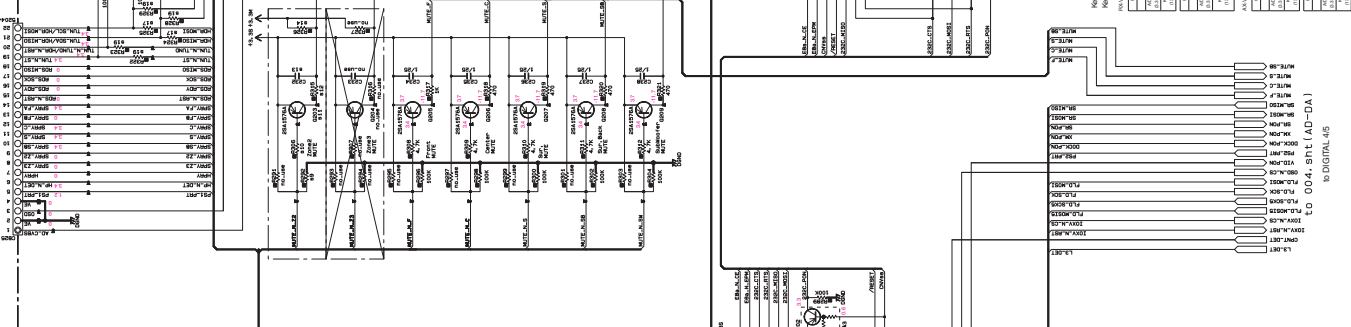

Table with 2 columns: Pin No. and Signal Name. Lists pins 301 through 400 and their corresponding signals.

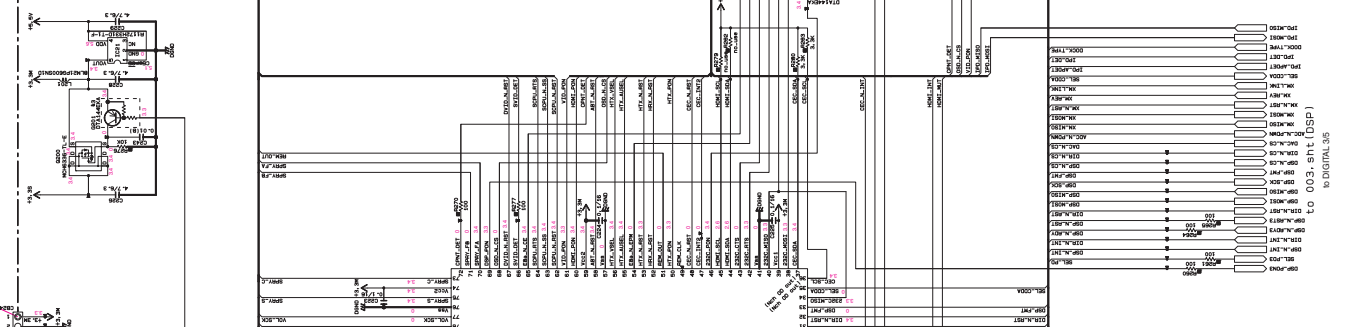

Table with 2 columns: Pin No. and Signal Name. Lists pins 401 through 500 and their corresponding signals.



Table with 2 columns: Pin No. and Signal Name. Lists pins 501 through 600 and their corresponding signals.

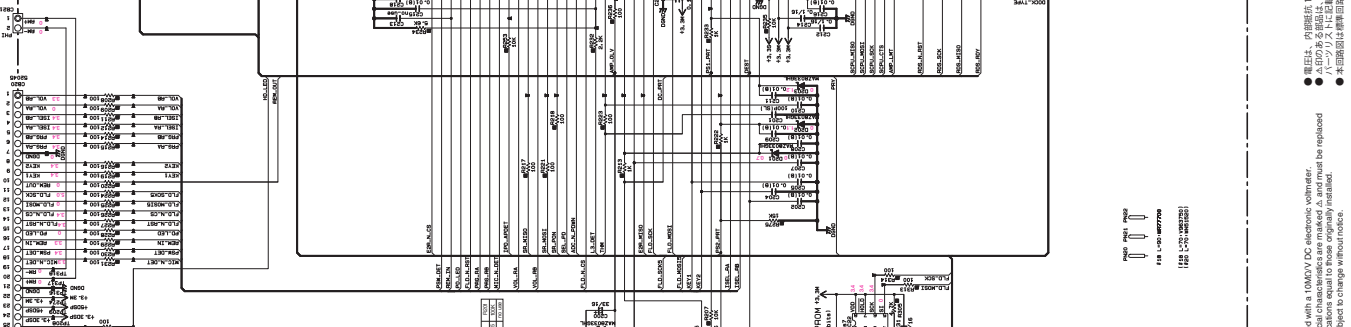
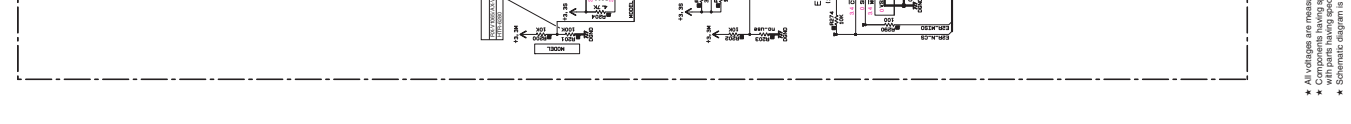
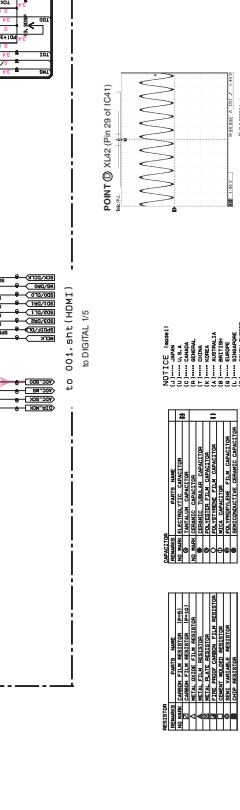
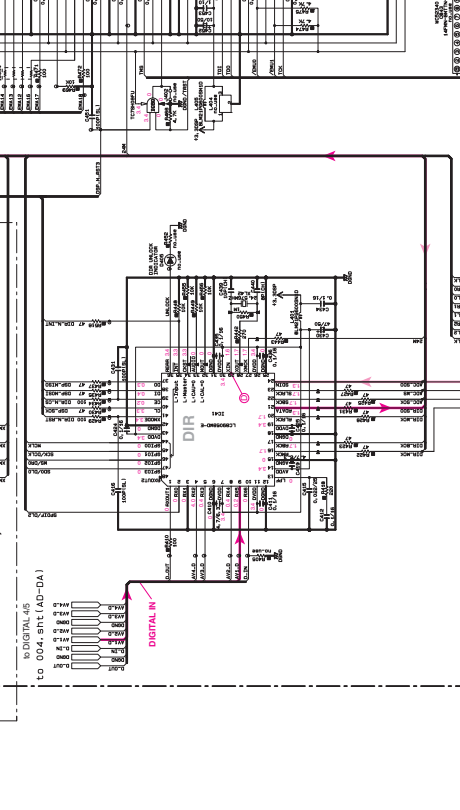
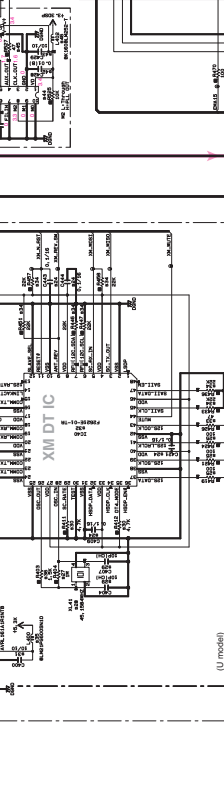
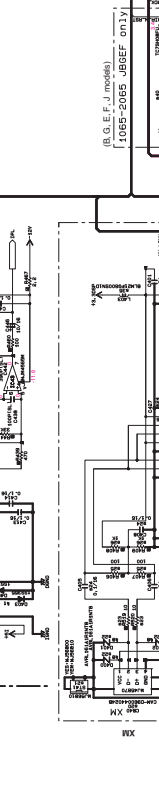
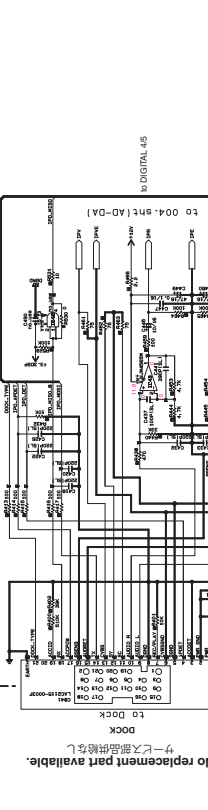
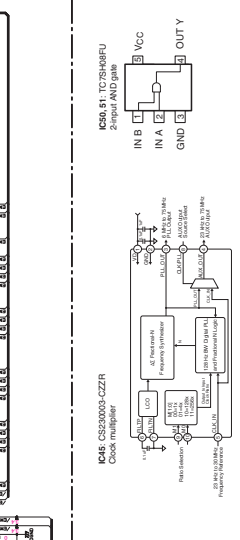
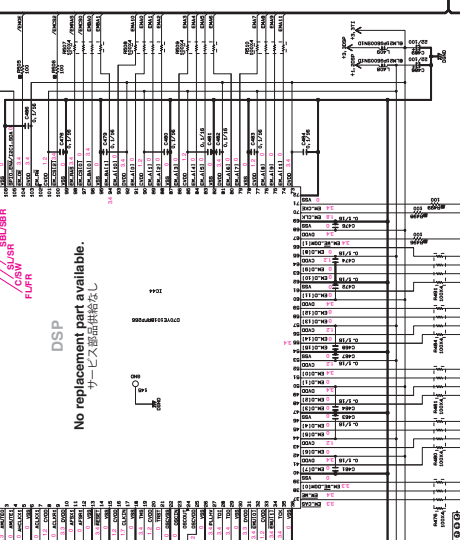
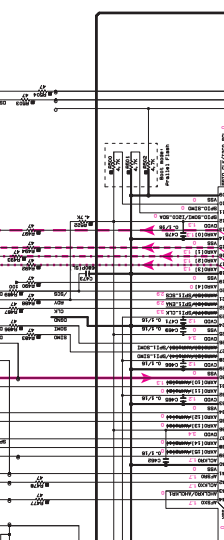
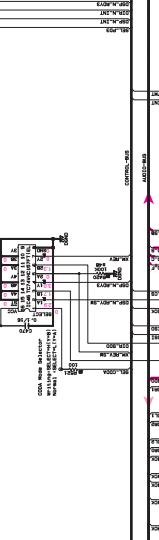
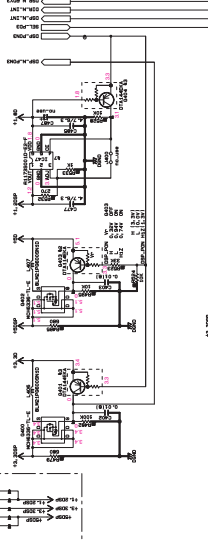
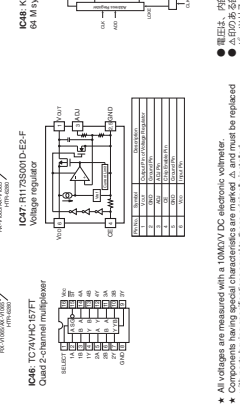
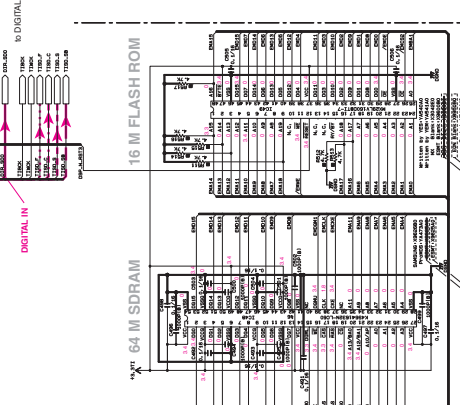
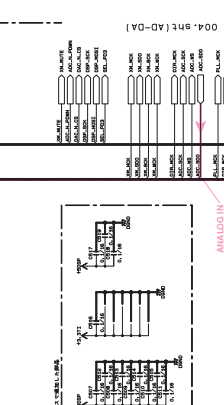
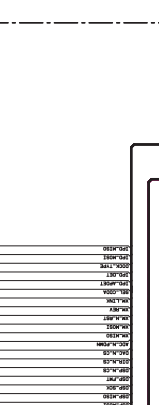
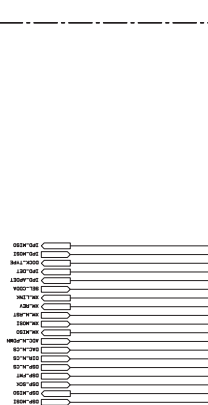
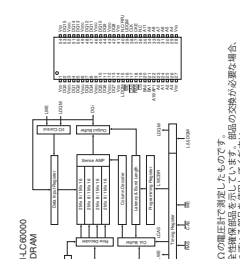
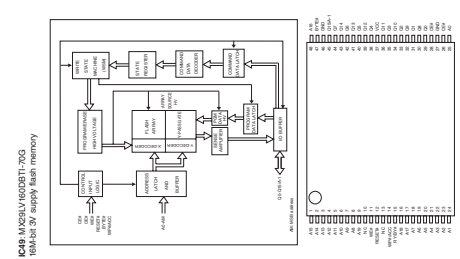
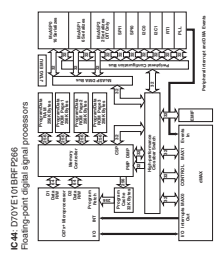
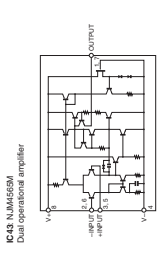
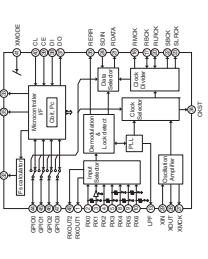
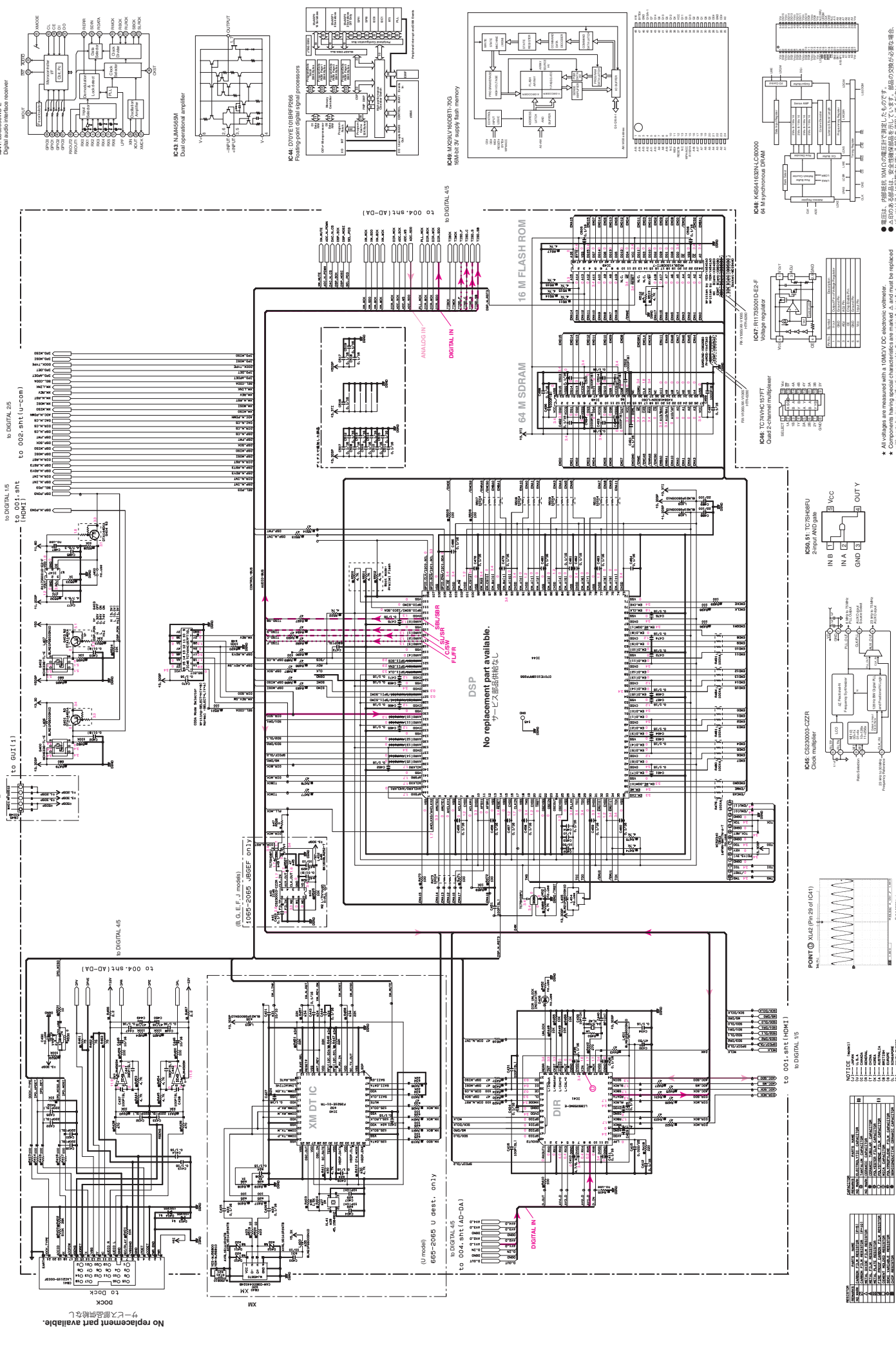

Table with 2 columns: Pin No. and Signal Name. Lists pins 601 through 700 and their corresponding signals.



All voltages are measured with a 10MΩ DC electronic voltmeter.
 Components having special characteristics are marked A, and must be replaced with components having special characteristics.
 Schematic diagram is subject to change without notice.



All voltages are measured with a 10MΩV DC electronic voltmeter.
 Components having special characteristics are marked A, and must be replaced with the same type.
 Schematic diagrams are subject to change without notice.

Page 130
to VIDEO (9), (23)91
(S, G, E, F, middle)

Page 128
to VIDEO (1), (2)300

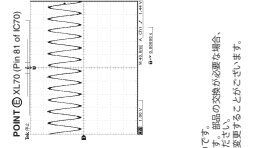
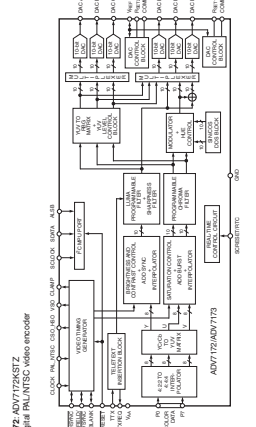
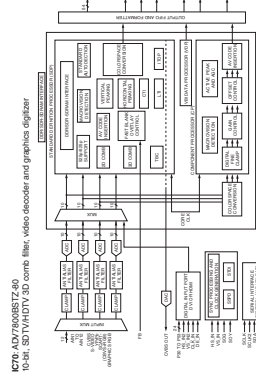
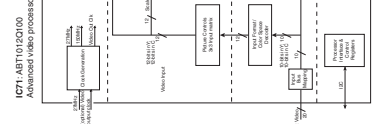
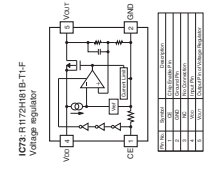
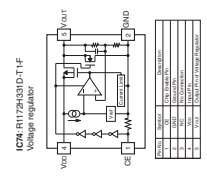
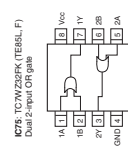
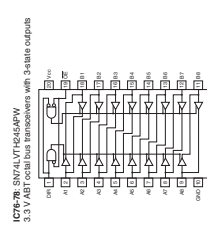
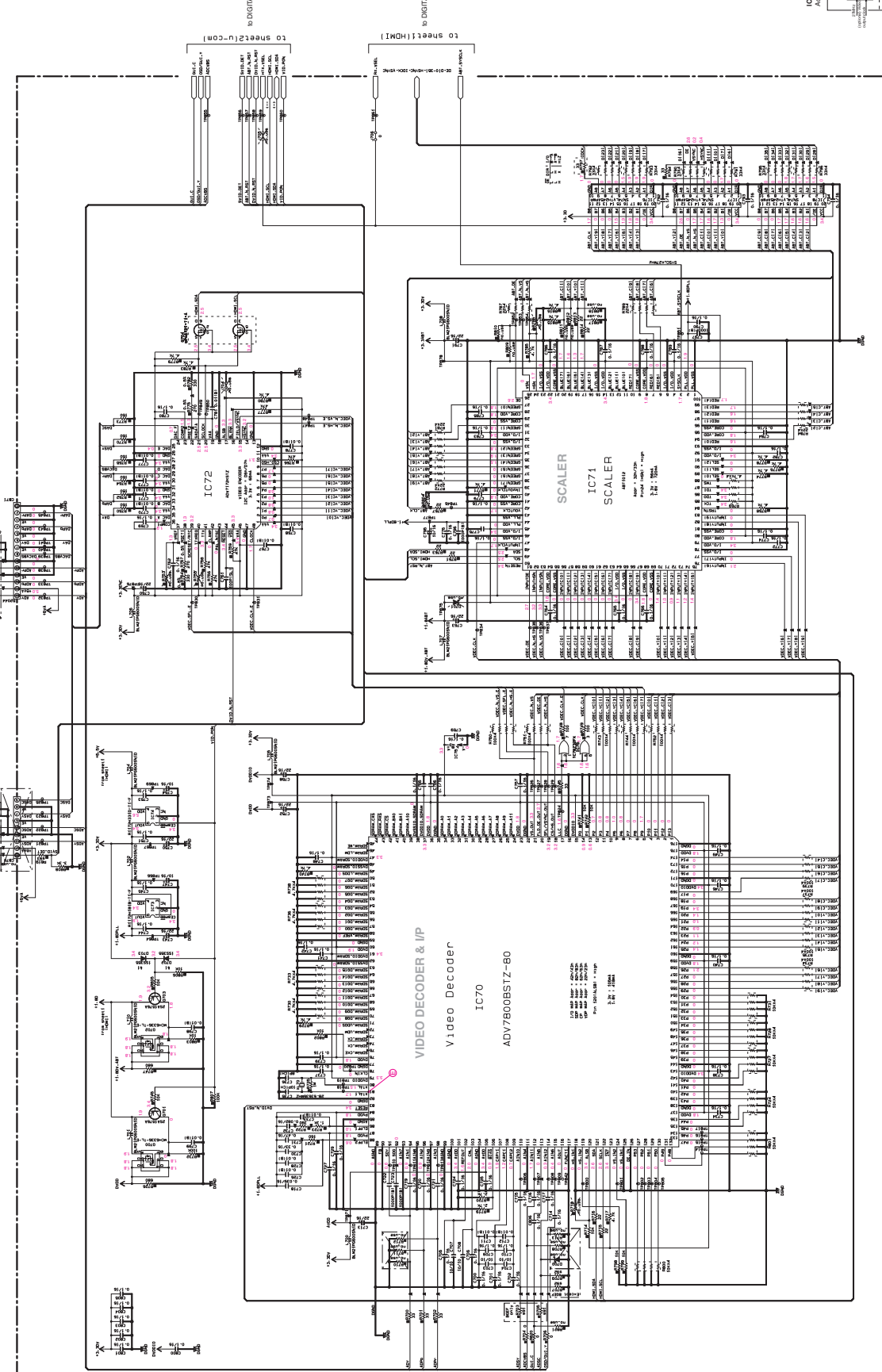

NOTICE (重要事項)
● 電圧は、内部規格 (D/C) の値で保証したものです。
● A印のある部品は、安全検査結果を示しています。部品の交換が必要なく、
● A印のない部品は、安全検査結果を示していません。部品の交換が必要なく、
● A印のない部品は、安全検査結果を示していません。部品の交換が必要なく、

DIGITAL (5)

REVISION	DATE	NAME
1	2004.11.18	Y. KAWANO
2	2005.03.10	Y. KAWANO
3	2005.03.10	Y. KAWANO
4	2005.03.10	Y. KAWANO
5	2005.03.10	Y. KAWANO
6	2005.03.10	Y. KAWANO
7	2005.03.10	Y. KAWANO
8	2005.03.10	Y. KAWANO
9	2005.03.10	Y. KAWANO
10	2005.03.10	Y. KAWANO

* All voltages are measured with a 10kΩV DC electronic voltmeter.
* Components having special characteristics are marked A, and must be replaced with the same type.
* Schematic diagram is subject to change without notice.

OPERATION 1/2

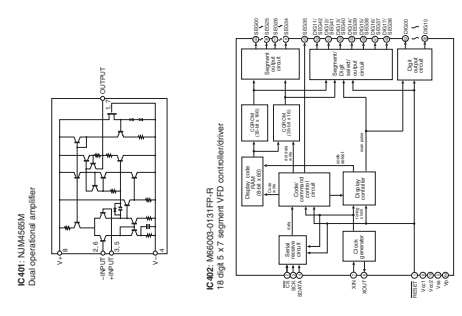
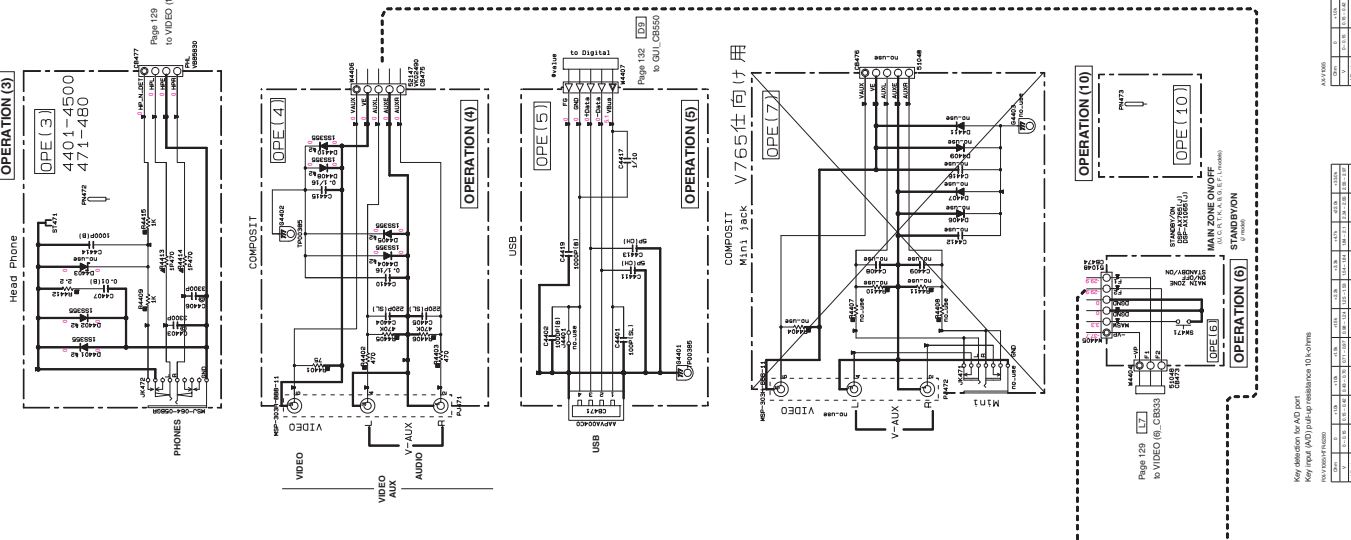
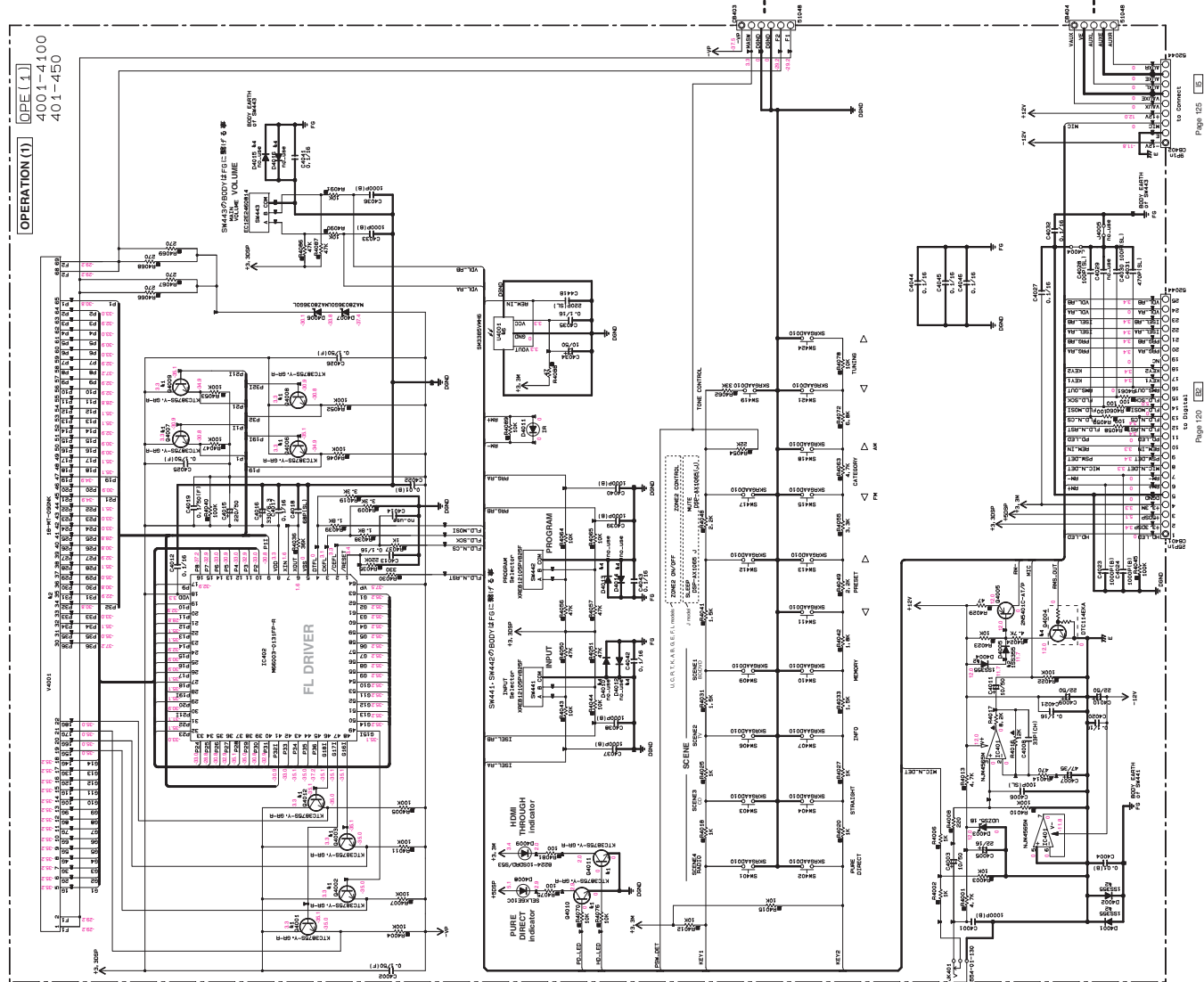

Interchangeable Parts at Manufacture Stage

MARK	REFERENCE DESIGN NUMBER	PART NAME	MANUFACTURE
1	4001-4100	RESISTOR	DAIICHI ELECTRONIC
2	4001-4100	RESISTOR	DAIICHI ELECTRONIC
3	4001-4100	RESISTOR	DAIICHI ELECTRONIC
4	4001-4100	RESISTOR	DAIICHI ELECTRONIC

RESISTOR

MARK	REFERENCE DESIGN NUMBER	PART NAME	MANUFACTURE
1	4001-4100	RESISTOR	DAIICHI ELECTRONIC
2	4001-4100	RESISTOR	DAIICHI ELECTRONIC
3	4001-4100	RESISTOR	DAIICHI ELECTRONIC
4	4001-4100	RESISTOR	DAIICHI ELECTRONIC

NOTICE (Items 1)

MARK	REFERENCE DESIGN NUMBER	PART NAME	MANUFACTURE
1	4001-4100	RESISTOR	DAIICHI ELECTRONIC
2	4001-4100	RESISTOR	DAIICHI ELECTRONIC
3	4001-4100	RESISTOR	DAIICHI ELECTRONIC
4	4001-4100	RESISTOR	DAIICHI ELECTRONIC

Key: (U) U.S.A., (J) JAPAN, (K) KOREA, (L) LATIN AMERICA, (M) MEXICO, (N) NETHERLANDS, (O) OTHER, (P) POLAND, (Q) PORTUGAL, (R) ROMANIA, (S) SOUTH AFRICA, (T) TAIWAN, (U) U.S.A., (V) VIETNAM, (W) WEST GERMANY, (X) XINJIANG, (Y) YUKON, (Z) ZAMBIA.

MARK	REFERENCE DESIGN NUMBER	PART NAME	MANUFACTURE
1	4001-4100	RESISTOR	DAIICHI ELECTRONIC
2	4001-4100	RESISTOR	DAIICHI ELECTRONIC
3	4001-4100	RESISTOR	DAIICHI ELECTRONIC
4	4001-4100	RESISTOR	DAIICHI ELECTRONIC

All voltages are measured with a 10MΩV DC electronic voltmeter.
 Components having special characteristics are marked with a star and must be replaced with the same type.
 Schematic diagram is subject to change without notice.

IC	MARKING	DESCRIPTION	REMARKS
101	7805	VOLTAJE REGULADOR	
102	7805	VOLTAJE REGULADOR	
103	7805	VOLTAJE REGULADOR	
104	7805	VOLTAJE REGULADOR	
105	7805	VOLTAJE REGULADOR	
106	7805	VOLTAJE REGULADOR	
107	7805	VOLTAJE REGULADOR	
108	7805	VOLTAJE REGULADOR	
109	7805	VOLTAJE REGULADOR	
110	7805	VOLTAJE REGULADOR	
111	7805	VOLTAJE REGULADOR	
112	7805	VOLTAJE REGULADOR	
113	7805	VOLTAJE REGULADOR	
114	7805	VOLTAJE REGULADOR	
115	7805	VOLTAJE REGULADOR	
116	7805	VOLTAJE REGULADOR	
117	7805	VOLTAJE REGULADOR	
118	7805	VOLTAJE REGULADOR	
119	7805	VOLTAJE REGULADOR	
120	7805	VOLTAJE REGULADOR	
121	7805	VOLTAJE REGULADOR	
122	7805	VOLTAJE REGULADOR	
123	7805	VOLTAJE REGULADOR	
124	7805	VOLTAJE REGULADOR	
125	7805	VOLTAJE REGULADOR	
126	7805	VOLTAJE REGULADOR	
127	7805	VOLTAJE REGULADOR	
128	7805	VOLTAJE REGULADOR	
129	7805	VOLTAJE REGULADOR	
130	7805	VOLTAJE REGULADOR	
131	7805	VOLTAJE REGULADOR	
132	7805	VOLTAJE REGULADOR	
133	7805	VOLTAJE REGULADOR	
134	7805	VOLTAJE REGULADOR	
135	7805	VOLTAJE REGULADOR	
136	7805	VOLTAJE REGULADOR	
137	7805	VOLTAJE REGULADOR	
138	7805	VOLTAJE REGULADOR	
139	7805	VOLTAJE REGULADOR	
140	7805	VOLTAJE REGULADOR	
141	7805	VOLTAJE REGULADOR	
142	7805	VOLTAJE REGULADOR	
143	7805	VOLTAJE REGULADOR	
144	7805	VOLTAJE REGULADOR	
145	7805	VOLTAJE REGULADOR	
146	7805	VOLTAJE REGULADOR	
147	7805	VOLTAJE REGULADOR	
148	7805	VOLTAJE REGULADOR	
149	7805	VOLTAJE REGULADOR	
150	7805	VOLTAJE REGULADOR	
151	7805	VOLTAJE REGULADOR	
152	7805	VOLTAJE REGULADOR	
153	7805	VOLTAJE REGULADOR	
154	7805	VOLTAJE REGULADOR	
155	7805	VOLTAJE REGULADOR	
156	7805	VOLTAJE REGULADOR	
157	7805	VOLTAJE REGULADOR	
158	7805	VOLTAJE REGULADOR	
159	7805	VOLTAJE REGULADOR	
160	7805	VOLTAJE REGULADOR	
161	7805	VOLTAJE REGULADOR	
162	7805	VOLTAJE REGULADOR	
163	7805	VOLTAJE REGULADOR	
164	7805	VOLTAJE REGULADOR	
165	7805	VOLTAJE REGULADOR	
166	7805	VOLTAJE REGULADOR	
167	7805	VOLTAJE REGULADOR	
168	7805	VOLTAJE REGULADOR	
169	7805	VOLTAJE REGULADOR	
170	7805	VOLTAJE REGULADOR	
171	7805	VOLTAJE REGULADOR	
172	7805	VOLTAJE REGULADOR	
173	7805	VOLTAJE REGULADOR	
174	7805	VOLTAJE REGULADOR	
175	7805	VOLTAJE REGULADOR	
176	7805	VOLTAJE REGULADOR	
177	7805	VOLTAJE REGULADOR	
178	7805	VOLTAJE REGULADOR	
179	7805	VOLTAJE REGULADOR	
180	7805	VOLTAJE REGULADOR	
181	7805	VOLTAJE REGULADOR	
182	7805	VOLTAJE REGULADOR	
183	7805	VOLTAJE REGULADOR	
184	7805	VOLTAJE REGULADOR	
185	7805	VOLTAJE REGULADOR	
186	7805	VOLTAJE REGULADOR	
187	7805	VOLTAJE REGULADOR	
188	7805	VOLTAJE REGULADOR	
189	7805	VOLTAJE REGULADOR	
190	7805	VOLTAJE REGULADOR	
191	7805	VOLTAJE REGULADOR	
192	7805	VOLTAJE REGULADOR	
193	7805	VOLTAJE REGULADOR	
194	7805	VOLTAJE REGULADOR	
195	7805	VOLTAJE REGULADOR	
196	7805	VOLTAJE REGULADOR	
197	7805	VOLTAJE REGULADOR	
198	7805	VOLTAJE REGULADOR	
199	7805	VOLTAJE REGULADOR	
200	7805	VOLTAJE REGULADOR	

IC	MARKING	DESCRIPTION	REMARKS
101	7805	VOLTAJE REGULADOR	
102	7805	VOLTAJE REGULADOR	
103	7805	VOLTAJE REGULADOR	
104	7805	VOLTAJE REGULADOR	
105	7805	VOLTAJE REGULADOR	
106	7805	VOLTAJE REGULADOR	
107	7805	VOLTAJE REGULADOR	
108	7805	VOLTAJE REGULADOR	
109	7805	VOLTAJE REGULADOR	
110	7805	VOLTAJE REGULADOR	
111	7805	VOLTAJE REGULADOR	
112	7805	VOLTAJE REGULADOR	
113	7805	VOLTAJE REGULADOR	
114	7805	VOLTAJE REGULADOR	
115	7805	VOLTAJE REGULADOR	
116	7805	VOLTAJE REGULADOR	
117	7805	VOLTAJE REGULADOR	
118	7805	VOLTAJE REGULADOR	
119	7805	VOLTAJE REGULADOR	
120	7805	VOLTAJE REGULADOR	
121	7805	VOLTAJE REGULADOR	
122	7805	VOLTAJE REGULADOR	
123	7805	VOLTAJE REGULADOR	
124	7805	VOLTAJE REGULADOR	
125	7805	VOLTAJE REGULADOR	
126	7805	VOLTAJE REGULADOR	
127	7805	VOLTAJE REGULADOR	
128	7805	VOLTAJE REGULADOR	
129	7805	VOLTAJE REGULADOR	
130	7805	VOLTAJE REGULADOR	
131	7805	VOLTAJE REGULADOR	
132	7805	VOLTAJE REGULADOR	
133	7805	VOLTAJE REGULADOR	
134	7805	VOLTAJE REGULADOR	
135	7805	VOLTAJE REGULADOR	
136	7805	VOLTAJE REGULADOR	
137	7805	VOLTAJE REGULADOR	
138	7805	VOLTAJE REGULADOR	
139	7805	VOLTAJE REGULADOR	
140	7805	VOLTAJE REGULADOR	
141	7805	VOLTAJE REGULADOR	
142	7805	VOLTAJE REGULADOR	
143	7805	VOLTAJE REGULADOR	
144	7805	VOLTAJE REGULADOR	
145	7805	VOLTAJE REGULADOR	
146	7805	VOLTAJE REGULADOR	
147	7805	VOLTAJE REGULADOR	
148	7805	VOLTAJE REGULADOR	
149	7805	VOLTAJE REGULADOR	
150	7805	VOLTAJE REGULADOR	
151	7805	VOLTAJE REGULADOR	
152	7805	VOLTAJE REGULADOR	
153	7805	VOLTAJE REGULADOR	
154	7805	VOLTAJE REGULADOR	
155	7805	VOLTAJE REGULADOR	
156	7805	VOLTAJE REGULADOR	
157	7805	VOLTAJE REGULADOR	
158	7805	VOLTAJE REGULADOR	
159	7805	VOLTAJE REGULADOR	
160	7805	VOLTAJE REGULADOR	
161	7805	VOLTAJE REGULADOR	
162	7805	VOLTAJE REGULADOR	
163	7805	VOLTAJE REGULADOR	
164	7805	VOLTAJE REGULADOR	
165	7805	VOLTAJE REGULADOR	
166	7805	VOLTAJE REGULADOR	
167	7805	VOLTAJE REGULADOR	
168	7805	VOLTAJE REGULADOR	
169	7805	VOLTAJE REGULADOR	
170	7805	VOLTAJE REGULADOR	
171	7805	VOLTAJE REGULADOR	
172	7805	VOLTAJE REGULADOR	
173	7805	VOLTAJE REGULADOR	
174	7805	VOLTAJE REGULADOR	
175	7805	VOLTAJE REGULADOR	
176	7805	VOLTAJE REGULADOR	
177	7805	VOLTAJE REGULADOR	
178	7805	VOLTAJE REGULADOR	
179	7805	VOLTAJE REGULADOR	
180	7805	VOLTAJE REGULADOR	
181	7805	VOLTAJE REGULADOR	
182	7805	VOLTAJE REGULADOR	
183	7805	VOLTAJE REGULADOR	
184	7805	VOLTAJE REGULADOR	
185	7805	VOLTAJE REGULADOR	
186	7805	VOLTAJE REGULADOR	
187	7805	VOLTAJE REGULADOR	
188	7805	VOLTAJE REGULADOR	
189	7805	VOLTAJE REGULADOR	
190	7805	VOLTAJE REGULADOR	
191	7805	VOLTAJE REGULADOR	
192	7805	VOLTAJE REGULADOR	
193	7805	VOLTAJE REGULADOR	
194	7805	VOLTAJE REGULADOR	
195	7805	VOLTAJE REGULADOR	
196	7805	VOLTAJE REGULADOR	
197	7805	VOLTAJE REGULADOR	
198	7805	VOLTAJE REGULADOR	
199	7805	VOLTAJE REGULADOR	
200	7805	VOLTAJE REGULADOR	

NOTICE (continued)
 1. All voltages are measured with a 10MΩV DC electronic voltmeter.
 2. Components having special characteristics are marked A, and must be replaced with the same type and manufacturer's part.
 3. Schematic diagrams are subject to change without notice.

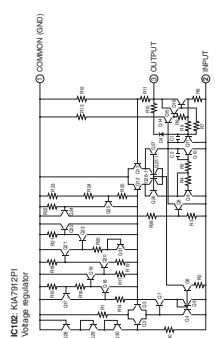
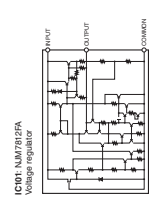
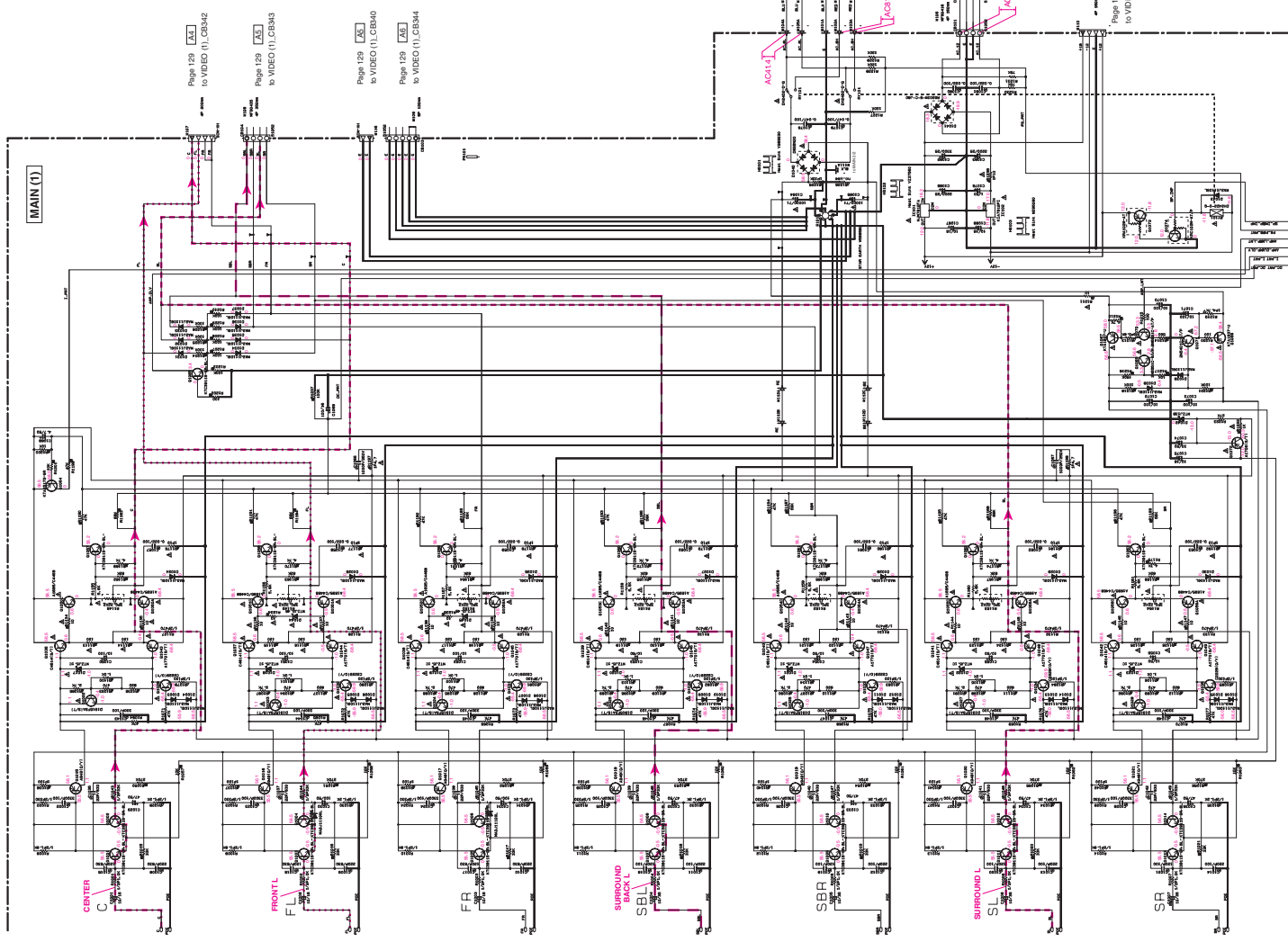

VOLTAGE SELECTOR	1-2-5-6
250-240V	2-3-7
230V	3-8
120V	4-9-1

● 電圧は、内阻無限大の電圧計で測定したものです。
 ● A印のある部品は、安全特種部品を示しています。部品の交換が必要の場合は、同じメーカーの同等品を必ず取り替えてください。
 ● 本図面は仕様変更のため、内容が異なる場合があります。

REV	DATE	BY	CHK	DESCRIPTION
1				
2				
3				
4				
5				
6				
7				
8				
9				
10				

NO.	REVISIONS	DATE	BY	CHK	DESCRIPTION
01					
02					
03					
04					
05					
06					
07					
08					
09					
10					
11					
12					
13					
14					
15					
16					
17					
18					
19					
20					

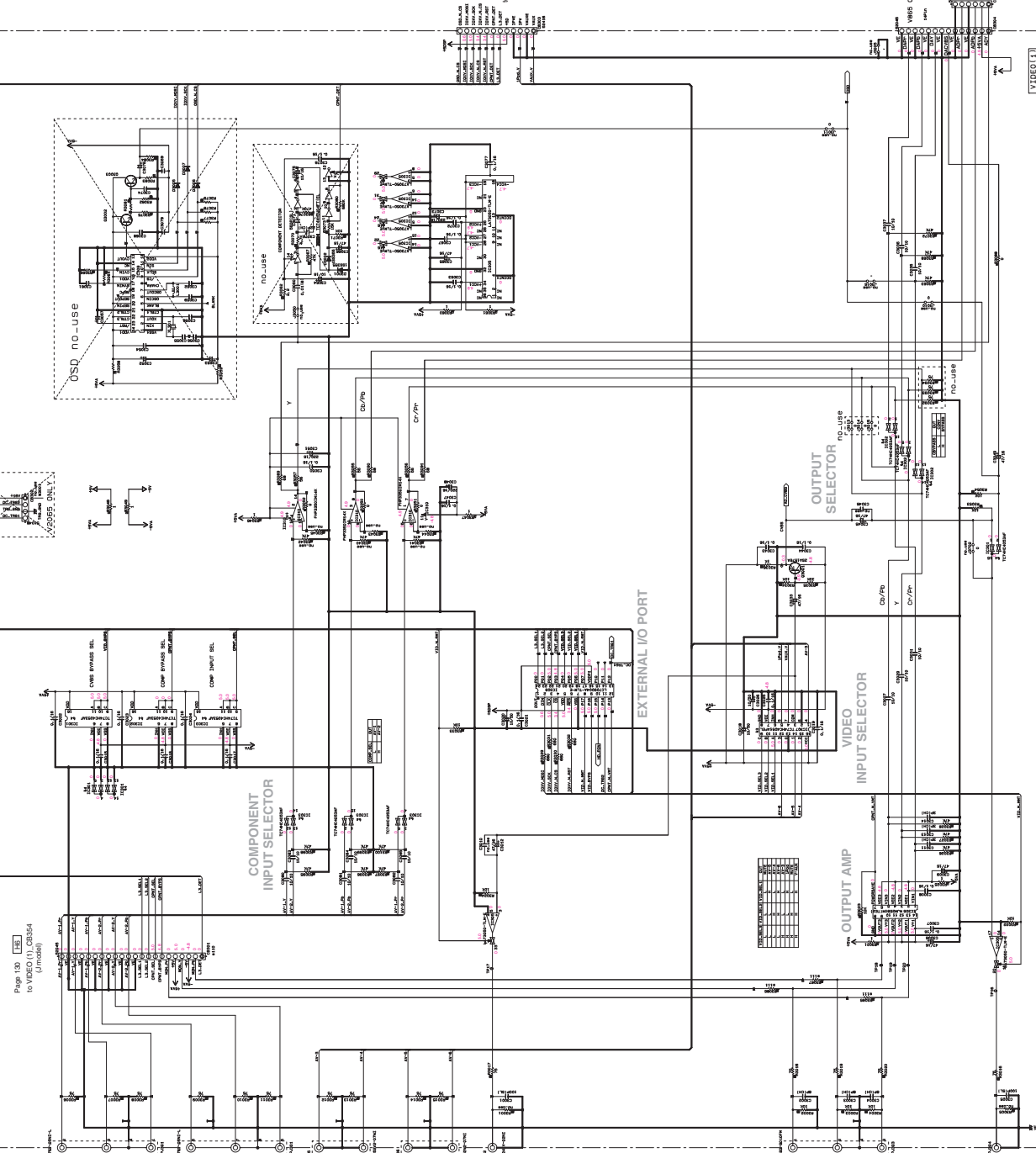
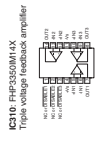
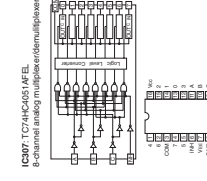
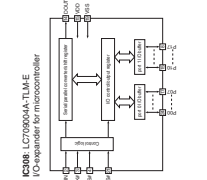
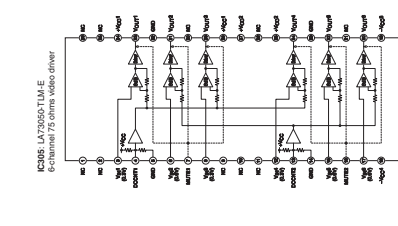
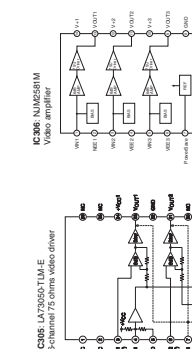
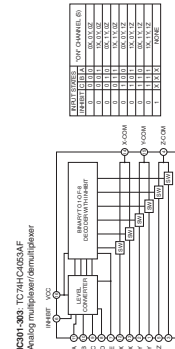

To Digital

Page 130 130
to VIDEO 1/3 CB54
(11/2001)

Page 123 123
to OPERATION (2)_CB49

Page 123 123
to DIGITAL CB71

NOTICE (New!!)

- ① U.S.A.
- ② U.S.A.
- ③ U.S.A.
- ④ U.S.A.
- ⑤ U.S.A.
- ⑥ U.S.A.
- ⑦ U.S.A.
- ⑧ U.S.A.
- ⑨ U.S.A.
- ⑩ U.S.A.

RESISTOR	JAPAN ELECTRONIC COMPONENTS CO., LTD.
①	RESISTOR
②	RESISTOR
③	RESISTOR
④	RESISTOR
⑤	RESISTOR
⑥	RESISTOR
⑦	RESISTOR
⑧	RESISTOR
⑨	RESISTOR
⑩	RESISTOR

CAPACITOR	JAPAN ELECTRONIC COMPONENTS CO., LTD.
①	CAPACITOR
②	CAPACITOR
③	CAPACITOR
④	CAPACITOR
⑤	CAPACITOR
⑥	CAPACITOR
⑦	CAPACITOR
⑧	CAPACITOR
⑨	CAPACITOR
⑩	CAPACITOR

All voltages are measured with a 10MΩ DC electronic voltmeter.
 * Components having special characteristics are marked Δ, and must be replaced accordingly.
 † Schematic diagrams is subject to change without notice.

REVISIONS

REV. NO.	DATE	DESCRIPTION
1	1997.08.20	INITIAL DESIGN
2	1997.09.10	DESIGN CHANGES
3	1997.10.15	DESIGN CHANGES
4	1997.11.20	DESIGN CHANGES
5	1998.01.10	DESIGN CHANGES
6	1998.02.20	DESIGN CHANGES
7	1998.03.15	DESIGN CHANGES
8	1998.04.10	DESIGN CHANGES
9	1998.05.05	DESIGN CHANGES
10	1998.06.01	DESIGN CHANGES

NOTICE (Imps)

① 日本国
② 中国
③ 台湾
④ 香港
⑤ 韓国
⑥ 米国
⑦ 英国
⑧ 西ドイツ
⑨ 東ドイツ
⑩ フランス
⑪ イタリア
⑫ スペイン
⑬ 米国
⑭ 日本国

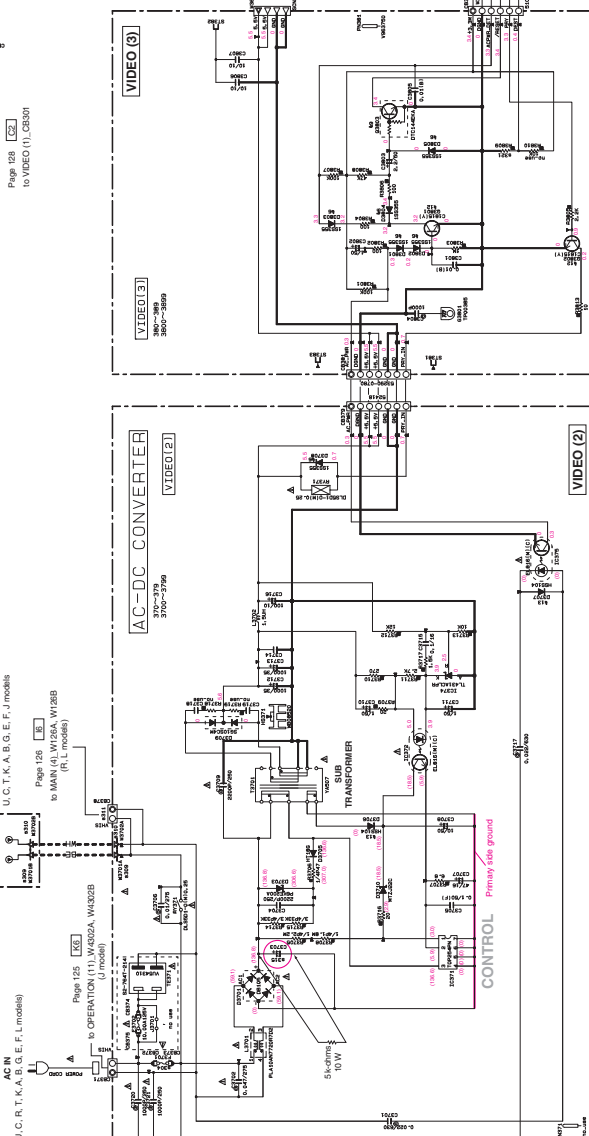
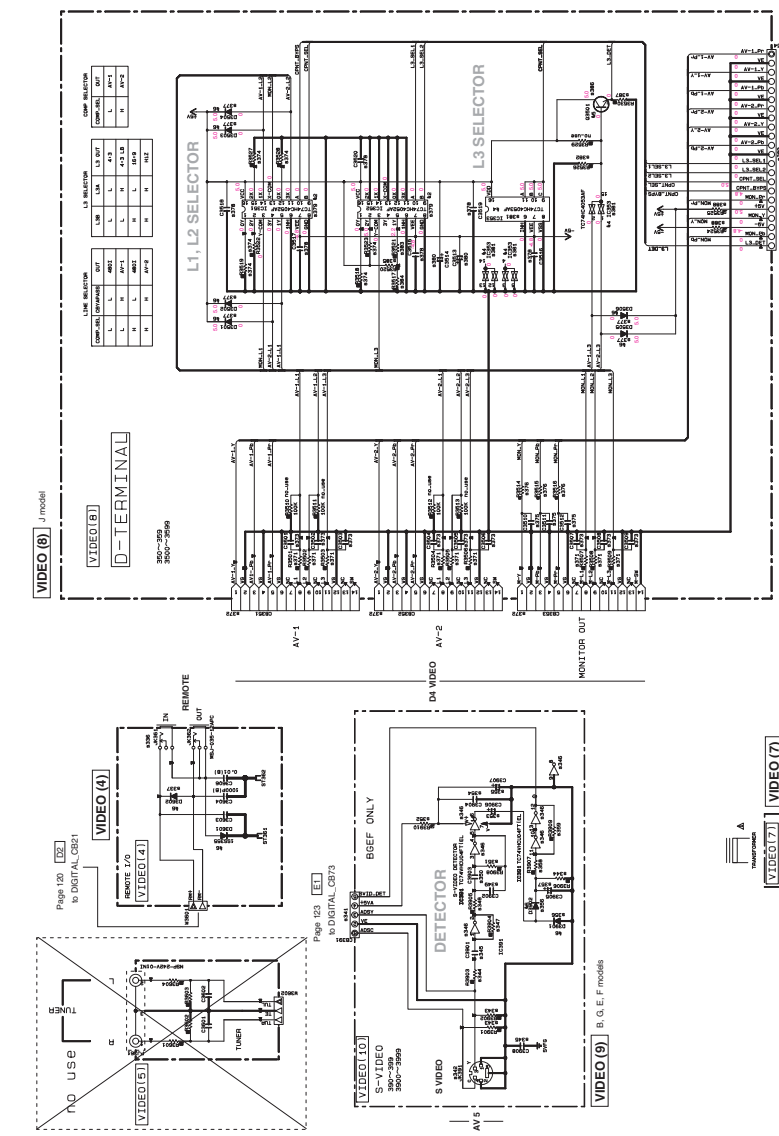
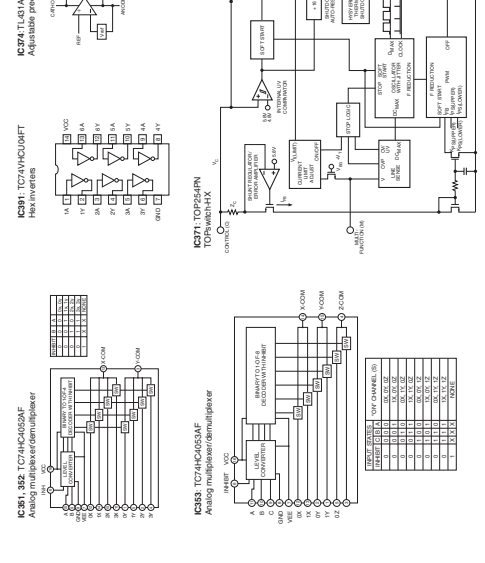

CAUTION
Safety measure: This product contains high voltage and has dangerous. Be aware to take safety measures when servicing. High voltage parts are located in the following positions:
• Note the positions indicated below are dangerous even after the power is turned off because an electric charge remains and high voltage continues to exist there.
• Before starting any repair work, perform discharge by connecting a discharge resistor (500ohm/10W) between terminals at following positions. The time required for C303 on VIDEO (2) PCB is 30 seconds.

安全対策
この製品には高電圧が残留し、修理の際は、必ず安全対策を講ずるべきです。高電圧部は、以下の位置に存在します。
• 電源を切断した後も、高電圧が残留し、修理作業中に感電する恐れがあります。
• 修理作業を行う前に、500Ω/10Wの放電抵抗を以下の端子間に接続して放電してください。VIDEO (2) PCBのC303の放電時間は30秒です。

All voltages are measured with a 10MΩV DC electronic voltmeter.
Components having special characteristics are marked Δ, and must be replaced accordingly.
Schematic diagrams are subject to change without notice.

電圧は、10MΩV DC電圧計で測定したものです。
△印のある部品は、安全特性が特別を示しています。取替の際は必ず注意してください。
本図面は仕様変更により、内容が異なる場合があります。

PARAMETERS DATA AT 25°C (TYPICAL VALUE)

1	100
2	100
3	100
4	100
5	100
6	100
7	100
8	100
9	100
10	100
11	100
12	100
13	100
14	100
15	100
16	100
17	100
18	100
19	100
20	100
21	100
22	100
23	100
24	100
25	100
26	100
27	100
28	100
29	100
30	100
31	100
32	100
33	100
34	100
35	100
36	100
37	100
38	100
39	100
40	100
41	100
42	100
43	100
44	100
45	100
46	100
47	100
48	100
49	100
50	100

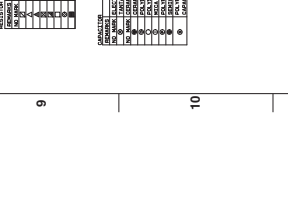
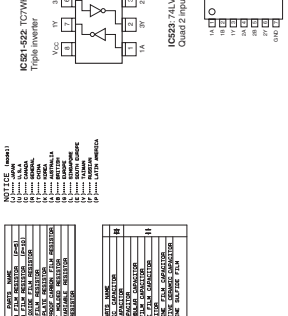
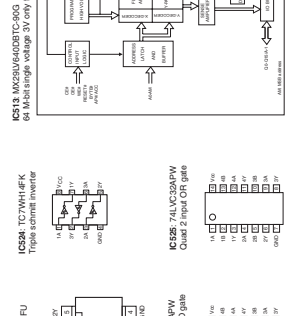
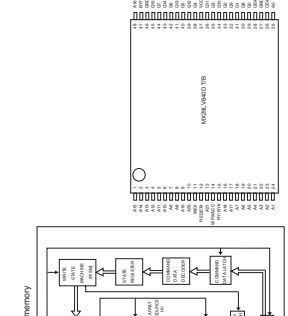
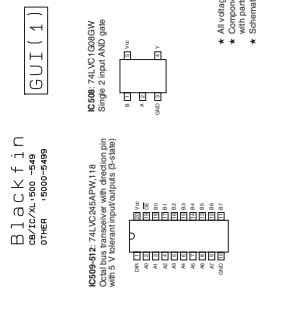
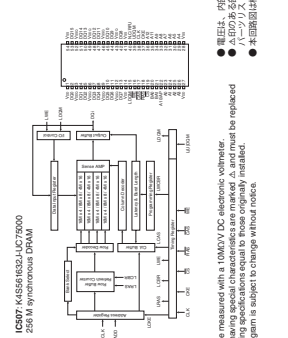
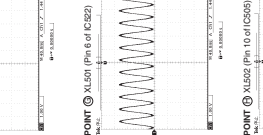
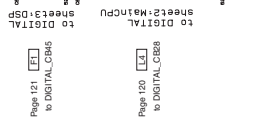
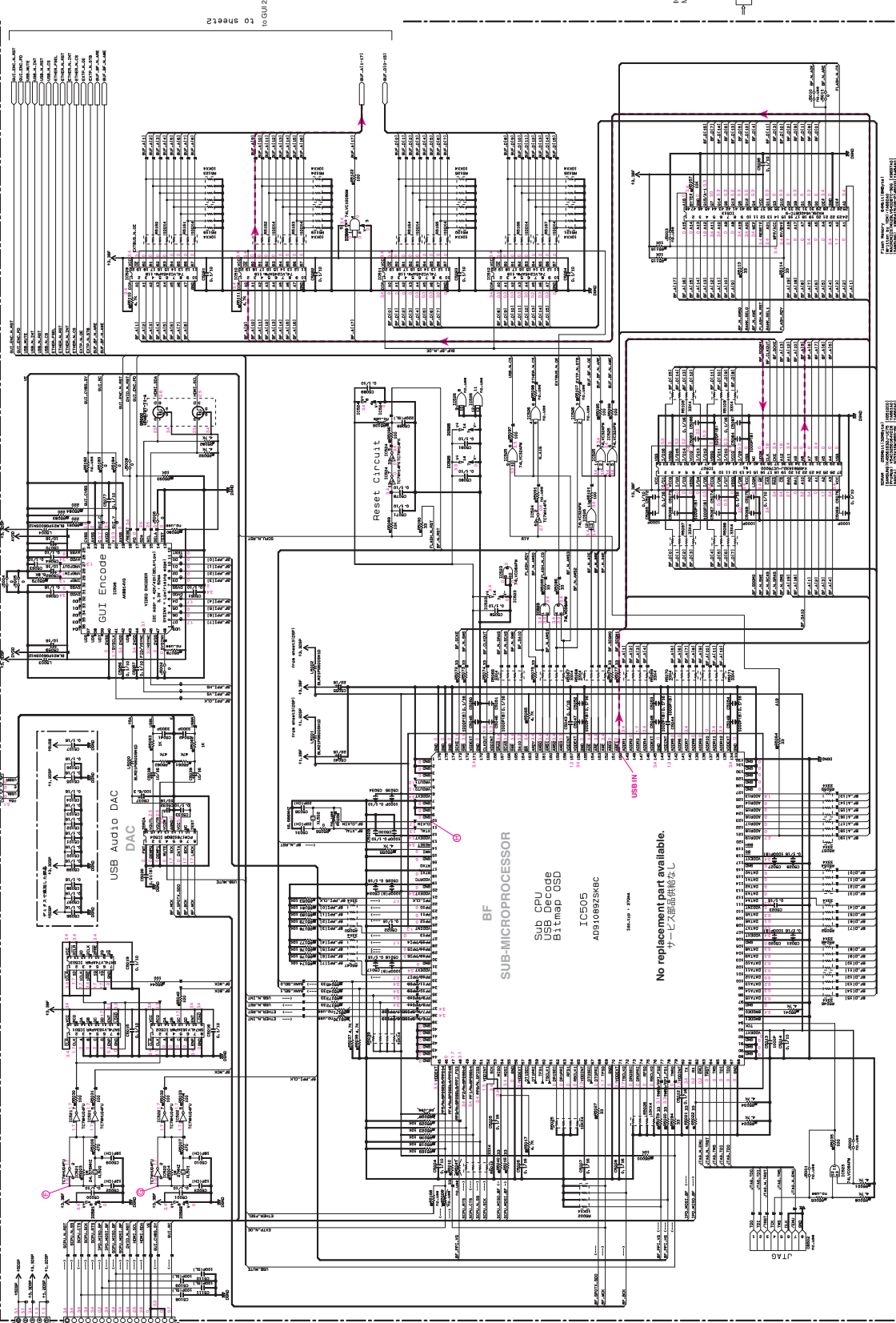
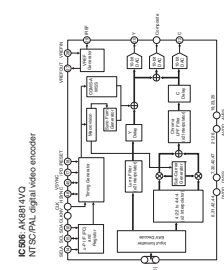
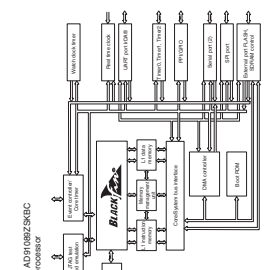
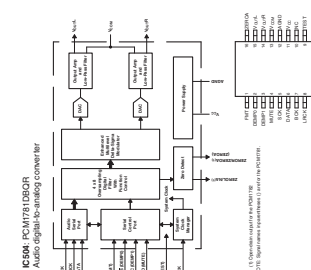
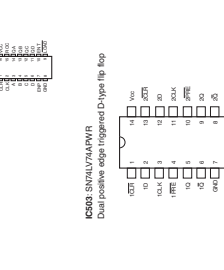
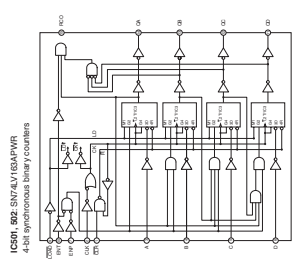

● 電圧は、内蔵抵抗 10MΩ の電圧計で測定したものです。
 ● Δ印のある部品は、安全確保部品を示しています。部品の交換が必要の場合、
 ▲印のある部品は、安全確保部品を示しています。部品の交換が必要の場合、
 ● 本図は、標準的な部品構成を示しています。

▲ All voltages are measured with a 10MΩ DC electronic voltmeter.
 ▲ Components having special characteristics are marked Δ, and must be replaced
 ▲ Components having special characteristics are marked ▲, and must be replaced
 ● Standard layout is subject to change without notice.

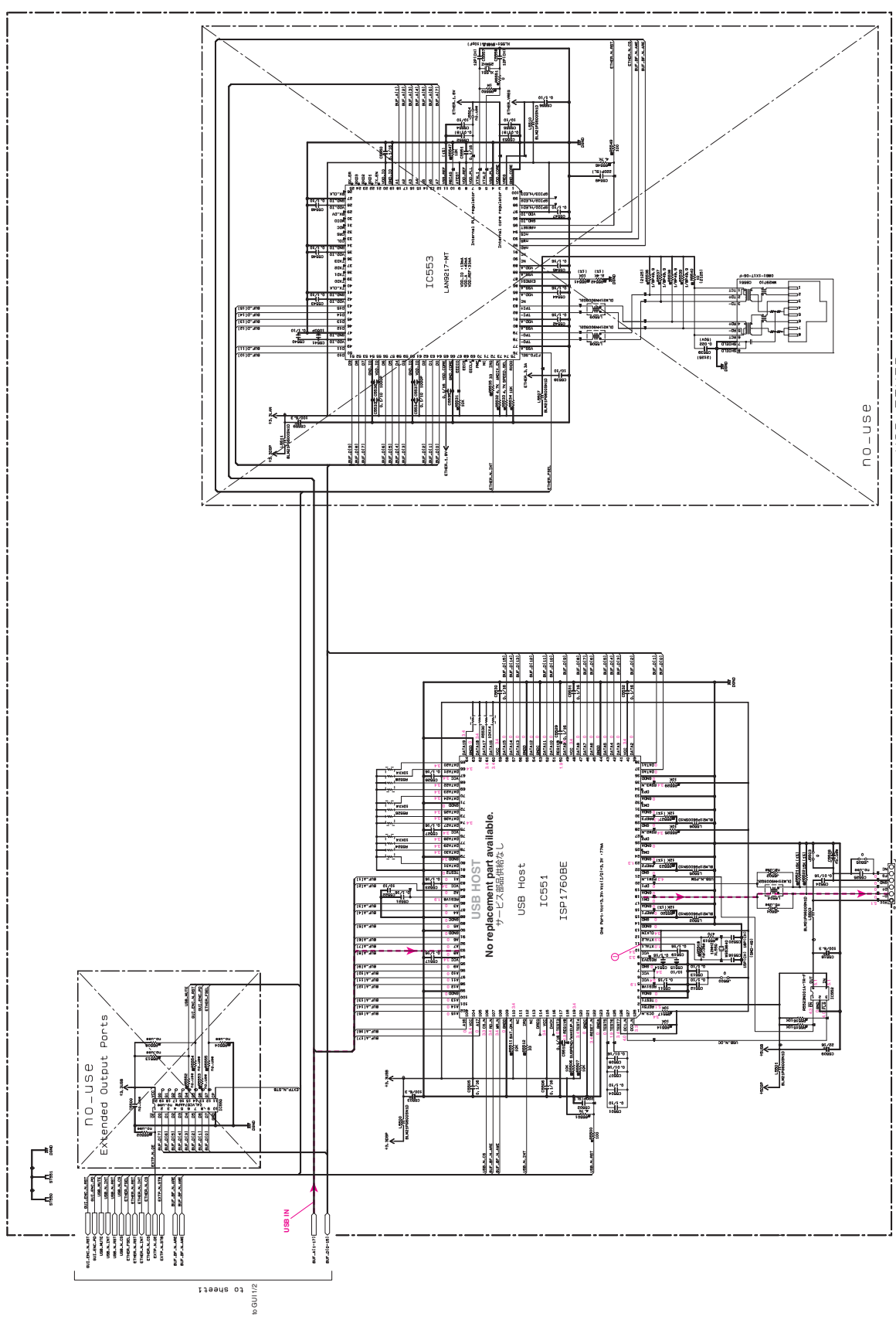

IC551: ISP1760BE
Extended In-Signal USB Host Controller

IC552: R6552N001ATH-F
High side switch IC

no_USE

USB ETHER
CHIRK 1550V-9599

From OPE (1)
USB

Page 124
OPERATION (6) V4407

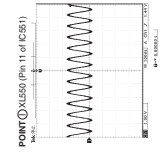

RESISTOR

REMARKS	DATE	NAME
①	15.11.14	YUKI
②	15.11.14	YUKI
③	15.11.14	YUKI
④	15.11.14	YUKI
⑤	15.11.14	YUKI
⑥	15.11.14	YUKI
⑦	15.11.14	YUKI
⑧	15.11.14	YUKI
⑨	15.11.14	YUKI
⑩	15.11.14	YUKI
⑪	15.11.14	YUKI
⑫	15.11.14	YUKI
⑬	15.11.14	YUKI
⑭	15.11.14	YUKI
⑮	15.11.14	YUKI
⑯	15.11.14	YUKI
⑰	15.11.14	YUKI
⑱	15.11.14	YUKI
⑲	15.11.14	YUKI
⑳	15.11.14	YUKI
㉑	15.11.14	YUKI
㉒	15.11.14	YUKI
㉓	15.11.14	YUKI
㉔	15.11.14	YUKI
㉕	15.11.14	YUKI
㉖	15.11.14	YUKI
㉗	15.11.14	YUKI
㉘	15.11.14	YUKI
㉙	15.11.14	YUKI
㉚	15.11.14	YUKI
㉛	15.11.14	YUKI
㉜	15.11.14	YUKI
㉝	15.11.14	YUKI
㉞	15.11.14	YUKI
㉟	15.11.14	YUKI
㊱	15.11.14	YUKI
㊲	15.11.14	YUKI
㊳	15.11.14	YUKI
㊴	15.11.14	YUKI
㊵	15.11.14	YUKI
㊶	15.11.14	YUKI
㊷	15.11.14	YUKI
㊸	15.11.14	YUKI
㊹	15.11.14	YUKI
㊺	15.11.14	YUKI
㊻	15.11.14	YUKI
㊼	15.11.14	YUKI
㊽	15.11.14	YUKI
㊾	15.11.14	YUKI
㊿	15.11.14	YUKI

CAPACITOR

REMARKS	DATE	NAME
①	15.11.14	YUKI
②	15.11.14	YUKI
③	15.11.14	YUKI
④	15.11.14	YUKI
⑤	15.11.14	YUKI
⑥	15.11.14	YUKI
⑦	15.11.14	YUKI
⑧	15.11.14	YUKI
⑨	15.11.14	YUKI
⑩	15.11.14	YUKI
⑪	15.11.14	YUKI
⑫	15.11.14	YUKI
⑬	15.11.14	YUKI
⑭	15.11.14	YUKI
⑮	15.11.14	YUKI
⑯	15.11.14	YUKI
⑰	15.11.14	YUKI
⑱	15.11.14	YUKI
⑲	15.11.14	YUKI
⑳	15.11.14	YUKI
㉑	15.11.14	YUKI
㉒	15.11.14	YUKI
㉓	15.11.14	YUKI
㉔	15.11.14	YUKI
㉕	15.11.14	YUKI
㉖	15.11.14	YUKI
㉗	15.11.14	YUKI
㉘	15.11.14	YUKI
㉙	15.11.14	YUKI
㉚	15.11.14	YUKI
㉛	15.11.14	YUKI
㉜	15.11.14	YUKI
㉝	15.11.14	YUKI
㉞	15.11.14	YUKI
㉟	15.11.14	YUKI
㊱	15.11.14	YUKI
㊲	15.11.14	YUKI
㊳	15.11.14	YUKI
㊴	15.11.14	YUKI
㊵	15.11.14	YUKI
㊶	15.11.14	YUKI
㊷	15.11.14	YUKI
㊸	15.11.14	YUKI
㊹	15.11.14	YUKI
㊺	15.11.14	YUKI
㊻	15.11.14	YUKI
㊼	15.11.14	YUKI
㊽	15.11.14	YUKI
㊾	15.11.14	YUKI
㊿	15.11.14	YUKI

● 電圧は、内部規格 (MCO) の値に準じて設計したものです。
 ● △印のある部品は、安全規格部品を示しています。規格の交換が必要の場合、△印のある部品に同等以上の規格の部品を交換してください。
 ● 本回路図は標準回路図です。実際の回路は、お客様の仕様に応じて変更することがあります。

★ All voltages are measured with a 10MΩV DC electronic voltmeter.
 ★ Components having special characteristics are marked △, and must be replaced with components having the same characteristics when replaced.
 ★ Schematic diagram is subject to change without notice.

■ REPLACEMENT PARTS LIST

• ELECTRICAL COMPONENT PARTS

WARNING

- Components having special characteristics are marked Δ and must be replaced with parts having specifications equal to those originally installed.
- Δ 印のある部分は、安全確保部品を示しています。部品の交換が必要な場合、パーツリストに記載されている部品を使用してください。
- 部品価格ランクは、予告なく変更することがあります。

ABBREVIATIONS IN THIS LIST ARE AS FOLLOWS:

C.A.EL.CHP	: CHIP ALUMI.ELECTROLYTIC CAP	L.EMIT	: LIGHT EMITTING MODULE
C.CE	: CERAMIC CAP	LED.DSPLY	: LED DISPLAY
C.CE.ARRAY	: CERAMIC CAP ARRAY	LED.INFRD	: LED, INFRARED
C.CE.CHP	: CHIP CERAMIC CAP	MODUL.RF	: MODULATOR, RF
C.CE.ML	: MULTILAYER CERAMIC CAP	PHOT.CPL	: PHOTO COUPLER
C.CE.M.CHP	: CHIP MULTILAYER CERAMIC CAP	PHOT.INTR	: PHOTO INTERRUPTER
C.CE.SAFTY	: RECOGNIZED CERAMIC CAP	PHOT.RFLCT	: PHOTO REFLECTOR
C.CE.TUBLR	: CERAMIC TUBULAR CAP	PIN.TEST	: PIN, TEST POINT
C.CE.SMI	: SEMI CONDUCTIVE CERAMIC CAP	PLST.RIVET	: PLASTIC RIVET
C.EL	: ELECTROLYTIC CAP	R.ARRAY	: RESISTOR ARRAY
C.MICA	: MICA CAP	R.CAR.	: CARBON RESISTOR
C.ML.FLM	: MULTILAYER FILM CAP	R.CAR.CHP	: CHIP RESISTOR
C.MP	: METALLIZED PAPER CAP	R.CAR.FP	: FLAME PROOF CARBON RESISTOR
C.MYLAR	: MYLAR FILM CAP	R.FUS	: FUSABLE RESISTOR
C.MYLAR.ML	: MULTILAYER MYLAR FILM CAP	R.MTL.CHP	: CHIP METAL FILM RESISTOR
C.PAPER	: PAPER CAPACITOR	R.MTL.FLM	: METAL FILM RESISTOR
C.PLS	: POLYSTYRENE FILM CAP	R.MTL.OXD	: METAL OXIDE FILM RESISTOR
C.POL	: POLYESTER FILM CAP	R.MTL.PLAT	: METAL PLATE RESISTOR
C.POLY	: POLYETHYLENE FILM CAP	RSNR.CE	: CERAMIC RESONATOR
C.PP	: POLYPROPYLENE FILM CAP	RSNR.CRYS	: CRYSTAL RESONATOR
C.TNTL	: TANTALUM CAP	R.TW.GEM	: TWIN CEMENT FIXED RESISTOR
C.TNTL.CHP	: CHIP TANTALUM CAP	R.CEMENT	: CEMENT RESISTOR
C.TRIM	: TRIMMER CAP	SCR.BND.HD	: BIND HEAD B-TIGHT SCREW
CN	: CONNECTOR	SCR.BW.HD	: BW HEAD TAPPING SCREW
CN.BS.PIN	: CONNECTOR, BASE PIN	SCR.CUP	: CUP TIGHT SCREW
CN.CANNON	: CONNECTOR, CANNON	SCR.TERM	: SCREW TERMINAL
CN.DIN	: CONNECTOR, DIN	SCR.TR	: SCREW, TRANSISTOR
CN.FLAT	: CONNECTOR, FLAT CABLE	SUPRT.PCB	: SUPPORT, P.C.B.
CN.POST	: CONNECTOR, BASE POST	SURG.PRTCT	: SURGE PROTECTOR
COIL.MX.AM	: COIL, AM MIX	SW.TACT	: TACT SWITCH
COIL.AT.FM	: COIL, FM ANTENNA	SW.LEAF	: LEAF SWITCH
COIL.DT.FM	: COIL, FM DETECT	SW.LEVER	: LEVER SWITCH
COIL.MX.FM	: COIL, FM MIX	SW.MICRO	: MICRO SWITCH
COIL.OUTPT	: OUTPUT COIL	SW.PUSH	: PUSH SWITCH
DIOD.ARRAY	: DIODE ARRAY	SW.RT.ENC	: ROTARY ENCODER
DIODE.BRG	: DIODE BRIDGE	SW.RT.MTR	: ROTARY SWITCH WITH MOTOR
DIODE.CHP	: CHIP DIODE	SW.RT	: ROTARY SWITCH
DIODE.VAR	: VARACTOR DIODE	SW.SLIDE	: SLIDE SWITCH
DIOD.Z.CHP	: CHIP ZENER DIODE	TERM.SP	: SPEAKER TERMINAL
DIODE.ZENR	: ZENER DIODE	TERM.WRAP	: WRAPPING TERMINAL
DSCR.CE	: CERAMIC DISCRIMINATOR	THRMST.CHP	: CHIP THERMISTOR
FER.BEAD	: FERRITE BEADS	TR.CHP	: CHIP TRANSISTOR
FER.CORE	: FERRITE CORE	TR.DGT	: DIGITAL TRANSISTOR
FET.CHP	: CHIP FET	TR.DGT.CHP	: CHIP DIGITAL TRANSISTOR
FL.DSPLY	: FLUORESCENT DISPLAY	TRANS	: TRANSFORMER
FLTR.CE	: CERAMIC FILTER	TRANS.PULS	: PULSE TRANSFORMER
FLTR.COMB	: COMB FILTER MODULE	TRANS.PWR	: POWER TRANSFORMER ASS'Y
FLTR.LC.RF	: LC FILTER, EMI	TUNER.AM	: TUNER PACK, AM
GND.MTL	: GROUND PLATE	TUNER.FM	: TUNER PACK, FM
GND.TERM	: GROUND TERMINAL	TUNER.PK	: FRONT-END TUNER PACK
HOLDER.FUS	: FUSE HOLDER	VR	: ROTARY POTENTIOMETER
IC.PRTCT	: IC PROTECTOR	VR.MTR	: POTENTIOMETER WITH MOTOR
JUMPER.CN	: JUMPER CONNECTOR	VR.SW	: POTENTIOMETER WITH ROTARY SW
JUMPER.TST	: JUMPER, TEST POINT	VR.SLIDE	: SLIDE POTENTIOMETER
L.DTCT	: LIGHT DETECTING MODULE	VR.TRIM	: TRIMMER POTENTIOMETER

P.C.B. DIGITAL

Ref No.	Part No.	Description	Remarks	Markets	部 品 名	ランク	
*	WR435600	P. C. B.	DIGITAL	V1065	J	PCB DIGITAL	
*	WR435700	P. C. B.	DIGITAL	V1065	U	PCB DIGITAL	
*	WR436500	P. C. B.	DIGITAL	6280	U	PCB DIGITAL	
*	WR435800	P. C. B.	DIGITAL	V1065	CRTKAL	PCB DIGITAL	
*	WR436600	P. C. B.	DIGITAL	6280	C	PCB DIGITAL	
*	WR435900	P. C. B.	DIGITAL	V1065	BGEF	PCB DIGITAL	
CB1-4	WM462600	CN. HDMI	19P SE			コネクタ HDMI	04
CB6	WM462600	CN. HDMI	19P SE			コネクタ HDMI	04
CB7	LB918040	CN. BS. PIN	4P			ベース付ポスト	01
CB20	VP082900	CN. BS. PIN	25P			FFCコネクタ	02
CB21	VB389800	CN. BS. PIN	2P			ベースピン	01
CB22	VK024700	CN. BS. PIN	3P			ワイヤートラップ	01
CB23	VK025600	CN. BS. PIN	12P			ワイヤートラップ	01
CB24	VF728300	CN	6P			コネクタ	01
CB25	VQ045200	CN. BS. PIN	22P			FFCコネクタ	01
CB27	VQ047200	CN. BS. PIN	9P			FFCコネクタ	01
CB28	VQ044700	CN. BS. PIN	16P			FFCコネクタ	01
CB40	WJ458700	CN. XM	4P, CAM-D96		U	XMコネクタ	
CB61-63	V9356900	CN. JE	19P SE			JEコネクタプラグ	
CB71	VF982200	CN. BS. PIN	14P			コネクタ	02
CB73	VQ044100	CN. BS. PIN	5P		BGEF	FFCコネクタ	01
C1-2	US135100	C. CE. CHP	0. 1uF 16V			チップセラコン	01
C3-4	WD758300	C. CE. CHP	10uF 10V			チップセラコン	01
C5-14	US135100	C. CE. CHP	0. 1uF 16V			チップセラコン	01
C15-24	US063100	C. CE. CHP	1000pF 50V B			チップセラコン	01
C25-26	US135100	C. CE. CHP	0. 1uF 16V			チップセラコン	01
C27	US060700	C. CE. CHP	7pF 50V B			チップセラコン	01
C28	US060500	C. CE. CHP	5pF 50V B			チップセラコン	01
C29	US135100	C. CE. CHP	0. 1uF 16V			チップセラコン	01
C30	WD758300	C. CE. CHP	10uF 10V			チップセラコン	01
C31-32	US135100	C. CE. CHP	0. 1uF 16V			チップセラコン	01
C33	US063100	C. CE. CHP	1000pF 50V B			チップセラコン	01
C34	US135100	C. CE. CHP	0. 1uF 16V			チップセラコン	01
C35	WD758300	C. CE. CHP	10uF 10V			チップセラコン	01
C36	US135100	C. CE. CHP	0. 1uF 16V			チップセラコン	01
C37	US063100	C. CE. CHP	1000pF 50V B			チップセラコン	01
C38-40	WD758300	C. CE. CHP	10uF 10V			チップセラコン	01
C41-43	US063100	C. CE. CHP	1000pF 50V B			チップセラコン	01
C44-46	US135100	C. CE. CHP	0. 1uF 16V			チップセラコン	01
C47	WD758300	C. CE. CHP	10uF 10V			チップセラコン	01
C48	US135100	C. CE. CHP	0. 1uF 16V			チップセラコン	01
C50	WD758300	C. CE. CHP	10uF 10V			チップセラコン	01
C51	US135100	C. CE. CHP	0. 1uF 16V			チップセラコン	01
C53-54	US135100	C. CE. CHP	0. 1uF 16V			チップセラコン	01
C55-56	WD758300	C. CE. CHP	10uF 10V			チップセラコン	01
C57	US063100	C. CE. CHP	1000pF 50V B			チップセラコン	01
C58	WD758300	C. CE. CHP	10uF 10V			チップセラコン	01
C59-61	US135100	C. CE. CHP	0. 1uF 16V			チップセラコン	01
C62	WG251600	C. CE. CHP	4. 7uF 6. 3V			チップセラコン	01
C64-66	US135100	C. CE. CHP	0. 1uF 16V			チップセラコン	01
C67	WG251600	C. CE. CHP	4. 7uF 6. 3V			チップセラコン	01
C69	UF027470	C. EL. CHP	47uF 10V			チップケミコン	01
C71-72	US135100	C. CE. CHP	0. 1uF 16V			チップセラコン	01
C73-74	WJ344400	C. CE. CHP	22uF 6. 3V			チップセラコン	01
C75	WD758300	C. CE. CHP	10uF 10V			チップセラコン	01
C76	US135100	C. CE. CHP	0. 1uF 16V			チップセラコン	01
C77	WD758300	C. CE. CHP	10uF 10V			チップセラコン	01

* New Parts * 新規部品

P.C.B. DIGITAL

Ref No.	Part No.	Description	Remarks	Markets	部 品 名	ランク
C78	US135100	C. CE. CHP	0. 1uF 16V		チップセラコン	01
C79-80	US062220	C. CE. CHP	220pF 50V B		チップセラコン	01
C81-82	US135100	C. CE. CHP	0. 1uF 16V		チップセラコン	01
C83	US063330	C. CE. CHP	3300pF 50V B		チップセラコン	01
C84	US063470	C. CE. CHP	4700pF 50V B		チップセラコン	01
C85	US063120	C. CE. CHP	1200pF 50V B		チップセラコン	01
C86	US135100	C. CE. CHP	0. 1uF 16V		チップセラコン	01
C87	US063120	C. CE. CHP	1200pF 50V B		チップセラコン	01
C88-90	US135100	C. CE. CHP	0. 1uF 16V		チップセラコン	01
C91-92	WD758300	C. CE. CHP	10uF 10V		チップセラコン	01
C93	US135100	C. CE. CHP	0. 1uF 16V		チップセラコン	01
C94	WD758300	C. CE. CHP	10uF 10V		チップセラコン	01
C97-101	US135100	C. CE. CHP	0. 1uF 16V		チップセラコン	01
C102	UR267470	C. EL	47uF 50V		ケミコン	01
C103	WG251600	C. CE. CHP	4. 7uF 6. 3V		チップセラコン	01
C104	US135100	C. CE. CHP	0. 1uF 16V		チップセラコン	01
C105	WH772100	C. EL	1000uF 10V		ケミコン	04
C106-124	US135100	C. CE. CHP	0. 1uF 16V		チップセラコン	01
C136	US135100	C. CE. CHP	0. 1uF 16V		チップセラコン	01
C137-138	US062470	C. CE. CHP	470pF 50V B		チップセラコン	01
C200	UR837330	C. EL	33uF 16V		ケミコン	01
C201	US062100	C. CE. CHP	100pF 50V B		チップセラコン	01
C202	US064100	C. CE. CHP	0. 01uF 50V B		チップセラコン	01
C204-205	US064100	C. CE. CHP	0. 01uF 50V B		チップセラコン	01
C207-211	US064100	C. CE. CHP	0. 01uF 50V B		チップセラコン	01
C212	US135100	C. CE. CHP	0. 1uF 16V		チップセラコン	01
C214	US135100	C. CE. CHP	0. 1uF 16V		チップセラコン	01
C215-216	US064100	C. CE. CHP	0. 01uF 50V B		チップセラコン	01
C217	US135100	C. CE. CHP	0. 1uF 16V		チップセラコン	01
C218-219	US064100	C. CE. CHP	0. 01uF 50V B		チップセラコン	01
C220-225	US135100	C. CE. CHP	0. 1uF 16V		チップセラコン	01
C226	WG251600	C. CE. CHP	4. 7uF 6. 3V		チップセラコン	01
C228-229	WG251600	C. CE. CHP	4. 7uF 6. 3V		チップセラコン	01
C231	US135100	C. CE. CHP	0. 1uF 16V		チップセラコン	01
C232	US046100	C. CE. CHP	1uF 25V	UCRTKABGEFL	チップセラコン	01
C234-238	US046100	C. CE. CHP	1uF 25V		チップセラコン	01
C239-242	US062100	C. CE. CHP	100pF 50V B		チップセラコン	01
C243	US064100	C. CE. CHP	0. 01uF 50V B		チップセラコン	01
C244-254	US135100	C. CE. CHP	0. 1uF 16V		チップセラコン	01
C400-401	WD758300	C. CE. CHP	10uF 10V	U	チップセラコン	01
C402-403	US064100	C. CE. CHP	0. 01uF 50V B		チップセラコン	01
C404	US061100	C. CE. CHP	10pF 50V B	U	チップセラコン	01
C405-406	US035100	C. CE. CHP	0. 1uF 16V B	U	チップセラコン	01
C407	US061100	C. CE. CHP	10pF 50V B	U	チップセラコン	01
C408-409	US035100	C. CE. CHP	0. 1uF 16V B	U	チップセラコン	01
C410	WG251600	C. CE. CHP	4. 7uF 6. 3V		チップセラコン	01
C411	US135100	C. CE. CHP	0. 1uF 16V		チップセラコン	01
C412	US035100	C. CE. CHP	0. 1uF 16V B		チップセラコン	01
C413-414	US135100	C. CE. CHP	0. 1uF 16V		チップセラコン	01
C415	US044220	C. CE. CHP	0. 022uF 25V B		チップセラコン	01
C416	US062100	C. CE. CHP	100pF 50V B		チップセラコン	01
C418	US062220	C. CE. CHP	220pF 50V B		チップセラコン	01
C419	WG251600	C. CE. CHP	4. 7uF 6. 3V		チップセラコン	01
C420	US062220	C. CE. CHP	220pF 50V B		チップセラコン	01
C421	US035100	C. CE. CHP	0. 1uF 16V B	U	チップセラコン	01
C422	US062220	C. CE. CHP	220pF 50V B		チップセラコン	01
C423	US035100	C. CE. CHP	0. 1uF 16V B	JBGEF	チップセラコン	01

* New Parts * 新規部品

P.C.B. DIGITAL

Ref No.	Part No.	Description	Remarks	Markets	部 品 名	ランク
C424-425	US135100	C. CE. CHP	0. 1uF 16V		チップセラコン	01
C426	US062220	C. CE. CHP	220pF 50V B		チップセラコン	01
C427	US035100	C. CE. CHP	0. 1uF 16V B	U	チップセラコン	01
C428	US064100	C. CE. CHP	0. 01uF 50V B	JBGEF	チップセラコン	01
C429	WD758300	C. CE. CHP	10uF 10V	JBGEF	チップセラコン	01
C430	UR067470	C. EL	47uF 50V		ケミコン	01
C431	US062100	C. CE. CHP	100pF 50V B		チップセラコン	01
C432-433	US062220	C. CE. CHP	220pF 50V B		チップセラコン	01
C434-436	US135100	C. CE. CHP	0. 1uF 16V		チップセラコン	01
C437-438	US062100	C. CE. CHP	100pF 50V B		チップセラコン	01
C439	US061100	C. CE. CHP	10pF 50V B		チップセラコン	01
C440	US060800	C. CE. CHP	8pF 50V B		チップセラコン	01
C441-442	US062390	C. CE. CHP	390pF 50V B		チップセラコン	01
C443-444	US035100	C. CE. CHP	0. 1uF 16V B	U	チップセラコン	01
C445-446	UR837100	C. EL	10uF 16V		ケミコン	01
C447-448	US135100	C. CE. CHP	0. 1uF 16V		チップセラコン	01
C449-450	UR237470	C. EL	47uF 16V		ケミコン	01
C451	US062100	C. CE. CHP	100pF 50V B		チップセラコン	01
C452	UR067100	C. EL	10uF 50V		ケミコン	01
C453	US126100	C. CE. CHP	1uF 10V		チップセラコン	01
C454-472	US135100	C. CE. CHP	0. 1uF 16V		チップセラコン	01
C473	US062680	C. CE. CHP	680pF 50V B		チップセラコン	01
C474-476	US135100	C. CE. CHP	0. 1uF 16V		チップセラコン	01
C477	WG251600	C. CE. CHP	4. 7uF 6. 3V		チップセラコン	01
C478-484	US135100	C. CE. CHP	0. 1uF 16V		チップセラコン	01
C485	WG251600	C. CE. CHP	4. 7uF 6. 3V		チップセラコン	01
C486	US135100	C. CE. CHP	0. 1uF 16V		チップセラコン	01
C488-489	UU297220	C. EL	22uF 100V		ケミコン	01
C491-493	US135100	C. CE. CHP	0. 1uF 16V		チップセラコン	01
C494-496	US063100	C. CE. CHP	1000pF 50V B		チップセラコン	01
C497-498	US135100	C. CE. CHP	0. 1uF 16V		チップセラコン	01
C499-502	US063100	C. CE. CHP	1000pF 50V B		チップセラコン	01
C503-519	US135100	C. CE. CHP	0. 1uF 16V		チップセラコン	01
C600	WK041800	C. EL	10uF 16V		ケミコン	01
C601-603	US135100	C. CE. CHP	0. 1uF 16V		チップセラコン	01
C604-605	US064100	C. CE. CHP	0. 01uF 50V B		チップセラコン	01
C606	UR067100	C. EL	10uF 50V		ケミコン	01
C607	US064100	C. CE. CHP	0. 01uF 50V B	U	チップセラコン	01
C608-609	US135100	C. CE. CHP	0. 1uF 16V		チップセラコン	01
C610	US126100	C. CE. CHP	1uF 10V		チップセラコン	01
C611	US062100	C. CE. CHP	100pF 50V B		チップセラコン	01
C612	UR067100	C. EL	10uF 50V		ケミコン	01
C613-614	US126100	C. CE. CHP	1uF 10V		チップセラコン	01
C615	UR237100	C. EL	10uF 16V	U	ケミコン	01
C616-617	US135100	C. CE. CHP	0. 1uF 16V	U	チップセラコン	01
C618	US063100	C. CE. CHP	1000pF 50V B		チップセラコン	01
C619	US135100	C. CE. CHP	0. 1uF 16V		チップセラコン	01
C620	UR348100	C. EL	100uF 25V		ケミコン	01
C621	UR218100	C. EL	100uF 6. 3V	U	ケミコン	01
C622	UR067100	C. EL	10uF 50V		ケミコン	01
C623	US135100	C. CE. CHP	0. 1uF 16V		チップセラコン	01
C624	WK041800	C. EL	10uF 16V		ケミコン	01
C625	US135100	C. CE. CHP	0. 1uF 16V		チップセラコン	01
C626	UR067100	C. EL	10uF 50V		ケミコン	01
C627-628	WJ603600	C. MYLAR	820pF 50V J		マイラーコン	01
C629-630	UR837100	C. EL	10uF 16V	U	ケミコン	01
C633-634	UR067100	C. EL	10uF 50V		ケミコン	01

* New Parts * 新規部品

P.C.B. DIGITAL

Ref No.	Part No.	Description	Remarks	Markets	部 品 名	ランク
C635-642	US062100	C. CE. CHP	100pF 50V B		チップセラコン	01
C643-644	US663330	C. CE. CHP	3300pF 50V	U	チップセラコン	
C700-702	US135100	C. CE. CHP	0. 1uF 16V		チップセラコン	01
C703-704	WD758300	C. CE. CHP	10uF 10V		チップセラコン	01
C705-706	US135100	C. CE. CHP	0. 1uF 16V		チップセラコン	01
C707-708	WD758300	C. CE. CHP	10uF 10V		チップセラコン	01
C709-710	US135100	C. CE. CHP	0. 1uF 16V		チップセラコン	01
C711-712	US064100	C. CE. CHP	0. 01uF 50V B		チップセラコン	01
C713	UF037220	C. EL. CHP	22uF 16V		チップケミコン	01
C714-717	US135100	C. CE. CHP	0. 1uF 16V		チップセラコン	01
C718	US034390	C. CE. CHP	0. 039uF 16V B		チップセラコン	01
C719-721	US135100	C. CE. CHP	0. 1uF 16V		チップセラコン	01
C722-723	US063100	C. CE. CHP	1000pF 50V B		チップセラコン	01
C724-725	US135100	C. CE. CHP	0. 1uF 16V		チップセラコン	01
C726	US064100	C. CE. CHP	0. 01uF 50V B		チップセラコン	01
C727	US135100	C. CE. CHP	0. 1uF 16V		チップセラコン	01
C728	US064100	C. CE. CHP	0. 01uF 50V B		チップセラコン	01
C729	US135100	C. CE. CHP	0. 1uF 16V		チップセラコン	01
C730	VZ243400	C. CE. CHP	0. 33uF 16V		チップセラコン	01
C731	VZ281900	C. CE. CHP	0. 47uF 16V K		チップセラ	01
C732	US034820	C. CE. CHP	0. 082uF 16V K		チップセラコン	01
C733	US064100	C. CE. CHP	0. 01uF 50V B		チップセラコン	01
C734	US135100	C. CE. CHP	0. 1uF 16V		チップセラコン	01
C735	US061100	C. CE. CHP	10pF 50V B		チップセラコン	01
C736	US060800	C. CE. CHP	8pF 50V B		チップセラコン	01
C737-742	US135100	C. CE. CHP	0. 1uF 16V		チップセラコン	01
C743	UF037220	C. EL. CHP	22uF 16V		チップケミコン	01
C744-746	US135100	C. CE. CHP	0. 1uF 16V		チップセラコン	01
C747	UF037100	C. EL. CHP	10uF 16V		チップケミコン	01
C748-749	US135100	C. CE. CHP	0. 1uF 16V		チップセラコン	01
C750	UF037220	C. EL. CHP	22uF 16V		チップケミコン	01
C751	US135100	C. CE. CHP	0. 1uF 16V		チップセラコン	01
C752	UF037220	C. EL. CHP	22uF 16V		チップケミコン	01
C753	US135100	C. CE. CHP	0. 1uF 16V		チップセラコン	01
C754	UF037100	C. EL. CHP	10uF 16V		チップケミコン	01
C755-757	US135100	C. CE. CHP	0. 1uF 16V		チップセラコン	01
C758	UF037220	C. EL. CHP	22uF 16V		チップケミコン	01
C759	US135100	C. CE. CHP	0. 1uF 16V		チップセラコン	01
C760	UF037220	C. EL. CHP	22uF 16V		チップケミコン	01
C761	US062100	C. CE. CHP	100pF 50V B		チップセラコン	01
C762	US135100	C. CE. CHP	0. 1uF 16V		チップセラコン	01
C763	UF037220	C. EL. CHP	22uF 16V		チップケミコン	01
C764-766	US135100	C. CE. CHP	0. 1uF 16V		チップセラコン	01
C767-768	US064100	C. CE. CHP	0. 01uF 50V B		チップセラコン	01
C769	US135100	C. CE. CHP	0. 1uF 16V		チップセラコン	01
C770-771	US064100	C. CE. CHP	0. 01uF 50V B		チップセラコン	01
C772	US135100	C. CE. CHP	0. 1uF 16V		チップセラコン	01
C773	US064100	C. CE. CHP	0. 01uF 50V B		チップセラコン	01
C774-776	US135100	C. CE. CHP	0. 1uF 16V		チップセラコン	01
C777-778	US064100	C. CE. CHP	0. 01uF 50V B		チップセラコン	01
C779-780	US135100	C. CE. CHP	0. 1uF 16V		チップセラコン	01
C781	US064100	C. CE. CHP	0. 01uF 50V B		チップセラコン	01
C782-790	US135100	C. CE. CHP	0. 1uF 16V		チップセラコン	01
C791	UF037220	C. EL. CHP	22uF 16V		チップケミコン	01
C792-794	US135100	C. CE. CHP	0. 1uF 16V		チップセラコン	01
C795	UF037100	C. EL. CHP	10uF 16V		チップケミコン	01
C796-797	US063100	C. CE. CHP	1000pF 50V B		チップセラコン	01

* New Parts * 新規部品

P.C.B. DIGITAL

Ref No.	Part No.	Description	Remarks	Markets	部 品 名	ランク	
C798-799	US064100	C. CE. CHP	0. 01uF 50V B			チップセラコン	01
C800-806	US135100	C. CE. CHP	0. 1uF 16V			チップセラコン	01
D2	WE674800	DIODE	AVRL161A1R1NTB			チップバリスタ	01
D11-14	WE674800	DIODE	AVRL161A1R1NTB			チップバリスタ	01
D23-26	WE674800	DIODE	AVRL161A1R1NTB			チップバリスタ	01
D35-38	WE674800	DIODE	AVRL161A1R1NTB			チップバリスタ	01
D47-49	WE674800	DIODE	AVRL161A1R1NTB			チップバリスタ	01
D60-61	WE674800	DIODE	AVRL161A1R1NTB			チップバリスタ	01
D62	VV220700	DIODE. SHOT	RB501V-40			ショットキーダイオード	01
D63-64	V6267600	DIODE	RB051L-40			ダイオード	01
D65	WE674800	DIODE	AVRL161A1R1NTB			チップバリスタ	01
D200-204	VU990900	DIODE. ZENR	MAZ8033GHL 3. 4V			ツェナーダイオード	01
D400-402	WE674800	DIODE	AVRL161A1R1NTB		U	チップバリスタ	01
D403-404	VT332900	DIODE	1SS355			ダイオード	01
D600	VT332900	DIODE	1SS355			ダイオード	01
D602-603	VT332900	DIODE	1SS355			ダイオード	01
D702-703	VT332900	DIODE	1SS355			ダイオード	01
IC2	XZ287A00	IC	SN74LVC245APWR			ロジック I C	02
IC3	XS775A00	IC	TC7SH04FU			ロジック I Cフラット	01
IC5	X7195A00	IC	R1172S121D-E2-F			電源 I C	04
IC10	X7741A00	IC	NJM2867F3-05 (TE1)			電源 I C	02
IC11	X0199B00	IC	TC74VHC157FT (EL, K)			ロジック I C	01
* IC13	YA255A00	IC	R1172H501D-T1-F			電源 I C	01
IC20	X8328A00	IC. CPU	M30878FJBGPF	unwritten		I C CPU	10
IC21	X8194A00	IC	R1172H331D-T1-F			電源 I C	03
* IC22	YA398A00	IC. MEMORY	LE25LA322M-TLM-E		JCRTKABGEFL	メモリ I C	
* IC22	YA739A00	IC. MEMORY	LE25LB2562M-TLM-E		U	メモリ I C	
IC40	X8192A00	IC	F2621E-01-TR		U	I C	
* IC41	YA399A00	IC	LC89058WD-E			I C	
IC43	X7378A00	IC	NJM4565M (TE1)			アンプ I C	01
* IC45	X9798B00	IC	CS230003-CZZR		JBGEF	I C デジタル	
IC46	X0199B00	IC	TC74VHC157FT (EL, K)			ロジック I C	01
* IC47	YC008A00	IC	R1173S001D-E2-F			電源 I C	
IC48	X9626B00	IC. MEMORY	K4S641632N-LC60000			メモリ I C 64 M	
* IC49	YA541A00	IC. MEMORY	MX29LV160DBT1-70G	written		メモリ I C 16 M	
IC50	XR680A00	IC	TC7SH08FU (TE85L, JF)			ロジック I C	01
IC51	XR680A00	IC	TC7SH08FU (TE85L, JF)		JBGEF	ロジック I C	01
IC61	X7375A00	IC	PCM1781DBQR		U	I C	04
IC62	X0199B00	IC	TC74VHC157FT (EL, K)			ロジック I C	01
IC63	XS534A00	IC	NJM78M05DL1A			電源 I C	02
IC65	X7355A00	IC	PCM1680DBQR			I C	07
IC66	X7357A00	IC	PCM1803DBR			I C	04
IC67	X3586B00	IC	TC74VHCT08AFT EL, K			ロジック I C	01
IC68	XR680A00	IC	TC7SH08FU (TE85L, JF)		U	ロジック I C	01
IC70	X9393A00	IC	ADV7800BSTZ-80			I C ビデオデコーダ	13
* IC71	YA215A00	IC	ABT1012			ビデオスケーラ	
IC72	X6671A00	IC	ADV7172KSTZ			I C	09
IC73	X9460A00	IC	R1172H181B-T1-F			電源 I C	03
IC74	X8194A00	IC	R1172H331D-T1-F			電源 I C	03
IC75	X8531A00	IC	TC7WZ32FK			ロジック I C	02
IC76-78	XZ283A00	IC	SN74LVTH245APW BUS			ロジック I C	04
Q1-8	VQ986700	TR	2SC4081 T106			トランジスタ	01
Q200	WQ381000	FET	MCH6336-TL-E			MOS FET	
Q201-202	VV655300	TR. DGT	DTA144EKA			デジタルトランジスタ	01
Q203	VR936300	TR	2SA1576A T106		UCR TKABGEFL	トランジスタ	01
Q205-209	VR936300	TR	2SA1576A T106			トランジスタ	01
Q400	WQ381000	FET	MCH6336-TL-E			MOS FET	

* New Parts * 新規部品

P.C.B. DIGITAL and P.C.B. OPERATION

Ref No.	Part No.	Description	Remarks	Markets	部 品 名	ランク
Q401	VV655300	TR. DGT	DTA144EKA		デジタルトランジスタ	01
Q402	WQ381000	FET	MCH6336-TL-E		MOS FET	
Q403	VV655000	TR. DGT	DTA114EKA		デジタルトランジスタ	01
Q404	VV655300	TR. DGT	DTA144EKA		デジタルトランジスタ	01
Q600	VV655200	TR. DGT	DTA143EKA		デジタルトランジスタ	01
Q601	VV655700	TR. DGT	DTC144EKA		デジタルトランジスタ	01
Q700	WQ381000	FET	MCH6336-TL-E		MOS FET	
Q701	VR936300	TR	2SA1576A T106		トランジスタ	01
Q702	WQ381000	FET	MCH6336-TL-E		MOS FET	
Q703	VR936300	TR	2SA1576A T106		トランジスタ	01
Q704	WE834500	FET	UPA672T-T1-A		FET	01
R88	V8070100	R. MTL. FLM	2. 2Ω 1W		金属被膜抵抗	01
R201	RD358100	R. CHP	100KΩ 1/16W J	V1065	チップ抵抗	01
R466-467	HV753220	R. CAR. FP	2. 2Ω 1/4W		不燃化カーボン抵抗	01
R601	WQ072300	R. MTL. OXD	2. 2Ω 1W		酸化金属被膜抵抗	
R601	V8070100	R. MTL. FLM	2. 2Ω 1W		金属被膜抵抗	01
R607	HV753220	R. CAR. FP	2. 2Ω 1/4W		不燃化カーボン抵抗	01
ST1-2	V4040500	SCR. TERM	M3		スクリュー/ターミナル	01
* XL1	WR725300	RSNR. CRY	27MHz SMD-49		水晶振動子	
XL20	WF997400	RSNR. CE	20MHz		セラミック振動子	02
* XL41	WR846900	RSNR. CRY	45. 1984MHz DSX321G	U	水晶振動子	
XL42	V3625700	RSNR. CRY	24. 576MHz		水晶振動子	03
XL70	VZ772700	RSNR. CRY	28. 63636MHz		水晶振動子	03
* * * * *	WR434700	P. C. B.	OPERATION	J	PCB OPERATION	
	WR434800	P. C. B.	OPERATION	U	PCB OPERATION	
	WR434900	P. C. B.	OPERATION	CRTA	PCB OPERATION	
	WR435000	P. C. B.	OPERATION	KBGEFL	PCB OPERATION	
CB401	VQ045400	CN. BS. PIN	25P		FFCコネクタ	03
CB402	VQ044400	CN. BS. PIN	9P		FFCコネクタ	01
CB451	VQ961100	CN. BS. PIN	8P		ハウジング	01
CB452	V9357000	CN	19P TE		JEコネクタ	
CB454	VQ962100	CN. BS. PIN	18P		ハウジング	03
CB455	V9357000	CN	19P TE		JEコネクタ	
CB456	VQ961800	CN. BS. PIN	15P		ハウジング	01
CB457	VQ961400	CN. BS. PIN	11P		ハウジング	03
CB458	V9357000	CN	19P TE		JEコネクタ	
CB459	VQ963300	CN. BS. PIN	12P		ウエハー	01
CB460	VQ963100	CN. BS. PIN	10P		ウエハー	01
CB461	VQ044400	CN. BS. PIN	9P		FFCコネクタ	01
CB462	VK026400	CN. BS. PIN	5P		ワイヤートラップ	01
CB463	VQ585700	CN. JUMPER	7P		ジャンパーコネクタ	03
CB471	WQ680200	CN. USB	4P TE AAPVA004C0		USBコネクタ	
CB475	VK024900	CN. BS. PIN	52147 5P TE		ワイヤートラップ	01
CB477	VB858300	CN. BS. PIN	4P		コネクタベースポスト	01
C4001	US063100	C. CE. CHP	1000pF 50V B		チップセラコン	01
C4002	US065100	C. CE. CHP	0. 1uF 50V B		チップセラコン	01
C4003	UR067100	C. EL	10uF 50V		ケミコン	01
C4004	US064100	C. CE. CHP	0. 01uF 50V B		チップセラコン	01
C4005	UR837220	C. EL	22uF 16V		ケミコン	01
C4006	US062100	C. CE. CHP	100pF 50V B		チップセラコン	01
C4007	UR257470	C. EL	47uF 35V		ケミコン	01
C4008	US061330	C. CE. CHP	33pF 50V B		チップセラコン	01
C4009-4010	UR267220	C. EL	22uF 50V		ケミコン	01
C4011	UR067100	C. EL	10uF 50V		ケミコン	01

* New Parts * 新規部品

P.C.B. OPERATION

Ref No.	Part No.	Description	Remarks	Markets	部 品 名	ランク
C4012-4013	US135100	C. CE. CHP	0. 1uF 16V		チップセラコン	01
C4015	UR268220	C. EL	220uF 50V		ケミコン	01
C4016	UM388330	C. EL	330uF 6. 3V		ケミコン	01
C4017	US135100	C. CE. CHP	0. 1uF 16V		チップセラコン	01
C4018	US061680	C. CE. CHP	68pF 50V B		チップセラコン	01
C4019	US065100	C. CE. CHP	0. 1uF 50V B		チップセラコン	01
C4020-4021	US135100	C. CE. CHP	0. 1uF 16V		チップセラコン	01
C4022	US064100	C. CE. CHP	0. 01uF 50V B		チップセラコン	01
C4023-4024	US063100	C. CE. CHP	1000pF 50V B		チップセラコン	01
C4025-4026	US065100	C. CE. CHP	0. 1uF 50V B		チップセラコン	01
C4027	US135100	C. CE. CHP	0. 1uF 16V		チップセラコン	01
C4028	US062100	C. CE. CHP	100pF 50V B		チップセラコン	01
C4030	US062100	C. CE. CHP	100pF 50V B		チップセラコン	01
C4031	US062470	C. CE. CHP	470pF 50V B		チップセラコン	01
C4032	US135100	C. CE. CHP	0. 1uF 16V		チップセラコン	01
C4033	US063100	C. CE. CHP	1000pF 50V B		チップセラコン	01
C4034	UM417100	C. EL	10uF 50V		ケミコン	01
C4035	US135100	C. CE. CHP	0. 1uF 16V		チップセラコン	01
C4036-4040	US063100	C. CE. CHP	1000pF 50V B		チップセラコン	01
C4041-4046	US135100	C. CE. CHP	0. 1uF 16V		チップセラコン	01
C4202	US063100	C. CE. CHP	1000pF 50V B	U	チップセラコン	01
C4205-4211	US062220	C. CE. CHP	220pF 50V B	U	チップセラコン	01
C4212	US062100	C. CE. CHP	100pF 50V B		チップセラコン	01
C4213	UR267100	C. EL	10uF 50V		ケミコン	
C4214	WK041800	C. EL	10uF 16V		ケミコン	01
C4215	WJ603500	C. MYLAR	680pF 50V		マイラーコン	
C4216	US135100	C. CE. CHP	0. 1uF 16V		チップセラコン	01
C4217	UR267470	C. EL	47uF 50V		ケミコン	01
C4218	US135100	C. CE. CHP	0. 1uF 16V		チップセラコン	01
C4219	UR267470	C. EL	47uF 50V		ケミコン	01
C4220	WJ603500	C. MYLAR	680pF 50V		マイラーコン	
C4221	WK041800	C. EL	10uF 16V		ケミコン	01
C4222	UR267100	C. EL	10uF 50V		ケミコン	
C4223-4224	US062100	C. CE. CHP	100pF 50V B		チップセラコン	01
C4225	UR267100	C. EL	10uF 50V		ケミコン	
C4226	WK041800	C. EL	10uF 16V		ケミコン	01
C4227	WJ603500	C. MYLAR	680pF 50V		マイラーコン	
C4228-4229	US135100	C. CE. CHP	0. 1uF 16V		チップセラコン	01
C4230	WJ605800	C. MYLAR	0. 047uF 50V J		マイラーコン	01
C4231-4232	UR267100	C. EL	10uF 50V		ケミコン	
C4233	WJ604700	C. MYLAR	6800pF 50V		マイラーコン	
C4234	US062100	C. CE. CHP	100pF 50V B		チップセラコン	01
C4235	UR267100	C. EL	10uF 50V		ケミコン	
C4236	WK041800	C. EL	10uF 16V		ケミコン	01
C4237	WJ603500	C. MYLAR	680pF 50V		マイラーコン	
C4238-4239	US135100	C. CE. CHP	0. 1uF 16V		チップセラコン	01
C4240	WJ603500	C. MYLAR	680pF 50V		マイラーコン	
C4241	WK041800	C. EL	10uF 16V		ケミコン	01
C4242	UR267100	C. EL	10uF 50V		ケミコン	
C4243-4244	US062100	C. CE. CHP	100pF 50V B		チップセラコン	01
C4245	UR267100	C. EL	10uF 50V		ケミコン	
C4246	WK041800	C. EL	10uF 16V		ケミコン	01
C4247	WJ603500	C. MYLAR	680pF 50V		マイラーコン	
C4248-4249	US135100	C. CE. CHP	0. 1uF 16V		チップセラコン	01
C4250	WJ603500	C. MYLAR	680pF 50V		マイラーコン	
C4251	WK041800	C. EL	10uF 16V		ケミコン	01
C4252	UR267100	C. EL	10uF 50V		ケミコン	

* New Parts * 新規部品

P.C.B. OPERATION

Ref No.	Part No.	Description	Remarks	Markets	部 品 名	ランク
C4253	US062100	C. CE. CHP	100pF 50V B		チップセラコン	01
C4254-4255	UR067100	C. EL	10uF 50V		ケミコン	01
C4301-4302	UR267470	C. EL	47uF 50V		ケミコン	01
C4303-4304	WJ603700	C. MYLAR	1000pF 50V		マイラーコン	01
C4305-4306	UR267100	C. EL	10uF 50V		ケミコン	
C4307-4308	WJ605600	C. MYLAR	0.033uF 50V		マイラーコン	
C4309-4310	WJ604900	C. MYLAR	9100pF 50V		マイラーコン	
C4311-4312	UR218220	C. EL	220uF 6.3V		ケミコン	
C4313-4314	WJ603100	C. MYLAR	220pF 50V		マイラーコン	01
C4315	WJ603100	C. MYLAR	220pF 50V	CRTKABGEFL	マイラーコン	01
C4316	WJ603100	C. MYLAR	220pF 50V	CRTKABGEFL	マイラーコン	01
C4317	US064100	C. CE. CHP	0.01uF 50V B		チップセラコン	01
C4318-4321	WJ605000	C. MYLAR	0.01uF 50V J		マイラーコン	01
C4401	US062100	C. CE. CHP	100pF 50V B		チップセラコン	01
C4402	US063100	C. CE. CHP	1000pF 50V B		チップセラコン	01
C4403	WJ604300	C. MYLAR	3300pF 50V		マイラーコン	
C4404-4405	US062220	C. CE. CHP	220pF 50V B		チップセラコン	01
C4406	WJ604300	C. MYLAR	3300pF 50V		マイラーコン	
C4407	US064100	C. CE. CHP	0.01uF 50V B		チップセラコン	01
C4410	US135100	C. CE. CHP	0.1uF 16V		チップセラコン	01
C4411	US060500	C. CE. CHP	5pF 50V B		チップセラコン	01
C4413	US060500	C. CE. CHP	5pF 50V B		チップセラコン	01
C4414	US063100	C. CE. CHP	1000pF 50V B		チップセラコン	01
C4415	US135100	C. CE. CHP	0.1uF 16V		チップセラコン	01
C4417	US126100	C. CE. CHP	1uF 10V		チップセラコン	01
C4418	US062220	C. CE. CHP	220pF 50V B		チップセラコン	01
C4419	US063100	C. CE. CHP	1000pF 50V B		チップセラコン	01
D4001-4002	VT332900	DIODE	1SS355		ダイオード	01
D4003	VU171900	DIODE. ZENR	UDZ5.1B 5.1V		ツェナーダイオード	01
D4004-4005	VT332900	DIODE	1SS355		ダイオード	01
D4006-4007	VU991000	DIODE. ZENR	MAZ8036GLL 3.5V		ツェナーダイオード	01
D4008	WG760400	LED	SELK6E10C BLUE		LED	04
* D4009	WR095700	LED	8224-10SDRD/S530A3		LED	01
D4011	V2598200	LED	S1R-505ST		LED	01
D4301-4302	VV659300	DIODE. ZENR	RLZ7.5B 7.5V		ツェナーダイオード	01
D4303	VT332900	DIODE	1SS355		ダイオード	01
D4401-4402	VT332900	DIODE	1SS355		ダイオード	01
D4404-4405	VT332900	DIODE	1SS355		ダイオード	01
D4408	VT332900	DIODE	1SS355		ダイオード	01
D4410	VT332900	DIODE	1SS355		ダイオード	01
IC401	X7378A00	IC	NJM4565M (TE1)		アンプ IC	01
IC402	X6386A00	IC	M66003-0131FP		IC	07
IC451-454	X5482A00	IC	NE5532DR OP AMP		アンプ IC	01
IC461	X3505A00	IC	NJM2068MD-TE2		アンプ IC	02
JK401	WC814400	JACK. MNI	JY-3554-01-130		ミニジャック	02
JK451	VV269500	CN	8P DIN	U	複合コネクタ	03
JK472	V9408200	JACK. PHONE	MSJ-064-05B GR		ホーンジャック	03
PJ461	WD599600	JACK. PIN	2P MSP-252V2-06 NI		ピンジャック 2P	01
PJ471	WJ117500	JACK. PIN	3P		ピンジャック	03
Q4001-4003	WC529400	TR	KTC3875S Y GR RTK		トランジスタ	01
Q4004	VV655400	TR. DGT	DTC114EKA		デジタルトランジスタ	01
Q4005	WC397700	TR	2N5401C-AT		トランジスタ	
Q4006-4012	WC529400	TR	KTC3875S Y GR RTK		トランジスタ	01
Q4301	VV655400	TR. DGT	DTC114EKA		デジタルトランジスタ	01
Q4302	VV655000	TR. DGT	DTA114EKA		デジタルトランジスタ	01
R4208-4209	WQ072300	R. MTL. OXD	2.2Ω 1W		酸化金属被膜抵抗	
R4301-4302	WQ964700	R. MTL. OXD	470Ω 1W		酸化金属被膜抵抗	

* New Parts * 新規部品

P.C.B. OPERATION and P.C.B. MAIN

Ref No.	Part No.	Description	Remarks	Markets	部 品 名	ランク
R4320-4321	HV757100	R. CAR. FP	10KΩ 1/4W		不燃化カーボン抵抗	01
R4413-4414	V8071300	R. MTL. FLM	470Ω 1W		金属被膜抵抗	
RY461	WJ122400	RELAY	981-2A-24DS-SP7		リレー 24V	04
ST451	V4040500	SCR. TERM	M3	JCRTKABGEFL	スクリュー／ターミナル	01
ST461	V4040500	SCR. TERM	M3		スクリュー／ターミナル	01
ST471	V4040500	SCR. TERM	M3		スクリュー／ターミナル	01
SW401-404	WD483100	SW. TACT	SKRGAAD010		タクト SW	01
SW406-407	WD483100	SW. TACT	SKRGAAD010		タクト SW	01
SW409-413	WD483100	SW. TACT	SKRGAAD010		タクト SW	01
SW415	WD483100	SW. TACT	SKRGAAD010		タクト SW	01
SW417-419	WD483100	SW. TACT	SKRGAAD010		タクト SW	01
SW421	WD483100	SW. TACT	SKRGAAD010		タクト SW	01
SW424	WD483100	SW. TACT	SKRGAAD010		タクト SW	01
SW441-442	V9266400	SW. RT. ENC	XREB12105PVB25F		ロータリーエンコーダ	02
SW443	V9597100	SW. RT. ENC	EC12E2460802		ロータリーエンコーダ	04
SW471	WD483100	SW. TACT	SKRGAAD010		タクト SW	01
TE461	WK560800	TERM. SP	4P MST-204V1-01 NC	JUCRTA	スピーカーターミナル	04
TE461	WK560900	TERM. SP	4P MST-204V1-01 WC	KBGEFL	スピーカーターミナル	
TE463	WB782600	AC INLET	R-30190 (26)	J	A Cインレット 2P	
U4001	WQ600700	L. DTCT	SM3385VMH6		リモコン受光ユニット	03
V4001	WQ842100	FL. DSPLY	18-MT-09GNK		蛍光表示管	08
	V6007100	SPACER. FL	4. 6/10/32		スペーサ FL	
*	WR431100	P. C. B.	MAIN		P C B M A I N	
*	WR431200	P. C. B.	MAIN		P C B M A I N	
*	WR431200	P. C. B.	MAIN	V1065	P C B M A I N	
*	WR431700	P. C. B.	MAIN	6280	P C B M A I N	
*	WR431300	P. C. B.	MAIN		P C B M A I N	
*	WR431400	P. C. B.	MAIN		P C B M A I N	
*	WR431500	P. C. B.	MAIN		P C B M A I N	
CB111-112	WN077700	CLIP. FUSE	CLIP PFC5000-0202F		ヒューズクリップ	
CB152	VQ962900	CN. BS. PIN	8P		ウエハー	01
CB153	VQ963900	CN. BS. PIN	18P		ウエハー	03
CB154	VQ963600	CN. BS. PIN	15P		ウエハー	01
CB155	VQ963200	CN. BS. PIN	11P		ウエハー	03
C1001-1003	WK041800	C. EL	10uF 16V		ケミコン	01
C1004-1007	UR257100	C. EL	10uF 35V		ケミコン	01
C1008-1010	WE100900	C. PP	220pF 630V		PPコン	02
C1011-1014	WN164200	C. PP	220pF 100V		PPコン	01
C1015-1017	WE100600	C. PP	120pF 630V		PPコン	
C1018-1021	WQ107500	C. PP	120pF 100V		PPコン	
C1022-1024	WE102300	C. PP	3300pF 100V		PPコン	01
C1025-1028	WN164900	C. PP	3300pF 100V		PPコン	01
C1029	UR067470	C. EL	47uF 50V		ケミコン	01
C1030-1031	UR068100	C. EL	100uF 50V		ケミコン	01
C1032-1035	UR067470	C. EL	47uF 50V		ケミコン	01
C1036-1042	WE100200	C. PP	22pF 630V		PPコン	01
C1043-1049	WN164300	C. PP	330pF 100V		PPコン	01
C1050-1052	UR397100	C. EL	10uF 100V		ケミコン	03
C1053-1056	UR067100	C. EL	10uF 50V		ケミコン	01
C1057-1063	WN165500	C. PP	0. 022uF 100V		PPコン	01
C1066-1067	WN156000	C. PP	1000pF 250V		PPコン	01
C1068	UR866470	C. EL	4. 7uF 50V		ケミコン	01
C1069	UR838100	C. EL	100uF 16V		ケミコン	01
C1070-1073	UR297100	C. EL	10uF 100V		ケミコン	

* New Parts * 新規部品

P.C.B. MAIN

△

Ref No.	Part No.	Description	Remarks	Markets	部 品 名	ランク
C1074	UR267330	C. EL 33uF 50V			ケミコン	01
C1075	WK041800	C. EL 10uF 16V			ケミコン	01
C1076	UR266100	C. EL 1uF 50V			ケミコン	01
C1078-1079	WP421000	C. PP 0.047uF 100V			PPコン	
C1080-1081	WN165500	C. PP 0.022uF 100V			PPコン	01
C1082	UR049330	C. EL 3300uF 25V			ケミコン	03
C1083	UR049220	C. EL 2200uF 25V			ケミコン	01
C1084-1085	WP370300	C. EL 10000uF 71V			ケミコン	
C1086	UR049220	C. EL 2200uF 25V			ケミコン	01
C1087-1088	WK041800	C. EL 10uF 16V			ケミコン	01
C1089	US135100	C. CE. CHP 0.1uF 16V			チップセラコン	01
C1509	UR067470	C. EL 47uF 50V			ケミコン	01
C1510-1512	US135100	C. CE. CHP 0.1uF 16V			チップセラコン	01
C1513-1514	US061220	C. CE. CHP 22pF 50V B			チップセラコン	01
C1515-1516	US135100	C. CE. CHP 0.1uF 16V			チップセラコン	01
C1517-1520	US062220	C. CE. CHP 220pF 50V B			チップセラコン	01
C1521	UR267100	C. EL 10uF 50V			ケミコン	
C1522	US061470	C. CE. CHP 47pF 50V B			チップセラコン	01
C1523	UR238100	C. EL 100uF 16V			ケミコン	
C1524	US061470	C. CE. CHP 47pF 50V B			チップセラコン	01
C1525	UR267100	C. EL 10uF 50V			ケミコン	
C1526-1527	UR238100	C. EL 100uF 16V			ケミコン	
C1528-1529	US062220	C. CE. CHP 220pF 50V B			チップセラコン	01
C1530	UR238100	C. EL 100uF 16V			ケミコン	
C1531	UR267330	C. EL 33uF 50V			ケミコン	01
C1532-1533	UR238100	C. EL 100uF 16V			ケミコン	
C1534-1535	US062220	C. CE. CHP 220pF 50V B			チップセラコン	01
C1536	UR238100	C. EL 100uF 16V			ケミコン	
C1537	WJ605600	C. MYLAR 0.033uF 50V			マイラーコン	
C1538	VR169000	C. MYLAR 0.33uF 50V			マイラーコン	01
C1539	WJ604800	C. MYLAR 8200pF 50V			マイラーコン	
C1540	WJ605600	C. MYLAR 0.033uF 50V			マイラーコン	
C1541	VR169000	C. MYLAR 0.33uF 50V			マイラーコン	01
C1542	US135100	C. CE. CHP 0.1uF 16V			チップセラコン	01
C1543	WJ604800	C. MYLAR 8200pF 50V			マイラーコン	
C1544	US062220	C. CE. CHP 220pF 50V B			チップセラコン	01
C1545	US135100	C. CE. CHP 0.1uF 16V			チップセラコン	01
C1546	US062220	C. CE. CHP 220pF 50V B			チップセラコン	01
C1547	UR267100	C. EL 10uF 50V			ケミコン	
C1549	UR267100	C. EL 10uF 50V			ケミコン	
C1551	US062220	C. CE. CHP 220pF 50V B			チップセラコン	01
C1552	UR267100	C. EL 10uF 50V			ケミコン	
C1553-1554	UR266220	C. EL 2.2uF 50V			ケミコン	
C1555-1556	UR267100	C. EL 10uF 50V			ケミコン	
C1557	US062220	C. CE. CHP 220pF 50V B			チップセラコン	01
C1558-1559	UR267470	C. EL 47uF 50V			ケミコン	01
C1560	US062220	C. CE. CHP 220pF 50V B			チップセラコン	01
C1563	US062220	C. CE. CHP 220pF 50V B			チップセラコン	01
C1566	US062220	C. CE. CHP 220pF 50V B			チップセラコン	01
C1567	VR169200	C. MYLAR 0.47uF 50V			マイラーコン	01
C1568	VR169200	C. MYLAR 0.47uF 50V			マイラーコン	01
C1568	VR169200	C. MYLAR 0.47uF 50V	V1065	JURTKABGEFL C	マイラーコン	01
C1569	US062220	C. CE. CHP 220pF 50V B			チップセラコン	01
C1570	UR267100	C. EL 10uF 50V			ケミコン	
C1571	UR267100	C. EL 10uF 50V			ケミコン	
C1571	UR267100	C. EL 10uF 50V	V1065	JURTKABGEFL C	ケミコン	
C1572-1573	US062100	C. CE. CHP 100pF 50V B			チップセラコン	01

* New Parts * 新規部品

RX-V1065/HTR-6280/
AX-V1065

P.C.B. MAIN

Ref No.	Part No.	Description	Remarks	Markets	部 品 名	ランク
C1574	UR267100	C. EL	10uF 50V		ケミコン	
C1575	US061470	C. CE. CHP	47pF 50V B		チップセラコン	01
C1576	UR267100	C. EL	10uF 50V		JURTKABGEFL	
C1576	UR267100	C. EL	10uF 50V	V1065	C	ケミコン
C1577	UR267100	C. EL	10uF 50V		ケミコン	
C1578	US061470	C. CE. CHP	47pF 50V B		チップセラコン	01
C1579	UR267100	C. EL	10uF 50V		ケミコン	
C1580	UR837100	C. EL	10uF 16V		UCRTKABGEFL	01
C1581	US061470	C. CE. CHP	47pF 50V B		UCRTKABGEFL	01
C1582	US061470	C. CE. CHP	47pF 50V B		UCRTKABGEFL	01
C1583-1584	UR267470	C. EL	47uF 50V		ケミコン	01
C1585	UR837100	C. EL	10uF 16V		UCRTKABGEFL	01
C1588-1591	UR267100	C. EL	10uF 50V		ケミコン	
C1594-1595	US062470	C. CE. CHP	470pF 50V B		チップセラコン	01
C1596	US064100	C. CE. CHP	0. 01uF 50V B		チップセラコン	01
C1597-1598	US062470	C. CE. CHP	470pF 50V B		チップセラコン	01
C1599-1602	UR267100	C. EL	10uF 50V		ケミコン	
C1603-1604	US062470	C. CE. CHP	470pF 50V B		チップセラコン	01
C1605-1606	US064100	C. CE. CHP	0. 01uF 50V B		チップセラコン	01
C1607	US062470	C. CE. CHP	470pF 50V B		チップセラコン	01
C1608	US064100	C. CE. CHP	0. 01uF 50V B		JURTKABGEFL	01
C1608	US064100	C. CE. CHP	0. 01uF 50V B	V1065	C	チップセラコン
C1609-1610	US064100	C. CE. CHP	0. 01uF 50V B		チップセラコン	01
D1001-1016	VR496500	DIODE. CHP	MA111 FLAT TP		チップダイオード	
△ D1017-1023	VG437500	DIODE. ZENR	MTZJ5. 1C 5. 1V		ツェナーダイオード	01
D1024-1039	VR496500	DIODE. CHP	MA111 FLAT TP		チップダイオード	
△ D1040	WK611100	DIODE. BRG	D6SBN20 6A 200V		ダイオードブリッジ	05
△ D1041	WH487300	DIODE. BRG	RS203M 2. 0A 200V		ダイオードブリッジ	02
D1042	VG440500	DIODE. ZENR	MTZJ13B 13V		ツェナーダイオード	01
D1043	VR496500	DIODE. CHP	MA111 FLAT TP		チップダイオード	
△ D1044-1045	VG435500	DIODE. ZENR	MTZJ2. 4B 2. 4V		ツェナーダイオード	01
D1501-1502	VG438400	DIODE. ZENR	MTZJ6. 8C 6. 8V		ツェナーダイオード	01
△ F100	KB000780	FUSE	T5A 250V		R ヒューズ	02
G101	V5995800	PLATE. GND			アースプレート	
△ IC101	XJ608A00	IC	NJM7812FA		I C	02
△ IC102	X4154A00	IC	KIA7912PI		電源 I C	
* IC103	YA381A00	IC	LM19C1Z/LF THERMAL		電源 I C	
IC152	XZ509A00	IC	TC74VHCU04FT INVER		ロジック I C	01
* IC153	YA361A00	IC	R2A15220FP		I C	
IC154	X7378A00	IC	NJM4565M (TE1)		アンプ I C	01
PJ150	V5715300	JACK. PIN	2P OR/OR		ピンジャック	02
PJ151	V7046800	JACK. PIN	6P MSP-246V1-01NI		ピンジャック	04
PJ152-153	V7046700	JACK. PIN	4P MSP-244V1-01NI		ピンジャック	03
PJ154	WG674900	JACK. PIN	4P		ピンジャック 4 P	02
PJ155	V7046700	JACK. PIN	4P MSP-244V1-01NI		UCRTKABGEFL	03
PJ157	V7046700	JACK. PIN	4P MSP-244V1-01NI		ピンジャック	03
PJ158	WG674900	JACK. PIN	4P		ピンジャック 4 P	02
PJ159	V7189700	JACK. PIN	1P		JURTKABGEFL	01
PJ159	V7189700	JACK. PIN	1P	V1065	C	ピンジャック
PJ160	WC612700	JACK. PIN	2P		J	ピンジャック
Q1001-1014	WC139600	TR	KTC3911S GR BL		トランジスタ	01
Q1015-1021	V3966800	TR	2SA949 O, Y		トランジスタ	02
△ Q1022-1028	VK432900	TR	2SD1915F S, T		トランジスタ	01
△ Q1029-1035	VR325600	TR	2SC2229 O, Y		トランジスタ	01
△ Q1036-1042	V4096100	TR	2SC4614 S, T		トランジスタ	02
△ Q1043-1049	V4096000	TR	2SA1770 S, T		トランジスタ	03
△ Q1050-1056	VR355900	TR. PAIR	A1695/C4468 OPY		ペアトランジスタ	07

* New Parts * 新規部品

P.C.B. MAIN

Ref No.	Part No.	Description	Remarks	Markets	部 品 名	ランク
Q1057-1063	WC139600	TR	KTC3911S GR BL		トランジスタ	01
Q1064	WH372100	TR	KTA1517S GR TP		トランジスタ	01
Q1065	WC139600	TR	KTC3911S GR BL		トランジスタ	01
△ Q1067-1068	WC292600	TR	KTA1837-U		トランジスタ	
△ Q1069-1070	WC398400	TR	2N5551C-AT		トランジスタ	01
△ Q1071	WC397700	TR	2N5401C-AT		トランジスタ	
△ Q1072	VP872600	TR	2SA1708 S, T		トランジスタ	01
Q1073	WC398500	TR. DGT	KRA102M-AT		デジタルトランジスタ	01
Q1074	WC529200	TR. DGT	KRC102M-AT		デジタルトランジスタ	01
Q1500-1504	VZ725900	TR	2SD1938F S, T		トランジスタ	01
Q1507	VZ725900	TR	2SD1938F S, T	V1065	JURTKABGEFL C	トランジスタ 01
Q1507	VZ725900	TR	2SD1938F S, T		トランジスタ	01
Q1508	VZ725900	TR	2SD1938F S, T		トランジスタ	01
Q1509	VZ725900	TR	2SD1938F S, T	V1065	JURTKABGEFL C	トランジスタ 01
Q1509	VZ725900	TR	2SD1938F S, T		トランジスタ	01
Q1510	VZ725900	TR	2SD1938F S, T		トランジスタ	01
Q1511	VZ725900	TR	2SD1938F S, T		トランジスタ	01
Q1512	VZ725900	TR	2SD1938F S, T		トランジスタ	01
Q1513	VZ725900	TR	2SD1938F S, T		トランジスタ	01
Q1514	VZ725900	TR	2SD1938F S, T		トランジスタ	01
Q1519-1527	VZ725900	TR	2SD1938F S, T		トランジスタ	01
R1001-1007	HF356100	R. CAR	1KΩ 1/2W		カーボン抵抗	
R1008-1014	HF356180	R. CAR	1.8KΩ 1/2W		カーボン抵抗	
R1022-1028	HF355330	R. CAR	330Ω 1/2W		カーボン抵抗	
R1029-1035	HL006120	R. MTL. OXD	1.2KΩ 1/2W		酸化金属被膜抵抗	
R1036-1042	V8070900	R. MTL. FLM	100Ω 1W		金属被膜抵抗	01
R1043-1049	HL007330	R. MTL. OXD	33KΩ 1/2W		酸化金属被膜抵抗	01
R1079-1085	HL005120	R. MTL. OXD	120Ω 1/2W		酸化金属被膜抵抗	01
R1086-1092	WG727400	R. MTL. FLM	2.7KΩ 1/4W		金属被膜抵抗	01
R1093-1099	WG725600	R. MTL. FLM	470Ω 1/4W		金属被膜抵抗	01
R1100-1106	WG726400	R. MTL. FLM	1KΩ 1/4W		金属被膜抵抗	01
R1107-1112	WG726200	R. MTL. FLM	820Ω 1/4W		金属被膜抵抗	01
△ R1113-1126	HV755120	R. CAR. FP	120Ω 1/4W		不燃化カーボン抵抗	01
△ R1127-1133	HF355470	R. CAR	470Ω 1/2W		カーボン抵抗	
△ R1134-1147	HV754100	R. CAR. FP	10Ω 1/4W		不燃化カーボン抵抗	01
△ R1148-1154	WP839400	R. WW	0.22+0.22 3W		セメント抵抗	01
△ R1176-1182	V8070300	R. MTL. FLM	10Ω 1W		金属被膜抵抗	
△ R1197-1198	V8070200	R. MTL. FLM	4.7Ω 1W		金属被膜抵抗	
△ R1211	HV754100	R. CAR. FP	10Ω 1/4W		不燃化カーボン抵抗	01
R1213	V8072100	R. MTL. OXD	5.6KΩ 1W		酸化金属被膜抵抗	
R1214	HV755560	R. CAR. FP	560Ω 1/4W		不燃化カーボン抵抗	01
R1219	V8072000	R. MTL. OXD	4.7KΩ 1W		酸化金属被膜抵抗	
△ R1222	HV756100	R. CAR. FP	1KΩ 1/4W		不燃化カーボン抵抗	01
R1225	VP941900	R. MTL. OXD	15KΩ 1W		酸化金属被膜抵抗	01
△ R1234-1235	HV754100	R. CAR. FP	10Ω 1/4W		不燃化カーボン抵抗	01
R1236	WG726200	R. MTL. FLM	820Ω 1/4W		金属被膜抵抗	01
△ R1238	V8070300	R. MTL. FLM	10Ω 1W		金属被膜抵抗	
R1504	HV753100	R. CAR. FP	1Ω 1/4W		不燃化カーボン抵抗	01
R1573	WQ835700	R. MTL. OXD	82Ω 1W		酸化金属被膜抵抗	
R1575	WQ835700	R. MTL. OXD	82Ω 1W		酸化金属被膜抵抗	
R1664-1665	HV755100	R. CAR. FP	100Ω 1/4W		不燃化カーボン抵抗	01
△ RY101	WE648700	RELAY	DC DH24D2-0-Q		リレー 24V	06
ST100	V4040500	SCR. TERM	M3		スクリュー/ターミナル	01
ST101	WA246200	SCR. TERM	3.5		スクリューターミナル	
△ SW101	WB493700	VOLT. SELCT	R8140246	R	電圧切替器	
△ SW101	WD073700	VOLT. SELCT	R8140254	L	電圧切替器	
U1500-1501	WH169900	CN. PHOTO. R	1P GP1FAV51RKOF		光ファイバー受信器	04

* New Parts * 新規部品

RX-V1065/HTR-6280/
AX-V1065

P.C.B. MAIN and P.C.B. VIDEO

Ref No.	Part No.	Description	Remarks	Markets	部 品 名	ランク	
	WE774200	SCR. BND. HD	3x10 MFZN2W3			バインドBタイトネジ	01
*	WR432700	P. C. B.	VIDEO		J	PCB VIDEO	
*	WR432800	P. C. B.	VIDEO		U	PCB VIDEO	
*	WR432900	P. C. B.	VIDEO	V1065	C	PCB VIDEO	
*	WR433600	P. C. B.	VIDEO	6280	C	PCB VIDEO	
*	WR433000	P. C. B.	VIDEO		R	PCB VIDEO	
*	WR433100	P. C. B.	VIDEO		T	PCB VIDEO	
*	WR433200	P. C. B.	VIDEO		K	PCB VIDEO	
*	WR433300	P. C. B.	VIDEO		A	PCB VIDEO	
*	WR433400	P. C. B.	VIDEO		BGEF	PCB VIDEO	
*	WR433500	P. C. B.	VIDEO		L	PCB VIDEO	
CB301	VQ047700	CN. BS. PIN	22P		J	FFCコネクター	01
CB303	VQ961500	CN. BS. PIN	12P			ハウジング	01
CB304	VN394900	CN. BS. PIN	14P			FFCコネクター	01
CB321	VM859500	CN. BS. PIN	11P		JCRTKABGEFL	FFCコネクター	01
CB322	VM923600	CN. BS. PIN	13P		U	FFCコネクター	01
CB332	VQ961300	CN. BS. PIN	10P			ハウジング	01
CB333	VK024700	CN. BS. PIN	3P			ワイヤートラップ	01
CB340	LB918020	CN. BS. PIN	2P			ベース付ポスト	01
CB342	LB918040	CN. BS. PIN	4P			ベース付ポスト	01
CB343	VZ130900	CN. JUMPER	4P			ジャンパーコネクター	01
CB344	VQ585500	CN. JUMPER	5P			ジャンパーコネクター	02
CB346	VB390000	CN. BS. PIN	4P			ベースピン	01
CB349	VQ047700	CN. BS. PIN	22P			FFCコネクター	01
CB351-353	WD398400	CN. DIN	14P YKF45-3011		J	DINコネクタ	05
CB354	VQ047700	CN. BS. PIN	22P		J	FFCコネクター	01
CB371	VG879900	CN. BS. PIN	2P			ベースピン	01
CB372-373	WN103000	CLIP. FUSE	TP00351-31			ヒューズクリップ	01
CB378	VG879900	CN. BS. PIN	2P		RL	ベースピン	01
CB379	VQ961000	CN. BS. PIN	7P			ハウジング	02
CB381	VQ962800	CN. BS. PIN	7P			ウエハー	02
CB391	VQ044100	CN. BS. PIN	5P		BGEF	FFCコネクター	01
C3001	US062100	C. CE. CHP	100pF 50V B			チップセラコン	01
C3002-3004	US060800	C. CE. CHP	8pF 50V B			チップセラコン	01
C3005	US062100	C. CE. CHP	100pF 50V B			チップセラコン	01
C3006	UR237470	C. EL	47uF 16V			ケミコン	01
C3007-3008	US135100	C. CE. CHP	0.1uF 16V			チップセラコン	01
C3009	UR237470	C. EL	47uF 16V			ケミコン	01
C3011	US060300	C. CE. CHP	3pF 50V B			チップセラコン	01
C3012	UR837470	C. EL	47uF 16V			ケミコン	01
C3013-3014	US060300	C. CE. CHP	3pF 50V B			チップセラコン	01
C3015-3017	US135100	C. CE. CHP	0.1uF 16V			チップセラコン	01
C3018	UR267100	C. EL	10uF 50V			ケミコン	
C3019	US135100	C. CE. CHP	0.1uF 16V			チップセラコン	01
C3020	UR267100	C. EL	10uF 50V			ケミコン	
C3021-3025	US135100	C. CE. CHP	0.1uF 16V			チップセラコン	01
C3026	UR267100	C. EL	10uF 50V			ケミコン	
C3027	WD758300	C. CE. CHP	10uF 10V			チップセラコン	01
C3029	WD758300	C. CE. CHP	10uF 10V			チップセラコン	01
C3031	WD758300	C. CE. CHP	10uF 10V			チップセラコン	01
C3033	UR837470	C. EL	47uF 16V			ケミコン	01
C3035-3037	WD758300	C. CE. CHP	10uF 10V			チップセラコン	01
C3043-3044	US135100	C. CE. CHP	0.1uF 16V			チップセラコン	01
C3045	UR837470	C. EL	47uF 16V			ケミコン	01

* New Parts * 新規部品

P.C.B. VIDEO

Ref No.	Part No.	Description	Remarks	Markets	部 品 名	ランク
C3047	US135100	C. CE. CHP	0. 1uF 16V		チップセラコン	01
C3048	UR238220	C. EL	220uF 16V		ケミコン	01
C3049	UR837470	C. EL	47uF 16V		ケミコン	01
C3050	US135100	C. CE. CHP	0. 1uF 16V		チップセラコン	01
C3051	UR238220	C. EL	220uF 16V		ケミコン	01
C3063	US135100	C. CE. CHP	0. 1uF 16V		チップセラコン	01
C3065	UR237470	C. EL	47uF 16V		ケミコン	01
C3067	US135100	C. CE. CHP	0. 1uF 16V		チップセラコン	01
C3072	US135100	C. CE. CHP	0. 1uF 16V		チップセラコン	01
C3073	UR238220	C. EL	220uF 16V		ケミコン	01
C3077	US135100	C. CE. CHP	0. 1uF 16V		チップセラコン	01
C3080-3085	WD758300	C. CE. CHP	10uF 10V		チップセラコン	01
C3201	US061270	C. CE. CHP	27pF 50V B	BGEF	チップセラコン	01
C3202	UR237100	C. EL	10uF 16V	BGEF	ケミコン	
C3203	US061270	C. CE. CHP	27pF 50V B	BGEF	チップセラコン	01
C3204-3205	US135100	C. CE. CHP	0. 1uF 16V	BGEF	チップセラコン	01
C3206	US062560	C. CE. CHP	560pF 50V B	BGEF	チップセラコン	01
C3207-3208	US062330	C. CE. CHP	330pF 50V B	BGEF	チップセラコン	01
C3209	US135100	C. CE. CHP	0. 1uF 16V	BGEF	チップセラコン	01
C3211	UR237470	C. EL	47uF 16V	BGEF	ケミコン	01
C3212-3213	UR237470	C. EL	47uF 16V	JCRTKABGEFL	ケミコン	01
C3214	UR237470	C. EL	47uF 16V	JCRTKABGEFL	ケミコン	01
C3215	US062100	C. CE. CHP	100pF 50V B		チップセラコン	01
C3217	US062100	C. CE. CHP	100pF 50V B	JCRTKABGEFL	チップセラコン	01
C3218	US062100	C. CE. CHP	100pF 50V B		チップセラコン	01
C3220	US064100	C. CE. CHP	0. 01uF 50V B	U	チップセラコン	01
C3221	US062100	C. CE. CHP	100pF 50V B		チップセラコン	01
C3303-3305	VR324900	C. MYLAR	0. 1uF 100V		マイラーコン	01
C3307	WG601900	C. EL	10000uF 16V		ケミコン	04
C3308	UR278100	C. EL	100uF 63V		ケミコン	01
C3309	UR03A100	C. EL	10000uF 16V		ケミコン	
C3310	UR039470	C. EL	4700uF 16V		ケミコン	03
C3311	UR266100	C. EL	1uF 50V		ケミコン	01
C3312	UR267220	C. EL	22uF 50V		ケミコン	01
C3313	UR266100	C. EL	1uF 50V	U	ケミコン	01
C3314	UR266100	C. EL	1uF 50V		ケミコン	01
C3315	UR267100	C. EL	10uF 50V		ケミコン	
C3316	UR268100	C. EL	100uF 50V		ケミコン	
C3317	UR266100	C. EL	1uF 50V	U	ケミコン	01
C3318	UR237470	C. EL	47uF 16V	U	ケミコン	01
C3319	UR266100	C. EL	1uF 50V		ケミコン	01
C3320-3321	UR267330	C. EL	33uF 50V		ケミコン	01
C3324	UR237470	C. EL	47uF 16V	U	ケミコン	01
C3403-3409	WJ605000	C. MYLAR	0. 01uF 50V J		マイラーコン	01
C3410-3416	WJ605200	C. MYLAR	0. 015uF 50V		マイラーコン	
C3501-3509	US064100	C. CE. CHP	0. 01uF 50V B	J	チップセラコン	01
C3510-3512	US060800	C. CE. CHP	8pF 50V B	J	チップセラコン	01
C3513-3514	UR267100	C. EL	10uF 50V	J	ケミコン	
C3515-3520	US135100	C. CE. CHP	0. 1uF 16V	J	チップセラコン	01
C3603-3604	US063100	C. CE. CHP	1000pF 50V B		チップセラコン	01
C3606	US064100	C. CE. CHP	0. 01uF 50V B		チップセラコン	01
C3701	WQ852400	C. POL. MTL	0. 022uF 630V		メタライズドポリコン	01
C3702	WK005000	C. CE. SAFTY	0. 047uF 275V		規格認定コンデンサ	01
C3703	WR082000	C. EL	100uF 220V	JUC	ケミコン	04
C3703	WR082100	C. EL	100uF 400V	R	ケミコン	
C3703	WQ852500	C. EL	68uF 400V	TKABGEFL	ケミコン	
* C3704	WR182800	C. CE. CHP	2200pF 250V		チップセラコン	

△

* New Parts * 新規部品

RX-V1065/HTR-6280/
AX-V1065

P.C.B. VIDEO

Ref No.	Part No.	Description	Remarks	Markets	部 品 名	ランク
	C3705	US065100 C. CE. CHP	0. 1uF 50V B		チップセラコン	01
	C3706	V6185300 C. CE. SAFTY	0. 01uF 275V		規格認定コンデンサ	01
	C3707	UR837470 C. EL	47uF 16V		ケミコン	01
	C3708	UR867100 C. EL	10uF 50V		ケミコン	01
△	C3709	WQ902200 C. CE. SAFTY	2200pF 250V		規格認定コン	
	C3710-3711	UR866100 C. EL	1uF 50V		ケミコン	01
	C3712-3713	WH777900 C. EL	1000uF 35V		ケミコン	03
	C3714	US046100 C. CE. CHP	1uF 25V		チップセラコン	01
	C3715	US135100 C. CE. CHP	0. 1uF 16V		チップセラコン	01
	C3716	WH771300 C. EL	100uF 10V		ケミコン	01
	C3717	WQ852400 C. POL. MTL	0. 022uF 630V		メタライズドポリコン	01
△	C3720-3721	WQ902300 C. CE. SAFTY	1000pF 250V		規格認定コンデンサ	01
	C3801	US064100 C. CE. CHP	0. 01uF 50V B		チップセラコン	01
	C3802	V7887800 C. EL	1uF 50V		ケミコン	
	C3803	WJ335500 C. EL	2. 2uF 50V		ケミコン	01
	C3804	WJ603700 C. MYLAR	1000pF 50V		マイラーコン	01
	C3805	US064100 C. CE. CHP	0. 01uF 50V B		チップセラコン	01
	C3806-3807	WD758300 C. CE. CHP	10uF 10V		チップセラコン	01
	C3901	US064100 C. CE. CHP	0. 01uF 50V B	BGEF	チップセラコン	01
	C3902	US062120 C. CE. CHP	120pF 50V B	BGEF	チップセラコン	01
	C3903	US062220 C. CE. CHP	220pF 50V B	BGEF	チップセラコン	01
	C3904	US135100 C. CE. CHP	0. 1uF 16V	BGEF	チップセラコン	01
	C3905	UR837470 C. EL	47uF 16V	BGEF	ケミコン	01
	C3906	UR837100 C. EL	10uF 16V	BGEF	ケミコン	01
	C3907	UR818470 C. EL	470uF 6. 3V	BGEF	ケミコン	01
	C3908	US064100 C. CE. CHP	0. 01uF 50V B	BGEF	チップセラコン	01
	D3201	VG436100 DIODE. ZENR	MTZJ3. 3B 3. 3V	BGEF	ツェナーダイオード	01
	D3202	VG439500 DIODE. ZENR	MTZJ10B 10V		ツェナーダイオード	01
	D3202	VG439500 DIODE. ZENR	MTZJ10B 10V	JCRTKABGEFL	ツェナーダイオード	01
	D3302	WH487300 DIODE. BRG	RS203M 2. 0A 200V		ダイオードブリッジ	02
	D3304	WH487300 DIODE. BRG	RS203M 2. 0A 200V		ダイオードブリッジ	02
	D3306	VV307700 DIODE	1N4002S		ダイオード	01
	D3307	VG440200 DIODE. ZENR	MTZJ12B 12V	R	ツェナーダイオード	01
	D3308	VG444700 DIODE. ZENR	MTZ J 39D 39. 0V TP		ツェナーダイオード	01
	D3309	VT332900 DIODE	1SS355	U	ダイオード	01
	D3310	VT332900 DIODE	1SS355		ダイオード	01
	D3311	VT332900 DIODE	1SS355	U	ダイオード	01
	D3313-3314	VT332900 DIODE	1SS355	U	ダイオード	01
	D3320	VG437400 DIODE. ZENR	MTZJ5. 1B 5. 1V		ツェナーダイオード	01
	D3403-3407	VT332900 DIODE	1SS355		ダイオード	01
	D3501-3506	VT332900 DIODE	1SS355	J	ダイオード	01
	D3601	VT332900 DIODE	1SS355		ダイオード	01
	D3602	VT332900 DIODE	1SS355	UCRTKABGEFL	ダイオード	01
△	D3701	WH471700 DIODE. BRG	DB105 1A 600V		ダイオードブリッジ	02
	D3703	WN672400 DIODE. ZENR	P6KE200A 200V		ツェナーダイオード	03
	D3705	WQ647500 DIODE	HT18G		ダイオード	
	D3706-3707	VD631600 DIODE	1SS133, 176		ダイオード	01
	D3708	VT332900 DIODE	1SS355		ダイオード	01
	D3709	WR007000 DIODE. SCHO	10A 40V SG10SC4M		ショットキーダイオード	03
	D3710	VG442200 DIODE. ZENR	MTZJ22C 22V		ツェナーダイオード	01
	D3801-3805	VT332900 DIODE	1SS355		ダイオード	01
	D3901-3902	VT332900 DIODE	1SS355	BGEF	ダイオード	01
△	F3701	WQ211200 FUSE	10A 125V	JUC	ヒューズ	01
△	F3701	WB760600 FUSE	T6. 3A 250V	R	ヒューズ	01
△	F3701	WM933100 FUSE	T5A 250V	TKABGEFL	ヒューズ	01
	IC301-303	XY879A00 IC	TC74HC4053AF (EL)		ロジック I C	03
	IC305	X6742A00 IC	LA73050-TLM-E		アンプ I C	04

* New Parts * 新規部品

P.C.B. VIDEO

Ref No.	Part No.	Description	Remarks	Markets	部 品 名	ランク
IC306	X2904A00	IC	NJM2581M VIDEO AMP		アンプ I C	06
IC307	XY549A00	IC	TC74HC4051AFEL		ロジック I C	02
IC308	X7779A00	IC	LC709004A-TLM-E		ロジック I C	04
IC310	X8875A00	IC	FHP33501M14X		アンプ I C	04
IC321	X8235A00	IC	LC72725KM		I C	
IC331	X8276A00	IC	NJM2396F05		電源 I C	04
IC332-333	X8035A00	IC	BA00JC5WT-V5		電源 I C	04
IC334	X6143A00	IC	NJM2388F05 5.0V		電源 I C	04
IC351-352	XS790A00	IC	TC74HC4052AF MPX		ロジック I C	02
IC353	XY879A00	IC	TC74HC4053AF (EL)		ロジック I C	03
* IC371	YA565A00	IC	TOP254PN SW		電源 I C	07
△ IC372	WQ867100	PHOT. CPL	EL816 (M) (C)		フォトカプラ	01
* IC374	YA276A00	IC	TL431AC 2.5-36V		電源 I C	02
△ IC375	WQ867100	PHOT. CPL	EL816 (M) (C)		フォトカプラ	01
IC391	XZ509A00	IC	TC74VHC04FT INVER		ロジック I C	01
JK321	V9435700	JACK. MNI	MSJ-035-12APC	V1065	モノラル ミニジャック	01
JK321	V9435700	JACK. MNI	MSJ-035-12APC		モノラル ミニジャック	01
JK361	V9435700	JACK. MNI	MSJ-035-12APC		モノラル ミニジャック	01
JK362	V9435700	JACK. MNI	MSJ-035-12APC		モノラル ミニジャック	01
JK391	V6931000	CN. DIN	1P YKF51-5506		1 連 S 端子	02
PJ301	WG505100	JACK. PIN	6P		ピンジャック	04
PJ302	V7189800	JACK. PIN	1P		ピンジャック	01
PJ303	WH381400	JACK. PIN	3P JACK G, B, R		ピンジャック	03
PJ304	V7189800	JACK. PIN	1P		ピンジャック	01
PJ305-306	V7190000	JACK. PIN	2P		ピンジャック	
Q3001	VR936300	TR	2SA1576A T106		トランジスタ	01
Q3201	iC174020	TR	2SC1740S QRS		トランジスタ	01
Q3203	iC181510	TR	2SC1815 Y		トランジスタ	01
Q3204	iA101510	TR	2SA1015 Y	V1065	トランジスタ	01
Q3204	iA101510	TR	2SA1015 Y		トランジスタ	01
Q3205	iC181510	TR	2SC1815 Y		トランジスタ	01
Q3205	iC181510	TR	2SC1815 Y	V1065	トランジスタ	01
Q3206	WG538600	TR	KTA1046-Y-U/P		トランジスタ	02
Q3206	WG538600	TR	KTA1046-Y-U/P	V1065	トランジスタ	02
Q3207	iC181510	TR	2SC1815 Y		トランジスタ	01
Q3207	iC181510	TR	2SC1815 Y	V1065	トランジスタ	01
Q3301	VP872600	TR	2SA1708 S, T		トランジスタ	
Q3302	iA101510	TR	2SA1015 Y		トランジスタ	01
Q3303	WG538600	TR	KTA1046-Y-U/P		トランジスタ	02
Q3304	iA101510	TR	2SA1015 Y		トランジスタ	01
Q3305	iC181510	TR	2SC1815 Y		トランジスタ	01
Q3405	VV655400	TR. DGT	DTC114EKA		デジタルトランジスタ	01
Q3406	VV655000	TR. DGT	DTA114EKA		デジタルトランジスタ	01
Q3407	VV655400	TR. DGT	DTC114EKA		デジタルトランジスタ	01
Q3408	VV655000	TR. DGT	DTA114EKA		デジタルトランジスタ	01
Q3409	VV655400	TR. DGT	DTC114EKA		デジタルトランジスタ	01
Q3410	VV655000	TR. DGT	DTA114EKA		デジタルトランジスタ	01
Q3411	VV655400	TR. DGT	DTC114EKA		デジタルトランジスタ	01
Q3412	VV655000	TR. DGT	DTA114EKA		デジタルトランジスタ	01
Q3413	VV655400	TR. DGT	DTC114EKA		デジタルトランジスタ	01
Q3414	VV655000	TR. DGT	DTA114EKA		デジタルトランジスタ	01
Q3501	VV556400	TR	2SC2412K Q, R, S		トランジスタ	01
Q3801-3802	iC181510	TR	2SC1815 Y		トランジスタ	01
Q3803	VV655700	TR. DGT	DTC144EKA		デジタルトランジスタ	01
R3021	HV753100	R. CAR. FP	1Ω 1/4W		不燃化カーボン抵抗	01
R3025	HV753100	R. CAR. FP	1Ω 1/4W		不燃化カーボン抵抗	01
R3046-3049	HV753100	R. CAR. FP	1Ω 1/4W		不燃化カーボン抵抗	01

* New Parts * 新規部品

RX-V1065/HTR-6280/
AX-V1065

P.C.B. VIDEO and P.C.B. GUI

Ref No.	Part No.	Description	Remarks	Markets	部 品 名	ランク
R3060-3061	HV753100	R. CAR. FP	1Ω 1/4W		不燃化カーボン抵抗	01
R3208	HV755680	R. CAR. FP	680Ω 1/4W	BGEF	不燃化カーボン抵抗	01
R3210	HV754180	R. CAR. FP	18Ω 1/4W	JCRTKABGEFL	不燃化カーボン抵抗	01
R3213	HV753560	R. CAR. FP	5.6Ω 1/4W	URTKABGEFL	不燃化カーボン抵抗	01
R3213	HV753560	R. CAR. FP	5.6Ω 1/4W	V1065 C	不燃化カーボン抵抗	01
R3301	HV753220	R. CAR. FP	2.2Ω 1/4W		不燃化カーボン抵抗	01
R3306	HV756100	R. CAR. FP	1KΩ 1/4W		不燃化カーボン抵抗	01
R3315-3316	HV756470	R. CAR. FP	4.7KΩ 1/4W		不燃化カーボン抵抗	01
R3403-3406	HV757100	R. CAR. FP	10KΩ 1/4W		不燃化カーボン抵抗	01
R3524-3525	HV753100	R. CAR. FP	1Ω 1/4W	J	不燃化カーボン抵抗	01
R3910	HV753220	R. CAR. FP	2.2Ω 1/4W	BGEF	不燃化カーボン抵抗	01
RY341-345	WJ122400	RELAY	981-2A-24DS-SP7		リレー 24V	04
△ RY371	WQ804100	RELAY	DC DLS5D1-0(M) 0.25		リレー	04
ST331-332	V4040500	SCR. TERM	M3		スクリュー／ターミナル	01
ST361-362	V4040500	SCR. TERM	M3		スクリュー／ターミナル	01
ST371	V4040500	SCR. TERM	M3		スクリュー／ターミナル	01
ST381-383	V4040500	SCR. TERM	M3		スクリュー／ターミナル	01
△ * T3701	YA507A00	TRANS. PWR			サプトランス	07
TE341	WK560800	TERM. SP	4P MST-204V1-01 NC	JUCRTA	スピーカーターミナル	04
TE341	WK560900	TERM. SP	4P MST-204V1-01 WC	KBGEFL	スピーカーターミナル	
TE342	WK561000	TERM. SP	6P MST-207V1-01 NC	JUCRTA	スピーカーターミナル	05
TE342	WK561100	TERM. SP	6P MST-207V1-01 WC	KBGEFL	スピーカーターミナル	
TE343	WK560800	TERM. SP	4P MST-204V1-01 NC	JUCRTA	スピーカーターミナル	04
TE343	WK560900	TERM. SP	4P MST-204V1-01 WC	KBGEFL	スピーカーターミナル	
XL321	V2731100	RSNR. CRYST	4.332M HC-49/U	BGEF	水晶振動子	
	WE774200	SCR. BND. HD	3x10 MFZN2W3		バインドBタイトネジ	01
* WR437000	P. C. B.	GUI			P C B G U I	
CB500	VK026400	CN. BS. PIN	5P		ワイヤートラップ	01
CB501	VQ044700	CN. BS. PIN	16P		FFCコネクタ	01
CB503	VK026300	CN. BS. PIN	4P		ワイヤートラップ	01
CB550	VB858500	CN. BS. PIN	6P		ベースピン	01
C5000-5001	US625100	C. CE. CHP	0.100uF 10V		チップセラコン	01
C5002-5003	US061120	C. CE. CHP	12pF 50V B		チップセラコン	01
C5004	US625100	C. CE. CHP	0.100uF 10V		チップセラコン	01
C5005-5008	US135100	C. CE. CHP	0.1uF 16V		チップセラコン	01
C5009-5010	US061180	C. CE. CHP	18pF 50V B		チップセラコン	01
C5012	US135100	C. CE. CHP	0.1uF 16V		チップセラコン	01
C5013	US663100	C. CE. CHP	1000pF 50V		チップセラコン	01
C5014-5016	US625100	C. CE. CHP	0.100uF 10V		チップセラコン	01
C5017	US135100	C. CE. CHP	0.1uF 16V		チップセラコン	01
C5018	US063100	C. CE. CHP	1000pF 50V B		チップセラコン	01
C5019	US625100	C. CE. CHP	0.100uF 10V		チップセラコン	01
C5020	US063100	C. CE. CHP	1000pF 50V B		チップセラコン	01
C5021-5024	US135100	C. CE. CHP	0.1uF 16V		チップセラコン	01
C5025	US063100	C. CE. CHP	1000pF 50V B		チップセラコン	01
C5026	US064100	C. CE. CHP	0.01uF 50V B		チップセラコン	01
C5027	US063100	C. CE. CHP	1000pF 50V B		チップセラコン	01
C5028	US135100	C. CE. CHP	0.1uF 16V		チップセラコン	01
C5029	US625100	C. CE. CHP	0.100uF 10V		チップセラコン	01
C5030	US663100	C. CE. CHP	1000pF 50V		チップセラコン	01
C5031	US061220	C. CE. CHP	22pF 50V B		チップセラコン	01
C5032	UF037100	C. EL. CHP	10uF 16V		チップケミコン	01
C5033-5034	US625100	C. CE. CHP	0.100uF 10V		チップセラコン	01
C5035	US663100	C. CE. CHP	1000pF 50V		チップセラコン	01

* New Parts * 新規部品

P.C.B. GUI

Ref No.	Part No.	Description	Remarks	Markets	部 品 名	ランク
C5036	US061220	C. CE. CHP	22pF 50V B		チップセラコン	01
C5037	UF018100	C. EL. CHP	100uF 6.3V		チップケミコン	01
C5038-5039	UF037100	C. EL. CHP	10uF 16V		チップケミコン	01
C5040	UF037220	C. EL. CHP	22uF 16V		チップケミコン	01
C5041-5042	US663330	C. CE. CHP	3300pF 50V		チップセラコン	
C5043	US135100	C. CE. CHP	0.1uF 16V		チップセラコン	01
C5044-5049	US063100	C. CE. CHP	1000pF 50V B		チップセラコン	01
C5050-5054	US135100	C. CE. CHP	0.1uF 16V		チップセラコン	01
C5055	UF037220	C. EL. CHP	22uF 16V		チップケミコン	01
C5056-5058	US625100	C. CE. CHP	0.100uF 10V		チップセラコン	01
C5059	UF037100	C. EL. CHP	10uF 16V		チップケミコン	01
C5060	US135100	C. CE. CHP	0.1uF 16V		チップセラコン	01
C5061	US625100	C. CE. CHP	0.100uF 10V		チップセラコン	01
C5062	UF037100	C. EL. CHP	10uF 16V		チップケミコン	01
C5063-5064	US625100	C. CE. CHP	0.100uF 10V		チップセラコン	01
C5065	US663100	C. CE. CHP	1000pF 50V		チップセラコン	01
C5066-5067	US063100	C. CE. CHP	1000pF 50V B		チップセラコン	01
C5068-5069	US663100	C. CE. CHP	1000pF 50V		チップセラコン	01
C5070	UF037100	C. EL. CHP	10uF 16V		チップケミコン	01
C5071-5072	US625100	C. CE. CHP	0.100uF 10V		チップセラコン	01
C5073-5074	US135100	C. CE. CHP	0.1uF 16V		チップセラコン	01
C5075-5078	US625100	C. CE. CHP	0.100uF 10V		チップセラコン	01
C5080-5081	US625100	C. CE. CHP	0.100uF 10V		チップセラコン	01
C5083-5084	US063100	C. CE. CHP	1000pF 50V B		チップセラコン	01
C5086-5087	US135100	C. CE. CHP	0.1uF 16V		チップセラコン	01
C5088	US062220	C. CE. CHP	220pF 50V B		チップセラコン	01
C5089	US625100	C. CE. CHP	0.100uF 10V		チップセラコン	01
C5091-5095	US625100	C. CE. CHP	0.100uF 10V		チップセラコン	01
C5096-5107	US135100	C. CE. CHP	0.1uF 16V		チップセラコン	01
C5108-5111	US062100	C. CE. CHP	100pF 50V B		チップセラコン	01
C5501	US625100	C. CE. CHP	0.100uF 10V		チップセラコン	01
C5502	US062220	C. CE. CHP	220pF 50V B		チップセラコン	01
C5503	UF018100	C. EL. CHP	100uF 6.3V		チップケミコン	01
C5504	US625100	C. CE. CHP	0.100uF 10V		チップセラコン	01
C5505-5506	US135100	C. CE. CHP	0.1uF 16V		チップセラコン	01
C5507-5508	US634100	C. CE. CHP	0.01uF 16V		チップセラコン	01
C5509	UF037220	C. EL. CHP	22uF 16V		チップケミコン	01
C5510-5511	US135100	C. CE. CHP	0.1uF 16V		チップセラコン	01
C5512-5513	US625100	C. CE. CHP	0.100uF 10V		チップセラコン	01
C5514	US135100	C. CE. CHP	0.1uF 16V		チップセラコン	01
C5515	WD758300	C. CE. CHP	10uF 10V		チップセラコン	01
C5516	US061150	C. CE. CHP	15pF 50V B		チップセラコン	01
C5517	US135100	C. CE. CHP	0.1uF 16V		チップセラコン	01
C5518	UF018100	C. EL. CHP	100uF 6.3V		チップケミコン	01
C5519	US135100	C. CE. CHP	0.1uF 16V		チップセラコン	01
C5520	US061180	C. CE. CHP	18pF 50V B		チップセラコン	01
C5521	US135100	C. CE. CHP	0.1uF 16V		チップセラコン	01
C5522	WD758300	C. CE. CHP	10uF 10V		チップセラコン	01
C5523	US135100	C. CE. CHP	0.1uF 16V		チップセラコン	01
C5524	US634100	C. CE. CHP	0.01uF 16V		チップセラコン	01
C5527-5532	US135100	C. CE. CHP	0.1uF 16V		チップセラコン	01
IC501-502	X7678A00	IC	SN74LV163APWR CNT		ロジック IC	01
IC503	X5534A00	IC	SN74LV74APWR D-FF		ロジック IC	01
IC504	X7375A00	IC	PCM1781DBQR		IC	04
* IC506	YA322A00	IC	AK8814VQ		IC	
IC507	X6512C00	IC. MEMORY	K4S561632J-UC75000		メモリ IC	07
* IC508	YA350A00	IC	74LVC1G08GW AND		ロジック IC	

* New Parts * 新規部品

P.C.B. GUI

Ref No.	Part No.	Description	Remarks	Markets	部 品 名	ランク
IC509-512	XZ286A00	IC	74LVC245APW118		ロジック I C	02
* IC513	YA660A00	IC. MEMORY	MX29LV640DBTC-90G	written	メモリ I C	
IC521-522	X4063A00	IC	TC7WU04FU		ロジック I C	
* IC523	YA354A00	IC	74LVC08APW AND		ロジック I C	
IC524	X8386A00	IC	TC7WH14FK (TE85L, F)		ロジック I C	01
* IC525	YA356A00	IC	74LVC32APW OR		ロジック I C	
IC552	X8096A00	IC	R5523N001A-TR-F		電源 I C	03
Q5000	WE834500	FET	UPA672T-T1-A		F E T	01
ST550-551	V4040500	SCR. TERM	M3		スクリュー／ターミナル	01
XL500	V3625700	RSNR. CRY	24. 576MHz		水晶振動子	03
XL501	WH625000	RSNR. CRY	27MHz		水晶振動子	03
XL502	WB551700	RSNR. CRY	16. 666MHz SMD-49		水晶振動子	03
XL550	WG538400	RSNR. CRY	12MHz		水晶振動子	

* New Parts * 新規部品

Carbon Resistors

Value	1/4W Type Part No.	1/6W Type Part No.	Value	1/4W Type Part No.	1/6W Type Part No.
1.0 Ω	HJ35 3100	HF85 3100	11 kΩ	HF45 7110	HF45 7110
1.8 Ω	HJ35 3180	*	12 kΩ	HJ35 7120	HF85 7120
2.2 Ω	HJ35 3220	HF85 3220	13 kΩ	HF45 7130	HF45 7130
3.3 Ω	HJ35 3330	HF85 3330	15 kΩ	HF45 7150	HF45 7150
4.7 Ω	HJ35 3470	HF85 3470	18 kΩ	HF45 7180	HF45 7180
5.6 Ω	HJ35 3560	HF85 3560	22 kΩ	HF45 7220	HF45 7220
10 Ω	HF45 4100	HF45 4100	24 kΩ	HF45 7240	HF45 7240
15 Ω	HJ35 4150	HF85 4150	27 kΩ	HJ35 7270	HF85 7270
22 Ω	HF45 4220	HF45 4220	30 kΩ	HF45 7300	HF45 7300
27 Ω	HJ35 4270	HF85 4270	33 kΩ	HF45 7330	HF45 7330
33 Ω	HF45 4330	HF45 4330	36 kΩ	HF45 7360	HF45 7360
39 Ω	HJ35 4470	HF85 4390	39 kΩ	HF45 7390	HF45 7390
47 Ω	HF45 4470	HF45 4470	47 kΩ	HF45 7470	HF45 7470
56 Ω	HF45 4560	HF45 4560	51 kΩ	HF45 7510	HF45 7510
68 Ω	HF45 4680	HF45 4680	56 kΩ	HF45 7560	HF45 7560
75 Ω	HF45 4750	HF45 4750	62 kΩ	HF45 7620	HF45 7620
82 Ω	HF45 4820	HF45 4820	68 kΩ	HF45 7680	HF45 7680
91 Ω	HF45 4910	HF45 4910	82 kΩ	HF45 7820	HF45 7820
100 Ω	HF45 5100	HF45 5100	91 kΩ	HF45 7910	HF45 7910
110 Ω	HJ35 5110	HF85 5110	100 kΩ	HF45 8100	HF45 8100
120 Ω	HF45 5120	HF45 5120	110 kΩ	HF45 8110	HF45 8110
150 Ω	HF45 5150	HF45 5150	120 kΩ	HF45 8120	HF45 8120
180 Ω	HJ35 5160	*	130 kΩ	HF45 8130	HF45 8130
180 Ω	HF45 5180	HF45 5180	150 kΩ	HF45 8150	HF45 8150
200 Ω	HF45 5200	HF45 5200	180 kΩ	HF45 8180	HF45 8180
220 Ω	HF45 5220	HF45 5220	220 kΩ	HJ35 8220	HF85 8220
270 Ω	HF45 5270	HF45 5270	270 kΩ	HF45 8270	HF45 8270
330 Ω	HF45 5330	HF45 5330	300 kΩ	HF45 8300	HF45 8300
390 Ω	HF45 5390	HF45 5390	330 kΩ	HF45 8330	HF45 8330
430 Ω	HF45 5430	HF45 5430	390 kΩ	HJ35 8390	HF85 8390
470 Ω	HF45 5470	HF45 5470	470 kΩ	HF45 8470	HF45 8470
510 Ω	HF45 5510	HF45 5510	560 kΩ	HJ35 8560	HF85 8560
560 Ω	HF45 5560	HF45 5560	680 kΩ	HJ35 8680	HF85 8680
680 Ω	HF45 5680	HF45 5680	820 kΩ	HJ35 8820	HF85 8820
820 Ω	HF45 5820	HF45 5820	1.0 MΩ	HF45 9100	HF45 9100
910 Ω	HF45 5910	HF45 5910	1.2 MΩ	HJ35 9120	*
1.0 kΩ	HF45 6100	HF45 6100	1.5 MΩ	HJ35 9150	HF85 9150
1.2 kΩ	HF45 6120	HF45 6120	1.8 MΩ	HJ35 9180	HF85 9180
1.5 kΩ	HF45 6150	HF45 6150	2.2 MΩ	HJ35 9220	HF85 9220
1.8 kΩ	HF45 6180	HF45 6180	3.3 MΩ	HJ35 9330	HF85 9330
2.0 kΩ	HJ35 6200	HF85 6200	3.9 MΩ	HJ35 9390	*
2.2 kΩ	HF45 6220	HF45 6220	4.7 MΩ	HJ35 9470	HF85 9470
2.4 kΩ	HJ35 6240	HF85 6240			
2.7 kΩ	HF45 6270	HF45 6270			
3.0 kΩ	HF45 6300	HF45 6300			
3.3 kΩ	HF45 6330	HF45 6330			
3.6 kΩ	HJ35 6360	HF85 6360			
3.9 kΩ	HF45 6390	HF45 6390			
4.7 kΩ	HF45 6470	HF45 6470			
5.1 kΩ	HF45 6510	HF45 6510			
5.6 kΩ	HF45 6560	HF45 6560			
6.8 kΩ	HF45 6680	HF45 6680			
8.2 kΩ	HF45 6820	HF45 6820			
9.1 kΩ	HF45 6910	HF45 6910			
10 kΩ	HF45 7100	HF45 7100			

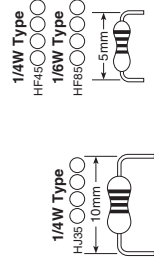

* : Not available

• OVERALL ASSY

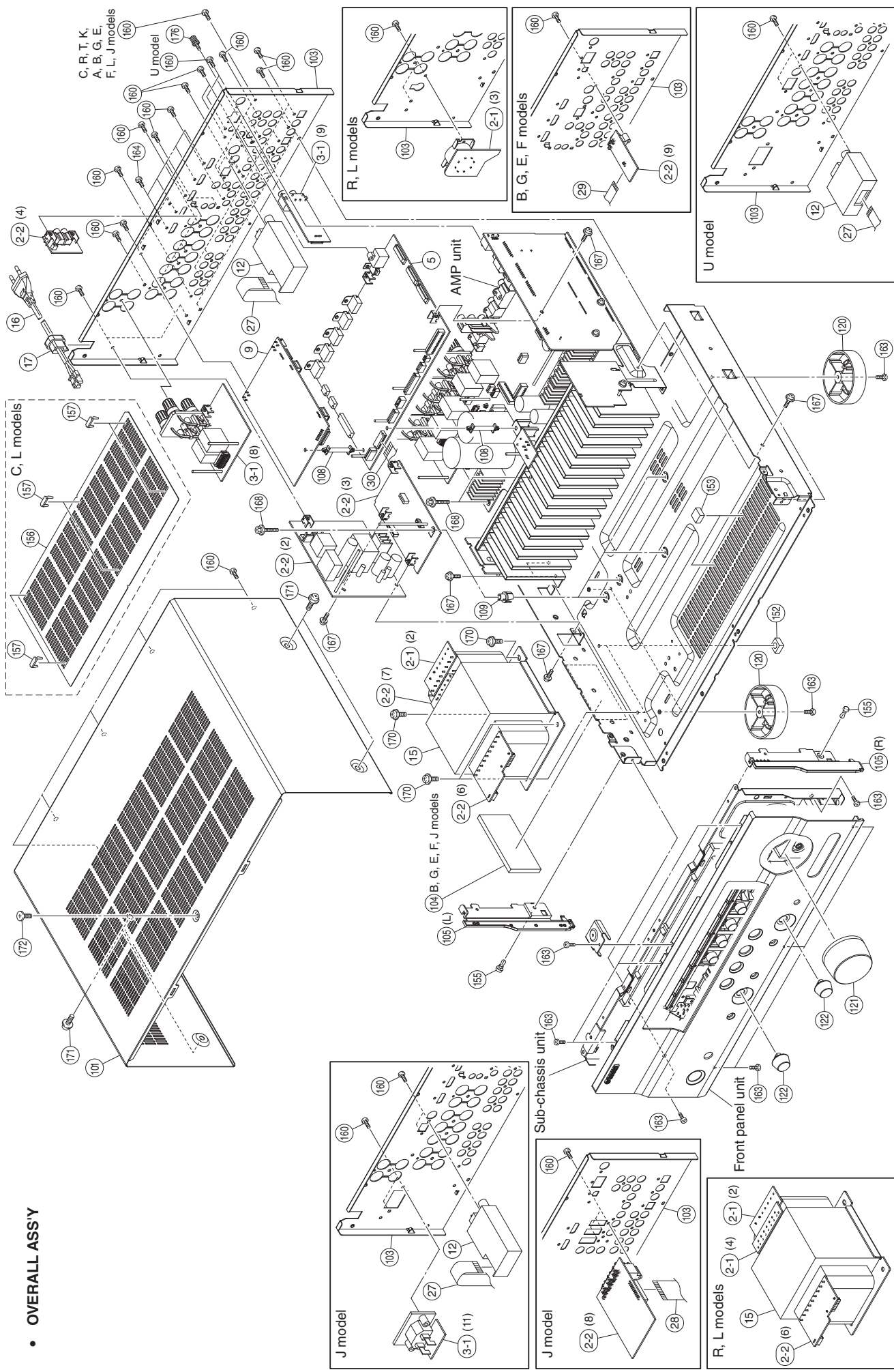

Ref No.	Part No.	Description	Remarks	Markets	部 品 名	ランク
* 2-1	WR431100	P.C.B. ASS'Y		J	PCB MAIN	
* 2-1	WR431200	P.C.B. ASS'Y		UC	PCB MAIN	
* 2-1	WR431300	P.C.B. ASS'Y		R	PCB MAIN	
* 2-1	WR431400	P.C.B. ASS'Y		TKABGEF	PCB MAIN	
* 2-1	WR431500	P.C.B. ASS'Y		L	PCB MAIN	
* 2-2	WR432700	P.C.B. ASS'Y		J	PCB VIDEO	
* 2-2	WR432800	P.C.B. ASS'Y		U	PCB VIDEO	
* 2-2	WR432900	P.C.B. ASS'Y		C	PCB VIDEO	
* 2-2	WR433000	P.C.B. ASS'Y		R	PCB VIDEO	
* 2-2	WR433100	P.C.B. ASS'Y		T	PCB VIDEO	
* 2-2	WR433200	P.C.B. ASS'Y		K	PCB VIDEO	
* 2-2	WR433300	P.C.B. ASS'Y		A	PCB VIDEO	
* 2-2	WR433400	P.C.B. ASS'Y		BGEF	PCB VIDEO	
* 2-2	WR433500	P.C.B. ASS'Y		L	PCB VIDEO	
* 3-1	WR434700	P.C.B. ASS'Y	OPERATION	J	PCB OPERATION	
* 3-1	WR434800	P.C.B. ASS'Y	OPERATION	U	PCB OPERATION	
* 3-1	WR434900	P.C.B. ASS'Y	OPERATION	ORTA	PCB OPERATION	
* 3-1	WR435000	P.C.B. ASS'Y	OPERATION	KBGEFL	PCB OPERATION	
* 5	WR435600	P.C.B. ASS'Y	DIGITAL	J	PCB DIGITAL	VI065
* 5	WR435700	P.C.B. ASS'Y	DIGITAL	U	PCB DIGITAL	VI065
* 5	WR435800	P.C.B. ASS'Y	DIGITAL	U	PCB DIGITAL	6280
* 5	WR435800	P.C.B. ASS'Y	DIGITAL	U	PCB DIGITAL	6280
* 5	WR435900	P.C.B. ASS'Y	DIGITAL	C	PCB DIGITAL	6280
* 5	WR435900	P.C.B. ASS'Y	DIGITAL	BGEF	PCB DIGITAL	VI065
* 9	WR437000	P.C.B. ASS'Y	GUI		PCB GUI	
12	W0756500	AM/FM TUNER	FAEH06-J	J	AM/FMチューナー	
* 12	WT510100	HD RADIO TUNER	FAEH06-A	U	HDチューナー	
12	W0756600	AM/FM TUNER	FAEH06-A	ORTL	AM/FMチューナー	
12	W0756700	AM/FM TUNER	FAEH06-E	KABGEF	AM/FMチューナー	
* 15	YA753A00	POWER TRANSFORMER		J	電源トランス	
* 15	YA684A00	POWER TRANSFORMER		UC	電源トランス	
* 15	YA685A00	POWER TRANSFORMER		RL	電源トランス	
* 15	YA686A00	POWER TRANSFORMER		TK	電源トランス	
* 15	YA687A00	POWER TRANSFORMER		A	電源トランス	
* 15	YA754A00	POWER TRANSFORMER		BGEF	電源トランス	
* 16	WB120500	POWER CABLE		UC	電源コード	
* 16	WB992700	POWER CABLE		R	電源コード	
* 16	WB120600	POWER CABLE		T	電源コード	
* 16	WB753000	POWER CABLE		K	電源コード	
* 16	WB743700	POWER CABLE		A	電源コード	
* 16	WB122000	POWER CABLE		B	電源コード	
* 16	WB336900	POWER CABLE		BGEFL	電源コード	
17	V2438700	CORD STOPPER		UCRTKABGEFL	コードストッパー	02
* 27	WR285000	FLEXIBLE FLAT CABLE	1P1 250mm P=1.25	J	カード電線	
* 27	WR285100	FLEXIBLE FLAT CABLE	13P 250mm P=1.25	U	カード電線	
* 27	WR284900	FLEXIBLE FLAT CABLE	11P 100mm P=1.25	ORTKABGEFL	カード電線	
* 28	WR285400	FLEXIBLE FLAT CABLE	22P 100mm P=1.25	J	カード電線	
* 29	WR284700	FLEXIBLE FLAT CABLE	5P 180mm P=1.25	BGEF	カード電線	
* 30	WF116070	FLEXIBLE FLAT CABLE	16P 70mm P=1.25		カード電線	
* 101	W0665600	TOP COVER			トップカバー	
* 101	W0665500	TOP COVER			トップカバー	
* 101	W0665700	TOP COVER			トップカバー	
* 103	W0668000	REAR PANEL		J	リアパネル	VI065

* New Parts * 新規部品

Ref No.	Part No.	Description	Remarks	Markets	部 品 名	ランク
* 103	W0667100	REAR PANEL	VI065	U	リアパネル	
* 103	W0668100	REAR PANEL	6280	U	リアパネル	
* 103	W0667200	REAR PANEL	VI065	C	リアパネル	
* 103	W0668200	REAR PANEL	6280	C	リアパネル	
* 103	W0667300	REAR PANEL	VI065	R	リアパネル	
* 103	W0667400	REAR PANEL	VI065	T	リアパネル	
* 103	W0667500	REAR PANEL	VI065	K	リアパネル	
* 103	W0667600	REAR PANEL	VI065	A	リアパネル	
* 103	W0667700	REAR PANEL	VI065	BGEF	リアパネル	
* 103	W0667900	REAR PANEL	VI065	L	リアパネル	
104	V3198100	DAMPER	GUARD	JBBEF	ダンパー	01
* 105	WR005100	PLATE SIDE	L/R 1pair	GD	プレートサイド	
* 105	WR004900	PLATE SIDE	L/R 1pair	BL	プレートサイド	
* 105	WR005000	PLATE SIDE	L/R 1pair	TI	プレートサイド	
* 109	WS000800	SPACER SUPPORT	LCA4-29M PIN		スペーサーサポート	
108	W0664500	SUPPORT HB			サポートHB	
120	V0042500	LEG	D60XH21 GD	GD	レッグ	03
120	V0025000	LEG	D60XH21 HS	BL, TI	レッグ	02
121	WJ181400	KNOB	D50	BL	ノブ	08
121	WJ181300	KNOB	D50	BL	ノブ	
121	WJ181500	KNOB	D50	TI	ノブ	08
* 122	WR004800	KNOB D20	GD	GD	ノブD20	
* 122	WR004600	KNOB D20	BL	BL	ノブD20	
* 122	WR004700	KNOB D20	TI	TI	ノブD20	
152	W0879000	DAMPER	SCREEN MASK		ダンパー	
153	WR377400	DAMPER	14x10x10		ダンパー	
155	V0366800	PUSH RIVET	P3555-B		プッシュリベット	01
156	W0667900	SHEET TOP		CL	シート トップ	
157	WJ053300	RIVET TOP		CL	リベットトップ	
160	WE774100	BIND HEAD BONDING B-T. SCREW	3x8 MFZN2B3		ボンディングバインドネジ	01
163	WE743000	BIND HEAD B-TIGHT SCREW	3x8 MFZN2W3		バインドバインドネジ	01
164	WE879000	BIND HEAD S-TIGHT SCREW	3x6 MFZN2W3		バインドSタイプネジ	01
167	WF002600	PW HEAD B-TIGHT SCREW	3x6 MFZN2W3		PWヘッドバインドネジ	01
168	WE774600	SCREW IC	3x18 MFZN2W3		スクリーン IC	01
170	WE774700	BIND HEAD S-TIGHT SCREW	4x10 MFZN2W3		バインドSタイプネジ	01
171	VD069600	PW HEAD S-TIGHT SCREW	4x8-10 MFN133	GD, TI	PWヘッドSタイプネジ	01
171	WH313200	PW HEAD S-TIGHT SCREW	4x8-10 MFN138L	BL	PWヘッドSタイプネジ	01
172	WE200400	DISH HEAD B-TIGHT SCREW	3x6 MFN133	GD, TI	DISH バインドネジ	01
172	WE200500	DISH HEAD B-TIGHT SCREW	3x6 MFN138L	BL	DISH バインドネジ	01
176	FA627310	GROUND TERMINAL			GNDターミナル	01

* New Parts * 新規部品

RX-V1065/HTR-6280/AX-V1065

• ACCESSORIES

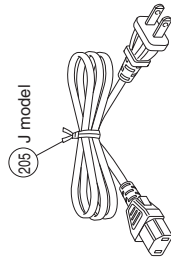
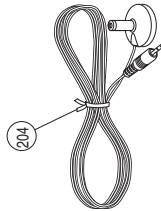
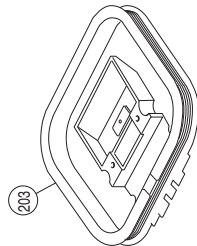
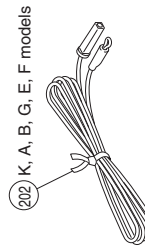
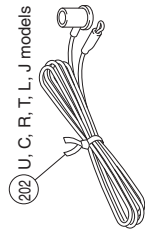
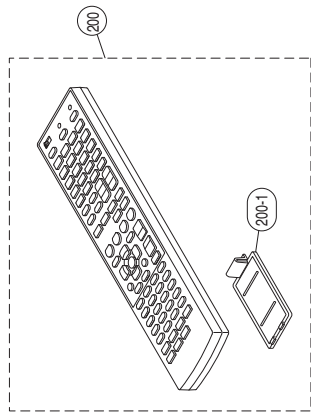

Ref No.	Part No.	Description	Remarks	Markets	部 品 名	ランク
* 200	WR002000	REMOTE CONTROL	RAV286	J	リモコン	
* 200	WR002100	REMOTE CONTROL	RAV287	U	リモコン	
* 200	WR002200	REMOTE CONTROL	RAV288	CRAL	リモコン	
* 200	WR002800	REMOTE CONTROL	RAV294	TRBGEF	リモコン	
200-1	AAV82380	BATTERY COVER			電池蓋	03
202	V6267000	INDOOR FM ANTENNA	1.4m 1pc	JUCRTL	F M簡易アンテナ	03
202	V0147100	INDOOR FM ANTENNA	1.4m 1pc	KABGEF	F M簡易アンテナ	02
203	VR248500	AM LOOP ANTENNA	1.0m 1pc	JURTKABGEFL	A Mループアンテナ	03
203	ME746800	AM LOOP ANTENNA	1.2m 1pc	U	A Mループアンテナ	
204	WN648600	OPTIMIZER MICROPHONE	6.0m 1pc		オプティマイザーマイク	08
205	WD292100	POWER CABLE BATTERY	2.0m 1pc R03,AAA,UM-4 2pcs	J	電源コード 単4乾電池	08
		SERVICE TOOLS				
	WR492800	RS232C CONVERTER ADAPTOR	3.3Vtype with FFC9P		サービス用部品	13
	MF125400	FLEXIBLE FLAT CABLE	25P 400mm P=1, 2.5		RS232C変換アダプタ	
	MF109400	FLEXIBLE FLAT CABLE	9P 400mm P=1, 2.5		カード電線	
					カード電線	02

* New Parts * 新発部品

• FRONT PANEL UNIT and SUB-CHASSIS UNIT

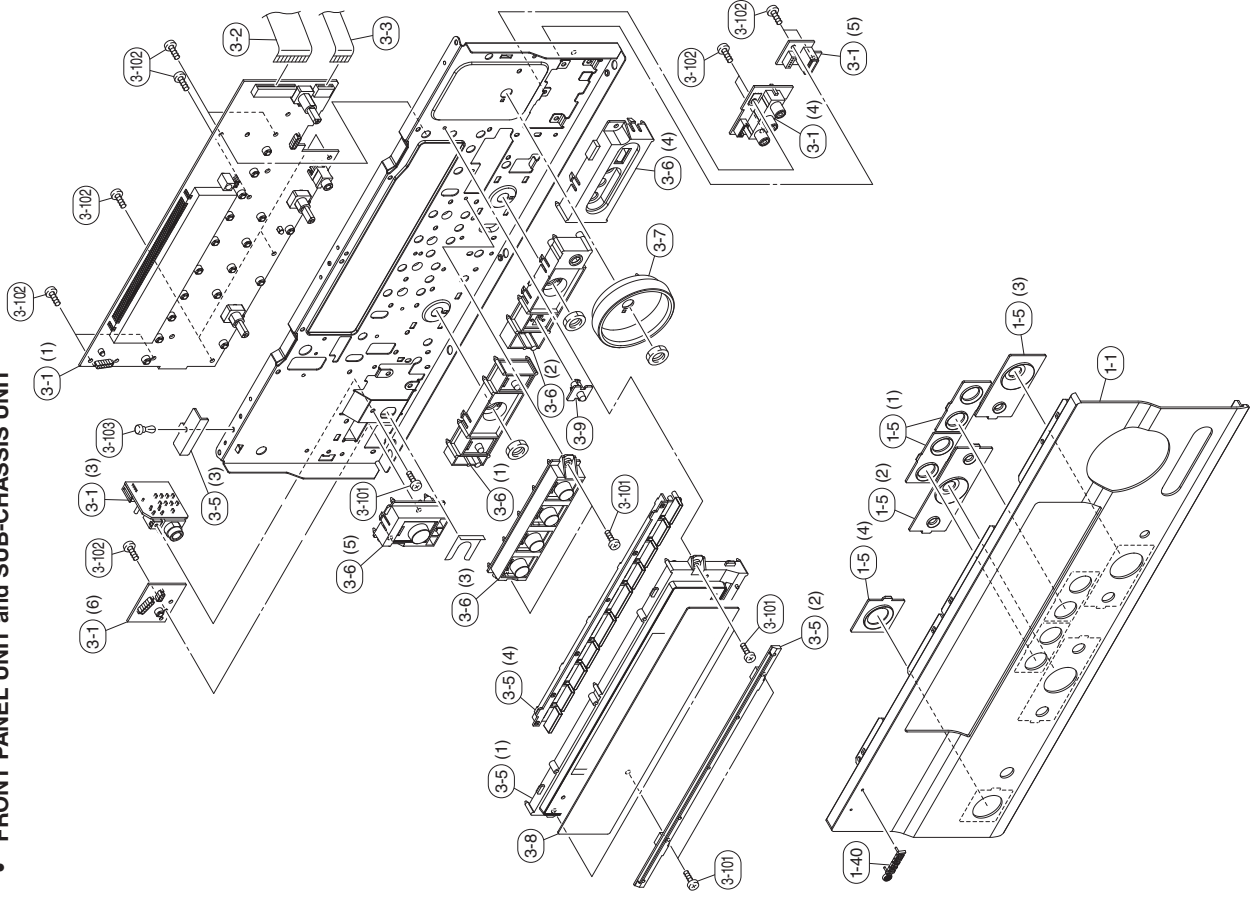

Ref No.	Part No.	Description	Remarks	Markets	部 品 名	ランク
* 1-1	WR004500	FRONT PANEL	VI065GD	RT	フロントパネル	
* 1-1	WR004100	FRONT PANEL	VI065BL	J	フロントパネル	
* 1-1	WR003800	FRONT PANEL	VI065BL	U	フロントパネル	
* 1-1	WR073500	FRONT PANEL	6280BL	U	フロントパネル	
* 1-1	WR003900	FRONT PANEL	VI065BL	CRTKARBEFL	フロントパネル	
* 1-1	WR004000	FRONT PANEL	6280BL	C	フロントパネル	
* 1-1	WR004300	FRONT PANEL	VI065TI	KGEFL	フロントパネル	
* 1-5	WR005400	ESCUTCHEON	GD		エスカッション	
* 1-5	WR005200	ESCUTCHEON	BL		エスカッション	
* 1-5	WR005300	ESCUTCHEON	TI		エスカッション	
1-40	V6034200	EMBLEM	GD		エンブレム	03
1-40	V6034100	EMBLEM	BL, TI		エンブレム	03
* 3-1	WR434700	P.C.B. ASS'Y	OPERATION	J	PCB OPERATION	
* 3-1	WR434800	P.C.B. ASS'Y	OPERATION	U	PCB OPERATION	
* 3-1	WR434900	P.C.B. ASS'Y	OPERATION	GRTA	PCB OPERATION	
* 3-1	WR435000	P.C.B. ASS'Y	OPERATION	KGEFL	PCB OPERATION	
* 3-2	WR482100	FLEXIBLE FLAT CABLE	25P 250mm P=1.25		カード電線	
* 3-3	WR284800	FLEXIBLE FLAT CABLE	9P 250mm P=1.25		サブパネル	
* 3-5	WR006800	SUB PANEL			ボタンケース	
* 3-6	WR068000	BUTTON CASE	GD	R	ボタンケース	
* 3-6	WS075700	BUTTON CASE	GD	T	ボタンケース	
* 3-6	WR068100	BUTTON CASE	BL	J	ボタンケース	
* 3-6	WR067800	BUTTON CASE	BL	U	ボタンケース	
* 3-6	WS075500	BUTTON CASE	BL	CRKARBEFL	ボタンケース	
* 3-6	WR067900	BUTTON CASE	TI	T	ボタンケース	
* 3-7	WR006300	ESCUTCHEON VOLUME	GD		エスカッションVOLUME	
* 3-7	WR006100	ESCUTCHEON VOLUME	GD		エスカッションVOLUME	
* 3-7	WR006200	ESCUTCHEON VOLUME	BL		エスカッションVOLUME	
* 3-8	WR006700	SHEET WINDOW	TI		シートウインドウ	
* 3-8	WR006500	SHEET WINDOW	GD	J	シートウインドウ	
* 3-8	WR006600	SHEET WINDOW	BL	U	シートウインドウ	
* 3-8	WS075100	SHEET WINDOW	BL	CRKARBEFL	シートウインドウ	
* 3-9	WR006400	LENS BUTTON			レンズボタン	
3-101	WE774300	BIND HEAD B-TIGHT SCREW	3x8 MFZWN3		バインドBタイトネジ	01
3-102	WE774800	BIND HEAD P-TIGHT SCREW	3x8 MFZWN3		バインドPタイトネジ	01
3-103	V0366800	PUSH RIVET	P3555-B		プッシュリベット	01

* New Parts * 新規部品

RX-V1065/HTR-6280/AX-V1065

• AMP UNIT

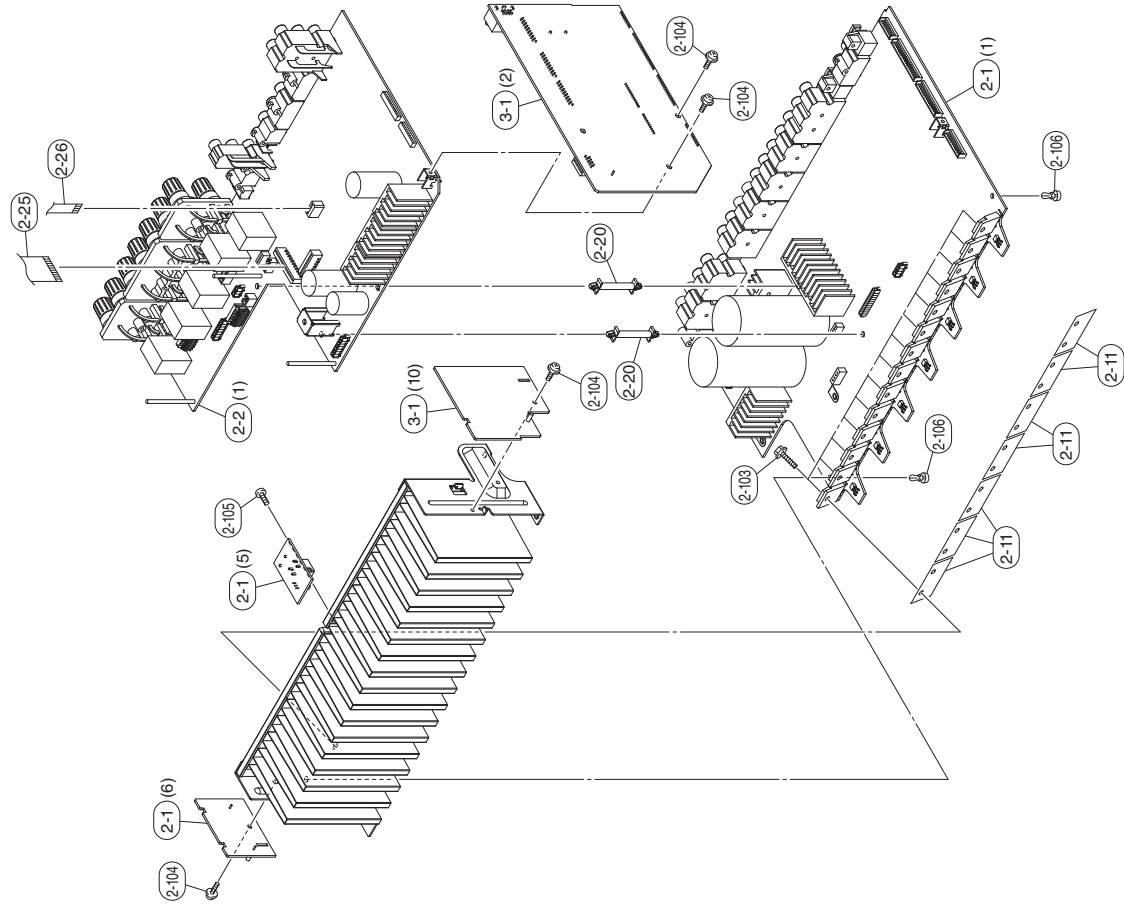

Ref No.	Part No.	Description	Remarks	Markets	部 品 名	ランク
* 2-1	WR431100	P.C.B. ASS'Y		J	PCB MAIN	
* 2-1	WR431200	P.C.B. ASS'Y		UC	PCB MAIN	
* 2-1	WR431300	P.C.B. ASS'Y		R	PCB MAIN	
* 2-1	WR431400	P.C.B. ASS'Y		TK&GEEF	PCB MAIN	
* 2-1	WR431500	P.C.B. ASS'Y		L	PCB MAIN	
* 2-2	WR432700	P.C.B. ASS'Y		J	PCB VIDEO	
* 2-2	WR432800	P.C.B. ASS'Y		U	PCB VIDEO	
* 2-2	WR432900	P.C.B. ASS'Y		C	PCB VIDEO	
* 2-2	WR433000	P.C.B. ASS'Y		R	PCB VIDEO	
* 2-2	WR433100	P.C.B. ASS'Y		T	PCB VIDEO	
* 2-2	WR433200	P.C.B. ASS'Y		K	PCB VIDEO	
* 2-2	WR433300	P.C.B. ASS'Y		A	PCB VIDEO	
* 2-2	WR433400	P.C.B. ASS'Y		B&GFL	PCB VIDEO	
* 2-2	WR433500	P.C.B. ASS'Y		L	PCB VIDEO	
* 2-11	WD753200	MICA SHEET	TB-1021		マイカシート	
* 2-20	WS000800	SPACER SUPPORT	LCAF-29M PIN		スペーサーサポート	
* 2-25	WR285500	FLEXIBLE FLAT CABLE	22P 140mm P=1.25		カード電線	
* 2-26	WR285300	FLEXIBLE FLAT CABLE	14P 200mm P=1.25		カード電線	
2-103	WF208000	HEXAGONAL HEAD B-TIGHT SCREW	3x15 SP MFZ12W3		六角Bタイトネジ	01
2-104	WF002600	PH HEAD B-TIGHT SCREW	3x8 MFZ12W3		PWヘッドBタイトネジ	01
2-105	WF774300	BIND HEAD B-TIGHT SCREW	3x8 MFZ12W3		バインドヘッドタイトネジ	01
2-106	VG368600	PUSH RIVET	P3555-B		プッシュリベット	
* 3-1	WR434700	P.C.B. ASS'Y	OPERATION	J	PCB OPERATION	
* 3-1	WR434800	P.C.B. ASS'Y	OPERATION	U	PCB OPERATION	
* 3-1	WR434900	P.C.B. ASS'Y	OPERATION	CRTA	PCB OPERATION	
* 3-1	WR435000	P.C.B. ASS'Y	OPERATION	KBGFL	PCB OPERATION	

* New Parts * 新発部品

1 ■ REMOTE CONTROL

- RAV287: U model / RAV288: C, R, A, L models / RAV294: T, K, B, E, F models / RAV286: J model

SCHEMATIC DIAGRAMS

RAV286/RAV287/RAV288

PANELS

RAV287
(U model)

RAV288
(C, R, A, L models)

RAV294
(T, K, B, G, E, F models)

RAV286
(J model)

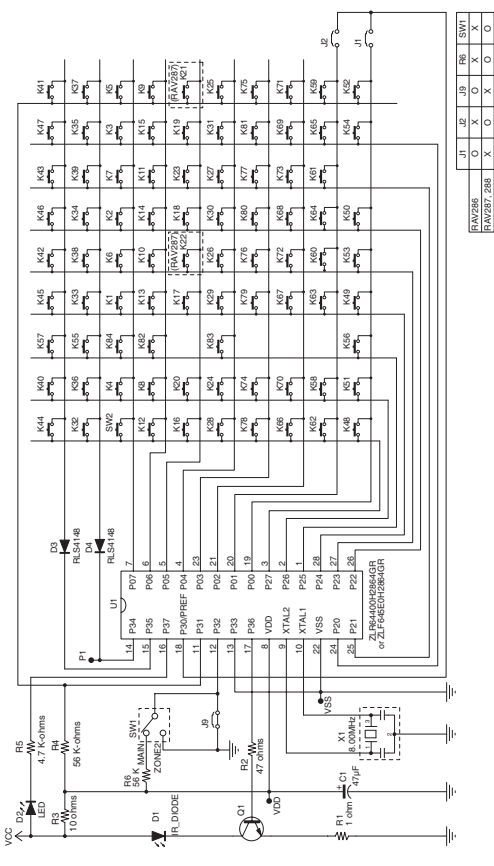

RAV294

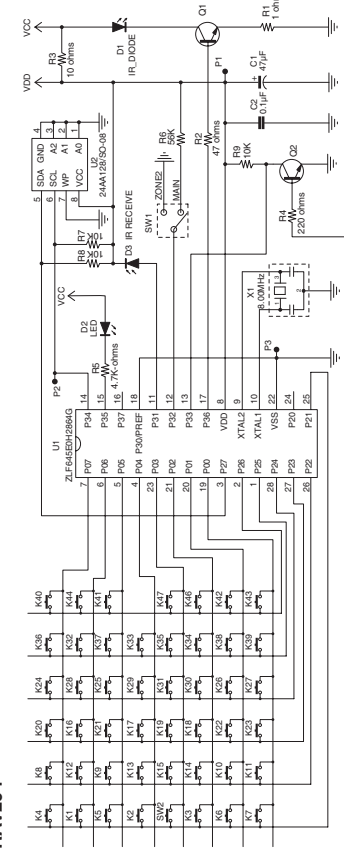

● These PADs are test point ISF in the production line
Revision history:

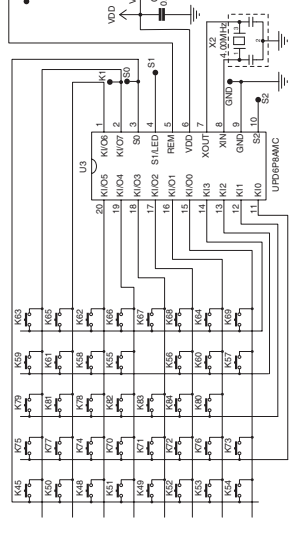

KEY NO. LAYOUT

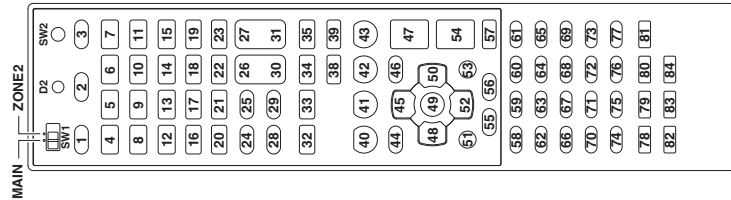

KEY CODE

GROUP	PRE SET	Key No.	FUNCTION	COM	ID1	MAIN [MAIN]	ZONE2 [ZONE2]	MAIN [MAIN]	ZONE2 [ZONE2]	ID2
POWER	-	SW1	MAINZONE 2 TRANSMIT	-	-	-	-	-	-	-
	-	SW2	CODE SET	-	-	-	-	-	-	-
	-	K2	SLEEP	0	7A-30	7A-30CE	7A-31CF	7A-30CE	7A-31CF	-
	-	K3	POWER	0	7E-2A	7E-2AD4	7A-453B	7E-2AD4	7A-453B	-
	-	K4	HDMI-1	0	7A-4738	7A-4739	7A-4836	7A-4739	7A-4836	-
	-	K5	HDMI-2	0	7A-4A35	7A-4A34	7A-4B35	7A-4A34	7A-4B35	-
	-	K6	HDMI-3	0	7A-4D32	7A-4D33	7A-4E30	7A-4D33	7A-4E30	-
	-	K7	HDMI-4	0	7A-502F	7A-502E	7A-512F	7A-502E	7A-512F	-
	-	K8	AV-1	0	7A-532C	7A-532D	7A-542A	7A-532D	7A-542A	-
	-	K9	AV-2	0	7A-5629	7A-5628	7A-5729	7A-5628	7A-5729	-
	-	K10	AV-3	0	7A-5926	7A-5927	7A-5A24	7A-5927	7A-5A24	-
-	K11	AV-4	0	7A-5C23	7A-5C22	7A-5D23	7A-5C22	7A-5D23	-	
-	K12	AV-5	0	7A-5F20	7A-5F21	7A-601E	7A-5F21	7A-601E	-	
-	K13	AV-6	0	7A-621D	7A-621C	7A-631D	7A-621C	7A-631D	-	
-	K14	AUDIO-1	0	7A-651A	7A-651B	7A-6618	7A-651B	7A-6618	-	
-	K15	AUDIO-2	0	7A-6817	7A-6816	7A-6917	7A-6816	7A-6917	-	
-	K16	V-AUX	0	7A-65	7A-55AB	7A-D826	7A-55AB	7A-D826	-	
-	K17	[A] (RAV290, 291) [PHONO] (RAV289, 292, 295)	0	7A-14	7A-D0	7A-14EA	7A-D02E	7A-14EA	7A-D02E	-
-	K23	MULTI CH	0	7A-87	-	7A-8779	-	7A-8779	-	
-	K18	[B] (RAV290, 291) [A] (RAV289, 292, 295)	0	7F01-3F	7F01-40	7F01-3FC1	7F01-40BE	7F01-3FC1	7F01-40BE	-
-	K19	DOCK	0	7F01-4A	7F01-4B	7F01-4AB4	7F01-4BB5	7F01-4AB4	7F01-4BB5	-
-	K20	TUNER	0	7A-16	7A-D2	7A-16E8	7A-D22C	7A-16E8	7A-D22C	-
-	K21	SIRIUS (RAV290) U model	0	7A-39	7A-3A	7A-39C7	7A-3AC4	7A-39C7	7A-3AC4	-
-	K22	XM (RAV290) U model	0	7A-B4	7A-B8	7A-B44A	7A-B846	7A-B44A	7A-B846	-
-	K24	CATEGORY (-) FM	0	7F01-5827	7F01-5826	7F01-5826	7F01-5927	7F01-5826	7F01-5927	-
-	K25	CATEGORY (+) AM	0	7F01-552A	7F01-5529	7F01-552B	7F01-5628	7F01-5529	7F01-5628	-
-	K26	PRESET (+)	0	7F01-5B24	7F01-5C23	7F01-5B25	7F01-5C22	7F01-5B25	7F01-5C22	-
-	K27	TUNING(CH +)	0	7F01-611E	7F01-621D	7F01-611F	7F01-621C	7F01-611F	7F01-621C	-
-	K28	INFO	0	7A-2758	7A-2857	7A-2759	7A-2856	7A-2759	7A-2856	-
-	K29	MEMORY	0	7F01-6718	7F01-6817	7F01-6719	7F01-6816	7F01-6719	7F01-6816	-
-	K30	PRESET (-)	0	7F01-5E21	7F01-5F20	7F01-5E20	7F01-5F21	7F01-5E20	7F01-5F21	-
-	K31	TUNING(CH -)	0	7F01-641B	7F01-651A	7F01-641A	7F01-651B	7F01-641A	7F01-651B	-
-	K32	MOVIE	0	7A-88	-	7A-8876	-	7A-8876	-	
-	K33	MUSIC	0	7A-89	-	7A-8977	-	7A-8977	-	
-	K34	STEREO/ENHANCER	0	7A-94	-	7A-946A	-	7A-946A	-	
-	K35	SUR. DECODE	0	7A-8D	-	7A-8D73	-	7A-8D73	-	
-	K38	STRAIGHT	0	7A-56	-	7A-56A8	-	7A-56A8	-	
-	K39	PURE DIRECT	0	7A-DD	-	7A-DD23	-	7A-DD23	-	
-	K40	BD/DVD	0	7A-007F	7A-017E	7A-007E	7A-017F	7A-007E	7A-017F	-
-	K41	TV	0	7A-037C	7A-047B	7A-037D	7A-047A	7A-037D	7A-047A	-
-	K42	CD	0	7A-0679	7A-0778	7A-0678	7A-0779	7A-0678	7A-0779	-
-	K43	RADIO or GAME	0	7A-0876	7A-0A75	7A-0877	7A-0A74	7A-0877	7A-0A74	-

GROUP	PRE SET	Key No.	FUNCTION	COM	ID1	MAIN	ZONE2	MAIN	ZONE2	ID2
MENU	-	K44	SETUP	0	7A-84	7A-847A	-	7A-847A	-	-
CURSOR	-	K46	OPTION	0	7A-6B14	* enter into AMP MODE	7A-6B15	* enter into AMP MODE	-	-
	-	K45	UP	-	7A-9D	-	7A-9D63	-	-	-
	-	K48	LEFT	-	7A-9F	-	7A-9F61	-	-	-
	-	K49	RIGHT	-	7A-9E	-	7A-9E20	-	-	-
	-	K50	ENTER	-	7A-AA	-	7A-9A54	-	-	-
	-	K51	RETURN	-	7A-9C	-	7A-9C82	-	-	-
	-	K52	DOWN	-	7F01-60	7F01-609E	7F01-607E	7F01-609E	7F01-607E	-
	-	K53	(DISPLAY)	0	7A-1A	7A-DA	7A-DA24	7A-1AE4	7A-DA24	-
	-	K54	VOLUME (+)	0	7A-1B	7A-DB	7A-DB25	7A-1BE5	7A-DB25	-
	-	K57	MUTE	0	7A-1C	7A-DC	7A-DC22	7A-1CE2	7A-DC22	-
	-	K1	POWER (SOURCE)	0	-	-	-	-	-	-
-	K55	TOP MENU	-	-	-	-	-	-	-	
-	K56	MENU	-	-	-	-	-	-	-	
-	K58	REC	-	-	-	-	-	-	-	
-	K59	PLAY	-	-	-	-	-	-	-	
-	K60	STOP	-	-	-	-	-	-	-	
-	K61	PAUSE	-	-	-	-	-	-	-	
-	K62	REW	-	-	-	-	-	-	-	
-	K63	FF	-	-	-	-	-	-	-	
-	K64	SKIP (-)	-	-	-	-	-	-	-	
-	K65	SKIP (+)	-	-	-	-	-	-	-	
-	K66	1	-	-	-	-	-	-	-	
-	K67	2	-	-	-	-	-	-	-	
-	K68	3	-	-	-	-	-	-	-	
-	K69	4	-	-	-	-	-	-	-	
-	K70	5	-	-	-	-	-	-	-	
-	K71	6	-	-	-	-	-	-	-	
-	K72	7	-	-	-	-	-	-	-	
-	K73	8	-	-	-	-	-	-	-	
-	K74	9	-	-	-	-	-	-	-	
-	K75	0	-	-	-	-	-	-	-	
-	K76	+10	-	-	-	-	-	-	-	
-	K77	ENT	-	-	-	-	-	-	-	
-	K78	TV INPUT	-	-	-	-	-	-	-	
-	K79	TV VOL. (+)	-	-	-	-	-	-	-	
-	K80	TV CH. (+)	-	-	-	-	-	-	-	
-	K82	TV MUTE	-	-	-	-	-	-	-	
-	K83	TV VOL. (-)	-	-	-	-	-	-	-	
-	K84	TV CH. (-)	-	-	-	-	-	-	-	

* Function code

* Function code

* TV mode

Advanced setup

In the advanced setup menu, you can set basic operations of this unit, such as on and off of a bi-amp connection, or initialize user settings.

- 1 Set this unit to standby.
- 2 While holding down **ⓄSTRAIGHT** on the front panel, press **ⓄMAIN ZONE ON/OFF**. Keep holding down **ⓄSTRAIGHT** until "ADVANCED SETUP" appears on the front panel display.

ADVANCED SETUP

- 3 Rotate the **ⓄPROGRAM** selector to select the parameter you want to change.

The default setting are marked with "ns".

※ Set values are placed in XXX of the following parameters on an actual display screen.

SP IMP. - XXX

Choices: 60MIN, 80MIN*

Selects output impedance of this unit according to connected speakers. When you connect 4-ohm speakers to the FRONT speaker terminals, set "SP IMP." to "60MIN".

REMOTE ID - XXX

Choices: ID1*, ID2

Sets a remote control ID. When using multiple Yamaha AV receivers, you can operate them with a single remote control by setting the receiver IDs to the same setting.

SR PIN - XXX

Choices: RESET, CANCEL*

Resets Parental lock cord when using SIRIUS Satellite tuner.

BI AMP - XXX

Choices: ON, OFF*

Switches on and off of bi-amp connection of main speakers.

SCENE IR - XXX

Choices: ON*, OFF

Selects whether or not to transmit the control signals to an external component connected to the REMOTE OUT jack on this unit when BD/DVD or CD SCENE function is selected.

MON. CHK - XXX

Choices: YES*, SKIP

Adds upscaling limitation on output signals to a video monitor connected to this unit via the HDMI OUT jack.

- 3 Enter the desired remote control ID code.

To switch to ID1:

Press **ⓄNumeric keys** to enter "5019".

To switch to ID2:

Press **ⓄNumeric keys** to enter "5020".

Once the remote control code is registered,

ⓄTRANSMIT blinks twice.

If it fails, **ⓄTRANSMIT** blinks six times. Repeat from step 1.

※

* If you initialize the settings of this unit, "REMOTE ID" (remote control code of this unit) is set to "ID1".

- 4 Press **ⓄSTRAIGHT** repeatedly to change the selected parameter setting.

To change other settings, repeat steps 3 and 4.

- 5 Press **ⓄMAIN ZONE ON/OFF** to set this unit to standby.

The settings you made are reflected next time you turn on this unit.

Updating the firmware

You can check the firmware of this unit and update the firmware using the USB port on the front panel.

Select the following parameter in step 3 above.

FIRM UPDATE

Updates the firmware of this unit. To update the firmware, select "FIRM UPDATE" and then press **ⓄSTRAIGHT**.

Notes

- Do not use this feature unless you need to update the firmware.
- Be sure to read information supplied with updates before updating the firmware.

VER. XXX.XX.XX.XX.XX.XX

Displays the firmware of this unit.

Setting a remote control ID

Two IDs are provided for the remote control of this unit. If another Yamaha amplifier is in the same room, setting a different remote control ID to this unit prevents unwanted operation of the other amplifier.

"ID1" is set for both the main unit and remote control by default. If you have changed the remote control ID, make sure that you select the same ID for the main unit in the advanced setup menu.

- 1 Press **ⓄCODE SET** on the remote control using a pointed object such as the tip of a ballpoint pen.

ⓄTRANSMIT blinks twice.

- 2 Press **ⓄON SCREEN**.

本機の基本設定 / 初期化を行う (アドバンスドセットアップメニュー)

アドバンスドセットアップメニューでは、バイアンプ接続のオン/オフといった本機の基本設定や、ユーザー設定の初期化を行うことができます。

1 本機の電源をスタンバイに切り替えます。

- 2 フロントパネルディスプレイに以下のように表示されるまで、フロントパネルの
 Ⓟ**STRAIGHT** を押しながら、
 Ⓛ**STANDBY/ON** を押す。

ADVANCED SETUP

3 Ⓞ**PROGRAM** セレクターを回して、以下の中から設定したい項目を選択する。

「*」は初期設定を表します。



• 実際のディスプレイ表示は、「XXX」の部分に設定値が入ります。

REMOTE ID - XXXX

選択項目： ID1* / ID2

リモコンのIDを設定します。ヤマハ製AVアンプを複数使用する場合、各アンプのIDを同じ設定にすると、1つのリモコンですべてのアンプを操作できます。IDを分けた場合は、それぞれのリモコンで、アンプごとに操作できます。

BI-AMP - XXX

選択項目： ON / OFF*

メインスピーカーをバイアンプ接続で使用するか動作を切り替えます。

SCENE IR - XXX

選択項目： ON* / OFF

BD/DVDまたはCDシーン機能を使用するとき、REMOTE OUT 端子から外部機器へのコントロール信号送信動作を設定します。

MON. CHK - XXXX

選択項目： YES* / SKIP

HDMI OUT 端子に接続したモニターへの出力信号に、解像度変換（アップスケーリング）の制限をかけます。

INIT-XXXXXXXXXX

選択項目： DSP PARAM / VIDEO / ALL / CANCEL*

本機に記憶された各種設定を初期化します。初期化する内容は、以下の中から選択できます。

DSP PARAM：音場プログラムの設定

VIDEO： セットアップメニューで行ったビデオコンバージョン設定（解像度 / アスペクト比）および画面表示位置
 ALL： すべての設定
 CANCEL： 初期化のキャンセル

4 Ⓟ**STRAIGHT** を繰り返し押して、目的の設定値を選択する。

ここで選択した内容は、次に電源をオンにしたときに実行されます。手順3と4を繰り返して、複数の項目を設定することも可能です。

5 Ⓛ**STANDBY/ON** を押して電源を切り、もう一度 Ⓛ**STANDBY/ON** を押す。

手順4で行なった設定が反映され、本機の電源がオンになります。手順3で初期化を選択した場合は初期化が実行されます。

ファームウェアをアップデートする

本機は、フロントパネルに装備している USB 端子を使ってファームウェアをアップデートできます。また、現在のファームウェアのバージョンを確認できます。左記の手順3で以下の項目を選択してください。

FIRM UPDATE

ファームウェアをアップデートします。ファームウェアをアップデートするには、「FIRM UPDATE」を選択してから Ⓟ**STRAIGHT** を押してください。

ご注意

- ファームウェアのアップデートが必要なとき以外はこの機能を使用しないでください。
- ファームウェアをアップデートする前に、アップデートファイルと一緒に提供されるインフォメーションをよくお読みください。

VERXXX.XXX.XXX

ファームウェアのバージョンを表示します。

リモコン ID を設定する

本機のリモコンは、2つのID（リモコンID）からいずれか1つを選択することができます。本機を設置している部屋で別のヤマハ製アンプをお使いの場合、本機のリモコンIDを切り替えることで、もう1台のアンプが動作するのを防止できます。

工場出荷時には、リモコン側、アンプ側ともにID1に設定されています。本機のリモコンIDを切り替えた場合、「ADVANCED SETUP」の「REMOTE ID」で必ずアンプ側のIDも切り替えてください。

本機の基本設定 / 初期化を行う (アドバンスセットアップメニュー)

- 1 ボールペンなどの先の細いもので、リモコンの **⑬CODE SET** を押す。
⑭**TRANSMIT** が 2 回点滅します。
- 2 リモコンの **⑩ON SCREEN** を押す。
- 3 リモコン ID コードを入力する。
リモコン ID1 に切り替える場合：
⑬ **数字キー** を押して「5019」と入力します。
リモコン ID2 に切り替える場合：
⑬ **数字キー** を押して「5020」と入力します。

登録が完了すると、コード入力後にリモコンの **⑭TRANSMIT** が 2 回点滅します。
リモコンの **⑭TRANSMIT** が 6 回点滅した場合は、リモコンコードの入力に失敗したことを表します。もう一度手順 1 からやり直してください。



- リモコンコードを初期化すると、リモコンID1に戻ります。

MEMO

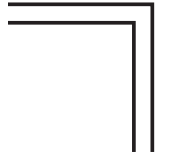
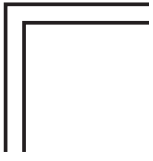

RX-V1065/HTR-6280/
AX-V1065

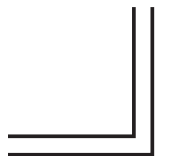
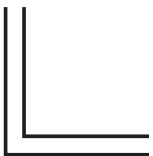

**RX-V1065/HTR-6280/
AX-V1065**

