

AV RECEIVER RX-V1067/HTR-8063/ RX-A1000 SERVICE MANUAL

RX-V1067/HTR-8063/
RX-A1000

Note: When IC502 of NET P.C.B. or NET P.C.B. is replaced, the network function of this unit will not operate properly without additional setting.

In such case, report the serial number of this unit to the following e-mail address.

Yamaha Corporation will reply providing the setting procedure to make the network function of this unit operate properly.

注意: NET P.C.B. および IC502 (NET P.C.B.) を交換した場合、本機のネットワーク機能が正常に動作しません。

正常に動作させるための設定方法は、YJC (Yamaha Corporation Japan) からご連絡します。

はじめに、交換した本機のシリアルナンバーを下記の E-mail アドレスへ報告してください。

E-mail: ycav-ysiss@gmx.yamaha.com

IMPORTANT NOTICE

This manual has been provided for the use of authorized YAMAHA Retailers and their service personnel.

It has been assumed that basic service procedures inherent to the industry, and more specifically YAMAHA Products, are already known and understood by the users, and have therefore not been restated.

WARNING: Failure to follow appropriate service and safety procedures when servicing this product may result in personal injury, destruction of expensive components, and failure of the product to perform as specified. For these reasons, we advise all YAMAHA product owners that any service required should be performed by an authorized YAMAHA Retailer or the appointed service representative.

IMPORTANT: The presentation or sale of this manual to any individual or firm does not constitute authorization, certification or recognition of any applicable technical capabilities, or establish a principle-agent relationship of any form.

The data provided is believed to be accurate and applicable to the unit(s) indicated on the cover. The research, engineering, and service departments of YAMAHA are continually striving to improve YAMAHA products. Modifications are, therefore, inevitable and specifications are subject to change without notice or obligation to retrofit. Should any discrepancy appear to exist, please contact the distributor's Service Division.

WARNING: Static discharges can destroy expensive components. Discharge any static electricity your body may have accumulated by grounding yourself to the ground buss in the unit (heavy gauge black wires connect to this buss).

IMPORTANT: Turn the unit OFF during disassembly and part replacement. Recheck all work before you apply power to the unit.

CONTENTS

TO SERVICE PERSONNEL	2	DISPLAY DATA	68-70
FRONT PANELS	3-4	IC DATA	71-90
REAR PANELS	5-8	PIN CONNECTION DIAGRAMS	91-94
REMOTE CONTROL PANELS	9	BLOCK DIAGRAMS	95-99
SPECIFICATIONS / 参考仕様	10-15	PRINTED CIRCUIT BOARDS	100-126
INTERNAL VIEW	16	SCHEMATIC DIAGRAMS	127-145
SERVICE PRECAUTIONS / サービス時の注意事項	16	REPLACEMENT PARTS LIST	147-177
DISASSEMBLY PROCEDURES / 分解手順	17-20	REMOTE CONTROL	178-180
UPDATING FIRMWARE / ファームウェアの書き込み	21-22	ADVANCED SETUP	181-183
AMP ADJUSTMENT / アンプ部調整	23-25	本機の基本設定 / 初期化を行う	184-185
SELF-DIAGNOSTIC FUNCTION / ダイアグ (自己診断機能)	26-67		



このサービスマニュアルは、エコマーク認定の再生紙を使用しています。
This Service Manual uses recycled paper.

101183

Copyright © 2010 YAMAHA CORPORATION All rights reserved.
This manual is copyrighted by YAMAHA and may not be copied or
redistributed either in print or electronically without permission.



YAMAHA

YAMAHA CORPORATION
P.O.Box 1, Hamamatsu, Japan

'10.08

■ TO SERVICE PERSONNEL

1. Critical Components Information

Components having special characteristics are marked Δ and must be replaced with parts having specifications equal to those originally installed.

2. Leakage Current Measurement (For 120V Models Only)

When service has been completed, it is imperative to verify that all exposed conductive surfaces are properly insulated from supply circuits.

- Meter impedance should be equivalent to 1500 ohms shunted by 0.15 μ F.

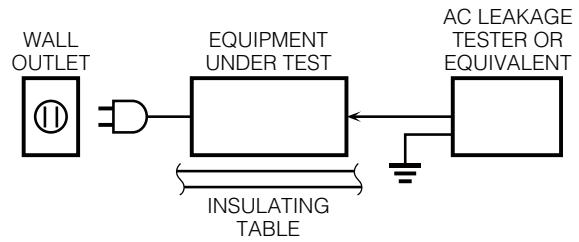

- Leakage current must not exceed 0.5mA.
- Be sure to test for leakage with the AC plug in both polarities.



For U model

“CAUTION”

“F2003: FOR CONTINUED PROTECTION AGAINST RISK OF FIRE, REPLACE ONLY WITH SAME TYPE 10A, 125V FUSE.”

For C model

CAUTION

F2003: REPLACE WITH SAME TYPE 10A, 125V FUSE.

ATTENTION

F2003: UTILISER UN FUSIBLE DE RECHANGE DE MÊME TYPE DE 10A, 125V.

WARNING: CHEMICAL CONTENT NOTICE!

This product contains chemicals known to the State of California to cause cancer, or birth defects or other reproductive harm.

DO NOT PLACE SOLDER, ELECTRICAL/ELECTRONIC OR PLASTIC COMPONENTS IN YOUR MOUTH FOR ANY REASON WHATSOEVER!

Avoid prolonged, unprotected contact between solder and your skin! When soldering, do not inhale solder fumes or expose eyes to solder/flux vapor!

If you come in contact with solder or components located inside the enclosure of this product, wash your hands before handling food.

About lead free solder / 無鉛ハンダについて

All of the P.C.B.s installed in this unit and solder joints are soldered using the lead free solder.

Among some types of lead free solder currently available, it is recommended to use one of the following types for the repair work.

- Sn + Ag + Cu (tin + silver + copper)
- Sn + Cu (tin + copper)
- Sn + Zn + Bi (tin + zinc + bismuth)

Caution:

As the melting point temperature of the lead free solder is about 30°C to 40°C (50°F to 70°F) higher than that of the lead solder, be sure to use a soldering iron suitable to each solder.

本機に搭載されているすべての基板およびハンダ付けによる接合部は無鉛ハンダでハンダ付けされています。

無鉛ハンダにはいくつかの種類がありますが、修理時には下記のような無鉛ハンダの使用を推奨します。

- Sn+Ag+Cu (錫 + 銀 + 銅)
- Sn+Cu (錫 + 銅)
- Sn+Zn+Bi (錫 + 亜鉛 + ビスマス)

注意：

無鉛ハンダの融点温度は通常の鉛入りハンダに比べ 30 ~ 40°C程度高くなっていますので、それぞれのハンダに合ったハンダごてをご使用ください。

FRONT PANELS

RX-V1067 (R, T, K, A, B, G, F, L, J models)

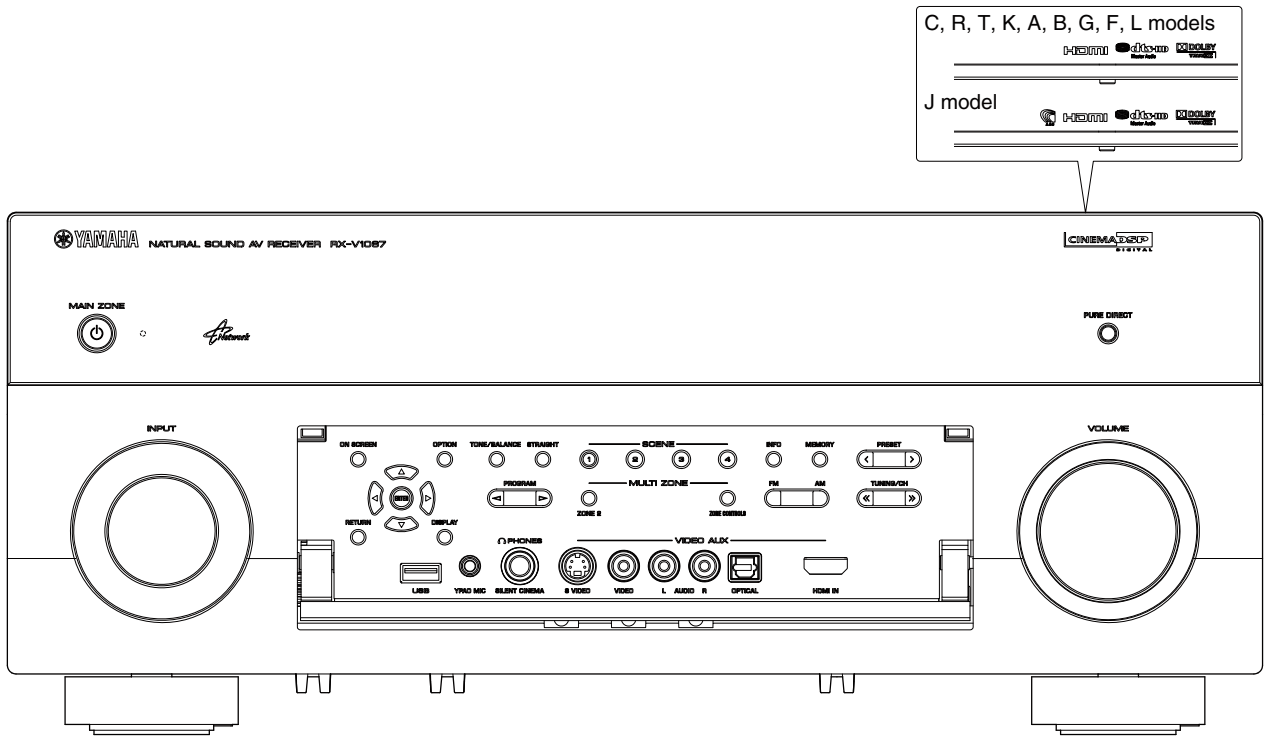

HTR-8063 (C model)

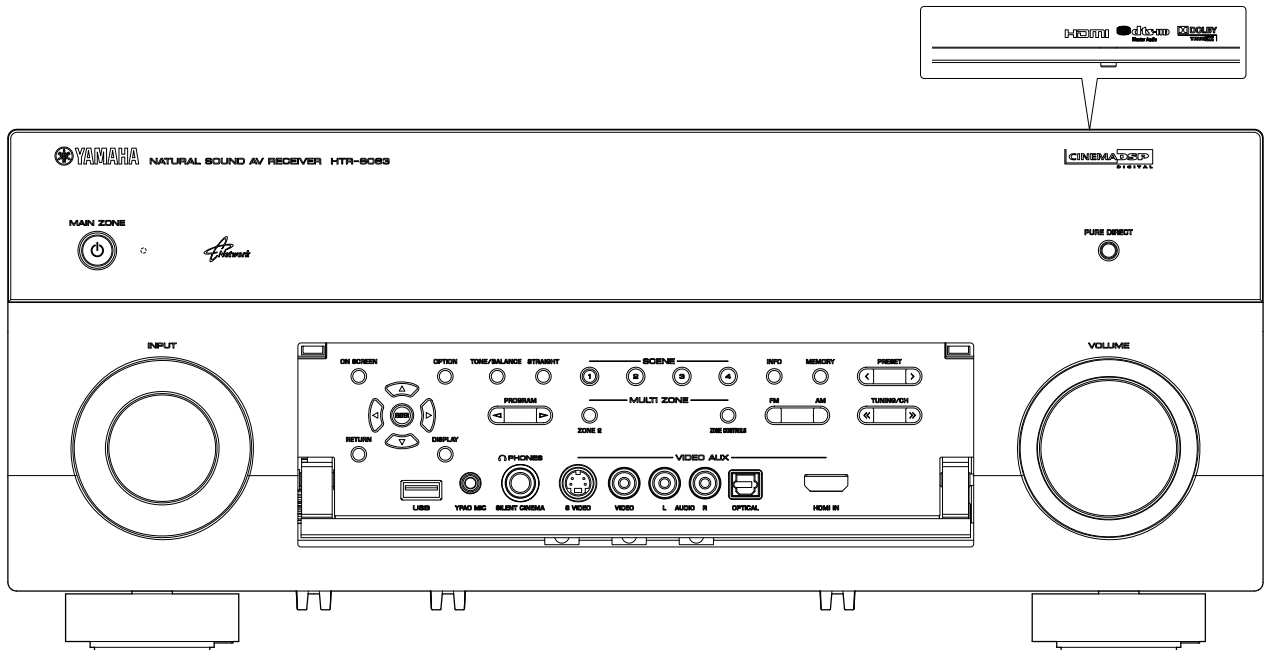

RX-V1067/HTR-8063/
RX-A1000

RX-V1067/HTR-8063/RX-A1000

RX-A1000 (U model)

RX-V1067/HTR-8063/
RX-A1000

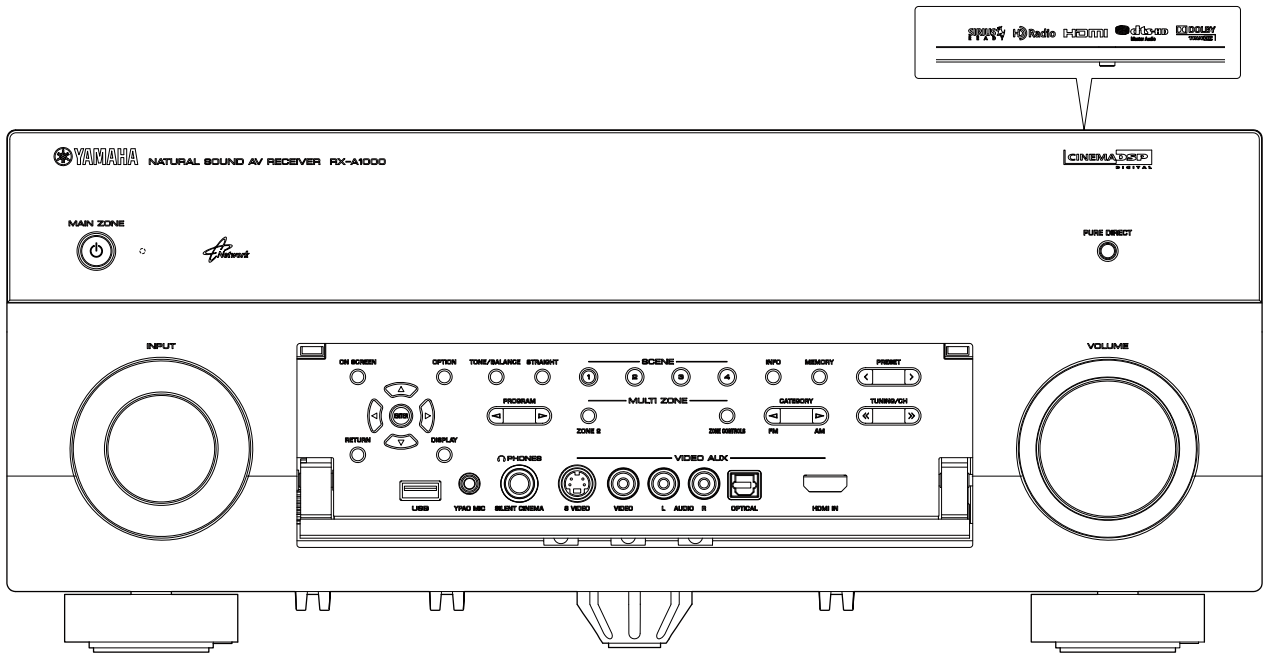

RX-A1000 (C, A models)

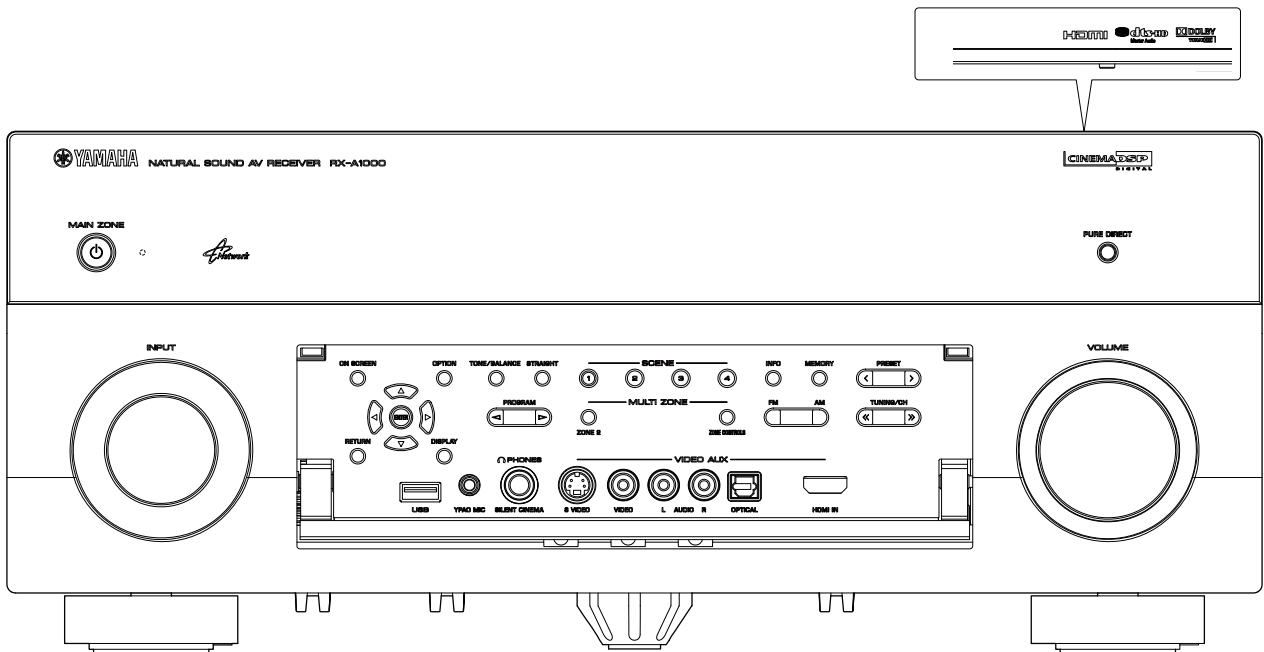

REAR PANELS

RX-V1067 (R model)

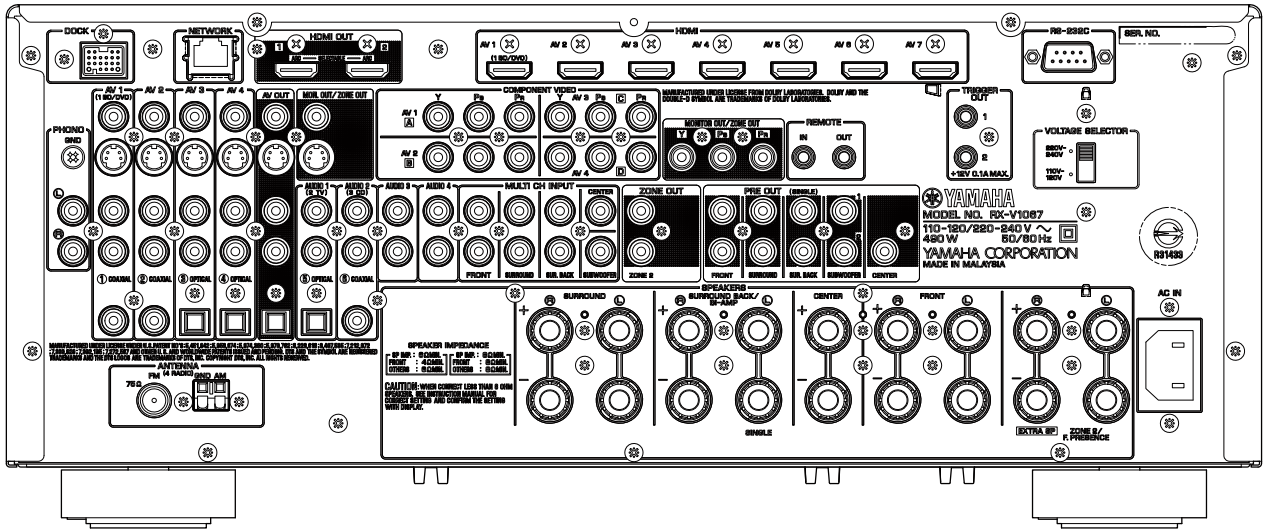

RX-V1067 (T model)

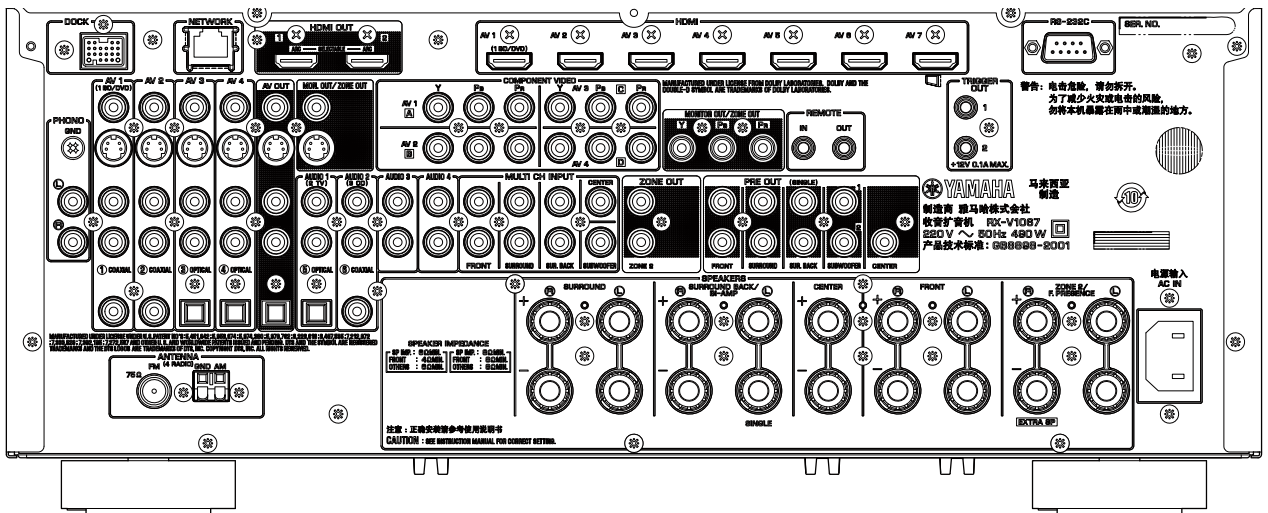

RX-V1067 (K model)

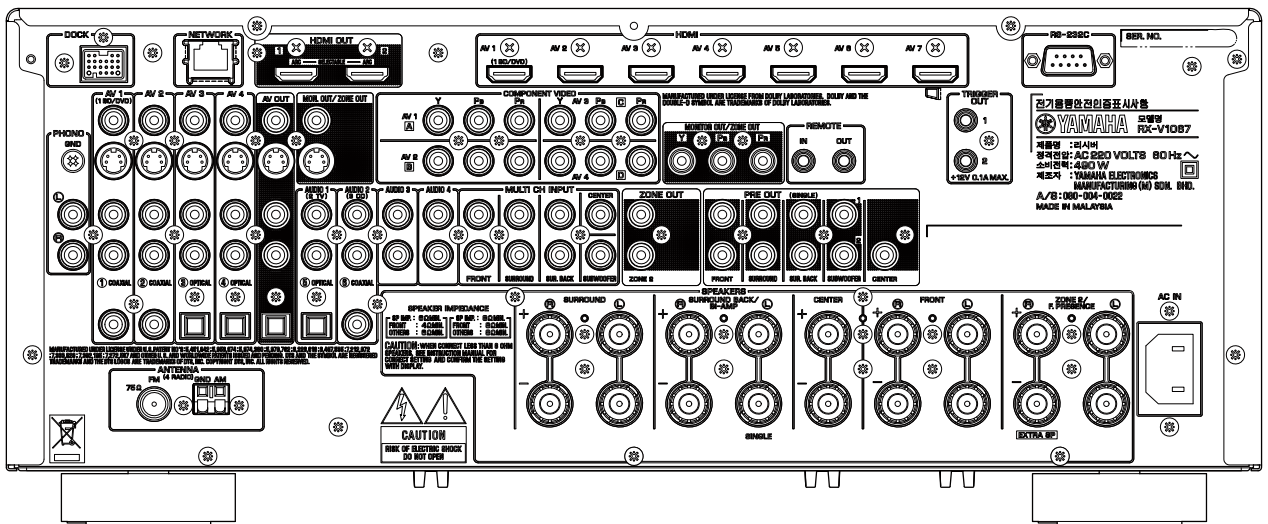

RX-V1067/HTR-8063/RX-A1000

RX-V1067 (A model)

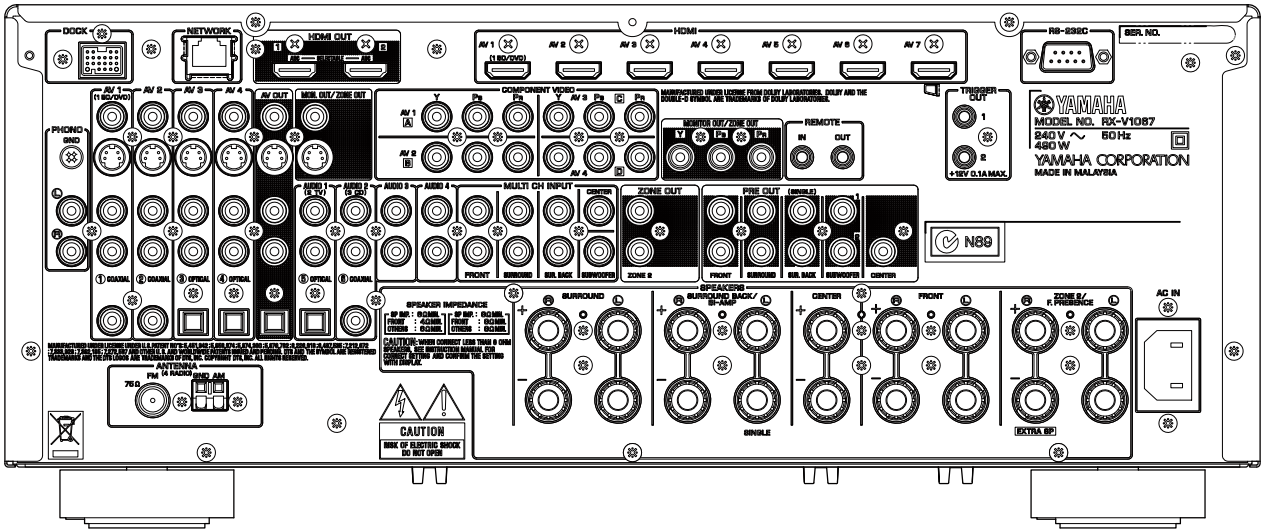

RX-V1067 (B, G, F models)

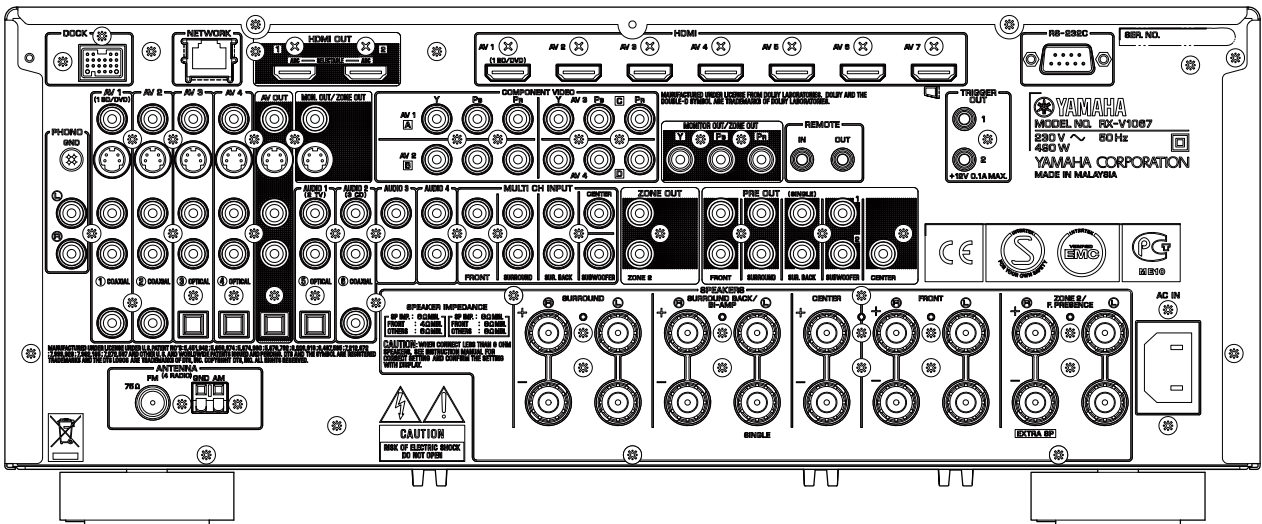

RX-V1067 (L model)

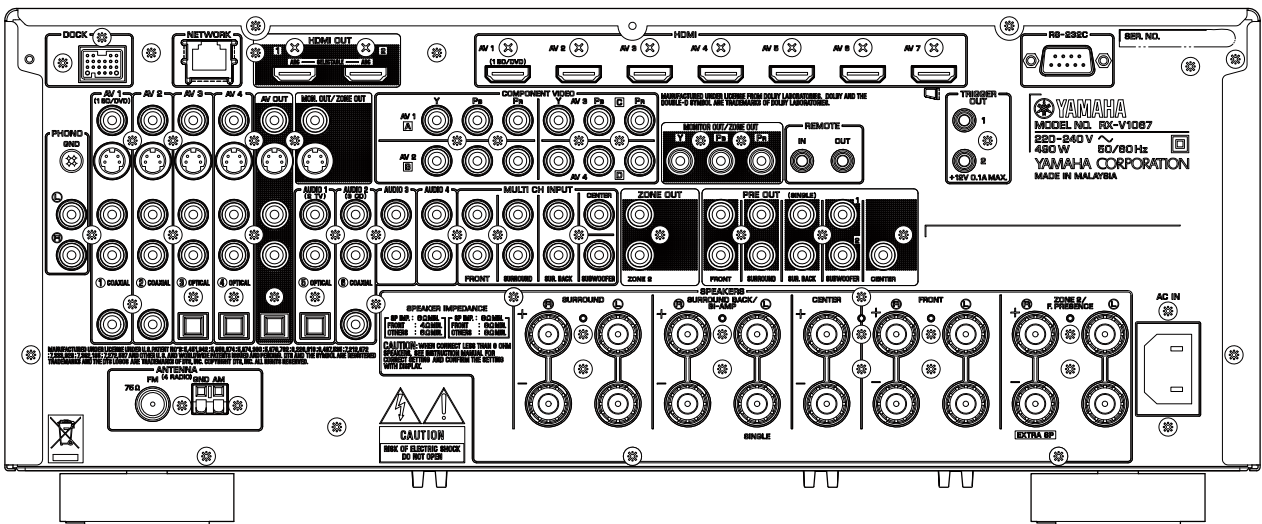

RX-V1067 (J model)

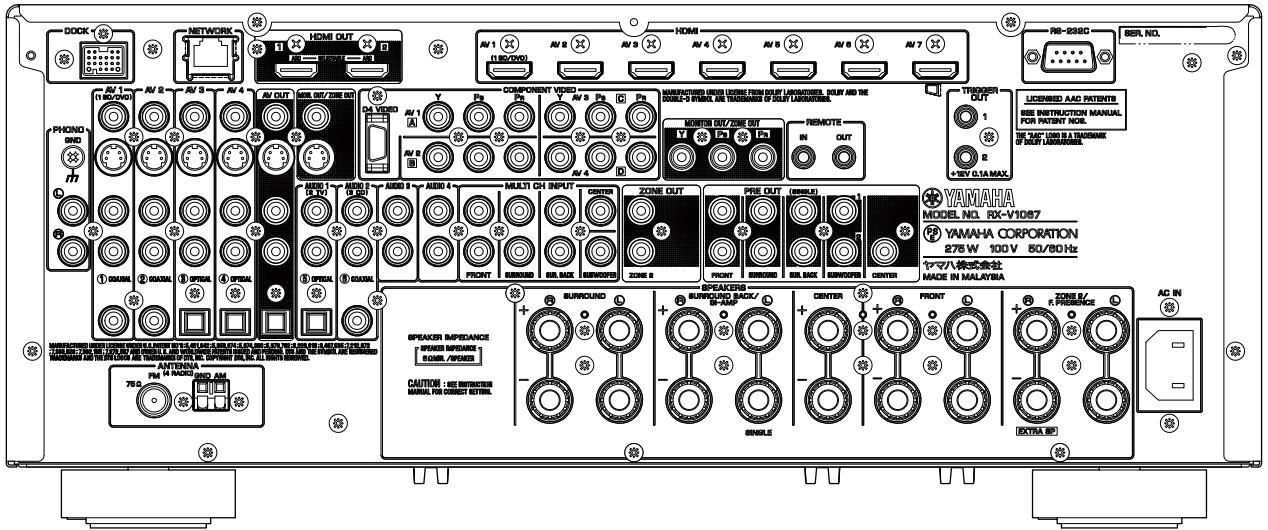

RX-V1067/HTR-8063/
RX-A1000

HTR-8063 (C model)

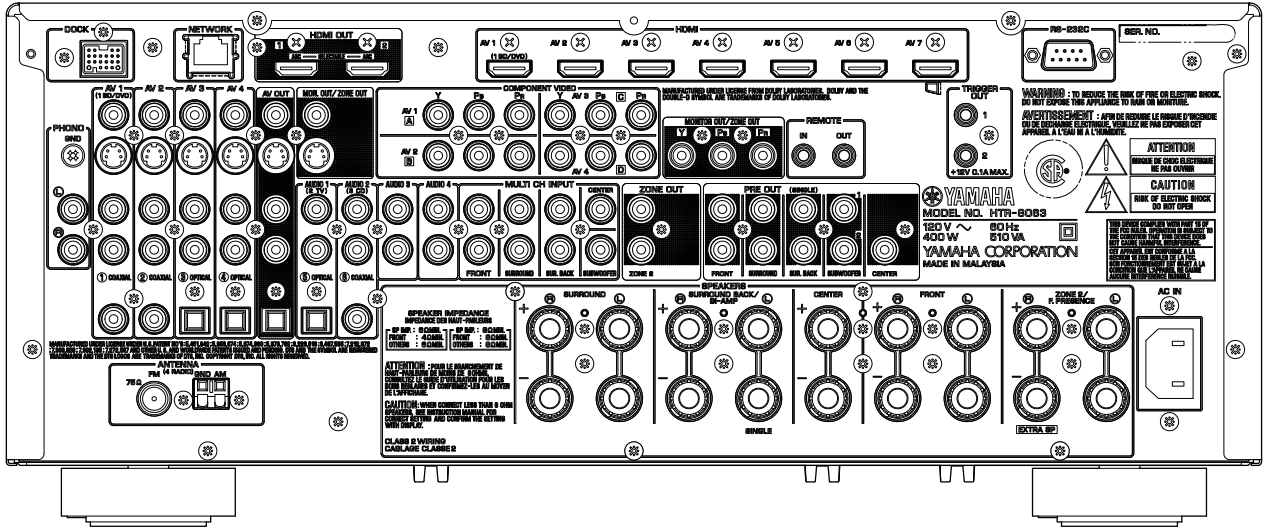

RX-A1000 (U model)

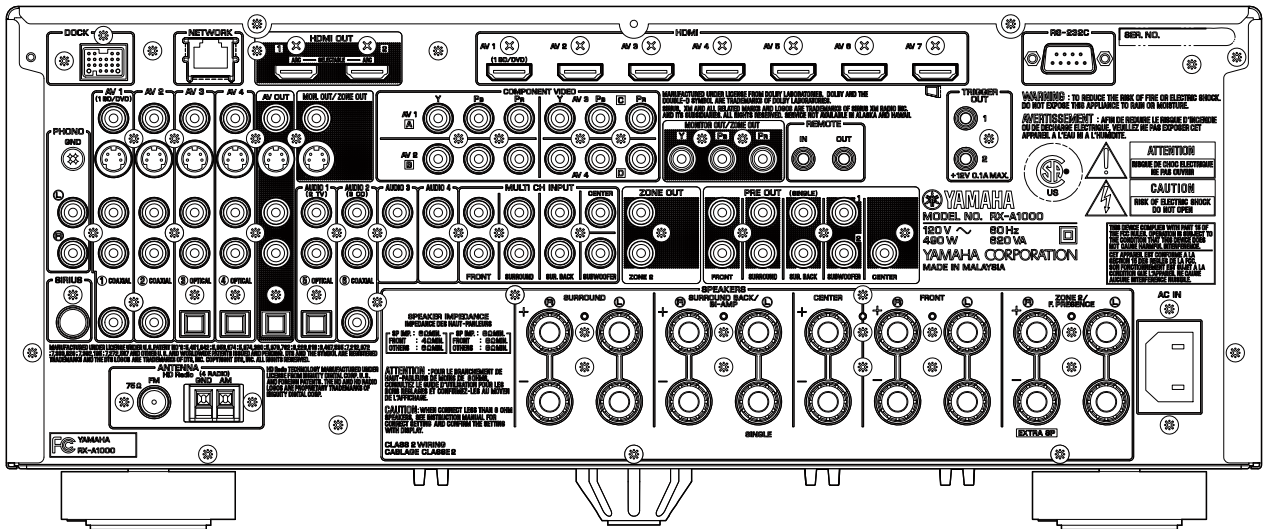

RX-A1000 (C model)

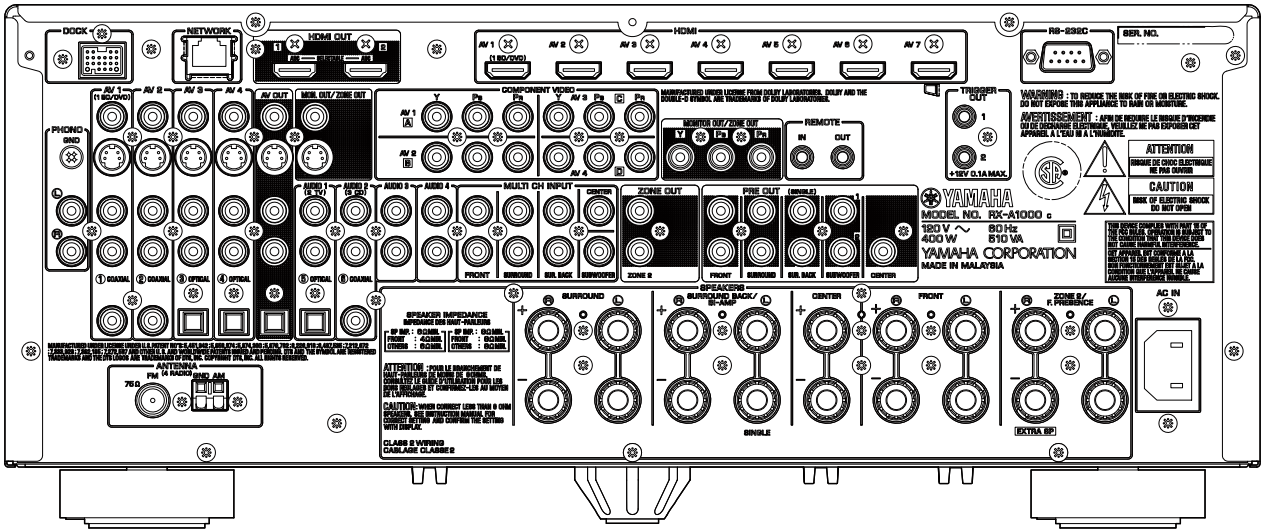

RX-A1000 (A model)

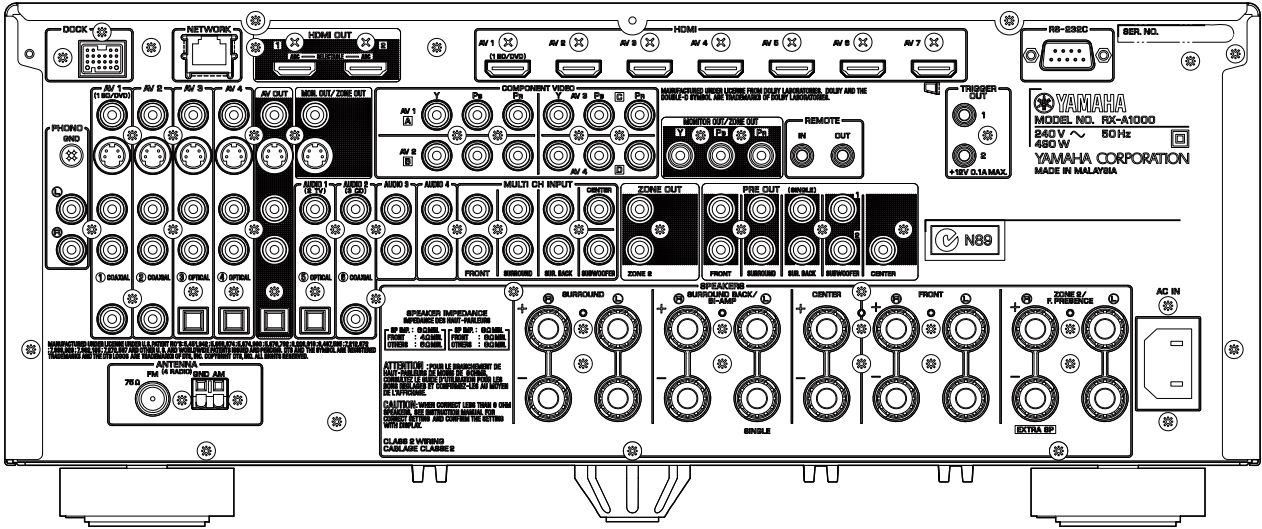

REMOTE CONTROL PANELS

RAV346

(U model)

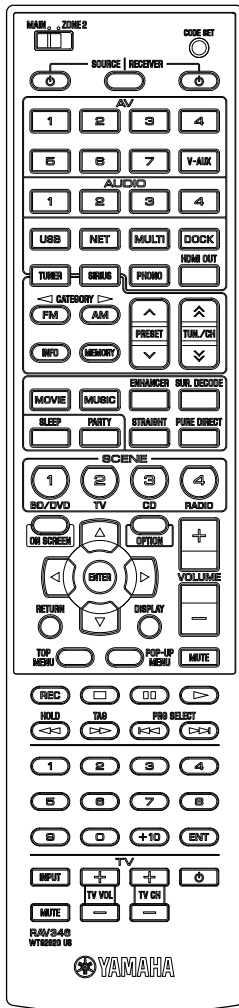

RAV347

(C, R, A, L, J models)

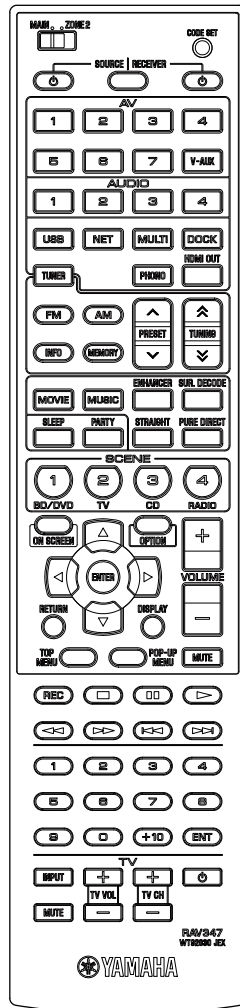

RAV348

(T, K, B, G, F models)

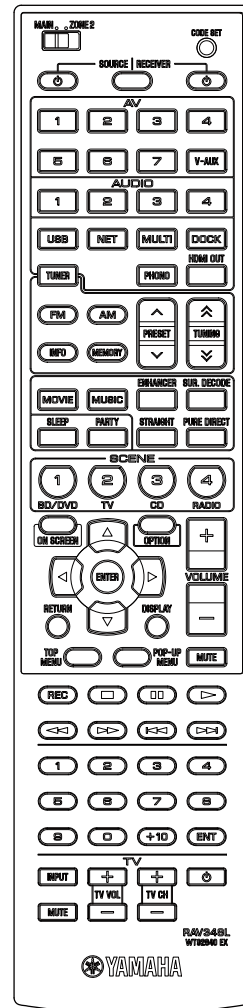

RX-V1067/HTR-8063/
RX-A1000

■ SPECIFICATIONS / 参考仕様

■ Audio Section / オーディオ部

Minimum RMS Output Power (Power Amp. Section) / 定格出力 (パワーアンプ部)

[RX-V1067/RX-A1000] (20 Hz to 20 kHz, 0.06 % THD)

U, C, R, T, K, A, B, G, F, L models (8 ohms)	
FRONT L/R	105 W + 105 W
CENTER	105 W
SURROUND L/R	105 W + 105 W
SURROUND BACK L/R	105 W + 105 W
J model (6 ohms)	
FRONT L/R	105 W + 105 W
CENTER	105 W
SURROUND L/R	105 W + 105 W
SURROUND BACK L/R	105 W + 105 W

[HTR-8063] (1 kHz, 0.7 % THD, 8 ohms)

U, C models	
FRONT L/R	120 W + 120 W
CENTER	120 W
SURROUND L/R	120 W + 120 W
SURROUND BACK L/R	120 W + 120 W

Maximum Effective Output Power / 実用最大出力 (非同時駆動) (1 kHz, 10 % THD, JEITA)

R, T, K, L models (8 ohms)	
FRONT L/R	145 W + 145 W
CENTER	145 W
SURROUND L/R	145 W + 145 W
SURROUND BACK L/R	145 W + 145 W
J model (6 ohms)	
FRONT L/R	145 W + 145 W
CENTER	145 W
SURROUND L/R	145 W + 145 W
SURROUND BACK L/R	145 W + 145 W

Max. Power Per Channel (1 kHz, 0.7 % THD, 4 ohms)

[B, G, F models]	
FRONT L/R	165 W + 165 W
CENTER	165 W
SURROUND L/R	165 W + 165 W
SURROUND BACK L/R	165 W + 165 W

IEC Power (1 kHz, 0.06 % THD, 8 ohms) [B, G, F models]

FRONT L/R drive	110 W + 110 W
-----------------	---------------

Dynamic Power Per Channel (IHF) [U, C, R, T, K, A, L models]

FRONT L/R drive (8 / 6 / 4 / 2 ohms)	135 / 165 / 210 / 280 W
---	-------------------------

Dynamic Headroom [U, C, R, T, K, A, L models]

8 ohms	1.1 dB
--------	--------

Damping Factor / ダンピングファクタ (1 kHz, 8 ohms)

FRONT L/R	150 or more
-----------	-------------

Input Sensitivity/Input Impedance / 入力感度/入力インピーダンス (1 kHz, 100 W/8 ohms)

PHONO (MM)	3.5 mV / 47 k-ohms
AUDIO2, etc.	200 mV / 47 k-ohms
MULTI CH INPUT FRONT L/R, CENTER, SURROUND L/R, SURROUND BACK L/R, SUBWOOFER	200 mV / 47 k-ohms

Maximum Input Signal / 最大許容入力 (1 kHz)

PHONO (MM) (0.1 % THD)	60 mV or more
AUDIO2, etc. (0.5 % THD)	2.4 V or more

Output Level/Output Impedance / 出力電圧/出力インピーダンス

AV OUT	200 mV / 1.2 k-ohms
HEADPHONE OUT	150 mV / 100 ohms
PRE OUT FRONT, CENTER, SURROUND, SURROUND BACK (1 kHz) SUBWOOFER (50 Hz)	1.0 V / 1.2 k-ohms
ZONE2 OUT	1.0 V / 1.2 k-ohms

Frequency Response / 周波数特性 (10 Hz to 100 kHz)

AUDIO2, etc. to FRONT L/R (Pure Direct)	0 / -3.0 dB
---	-------------

RIAA Equalization Deviation / RIAA 偏差 (20 Hz to 20 kHz)

PHONO (MM)	0 ±0.5 dB
------------	-----------

Total Harmonic Distortion / 全高調波歪率 (20 Hz to 20 kHz)

PHONO (MM) to AV OUT (1 V)	0.02 % or less
AV1 etc. to SP OUT FRONT L/R (55 W/8 ohms)	0.04 % or less

Signal to Noise Ratio / 信号対雑音比 (IHF-A Network)

PHONO (MM) (Input shorted) to AV OUT	
U, C, R, T, K, L models (5 mV)	86 dB or more
A, B, G, F models (5 mV)	81 dB or more
J model (2.5 mV)	80 dB or more
AUDIO2, etc. (Input shorted) to SP OUT	
200 mV	98 dB or more
250 mV	100 dB or more

Residual Noise / 残留ノイズ (IHF-A Network)

FRONT L/R to SP OUT	150 μV or less
---------------------	----------------

Channel Separation / チャンネルセパレーション (1 kHz / 10 kHz)

PHONO (Input shorted)	60 dB or more / 55 dB or more
AV1, etc. (Input 5.1 k-ohms shorted)	60 dB or more / 45 dB or more

Volume Control / 音量調整

Main Zone	MUTE / -80 dB to +16.5 dB / 0.5 dB step
Other Zone (ZONE2)	MUTE / -80 dB to +16.5 dB / 0.5 dB step

Tone Control Characteristics / トーンコントロール特性

Main Zone (FRONT)	
BASS	
Boost/Cut	±6 dB / 0.5 dB step / 50 Hz
Turnover frequency	350 Hz
TREBLE	
Boost/Cut	±6 dB / 0.5 dB step / 20 kHz
Turnover frequency	3.5 kHz
Other Zone (ZONE2)	
BASS	
Boost/Cut	±10 dB / 2 dB step / 100 Hz
Turnover frequency	350 Hz
TREBLE	
Boost/Cut	±10 dB / 2 dB step / 10 kHz
Turnover frequency	3.5 kHz

Filter Characteristics / フィルタ特性

(fc=40/60/80/90/100/110/120/160/200 Hz)

High Pass Filter (H.P.F.) FRONT, CENTER, SURROUND, SURROUND BACK small	12 dB/oct.
Low Pass Filter (L.P.F.) SUBWOOFER	24 dB/oct.

■ Video Section / ビデオ部

Video Signal Type / ビデオ信号方式

Wall paper/GUI / 壁紙 / GUI (Monitor/Zone out)	
U, C, R, K, J modelsNTSC/PAL
T, A, B, G, F, L modelsPAL/NTSC
Video conversion / ビデオコンバージョン	
NTSC/PAL

Composite Video Signal Level / コンポジットビデオ信号

 1 Vp-p / 75 ohms
--	------------------------

S-Video Signal Level / S ビデオ信号

Y 1 Vp-p / 75 ohms
C (NTSC) 0.286 Vp-p / 75 ohms
(PAL) 0.3 Vp-p / 75 ohms

Component Video Signal Level / コンポーネントビデオ信号

Y 1 Vp-p / 75 ohms
Pb/Pr 0.7 Vp-p / 75 ohms

D4 Video Signal Level / D4 ビデオ信号 [J model]

Y 1 Vp-p / 75 ohms
Pb/Pr 0.7 Vp-p / 75 ohms

Video Maximum Input Level / ビデオ最大許容入力 (VIDEO conversion OFF)

 1.5 Vp-p or more
--	------------------------

Signal to Noise Ratio / 信号対雑音比 (VIDEO conversion OFF)

 60 dB or more
--	---------------------

Frequency Response / 周波数帯域 (VIDEO conversion OFF)

(Monitor/Zone out)

Component video signal / コンポーネントビデオ信号	
 5 Hz to 100 MHz, ±3 dB
D4 video signal / D4 ビデオ信号 [J model]	
 5 Hz to 100 MHz, ±3 dB

■ FM Section / FM 部

Tuning Range / 受信周波数範囲

U, C models 87.5 to 107.9 MHz
R, L models 87.5 to 108.0 / 87.50 to 108.00 MHz
T, K, A, B, G, F models 87.50 to 108.00 MHz
J model 76.0 to 90.0 MHz

50 dB Quietening Sensitivity / 50 dB SN 感度 (IHF)

(1 kHz, 100 % MOD.)

Mono 3.0 µV (20.8 dBf)
------	-------------------------

Signal to Noise Ratio / S / N 比 (IHF)

U model (HD) 80 dB
C, R, T, K, A, B, G, F, L, J models (Mono) 74 dB
C, R, T, K, A, B, G, F, L, J models (Stereo) 70 dB

Harmonic Distortion / 歪率 (1 kHz)

U model (HD) 0.03 %
C, R, T, K, A, B, G, F, L, J models (Mono) 0.3 %
C, R, T, K, A, B, G, F, L, J models (Stereo) 0.3 %

Antenna Input / アンテナ入力

 75 ohms unbalanced
--	--------------------------

■ AM Section / AM 部

Tuning Range / 受信周波数範囲

U, C models 530 to 1,710 kHz
R, L models 530 to 1,710 / 531 to 1,611 kHz
T, K, A, B, G, F, J models 531 to 1,611 kHz

Antenna / アンテナ

 Loop antenna
--	--------------------

■ General / 総合

Power Supply / 電源電圧

U, C models AC 120 V, 60 Hz
R model AC 110-120/220-240 V, 50/60 Hz
T model AC 220 V, 50 Hz
K model AC 220 V, 60 Hz
A model AC 240 V, 50 Hz
B, G, F models AC 220 V, 50 Hz
L model AC 220-240 V, 50/60 Hz
J model AC 100 V, 50/60 Hz

Power Consumption / 消費電力

U model 490 W / 620 VA
C model 400 W / 510 VA
R, T, K, A, B, G, F, L models 490 W
J model 275 W

Standby Power Consumption (reference data) / 待機時消費電力 (参考値)

HDMI control: OFF / Standby through: OFF	
 0.2 W or less
HDMI control: ON / Standby through: ON	
Input: AV1 (HDMI no signal)	
 2.7 W (typical)
NET Standby: ON	
 4.5 W (typical)

Maximum Power Consumption (7ch drive, 10 % THD) [R, L models]

 1,190 W
--	---------------

Dimensions (W x H x D) / 寸法 (幅 × 高さ × 奥行き)

 435 x 182 x 430 mm (17-1/8" x 7-1/8" x 16-7/8")
--	---

Weight / 質量

 14.7 kg (32.4 lbs.)
--	---------------------------

Finish / 仕上げ

[RX-V1067]	
J model Gold color
R, T, K, A, B, G, F, L, J models Black color
R, G, F, L models Titanium color
[HTR-8063]	
C model Black color
[RX-A1000]	
U, C, A models Black color

Accessories / 付属品

Remote control x 1
Batteries (R03, AAA, UM-4) x 2
Indoor FM antenna (1.4 m) x 1
AM loop antenna (1.2 m) x 1
YPAO microphone (6.0 m) x 1
Power cable (2 m) (U, C, R, T, K, A, B, G, F, J models) x 1
(2 m) (L model) x 2

* Specifications are subject to change without notice.

※ 参考仕様および外観は、製品の改良のため予告なく変更することがあります。

U U.S.A. model	B British model
C Canadian model	G European model
R General model	F Russian model
T Chinese model	L Singapore model
K Korean model	J Japanese model
A Australian model		



Manufactured under license from Dolby Laboratories. Dolby, Pro Logic and the double-D symbol are trademarks of Dolby Laboratories.

ドルビーラボラトリーズからの実施権に基づき製造されています。「ドルビー」、「PRO LOGIC」、「Surround EX」およびダブルD記号 、ドルビーラボラトリーズの商標です。



DTS and the Symbol are registered trademarks, & DTS-HD, DTS-HD Master Audio, and the DTS logos are trademarks of DTS, Inc. Product includes software. © DTS, Inc. All Rights Reserved.

DTS および記号は DTS 社の登録商標です。また、DTS-HD、DTS-HD Master Audio、および DTS ロゴは DTS 社の商標です。製品にはソフトウェアを含みます。著作権 DTS 社。不許複製。

iPod™, iPhone™

"iPod" is a trademark of Apple Inc., registered in the U.S. and other countries. "iPhone" is a trademark of Apple Inc.

iPod は、米国および他の国々で登録された Apple Inc. の商標または登録商標です。

iPhone は、Apple Inc. の商標または登録商標です。



Fraunhofer Institut Integrierte Schaltungen

MPEG Layer-3 audio coding technology licensed from Fraunhofer IIS and Thomson.

MPEG Layer 3 音声圧縮技術は Fraunhofer IIS および Thomson によってライセンス供与されています。



This receiver supports network connections.

本機はネットワーク接続に対応しています。

HD Radio

HD Radio™ Technology Manufactured Under License From iBiquity Digital Corp. U.S. and Foreign Patents. HD Radio™ and the HD Radio logo are proprietary trademarks of iBiquity Digital Corp.

Bluetooth™

Bluetooth is a registered trademark of the Bluetooth SIG and is used by Yamaha in accordance with a license agreement.

Bluetooth は、Bluetooth SIG の登録商標でありヤマハはライセンスに基づき使用しています。



"HDMI," the "HDMI" logo and "High-Definition Multimedia Interface" are trademarks, or registered trademarks of HDMI Licensing LLC.

HDMI、HDMI ロゴ、および High-Definition Multimedia Interface は、HDMI Licensing, LLC の商標または登録商標です。

x.v.Color™

"x.v.Color" is a trademark of Sony Corporation.

「x.v.Color」は、ソニー株式会社の商標です。

SILENT™ CINEMA

"SILENT CINEMA" is a trademark of Yamaha Corporation.

「サイレントシネマ™ SILENT CINEMA™」はヤマハ株式会社の登録商標です。



SIRIUS, XM and all related marks and logos are trademarks of Sirius XM Radio Inc. and its subsidiaries. All rights reserved. **Service not available in Alaska and Hawaii.**



Rhapsody and the Rhapsody logo are registered trademarks of RealNetworks, Inc.



AAC ロゴマーク  はドルビーラボラトリーズの商標です。

• DIMENSIONS / 寸法図

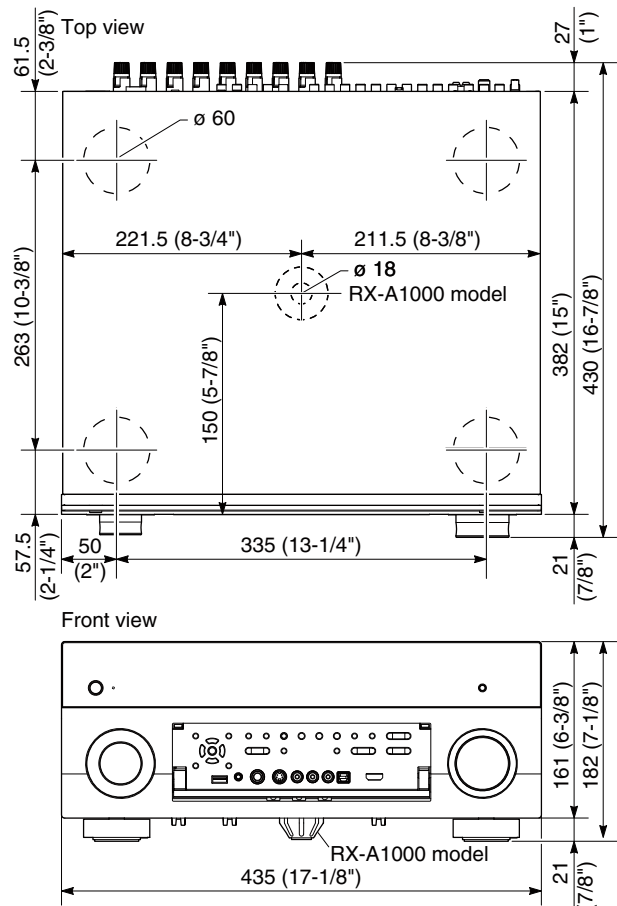

Unit: mm (inch)
単位: mm (インチ)

• **SELECT MENU**

Sound field parameters

Category	Program	Parameter																											
		Decode Type (*1)	DSP Level: -6 to +3 dB, [0]	Initial Delay: 1 to 99 ms	Room Size: 0.1 to 2.0	Liveness: 0 to 10	Surround Initial Delay: 1 to 49 ms	Surround Room Size: 0.1 to 2.0	Surround Liveness: 0 to 10	Center Level: 0 to 100 %, [100 %]	Surround L Level: 0 to 100 %, [100 %]	Surround R Level: 0 to 100 %, [100 %]	Surround Back Initial Delay: 1 to 49 ms	Surround Back Room Size: 0.1 to 2.0	Surround Back Liveness: 0 to 10	Surround Back L Level: 0 to 100 %, [7.1CH: 35 %, 6.1CH: 50 %]	Surround Back R Level: 0 to 100 %, [7.1CH: 35 %, 6.1CH: 50 %]	Front Presence L Level: 0 to 100 % [33 %]	Front Presence R Level: 0 to 100 % [33 %]	Reverb Time: 1.0 to 5.0 s	Reverb Delay: 0 to 250 ms	Reverb Level: 0 to 100 %	Direct: Auto / Off, [Auto]	Panorama: Off / On, [Off]	Center Width: 0 to 7, [3]	Dimension: -3 to +3, [0]	Center Image: 0.0 to 1.0, [0.3]	Reset	
MOVIE	Standard	●	●					●				●	●	●															●
	Spectacle	●	●	●	●			●	●			●	●	●															●
	Sci-Fi	●	●	●	●			●	●			●	●	●															●
	Adventure	●	●	●	●			●	●			●	●	●															●
	Drama	●	●	●	●			●	●			●	●	●															●
	Mono Movie		●	●	●	●		●				●	●							●	●	●						●	
ENTERTAINMENT	Sports		●	●	●			●	●			●	●							●	●	●						●	
	Action Game		●	●	●			●	●			●	●							●	●	●						●	
	Roleplaying Game		●	●	●			●	●			●	●							●	●	●						●	
	Music Video		●	●	●			●	●			●	●							●	●	●						●	
CLASSICAL	Hall in Munich		●	●	●	●																						●	
	Hall in Vienna		●	●	●	●																						●	
	Chamber		●	●		●														●	●	●						●	
LIVE/CLUB	Cellar Club		●	●	●	●														●	●	●						●	
	The Roxy Theatre		●	●	●	●														●	●	●						●	
	The Bottom Line		●	●	●	●														●	●	●						●	
STEREO	2ch Stereo																							●				●	
	7ch Stereo									●	●	●							●	●	●	●						●	
ENHANCER	Enhancer On																											●	
	Enhancer Off																											●	
SUR. DECODE	Surround Decoder	●																										●	
STRAIGHT																													

*1 Surround Decoder

Decode Type	Pro Logic
	PL IIx Movie / PL II Movie
	PL IIx Music / PL II Music
	PL IIx Game / PL II Game
	Neo:6 Cinema
	Neo:6 Music

• SET MENU TABLE / セットメニュー

MAIN MENU	SUB-MENU	PARAMETER	VALUE [INITIAL VALUE]		
Speaker Setup	Auto	Measure	Optimizes the speaker configuration automatically using YPAO.		
		Multi Position	Yes / No		
		Result	Not Available		
	Manual	Setting Pattern			
		Setting Data Copy		Pattern1 ▶ 2 / Pattern2 ▶ 1	
		Power Amp Assign		[7ch Normal] / 7ch +1ZONE / 5ch BI-AMP	
		Configuration	Front speaker		Large / [Small] * When "Subwoofer" is set to "None," "Front" is disabled.
			Center speaker		Large / [Small] / None
			Surround speaker L/R		Large / [Small] / None
			Surround Back speaker L/R		Large x1 / Large x2 / Small x1 / [Small x2] / None
			Front Presence		[Use] / None
			Subwoofer		[Use] / None
			Extra Bass		Not Available
			Bass Cross Over		40 / 60 / [80] / 90 / 100 / 110 / 120 / 160 / 200 Hz
		Distance			Meter / [Feet]
			Front L		0.30 to 24.00 m, [3.00 m], 0.05 m step 1.0 to 80.0 ft, [10.0 ft], 0.2 ft step
			Front R		
			Center		
			Surround L		
			Surround R		
			Surround Back L		
			Surround Back R		
			Front Presence L		
			Front Presence R		
		Subwoofer			
		Level	Front L		-10.0 to +10.0 dB, [0.0 dB], 0.5 dB step
			Front R		
			Center		
			Surround L		
			Surround R		
	Surround Back L				
	Surround Back R				
	Front Presence L				
Front Presence R					
Parametric EQ	PEQ Select		Manual / Flat / Front / Natural / [Through]		
			Flat > Manual / Front > Manual / Natural > Manual * Select "ENTER"		
PEQ Data Copy	Front L	Band / Gain	▶ Band: #1 to #7		
	Front R		▲ Gain: -20.0 to +6.0 dB, [0.0 dB], 0.5 dB step		
	Center	Freq. / Gain	▶ Frequency: 31.3 Hz to 16.0 kHz, [62.5 Hz]		
	Surround L		▲ Gain: -20.0 to +6.0 dB, [0.0 dB], 0.5 dB step		
	Surround R	Q / Gain	▶ Q: 0.500 to 10.080, [1.000]		
	Surround Back L		▲ Gain: -20.0 to +6.0 dB, [0.0 dB], 0.5 dB step		
	Surround Back R	Reset	Yes / No * Select "ENTER"		
	Front Presence L		* When "PEQ Select" is set to "Manual," this section is disabled.		
	Front Presence R				
	Subwoofer				
Test Tone			[Off] / On		
Sound Setup	Lipsync		Manual / [Auto]		
		Select "Manual"	0 to 250 ms, [0 ms], 1 ms step		
	Dynamic Range		[MAX] / STD / MIN/AUTO		
	Max. Volume		-30.0 to +16.5 dB (Maximum volume), [+16.5 dB], 5.0 dB step		
	Initial Volume		[Off] / On		
		Select "On"	Mute, -80 to +16.5 dB, [0.0 dB], 0.5 dB step		
Adaptive DSP Level		[On] / Off			
Video Setup	Analog to Analog Conversion		Off / [On]		
			[Off] / On		
	Processing	Resolution	[Auto] / 480p / 720p / 1080i / 1080p / Through * Select "ENTER"		
	Aspect		[Through] / 16:9 Normal		

RX-V1067/HTR-8063/RX-A1000

MAIN MENU	SUB-MENU		PARAMETER	VALUE [INITIAL VALUE]		
HDMI Setup	HDMI Control			[Off] / On		
	Control Select			OUT1 (TV1) / OUT2 (TV2)		
	ARC (Audio Return Channel)			Off / [On]		
	TV Audio Input	TV1		AV1 / AV2 / AV3 / [AV4] / AV5 / AV6 / AUDIO1 / AUDIO2		
		TV2		AV1 / AV2 / AV3 / AV4 / AV5 / AV6 / [AUDIO1] / AUDIO2		
	Audio Output	Amp		[On] / Off		
		OUT1		On / [Off]		
		OUT2		On / [Off]		
Standby Through			[Off] / On * When HDMI Control is set to "On", "Standby Through" is disabled.			
Network Setup	IP Address	DHCP		Off / [On]		
		Manual Setup	IP Address			
			Subnet Mask			
			Default Gateway			
	DNS (Primary) / DNS (Secondary)					
	Network Standby			[Off] / On		
	MAC Address Filter		Mode	[Off] / On		
		Address Setup				
Multi Zone Setup	Zone2 Set	Volume		Fixed / [Variable]		
		Max. Volume		-30.0 to +16.5 dB (maximum volume), [+16.5 dB], 5.0 dB step		
		Initial Volume		Off / Mute / -80.0 to +16.5 dB, [Off], 5.0 dB step		
		Mono		[Off] / On		
	Monitor Out Assign			[Main] / Zone2		
	Party Mode Set	Target: Zone2		Disable / [Enable]		
	Zone Scene Rename					
Zone Rename			Disable / [Enable]			
Function Setup	Auto Power Down	Timer		4hours / 8hours / 12hours / [Off]		
	Display Set	Front Panel Display	Dimmer	-4 to 0		
			Scroll			
	Wall Paper			Picture1 / Picture2 / Picture3 / Gray		
	Trigger Output	Trigger Mode			[Power] / Source / Manual	
		Target Zone			Main / Zone2 / [All] * When "Trigger Mode" is set to "Power", "Target Zone" is disabled.	
		Target Source	HDMI1			Low / [High] * When "Trigger Mode" is set to "Source", "Target Source" is disabled.
			HDMI2			
			HDMI3			
			HDMI4			
HDMI5						
AV1						
AV2						
AV3						
AV4						
AV5						
AV6						
VIDEO AUX						
TUNER						
Sirius Satellite Radio						
AUDIO1						
AUDIO2						
DOCK						
MULTI CH						
Manual			Low / [High] * When "Trigger Mode" is set to "Manual", "Manual" is disabled.			
Memory Guard			[Off] / On			
Language Setup				English (English), 日本語 (Japanese), Français (French), Deutsch (German), Español (Spanish), Русский (Russian)		

INTERNAL VIEW

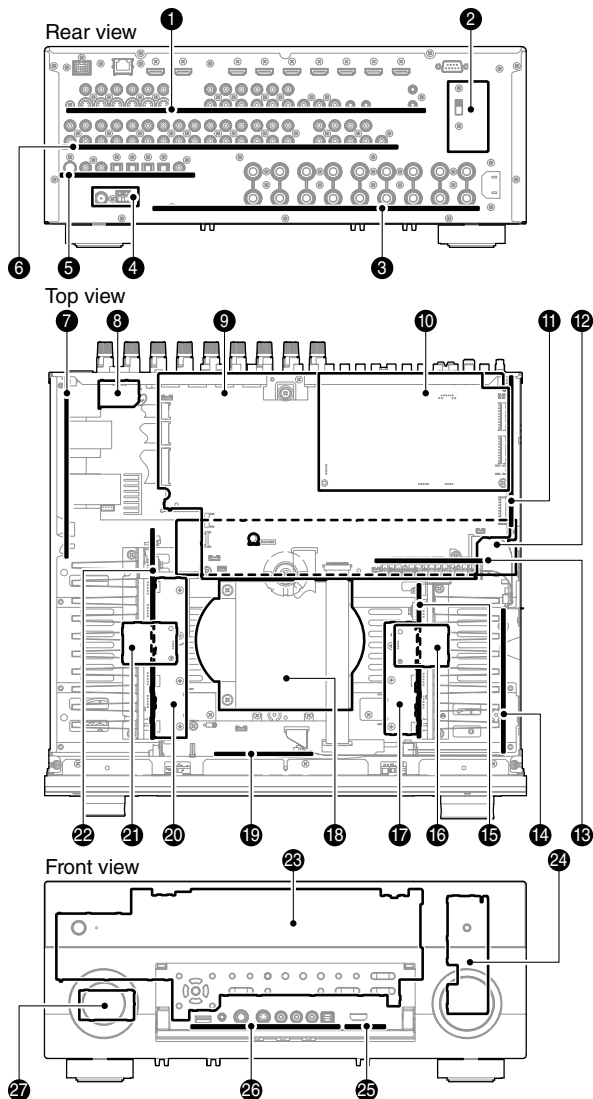

- ❶ VIDEO (1) P.C.B.
- ❷ POWER (2) P.C.B. (R model)
- ❸ MAIN (3) P.C.B.
- ❹ AM/FM TUNER (C, R, T, K, A, B, G, F, L, J models)
HD RADIO TUNER (U model)
- ❺ FUNCTION (2) P.C.B.
- ❻ FUNCTION (1) P.C.B.
- ❼ POWER (1) P.C.B.
- ❽ DIGITAL (3) P.C.B.
- ❾ DIGITAL (1) P.C.B.
- ❿ NET P.C.B.
- ⓫ FUNCTION (3) P.C.B.
- ⓬ VIDEO (2) P.C.B.
- ⓭ POWER (4) P.C.B.
- ⓮ POWER (3) P.C.B.
- ⓯ MAIN (2) P.C.B.
- ⓰ MAIN (5) P.C.B.
- ⓱ VIDEO (5) P.C.B.
- ⓲ POWER TRANSFORMER
- ⓳ VIDEO (3) P.C.B.
- ⓴ VIDEO (4) P.C.B.
- ⓵ MAIN (4) P.C.B.
- ⓶ MAIN (1) P.C.B.
- ⓷ OPERATION (1) P.C.B.
- ⓸ OPERATION (3) P.C.B.
- ⓹ DIGITAL (2) P.C.B.
- ⓺ OPERATION (2) P.C.B.
- ⓻ OPERATION (4) P.C.B.

SERVICE PRECAUTIONS / サービス時の注意事項

Safety measures

- Some internal parts in this product contain high voltages and are dangerous.
Be sure to take safety measures during servicing, such as wearing insulating gloves.
- Note that positions indicated below are dangerous even after the power is turned off because an electric charge remains and a high voltage continues to exist there.
Before starting any repair work, perform discharge by connecting a discharge resistor (5k-ohms/10W) between terminals at following positions.
The time required for discharging is about 30 seconds.

C1105 and C1106 on MAIN (3) P.C.B.
C2016 on POWER (1) P.C.B.

Refer to "PRINTED CIRCUIT BOARDS: MAIN (3) P.C.B. and POWER (1) P.C.B."

安全対策

- この製品の内部には高電圧部分があり危険です。修理の際は、絶縁性の手袋を使用するなどの安全対策を行ってください。
- 下記箇所には電源を OFF にした後も電荷が残り、高電圧が維持されており危険です。
修理作業前に放電用抵抗 (5 k Ω /10 W) を下記箇所の端子間に接続して放電してください。
放電所用時間は約 30 秒間です。

MAIN (3) P.C.B. の C1105、C1106
POWER (1) P.C.B. の C2016

"PRINTED CIRCUIT BOARDS : MAIN (3) P.C.B.、POWER (1) P.C.B." を参照してください。

■ DISASSEMBLY PROCEDURES / 分解手順

(Remove parts in the order as numbered.)
Disconnect the power cable from the AC outlet.

(番号順に部品を取り外してください。)
AC 電源コンセントから、電源コードを抜いてください。

1. Removal of Top Cover

- a. Remove 4 screws (①), 4 screws (②) and 2 screws (③). (Fig. 1)
- b. Lift the rear of the top cover to remove it. (Fig. 1)

1. トップカバーの外し方

- a. ①のネジ4本、②のネジ4本、③のネジ2本を外します。(Fig. 1)
- b. トップカバーの後部を持ち上げ、取り外します。(Fig. 1)

2. Removal of Front Panel Unit and Sub-chassis Unit

- a. Remove 6 screws (④) and then remove the front panel unit forward. (Fig. 1)
- b. Remove 4 push rivets and then remove the side plate (L) and (R). (Fig. 1)
- c. Remove 2 screws (⑤), 2 screws (⑥), 2 screws (⑦) and screw (⑧). (Fig. 1)
- d. Remove CB8, CB361, CB454, CB511, CB806 and CB914. (Fig. 1)
- e. Release 2 hooks, and remove the front panel unit. (Fig. 1)

2. フロントパネルユニットとサブシャーシユニットの外し方

- a. ④のネジ6本を外し、フロントパネルユニットを前方に取り外します。(Fig. 1)
- b. プッシュリベット4個を外し、サイドプレート (L) / (R) を取り外します。(Fig. 1)
- c. ⑤のネジ2本、⑥のネジ2本、⑦のネジ2本、⑧のネジ1本を外します。(Fig. 1)
- d. CB8、CB361、CB454、CB511、CB806、CB914を外します。(Fig. 1)
- e. フック2箇所を外し、フロントパネルユニットを取り外します。(Fig. 1)

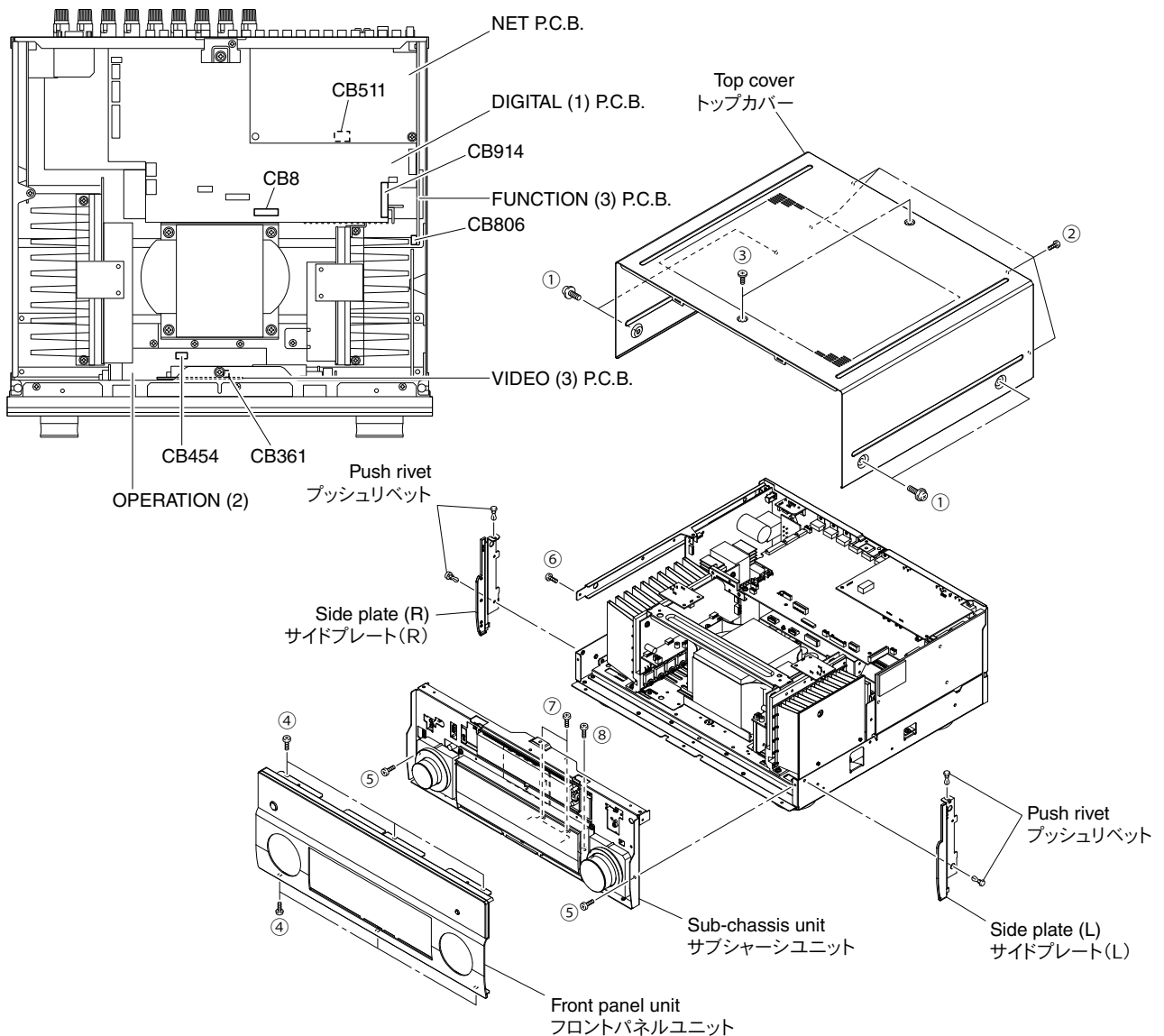

Fig. 1

3. Removal of NET P.C.B.

- a. Remove screw (9). (Fig. 2)
- b. Remove 2 screws (10). (Fig. 3)
- c. Remove CB505 and CB512 and then remove the NET P.C.B. which is connected directly to the DIGITAL (1) P.C.B. with board-to-board connectors. (Fig. 2)

3. NET P.C.B. の外し方

- a. 9 のネジ 1 本を外します。(Fig. 2)
- b. 10 のネジ 2 本を外します。(Fig. 3)
- c. CB505、CB512 を外し、NET P.C.B. を取り外します。ただし、NET P.C.B. は DIGITAL (1) P.C.B. に基板対基板コネクタで直接接続されています。(Fig. 2)

4. Removal of DIGITAL (1) P.C.B.

- a. Remove screw (11) and screw (12). (Fig. 2)
- b. Remove 9 screws. (13) and screw (14). (Fig. 3)
- c. Remove CB32, CB34, CB73, CB901, CB903, CB905, CB908-910, CB912 and CB944. (Fig. 2)
- d. Remove CB917-918, CB920 and then remove the DIGITAL (1) P.C.B. which is connected directly to the FUNCTION (2) P.C.B. with board-to-board connectors. (Fig. 2)

4. DIGITAL (1) P.C.B. の外し方

- a. 11 のネジ 1 本、12 のネジ 1 本を外します。(Fig. 2)
- b. 13 ネジ 9 本、14 のネジ 1 本を外します。(Fig. 3)
- c. CB32、CB34、CB73、CB901、CB903、CB905、CB908 ~ 910、CB912、CB944 を外します。(Fig. 2)
- d. CB917 ~ 918 と CB920 を外し、DIGITAL (1) P.C.B. を取り外します。ただし、DIGITAL (1) P.C.B. は FUNCTION (2) P.C.B. に基板対基板コネクタで直接接続されています。(Fig. 2)

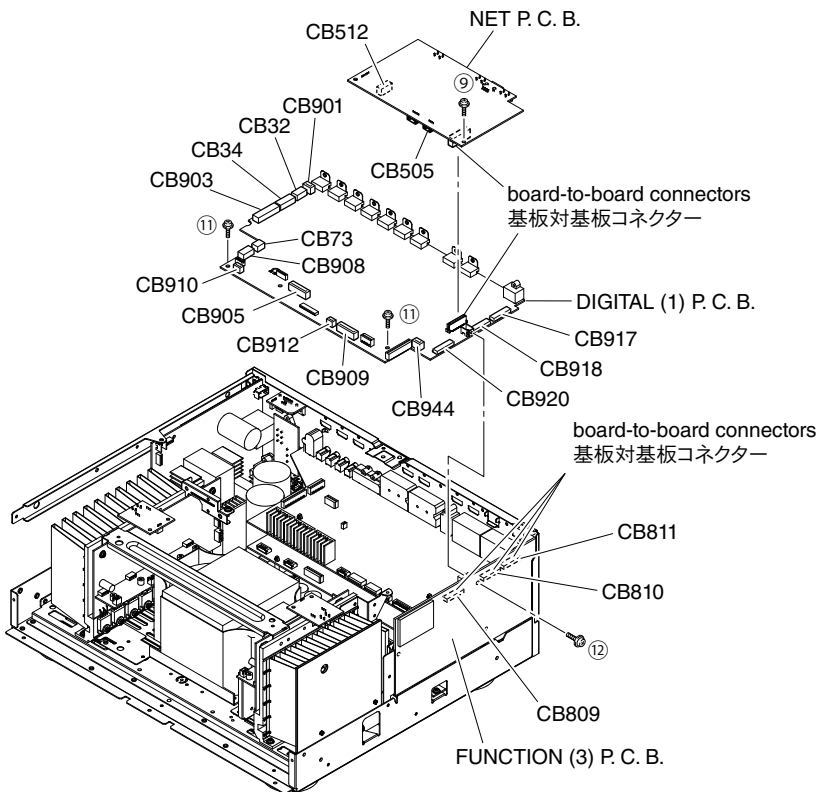

Fig. 2

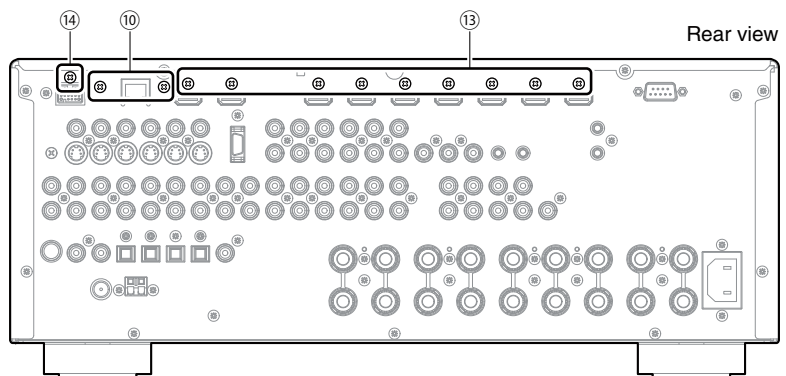

Fig. 3

5. Removal of VIDEO (1) P.C.B.

- a. Remove 11 screws (15). (Fig. 4)
- b. Remove CB304 and CB331~332. (Fig. 5)
- c. Unlock and remove CB333. (Fig. 5)
- d. Release 2 hooks and then remove the VIDEO (1) P.C.B. (Fig. 5)

5. VIDEO (1) P.C.B. の外し方

- a. ⑮のネジ12本を外します。(Fig. 4)
- b. CB304、CB331～332を外します。(Fig. 5)
- c. ロックを外しCB333を外します。(Fig. 5)
- d. フック2ヶ所を外し、VIDEO(1)P.C.B.を取り外します。(Fig. 5)

6. Removal of FUNCTION (1)~(3) P.C.B.s

- a. Remove screw (16). (Fig. 5)
- b. Remove 20 (U model)/19 (C, R, T, K, A, B, G, F, L models) screws (17). (Fig. 4)
- c. Remove CB706~707 and CB855. (Fig. 5)
- d. Release hook and then remove the FUNCTION (1) P.C.B. together with the FUNCTION (2) and (3) P.C.B.s. (Fig. 5)

6. FUNCTION (1) ~ (3) P.C.B. の外し方

- a. ⑯のネジ1本を外します。(Fig. 5)
- b. ⑰のネジ19本を外します。(Fig. 4)
- c. CB706～707、CB855を外します。(Fig. 5)
- d. フック1ヶ所を外し、FUNCTION(1)P.C.B.をFUNCTION(2)、(3)P.C.B.と一緒に取り外します。(Fig. 5)

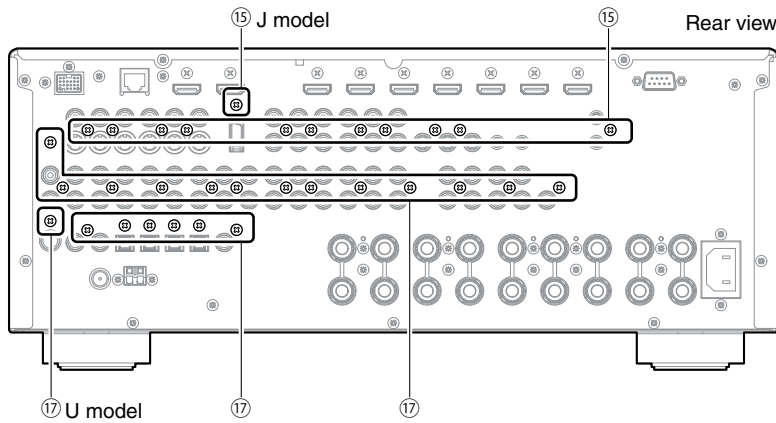

Fig. 4

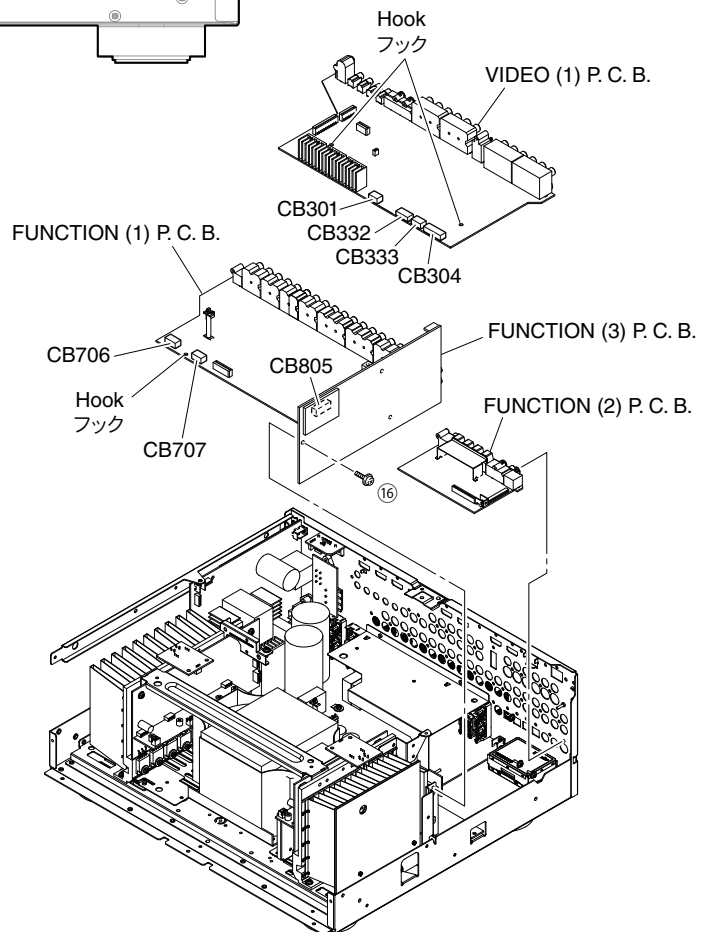
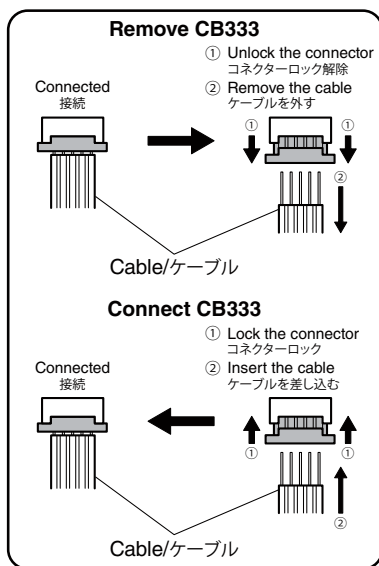

Fig. 5

When checking the P.C.B.:

- Put the rubber sheet and the cloth over this unit. Follow the procedure below to place the amp unit. (Fig. 6)
- Connect the ground points of the heatsink and sub-chassis unit to the chassis with a ground lead or the like. (Fig. 6)
- When connecting the flexible flat cable, be careful with polarity.
- Reconnect all cables (connectors) that have been disconnected.

P.C.B. をチェックする場合には：

- 本機の上にゴムシートと布を敷き、下図のようにアンプユニットを置きます。(Fig. 6)
- ヒートシンクとサブシャーシユニットのアースをリード線等でシャーシに接続してください。(Fig. 6)
- フラットケーブルを接続する際、極性に注意してください。
- 外したケーブル(コネクター)をすべて接続します。

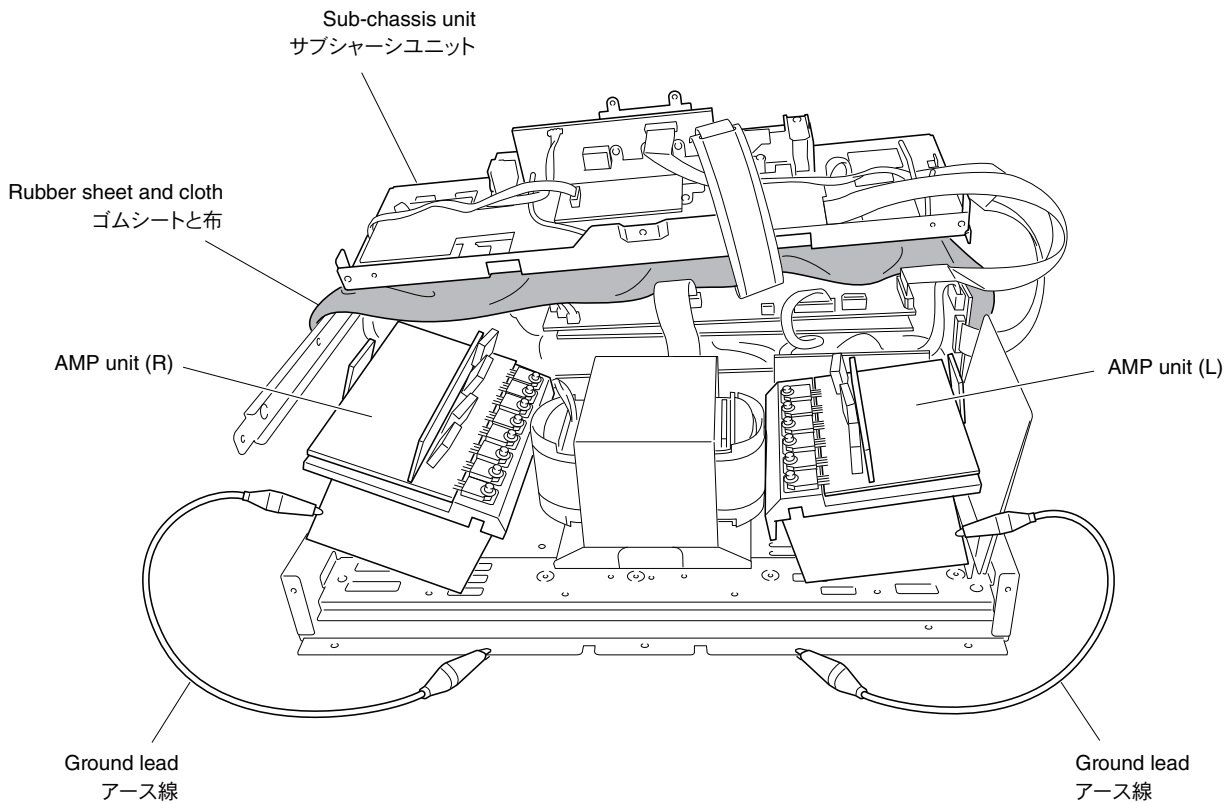

Fig. 6

■ UPDATING FIRMWARE / ファームウェアの書き込み

When the following parts are replaced, the firmware must be updated to the latest version.

- DIGITAL P.C.B.
- IC909 (GUI (FPGA) FLASH ROM) of DIGITAL P.C.B.
- IC951 (TI (DSP) FLASH ROM) of DIGITAL P.C.B.
- NET P.C.B.

● Confirmation of firmware version and checksum

Before and after updating the firmware, check the firmware version and checksum by using the self-diagnostic function menu.

Start up the self-diagnostic function and select "S4. ROM VER/SUM" menu.

Using the sub-menu, have the firmware version and checksum displayed, and note them down.

(See "SELF-DIAGNOSTIC FUNCTION")

- * When the firmware version is different from written one after updating, perform the updating procedure again from the beginning.

● Initializing the back-up IC (EEPROM: IC903 of the DIGITAL P.C.B.)

After updating the firmware, the back-up IC MUST be initialized by the following procedure to have proper memorization of the set up information (soundfield parameters, system memory and tuner presetting, etc.).

Start up the self-diagnostic function and select "S3. FACTORY PRESET" menu. (See "SELF-DIAGNOSTIC FUNCTION")

Select "PRESET RSRV", press the "MAIN ZONE ϕ " key of this unit to turn off the power once and turn on the power again. Then the back-up IC is initialized.

● Required Tools

- USB storage device
- Firmware
RX-V1067/HTR-8063/RX-A1000:
RX-V1067_xxxx.bin

● Preparation

1. Download the latest firmware from the specified download source to the folder of the PC.
2. Copy the latest firmware from the PC to the root folder of the USB storage device.

Note) When the latest firmware is copied to a sub-folder of the USB storage device, the update will not proceed.

下記の部品を交換した場合、ファームウェアを最新バージョンにアップデートする必要があります。

- DIGITAL P.C.B.
- DIGITAL P.C.B. の IC909 (GUI (FPGA) フラッシュ ROM)
- DIGITAL P.C.B. の IC951 (TI (DSP) フラッシュ ROM)
- NET P.C.B.

● ファームウェアのバージョンとチェックサムの確認

ファームウェアのアップデートの前後に、ファームウェアのバージョンとチェックサムをダイアグで確認します。

ダイアグを起動し、「S4. ROM VER/SUM」を選択します。

サブメニューでファームウェアのバージョンとチェックサムを表示し、それらを書きとめます。
(「ダイアグ」参照)

- ※ アップデート後、ファームウェアのバージョンが書き込まれたものと異なる場合、アップデートの操作を最初からやり直してください。

● バックアップ IC の初期化 (EEPROM : DIGITAL P.C.B. の IC903)

ファームウェアのアップデート後、設定情報 (音場プログラムのパラメーターやシステムメモリー、チューナープリセット等) を正常に記憶するために、下記の方法でバックアップ IC を初期化する必要があります。

本機のダイアグを起動し、「S3. FACTORY PRESET」を選択します。
(「ダイアグ」参照)

「PRESET RSRV」を選択し、「MAIN ZONE ϕ 」キーを押して電源を一度きってから、もう一度電源を入れるとバックアップ IC が初期化されます。

● 必要なツール

- USB フラッシュメモリー
- ファームウェア
RX-V1067/HTR-8063/RX-A1000 :
RX-V1067_xxxx.bin

● 準備

1. 指定のダウンロード先から、最新のファームウェアを PC のフォルダへダウンロードしてください。
2. 最新のファームウェアを USB フラッシュメモリーのルートフォルダにコピーします。

注意) 最新のファームウェアをサブフォルダにコピーした場合、本機へ書き込みできません。

● Operation Procedures

1. Insert the USB storage device to the USB terminal located on the front panel of this unit. (Fig. 1)
2. While pressing the "PURE DIRECT" key of this unit, connect the power cable of this unit to the AC outlet. (Fig. 1)

● 操作手順

1. 本機の USB 端子に USB フラッシュメモリーを差し込みます。(Fig. 1)
2. 本機の "PURE DIRECT" キーを押しながら、本機の電源コードを AC コンセントに接続します。(Fig. 1)

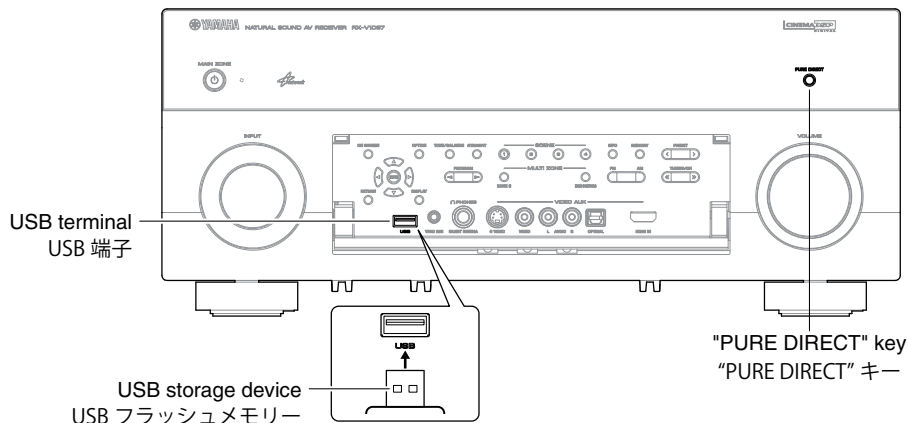

Fig. 1

The USB UPDATE mode is activated and "USB UPDATE" is displayed. Writing of the firmware starts automatically. (Fig. 2)

USB UPDATE が起動し、“USB UPDATE” が表示されて、ファームウェアの書き込みが自動で開始されます。(Fig. 2)

Writing is started. / 書き込み開始

Writing being executed. / 書き込み中

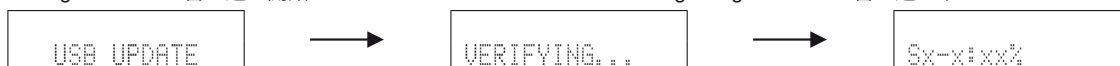

Fig. 2

4. When writing of the firmware is completed, "UPDATE SUCCESS", "PLEASE..." and "POWER OFF!" are displayed repeatedly. (Fig. 3)

4. ファームウェアの書き込み完了後、“UPDATE SUCCESS”、“PLEASE...”、“POWER OFF!” が繰り返し表示されます。(Fig. 3)

Writing is completed. / 書き込み完了

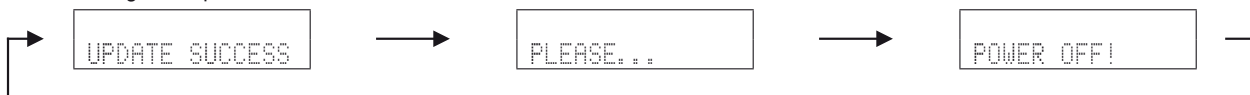

Fig. 2

5. Press the "MAIN ZONE Ⓟ" key of this unit to turn off the power.
6. Remove the USB storage device from the USB terminal located on the front panel of this unit. (Fig. 1)
7. Start up the self-diagnostic function and check that the firmware version and checksum are the same as written ones. (See "Confirmation of firmware version and checksum")

5. 本機の "MAIN ZONE Ⓟ" キーを押して電源を切ります。
6. 本機の USB 端子から USB フラッシュメモリーを抜きます。(Fig. 1)
7. ダイアグを起動し、ファームウェアのバージョンとチェックサムが、書き込まれたものと同じであることを確認します。(“ファームウェアのバージョンとチェックサムの確認” 参照)

■ AMP ADJUSTMENT / アンプ部調整

Perform all adjustments with no signal applied.

無信号状態ですべての調整を行います。

● Idling Current Adjustment

1. Turn all the semi-fixed variable resistors for idling current adjustment counterclockwise fully.
2. Turn on the power to this unit.
3. Adjust all channels so that the voltage value at test point is DC 20 mV.
4. Readjust all channels so that the voltage value at test point is the same as center value of the specified range.

● アイドリング電流調整

1. すべてのチャンネルのアイドル調整用半固定ボリュームを左いっぱいに戻します。
2. 本機に電源を投入します。
3. テストポイント電圧が DC 20 mV になるようにすべてのチャンネルを調整します。
4. テストポイント電圧が表の規格の中心値になるようにすべてのチャンネルを再調整します。

● DC Offset Confirmation

After idling current adjustment, confirm that DC offset of all channels are within the specified range.

● DC オフセット確認

アイドル調整後、すべてのチャンネルの DC オフセットが規格以内であることを確認します。

VIDEO (4) P.C.B.

Item チャンネル	Idling current adjustments アイドル電流調整			DC offset confirmations DC オフセット確認	
	Test Point テストポイント	Adjustment Point 調整箇所	Rating 規格	Test Point テストポイント	Rating 規格
Center	CB372 pin1, pin2	VR371	DC 15 ±2 mV	Speaker Terminal (TE101)	DC 0 mV to +100 mV
Surround L	CB376 pin1, pin2	VR373		Speaker Terminal (TE104)	
Front L	CB374 pin1, pin2	VR372		Speaker Terminal (TE101)	
Surround Back L	CB378 pin1, pin2	VR374		Speaker Terminal (TE103)	

VIDEO (4) P.C.B.

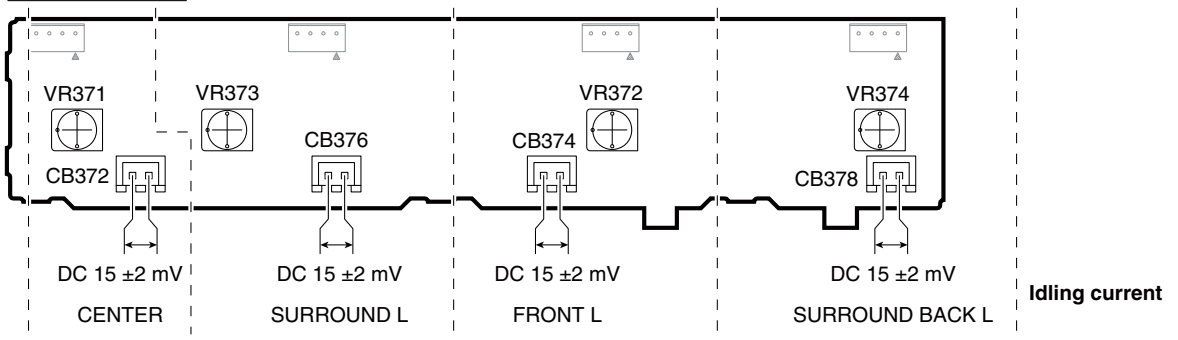

VIDEO (4)

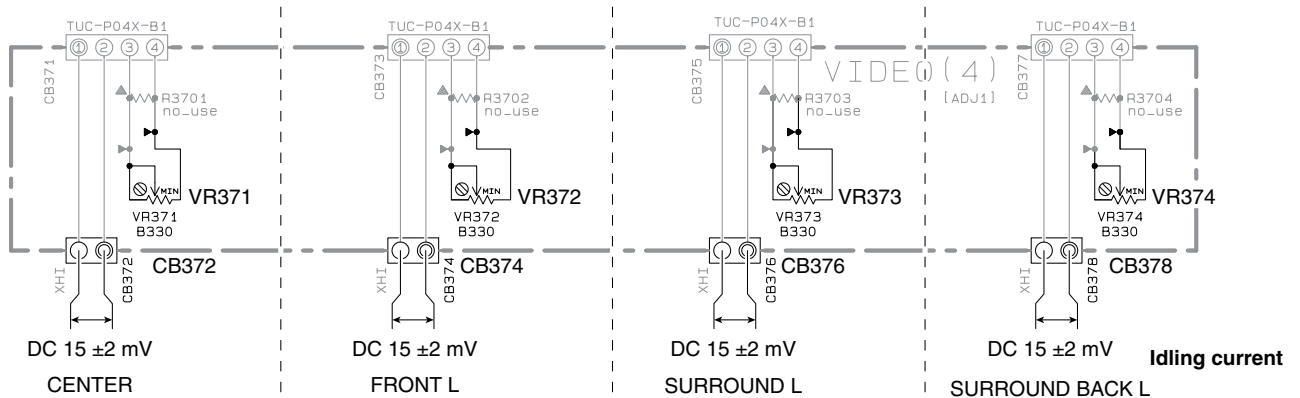

RX-V1067/HTR-8063/
RX-A1000

VIDEO (5) P.C.B.

Item チャンネル	Idling current adjustments アイドリング電流調節			DC offset confirmations DC オフセット確認	
	Test Point テストポイント	Adjustment Point 調整箇所	Rating 規格	Test Point テストポイント	Rating 規格
Surround Back R	CB382 pin1, pin2	VR381	DC 15 ±2 mV	Speaker Terminal (TE103)	DC 0 mV to +100 mV
Front R	CB386 pin1, pin2	VR383		Speaker Terminal (TE101)	
Surround R	CB384 pin1, pin2	VR382		Speaker Terminal (TE104)	

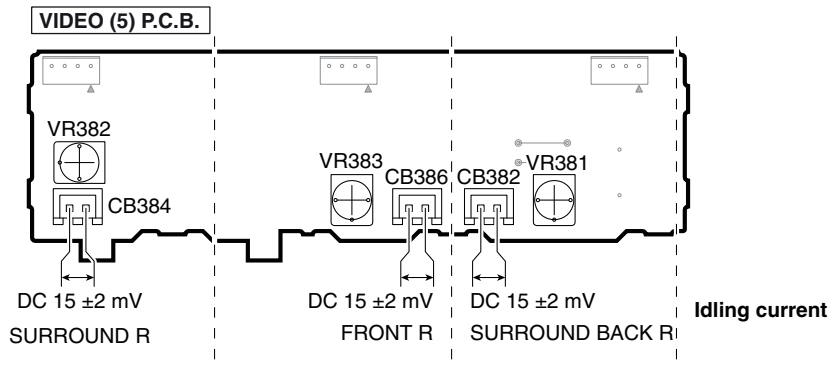

VIDEO (5)

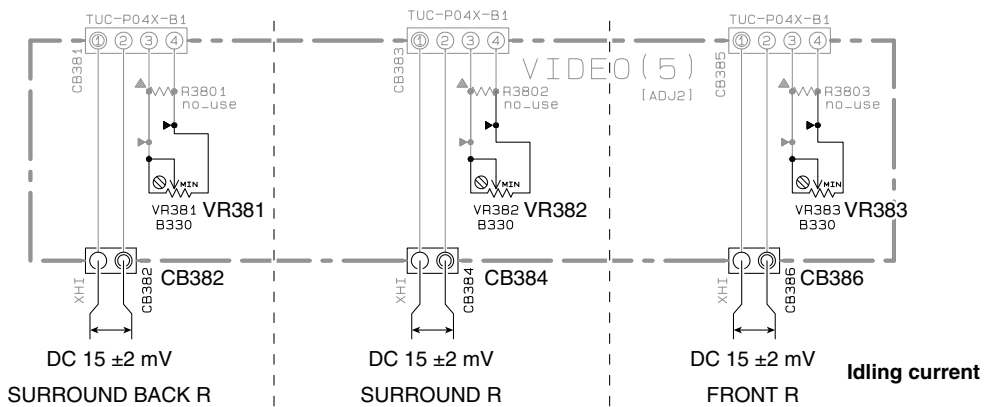

MEMO

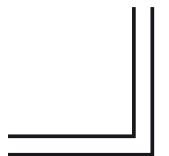
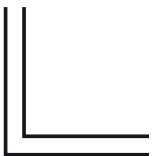
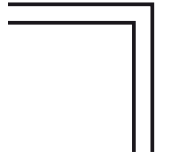
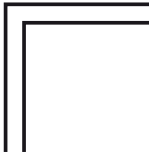

■ SELF-DIAGNOSTIC FUNCTION / ダイアグ (自己診断機能)

This unit has self-diagnostic functions that are intended for inspection, measurement and location of faulty point.

There are 24 main menu items, each of which has sub-menu items.

Listed in the table below are main menu items and sub-menu items.

Note that not all menu items listed will apply to the models covered in this service manual.

本機には、検査、測定、不良個所の発見を目的にしたダイアグ (自己診断機能) があります。

ダイアグメニューは 24 個あり、そのそれぞれにサブメニューがあります。

下表はダイアグメニュー一覧です。

下表の全ダイアグメニュー項目が、このサービスマニュアル記載のモデルに適用されるとは限りません。

No.	Main menu	No.	Sub-menu
A: Audio system / オーディオ系			
A1	DSP AUDIO	1	DSP MARGIN
		2	DSP NON MARGIN
		3	INVALID ITEM (Not for service / サービスでは使用しません)
		4	PLL=OFF
A2	DIRECT AUDIO	1	ANALOG DIRECT
A3	HDMI AUDIO	1	HDMI AUTO
		2	INVALID ITEM (Not for service / サービスでは使用しません)
		3	ARC1
		4	ARC2
A4	SPEAKERS SET	1	BI-AMP
		2	ZONE/TONE=MAX
		3	ZONE/TONE=MIN
		4	ZONE MONO ON
		5	ZONE MONO OFF
		6	D-PARTY MODE
		7	FULL MUTE
		8	EXTERNAL PRESENCE (Not for service / サービスでは使用しません)
		9	INTERNAL PRESENCE (Not for service / サービスでは使用しません)
A5	MULTI CHANNEL INPUT	1	8 CHANNEL INPUT 8 ohms
		2	8 CHANNEL INPUT 6 ohms
A6	MIC CHECK	1	MIC ROUTE CHECK
A7	MANUAL TEST	1	TEST ALL
		2	TEST FRONT L
		3	TEST CENTER
		4	TEST FRONT R
		5	TEST SURROUND R
		6	TEST SURROUND BACK R
		7	TEST SURROUND BACK L
		8	TEST SURROUND L
		9	TEST FRONT PRESENCE L
		10	TEST FRONT PRESENCE R
		11	INVALID ITEM (Not for service / サービスでは使用しません)
		12	INVALID ITEM (Not for service / サービスでは使用しません)
		13	TEST LFE 1
		14	INVALID ITEM (Not for service / サービスでは使用しません)
D: Display system / 表示系			
D1	FL CHECK	1	FL CHECK
		2	ALL SEGMENT OFF
		3	ALL SEGMENT ON
		4	CHECK PATTERN

No.	Main menu	No.	Sub-menu
Z: Zone system / ZONE 系			
Z1	ZONE TEST	1	AV1 (Not for service / サービスでは使用しません)
		2	AV2 (Not for service / サービスでは使用しません)
		3	AV3 (Not for service / サービスでは使用しません)
		4	AV4 (Not for service / サービスでは使用しません)
		5	AUDIO1
		6	AUDIO2
		7	AUDIO3
		8	AUDIO4
		9	V-AUX
		10	PHONO
R: Radio and satellite broadcasting system / チューナー・衛星放送系			
R1	SIRIUS (U model)	1	SIRIUS
		2	SR
		3	SSP
		4	MAC
		5	ADP
		6	PRDID
		7	SEQID
U: Universal system / 特殊端子系			
U1	DOCK	1	DOCK
U2	USB	1	VNP2 TEST 1kHz
		2	VNP2 TEST 20Hz
		3	VNP2 TEST 20kHz
		4	USB FRONT 1 TRACK
		5	USB FRONT 2 TRACK
U3	INVALID ITEM (Not for service / サービスでは使用しません)		
N: Network system / ネットワーク系			
N1	NETWORK	1	IP ADDRESS CHECK
		2	MAC ADDRESS CHECK
		3	LINK CHECK
		4	EXT TEST
		5	PHY TEST
		6	LINE NOISE 10
		7	LINE NOISE 100
		8	I2C EPROM
		9	RAM BUS
		10	INVALID ITEM (Not for service / サービスでは使用しません)
		11	SYNC SERIAL
		12	MAC ADDRESS
C: Communication system / 通信・バスライン系			
C1	DIGITAL PCB CHECK	1	ALL
		2	BUS FLASH ROM
		3	BUS FPGA
		4	I2C
		5	FPGA RAM
		6	BUS DIR
		7	BUS DSP1
		8	EEPROM
		9	RS-232C LOOPBACK TEST
		10	BUS NPGA
C2	HDMI INFO	1	HMN
		2	HID

No.	Main menu	No.	Sub-menu
V: Video system / ビデオ系			
V1	ANALOG VIDEO CHECK	1	ANALOG BYPASS
		2	DIGITAL BYPASS
		3	ZONE BYPASS
		4	MUTE CHECK
		5	TEST PATTERN
		6	VIDEO IN
V2	DIGITAL VIDEO CHECK	1	LOOPBACK TEST 1
		2	LOOPBACK TEST 2
		3	LOOPBACK TEST 3 (Not for service / サービスでは使用しません)
		4	HDMI REPEAT
		5	DIGITAL CVBS
		6	DIGITAL Y/C
		7	DIGITAL COMPONENT
		8	DIGITAL COMPONENT SC
		9	GUI-VIDEO OUT
P: Power and protection system / 電源・プロテクション系			
P1	SYSTEM MONITOR	1	DC
		2	PS1/PS2
		3	TM
		4	OUTPUT LEVEL
		5	LIMITER CONTROL
		6	L3 (J model)
		7	KEY1/KEY2/KEY3
P2	PROTECTION HISTORY	1	HISTORY 1
		2	HISTORY 2
		3	HISTORY 3
		4	HISTORY 4
S: System and version system / システム・バージョン系			
S1	FIRMWARE UPDATE	1	F/W UPDATE (Not for service / サービスでは使用しません)
S2	SET INFORMATION	1	MODEL
		2	DESTINATION
		3	DEBUG (Not for service / サービスでは使用しません)
S3	FACTORY PRESET	1	PRESET INH/RSRV
S4	ROM VERSION/CHECKSUM	1	SYSTEM VERSION
		2	MICROPROCESSOR VERSION
		3	MICROPROCESSOR CHECKSUM
		4	FLASH ROM VERSION
		5	FLASH ROM CHECKSUM
		6	VNP2 VERSION
		7	VNP2 CHECKSUM
		8	DSP1 VERSION
		9	DSP1 CHECKSUM
		10	DSP2 VERSION (Not for service / サービスでは使用しません)
		11	DSP2 CHECKSUM (Not for service / サービスでは使用しません)
		12	GUI VERSION
		13	FPGA GUI VERSION
		14	FPGA IP VERSION
		15	SIRIUS VERSION
		16	HQV VERSION (Not for service / サービスでは使用しません)
		17	HD RADIO VERSION (U model)

● Starting Self-Diagnostic Function

While pressing the “TONE/BALANCE” and “INFO” keys of this unit as shown in the figure below, press the “MAIN ZONE” key of this unit to turn on the power.

The self-diagnostic function mode is activated.

● ダイアグの起動

本機の下図に示す “TONE/BALANCE” と “INFO” キーを押しながら “MAIN ZONE” キーを押して電源を入れます。ダイアグが起動します。

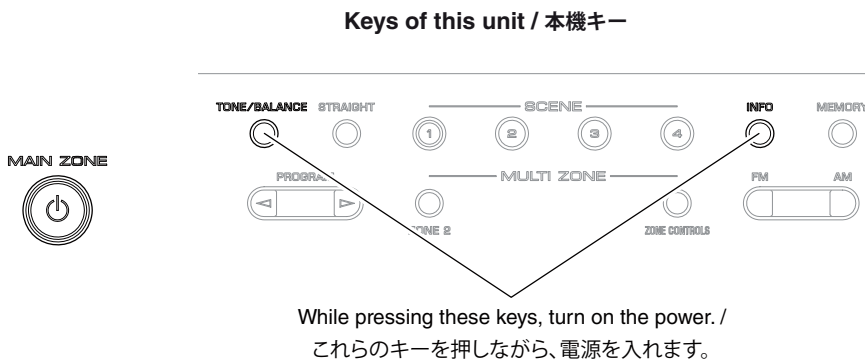

● Starting Self-Diagnostic Function in the protection cancel mode

If the protection function works and causes hindrance to trouble shoot, cancel the protection function as described below, and it will be possible to enter the self-diagnostic function mode.

(The protection functions other than the excess current detect function will be disabled.)

While pressing the “TONE/BALANCE” and “INFO” keys as shown in the figure above, press the “MAIN ZONE” key to turn on the power and keep pressing those 2 keys for 3 seconds or longer.

The self-diagnostic function mode is activated with the protection functions disabled.

In this mode, the “SLEEP” segment of the FL display of this unit flashes to indicate that the mode is self-diagnostic function mode with the protection functions disabled.

● プロテクション解除モードでの起動

プロテクションが動作することにより、故障箇所の診断に支障をきたすような場合は、次の方法によりプロテクションを解除した状態でダイアグモードに入ることができます。

(過電流検出以外のプロテクション動作を解除する)

上図に示す “TONE/BALANCE” と “INFO” キーを押しながら “MAIN ZONE” キーを押して電源を入れ、2つのキーを3秒以上押し続けます。

プロテクション解除モードでダイアグが起動します。

このモードでは本機 FL の “SLEEP” セグメントが点滅し、プロテクションを解除した状態でのダイアグモードであることを知らせます。

CAUTION!

Using this product with the protection function disabled may cause further damage to this unit. Use special care for this point when using this mode.

注意!

プロテクションを解除した状態でのダイアグモードは、危険な状態でもプロテクションが作動しないため、動作させると、機器を破壊することがあります。このモードを使用する場合は十分注意してください。

RX-V1067/HTR-8063/
RX-A1000

● Canceling Self-Diagnostic Function

1. Before canceling self-diagnostic function, execute setting for FACTORY PRESET of main menu No. S3. (Memory initialization inhibited or Memory initialized).
 - * In order to keep the user memory preserved, be sure to select PRESET INHIBIT (Memory initialization inhibited).
2. Press the "MAIN ZONE \odot " key of this unit to turn off the power.

● Display provided when Self-Diagnostic Function started

The display is as described below depending on the situation the last time the power to this unit is turned off.

1. When the power is turned off by usual operation:

The FL display of this unit displays "NO PROTECT" then the main menu (sub-menu "A1-1. DSP MARGIN" of main menu No. A1 DSP AUDIO) a few seconds later.

Opening message / オープニング表示

NO PROTECT

After a few seconds / 数秒後

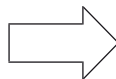

A1-1
DSP MARGIN

Main menu display / メインメニュー表示

● ダイアグの解除

1. ダイアグを解除する前に、メインメニュー No. S3. FACTORY PRESET (メモリーの初期化禁止/またはメモリーの初期化) の設定をします。
 - ※ ユーザーメモリーを保持したい場合は、必ず PRESET INHIBIT (メモリー初期化禁止) を選択してください。
2. 本機の "MAIN ZONE \odot " キーを押して電源を切ります。

● ダイアグ起動時の表示

最後に本機の電源が切れたときの状況により、下記のように表示されます。

1. 通常の操作で電源を切った場合：

本機の FL ディスプレイに "NO PROTECT" が表示されます。数秒後、メインメニュー A1 DSP AUDIO のサブメニュー "A1-1 DSP MARGIN" が表示されます。

2. When the protection function worked to turn off the power:

The FL display of this unit displays the data of protection function which worked at that time then the main menu (sub-menu "A1-1. DSP MARGIN" of main menu No. A1 DSP AUDIO) a few seconds later.

Note: At that time if you reactivate the self-diagnostic function after turning off the power once by pressing the "MAIN ZONE 0" key, "NO PROTECT" will be displayed because that situation is equal to "1. When the power is turned off by usual operation:" described above. However the protection function history is stored in a back-up IC with a backup. For details, refer to main menu P2 PROTECTION HISTORY.

2-1. When there is a history of protection function due to excess current.

2. プロテクションが働いて電源が切れた場合：

本機の FL ディスプレイにそのときに働いたプロテクションの情報が表示されます。数秒後、メインメニュー A1 DSP AUDIO のサブメニュー "A1-1 DSP MARGIN" が表示されます。

注) このときに "MAIN ZONE 0" キーを押していったん電源を切った後にダイアグを再起動すると、上述の「1. 通常の操作で電源を切った場合」に相当するので、"NO PROTECT" が表示されます。

ただし、プロテクションの履歴はメモリーにバックアップして記憶されます。詳細は、メインメニュー P2 PROTECTION HISTORY を参照してください。

2-1. 過電流によるプロテクション履歴がある場合



Cause: An excessive current flowed through the power amplifier.

Supplementary information: As current of the power amplifier is detected, the abnormal channel can be identified by checking the current detect transistor.

Turning on the power without correcting the abnormality will cause the protection function to work immediately and the power supply will instantly be shut off.

原因： パワーアンプに過電流が流れた。

補足： パワーアンプの電流を検出していますので、電流検出トランジスタをチェックすれば異常チャンネルが特定できます。

異常状態のまま電源を入れると、瞬時にプロテクションが働き、すぐに電源が切れます。

Notes)

- Applying the power to this unit without correcting the abnormality can be dangerous and cause additional circuit damage. To avoid this, if "I PROTECT" protection function works 1 time, the power will not turn on even when the "MAIN ZONE 0" key is pressed. In order to turn on the power again, start up the self-diagnostic function.
- The output transistors in each amplifier channel should be checked for damage before applying power to this unit.
- Amplifier current should be monitored by measuring DC voltage across the emitter resistors for each channel.

注意！

- 異常状態のまま本機の電源を入れると、危険な状態になり、さらに回路が損傷を受ける原因になります。それを避けるために、「I PROTECT」が1回働いた場合、それ以降 "MAIN ZONE 0" キーを押しても電源が入らなくなります。再度電源を入れる場合、ダイアグを起動してください。
- 本機の電源をいれる前に、各パワーアンプの出力トランジスタに損傷がないかチェックしてください。
- パワーアンプの電流は、各チャンネルのエミッターの抵抗器間 DC 電圧を測定することによりモニターしてください。

2-2. When the protection function worked due to abnormal DC output.

DC PRT:xxxxH

AD conversion value when the protection function is working
 プロテクションが働いたときの電圧の A/D 変換値

Cause: DC output of the power amplifier is abnormal.

Supplementary information: The protection function worked due to a DC voltage appearing at the speaker terminal. A cause could be a defect in the amplifier.

Turning on the power without correcting the abnormality will cause the protection function to work in 3 seconds and the power supply will be shut off.

2-2. DC 出力異常によりプロテクションが働いた場合

原因: パワーアンプの DC 出力が異常。

補足: アンプの故障でスピーカー端子に直流電圧が DC 掛かるなどが原因で、プロテクションが働いたことを示します。

異常状態のまま電源を入れると、瞬時にプロテクションが働き、電源が切れます。

2-3. When the protection function worked due to abnormal voltage in the power supply section.

PSx PRT:xxxL

AD conversion value when the protection function is working
 プロテクションが働いたときの電圧の A/D 変換値

Cause: The voltage in the power supply section is abnormal.

Supplementary information: The protection function worked due to a defect or overload in the power supply.

Turning on the power without correcting the abnormality will cause the protection function to work in 1 seconds and the power supply will be shut off.

2-3. 電源部の電圧異常によりプロテクションが働いた場合

原因: 電源部の電圧が異常。

補足: 電源電圧による原因で、プロテクションが働いたことを示します。

異常状態のまま電源を入れると、1 秒後にプロテクションが働き、電源が切れます。

Notes)

- Applying the power to this unit without correcting the abnormality can be dangerous and cause additional circuit damage. To avoid this, if "PS" and "DC" protection function works 3 times consecutively, the power will not turn on even when the "MAIN ZONE \odot " key is pressed. In order to turn on the power again, start up the self-diagnostic function.
- The output transistors in each amplifier channel should be checked for damage before applying power to this unit.
- Amplifier current should be monitored by measuring DC voltage across the emitter resistors for each channel.

注意!

- 異常状態のまま本機の電源を入れると、危険な状態になり、さらに回路が損傷を受ける原因になります。それを避けるために、「DC」、「PS」プロテクションが連続して3回目働いた場合、それ以降「MAIN ZONE \odot 」キーを押しても電源が入らなくなります。再度電源を入れる場合、ダイアグを起動してください。
- 本機の電源をいれる前に、各パワーアンプの出力トランジスタに損傷がないかチェックしてください。
- パワーアンプの電流は、各チャンネルのエミッターの抵抗器間 DC 電圧を測定することによりモニターしてください。

2-4. When the protection function worked due to excessive heatsink temperature.

2-4. ヒートシンクの異常温度によりプロテクションが働いた場合

```
TMP PRT:xxxL
```

AD conversion value when the protection function is working
プロテクションが働いたときの電圧の A/D 変換値

Cause: The temperature of the heatsink is excessive.

Supplementary information: The protection function worked due to the temperature limit being exceeded. Causes could be poor ventilation or a defect related to the thermal sensor.

Turning on the power without correcting the abnormality will cause the protection function to work in 1 seconds and the power supply will be shut off.

原因： ヒートシンクの温度が異常。

補足： 温度制限を越えた原因で、プロテクションが働いたことを示します。

異常状態のまま電源を入れると、1 秒後にプロテクションが働き、電源が切れます。

● History of protection function

When the protection function has worked, its history is stored in memory with a backup.

Even if no abnormality is noted while servicing the unit, an abnormality which has occurred previously can be defined as long as the backup data has been stored.

For details, refer to main menu P2 PROTECTION HISTORY.

● プロテクションの履歴

プロテクションが働いた場合、その履歴をバックアップして記憶しています。

修理のときに異常が認められなくても、バックアップが残っていれば、お客様のところで起きた異常を区別できます。

詳細は、メインメニュー P2 PROTECTION HISTORY を参照してください。

● Operation procedure of Main menu and Sub-menu

There are 25 main menu items, each of having sub-menu items.

Main menu selection

Select the menu using "SCENE 2" (forward) and "SCENE 1" (reverse) keys.

Sub-menu selection

Select the sub-menu using "SCENE 4" (forward) and "SCENE 3" (reverse) keys.

● メインメニューとサブメニューの操作

ダイアグには No. 1～25 のメインメニューがあり、それぞれにサブメニューがあります。

メインメニューの選択

"SCENE 2" (順送り)、"SCENE 1" (逆送り) キーで選択します。

サブメニューの選択

"SCENE 4" (順送り)、"SCENE 3" (逆送り) キーで選択します。

Keys of this unit / 本機キー

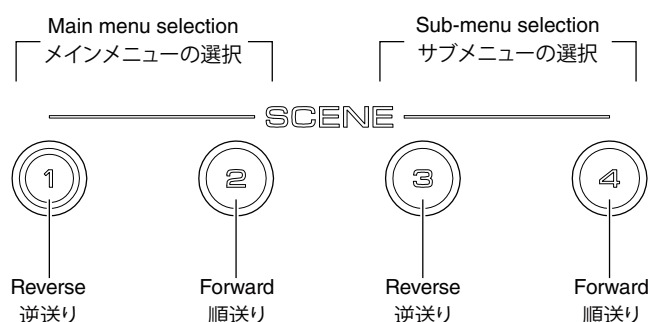

● Functions in Self-Diagnostic Function mode

In addition to the self-diagnostic function menu items, functions as listed below are available.

- Power ON/OFF
- Master volume
- Muting
- Input selection

* Functions related to the tuner and the set menu are not available.

● ダイアグ中の機能

ダイアグメニューの他に、以下の機能が動作します。

- 電源 オン/オフ
- マスターボリューム
- ミューティング
- インプットセレクト

※ チューナー関連、セットメニュー関連は機能しません。

● Initial settings used to start Self-Diagnostic Function

The following initial settings are used when starting self-diagnostic function.

When self-diagnostic function is canceled, these settings are restored to those before starting self-diagnostic function.

- Master volume: -20 dB / Zone volume: +2.5dB
- Input: AV1
- Main menu: A1-1. DSP MARGIN
- Speaker setting: LARGE, Bass out to SWFR (All channels)
- HDMI Control: Off
- Zone 2: On

● ダイアグ開始時の初期設定

ダイアグ開始時に以下のような設定になります。

ダイアグ解除時にはダイアグ開始前の状態に戻ります。

- マスターボリューム: -20 dB
- インプット: AV1
- メインメニュー: A1-1. DSP MARGIN
- スピーカー設定: LARGE、Bass out to SWFR (すべてのチャンネル)
- HDMI コントロール: OFF

● **Details of Self-Diagnostic Function menu**

A1. DSP AUDIO

This menu is used to check audio signal route via DSP.

A1-1. DSP MARGIN

The audio signal is output including the head margin via DSP.

Head margin
 Front L/R, Center, Surround L/R,
 Surround Back L/R: +12 dB
 Subwoofer: +18 dB

* When input source is stereo, signal is assigned as below.

Front L: Front L, Center, Surround L,
 Surround Back L, Presence L
 Front R: Front R, Surround R, Surround Back
 R, Presence R
 Front L +10 dB: Subwoofer

```
A1-1
DSP MARGIN
```

A1-2. DSP NON MARGIN

The audio signal is output without including the head margin via DSP.

Front L/R, Center, Surround L/R,
 Surround Back L/R: 0 dB
 Subwoofer: -10 dB

```
A1-2
DSP NON MARGIN
```

A1-3. INVALID ITEM

Not for service.

```
A1-3
INVALID ITEM
```

A1-4. PLL OFF

The audio signal is output turns off the PLL (IC943) via DSP.

```
A1-4
PLL=OFF
```

● **ダイアグメニュー詳細**

A1. DSP AUDIO

DSP を経由するオーディオ信号経路をチェックします。

A1-1. DSP MARGIN

音声信号が DSP を経由してヘッドマージンを含んで出力されます。

ヘッドマージン
 Front L/R, Center, Surround L/R,
 Surround Back L/R : +12 dB
 Subwoofer : +18 dB

※ 2ch 信号入力時、以下のように信号が振り分けられて出力されます。

Front L : Front L, Center, Surround L,
 Surround Back L, Presence L
 Front R : Front R, Surround R, Surround
 Back R, Presence R
 Front L +10 dB : Subwoofer

A1-2. DSP NON MARGIN

音声信号が DSP を経由してヘッドマージンを含まず出力されます。

Front L/R, Center, Surround L/R,
 Surround Back L/R : 0 dB
 Subwoofer : -10 dB

A1-3. INVALID ITEM

サービスでは使用しません。

A1-4. PLL OFF

音声信号が DSP を経由して PLL (IC943) をオフにして出力されます。

A2. DIRECT AUDIO

This menu is used to check audio signal route of PURE DIRECT.

A2-1. ANALOG DIRECT

The analog input audio signal is output to FRONT L/R in PURE DIRECT mode.

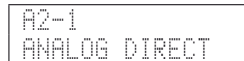

INPUT: AV5 ANALOG
SPEAKER OUT: 1 kHz, SUBWOOFER OUTPUT: 50 Hz

Sub-menu	Input level	Volume	SPEAKERS OUTPUT					SUBWOOFER OUTPUT
			FRONT	CENTER	SURROUND	SURROUND BACK/BI-AMP	F.PRESENCE ZONE2	
ANALOG DIRECT	Both ch, -20 dBm	+6.5 dB	+13.0 dBm	- ∞	- ∞	- ∞	-	- ∞

ANALOG BYPASS

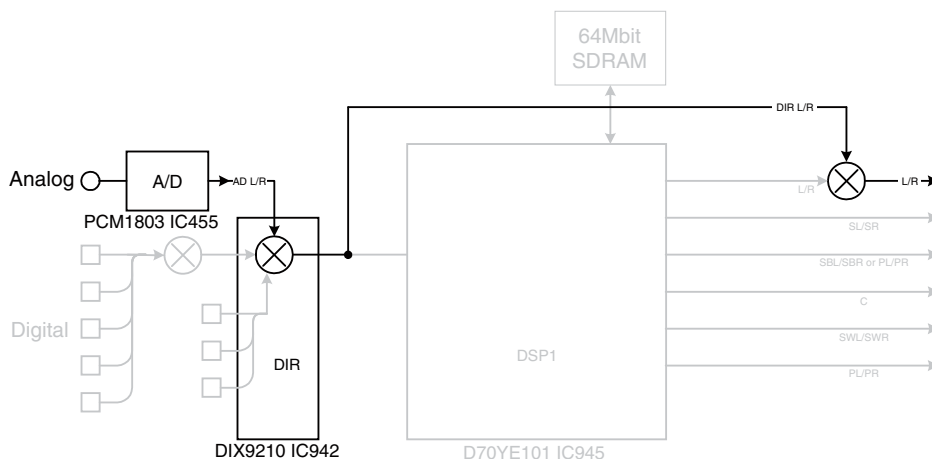

(Shaded items not used in this mode)

A2. DIRECT AUDIO

PURE DIRECT のオーディオ信号経路をチェックします。

A2-1. ANALOG DIRECT

アナログ入力の音声信号が PURE DIRECT で FRONT L/R へ出力されます。

A3. HDMI AUDIO

This menu is used to check the route of audio signal input to HDMI IN/OUT.

- * Before checks using sub-menu A3-3 and A3-4, be sure to connect a TV monitor equipped with Audio Return Channel function to this unit.

A3. HDMI AUDIO

HDMI IN/OUT に入力されたオーディオ信号の経路をチェックします。

- ※ サブメニュー A3-3、A3-4 でのチェックの前に、必ず Audio Return Channel 機能に対応しているテレビを接続してください。

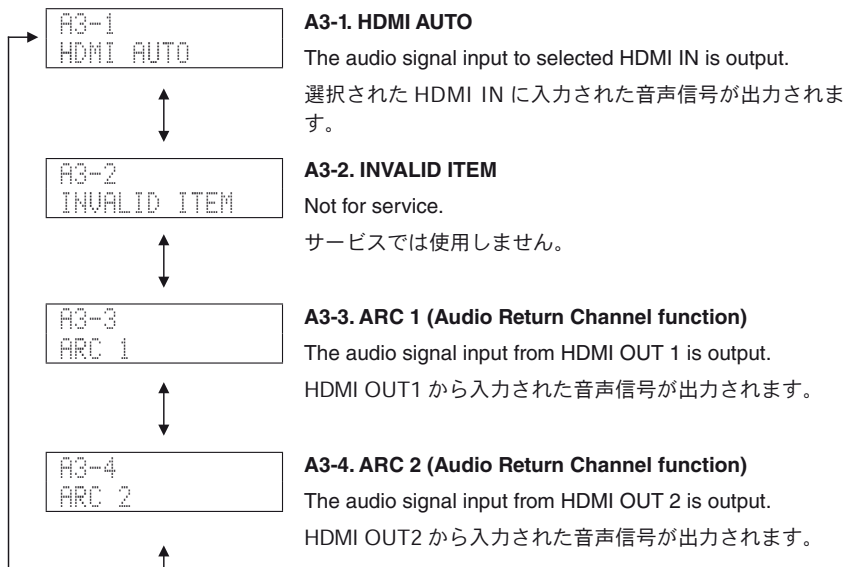

A4. SPEAKERS SET

This menu is used to check the speaker output.

A4. SPEAKERS SET

スピーカー出力をチェックします。

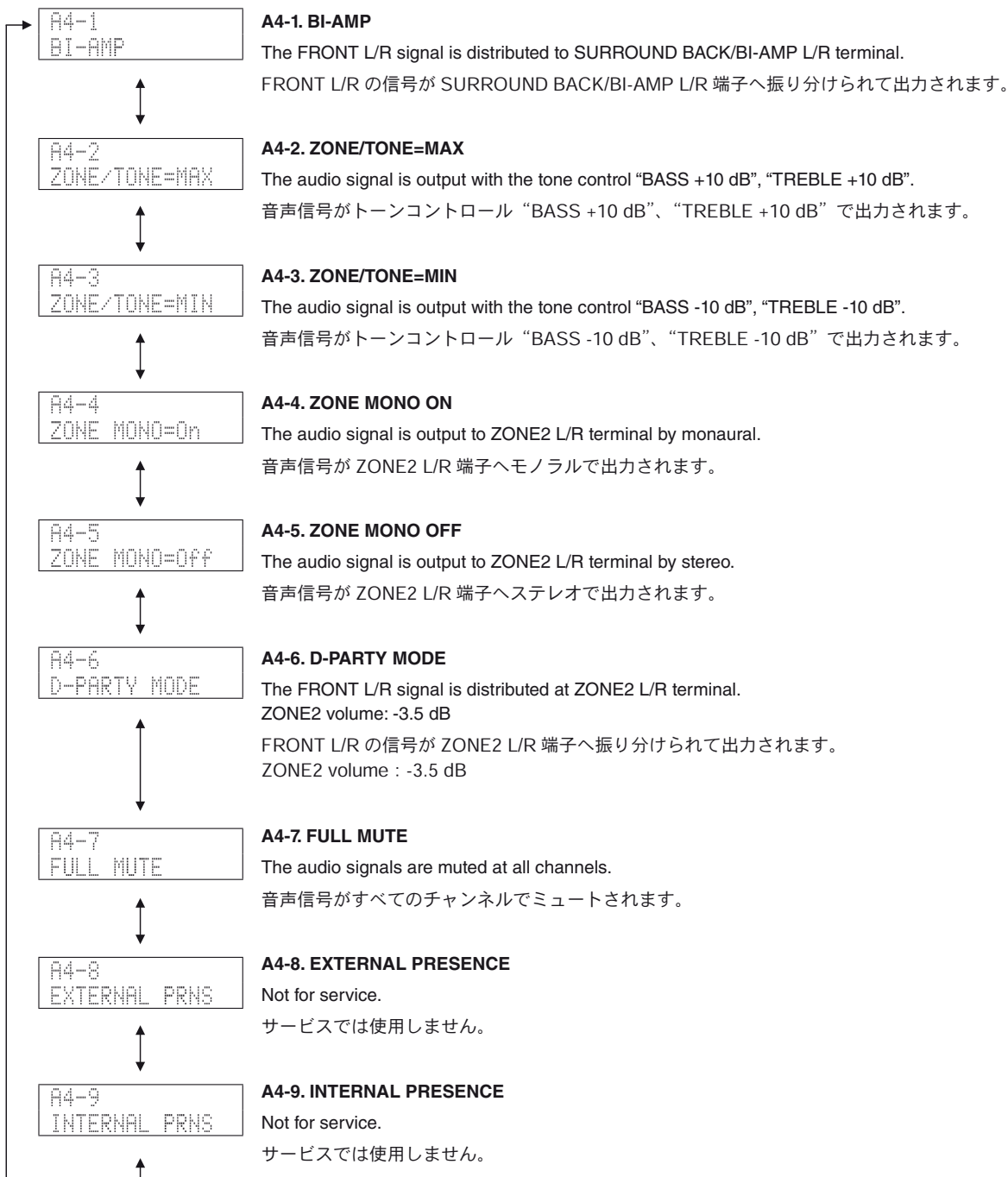

INPUT: AV5 ANALOG

SPEAKER OUT: 1 kHz, SUBWOOFER OUTPUT: 50 Hz

Sub-memu	Input level	Volume	SPEAKERS OUTPUT					SUB-WOOFER OUTPUT
			FRONT	CENTER	SURROUND	SURROUND BACK	PRESENCE/ ZONE2	
BI-AMP	Both ch, -20 dBm	+6.5 dB	+13.0 dBm	+13.0 dBm	+13.0 dBm	+13.0 dBm	+13.0 dBm	-7.5 dBm
ZONE/TONE=MAX	Both ch, -20 dBm	+6.5 dB	+14.0 dBm	+13.0 dBm	+13.0 dBm	+13.0 dBm	+13.0 dBm	-7.5 dBm
ZONE/TONE=MIN	Both ch, -20dBm	+6.5 dB	+12.0 dBm	+13.0 dBm	+13.0 dBm	+13.0 dBm	+13.0 dBm	-7.5 dBm
ZONE MONO ON	Both ch, -20 dBm	+6.5 dB	-	-	-	-	-	-
ZONE MONO OFF	Both ch, -20 dBm	+6.5 dB	-	-	-	-	-	-
D-PARTY MODE	Both ch, -20 dBm	+6.5 dB	+13.0 dBm	+13.0 dBm	+13.0 dBm	+13.0 dBm	+13.0 dBm	-7.5 dBm
FULL MUTE	Both ch, -20 dBm	+6.5 dB	+13.0 dBm	- ∞	- ∞	- ∞	- ∞	- ∞
EXTERNAL PRESENCE (Not for service / サービスでは使用しません)	Both ch, -20 dBm	+6.5 dB	-	-	-	-	-	-
INTERNAL PRESENCE (Not for service / サービスでは使用しません)	Both ch, -20 dBm	+6.5 dB	-	-	-	-	-	-

RX-V1067/HTR-8063/RX-A1000

A5. MULTI CHANNEL INPUT

This menu is used to check the route of audio signal input to MULTI CHANNEL INPUT.

A5-1. 8 CHANNEL INPUT 8 ohms

The audio signal input to MULTI CHANNEL INPUT is output with the speaker impedance “8 ohms” setting.



A5-2. 8 CHANNEL INPUT 6 ohms

The audio signal input to MULTI CHANNEL INPUT is output with the speaker impedance “6 ohms” setting.

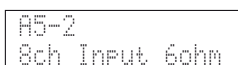

A5. MULTI CHANNEL INPUT

MULTI CHANNEL INPUT に入力されたオーディオ信号の経路をチェックします。

A5-1. 8 CHANNEL INPUT 8 ohms

MULTI CHANNEL INPUT に入力された音声信号がスピーカーインピーダンス “8 オーム” で出力されます。

A5-2. 8 CHANNEL INPUT 6 ohms

MULTI CHANNEL INPUT に入力された音声信号がスピーカーインピーダンス “6 オーム” で出力されます。

A6. MIC CHECK

A6-1. MIC ROUTE CHECK

The signals input through the YPAO microphone are output to only FRONT L channel via A/D-D/A.



A6. MIC CHECK

A6-1. MIC ROUTE CHECK

YPAO マイクに入力された信号が A/D - D/A 経由で FRONT L チャンネルのみへ出力されます。

A7. MANUAL TEST

The built-in noise generator of DSP outputs the test noise or test tone through the channels specified by using the sub-menu.

The noise frequency for LFE is 30 to 80 Hz. Other than that, the noise frequency is 500 to 2 kHz.

The tone frequency for LFE is 50 Hz sine wave. Other than that, the tone frequency is 1 kHz sine wave.

A7. MANUAL TEST

DSP 内蔵のノイズ発生回路によって、サブメニューで指定したチャンネルへテストノイズ・テストトーンが出力されます。

LFE 用のノイズ周波数は 30 ~ 80 Hz、それ以外はノイズ周波数 500 ~ 2 kHz となります。

LFE 用のトーン周波数は 50 Hz の正弦波、それ以外のトーン周波数は 1 kHz の正弦波になります。

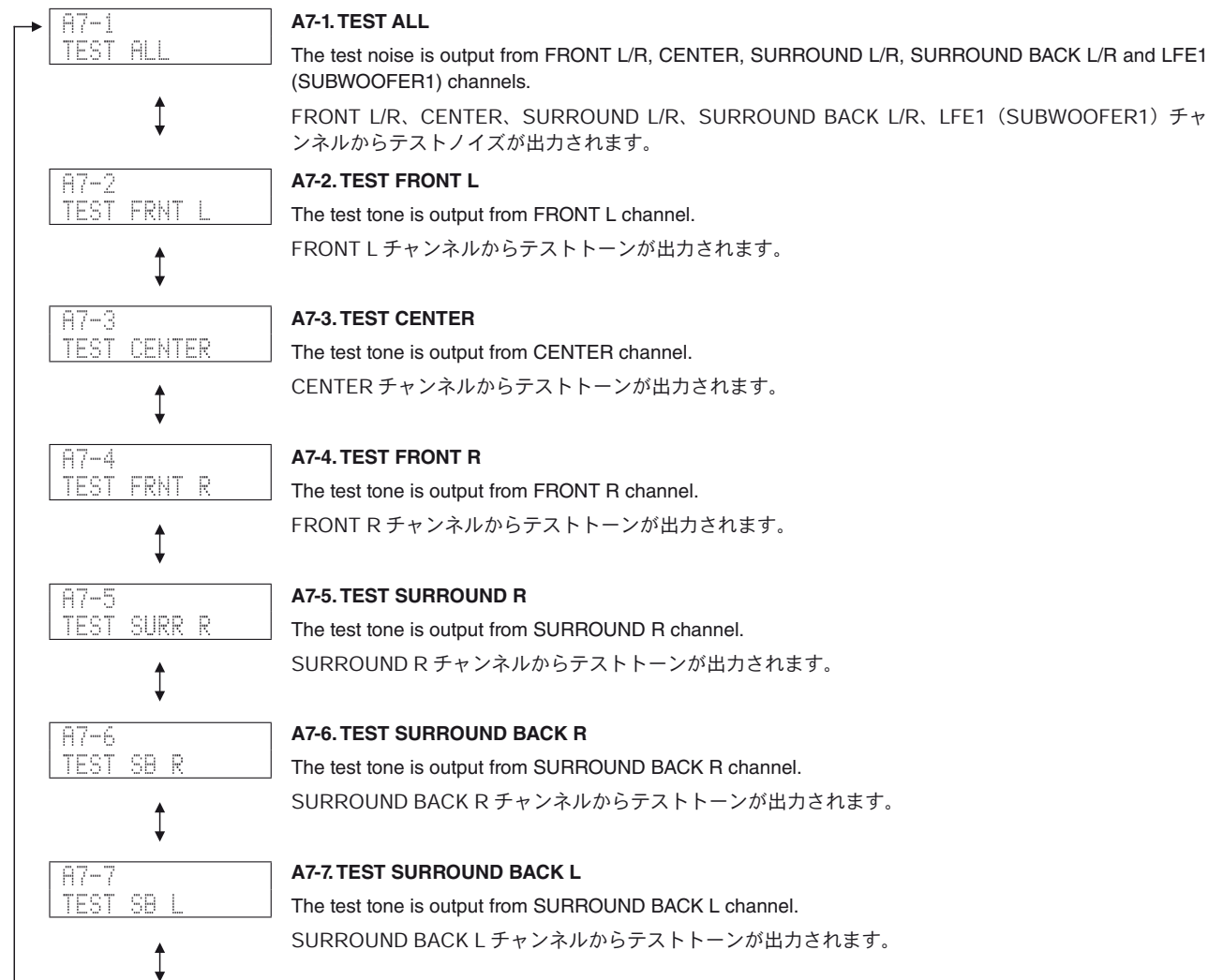

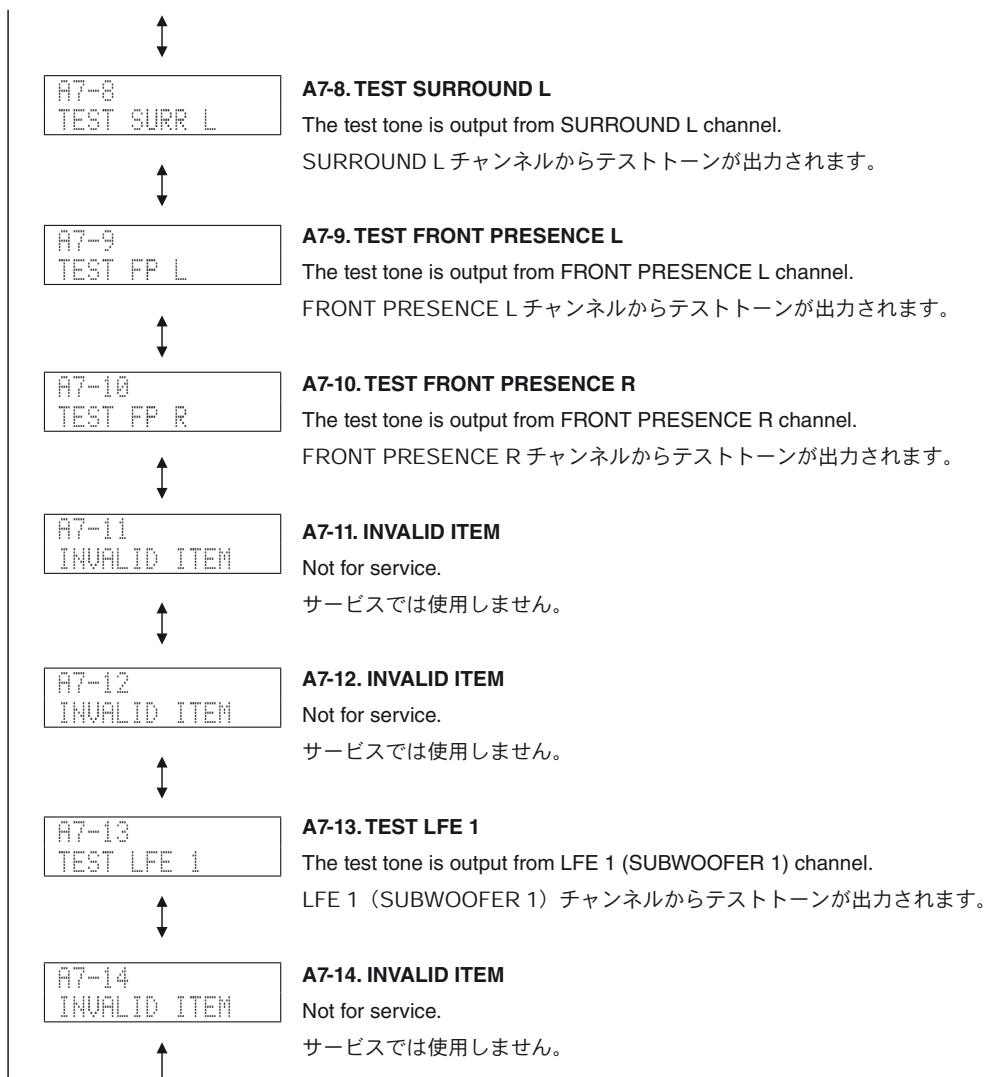

D1. FL CHECK

This menu is used to check the FL display.

D1. FL CHECK

FL 表示をチェックします。

FL display / FL 表示

D1-1. INITIAL DISPLAY / 初期表示



D1-2. ALL SEGMENT OFF / 全セグメント消灯



D1-3. ALL SEGMENT ON / 全セグメント点灯

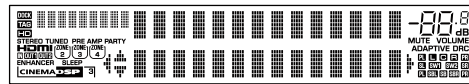

* After check, change to next menu at once.
確認後、すみやかに次のサブメニューを選択してください。

D1-4. CHECK PATTERN / チェックパターン

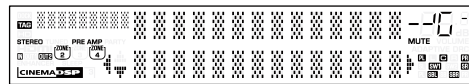

Lighting on segments in lattice. / セグメント格子状点灯



Short / ショート

Normal / 正常

Segment conditions of the FL driver and the FL tube are checked by turning ON and OFF all segments.

Next, the operation of the FL driver is checked by using the dimmer control.

Then a short between segments next to each other is checked by turning ON and OFF all segments alternately (in lattice).

(In the above example, the segments in the second row from the top are shorted.)

全セグメント消灯・全セグメント点灯により FL ドライバー、FL 管のセグメントの不良を確認します。

次に、ディマーコントロールによって FL ドライバーの動作チェックを行います。

さらに全セグメントを交互（格子状）に点灯／消灯することで、隣り合うセグメントのショートをチェックします。

（上記の例は、上から 2 列目のセグメントがショートしています。）

Z1. ZONE TEST

This menu is used to check audio signal route to ZONE 2 PRE OUT.

Z1. ZONE TEST

ZONE 2 PRE OUT へのオーディオ信号経路をチェックします。

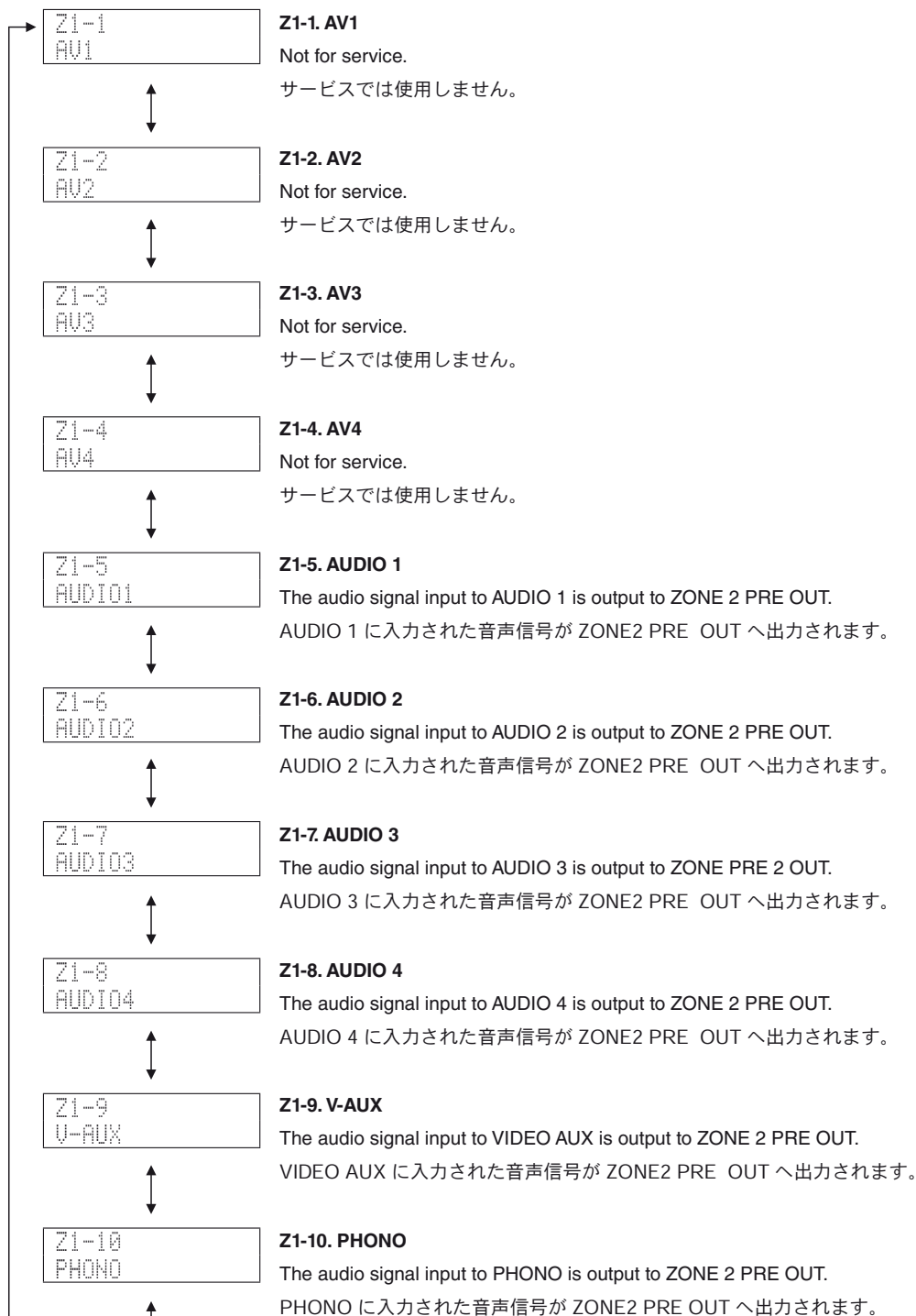

R1. SIRIUS (U model)

The SIRIUS information are displayed.

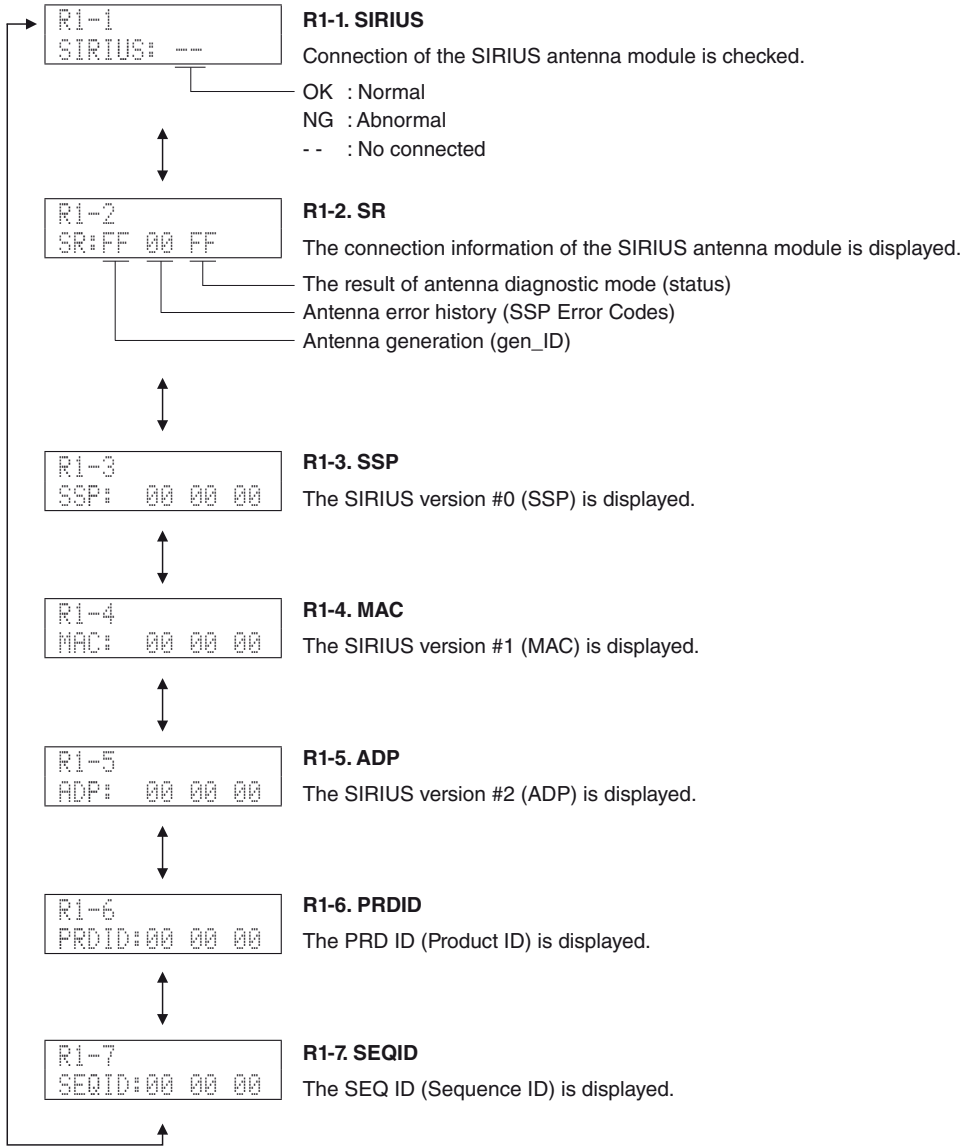

RX-V1067/HTR-8063/RX-A1000

U1. DOCK

This menu is used to check the DOCK connector without the iPod itself.

With the power to this unit turned off, short between pins No. 14 (TX) and No. 18 (RX), between pins No. 4 (iPDET) and No. 8 (DGND). Also, connect a 10 k-ohms, 1/4 W resistor between pins NO. 21 (DKID) and No. 8 (DGND). (Make sure that the power is turned off when shorting pins.)

Start up the self-diagnostic function and select this menu.

The check result is displayed according to the following display specifications.

Note) Be sure to return the shorted pins to their original condition after executing this test.

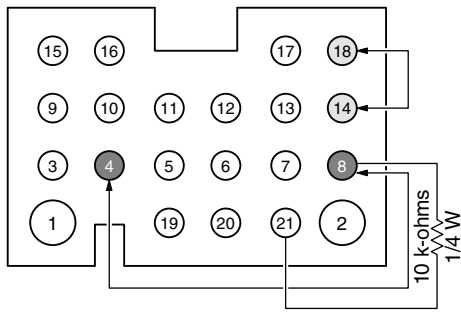

DOCK CONNECTOR

U1. DOCK

iPod 本体無しで、DOCK コネクタの検査を行うメニューです。

本機の電源を切った状態で、DOCK コネクタの 14 ピン (TX) と 18 ピン (RX)、4 ピン (iPDET) と 8 ピン (DGND) をショートさせます。また、21 ピン (DKID) と 8 ピン (DGND) の間に 10 k Ω、1/4 W 抵抗を接続します。(ショートさせる時は、必ず電源を切ってください。)

ダイアグを起動して本メニューを選択します。

下記表示仕様に従って、チェック結果が表示されます。

注意) 検査後、ショートしたピンを必ず元の状態に戻してください。

U1-1
DOCK: NG NNNN

Check item / チェック項目	Result / 結果		Display / 表示
UART loop back test UART ループバックテスト	OK		Y
	NG		N
DOCK_AP (iPod accessory power) detection DOCK AP (iPod accessory power) 検出	-	High = YES	Y
		Low = No	N
DOCK_PON (iPod installation to DOCK) detection DOCK PON (iPod installation to DOCK) 検出	IC904 pin No. 9	Low = installed / 装着	Y
		High = not installed / 非装着	N
DOCK_N_DET (DOCK ID) detection DOCK_N_DET (DOCK ID) 検出	IC908 pin No. 34	10 k-ohms, 1/4 W pull down	Y
		Other	N

U2. USB

This menu is used to check audio signal route of USB.

U2-1. VNP2 TEST 1kHz

The built-in noise generator of VNP2 (IC504 of the NET P.C.B.) outputs the 1 kHz test tone.

U2. USB

USB のオーディオ信号経路をチェックします。

U2-1. VNP2 TEST 1kHz

VNP2 (NET P.C.B. の IC504) 内蔵のノイズ発生回路によって、1 kHz のテストトーンが出力されます。



Signal path of test tone output / テストトーン出力の信号経路

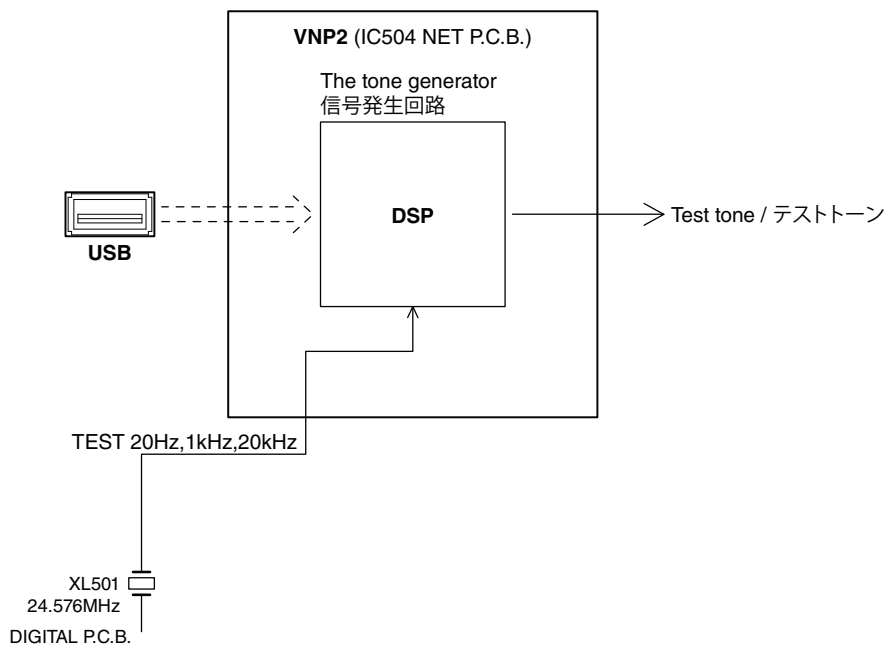

U2-2. VNP2 TEST 20Hz

The built-in noise generator of VNP2 (IC504 of the NET P.C.B.) outputs the 20 Hz test tone.

U2-2. VNP2 TEST 20Hz

VNP2 (NET P.C.B. の IC504) 内蔵のノイズ発生回路によって、20 Hz のテストトーンが出力されます。

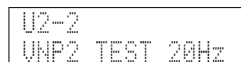

U2-3. VNP2 TEST 20kHz

The built-in noise generator of VNP2 (IC504 of the NET P.C.B.) outputs the 20 kHz test tone.

```
U2-3
VNP2 TEST 20k
```

U2-3. VNP2 TEST 20kHz

VNP2 (NET P.C.B. の IC504) 内蔵のノイズ発生回路によって、20 kHz のテストトーンが出力されます。

U2-4. USB FRONT 1 TRACK

The music file stored in the USB storage device is reproduced.

- a. Copy 2 or more music files from PC to the root folder of the USB storage device.
- b. Insert the USB storage device to the USB terminal of this unit.

The 1st music file stored in the USB storage device connected to the USB terminal is reproduced.

```
U2-4
USB F 1 TRACK
```

U2-4. USB FRONT 1 TRACK

USB フラッシュメモリーに記録された音楽ファイルを再生します。

- a. USB フラッシュメモリーのルートフォルダに(PC から)音楽ファイルを2曲以上コピーします。
- b. USB フラッシュメモリーを本機のUSB端子に接続します。

USB端子に接続されたUSBフラッシュメモリーの音楽ファイルの1曲目が再生されます。

U2-5. USB FRONT 2 TRACK

The 2nd music file stored in the USB storage device connected to the USB terminal is reproduced.

```
U2-5
USB F 2 TRACK
```

U2-5. USB FRONT 2 TRACK

USB端子に接続されたUSBフラッシュメモリーの音楽ファイルの2曲目が再生されます。

U3. INVALID ITEM

Not for service.

```
U3-1
INVALID ITEM
```



U3. INVALID ITEM

サービスでは使用しません。

```
U3-2
INVALID ITEM
```

N1. NETWORK

This menu is used to check signal route of NETWORK.

- * When the network condition varies while sub-menu is displayed (e.g., the network is deactivated once), the correct result will not be displayed. In that case, once turn off the power to this unit, then start up the self-diagnostic function again and select this menu.

N1-1. IP ADDRESS CHECK

IP address obtained is checked.

```
N1-1
IP AD CHECK:NG
```

N1. NETWORK

ネットワークの信号経路をチェックします。

- ※ サブメニュー表示中にネットワークの状態が変わると（たとえばネットワークが一時切れるなど）正しい結果が表示されません。その場合、一度本機の電源を切り、ダイアグを再起動して本メニューを選択します。

N1-1. IP ADDRESS CHECK

IP アドレスの取得状態をチェックします。

- OK: Connected (IP address obtained)
接続 (IP アドレス取得完了)
- NG: No traffic / Unconnected
通信不能 / 未接続

N1-2. MAC ADDRESS CHECK

MAC address information is checked.

```
N1-2
MAC AD CHK:OK
```

N1-2. MAC ADDRESS CHECK

MAC アドレス情報をチェックします。

- OK: Normal / 正常
- NG: Unwritten / 書き込まれていない

N1-3. LINK CHECK

LAN cable connection is checked.

```
N1-3
LINK CHK:OK
```

N1-3. LINK CHECK

LAN ケーブルの接続状態をチェックします。

- OK: Normal / 正常
- NG: Unconnected / 未接続

N1-4. EXT TEST

This menu is used to check the NETWORK connector.

With the power to this unit turned off, short between pins No. 1 (Tx+) and No. 3 (Rx+) and between pins No. 2 (Tx-) and No. 6 (Rx-) of the NETWORK connector.

(Be sure to turn off the power to this unit when shorting these pins.)

Start up the self-diagnostic function and select this menu.

Note) Be sure to return the shorted pins to their original condition after executing this test.

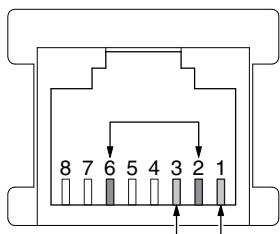

NETWORK connector

N1-4. EXT TEST

NETWORK コネクタの送受信テストを行います。

本機の電源を切った状態で、NETWORK コネクタの1ピン (Tx+) と3ピン (Rx+)、2ピン (Tx-) と6ピン (Rx-) をショートさせます。

(ショートさせるときは必ず本機の電源を切ってください。)

ダイアグを起動して本メニューを選択します。

注意) 検査後、ショートしたピンを必ず元の状態に戻してください。

```
N1-4
EXT TEST:OK
```

OK: Normal / 正常
NG: Abnormal / 異常

N1-5. PHY TEST

Communication and bus line connection between PHY (IC513) and VNP2 (IC504) are checked.

N1-5. PHY TEST

PHY (IC513) と VNP2 (IC504) の通信・バスラインの接続をチェックします。

```
N1-5
PHY TEST:OK
```

OK: No error detected / 不良検出なし
NG: An error is detected / 不良検出あり

N1-6. LINE NOISE 10

Not for service.

N1-6. LINE NOISE 10

サービスでは使用しません。

```
N1-6
LINE NOISE 10
```

N1-7. LINE NOISE 100

Not for service.

N1-7. LINE NOISE 100

サービスでは使用しません。

```
N1-7
LINE NOISE 100
```

N1-8. I2C EEPROM

The Read check of EEPROM (IC506) is executed.

N1-8. I2C EEPROM

EEPROM (IC506) の読み出しをチェックします。

```
N1-8
I2C-EEPROM:OK
```

OK: No error detected / 不良検出なし
NG: An error is detected / 不良検出あり

N1-9. RAM BUS

Communication and bus line connection between RAM (IC501, IC503) and VNP2 (IC504) are checked.

N1-9. RAM BUS

RAM (IC501、IC503) と VNP2 (IC504) の通信・バスラインの接続をチェックします。

```
N1-9
RAM BUS:OK
```

N1-10. INVALID ITEM

Not for service.

N1-10.INVALID ITEM

サービスでは使用しません。

```
N1-10
INVALID ITEM
```

N1-11. SYNC SERIAL

Communication and bus line connection between microprocessor (IC908) and VNP2 (IC504) are checked.

N1-11.SYNC SERIAL

マイコン (IC908) と VNP2 (IC504) の通信・バスラインの接続をチェックします。

```
N1-11
SYNC SERIAL:OK
```

OK: No error detected / 不良検出なし
NG: An error is detected / 不良検出あり

N1-12. MAC ADDRESS

The MAC address is displayed.

N1-12.MAC ADDRESS

MAC アドレスが表示されます。

```
N1-12
00A0DE710077
```

C1. DIGITAL P.C.B. CHECK

This menu is used to check the communication and bus line connection between devices on the DIGITAL P.C.B..

C1-1. ALL

The synthetic judgment result is displayed.

OK : No error detected
NG : An error is detected

```
C1-1
ALL:OK
```

C1-2. BUS FLASH ROM

Reading/writing FLASH ROM (IC951) are checked.

OK : No error detected
NG : An error is detected

```
C1-2
BUS_FLASH:OK
```

C1-3. BUS FPGA

Communication and bus line connection between microprocessor (IC908) and FPGA (IC64) are checked.

OK : No error detected
NG : An error is detected

```
C1-3
BUS_FPGA:OK
```

C1. DIGITAL P.C.B. CHECK

DIGITAL P.C.B.の各デバイス間の通信・バスラインの接続をチェックします。

C1-1. ALL

総合判定結果を表示します。

OK : 不良検出なし
NG : 不良検出あり

C1-2. BUS FLASH ROM

FLASH ROM (IC951) の読み出し・書き込みをチェックします。

OK : 不良検出なし
NG : 不良検出あり

C1-3. BUS FPGA

マイコン (IC908) と FPGA (IC64) の通信・バスラインの接続をチェックします。

OK : 不良検出なし
NG : 不良検出あり

C1-4. I2C

The I2C (Inter integrated route) bus line connection is checked.

- 0 : No error detected
- 1 : An error is detected

C1-4. I2C

I2C (Inter integrated route) バスラインの接続をチェックします。

- 0 : 不良検出なし
- 1 : 不良検出あり

```
C1-4
I2C:00000000-0
```

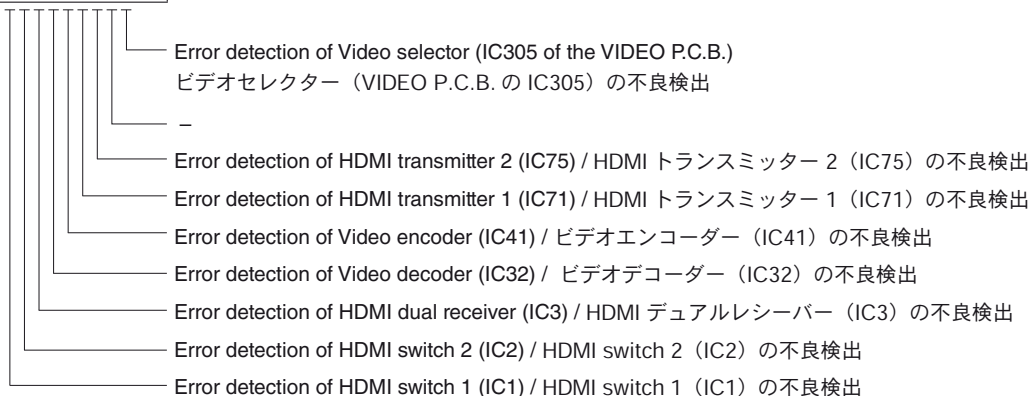

C1-5. FPGA RAM

Reading/writing SDRAM (IC62) are checked.

- OK : No error detected
- NG : An error is detected

C1-5. FPGA RAM

SDRAM (IC62) の読み出し・書き込みをチェックします。

- OK : 不良検出なし
- NG : 不良検出あり

```
C1-5
FPGA_RAM:OK
```

C1-6. BUS DIR

Communication and bus line connection between microprocessor (IC908) and DIR (IC42) are checked.

- OK : No error detected
- NG : An error is detected

C1-6. BUS DIR

マイコン (IC908) と DIR (IC42) の通信・バスラインの接続をチェックします。

- OK : 不良検出なし
- NG : 不良検出あり

```
C1-6
DIR_BUS:OK
```

C1-7. BUS DSP1

Communication and bus line connection between microprocessor (IC908) and DSP1 (IC45) are checked.

- OK : No error detected
- NG : An error is detected

```
C1-7
DSP1 BUS:OK
```

C1-7. BUS DSP1

マイコン (IC908) と DSP1 (IC45) の通信・バスラインの接続をチェックします。

- OK : 不良検出なし
- NG : 不良検出あり

C1-8. EEPROM

Reading EEPROM (IC903) is checked.

- OK : No error detected
- NG : An error is detected

```
C1-8
EEPROM:OK
```

C1-8. EEPROM

EEPROM (IC903) の読み出しをチェックします。

- OK : 不良検出なし
- NG : 不良検出あり

C1-9. RS-232C LOOPBACK TEST

Transmission of the RS-232C terminal is checked. "OK" appears when the data is transmitted properly and "NG" when it is not.

With the power to this unit turned off, short between pins No. 2 (RxD) and No. 3 (TxD) of the RS-232C terminal.

(Be sure to turn off the power when shorting the pins.)

Start up the self-diagnostic function and select this menu.

```
C1-9
232C DATA:OK
```

C1-9. RS-232C LOOPBACK TEST

RS-232C 端子の送受信チェックを行います。正常に送受信完了した場合、“OK” と表示します。正常に送受信しなかった場合は“NG” と表示します。

本機の電源を切った状態で、RS232C 端子の 2 ピン (RxD) と 3 ピン (TxD) をショートさせます。

(ショートさせるときは必ず電源を切ってください。)

ダイアグを起動して本メニューを選択します。

RS-232C terminal

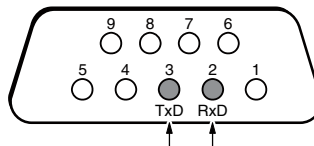

C1-10. BUS NPGA

Communication and bus line connection between microprocessor (IC908) and DSP1 (IC931) are checked.

- OK : No error detected
- NG : An error is detected

```
C1-10
BUS NPGA:OK
```

C1-10. BUS NPGA

マイコン (IC908) と NPGA (IC931) の通信・バスラインの接続をチェックします。

- OK : 不良検出なし
- NG : 不良検出あり

C2. HDMI INFORMATION

This menu is used to display information about HDMI.

C2-1. HDMI model name

The model name of this unit written in HDMI module is displayed.

RX-V1067
HTR-8063
RX-A1000

```
C2-1  
HMN:RX-V1067
```

C2-2. HDMI product ID

The product ID of this unit written in HDMI module is displayed.

RX-V1067 : 314F
HTR-8063 : 3150
RX-A1000 : 3151

```
C2-2  
HID:314F
```

C2. HDMI INFORMATION

HDMI に関する情報が表示されます。

C2-1. HDMI model name

HDMI モジュールに書き込まれている本機モデル名が表示されます。

RX-V1067
HTR-8063
RX-A1000

C2-2. HDMI product ID

HDMI モジュールに書き込まれている本機のプロダクト ID が表示されます。

RX-V1067 : 314F
HTR-8063 : 3150
RX-A1000 : 3151

V1. ANALOG VIDEO CHECK

This menu is used to check the analog video signal route.

V1-1. ANALOG BYPASS

The video signal is converted and output as shown below.

V1. ANALOG VIDEO CHECK

アナログ映像信号の経路をチェックします。

V1-1. ANALOG BYPASS

映像信号が以下のように変換され、出力されます。

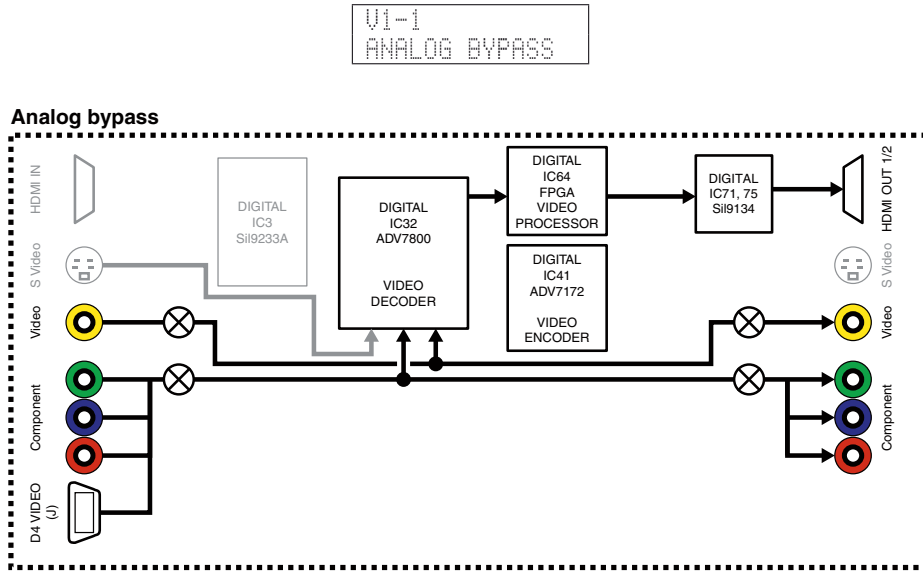

V1-2. DIGITAL BYPASS

The video signal is converted and output as shown below.

V1-2. DIGITAL BYPASS

映像信号が以下のように変換され、出力されます。

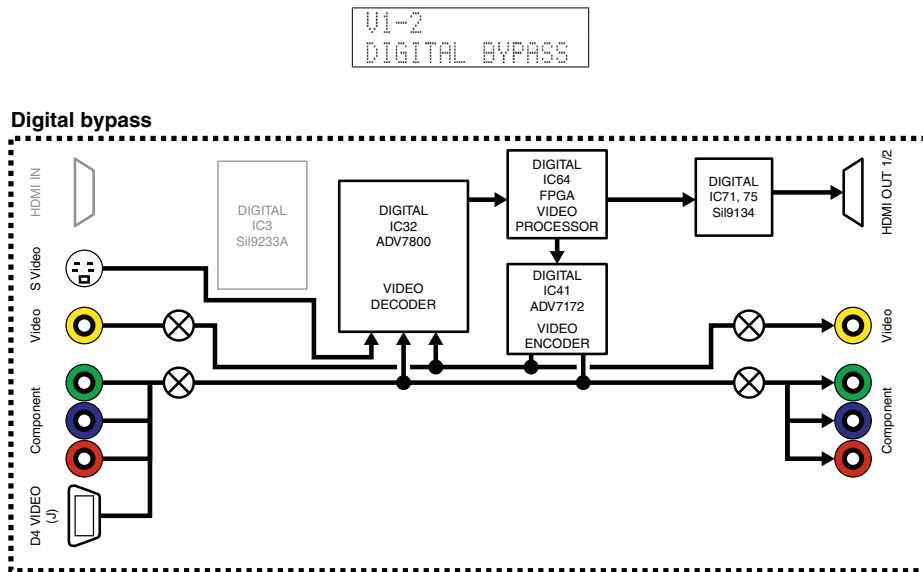

RX-V1067/HTR-8063/
RX-A1000

V1-3. ZONE BYPASS

Not for service.



V1-3. ZONE BYPASS

サービスでは使用しません。

V1-4. MUTE CHECK

The video signal is muted.

MUTE signals "VID_N_MMT" (8 pin), "CPNT_N_VMT" (12 pin) and "VID_N_RMT" (17 pin) are output from the IC of the VIDEO P.C.B..



V1-4. MUTE CHECK

映像信号がミュートされます。

VIDEO P.C.B. の IC308 から MUTE 信号 "VID_N_MMT" (8 pin)、"CPNT_N_VMT" (12 pin)、"VID_N_RMT" (17 pin) が出力されます。

V1-5. TEST PATTERN

The test pattern is output from video encoder (IC41 of the DIGITAL P.C.B.).



V1-5. TEST PATTERN

ビデオエンコーダー (DIGITAL P.C.B. の IC41) からテストパターンが出力されます。

Test pattern

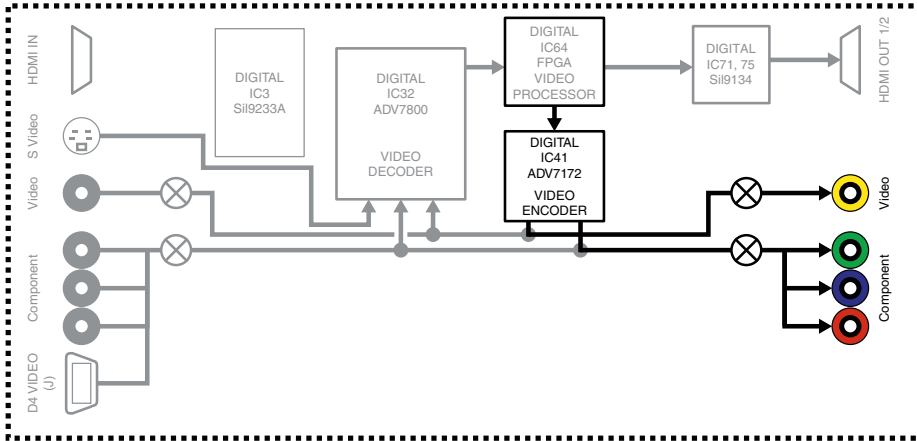

Test pattern

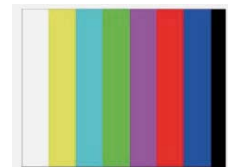

V1-6. VIDEO INFORMATION

The information of input analog video signals is displayed.



V1-6. VIDEO INFORMATION

入力されているアナログ映像信号の情報が表示されます。

V2. DIGITAL VIDEO CHECK

This menu is used to check the digital video signal route. Before checks using sub-menu V2-1 and V2-2, connect between HDMI OUT and HDMI IN terminals of this unit with an HDMI cable in advance.

V2-1. LOOPBACK TEST 1

The video signal route as shown below is checked automatically and result (OK or NG) is displayed.

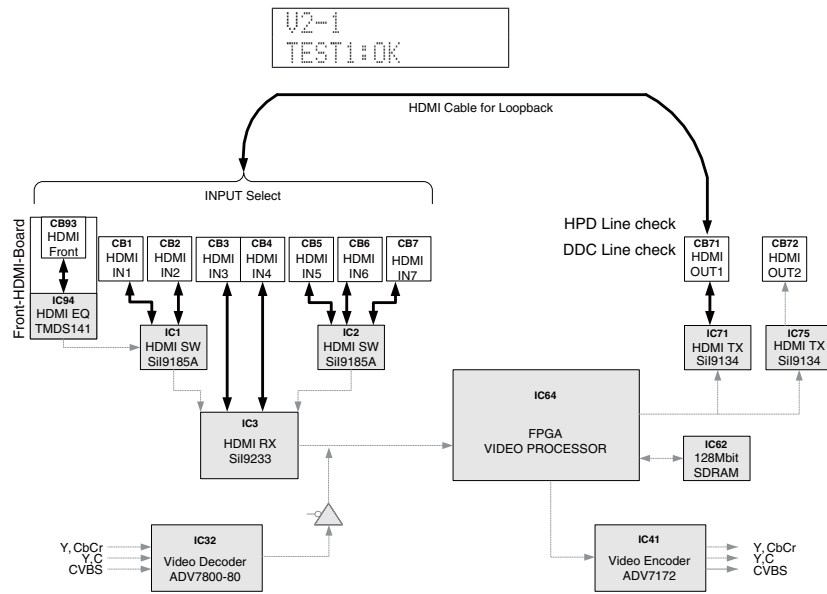

V2. DIGITAL VIDEO CHECK

デジタル映像信号の経路をチェックします。

サブメニュー V2-1、V2-2 でのチェックの前に、あらかじめ本機の HDMI OUT 端子と IN 端子間を HDMI ケーブルで接続してください。

V2-1. LOOPBACK TEST 1

以下に示す映像信号経路が自動的にチェックされ、その結果 (OK または NG) が表示されます。

V2-2. LOOPBACK TEST 2

The video signal route as shown below is checked automatically and result (OK or NG) is displayed.

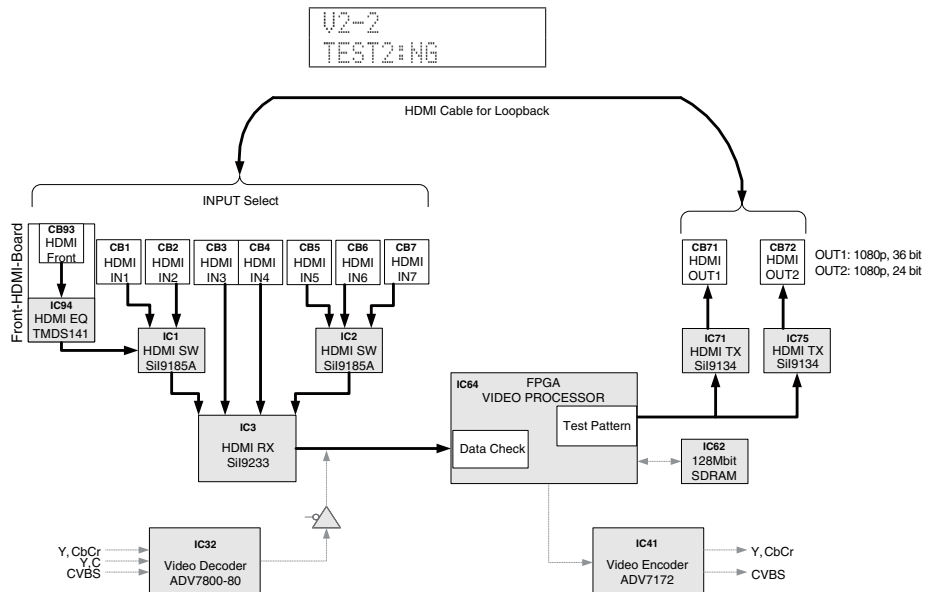

V2-2. LOOPBACK TEST 2

以下に示す映像信号経路が自動的にチェックされ、その結果 (OK または NG) が表示されます。

RX-V1067/HTR-8063/RX-A1000

V2-3. LOOPBACK TEST 3

Not for service.



V2-3. LOOPBACK TEST 3

サービスでは使用しません。

V2-4. HDMI REPEAT

* Before check using sub-menu V2-4, disconnect the HDMI cable connected between HDMI OUT and HDMI IN terminals of this unit.

The video/audio signals input to HDMI IN terminal are output to HDMI OUT terminal.

V2-4. HDMI REPEAT

※ サブメニュー V2-4 でのチェックの前に、本機の HDMI OUT 端子と IN 端子間に接続されている HDMI ケーブルを外します。

HDMI IN 端子から入力された映像信号と音声信号が HDMI OUT 端子へ出力されます。

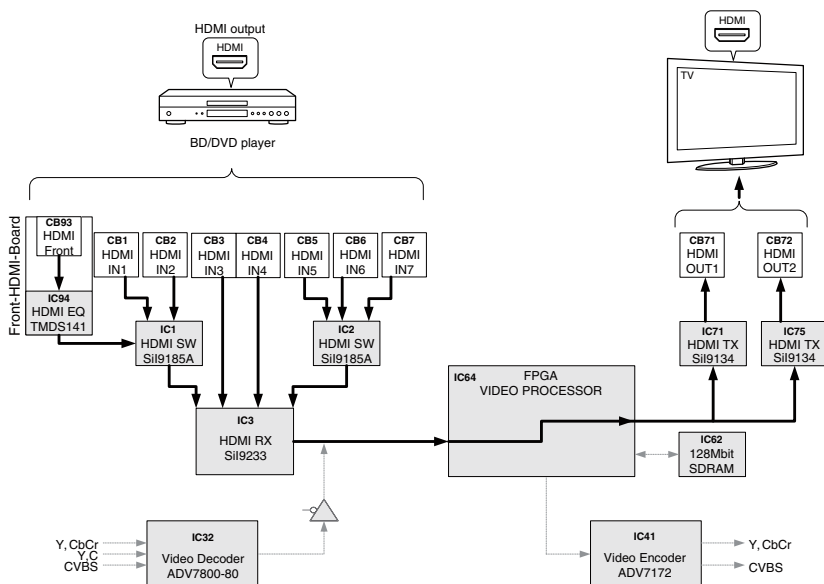

V2-5. DIGITAL CVBS

The video (CVBS) signal is converted and output as shown below.

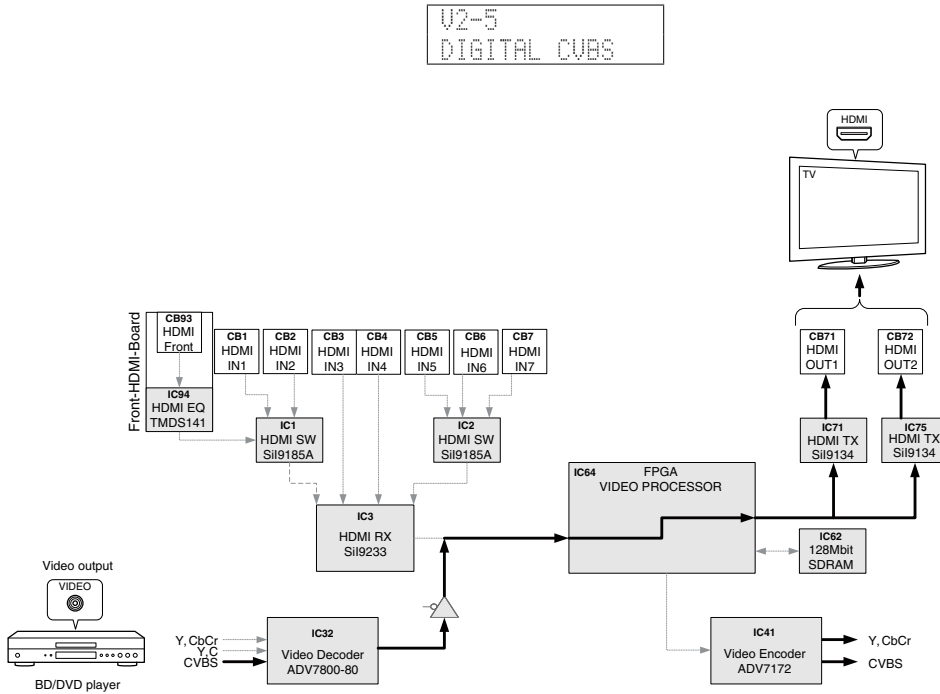

V2-5. DIGITAL CVBS

映像信号が以下のように変換され、出力されます。

V2-5
DIGITAL CVBS

V2-6. DIGITAL Y/C

The s-video (Y, C) signal is converted and output as shown below.

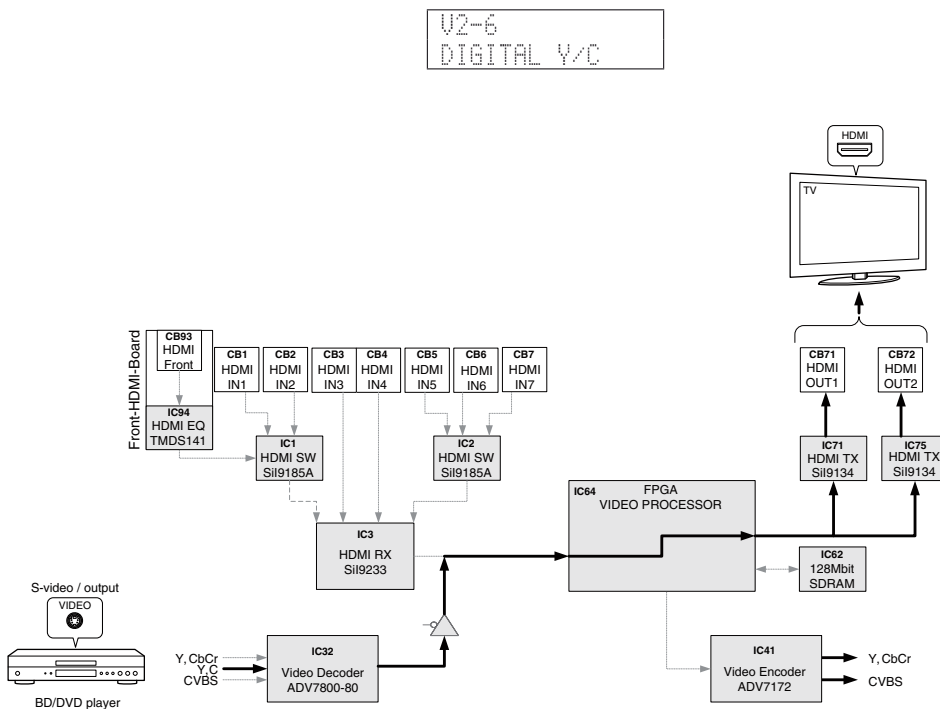

V2-6. DIGITAL Y/C

映像信号が以下のように変換され、出力されます。

V2-6
DIGITAL Y/C

RX-V1067/HTR-8063/RX-A1000

V2-7. DIGITAL COMPONENT

The component video (Y, Cb, Cr) signal is converted and output as shown below.

V2-7. DIGITAL COMPONENT

映像信号が以下のように変換され、出力されます。

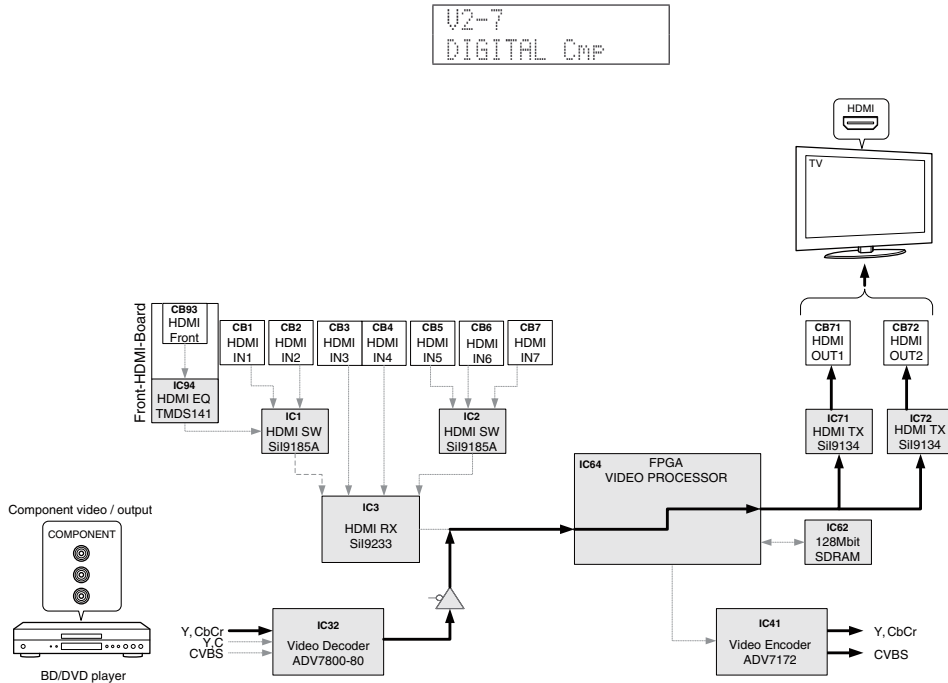

V2-8. DIGITAL COMPONENT SC

The component video (Y, Cb, Cr) signal is converted and output as shown below.

HDMI video output up-scaling: 480i/p, 576i/p => 1080p

V2-8. DIGITAL COMPONENT SC

映像信号が以下のように変換され、出力されます。

アップスケーリング：480i/p、576i/p => 1080p

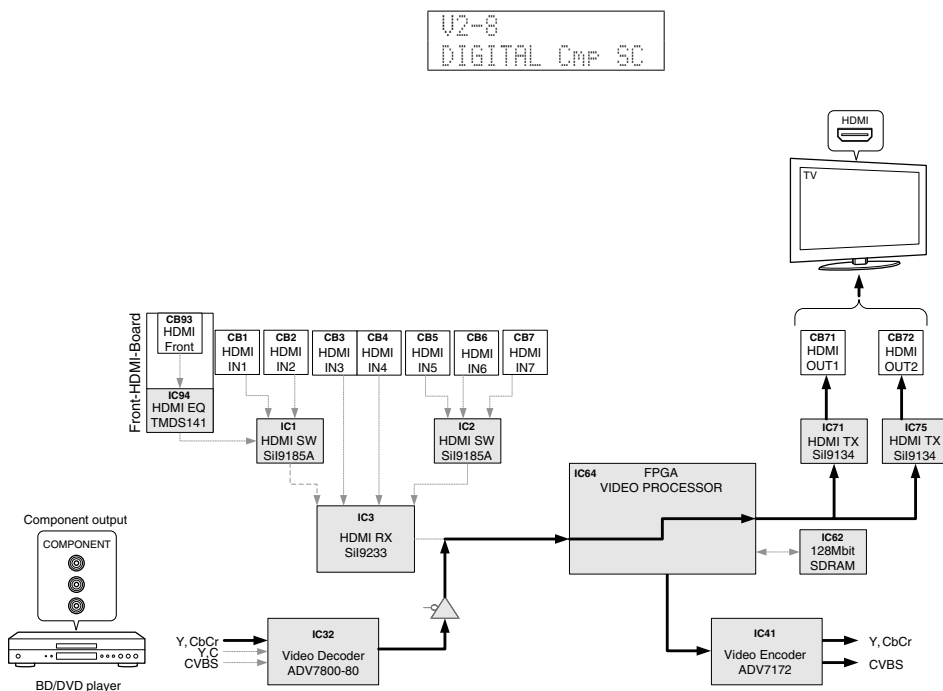

V2-9. GUI-VIDEO OUT

The GUI from FPGA (IC64 of the DIGITAL P.C.B.) is output.

V2-9. GUI-VIDEO OUT

FPGA (DIGITAL P.C.B. の IC64) から GUI が出力されます。

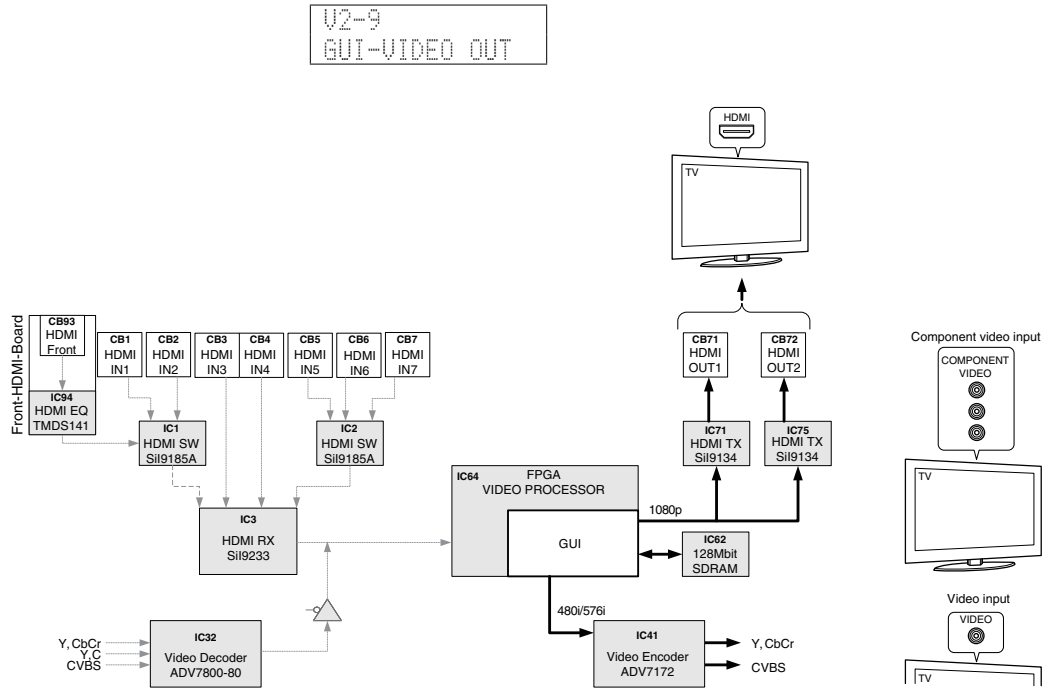

P1. SYSTEM MONITOR

This menu is used to display the A/D conversion value of the microprocessor which detects panel keys of this unit and protection functions by using the sub-menu.

When "P1-7. KEY1/KEY2" sub-menu is selected, keys become non-operable due to detection of the values of all keys. However, it is possible to advance to the next sub-menu by pressing the "SCENE 4" (forward) or "SCENE 3" (reverse) key of the remote control.

* Numeric values in the figure are given as reference only.

P1-1. DC

DC: Power amplifier DC (DC voltage) output is detected.
The voltage at 1 pin (DC_PRT) of IC902 is displayed.
Normal value: 35 to 68
(Reference voltage: 3.3 V=255)

* If DC becomes out of the normal value range, the protection function works to turn off the power.

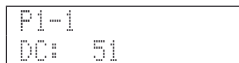

P1. SYSTEM MONITOR

本機パネルキー、プロテクションなどを検出しているマイコンの A/D 変換値を、サブメニューで表示します。

サブメニュー "P1-7. KEY1/KEY2" にすると、全キーの値を検出するためキー操作はできなくなりますが、リモコンの "SCENE 4" (順送り) または "SCENE 3" (逆送り) キーを押すことにより、次のサブメニューに進めることができます。

※ 図中の数値は参考例です。

P1-1. DC

DC: パワーアンプ DC (直流電圧) 出力の検出
IC902 の 1 ピン (DC_PRT) の電圧が表示されます。
正常値: 35 ~ 68
(基準電圧: 3.3 V=255)

※ DC が正常値を外れるとプロテクションが働き、電源が切れます。

P1-2. PS1/PS2

Power supply voltage protection detection
The voltage at 2 pin (PS1_PRT)/1 pin (PS2_PRT) of IC902 are displayed.

Voltage detects

PS1: +3.3s, ACBL, ACM1, ACM2, +5, DCDC, -3.3V, +3.3HDR (U model)

PS2: ±12A, ±12RY, +5A, +44V, +5DK

Normal value

PS1: 84 to 141 (Nomal), 132 to 190 (PURE DIRECT)

PS2: 81 to 153
(Reference voltage: 3.3 V=255)

* If PS1 or PS2 becomes out of the normal value range, the protection function works to turn off the power.

```
P1-2
PS: 114 / 119
```

P1-3. TM1/TM2

TM: Temperature of the heatsink is detected.
The voltage at 2 pin (TMH1)/4 pin (THM2) of IC902 is displayed.

Normal value

TM1: 116 to 255

TM2: 116 to 255

(Reference voltage: 3.3 V=255)

* If TM becomes out of the normal value range, the protection function works to turn off the power.

```
P1-3
TM: 103 / 103
```

P1-4. OUTPUT LEVEL

Output level of speaker output is detected.
The voltage at 4 pin (AMP_OLV) of IC901 is displayed.

(Reference voltage: 3.3 V=255)

```
P1-4
OUTLVL: 0
```

P1-2. PS1/PS2

電源電圧プロテクションの検出
IC901 の 2 ピン (PS1_PRT) / 1 ピン (PS2_PRT) の電圧が表示されます。

検出電圧

PS1: +3.3s, ACBL, ACM1, ACM2, +5, DCDC, -3.3V

PS2: ±12A, ±12RY, +5A, +44V, +5DK

正常値

PS1: 84 ~ 141 (通常) 132 ~ 190 (PURE DIRECT)

PS2: 81 ~ 153
(基準電圧: 3.3 V=255)

※ PS1 または PS2 が正常値を外れるとプロテクションが働き、電源が切れます。

P1-3. TM1/TM2

TM: ヒートシンク温度の検出
IC902 の 2 ピン (TMH1) / 4 ピン (THM2) の電圧が表示されます。

正常値

TM1: 116 ~ 255

TM2: 116 ~ 255

(基準電圧: 3.3 V=255)

※ TM が正常値を外れるとプロテクションが働き、電源が切れます。

P1-4. OUTPUT LEVEL

スピーカー出力の出力レベルの検出
IC901 の 4 ピン (AMP_OLV) の電圧が表示されます。

(基準電圧: 3.3 V=255)

P1-5. LIMITER CONTROL

Power limiter control is detected.
 The voltage at 4 pin (AMP_OLV) of IC901 is displayed.
 (Reference voltage: 3.3 V=255)



P1-5. LIMITER CONTROL

電源リミッター制御の検出
 IC901 の 4 ピン (AMP_OLV) の電圧が表示されます。
 (基準電圧：3.3 V=255)

P1-6. L3 (J model)

Not for service.



P1-6. L3 (J model)

D 端子の L3 レベルの検出
 IC901 の 13 ピン (L3_DET) の電圧が表示されます。
 (基準電圧：3.3 V=255)

P1-7. KEY1/KEY2

Panel key of this unit is detected.
 When the A/D conversion value of the panel key becomes out of the specified range, normal operation will not be available.
 In that case, check the constant of voltage dividing resistor, solder condition, etc. Refer to table.
 * When “P1-7. KEY1/KEY2” sub-menu is selected, keys become non-operable due to detection of the values of all keys. However, it is possible to advance to the next sub-menu by pressing the “SCENE 4” (forward) or “SCENE 3” (reverse) key of the remote control.
 (Reference voltage: 3.3 V=255)

P1-7. KEY1/KEY2

本機パネルキーの検出
 パネルキーの A/D 値が規定範囲から外れると、正常な動きをしません。
 下表をご覧になり、各キーの分圧抵抗の定数、ハンダ不良等の確認をしてください。
 ※ サブメニュー “P1-7. KEY1/KEY2” にすると、全キーの値を検出するためキー操作はできなくなりますが、リモコンの “SCENE 4” (順送り) または “SCENE 3” (逆送り) キーを押すことにより、次のサブメニューに進めることができます。
 (基準電圧：3.3 V=255)

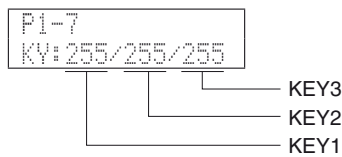

Display / 表示	KY_AD1
0 - 9	SCENE 4
10 - 27	SCENE 3
28 - 44	SCENE 2
45 - 63	SCENE 1
64 - 83	ZONE2 CONTROL
119 - 137	MAIN ZONE ⏪
255	Key off

Display / 表示	KY_AD2
0 - 9	STRAIGHT
10 - 27	TONE BALANCE
28 - 44	OPTION
45 - 63	△
64 - 83	ON SCREEN
84 - 100	<
101 - 118	ENTER
119 - 137	>
138 - 155	PROGRAM <
156 - 173	PROGRAM >
174 - 191	DISPLAY
192 - 209	▽
210 - 227	RETURN
255	Key off

Display / 表示	KY_AD3
0 - 9	PRESET >
10 - 27	PRESET <
28 - 44	MEMORY
45 - 63	INFO
64 - 83	ZONE CONTROLS
84 - 100	FM
101 - 118	AM
119 - 137	TUNING/CH <<
138 - 155	TUNING/CH >>
156 - 173	PURE DIRECT
255	Key off

P2. PROTECTION HISTORY

This menu is used to display the history of protection function.

All history of protection function will be erased by pressing the "STRAIGHT" key.

* Numeric values in the figure are given as reference only.

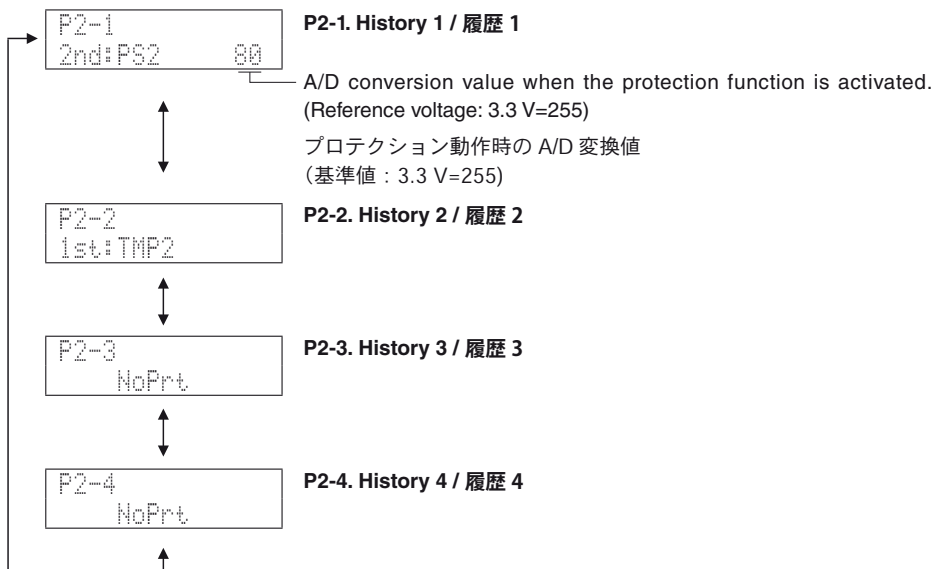

P2. PROTECTION HISTORY

プロテクション履歴が表示されます。

“STRAIGHT” キーを押すとプロテクション履歴はすべて消去されます。

※ 図中の数値は参考例です。

S1. F/W UPDATE

Not for service.



S1. F/W UPDATE

サービスでは使用しません。

S2. SET INFORMATION

The model name and destination are displayed.

S2-1. MODEL

The model name of this unit is displayed.

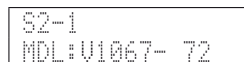

A/D conversion value / A/D 変換値
 Model name / モデル名
 V1067 : RX-V1067
 H8063 : HTR-8063
 A1000 : RX-A1000

S2. SET INFORMATION

モデル名、仕向け先が表示されます。

S2-1. MODEL

本機のモデル名が表示されます。

Model name	RX-V1067	RX-A1000	HTR-8063
A/D conversion value (3.3 V=255)	59-81	82-103	104-127

S2-2. DESTINATION

The destination of this unit is displayed.

S2-2. DESTINATION

本機の仕向け先が表示されます。



A/D conversion value / A/D 変換値
Destination / 仕向け先

Destination	J	U	C	R	T	K	A	B, G, F	L
A/D conversion value (3.3 V=255)	0 - 12	13 - 40	41 - 67	68 - 92	93 - 115	116 - 140	141 - 169	199 - 221	222 - 244

S2-3. DEBUG

Not for service.

S2-3. DEBUG

サービスでは使用しません。

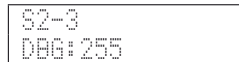

S3. FACTORY PRESET

This menu is used to reserve/inhibit initialization of the back-up IC (EEPROM: IC903 of the DIGITAL P.C.B.).

S3. FACTORY PRESET

バックアップ IC (EEPROM : DIGITAL P.C.B. の IC903) の初期化を予約/禁止します。

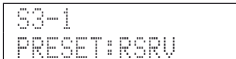
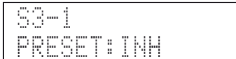

S3-1. PRESET INHIBIT (Initialization inhibited) / **PRESET INHIBIT** (初期化禁止)

Initialization of the back-up IC is not executed. Select this sub-menu to protect the values set by the user.
バックアップ用 IC の初期化は行われません。ユーザーの設定値を保護するときは、こちらを選択してください。

S3-1. PRESET RESERVED (Initialization reserved) / **PRESET RESERVED** (初期化予約)

Initialization of the back-up IC is reserved. (Actual initialization is executed the next time the power is turned on.) To reset to the original factory settings or to reset the backup IC, select this sub-menu and press the "MAIN ZONE 0" key to turn off the power. Any protection history also will be initialized at the same time.

ユーザーメモリの初期化が予約されます。(実際に初期化されるのは、次回の電源投入時です。)工場出荷時やユーザーメモリをリセットしたいときは、こちらを選択してから "MAIN ZONE 0" キーを押して電源を切ってください。このとき、プロテクション履歴も初期化されます。

CAUTION: Before setting to the PRESET RESERVED, write down the existing preset memory content of the tuner. (This is because setting to the PRESET RESERVED will cause the user memory content to be erased.)

注意: PRESET RESERVED を選んで初期化をする前に、チューナーのユーザーメモリーの内容を書き写してください。(初期化をすると、チューナーのユーザーメモリーの内容は消えてしまいます。)

S4. ROM VERSION/CHECKSUM

The firmware version and checksum values are displayed.

The checksum is obtained by adding the data at every 8-bit and expressing the result as a 4-figure hexadecimal notation.

* Numeric values in the figure are given as reference only.

S4. ROM VERSION/CHECKSUM

ファームウェアのバージョン、チェックサムが表示されます。

チェックサムは、データを8ビットごとに加算していき、4桁の16進数で表記したものです。

※ 図中の数値は参考例です。

S4-1
SYS-VER. 0.35

S4-1. SYSTEM VERSION

The firmware version of this unit is displayed.

本機のファームウェアのバージョンが表示されます。

S4-2
VER. B0038

S4-2. MICROPROCESSOR VERSION

The firmware version of MICROPROCESSOR (IC908 DIGITAL P.C.B.) is displayed.

マイコン (IC908 DIGITAL P.C.B.) のファームウェアのバージョンが表示されます。

S4-3
SUM. BD1D

S4-3. MICROPROCESSOR CHECKSUM

The checksum value of MICROPROCESSOR (IC908 DIGITAL P.C.B.) is displayed.

マイコン (IC908 DIGITAL P.C.B.) のチェックサムが表示されます。

S4-4
FR-V. 00058

S4-4. FLASH ROM VERSION

The firmware version of FLASH ROM (IC951 DIGITAL P.C.B.) is displayed.

FLASH ROM (IC951 DIGITAL P.C.B.) のファームウェアのバージョンが表示されます。

S4-5
FR-S. 4805

S4-5. FLASH ROM CHECKSUM

The checksum value of FLASH ROM (IC951 DIGITAL P.C.B.) is displayed.

FLASH ROM (IC951 DIGITAL P.C.B.) のチェックサムが表示されます。

S4-6
S-VER. -----

S4-6. VNP2 VERSION

Not for service.

サービスでは使用しません。

S4-7
S-SUM. -----

S4-7. VNP2 CHECKSUM

Not for service.

サービスでは使用しません。

S4-8
D1-V. 1.05r1

S4-8. DSP1 VERSION

The firmware version of DSP1 (IC945 DIGITAL P.C.B.) is displayed.

DSP1 (IC945 DIGITAL P.C.B.) のファームウェアのバージョンが表示されます。

S4-9
D1-S. AEC1D6E3

S4-9. DSP1 CHECKSUM

The checksum value of DSP1 (IC945 DIGITAL P.C.B.) is displayed.

DSP1 (IC945 DIGITAL P.C.B.) のチェックサムが表示されます。

S4-10
INVALID ITEM

S4-10. INVALID ITEM

Not for service.

サービスでは使用しません。

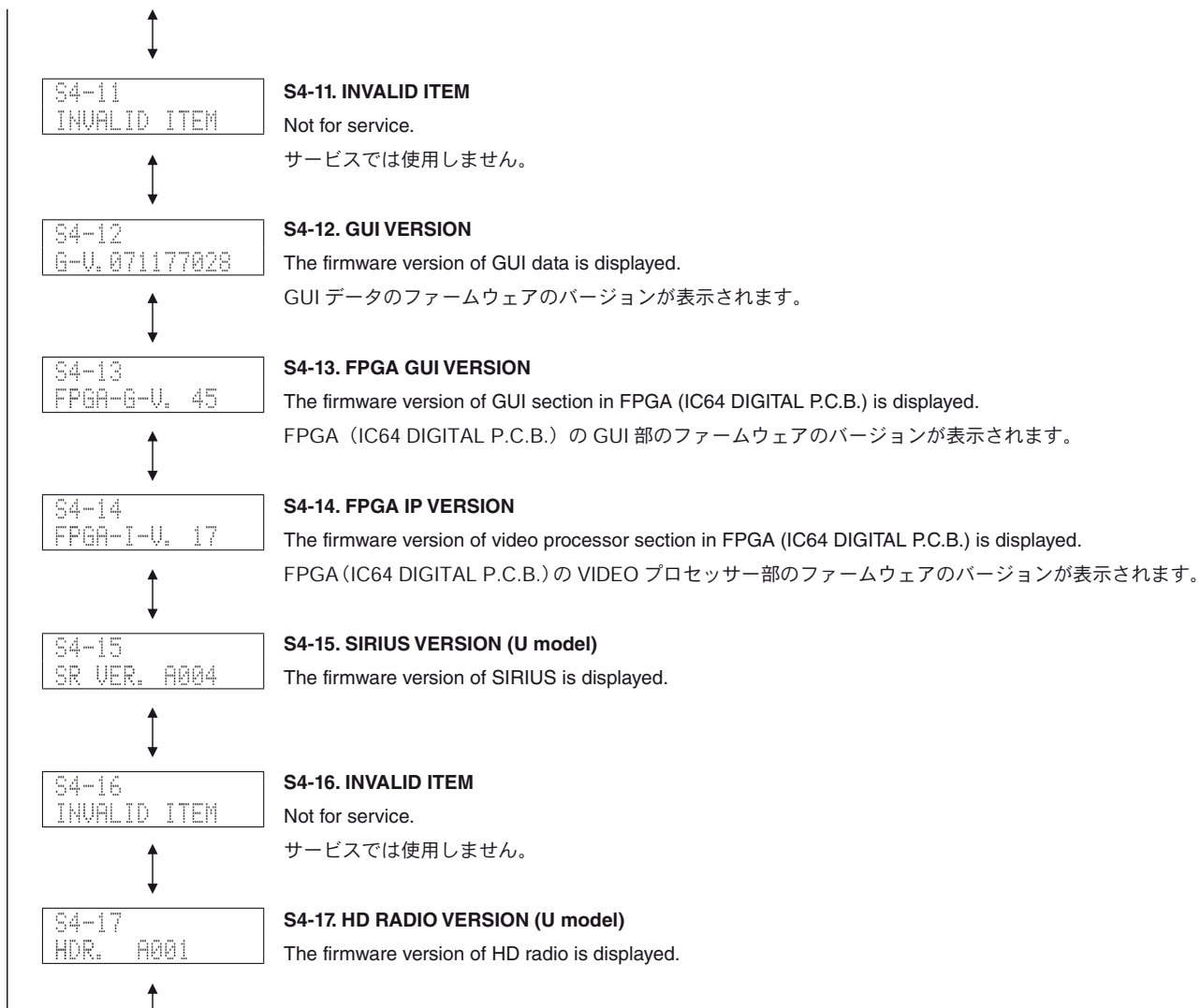

■ DISPLAY DATA

● V4001 : 23-MT-03GINK (OPERATION P.C.B.)

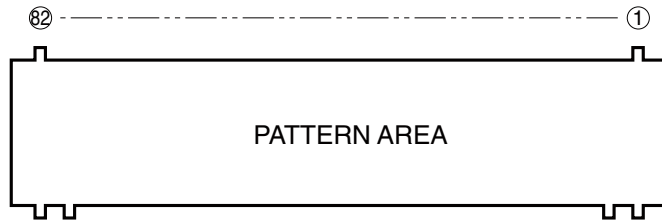

● PIN CONNECTION

Pin No.	82	81	80	79	78	77	76	75	74	73	72	71	70	69	68	67	66	65	64	63	62	61
Connection	F2	F2	NP	NP	NP	NP	LGND	PGND	VH	VDD	OSC	RESET	CS	CP	DA	TSA	TSB	NP	NP	NP	NP	NP

Pin No.	60	59	58	57	56	55	54	53	52	51	50	49	48	47	46	45	44	43	42	41	40	39	38	37	36	35	34	33	32	31
Connection	NP	NP	NP	NP	NP	NP	NP	NP	NP	NP	NP	NP	NP	NP	NP	NP	NP	NP	NP	NP	NP	NP	NP	NP	NP	NP	NP	NP	NP	NP

Pin No.	30	29	28	27	26	25	24	23	22	21	20	19	18	17	16	15	14	13	12	11	10	9	8	7	6	5	4	3	2	1
Connection	NP	NP	NP	NP	NP	NP	NP	NP	NP	NP	NP	NP	NP	NC	NC	NC	NC	NC	NC	NC	NC	Q23G	23G	NP	NP	NP	NP	NP	F1	F1

Note : 1) F1, F2 Filament pin 2) NP No pin 3) DL Datum line pin 4) LGND Logic GND pin 5) PGND Power GND pin
 6) HV High voltage supply pin 7) VDD Logic voltage supply pin 8) OSC Pin for self-oscillation 9) RESET Reset input
 10) CS Chip select input pin 11) CP Shift resist clock 12) DA Serial data input 13) TSA,B Test pin
 14) Solder composition is Sn-3Ag-0.5Cu. 15) Field of vision is a minimum of 25.0° from the upper side. 22.8° from the lower side.
 16) 23G Grid 17) Q23G Driver output port 18) NC No connection

● GRID ASSIGNMENT

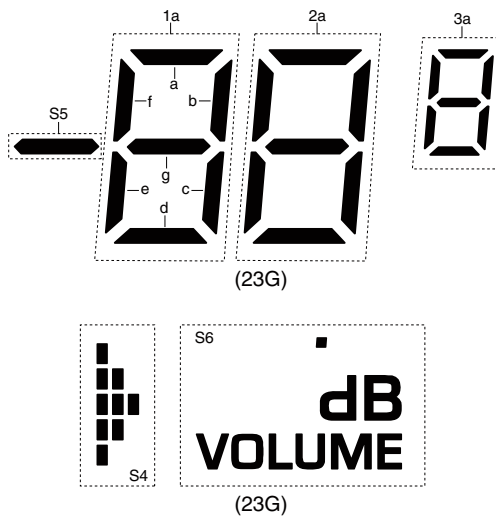
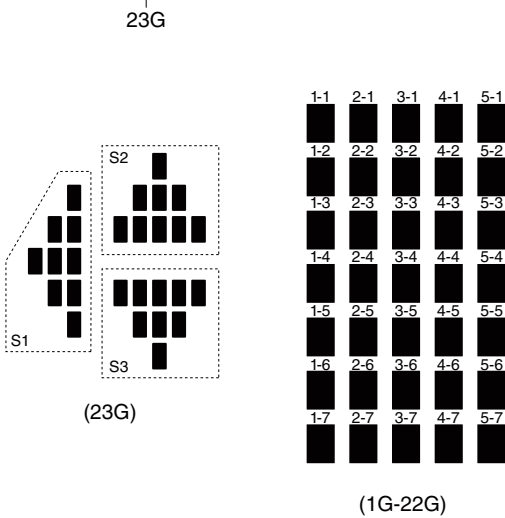
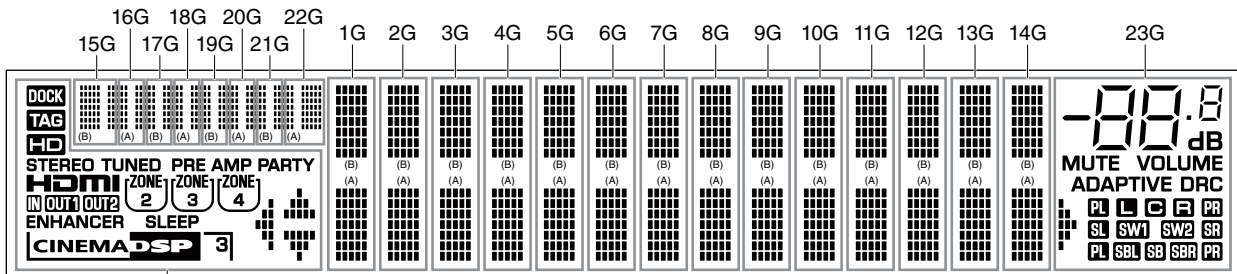

RX-V1067/HTR-8063/RX-A1000

• Anode connection

	1G-14G	15G	16G, 17G	18, 19G	20G, 21G	22G	23G		1G-14G	15G, 16G	17G, 18G	19, 20G	21G, 21G	23G
D0B	1-1B	1-1B	1-1B	1-1B	1-1B	1-1B	1a	D0A	1-1A	1-1A	1-1A	1-1A	1-1A	DOCK
D1B	2-1B	2-1B	2-1B	2-1B	2-1B	2-1B	2a	D1A	2-1A	2-1A	2-1A	2-1A	2-1A	TAG
D2B	3-1B	3-1B	3-1B	3-1B	3-1B	3-1B	3a,3f,3c,3d	D2A	3-1A	3-1A	3-1A	3-1A	3-1A	HD
D3B	4-1B	4-1B	4-1B	4-1B	4-1B	4-1B	1b	D3A	4-1A	4-1A	4-1A	4-1A	4-1A	STEREO
D4B	5-1B	5-1B	5-1B	5-1B	5-1B	5-1B	2b	D4A	5-1A	5-1A	5-1A	5-1A	5-1A	HDMI
D5B	1-2B	1-2B	1-2B	1-2B	1-2B	1-2B	3g	D5A	1-2A	1-2A	1-2A	1-2A	1-2A	IN
D6B	2-2B	2-2B	2-2B	2-2B	2-2B	2-2B	1f	D6A	2-2A	2-2A	2-2A	2-2A	2-2A	OUT1
D7B	3-2B	3-2B	3-2B	3-2B	3-2B	3-2B	2f	D7A	3-2A	3-2A	3-2A	3-2A	3-2A	OUT2
D8B	4-2B	4-2B	4-2B	4-2B	4-2B	4-2B	3b,3e	D8A	4-2A	4-2A	4-2A	4-2A	4-2A	ENHANCER
D9B	5-2B	5-2B	5-2B	5-2B	5-2B	5-2B	1g	D9A	5-2A	5-2A	5-2A	5-2A	5-2A	ZONE 2
D10B	1-3B	1-3B	1-3B	1-3B	1-3B	1-3B	2g	D10A	1-3A	1-3A	1-3A	1-3A	1-3A	ZONE 3
D11B	2-3B	2-3B	2-3B	2-3B	2-3B	2-3B	S5	D11A	2-3A	2-3A	2-3A	2-3A	2-3A	ZONE 4
D12B	3-3B	3-3B	3-3B	3-3B	3-3B	3-3B	1c	D12A	3-3A	3-3A	3-3A	3-3A	3-3A	SLEEP
D13B	4-3B	4-3B	4-3B	4-3B	4-3B	4-3B	2c	D13A	4-3A	4-3A	4-3A	4-3A	4-3A	CINEMA DSP
D14B	5-3B	5-3B	5-3B	5-3B	5-3B	5-3B	1e	D14A	5-3A	5-3A	5-3A	5-3A	5-3A	3
D15B	1-4B	1-4B	1-4B	1-4B	1-4B	1-4B	2e	D15A	1-4A	1-4A	1-4A	1-4A	1-4A	S1
D16B	2-4B	2-4B	2-4B	2-4B	2-4B	2-4B	1d	D16A	2-4A	2-4A	2-4A	2-4A	2-4A	S1
D17B	3-4B	3-4B	3-4B	3-4B	3-4B	3-4B	2d	D17A	3-4A	3-4A	3-4A	3-4A	3-4A	S3
D18B	4-4B	4-4B	4-4B	4-4B	4-4B	4-4B	S6	D18A	4-4A	4-4A	4-4A	4-4A	4-4A	TUNED
D19B	5-4B	5-4B	5-4B	5-4B	5-4B	5-4B	MUTE	D19A	5-4A	5-4A	5-4A	5-4A	5-4A	PRE AMP
D20B	1-5B	1-5B	1-5B	1-5B	1-5B	1-5B	ADAPTIVE DRC	D20A	1-5A	1-5A	1-5A	1-5A	1-5A	PARTY
D21B	2-5B	2-5B	2-5B	2-5B	2-5B	2-5B	PL (UP)	D21A	2-5A	2-5A	2-5A	2-5A	2-5A	S4
D22B	3-5B	3-5B	3-5B	3-5B	3-5B	3-5B	L	D22A	3-5A	3-5A	3-5A	3-5A	3-5A	-
D23B	4-5B	4-5B	4-5B	4-5B	4-5B	4-5B	C	D23A	4-5A	4-5A	4-5A	4-5A	4-5A	-
D24B	5-5B	5-5B	5-5B	5-5B	5-5B	5-5B	F	D24A	5-5A	5-5A	5-5A	5-5A	5-5A	-
D25B	1-6B	1-6B	1-6B	1-6B	1-6B	1-6B	PR (UP)	D25A	1-6A	1-6A	1-6A	1-6A	1-6A	-
D26B	2-6B	2-6B	2-6B	2-6B	2-6B	2-6B	SL	D26A	2-6A	2-6A	2-6A	2-6A	2-6A	-
D27B	3-6B	3-6B	3-6B	3-6B	3-6B	3-6B	SW1	D27A	3-6A	3-6A	3-6A	3-6A	3-6A	-
D28B	4-6B	4-6B	4-6B	4-6B	4-6B	4-6B	SW2	D28A	4-6A	4-6A	4-6A	4-6A	4-6A	-
D29B	5-6B	5-6B	5-6B	5-6B	5-6B	5-6B	SR	D29A	5-6A	5-6A	5-6A	5-6A	5-6A	-
D30B	1-7B	1-7B	1-7B	1-7B	1-7B	1-7B	PL (DOWN)	D30A	1-7A	1-7A	1-7A	1-7A	1-7A	-
D31B	2-7B	2-7B	2-7B	2-7B	2-7B	2-7B	SBL	D31A	2-7A	2-7A	2-7A	2-7A	2-7A	-
D32B	3-7B	3-7B	3-7B	3-7B	3-7B	3-7B	SB	D32A	3-7A	3-7A	3-7A	3-7A	3-7A	-
D33B	4-7B	4-7B	4-7B	4-7B	4-7B	4-7B	SBR	D33A	4-7A	4-7A	4-7A	4-7A	4-7A	-
D34B	5-7B	5-7B	5-7B	5-7B	5-7B	5-7B	PR (DOWN)	D34A	5-7A	5-7A	5-7A	5-7A	5-7A	-

RX-V1067/HTR-8063/
RX-A1000

• Timing chart

	1G-14G	15G	16G, 17G	18, 19G	20G, 21G	22G	23G
D0B	T1-T14	T15	T17	T19	T21	T23	T24
D1B	T1-T14	T15	T17	T19	T21	T23	T24
D2B	T1-T14	T15	T17	T19	T21	T23	T24
D3B	T1-T14	T15	T17	T19	T21	T23	T24
D4B	T1-T14	T15	T17	T19	T21	T23	T24
D5B	T1-T14	T15	T17	T19	T21	T23	T24
D6B	T1-T14	T15	T17	T19	T21	T23	T24
D7B	T1-T14	T15	T17	T19	T21	T23	T24
D8B	T1-T14	T15	T17	T19	T21	T23	T24
D9B	T1-T14	T15	T17	T19	T21	T23	T24
D10B	T1-T14	T15	T17	T19	T21	T23	T24
D11B	T1-T14	T15	T17	T19	T21	T23	T24
D12B	T1-T14	T15	T17	T19	T21	T23	T24
D13B	T1-T14	T15	T17	T19	T21	T23	T24
D14B	T1-T14	T15	T17	T19	T21	T23	T24
D15B	T1-T14	T15	T17	T19	T21	T23	T24
D16B	T1-T14	T15	T17	T19	T21	T23	T24
D17B	T1-T14	T15	T17	T19	T21	T23	T24
D18B	T1-T14	T15	T17	T19	T21	T23	T24
D19B	T1-T14	T15	T17	T19	T21	T23	T24
D20B	T1-T14	T15	T17	T19	T21	T23	T24
D21B	T1-T14	T15	T17	T19	T21	T23	T24
D22B	T1-T14	T15	T17	T19	T21	T23	T24
D23B	T1-T14	T15	T17	T19	T21	T23	T24
D24B	T1-T14	T15	T17	T19	T21	T23	T24
D25B	T1-T14	T15	T17	T19	T21	T23	T24
D26B	T1-T14	T15	T17	T19	T21	T23	T24
D27B	T1-T14	T15	T17	T19	T21	T23	T24
D28B	T1-T14	T15	T17	T19	T21	T23	T24
D29B	T1-T14	T15	T17	T19	T21	T23	T24
D30B	T1-T14	T15	T17	T19	T21	T23	T24
D31B	T1-T14	T15	T17	T19	T21	T23	T24
D32B	T1-T14	T15	T17	T19	T21	T23	T24
D33B	T1-T14	T15	T17	T19	T21	T23	T24
D34B	T1-T14	T15	T17	T19	T21	T23	T24

	1G-14G	15G, 16G	17G, 18G	19, 20G	21G, 21G	23G
D0A	T1-T14	T15	T17	T19	T21	T23
D1A	T1-T14	T15	T17	T19	T21	T23
D2A	T1-T14	T15	T17	T19	T21	T23
D3A	T1-T14	T15	T17	T19	T21	T23
D4A	T1-T14	T15	T17	T19	T21	T23
D5A	T1-T14	T15	T17	T19	T21	T23
D6A	T1-T14	T15	T17	T19	T21	T23
D7A	T1-T14	T15	T17	T19	T21	T23
D8A	T1-T14	T15	T17	T19	T21	T23
D9A	T1-T14	T15	T17	T19	T21	T23
D10A	T1-T14	T15	T17	T19	T21	T23
D11A	T1-T14	T15	T17	T19	T21	T23
D12A	T1-T14	T15	T17	T19	T21	T23
D13A	T1-T14	T15	T17	T19	T21	T23
D14A	T1-T14	T15	T17	T19	T21	T23
D15A	T1-T14	T15	T17	T19	T21	T23
D16A	T1-T14	T15	T17	T19	T21	T23
D17A	T1-T14	T15	T17	T19	T21	T23
D18A	T1-T14	T15	T17	T19	T21	T23
D19A	T1-T14	T15	T17	T19	T21	T23
D20A	T1-T14	T15	T17	T19	T21	T23
D21A	T1-T14	T15	T17	T19	T21	T23
D22A	T1-T14	T15	T17	T19	T21	-
D23A	T1-T14	T15	T17	T19	T21	-
D24A	T1-T14	T15	T17	T19	T21	-
D25A	T1-T14	T15	T17	T19	T21	-
D26A	T1-T14	T15	T17	T19	T21	-
D27A	T1-T14	T15	T17	T19	T21	-
D28A	T1-T14	T15	T17	T19	T21	-
D29A	T1-T14	T15	T17	T19	T21	-
D30A	T1-T14	T15	T17	T19	T21	-
D31A	T1-T14	T15	T17	T19	T21	-
D32A	T1-T14	T15	T17	T19	T21	-
D33A	T1-T14	T15	T17	T19	T21	-
D34A	T1-T14	T15	T17	T19	T21	-

RX-V1067/HTR-8063/
RX-A1000

■ IC DATA

IC741, 742: R2A15220FP (FUNCTION P.C.B.)
 8-channel electronic volume with 11 input selector and tone control

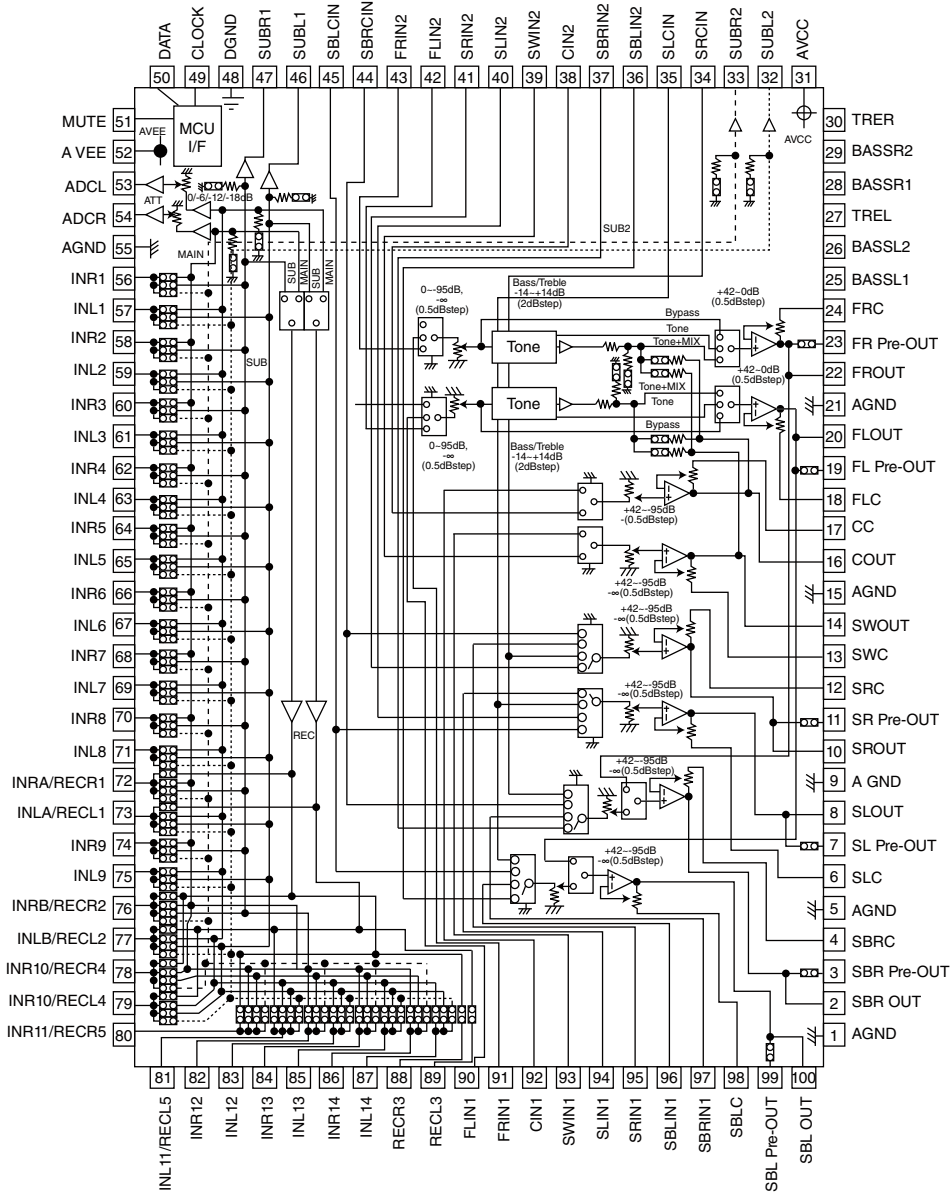

RX-V1067/HTR-8063/
 RX-A1000

Pin No.	Port name	Function Name	Detail of Function
1	AGND	AE	Analog ground of internal circuit
2	SBROUT	VOSBL	Output pin of FL/FR/C/SW/SL/SR/SBL/SBR channel
3	SBR Pre-OUT	VOPSB	Pre-output pin of FL/FR/SL/SR/SBL/SBR channel
4	SBRC	AE	Connects capacitor for reducing click noise of L/R/C/SW/SL/SR/SBL/SBR channel volume
5	AGND	AE	Analog ground of internal circuit
6	SLC	VOPSR	Connects capacitor for reducing click noise of L/R/C/SW/SL/SR/SBL/SBR channel volume
7	SL Pre-OUT	VOSR	Pre-output pin of FL/FR/SL/SR/SBL/SBR channel
8	SLOUT	AE	Output pin of FL/FR/C/SW/SL/SR/SBL/SBR channel
9	AGND	AE	Analog ground of internal circuit
10	SROUT	VOSL	Output pin of FL/FR/C/SW/SL/SR/SBL/SBR channel
11	SR Pre-OUT	VOPSL	Pre-output pin of FL/FR/SL/SR/SBL/SBR channel
12	SRC	AE	Connects capacitor for reducing click noise of L/R/C/SW/SL/SR/SBL/SBR channel volume
13	SWC	AE	Connects capacitor for reducing click noise of L/R/C/SW/SL/SR/SBL/SBR channel volume
14	SWOUT	VOSW	Output pin of FL/FR/C/SW/SL/SR/SBL/SBR channel
15	AGND	AE	Analog ground of internal circuit
16	COUT	VOC	Output pin of FL/FR/C/SW/SL/SR/SBL/SBR channel
17	CC	AE	Connects capacitor for reducing click noise of L/R/C/SW/SL/SR/SBL/SBR channel volume
18	FLC	AE	Connects capacitor for reducing click noise of L/R/C/SW/SL/SR/SBL/SBR channel volume
19	FL Pre-OUT	VOPFR	Pre-output pin of FL/FR/SL/SR/SBL/SBR channel
20	FLOUT	VOFR	Output pin of FL/FR/C/SW/SL/SR/SBL/SBR channel
21	AGND	POE	Analog ground of internal circuit
22	FROUT	VOFL	Output pin of FL/FR/C/SW/SL/SR/SBL/SBR channel
23	FR Pre-OUT	VOPFL	Pre-output pin of FL/FR/SL/SR/SBL/SBR channel
24	FRC	AE	Connects capacitor for reducing click noise of L/R/C/SW/SL/SR/SBL/SBR channel volume
25	BASSL1	AE	Frequency characteristic setting pin of L/R channel tone control (Bass)
26	BASSL2	AE	Frequency characteristic setting pin of L/R channel tone control (Bass)
27	TREL	AE	Frequency characteristic setting pin of L/R channel tone control (Treble)
28	BASSR1	AE	Frequency characteristic setting pin of L/R channel tone control (Bass)
29	BASSR2	AE	Frequency characteristic setting pin of L/R channel tone control (Bass)
30	TRER	AE	Frequency characteristic setting pin of L/R channel tone control (Treble)
31	AVCC	VCC	Positive power supply to internal circuit
32	SUBL1	N.C.	Output pin for L/R channel SUB1/SUB2 output
33	SUBL2	N.C.	Output pin for L/R channel SUB1/SUB2 output
34	SRCIN	N.C.	3rd multi input pin for SBL/SBR/SL/SR channel volume that is able to swap SBR/SBL with SR/SL
35	SLCIN	N.C.	3rd multi input pin for SBL/SBR/SL/SR channel volume that is able to swap SBR/SBL with SR/SL
36	SBLIN2	8SBR	Multi input pin of L/R/C/SW/SL/SR/SBL/SBR channel (Multi IN 1/2)
37	SBRIN2	8SBL	Multi input pin of L/R/C/SW/SL/SR/SBL/SBR channel (Multi IN 1/2)
38	CIN2	8C	Multi input pin of L/R/C/SW/SL/SR/SBL/SBR channel (Multi IN 1/2)
39	SWIN2	8SW	Multi input pin of L/R/C/SW/SL/SR/SBL/SBR channel (Multi IN 1/2)
40	SLIN2	8SR	Multi input pin of L/R/C/SW/SL/SR/SBL/SBR channel (Multi IN 1/2)
41	SRIN2	8SL	Multi input pin of L/R/C/SW/SL/SR/SBL/SBR channel (Multi IN 1/2)
42	FLIN2	8FR	Multi input pin of L/R/C/SW/SL/SR/SBL/SBR channel (Multi IN 1/2)
43	FRIN2	8FL	Multi input pin of L/R/C/SW/SL/SR/SBL/SBR channel (Multi IN 1/2)
44	SBRCIN	Z2L	3rd multi input pin for SBL/SBR/SL/SR channel volume that is able to swap SBR/SBL with SR/SL
45	SBLCIN	Z2R	3rd multi input pin for SBL/SBR/SL/SR channel volume that is able to swap SBR/SBL with SR/SL
46	SUBL1	Z2R	Output pin for L/R channel SUB1/SUB2 output
47	SUBR1	Z2L	Output pin for L/R channel SUB1/SUB2 output
48	DGND	MG	Digital ground of internal circuit
49	DATA	VOL_SCK	Input pin of control data
50	CLOCK	VOL_MOSI	Input pin of control clock

Pin No.	Port name	Function Name	Detail of Function
51	MUTE	AE	Outside mute control pin
52	AVEE	-	Negative power supply to internal circuit
53	ADCL	ADR	Output pin for L/R channel ADC
54	ADCR	ADL	Output pin for L/R channel ADC
55	AGND	AE	Analog ground of internal circuit
56	INR1	AU2L	Input pin of L/R channel (Input selector)
57	INL1	AU2R	Input pin of L/R channel (Input selector)
58	INR2	AU1L	Input pin of L/R channel (Input selector)
59	INL2	AU1R	Input pin of L/R channel (Input selector)
60	INR3	AV-6L	Input pin of L/R channel (Input selector)
61	INL3	AV-6R	Input pin of L/R channel (Input selector)
62	INR4	AV-5L	Input pin of L/R channel (Input selector)
63	INL4	AV-5R	Input pin of L/R channel (Input selector)
64	INR5	PHL	Input pin of L/R channel (Input selector)
65	INL5	PHR	Input pin of L/R channel (Input selector)
66	INR6	SRL	Input pin of L/R channel (Input selector)
67	INL6	SRR	Input pin of L/R channel (Input selector)
68	INR7	IPL	Input pin of L/R channel (Input selector)
69	INL7	IPR	Input pin of L/R channel (Input selector)
70	INR8	XML	Input pin of L/R channel (Input selector)
71	INL8	XMR	Input pin of L/R channel (Input selector)
72	INRA/RECR1	AV-OUT_L	Output pin for L/R channel (input selector)/Output pin for L/R channel REC output
73	INLA/RECL1	AV-OUT_R	Output pin for L/R channel (input selector)/Output pin for L/R channel REC output
74	INR9	USBL	Input pin of L/R channel (Input selector)
75	INL9	USBR	Input pin of L/R channel (Input selector)
76	INRB/RECR2	AOL	Output pin for L/R channel (input selector)/Output pin for L/R channel REC output
77	INLB/RECL2	AOR	Output pin for L/R channel (input selector)/Output pin for L/R channel REC output
78	INR10/RECR4	TUL	Output pin for L/R channel (input selector)/Output pin for L/R channel REC output
79	INL10/RECL4	TUR	Output pin for L/R channel (input selector)/Output pin for L/R channel REC output
80	INR11/RECR5	MIC	Output pin for L/R channel (input selector)/Output pin for L/R channel REC output
81	INL11/RECL5	AE	Output pin for L/R channel (input selector)/Output pin for L/R channel REC output
82	INR12	AUXL	Input pin of L/R channel (Input selector)
83	INL12	AUXR	Input pin of L/R channel (Input selector)
84	INR13	AE	Input pin of L/R channel (Input selector)
85	INL13	AE	Input pin of L/R channel (Input selector)
86	INR14	AE	Input pin of L/R channel (Input selector)
87	INL14	AE	Input pin of L/R channel (Input selector)
88	RECR3	N.C.	Output pin for L/R channel REC output
89	RECL3	N.C.	Output pin for L/R channel REC output
90	FLIN1	DAFR	Multi input pin of L/R/C/SW/SL/SR/SBL/SBR channel (Multi IN 1/2)
91	FRIN1	DAFL	Multi input pin of L/R/C/SW/SL/SR/SBL/SBR channel (Multi IN 1/2)
92	CIN1	DAC	Multi input pin of L/R/C/SW/SL/SR/SBL/SBR channel (Multi IN 1/2)
93	SWIN1	DASW	Multi input pin of L/R/C/SW/SL/SR/SBL/SBR channel (Multi IN 1/2)
94	SLIN1	DASR	Multi input pin of L/R/C/SW/SL/SR/SBL/SBR channel (Multi IN 1/2)
95	SEIN1	DASL	Multi input pin of L/R/C/SW/SL/SR/SBL/SBR channel (Multi IN 1/2)
96	SBLIN1	DASBR	Multi input pin of L/R/C/SW/SL/SR/SBL/SBR channel (Multi IN 1/2)
97	SBRIN1	DASBL	Multi input pin of L/R/C/SW/SL/SR/SBL/SBR channel (Multi IN 1/2)
98	SBLC	AE	Connects capacitor for reducing click noise of L/R/C/SW/SL/SR/SBL/SBR channel volume
99	SBL Pre-OUT	VOPSB	Pre-output pin of FL/FR/SL/SR/SBL/SBR channel
100	SBL OUT	VOSBR	Output pin of FL/FR/C/SW/SL/SR/SBL/SBR channel

IC945: D70YE101BRFP266 (DIGITAL P.C.B.)

Decoder/Post processor

* No replacement part available. / サービス部品供給なし

RX-V1067/HTR-8063/
RX-A1000

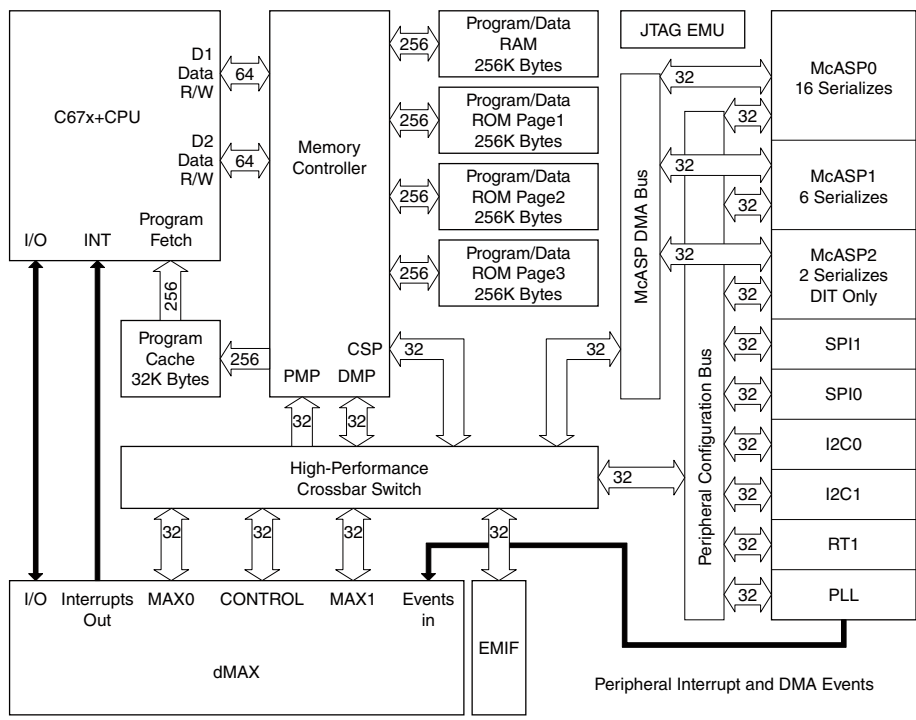
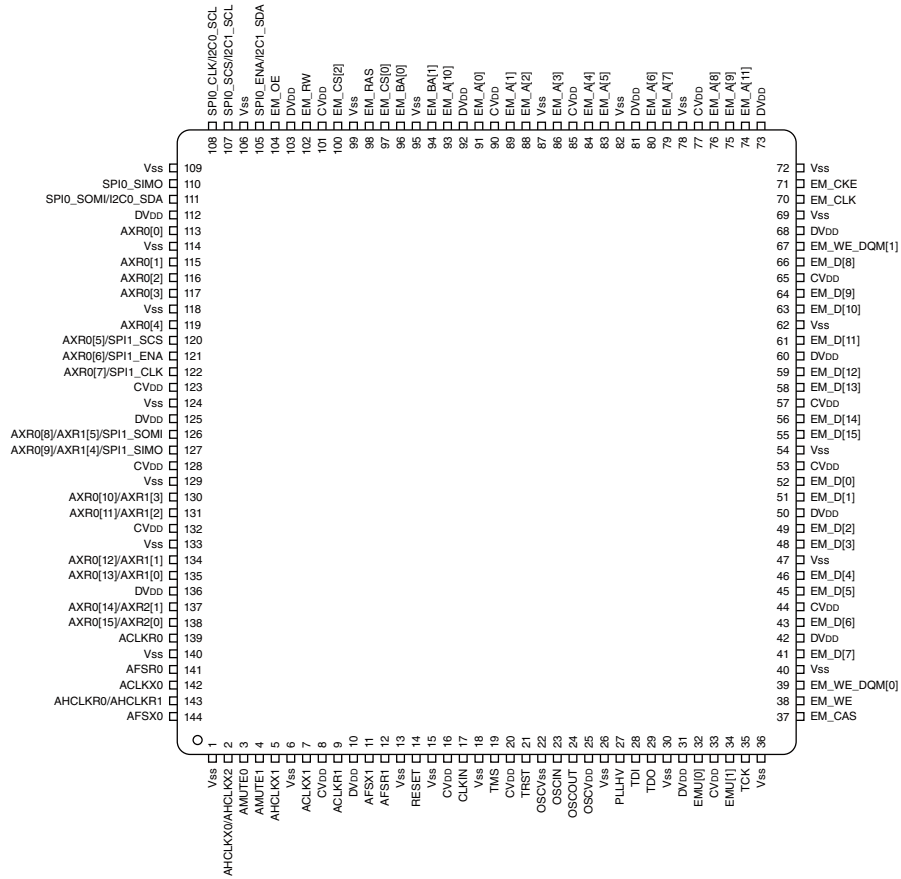

No.	Function Name (P.C.B.)	TYPE ⁽¹⁾	PULL ⁽²⁾	GPIO ⁽³⁾	Detail of Function
1	VSS				
2	AHCLKX0/AHCLKX2	IO	–	Y	McASP0 and McASP2 transmit master clock
3	AMUTE0	IO	–	Y	McASP0 mute output
4	AMUTE1	IO	–	Y	McASP1 mute output
5	AHCLKX1	IO	–	Y	McASP1 transmit master clock
6	VSS				
7	ACLKX1	IO	–	Y	McASP1 transmit bit clock
8	CVDD				
9	ACLKR1	IO	–	Y	McASP1 receive bit clock
10	DVDD				
11	AFSX1	IO	–	Y	McASP1 transmit frame Sync (L/R clock)
12	AFSR1	IO	–	Y	McASP1 receive frame Sync (L/R clock)
13	VSS				
14	RESET	IO	–	N	Device reset pin
15	VSS				
16	CVDD				
17	CLKIN	IO	–	N	Alternate clock input (3.3-V LVCMOS input)
18	VSS				
19	TMS	IO	IPU	N	Test mode select
20	CVDD				
21	TRST	IO	IPU	N	Test reset
22	OSCVSS	PWR	–	N	Oscillator Vss tap point (for filter only)
23	OSCIN	IO	–	N	1.2-V oscillator input
24	NC	O	–	N	
25	OSCVDD	PWR	–	N	Oscillator 1.2-V Vpp tap point (for filter only)
26	VSS				
27	PLLHV	PWR	–	N	PLL 3.3-V supply input (requires external filter)
28	TDI	IO	IPU	N	Test data in
29	TDO	OZ	IPU	N	Test data out
30	VSS				
31	DVDD				
32	EMU[0]	IO	IPU	N	Emulation pin 0
33	CVDD				
34	EMU[1]	IO	IPU	N	Emulation pin 1
35	TCK	IO	IPU	N	Test clock
36	Ground(Vss)				
37	EM_CAS	O	–	N	SDRAM column address strobe
38	EM_WE	O	–	N	SDRAM write enable
39	EM_WE_DQM[0]	O	–	N	Write enable or byte enable for EM_D [7:0]
40	VSS				
41	EM_D[7]	IO	–	N	EMIF data bus [lower 16-bits]
42	DVDD				
43	EM_D[6]	IO	–	N	EMIF data bus [lower 16-bits]
44	CVDD				
45	EM_D[5]	IO	–	N	EMIF data bus [lower 16-bits]
46	EM_D[4]	IO	–	N	EMIF data bus [lower 16-bits]
47	VSS				
48	EM_D[3]	IO	–	N	EMIF data bus [lower 16-bits]
49	EM_D[2]	IO	–	N	EMIF data bus [lower 16-bits]
50	DVDD				

No.	Function Name (P.C.B.)	TYPE ⁽¹⁾	PULL ⁽²⁾	GPIO ⁽³⁾	Detail of Function
51	EM_D[1]	IO	–	N	EMIF data bus [lower 16-bits]
52	EM_D[0]	IO	–	N	EMIF data bus [lower 16-bits]
53	CVDD				
54	VSS				
55	EM_D[15]	IO	–	N	EMIF data bus [lower 16-bits]
56	EM_D[14]	IO	–	N	EMIF data bus [lower 16-Bits]
57	CVDD				
58	EM_D[13]	IO	–	N	EMIF data bus [lower 16-Bits]
59	EM_D[12]	IO	–	N	EMIF data bus [lower 16-Bits]
60	DVDD				
61	EM_D[11]	IO	–	N	EMIF data bus [lower 16-Bits]
62	VSS				
63	EM_D[10]	IO	–	N	EMIF data bus [lower 16-Bits]
64	EM_D[9]	IO	–	N	EMIF data bus [lower 16-Bits]
65	CVDD				
66	EM_D[8]	IO	–	N	EMIF data bus [lower 16-bits]
67	EM_WE_DQM[1]	O	–	N	Write enable or byte enable for EM_D [15:8]
68	DVDD				
69	VSS				
70	EM_CLK	O	–	N	SDRAM clock
71	EM_CKE	O	–	N	SDRAM clock enable
72	VSS				
73	DVDD				
74	EM_A[11]	O	–	N	EMIF address bus
75	EM_A[9]	O	–	N	EMIF address bus
76	EM_A[8]	O	–	N	EMIF address bus
77	CVDD				
78	VSS				
79	EM_A[7]	O	–	N	EMIF address bus
80	EM_A[6]	O	–	N	EMIF address bus
81	DVDD				
82	VSS				
83	EM_A[5]	O	–	N	EMIF address bus
84	EM_A[4]	O	–	N	EMIF address bus
85	CVDD				
86	EM_A[3]	O	–	N	EMIF address bus
87	VSS				
88	EM_A[2]	O	–	N	EMIF address bus
89	EM_A[1]	O	–	N	EMIF address bus
90	CVDD				
91	EM_A[0]	O	–	N	EMIF address bus
92	DVDD				
93	EM_A[10]	O	–	N	EMIF address bus
94	EM_BA[1]	O	–	N	SDRAM bank address and asynchronous memory Low-Order address
95	VSS				
96	EM_BA[0]	O	–	N	SDRAM bank address and asynchronous memory Low-Order address
97	EM_CS[0]	O	–	N	SDRAM chip select
98	EM_RAS	O	–	N	SDRAM row address strobe
99	VSS				
100	EM_CS[2]	O	–	N	Asynchronous memory chip select

No.	Function Name (P.C.B.)	TYPE ⁽¹⁾	PULL ⁽²⁾	GPIO ⁽³⁾	Detail of Function
101	CVDD				
102	NC	O	–	N	Asynchronous memory read/not write
103	DVDD				
104	EM_OE	O	–	N	SDRAM output enable
105	SPI0_ENA/I2C1_SDA	IO	–	Y	SPI0 enable (ready) or I2c1 serial data
106	VSS				
107	SPI0_ENA/I2C1_SCL	IO	–	Y	SPI0 enable (ready) or I2c1 serial clock
108	SPI0_CLK/I2C0_SCL	IO	–	Y	SPI0 serial clock or I2c0 serial clock
109	VSS				
110	SPI0_SIMO	IO	–	Y	SPI0 data pin slave in master out
111	SPI0_SOMI/I2C0_SDA	IO	–	Y	SPI0 data pin slave out master in or I2C0 serial data
112	DVDD				
113	AXR0[0]	IO	–	Y	McASP0 serial data 0
114	VSS				
115	AXR0[1]	IO	–	Y	McASP0 serial data 1
116	AXR0[2]	IO	–	Y	McASP0 serial data 2
117	AXR0[3]	IO	–	Y	McASP0 serial data 3
118	VSS				
119	AXR0[4]	IO	–	Y	McASP0 serial data 4
120	SPI1_SCS	IO	–	Y	McASP0 serial data 5 or SPI1 slave chip select
121	SPI1_ENA	IO	–	Y	McASP0 serial data 6 or SPI1 enable (ready)
122	SPI1_CLK	IO	–	Y	McASP0 serial data 7 or SPI1 serial clock
123	CVDD				
124	VSS				
125	DVDD				
126	/SPI1_SOMI	IO	–	Y	McASP0 serial data 8 or McASP1 serial data 5 or SPI1 data pin slave out master in
127	/SPI1_SIMO	IO	–	Y	McASP0 serial data 9 or McASP1 serial data 4 or SPI1 data pin slave in master out
128	CVDD				
129	VSS				
130	AXR0[10]	IO	–	Y	McASP0 serial data 10 or McASP1 serial data 3
131	AXR0[11]	IO	–	Y	McASP0 serial data 11 or McASP1 serial data 2
132	CVDD				
133	VSS				
134	AXR0[12]	IO	–	Y	McASP0 serial data 12 or McASP1 serial data 1
135	AXR0[13]	IO	–	Y	McASP0 serial data 13 or McASP1 serial data 0
136	DVDD				
137	AXR0[14]	IO	–	Y	McASP0 serial data 14 or McASP2 serial data 1
138	AXR0[15]	IO	–	Y	McASP0 serial data 15 or McASP2 serial data 0
139	ACLKR0	IO	–	Y	McASP0 receive bit clock
140	VSS				
141	AFSR0	IO	–	Y	McASP0 receive frame Sync (L/R clock)
142	ACLKX0	IO	–	Y	McASP0 transmit bit clock
143	AHCLKR0/AHCLKR1	IO	–	Y	McASP0 and McASP1 receive master clock
144	AFSX0	IO	–	Y	McASP0 transmit frame Sync (L/R clock)

IC908: R5F64169DFD (DIGITAL P.C.B.)

Microprocessor

* No replacement part available. / サービス部品供給なし

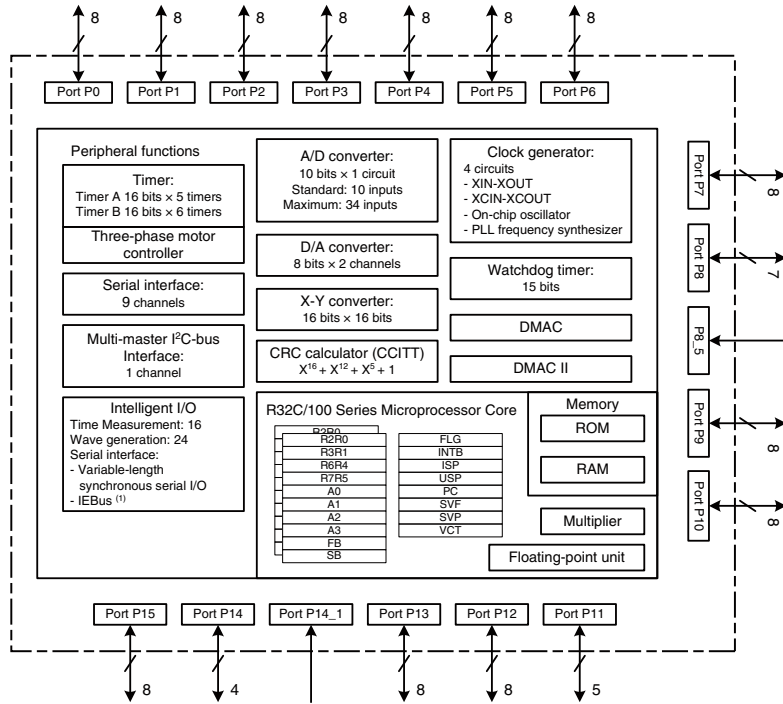

Note: 1. IEBus is a trademark of NEC Electronics Corporation.

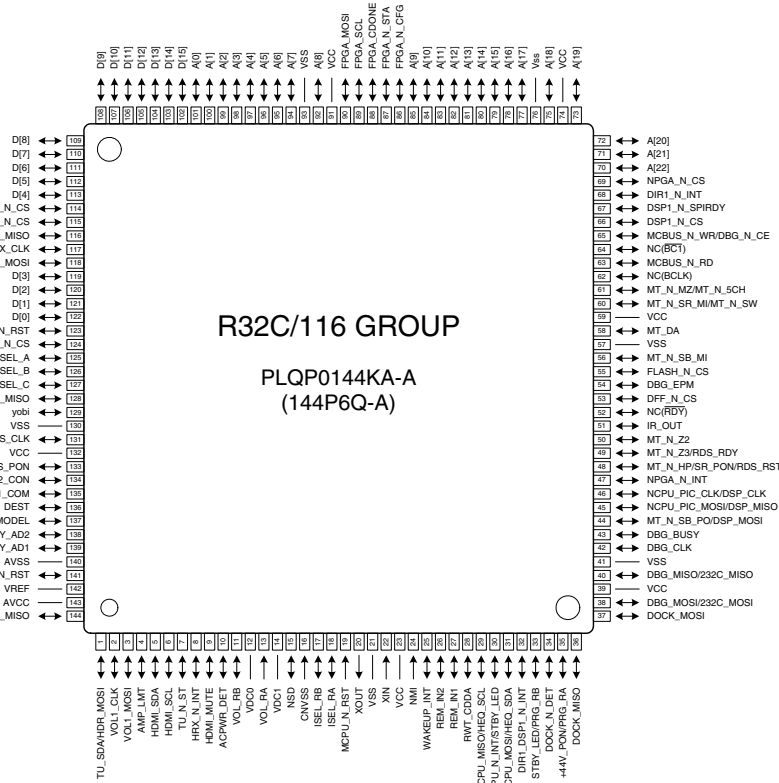

Notes:
 1. Pin names in brackets [] represent a functional signal as a whole and should not be considered as two separate pins.
 2. The position of pin number 1 varies by product. Refer to the index mark in attached "Package Dimensions".

RX-V1067/HTR-8063/RX-A1000

Pin No.	Port Name	Use Port	Function Name	Terminal Processing	Related Power Supply				Detail of Function	
					OFF		ON			
					I/O	Logic	I/O	Logic		
1	SRXD4/SDA4/ TXD4/ANEX1/ P9_6	TXD4	HDR_MOSI	3.3kPU	PRY	O	Low	O	Data	HD Radio or DAB transmission data (U model)
		SDA4	TU_SDA		PRY	O	Low	I/O	Data	Tuner I2C data (C, R, T, K, A, B, G, F, L, J models)
2	CLK4/ANEX0/ P9_5	P9_5	VOL1_CLK		PRY	O	Low	O	Clock	Volume/ZoneTone/Selector-1 communication clock
3	SS4/RTS4/ CTS4/TB4IN/ DA1/P9_4	P9_4	VOL_MOSI		PRY	O	Low	O	Data	Volume/ZoneTone/Selector-1 and 2 communication data
4	SS3/RTS3/ CTS3/TB3IN/ DA0/P9_3	DA0	AMP_LMT		PRY	I	---	O	D/A	Limiter control
5	IEOUT/ISTXD2/ OUTC2_0/ SRXD3/SDA3/ TXD3/TB2IN/ P9_2	SDA3	HDMI_SDA	V encoder suction prevention	HDMI_PON	O	Low	I/O	Data	HDMI and AVVIDEO 400k I2C data
6	IEIN/ISRXD2/ STXD3/SCL3/ RXD3/TB1IN/ P9_1	SCL3	HDMI_SCL	V encoder suction prevention	HDMI_PON	O	Low	O	Clock	HDMI and AVVIDEO 400k I2C clock
7	CLK3/TB0IN/ P9_0	P9_0	TU_N_ST	47kPU	PRY	O	Low	I	L act	Tuner Stereo detection
8	INT8/P14_6	INT8	HRX_N_ INT		HDMI_PON	O	Low	I	L act	HDMI RX interrupt
9	INT7/P14_5	INT7	HDMI_ MUTE		HDMI_PON	O	Low	I	H act	HDMI mute
10	INT6/P14_4	INT6	ACPWR_ DET	100kPU +3.3M	AC	I	---	I	L act	AC power detect
11	P14_3	P14_3	VOL_RB		DSP_PON	I	---	I		Volume B
12	VDC0	VDC0	VDC0							---
13	P14_1	P14_1	VOL_RA		DSP_PON	I	---	I		Volume A (Port only for input)
14	VDC1	VDC1	VDC1							---
15	NSD	NSD	NSD	4.7kPU						Debugger
16	CNVSS	CNVSS	DBG_ CNVSS	68kPD						---
17	XCIN/P8_7	P8_7	ISEL_RB		DSP_PON	I	---	I		Input selector B
18	XCOU/P8_6	P8_6	ISEL_RA		DSP_PON	I	---	I		Input selector A
19	RESET	RESET	MCPU_N_ RST	10kPU						---
20	XOUT	XOUT	XOUT							---
21	VSS	VSS	VSS							---
22	XIN	XIN	XIN							---
23	VCC	VCC	VCC							---
24	NMI/P8_5	NMI	NMI	1kPU						---
25	INT2/P8_4	INT2	WAKEUP_ INT	Odd/even number detection circuit	AC	O	Low	I	Both edges	Power switches, MISO interrupt of 232C and DOCK (Sleep state restored)
26	INT1/P8_3	INT1	REM_IN2	100kPU	AC	O	Low	I	L act	Remote control pulse input 2 (5V tolerant)
27	INT0/P8_2	INT0	REM_IN1	100kPU	AC	O	Low	I	L act	Remote control pulse input 1 (5V tolerant)
28	UD0B/UD1B/ IIO1_5/RTS5/ CTS5/SS5/U/ TA4IN/P8_1	P8_1	RWT_ CDDA		DSP_PON	O	Low	O	H act	CDDA rewrite path selection
29	UD0A/UD1A/ RXD5/SCL5/ STXD5/U/ TA4OUT/P8_0	RXD5	NCPU_ MISO		NET_PON	O	Low	I	Data	Network module receive data
30	UD0B/UD1B/ IIO1_4/CLK5/ TA3IN/P7_7	TA3IN	NCPU_N_ INT		NET_PON	O	Low	I	L act	Network microprocessor interrupt
31	UD0A/UD1A/ IIO1_3/RTS8/ CTS8/TXD5/ SDA5/SRXD5/ TA3OUT/P7_6	TXD5	NCPU_ MOSI		NET_PON	O	Low	O	Data	Network module transmission data

Pin No.	Port Name	Use Port	Function Name	Terminal Processing	Related Power Supply				Detail of Function	
					OFF		ON			
					I/O	Logic	I/O	Logic		
32	IIO1_2/RXD8/W/TA2IN/P7_5	TA2IN	DIR1_DSP1_N_INT	10kPU	DSP_PON	O	Low	I	L act	DIR1/DSP1 interrupt
33	IIO1_1/CLK8/W/TA2OUT/P7_4	P7_4	STBY_LED		AC	O	Low	O	H act	Standby LED control for high quality model
34	IIO1_0/TXD8/SS2/RTS2/CTS2/V/TA11N/P7_3	TA11N	DOCK_N_DET		AC	O	Low	I	L act	iPod detect
35	CLK2/V/TA1OUT/P7_2	P7_2	+44V_PON	47kPD	DSP_PON	O	Low	O	H act	FL driver power supply
36	MSCL/IEIN/ISRXD2/OUTC2_2/IIO1_7/STXD2/SCL2/RXD2/TA0IN/TB5IN/P7_1	RXD2	DOCK_MISO	Suction prevention when AC is turned off	DOCK_PON	O	Low	I	Data	DOCK reception data
37	TA0OUT/TXD2/SDA2/SRXD2/IIO1_6/OUTC2_0/ISTXD2/IEOUT/MSDA/P7_0	TXD2	DOCK_MOSI		DOCK_PON	O	Low	O	Data	DOCK transmission data
38	TXD1/SDA1/SRXD1/P6_7	TXD1	DBG_MOSI	100kPU	AC	O	Low	O	Data	Debug/E8a
39	VCC	VCC	VCC							---
40	RXD1/SCL1/STXD1/P6_6	RXD1	DBG_MISO	100kPU	AC	O	Low	I	Data	Debug/E8a
41	VSS	VSS	VSS							---
42	CLK1/P6_5	CLK1	DBG_CLK	100kPU	AC	O	Low	I	Clock	E8a
43	CTS1/RTS1/SS1/OUTC2_1/ISCLK2/P6_4	P6_4	DBG_BUSY		AC	O	Low	O		E8a
44	TXD0/SDA0/SRXD0/P6_3	P6_3	MT_N_SB_PO	100kPD	+3.3S_PON	O	Low	O	L act	Mute SB (PREOUT)
45	TB2IN/RXD0/SCL0/STXD0/P6_2	RXD0	NCPU_PIC_MOSI		NET_PON	O	Low	I	Data	Network module image receive data
46	TB1IN/CLK0/P6_1	CLK0	NCPU_PIC_CLK		NET_PON	O	Low	I	Clk	Network module image clock
47	TB0IN/CTS0/RTS0/SS0/P6_0	TB0IN	NPGA_N_INT		HDMI_PON	O	Low	I	L act	Interrupt from NPGA
48	D31/OUTC2_7/P13_7	P13_7	MT_N_HP	100kPD	+3.3S_PON	O	Low	O	L act	Mute headphone
49	D30/OUTC2_1/ISCLK2/P13_6	P13_6	MT_N_Z3	100kPD	+3.3S_PON	O	Low	O	L act	Mute Zone3/Rear Presence (PREOUT)
50	D29/OUTC2_2/ISRXD2/IEIN/P13_5	P13_5	MT_N_Z2	100kPD	+3.3S_PON	O	Low	O	L act	Mute Zone2/Front Presence (PREOUT)
51	D28/OUTC2_0/ISTXD2/IEOUT/P13_4	ISTXD2	IR_OUT		AC	O	Low	O	Data	Remote control code output
52	RDY/CS3/CTS7/RTS7/P5_7	RDY	NC(RDY)		HDMI_PON	O	Low	B	Bus	External bus
53	ALE/CS2/RXD7/P5_6	CS2	DFF_N_CS		HDMI_PON	O	Low	B	Bus	External bus
54	HOLD/CLK7/P5_5	P5_5	DBG_EPM	22kPU and 3.3kPD	AC	I	---	I		E8a
55	HLDA/CS1/TXD7/P5_4	CS1	FLASH_N_CS		HDMI_PON	O	Low	B	Bus	External bus
56	D27/OUTC2_3/P13_3	P13_3	MT_N_SB_MI	100kPD	+3.3S_PON	O	Low	O	L act	Mute surround back (Main amp input)
57	VSS	VSS	VSS							---
58	D26/OUTC2_6/P13_2	P13_2	MT_DA		DSP_PON	O	Low	O	H act	Mute digital audio

Pin No.	Port Name	Use Port	Function Name	Terminal Processing	Related Power Supply				Detail of Function	
					OFF		ON			
					I/O	Logic	I/O	Logic		
59	VCC	VCC	VCC						---	
60	D25/OUTC2_5/ P13_1	P13_1	MT_N_SR_MI	100kPD	+3.3S_PON	O	Low	O	L act	Mute Surround (Main amp input)
61	D24/OUTC2_4/ P13_0	P13_0	MT_N_MZ	100kPD	+3.3S_PON	O	Low	O	L act	Mute Main Zone (Preout/Main amp input)
62	CLKOUT/BCLK/ R5_3	BCLK	NC(BCLK)		HDMI_PON	O	Low	B	Bus	Used by external bus
63	RD/P5_2	RD	MCBUS_N_RD		HDMI_PON	O	Low	B	Bus	External bus
64	WR1/BC1/P5_1	BC1	NC(BC1)		HDMI_PON	O	Low	B	Bus	Used by external bus
65	WR0/WR/P5_0	WR	MCBUS_N_WR		HDMI_PON	I	---	B	Bus	External bus
66	D23/P12_7	P12_7	DSP1_N_CS		DSP_PON	O	Low	O	L act	DSP1 chip select
67	D22/P12_6	P12_6	DSP1_N_SPIRDY		DSP_PON	O	Low	I	L act	DSP1 SPI Ready
68	D21/P12_5	P12_5	DIR1_N_INT		DSP_PON	O	Low	I	L DIR	For discrimination of DIR1/DSP1 interrupt
69	CS0/A23/TXD6/ SDA6/SRXD6/ P4_7	CS0	NPGA_N_CS		HDMI_PON	O	Low	B	Bus	External bus
70	CS1/A22/RXD6/ SCL6/STXD6/ P4_6	A22	A[22]		HDMI_PON	O	Low	B	Bus	External bus
71	CS2/A21/CLK6/ P4_5	A21	A[21]		HDMI_PON	O	Low	B	Bus	External bus
72	CS3/A20/CTS6/ RTS6/SS6/P4_4	A20	A[20]		HDMI_PON	O	Low	B	Bus	External bus
73	A19/TXD3/ SDA3/SRXD3/ OUTC2_0/ ISTXD2/IEOUT/ P4_3	A19	A[19]		HDMI_PON	O	Low	B	Bus	External bus
74	VCC	VCC	VCC							---
75	A18/RXD3/ SCL3/STXD3/ ISRXD2/IEIN/ P4_2	A18	A[18]		HDMI_PON	O	Low	B	Bus	External bus
76	VSS	VSS	VSS							---
77	A17/CLK3/P4_1	A17	A[17]		HDMI_PON	O	Low	B	Bus	External bus
78	A16/CTS3/RTS3/ SS3/P4_0	A16	A[16]		HDMI_PON	O	Low	B	Bus	External bus
79	A15/[A15/D15]/ TA4IN/U/P3_7	A15	A[15]		HDMI_PON	O	Low	B	Bus	External bus
80	A14/[A14/D14]/ TA4OUT/U/P3_6	A14	A[14]		HDMI_PON	O	Low	B	Bus	External bus
81	A13/[A13/D13]/ TA2IN/W/P3_5	A13	A[13]		HDMI_PON	O	Low	B	Bus	External bus
82	A12/[A12/D12]/ TA2OUT/W/P3_4	A12	A[12]		HDMI_PON	O	Low	B	Bus	External bus
83	A11/[A11/D11]/ TA1IN/V/P3_3	A11	A[11]		HDMI_PON	O	Low	B	Bus	External bus
84	A10/[A10/D10]/ TA1OUT/V/P3_2	A10	A[10]		HDMI_PON	O	Low	B	Bus	External bus
85	A9/[A9/D9]/ TA3OUT/UD0B/ UD1B/P3_1	A9	A[9]		HDMI_PON	O	Low	B	Bus	External bus
86	D20/P12_4	P12_4	FPGA_N_CFG	10kPU	HDMI_PON	O	Low	O	L act	FPGA nCONF
87	D19/CTS6/ RTS6/SS6/ P12_3	P12_3	FPGA_N_STA	10kPU	HDMI_PON	I	---	I	L act	FPGA nSTATUS
88	D18/RXD6/ SCL6/STXD6/ P12_2	P12_2	FPGA_CDONE	10kPU	HDMI_PON	I	---	I	H act	FPGA CONF DONE

Pin No.	Port Name	Use Port	Function Name	Terminal Processing	Related Power Supply				Detail of Function	
					OFF		ON			
					I/O	Logic	I/O	Logic		
89	D17/CLK6/ P12_1	CLK6	FPGA_SCL		HDMI_PON	O	Low	O	Clk	FPGA clock (at Boot)
90	D16/TXD6/ SDA6/SRXD6/ P12_0	TXD6	FPGA_MOSI		HDMI_PON	O	Low	O	Data	FPGA transmission data (at Boot)
91	VCC	VCC	VCC							---
92	A8/[A8/D8]/ TA0OUT/UD0A/ UD1A/P3_0	A8	A[8]		HDMI_PON	O	Low	B	Bus	External bus
93	VSS	VSS	VSS							---
94	A7/[A7/D7]/ AN2_7/P2_7	A7	A[7]		HDMI_PON	O	Low	B	Bus	External bus
95	A6/[A6/D6]/ AN2_6/P2_6	A6	A[6]		HDMI_PON	O	Low	B	Bus	External bus
96	A5/[A5/D5]/ AN2_5/P2_5	A5	A[5]		HDMI_PON	O	Low	B	Bus	External bus
97	A4/[A4/D4]/ AN2_4/P2_4	A4	A[4]		HDMI_PON	O	Low	B	Bus	External bus
98	A3/[A3/D3]/ AN2_3/P2_3	A3	A[3]		HDMI_PON	O	Low	B	Bus	External bus
99	A2/[A2/D2]/ AN2_2/P2_2	A2	A[2]		HDMI_PON	O	Low	B	Bus	External bus
100	A1/[A1/D1]/BC2/ [BC2/D1]/AN2_1/ P2_1	A1	A[1]		HDMI_PON	O	Low	B	Bus	External bus
101	A0/[A0/D0]/BC0/ [BC0/D0]/AN2_0/ P2_0	A0	A[0]		HDMI_PON	O	Low	B	Bus	External bus
102	D15/INT5/ IIO0_7/IIO1_7/ P1_7	D15	D[15]	100kPD	HDMI_PON	I	---	B	Bus	External bus
103	D14/INT4/ IIO0_6/IIO1_6/ P1_6	D14	D[14]	100kPD	HDMI_PON	I	---	B	Bus	External bus
104	D13/INT3/ IIO0_5/IIO1_5/ P1_5	D13	D[13]	100kPD	HDMI_PON	I	---	B	Bus	External bus
105	D12/IIO0_4/ IIO1_4/P1_4	D12	D[12]	100kPD	HDMI_PON	I	---	B	Bus	External bus
106	D11/IIO0_3/ IIO1_3/P1_3	D11	D[11]	100kPD	HDMI_PON	I	---	B	Bus	External bus
107	D10/IIO0_2/ IIO1_2/P1_2	D10	D[10]	100kPD	HDMI_PON	I	---	B	Bus	External bus
108	D9/IIO0_1/ IIO1_1/P1_1	D9	D[9]	100kPD	HDMI_PON	I	---	B	Bus	External bus
109	IIO0_0/IIO1_0/ D8/P1_0	D8	D[8]	100kPD	HDMI_PON	I	---	B	Bus	External bus
110	AN0_7/D7/P0_7	D7	D[7]	100kPD	HDMI_PON	I	---	B	Bus	External bus
111	AN0_6/D6/P0_6	D6	D[6]	100kPD	HDMI_PON	I	---	B	Bus	External bus
112	AN0_5/D5/P0_5	D5	D[5]	100kPD	HDMI_PON	I	---	B	Bus	External bus
113	AN0_4/D4/P0_4	D4	D[4]	100kPD	HDMI_PON	I	---	B	Bus	External bus
114	WR3/BC3/P11_4	P11_4	EEP_N_CS	10kPU	AC	O	Low	O	L act	EEPROM chip select
115	IIO1_3/RTS8/ CTS8/WR2/CS3/ P11_3	CS3	FPGA_N_CS		HDMI_PON	O	Low	B	Bus	External bus
116	IIO1_2/RXD8/ CS2/P11_2	RXD8	EEP_MISO		AC	O	Low	I	Data	FL/Expansion IO/EEPROM reception data
117	IIO1_1/CLK8/ CS1/P11_1	CLK8	EX_CLK	FL/expansion, suction prevention	AC	O	Low	O	Clk	FL/Expansion IO/EEPROM communication clock
118	IIO1_0/TXD8/ CS0/P11_0	TXD8	EX_MOSI	FL/expansion, suction prevention	AC	O	Low	O	Data	FL/Expansion IO/EEPROM transmission data
119	AN0_3/D3/P0_3	D3	D[3]	100kPD	HDMI_PON	I	---	B	Bus	External bus
120	AN0_2/D2/P0_2	D2	D[2]	100kPD	HDMI_PON	I	---	B	Bus	External bus
121	AN0_1/D1/P0_1	D1	D[1]	100kPD	HDMI_PON	I	---	B	Bus	External bus

Pin No.	Port Name	Use Port	Function Name	Terminal Processing	Related Power Supply				Detail of Function	
					OFF		ON			
					I/O	Logic	I/O	Logic		
122	AN0_0/D0/P0_0	D0	D[0]	100kPD	HDMI_PON	I	---	B	Bus	External bus
124	IIO0_6/CLK6/ AN15_6/P15_6	P15_6	EX12_N_CS		HDMI_PON	O	Low	O	L act	Expansion IO 1/2 chip select
125	IIO0_5/RXD6/ SCL6/STXD6/ AN15_5/P15_5	P15_5	AD_SEL_A		+3.3S_PON	O	Low	O		AD select A
126	IIO0_4/TXD6/ SDA6/SRXD6/ AN15_4/P15_4	P15_4	AD_SEL_B		+3.3S_PON	O	Low	O		AD select B
127	IIO0_3/RTS7/ CTS7/AN15_3/ P15_3	P15_3	AD_SEL_C		+3.3S_PON	O	Low	O		AD select C
128	IIO0_2/RXD7/ AN15_2/P15_2	RXD7	232C_MISO		AC	O	Low	I	Data	External RS-232C receive data
129	IIO0_1/CLK7/ AN15_1/P15_1	P15_1	VIDI2C_ON	10KPD	HDMI_PON	O	Low	O	H act	I2C line switch to Video device
130	VSS	VSS	VSS							---
131	IIO0_0/TXD7/ AN15_0/P15_0	TXD7	232C_MOSI		AC	O	Low	O	Data	External RS-232C transmission data
132	VCC	VCC	VCC							---
133	KI3/AN_7/P10_7	P10_7	+3.3S_PON		AC	O	Low	O	H act	+3.3S power on
134	KI2/AN_6/P10_6	AN_6	AD2_COM		+3.3S_PON	O	Low	I	A/D	AD selector 2 COM input
135	KI1/AN_5/P10_5	AN_5	AD1_COM		+3.3S_PON	O	Low	I	A/D	AD selector 1 COM input
136	KI0/AN_4/P10_4	AN_4	DEST		AC	O	Low	I	A/D	Destination discrimination
137	AN_3/P10_3	AN_3	MODEL		AC	O	Low	I	A/D	Model discriminate
138	AN_2/P10_2	AN_2	KY_AD2		AC	O	Low	I	A/D	Key 2
139	AN_1/P10_1	AN_1	KY_AD1		AC	O	Low	I	A/D	Key 1
140	AVSS	AVSS	AVSS							---
141	AN_0/P10_0	P10_0	HDR_N_RST		PRY	O	Low	O	L act	HD Radio reset (U model)
		P10_0	TU_N_TND	47kPU	+3.3S_PON	O	Low	I	L act	Tuner tuned (C, R, T, K, A, B, G, F, L, J models)
142	VREF	VREF	VREF							---
143	AVCC	AVCC	AVCC							---
144	STXD4/SCL4/ RXD4/ADTRG/ P9_7	RXD4	HDR_MISO		PRY	O	Low	I	Data	HD Radio or DAB receive data (U model)
		SCL4	TU_SCL	3.3kPU	PRY	O	Low	O	Data	Tuner I2C clock (C, R, T, K, A, B, G, F, L, J models)

Key detection for A/D port

Key input (A/D) pull-up resistance 10 k-ohms

Ohm	0	+ 0.82 k	+ 0.82 k	+ 1.0 k	+ 1.5 k	+ 2.7 k
V	0 - 0.125	0.125 - 0.358	0.358 - 0.577	0.577 - 0.828	0.828 - 1.078	1.535 - 1.777
A/D conversion value (3.3 V=255)	0 - 9	10 - 27	28 - 44	45 - 63	64 - 83	119 - 137
KY_AD1 (139 pin of the microprocessor)	SCENE 4	SCENE 3	SCENE 2	SCENE 1	ZONE2 ON/OFF	MAIN ZONE \downarrow

Ohm	0	+ 0.82 k	+ 0.82 k	+ 1.0 k	+ 1.5 k	+ 1.5 k	+ 1.8 k	+ 2.7 k	+ 3.3 k	+ 4.7 k	+ 6.8 k	+ 12.0 k	+ 22.0 k
V	0 - 0.125	0.125 - 0.358	0.358 - 0.577	0.577 - 0.828	0.828 - 1.078	1.078 - 1.299	1.299 - 1.535	1.535 - 1.777	1.777 - 2.010	2.010 - 2.241	2.241 - 2.476	2.476 - 2.709	2.709 - 2.940
A/D conversion value (3.3 V=255)	0 - 9	10 - 27	28 - 44	45 - 63	64-83	84 - 100	101 - 118	119 - 137	138 - 155	156 - 173	174 - 191	192 - 209	210 - 227
KY_AD2 (138 pin of the microprocessor)	STRAIGHT	TONE BALANCE	OPTION	Δ	ON SCREEN	<	ENTER	>	PROGRAM <	PROGRAM >	DISPLAY	∇	RETURN

Ohm	0	+ 0.82 k	+ 0.82 k	+ 1.0 k	+ 1.5 k	+ 1.5 k	+ 1.8 k	+ 2.7 k	+ 3.3 k	+ 4.7 k
V	0 - 0.125	0.125 - 0.358	0.358 - 0.577	0.577 - 0.828	0.828 - 1.078	1.078 - 1.299	1.299 - 1.535	1.535 - 1.777	1.777 - 2.010	2.010 - 2.241
A/D conversion value (3.3 V=255)	0 - 9	10 - 27	28 - 44	45 - 63	64 - 83	84 - 100	101 - 118	119 - 137	138 - 155	156 - 173
KY_AD3 (14 pin of the IC902)	PRESET >	PRESET <	MEMORY	INFO	ZONE CONTROLS	FM	AM	TUNING/CH <<	TUNING/CH >>	PURE DIRECT

Destination detection for AD port

Pull-up resistance 10 k-ohms

Destination	J	U	C	R	T	K	A	B, G, F	L
A/D conversion value (3.3 V=255)	0 - 12	13 - 40	41 - 67	68 - 92	93 - 115	116 - 140	141 - 169	199 - 221	222 - 244

Model detection for A/D port

Model input (A/D) pull-up resistance 10 k-ohms

Model name	RX-V1067	RX-A1000	HTR-8063
A/D conversion value (3.3 V=255)	59-81	82-103	104-127

• Microprocessor extended port

IC901, 902: SN74LV4051APWR (DIGITAL P.C.B.)
8-channel analog multiplexers/demultiplexers

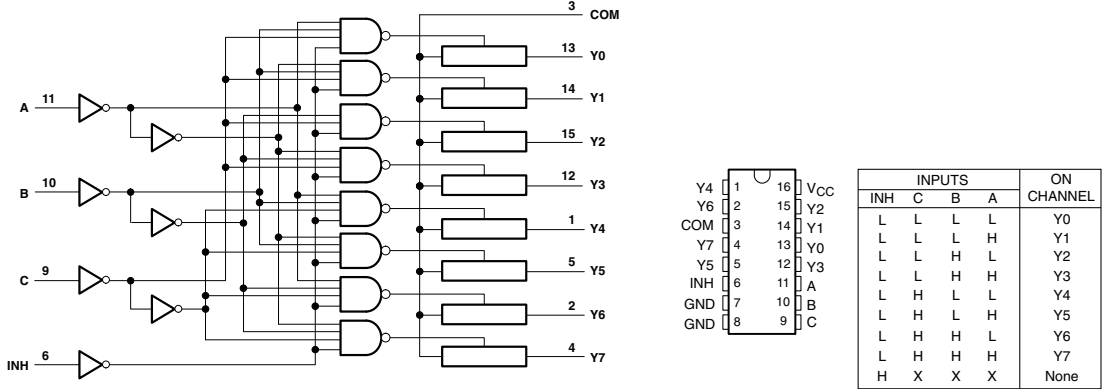

Pin No.	Port Name	Function Name	Terminal Processing	I/O	Related Power Supply				Detail of Function	
					OFF		ON			
					I/O	Logic	I/O	Logic		
AD selector 1 (AD1_COM signal is input into AN_5 of R32C)										
1	Y4	PS2_PRT		I	+3.3S_PON	I	---	I	A/D	Power supply protection 2
2	Y6	PS1_PRT		I	+3.3S_PON	I	---	I	A/D	Power supply protection 1
4	Y7	AMP_OLV		I	PRY	I	---	I	A/D	Amplifier output level detection
5	Y5	I_PRT		I	PRY	I	---	I	H act	Current protection
12	Y3	L3_DET		I	VID_PON	I	---	I	A/D	D terminal L3 detection
13	Y0	SV_DET		I	VID_PON	I	---	I	H act	S-video detect
14	Y1	HP_N_DET		I	DSP_PON	I	---	I	L act	Headphone detection
15	Y2	-		I	+3.3S_PON	I	---	I	---	Spare
AD selector 2 (AD2_COM signal is input into AN_6 of R32C)										
1	Y4	DC_PRT		I	PRY	I	---	I	A/D	DC protection
2	Y6	THM1		I	+3.3S_PON	I	---	I	A/D	Temperature detection 1
4	Y7	THM2		I	+3.3S_PON	I	---	I	A/D	Temperature detection 2
5	Y5	MIC_N_DET		I	DSP_PON	I	---	I	L act	Microphone detection
12	Y3	DOCK_AP	Suction prevention when AC is turned off	I	+3.3S_PON	I	---	I	L act	iPod accessory power
13	Y0	DOCK_ID		I	+3.3S_PON	I	---	I	A/D	DOCK ID detection
14	Y1	KY_AD3		I	+3.3S_PON	I	---	I	A/D	Key 3
15	Y2	MODE	10kPU	I	+3.3S_PON	I	---	I	A/D	For special mode discriminate

DOCK detection for AD port
Pull-up resistance 10 k-ohms

DOCK type	Bluetooth (YBA-10)	Wireless iPod (YID-W10)	iPod		No connected
			(YDS-11/12(B*))	(YDS-12(A*))	
A/D conversion value (3.3V=255)	5-25	85-100	120-140	150-170	255

* Mode switch setting of the YDS-12
YDS-12のモードスイッチ設定

IC904, 905: TC74VHC273FT (DIGITAL P.C.B.)
Octal D-type flip-flop with clear

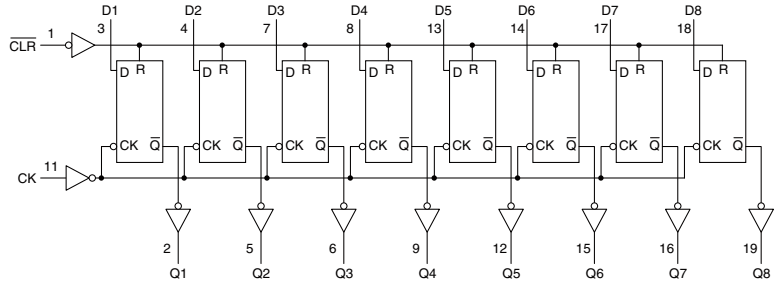
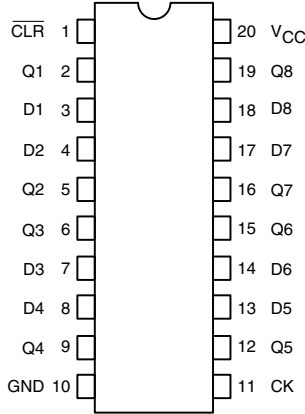

CLR	Inputs		Output	Function
	D	CK	Q	
L	X	X	L	Clear
H	L	↑	L	-
H	H	↑	H	-
H	X	↓	Q _n	No Change

Pin No.	R32C external bus data	Use Port	Function Name	Terminal Processing	Related power supply				Detail of Function
					OFF		ON		
					I/O	Logic	I/O	Logic	
D-FF(1)									
2	D0	Q1	MONO_Z2	PRY	O	Low	O	H mono	Zone2 stereo/mono output switch
5	D1	Q2	MONO_Z3	PRY	O	Low	O	H mono	Zone3 stereo/mono output switch
6	D2	Q3	Z2_SRAMP	PRY	O	Low	O	H act	Zone2 is input to SR amplifier
9	D3	Q4	Z3_SRAMP	PRY	O	Low	O	H act	Zone3 is input to SR amplifier
12	D4								
15	D5	Q6	PRY	PRY	O	Low	O	H act	Power relay
16	D6	Q7	DIR1_N_RST	DSP_PON	O	Low	O	L act	DIR1 reset
19	D7	Q8	DSP1_N_RST	DSP_PON	O	Low	O	L act	DSP1 reset
D-FF(2)									
2	D8	Q1	DIR1_N_CS	DSP_PON	O	Low	O	L act	DIR1 chip select
5	D9	Q2	DAC1_N_CS	DSP_PON	O	Low	O	L act	DAC chip select
6	D10	Q3	ADC_N_RST	DSP_PON	O	Low	O	L act	ADC reset (power down)
9	D11	Q4	DOCK_PON	DOCK_PON	O	Low	O	H act	DOCK power supply
12	D12	Q5	FL_N_RST	DSP_PON	O	Low	O	L act	FLD reset
15	D13	Q6	FL_N_CS	DSP_PON	O	Low	O	L act	FLD chip select
16	D14	Q7	UAW_PON	UAW_PON	O	Low	O	H act	UAW power supply
19	D15	Q8	PD_LED	PRY	O	Low	O	H act	Pure Direct LED

RX-V1067/HTR-8063/RX-A1000

IC504: YTD-446CZ (VIDEO P.C.B.)

VNP2 (Video and network processor)

* **No replacement part available. / サービス部品供給なし**

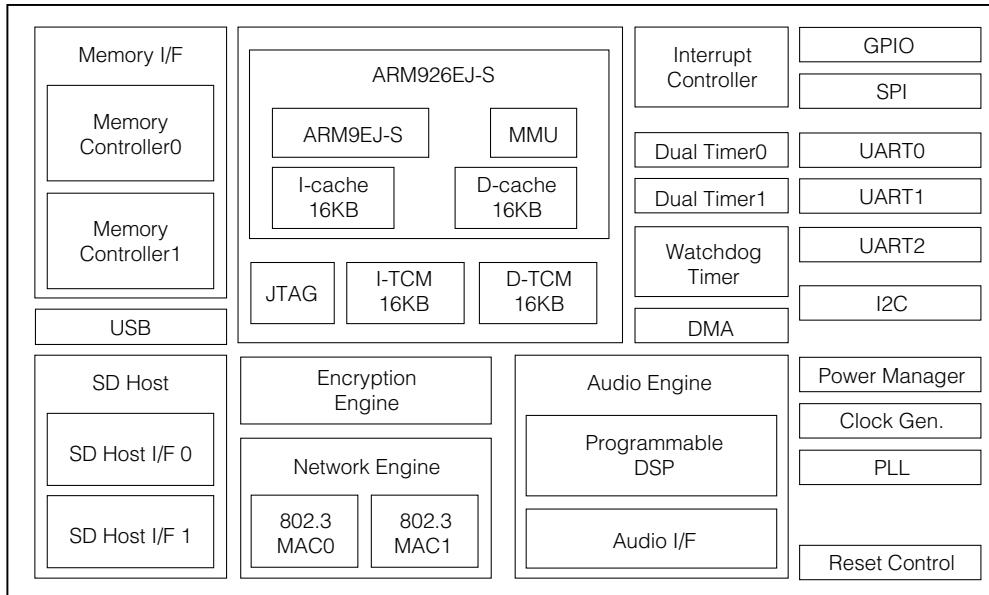

Pin No.	Port Name	Function Name	Terminal Processing	Processing Condition when not used		Condition when used		Related Power Supply		Detail of Function
				Condi- tion	Proce- ssing	DIR	Logic	OFF		
								I/O	Logic	
M25	nRESET	VNP2_N_RST	10kPD	-	-	I	L act			System reset terminal
T25	XI_S	-	5MHz quartz crystal unit	-	-	I	Clock			System clock crystal oscillation terminal
T24	XO_S	-	5MHz quartz crystal unit	-	-	O	Clock			System clock crystal oscillation terminal
AE24	XI_A	-	24.576MHz crystal oscillator	-	-	I	Clock			Audio clock crystal oscillation terminal
AD24	XO_A	-	OPEN	-	-	O	Clock			
T22	TEST0	TEST0	10kPU	-	-	I	H act			System reset terminal
R23	TEST1	-	GND at J	-	-	I	H act			
T23	TEST2	-	GND at J	-	-	I	H act			
L23	nSCS3	N_SCS3		-	-	O	BUS			Chip select 3
L24	nSCS2	N_SCS2		-	-	O	BUS			Chip select 2
K23	nSCS1	N_SCS1		-	-	O	BUS			Chip select 1 FLASH_N_CS
L24	nSCS0	N_SCS0		-	-	O	BUS			Chip select 0
J23	nSLBE	N_SLBE		-	-	O	BUS			Lower byte enable
J24	nSUBE	N_SUBE		-	-	O	BUS			Upper byte enable
K25	nSWR	N_SWE		-	-	O	BUS			Write enable
J25	nSRD	N_SRD		-	-	O	BUS			Read enable
**	SA[22:0]	SRA[22:0]		-	-	O	BUS			External I/O address bus
**	SD[15:0]	SRD[15:0]	10kPU	-	-	B	BUS			External I/O data bus
B1	SCLK0	SDRAM_CLK0		-	-	O	Clock			SDRAM clock enable
C1	SCKE0	SDRAM_CKE0		-	-	O	H act			SDRAM clock enable
D1	SCLK1	SDRAM_CLK1		-	-	O	Clock			SDRAM clock enable
E1	SCKE1	SDRAM_CKE1		-	-	O	H act			SDRAM clock enable
F1	nCS1	-		-	-	O	BUS			SDRAM chip select 1

Pin No.	Port Name	Function Name	Terminal Processing	Processing Condition when not used		Condition when used		Related Power Supply			Detail of Function
				Condition	Processing	DIR	Logic	OFF			
								I/O	Logic		
C2	nCS0	SDRAM_N_CS0		-	-	O	BUS				SDRAM chip select 0
E3	nWE	SDRAM_N_WE		-	-	O	BUS				SDRAM write enable
F2	nRAS	SDRAM_N_RAS		-	-	O	BUS				SDRAM row address strobe
E2	nCAS	SDRAM_N_CAS		-	-	O	BUS				SDRAM column address strobe
A9	DQM3	SDRAM_DQM3		-	-	O	BUS				SDRAM data input/output mask3
B9	DQM2	SDRAM_DQM2		-	-	O	BUS				SDRAM data input/output mask2
C9	DQM1	SDRAM_DQM1		-	-	O	BUS				SDRAM data input/output mask1
C10	DQM0	SDRAM_DQM0		-	-	O	BUS				SDRAM data input/output mask0
**	A[12:0]	SDRAM_A[11:0]		-	-	O	BUS				SDRAM address bus
J2	A13	SDRAM_BA0		-	-	O	BUS				SDRAM bank select BA0
J1	A14	SDRAM_BA1		-	-	O	BUS				SDRAM bank select BA1
**	D[31:0]	SDRAM_DQ[31:0]		-	-	B	BUS				SDRAM data bus
M24	nINT1	-	10kPU	-	-	I	Interrupt				Empty
M23	nINT2	PHY0_N_INT	10kPU	-	-	I	Interrupt				Interrupt from PHY
AE7	TXD0	DBG_TXD		-	-	O	UART TX				Serial for debug
AE8	RXD0	DBG_RXD	10kPD	-	-	I	UART RX				Serial for debug
AD7	AGPIO[4]	DBG_LED0	10kPU	-	-	O	Data				LED for debug
AD8	AGPIO[1]	DBG_LED1	10kPU	-	-	O	Data				LED for debug
AC8	AGPIO[2]	NCPU_N_INT		-	-	O	Data				Interrupt to main microprocessor
AE5	TXD1	NCPU_MISO		-	-	O	UART TX				Microprocessor communication VNP2->R32C
AE6	RXD1	NCPU_MOSI	10kPD	-	-	I	UART RX				Microprocessor communication R32C->VNP2
AD5	AGPIO[10]	-	10kPD	Always	I	-	-				Empty
AD6	AGPIO[7]	-	10kPD	Always	I	-	-				Empty
AC6	AGPIO[8]	PHY01_N_RST	10kPD	-	-	O	Data				PHY reset
AD4	AGPIO[13]	USB_HIZ	10kPU	-	-	O	Data				Not used (H: USB disconnected L: USB connected)
AC5	AGPIO[11]	N_WOL	100kPU	-	-	O	Data				No used (Wake on lan)
AE4	ABPIO[12]	USB_N_FRONT	10kPD	-	-	O	Data				No used (H: Rear USB disconnected L: Front USB)
AC7	AGPIO[5]	-	10kPU	Always	I	-	-				Empty
AE2	AGPIO[18]	-	10kPD	Always	I	-	-				Empty
AE3	RXD2	DOCK_MISO	10kPD	-	-	I	UART RX	DOCK_ON UAW_ON	I		iPOD receive data
AD2	AGPIO[19]	-	10kPD	Always	I	-	-				Empty
AD3	AGPIO[16]	-	10kPD	Always	I	-	-				Empty
AD1	AGPIO[20]	PHY0_N_100M	4.7kPU	-	-	I	Data				H: Ether 10Mbps L: Ether 100Mbps
AC4	PARITY/ AGPIO[14]	PHY0_N_FDX	4.7kPU	-	-	I	Data				H: Ether half duplex L: Ether full duplex
AC3	SIMRST/ AGPIO[17]	PHY0_PD		-	-	O	Data				H: Ether low power L: Ether normal power
AA1	I2C_SDA	EEP_SDA	2.2kPU	-	-	B	Data				I2C EEPROM SDA
Y1	I2C_SCL	EEP_SCL	2.2kPU	-	-	O	Clock				I2C EEPROM SCL
Y3	SPI_SCK	NCPU_PIC_SCK		-	-	O	Clock				Image data transmission clock
W3	SPI_CS0	DSP2_N_CS2	10kPD	-	-	O	Data				No used (DSP2 SPI chip select)

Pin No.	Port Name	Function Name	Terminal Processing	Processing Condition when not used		Condition when used		Related Power Supply			Detail of Function
				Condi-tion	Proce-ssing	DIR	Logic	OFF			
								I/O	Logic		
V1	BGPIO[7]	DSP2_N_SPIRDY	4.7kPU	-	-	I	-				No used (DSP2 SPI ready signal)
V2	BGPIO[8]	DA_MUTE	10kPU	-	-	O	H act				Zone DAC mute
V3	BGPIO[9]	-	10kPD	Always	I	O	Data				
W1	SPI_SDI	DSP_MISO	10kPD	-	-	I	SPI RX				No used (DSP2 SPI MISO)
W2	SPI_SDO	NCPU_PIC_MOSI		-	-	O	SPI TX				Image data
N25	BGPIO[16]	BGPIO16	10kPD	Always	I	-	-				Empty
N24	BGPIO[17]	BGPIO17	10kPD	Always	I	-	-				Empty
N23	BGPIO[18]	BGPIO18	10kPD	Always	I	-	-				Empty
P25	BGPIO[19]	BGPIO19	10kPD	Always	I	-	-				Empty
P24	BGPIO[20]	BGPIO20	10kPD	Always	I	-	-				Empty
P23	BGPIO[21]	REV0	10kPU GND at J	-	-	I	Data				L: 2 types of crystals used H: 1 type of crystal used Model distinction
Y2	BGPIO[2]		10kPD	Always	I	-	-				Empty
R25	BGPIO[22]	REV1	10kPU GND at J	-	-	I	Data				No used (For hardware version)
R24	BGPIO[23]	REV2	10kPU GND at J	-	-	I	Data				No used (For hardware version)
R1	SDO_ABCK	NCPU_BCK		-	-	O	Clock	DSP_PON	O	Low	Audio output bit clock
U2	BGPIO[11]	-		Always	O/L	-	-				Empty
P1	SDO_AWCK	NCPU_WCK		-	-	O	Clock	DSP_PON	O	Low	Audio output word clock
U3	BGPIO[12]	-		Always	O/L	-	-				Empty
U1	SDO_MCK	NCPU_MCK		-	-	O	Clock	DSP_PON	O	Low	Audio output master clock
P2	SDO3	NCPU_SD3		-	-	O	Data				No used (Audio output data 3)
P3	SDO2	NCPU_SD2		-	-	O	Data				No used (Audio output data 2)
R2	SDO1	NCPU_SD1		-	-	O	Data				No used (Audio output data 1)
R3	SDO0	NCPU_SD0		-	-	O	Data	DSP_PON	O	Low	Audio output data 0
N1	SDI_ABCK		GND	-	-	I	Clock				No used
T2	BGPIO[14]	DBG_DIP0	10kPU	-	-	I	Data				DIP SW0 for debug
M1	SDI_AWCK		GND	-	-	I	Clock				No used
T3	BGPIO[15]	DBG_DIP1	10kPU	-	-	I	Data				DIP SW1 for debug
T1	SDI_MCK				O/L	-	-				
M2	SDI3		GND	-	-	I	Data				No used
M3	SDI2		GND	-	-	I	Data				No used
N2	SDI1		GND	-	-	I	Data				No used
N3	SDI0		GND	-	-	I	Data				No used
AE16	USBP	USBP	15kPD	-	-	B	Data				USB data +
AD16	USBM	USBM	15kPD	-	-	B	Data				USB data -
AB16	USB_PWEN	USB_PWEN		-	-	O	H act				USB power enable
AC17	USB_OC	USB_OC		-	-	I	H act				USB over current detection
AE12	MAC_REF_CLK	PHY01_REF_CLK		-	-	O	Clock				MAC0 RMII clock output
AE13	MAC0_RXD0	PHY0_RXD0		-	-	I	Data				MAC0 RMII reception data 0
AD13	MAC0_RXD1	PHY0_RXD1		-	-	I	Data				MAC0 RMII reception data 1
AC13	MAC0_RXER	PHY0_RXER	4.7kPD	-	-	I	Data				MAC0 RMII reception error
AE14	MAC0_TXD0	PHY0_TXD0		-	-	O	Data				MAC0 RMII transmission data 0
AD14	MAC0_TXD1	PHY0_TXD1		-	-	O	Data				MAC0 RMII transmission data 1
AC14	MAC0_TXEN	PHY0_TXEN		-	-	O	Data				MAC0 RMII transmission enable
AD12	MAC0_CRS_DV	PHY0_CRS_DV		-	-	I	Data				MAC0 RMII career detection
AE15	MAC0_MDC	PHY0_MDC		-	-	O	Clock				MAC0 RMII MI clock
AD15	MAC0_MDIO	PHY0_MDIO	4.7kPU	-	-	B	Data				MAC0 RMII MI data

IC931: MB87L8760 (DIGITAL P.C.B.)

NPGA

* No replacement part available. / サービス部品供給なし

Pin No.	Port Name		Use Port	Function Name	Terminal Processing	Related Power Supply				Detail of Function	
						OFF		ON			
						I/O	Logic	I/O	Logic		
32	SCK0	SPI0	SCK0	DSP_CLK		DSP_PON	O	Low	O	Clk	DSP communication clock
33	SO0	SPI0	SO0	DSP_MOSI		DSP_PON	O	Low	O	Data	DSP transmission data
34	SI0	SPI0	SI0	DSP_MISO	10kPD	DSP_PON	I	---	I	Data	DSP receive data
40	SCK1	SPI1									Usable as output port
41	SO1	SPI1									Usable as output port
42	SI1	SPI1									
43	SCK2	SPI2									Usable as output port
44	SO2	SPI2									Usable as output port
47	SI2	SPI2									
48	TXD0	UART0	TXD0	SR_MOSI	"5V lever shift Raise \$LCR SB"	SR_PON	O	Low	O	Data	SIRIUS transmission data
49	RXD0	UART0	RXD0	SR_MISO	"3.3V level shift 10kPD"	SR_PON	I	---	I	Data	SIRIUS receive data
57	TXD1	UART1	TXD1	SCR_MOSI	"Switch to SCL2 with JW Raise \$LCR SB"	HDMI_PON	O	Low	O	Data	Video scaler debug transmission data
58	RXD1	UART1	RXD1	SCR_MISO	"Switch to SDA2 with JW 10kPD"	HDMI_PON	I	---	I	Data	Video scaler debug receive data
69	TXD2	UART2	TXD2	IRB_MOSI	Raise \$LCR SB	PRY	O	Low	O	Data	IR blaster transmission data
70	RXD2	UART2	RXD2	IRB_MISO	10kPD	PRY	I	---	I	Data	IR blaster receive data
11	SCL0	I2C0	SCL0	HEQ_SCL	2.2kPU	HDMI_PON	O	Low	O	Clock	HDMI switcher 100k I2C clock
12	SDA0	I2C0	SDA0	HEQ_SDA	2.2kPU	HDMI_PON	O	Low	I/O	Data	HDMI switcher 100k I2C data
25	SCL1	I2C1	SCL1	SCR_SCL	2.2kPU	HDMI_PON	O	Low	O	Clock	Video scaler 400k I2C clock
26	SDA1	I2C1	SDA1	SCR_SDA	2.2kPU	HDMI_PON	O	Low	I/O	Data	Video scaler 400k I2C data
27	SCL2	I2C2	SCL2	SCR_DBG_SCL	"Switch to TXD1 with JW 2.2kPU"	HDMI_PON	O	Low	O	Clock	Video scaler debug 400k I2C clock
28	SDA2	I2C2	SDA2	SCR_DBG_SDA	"Switch to RXD1 with JW 2.2kPU"	HDMI_PON	O	Low	I/O	Data	Video scaler debug 400k I2C data
109	PIO_MCLKI	0	IN	RDS_RDY	10kPU+100kPD	PRY	I	---	I	H act	RDS ready
111	PI1_LRCK	1	IN	RDS_MISO	10kPD	PRY	I	---	I	Data	RDS data
77	PI2_X0IN	2	IN								GND at 0J if not assigned
80	PI3_X1IN	3	IN								GND at 0J if not assigned
50	PI4_XCTS0	4	IN								GND at 0J if not assigned
59	PI5_XCTS1	5	IN								GND at 0J if not assigned
71	PI6_XCTS2	6	IN								GND at 0J if not assigned
99	PO0_MCLKO	7	OUT	RDS_CLK		PRY	O	Low	O	Clock	RDS clock
94	PO1_XLOCK	8	OUT	RDS_RST		PRY	O	Low	O	H act	RDS reset
97	PO2		OUT	DAC_N_RST_F		DSP_PON	O	Low	O	L act	MainZone DAC reset Front (PCM1789)
98	PO3		OUT	DAC_N_RST		DSP_PON	O	Low	O	L act	MainZone DAC reset Center/Surround/Surround Back/SW (PCM1789)
51	PO4_XRTS0		OUT				O	Low	O	Low	
60	PO5_XRTS1		OUT				O	Low	O	Low	
72	PO6_XRTS2	13	OUT								Open if not assigned
8	PWM0	14	OUT								Open if not assigned
23	PWM1	15	OUT								Open if not assigned
3	PIO0_0 [PIO0]	16	IN		10kPD	HDMI_PON	O	Low	O	Low	Set to OUT if not assigned
4	PIO0_1 [PIO1]	17	IN		10kPD	HDMI_PON	O	Low	O	Low	Set to OUT if not assigned
5	PIO0_2 [PIO2]	18	IN	HTX1_N_INT	10kPU	HDMI_PON	I	---	I	L act	HDMI TX1 interrupt (reserve)
6	PIO0_3 [PIO3]	19	IN	HTX2_N_INT	10kPU	HDMI_PON	I	---	I	L act	HDMI TX2 interrupt (reserve)
7	PIO0_4 [PIO4]	20	IN	DSP2_N_SPIRDY	"4.7kPU at 100kPD and Net 31, 35"	DSP_PON	O	Low	I	L act	DSP2 SPI ready
24	PIO0_5 [PIO5]	21	IN	SCR_N_INT	10kPU	HDMI_PON	I	---	I	L act	Interrupt of scaler
31	PIO0_6 [PIO6]	22	IN		10kPD	HDMI_PON	O	Low	O	Low	Set to OUT if not assigned
35	PIO0_7 [PIO7]	23	IN		10kPD	HDMI_PON	O	Low	O	Low	Set to OUT if not assigned

Pin No.	Port Name		Use Port	Function Name	Terminal Processing	Related Power Supply				Detail of Function	
						OFF		ON			
						I/O	Logic	I/O	Logic		
36	PIO1_0 [PIO8]	24	OUT	SR_PON	PD in digital trans	DSP_PON	O	Low	O	H act	SIRIUS power supply control
61	PIO1_1 [PIO9]	25	OUT	NCPU_PON	10kPD	N C P U _ P O N	O	Low	O	H act	Network module power supply control
62	PIO1_2 [PIO10]	26	OUT	TVD_SEL		DSP_PON	O	Low	O	L Opt	HDMI SPDIF/AudioReturnCh (TV sound) switch
63	PIO1_3 [PIO11]	27	OUT		10kPD	HDMI_PON	O	Low	O	Low	Set to OUT if not assigned
64	PIO1_4 [PIO12]	28	OUT	AVD_I2C_ON	10kPD	HDMI_PON	O	Low	O	H act	I2C line ON/OFF to analog video
67	PIO1_5 [PIO13]	29	OUT		10kPD	HDMI_PON	O	Low	O	Low	Set to OUT if not assigned
68	PIO1_6 [PIO14]	30	OUT		10kPD	HDMI_PON	O	Low	O	Low	Set to OUT if not assigned
120	PIO1_7 [PIO15]	31	OUT	PLL_ON	10kPU	DSP_PON	O	Low	O	H act	on when CS2300 PLL on/off H: (spare)
13	PIO2_0 [PIO16]	32	OUT	DSP2_N_RST	10kPD	DSP_PON	O	Low	O	L act	Reset of DSP2
14	PIO2_1 [PIO17]	33	OUT		10kPD	HDMI_PON	O	Low	O	Low	Set to OUT if not assigned
15	PIO2_2 [PIO18]	34	OUT		10kPD	HDMI_PON	O	Low	O	Low	Set to OUT if not assigned
16	PIO2_3 [PIO19]	35	OUT	SCR_N_RST	10kPD	HDMI_PON	O	Low	O	L act	Reset of VHD1900(ABT1030)
17	PIO2_4 [PIO20]	36	OUT	EX3_N_RST	10kPD	PRY	O	Low	O	L act	Reset of expand IO3
20	PIO2_5 [PIO21]	37	OUT	NCPU_N_RST	10kPU	N C P U _ P O N	I	---	O	L act	Network microprocessor reset
21	PIO2_6 [PIO22]	38	OUT		10kPD	HDMI_PON	O	Low	O	Low	Set to OUT if not assigned
22	PIO2_7 [PIO23]	39	OUT		10kPD	HDMI_PON	O	Low	O	Low	Set to OUT if not assigned
39	PIO3_0 [PIO24]	40	OUT		10kPD	HDMI_PON	O	Low	O	Low	Set to OUT if not assigned
52	PIO3_1 [PIO25]	41	OUT		10kPD	HDMI_PON	O	Low	O	Low	Set to OUT if not assigned
53	PIO3_2 [PIO26]	42	OUT	EX3_N_CS	10kPU	PRY	O	Low	O	H act	Chip select of expand IO3
56	PIO3_3 [PIO27]	43	OUT	DSP2_N_CS		DSP_PON	O	Low	O	L act	Chip select of DSP2
119	PIO3_4 [PIO28]	44	OUT	DAC_N_CS_FP	10kPU not needed	DSP_PON	O	Low	O	L act	For resistor set of DAC (MainZone PCM1789)
121	PIO3_5 [PIO29]	45	OUT	DAC_N_CS_RP	10kPU not needed	DSP_PON	O	Low	O	L act	For resistor set of DAC (Zone2 PCM1781)
123	PIO3_6 [PIO30]	46	OUT		10kPD	HDMI_PON	O	Low	O	Low	Set to OUT if not assigned
125	PIO3_7 [PIO31]	47	OUT	VOL2_CLK		PRY	O	Low	O	Clock	Volume/ZoneTone/Selector2 communication clock

PIN CONNECTION DIAGRAMS

• ICs

<p>ADV7172KST</p>	<p>ADV7800BSTZ-80</p>	<p>BA15218F</p>	<p>BD6517F-E2</p>	<p>CS230011-CZZR</p>	
<p>D70YE101BRFP266 R5F64169DFD</p>	<p>SiI9233ACTU MB87L8760</p>	<p>DIX9210PTR</p>	<p>EN5337QI</p>	<p>FHP3350IM14X</p>	<p>IP101ALF</p>
<p>KIA7812API</p>	<p>KIA7912PI</p>	<p>L6566BTR</p>	<p>LB1836M-TLM-E</p>	<p>LC709004A-TLM-E</p>	
<p>LC72725KM-UY-TLM-E</p>	<p>LE25CB5122M-TLM-E LE25LB2562M-TLM-E</p>	<p>LM19CIZ/LF</p>	<p>M12L128168A-5TG2T</p>	<p>MX29GL128ELT2I-90G</p>	
<p>MX29LV160DBTI-70G MX29LV640EBTI-70G</p>	<p>NJM2068MD-TE2</p>	<p>NJM2388F33</p> <p>1. VIN 2. VOUT 3. GND 4. ON/OFF CONTROL</p>	<p>NJM2867F3-05 (TE1)</p>	<p>NJM431U</p> <p>1: REFERENCE 2: ANODE 3: CATHODE</p>	<p>NJM4565M NJM4580E</p>

RX-V1067/HTR-8063/RX-A1000

• ICs

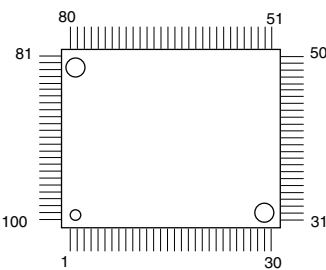
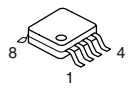
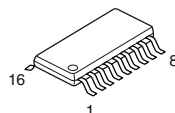
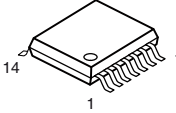
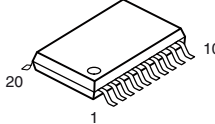
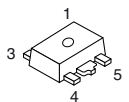
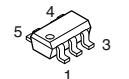
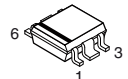
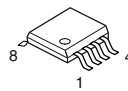
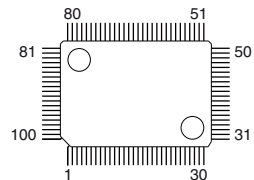
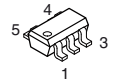
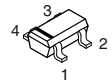
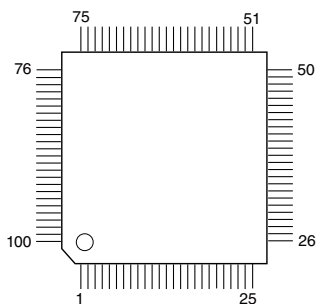
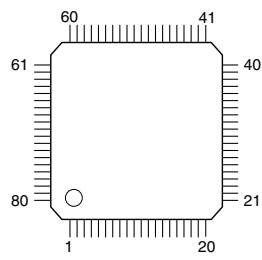
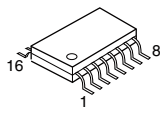
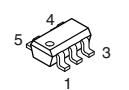
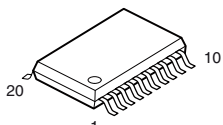
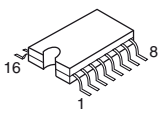
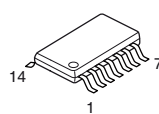
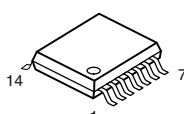
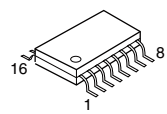
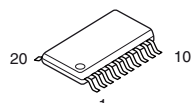
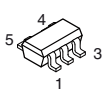
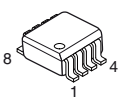
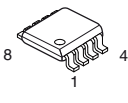
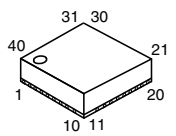
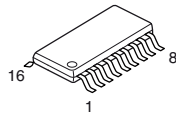
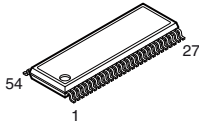
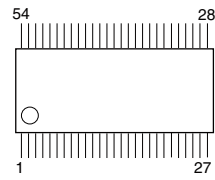
<p>NJW1327FU1</p> 	<p>PCA9517DP</p> 	<p>PCM1781DBQR</p> 	<p>PCM1789PWR</p> 	<p>PCM1803DBR</p> 	
<p>R1172H121D-T1-F R1172H501D-T1-F</p> 	<p>R1172N501D-TR-F</p> 	<p>R1172S331B-E2-F</p> 	<p>R1EX24128ASAS0A</p> 	<p>R2A15220FP</p> 	
<p>R3112N251A-TR R3112N421A-TR-F</p> 	<p>RP130Q121D-TR-F RP130Q181D-TR-F RP130Q331D-TR-F RP130Q501D-TR-F</p> 	<p>SiI9134CTU</p> 	<p>SiI9185ACTU</p> 		
<p>SN74LV4051APWR</p> 	<p>SN74LVC1G17DCKR</p> 	<p>SN74LVC245APWR</p> 	<p>TC74HC4051AFEL TC74HC4052AF</p> 	<p>TC74VHC08FT TC74VHCT08AFT TC74VHCU04FT</p> 	
<p>TC74VHC126FT TC74VHC86FT (EL)</p> 	<p>TC74VHC157FT</p> 	<p>TC74VHC273FT (EL,K)</p> 	<p>TC7SH08FU TC7SH32FU TC7SH125FU</p> 	<p>TC7WH04FU TC7WHU04FU</p> 	<p>TC7WH14FK TC7WH157FK</p> 
<p>TMDS141RHAR</p> 	<p>TRS3221ECPWR</p> 	<p>V54C365164VEI6</p> 	<p>W9825G6EH-75</p> 		





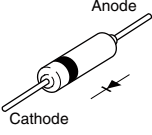
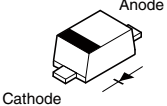
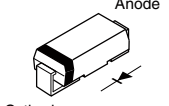
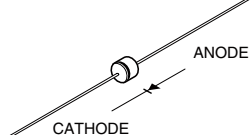
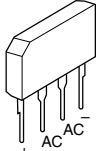
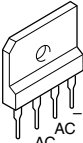
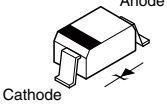
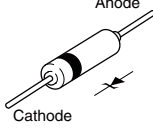
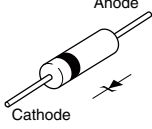
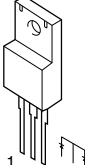
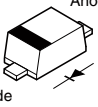
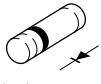
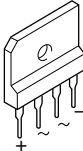
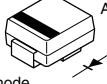
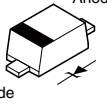





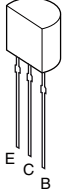
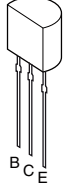

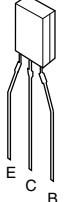
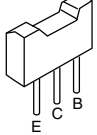
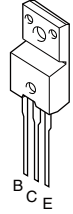
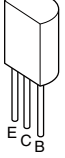

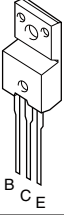

RX-V1067/HTR-8063/
RX-A1000

• Diodes

<p>1N4002S</p> 	<p>1SS355</p> 	<p>D1FL20U-5063</p> 	<p>D1NL20U-5083</p> 	<p>D2SBA60-7001</p> 
<p>DS4BS6-7101 4A 60V D6SBN20</p> 	<p>HZU4.7B2 TRF-E HZU15B2 TRF-E</p> 	<p>MTZJ5.1C</p> 	<p>P6KE200ARL</p> 	<p>RB215T-60</p> 
<p>RB501V-40</p> 	<p>RLS245</p> 	<p>RS605M-B-C-J81</p> 	<p>STTH110A</p> 	<p>UDZS3.3B 3.3V UDZS3.6B 3.6V UDZS5.1B 5.1V UDZS6.2B 6.2V UDZS7.5B 7.5V UDZS8.2B 8.2V UDZS10B 10V UDZS13B 13V UDZS22B 22V</p> 

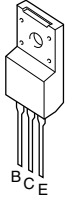
RX-V1067/HTR-8063/
RX-A1000

• Transistors

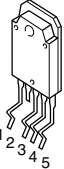
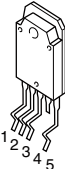
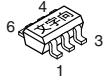
<p>2N5401C-AT/P 2SA1015-Y</p> 	<p>2N5551C-AT</p> 	<p>2SA1576A</p> 	<p>2SA1208S/T-AE 2SC2910S/T-AE</p> 	<p>2SA1708 2SC4488</p> 	<p>2SB1257</p> 	<p>2SC1815 Y</p> 
<p>2SC2412K</p> 	<p>2SD2704 K 2SC3906K</p> 	<p>2SC4081 T106</p> 	<p>2SC5938A</p> 	<p>2SD2014</p> 	<p>2SK208-Y</p> 	<p>2SK3288ENTL-E</p> 
<p>DTA114EKA DTA143EKA DTA144EKA DTC114EKA DTC144EKA</p>  <p>1: GND 2: IN 3: OUT</p>	<p>HN4C06J</p>  <p>1. BASE 1 (B1) 2. EMITTER (E) 3. BASE 2 (B2) 4. COLLECTOR 2 (C2) 5. COLLECTOR 1 (G2)</p>	<p>KRA104S-RTK KRC104S-RTK</p> 	<p>KTA1046-Y-U/P KTA1837-U/P</p> 	<p>KTA1504S KTA1517S</p> 		
<p>KTC3875S</p> 	<p>MCH6336-TL-E</p>  <p>1. Drain 2. Drain 3. Gate 4. Source 5. Drain 6. Drain</p>	<p>STD01P</p> 	<p>STD01N</p> 	<p>μPA672T-T1-A</p>  <p>1. Source 1 (S1) 2. Gate 1 (G1) 3. Drain 2 (D2) 4. Source 2 (S2) 5. Gate 2 (G2) 6. Drain 1 (D1)</p>		

RX-V1067/HTR-8063/
RX-A1000

BLOCK DIAGRAMS

AUDIO Section Block Diagram

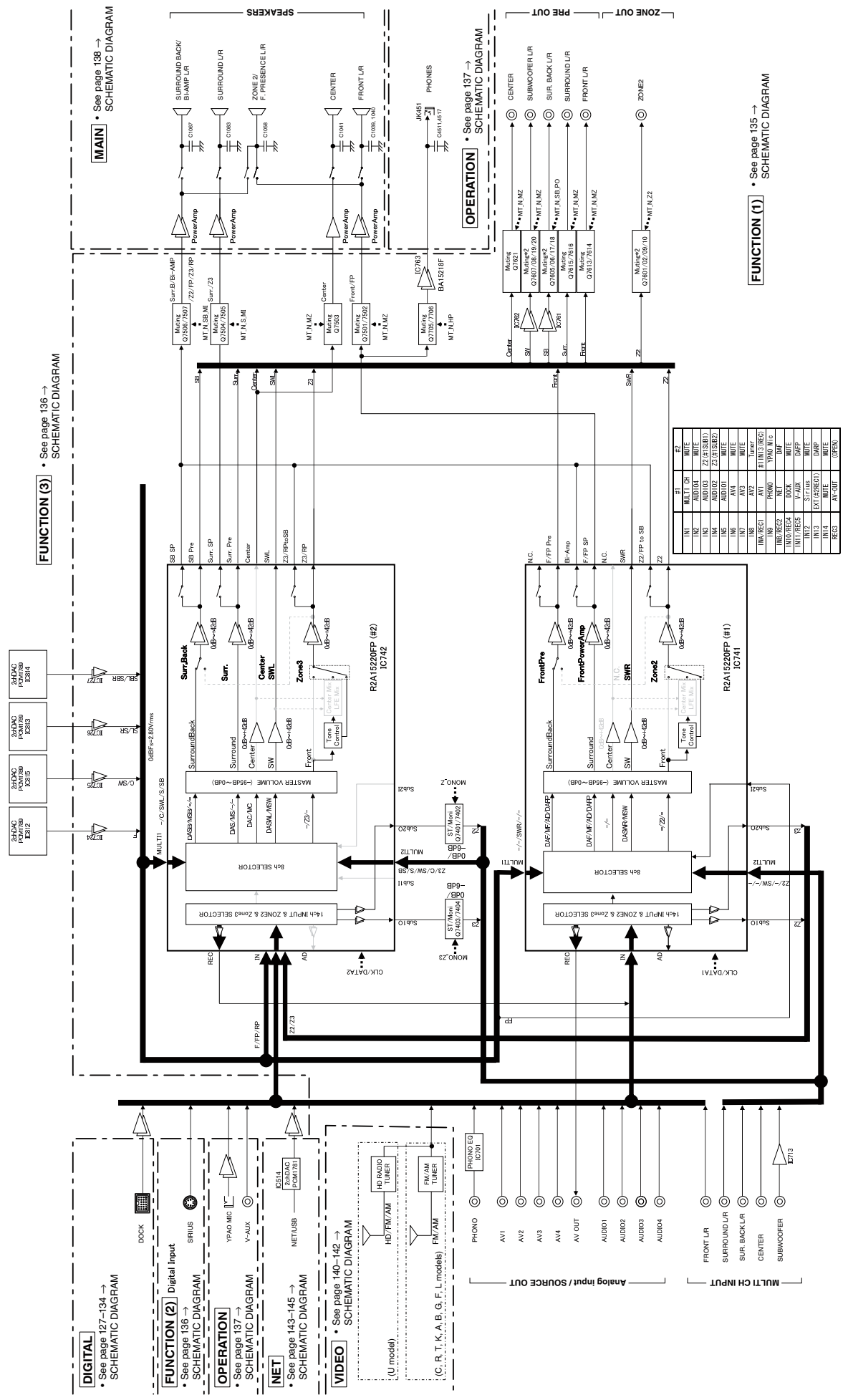

DIGITAL
 • See page 136 → SCHEMATIC DIAGRAM
 • See page 137 → SCHEMATIC DIAGRAM
 • See page 138 → SCHEMATIC DIAGRAM

FUNCTION (2)
 • See page 136 → SCHEMATIC DIAGRAM
 • See page 137 → SCHEMATIC DIAGRAM
 • See page 138 → SCHEMATIC DIAGRAM

OPERATION
 • See page 137 → SCHEMATIC DIAGRAM
 • See page 138 → SCHEMATIC DIAGRAM

NET
 • See page 143-145 → SCHEMATIC DIAGRAM

VIDEO
 • See page 140-142 → SCHEMATIC DIAGRAM

PHONO
 AV1
 AV2
 AV3
 AV4
 AV OUT
 AUDIO1
 AUDIO2
 AUDIO3
 AUDIO4
 FRONT L/R
 SURROUND L/R
 SUR. BACK L/R
 CENTER
 SUBWOOFER

IN	OUT	REMARKS
INT	MULTI OR	MUTE
INT	AUDIO1	Z2 (MTR)
INT	IM	Z1 (MTR)
INT	AM102	Z1 (SBR2)
INT	AM101	MUTE
INT	AV4	MUTE
INT	AV3	MUTE
INT	AV2	MUTE
INT	AV1	BT (SBR2)
INT	PHONO	YPAO N.C.
INT	REC2	NET
INT	REC4	DOCK
INT	REC5	NET
INT	REC6	NET
INT	REC3	EXT (REC1)
INT	REC4	MUTE
INT	REC3	AV-OUT
INT	REC3	AV-OUT

FUNCTION (1)
 • See page 135 → SCHEMATIC DIAGRAM

OPERATION
 • See page 137 → SCHEMATIC DIAGRAM

MAIN
 • See page 138 → SCHEMATIC DIAGRAM

FUNCTION (3)
 • See page 136 → SCHEMATIC DIAGRAM

DIGITAL P.C.B. Section Block Diagram

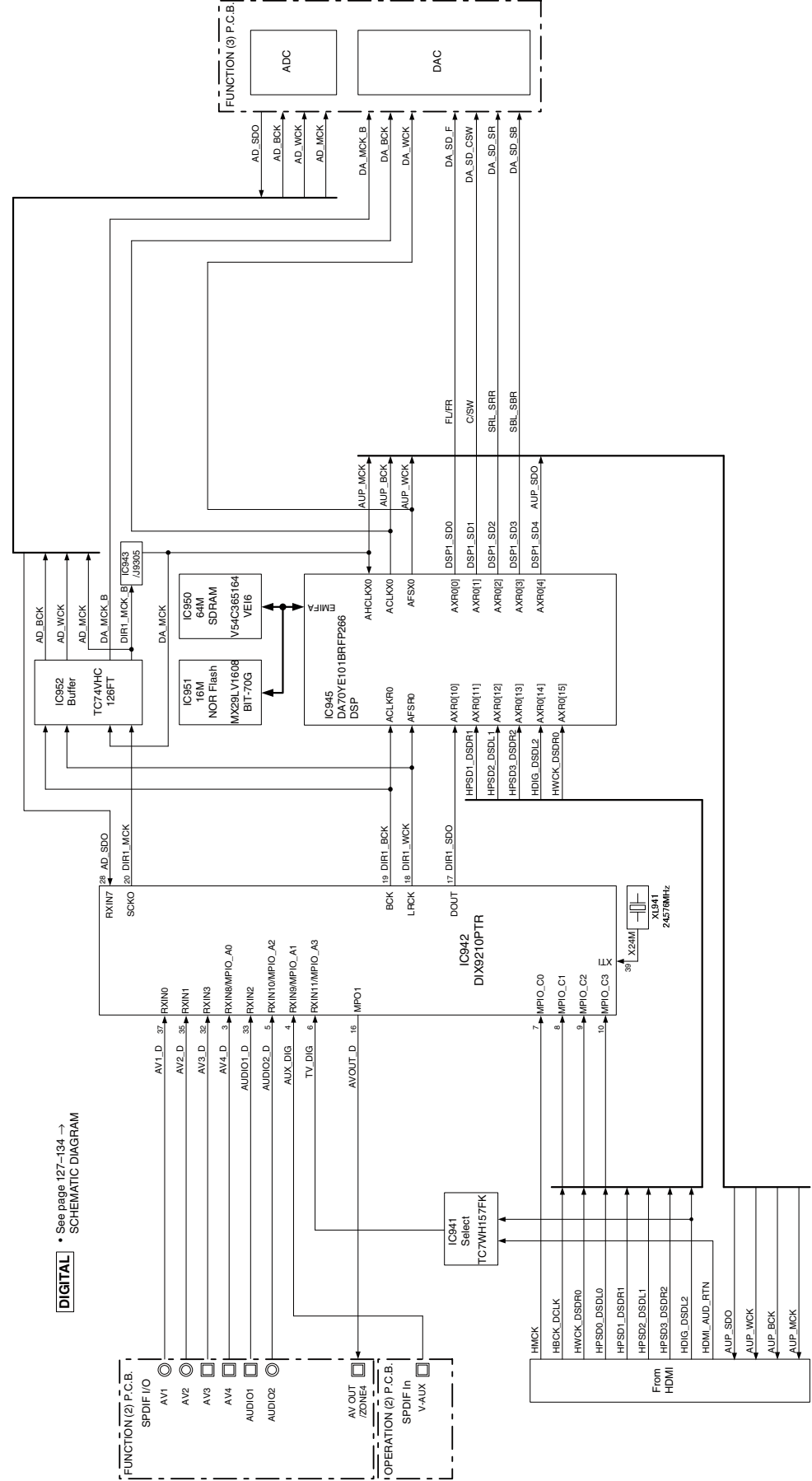

DIGITAL • See page 127-134 → SCHEMATIC DIAGRAM

HDMI/VIDEO Section Block Diagram

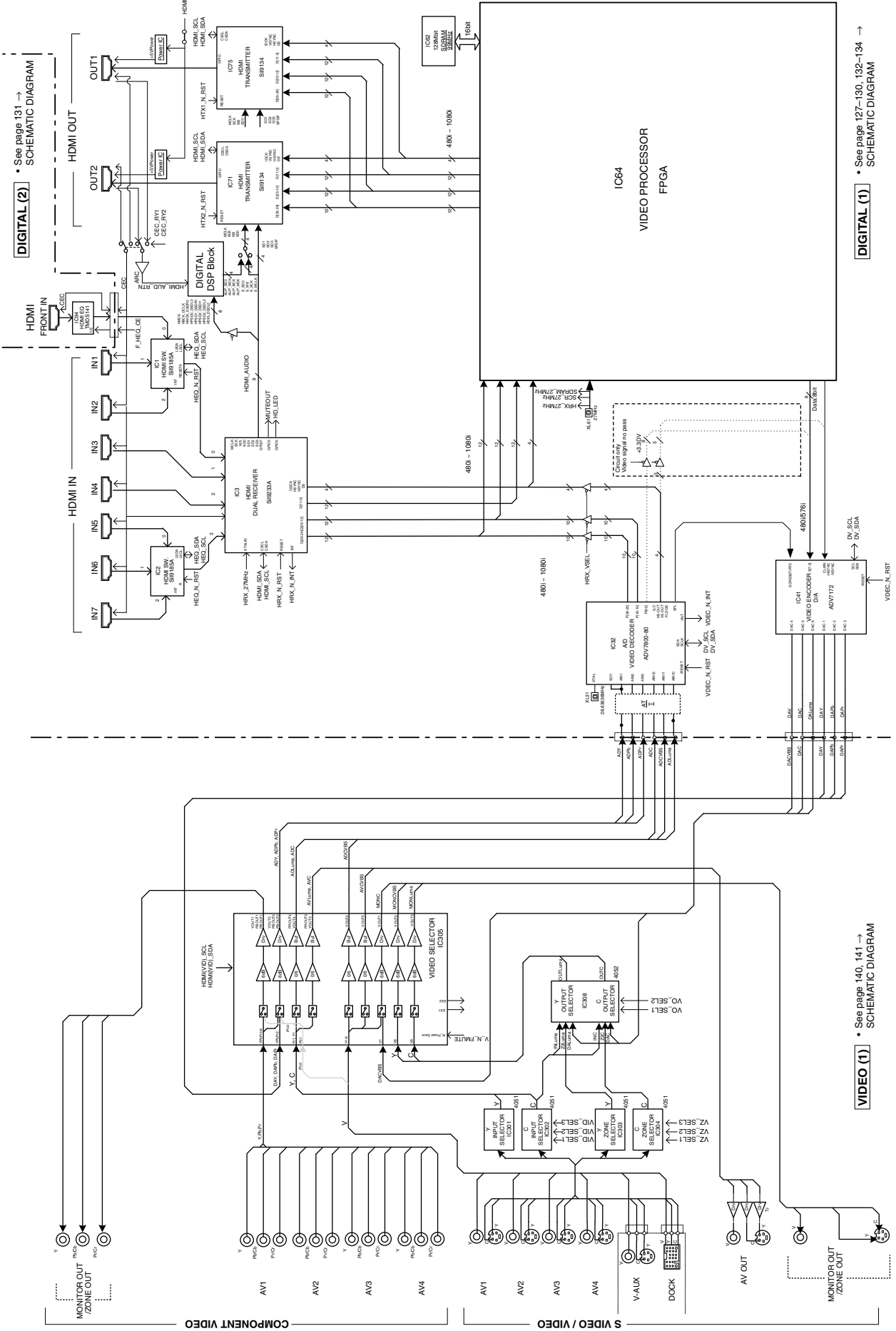

DIGITAL (2) • See page 131 → SCHEMATIC DIAGRAM

DIGITAL (1) • See page 127-130, 132-134 → SCHEMATIC DIAGRAM

VIDEO (1) • See page 140, 141 → SCHEMATIC DIAGRAM

Power Supply and Protection Section Block Diagram

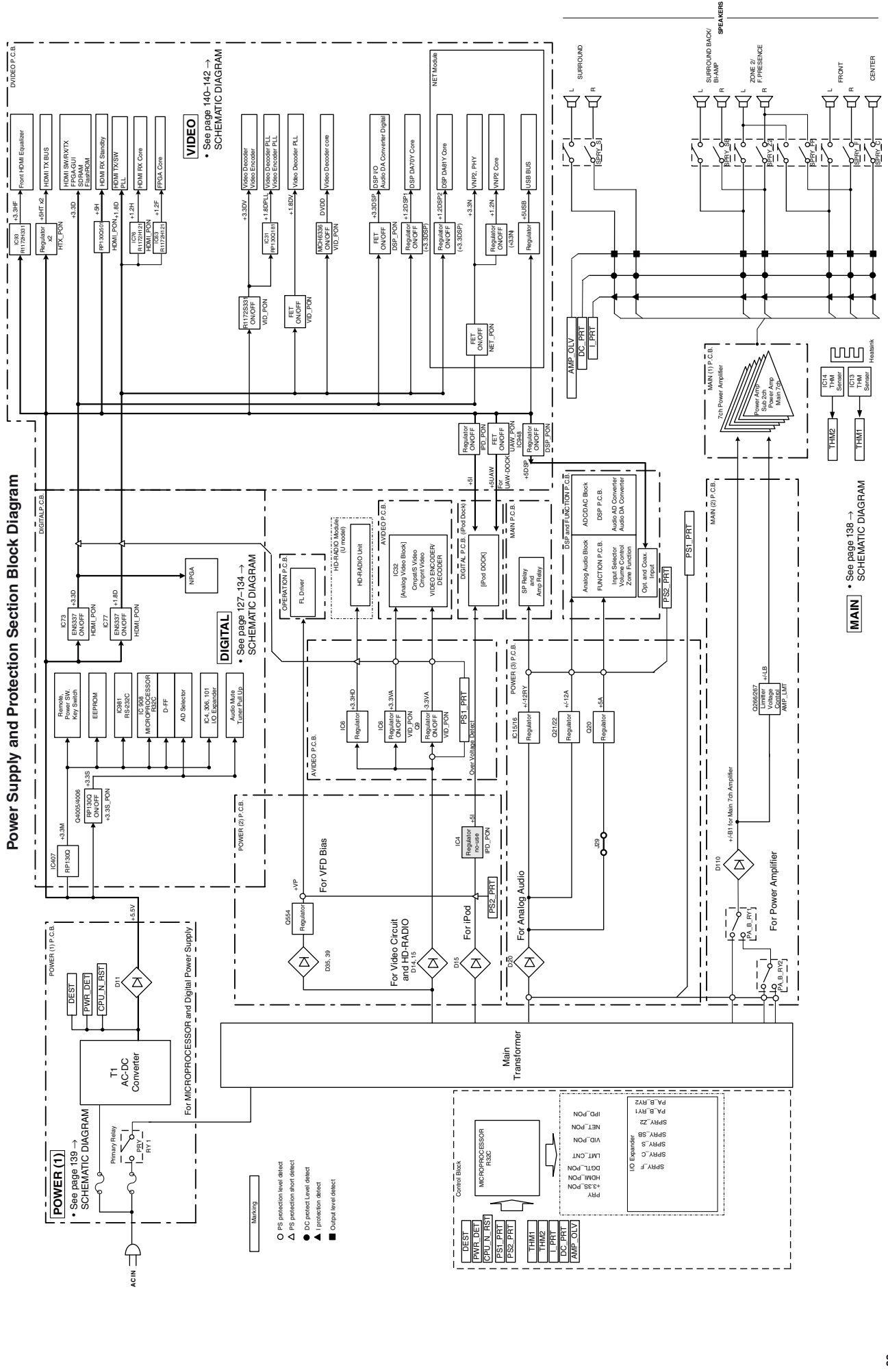

VIDEO
• See page 140-142 →
SCHEMATIC DIAGRAM

DIGITAL
• See page 127-134 →
SCHEMATIC DIAGRAM

MAIN
• See page 138 →
SCHEMATIC DIAGRAM

- Marking
- PS protection level detect
 - △ PS protection short detect
 - OVC protection level detect
 - ▲ Over-current protect detect
 - Output level detect

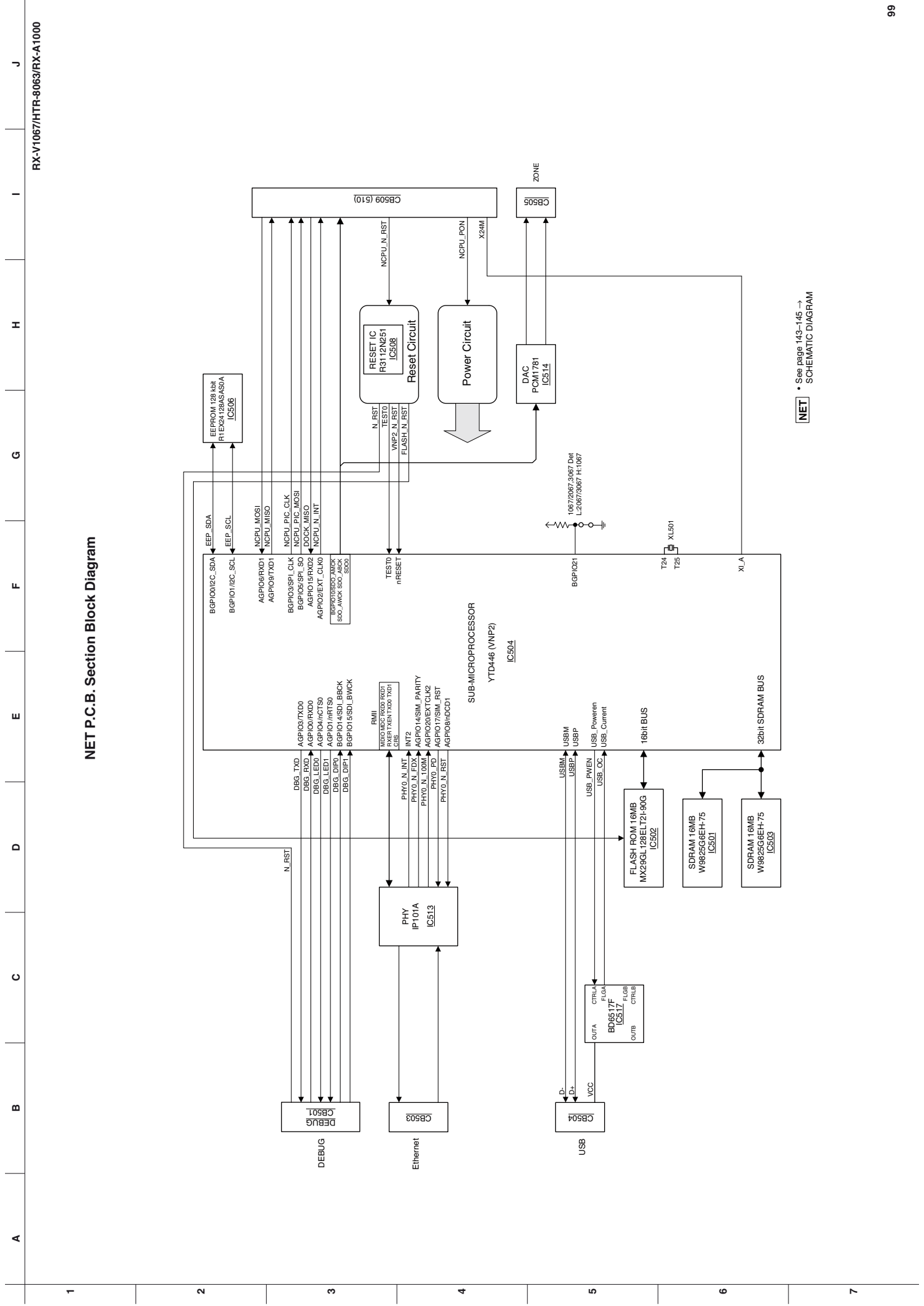

NET P.C.B. Section Block Diagram

NET • See page 143-145 → SCHEMATIC DIAGRAM

PRINTED CIRCUIT BOARDS

DIGITAL (1) P.C.B. (Side A)

Semiconductor Location

Ref no.	Location	Ref no.	Location	Ref no.	Location	Ref no.	Location	Ref no.	Location	Ref no.	Location
D701	D2	IC2	I3	IC36	H4	IC62	H4	IC73	F4	IC73	G5
D702	C2	IC3	H3	IC37	H4	IC63	G5	IC74	C3	IC80	E3
D705	D2	IC4	E5	IC38	H4	IC64	F4	IC75	E4	IC904	E5
D706	D2	IC31	H5	IC39	H4	IC65	F4	IC76	H3	IC905	E5
D9002	D6	IC32	H4	IC40	H4	IC71	D3	IC77	H5	IC906	E6
IC1	F3	IC33	H5	IC41	I3	IC72	D3	IC78	D3	IC907	E6
										IC913	B5
										IC908	D5
										IC909	D4
										IC910	E4
										IC911	D6
										IC912	D6
										IC913	B5
										IC914	B4
										IC915	B3
										IC945	C4
										IC946	C3
										IC947	C3
										IC948	B3
										IC949	C3

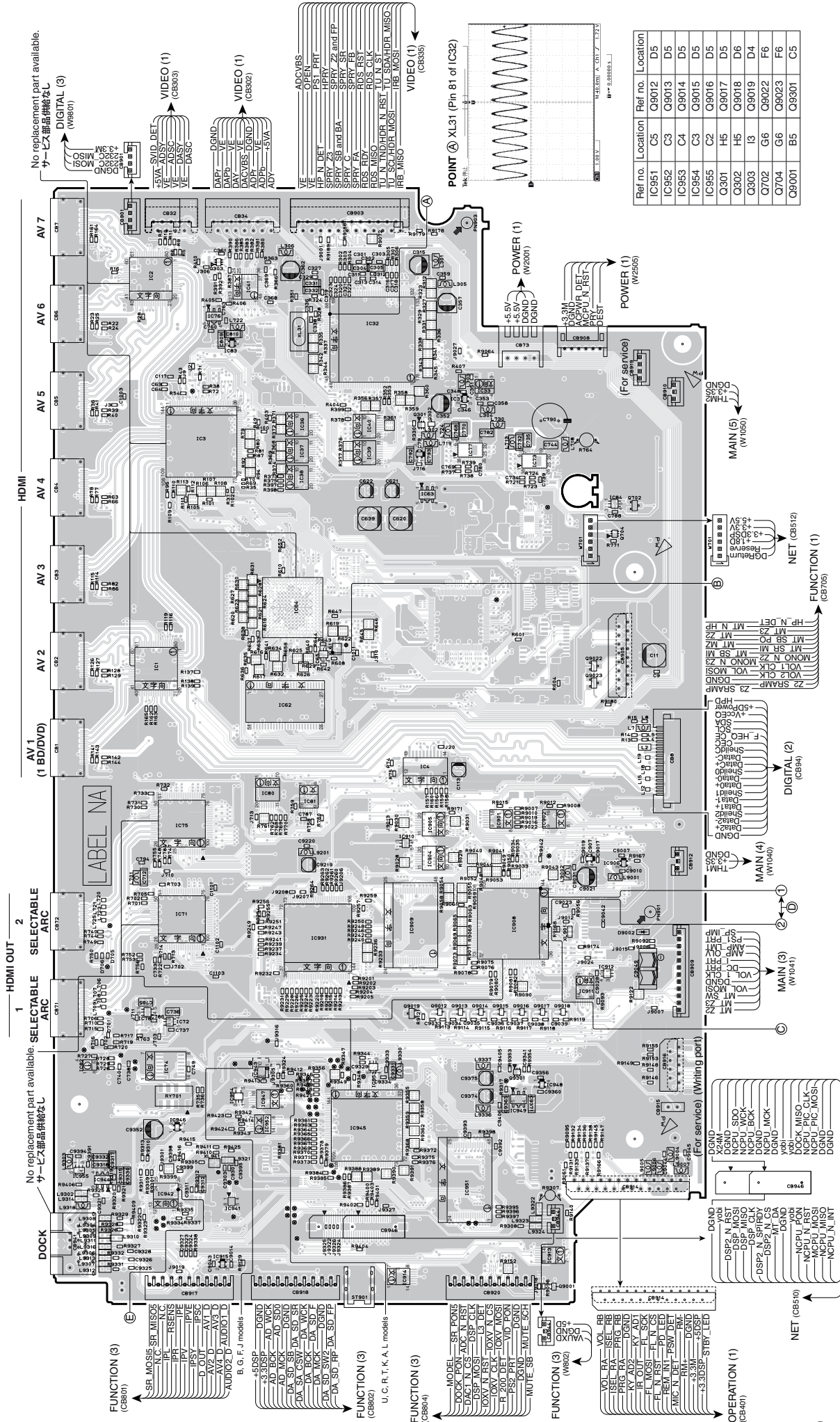

Ref no.	Location	Ref no.	Location	Ref no.	Location
IC951	C5	Q9012	D5		
IC952	C3	Q9013	D5		
IC953	C4	Q9014	D5		
IC954	C3	Q9015	D5		
IC955	C2	Q9016	D5		
Q301	H5	Q9017	D5		
Q302	H5	Q9018	D6		
Q303	I3	Q9019	D4		
Q702	G6	Q9022	F6		
Q704	G6	Q9023	F6		
Q9001	B5	Q9301	C5		

DIGITAL (1) P.C.B. (Side B)

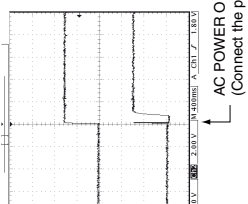

AC POWER ON
(Connect the power cable)

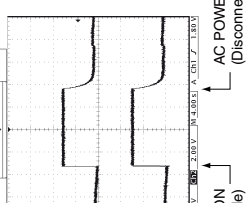

AC POWER OFF
(Disconnect the power cable)

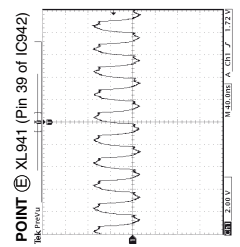
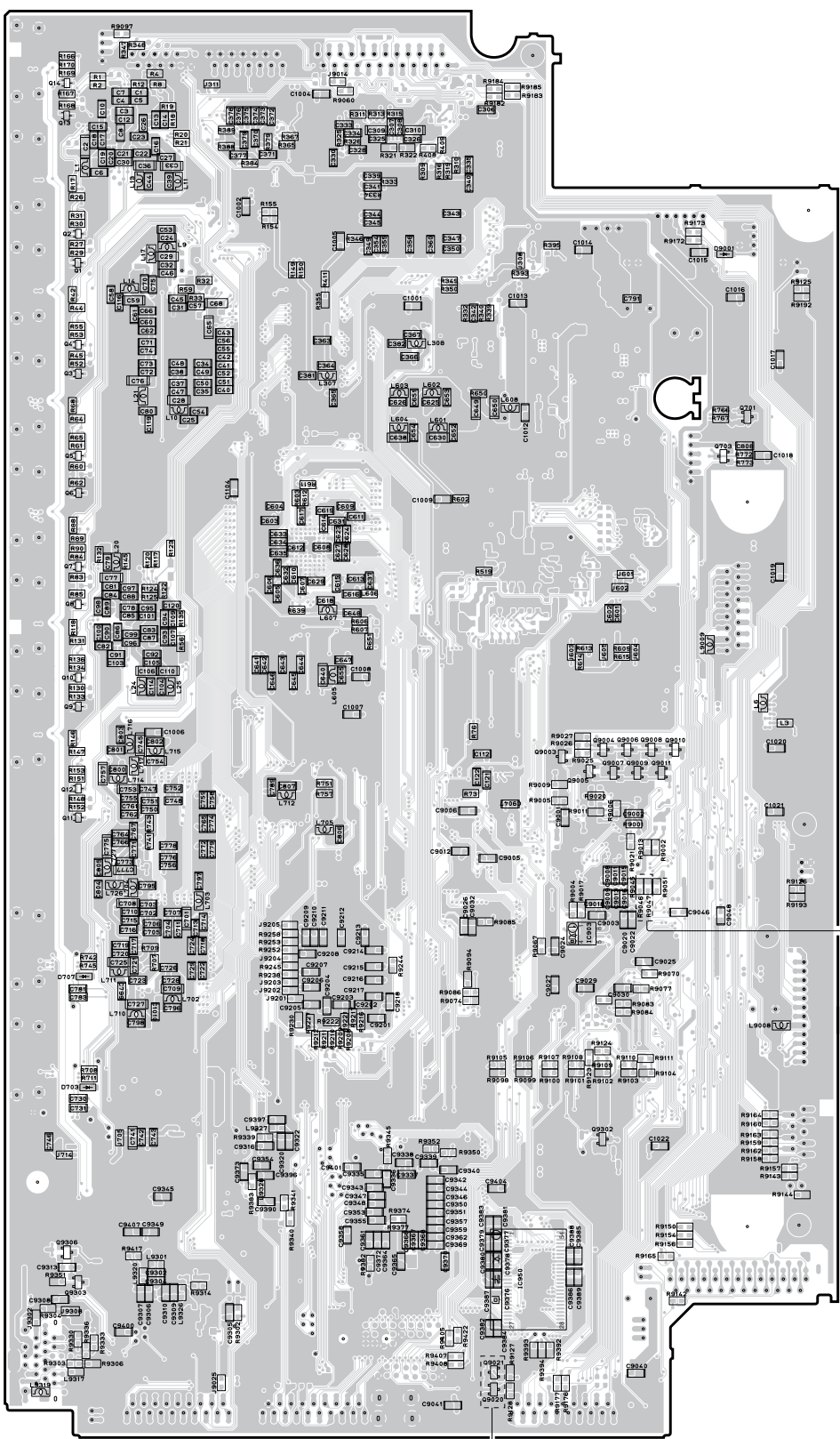
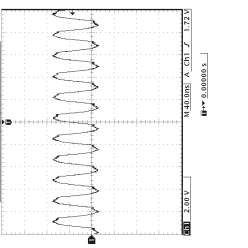
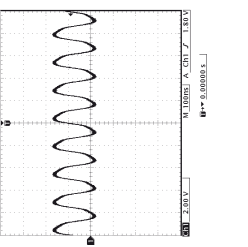

• Semiconductor Location

Ref no.	Location	Ref no.	Location
D703	C2	Q14	H2
D707	D2	Q701	G6
D9001	H6	Q703	F6
IC9003	D5	Q9003	E5
IC950	B5	Q9004	E5
Q1	G2	Q9005	E5
Q2	H2	Q9006	E5
Q3	G2	Q9007	E5
Q4	G2	Q9008	E5
Q5	F2	Q9009	E5
Q6	F2	Q9010	E6
Q7	F2	Q9011	E6
Q8	F2	Q9020	A5
Q9	E2	Q9021	A5
Q10	E2	Q9302	C5
Q11	D2	Q9303	B2
Q12	E2	Q9306	B2
Q13	H2		

C, R, T, K, A, B, G, F, L, J models

DIGITAL (2) P.C.B. (Side A)

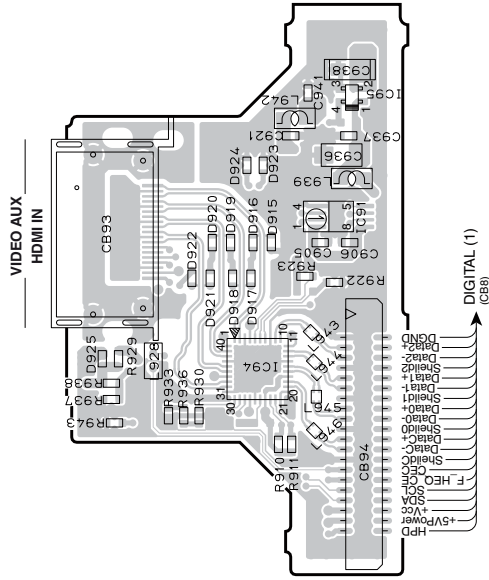

DIGITAL (3) P.C.B. (Side A)

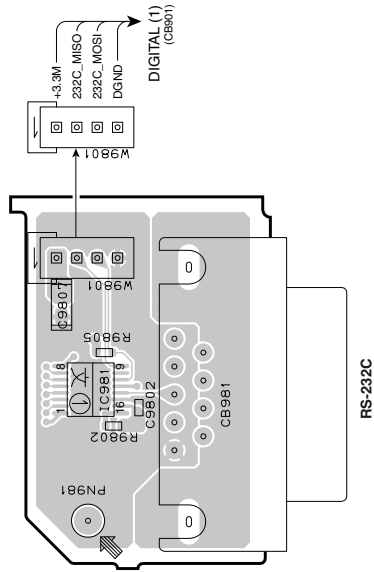

• Semiconductor Location

Ref no.	Location
D915	D4
D916	D3
D917	D3
D918	D3
D919	D3
D920	D3
D921	D3
D922	D3
D923	D3
D924	D3
D925	C3
IC91	D4
IC94	C3
IC95	E4
IC981	H3

1

2

3

4

5

6

7

DIGITAL (2) P.C.B. (Side B)

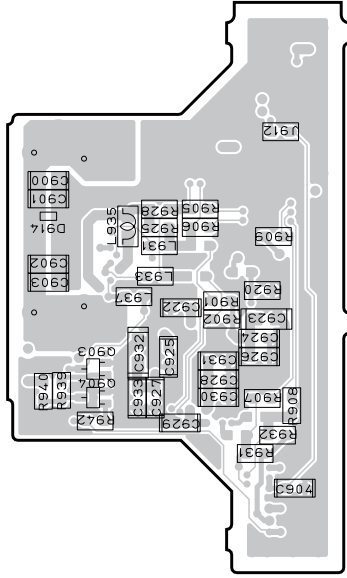

DIGITAL (3) P.C.B. (Side B)

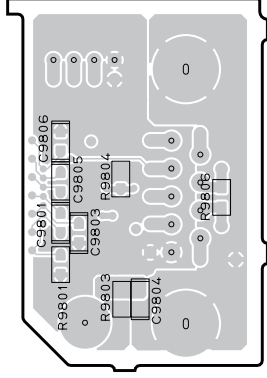

• Semiconductor Location

Ref no.	Location
D914	D3
Q903	C3
Q904	C3

FUNCTION (1) P.C.B. (Side A)

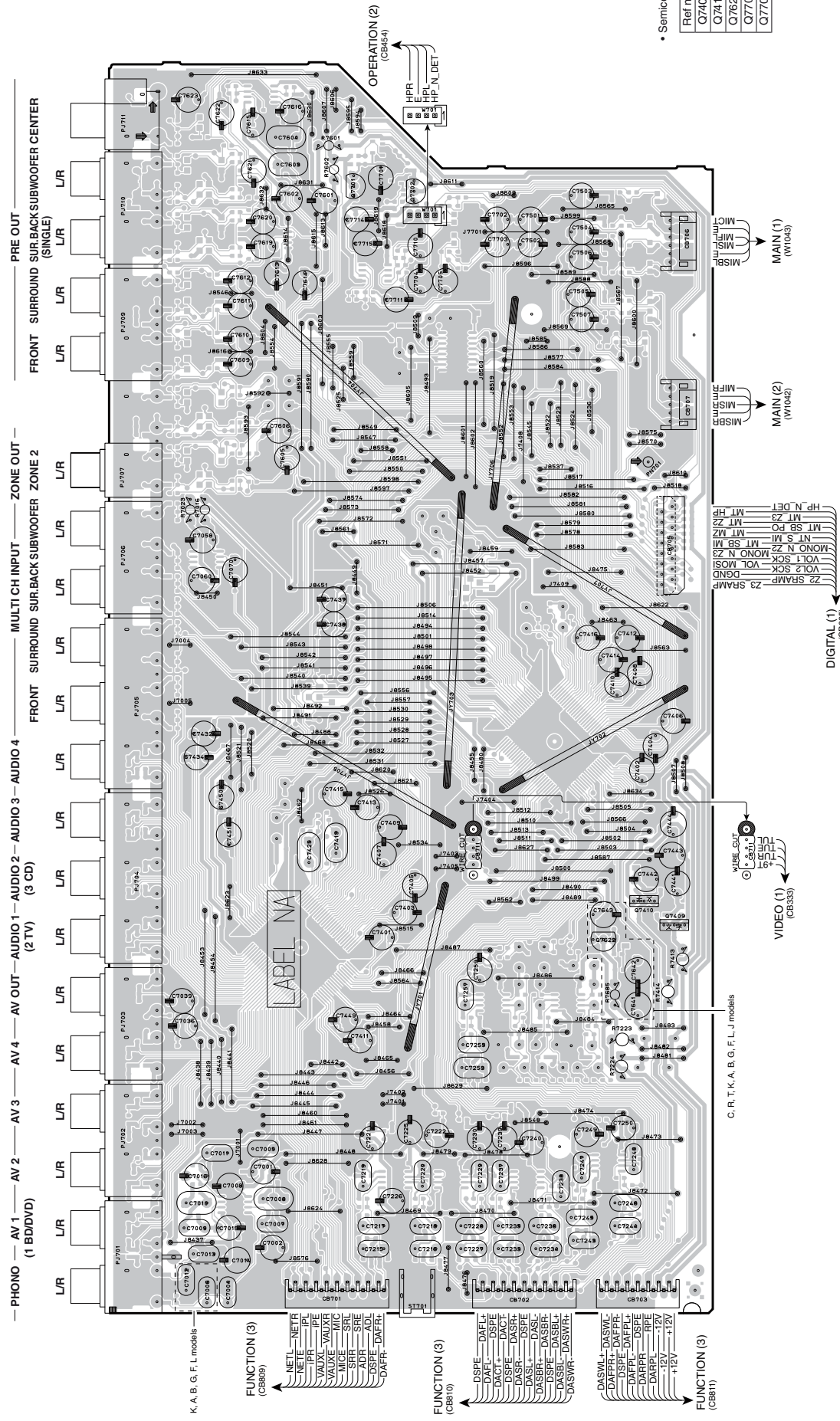

• Semiconductor Location

Ref no.	Location
C7409	D6
C7410	D6
C7622	D6
C7701	I4
C7702	I4

FUNCTION (1) P.C.B. (Side B)

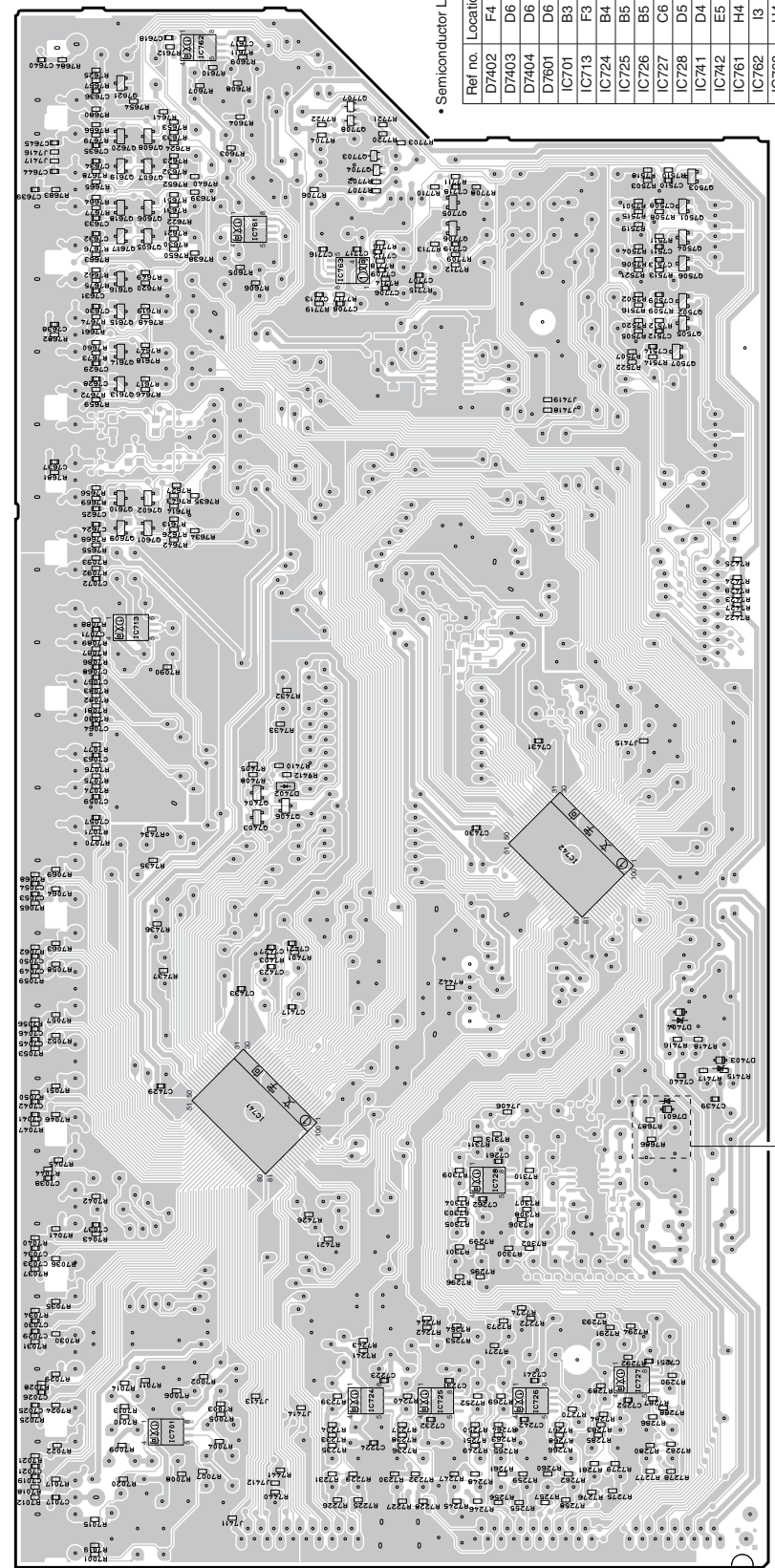

• Semiconductor Location

Ref no.	Location	Ref no.	Location
D7402	F4	Q7507	H6
D7403	D6	Q7601	G3
D7404	D6	Q7602	G3
D7601	D6	Q7605	H3
IC701	B3	Q7606	H3
IC713	F3	Q7607	I3
IC724	B4	Q7608	I3
IC725	B5	Q7609	G3
IC726	B5	Q7610	G3
IC727	D6	Q7613	H3
IC728	C5	Q7614	H3
IC741	D4	Q7615	H3
IC742	E5	Q7616	H3
IC761	H4	Q7617	H3
IC762	I3	Q7618	H3
IC763	H4	Q7619	I3
Q7403	E4	Q7620	I3
Q7404	E4	Q7621	I3
Q7501	H6	Q7703	I4
Q7502	H6	Q7704	I4
Q7503	I6	Q7705	H5
Q7504	H6	Q7706	H5
Q7505	H6	Q7707	I4
Q7506	H6	Q7708	I4

C.R.T.K.A.B.G.F.L.J.models

FUNCTION (2) P.C.B. (Side A)

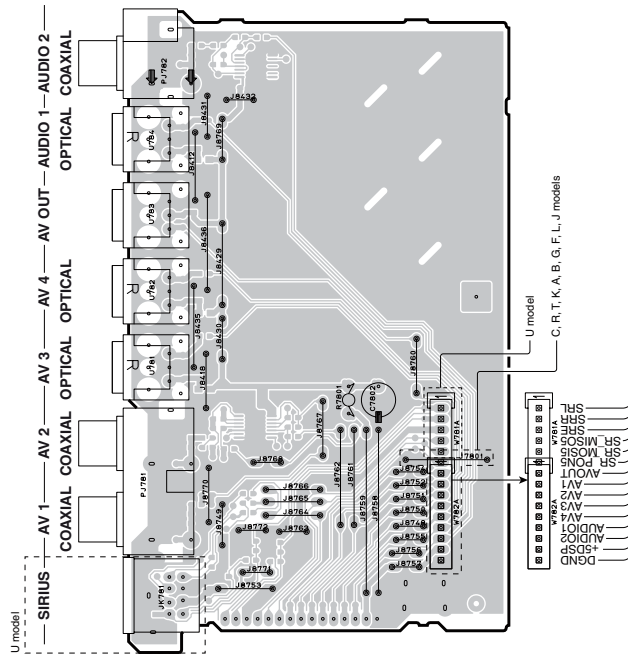

FUNCTION (3) P.C.B. (Side A)

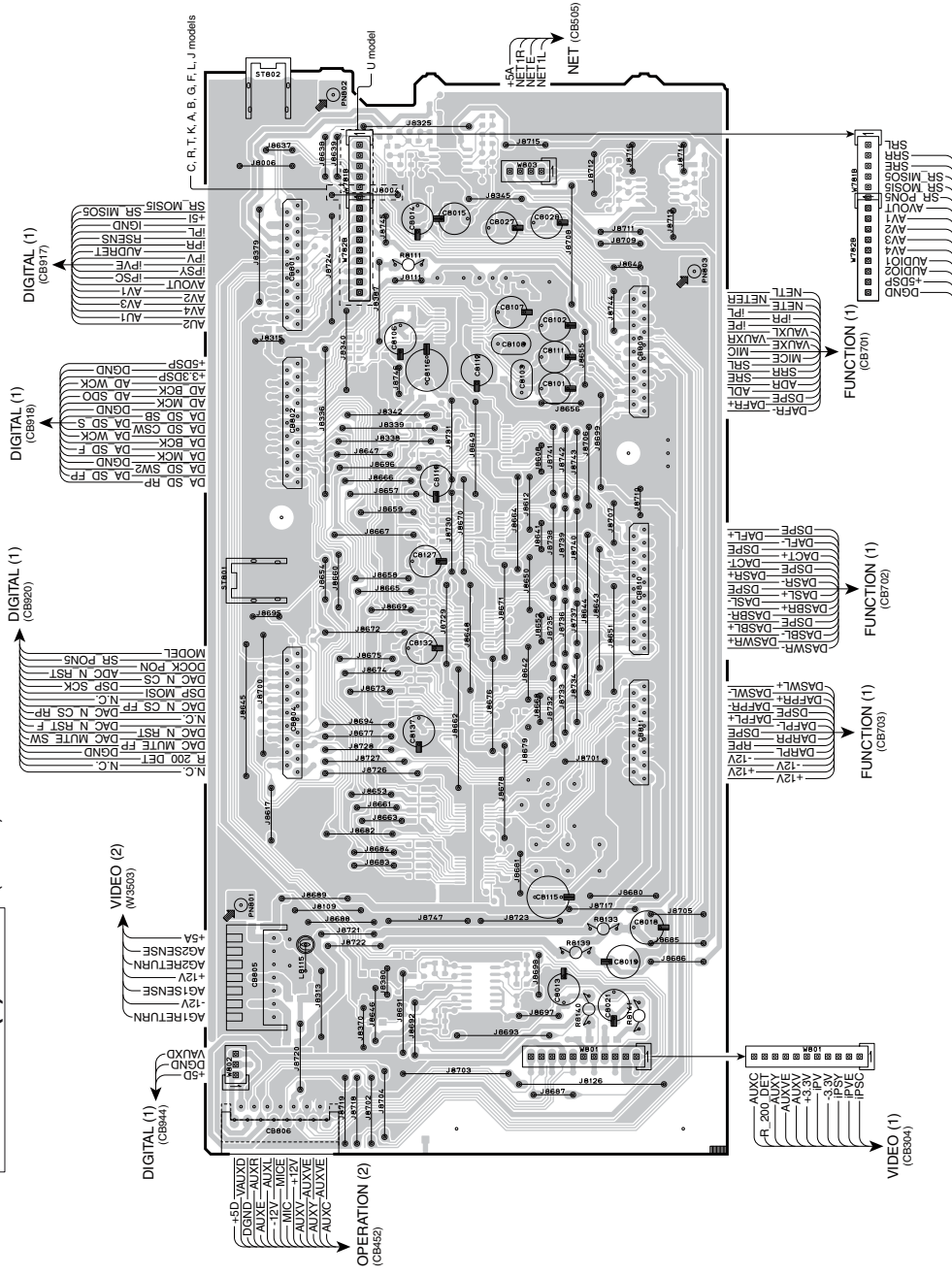

1

FUNCTION (2) P.C.B. (Side B)

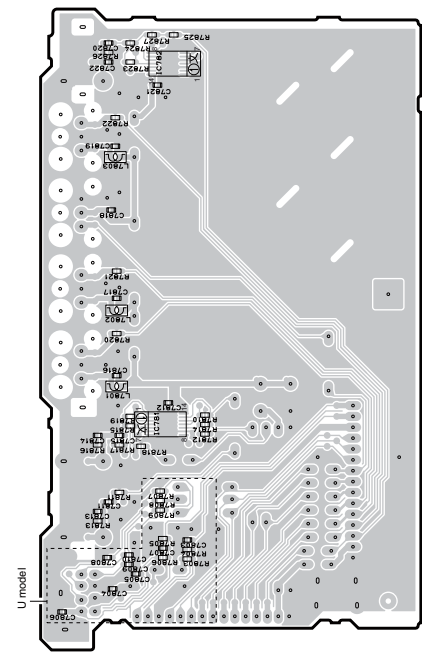

2

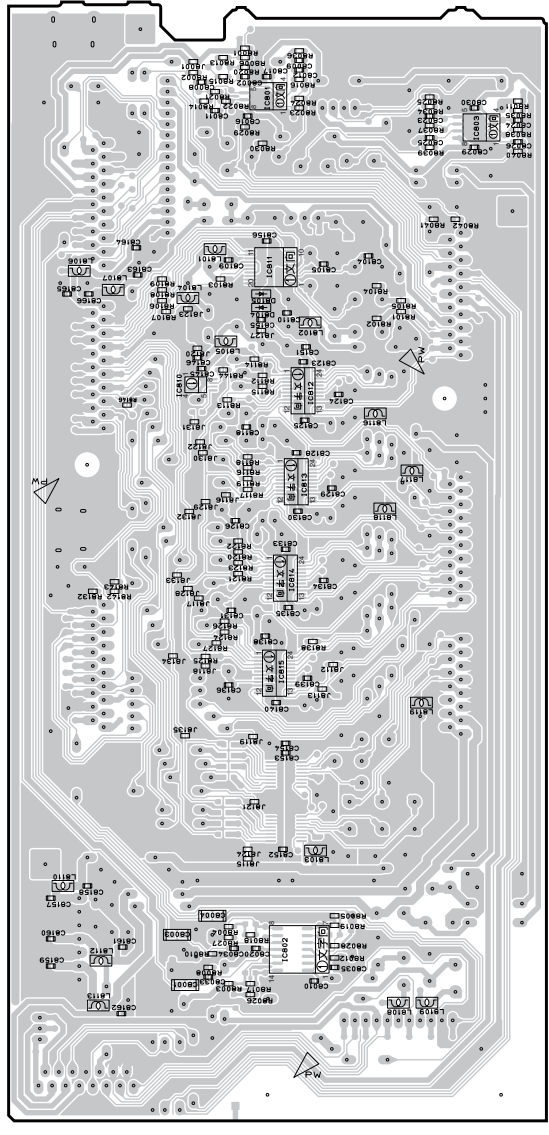

3

4

5

• Semiconductor Location

Ref. no.	Location
D8104	I4
D8105	I4
IC781	B3
IC782	D3
IC801	J4
IC802	F4
IC803	J5
IC810	H3
IC811	I4
IC812	H4
IC813	H4
IC814	G4
IC815	G4

6

7

OPERATION (1) P.C.B. (Side A)

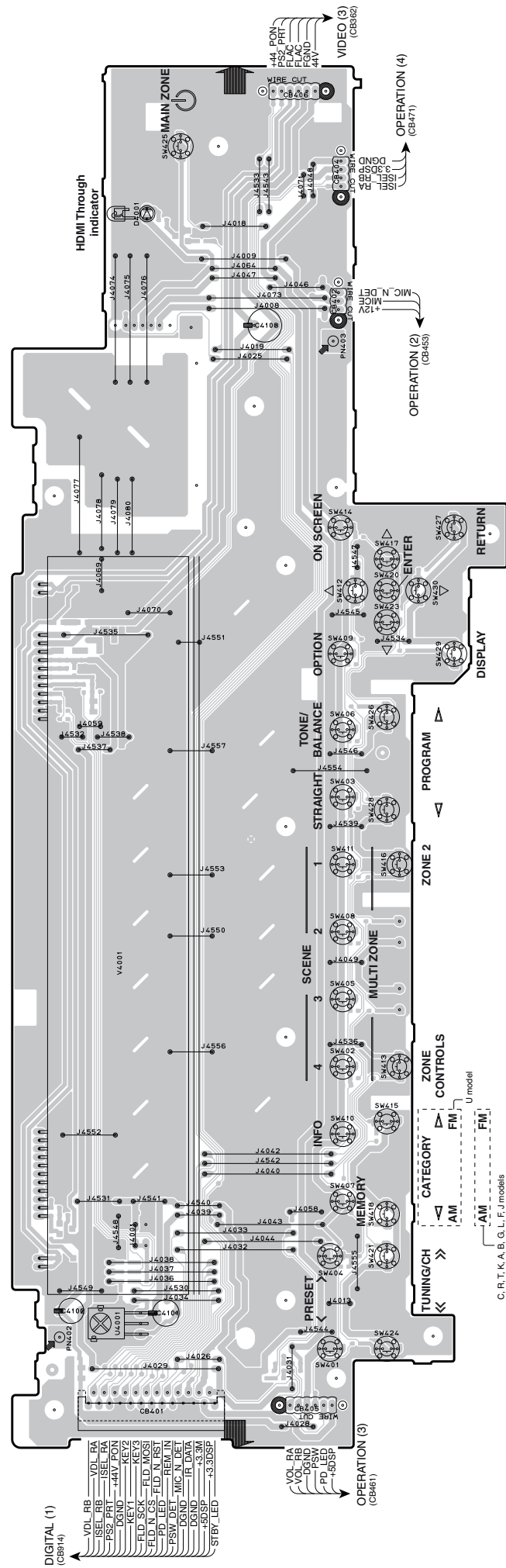

• Semiconductor Location

Ref. no.	Location
D4001	I3

C, P, T, K, A, B, G, L, F, J models

OPERATION (1) P.C.B. (Side B)

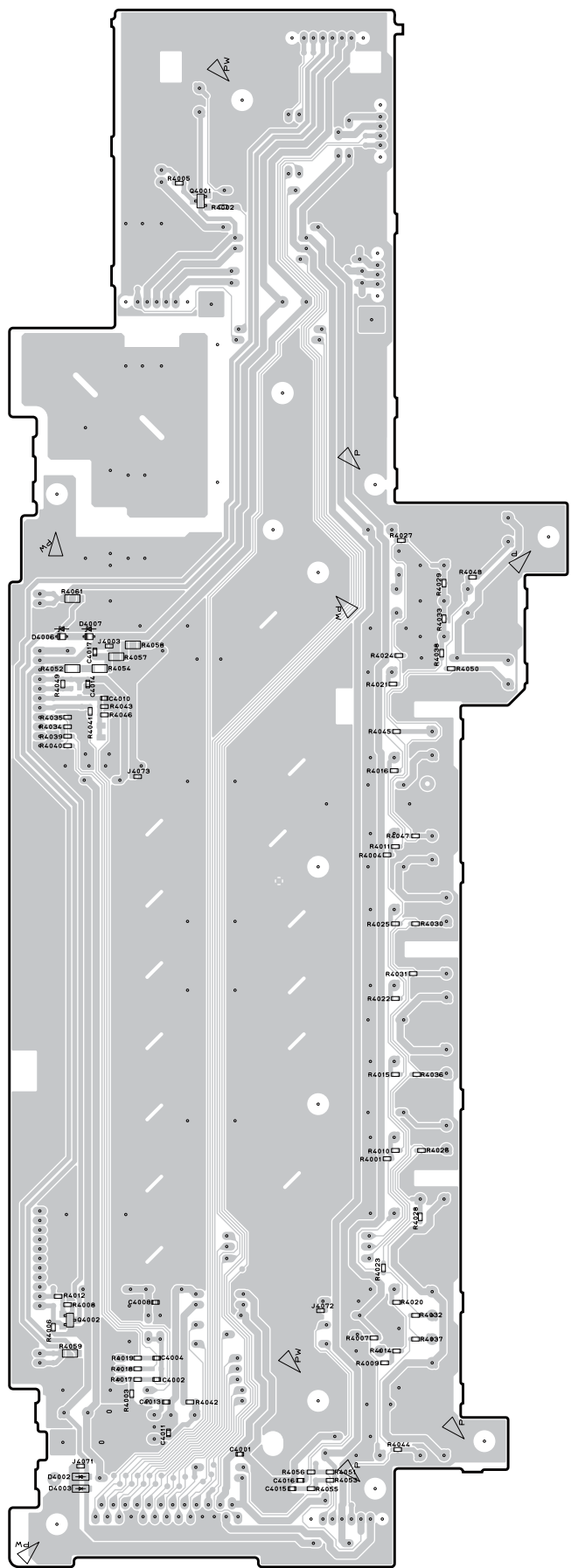

• Semiconductor Location

Ref no.	Location
D4002	B3
D4003	B3
D4006	G3
D4007	G3
C4001	I3
C4002	C3

OPERATION (2) P.C.B. (Side A)

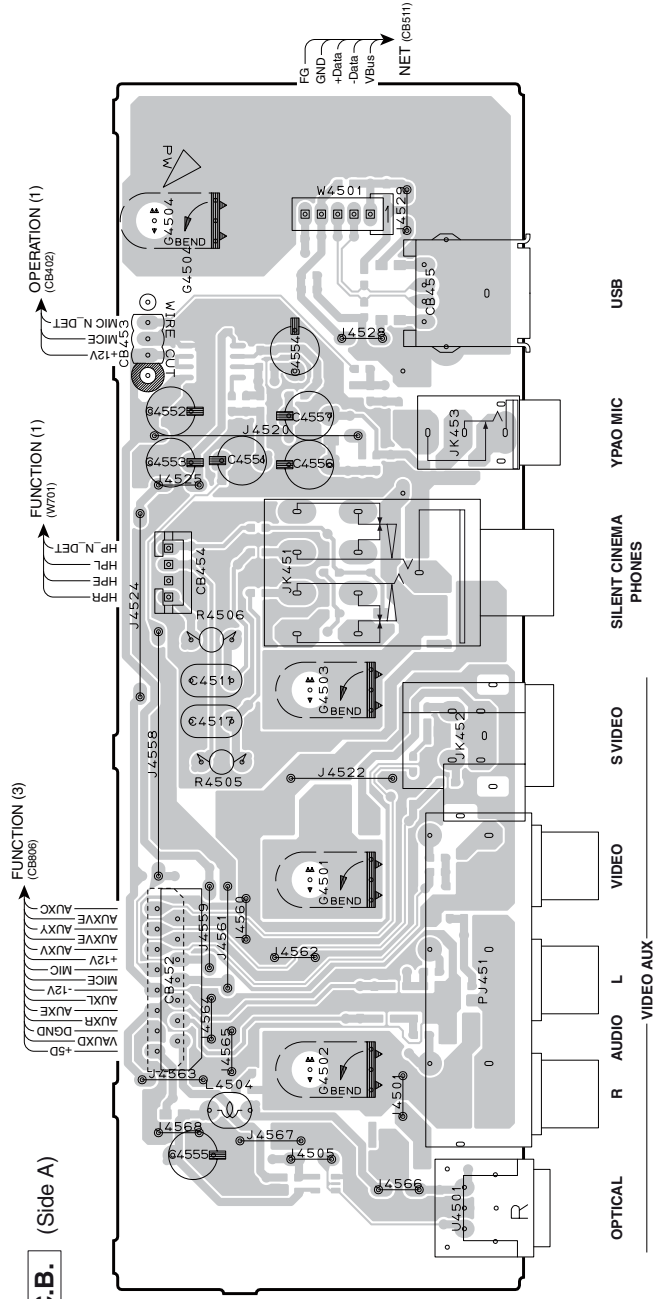

OPERATION (3) P.C.B. (Side A)

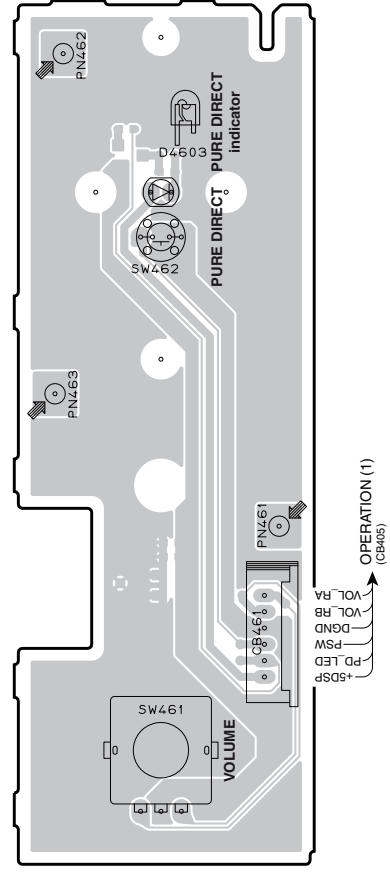

OPERATION (4) P.C.B. (Side A)

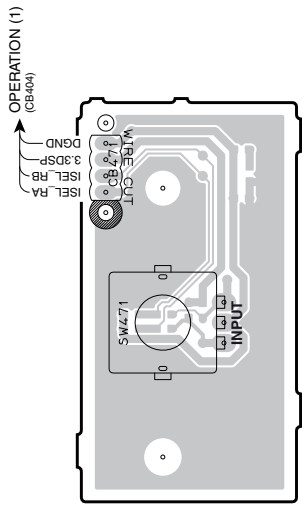

• Semiconductor Location

Ref no	Location
D4603	E6

OPERATION (2) P.C.B. (Side B)

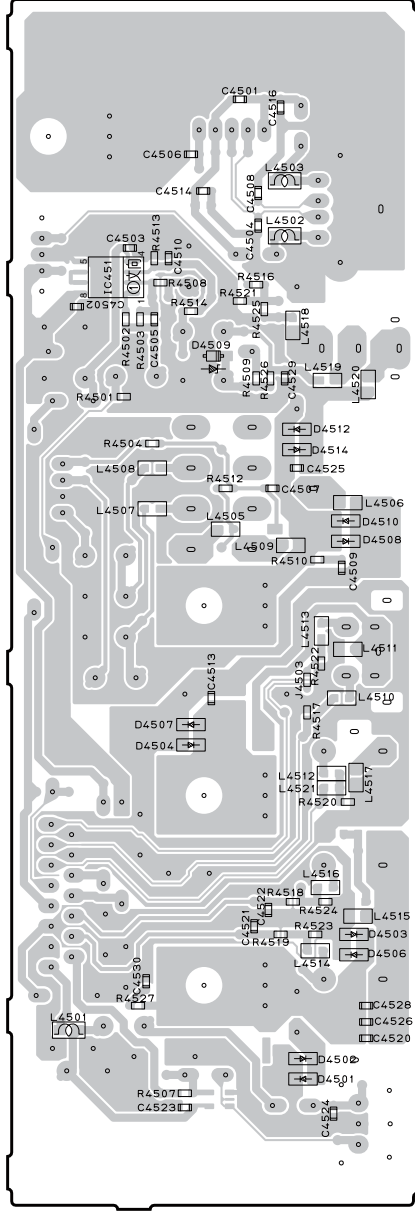

• Semiconductor Location

Ref no.	Location
D4501	C3
D4502	C3
D4503	D3
D4504	E3
D4506	E3
D4507	E3
D4508	F3
D4509	G3
D4510	F3
D4512	F3
D4514	F3
IC4511	G2
C4501	E6

OPERATION (3) P.C.B. (Side B)

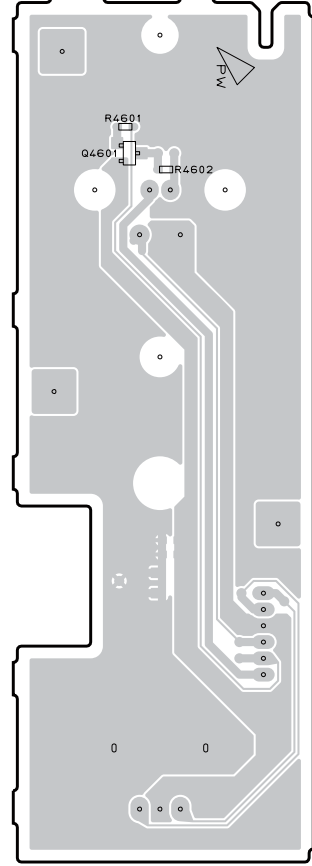

OPERATION (4) P.C.B. (Side B)

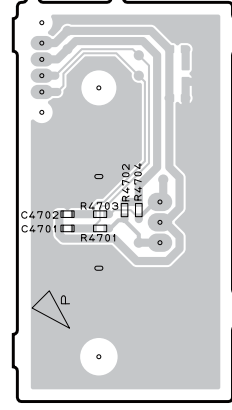

MAIN (1) P.C.B. (Side A)

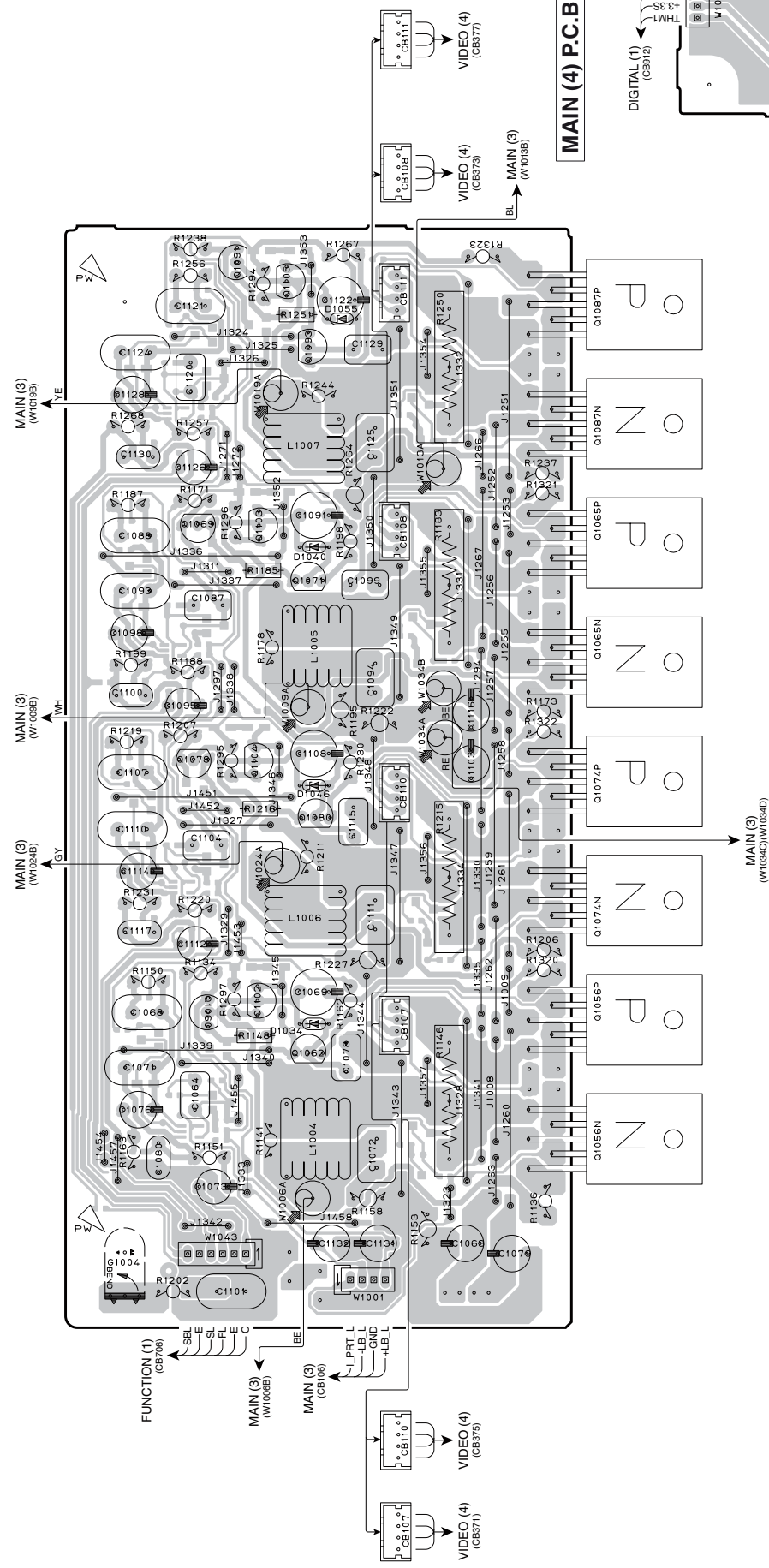

• Semiconductor Location

Ref no.	Location	Ref no.	Location	Ref no.	Location
D1034	D3	Q1065N	F5	Q1087P	H5
D1040	G3	Q1065P	G5	Q1087N	H3
D1046	E3	Q1069	G3	Q1093	H3
D1055	H4	Q1071	F3	Q1102	D3
IC102	J6	Q1074N	E5	Q1103	G3
Q1056N	C5	Q1074P	E5	Q1104	E3
Q1056P	D5	Q1078	D5	Q1105	H3
Q1060	D3	Q1080	E3		
Q1062	D3	Q1087N	G5		

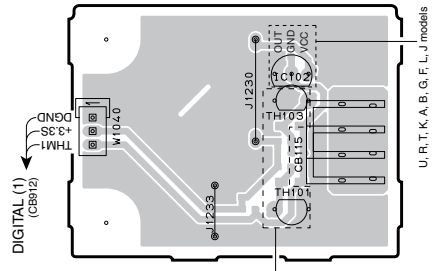

MAIN (1) P.C.B. (Side B)

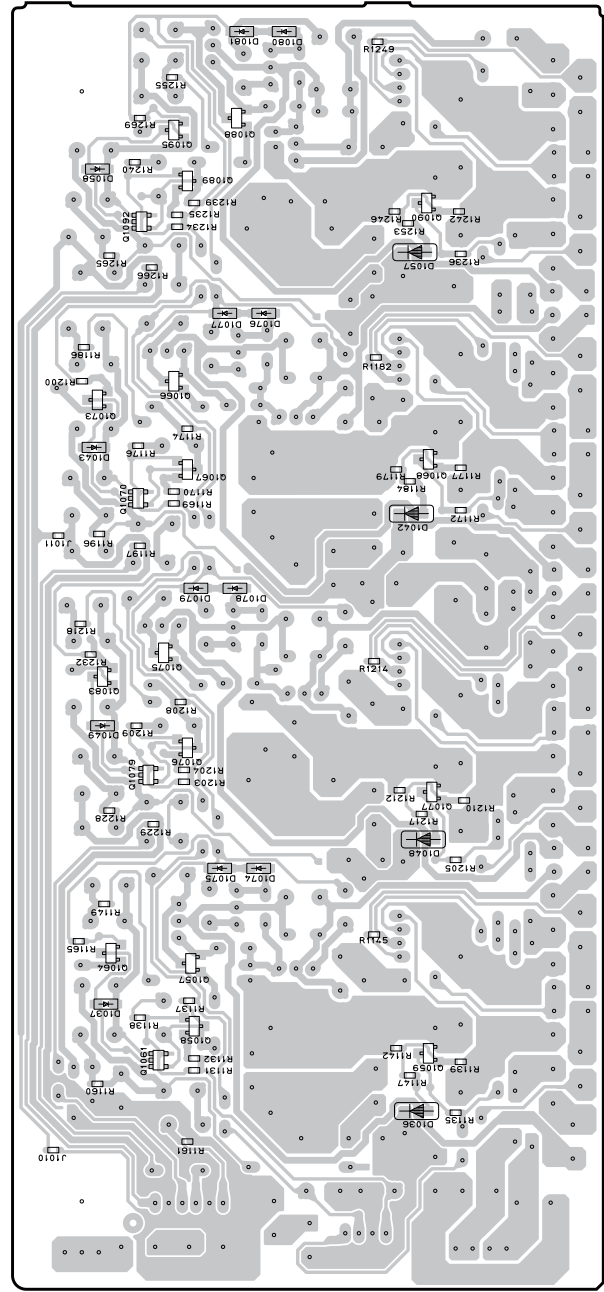

MAIN (4) P.C.B. (Side B)

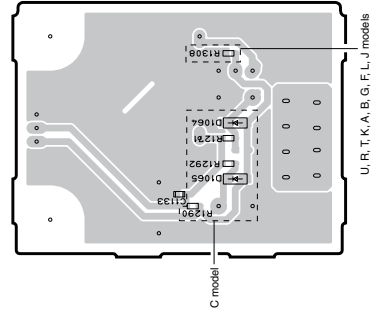

• Semiconductor Location

Ref no.	Location	Ref no.	Location
D1036	C4	D1077	G3
D1037	C2	D1078	E3
D1042	F4	D1079	E3
D1043	F2	D1080	H3
D1048	D4	D1081	H3
D1049	E2	Q1057	D3
D1057	G4	Q1058	C3
D1058	G2	Q1059	C4
D1064	J6	Q1061	C3
D1065	I6	Q1064	D2
D1074	D3	Q1066	F3
D1075	D3	Q1067	F3
D1076	G3	Q1068	F4
		Q1070	F3
		Q1073	F2
		Q1075	E3
		Q1076	E3
		Q1077	D4
		Q1079	E3
		Q1083	E2
		Q1088	H3
		Q1089	G3
		Q1090	G4
		Q1092	G3
		Q1095	H3

U, R, T, K, A, B, G, F, L, J models

MAIN (2) P.C.B. (Side A)

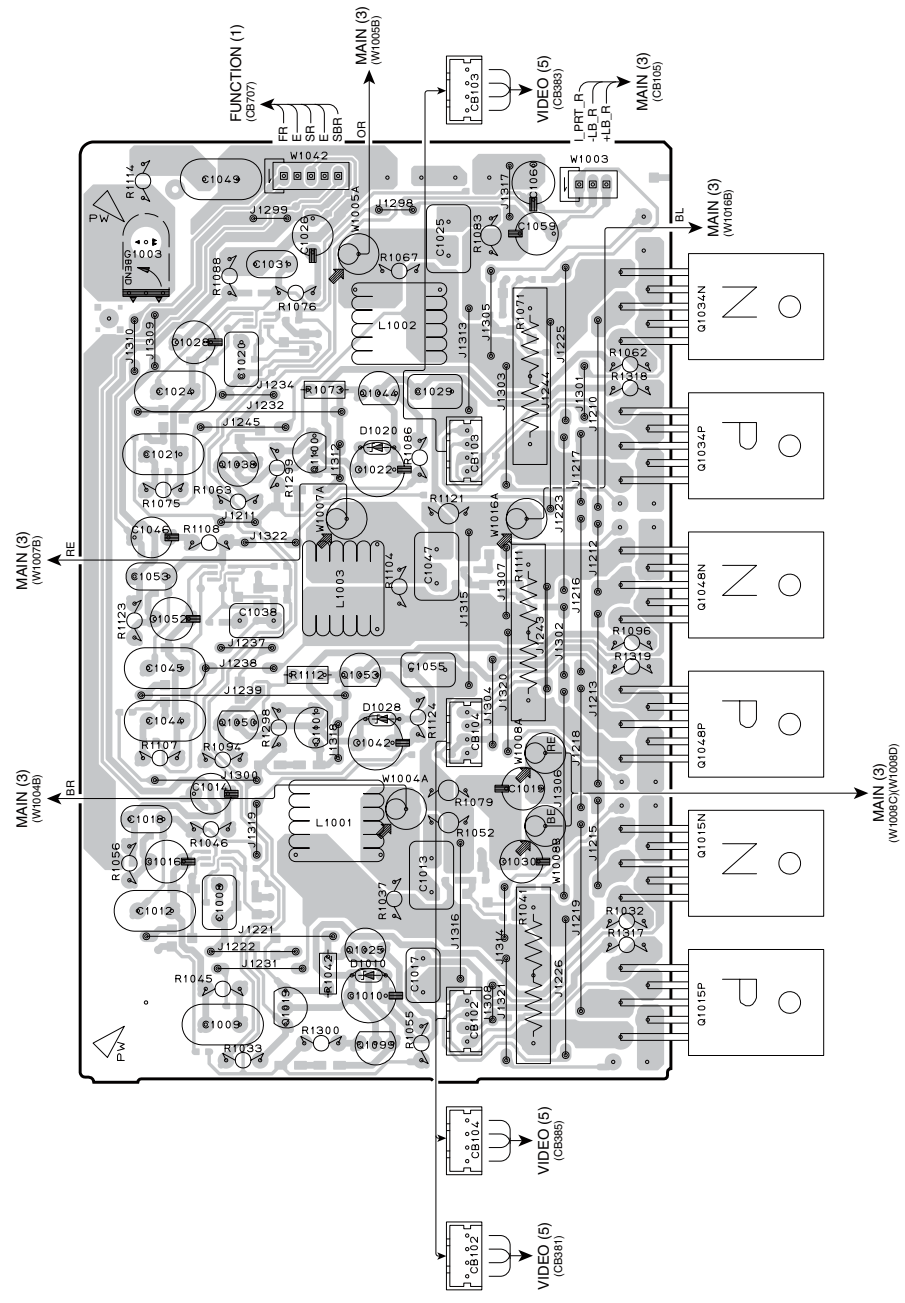

• Semiconductor Location

Ref. no.	Location	Ref. no.	Location	Ref. no.	Location
D1010	C3	Q1025	C3	Q1050	D3
D1020	E3	Q1034N	F5	Q1053	D3
D1028	D3	Q1034P	E5	Q1099	B3
IC103	I6	Q1038	E3	Q1100	E3
Q1015N	C5	Q1044	F3	Q1101	D3
Q1015P	C5	Q1048N	E5		
Q1019	C3	Q1048P	D5		

MAIN (5) P.C.B. (Side A)

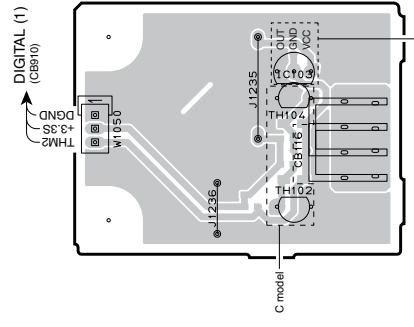

MAIN (2) P.C.B. (Side B)

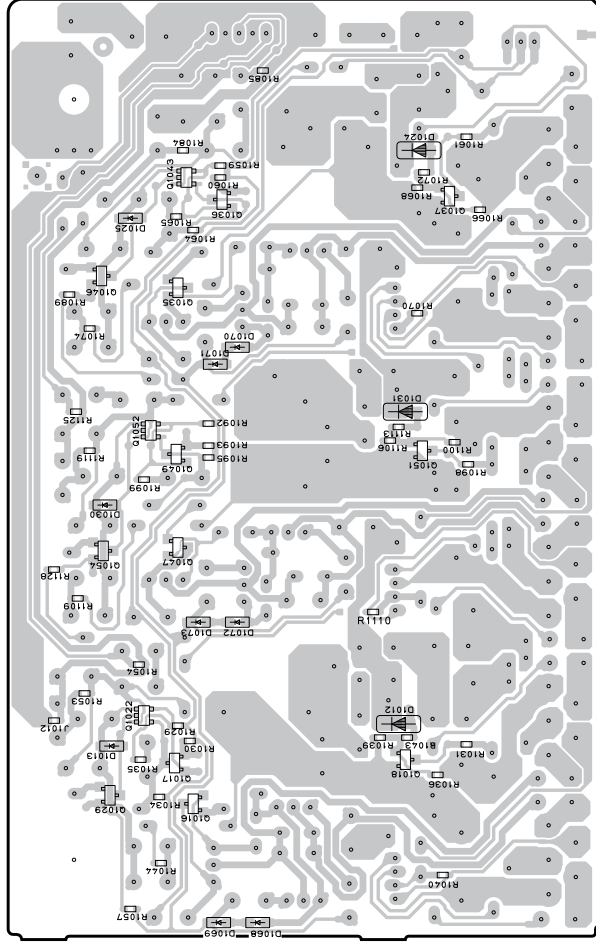

MAIN (5) P.C.B. (Side B)

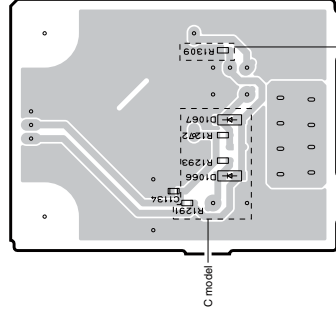

• Semiconductor Location

Ref no.	Location	Ref no.	Location	Ref no.	Location
D1012	C4	D1070	E3	Q1036	F3
D1013	C3	D1071	E3	Q1037	F4
D1024	F4	D1072	D3	Q1043	F3
D1025	F3	D1073	D3	Q1046	E3
D1030	D3	Q1016	C3	Q1047	D3
D1031	E4	Q1017	C3	Q1049	D3
D1066	H6	Q1018	C4	Q1051	D4
D1067	I6	Q1022	C3	Q1052	E3
D1068	B3	Q1029	C3	Q1054	D3
D1069	B3	Q1035	E3		

U. R. T. K. A. B. G. F. L. J models

Notes

Safety measures

- Some internal parts in this product contain high voltages and are dangerous. Be sure to take safety measures during servicing, such as wearing insulating gloves.
- Note that positions indicated below are dangerous even after the power is turned off because an electric charge remains and a high voltage continues to exist there. Before starting any repair work, perform discharge by connecting a discharge resistor (5k-ohms/10W) between terminals at following positions. The time required for discharging is about 30 seconds.
- C1105 and C1106 on MAIN (3) P.C.B.

注意

安全対策

- この製品の内部には高電圧部分があり危険です。修理の際は、絶縁性の手袋を使用するなどの安全対策を行ってください。
- 下記箇所には電源をOFFにした後も電荷が残り、高電圧が維持されており危険です。修理作業前に放電用抵抗 (5kΩ/10W) を下記箇所の端子間に接続して放電してください。放電所要時間は約 30 秒間です。
- MAIN (3) P.C.B. の C1105 と C1106

MAIN (3) P.C.B. (Side A)

SPEAKERS

SURROUND
R +/-
L +/-

SURROUND BACK/
BI-AMP
R +/-
L +/-

FRONT
R +/-
L +/-

ZONE 2/
F-PRESENCE
R +/-
L +/-

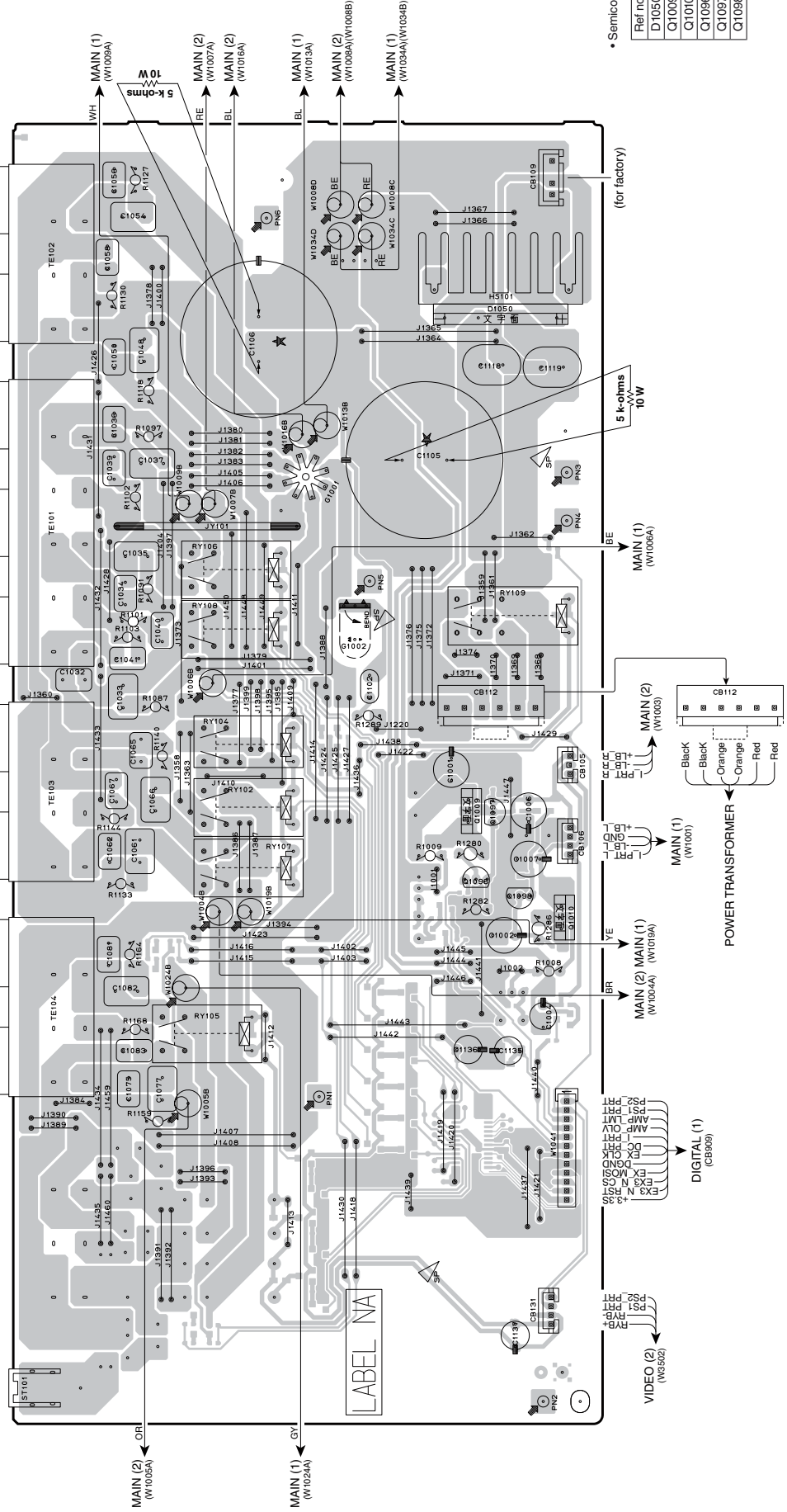

• Semiconductor Location

Ref. no.	Location
D1050	H5
Q1009	E5
Q1010	D6
Q1096	E5
Q1097	E5
Q1098	E6

MAIN (3) P.C.B. (Side B)

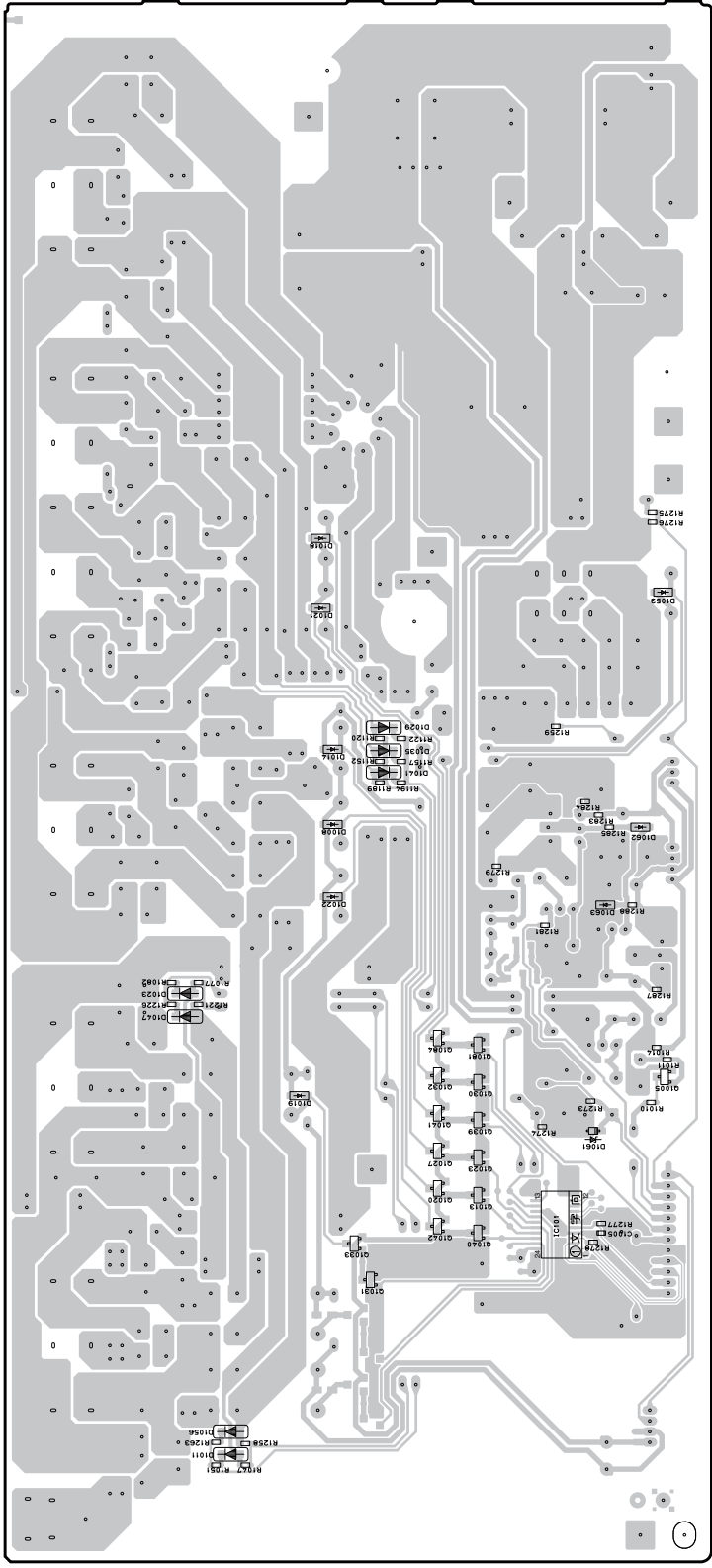

• Semiconductor Location

Ref no.	Location
D1008	E4
D1011	B4
D1014	E4
D1018	F4
D1019	D4
D1021	E4
D1022	E4
D1023	D4
D1029	F4
D1035	E4
D1041	E4
D1047	D4
D1053	F6
D1056	B4
D1061	D6
D1062	E6
D1063	E6
IC101	C5
Q1005	D6
Q1013	C5
Q1020	C5
Q1023	C5
Q1027	D5
Q1030	D5
Q1031	C4
Q1032	D5
Q1033	C4
Q1039	D5
Q1040	C5
Q1041	D5
Q1042	C5
Q1081	D5
Q1084	D5

- Some internal parts in this product contain high voltages and are dangerous. Be sure to take safety measures during servicing, such as wearing insulating gloves.
- Note that positions indicated below are dangerous even after the power is turned off because an electric charge remains and a high voltage continues to exist there. Before starting any repair work, perform discharge by connecting a discharge resistor (5k-ohms/10W) between terminals at following positions. The time required for discharging is about 30 seconds.

POWER (1) P.C.B. (Side A)

注意)

- この製品の内部には高電圧部分があり危険です。修理の際は、絶縁性の手袋を使用するなどの安全対策を行ってください。
- 下記箇所には電源をOFFにした後も電荷が残り、高電圧が維持されており危険です。修理作業前に放電用抵抗 (5kΩ/10W) を下記箇所の端子間接続して放電してください。放電所要時間は約30秒間です。

POWER (1) P.C.B.のC2016

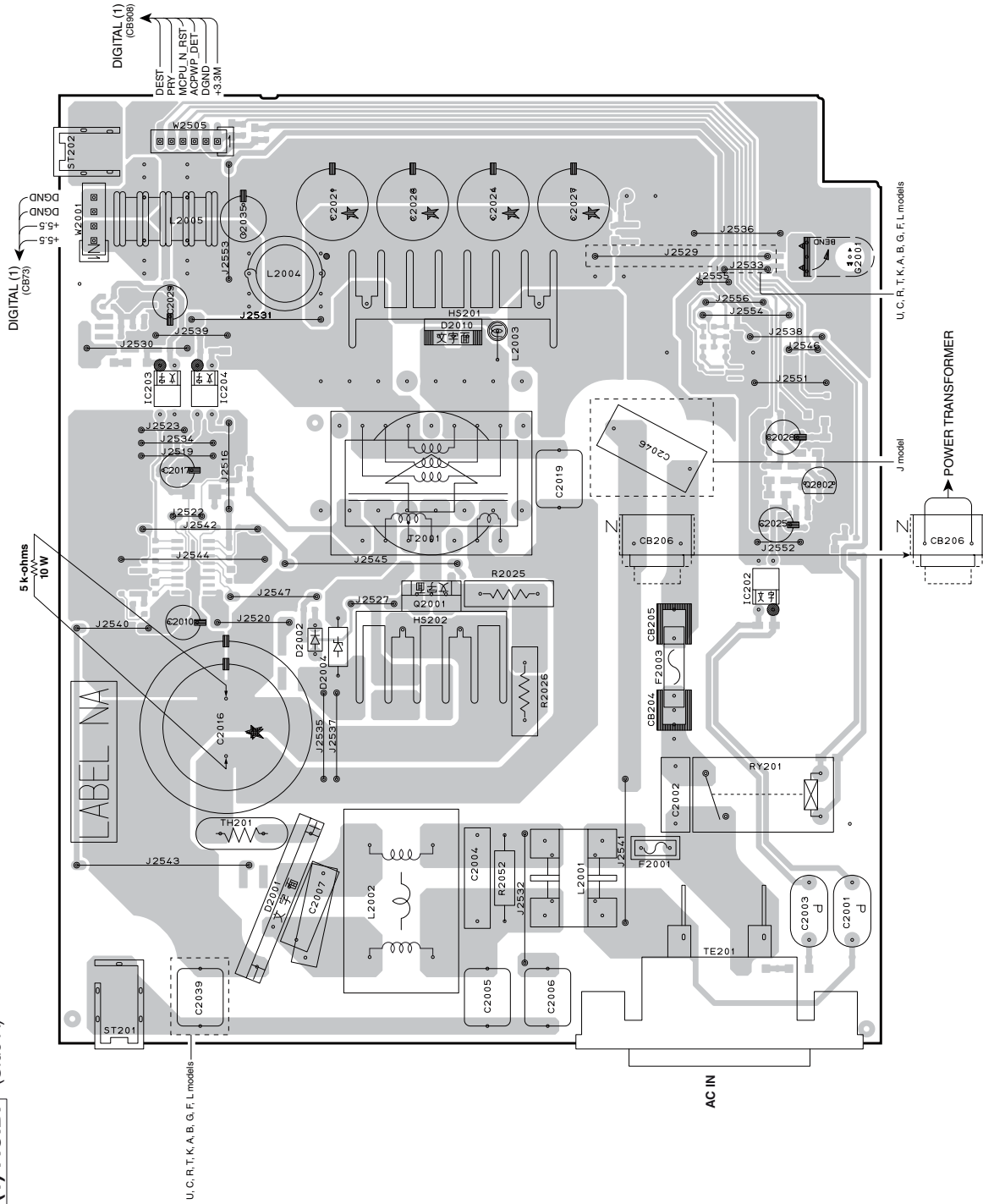

• Semiconductor Location

Ref no.	Location
D2001	D3
D2002	E3
D2004	E3
D2010	G4
IC202	F6
ID203	G2
ID204	G3
Q2001	F4
Q2002	F6

POWER (1) P.C.B. (Side B)

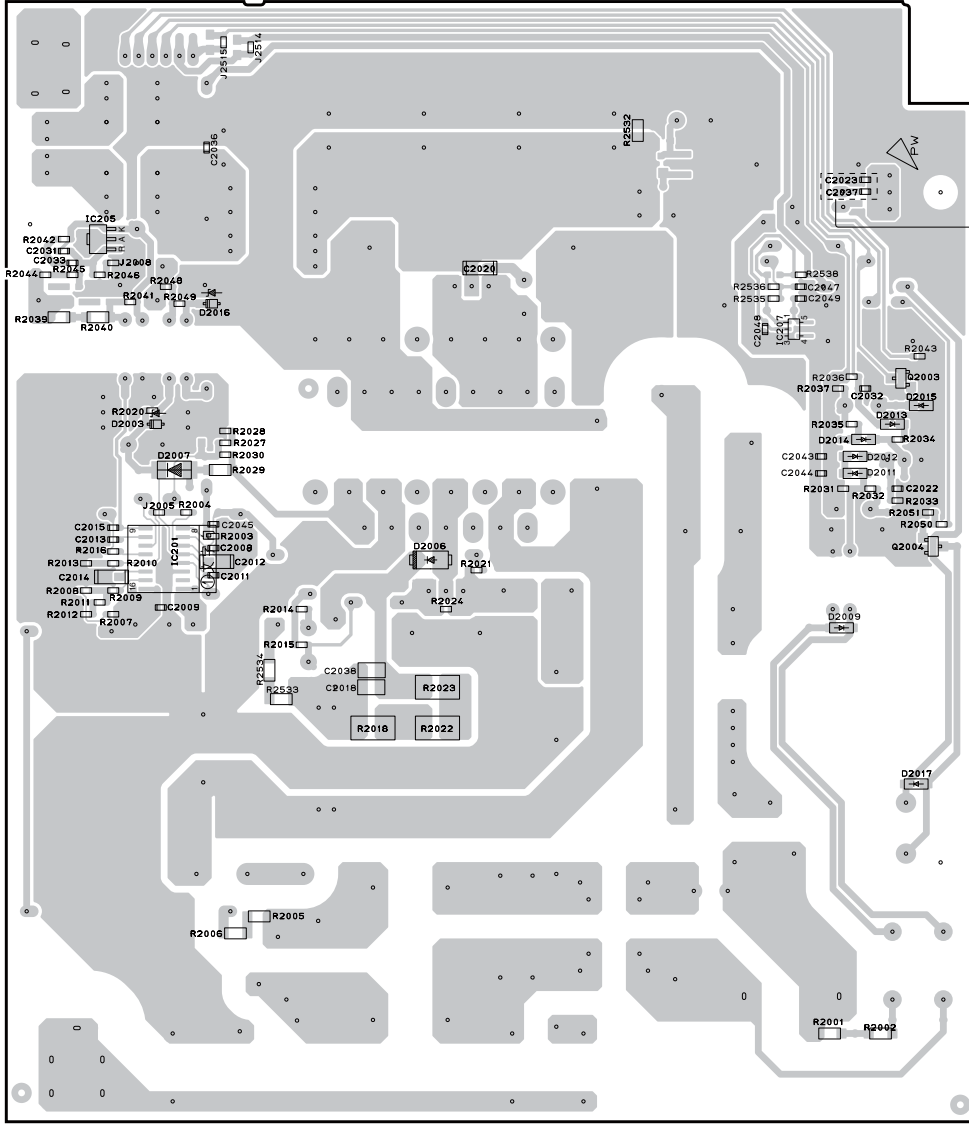

U.C.I.R.T.K.A.B.G.F.L.models

• Semiconductor Location

Ref no.	Location
D2003	F2
D2006	E4
D2007	F3
D2009	E6
D2011	F6
D2012	F6
D2013	F6
D2014	F6
D2015	F6
D2016	G3
D2017	D6
IC201	E3
IC205	G2
IC207	F6
Q2003	F6
Q2004	E6

1

POWER (2) P.C.B. (Side A)

R model

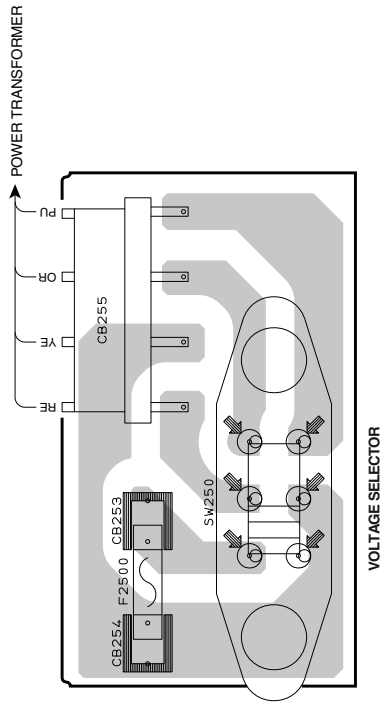

2

3

4

5

POWER (3) P.C.B. (Side A)

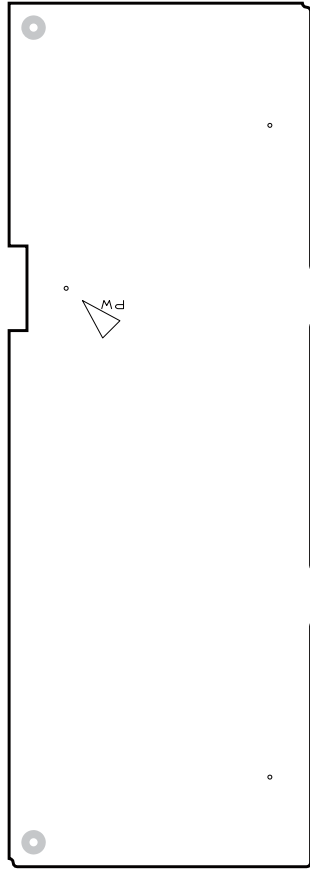

6

POWER (4) P.C.B. (Side A)

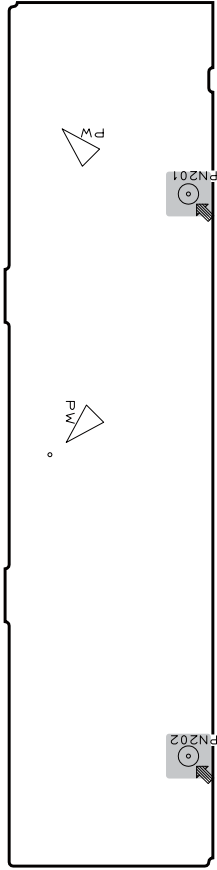

7

A

B

C

D

E

F

G

H

I

J

RX-V1067/HTF-8063/RX-A1000

POWER (2) P.C.B. (Side B)
R model

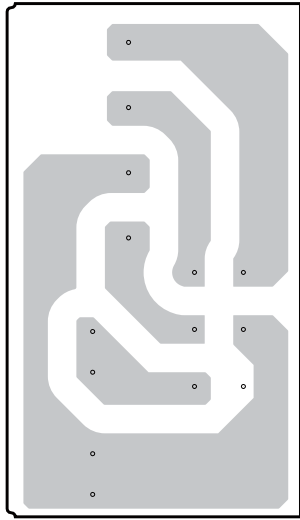

POWER (3) P.C.B. (Side B)

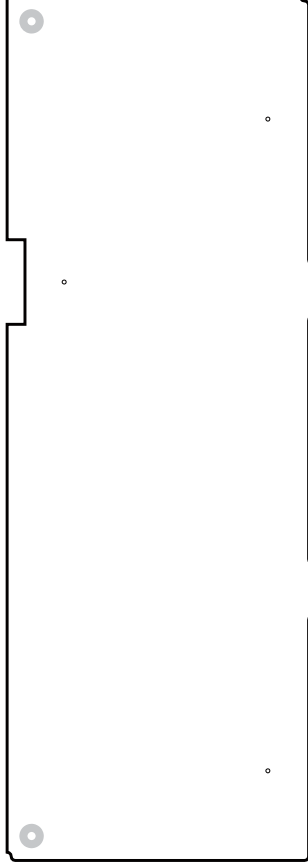

POWER (4) P.C.B. (Side B)

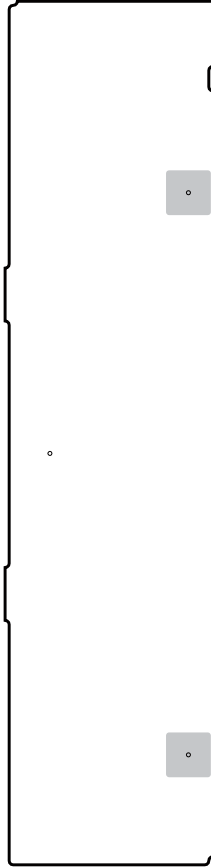

VIDEO (1) P.C.B. (Side A)

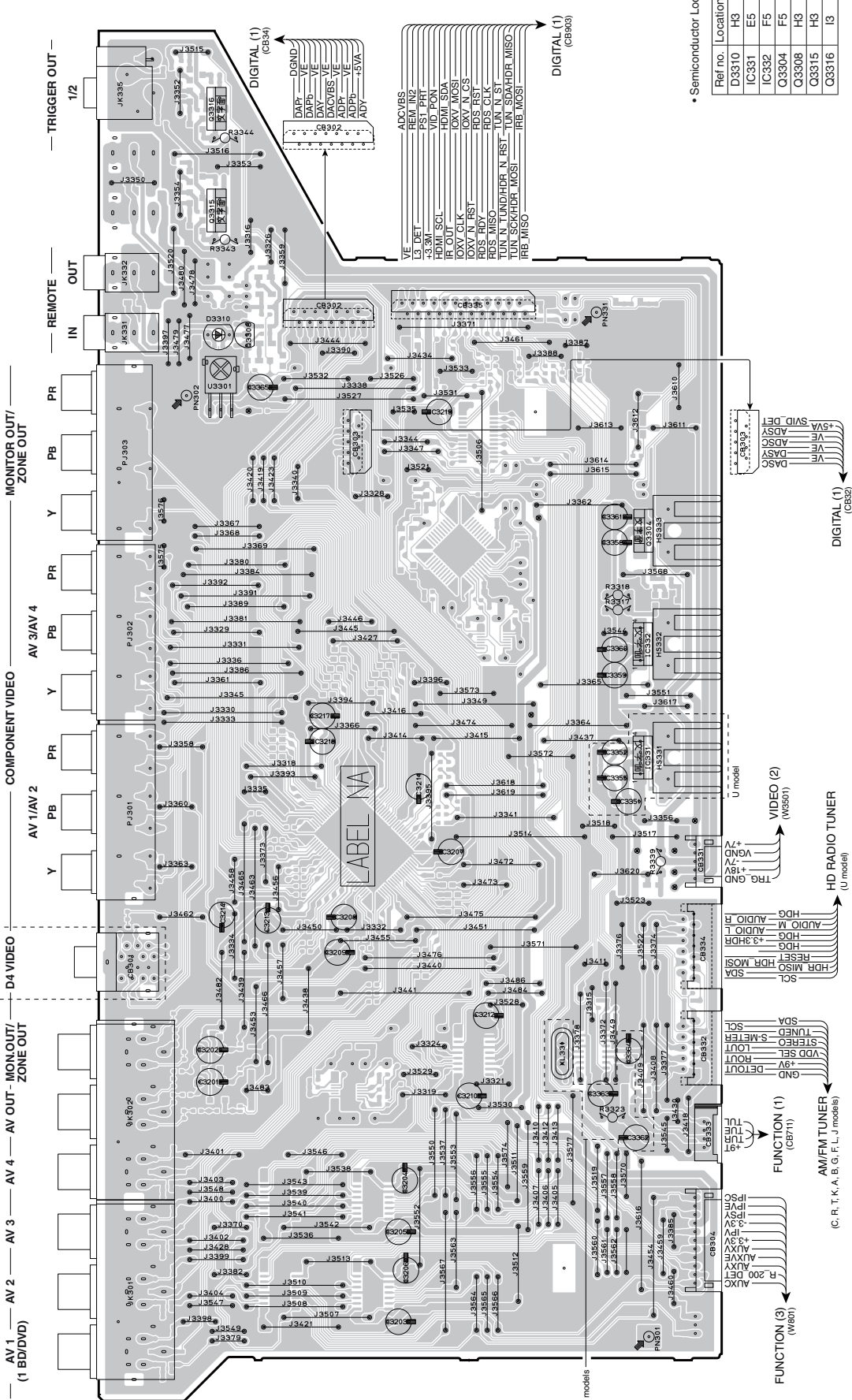

• Semiconductor Location

Ref no.	Location
D3310	H3
IC331	E5
IC332	F5
Q3304	F5
Q3308	H3
Q3315	H3
Q3316	I3

1

2

3

4

5

6

7

VIDEO (1) P.C.B. (Side B)

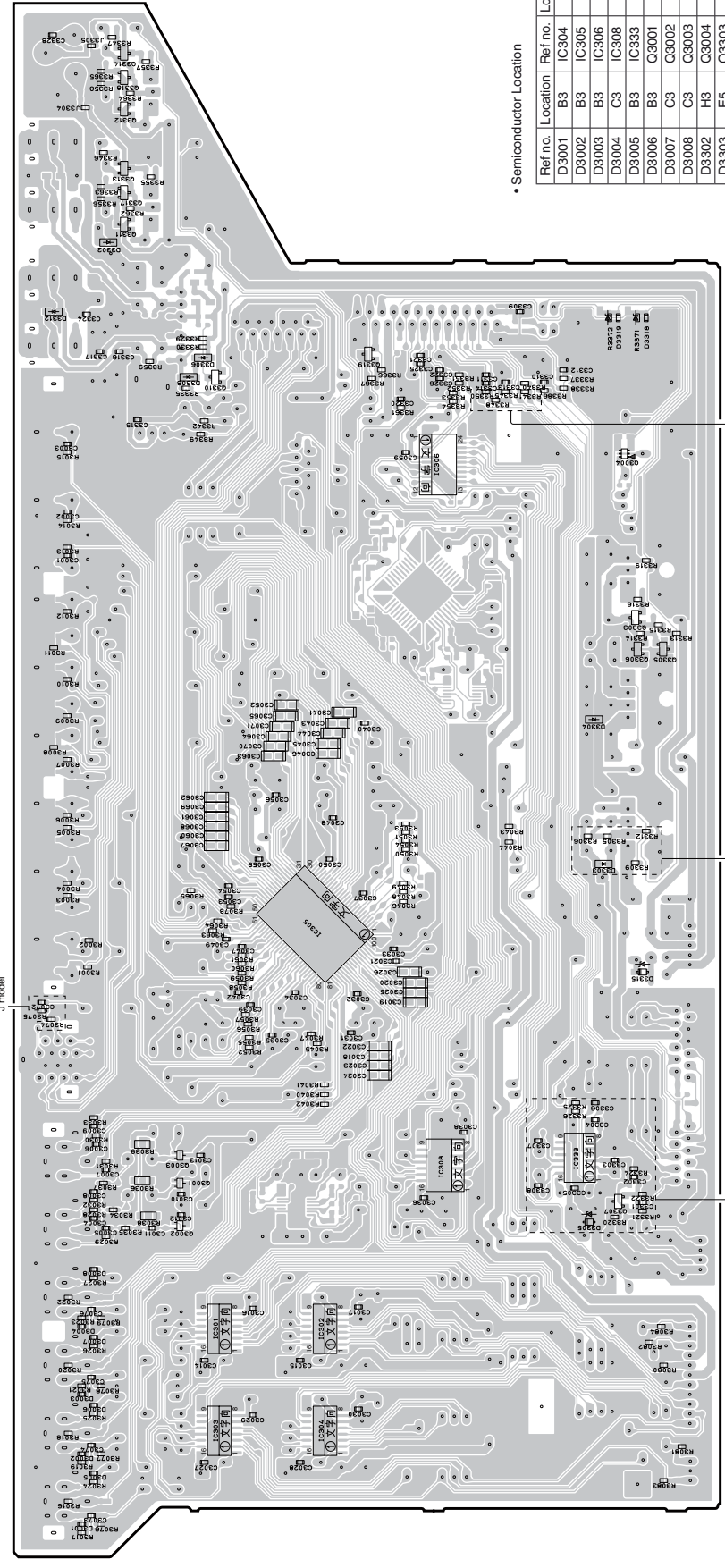

• Semiconductor Location

Ref no.	Location	Ref no.	Location
D3001	B3	IC304	B4
D3002	B3	IC305	E4
D3003	B3	IC306	G4
D3004	C3	IC308	C4
D3005	B3	IC303	C5
D3006	B3	Q3001	C3
D3007	C3	Q3002	C3
D3008	C3	Q3003	C3
D3009	H3	Q3004	G6
D3010	F5	Q3303	F6
D3011	F5	Q3305	F6
D3012	H3	Q3306	F6
D3013	H3	Q3307	C5
D3014	H3	Q3311	H3
D3015	H2	Q3312	I3
D3016	D6	Q3312	I3
D3017	H6	Q3313	I3
D3018	H6	Q3314	I3
D3019	H5	Q3317	I3
D3020	C3	Q3317	I3
D3021	C4	Q3318	I3
D3022	B3	Q3319	H4

VIDEO (2) P.C.B. (Side A)

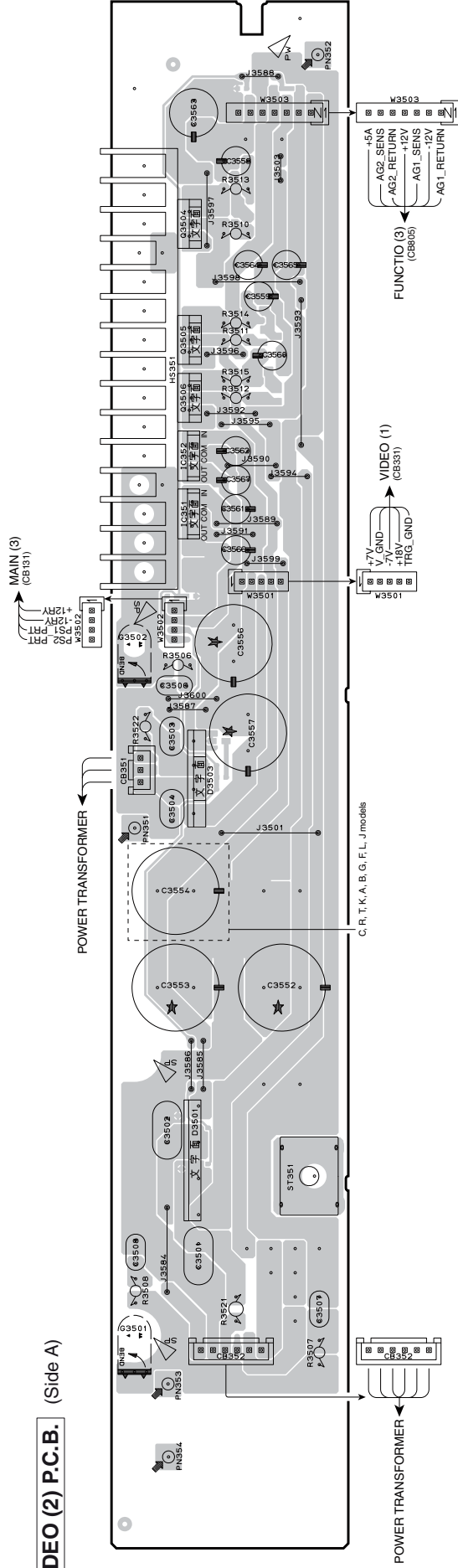

POWER TRANSFORMER

C, R, T, K, A, B, G, F, L, J models

VIDEO (3) P.C.B. (Side A)

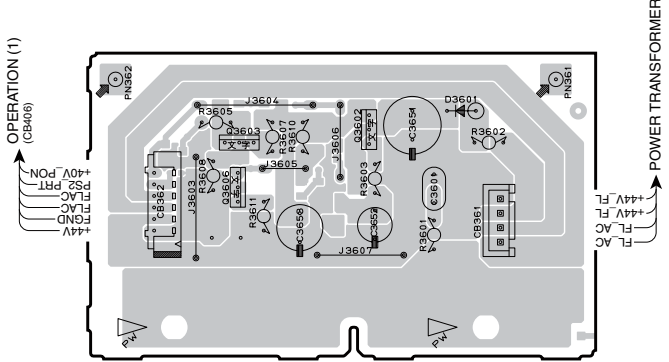

OPERATION (1)

POWER TRANSFORMER

VIDEO (4) P.C.B. (Side A)

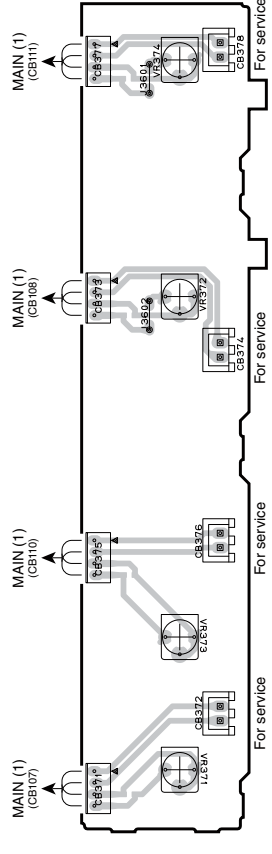

For service

VIDEO (5) P.C.B. (Side A)

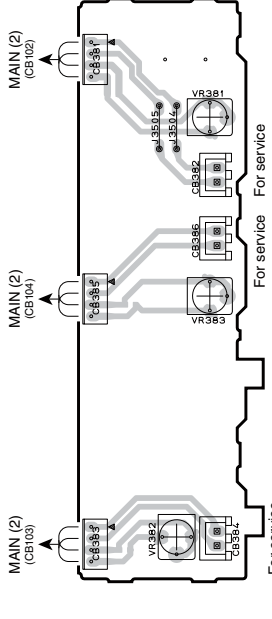

For service

• Semiconductor Location

Ref no.	Location	Ref no.	Location
D3501	C2	Q3505	H2
D3503	F2	Q3506	H2
D3601	B6	Q3602	B6
IC351	G2	Q3603	B5
IC352	H2	Q3606	B5
Q3504	I2		

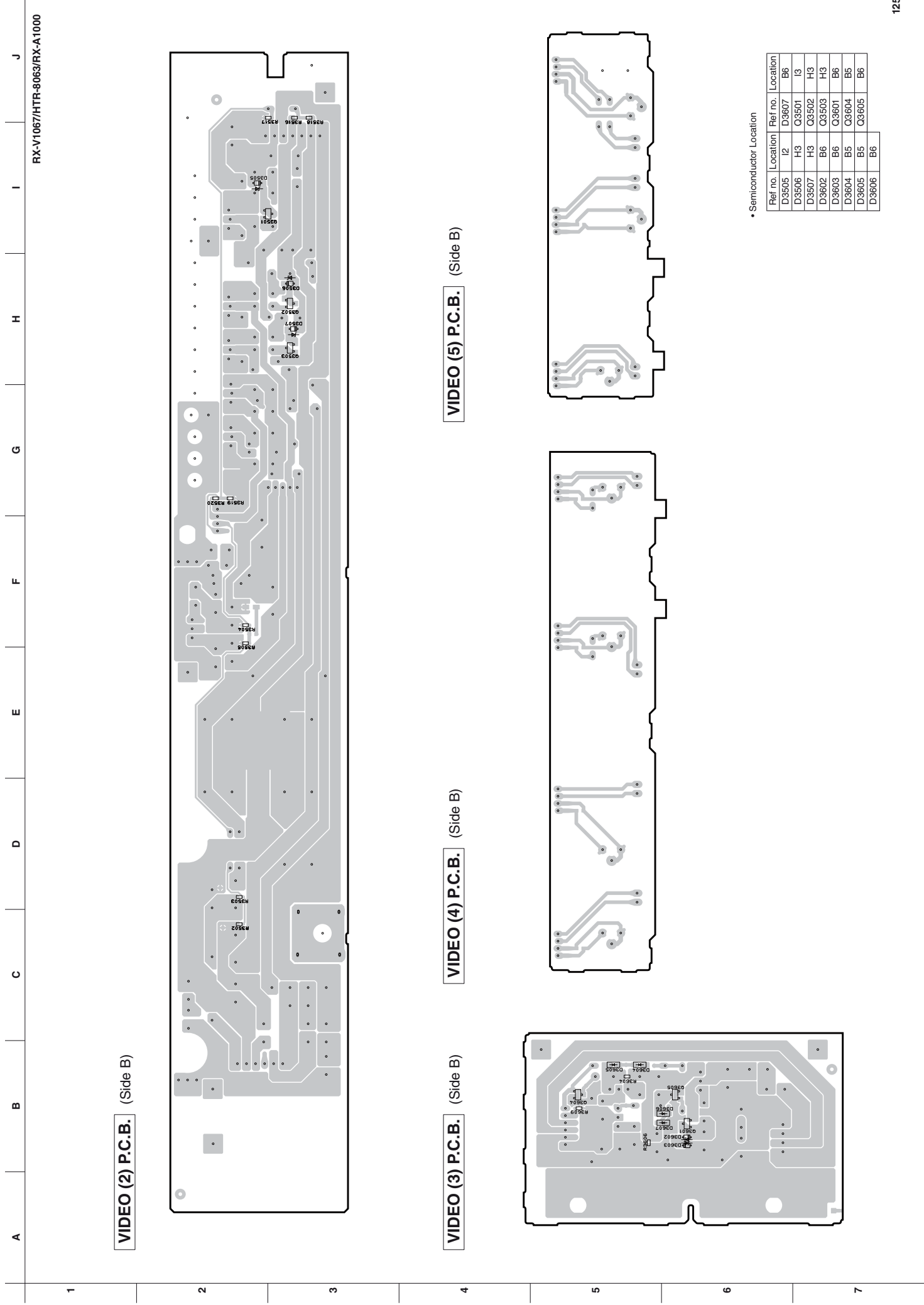

VIDEO (2) P.C.B. (Side B)

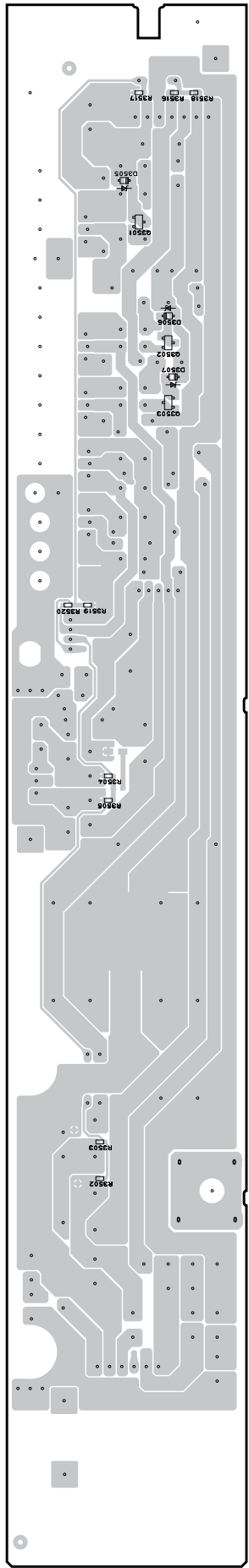

VIDEO (3) P.C.B. (Side B)

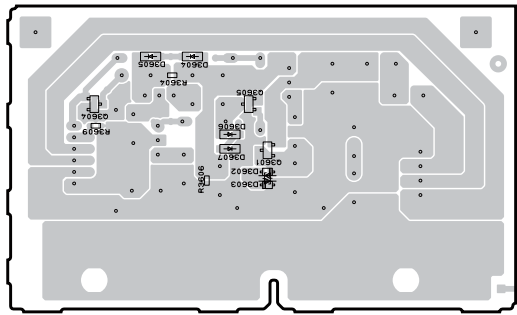

VIDEO (4) P.C.B. (Side B)

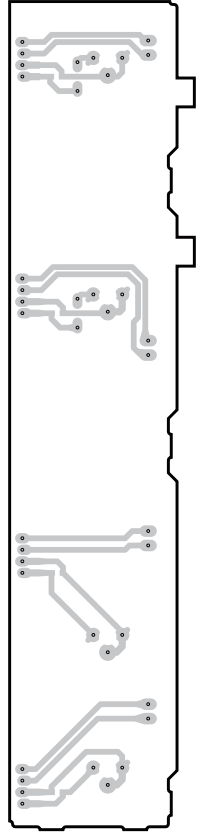

VIDEO (5) P.C.B. (Side B)

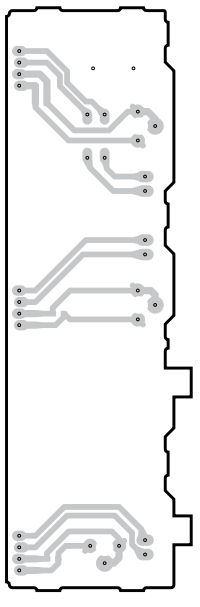

• Semiconductor Location

Ref no.	Location	Ref no.	Location
D3505	I2	D3607	B6
D3506	H3	Q3501	I3
D3507	H3	Q3502	H3
D3602	B6	Q3503	H3
D3603	B6	Q3601	B6
D3604	B5	Q3604	B5
D3605	B5	Q3605	B6
D3606	B6		

NET P.C.B. (Side A)

NET P.C.B. (Side B)

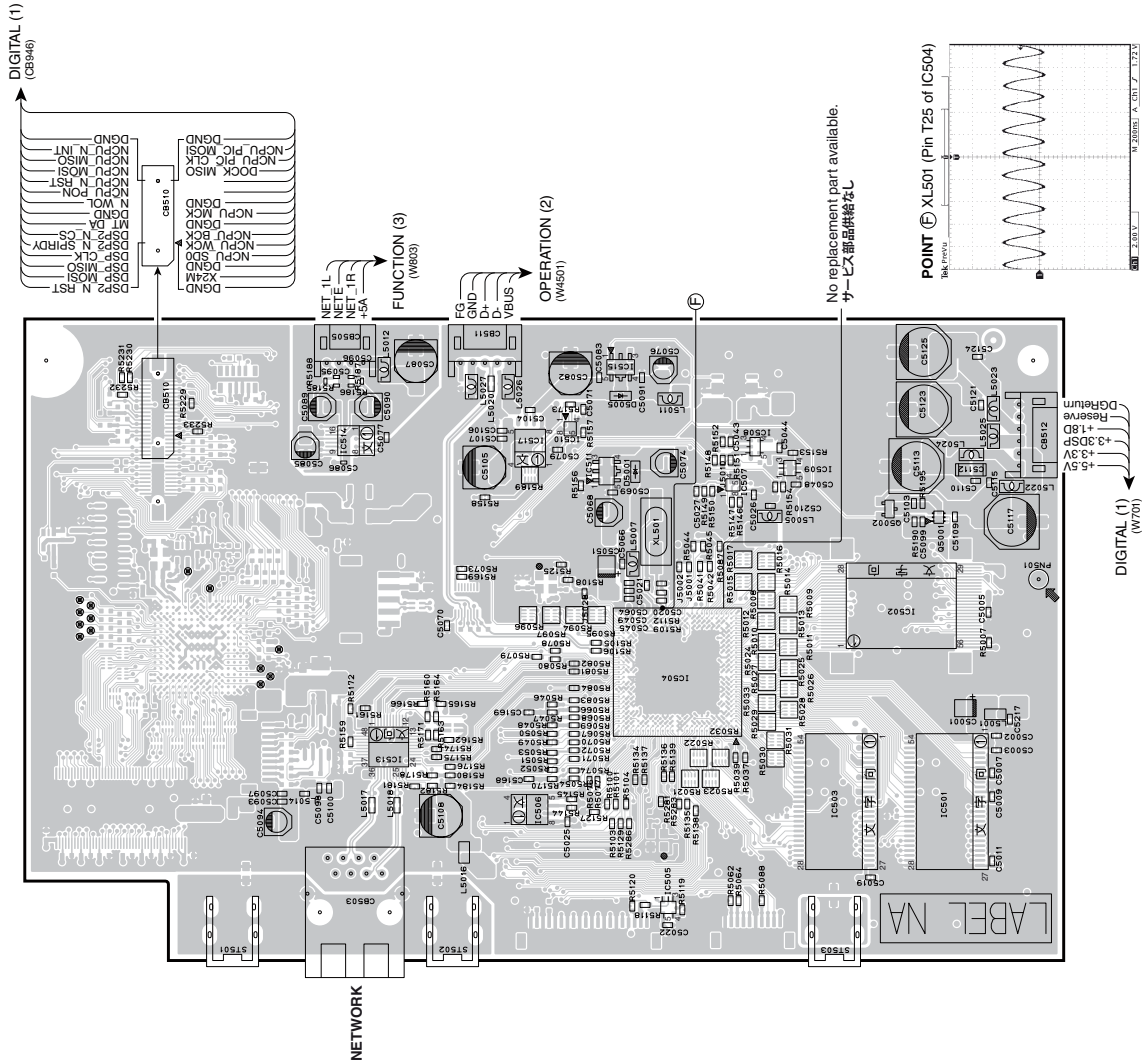

• Semiconductor Location

Ref no.	Location
D5001	D5
D5005	D5
IC501	B6
IC502	C6
IC503	B6
IC504	C5
IC505	B5
IC506	B4
IC507	D5
IC508	D5
IC509	D5
IC510	D4
IC511	D5
IC514	D3
IC515	D5
IC517	D4
IC525	H3
Q5001	D6
Q5002	D6

SCHEMATIC DIAGRAMS
DIGITAL 1/8

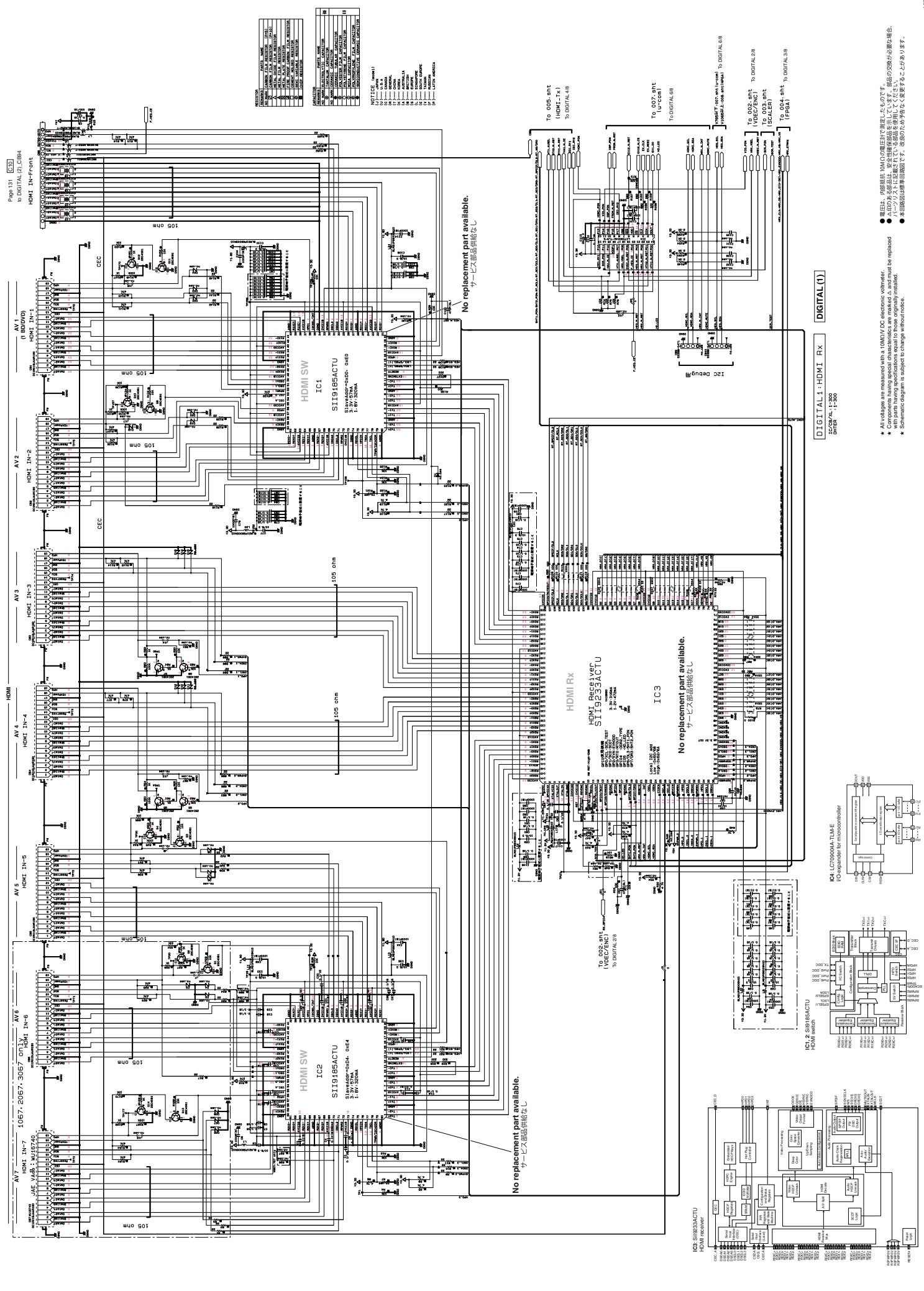

- 電圧は、内蔵回路 (MCO) の動作に準拠したものです。
- ▲ 印のある部品は、安全規格部品を示しています。規格の交換が必要な場合、▲印のある部品に同等の規格部品を必ず取り替えてください。
- ★ 本図面の仕様と異なる場合があります。ご了承ください。

- ★ All voltages are measured with a 10MΩ VDC electronic voltmeter.
- ▲ Components having special characteristics are marked ▲, and must be replaced with parts having same characteristics as original to ensure proper operation.
- ★ Schematic diagram is subject to change without notice.

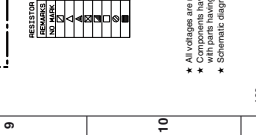
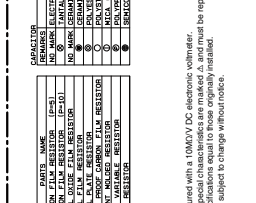
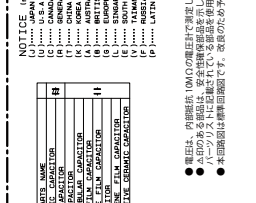
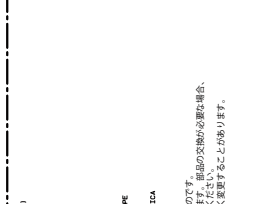
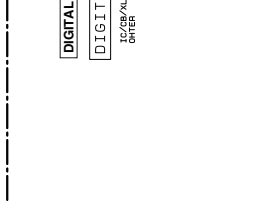
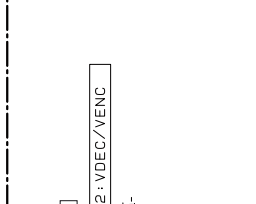
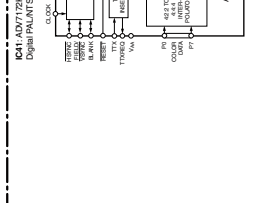
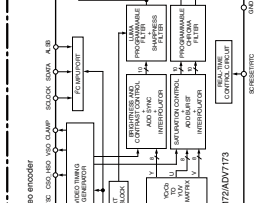
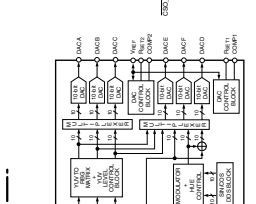
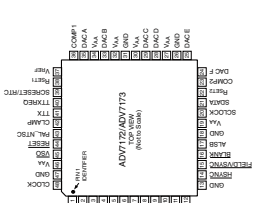
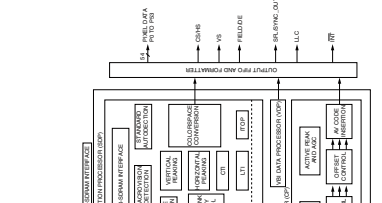
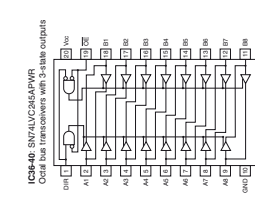
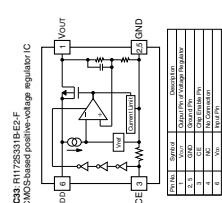
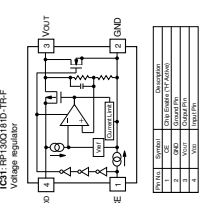
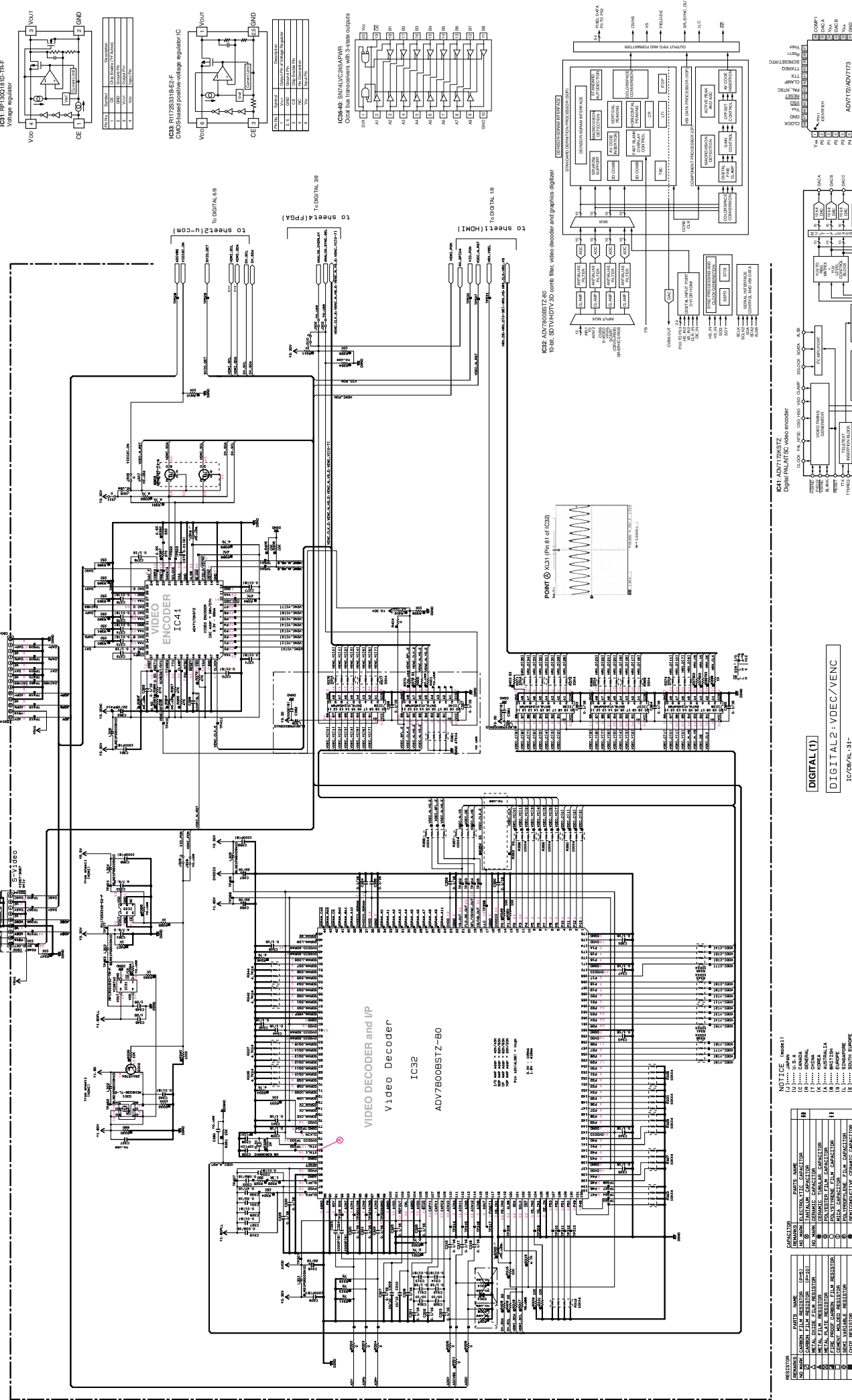

REVISION	REMARKS	DATE	NAME
1			
2			
3			
4			
5			
6			
7			
8			
9			
10			

* All voltages are measured with a 100kV DC electronic voltmeter.
 * Components having special characteristics are marked A, and must be replaced with components of the same type.
 * Schematic diagram is subject to change without notice.

NOTICE (Notes 1)
 UJ..... U.S.A.
 US..... U.S.A.
 G..... GENERAL
 J..... JAPAN
 K..... KOREA
 M..... MALAYSIA
 O..... OCEANIA
 P..... PAKISTAN
 S..... SINGAPORE
 T..... TAIWAN
 W..... WESTERN EUROPE
 Y..... YUKON
 Z..... ZAMBIA
 A..... ALGERIA
 B..... BENIN
 C..... CAMBODIA
 D..... CANADA
 E..... CHINA
 F..... FRANCE
 H..... HONG KONG
 I..... INDIA
 L..... LITHUANIA
 N..... NETHERLANDS
 P..... POLAND
 R..... ROMANIA
 S..... SLOVAKIA
 T..... THAILAND
 U..... UNITED KINGDOM
 V..... VIETNAM
 W..... WESTERN EUROPE
 Y..... YUKON
 Z..... ZAMBIA

DIGITAL (1)
DIGITAL 2: VDEC/VENC
IC32/AL31-01

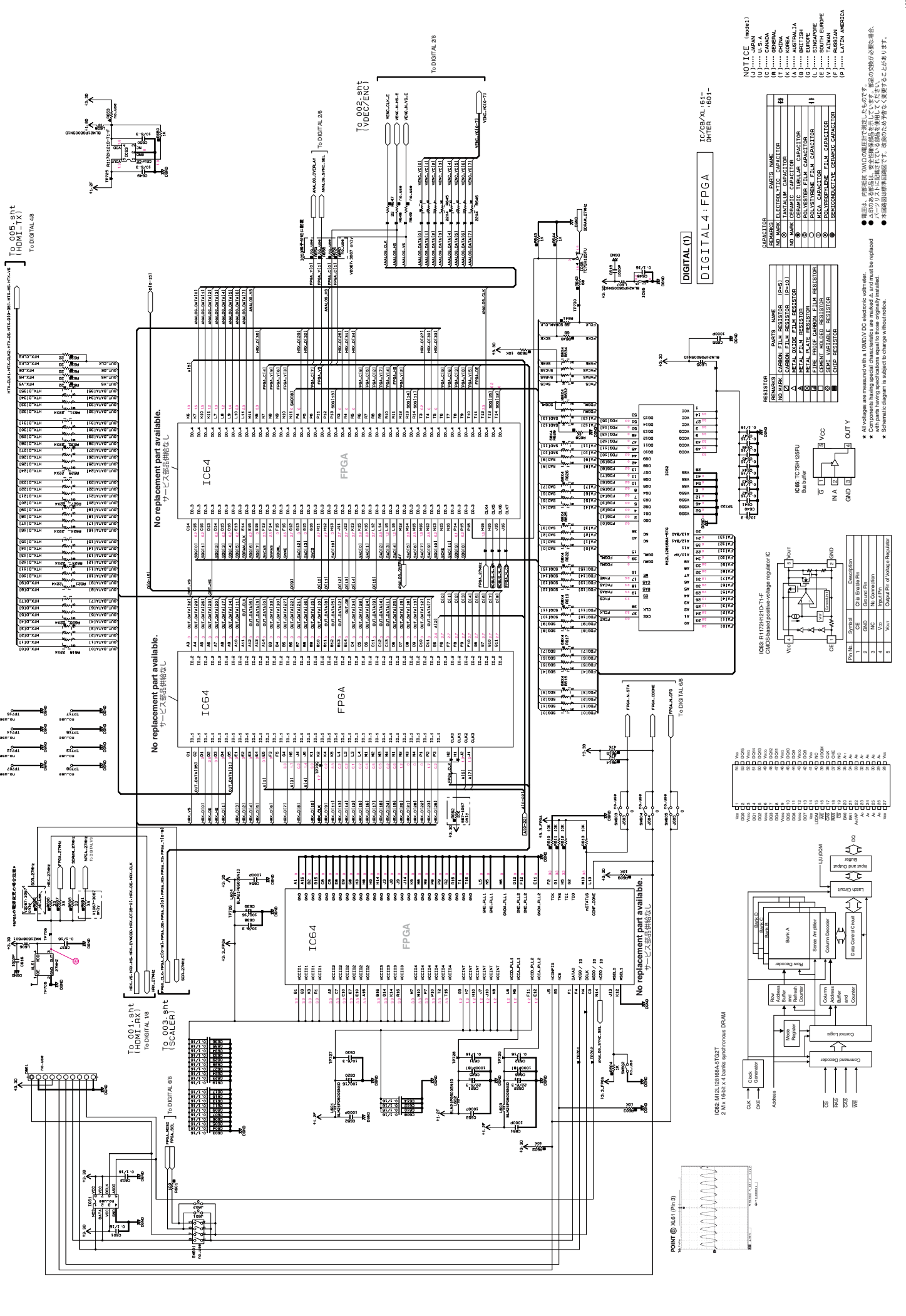

NOTICE (Import)

(U)..... U.S.A.
 (J)..... JAPAN
 (R)..... GENERAL
 (T)..... CHINA
 (A)..... AUSTRALIA
 (B)..... BRITISH
 (S)..... SINGAPORE
 (E)..... SOUTH EUROPE
 (V)..... TAIWAN
 (P)..... LATIN AMERICA

RESISTOR

REMARKS	PARTIAL NAME
NO. MARK	RESISTOR
RESISTOR	RESISTOR
NO. MARK	CERAMIC CAPACITOR
RESISTOR	CERAMIC CAPACITOR
NO. MARK	FILM CAPACITOR
RESISTOR	FILM CAPACITOR
NO. MARK	SEMI-CONDUCTIVE CERAMIC CAPACITOR
RESISTOR	SEMI-CONDUCTIVE CERAMIC CAPACITOR

IC64 R172H12LD-TL-F

Pin No.	Symbol	Description
1	VCC	Core Vcc
2	GND	No Connection
3	VCC	Input Vcc
4	Vcc	Core Vcc of Voltage Regulator
5	Vcc	Core Vcc of Voltage Regulator

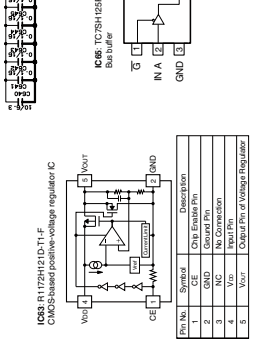

IC64 M1010R8A-E00T

Pin No.	Symbol	Description
1	CLK	Core Clock
2	CE	Core Enable
3	NC	No Connection
4	Input Pin	Input Pin
5	Vcc	Core Vcc of Voltage Regulator

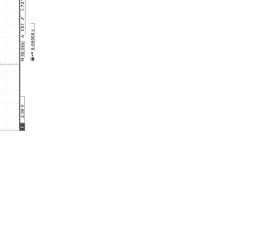
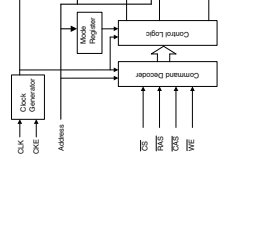
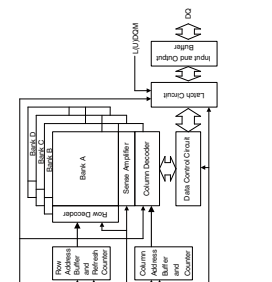

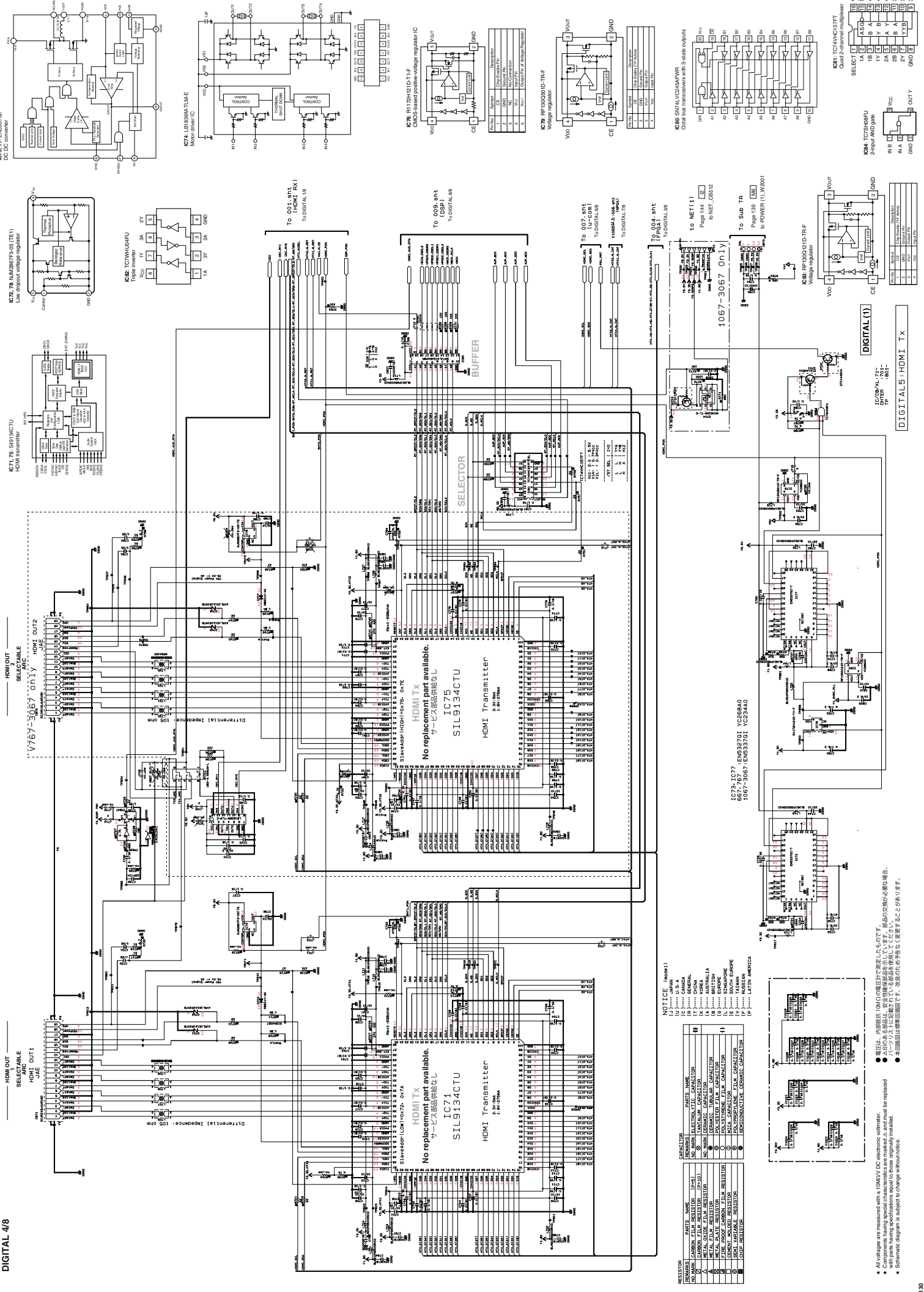

IC71.76 8P134CTU
HDMI transmitter

IC72.76 NM2879-05 (RE1)
Low dropout voltage regulator

IC73.77 EN53701
DC converter

IC74.18B86M1LAE
Motor driver IC

IC75.79 1P1000D1D-TRF
Voltage regulator

IC76.77 EN53701
DC converter

IC77.67 EN53701 V2268A0
1067-3067 Only

IC78.79 1P1000D1D-TRF
Voltage regulator

IC81.7C74VHC10DFT
Gate 2-output inverter

IC84.7C75SRBU
2-pin output

IC85.79 1P1000D1D-TRF
Voltage regulator

IC86.79 1P1000D1D-TRF
Voltage regulator

HDMI Tx
No replacement part available.
9-7-2 対応機種なし
IC71
SIL9134CTU
HDMI Transmitter
3.3V 27pin

HDMI Tx
No replacement part available.
9-7-2 対応機種なし
IC75
SIL9134CTU
HDMI Transmitter
3.3V 27pin

HDMI Tx
No replacement part available.
9-7-2 対応機種なし
IC77
SIL9134CTU
HDMI Transmitter
3.3V 27pin

HDMI Tx
No replacement part available.
9-7-2 対応機種なし
IC79
SIL9134CTU
HDMI Transmitter
3.3V 27pin

HDMI Tx
No replacement part available.
9-7-2 対応機種なし
IC81
SIL9134CTU
HDMI Transmitter
3.3V 27pin

NOTICE (Note1)

- U JAPAN
- C CANADA
- G GENERAL
- I ITALY
- K KOREA
- B BRAZIL
- S SPAIN
- E EUROPE
- SE SOUTH EUROPE
- T TAIWAN
- IP LATIN AMERICA

RESISTOR	CAPACITOR
① CARBON FILM RESISTOR (PS)	① CERAMIC CAPACITOR (C)
② CARBON FILM RESISTOR (PS)	② CERAMIC CAPACITOR (C)
③ METAL FILM RESISTOR (PS)	③ CERAMIC CAPACITOR (C)
④ METAL FILM RESISTOR (PS)	④ CERAMIC CAPACITOR (C)
⑤ METAL FILM RESISTOR (PS)	⑤ CERAMIC CAPACITOR (C)
⑥ METAL FILM RESISTOR (PS)	⑥ CERAMIC CAPACITOR (C)
⑦ METAL FILM RESISTOR (PS)	⑦ CERAMIC CAPACITOR (C)
⑧ METAL FILM RESISTOR (PS)	⑧ CERAMIC CAPACITOR (C)
⑨ METAL FILM RESISTOR (PS)	⑨ CERAMIC CAPACITOR (C)
⑩ METAL FILM RESISTOR (PS)	⑩ CERAMIC CAPACITOR (C)
⑪ METAL FILM RESISTOR (PS)	⑪ CERAMIC CAPACITOR (C)
⑫ METAL FILM RESISTOR (PS)	⑫ CERAMIC CAPACITOR (C)
⑬ METAL FILM RESISTOR (PS)	⑬ CERAMIC CAPACITOR (C)
⑭ METAL FILM RESISTOR (PS)	⑭ CERAMIC CAPACITOR (C)
⑮ METAL FILM RESISTOR (PS)	⑮ CERAMIC CAPACITOR (C)
⑯ METAL FILM RESISTOR (PS)	⑯ CERAMIC CAPACITOR (C)
⑰ METAL FILM RESISTOR (PS)	⑰ CERAMIC CAPACITOR (C)
⑱ METAL FILM RESISTOR (PS)	⑱ CERAMIC CAPACITOR (C)
⑲ METAL FILM RESISTOR (PS)	⑲ CERAMIC CAPACITOR (C)
⑳ METAL FILM RESISTOR (PS)	⑳ CERAMIC CAPACITOR (C)
㉑ METAL FILM RESISTOR (PS)	㉑ CERAMIC CAPACITOR (C)
㉒ METAL FILM RESISTOR (PS)	㉒ CERAMIC CAPACITOR (C)
㉓ METAL FILM RESISTOR (PS)	㉓ CERAMIC CAPACITOR (C)
㉔ METAL FILM RESISTOR (PS)	㉔ CERAMIC CAPACITOR (C)
㉕ METAL FILM RESISTOR (PS)	㉕ CERAMIC CAPACITOR (C)
㉖ METAL FILM RESISTOR (PS)	㉖ CERAMIC CAPACITOR (C)
㉗ METAL FILM RESISTOR (PS)	㉗ CERAMIC CAPACITOR (C)
㉘ METAL FILM RESISTOR (PS)	㉘ CERAMIC CAPACITOR (C)
㉙ METAL FILM RESISTOR (PS)	㉙ CERAMIC CAPACITOR (C)
㉚ METAL FILM RESISTOR (PS)	㉚ CERAMIC CAPACITOR (C)
㉛ METAL FILM RESISTOR (PS)	㉛ CERAMIC CAPACITOR (C)
㉜ METAL FILM RESISTOR (PS)	㉜ CERAMIC CAPACITOR (C)
㉝ METAL FILM RESISTOR (PS)	㉝ CERAMIC CAPACITOR (C)
㉞ METAL FILM RESISTOR (PS)	㉞ CERAMIC CAPACITOR (C)
㉟ METAL FILM RESISTOR (PS)	㉟ CERAMIC CAPACITOR (C)
㊱ METAL FILM RESISTOR (PS)	㊱ CERAMIC CAPACITOR (C)
㊲ METAL FILM RESISTOR (PS)	㊲ CERAMIC CAPACITOR (C)
㊳ METAL FILM RESISTOR (PS)	㊳ CERAMIC CAPACITOR (C)
㊴ METAL FILM RESISTOR (PS)	㊴ CERAMIC CAPACITOR (C)
㊵ METAL FILM RESISTOR (PS)	㊵ CERAMIC CAPACITOR (C)
㊶ METAL FILM RESISTOR (PS)	㊶ CERAMIC CAPACITOR (C)
㊷ METAL FILM RESISTOR (PS)	㊷ CERAMIC CAPACITOR (C)
㊸ METAL FILM RESISTOR (PS)	㊸ CERAMIC CAPACITOR (C)
㊹ METAL FILM RESISTOR (PS)	㊹ CERAMIC CAPACITOR (C)
㊺ METAL FILM RESISTOR (PS)	㊺ CERAMIC CAPACITOR (C)
㊻ METAL FILM RESISTOR (PS)	㊻ CERAMIC CAPACITOR (C)
㊼ METAL FILM RESISTOR (PS)	㊼ CERAMIC CAPACITOR (C)
㊽ METAL FILM RESISTOR (PS)	㊽ CERAMIC CAPACITOR (C)
㊾ METAL FILM RESISTOR (PS)	㊾ CERAMIC CAPACITOR (C)
㊿ METAL FILM RESISTOR (PS)	㊿ CERAMIC CAPACITOR (C)

* All voltages are measured with a 10MΩV DC electronic voltmeter.
* Components having special characteristics are marked A, and must be replaced with the same type as shown in the original drawing.
* Schematic diagram is subject to change without notice.

HDMI IN-FrontPanel

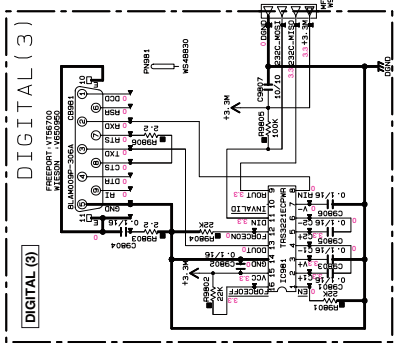
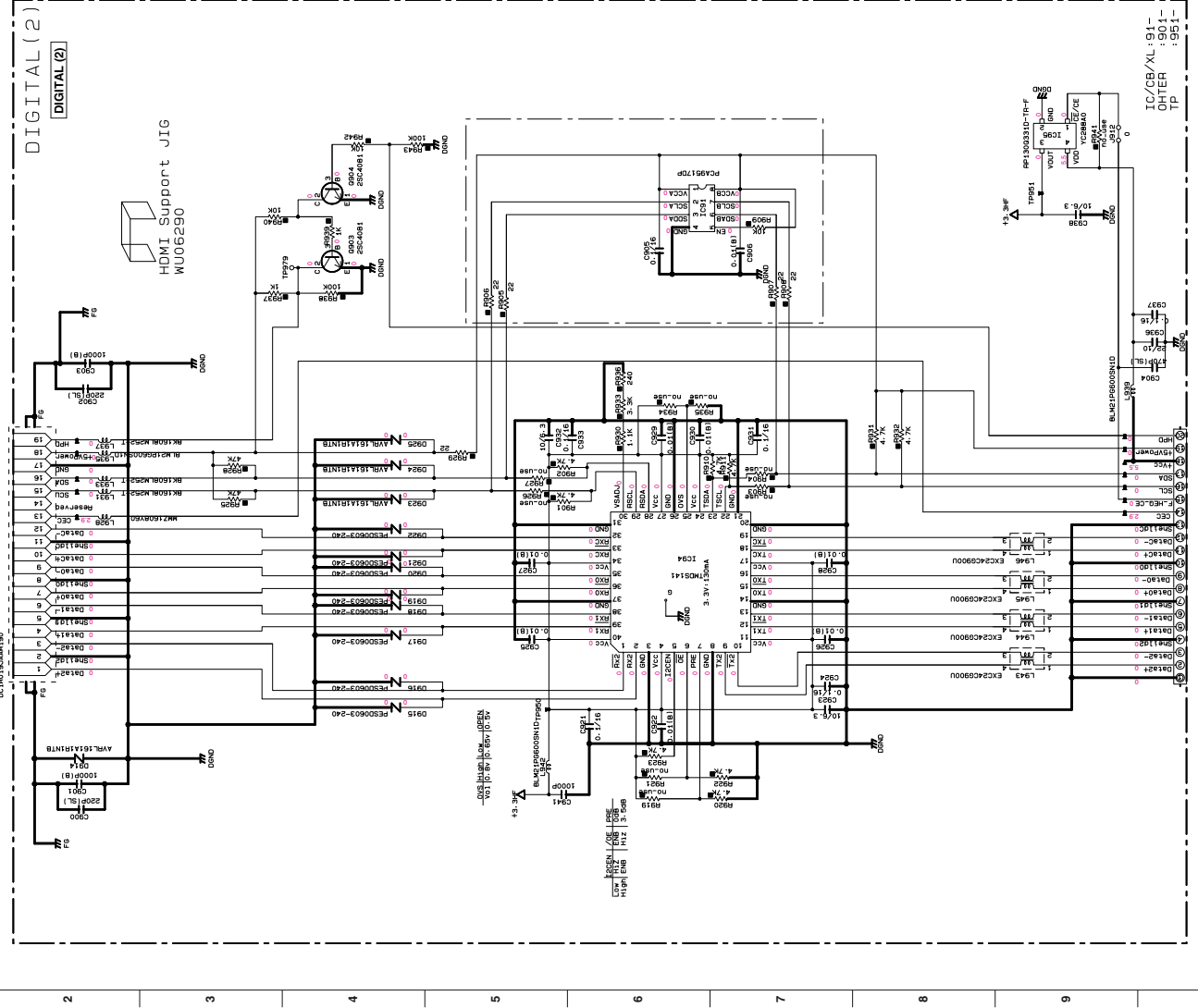

to DIGITAL(1)

RESISTOR PART LIST

REF	LOC	DESCRIPTION	U	CRITICAL
R12	R0920	10K	X	X
R13	R0921	10K	X	X
R17	R0923	10K	X	X
R20	R0924	10K	X	X
R25	R0925	10K	X	X
R71	R0943	10K	X	X
R72	R0944	10K	X	X
R73	R0945	10K	X	X

NOTICE (notes)

① JAPAN
② CANADA
③ CHINA
④ KOREA
⑤ BRITISH
⑥ SINGAPORE
⑦ SOUTH AFRICA
⑧ SOUTH AMERICA
⑨ HONG KONG
⑩ TAIWAN
⑪ MALAYSIA
⑫ PHILIPPINES
⑬ THAILAND
⑭ INDONESIA
⑮ AUSTRALIA
⑯ NEW ZEALAND
⑰ SOUTH AFRICA
⑱ SOUTH AMERICA
⑲ HONG KONG
⑳ TAIWAN
㉑ MALAYSIA
㉒ PHILIPPINES
㉓ THAILAND
㉔ INDONESIA
㉕ AUSTRALIA
㉖ NEW ZEALAND

COMPONENTS

REF	LOC	DESCRIPTION	U	CRITICAL
C1	C0001	100nF	X	X
C2	C0002	100nF	X	X
C3	C0003	100nF	X	X
C4	C0004	100nF	X	X
C5	C0005	100nF	X	X
C6	C0006	100nF	X	X
C7	C0007	100nF	X	X
C8	C0008	100nF	X	X
C9	C0009	100nF	X	X
C10	C0010	100nF	X	X
C11	C0011	100nF	X	X
C12	C0012	100nF	X	X
C13	C0013	100nF	X	X
C14	C0014	100nF	X	X
C15	C0015	100nF	X	X
C16	C0016	100nF	X	X
C17	C0017	100nF	X	X
C18	C0018	100nF	X	X
C19	C0019	100nF	X	X
C20	C0020	100nF	X	X
C21	C0021	100nF	X	X
C22	C0022	100nF	X	X
C23	C0023	100nF	X	X
C24	C0024	100nF	X	X
C25	C0025	100nF	X	X
C26	C0026	100nF	X	X
C27	C0027	100nF	X	X
C28	C0028	100nF	X	X
C29	C0029	100nF	X	X
C30	C0030	100nF	X	X
C31	C0031	100nF	X	X
C32	C0032	100nF	X	X
C33	C0033	100nF	X	X
C34	C0034	100nF	X	X
C35	C0035	100nF	X	X
C36	C0036	100nF	X	X
C37	C0037	100nF	X	X
C38	C0038	100nF	X	X
C39	C0039	100nF	X	X
C40	C0040	100nF	X	X
C41	C0041	100nF	X	X
C42	C0042	100nF	X	X
C43	C0043	100nF	X	X
C44	C0044	100nF	X	X
C45	C0045	100nF	X	X
C46	C0046	100nF	X	X
C47	C0047	100nF	X	X
C48	C0048	100nF	X	X
C49	C0049	100nF	X	X
C50	C0050	100nF	X	X
C51	C0051	100nF	X	X
C52	C0052	100nF	X	X
C53	C0053	100nF	X	X
C54	C0054	100nF	X	X
C55	C0055	100nF	X	X
C56	C0056	100nF	X	X
C57	C0057	100nF	X	X
C58	C0058	100nF	X	X
C59	C0059	100nF	X	X
C60	C0060	100nF	X	X
C61	C0061	100nF	X	X
C62	C0062	100nF	X	X
C63	C0063	100nF	X	X
C64	C0064	100nF	X	X
C65	C0065	100nF	X	X
C66	C0066	100nF	X	X
C67	C0067	100nF	X	X
C68	C0068	100nF	X	X
C69	C0069	100nF	X	X
C70	C0070	100nF	X	X
C71	C0071	100nF	X	X
C72	C0072	100nF	X	X
C73	C0073	100nF	X	X
C74	C0074	100nF	X	X
C75	C0075	100nF	X	X
C76	C0076	100nF	X	X
C77	C0077	100nF	X	X
C78	C0078	100nF	X	X
C79	C0079	100nF	X	X
C80	C0080	100nF	X	X
C81	C0081	100nF	X	X
C82	C0082	100nF	X	X
C83	C0083	100nF	X	X
C84	C0084	100nF	X	X
C85	C0085	100nF	X	X
C86	C0086	100nF	X	X
C87	C0087	100nF	X	X
C88	C0088	100nF	X	X
C89	C0089	100nF	X	X
C90	C0090	100nF	X	X
C91	C0091	100nF	X	X
C92	C0092	100nF	X	X
C93	C0093	100nF	X	X
C94	C0094	100nF	X	X
C95	C0095	100nF	X	X
C96	C0096	100nF	X	X
C97	C0097	100nF	X	X
C98	C0098	100nF	X	X
C99	C0099	100nF	X	X
C100	C0100	100nF	X	X

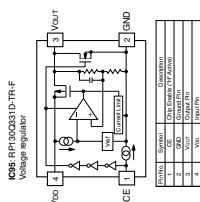
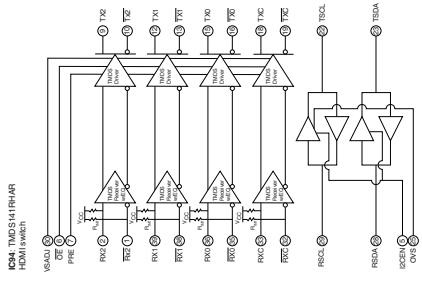
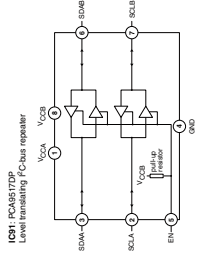

★ All voltages are measured with a 10MΩ VDC electronic voltmeter.
★ Components having special characteristics are marked Δ, and must be replaced with the same type.
★ Schematic diagram is subject to change without notice.

DIGITAL6: Front HDMI & 232C

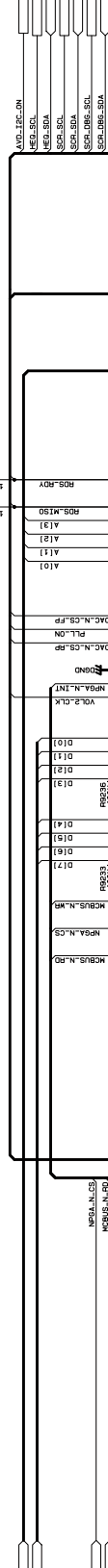

DIGITAL 7/8

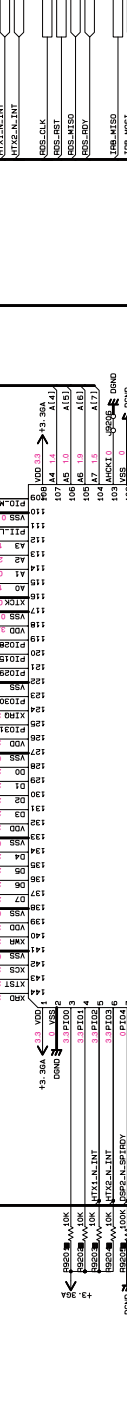

DIGITAL 7/8

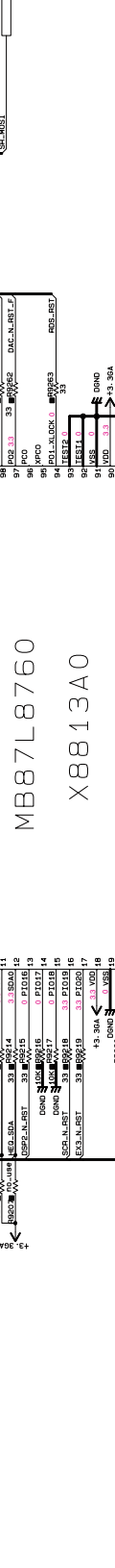

DIGITAL 7/8

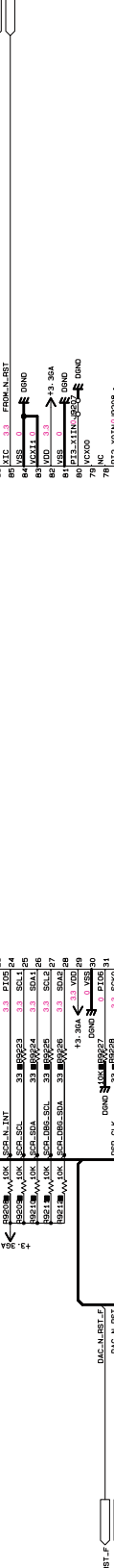

DIGITAL 7/8

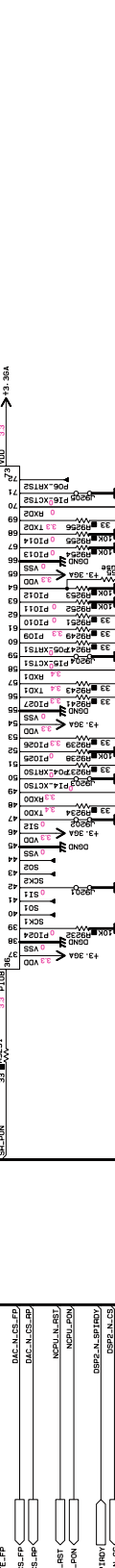

DIGITAL 7/8

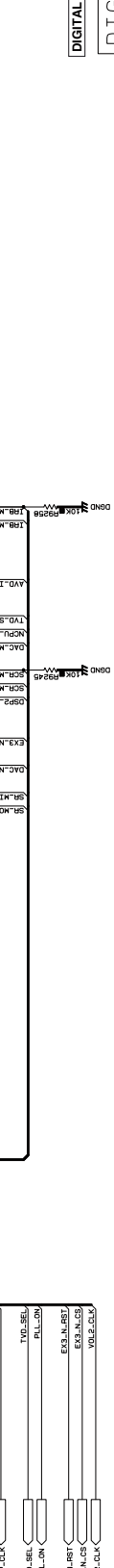

DIGITAL 7/8

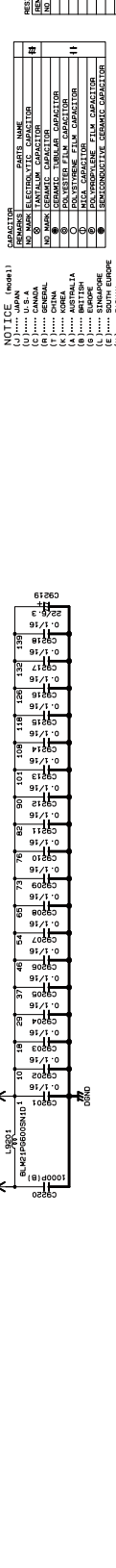

DIGITAL 7/8



NOTICE (note1)

⌘ ... U.S.A
 ① ... CANADA
 ② ... CHINA
 ③ ... HONG KONG
 ④ ... AUSTRALIA
 ⑤ ... SOUTH AFRICA
 ⑥ ... TAIWAN
 ⑦ ... EUROPE
 ⑧ ... LATIN AMERICA

RESISTOR

① ... 1/4W
 ② ... 1/8W
 ③ ... 1/16W
 ④ ... 1/10W
 ⑤ ... 1/5W
 ⑥ ... 1/2W
 ⑦ ... 1W
 ⑧ ... 2W
 ⑨ ... 3W
 ⑩ ... 5W
 ⑪ ... 10W
 ⑫ ... 20W
 ⑬ ... 30W
 ⑭ ... 50W
 ⑮ ... 100W

RESISTOR

① ... 1/4W
 ② ... 1/8W
 ③ ... 1/16W
 ④ ... 1/10W
 ⑤ ... 1/5W
 ⑥ ... 1/2W
 ⑦ ... 1W
 ⑧ ... 2W
 ⑨ ... 3W
 ⑩ ... 5W
 ⑪ ... 10W
 ⑫ ... 20W
 ⑬ ... 30W
 ⑭ ... 50W
 ⑮ ... 100W

CAPACITOR

① ... 0.1μF
 ② ... 0.2μF
 ③ ... 0.5μF
 ④ ... 1μF
 ⑤ ... 2μF
 ⑥ ... 5μF
 ⑦ ... 10μF
 ⑧ ... 20μF
 ⑨ ... 50μF
 ⑩ ... 100μF
 ⑪ ... 200μF
 ⑫ ... 500μF
 ⑬ ... 1000μF
 ⑭ ... 2000μF
 ⑮ ... 5000μF
 ⑯ ... 10000μF

CAPACITOR

① ... 0.1μF
 ② ... 0.2μF
 ③ ... 0.5μF
 ④ ... 1μF
 ⑤ ... 2μF
 ⑥ ... 5μF
 ⑦ ... 10μF
 ⑧ ... 20μF
 ⑨ ... 50μF
 ⑩ ... 100μF
 ⑪ ... 200μF
 ⑫ ... 500μF
 ⑬ ... 1000μF
 ⑭ ... 2000μF
 ⑮ ... 5000μF
 ⑯ ... 10000μF

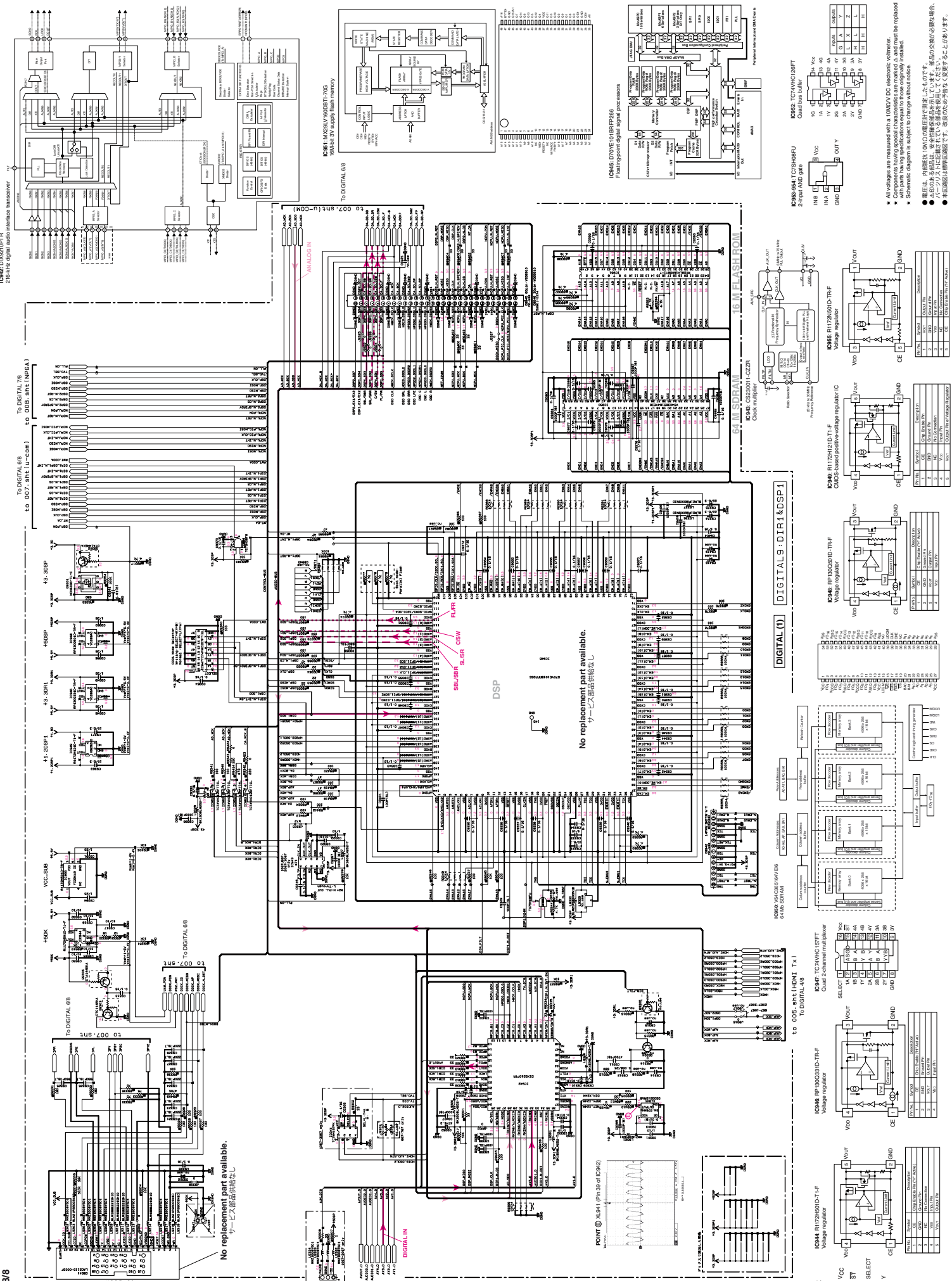

No replacement part available.
サービス提供なし

No replacement part available.
サービス提供なし

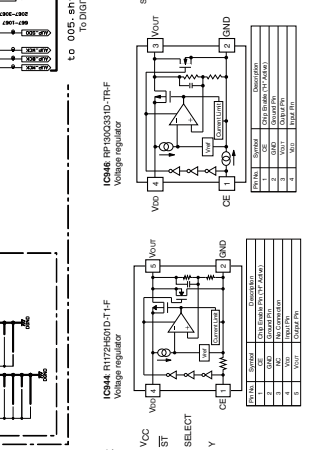
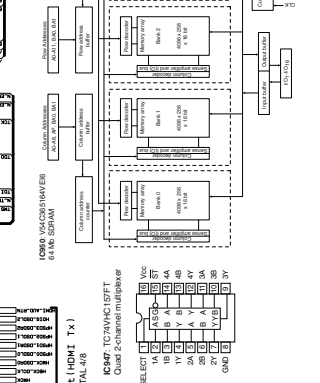
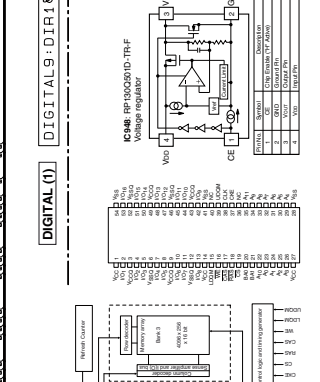
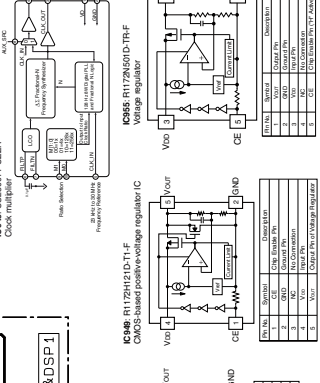
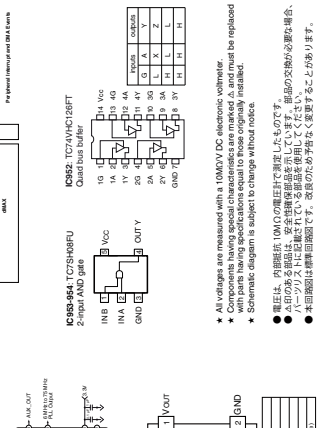
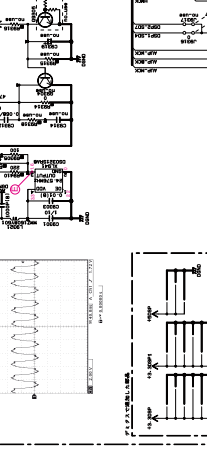
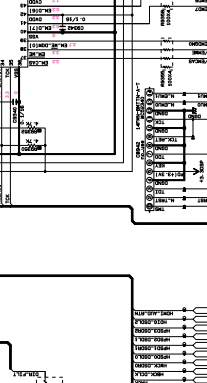
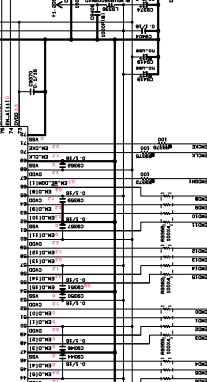
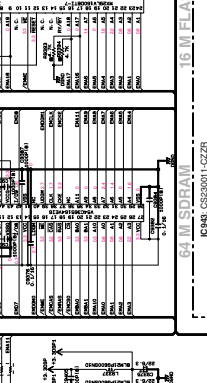
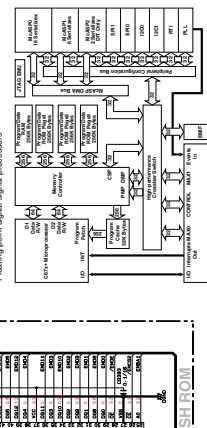
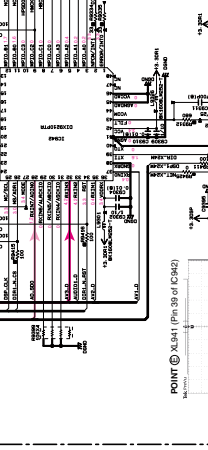
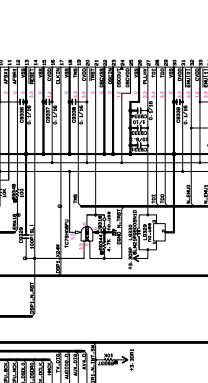
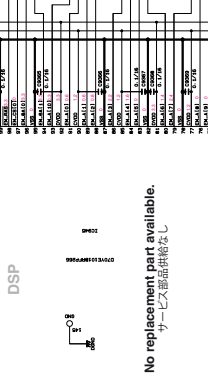
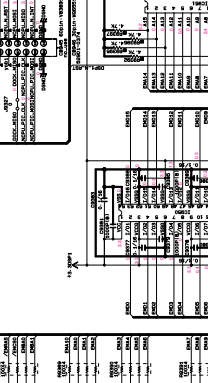
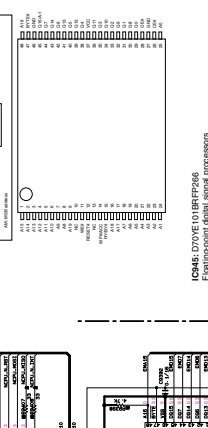
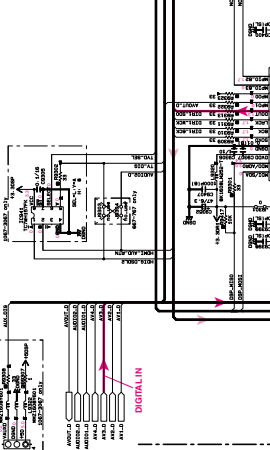
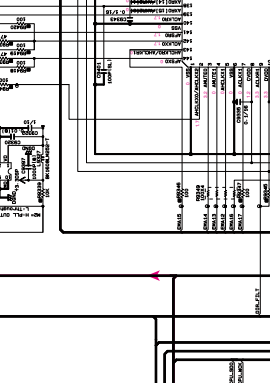
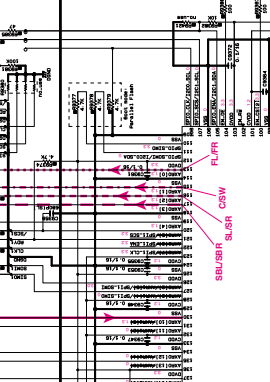
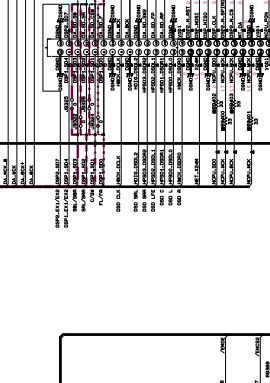
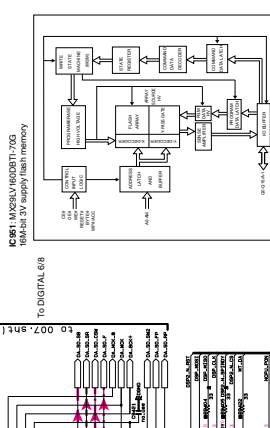
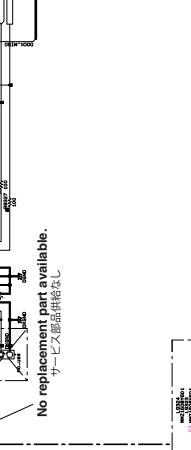
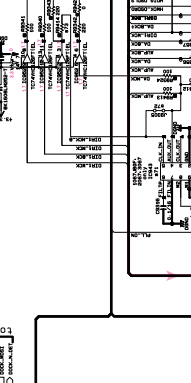
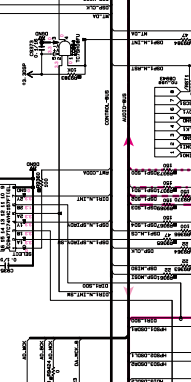
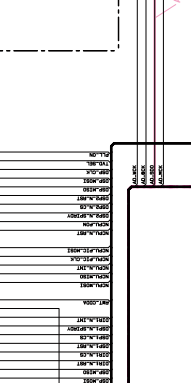
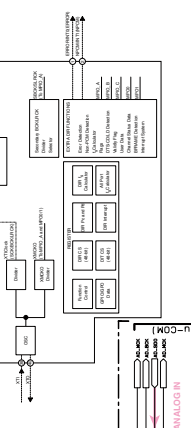
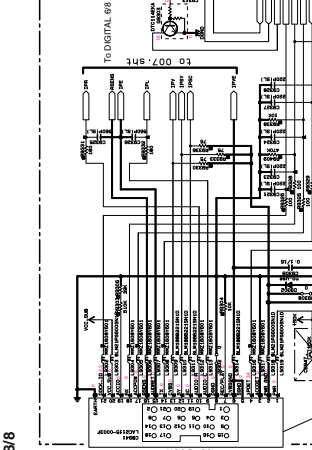
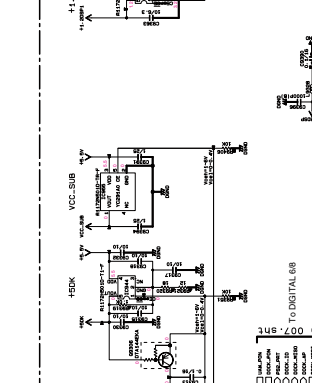
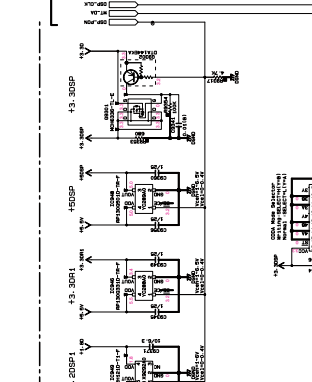
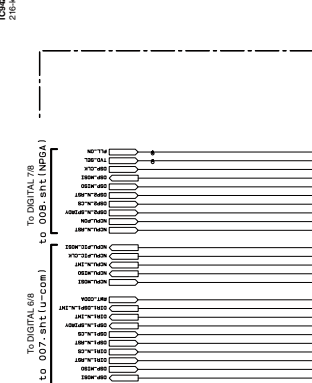
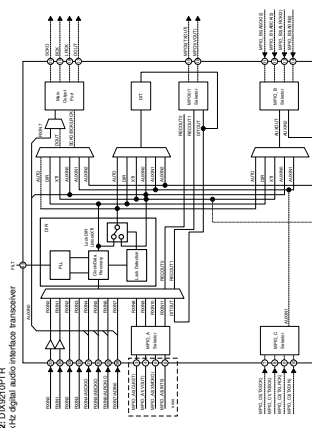

● 補正は、内蔵レジスタの内容を再設定した後の再帰的初期化が必要の場合。
● 一時的な不具合を修正するための再帰的初期化が必要の場合。
● 本印刷物は単行本図面です。変更のため番号が変更される場合があります。

FUNCTION 1/2

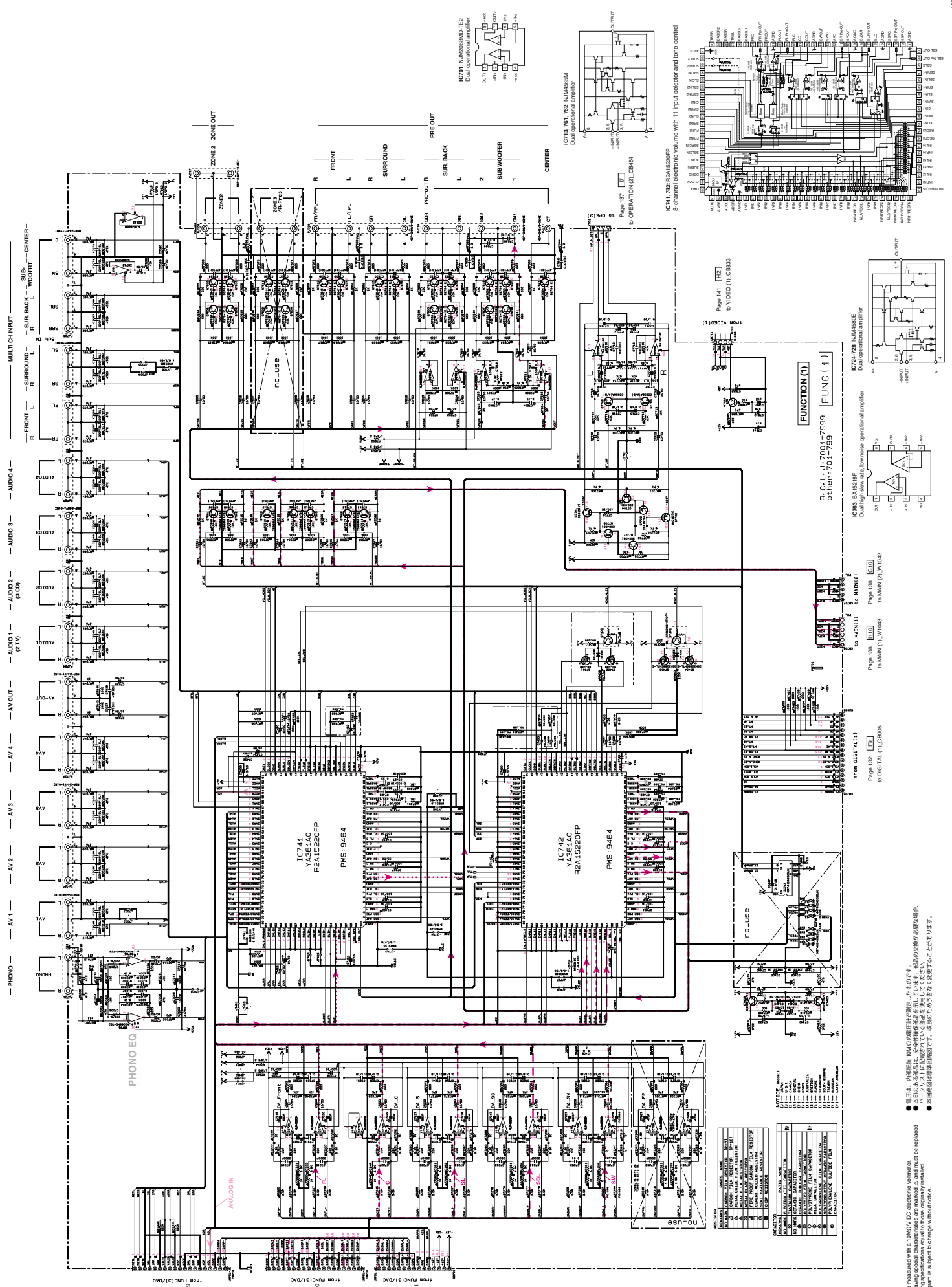

● 部品は、内蔵規格 (DMM) の電圧許容値に準拠して設計されています。
 ● 印の異なる部品は、安全規格を満たしていません。部品の交換が必要の場合、必ず印の異なる部品に交換してください。部品の交換は必ずしも必要ではありません。
 ● 本図は、部品が正常に動作することを保証するものではありません。

* All values are measured with a 10M Ω DC electronic voltmeter.
 * Components having special characteristics are marked Δ , and must be replaced with the same type or to the same or better specifications.
 * Schematic diagram is subject to change without notice.

FUNCTION 2/2

Table with columns: BLOCK, I/O, IC, PART, REF, PART, REF, PART, REF. Lists various components and their reference designators.

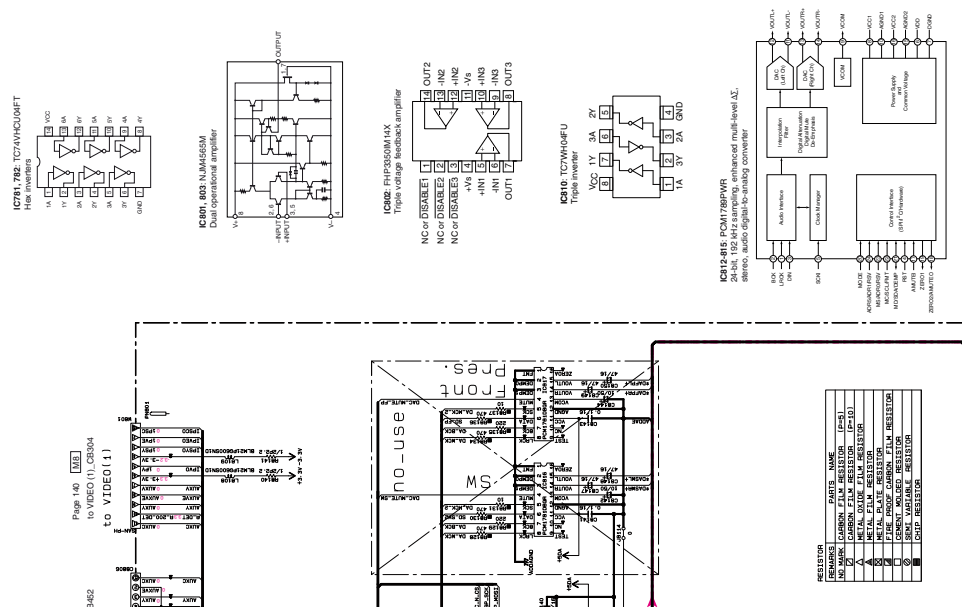

Page 102 IC102 (U)_CB718 TO DIGITAL (1)_CB760

Page 103 IC103 (U)_CB719 TO DIGITAL (1)_CB760

Page 104 IC104 (U)_CB720 TO DIGITAL (1)_CB760

Page 105 IC105 (U)_CB721 TO DIGITAL (1)_CB760

Page 106 IC106 (U)_CB722 TO DIGITAL (1)_CB760

Page 107 IC107 (U)_CB723 TO DIGITAL (1)_CB760

Page 108 IC108 (U)_CB724 TO DIGITAL (1)_CB760

Page 109 IC109 (U)_CB725 TO DIGITAL (1)_CB760

Page 110 IC110 (U)_CB726 TO DIGITAL (1)_CB760

Page 111 IC111 (U)_CB727 TO DIGITAL (1)_CB760

Page 112 IC112 (U)_CB728 TO DIGITAL (1)_CB760

Page 113 IC113 (U)_CB729 TO DIGITAL (1)_CB760

Page 114 IC114 (U)_CB730 TO DIGITAL (1)_CB760

Page 115 IC115 (U)_CB731 TO DIGITAL (1)_CB760

Page 116 IC116 (U)_CB732 TO DIGITAL (1)_CB760

Page 117 IC117 (U)_CB733 TO DIGITAL (1)_CB760

Page 118 IC118 (U)_CB734 TO DIGITAL (1)_CB760

Page 119 IC119 (U)_CB735 TO DIGITAL (1)_CB760

Page 120 IC120 (U)_CB736 TO DIGITAL (1)_CB760

Page 121 IC121 (U)_CB737 TO DIGITAL (1)_CB760

Page 122 IC122 (U)_CB738 TO DIGITAL (1)_CB760

Page 123 IC123 (U)_CB739 TO DIGITAL (1)_CB760

Page 124 IC124 (U)_CB740 TO DIGITAL (1)_CB760

Page 125 IC125 (U)_CB741 TO DIGITAL (1)_CB760

Page 126 IC126 (U)_CB742 TO DIGITAL (1)_CB760

Page 127 IC127 (U)_CB743 TO DIGITAL (1)_CB760

Page 128 IC128 (U)_CB744 TO DIGITAL (1)_CB760

Page 129 IC129 (U)_CB745 TO DIGITAL (1)_CB760

Page 130 IC130 (U)_CB746 TO DIGITAL (1)_CB760

Page 131 IC131 (U)_CB747 TO DIGITAL (1)_CB760

Page 132 IC132 (U)_CB748 TO DIGITAL (1)_CB760

Page 133 IC133 (U)_CB749 TO DIGITAL (1)_CB760

Page 134 IC134 (U)_CB750 TO DIGITAL (1)_CB760

Page 135 IC135 (U)_CB751 TO DIGITAL (1)_CB760

Page 136 IC136 (U)_CB752 TO DIGITAL (1)_CB760

Page 137 IC137 (U)_CB753 TO DIGITAL (1)_CB760

Page 138 IC138 (U)_CB754 TO DIGITAL (1)_CB760

Page 139 IC139 (U)_CB755 TO DIGITAL (1)_CB760

Page 140 IC140 (U)_CB756 TO DIGITAL (1)_CB760

Page 141 IC141 (U)_CB757 TO DIGITAL (1)_CB760

Page 142 IC142 (U)_CB758 TO DIGITAL (1)_CB760

Page 143 IC143 (U)_CB759 TO DIGITAL (1)_CB760

Page 144 IC144 (U)_CB760 TO DIGITAL (1)_CB760

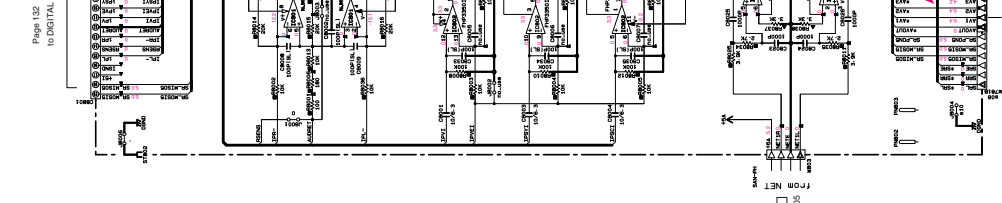
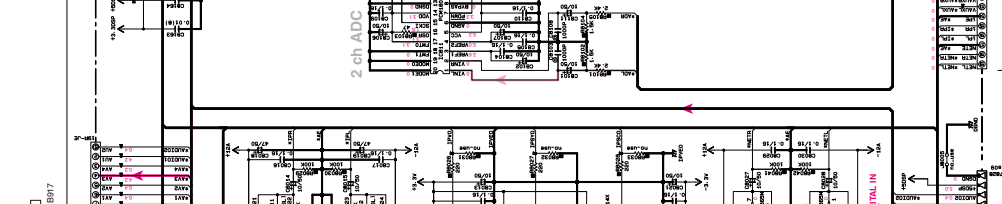
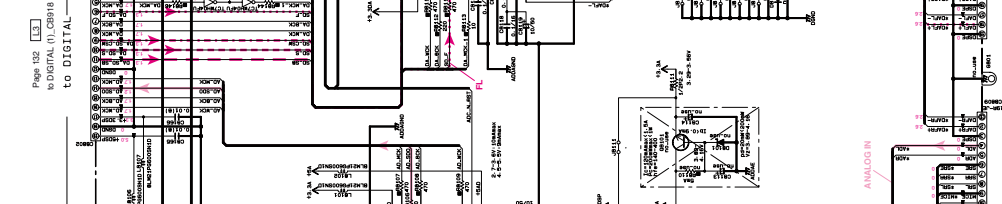
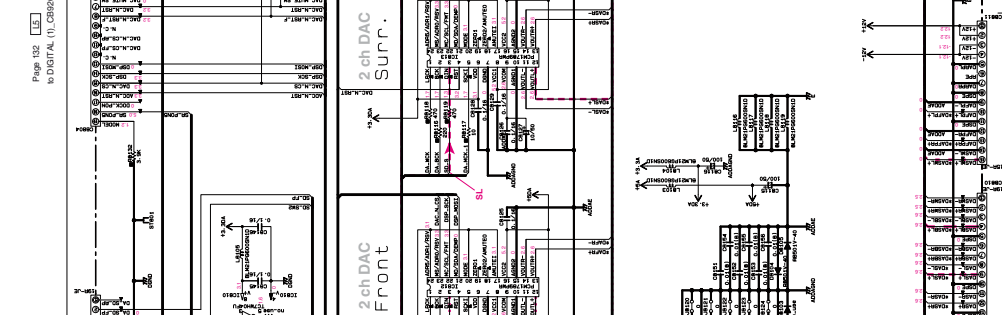

TABLES: PARTS NAME, REMARKS, and CARACTERISTICS. These tables provide specifications and notes for components used in the sub-functions.

● All voltages are measured with a 10MΩV DC electronic voltmeter.
▲ If any of the components are marked with special characteristics, they must be replaced by the same type and manufacturer's part as specified.
✦ Components having special characteristics are marked ▲, and must be replaced by the same type and manufacturer's part as specified.

OPERATION

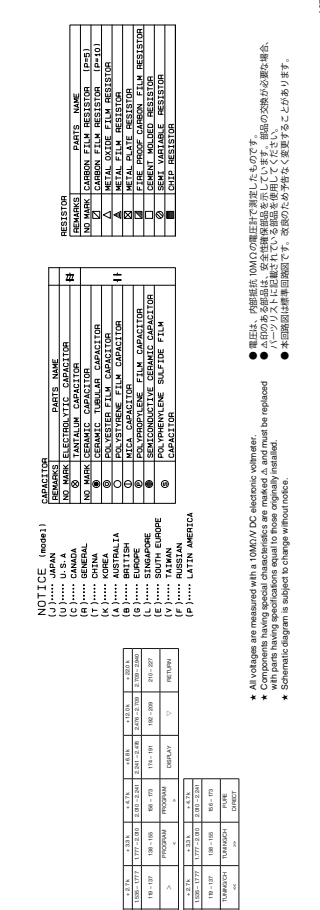
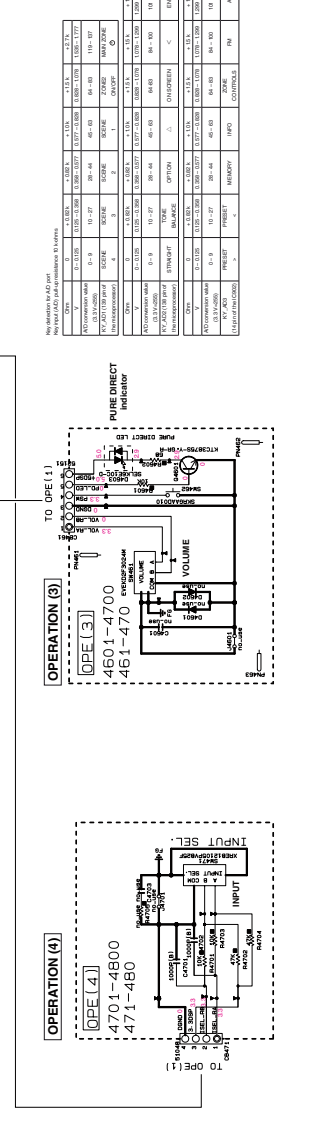
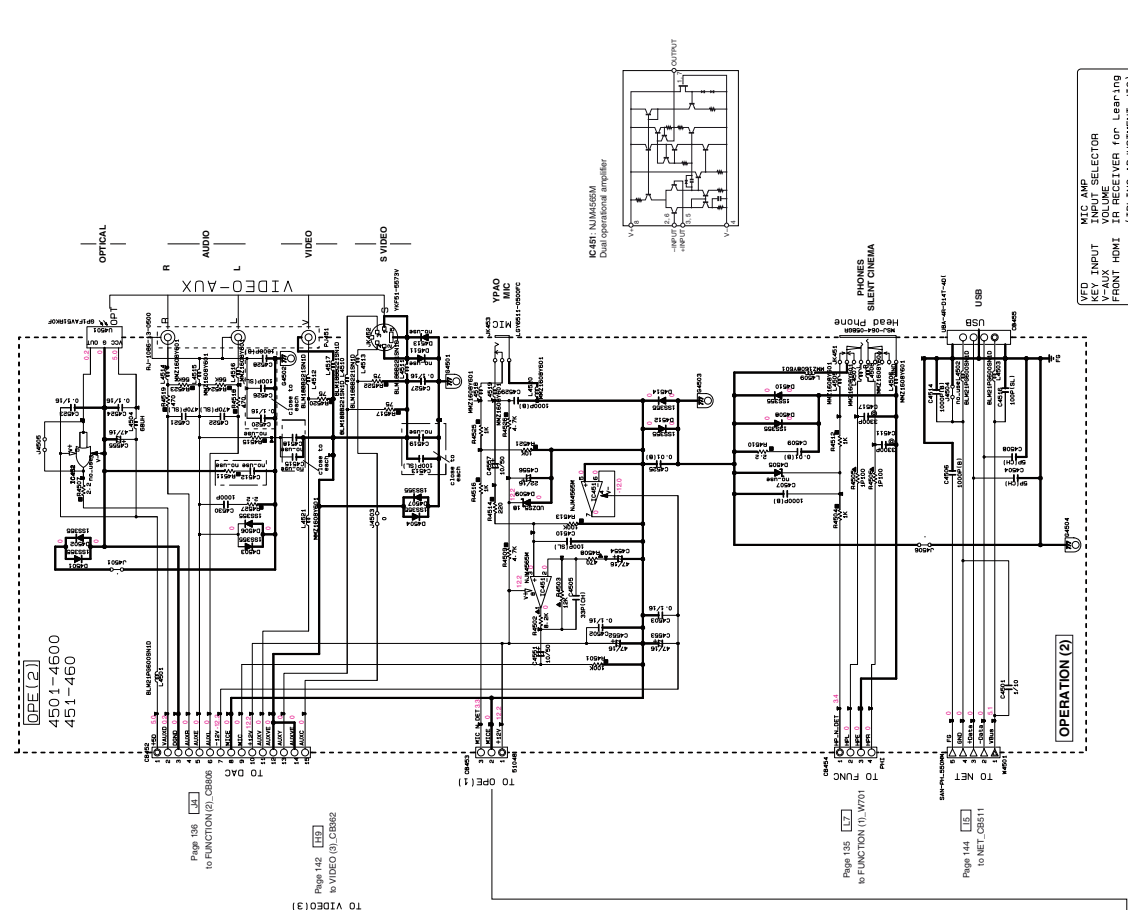
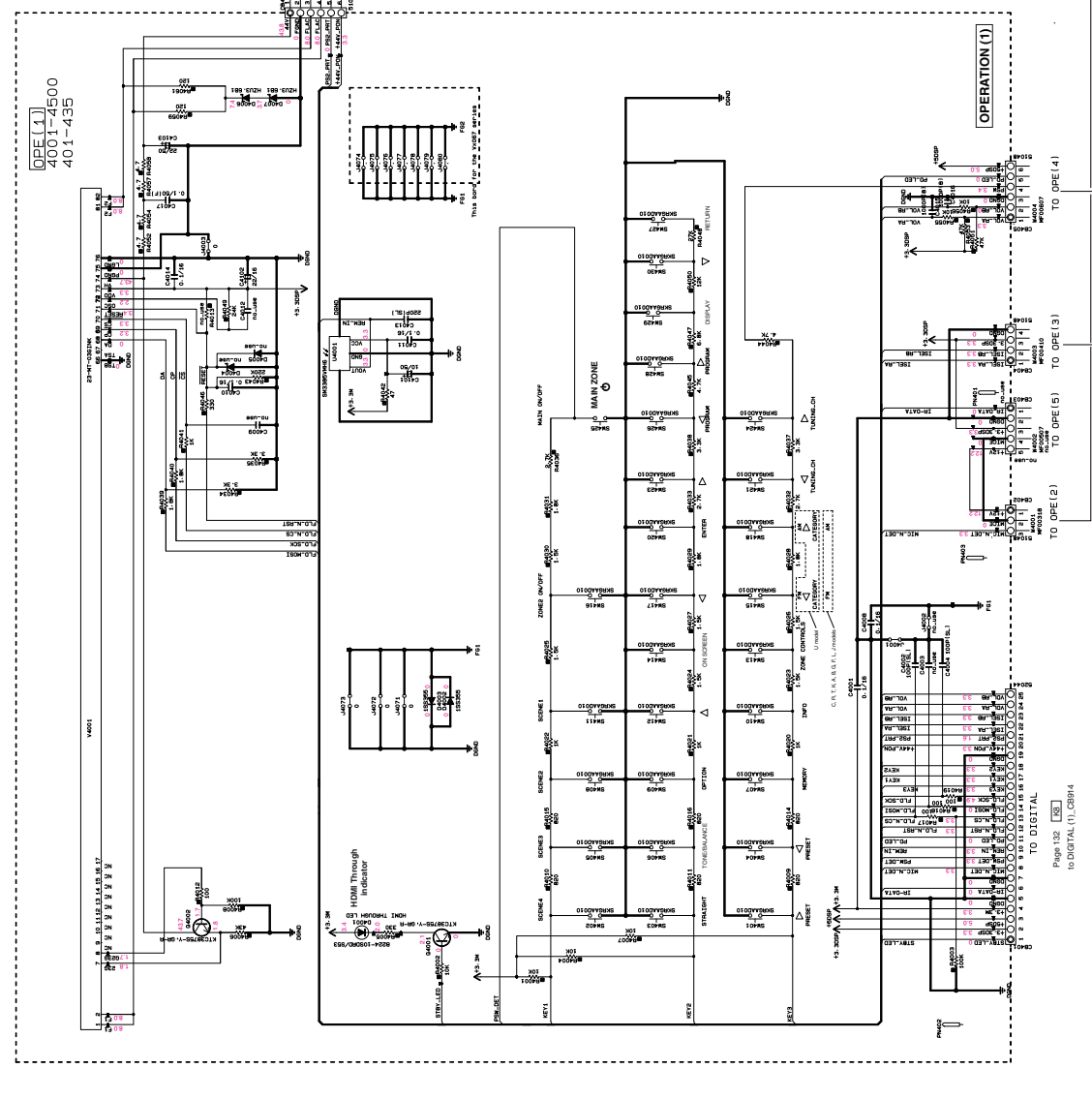

NOTICE (repea1)

REMARKS	CAPACITOR	REMARKS
(U).....JAPAN	①.....JAPAN	
(C).....CANADA	②.....CANADA	
(G).....USA	③.....USA	
(K).....KOREA	④.....KOREA	
(E).....EUROPE	⑤.....EUROPE	
(B).....BRITAIN	⑥.....BRITAIN	
(S).....SPAIN	⑦.....SPAIN	
(I).....ITALY	⑧.....ITALY	
(F).....FRANCE	⑨.....FRANCE	
(D).....GERMANY	⑩.....GERMANY	
(A).....AUSTRALIA	⑪.....AUSTRALIA	
(V).....VENEZUELA	⑫.....VENEZUELA	
(M).....MEXICO	⑬.....MEXICO	
(P).....PERU	⑭.....PERU	
(C).....CHINA	⑮.....CHINA	
(R).....RUSSIA	⑯.....RUSSIA	
(S).....SOUTH AFRICA	⑰.....SOUTH AFRICA	
(T).....TAIWAN	⑱.....TAIWAN	
(U).....USA	⑲.....USA	
(M).....MEXICO	⑳.....MEXICO	
(A).....AUSTRALIA	㉑.....AUSTRALIA	
(V).....VENEZUELA	㉒.....VENEZUELA	
(M).....MEXICO	㉓.....MEXICO	
(P).....PERU	㉔.....PERU	
(C).....CHINA	㉕.....CHINA	
(R).....RUSSIA	㉖.....RUSSIA	
(S).....SOUTH AFRICA	㉗.....SOUTH AFRICA	
(T).....TAIWAN	㉘.....TAIWAN	
(U).....USA	㉙.....USA	
(M).....MEXICO	㉚.....MEXICO	
(A).....AUSTRALIA	㉛.....AUSTRALIA	
(V).....VENEZUELA	㉜.....VENEZUELA	
(M).....MEXICO	㉝.....MEXICO	
(P).....PERU	㉞.....PERU	
(C).....CHINA	㉟.....CHINA	
(R).....RUSSIA	㊱.....RUSSIA	
(S).....SOUTH AFRICA	㊲.....SOUTH AFRICA	
(T).....TAIWAN	㊳.....TAIWAN	
(U).....USA	㊴.....USA	
(M).....MEXICO	㊵.....MEXICO	
(A).....AUSTRALIA	㊶.....AUSTRALIA	
(V).....VENEZUELA	㊷.....VENEZUELA	
(M).....MEXICO	㊸.....MEXICO	
(P).....PERU	㊹.....PERU	
(C).....CHINA	㊺.....CHINA	
(R).....RUSSIA	㊻.....RUSSIA	
(S).....SOUTH AFRICA	㊼.....SOUTH AFRICA	
(T).....TAIWAN	㊽.....TAIWAN	
(U).....USA	㊾.....USA	
(M).....MEXICO	㊿.....MEXICO	

REMARKS

REMARKS	PARTS NAME
①	RESISTOR
②	RESISTOR
③	RESISTOR
④	RESISTOR
⑤	RESISTOR
⑥	RESISTOR
⑦	RESISTOR
⑧	RESISTOR
⑨	RESISTOR
⑩	RESISTOR
⑪	RESISTOR
⑫	RESISTOR
⑬	RESISTOR
⑭	RESISTOR
⑮	RESISTOR
⑯	RESISTOR
⑰	RESISTOR
⑱	RESISTOR
⑲	RESISTOR
⑳	RESISTOR
㉑	RESISTOR
㉒	RESISTOR
㉓	RESISTOR
㉔	RESISTOR
㉕	RESISTOR
㉖	RESISTOR
㉗	RESISTOR
㉘	RESISTOR
㉙	RESISTOR
㉚	RESISTOR
㉛	RESISTOR
㉜	RESISTOR
㉝	RESISTOR
㉞	RESISTOR
㉟	RESISTOR
㊱	RESISTOR
㊲	RESISTOR
㊳	RESISTOR
㊴	RESISTOR
㊵	RESISTOR
㊶	RESISTOR
㊷	RESISTOR
㊸	RESISTOR
㊹	RESISTOR
㊺	RESISTOR
㊻	RESISTOR
㊼	RESISTOR
㊽	RESISTOR
㊾	RESISTOR
㊿	RESISTOR

REMARKS

REMARKS	PARTS NAME
①	RESISTOR
②	RESISTOR
③	RESISTOR
④	RESISTOR
⑤	RESISTOR
⑥	RESISTOR
⑦	RESISTOR
⑧	RESISTOR
⑨	RESISTOR
⑩	RESISTOR
⑪	RESISTOR
⑫	RESISTOR
⑬	RESISTOR
⑭	RESISTOR
⑮	RESISTOR
⑯	RESISTOR
⑰	RESISTOR
⑱	RESISTOR
⑲	RESISTOR
⑳	RESISTOR
㉑	RESISTOR
㉒	RESISTOR
㉓	RESISTOR
㉔	RESISTOR
㉕	RESISTOR
㉖	RESISTOR
㉗	RESISTOR
㉘	RESISTOR
㉙	RESISTOR
㉚	RESISTOR
㉛	RESISTOR
㉜	RESISTOR
㉝	RESISTOR
㉞	RESISTOR
㉟	RESISTOR
㊱	RESISTOR
㊲	RESISTOR
㊳	RESISTOR
㊴	RESISTOR
㊵	RESISTOR
㊶	RESISTOR
㊷	RESISTOR
㊸	RESISTOR
㊹	RESISTOR
㊺	RESISTOR
㊻	RESISTOR
㊼	RESISTOR
㊽	RESISTOR
㊾	RESISTOR
㊿	RESISTOR

REMARKS

REMARKS	PARTS NAME
①	RESISTOR
②	RESISTOR
③	RESISTOR
④	RESISTOR
⑤	RESISTOR
⑥	RESISTOR
⑦	RESISTOR
⑧	RESISTOR
⑨	RESISTOR
⑩	RESISTOR
⑪	RESISTOR
⑫	RESISTOR
⑬	RESISTOR
⑭	RESISTOR
⑮	RESISTOR
⑯	RESISTOR
⑰	RESISTOR
⑱	RESISTOR
⑲	RESISTOR
⑳	RESISTOR
㉑	RESISTOR
㉒	RESISTOR
㉓	RESISTOR
㉔	RESISTOR
㉕	RESISTOR
㉖	RESISTOR
㉗	RESISTOR
㉘	RESISTOR
㉙	RESISTOR
㉚	RESISTOR
㉛	RESISTOR
㉜	RESISTOR
㉝	RESISTOR
㉞	RESISTOR
㉟	RESISTOR
㊱	RESISTOR
㊲	RESISTOR
㊳	RESISTOR
㊴	RESISTOR
㊵	RESISTOR
㊶	RESISTOR
㊷	RESISTOR
㊸	RESISTOR
㊹	RESISTOR
㊺	RESISTOR
㊻	RESISTOR
㊼	RESISTOR
㊽	RESISTOR
㊾	RESISTOR
㊿	RESISTOR

REMARKS

REMARKS	PARTS NAME
①	RESISTOR
②	RESISTOR
③	RESISTOR
④	RESISTOR
⑤	RESISTOR
⑥	RESISTOR
⑦	RESISTOR
⑧	RESISTOR
⑨	RESISTOR
⑩	RESISTOR
⑪	RESISTOR
⑫	RESISTOR
⑬	RESISTOR
⑭	RESISTOR
⑮	RESISTOR
⑯	RESISTOR
⑰	RESISTOR
⑱	RESISTOR
⑲	RESISTOR
⑳	RESISTOR
㉑	RESISTOR
㉒	RESISTOR
㉓	RESISTOR
㉔	RESISTOR
㉕	RESISTOR
㉖	RESISTOR
㉗	RESISTOR
㉘	RESISTOR
㉙	RESISTOR
㉚	RESISTOR
㉛	RESISTOR
㉜	RESISTOR
㉝	RESISTOR
㉞	RESISTOR
㉟	RESISTOR
㊱	RESISTOR
㊲	RESISTOR
㊳	RESISTOR
㊴	RESISTOR
㊵	RESISTOR
㊶	RESISTOR
㊷	RESISTOR
㊸	RESISTOR
㊹	RESISTOR
㊺	RESISTOR
㊻	RESISTOR
㊼	RESISTOR
㊽	RESISTOR
㊾	RESISTOR
㊿	RESISTOR

●電圧は、内蔵規格 (VDC) の値で設計されたものです。
 ●△印のある部品は、安全規格部品を示しています。規格の交換が必要場合は、
 ●△印のある部品に安全規格部品を交換してください。
 ●本図面は標準品を示しています。お客様の仕様により変更がある場合があります。

MAIN

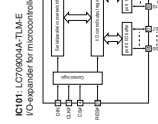

Notes
Safety measures
In this product, high voltages and no capacitors. Be sure to take safety measures during servicing, such as wearing insulating gloves. Before starting any repair work, perform discharge by connecting a discharge resistor (discharge resistor) between terminals at following positions. C105 and C106 on MAIN (3) P.C.B.

注意
安全対策
この製品には高電圧部分及び高容量のコンデンサが搭載されています。修理の際は、絶縁手袋等の保護用具を用いるなどの安全対策を行ってください。
修理作業前に必ず放電作業を行い、放電抵抗（放電抵抗）を高電圧端子と接地端子との間に接続して放電してください。放電時間約30分間です。
MAIN (3) の C105 と C106

Page 142 [16] to VIDEO (5), Y1626

--- CENTER FRONT ---
--- ZONE/F-PRESERVE ---
--- SURROUND BACK/BIAMP ---
--- SURROUND ---

Page 138 [16] to MAIN (2), Y1031

Page 138 [16] to MAIN (1), Y1001

Page 132 [16] to DIGITAL (1), CB909

Page 132 [16] to DIGITAL (1), CB912

Page 132 [16] to DIGITAL (1), CB910

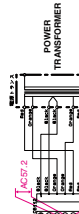
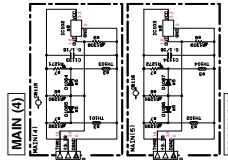

Page 142 [16] to VIDEO (5), Y1626

--- CENTER FRONT ---
--- ZONE/F-PRESERVE ---
--- SURROUND BACK/BIAMP ---
--- SURROUND ---

Page 138 [16] to MAIN (2), Y1031

Page 138 [16] to MAIN (1), Y1001

Page 132 [16] to DIGITAL (1), CB909

Page 132 [16] to DIGITAL (1), CB912

Page 132 [16] to DIGITAL (1), CB910

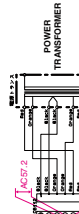
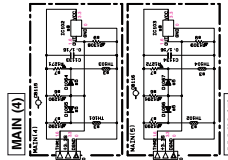

Page 138 [16] to MAIN (3), CB106

Page 138 [16] to VIDEO (4), CB355

Page 142 [16] to VIDEO (4), CB371

Page 142 [16] to VIDEO (4), CB375

Page 142 [16] to VIDEO (4), CB377

Page 142 [16] to VIDEO (4), CB375

Page 142 [16] to VIDEO (4), CB375

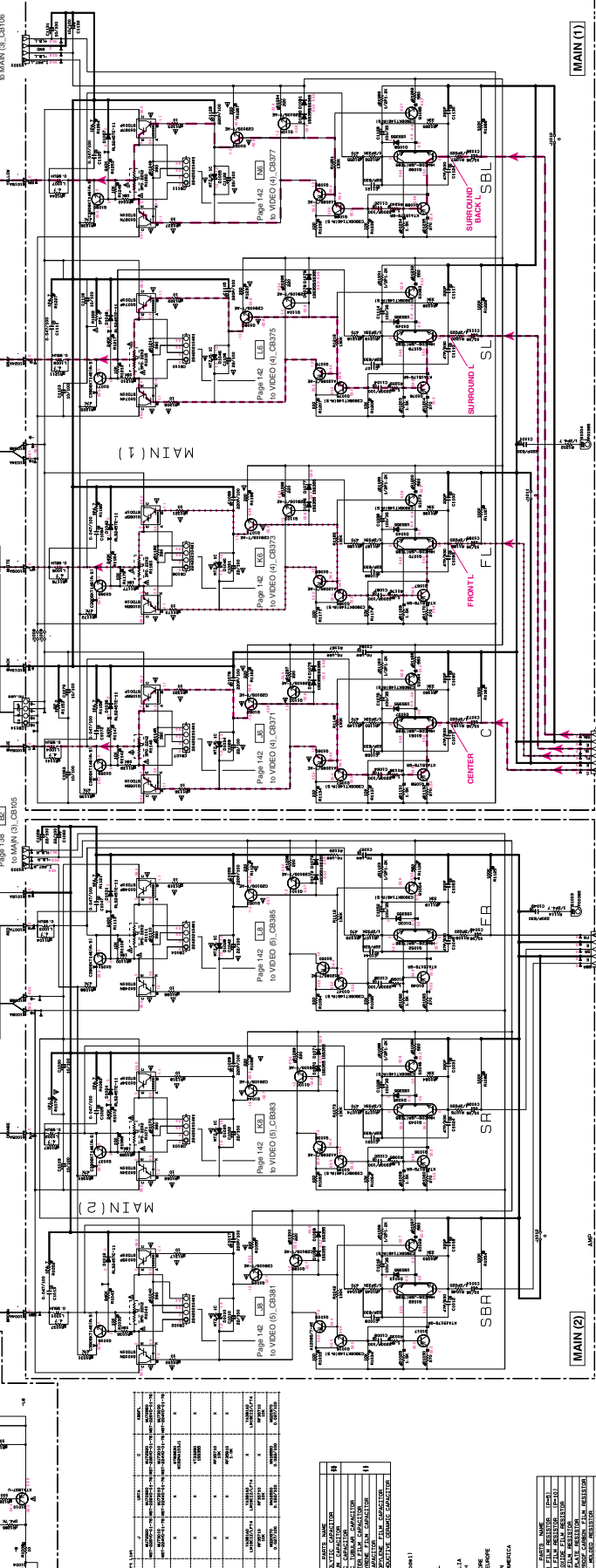

Page 142 [16] to FUNCTION (1), CB376

Page 142 [16] to FUNCTION (1), CB377

Page 142 [16] to FUNCTION (1), CB376

Page 142 [16] to FUNCTION (1), CB377

Page 142 [16] to FUNCTION (1), CB376

Page 142 [16] to FUNCTION (1), CB376

Table with 4 columns: REFERENCE DESIGNATOR, PART NUMBER, DESCRIPTION, and QUANTITY. Lists various electronic components like resistors, capacitors, and ICs.

Table with 2 columns: CAPACITOR and RESISTOR. Lists component values and types for various positions.

NOTICE
1. All voltages are measured with a 100kV DC electronic voltmeter.
2. Components having special characteristics are marked A, and must be replaced with the same type and manufacturer's part.
3. Schematic diagram is subject to change without notice.

Table with 2 columns: REFERENCE DESIGNATOR and PART NUMBER. Lists specific component identifiers.

All voltages are measured with a 100kV DC electronic voltmeter.
Components having special characteristics are marked A, and must be replaced with the same type and manufacturer's part.
Schematic diagram is subject to change without notice.

POWER

NOTICE (Rev.01)
 ① This is a U.S.A. patent.
 ② This is a U.S.A. patent.
 ③ This is a U.S.A. patent.
 ④ This is a U.S.A. patent.
 ⑤ This is a U.S.A. patent.
 ⑥ This is a U.S.A. patent.
 ⑦ This is a U.S.A. patent.
 ⑧ This is a U.S.A. patent.
 ⑨ This is a U.S.A. patent.
 ⑩ This is a U.S.A. patent.
 ⑪ This is a U.S.A. patent.
 ⑫ This is a U.S.A. patent.
 ⑬ This is a U.S.A. patent.
 ⑭ This is a U.S.A. patent.
 ⑮ This is a U.S.A. patent.
 ⑯ This is a U.S.A. patent.
 ⑰ This is a U.S.A. patent.
 ⑱ This is a U.S.A. patent.
 ⑲ This is a U.S.A. patent.
 ⑳ This is a U.S.A. patent.
 ㉑ This is a U.S.A. patent.
 ㉒ This is a U.S.A. patent.
 ㉓ This is a U.S.A. patent.
 ㉔ This is a U.S.A. patent.
 ㉕ This is a U.S.A. patent.
 ㉖ This is a U.S.A. patent.
 ㉗ This is a U.S.A. patent.
 ㉘ This is a U.S.A. patent.
 ㉙ This is a U.S.A. patent.
 ㉚ This is a U.S.A. patent.
 ㉛ This is a U.S.A. patent.
 ㉜ This is a U.S.A. patent.
 ㉝ This is a U.S.A. patent.
 ㉞ This is a U.S.A. patent.
 ㉟ This is a U.S.A. patent.
 ㊱ This is a U.S.A. patent.
 ㊲ This is a U.S.A. patent.
 ㊳ This is a U.S.A. patent.
 ㊴ This is a U.S.A. patent.
 ㊵ This is a U.S.A. patent.
 ㊶ This is a U.S.A. patent.
 ㊷ This is a U.S.A. patent.
 ㊸ This is a U.S.A. patent.
 ㊹ This is a U.S.A. patent.
 ㊺ This is a U.S.A. patent.
 ㊻ This is a U.S.A. patent.
 ㊼ This is a U.S.A. patent.
 ㊽ This is a U.S.A. patent.
 ㊾ This is a U.S.A. patent.
 ㊿ This is a U.S.A. patent.
 (P) © 2008 SONY ELECTRONICS INC. MADE IN JAPAN

MODEL	J	LC	N	NL	TK	BMF
RX-V1067	V1060	V1042	V1043	V1044	V1045	V1051
RX-V1067	V1055	V1046	V1047	V1048	V1049	V1054
RX-V1067	V1055	V1046	V1047	V1048	V1049	V1054
RX-V1067	V1055	V1046	V1047	V1048	V1049	V1054
RX-V1067	V1055	V1046	V1047	V1048	V1049	V1054

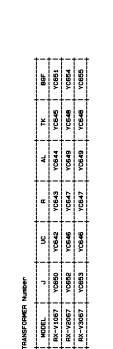

MODEL	J	LC	N	NL	TK	BMF
RX-V1067	V1060	V1042	V1043	V1044	V1045	V1051
RX-V1067	V1055	V1046	V1047	V1048	V1049	V1054
RX-V1067	V1055	V1046	V1047	V1048	V1049	V1054
RX-V1067	V1055	V1046	V1047	V1048	V1049	V1054
RX-V1067	V1055	V1046	V1047	V1048	V1049	V1054

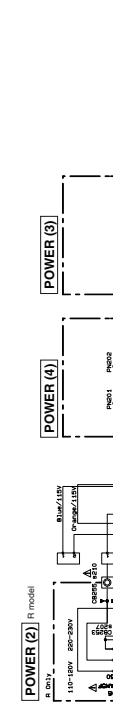

MODEL	J	LC	N	NL	TK	BMF
RX-V1067	V1060	V1042	V1043	V1044	V1045	V1051
RX-V1067	V1055	V1046	V1047	V1048	V1049	V1054
RX-V1067	V1055	V1046	V1047	V1048	V1049	V1054
RX-V1067	V1055	V1046	V1047	V1048	V1049	V1054
RX-V1067	V1055	V1046	V1047	V1048	V1049	V1054

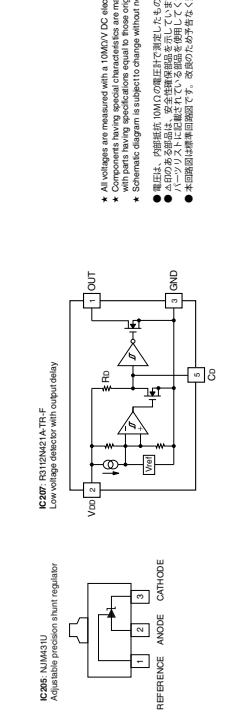
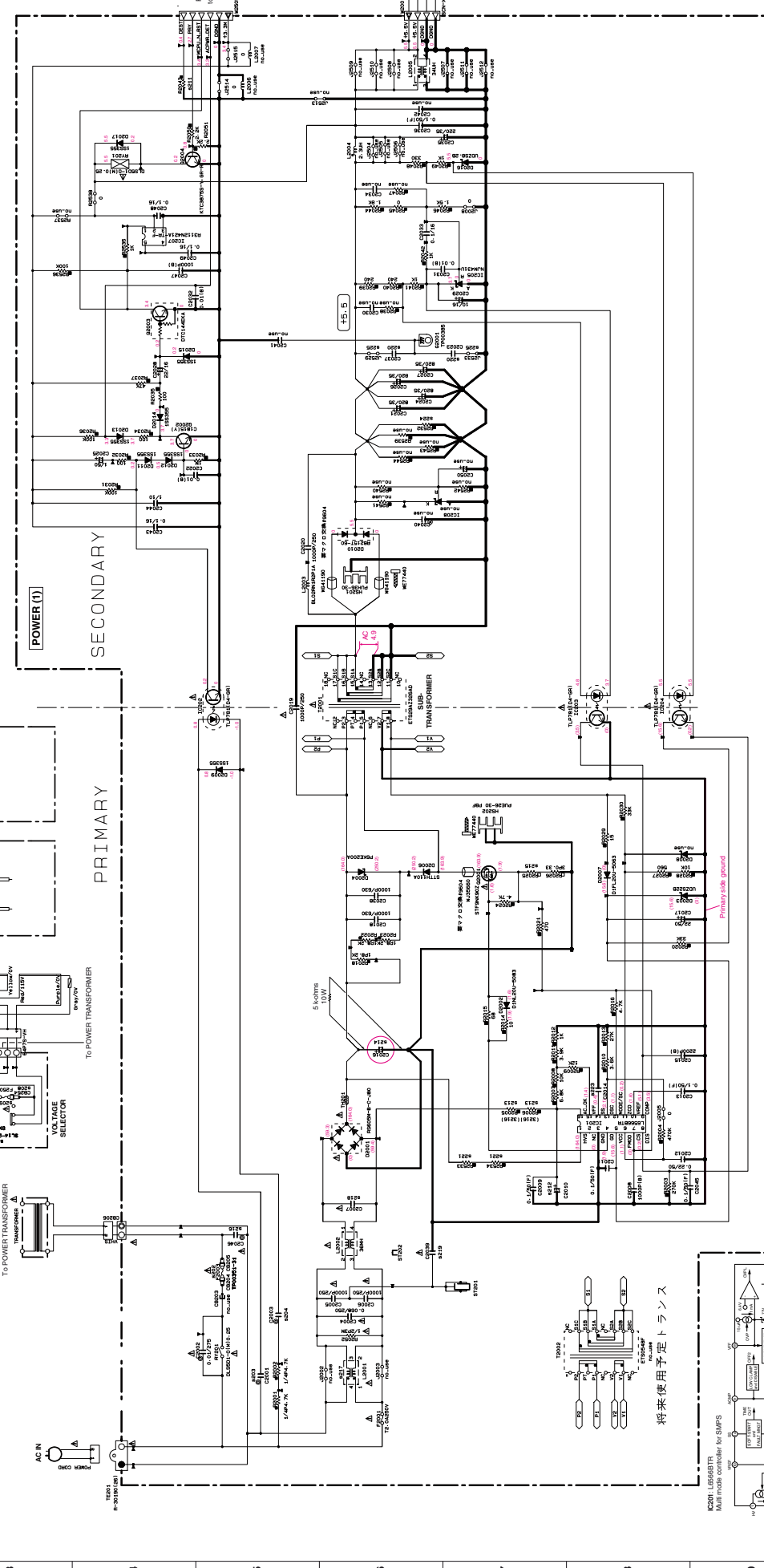

Note:
 Safety means
 • Some internal parts in this product contain high voltages and are dangerous. Be sure to take safety measures during servicing, such as wearing insulating gloves.
 • Before starting any repair work, set form discharge by connecting a discharge resistor (8k-ohm/10W) between terminals at following positions. The time required for discharging is about 30 seconds.
 • Use the discharge resistor (8k-ohm/10W) for 10 seconds.
 (P) © 2008 SONY ELECTRONICS INC. MADE IN JAPAN

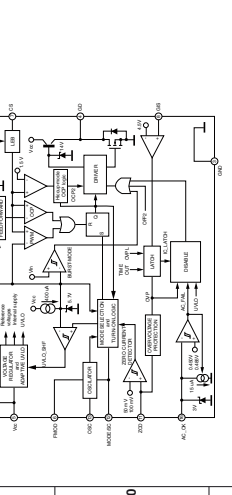

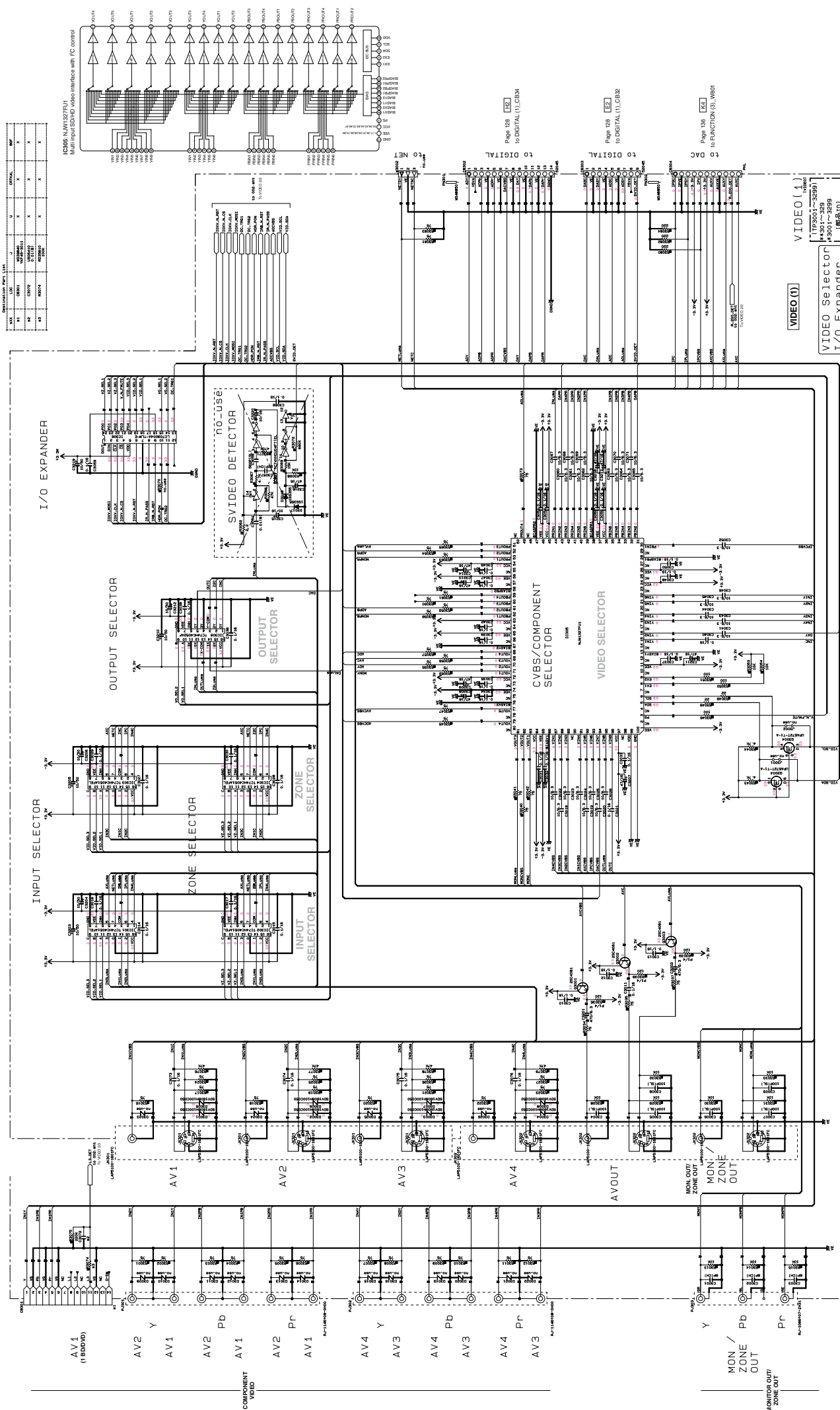

OPTIONAL PART LIST

NO.	QTY.	DESCRIPTION	U	C	L	M	N
41	1	RESISTOR	X				
42	1	RESISTOR	X				
43	1	RESISTOR	X				
44	1	RESISTOR	X				
45	1	RESISTOR	X				
46	1	RESISTOR	X				
47	1	RESISTOR	X				
48	1	RESISTOR	X				
49	1	RESISTOR	X				
50	1	RESISTOR	X				

IC505: MAX9270(1)
Multiinput/SD video interface with IC control

Page 128 [E2]
to DIGITAL (1), CR30

Page 128 [E2]
to DIGITAL (1), CR32

Page 106 [K1]
to FUNCTION (3), V601

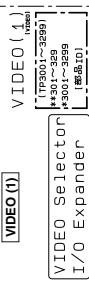

IC306: L709000A-TLME
IC Expander for monochrome

IC307: T5243C4045AT
Analog multiplexer/demultiplexer

IC308: T5243C4045AT
8-channel analog multiplexer/demultiplexer

NOTICE (New)

①	RESISTOR	1/4W
②	RESISTOR	1/4W
③	RESISTOR	1/4W
④	RESISTOR	1/4W
⑤	RESISTOR	1/4W
⑥	RESISTOR	1/4W
⑦	RESISTOR	1/4W
⑧	RESISTOR	1/4W
⑨	RESISTOR	1/4W
⑩	RESISTOR	1/4W
⑪	RESISTOR	1/4W
⑫	RESISTOR	1/4W
⑬	RESISTOR	1/4W
⑭	RESISTOR	1/4W
⑮	RESISTOR	1/4W
⑯	RESISTOR	1/4W
⑰	RESISTOR	1/4W
⑱	RESISTOR	1/4W
⑲	RESISTOR	1/4W
⑳	RESISTOR	1/4W
㉑	RESISTOR	1/4W
㉒	RESISTOR	1/4W
㉓	RESISTOR	1/4W
㉔	RESISTOR	1/4W
㉕	RESISTOR	1/4W
㉖	RESISTOR	1/4W
㉗	RESISTOR	1/4W
㉘	RESISTOR	1/4W
㉙	RESISTOR	1/4W
㉚	RESISTOR	1/4W
㉛	RESISTOR	1/4W
㉜	RESISTOR	1/4W
㉝	RESISTOR	1/4W
㉞	RESISTOR	1/4W
㉟	RESISTOR	1/4W
㊱	RESISTOR	1/4W
㊲	RESISTOR	1/4W
㊳	RESISTOR	1/4W
㊴	RESISTOR	1/4W
㊵	RESISTOR	1/4W
㊶	RESISTOR	1/4W
㊷	RESISTOR	1/4W
㊸	RESISTOR	1/4W
㊹	RESISTOR	1/4W
㊺	RESISTOR	1/4W
㊻	RESISTOR	1/4W
㊼	RESISTOR	1/4W
㊽	RESISTOR	1/4W
㊾	RESISTOR	1/4W
㊿	RESISTOR	1/4W

● 電圧は、内蔵の 100V DC 電圧で測定したものです。
● A印のある部品は、安全規格が明示されています。部品の交換が必要の場合、A印のある部品に同等品を必ず取り替えてください。
● 本図面は特許申請中です。各部分の名称、寸法等は、変更される場合があります。

● All voltages are measured with a 100V DC electronic voltmeter.
● Components having special characteristics are marked A, and must be replaced with components having special characteristics equal to those originally installed.
● Some parts are subject to change without notice.

Page 132 132
TO DIGITAL (1), CB903
TO DIGITAL

Page 135 135
TO AM/FM TUNER
TO FUNCTION (1), CB711
TO HD RADIO

Page 136 136
TO AM/FM TUNER
TO TUNER PACK

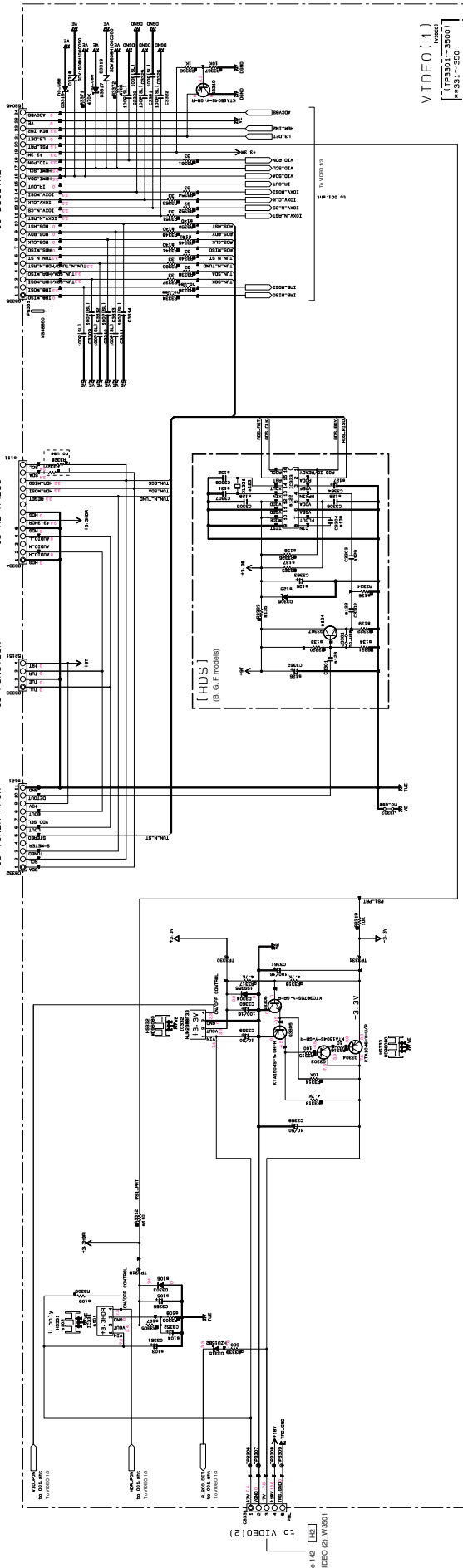

VIDEO (1)

VIDEO (1)

VIDEO (1)

VIDEO (1)

VIDEO (1)

VIDEO (1)

VIDEO (1)

VIDEO (1)

VIDEO (1)

RECOMMENDED PARTS LIST

NO.	QTY.	DESCRIPTION	REF.
101	1	RESISTOR	R1
102	1	RESISTOR	R2
103	1	RESISTOR	R3
104	1	RESISTOR	R4
105	1	RESISTOR	R5
106	1	RESISTOR	R6
107	1	RESISTOR	R7
108	1	RESISTOR	R8
109	1	RESISTOR	R9
110	1	RESISTOR	R10
111	1	RESISTOR	R11
112	1	RESISTOR	R12
113	1	RESISTOR	R13
114	1	RESISTOR	R14
115	1	RESISTOR	R15
116	1	RESISTOR	R16
117	1	RESISTOR	R17
118	1	RESISTOR	R18
119	1	RESISTOR	R19
120	1	RESISTOR	R20
121	1	RESISTOR	R21
122	1	RESISTOR	R22
123	1	RESISTOR	R23
124	1	RESISTOR	R24
125	1	RESISTOR	R25
126	1	RESISTOR	R26
127	1	RESISTOR	R27
128	1	RESISTOR	R28
129	1	RESISTOR	R29
130	1	RESISTOR	R30
131	1	RESISTOR	R31
132	1	RESISTOR	R32
133	1	RESISTOR	R33
134	1	RESISTOR	R34
135	1	RESISTOR	R35
136	1	RESISTOR	R36
137	1	RESISTOR	R37
138	1	RESISTOR	R38
139	1	RESISTOR	R39
140	1	RESISTOR	R40
141	1	RESISTOR	R41
142	1	RESISTOR	R42
143	1	RESISTOR	R43
144	1	RESISTOR	R44
145	1	RESISTOR	R45
146	1	RESISTOR	R46
147	1	RESISTOR	R47
148	1	RESISTOR	R48
149	1	RESISTOR	R49
150	1	RESISTOR	R50
151	1	RESISTOR	R51
152	1	RESISTOR	R52
153	1	RESISTOR	R53
154	1	RESISTOR	R54
155	1	RESISTOR	R55
156	1	RESISTOR	R56
157	1	RESISTOR	R57
158	1	RESISTOR	R58
159	1	RESISTOR	R59
160	1	RESISTOR	R60
161	1	RESISTOR	R61
162	1	RESISTOR	R62
163	1	RESISTOR	R63
164	1	RESISTOR	R64
165	1	RESISTOR	R65
166	1	RESISTOR	R66
167	1	RESISTOR	R67
168	1	RESISTOR	R68
169	1	RESISTOR	R69
170	1	RESISTOR	R70
171	1	RESISTOR	R71
172	1	RESISTOR	R72
173	1	RESISTOR	R73
174	1	RESISTOR	R74
175	1	RESISTOR	R75
176	1	RESISTOR	R76
177	1	RESISTOR	R77
178	1	RESISTOR	R78
179	1	RESISTOR	R79
180	1	RESISTOR	R80
181	1	RESISTOR	R81
182	1	RESISTOR	R82
183	1	RESISTOR	R83
184	1	RESISTOR	R84
185	1	RESISTOR	R85
186	1	RESISTOR	R86
187	1	RESISTOR	R87
188	1	RESISTOR	R88
189	1	RESISTOR	R89
190	1	RESISTOR	R90
191	1	RESISTOR	R91
192	1	RESISTOR	R92
193	1	RESISTOR	R93
194	1	RESISTOR	R94
195	1	RESISTOR	R95
196	1	RESISTOR	R96
197	1	RESISTOR	R97
198	1	RESISTOR	R98
199	1	RESISTOR	R99
200	1	RESISTOR	R100

NOTICE (GROUP 1)

U.S.A. & CANADA: JENSEN ELECTRONIC VOLTMETER, INC. (U.S.A. & CANADA)
 EUROPE: JENSEN ELECTRONIC VOLTMETER, INC. (EUROPE)
 CHINA: JENSEN ELECTRONIC VOLTMETER, INC. (CHINA)
 AUSTRALIA: JENSEN ELECTRONIC VOLTMETER, INC. (AUSTRALIA)
 SINGAPORE: JENSEN ELECTRONIC VOLTMETER, INC. (SINGAPORE)
 TAIWAN: JENSEN ELECTRONIC VOLTMETER, INC. (TAIWAN)
 LATIN AMERICA: JENSEN ELECTRONIC VOLTMETER, INC. (LATIN AMERICA)

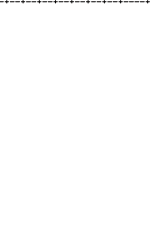

VIDEO (1)

VIDEO (1)

VIDEO (1)

VIDEO (1)

VIDEO (1)

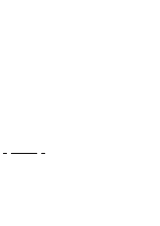
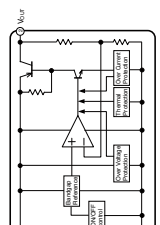
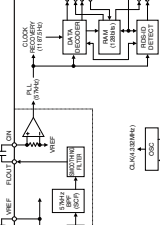
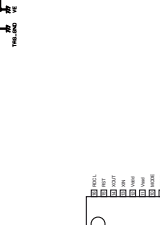

●電圧は、内蔵電圧 IC301の電圧計で測定したものです。
 ●△印のある部品は、安全規格部品を示しています。規格の交換が必要になる。
 ●△印のある部品は、安全規格部品を示しています。規格の交換が必要になる。
 ●本図面の仕様は、変更される場合があります。

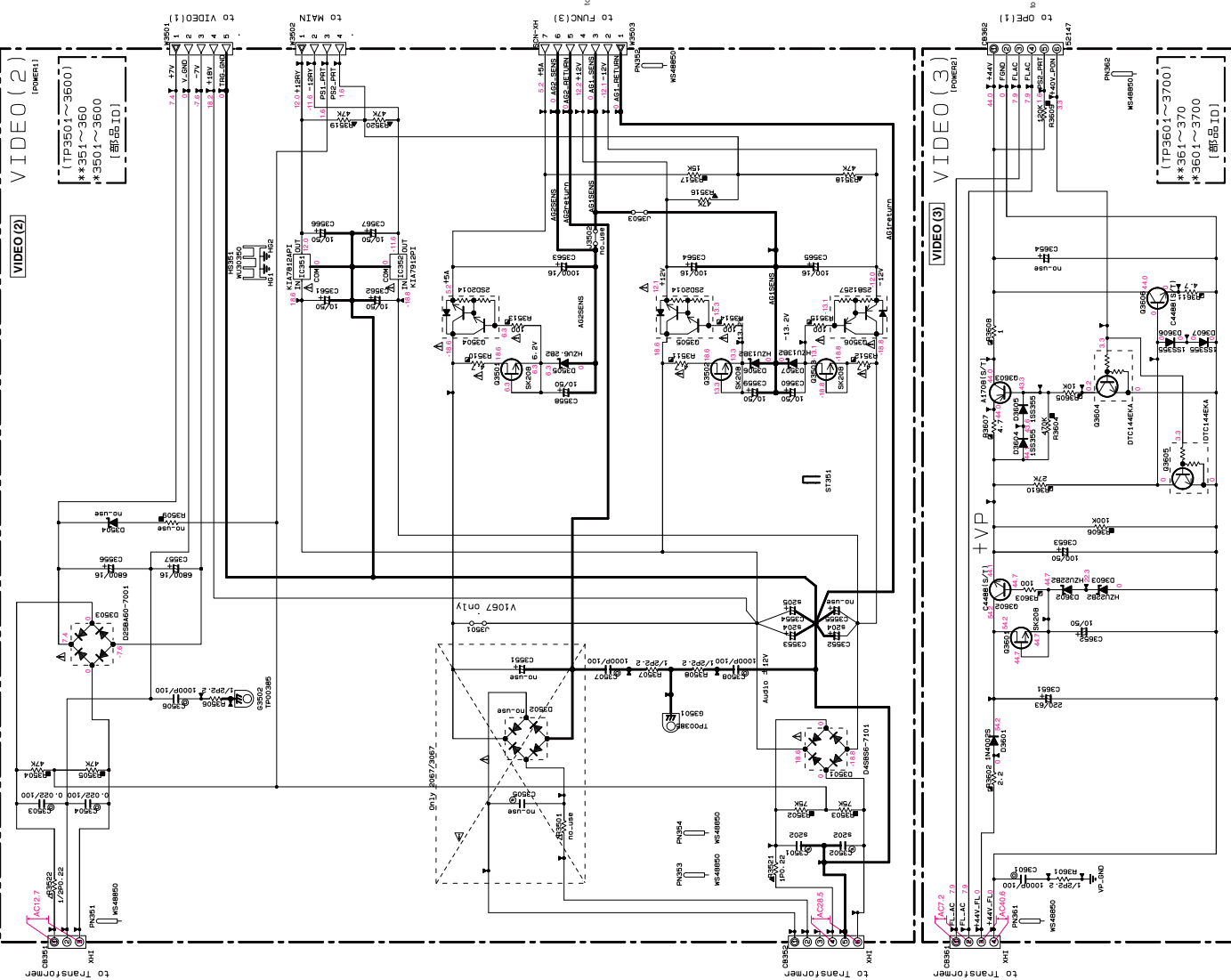

Destination Part List

QXX	LOC	QTY	CRITICAL	REF
C9502	M74790	1000P/100		ME10170
C9501	M74790	1000P/100		ME10170
C9503	88007/25	88007/25		88007/25
C9504	88007/25	88007/25		88007/25
R9501	U804933	3300/25		U804933
R9502	3300/25	3300/25		3300/25

Page 141 [A3]
to VIDEO (1), CB139

Page 138 [LZ]
to MAIN (2), CB131

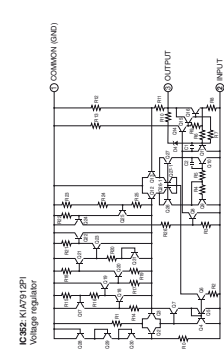
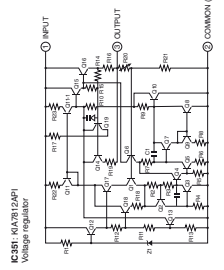

Page 136 [LX]
to FUNCTION (3), CB805

Page 138 [L7]
to MAIN (1), CB107

Page 138 [LZ]
to MAIN (1), CB110

Page 138 [L7]
to MAIN (1), CB111

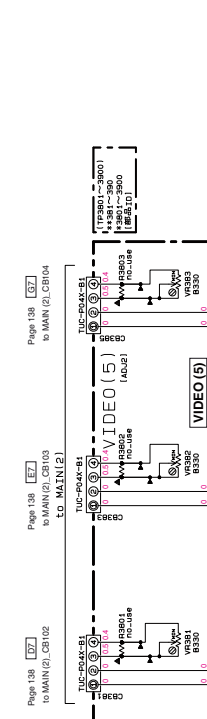
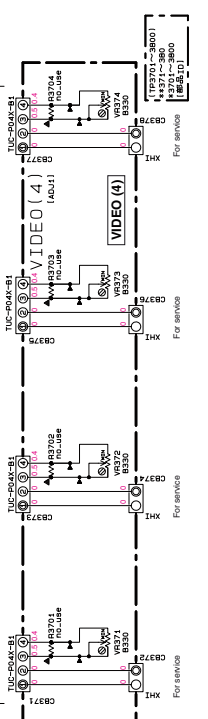

POWER SUPPLY
VIDEO/AUDIO/DAC/VFD
IDLING ADJUSTER

• All voltages are measured with a 100kV DC electronic voltmeter.
 • Components having special characteristics are marked Δ, and must be replaced with the same type or one having equal or better characteristics.
 • Schematic diagram is subject to change without notice.

NET2: PHY USB DAC

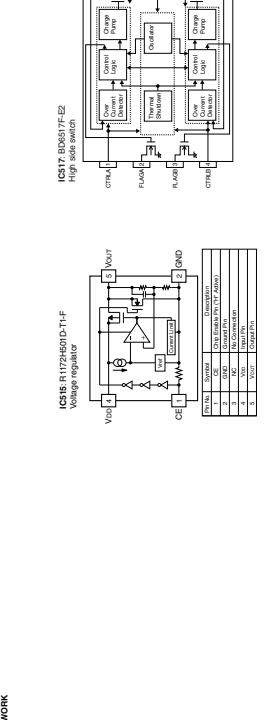
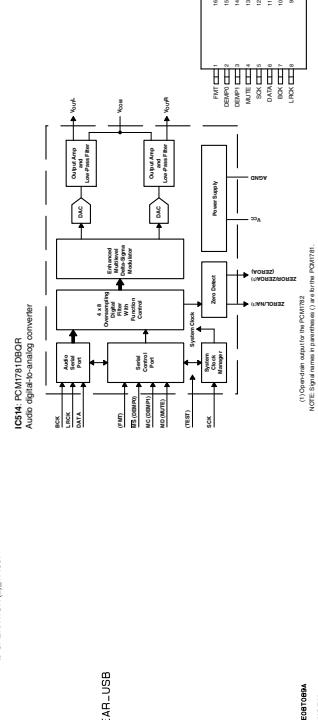
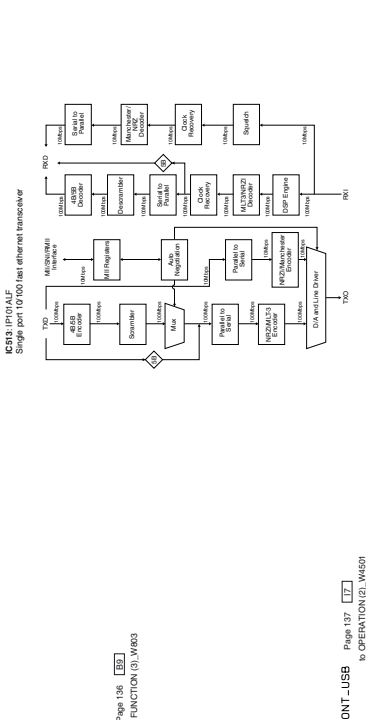
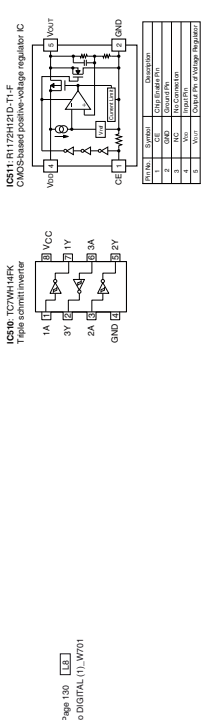
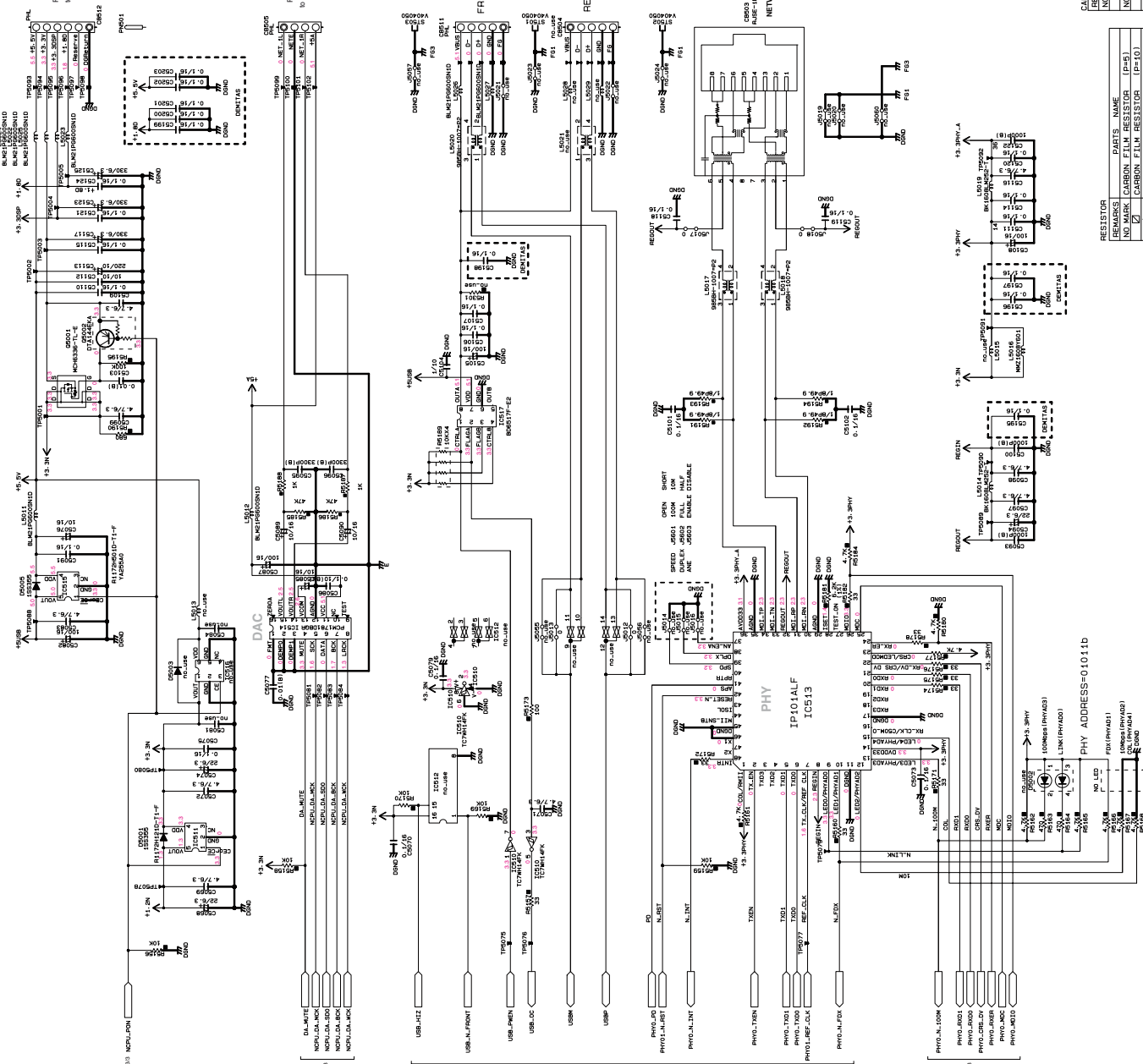

NOTICE (cont'd.)

(J) JAPAN
 (U) U.S.A.
 (C) CANADA
 (P) GENERAL
 (S) SOUTH AMERICA
 (K) KOREA
 (A) AUSTRALIA
 (B) BRITISH
 (M) MALAYSIA
 (I) INDIA
 (S) SINGAPORE
 (E) SOUTH EUROPE
 (V) TAIWAN
 (R) RUSSIAN
 (P) LATIN AMERICA

REMARKS	PARTS NAME
NO MARK	ELECTROMETRIC CAPACITOR
①	CERAMIC CAPACITOR
②	CERAMIC TUBULAR CAPACITOR
③	POLYMER FILM CAPACITOR
④	METAL FILM CAPACITOR
⑤	METAL POLYMER CAPACITOR
⑥	POLYPROPYLENE FILM CAPACITOR
⑦	SEMICONDUCTIVE CERAMIC CAPACITOR
⑧	POLYPHENYLENE SULFIDE FILM CAPACITOR

REMARKS	PARTS NAME
NO MARK	CARBON FILM RESISTOR (P45)
①	CARBON FILM RESISTOR (P10)
②	METAL OXIDE FILM RESISTOR
③	METAL FILM RESISTOR
④	F.FBE PROPOSE CARBON FILM RESISTOR
⑤	CEMENT-MOLDED RESISTOR
⑥	SEMICONDUCTIVE CERAMIC RESISTOR
⑦	LOGIC RESISTOR

* All voltages are measured with a 100kV DC electronic voltmeter.
 * Components having special characteristics are marked Δ, and must be replaced with components having the same characteristics as those originally installed.
 * Symbols designating a subject to change are shown in red.

NET 3 : DSP2

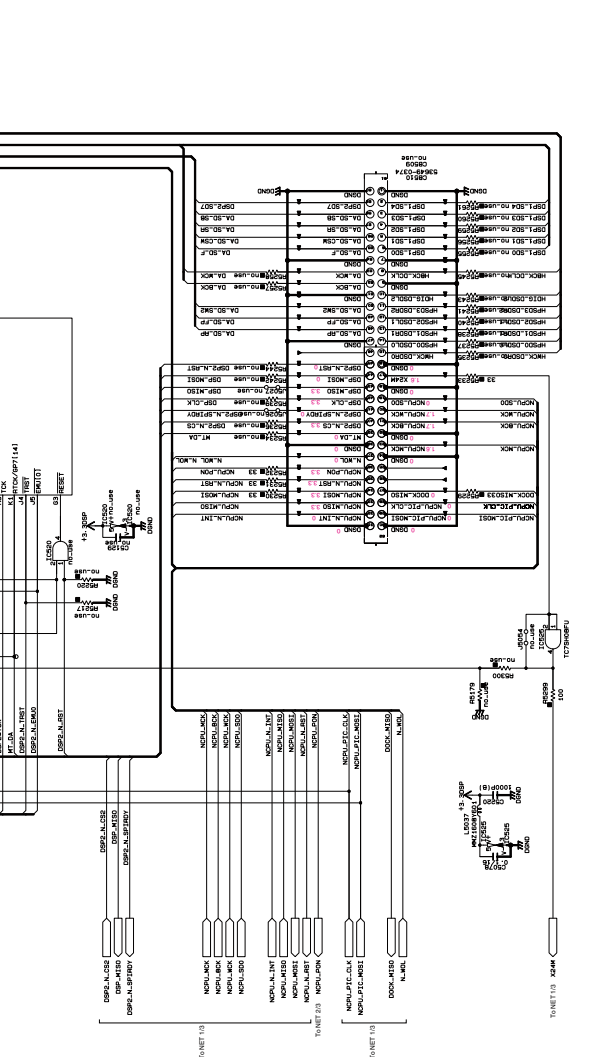
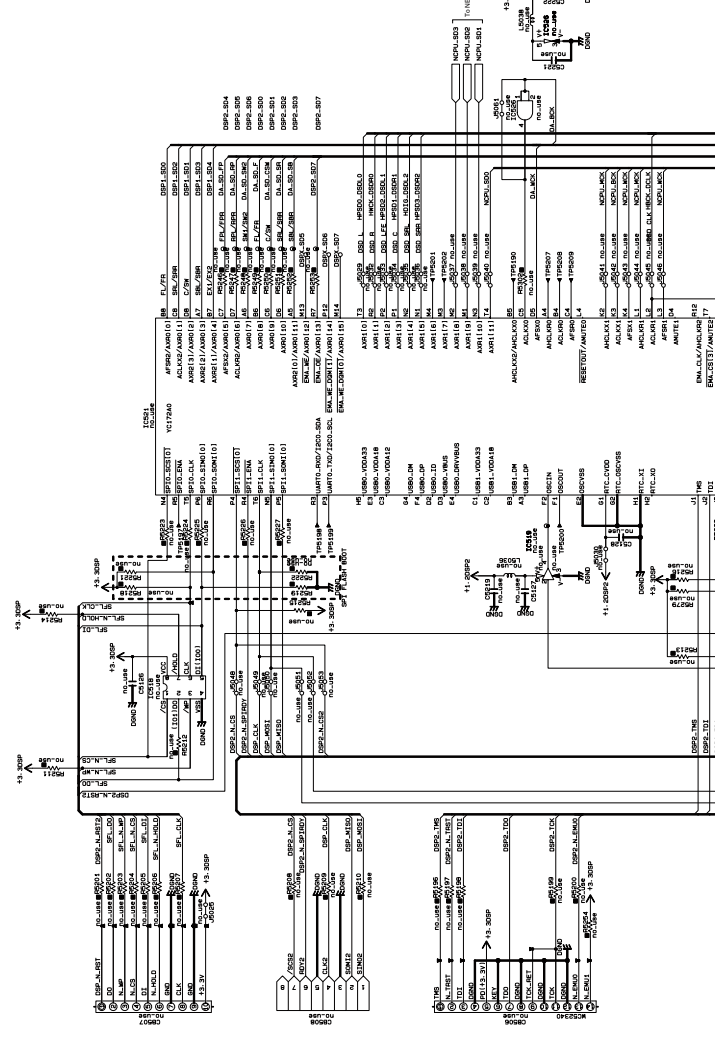
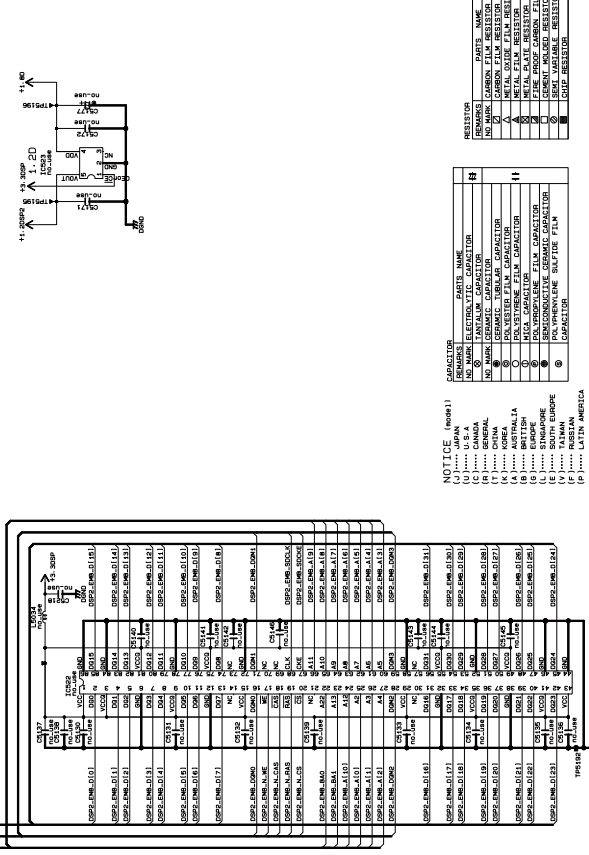
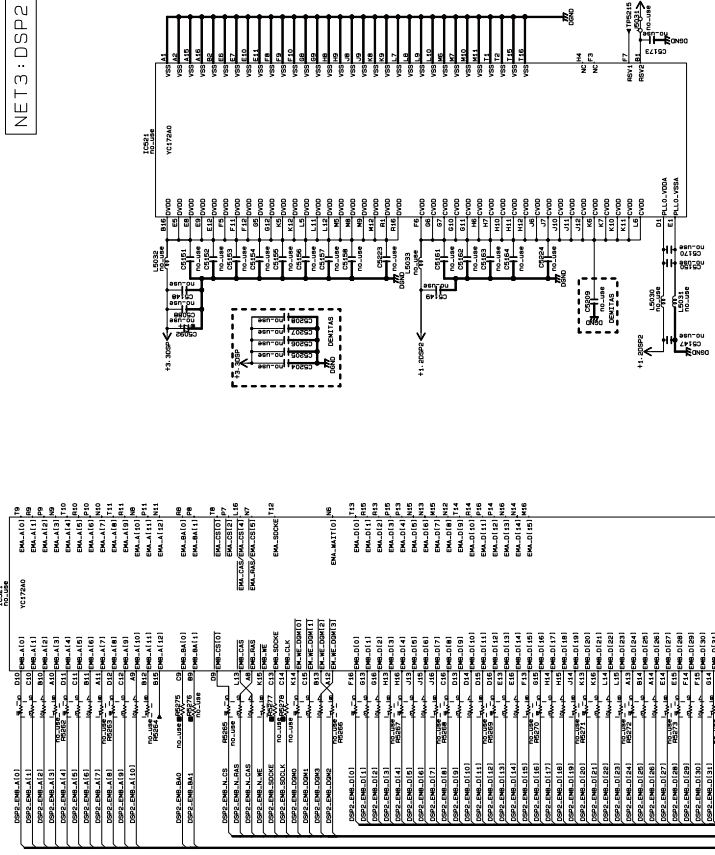

NOTICE (cont.)

REMARK	DATE	NAME
①	U.S.A	①
②	JAPAN	②
③	EUROPE	③
④	INDONESIA	④
⑤	AUSTRALIA	⑤
⑥	INDONESIA	⑥
⑦	SINGAPORE	⑦
⑧	INDONESIA	⑧
⑨	INDONESIA	⑨
⑩	INDONESIA	⑩

REMARK	DATE	NAME
①	U.S.A	①
②	JAPAN	②
③	EUROPE	③
④	INDONESIA	④
⑤	AUSTRALIA	⑤
⑥	INDONESIA	⑥
⑦	SINGAPORE	⑦
⑧	INDONESIA	⑧
⑨	INDONESIA	⑨
⑩	INDONESIA	⑩

★ All voltage are measured with a 1000V DC electronic voltmeter.
 ★ Components having special characteristics are marked Δ and must be replaced
 with parts having same special characteristics to be replaced.
 ★ Schematic diagram is subject to change without notice.

■ REPLACEMENT PARTS LIST

● ELECTRICAL COMPONENT PARTS

WARNING

- Components having special characteristics are marked Δ and must be replaced with parts having specifications equal to those originally installed.
- Δ 印のある部分は、安全確保部品を示しています。部品の交換が必要な場合、パーツリストに記載されている部品を使用してください。
- 部品価格ランクは、予告なく変更することがあります。

ABBREVIATIONS IN THIS LIST ARE AS FOLLOWS:

C.A.EL.CHP	: CHIP ALUMI.ELECTROLYTIC CAP	JUMPER.TST	: JUMPER,TEST POINT
C.CE	: CERAMIC CAP	L.DTCT	: LIGHT DETECTING MODULE
C.CE.ARRAY	: CERAMIC CAP ARRAY	LED.CHP	: CHIP LED
C.CE.CHP	: CHIP CERAMIC CAP	LED.DSPLY	: LED DISPLAY
C.CE.M.CHP	: CHIP MULTILAYER CERAMIC CAP	LED.INFRD	: LED,INFRARED
C.CE.SAFTY	: RECOGNIZED CERAMIC CAP	PHOT.CPL	: PHOTO COUPLER
C.CE.TUBLR	: CERAMIC TUBULAR CAP	PHOT.INTR	: PHOTO INTERRUPTER
C.CE.SMI	: SEMI CONDUCTIVE CERAMIC CAP	PHOT.RFLCT	: PHOTO REFLECTOR
C.EL	: ELECTROLYTIC CAP	PHOT.TR	: PHOTO TRANSISTOR
C.EL.BP	: BIPOLAR ELECTROLYTIC CAP	PIN.TEST	: PIN,TEST POINT
C.EL.CHP	: CHIP ELECTROLYTIC CAP	R.ARRAY	: RESISTOR ARRAY
C.MICA	: MICA CAP	R.CAR.	: CARBON RESISTOR
C.ML.FLM	: MULTILAYER FILM CAP	R.CAR.CHP	: CHIP RESISTOR
C.MP	: METALLIZED POLYESTER FILM CAP	R.CAR.FP	: FLAME PROOF CARBON RESISTOR
C.MYLAR	: MYLAR FILM CAP	R.CEMENT	: CEMENT RESISTOR
C.MYLAR.ML	: MULTILAYER MYLAR FILM CAP	R.FUS	: FUSIBLE RESISTOR
C.NIOB.OXD	: NIOBIUM OXIDE CAP	R.MTL.CHP	: CHIP METAL FILM RESISTOR
C.PAPER	: PAPER CAPACITOR	R.MTL.FLM	: METAL FILM RESISTOR
C.PLS	: POLYSTYRENE FILM CAP	R.MTL.OXD	: METAL OXIDE FILM RESISTOR
C.POL	: POLYESTER FILM CAP	R.MTL.PLAT	: METAL PLATE RESISTOR
C.PP	: POLYPROPYLENE FILM CAP	RSNR.GE	: CERAMIC RESONATOR
C.PP.CHP	: CHIP POLYPROPYLENE FILM CAP	RSNR.CRYS	: CRYSTAL RESONATOR
C.TNTL	: TANTALIUM CAP	SCR.BND.HD	: BIND HEAD B-TIGHT SCREW
C.TNTL.CHP	: CHIP TANTALIUM CAP	SCR.TERM	: SCREW TERMINAL
C.TRIM	: TRIMMER CAP	SCR.TR	: SCREW,TRANSISTOR
CN	: CONNECTOR	SURG.PRTCT	: SURGE PROTECTOR
CN.BS.PIN	: CONNECTOR,BASE PIN	SUPRT.PCB	: P.C.B. SUPPORT
CN.CANNON	: CONNECTOR,CANNON	SW.LEVER	: LEVER SWITCH
CN.DIN	: CONNECTOR,DIN	SW.MICRO	: MICRO SWITCH
CN.FLAT	: CONNECTOR,FLAT CABLE	SW.LEAF	: LEAF SWITCH
CN.FFC	: CONNECTOR,FLEXIBLE FLAT CABLE	SW.PUSH	: PUSH SWITCH
CN.HDMI	: HDMI CONNECTOR	SW.RT	: ROTARY SWITCH
CN.PHOTO.R	: PHOTO FIBER SENSOR,RECEIVED	SW.RT.ENC	: ROTARY ENCODER
CN.PHOTO.T	: PHOTO FIBER SENSOR,TRANSMITTED	SW.RT.MTR	: ROTARY SWITCH WITH MOTOR
DIODE.ARRAY	: DIODE ARRAY	SW.SLIDE	: SLIDE SWITCH
DIODE.BRG	: DIODE BRIDGE	SW.TACT	: TACT SWITCH
DIODE.CHP	: CHIP DIODE	TERM.SP	: SPEAKER TERMINAL
DIODE.VAR	: VARACTOR DIODE	TERM.WRAP	: WRAPPING TERMINAL
DIODE.ZENR	: ZENER DIODE	THRMST.CHP	: CHIP THERMISTOR
DIODE.Z.CHP	: CHIP ZENER DIODE	TR	: TRANSISTOR
DIODE.SCHOTTKY	: SCHOTTKY BARRIER DIODE	TR.CHP	: CHIP TRANSISTOR
DIODE.PHOT	: PHOTO DIODE	TR.DGT	: DIGITAL TRANSISTOR
FER.BEAD	: FERRITE BEADS	TR.DGT.CHP	: CHIP DIGITAL TRANSISTOR
FER.CORE	: FERRITE CORE	TR.PAIR	: PAIR TRANSISTOR
FET.CHP	: CHIP FET	TRANS	: TRANSFORMER
FL.DSPLY	: FLUORESCENT DISPLAY	TRANS.PULS	: PULSE TRANSFORMER
FLTR.CE	: CERAMIC FILTER	TRANS.PWR	: POWER TRANSFORMER
FLTR.COMB	: COMB FILTER MODULE	VOLT.SELCT	: VOLTAGE SELECTOR
FLTR.LC.RF	: LC FILTER,EMI	VR	: ROTARY POTENTIOMETER
FUSE.CHP	: CHIP FUSE	VR.MTR	: POTENTIOMETER WITH MOTOR
GND.MTL	: GROUND PLATE	VR.SLIDE	: SLIDE POTENTIOMETER
GND.TERM	: GROUND TERMINAL	VR.SW	: POTENTIOMETER WITH SWITCH
JUMPER.CN	: JUMPER CONNECTOR	VR.TRIM	: TRIMMER POTENTIOMETER

P.C.B. DIGITAL

Ref No.	Part No.	Description	Remarks	Markets	部 品 名	ランク
*	WU704700	P. C. B.	DIGITAL	JBGF	PCB DIGITAL	
*	WU704800	P. C. B.	DIGITAL	U	PCB DIGITAL	
*	WU704900	P. C. B.	DIGITAL	CRTKAL	PCB DIGITAL	
CB1-7	WU167400	CN. HDMI	HDMI 19P SE		HDMIコネクタ	04
CB8	WD295600	CN. BS. PIN	20P SE		FFCコネクタ	03
CB32	VQ044400	CN. BS. PIN	9P		FFCコネクタ	01
CB34	VF982200	CN. BS. PIN	14P		コネクタ	02
CB71-72	WU167400	CN. HDMI	HDMI 19P SE		HDMIコネクタ	04
CB73	LB919040	CN. BS. PIN	4P		ベース付ポスト	01
CB93	WU167400	CN. HDMI	HDMI 19P SE		HDMIコネクタ	04
CB94	VY939800	CN. BS. PIN	20P TE		FFCコネクタ	02
CB901	VB390000	CN. BS. PIN	4P		ベースピン	01
CB903	VP798200	CN. BS. PIN	24P		FFCコネクタ	01
CB905	VM859700	CN. BS. PIN	16P		FFCコネクタ	01
CB908	VB858500	CN. BS. PIN	6P		ベースピン	01
CB909	VB390800	CN. BS. PIN	12P		コネクタベースポスト	01
CB910	VB389900	CN. BS. PIN	3P		ベースピン	01
CB912	VB389900	CN. BS. PIN	3P		ベースピン	01
CB914	VP082900	CN. BS. PIN	25P		FFCコネクタ	02
CB915	VG518300	PIN. BASE	2P RF TE		ベースピン	01
CB916	VQ047200	CN. BS. PIN	9P		FFCコネクタ	01
CB917-918	V9356900	CN. JE	19P SE		JEコネクタプラグ	
CB919	VB390000	CN. BS. PIN	4P		ベースピン	01
CB920	V9356900	CN. JE	19P SE		JEコネクタプラグ	
CB944	VB389900	CN. BS. PIN	3P		ベースピン	01
* CB946	WQ655100	CN. SOCKET	30P TE		基板用コネクタ	
* CB981	WT567000	CN. RS-232C	RS-232C 8LAM009P-306A		コネクタソケット	
C1	US135100	C. CE. CHP	0. 1uF 16V		チップセラコン	01
C2	WG888300	C. CE. M. CHP	10uF 6. 3V		チップ積層セラコン	01
C3-5	US064100	C. CE. CHP	0. 01uF 50V B		チップセラコン	01
C6	US063100	C. CE. CHP	1000pF 50V B		チップセラコン	01
C7-9	US135100	C. CE. CHP	0. 1uF 16V		チップセラコン	01
C10	US064100	C. CE. CHP	0. 01uF 50V B		チップセラコン	01
C11	UF438100	C. EL. CHP	100uF 16V		チップケミコン	01
C12-13	US064100	C. CE. CHP	0. 01uF 50V B		チップセラコン	01
C14	US135100	C. CE. CHP	0. 1uF 16V		チップセラコン	01
C15-17	US064100	C. CE. CHP	0. 01uF 50V B		チップセラコン	01
C18-19	US135100	C. CE. CHP	0. 1uF 16V		チップセラコン	01
C20-23	US064100	C. CE. CHP	0. 01uF 50V B		チップセラコン	01
C24-27	US135100	C. CE. CHP	0. 1uF 16V		チップセラコン	01
C28-29	WG888300	C. CE. M. CHP	10uF 6. 3V		チップ積層セラコン	01
C30-32	US135100	C. CE. CHP	0. 1uF 16V		チップセラコン	01
C33	WG888300	C. CE. M. CHP	10uF 6. 3V		チップ積層セラコン	01
C34-35	US135100	C. CE. CHP	0. 1uF 16V		チップセラコン	01
C36	WG888300	C. CE. M. CHP	10uF 6. 3V		チップ積層セラコン	01
C37-38	US135100	C. CE. CHP	0. 1uF 16V		チップセラコン	01
C39	US063100	C. CE. CHP	1000pF 50V B		チップセラコン	01
C40-43	US135100	C. CE. CHP	0. 1uF 16V		チップセラコン	01
C44	US063100	C. CE. CHP	1000pF 50V B		チップセラコン	01
C45-52	US064100	C. CE. CHP	0. 01uF 50V B		チップセラコン	01
C53-54	US063100	C. CE. CHP	1000pF 50V B		チップセラコン	01
C55-56	US064100	C. CE. CHP	0. 01uF 50V B		チップセラコン	01
C57	US062470	C. CE. CHP	470pF 50V B		チップセラコン	01
C58	US135100	C. CE. CHP	0. 1uF 16V		チップセラコン	01
C59	WG888300	C. CE. M. CHP	10uF 6. 3V		チップ積層セラコン	01
C60-61	US135100	C. CE. CHP	0. 1uF 16V		チップセラコン	01
C62	US063100	C. CE. CHP	1000pF 50V B		チップセラコン	01

* New Parts * 新規部品

P.C.B. DIGITAL

Ref No.	Part No.	Description	Remarks	Markets	部 品 名	ランク
C63-64	US135100	C. CE. CHP	0. 1uF 16V		チップセラコン	01
C65	WD758300	C. CE. CHP	10uF 10V		チップセラコン	01
C66	US063100	C. CE. CHP	1000pF 50V B		チップセラコン	01
C68	WD758300	C. CE. CHP	10uF 10V		チップセラコン	01
C70-72	US063100	C. CE. CHP	1000pF 50V B		チップセラコン	01
C73-75	US135100	C. CE. CHP	0. 1uF 16V		チップセラコン	01
C76-77	WG888300	C. CE. M. CHP	10uF 6. 3V		チップ積層セラコン	01
C78	US135100	C. CE. CHP	0. 1uF 16V		チップセラコン	01
C79	US063100	C. CE. CHP	1000pF 50V B		チップセラコン	01
C80-83	US135100	C. CE. CHP	0. 1uF 16V		チップセラコン	01
C84-96	US064100	C. CE. CHP	0. 01uF 50V B		チップセラコン	01
C97-101	US135100	C. CE. CHP	0. 1uF 16V		チップセラコン	01
C103	US135100	C. CE. CHP	0. 1uF 16V		チップセラコン	01
C104	US063100	C. CE. CHP	1000pF 50V B		チップセラコン	01
C105	US135100	C. CE. CHP	0. 1uF 16V		チップセラコン	01
C106	WG888300	C. CE. M. CHP	10uF 6. 3V		チップ積層セラコン	01
C107	US135100	C. CE. CHP	0. 1uF 16V		チップセラコン	01
C109	US135100	C. CE. CHP	0. 1uF 16V		チップセラコン	01
C110	WG888300	C. CE. M. CHP	10uF 6. 3V		チップ積層セラコン	01
C112	US135100	C. CE. CHP	0. 1uF 16V		チップセラコン	01
C113	UF417220	C. EL. CHP	22uF 6. 3V		チップケミコン	01
C114	US063100	C. CE. CHP	1000pF 50V B		チップセラコン	01
C116-117	US063100	C. CE. CHP	1000pF 50V B		チップセラコン	01
C119	US063100	C. CE. CHP	1000pF 50V B		チップセラコン	01
C120	US062470	C. CE. CHP	470pF 50V B		チップセラコン	01
C121-122	US062100	C. CE. CHP	100pF 50V B		チップセラコン	01
C301-303	US135100	C. CE. CHP	0. 1uF 16V		チップセラコン	01
C304-305	WD758300	C. CE. CHP	10uF 10V		チップセラコン	01
C306	US063100	C. CE. CHP	1000pF 50V B		チップセラコン	01
C307-308	US135100	C. CE. CHP	0. 1uF 16V		チップセラコン	01
C309-310	WD758300	C. CE. CHP	10uF 10V		チップセラコン	01
C311-312	US135100	C. CE. CHP	0. 1uF 16V		チップセラコン	01
C313-314	US064100	C. CE. CHP	0. 01uF 50V B		チップセラコン	01
C315	UF037220	C. EL. CHP	22uF 16V		チップケミコン	01
C316-318	US135100	C. CE. CHP	0. 1uF 16V		チップセラコン	01
C319	US034390	C. CE. CHP	0. 039uF 16V B		チップセラコン	01
C320-322	US135100	C. CE. CHP	0. 1uF 16V		チップセラコン	01
C323-324	US063100	C. CE. CHP	1000pF 50V B		チップセラコン	01
C325-326	US135100	C. CE. CHP	0. 1uF 16V		チップセラコン	01
C327	US064100	C. CE. CHP	0. 01uF 50V B		チップセラコン	01
C328	US135100	C. CE. CHP	0. 1uF 16V		チップセラコン	01
C329	US064100	C. CE. CHP	0. 01uF 50V B		チップセラコン	01
C330	US135100	C. CE. CHP	0. 1uF 16V		チップセラコン	01
C331	VZ243400	C. CE. CHP	0. 33uF 16V		チップセラコン	01
C332	VZ281900	C. CE. CHP	0. 47uF 16V K		チップセラコン	01
C333	US034820	C. CE. CHP	0. 082uF 16V K		チップセラコン	01
C334	US064100	C. CE. CHP	0. 01uF 50V B		チップセラコン	01
C335	US135100	C. CE. CHP	0. 1uF 16V		チップセラコン	01
C336	US061100	C. CE. CHP	10pF 50V B		チップセラコン	01
C338	US060800	C. CE. CHP	8pF 50V B		チップセラコン	01
C339-341	US135100	C. CE. CHP	0. 1uF 16V		チップセラコン	01
C342	US064100	C. CE. CHP	0. 01uF 50V B		チップセラコン	01
C343-345	US135100	C. CE. CHP	0. 1uF 16V		チップセラコン	01
C346	US046100	C. CE. CHP	1uF 25V		チップセラコン	01
C347	US135100	C. CE. CHP	0. 1uF 16V		チップセラコン	01
C348	US046100	C. CE. CHP	1uF 25V		チップセラコン	01
C349-350	US135100	C. CE. CHP	0. 1uF 16V		チップセラコン	01

* New Parts * 新規部品

P.C.B. DIGITAL

Ref No.	Part No.	Description	Remarks	Markets	部 品 名	ランク
C351	WG251600	C. CE. CHP	4. 7uF 6. 3V		チップセラコン	01
C352	WP092800	C. EL. CHP	22uF 16V		チップケミコン	01
C353	WG251600	C. CE. CHP	4. 7uF 6. 3V		チップセラコン	01
C354-356	US135100	C. CE. CHP	0. 1uF 16V		チップセラコン	01
C357	WP092800	C. EL. CHP	22uF 16V		チップケミコン	01
C358-359	US063100	C. CE. CHP	1000pF 50V B		チップセラコン	01
C360	US135100	C. CE. CHP	0. 1uF 16V		チップセラコン	01
C361	US063100	C. CE. CHP	1000pF 50V B		チップセラコン	01
C362	UF037220	C. EL. CHP	22uF 16V		チップケミコン	01
C363-367	US135100	C. CE. CHP	0. 1uF 16V		チップセラコン	01
C368	US062100	C. CE. CHP	100pF 50V B		チップセラコン	01
C369	US135100	C. CE. CHP	0. 1uF 16V		チップセラコン	01
C370-371	US064100	C. CE. CHP	0. 01uF 50V B		チップセラコン	01
C372	US135100	C. CE. CHP	0. 1uF 16V		チップセラコン	01
C373-377	US064100	C. CE. CHP	0. 01uF 50V B		チップセラコン	01
C378	US135100	C. CE. CHP	0. 1uF 16V		チップセラコン	01
C379	US064100	C. CE. CHP	0. 01uF 50V B		チップセラコン	01
C381-382	US063100	C. CE. CHP	1000pF 50V B		チップセラコン	01
C601-615	US135100	C. CE. CHP	0. 1uF 16V		チップセラコン	01
C616	US163100	C. CE. CHP	1000pF 50V		チップセラコン	01
C617	US135100	C. CE. CHP	0. 1uF 16V		チップセラコン	01
C618	US163100	C. CE. CHP	1000pF 50V		チップセラコン	01
C619	US135100	C. CE. CHP	0. 1uF 16V		チップセラコン	01
C620	UF438100	C. EL. CHP	100uF 16V		チップケミコン	01
C621-622	UF417220	C. EL. CHP	22uF 6. 3V		チップケミコン	01
C623-624	US135100	C. CE. CHP	0. 1uF 16V		チップセラコン	01
C625-626	US063100	C. CE. CHP	1000pF 50V B		チップセラコン	01
C627-629	US135100	C. CE. CHP	0. 1uF 16V		チップセラコン	01
C630	WG888300	C. CE. M. CHP	10uF 6. 3V		チップ積層セラコン	01
C631-637	US135100	C. CE. CHP	0. 1uF 16V		チップセラコン	01
C638	WG888300	C. CE. M. CHP	10uF 6. 3V		チップ積層セラコン	01
C639	UF438100	C. EL. CHP	100uF 16V		チップケミコン	01
C640	WG888300	C. CE. M. CHP	10uF 6. 3V		チップ積層セラコン	01
C641-648	US135100	C. CE. CHP	0. 1uF 16V		チップセラコン	01
C649-650	WG888300	C. CE. M. CHP	10uF 6. 3V		チップ積層セラコン	01
C651-655	US163100	C. CE. CHP	1000pF 50V		チップセラコン	01
C701	WD758300	C. CE. CHP	10uF 10V		チップセラコン	01
C702	US064100	C. CE. CHP	0. 01uF 50V B		チップセラコン	01
C703	US135100	C. CE. CHP	0. 1uF 16V		チップセラコン	01
C704	US064100	C. CE. CHP	0. 01uF 50V B		チップセラコン	01
C705	US135100	C. CE. CHP	0. 1uF 16V		チップセラコン	01
C706-707	US064100	C. CE. CHP	0. 01uF 50V B		チップセラコン	01
C708-709	WD758300	C. CE. CHP	10uF 10V		チップセラコン	01
C710-711	US135100	C. CE. CHP	0. 1uF 16V		チップセラコン	01
C712	WD758300	C. CE. CHP	10uF 10V		チップセラコン	01
C713	US135100	C. CE. CHP	0. 1uF 16V		チップセラコン	01
C714-718	US064100	C. CE. CHP	0. 01uF 50V B		チップセラコン	01
C719	US135100	C. CE. CHP	0. 1uF 16V		チップセラコン	01
C720-722	US064100	C. CE. CHP	0. 01uF 50V B		チップセラコン	01
C723-724	US135100	C. CE. CHP	0. 1uF 16V		チップセラコン	01
C725	WD758300	C. CE. CHP	10uF 10V		チップセラコン	01
C726	US064100	C. CE. CHP	0. 01uF 50V B		チップセラコン	01
C727	WD758300	C. CE. CHP	10uF 10V		チップセラコン	01
C728	US064100	C. CE. CHP	0. 01uF 50V B		チップセラコン	01
C729	US135100	C. CE. CHP	0. 1uF 16V		チップセラコン	01
C730-731	US046100	C. CE. CHP	1uF 25V		チップセラコン	01
C732	WP882000	C. CE. CHP	10uF 6. 3V		チップセラコン	01

* New Parts * 新規部品

P.C.B. DIGITAL

Ref No.	Part No.	Description	Remarks	Markets	部 品 名	ランク
C733	US062470	C. CE. CHP	470pF 50V B		チップセラコン	01
C734	US061270	C. CE. CHP	27pF 50V B		チップセラコン	01
C735	WD758200	C. CE. CHP	47uF 6. 3V		チップセラコン	01
C736	WQ614300	C. CE. CHP	22uF 10VE		チップセラコン	01
C737	US135100	C. CE. CHP	0. 1uF 16V		チップセラコン	01
C738	US061220	C. CE. CHP	22pF 50V B		チップセラコン	01
C739	US034270	C. CE. CHP	0. 027uF 16V		チップセラコン	01
C740	US135100	C. CE. CHP	0. 1uF 16V		チップセラコン	01
C741	WG888300	C. CE. M. CHP	10uF 6. 3V		チップ積層セラコン	01
C742-743	US135100	C. CE. CHP	0. 1uF 16V		チップセラコン	01
C744	WQ614300	C. CE. CHP	22uF 10VE		チップセラコン	01
C745	WD758300	C. CE. CHP	10uF 10V		チップセラコン	01
C746	US046100	C. CE. CHP	1uF 25V		チップセラコン	01
C747	US135100	C. CE. CHP	0. 1uF 16V		チップセラコン	01
C748	US064100	C. CE. CHP	0. 01uF 50V B		チップセラコン	01
C749-750	US135100	C. CE. CHP	0. 1uF 16V		チップセラコン	01
C751-752	US064100	C. CE. CHP	0. 01uF 50V B		チップセラコン	01
C753-754	WD758300	C. CE. CHP	10uF 10V		チップセラコン	01
C755-756	US135100	C. CE. CHP	0. 1uF 16V		チップセラコン	01
C757	WD758300	C. CE. CHP	10uF 10V		チップセラコン	01
C758	US135100	C. CE. CHP	0. 1uF 16V		チップセラコン	01
C759	US064100	C. CE. CHP	0. 01uF 50V B		チップセラコン	01
C760	WG251600	C. CE. CHP	4. 7uF 6. 3V		チップセラコン	01
C761-762	US064100	C. CE. CHP	0. 01uF 50V B		チップセラコン	01
C763	WG251600	C. CE. CHP	4. 7uF 6. 3V		チップセラコン	01
C764-765	US064100	C. CE. CHP	0. 01uF 50V B		チップセラコン	01
C766	US135100	C. CE. CHP	0. 1uF 16V		チップセラコン	01
C767	US064100	C. CE. CHP	0. 01uF 50V B		チップセラコン	01
C768	WP882000	C. CE. CHP	10uF 6. 3V		チップセラコン	01
C769	US061270	C. CE. CHP	27pF 50V B		チップセラコン	01
C770	WD758200	C. CE. CHP	47uF 6. 3V		チップセラコン	01
C771-772	US064100	C. CE. CHP	0. 01uF 50V B		チップセラコン	01
C773-774	US135100	C. CE. CHP	0. 1uF 16V		チップセラコン	01
C775	WD758300	C. CE. CHP	10uF 10V		チップセラコン	01
C776	US064100	C. CE. CHP	0. 01uF 50V B		チップセラコン	01
C777	WD758300	C. CE. CHP	10uF 10V		チップセラコン	01
C778	US064100	C. CE. CHP	0. 01uF 50V B		チップセラコン	01
C779	US135100	C. CE. CHP	0. 1uF 16V		チップセラコン	01
C780	US034270	C. CE. CHP	0. 027uF 16V		チップセラコン	01
C781	US046100	C. CE. CHP	1uF 25V		チップセラコン	01
C782	WQ614300	C. CE. CHP	22uF 10VE		チップセラコン	01
C783	US046100	C. CE. CHP	1uF 25V		チップセラコン	01
C784	US062470	C. CE. CHP	470pF 50V B		チップセラコン	01
C785	WQ614300	C. CE. CHP	22uF 10VE		チップセラコン	01
C786-789	US135100	C. CE. CHP	0. 1uF 16V		チップセラコン	01
C790	WH772100	C. EL	1000uF 10V		ケミコン	04
C791	US135100	C. CE. CHP	0. 1uF 16V		チップセラコン	01
C792	WG888300	C. CE. M. CHP	10uF 6. 3V		チップ積層セラコン	01
C793	WD758300	C. CE. CHP	10uF 10V		チップセラコン	01
C794-807	US063100	C. CE. CHP	1000pF 50V B		チップセラコン	01
C808	US064100	C. CE. CHP	0. 01uF 50V B		チップセラコン	01
C809	WG888300	C. CE. M. CHP	10uF 6. 3V		チップ積層セラコン	01
C810	WD758300	C. CE. CHP	10uF 10V		チップセラコン	01
C900	US062220	C. CE. CHP	220pF 50V B		チップセラコン	01
C901	US063100	C. CE. CHP	1000pF 50V B		チップセラコン	01
C902	US062220	C. CE. CHP	220pF 50V B		チップセラコン	01
C903	US063100	C. CE. CHP	1000pF 50V B		チップセラコン	01

* New Parts * 新規部品

P.C.B. DIGITAL

Ref No.	Part No.	Description	Remarks	Markets	部 品 名	ランク
C904	US062470	C. CE. CHP	470pF 50V B		チップセラコン	01
C905	US135100	C. CE. CHP	0. 1uF 16V		チップセラコン	01
C906	US064100	C. CE. CHP	0. 01uF 50V B		チップセラコン	01
C921	US135100	C. CE. CHP	0. 1uF 16V		チップセラコン	01
C922	US064100	C. CE. CHP	0. 01uF 50V B		チップセラコン	01
C923	WG888300	C. CE. M. CHP	10uF 6. 3V		チップ積層セラコン	01
C924	US135100	C. CE. CHP	0. 1uF 16V		チップセラコン	01
C925-930	US064100	C. CE. CHP	0. 01uF 50V B		チップセラコン	01
C931	US135100	C. CE. CHP	0. 1uF 16V		チップセラコン	01
C932	WG888300	C. CE. M. CHP	10uF 6. 3V		チップ積層セラコン	01
C933	US135100	C. CE. CHP	0. 1uF 16V		チップセラコン	01
C936	WG614300	C. CE. CHP	22uF 10VE		チップセラコン	01
C937	US135100	C. CE. CHP	0. 1uF 16V		チップセラコン	01
C938	WG888300	C. CE. M. CHP	10uF 6. 3V		チップ積層セラコン	01
C941	US163100	C. CE. CHP	1000pF 50V		チップセラコン	01
C1001-1022	US135100	C. CE. CHP	0. 1uF 16V		チップセラコン	01
C1101-1104	US135100	C. CE. CHP	0. 1uF 16V		チップセラコン	01
C9001-9003	US135100	C. CE. CHP	0. 1uF 16V		チップセラコン	01
C9005-9006	US135100	C. CE. CHP	0. 1uF 16V		チップセラコン	01
C9007	US046100	C. CE. CHP	1uF 25V		チップセラコン	01
C9008-9009	US063100	C. CE. CHP	1000pF 50V B		チップセラコン	01
C9010	WG251600	C. CE. CHP	4. 7uF 6. 3V		チップセラコン	01
C9011	US063100	C. CE. CHP	1000pF 50V B		チップセラコン	01
C9012	US135100	C. CE. CHP	0. 1uF 16V		チップセラコン	01
C9013	US063100	C. CE. CHP	1000pF 50V B		チップセラコン	01
C9014	US046100	C. CE. CHP	1uF 25V		チップセラコン	01
C9015-9016	US063100	C. CE. CHP	1000pF 50V B		チップセラコン	01
C9017	US046100	C. CE. CHP	1uF 25V		チップセラコン	01
C9018	US135100	C. CE. CHP	0. 1uF 16V		チップセラコン	01
C9019	WG251600	C. CE. CHP	4. 7uF 6. 3V		チップセラコン	01
C9020	US135100	C. CE. CHP	0. 1uF 16V		チップセラコン	01
C9021	UF417470	C. EL. CHP	47uF 6. 3V		チップケミコン	01
C9022	US135100	C. CE. CHP	0. 1uF 16V		チップセラコン	01
C9023	WG251600	C. CE. CHP	4. 7uF 6. 3V		チップセラコン	01
C9024-9030	US135100	C. CE. CHP	0. 1uF 16V		チップセラコン	01
C9031	US063100	C. CE. CHP	1000pF 50V B		チップセラコン	01
C9032	US135100	C. CE. CHP	0. 1uF 16V		チップセラコン	01
C9033-9039	US046100	C. CE. CHP	1uF 25V		チップセラコン	01
C9040-9041	US135100	C. CE. CHP	0. 1uF 16V		チップセラコン	01
C9042	US063100	C. CE. CHP	1000pF 50V B		チップセラコン	01
C9043	US046100	C. CE. CHP	1uF 25V		チップセラコン	01
C9044-9045	US063100	C. CE. CHP	1000pF 50V B		チップセラコン	01
C9046	US062100	C. CE. CHP	100pF 50V B		チップセラコン	01
C9047	US063100	C. CE. CHP	1000pF 50V B		チップセラコン	01
C9048	US062100	C. CE. CHP	100pF 50V B		チップセラコン	01
C9049	V3860300	C. EL.	0. 047F 5. 5V		ダイナキャパシタ	04
C9201-9218	US135100	C. CE. CHP	0. 1uF 16V		チップセラコン	01
C9219	UF417220	C. EL. CHP	22uF 6. 3V		チップケミコン	01
C9220	US063100	C. CE. CHP	1000pF 50V B		チップセラコン	01
C9301-9302	US126100	C. CE. CHP	1uF 10V		チップセラコン	01
C9303-9304	US064100	C. CE. CHP	0. 01uF 50V B		チップセラコン	01
C9305	US135100	C. CE. CHP	0. 1uF 16V		チップセラコン	01
C9306	US126100	C. CE. CHP	1uF 10V		チップセラコン	01
C9307	US064100	C. CE. CHP	0. 01uF 50V B		チップセラコン	01
C9308	US135100	C. CE. CHP	0. 1uF 16V		チップセラコン	01
C9309	US126100	C. CE. CHP	1uF 10V		チップセラコン	01
C9310	US064100	C. CE. CHP	0. 01uF 50V B		チップセラコン	01

* New Parts * 新規部品

P.C.B. DIGITAL

Ref No.	Part No.	Description	Remarks	Markets	部 品 名	ランク
C9311	US063470	C. CE. CHP	4700pF 50V B		チップセラコン	01
C9312	UB214680	C. CE. CHP	0.068uF 25V		チップセラコン	01
C9313	US035100	C. CE. CHP	0.1uF 16V B		チップセラコン	01
C9315	WD758300	C. CE. CHP	10uF 10V		チップセラコン	01
C9316	US035100	C. CE. CHP	0.1uF 16V B		チップセラコン	01
C9317-9318	WD758300	C. CE. CHP	10uF 10V		チップセラコン	01
C9320	US064100	C. CE. CHP	0.01uF 50V B		チップセラコン	01
C9321	US062220	C. CE. CHP	220pF 50V B		チップセラコン	01
C9322	US126100	C. CE. CHP	1uF 10V		チップセラコン	01
C9323-9324	US062220	C. CE. CHP	220pF 50V B		チップセラコン	01
C9325-9326	US062560	C. CE. CHP	560pF 50V B		チップセラコン	01
C9327-9328	US062220	C. CE. CHP	220pF 50V B		チップセラコン	01
C9329	US062100	C. CE. CHP	100pF 50V B		チップセラコン	01
C9330	WD758300	C. CE. CHP	10uF 10V		チップセラコン	01
C9331	WG888300	C. CE. M. CHP	10uF 6.3V		チップ積層セラコン	01
C9332	WD758300	C. CE. CHP	10uF 10V		チップセラコン	01
C9333	US126100	C. CE. CHP	1uF 10V		チップセラコン	01
C9334-9340	US135100	C. CE. CHP	0.1uF 16V		チップセラコン	01
C9341	US064100	C. CE. CHP	0.01uF 50V B		チップセラコン	01
C9342-9344	US135100	C. CE. CHP	0.1uF 16V		チップセラコン	01
C9345	US046100	C. CE. CHP	1uF 25V		チップセラコン	01
C9346-9348	US135100	C. CE. CHP	0.1uF 16V		チップセラコン	01
C9349	US046100	C. CE. CHP	1uF 25V		チップセラコン	01
C9350-9351	US135100	C. CE. CHP	0.1uF 16V		チップセラコン	01
C9352	UF417470	C. EL. CHP	47uF 6.3V		チップケミコン	
C9353-9355	US135100	C. CE. CHP	0.1uF 16V		チップセラコン	01
C9356	US046100	C. CE. CHP	1uF 25V		チップセラコン	01
C9357	US135100	C. CE. CHP	0.1uF 16V		チップセラコン	01
C9358	US062680	C. CE. CHP	680pF 50V B		チップセラコン	01
C9359	US135100	C. CE. CHP	0.1uF 16V		チップセラコン	01
C9360	US046100	C. CE. CHP	1uF 25V		チップセラコン	01
C9361-9362	US135100	C. CE. CHP	0.1uF 16V		チップセラコン	01
C9363	WG888300	C. CE. M. CHP	10uF 6.3V		チップ積層セラコン	01
C9364-9370	US135100	C. CE. CHP	0.1uF 16V		チップセラコン	01
C9371	WG888300	C. CE. M. CHP	10uF 6.3V		チップ積層セラコン	01
C9372-9373	US135100	C. CE. CHP	0.1uF 16V		チップセラコン	01
C9374-9375	UF417220	C. EL. CHP	22uF 6.3V		チップケミコン	01
C9376-9378	US135100	C. CE. CHP	0.1uF 16V		チップセラコン	01
C9379-9381	US063100	C. CE. CHP	1000pF 50V B		チップセラコン	01
C9382-9383	US135100	C. CE. CHP	0.1uF 16V		チップセラコン	01
C9384-9387	US063100	C. CE. CHP	1000pF 50V B		チップセラコン	01
C9388-9390	US135100	C. CE. CHP	0.1uF 16V		チップセラコン	01
C9391	US046100	C. CE. CHP	1uF 25V		チップセラコン	01
C9392-9393	US135100	C. CE. CHP	0.1uF 16V		チップセラコン	01
C9394	US046100	C. CE. CHP	1uF 25V		チップセラコン	01
C9395-9397	US063100	C. CE. CHP	1000pF 50V B		チップセラコン	01
C9398-9401	US062100	C. CE. CHP	100pF 50V B		チップセラコン	01
C9404	US135100	C. CE. CHP	0.1uF 16V		チップセラコン	01
C9405-9407	US063100	C. CE. CHP	1000pF 50V B		チップセラコン	01
C9801-9806	US135100	C. CE. CHP	0.1uF 16V		チップセラコン	01
C9807	WD758300	C. CE. CHP	10uF 10V		チップセラコン	01
D701-702	WE674800	DIODE	AVRL161A1R1NTB		チップバリスタ	01
D703	VV220700	DIODE. SCHOTTKY	RB501V-40		ショットキーダイオード	01
D705-706	WE674800	DIODE	AVRL161A1R1NTB		チップバリスタ	01
D707	VV220700	DIODE. SCHOTTKY	RB501V-40		ショットキーダイオード	01
D914	WE674800	DIODE	AVRL161A1R1NTB		チップバリスタ	01
D915-922	WP385600	PESD	PESD0603-240		ポリマーESD	

* New Parts * 新規部品

P.C.B. DIGITAL

Ref No.	Part No.	Description	Remarks	Markets	部 品 名	ランク
D923-925	WE674800	DIODE	AVRL161A1R1NTB		チップバリスタ	01
D9001	VT332900	DIODE	1SS355		ダイオード	01
D9002	VV220700	DIODE. SCHOTTKY	RB501V-40		ショットキーダイオード	01
IC4	X7779A00	IC	LC709004A-TLM-E		ロジック IC	04
IC31	YC287A00	IC	RP130Q181D-TR-F		電源 IC	01
IC32	X9393A00	IC	ADV7800BSTZ-80		IC ビデオデコーダ	13
IC33	X8897A00	IC	R1172S331B-E2-F		電源 IC	03
IC36-40	XZ287A00	IC	SN74LVC245APWR		ロジック IC	02
IC41	X6671A00	IC	ADV7172KSTZ		IC	09
IC62	X9745B00	IC. MEMORY	M12L128168A-5TG2T		メモリ IC	07
IC63	X9292A00	IC	R1172H121D-T1-F		電源 IC	01
IC65	X8378A00	IC	TC7SH125FU (TE85L, F		ロジック IC	01
IC72	X7741A00	IC	NJM2867F3-05 (TE1)		電源 IC	02
* IC73	YC234A00	IC	EN5337Q1-T		電源 IC	
IC74	X2482A00	IC	LB1836M-TE-L		IC	03
IC76	X9292A00	IC	R1172H121D-T1-F		電源 IC	01
* IC77	YC234A00	IC	EN5337Q1-T		電源 IC	
IC78	X7741A00	IC	NJM2867F3-05 (TE1)		電源 IC	02
IC79	YC289A00	IC	RP130Q501D-TR		電源 IC	01
IC80	XZ287A00	IC	SN74LVC245APWR		ロジック IC	02
IC81	X0199B00	IC	TC74VHC157FT (EL, K)		ロジック IC	01
IC82	X4063A00	IC	TC7WHU04FU		ロジック IC	
IC83	YC286A00	IC	RP130Q121D-TR-F		電源 IC	01
IC84	XR680A00	IC	TC7SH08FU (TE85L, JF		ロジック IC	01
IC91	X8368A00	IC	PCA9517DP		ロジック IC	
IC94	YC218A00	IC	TMDS141 HDMI SW.		IC	07
IC95	YC288A00	IC	RP130Q331D-TR-F		電源 IC	01
IC901-902	X5875A00	IC	SN74LV4051APWR		ロジック IC	01
IC903	YA739A00	IC. MEMORY	LE25LB2562M-TLM-E		メモリ IC	04
IC903	YA739A00	IC. MEMORY	LE25LB2562M-TLM-E		メモリ IC	04
* IC903	YC364A00	IC	LE25CB5122M-TLM-E		メモリ IC	
IC904-905	X7942B00	IC	TC74VHC273FT (EL, K)		ロジック IC	01
IC906-907	YC288A00	IC	RP130Q331D-TR-F		電源 IC	01
* IC909	YC622C00	IC. MEMORY	MX29LV640EBT1-70G	written	メモリ IC	
IC910	XW633A00	IC	TC7SH32FU		ロジック IC フラット	01
IC911	XZ493A00	IC	TC74VHC86FT (EL) EX		ロジック IC	02
IC912	X4453A00	IC	SN74LVC1G17DCKR		ロジック IC	01
IC913	X3586B00	IC	TC74VHCT08AFT EL, K		ロジック IC	01
IC914	XV891B00	IC	TC74VHC08FT (EL, K)		ロジック IC	01
IC915	YC289A00	IC	RP130Q501D-TR		電源 IC	01
IC931	X8813A00	IC	MB87L8760		IC デジタル	08
IC941	X8394A00	IC	TC7WH157FK (TE85L, F		ロジック IC	01
IC942	YC214A00	IC	DIX9210PT (R)		IC	07
* IC943	YC540A00	IC	CS230011-CZZR		IC デジタル	
* IC943	YC540A00	IC	CS230011-CZZR		IC デジタル	
IC944	YA255A00	IC	R1172H501D-T1-F		電源 IC	03
IC946	YC288A00	IC	RP130Q331D-TR-F		電源 IC	01
IC947	X0199B00	IC	TC74VHC157FT (EL, K)		ロジック IC	01
IC948	YC289A00	IC	RP130Q501D-TR		電源 IC	01
IC949	X9292A00	IC	R1172H121D-T1-F		電源 IC	01
IC950	YA473A00	IC. MEMORY	V54C365164VE16		メモリ IC	07
* IC951	YC576E00	IC. MEMORY	MX29LV160DBT1	written	メモリ IC 16M	
IC952	X2891B00	IC	TC74VHC126FT (EL, K)		ロジック IC	01
IC953-954	XR680A00	IC	TC7SH08FU (TE85L, JF		ロジック IC	01
IC955	YC291A00	IC	R1172N501D-TR-F		電源 IC	02
* IC981	YC321A00	IC	TRS3221ECPWR		IC	
PN901	WS488500	STYLE. PIN	L=90 #18		スタイルピン	01

* New Parts * 新規部品

P.C.B. DIGITAL and P.C.B. FUNCTION

Ref No.	Part No.	Description	Remarks	Markets	部 品 名	ランク
PN903	WS488500	STYLE. PIN	L=90 #18		スタイルピン	01
Q1-14	VQ986700	TR	2SC4081 T106		トランジスタ	01
Q301	WQ381000	FET	MCH6336-TL-E		MOS FET	01
Q302	VR936300	TR	2SA1576A T106		トランジスタ	01
Q303	WE834500	FET	UPA672T-T1-A		FET	01
Q701	VV655300	TR. DGT	DTA144EKA		デジタルトランジスタ	01
Q702	VV655700	TR. DGT	DTC144EKA		デジタルトランジスタ	01
Q703	VV655000	TR. DGT	DTA114EKA		デジタルトランジスタ	01
Q704	WQ381000	FET	MCH6336-TL-E		MOS FET	01
Q903-904	VQ986700	TR	2SC4081 T106		トランジスタ	01
Q9001	VR936300	TR	2SA1576A T106		トランジスタ	01
Q9003	WC529500	TR	KTA1504S Y GR RTK		トランジスタ	01
Q9004	WC529400	TR	KTC3875S Y GR RTK		トランジスタ	01
Q9005	WC529500	TR	KTA1504S Y GR RTK		トランジスタ	01
Q9006	WC529400	TR	KTC3875S Y GR RTK		トランジスタ	01
Q9007	WC529500	TR	KTA1504S Y GR RTK		トランジスタ	01
Q9008	WC529400	TR	KTC3875S Y GR RTK		トランジスタ	01
Q9009	WC529500	TR	KTA1504S Y GR RTK		トランジスタ	01
Q9010	WC529400	TR	KTC3875S Y GR RTK		トランジスタ	01
Q9011	WC529500	TR	KTA1504S Y GR RTK		トランジスタ	01
Q9012-9018	VR936300	TR	2SA1576A T106		トランジスタ	01
Q9019	WC529400	TR	KTC3875S Y GR RTK		トランジスタ	01
Q9020	VV655200	TR. DGT	DTA143EKA	U	デジタルトランジスタ	01
Q9021	VV655700	TR. DGT	DTC144EKA	U	デジタルトランジスタ	01
Q9022-9023	VV655300	TR. DGT	DTA144EKA		デジタルトランジスタ	01
Q9301	WQ381000	FET	MCH6336-TL-E		MOS FET	01
Q9302	VV655300	TR. DGT	DTA144EKA		デジタルトランジスタ	01
Q9303	VV655400	TR. DGT	DTC114EKA		デジタルトランジスタ	01
Q9306	VV655300	TR. DGT	DTA144EKA		デジタルトランジスタ	01
R764	WB784700	R. MTL. FLM	6. 8Ω 1W		金属被膜抵抗	01
R9307	HV753100	R. CAR. FP	1Ω 1/4W		不燃化カーボン抵抗	01
RY701	WN307700	RELAY	DC4. 5V UB2-4. 5SNUN		リレー	07
ST901	V4040500	SCR. TERM	M3		スクリュー/ターミナル	01
XL31	VZ772700	RSNR. CRY	28. 63636MHz		水晶振動子	03
XL61	WK841200	RESONATOR	27MHz DS0321SRAB		水晶発振器	05
XL901	WA782500	RSNR. CE	8MHz		セラミック振動子	01
XL941	WH714200	RESONATOR	24. 576MHz DS0321SR		水晶発振器	05
* 7	WU708600	P. C. B.	FUNCTION	V1067	JCRT	PCB FUNCTION
* 7	WU709200	P. C. B.	FUNCTION	A1000	U	PCB FUNCTION
* 7	WU709100	P. C. B.	FUNCTION	8063	C	PCB FUNCTION
* 7	WU709300	P. C. B.	FUNCTION	A1000	C	PCB FUNCTION
* 7	WU708800	P. C. B.	FUNCTION	V1067	KABGFL	PCB FUNCTION
* 7	WU709400	P. C. B.	FUNCTION	A1000	A	PCB FUNCTION
CB701-702	V9356900	CN. JE	19P SE		JEコネクタープラグ	
CB703	VU443800	CN. JE	15P SE		JEコネクタープラグ	01
CB705	VM859700	CN. BS. PIN	16P		FFCコネクター	01
CB706	VB858500	CN. BS. PIN	6P		ベースピン	01
CB707	VB858400	CN. BS. PIN	5P		ベースピン	01
CB801-802	V9357000	CN	19P TE		JEコネクター	
CB804	V9357000	CN	19P TE		JEコネクター	
CB805	LB919070	CN. BS. PIN	7P		ベース付ポスト	01
CB806	VM929900	CN. BS. PIN	15P		FPCコネクター	01
CB809-810	V9357000	CN	19P TE		JEコネクター	
CB811	VU446000	CN. BS. PIN	15P TE		JE コネクタ	02

* New Parts * 新規部品

P.C.B. FUNCTION

Ref No.	Part No.	Description	Remarks	Markets	部 品 名	ランク
C7001	UR267100	C. EL	10uF 50V		ケミコン	
C7002	UR218220	C. EL	220uF 6.3V		ケミコン	
C7003	UR067470	C. EL	47uF 50V		ケミコン	01
C7004	WJ603100	C. MYLAR	220pF 50V		マイラーコン	01
C7005	WJ603700	C. MYLAR	1000pF 50V		マイラーコン	01
C7006	WJ603100	C. MYLAR	220pF 50V	KABGFL	マイラーコン	01
C7007	WJ604900	C. MYLAR	9100pF 50V		マイラーコン	
C7008	WJ605600	C. MYLAR	0.033uF 50V		マイラーコン	
C7009	WJ604900	C. MYLAR	9100pF 50V		マイラーコン	
C7010	WJ605600	C. MYLAR	0.033uF 50V		マイラーコン	
C7011	WJ603700	C. MYLAR	1000pF 50V		マイラーコン	01
C7012	WJ603100	C. MYLAR	220pF 50V	KABGFL	マイラーコン	01
C7013	WJ603100	C. MYLAR	220pF 50V		マイラーコン	01
C7014	UR067470	C. EL	47uF 50V		ケミコン	01
C7015	UR218220	C. EL	220uF 6.3V		ケミコン	
C7016	UR267100	C. EL	10uF 50V		ケミコン	
C7017	US064100	C. CE. CHP	0.01uF 50V B		チップセラコン	01
C7019	US062220	C. CE. CHP	220pF 50V B		チップセラコン	01
C7021	US062220	C. CE. CHP	220pF 50V B		チップセラコン	01
C7025-7026	US062220	C. CE. CHP	220pF 50V B		チップセラコン	01
C7029-7030	US062220	C. CE. CHP	220pF 50V B		チップセラコン	01
C7033-7034	US062220	C. CE. CHP	220pF 50V B		チップセラコン	01
C7036	UR267100	C. EL	10uF 50V		ケミコン	
C7037-7038	US061470	C. CE. CHP	47pF 50V B		チップセラコン	01
C7039	UR267100	C. EL	10uF 50V		ケミコン	
C7041-7042	US062220	C. CE. CHP	220pF 50V B		チップセラコン	01
C7045-7046	US062220	C. CE. CHP	220pF 50V B		チップセラコン	01
C7049-7050	US062220	C. CE. CHP	220pF 50V B		チップセラコン	01
C7053-7054	US062220	C. CE. CHP	220pF 50V B		チップセラコン	01
C7057	US062220	C. CE. CHP	220pF 50V B		チップセラコン	01
C7058	UR067470	C. EL	47uF 50V		ケミコン	01
C7059	US062220	C. CE. CHP	220pF 50V B		チップセラコン	01
C7060	UR067470	C. EL	47uF 50V		ケミコン	01
C7063-7064	US062220	C. CE. CHP	220pF 50V B		チップセラコン	01
C7067-7068	US062220	C. CE. CHP	220pF 50V B		チップセラコン	01
C7070	UR267100	C. EL	10uF 50V		ケミコン	
C7071-7072	US062220	C. CE. CHP	220pF 50V B		チップセラコン	01
C7215-7216	WJ604400	C. MYLAR	3900pF 50V J		マイラーコン	01
C7217-7220	WJ603400	C. MYLAR	560pF 50V		マイラーコン	
C7221-7222	UR267100	C. EL	10uF 50V		ケミコン	
C7223-7224	US035100	C. CE. CHP	0.1uF 16V B		チップセラコン	01
C7225-7226	UR038100	C. EL	100uF 16V		ケミコン	
C7227	WJ604400	C. MYLAR	3900pF 50V J		マイラーコン	01
C7228-7229	WJ603400	C. MYLAR	560pF 50V		マイラーコン	
C7230	UR267100	C. EL	10uF 50V		ケミコン	
C7231-7232	US035100	C. CE. CHP	0.1uF 16V B		チップセラコン	01
C7233-7234	WJ604400	C. MYLAR	3900pF 50V J		マイラーコン	01
C7235-7238	WJ603400	C. MYLAR	560pF 50V		マイラーコン	
C7239-7240	UR267100	C. EL	10uF 50V		ケミコン	
C7241-7242	US035100	C. CE. CHP	0.1uF 16V B		チップセラコン	01
C7243-7244	WJ604400	C. MYLAR	3900pF 50V J		マイラーコン	01
C7245-7248	WJ603400	C. MYLAR	560pF 50V		マイラーコン	
C7249-7250	UR267100	C. EL	10uF 50V		ケミコン	
C7251-7252	US035100	C. CE. CHP	0.1uF 16V B		チップセラコン	01
C7253	WJ605000	C. MYLAR	0.01uF 50V J		マイラーコン	01
C7255	WJ604700	C. MYLAR	6800pF 50V		マイラーコン	
C7257	WJ604700	C. MYLAR	6800pF 50V		マイラーコン	

* New Parts * 新規部品

P.C.B. FUNCTION

Ref No.	Part No.	Description	Remarks	Markets	部 品 名	ランク
C7259	UR267100	C. EL	10uF 50V		ケミコン	
C7261-7262	US035100	C. CE. CHP	0. 1uF 16V B		チップセラコン	01
C7401-7408	UR238100	C. EL	100uF 16V		ケミコン	
C7409-7410	UR267330	C. EL	33uF 50V		ケミコン	01
C7411	UR267100	C. EL	10uF 50V		ケミコン	
C7412-7416	UR238100	C. EL	100uF 16V		ケミコン	
C7417	US034330	C. CE. CHP	0. 033uF 16V B		チップセラコン	01
C7419	VR169000	C. MYLAR	0. 33uF 50V		マイラーコン	01
C7421	US063820	C. CE. CHP	8200pF 50V B		チップセラコン	01
C7423	US034330	C. CE. CHP	0. 033uF 16V B		チップセラコン	01
C7425	VR169000	C. MYLAR	0. 33uF 50V		マイラーコン	01
C7427	US063820	C. CE. CHP	8200pF 50V B		チップセラコン	01
C7429-7431	US035100	C. CE. CHP	0. 1uF 16V B		チップセラコン	01
C7432	UR267100	C. EL	10uF 50V		ケミコン	
C7433	US035100	C. CE. CHP	0. 1uF 16V B		チップセラコン	01
C7434	UR267100	C. EL	10uF 50V		ケミコン	
C7437-7438	UR267100	C. EL	10uF 50V		ケミコン	
C7439-7440	US035100	C. CE. CHP	0. 1uF 16V B		チップセラコン	01
C7441-7442	UR067100	C. EL	10uF 50V		ケミコン	01
C7443-7444	UR067470	C. EL	47uF 50V		ケミコン	01
C7449-7451	UR267100	C. EL	10uF 50V		ケミコン	
C7501-7507	UR267100	C. EL	10uF 50V		ケミコン	
C7508-7514	US061470	C. CE. CHP	47pF 50V B		チップセラコン	01
C7601-7602	UR067470	C. EL	47uF 50V		ケミコン	01
C7603-7604	VR169200	C. MYLAR	0. 47uF 50V		マイラーコン	01
C7605-7606	UR267100	C. EL	10uF 50V		ケミコン	
C7609-7616	UR267100	C. EL	10uF 50V		ケミコン	
C7617-7618	US062100	C. CE. CHP	100pF 50V B		チップセラコン	01
C7619-7623	UR267100	C. EL	10uF 50V		ケミコン	
C7624-7625	US061470	C. CE. CHP	47pF 50V B		チップセラコン	01
C7628-7636	US061470	C. CE. CHP	47pF 50V B		チップセラコン	01
C7637-7640	US064100	C. CE. CHP	0. 01uF 50V B		チップセラコン	01
C7641	UR067470	C. EL	47uF 50V	JCRTKABGFL	ケミコン	01
C7641-7642	UR067470	C. EL	47uF 50V		ケミコン	01
C7642	UR067470	C. EL	47uF 50V	JCRTKABGFL	ケミコン	01
C7643	UR067470	C. EL	47uF 50V		ケミコン	01
C7643	UR067470	C. EL	47uF 50V	JCRTKABGFL	ケミコン	01
C7644-7645	US064100	C. CE. CHP	0. 01uF 50V B		チップセラコン	01
C7701	UR038100	C. EL	100uF 16V		ケミコン	
C7702-7705	UR267100	C. EL	10uF 50V		ケミコン	
C7706-7709	US062100	C. CE. CHP	100pF 50V B		チップセラコン	01
C7710-7711	UR267100	C. EL	10uF 50V		ケミコン	
C7712-7713	US061100	C. CE. CHP	10pF 50V B		チップセラコン	01
C7714-7715	UR038100	C. EL	100uF 16V		ケミコン	
C7716-7719	US035100	C. CE. CHP	0. 1uF 16V B		チップセラコン	01
C7802	UR067470	C. EL	47uF 50V		ケミコン	01
C7803	US062220	C. CE. CHP	220pF 50V B	U	チップセラコン	01
C7804	US063100	C. CE. CHP	1000pF 50V B	U	チップセラコン	01
C7805-7810	US062220	C. CE. CHP	220pF 50V B	U	チップセラコン	01
C7811-7812	US035100	C. CE. CHP	0. 1uF 16V B		チップセラコン	01
C7813-7814	US061220	C. CE. CHP	22pF 50V B		チップセラコン	01
C7815-7821	US035100	C. CE. CHP	0. 1uF 16V B		チップセラコン	01
C7822	US061220	C. CE. CHP	22pF 50V B		チップセラコン	01
C8001	WP882000	C. CE. CHP	10uF 6. 3V		チップセラコン	
C8002	US062100	C. CE. CHP	100pF 50V B		チップセラコン	01
C8003-8004	WP882000	C. CE. CHP	10uF 6. 3V		チップセラコン	
C8008-8009	US062100	C. CE. CHP	100pF 50V B		チップセラコン	01

* New Parts * 新規部品

P.C.B. FUNCTION

Ref No.	Part No.	Description	Remarks	Markets	部 品 名	ランク
C8010	US035100	C. CE. CHP	0. 1uF 16V B		チップセラコン	01
C8011-8012	US062100	C. CE. CHP	100pF 50V B		チップセラコン	01
C8013	UR067100	C. EL	10uF 50V		ケミコン	01
C8014-8015	UR267100	C. EL	10uF 50V		ケミコン	
C8016-8017	US035100	C. CE. CHP	0. 1uF 16V B		チップセラコン	01
C8018-8019	UR067470	C. EL	47uF 50V		ケミコン	01
C8020	US035100	C. CE. CHP	0. 1uF 16V B		チップセラコン	01
C8021	UR067100	C. EL	10uF 50V		ケミコン	01
C8023-8026	US163100	C. CE. CHP	1000pF 50V		チップセラコン	01
C8027-8028	UR267100	C. EL	10uF 50V		ケミコン	
C8029-8030	US035100	C. CE. CHP	0. 1uF 16V B		チップセラコン	01
C8033-8035	US062100	C. CE. CHP	100pF 50V B		チップセラコン	01
C8101	UR267100	C. EL	10uF 50V		ケミコン	
C8102	UR067100	C. EL	10uF 50V		ケミコン	01
C8103	WJ603700	C. MYLAR	1000pF 50V		マイラーコン	01
C8104-8105	US035100	C. CE. CHP	0. 1uF 16V B		チップセラコン	01
C8106-8107	UR067100	C. EL	10uF 50V		ケミコン	01
C8108	WJ603700	C. MYLAR	1000pF 50V		マイラーコン	01
C8109-8110	US035100	C. CE. CHP	0. 1uF 16V B		チップセラコン	01
C8111	UR267100	C. EL	10uF 50V		ケミコン	
C8112	UR067100	C. EL	10uF 50V		ケミコン	01
C8115-8116	UR068100	C. EL	100uF 50V		ケミコン	01
C8118	US035100	C. CE. CHP	0. 1uF 16V B		チップセラコン	01
C8119	UR067100	C. EL	10uF 50V		ケミコン	01
C8123-8126	US035100	C. CE. CHP	0. 1uF 16V B		チップセラコン	01
C8127	UR067100	C. EL	10uF 50V		ケミコン	01
C8128-8131	US035100	C. CE. CHP	0. 1uF 16V B		チップセラコン	01
C8132	UR067100	C. EL	10uF 50V		ケミコン	01
C8133-8136	US035100	C. CE. CHP	0. 1uF 16V B		チップセラコン	01
C8137	UR067100	C. EL	10uF 50V		ケミコン	01
C8138-8140	US035100	C. CE. CHP	0. 1uF 16V B		チップセラコン	01
C8145-8146	US035100	C. CE. CHP	0. 1uF 16V B		チップセラコン	01
C8151-8166	US064100	C. CE. CHP	0. 01uF 50V B		チップセラコン	01
D7402	VT332900	DIODE	1SS355		ダイオード	01
D7403-7404	VU172300	DIODE. ZENR	UDZS7. 5B 7. 5V		ツェナーダイオード	01
D7601	VU172600	DIODE. ZENR	UDZS10B 10V	JCRTKABGFL	ツェナーダイオード	01
D7601	VU172600	DIODE. ZENR	UDZS10B 10V		ツェナーダイオード	01
D8104-8105	VV220700	DIODE. SCHOTTKY	RB501V-40		ショットキーダイオード	01
IC701	X3505A00	IC	NJM2068MD-TE2		アンプ I C	02
IC713	X7378A00	IC	NJM4565M (TE1)		アンプ I C	01
IC724-728	X2331A00	IC	NJM4580E OP AMP		アンプ I C	01
IC741-742	YA361A00	IC	R2A15220FP		I C	07
IC761-762	X7378A00	IC	NJM4565M (TE1)		アンプ I C	01
IC763	XS377A00	IC	BA15218F OP AMP		アンプ I C	01
IC781-782	XZ509A00	IC	TC74VHC04FT INVER		ロジック I C	01
IC801	X7378A00	IC	NJM4565M (TE1)		アンプ I C	01
IC802	X8875A00	IC	FHP33501M14X		アンプ I C	04
IC803	X7378A00	IC	NJM4565M (TE1)		アンプ I C	01
IC810	XY363A00	IC	TC7WHO4FU (TE12L, F)		ロジック I C	01
IC811	X7357A00	IC	PCM1803DBR		I C	04
* IC812-815	YC508A00	IC	PCM1789PWR		D/Aコンバーター	
JK781	VV269500	CN	8P DIN	U	複合コネクタ	03
PJ701	V8041300	JACK. PIN	4P MSP-244V6-01NI		ピンジャック	
PJ702-703	V7046700	JACK. PIN	4P MSP-244V1-01NI		ピンジャック	03
PJ704-705	V7046800	JACK. PIN	6P MSP-246V1-01NI		ピンジャック	04
PJ706	WRO95600	JACK. PIN	4P MSP-244V1-19NI		ピンジャック	02
* PJ707	WH671500	JACK. PIN	2P MSP-242V1-01NI		ピンジャック	

* New Parts * 新規部品

P.C.B. FUNCTION and P.C.B. OPERATION

Ref No.	Part No.	Description	Remarks	Markets	部 品 名	ランク
PJ709	V7046700	JACK. PIN	4P MSP-244V1-01N1		ピンジャック	03
PJ710	WR095600	JACK. PIN	4P MSP-244V1-19N1		ピンジャック	02
PJ711	V7189700	JACK. PIN	1P		ピンジャック	01
PJ781	V5715300	JACK. PIN	2P OR/OR		ピンジャック	02
PJ782	V8795700	JACK. PIN	1P		ピンジャック	01
Q7403-7404	WC631700	FET	2SK3288		F E T	
Q7406	WC435100	TR. DGT	KRC104S-RTK		デジタルトランジスタ	01
Q7409	VP872700	TR	2SC4488 S, T		トランジスタ	01
Q7410	VP872600	TR	2SA1708 S, T		トランジスタ	01
Q7501-7507	WC756200	TR	2SC5938A A, B		トランジスタ	01
Q7601-7602	WC883400	TR	2SD2704 K		トランジスタ	
Q7605-7610	WC883400	TR	2SD2704 K		トランジスタ	
Q7613-7621	WC883400	TR	2SD2704 K		トランジスタ	
Q7622	iC181510	TR	2SC1815 Y	JCRTKABGFL	トランジスタ	01
Q7622	iC181510	TR	2SC1815 Y	JCRTKABGFL	トランジスタ	01
Q7701	iC181510	TR	2SC1815 Y	JCRTKABGFL	トランジスタ	01
Q7702	iA101510	TR	2SA1015 Y	JCRTKABGFL	トランジスタ	01
Q7703	VR936300	TR	2SA1576A T106	JCRTKABGFL	トランジスタ	01
Q7704	VQ986700	TR	2SC4081 T106	JCRTKABGFL	トランジスタ	01
Q7705-7706	WC756200	TR	2SC5938A A, B	JCRTKABGFL	トランジスタ	01
Q7707-7708	VQ986700	TR	2SC4081 T106	JCRTKABGFL	トランジスタ	01
R7016	HF353220	R. CAR	2. 2Ω 1/2W		カーボン抵抗	
R7023	HF353220	R. CAR	2. 2Ω 1/2W		カーボン抵抗	
R7223-7224	HF353220	R. CAR	2. 2Ω 1/2W		カーボン抵抗	
R7413-7414	V8070500	R. MTL. FLM	22Ω 1W		金属被膜抵抗	01
R7601-7602	HF353220	R. CAR	2. 2Ω 1/2W		カーボン抵抗	
R7685	HV754180	R. CAR. FP	18Ω 1/4W	JCRTKABGFL	不燃化カーボン抵抗	01
R7685	HV754180	R. CAR. FP	18Ω 1/4W	JCRTKABGFL	不燃化カーボン抵抗	01
R7801	HF353220	R. CAR	2. 2Ω 1/2W		カーボン抵抗	
R8111	HF353220	R. CAR	2. 2Ω 1/2W		カーボン抵抗	
R8133	HF353220	R. CAR	2. 2Ω 1/2W		カーボン抵抗	
R8139-8141	HF353220	R. CAR	2. 2Ω 1/2W		カーボン抵抗	
ST701	V4040500	SCR. TERM	M3		スクリュー/ターミナル	01
ST801-802	V4040500	SCR. TERM	M3		スクリュー/ターミナル	01
U781-782	WH169900	CN. PHOTO. R	1P GP1FAV51RKOF		光ファイバー受信器	04
U783	WH536900	CN. PHOTO. T	1P GP1FAV51TKOF		光ファイバー送信器	04
U784	WH169900	CN. PHOTO. R	1P GP1FAV51RKOF		光ファイバー受信器	04
*	WU710000	P. C. B.	OPERATION		PCB OPERATION	
CB401	VQ045400	CN. BS. PIN	25P		FFCコネクタ	03
CB452	VM859600	CN. BS. PIN	15P		FFCコネクタ	01
CB454	VB390000	CN. BS. PIN	4P		ベースピン	01
CB455	WG668100	CN. USB	4P SE		USBコネクタ	04
CB461	VK026500	CN. BS. PIN	6P		ワイヤートラップ	01
C4001	US135100	C. CE. CHP	0. 1uF 16V		チップセラコン	01
C4002	US062100	C. CE. CHP	100pF 50V B		チップセラコン	01
C4004	US062100	C. CE. CHP	100pF 50V B		チップセラコン	01
C4008	US135100	C. CE. CHP	0. 1uF 16V		チップセラコン	01
C4010-4011	US135100	C. CE. CHP	0. 1uF 16V		チップセラコン	01
C4013	US062220	C. CE. CHP	220pF 50V B		チップセラコン	01
C4014	US135100	C. CE. CHP	0. 1uF 16V		チップセラコン	01
C4015-4016	US063100	C. CE. CHP	1000pF 50V B		チップセラコン	01
C4017	US065100	C. CE. CHP	0. 1uF 50V B		チップセラコン	01
C4101	UM417100	C. EL	10uF 50V		ケミコン	01
C4102	UM397220	C. EL	22uF 25V		ケミコン	01

* New Parts * 新規部品

P.C.B. OPERATION

Ref No.	Part No.	Description	Remarks	Markets	部 品 名	ランク
C4103	UM417220	C. EL	22uF 50V		ケミコンK S	01
C4501	US126100	C. CE. CHP	1uF 10V		チップセラコン	01
C4502-4503	US135100	C. CE. CHP	0. 1uF 16V		チップセラコン	01
C4504	US060500	C. CE. CHP	5pF 50V B		チップセラコン	01
C4505	US061330	C. CE. CHP	33pF 50V B		チップセラコン	01
C4506-4507	US063100	C. CE. CHP	1000pF 50V B		チップセラコン	01
C4508	US060500	C. CE. CHP	5pF 50V B		チップセラコン	01
C4509	US064100	C. CE. CHP	0. 01uF 50V B		チップセラコン	01
C4510	US062100	C. CE. CHP	100pF 50V B		チップセラコン	01
C4511	WJ604300	C. MYLAR	3300pF 50V		マイラーコン	
C4513	US062100	C. CE. CHP	100pF 50V B		チップセラコン	01
C4514	US063100	C. CE. CHP	1000pF 50V B		チップセラコン	01
C4516	US062100	C. CE. CHP	100pF 50V B		チップセラコン	01
C4517	WJ604300	C. MYLAR	3300pF 50V		マイラーコン	
C4520	US135100	C. CE. CHP	0. 1uF 16V		チップセラコン	01
C4521-4522	US062470	C. CE. CHP	470pF 50V B		チップセラコン	01
C4523-4524	US135100	C. CE. CHP	0. 1uF 16V		チップセラコン	01
C4525	US064100	C. CE. CHP	0. 01uF 50V B		チップセラコン	01
C4526	US062100	C. CE. CHP	100pF 50V B		チップセラコン	01
C4527	US135100	C. CE. CHP	0. 1uF 16V		チップセラコン	01
C4528-4529	US063100	C. CE. CHP	1000pF 50V B		チップセラコン	01
C4530	US163100	C. CE. CHP	1000pF 50V		チップセラコン	01
C4551	UR067100	C. EL	10uF 50V		ケミコン	01
C4552-4555	UR237470	C. EL	47uF 16V		ケミコン	01
C4556	UR837220	C. EL	22uF 16V		ケミコン	01
C4557	UR067100	C. EL	10uF 50V		ケミコン	01
C4701-4702	US063100	C. CE. CHP	1000pF 50V B		チップセラコン	01
D4001	WR095700	LED	8224-10SDRD/S530A3		LED	01
D4002-4003	VT332900	DIODE	1SS355		ダイオード	01
D4006-4007	VU171500	DIODE. ZENR	UDZS3. 6B 3. 6V		ツェナーダイオード	01
D4501-4504	VT332900	DIODE	1SS355		ダイオード	01
D4506-4508	VT332900	DIODE	1SS355		ダイオード	01
D4509	VU171900	DIODE. ZENR	UDZS5. 1B 5. 1V		ツェナーダイオード	01
D4510	VT332900	DIODE	1SS355		ダイオード	01
D4512	VT332900	DIODE	1SS355		ダイオード	01
D4514	VT332900	DIODE	1SS355		ダイオード	01
* D4603	WS293000	LED	blue SELK6E10C-D		LED	
IC451	X7378A00	IC	NJM4565M (TE1)		アンプ I C	01
JK451	V9408200	JACK. PHONE	MSJ-064-05B GR		ホーンジャック	03
JK452	V2589500	CN. DIN	1P		ミニD I Nコネクタ	02
JK453	WB751700	JACK. MNI	LGY6511-0500		モノラルミニジャック	01
PJ451	V6222800	JACK. P I N	3P		ピンジャック	04
Q4001-4002	WC529400	TR	KTC3875S Y GR RTK		トランジスタ	01
Q4601	WC529400	TR	KTC3875S Y GR RTK		トランジスタ	01
R4505-4506	V8070900	R. MTL. FLM	100Ω 1W		金属被膜抵抗	01
SW401-418	WD483100	SW. TACT	SKRGAAD010		タクト SW	01
SW420-421	WD483100	SW. TACT	SKRGAAD010		タクト SW	01
SW423-430	WD483100	SW. TACT	SKRGAAD010		タクト SW	01
SW461	V9281300	SW. RT. ENC	EVEKD2F3024B		ロータリーエンコーダ	02
SW462	WD483100	SW. TACT	SKRGAAD010		タクト SW	01
SW471	WQ291600	SW. RT. ENC	XREB12105PVB25F INA		ロータリーエンコーダ	02
U4001	WQ600700	L. DTCT	SM3385VMH6		リモコン受光ユニット	03
U4501	WH169900	CN. PHOTO. R	1P GP1FAV51RKOF		光ファイバー受信器	04
* V4001	WT943500	FL. DSPLY	23-MT-03G1NK		蛍光表示管	
	V6007100	SPACER. FL	4. 6/10/32		スペーサ F L	

* New Parts * 新規部品

P.C.B. MAIN

	Ref No.	Part No.	Description	Remarks	Markets	部 品 名	ランク
*		WU705600	P. C. B.	MAIN	J	P C B M A I N	
*		WU705700	P. C. B.	MAIN	URTA	P C B M A I N	
*		WU705800	P. C. B.	MAIN	C	P C B M A I N	
*		WU705900	P. C. B.	MAIN	KBGFL	P C B M A I N	
	CB102-104	V7825400	CN	4P TE TUC SERIES		コネクタープラグ	01
	CB105	VB389900	CN. BS. PIN	3P		ベースピン	01
	CB106	VB390000	CN. BS. PIN	4P		ベースピン	01
	CB107-108	V7825400	CN	4P TE TUC SERIES		コネクタープラグ	01
	CB109	WB127100	CN. BS. PIN	3P		ベース付ポスト	
	CB110-111	V7825400	CN	4P TE TUC SERIES		コネクタープラグ	01
	CB112	LB932060	CN. BS. PIN	6P		ベースポスト	01
	CB115-116	WA246200	SCR. TERM	3. 5		スクリューターミナル	
	CB131	VB390000	CN. BS. PIN	4P		ベースピン	01
*	C1001-1002	UR397220	C. EL	22uF 100V		ケミコン	
	C1004	UR296470	C. EL	4. 7uF 100V		ケミコン	01
	C1005	US135100	C. CE. CHP	0. 1uF 16V		チップセラコン	01
*	C1006-1007	UR397220	C. EL	22uF 100V		ケミコン	
	C1008	WN164800	C. PP	2200pF 100V		PPコン	01
	C1009	WE100200	C. PP	22pF 630V K		PPコン	01
△ *	C1010	UR397220	C. EL	22uF 100V		ケミコン	
	C1012	WE100400	C. PP	47pF 630V K		PPコン	
	C1013	WP421000	C. PP	0. 047uF 100V		PPコン	
	C1014	WK041800	C. EL	10uF 16V		ケミコン	01
	C1016	UR058100	C. EL	100uF 35V		ケミコン	01
	C1017	WN164200	C. PP	220pF 100V		PPコン	01
	C1018	WJ603100	C. MYLAR	220pF 50V		マイラーコン	01
	C1019	UR397100	C. EL	10uF 100V		ケミコン	03
	C1020	WN164800	C. PP	2200pF 100V		PPコン	01
	C1021	WE100200	C. PP	22pF 630V K		PPコン	01
△ *	C1022	UR397220	C. EL	22uF 100V		ケミコン	
	C1024	WE100400	C. PP	47pF 630V K		PPコン	
	C1025	WP421000	C. PP	0. 047uF 100V		PPコン	
	C1026	WK041800	C. EL	10uF 16V		ケミコン	01
	C1028	UR058100	C. EL	100uF 35V		ケミコン	01
	C1029	WN164200	C. PP	220pF 100V		PPコン	01
	C1030	UR397100	C. EL	10uF 100V		ケミコン	03
	C1031	WJ603100	C. MYLAR	220pF 50V		マイラーコン	01
	C1032	WJ605000	C. MYLAR	0. 01uF 50V J		マイラーコン	01
	C1033	WN165500	C. PP	0. 022uF 100V		PPコン	01
	C1034	WJ605000	C. MYLAR	0. 01uF 50V J		マイラーコン	01
	C1035	WN165500	C. PP	0. 022uF 100V		PPコン	01
	C1036	WJ605000	C. MYLAR	0. 01uF 50V J		マイラーコン	01
	C1037	WN165500	C. PP	0. 022uF 100V		PPコン	01
	C1038	WN164800	C. PP	2200pF 100V		PPコン	01
	C1039-1041	WJ605000	C. MYLAR	0. 01uF 50V J		マイラーコン	01
△ *	C1042	UR397220	C. EL	22uF 100V		ケミコン	
	C1044	WE100200	C. PP	22pF 630V K		PPコン	01
	C1045	WE100400	C. PP	47pF 630V K		PPコン	
	C1046	WK041800	C. EL	10uF 16V		ケミコン	01
	C1047	WP421000	C. PP	0. 047uF 100V		PPコン	
	C1048	WN165500	C. PP	0. 022uF 100V		PPコン	01
	C1049	WE100900	C. PP	220pF 630V K		PPコン	02
	C1050	WJ605000	C. MYLAR	0. 01uF 50V J		マイラーコン	01
	C1052	UR058100	C. EL	100uF 35V		ケミコン	01
	C1053	WJ603100	C. MYLAR	220pF 50V		マイラーコン	01
	C1054	WN165500	C. PP	0. 022uF 100V		PPコン	01
	C1055	WN164200	C. PP	220pF 100V		PPコン	01

* New Parts * 新規部品

RX-V1067/HTR-8063/
RX-A1000

P.C.B. MAIN

Ref No.	Part No.	Description	Remarks	Markets	部 品 名	ランク
C1056	WJ605000	C. MYLAR	0. 01uF 50V J		マイラーコン	01
C1058	WJ605000	C. MYLAR	0. 01uF 50V J		マイラーコン	01
C1059-1060	UR297220	C. EL	22uF 100V		ケミコン	01
C1061	WN165500	C. PP	0. 022uF 100V		PPコン	01
C1062	WJ605000	C. MYLAR	0. 01uF 50V J		マイラーコン	01
C1063	UR397100	C. EL	10uF 100V		ケミコン	03
C1064	WN164800	C. PP	2200pF 100V		PPコン	01
C1065	WJ605000	C. MYLAR	0. 01uF 50V J		マイラーコン	01
C1066	WN165500	C. PP	0. 022uF 100V		PPコン	01
C1067	WJ605000	C. MYLAR	0. 01uF 50V J		マイラーコン	01
C1068	WE100200	C. PP	22pF 630V K		PPコン	01
△ * C1069	UR397220	C. EL	22uF 100V		ケミコン	
C1071	WE100400	C. PP	47pF 630V K		PPコン	
C1072	WP421000	C. PP	0. 047uF 100V		PPコン	
C1073	WK041800	C. EL	10uF 16V		ケミコン	01
C1075	WJ605000	C. MYLAR	0. 01uF 50V J		マイラーコン	01
C1076	UR058100	C. EL	100uF 35V		ケミコン	01
C1077	WN165500	C. PP	0. 022uF 100V		PPコン	01
C1078	WN164200	C. PP	220pF 100V		PPコン	01
C1079	UR397100	C. EL	10uF 100V		ケミコン	03
C1080	WJ603100	C. MYLAR	220pF 50V		マイラーコン	01
C1081	WJ605000	C. MYLAR	0. 01uF 50V J		マイラーコン	01
C1082	WN165500	C. PP	0. 022uF 100V		PPコン	01
C1083	WJ605000	C. MYLAR	0. 01uF 50V J		マイラーコン	01
C1087	WN164800	C. PP	2200pF 100V		PPコン	01
C1088	WE100200	C. PP	22pF 630V K		PPコン	01
△ * C1091	UR397220	C. EL	22uF 100V		ケミコン	
C1093	WE100400	C. PP	47pF 630V K		PPコン	
C1094	WP421000	C. PP	0. 047uF 100V		PPコン	
C1095	WK041800	C. EL	10uF 16V		ケミコン	01
C1098	UR058100	C. EL	100uF 35V		ケミコン	01
C1099	WN164200	C. PP	220pF 100V		PPコン	01
C1100	WJ603100	C. MYLAR	220pF 50V		マイラーコン	01
C1101	WE100900	C. PP	220pF 630V K		PPコン	02
C1102	WJ608900	C. MYLAR	1000pF 100V		マイラーコン	01
C1103	UR397100	C. EL	10uF 100V		ケミコン	03
C1104	WN164800	C. PP	2200pF 100V		PPコン	01
C1105-1106	WJ788600	C. EL	12000uF 71V		ケミコン	08
C1107	WE100200	C. PP	22pF 630V K		PPコン	01
△ * C1108	UR397220	C. EL	22uF 100V		ケミコン	
C1110	WE100400	C. PP	47pF 630V K		PPコン	
C1111	WP421000	C. PP	0. 047uF 100V		PPコン	
C1112	WK041800	C. EL	10uF 16V		ケミコン	01
C1114	UR058100	C. EL	100uF 35V		ケミコン	01
C1115	WN164200	C. PP	220pF 100V		PPコン	01
C1116	UR397100	C. EL	10uF 100V		ケミコン	03
C1117	WJ603100	C. MYLAR	220pF 50V		マイラーコン	01
C1118	WQ209700	C. PP	0. 027uF 100V	JKBGFL	PPコン	
C1118	WN165500	C. PP	0. 022uF 100V	UCRTA	PPコン	01
C1119	WQ209700	C. PP	0. 027uF 100V	JKBGLF	PPコン	
C1119	WN165500	C. PP	0. 022uF 100V	UCRTA	PPコン	01
C1120	WN164800	C. PP	2200pF 100V		PPコン	01
C1121	WE100200	C. PP	22pF 630V K		PPコン	01
△ * C1122	UR397220	C. EL	22uF 100V		ケミコン	
C1124	WE100400	C. PP	47pF 630V K		PPコン	
C1125	WP421000	C. PP	0. 047uF 100V		PPコン	
C1126	WK041800	C. EL	10uF 16V		ケミコン	01

* New Parts * 新規部品

RX-V1067/HTR-8063/
RX-A1000

P.C.B. MAIN

Ref No.	Part No.	Description	Remarks	Markets	部 品 名	ランク
C1128	UR058100	C. EL	100uF 35V		ケミコン	01
C1129	WN164200	C. PP	220pF 100V		PPコン	01
C1130	WJ603100	C. MYLAR	220pF 50V		マイラーコン	01
C1131-1132	UR397100	C. EL	10uF 100V		ケミコン	03
C1133-1134	US135100	C. CE. CHP	0. 1uF 16V		チップセラコン	01
C1135	UR067470	C. EL	47uF 50V		ケミコン	01
C1136	UR238220	C. EL	220uF 16V		ケミコン	01
C1137	UR348100	C. EL	100uF 25V		ケミコン	01
D1008	VT332900	DIODE	1SS355		ダイオード	01
△ D1010	VG437500	DIODE. ZENR	MTZJ5. 1C 5. 1V		ツェナーダイオード	01
D1011-1012	VH282500	DIODE	RLS245		ダイオード	01
D1013-1014	VT332900	DIODE	1SS355		ダイオード	01
D1018-1019	VT332900	DIODE	1SS355		ダイオード	01
△ D1020	VG437500	DIODE. ZENR	MTZJ5. 1C 5. 1V		ツェナーダイオード	01
D1021-1022	VT332900	DIODE	1SS355		ダイオード	01
D1023-1024	VH282500	DIODE	RLS245		ダイオード	01
D1025	VT332900	DIODE	1SS355		ダイオード	01
△ D1028	VG437500	DIODE. ZENR	MTZJ5. 1C 5. 1V		ツェナーダイオード	01
D1029	VH282500	DIODE	RLS245		ダイオード	01
D1030	VT332900	DIODE	1SS355		ダイオード	01
D1031	VH282500	DIODE	RLS245		ダイオード	01
△ D1034	VG437500	DIODE. ZENR	MTZJ5. 1C 5. 1V		ツェナーダイオード	01
D1035-1036	VH282500	DIODE	RLS245		ダイオード	01
D1037	VT332900	DIODE	1SS355		ダイオード	01
△ D1040	VG437500	DIODE. ZENR	MTZJ5. 1C 5. 1V		ツェナーダイオード	01
D1041-1042	VH282500	DIODE	RLS245		ダイオード	01
D1043	VT332900	DIODE	1SS355		ダイオード	01
△ D1046	VG437500	DIODE. ZENR	MTZJ5. 1C 5. 1V		ツェナーダイオード	01
D1047-1048	VH282500	DIODE	RLS245		ダイオード	01
D1049	VT332900	DIODE	1SS355		ダイオード	01
△ D1050	WK611100	DIODE. BRG	D6SBN20 6A 200V		ダイオードブリッジ	05
D1053	VT332900	DIODE	1SS355		ダイオード	01
△ D1055	VG437500	DIODE. ZENR	MTZJ5. 1C 5. 1V		ツェナーダイオード	01
D1056-1057	VH282500	DIODE	RLS245		ダイオード	01
D1058	VT332900	DIODE	1SS355		ダイオード	01
* D1061	WS693600	DIODE. ZENR	HZU4. 7B2 TRF-E		ツェナーダイオード	01
D1062-1063	VT332900	DIODE	1SS355		ダイオード	01
D1064-1067	VT332900	DIODE	1SS355	C	ダイオード	01
D1068-1081	VT332900	DIODE	1SS355		ダイオード	01
G1001	V5995800	PLATE. GND			アースプレート	
IC101	X7779A00	IC	LC709004A-TLM-E		ロジック I C	04
IC102	YA381A00	IC	LM19C1Z/LF THERMAL	JURTKABGFL	電源 I C	04
IC103	YA381A00	IC	LM19C1Z/LF THERMAL	JURTKABGFL	電源 I C	04
PN1-6	WS488500	STYLE. PIN	L=90 #18		スタイルピン	01
Q1005	WH372100	TR	KTA1517S GR TP		トランジスタ	01
△ Q1009-1010	WC292600	TR	KTA1837-U		トランジスタ	02
Q1013	WC435100	TR. DGT	KRC104S-RTK		デジタルトランジスタ	01
△ * Q1015	WT919900	TR. PAIR	STD01P/N, O, Y		ペアトランジスタ	01
Q1016	WF549900	TR	2SC3906K T146 R, S		トランジスタ	01
Q1017	WH372100	TR	KTA1517S GR TP		トランジスタ	01
Q1018	WF549900	TR	2SC3906K T146 R, S		トランジスタ	01
* Q1019	WU085300	TR	2SA1208S/T-AE		トランジスタ	01
Q1020	WC434900	TR. DGT	KRA104S-RTK		デジタルトランジスタ	01
Q1022	WH199400	IC	HN4C06J		トランジスタアレイ	01
Q1023	WC435100	TR. DGT	KRC104S-RTK		デジタルトランジスタ	01
△ * Q1025	WU085400	TR	2SC2910S/T-AE		トランジスタ	01
Q1027	WC434900	TR. DGT	KRA104S-RTK		デジタルトランジスタ	01

* New Parts * 新規部品

RX-V1067/HTR-8063/
RX-A1000

P.C.B. MAIN

Ref No.	Part No.	Description	Remarks	Markets	部 品 名	ランク
Q1029	WF549900	TR	2SC3906K T146 R, S		トランジスタ	01
Q1030-1031	WC435100	TR. DGT	KRC104S-RTK		デジタルトランジスタ	01
Q1032-1033	WC434900	TR. DGT	KRA104S-RTK		デジタルトランジスタ	01
△ * Q1034	WT919900	TR. PAIR	STD01P/N, O, Y		ペアトランジスタ	
Q1035	WF549900	TR	2SC3906K T146 R, S		トランジスタ	01
Q1036	WH372100	TR	KTA1517S GR TP		トランジスタ	01
Q1037	WF549900	TR	2SC3906K T146 R, S		トランジスタ	01
* Q1038	WU085300	TR	2SA1208S/T-AE		トランジスタ	
Q1039-1040	WC435100	TR. DGT	KRC104S-RTK		デジタルトランジスタ	01
Q1041-1042	WC434900	TR. DGT	KRA104S-RTK		デジタルトランジスタ	01
Q1043	WH199400	IC	HN4C06J		トランジスタアレイ	01
△ * Q1044	WU085400	TR	2SC2910S/T-AE		トランジスタ	
Q1046-1047	WF549900	TR	2SC3906K T146 R, S		トランジスタ	01
△ * Q1048	WT919900	TR. PAIR	STD01P/N, O, Y		ペアトランジスタ	
Q1049	WH372100	TR	KTA1517S GR TP		トランジスタ	01
* Q1050	WU085300	TR	2SA1208S/T-AE		トランジスタ	
Q1051	WF549900	TR	2SC3906K T146 R, S		トランジスタ	01
Q1052	WH199400	IC	HN4C06J		トランジスタアレイ	01
△ * Q1053	WU085400	TR	2SC2910S/T-AE		トランジスタ	
Q1054	WF549900	TR	2SC3906K T146 R, S		トランジスタ	01
△ * Q1056	WT919900	TR. PAIR	STD01P/N, O, Y		ペアトランジスタ	
Q1057	WF549900	TR	2SC3906K T146 R, S		トランジスタ	01
Q1058	WH372100	TR	KTA1517S GR TP		トランジスタ	01
Q1059	WF549900	TR	2SC3906K T146 R, S		トランジスタ	01
* Q1060	WU085300	TR	2SA1208S/T-AE		トランジスタ	
Q1061	WH199400	IC	HN4C06J		トランジスタアレイ	01
△ * Q1062	WU085400	TR	2SC2910S/T-AE		トランジスタ	
Q1064	WF549900	TR	2SC3906K T146 R, S		トランジスタ	01
△ * Q1065	WT919900	TR. PAIR	STD01P/N, O, Y		ペアトランジスタ	
Q1066	WF549900	TR	2SC3906K T146 R, S		トランジスタ	01
Q1067	WH372100	TR	KTA1517S GR TP		トランジスタ	01
Q1068	WF549900	TR	2SC3906K T146 R, S		トランジスタ	01
* Q1069	WU085300	TR	2SA1208S/T-AE		トランジスタ	
Q1070	WH199400	IC	HN4C06J		トランジスタアレイ	01
△ * Q1071	WU085400	TR	2SC2910S/T-AE		トランジスタ	
Q1073	WF549900	TR	2SC3906K T146 R, S		トランジスタ	01
△ * Q1074	WT919900	TR. PAIR	STD01P/N, O, Y		ペアトランジスタ	
Q1075	WF549900	TR	2SC3906K T146 R, S		トランジスタ	01
Q1076	WH372100	TR	KTA1517S GR TP		トランジスタ	01
Q1077	WF549900	TR	2SC3906K T146 R, S		トランジスタ	01
* Q1078	WU085300	TR	2SA1208S/T-AE		トランジスタ	
Q1079	WH199400	IC	HN4C06J		トランジスタアレイ	01
△ * Q1080	WU085400	TR	2SC2910S/T-AE		トランジスタ	
Q1081	WC435100	TR. DGT	KRC104S-RTK		デジタルトランジスタ	01
Q1083	WF549900	TR	2SC3906K T146 R, S		トランジスタ	01
Q1084	WC434900	TR. DGT	KRA104S-RTK		デジタルトランジスタ	01
△ * Q1087	WT919900	TR. PAIR	STD01P/N, O, Y		ペアトランジスタ	
Q1088	WF549900	TR	2SC3906K T146 R, S		トランジスタ	01
Q1089	WH372100	TR	KTA1517S GR TP		トランジスタ	01
Q1090	WF549900	TR	2SC3906K T146 R, S		トランジスタ	01
* Q1091	WU085300	TR	2SA1208S/T-AE		トランジスタ	
Q1092	WH199400	IC	HN4C06J		トランジスタアレイ	01
△ * Q1093	WU085400	TR	2SC2910S/T-AE		トランジスタ	
Q1095	WF549900	TR	2SC3906K T146 R, S		トランジスタ	01
Q1096-1097	WC398400	TR	2N5551C-AT		トランジスタ	01
Q1098	WC397700	TR	2N5401C-AT		トランジスタ	01
△ * Q1099-1105	WU085400	TR	2SC2910S/T-AE		トランジスタ	

* New Parts * 新規部品

P.C.B. MAIN

Ref No.	Part No.	Description	Remarks	Markets	部 品 名	ランク
△	R1008-1009	HV754100 R. CAR. FP	10Ω 1/4W		不燃化カーボン抵抗	01
△	R1032	HV754100 R. CAR. FP	10Ω 1/4W		不燃化カーボン抵抗	01
	R1033	HV755100 R. CAR. FP	100Ω 1/4W		不燃化カーボン抵抗	01
	R1037	HV753470 R. CAR. FP	4.7Ω 1/4W		不燃化カーボン抵抗	01
△ *	R1041	WU208600 R. WW	0.22Ω x2 RF3EGJR22		セメント抵抗	
	R1045	V8072600 R. MTL. OXD	33KΩ 1W		酸化金属被膜抵抗	
	R1046	HF355220 R. CAR	220Ω 1/2W		カーボン抵抗	
	R1052	V8070200 R. MTL. FLM	4.7Ω 1W		金属被膜抵抗	
△	R1055	HV755220 R. CAR. FP	220Ω 1/4W		不燃化カーボン抵抗	01
	R1056	HL006120 R. MTL. OXD	1.2KΩ 1/2W		酸化金属被膜抵抗	01
△	R1062	HV754100 R. CAR. FP	10Ω 1/4W		不燃化カーボン抵抗	01
	R1063	HV755100 R. CAR. FP	100Ω 1/4W		不燃化カーボン抵抗	01
	R1067	HV753470 R. CAR. FP	4.7Ω 1/4W		不燃化カーボン抵抗	01
△ *	R1071	WU208600 R. WW	0.22Ω x2 RF3EGJR22		セメント抵抗	
	R1075	V8072600 R. MTL. OXD	33KΩ 1W		酸化金属被膜抵抗	
	R1076	HF355220 R. CAR	220Ω 1/2W		カーボン抵抗	
△	R1079	V8070000 R. MTL. FLM	1Ω 1W		金属被膜抵抗	01
	R1083	V8070200 R. MTL. FLM	4.7Ω 1W		金属被膜抵抗	
△	R1086	HV755220 R. CAR. FP	220Ω 1/4W		不燃化カーボン抵抗	01
	R1087	HV753470 R. CAR. FP	4.7Ω 1/4W		不燃化カーボン抵抗	01
	R1088	HL006120 R. MTL. OXD	1.2KΩ 1/2W		酸化金属被膜抵抗	01
	R1091	HV753470 R. CAR. FP	4.7Ω 1/4W		不燃化カーボン抵抗	01
	R1094	HV755100 R. CAR. FP	100Ω 1/4W		不燃化カーボン抵抗	01
△	R1096	HV754100 R. CAR. FP	10Ω 1/4W		不燃化カーボン抵抗	01
	R1097	HV753470 R. CAR. FP	4.7Ω 1/4W		不燃化カーボン抵抗	01
	R1101-1103	HF353470 R. CAR	4.7Ω 1/2W		カーボン抵抗	
	R1104	HV753470 R. CAR. FP	4.7Ω 1/4W		不燃化カーボン抵抗	01
	R1107	V8072600 R. MTL. OXD	33KΩ 1W		酸化金属被膜抵抗	
	R1108	HF355220 R. CAR	220Ω 1/2W		カーボン抵抗	
△ *	R1111	WU208600 R. WW	0.22Ω x2 RF3EGJR22		セメント抵抗	
	R1114	HF353470 R. CAR	4.7Ω 1/2W		カーボン抵抗	
	R1118	HV753470 R. CAR. FP	4.7Ω 1/4W		不燃化カーボン抵抗	01
	R1121	V8070200 R. MTL. FLM	4.7Ω 1W		金属被膜抵抗	
	R1123	HL006120 R. MTL. OXD	1.2KΩ 1/2W		酸化金属被膜抵抗	01
△	R1124	HV755220 R. CAR. FP	220Ω 1/4W		不燃化カーボン抵抗	01
	R1127	HV753470 R. CAR. FP	4.7Ω 1/4W		不燃化カーボン抵抗	01
	R1130	HF353470 R. CAR	4.7Ω 1/2W		カーボン抵抗	
	R1133	HV753470 R. CAR. FP	4.7Ω 1/4W		不燃化カーボン抵抗	01
	R1134	HV755100 R. CAR. FP	100Ω 1/4W		不燃化カーボン抵抗	01
△	R1136	HV754100 R. CAR. FP	10Ω 1/4W		不燃化カーボン抵抗	01
	R1140-1141	HV753470 R. CAR. FP	4.7Ω 1/4W		不燃化カーボン抵抗	01
	R1144	HF353470 R. CAR	4.7Ω 1/2W		カーボン抵抗	
△ *	R1146	WU208600 R. WW	0.22Ω x2 RF3EGJR22		セメント抵抗	
	R1150	V8072600 R. MTL. OXD	33KΩ 1W		酸化金属被膜抵抗	
	R1151	HF355220 R. CAR	220Ω 1/2W		カーボン抵抗	
△	R1153	V8070000 R. MTL. FLM	1Ω 1W		金属被膜抵抗	01
	R1158	V8070200 R. MTL. FLM	4.7Ω 1W		金属被膜抵抗	
	R1159	HV753470 R. CAR. FP	4.7Ω 1/4W		不燃化カーボン抵抗	01
△	R1162	HV755220 R. CAR. FP	220Ω 1/4W		不燃化カーボン抵抗	01
	R1163	HL006120 R. MTL. OXD	1.2KΩ 1/2W		酸化金属被膜抵抗	01
	R1164	HV753470 R. CAR. FP	4.7Ω 1/4W		不燃化カーボン抵抗	01
	R1168	HF353470 R. CAR	4.7Ω 1/2W		カーボン抵抗	
	R1171	HV755100 R. CAR. FP	100Ω 1/4W		不燃化カーボン抵抗	01
△	R1173	HV754100 R. CAR. FP	10Ω 1/4W		不燃化カーボン抵抗	01
	R1178	HV753470 R. CAR. FP	4.7Ω 1/4W		不燃化カーボン抵抗	01
△ *	R1183	WU208600 R. WW	0.22Ω x2 RF3EGJR22		セメント抵抗	
	R1187	V8072600 R. MTL. OXD	33KΩ 1W		酸化金属被膜抵抗	

* New Parts * 新規部品

RX-V1067/HTR-8063/
RX-A1000

P.C.B. MAIN

Ref No.	Part No.	Description	Remarks	Markets	部 品 名	ランク	
	R1188	HF355220 R. CAR	220Ω 1/2W			カーボン抵抗	
	R1195	V8070200 R. MTL. FLM	4.7Ω 1W			金属被膜抵抗	
△	R1198	HV755220 R. CAR. FP	220Ω 1/4W			不燃化カーボン抵抗	01
	R1199	HL006120 R. MTL. OXD	1.2KΩ 1/2W			酸化金属被膜抵抗	01
	R1202	HF353470 R. CAR	4.7Ω 1/2W			カーボン抵抗	
△	R1206	HV754100 R. CAR. FP	10Ω 1/4W			不燃化カーボン抵抗	01
	R1207	HV755100 R. CAR. FP	100Ω 1/4W			不燃化カーボン抵抗	01
	R1211	HV753470 R. CAR. FP	4.7Ω 1/4W			不燃化カーボン抵抗	01
△ *	R1215	WU208600 R. WW	0.22Ω x2 RF3EGJR22			セメント抵抗	
	R1219	V8072600 R. MTL. OXD	33KΩ 1W			酸化金属被膜抵抗	
	R1220	HF355220 R. CAR	220Ω 1/2W			カーボン抵抗	
△	R1222	V8070000 R. MTL. FLM	1Ω 1W			金属被膜抵抗	01
	R1227	V8070200 R. MTL. FLM	4.7Ω 1W			金属被膜抵抗	
△	R1230	HV755220 R. CAR. FP	220Ω 1/4W			不燃化カーボン抵抗	01
	R1231	HL006120 R. MTL. OXD	1.2KΩ 1/2W			酸化金属被膜抵抗	01
△	R1237	HV754100 R. CAR. FP	10Ω 1/4W			不燃化カーボン抵抗	01
	R1238	HV755100 R. CAR. FP	100Ω 1/4W			不燃化カーボン抵抗	01
	R1244	HV753470 R. CAR. FP	4.7Ω 1/4W			不燃化カーボン抵抗	01
△ *	R1250	WU208600 R. WW	0.22Ω x2 RF3EGJR22			セメント抵抗	
	R1256	V8072600 R. MTL. OXD	33KΩ 1W			酸化金属被膜抵抗	
	R1257	HF355220 R. CAR	220Ω 1/2W			カーボン抵抗	
	R1264	V8070200 R. MTL. FLM	4.7Ω 1W			金属被膜抵抗	
△	R1267	HV755220 R. CAR. FP	220Ω 1/4W			不燃化カーボン抵抗	01
	R1268	HL006120 R. MTL. OXD	1.2KΩ 1/2W			酸化金属被膜抵抗	01
	R1280	V8072100 R. MTL. OXD	5.6KΩ 1W			酸化金属被膜抵抗	
	R1282	HV755560 R. CAR. FP	560Ω 1/4W			不燃化カーボン抵抗	01
	R1286	V8072000 R. MTL. OXD	4.7KΩ 1W			酸化金属被膜抵抗	
	R1289	HF353220 R. CAR	2.2Ω 1/2W			カーボン抵抗	
	R1294-1300	HV755220 R. CAR. FP	220Ω 1/4W			不燃化カーボン抵抗	01
△	R1317-1323	HV754100 R. CAR. FP	10Ω 1/4W			不燃化カーボン抵抗	01
	RY102	WJ122400 RELAY	981-2A-24DS-SP7			リレー 24V	04
	RY104-108	WJ122400 RELAY	981-2A-24DS-SP7			リレー 24V	04
	RY109	WE648700 RELAY	DC DH24D2-0-Q			リレー 24V	06
	ST101	V4040500 SCR. TERM	M3			スクリュー／ターミナル	01
*	TE101	WU729200 TERM. SP	6P MST-226VD-01	JUCRTA		スピーカー端子	
*	TE101	WU729600 TERM. SP	6P MST-226VD-01	KBGFL		スピーカー端子	
*	TE102	WU730100 TERM. SP	4P MST-224VD-01-76	JUCRTA		スピーカー端子	
*	TE102	WU730300 TERM. SP	4P MST-224VD-01-76	KBGFL		スピーカー端子	
*	TE103	WU730100 TERM. SP	4P MST-224VD-01-76	JUCRTA		スピーカー端子	
*	TE103	WU730300 TERM. SP	4P MST-224VD-01-76	KBGFL		スピーカー端子	
*	TE104	WU730100 TERM. SP	4P MST-224VD-01-76	JUCRTA		スピーカー端子	
*	TE104	WU730300 TERM. SP	4P MST-224VD-01-76	KBGFL		スピーカー端子	
*	TH101-104	WT698300 THERMISTOR	WC92NA103J1	C		NTCサーミスタ	
		WE774200 SCR. BND. HD	3x10 MFZN2W3			バインドBタイトネジ	01

* New Parts * 新規部品

P.C.B. POWER

Ref No.	Part No.	Description	Remarks	Markets	部 品 名	ランク
*	WU707300	P. C. B.	POWER		J PCB POWER	
*	WU707400	P. C. B.	POWER		U PCB POWER	
*	WU707500	P. C. B.	POWER		C PCB POWER	
*	WU707600	P. C. B.	POWER		R PCB POWER	
*	WU707700	P. C. B.	POWER		T PCB POWER	
*	WU707800	P. C. B.	POWER		K PCB POWER	
*	WU707900	P. C. B.	POWER		A PCB POWER	
*	WU708000	P. C. B.	POWER		BGF PCB POWER	
*	WU708100	P. C. B.	POWER		L PCB POWER	
△	CB204-205	WN103000	CL IP. FUSE	TP00351-31		ヒューズクリップ 01
	CB206	VG879900	CN. BS. PIN	2P		ベースピン 01
	CB253-254	WN103000	CL IP. FUSE	TP00351-31	R	ヒューズクリップ 01
△	* CB255	V9377900	CN. BS. PIN	4P	R	ベース付ポスト
	* C2001	WU536600	C. POL. MTL	0.047uF 630V	JUC	メタライズドポリコン
	* C2001	WQ852400	C. POL. MTL	0.022uF 630V	RTKABGFL	メタライズドポリコン 01
△	* C2002	V6185300	C. CE. SAFTY	0.01uF 275V		規格認定コンデンサ 01
	* C2003	WU536600	C. POL. MTL	0.047uF 630V	JUC	メタライズドポリコン
	* C2003	WQ852400	C. POL. MTL	0.022uF 630V	RTKABGFL	メタライズドポリコン 01
△	* C2004	V6150400	C. CE. SAFTY	0.068uF 250V		規格認定コン
△	* C2005-2006	WHO35900	C. CE. SAFTY	1000pF 250V		規格認定コンデンサ 01
△	* C2007	V6150400	C. CE. SAFTY	0.068uF 250V	J	規格認定コン
△	* C2007	WR977400	C. CE. SAFTY	0.022uF 250V	UCRTKABGFL	規格認定コンデンサ
	C2008	US063100	C. CE. CHP	1000pF 50V B		チップセラコン 01
	C2009	US065100	C. CE. CHP	0.1uF 50V B		チップセラコン 01
	C2010	WP340600	C. EL	47uF 35V	JUCR	ケミコン 01
	C2010	WJ047200	C. EL	22uF 50V	TKABGFL	ケミコン V Z 01
	C2011	US065100	C. CE. CHP	0.1uF 50V B		チップセラコン 01
	C2012	WQ286600	C. CE. CHP	0.22uF 50V		チップセラコン 01
	C2013	US065100	C. CE. CHP	0.1uF 50V B		チップセラコン 01
	C2014	UB215100	C. CE. CHP	0.1uF 25V	JUCTKABGFL	チップセラコン 01
	C2014	UB214470	C. CE. CHP	0.047uF 25V	R	チップセラコン 01
	C2015	US063220	C. CE. CHP	2200pF 50V B		チップセラコン 01
	* C2016	WU898700	C. EL	390uF 200V	JUC	ケミコン
	* C2016	WU464200	C. EL	390uF 400V	R	ケミコン
	* C2016	WU898800	C. EL	100uF 400V	TKABGFL	ケミコン
	C2017	WJ047200	C. EL	22uF 50V		ケミコン V Z 01
	C2018	WJ322300	C. CE. M. CHP	1000pF 630V		チップ積層セラコン 01
	C2019	WHO35900	C. CE. SAFTY	1000pF 250V		規格認定コンデンサ 01
	C2020	WK413800	C. CE. M. CHP	1000pF 250V		チップ積層セラコン 01
	* C2021	WU278700	C. EL	820uF 35V		ケミコン
	C2022	US064100	C. CE. CHP	0.01uF 50V B		チップセラコン 01
	C2023	US063220	C. CE. CHP	2200pF 50V B	UCRTKABGFL	チップセラコン 01
	* C2024	WU278700	C. EL	820uF 35V		ケミコン
	C2025	V7887800	C. EL	1uF 50V		ケミコン
	* C2026-2027	WU278700	C. EL	820uF 35V		ケミコン
△	C2028	UR837220	C. EL	22uF 16V		ケミコン 01
	C2029	WN951300	C. EL	10uF 16V		ケミコン 01
	C2031-2032	US064100	C. CE. CHP	0.01uF 50V B		チップセラコン 01
	C2033	US035100	C. CE. CHP	0.1uF 16V B		チップセラコン 01
	C2035	WQ072600	C. EL	220uF 35V		ケミコン 01
	C2036	US065100	C. CE. CHP	0.1uF 50V B		チップセラコン 01
	C2037	US063220	C. CE. CHP	2200pF 50V B	UCRTKABGFL	チップセラコン 01
	C2038	WJ322300	C. CE. M. CHP	1000pF 630V		チップ積層セラコン 01
△	C2039	WHO36100	C. CE. SEFTY	2200pF 250V	UCRTKABGFL	規格認定コンデンサK X 01
	C2043	US035100	C. CE. CHP	0.1uF 16V B		チップセラコン 01
	C2044	US126100	C. CE. CHP	1uF 10V		チップセラコン 01
	C2045	US065100	C. CE. CHP	0.1uF 50V B		チップセラコン 01

* New Parts * 新規部品

RX-V1067/HTR-8063/
RX-A1000

P.C.B. POWER and P.C.B. VIDEO

	Ref No.	Part No.	Description	Remarks	Markets	部 品 名	ランク	
△	C2046	V5877700	C. MYLAR	0. 22uF 250V		J	マイラーコン	03
	C2047	US063100	C. CE. CHP	1000pF 50V B			チップセラコン	01
	C2048-2049	US035100	C. CE. CHP	0. 1uF 16V B			チップセラコン	01
△ *	D2001	WJ441800	DIODE	RS605M-B-C-J81			D i スタック	
	D2002	VN478200	DIODE	D1NL20U			ダイオード	01
	D2003	VU173400	DIODE. ZENR	UDZS22B 22V			ツェナーダイオード	01
	D2004	WN672400	DIODE. ZENR	P6KE200A 200V			ツェナーダイオード	03
	D2006	WJ151900	DIODE	STTH110A			ダイオード	03
	D2007	VV463000	DIODE. CHP	1. 1A 200V D1FL20U			チップダイオード	01
	D2009	VT332900	DIODE	1SS355			ダイオード	01
*	D2010	WJ458600	DIODE. SCHOTTKY	RB215T-60 20A 60V			ショットキーダイオード	
	D2011-2015	VT332900	DIODE	1SS355			ダイオード	01
	D2016	VU172400	DIODE. ZENR	UDZS8. 2B 8. 2V			ツェナーダイオード	
	D2017	VT332900	DIODE	1SS355			ダイオード	01
△ *	F2001	WR944000	FUSE	2A 250V			ヒューズ	
△	F2003	WQ211200	FUSE	10A 125V		JUCR	ヒューズ	01
△	F2003	WB760600	FUSE	T6. 3A 250V		TKABGFL	ヒューズ	01
△	F2500	WB760600	FUSE	T6. 3A 250V		R	ヒューズ	01
	IC201	X9806A00	IC	L6566BTR SW DENGEN			電源 I C	04
△	IC202-204	WP388200	PHOT. CPL	TLP781 (D4-GR, F)			フォトカプラ	01
	IC205	X6770A00	IC	NJM431U (TE1)			電源 I C	01
	IC207	X8147A00	IC	R3112N421A-TR-F			ロジック I C	01
△ *	Q2001	WT687800	FET	STF9NK90Z 8. 0A ST			F E T	
	Q2002	iC181510	TR	2SC1815 Y			トランジスタ	01
	Q2003	VV655700	TR. DGT	DTC144EKA			デジタルトランジスタ	01
	Q2004	WC529400	TR	KTC3875S Y GR RTK			トランジスタ	01
*	R2025	WU985400	R. WW	0. 27Ω 3W K		JUCR	セメント抵抗	
*	R2025	WQ526100	R. CEMENT	0. 33Ω 3W		TKABGFL	セメント抵抗	
*	R2025	WU985400	R. WW	0. 27Ω 3W K			セメント抵抗	
*	R2026	WQ526100	R. CEMENT	0. 33Ω 3W			セメント抵抗	
△ *	R2052	WU547900	R. OTHER	3MΩ 1/2W			放電抵抗	
△	RY201	WQ804100	RELAY	DC DLS5D1-0 (M) 0. 25			リレー	04
	ST202	V4040500	SCR. TERM	M3			スクリュー/ターミナル	01
△	SW250	VZ075500	SW. SLIDE	SL14-22AM5F		R	スライドSW	03
△ *	T2001	YC554A00	TRANS. PWR	ETS0674B			サブトランス	
△	TE201	WB782600	INLET. AC	R-30190 (26)			A C インレット 2 P	
△	TH201	WF544600	POSISTOR	NTPAD5R1LDNBO 5. 1			サーミスタ	03
		WE774200	SCR. BND. HD	3x10 MFZN2W3			バインドBタイトネジ	01
*		WU709500	P. C. B.	VIDEO		J	P C B V I D E O	
*		WU709600	P. C. B.	VIDEO		U	P C B V I D E O	
*		WU709700	P. C. B.	VIDEO		CRTKAL	P C B V I D E O	
*		WU709800	P. C. B.	VIDEO		BGF	P C B V I D E O	
	CB301	WD398400	CN. DIN	14P YKF45-3011			D I N コネクタ	05
	CB301	WD398400	CN. DIN	14P YKF45-3011		J	D I N コネクタ	05
	CB302	VN394900	CN. BS. PIN	14P			F F C コネクタ	01
	CB303	VQ047200	CN. BS. PIN	9P			F F C コネクタ	01
	CB304	VB389600	CN. BS. PIN	11P			コネクタベースポスト	01
	CB331	VB858400	CN. BS. PIN	5P			ベースピン	01
	CB332	VQ044500	CN. BS. PIN	11P		JCRTKABGFL	F F C コネクタ	01
	CB333	VK026300	CN. BS. PIN	4P			ワイヤートラップ	01
	CB334	VQ044600	CN. BS. PIN	13P		U	F F C コネクタ	01
	CB335	VP127700	CN	24P			コネクタ	01
	CB351	LB918030	CN. BS. PIN	3P			ベース付ポスト	01
	CB352	LB918060	CN. BS. PIN	6P			ベース付ポスト	01

* New Parts * 新規部品

P.C.B. VIDEO

Ref No.	Part No.	Description	Remarks	Markets	部 品 名	ランク
CB361	LB918040	CN. BS. PIN	4P		ベース付ポスト	01
CB362	VF728300	CN	6P		コネクタ	01
CB371	V7827100	SOCKET	4P TE TUC SERIES		コネクタソケット	01
CB372	LB918020	CN. BS. PIN	2P		ベース付ポスト	01
CB373	V7827100	SOCKET	4P TE TUC SERIES		コネクタソケット	01
CB374	LB918020	CN. BS. PIN	2P		ベース付ポスト	01
CB375	V7827100	SOCKET	4P TE TUC SERIES		コネクタソケット	01
CB376	LB918020	CN. BS. PIN	2P		ベース付ポスト	01
CB377	V7827100	SOCKET	4P TE TUC SERIES		コネクタソケット	01
CB378	LB918020	CN. BS. PIN	2P		ベース付ポスト	01
CB381	V7827100	SOCKET	4P TE TUC SERIES		コネクタソケット	01
CB382	LB918020	CN. BS. PIN	2P		ベース付ポスト	01
CB383	V7827100	SOCKET	4P TE TUC SERIES		コネクタソケット	01
CB384	LB918020	CN. BS. PIN	2P		ベース付ポスト	01
CB385	V7827100	SOCKET	4P TE TUC SERIES		コネクタソケット	01
CB386	LB918020	CN. BS. PIN	2P		ベース付ポスト	01
C3001-3003	US060800	C. CE. CHP	8pF 50V B		チップセラコン	01
C3004-3009	US062100	C. CE. CHP	100pF 50V B		チップセラコン	01
C3010-3017	US135100	C. CE. CHP	0. 1uF 16V		チップセラコン	01
C3018-3020	WP882000	C. CE. CHP	10uF 6. 3V		チップセラコン	01
C3021	US135100	C. CE. CHP	0. 1uF 16V		チップセラコン	01
C3022-3026	WP882000	C. CE. CHP	10uF 6. 3V		チップセラコン	01
C3027-3040	US135100	C. CE. CHP	0. 1uF 16V		チップセラコン	01
C3041	WP882000	C. CE. CHP	10uF 6. 3V		チップセラコン	01
C3042	US135100	C. CE. CHP	0. 1uF 16V		チップセラコン	01
C3043-3046	WP882000	C. CE. CHP	10uF 6. 3V		チップセラコン	01
C3047-3050	US135100	C. CE. CHP	0. 1uF 16V		チップセラコン	01
C3052	WP882000	C. CE. CHP	10uF 6. 3V		チップセラコン	01
C3053-3056	US135100	C. CE. CHP	0. 1uF 16V		チップセラコン	01
C3059	US135100	C. CE. CHP	0. 1uF 16V		チップセラコン	01
C3060-3065	WP882000	C. CE. CHP	10uF 6. 3V		チップセラコン	01
C3067-3071	WP882000	C. CE. CHP	10uF 6. 3V		チップセラコン	01
C3072-3076	US135100	C. CE. CHP	0. 1uF 16V		チップセラコン	01
C3201-3202	UR018470	C. EL	470uF 6. 3V		ケミコン	01
C3203-3206	UR067100	C. EL	10uF 50V		ケミコン	01
C3207-3209	UR037470	C. EL	47uF 16V		ケミコン	01
C3210	UR067100	C. EL	10uF 50V		ケミコン	01
C3211	UR037470	C. EL	47uF 16V		ケミコン	01
C3212	UR067100	C. EL	10uF 50V		ケミコン	01
C3213-3214	UR037470	C. EL	47uF 16V		ケミコン	01
C3217-3218	UR037470	C. EL	47uF 16V		ケミコン	01
C3219	UR067100	C. EL	10uF 50V		ケミコン	01
C3301	US135100	C. CE. CHP	0. 1uF 16V	BGF	チップセラコン	01
C3302-3303	US062330	C. CE. CHP	330pF 50V B	BGF	チップセラコン	01
C3304	US062560	C. CE. CHP	560pF 50V B	BGF	チップセラコン	01
C3305-3306	US135100	C. CE. CHP	0. 1uF 16V	BGF	チップセラコン	01
C3307-3308	US061270	C. CE. CHP	27pF 50V B	BGF	チップセラコン	01
C3309-3314	US062100	C. CE. CHP	100pF 50V B		チップセラコン	01
C3315	US135100	C. CE. CHP	0. 1uF 16V		チップセラコン	01
C3316-3317	US063100	C. CE. CHP	1000pF 50V B		チップセラコン	01
C3320-3322	US062100	C. CE. CHP	100pF 50V B		チップセラコン	01
C3324	US063100	C. CE. CHP	1000pF 50V B		チップセラコン	01
C3325-3326	US062100	C. CE. CHP	100pF 50V B		チップセラコン	01
C3328	US064100	C. CE. CHP	0. 01uF 50V B		チップセラコン	01
C3351	UR067100	C. EL	10uF 50V	U	ケミコン	01
C3352	UR038100	C. EL	100uF 16V	U	ケミコン	01
C3355	UR038100	C. EL	100uF 16V	U	ケミコン	01

* New Parts * 新規部品

P.C.B. VIDEO

Ref No.	Part No.	Description	Remarks	Markets	部 品 名	ランク
C3358-3359	UR067100	C. EL	10uF 50V		ケミコン	01
C3360-3361	UR038100	C. EL	100uF 16V		ケミコン	
C3362-3363	UR037470	C. EL	47uF 16V	BGF	ケミコン	01
C3364	UR237100	C. EL	10uF 16V	BGF	ケミコン	
C3365	UR038100	C. EL	100uF 16V		ケミコン	
C3501	WE101700	C. PP	1000pF 100V J	JBGF	PPコン	
C3501	WJ608900	C. MYLAR	1000pF 100V	UCRTKAL	マイラーコン	01
C3502	WE101700	C. PP	1000pF 100V J	JBGF	PPコン	
C3502	WJ608900	C. MYLAR	1000pF 100V	UCRTKAL	マイラーコン	01
C3503-3504	WJ610600	C. MYLAR	0.022uF 100V		マイラーコン	01
C3506-3508	WJ608900	C. MYLAR	1000pF 100V		マイラーコン	01
C3552	WQ785400	C. EL	6800uF 25V	JBGF	ケミコン	04
C3552	UR049680	C. EL	6800uF 25V	UCRTKAL	ケミコン	
C3553	WQ785400	C. EL	6800uF 25V	JBGF	ケミコン	04
C3553	UR049680	C. EL	6800uF 25V	UCRTKAL	ケミコン	
* C3554	WR133600	C. EL	3300uF 25V	JBGF	ケミコン	
* C3554	UR049330	C. EL	3300uF 25V	CRTKAL	ケミコン	03
* C3556-3557	UR039680	C. EL	6800uF 16V		ケミコン	
△ C3558-3562	UR067100	C. EL	10uF 50V		ケミコン	01
C3563	UU239100	C. EL	1000uF 16V		ケミコン FW	01
C3564-3565	UU238100	C. EL	100uF 16V		ケミコン	01
C3566-3567	UR067100	C. EL	10uF 50V		ケミコン	01
C3601	WJ608900	C. MYLAR	1000pF 100V		マイラーコン	01
C3651	UR078220	C. EL	220uF 63V		ケミコン	01
C3652	UR067100	C. EL	10uF 50V		ケミコン	01
C3653	UR068100	C. EL	100uF 50V		ケミコン	01
D3001-3008	WJ586300	VARI STOR	SDV1608H100C050YPT		チップバリスタ	01
D3302	VT332900	DIODE	1SS355		ダイオード	01
D3303	VT332900	DIODE	1SS355	U	ダイオード	01
D3304	VT332900	DIODE	1SS355		ダイオード	01
D3305	VU171400	DIODE. ZENR	UDZS3. 3B 3. 3V	BGF	ツェナーダイオード	
D3306	VT332900	DIODE	1SS355		ダイオード	01
D3308	VT332900	DIODE	1SS355		ダイオード	01
D3310	V2598200	LED	SIR-505ST		LED	01
D3312	VT332900	DIODE	1SS355		ダイオード	01
* D3315	WS698100	DIODE. ZENR	HZU15B2 TRF-E		ツェナーダイオード	
△ D3318-3319	WJ586300	VARI STOR	SDV1608H100C050YPT		チップバリスタ	01
△ * D3501	WN629800	DIODE. BRG	4A 60V D4SBS6-7101		ダイオードブリッジ	05
△ * D3503	WU575300	DIODE. BRG	D2SBA60-7001		ダイオードブリッジ	
D3505	VU172100	DIODE. ZENR	UDZS6. 2B 6. 2V		ツェナーダイオード	01
D3506-3507	VU172900	DIODE. ZENR	UDZS13B 13V		ツェナーダイオード	01
D3601	VV307700	DIODE	1N4002S		ダイオード	01
D3602-3603	VU173400	DIODE. ZENR	UDZS22B 22V		ツェナーダイオード	01
D3604-3607	VT332900	DIODE	1SS355		ダイオード	01
* IC301-304	XY549A00	IC	TC74HC4051AFEL		ロジック IC	02
* IC305	YC232A00	IC	NJW1327FU1		IC	
IC306	X7779A00	IC	LC709004A-TLM-E		ロジック IC	04
IC308	XS790A00	IC	TC74HC4052AF MPX		ロジック IC	02
IC331	X6248A00	IC	NJM2388F33	U	電源 IC	04
IC332	X6248A00	IC	NJM2388F33		電源 IC	04
* IC333	X8235A00	IC	LC72725KM	BGF	IC	
IC351	X4153A00	IC	KIA7812AP1		電源 IC	02
IC352	X4154A00	IC	KIA7912P1		電源 IC	03
JK301-302	WD396300	JACK. PIN	LAP5100-1601FC		ピンジャック + S	04
JK331-332	V9435700	JACK. MNI	MSJ-035-12APC		モノラル ミニジャック	01
JK335	WD195900	JACK. MNI	2P		ミニ ジャック	03
* PJ301-302	WG583200	JACK. PIN	6P RJ-1146+08-OH00		ピンジャック	

* New Parts * 新規部品

P.C.B. VIDEO and P.C.B. NET

Ref No.	Part No.	Description	Remarks	Markets	部 品 名	ランク
* PJ303	WT866100	JACK. PIN	3P RJ-1086+07-ZH31		ピンジャック	
PN301-302	WS488500	STYLE. PIN	L=90 #18		スタイルピン	01
PN331	WS488500	STYLE. PIN	L=90 #18		スタイルピン	01
PN351-354	WS488500	STYLE. PIN	L=90 #18		スタイルピン	01
PN361-362	WS488500	STYLE. PIN	L=90 #18		スタイルピン	01
Q3001-3003	VQ986700	TR	2SC4081 T106		トランジスタ	01
Q3004	WE834500	FET	UPA672T-T1-A		F E T	01
Q3303	WC529500	TR	KTA1504S Y GR RTK		トランジスタ	
Q3304	WG538600	TR	KTA1046-Y-U/P		トランジスタ	02
Q3305	WC529500	TR	KTA1504S Y GR RTK		トランジスタ	
Q3306	WC529400	TR	KTC3875S Y GR RTK		トランジスタ	01
Q3307	VV556400	TR	2SC2412K Q, R, S	BGF	トランジスタ	01
Q3308	WC397700	TR	2N5401C-AT		トランジスタ	01
Q3310	VV655400	TR. DGT	DTC114EKA		デジタルトランジスタ	01
Q3311-3312	WC529500	TR	KTA1504S Y GR RTK		トランジスタ	
Q3313-3314	WC529400	TR	KTC3875S Y GR RTK		トランジスタ	01
Q3315-3316	WG538600	TR	KTA1046-Y-U/P		トランジスタ	02
Q3317-3318	WC529400	TR	KTC3875S Y GR RTK		トランジスタ	01
Q3319	WC529500	TR	KTA1504S Y GR RTK		トランジスタ	
Q3501-3503	VR043100	FET	2SK208 Y		チップ F E T	01
△ Q3504-3505	WF691400	TR	2SD2014		トランジスタ	03
△ Q3506	WF691300	TR	2SB1257		トランジスタ	03
Q3601	VR043100	FET	2SK208 Y		チップ F E T	01
Q3602	VP872700	TR	2SC4488 S, T		トランジスタ	01
Q3603	VP872600	TR	2SA1708 S, T		トランジスタ	01
Q3604-3605	VV655700	TR. DGT	DTC144EKA		デジタルトランジスタ	01
Q3606	VP872700	TR	2SC4488 S, T		トランジスタ	01
R3317-3318	HV756470	R. CAR. FP	4. 7KΩ 1/4W	BGF	不燃化カーボン抵抗	01
R3323	HV755680	R. CAR. FP	680Ω 1/4W		不燃化カーボン抵抗	01
R3339	HV755680	R. CAR. FP	680Ω 1/4W		不燃化カーボン抵抗	01
R3343-3344	HV753560	R. CAR. FP	5. 6Ω 1/4W		不燃化カーボン抵抗	01
R3506-3508	HF353220	R. CAR	2. 2Ω 1/2W		カーボン抵抗	
△ R3510-3512	HV753470	R. CAR. FP	4. 7Ω 1/4W		不燃化カーボン抵抗	01
△ R3513-3515	HV755100	R. CAR. FP	100Ω 1/4W		不燃化カーボン抵抗	01
R3521	WJ787500	R. MTL. FLM	0. 22Ω 1W		金属被膜抵抗	01
R3522	HL002220	R. MTL. OXD	0. 22Ω 1/2W		酸化金属被膜抵抗	01
R3601	HF353220	R. CAR	2. 2Ω 1/2W		カーボン抵抗	
R3602	HV753220	R. CAR. FP	2. 2Ω 1/4W		不燃化カーボン抵抗	01
R3603	HV755100	R. CAR. FP	100Ω 1/4W		不燃化カーボン抵抗	01
R3605	HV757100	R. CAR. FP	10KΩ 1/4W		不燃化カーボン抵抗	01
R3607	HV753470	R. CAR. FP	4. 7Ω 1/4W		不燃化カーボン抵抗	01
R3608	HV753100	R. CAR. FP	1Ω 1/4W		不燃化カーボン抵抗	01
R3610	HV757270	R. CAR. FP	27KΩ 1/4W		不燃化カーボン抵抗	01
R3611	HV753470	R. CAR. FP	4. 7Ω 1/4W		不燃化カーボン抵抗	01
U3301	WQ600700	L. DTCT	SM3385VMH6		リモコン受光ユニット	03
VR371-374	WK973400	VR. TRIM	B 330 RX 3P		半固定VR	01
VR381-383	WK973400	VR. TRIM	B 330 RX 3P		半固定VR	01
* XL331	V2731100	RSNR. CRYST	4. 332M HC-49/U	BGF	水晶振動子	
	WE774200	SCR. BND. HD	3x10 MFZN2W3		バインドBタイトネジ	01
* WU705500		P. C. B.	NET		P C B N E T	
CB503	WG468100	CN. NETWORK	8P RJSE-1E08T089A		モジュラーコネクター	05
CB505	VB858300	CN. BS. PIN	4P		コネクターベースポスト	01
* CB510	WT930600	CN	30P TE		コネクタープラグ	
CB511	VB858400	CN. BS. PIN	5P		ベースピン	01

* New Parts * 新規部品

P.C.B. NET

Ref No.	Part No.	Description	Remarks	Markets	部 品 名	ランク
CB512	VB858500	CN. BS. PIN	6P		ベースピン	01
C5001	WK978200	C. NIOB. OXD	100uF 4V		酸化ニオブコンデンサ	
C5002	US135100	C. CE. CHP	0. 1uF 16V		チップセラコン	01
C5003	US064100	C. CE. CHP	0. 01uF 50V B		チップセラコン	01
C5004-5005	US135100	C. CE. CHP	0. 1uF 16V		チップセラコン	01
C5006	WG888300	C. CE. M. CHP	10uF 6. 3V		チップ積層セラコン	01
C5007	US135100	C. CE. CHP	0. 1uF 16V		チップセラコン	01
C5008	US064100	C. CE. CHP	0. 01uF 50V B		チップセラコン	01
C5009	US135100	C. CE. CHP	0. 1uF 16V		チップセラコン	01
C5011	US064100	C. CE. CHP	0. 01uF 50V B		チップセラコン	01
C5012	US135100	C. CE. CHP	0. 1uF 16V		チップセラコン	01
C5013	US064100	C. CE. CHP	0. 01uF 50V B		チップセラコン	01
C5014-5015	US135100	C. CE. CHP	0. 1uF 16V		チップセラコン	01
C5016	US064100	C. CE. CHP	0. 01uF 50V B		チップセラコン	01
C5017	US135100	C. CE. CHP	0. 1uF 16V		チップセラコン	01
C5019	US064100	C. CE. CHP	0. 01uF 50V B		チップセラコン	01
C5020-5021	US061220	C. CE. CHP	22pF 50V B		チップセラコン	01
C5022	US135100	C. CE. CHP	0. 1uF 16V		チップセラコン	01
C5025-5027	US135100	C. CE. CHP	0. 1uF 16V		チップセラコン	01
C5029-5030	US135100	C. CE. CHP	0. 1uF 16V		チップセラコン	01
C5031	US126100	C. CE. CHP	1uF 10V		チップセラコン	01
C5032	US135100	C. CE. CHP	0. 1uF 16V		チップセラコン	01
C5033	US126100	C. CE. CHP	1uF 10V		チップセラコン	01
C5034-5042	US135100	C. CE. CHP	0. 1uF 16V		チップセラコン	01
C5043	US126100	C. CE. CHP	1uF 10V		チップセラコン	01
C5044	US063680	C. CE. CHP	6800pF 50V B		チップセラコン	01
C5045-5047	WG251600	C. CE. CHP	4. 7uF 6. 3V		チップセラコン	01
C5048-5050	US135100	C. CE. CHP	0. 1uF 16V		チップセラコン	01
C5051	WK978200	C. NIOB. OXD	100uF 4V		酸化ニオブコンデンサ	
C5052	US135100	C. CE. CHP	0. 1uF 16V		チップセラコン	01
C5053	WG251600	C. CE. CHP	4. 7uF 6. 3V		チップセラコン	01
C5054	US135100	C. CE. CHP	0. 1uF 16V		チップセラコン	01
C5055	US126100	C. CE. CHP	1uF 10V		チップセラコン	01
C5056	US135100	C. CE. CHP	0. 1uF 16V		チップセラコン	01
C5057	US126100	C. CE. CHP	1uF 10V		チップセラコン	01
C5058	US135100	C. CE. CHP	0. 1uF 16V		チップセラコン	01
C5059	US126100	C. CE. CHP	1uF 10V		チップセラコン	01
C5060	US135100	C. CE. CHP	0. 1uF 16V		チップセラコン	01
C5061	US126100	C. CE. CHP	1uF 10V		チップセラコン	01
C5062-5063	US135100	C. CE. CHP	0. 1uF 16V		チップセラコン	01
C5064-5065	US062100	C. CE. CHP	100pF 50V B		チップセラコン	01
C5066-5067	US063100	C. CE. CHP	1000pF 50V B		チップセラコン	01
C5068	UF017220	C. EL. CHP	22uF 6. 3V		チップケミコン	01
C5069	WG251600	C. CE. CHP	4. 7uF 6. 3V		チップセラコン	01
C5070	US135100	C. CE. CHP	0. 1uF 16V		チップセラコン	01
C5071-5072	WG251600	C. CE. CHP	4. 7uF 6. 3V		チップセラコン	01
C5073	US135100	C. CE. CHP	0. 1uF 16V		チップセラコン	01
C5074	UF017220	C. EL. CHP	22uF 6. 3V		チップケミコン	01
C5075	US135100	C. CE. CHP	0. 1uF 16V		チップセラコン	01
C5076	UF037100	C. EL. CHP	10uF 16V		チップケミコン	01
C5077	US064100	C. CE. CHP	0. 01uF 50V B		チップセラコン	01
C5078-5079	US135100	C. CE. CHP	0. 1uF 16V		チップセラコン	01
C5080	WG888300	C. CE. M. CHP	10uF 6. 3V		チップ積層セラコン	01
C5082	UF038100	C. EL. CHP	100uF 16V		チップケミコン	01
C5083	WG251600	C. CE. CHP	4. 7uF 6. 3V		チップセラコン	01
C5085	UF037100	C. EL. CHP	10uF 16V		チップケミコン	01
C5086	US625100	C. CE. CHP	0. 100uF 10V		チップセラコン	01

* New Parts * 新規部品

Carbon Resistors

Value	1/4W Type Part No.	1/6W Type Part No.	Value	1/4W Type Part No.	1/6W Type Part No.
1.0 Ω	HJ35 3100	HF85 3100	11 kΩ	HF45 7110	HF45 7110
1.8 Ω	HJ35 3180	*	12 kΩ	HJ35 7120	HF85 7120
2.2 Ω	HJ35 3220	HF85 3220	13 kΩ	HF45 7130	HF45 7130
3.3 Ω	HJ35 3300	HF85 3300	15 kΩ	HF45 7150	HF45 7150
3.7 Ω	HJ35 3470	HF85 3470	18 kΩ	HF45 7180	HF45 7180
5.6 Ω	HJ35 3560	HF85 3560	22 kΩ	HF45 7220	HF45 7220
10 Ω	HF45 4100	HF45 4100	24 kΩ	HF45 7240	HF45 7240
15 Ω	HJ35 4150	HF85 4150	27 kΩ	HJ35 7270	HF85 7270
22 Ω	HF45 4220	HF45 4220	30 kΩ	HF45 7300	HF45 7300
27 Ω	HJ35 4270	HF85 4270	33 kΩ	HF45 7330	HF45 7330
33 Ω	HF45 4330	HF45 4330	36 kΩ	HF45 7360	HF45 7360
39 Ω	HJ35 4470	HF85 4390	39 kΩ	HF45 7390	HF45 7390
47 Ω	HF45 4470	HF45 4470	47 kΩ	HF45 7470	HF45 7470
56 Ω	HF45 4560	HF45 4560	51 kΩ	HF45 7510	HF45 7510
68 Ω	HF45 4680	HF45 4680	56 kΩ	HF45 7560	HF45 7560
75 Ω	HF45 4750	HF45 4750	62 kΩ	HF45 7620	HF45 7620
82 Ω	HF45 4820	HF45 4820	68 kΩ	HF45 7680	HF45 7680
91 Ω	HF45 4910	HF45 4910	82 kΩ	HF45 7820	HF45 7820
100 Ω	HF45 5100	HF45 5100	91 kΩ	HF45 7910	HF45 7910
110 Ω	HJ35 5110	HF85 5110	100 kΩ	HF45 8100	HF45 8100
120 Ω	HF45 5120	HF45 5120	110 kΩ	HF45 8110	HF45 8110
150 Ω	HF45 5150	HF45 5150	120 kΩ	HF45 8120	HF45 8120
160 Ω	HJ35 5160	*	130 kΩ	HF45 8130	*
180 Ω	HF45 5180	HF45 5180	150 kΩ	HF45 8150	HF45 8150
200 Ω	HF45 5200	HF45 5200	180 kΩ	HF45 8180	HF45 8180
220 Ω	HF45 5220	HF45 5220	220 kΩ	HJ35 8220	HF85 8220
270 Ω	HF45 5270	HF45 5270	270 kΩ	HF45 8270	HF45 8270
330 Ω	HF45 5330	HF45 5330	300 kΩ	HF45 8300	HF45 8300
390 Ω	HF45 5390	HF45 5390	330 kΩ	HF45 8330	HF45 8330
430 Ω	HF45 5430	HF45 5430	390 kΩ	HJ35 8390	HF85 8390
470 Ω	HF45 5470	HF45 5470	470 kΩ	HF45 8470	HF45 8470
510 Ω	HF45 5510	HF45 5510	560 kΩ	HJ35 8560	HF85 8560
560 Ω	HF45 5560	HF45 5560	680 kΩ	HJ35 8680	HF85 8680
680 Ω	HF45 5680	HF45 5680	820 kΩ	HJ35 8820	HF85 8820
820 Ω	HF45 5820	HF45 5820	1.0 MΩ	HF45 9100	HF45 9100
910 Ω	HF45 5910	HF45 5910	1.2 MΩ	HJ35 9120	*
1.0 kΩ	HF45 6100	HF45 6100	1.5 MΩ	HJ35 9150	HF85 9150
1.2 kΩ	HF45 6120	HF45 6120	1.8 MΩ	HJ35 9180	HF85 9180
1.5 kΩ	HF45 6150	HF45 6150	2.2 MΩ	HJ35 9220	HF85 9220
1.8 kΩ	HF45 6180	HF45 6180	3.3 MΩ	HJ35 9330	HF85 9330
2.0 kΩ	HJ35 6200	HF85 6200	3.9 MΩ	HJ35 9390	*
2.2 kΩ	HF45 6220	HF45 6220	4.7 MΩ	HJ35 9470	HF85 9470
2.4 kΩ	HJ35 6240	HF85 6240			
2.7 kΩ	HF45 6270	HF45 6270			
3.0 kΩ	HF45 6300	HF45 6300			
3.3 kΩ	HF45 6330	HF45 6330			
3.6 kΩ	HJ35 6360	HF85 6360			
3.9 kΩ	HF45 6390	HF45 6390			
4.7 kΩ	HF45 6470	HF45 6470			
5.1 kΩ	HF45 6510	HF45 6510			
5.6 kΩ	HF45 6560	HF45 6560			
6.8 kΩ	HF45 6680	HF45 6680			
8.2 kΩ	HF45 6820	HF45 6820			
9.1 kΩ	HF45 6910	HF45 6910			
10 kΩ	HF45 7100	HF45 7100			

1/4W Type

10mm

1/6W Type

5mm

* : Not available

P.C.B. NET

Ref No.	Part No.	Description	Remarks	Markets	部 品 名	ソケット
C5087	UF038100	C. EL. CHP	16V		チップケミコン	01
C5089-5090	UF037100	C. EL. CHP	100uF		チップケミコン	01
C5091	US135100	C. CE. CHP	0.1uF		チップセラコン	01
C5093	US063100	C. CE. CHP	1000pF		チップセラコン	01
C5094	UF017220	C. EL. CHP	22uF		チップケミコン	01
C5095-5096	US663330	C. CE. CHP	3300pF		チップセラコン	01
C5097-5099	WG251600	C. CE. CHP	4.7uF		チップセラコン	01
C5100	US063100	C. CE. CHP	1000pF		チップセラコン	01
C5101-5102	US135100	C. CE. CHP	0.1uF		チップセラコン	01
C5103	US064100	C. CE. CHP	0.01uF		チップセラコン	01
C5104	US126100	C. CE. CHP	1uF		チップセラコン	01
C5105	UF038100	C. EL. CHP	100uF		チップセラコン	01
C5106-5107	US135100	C. CE. CHP	0.1uF		チップセラコン	01
C5108	UF038100	C. EL. CHP	100uF		チップケミコン	01
C5109	WG251600	C. CE. CHP	4.7uF		チップセラコン	01
C5110-5111	US135100	C. CE. CHP	0.1uF		チップセラコン	01
C5112	MD758300	C. CE. CHP	10uF		チップセラコン	01
C5113	MG891400	C. EL. CHP	220uF		チップセラコン	01
C5114-5115	US135100	C. CE. CHP	0.1uF		チップセラコン	01
C5116	WG251600	C. CE. CHP	4.7uF		チップセラコン	01
C5117	MG890600	C. EL	330uF		チップセラコン	01
C5118-5121	US135100	C. CE. CHP	0.1uF		ケミコン PURE	01
C5122	US063100	C. CE. CHP	1000pF		チップセラコン	01
C5123	MG890600	C. EL	330uF		ケミコン PURE	01
C5124	US135100	C. CE. CHP	0.1uF		チップセラコン	01
C5125	MG890600	C. EL	330uF		ケミコン PURE	01
C5159-5160	US135100	C. CE. CHP	0.1uF		チップセラコン	01
C5165-5169	US135100	C. CE. CHP	0.1uF		チップセラコン	01
C5178-5203	US135100	C. CE. CHP	0.1uF		チップセラコン	01
C5210-5212	US063100	C. CE. CHP	1000pF		チップセラコン	01
C5216-5217	US063100	C. CE. CHP	1000pF		チップセラコン	01
C5220	US063100	C. CE. CHP	1000pF		チップセラコン	01
D8001	VT332900	D10DE	1S3355		ダイオード	01
D5005	VT332900	D10DE	1S3355		ダイオード	01
C6501	X4943000	IC	W982566EH-75 SDRAM		メモリーIC	06
C6502	YC587000	IC. MEMORY	MX29GL128ELT21-906	Written	メモリーIC	06
C6503	X4943000	IC	W982566EH-75 SDRAM		メモリーIC	06
C6505	XR680A00	IC	TC7SH08FU (TE85L, JF)		ロジックIC	01
C6506	YC621A00	IC. MEMORY	RIEX24128AS30A EE		メモリーIC	01
C6507	X8386A00	IC	TC7NH14FK (TE85L, F)		ロジックIC	01
C6508	X7717A00	IC	R3112N251A-TR		ロジックIC	01
C6509	X8378A00	IC	TC7SH125FU (TE85L, F)		ロジックIC	01
C6510	X8386A00	IC	TC7NH14FK (TE85L, F)		ロジックIC	01
C6511	X9292A00	IC	R1172H121D-T1-F		電源IC	01
C6513	X9174A00	IC	IP101ALF		IC デジタル	07
C6514	X7375A00	IC	PM1781DBQR		IC	04
C6515	YA255A00	IC	R1172H501D-T1-F		電源IC	03
C6517	X7951A00	IC	BD6517F-E2		電源IC	04
C6525	XR680A00	IC	TC7SH08FU (TE85L, JF)		ロジックIC	01
C6501	WG331000	FEET	MCH6336-TL-E		MOS FET	01
C6502	WV653000	TR. D6T	DTA144EKA		デジタルトランジスタ	01
JS1501-503	V4040500	SCR. TERM	M3		スクリュー/ターミナル	01
XL501	MD046100	RSNR. QRY5	5MHz		水晶振動子	01

* : New Parts * 新部品

A B C D E F G H I J

RX-V1067/HTR-8063/RX-A1000

• OVERALL ASSY

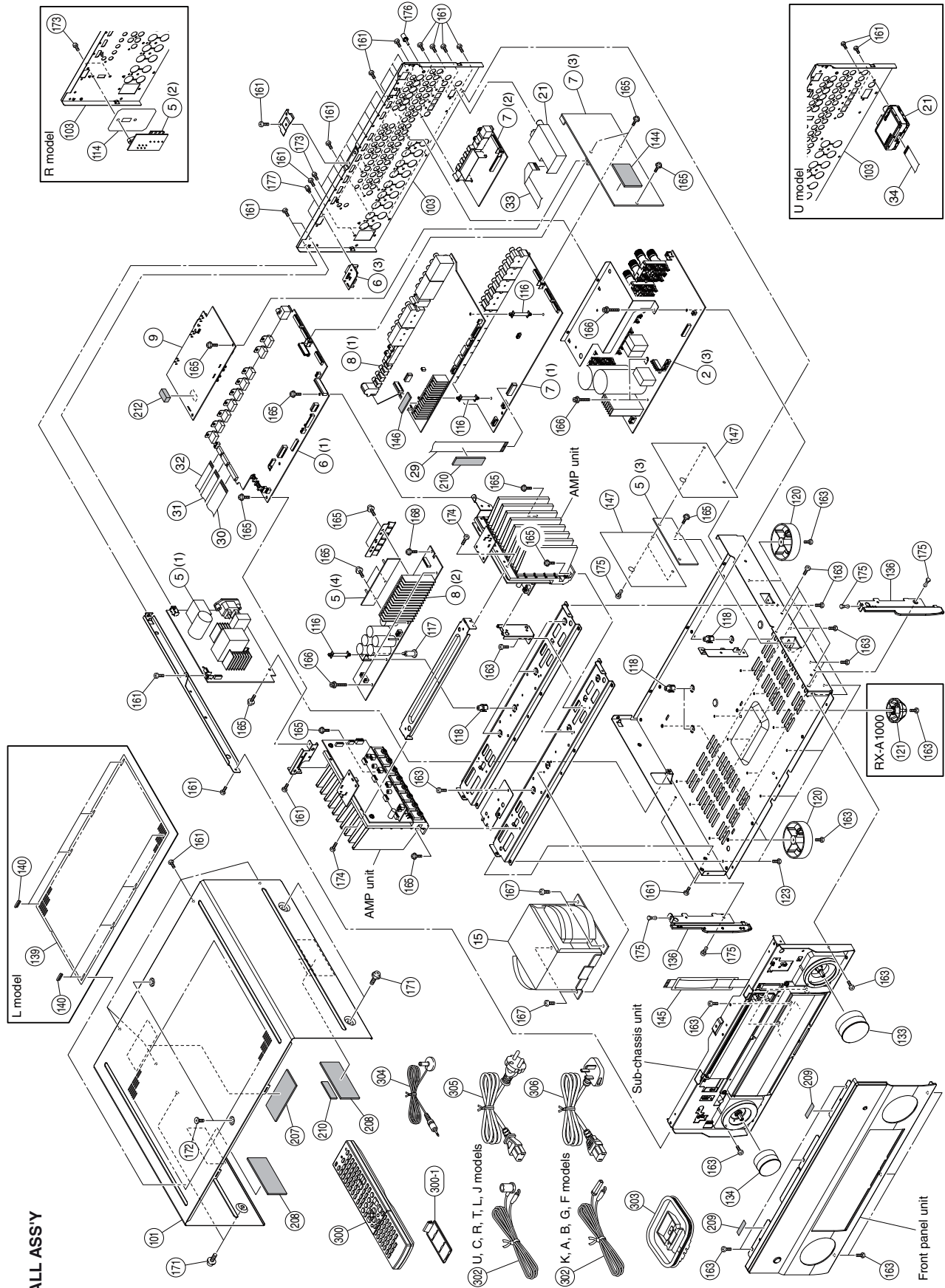

Ref No.	Part No.	Description	Remarks	Markets	部 品 名	ランク
* 136	WU289200	PLATE SIDE	GD		プレートサイド	
* 136	WU289100	PLATE SIDE	BL		プレートサイド	
* 136	WU289100	PLATE SIDE	TI		プレートサイド	
* 139	WU589700	SHEET TOP		L	シート トップ	
* 140	WU053800	RIVET TOP		L	リベット トップ	
* 144	WU538300	DAMPER			ダンパー	
* 145	WU739500	BARRIER FFC			バリアー FFC	
* 146	WU538400	DAMPER			ダンパー	
* 147	WU341900	SHEET BARRIER HS			シート バリアHS	
161	WE774100	BIND HEAD BONDING B-T. SCREW			ボンドヘッドボンドing B-T.ネジ	1
163	WE774300	BIND HEAD B-TIGHT SCREW			ボンドヘッドB-T.タイトネジ	1
165	WE774600	PW HEAD B-TIGHT SCREW			ヘッドB-T.タイトネジ	1
166	WE774600	SCREW IC			スクリュー IC	1
167	WU048900	BIND HEAD S-TIGHT SCREW			ヘッドS.タイトネジ	1
171	VD069600	PW HEAD S-TIGHT SCREW	GD, TI		PWヘッドS.タイトネジ	1
171	VH313200	PW HEAD S-TIGHT SCREW	BL		PWヘッドS.タイトネジ	1
172	VZ893000	SPECIAL S-TIGHT SCREW	GD, TI		特殊ネジS.タイトネジ	2
172	WE521000	SPECIAL S-TIGHT SCREW	BL		特殊ネジS.タイトネジ	1
173	WE371900	BIND HEAD S-TIGHT SCREW			ヘッドS.タイトネジ	1
174	WE774200	BIND HEAD B-TIGHT SCREW			ヘッドB-T.タイトネジ	1
175	V0386800	PUSH RIVET			プッシュリベット	1
176	AA627310	GROUND TERMINAL			グランドターミナル	1
177	V6509600	JACK SCREW			ジャックスクリュー	1
207	W6160000	DAMPER			ダンパー	4
208	WV3198100	DAMPER			ダンパー	1
* 209	WV474600	SHEET CUSHION			シートクッション	1
* 210	WU0205000	DAMPER			ダンパー	1
* 212	WV9004000	SOFT SHIELD			ソフトシールド	1
* 300	WT928300	ACCESSORIES			付属品	3
* 300	WT928200	REMOTE CONTROL		JCRAL	リモコン	3
* 300	WT928400	REMOTE CONTROL		U	リモコン	3
* 300-1	AA823800	BATTERY COVER		TG6F	電池蓋	2
302	V6267000	INDOOR FM ANTENNA		JUCRTL	FM簡易アンテナ	3
302	V0147100	INDOOR FM ANTENNA		KABGF	FM簡易アンテナ	2
303	W0307400	AM LOOP ANTENNA		JCRTKABGF	AMループアンテナ	6
303	WE746800	AM LOOP ANTENNA		U	AMループアンテナ	2
304	WV6496000	YPAO MICROPHONE			YPAOマイク	8
* 305	WU2921000	POWER CABLE		J	電源コード	8
* 305	WU9003000	POWER CABLE		UC	電源コード	5
* 305	W03910000	POWER CABLE		R	電源コード	5
* 305	V93584000	POWER CABLE		T	電源コード	5
* 305	W16674000	POWER CABLE		K	電源コード	7
* 305	W07509000	POWER CABLE		A	電源コード	7
* 305	WU9002000	POWER CABLE		B	電源コード	6
* 305	WU9001000	POWER CABLE		GL	電源コード	6
* 305	V77049000	POWER CABLE		F	電源コード	6
* 306	WU5770000	BATTERY		L	単4乾電池	6
					R03, AAA, UM-4 2pcs	

* New Parts * 新規部品

Ref No.	Part No.	Description	Remarks	Markets	部 品 名	ランク
* 5	WU707300	POWER		J	PCB POWER	
* 5	WU707400	P.C.B. ASS Y		U	PCB POWER	
* 5	WU707500	P.C.B. ASS Y		C	PCB POWER	
* 5	WU707600	P.C.B. ASS Y		R	PCB POWER	
* 5	WU707700	P.C.B. ASS Y		T	PCB POWER	
* 5	WU707800	P.C.B. ASS Y		K	PCB POWER	
* 5	WU707900	P.C.B. ASS Y		A	PCB POWER	
* 5	WU708000	P.C.B. ASS Y		BGF	PCB POWER	
* 5	WU708100	P.C.B. ASS Y		L	PCB POWER	
* 6	WU704700	DIGITAL		JBGF	PCB POWER	
* 6	WU704800	P.C.B. ASS Y		U	PCB DIGITAL	
* 6	WU704900	P.C.B. ASS Y		CRTKAL	PCB DIGITAL	
* 7	WU708200	FUNCTION	V1067	JCRTL	PCB FUNCTION	
* 7	WU709100	P.C.B. ASS Y	A1000	U	PCB FUNCTION	
* 7	WU709300	P.C.B. ASS Y	8063	C	PCB FUNCTION	
* 7	WU708800	P.C.B. ASS Y	V1067	KABGF	PCB FUNCTION	
* 7	WU709400	P.C.B. ASS Y	A1000	A	PCB FUNCTION	
* 8	WU709500	VIDEO		J	PCB VIDEO	
* 8	WU709600	P.C.B. ASS Y		U	PCB VIDEO	
* 8	WU709700	P.C.B. ASS Y		CRTKAL	PCB VIDEO	
* 8	WU709800	P.C.B. ASS Y		BGF	PCB VIDEO	
* 9	WU706500	P.C.B. ASS Y		J	PCB NET	
* 15	YG650A00	POWER TRANSFORMER		J	電源トランス	
* 15	YG642A00	POWER TRANSFORMER		UC	電源トランス	
* 15	YG643A00	POWER TRANSFORMER		R	電源トランス	
* 15	YG645A00	POWER TRANSFORMER		TK	電源トランス	
* 15	YG644A00	POWER TRANSFORMER		AL	電源トランス	
* 15	W0756500	AM/FM TUNER		BGF	電源トランス	
* 21	W1510100	HD RADIO TUNER		J	AM/FMチューナー	11
* 21	W0756600	AM/FM TUNER		U	HDチューナー	
* 21	W0756700	AM/FM TUNER		CRTL	AM/FMチューナー	
* 21	W0756800	AM/FM TUNER		KABGF	AM/FMチューナー	
29	MF116140	FLEXIBLE FLAT CABLE	P=1.25		カード電線	1
30	MF124100	FLEXIBLE FLAT CABLE	24P 100mm		カード電線	2
31	MF114100	FLEXIBLE FLAT CABLE	P=1.25		カード電線	2
32	MF109180	FLEXIBLE FLAT CABLE	9P 180mm		カード電線	3
33	MF112100	FLEXIBLE FLAT CABLE	P=1.25		カード電線	3
34	MF112350	FLEXIBLE FLAT CABLE	13P 250mm		カード電線	3
* 101	WU295800	TOP COVER	GD		トップカバー	
* 101	WU295900	TOP COVER	BL		トップカバー	
* 101	WU295700	TOP COVER	TI		トップカバー	
* 103	WU296900	REAR PANEL		J	リアパネル	
* 103	WU296400	REAR PANEL		U	リアパネル	
* 103	WU297100	REAR PANEL	8063	C	リアパネル	
* 103	WU296500	REAR PANEL	A1000	C	リアパネル	
* 103	WU296600	REAR PANEL		R	リアパネル	
* 103	WU296700	REAR PANEL		T	リアパネル	
* 103	WU296800	REAR PANEL		KABGF	リアパネル	
* 114	WS000800	SHEET BARRIER		R	シート バリア	
* 116	VF930800	SPACER SUPPORT	LCM-20M PIN		スペーササポート	1
* 117	WU664500	LOOKING CARD SPACER	KGLS-12RT		ロッキングカードスペース	1
* 118	WU664500	SUPPORT HB			サポートHB	1
120	V0042500	LEG	GD		レッグ	3
120	W0325000	LEG	V1067BL, 8063BL, TI		レッグ	2
120	W0325000	LEG	A1000BL		レッグ	3
121	WU139700	GENTER LEG	GD		センターレッグ	3
* 133	WU534600	KNOB			ノブ	
* 134	WU534500	KNOB			ノブ	
* 133	WU691900	KNOB			ノブ	8
* 133	WU534700	KNOB			ノブ	
* 134	WU534000	KNOB			ノブ	
* 134	WU533900	KNOB			ノブ	
* 134	WU191700	KNOB			ノブ	
* 134	WU534100	KNOB			ノブ	8

* New Parts * 新規部品

RX-V1067HTR-8063/RX-A1000

• FRONT PANEL UNIT and SUB-CHASSIS UNIT

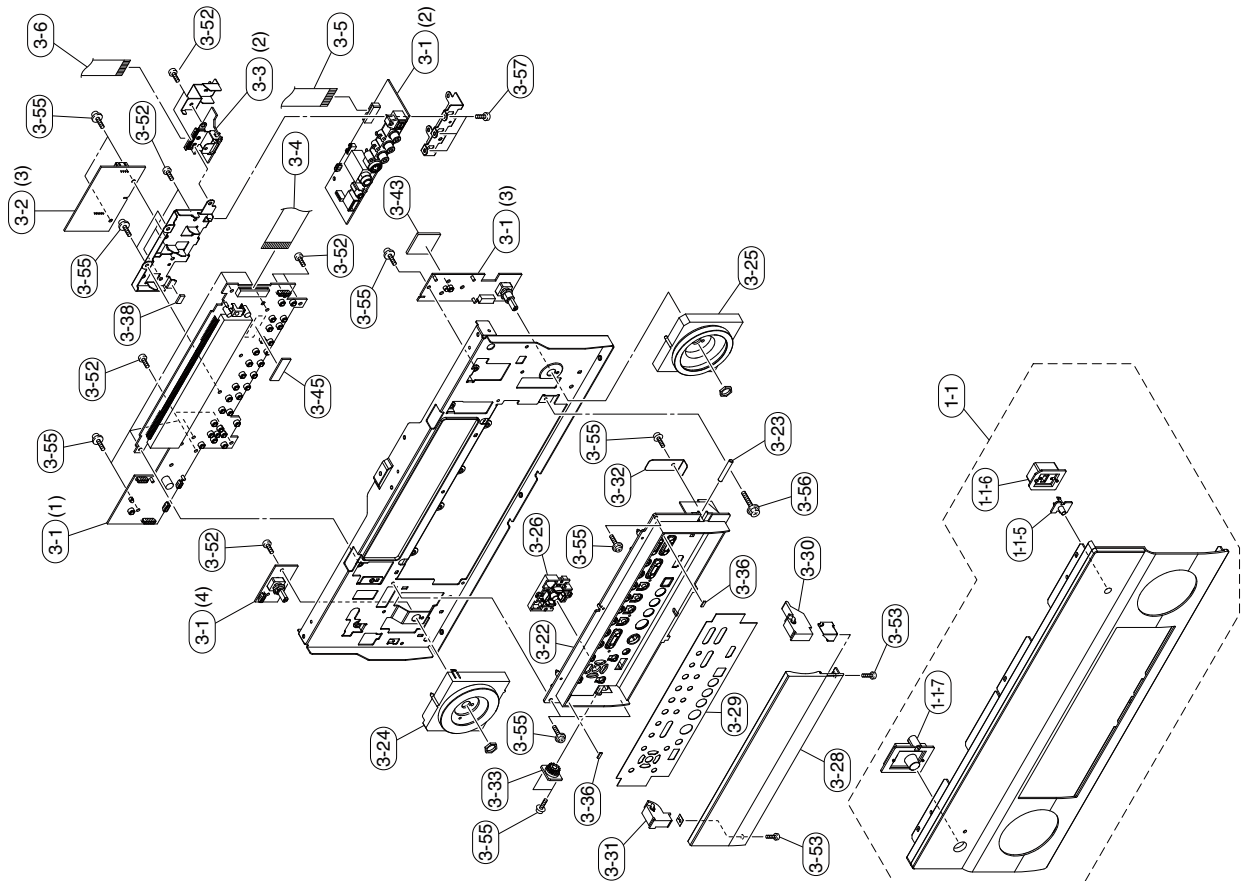

Ref No.	Part No.	Description	Remarks	Markets	部 品 名	ランク
* 1-1	WU702200	FRONT PANEL UNIT	V10676D		Fパネルユニット	
* 1-1	WU701900	FRONT PANEL UNIT	V10678L		Fパネルユニット	
* 1-1	WU702000	FRONT PANEL UNIT	V10678L		Fパネルユニット	
* 1-1	WU702400	FRONT PANEL UNIT	8063BL		Fパネルユニット	
* 1-1	WU044600	FRONT PANEL UNIT	A1000BL		Fパネルユニット	
* 1-1	WU702100	FRONT PANEL UNIT	V10678L		Fパネルユニット	
* 1-1	WU709500	FRONT PANEL UNIT	8063BL		Fパネルユニット	
* 1-1	WU044700	FRONT PANEL UNIT	A1000BL		Fパネルユニット	
* 1-1	WU952600	FRONT PANEL UNIT	A1000		Fパネルユニット	
* 1-1	WU702300	FRONT PANEL UNIT	V10677I		レンズ ボタン	
* 1-1-5	WU155600	LENS BUTTON			ボタン	
* 1-1-6	WU155500	BUTTON			ボタン	
* 1-1-7	WU155400	BUTTON			ボタン	
* 3-1	WU710000	P.C.B. ASS'Y			PCB OPERATION	
* 3-4	MF125350	FLEXIBLE FLAT CABLE	29P 350mm P=1.25		カード電線	
* 3-5	MF115400	FLEXIBLE FLAT CABLE	19P 400mm P=1.25		カード電線	
* 3-6	WU294900	FLEXIBLE FLAT CABLE	20P 210mm P=1		サブパネル	
* 3-22	WU305200	SUB PANEL		JORTKABRFL	サブパネル	01
* 3-22	WU920000	SUB PANEL		U	サブパネル	
* 3-22	WU305100	SUB PANEL			サブパネル	
* 3-22	WU305300	SUB PANEL			サブパネル	
* 3-23	WU286900	SHAFT			シャフト	
* 3-24	WU607900	ESCUITCHEON			エスカッション	
* 3-24	WU607700	ESCUITCHEON			エスカッション	
* 3-24	WU607800	ESCUITCHEON			エスカッション	
* 3-25	WU154900	ESCUITCHEON			エスカッション	
* 3-25	WU154700	ESCUITCHEON			エスカッション	
* 3-25	WU154800	ESCUITCHEON			エスカッション	
* 3-26	WU307700	BUTTON CR			ボタン CR	
* 3-26	WU307600	BUTTON CR			ボタン CR	
* 3-26	WU307800	BUTTON CR			ボタン CR	
* 3-28	WU308700	PANEL LID			パネルリッド	
* 3-28	WU308600	PANEL LID			パネルリッド	
* 3-28	WU308800	PANEL LID			パネルリッド	
* 3-29	WU307000	PLATE SP			プレートSP	
* 3-29	WU306800	PLATE SP		JORTKABRFL	プレートSP	01
* 3-29	WU306700	PLATE SP		U	プレートSP	01
* 3-29	WU307200	PLATE SP			プレートSP	
* 3-30	WU432100	HINGE L			ヒンジ L	01
* 3-30	WU432000	HINGE L			ヒンジ L	01
* 3-30	WU432200	HINGE L			ヒンジ L	01
* 3-31	V6005400	HINGE R			ヒンジ R	01
* 3-31	V6005300	HINGE R			ヒンジ R	01
* 3-31	V6005500	HINGE R			ヒンジ R	01
* 3-32	W4593300	SPRING LID			スプリングリッド	01
* 3-33	Y9124600	DAMPER GEAR			ダンパーギヤ	03
* 3-36	Y1940400	CUSHION LID			クッションLID	01
* 3-38	WU144500	CUSHION 5X10			クッション5X10	01
* 3-43	WU538200	DAMPER	30x30x3		ダンパー	
* 3-45	WU538400	DAMPER	10x30x1		ダンパー	
* 3-52	WF266600	BIND HEAD P-TIGHT SCREW	T=0.8 3x8		バインドヘッドネジ	01
* 3-52	WF266600	BIND HEAD P-TIGHT SCREW	5x10 3x8		バインドヘッドネジ	01
* 3-53	WE973700	BIND HEAD P-TIGHT SCREW	2.6x6		バインドヘッドネジ	01
* 3-55	WU959600	PH HEAD TAPPING B-T. SCREW	3x6-8		六角バインドヘッドネジ	01
* 3-56	WU220800	HEXAGONAL HEAD B-TIGHT SCREW	3x15 SP		六角バインドヘッドネジ	01
* 3-57	WE774300	BIND HEAD B-TIGHT SCREW	3x8		バインドヘッドネジ	01

* New Parts * 新発部品

• AMP UNIT

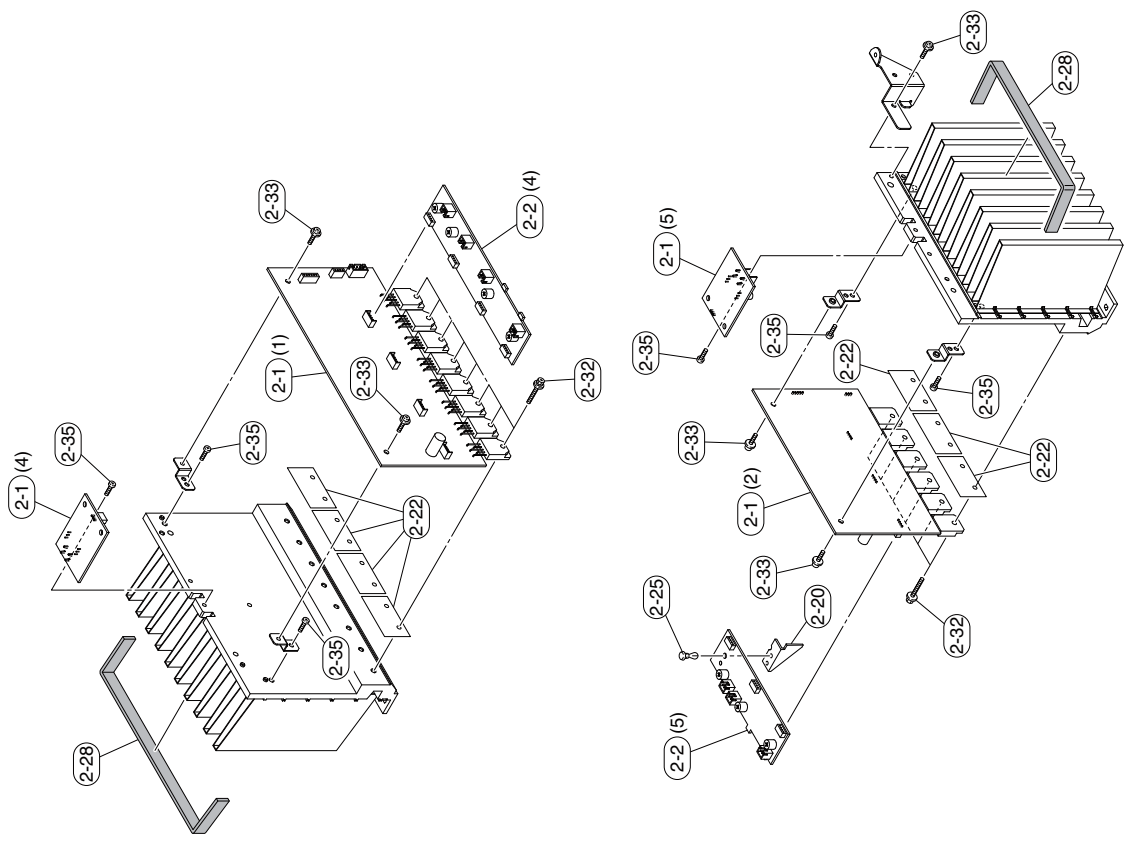

Ref No.	Part No.	Description	Remarks	Markets	部 品 名	ランク
* 2-1	WJ706600	P.C.B. ASS'Y	MAIN	J	PCB MAIN	
* 2-1	WJ705700	P.C.B. ASS'Y	MAIN	URTA	PCB MAIN	
* 2-1	WJ706800	P.C.B. ASS'Y	MAIN	C	PCB MAIN	
* 2-1	WJ706900	P.C.B. ASS'Y	MAIN	KGRFL	PCB MAIN	
* 2-20	WJ517800	SUPPORT HOLDER			サポ-トホルダー	
2-22	W0753200	MICA SHEET	TB-1021		マイカシート	01
2-25	VG086600	PUSH RIVET	P0555-B		プッシュリベット	01
2-28	WJ873800	DAMPER	10X220X1		ダンパー	
* 2-32	WJ220800	HEXAGONAL HEAD B-TIGHT SCREW 3x15 SP	MFZN2W3		六角Bタイトネジ	01
2-33	WJ002600	PH HEAD B-TIGHT SCREW 3x8	MFZN2W3		PWヘッドBタイトネジ	01
2-35	WE774300	BIND HEAD B-TIGHT SCREW 3x8	MFZN2W3		バインドBタイトネジ	01

** New Parts * 新規部品

REMOTE CONTROL

- RAV346: U model / RAV347: C, R, A, L, J models / RAV348: T, K, B, G, F models
- SCHEMATIC DIAGRAMS
- RAV346/RAV347

PANELS

RAV346
(U model)

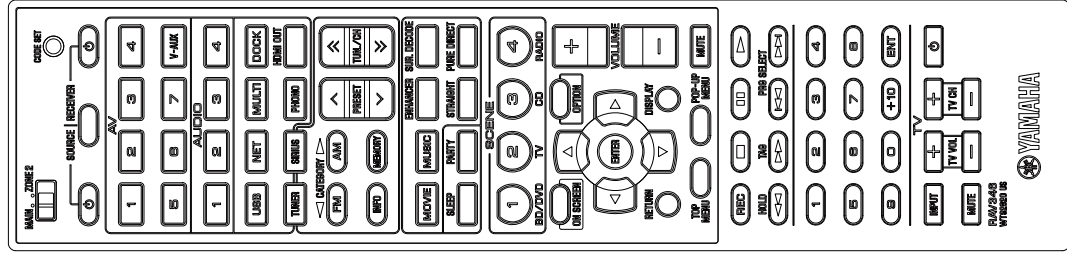

RAV347
(C, R, A, L, J models)

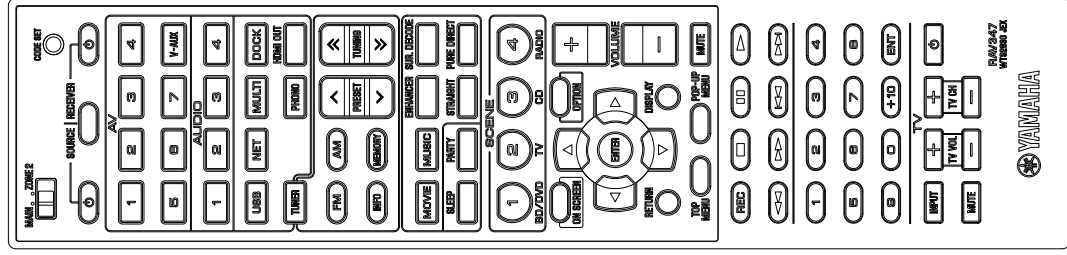

RAV348
(T, K, B, G, F models)

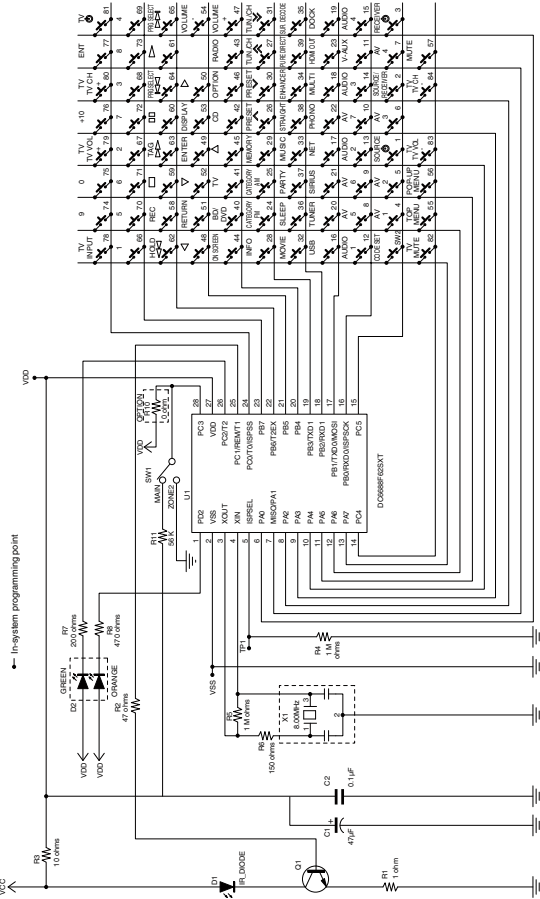
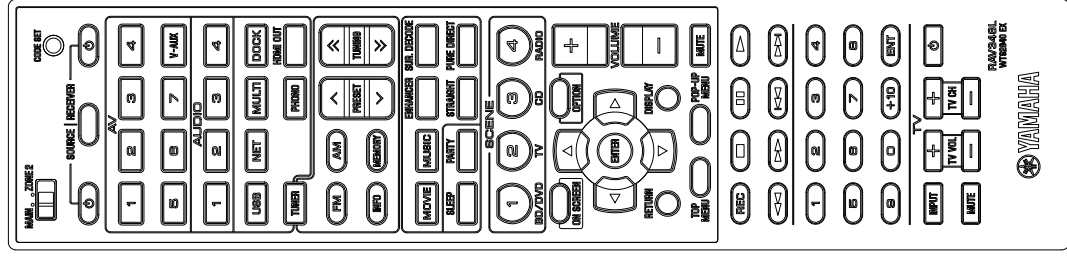

RAV348

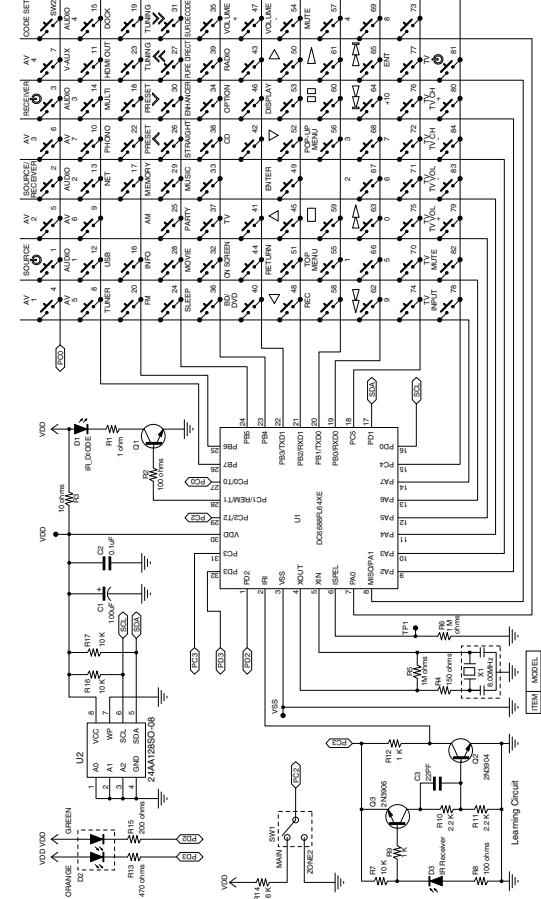

● These PADs are test point for ISP in the production line

KEY NO. LAYOUT

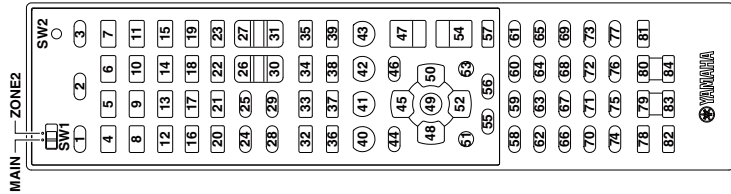

KEY CODE

Key No.	FUNCTION	ID-1		ID-2	
		MAIN	ZONE2	MAIN	ZONE2
SW1	MAIN/ZONE2	[MAIN]	[ZONE2]	[MAIN]	[ZONE2]
LED1	-	-	-	-	-
SW2	CODE SET	-	-	-	-
K2	SOURCE/RECEIVER	* select RCU mode 'SOURCE' or 'RECEIVER'			
K3	RECEIVER (mode fixed)	7E-2A	7A-463A	7E-2AD4	7A-453B
K4	AV1	7A-592C	7A-542B	7A-592D	7A-542A
K5	AV2	7A-5929	7A-5728	7A-5928	7A-5729
K6	AV3	7A-5926	7A-5A25	7A-5927	7A-5A24
K7	AV4	7A-5C23	7A-5D22	7A-5C22	7A-5D23
K8	AV5	7A-5F20	7A-601F	7A-5F21	7A-601E
K9	AV6	7A-621D	7A-631C	7A-621D	7A-631D
K10	AV7	7A-7609	7A-7708	7A-7608	7A-7709
K11	V.AUX	7A-7906	7A-7A05	7A-7907	7A-7A04
K12	AUDIO-1	7A-651A	7A-6619	7A-651B	7A-6618
K13	AUDIO-2	7A-6817	7A-6916	7A-6816	7A-6917
K14	AUDIO-3	7A-7C03	7A-7D02	7A-7C02	7A-7D03
K15	AUDIO-4	7A-7F00	7A-80FF	7A-7F01	7A-80FE
K16	USB	7F01-720D	7F01-730C	7F01-720C	7F01-730D
K17	NET	7F01-3F	7F01-40	7F01-3FC1	7F01-40BE
K18	MULTI	7A-87	-	7A-8779	-
K19	DOCK	7F01-4A	7F01-4B	7F01-4AB4	7F01-4BB5
K20	TUNER	7A-16	7A-D2	7A-16E8	7A-D2C2
K21	SIRIUS (RAV346)	7A-39	7A-3A	7A-39C7	7A-3AC4
K22	PHONO	7A-14	7A-D0	7A-14EA	7A-D02E
K23	HDMI OUT	7A-35	-	7A-35CB	-
K36	SLEEP	7A-30	7A-31	7A-30CE	7A-31CF
K37	PARTY	7A-34	7A-34	7A-34CA	7A-34CA
K24	FM (RAV347, 348)	7F01-5827	7F01-5926	7F01-5826	7F01-5927
K25	FM (RAV347, 348)	7F01-582A	7F01-5929	7F01-582B	7F01-5928
K26	PRESET ^	7F01-5B24	7F01-5C23	7F01-5B25	7F01-5C22
K27	TUNING/CH ^ (RAV346)	7F01-611E	7F01-621D	7F01-611F	7F01-621C
K28	TUNING/CH ^ (RAV347, 348)	7A-2758	7A-2857	7A-2759	7A-2856
K29	INFO	7F01-6718	7F01-6817	7F01-6719	7F01-6816
K30	MEMORY	7F01-5E21	7F01-5F20	7F01-5E20	7F01-5F21
K31	PRESET v	7F01-641B	7F01-651A	7F01-641A	7F01-651B
K32	TUNING/CH v (RAV346)	7A-88	-	7A-8876	-
K33	TUNING/CH v (RAV347, 348)	7A-89	-	7A-8977	-
K34	MUSIC	7A-94	-	7A-946A	-
K35	ENHANCER	7A-8D	-	7A-8D73	-
K36	SUR.DECODE	7A-86	-	7A-8673	-
K38	STRAIGHT	7A-56	-	7A-56A8	-
K39	PURE DIRECT	7A-DD	-	7A-DD23	-
K40	BD/DVD (SCENE1)	7A-007F	7A-017E	7A-007E	7A-017F
K41	TV (SCENE2)	7A-037C	7A-047B	7A-037D	7A-047A
K42	CD (SCENE3)	7A-0679	7A-0778	7A-0678	7A-0779
K43	RADIO (SCENE4)	7A-0976	7A-0A75	7A-0977	7A-0A74
K44	ON SCREEN	7A-8A	7A-8B44	7A-8A74	7A-8B45
K46	OPTION	7A-6B14	7A-6C13	7A-6B15	7A-6C12
K47	VOLUME (+)	7A-1A	7A-DA	7A-1AE4	7A-DA24
K54	VOLUME (-)	7A-1B	7A-DB	7A-1BE5	7A-DB25
K57	MUTE	7A-1C	7A-DC	7A-1CE2	7A-DC22

Key No.	FUNCTION	ID-1		ID-2	
		MAIN	ZONE2	MAIN	ZONE2
K45	▲ (UP)	7A-9D	7A-2B54	7A-9D63	7A-2B55
K48	◀ (LEFT)	7A-9F	7A-2D52	7A-9F61	7A-2D53
K49	ENTER	7A-DE	7A-2F50	7A-DE20	7A-2F51
K50	▶ (RIGHT)	7A-9E	7A-2E51	7A-9E60	7A-2E50
K51	RETURN	7A-AA	7A-3C43	7A-AA54	7A-3C42
K52	▼ (DOWN)	7A-9C	7A-2C53	7A-9C62	7A-2C52
K53	DISPLAY	7F01-80	7F01-80	7F01-809E	7F01-807E
K58	REC	7F01-66	7F01-86	7F01-6698	7F01-8678
K59	■ (STOP)	7F01-69	7F01-89	7F01-6997	7F01-8977
K60	■ (PAUSE)	7F01-67	7F01-87	7F01-6799	7F01-8779
K61	▶ (PLAY)	7F01-68	7F01-88	7F01-6896	7F01-8876
K62	◀ (REW) / HOLD (RAV346)	7F01-6A	7F01-8A	7F01-6A94	7F01-8A74
K63	▶ (FF) / TAG (RAV346)	7F01-6B	7F01-8B	7F01-6B95	7F01-8B75
K64	▶ (SKIP -) / PRG SELECT (RAV346)	7F01-6C	7F01-8C	7F01-6C92	7F01-8C72
K65	▶ (SKIP +) / PRG SELECT (RAV346)	7F01-6D	7F01-8D	7F01-6D93	7F01-8D73
K66	1	7F01-51	7F01-71	7F01-51AF	7F01-71BF
K67	2	7F01-52	7F01-72	7F01-52AC	7F01-729C
K68	3	7F01-53	7F01-73	7F01-53AD	7F01-738D
K69	4	7F01-54	7F01-74	7F01-54AA	7F01-748A
K70	5	7F01-55	7F01-75	7F01-55AB	7F01-758B
K71	6	7F01-56	7F01-76	7F01-56A8	7F01-7688
K72	7	7F01-57	7F01-77	7F01-57A9	7F01-7789
K73	8	7F01-58	7F01-78	7F01-58A6	7F01-7886
K74	9	7F01-59	7F01-79	7F01-59A7	7F01-7987
K75	0	7F01-5A	7F01-7A	7F01-5AA4	7F01-7A84
K76	+10	7F01-5B	7F01-7B	7F01-5BA5	7F01-7B85
K77	ENT	7F01-5C	7F01-7C	7F01-5CA2	7F01-7C82
K1	⊕ (SOURCE)	SOURCE			
K55	TOP MENU	SOURCE			
K56	POP-UP MENU	SOURCE			
K78	TV INPUT	SOURCE (TV)			
K79	TV VOL (+)	SOURCE (TV)			
K80	TV CH (+)	SOURCE (TV)			
K81	TV MUTE	SOURCE (TV)			
K82	TV VOL (-)	SOURCE (TV)			
K83	TV CH (-)	SOURCE (TV)			
K84	TV CH (-)	SOURCE (TV)			

* K81: able to preset the code (only from TV library) in K78/K79/K80/K81/K82/K83/K84.

■ ADVANCED SETUP

The Advanced Setup menu can be used for unit initialization and other useful extended functions. The Advanced Setup menu can be operated as follows.

Displaying/Setting the Advanced Setup menu

- 1 Switch this unit to the standby mode.
- 2 Press MAIN ZONE \odot while pressing and holding STRAIGHT on the front panel.
Release STRAIGHT when "ADVANCED SETUP" is displayed on the front panel display.
After a few seconds, the top menu items are displayed.

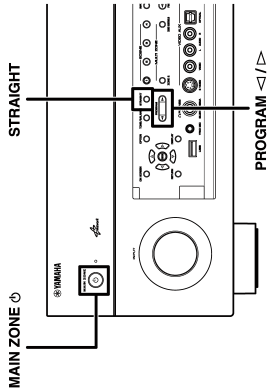

3 Press PROGRAM </> repeatedly to select the item to be set from the following items.

In the Advanced Setup menu, you can set the following settings.

SPEAKER IMP.	Sets the impedance of speakers.
REMOTE SENSOR	Activate or deactivate the signal-receiving capability of the remote control sensor.
REMOTE CON AMP	Changes the remote control ID of a receiver.
SIRIUS PIN (U model)	Resets the parental lock code for the SIRIUS Satellite Radio tuner.
TUNER FRQ STEP (R, L models)	Selects one of the following FM/AM frequency steps.
TU FORMAT	Specifies the TV's color encoding format.
MONITOR CHECK	Removes the up-scaling limitation on HDMI video output.
RECOU./BACKUP	Save and restore the settings of this unit.
INITIALIZE	Initializes various settings for this unit.
FIRM UPDATE	Update the firmware of this unit.
VERSION	Check the version of firmware currently installed on this unit.

4 Press STRAIGHT repeatedly to select the value you want to change.

- 5 Switch this unit to the standby mode, and then switch it on again.
The settings become effective and the unit is powered on.

Setting the impedance of speakers

SPEAKER IMP.
80MIN

Changes the unit settings depending on the impedance of the speakers connected. Ψ 1

80MIN Select the impedance when 6 Ω speakers are connected.

80MAX Select the impedance when speakers above 8 Ω are connected.

Ψ 1 : For detailed procedures of speaker impedance settings, refer to "Changing speaker impedance".

Remote sensor

REMOTE SENSOR
ON

Activate or deactivate the signal-receiving capability of the remote control sensor on the front panel of this unit.

ON (Default) Activate the signal-receiving capability of the remote control sensor

OFF Deactivate the signal-receiving capability of the remote control sensor

"ON" is recommended in most cases.

Avoiding crossing remote control signals when using multiple Yamaha receivers

REMOTE CON AMP
ID1

The remote control of the unit can only receive signals from a receiver which has an identical ID (remote control ID). When using multiple Yamaha AV receivers, you can set each remote control with a unique remote control ID for its corresponding receiver.

On the contrary, if you are setting the same remote control ID for all receivers, you can use one remote control to operate 2 receivers.

ID1 (Default) Receives the remote control signals set in ID1.

ID2 Receives the remote control signals set in ID2.

ID1 is set for both remote control and receiver by default. To avoid crossing remote control, change the remote control ID for both remote control and receiver.

■ To change the remote control ID

Perform each of the following steps within 1 minute. Settings will be automatically stopped if more than 1 minute passes since the last operation. To reset, repeat from step 1.

- 1 Press **15** CODE SET using a pointed object such as the tip of a ballpoint pen.
- 2 Press **16** SOURCE/RECEIVER.
- 3 Enter the desired remote control ID code.

To switch to ID1:
Enter "5019" using **13** Numeric keys.

To switch to ID2:
Enter "5020" using **13** Numeric keys.

Once the remote control code is registered successfully **16** SOURCE/RECEIVER will blink twice.

Registration successful: blinks twice
Registration failed: blinks 6 times

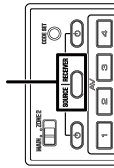

- If setup fails, repeat from step 1.
- Returns to ID1 after the remote control code is initialized.

Resetting the SIRIUS Satellite Radio™ parental lock code (U model)

SIRIUS PIN
CANCEL

Reset the SIRIUS Satellite Radio parental lock code to the factory default setting. If you forget the code, it can be reset.

RESET	Resets the code to the factory default setting.
CANCEL (Default)	Cancels resetting of the parental lock code.

Changing FM/AM frequency steps (R, L models)

TUNER FREQ STEP
AM9/FM50

You can select one of the following FM/AM frequency steps: **1**

AM10/FM100	You can adjust the AM frequency by steps of 10kHz and FM by steps of 100kHz.
AM9/FM50 (Default)	You can adjust the AM frequency by steps of 9kHz and FM by steps of 50kHz.

1: For details on setting FM/AM frequency steps, refer to "FM/AM tuning".

Changing TV format

TV FORMAT
NTSC

Change the color encoding format of OSD to PAL or NTSC (default), to match the format used by the TV connected via the HDMI OUT 1-2 or VIDEO (MONITOR OUT) jack.

Removing HDMI video output up-scaling limits

MONITOR CHECK
YES

Removes the up-scaling limitation on video resolution when this unit and a TV are connected via HDMI jacks. If a resolution supported by the monitor cannot be detected when configuring the up-scaling settings, this setting will remove the output limitation.

YES (Default)	Video output signals of a resolution not supported by the TV will not be transmitted.
SKIP	This unit ignores the TV's support capability and transmits input video signals to the TV.

Recovery and backup of the system settings

RECOV./BACKUP
BACKUP

Save and restore the settings of this unit.

1 Press STRAIGHT repeatedly to select "BACKUP" or "RECOVERY" and press INFO on the front panel.

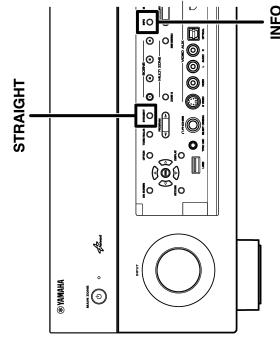

RECOVERY ¹	Restores settings for this unit that have been saved.
BACKUP	Saves the current settings of this unit.

2 Press INFO to execute the "BACKUP" or "RECOVERY". **1**

- The settings except the system settings of this unit such as HD Radio tag or the account informations on Rhapsody and SIRIUS Internet Radio cannot be saved. (U model)
- "RECOVERY" cannot be selected if settings have not be previously saved.

1: After performing "RECOVERY", turn off this unit.

Initializing various settings for this unit

INITIALIZE
CANCEL

Initializes various settings stored in this unit and sets it back to default.

Select the items to be initialized from the following.

DSP PARAM	Initializes all parameters for the sound programs.
UIDED	Resets video conversion settings (resolution/aspect ratio) in the Setup menu.
NETWORK	Resets the settings of network such as IP address or the account of vTuner.
ALL	Resets this unit to default factory settings.
CANCEL (Default)	Does not initialize.

When an option other than CANCEL is selected, the applicable default settings will be restored when the unit switches to standby mode.

Firmware update

FIRM UPDATE
USB

Update the firmware of this unit. For details on updating the firmware, refer to information supplied with updates. When this unit detects the latest firmware over a network, the message indicating that the firmware is released is displayed in the System information.

1 Press STRAIGHT repeatedly to select "USB" or "NETWORK."

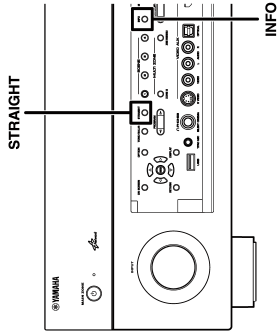

USB (Default)	Updates the firmware of this unit using a USB flash drive.
NETWORK	Updates the firmware of this unit via network.

2 Press INFO to start update with the selected option.

- Do not use this feature unless the firmware must be updated.
- Be sure to read the information supplied with updates before updating firmware.

Firmware version

VERSION
XX.XXX

Check the version of firmware currently installed on this unit.

About the latest firmware

When installing the latest firmware, the new functions or fix of failure may be served.

- The latest firmware can be downloaded from our website.
- While displaying the ON SCREEN menu or "System" from Information menu, the information on the latest firmware is displayed via a network.

■ 本機の設定を変更する

アドバンスドセットアップメニューでは、本機の基本設定や、ユーザー設定の初期化を行うことができます。アドバンスドセットアップメニューは次の方法で操作できます。

アドバンスドセットアップメニューの表示/設定

1 本機の電源をスタンバイにする。
本機の電源が ON の場合、**⏻** を押して本機をスタンバイの状態にしてください。

2 フロントパネルの STRAIGHT を押しながら **⏻ を押す。**
フロントパネルディスプレイに「ADVANCED SETUP」と表示されたら両方のキーから手を離してください。しばらくすると、先頭のメニュー項目が表示されます。

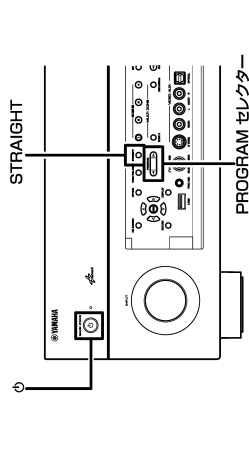

3 PROGRAM </> を使って、次の中から設定したい項目を選ぶ。
アドバンスドセットアップメニューでは次の機能を設定できます。

REMOTE SENSOR	リモートセンサーの受信可/不可を切り替えます。
REMOTE CON AMP	本機のリモコン ID を変更します。

受信するリモコン ID を変更する

REMOTE CON AMP ID1

本機のリモコンは、ID (リモコン ID) が一致するレシーバーのみ受信できます。ヤマハ製 AV レシーバーを複数使用する場合は、それぞれのリモコンで各レシーバーを操作するために、リモコン ID が重ならないようにリモコン ID を設定します。各レシーバーを同じリモコン ID に設定すれば、1 つのリモコンで 2 台のレシーバーを操作することも可能です。

ID1 (初期設定)	ID1 に設定されたリモコンの操作を受信します。
ID2	ID2 に設定されたリモコンの操作を受信します。

工場出荷時には、リモコン側、レシーバー側ともに ID1 に設定されています。リモコンの混信を防ぎたい場合は、レシーバー/リモコン共にリモコン ID を変更してください。

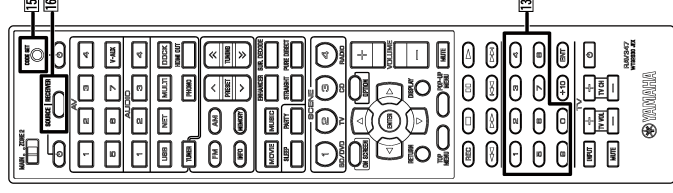

- 13** 数字キー
- 15** CODE SET
- 16** SOURCE/RECEIVER

● **リモコン側の ID を変更するには**
次の手順はそれぞれ 1 分以内に操作してください。最後に操作してから 1 分以上経過すると、設定が自動で中止されます。再度設定する場合は、手順 1 からやり直してください。

1 ボールペンなどの先の細いもので、リモコンの **CODE SET** を押す。

2 リモコンの **SOURCE/RECEIVER** を押す。

3 希望するリモコン ID に応じてコードを入力する。

- ① リモコン ID1 に切り替える場合：
② **数字キー** を使って「5019」と入力します。
リモコン ID2 に切り替える場合：
③ **数字キー** を使って「5020」と入力します。
ID 変更が完了すると、**SOURCE/RECEIVER** が 2 回点滅します。

- 設定に失敗した場合は、**SOURCE/RECEIVER** が 6 回点滅します。ID 変更をやり直すには、もう一度手順 1 から操作してください。
- リモコンコードを初期化 (emp.95) すると、ID1 に戻ります。

テレビの映像フォーマットの変更

TV FORMAT NTSC

お使いのテレビに合わせて、本機の MONITOR OUT 端子および HDMI OUT 端子から出力される壁紙の信号方式を PAL か NTSC (初期設定) に切り替えます。

4 STRAIGHT を何度か押して設定値を選ぶ。

5 電源をスタンバイにしてから、再度電源をオンにする。
選んだ設定が反映され、本機の電源がオンになります。初期化を選択した場合は、再度電源をオンにするまで初期化が実行されます。

リモートセンサーを設定する

REMOTE SENSOR ON

本機のプロントパネルがリモコンからの信号を受信するかどうかを設定します。

ON (初期設定)	リモコンからの信号を受信します。
OFF	リモコンからの信号を受信しません。

通常時は、この設定は「ON」にしておいてください。

HDMI 映像出力の制限解除

MONITOR CHECK
YES

本機とテレビを HDMI 接続した際、アナログ映像を解像度変換（アップスケーリング）して出力する際の制限を解除します。

アップスケーリングの設定をするときやテレビ側が対応する解像度が検出されないときは、この設定で出力制限を解除してください。

YES (初期設定)	テレビ側が対応しない解像度の映像は出力しません。
SKIP	テレビ側の対応可否にかかわらず、本機に入力された映像をテレビに出力します。

システム設定の復元とバックアップ

RECOV./BACKUP
BACKUP

本機の設定を保存／復元します。

- 1 フロントパネルの STRAIGHT を何度か押し、フロントパネルの「BACKUP」または「RECOVERY」を選び、フロントパネルの INFO を押す。

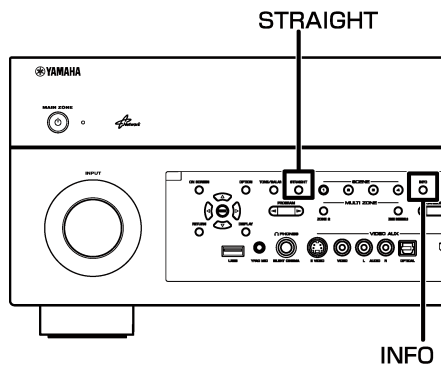

- 2 INFO を押し、「BACKUP」または「RECOVERY」を実行する。

RECOVERY	保存されている設定を呼び出します。
BACKUP	現在の設定を保存します。

設定が保存されていない場合は、「RECOVERY」を選択することはできません。

各種設定の初期化

INITIALIZE
CANCEL

本機に記憶されている設定情報を初期化し、工場出荷時に戻します。

初期化する内容は下記から選択できます。

DSP PARAM	サウンドプログラムのすべての設定を初期化します。
VIDEO	アップスケーリングの設定（解像度 / アスペクト比）やテレビ画面のメニュー（オンスクリーンディスプレイ）の表示位置を初期化します。
NETWORK	IP アドレスや v チューナーのアカウントなど、ネットワークの設定を初期化します。
ALL	すべての設定を工場出荷時の状態に初期化します。
CANCEL (初期設定)	初期化しません。

**RX-V1067/HTR-8063/
RX-A1000**

