

7946

STEREO CASSETTE DECK

K-1020

SERVICE MANUAL

FRONT PANEL

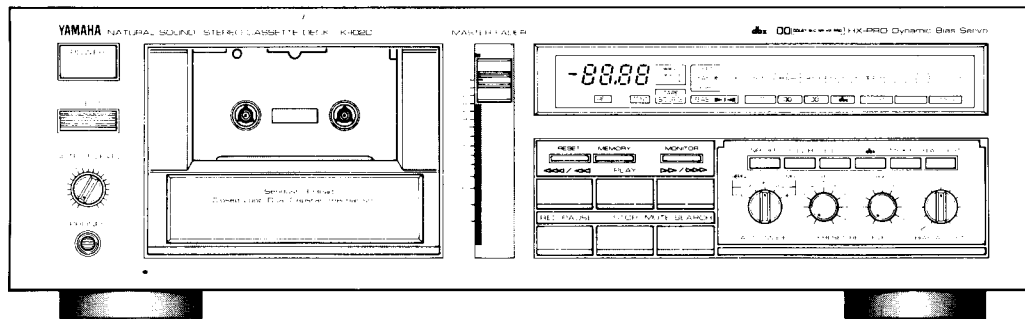

IMPORTANT NOTICE

This manual has been provided for the use of authorized Yamaha Retailers and their service personnel. It has been assumed that basic service procedures inherent to the industry, and more specifically Yamaha Products, are already known and understood by the users, and have therefore not been restated.

WARNING: Failure to follow appropriate service and safety procedures when servicing this product may result in personal injury, destruction of expensive components and failure of the product to perform as specified. For these reasons, we advise all Yamaha product owners that all service required should be performed by an authorized Yamaha Retailer or the appointed service representative.

IMPORTANT: The presentation or sale of this manual to any individual or firm does not constitute authorization, certification, recognition of any applicable technical capabilities, or establish a principle agent relationship of any form.

The data provided is believed to be accurate and applicable to the unit/s indicated on the cover. The research, engineering, and service departments of Yamaha are continually striving to improve Yamaha products. Modifications are, therefore, inevitable and changes in specification are subject to change without notice or obligation to retrofit. Should any discrepancy appear to exist, please contact the distributor's Service Division.

WARNING: Static discharges can destroy expensive components. Discharge any static electricity your body may have accumulated by grounding yourself to the ground buss in the unit (heavy gauge black wires connect to this buss).

IMPORTANT: Turn the unit OFF during disassembly and parts replacement. Recheck all work before you apply power to the unit.

CONTENTS

TO SERVICE PERSONEL	1	LSI DATA TABLES	12
REAR PANELS	1	TIMING CHART	13
BLOCK DIAGRAM	2	PRINTED CIRCUIT BOARD (Pattern Side) . .	14 ~ 17
SPECIFICATIONS	3	WIRING	18
INTERNAL VIEW	3	IC BLOCK	19 ~ 21
DISASSEMBLY PROCEDURES	4 ~ 6	SCHEMATIC DIAGRAM	22, 23
MECHANICAL ADJUSTMENTS	7 ~ 9	PARTS LIST	24 ~ 36
ELECTRICAL ADJUSTMENTS	9 ~ 11		

004587

SINCE 1887



YAMAHA

NIPPON GAKKI CO., LTD. HAMAMATSU, JAPAN
2.6k-633 Printed in Japan. '85.1

K-1020

15071

■ TO SERVICE PERSONNEL

1. Critical Components Information.
Components having special characteristics are marked and must be replaced with parts having specifications equal to those originally installed.
2. Leakage Current Measurement (For 120V Model Only).
When service has been completed, it is imperative that you verify that all exposed conductive surfaces are properly insulated from supply circuits.
 - Meter impedance should be equivalent to 1500 ohm shunted by 0.15μF
 - Leakage current must not exceed 0.5mA.
 - Be sure to test for leakage with the AC plug in both polarities.

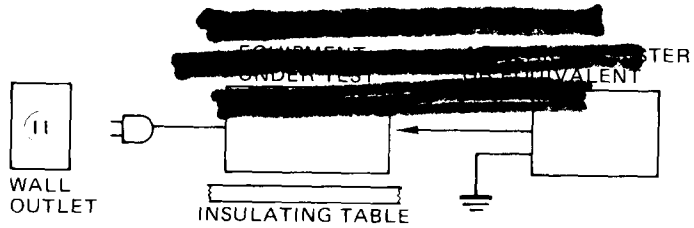

■ REAR PANELS

U.S.A. & Canadian models

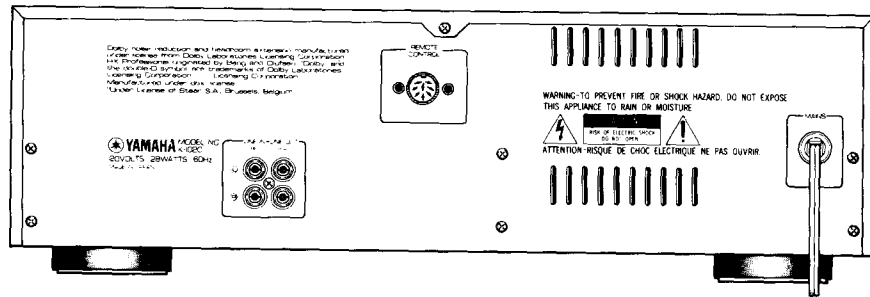

General model

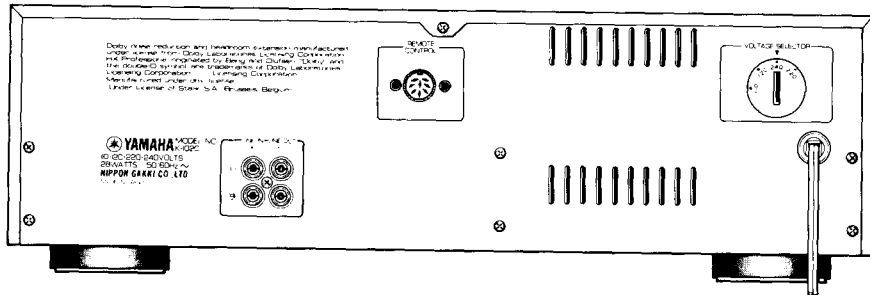

British & Australian models

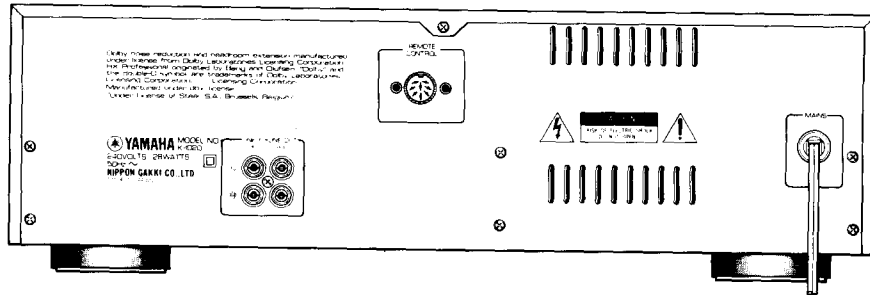

European model

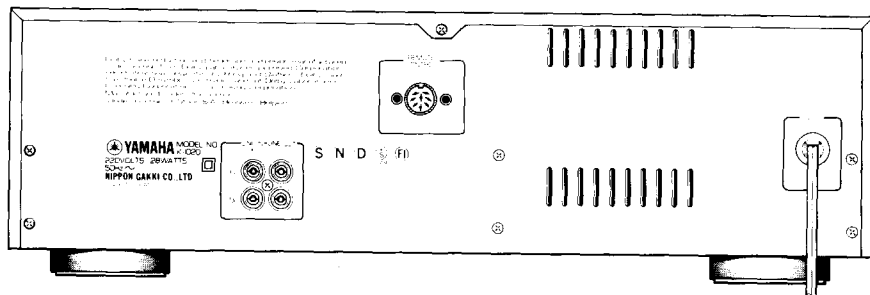

K-1020

BLOCK DIAGRAM

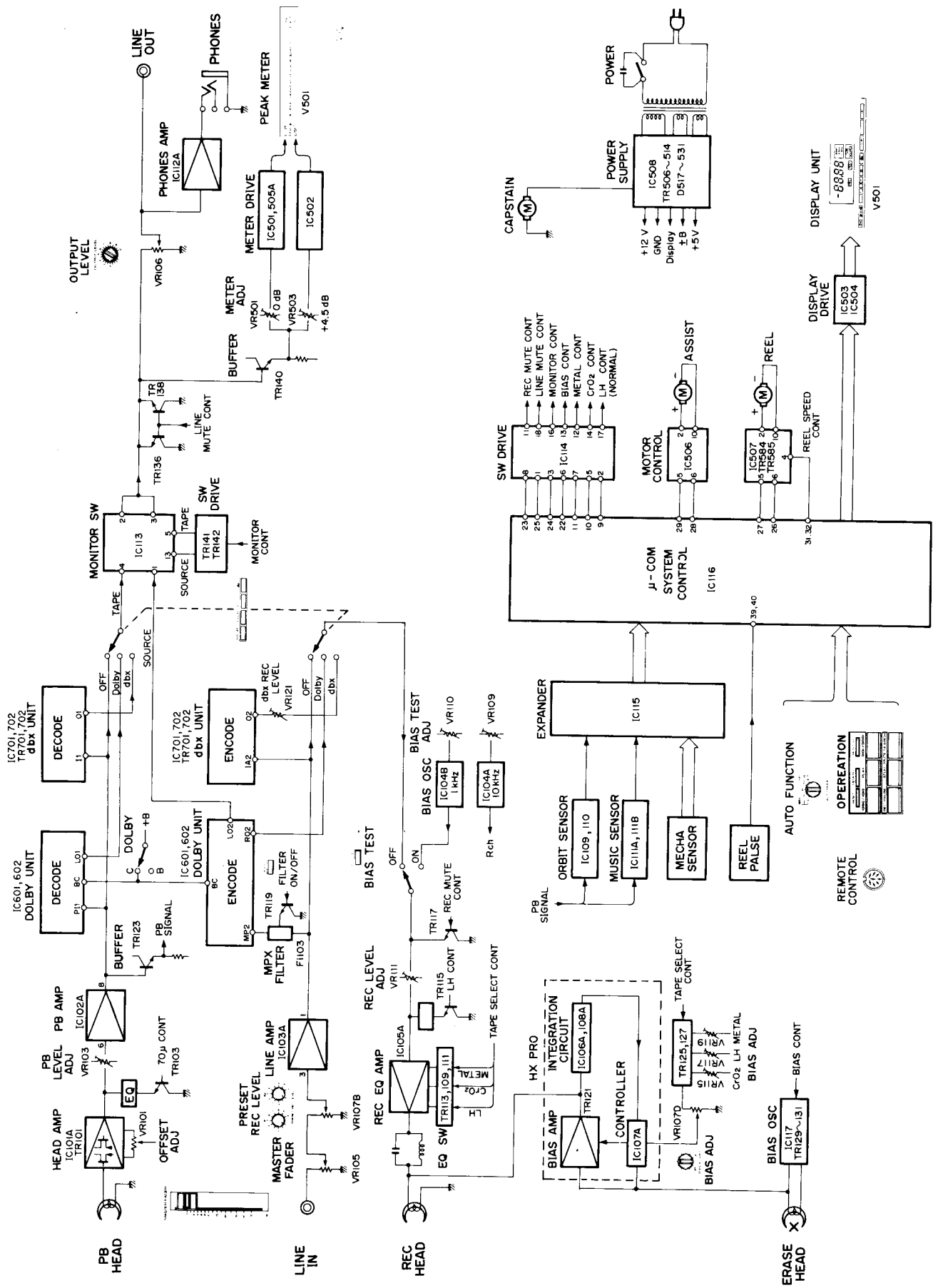

SPECIFICATIONS

Type	4-track, 2-channel stereo	
Head	R & P Heads: Combination, Pure Sendust with triple-laminated core Erase Heads: Ion-plating Ferrite, Double-gap	
Motors	Capstan: DC Servo Motor Reel: Flat torque DC Motor Assist: DC Motor	
Wow & Flutter	No more than $\pm 0.06\%$ (W. Peak); No more than 0.03% (W. RMS)	
Fast Wind Time	About 70 seconds/45 seconds (High Speed winding) (C-60)	
Frequency Response	Normal tape (-20dB) 20 to 18,000Hz ± 3 dB Chrome tape (-20dB) 20 to 20,000Hz ± 3 dB Metal tape (-20dB) 20 to 23,000Hz ± 3 dB	
Signal to Noise Ratio	Dolby off More than 59 dB Dolby B on More than 67 dB Dolby C on More than 75 dB dbx on More than 95 dB	
Harmonic Distortion	Normal tape Less than 0.5% Chrome tape Less than 0.5% Metal tape Less than 0.8%	

Input Sensitivity Impedance	Line 40 mV/30 k-ohms	
Output Level/Load Impedance	Line 360 mV/47 k-ohms Headphones 3.6 mW/8 ohms Channel Separation (3150 Hz) 40 dB Cross Talk (125 Hz) 60 dB	
Power Supplies	U.S. & Canadian Models 120V AC, 60Hz European Model 220V AC, 50Hz British & Australian Models 240V AC, 50Hz General Model 110/120/220/240V AC, 50/60Hz	
Power Consumption	28 watts	
Dimensions (W x H x D)	435 x 134 x 380 mm 17-1/8" x 5-1/4" x 15"	
Weight	7.6 kg (16 lbs. 12 oz.)	

Specifications are subject to change without notice.

- (U)..... U.S.A. model
(C)..... Canadian model
(A)..... Australian model
(G)..... European model
(B)..... British model
(R)..... General model

INTERNAL VIEW

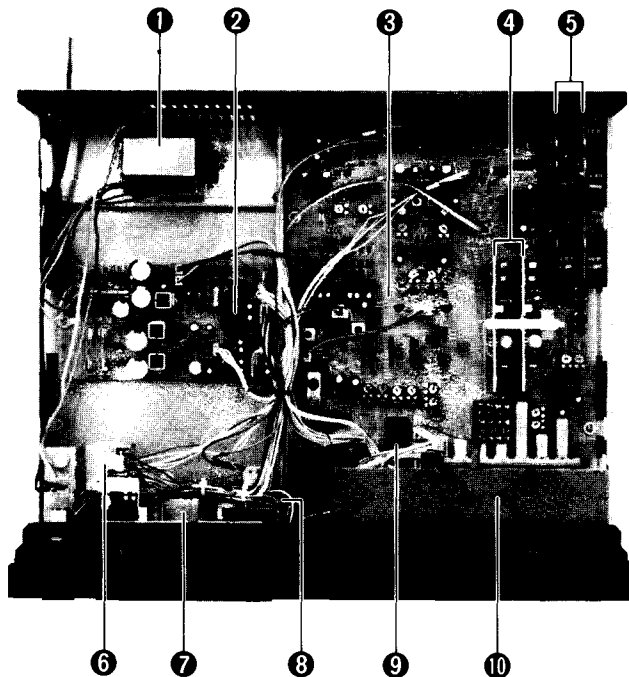

- ① POWER TRANSFORMER
U.S.A. & Canadian models: GA68590
European model: GA68600
Australian & British models: GA68610
General model: GA68620
- ② POWER CIRCUIT BOARD (1)
- ③ MAIN CIRCUIT BOARD (1)
- ④ dbx Circuit Board
- ⑤ Dolby Circuit Board
- ⑥ CAPSTAN MOTOR
- ⑦ REEL MOTOR
- ⑧ ASSIST MOTOR
- ⑨ μ -COM IC: LM6402G-494
- ⑩ POWER CIRCUIT BOARD

DISASSEMBLY PROCEDURES

1. Adjustment of mechanism unit and replacement of head parts.

- Remove the cassette lid.
 - Remove 2 screws ① in Fig. 1 and remove the blind plate.
 - Remove 4 screws ② in Fig. 1 and remove the front plate.
- * In this state, the head can be adjusted and its parts can be replaced.

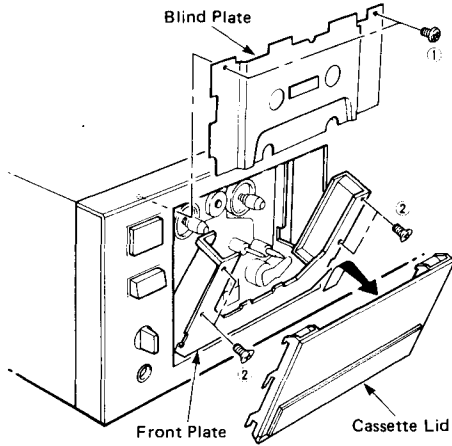

Fig. 1

- Remove 2 screws ③ in Fig. 2 and replace the record/playback head.
- Remove the screw ④ in Fig. 2 and replace the erase head.
- Remove the E ring ⑤ in Fig. 2 and replace the supply side pinch roller.
- Remove the E ring ⑥ in Fig. 2 and replace the take-up side pinch roller.
- Remove the washer ⑦ in Fig. 2 and replace the idler.

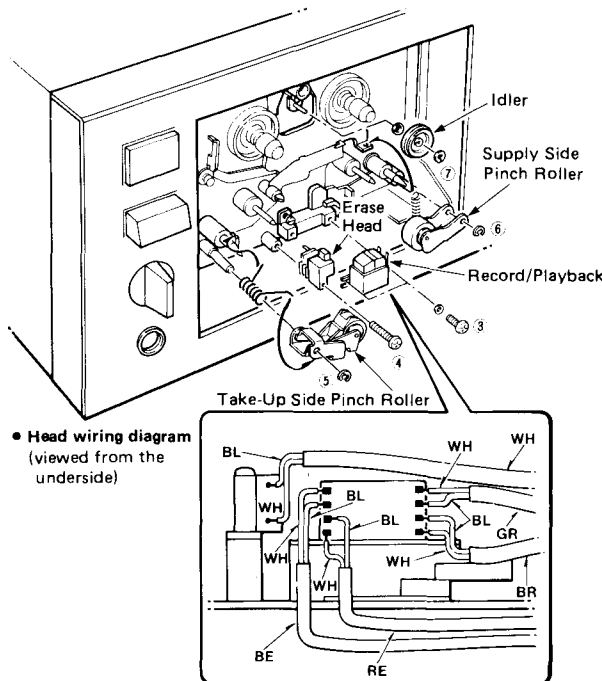

Fig. 2

2. Removal of mechanism unit

- Remove 5 screws ⑧ in Fig. 3 and remove the top cover.
- Remove the cassette lid.

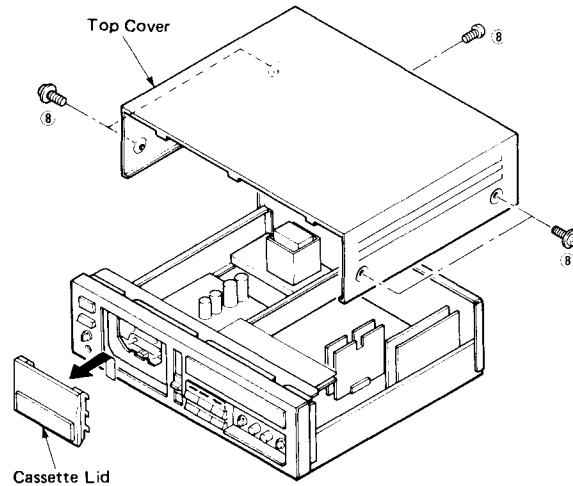
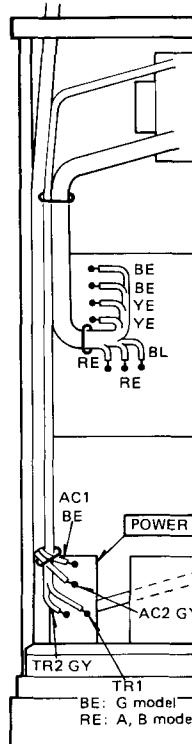

Fig. 3

- Disconnect connectors #1 through #5, #7 and #8 in Fig. 4.

CONNECTOR WIRING

• A, G, B models



• R model

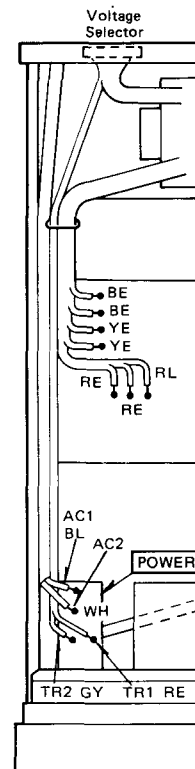

• U, C models

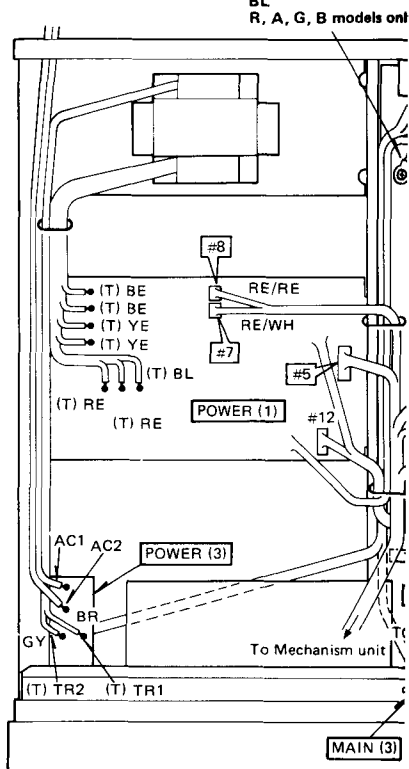

- c. Remove 3 screws ⑪ in Fig. 7 and replace the capstan motor.

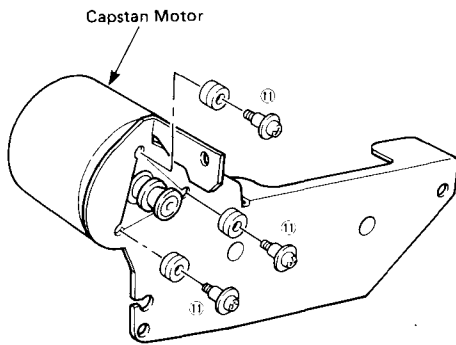

Fig. 7

4. Replacement of reel motor

- a. Remove the mechanism unit.
 - b. Remove 2 screws ⑫ in Fig. 8 and remove the blind plate.
 - c. Remove the reel base as shown in Fig. 8.
- * Note that coil springs of the supply reel and takeup reel are different.
 Supply side: Silver
 Take-up side: Green
- d. Remove the back plate (Refer to Fig. 6.)
 - e. Remove the washer ⑬ in Fig. 8 and remove the flywheel (take-up side).

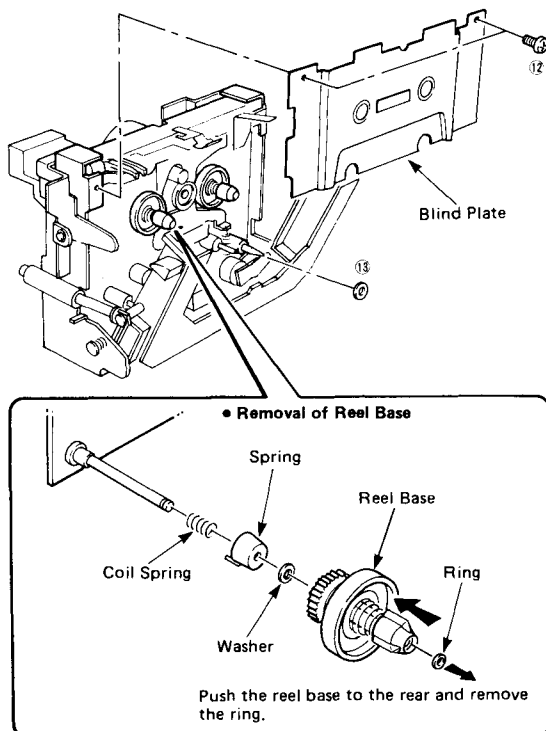

Fig. 8

- f. Remove 2 screws ⑭ and nuts ⑮ in Fig. 9 and remove the reel motor installation plate.
- g. Remove 2 screws ⑯ in Fig. 9 and replace the reel motor.

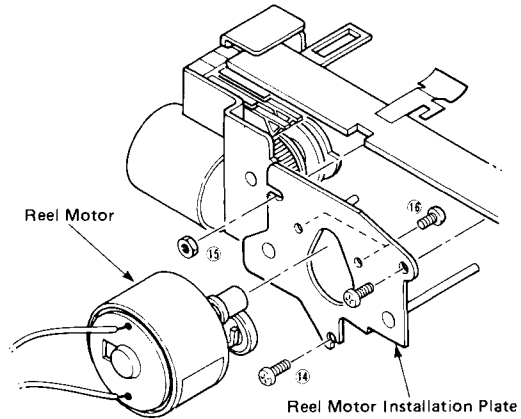

Fig. 9

5. Replacement of assist motor

- a. Remove the top cover.
- b. Remove the blind plate.
- c. Remove 2 screws ⑰ in Fig. 10 and remove the assist motor installation plate.
- d. Remove 2 screws ⑱ in Fig. 10 and replace the assist motor.

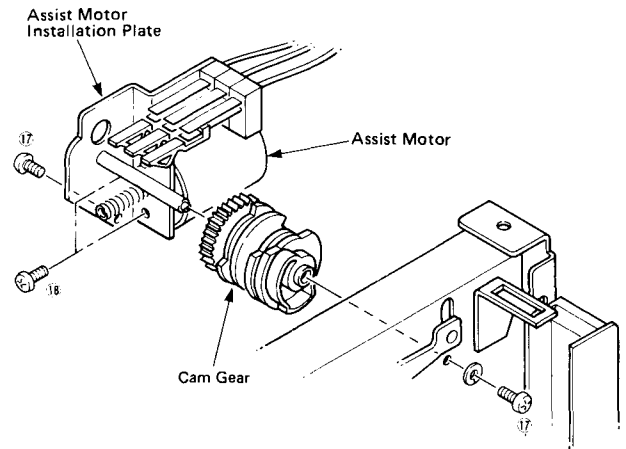

Fig. 10

K-1020

MECHANICAL ADJUSTMENTS

1. Before adjustment

- Since head magnetization, dust accumulations, etc. are likely to introduce error in the various characteristics, it is very important that the heads are properly demagnetized and cleaned.

2. Instruments required

- Head Gauge (M-300)
- Audio frequency oscillator
- Oscilloscope
- Mirror Cassette (MC-109C)
- Torque meter
- Wow/flutter meter
- D.C.V.M. (DC Voltmeter)
- A.C.V.M. (AC Voltmeter)

Step	Adjustment item	Tape	Test Point	Instrument required	Mode	Measurement Conditions	Adjustment Parts	Rating	Remarks
1	Check clearance between take-up side pinch roller and capstan shaft.				PAUSE		Fig. A	More than 0.5mm	
2	Pinch Roller Timing				STOP	With head base pushed up, check timing at which pinch rollers on supply side and take-up side contact capstan.	Fig. B	Take-up side pinch roller should start rotating first.	If timing of both sides is simultaneous or supply side precedes, adjustment is required.
3	Height of record/playback head and tape guide		Fig. D	Headgauge (M-300)			Height adjusting screw of record/playback head tape guide (Fig. C)	Head gauge should pass through smoothly without its block contacting record/playback head guide.	
4	Record/playback head tilt angle			Headgauge (M-300)		With M-300 block placed vertically on record/playback head, adjust so that M-300 gauge and block becomes parallel (Fig. E)	Tilt angle adjusting screw (Fig. C)	M-300 gauge and block should be parallel.	Place M-300 block vertically on head leaving space between M-300 block and gauge.
5	Supply side pinch roller height		Fig. F	Headgauge (M-300)			Supply side pinch roller height adjusting screw (Fig. C)	Head gauge should pass through smoothly without its block contacting pinch roller guide. (Fig. F)	
6	Azimuth	10kHz, -10dB (MTT-114)	LINE OUT	A.C.V.M. Oscilloscope	PB		Azimuth adjusting screw (Fig. C)	Playback output of L and R is maximum and phase difference should be minimum. (Phase difference less than 60°)	Repeat adjustments in steps 3 to 6 and apply screw lock paint upon completion of adjustments.
7	Check position of erase head and tape movement.			Mirror cassette (MC-109C)	PB			Tape should move in the center of erase head smoothly. Capstan (supply side) should move smoothly. (Fig. G)	Adjust by using spacer as shown in Fig. H.
8	Check each torque.			Torque meter (Cassette type)		Measure FF, REW torque, take up torque and back tension torque.	Back tension: Adjust leaf spring (5 steps) (Fig. I)	Take-up torque 35 ~ 55g/cm FF, REW torque more than 70g/cm Back tension: 5 ~ 10g/cm	To obtain take-up torque, read the center of deflection.
9	Check FF and REW take up times	AC-512, 712, 223 C-60						Normal: Less than 85 seconds High speed: Less than 55 seconds	
10	Tape speed	3kHz, -10dB (MTT-111)	LINE OUT	Wow/flutter meter Frequency counter	PB	Check speed while playing back 3kHz test tape.	Semi fixed variable resistor at the back of the Capstan Motor. (Fig. J)	3000 + $\frac{5}{-15}$ Hz	
	Wow/Flutter							Less than 0.05% (WRMS)	Check wow/flutter while confirming approximately 3kHz frequency with wow/flutter meter counter.

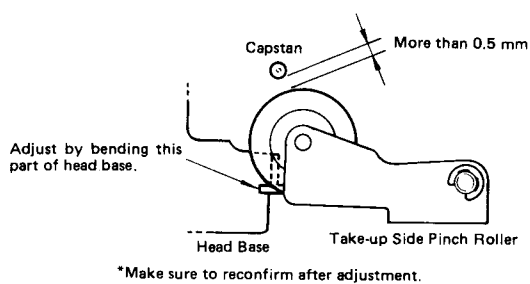

Fig. A

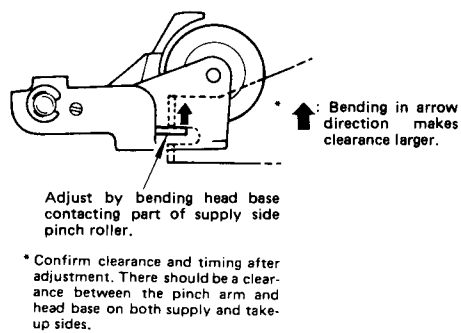

Fig. B

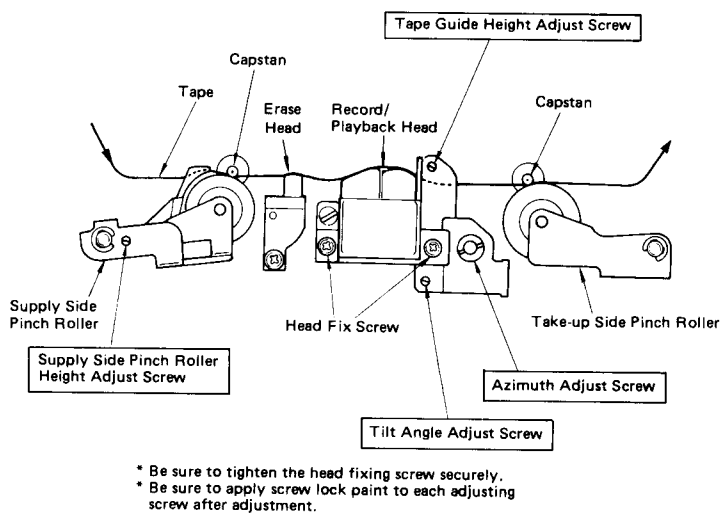

Fig. C

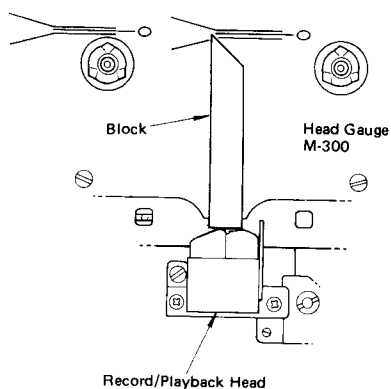

Fig. D

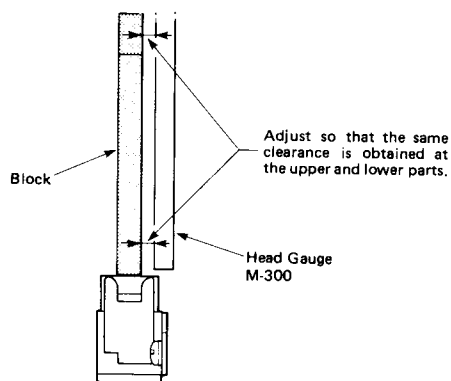

Fig. E

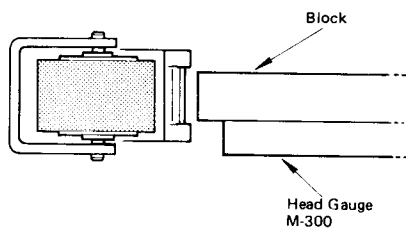

Fig. F

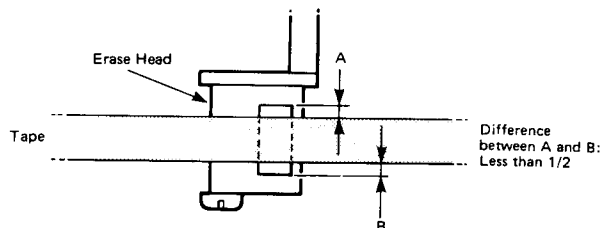
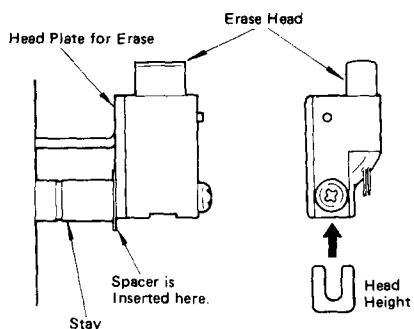

Fig. G



* Use spacer to adjust the head height.

Fig. H

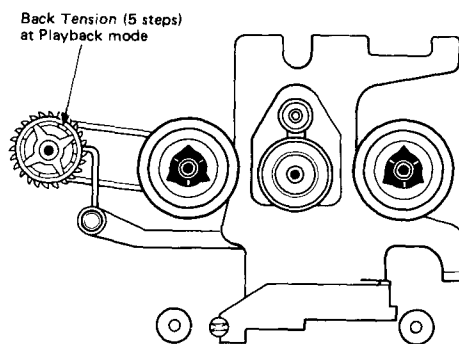

Fig. I

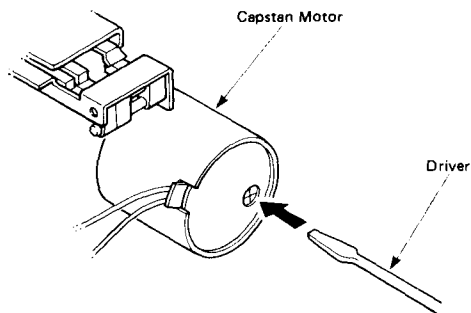

Fig. J

ELECTRICAL ADJUSTMENTS

PLAYBACK ADJUSTMENTS

* Make sure to use a new tape of IEC standards for a test tape.

Alignment tape

Normal TDK AC223 or YAMAHA NR 60

CrO₂ TDK AC512 or YAMAHA CR 60

METAL TDK AC712 or YAMAHA MR 60

* Use 360mV (-9dBV) for 0dB as the standard level of this unit.

• Proceed with the playback adjustments after having finished the mechanical adjustments.

Step	Adjustment item	Tape	Point of Measurement	Instrument required	Mode	Adjustment Part	Rating
1	EQ Amp. DC. Offset		TP1 (L) ~ E TP2 (R) ~ E	D.C.V.M.	STOP	VR101 (L) VR102 (R)	0 ± 2V D.C.
2	Playback level	MTT-212C (315Hz 160nwb/m)	LINE OUT	A.C.V.M. (AC Volt/dB Meter)	PB	VR103 (L) VR104 (R)	360 ± 25mV (-9.0 ± 1 dBV)
3	Playback frequency response confirmation	MTT-356U (3180 + 70μs) MTT-256U (3180 + 120μs)	LINE OUT	A.C.V.M.	PB		Frequency response should be within speci- fication in Fig. K.
4	dbx IC		TP1 ~ TP2 (dbx circuit board)	D.C.V.M.	STOP	VR701 (dbx circuit board)	15 ± 2mV D.C.

RECORDING ADJUSTMENT

• Proceed with the recording adjustments after having finished the playback adjustments.

Step	Adjustment item	Tape	Test Point	Instrument required	Mode	Measurement Conditions	Adjustment Parts	Rating	Remarks
1	Peak Level Meter (+4.5dB)		LINE OUT	A.C.V.M.	SOURCE	Apply a 1kHz sine wave signal from LINE IN so that LINE OUT voltage is 600mV (-4.5dBV).	VR503 (L) VR504 (R)	+4dB segment (red) should light.	When MASTER FADER is decreased L and R segments around 0dB should fade out almost simultaneously.
	Peak Level Meter (0dB)		LINE IN	Audio frequency oscillator					

K-1020

Step	Adjustment Item	Tape	Test Point	Instrument Required	Mode	Measurement Conditions	Adjustment Parts	Rating	Remarks
2	BIAS Oscillation level	METAL	TP5 TP6	A.C.V.M.	REC	BIAS ADJUST → Maximum (VR107) Set VR119 and 120 all the way to the left.	L109 L110	Adjust so that oscillation output is maximum.	
3	BIAS Leak	METAL	LINE OUT	A.C.V.M.	REC TAPE	With no signal applied (REC at minimum), set BIAS ADJUST to maximum and measure bias leak at LINE OUT when recording and monitoring simultaneously (TAPE mode) by using a metal tape.	Fi101 (L) Fi102 (R)	Less than 13mV	Adjust so as to minimize bias leak.
4	Recording Level (Through)	AC-712 INPUT SIGNAL (1kHz, -20dB)	LINE OUT LINE IN	A.C.V.M. Audio frequency oscillator	REC TAPE NR → OFF	① Set VR119 and 120 as the midpoint. ② Apply a 1kHz sine wave signal from LINE IN so that LINE OUT voltage is 36mV (-29dBV). ③ Record the signal and adjust so that there is no level difference when SOURCE/TAPE is switched.	VR111 (L) VR112 (R)	±0.5dB	The reference tape of this unit is AC-720 (equivalent to TDK-MA). If other tape is used, slight difference in level results.
5	Recording Level (dbx)	AC-712 INPUT SIGNAL (1kHz, -20dB)	LINE OUT LINE IN	A.C.V.M. Audio frequency oscillator	REC TAPE NR → dbx	① Apply a 1kHz sine wave signal from LINE IN so that LINE OUT voltage is 36mV (-29dBV). ② Record the signal and adjust so that there is no level difference when SOURCE/TAPE is switched.	VR121 (L) VR122 (R)	±0.5dB	Each adjustment in step 4 should be completed.
6	Recording BIAS (METAL)	AC-712 INPUT SIGNAL (1kHz, 10kHz, -20dB)	LINE OUT	A.C.V.M.	REC TAPE NR → OFF	① Confirm the 1kHz record/playback level (Step 4). ② Record and playback a 10 kHz (-20dB) signal and adjust so that the same level as the above ① level is obtained.	VR119 (L) VR120 (R)	Frequency response should satisfy Fig. L.	As ORBiT signal is 1kHz and 10kHz, use a 1kHz signal and a 10kHz one when adjusting recording/playback frequency response and confirm that each rating is satisfied. If other frequency is used for adjustment, Bias indicator may indicate an error.
7	Recording BIAS (CrO ₂)	AC-512 INPUT SIGNAL (1kHz, 10kHz, -20dB)	LINE OUT LINE IN	A.C.V.M. Audio frequency oscillator	REC TAPE	① Record and playback a 1kHz (-20dB) signal and read the level. (A slight difference results as record/playback level of this unit is set to AC-712.) ② Apply a 10kHz signal from LINE IN so that LINE OUT voltage is 36mV (-29dBV: voltage 20dB lower than the standard level) ③ Record the signal and adjust so that the same level as the above ① level is obtained.	VR115 (L) VR116 (R)	Frequency response should satisfy Fig. M.	As ORBiT signal is 1kHz and 10kHz, use a 1kHz signal and a 10kHz one when adjusting recording/playback frequency response and confirm that each rating is satisfied. If other frequency is used for adjustment, Bias indicator may indicate an error.
8	Recording BIAS (Normal)	AC-223 INPUT SIGNAL (1kHz, 10kHz, -20dB)	LINE OUT	A.C.V.M.	REC TAPE	① Record and playback a 1kHz (-20dB) signal and read the level. ② Record and playback a 10kHz (-20dB) signal and adjust so that the same level as the above ① level is obtained.	VR117 (L) VR118 (R)	Frequency response should satisfy Fig. N.	
9	BIAS Test (LOW)	AC-712	TP3	A.C.V.M.	BIAS TEST REC BIAS ADJ Center.	Set METAL (AC-712) and perform BIAS TEST.	VR110	30 ± 5mV	Each adjustment in Steps 4 and 6 should be completed. Confirm adjustment is made within ±2 graduation when BIAS TEST is performed with other tape (AC-512, 223).
	BIAS Test (High)		BIAS Indicator			VR109	▶◀ should light.		

Step	Adjustment Item	Tape	Test Point	Instrument Required	Mode	Measurement Conditions	Adjustment Parts	Rating	Remarks
2	BIAS Oscillation level	METAL	TP5 TP6	A.C.V.M.	REC	BIAS ADJUST → Maximum (VR107) Set VR119 and 120 all the way to the left.	L109 L110	Adjust so that oscillation output is maximum.	
3	BIAS Leak	METAL	LINE OUT	A.C.V.M.	REC TAPE	With no signal applied (REC at minimum), set BIAS ADJUST to maximum and measure bias leak at LINE OUT when recording and monitoring simultaneously (TAPE mode) by using a metal tape.	Fi101 (L) Fi102 (R)	Less than 13mV	Adjust so as to minimize bias leak.
4	Recording Level (Through)	AC-712 INPUT SIGNAL (1kHz, -20dB)	LINE OUT LINE IN	A.C.V.M.	REC TAPE NR → OFF	① Set VR119 and 120 as the midpoint. ② Apply a 1kHz sine wave signal from LINE IN so that LINE OUT voltage is 36mV (-29dBV). ③ Record the signal and adjust so that there is no level difference when SOURCE/TAPE is switched.	VR111 (L) VR112 (R)	±0.5dB	The reference tape of this unit is AC-720 (equivalent to TDK-MA). If other tape is used, slight difference in level results.
5	Recording Level (dbx)	AC-712 INPUT SIGNAL (1kHz, -20dB)	LINE OUT LINE IN	A.C.V.M.	REC TAPE NR → dbx	① Apply a 1kHz sine wave signal from LINE IN so that LINE OUT voltage is 36mV (-29dBV). ② Record the signal and adjust so that there is no level difference when SOURCE/TAPE is switched.	VR121 (L) VR122 (R)	±0.5dB	Each adjustment in step 4 should be completed.
6	Recording BIAS (METAL)	AC-712 INPUT SIGNAL (1kHz, 10kHz, -20dB)	LINE OUT	A.C.V.M.	REC TAPE NR → OFF	① Confirm the 1kHz record/playback level (Step 4). ② Record and playback a 10 kHz (-20dB) signal and adjust so that the same level as the above ① level is obtained.	VR119 (L) VR120 (R)	Frequency response should satisfy Fig. L.	As ORBiT signal is 1kHz and 10kHz, use a 1kHz signal and a 10kHz one when adjusting recording/playback frequency response and confirm that each rating is satisfied. If other frequency is used for adjustment, Bias indicator may indicate an error.
7	Recording BIAS (CrO ₂)	AC-512 INPUT SIGNAL (1kHz, 10kHz, -20dB)	LINE OUT LINE IN	A.C.V.M.	REC TAPE	① Record and playback a 1kHz (-20dB) signal and read the level. (A slight difference results as record/playback level of this unit is set to AC-712.) ② Apply a 10kHz signal from LINE IN so that LINE OUT voltage is 36mV (-29dBV: voltage 20dB lower than the standard level) ③ Record the signal and adjust so that the same level as the above ① level is obtained.	VR115 (L) VR116 (R)	Frequency response should satisfy Fig. M.	As ORBiT signal is 1kHz and 10kHz, use a 1kHz signal and a 10kHz one when adjusting recording/playback frequency response and confirm that each rating is satisfied. If other frequency is used for adjustment, Bias indicator may indicate an error.
8	Recording BIAS (Normal)	AC-223 INPUT SIGNAL (1kHz, 10kHz, -20dB)	LINE OUT	A.C.V.M.	REC TAPE	① Record and playback a 1kHz (-20dB) signal and read the level. ② Record and playback a 10kHz (-20dB) signal and adjust so that the same level as the above ① level is obtained.	VR117 (L) VR118 (R)	Frequency response should satisfy Fig. N.	
9	BIAS Test (LOW)	AC-712	TP3	A.C.V.M.	BIAS TEST REC BIAS ADJ Center.	Set METAL (AC-712) and perform BIAS TEST.	VR110	30 ± 5mV	Each adjustment in Steps 4 and 6 should be completed. Confirm adjustment is made within ±2 graduation when BIAS TEST is performed with other tape (AC-512, 223).
	BIAS Test (High)		BIAS Indicator				VR109	▶◀ should light.	

ER increased L
ints should
most simul-

• **PLAYBACK FREQUENCY RESPONSE**

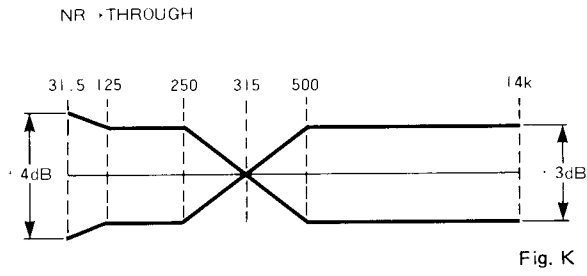

• **RECORDING FREQUENCY RESPONSE**

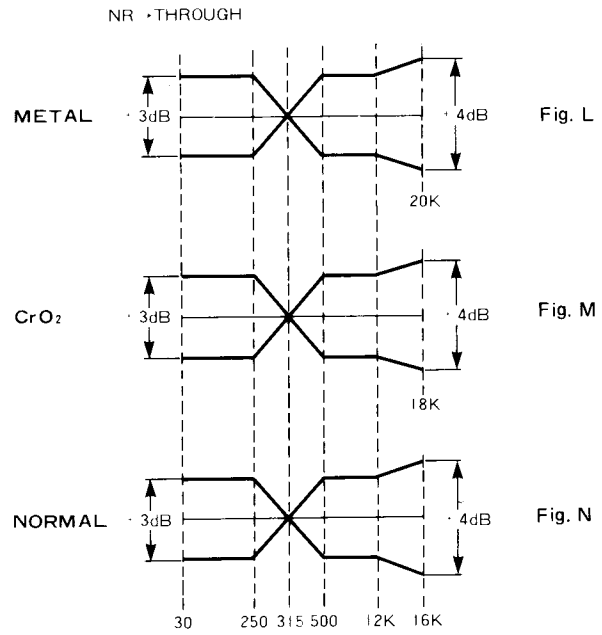

• **TEST POINT**

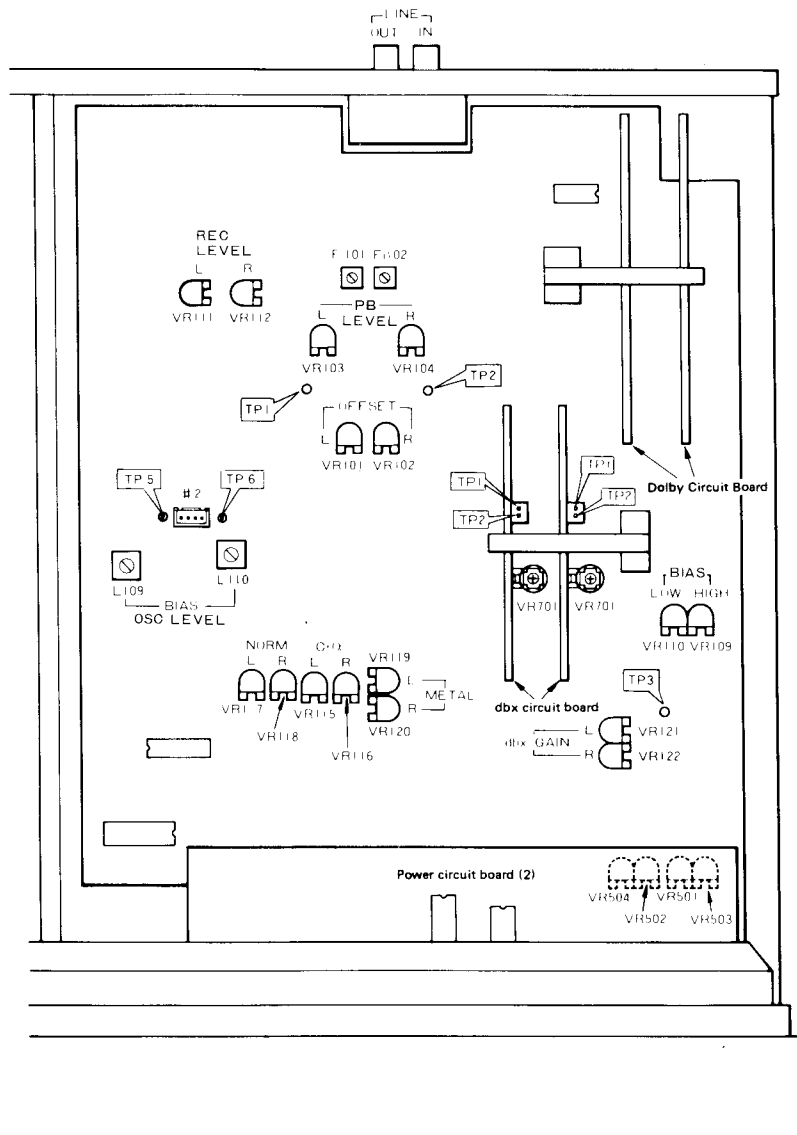

LSI DATA TABLES

• LM6402G-494

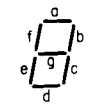
No.	NAME	FUNCTION	No.	NAME	FUNCTION	
1	Xtal	CLOCK, Microcomputer (800 kHz)	42	EXtal	CLOCK, Microcomputer (800 kHz)	
2	C ₀	(1 figure) KEY SCAN 1 DISPLAY (2 figure) KEY SCAN 2 DIGIT (3 figure) KEY SCAN 3 OUTPUT (4 figure) KEY SCAN 4	41	VDD	+5V	
3	C ₁		40	B ₃	PULSE INPUT, Reel stand (Take-up)	
4	C ₂		39	B ₂	PULSE INPUT, Reel stand (Supply)	
5	C ₃		38	B ₁	KEY SCAN INPUT	
6	INT	37	B ₀			
7	RES	36	A ₃			
8	D ₀	35	A ₂			
9	D ₁	34	A ₁			
10	D ₂	CrO ₂ TAPE	33	A ₀	Speed Control of Reel Motor 2	
11	D ₃	METAL TAPE	32	I ₂		
12	E ₀	a. MEMORY b. BIAS [▶:] c. ▶: d. :◀ e. TAPE f. O-M REPEAT g. FULL REPEAT —, REC, *, TEST	31	I ₁	Speed Control of Reel Motor 1	
13	E ₁		30	I ₀	Not Use	
14	E ₂		LED SEGMENT OUTPUT 	29	H ₃	Assist Motor Control
15	E ₃			28	H ₂	
16	F ₀			27	H ₁	Reel Motor Control
17	F ₁			26	H ₀	
18	F ₂			25	G ₃	LINE MUTE OUTPUT Signal
19	F ₃	24	G ₂	MONITOR SW Signal		
20	TEST	Gnd.	23	G ₁	REC MUTE OUTPUT Signal	
21	Vss	Gnd.	22	G ₀	REC BIAS OUTPUT Signal	

• MODE VS OUTPUT

Terminal	NAME	STOP	FF	FF (High Speed)	REW	REW (High Speed)	PLAY	REC/PAUSE	REC/PLAY	CUE	REVIEW
22 · G ₀	BIAS	H	H	H	H	H	H	—	L	H	H
23 · G ₁	REC MUTE	L	L	L	L	L	L	L	H	L	L
24 · G ₂	MONITOR	—	—	—	—	—	**L	***H	***H	—	—
25 · G ₃	LINE MUTE	*	*	*	*	*	H	*	*	*	*
26 · H ₀	REEL · R	L	L	L	H	H	L	L	L	L	H
27 · H ₁	REEL · F	L	H	H	L	L	H	L	H	H	L
31 · I ₁	REEL 1	H	L	L	L	L	H	H	H	L	L
32 · I ₂	REEL 2	H	H	L	H	L	H	H	H	H	H

Note :

- L Low level
- H High level
- Holding premode
- ** L changes when operation is ON.
- *** H changes at initial REC.
- * L changes when TAPE is selected.
H changes when SOURCE is selected.

TIMING CHART

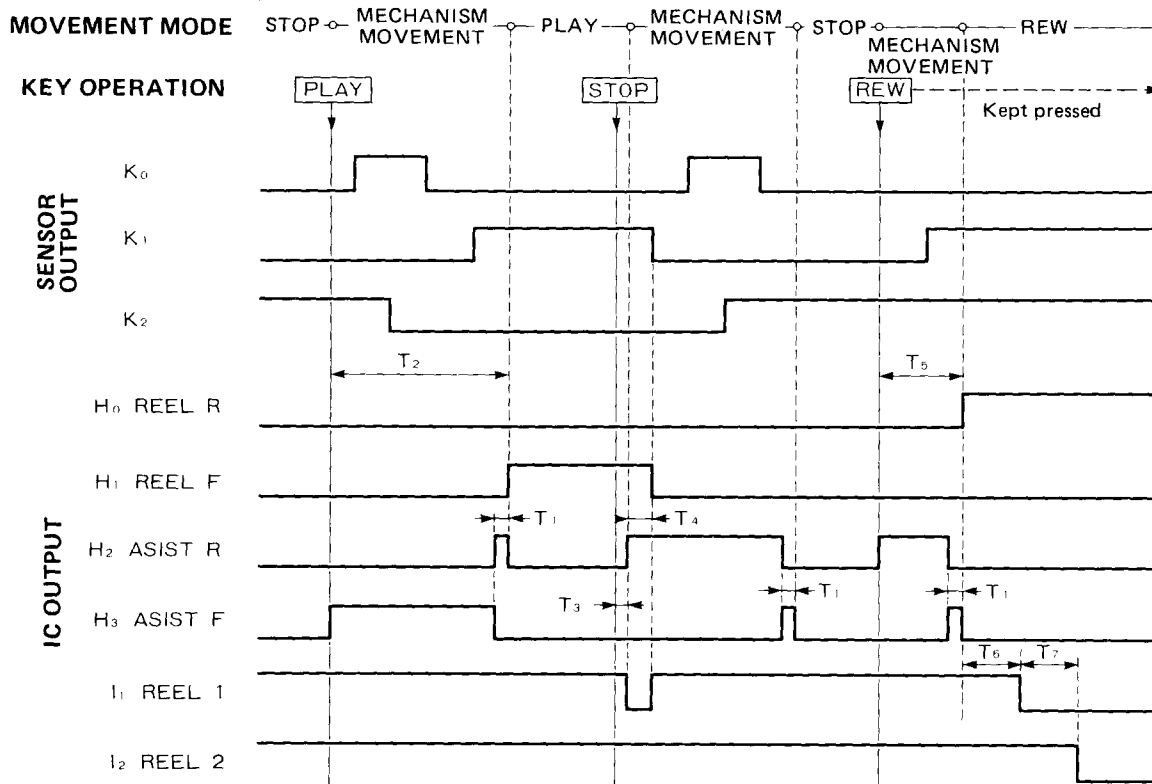

T₁: Reversing due to assist motor stop ... About 14 msec
 T₂: Play operation time ... About 300 msec
 T₃: Delay of play → STOP ... About 15 msec
 T₄: Reel motor running time before shifting out of the previous mode ... About 50 msec

T₅: Operation time of STOP → REW ... About 90 msec
 T₆: Delay before fast forward voltage ... About 260 msec
 T₇: Delay before high speed fast forward voltage ... About 300 msec

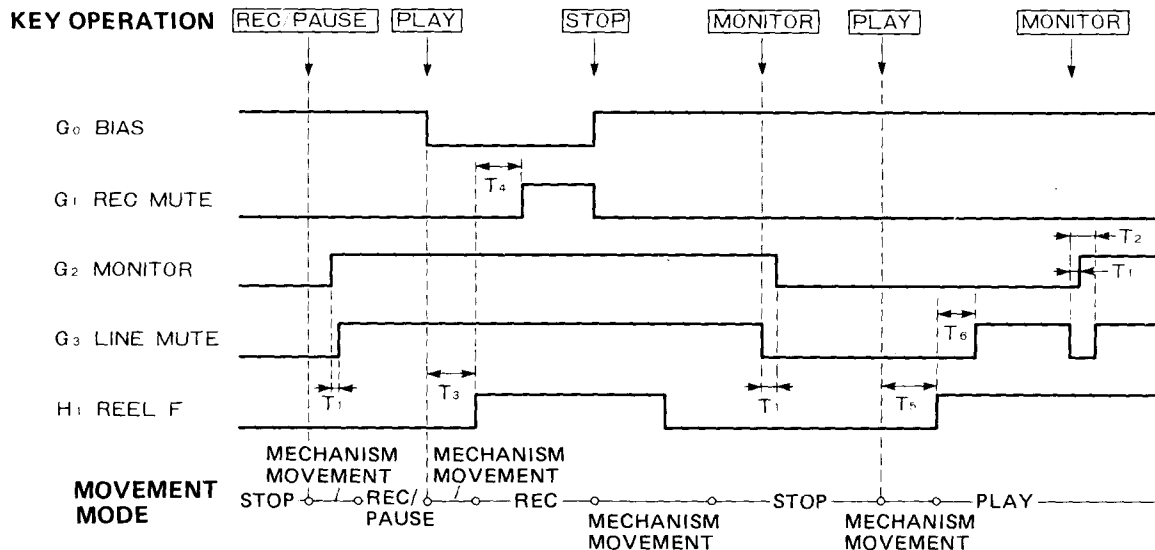

T₁: Monitor mute delay ... About 25μsec
 T₂: Monitor switching mute ... About 50 msec
 T₃: Operation of PAUSE → PLAY ... About 150 msec

T₄: REC mute delay ... About 250 msec
 T₅: PLAY operation ... About 300 msec
 T₆: Line mute delay ... About 250 msec
 (to wait til running is stabilized)

PRINTED CIRCUIT BOARD (Pattern side)

• Main Circuit Board (1)

TO: POWER SUPPLY C. BOARD (1) ←

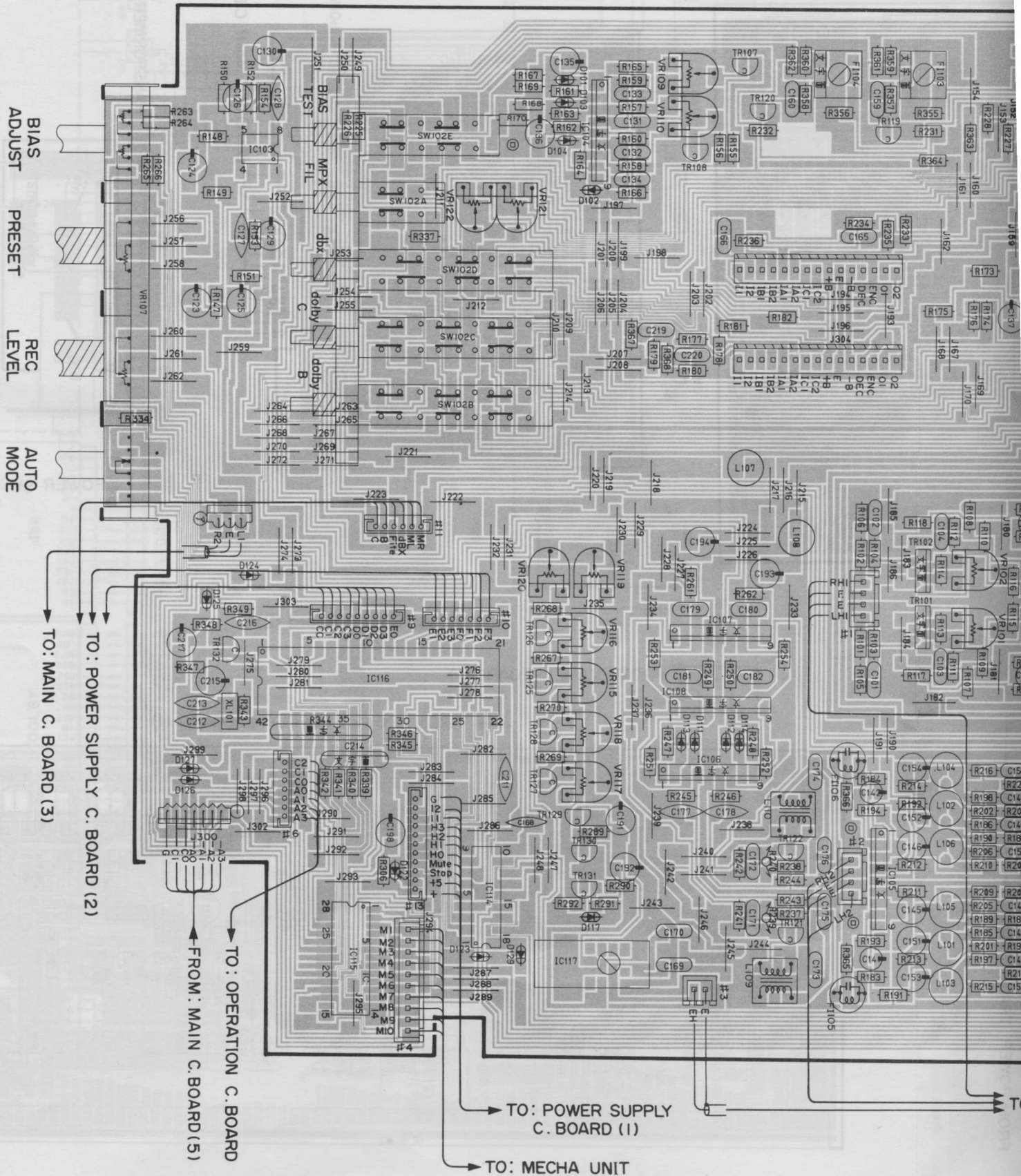

Note)
文字面 : Letter side

SUPPLY C. BOARD (1)

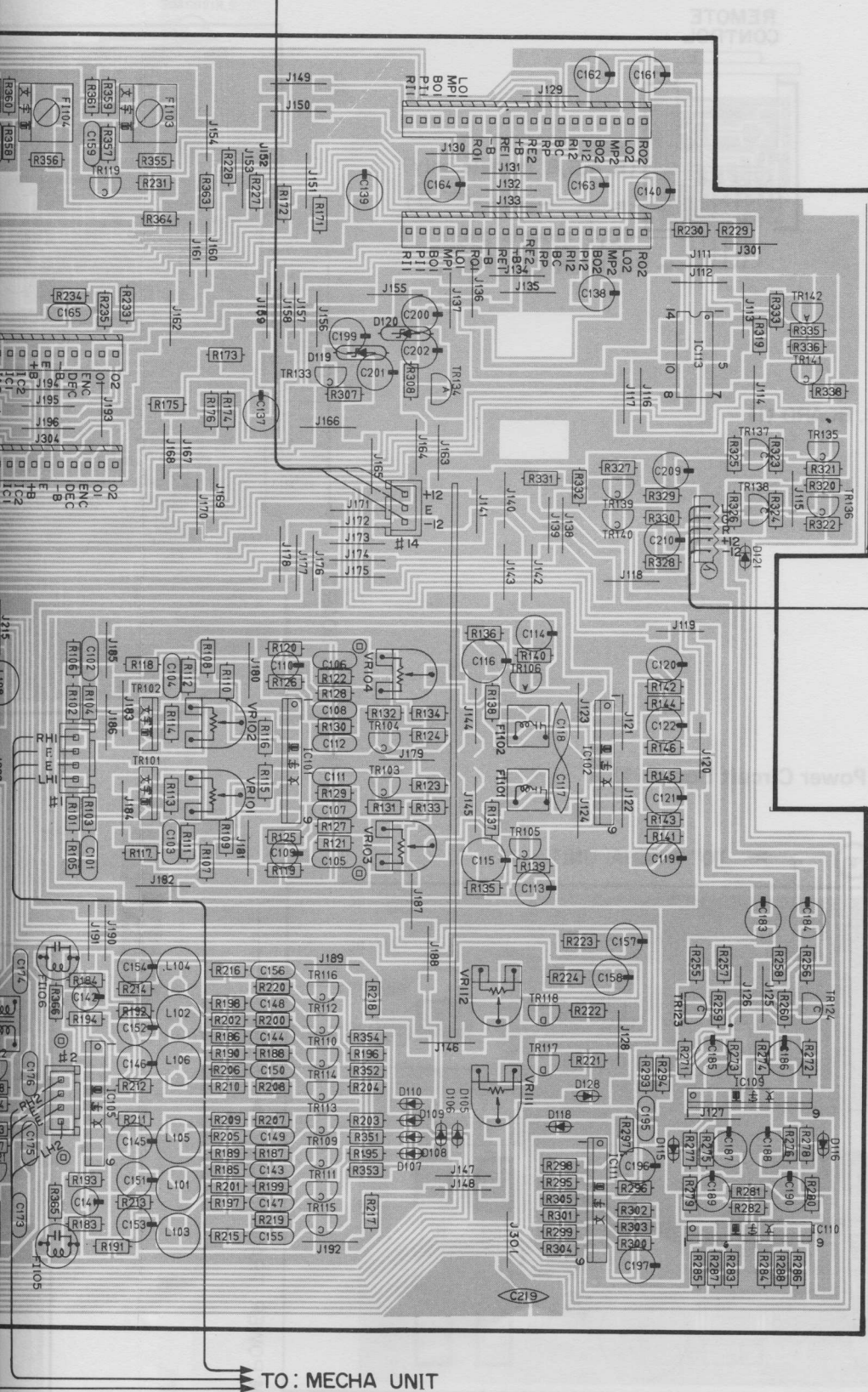

● Main Circuit Board (2)

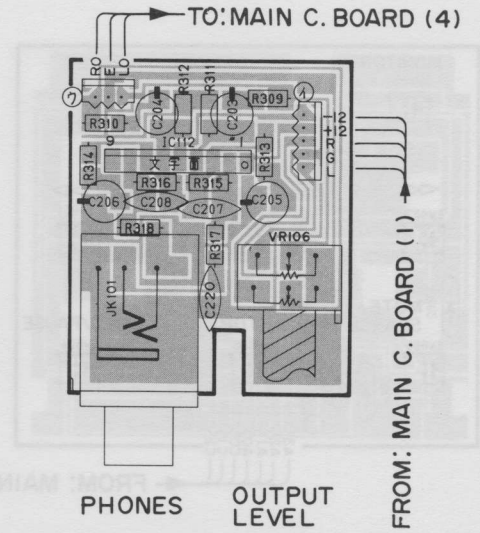

● Main Circuit Board (3)

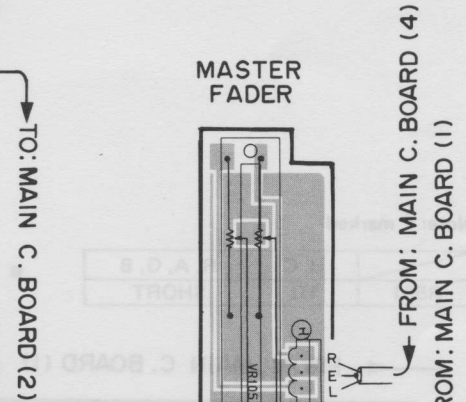

● Main Circuit Board (4)

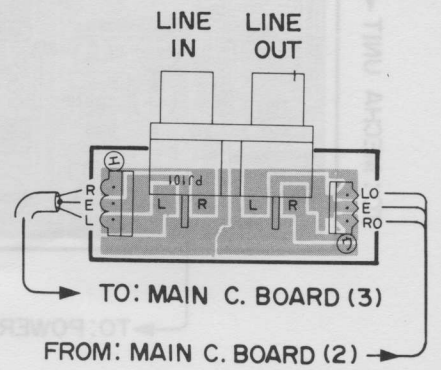

PRINTED CIRCUIT BOARD (Pattern side)

• Operation Circuit Board

• Main Circuit Board (5)

• Dolby Circuit Board

Note)

文字面 : Letter side

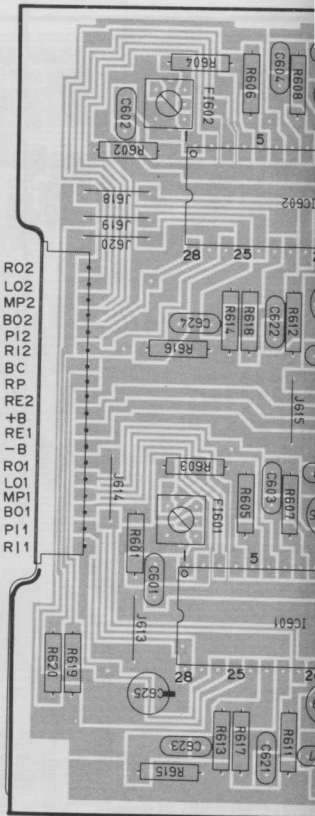
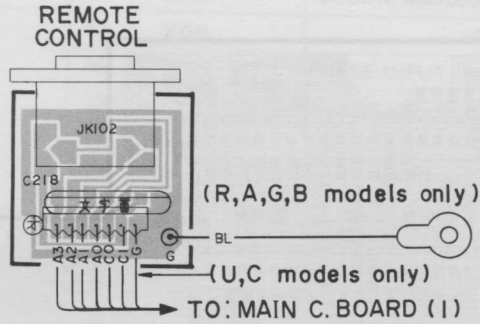
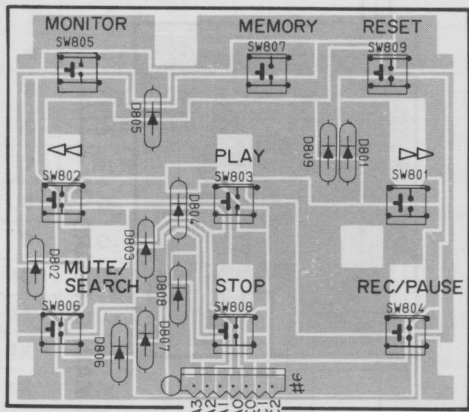

FROM: MAIN C. BOARD (1)

FROM: MAIN C. BOARD (1)

Note: * marked

	U, C	R, A, G, B
R561	1Ω	SHORT

• Power Circuit Board (1)

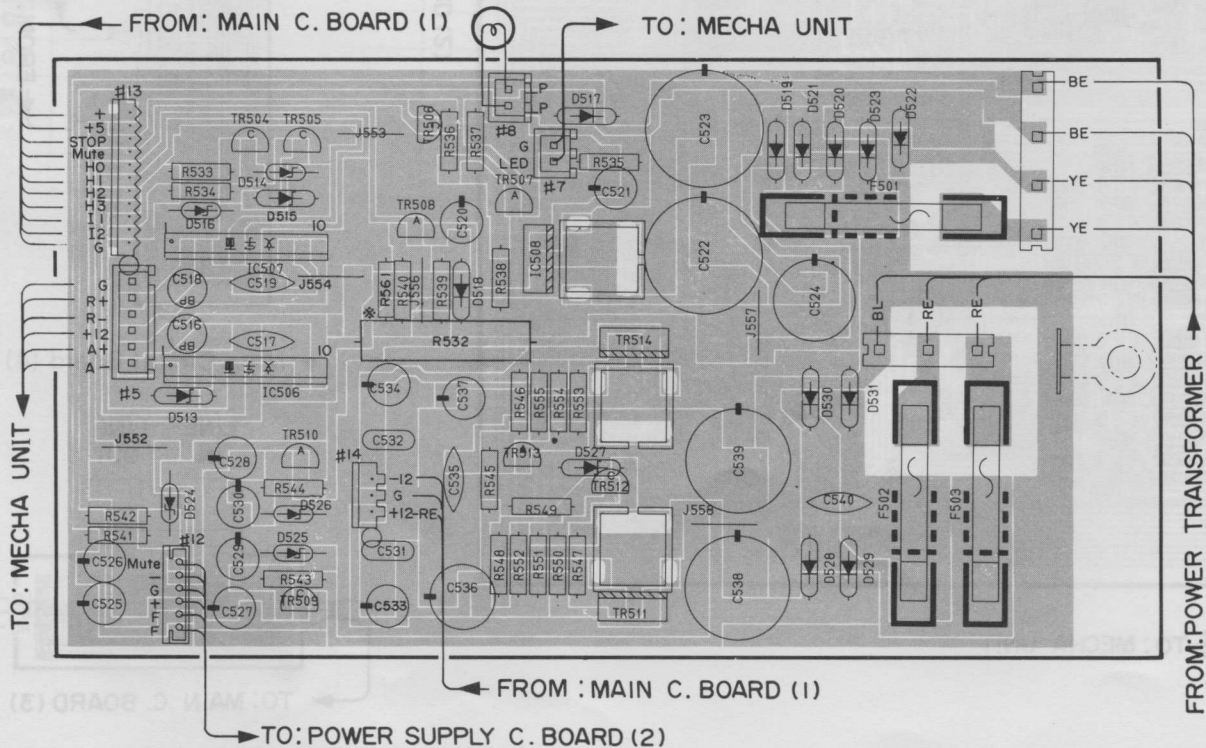

FROM: MAIN C. BOARD (1)

TO: MECHA UNIT

TO: MECHA UNIT

FROM: POWER TRANSFORMER

FROM: MAIN C. BOARD (1)

TO: POWER SUPPLY C. BOARD (2)

Circuit Board

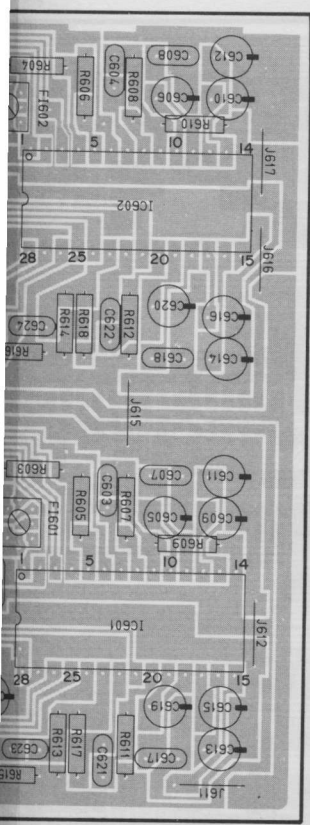

• dbx Circuit Board

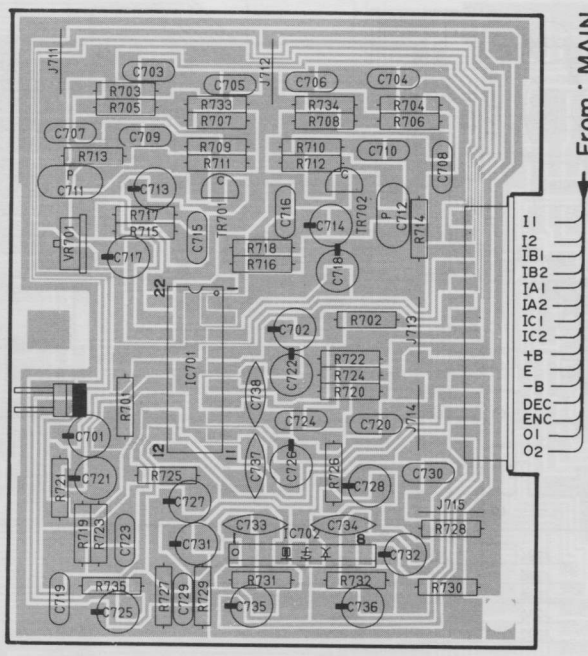

From: MAIN C. BOARD (1)

• Power Circuit Board (3)

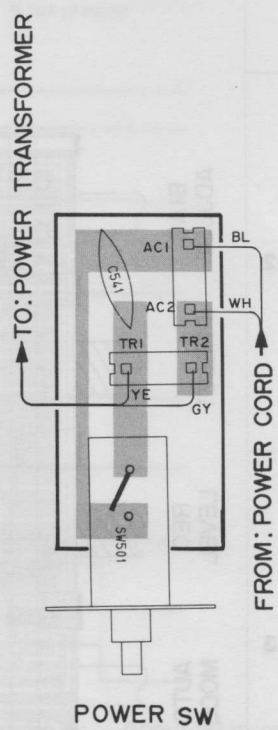

• Power Circuit Board (2)

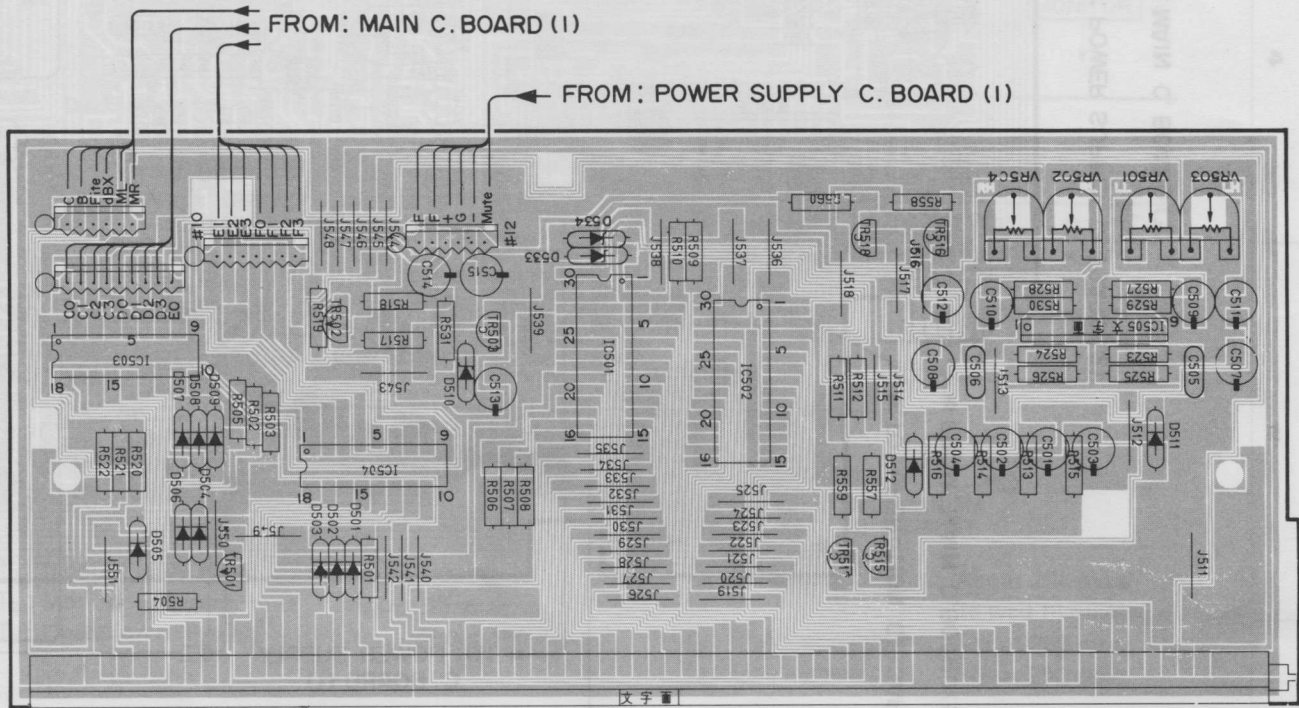

WIRING

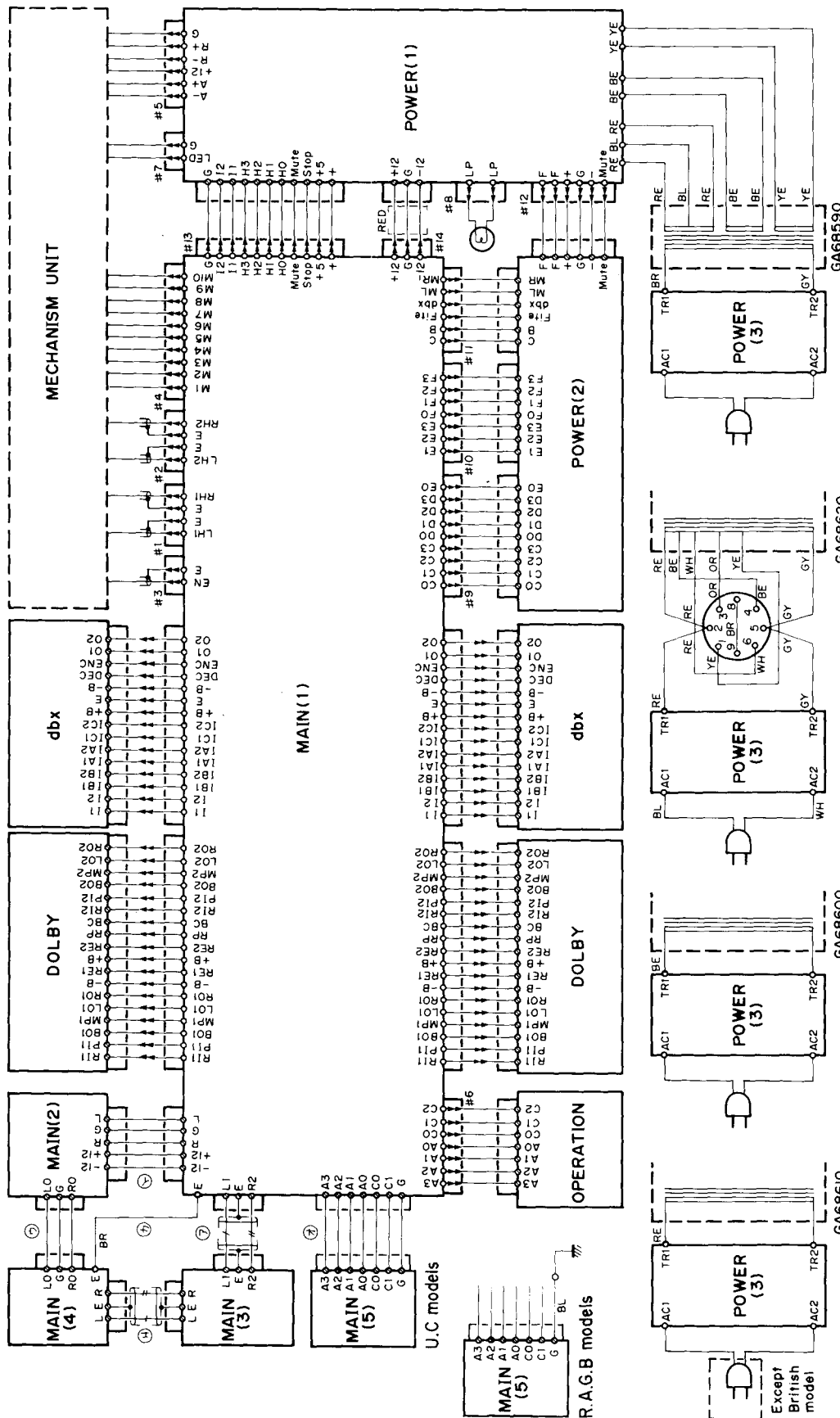

U.S.A & Canadian models

General model

European model

Australian & British models
Except British model

VOLTAGE SELECTOR

Voltage	Terminal No.
110V	5-4 2-1
120V	6-5 3-2
220V	7-1 8-4
240V	7-6 8-3

K-1020

IC BLOCK

IC101, 102, 104, 107 ~ 111, 505, 702: AN6551 or NJM4558S or BA715

IC105, 112: NJM4556S
IC106: NJM4560S

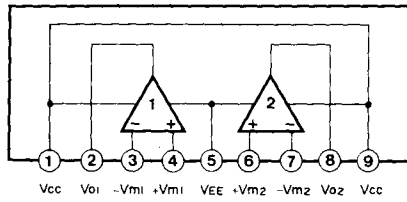

IC103: NJM2043D

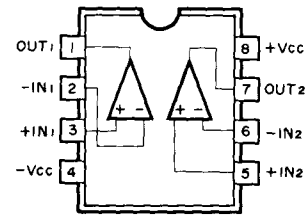

IC113: μ PD4066BC or LC4066B or M4066BP

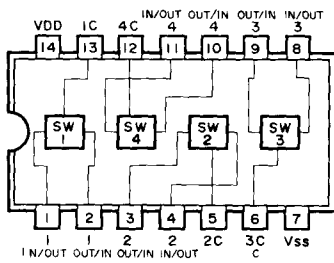

IC114, 503, 504: AN6873 or LB1241

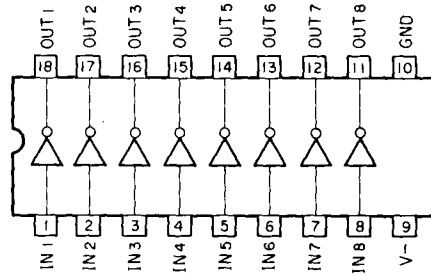

IC501, 502: HA12067NT

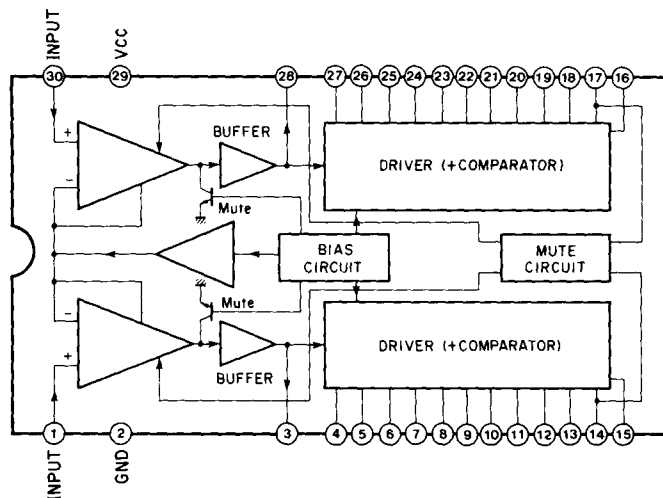

IC506, 507: BA6209

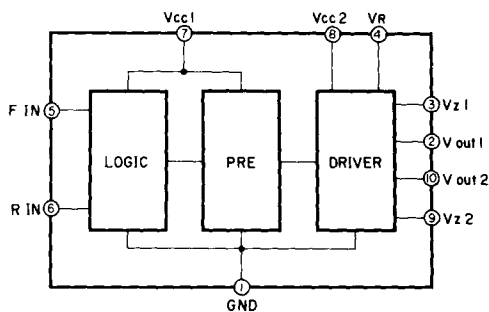

K-1020

IC601, 602: TEA0665

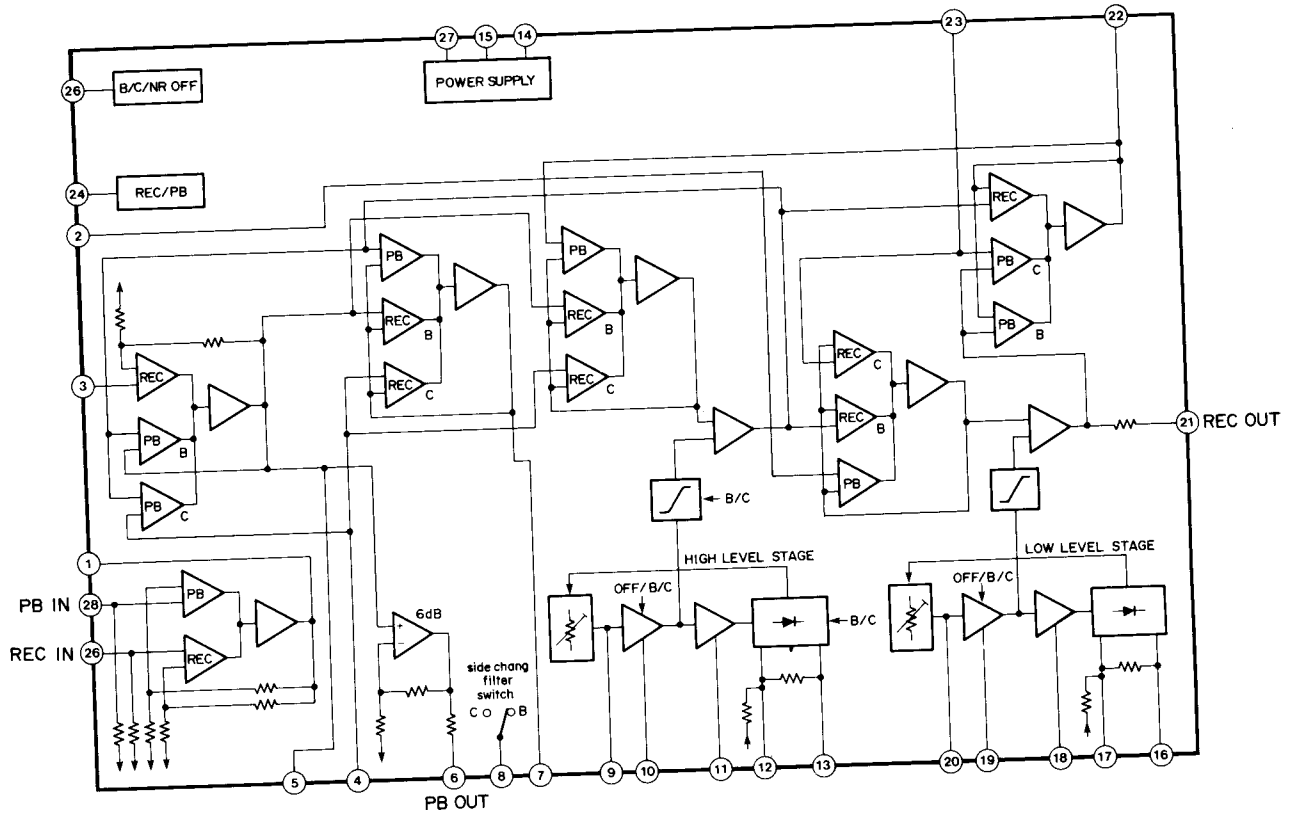

IC701: AN6291

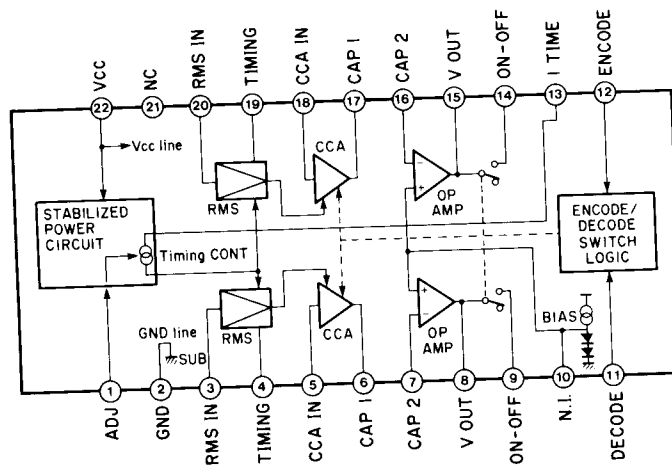

SCHEMATIC DIAGRAM

1
2
3
4
5
6

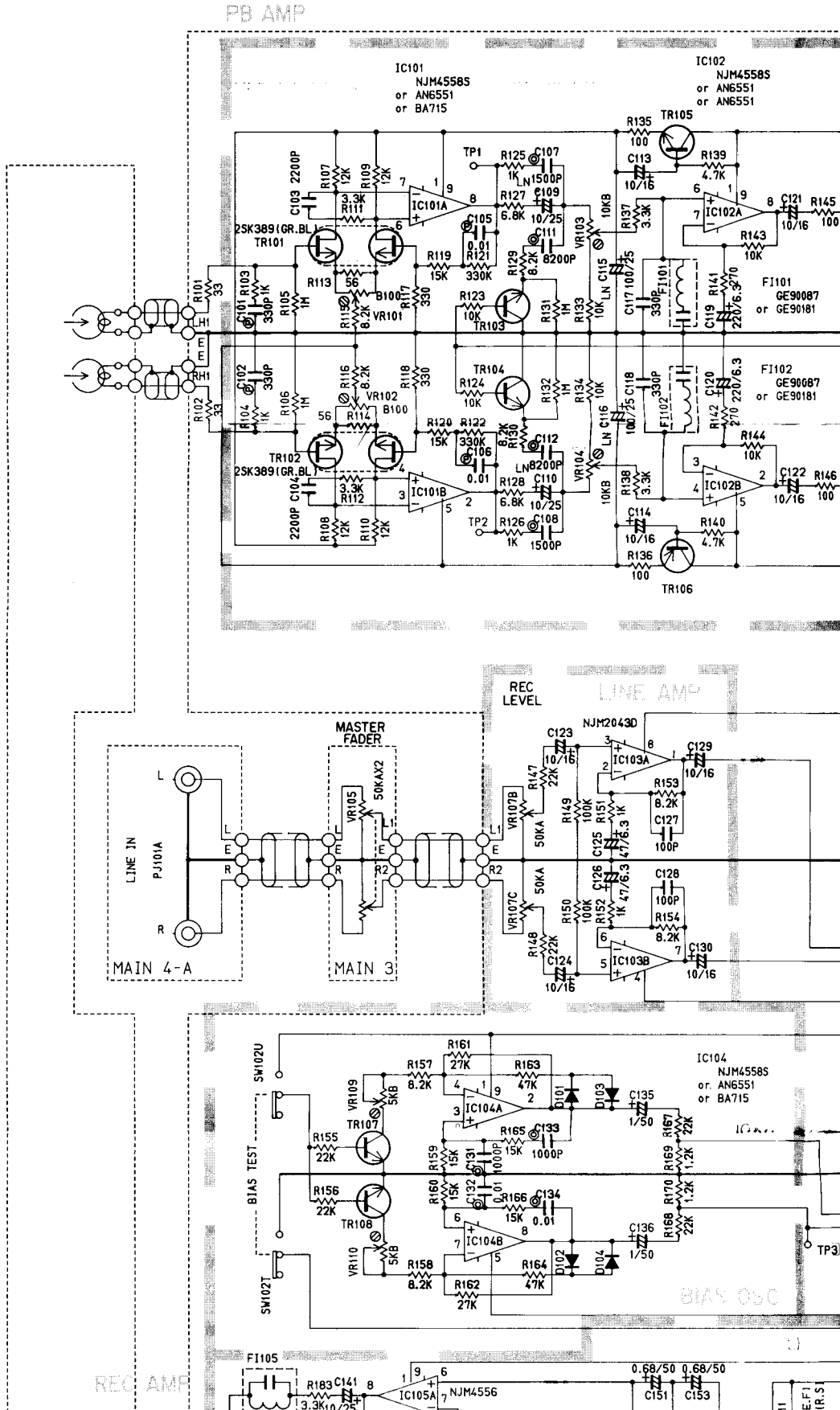

H

I

J

K

DBX (DECODE)

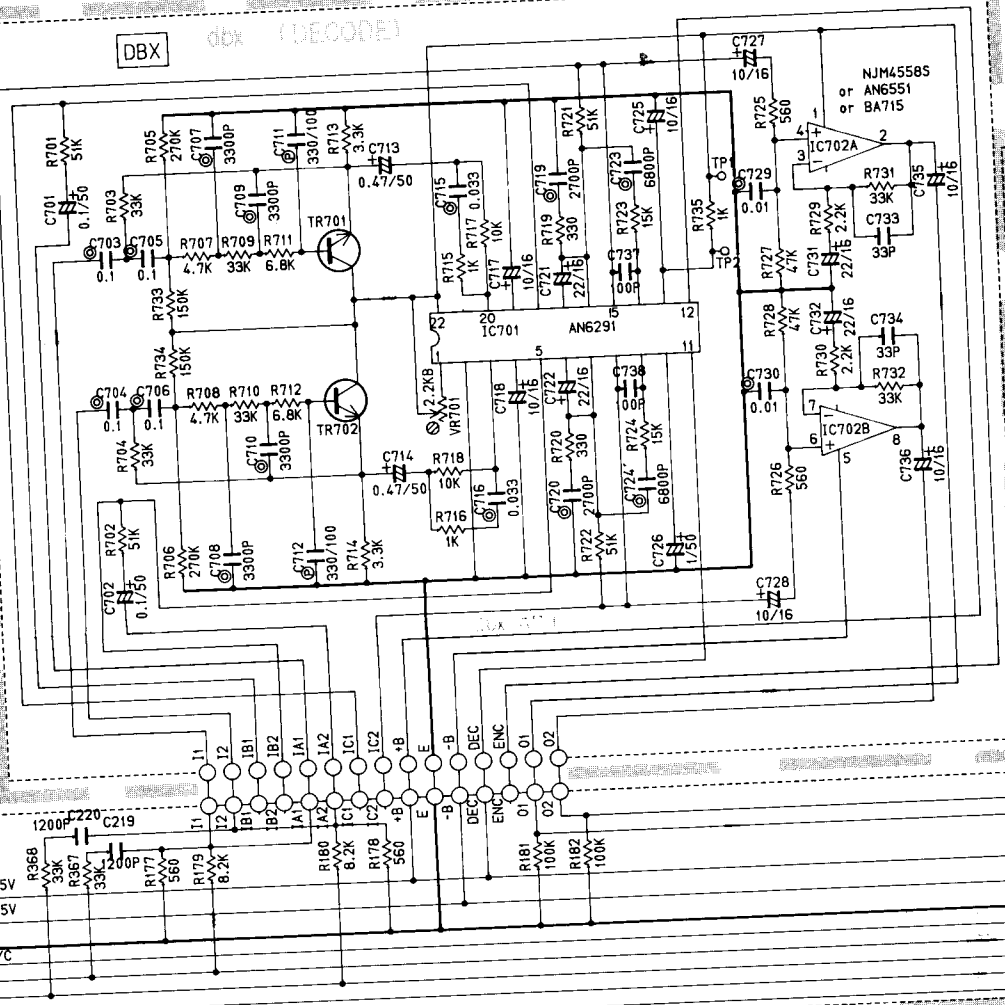

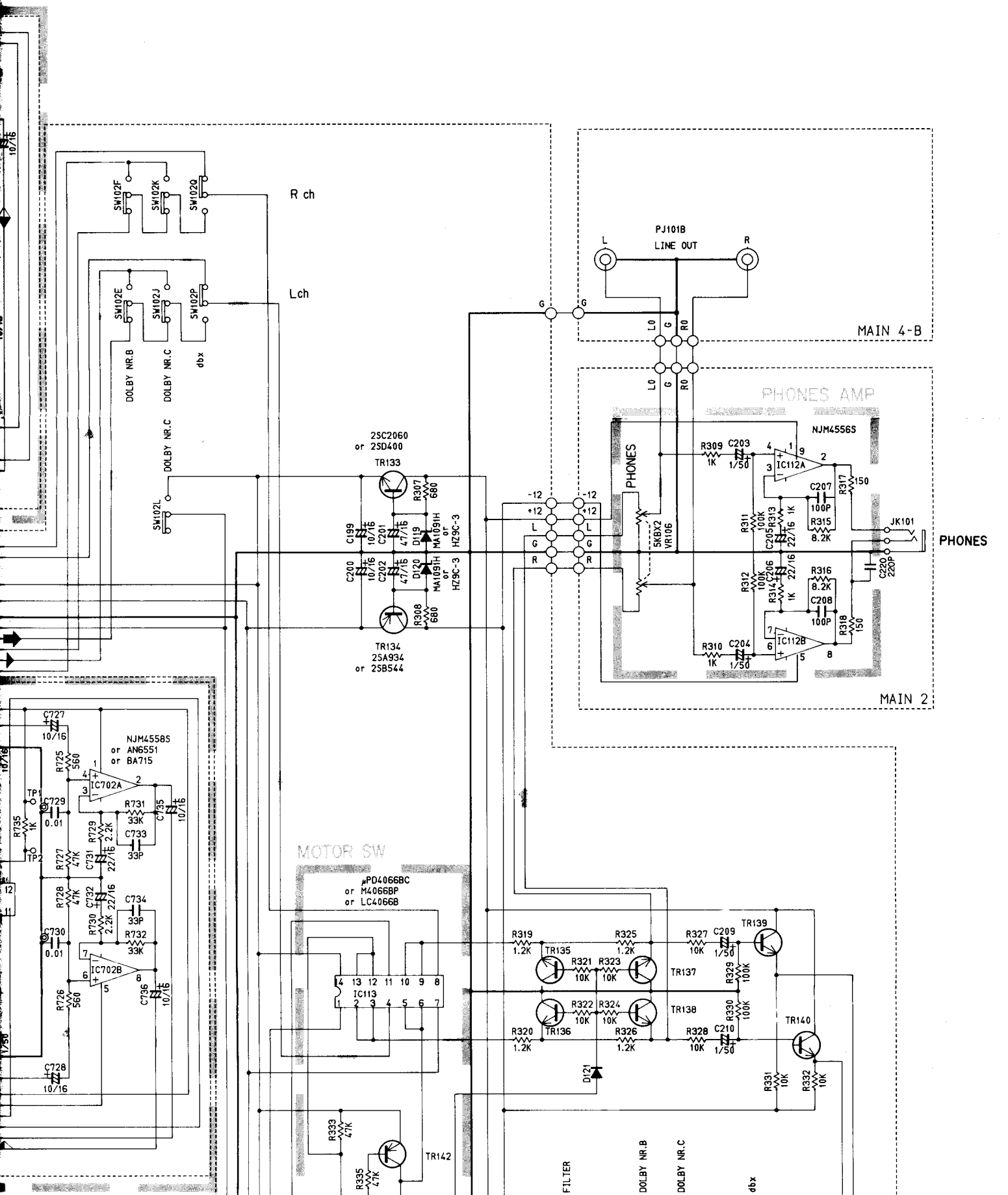

R ch

L ch

PJ101B

LINE OUT

MAIN 4-B

PHONES AMP

PHONES

MAIN 2

MOTOR SW

FILTER

DOLBY NR.B

DOLBY NR.C

dbx

25C2060
or 25D400
TR133

TR134
25A934
or 25B544

NJM4556S

NJM4556S
or AN6551
or BA715

PD4066BC
or M4066BP
or LC4066B

TR135

TR137

TR139

TR136

TR138

TR140

TR142

R333

R335

R319

R321

R323

R327

R320

R322

R324

R328

R330

R332

R334

R336

R338

R340

R342

R344

R346

R348

R350

R352

C199

C200

C201

C202

C203

C204

C205

C206

C207

C208

C209

C727

C728

C729

C730

C731

C732

C733

C734

C735

C736

C737

C738

R307

R308

R309

R310

R311

R312

R313

R314

R315

R316

R317

R318

R319

R320

R300

R301

R302

R303

R304

R305

R306

R307

R308

R309

R310

R311

R312

R313

R314

R315

R316

R317

R318

R319

R320

R321

R322

R323

R324

R325

R326

R327

R328

R329

R330

R331

R332

R333

R334

R335

R336

R337

R338

R339

R340

R341

R342

R343

R344

R345

R346

R347

R348

R349

R350

R351

R352

R353

R354

R355

R356

R357

R358

R359

R360

R361

R362

R363

R364

R365

R366

R367

R368

R369

R370

R371

R372

R373

R374

R375

R376

R377

R378

R379

R380

R381

R382

R383

R384

R385

R386

R387

R388

R389

R390

R391

R392

R393

R394

R395

R396

R397

R398

R399

R400

R401

R402

R403

R404

R405

R406

R407

R408

R409

R410

R411

R412

R413

R414

R415

R416

R417

R418

R419

R420

R421

R422

R423

R424

R425

R426

R427

R428

R429

R430

R431

R432

R433

R434

R435

R436

R437

R438

R439

R440

R441

R442

R443

R444

R445

R446

R447

R448

R449

R450

R451

R452

R453

R454

R455

R456

R457

R458

R459

R460

R461

R462

R463

R464

R465

R466

R467

R468

R469

R470

R471

R472

R473

R474

R475

R476

R477

R478

R479

R480

R481

R482

R483

R484

R485

R486

R487

R488

R489

R490

R491

R492

R493

R494

R495

R496

R497

R498

R499

R500

R501

R502

R503

R504

R505

R506

R507

R508

R509

R510

R511

R512

R513

R514

R515

R516

R517

R518

R519

R520

R521

R522

R523

R524

R525

R526

R527

R528

R529

R530

R531

R532

R

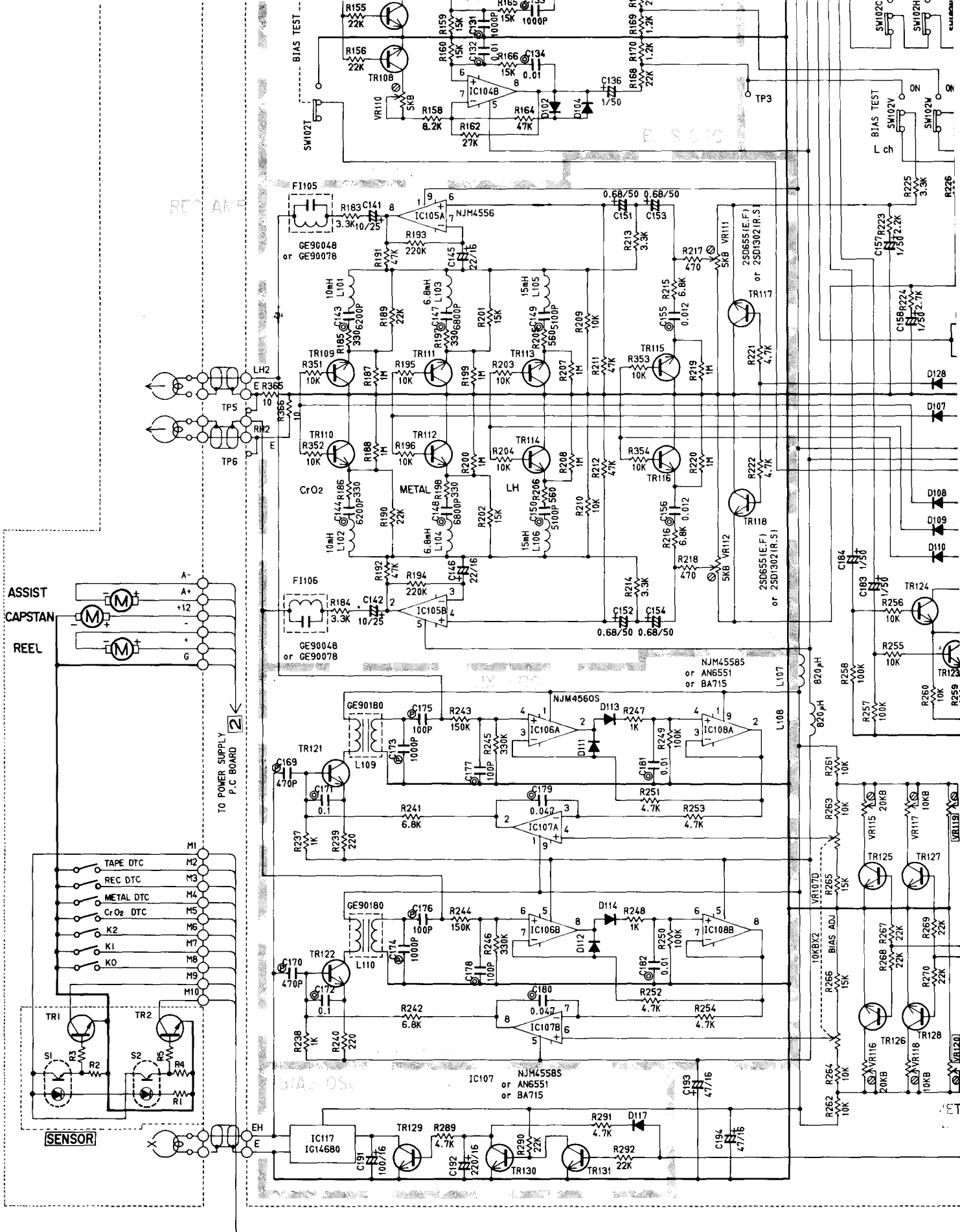

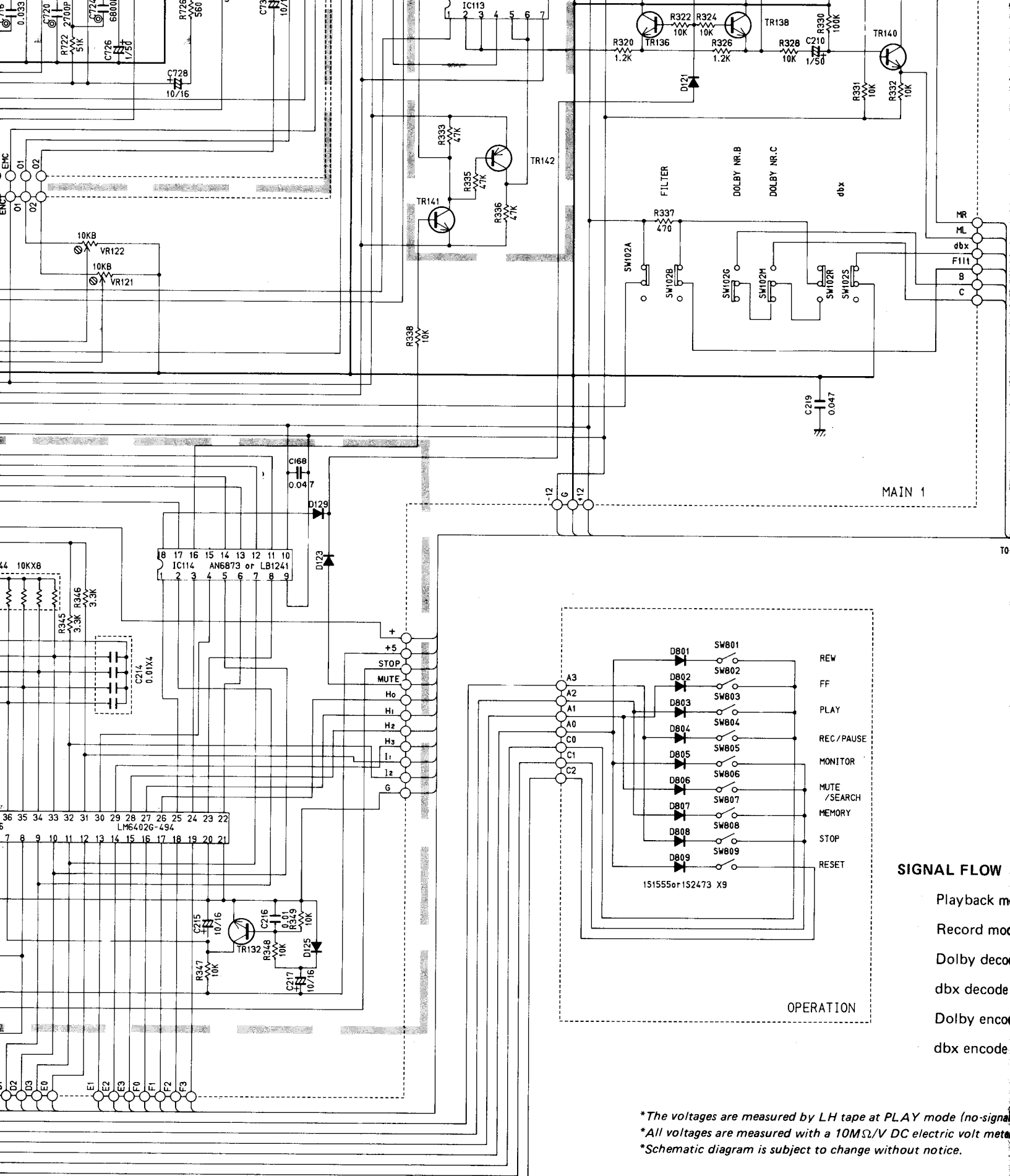

*The voltages are measured by LH tape at PLAY mode (no-signal)
 *All voltages are measured with a 10MΩ/V DC electric volt meter
 *Schematic diagram is subject to change without notice.

CAUTION

- Components having special characteristics are marked Δ and should not be replaced with parts having specifications equal to those original

SIGNAL FLOW

- Playback mode
- Record mode
- Dolby decode
- dbx decode
- Dolby encode
- dbx encode

SCHEMATIC DIAGRAM

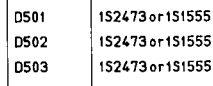
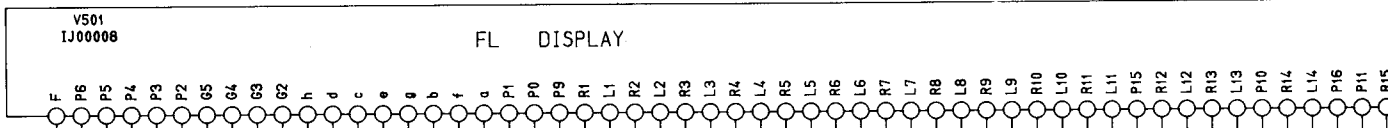

DISPLAY DRIVE

METER DRIVE

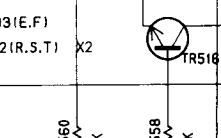
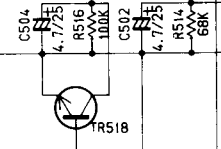
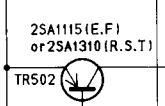
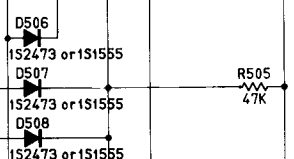
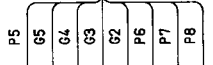
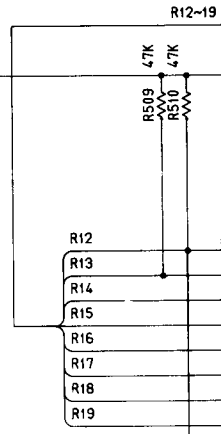
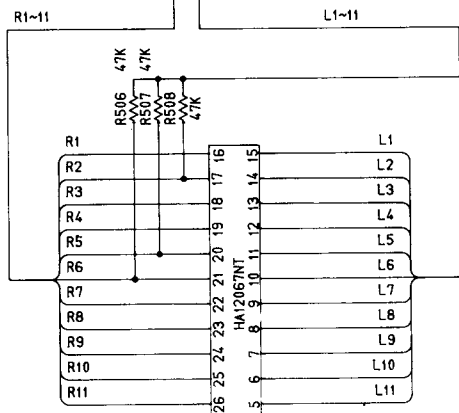
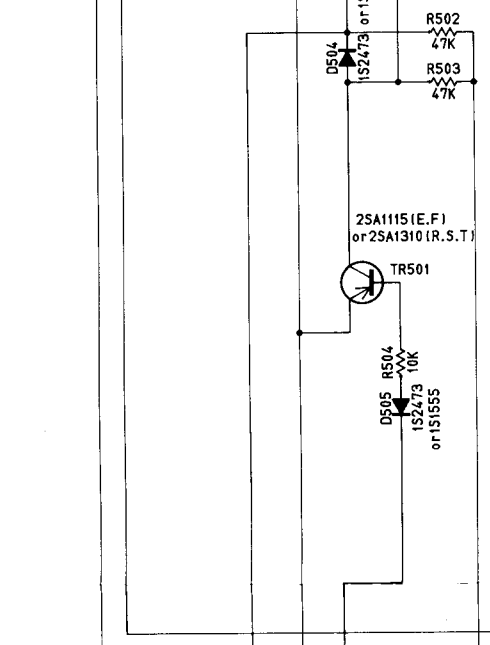

2

3

4

5

6

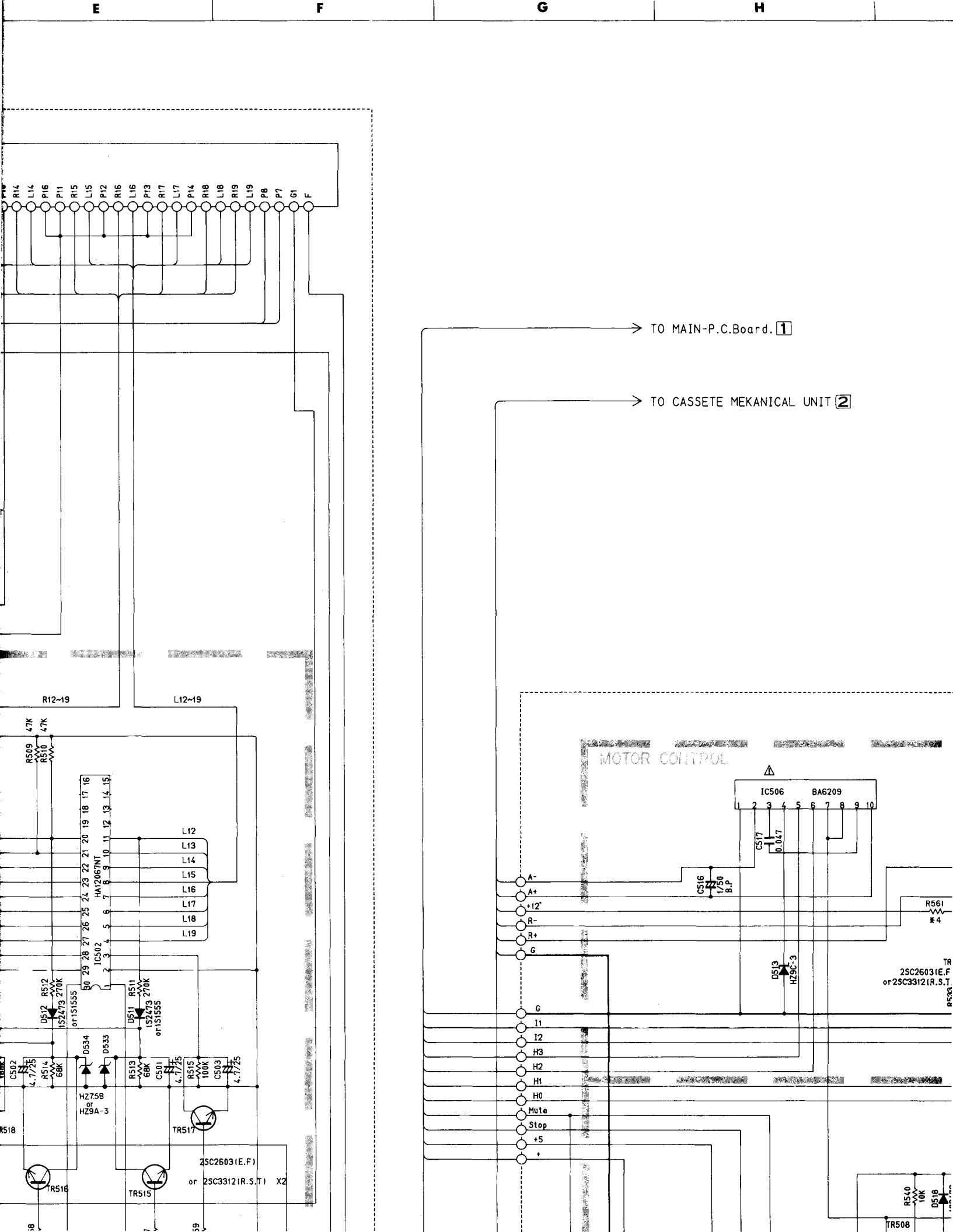

E

F

G

H

R14 L14 P16 P11 R15 L15 P12 R16 L16 P13 R17 L17 P14 R18 L18 R19 L19 P8 P7 G1 F

TO MAIN-P.C.Board. 1

TO CASSETTE MEKANICAL UNIT 2

R12-19 L12-19

MOTOR CONTROL

IC506 BA6209

TR 2SC2603 (E.F.) or 2SC3312 (R.S.T.)

R540 10K DS13 TR508

V501 (Display Unit)

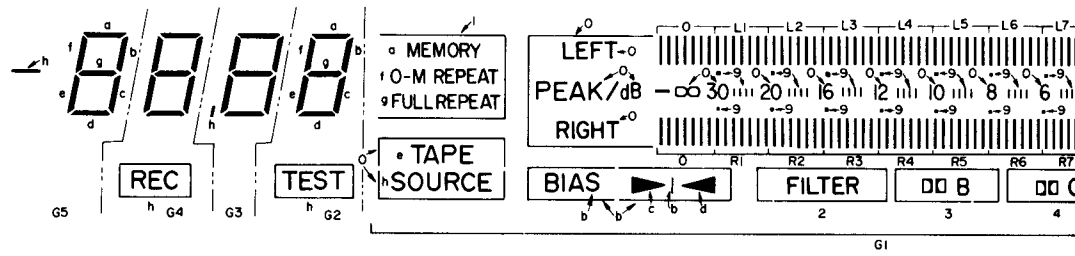

Pin assignment

Pin No.	1	2	3	4	5	6	7	8	9	10	11	12	13	14	15	16
Assignment	F	P6	P5	P4	P3	P2	G5	G4	G3	G2	h	d	c	e	g	b
Pin No.	26	27	28	29	30	31	32	33	34	35	36	37	38	39	40	41
Assignment	R3	L3	R4	L4	R5	L5	R6	L6	R7	L7	R8	L8	R9	L9	R10	L10
Pin No.	51	52	53	54	55	56	57	58	59	60	61	62	63	64	65	66
Assignment	L14	P16	P11	R15	L15	P12	R16	L16	P13	R17	L17	P14	R18	L18	R19	L19

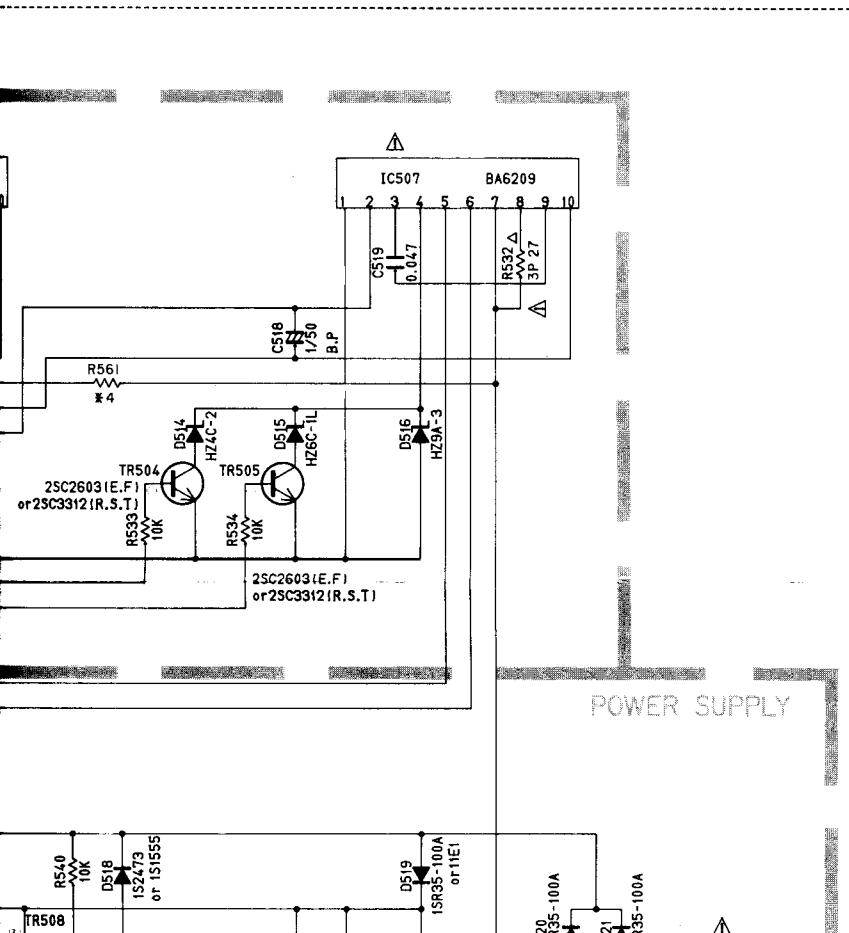

POWER SUPPLY

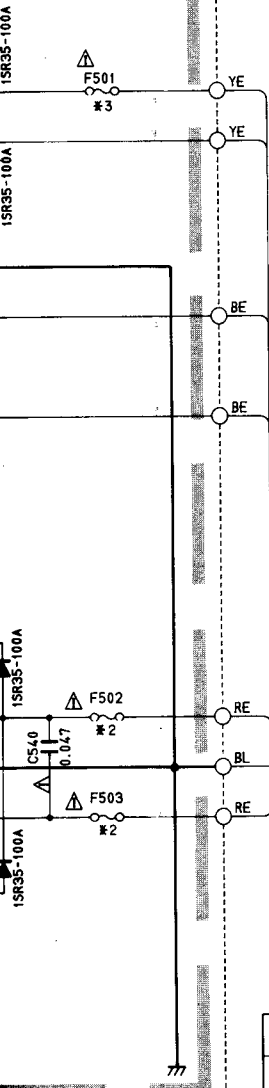

U.S.A & Canadian models

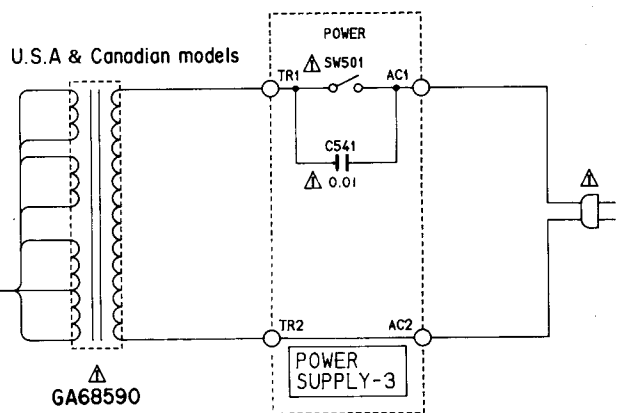

	R	U	C	A	G	B
✖2 F502,503	T1.0A 250V	1.0A 250V	→	T800mA 250V		→
✖3 F501	T2.0A 250V	2.0A 250V	→	T1.0A 250V		→
✖4 R561	SHORT			SHORT		→

Australian & British models

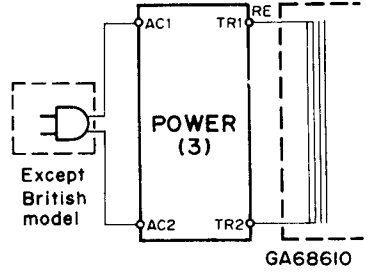

European model

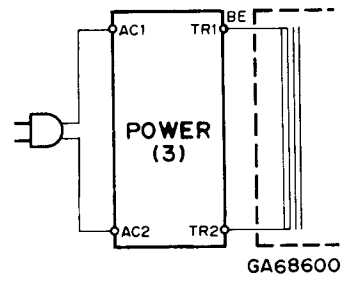

General model

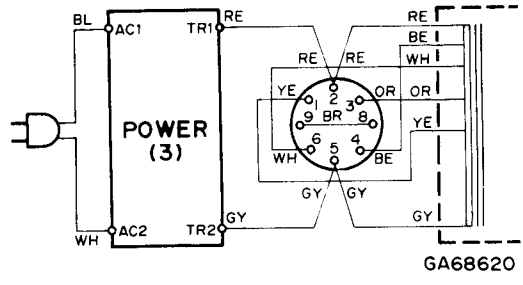

VOLTAGE SELECTOR

Voltage	Terminal No.	
110V	5-4	2-1
120V	6-5	3-2
220V	7-1	8-4
240V	7-6	8-3

Special characteristics are marked Δ and must be in accordance with specifications equal to those originally installed.

*The voltages are measured by LH tape at PLAY mode (no-signal condition)
 *All voltages are measured with a 10M Ω /V DC electric volt meter.
 *Schematic diagram is subject to change without notice.

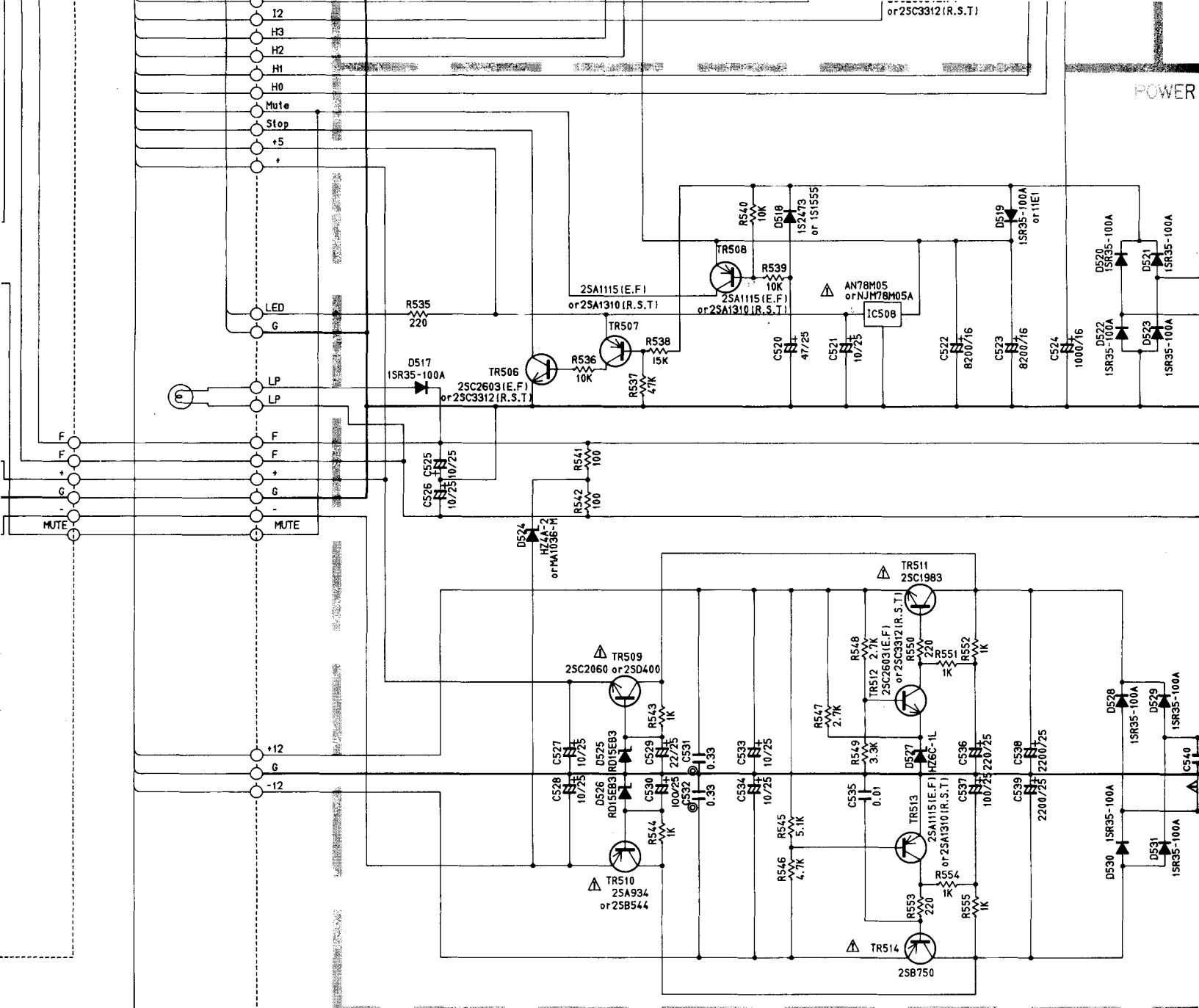

POWER SUPPLY-1

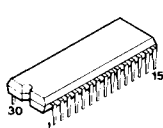
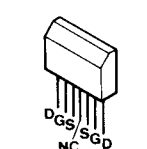
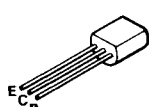
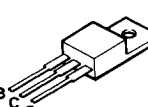
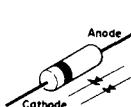
<p>HA12067NT</p> 	<p>2SK389 (GR, BL)</p> 	<p>2SA1115 (E, F) 2SD1302 (R, S) 2SA1310 (R, S, T) 2SC2634 (R, S, T) 2SA934 2SB544 2SC2603 (E, F) 2SC3312 (R, S, T) 2SC2060 2SD400 2SD655</p> 	<p>2SC1983 2SB750</p> 	<p>ISS/33 MA1036-M HZ9C-3 HZ4C2 MA1091-H 1SR35-100A RD15EB3 HZ9A-3 HZ6C-1L IS2473 IS1555 HZ4A2</p> 
---	--	---	--	--

CAUTION
 • Components having special ch
 replaced with parts having sp

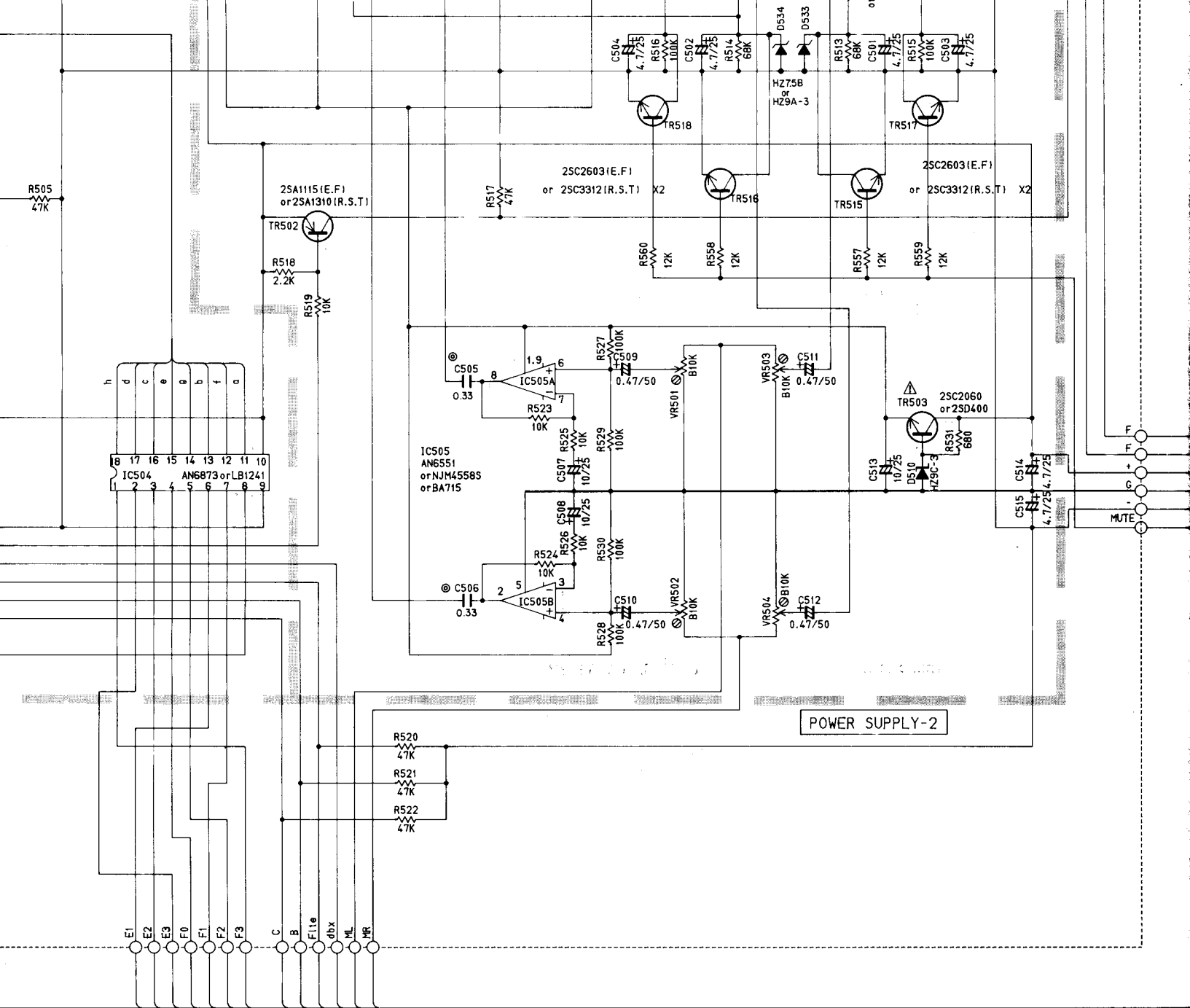

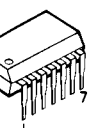
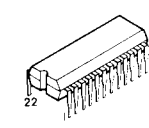
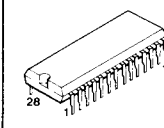
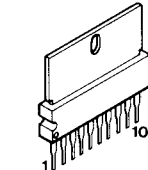
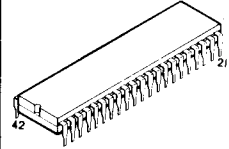
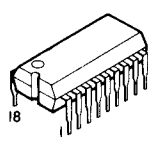
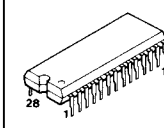
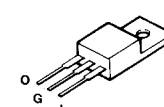
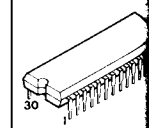
066BC 66B 66BP 	AN6291 	TEA0665 	BA6209 	LM6402G-494 	LB1241 AN6873 	LC7800 	AN78M05 NJM78M05A 	HA12067NT 
---	--	---	--	---	--	--	---	---

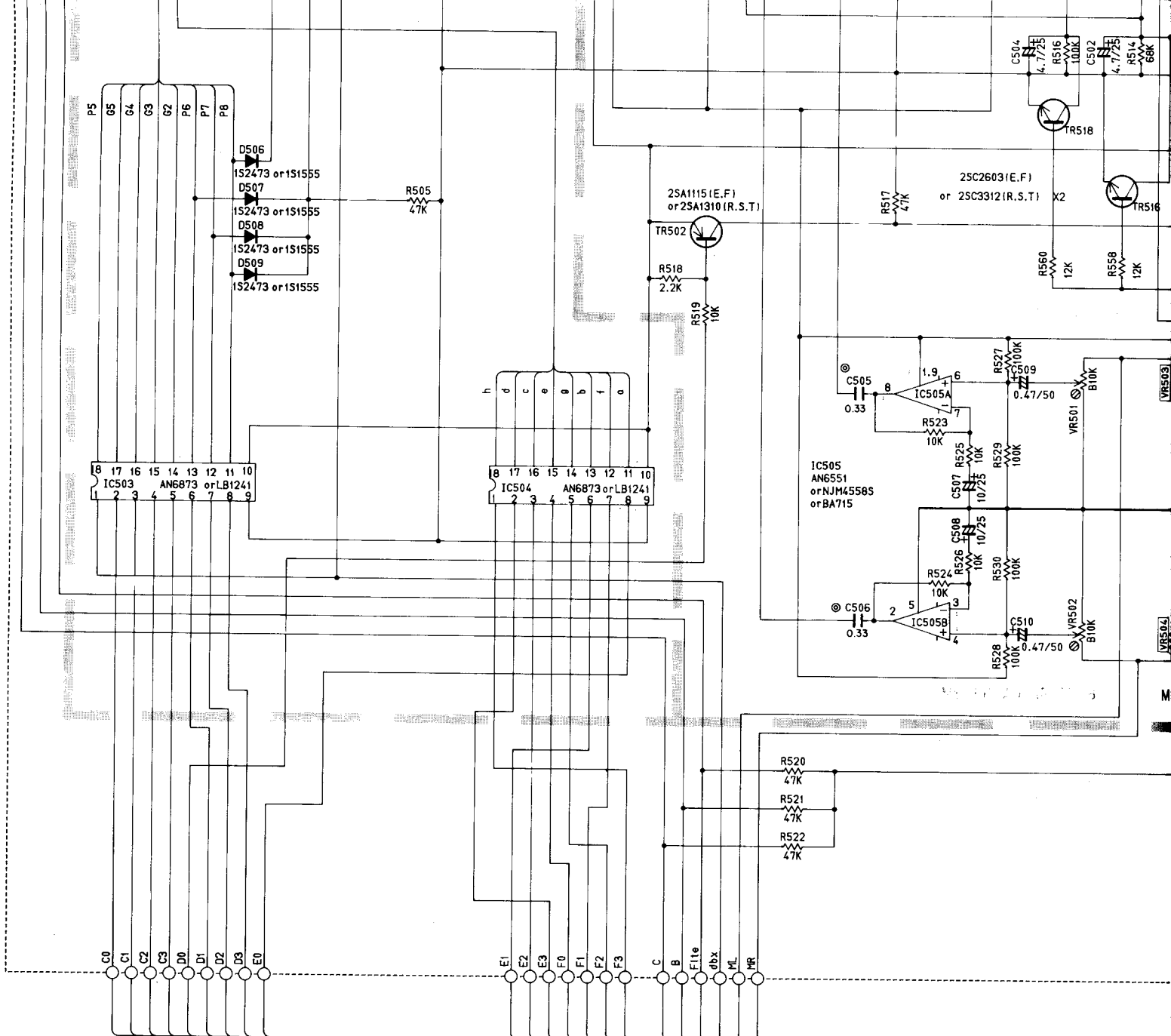

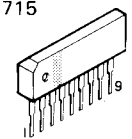
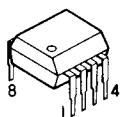
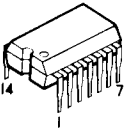
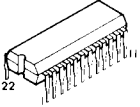
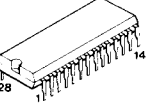
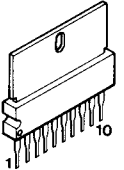
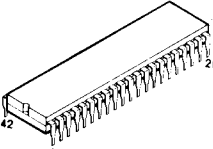
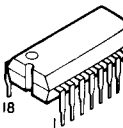
<p>NJM4558S NJM4556S AN6551 BA715</p> 	<p>NJM2043D</p> 	<p>μPD4066BC LC4066B M4066BP</p> 	<p>AN6291</p> 	<p>TEA0665</p> 	<p>BA6209</p> 	<p>LM6402G-494</p> 	<p>LB1241 AN6873</p> 
---	---	--	---	---	---	--	--

PARTS LIST

K-1020

■ WARNING

UL Standard 1270 requires that components marked \triangle be replacement with parts having specifications equal to those originally installed.

- Carbon resistors of this cassette deck are 1/4W. There is no description about them in this parts list. Use the "Part No." HJ35○○○○ or equivalent.

■ ELECTRICAL PARTS

Ref. No.	Part No.	Description	部 品 名	Remarks	Common Model	Markets	ランク
※	NA 08 61 80	Operation Circuit Board		オペレーションシート			
	iF 00 00 40	Diode	IS1555	ダイオード	D801~809		
	KA 90 63 80	Switch	5MEVQ-QRB-04M	ライトタッチスイッチ	SW801~809		
※	NA 08 62 00	Main Circuit Board		メインシート	Silver	J	
※	NA 08 62 10	"		"	Silver	U, C	
※	NA 08 62 20	"		"	Black	J	
※	NA 08 62 30	"		"	Black	U, C	
※	NA 08 62 40	"		"	Silver	R, A, G, B	
※	NA 08 62 50	"		"	Black	R, A, G, B	
	FG 41 21 00	Ceramic Cap	100pF 50V	セラコン	C127,128,177,178,207,208		
	FG 41 22 20	"	220pF 50V	"	C212, 213, 220		
	FG 41 23 30	"	330pF 50V	"	C117, 118		
	FG 44 41 00	"	0.01 μ F 50V	"	C211, 216		
	FG 44 44 70	"	0.047 μ F 50V	"	C168, 219		
	UM 05 71 00	Electrolytic Cap	10 μ F 25V	ケミコン	C109, 110, 141, 142		
	UM 05 81 00	"	100 μ F 25V	"	C115, 116		
	FZ 00 35 70	Capacitor Array	0.01 μ F×6	コンデンサーアレー	C218	R,U,A,G,C,B	
	FZ 00 37 50	"	0.01 μ F×4	"	C214		
	UA 25 33 30	Mylar Cap	3300pF 50V	マイラーコン	C159, 160		
	FA 15 35 10	"	5100pF 50V	"	C149, 150		
	FA 15 36 20	"	6200pF 50V	"	C143, 144, 147, 148		
	UA 25 36 80	"	6800pF 50V	"	C165, 166		
	UA 25 38 20	"	8200pF 50V	"	C111, 112		
	UA 25 31 00	"	1000pF 50V	"	C131, 133		
	FA 15 31 20	"	1200pF 50V	"	C219, 220		
	UA 25 31 50	"	1500pF 50V	"	C107, 108		
	UA 25 32 20	"	2200pF 50V	"	C103, 104		
	UA 25 41 00	"	0.01 μ F 50V	"	C132,134,181,182,195		
	UA 25 41 20	"	0.012 μ F 50V	"	C155, 156		
	UA 25 44 70	"	0.047 μ F 50V	"	C179, 180		
	UA 25 51 00	"	0.1 μ F 50V	"	C171, 172		
	UW 93 82 20	Electrolytic Cap	220 μ F 16V	ケミコン	C192		
	UT 45 21 00	Polypropylene Film Cap	100pF 100V	ポリプロコン	C175, 176		
	UT 45 23 30	"	330pF 100V	"	C101, 102		
	UT 45 24 70	"	470pF 100V	"	C169, 170		
	FT 15 31 00	"	1000pF 100V	"	C173, 174		
	UT 45 41 00	"	0.01 μ F 100V	"	C105, 106		
	UW 91 74 70	Electrolytic Cap	47 μ F 6.3V	ケミコン	C125, 126		
	UW 91 82 20	"	220 μ F 6.3V	"	C119, 120		
	UW 93 71 00	"	10 μ F 16V	"	C113,114,121~124,129,130,187,188,198~200,215,217		
	UW 93 72 20	"	22 μ F 16V	"	C145, 146, 205, 206		
	UW 93 74 70	"	47 μ F 16V	"	C193, 194, 201, 202		
	UW 93 81 00	"	100 μ F 16V	"	C191		
	UW 94 64 70	"	4.7 μ F 25V	"	C137~140,161~164,189,190		
	UW 56 56 80	"	0.68 μ F 50V	"	C151~154		
	UW 96 61 00	"	1 μ F 50V	"	C135,136,157,158,183~186,196,197,203,204,209,210		
	GE 20 05 10	Dolby Filter		ドルビーフィルター	F1103, 104	K-720	
	GE 90 04 80	Bias Trap Coil	105kHz	バイアストラップコイル	F1105,106	併用	
	GE 90 07 80	"	105kHz	"	"	interchangeable	

K-1020

New Parts (新規部品)

Ref. No.	Part No.	Description	部 品 名	Remarks	Common Model	Markets	ランク
※	GE 90 08 70	Bias Trap Coil	105kHz	バイアストラップコイル	C101,102 } 併用		
	GE 90 18 10	"	105kHz	"	" } interchangeable		
	GE 90 09 60	Coil	820 μ H	コ イ ル	L107, 108		
※	GE 90 16 10	"	6.8mH	"	L103, 104		
	GE 90 16 30	"	10mH	"	L101, 102		
	GE 90 16 50	"	15mH	"	L105, 106		
	GE 90 18 00	"		ステップアップコイル	L108, 109		
	GG 00 07 20	Ceramic Crystal Unit	CSB800A	セラミック発振子	XL101		
※	HQ 40 02 70	Slide Potentiometer	A50k Ω ×2	スライド可変抵抗器	VR105		
※	HS 11 06 20	Switch Potentiometer Unit		スイッチ・可変抵抗器ユニット	VR107		
※	HS 41 27 40	Potentiometer	A5k Ω ×2	可 変 抵 抗 器	VR106		
※	HT 37 03 00	Pre-Set Potentiometer	B100 Ω	半 固 定 抵 抗	VR101, 102		
	HT 37 03 70	"	B5k Ω	"	VR109~112		
	HT 37 03 80	"	B10k Ω	"	VR103, 104, 117, 118, 121, 122		
	HT 37 03 90	"	B20k Ω	"	VR115, 116, 119, 120		
	HV 45 51 50	Flame Proof Carbon Resistor	150 Ω	不燃化カーボン抵抗	R239, 240		
	HZ 00 28 80	Resistor Array	10k Ω ×8	抵 抗 ア レ ー	R344		
	iA 11 15 10	Transistor	2SA1115 (E, F)	ト ラ ン ジ ス タ	TR106, 142		
	iA 09 34 00	"	2SA934	"	TR134 } 併用		
	iB 05 44 20	"	2SB544	"	" } interchangeable		
	iC 26 03 10	"	2SC2603 (E, F)	"	TR103~105,107~116, 119~132,135~141		
	iC 20 60 00	"	2SC2060	"	TR133 } 併用		
	iD 04 00 00	"	2SD400	"	" } interchangeable		
	iD 06 55 10	"	2SD655 (E, F)	"	TR117,118 } 併用		
	iD 13 02 00	"	2SD1302 (R, S)	"	" } interchangeable		
	iE 10 45 00	Dual FET	2SK389 (GR, BL)	デュアル F E T	TR101, 102		
	iF 00 61 30	Diode	1SS133	ダ イ オ ー ド	D101~118, 121~125, 128, 129		
	iF 00 61 30	"	1SS133	"	D126, 127	R,U,A,G,C,B	
	iF 00 33 20	Zener Diode	HZ9C-3	ツェナーダイオード	D119,120 } 併用		
	iF 00 68 80	"	MA1091-H	"	" } interchangeable		
	iG 07 74 00	IC	NJM4556S	I C	IC105, 112		
	iG 12 18 00	"	NJM4560S	"	IC106		
	iG 03 47 00	"	AN6551	"	IC101,102,104, 107~111 } 併用		
	iG 07 68 00	"	NJM4558S	"	" } interchangeable		
	iG 13 22 00	"	BA715	"	"		
※	iG 12 15 00	"	NJM2043D	"	IC103		
	iG 06 16 00	"	μ PD4066BC	"	IC113 } 併用		
	iG 08 92 00	"	LC4066B	"	" } interchangeable		
	iG 11 05 00	"	M4066BP	"	"		
	iG 14 59 00	"	AN6873	"	IC114 } 併用	K-720	
※	iG 14 62 00	"	LB1241	"	" } interchangeable		
	iG 14 63 00	"	LC7800	"	IC115	K-720	
※	iG 14 64 00	"	LM6402G-494	"	IC116		
※	iG 14 68 00	Bias Osc Block		バイアス発振ブロック	IC117		
※	KA 80 49 50	Push Switch		プッシュスイッチ	SW102		

※New Parts (新規部品)

※New Pa

Ref. No.	Part No.	Description	部 品 名	Remarks	Common Model	Markets	ランク
	LB 30:21:40	Phone Jack					
	LB 30:21:50	"	ヘッドホンジャック	JK101	Black		
	LB 60:50:30	DIN Jack	8P	"	Silver		
			D I N ジャック	JK102		R,U,C,A,G,B	
	LB 40:12:90	Pin Jack	4P	ピンジャック	PJ101		
	LA 00:41:20	Test Point Pin		テストポイントピン			
	BB 07:04:20	Bus Bar	l=100	バスバ			
*	NA 08:62:60	Power Circuit Board		電 源 シ ー ト			
*	NA 08:62:70	"		"		J	
*	NA 08:62:80	"		"		U, C	
*	NA 08:64:50	"		"		A, G, B	
	FG 44:41:00	Ceramic Cap	0.01 μ F 50V	セラコン	C535	R	
	FG 44:44:70	"	0.047 μ F 50V	"	C517, 519, 540		
	Fi 40:41:00	"	0.01 μ F AC250V	"	C541	J	
	Fi 41:41:00	"	0.01 μ F	"	"	"	
	UA 55:53:30	Mylar Cap	0.33 μ F 50V	マイラーコン	C531, 532, 505, 506	R,U,A,G,C,B	
	Ui 93:98:20	Electrolytic Cap	8200 μ F 16V	ケミコン	C522, 523		
	UK 16:61:00	"	1 μ F 50V	B P コ ン	C516, 518		
	UW 94:64:70	"	4.7 μ F 25V	ケミコン	C501~504,514,515		
	UW 94:71:00	"	10 μ F 25V	"	C507,508,513,521,525~528,533,534		
	UW 94:72:20	"	22 μ F 25V	"	C529		
	UW 94:81:00	"	100 μ F 25V	"	C537, 530		
	UW 96:54:70	"	0.47 μ F 50V	"	C509~512		
	UW 83:91:00	"	1000 μ F 16V	"	C524		
	UW 94:82:20	"	220 μ F 25V	"	C536		
	UW 94:92:20	"	2200 μ F 25V	"	C538, 539		
	UW 94:74:70	"	47 μ F 25V	"	C520		
	HL 33:42:70	Metal Oxide Film Resistor	27 Ω 3P	酸金抵抗	R532		
	HT 37:03:80	Pre-Set Potentiometer	B10k Ω	半固定抵抗	VR501~504		
	iA 09:34:00	Transistor	2SA934	トランジスタ	TR510	併用	
	iB 05:44:20	"	2SB544	"	"	Interchangeable	
	iA 11:15:10	"	2SA1115 (E, F)	"	TR501,502,507,508,513		
	iB 07:50:00	"	2SB750	"	TR514		
	iC 19:83:00	"	2SC1983	"	TR511		
	iC 26:03:10	"	2SC2603 (E, F)	"	TR504~506,512,515~518		
	iC 20:60:00	"	2SC2060	"	TR503,509	併用	
	iD 04:00:00	"	2SD400	"	"	Interchangeable	
	iF 00:17:00	Zener Diode	RD15EB3	ツェナーダイオード	D525, 526		
	iF 00:25:60	"	HZ9A-3	"	D516, 534, 533		
	iF 00:15:10	"	HZ6C-1L	"	D515, 527		
	iF 00:00:40	Diode	IS1555	ダイオード	D501~509,511,512,518		
	iF 00:33:20	Zener Diode	HZ9C-3	ツェナーダイオード	D510, 513		
	iF 00:38:20	"	HZ4A2	"	D524		
	iF 00:38:90	"	HZ4C2	"	D514		
	iH 00:14:30	Diode	ISR35-100A	ダイオード	D517,519~523,528~531		
	iF 00:15:40	Zener Diode	HZ9A	ツェナーダイオード	D533, 534	併用	
	iF 00:64:70	"	MTZ7.5B	"	"	Interchangeable	

*New Parts (新規部品)

K-1020

Ref. No.	Part No.	Description	部 品 名		Remarks	Common Model	Markets	ランク
	iG 07:53:00	IC	AN78M05	I	C	IC508	併用	
	iG 07:56:00	"	MJM78M05A	"	"	"	Interchangeable	
	iG 03:47:00	"	AN6551	"	"	IC505	併用	
	iG 07:68:00	"	NJM4558S	"	"	"	Interchangeable	
	iG 13:22:00	"	BA715	"	"	"	"	
	iG 10:11:00	"	BA6209	"	"	IC506, 507	"	
	iG 14:60:00	"	HA12067NT	"	"	IC501, 502	"	K-720
	iG 14:59:00	"	AN6873	"	"	IC503,504	併用	"
*	iG 14:62:00	"	LB1241	"	"	"	Interchangeable	
*	iJ 00:00:80	Display Unit		螢 光 表 示 管	V501			
	KA 80:32:90	Power Switch	SDLC1P002	パ ワ ー ス イ ッ チ	SW501	"	併用	
	KA 80:36:10	"	ESB8213A-F	"	"	"	Interchangeable	
	KB 00:03:30	Fuse	T1.0A 250V	ヒ ュ ー ズ	F502, 503			J, R
	KB 00:07:20	"	T800mA 250V	"	"			A, G, B
	KB 00:10:60	"	1.0A 250V	"	"			U, C
	KB 00:03:50	"	T2.0A 250V	"	F501			J, R
	KB 00:07:30	"	T1.0A 250V	"	"			A, G, B
	KB 00:12:40	"	2.0A 250V	"	"			U, C
	LA 00:21:40	Lapping Terminal	P=10 2P i-Type	i 型ラッピング端子板				
	LA 00:23:20	"	P=7.5 3P i-Type	"				
	LA 00:23:30	"	P=7.5 4P i-Type	"				
	LB 20:18:80	Fuse Holder Pin		ヒューズホルダーピン				
*	AA 62:43:00	Holder, FL		F L ホ ル ダ ー				
	BB 06:62:90	Ground Washer		アースワッシャー				
	BA 08:40:00	Heat Sink		放 熱 板				
	CB 60:56:20	Plastic Rivet		プラスチックリベット				
	Ei 03:00:66	Binding Head Tapping Screw	3x6 ZMC2-Y	バインドタッピングネジ	PACK			
*	CB 63:91:70	Filter, FL		F L フィルター				
*	NA 08:62:90	Dolby Circuit Board		ドルビーシート				
	UA 25:34:70	Mylar Cap	4700pF 50V	マイラーコン	C603, 604, 621, 622			
	UA 25:31:00	"	1000pF 50V	"	C601, 602			
	UA 25:41:00	"	0.01μF 50V	"	C623, 624			
	UA 25:44:70	"	0.047μF 50V	"	C607, 608, 617, 618			
	UW 93:71:00	Electrolytic Cap	10μF 16V	ケ ミ コ ン	C605,606,619,620,625			
	UW 56:52:20	"	0.22μF 50V	"	C609, 610, 615, 616			
	UW 56:56:80	"	0.68μF 50V	"	C611~614			
	GE 90:06:80	Coil	20kHz	スキューイングコイル	Fi601,602	併用		
	GE 90:07:90	"	19kHz	トラップコイル	"	Interchangeable		
*	iG 14:47:00	IC	TEA0665	I	C	IC601, 602		
	LB 02:01:80	Connector	18P	S H V Q コネクター				K-720
	NA 08:63:00	dbx Circuit Board		d b x シ ー ト				K-720
	FG 41:13:30	Ceramic Cap	33pF 50V	セラコン	C733, 734			
	FG 41:21:00	"	100pF 50V	"	C737, 738			
	UA 25:32:70	Mylar Cap	2700pF 50V	マイラーコン	C719, 720			

*New Parts (新規部品)

1 ■ EXPLODED VIEW

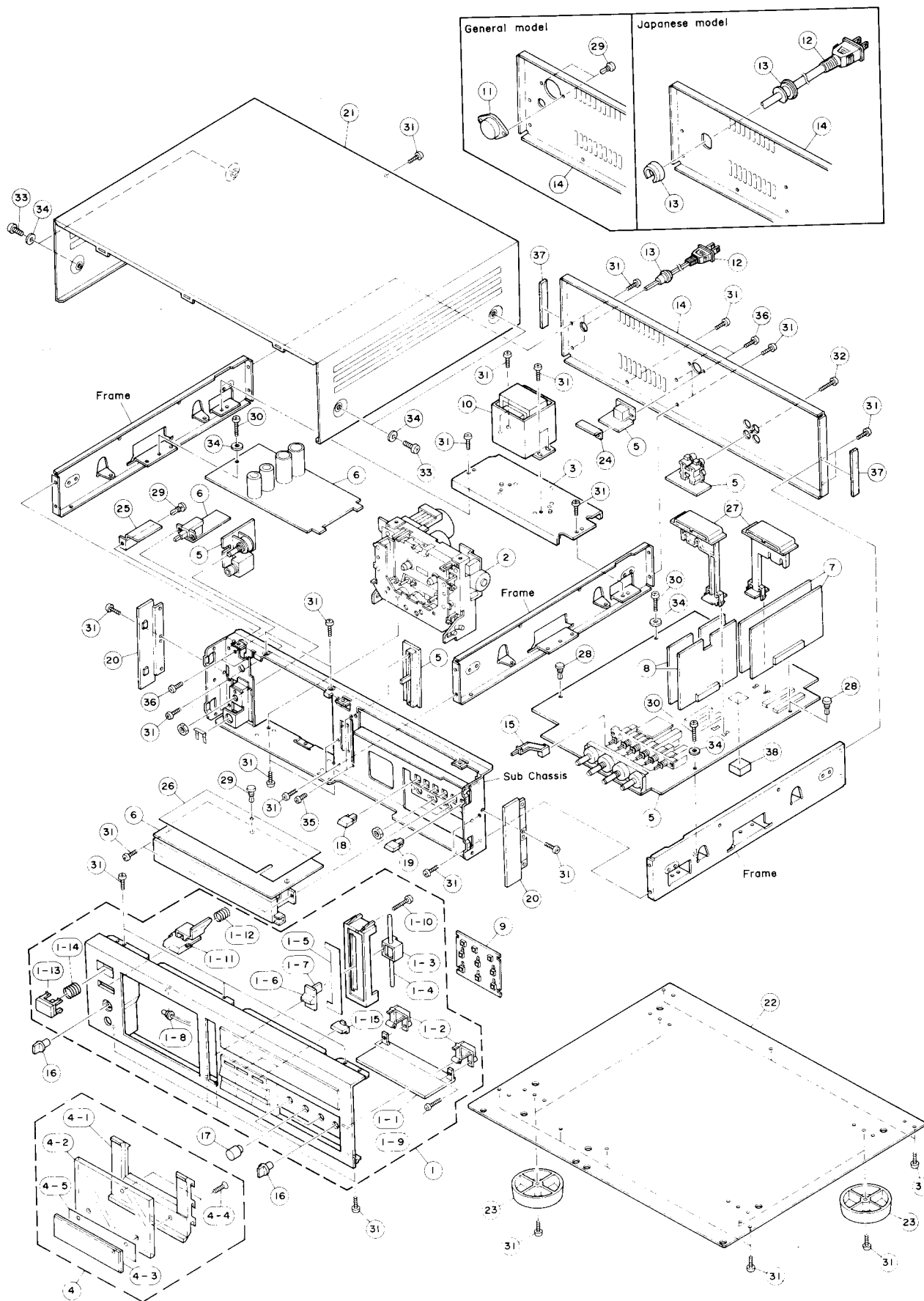

*2
F3
*3
F5
*4
R56

ori

MECHANISM PARTS

Ref. No.	Part No.	Description	部 品 名	Remarks	Common Model	Markets	ランク
* 1	NB 62:45:20	Panel Unit	パネルユニット	Silver		J	
* "	NB 62:45:30	"	"	Black		J	
* "	NB 62:47:30	"	"	Silver		R,U,A,G,C,B	
* "	NB 62:47:40	"	"	Black		R,U,A,G,C,B	
* 1-1	BA 09:13:50	Pocket Panel	ポケットパネル	Silver			
* "	BA 09:13:60	"	"	Black			
* 1-2	CB 63:64:20	Arm	アーム				
* 1-3	CB 63:64:30	Slider	スライダ				
* 1-4	AA 61:93:20	Shaft (L)	シャフト(L)				
* 1-5	BA 09:13:70	Plate, VR	VRプレート	Silver	CD-X1		
* "	BA 09:13:80	"	"	Black			
* 1-6	BA 09:18:60	Slide Knob	スライドつまみ	Silver			
* "	BA 09:18:70	"	"	Black			
* 1-7	AA 62:41:50	Slide Lever	スライドレバー	Silver			
* "	AA 62:41:60	"	"	Black			
* 1-8	JB 00:12:50	Lamp	パイロットランプ				
* 1-9	Ei 12:60:86	Binding Head Tapping Screw	2.6X8 ZMC2-Y	Silver	PACK		
* "	Ei 32:60:86	"	2.6X8 FCRM3-BI	Black	PACK		
* 1-10	Ei 03:01:26	"	3X12 ZMC2-Y	PACK			
* 1-11	CB 63:63:70	Button, EJ	ボタン EJ	Silver			
* "	CB 63:63:80	"	"	Black			
* 1-12	AA 62:43:20	Spring	スプリング				
* 1-13	NB 61:41:30	Button (P) Ass'y	ボタン(P) Ass'y	Silver			
* "	NB 61:41:40	"	"	Black			
* 1-14	AA 61:78:80	Spring	スプリング		A-700		
* 1-15	CB 63:64:10	Push Button	プッシュボタン	Silver			
* "	CB 64:33:80	"	"	Black			
* 2	NB 62:50:20	Mechanism Unit	メカユニット				
* 3	BA 09:14:90	Holder, Transformer	トランスホルダー				
* 4	NB 62:46:20	Lid Ass'y	リッド Ass'y	Silver			
* "	NB 62:46:30	"	"	Black			
* 4-1	CB 63:74:10	Holder	ガラスホルダー				
* 4-2	CG 06:12:30	Lid Glass	リッドガラス				
* 4-3	BA 09:16:30	Lid Panel	リッドパネル	Silver			
* "	BA 09:16:40	"	"	Black			
* 4-4	EB 33:01:06	Flat Head Screw	3X10 FCRM3-BI	PACK			
* 4-5	CA 07:73:50	Lid Sheet	リッドシート				
* 5	NA 08:62:00	Main Circuit Board	メインシート	Silver		J	
* "	NA 08:62:10	"	"	Black		U, C	
* "	NA 08:62:20	"	"	Black		J	
* "	NA 08:62:30	"	"	Black		U, C	
* "	NA 08:62:40	"	"	Silver		R, A, G, B	
* "	NA 08:62:50	"	"	Black		R, A, G, B	
* 6	NA 08:62:60	Power Circuit Board	電源シート			J	
* "	NA 08:62:70	"	"			U, C	
* "	NA 08:62:80	"	"			A, G, B	
* "	NA 08:64:50	"	"			R	
* 7	NA 08:62:90	Dolby Circuit Board	ドルビーシート				
* 8	NA 08:63:00	dbx Circuit Board	dbxシート				
* 9	NA 08:61:80	Operation Circuit Board	オペレーションシート		K-720		
* 10	GA 68:58:00	Power Transformer	電源トランス			J	
* "	GA 68:59:00	"	"			U, C	
* "	GA 68:60:00	"	"			G	

*New Parts (新規部品)

Ref. No.	Part No.	Description	部 品 名	Remarks	Common Model	Markets	ランク
※ 10	GA 68 61 00	Power Transformer	電 源 ト ラ ン ス			A, B	△
※ "	GA 68 62 00	"	"			R	△
11	LB 20 14 80	Voltage Selector	電 圧 切 換 器			R	△
※ 12	MG 00 21 90	Power Cord	電 源 コ ー ド			J	△
"	MG 00 08 40	"	"	併用		U, C	△
"	MG 00 12 40	"	"	Interchangeable		U, C	△
"	MG 00 09 20	"	"	併用		A	△
"	MG 00 14 90	"	"	Interchangeable		A	△
"	MG 00 09 60	"	"	併用		G	△
"	MG 00 16 20	"	"	Interchangeable		G	△
"	MG 00 16 30	"	"			R	△
"	MG 00 18 60	"	"			B	△
13	CB 61 68 10	Cord Stopper	コ ー ド ス ト ッ パ ー			U, C	
"	CB 62 01 90	"	"			R, A, G, B	
※ 14	AA 62 42 90	Rear Panel	リ ア パ ネ ル			J	
※ "	AA 62 44 20	"	"			R	
※ "	AA 62 44 30	"	"			U, C	
※ "	AA 62 44 40	"	"			A, B	
※ "	AA 62 44 50	"	"			G	
※ 15	CB 63 63 90	Rod Switch	ロ ッ ド ス イ ッ チ				
16	CB 63 42 60	Knob	ツ マ ミ	Silver	K-720		
"	CB 63 42 70	"	"	Black	K-720		
※ 17	CB 63 79 40	"	"	Silver			
"	CB 62 08 20	"	"	Black	A-1000		
18	CB 63 42 20	Push Button	プ ッ シ ュ ボ タ ン	Silver			
"	CB 63 42 30	"	"	Black			
※ 19	CB 64 08 00	" (Red)	" (ア カ)				
20	CB 62 07 10	Side Cover	サ イ ド カ バ ー	Silver	A-720		
"	CB 62 07 20	"	"	Black	A-720		
※ 21	AA 62 43 30	Top Cover	ト ッ プ カ バ ー	Silver			
※ "	AA 62 43 40	"	"	Black			
※ 22	AA 62 42 80	Bottom Cover	ボ ト ム カ バ ー				
23	NB 62 01 40	Leg	脚				
24	AA 60 74 20	Nut	連 ナ ッ ト				
※ 25	CB 64 11 80	Isolation Cover	絶 縁 カ バ ー				
※ 26	CA 07 72 10	Isolation Fiber	絶 縁 フ ァ イ バ ー				
※ 27	CB 64 18 80	P. C. B Support	P. C. B サ ポ ー ト				
28	CB 60 56 20	Plastic Rivet	プ ラ ス チ ッ ク リ ベ ッ ト				
29	CB 06 88 80	"	"				
30	Ei 33 00 86	Binding Head Tapping Screw	FCRM3-BI	バ イ ン ド タ ッ ピ ン グ ネ ジ	PACK		
31	Ei 33 00 66	"	3×6 FCRM3-BI	"	PACK		
32	Ei 33 01 06	"	3×10 FCRM3-BI	"	PACK		
33	ED 14 00 86	BW Head Tapping Screw	4×8 FNM3-3g	バ イ ン ド 小 ネ ジ	PACK	Silver	
"	ED 34 00 86	"	4×8 FCRM3-BI	"	PACK	Black	
34	EV 20 30 36	Plain Washer	φ3 FCRM3-BI	平 座 金	PACK		
35	ED 02 00 36	Binding Head Screw	2×3 ZMC2-Y	バ イ ン ド 小 ネ ジ	PACK		
36	ED 33 00 66	"	3×6 FCRM3-BI	"	PACK		
37	CB 62 38 70	Isolation Rubber		防 振 ゴ ム			
38	CB 63 07 60	Dampar (M)		ダ ン パ ー (M)			
39	EV 20 10 46	Plain Washer	φ4 FNM3-3g	平 座 金	PACK	Silver	
"	EV 20 30 46	"	φ4 FCRM3-3g	"	PACK	Black	
		Accessories		付 属 品			
	Mi 06 62 10	Pin Cord	1.2m	ピ ン コ ー ド			

※New Parts (新規部品)

EXPLODED VIEW(MECHA UNIT)

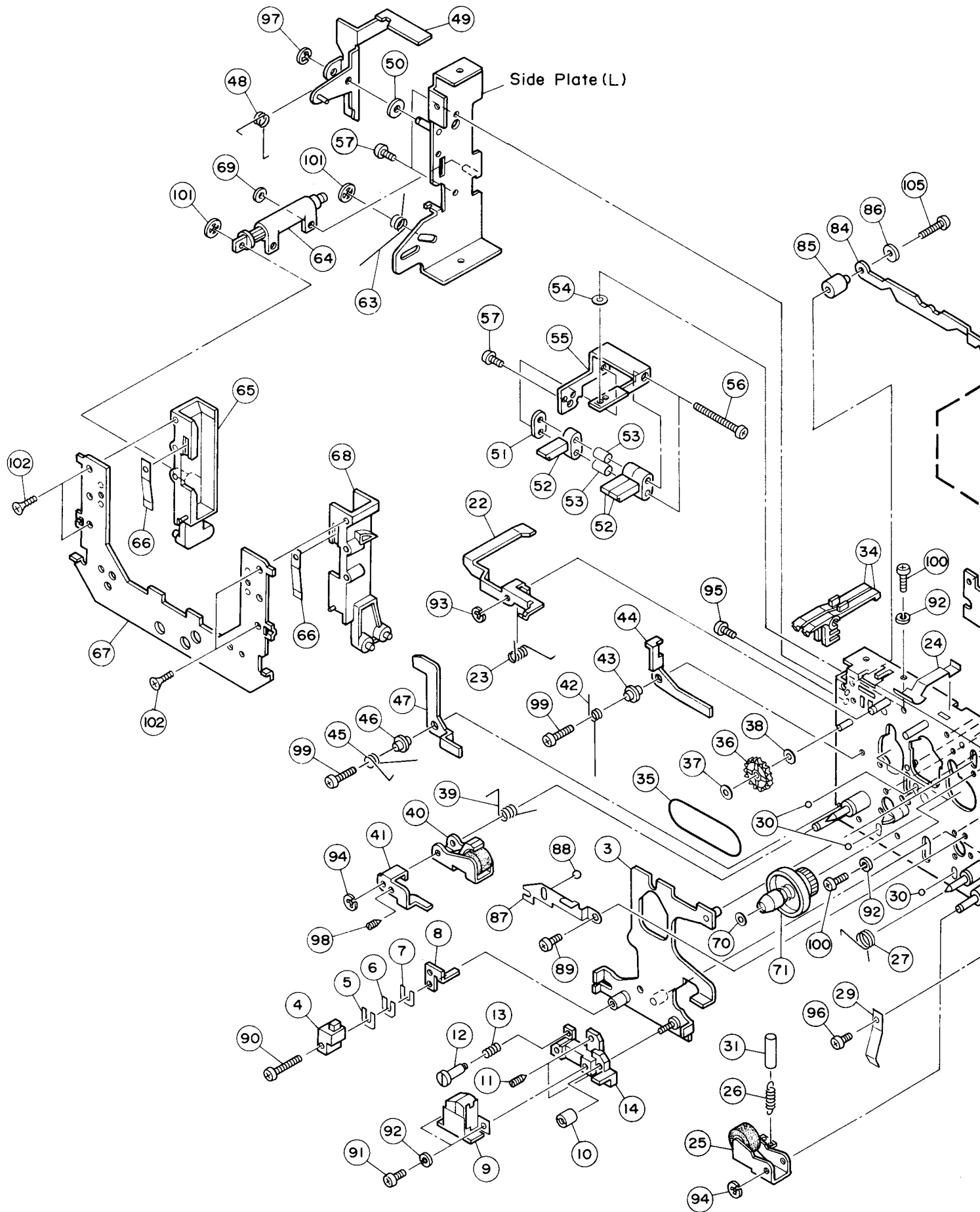

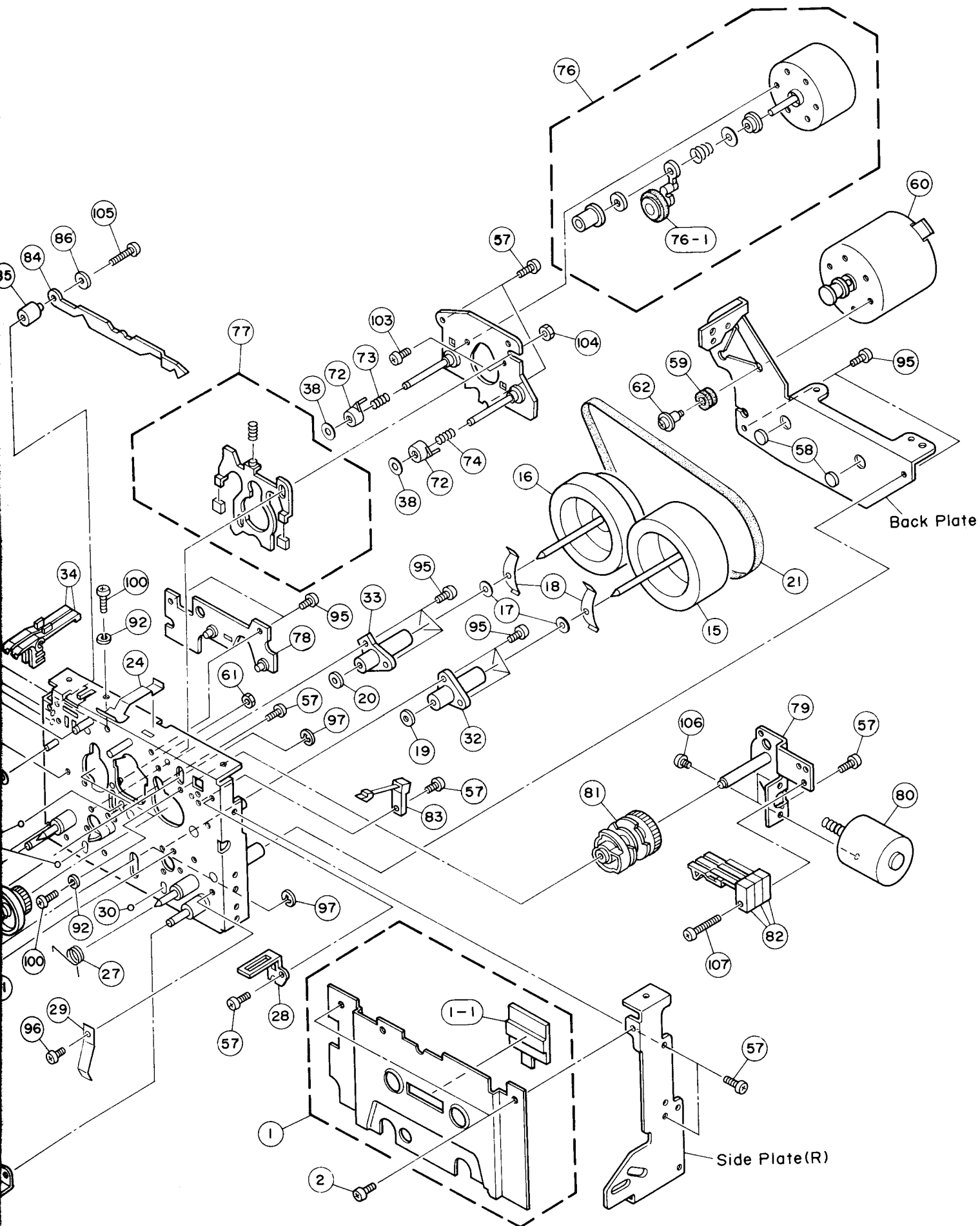

MECHANISM PARTS(MECHA UNIT)

Ref. No.	Part No.	Description	部 品 名	Remarks	Common Model	Markets	ランク
※	NB 62:50:20	Mechanism Unit	メカユニット				
※	1 NB 62:46:40	Blind Plate Ass'y	ブラインドプレートAss'y				
	1-1 iF 00:35:70	LED (Yellow)	L E D (キ)				
※	2 Ei 32:60:46	Binding Head Tapping Screw	2.6×4 FCRM3-BI	バインドタッピングネジ	PACK		
※	3 XX 64:06:10	Head Base	ヘッドベースカシメ組				
※	4 XX 64:06:20	Erase Head	消 去 ヘ ッ ド				
※	5 XX 64:06:30	Spacer	t0.06	ス ペ ー サ ー			
※	6 XX 64:06:40	"	t0.03	"			
※	7 XX 64:06:50	"	t0.1	"			
※	8 XX 64:06:60	Head Plate for Erase	E ヘ ッ ド 板 (B)				
※	9 XX 64:06:70	R/P Combination Head	R / P コ ン ビ ヘ ッ ド				
※	10 XX 64:06:80	Nut	調 整 ナ ッ ト				
※	11 XX 64:06:90	Screw	M2×4	止 メ ネ ジ			
※	12 XX 64:07:00	"		軸			
※	13 XX 64:07:10	Coil Spring		圧 縮 コ イ ル バ ネ			
※	14 XX 64:07:20	Head Block		ヘ ッ ド ブ ロ ッ ク			
※	15 XX 64:07:30	Flywheel	φ2.5	フ ラ イ ホ イ ー ル			
※	16 XX 64:07:40	"	φ2.2	"			
※	17 XX 64:07:50	Washer	φ2.6×φ4.7×t0.5	ワ ッ シ ャ ー			
※	18 XX 64:07:60	Spring Plate		板 バ ネ			
※	19 XX 64:07:70	Plain Washer	φ2.5	座 金			
※	20 XX 64:07:80	"	φ2.2	"			
※	21 XX 64:07:90	Belt, Flywheel		平 ベ ル ト			
※	22 XX 64:08:00	Sensor Lever		検 知 レ バ ー			
※	23 XX 64:08:10	Coil Spring		コ イ ル バ ネ			
※	24 XX 64:08:20	Spring Plate		カ セ ッ ト 押 え バ ネ			
※	25 XX 64:08:30	Pinch Arm Ass'y		ピンチアームAss'y			
※	26 XX 64:08:40	Coil Spring		引 張 コ イ ル バ ネ			
※	27 XX 64:08:50	"		ネ ジ リ コ イ ル バ ネ			
※	28 XX 64:08:60	Plate		保 護 板			
※	29 XX 64:08:70	Spring Plate		カ セ ッ ト バ ネ			
※	30 EZ 00:15:30	Steel Ball	φ2	ス チ ー ル ボ ー ル			
※	31 XX 64:14:20	Tube	l=19	チ ュ ー ブ			
※	32 XX 64:08:80	Stand	φ2.5	キャブスタンスタンド			
※	33 XX 64:08:90	"	φ2.2	"			
※	34 XX 64:09:00	Lever, REC		R E C レ バ ー			
※	35 XX 64:09:10	Belt		角 ベ ル ト			
※	36 XX 64:09:20	Pully Unit		プ ー リ ー ユ ニ ッ ト			
※	37 XX 64:03:30	Washer	φ1.8×φ3.8×t0.5	ポリスライダワーッシャー	K-720		
※	38 XX 64:03:60	"	φ2.1×φ4.5×t0.1	ワ ッ シ ャ ー	"		
※	39 XX 64:09:30	Coil Spring		コ イ ル バ ネ			
※	40 XX 64:09:40	Pinch Roller Ass'y		SピンチローラーAss'y			
※	41 XX 64:09:50	Plate, ADJ		調 整 板			
※	42 XX 64:09:60	Coil Spring		コ イ ル バ ネ			
※	43 XX 64:09:70	Coller		カ ラ ー			
※	44 XX 64:09:80	Change Lever		切 換 レ バ ー			
※	45 XX 64:09:90	Coil Spring		コ イ ル バ ネ			
※	46 XX 64:10:00	Coller		カ ラ ー			
※	47 XX 64:10:10	Locked Plate		ロ ッ ク 板			
※	48 XX 64:10:20	Coil Spring		コ イ ル バ ネ			
※	49 XX 64:10:30	Lever, Eject		解除レバー圧入組			
※	50 XX 64:10:40	Plain Washer	φ4.4×φ10×t0.5	平 座 金			
※	51 XX 64:10:50	Washer	4.4×10.4×1.0	ワ ッ シ ャ ー			

※New Parts (新規部品)

Ref. No.	Part No.	Description	部品名	Remarks	Common Model	Markets	ランク
※ 52	XX 64 10 60	Leaf Switch	リーフスイッチ				
※ 53	XX 64 10 70	Coller	カ ラ ー				
※ 54	XX 64 10 80	Washer	ワ ッ シ ャ ー	φ2.7×φ5×t0.5			
※ 55	XX 64 10 90	Plate	S W 取 付 板				
※ 56	XX 64 11 00	Screw	ピ ス				
※ 57	XX 62 36 50	Pan Head Screw	ナ ベ 小 ネ ジ	M2.5×6 ZMC2-Y			
※ 58	XX 64 11 10	Thrust Stand	ス ラ ス ト 受				
※ 59	XX 64 11 20	Cushion Rubber	ゴ ム 座				
※ 60	XX 64 14 10	Capstan Motor Ass'y	キャプスタンモーター組				
※ 61	EV 10 02 66	Hexagonal Nut	六 角 ナ ッ ト	M2.6		PACK	
※ 62	XX 64 11 30	Screw	モ ー タ ー 止 メ ネ ジ				
※ 63	XX 64 11 40	Coil Spring	コ イ ル バ ネ				
※ 64	XX 64 11 50	Damper Unit	ダンパーユニット				
※ 65	XX 64 11 60	Holder (L)	ホ ル ダ ー (左)				
※ 66	XX 64 11 70	Spring	カ セ ッ ト バ ネ				
※ 67	XX 64 11 80	Front Plate	フ ロ ン ト プ レ ー ト				
※ 68	XX 64 11 90	Holder (R)	ホ ル ダ ー (右)				
※ 69	XX 64 12 00	Washer	座 金	φ2.2×φ5×t0.2			
※ 70	XX 64 12 10	"	ポリスライダークワッシャー	φ1.8×φ3.2×t0.5			
※ 71	XX 64 12 20	Reel Base Ass'y	リ ー ル 台 総 組				
※ 72	XX 64 12 30	Spring Stand	バ ネ 受				
※ 73	XX 64 12 40	Coil Spring	圧 縮 コ イ ル バ ネ				
※ 74	XX 64 12 50	"	"				
※ 75	XX 64 12 60	Holder, Motor	モ ー タ ー 取 付 板				
※ 76	XX 64 12 70	Reel Motor Ass'y	リールモーターAss'y				
※ 76-1	XX 64 12 80	Idler Lever Ass'y	アイドラレバー組				
※ 77	XX 64 12 90	Lever Ass'y, Brake	ブ レ ー キ 板 組				
※ 78	XX 64 13 00	Sensor Circuit Board	セ ン サ ー 基 板 組				
※ 79	XX 64 13 10	PAD Holder	P A D ホ ル ダ ー				
※ 80	XX 64 13 20	PAD Motor	P A D モ ー タ ー				
※ 81	XX 64 13 30	Gear, Cum	カ ム ギ ヤ				
※ 82	XX 64 13 40	Leaf Switch	リ ー フ ス イ ッ チ				
※ 83	XX 64 13 50	"	"				
※ 84	XX 64 13 60	Plate, Joint	連 結 板				
※ 85	XX 64 13 70	Coller	カ ラ ー				
※ 86	XX 64 13 80	Plain Washer	平 座 金	φ8×φ2.6×t1.0			
※ 87	XX 64 13 90	Head Holder Plate	ヘ ッ ド 押 え 板				
※ 88	EX 60 01 30	Steel Ball	ス チ ー ル ボ ー ル	3φ			
※ 89	EA 03 00 46	Pan Head Screw	ナ ベ 小 ネ ジ	M3×4 ZMC2-Y		PACK	
※ 90	ED 02 01 26	Binding Head Screw	バ イ ン ド 小 ネ ジ	M2×12 ZMC2-Y		PACK	
※ 91	EA 02 00 46	Pan Head Screw	ナ ベ 小 ネ ジ	M2×4 ZMC2-Y		PACK	
※ 92	EV 30 02 06	Spring Washer	ス プ リ ン グ ワ ッ シ ャ ー	φ2 ZMC2-Y		PACK	
※ 93	EV 50 12 56	E-Ring	E リ ン グ	φ2.5 FNM3-3g		PACK	
※ 94	EV 50 12 06	"	"	φ2 FNM3-3g		PACK	
※ 95	XX 62 36 60	Pan Head Screw	ナ ベ 小 ネ ジ	M2.5×5 ZMC2-Y			
※ 96	XX 62 36 70	Truss Head Tapping Screw	ト ラ ス タ ッ ピ ン グ ネ ジ	2×3.2 ZMC2-Y			
※ 97	EV 50 13 06	E-Ring	E リ ン グ	φ3 ZMC2-Y		PACK	
※ 98	XX 64 14 00	Screw	止 メ ネ ジ	M2×3			
※ 99	EA 02 51 00	Pan Head Screw	ナ ベ 小 ネ ジ	M2.5×10 ZMC2-Y		PACK	
100	EA 02 00 56	"	"	M2×5 ZMC2-Y			
101	EX 60 01 20	CS-Ring	C S リ ン グ	CS2.4mm			
102	EN 39 00 20	Flat Head Tapping Screw	サ ラ タ ッ ピ ン グ ネ ジ	2.6×8 ZMC2-Y			
103	EA 02 60 36	Pan Head Screw	ナ ベ 小 ネ ジ	M2.6×3 ZMC2-Y		PACK	

※New Parts (新規部品)

K-1020

YAMAHA

K-1020

