

STÉREO CASSETTE DECK K-520

SERVICE MANUAL

昭和59年 2 月発売
54.8K

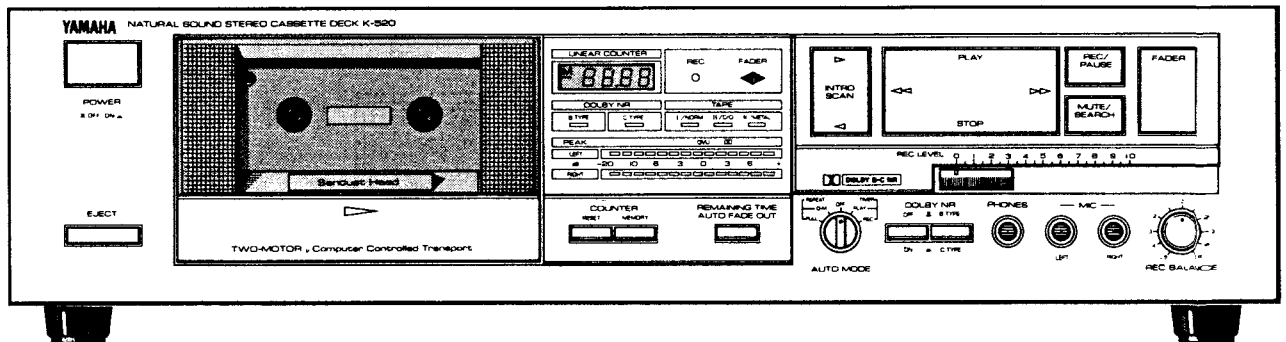

■ 目次/CONTENTS

TO SERVICE PERSONNEL	1
REAR PANEL	1
BLOCK DIAGRAM	2
SPECIFICATIONS	2
各部の名称 /INTERNAL VIEW	3
分解手順/DISASSEMBLY PROCEDURES ..	3
調整 /ADJUSTMENT	4 ~ 7
SCHEMATIC DIAGRAM	8
LSI DATA/IC BLOCK DIAGRAM/ COUNTER METER UNIT/WIRING DIAGRAM	9
PRINTED CIRCUIT BOARD	10/11
EXPLODED VIEW	12
PARTS LIST	13 ~ 19

004549

SINCE 1887



YAMAHA

NIPPON GAKKI CO., LTD. HAMAMATSU, JAPAN

3.4K-722 Printed in Japan 84.3

■ TO SERVICE PERSONNEL

1. Critical Components Information.
Components having special characteristics are marked Δ and must be replaced with parts having specifications equal to those originally installed.
2. Leakage Current Measurement (For 120V Model Only).
When service has been completed, it is imperative that you verify that all exposed conductive surfaces are properly insulated from supply circuits.
 - Meter impedance should be equivalent to 1500 ohm shunted by 0.15 μ F.
 - Leakage current must not exceed 0.5mA.
 - Be sure to test for leakage with the AC plug in both polarities.

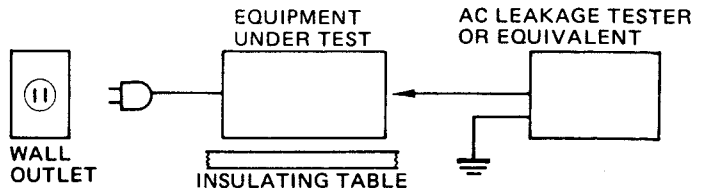

■ REAR PANELS

• GENERAL Model

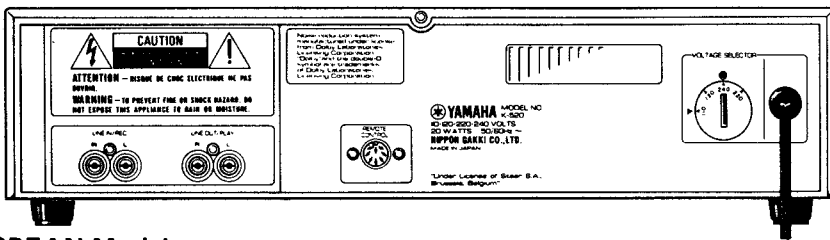

• EUROPEAN Model

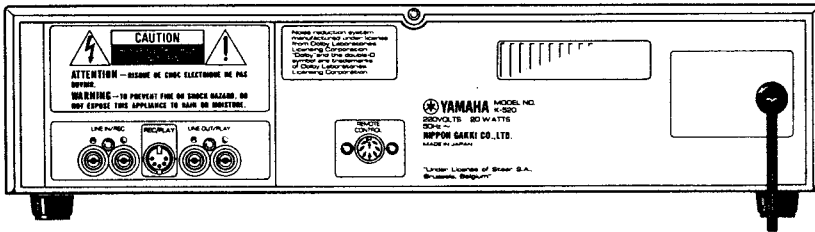

• JAPANESE Model

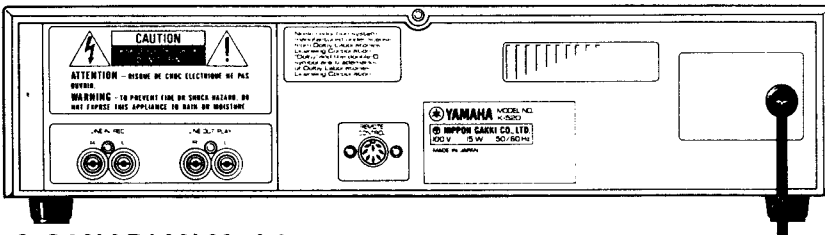

• U.S.A. & CANADIAN Models

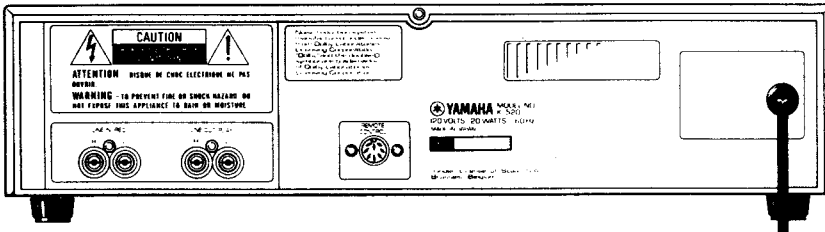

• BRITISH & AUSTRALIAN Models

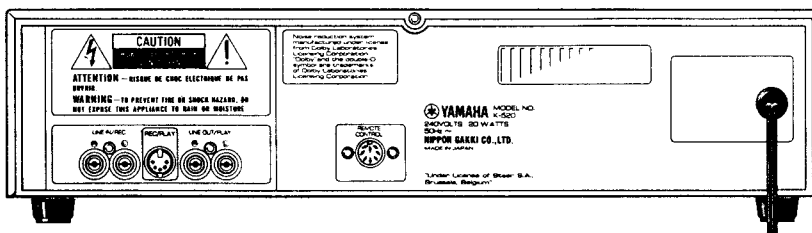

* DIN JACK: Except Australian model

BLOCK DIAGRAM

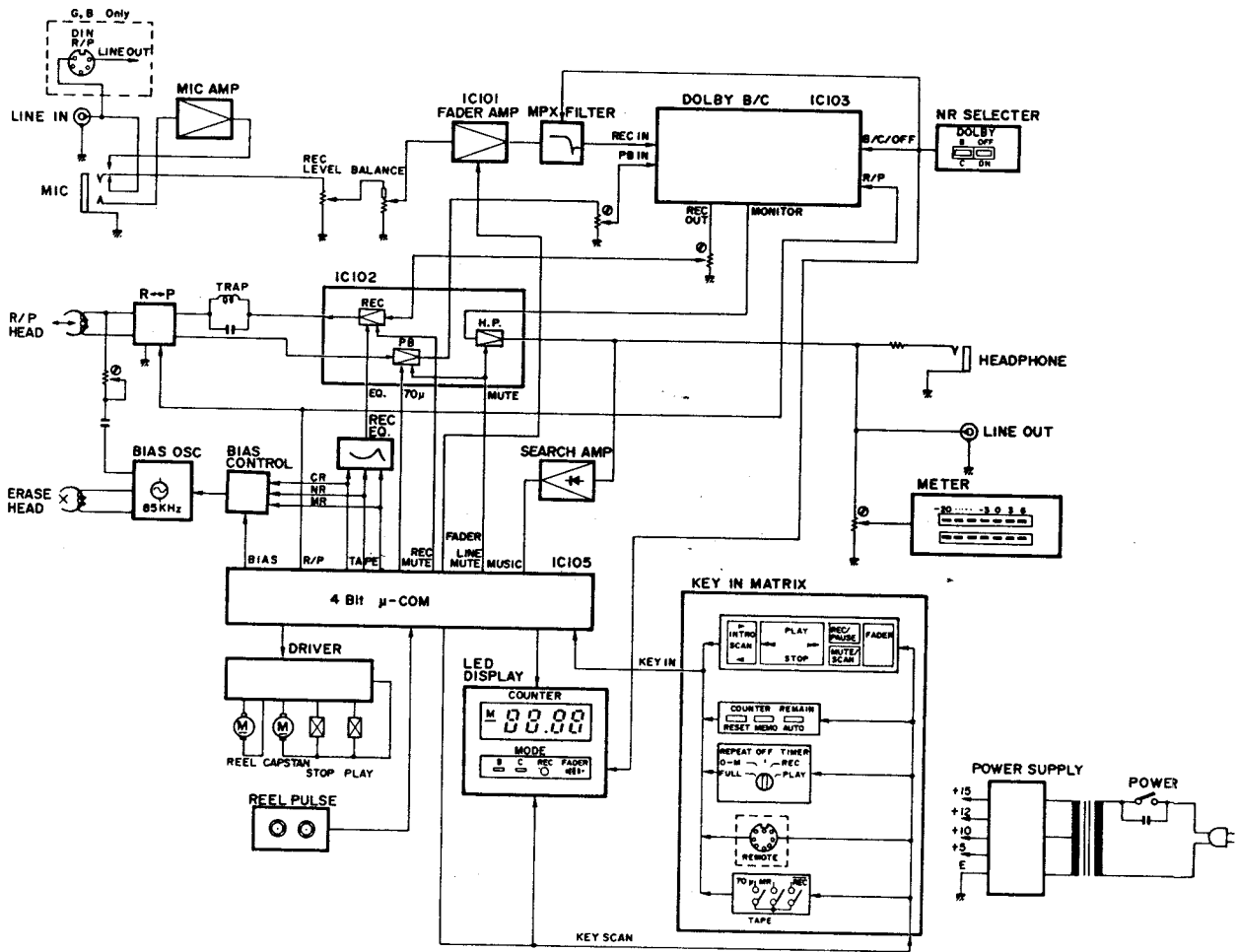

SPECIFICATIONS

Type	4-track, 2-channel recording and playback stereo cassette tape deck
Heads	
Rec/Play head	Sendust
Erase head	Ferrite
Motors	
Capstan	DC servo motor
Reel	Flat torque DC motor
Wow and Flutter	Less than ±0.08% W.Peak Less than 0.05% W.RMS
Fast winding time	Within 70 seconds (C-60)
Frequency response	
Normal tape (-20dB)	40 to 16,000 Hz ±3dB
Chrome tape (-20dB)	40 to 17,000 Hz ±3dB
Metal tape (-20dB)	40 to 19,000 Hz ±3dB
Signal to Noise ratio	
Dolby off	58 dB
Dolby B on	66 dB
Dolby C on	74 dB
Harmonic distortion	Less than 1%
Input Sensitivity/Impedance	
Mic	0.35 mV/5 k-ohms
Line	55 mV/50 k-ohms

Output Level/Load Impedance	
Line	360 mV/47 k-ohms
Headphones	60 mV/8 ohms
Power Supplies	
U.S. & Canadian Models	120V AC, 60Hz
European Model	220V AC, 50Hz
British & Australian Models	240V AC, 50Hz
General Model	110/120/220/240V AC, 50/60Hz
Japanese Model	100V AC, 50/60Hz
Power consumption	20 W
Dimensions (W x H x D)	435 x 112 x 274 mm (17-1/8" x 4-13/32" x 10-3/4")
Weight	4.2 kg (9.24 lbs)

Specification subject to change without notice.
* TM Dolby laboratories Licensing Corp.

- (J) Japanese model
- (U)..... U.S.A. model
- (C)..... Canadian model
- (A)..... Australian model
- (G)..... European model
- (B)..... British model
- (R)..... General model

■各部の名称/INTERNAL VIEW

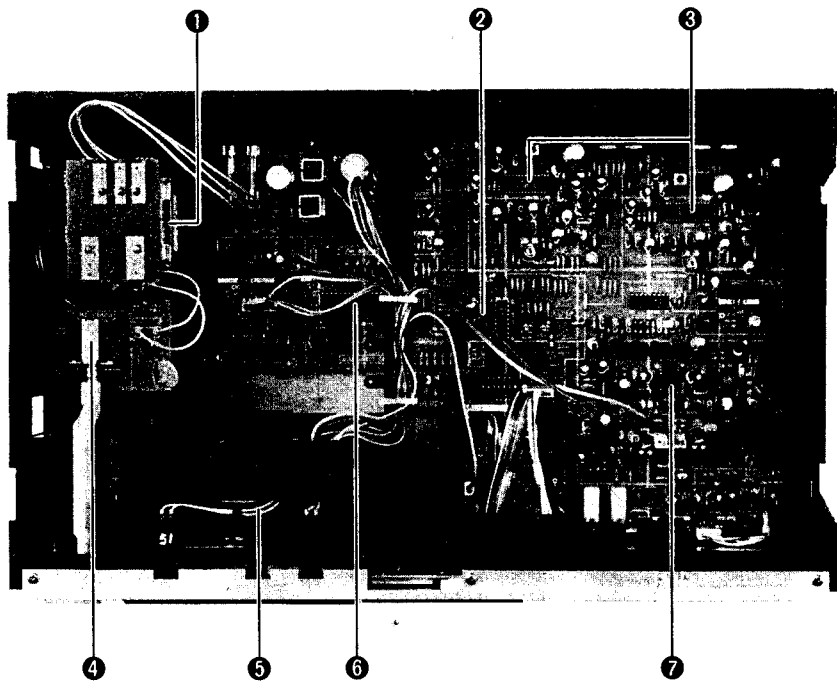

① POWER TRANSFORMER

J: GA67430
 U.C.: GA67440
 R: GA67450
 G: GA67460
 A, B: GA67470

② MAIN CIRCUIT BOARD

③ DOLBY IC : AN7370

④ POWER SWITCH

⑤ CASSETTE MECHANISM UNIT

⑥ μ -COM IC : LM8402A

⑦ REC/PB AMP IC : HA12051

■分解手順/DISASSEMBLY PROCEDURES

(番号順に取りはずしを行なってください。)

(Remove parts in disassembly order as numbered.)

1. トップカバーのはずし方

a. ①のネジ4本と②のプラスチックリベットをはずす。

1. Removal of Top Cover

a. Remove 4 screws (①) and plastic rivet (②).

2. フロントパネルのはずし方

a. ③のネジ7本をはずす。

2. Removal of Front Panel

a. Remove 7 screws (③).

3. ボトムカバーのはずし方

a. ④のネジ7本をはずす。

3. Removal of Bottom Cover

a. Remove 7 screws (④).

4. カセットメカユニットのはずし方

a. ⑤のネジ4本をはずし、ゆっくりとカセットメカユニットを手前に引き出す。

b. その際、必要なコネクターをはずす。

4. Removal of Cassette Mechanism Unit

a. Remove 4 screws (⑤) and then pull out the cassette mechanism unit in this side gently.

b. Detach the necessary connectors.

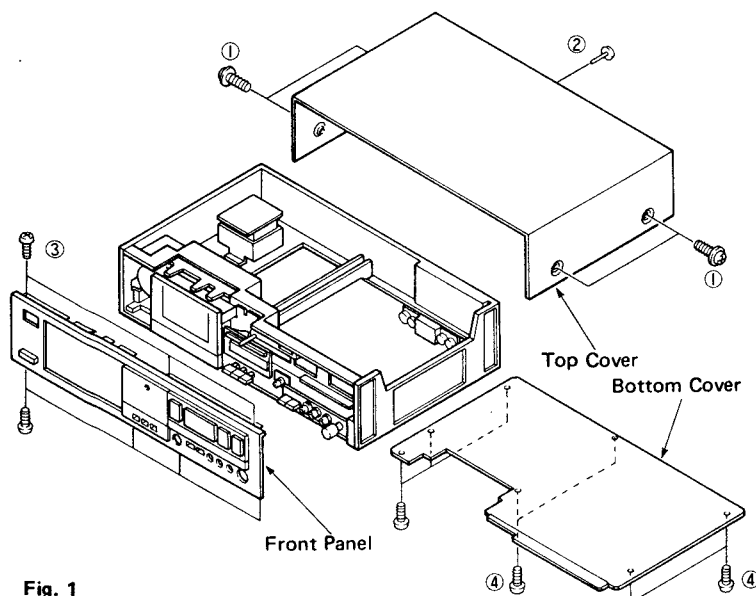

Fig. 1

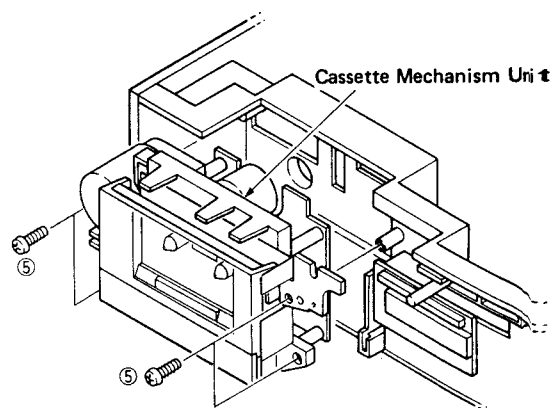

Fig. 2

■調整/ADJUSTMENTS

(電源電圧が100V±10%であることを確認してください。)

1. 調整の前に

- 帯磁およびヨゴレなどによる各測定誤差をなくすため、ヘッドイレース、ヘッドクリーニングを行なってください。
- 録音系の調整は再生系の調整が終わってから行なってください。

2. 測定器略称

W.F : ワウフラッター計
 FC : 周波数カウンター
 ACVM : 交流電圧計
 OSCI : オシロスコープ
 LOW.F : 低周波発振器

1. Before adjustment

- Since head magnetization, dust accumulations, etc. are likely to introduce error in the various characteristics, it is very important that the heads are properly demagnetized and cleaned.
- Proceed with the recording section adjustment after having finished the playback section adjustment.

2. Measuring instruments abbreviation

W.F : Wow/Flutter metter
 FC : Frequency counter
 ACVM : AC voltagemeter
 OSCI : Oscilloscope
 LOW.F : Low frequency generator

Step ステップ	Adjustment item 調整項目	Tape テープ	Instrument required 測定器	Mode モード	Measurement Conditions 測定条件	Test Point テストポイント	Adjustment parts 調整箇所	Rating 規格	Remarks 備考
1	Tape speed テープスピード	MTT-111 3kHz, -10dB (250nwb/m)	W.F FC	PB	Perform adjustment at the center of the test tape length if possible. テストテープは、テープの中心付近を使用してください。	LINE OUT	Semi fixed variable resistor at the back of the capstan motor. (Fig. 3) キャプスタンモーター内部の半固定抵抗	3000Hz ± 15Hz	
2	Azimuth アジマス	MTT-114 10kHz, -10dB (250nwb/m)	ACVM OSCI	PB		LINE OUT	Azimuth adjustment screw アジマス調整ネジ (Fig. 3)	Set both channel levels to maximum output level. 両チャンネルの出力レベルが最大になること。	After the adjustment, make sure to apply screw lock paint. 調整後は必ずネジロックを施してください。
3	Playback level 再生レベル	MTT-212C 315Hz 160nwb/m or MTT-212 315Hz, 250nwb/m	ACVM	PB		LINE OUT	VR105(Lch) VR106(Rch)	160nwb/m: 360mV±25mV 250nwb/m: 570mV±35mV	Fig. 4
4	Meter メーター	CrO ₂ Tape	ACVM LOW. F	REC/ PAUSE	Apply a 1kHz signal to LINE IN terminals. Set the REC LEVEL knob so that LINE OUT voltage is 360mV ± 25mV LINE INから1kHzの信号を加え、LINE OUTが360mV ± 25mVとなるようにする。	Peak level meter ピークレベルメーター	VR109(Lch) VR110(Rch)	Adjust VR109 and VR110 to the lowest level where the 0dB display part of the level meter light up. レベルメーター 0dB表示が点灯する最小レベルに調整する。	
5	Record level 録音レベル	CrO ₂ Tape	ACVM LOW. F	REC/PB		LINE OUT	VR103(Lch) VR104(Rch)	Set the same level of the record and playback level 信号を録音・再生して同じレベルになるようにする。 (360mV±25mV)	
6	Record bias 録音バイアス	LH Tape CrO ₂ Tape Metal Tape	ACVM LOW. F	REC/PB	Apply signals to LINE IN terminals. Set the REC LEVEL knob so that LINE OUT voltage is -20dB	LINE OUT	VR107(Lch) VR108(Rch)	Set the same level of the record and playback level 信号を録音・再生して同じレベルになるようにする。	Table 1 も特性を満足すること。

● テストポイント / TEST POINT

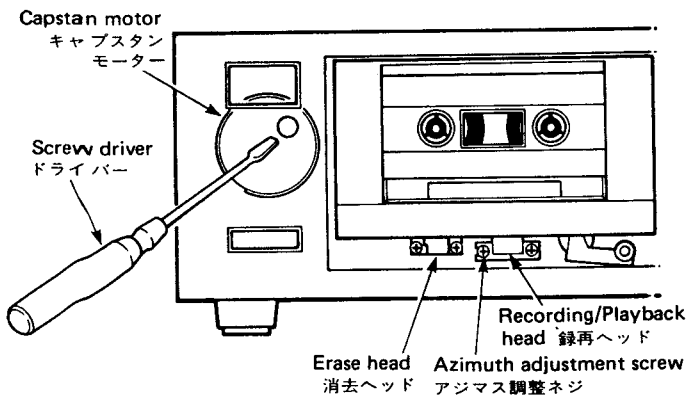
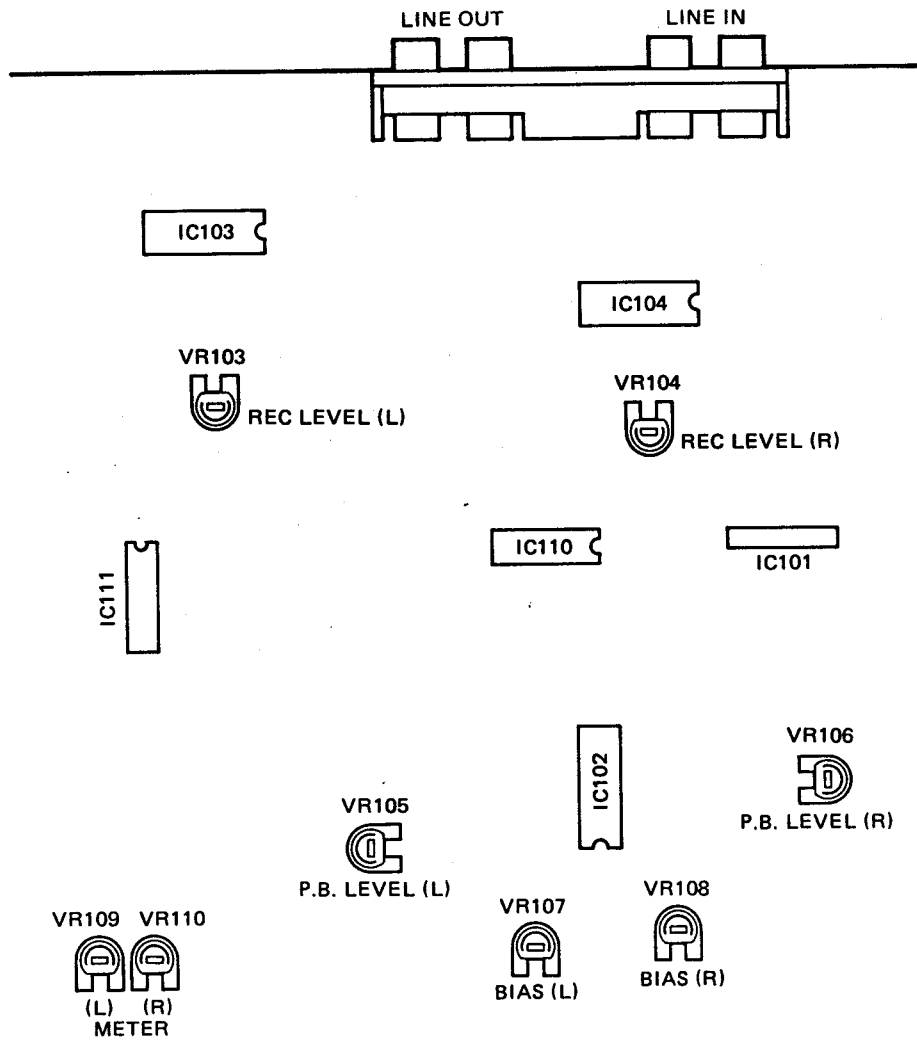

Fig. 3

● 再生周波数特性 / PLAYBACK FREQUENCY RESPONSE

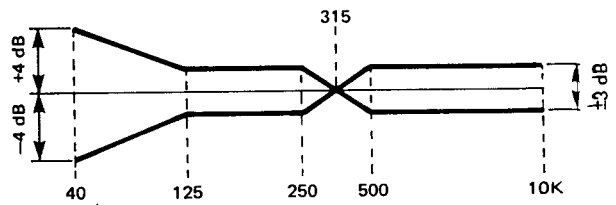

Fig. 4

● 総合周波数特性 / TOTAL FREQUENCY RESPONSE (-20dB)

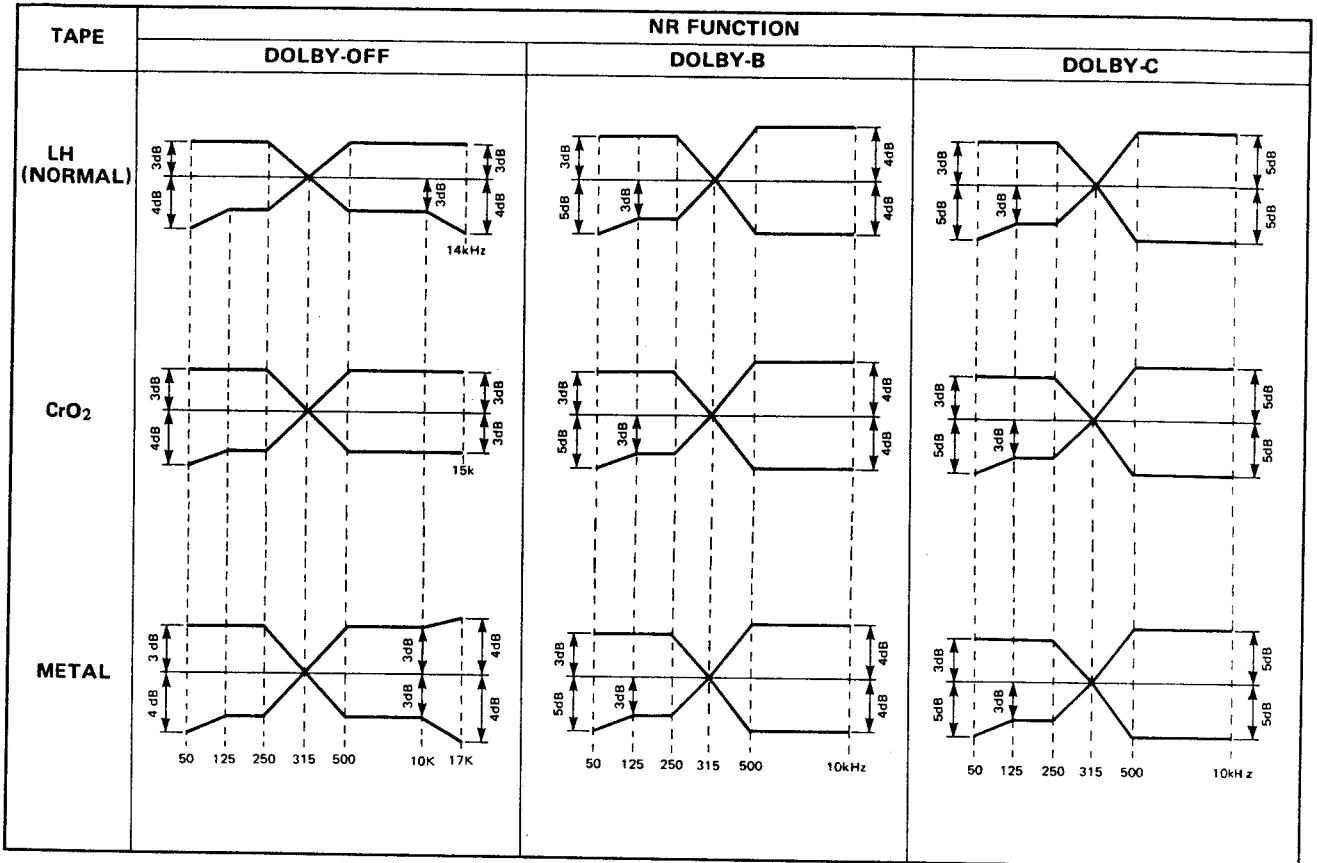
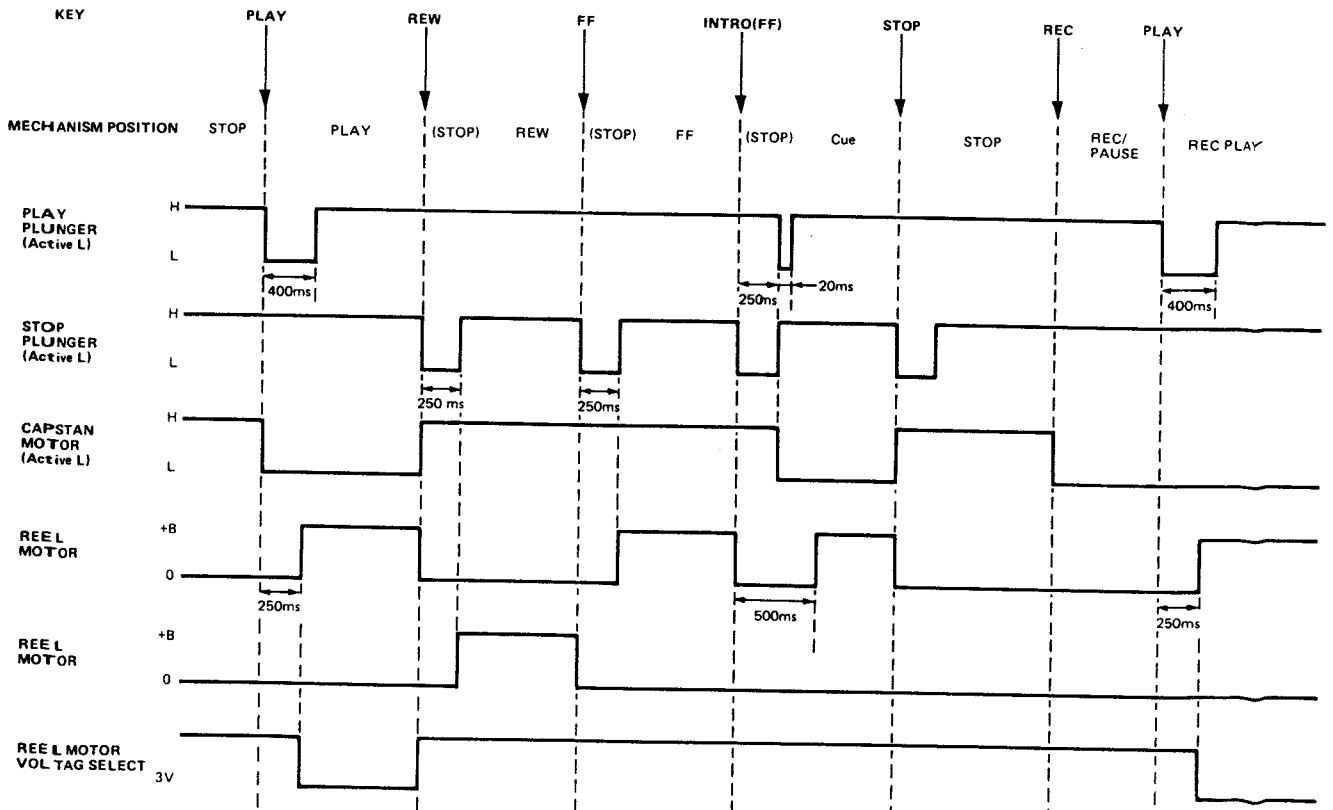
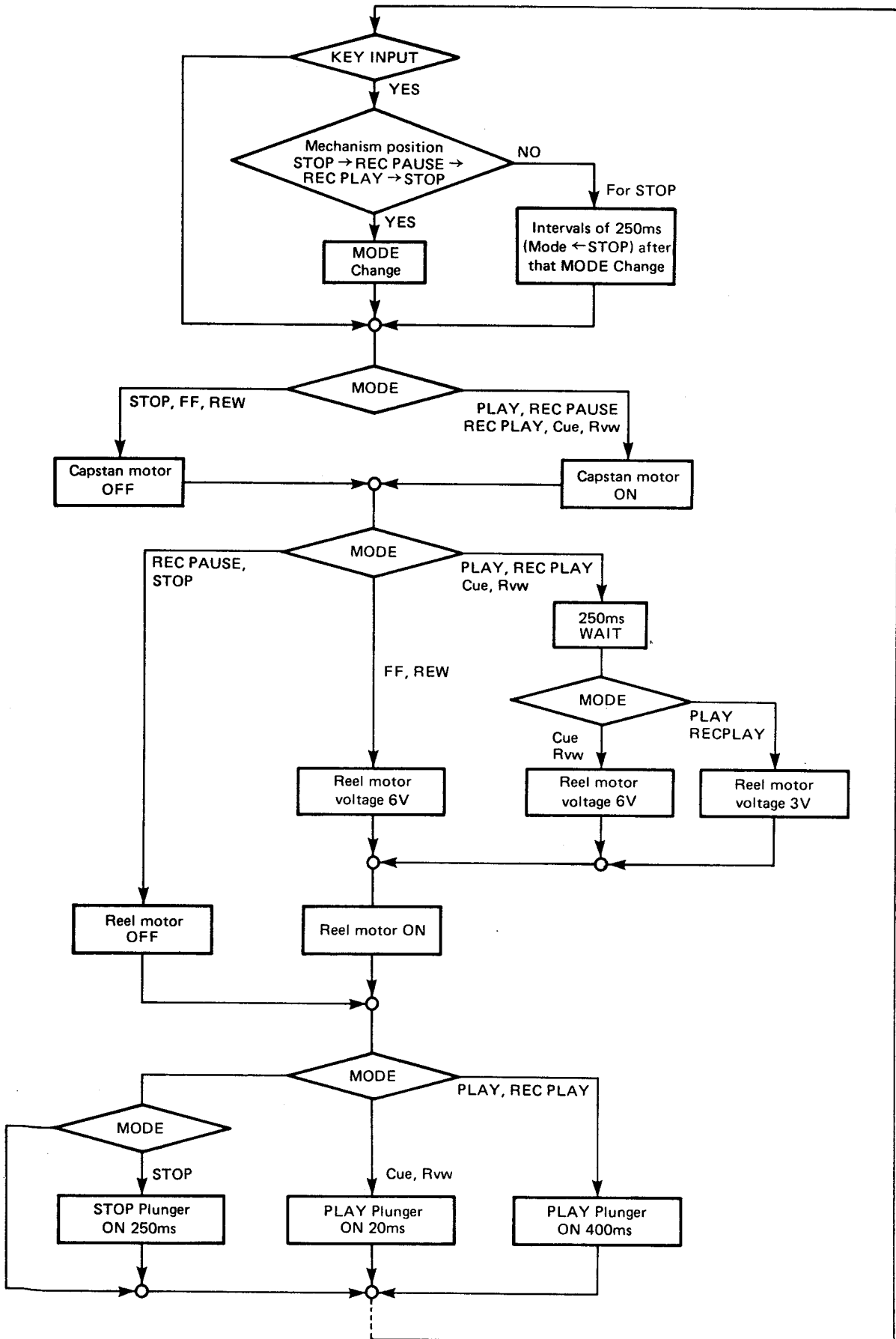

Table 1

● TIMING CHART (Mechanism Control)



• MECHANISM CHART



SCHEMATIC DIAGRAM

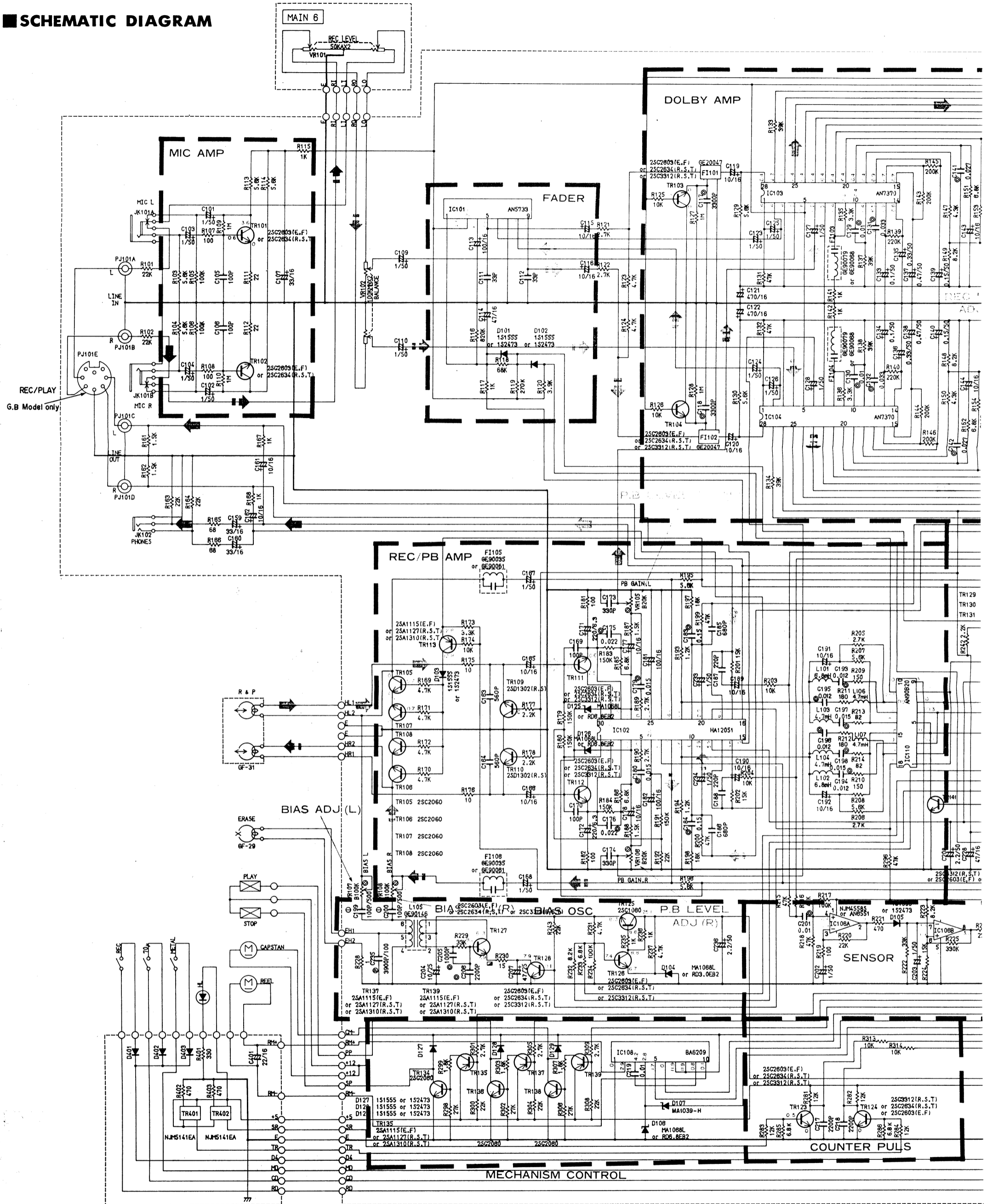

CAPACITOR	
REMARKS	
NO MARK	CERAMIC CAPACITOR
●	POLYESTER FILM CAPACITOR
○	POLYPROPYLENE CAPACITOR
NO MARK	ELECTROLYTIC CAPACITOR
●	TANTALUM CAPACITOR
RESISTOR	
REMARKS	
NO MARK	CARBON FILM RESISTOR
▲	METAL OXIDE FILM RESISTOR
●	SEMI VARIABLE RESISTOR
■	FLAME PROOF CARBON RESISTOR

●各部電圧は、LHテープでPLAY時の電圧を示します。
 ●電圧は、内部抵抗10MΩの電圧計で測定した値を示します。
 ●△印のある部分は、安全性確保部品を示しています。部品の交換が必要な場合、パーツリストに記載されている部品を使用してください。
 ●本回路は標準回路です。改良のため予告なく変更することがございます。

●The voltages are measured by LH tape at PLAY mode (no-signal condition)
 ●All voltages are measured with a 10MΩ/V DC electric volt meter.
 ●Components having special characteristics are marked △ and must be replaced with parts having specifications equal to those originally installed.
 ●Schematic diagram is subject to change without notice.

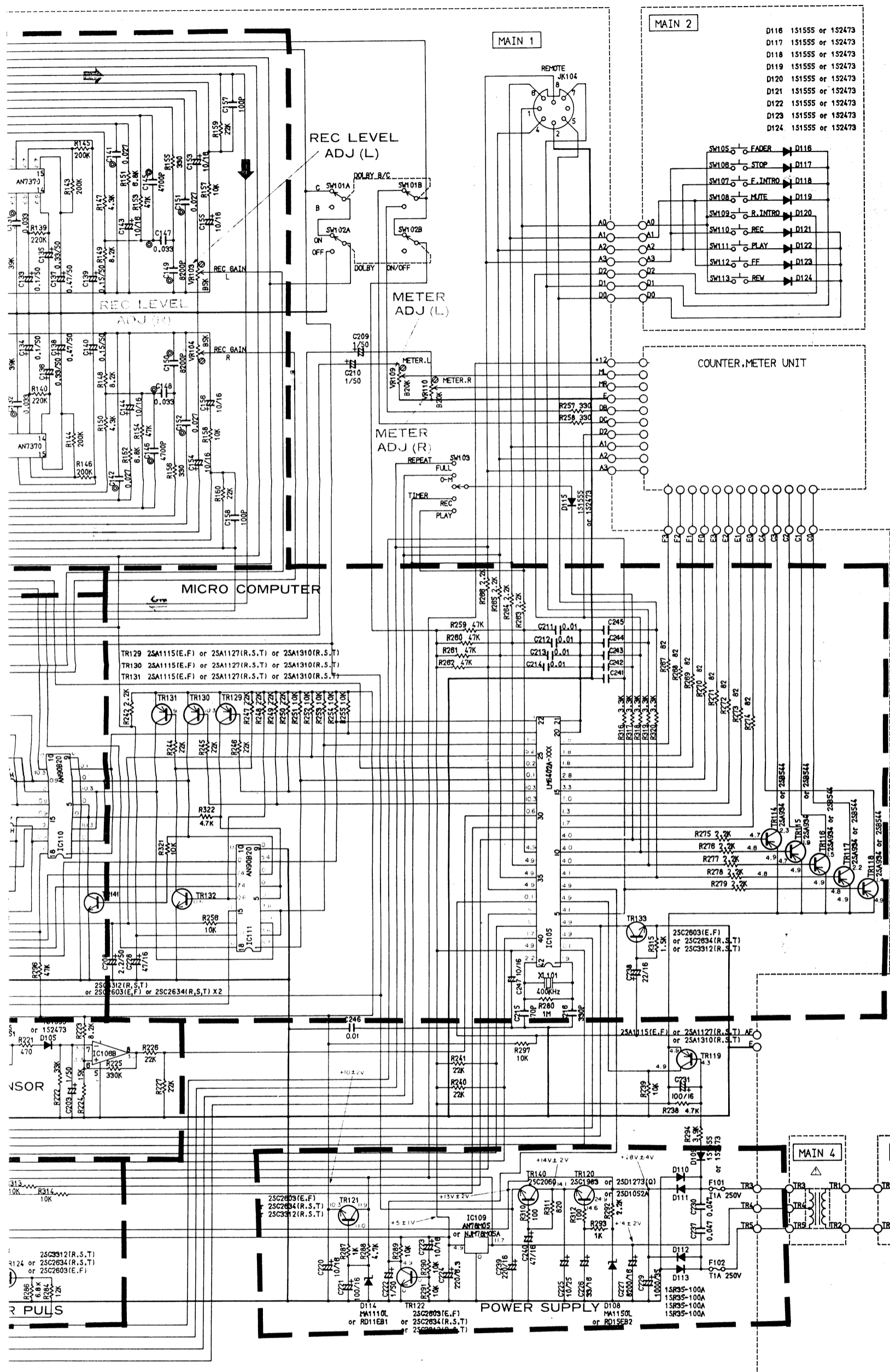

PIN CONNECTION DIAGRAM OF TRANSISTORS, DIODES AND ICS.

2SA1115 (E, F) 2SA1127 (R, S, T) 2SA1310 (R, S, T) 2SC2603 (E, F) 2SC2634 (R, S, T) 2SC3312 (R, S, T)	
2SC1983 2SD1052A 2SD1273 (Q)	
AN78M05 NJM78M05A	
1S1555 1S2473 RD6.8EB2 MA1068L RD11EB1 MA1110L RD15EB3 MA1150L	
RD3.6EB1 MA1036-M 1SR35-100A MA1039-H	
NJM4558S AN6551	
AN5733	
BA6209	
AN90B20	
AN7370	
HA12051	
LM6402A-345	

VOLTAGE TABLE

CHECK ITEM	MODE	POINT	VOLTAGE
CAPSTAN MOTOR	PLAY	+12/CM-	+14V ± 2V
REEL MOTOR (1)	FF	RM+/RM-	+6.5V ± 1V
" (2)	PLAY	RM+/RM-	+ 3V ± 1V
PLAY PLUNGER	PLAY ON	+12/PP	+14V ± 2V
STOP PLUNGER	STOP ON	+12/SP	+14V ± 2V
BIAS OSC (LH)	REC PLAY	TR125 EMITTER	+8.5V ± 2V
" (CrO ₂)	REC PLAY	TR125 EMITTER	+12V ± 2V
" (METAL)	REC PLAY	TR125 EMITTER	+19V ± 2V

This schematic diagram is for Japanese model. As the following parts and values differ from each model, so refer to the corresponding column.

	J	R	U,C	O,B	A
F101, 102	TIA250V	TIA250V	IA250V	T800mA 250V	TIA250V
C232	0.01/250	0.01	0.01	0.01	0.01/250
C241 ~ 245		0.01	0.01	0.01	0.01

- J Japanese model
- U U.S.A. model
- C Canadian model
- R General model
- A Australian model
- G European model
- B British model

Y mode In-sional condi-

tric volt meter.

marked Δ and must be those originally installed.

otice.

LM6402A-345 (IC105)

PIN No.	NAME	FUNCTION	PIN No.	NAM
1	Xtal	CLOCK Microcomputer 400kHz	42	EXte
2	C ₀	Capstan Stop plunger Play plunger Control	41	VDC
3	C ₁		40	B ³
4	C ₂		39	B ²
5	C ₃	LED DIGIT OUTPUT (Dot LED) · KEY SCAN5	38	B ¹
6	iNT	POWER OFF DETECT (Power off at "L" level)	37	B ⁰
7	RES	RESET, Microcomputer (Reset at "L" level)	36	A ³
8	D ₀	LED DIGIT OUTPUT (1 figure) · KEY SCAN 1 (2 figure) · " 2 (3 figure) · " 3 (4 figure) · " 4	35	A ²
9	D ₁		34	A ¹
10	D ₂		33	A ⁰
11	D ₃		32	I ₂
12	E ₀	LED SEGMENT OUTPUT a · M b · - c · d · (FADER) e · REC f · NORM. g · CrO ₂ · METAL	31	I ₁
13	E ₁		30	I ₀
14	E ₂		29	H ³
15	E ₃		28	H ²
16	F ₀		27	H ¹
17	F ₁		26	H ⁰
18	F ₂		25	G ³
19	F ₃		24	G ₂
20	TEST		Gnd.	23
21	V _{ss}	Gnd.	22	G ⁰

MATRIX OF INPUT

PORT	D ₀	D ₁	D ₂
A ₀	REW	INTRO SCAN (FF)	INTRO SCAN (R
A ₁	FF	REC MUTE	REMAINING TI
A ₂	PLAY	FADER	COUNTER RES
A ₃	REC	STOP	COUNTER MEM

IC BLOCK DIAGRAM

IC101 : AN5733

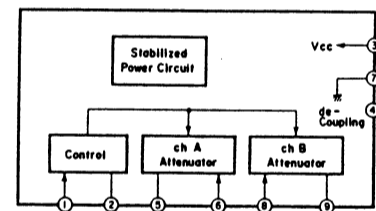

IC103, 104 : AI

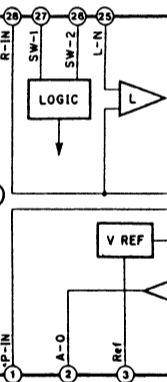

IC102 : HA12051

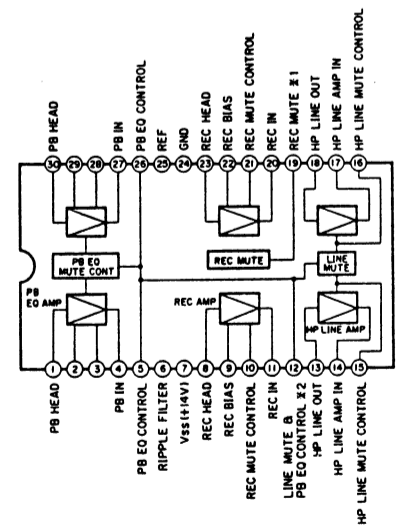

#1. REC MUTE CONTROL VOLTAGE
L(HSV): MUTE ON
L(LOV): MUTE OFF
#2. LINE MUTE & PB EO SW CONTROL VOLTAGE
H(HSV): MUTE OFF e=70µs
M(SV): MUTE OFF e=120µs
L(LOV): MUTE ON e=120µs

FADER MOVEMENTS

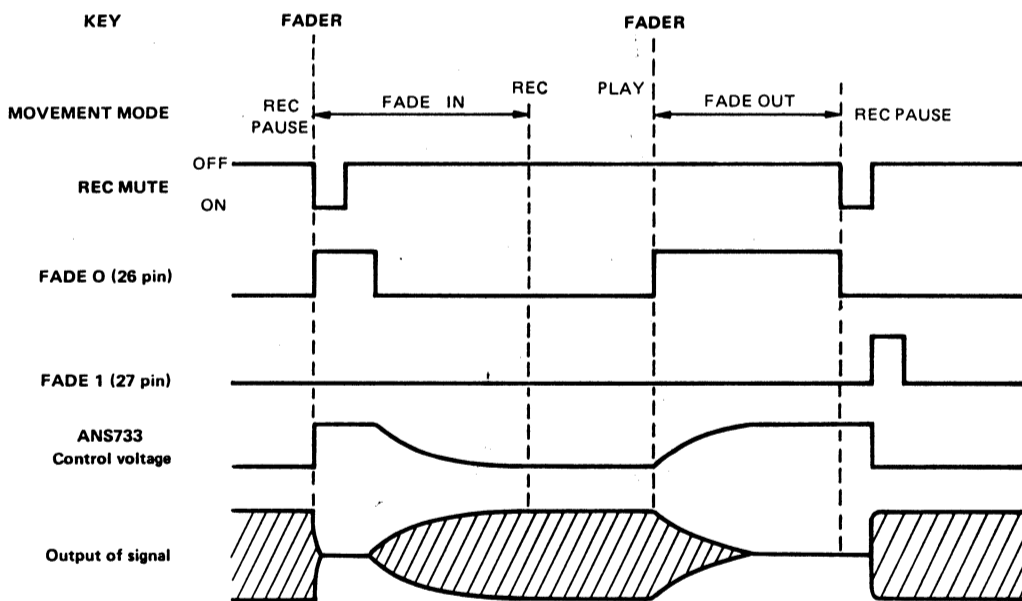

MECHANISM CONTROL CHART

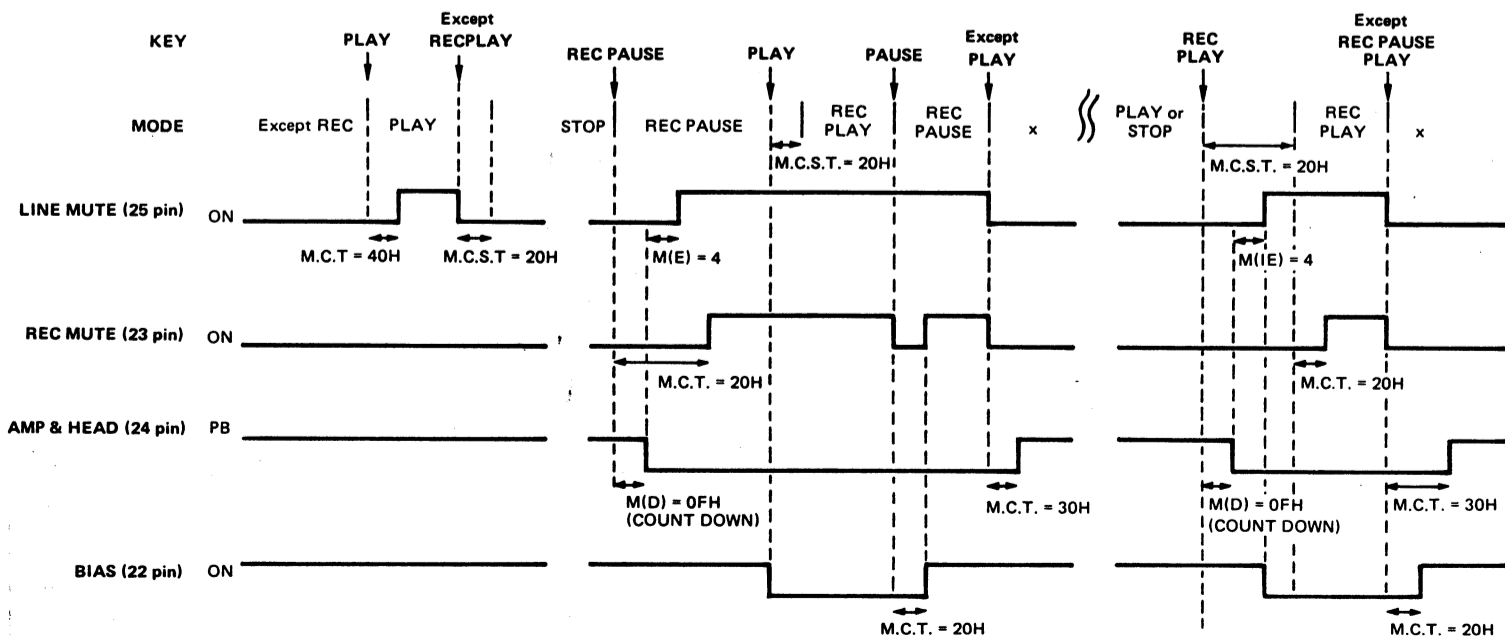

M.C.T. : Mechanism Control Time
M.C.S.T.: Mechanism Control stabilized time

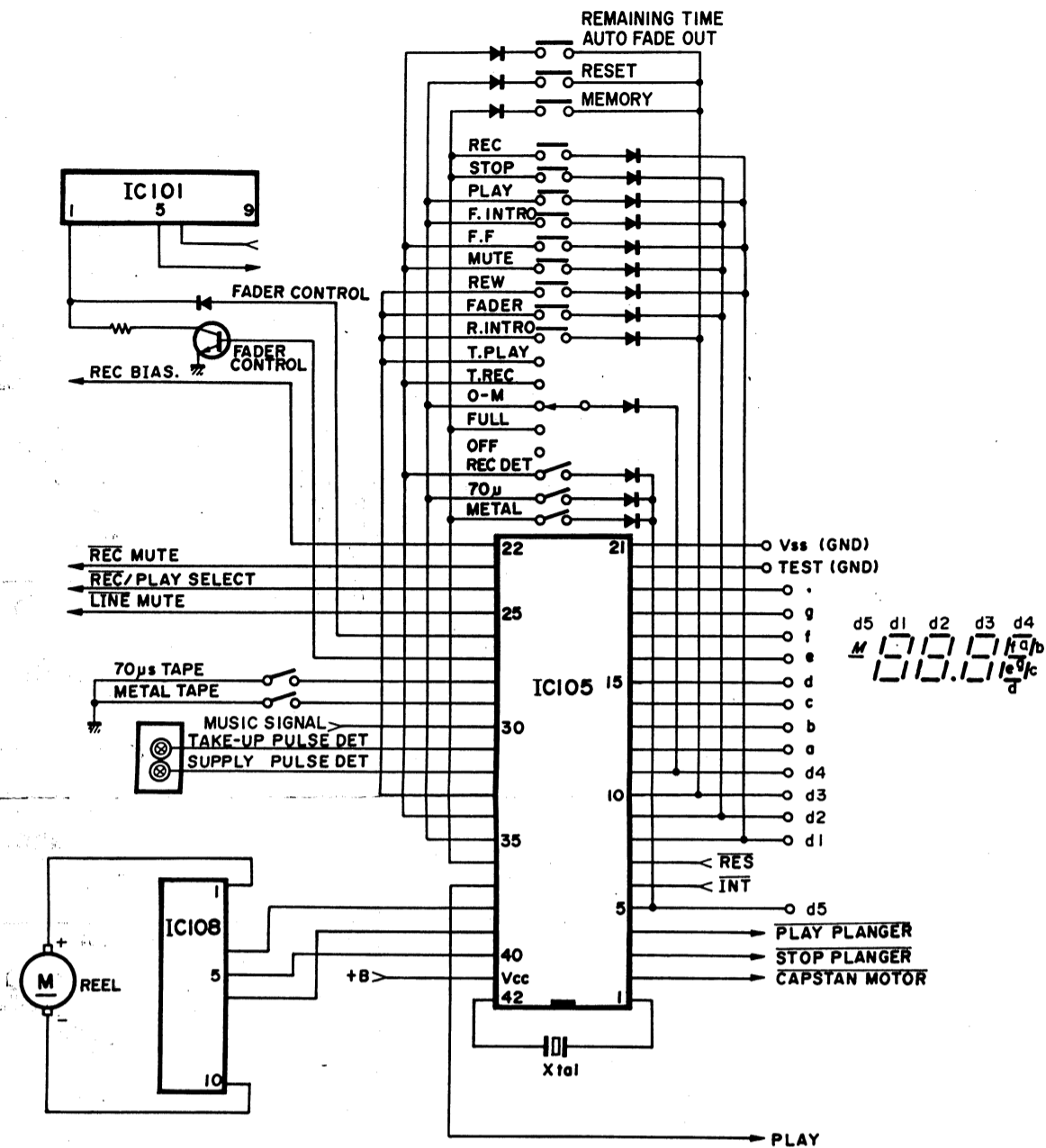

FADER MOVEMENTS

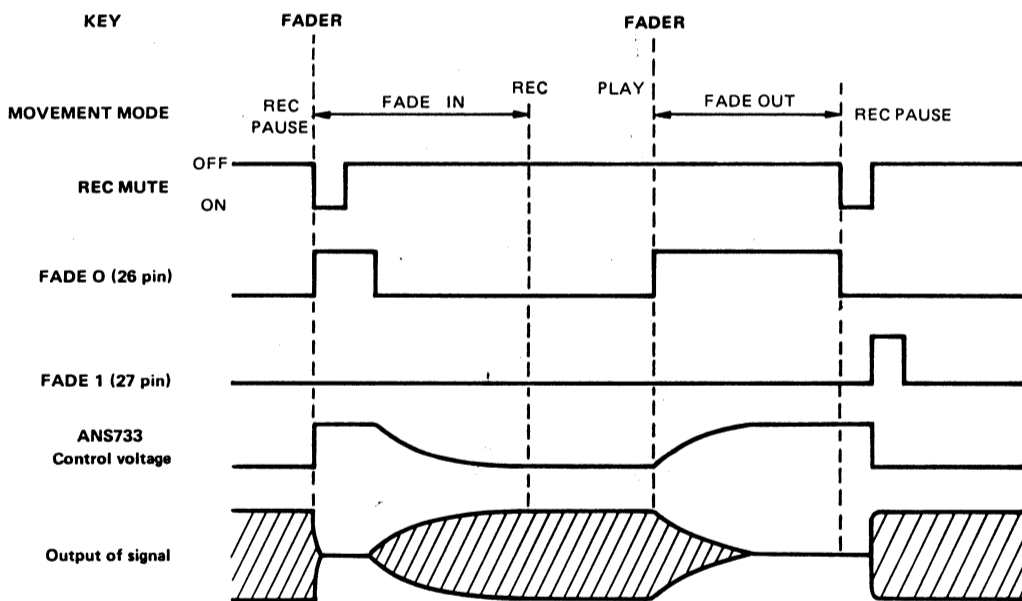

MECHANISM CONTROL CHART

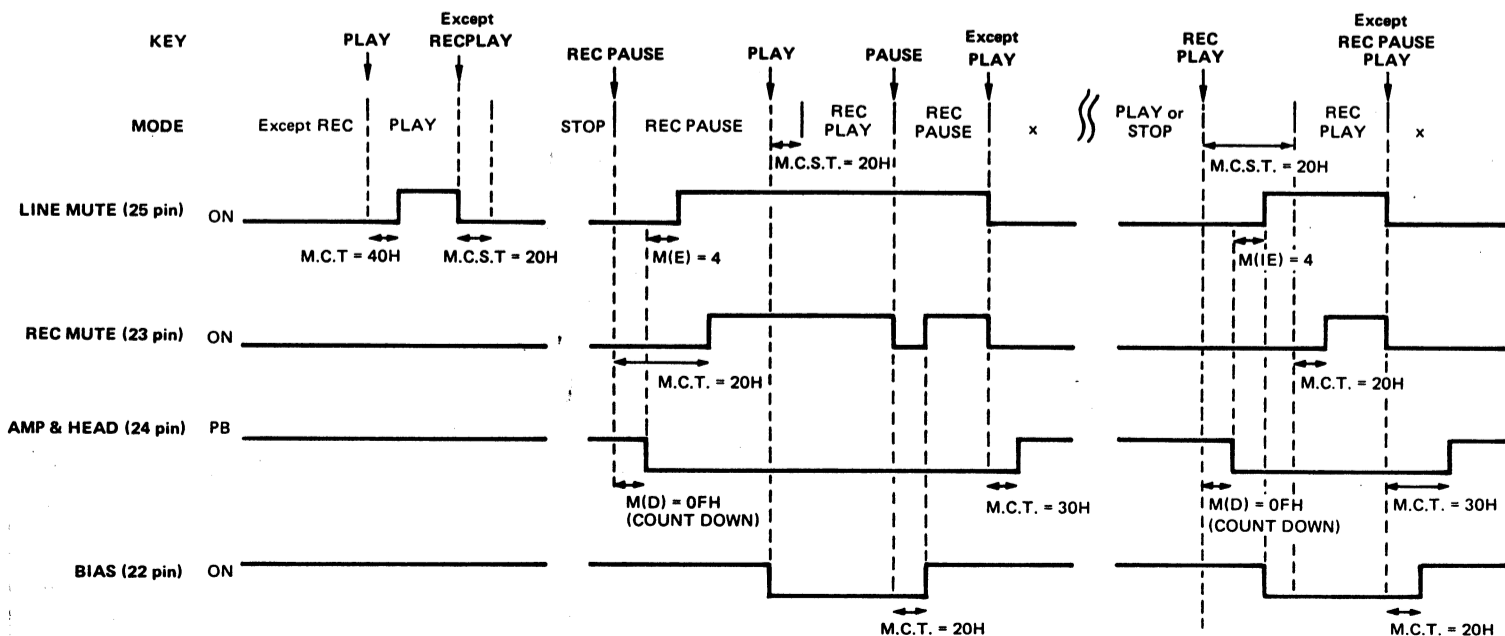

M.C.T. : Mechanism Control Time
M.C.S.T.: Mechanism Control stabilized time

COUNTER METER UNIT

PIN No.	NAME	FUNCTION
42	EXtal	CLOCK, Microcomputer 400kHz
41	VDD	+5V
40	B ³	Direction control of REEL MOTOR
39	B ²	
38	B ¹	
37	B ⁰	PLAY SIGNAL OUTPUT
36	A ³	Operation key and control switches, Sensor
35	A ²	
34	A ¹	
33	A ⁰	
32	I ₂	PULSE INPUT, Reel stand (Left)
31	I ₁	PULSE INPUT, Reel stand (Right)
30	I ₀	SIGNAL INPUT, Music blank (Music blank at "H" level)
29	H ³	METAL TAPE SIGNAL OUTPUT
28	H ²	70μs TAPE SIGNAL OUTPUT
27	H ¹	FADER control
26	H ⁰	
25	G ³	LINE MUTE (Mute ON at "L" level)
24	G ₂	REC SELECT (Recording at "L" level)
23	G ¹	REC MUTE (Mute ON at "L" level)
22	G ⁰	REC BIAS control (Bias ON at "L" level)

	D ₂	D ₃	C ₃
INTRO SCAN (REW)	TIMER PLAY	REC INHIBIT	
REMAINING TIME	TIMER REC	70μs TAPE	
COUNTER RESET	O ~ M REPEAT	METAL TAPE	
COUNTER MEMORY	FULL REPEAT		

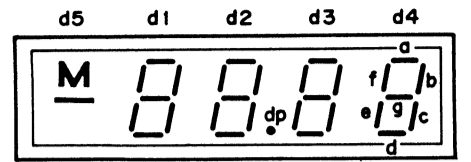
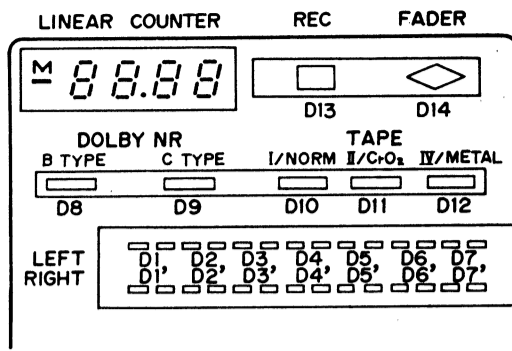

COUNTER METER UNIT SLK-5485

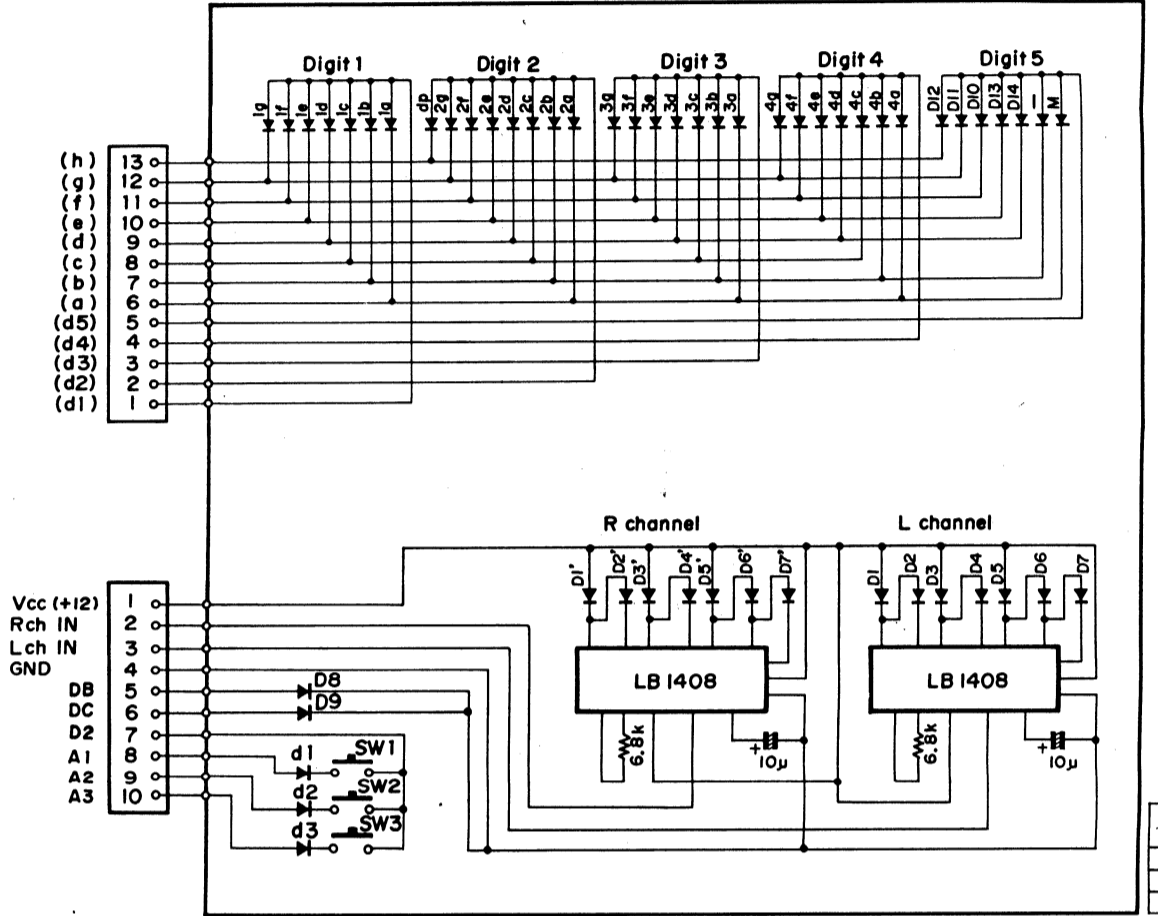

NO. 1
SW1
SW2
SW3

IC103, 104 : AN7370

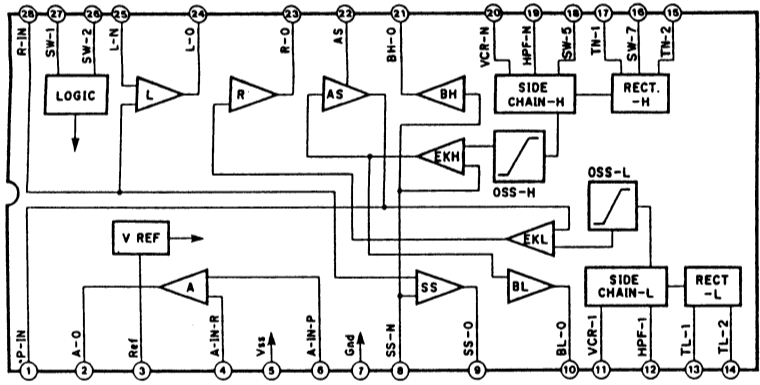

IC108 : BA6209

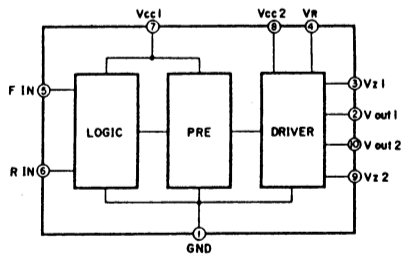

IC110, 111 : AN90B20

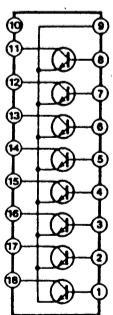

WIRING DIAGRAM

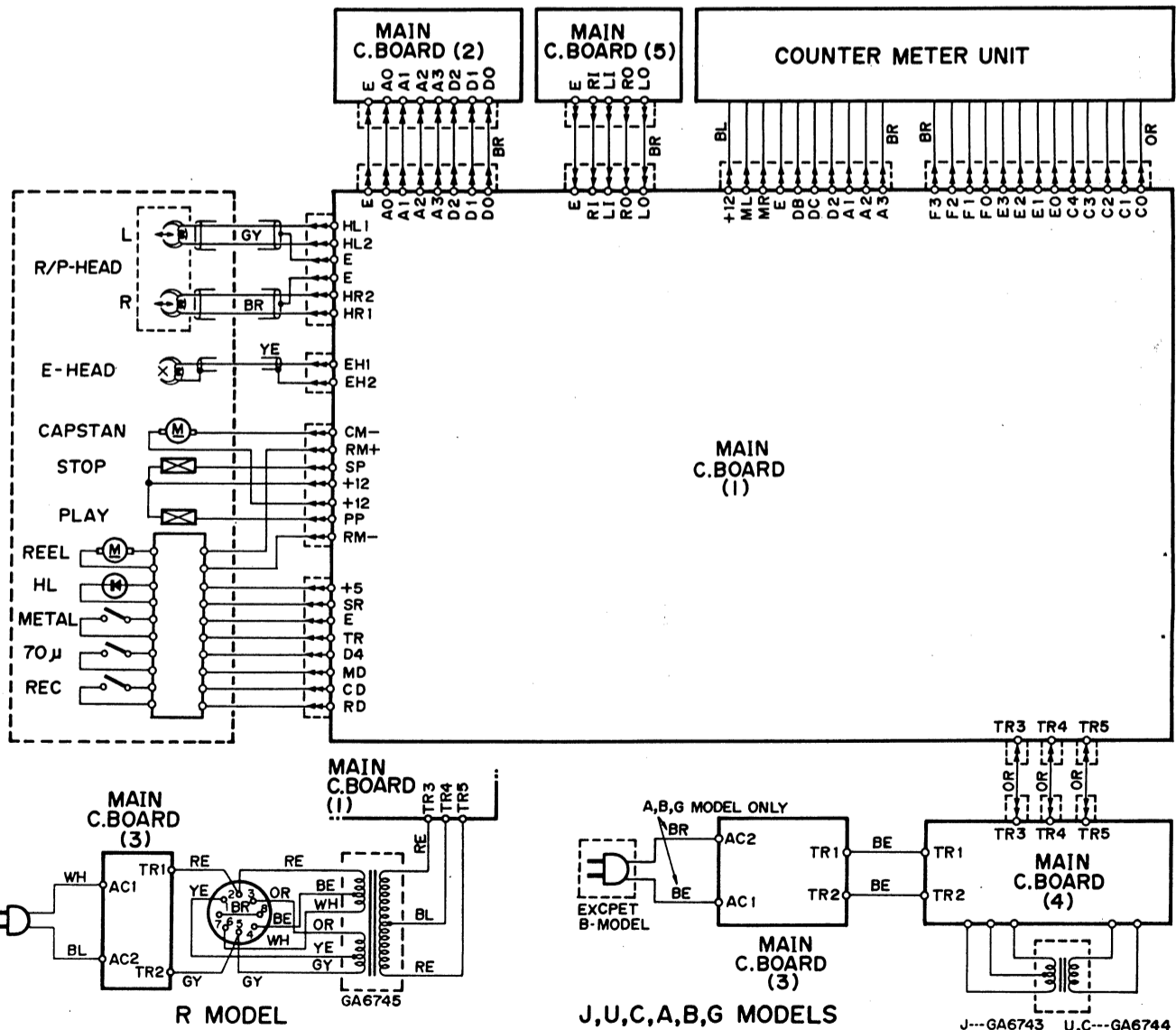

VOLTAGE SELECTOR

Voltage	Terminal No.
110V	5-4 2-1
120V	6-5 3-2
220V	7-1 8-4
240V	7-6 8-3

J---GA6743 U,C---GA6744
G---GA6746 A,B---GA6747

PRINTED CIRCUIT BOARD

Main Circuit Board (1)

Note
文字面 : Letter side

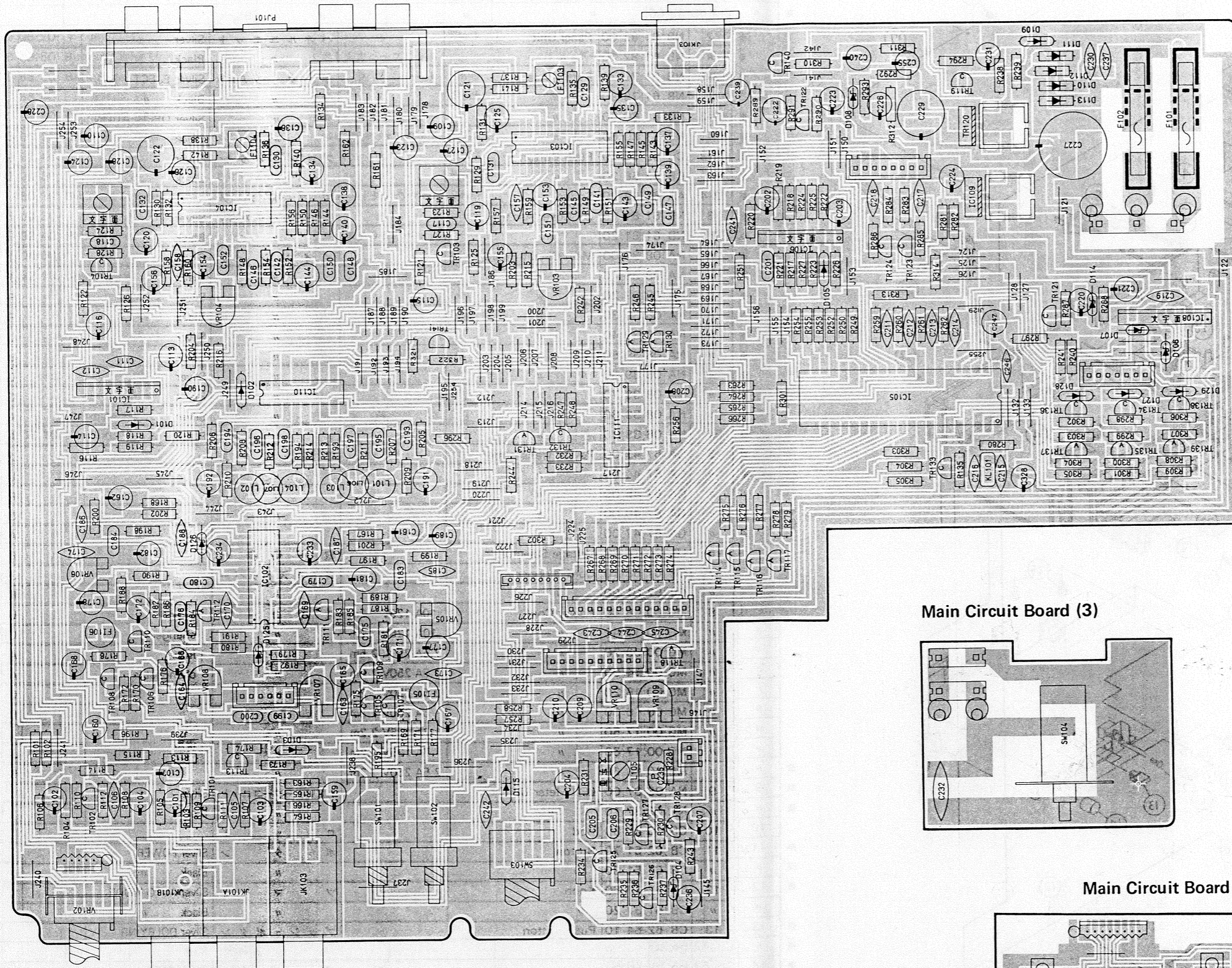

Main Circuit Board (4)

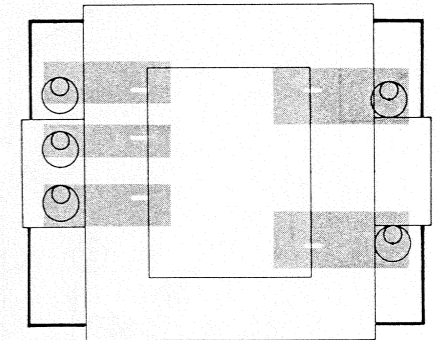

Main Circuit Board (3)

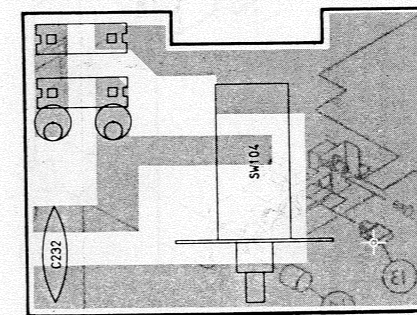

Main Circuit Board (5)

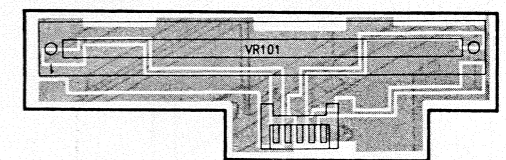

Main Circuit Board (2)

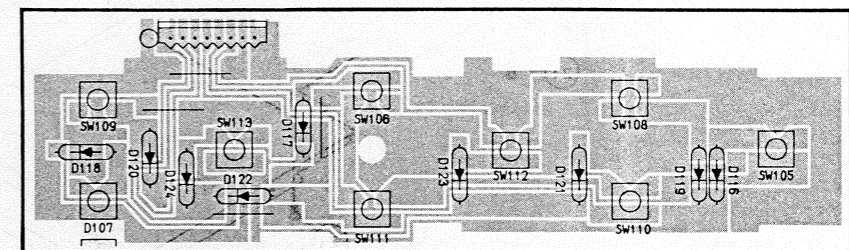

1

2

3

4

5

6

EXPLODED VIEW

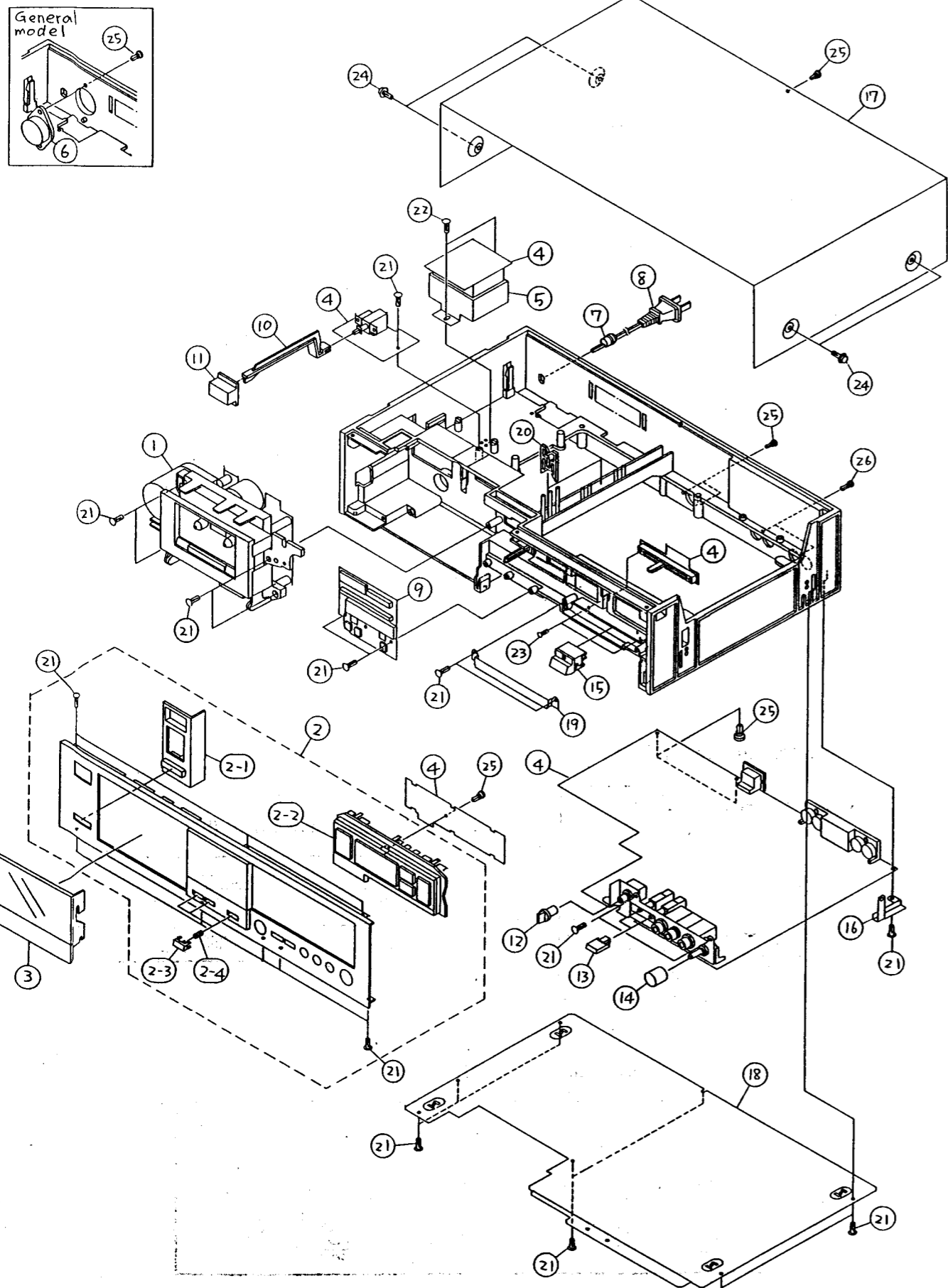

PARTS LIST

- △印のある部品は、安全性確保部品を示しています。部品の交換が必要な場合、パーツリストに記載されている部品を使用してください。
- Components having special characteristics are marked △ and must be replaced with parts having specifications equal to those originally installed.

MECHANISM PARTS

Ref. No.	Part No.	Description	部品名	Remarks	Common Model	Markets	ランク
* 1	SM 60 32 00	Mechanism Unit	TM-7B	メカユニット	Silver		230
* "	SM 60 33 00	"	"	"	Black		230
* 2	NB 61 82 00	Panel Unit		パネルユニット	Silver		140
* "	NB 61 82 10	"		"	Black		140
* 2-1	NB 61 79 70	Button Ass'y		ボタン Ass'y	Silver EJECT		030
* "	NB 61 79 80	"		"	Black "		03*
* 2-2	NB 61 80 50	"		"	Silver OPERATION		080
* "	NB 61 80 60	"		"	Black "		070
* 2-3	CB 62 56 10	Push Button		プッシュボタン	Silver		010
* "	CB 62 56 20	"		"	Black		01*
* 2-4	AA 61 99 20	Spring		スプリング			010
* 3	NB 61 81 10	Lid Cover Ass'y		リッドカバー Ass'y	Silver		060
* "	NB 61 81 20	"		"	Black		060
* 4	NA 08 39 00	Main Circuit Board		メインシート	Silver	J	310
* "	NA 08 39 10	"		"	Black	J	310
* "	NA 08 39 20	"		"	Silver	R	
* "	NA 08 39 30	"		"	Black	R	
* "	NA 08 39 40	"		"	Silver	U,C	
* "	NA 08 39 50	"		"	Black	U,C	
* "	NA 08 39 60	"		"	Silver	G,B	
* "	NA 08 39 70	"		"	Black	G,B	
* "	NA 08 39 80	"		"	Silver	A	
* "	NA 08 39 90	"		"	Black	A	
* 5	GA 67 43 00	Power Transformer		電源トランス		J	080 △
* "	GA 67 44 00	"		"		U,C	△
* "	GA 67 45 00	"		"		R	△
* "	GA 67 46 00	"		"		G	△
* "	GA 67 47 00	"		"		A,B	△
6	LB 20 14 80	Voltage Selector		電圧切換器		R	△
7	CB 61 68 10	Cord Stopper		コードストッパー		J,U,C	010
"	CB 62 01 90	"		"		R,A,G,B	
8	MG 00 08 40	Power Cord	10A 125V 2m	電源コード	Inter-changeable	U,C	△
"	MG 00 12 40	"	10A 125V 2m	"		U,C	△
"	MG 00 09 20	"	7.5A 250V 2.5m	"	Inter-changeable	A	△
"	MG 00 14 90	"	7.5A 250V 2.5m	"		A	△
"	MG 00 16 20	"	2.5A 250V 2m	"		G	△
"	MG 00 16 30	"	6A 250V 2m	"		R	△
"	MG 00 17 50	"	7A 125V 2.2m	"	併用	J	040 △
"	MG 00 17 60	"	7A 125V 2.2m	"		J	040 △
* "	MG 00 18 60	"	2.5A 250V 2m	"		B	△
* 9	NA 08 37 00	LED Meter Unit		LEDメーターユニット	Silver		140
* "	NA 08 37 10	"		"	Black		140
10	CB 60 80 90	Rod		ロッド			020
* 11	CB 62 51 70	Button		ボタン	Silver POWER		020
* "	CB 62 51 80	"		"	Black "		020
* 12	CB 62 52 60	Knob		つまみ	Silver AUTO MODE		02*
"	CB 61 37 20	"		"	Black "		020
* 13	CB 62 54 10	Push Button		プッシュボタン	Silver DOLBY NR		010
* "	CB 62 54 20	"		"	Black "		010
* 14	CB 62 60 30	Knob		つまみ	Silver REC BALANCE		020
* "	CB 62 60 40	"		"	Black "		020
* 15	NB 61 80 90	Slid Knob Ass'y		スライドつまみ Ass'y	Silver REC LEVEL		030
* "	NB 61 81 00	"		"	Black "		030

*New Parts (新規部品)

ランク : Japan only

Ref. No.	Part No.	Description	部 品 名	Remarks	Common Model	Markets	ランク
16	AA:61:05:70	Ground Plate	アース金具				010
※	17	AA:62:05:10	Top Cover	トップカバー	Silver		080
※	"	AA:62:05:20	"	"	Black		080
18	NB:60:69:60	Buttom Cover Unit	ボトムカバーユニット		K-500		060
※	19	BA:08:86:30	Back Plate	バックプレート	Silver		030
※	"	BA:08:86:40	"	"	Black		030
20	CB:60:99:80	Clamper, Cord	コードクランパー				010
21	Ei:03:01:06	Binding Head Tapping Screw	3×10 ZMC2-Y	バインドタッピングネジ	PACK		010
22	Ei:04:01:46	"	4×14 ZMC2-Y	"	PACK		010
23	ED:02:00:66	"	2×6 ZMC2-Y	"	PACK		010
24	EK:13:50:30	BW Head Tapping Screw	4×12 FNM3-3g	BWヘッドタッピングネジ	Silver		010
"	EK:33:60:30	"	4×12 FCM3-BI	"	Black		010
25	CB:60:32:40	Plastic Rivet	プラスチックリベット				010
26	CB:61:04:00	"	"				010
※	27	AA:61:22:10	Shield Plate	シールド板			020
		Accessories	付 属 品				
	Mi:06:62:10	Pin Cord	1.2m	ピンコード			050

※New Parts (新規部品)

ランク : J₃ pan only

■EXPLODED VIEW (CASSETTE MECHANISM)

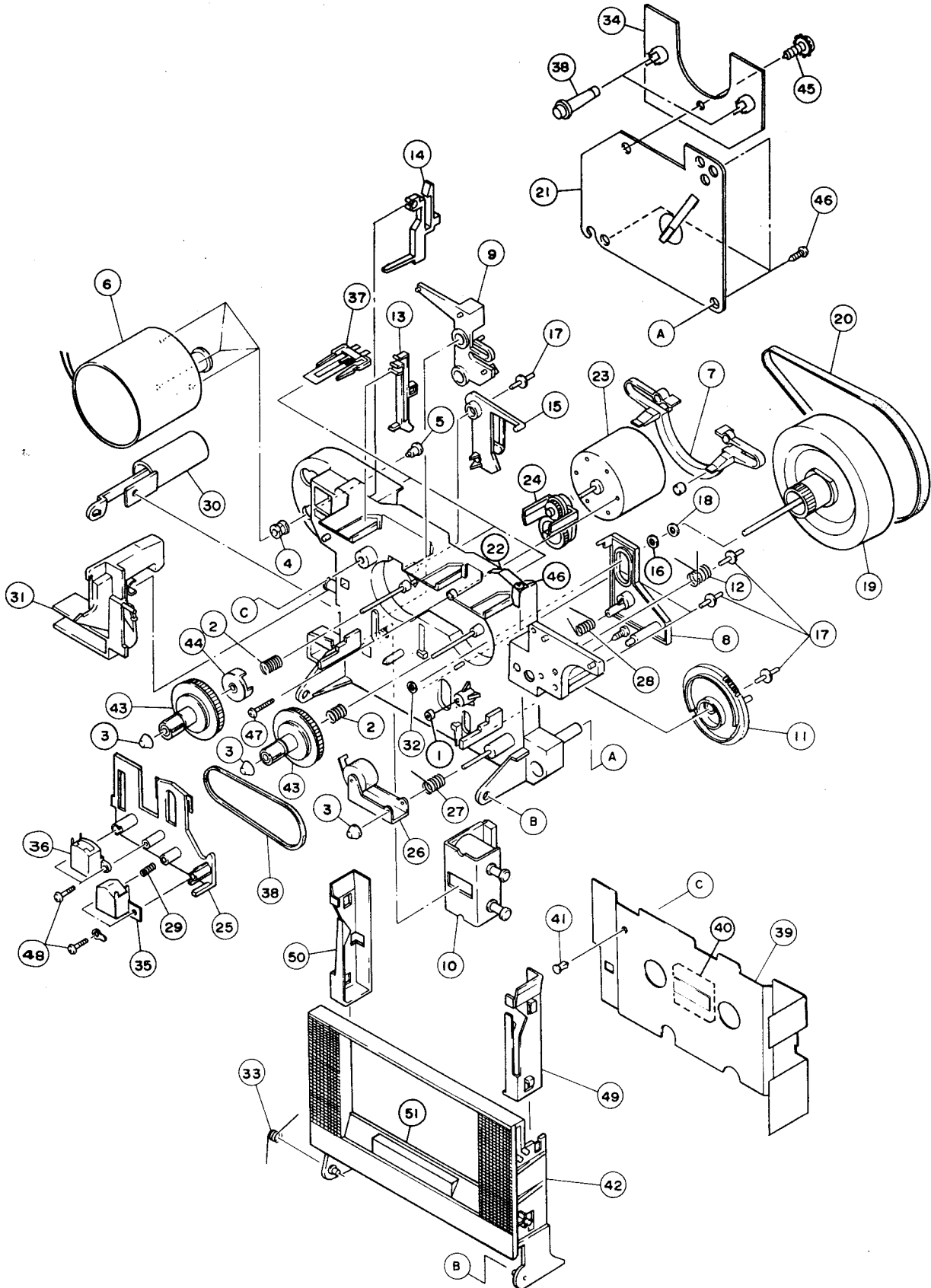

■CASSETTE MECHANISM PARTS

Ref. No.	Part No.	Description	部 品 名	Remarks	Common Model	Markets	ランク
*	SM 60 32 00	Cassette Mechanism Unit	TM-7B (S)	カセットメカユニット			230
*	SM 60 33 00	"	TM-7B (B)	"			230
*	1 BB 07 00 90	Oil-less Metal		オイルレスメタル			010
	2 AA 60 88 80	Spring, BT		B T スプリング			010
	3 CB 60 61 50	Reel Cap		リールキャップ			010
	4 CB 61 11 80	Mounting Plate, Motor		モーター取付座			010
	5 AA 60 66 50	Screw, Motor		モーター取付ネジ			010
*	6 JC 00 10 70	Capstan Motor	BFA2R	キャプスタンモーター			080
	7 NB 60 58 00	Brake Ass'y		ブレーキ Ass'y			020
	8 CB 60 61 60	Cam Follower		カムフォロア			010
	9 CB 60 61 70	Play-Triger		P L A Y トリガ			010
	10 JF 00 03 30	Solenoid Ass'y		ソレノイド Ass'y			060
	11 CB 60 61 80	Cam		カム			010
	12 AA 60 88 90	Spring, Cam		カムスプリング			010
*	13 CB 62 28 70	Lever		C - R レバー			010
*	14 CB 62 28 80	Senser Tape		テープセンサー			010
	15 CB 60 61 90	Stop-Triger		S T O P トリガ			010
	16 CB 60 62 10	Washer	PW-2.5-7	ポリスライダークワッシャー			010
	17 CB 60 62 00	Rivet		リベット			010
	18 CX 60 01 60	Washer	2.6×4.7×0.13	ポリスライダークワッシャー			010
	19 NB 60 33 70	Flywheel Ass'y		フライホイール Ass'y			060
	20 CB 60 62 20	Belt Main		メインベルト			020
*	21 NB 61 50 70	Back Plate Ass'y		バックプレート Ass'y			030
*	22 AA 62 24 30	Plate, Spring		スプリングプレート			010
	23 JC 00 07 20	Reel Motor	BFS9B	リールモーター			070
*	24 NB 61 50 00	Gear Ass'y		ギヤ Ass'y			040
*	25 CB 62 28 90	Head Base		ヘッドベース			010
	26 NB 61 50 60	Pinch Roller Ass'y		ピンチローラー Ass'y			030
	27 AA 60 89 10	Spring, Return		リターンスプリング			010
	28 AA 60 89 20	Spring, Head Base		ヘッドベーススプリング			010
	29 AA 60 89 30	Spring, R/P Head		ヘッドスプリング			010
	30 NB 60 33 40	Damper Ass'y		ダンパー Ass'y			030
	31 CB 60 61 10	Lever, Lock		ロックレバー			020
	32 CB 08 26 10	Washer		キャプスタンワッシャー			010
	33 AA 60 88 70	Spring, Housing		ハウジングスプリング			010
*	34 NA 08 34 20	Photo Reflector Circuit Board		フォトリアフレクターシート			090
*	35 GF 00 03 10	REC/Playback Head		録再ヘッド			090
*	36 GF 00 02 90	Erase Head		消去ヘッド			040
	37 KA 60 05 20	Leaf Switch		リーフスイッチ			020
*	38 CB 62 29 10	Photo Grass		フォトグラス			010
*	39 NB 61 86 70	Blind Plate Ass'y		ブラインドプレート Ass'y			060
	40 iF 00 35 70	LED	SLF-301C	L E D			010
	41 CB 06 88 80	Plastic Rivet		プラスチックリベット			010
*	42 CB 62 69 80	Housing	(GY)	ハウジング	Silver		05*
*	" CB 62 69 90	"	(BL)	"	Black		05*
*	43 NB 62 09 70	Reel Base Ass'y		リール台 Ass'y			020
*	44 NB 61 86 40	Disc Ass'y, BT		バックテンションディスク Ass'y			020
	45 Ei 03 00 86	Binding Head Tapping Screw	3×8 ZMC2-Y	バインドタッピングネジ	PACK		010
	46 Ei 03 01 06	"	3×10 ZMC2-Y	"	PACK		010
	47 EA 02 62 06	Pan Head Screw	2.6×20 ZMC2-Y	ナベ小ネジ	PACK		010
	48 ED 02 01 26	Binding Head Screw	2×12 ZMC2-Y	バインド小ネジ	PACK		010
	49 CB 60 98 80	Guide R, Cassette		カセットガイドR			010
*	50 CB 62 85 70	Guide L, Cassette		カセットガイドL			01*
*	51 CB 62 64 70	Enblem		エンブレム	Silver		030
*	" CB 62 64 80	"		"	Black		030

*New Parts (新規部品)

ランク : J₃ pan only

※この部品は、1/4Wタイプ。このパーツリストには、記載してありませぬので、部品番号がHJ350000タイプまたは同等品を使用してください。

● Carbon resistors of this deck are 1/4W.
There is no description about them in this parts list.
Use the "Part No." HJ350000 or equivalent.

ELECTRICAL PARTS

Ref. No.	Part No.	Description	部 品 名	Remarks	Common Model	Markets	ランク
※	NA 08 39 00	Main Circuit Board	メ イ ン シ ー ト	Silver		J	310
※	NA 08 39 10	"	"	Black		J	310
※	NA 08 39 20	"	"	Silver		R	
※	NA 08 39 30	"	"	Black		R	
※	NA 08 39 40	"	"	Silver		U,C	
※	NA 08 39 50	"	"	Black		U,C	
※	NA 08 39 60	"	"	Silver		G,B	
※	NA 08 39 70	"	"	Black		G,B	
※	NA 08 39 80	"	"	Silver		A	
※	NA 08 39 90	"	"	Black		A	
	FU 15 21 00	Mica Cap	マ イ カ コ ン	100pF 500V	C199,200		021
	Fi 40 41 00	Ceramic Cap	セ ラ コ ン	0.01 μ F 250V	C232	J,A	012
	Fi 41 41 00	"	"	0.01 μ F	"	R,U,G,C,B	
	UA 25 31 00	Mylar Cap	マ イ ラ ー コ ン	1000pF 50V	C205		021
	UA 25 32 20	"	"	2200pF 50V	C206		021
	UA 25 33 30	"	"	3300pF 50V	C117,118		021
	UA 25 34 70	"	"	4700pF 50V	C145,146		021
	UA 25 38 20	"	"	8200pF 50V	C149,150		021
	UA 25 41 00	"	"	0.01 μ F 50V	C129,130,201		021
	UA 25 41 20	"	"	0.012 μ F 50V	C193~196		021
	UA 25 41 50	"	"	0.015 μ F 50V	C179,180,197,198		021
	UA 25 42 20	"	"	0.022 μ F 50V	C175,176		021
	UA 25 42 70	"	"	0.027 μ F 50V	C141,142,151,152		021
	UA 25 43 30	"	"	0.033 μ F 50V	C131,132,147,148		021
	UA 25 51 50	"	"	0.15 μ F 50V	C183,184		021
	FG 41 13 30	Ceramic Cap	セ ラ コ ン	33pF 50V	C111,112		010
	FG 41 21 00	"	"	100pF 50V	C105,106,157,158,169,170		010
	FG 41 22 20	"	"	220pF 50V	C187,188		010
	FG 41 23 30	"	"	330pF 50V	C173,174,216		010
	FG 41 24 70	"	"	470pF 50V	C215		010
	FG 41 25 60	"	"	560pF 50V	C163,164		010
	FG 41 26 80	"	"	680pF 50V	C185,186		010
	FG 41 32 20	"	"	2200pF 50V	C217,218		010
	FG 44 41 00	"	"	0.01 μ F 50V	C211~214,219,246		010
	FG 44 41 00	"	"	0.01 μ F 50V	C241~245	R,U,A,G,C,B	
	FG 44 44 70	"	"	0.047 μ F 50V	C230,237		010
	FT 16 33 90	Polypropylene Cap	ポ リ プ ロ コ ン	3900 μ F 100V	C235		030
	UW 91 82 20	Electrolytic Cap	ケ ミ コ ン	220 μ F 6.3V	C171,172,224		010
	UW 93 71 00	"	"	10 μ F 16V	C115,161,162,189,190,116,119,120,143,144,153~156,165,166,177,178,191,192,220,223,247		010
	UW 93 72 20	"	"	22 μ F 16V	C238		010
	UW 93 73 30	"	"	33 μ F 16V	C226,107,159,160		010
	UW 93 74 70	"	"	47 μ F 16V	C114,228,240		010
	UW 93 81 00	"	"	100 μ F 16V	C113,181,182,221,231		010
	UW 93 82 20	"	"	220 μ F 16V	C239		010
	UW 94 71 00	"	"	10 μ F 25V	C204,225		010
	UW 94 74 70	"	"	47 μ F 25V	C207		010
	UW 56 51 00	"	"	0.1 μ F 50V	C133,134		010
	UW 56 51 50	"	"	0.15 μ F 50V	C139,140		010
	UW 56 53 30	"	"	0.33 μ F 50V	C135,136		010
	UW 96 54 70	"	"	0.47 μ F 50V	C137,138		010
	UW 96 61 00	"	"	1 μ F 50V	C101~104,109,110,123~128,167,168,202,203,209,210,222,233,234		010
	UW 96 62 20	"	"	2.2 μ F 50V	C208,236		010
	UW 93 84 70	"	"	470 μ F 16V	C121,122		021
	UJ 15 91 00	"	"	1000 μ F 35V	C229		030
	Ui 93 98 20	"	"	8200 μ F 16V	C227		040

※New Parts (新規部品)

ランク : Japan only

Ref. No.	Part No.	Description	部 品 名	Remarks	Common Model	Markets	ランク
	GE 20 04 70	Dolby Filter		ドルビーフィルター	Fi101,102		030
	GE 90 03 50	Bias Trap Coil	85kHz	バイアストラップコイル	Fi105,106	} 併用 Inter-changeable	020
	GE 90 06 10	"	"	"	"		020
	GE 90 06 80	Coil	20kHz	スキューイングコイル	Fi103,104	} 併用 Inter-changeable	020
	GE 90 07 90	"	19kHz	トラップコイル	"		020
	GE 90 16 00	Coil	5.6mH	コ イ ル	L103,104		020
	GE 90 16 10	"	6.8mH	"	L101,102		020
*	GE 90 14 60	"		バイアスOSCコイル	L105		020
*	GE 90 15 90	"	4.7mH	コ イ ル	L106,107		020
	HV 55 41 50	Flame Proof Carbon Resistor	15Ω	不燃カーボン抵抗	R230		010
	GG 00 05 00	Ceramic Crystal Unit	400kHz	セラミック振動子	XL101		030
	HQ 40 02 60	Variable Resistor	A50kΩ×2	スライドボリューム	VR101		050
	HS 31 24 70	"	MN100kΩ	可変抵抗器	VR102		030
	HT 37 03 70	Semi Variable Resistor	B5kΩ	半固定抵抗	VR103,104		010
*	HT 37 03 90	"	B20kΩ	"	VR105,106,109,110		01*
*	HT 37 04 20	"	B100kΩ	"	VR107,108		01*
	iA 09 34 00	Transistor	2SA934	トランジスタ	TR114~118	} 併用 Inter-changeable	030
	iB 05 44 20	"	2SB544	"	"		030
	iA 11 15 10	"	2SA1115 (E,F)	"	TR113,119,129~131 135,137,139	} 併用 Inter-changeable	031
	iA 11 27 00	"	2SA1127 (R,S,T)	"	"		031
	iX 60 31 70	"	2SA1310 (R,S,T)	"	"		03*
	iC 20 60 00	"	2SC2060	"	TR125,134,136,138, 140,105~108	} 併用 Inter-changeable	030
	iC 26 03 10	"	2SC2603 (E,F)	"	TR101~104,111,112,121~124 126~128,132,133,141		031
	iC 26 34 00	"	2SC2634 (R,S,T)	"	"		031
*	iX 60 31 80	"	2SC3312 (R,S,T)	"	"	changeable	03*
	iD 13 02 00	"	2SD1302 (R,S)	"	TR109, 110		031
	iC 19 83 00	"	2SC1983	"	TR120	} 併用 Inter-changeable	030
	iD 12 73 00	"	2SD1273 (Q)	"	"		030
	iD 10 52 10	"	2SD1052A	"	"		030
	iF 00 06 70	Diode	IS2473	ダイオード	D101~103,105,109, 115~124,127~129	} 併用 Inter-changeable	010
	iF 00 00 40	"	IS1555	"	"		010
	iF 00 16 70	Zener Diode	RD6.8EB2	ツェナーダイオード	D125,126,104,106	} 併用 Inter-changeable	010
*	iF 00 67 80	"	MA1068L	"	"		010
*	iF 00 64 90	"	RD11EB1	"	D114	} 併用 Inter-changeable	010
*	iF 00 69 30	"	MA1110L	"	"		010
	iF 00 17 00	"	RD15EB3	"	D108	} 併用 Inter-changeable	010
*	iF 00 70 50	"	MA1150L	"	"		010
*	iF 00 66 20	"	MA1039-H	"	D107		010
	iH 00 14 30	Diode	ISR-100A	ダイオード	D110~113		010
	iG 07 53 00	IC	AN78M05	I C	IC109	} 併用 Inter-changeable	031
	iG 07 56 00	"	NJM78M05A	"	"		031
	iG 07 68 00	"	NJM4558S	"	IC106	} 併用 Inter-changeable	030
	iG 03 47 00	"	AN6551	"	"		030
	iG 08 99 00	"	AN90B20	トランジスタアレイ	IC110,111		040
	iG 10 11 00	"	BA6209	I C	IC108		050
	iG 11 02 00	"	AN5733	"	IC101		050
	iG 11 65 00	"	AN7370	"	IC103,104		080
*	iG 12 51 00	"	HA12051	"	IC102		070

* New Parts (新規部品)

Ref. No.	Part No.	Description	部 品 名	Remarks	Common Model	Markets	ランク
*	iG 12 66 00	IC	LM6402A-345	I C IC105			070
	KA 80 28 20	Push Switch		プッシュスイッチ	SW101,102		030
*	KA 50 19 60	Rotary Switch		ロータリースイッチ	SW103		050
*	KA 80 36 10	Push Switch		プッシュスイッチ	SW104		030
	KA 90 63 80	Switch		ライトタッチスイッチ	SW105-113		010
	KB 00 03 30	Fuse	TIA 250V	ヒューズ		J,R,A	010
	KB 00 07 20	"	T800mA 250V	"		G,B	
	KB 00 10 60	"	IA 250V	"		U,C	
*	LB 30 21 50	Phone Jack		ホーンジャック	Silver JK102		030
*	LB 30 21 40	"		"	Black "		030
	LB 60 50 30	DIN Jack		D I N ジャック	JK103	R,U,A,G,C,B	
*	LB 60 69 90	Mic Jack		マイクジャック	Silver JK101		040
	LB 60 70 00	"		"	Black "		040
	LB 40 08 00	Pin Jack	4P	ピンジャック	PJ101	J,R,U,A,C	030
*	LB 60 71 80	"	"	"	"	G,B	
	LA 00 21 40	Wrapping Terminal	P=10 2P i-Type	i型ラッピング端子板			010
	LA 00 21 50	"	P=10 3P i-Type	"		R	
	LB 20 18 80	Fuse Holder Pin		ヒューズホルダーピン			010
	LB 91 80 20	Base Pin	2P i-Type	ベースピン			010
	LB 91 80 60	"	6P i-Type	"			010
	LB 91 80 70	"	7P i-Type	"			010
	LB 91 80 80	"	8P i-Type	"			010
	LB 91 81 00	"	10P i-Type	"			020
	LB 91 81 30	"	13P i-Type	"			020
	LB 92 60 50	2.5 Pitch Short Plug	5P L-Type	2.5ピッチショートプラグ			010
	LB 92 50 80	"	8P i-Type	"			010
*	AA 61 99 00	Bracket		P C B ブラケット			020
	BA 08 40 00	Heat Sink		放 熱 板			020
	CB 61 22 40	Cushion		シートクッション			010
*	CB 62 23 90	Plastic Rivet		プラスチックリベット			010
	Ei 03 00 66	Binding Head Tapping Screw	3x6 ZMC2-Y	バインドタッピングネジ	PACK		010
*	NA 08 37 00	Meter Unit		メーターユニット	Silver		140
*	NA 08 37 10	"		"	Black		140

*New Parts (新規部品)

ランク : Japan only