

STEREO DOUBLE CASSETTE DECK KX-W421/W321/K-903

SERVICE MANUAL



IMPORTANT NOTICE

This manual has been provided for the use of authorized YAMAHA Retailers and their service personnel. It has been assumed that basic service procedures inherent to the industry, and more specifically YAMAHA Products, are already known and understood by the users, and have therefore not been restated.

WARNING: Failure to follow appropriate service and safety procedures when servicing this product may result in personal injury, destruction of expensive components, and failure of the product to perform as specified. For these reasons, we advise all YAMAHA product owners that any service required should be performed by an authorized YAMAHA Retailer or the appointed service representative.

IMPORTANT: The presentation or sale of this manual to any individual or firm does not constitute authorization, certification or recognition of any applicable technical capabilities, or establish a principle-agent relationship of any form.

The data provided is believed to be accurate and applicable to the unit(s) indicated on the cover. The research, engineering, and service departments of YAMAHA are continually striving to improve YAMAHA products. Modifications are, therefore, inevitable and specifications are subject to change without notice or obligation to retrofit. Should any discrepancy appear to exist, please contact the distributor's Service Division.

WARNING: Static discharges can destroy expensive components. Discharge any static electricity your body may have accumulated by grounding yourself to the ground buss in the unit (heavy gauge black wires connect to this buss).

IMPORTANT: Turn the unit OFF during disassembly and part replacement. Recheck all work before you apply power to the unit.

■ CONTENTS

TO SERVICE PERSONNEL	1	DISPLAY DATA	19
FRONT PANELS	2	KX-W421 BLOCK DIAGRAM	20
REAR PANELS	3	SCHEMATIC DIAGRAM	21~23
KX-W421 SPECIFICATIONS	4	KX-W321/K-903 SPECIFICATIONS	24
KX-W421 INTERNAL VIEW	4	KX-W321/K-903 INTERNAL VIEW	24
DISASSEMBLY PROCEDURES	5~6	KX-W321/K-903 ADJUSTMENTS	25~29
KX-W421 ADJUSTMENTS	7~11	KX-W321/K-903 PRINTED CIRCUIT BOARD	30~33
KX-W421 PRINTED CIRCUIT BOARD	12~15	KX-W321/K-903 BLOCK DIAGRAM	34
μ-COM DATA	16~18	PARTS LIST	35~51

100621

YAMAHA
YAMAHA CORPORATION
P.O.Box1.Hamamatsu.Japan

2.8K-514 (PM) Printed in Japan '98.3

■ TO SERVICE PERSONNEL

1. Critical Components information.

Components having special characteristics are marked Δ and must be replaced with parts having specifications equal to those originally installed.

2. Leakage Current Measurement (For 120V Model only).

When service has been completed, it is imperative that you verify that all exposed conductive surfaces are properly insulated from supply circuits.

- Meter impedance should be equivalent to 1500 ohm shunted by $0.15\mu\text{F}$.
- Leakage current must not exceed 0.5mA.
- Be sure to test for leakage with the AC plug in both polarities.

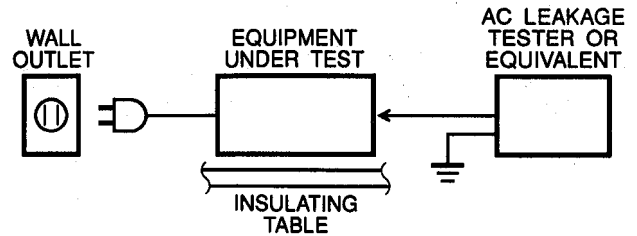

Dolby noise reduction manufactured under license from Dolby Laboratories Licensing Corporation.
"DOLBY" and the double-D symbol $\square\square$ are trademarks of Dolby Laboratories Licensing Corporation.

WARNING: CHEMICAL CONTENT NOTICE!

The solder used in the production of this product contains LEAD. In addition, other electrical/electronic and/or plastic (where applicable) components may also contain traces of chemicals found by the California Health and Welfare Agency (and possibly other entities) to cause cancer and/or birth defects or other reproductive harm.

DO NOT PLACE SOLDER, ELECTRICAL/ELECTRONIC OR PLASTIC COMPONENTS IN YOUR MOUTH FOR ANY REASON WHATSOEVER!

Avoid prolonged, unprotected contact between solder and your skin! When soldering, do not inhale solder fumes or expose eyes to solder/flux vapor!

If you come in contact with solder or components located inside the enclosure of this product, wash your hands before handling food.

KX-W421
KX-W321/K-903

■ **FRONT PANELS**

● **KX-W421**

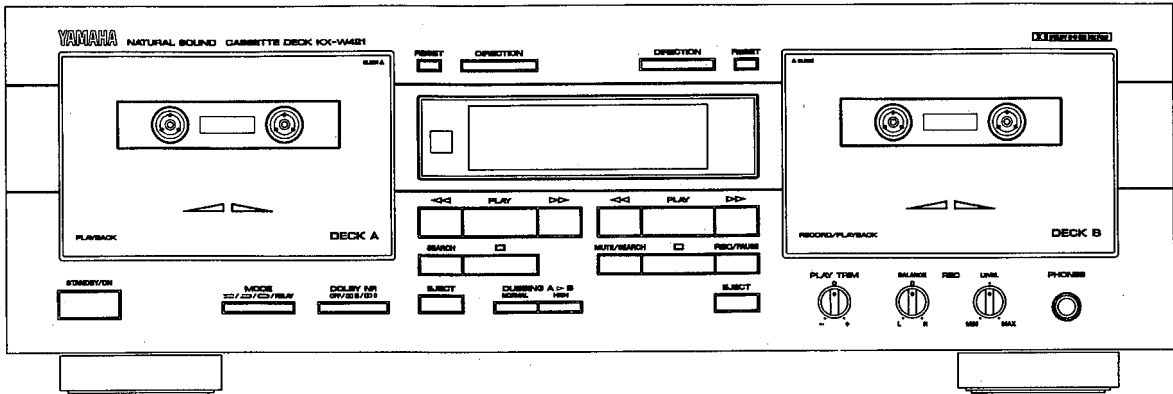

● **KX-W321**

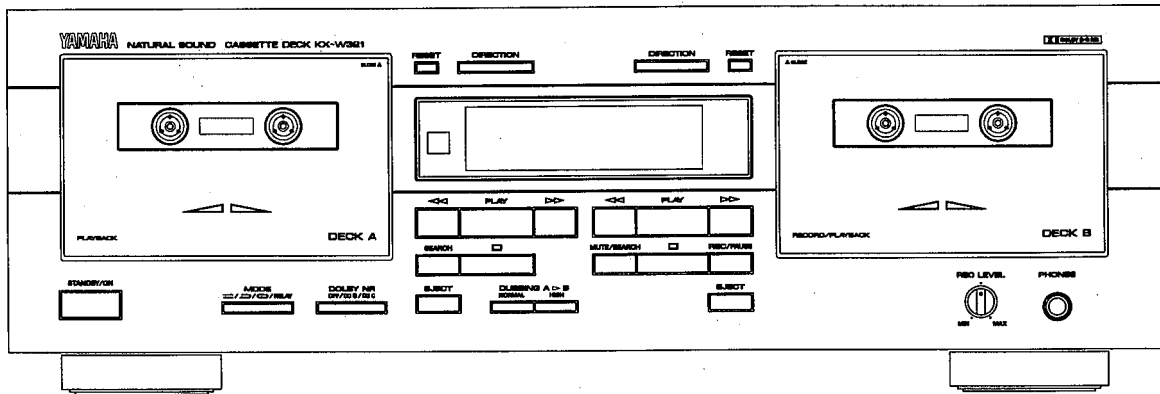

● **K-903**

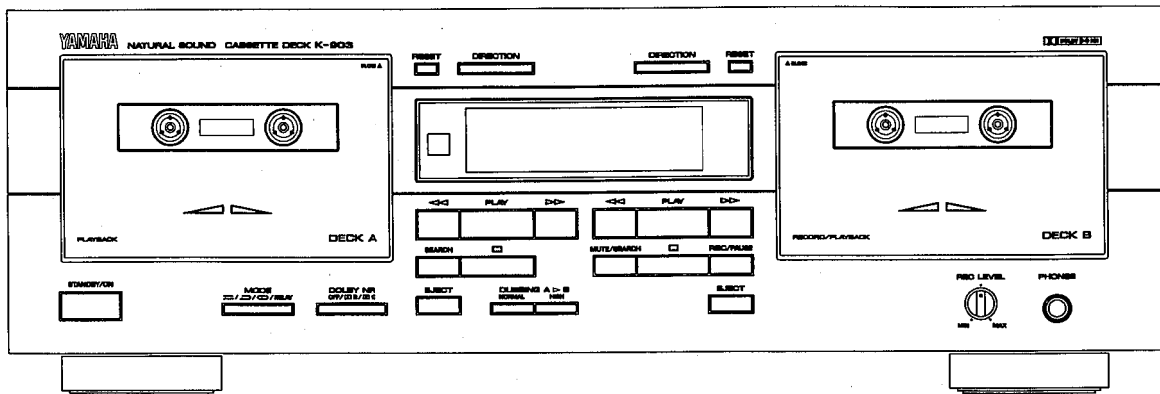

KX-W421
KX-W321/K-903

REAR PANELS

U, C models

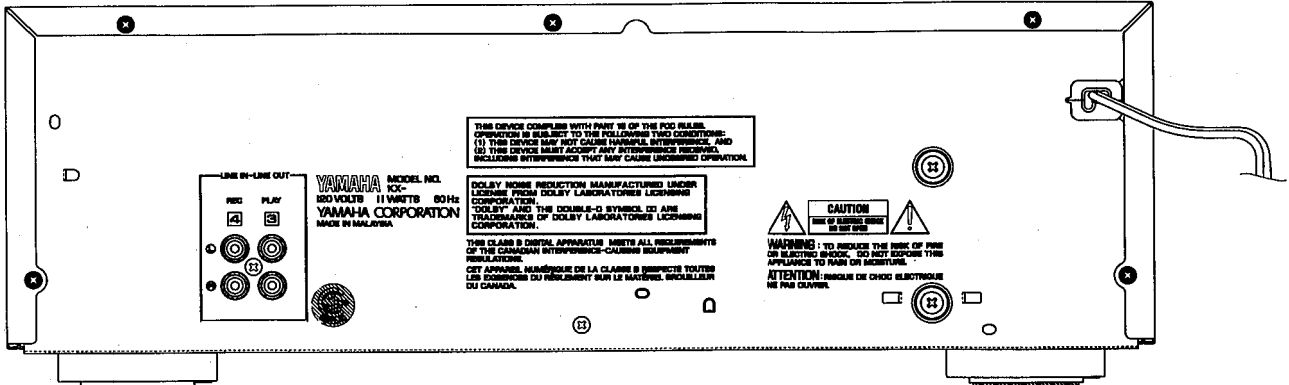

R, T models

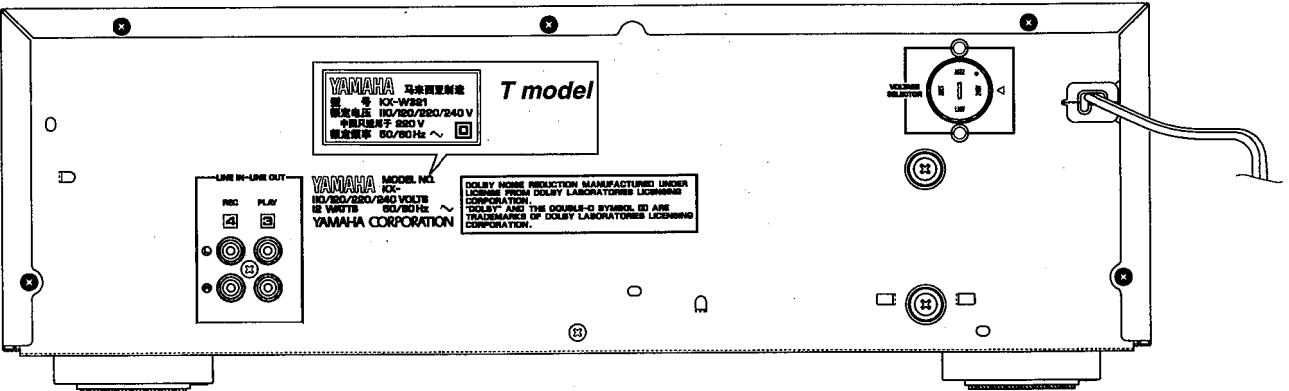

A model

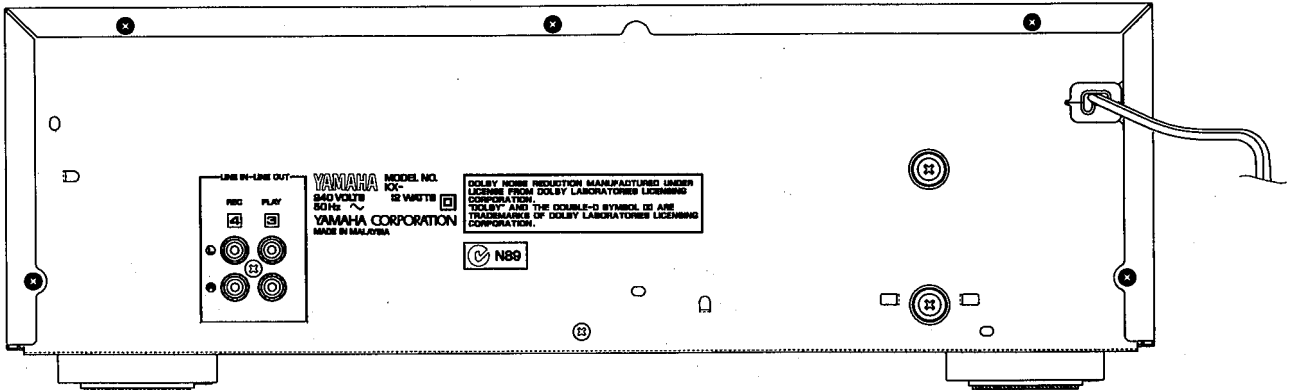

B, G models

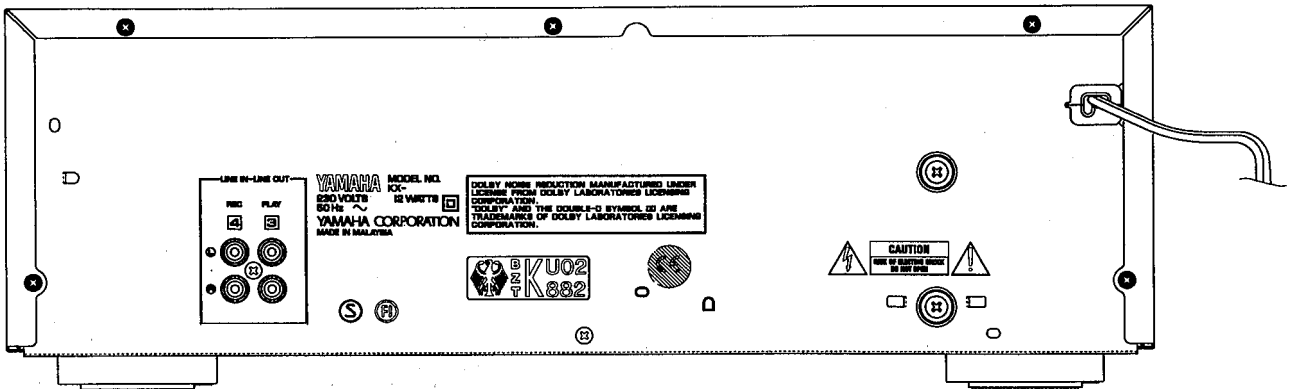

KX-W421

■ KX-W421 SPECIFICATIONS

Type	Auto Reverse 4-Track 2-Channel recording and playback/ playback stereo double Cassette Deck
Heads	REC/PB Hard permalloy Erase Double Gap Ferrite PB Hard permalloy
Motors	Main DC servo motor x 2
Wow & Flutter	W.PEAK ±0.15% W.RMS 0.08%
Fast Winding Time	about 100 seconds (C-60 tape)
Frequency Response (-20dB)	Normal tape(Type I) 20-17000Hz±3dB CrO2 tape(Type II) 20-18000Hz±3dB Metal tape(Type IV) 20-20000Hz±3dB
S/N Ratio (S: 3rd harmonic distortion 3% /N: Weighted)	NR off 58dB Dolby B NR on 66dB Dolby C NR on 74dB
Harmonic distortion (315Hz 3rd 160 nmb/m -4dB)	0.8%
Channel Separation(1kHz)	More than 40dB
Crosstalk(125Hz)	More than 55dB
Input Sensitivity/Impedance (0dB)	Line 100mV/43kΩ
Output Level (0dB)	Line 570mV/1.4kΩ Headphones 0.25mW/8Ω
Power Requirements	U,C models AC120V, 60Hz B,G models AC230V, 50Hz A model AC240V, 50Hz R model AC110, 120, 220, 240V,50/60Hz

Power Consumption	14W (Standby 7W)
Dimensions (W x H x D)	435 x 146 x 279mm (17-1/8" x 5-3/4" x 11")
Weight	5.0kg(11lbs)
Accessories	Input, output cords (RCA type)

* Specifications are subject to change without notice.

- U U.S.A. model
- C Canadian model
- R General model
- A Australian model
- B British model
- G European model

● DIMENSIONS

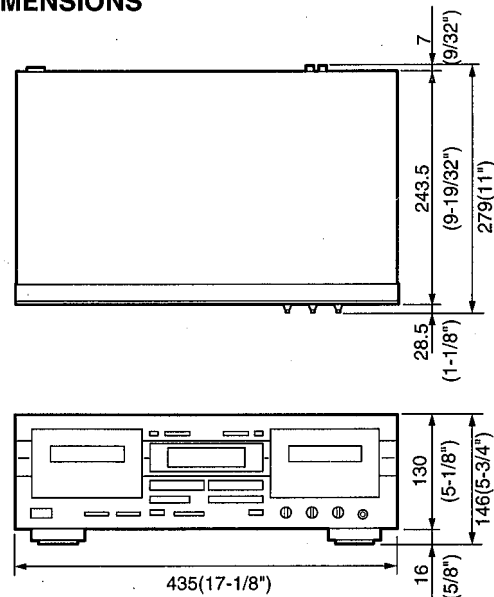

Unit: mm (inch)

■ KX-W421 INTERNAL VIEW

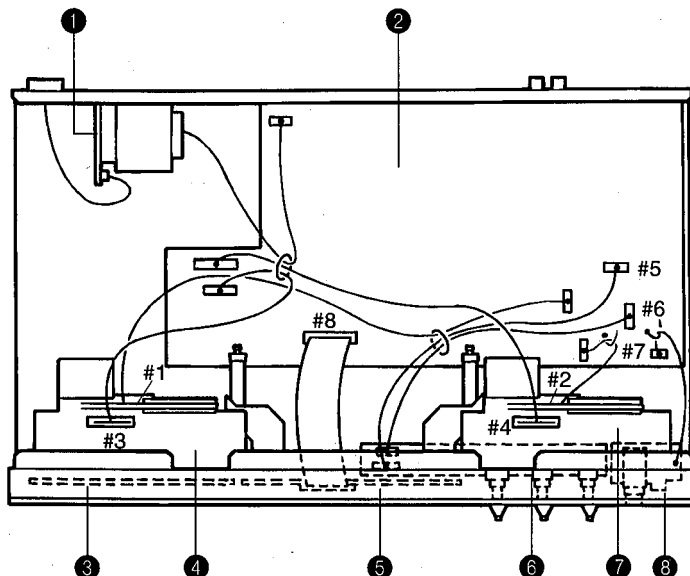

- ① MAIN P.C.B. ASS'Y (4)
- ② MAIN P.C.B. ASS'Y (1)
- ③ OPERATION P.C.B. ASS'Y (2)
- ④ CASSETTE MECHANISM UNIT (DECK A)
- ⑤ OPERATION P.C.B. ASS'Y (1)
- ⑥ MAIN P.C.B. ASS'Y (2)
- ⑦ CASSETTE MECHANISM UNIT (DECK B)
- ⑧ MAIN P.C.B. ASS'Y (3)

DISASSEMBLY PROCEDURES

(Remove parts in disassembly order as numbered.)

1. Removal of Top Cover

Remove 8 screws (①) in Fig. 1.

2. Removal of Front Panel

- a. Remove the Lid Panels.
- b. Remove 2 push rivets (②) in Fig. 1.
- c. Remove 8 screws (③) in Fig. 1.
- d. Pull out 4 connectors (#5 to #8).
(#5 is KX-W421 only)
(see page4, INTERNAL VIEW)

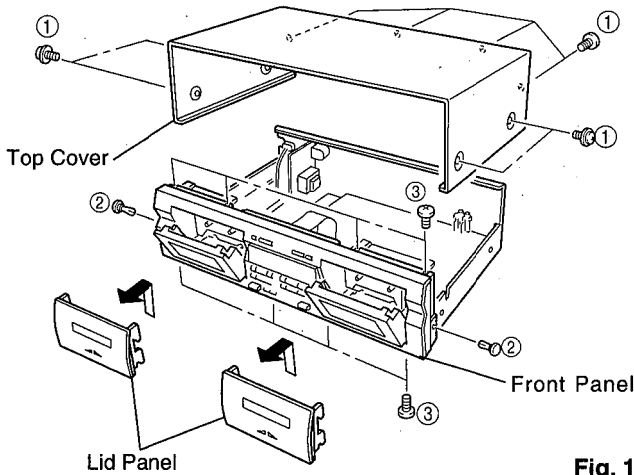

Fig. 1

3. Removal of Cassette Mechanism Unit (DECK A, B)

- a. Remove 2 screws (④) and loosen 2 screws (⑤) in Fig. 2 and then pull out the Cassette Mechanism Units.
- b. Remove 4 connectors (#1 to #4) at the Mechanism side in Fig. 2. (see page 4, INTERNAL VIEW)

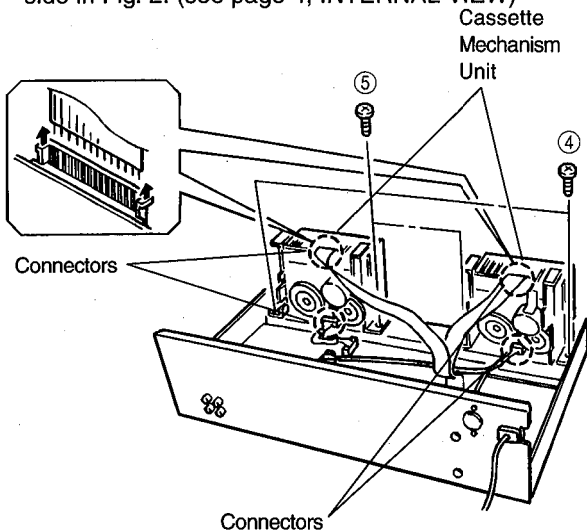

Fig. 2

4. Removal of Housing Ass'y (DECK B)

- a. Detach the spring in Fig. 3.
- b. Remove lower part of the Housing Ass'y by pressing it to the outside.
- c. Remove the Housing Ass'y from the damper arm.
*Damper arm of DECK A on the rightside.

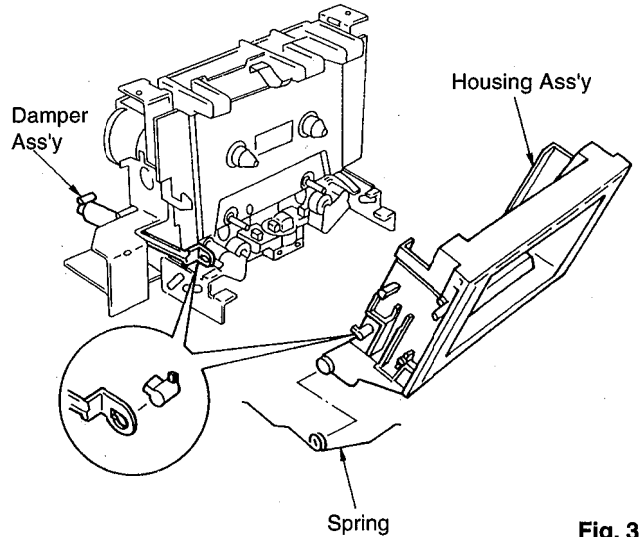

Fig. 3

5. Removal of Pinch Roller

Unhook at 2 places as shown in Fig. 4 and remove the Pinch Roller Ass'y (L, R).

6. Removal of Head Unit

Remove 2 screws (⑥) in Fig. 4 and then remove the Head Unit.

*Perform the adjustment of azimuth after attaching the Head Unit.

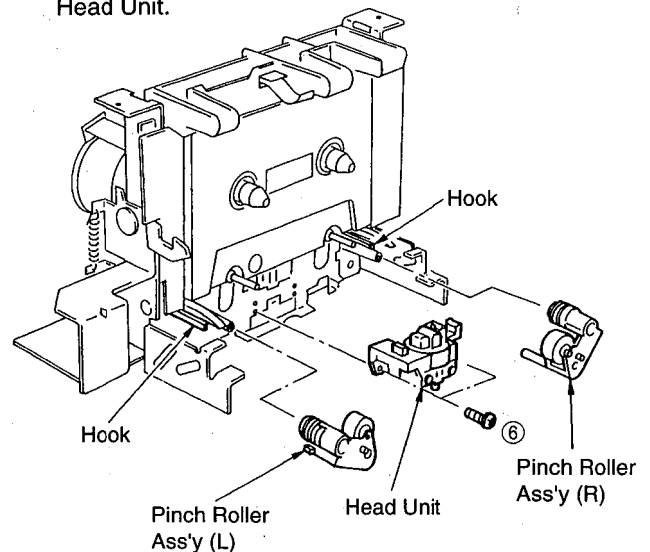

Fig. 4

KX-W421

KX-W321/K-903

7. Removal of Main Motor

- a. Remove 2 screws (⑦) in Fig. 4.
- b. Remove the Back Plate.
*When reinstalling it, be sure to fit its lower ends to the positioning hooks in Fig. 5.
- c. Remove the solder fixing wires of Main Motor.
- d. Remove 2 screws (⑧) and then remove the Main Motor in Fig. 5.

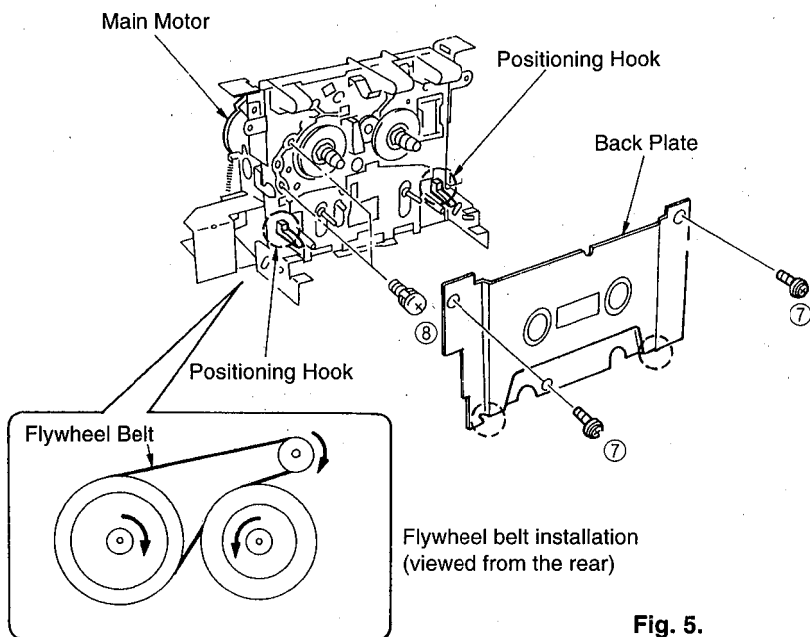
**Fig. 5.**

■ KX-W421 ADJUSTMENTS

1. Before adjustment:

- Make sure that AC line voltage comes within

Models	AC line voltage
U, C	120V ± 10%
B, G	230V ± 10%
A	240V ± 10%

- Since head magnetization, dust accumulations, etc. are likely to introduce error in the various characteristics, it is very important that the heads are properly demagnetized and cleaned.
- Make adjustments of mechanical system, playback system and recording system in that order.
- Except for azimuth adjustment, adjust in the forward direction.
- Press RESET key and PLAY key simultaneously, enters CLEANING MODE. (playback mode without a cassette tape.)
In this mode, Power ON/OFF in not affected.
During this mode, DIRECTION key is operational.
To escape from this mode, press STOP, FF, REW or POWER key.

● Test Conditions

- PLAY TRIM → Center
- REC LEVEL → Max
- REC BALANCE → Center

2. Instruments required

- Audio frequency oscillator
- ACVM (or dual channel ACVM)
- Wow/flutter meter
- Oscilloscope
- Frequency counter
- Torque meter
- TW-2111A (TX911580) ... Take up/back tension (FWD)
- TW-2121A (TX911570) ... Take up/back tension (RVS)
- CT-160L (TX911120) FF/REW
- DCVM

3. Test tape required

- MTT-111N (TX911650) Normal speed
- TCW-211 (TX911550) High speed
- MTT-114N (TX911680) Azimuth
- MTT-212N (TX911660) Playback level
- MTT-256 (TX911300) Playback frequency response (Normal)
- MTT-356 (TX911310) Playback frequency response (CrO₂)
- Reference tape
- Normal (LH) : TDK AC225 (VU16720)
- High (CrO₂) : TDK AC514 (VU16730)
- METAL : TDK AC713(VU16740)

MECHANICAL ADJUSTMENT

Step	Item to be Adjusted	Tape	Instrument required	Mode	Adjustment part	Rating	Remarks
1	Check each torque	CT-160L (FF, REW)	Torque meter	FF REW		FF, REW torque: more than 70g/cm.	
		TW-2111A (FWD)		PLAY	Take up torque : 25~70g/cm.		
		TW-2121A (RVS)			Back tension : 1.5~6g/cm.		
2	Check FF, REW take up time	AC-514 (C-60)		FF REW		85 to 115 seconds.	
3	Azimuth	MTT-114N 10kHz, -10dB	ACVM Oscilloscope	PLAY	Azimuth adjustment screw	Playback output of L and R is maximum and phase difference should be minimum in both directions. (Fig. A.)	After the adjustment make sure to apply screw lock paint.
4	Tape Speed [Adjust the high speed initially, and next the normal speed.]	TCW-211 1.5kHz, -4dB	Frequency counter	PLAY (HIGH)	DECK A VR1	DECK A : * 3000Hz ± 15Hz	During playback, press the PLAY key and H.Dubbing key simultaneously to enter high speed mode.
					DECK B VR2	DECK B : * 3000Hz ± 15Hz	
		MTT-111N 3kHz, -10dB		PLAY (NORM)	DECK A VR5	DECK A : * 3000Hz ± 15Hz	
					DECK B VR6	DECK B : * 3000Hz ± 15Hz	
5	Wow/Flutter	MTT-111N 3kHz, -10dB	Wow/flutter meter	PLAY		Less than 0.15% (WRMS)	Perform adjustment at the center of the test tape length if possible.

*Specifications after replacement of the motor are as follows.

PLAY (HIGH)	DECK A : 2980Hz ± 15Hz
	DECK B : 2980Hz ± 15Hz

PLAY (NORM)	DECK A : 2980Hz ± 15Hz
	DECK B : 2980Hz ± 15Hz

KX-W421

● TEST POINT

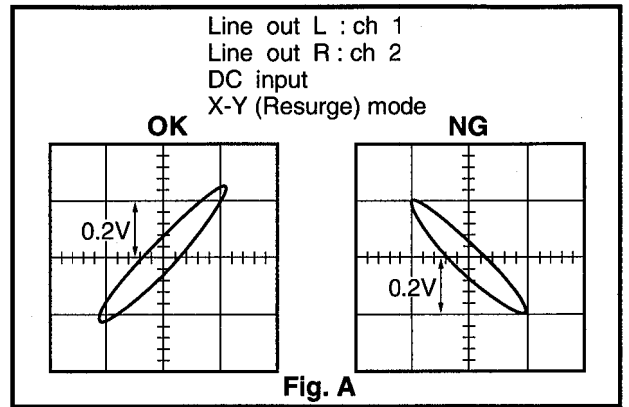
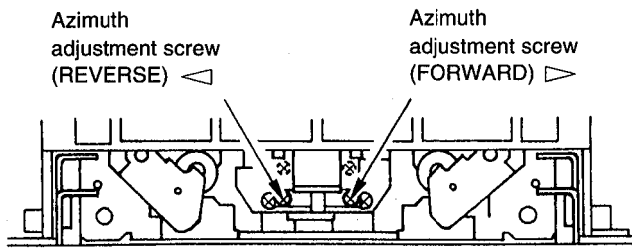

MAIN P.C.B. (1)

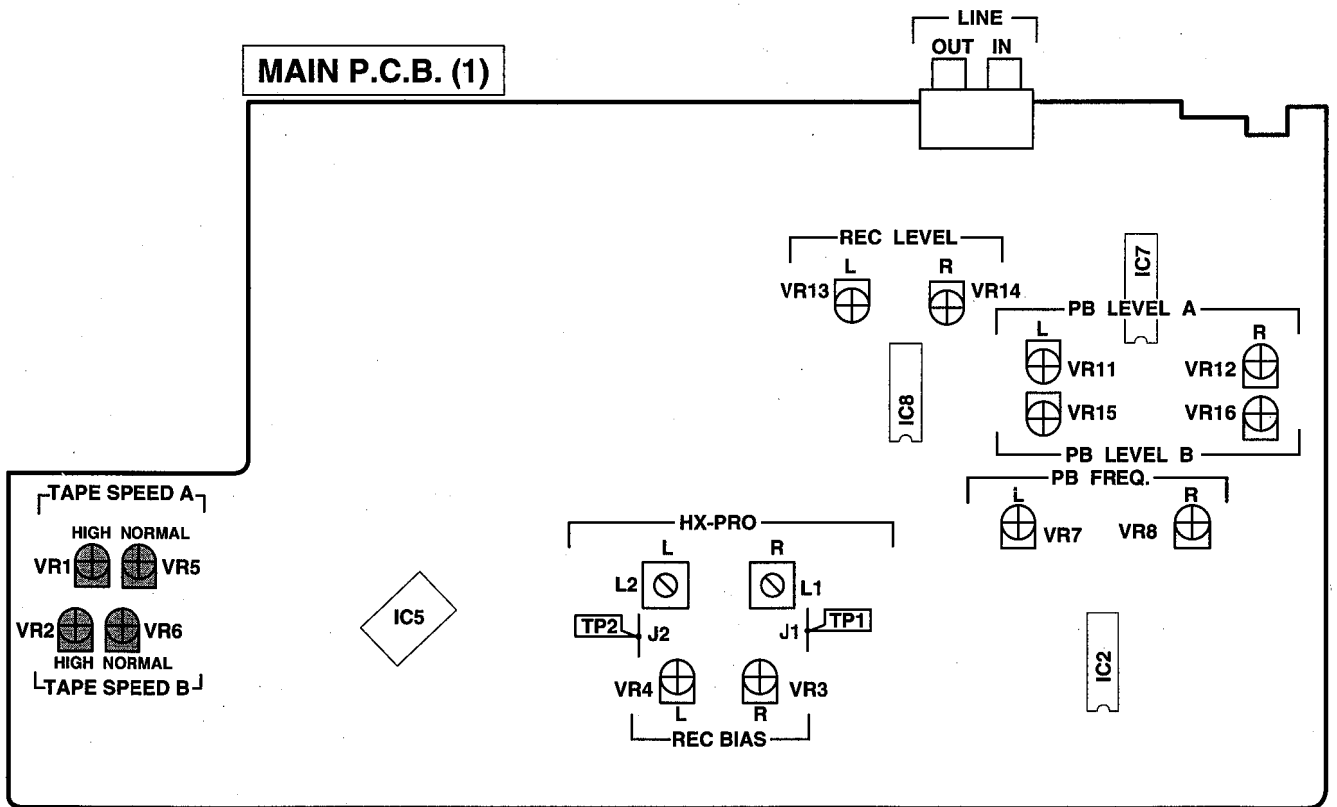

ELECTRICAL ADJUSTMENT

- Use 560mV (250nwb/m) for 0dB as the standard level of the unit.
0dB = 250nwb/m (315Hz) = -5dBV (Line out level)

<Playback section>

Step	Item to be Adjusted	Tape	Instrument required	Mode	Measurement conditions	Points of measurement	Adjustment parts	Rating
1	Playback level (315Hz) (DECK A, DECK B)	MTT-212N 315Hz 250nwb/m	ACVM	PLAY		LINE OUT	DECK A VR11 (L ch) VR12 (R ch) DECK B VR15 (L ch) VR16 (R ch)	-5 ± 0.3 dBV
2	Playback level (10kHz) (DECK A)	MTT-114N 10kHz,-10dB	ACVM	PLAY		LINE OUT	VR7 (L ch) VR8 (R ch)	-15 ± 1.0 dBV
3	Confirmation of playback frequency response	Test tape for frequency check, 3180 μs + 120 μs (LH) (MTT-256) 3180 μs + 70 μs (CrO ₂) (MTT-356)	ACVM Oscilloscope	PLAY		LINE OUT		Check that the 10kHz playback level is within 0 ± 3dB of the 315Hz playback level. (Fig. B)

● PLAYBACK FREQUENCY RESPONSE

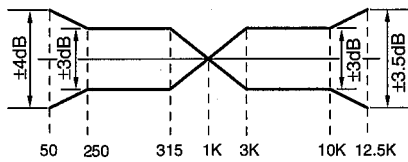
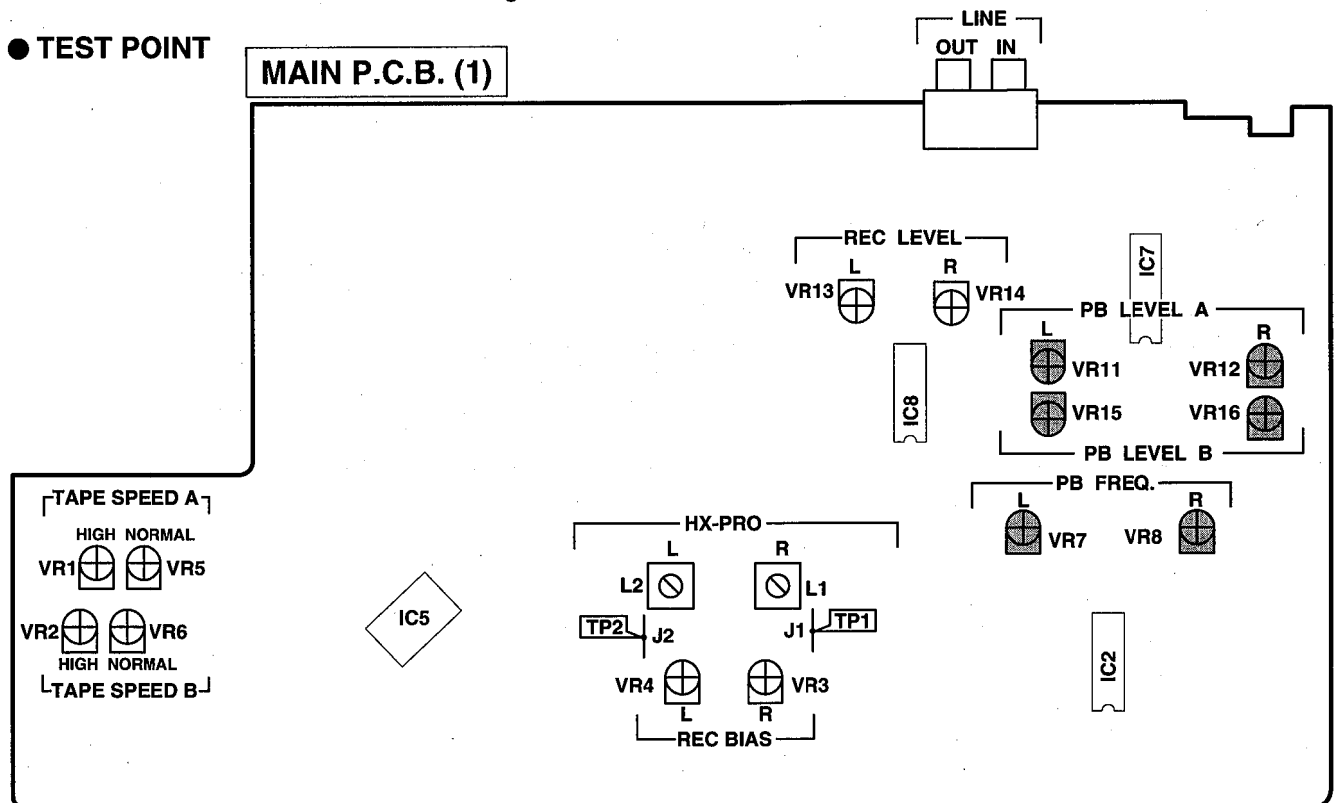

Fig. B

● TEST POINT



<Recording section>

Step	Item to be Adjusted	Tape	Instrument required	Mode	Measurement conditions	Points of measurement	Adjustment parts	Rating
1	HX PRO (DECK B)	AC-514 High (CrO ₂)	DCVM Oscilloscope	REC/PLAY		DECK B TP2(L: J2)-G TP1(R: J1)-G	DECK B L2 (L ch) L1 (R ch)	Adjust L2 and L1 so that the DC voltage is minimized at TP2(L ch) and TP1(R ch).
2	Recording level (DECK B)	AC-514 High (CrO ₂)	ACVM Audio frequency oscillator	REC	1. Set REC LEVEL to maximum. 2. Input 315Hz Signal to LINE IN TERMINAL from Audio Frequency Oscillator. Adjust output level of Audio Frequency Oscillator so that the voltage of LINE OUT TERMINAL becomes -25dBV.	LINE OUT	VR13 (L ch) VR14 (R ch)	Adjust for equal level of the record and playback levels. (-25 ± 0.3 dBV)
3	Recording bias (Total frequency response) (DECK B)	AC-514 High (CrO ₂) AC-225 Normal (LH) AC-713 METAL	ACVM Audio frequency oscillator	REC	1. Set REC LEVEL to maximum. 2. Input 12.5kHz Signal to LINE IN TERMINAL from Audio Frequency Oscillator. Adjust output level of Audio Frequency Oscillator so that the voltage of LINE OUT TERMINAL becomes -25dBV.	LINE OUT	DECK B VR4 (L ch) VR3 (R ch)	Adjust for equal level of the record and playback levels. (-25 ± 0.5 dBV) Adjust for equal level of the record and playback levels. (Table 1) Perform record bias adjustment of high (CrO ₂) tape again, if the rating was not satisfied.
4	Confirmation of recorded level	AC-514 High (CrO ₂)	ACVM Audio frequency oscillator	REC		LINE OUT		Confirm recorded level rating as in step 2. When recorded level rating is improper, go back to step 2 and also carry out confirmation in step 4 again.

● TOTAL FREQUENCY RESPONSE (-20dB)

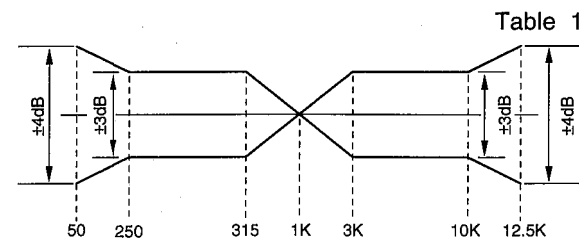

Table 1

NR : NR off / Dolby B NR on / Dolby C NR on
(B&C NR : Reference level must be recorded level.)
TAPE : Normal (LH) / High (CrO₂) / METAL

● DUBBING RESPONSE (-20dB)

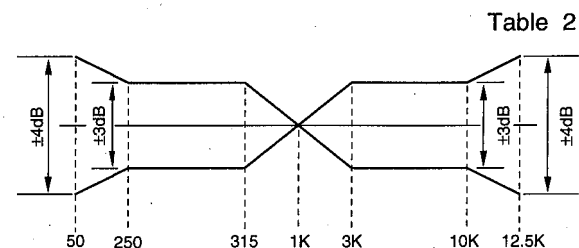

Table 2

SPEED : Normal/High
TAPE : Normal (LH) → Normal (LH)
High (CrO₂) → High (CrO₂)
High (CrO₂) → METAL

REMOTE CONTROL FUNCTION

● Remote Control

Custom code	Function (Data)
7F, 7A, 7E	STOP(03), PLAY (00), FF (02), REW (01), REC/PAUSE (04), REC MUTE (05), SEARCH >> (0A), SEARCH <<(0B), DECK A/B (06), COUNTER RESET (0D), DIR A (07), DIR B (08), DUBBING (09)

● Synchro Recode

Custom code	Function (Data)
7Q (CD Player)	SYNCHRO (50), PLAY (02), PAUSE (55), PAUSE/STOP (03), STOP (56), OPEN/CLOSE (01)

● TEST POINT

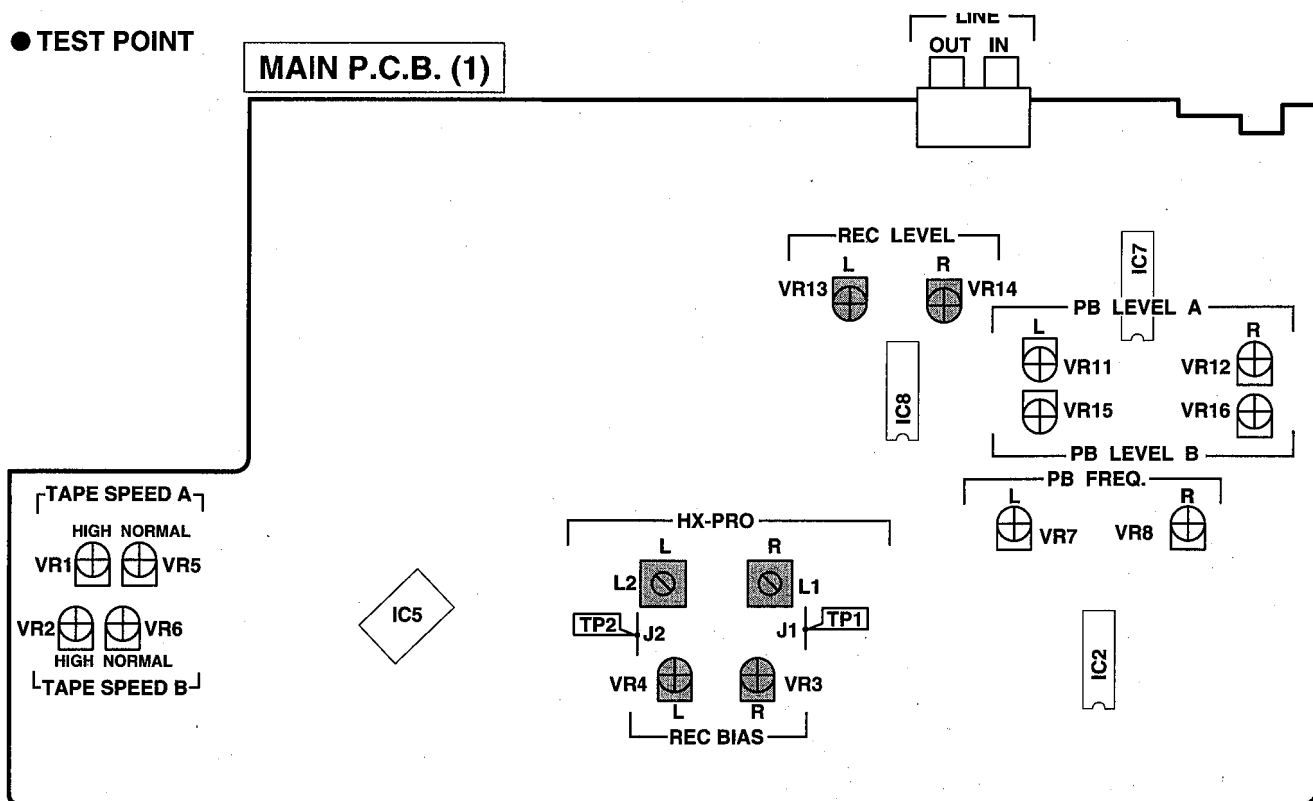

TEST MODE (DISPLAY Check)

Enter the TEST MODE by pressing the POWER SW while pressing the RESET KEY (DECK A) when the power is OFF. (Backup data is initialized.)

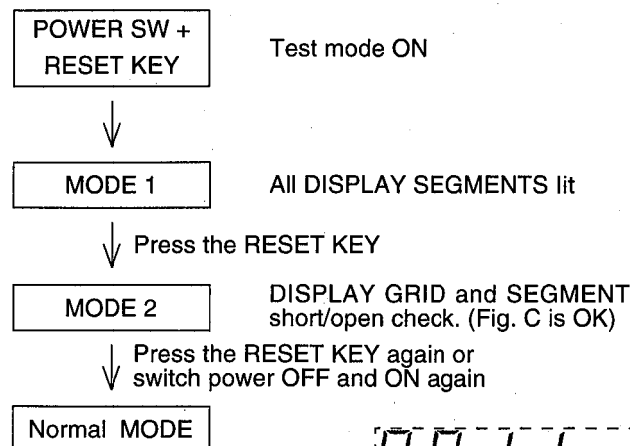

Fig. C

● Backup data at power off (AC plug)

μ-COM backup data (About 2 weeks) maintenance controls as follows.

- Power ON/OFF
- DIR A, DIR B
- Tape counter
- Dolby NR
- Reverse mode

KX-W421 PRINTED CIRCUIT BOARD (Foil side)

①-③ : TEST POINT WAVEFORMS(See page 22)

MAIN P. C. B. (1)

Semiconductor Location

Ref. No.	Location
D1	G5
D2	G4
D3	D3
D4	F5
D5	F4
D6	G4
D7	G4
D8	E3
D9	E3
D10	E3
D11	E4
D12	E5
D13	D2
D14	E2
D15	D3
D16	E2
D17	F3
D18	F3
D19	F2
D20	F3
D21	F2
D22	F3
D23	F3
D25	C3
D26	C3
D27	F2
D28	F2
D29	F2
D30	F2
IC1	C5
IC2	B4
IC3	D4
IC4	B3
IC5	E4
IC6	E3
IC7	B3
IC8	C3
IC9	A4
IC10	D2
IC11	E3
Q1	C4
Q2	C4
Q3	D4
Q4	D4
Q5	G4
Q6	G4
Q9	D5
Q10	D5
Q11	D3
Q12	D3
Q13	G4
Q14	G5
Q15	F4
Q16	G4
Q17	G4
Q18	F4
Q24	F4
Q25	F5
Q26	F5
Q27	F4
Q28	F4
Q29	B4
Q30	B4
Q39	E4
Q40	E3
Q43	F5
Q44	D2
Q46	F5
Q47	F5
Q48	D2
Q49	E2
Q50	F3
Q51	F3
Q52	F3
Q56	C3
Q57	C2
Q58	C2
Q59	C4
Q60	B3
Q61	B3
Q62	B3
Q63	B3

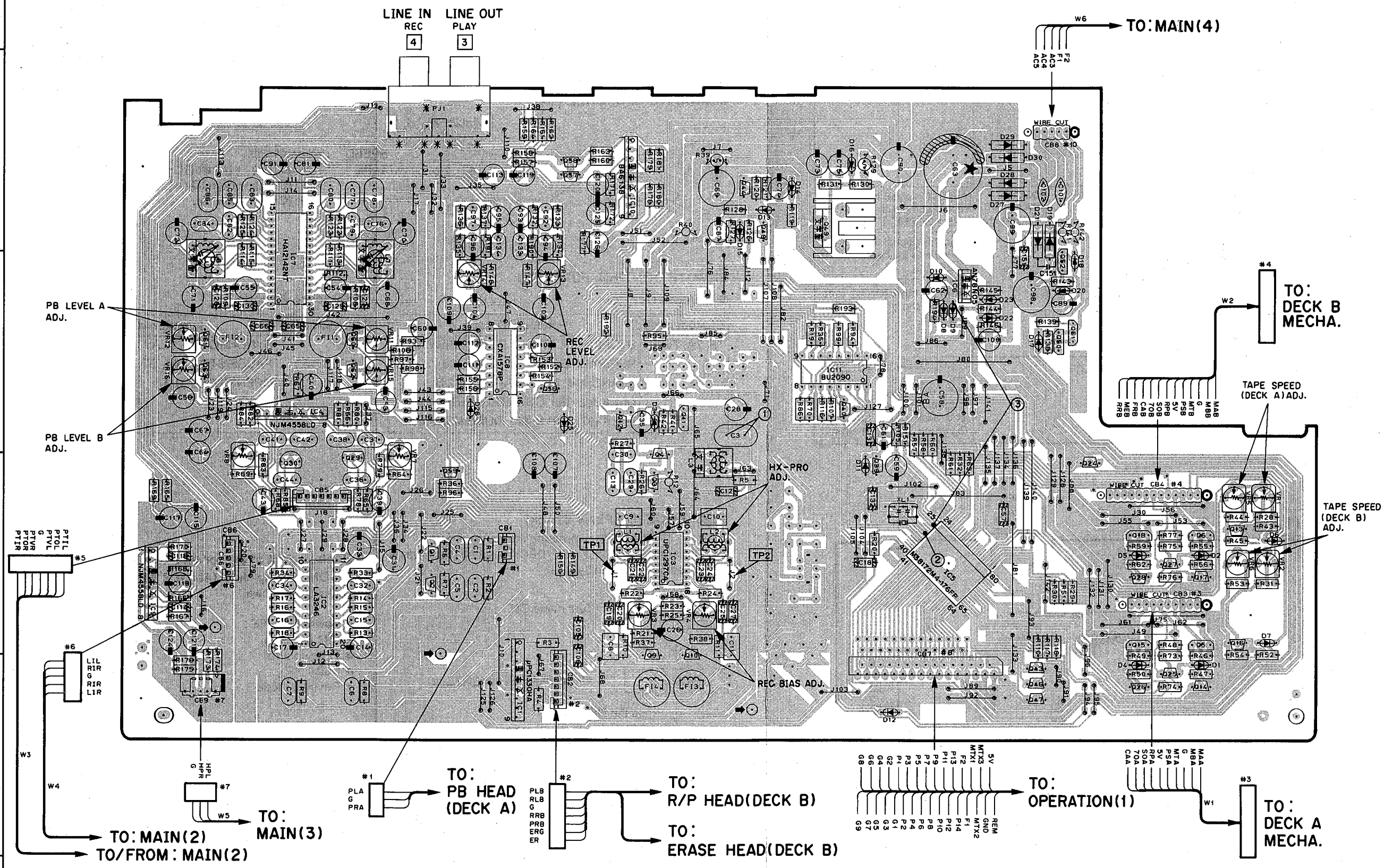

■ KX-W421 PRINTED CIRCUIT BOARD (Foil side)

MAIN P. C. B. (2)

OPERATION P. C. B. (2)

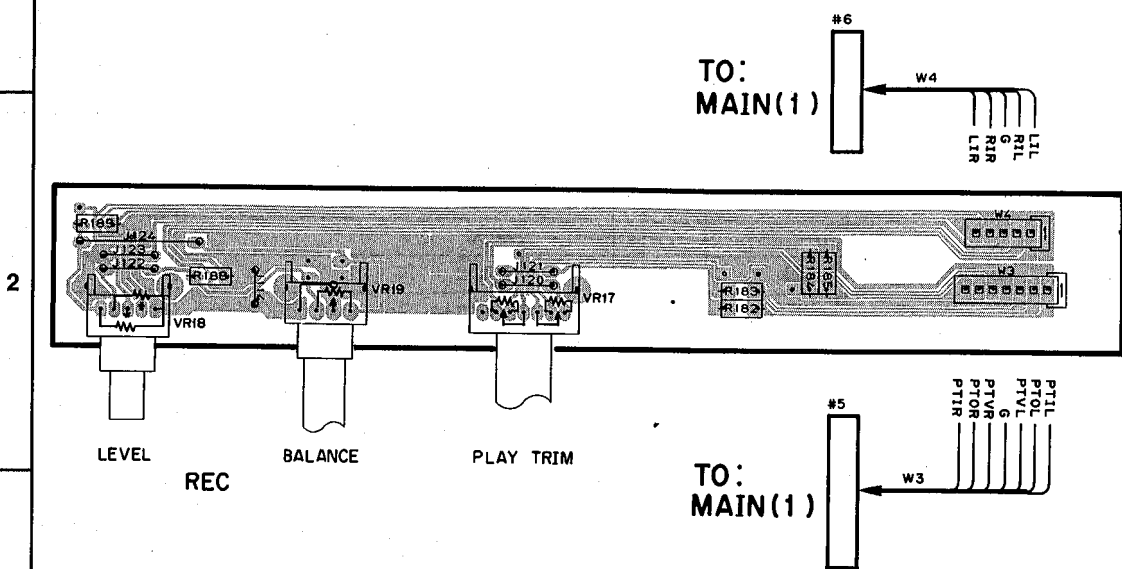

MAIN P. C. B. (3)

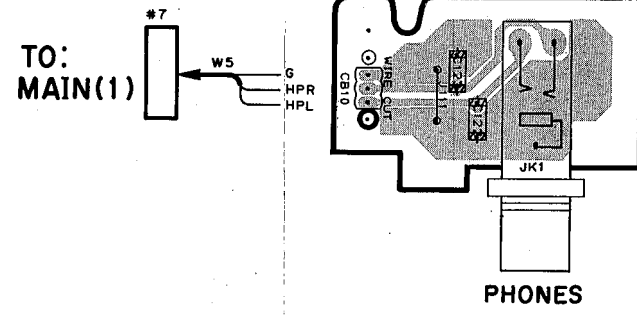
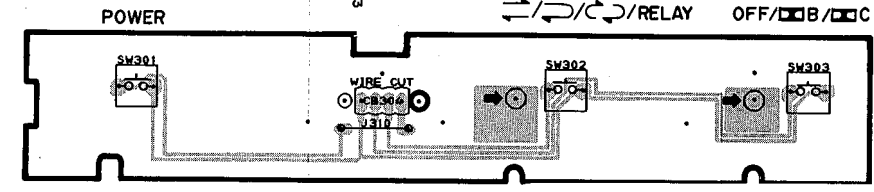

OPERATION P. C. B. (1)

**● U, C, A, B and G models
MAIN P. C. B. (4)**

**● R model
MAIN P. C. B. (4)**

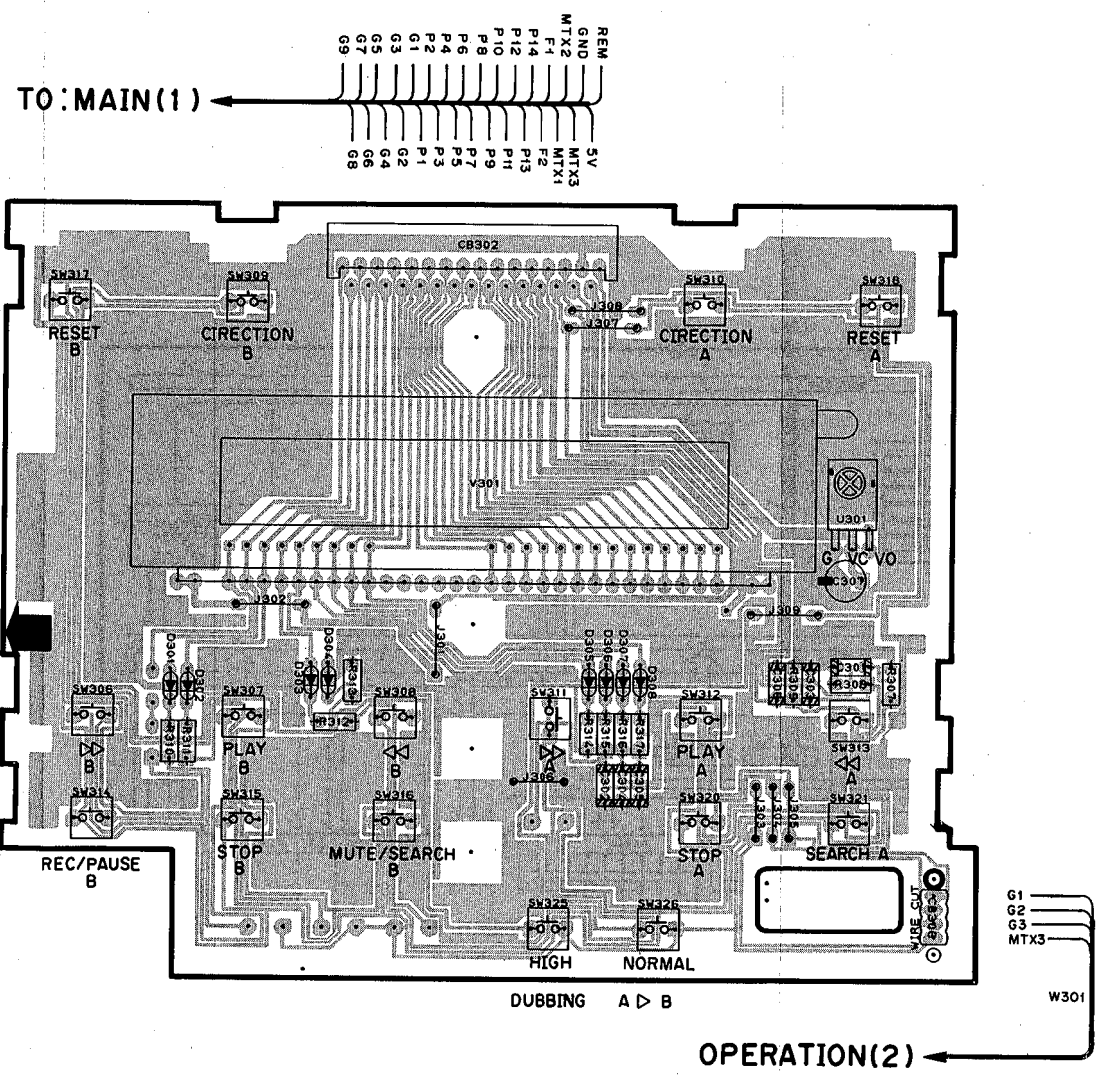
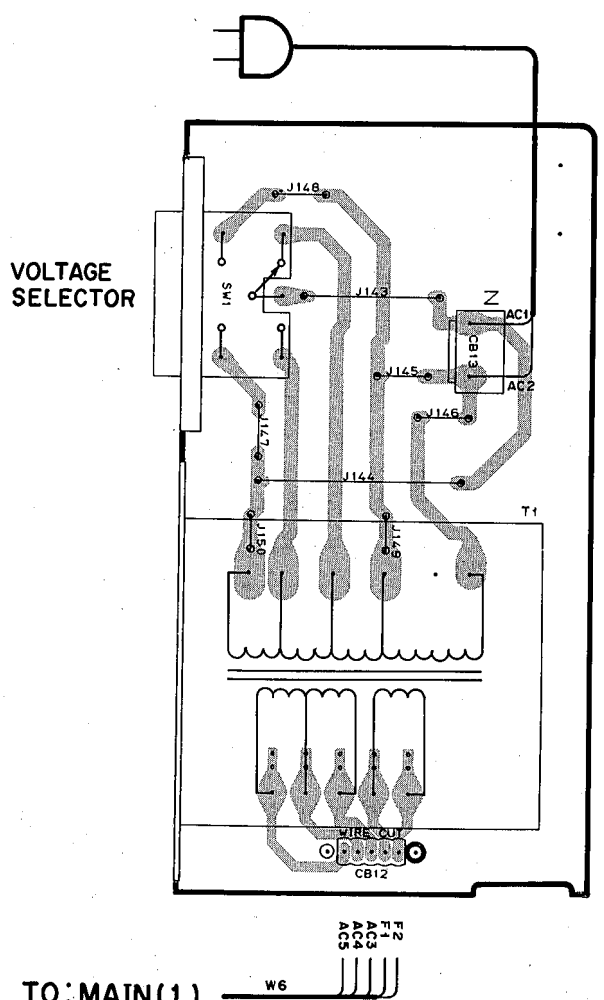
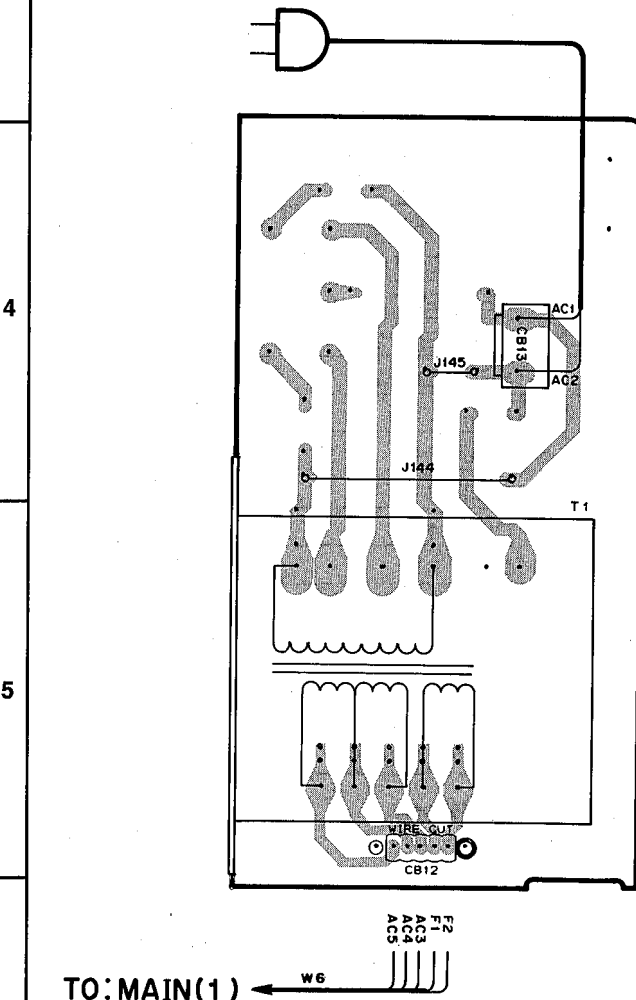

● Semiconductor Location

Ref.No.	Location
D301	E5
D302	E5
D303	E5
D304	E5
D305	F5
D306	F5
D307	F5
D308	F5

■ **μ-COM DATA**

IC5 : M38172M4-176FP
8 bit μ-COM

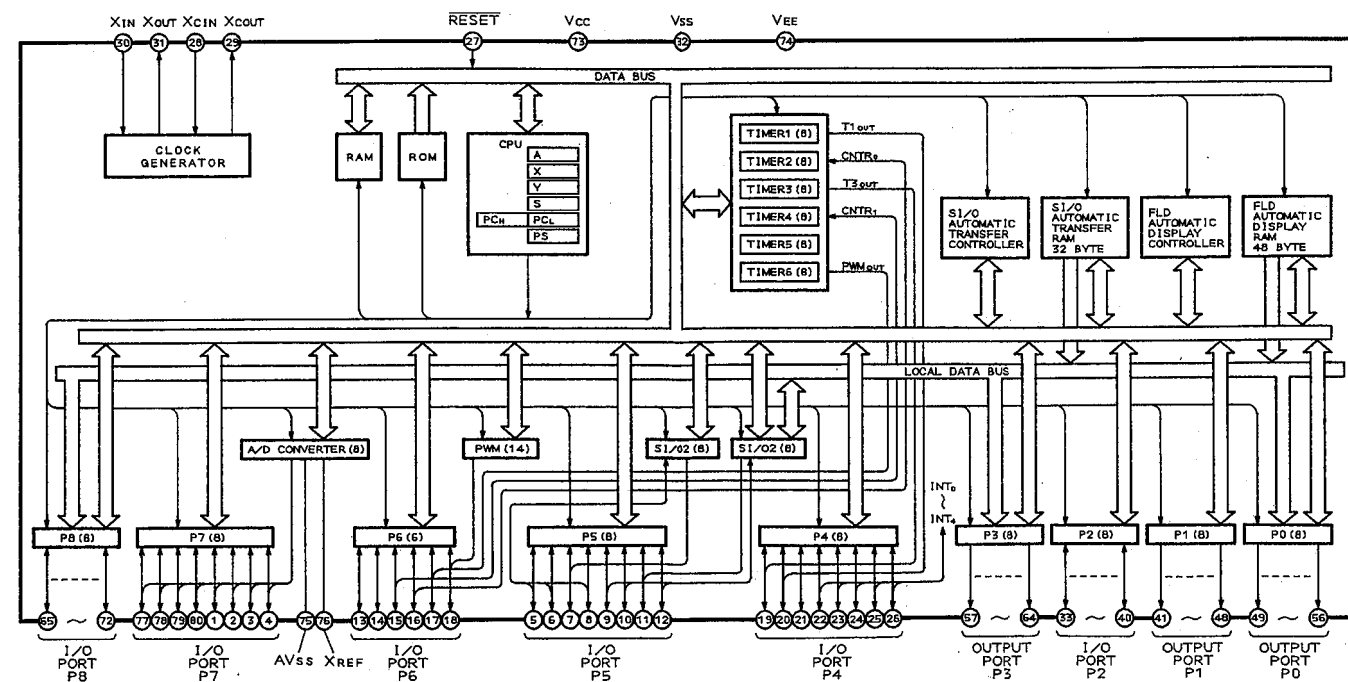
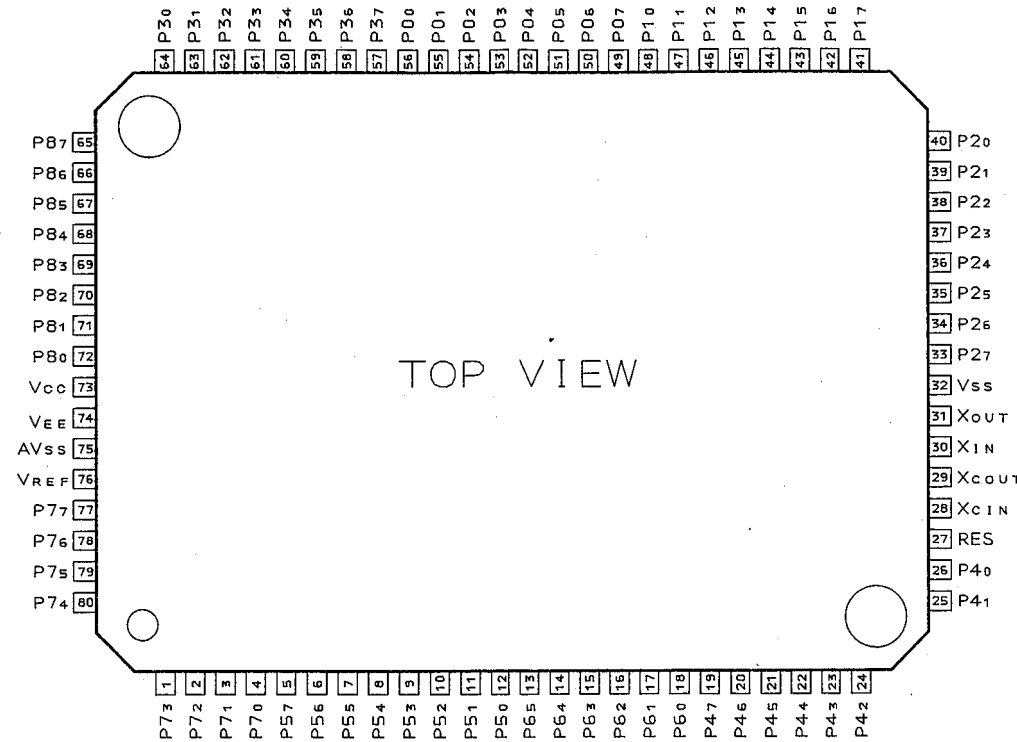

No.	Port	I/O	Function	Logic	No.	Port	I/O	Function	Logic
1	P73	I	MECHA. SW CrO ₂ (DECK A)		80	P74	I	MECHA. SW CASS (DECK A)	
2	P72	I	MECHA. SW PLAY (DECK A)		79	P75	I	GND	
3	P71	I	Meter (Lch)		78	P76	I	GND	
4	P70	I	Meter (Rch)		77	P77	I	GND	
5	P57	I	MECHA. Reel Pulse (DECK A)		76	VREF		+5V	
6	P56	I	MECHA. Reel Pulse (DECK B)		75	AVss		GND	
7	P55	O	OPEN		74	VEE		-21V	
8	P54	O	BIAS ON/OFF (DECK B)	L:ON	73	Vcc		+5V	
9	P53	O	GND	L:RESET	72	P80	O	MECHA. Solenoid (DECK A)	H:ON
10	P52	O	OPEN		71	P81	O	MECHA. Main Motor (DECK A)	H:ON
11	P51	O	OPEN		70	P82	O	Rec Mute (DECK B)	H:ON
12	P50	O	OPEN		69	P83	O	OPEN	
13	P65	O	MECHA. HIGH SPEED	H:NORMAL	68	P84	O	Line Mute	H:ON
14	P64	O	MECHA. Main Motor (DECK B)	H:ON	67	P85	I	Key Matrix (3)	
15	P63	O	MECHA. Solenoid (DECK B)	H:ON	66	P86	I	Key Matrix (2) *	
16	P62	O	OPEN		65	P87	I	Key Matrix (1)	
17	P61	O	OPEN		64	P30	O	SEGMENT 14	
18	P60	O	OPEN		63	P31	O	SEGMENT 13	
19	P47	I	MECHA. SW REC. R (DECK B)		62	P32	O	SEGMENT 12	
20	P46	I	MECHA. SW METAL (DECK B)		61	P33	O	SEGMENT 11	
21	P45	I	MECHA. SW REC. F (DECK B)		60	P34	O	SEGMENT 10	
22	P44	I	MECHA. SW CASS (DECK B)		59	P35	O	SEGMENT 9	
23	P43	I	MECHA. SW CrO ₂ (DECK B)		58	P36	O	SEGMENT 8	
24	P42	I	MECHA. SW PLAY (DECK B)		57	P37	O	SEGMENT 7	
25	P41	I	Remote Control	INT1	56	P00	O	SEGMENT 6	
26	P40	I	Power Pulse	INT0	55	P01	O	SEGMENT 5	
27	RES		Reset		54	P02	O	SEGMENT 4	
28	XCIN		GND		53	P03	O	SEGMENT 3	
29	XCOUT		OPEN		52	P04	O	SEGMENT 2	
30	XIN		4MHz		51	P05	O	SEGMENT 1	
31	XOUT		4MHz		50	P06	O	DIGIT 1	
32	Vss		GND		49	P07	O	DIGIT 2	
33	P27	O	EXPANDER IC Data		48	P10	O	DIGIT 3	
34	P26	O	EXPANDER IC Clock		47	P11	O	DIGIT 4	
35	P25	O	OPEN		46	P12	O	DIGIT 5	
36	P24	O	REC/PB Select (DECK B)	H:REC	45	P13	O	DIGIT 6	
37	P23	O	OPEN		44	P14	O	DIGIT 7	
38	P22	O	OPEN		43	P15	O	DIGIT 8	
39	P21	O	BIAS NORMAL (DECK B)	H:NORMAL	42	P16	O	DIGIT 9	
40	P20	O	BIAS HIGH (DECK B)	H:HIGH	41	P17	O	Display ON/OFF	

* Key Matrix (2) : When the microprocessor is reset, "DIGIT 9 ON" and "L" at G model only.

KX-W421

KX-W321/K-903

● CONDITION OF OUTPUT PORT IN EXPANDER IC (IC11:BU2090)

No.	Port	Function	Logic	No.	Port	Function	Logic
1	Vss	GND		16	VDD	+5V	
2	DATA	μ-COM Data Input		15	Q11	DOLBY IC MPX	L:ON(*2)
3	CLK	μ-COM Clock Input		14	Q10	DOLBY IC REC/PB	H:REC
4	Q0	REC AMP METAL	(*1)	13	Q9	DOLBY IC B/C	L:B
5	Q1	REC AMP HD	H:HD	12	Q8	DOLBY IC ON/OFF	H:ON
6	Q2	REC AMP 70	(*1)	11	Q7	PB AMP A/B 2	L:A
7	Q3	PB AMP A/B 1	L:A	10	Q6	PB AMP /HDP	L:HDP
8	Q4	PB AMP 70P	H:70P	9	Q5	PB AMP HDP	H:HDP

*1 LOGIC OF REC AMP

Port	TAPE TYPE		
	Normal	High	METAL
4Pin:METAL	H	H	L
6Pin:70	L	H	H

*2 DOLBY IC MPX:Dolby B & C at REC mode only to result "ON".

■ DISPLAY DATA

● V301 : BJ416GK(VU038000)

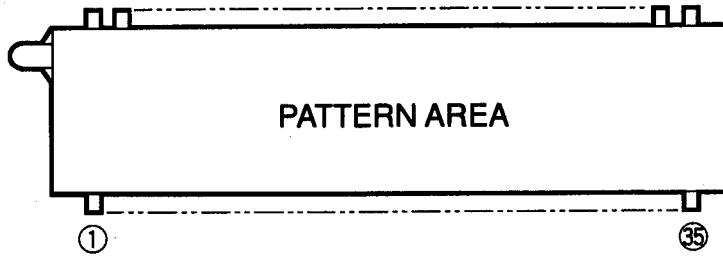

• PIN CONNECTION

Pin No.	1	2	3	4	5	6	7	8	9	10	11	12	13	14	15	16	17	18
CONNECTION	F1	F1	NP	P14	P13	P12	P11	P10	P9	P8	P7	P6	P5	P4	P3	P2	P1	NC

Pin No.	19	20	21	22	23	24	25	26	27	28	29	30	31	32	33	34	35
CONNECTION	NC	NC	NC	NC	NC	1G	2G	3G	4G	5G	6G	7G	8G	9G	NP	F2	F2

- NOTE 1) F1, F2 Filament
 2) NP No pin
 3) NC No connection
 4) DL Datum Line
- 5) 1G-9G Grid
 6) Angle of visual field
 28°min. on upper side.
 31°min. on lower side.

• GRID ASSIGNMENT

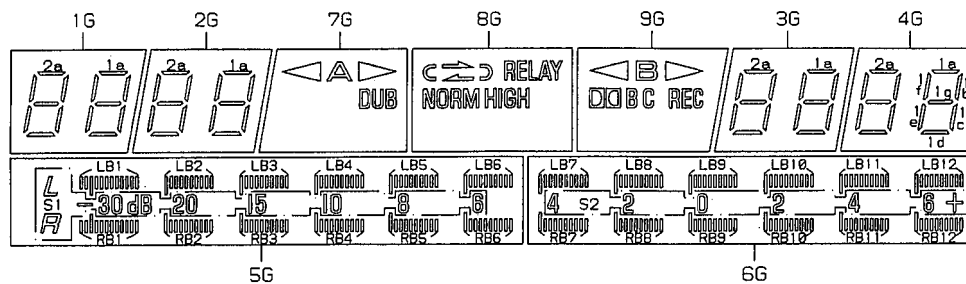

• ANODE CONNECTION

	1G	2G	3G	4G	5G	6G	7G	8G	9G
P1	2a	2a	2a	2a	LB1	LB7	◁	⊂	◁
P2	2b	2b	2b	2b	LB2	LB8	△	⊃	▷
P3	2c	2c	2c	2c	LB3	LB9	▷	⊂	▷
P4	2d	2d	2d	2d	LB4	LB10	—	RELAY	⊂
P5	2e	2e	2e	2e	LB5	LB11	DUB	NORM	B
P6	2f	2f	2f	2f	LB6	LB12	—	HIGH	C
P7	2g	2g	2g	2g	RB1	RB7	—	—	REC
P8	1a	1a	1a	1a	RB2	RB8	—	—	—
P9	1b	1b	1b	1b	RB3	RB9	—	—	—
P10	1c	1c	1c	1c	RB4	RB10	—	—	—
P11	1d	1d	1d	1d	RB5	RB11	—	—	—
P12	1e	1e	1e	1e	RB6	RB12	—	—	—
P13	1f	1f	1f	1f	S1	S2	—	—	—
P14	1g	1g	1g	1g	—	—	—	—	—

KX-W421

KX-W421 BLOCK DIAGRAM

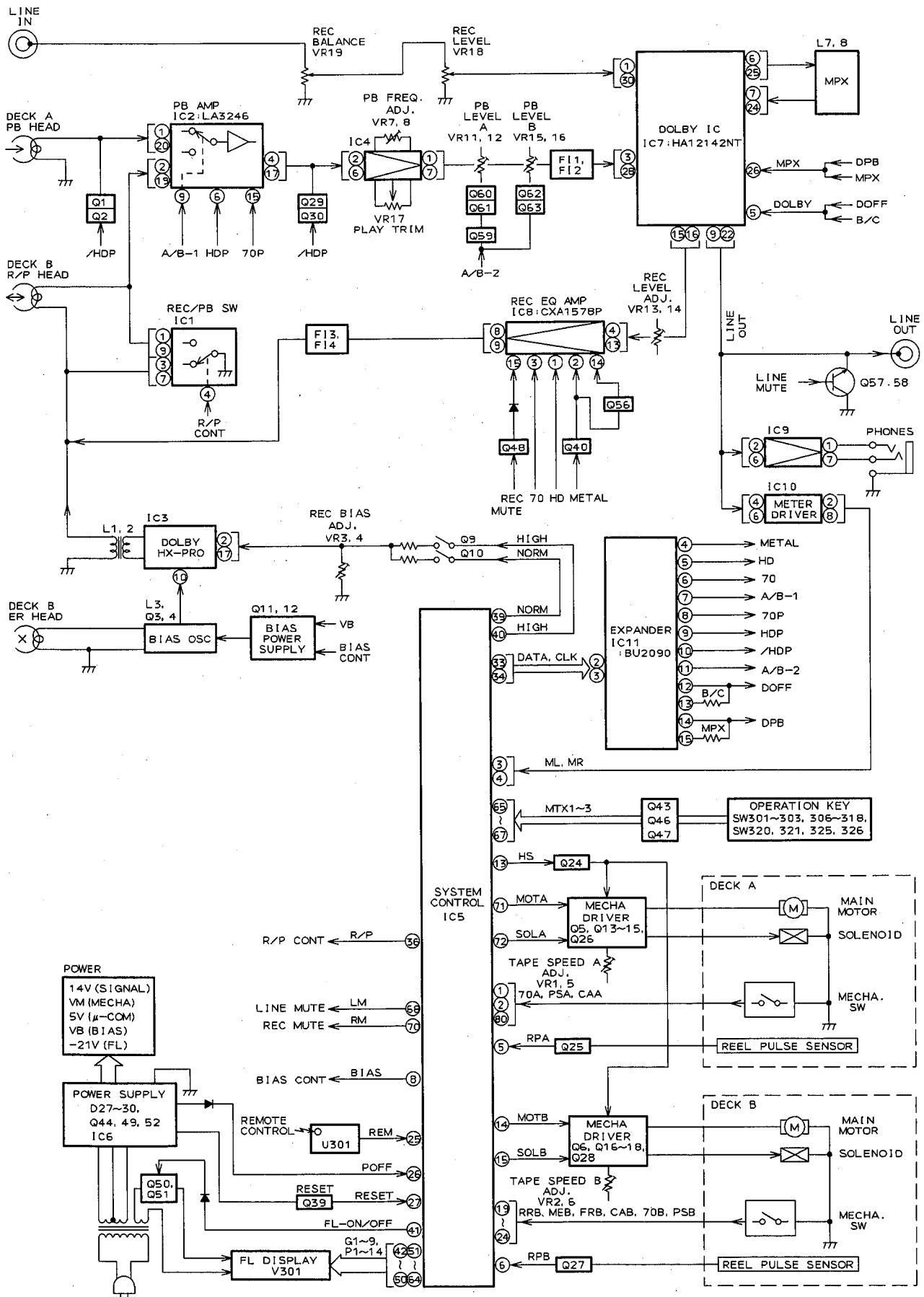

KX-W421
KX-W321/K-903

1 ■ SCHEMATIC DIAGRAM

●  marked voltages are measured using LH tape in the PLAY mode (no-signal condition)

2 ● DECK A MECHA.

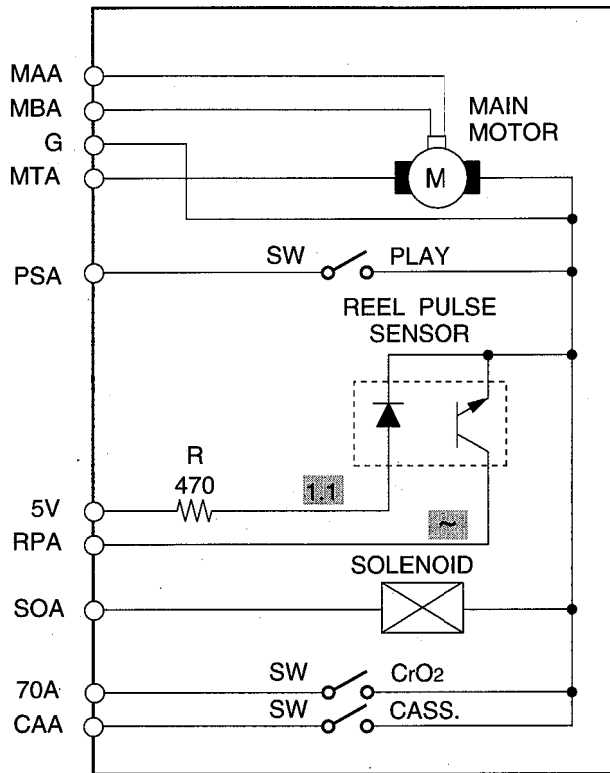

3

4 ● DECK B MECHA.

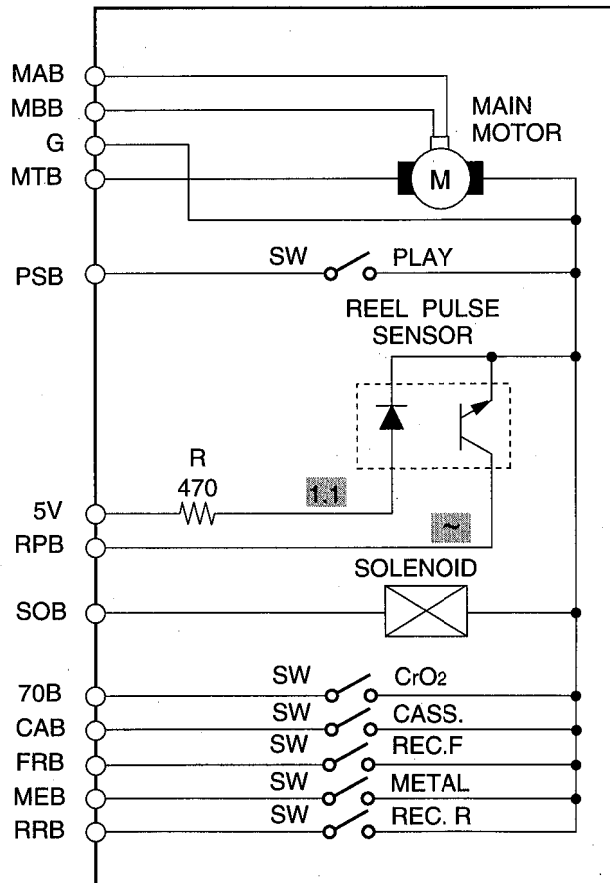

KX-W421 SCHEMATIC DIAGRAM

● The voltages are measured using LH tape in the PLAY mode (no-signal condition). Only the voltages in () are in the REC mode.

PLAY mode		REC mode	
DECK A	:PLAY(→)	DECK B	:REC(←)
DOLBY NR	:OFF	DOLBY NR	:DOLBY B ON
TAPE	:NORMAL	TAPE	:METAL

KX-W421

IC1 : μPC1330HA
2ch Head Selector Switch

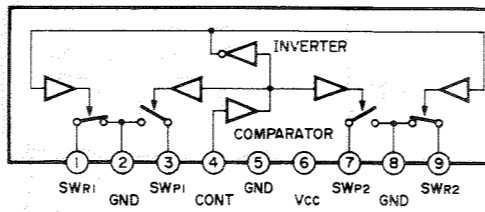

IC2 : LA3246
Playback Amp

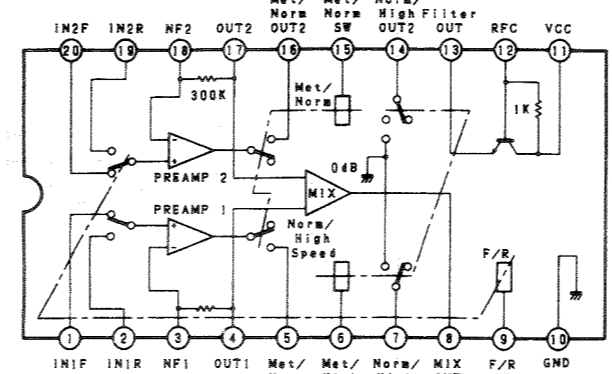

IC3 : μPC1297CA
Dolby HX PRO

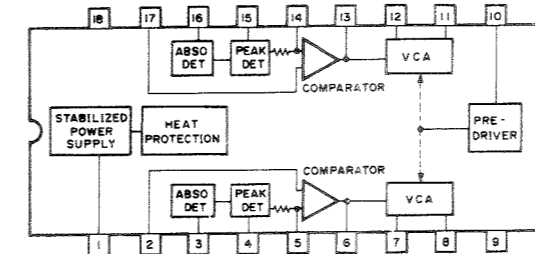

IC4,9 : NJM4558L
Dual OP-Amp

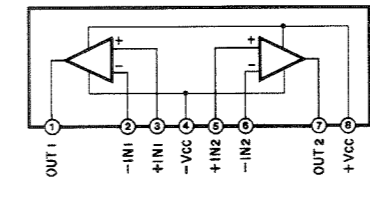

IC7 : HA12142NT
Dolby B&C-Type Noise Reduction Processor

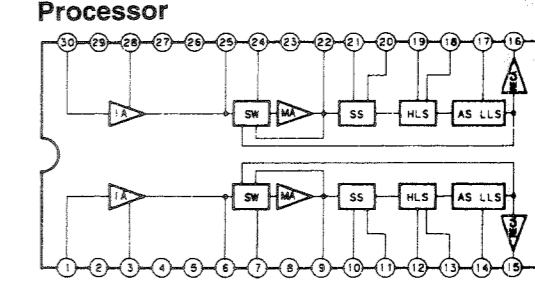

IC8 : CXA1578P
Recording Equalizer Amp

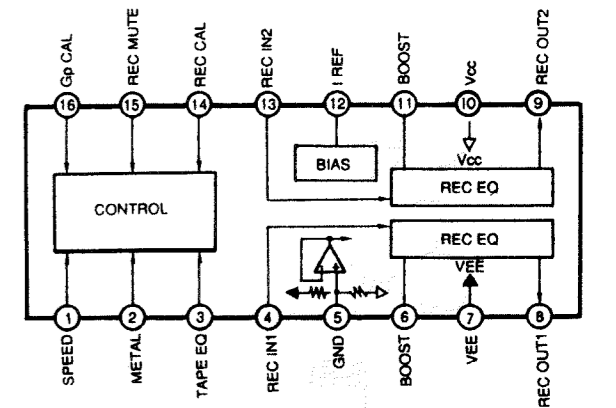

IC10 : BA6138
Dual 1/2 Compressor

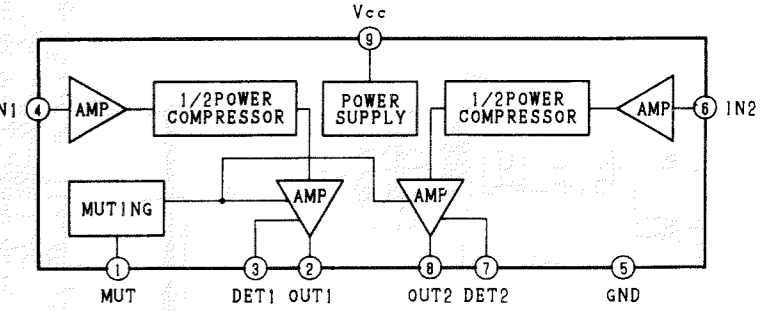

IC11 : BU2090
Serial In/Parallel out Driver

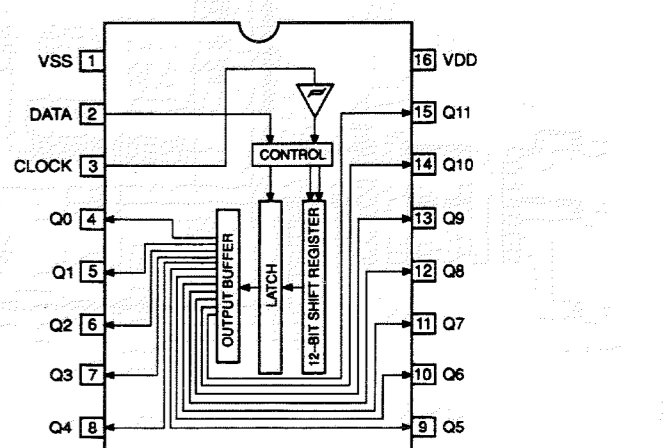

TEST POINT WAVEFORMS

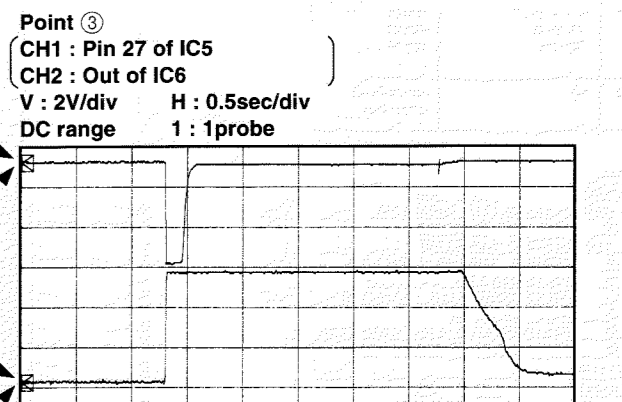
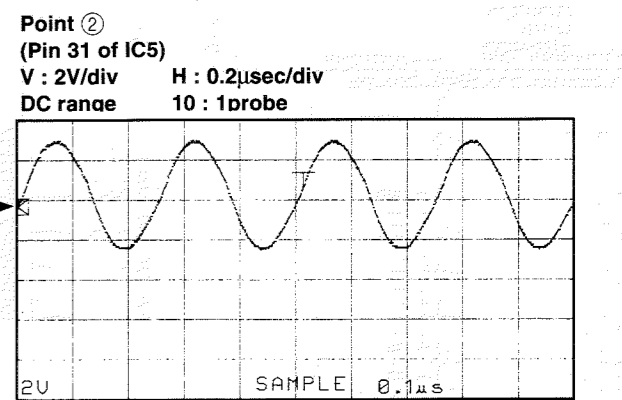
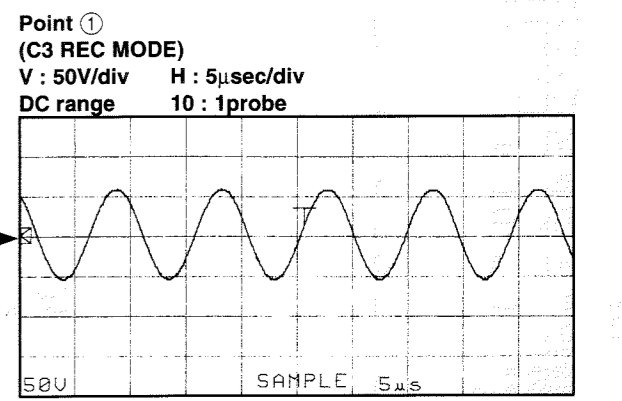

With the POWER switch turned ON, connect the power cord to the AC outlet.
Disconnect the power cord from the AC outlet.

(This waveform is not available by pushing the power switch ON and OFF.)

NOTICE (MODE)

- (J)..... JAPANESE
 - (U)..... U.S.A
 - (C)..... CANADIAN
 - (R)..... GENERAL
 - (A)..... AUSTRALIAN
 - (B)..... BRITISH
 - (D)..... EUROPEAN
 - (T)..... CHINA
 - (L)..... SINDHAPPE
- Inseparable Parts at Manufacturer's Step
Mark Reference Parts Number Parts Name

Part No.	Parts Name
IC1	μPC1330HA
IC2	LA3246
IC3	μPC1297CA
IC4,9	NJM4558L
IC7	HA12142NT
IC8	CXA1578P
IC10	BA6138
IC11	BU2090

Part No.	Parts Name
C1	100μF 50V
C2	100μF 50V
C3	100μF 50V
C4	100μF 50V
C5	100μF 50V
C6	100μF 50V
C7	100μF 50V
C8	100μF 50V
C9	100μF 50V
C10	100μF 50V
C11	100μF 50V
C12	100μF 50V
C13	100μF 50V
C14	100μF 50V
C15	100μF 50V
C16	100μF 50V
C17	100μF 50V
C18	100μF 50V
C19	100μF 50V
C20	100μF 50V
C21	100μF 50V
C22	100μF 50V
C23	100μF 50V
C24	100μF 50V
C25	100μF 50V
C26	100μF 50V
C27	100μF 50V
C28	100μF 50V
C29	100μF 50V
C30	100μF 50V
C31	100μF 50V
C32	100μF 50V
C33	100μF 50V
C34	100μF 50V
C35	100μF 50V
C36	100μF 50V
C37	100μF 50V
C38	100μF 50V
C39	100μF 50V
C40	100μF 50V
C41	100μF 50V
C42	100μF 50V
C43	100μF 50V
C44	100μF 50V
C45	100μF 50V
C46	100μF 50V
C47	100μF 50V
C48	100μF 50V
C49	100μF 50V
C50	100μF 50V
C51	100μF 50V
C52	100μF 50V
C53	100μF 50V
C54	100μF 50V
C55	100μF 50V
C56	100μF 50V
C57	100μF 50V
C58	100μF 50V
C59	100μF 50V
C60	100μF 50V
C61	100μF 50V
C62	100μF 50V
C63	100μF 50V
C64	100μF 50V
C65	100μF 50V
C66	100μF 50V
C67	100μF 50V
C68	100μF 50V
C69	100μF 50V
C70	100μF 50V
C71	100μF 50V
C72	100μF 50V
C73	100μF 50V
C74	100μF 50V
C75	100μF 50V
C76	100μF 50V
C77	100μF 50V
C78	100μF 50V
C79	100μF 50V
C80	100μF 50V
C81	100μF 50V
C82	100μF 50V
C83	100μF 50V
C84	100μF 50V
C85	100μF 50V
C86	100μF 50V
C87	100μF 50V
C88	100μF 50V
C89	100μF 50V
C90	100μF 50V
C91	100μF 50V
C92	100μF 50V
C93	100μF 50V
C94	100μF 50V
C95	100μF 50V
C96	100μF 50V
C97	100μF 50V
C98	100μF 50V
C99	100μF 50V
C100	100μF 50V

PIN CONNECTION DIAGRAM OF TRANSISTORS, DIODES AND ICs.

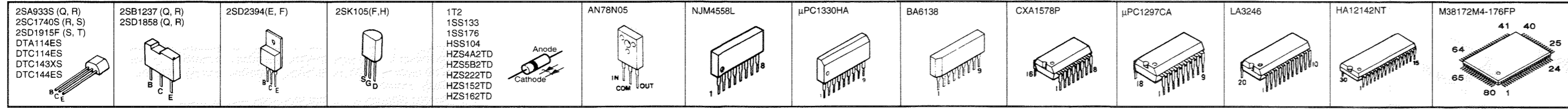

• All voltages are measured with a 10MΩ/V DC electric volt meter.
• Components having special characteristics are marked Δ and must be replaced with parts having specifications equal to those originally installed.
• Schematic diagram is subject to change without notice.

KX-W321/K-903 SCHEMATIC DIAGRAM

● The voltages are measured using LH tape in the PLAY mode (no-signal condition)
 Only the voltages in () are in the REC mode.

PLAY mode		REC mode	
DECK A	: PLAY(⇒)	DECK B	: REC(⇒)
DOLBY NR	: OFF	DOLBY NR	: DOLBY B ON
TAPE	: NORMAL	TAPE	: METAL

IC1 : μPC1330HA
2ch Head Selector Switch

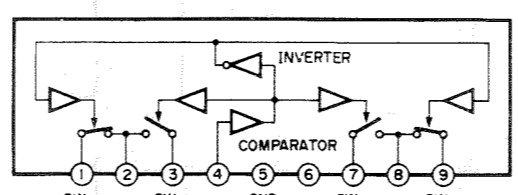

IC2 : LA3246
Playback Amp

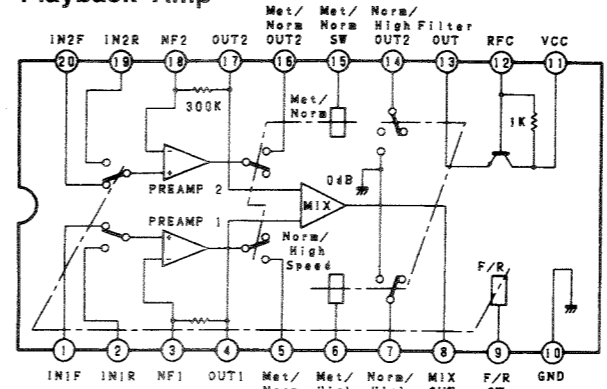

IC7 : HA12142NT
Dolby B&C-Type Noise Reduction Processor

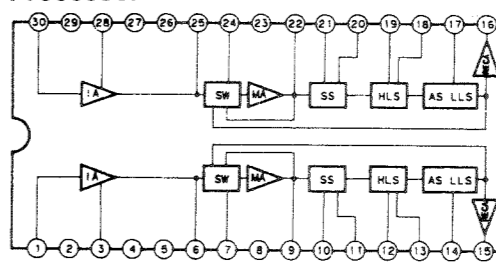

IC8 : CXA1578P
Recording Equalizer Amp

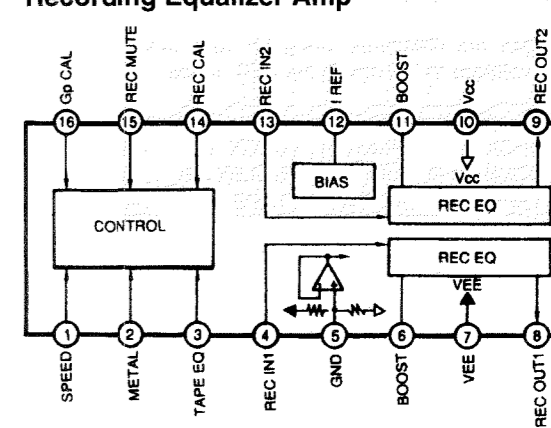

IC9 : NJM4558L
Dual OP-Amp

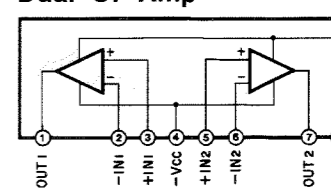

IC10 : BA6138
Dual 1/2 Compressor

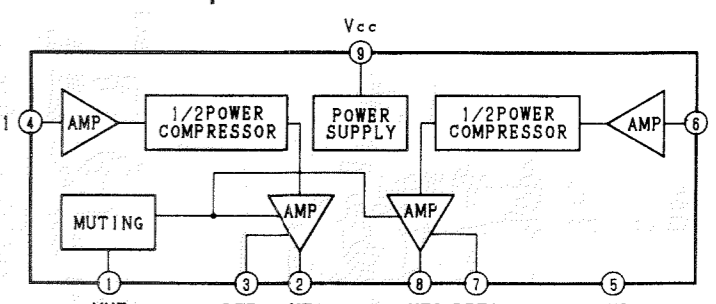

IC11 : BU2090
Serial In/Parallel out Driver

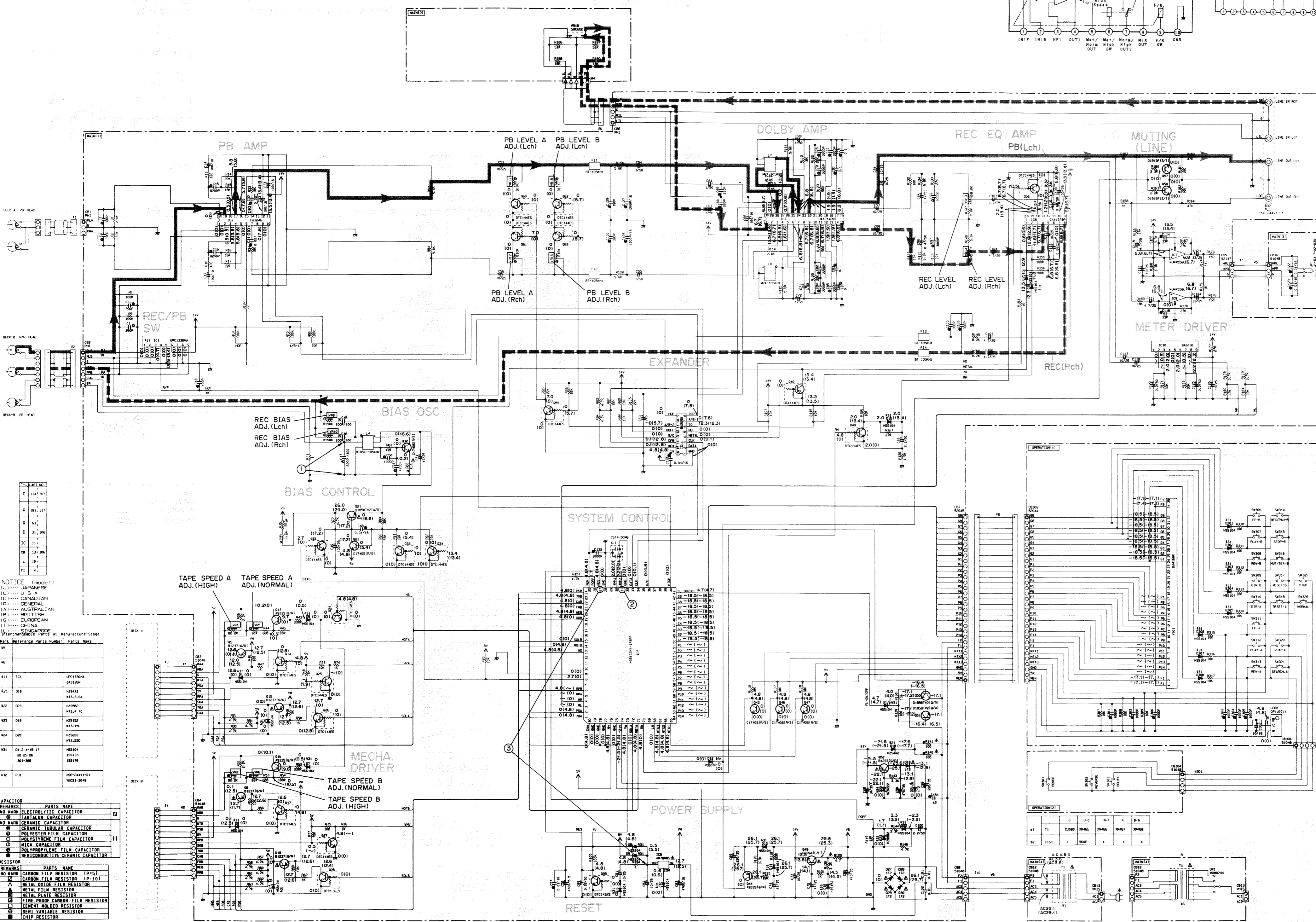
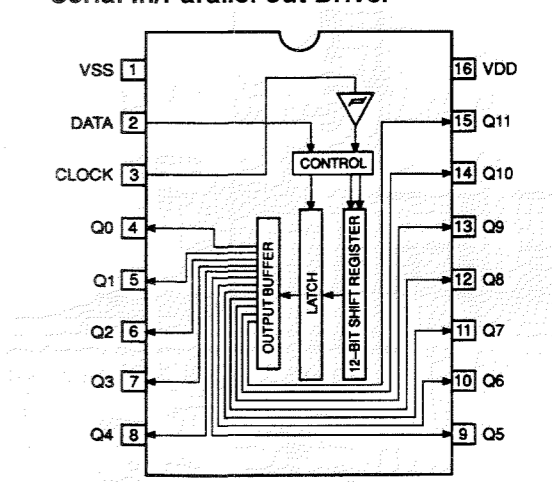

NOTICE
 (1)..... JAPANESE
 (2)..... U.S.A.
 (3)..... CANADIAN
 (4)..... GENERAL
 (A)..... AUSTRALIAN
 (B)..... BRITISH
 (C)..... EUROPEAN
 (1)..... CHINA
 (2)..... SINGAPORE
 Interchangeable parts at Manufacture Stage

Part No.	Part Name	Part No.	Part Name
45	IC1	μPC1330HA	2ch Head Selector Switch
46	IC2	LA3246	Playback Amp
47	IC3	HA12142NT	Dolby B&C-Type Noise Reduction Processor
48	IC4	CXA1578P	Recording Equalizer Amp
49	IC5	NJM4558L	Dual OP-Amp
50	IC6	BA6138	Dual 1/2 Compressor
51	IC7	BU2090	Serial In/Parallel out Driver
52	IC8	MECHA DRIVER	Mechanical Driver
53	IC9	METER DRIVER	Meter Driver
54	IC10	POWER SUPPLY	Power Supply
55	IC11	RESET	Reset

REMARKS	PARTS NAME
NO MARK	ELECTROLYTIC CAPACITOR
NO MARK	TANTALUM CAPACITOR
NO MARK	CERAMIC TUBULAR CAPACITOR
NO MARK	POLYESTER FILM CAPACITOR
NO MARK	POLYPROPYLENE FILM CAPACITOR
NO MARK	MICA CAPACITOR
NO MARK	POLYIMIDE FILM CAPACITOR
NO MARK	SEMICONDUCTIVE CERAMIC CAPACITOR
NO MARK	CARBON FILM RESISTOR (P-5)
NO MARK	CARBON FILM RESISTOR (P-10)
NO MARK	METAL FILM RESISTOR
NO MARK	METAL PLATE RESISTOR
NO MARK	FINE PROOF CARBON FILM RESISTOR
NO MARK	GENERAL PURPOSE RESISTOR
NO MARK	VARIABLE RESISTOR
NO MARK	CHIP RESISTOR

TEST POINT WAVEFORMS

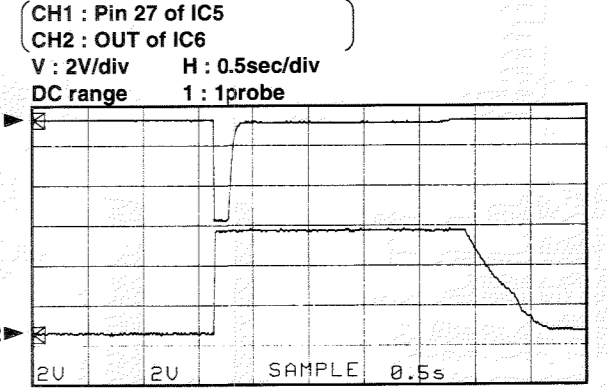
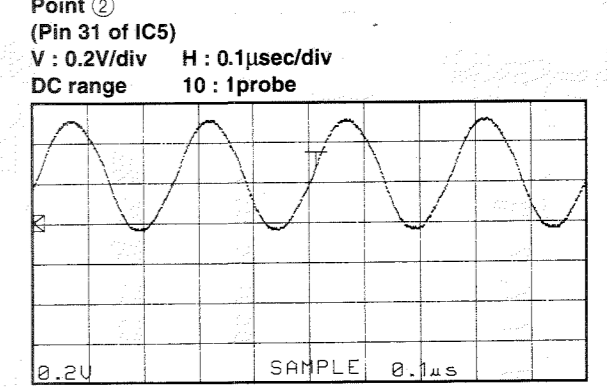
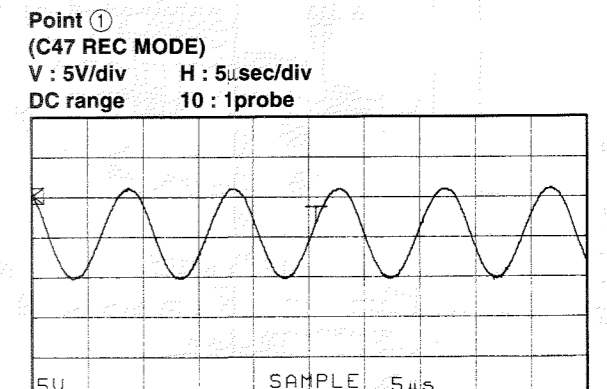

▲ With the POWER switch turned ON, connect the power cord to the AC outlet.
 ▲ Disconnect the power cord from the AC outlet.

(This waveform is not available by pushing the power switch ON and OFF.)

PIN CONNECTION DIAGRAM OF TRANSISTORS, DIODES AND ICs.

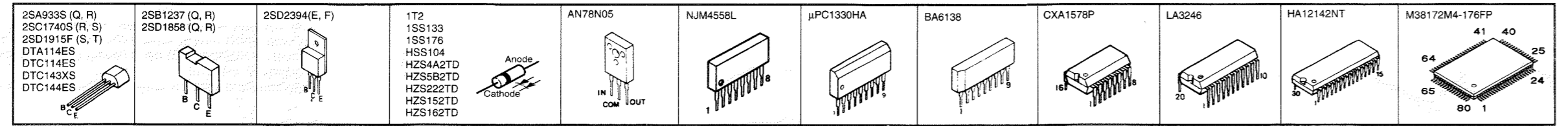

* All voltages are measured with a 10MQ/V DC electric volt meter.
 * Components having special characteristics are marked ▲ and must be replaced with parts having specifications equal to those originally installed.
 * Schematic diagram is subject to change without notice.

■ KX-W321/K-903 SPECIFICATIONS

Type		Auto Reverse
4-Track 2-Channel recording and playback/ playback stereo double Cassette Deck		
Heads		
REC/PB		Hard permalloy
Erase		Double Gap Ferrite
PB		Hard permalloy
Motors		
Main		DC servo motor x 2
Wow & Flutter		
W.PEAK		±0.15%
W.RMS		0.08%
Fast Winding Time about 100 seconds (C-60 tape)		
Frequency Response (-20dB)		
Normal tape (Type I)		20-16000Hz±3dB
High tape (Type II)		20-17000Hz±3dB
Metal tape (Type IV)		20-19000Hz±3dB
S/N Ratio (S: 3rd harmonic distortion 3% /N: Weighted)		
NR off		58dB
Dolby B NR on		66dB
Dolby C NR on		74dB
Harmonic distortion (315Hz 3rd 160 nmb/m -4dB) 1.0%		
Channel Separation (1kHz)		More than 40dB
Crosstalk (125Hz)		More than 55dB
Input Sensitivity/Impedance (0dB)		
Line		100mV/43kΩ
Output Level (0dB)		
Line		570mV/1.4kΩ
Headphones		0.25mW/8Ω
Power Requirements		
U,C models		AC120V, 60Hz
B,G models		AC230V, 50Hz
A model		AC240V, 50Hz
R, T models		AC110, 120, 220, 240V,50/60Hz

Power Consumption

U, C models	11W (Standby 7W)
Except U, C models	12W (Standby 7W)

Dimensions (W x H x D)

435 x 146 x 279mm (17-1/8" x 5-3/4" x 11")

Weight

5.0kg(11lbs)

Accessories

Input, output cords (RCA type)

* Specifications are subject to change without notice.

U U.S.A. model

C Canadian model

R General model

A Australian model

B British model

G European model

T China model

● DIMENSIONS

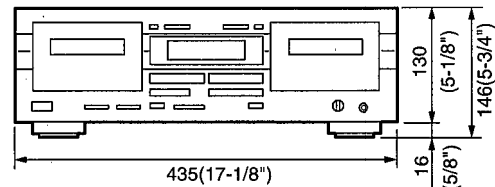
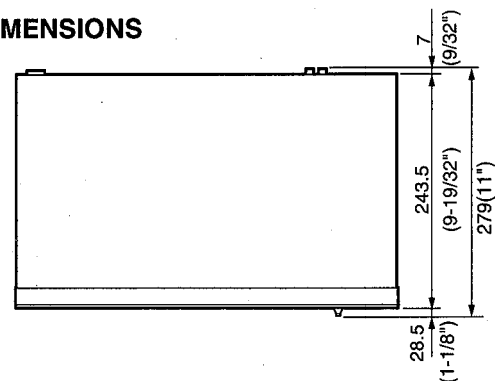

Unit: mm (inch)

■ KX-W321/K-903 INTERNAL VIEW

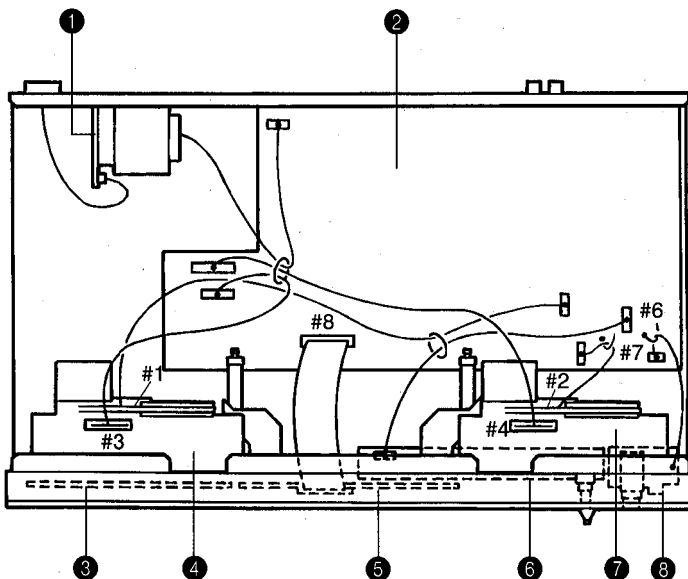

- ① MAIN P.C.B. ASS'Y (4)
- ② MAIN P.C.B. ASS'Y (1)
- ③ OPERATION P.C.B. ASS'Y (2)
- ④ CASSETTE MECHANISM UNIT (DECK A)
- ⑤ OPERATION P.C.B. ASS'Y (1)
- ⑥ MAIN P.C.B. ASS'Y (2)
- ⑦ CASSETTE MECHANISM UNIT (DECK B)
- ⑧ MAIN P.C.B. ASS'Y (3)

■ KX-W321/K-903 ADJUSTMENTS

1. Before adjustment:

- Make sure that AC line voltage comes within

Models	AC line voltage
U, C	120V ± 10%
B, G	230V ± 10%
A	240V ± 10%

- Since head magnetization, dust accumulations, etc. are likely to introduce error in the various characteristics, it is very important that the heads are properly demagnetized and cleaned.
- Make adjustments of mechanical system, playback system and recording system in that order.
- Except for azimuth adjustment, adjust in the forward direction.
- Press RESET key and PLAY key simultaneously, enters CLEANING MODE. (playback mode without a cassette tape.)
In this mode, Power ON/OFF in not affected.
During this mode, DIRECTION key is operational.
To escape from this mode, press STOP, FF, REW or POWER key.

- Test Conditions
REC LEVEL → Max

2. Instruments required

- Audio frequency oscillator
- ACVM (or dual channel ACVM)
- Wow/flutter meter
- Oscilloscope
- Frequency counter
- Torque meter
TW-2111A (TX911580) ... Take up/back tension (FWD)
TW-2121A (TX911570) ... Take up/back tension (RVS)
CT-160L (TX911120) FF/REW
- DCVM

3. Test tape required

- MTT-111N (TX911650) Normal speed
- TCW-211 (TX911550) High speed
- MTT-114N (TX911680) Azimuth
- MTT-212N (TX911660) Playback level
- MTT-256 (TX911300) Playback frequency response (Normal)
- MTT-356 (TX911310) Playback frequency response (CrO2)
- Reference tape
Normal (LH) : TDK AC225 (VU16720)
High (CrO2) : TDK AC514 (VU16730)
METAL : TDK AC713(VU16740)

MECHANICAL ADJUSTMENT

Step	Item to be Adjusted	Tape	Instrument required	Mode	Adjustment part	Rating	Remarks	
1	Check each torque	CT-160L (FF, REW)	Torque meter	FF REW		FF, REW torque: more than 70g/cm.		
		TW-2111A (FWD)				PLAY		Take up torque : 25~70g/cm.
		TW-2121A (RVS)						Back tension : 1.5~6g/cm.
2	Check FF, REW take up time	AC-514 (C-60)		FF REW		85 to 115 seconds.		
3	Azimuth	MTT-114N 10kHz, -10dB	ACVM Oscilloscope	PLAY	Azimuth adjustment screw	Playback output of L and R is maximum and phase difference should be minimum in both directions. (Fig. A.)	After the adjustment make sure to apply screw lock paint.	
4	Tape Speed [Adjust the high speed initially, and next the normal speed.]	TCW-211 1.5kHz, -4dB	Frequency counter	PLAY (HIGH)	DECK A VR1	DECK A : * 3000Hz ± 15Hz	During playback, press the PLAY key and H.Dubbing key simultaneously to enter high speed mode.	
					DECK B VR2	DECK B : * 3000Hz ± 15Hz		
		MTT-111N 3kHz, -10dB		PLAY (NORM)	DECK A VR5	DECK A : * 3000Hz ± 15Hz		
					DECK B VR6	DECK B : * 3000Hz ± 15Hz		
5	Wow/Flutter	MTT-111N 3kHz, -10dB	Wow/flutter meter	PLAY		Less than 0.15% (WRMS)	Perform adjustment at the center of the test tape length if possible.	

*Specifications after replacement of the motor are as follows.

PLAY (HIGH)	DECK A : 2980Hz ± 15Hz	PLAY (NORM)	DECK A : 2980Hz ± 15Hz
	DECK B : 2980Hz ± 15Hz		DECK B : 2980Hz ± 15Hz

● TEST POINT

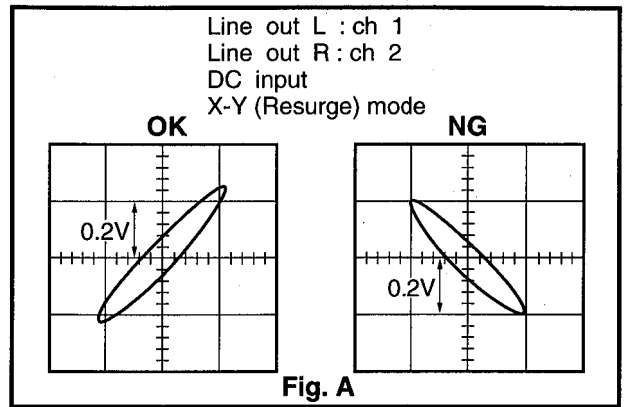
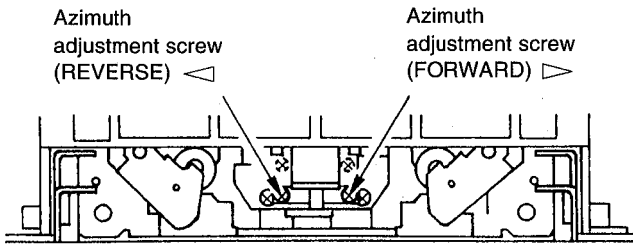

MAIN P.C.B. (1)

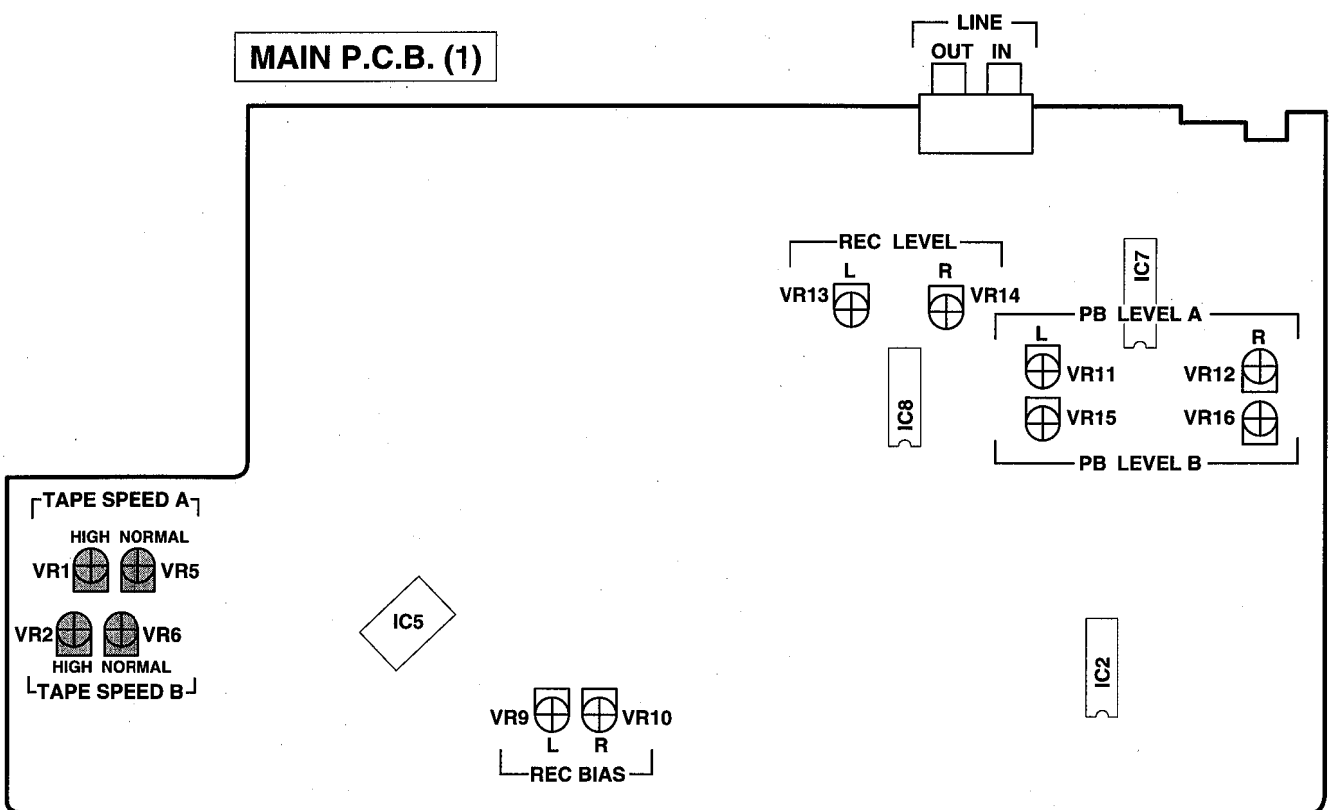

ELECTRICAL ADJUSTMENT

- Use 560mV (250nwb/m) for 0dB as the standard level of the unit.
0dB = 250nwb/m (315Hz) = -5dBV (Line out level)

<Playback section>

Step	Item to be Adjusted	Tape	Instrument required	Mode	Measurement conditions	Points of measurement	Adjustment parts	Rating
1	Playback level (315Hz) (DECK A, DECK B)	MTT-212N 315Hz 250nwb/m	ACVM	PLAY		LINE OUT	DECK A VR11 (L ch) VR12 (R ch) DECK B VR15 (L ch) VR16 (R ch)	-5 ± 0.3 dBV
2	Confirmation of playback frequency response	Test tape for frequency check, 3180 μs + 120 μs (LH) (MTT-256) 3180 μs + 70 μs (CrO2) (MTT-356)	ACVM Oscilloscope	PLAY		LINE OUT		Check that the 10kHz playback level is within 0 ± 3dB of the 315Hz playback level. (Fig. B)

● PLAYBACK FREQUENCY RESPONSE

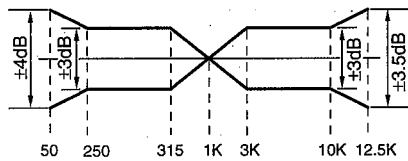
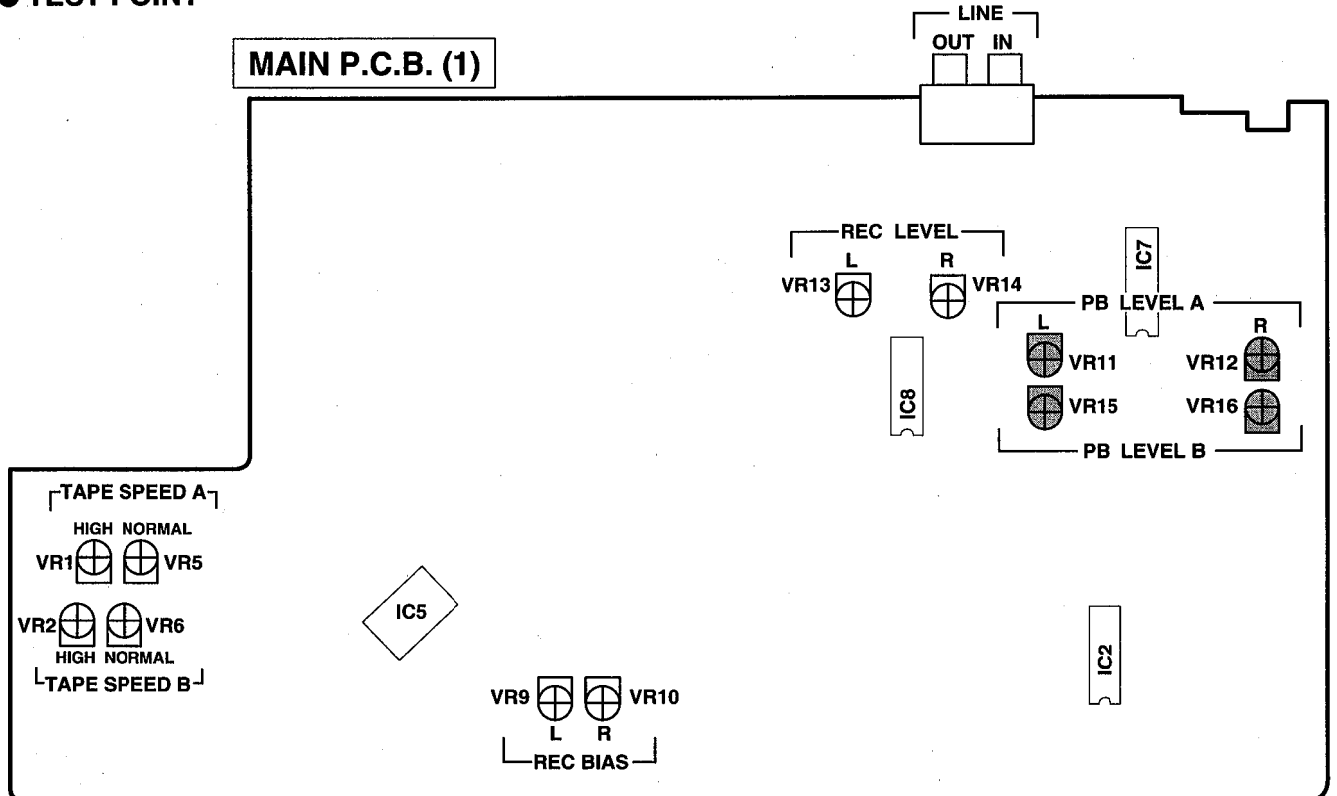

Fig. B

● TEST POINT



<Recording section>

Step	Item to be Adjusted	Tape	Instrument required	Mode	Measurement conditions	Points of measurement	Adjustment parts	Rating
1	Recording level (DECK B)	AC-514 High (CrO ₂)	ACVM Audio frequency oscillator	REC	1. Set REC LEVEL to maximum. 2. Input 315Hz Signal to LINE IN TERMINAL from Audio Frequency Oscillator. Adjust output level of Audio Frequency Oscillator so that the voltage of LINE OUT TERMINAL becomes -25dBV.	LINE OUT	VR13 (L ch) VR14 (R ch)	Adjust for equal level of the record and playback levels. (-25 ± 0.3 dBV)
2	Recording bias (Total frequency response) (DECK B)	AC-514 High (CrO ₂) AC-225 Normal (LH) AC-713 METAL	ACVM Audio frequency oscillator	REC	1. Set REC LEVEL to maximum. 2. Input 12.5kHz Signal to LINE IN TERMINAL from Audio Frequency Oscillator. Adjust output level of Audio Frequency Oscillator so that the voltage of LINE OUT TERMINAL becomes -25dBV.	LINE OUT	DECK B VR9 (L ch) VR10 (R ch)	Adjust for equal level of the record and playback levels. (-25 ± 0.5 dBV) Adjust for equal level of the record and playback levels. (Table 1) Perform record bias adjustment of high (CrO ₂) tape again, if the rating was not satisfied.
3	Confirmation of recorded level	AC-514 High (CrO ₂)	ACVM Audio frequency oscillator	REC		LINE OUT		Confirm recorded level rating as in step 1. When recorded level rating is improper, go back to step 1 and also carry out confirmation in step 3 again.

● TEST POINT

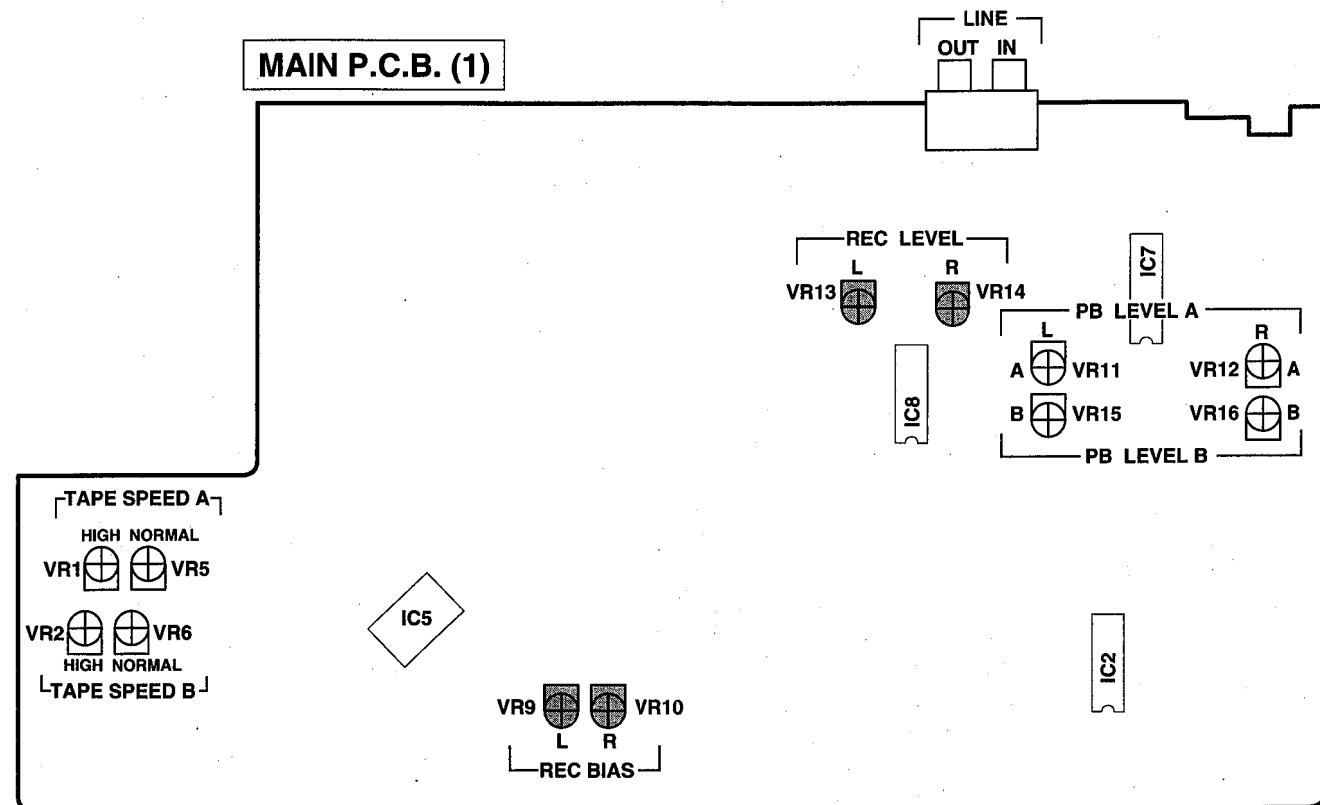

● TOTAL FREQUENCY RESPONSE (-20dB)

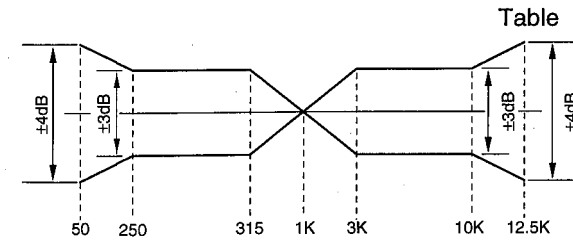

NR : NR off / Dolby B NR on / Dolby C NR on
(B&C NR : Reference level must be recorded level.)
TAPE : Normal (LH) / High (CrO₂) / METAL

● DUBBING RESPONSE (-20dB)

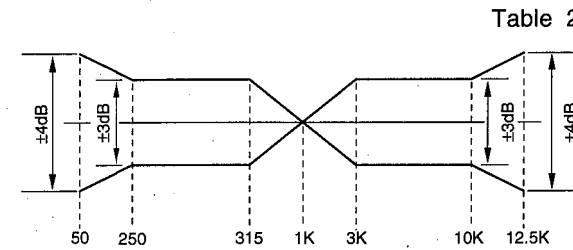

SPEED : Normal/High
TAPE : Normal (LH) → Normal (LH)
High (CrO₂) → High (CrO₂)
High (CrO₂) → METAL

REMOTE CONTROL FUNCTION

● Remote Control

Custom code	Function (Data)
7F, 7A, 7E	STOP (03), PLAY (00), FF (02), REW (01), REC/PAUSE (04), REC MUTE (05), SEARCH >> (0A), SEARCH << (0B), DECK A/B (06), COUNTER RESET (0D), DIR A (07), DIR B (08), DUBBING (09)

● Synchro Recode

Custom code	Function (Data)
7Q (CD Player)	SYNCHRO (50), PLAY (02), PAUSE (55), PAUSE/STOP (03), STOP (56), OPEN/CLOSE (01)

TEST MODE (DISPLAY Check)

Enter the TEST MODE by pressing the POWER SW while pressing the RESET KEY (DECK A) when the power is OFF. (Backup data is initialized.)

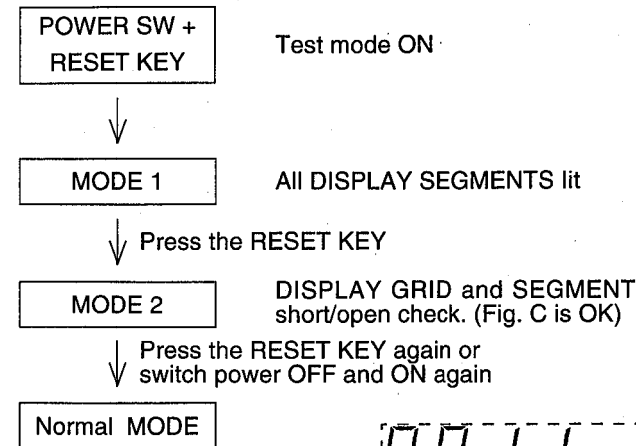
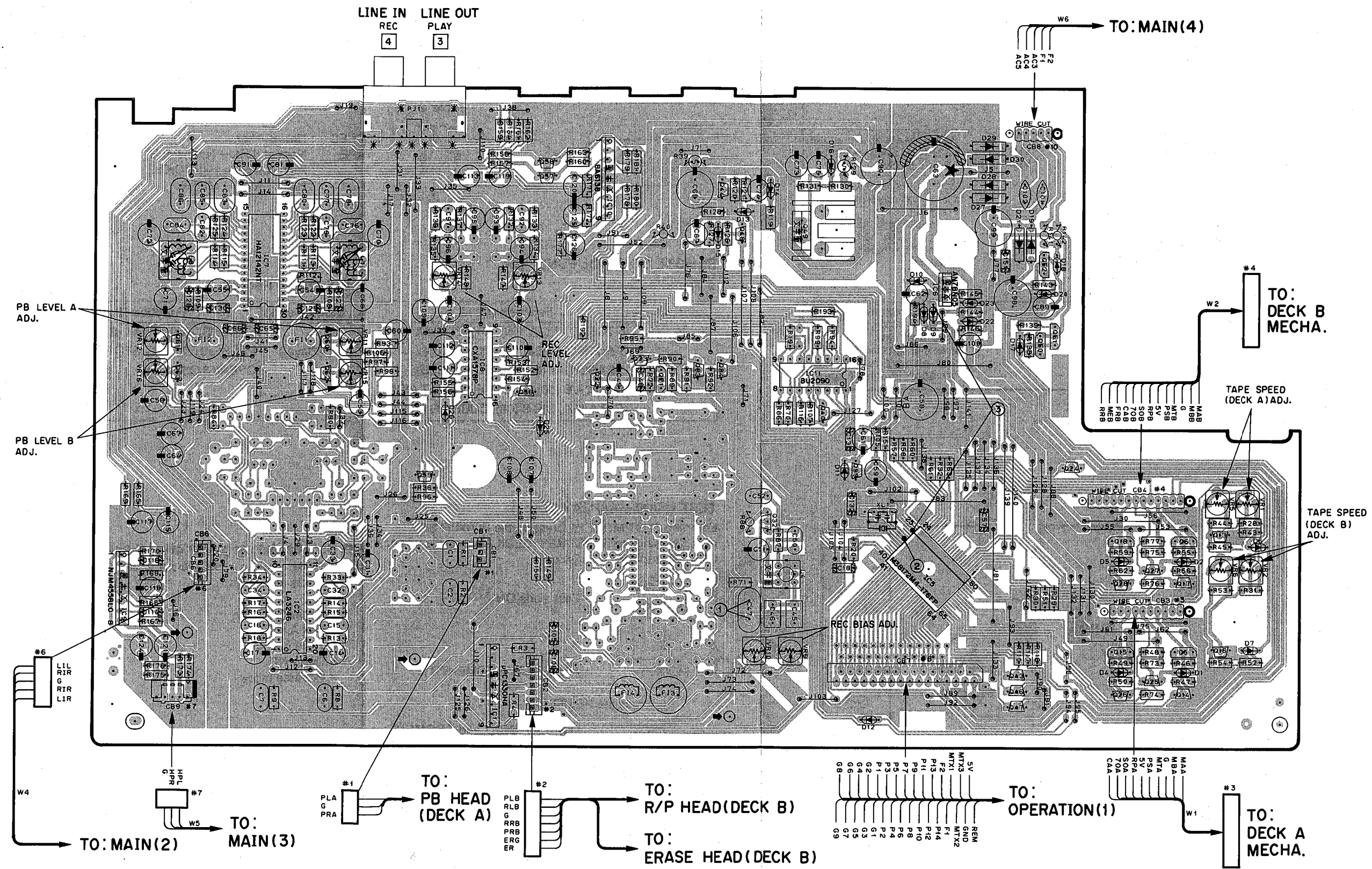

Fig. C

KX-W321/K-903 PRINTED CIRCUIT BOARD (Foil side)

①-③ : TEST POINT WAVEFORMS(See page 23)

MAIN P. C. B. (1)



● Semiconductor Location

Ref. No.	Location
D1	G5
D2	G4
D3	D3
D4	F5
D5	F4
D6	G4
D7	G4
D8	E3
D9	E3
D10	E3
D11	E4
D12	E5
D13	D2
D14	E2
D15	D3
D16	E2
D17	F3
D18	F3
D19	F2
D20	F3
D21	F2
D22	F3
D23	F3
D25	C3
D26	C3
D27	F2
D28	F2
D29	F2
D30	F2
IC1	C5
IC2	B4
IC5	E4
IC6	E3
IC7	B3
IC8	C3
IC9	A4
IC10	D2
IC11	E3
Q5	G4
Q6	G4
Q13	G4
Q14	G5
Q15	F4
Q16	G4
Q17	G4
Q18	F4
Q21	D3
Q22	D3
Q23	D3
Q24	F4
Q25	F5
Q26	F5
Q27	F4
Q28	F4
Q32	E4
Q33	D3
Q34	D3
Q39	E4
Q40	E3
Q43	F5
Q44	D2
Q46	F5
Q47	F5
Q48	D2
Q49	E2
Q50	F3
Q51	F3
Q52	F3
Q56	C3
Q57	C2
Q58	C2
Q59	C4
Q60	B3
Q61	B3
Q62	B3
Q63	B3

■ KX-W321/K-903 PRINTED CIRCUIT BOARD (Foil side)

1
2
3
4
5
6

MAIN P. C. B. (2)

OPERATION P. C. B. (2)

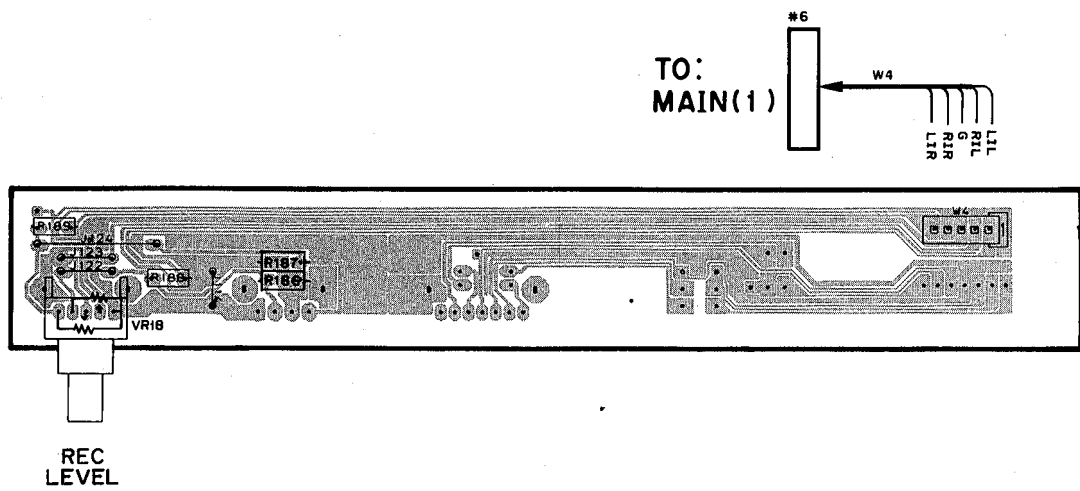

MAIN P. C. B. (3)

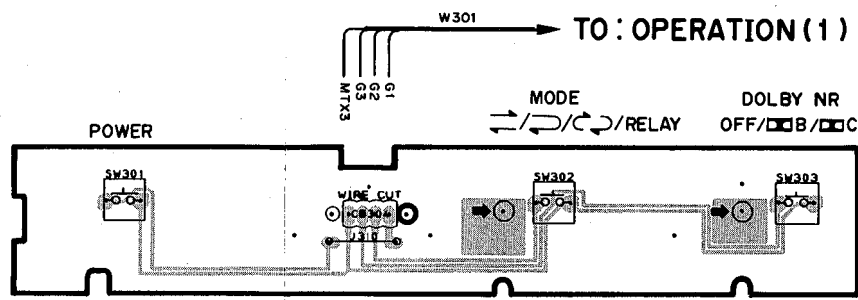

TO: MAIN(1)

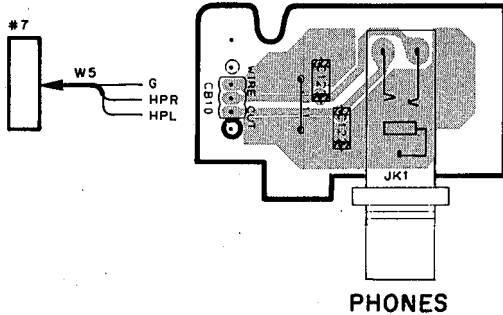

OPERATION P. C. B. (1)

● U, C, A, B and G models

● R and T models

MAIN P. C. B. (4)

MAIN P. C. B. (4)

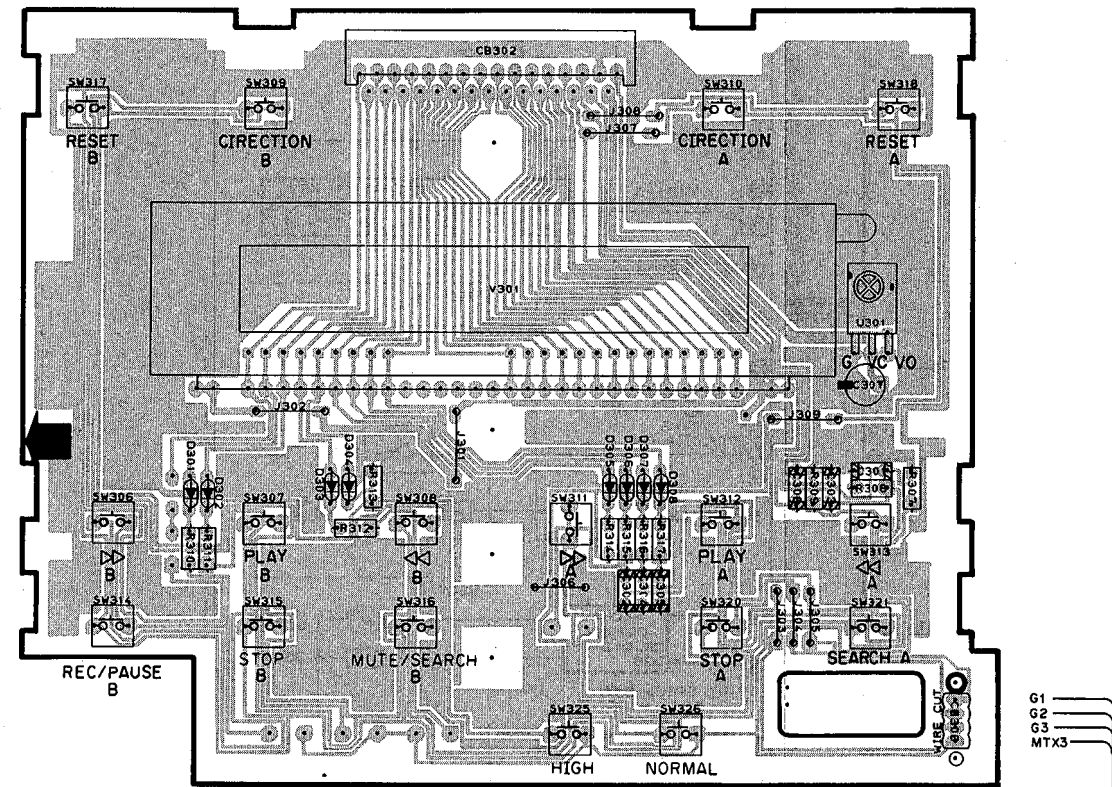
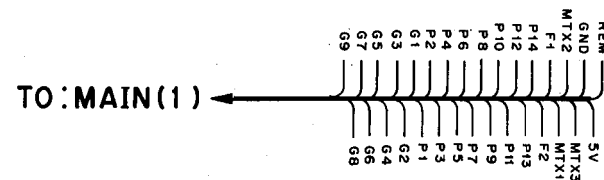
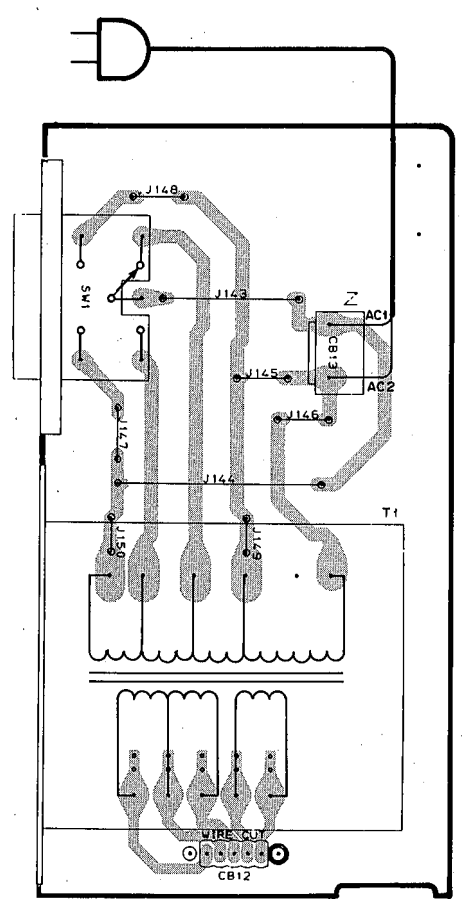
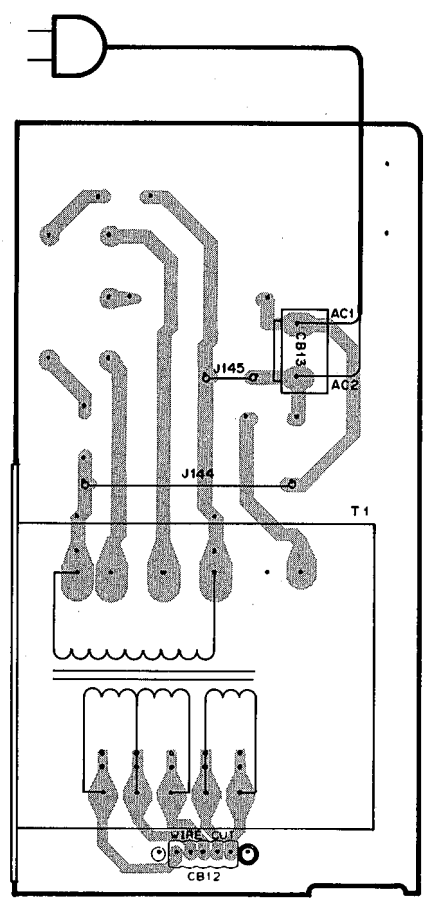

● Semiconductor Location

Ref.No.	Location
D301	E5
D302	E5
D303	E5
D304	E5
D305	F5
D306	F5
D307	F5
D308	F5

KX-W321/K-903 BLOCK DIAGRAM

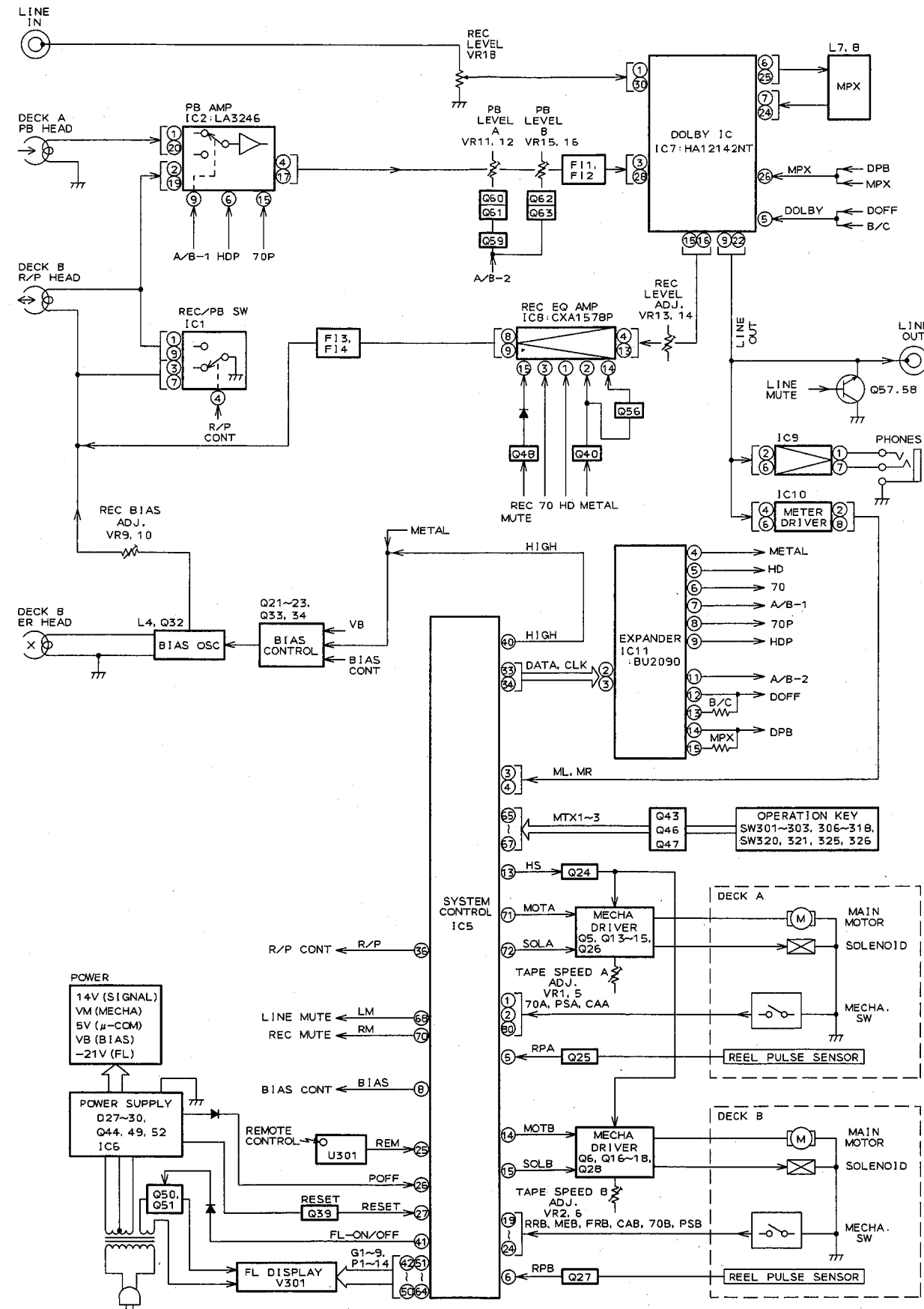

PARTS LIST

■ ELECTRICAL PARTS

■ WARNING

Components having special characteristics are marked \triangle and must be replaced with parts having specifications equal to those originally installed.

- Carbon resistors (1/6W or 1/4W) are not included in the ELECTRICAL PARTS List. For the parts Nos. of the carbon resistores, refer to the last page.

ABBREVIATIONS IN THIS LIST ARE AS FOLLOWS:

C. A. EL. CHP	: CHIP ALUMI. ELECTROLYTIC CAP	L. EMIT	: LIGHT EMITTING MODULE
C. CE	: CERAMIC CAP	LED. DSPLY	: LED DISPLAY
C. CE. ARRAY	: CERAMIC CAP ARRAY	LED. INFRD	: LED, INFRARED
C. CE. CHP	: CHIP CERAMIC CAP	MODUL. RF	: MODULATOR, RF
C. CE. ML	: MULTILAYER CERAMIC CAP	PHOT. CPL	: PHOTO COUPLER
C. CE. M. CHP	: CHIP MULTILAYER CERAMIC CAP	PHOT. INTR	: PHOTO INTERRUPTER
C. CE. SAFTY	: RECOGNIZED CERAMIC CAP	PHOT. RFLCT	: PHOTO REFLECTOR
C. CE. TUBLR	: CERAMIC TUBULAR CAP	PIN. TEST	: PIN, TEST POINT
C. CE. SMI	: SEMI CONDUCTIVE CERAMIC CAP	PLST. RIVET	: PLASTIC RIVET
C. EL	: ELECTROLYTIC CAP	R. ARRAY	: RESISTOR ARRAY
C. MICA	: MICA CAP	R. CAR	: CARBON RESISTOR
C. ML. FLM	: MULTILAYER FILM CAP	R. CAR. CHP	: CHIP RESISTOR
C. MP	: METALLIZED PAPER CAP	R. CAR.FP	: FLAME PROOF CARBON RESISTOR
C. MYLAR	: MYLAR FILM CAP	R. FUS	: FUSABLE RESISTOR
C. MYLAR. ML	: MULTILAYER MYLAR FILM CAP	R. MTL. CHP	: CHIP METAL FILM RESISTOR
C. PAPER	: PAPER CAPACITOR	R. MTL. FILM	: METAL FILM RESISTOR
C. PLS	: POLYSTYRENE FILM CAP	R. MTL. OXD	: METAL OXIDE FILM RESISTOR
C. POL	: POLYESTER FILM CAP	R. MTL. PLAT	: METAL PLATE RESISTOR
C. POLY	: POLYETHYLENE FILM CAP	RSNR. CE	: CERAMIC RESONATOR
C. PP	: POLYPROPYLENE FILM CAP	RSNR. CRYST	: CRYSTAL RESONATOR
C. TNTL	: TANTALUM CAP	R. TW. CEM	: TWIN CEMENT FIXED RESISTOR
C. TNT. CHP	: CHIP TANTALUM CAP	R. WW	: WIRE WOUND RESISTOR
C. TRIM	: TRIMMER CAP	SCR. BND. HD	: BIND HEAD B-TITE SCREW
CN	: CONNECTOR	SCR. BW. HD	: BW HEAD TAPPING SCREW
CN. BS. PIN	: CONNECTOR, BASE PIN	SCR. CUP	: CUP TITE SCREW
CN. CANNON	: CONNECTOR, CANNON	SCR. TERM	: SCREW TERMINAL
CN. DIN	: CONNECTOR, DIN	SCR. TR	: SCREW, TRANSISTOR
CN. FLAT	: CONNECTOR, FLAT CABLE	SUPRT. PCB	: SUPPORT, P. C. B.
CN. POST	: CONNECTOR, BASE POST	SURG. PRTCT	: SURGE PROTECTOR
COIL. MX. AM	: COIL, AM MIX	SW. TACT	: TACT SWITCH
COIL. AT. FM	: COIL, FM ANTENNA	SW. LEAF	: LEAF SWITCH
COIL. DT. FM	: COIL, FM DETECT	SW. LEVER	: LEVER SWITCH
COIL. MX. FM	: COIL, FM MIX	SW. MICRO	: MICRO SWITCH
COIL. OUTPT	: OUTPUT COIL	SW. PUSH	: PUSH SWITCH
DIOD. ARRAY	: DIODE ARRAY	SW. RT. ENC	: ROTARY ENCODER
DIODE. BRG	: DIODE BRIDGE	SW. RT. MTR	: ROTARY SWITCH WITH MOTOR
DIODE. CHP	: CHIP DIODE	SW. RT	: ROTARY SWITCH
DIODE. VAR	: VARACTOR DIODE	SW. SLIDE	: SLIDE SWITCH
DIOD. Z. CHP	: CHIP ZENER DIODE	TERM. SP	: SPEAKER TERMINAL
DIODE. ZENR	: ZENER DIODE	TERM. WRAP	: WRAPPING TERMINAL
DSCR. CE	: CERAMIC DISCRIMINATOR	THRMST. CHP	: CHIP THERMISTOR
FER. BEAD	: FERRITE BEADS	TR. CHP	: CHIP TRANSISTOR
FER. CORE	: FERRITE CORE	TR. DGT	: DIGITAL TRANSISTOR
FET. CHP	: CHIP FET	TR. DGT. CHP	: CHIP DIGITAL TRANSISTOR
FL. DSPLY	: FLUORESCENT DISPLAY	TRANS	: TRANSFORMER
FLTR. CE	: CERAMIC FILTER	TRANS. PULS	: PULSE TRANSFRMER
FLTR. COMB	: COMB FILTER MODULE	TRANS. PWR	: POWER TRANSFORMER ASS'y
FLTR. LC. RF	: LC FILTER, EMI	TUNER. AM	: TUNER PACK, AM
GND. MTL	: GROUND PLATE	TUNER. FM	: TUNER PACK, FM
GND. TERM	: GROUND TERMINAL	TUNER. PK	: FRONT-END TUNER PACK
HOLDER. FUS	: FUSE HOLDER	VR	: ROTARY POTENTIOMETER
IC. PRTCT	: IC PROTECTOR	VR. MTR	: POTENTIOMETER WITH MOTOR
JUMPER. CN	: JUMPER CONNECTOR	VR. SW	: POTENTIOMETER WITH ROTARY SW
JUMPER. TST	: JUMPER, TEST POINT	VR. SLIDE	: SLIDE POTENTIOMETER
L. DTCT	: LIGHT DETECTING MODULE	VR. TRIM	: TRIMMER POTENTIOMETER

Note) Those parts marked with "#" are not included in the P. C. B. Ass'y.

KX-W421 MAIN P.C.B.

Schm Ref	PART NO.	Description		
	VU207100	P.C.B.	MAIN(UO)	
	VU207200	P.C.B.	MAIN(R)	
	VU207300	P.C.B.	MAIN(A)	
	VU207400	P.C.B.	MAIN(BG)	
CB1	VD004600	CN.BS.PIN	3P	
CB2	VD005000	CN.BS.PIN	7P	
CB3	Vi878800	CN.BS.PIN	10P	
CB4	Vi879100	CN.BS.PIN	13P	
CB5	VD005000	CN.BS.PIN	7P	
CB6	VD004800	CN.BS.PIN	5P	
CB7	VQ048000	CN.BS.PIN	31P	
CB8	Vi878300	CN.BS.PIN	5P	
CB9	VK024700	CN.BS.PIN	3P	
CB10	Vi878100	CN.BS.PIN	3P	
CB12	Vi878300	CN.BS.PIN	5P	
CB13	VG879900	CN.BS.PIN	2P	
C1	UA652330	C.MYLAR	330pF	50V
C2	UA652330	C.MYLAR	330pF	50V
C3	UT454100	C.PP	0.01uF	100V
C4	UA652100	C.MYLAR	100pF	50V
C5	UA652100	C.MYLAR	100pF	50V
C6	UA652390	C.MYLAR	390pF	50V
C7	UA652390	C.MYLAR	390pF	50V
C8	VS204800	C.PP	100pF	100V
C9	VS205200	C.PP	470pF	100V
C10	VS205200	C.PP	470pF	100V
C11	VS204800	C.PP	100pF	100V
C12	VF466800	C.CE.TUBLR	100pF	50V
C13	UA653820	C.MYLAR	8200pF	50V
C14	VF760000	C.EL	100uF	10V
C15	UA653820	C.MYLAR	8200pF	50V
C16	UA653820	C.MYLAR	8200pF	50V
C17	VF760000	C.EL	100uF	10V
C18	VF466800	C.CE.TUBLR	100pF	50V
C19	VG278800	C.CE.TUBLR	560pF	50V
C20	VF467300	C.CE.TUBLR	0.01uF	16V
C21	VG280100	C.CE.TUBLR	0.022uF	25V
C22	VG280100	C.CE.TUBLR	0.022uF	25V
C23	VG280100	C.CE.TUBLR	0.022uF	25V
C24	VG280100	C.CE.TUBLR	0.022uF	25V
C25	VF467300	C.CE.TUBLR	0.01uF	16V
C26	UR847100	C.EL	10uF	25V
C27	VG278800	C.CE.TUBLR	560pF	50V
C28	UR848100	C.EL	100uF	25V
C29	UA653220	C.MYLAR	2200pF	50V
C30	UA653220	C.MYLAR	2200pF	50V
C31	VF964800	C.EL	100uF	16V
C32	UA654270	C.MYLAR	0.027uF	50V
C33	VF964800	C.EL	100uF	16V
C34	UA654270	C.MYLAR	0.027uF	50V
* C35	UR847220	C.EL	22uF	25V
C36	UA653120	C.MYLAR	1200pF	50V
C37	UA653100	C.MYLAR	1000pF	50V

* New Parts

Schm Ref	PART NO.	Description		
C38	UA653120	C.MYLAR	1200pF	50V
C39	UR847100	C.EL	10uF	25V
C40	UR847100	C.EL	10uF	25V
C41	UA653100	C.MYLAR	1000pF	50V
C42	UA653120	C.MYLAR	1200pF	50V
C43	UR847100	C.EL	10uF	25V
C44	UA653120	C.MYLAR	1200pF	50V
C53	UR847100	C.EL	10uF	25V
C54	VJ839100	C.EL	1uF	50V
C55	VJ839100	C.EL	1uF	50V
C56	UR847100	C.EL	10uF	25V
C57	VF467300	C.CE.TUBLR	0.01uF	16V
C58	VT180400	C.EL	4700uF	5.5V
C59	UR865220	C.EL	0.22uF	50V
C60	VJ839100	C.EL	1uF	50V
C61	UR847100	C.EL	10uF	25V
C62	UR847100	C.EL	10uF	25V
* C63	UR739470	C.EL	4700uF	16V
C64	VJ839100	C.EL	1uF	50V
C65	VG278400	C.CE.TUBLR	220pF	50V
C66	VG278400	C.CE.TUBLR	220pF	50V
C67	VJ839100	C.EL	1uF	50V
C68	VF964800	C.EL	100uF	16V
C69	UR858220	C.EL	220uF	35V
C70	VJ839100	C.EL	1uF	50V
C71	VJ839100	C.EL	1uF	50V
C72	VJ839100	C.EL	1uF	50V
C73	UR847100	C.EL	10uF	25V
C74	UR857220	C.EL	22uF	35V
C75	UR847470	C.EL	47uF	25V
C76	UA653220	C.MYLAR	2200pF	50V
C77	UA653220	C.MYLAR	2200pF	50V
C78	UA655100	C.MYLAR	0.1uF	50V
C79	UA653220	C.MYLAR	2200pF	50V
C80	UA655100	C.MYLAR	0.1uF	50V
C81	UR847100	C.EL	10uF	25V
C82	UA653220	C.MYLAR	2200pF	50V
C83	UA655100	C.MYLAR	0.1uF	50V
C84	UA653220	C.MYLAR	2200pF	50V
C85	UA653220	C.MYLAR	2200pF	50V
C86	UA655100	C.MYLAR	0.1uF	50V
C87	UR866220	C.EL	2.2uF	50V
C89	UR857100	C.EL	10uF	35V
* C90	UR758470	C.EL	470uF	35V
C91	UR847100	C.EL	10uF	25V
C92	UA653330	C.MYLAR	3300pF	50V
C93	UR847100	C.EL	10uF	25V
C94	UR865470	C.EL	0.47uF	50V
C95	UR847100	C.EL	10uF	25V
C96	UR865470	C.EL	0.47uF	50V
C97	UA653330	C.MYLAR	3300pF	50V
* C98	UR758470	C.EL	470uF	35V
C99	UR858220	C.EL	220uF	35V

* New Parts

KX-W421 MAIN P.C.B.

Schm Ref	PART NO.	Description			Schm Ref	PART NO.	Description		
	C100	UR866220	C.EL	2.2uF 50V		D18	VM973700	DIODE.ZENR	HZS4A2TD 4.0V
	C101	FG214100	C.CE	0.01uF 50V	△	D19	VS997800	DIODE	1T2
*	C102	FG214100	C.CE	0.01uF 50V		D20	VM976200	DIODE.ZENR	HZS222TD 22V
*	C103	UR846470	C.EL	4.7uF 25V	△	D21	VS997800	DIODE	1T2
	C104	UR846470	C.EL	4.7uF 25V		D22	VD631600	DIODE	1SS133,176,HSS104
	C105	VG278600	C.CE.TUBLR	330pF 50V		D23	VM974100	DIODE.ZENR	HZS5B2TD 5.0V
	C106	VG278600	C.CE.TUBLR	330pF 50V		D25	VD631600	DIODE	1SS133,176,HSS104
*	C107	UR846470	C.EL	4.7uF 25V		D26	VD631600	DIODE	1SS133,176,HSS104
*	C108	UR846470	C.EL	4.7uF 25V	△	D27	VS997800	DIODE	1T2
	C109	UR848100	C.EL	100uF 25V	△	D28	VS997800	DIODE	1T2
	C110	UJ865680	C.EL	0.68uF 50V	△	D29	VS997800	DIODE	1T2
	C111	UR847100	C.EL	10uF 25V	△	D30	VS997800	DIODE	1T2
	C112	UJ865680	C.EL	0.68uF 50V		Fi1	GE900780	COIL.BIAS	105KHz
	C113	UR847100	C.EL	10uF 25V		Fi2	GE900780	COIL.BIAS	105KHz
	C114	VG277000	C.CE.TUBLR	33pF 50V		Fi3	GE900780	COIL.BIAS	105KHz
*	C115	UR846470	C.EL	4.7uF 25V		Fi4	GE900780	COIL.BIAS	105KHz
	C116	UR847100	C.EL	10uF 25V		IC1	XD864A00	IC	uPC1330HA
*	C117	UR846470	C.EL	4.7uF 25V		IC2	XF870A00	IC	LA3246
	C118	VG277000	C.CE.TUBLR	33pF 50V		IC3	XA300A00	IC	uPC1297CA
	C119	UR847100	C.EL	10uF 25V		IC4	XM922A00	IC	NJM4558L
	C120	UR866220	C.EL	2.2uF 50V		IC5	XR635C00	IC	M38172M4-176FP CPU
*	C121	UR847330	C.EL	33uF 25V	△	IC6	XA507A00	IC	AN78N05
	C122	VF467300	C.CE.TUBLR	0.01uF 16V		IC7	XH741A00	IC	HA12142NT
	C123	VF467300	C.CE.TUBLR	0.01uF 16V		IC8	XK202A00	IC	CXA1578P
*	C124	UR847330	C.EL	33uF 25V		IC9	XM922A00	IC	NJM4558L
	C125	UR866220	C.EL	2.2uF 50V		IC10	iG074900	IC	BA6138
	C126	UR847100	C.EL	10uF 25V		IC11	XP265A00	IC	BU2090
	C127	VG279100	C.CE.TUBLR	1200pF 16V		JK1	VS899700	JACK.PHONE	JY-6317-02-030
	C128	VG279100	C.CE.TUBLR	1200pF 16V		L1	VA709900	COIL	105KHz
	C129	VG278700	C.CE.TUBLR	390pF 50V		L2	VA709900	COIL	105KHz
	C130	VG278700	C.CE.TUBLR	390pF 50V		L3	VR515300	COIL.BIAS	105KHz
	C131	VF467300	C.CE.TUBLR	0.01uF 16V		L7	GE200510	COIL.MPX	
	C132	VF467000	C.CE.TUBLR	1000pF 50V		L8	GE200510	COIL.MPX	
	C133	UA653100	C.MYLAR	1000pF 50V		PJ1	VT029100	JACK.PIN	4P
	C134	UA653100	C.MYLAR	1000pF 50V		Q1	VG722000	TR.DGT	DTC144ES
	C151	VG278800	C.CE.TUBLR	560pF 50V(UC)		Q2	VG722000	TR.DGT	DTC144ES
	D1	VD631600	DIODE	1SS133,176,HSS104		Q3	iC174020	TR	2SC1740S R,S
	D2	VD631600	DIODE	1SS133,176,HSS104		Q4	iC174020	TR	2SC1740S R,S
	D3	VM975900	DIODE.ZENR	HZS162TD 16V	△	Q5	VE613300	TR	2SB1237 Q,R
	D4	VD631600	DIODE	1SS133,176,HSS104	△	Q6	VE613300	TR	2SB1237 Q,R
	D5	VD631600	DIODE	1SS133,176,HSS104		Q9	VD678700	TR.DGT	DTC114ES
	D6	VD631600	DIODE	1SS133,176,HSS104		Q10	VD678700	TR.DGT	DTC114ES
	D7	VD631600	DIODE	1SS133,176,HSS104	△	Q11	VE613400	TR	2SD1858 Q,R
	D8	VD631600	DIODE	1SS133,176,HSS104		Q12	VD678700	TR.DGT	DTC114ES
	D9	VD631600	DIODE	1SS133,176,HSS104		Q13	iA093320	TR	2SA933S Q,R
	D10	VD631600	DIODE	1SS133,176,HSS104		Q14	VD678700	TR.DGT	DTC114ES
	D11	VD631600	DIODE	1SS133,176,HSS104	△	Q15	VE613300	TR	2SB1237 Q,R
	D12	VD631600	DIODE	1SS133,176,HSS104		Q16	iA093320	TR	2SA933S Q,R
	D13	VD631600	DIODE	1SS133,176,HSS104		Q17	VD678700	TR.DGT	DTC114ES
	D14	VD631600	DIODE	1SS133,176,HSS104	△	Q18	VE613300	TR	2SB1237 Q,R
	D15	VD631600	DIODE	1SS133,176,HSS104		Q24	VD678700	TR.DGT	DTC114ES
	D16	VM975800	DIODE.ZENR	HZS152TD 15V		Q25	VG722000	TR.DGT	DTC144ES
	D17	VD631600	DIODE	1SS133,176,HSS104		Q26	VD678700	TR.DGT	DTC114ES

* New Parts

* New Parts

KX-W421 MAIN P.C.B. & OPERATION P. C. B.

Schm Ref	PART NO.	Description		
Q27	VG722000	TR.DGT	DTC144ES	
Q28	VD678700	TR.DGT	DTC114ES	
Q29	iE101280	FET	2SK105 F,H	
Q30	iE101280	FET	2SK105 F,H	
Q39	VD488500	TR.DGT	DTC143XS	
Q40	VD678500	TR.DGT	DTA114ES	
Q43	iC174020	TR	2SC1740S R,S	
Q44	iA093320	TR	2SA933S Q,R	
Q46	iC174020	TR	2SC1740S R,S	
Q47	iC174020	TR	2SC1740S R,S	
Q48	VD678700	TR.DGT	DTC114ES	
△ Q49	VS883400	TR	2SD2394 E,F	
Q50	VE613400	TR	2SD1858 Q,R	
Q51	VE613400	TR	2SD1858 Q,R	
△ Q52	VE613300	TR	2SB1237 Q,R	
Q56	VG722000	TR.DGT	DTC144ES	
Q57	VK432900	TR	2SD1915F S,T	
Q58	VK432900	TR	2SD1915F S,T	
Q59	VG722000	TR.DGT	DTC144ES	
Q60	VG722000	TR.DGT	DTC144ES	
Q61	VG722000	TR.DGT	DTC144ES	
Q62	VG722000	TR.DGT	DTC144ES	
Q63	VG722000	TR.DGT	DTC144ES	
△ R12	HV753820	R.CAR.FP	8.2Ω	1/4W
△ R39	VK187000	R.FUS	22Ω	1/4W
△ R40	HV454220	R.CAR.FP	22Ω	1/4W
△ R129	VE009700	R.FUS	4.7Ω	1/4W
△ R141	HV455100	R.CAR.FP	100Ω	1/4W
△ R142	HV455100	R.CAR.FP	100Ω	1/4W
SW1	VG388100	VOLT.SELCT	HXW0244-01-080(R)	
△ T1	XR465A00	TRANS.PWR	(UC)	
△ T1	XR466A00	TRANS.PWR	(R)	
△ T1	XR467A00	TRANS.PWR	(A)	
△ T1	XR468A00	TRANS.PWR	(BG)	
△ T1	XR468A00	TRANS.PWR		
VR1	VJ693200	VR.TRIM	B2.2KΩ	
VR2	VJ693200	VR.TRIM	B2.2KΩ	
VR3	VJ693600	VR.TRIM	B10KΩ	
VR4	VJ693600	VR.TRIM	B10KΩ	
VR5	VJ693000	VR.TRIM	B1KΩ	
VR6	VJ693000	VR.TRIM	B1KΩ	
VR7	VJ694200	VR.TRIM	B100KΩ	
VR8	VJ694200	VR.TRIM	B100KΩ	
VR11	VJ693600	VR.TRIM	B10KΩ	
VR12	VJ693600	VR.TRIM	B10KΩ	
VR13	VJ693600	VR.TRIM	B10KΩ	
VR14	VJ693600	VR.TRIM	B10KΩ	
VR15	VJ693600	VR.TRIM	B10KΩ	
VR16	VJ693600	VR.TRIM	B10KΩ	
VR17	VT738900	VR	B100KΩ	
VR18	VT738800	VR	A50KΩ	
VR19	VT738700	VR	B100KΩ	
XL1	VE906000	RSNR.CE	4MHz	

* New Parts

Schm Ref	PART NO.	Description		
	VB966900	CN	IMSA-6024	
	VR506800	HEAT.SINK	PUH16-25	
	ED330066	SCR.BND.HD	3x6	FCRM3-BL
*	VZ785400	P.C.B.	OPERATION	
CB302	VQ046000	CN.BS.PIN	31P	
CB304	Vi878200	CN.BS.PIN	4P	
CB306	Vi878200	CN.BS.PIN	4P	
C301	VF467000	C.CE.TUBLR	1000pF	50V
C302	VF467000	C.CE.TUBLR	1000pF	50V
C303	VF467000	C.CE.TUBLR	1000pF	50V
C304	VF467000	C.CE.TUBLR	1000pF	50V
C305	VF467000	C.CE.TUBLR	1000pF	50V
C306	VF467000	C.CE.TUBLR	1000pF	50V
C307	VJ836900	C.EL	10uF	16V
D301	VD631600	DIODE	1SS133,176,HSS104	
D302	VD631600	DIODE	1SS133,176,HSS104	
D303	VD631600	DIODE	1SS133,176,HSS104	
D304	VD631600	DIODE	1SS133,176,HSS104	
D305	VD631600	DIODE	1SS133,176,HSS104	
D306	VD631600	DIODE	1SS133,176,HSS104	
D307	VD631600	DIODE	1SS133,176,HSS104	
D308	VD631600	DIODE	1SS133,176,HSS104	
SW301	VG392900	SW.TACT	SKHVAA	
SW302	VG392900	SW.TACT	SKHVAA	
SW303	VG392900	SW.TACT	SKHVAA	
SW306	VG392900	SW.TACT	SKHVAA	
SW307	VG392900	SW.TACT	SKHVAA	
SW308	VG392900	SW.TACT	SKHVAA	
SW309	VG392900	SW.TACT	SKHVAA	
SW310	VG392900	SW.TACT	SKHVAA	
SW311	VG392900	SW.TACT	SKHVAA	
SW312	VG392900	SW.TACT	SKHVAA	
SW313	VG392900	SW.TACT	SKHVAA	
SW314	VG392900	SW.TACT	SKHVAA	
SW315	VG392900	SW.TACT	SKHVAA	
SW316	VG392900	SW.TACT	SKHVAA	
SW317	VG392900	SW.TACT	SKHVAA	
SW318	VG392900	SW.TACT	SKHVAA	
SW320	VG392900	SW.TACT	SKHVAA	
SW321	VG392900	SW.TACT	SKHVAA	
SW325	VG392900	SW.TACT	SKHVAA	
SW326	VG392900	SW.TACT	SKHVAA	
U301	VU591000	L.DTCT	GP1U271X	
V301	VU038000	FL.DSPLY	BJ416GK	
	VB966900	CN	IMSA-6024	
	VQ948800	SHEET	FL	
	VQ948200	SPACER	FL	

* New Parts

KX-W321/K-903 MAIN P.C.B.

Schm Ref	PART NO.	Description		
	VU210400	P.C.B.	MAIN(UO)	
	VU210500	P.C.B.	MAIN(RT)	
	VU210600	P.C.B.	MAIN(A)	
	VU210700	P.C.B.	MAIN(BG)	
CB1	VD004600	CN.BS.PIN	3P	
CB2	VD005000	CN.BS.PIN	7P	
CB3	Vi878800	CN.BS.PIN	10P	
CB4	Vi879100	CN.BS.PIN	13P	
CB6	VD004800	CN.BS.PIN	5P	
CB7	VQ048000	CN.BS.PIN	31P	
CB8	Vi878300	CN.BS.PIN	5P	
CB9	VK024700	CN.BS.PIN	3P	
CB10	Vi878100	CN.BS.PIN	3P	
CB12	Vi878300	CN.BS.PIN	5P	
CB13	VG879900	CN.BS.PIN	2P	
C1	UA652390	C.MYLAR	390pF	50V
C2	UA652390	C.MYLAR	390pF	50V
C6	UA652390	C.MYLAR	390pF	50V
C7	UA652390	C.MYLAR	390pF	50V
C14	VF760000	C.EL	100uF	10V
C15	UA653820	C.MYLAR	8200pF	50V
C16	UA653820	C.MYLAR	8200pF	50V
C17	VF760000	C.EL	100uF	10V
C18	VF466800	C.CE.TUBLR	100pF	50V
C31	VF964800	C.EL	100uF	16V
C32	UA654270	C.MYLAR	0.027uF	50V
C33	VF964800	C.EL	100uF	16V
C34	UA654270	C.MYLAR	0.027uF	50V
C45	VS204800	C.PP	100pF	100V
C46	VS204800	C.PP	100pF	100V
C47	UT653820	C.PP	8200pF	100V
C48	VF467300	C.CE.TUBLR	0.01uF	16V
C49	UR848100	C.EL	100uF	25V
C50	UA653100	C.MYLAR	1000pF	50V
C51	UR847470	C.EL	47uF	25V
C52	UA653470	C.MYLAR	4700pF	50V
C53	UR847100	C.EL	10uF	25V
C54	VJ839100	C.EL	1uF	50V
C55	VJ839100	C.EL	1uF	50V
C56	UR847100	C.EL	10uF	25V
C57	VF467300	C.CE.TUBLR	0.01uF	16V
C58	VT180400	C.EL	4700uF	5.5V
C59	UR865220	C.EL	0.22uF	50V
C60	VJ839100	C.EL	1uF	50V
C61	UR847100	C.EL	10uF	25V
C62	UR847100	C.EL	10uF	25V
* C63	UR739470	C.EL	4700uF	16V
C64	VJ839100	C.EL	1uF	50V
C65	VG278400	C.CE.TUBLR	220pF	50V
C66	VG278400	C.CE.TUBLR	220pF	50V
C67	VJ839100	C.EL	1uF	50V
C68	VF964800	C.EL	100uF	16V
C69	UR858220	C.EL	220uF	35V

* New Parts

Schm Ref	PART NO.	Description		
C70	VJ839100	C.EL	1uF	50V
C71	VJ839100	C.EL	1uF	50V
C72	VJ839100	C.EL	1uF	50V
C73	UR847100	C.EL	10uF	25V
C74	UR857220	C.EL	22uF	35V
C75	UR847470	C.EL	47uF	25V
C76	UA653220	C.MYLAR	2200pF	50V
C77	UA653220	C.MYLAR	2200pF	50V
C78	UA655100	C.MYLAR	0.1uF	50V
C79	UA653220	C.MYLAR	2200pF	50V
C80	UA655100	C.MYLAR	0.1uF	50V
C81	UR847100	C.EL	10uF	25V
C82	UA653220	C.MYLAR	2200pF	50V
C83	UA655100	C.MYLAR	0.1uF	50V
C84	UA653220	C.MYLAR	2200pF	50V
C85	UA653220	C.MYLAR	2200pF	50V
C86	UA655100	C.MYLAR	0.1uF	50V
C87	UR866220	C.EL	2.2uF	50V
C89	UR857100	C.EL	10uF	35V
* C90	UR758470	C.EL	470uF	35V
C91	UR847100	C.EL	10uF	25V
C92	UA653300	C.MYLAR	3000pF	50V
C93	UR847100	C.EL	10uF	25V
C94	UR865470	C.EL	0.47uF	50V
C95	UR847100	C.EL	10uF	25V
C96	UR865470	C.EL	0.47uF	50V
C97	UA653300	C.MYLAR	3000pF	50V
* C98	UR758470	C.EL	470uF	35V
C99	UR858220	C.EL	220uF	35V
C100	UR866220	C.EL	2.2uF	50V
C101	FG214100	C.CE	0.01uF	50V
C102	FG214100	C.CE	0.01uF	50V
* C103	UR846470	C.EL	4.7uF	25V
* C104	UR846470	C.EL	4.7uF	25V
C105	VG278600	C.CE.TUBLR	330pF	50V
C106	VG278600	C.CE.TUBLR	330pF	50V
* C107	UR846470	C.EL	4.7uF	25V
* C108	UR846470	C.EL	4.7uF	25V
C109	UR848100	C.EL	100uF	25V
C110	UJ865680	C.EL	0.68uF	50V
C111	UR847100	C.EL	10uF	25V
C112	UJ865680	C.EL	0.68uF	50V
C113	UR847100	C.EL	10uF	25V
C114	VG277000	C.CE.TUBLR	33pF	50V
* C115	UR846470	C.EL	4.7uF	25V
C116	UR847100	C.EL	10uF	25V
* C117	UR846470	C.EL	4.7uF	25V
C118	VG277000	C.CE.TUBLR	33pF	50V
C119	UR847100	C.EL	10uF	25V
C120	UR866220	C.EL	2.2uF	50V
* C121	UR847330	C.EL	33uF	25V
C122	VF467300	C.CE.TUBLR	0.01uF	16V
C123	VF467300	C.CE.TUBLR	0.01uF	16V

* New Parts

KX-W321/K-903 MAIN P.C.B.

Schm Ref	PART NO.	Description		
* C124	UR847330	C.EL	33uF	25V
C125	UR866220	C.EL	2.2uF	50V
C126	UR847100	C.EL	10uF	25V
C127	VG279100	C.CE.TUBLR	1200pF	16V
C128	VG279100	C.CE.TUBLR	1200pF	16V
C129	VG278700	C.CE.TUBLR	390pF	50V
C130	VG278700	C.CE.TUBLR	390pF	50V
C131	VF467300	C.CE.TUBLR	0.01uF	16V
C132	VF467000	C.CE.TUBLR	1000pF	50V
C151	VG278800	C.CE.TUBLR	560pF	50V(UC)
D1	VD631600	DIODE	1SS133,176,HSS104	
D2	VD631600	DIODE	1SS133,176,HSS104	
D4	VD631600	DIODE	1SS133,176,HSS104	
D5	VD631600	DIODE	1SS133,176,HSS104	
D6	VD631600	DIODE	1SS133,176,HSS104	
D7	VD631600	DIODE	1SS133,176,HSS104	
D8	VD631600	DIODE	1SS133,176,HSS104	
D9	VD631600	DIODE	1SS133,176,HSS104	
D10	VD631600	DIODE	1SS133,176,HSS104	
D11	VD631600	DIODE	1SS133,176,HSS104	
D12	VD631600	DIODE	1SS133,176,HSS104	
D13	VD631600	DIODE	1SS133,176,HSS104	
D14	VD631600	DIODE	1SS133,176,HSS104	
D15	VD631600	DIODE	1SS133,176,HSS104	
D16	VM975800	DIODE.ZENR	HZS152TD	15V
D17	VD631600	DIODE	1SS133,176,HSS104	
D18	VM973700	DIODE.ZENR	HZS4A2TD	4.0V
△ D19	VS997800	DIODE	1T2	
D20	VM976200	DIODE.ZENR	HZS222TD	22V
△ D21	VS997800	DIODE	1T2	
D22	VD631600	DIODE	1SS133,176,HSS104	
D23	VM974100	DIODE.ZENR	HZS5B2TD	5.0V
D25	VD631600	DIODE	1SS133,176,HSS104	
D26	VD631600	DIODE	1SS133,176,HSS104	
△ D27	VS997800	DIODE	1T2	
△ D28	VS997800	DIODE	1T2	
△ D29	VS997800	DIODE	1T2	
△ D30	VS997800	DIODE	1T2	
Fi1	GE900780	COIL.BIAS	105KHz	
Fi2	GE900780	COIL.BIAS	105KHz	
Fi3	GE900780	COIL.BIAS	105KHz	
Fi4	GE900780	COIL.BIAS	105KHz	
IC1	XD864A00	IC	uPC1330HA	
IC2	XF870A00	IC	LA3246	
IC5	XR635C00	IC	M38172M4-176FP CPU	
△ IC6	XA507A00	IC	AN78N05	
IC7	XH741A00	IC	HA12142NT	
IC8	XK202A00	IC	CXA1578P	
IC9	XM922A00	IC	NJM4558L	
IC10	IG074900	IC	BA6138	
IC11	XP265A00	IC	BU2090	
JK1	VS899700	JACK.PHONE	JY-6317-02-030	
L4	VM547800	COIL.BIAS	105KHz	

* New Parts

Schm Ref	PART NO.	Description	
L7	GE200510	COIL.MPX	
L8	GE200510	COIL.MPX	
PJ1	VT029100	JACK.PIN	4P
△ Q5	VE613300	TR	2SB1237 Q,R
△ Q6	VE613300	TR	2SB1237 Q,R
Q13	iA093320	TR	2SA933S Q,R
Q14	VD678700	TR.DGT	DTC114ES
△ Q15	VE613300	TR	2SB1237 Q,R
Q16	iA093320	TR	2SA933S Q,R
Q17	VD678700	TR.DGT	DTC114ES
△ Q18	VE613300	TR	2SB1237 Q,R
△ Q21	VE613400	TR	2SD1858 Q,R
Q22	VD678700	TR.DGT	DTC114ES
Q23	iC174020	TR	2SC1740S R,S
Q24	VD678700	TR.DGT	DTC114ES
Q25	VG722000	TR.DGT	DTC144ES
Q26	VD678700	TR.DGT	DTC114ES
Q27	VG722000	TR.DGT	DTC144ES
Q28	VD678700	TR.DGT	DTC114ES
Q32	iC174020	TR	2SC1740S R,S
Q33	VG722000	TR.DGT	DTC144ES
Q34	VG722000	TR.DGT	DTC144ES
Q39	VD488500	TR.DGT	DTC143XS
Q40	VD678500	TR.DGT	DTA114ES
Q43	iC174020	TR	2SC1740S R,S
Q44	iA093320	TR	2SA933S Q,R
Q46	iC174020	TR	2SC1740S R,S
Q47	iC174020	TR	2SC1740S R,S
Q48	VD678700	TR.DGT	DTC114ES
△ Q49	VS883400	TR	2SD2394 E,F
Q50	VE613400	TR	2SD1858 Q,R
Q51	VE613400	TR	2SD1858 Q,R
△ Q52	VE613300	TR	2SB1237 Q,R
Q56	VG722000	TR.DGT	DTC144ES
Q57	VK432900	TR	2SD1915F S,T
Q58	VK432900	TR	2SD1915F S,T
Q59	VG722000	TR.DGT	DTC144ES
Q60	VG722000	TR.DGT	DTC144ES
Q61	VG722000	TR.DGT	DTC144ES
Q62	VG722000	TR.DGT	DTC144ES
Q63	VG722000	TR.DGT	DTC144ES
△ R39	VK187000	R.FUS	22Ω 1/4W
△ R40	HV454220	R.CAR.FP	22Ω 1/4W
△ R88	HV453560	R.CAR.FP	5.6Ω 1/4W
△ R129	VE009700	R.FUS	4.7Ω 1/4W
△ R141	HV455100	R.CAR.FP	100Ω 1/4W
△ R142	HV455100	R.CAR.FP	100Ω 1/4W
SW1	VG388100	VOLT.SELCT	HXW0244-01-080(RT)
△ T1	XR465A00	TRANS.PWR	(UC)
△ T1	XR466A00	TRANS.PWR	(RT)
△ T1	XR467A00	TRANS.PWR	(A)
△ T1	XR468A00	TRANS.PWR	(BG)
VR1	VJ693200	VR.TRIM	B2.2KΩ

* New Parts

KX-W321/K-903 MAIN P.C.B. & OPERATION P. C. B.

Schm Ref	PART NO.	Description	
VR2	VJ693200	VR.TRIM	B2.2KΩ
VR5	VJ693000	VR.TRIM	B1KΩ
VR6	VJ693000	VR.TRIM	B1KΩ
VR9	VJ694300	VR.TRIM	B150KΩ
VR10	VJ694300	VR.TRIM	B150KΩ
VR11	VJ693600	VR.TRIM	B10KΩ
VR12	VJ693600	VR.TRIM	B10KΩ
VR13	VJ693600	VR.TRIM	B10KΩ
VR14	VJ693600	VR.TRIM	B10KΩ
VR15	VJ693600	VR.TRIM	B10KΩ
VR16	VJ693600	VR.TRIM	B10KΩ
VR18	VT738800	VR	A50KΩ
XL1	VE906000	RSNR.CE	4MHz
	VB966900	CN	IMSA-6024
	VR506800	HEAT,SINK	PUH16-25
	ED330066	SCR.BND.HD	3x6 FCRM3-BL
*	VZ785400	P.C.B.	OPERATION
CB302	VQ046000	CN.BS.PIN	31P
CB304	Vi878200	CN.BS.PIN	4P
CB306	Vi878200	CN.BS.PIN	4P
C301	VF467000	C.CE.TUBLR	1000pF 50V
C302	VF467000	C.CE.TUBLR	1000pF 50V
C303	VF467000	C.CE.TUBLR	1000pF 50V
C304	VF467000	C.CE.TUBLR	1000pF 50V
C305	VF467000	C.CE.TUBLR	1000pF 50V
C306	VF467000	C.CE.TUBLR	1000pF 50V
C307	VJ836900	C.EL	10uF 16V
D301	VD631600	DIODE	1SS133,176,HSS104
D302	VD631600	DIODE	1SS133,176,HSS104
D303	VD631600	DIODE	1SS133,176,HSS104
D304	VD631600	DIODE	1SS133,176,HSS104
D305	VD631600	DIODE	1SS133,176,HSS104
D306	VD631600	DIODE	1SS133,176,HSS104
D307	VD631600	DIODE	1SS133,176,HSS104
D308	VD631600	DIODE	1SS133,176,HSS104
SW301	VG392900	SW.TACT	SKHVAA
SW302	VG392900	SW.TACT	SKHVAA
SW303	VG392900	SW.TACT	SKHVAA
SW306	VG392900	SW.TACT	SKHVAA
SW307	VG392900	SW.TACT	SKHVAA
SW308	VG392900	SW.TACT	SKHVAA
SW309	VG392900	SW.TACT	SKHVAA
SW310	VG392900	SW.TACT	SKHVAA
SW311	VG392900	SW.TACT	SKHVAA
SW312	VG392900	SW.TACT	SKHVAA
SW313	VG392900	SW.TACT	SKHVAA
SW314	VG392900	SW.TACT	SKHVAA
SW315	VG392900	SW.TACT	SKHVAA
SW316	VG392900	SW.TACT	SKHVAA
SW317	VG392900	SW.TACT	SKHVAA

* New Parts

Schm Ref	PART NO.	Description	
SW318	VG392900	SW.TACT	SKHVAA
SW320	VG392900	SW.TACT	SKHVAA
SW321	VG392900	SW.TACT	SKHVAA
SW325	VG392900	SW.TACT	SKHVAA
SW326	VG392900	SW.TACT	SKHVAA
U301	VU591000	L.DTCT	GP1U271X
V301	VU038000	FL.DSPLY	BJ416GK
	VB966900	CN	IMSA-6024
	VQ948800	SHEET	FL
	VQ948200	SPACER	FL

* New Parts

EXPLODED VIEW (KX-W421)

1
2
3
4
5
6
7

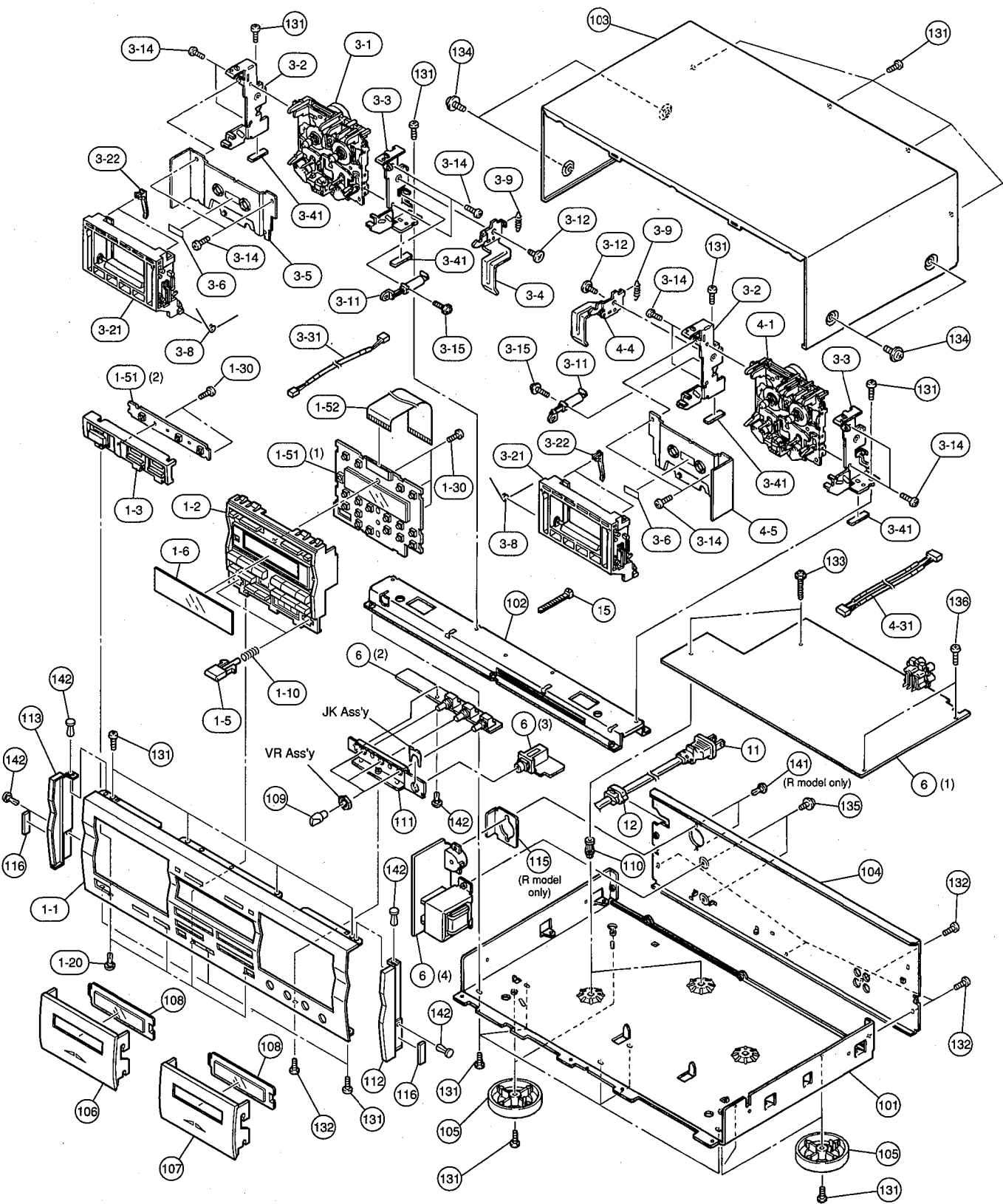

MECHANICAL PARTS (KX-W421)

Ref. No.	PART NO.	Description	Remarks	Markets
* 1-1	VZ442500	FRONT PANEL	BL	
* 1-1	VZ442700	FRONT PANEL	TI	
* 1-2	VZ444000	SUB PANEL	BL	
* 1-2	VZ444100	SUB PANEL	TI	
* 1-3	VZ444400	BUTTON CASE	BL	
* 1-3	VZ444500	BUTTON CASE	TI	
* 1-5	VZ445800	BUTTON, EJ	BL	
* 1-5	VZ445900	BUTTON, EJ	TI	
* 1-6	VZ446600	SHEET, WINDOW		
1-10	VT754700	SPRING		D6.4C
1-20	VQ368500	PUSH RIVET		P3545-B
1-30	EX600310	BIND HEAD P-TITE SCREW		3x8 FCRM3-BL
* 1-51	VZ785400	P.C.B. ASS'Y		OPERATION
1-52	MF131200	FLEXIBLE FLAT CABLE		31P 200mm
3-1	VT880400	CASSETTE DECK MECHANISM		PB(DECK-A)
3-2	VZ134600	HOLDER L, MECH		
3-3	VZ134700	HOLDER R, MECH		
3-4	VT753200	EJECT LEVER		L
3-5	VT810200	BACK PLATE, L		
3-6	VQ146900	LABEL B.P		
3-8	VT754900	SPRING		EJ
3-9	VU198200	SPRING		LEVER
3-11	VR020600	DAMPER, AIR		FP472-11
3-12	VR020500	SHOULDER SCREW		ST3 D6x4
3-14	VR278600	BIND HEAD S-TITE SCREW		2.6x6 FCRM3-BL
3-15	EK096060	PW HEAD S-TITE SCREW		2.5x12 FCRM3-BL
3-21	VQ860400	CASSETTE HOUSING		
3-22	VM868200	GUIDE, CASSETTE		
3-31	VU161900	CONNECTOR ASS'Y		3P 300mm
3-41	VU591600	DAMPER		6x25
4-1	VS906400	CASSETTE DECK MECHANISM		REC/PB(DECK-B)
4-4	VT753300	EJECT LEVER		R
4-5	VT848200	BACK PLATE, R		
4-31	VR797800	CONNECTOR ASS'Y		7P 100mm
6	VU207100	P.C.B. ASS'Y		MAIN (UC)
6	VU207200	P.C.B. ASS'Y		MAIN (R)
6	VU207300	P.C.B. ASS'Y		MAIN (A)
6	VU207400	P.C.B. ASS'Y		MAIN (BG)
△ 11	VL238100	POWER CORD ASS'Y		(R)
△ 11	VN363700	POWER CORD ASS'Y		(G)
△ 11	VQ508600	POWER CORD ASS'Y		(A)
△ 11	VV437200	POWER CORD ASS'Y		(UC)
△ 11	VV437300	POWER CORD ASS'Y		(B)
12	VN158600	CORD STOPPER		No.2104
15	VU590000	BINDING TIE		CBTD001B
101	VT752300	CHASSIS		
102	VT752400	FRAME, BASE		
* 103	VZ440000	TOP COVER	BL	
* 103	VZ440100	TOP COVER	TI	
* 104	VZ440800	REAR PANEL		(UC)
* 104	VZ440900	REAR PANEL		(R)
* 104	VZ441000	REAR PANEL		(A)
* 104	VZ441100	REAR PANEL		(BG)

* New Parts

Ref. No.	PART NO.	Description	Remarks	Markets
105	VQ780300	LEG		D60xH16
* 106	VZ445200	LID, A	BL	
* 106	VZ445300	LID, A	TI	
* 107	VZ445400	LID, B	BL	
* 107	VZ445500	LID, B	TI	
* 108	VZ446500	WINDOW, LID		
109	VU463400	KNOB, VR K		D10
109	VU463500	KNOB, VR K		D10
110	VU981200	SUPPORT, P.C.B.		No.3596
* 111	VZ440400	BRACKET		VR
* 112	VZ446000	SIDEPLATE, R	BL	
* 112	VZ446100	SIDEPLATE, R	TI	
* 113	VZ446200	SIDEPLATE, L	BL	
* 113	VZ446300	SIDEPLATE, L	TI	
115	VT969100	BARRIER, SW		(R)
116	VS699700	DAMPER		SIDE
131	Ei330086	BIND HEAD B-TITE SCREW		3x8 FCRM3-BL
132	VN413300	BIND HEAD BONDING B-T. SCREW		3x8 MFZN2-BL
133	EX602560	PW HEAD P-TITE SCREW		3x20-8 FCRM3-BL
134	EK365090	PW HEAD S-TITE SCREW	BL	4x8-10 FCRM3-BL
134	EX601150	BW HEAD S-TITE SCREW	TI	4x8-10 FNM3-BL
135	VU081700	PAN W.HEAD TAPPING SCREW		4x6-10 MFZN2-BL
136	VT669300	PW HEAD B-TITE SCREW		3x8-8 MFC2
141	VR101100	PUSH RIVET		P3065-B
142	VQ368500	PUSH RIVET		P3545-B
		ACCESSORIES		
	VY952200	PIN-PLUG CORD		2P 1.0m

* New Parts

1 EXPLODED VIEW (KX-W321/K-903)

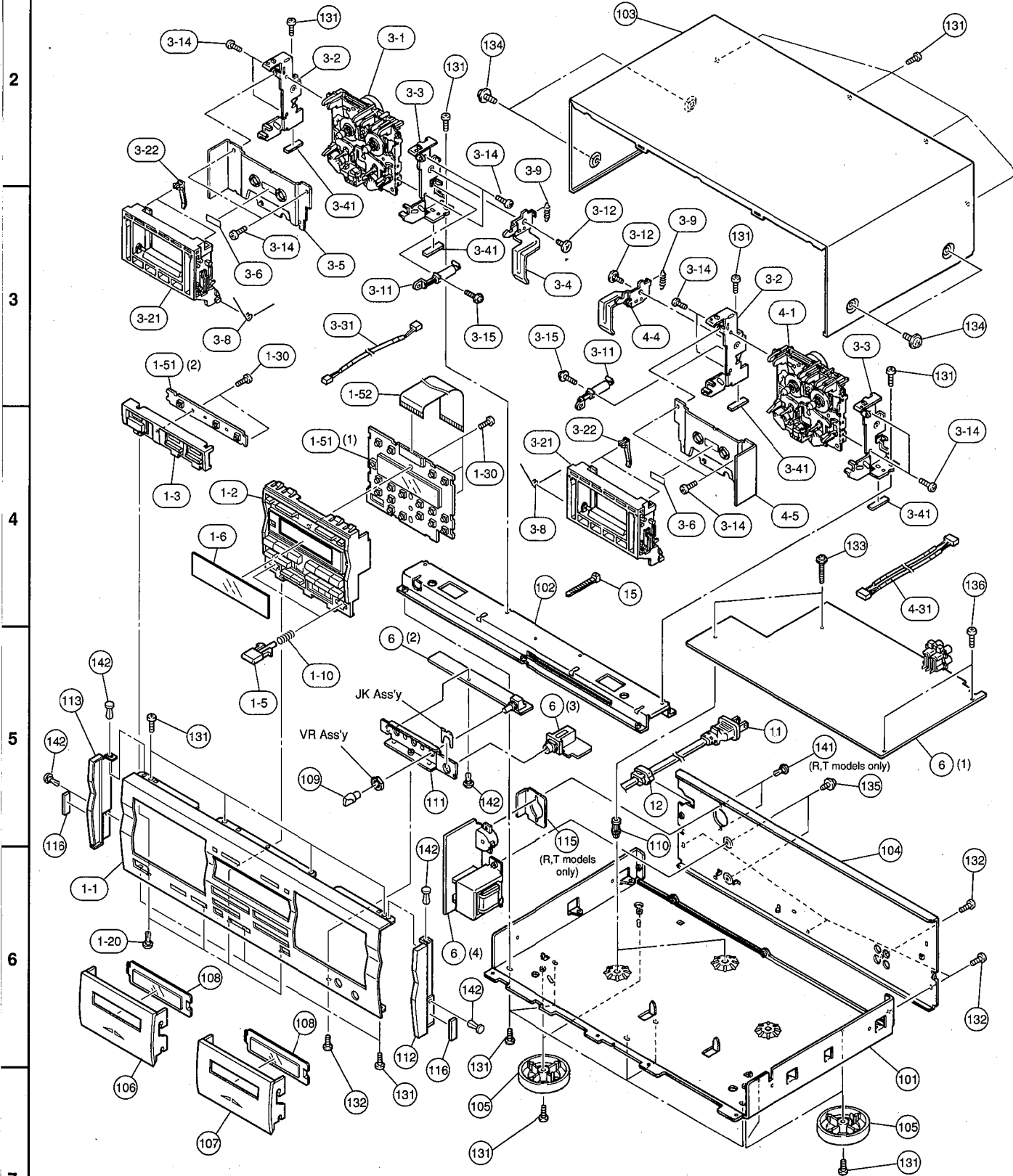

MECHANICAL PARTS (KX-W321/K-903)

Ref. No.	PART NO.	Description	Remarks	Markets
* 1-1	VZ442800	FRONT PANEL	KX-W321 BL	
* 1-1	VZ442900	FRONT PANEL	KX-W321 TI	
* 1-1	VZ443000	FRONT PANEL	K-903	
* 1-2	VZ444000	SUB PANEL	BL	
* 1-2	VZ444100	SUB PANEL	TI	
* 1-3	VZ444400	BUTTON CASE	BL	
* 1-3	VZ444500	BUTTON CASE	TI	
* 1-5	VZ445800	BUTTON, EJ	BL	
* 1-5	VZ445900	BUTTON, EJ	TI	
* 1-6	VZ446600	SHEET, WINDOW		
1-10	VT754700	SPRING	D6.4C	
1-20	VQ368500	PUSH RIVET	P3545-B	
1-30	EX600310	BIND HEAD P-TITE SCREW	3x8 FCRM3-BL	
* 1-51	VZ785400	P.C.B. ASS'Y	OPERATION	
1-52	MF131200	FLEXIBLE FLAT CABLE	31P 200mm	
3-1	VT880400	CASSETTE DECK MECHANISM	PB(DECK-A)	
* 3-2	VZ134600	HOLDER L, MECH		
* 3-3	VZ134700	HOLDER R, MECH		
3-4	VT753200	EJECT LEVER	L	
3-5	VT810200	BACK PLATE, L		
3-6	VQ146900	LABEL B.P		
3-8	VT754900	SPRING	EJ	
3-9	VU198200	SPRING	LEVER	
3-11	VR020600	DAMPER, AIR	FP472-11	
3-12	VR020500	SHOULDER SCREW	ST3 D6x4	
3-14	VR278600	BIND HEAD S-TITE SCREW	2.6x6	FCRM3-BL
3-15	EK096060	PW HEAD S-TITE SCREW	2.5x12	FCRM3-BL
3-21	VQ860400	CASSETTE HOUSING		
3-22	VM868200	GUIDE, CASSETTE		
3-31	VU161900	CONNECTOR ASS'Y	3P 300mm	
3-41	VU591600	DAMPER	6x25	
4-1	VS906400	CASSETTE DECK MECHANISM	REC/PB(DECK-B)	
4-4	VT753300	EJECT LEVER	R	
4-5	VT848200	BACK PLATE, R		
4-31	VR797800	CONNECTOR ASS'Y	7P 100mm	
6	VU210400	P.C.B. ASS'Y	MAIN	(UC)
6	VU210500	P.C.B. ASS'Y	MAIN	(RT)
6	VU210600	P.C.B. ASS'Y	MAIN	(A)
6	VU210700	P.C.B. ASS'Y	MAIN	(G)
△ 11	VL238100	POWER CORD ASS'Y		(R)
△ 11	VN363700	POWER CORD ASS'Y		(G)
△ 11	VQ508600	POWER CORD ASS'Y		(A)
△ 11	VV437200	POWER CORD ASS'Y		(UC)
△ 11	VV437300	POWER CORD ASS'Y		(B)
△* 11	VZ542500	POWER CORD ASS'Y		(T)
12	VN158600	CORD STOPPER	No.2104	
15	VU590000	BINDING TIE	CBTD001B	
101	VT752300	CHASSIS		
102	VT752400	FRAME, BASE		
103	VZ440000	TOP COVER	BL	
* 103	VZ440100	TOP COVER	TI	
* 104	VZ441300	REAR PANEL	KX-W321	(UC)
* 104	VZ441400	REAR PANEL	KX-W321	(RT)

* New Parts

Ref. No.	PART NO.	Description	Remarks	Markets
* 104	VZ441500	REAR PANEL	KX-W321	(A)
* 104	VZ441600	REAR PANEL	KX-W321	(G)
* 104	VZ441700	REAR PANEL	K-903	(UC)
* 104	VZ442000	REAR PANEL	K-903	(A)
105	VQ780300	LEG	D60xH16 KX-W321	
105	VQ982800	LEG	D60xH16 K-903	
* 106	VZ445200	LID, A	KX-W321 BL	
* 106	VZ445300	LID, A	KX-W321 TI	
* 106	VZ701500	LID, A	K-903	
* 107	VZ445400	LID, B	KX-W321 BL	
* 107	VZ445500	LID, B	KX-W321 TI	
* 107	VZ701600	LID, B	K-903	
* 108	VZ446500	WINDOW, LID		
109	VU463400	KNOB, VR K	D10 BL	
109	VU463500	KNOB, VR K	D10 TI	
110	VU981200	SUPPORT, P.C.B.	No.3596	
* 111	VZ440400	BRACKET	VR	
* 112	VZ446000	SIDEPLATE, R	BL	
* 112	VZ446100	SIDEPLATE, R	TI	
* 113	VZ446200	SIDEPLATE, L	BL	
* 113	VZ446300	SIDEPLATE, L	TI	
115	VT969100	BARRIER, SW		(RT)
116	VS699700	DAMPER	SIDE	
131	Ei330086	BIND HEAD B-TITE SCREW	3x8 FCRM3-BL	
132	VN413300	BIND HEAD BONDING B-T. SCREW	3x8 MFZN2-BL	
133	EX602560	PW HEAD P-TITE SCREW	3x20-8 FCRM3-BL	
134	EK365090	PW HEAD S-TITE SCREW	4x8-10 FCRM3-BL	BL
134	EX601150	BW HEAD S-TITE SCREW	4x8-10 FNM3-BL	TI
135	VU081700	PAN W.HEAD TAPPING SCREW	4x6-10 MFZN2-BL	
136	VT669300	PW HEAD B-TITE SCREW	3x8-8 MFC2	
141	VR101100	PUSH RIVET	P3065-B	(RT)
142	VQ368500	PUSH RIVET	P3545-B	
	VY952200	ACCESSORIES PIN-PLUG CORD	2P 1.0m	

* New Parts

1 ■ EXPLODED VIEW (Cassette Deck Mechanism)

● DECK A

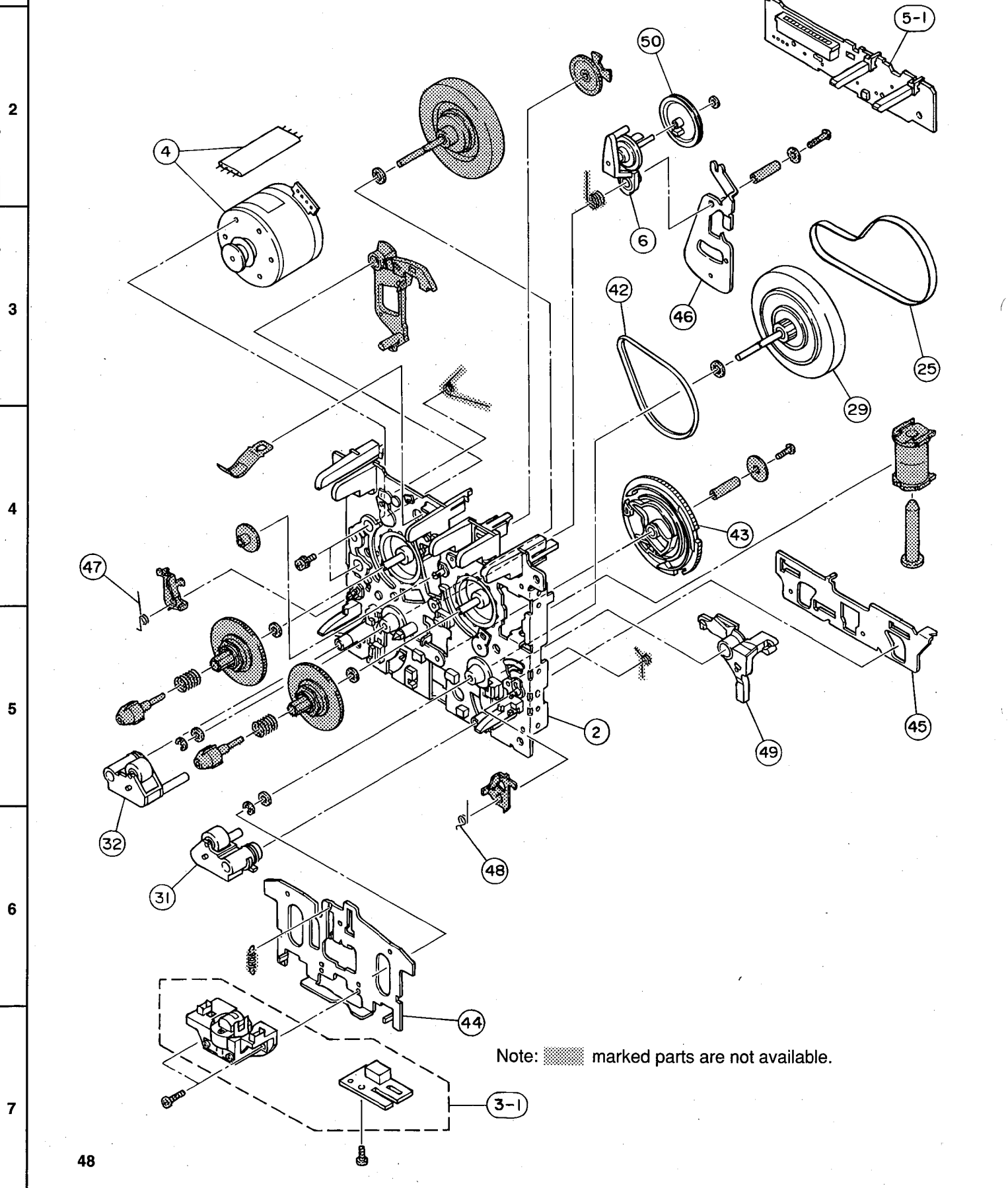

A B C D E

KX-W421
KX-W321/K-903

1 ■ EXPLODED VIEW (Cassette Deck Mechanism)

● DECK B

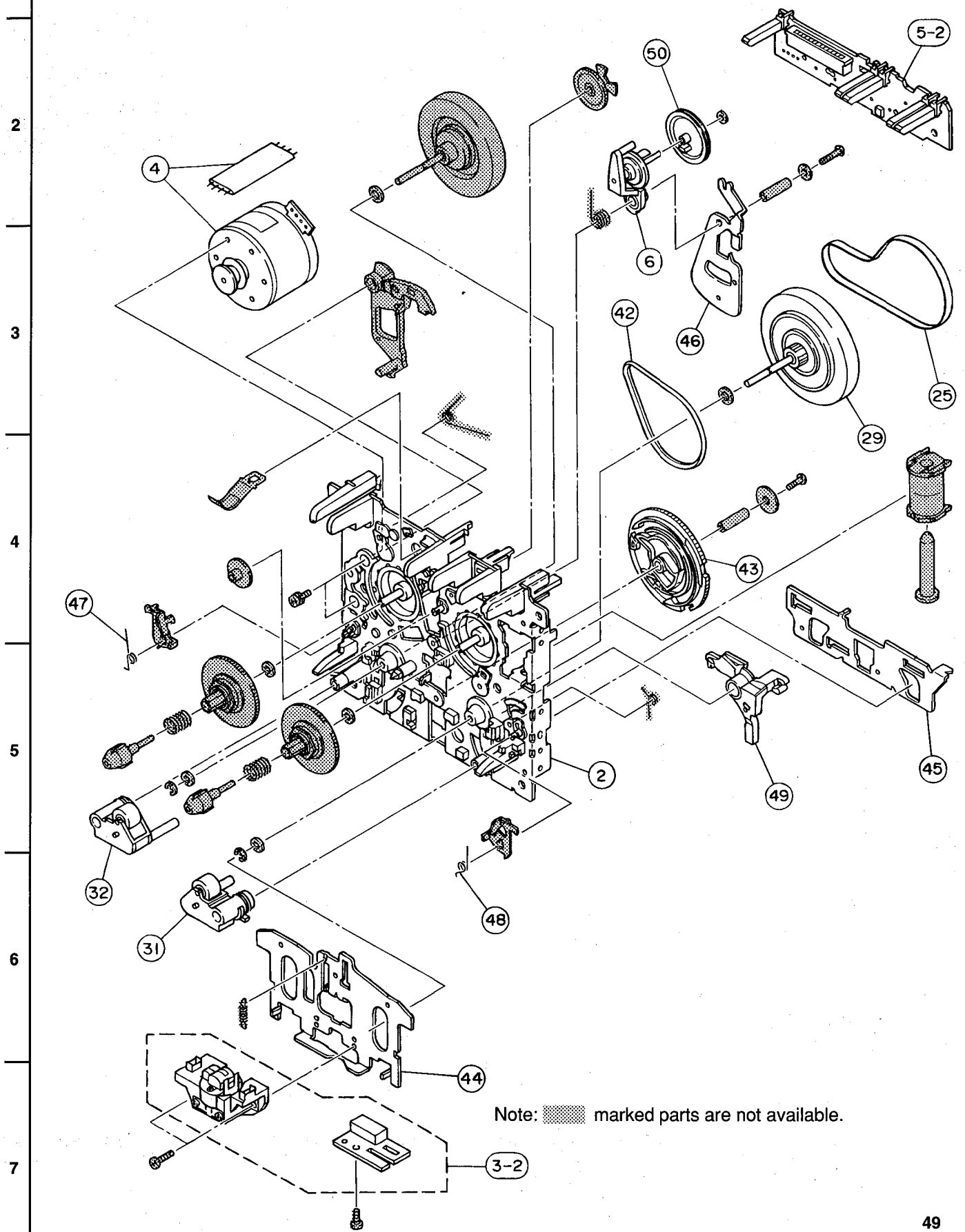

KX-W421
KX-W321/K-903

1 ■ MECHANICAL PARTS (Cassette Deck Mechanism)

Ref. No.	PART NO.	Description	Remarks	Markets
	VT880400	CASSETTE DECK MECHANISM	PB(DECK-A)	
	VS906400	CASSETTE DECK MECHANISM	REC/PB(DECK-B)	
2	NX613010	CHASSIS BASE ASS'Y	F612201	
3-1	GX608560	HEAD PLATE ASS'Y	(DECK-A)	F513718
3-2	GX608570	HEAD PLATE ASS'Y	(DECK-B)	F513719
4	JX601450	MOTOR ASS'Y, MAIN	F525304	
5-1	NX612991	P.C.B. ASS'Y	CONTROL(DECK-A)	F567590
5-2	NX612981	P.C.B. ASS'Y	CONTROL(DECK-B)	F567591
6	NX612971	CLUTCH ASS'Y	F522030	
25	CX672970	BELT, MAIN	FF17G31	
29	NX612960	FLYWHEEL ASS'Y	F522029	
31	NX612930	PINCH ROLLER ASS'Y, R	F514118	
32	NX612940	PINCH ROLLER ASS'Y, L	F514119	
42	CX675180	BELT, F/R	FF18W11	
43	CX677140	CAM, GEAR	FD52Y20	
44	AX622240	HEAD BASE	FC61K18	
45	AX622210	PLATE, SLIDE	FC61L17	
46	CX677130	LEVER	F/R	FC62G12
47	AX622220	SPRING L, INTERLOCK	FK32N11	
48	AX622230	SPRING R, INTERLOCK	FK32P11	
49	AX623590	LOCK LEVER	FD53D19	
50	CX679800	PULLY, CLUTCH	FD53F14	

* New Parts

Parts List for Carbon Resistors

Value	1/4W Type Part No.	1/6W Type Part No.	Value	1/4W Type Part No.	1/6W Type Part No.
1.0 Ω	HJ35 3100	HF85 3100	10 kΩ	HF45 7100	HF45 7100
1.8 Ω	HJ35 3180	*	11 kΩ	HF45 7110	HF45 7110
2.2 Ω	HJ35 3220	HF85 3220	12 kΩ	HJ35 7120	HF85 7120
3.3 Ω	HJ35 3330	HF85 3330	13 kΩ	HF45 7130	HF45 7130
4.7 Ω	HJ35 3470	HF85 3470	15 kΩ	HF45 7150	HF45 7150
5.6 Ω	HJ35 3560	HF85 3560	18 kΩ	HF45 7180	HF45 7180
10 Ω	HF45 4100	HF45 4100	22 kΩ	HF45 7220	HF45 7220
15 Ω	HJ35 4150	HF85 4150	24 kΩ	HF45 7240	HF45 7240
22 Ω	HF45 4220	HF45 4220	27 kΩ	HJ35 7270	HF85 7270
27 Ω	HJ35 4270	HF85 4270	30 kΩ	HF45 7300	HF45 7300
33 Ω	HF45 4330	HF45 4330	33 kΩ	HF45 7330	HF45 7330
39 Ω	HJ35 4390	HF85 4390	36 kΩ	HF45 7360	HF45 7360
47 Ω	HF45 4470	HF45 4470	39 kΩ	HF45 7390	HF45 7390
56 Ω	HF45 4560	HF45 4560	47 kΩ	HF45 7470	HF45 7470
68 Ω	HF45 4680	HF45 4680	51 kΩ	HF45 7510	HF45 7510
75 Ω	HF45 4750	HF45 4750	56 kΩ	HF45 7560	HF45 7560
82 Ω	HF45 4820	HF45 4820	62 kΩ	HF45 7620	HF45 7620
91 Ω	HF45 4910	HF45 4910	68 kΩ	HF45 7680	HF45 7680
100 Ω	HF45 5100	HF45 5100	82 kΩ	HF45 7820	HF45 7820
110 Ω	HJ35 5110	HF85 5110	91 kΩ	HF45 7910	HF45 7910
120 Ω	HF45 5120	HF45 5120	100 kΩ	HF45 8100	HF45 8100
150 Ω	HF45 5150	HF45 5150	110 kΩ	HF45 8110	HF45 8110
160 Ω	HJ35 5160	*	120 kΩ	HF45 8120	HF45 8120
180 Ω	HF45 5180	HF45 5180	150 kΩ	HF45 8150	HF45 8150
200 Ω	HF45 5200	HF45 5200	180 kΩ	HF45 8180	HF45 8180
220 Ω	HF45 5220	HF45 5220	220 kΩ	HJ35 8220	HF85 8220
270 Ω	HF45 5270	HF45 5270	270 kΩ	HF45 8270	HF45 8270
330 Ω	HF45 5330	HF45 5330	300 kΩ	HF45 8300	HF45 8300
390 Ω	HF45 5390	HF45 5390	330 kΩ	HF45 8330	HF45 8330
430 Ω	HF45 5430	HF45 5430	390 kΩ	HJ35 8390	HF85 8390
470 Ω	HF45 5470	HF45 5470	470 kΩ	HF45 8470	HF45 8470
510 Ω	HF45 5510	HF45 5510	560 kΩ	HJ35 8560	HF85 8560
560 Ω	HF45 5560	HF45 5560	680 kΩ	HJ35 8680	HF85 8680
680 Ω	HF45 5680	HF45 5680	820 kΩ	HJ35 8820	HF85 8820
820 Ω	HF45 5820	HF45 5820	1.0 MΩ	HF45 9100	HF45 9100
910 Ω	HF45 5910	HF45 5910	1.2 MΩ	HJ35 9120	*
1.0 kΩ	HF45 6100	HF45 6100	1.5 MΩ	HJ35 9150	HF85 9150
1.2 kΩ	HF45 6120	HF45 6120	1.8 MΩ	HJ35 9180	HF85 9180
1.5 kΩ	HF45 6150	HF45 6150	2.2 MΩ	HJ35 9220	HF85 9220
1.8 kΩ	HF45 6180	HF45 6180	3.3 MΩ	HJ35 9330	HF85 9330
2.0 kΩ	HJ35 6200	HF85 6200	3.9 MΩ	HJ35 9390	*
2.2 kΩ	HF45 6220	HF45 6220	4.7 MΩ	HJ35 9470	HF85 9470
2.4 kΩ	HJ35 6240	HF85 6240			
2.7 kΩ	HF45 6270	HF45 6270			
3.0 kΩ	HF45 6300	HF45 6300			
3.3 kΩ	HF45 6330	HF45 6330			
3.6 kΩ	HJ35 6360	HF85 6360			
3.9 kΩ	HF45 6390	HF45 6390			
4.7 kΩ	HF45 6470	HF45 6470			
5.1 kΩ	HF45 6510	HF45 6510			
5.6 kΩ	HF45 6560	HF45 6560			
6.8 kΩ	HF45 6680	HF45 6680			
8.2 kΩ	HF45 6820	HF45 6820			
9.1 kΩ	HF45 6910	HF45 6910			

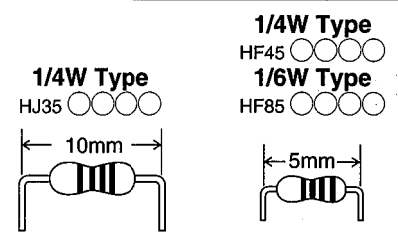

*: Not available

KX-W421/W321/K-903

YAMAHA