

K-950

SERVICE MANUAL

FRONT PANEL

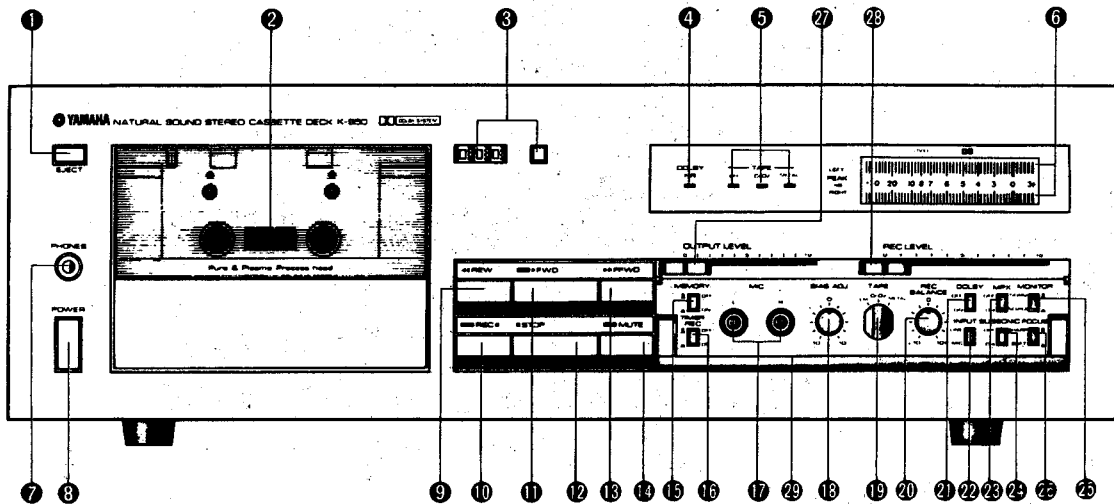

- ① Eject Button (EJECT)
- ② Cassette Compartment
- ③ Tape Counter/Reset Button
- ④ Dolby NR Indicator (DOLBY NR)
- ⑤ Tape Indicators (TAPE)
- ⑥ Bar-graph Peak Level Meters (PEAK)
- ⑦ Headphone Jack (PHONES)
- ⑧ Power Switch (POWER)
- ⑨ Rewind Button (REW ◀)
- ⑩ Record Standby Button (REC ||)
- ⑪ Playback Button (FWD ▶)
- ⑫ Stop Button (STOP ■)
- ⑬ Fast Forward Button (F. FWD ▶▶)
- ⑭ REC Muting Button (MUTE)
- ⑮ Memory Switch (MEMORY)
- ⑯ Timer Recording Button (TIMER REC)
- ⑰ Microphone Jacks, L and R (MIC)
- ⑱ Bias Adjusting Knob (BIAS ADJ)
- ⑲ Tape Selector Switch (TAPE)
- ⑳ REC Balance Control (REC BALANCE)
- ㉑ Dolby NR Switch (DOLBY)
- ㉒ Input Change Over Switch (INPUT)
- ㉓ Multiplex Filter Switch (MPX)
- ㉔ Subsonic Filter Switch (SUBSONIC)
- ㉕ Source Monitor Switch (MONITOR)
- ㉖ Focus Switch (FOCUS)
- ㉗ Output Level Control (OUTPUT LEVEL)
- ㉘ Record Input Level Control (REC LEVEL)
- ㉙ Sealing Panel

CONTENTS

INTERNAL VIEW	1
DISASSEMBLY PROCEDURE	2
OVERALL ADJUSTMENT	4
ADJUSTING POINTS	6
SPECIFICATIONS	7
BLOCK DIAGRAM	7
WIRING	8
SCHEMATIC DIAGRAM	10
IC FUNCTIONAL BLOCK DIAGRAM	11

004401

SINCE 1887



YAMAHA

NIPPON GAKKI CO., LTD. HAMAMATSU, JAPAN

'80. 4. 2.4K K.T Printed in Japan.

INTERNAL VIEW

Top View

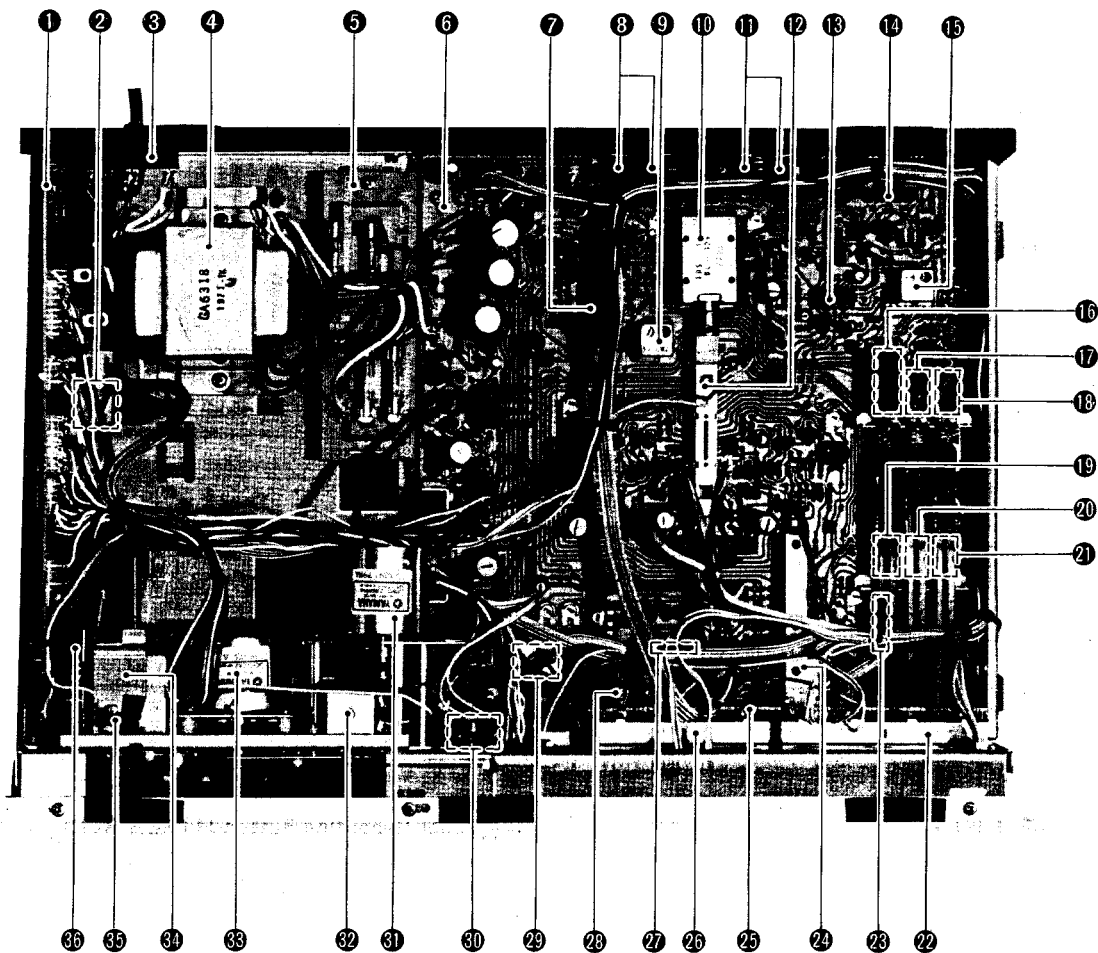

- | | |
|--|---|
| 1 Control C. Board | 17 MPX Switch (SW103-2) |
| 2 Power Switch | 18 MONITOR Switch (SW103-3) |
| 3 Relay Terminal | 19 INPUT Switch (SW104-1) |
| 4 Power Transformer | 20 SUBSONIC Switch (SW104-2) |
| GA63190: U.S. and Canadian Models | 21 FOCUS Switch (SW104-3) |
| GA63200: N. European Model | 22 REC LEVEL Variable Resistor (VR112) |
| GA63220: Australian and British Models | 23 REC Amplifier IC (IC102) |
| GA63210: General Model | 24 TAPE Switch (SW102) |
| 5 REC/PB C. Board-4 | 25 REC/PB C. Board |
| 6 REC/PB C. Board | 26 OUTPUT LEVEL Variable Resistor (VR113) |
| 7 DOLBY IC (IC103) | 27 REC Amplifier IC (IC101) |
| 8 Pin Jack (LINE OUT/PLAY) | 28 REC/PB C. Board-3 |
| 9 MPX Filter (L109) | 29 BIAS OSC IC (IC106) |
| 10 REC/PB Plunger | 30 Hall IC (IC603)/Counter |
| 11 Pin Jack (LIN IN/REC) | 31 Capstan Motor |
| 12 REC/PB Switch (SW101) | 32 Plunger (BRAKE) |
| 13 DOLBY IC (IC104) | 33 Reel Motor |
| 14 Headphone Amplifier IC (IC105) | 34 Plunger (HEAD) |
| 15 MPX Filter (L110) | 35 Microswitch (REC INH) |
| 16 DOLBY NR Switch (SW103-1) | 36 Microswitch (EJECT) |

■ PARTS LIST (All over)

K-950

Ref. No.	Part No.			Description	(部 品 名)	Remarks	Common model	Markets
※ 1	32:01:88	SM:60:06:00	TM-2B Cassette Mechanism	TA-2B総組立				J
※ 2	32:00:00	NB:09:49:60	Front Panel Unit (Silver)	パネルユニット(シルバー)				J
※ "	32:00:00	NB:09:49:70	"	"				R, U, A, G, C, B
※ "	32:00:00	NB:09:50:10	Front Panel Unit (Black)	パネルユニット(ブラック)				J
※ "	32:00:00	NB:09:50:20	"	"				R, U, A, G, C, B
※ 2-1	32:00:00	NB:09:49:80	Sealing Box Ass'y (Silver)	シーリングBox Ass'y	シルバー			
※ "	32:00:00	NB:09:50:30	" (Black)	"	ブラック			
2-1-1	32:00:00	CB:08:82:20	Sealing Box (Silver)	シーリングBox	シルバー	TC-920		
"	32:00:00	CB:08:87:20	" (Black)	"	ブラック	TC-920B		
2-1-2	32:00:00	CB:08:82:10	Door Lever (Silver)	ドアレバー	シルバー	TC-920		
"	32:00:00	CB:08:87:10	" (Black)	"	ブラック	TC-920B		
2-1-3	32:00:00	CB:08:82:80	Slider	スライダー				
※ 2-1-4	32:00:00	CB:09:22:10	Push Button (Silver)	Pushボタン	シルバー	TC-920		
※ "	32:00:00	CB:09:22:20	" (Black)	"	ブラック	TC-920B		
2-1-5	42:00:00	CB:07:41:90	Tape 5×100m	セキスイダブルタックテープ	1m当り単価			
※ 2-1-6	32:00:00	BA:07:81:40	Box Panel (Silver)	Boxパネル	シルバー			
※ "	32:00:00	BA:07:81:70	" (Black)	"	ブラック			
2-1-7	32:00:00	BA:07:43:00	VR Panel	VRパネル	シルバー	TC-920		
※ "	32:00:00	BA:07:46:20	Panel	"	ブラック	TC-920B		
2-1-8	32:00:00	BA:07:43:10	Sealing Panel (Silver)	シーリングパネル	シルバー	TC-920		
"	32:00:00	BA:07:46:30	" (Black)	"	ブラック	TC-920B		
2-1-9	32:00:00	AA:09:43:10	Shaft For Variabl Resister	VRシャフト		TC-920		
2-1-10	32:00:00	AA:09:51:90	Spring (Push Button)	Pushスプリング				
2-1-11	42:00:00	ED:03:00:60	Bind Head Screw 3×6 (ZMC2-Y)	バインド小ネジ				
2-2	42:00:00	KA:90:09:50	Operation Switch Ass'y (Silver)	操作スイッチAss'y	シルバー	TC-920		
"	42:00:00	KA:90:09:90	" (Black)	"	ブラック	TC-920B		
※ 2-3	32:00:00	BA:07:45:40	Operation Panel A (Silver)	操作パネルA	シルバー	TC-920		
※ "	32:00:00	BA:07:46:60	" (Black)	"	ブラック	TC-920B		
※ 2-4	32:00:00	BA:07:45:50	Operation Panel B (Silver)	操作パネルB	シルバー	TC-920		
※ "	32:00:00	BA:07:46:70	" (Black)	"	ブラック	TC-920B		
2-5	32:00:00	CB:08:82:30	Slide Knob (Silver)	スライドつまみ	シルバー	TC-920		
"	32:00:00	CB:08:87:30	" (Black)	"	ブラック	TC-920B		
2-6	32:00:00	CB:08:82:40	Button Guide (E-Type) (Silver)	ボタンガイドE	シルバー	TC-920		
"	32:00:00	CB:08:87:40	" (Black)	"	ブラック	TC-920B		
2-7	32:00:00	CB:08:82:90	Button Guide (P-Type) (Silver)	ボタンガイドP	シルバー	TC-920		
"	32:00:00	CB:08:87:60	" (Black)	"	ブラック	TC-920B		
※ 2-8	32:00:00	CB:09:61:20	Meter Panel	メーターパネル				
2-9	32:00:00	CB:08:13:20	Stopper For Spring	バネストッパー		TC-1000		
2-10	32:00:00	CB:08:13:30	Button EJECT (Silver)	エジェクトボタン	シルバー	TC-1000		
"	32:00:00	CB:08:77:10	" (Black)	"	ブラック	TC-920B		
※ 2-11	42:00:00	CB:09:04:80	Filter	フィルター				
※ 2-12	42:00:00	CB:07:41:90	Tape 5×30	セキスイダブルタックテープ	1m当り単価			
※ 2-13	42:00:00	CB:07:41:90	" 5×80	"	"			
2-14	42:00:00	CB:07:42:00	" 10×20	"	"			
※ 2-15	42:00:00	CB:09:80:40	Tape For Contorol Panel	操作パネル接着紙				
2-16	32:00:00	AA:08:79:10	Spring	ブッシュスプリング		TC-1000		
2-17	42:00:00	ED:03:00:50	Bind Head Screw 3×5S(ZMC2-Y)	バインド小ネジ				
※ 3	32:00:00	NB:09:49:90	Cassette Lid Unit (Silver)	カセット蓋ユニット	シルバー			
※ "	32:00:00	NB:09:50:40	" (Black)	"	ブラック			
※ 3-1	42:00:00	EB:03:00:60	Flat Head Screw 3×6 (ZMC2-Y)	皿小ネジ				
※ 3-2	32:00:00	CB:09:61:30	Plate	ガラス受板				
4	32:00:00	AA:09:43:60	Bottom Cover	ボトムカバー		TC-920		
5	32:00:00	CB:08:03:50	Leg	脚				

※ : New Part (新部品)

DESTINATION ABBREVIATIONS

J; Japan, R; General, U; U. S. A., C; Canadian, B; British, G; North European, A; Australian

Ref. No.	Part No.		Description	(部 品 名)	Remarks	Common model	Markets
6	32:00:00	NA 07 21:00	Control C Board	コントロールシート		TC-920	
* 7	32:00:00	NA 07 41:50	REC/PB C-Board (J.R.A)	録再シート			J, R, A
* "	32:00:00	NA 07 41:60	" (G. B)	"			G, B
* "	32:00:00	NA 07 41:70	" (U, C)	"			U, C
8	42:00:00	LB 30 08:80	MIC Jack (Silver)	マイクジャック	シルバー	TC-920	
"	42:00:00	LB 30 09:30	" (Black)	"	ブラック	TC-920B	
9	42:00:00	LB 30 08:90	Head Phone Jack (Silver)	ヘッドホンジャック	シルバー		
"	42:00:00	LB 30 09:40	" (Black)	"	ブラック		
* 10	42:00:00	KA 80 14:70	Power Switch J-P3050 120V 3A	電源プッシュスイッチ			J, R
"	42:00:00	KA 80 05:00	" SDG1P 125V 5A	"			U, C
"	42:00:00	KA 80 05:10	" SDG5P-E 250V 5/80A	"			A, G, B
11	42:00:00	FZ 00 20:30	Ceramic Capacitor 250VAC 0.01 μ F	セラコン			J, R, U
"	42:00:00	FZ 00 15:60	Spark Killer ECN-C4A,450VC,0.01 μ F	スパークキラーコン			A, G, B
12	42:00:00	CB 09 52:60	Cover For Capacitor SB-0833	コンデンサカバー、丸型			J, R, U, C
"	42:00:00	CB 08 86:90	" SB-0866	" 角型			A, G, B
13	32:00:00	AA 09 54:60	Switch Bracket	SWブラケット			
14	42:00:00	ED 03 00:40	Bind Head Screw 3 \times 4 (ZMC2-Y)	バインド小ネジ			
* 15	42:00:00	GA 63 18:10	Power Transformer	電源トランス			J
* "	42:00:00	GA 63 19:00	"	"			U, C
* "	42:00:00	GA 63 20:00	"	"			G
* "	42:00:00	GA 63 22:00	"	"			A, B
* 15-1	42:00:00	GA 63 21:00	"	"			R,
15-2	42:00:00	LB 20 02:60	Voltage Selector	電圧切換器			R
15-3	42:00:00	LB 20 12:10	Fuse Holder 1PFH	ヒューズホルダー			R
16	42:00:00	MG 00 04:10	AC Cord 2.2m, 7A 125V	電源コード			J
"	42:00:00	MG 00 07:80	" 2m, 6A 250V	"			R
"	42:00:00	MG 00 08:40	" SDT-1 POT-64 10A, 125V	"			U, C
"	42:00:00	MG 00 09:20	" 2.5m, 7.5A, 250V	"			A
* "	42:00:00	MG 00 09:50	" 2m, 2.5A, 250V	"			G
* "	42:00:00	MG 00 10:00	" 2m, 6A, 300/500	"			B
17	42:00:00	CB 06 86:30	Cord Stopper SR-3P-4	コードストッパー			J, U, C
"	42:00:00	CB 07 27:50	" SR-4N-4	"			R, A, G, B
* 18	42:00:00	Ji 00 11:80	Bar-Graph Meter	バーグラフメーター			
19	42:00:00	KB 00 03:10	Fuse T 0.5A, 250V	ヒューズ			R
20	42:00:00	KB 00 03:30	" T 1.0A, 250V	"			R, A
20-1	42:00:00	KB 00 07:00	" T 200mA, 250V	"			G, B
21	42:00:00	LA 00 10:00	Lug Terminal CV-3P	ラグ端子板			J, U, A, C, B
21-1	42:00:00	LA 00 29:50	2P Terminal MA0092	2P中継端子台			R, G
22	42:00:00	LB 20 12:10	Fuse Holder 1PFH	ヒューズホルダー			R
"	42:00:00	LB 20 14:70	" 1PFH-M	"			G, B
23	42:00:00	PB 06 15:40	Counter (Silver)	カウンター	シルバー	TC-920	
"	42:00:00	PB 06 11:20	" (Black)	"	ブラック	TC-920B	
24	32:00:00	NB 08 80:40	Rod (Push Button A) (Silver)	Pushボタン圧入 A	シルバー	TC-920	
"	32:00:00	NB 08 83:20	" (Black)	"	ブラック	TC-920B	
25	32:00:00	NB 08 80:50	Rod (Push Button B) (Silver)	Pushボタン圧入 B	シルバー	TC-920	
"	32:00:00	NB 08 83:30	" (Black)	"	ブラック	TC-920B	
26	32:00:00	NB 08 80:60	Rod (Push Button P) (Silver)	Pushボタン圧入 P	シルバー	TC-920	
"	32:00:00	NB 08 83:40	" (Black)	"	ブラック	TC-920	
* 27	32:00:00	AA 60 14:10	Rear Panel J	リアパネル J			J
* "	32:00:00	AA 60 14:20	" U. C	" U. C			U, C
* "	32:00:00	AA 60 14:30	" G	" G			G
* "	32:00:00	AA 60 14:50	" R	" R			R
* "	32:00:00	AA 60 14:60	" A	" A			A

* : New Part (新部品)

K-950 ■ EXPLODED VIEW (All over(2))

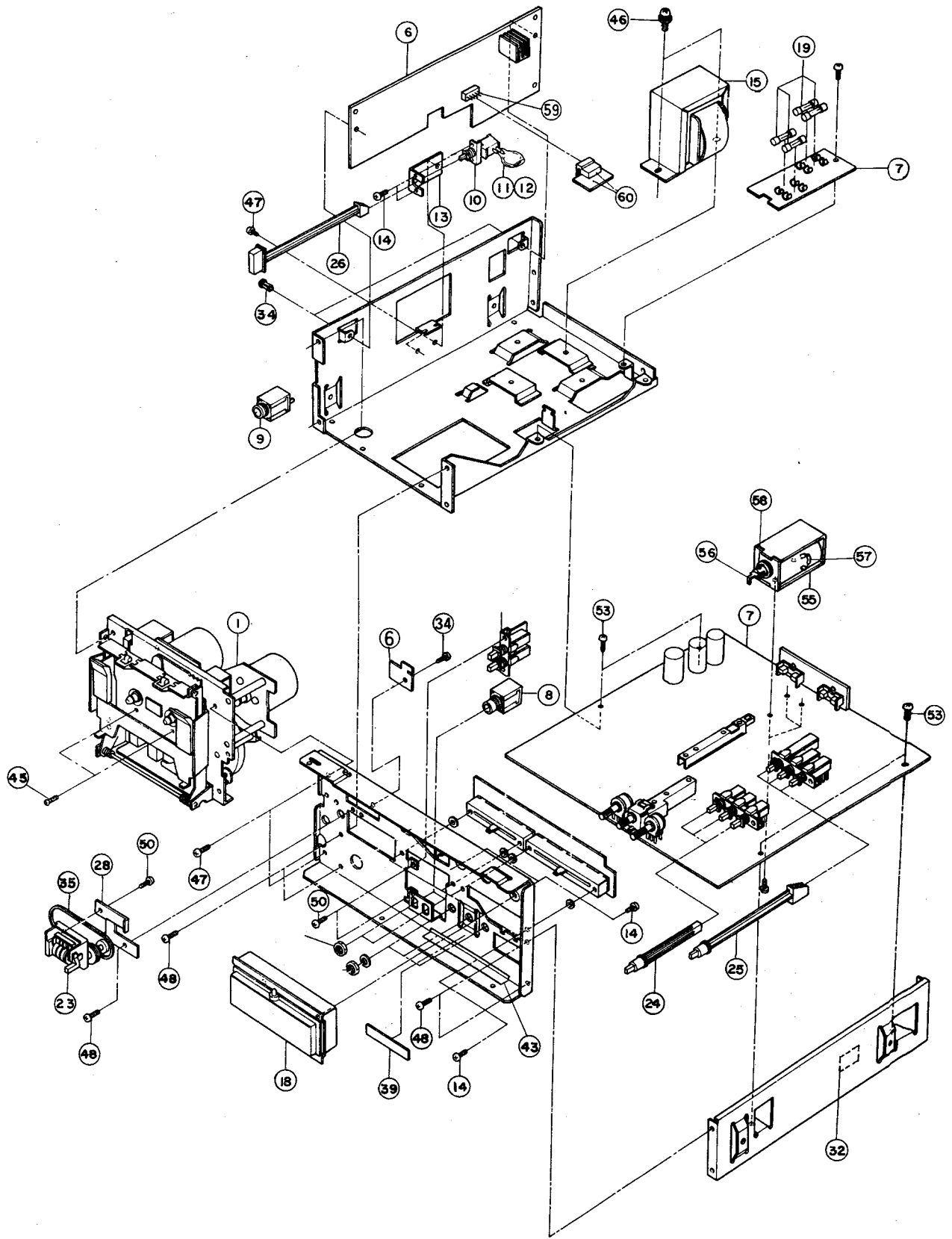

Ref. No.	Part No.		Description	(部 品 名)	Remarks	Common model	Markets
* 27	32:00:00	AA:60:14:70	Rear Panel	B	リアパネルB		B
28	32:00:00	AA:09:43:20	Holder (Counter)		カウンターホルダー		
29	32:00:00	AA:09:49:70	Top Cover	(Black)	トップカバー	ブラック	TC-920B
30	32:00:00	BA:07:45:20	V-R Knob	(Silver)	VR ツマミ	シルバー	TC-920
"	32:00:00	BA:07:46:40	"	(Black)	"	ブラック	TC-920B
31	32:00:00	BA:07:45:30	Switch Knob	(Silver)	SW ツマミ	シルバー	TC-920
"	32:00:00	BA:07:46:50	"	(Black)	"	ブラック	TC-920B
* 32	32:00:00	CB:09:78:80	Cord Stopper		コードクランパー		
33	32:00:00	CB:08:89:30	Plastic Rivet	φ4	プラスチックリベット		
34	42:00:00	CB:06:88:80	"	φ3	"		
35	32:00:00	CB:08:83:10	Counter Belt		カウンターベルト		TC-920
36	42:00:00	CB:08:88:80	Tape (Anti Vibration)		防振テープ		" J
37	42:00:00	CB:08:88:90	"		"		" J
38	42:00:00	CB:08:94:50	"		"		" J
39	42:00:00	CB:09:04:90	Rubber Plate		ゴムプレート		"
* 40	42:00:00	CB:09:14:80	Tape (Anti Vibration)		防振テープ	1m当り単位	"
41	42:00:00	CB:09:19:00	Rubber (Anti Vibration)		防振ゴム		U
* 43	42:00:00	CB:09:18:50	Tape 40×180mm (Only Black Type)		アセテートクロス粘着テープ	ブラック専用	
44	42:00:00	EZ:00:08:30	B.W Head Screw 4×8S (FNM3-3g)		鉄ブレイザーワッシャー ヘッド小ネジ		J
"	42:00:00	EZ:00:06:90	" 4×8S (FCM3-BI)		" (ブラック)		R, U, A, G, C, B
* 45	42:00:00	EK:32:50:10	Truss Head Tapping Screw (Type-II) 2.6×6 (FCM3-BI)		トラスタッピングネジ (2種ミソ)		
* 46	42:00:00	EK:01:50:10	Pan Head Screw (Sems Type)(Three Peace) 4×8(ZMC2-Y)		セムスナベ小ネジ (スリーピース)		
* 47	42:00:00	EK:09:60:10	Bind Head Tap-Tyght Screw (S-Tight) 3×6 (ZMC2-Y)		バインドタツプタイト (Sタイト)		
48	42:00:00	EK:09:50:20	Bind Head Tap-Tyght Screw (B-Tight) 3×6 (ZMC2-Y)		バインドタツプタイト (Bタイト)		
* 49	42:00:00	EK:39:50:30	" " (FCM3-BI)		"		
50	42:00:00	ED:03:00:40	Bind Head Screw 3×4 (ZMC2-Y)		バインド小ネジ		
51	42:00:00	EN:33:00:20	Bind Head Tapping Screw (Type-II) 3×6 (FCM3-BI)		バインドタツピングネジ (2種ミソ)		J, U, A, C, B
"	42:00:00	ED:93:00:50	Bind Head Screw 3×5 (FCM3-BI)		バインド小ネジ		
52	42:00:00	EV:10:03:00	Hexagonal Nut M3 (ZMC2-Y)		六角ナット		R, G, B
53	42:00:00	EK:03:00:60	B-W Head Tapping Screw (Type-II) 3×8 (ZMC2-Y)		ブレイザーヘッドタツピングネジ (2種ミソ)		
* 54	42:00:00	EV:90:01:00	Washer 0.8×4.1×9.5		ファイバーワッシャ		
* 55	42:00:00	JF:00:02:60	Solenoid TDS-10A		ソレノイド		
56	32:00:00	CB:09:35:50	Solenoid Joint		ソレノイドジョイント		
57	42:00:00	i H:00:02:40	Diode 1S1885		ダイオード		
58	42:00:00	EZ:00:06:80	Spring Pin φ3×10		波形スプリングピン		
59	42:00:00	BB:00:44:30	Connect Pin 2.5-Pitch SHF-001T-08CS		2.5ピッチコンタクトピン		
60	42:00:00	LB:60:24:50	Housing 2.5-Pitch H10P-SHF		2.5ピッチハウジング		

* : New Part (新部品)

EXPLODED VIEW (TM-2B Mechanism Ass'y)

K-950

PARTS LIST (TM-2B Mechanism Ass'y)

K-950

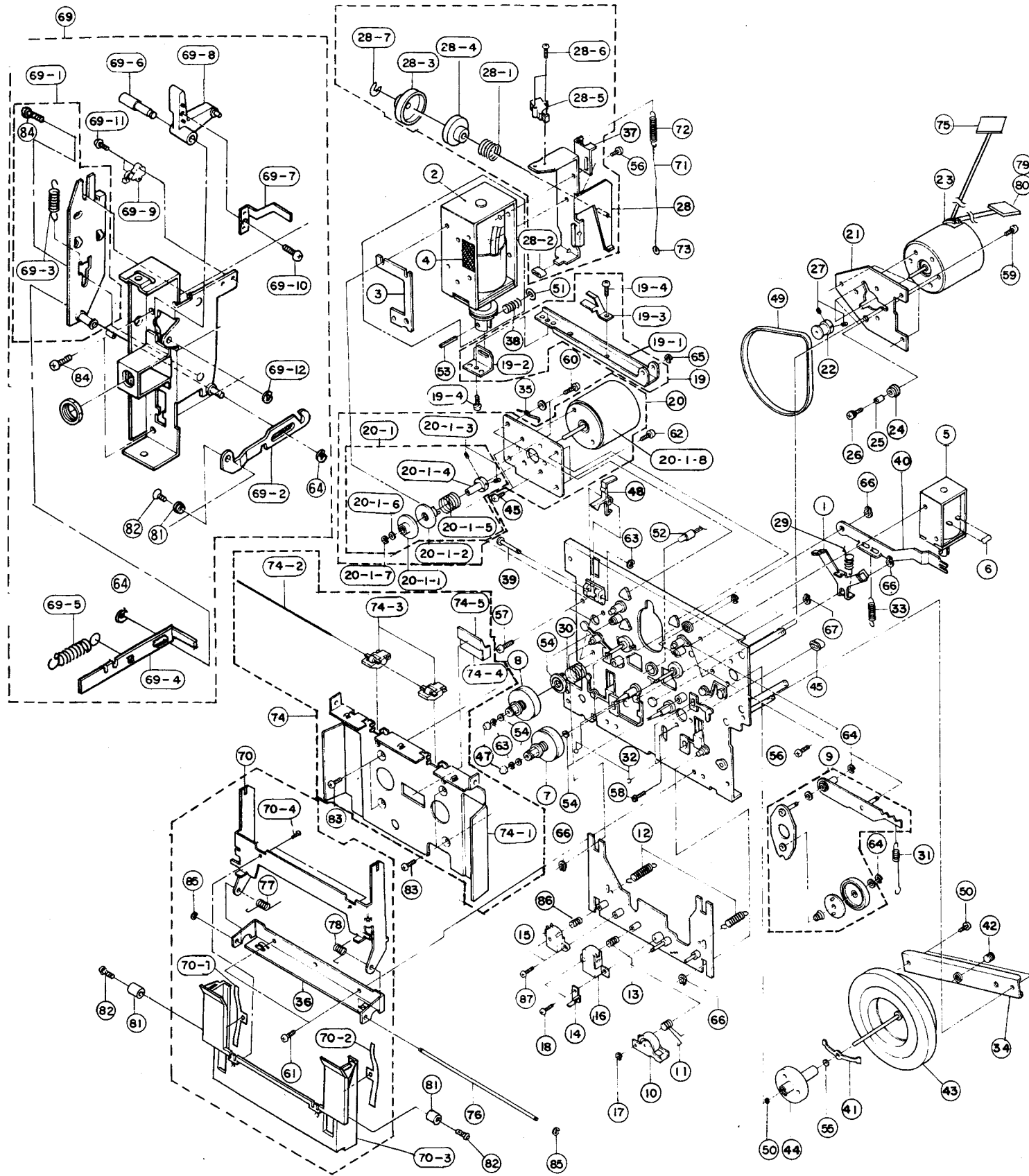

Ref. No.	Part No.	Description	(部 品 名)	Remarks	Common model	Markets
*	32:01:88 SM:60:06:00	TM-2B Cassette Mechanism	TM-2B総組立			
1	32:00:00 NB:08:78:70	Brake Plate Ass'y	ブレーキプレートAss'y			
*	2 42:00:00 JF:00:02:40	Solenoid TDS-12C	ソレノイド			
3	32:00:00 BA:07:03:60	Spacer (Solenoid)	プランジャースペーサー			
4	42:00:00 CB:07:96:40	Tape 8×25	ダブルタックテープ	1m当り単価		
*	5 42:00:00 JF:00:02:50	Solenoid TDS-08A	ソレノイド			
6	42:00:00 i H:00:02:40	Diode 1S1885	ダイオード			
7	32:00:00 NB:08:75:00	Reel Base Ass'y (Take-up)	リール台Ass'y(T)			
8	32:00:00 NB:08:74:90	" (Supply)	" (S)			
*	9 32:00:00 NB:09:01:20	Idler Ass'y	アイドラAss'y			
10	32:00:00 NB:08:79:40	Pinch Roller Unit	ピンチローラーユニット			
11	32:00:00 AA:08:70:30	Spring (Pinch Roller)	ピンチローラー springs			TM-1A
*	12 32:00:00 AA:60:16:70	Spring	ベース戻しバネ			
13	32:00:00 AA:08:70:20	Spring (Head Adjust)	ヘッド調整バネ			
*	14 32:00:00 BB:09:66:70	Wire Clamper	束線止め			
*	15 42:00:00 GF:00:01:00	Erase Head	消去ヘッド			
*	16 32:00:00 GF:00:01:20	REC/Playback Head	録再ヘッド			
17	42:00:00 EV:50:11:50	Stop Ring (E-Type) ETWJ-1.5φ	E型止め輪			
18	42:00:00 ED:02:00:50	Bind Head Screw 2×5 (ZMC2-Y)	バインド小ネジ			
*	19 32:00:00 NB:08:79:50	Lever Ass'y (Head Operation)	ヘッド作動レバーAss'y			
19-1	32:00:00 AA:08:68:70	Lever (Head Operation)	ヘッド作動レバー			TM-1A
19-2	32:00:00 BB:06:53:30	Coupling Plate (Solenoid)	ソレノイド連結板			
19-3	32:00:00 BB:06:75:60	Spring	ベース作動バネ			
19-4	42:00:00 EK:09:00:10	Bind Head Tap-Tight 3×6 (ZMC2-Y)	バインドタップタイト			
*	20 32:00:00 NB:08:79:60	Reel Motor Ass'y	リールモーターAss'y			
*	20-1 32:00:00 NB:08:93:50	Motor Clutch Ass'y	モータークラッチAss'y			
20-1-1	32:00:00 NB:08:10:90	Motor Pulley Ass'y	モータープーリーAss'y			
20-1-2	32:00:00 CB:08:04:60	Pulley Clutch	プーリークラッチ			
20-1-3	42:00:00 EZ:00:07:40	Set Screw 2.6×4	くぼみ先止めネジ			
20-1-4	32:00:00 BB:06:86:90	Motor Shaft	モーターシャフト			
20-1-5	32:00:00 AA:08:96:60	Spring (Clutch)	クラッチバネ			
20-1-6	42:00:00 EV:90:02:10	Washer φ2.1×φ4×0.25	ポリスライダワッシャー			
20-1-7	42:00:00 EV:50:11:50	Stop Ring (E-Type) ETWJ-1.5	E型止め輪			
20-1-8	42:00:00 JC:00:04:20	Reel Motor	リールモーター			TC-920
21	32:00:00 AA:09:49:30	Motor Bracket	モーターブラケット			
22	32:00:00 BB:06:86:80	Motor Pulley C	モータープーリーC			
*	23 42:00:00 JC:00:05:50	Motor	キャプスタンモーター			
24	32:00:00 CB:08:28:20	Spacer (Motor Mounting)	モーター取付座			
25	32:00:00 BA:07:45:70	Collar (Motor Mounting)	取付座カラー			
26	42:00:00 EK:06:50:50	B.W.Head Screw 2.6×6 (ZMC2-Y)	ブレイザーワッシャー小ネジ			
27	42:00:00 EZ:00:07:40	Set Screw 2.6×4	くぼみ先止めネジ			
*	28 32:00:00 NB:09:49:10	Dunper Base Ass'y	ダンパーベースAss'y			
*	28-1 32:00:00 AA:60:13:30	Spring (Clutch)	クラッチバネ			
28-2	32:00:00 CB:08:85:10	Stopper	ストッパー			TM-2A
*	28-3 32:00:00 CB:09:60:90	Pulley	糸掛プーリー			
*	28-4 32:00:00 CB:09:61:00	Clutch	クラッチ			
*	28-5 42:00:00 KA:60:04:40	Micro Switch SMA012A	マイクロSW			
28-6	42:00:00 ED:02:00:80	Bind Head Screw 2×8 (ZMC2-Y)	バインド小ネジ			
28-7	42:00:00 EV:50:12:00	Stop Ring (E-Type) ETWJ-2	E型止め輪			
29	32:00:00 AA:09:48:80	Spring (Brake Mechanism)	ブレーキ戻しバネ			TM-2A
30	32:00:00 AA:08:70:10	Spring (Back-tension)	バックテンションバネ			TM-1A
31	32:00:00 AA:08:70:70	Spring (Idler Arm)	アイドラアームバネ			
32	42:00:00 EZ:00:15:10	Steel Ball 3/32inch	スチールボール			

* : New Part (新部品)

Ref. No.	Part No.	Description	(部 品 名)	Remarks	Common model	Markets
33	32:00:00 AA:09:48:70	Spring (Brake)	ブレーキバネ			
34	32:00:00 AA:08:64:80	Bridge (Flywheel)	フライホイールブリッジ		TM-1A	
35	32:00:00 AA:06:57:00	Wire Clamper	束線止め			
36	32:00:00 AA:09:42:40	Housing Base	ハウジング受板		TM-2A	
37	32:00:00 AA:09:66:20	Adjust Plate (Eject)	イジェクト調整板		"	
* 38	32:00:00 AA:60:13:00	Spring (Damper)	ダンパーバネ			
39	32:00:00 BB:06:54:40	Shaft For Ref No 48	ツメ軸		TM-1A	
40	32:00:00 BB:06:75:50	Lever (Brake)	ブレーキレバー		TM-2A	
41	32:00:00 BB:06:53:00	Spring (Flywheel)	フライホイールバネ		TM-1A	
42	32:00:00 CB:08:18:30	Fixing Screw, Flywheel	フライホイール止めネジ		"	
43	32:00:00 BE:06:03:40	Flywheel Ass'y	フライホイール組み立て		"	
44	32:00:00 BE:06:03:50	Metal Case Ass'y	メタルケース組み立て		"	
45	32:00:00 CB:08:68:30	Rubber (Stopper)	ストッパゴム		"	
46	32:00:00 CB:08:05:10	Reel Base	リール台受		"	
47	32:00:00 CB:09:24:00	Reel Cap	リールキャップ		"	
48	32:00:00 CB:08:83:40	Actuator, Detection Record Lock	誤消去ツメ		TM-1A	
49	32:00:00 CB:08:25:50	Belt, Flywheel	平ベルト		"	
50	42:00:00 CB:08:26:10	Washer (Capstan)	キャプスタンワッシャー			
* 51	32:00:00 CB:09:60:80	Washer	ダンパーワッシャー			
52	42:00:00 JB:00:04:00	Pilot Lamp 12V 60mA	パイロットランプリード式			
* 53	42:00:00 EZ:00:06:70	Spring Pin φ3×30	波形スプリングピン			
54	42:00:00 EV:90:00:40	Washer φ2.1×φ4×0.25t, STW-FT20	ポリスライダワッシャー			
55	42:00:00 EV:90:00:50	" φ2.6×φ4.7×0.25t, STW-FT25	"			
56	42:00:00 ED:03:00:40	Bind Head Screw 3×4 (ZMC2-Y)	バインド小ネジ			
57	42:00:00 ED:03:00:60	" 3×6 (")	"			
58	42:00:00 ED:02:60:80	" 2.6×8 (")	"			
59	42:00:00 EZ:00:05:80	Pan Head Screw (Sems-Type) 3×8 (")	セムスナベ小ネジ	バネ座付		
60	42:00:00 EN:03:00:60	Bind Head Tapping Screw (Type II) 3×10 (")	バインドタッピングネジ	2種ミソ		
61	42:00:00 EK:05:70:10	Pan Head Tap-Tight Screw 3×6 (")	ナベタップタイトネジ	Sタイト		
62	42:00:00 EN:02:00:30	Pan Head Tapping Screw (Type II) 3×8 (")	ナベタッピングネジ	2種ミソ		
63	42:00:00 EV:50:11:50	Retaining Ring ETWJ-1.5	E型止め輪			
64	42:00:00 EV:50:12:00	" ETWJ-2	"			
65	42:00:00 EV:50:12:50	" ETWJ-2.5	"			
66	42:00:00 EV:52:13:00	" CSTW-3	CS型止め輪			
67	42:00:00 EZ:00:10:10	Grip Ring GTW-3	グリップ型止め輪			
* 69	32:00:00 NB:09:49:20	Sub	サブシール Ass'y			
* 69-1	32:00:00 NB:09:70:40	Plate (Eject Operate) Ass'y	イジェクト作動板 Ass'y			
* 69-2	32:00:00 AA:60:13:40	Lock Lever	ロックレバー			
* 69-3	32:00:00 AA:60:13:50	Leaf Spring	作動板バネ			
* 69-4	32:00:00 AA:60:13:60	Slider	スライダ			
* 69-5	32:00:00 AA:60:13:70	Spring (Slider)	スライダバネ			
69-6	32:00:00 BB:06:76:30	Saft (Eject lever)	イジェクトレバー軸		TM-2A	
69-7	32:00:00 BB:06:76:80	Lever	解除レバー		"	
69-8	32:00:00 CB:08:84:00	Lever (Eject)	イジェクトレバー		"	
69-9	42:00:00 KA:60:04:40	Micro Switch SMA012A	マイクロSW			
69-10	42:00:00 EN:03:01:10	Bind Head Tapping Screw 2.6×6 (ZMC2-Y)	バインドタッピングネジ	2種ミソ		
69-11	42:00:00 ED:02:00:80	Bind Head Screw 2×8 (")	バインド小ネジ			
69-12	42:00:00 EV:50:12:00	Retaining Ring ETWJ-2	E型止め輪			
* 70	32:00:00 NB:09:49:50	Housing Ass'y	ハウジング Ass'y			
* 70-1	32:00:00 BB:06:87:20	Spring (Hold for Cassette) (Left)	ハーフ押えバネ(L)			
* 70-2	32:00:00 BB:06:87:30	" (Right)	" (R)			
* 70-3	32:00:00 CB:09:61:10	Guide for Cassette half	カセットガイド			
70-4	42:00:00 EB:32:60:40	Flat Head Screw 2.6×4 (FCM3-BI)	皿小ネジ			

* : New Part (新部品)

Ref. No.	Part No.	Description	(部 品 名)	Remarks	Common model	Markets
71	42:00:00 CB:07:70:70	Dial Strings φ0.39×150	ダイヤル糸	1m当り単価		
72	32:00:00 AA:09:41:80	Spring (For Dial Strings)	糸巻バネ			
73	42:00:00 EV:90:09:00	Washer φ5	ポリワッシャー			
* 74	32:00:00 NB:08:80:20	Blind Plate Ass'y	ブラインドプレート Ass'y		TM-2A	
* 74-1	32:00:00 AA:60:16:90	Blind Plate	ブラインドプレート		"	
74-2	32:00:00 AA:09:42:00	Spring-rod	押えバネ			
74-3	32:00:00 CB:09:67:60	Holder, Cassete half	ハーフ押え			
74-4	32:00:00 CB:08:04:90	Lens, Pilot lamp	テーブルレンズ		TC-1000	
74-5	42:00:00 CB:07:96:40	Tape 8×18mm	セキスイダブルタックテープ	1m当り単価		
75	32:00:00 NA:07:22:20	Connector C, Board	コネクターシート		TM-2A	
76	32:00:00 AA:09:42:50	Shaft	受 軸			
77	32:00:00 AA:09:42:90	Spring, Eject (L)	イジェクトバネ(L)			
78	32:00:00 AA:09:43:00	" Eject (R)	" (R)			
79	42:00:00 LB:20:13:80	Connector Housing, Plug S2P-SHF	コネクター2P			
80	42:00:00 BB:00:44:30	Female Contact Pin SHF-001T	コンタクトピン			
81	32:00:00 AA:60:16:20	Collar A	カラーA			
* 82	42:00:00 EB:02:60:50	Flat Head Screw 2.6×5 (ZMC2-Y)	皿小ネジ			
* 83	42:00:00 EK:32:50:10	Trus Head Tapping Screw (Type II) 2.6×6 (FCM3-BI)	トラスタッピングネジ	2種ミソ		
* 84	42:00:00 EK:09:60:10	Bind Head Tap Tight (S-Tight) Screw 3×8 (ZMC2-Y)	バインドタップタイト (Sタイト)			
85	42:00:00 EV:50:12:00	Retaining Ring ETWJ-2	E型止め輪			
* 86	32:00:00 AA:60:29:90	Spring	消去スプリング			
87	42:00:00 EA:02:00:60	Bind Head Screw 2×6S(ZMC2-Y)	バインド小ネジ			

* : New Part (新部品)

PARTS LIST

K-950

■ CONTENTS	Page
■ EXPLODED VIEW(All over (1)).....	1
■ PARTS LIST(All over).....	2
■ EXPLODED VIEW(All over(2)).....	4
■ EXPLODED VIEW(TM-2B Mechanism Ass'y).....	6
■ PARTS LIST(TM-2B Mechanism Ass'y).....	7
■ PARTS LIST(REC/P.B.C. Board).....	10
■ PARTS LIST(Control C. Board).....	15

SINCE 1887



YAMAHA

NIPPON GAKKI CO., LTD. HAMAMATSU, JAPAN

004401

K-950 ■ EXPLODED VIEW (All over(1))

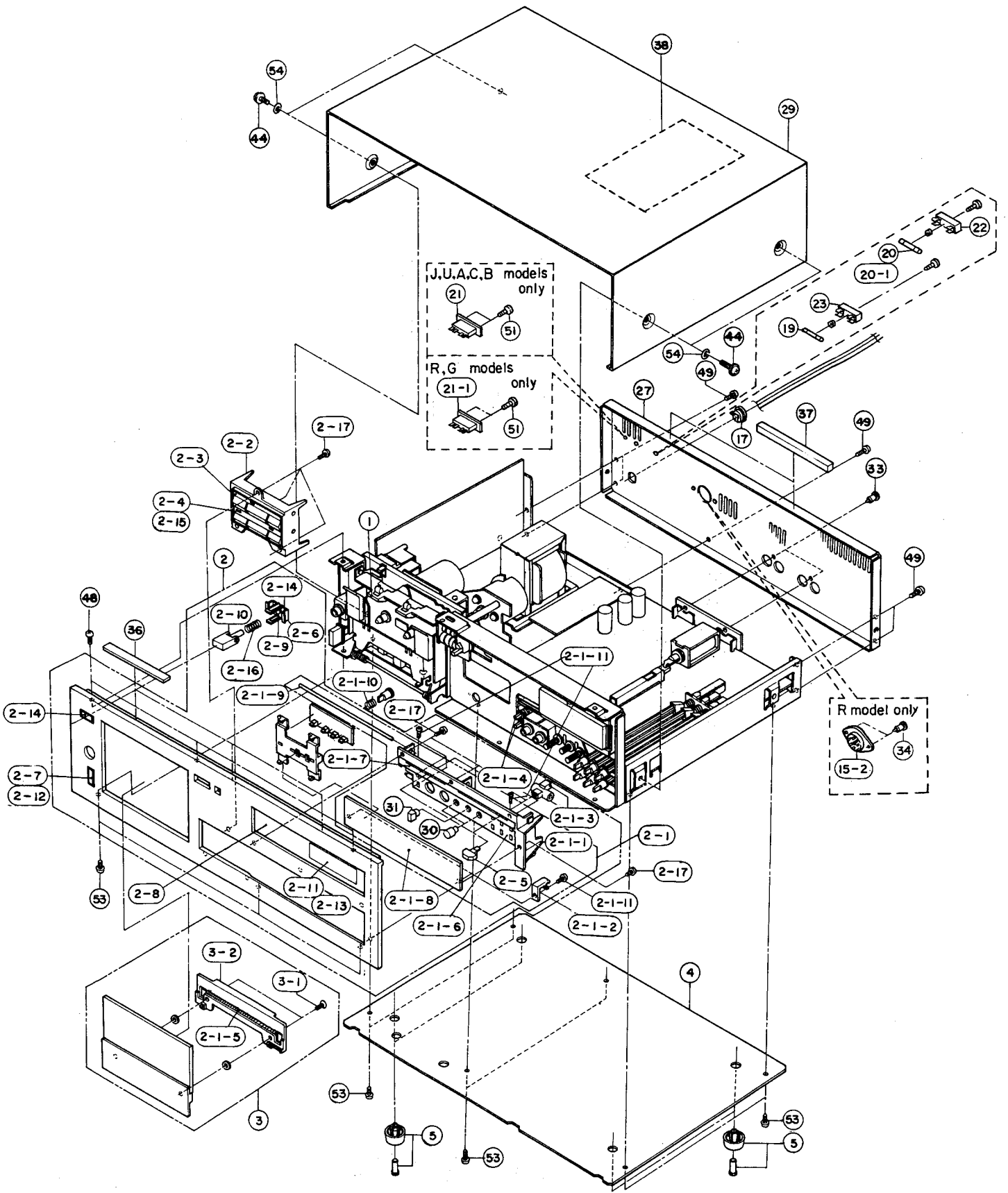

■ DISASSEMBLY PROCEDURE

1. Removal of Top Cover

- 1) Loosen screws ① ~ ④ shown in Photo 1.
- 2) Remove the top cover, sliding it toward the rear panel.

2. Removal of Bottom Cover

To remove bottom cover, loosen screws ⑤ ~ ⑩ shown in Photo 1.

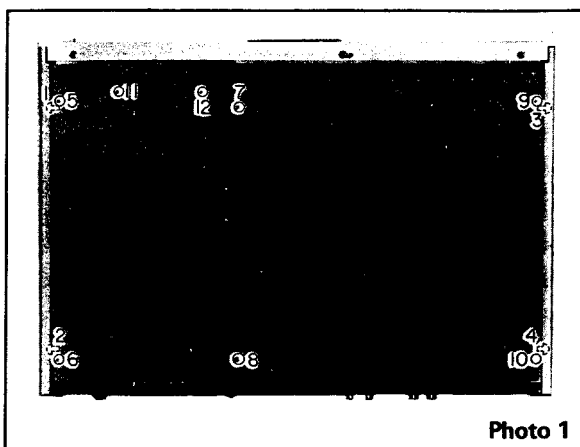

Photo 1

3. Removal of Front Panel and LED Circuit Board

- 1) Take off top and bottom covers. (Refer to Steps 1 and 2.)
- 2) Pull out the BIAS ADJ, TAPE and REC BALANCE knobs ① ~ ③ shown in Photo 2. (The TAPE knob may be hard to remove.)
- 3) Remove the connectors ① and ②. (Photo 3)
- 4) Loosen screws ① ~ ③ shown in Photo 4 as well as screws ① ~ ③ shown in Photo 5 and remove the front panel.
 - Be careful not to disconnect the lead wires of the LED circuit board.
 - When reassembling the front panel, match the front panel knobs and the REC LEVEL and OUTPUT LEVEL variable resistors first.
- 5) Now, the LED circuit board can be removed by loosening screws ① and ② shown in Photo 6.

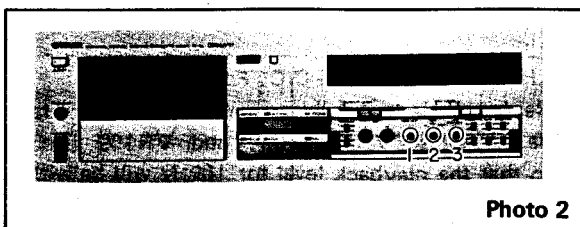

Photo 2

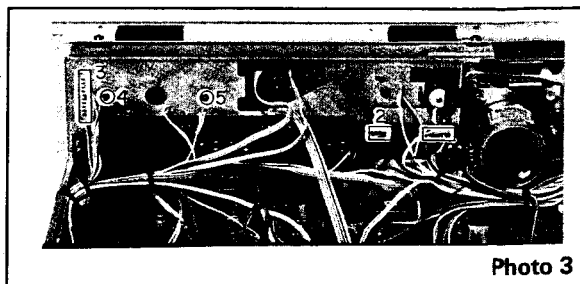

Photo 3

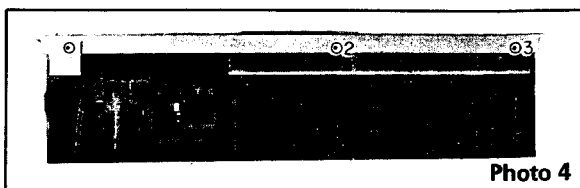

Photo 4

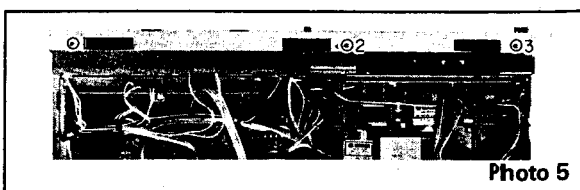

Photo 5

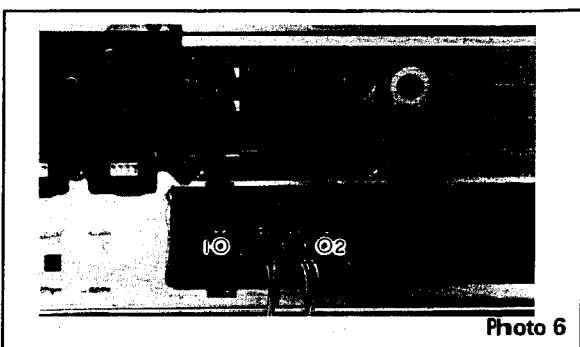

Photo 6

4. Removal of Mechanical Unit

- 1) Take off the front panel. (Refer to Step 3.)
- 2) Disconnect the lead wires connected to the mechanical unit from the circuit board.
- 3) Loosen screws ① and ② shown in Photo 1.
- 4) Take off the screw ① shown in Photo 7, and disengage the rubber belt of the tape counter.
- 5) Pull out the power switch ② shown in Photo 7.
- 6) After loosening screws ③ ~ ⑥ shown in Photo 7, lift up the mechanical unit for removal.

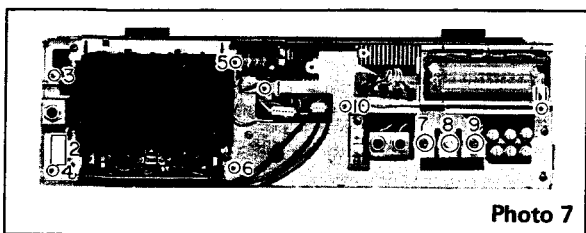

Photo 7

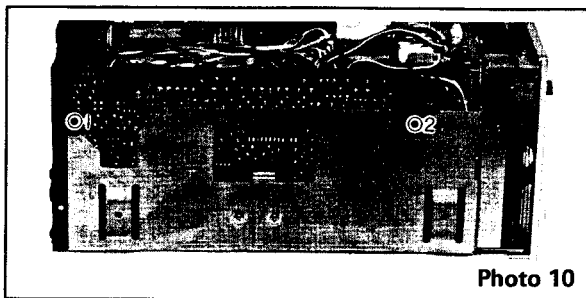

Photo 10

5. Removal of REC/PB Circuit Board

- 1) Take off the front panel. (Refer to Step 3.)
- 2) Disconnect the lead wires and connectors from the REC/PB circuit board.
- 3) Remove nuts ⑦ ~ ⑨ shown in Photo 7.
- 4) Remove the plastic revets ① and ② shown in Photo 8 by pushing them from the rear with a screwdriver. Loosen screws ③ ~ ⑨ and remove the rear panel.
- 5) After taking off screws ① ~ ④ shown in Photo 9, gently remove the REC/PB circuit board.

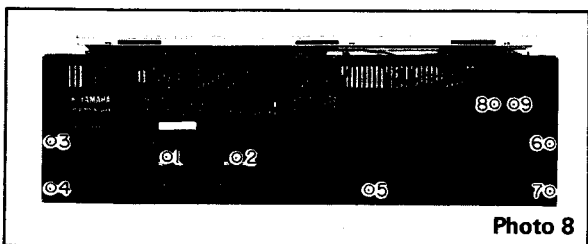

Photo 8

7. Removal of Peak Level Meter

- 1) Take off the front panel. (Refer to Step 3.)
- 2) The peak level meter can be dismantled by removing connector ③ and screws ④ and ⑤ shown in Photo 3.

8. Removal of VR Circuit Board

- 1) Take off the front panel. (Refer to Step 3.)
- 2) Disconnect the lead wires connected to the VR circuit board.
- 3) Loosen screws ⑩ and ⑪ shown in Photo 7. Remove the VR circuit board.

9. Removal of Fuse Circuit Board and Power Transformer

- 1) Take off the top cover. (Refer to Step 1.)
- 2) The fuse circuit board can be removed by loosening screw ⑤.
- 3) Loosen screws ⑥ and ⑦ shown in Photo 9 to dismantle the power transformer.

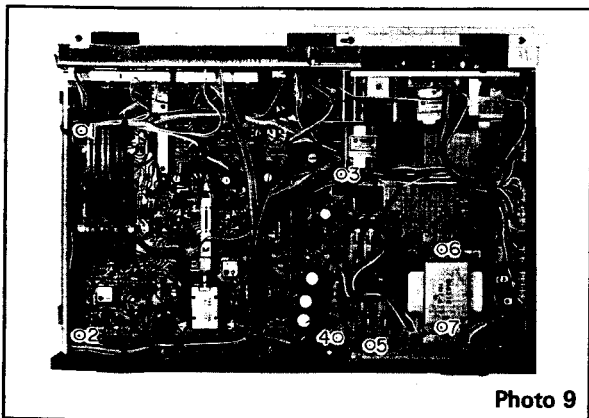

Photo 9

6. Removal of Control Circuit Board

- 1) Take off the top cover. (Refer to Step 1.)
- 2) Disconnect the connectors and lead wires connected to the control circuit board.
- 3) Remove the plastic rivets ① and ② shown in Photo 10 by pushing them from inside with a screwdriver. Remove the control circuit board.

OVERALL ADJUSTMENT

PREPARATION FOR ADJUSTMENT

- Set the INPUT switch to "LINE".

1. ADJUSTMENT OF PLAYBACK SYSTEM

1-1 Tape Speed Adjustment

- 1) Connect a frequency counter to the LINE OUT terminal.
- 2) While playing the speed test tape MTT-111 (3kHz), adjust the semi-fixed VR located inside the capstan motor for a frequency reading within $3,000 \pm \frac{1}{2}\%$ Hz. (Be careful not to push it with a \ominus screwdriver, as it will induce fluctuation because of the presence of a dust-prevention rubber.)

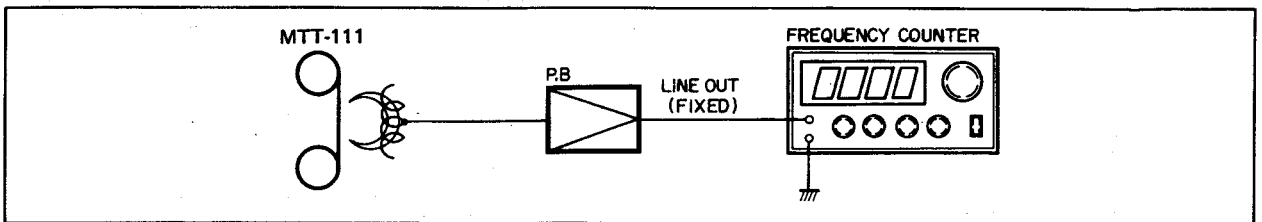
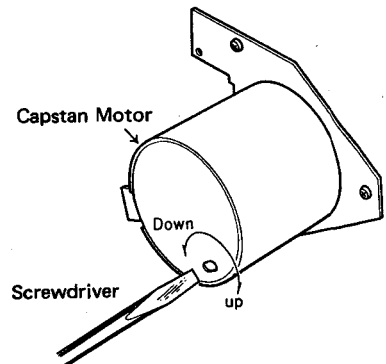

1-2 Playback Level Adjustment

- 1) Connect a voltmeter (VTVM) to the LINE OUT terminal.
- 2) Play the playback level test tape MTT-212C (160nWb/m, 333Hz, or 315Hz) and turn OUTPUT VR to

maximum. Adjust VR101 (L-ch) and VR102 (R-ch) for a reading of $-7\text{dBm} \pm 1\text{dBm}$ on the voltmeter.

NOTE: In case a 250nWb/m tape is used, adjust it for -3dBm . (MTT-212)

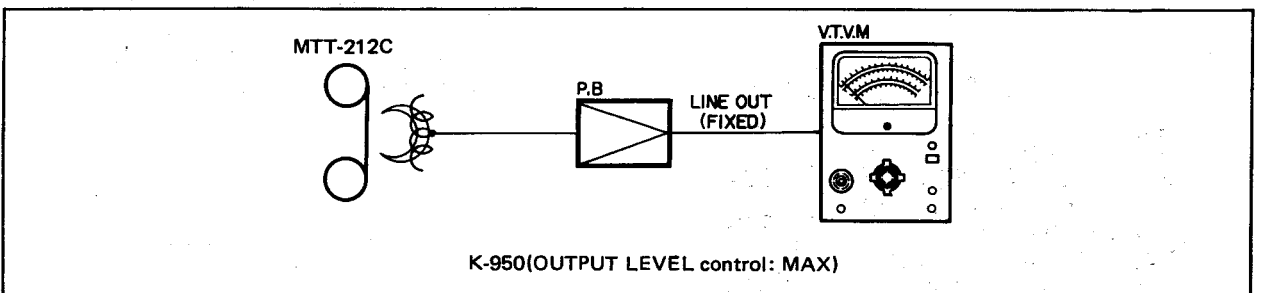

1-3 Playback Frequency Response Check

- TAPE Selector switch → LH position
 - Before making this adjustment, take off the cassette door and demagnetize the heads with a head eraser.
- 1) Connect a voltmeter (VTVM) to the LINE OUT terminal. (The OUTPUT VR should be turned up to maximum.)

- 2) Play the playback frequency response test tape (Type 1) MTT-216U, and confirm that the difference in the reading of the VTVM for 10kHz and that for 315Hz (or 333Hz) is within $\pm 3\text{dB}$.

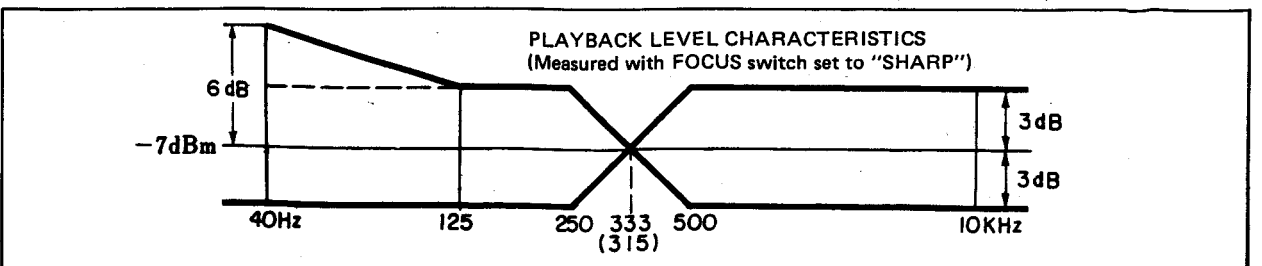

● HEAD AZIMUTH ADJUSTMENT

- 1) Connect 2 sets of voltmeters to the LINE OUT terminals (for L and R).
- 2) While playing the head azimuth test tape MTT-115L, or MTT114, adjust the head azimuth so that the output levels are at maximum and the same for L and R.

After adjustment, apply screw lock paint.

MTT-115L can be used for head azimuth adjustment as well as for frequency response check.

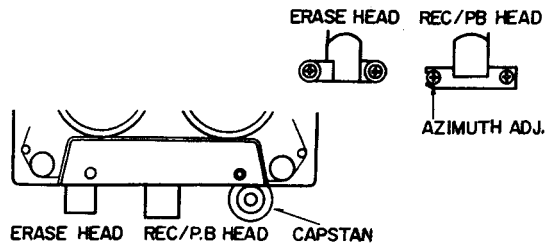

2. ADJUSTMENT OF RECORDING PARAMETERS

2-1 Peak Level Meter Adjustment

- 1) Connect a low frequency oscillator to the LINE IN terminal and a voltmeter to the LINE OUT terminal.
- 2) Put the set in the recording mode and apply a 1kHz, -10dBm signal to the LINE IN terminal. Adjust the LEVEL VR and BALANCE VR for an output of +1dBm at the LINE OUT terminal. (Set the TAPE SELECTOR switch to match the tape in use.)

- 3) In this condition, adjust VR105 (L-ch) and VR106 (R-ch) to the lowest level where the "0dB" point on the level meters (an extra two counts in the "+" direction from the 0dB indication) starts lighting up.

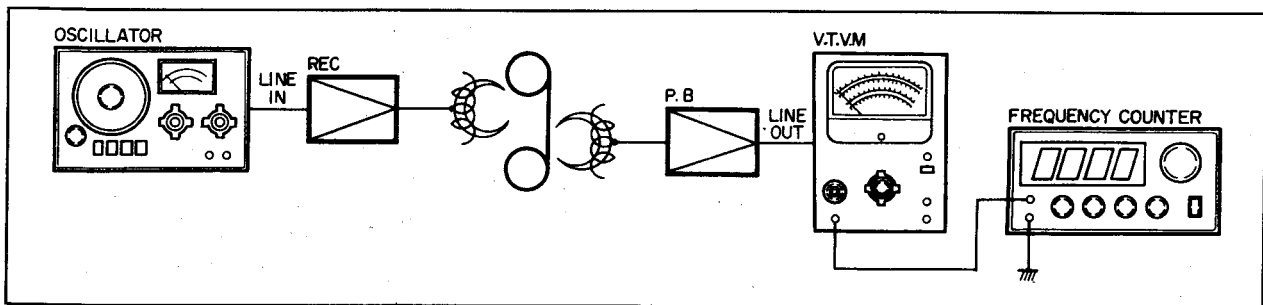

2-2 Recording Level Adjustment

- 1) Make the same connections as described in Step 2-1. (Set the TAPE position to "CrO₂" and use a CrO₂ tape) ... SA-60
- 2) With the set in the recording mode, apply a 333Hz, -10dBm signal to the LINE IN terminal, and adjust the REC LEVEL VR and REC BALANCE VR for an output of -7dBm at the LINE OUT terminal.
- 3) In this condition, record the signal using the CrO₂ tape. Play the tape back and adjust VR103 (L-ch) VR104 (R-ch) for an output level of -7 ± 1.5 dBm at the LINE OUT terminal.

- 2) Set the level so that an output of -27dBm (333Hz) will be obtained at the LINE OUT terminal.

● METAL (METAL Position)

Record separate signals in the frequency range from 1kHz ~ 15kHz and play the tape back. Adjust VRs 107 and 108 so that the playback level at 15kHz will be within ± 3 dB with regard to that at 1kHz. (Confirm with TDK MA-C46.)

● LH and CrO₂ (LH and CrO₂ Positions)

Record 1kHz and 10kHz signals and play the tape back. Adjust VR110 (LH) and VR109 (CrO₂) so that the playback level for 10kHz will be within ± 3 dB of that for 1kHz. (Confirm LH with MAXELL UD-60 and CrO₂ with AC-511.)

- Confirm that the adjusted recording bias falls within the range of the overall frequency response.

2-3 Recording Bias Adjustment

- Adjustments should be performed with the BIAS ADJ. VR set to the center position.
 - Switch off the MPX switch.
- 1) Make connections following the instructions given in step 2-1.

OVERALL CHARACTERISTICS DIAGRAM

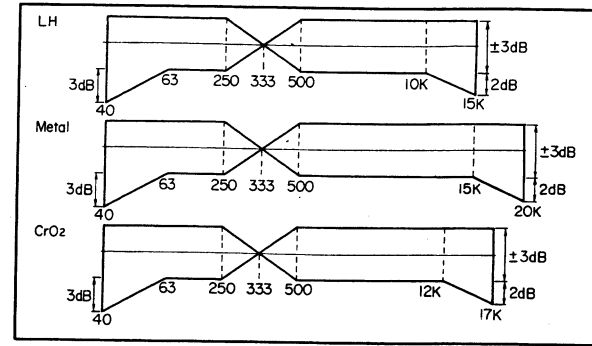

NR switched off. (In the diagram shown at left, the NR switch is switched off.)

- The channel difference should be within 6dB at 12kHz. This is the output obtained at LINE OUT in the reference playback mode after the following operations are performed. Adjust the set to the reference recording mode. Apply to LINE IN a signal of a level 20dB lower than the reference input level. Record the signal and play the tape back.

"Reference input level": LINE IN : -20dBm
MIC IN : -60dBm

NR switched on. (LH, METAL and CrO2)

- For the frequencies below 333Hz, it is the same as for NR OFF. Should be within ±4dB for frequencies from 333Hz up to 12kHz. Performed with FOCUS SW set to "SHARP".

ADJUSTING POINTS

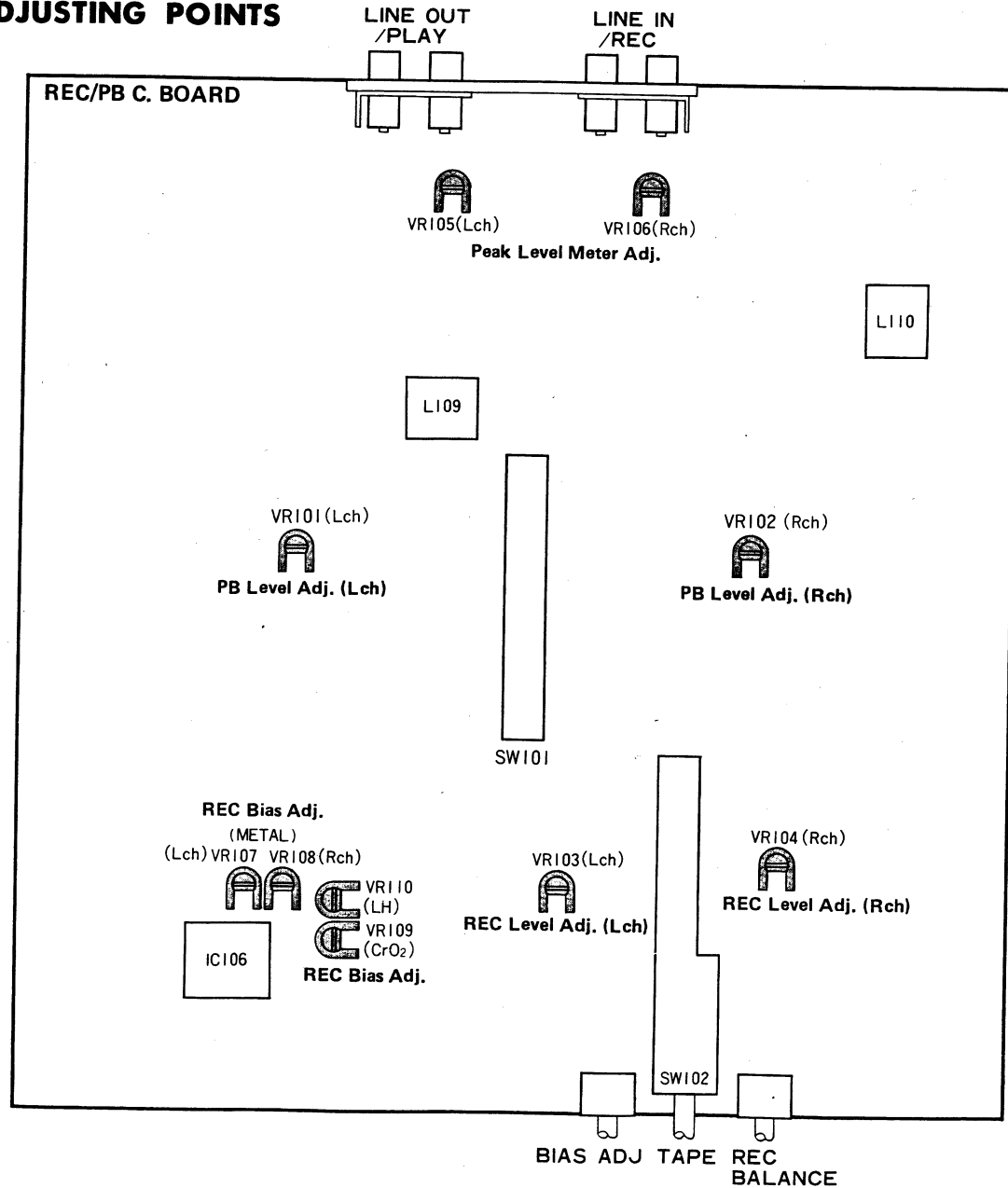

SPECIFICATIONS

Track Configuration 4-track 2-channel Stereo Cassette Deck

MECHANICAL SECTION

- Tape Speed 4.8cm/sec±1%
- Wow and Flutter 0.028% (WRMS), ±0.1% (DIN)
- Rapid Transport (F.FWD/REW) Within 75sec (for C-60 cassette)
- Motor FG servo DC motor (Capstan), Governorless DC motor (Reel)
- Operation Logic Controlled Feather Touch Operation, Full auto shut-off system
- Head Section 2-head Recording/Playback: Pure & Plasma Process Head, Erase: Ferrite Head

AMPLIFIER SECTION

- REC/PB Frequency Response 30 to 17,000Hz ±3dB (for LH tape), 30 to 19,000Hz ±3dB (for CrO2 tape), 30 to 22,000Hz ±3dB (for Metal alloy tape)
- Input Sensitivity/Impedance MIC: 0.3mV/5kΩ, LINE: 60mV/50kΩ

Output Level/Impedance

- LINE: 340mV/50kΩ (160nWb/m, PB Vol. MAX)
- PHONE: 8Ω 5mW/150Ω (1mW)
- Variable BIAS range ±8%
- Signal to Noise Ratio (CrO2) Better than 52dB (DIN 333Hz 3& without Dolby)
- Overall Distortion Less than 1.0% (for LH tape), Less than 1.5% (for CrO2 tape), Less than 1.0% (Metal alloy Tape) (160nWb/m, 1kHz)

GENERAL

- U.S. and Canadian Models 120V AC 60Hz
- North European Model 220V AC 50Hz
- General Model 110 to 130V/220 to 240V AC 50/60Hz
- British & Australian Models 240V AC 50Hz
- Power Consumption 26W
- Dimensions 435 x 140 x 305mm (W x H x D)
- Weight 8.8kg (19.4 lbs)

Specifications subject to change without notice.

BLOCK DIAGRAM

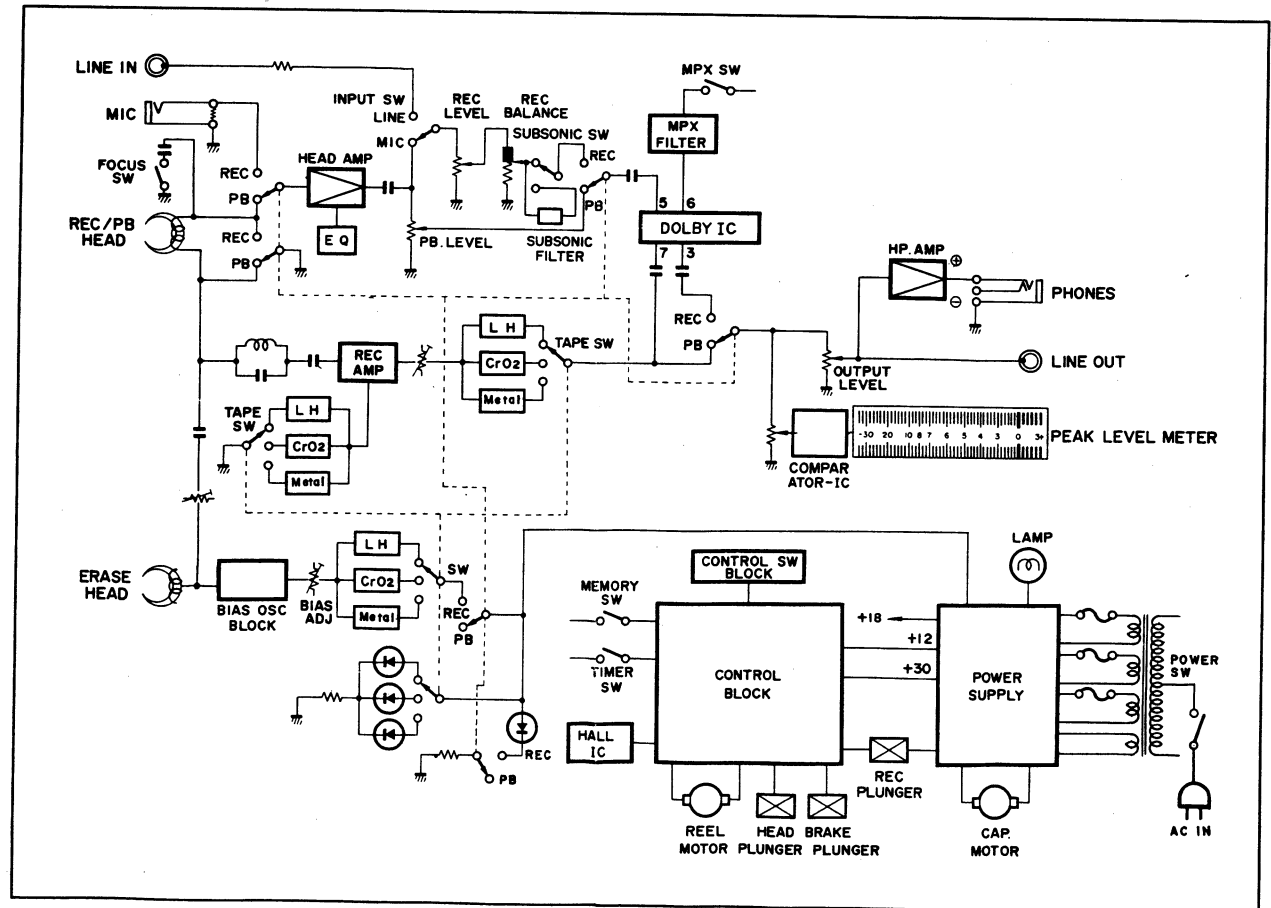

SCHEMATIC DIAGRAM

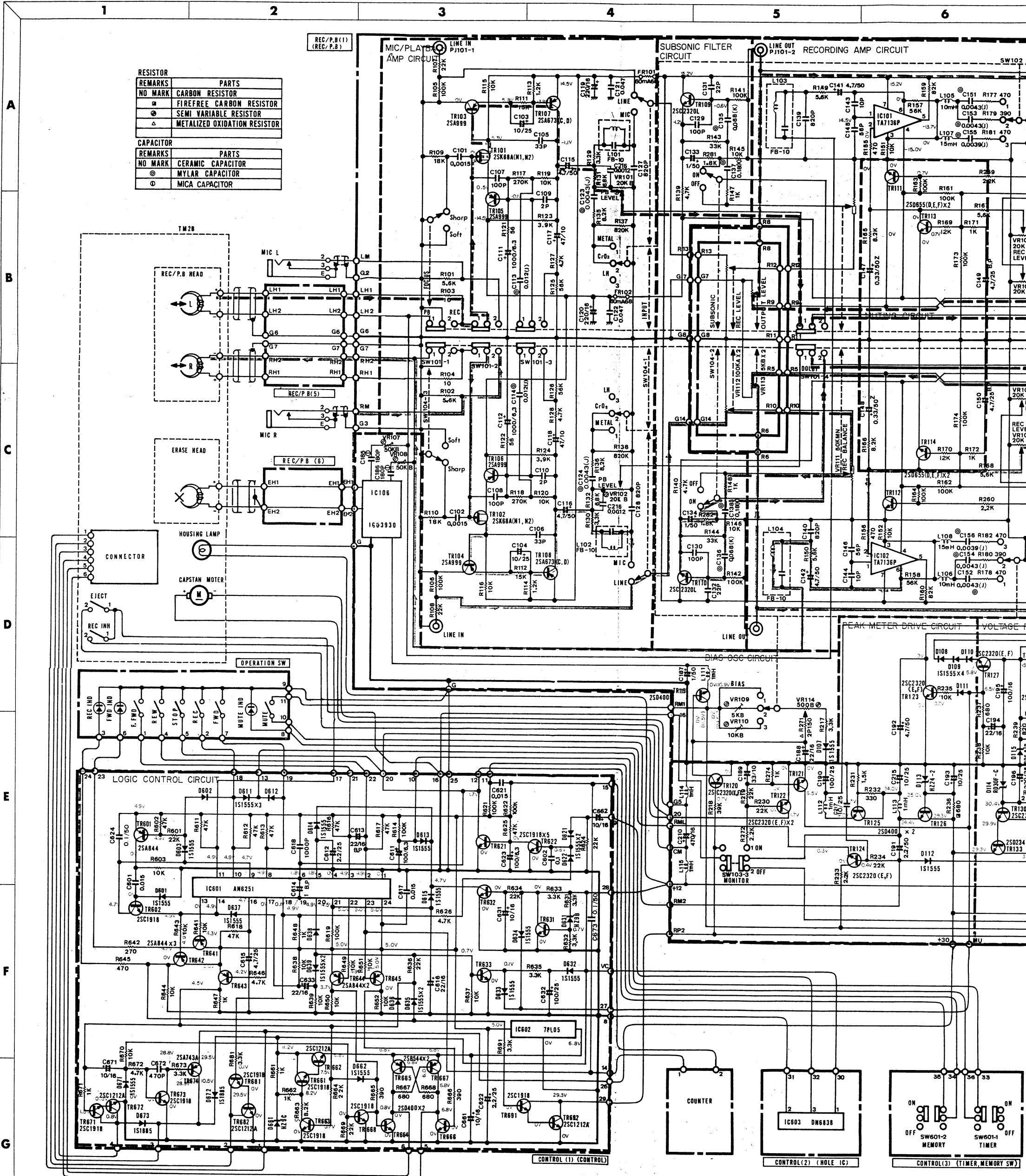

RESISTOR	
REMARKS	PARTS
NO MARK	CARBON RESISTOR
□	FIREFREE CARBON RESISTOR
△	SEMI VARIABLE RESISTOR
⊙	METALIZED OXIDATION RESISTOR

CAPACITOR	
REMARKS	PARTS
NO MARK	CERAMIC CAPACITOR
⊙	MYLAR CAPACITOR
⊖	MICA CAPACITOR

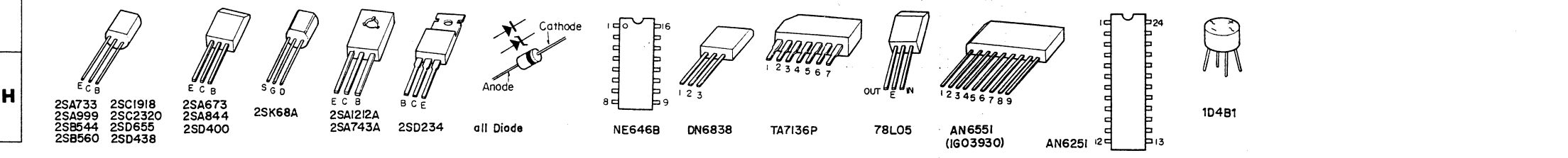

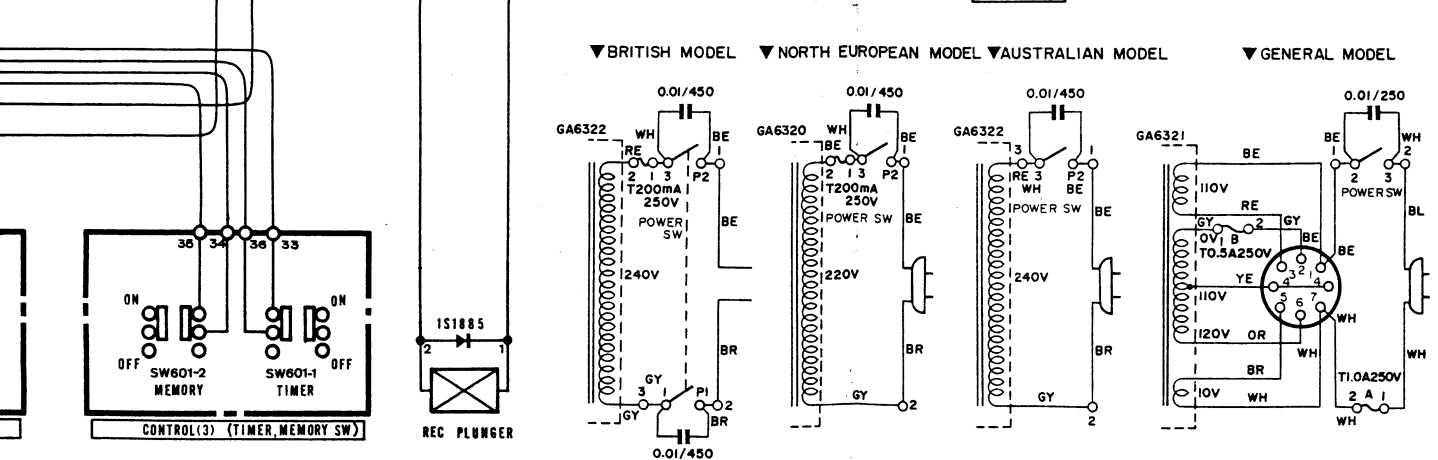
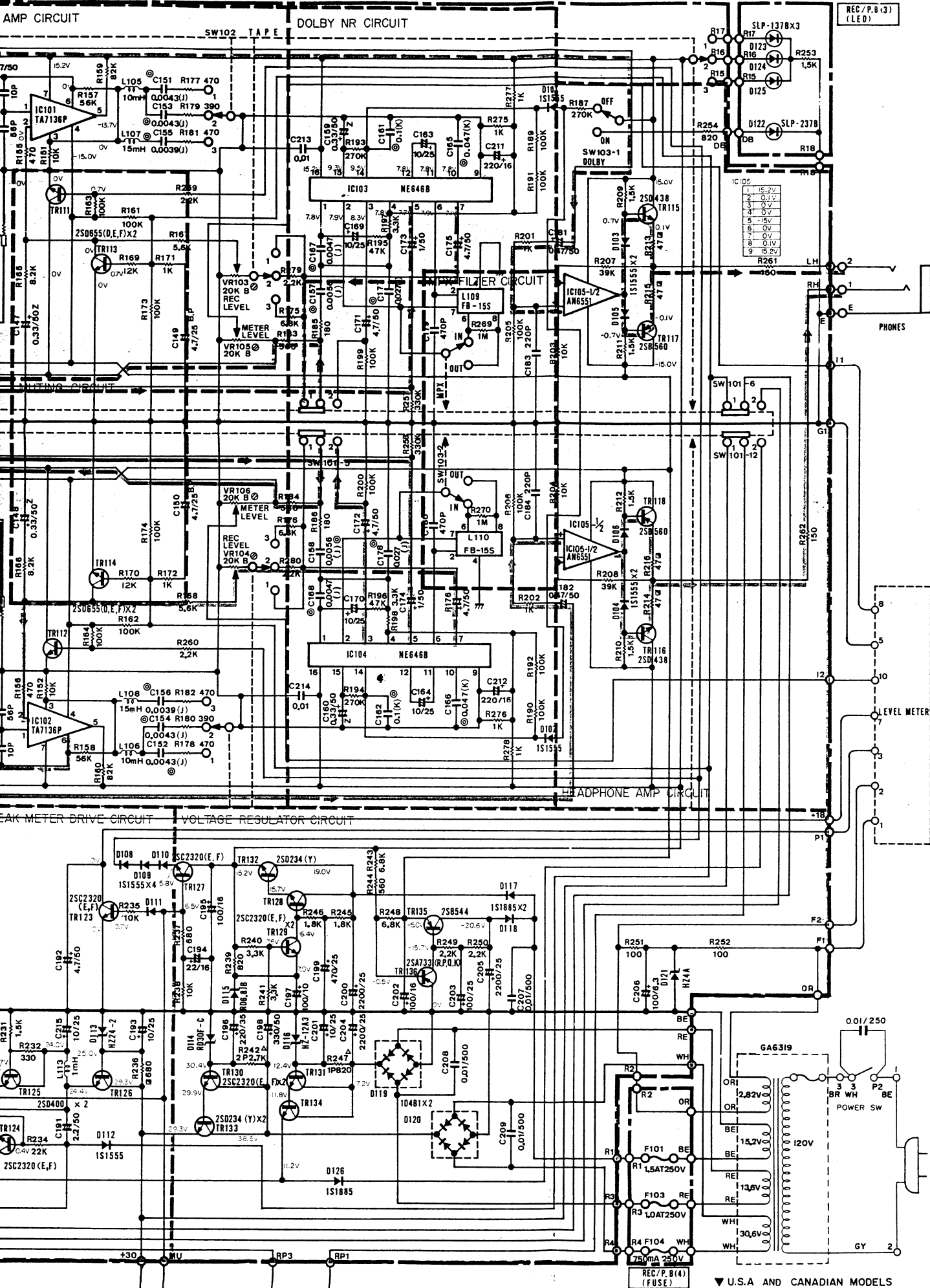

▼ U.S.A AND CANADIAN MODELS
 ▼ BRITISH MODEL ▼ NORTH EUROPEAN MODEL ▼ AUSTRALIAN MODEL ▼ GENERAL MODEL

- Notes)**
- Signal Flow**
 L-ch is indicated by in the playback mode.
 R-ch is indicated by in the recording mode.
 - CAUTION (Head Section)**
 As the lead wires inside the heads are liable to melt, the soldering iron should not be applied for more than 10 seconds.
 - Voltagess indicated for each section are those measured at power switch-on. Figures inside brackets are voltages for recording, while those indicated for the control circuit board are for playback.

	Fuse No.		
Destination	F101	F103	F104
J.R.A	1.0AT 250V	1.0AT 250V	1.0AT 250V
U.C	1.5AT 250V	1.0A 250V	750mA 250V
G.BB	400mAT 250V	1.0AT 250V	1.0AT 250V

IC FUNCTIONAL BLOCK DIAGRAM

AN6251

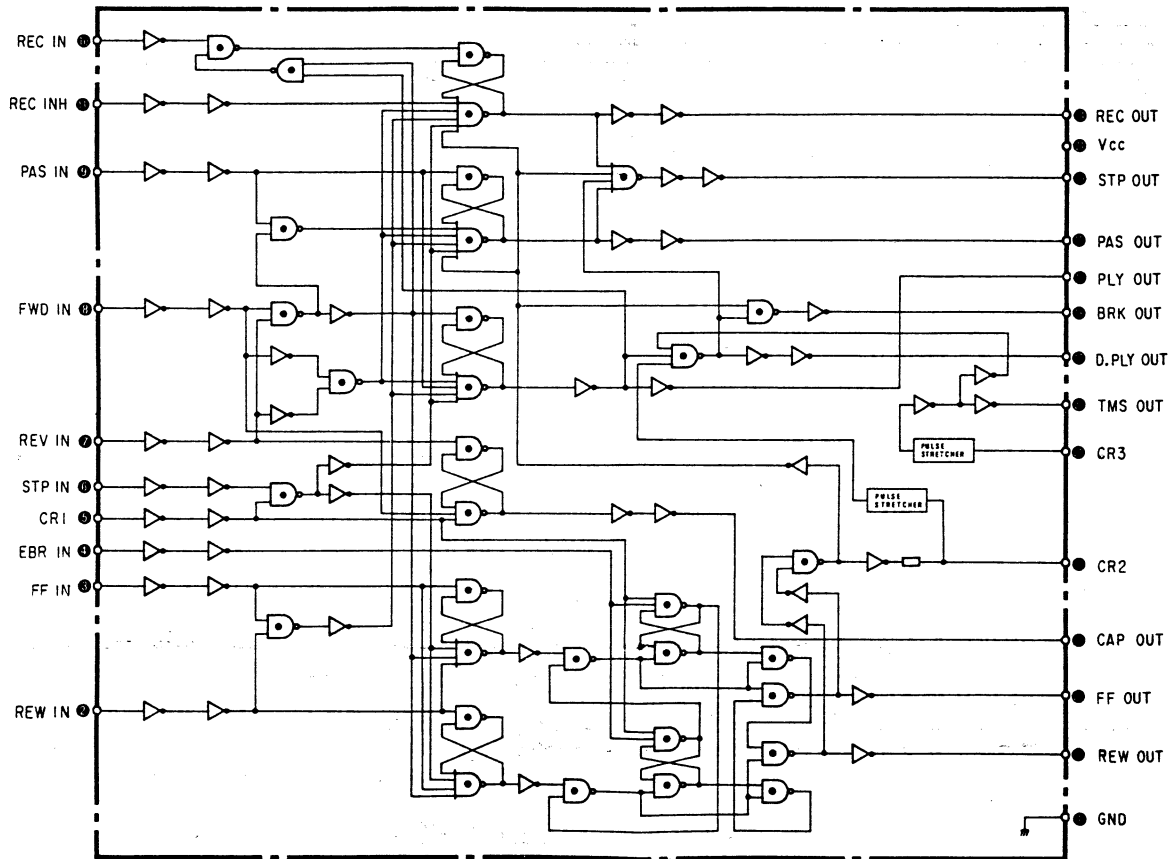

Top View

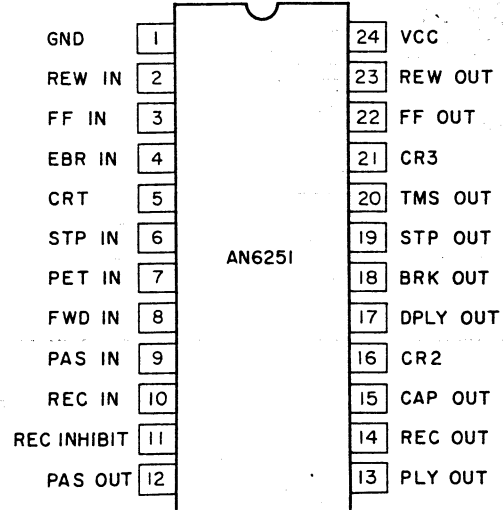

Truth Value Table (Negative Logic)

Terminal	22	23	13	17	15	12	19	14	18	20
Output Mode	FF out	REW out	PLY out	D PLY out	CAP out	PAS out	STP out	REC out	BRK out	TMS out
FWD	0	0	1	1Δ	0	0	0	0	1	0
REV	0	0	1	1Δ	1	0	0	0	1	0
FF	1	0	0	0	*	0	0	0	1	0
REW	0	1	0	0	*	0	0	0	1	0
STP	0	0	0	0	*	0	1	0	0	0
PAS	0	0	0	0	*	1	0	0	0	0
REC	0	0	0	0	*	0	0	1	0	0
REC PAS (F)	0	0	0	0	0	1	0	1	0	0
REC PAS (R)	0	0	0	0	1	1	0	1	0	0
REC FWD	0	0	1	1Δ	0	0	0	1	1	0
REC REV	0	0	1	1Δ	1	0	0	1	1	0

* Previous status maintained
Δ After a delay

NE646BN

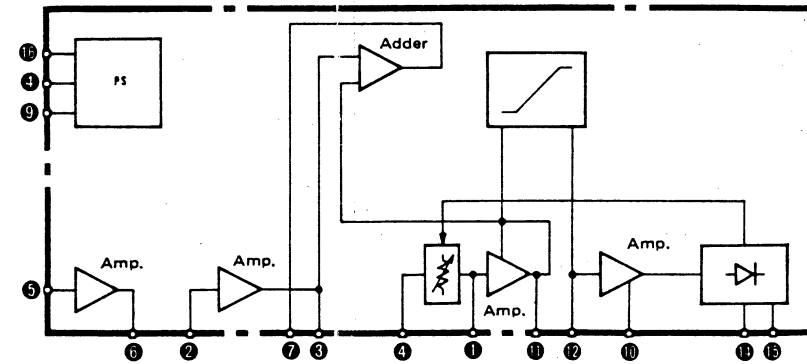

AN6551

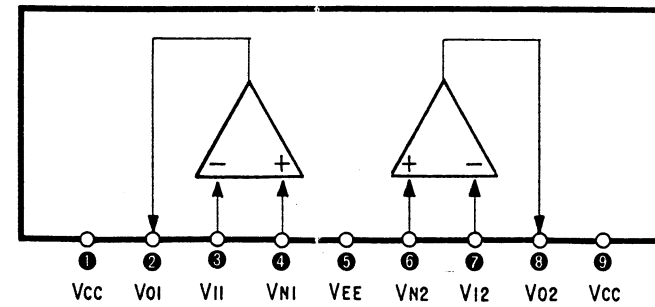

TA7136P

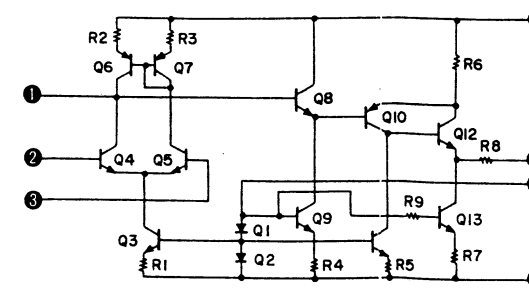

LOGIC SYMBOL

Function	LOGIC SYMBOL	
	MIL	
OR	A	Y
AND	A	Y
NOT (INVERTER)	A	Y
NOR	A	Y
NAND	A	Y

A	B	Y
L	L	L
H	L	H
L	H	H
H	H	H

A	B	Y
L	L	L
H	L	L
L	H	L
H	H	L

A	B	Y
L	L	L
H	L	L
L	H	L
H	H	L

A	B	Y
L	L	L
H	L	L
L	H	L
H	H	L

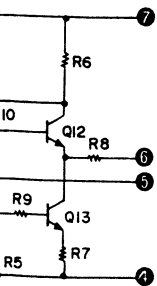
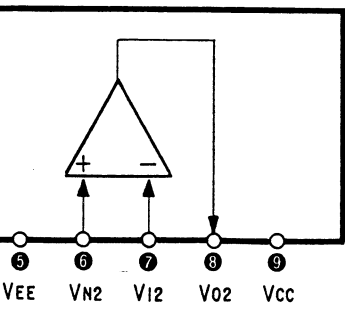
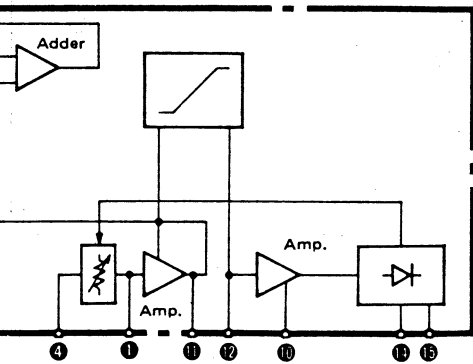

● LOGIC SYMBOL

Function	LOGIC SYMBOL	
	MIL	YAMAHA
OR		
AND		
NOT (INVERTER)		
NOR		
NAND		

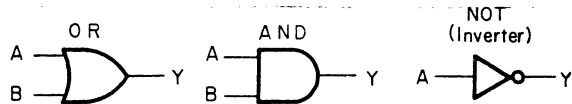

A	B	Y
L	L	L
H	L	H
L	H	H
H	H	H

A	B	Y
L	L	L
H	L	L
L	H	L
H	H	H

A	Y
L	H
H	L

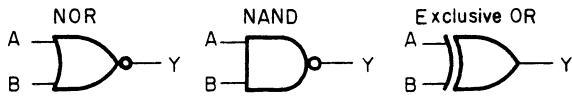

A	B	Y
L	L	H
H	L	L
L	H	L
H	H	L

A	B	Y
L	L	H
H	L	H
L	H	H
H	H	L

A	B	Y
L	L	L
H	L	H
L	H	H
H	H	L

■ PARTS LIST (REC/P.B.C. BOARD)

K-950

Ref. No.	Part No.	Description	(部 品 名)	Remarks	Common model	Markets
	32:00:00 NA:07:41:50	REC/P.B.C. BOARD	録音シート			
	32:00:00 NA:07:41:60	"	"			
	32:00:00 NA:07:41:70	"	"			
* C101	42:00:00 FG:51:31:50	Ceramic Capacitor 0.0015 μ F 50VB(K)	フォーミングセラコン			
C102						
C103	42:00:00 UW:84:71:00	Electrolytic Capacitor 10 μ F 25V	ケミコン小形自立形			
C104						
C105	42:00:00 FG:51:13:30	Ceramic Capacitor 33PF 50V SL(K)	フォーミングセラコン			
C106						
C107	42:00:00 FG:51:21:00	" 100PF "	"			
C108						
C109	42:00:00 FG:50:02:00	" 2PF 50V SL(F)	"			
C110						
C111	42:00:00 UW:81:91:00	Electrolytic Capacitor 1000 μ F 6.3V	ケミコン小形自立形			
C112						
C113	42:00:00 FA:15:41:20	Mylar Capacitor 0.012 μ F 50V MS(J)	マイラーコン			
C114						
C115	42:00:00 UW:86:64:70	Electrolytic Capacitor 4.7 μ F 50V	ケミコン小形自立形			
C116						
C117	42:00:00 UW:82:74:70	" 47 μ F 10V	"			
C118						
C119	42:00:00 UW:83:82:20	" 220 μ F 16V	"			
C120						
* C121	42:00:00 FG:54:44:70	Ceramic Capacitor 0.047 μ F 50V F(Z)	フォーミングセラコン			
C122						
C123	42:00:00 FA:15:34:30	Mylar Capacitor 0.0043 μ F 50V MS(J)	マイラーコン			
C124						
* C127	42:00:00 FG:51:28:20	Ceramic Capacitor 820PF 50V B(K)	フォーミングセラコン			
C128						
C129	42:00:00 FG:51:21:00	" 100PF 50V SL(K)	"			
C130						
* C131	42:00:00 FG:51:12:20	" 22PF 50V SL(K)	"			
C132						
C133	42:00:00 UW:86:61:00	Electrolytic Capacitor 1 μ F 50V	ケミコン小形自立形			
C134						
C135	42:00:00 FA:11:46:80	Mylar Capacitor 0.068 μ F 50V MS(K)	マイラーコン			
C136						
C137	42:00:00 FA:11:51:80	" 0.18 μ F "	"			
C138						
* C139	42:00:00 FG:51:28:20	Ceramic Capacitor 820PF 50V B(K)	フォーミングセラコン			
C140						
C141	42:00:00 UW:86:64:70	Electrolytic Capacitor 4.7 μ F 50V	ケミコン小形自立形			
C142						
C143	42:00:00 FG:51:11:00	Ceramic Capacitor 10PF 50V SL(K)	フォーミングセラコン			
C144						
C145	42:00:00 FG:51:15:60	" 56PF 50V SL(K)	"			
C146						
C147	42:00:00 FM:52:53:30	Electrolytic Capacitor 0.33 μ F 50V	Zコン			
C148						
C149	42:00:00 FM:22:64:70	Bipolar Capacitor(B.P)4.7 μ F 25V	B・Pコン			
C151	42:00:00 FA:15:34:30	Mylar Capacitor 0.0043 μ F 50V MS(J)	マイラーコン			
C152						
* C153	42:00:00 FA:15:34:30	" 0.0043 μ F "	"			
C154						
C155	42:00:00 FA:15:33:90	" 0.0039 μ F "	"			
C156						
C157	42:00:00 FA:15:35:60	" 0.0056 μ F "	"			
C158						
C159	42:00:00 FM:52:53:30	Electrolytic Capacitor 0.33 μ F 50V	Zコン			
C160						
C161	42:00:00 FA:11:51:00	Mylar Capacitor 0.1 μ F 50V MS(K)	マイラーコン			
C162						
C163	42:00:00 UW:84:71:00	Electrolytic Capacitor 10 μ 25V	ケミコン小形自立形			
C164						
C165	42:00:00 FA:11:44:70	Mylar Capacitor 0.047 μ F 50V MS(K)	マイラーコン			
C166						
C167	42:00:00 FA:15:34:70	" 0.0047 μ F 50V MS(J)	"			
C168						
C169	42:00:00 UW:84:71:00	Electrolytic Capacitor 10 μ F 25V	ケミコン小形自立形			
C170						
C171	42:00:00 UW:86:64:70	" 4.7 μ F 50V	"			
C172						
C173	42:00:00 FZ:00:05:70	" MS Type 1 μ F 50V	MSコン			
C174						
C175	42:00:00 UW:86:64:70	" 4.7 μ F 50V	ケミコン小形自立形			
C176						
C177	42:00:00 FA:15:42:70	Mylar Capacitor 0.027 μ F 50V MS	マイラーコン			
C178						
C179	42:00:00 FG:51:24:70	Ceramic Capacitor 470PF 50V B(K)	フォーミングセラコン			
C180						
C181	42:00:00 UW:86:54:70	Electrolytic Capacitor 0.47 μ F 50V	ケミコン小形自立形			
C182						
C183	42:00:00 FG:51:22:20	Ceramic Capacitor 220PF 50V SL(K)	フォーミングセラコン			
C184						
C185	42:00:00 FU:15:21:80	Mica Capacitor 180PF 500V(J)	シルバードマイカコン			
C186						
C187	42:00:00 UW:86:61:00	Electrolytic Capacitor 1 μ F 50V	ケミコン小形自立形			
C188	42:00:00 UW:83:72:20	" 22 μ F 16V	"			
* C189	42:00:00 UW:82:73:30	" 33 μ F 10V	"			
C190	42:00:00 UW:84:81:00	" 100 μ F 25V	"			
C191	42:00:00 UW:86:62:20	" 2.2 μ F 50V	"			
C192	42:00:00 UW:86:64:70	" 4.7 μ F 50V	"			
C193	42:00:00 UW:84:71:00	" 10 μ F 25V	"			

* : New Part (新部品)

Ref. No.	Part No.	Description	(部 品 名)	Remarks	Common model	Markets
C194	42:00:00 UW:83:72:20	Electrolytic Capacitor 22 μ F 16V	ケミコン小形自立形			
C195	42:00:00 UW:83:81:00	" 100 μ F 16V	"			
C196	42:00:00 UW:85:82:20	" 220 μ F 35V	"			
C197	42:00:00 UW:82:81:00	" 100 μ F 10V	"			
C198	42:00:00 UW:86:83:30	" 330 μ F 50V	"			
C199	42:00:00 UW:84:84:70	" 470 μ F 25V	"			
* C200	42:00:00 UW:84:92:20	" 2200 μ F 25V	"			
C201	42:00:00 UW:84:71:00	" 10 μ F 25V	"			
C202	42:00:00 UW:83:81:00	" 100 μ F 16V	"			
C203	42:00:00 UW:84:81:00	" 100 μ F 25V	"			
* C204	42:00:00 UW:84:92:20	" 2200 μ F 25V	"			
C205	42:00:00 UW:84:92:20	" 2200 μ F 25V	"			
C206	42:00:00 UW:81:81:00	" 100 μ F 6.3V	"			
C207	42:00:00 FH:23:41:00	Ceramic Capacitor 0.01 μ F 500V YZ(P)	セラコン			
C209	42:00:00 UW:83:84:70	Electrolytic Capacitor 470 μ F 16V	ケミコン小形自立形			
C211	42:00:00 UW:83:82:20	" 220 μ F 16V	"			
C212	42:00:00 UW:83:82:20	" 220 μ F 16V	"			
C213	42:00:00 FG:54:41:00	Ceramic Capacitor 0.01 μ F 50V F(Z)	セラコン			
C214	42:00:00 FG:54:41:00	Ceramic Capacitor 0.01 μ F 50V F(Z)	セラコン			
C215	42:00:00 FA:11:31:20	Mylar Capacitor 0.0012 μ F 50V MS(K)	マイラーコン			
C216	42:00:00 FA:11:31:20	Mylar Capacitor 0.0012 μ F 50V MS(K)	マイラーコン			
C217	42:00:00 UJ:44:71:00	Electrolytic Capacitor 10 μ F25V	ケミコン小形			
L101	42:00:00 GE:90:03:20	Bias Trap Coil FB-10	バイアストラップ			
L104	42:00:00 GE:90:03:20	Bias Trap Coil FB-10	バイアストラップ			
L105	42:00:00 GE:90:02:50	Coil 10mH	固定コイル			
L106	42:00:00 GE:90:02:50	Coil 10mH	固定コイル			
* L107	42:00:00 GE:90:04:30	" 15mH	"			
L108	42:00:00 GE:90:04:30	" 15mH	"			
L109	42:00:00 GE:20:02:50	MPX Filter FB-15S	MPXフィルタ			
L110	42:00:00 GE:20:02:50	MPX Filter FB-15S	MPXフィルタ			
L111	42:00:00 GE:90:03:00	Inducter 1mH (K)	固定インダクター			
L115	42:00:00 GE:90:03:00	Inducter 1mH (K)	固定インダクター			
R101	42:00:00 HJ:35:65:60	Carbon Resistor RD25 SM-8 5.6K Ω	カーボン抵抗			
R102	42:00:00 HJ:35:65:60	Carbon Resistor RD25 SM-8 5.6K Ω	カーボン抵抗			
R103	42:00:00 HJ:35:41:00	" 10 Ω	"			
R104	42:00:00 HJ:35:41:00	" 10 Ω	"			
R105	42:00:00 HJ:35:81:00	" 100K Ω	"			
R106	42:00:00 HJ:35:81:00	" 100K Ω	"			
R107	42:00:00 HJ:35:72:20	" 22K Ω	"			
R108	42:00:00 HJ:35:72:20	" 22K Ω	"			
R109	42:00:00 HJ:35:71:80	" 18K Ω	"			
R110	42:00:00 HJ:35:71:80	" 18K Ω	"			
R111	42:00:00 HJ:35:71:50	" 15K Ω	"			
R112	42:00:00 HJ:35:71:50	" 15K Ω	"			
R113	42:00:00 HJ:35:61:20	" 1.2K Ω	"			
R114	42:00:00 HJ:35:61:20	" 1.2K Ω	"			
R115	42:00:00 HJ:35:71:00	" 10K Ω	"			
R116	42:00:00 HJ:35:71:00	" 10K Ω	"			
R117	42:00:00 HJ:35:82:70	" 270K Ω	"			
R118	42:00:00 HJ:35:82:70	" 270K Ω	"			
R119	42:00:00 HJ:35:71:00	" 10K Ω	"			
R120	42:00:00 HJ:35:71:00	" 10K Ω	"			
R121	42:00:00 HJ:35:45:60	" 56 Ω	"			
R122	42:00:00 HJ:35:45:60	" 56 Ω	"			
R123	42:00:00 HJ:35:63:90	" 3.9K Ω	"			
R124	42:00:00 HJ:35:63:90	" 3.9K Ω	"			
R125	42:00:00 HJ:35:75:60	" 56K Ω	"			
R126	42:00:00 HJ:35:75:60	" 56K Ω	"			
R127	42:00:00 HJ:35:64:70	" 4.7K Ω	"			
R128	42:00:00 HJ:35:64:70	" 4.7K Ω	"			
R129	42:00:00 HJ:35:63:30	" 3.3K Ω	"			
R130	42:00:00 HJ:35:63:30	" 3.3K Ω	"			
R131	42:00:00 HJ:35:66:80	" 6.8K Ω	"			
R132	42:00:00 HJ:35:66:80	" 6.8K Ω	"			
R135	42:00:00 HJ:35:68:20	" 8.2K Ω	"			
R136	42:00:00 HJ:35:68:20	" 8.2K Ω	"			
R137	42:00:00 HJ:35:88:20	" 820K Ω	"			
R138	42:00:00 HJ:35:88:20	" 820K Ω	"			
R139	42:00:00 HJ:35:64:70	" 4.7K Ω	"			
R140	42:00:00 HJ:35:64:70	" 4.7K Ω	"			
R141	42:00:00 HJ:35:81:00	" 100K Ω	"			
R142	42:00:00 HJ:35:81:00	" 100K Ω	"			
R143	42:00:00 HJ:35:73:30	" 33K Ω	"			
R144	42:00:00 HJ:35:73:30	" 33K Ω	"			
R145	42:00:00 HJ:35:71:00	" 10K Ω	"			
R146	42:00:00 HJ:35:71:00	" 10K Ω	"			
R147	42:00:00 HJ:35:61:00	" 1K Ω	"			
R148	42:00:00 HJ:35:61:00	" 1K Ω	"			
R149	42:00:00 HJ:35:65:60	" 5.6K Ω	"			
R150	42:00:00 HJ:35:65:60	" 5.6K Ω	"			
R151	42:00:00 HJ:35:71:00	" 10K Ω	"			
R152	42:00:00 HJ:35:71:00	" 10K Ω	"			
R155	42:00:00 HJ:35:54:70	" 470 Ω	"			
R156	42:00:00 HJ:35:54:70	" 470 Ω	"			
R157	42:00:00 HJ:35:75:60	" 56K Ω	"			
R158	42:00:00 HJ:35:75:60	" 56K Ω	"			

* : New Part (新部品)

Ref. No.	Part No.			Description	(部 品 名)	Remarks	Common model	Markets
R159 R160	42:00:00	HJ 35 78 20	Carbon Resistor RD25 SM-8	82K Ω	カーボン抵抗			
R161	42:00:00	HJ 35 81 00	"	100K Ω	"			
R163 R164	42:00:00	HJ 35 81 00	"	100K Ω	"			
R165 R166	42:00:00	HJ 35 88 20	"	8.2K Ω	"			
R167 R168	42:00:00	HJ 35 65 60	"	5.6K Ω	"			
R169 R170	42:00:00	HJ 35 71 20	"	12K Ω	"			
R171	42:00:00	HJ 35 61 00	"	1K Ω	"			
R173 R174	42:00:00	HJ 35 81 00	"	100K Ω	"			
R175 R176	42:00:00	HJ 35 66 80	"	6.8K Ω	"			
R177 R178	42:00:00	HJ 35 54 70	"	470 Ω	"			
R179 R180	42:00:00	HJ 35 53 90	"	390 Ω	"			
R181 R182	42:00:00	HJ 35 54 70	"	470 Ω	"			
R183 R184	42:00:00	HJ 35 55 60	"	560 Ω	"			
R185 R186	42:00:00	HJ 35 51 80	"	180 Ω	"			
R187	42:00:00	HJ 35 82 70	"	270K Ω	"			
R189 R192	42:00:00	HJ 35 81 00	"	100K Ω	"			
R193 R194	42:00:00	HJ 35 82 70	"	270K Ω	"			
R195 R196	42:00:00	HJ 35 74 70	"	47K Ω	"			
R197 R198	42:00:00	HJ 35 63 30	"	3.3K Ω	"			
R199 R200	42:00:00	HJ 35 81 00	"	100K Ω	"			
R201 R202	42:00:00	HJ 35 61 00	"	1K Ω	"			
R203 R204	42:00:00	HJ 35 71 00	"	10K Ω	"			
R205 R206	42:00:00	HJ 35 81 00	"	100K Ω	"			
R207 R208	42:00:00	HJ 35 73 90	"	39K Ω	"			
R209 R212	42:00:00	HJ 35 61 50	"	1.5K Ω	"			
R213 R216	42:00:00	HV 35 44 70	Flame Proof Carbon Resistor RDF25	47 Ω	不燃化カーボン抵抗			
R217	42:00:00	HJ 35 63 30	Carbon Resistor RD25 SM-8	3.3K Ω	カーボン抵抗			
R218	42:00:00	HJ 35 73 90	"	39K Ω	"			
R219	42:00:00	HJ 35 72 20	"	22K Ω	"			
R230	42:00:00	HJ 35 72 20	"	22K Ω	"			
R231	42:00:00	HJ 35 61 50	"	1.5K Ω	"			
R232	42:00:00	HJ 35 53 30	"	330 Ω	"			
R233	42:00:00	HJ 35 62 20	"	2.2K Ω	"			
R234	42:00:00	HJ 35 72 20	"	22K Ω	"			
R235	42:00:00	HJ 35 71 00	"	10K Ω	"			
R236	42:00:00	HV 35 56 80	Flame Proof Carbon Resistor RDF25	680 Ω	不燃化カーボン抵抗			
R237	42:00:00	HJ 35 56 80	Carbon Resistor RD25 SM-8	680 Ω	カーボン抵抗			
R238	42:00:00	HJ 35 71 00	"	10K Ω	"			
R239	42:00:00	HJ 35 58 20	"	820 Ω	"			
R240 R241	42:00:00	HJ 35 63 30	"	3.3K Ω	"			
R242	42:00:00	HV 35 62 20	Flame Proof Carbon Resistor RDF25	2.2K	不燃化カーボン抵抗			
R243	42:00:00	HJ 35 66 80	Carbon Resistor RD25 SM-8	6.8K Ω	カーボン抵抗			
R244	42:00:00	HJ 35 55 60	"	560 Ω	"			
R245 R246	42:00:00	HJ 35 61 80	"	1.8K Ω	"			
R247	42:00:00	HL 31 58 20	Metal Oxide Film Resistor	820 Ω 1P	酸化抵抗			
R248	42:00:00	HJ 35 66 80	Carbon Resistor RD25 SM-8	6.8K Ω	カーボン抵抗			
R249 R250	42:00:00	HJ 35 62 20	"	2.2K Ω	"			
R251 R252	42:00:00	HJ 35 51 00	"	100 Ω	"			
R253	42:00:00	HJ 35 61 50	"	1.5K Ω	"			
R254	42:00:00	HJ 35 58 20	"	820 Ω	"			
R257 R258	42:00:00	HJ 35 83 30	"	330K Ω	"			
R259 R260	42:00:00	HJ 35 62 20	"	2.2K Ω	"			
R261 R262	42:00:00	HJ 35 51 50	"	150 Ω	"			

* : New Part (新部品)

Ref. No.	Part No.				Description	(部 品 名)	Remarks	Common model	Markets
R269 R270	42:00:00	HJ:35:91:00			Carbon Resistor RD25 SM-8 1M Ω	カーボン抵抗			
* R271	42:00:00	HL:32:51:50			Metal Oxide Film Resistor 150 Ω 2P	酸化膜抵抗			
R272	42:00:00	HJ:35:62:20			Carbon Resistor RD25 SM-8 2.2K Ω	カーボン抵抗			
R274 R278	42:00:00	HJ:35:61:00			" 1K Ω	"			
R279 R280	42:00:00	HJ:35:62:20			" 2.2K Ω	"			
R281 R282	42:00:00	HJ:35:61:80			" 1.8K Ω	"			
R283 R284	42:00:00	HJ:35:62:20			" 2.2K Ω	"			
VR101 ~106	42:00:00	HT:77:00:70			Semi Variable Resistor KVSF8-7PNF 20KB	半固定VR	Inter- changeable		
"	42:00:00	HT:37:00:80			" 20KB	"			
VR107 VR108	42:00:00	HT:37:01:00			" 50KB	"	Inter- changeable		
"	42:00:00	HT:77:00:80			" KVSF8-7PNF 50KB	"			
VR109	42:00:00	HT:77:00:50			" 5KB	"	Inter- changeable		
"	42:00:00	HT:37:00:50			" 5KB	"			
VR110	42:00:00	HT:37:00:20			" 10KB	"	Inter- changeable		
"	42:00:00	HT:77:00:60			" KVSF8-7PNF 10KB	"			
VR111	42:00:00	HS:41:09:00			Variable Resistor 50KMN \times 2	16 ϕ 2連VR			
* VR112	42:00:00	HQ:40:01:30			" (Slide type) 100KA \times 2	60形スライドVR			
VR113	42:00:00	HQ:41:00:10			" (Slide type) 5KB \times 2	45形 "			
VR114	42:00:00	HS:41:08:90			" 500B	16 ϕ 単連VR			
FR101 FR102	42:00:00	HW:19:46:80			Fuse Resistor 68 Ω 60mA	ヒューズ抵抗			
TR101 TR102	42:00:00	i E:10:05:40			F.E.T. 2SK68A (N1,N2)	F.E.T.			
TR103 TR108	42:00:00	i A:09:99:10			Transistor 2SA999 (E,F)	トランジスタ			
TR107 TR108	42:00:00	i A:06:73:10			" 2SA673A (C,D)	"			
TR109 TR110	42:00:00	i C:23:20:30			" 2SC2320L	"			
TR111 TR114	42:00:00	i D:06:55:00			" 2SD655 (D,E,F)	"			
TR115 TR116	42:00:00	i D:04:38:00			" 2SD438 (F,E)	"			
TR117 TR118	42:00:00	i B:05:60:00			" 2SB560	"			
TR119	42:00:00	i D:04:00:00			" 2SD400	"			
TR120 TR124	42:00:00	i C:23:20:10			" 2SC2320 (E,F)	"			
TR125 TR126	42:00:00	i D:04:00:00			" 2SD400	"			
TR127 TR131	42:00:00	i C:23:20:10			" 2SC2320 (E,F)	"			
TR132 TR134	42:00:00	i D:02:34:20			" 2SD234 Y	"			
TR135	42:00:00	i B:05:44:00			" 2SB544 (E,F)	"			
TR136	42:00:00	i A:07:33:00			" 2SA733 (R,P,Q,K)	"			
D101 D112	42:00:00	i F:00:00:40			Diode 1S1555	ダイオード			
* D113	42:00:00	i F:00:19:40			Zener Diode HZ24-2	ツェナーダイオード			
D114	42:00:00	i F:00:13:90			" RD30E-C	"			
D115	42:00:00	i F:00:14:20			" RD6,8J-B	"			
* D116	42:00:00	i F:00:19:20			" HZ12A3	"			
D117 D118	42:00:00	i H:00:02:40			Diode 1S1885	ダイオード			
D119 D120	42:00:00	i H:00:04:70			" 1D4B1	"			
* D121	42:00:00	i F:00:19:30			Zener Diode HZ4A	ツェナーダイオード			
D122	42:00:00	i F:00:12:70			LED (Green) SLP-237B	LED(緑)角型			
D123 D125	42:00:00	i F:00:12:60			" (Red) SLP-137B	" (赤) "			
D126	42:00:00	i H:00:02:40			Diode 1S1885	ダイオード			
IC101 IC102	42:00:00	i G:00:12:20			I.C. TA7136P	IC			
IC103 IC104	42:00:00	i G:03:46:00			I.C. NE646B (DOLBY)	"			
IC105	42:00:00	i G:03:47:00			I.C. AN6551	"			
* IC106	42:00:00	i G:03:93:00			OSC BLOCK	OSCブロック			

* : New Part (新部品)

Ref. No.	Part No.			Description	(部 品 名)	Remarks	Common model	Markets
SW101	42:00:00	KA:40:06:50	Slide Switch 12-2		スライドプルスイッチ			
SW102	42:00:00	KA:50:14:10	Rotary Slide Switch SRZV083S		ロータリースライドスイッチ			
* SW103	42:00:00	KA:80:13:90	Push Switch 4-2-2		プッシュスイッチ3連			
SW104	42:00:00	KA:80:09:60	Push Switch 2-2-2		プッシュスイッチ3連			
F101	42:00:00	KB:00:03:30	Fuse 1.0AT 250V		ヒューズタイラッシュ			J, R, A
F101	42:00:00	KB:00:06:60	Fuse 400mA 250		"			G, B
"	42:00:00	KB:00:12:90	" 1.5A 250(ULSS-2)		"			U, C
F103	42:00:00	KB:00:03:30	" 1.0AT 250V		"			J, R, A
F104	42:00:00	KB:00:07:30	" 1AT 250V		"			G, B
F104	42:00:00	KB:00:12:20	" 750mA 250V(ULST-4)		"			U, C
F103	42:00:00	KB:00:10:60	" 1A 250V(ULST-4)		"			U, C
PJ101	42:00:00	LB:40:05:80	Pin Jack 4P		ピンジャック			
*	42:00:00	BA:07:28:30	Heat Sink		放熱板			
	32:00:00	BA:07:82:90	"		"			
	42:00:00	LB:20:09:00	Fuse Holder Pin PC YSH 402P		ヒューズホルダーピン			J, R, U, A, C
	42:00:00	LB:20:10:60	" 403T		"			G, B
	42:00:00	LA:00:25:30	Wrapping Terminal P=(0) 1P		i型ラッピング端子板			
	42:00:00	LA:00:25:40	" P=5(0)2P		"			
	42:00:00	LA:00:25:50	" P=5(10) 3P		"			
	42:00:00	LA:00:20:40	" P=5 5P		"			
	42:00:00	LA:00:25:60	" P=7.5(0) 2P		"			
	42:00:00	LA:00:23:20	" P=7.5 3P		"			
	42:00:00	LA:00:21:40	" P=10 2P		"			
	42:00:00	LA:00:25:00	" 1P		"			
	42:00:00	LB:20:13:90	Base Pin 2.5 Pitch TEB 2P-SHF		ベースピン			
	42:00:00	EA:03:00:40	Pan Head Screw 3×4S ZMC2-Y		ナベ小ネジ			
	32:00:00	CB:08:83:00	L. E. D. Holder #8830		LED枠			
	42:00:00	EN:01:00:10	Pan Head Tapping Screw (Type II) 2.6×6		2種ミソタッピングネジ			
	32:00:00	CB:07:28:80	Isolation Bush 7288		絶縁ブッシュ			
	42:00:00	i L:00:02:70	Mica Base AC229		マイカーベース3本足			
	42:00:00	LA:00:21:10	Wrapping Terminal P=5 2P		i型ラッピング端子板			
	42:00:00	LA:00:20:00	" P=7.5 2P		"			
	42:00:00	LA:00:21:20	" P=5 3P		"			
	42:00:00	LA:00:25:70	" P=7.5(0) 3P		"			
	42:00:00	EA:02:60:60	Pan Head Screw 2.6×6S ZMC-Y		ナベ小ネジ			
	42:00:00	EV:42:00:30	Washer φ3 (ZMC2-Y)		外歯形歯付座金			

* : New Part (新部品)

K-950 ■ PARTS LIST (Control C. Board)

Ref. No.	Part No.		Description	(部 品 名)	Remarks	Common model	Markets
	32:00:00	NA:07:21:00	Control C.Board	コントロールシート			
C601	42:00:00	FG:24:41:50	Ceramic Capacitor 0.015 μ F 50V	セラコン			
C602	42:00:00	FJ:36:54:70	Electrolytic Capacitor 0.47 μ F 50V	ケミコンタテ型			
C611	42:00:00	FJ:21:81:00	" 100 μ F 6.3V	"			
C612	42:00:00	FJ:24:62:20	" 2.2 μ F 25V	"			
C613	42:00:00	FM:09:72:20	B.P Electrolytic Capacitor 22 μ F 16V	B.Pケミコンタテ型			
C614	42:00:00	FM:11:61:00	" 1 μ F 50V	"			
C615	42:00:00	FJ:24:64:70	Electrolytic Capacitor 4.7 μ F 25V	ケミコンタテ型			
C616	42:00:00	FJ:23:72:20	" 22 μ F 16V	"			
C617	42:00:00	FG:24:41:50	Ceramic Capacitor 0.015 μ F 50V	セラコン			
C618	42:00:00	FG:21:31:00	" 1000PF 50V(K)	"			
C621	42:00:00	FG:24:41:50	" 0.015 μ F 50V	"			
C622	42:00:00	FJ:23:71:00	Electrolytic Capacitor 10 μ F 16V	ケミコンタテ型			
C623	42:00:00	FJ:21:81:00	" 100 μ F 6.3V	"			
C624	42:00:00	FS:44:51:00	Ceramic Capacitor 0.1 μ F 50V	セラコン			
C632	42:00:00	FJ:24:81:00	Electrolytic Capacitor 100 μ F 25V	ケミコンタテ型			
C633	42:00:00	FJ:23:72:20	" 22 μ F 16V	"			
C661	42:00:00	FJ:23:71:00	" 10 μ F 16V	"			
C662	42:00:00	FJ:24:62:20	" 2.2 μ F 25V	"			
C671	42:00:00	FJ:23:71:00	" 10 μ 16V	"			
C672	42:00:00	FG:21:24:70	Ceramic Capacitor 470PF 50V	セラコン			
C673	42:00:00	FG:24:51:00	" 0.1 μ F 50V	"			
R601	42:00:00	HJ:15:72:20	Carbon Resistor 22K Ω	カーボン抵抗			
R602	42:00:00	HJ:15:74:70	" 47K Ω	"			
R603 R604	42:00:00	HJ:15:71:00	" 10K Ω	"			
R611 R613	42:00:00	HJ:15:74:70	" 47K Ω	"			
R614	42:00:00	HJ:15:81:00	" 100K Ω	"			
R616 R618	42:00:00	HJ:15:74:70	" 47K Ω	"			
R619	42:00:00	HJ:15:81:00	" 100K Ω	"			
R621 R622	42:00:00	HJ:15:81:00	" 100K Ω	"			
R624	42:00:00	HJ:15:72:20	" 22K Ω	"			
R625	42:00:00	HJ:15:74:70	" 47K Ω	"			
R626	42:00:00	HJ:15:64:70	" 4.7K Ω	"			
R631 R633	42:00:00	HJ:15:63:30	" 3.3K Ω	"			
R634	42:00:00	HJ:15:72:20	" 22K Ω	"			
R635	42:00:00	HJ:15:63:30	" 3.3K Ω	"			
R636	42:00:00	HJ:15:72:20	" 22K Ω	"			
R637 R639	42:00:00	HJ:15:71:00	" 10K Ω	"			
R641	42:00:00	HJ:15:71:00	" 10K Ω	"			
R642	42:00:00	HJ:15:52:70	" 270 Ω	"			
R643 R644	42:00:00	HJ:15:71:00	" 10K Ω	"			
R645	42:00:00	HJ:15:54:70	" 470 Ω	"			
R646	42:00:00	HJ:15:64:70	" 4.7K Ω	"			
R647 R648	42:00:00	HJ:15:61:00	" 1K Ω	"			
R649 R652	42:00:00	HJ:15:71:00	" 10K Ω	"			
R661 R662	42:00:00	HJ:15:61:00	" 1K Ω	"			
R663	42:00:00	HJ:15:68:20	" 8.2 Ω	"			
R664	42:00:00	HJ:15:72:20	" 22K Ω	"			
R665 R666	42:00:00	HJ:15:56:80	" 680 Ω	"			
R667 R668	42:00:00	HJ:15:53:90	" 390 Ω	"			
R669	42:00:00	HJ:15:72:20	" 22K Ω	"			
R670	42:00:00	HJ:15:71:00	" 10K Ω	"			
R671	42:00:00	HJ:15:61:00	" 1K Ω	"			

* : New Part (新部品)

Ref. No.	Part No.				Description	(部 品 名)	Remarks	Common model	Markets
R672	42:00:00	HJ	15:64:70		Carbon Resistor	4.7K Ω	カーボン抵抗		
R673	42:00:00	HJ	15:63:30		"	3.3K Ω	"		
R681 R691	42:00:00	HJ	15:63:30		"	3.3K Ω	"		
TR601	42:00:00	i A	08:44:00		Transistor	2SA844	トランジスター		
TR602	42:00:00	i C	19:18:00		"	2SC1918	"		
TR621 TR622	42:00:00	i C	19:18:00		"	2SC1918	"		
TR631 TR633	42:00:00	i C	19:18:00		"	2SC1918	"		
TR641 TR648	42:00:00	i A	08:44:00		"	2SA844	"		
TR661	42:00:00	i C	19:18:00		"	2SC1918	"		
TR662	42:00:00	i C	12:12:00		"	2SC1212A	"		
TR663	42:00:00	i C	19:18:00		"	2SC1918	"		
TR664	42:00:00	i D	04:00:00		"	2SD400	"		
TR665	42:00:00	i B	05:44:00		"	2SB544	"		
TR666	42:00:00	i D	04:00:00		"	2SD400	"		
TR667	42:00:00	i B	05:44:00		"	2SB544	"		
TR668 TR671	42:00:00	i C	19:18:00		"	2SC1918	"		
TR672	42:00:00	i C	12:12:00		"	2SC1212A	"		
TR673	42:00:00	i C	19:18:00		"	2SC1918	"		
TR674	42:00:00	i A	07:43:00		"	2SA743A	"		
TR681	42:00:00	i C	19:18:00		"	2SC1918	"		
TR682	42:00:00	i C	12:12:00		"	2SC1212A	"		
TR691	42:00:00	i C	19:18:00		"	2SC1918	"		
TR692	42:00:00	i C	12:12:00		"	2SC1212A	"		
D601 D603	42:00:00	i F	00:00:40		Diode	1S1555	ダイオード		
D611 D615	42:00:00	i F	00:00:40		"	1S1555	"		
D621 D622	42:00:00	i F	00:00:40		"	1S1555	"		
D631	42:00:00	i F	00:14:10		Zener Diode	HZ9B	ツェナーダイオード		
D632 D639	42:00:00	i F	00:00:40		Diode	1S1555	ダイオード		
D661	42:00:00	i F	00:13:30		Zener Diode	HZ9C	ツェナーダイオード		
D662	42:00:00	i F	00:00:40		Diode	1S1555	ダイオード		
D671	42:00:00	i F	00:00:40		"	"	"		
D672 D673	42:00:00	i H	00:02:40		"	1S1885	"		
IC601	42:00:00	i G	03:03:00		IC	AN6251	IC		
IC602	42:00:00	i G	03:16:00		"	78L05	"		
IC603	42:00:00	i G	03:04:50		"	DN6838	"		
SW601	42:00:00	KA	80:09:40		Push Switch		プッシュスイッチ		
	42:00:00	LA	00:23:90		L Type Lapping Plate	P=7.5 2P	L型ラッピング端子板		
	42:00:00	LA	00:23:80		"	P=5 5P	"		
	42:00:00	LB	60:29:40		Post (6P)	B6P-SHF-1	6Pベース付ポスト		
	42:00:00	BA	07:28:30		Heat Sink	#7283	放熱器		
	42:00:00	EA	03:00:60		Pan Head Screw	3 \times 6S ZMC2-Y	ナベ小ネジ		
	42:00:00	Mi	06:72:50		Ribbon Wire	2P $t=300$	リボンワイヤUL2468		
	42:00:00	Mi	06:78:50		"	4P $t=300$	" "		

* : New Part (新部品)