

STEREO CASSETTE DECK KX-393/493

SERVICE MANUAL

IMPORTANT NOTICE

This manual has been provided for the use of authorized YAMAHA Retailers and their service personnel. It has been assumed that basic service procedures inherent to the industry, and more specifically YAMAHA Products, are already known and understood by the users, and have therefore not been restated.

WARNING: Failure to follow appropriate service and safety procedures when servicing this product may result in personal injury, destruction of expensive components and failure of the product to perform as specified. For these reasons, we advise all YAMAHA product owners that all service required should be performed by an authorized YAMAHA Retailer or the appointed service representative.

IMPORTANT: The presentation or sale of this manual to any individual or firm does not constitute authorization, certification or recognition of any applicable technical capabilities, or establish a principle-agent relationship of any form.

The data provided is believed to be accurate and applicable to the unit(s) indicated on the cover. The research, engineering, and service departments of YAMAHA are continually striving to improve YAMAHA products. Modifications are, therefore, inevitable and specifications are subject to change without notice or obligation to retrofit. Should any discrepancy appear to exist, please contact the distributor's Service Division.

WARNING: Static discharges can destroy expensive components. Discharge any static electricity your body may have accumulated by grounding yourself to the ground buss in the unit (heavy gauge black wires connect to this buss).

IMPORTANT: Turn the unit OFF during disassembly and parts replacement. Recheck all work before you apply power to the unit.

■ CONTENTS

TO SERVICE PERSONNEL	1	DISPLAY DATA	15
FRONT PANELS	1	KX-393 BLOCK DIAGRAM	16
REAR PANEL	2	KX-493 BLOCK DIAGRAM	17
SPECIFICATIONS	3	KX-393 PRINTED CIRCUIT BOARD	18~21
INTERNAL VIEW	4	KX-493 PRINTED CIRCUIT BOARD	22~25
DISASSEMBLY PROCEDURES	5~7	KX-393 SCHEMATIC DIAGRAM	26
ADJUSTMENTS	8~11	KX-493 SCHEMATIC DIAGRAM	27
μ-COM DATA	12~14	PARTS LIST	28~45

100620

YAMAHA
YAMAHA CORPORATION
P.O. Box 1, Hamamatsu, Japan

2.82K-724 ☐ (K) Printed in Japan '98.1

KX-393/493

■ TO SERVICE PERSONNEL

1. Critical Components Information.
Components having special characteristics are marked Δ and must be replaced with parts having specifications equal to those originally installed.
 2. Leakage Current Measurement (For 120V Models Only).
When service has been completed, it is imperative to verify that all exposed conductive surfaces are properly insulated from supply circuits.
- Meter impedance should be equivalent to 1500 ohm shunted by 0.15 μ F.

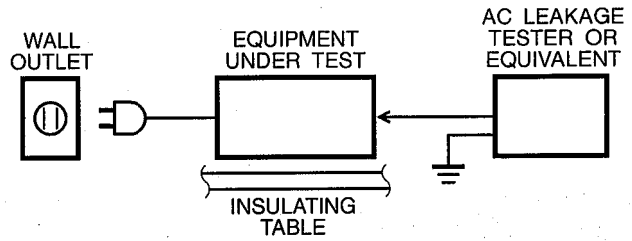

- Leakage current must not exceed 0.5mA.
- Be sure to test for leakage with the AC plug in both polarities.

WARNING: CHEMICAL CONTENT NOTICE!

The solder used in the production of this product contains LEAD. In addition, other electrical/electronic and/or plastic (where applicable) components may also contain traces of chemicals found by the California Health and Welfare Agency (and possibly other entities) to cause cancer and/or birth defects or other reproductive harm.

DO NOT PLACE SOLDER, ELECTRICAL/ELECTRONIC OR PLASTIC COMPONENTS IN YOUR MOUTH FOR ANY REASON WHATSOEVER!

Avoid prolonged, unprotected contact between solder and your skin! When soldering, do not inhale solder fumes or expose eyes to solder/flux vapor!

If you come in contact with solder or components located inside the enclosure of this product, wash your hands before handling food.

■ FRONT PANELS

▼ KX-393

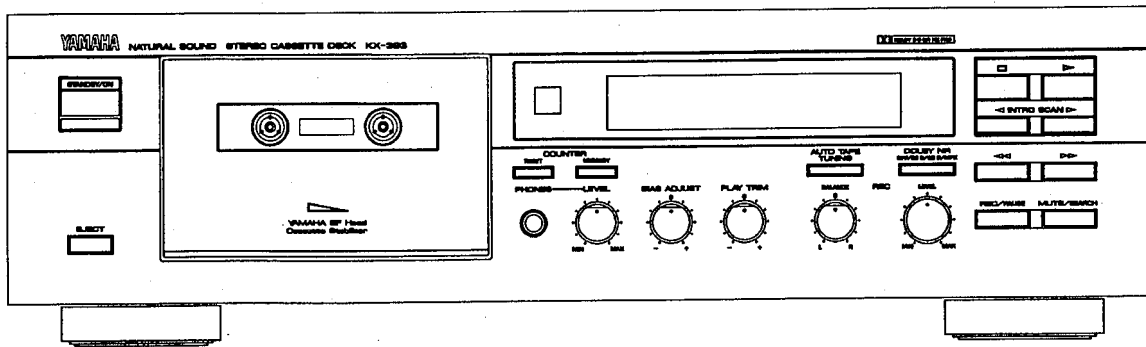

▼ KX-493

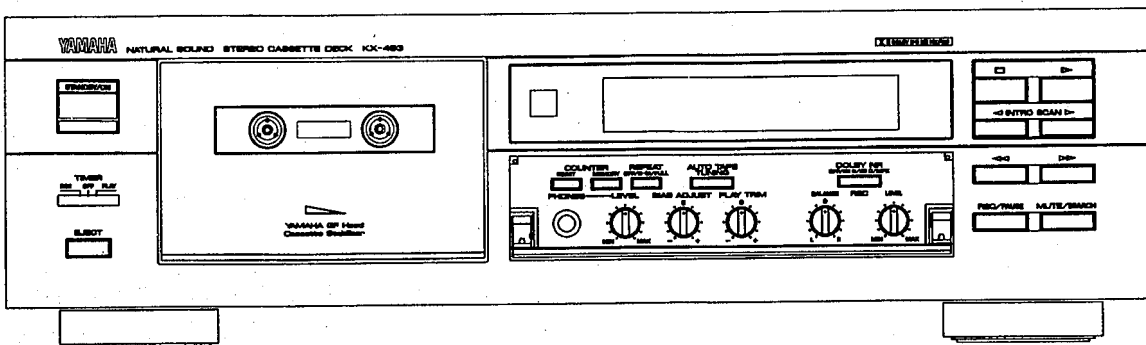

REAR PANEL

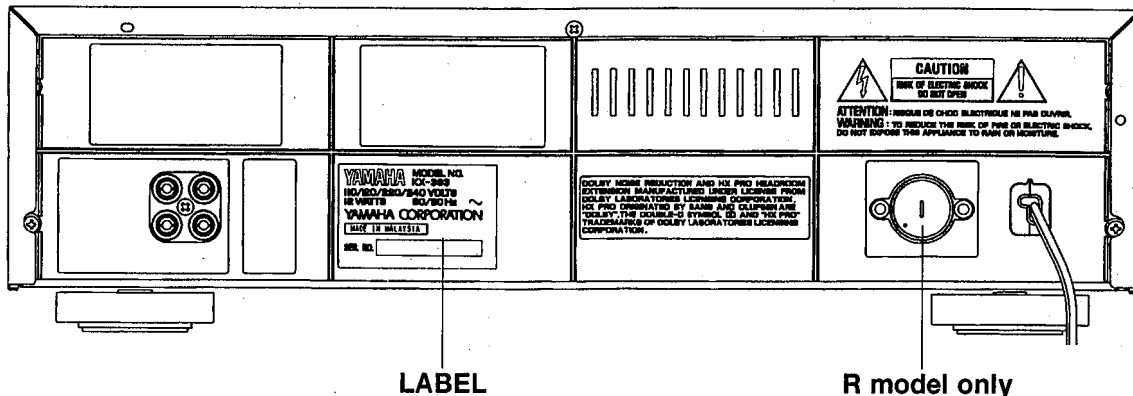

▼ LABEL B, G models

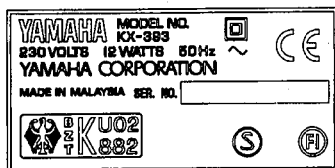

▼ LABEL R model

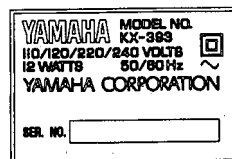

▼ LABEL U, C models

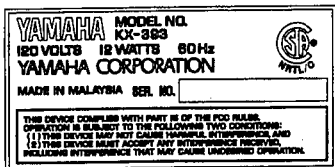

▼ LABEL A model

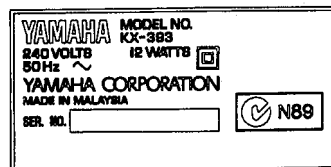

Dolby noise reduction and HX PRO headroom extension manufactured under license from Dolby Laboratories Licensing Corporation.
HX PRO originated by Bang and Olufsen. "DOLBY", the double-D symbol and "HX PRO" are trademarks of Dolby Laboratories Licensing Corporation.

■ KX-393 SPECIFICATIONS

Type	4-Track 2-Channel recording and playback stereo Cassette Deck	
Heads	REC/PB Erase	GF Head (Hard permalloy) Double Gap Ferrite
Motors	Main	DC servo motor x 1
Wow & Flutter	W.PEAK W.RMS	±0.12% 0.07%
Fast Winding Time	about 100 seconds (C-60 tape)	
Frequency Response (-20dB)		
	Type I/Normal tape	20-16000Hz±3dB
	Type II/High (CrO ₂) tape	20-17000Hz±3dB
	Type IV/Metal tape	20-19000Hz±3dB
S/N Ratio	NR off Dolby B NR on Dolby C NR on	58dB 66dB 74dB
Harmonic Distortion (315Hz, 3rd)	Less than 0.8%	
Channel Separation (1kHz)	More than 40dB	
Crosstalk (125Hz)	More than 55dB	
Input Sensitivity/ Impedance (0dB)		
	Line	100mV/50kΩ
Output Level (0dB)		
	Line Headphones	570mV/1kΩ 1.5mW/8Ω
Power Supplies		
	U, C models B, G models A model R model	AC120V, 60Hz AC230V, 50Hz AC240V, 50Hz AC110, 120, 220, 240V, 50/60Hz
Power Consumption	Power on Standby	12W 5W
Dimensions (W x H x D)	435 x 125.5 x 283 mm (17-1/8" x 4-15/16" x 11-1/8")	
Weight	4.4kg (9 lbs 11 oz)	
Accessories	Input, output cords (RCA type)	

*Specifications are subject to change without notice.

- U U.S.A model
- C Canadian model
- R General model
- A Australian model
- B British model
- G European model

■ KX-493 SPECIFICATIONS

Type	4-Track 2-Channel recording and playback stereo Cassette Deck	
Heads	REC/PB Erase	GF Head (Hard permalloy) Double Gap Ferrite
Motors	Capstan Reel	DC servo motor x 1 DC motor x 1
Wow & Flutter	W.PEAK W.RMS	±0.08% 0.05%
Fast Winding Time	about 90 seconds (C-60 tape)	
Frequency Response (-20dB)		
	Type I/Normal tape	20-17000Hz±3dB
	Type II/High (CrO ₂) tape	20-18000Hz±3dB
	Type IV/Metal tape	20-20000Hz±3dB
S/N Ratio	NR off Dolby B NR on Dolby C NR on	60dB 68dB 76dB
Harmonic Distortion (315Hz, 3rd)	Less than 0.8%	
Channel Separation (1kHz)	More than 40dB	
Crosstalk (125Hz)	More than 55dB	
Input Sensitivity/ Impedance (0dB)		
	Line	100mV/50kΩ
Output Level (0dB)		
	Line Headphones	570mV/1kΩ 1.5mW/8Ω
Power Supplies		
	B, G models A model R model	AC230V, 50Hz AC240V, 50Hz AC110, 120, 220, 240V, 50/60Hz
Power Consumption	Power on Standby	16W 5W
Dimensions (W x H x D)	435 x 125.5 x 278.5 mm (17-1/8" x 4-15/16" x 10-15/16")	
Weight	4.5kg (9 lbs 14 oz)	
Accessories	Input, output cords (RCA type)	

*Specifications are subject to change without notice.

- R General model
- A Australian model
- B British model
- G European model

Memory Backup (about 2 weeks)

- Power on/off
- Tape counter
- Dolby NR mode
- Auto tape tuning

Memory Backup (about 2 weeks)

- Power on/off
- Tape counter
- Dolby NR mode
- Auto tape tuning
- Repeat mode

■ KX-393 INTERNAL VIEW

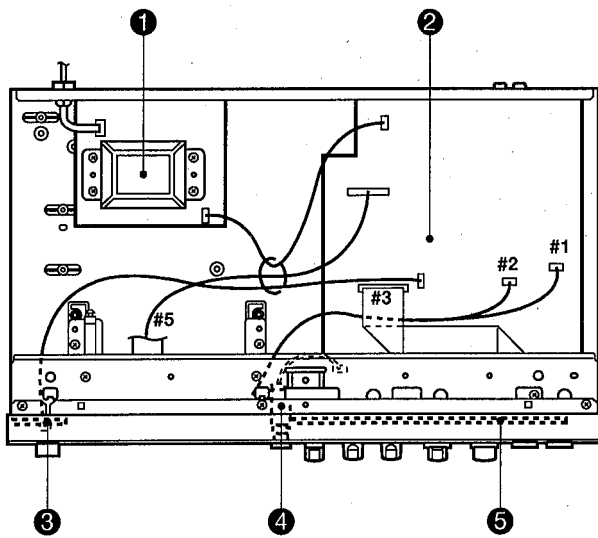

- ① P.C.B. TRANS
- ② P.C.B. MAIN (1)
- ③ P.C.B. MAIN (4)
- ④ P.C.B. MAIN (3)
- ⑤ P.C.B. MAIN (2)

■ KX-493 INTERNAL VIEW

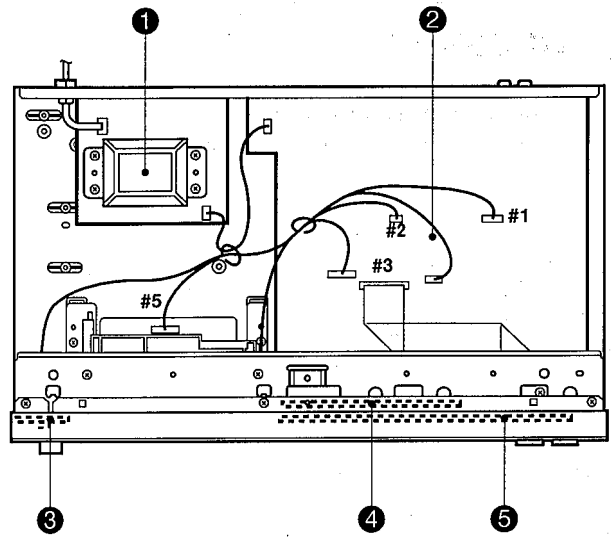

- ① P.C.B. MAIN (5) J, A, B, G models
P.C.B. TRANS R model
- ② P.C.B. MAIN (1)
- ③ P.C.B. MAIN (4)
- ④ P.C.B. MAIN (3)
- ⑤ P.C.B. MAIN (2)

● DIMENSIONS

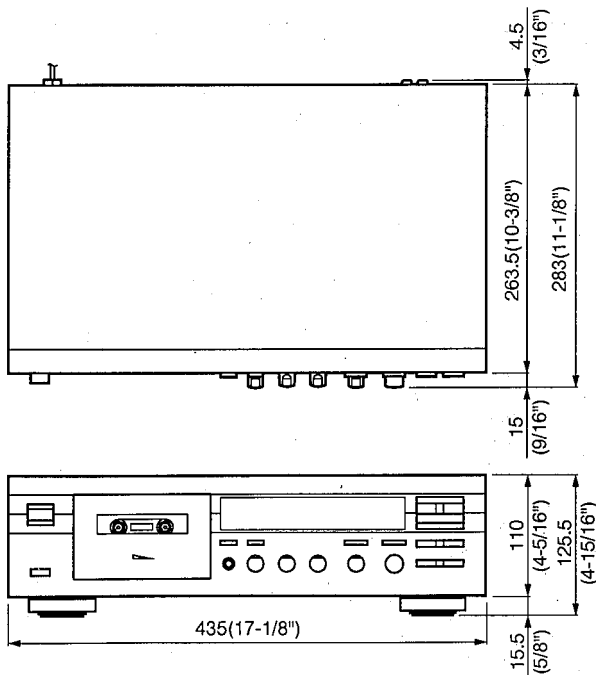

Unit : mm (inch)

● DIMENSIONS

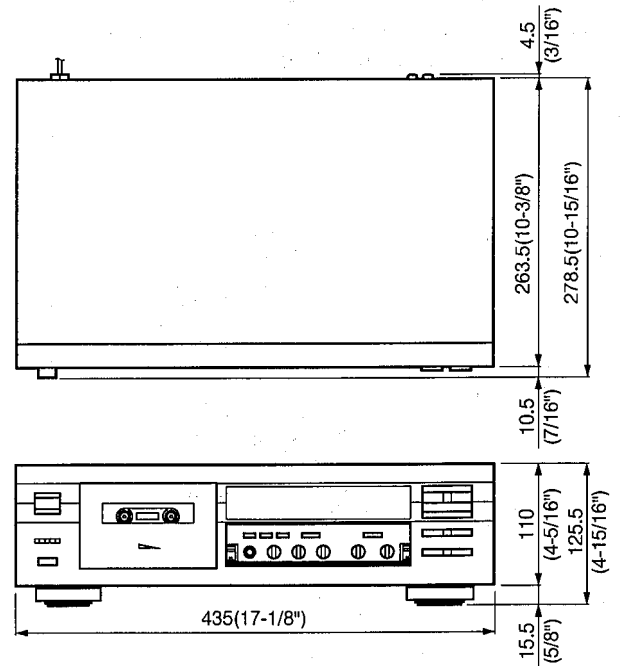

Unit : mm (inch)

DISASSEMBLY PROCEDURES (Remove parts in disassembly order as numbered)

KX-393

1. Removal of Top Cover

Remove 4 screws (①) and 1 screw (②) in Fig. 1.

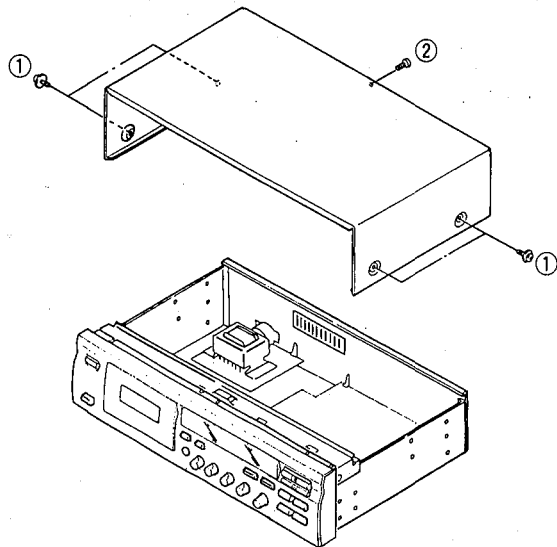

Fig. 1

2. Removal of Front Panel

- a. Remove 6 screws (③) in Fig. 2.
- b. Remove 5 knobs (A, B) in Fig. 2.
- c. Detach the hook and remove the P.C.B. Main (4).
- d. Remove 1 connector (#3).

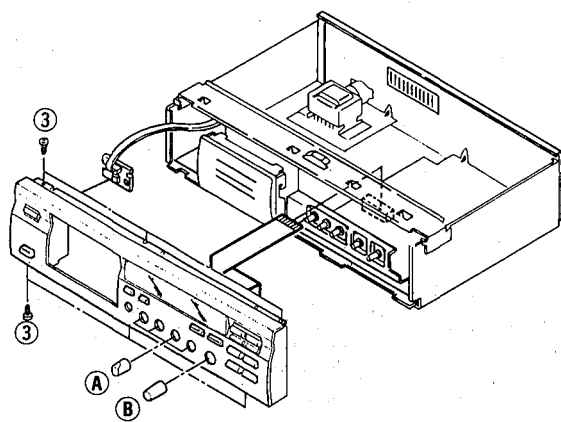

Fig. 2

KX-493

1. Removal of Top Cover

Remove 4 screws (①) and 1 screw (②) in Fig. 1.

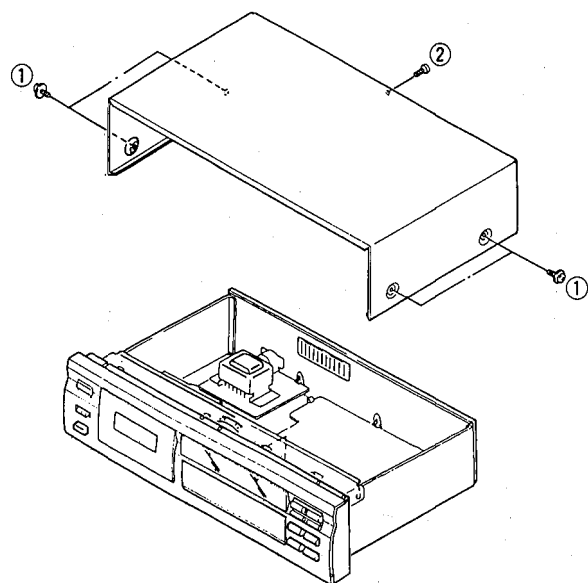

Fig. 1

2. Removal of Front Panel

- a. Remove 6 screws (③) and 1 plastic rivet (A) in Fig. 2.
- b. Remove 5 knobs in Fig. 2 after opening the sub panel.
- c. Remove 1 plastic rivet (B) in Fig. 2 and then remove the P.C.B. Main (4).
- d. Remove 1 connector (#3).

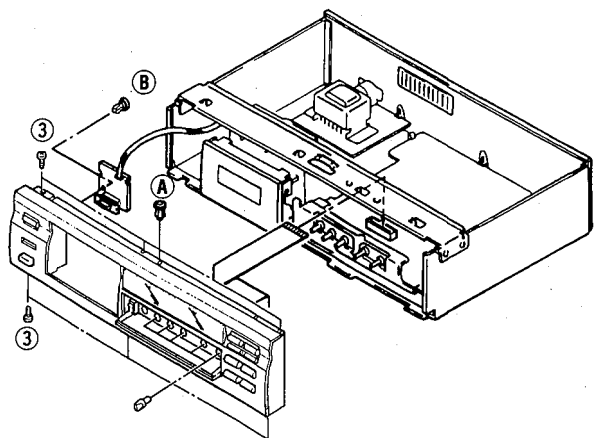

Fig. 2

3. Removal of Cassette Mechanism Unit

- a. Remove 4 screws (④) in Fig. 3.
- b. Remove the Cassette Mechanism Unit after sliding it toward the back.
- c. Remove 3 connectors (#1, #2, #5).
(See page 4)

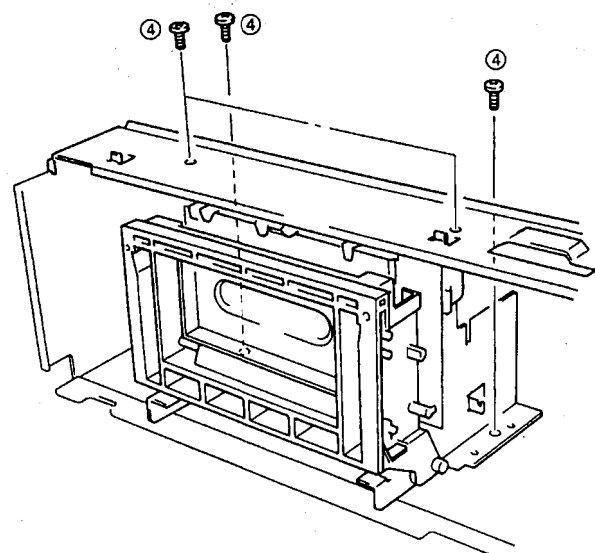

Fig. 3

4. Removal of Housing Ass'y

- a. Detach the spring in Fig. 4.
- b. Remove lower part of the Housing Ass'y by pressing it to outside.
- c. Remove the Housing Ass'y from the Damper Arm.

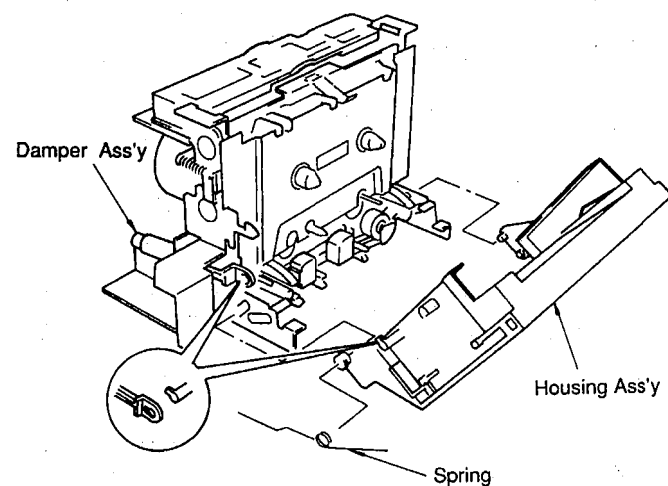

Fig. 4

5. Removal of Pinch Roller

- Pull off 1 hook and then remove the Pinch Roller in Fig. 5.

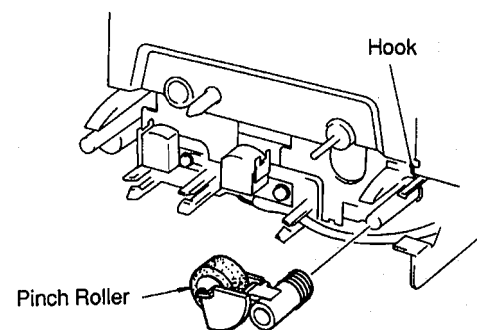

Fig. 5

6. Removal of Heads

- a. Remove 2 screws (⑤) and then remove the Recording/Playback Head in Fig. 6.
- b. Remove 2 screws (⑥) and then remove the Erase Head in Fig. 6.

* Perform the adjustment of azimuth after attaching the Head.

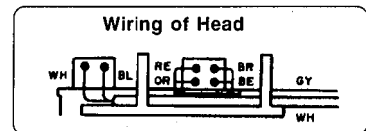
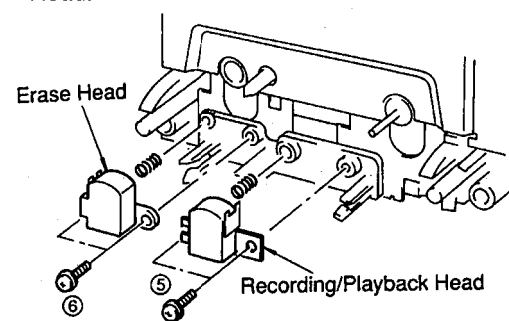

Fig. 6

7. Removal of Back Plate

- Remove 1 screw (⑦) and 1 plastic rivet (⑧) and then remove the Back Plate in Fig. 7.

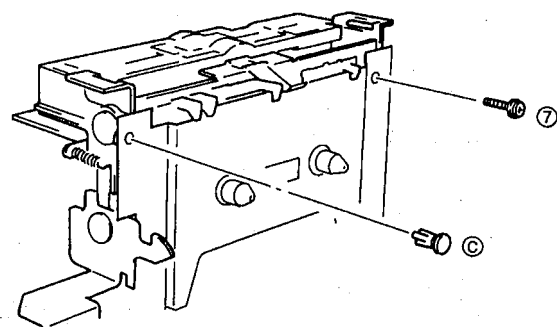

Fig. 7

KX-393

8. Removal of Main Motor

- Remove 2 screws (⑧) and then remove the Main Motor in Fig. 8.

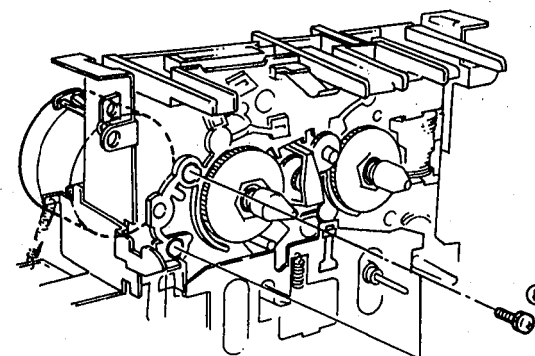

Fig. 8

9. Removal of P.C.B. Main (1)

- Remove 4 screws (⑨) and detach 2 hooks in Fig. 9.

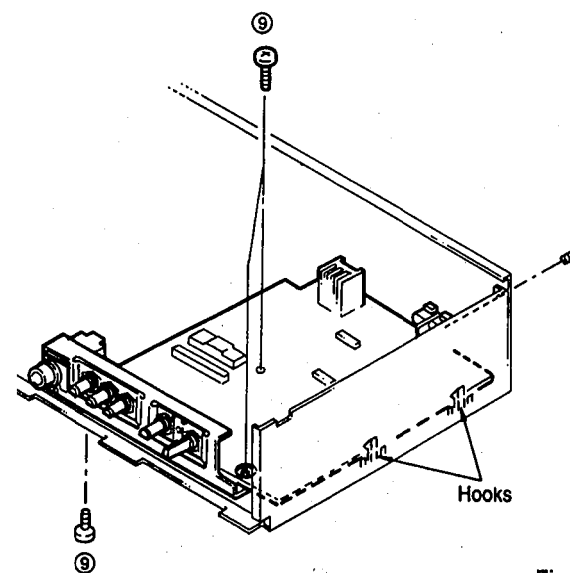

Fig. 9

KX-493

8. Removal of Capstan Motor & Reel Motor

- a. Remove 2 screws (⑧) and then remove the Capstan motor in Fig. 8.
- b. Remove 2 screws (⑨) and detach 2 hooks of the P.C.B. Cassette Mechanism, then remove the Reel Motor in Fig. 8.

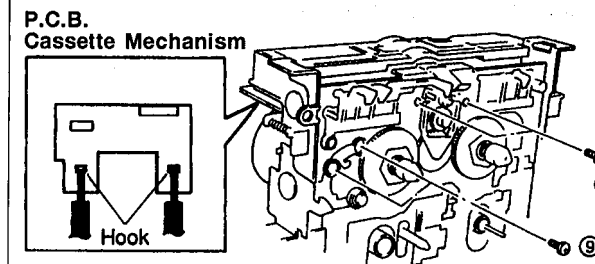

Fig. 8

9. Removal of P.C.B. Main (1)

- Remove 4 screws (⑩) and detach 4 hooks in Fig. 9.

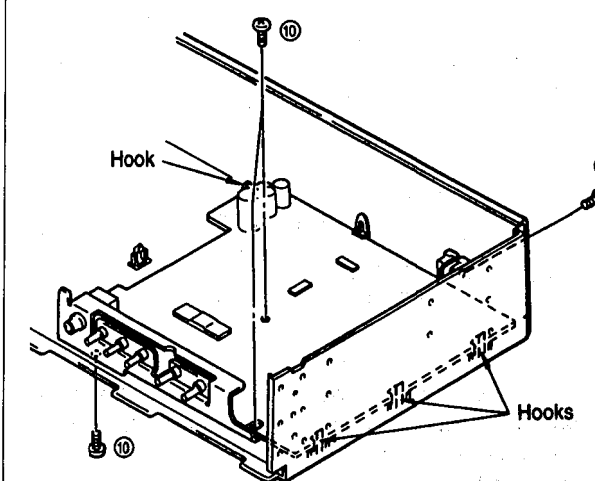

Fig. 9

ADJUSTMENTS

1. Before adjustment :

- Since head magnetization, dust accumulations, etc. are likely to introduce error in the various characteristics, it is very important that the heads are properly demagnetized and cleaned.
- Make adjustments of mechanical system, playback system and recording system in that order.
- Test Conditions

PLAY TRIM	→ Center
BAIS ADJUST	→ Center
REC LEVEL	→ Max
REC BALANCE	→ Center
PHONES LEVEL	→ Max
DOLBY NR	→ OFF

2. Instruments required

- Audio frequency oscillator
- ACVM or dual channel (ACVM)
- Wow/flutter meter
- Oscilloscope
- Frequency counter
- DCVM
- Torque meter
TW-2111A (TX911580) Take up/back tension (FWD)
CT-160L (TX911120) FF/REW

3. Test tape required

- MTT-111N (TX911650) Normal speed
- MTT-114N (TX911680) Azimuth
- MTT-212N (TX911660) Playback level
- MTT-256 (TX911300) Playback frequency response (Normal)
- MTT-356 (TX911310) Playback frequency response (CrO2)
- Reference tape
Type I/Normal (LH) TDK AC225 (VU167200)
Type II/High (CrO2) TDK AC514 (VU167300)
Type IV/METAL TDK AC713 (VU167400)

"MECHANICAL ADJUSTMENT"

Step	Item to be Adjusted	Tape	Instrument required	Mode	Adjustment part	Rating	Remarks
1	Check each torque	CT-160L (FF, REW)	Torque meter	FF	REW	FF, REW torque : more than 70g/cm.	Remove the damper and set the torque meter. (Fig. A)
		TW-2111A (FWD)					
2	Check FF, REW take up time	AC-225 (C-60)		FF REW		KX-393 : 85 to 115 seconds. KX-493 : 75 to 105 seconds.	
3	Azimuth	MTT-114N 10kHz, -10dB	ACVM Oscilloscope	PLAY	Azimuth adjustment screw.	Playback output of L and R is maximum and phase difference should be minimum. (Fig. B)	After the adjustment make sure to apply screw lock paint.
4	Tape Speed	MTT-111N 3kHz, -10dB	Frequency counter	PLAY	Potentiometer at the back of the capstan motor.	3005Hz ± 15Hz	Perform adjustment at the center of the test tape length if possible.
5	Wow/Flutter	MTT-111N 3kHz, -10dB	Wow/flutter meter	PLAY		KX-393 : Less than 0.15% (WRMS) KX-493 : Less than 0.14% (WRMS)	

● How to remove the damper from the housing ass'y.

1. Deress the damper with finger, and the damper can be removed from the shaft in Fig.A.
2. Take out the damper, lifting it up.

Note: When installing the damper, press out to snap into place after ensuring that the bottom damper levers do not jam when closing the door.

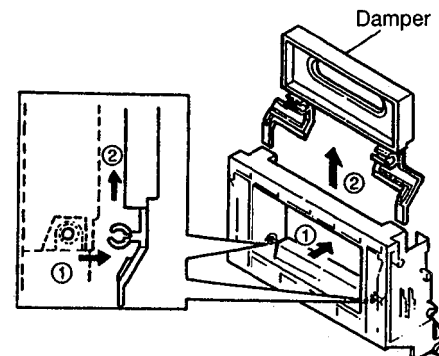
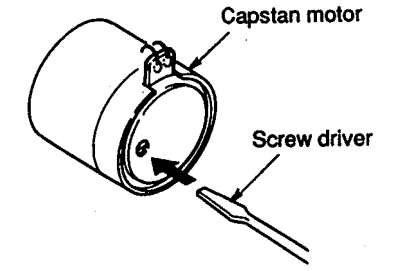
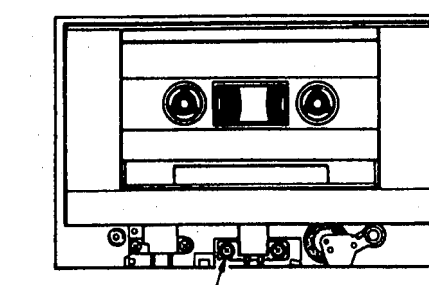
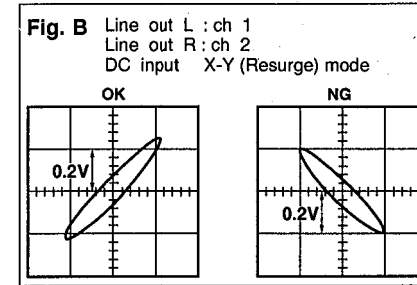

Fig. A



Azimuth adjustment screw

"ELECTRICAL ADJUSTMENT"

- Use 560mV (250nwb/m) for 0dB as the standard level of the unit.
0dB = 250nwb/m (315Hz) = -5dBV (Line out level)

FL TEST MODE (Note 1)

Enter the TEST MODE by pressing the POWER SW while pressing the RESET KEY when the power is OFF.

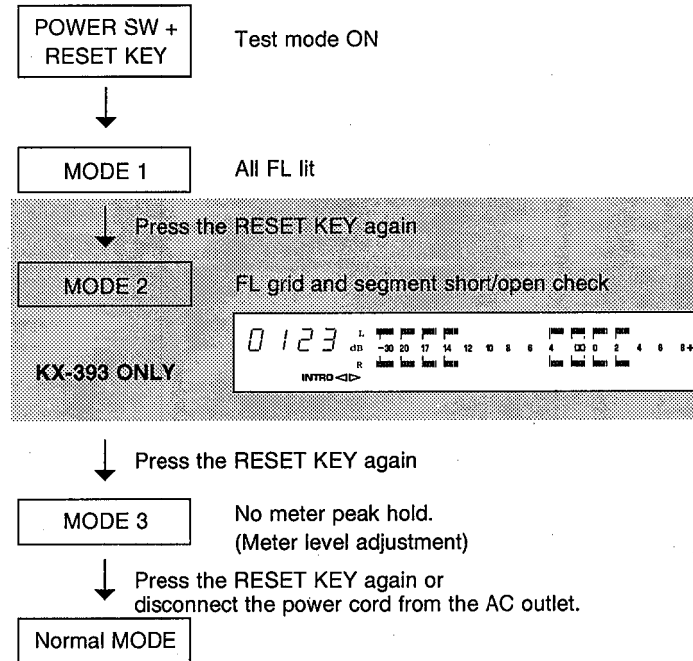

● PLAYBACK FREQUENCY RESPONSE

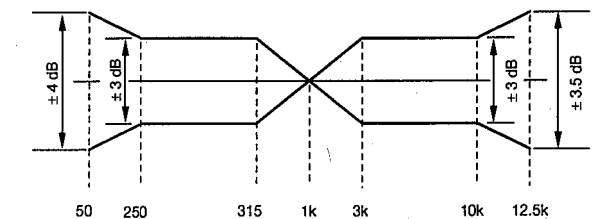

Fig. C

< Playback section > See page 11 for adjustment points

Step	Item to be Adjusted	Tape	Instrument required	Mode	Measurement conditions	Points of measurement	Adjustment parts	Rating
1	Playback level (315Hz)	MTT-212N 315Hz, 0dB 250nwb/m	ACVM	PLAY		LINE OUT	VR3 (L ch) VR4 (R ch)	-5dBV ±0.3dBV
2	Playback level (10kHz)	MTT-114N 10kHz, -10dB	ACVM	PLAY		LINE OUT	VR1 (L ch) VR2 (R ch)	-15dBV ±1.0dBV
3	Confirmation of playback frequency response	Test tape for frequency check. 3180µs±120µs (LH)(MTT-256) 3180µs±70µs (CrO2)(MTT-356)	ACVM Oscilloscope	PLAY		LINE OUT		Check that the 10kHz playback level is within 0 ± 3dB of the 1kHz playback level. (Fig. C)

< Recording section > See page 11 for adjustment points

Step	Item to be Adjusted	Tape	Instrument required	Mode	Measurement conditions	Points of measurement	Adjustment parts	Rating
1	Meter Level		ACVM Audio frequency oscillator	REC / PAUSE	1. Set the peek hold OFF. (Note 1) 2. Set REC LEVEL to maximum. 3. Input 315Hz signal to LINE IN terminal from Audio Frequency Oscillator. Adjust output level of Audio Frequency Oscillator so that the voltage of LINE OUT terminal becomes -5dBV.	Peak level meter	VR9 (L ch) VR10 (R ch)	Adjust VR9 and VR10 to the lowest level where the 0dB display part of the level meter lights up.
2	HX PRO	AC-514 High (CrO ₂)	DCVM	REC		TP1 (L) ~ G TP2 (R) ~ G	L3 (L ch) L4 (R ch)	Adjust L3 and L4 so that the DC voltage is minimized at TP1 (Lch) and TP2 (Rch).
3	Recording level	AC-514 High (CrO ₂)	ACVM Audio frequency oscillator	REC PLAY	1. Set REC LEVEL to maximum. 2. Input 315Hz signal to LINE IN terminal from Audio Frequency Oscillator. Adjust output level of Audio Frequency Oscillator so that the voltage of LINE OUT terminal becomes -25dBV.	LINE OUT	VR5 (L ch) VR6 (R ch)	Adjust for equal level of the record and playback levels. -25dBV ±0.3dBV
4	Recording bias (Total frequency response)	AC-514 High (CrO ₂) AC-225 Normal (LH) AC-713 METAL	ACVM Audio frequency oscillator	REC PLAY	1. Set REC LEVEL to maximum. 2. Input 12.5kHz signal to LINE IN terminal from Audio Frequency Oscillator. Adjust output level of Audio Frequency Oscillator so that the voltage of LINE OUT terminal becomes -25dBV.	LINE OUT	VR7 (L ch) VR8 (R ch)	Adjust for equal level of the record and playback levels. -25dBV ±0.5dBV Adjust for equal level of the record and playback levels. Fig. D Perform record bias adjustment of High (CrO ₂) tape again, if the rating was not satisfied.
5	Confirmation of recorded level	AC-514 High (CrO ₂)	ACVM Audio frequency oscillator	REC PLAY		LINE OUT		Confirm recorded level rating as in step 3. When recorded level rating is improper, go back to step 3 and also carry out adjustments in step 4 again.

● TOTAL FREQUENCY RESPONSE (-25dB)

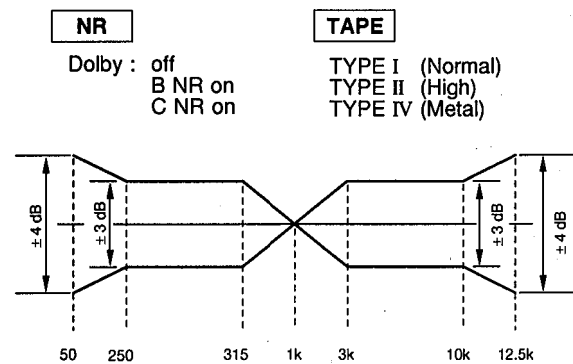
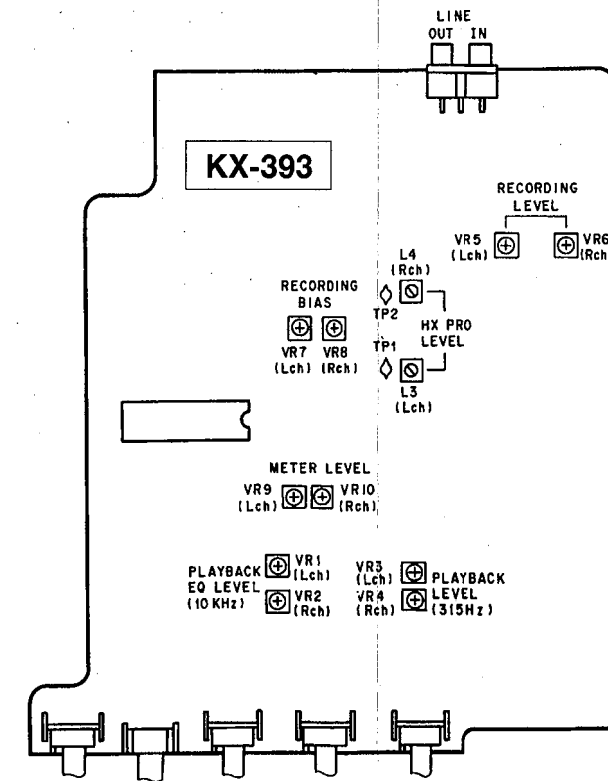
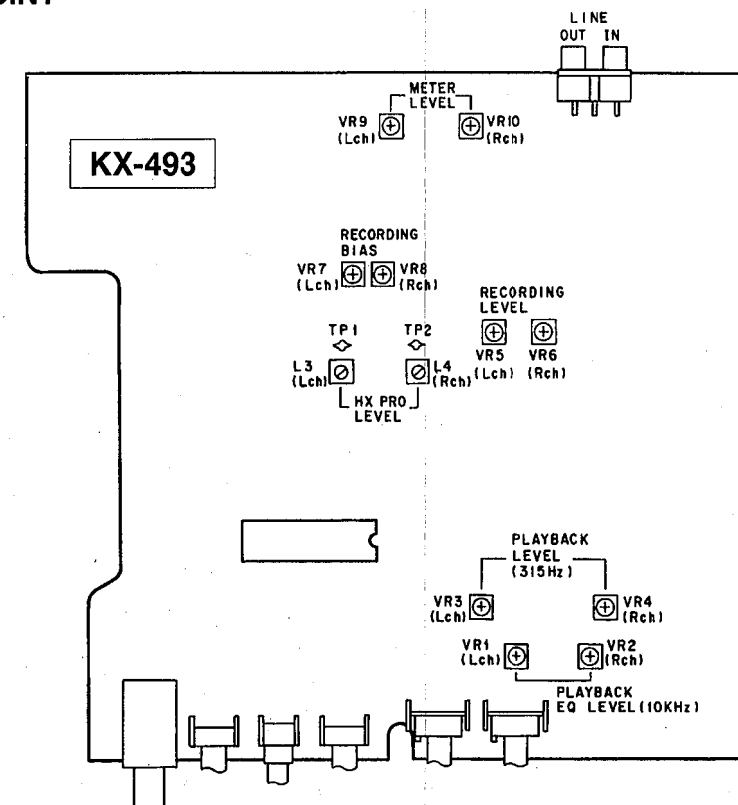

Fig. D

● KX-393 TEST POINT



● KX-493 TEST POINT



■ μ-COM DATA

LC65204A
4 bit μ-COM (System Control)

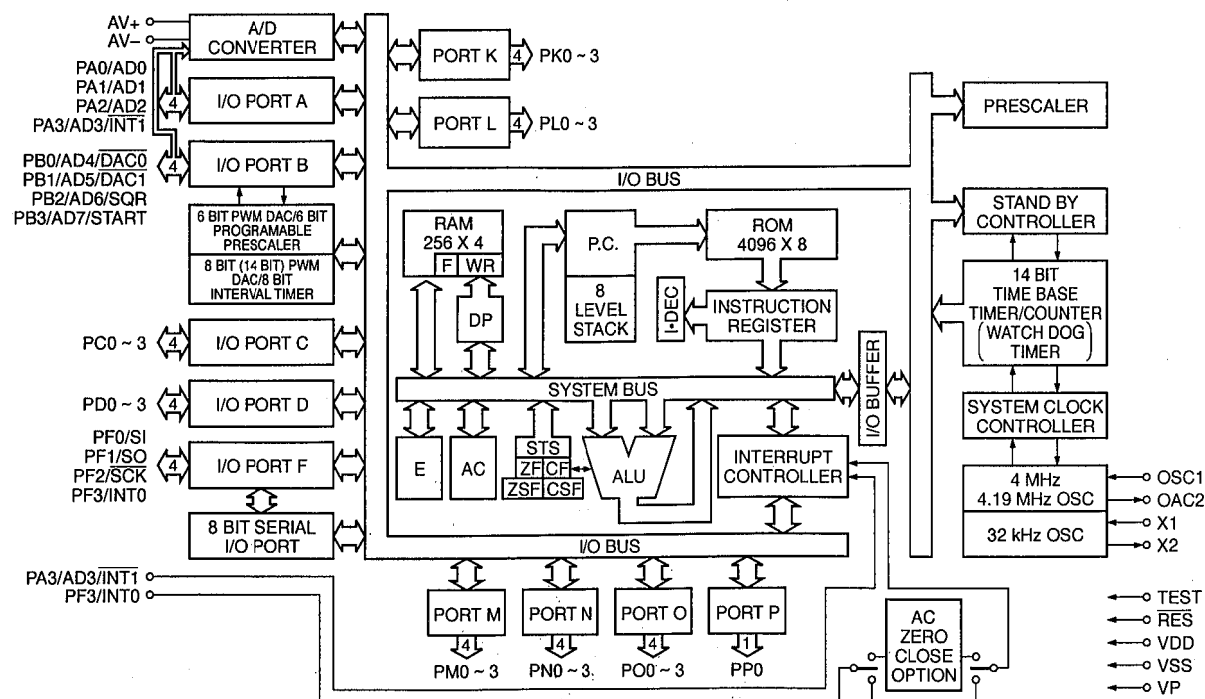
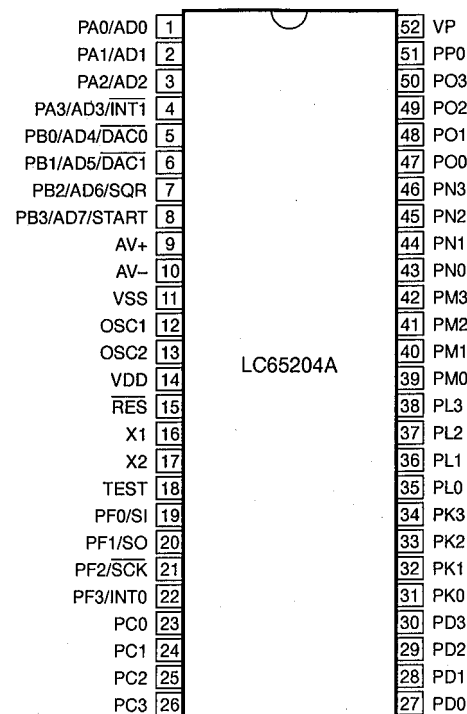

KX-393

IC12 : LC65204A-4G83

No.	Port	Function	Logic	No.	Port	Function	Logic
1	PA0	OPERATION KEY (1) A/D		52	Vp	- 21V	
2	PA1	OPERATION KEY (2) A/D		51	PP0	FL DIGIT 9	H : ON
3	PA2	METER INPUT (L) A/D		50	PO3	FL DIGIT 8	H : ON
4	PA3	METER INPUT (R) A/D		49	PO2	FL DIGIT 7	H : ON
5	PB0	MECHA SW A/D		48	PO1	FL DIGIT 6	H : ON
6	PB1	MECHA SW & TIMER A/D		47	PO0	FL DIGIT 5	H : ON
7	PB2	REEL PULSE		46	PN3	FL DIGIT 4	H : ON
8	PB3	POWER PULSE		45	PN2	FL DIGIT 3	H : ON
9	AV+	+5V		44	PN1	FL DIGIT 2	H : ON
10	AV-	GND		43	PN0	FL DIGIT 1	H : ON
11	VSS	GND		42	PM3	FL SEGMENT 1	H : ON
12	OSC1	4MHz		41	PM2	FL SEGMENT 2	H : ON
13	OSC2	4MHz		40	PM1	FL SEGMENT 3	H : ON
14	VDD	+5V		39	PM0	FL SEGMENT 4	H : ON
15	RES	RESET		38	PL3	FL SEGMENT 5	H : ON
16	X1	+5V		37	PL2	FL SEGMENT 6	H : ON
17	X2	OPEN		36	PL1	FL SEGMENT 7	H : ON
18	TEST	GND		35	PL0	FL SEGMENT 8	H : ON
19	PF0	PORT EXPANDER IC (CLOCK)		34	PK3	FL SEGMENT 9	H : ON
20	PF1	PORT EXPANDER IC (DATA)		33	PK2	FL FILAMENT ON/OFF	H : ON
21	PF2	BIAS	H : ON	32	PK1	REC/PB SELECT	H : PB
22	PF3	REMOCON INPUT		31	PK0	MPX FILTER	H : ON
23	PC0	MECHA DRIVE CM	H : ON	30	PD3	DOLBY 2 (DOLBY C ON/OFF)	H : OFF
24	PC1	MECHA DRIVE SOLENOID	H : ON	29	PD2	DOLBY 1 (DOLBY ON/OFF)	H : OFF
25	PC2	Not used (47k GND)		28	PD1	REC MUTE	H : ON
26	PC3	HEAD SELECT	H : REC	27	PD0	LINE MUTE	H : ON

OUTPUT OF EXPANDER (IC13) PORT

Pin No.	NAME	LOGIC	Pin No.	NAME	LOGIC
4	LH	H : ON	10	LEVEL 3	
5	HIGH	H : ON	11	LEVEL 4	
6	METAL	H : ON	12	BIAS 1	
7	70	H : ON	13	BIAS 2	
8	TAPE TUNING		14	BIAS 3	
9	LEVEL 1		15	BIAS 4	

CONDITION OF OUTPUT PORT IN DECK MODE

Pin No.	NAME	STOP	PLAY	FF/REW	SEARCH	REC PAUSE	REC
21	BIAS	H	H	H	H	H	L
27	LINE MUTE	L	L	H	L	H	H
28	REC MUTE	H	H	H	H	H	L
32	REC/PB SELECT	H	H	H	H	L	L

KX-493

IC13 : LC65204A-4C97

No.	Port	Function	Logic	No.	Port	Function	Logic
1	PA0	OPERATION KEY (1) A/D		52	Vp	- 21V	
2	PA1	OPERATION KEY (2) A/D		51	PP0	FL DIGIT 9	H : ON
3	PA2	METER INPUT (L) A/D		50	PO3	FL DIGIT 8	H : ON
4	PA3	METER INPUT (R) A/D		49	PO2	FL DIGIT 7	H : ON
5	PB0	MECHA SW A/D		48	PO1	FL DIGIT 6	H : ON
6	PB1	MECHA SW & TIMER A/D		47	PO0	FL DIGIT 5	H : ON
7	PB2	REEL PULSE		46	PN3	FL DIGIT 4	H : ON
8	PB3	POWER PULSE		45	PN2	FL DIGIT 3	H : ON
9	AV+	+5V		44	PN1	FL DIGIT 2	H : ON
10	AV-	GND		43	PN0	FL DIGIT 1	H : ON
11	VSS	GND		42	PM3	FL SEGMENT 1	H : ON
12	OSC1	4MHz		41	PM2	FL SEGMENT 2	H : ON
13	OSC2	4MHz		40	PM1	FL SEGMENT 3	H : ON
14	VDD	+5V		39	PM0	FL SEGMENT 4	H : ON
15	RES	RESET		38	PL3	FL SEGMENT 5	H : ON
16	X1	+5V		37	PL2	FL SEGMENT 6	H : ON
17	X2	OPEN		36	PL1	FL SEGMENT 7	H : ON
18	TEST	GND		35	PL0	FL SEGMENT 8	H : ON
19	PF0	PORT EXPANDER IC (CLOCK)		34	PK3	FL SEGMENT 9	H : ON
20	PF1	PORT EXPANDER IC (DATA)		33	PK2	FL FILAMENT ON/OFF	H : ON
21	PF2	BIAS	H : ON	32	PK1	DOLBY 2 (DOLBY C ON/OFF)	H : OFF
22	PF3	REMOCON INPUT		31	PK0	DOLBY 1 (DOLBY ON/OFF)	H : OFF
23	PC0	MECHA DRIVE CM	H : ON	30	PD3	MPX FILTER	H : ON
24	PC1	MECHA DRIVE SOLENOID	H : ON	29	PD2	REC/PB SELECT	H : PB
25	PC2	MECHA DRIVE REEL FF		28	PD1	REC MUTE	H : ON
26	PC3	MECHA DRIVE REEL REW		27	PD0	LINE MUTE	H : ON

OUTPUT OF EXPANDER (IC14) PORT

Pin No.	NAME	LOGIC	Pin No.	NAME	LOGIC
4	LH	L : ON	10	LEVEL 3	
5	HIGH	L : ON	11	LEVEL 4	
6	METAL	H : ON	12	BIAS 1	
7	TAPE TUNING	H : OFF	13	BIAS 2	
8	LEVEL 1		14	BIAS 3	
9	LEVEL 2		15	BIAS 4	

CONDITION OF OUTPUT PORT IN DECK MODE

Pin No.	NAME	STOP	PLAY	FF/REW	SEARCH	REC PAUSE	REC
21	BIAS	L	L	L	L	L	H
27	LINE MUTE	H	L	H	H	L	L
28	REC MUTE	H	H	H	H	H	L
29	REC/PB SELECT	H	H	H	H	L	L

■ DISPLAY DATA (VQ667400)

● V1 : BJ214GK

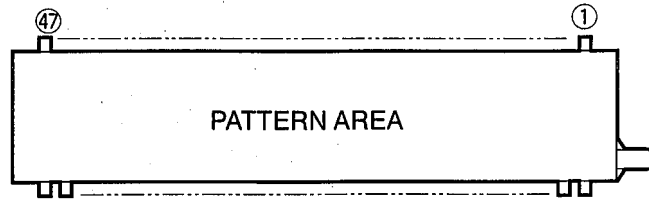

PIN CONNECTION

PIN NO.	1	2	3	4	5	6	7	8	9	10	11	12	13	14	15	16	17	18	19	20	21
CONNECTION	F1	F1	NP	NP	P10	P9	P8	P7	P6	P5	P4	P3	P2	P1	NC	NC	NC	NC	NC	NC	NC
PIN NO.	22	23	24	25	26	27	28	29	30	31	32	33	34	35	36	37	38	39	40	41	42
CONNECTION	NC	NC	NC	NC	NC	NC	NC	NC	NC	NC	NC	NC	NC	1G	2G	3G	4G	5G	6G	7G	8G
PIN NO.	43	44	45	46	47																
CONNECTION	9G	NP	NP	F2	F2																

NOTE 1) F1, F2 Filament
 2) NP No pin
 3) NC No connection
 4) P1~P10... Datum Line
 5) 1G~11G.. Grid

GRID ASSIGNMENT

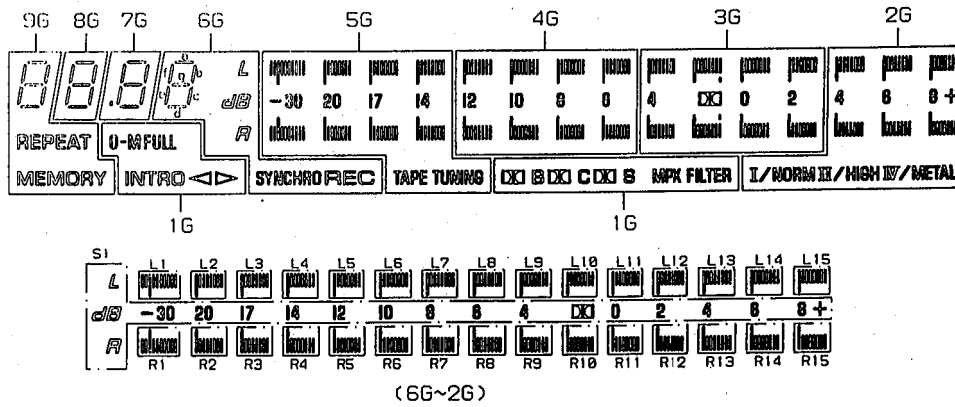

ANODE CONNECTION

	9G	8G	7G	6G	5G	4G	3G	2G	1G
P1	a	a	a	a	L1	L5	L9	L13	0-M
P2	b	b	b	b	L2	L6	L10	L14	FULL
P3	c	c	c	c	L3	L7	L11	L15	INTRO
P4	d	d	d	d	L4	L8	L12	I/NORM	<
P5	e	e	e	e	R1	R5	R9	R13	>
P6	f	f	f	f	R2	R6	R10	R14	DX B
P7	g	g	g	g	R3	R7	R11	R15	DX C
P8	REPEAT	—	o	SYNCHRO	R4	R8	R12	II/HIGH	DX S
P9	MEMORY	—	—	REC	TAPE TUNING	—	—	IV/METAL	MPX FILTER
P10	—	—	—	S1	S1	S1	S1	S1	—

■ KX-393 BLOCK DIAGRAM

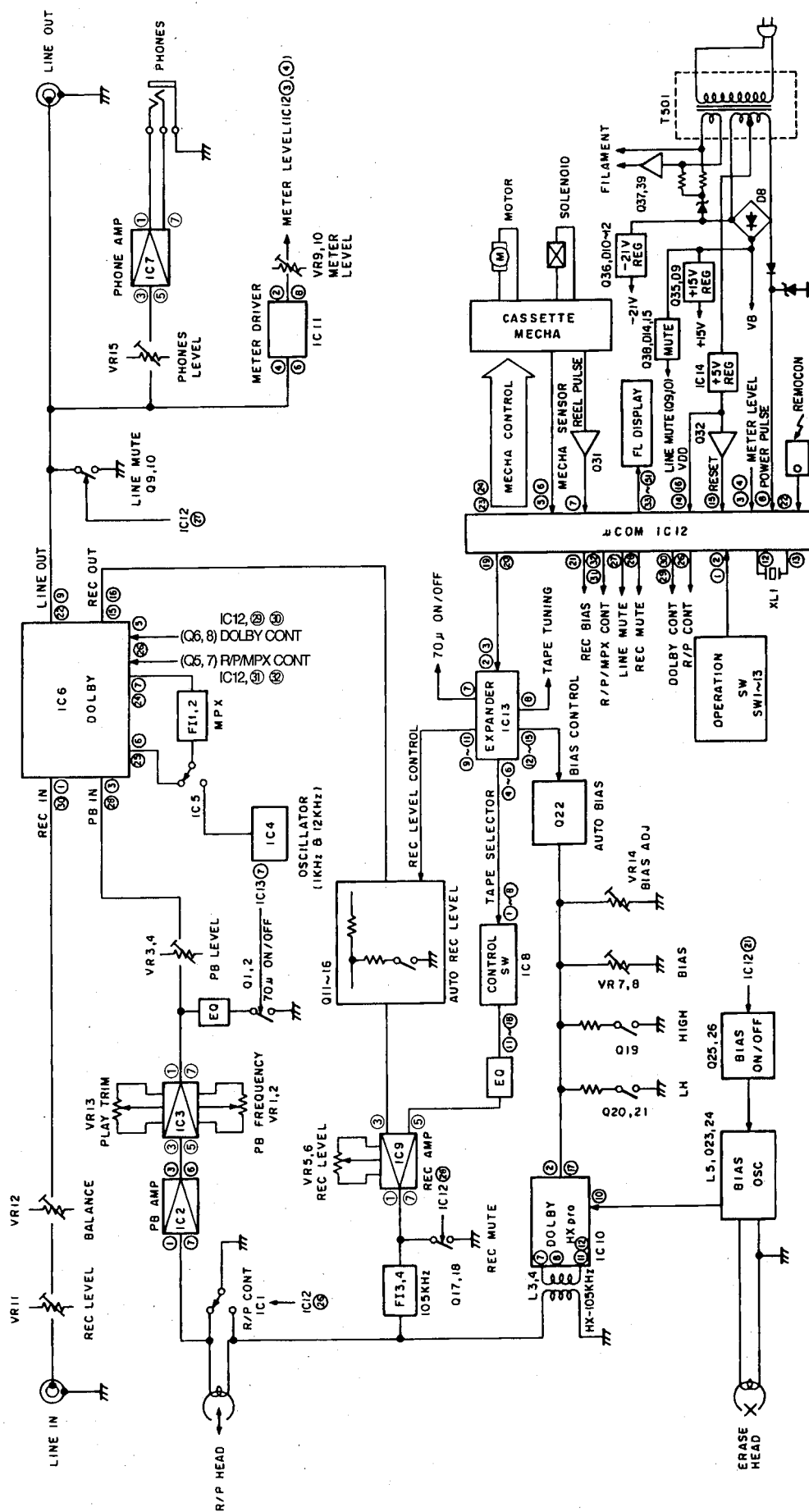

KX-393 SCHEMATIC DIAGRAM

The voltages are measured by LH tape at PLAY mode (no-signal condition). Only the voltages () are measured by METAL tape at REC mode.

Point ① (Both ends of C95) REC mode
V : 2V/div H : 5 μsec/div
DC range 1 : 1 probe

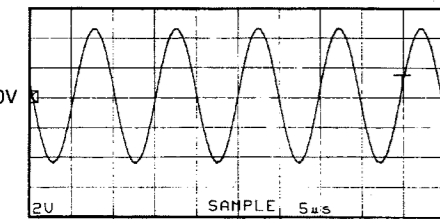

(BIAS OSC frequency 105kHz)

Point ② (Pin13 of IC12)
V : 0.2V/div H : 0.1 μsec/div
DC range 1 : 1 probe

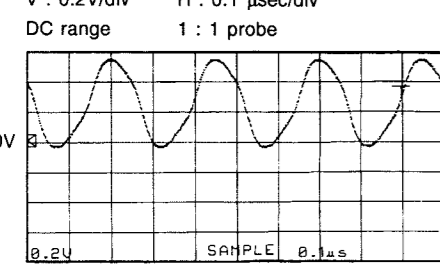

Point ③
CH1 : Pin15 of IC12 V : 0.2V/div (CH1)
CH2 : OUT of IC14 V : 2V/div (CH2)
H : 0.5 sec/div DC range 1 : 1 probe

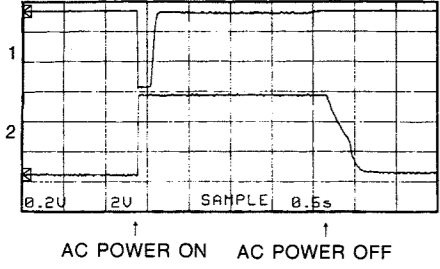

AC POWER ON AC POWER OFF

IC1 : μPC1330HA
2ch Head Selector Switch

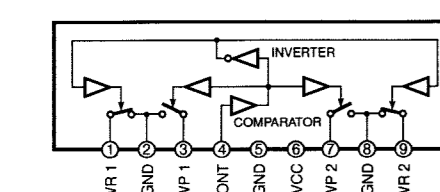

IC2 : LA3161
Dual OP-Amp

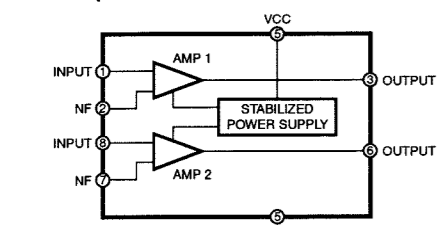

IC3, 9 : NJM4558L
IC7 : NJM4556AL
Dual OP-Amp

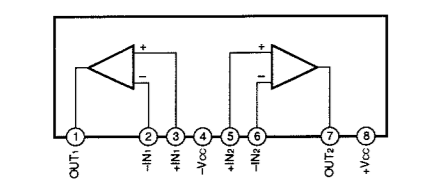

IC4 : TC4069UBP
Hex Inverter

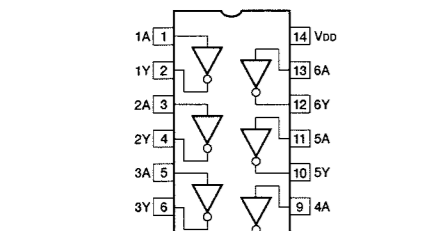

IC5 : μPD4066BC
Analog Switch

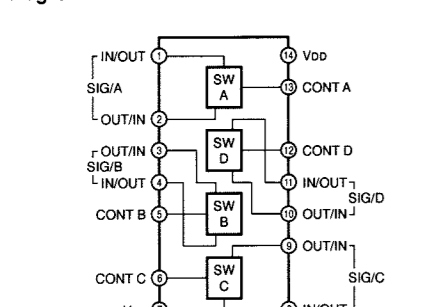

Cassette Mechanism

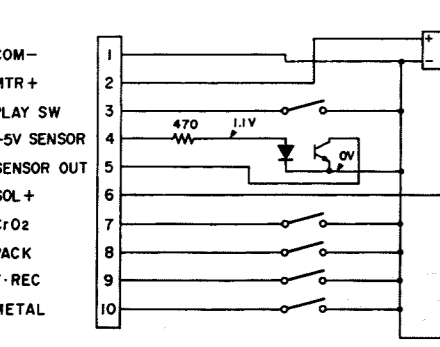

IC6 : HA12142NT
Dolby B&C-Type Noise Reduction Processor

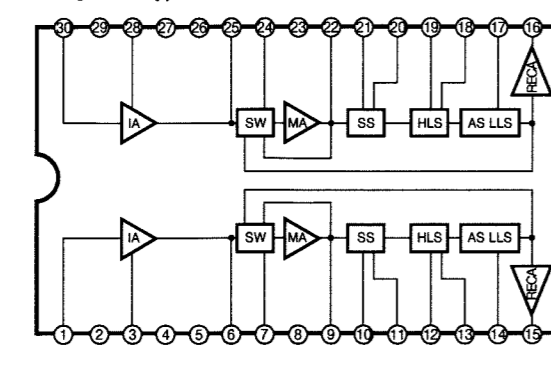

IC8 : AN9020
Transistor Arrays

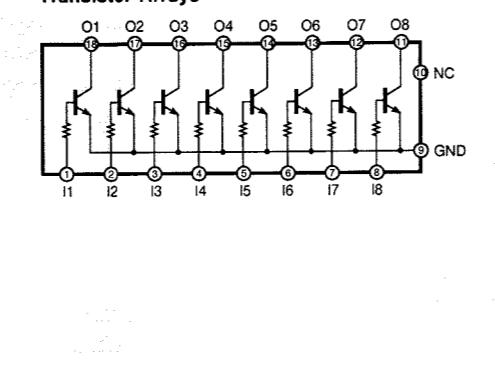

IC10 : μPC1297CA
Dolby HX-PRO

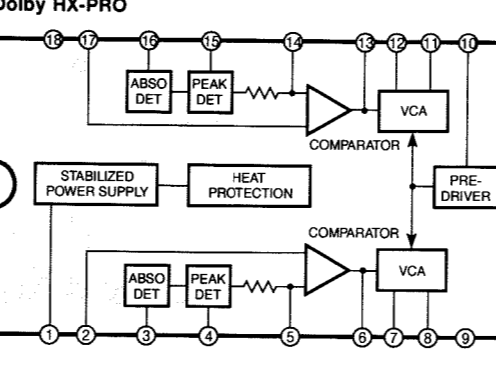

IC11 : BA6138
1/2 Power Compressor Amp

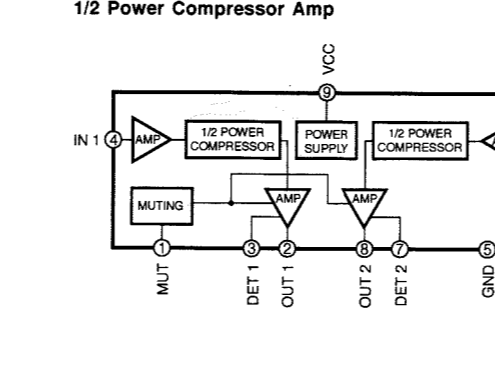

IC13 : BU2040
I/O Expander

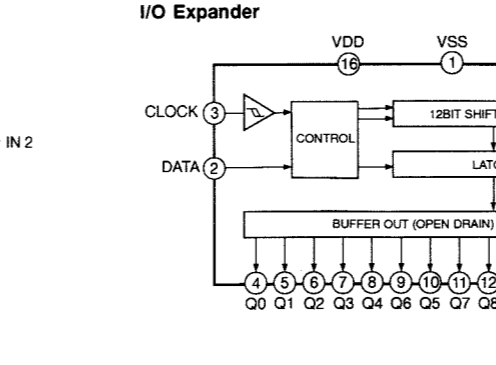

Table with columns for RESISTOR and CAPACITOR, listing part names and remarks.

NOTICE (mode1)
(J)..... JAPANESE
(U)..... U.S.A
(C)..... CANADIAN
(R)..... GENERAL
(A)..... AUSTRALIAN
(B)..... BRITISH
(G)..... EUROPEAN
(T)..... CHINA
(L)..... SINGAPORE

Interchangeable Parts at Manufacture-Stage table with columns for Mark, Reference Parts Number, and Parts Name.

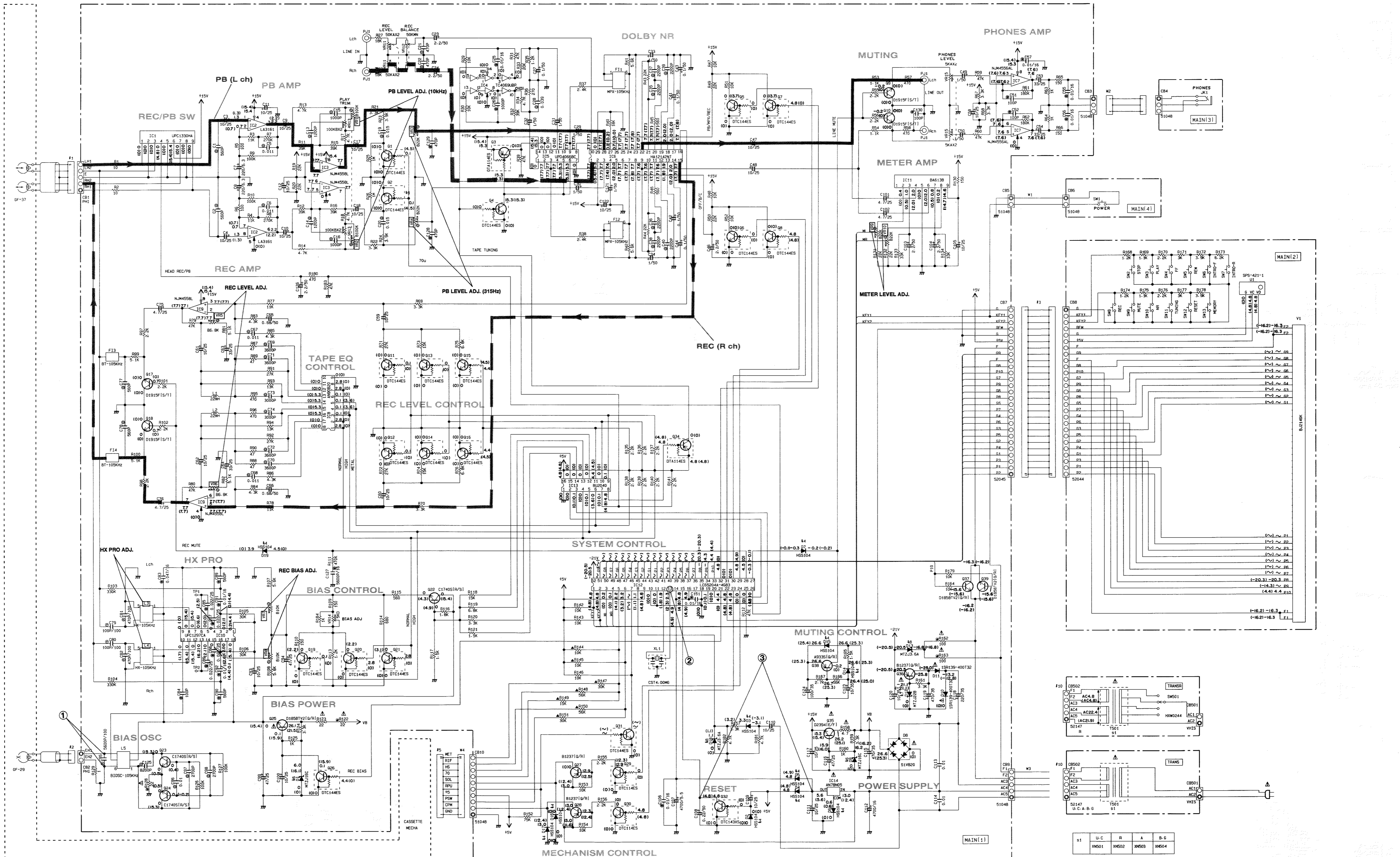

Table of components with columns for part number, description, and manufacturer.

Remote Control Data

Table mapping Remote Control Functions to Hex Custom Data.

All voltages are measured with a 10MΩ/V DC electric volt meter. Components having special characteristics are marked Δ and must be replaced with parts having specifications equal to those originally installed. Schematic diagram is subject to change without notice.

KX-493 SCHEMATIC DIAGRAM

● The voltages are measured by LH tape at PLAY mode (no-signal condition).
 Only the voltages () are measured by METAL tape at REC mode.

Point ① (Both ends of C98) REC mode
 V : 5V/div H : 5 μsec/div
 DC range 1 : 1 probe

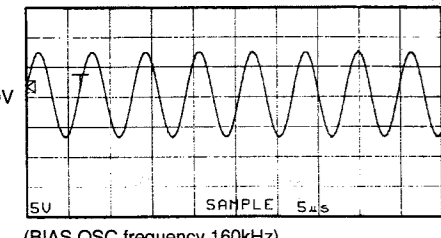

(BIAS OSC frequency 160kHz)

Point ② (Pin13 of IC13)
 V : 0.2V/div H : 0.1 μsec/div
 DC range 1 : 1 probe

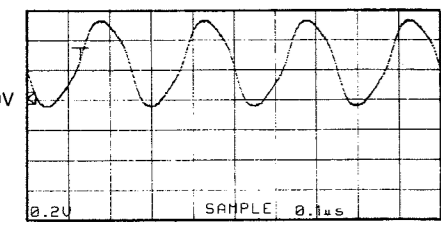

Point ③
 CH1 : Pin15 of IC13 V : 0.2V/div (CH1)
 CH2 : OUT of IC15 V : 2V/div (CH2)
 H : 0.5 sec/div DC range 1 : 1 probe

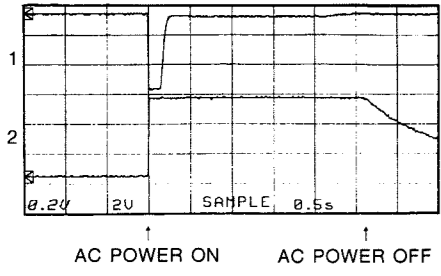

IC1 : μPC1330HA
 2ch Head Selector Switch

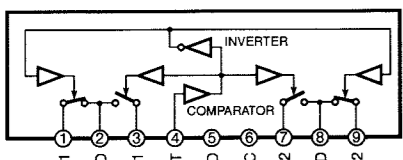

IC2 : NJM2043L
 IC3, 10 : NJM4558L
 IC7 : NJM4558L
 Dual Op-Amp

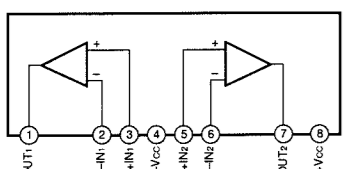

IC4 : TC4069UBP
 Hex Inverter

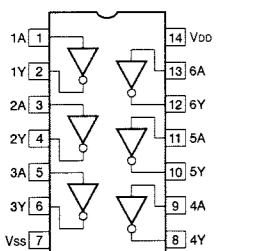

IC5 : μPD4066BC
 Analog Switch

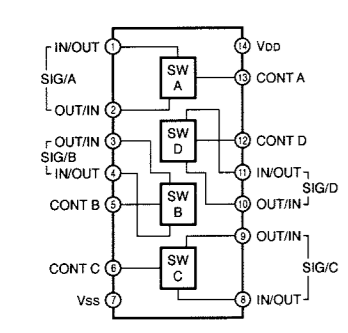

Cassette Mechanism

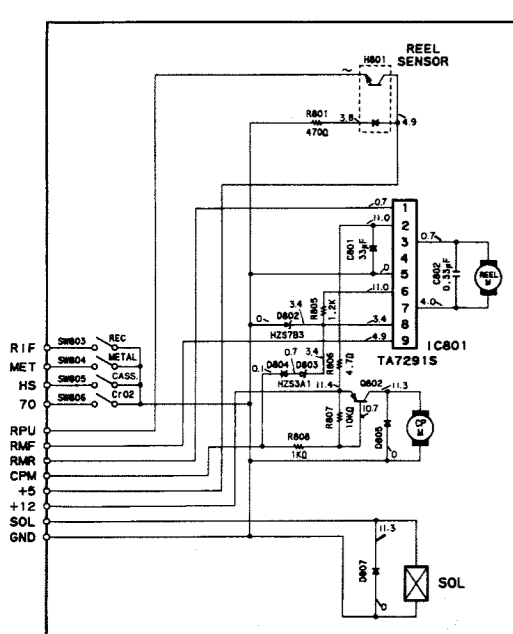

IC6 : HA12142NT
 Dolby B&C-Type Noise Reduction Processor

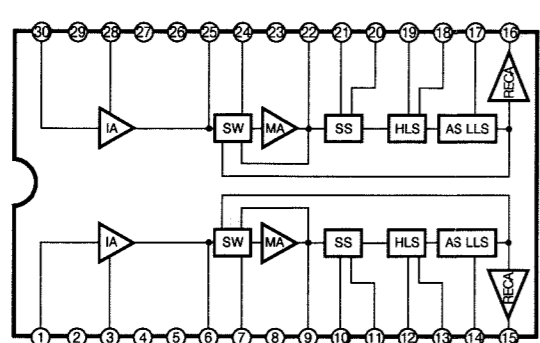

IC8, 9 : AN90B20
 Transistor Arrays

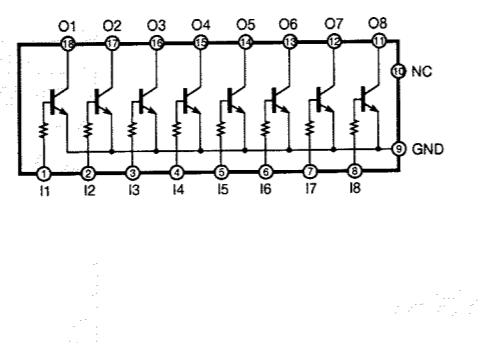

IC11 : μPC1297CA
 Dolby HX-PRO

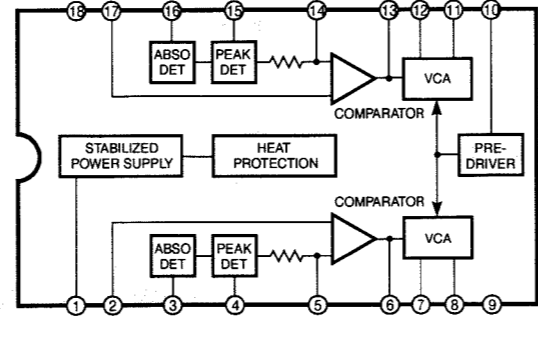

IC12 : BA6138
 1/2 Power Compressor Amp

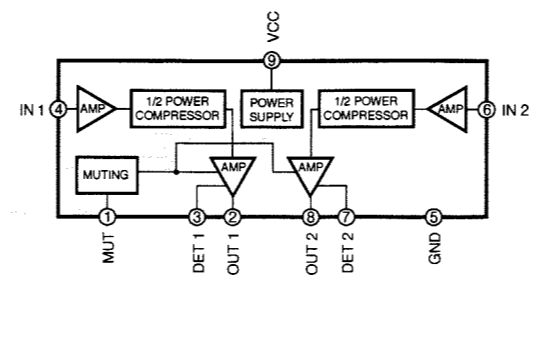

IC14 : BU2040
 I/O Expander

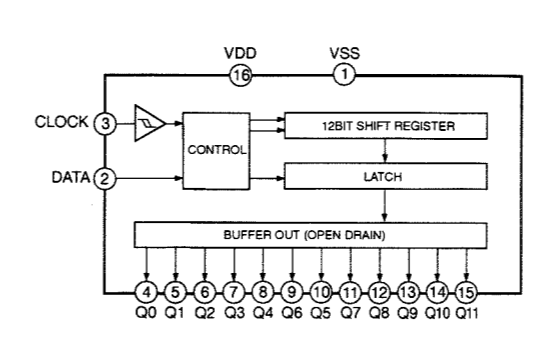

Remote Control Data

Function	HEX	
	CUSTOM	DATA
SINGLE DECK-INTRO SCAN <	7F	1E
SINGLE DECK-INTRO SCAN >	7F	1F
COUNTER RESET	7F	0D
SEARCH <>	7F	0B
SEARCH >>	7F	0A
<<	7F	01
PLAY	7F	00
>>	7F	02
REC/PAUSE	7F	04
STOP	7F	03
REC MUTE	7F	05

All voltages are measured with a 10MΩ/V DC electric volt meter.
 Components having special characteristics are marked Δ and must be replaced with parts having specifications equal to those originally installed.
 Schematic diagram is subject to change without notice.

RESISTOR		CAPACITOR	
REMARKS	PARTS NAME	REMARKS	PARTS NAME
NO MARK	CARBON FILM RESISTOR (R=5)	NO MARK	ELECTROLYTIC CAPACITOR
Δ	METAL OXIDE FILM RESISTOR	NO MARK	CERAMIC CAPACITOR
□	METAL FILM RESISTOR	○	CERAMIC TUBULAR CAPACITOR
△	METAL PLATE RESISTOR	○	POLYESTER FILM CAPACITOR
◇	FINE PITCH CARBON FILM RESISTOR	○	POLYPROPYLENE FILM CAPACITOR
◇	CEMENT WOUND RESISTOR	○	MICA CAPACITOR
◇	SEM1 VARIABLE RESISTOR	○	POLYPROPYLENE FILM CAPACITOR
◇	CHIP RESISTOR	●	SEMICONDUCTIVE CERAMIC CAPACITOR

NOTICE (model1)
 (J)..... JAPANESE
 (U)..... U. S. A
 (C)..... CANADIAN
 (R)..... GENERAL
 (A)..... AUSTRALIAN
 (B)..... BRITISH
 (G)..... EUROPEAN
 (T)..... CHINA
 (L)..... SINGAPORE

Mark	Reference Parts Number	Parts Name
k1		
k2		
k3		
k4	01-5.11.12-14-17-20-20 31-32	H5104 H5113 H5176

Interchangeable Parts at Manufacture-Stage	
k5	MTJ.06 H2842T0
k6	MTJ.06C H2842T0
k7	MTJ.06 H2842T0
k8	MTJ.06 H2842T0
k9	MTJ.06B H2829T0
k10	MTJ.03 H2842T0

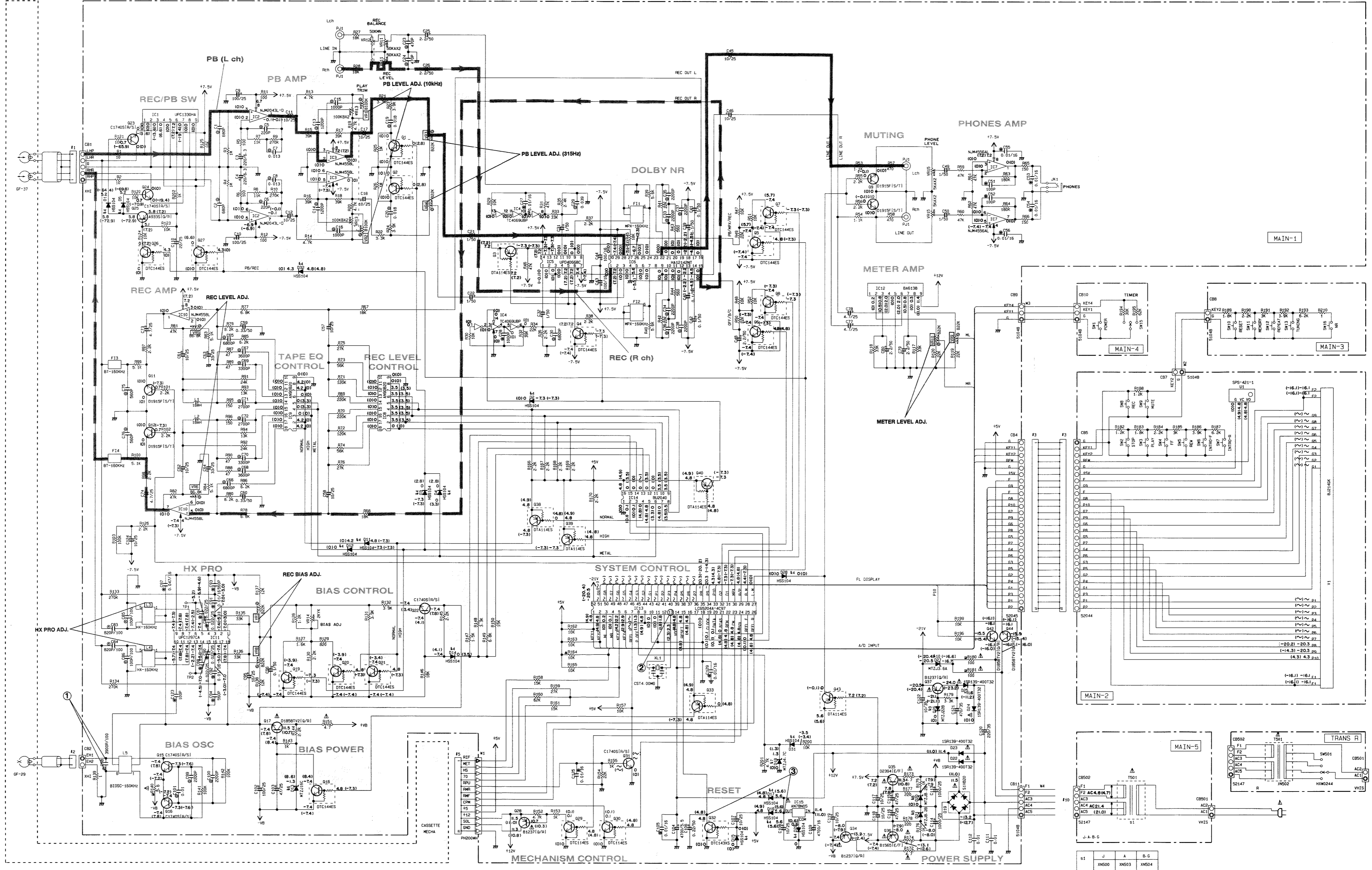
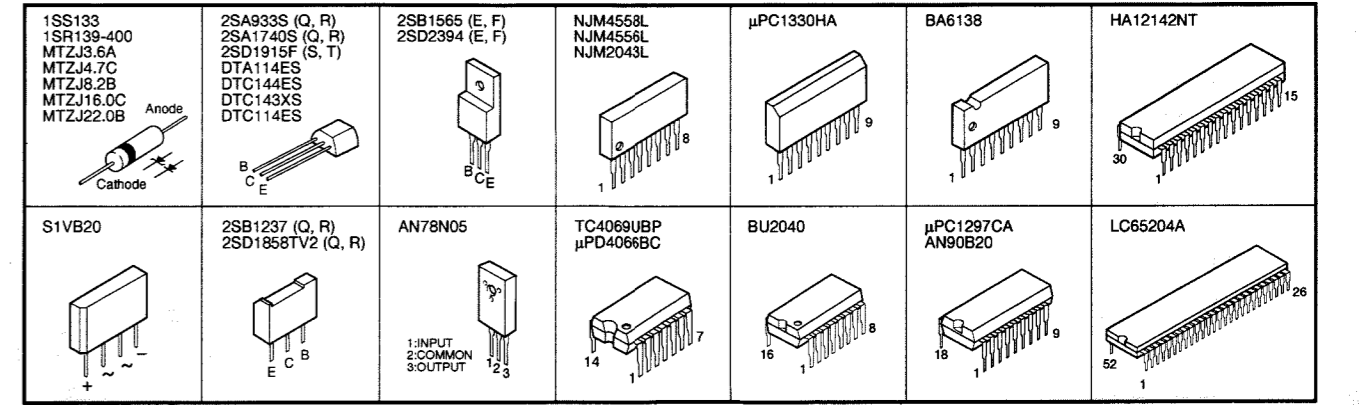

KX-393 PRINTED CIRCUIT BOARD (Foil side)

P. C. B. MAIN (1)

Point ① (Both ends of C95) REC mode
 V : 2V/div H : 5 μsec/div
 DC range 1 : 1 probe

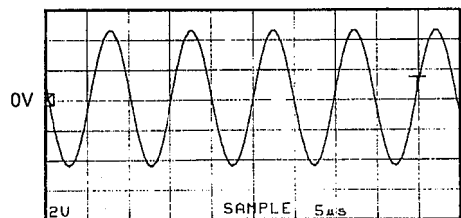

(BIAS OSC frequency 105kHz)

Point ② (Pin13 of IC12)
 V : 0.2V/div H : 0.1 μsec/div
 DC range 1 : 1 probe

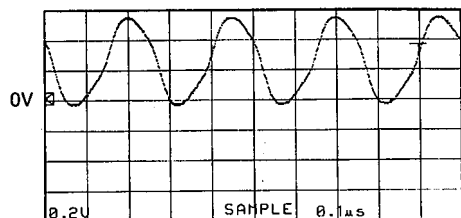

Point ③
 CH1 : Pin15 of IC12 V : 0.2V/div (CH1)
 CH2 : OUT of IC14 V : 2V/div (CH2)
 H : 0.5 sec/div DC range 1 : 1 probe

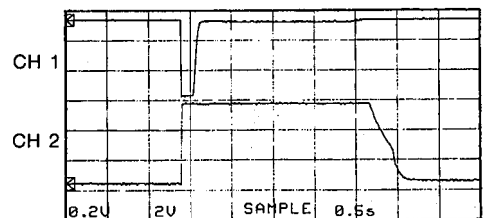

AC POWER ON AC POWER OFF

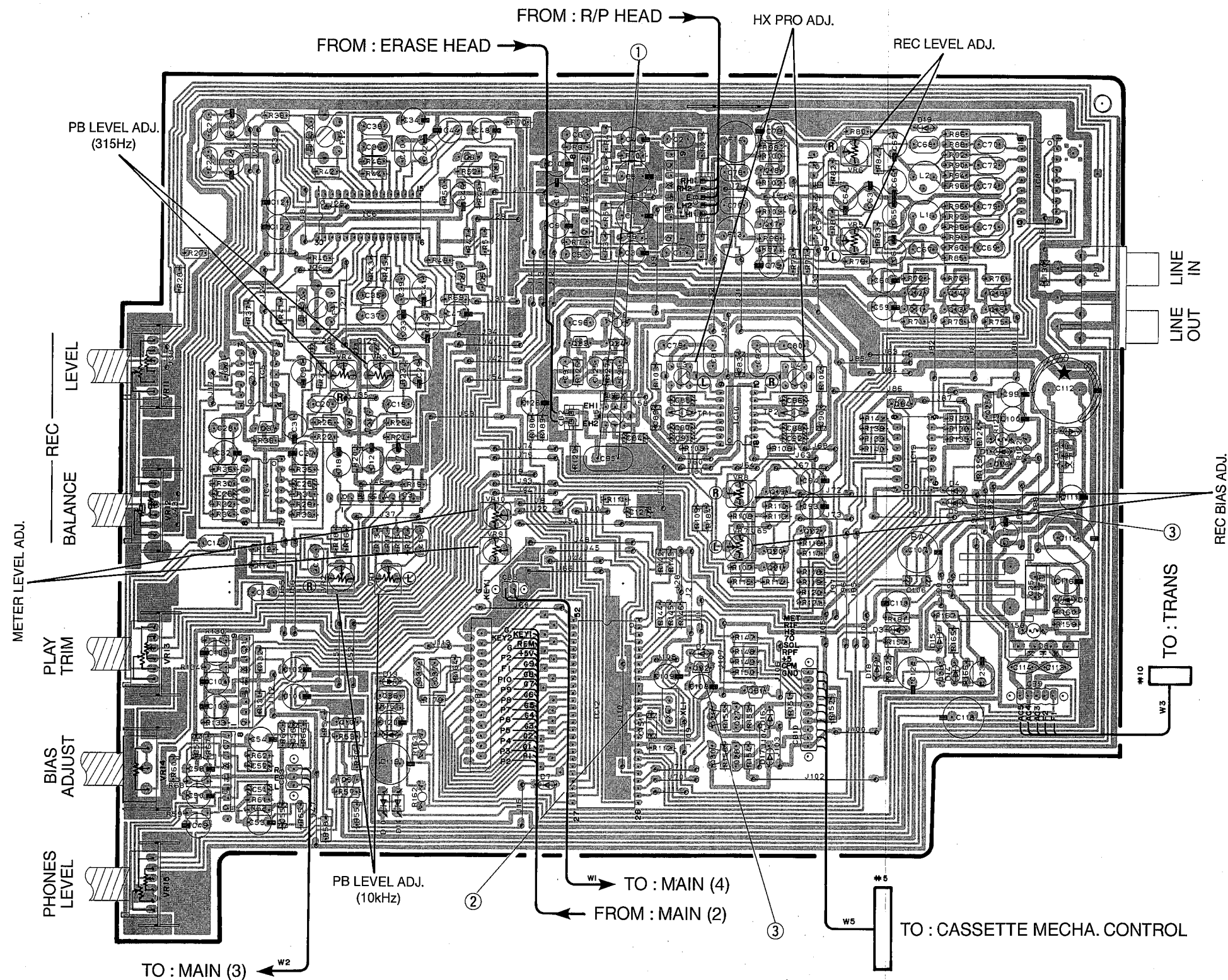

1
2
3
4
5
6

KX-393

KX-393 PRINTED CIRCUIT BOARD (Foil side)

P. C. B. MAIN (2)

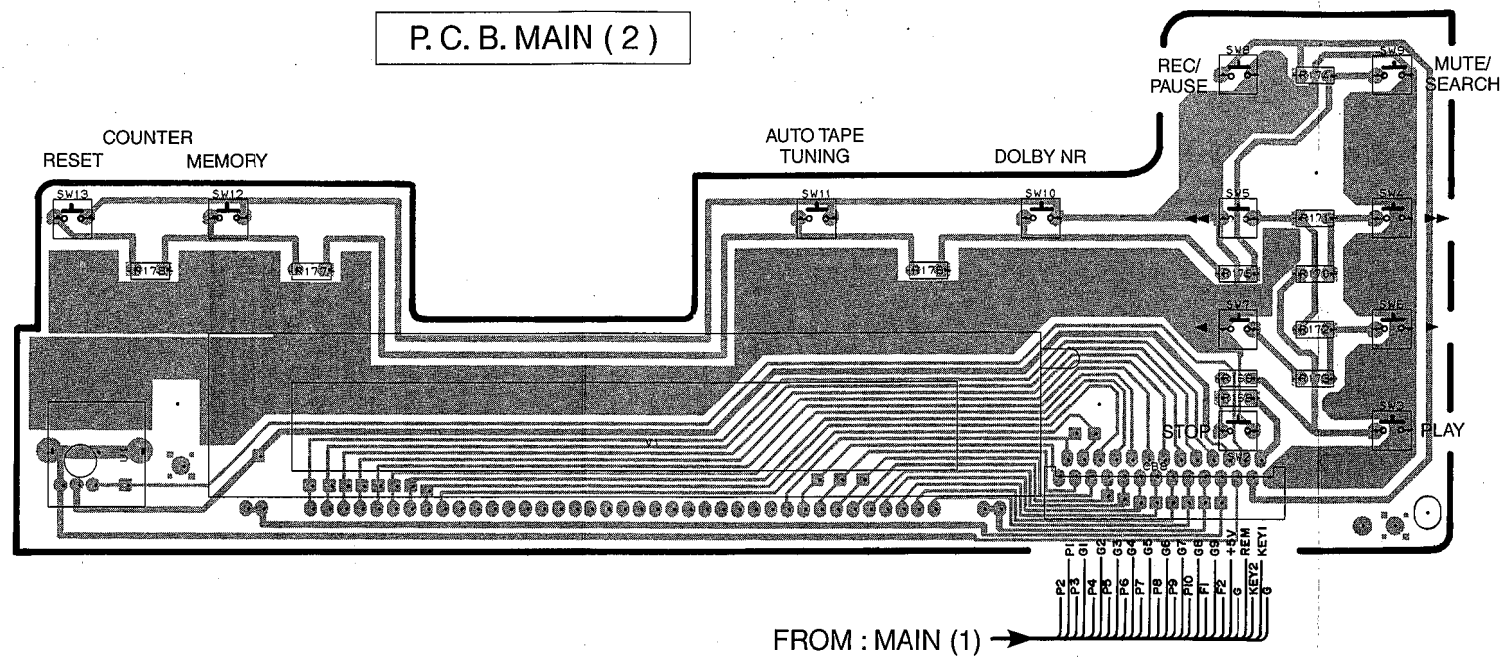

P. C. B. MAIN (3)

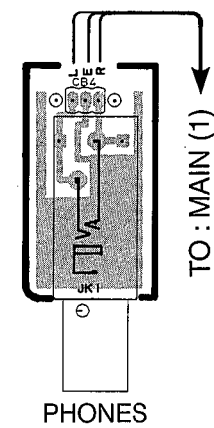

P. C. B. MAIN (4)

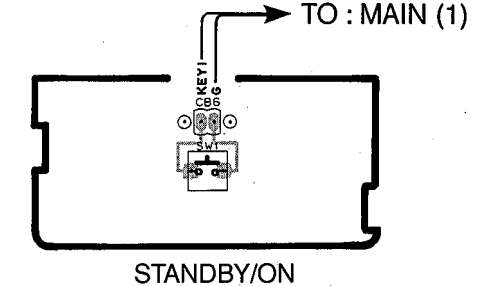

● Except R model
P. C. B. TRANS

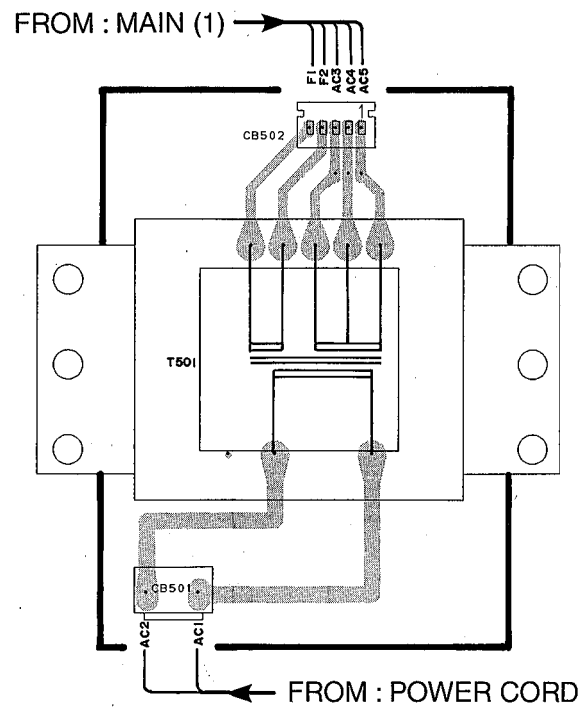

● R model
P. C. B. TRANS (R)

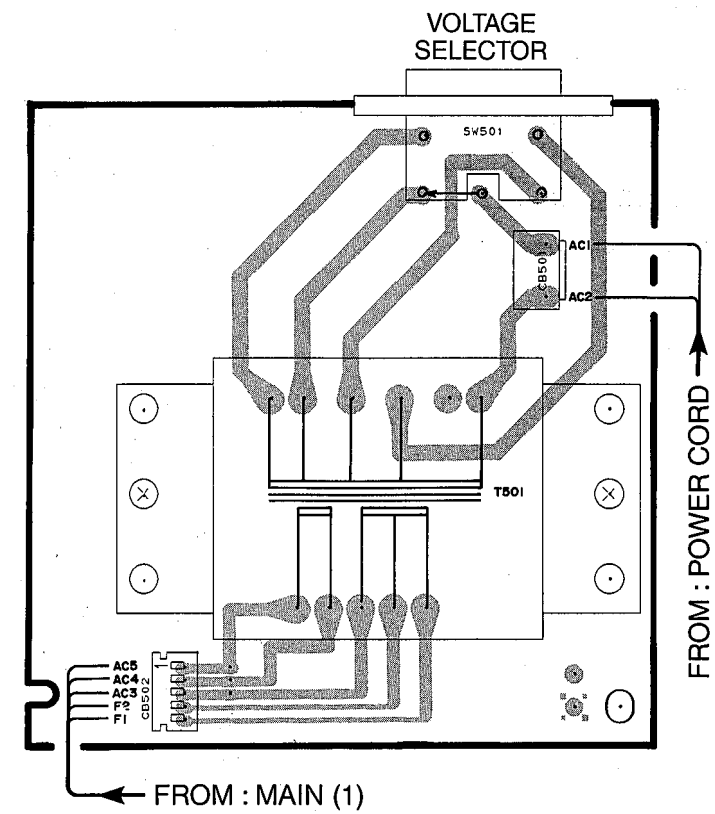

■ KX-493 PRINTED CIRCUIT BOARD (Foil side)

P.C.B. MAIN (1)

Point ① (Both ends of C98) REC mode
V : 5V/div H : 5 μsec/div
DC range 1 : 1 probe

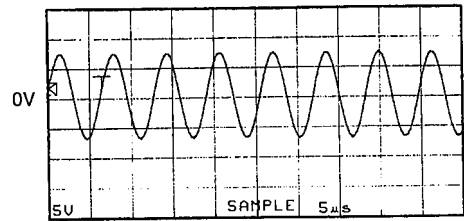

(BIAS OSC frequency 160kHz)

Point ② (Pin13 of IC13)
V : 0.2V/div H : 0.1 μsec/div
DC range 1 : 1 probe

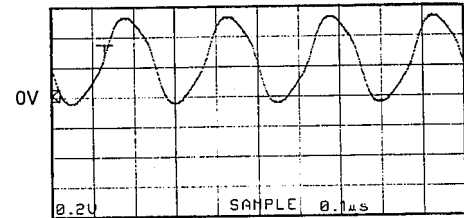

Point ③
CH1 : Pin15 of IC13 V : 0.2V/div (CH1)
CH2 : OUT of IC15 V : 2V/div (CH2)
H : 0.5 sec/div DC range 1 : 1 probe

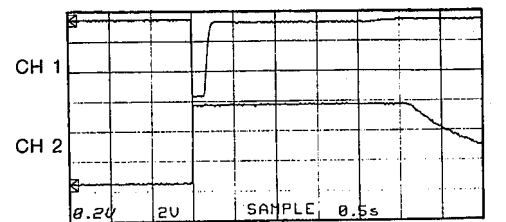

AC POWER ON AC POWER OFF

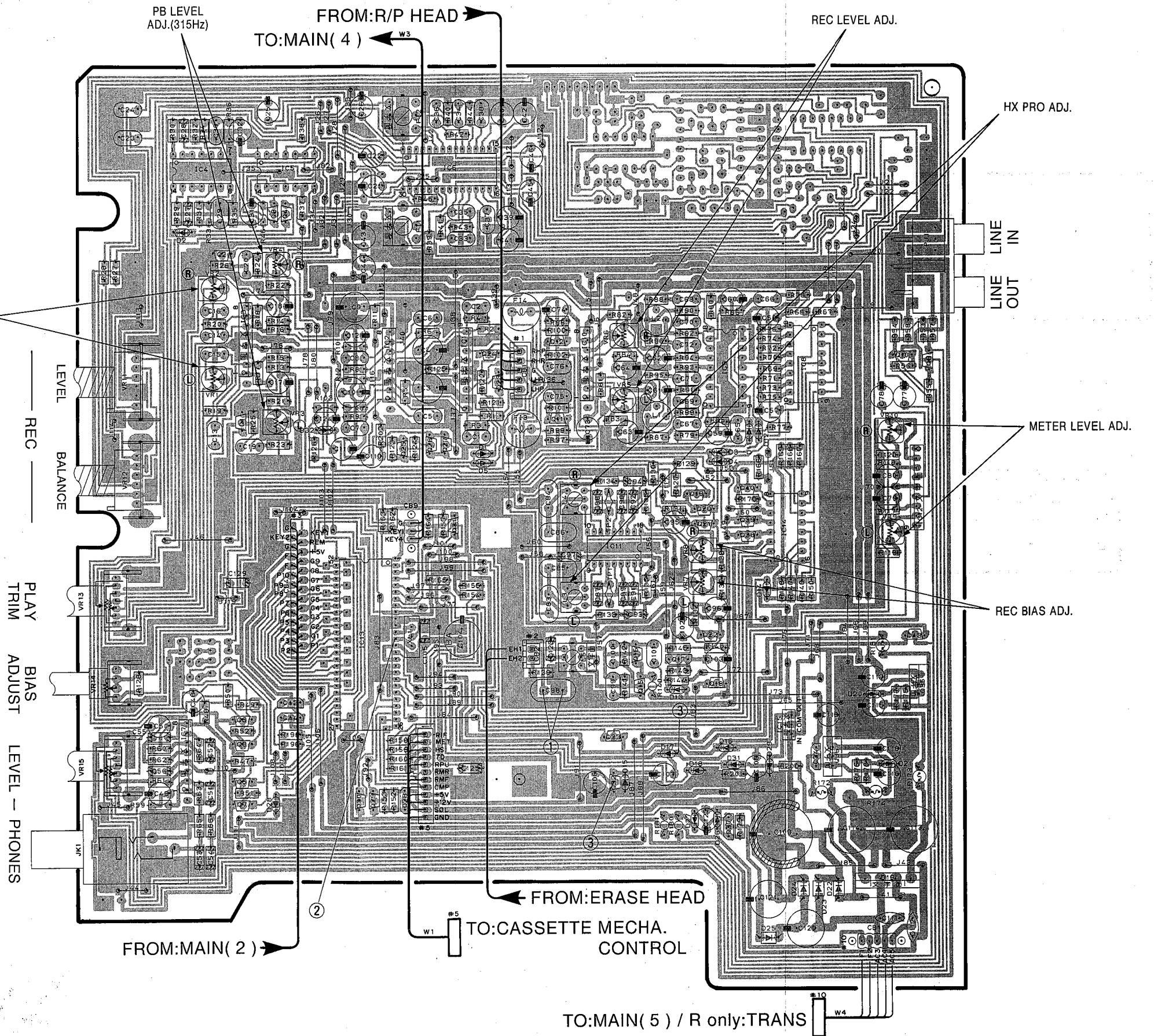

KX-493

■ KX-493 PRINTED CIRCUIT BOARD (Foil side)

1

P.C.B. MAIN (2)

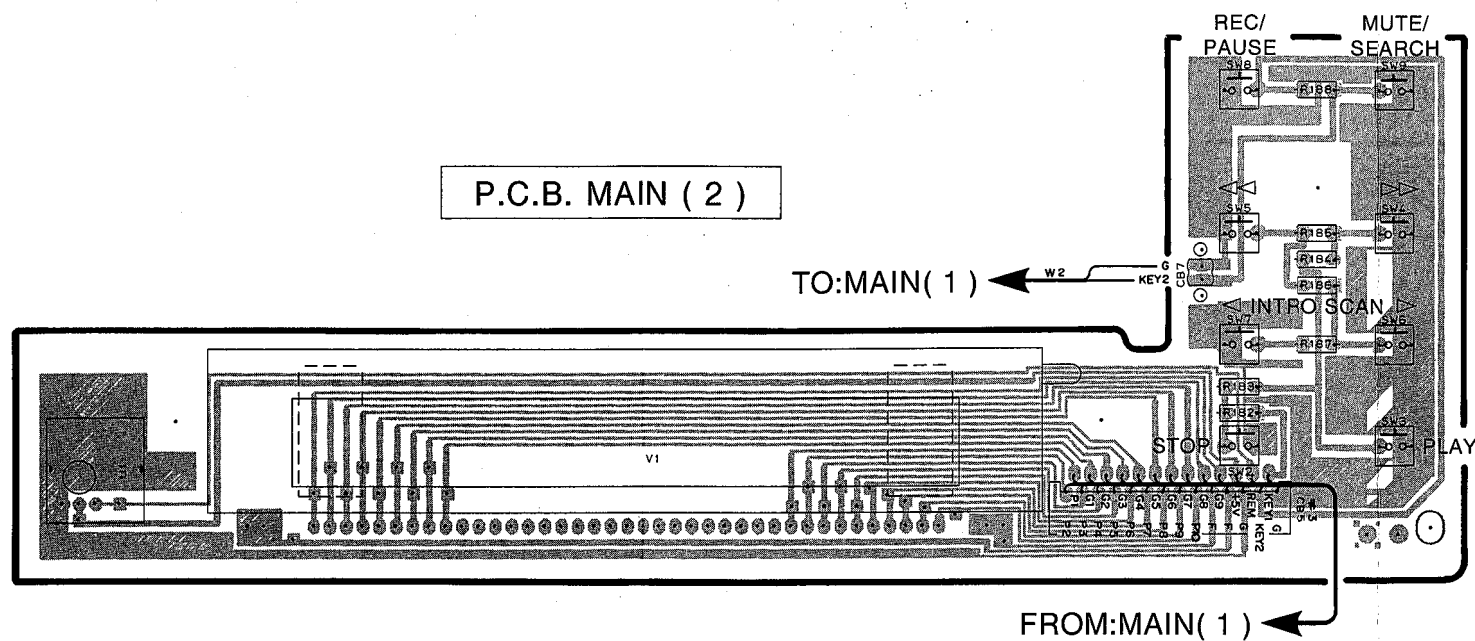

2

3

P.C.B. MAIN (3)

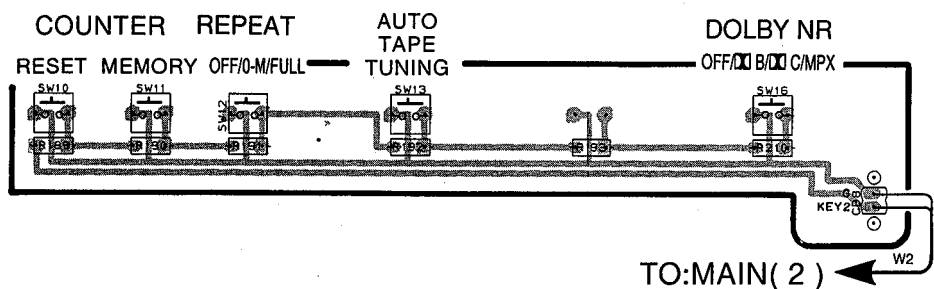

4

P.C.B. MAIN (4)

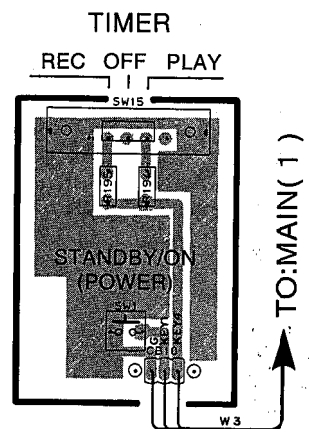

5

A B C D E F G H

● Except R model
P.C.B. MAIN (5)

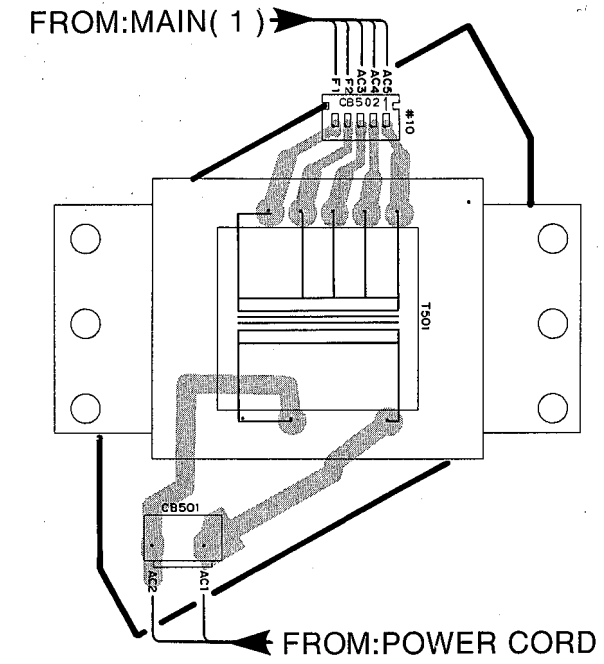

● R model
P.C.B. TRANS (R)

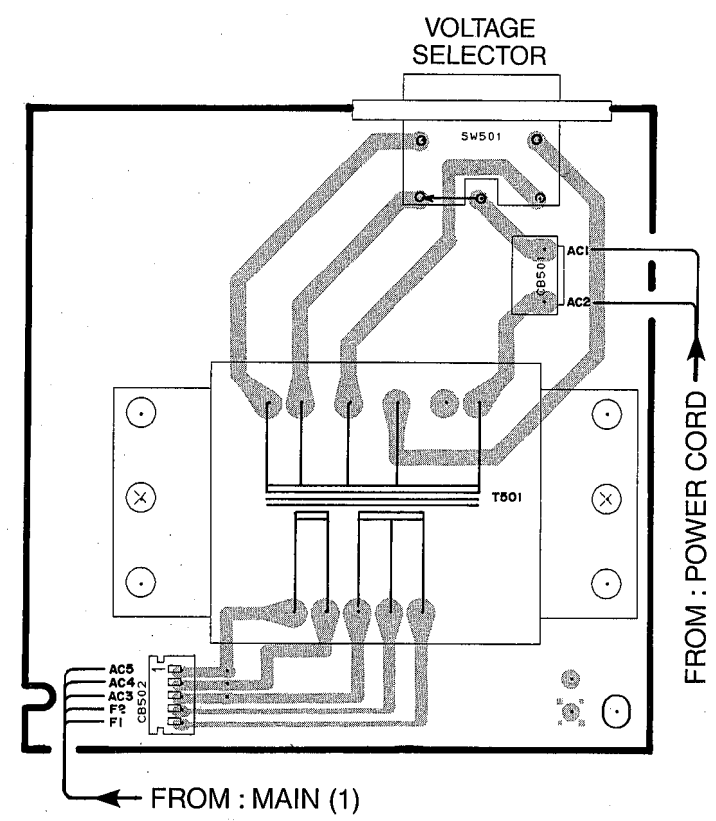

PARTS LIST

■ WARNING

Components having special characteristics are marked \triangle and must be replaced with parts having specifications equal to those originally installed.

- Carbon resistors (1/6W or 1/4W) are not included in the ELECTRICAL PARTS List. For the part Nos. of the carbon resistors, refer to the last page.

■ ELECTRICAL PARTS

ABBREVIATIONS IN THIS LIST ARE AS FOLLOWS :

C.A.EL.CHP	: CHIP ALUMI. ELECTROLYTIC CAP	L.EMIT	: LIGHT EMITTING MODULE
C.CE	: CERAMIC CAP	LED.DSPLY	: LED DISPLAY
C.CE.ARRAY	: CERAMIC CAP ARRAY	LED.INFRD	: LED, INFRARED
C.CE.CHP	: CHIP CERAMIC CAP	MODUL.RF	: MODULATOR, RF
C.CE.ML	: MULTILAYER CERAMIC CAP	PHOT.CPL	: PHOTO COUPLER
C.CE.M.CHP	: CHIP MULTILAYER CERAMIC CAP	PHOT.INTR	: PHOTO INTERRUPTER
C.CE.SAFTY	: RECOGNIZED CERAMIC CAP	PHOT.RFLCT	: PHOTO REFLECTOR
C.CE.TUBLR	: CERAMIC TUBULAR CAP	PIN.TEST	: PIN, TEST POINT
C.CE.SMI	: SEMI CONDUCTIVE CERAMIC CAP	PLST.RIVET	: PLASTIC RIVET
C.EL	: ELECTROLYTIC CAP	R.ARRAY	: RESISTOR ARRAY
C.MICA	: MICA CAP	R.CAR	: CARBON RESISTOR
C.ML.FLM	: MULTILAYER FILM CAP	R.CAR.CHP	: CHIP RESISTOR
C.MP	: METALLIZED PAPER CAP	R.CAR.FP	: FLAME PROOF CARBON RESISTOR
C.MYLAR	: MYLAR FILM CAP	R.FUS	: FUSABLE RESISTOR
C.MYLAR.ML	: MULTILAYER MYLAR FILM CAP	R.MTL.CHP	: CHIP METAL FILM RESISTOR
C.PAPER	: PAPER CAPACITOR	R.MTL.FLM	: METAL FILM RESISTOR
C.PLS	: POLYSTYRENE FILM CAP	R.MTL.OXD	: METAL OXIDE FILM RESISTOR
C.POL	: POLYESTER FILM CAP	R.MTL.PLAT	: METAL PLATE RESISTOR
C.POLY	: POLYETHYLENE FILM CAP	RSNR.CE	: CERAMIC RESONATOR
C.PP	: POLYPROPYLENE FILM CAP	RSNR.CRYS	: CRYSTAL RESONATOR
C.TNTL	: TANTALUM CAP	R.TW.CEM	: TWIN CEMENT FIXED RESISTOR
C.TNTL.CHP	: CHIP TANTALUM CAP	R.WW	: WIRE WOUND RESISTOR
C.TRIM	: TRIMMER CAP	SCR.BND.HD	: BIND HEAD B-TITE SCREW
CN	: CONNECTOR	SCR.BW.HD	: BW HEAD TAPPING SCREW
CN.BS.PIN	: CONNECTOR, BASE PIN	SCR.CUP	: CUP TITE SCREW
CN.CANNON	: CONNECTOR, CANNON	SCR.TERM	: SCREW TERMINAL
CN.DIN	: CONNECTOR, DIN	SCR.TR	: SCREW, TRANSISTOR
CN.FLAT	: CONNECTOR, FLAT CABLE	SUPRT.PCB	: SUPPORT, P.C.B.
CN.POST	: CONNECTOR, BASE POST	SURG.PRTCT	: SURGE PROTECTOR
COIL.MX.AM	: COIL, AM MIX	SW.TACT	: TACT SWITCH
COIL.AT.FM	: COIL, FM ANTENNA	SW.LEAF	: LEAF SWITCH
COIL.DT.FM	: COIL, FM DETECT	SW.LEVER	: LEVER SWITCH
COIL.MX.FM	: COIL, FM MIX	SW.MICRO	: MICRO SWITCH
COIL.OUTPT	: OUTPUT COIL	SW.PUSH	: PUSH SWITCH
DIOD.ARRAY	: DIODE ARRAY	SW.RT.ENC	: ROTARY ENCODER
DIODE.BRG	: DIODE BRIDGE	SW.RT.MTR	: ROTARY SWITCH WITH MOTOR
DIODE.CHP	: CHIP DIODE	SW.RT	: ROTARY SWITCH
DIODE.VAR	: VARACTOR DIODE	SW.SLIDE	: SLIDE SWITCH
DIOD.Z.CHP	: CHIP ZENER DIODE	TERM.SP	: SPEAKER TERMINAL
DIODE.ZENR	: ZENER DIODE	TERM.WRAP	: WRAPPING TERMINAL
DSCR.CE	: CERAMIC DISCRIMINATOR	THRMST.CHP	: CHIP THERMISTOR
FER.BEAD	: FERRITE BEADS	TR.CHP	: CHIP TRANSISTOR
FER.CORE	: FERRITE CORE	TR.DGT	: DIGITAL TRANSISTOR
FET.CHP	: CHIP FET	TR.DGT.CHP	: CHIP DIGITAL TRANSISTOR
FL.DSPLY	: FLUORESCENT DISPLAY	TRANS	: TRANSFORMER
FLTR.CE	: CERAMIC FILTER	TRANS.PULS	: PULSE TRANSFORMER
FLTR.COMB	: COMB FILTER MODULE	TRANS.PWR	: POWER TRANSFORMER ASS'y
FLTR.LC.RF	: LC FILTER ,EMI	TUNER.AM	: TUNER PACK, AM
GND.MTL	: GROUND PLATE	TUNER.FM	: TUNER PACK, FM
GND.TERM	: GROUND TERMINAL	TUNER.PK	: FRONT-END TUNER PACK
HOLDER.FUS	: FUSE HOLDER	VR	: ROTARY POTENTIOMETER
IC.PRTCT	: IC PROTECTOR	VR.MTR	: POTENTIOMETER WITH MOTOR
JUMPER.CN	: JUMPER CONNECTOR	VR.SW	: POTENTIOMETER WITH ROTARY SW
JUMPER.TST	: JUMPER, TESTING POINT	VR.SLIDE	: SLIDE POTENTIOMETER
L.DTCT	: LIGHT DETECTING MODULE	VR.TRIM	: TRIMMER POTENTIOMETER

Note) Those parts marked with "#" are not included in the P.C.B. ass'y.

KX-393 P.C.B. MAIN

Schm Ref.	PART NO.	Description		
	VR283300	P.C.B.	MAIN	
CB1	VD004800	CN. BS. PIN	5P	
CB2	VD004500	CN. BS. PIN	2P	
CB3	Vi878100	CN. BS. PIN	3P	
CB4	Vi878100	CN. BS. PIN	3P	
CB5	Vi878000	CN. BS. PIN	2P	
CB6	Vi878000	CN. BS. PIN	2P	
CB7	VQ047800	CN. BS. PIN	27P	
CB8	VQ045600	CN. BS. PIN	27P	
CB9	Vi878300	CN. BS. PIN	5P	
CB10	Vi878800	CN. BS. PIN	10P	
C1	UA652560	C. MYLAR	560pF	50V
C2	UA652560	C. MYLAR	560pF	50V
C3	VE742700	C. EL	10uF	50V
C4	VE742700	C. EL	10uF	50V
C5	UA654110	C. MYLAR	0.011uF	50V
C6	UA654110	C. MYLAR	0.011uF	50V
C7	VE016600	C. EL	220uF	6.3V
C8	VE016600	C. EL	220uF	6.3V
C9	UM417100	C. EL	10uF	50V
C10	UM417100	C. EL	10uF	50V
C11	VE742700	C. EL	10uF	50V
C12	UM417100	C. EL	10uF	50V
C13	UA653120	C. MYLAR	1200pF	50V
C14	UA653120	C. MYLAR	1200pF	50V
C15	UA653100	C. MYLAR	1000pF	50V
C16	UA653100	C. MYLAR	1000pF	50V
C17	UM417100	C. EL	10uF	50V
C18	UM417100	C. EL	10uF	50V
C19	UA654150	C. MYLAR	0.015uF	50V
C20	UA654150	C. MYLAR	0.015uF	50V
C21	UA652470	C. MYLAR	470pF	50V
C22	UA652470	C. MYLAR	470pF	50V
C23	VJ839200	C. EL	2.2uF	50V
C24	VJ839200	C. EL	2.2uF	50V
C25	VF467300	C. CE. TUBLR	0.01uF	16V
C26	VF467000	C. CE. TUBLR	1000pF	50V
C27	UM215100	C. EL	0.1uF	50V
C28	UA654390	C. MYLAR	0.039uF	50V
C29	VJ839100	C. EL	1uF	50V
C30	VJ839100	C. EL	1uF	50V
C31	VJ839100	C. EL	1uF	50V
C32	VJ839100	C. EL	1uF	50V
C33	VJ839100	C. EL	1uF	50V
C34	VJ839100	C. EL	1uF	50V
C35	UA653220	C. MYLAR	2200pF	50V
C36	UA653220	C. MYLAR	2200pF	50V
C37	UA653220	C. MYLAR	2200pF	50V
C38	UA653220	C. MYLAR	2200pF	50V
C39	UA653220	C. MYLAR	2200pF	50V
C40	UA653220	C. MYLAR	2200pF	50V
C41	UM215100	C. EL	0.1uF	50V
C42	UM215100	C. EL	0.1uF	50V

* New Parts

Schm Ref.	PART NO.	Description		
C43	UM215100	C. EL	0.1uF	50V
C44	UM215100	C. EL	0.1uF	50V
C46	VJ839200	C. EL	2.2uF	50V
C47	UM417100	C. EL	10uF	50V
C48	UM417100	C. EL	10uF	50V
C49	VJ839100	C. EL	1uF	50V
C50	VJ839100	C. EL	1uF	50V
C51	VF466800	C. CE. TUBLR	100pF	50V
C52	VF466800	C. CE. TUBLR	100pF	50V
C53	UJ167330	C. EL	33uF	50V
C54	UJ167330	C. EL	33uF	50V
C55	VF467300	C. CE. TUBLR	0.01uF	16V
C56	VF467300	C. CE. TUBLR	0.01uF	16V
C57	VF467300	C. CE. TUBLR	0.01uF	16V
C58	UM417100	C. EL	10uF	50V
C59	UM417100	C. EL	10uF	50V
C60	UM417100	C. EL	10uF	50V
C61	UM417100	C. EL	10uF	50V
C62	UM417100	C. EL	10uF	50V
C63	UJ167330	C. EL	33uF	50V
C64	UJ167330	C. EL	33uF	50V
C65	UJ865680	C. EL	0.68uF	50V
C66	UJ865680	C. EL	0.68uF	50V
C67	UA654110	C. MYLAR	0.011uF	50V
C68	UA654110	C. MYLAR	0.011uF	50V
C69	UA653360	C. MYLAR	3600pF	50V
C70	UA653360	C. MYLAR	3600pF	50V
C71	UA653360	C. MYLAR	3600pF	50V
C72	UA653360	C. MYLAR	3600pF	50V
C73	UA653300	C. MYLAR	3000pF	50V
C74	UA653300	C. MYLAR	3000pF	50V
C75	VE021900	C. EL	4.7uF	100V
C76	VE021900	C. EL	4.7uF	100V
C77	UA652560	C. MYLAR	560pF	50V
C78	UA652560	C. MYLAR	560pF	50V
C79	VS204800	C. PP	100pF	100V
C80	VS204800	C. PP	100pF	100V
C81	VS205200	C. PP	470pF	100V
C82	VS205200	C. PP	470pF	100V
C83	VJ599000	C. CE. TUBLR	0.047uF	16V
C84	VF466800	C. CE. TUBLR	100pF	50V
C85	VG280100	C. CE. TUBLR	0.022uF	25V
C86	VG280100	C. CE. TUBLR	0.022uF	25V
C87	VG280100	C. CE. TUBLR	0.022uF	25V
C88	VG280100	C. CE. TUBLR	0.022uF	25V
C89	VG278800	C. CE. TUBLR	560pF	50V
C90	VG278800	C. CE. TUBLR	560pF	50V
C91	VF467300	C. CE. TUBLR	0.01uF	16V
C92	VF467300	C. CE. TUBLR	0.01uF	16V
C93	UM417100	C. EL	10uF	50V
C94	UJ667470	C. EL	47uF	50V
C95	UT653560	C. PP	5600pF	100V
C96	UA654100	C. MYLAR	0.01uF	50V

* New Parts

KX-393 P.C.B. MAIN

Schm Ref.	PART NO.	Description		
C97	UA653270	C. MYLAR	2700pF	50V
C98	UA653270	C. MYLAR	2700pF	50V
C99	UJ667470	C. EL	47uF	50V
C100	UM417100	C. EL	10uF	50V
C101	UM416470	C. EL	4.7uF	50V
C102	UM416470	C. EL	4.7uF	50V
C103	VJ839200	C. EL	2.2uF	50V
C104	VJ839200	C. EL	2.2uF	50V
C105	UM417100	C. EL	10uF	50V
C106	VF467300	C. CE. TUBLR	0.01uF	16V
C107	VT180400	C. EL	4700uF	5.5V
C108	VJ838800	C. EL	0.22uF	50V
C109	UM417100	C. EL	10uF	50V
C110	UM417100	C. EL	10uF	50V
C111	UM417100	C. EL	10uF	50V
C112	VH520900	C. EL	4700uF	16V
C113	FG214100	C. CE	0.01uF	50V
C114	FG214100	C. CE	0.01uF	50V
C115	VE801600	C. EL	470uF	35V
C116	UJ667470	C. EL	47uF	50V
C117	VE742700	C. EL	10uF	50V
C118	UJ658220	C. EL	220uF	35V
C119	UJ658470	C. EL	470uF	35V
C120	UM417100	C. EL	10uF	50V
C121	VJ839100	C. EL	1uF	50V
C122	UM417100	C. EL	10uF	50V
C123	UM417100	C. EL	10uF	50V
C124	UJ668100	C. EL	100uF	50V
C125	UA653820	C. MYLAR	8200pF	50V
C126	VJ839200	C. EL	2.2uF	50V
C127	VG279800	C. CE. TUBLR	5600pF	16V
C128	VF466900	C. CE. TUBLR	470pF	50V
C129	VF466900	C. CE. TUBLR	470pF	50V
C130	VF466800	C. CE. TUBLR	100pF	50V
C151	VF467300	C. CE. TUBLR	0.01uF	16V
D1	VG441200	DIODE. ZENR	MTZJ16C	16V
D2	VD631600	DIODE	1SS133, 176, HSS104	
D3	VD631600	DIODE	1SS133, 176, HSS104	
D4	VD631600	DIODE	1SS133, 176, HSS104	
D5	VD631600	DIODE	1SS133, 176, HSS104	
D6	VD631600	DIODE	1SS133, 176, HSS104	
D7	VD631600	DIODE	1SS133, 176, HSS104	
△ D8	VQ379300	DIODE. BRG	S1VB20	1.0A 200V
D9	VG441200	DIODE. ZENR	MTZJ16C	16V
△ D10	VU264100	DIODE	1SR139-400	
△ D11	VU264100	DIODE	1SR139-400	
D12	VG442100	DIODE. ZENR	MTZJ22B	22V
D13	VG436200	DIODE. ZENR	MTZJ3.6A	3.6V
D14	VD631600	DIODE	1SS133, 176, HSS104	
D15	VD631600	DIODE	1SS133, 176, HSS104	
D16	VD631600	DIODE	1SS133, 176, HSS104	
D17	VD631600	DIODE	1SS133, 176, HSS104	
D18	VG436200	DIODE. ZENR	MTZJ3.6A	3.6V

* New Parts

Schm Ref.	PART NO.	Description	
D19	VD631600	DIODE	1SS133, 176, HSS104
Fi1	GE200510	COIL. MPX	
Fi2	GE200510	COIL. MPX	
Fi3	GE900780	COIL. BIAS	105KHz
Fi4	GE900780	COIL. BIAS	105KHz
IC1	XD864A00	IC	uPC1330HA
IC2	iG145500	IC	LA3161
IC3	XM922A00	IC	NJM4558L
IC4	iG001720	IC	TC4069UBP
IC5	iG037400	IC	uPD4066BC
IC6	XH741A00	IC	HA12142NT
IC7	XP844A00	IC	NJM4556AL
IC8	iG089900	IC	AN90B20
IC9	XM922A00	IC	NJM4558L
IC10	XA300A00	IC	uPC1297CA
IC11	iG074900	IC	BA6138
IC12	XR448A00	IC	LC65204A-4G83 CPU
IC13	XM974A00	IC	BU2040
△ IC14	XA507A00	IC	AN78N05
JK1	LB301720	JACK. PHONE	
L1	GE901670	COIL	22mH
L2	GE901670	COIL	22mH
L3	VA709900	COIL	105KHz
L4	VA709900	COIL	105KHz
L5	VN136200	COIL	105KHz
PJ1	LB401040	JACK. PIN	4P
Q1	VG722000	TR. DGT	DTC144ES
Q2	VG722000	TR. DGT	DTC144ES
Q3	VD678500	TR. DGT	DTA114ES
Q4	VG722000	TR. DGT	DTC144ES
Q5	VG722000	TR. DGT	DTC144ES
Q6	VG722000	TR. DGT	DTC144ES
Q7	VG722000	TR. DGT	DTC144ES
Q8	VG722000	TR. DGT	DTC144ES
Q9	VK432900	TR	2SD1915F S, T
Q10	VK432900	TR	2SD1915F S, T
Q11	VG722000	TR. DGT	DTC144ES
Q12	VG722000	TR. DGT	DTC144ES
Q13	VG722000	TR. DGT	DTC144ES
Q14	VG722000	TR. DGT	DTC144ES
Q15	VG722000	TR. DGT	DTC144ES
Q16	VG722000	TR. DGT	DTC144ES
Q17	VK432900	TR	2SD1915F S, T
Q18	VK432900	TR	2SD1915F S, T
Q19	VG722000	TR. DGT	DTC144ES
Q20	VG722000	TR. DGT	DTC144ES
Q21	VG722000	TR. DGT	DTC144ES
Q22	iC174020	TR	2SC1740S R, S
Q23	iC174020	TR	2SC1740S R, S
Q24	iC174020	TR	2SC1740S R, S
△ Q25	VE613400	TR	2SD1858 Q, R
Q26	VG722000	TR. DGT	DTC144ES
Q27	VE613300	TR	2SB1237 Q, R

* New Parts

KX-393/493

KX-393 P.C.B. MAIN & TRANS

Schm Ref.	PART NO.	Description
Q28	VE613300	TR 2SB1237 Q, R
Q29	VD678700	TR. DGT DTC114ES
Q30	VD678700	TR. DGT DTC114ES
Q31	VG722000	TR. DGT DTC144ES
Q32	VD488500	TR. DGT DTC143XS
Q34	VD678500	TR. DGT DTA114ES
△ Q35	VS883400	TR 2SD2394 E, F
△ Q36	VE613300	TR 2SB1237 Q, R
Q37	VE613400	TR 2SD1858 Q, R
Q38	iA093320	TR 2SA933S Q, R
Q39	VE613400	TR 2SD1858 Q, R
△ R122	HV454220	R. CAR. FP 22 Ω 1/4W
△ R123	VK187000	R. FUS 22 Ω 1/4W
△ R128	HV454220	R. CAR. FP 22 Ω 1/4W
R144	HU597100	R. MIL. FLM 10K Ω 1/4W
R145	HU597100	R. MIL. FLM 10K Ω 1/4W
R147	HU577300	R. MIL. FLM 30K Ω 1/4W
R148	HU577560	R. MIL. FLM 56K Ω 1/4W
R149	HU577150	R. MIL. FLM 15K Ω 1/4W
R150	HU577560	R. MIL. FLM 56K Ω 1/4W
R151	HU577300	R. MIL. FLM 30K Ω 1/4W
△ R158	VE009700	R. FUS 4.7 Ω 1/4W
△ R162	HV455100	R. CAR. FP 100 Ω 1/4W
△ R163	HV455100	R. CAR. FP 100 Ω 1/4W
SW1	VG392900	SW. TACT SKHVAA
SW2	VG392900	SW. TACT SKHVAA
SW3	VG392900	SW. TACT SKHVAA
SW4	VG392900	SW. TACT SKHVAA
SW5	VG392900	SW. TACT SKHVAA
SW6	VG392900	SW. TACT SKHVAA
SW7	VG392900	SW. TACT SKHVAA
SW8	VG392900	SW. TACT SKHVAA
SW9	VG392900	SW. TACT SKHVAA
SW10	VG392900	SW. TACT SKHVAA
SW11	VG392900	SW. TACT SKHVAA
SW12	VG392900	SW. TACT SKHVAA
SW13	VG392900	SW. TACT SKHVAA
TP1	VL448600	JUMPER. TST
TP2	VL448600	JUMPER. TST
U1	VK498900	L. DTCT S-100
V1	VQ667400	FL. DSPLY BJ214GK
VR1	VJ694200	VR. TRIM B100K Ω
VR2	VJ694200	VR. TRIM B100K Ω
VR3	VJ693800	VR. TRIM B22K Ω
VR4	VJ693800	VR. TRIM B22K Ω
VR5	VJ693500	VR. TRIM B6.8K Ω
VR6	VJ693500	VR. TRIM B6.8K Ω
VR7	VJ693600	VR. TRIM B10K Ω
VR8	VJ693600	VR. TRIM B10K Ω
VR9	VJ693800	VR. TRIM B22K Ω
VR10	VJ693800	VR. TRIM B22K Ω
VR11	VR090600	VR A50K Ω
VR12	VR090700	VR A50K Ω

* New Parts

Schm Ref.	PART NO.	Description
VR13	VR090800	VR B100K Ω
VR14	VR313800	VR D5K Ω
VR15	VR090500	VR A5K Ω
XL1	VE906000	RSNR. CE 4MHz
	VN126800	HEAT. SINK UOT-16C25-MP
	VR710800	PLATE W25
	VQ948200	SPACER FL
	VQ859800	SHEET. FL
	VR285000	P. C. B. TRANS (UC)
	VR285100	P. C. B. TRANS (A)
	VR285200	P. C. B. TRANS (BG)
	VR286200	P. C. B. TRANS (R)
CB501	VG879900	CN. BS. PIN 2P
CB502	VK024900	CN. BS. PIN 5P
SW501	VG388100	VOLT. SELCT HXW0244-01-080 (R)
△ T501	XN501A00	TRANS. PWR (UC)
△ T501	XN502A00	TRANS. PWR (R)
△ T501	XN503A00	TRANS. PWR (A)
△ T501	XN504A00	TRANS. PWR (BG)
	Ei030086	SCR. BND. HD 3x8 ZMC2-Y(R)

* New Parts

KX-393/493

KX-493 P.C.B. MAIN

Schm Ref.	PART NO.	Description		
	VR283500	P. C. B.	MAIN(R)	
	VR283600	P. C. B.	MAIN(A)	
	VR283700	P. C. B.	MAIN(BG)	
CB1	VL844900	CN. BS. PIN	5P	
CB2	LB918020	CN. BS. PIN	2P	
CB4	VQ047800	CN. BS. PIN	27P	
CB5	VQ045600	CN. BS. PIN	27P	
CB7	Vi878000	CN. BS. PIN	2P	
CB8	Vi878000	CN. BS. PIN	2P	
CB9	Vi878100	CN. BS. PIN	3P	
CB10	Vi878100	CN. BS. PIN	3P	
CB11	Vi878300	CN. BS. PIN	5P	
CB501	VG879900	CN. BS. PIN	2P(ABG)	
CB502	VK024900	CN. BS. PIN	5P(ABG)	
C1	UA652680	C. MYLAR	680pF	50V
C2	UA652680	C. MYLAR	680pF	50V
C3	VE016600	C. EL	220uF	6.3V
C4	VE016600	C. EL	220uF	6.3V
C5	UA652220	C. MYLAR	220pF	50V
C6	UA652220	C. MYLAR	220pF	50V
C7	UA654130	C. MYLAR	0.013uF	50V
C8	UA654130	C. MYLAR	0.013uF	50V
C9	VE018700	C. EL	100uF	25V
C10	VE018700	C. EL	100uF	25V
C11	UM417100	C. EL	10uF	50V
C12	UM417100	C. EL	10uF	50V
C13	UA653120	C. MYLAR	1200pF	50V
C14	UA653120	C. MYLAR	1200pF	50V
C15	UA653100	C. MYLAR	1000pF	50V
C16	UA653100	C. MYLAR	1000pF	50V
C17	UM417100	C. EL	10uF	50V
C18	UM417100	C. EL	10uF	50V
C19	UA654180	C. MYLAR	0.018uF	50V
C20	UA654180	C. MYLAR	0.018uF	50V
C21	VJ839100	C. EL	1uF	50V
C22	VJ839100	C. EL	1uF	50V
C23	UA652470	C. MYLAR	470pF	50V
C24	UA652470	C. MYLAR	470pF	50V
C25	VJ839200	C. EL	2.2uF	50V
C26	VJ839200	C. EL	2.2uF	50V
C27	VF467300	C. CE. TUBLR	0.01uF	16V
C28	VF467000	C. CE. TUBLR	1000pF	50V
C29	UA654390	C. MYLAR	0.039uF	50V
C30	UA653680	C. MYLAR	6800pF	50V
C31	VJ839100	C. EL	1uF	50V
C32	VJ839100	C. EL	1uF	50V
C33	UA653220	C. MYLAR	2200pF	50V
C34	UA653220	C. MYLAR	2200pF	50V
C35	UA653220	C. MYLAR	2200pF	50V
C36	UA653220	C. MYLAR	2200pF	50V
C37	UA653220	C. MYLAR	2200pF	50V
C38	UA653220	C. MYLAR	2200pF	50V
C39	UM215100	C. EL	0.1uF	50V

*New Parts

Schm Ref.	PART NO.	Description		
C40	UM215100	C. EL	0.1uF	50V
C41	UM215100	C. EL	0.1uF	50V
C42	UM215100	C. EL	0.1uF	50V
C43	VF964800	C. EL	100uF	16V
C44	VF964800	C. EL	100uF	16V
C45	UM417100	C. EL	10uF	50V
C46	UM417100	C. EL	10uF	50V
C48	VJ839200	C. EL	2.2uF	50V
C49	VJ839100	C. EL	1uF	50V
C50	VJ839100	C. EL	1uF	50V
C51	VF466800	C. CE. TUBLR	100pF	50V
C52	VF466800	C. CE. TUBLR	100pF	50V
C53	VF467300	C. CE. TUBLR	0.01uF	16V
C54	VF467300	C. CE. TUBLR	0.01uF	16V
C55	VF467300	C. CE. TUBLR	0.01uF	16V
C56	VF467300	C. CE. TUBLR	0.01uF	16V
C57	UM417100	C. EL	10uF	50V
C58	UM417100	C. EL	10uF	50V
C59	VJ402700	C. EL	0.33uF	50V
C60	VJ402700	C. EL	0.33uF	50V
C61	UM417100	C. EL	10uF	50V
C62	UM417100	C. EL	10uF	50V
C63	UJ167330	C. EL	33uF	50V
C64	UJ167330	C. EL	33uF	50V
C65	UA653680	C. MYLAR	6800pF	50V
C66	UA653680	C. MYLAR	6800pF	50V
C67	UA653360	C. MYLAR	3600pF	50V
C68	UA653360	C. MYLAR	3600pF	50V
C69	UA653330	C. MYLAR	3300pF	50V
C70	UA653330	C. MYLAR	3300pF	50V
C71	UA653270	C. MYLAR	2700pF	50V
C72	UA653270	C. MYLAR	2700pF	50V
C73	VE021900	C. EL	4.7uF	100V
C74	VE021900	C. EL	4.7uF	100V
C75	UA652560	C. MYLAR	560pF	50V
C76	UA652560	C. MYLAR	560pF	50V
C77	UM416470	C. EL	4.7uF	50V
C78	UM416470	C. EL	4.7uF	50V
C79	VJ839200	C. EL	2.2uF	50V
C80	VJ839200	C. EL	2.2uF	50V
C83	UT452820	C. PP	820pF	100V
C84	UT452820	C. PP	820pF	100V
C85	VS204800	C. PP	100pF	100V
C86	VS204800	C. PP	100pF	100V
C87	VG280100	C. CE. TUBLR	0.022uF	25V
C88	VG280100	C. CE. TUBLR	0.022uF	25V
C89	VG280100	C. CE. TUBLR	0.022uF	25V
C90	VG280100	C. CE. TUBLR	0.022uF	25V
C91	VF467300	C. CE. TUBLR	0.01uF	16V
C92	VF467300	C. CE. TUBLR	0.01uF	16V
C93	VG278800	C. CE. TUBLR	560pF	50V
C94	VG278800	C. CE. TUBLR	560pF	50V
C95	UM417100	C. EL	10uF	50V

*New Parts

KX-493 P.C.B. MAIN

Schm Ref.	PART NO.	Description
C96	UM215100	C. EL 0.1uF 50V
C97	VJ599000	C. CE. TUBLR 0.047uF 16V
C98	UT453390	C. PP 3900pF 100V
C99	UA653220	C. MYLAR 2200pF 50V
C100	UA653220	C. MYLAR 2200pF 50V
C101	UA654100	C. MYLAR 0.01uF 50V
C102	UJ648100	C. EL 100uF 25V
C103	UJ667470	C. EL 47uF 50V
C104	VT180400	C. EL 4700uF 5.5V
C105	VF467300	C. CE. TUBLR 0.01uF 16V
C106	VJ838800	C. EL 0.22uF 50V
C107	UM417100	C. EL 10uF 50V
C108	UM417100	C. EL 10uF 50V
C109	VH520900	C. EL 4700uF 16V
C110	UM407220	C. EL 22uF 25V
C111	FG214100	C. CE 0.01uF 50V
C112	FG214100	C. CE 0.01uF 50V
C113	VF606700	C. EL 1000uF 25V
C114	VF606700	C. EL 1000uF 25V
C115	UJ667470	C. EL 47uF 50V
C116	UJ667470	C. EL 47uF 50V
C117	VE742700	C. EL 10uF 50V
C118	VE742700	C. EL 10uF 50V
C119	UM417100	C. EL 10uF 50V
C120	UJ658220	C. EL 220uF 35V
C121	UJ658470	C. EL 470uF 35V
C122	UM417100	C. EL 10uF 50V
C123	VF466800	C. CE. TUBLR 100pF 50V
C124	UM417100	C. EL 10uF 50V
C125	VF467300	C. CE. TUBLR 0.01uF 16V
C129	VF467300	C. CE. TUBLR 0.01uF 16V
D1	VD631600	DIODE 1SS133, 176, HSS104
D2	VD631600	DIODE 1SS133, 176, HSS104
D3	VD631600	DIODE 1SS133, 176, HSS104
D4	VD631600	DIODE 1SS133, 176, HSS104
D5	VD631600	DIODE 1SS133, 176, HSS104
D11	VD631600	DIODE 1SS133, 176, HSS104
D12	VD631600	DIODE 1SS133, 176, HSS104
D13	VG441200	DIODE. ZENR MIZJ16C 16V
D14	VD631600	DIODE 1SS133, 176, HSS104
D15	VD631600	DIODE 1SS133, 176, HSS104
D16	VD631600	DIODE 1SS133, 176, HSS104
D17	VD631600	DIODE 1SS133, 176, HSS104
D18	VG437200	DIODE. ZENR MIZJ4.7C 4.7V
D19	VQ379300	DIODE. BRG S1VB20 1.0A 200V
D20	VG438900	DIODE. ZENR MIZJ8.2B 8.2V
D21	VG438900	DIODE. ZENR MIZJ8.2B 8.2V
D22	VU264100	DIODE 1SR139-400
D23	VU264100	DIODE 1SR139-400
D24	VU264100	DIODE 1SR139-400
D25	VU264100	DIODE 1SR139-400
D26	VG442100	DIODE. ZENR MIZJ22B 22V
D27	VG436200	DIODE. ZENR MIZJ3.6A 3.6V

Schm Ref.	PART NO.	Description
D28	VD631600	DIODE 1SS133, 176, HSS104
D29	VD631600	DIODE 1SS133, 176, HSS104
D31	VD631600	DIODE 1SS133, 176, HSS104
D32	VD631600	DIODE 1SS133, 176, HSS104
Fi1	VM548100	FLTR. MPX 160KHz MPX
Fi2	VM548100	FLTR. MPX 160KHz MPX
Fi3	VM548200	FLTR. LC 160KHz BEF
Fi4	VM548200	FLTR. LC 160KHz BEF
IC1	XD864A00	IC uPC1330HA
IC2	XR618A00	IC NJM2043L-D OP AMP
IC3	XM922A00	IC NJM4558L
IC4	iG001720	IC TC4069UBP
IC5	iG037400	IC uPD4066BC
IC6	XH741A00	IC HA12142NT
IC7	XP844A00	IC NJM4556AL
IC8	iG089900	IC AN90B20
IC9	iG089900	IC AN90B20
IC10	XM922A00	IC NJM4558L
IC11	XA300A00	IC uPC1297CA
IC12	iG074900	IC BA6138
IC13	XN483B00	IC LC65204A-4C97
IC14	XM974A00	IC BU2040
IC15	XA507A00	IC AN78N05
JK1	LB301370	JACK. PHONE
L1	GE901660	COIL 18mH
L2	GE901660	COIL 18mH
L3	VM548000	COIL 160KHz
L4	VM548000	COIL 160KHz
L5	VM620000	COIL. BIAS 160KHz
PJ1	LB401040	JACK. PIN 4P
Q1	VG722000	TR. DGT DTC144ES
Q2	VG722000	TR. DGT DTC144ES
Q3	VD678500	TR. DGT DTA114ES
Q4	VG722000	TR. DGT DTC144ES
Q5	VG722000	TR. DGT DTC144ES
Q6	VG722000	TR. DGT DTC144ES
Q7	VG722000	TR. DGT DTC144ES
Q8	VG722000	TR. DGT DTC144ES
Q9	VK432900	TR 2SD1915F S, T
Q10	VK432900	TR 2SD1915F S, T
Q11	VK432900	TR 2SD1915F S, T
Q12	VK432900	TR 2SD1915F S, T
Q15	iC174020	TR 2SC1740S R, S
Q16	iC174020	TR 2SC1740S R, S
Q17	VE613400	TR 2SD1858 Q, R
Q18	VG722000	TR. DGT DTC144ES
Q19	VG722000	TR. DGT DTC144ES
Q20	VG722000	TR. DGT DTC144ES
Q21	VG722000	TR. DGT DTC144ES
Q22	iC174020	TR 2SC1740S R, S
Q23	iC174020	TR 2SC1740S R, S
Q24	iC174020	TR 2SC1740S R, S
Q25	iA093320	TR 2SA933S Q, R

* New Parts

* New Parts

KX-493 P.C.B. MAIN & TRANS

Schm Ref.	PART NO.	Description	
Q26	VG722000	TR. DGT	DTC144ES
Q27	VG722000	TR. DGT	DTC144ES
Q28	VE613300	TR	2SB1237 Q, R
Q29	VD678700	TR. DGT	DTC114ES
Q30	VD678700	TR. DGT	DTC114ES
Q31	iC174020	TR	2SC1740S R, S
Q32	VD488500	TR. DGT	DTC143XS
Q33	VD678500	TR. DGT	DTA114ES
△ Q34	VE613300	TR	2SB1237 Q, R
△ Q35	VS883400	TR	2SD2394 E, F
△ Q36	VS883300	TR	2SB1565 E, F
△ Q37	VE613300	TR	2SB1237 Q, R
Q38	VD678500	TR. DGT	DTA114ES
Q39	VD678500	TR. DGT	DTA114ES
Q40	VD678500	TR. DGT	DTA114ES
Q42	VE613400	TR	2SD1858 Q, R
Q43	VD678500	TR. DGT	DTA114ES
Q44	VE613400	TR	2SD1858 Q, R
△ R140	HV453560	R. CAR. FP	5.6 Ω 1/4W
△ R151	VE009700	R. FUS	4.7 Ω 1/4W
R164	HU597100	R. MIL. FLM	10K Ω 1/4W
R172	VE009700	R. FUS	4.7 Ω 1/4W
△ R173	VE009700	R. FUS	4.7 Ω 1/4W
△ R174	VE009700	R. FUS	4.7 Ω 1/4W
△ R180	HV455100	R. CAR. FP	100 Ω 1/4W
△ R181	HV455100	R. CAR. FP	100 Ω 1/4W
SW1	VG392900	SW. TACT	SKHVAA
SW2	VG392900	SW. TACT	SKHVAA
SW3	VG392900	SW. TACT	SKHVAA
SW4	VG392900	SW. TACT	SKHVAA
SW5	VG392900	SW. TACT	SKHVAA
SW6	VG392900	SW. TACT	SKHVAA
SW7	VG392900	SW. TACT	SKHVAA
SW8	VG392900	SW. TACT	SKHVAA
SW9	VG392900	SW. TACT	SKHVAA
SW10	VG392900	SW. TACT	SKHVAA
SW11	VG392900	SW. TACT	SKHVAA
SW12	VG392900	SW. TACT	SKHVAA
SW13	VG392900	SW. TACT	SKHVAA
SW15	VF113100	SW. SLIDE	SSSU01
SW16	VG392900	SW. TACT	SKHVAA
△ T501	XN503A00	TRANS. PWR	(A)
△ T501	XN504A00	TRANS. PWR	(BG)
TP1	VL448600	JUMPER. TST	
TP2	VL448600	JUMPER. TST	
U1	VK498900	L. DTCT	S-100
V1	VQ667400	FL. DSPLY	BJ214GK
VR1	VJ694200	VR. TRIM	B100K Ω
VR2	VJ694200	VR. TRIM	B100K Ω
VR3	VJ693800	VR. TRIM	B22K Ω
VR4	VJ693800	VR. TRIM	B22K Ω
VR5	VJ693500	VR. TRIM	B6.8K Ω
VR6	VJ693500	VR. TRIM	B6.8K Ω

* New Parts

Schm Ref.	PART NO.	Description	
VR7	VJ693800	VR. TRIM	B22K Ω
VR8	VJ693800	VR. TRIM	B22K Ω
VR9	VJ693800	VR. TRIM	B22K Ω
VR10	VJ693800	VR. TRIM	B22K Ω
VR11	VR090600	VR	A50K Ω
VR12	VR114800	VR	A50K Ω
VR13	VM641000	VR	B100K Ω
VR14	VG237500	VR	2K Ω
VR15	VM640800	VR	A5K Ω
XL1	VE906000	RSNR. CE	4MHz
	VB966900	CN	IMS A-6024
	VQ948200	SPACER	FL
	VQ859800	SHEET. FL	
	VR286200	P. C. B.	TRANS(R)
CB501	VG879900	CN. BS. PIN	2P
CB502	VK024900	CN. BS. PIN	5P
SW501	VG388100	VOLT. SELCT	HXW0244-01-080
△ T501	XN502A00	TRANS. PWR	
	Ei030086	SCR. BND. HD	3x8 ZMC2-Y

* New Parts

A

B

C

D

E

KX-393/493

1 ■ KX-393 EXPLODED VIEW

1

2

3

4

5

6

7

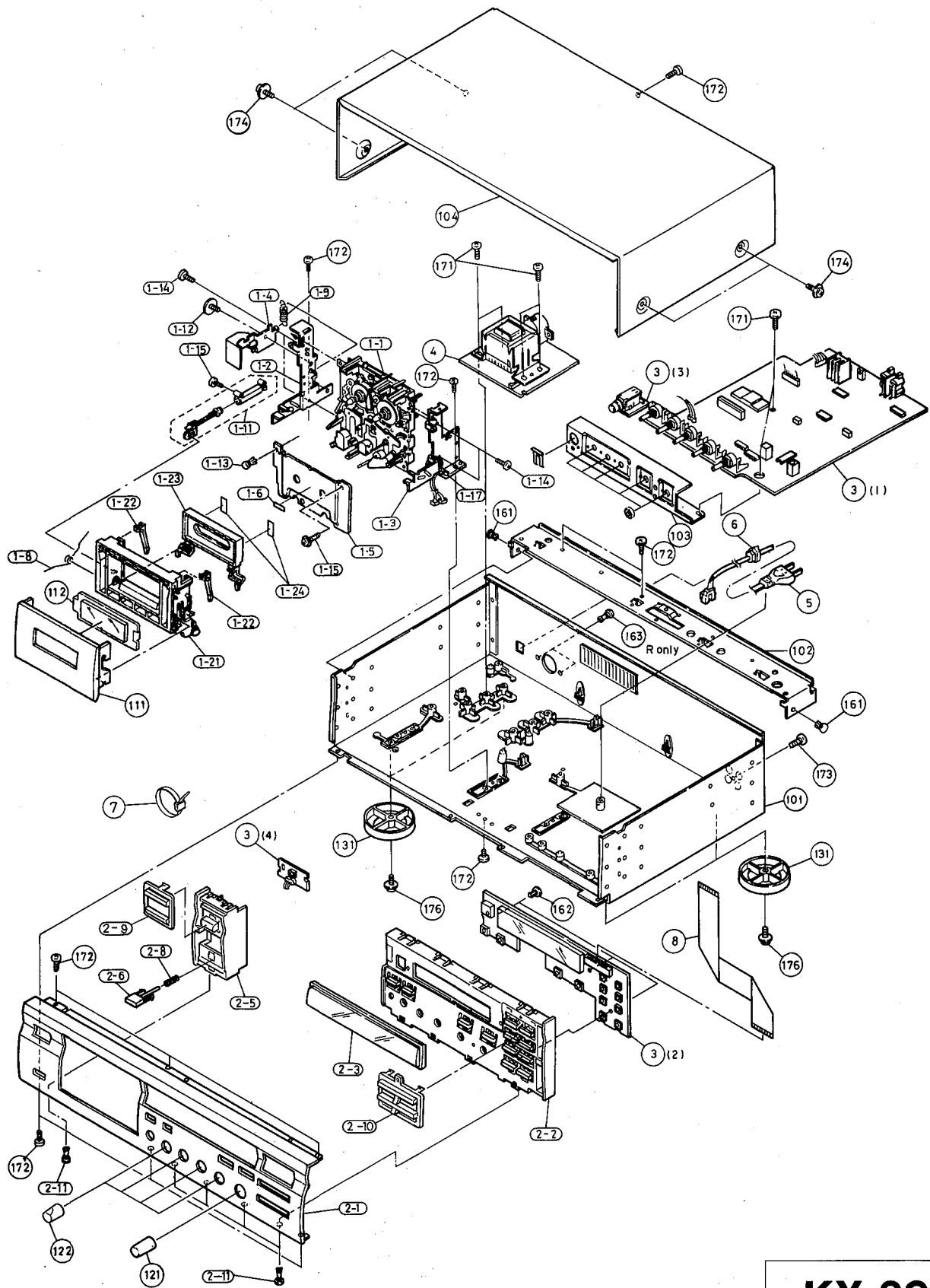

KX-393

■ KX-393 MECHANICAL PARTS

Ref. No.	PART NO.	Description	Remarks	Markets
1- 1	VR029600	CASSETTE DECK MECHANISM		
1- 2	VZ134800	HOLDER L, MECH		
1- 3	VZ134900	HOLDER R, MECH		
1- 4	VQ860500	EJECT LEVER		
1- 5	VQ860000	BACK PLATE		
1- 6	VQ146900	LABEL B.P		
1- 8	VM873800	SPRING	EJ	
1- 9	VU198200	SPRING	LEVER	
1-11	VR020600	DAMPER, AIR	FP472-11	
1-12	VR020500	SHOULDER SCREW	ST3 D6x4	
1-13	VQ368500	PUSH RIVET	P3545-B	
1-14	VR278600	BIND HEAD S-TITE SCREW	2.6x6 FCRM3-BL	
1-15	EK096060	PW HEAD S-TITE SCREW	2.5x12 FCRM3-BL	
1-17	VR316500	BINDING TIE	CV-70	
1-21	VQ860400	CASSETTE HOUSING		
1-22	VM868200	GUIDE, CASSETTE		
1-23	VQ860600	PLATE, DAMPER		
1-24	VT967100	DAMPER, STB		
* 2- 1	VZ442300	FRONT PANEL		BL
* 2- 1	VZ442400	FRONT PANEL		TI
* 2- 2	VZ443800	SUB PANEL		BL
* 2- 2	VZ443900	SUB PANEL		TI
* 2- 3	VZ446400	WINDOW PANEL, LID		
* 2- 5	VZ444200	BUTTON CASE		BL
* 2- 5	VZ444300	BUTTON CASE		TI
* 2- 6	VZ445600	BUTTON, EJ		BL
* 2- 6	VZ445700	BUTTON, EJ		TI
* 2- 8	VQ852900	SPRING	D6.4C	
* 2- 9	VZ444600	ESCUTCHEON, POWER		BL
* 2- 9	VZ444700	ESCUTCHEON, POWER		TI
* 2-10	VZ444800	ESCUTCHEON, SCAN		BL
* 2-10	VZ444900	ESCUTCHEON, SCAN		TI
2-11	VQ368600	PUSH RIVET	P3555-B	
3	VR283300	P. C. B. ASS'Y	MAIN	
4	VR285000	P. C. B. ASS'Y	TRANS	(UC)
4	VR285100	P. C. B. ASS'Y	TRANS	(A)
4	VR285200	P. C. B. ASS'Y	TRANS	(BG)
4	VR286200	P. C. B. ASS'Y	TRANS	(R)
△ 5	VL238100	POWER CORD ASS'Y		(R)
△ 5	VN363700	POWER CORD ASS'Y		
△ 5	VQ508600	POWER CORD ASS'Y		(A)
△ 5	VV437200	POWER CORD ASS'Y		(UC)
△ 5	VV437300	POWER CORD ASS'Y		(B)
6	VN158600	CORD STOPPER	No. 2104	
7	VU590000	BINDING TIE	CBTD001B	
8	MF127250	FLEXIBLE FLAT CABLE C&C	27P 250mm	
101	VM871200	CHASSIS		
101	VM871400	CHASSIS		(R)
102	VM634400	TOP FRAME		
103	VQ859100	BRACKET, VR		
* 104	VZ439700	TOP COVER		BL
* 104	VZ439800	TOP COVER		TI
* 111	VZ445000	LID		BL

* New Parts

Ref. No.	PART NO.	Description	Remarks	Markets
* 111	VZ445100	LID		TI
* 112	VZ446500	WINDOW, LID		
121	VQ779200	KNOB	D16	BL
121	VU097100	KNOB	D16	TI
122	VV311000	KNOB	D14	BL
122	VV311400	KNOB	D14	TI
131	VQ780300	LEG	D60xH16	
161	VQ368500	PUSH RIVET	P3545-B	
162	VQ368600	PUSH RIVET	P3555-B	
163	VR101100	PUSH RIVET	P3065-B	
171	EK093040	BIND HEAD P-TITE SCREW	3x12 ZMC2-Y	
172	Ei330086	BIND HEAD B-TITE SCREW	3x8 FCRM3-BL	
173	EN335030	BIND HEAD BONDING TAP. SCREW	3x10 FCRM3-BL	
174	EK365090	PW HEAD S-TITE SCREW	4x8-10 FCRM3-BL	BL
174	EX601150	BW HEAD S-TITE SCREW	4x8-10 FNM3-BL	TI
176	EK930010	PW HEAD B-TITE SCREW	3x8-8 FCRM3-BL	
		ACCESSORIES		
	VY952200	PIN-PLUG CORD	2P 1.0m	

* New Parts

KX-393/493

1 KX-493 EXPLODED VIEW

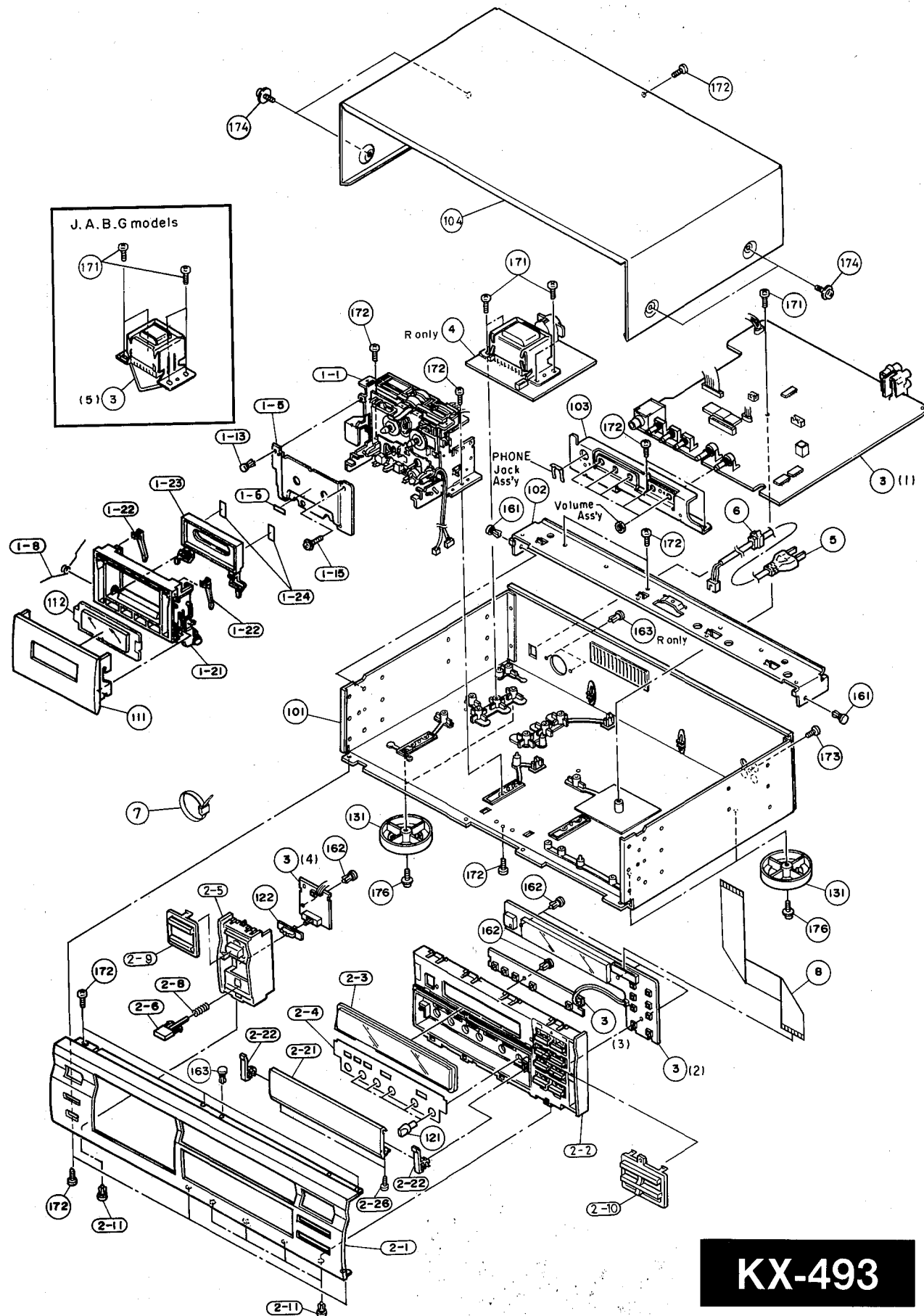

KX-493

1 KX-493 MECHANICAL PARTS

Ref. No.	PART NO.	Description	Remarks	Markets
* 1- 1	VZ455100	CASSETTE MECHANISM		
1- 5	VR398300	BACK PLATE	B	
1- 6	VQ146900	LABEL B.P.		
1- 8	VM873800	SPRING	EJ	
1-13	VQ368500	PUSH RIVET	P3545-B	
1-15	EK096060	PW HEAD S-TITE SCREW	2.5x12	FCRM3-BL
1-21	VQ860400	CASSETTE HOUSING		
1-22	VM868200	GUIDE, CASSETTE		
1-23	VQ860600	PLATE, DAMPER		
1-24	VK919000	DAMPER		
* 2- 1	VZ442100	FRONT PANEL		BL
* 2- 1	VZ442200	FRONT PANEL		TI
* 2- 2	VZ443600	SUB PANEL		BL
* 2- 2	VZ443700	SUB PANEL		TI
* 2- 3	VZ446400	WINDOW PANEL, LID		
* 2- 4	VZ446700	PLATE, SP		BL
* 2- 4	VZ446800	PLATE, SP		TI
* 2- 5	VZ444200	BUTTON CASE		BL
* 2- 5	VZ444300	BUTTON CASE		TI
* 2- 6	VZ445600	BUTTON, EJ		BL
* 2- 6	VZ445700	BUTTON, EJ		TI
2- 8	VQ852900	SPRING	D6.4C	
* 2- 9	VZ444600	ESCUTCHEON, POWER		BL
* 2- 9	VZ444700	ESCUTCHEON, POWER		TI
* 2-10	VZ444800	ESCUTCHEON, SCAN		BL
* 2-10	VZ444900	ESCUTCHEON, SCAN		TI
2-11	VQ368600	PUSH RIVET	P3555-B	
* 2-21	VZ443100	PANEL, LID		BL
* 2-21	VZ443200	PANEL, LID		TI
2-22	VQ859300	HINGE, LID		BL
2-22	VQ958500	HINGE, LID		TI
2-26	EX601590	BIND HEAD P-TITE SCREW	2.6x8	FCRM3-BL
3	VR283500	P. C. B. ASS'Y	MAIN	(R)
3	VR283600	P. C. B. ASS'Y	MAIN	(A)
3	VR283700	P. C. B. ASS'Y	MAIN	(G)
4	VR286200	P. C. B. ASS'Y	TRANS	(R)
△ 5	VL238100	POWER CORD ASS'Y		(R)
△ 5	VN363700	POWER CORD ASS'Y		(G)
△ 5	VQ508600	POWER CORD ASS'Y		(A)
△ 5	VV437300	POWER CORD ASS'Y		(B)
6	VN158600	CORD STOPPER	No. 2104	
7	VU590000	BINDING TIE	CBTD001B	
8	MF127250	FLEXIBLE FLAT CABLE C&C	27P 250mm	
101	VM871200	CHASSIS		(ABG)
101	VM871400	CHASSIS		(R)
102	VM634400	TOP FRAME		
103	VQ859200	BRACKET, VR		
* 104	VZ439700	TOP COVER		BL
* 104	VZ439800	TOP COVER		TI
* 111	VZ445000	LID		BL
* 111	VZ445100	LID		TI
* 112	VZ446500	WINDOW, LID		
121	VQ859400	KNOB, VR	D10	

* New Parts

Ref. No.	PART NO.	Description	Remarks	Markets
121	VU096800	KNOB, VR	D10	TI
122	VQ853500	KNOB, SL		BL
122	VU096900	KNOB, SL		TI
131	VQ780300	LEG	D60xH16	
161	VQ368500	PUSH RIVET	P3545-B	
162	VQ368600	PUSH RIVET	P3555-B	
163	VR101100	PUSH RIVET	P3065-B	
171	EK093040	BIND HEAD P-TITE SCREW	3x12	ZMC2-Y
172	E1330086	BIND HEAD B-TITE SCREW	3x8	FCRM3-BL
173	EN335030	BIND HEAD BONDING TAP. SCREW	3x10	FCRM3-BL
174	EK365090	PW HEAD S-TITE SCREW	4x8-10	FCRM3-BL
174	EX601150	BW HEAD S-TITE SCREW	4x8-10	FNM3-BL
176	EK930010	PW HEAD B-TITE SCREW	3x8-8	FCRM3-BL
	VY952200	ACCESSORIES PIN-PLUG CORD	2P 1.0m	

(R)

* New Parts

A

B

C

D

E

KX-393/493

1

EXPLODED VIEW (KX-393 Cassette Mechanism Unit)

KX-393

2

3

4

5

6

7

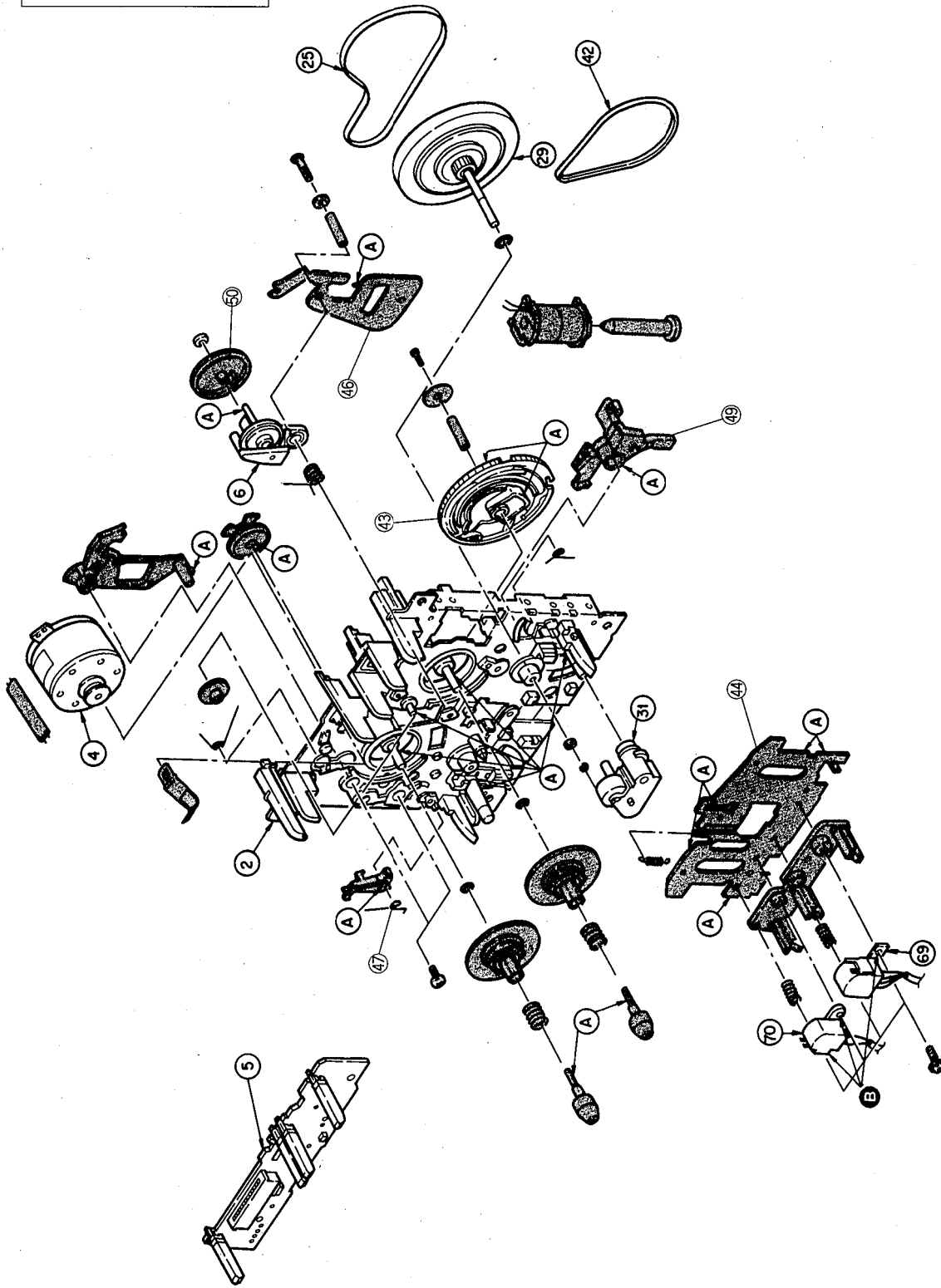

Note:  marked parts are not available.

 : MOLYKOTE X5 ... DAW CORNING CO., LTD. (LUBRICATION POINT)

 : SCREW LOCK ... THREE BOND CO., LTD. (APPLICATION POINT)

MECHANICAL PARTS (KX-393 Cassette Mechanism Unit)

Ref. No.	PART NO.	Description	Remarks	Markets
	VR029600	CASSETTE DECK MECHANISM		
2	NX613020	CHASSIS BASE ASS'Y	F612202	
4	JX601460	MOTOR ASS'Y, MAIN	F525305	
5	NX613000	P.C.B. ASS'Y	F567523	
6	NX612971	CLUTCH ASS'Y	F522030	
25	CX673050	BELT, MAIN	FF17W31	
29	NX612960	FLYWHEEL ASS'Y	F522029	
31	NX612950	PINCH ROLLER ASS'Y, R	F514120	
42	CX675180	BELT, F/R	FF18W11	
43	CX677140	CAM, GEAR	FD52Y20	
44	AX623570	HEAD BASE	FC61K28	
46	CX677130	LEVER	FC62G12	
47	AX622220	SPRING L, INTERLOCK	FK32N11	
49	AX623590	LOCK LEVER	FD53D19	
50	CX679800	PULLEY, CLUTCH	FD53F14	
69	GX603050	HEAD, REC/PB	FU15R12	
70	GX606840	HEAD, ERASE	FU19211	

* New Parts

KX-393/493

1

EXPLODED VIEW (KX-493 Cassette Mechanism Unit)

KX-493

2

3

4

5

6

7

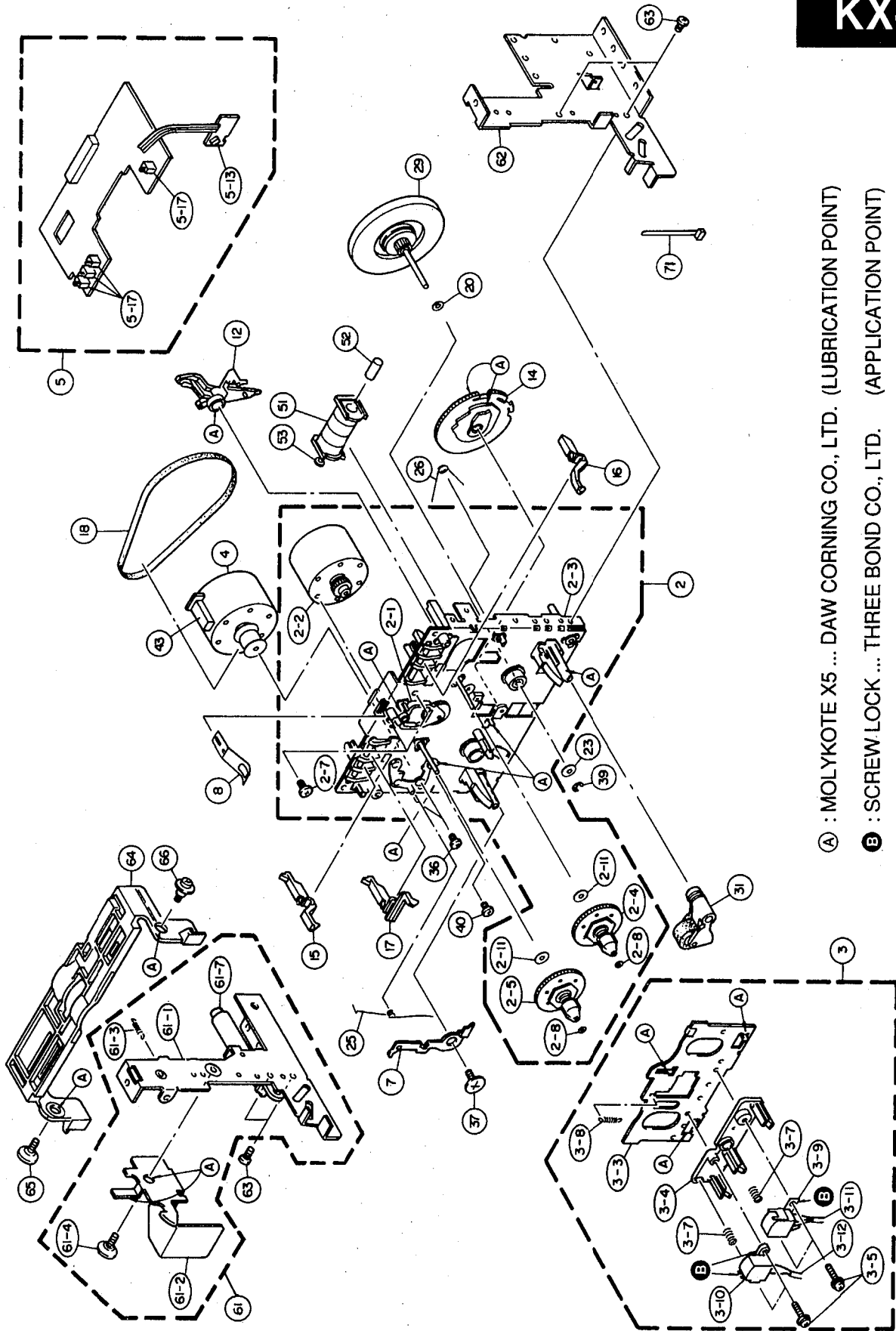

- (A) : MOLYKOTE X5 ... DAW CORNING CO., LTD. (LUBRICATION POINT)
- (B) : SCREW LOCK ... THREE BOND CO., LTD. (APPLICATION POINT)

MECHANICAL PARTS (KX-493 Cassette Mechanism Unit)

Ref. No.	PART NO.	Description	Remarks	Markets
*	VZ455100	CASSETTE MECHANISM		
2	AX616800	CHASSIS ASS'Y		F511529
2- 1	AX605120	IDLER ASS'Y		F517049
2- 2	JX600660	MOTOR ASS'Y, REEL		F564280
2- 3	AX616810	CHASSIS BASE ASS'Y		F612184
2- 4	AX605150	REEL BASE ASS'Y		F623037
2- 5	AX605160	REEL BASE ASS'Y		F623127
2- 7	AX616670	SCREW	2. 6x6. 4	FG15611A
2- 8	XX636610	WASHER	1. 7x3. 2-0. 25	FJ11117
2-11	XX641850	WASHER	2. 1x7-0. 25	UJ12V11
3	NX610710	PLATE HEAD ASS'y		F513664
3- 3	AX616820	HEAD BASE		FC52E46
* 3- 4	AX624670	HD BASE		FD45T18
3- 5	AX603110	SPECIAL SCREW	2x9	FG13718
3- 7	XX641720	SPRING	AZIMUTH	FK21U11
3- 8	AX600370	SPRING, HEAD BASE		FK26N14
3- 9	GX603050	HEAD, REC/PB		FU15R12
3-10	GX604820	HEAD, ERASE		FU20N11
3-11	MX601130	CONNECTOR		WH48C06
3-12	MX601140	CONNECTOR		WH50T05
4	NX608410	MOTOR ASS'Y, MAIN		F525269
5	NX610720	P. C. B. ASS'Y		F567476
5-13	ix618310	SENSOR	SPI-335-34-FG	AW13F00
5-17	KX601080	PUSH SWITCH		UE16E11
7	AX602510	PROTECT ARM, EJECT	L	FC39S33
8	AX608300	SPRING, CASSETTE HOLDER		FC52H13
12	BX602330	PLAY ARM		FD45G13
14	CX672960	CAM GEAR	3R	FD45B16
15	AX611250	SENSOR LEVER	REC	FD44T14
16	CX608720	SENSOR LEVER	CASS.	FD44Y12
17	CX612740	SENSOR LEVER	METAL TAPE	FD44V12
18	CX673050	BELT, MAIN		FF17W31
20	XX636810	WASHER	2. 6x0. 25	FJ11130
23	CX608740	WASHER	2. 6x0. 5	FJ11114
25	AX616690	SPRING, EJECT PROTECT	L	FK28M16
26	AX605650	SPRING, SLIDE		FK28R11
29	NX604300	FLYWHEEL ASS'Y		FR22D11
31	CX672980	PINCH ROLLER ASS'Y (R)		FR20L22
36	XX697410	SPECIAL SCREW	2. 6x5	FG11414
37	AX613160	SPECIAL SCREW	7. 7	UG15S11A
39	AX605640	E-RING		UG13U15
40	AX616830	SPECIAL SCREW	3x8	UG20B11
43	CX615200	CUSHION	HOLDER L	FF17C12
51	JX600430	SOLENOID ASS'Y		F765263
52	AX611260	STEEL CORE		FL39H12A
53	JX600440	PLUNGER		FL39K12
61	XX698140	PLATE HOLD ASS'Y		F573256
61-1	XX698150	HOLDER	L	FC58G14
61-2	BX602350	EJECT LEVER		FC58K11
61-3	AX616710	SPRING, EJECT ARM		FK31V11
61-4	AX613170	SPECIAL SCREW	4. 7	UG14M31
61-7	XX636970	DAMPER ASS'Y		FP47211
62	XX698160	HOLDER	R	FC58H14
63	Ei026046	BIND HEAD TAPPING SCREW	2. 6x4 ZMC2-Y	KG19428
64	CX672990	ARM, EJECT		FD50E13
65	AX613170	SPECIAL SCREW	4. 7	UG14M31
66	XX684660	SPECIAL SCREW		UG14L11
71	CB069250	BINDING TIE		FH12613

* New Parts

Parts List for Carbon Resistors

Value	1/4W Type Part No.	1/6W Type Part No.	Value	1/4W Type Part No.	1/6W Type Part No.
1.0 Ω	HJ35 3100	HF85 3100	10 kΩ	HF45 7100	HF45 7100
1.8 Ω	HJ35 3180	*	11 kΩ	HF45 7110	HF45 7110
2.2 Ω	HJ35 3220	HF85 3220	12 kΩ	HJ35 7120	HF85 7120
3.3 Ω	HJ35 3330	HF85 3330	13 kΩ	HF45 7130	HF45 7130
4.7 Ω	HJ35 3470	HF85 3470	15 kΩ	HF45 7150	HF45 7150
5.6 Ω	HJ35 3560	HF85 3560	18 kΩ	HF45 7180	HF45 7180
10 Ω	HF45 4100	HF45 4100	22 kΩ	HF45 7220	HF45 7220
15 Ω	HJ35 4150	HF85 4150	24 kΩ	HF45 7240	HF45 7240
22 Ω	HF45 4220	HF45 4220	27 kΩ	HJ35 7270	HF85 7270
27 Ω	HJ35 4270	HF85 4270	30 kΩ	HF45 7300	HF45 7300
33 Ω	HF45 4330	HF45 4330	33 kΩ	HF45 7330	HF45 7330
39 Ω	HJ35 4470	HF85 4390	36 kΩ	HF45 7360	HF45 7360
47 Ω	HF45 4470	HF45 4470	39 kΩ	HF45 7390	HF45 7390
56 Ω	HF45 4560	HF45 4560	47 kΩ	HF45 7470	HF45 7470
68 Ω	HF45 4680	HF45 4680	51 kΩ	HF45 7510	HF45 7510
75 Ω	HF45 4750	HF45 4750	56 kΩ	HF45 7560	HF45 7560
82 Ω	HF45 4820	HF45 4820	62 kΩ	HF45 7620	HF45 7620
91 Ω	HF45 4910	HF45 4910	68 kΩ	HF45 7680	HF45 7680
100 Ω	HF45 5100	HF45 5100	82 kΩ	HF45 7820	HF45 7820
110 Ω	HJ35 5110	HF85 5110	91 kΩ	HF45 7910	HF45 7910
120 Ω	HF45 5120	HF45 5120	100 kΩ	HF45 8100	HF45 8100
150 Ω	HF45 5150	HF45 5150	110 kΩ	HF45 8110	HF45 8110
160 Ω	HJ35 5160	*	120 kΩ	HF45 8120	HF45 8120
180 Ω	HF45 5180	HF45 5180	150 kΩ	HF45 8150	HF45 8150
200 Ω	HF45 5200	HF45 5200	180 kΩ	HF45 8180	HF45 8180
220 Ω	HF45 5220	HF45 5220	220 kΩ	HJ35 8220	HF85 8220
270 Ω	HF45 5270	HF45 5270	270 kΩ	HF45 8270	HF45 8270
330 Ω	HF45 5330	HF45 5330	300 kΩ	HF45 8300	HF45 8300
390 Ω	HF45 5390	HF45 5390	330 kΩ	HF45 8330	HF45 8330
430 Ω	HF45 5430	HF45 5430	390 kΩ	HJ35 8390	HF85 8390
470 Ω	HF45 5470	HF45 5470	470 kΩ	HF45 8470	HF45 8470
510 Ω	HF45 5510	HF45 5510	560 kΩ	HJ35 8560	HF85 8560
560 Ω	HF45 5560	HF45 5560	680 kΩ	HJ35 8680	HF85 8680
680 Ω	HF45 5680	HF45 5680	820 kΩ	HJ35 8820	HF85 8820
820 Ω	HF45 5820	HF45 5820	1.0 MΩ	HF45 9100	HF45 9100
910 Ω	HF45 5910	HF45 5910	1.2 MΩ	HJ35 9120	*
1.0 kΩ	HF45 6100	HF45 6100	1.5 MΩ	HJ35 9150	HF85 9150
1.2 kΩ	HF45 6120	HF45 6120	1.8 MΩ	HJ35 9180	HF85 9180
1.5 kΩ	HF45 6150	HF45 6150	2.2 MΩ	HJ35 9220	HF85 9220
1.8 kΩ	HF45 6180	HF45 6180	3.3 MΩ	HJ35 9330	HF85 9330
2.0 kΩ	HJ35 6200	HF85 6200	3.9 MΩ	HJ35 9390	*
2.2 kΩ	HF45 6220	HF45 6220	4.7 MΩ	HJ35 9470	HF85 9470
2.4 kΩ	HJ35 6240	HF85 6240			
2.7 kΩ	HF45 6270	HF45 6270			
3.0 kΩ	HF45 6300	HF45 6300			
3.3 kΩ	HF45 6330	HF45 6330			
3.6 kΩ	HJ35 6360	HF85 6360			
3.9 kΩ	HF45 6390	HF45 6390			
4.7 kΩ	HF45 6470	HF45 6470			
5.1 kΩ	HF45 6510	HF45 6510			
5.6 kΩ	HF45 6560	HF45 6560			
6.8 kΩ	HF45 6680	HF45 6680			
8.2 kΩ	HF45 6820	HF45 6820			
9.1 kΩ	HF45 6910	HF45 6910			

