

STEREO CASSETTE DECK KX-930

KX-930

SERVICE MANUAL

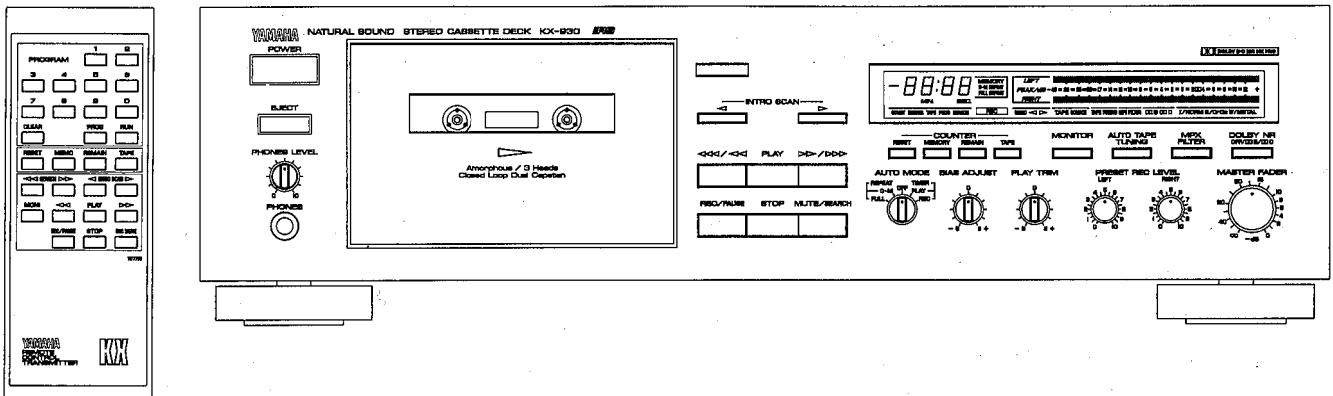

IMPORTANT NOTICE

This manual has been provided for the use of authorized Yamaha Retailers and their service personnel. It has been assumed that basic service procedures inherent to the industry, and more specifically Yamaha Products, are already known and understood by the users, and have therefore not been restated.

WARNING: Failure to follow appropriate service and safety procedures when servicing this product may result in personal injury, destruction of expensive components and failure of the product to perform as specified. For these reasons, we advise all Yamaha product owners that all service required should be performed by an authorized Yamaha Retailer or the appointed service representative.

IMPORTANT: The presentation or sale of this manual to any individual or firm does not constitute authorization, certification, recognition of any applicable technical capabilities, or establish a principle-agent relationship of any form.

The data provided is believed to be accurate and applicable to the unit(s) indicated on the cover. The research, engineering, and service departments of Yamaha are continually striving to improve Yamaha products. Modifications are, therefore, inevitable and specifications are subject to change without notice or obligation to retrofit. Should any discrepancy appear to exist, please contact the distributor's Service Division.

WARNING: Static discharges can destroy expensive components. Discharge any static electricity your body may have accumulated by grounding yourself to the ground buss in the unit (heavy gauge black wires connect to this buss).

IMPORTANT: Turn the unit OFF during disassembly and parts replacement. Recheck all work before you apply power to the unit.

CONTENTS

TO SERVICE PERSONEL	1	IC BLOCK	14, 15
SPECIFICATIONS	1	DISPLAY PIN CONNECTIONS	16
DIMENSIONS	1	BLOCK DIAGRAM	17
INTERNAL VIEW	2	PRINTED CIRCUIT BOARD	18~21
REAR PANELS	2	SCHEMATIC DIAGRAM	22~24
DISASSEMBLY PROCEDURES	3~5	WIRING	25
ADJUSTMENTS	6~9	PARTS LIST	26~36
μ-COM DATA	10~11	REMOTE CONTROL TRANSMITTER	37
TIMING CHART	12, 13		

100352

YAMAHA

YAMAHA CORPORATION HAMAMATSU, JAPAN
3.3K-813 ☐Ⓢ Printed in Japan '90.5

TO SERVICE PERSONNEL

- 1. Critical Components Information.
Components having special characteristics are marked **⚠** and must be replaced with parts having specifications equal to those originally installed.
- 2. Leakage Current Measurement (For 120 V Model Only).
When service has been completed, it is imperative that you verify that all exposed conductive surfaces are properly insulated from supply circuits.
 - Meter impedance should be equivalent to 1500 ohm shunted by 0.15 μF.
 - Leakage current must not exceed 0.5 mA.
 - Be sure to test for leakage with the AC plug in both polarities.

POLARIZATION
This product is equipped with a polarized alternating current line plug (a plug having one blade wider than the other). This plug will fit into the power outlet only one way. This is a safety feature. (U.C model only)

SPECIFICATIONS

Track Configuration 4 track, 2 channel stereo
Motor DC servo motor (capstan)
 Flat torque DC motor (reel)
 DC motor (assist)
Heads Recording/Playback: Amorphous
 with 12-laminated core
 Erase: Double Gap Ferrite

Rapid Transport
F. Fwd/Rew (Normal) 80 sec. (C-60)
F. Fwd/Rew (Fast) 50 sec. (C-60)

Wow and Flutter
WRMS 0.05%
W. Peak ±0.08%

Signal-to-Noise Ratio
Off better than 61 dB
Dolby B on better than 69 dB
Dolby C on better tahn 77 dB

Frequency Response
Normal tape (-20 dB) 20 – 18,000 Hz ±3 dB
CrO₂ tape (-20 dB) 20 – 20,000 Hz ±3 dB
Metal tape (-20 dB) 20 – 22,000 Hz ±3 dB

Harmonic Distortion
(315 Hz, 3rd) Less than 0.7%

Input Sensitivity/Impedance
Line 60 mV/35 k-ohms

Output Level
Line 360 mV/1 k-ohms
Phones 0.6 mW/8 ohms

Channel Separation (3150 Hz) 40 dB
Cross Talk (125 Hz) 55 dB

GENERAL
Power Supplies

U, C models	120 V, 60 Hz
G model	220 V, 50 Hz
A, B models	240 V, 50 Hz
R model	110/120/220/240 V, 50/60 Hz

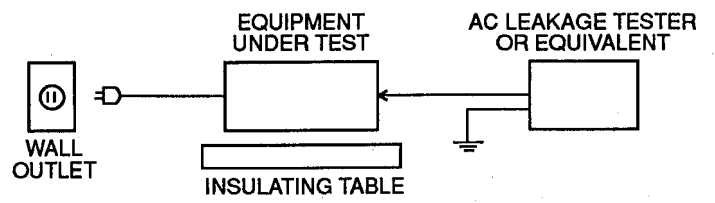

Dolby noise reduction and HX PRO headroom extension manufactured under license from Doly Laboratories Licensing Corporation. HX PRO originated by Bang and Olufsen. "Dolby", the double-D symbol and "HX PRO" are trademarks of Dolby Laboratories Licensing Corporation.

Power Consumption 18 W
Dimensions (W × H × D) 435 × 122 × 275 mm
 (17-1/8" × 4-13/16" × 10-13/16")
Weight 4.9 kg (10 lbs. 12 oz)

* Specifications subject to change without notice.

U U.S.A. model
C Canadian model
A Australian model
G European model
B British model
R General model

DIMENSIONS

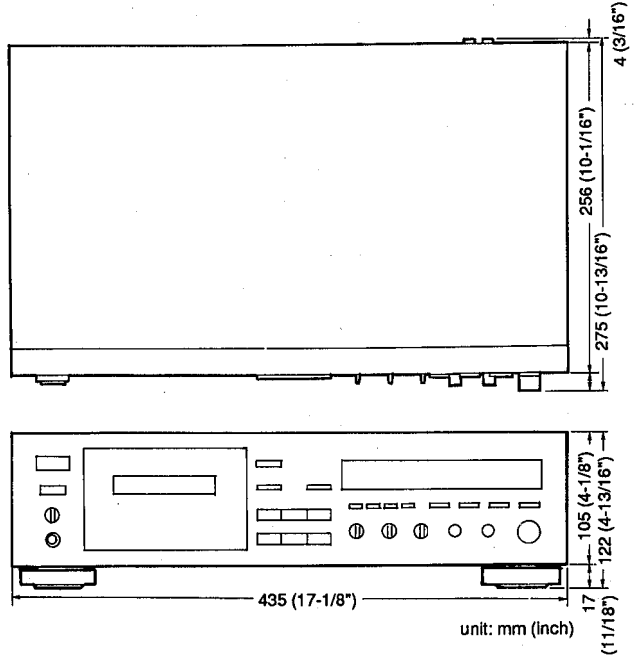

INTERNAL VIEW

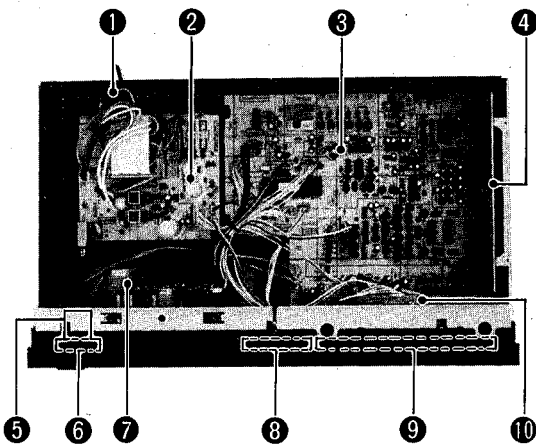

- 1 VOLTAGE SELECTOR (R model only)
- 2 POWER SUPPLY Circuit Board
- 3 MAIN Circuit Board (1)
- 4 MAIN Circuit Board (2)
- 5 MAIN Circuit Board (5)
- 6 MAIN Circuit Board (6)
- 7 CASSETTE MECHANISM
- 8 MAIN Circuit Board (3)
- 9 MAIN Circuit Board (4)
- 10 LCD Circuit Board

REAR PANELS

U.C. models

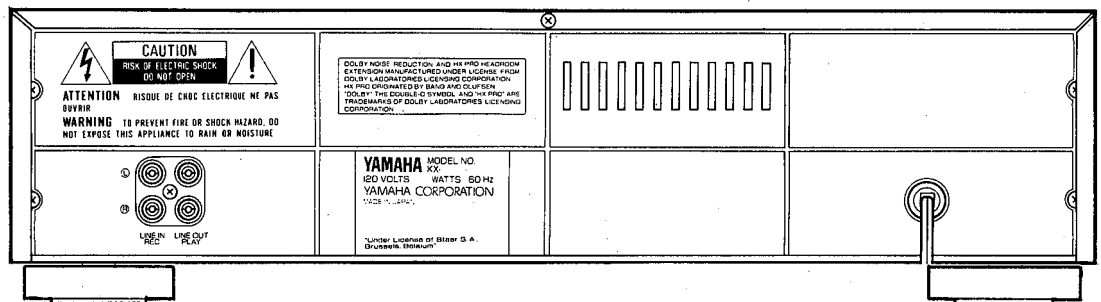

A, B models

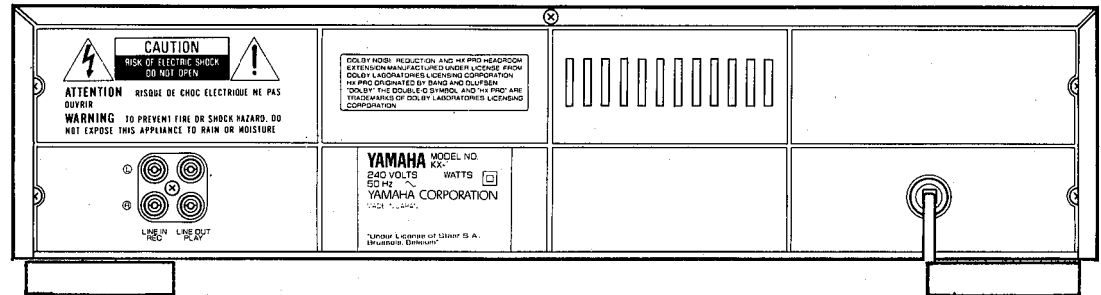

G model

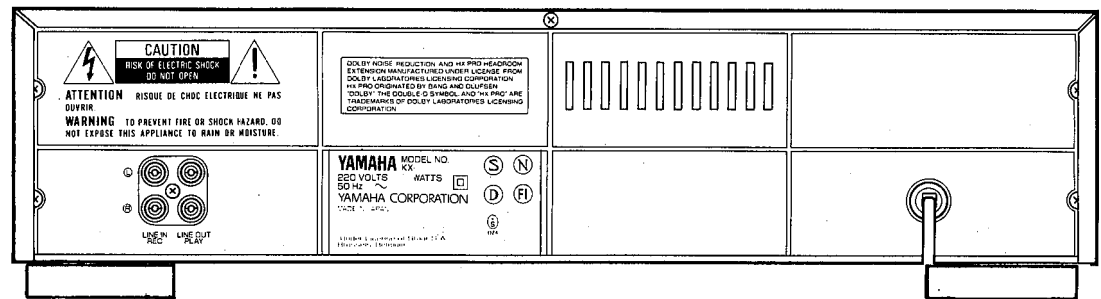

R model

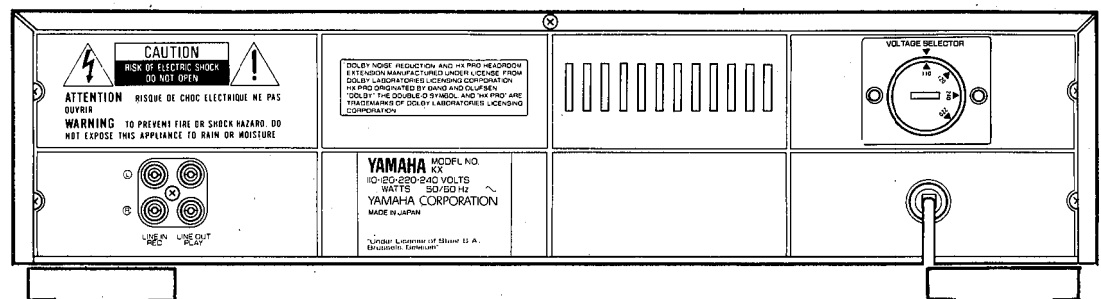

■ DISASSEMBLY PROCEDURES

(Remove parts in disassembly order as numbered)

● Removal of the Cabinet Parts

1. Removal of the Top Cover

- a. Remove the 5 screws(①) in fig. 1.

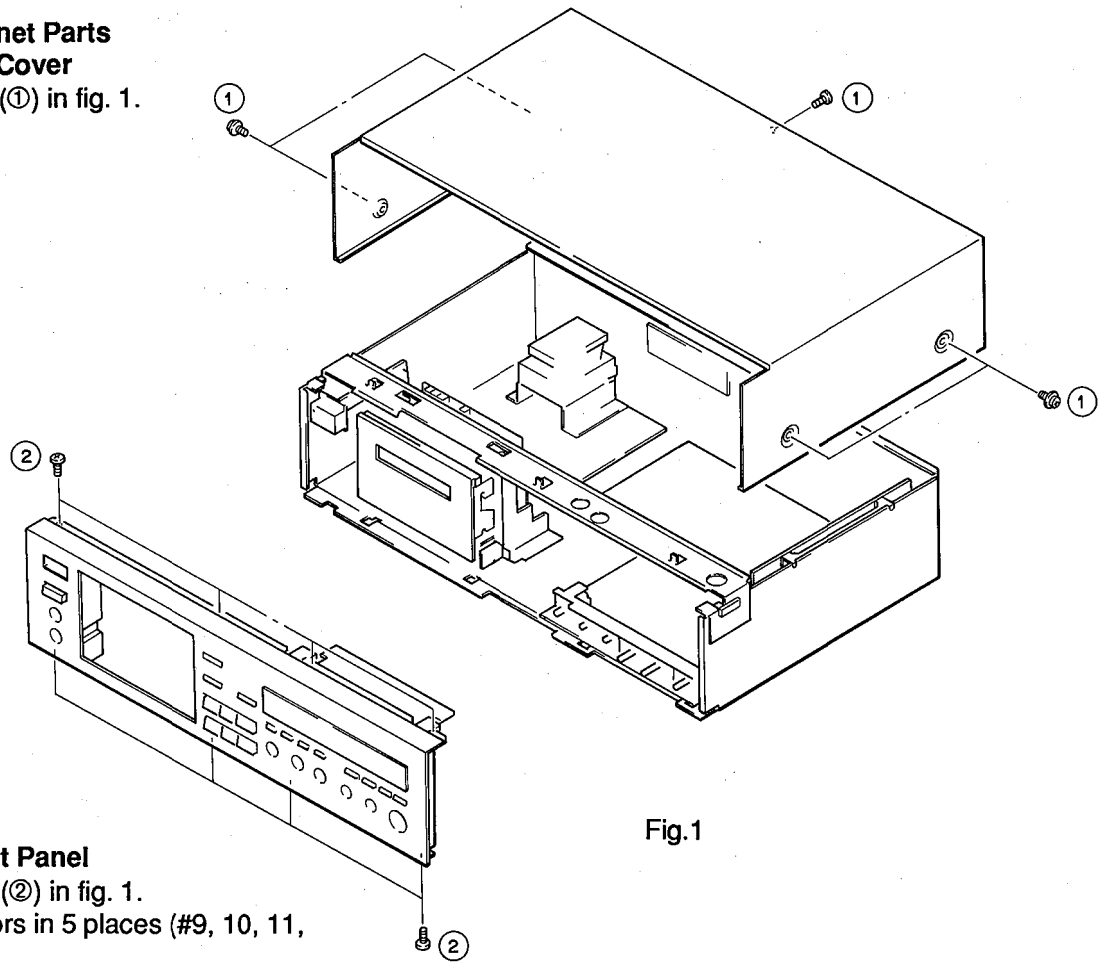

Fig.1

2. Removal of the Front Panel

- a. Remove the 8 screws(②) in fig. 1.
 b. Remove the connectors in 5 places (#9, 10, 11, 12, LCD).

3. Removal of the Cassette Mechanism Unit

- a. Remove the 4 screws(③) and the 2 screws (④) in fig. 2.
 b. Remove the connectors in 6 places (#1~#6).
 c. Remove the cassette mechanism unit after sliding it toward the front.

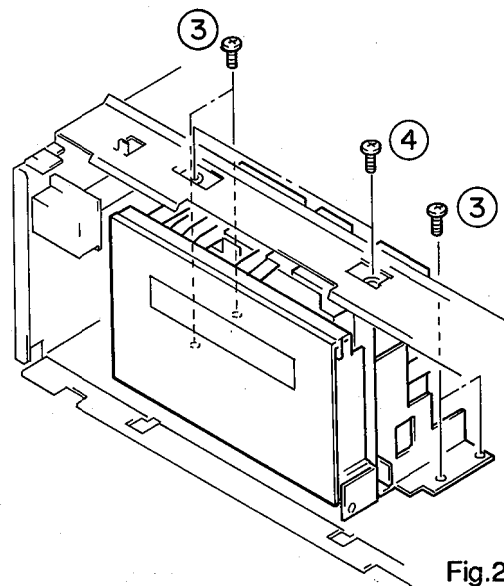

Fig.2

4. Removal of the Housing Frame and the Blind Plate

- a. Open the housing frame.
- b. Remove the spring.
- c. Remove the hooks (A) on both sides of the housing frame.
Remove the housing frame in the indicated direction.
- d. Remove the blind frame by removing the hooks on both sides of the plate in fig. 3. (The back light LED can be replaced when the blind plate is removed.)

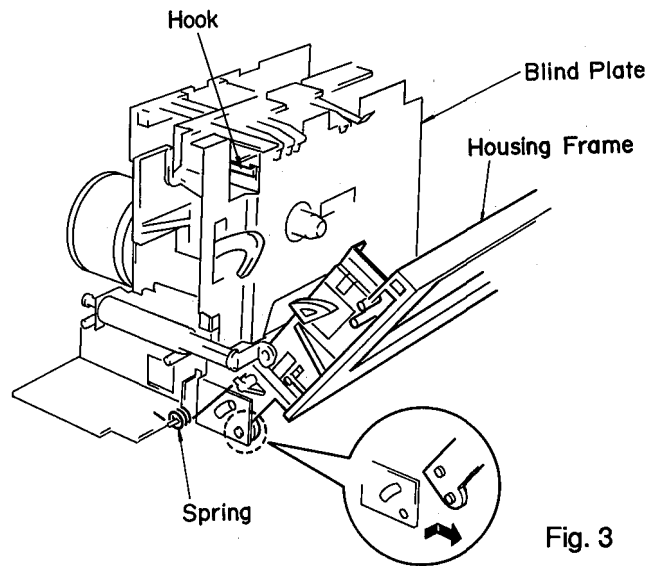

Fig. 3

5. Removal of the Pinch Roller

- a. Remove the arm adjust screw (5) in fig. 4.
- b. Remove the left pinch roller assembly.
- c. Remove the right pinch roller assembly after removing the hook.
- * When assembling the unit, make sure to place the spring of the pinch roller in the correct position.

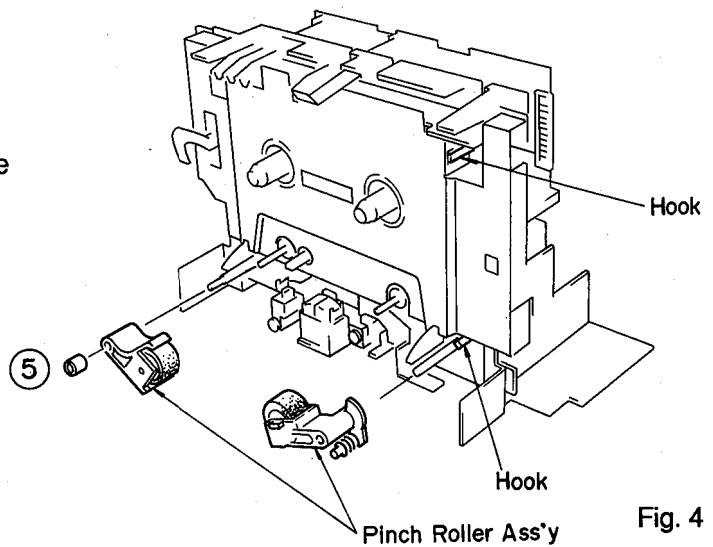

Fig. 4

6. Removal of the Heads

- a. Remove the recording/playback head by removing the 2 screws (6) in fig. 5.
- b. Remove the erase head by removing the screw (7) in fig. 5.

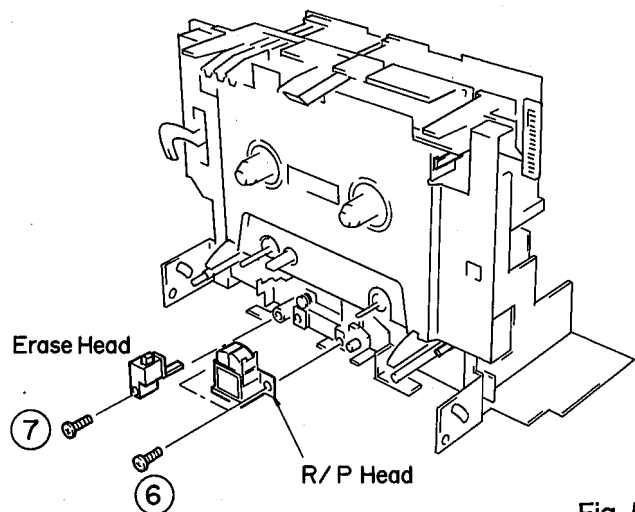

Fig. 5

7. Removal of the Reel Motor and the Motor Circuit Board

- a. Remove the blind plate.
- b. Remove the detector board by removing the hooks in fig. 6.
- c. Remove the 2 hooks (⑧) which mount the reel motor in fig. 6.
- d. Remove the reel motor and the motor circuit board by removing the screw (⑨) in fig. 7.

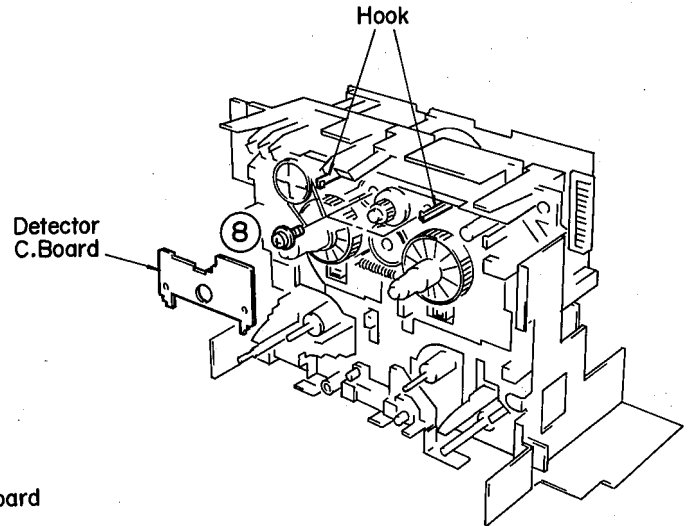

Fig. 6

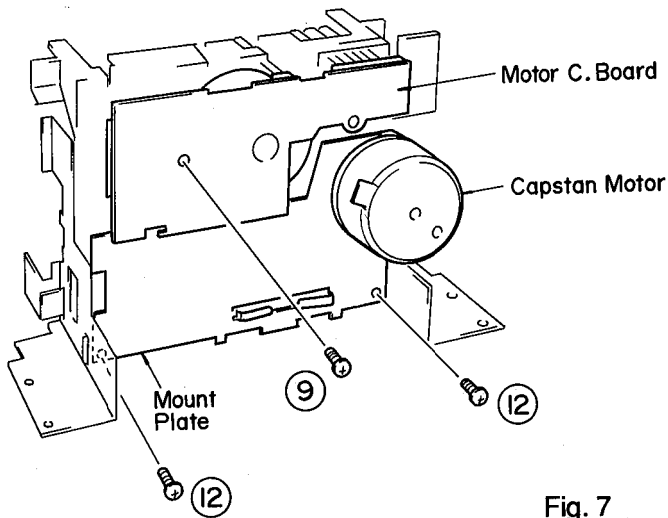

Fig. 7

8. Removal of the Capstan Motor

- a. Remove the blind plate.
- b. Remove both (right and left) the holder by removing the 2 screws (⑩) in fig. 8.
- c. Remove the 2 screw (⑪) in fig. 8.
- d. Remove the motor mount plate by removing the 2 screws (⑫) in fig. 7.

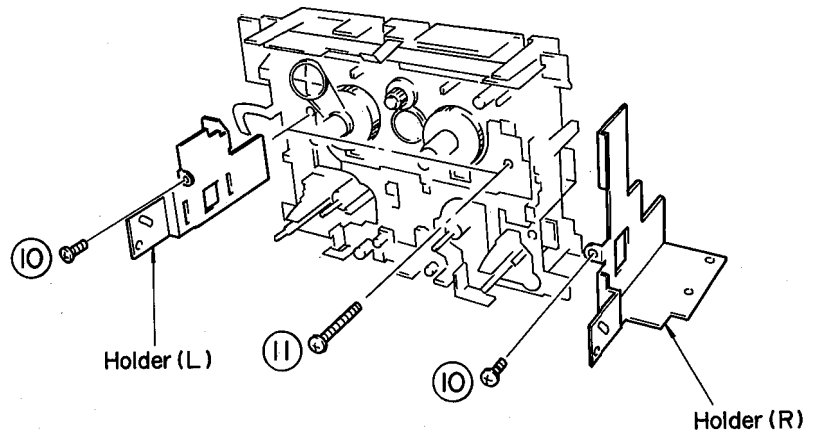

Fig. 8

ADJUSTMENTS

1. Before Adjustment:

- Make sure that AC line voltage is within:

Models	AC line voltage
U, C	120 V ± 10%
G	220 V ± 10%
A, B	240 V ± 10%

- Since head magnetization, dust accumulation, etc. are likely to cause error in the various characteristics, it is very important to keep the heads properly demagnetized and clean.

2. Instruments required

- Audio frequency oscillator (AF OSC)
- ACVM or dual channel ACVM
- Wow/flutter meter
- Torque meter
TW-2111 (TX911580)
CT160L (TX911120)

MECHANISM ADJUSTMENT

* For faster FF or REW mode, keep **▶▶▶▶▶** or **◀◀◀◀◀** button pressed for more than 2 seconds.

Step	Item to be Adjusted	Tape	Instrument required	Mode	Adjustment part	Rating	Remarks
1	Check each torque		Torque meter TW2111	PLAY		Take-up torque: 35 g·cm~55g·cm Back tension: 6g·cm~10g·cm	
			Torque meter CT160L	FF REW		Take-up torque: 70 g·cm~160g·cm	
2	Check FF REW take up times	AC-224 C-60		FF REW		Less than 100 seconds (Normal) Less than 65 seconds (Fast)	*
3	Check tape movement		Mirror cassette (MC-109C)	PLAY		Tape should be advanced in the center of head smoothly.	
4	Azimuth	MTT-114N 10 kHz, -10 dB	ACVM Oscilloscope	PLAY	Azimuth adjustment screw. (Fig. A)	Adjust the Azimuth so that the outputs of both Lch and Rch are maximum and the difference in the phase is minimum.	After the adjustment make sure to apply screw lock paint.
5	Tape speed	MTT-111N 3 kHz, -10 dB	Wow/flutter meter or Frequency counter	PLAY	Potentiometer at the back of the capstan motor. (Fig. B)	3000 Hz ±10 Hz (Point of Measurement: LINE OUT)	Perform adjustment at the position where the test tape is advanced/rewound to the middle if possible.
6	Wow/flutter	MTT-111N 3 kHz, -10 dB	Wow/flutter meter	PLAY		Less than 0.09% (JIS W. RMS)	

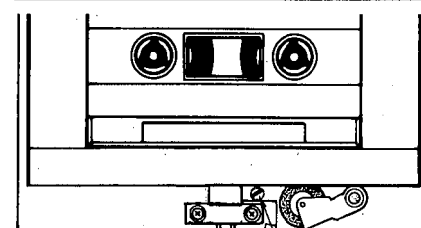

Azimuth adjustment screw

Fig. A

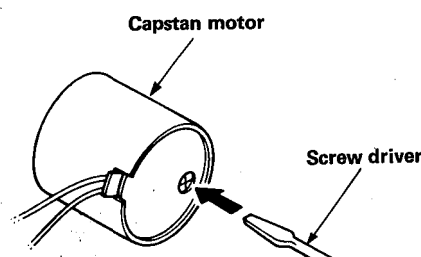

Fig. B

DCVM

- Mirror Cassette
MC-109C (TX911430)

3. Test tape required

- MTT-111N (TX911650): Tape Speed (Normal)
- MTT-114N (TX911680): Azimuth
- MTT-212CN (TX911670): Playback Level (160 nWb/m)
- MTT-256 (TX911300): Playback Frequency Response (LH)
- MTT-356 (TX911310): Playback Frequency Response (CrO₂)

Reference tape

- LH (Normal) : TDK AC224 (TX912190)
- CrO₂ : TDK SA-60 or TDK AC513 (TX911610)
- METAL : TDK AC712 (TX911590)

ELECTRIC ADJUSTMENT

* Standard level of this machine is that 160 nwb/m is 0 dB. (360 mV)

PLAYBACK ADJUSTMENT

Step	Adjustment Items	Tape	Instrument Required	Mode	Adjustment Part	Point of Measurement	Adjustment Method	Specification
1	Playback Level	MTT-212CN (160 nwb/m)	ACVM	PLAY	VR3 (Lch) VR4 (Rch)	LINE OUT	When MTT-212CN played back, adjust VR so that LINE OUT Terminal Voltage becomes Specification Value.	360 mV ± 25 mV
2	Confirmation of Playback Frequency Response	MTT-256 (LH: 3180 μs + 120 μs) MTT-356 (CrO ₂ : 3180 μs + 70 μs)	ACVM Oscilloscope	PLAY		LINE OUT	Make sure that level of LINE OUT is within the specification of Fig. C when Test Tape is played back.	0 dB ⁺⁴ / ₋₃ dB

PLAYBACK FREQUENCY RESPONSE

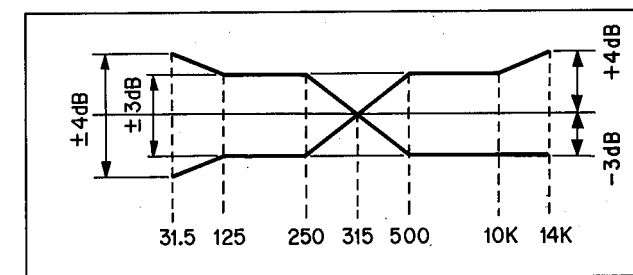
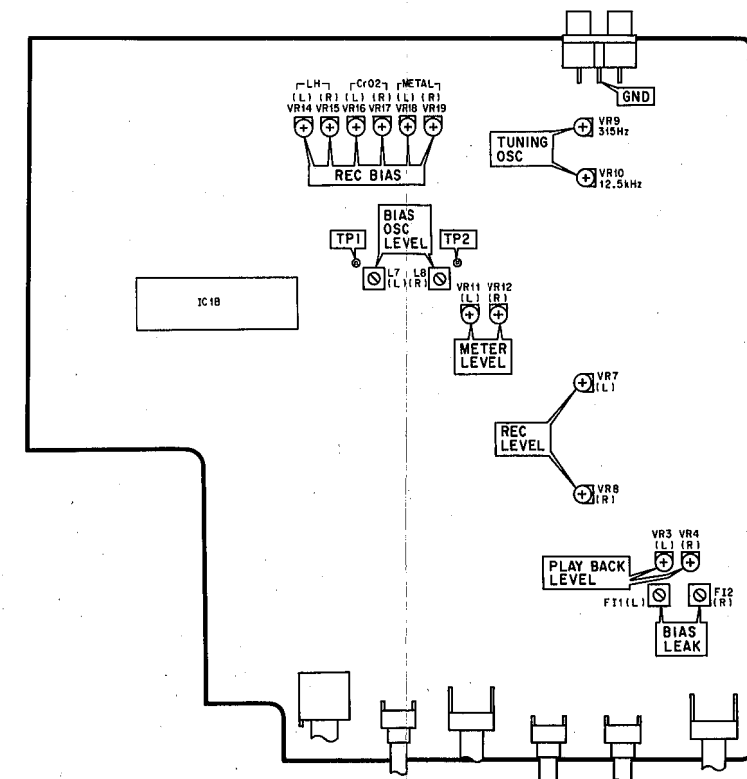

Fig. C

TEST POINT



● RECORDING ADJUSTMENT (BIAS ADJ. → VR Center, if not specified otherwise)

Step	Adjustment Items	Test Tape	Instrument Required	Mode	Adjustment Terms Point	Measurement Point	Adjustment	Rating
1	Meter Level	LH (AC224)	ACVM Audio Frequency Oscillator	REC/PAUSE MONITOR SOURCE PEAK HOLD OFF	1. Set REC LEVEL to maximum. 2. Input 315 Hz Signal to LINE IN TERMINAL from Audio Frequency Oscillator. Adjust output level of Audio Frequency Oscillator so that the voltage of LINE OUT TERMINAL becomes 360 mV.	Peak Level Meter	VR11 (Lch) VR12 (Rch)	Adjust VR to the minimum level where 0 dB segment (red) of peak level meter lights up.
2	Bias Oscillation Level (HX PRO)	METAL (AC712)	DCVM	REC PLAY		TP1-GND TP2-GND	L7 (Lch) L8 (Rch)	Connect DCVM between each TP-GND and adjust L7 and L8 to minimum.
3	Bias Leak	METAL (AC712)	ACVM	REC PLAY and MONITOR TAPE	1. Set VR18 and VR19 to maximum. (turn fully counterclockwise) 2. Set the BIAS ADJUST knob maximum.	LINE OUT TERMINAL	FI1 (Lch) FI2 (Rch)	Adjust FI so that the voltage of LINE OUT TERMINAL becomes minimum.
4	Recording Level	CrO ₂ (AC513 or SA60)	ACVM Audio Frequency Oscillator	REC PLAY and PLAY-BACK	• Set the Tape Monitor switch to SOURCE. 1. Set VR16 and VR17 to the center position. 2. Enter REC/PAUSE mode. 3. Input 315 Hz Signal to LINE IN TERMINAL from Audio Frequency Oscillator. Adjust REC LEVEL knob so that voltage of LINE OUT TERMINAL becomes 360 mV (0 dB). 4. Record the above-mentioned signal. 5. In recording mode, set the Tape Monitor switch to TAPE and adjust VR7 and VR8.	LINE OUT TERMINAL	VR7 (Lch) VR8 (Rch)	Adjust VR so that the voltage of LINE OUT TERMINAL becomes 360mV±25mV.
5	Recording Bias	LH (AC224) CrO ₂ (AC513 or SA60) and METAL (AC712)	ACVM Audio Frequency Oscillator	REC PLAY	• Set the Tape Monitor switch to SOURCE. 1. Set REC LEVEL to maximum. 2. Enter REC/PAUSE mode. 3. Input several frequency signals to LINE IN TERMINAL from Audio Frequency Oscillator. Adjust the level of LINE OUT TERMINAL so that the voltage becomes 36 mV (-20 dB). 4. Record the above-mentioned signal. 5. In recording mode, set the Tape Monitor switch to TAPE. Adjust the bias so that LINE OUTPUT in each frequency becomes 36mV. Confirm that the value satisfies Fig. D in each test tape.	LINE OUT TERMINAL	LH VR14 (Lch) VR15 (Rch) CrO ₂ VR16 (Lch) VR17 (Rch) METAL VR18 (Lch) VR19 (Rch)	Several frequency signals LH: 315 Hz, 16 kHz CrO ₂ : 315 Hz, 17 kHz METAL: 315 Hz, 18 kHz
6	Tape Tuning OSC Level		ACVM		Set to internal OSC test mode.	LINE OUT TERMINAL	VR9 (315Hz) VR10 (12.5kHz)	Adjust VR so that the voltage of LINE OUT TERMINAL becomes 36mV±2.5mV of 315Hz and 12.5kHz.

● LCD TEST & PEAK HOLD OFF

To test all the LCD, press the POWER button while pressing the RESET key. All the LCD lights. The peak hold OFF mode is entered when the RESET key is pressed after the LCD test. The unit returns to normal mode when the RESET key is pressed again.

● INTERNAL OSC TEST MODE

Insert a cassette tape (any type) during the peak off mode. Press the AUTO TAPE TUNIG key after REC/PAUSE mode is entered. The TAPE TUNING indicator blinks and the internal OSC starts oscillating. Oscillation frequency starts with 12.5 kHz and every press of the AUTO TAPE TUNIG key alternately changes the frequency between 315 Hz and 12.5 kHz. Press the RESET key after pressing the STOP key to return to the normal mode.

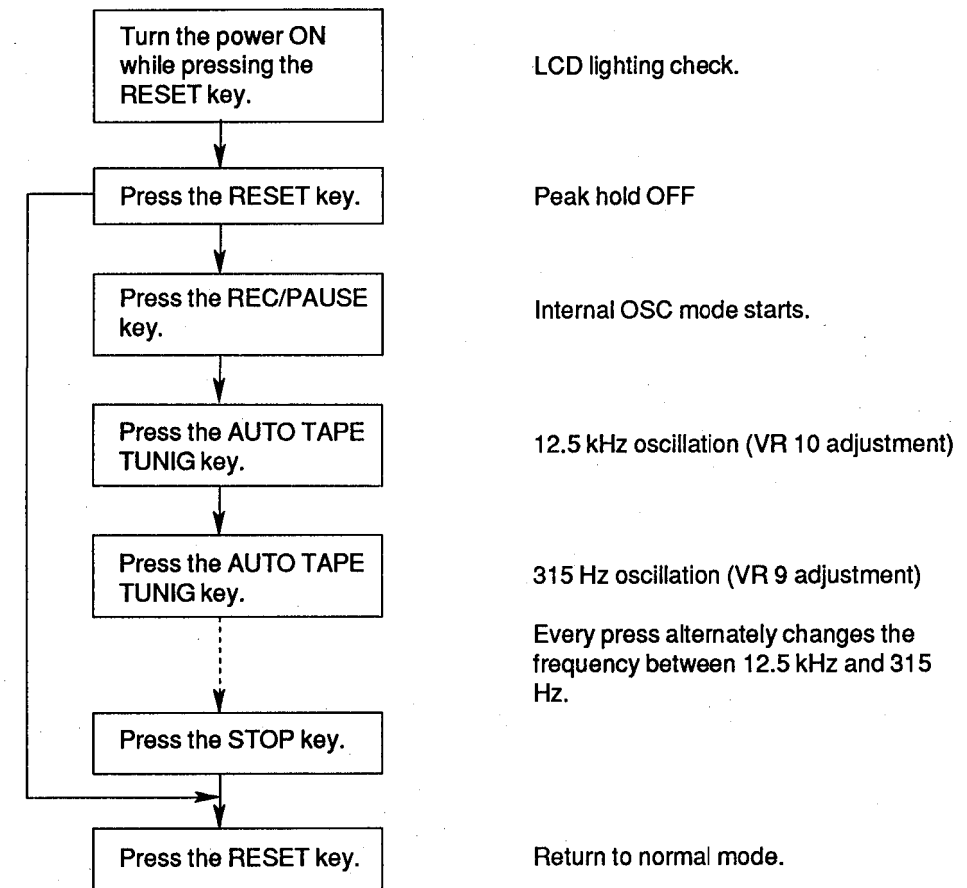

● TOTAL FREQUENCY RESPONSE

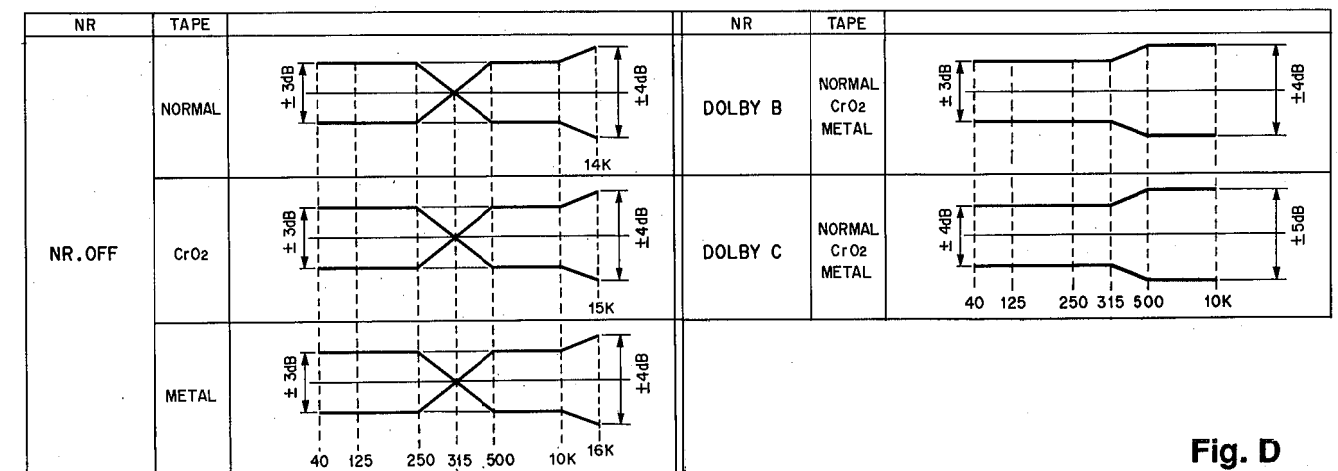
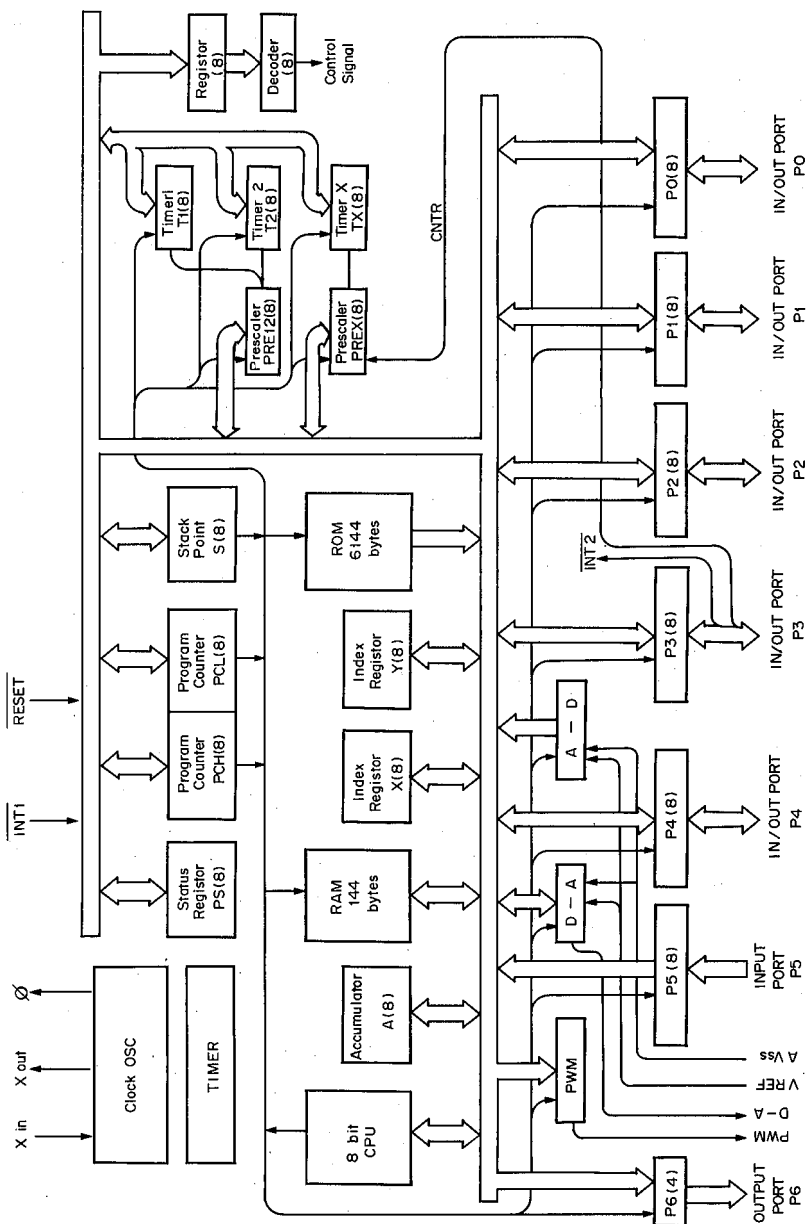
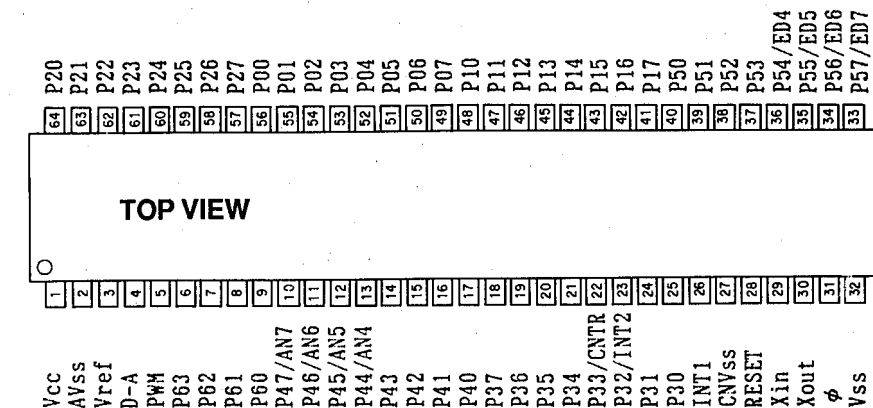

Fig. D

■ μ -COM DATA (IC18: M50746-300SP)



KX-930

● **μ-COM PORT (M50746-300SP)**

NO.	Terminal	Function	Remark
1	VCC	+4.4 V	
2	AVSS	GND for A-D, D-A	
3	VREF	Standard voltage of A-D, D-A (4.4 V)	
4	D-A	Auto-bias output	D-A
5	PWM	Not used	
6	P63	Dynamic output 1	Output
7	P62	Dynamic output 2	
8	P61	Dynamic output 3	
9	P60	Dynamic output 4	
10	AN7	Meter input Lch	A-D
11	AN6	Meter input Rch	
12	AN5	BIAS ADJ input	
13	AN4	Tact SW input	
14	P43	Monitor switch H→TAPE	Output
15	P42	10kHz ON/OFF H→ON	Output
16	P41	315Hz ON/OFF H→ON	
17	P40	LINE MUTE L→ON	Output
18	P37	Mechanical position SW A	Input
19	P36	Mechanical position SW C	
20	P35	Mechanical position SW B	
21	P34	AUTO MODE input Note) HHHL	Input
22	P33	AUTO MODE input Note) HLHL	
23	/INT2	Remote control input	
24	P31	AUTO MODE input Note) LHHH	
25	P30	BIAS ON/OFF H→ON	Output
26	/INT1	SLEEP Detection	
27	CNVSS	GND	
28	/RES	Reset input	
29	XIN	CLOCK 4MHz	
30	XOUT	CLOCK 4MHz	
31	Φ	Not used	
32	VSS	GND	

NO.	Terminal	Function	Remark
64	P20	Reel Motor speed control 2 H→PLAY	Output
63	P21	Reel Motor speed control 1 H→FF	
62	P22	Reel Motor control + H→Front	
61	P23	Reel Motor control - H→Rear	
60	P24	Assist Motor control H→PLAY	
59	P25	Assist Motor control H→FF	
58	P26	LCD Meter electric discharge H→ON	Output
57	P27	AUTO BIAS ON/OFF L→ON	Output
56	P00	REC sensitivity control 1 L→ON	Output
55	P01	REC sensitivity control 2 L→ON	
54	P02	REC sensitivity control 3 L→ON	
53	P03	REC sensitivity control 4 L→ON	
52	P04	Tape selector LH L→ON	Output
51	P05	Tape selector CrO ₂ L→ON	
50	P06	Tape selector METAL L→ON	
49	P07	REC MUTE L→ON	Output
48	P10	MPX ON/OFF H→ON	Output
47	P11	Dolby switch (B, C, OFF) HLL	
46	P12	Dolby switch LHL	
45	P13	70μ output L→ON	Output
44	P14	LCD output SCK	Output
43	P15	LCK output SO	
42	P16	LCD output CE	
41	P17	LCK output INH	
40	P50	METAL SW L→ON	Input
39	P51	70μ SW L→ON	
38	P52	Accidental Erasure SW L→ON	
37	P53	Half SW L→ON	
36	P54	Reel Pulse (S)	Input
35	P55	Reel Pulse (T)	
34	P56	Selection Pulse	Input
33	P57	POWER OFF Detection	Input

Note) Order: FULL, O-M, OFF, T-PLAY, T-REC

● **MODE & PIN SIGNAL ASSIGNMENT**

PIN NO.	PIN NAME	MODE						
		STOP	▶▶	▶▶▶	◀◀	◀◀◀	PLAY	REC PLAY
61	REEL -	L	L	L	H	H	L	L
62	REEL+	L	H	H	L	L	H	H
63	REEL SPEED 1	L	H	L	H	L	L	L
64	REEL SPEED 2	H	L	L	L	L	H	H
18	M POSITION A	L	L	L	L	L	H	H
19	M POSITION C	H	H	H	H	H	L	L
20	M POSITION B	L	L	L	L	L	L	L
17	LINE MUTE	*	*	*	*	*	H	H
25	BIAS ON/OFF	L	L	L	L	L	L	H
49	REC MUTE	L	L	L	L	L	L	H

*: L MONITOR = TAPE
H MONITOR = SOURCE

■ TIMING CHART

FORWARD DIRECTION 1

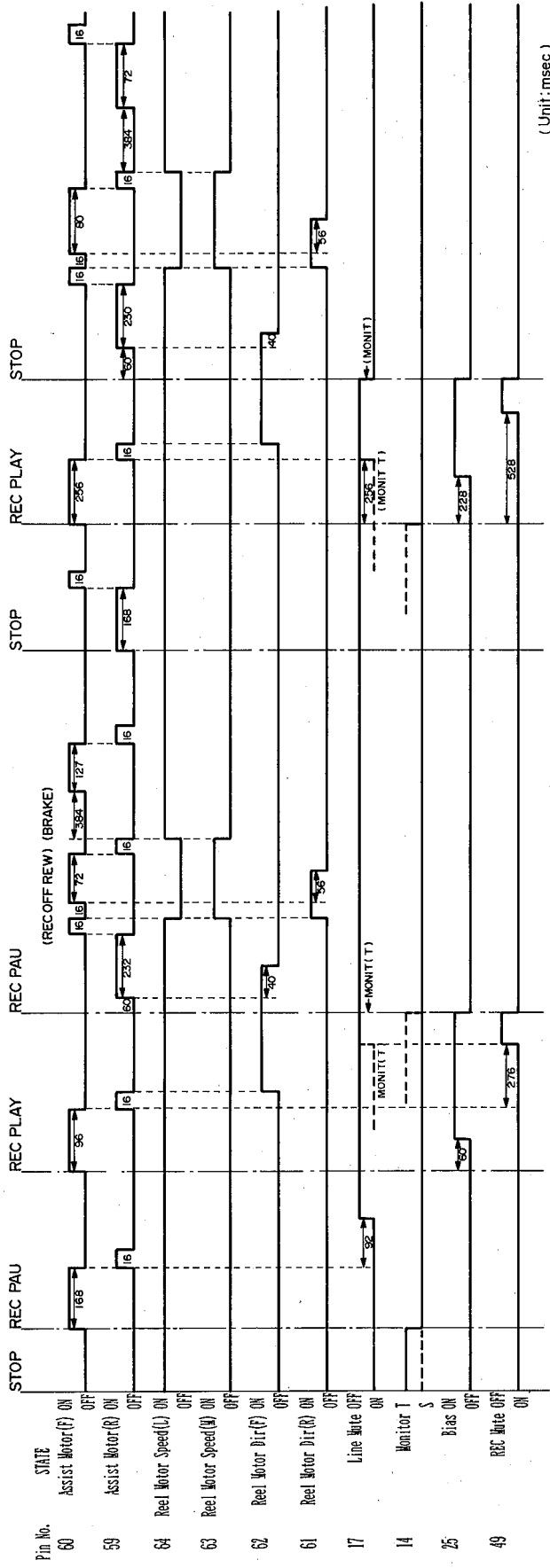

FORWARD DIRECTION 2

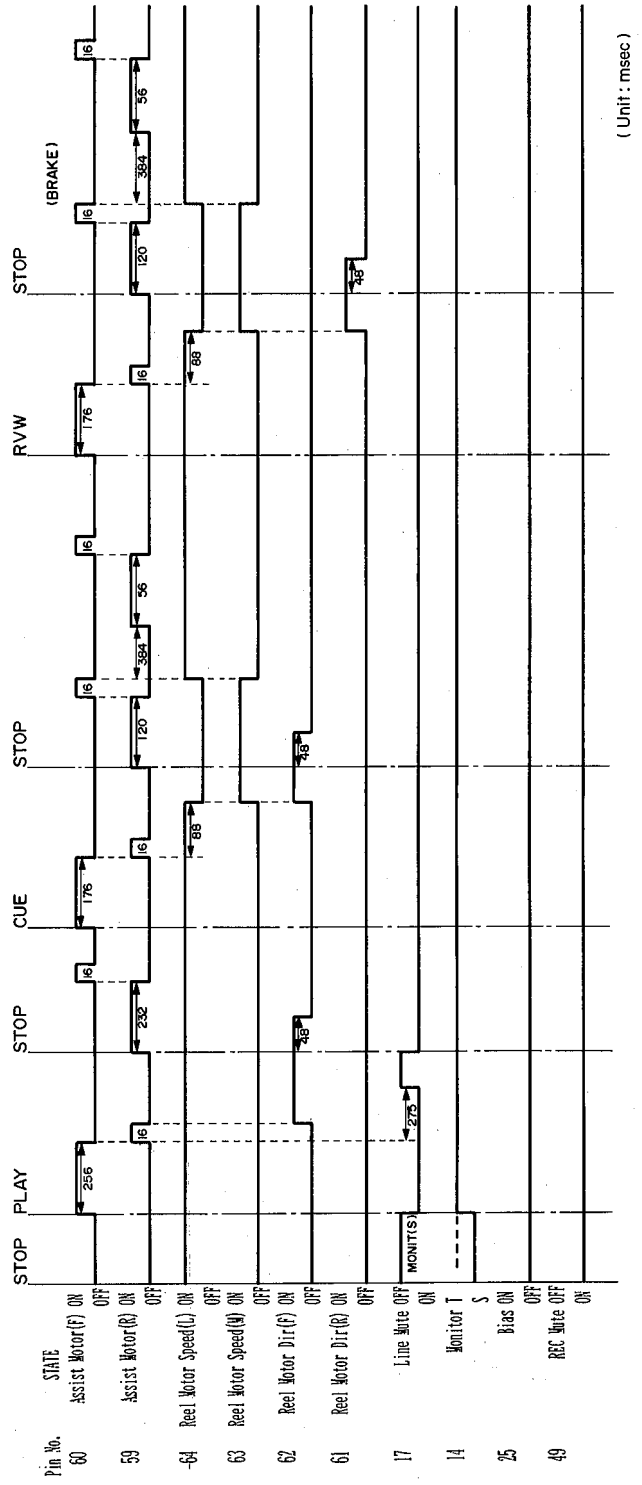

FORWARD DIRECTION 3

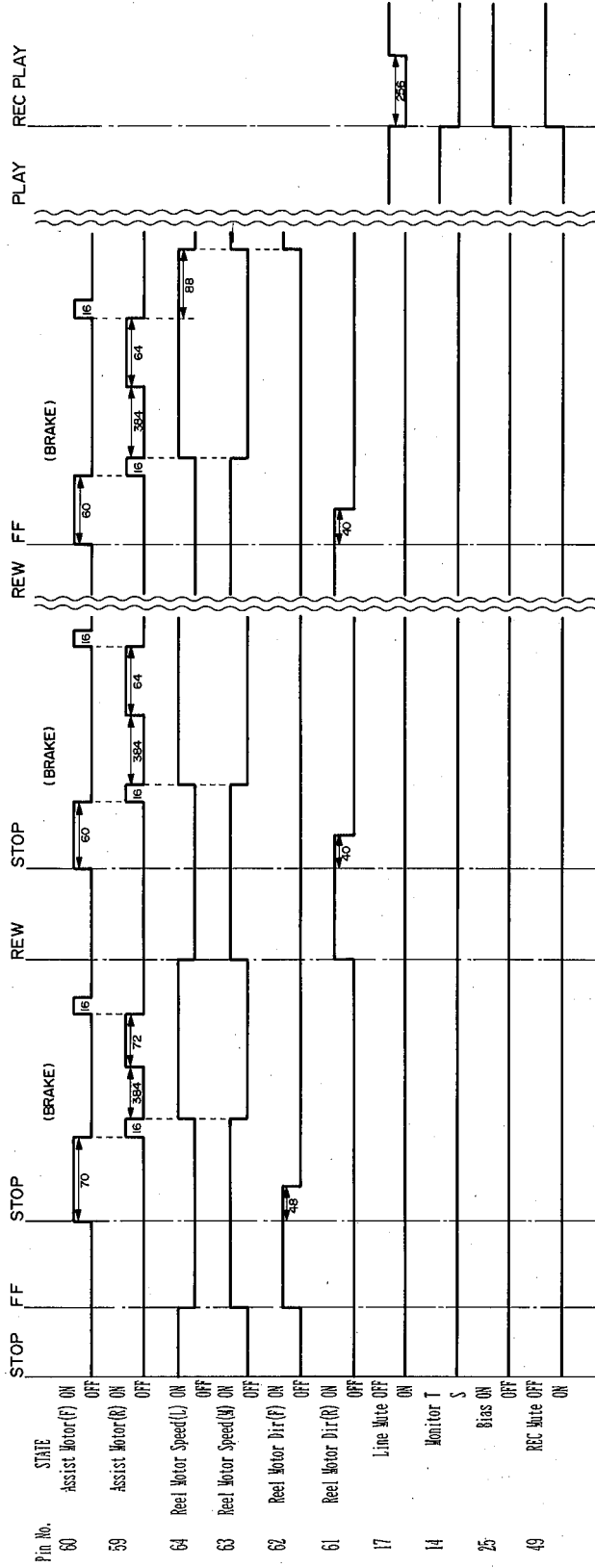

(Unit: msec)

IC BLOCK

IC20: μ PC1297CA
(Dolby HX PRO)

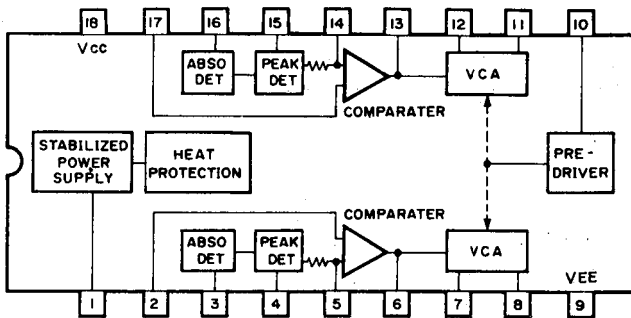

IC3, 4, 12: μ PD4066BC, LC4066B, M4066BP, MN4066B, BU4066B
(Analog Switch)

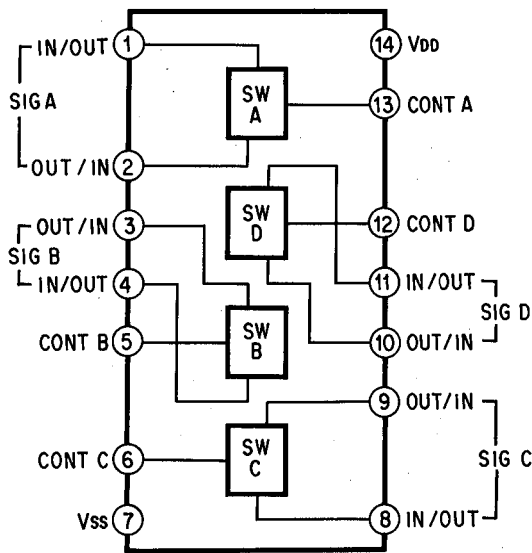

IC8, 9: AN90B20
(Transistor Array)

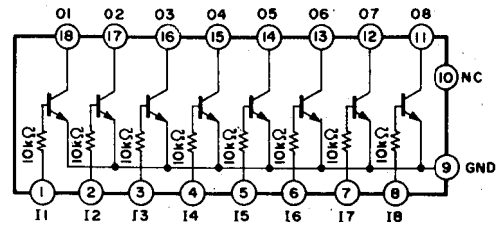

IC2, 5, 14, 16, 19: AN6551, NJM4558S, BA715
IC6, 7, 13: NJM4556S-A
(Dual Ope-amp.)

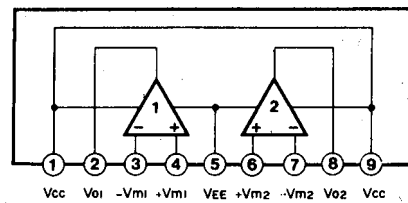

IC1: NJM2043S-D
(Pre-amp.)

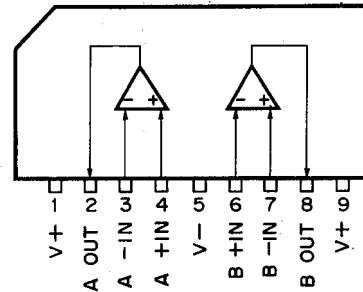

U1: GP1U501X
(Remote Control Receptor)

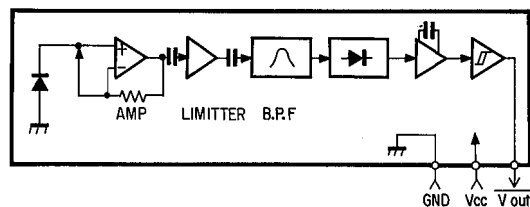

IC17: LB1649
(Motor Driver)

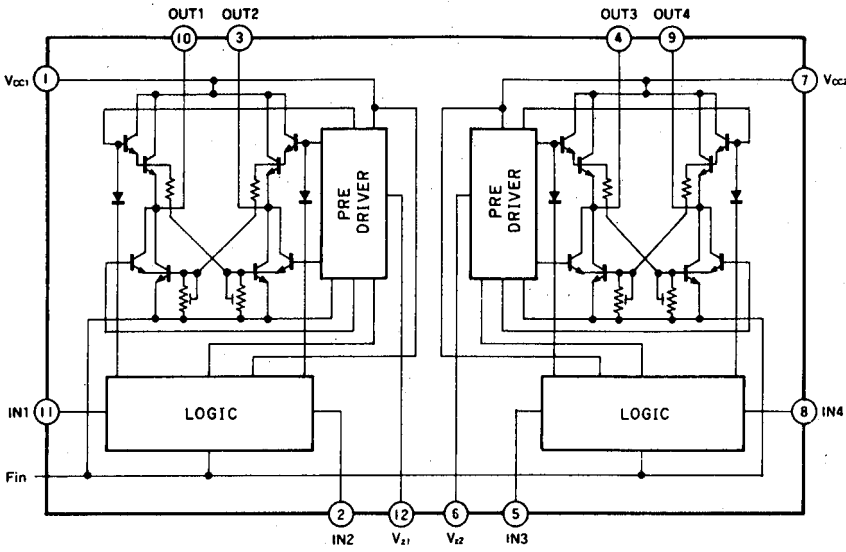

IC10, 11: CX20188
(Dolby NR)

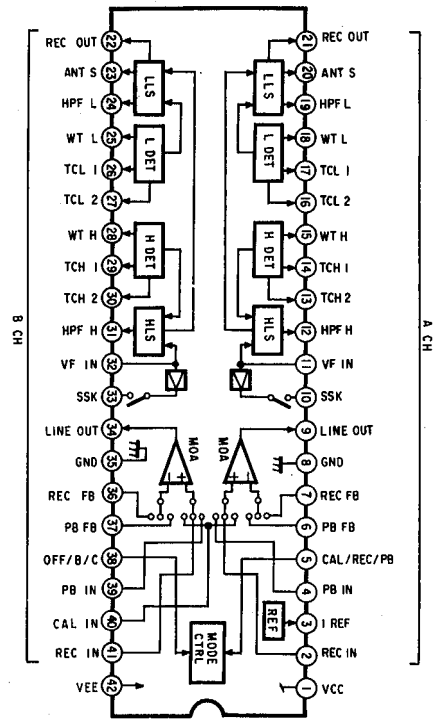

IC401: LC7582
(LCD Driver)

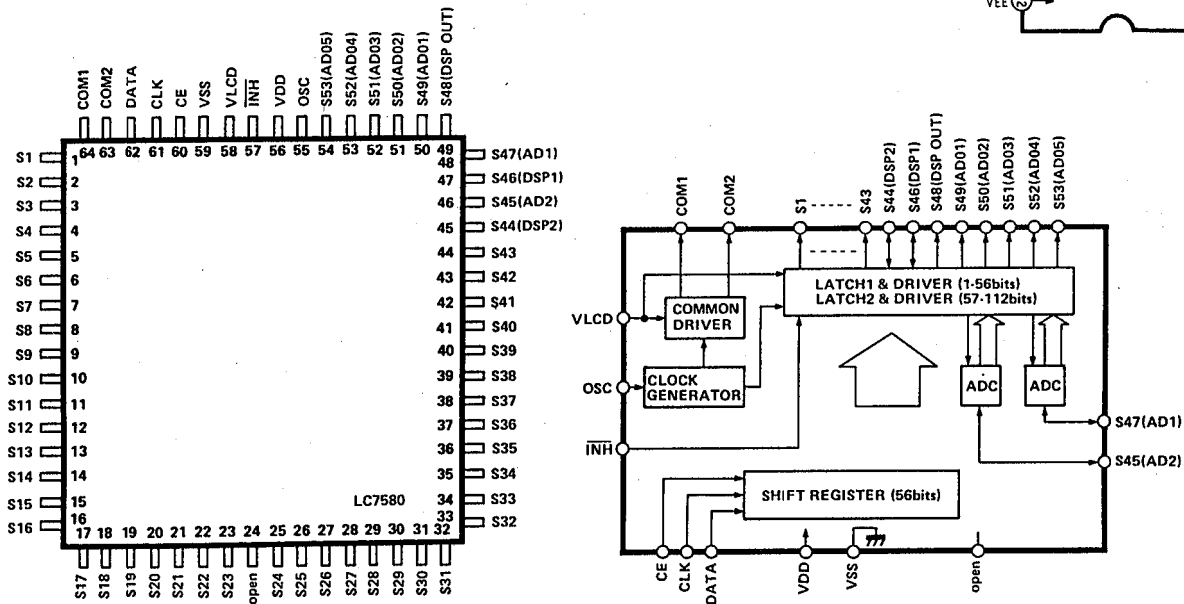

IC15: BA6138
(1/2W Power of Compressor Amp.)

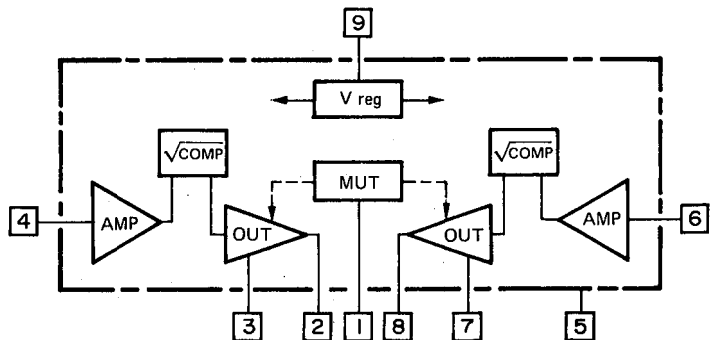

■ DISPLAY Pin Connection

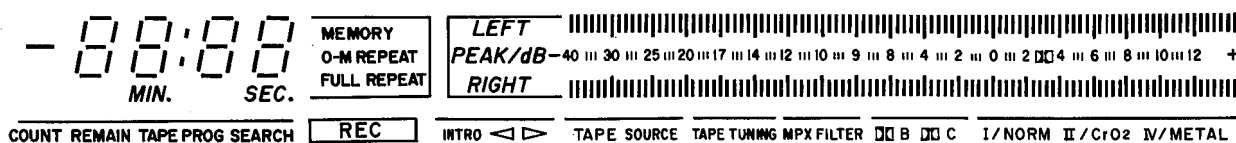

● SEGMENT

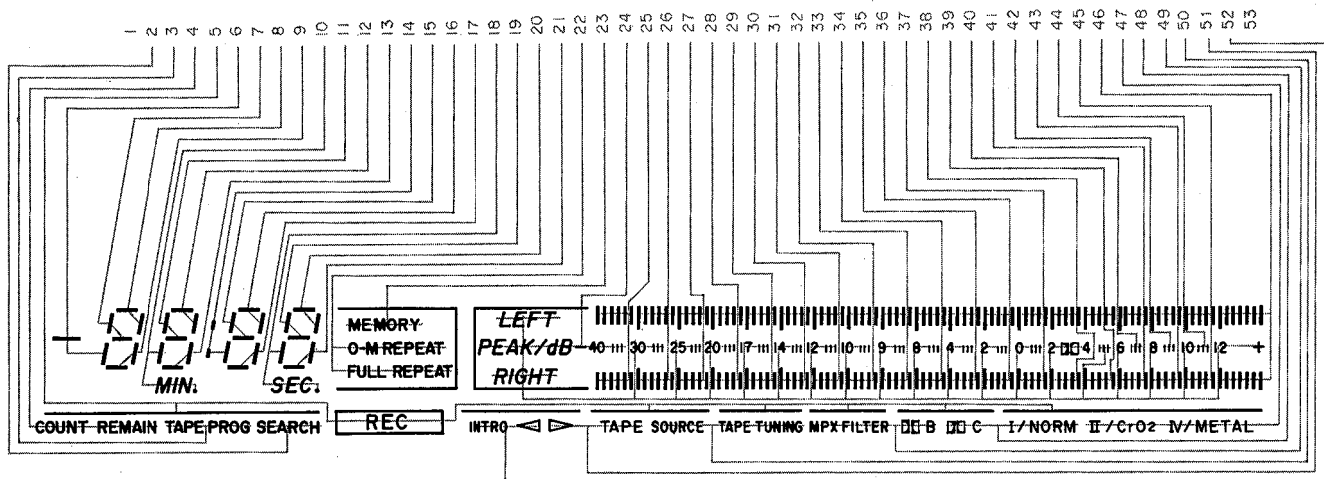

● COMMON

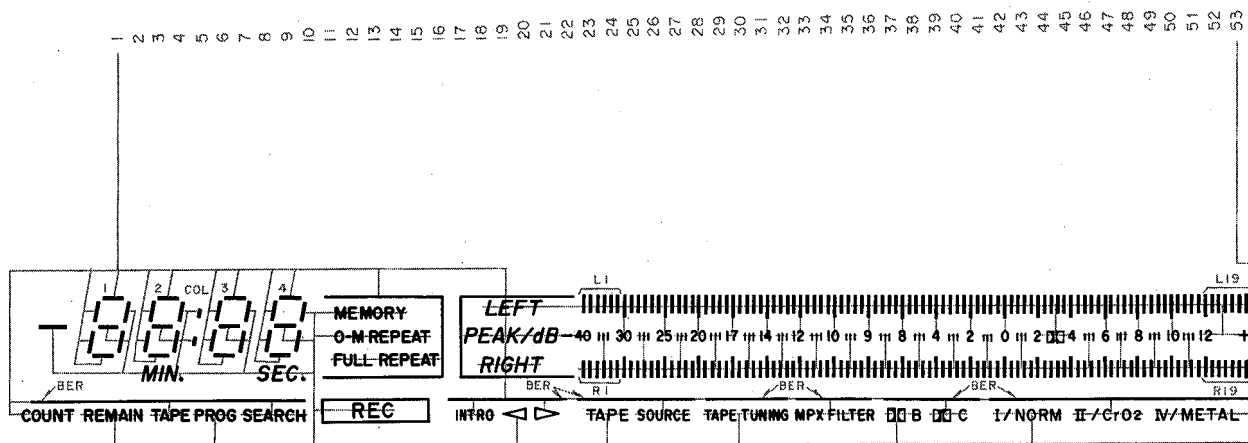

NO	1	2	3	4	5	6	7	8	9	10	11	12	13	14	15	16	17	18	19
COM1	COM	SEARCH	TAPE	COUNT	BER	1e	1f	1a	1d	2e	2f	2a	2d	3e	3f	3a	3d	4e	4f
COM2	—	—	PROG	REMAIN	REC	—	1g	1b	1c	MIN	2g	2b	2c	COL	3g	3b	3c	SEC	4g

NO	20	21	22	23	24	25	26	27	28	29	30	31	32	33	34	35	36	37	38
COM1	4a	4d	FULL	1)	L1	L2	L3	L4	L5	L6	L7	L8	L9	L10	L11	L12	L13	L14	
COM2	4b	4c	O-M	MEMO	S3	R1	R2	R3	R4	R5	R6	R7	R8	R9	R10	R11	R12	R13	R14

NO	39	40	41	42	43	44	45	46	47	48	49	50	51	52	53
COM1	L15	—	L16	—	L17	—	L18	L19	II/CrO2	□□ C	MPX FILTER	SOURCE	▷	INTRO	—
COM2	R15	S1	R16	S2	R17	S3	R18	R19	IV/MET	I/NOR	□□ B	TAPE TUNING	TAPE	◁	COM

1) LEFT PEAK/dB-40 30 25 20 17 14 12 10 9 8 4 2 0 2004 6 8 10 12 +
RIGHT

■ BLOCK DIAGRAM

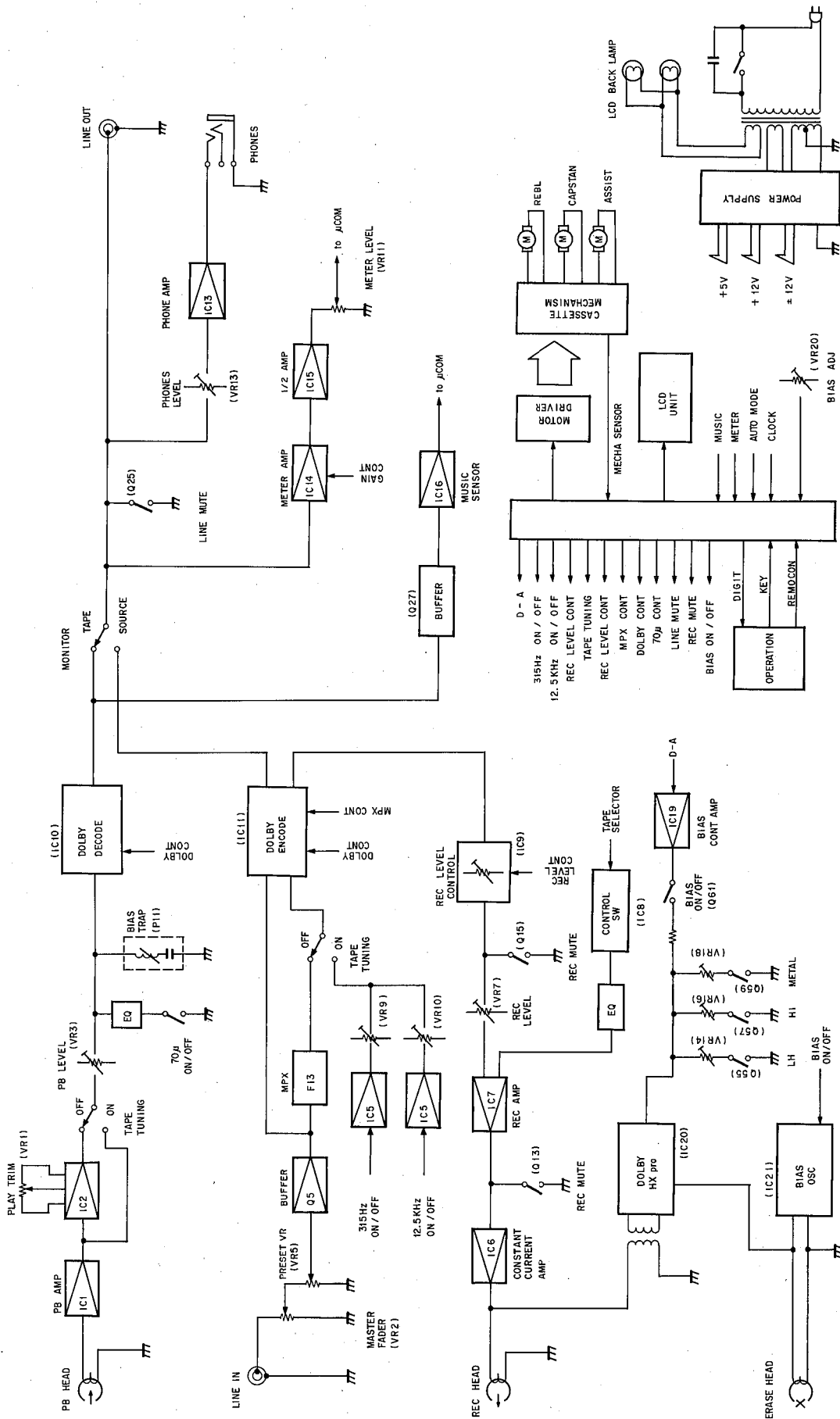

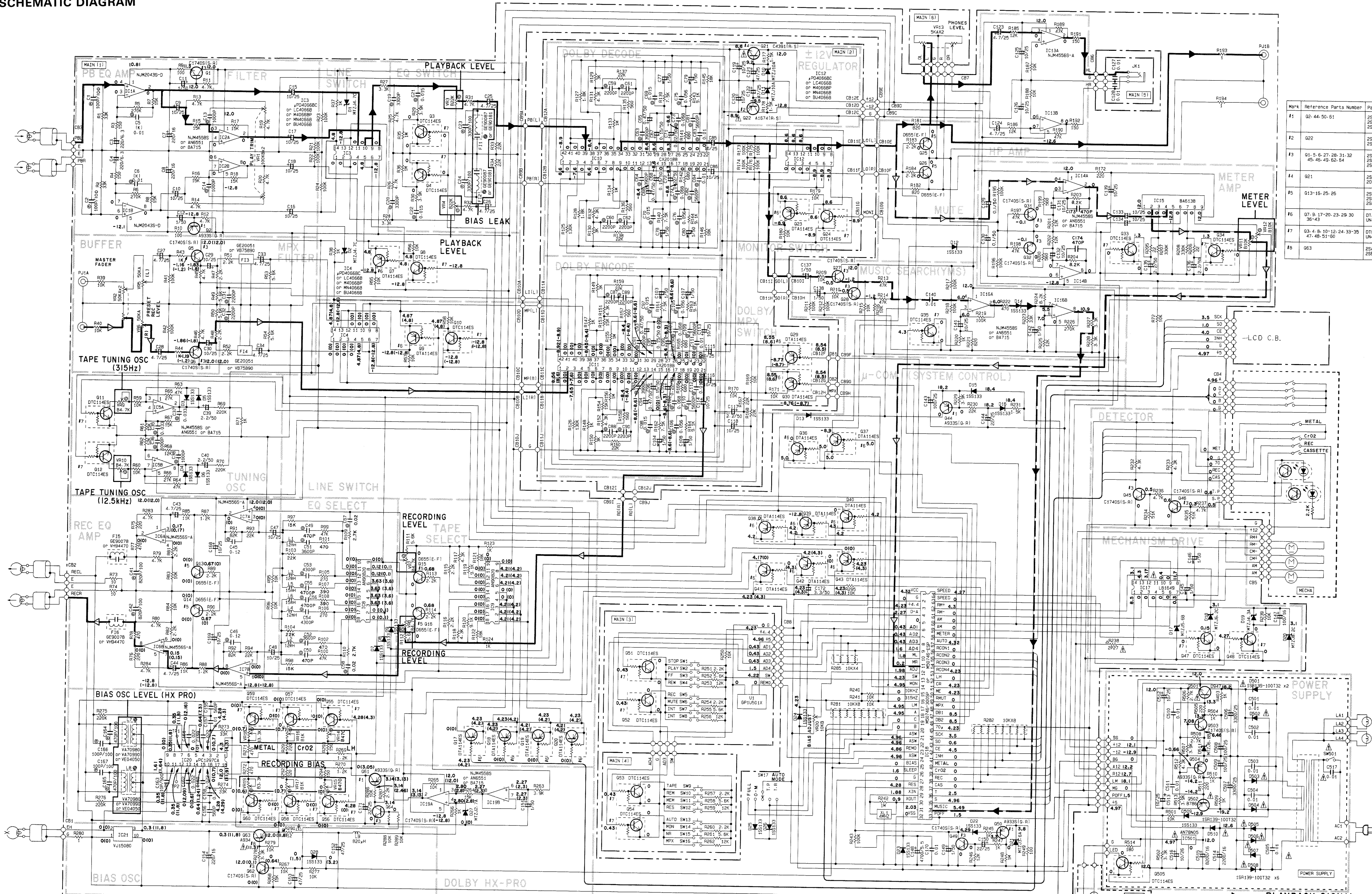

Part	Reference Parts Number	Parts Name
F1	92-44-50-51	25A9391 (R) 25A1115 (E, F) 25A1304 (G, H, S)
F2	922	25B1741 (R, S) 25B1271 (R, S)
F3	91-5-27-28-31-32 45-45-49-62-64	25C1740 (S, R) 25C2603 (E, F) 25C3911 (G, R, S)
F4	921	25C4391 (R, S) 25C1850 (R)
F5	913-15-25-26	25D661 (E, F) 25D1302 (R, S) 25D1408 (R, S)
F6	97-9-17-20-23-29-30 30-43	DTA114ES UN421
F7	93-4-6-10-12-24-33-35 47-48-51-52	DTA114ES UN421
F8	903	25A934 25B544

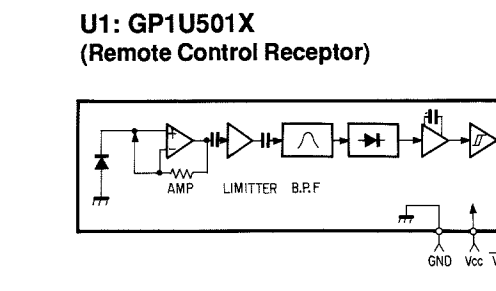
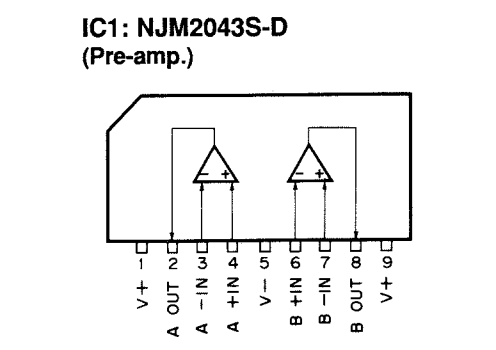
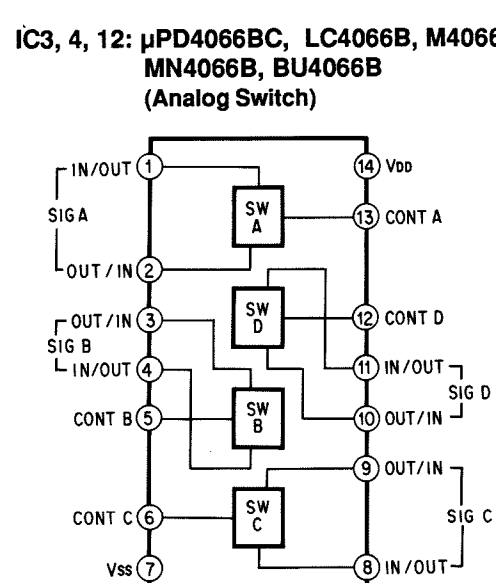
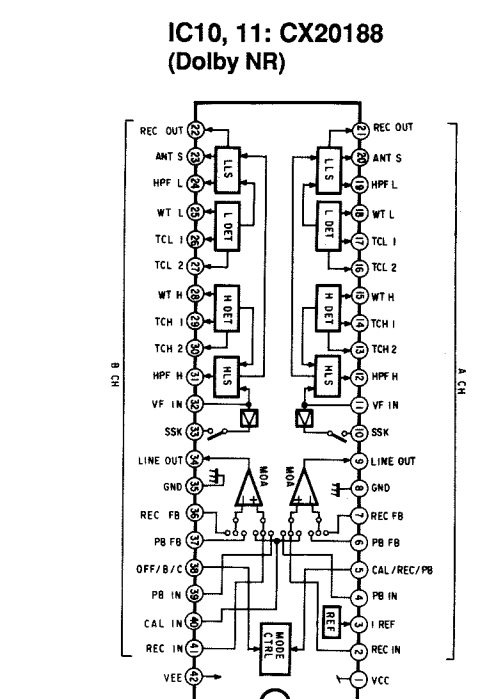

PLAYBACK SIGNAL
YMS SIGNAL
RECORDING SIGNAL
METER SIGNAL

The voltages indicated are when a normal position tape is used.
Playback voltage: Without parentheses
Recording voltage: Within parentheses

IC15: BA6138 (1/2W Power of Compressor Amp.)

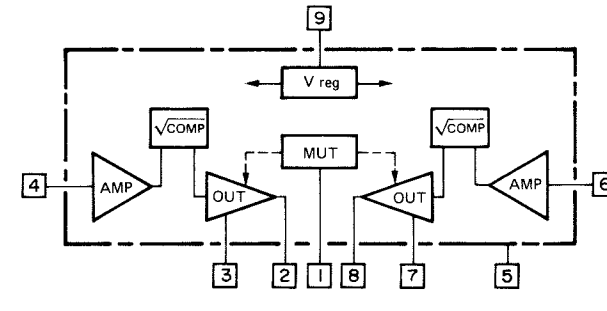

IC20: μPC1297CA (Dolby HX PRO)

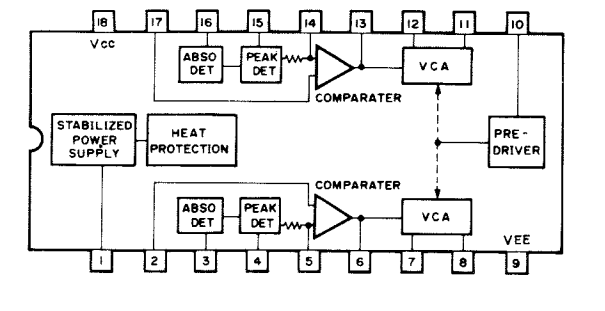

IC8, 9: AN90B20 (Transistor Array)

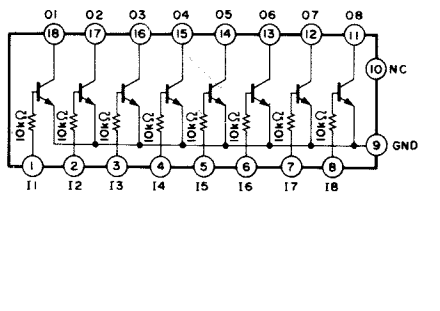

IC2, 5, 14, 16, 19: AN6551, NJM4558S, BA715 (Dual Ope-amp.)

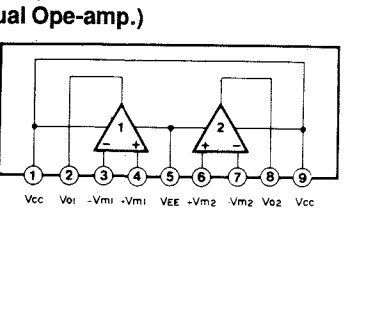

IC401: LC7582 (LCD Driver)

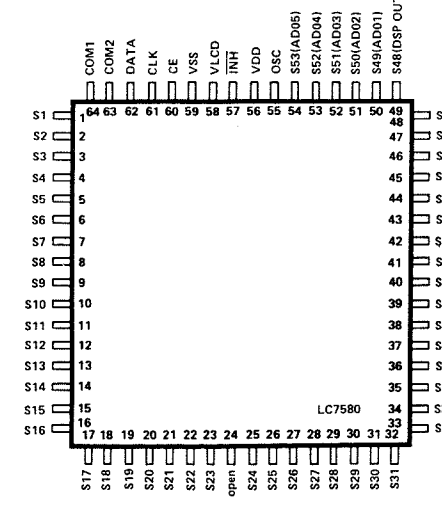

IC17: LB1649 (Motor Driver)

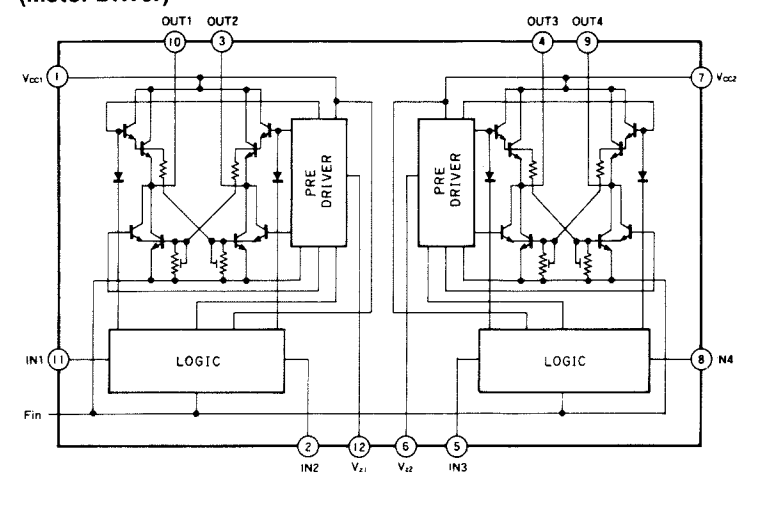

PIN CONNECTION DIAGRAM OF TRANSISTORS, DIODE AND ICs.

25A934	25D655	DTA114ES	25A1674	25B786	AN7805	NJM4558S	LB1649	μPC130HA	μPD4066BC	μPC1287CA	LC7582	CX20188	NS0746-300SP
25A1115	25D947	DTA114ES	25A1304	25B947	AN7805	AN6551	BA715	AN6551	M4066BP	AN90B20			
25A1304	25D1302	25B1858	25B544	25D1408	25C1740S	25C1740S	25C4391	BA6138	MN4066B				
25B786	25C2603	25C3911							BU4066B				

CAUTION
• Components having special characteristics are marked Δ and must be replaced with parts having specifications equal to those originally installed.
• All voltages are measured with a 10MΩ/V DC electric voltmeter.
• Schematic diagram is subject to change without notice.

● SCHEMATIC DIAGRAM

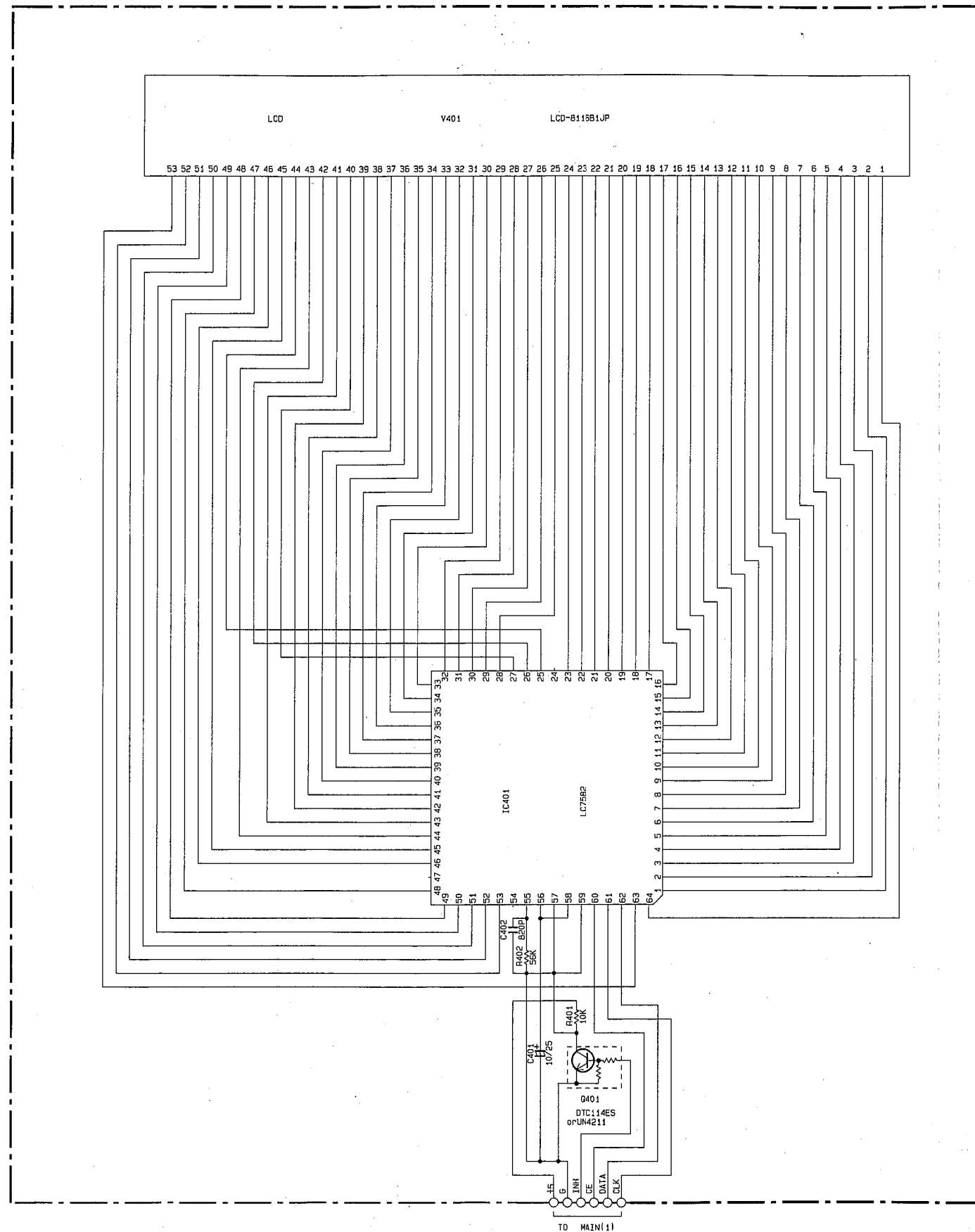

RESISTOR

REMARKS	PARTS NAME
NO MARK	CARBON FILM RESISTOR (1/6W)
☑	CARBON FILM RESISTOR (1/4W)
△	METAL OXIDE FILM RESISTOR
▲	METAL FILM RESISTOR
☒	METAL PLATE RESISTOR
▨	FIRE PROOF CARBON FILM RESISTOR
□	CEMENT MOLDED RESISTOR
⊗	SEMI VARIABLE RESISTOR
■	CHIP RESISTOR

CAPACITOR

REMARKS	PARTS NAME	
NO MARK	ELECTROLYTIC CAPACITOR	≠
⊗	TANTALUM CAPACITOR	≠
NO MARK	CERAMIC CAPACITOR	
⊙	POLYESTER FILM CAPACITOR	
○	POLYSTYRENE FILM CAPACITOR	≠
⊖	MICA CAPACITOR	
⊕	POLYPROPYLENE FILM CAPACITOR	
⊗	SEMICONDUCTIVE CERAMIC CAPACITOR	

NOTICE

(J)..... Japanese model
 (U)..... U.S.A model
 (C)..... Canadian model
 (A)..... Australian model
 (G)..... European model
 (B)..... British model
 (R)..... General model
 (P)..... RP model

PRINTED CIRCUIT BOARD (Pattern Side) (Note) 文字面: Component Side

1
2
3
4
5
6
7

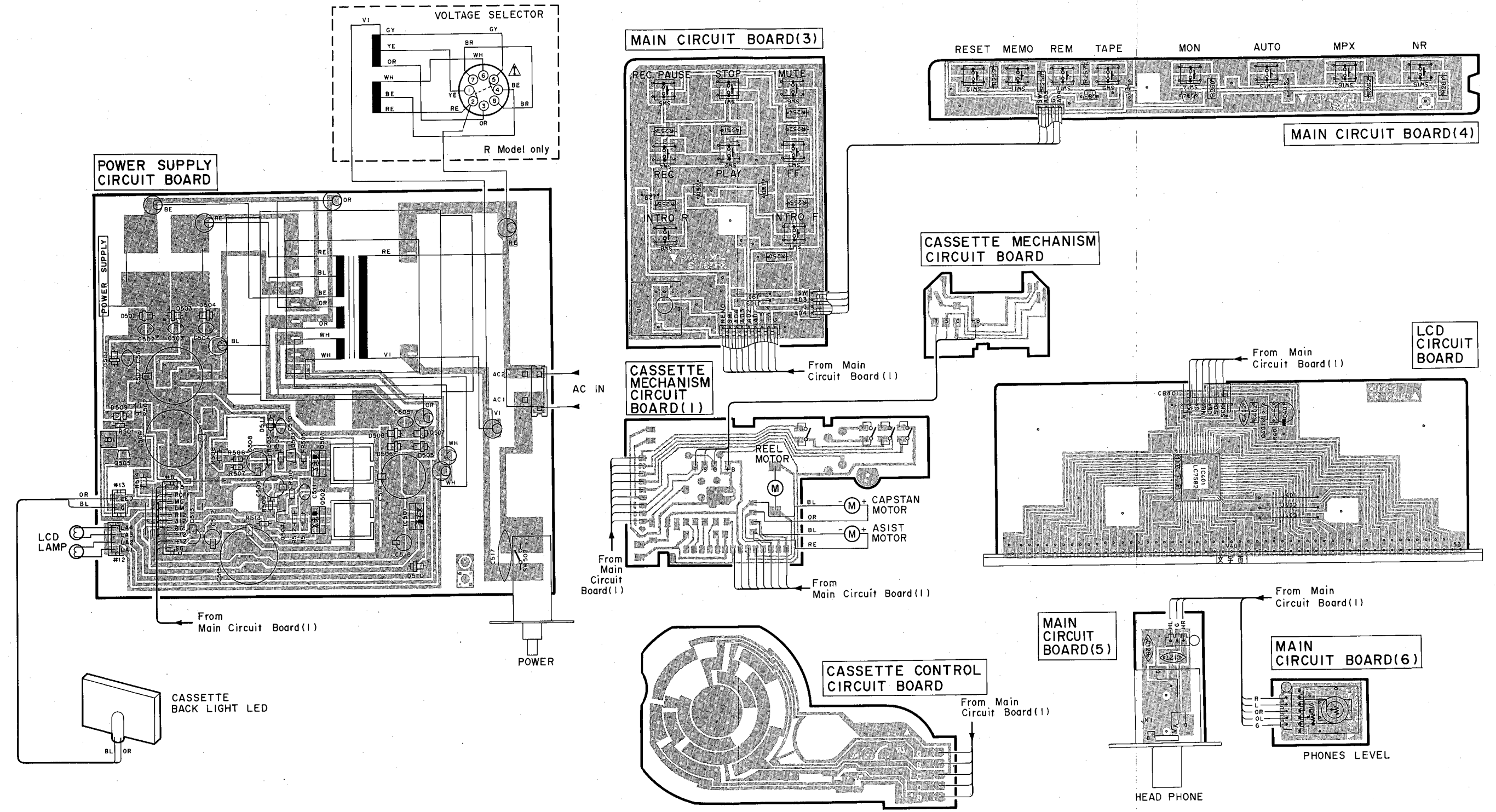

A

B

C

D

E

F

G

H

I

J

KX-930

● PRINTED CIRCUIT BOARD

(Pattern Side)

1

2

3

4

5

6

7

MAIN CIRCUIT BOARD (1)

MAIN CIRCUIT BOARD (2)

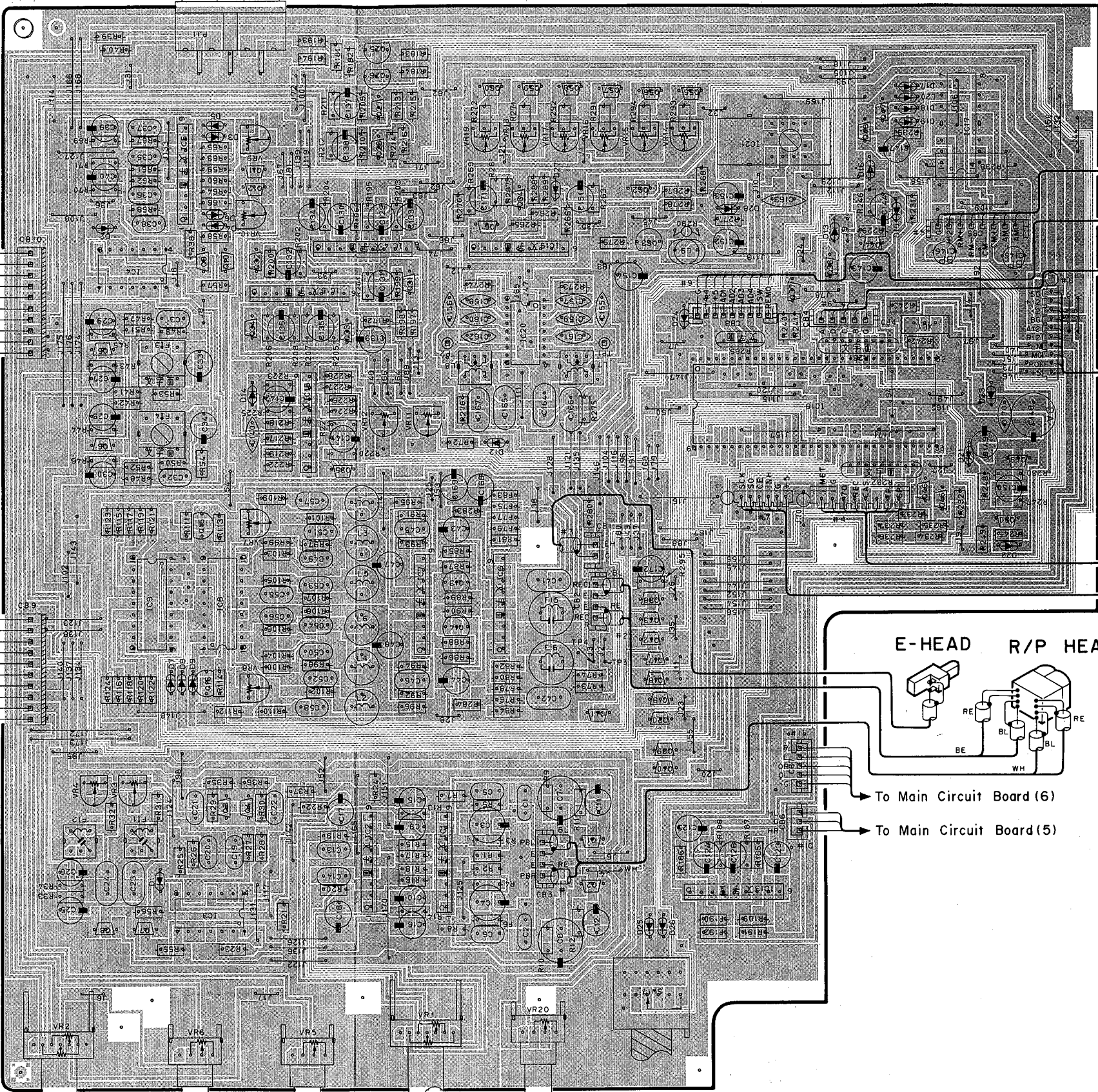
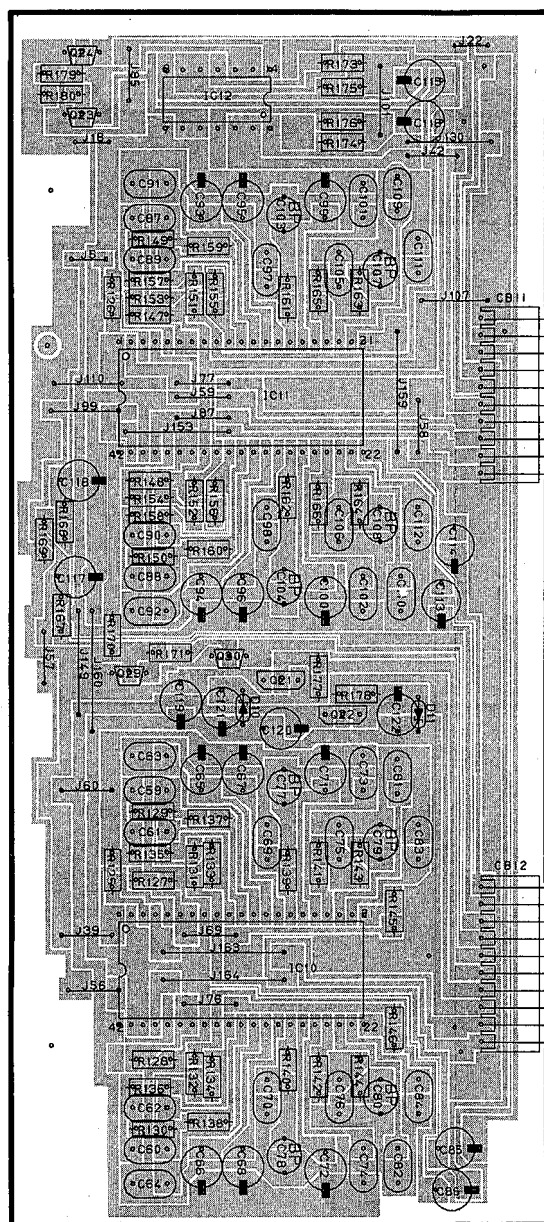

To Cassette Mechanism Circuit Board (1)

To Main Circuit Board (3)

To Cassette Control Circuit Board

To Power Supply Circuit Board

To Cassette Mechanism Circuit Board (1)

To LCD Circuit Board

E-HEAD R/P HEAD

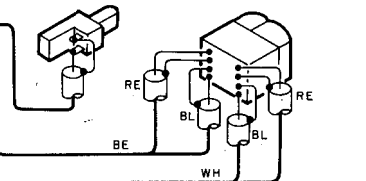

To Main Circuit Board (6)

To Main Circuit Board (5)

MASTER FADER

RIGHT PRESET REC LEVEL

PLAY TRIM

BIAS ADJUST

AUTO MODE

■ WIRING

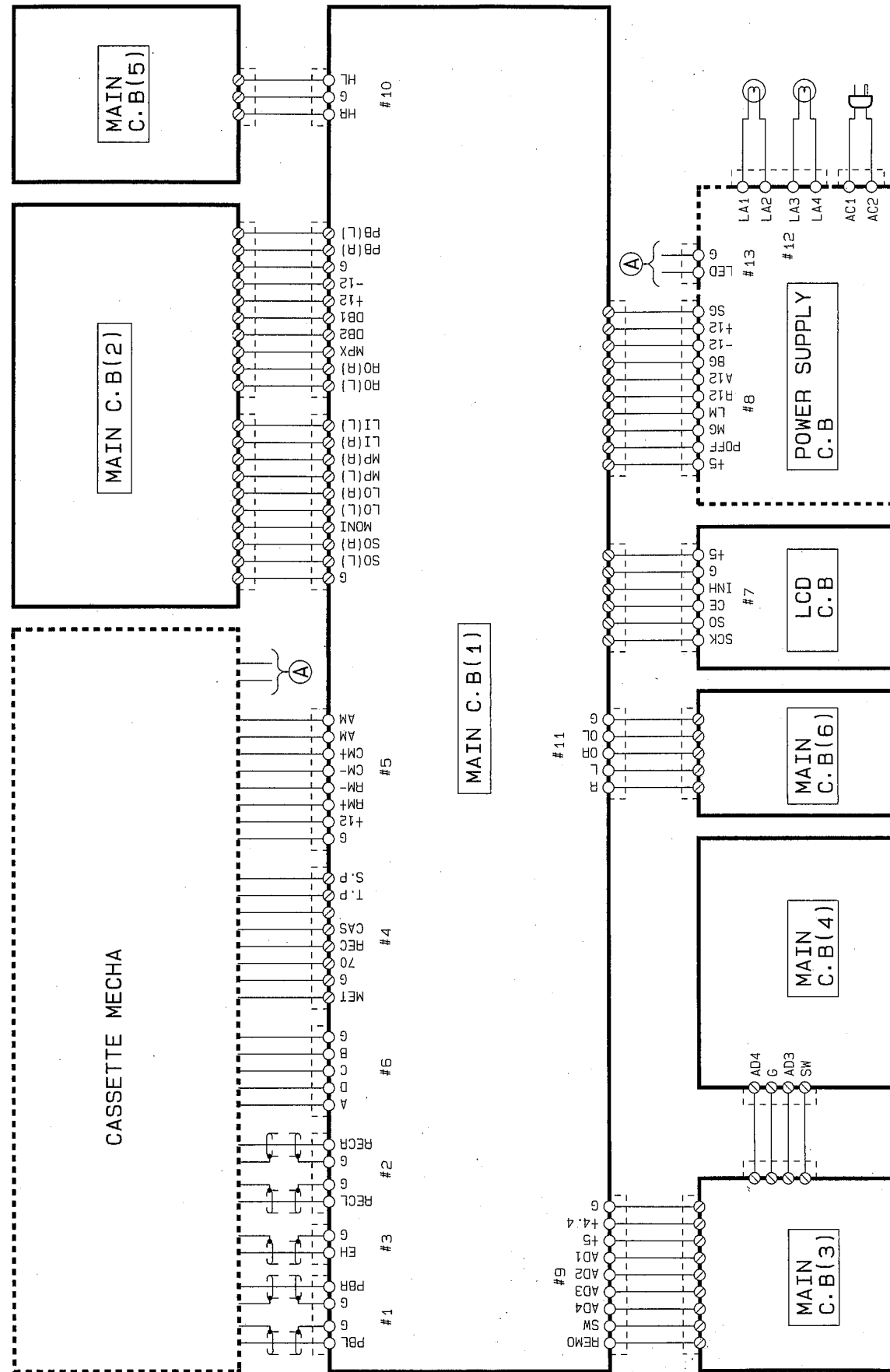

PARTS LIST

■ WARNING

Components having special characteristics are marked \triangle and must be replaced with parts having specifications equal to those originally installed.
 • Carbon resistors 1/6 W are not included in the ELECTRICAL PARTS list. For the parts No. of the carbon resistor, refer to the last Page.

■ ELECTRICAL PARTS

Ref. NO.	PART NO.	Description	部 品 名	Remarks	Markets	ランク
*	V1897000	MAIN CIRCUIT BOARD	メインシート			
	UA252470	MYLAR FILM CAP	マイラーコン	C49,50		
	FA153100	MYLAR FILM CAP	マイラーコン	C13,14,36,38		
	FA153220	MYLAR FILM CAP	マイラーコン	C31,32,59~62,87~90		
	FA153330	MYLAR FILM CAP	マイラーコン	C19,20		
	FA153380	MYLAR FILM CAP	マイラーコン	C51,52		
	FA153390	MYLAR FILM CAP	マイラーコン	C63,64,91,92		
	FA153430	MYLAR FILM CAP	マイラーコン	C53,54		
	FA153470	MYLAR FILM CAP	マイラーコン	C55,56		
	FA153580	MYLAR FILM CAP	マイラーコン	C81,82,109,110		
	FA154100	MYLAR FILM CAP	マイラーコン	C83,84,111,112		
	FA154150	MYLAR FILM CAP	マイラーコン	C21,22,69,70,97,98		
	FA154200	MYLAR FILM CAP	マイラーコン	C57,58		
	FA154330	MYLAR FILM CAP	マイラーコン	C35,37		
	FA154560	MYLAR FILM CAP	マイラーコン	C75,76,105,106		
	UA254680	MYLAR FILM CAP	マイラーコン	C73,74,101,102		
	FA155120	MYLAR FILM CAP	マイラーコン	C45,46		
	FZ006540	MYLAR FILM CAP	マイラーコン	C5,6		
	UT452100	POLYPROPYLENE FILM CAP	PPコン	C1,2,166,167		
	UT452330	POLYPROPYLENE FILM CAP	PPコン	C23,24		
	UT452470	POLYPROPYLENE FILM CAP	PPコン	C164,165		
	UT452820	POLYPROPYLENE FILM CAP	PPコン	C41,42		
	FH611100	CERAMIC CAP	セラコン	C163		
	FG212560	CERAMIC CAP	セラコン	C155,156		
	FG244100	CERAMIC CAP	セラコン	C127,128,140,157,158,		
	FG244220	CERAMIC CAP	セラコン	170		
	U1838100	ELECTROLYTIC CAP	ケミコン	C159~162		
	U1838220	ELECTROLYTIC CAP	ケミコン	C147		
	UH146470	ELECTROLYTIC CAP	ケミコン	C154		
	UH147100	ELECTROLYTIC CAP	ケミコン	C27,28,33,34,43,44,123		
	UH147220	ELECTROLYTIC CAP	ケミコン	,124,129,130		
	UJ147100	ELECTROLYTIC CAP	ケミコン	C15,16,20,30,47,48,115		
	UH147220	ELECTROLYTIC CAP	ケミコン	,116,118~120,125,126,		
	UJ147470	ELECTROLYTIC CAP	ケミコン	131~134,139,141		
	UJ148100	ELECTROLYTIC CAP	ケミコン	C144,150,171		
	UW565150	ELECTROLYTIC CAP	ケミコン	C121,122,152,153		
	UJ165220	ELECTROLYTIC CAP	ケミコン	C143		
	UJ165470	ELECTROLYTIC CAP	ケミコン	C67,68,95,96		
	UH166100	ELECTROLYTIC CAP	ケミコン	C71,72,99,100		
	UJ666220	ELECTROLYTIC CAP	ケミコン	C65,66,93,94		
	UH166330	ELECTROLYTIC CAP	ケミコン	C11,12,137,138,142,149		
	VE018000	ELECTROLYTIC CAP	ケミコン	,151		
	VE018200	ELECTROLYTIC CAP	ケミコン	C39,40,117,135,136		
	VE018300	ELECTROLYTIC CAP	ケミコン	C172		
	VE392400	ELECTROLYTIC CAP	ケミコン	C7,8		
	VB170100	ELECTROLYTIC CAP	バックアップケミコン	C25,26		
				C9,10,17,18,85,86,113,		
				114,168,169		
				C3,4		
				C148		

* : New Parts (新規部品)

ランク : Japan only

Ref. NO.	PART NO.	Description	部 品 名		Remarks	Markets	ランク
	FM116100	ELECTROLYTIC CAP	1uF	50V	B Pケミコン	C77~80,103,104,107,108,145,146	
	GE200510	COIL,MPX			MPXコイル	Fi3,4	
	GE900780	COIL,TRAP	105KHz		トラップコイル	Fi5,6	
	GE901810	COIL,TRAP	105KHz		トラップコイル	Fi1,2	
	VE040500	COIL,STEP UP	105KHz		ステップアップコイル	L7,8	
	GE901640	COIL	12mH		コイル	L1~4	
	GE901850	COIL	15mH		コイル	L5,6	
	GE900960	COIL	820mH		コイル	L9	
	HL324220	METAL OXIDE RESISTOR	22Ω	2W	酸化金属被膜抵抗	R238	△
	HV454120	FLAME PROOF CARBON RESISTOR	12Ω	1/4W	不燃化カーボン抵抗	R290	△
	VE111400	RESISTOR ARRAY	10Kx3		抵抗アレイ	R281,282	
	VG734100	RESISTOR ARRAY	10Kx4		抵抗アレイ	R285	
	IG076800	IC	NJM4558S		IC	IC2,5,14,16,19	
	IG077410	IC	NJM4558S-A		IC	IC6,7,13	
	IG082900	IC	NJM2043S-D		IC	IC8,9	
	IG089900	IC	AN90B20		IC	IC8,9	
	XA300001	IC	uPC1297CA		IC	IC20	
	XC771001	IC	CX20188		ドルビーIC	IC10,11	
	XD148001	IC	BU4066B		IC	IC3,4,12	
*	XA299001	IC	LB1649		IC	IC17	△
	XH569A00	IC	M50746-300SP		IC	IC18	
	IG074900	IC	BA6138		IC	IC15	
*	VJ150800	OSC. BLOCK,BIAS			パイアス発振ブロック	IC21	
	VF926500	LIGHT DETECTING MODULE			リモコン受光ユニット	U1	
	VE327300	TACT SWITCH	KHH-MA901		タクトSW	SW1~16	
	KA501960	ROTARY SWITCH	2-5	SRBU025	ロータリーSW	SW17 AUTO MODE	
	LA004120	PIN,TEST POINT			テストポイントピン	TP1,2	
	LB401050	PIN JACK	4P	T5859-A	ピンジャック	PJ1	
	VB097300	PHONES JACK			ヘッドホンジャック	JK1	
	VCO14600	BASE POST	EH	2P TE	コネクタベースポスト	CB1	
	VCO14800	BASE POST	EH	4P TE	コネクタベースポスト	CB2,3	
	VCO14900	BASE POST	EH	5P TE	コネクタベースポスト	CB4	
	VCO15200	BASE POST	EH	8P TE	コネクタベースポスト	CB5	
	VDO04600	BASE PIN	PH	3P TE	ベースピン	CB6	
	VDO04800	BASE PIN	PH	5P TE	ベースピン	CB7	
	VDO05200	BASE PIN	PH	9P TE	ベースピン	CB8	
	LB607870	BASE PIN		10P TE	ベースポスト	CB9,10	
*	LB023100	CONNECTOR	SQ	10P SE	SQコネクター	CB11,12	
	VD827600	CERAMIC RESONATOR	4MHz		セラミック振動子	XL1	
	VB861100	PRE-SET POTENTIOMETER	B1K		半固定VR	VR16,17 BIAS ADJ. CrO2	
	VB861000	PRE-SET POTENTIOMETER	B470		半固定VR	VR14,15 BIAS ADJ. LH	
	VB861300	PRE-SET POTENTIOMETER	B3.3K		半固定VR	VR18,19 BIAS ADJ. ME	
	VB861400	PRE-SET POTENTIOMETER	B4.7K		半固定VR	VR7~10 REC LEVEL,OSC	
	VB861500	PRE-SET POTENTIOMETER	B10K		半固定VR	VR11,12 METER LEVEL	
	VB861600	PRE-SET POTENTIOMETER	B22K		半固定VR	VR3,4 PLAY BACK LEVEL	
*	V1659900	POTENTIOMETER	A50K		ロータリーVR	VR5,6 PRESET REC LVL	
	V1847200	POTENTIOMETER	B10K		ロータリーVR	VR20 BIAS ADJ.	
	V1660000	POTENTIOMETER	A50Kx2		二連ロータリーVR	VR2 MASTER FADER	
	VF113700	POTENTIOMETER	A5Kx2		二連ロータリーVR	VR13 PHONES LEVEL	

* : New Parts (新規部品)

ランク : Japan only

Ref. NO.	PART NO.	Description	部 品 名		Remarks	Markets	ランク
	VI660100	POTENTIOMETER	B100Kx2	二連ロータリーVR	VR1 PLAY TRIM		
	IB054410	TRANSISTOR	2SB544	トランジスタ	Q63		△
	IA111510	TRANSISTOR	2SA1115 E,F	トランジスタ	Q2,44,50,61		
	VE813300	TRANSISTOR	2SB1237 Q,R	トランジスタ	Q22		△
	IC260310	TRANSISTOR	2SC2803 E,F	トランジスタ	Q1,5,6,27,28,31,32,45,		
	VE613400	TRANSISTOR	2SD1858 Q,R	トランジスタ	46,49,62,64 Q21		△
	VA710000	TRANSISTOR	2SD1468 Q,R,S	トランジスタ	Q13~16,25,28		
	VD678500	DIGITAL TRANSISTOR	DTA114ES	デジタルトランジスタ	Q7,9,17~20,23,29,30, 36~43		
	VD678700	DIGITAL TRANSISTOR	DTC114ES	デジタルトランジスタ	Q3,4,8,10~12,24, 33~35,47,48,51~80		
*	IF004600	DIODE	1SS133	ダイオード	D3~9,12~16,22~26,28		
	VG435600	ZENER DIODE	MTZJ2.7A	ツェナーダイオード	D27		
	VG436200	ZENER DIODE	MTZJ3.6A	ツェナーダイオード	D21		
*	VG436700	ZENER DIODE	MTZJ4.3A	ツェナーダイオード	D19		
	VG437200	ZENER DIODE	MTZJ4.7C	ツェナーダイオード	D1,2		
	VG437700	ZENER DIODE	MTZJ5.6B	ツェナーダイオード	D17		
	VG438100	ZENER DIODE	MTZJ6.2C	ツェナーダイオード	D18		
*	VG439000	ZENER DIODE	MTZJ8.2C	ツェナーダイオード	D20		
	VG439400	ZENER DIODE	MTZJ10A	ツェナーダイオード	D10,11		
	VI657000	HOLDER,VR		ホルダーVR			
	CB605620	PLASTIC RIVET		ブラリベット			
*	VI897100	LCD CIRCUIT BOARD		LCDシート			
	FG212820	CERAMIC CAP	820pF 50V	セラコン	C402		
	UH147100	ELECTROLYTIC CAP	10uF 25V	ケミコン	C401		
*	XB417001	IC	LC7582	IC	IC401		
	VI911800	LCD	LCD-8116B1JP	LCD表示器	V401		
	VB858500	BASE PIN	PH 6P SE	ベースピン	CB401		
	VD678700	DIGITAL TRANSISTOR	DTC114ES	デジタルトランジスタ	Q401		

* : New Parts (新規部品)

ランク : Japan only

Ref. NO.	PART NO.	Description	部 品 名	Remarks	Markets	ランク
	VJ018500	POWER UNIT	電源ユニット		UC	
	VJ018600	POWER UNIT	電源ユニット		R	
	VJ018700	POWER UNIT	電源ユニット		AB	
	VJ018800	POWER UNIT	電源ユニット		G	
	Fi514100	CERAMIC CAP	0.01uF	セラコン	C517	△
	Fi554100	CERAMIC CAP	0.01uF 50V	セラコン	C501~505,510,511	
	Ui939820	ELECTROLYTIC CAP	8200uF 16V	ケミコン	C515	
	UJ139220	ELECTROLYTIC CAP	2200uF 16V	ケミコン	C514	
	UJ648100	ELECTROLYTIC CAP	100uF 25V	ケミコン	C508,509	
	UJ147100	ELECTROLYTIC CAP	10uF 25V	ケミコン	C516	
	UH649330	ELECTROLYTIC CAP	3300uF 25V	ケミコン	C506,507	UCG
	VC780900	ELECTROLYTIC CAP	3300uF 25V	ケミコン	C506,507	RAB
	VE018300	ELECTROLYTIC CAP	10uF 25V	ケミコン	C512,513	
	iF003450	DIODE	1SS133	ダイオード	D509	
	VH770800	DIODE	1SR139-100T32	ダイオード	D501~508,510	△
	VG438300	ZENER DIODE	MTZJ6.8B	ツェナーダイオード	D511	
	iD094700	TRANSISTOR	2SD947	トランジスタ	Q501	△
	iD078600	TRANSISTOR	2SB786	トランジスタ	Q502	△
	iC260310	TRANSISTOR	2SC2603 E,F	トランジスタ	Q503	
	iA111510	TRANSISTOR	2SA1115 E,F	トランジスタ	Q504	
	VD678700	DIGITAL TRANSISTOR	DTC114ES	デジタルトランジスタ	Q505	
	XA507001	IC	AN78N05	IC	IC501	△
	XH406A00	POWER TRANSFORMER		電源トランス		UC
	XH407A00	POWER TRANSFORMER		電源トランス		R
	XH408A00	POWER TRANSFORMER		電源トランス		AB
	XH409A00	POWER TRANSFORMER		電源トランス		G
	KA805150	SWITCH,POWER		パワースイッチ		△
	BA084000	HEAT SINK		放熱板		△
	VE225700	BASE POST		ベース付ポスト		△
	VC014600	BASE PIN	EH i-TYPE 2P	ベースピン		△
	VD004700	BASE PIN	PH i-TYPE 4P	ベースピン		
	VD005300	BASE PIN	PH i-TYPE 10P	ベースピン		
	E1330066	BIND HEAD TAPPING SCREW	3x6 FCRN3-BL	バインドBタイトネジ	PACK	
	E1330086	BIND HEAD TAPPING SCREW	3x8 ZMC2	バインドBタイトネジ	PACK	
	LB201480	VOLTAGE SELECTOR		電圧切換器		R

* : New Parts (新規部品)

ランク : Japan only

A

B

C

D

E

KX-930

EXPLODED VIEW

1

2

3

4

5

6

7

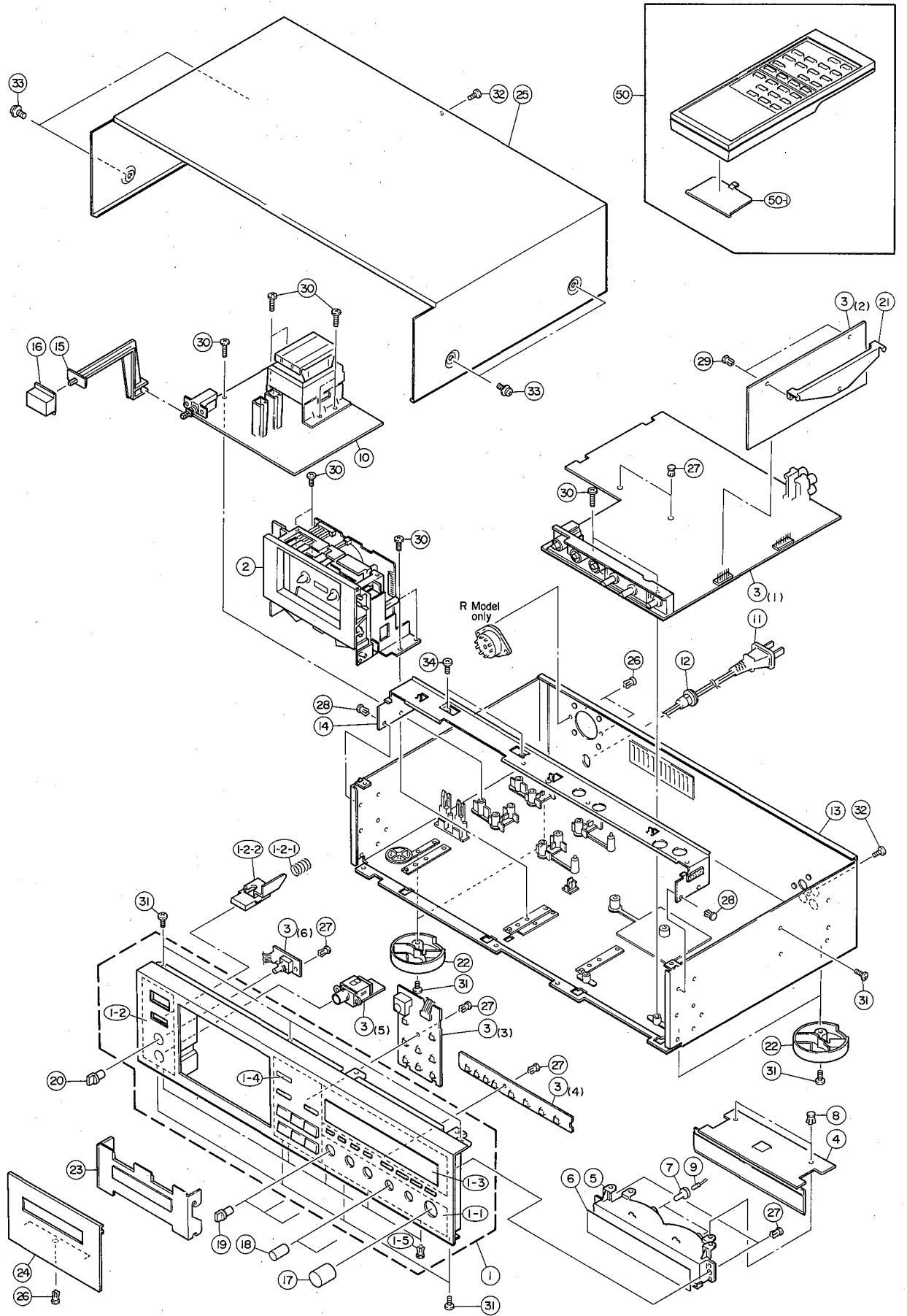

Ref. NO.	PART NO.	Description	部 品 名	Remarks	Markets	ランク
* 1	Vi896420	PANEL UNIT	パネルユニット	BL		
* 1	Vi896520	PANEL UNIT	パネルユニット	T		
* 1-1	Vi765700	SUB PANEL	サブパネル	BL		
* 1-1	Vi765800	SUB PANEL	サブパネル	T		
1-2	Vi806700	BUTTON ASS'Y	ボタンASSY	BL		
1-2	Vi806800	BUTTON ASS'Y	ボタンASSY	T		
1-2-1	VE931900	SPRING,EJECT	EJ EJスプリング			
* 1-2-2	Vi656300	BUTTON	EJ ボタン	BL		
* 1-2-2	Vi656400	BUTTON	EJ ボタン	T		
1-3	Vi657100	WINDOW	ウィンドウ	BL		
1-3	Vi657200	WINDOW	ウィンドウ	T		
1-4	VH897500	LENS	レンズ			
1-5	CB068880	PLASTIC RIVET	ブラリベット			
* 2	VJ009500	CASSETTE DECK MECHANISM	SME2354 カセットデッキメカ	BL		
* 2	VJ009600	CASSETTE DECK MECHANISM	SME2355 カセットデッキメカ	T		
* 3	Vi897000	MAIN CIRCUIT BOARD	メインシート			
* 4	Vi897100	LCD CIRCUIT BOARD	LCDシート			
5	VH400200	REFLECTOR	リフレクター			
6	VH409600	SHEET	D シート			
7	VF444500	LAMP CAP	AG-4015 ランプキャップ			
8	CB005620	PLASTIC RIVET	ブラリベット			
9	Vi284600	LAMP	150mV 8V ランプ			
* 10	VJ018500	POWER UNIT	電源ユニット		UC	
* 10	VJ018600	POWER UNIT	電源ユニット		R	
* 10	VJ018700	POWER UNIT	電源ユニット		AB	
* 10	VJ018800	POWER UNIT	電源ユニット		G	
11	VE640000	POWER CORD ASS'Y	パワーコードASSY		UC	
11	VE043100	POWER CORD ASS'Y	パワーコードASSY		B	
11	VE043400	POWER CORD ASS'Y	パワーコードASSY		G	
11	VE222900	POWER CORD ASS'Y	パワーコードASSY		R	
11	VE042900	POWER CORD ASS'Y	パワーコードASSY		A	
12	CB616810	CORD STOPPER	CW-22A コードストッパー		UC	
12	CB620190	CORD STOPPER	CW-22B コードストッパー		RABG	
13	NB630530	CHASSIS	シャーシ		UCABG	
13	NB630550	CHASSIS	シャーシ		R	
* 14	Vi923200	FLAME	T フレーム			
15	CB634280	ROD	P ロッド			
16	VH889400	BUTTON	POWER ボタン	BL		
16	VH889500	BUTTON	POWER ボタン	T		
17	VH815600	KNOB	H.FADER ノブ	BL		
17	VH815700	KNOB	H.FADER ノブ	T		
18	VH889000	KNOB	REC LEVEL ノブ	BL		
18	VH889100	KNOB	REC LEVEL ノブ	T		
19	VH888800	KNOB	MODE,BIAS,TRIM ノブ	BL		
19	VH888900	KNOB	MODE,BIAS,TRIM ノブ	T		
20	VH989000	KNOB	PHONES LEVEL ノブ	BL		
20	VH989100	KNOB	PHONES LEVEL ノブ	T		
21	VE009900	SUPPORT	PCB サポート			
* 22	VJ081400	LEG	レッグ	BL		
* 22	VJ081500	LEG	レッグ	T		

* : New Parts (新規部品)

ランク : Japan only

KX-930

KX-930

Ref. NO.	PART NO.	Description	部 品 名		Remarks	Markets	ランク
	V1656200	LID COVER					
* 24	V1963400	LID PANEL			BL		
* 24	V1963500	LID PANEL			T		
25	V1656700	TOP COVER			BL		
25	V1656800	TOP COVER			T		
26	CB068880	PLASTIC RIVET					
27	CB605620	PLASTIC RIVET					
28	CB601420	PLASTIC RIVET					
29	CB099600	PLASTIC RIVET					
30	E1030106	BIND HEAD P-TITE SCREW	3x10	ZMC2-Y	バインドタッピングネジ	PACK	
31	E1330086	BIND HEAD B-TITE SCREW	3x8	FCRM3-BL	バインドタッピングネジ	PACK	
32	EN335030	BIND HEAD BONDING TAP SCREW	3x10	FCRM3-BL	ボンディングネジ		
33	EK365040	BW HEAD SCREW	4x8-10	FCRM3-BL	BWネジ	BL	
33	EX601150	BW HEAD S-TYTE SCREW	4x8x10	FNM3-BL	BW Sタイトネジ	T	
34	EJ326086	PAN HEAD TAPPING SCREW	2.6x8	ZMC2-BL	ナバタッピングネジ		
	CB069250	BINDING TIE	BK-1		束線止め		
		ACCESSORIES			付属品		
	VE233300	PIN-PLUG CORD			ピンコードASSY		
* 50	V1777500	REMOTE CONTROL TRANSMITTER			リモコントランスミッター		
50-1	CX613770	LID			電池蓋		
		DRY CELL	UM-4.R06		マンガン電池		

* : New Parts (新規部品)

ランク : Japan only

MECHANISM EXPLODED VIEW

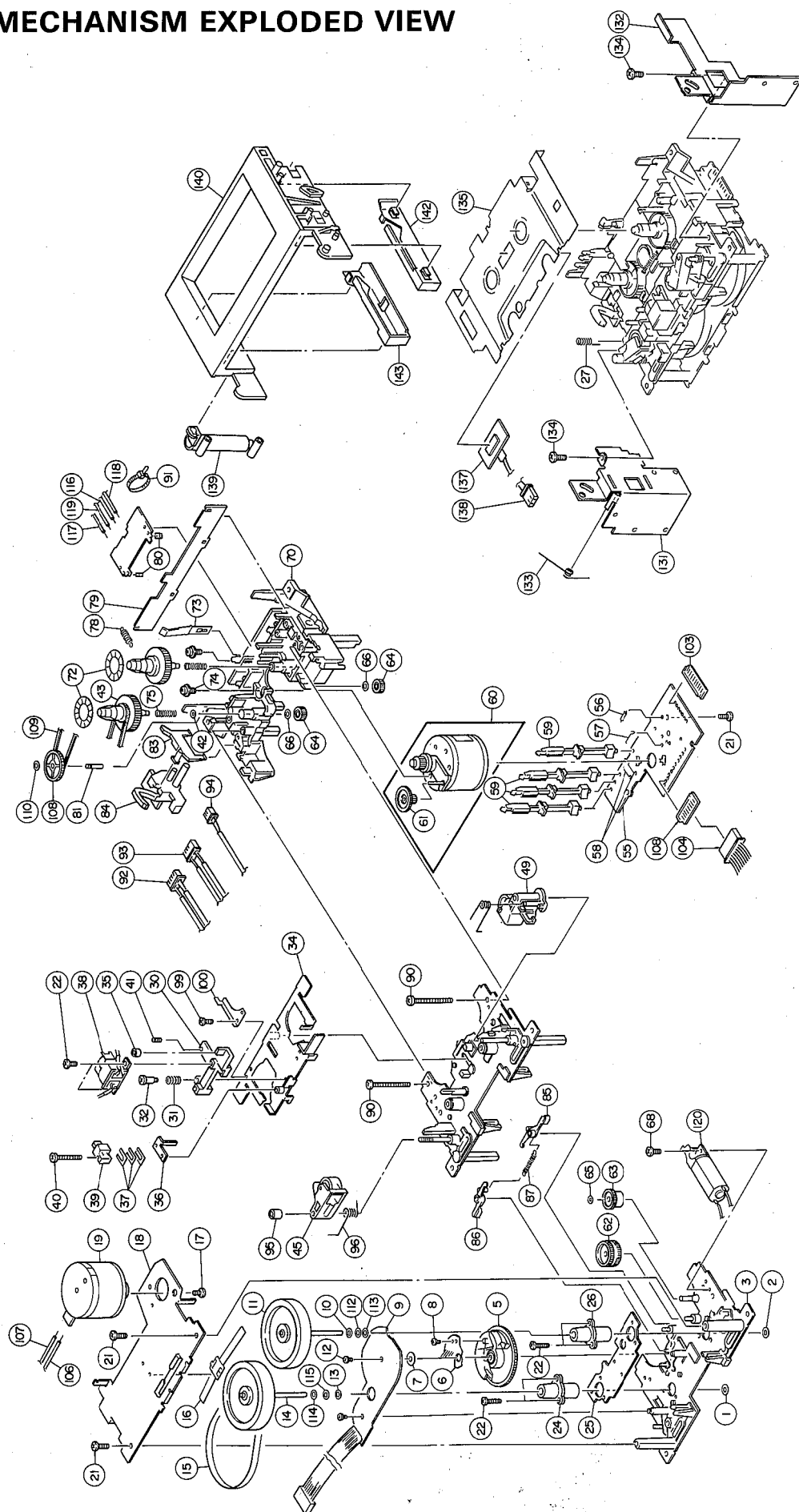

MECHANISM PARTS

Ref. NO.	PART NO.	Description	部 品 名	Remarks	Markets	ランク
*	VJ009500	CASSETTE DECK MECHANISM	カセットデッキメカ			
*	VJ009600	CASSETTE DECK MECHANISM	カセットデッキメカ			
*	1	AX610400 WASHER 2.5x7x0.8	座金		SEE1023002	
*	2	AX610410 WASHER 2.2x7x0.8	座金		SEE1023003	
*	3	NX607950 CHASSIS ASS'Y	メカシャーシASSY		SGD0100151	
*	5	CX614610 CAM	カム		KGD104231A	
*	6	AX610420 CONTACT, ROTARY TYPE	ロータリー接片		KGE104233A	
*	7	CX614620 WASHER 3x8x0.5	ワッシャー		KGE104234A	
*	8	XX674720 PAN HEAD SCREW 2x3	ナベ小ネジ		SEE3052201	
*	9	NX607960 CONTROL CIRCUIT BOARD	コントロール基板		SGE0800122	
*	10	CX614630 WASHER 2.2x7x0.2	ワッシャー		SGE3600802	
*	11	AX610430 FLYWHEEL	フライホイール		SGD3200502	
*	12	EA020030 PAN HEAD SCREW 2x3	ナベ小ネジ		KGE103483A	
*	13	CX614640 WASHER 2.6x7x0.13	ワッシャー		SEE1022838	
*	14	AX610440 FLYWHEEL	フライホイール		SGD3200401	
*	15	CX614650 BELT	ベルト		SGE1800301	
*	16	AX610450 HOLDER, THRUST	スラスト受		KGE103929C	
*	17	EA026036 PAN HEAD SCREW 2.6x3	ナベ小ネジ	PACK	14536	
*	18	AX610460 PLATE, MOTOR	モーター取付板		KGD103953B	
*	19	NX607970 MOTOR ASS'Y, CAPSTAN	キャプスタンモーターASSY		SGE0500422	
*	21	EJ026086 SCREW 2.6x8	タッピンネジ	PACK	SEE3054403	
*	22	AX610470 PAN HEAD S-TITE SCREW 2x4	ナベSタイトネジ	PACK	SEE3057807	
*	24	NX607980 CAPSTAN STAND ASS'Y	キャプスタンスタンド組		SGE0900801	
*	25	NX607990 CAPSTAN STAND ASS'Y	キャプスタンスタンド組		SGE0900802	
*	26	AX610480 PLATE	補強板		SGE1900701	
*	27	AX610490 COIL SPRING	圧縮コイルバネ		SGE2401901	
*	30	AX610500 HEAD BASE	HDブロック		SGD1100102	
*	31	AX610510 COIL SPRING	圧縮コイルバネ		SIE2402902	
*	32	AX610520 SHAFT	軸		SIE2205901	
*	34	NX608000 HEAD BASE ASS'Y	ヘッドベースASSY		SGE0200451	
*	35	AX610530 ADJUSTING NUT	調整ナット		SIE2300801	
*	36	NX608010 ERASE HEAD PLATE (B)	EヘッドASSY (B)		SIE2101901	
*	37	XX640640 SPACER t=0.03	スペーサー		SE13401103	
*	37	XX640630 SPACER t=0.06	スペーサー		SIE3401101	
*	37	XX640650 SPACER t=0.1	スペーサー		SIE3401102	
*	38	JX600760 HEAD	録再ヘッド		H53710110	
*	39	XX641440 ERASE HEAD	消去ヘッド		308763003	
*	40	XX674730 BIND HEAD SCREW 2x12	バインド小ネジ		SEE3053806	
*	41	ED020046 BIND HEAD SCREW 2x4	バインド小ネジ	PACK	SEE3053903	
*	42	AX610540 WASHER	ワッシャー		SGE3300501	
*	45	NX608020 PINCH ROLLER ARM ASS'Y	Sピンチアーム組		SGE0300301	
*	49	NX608030 PICH ROLLER ARM ASS'Y (R)	ピンチアーム右組		SGE0300103	
*	55	NX608040 CIRCUIT BOARD	プリント基板		KGD104113A	
*	56	HJ359220 CARBON RESISTOR 2.2KΩ 1/4W	固定抵抗器		SEE5021232	
*	57	NX602860 WIRE, EARTH	アース線		KGE104135A	
*	59	KX602890 LEAF SWITCH	リーフSW		KGD103952A	
*	60	NX608050 REEL MOTOR ASS'Y	リールモーターASSY		SGE0500103	
*	62	CX614660 IDLER GEAR	アイドル歯車		SGE2600202	
*	63	CX614670 GEAR	歯車		SGE2600102	
*	64	CX614680 PULLEY, BRAKE	ブレーキプーリー		KGE103997A	

* : New Parts (新規部品)

ランク : Japan only

KX-930

Ref. NO.	PART NO.	Description	部品名	Remarks	Markets	ランク
* 65	CX614690	WASHER	2.6x5x0.5	ワッシャー	SEE1022841	
* 66	CX614700	WASHER	2.6x5.5x0.13	ワッシャー	SEE1022820	
* 68	EA026046	PAN HEAD SCREW	2.6x4	ナベ小ネジ	SEE3057907	PACK
* 70	AX610550	SUB CHASSIS		サブシャーシ	KGC103950C	
* 73	AX610560	SPRING		カセットバネ	SGE2402002	
* 74	AX610570	SPECIAL SCREW	2.6x1.6	設付ナベ小ネジ	SEE3062201	
* 75	AX610580	COIL SPRING		圧縮コイルバネ	KGE103983A	
* 76	HX608060	REEL BASE ASS'Y		リール台ASSY	SGE0400111	
* 77	CX614710	REFLECTOR		6P反射板	SGE2800101	
* 78	AX610590	COIL SPRING		引張コイルバネ	SGE2400801	
* 79	AX610600	PLATE,CASSETTE HOLDER		カセット押え板	KGD104046B	
* 80	IX618150	PHOTO REFLECTOR		フォトリフレクタ	KGE104147A	
* 81	AX610610	SHAFT		軸	KGE103267A	
* 83	AX610620	LEVER		レバー	KGE103936A	
* 84	AX610630	EJECT LEVER		イジェクトレバー	SGD2000501	
* 85	NX608070	BRAKE LEVER (L) ASS'Y		ブレーキレバーL ASSY	SGE0700901	
* 86	NX608080	BRAKE LEVER (R) ASS'Y		ブレーキレバーR ASSY	SGE0701001	
* 87	AX610640	COIL SPRING		引張コイルバネ	KGE104008A	
* 90	EA026300	PAN HEAD SCREW	2.6x30	ナベ小ネジ	SEE3051403	
* 91	CB069250	BIND TIE		結束バンド	SGE3300801	
* 92	NX608090	CONNECTOR ASS'Y	2P ERASE H	コネクター付リード線	SEE2717954	
* 93	NX608100	CONNECTOR ASS'Y	4P REC H	コネクター付リード線	SEE2717947	
* 94	NX608110	CONNECTOR ASS'Y	4P PB H	コネクター付リード線	SEE2717946	
* 95	AX610650	ADJUST SCREW,P.ROLLER ARM		PRアームアジャストネジ	KGE103738B	
* 96	AX610660	PINCH ROLLER SPRING (SUPPLY)		Sピンチバネ	SGE2401801	
* 99	AX610670	PAN HEAD SCREW	2x2.5	ナベ小ネジ	SEE3052513	
* 100	AX610680	STOPPER		ストッパー	SGE1900601	
* 103	LX604780	BASE POST		ベース付ポスト	SEE552308	
* 104	NX608120	CONNECTOR ASS'Y	8P	コネクター付リード線	SGE8402301	
* 106	HX602870	LEAD	(BL)	リード線	SGE8400506	
* 107	HX602880	LEAD	(OR)	リード線	SGE8400402	
* 108	NX608130	PULLEY ASS'Y		プーリーASSY	KGE015113B	
* 109	CX614720	BELT		ベルト	SGE1800602	
* 110	XX640330	WASHER	1.8x3.8x0.5	ワッシャー	SEE1022818	
* 112	CX614730	WASHER	2.3x4.7x0.2	ワッシャー	SGE3600702	
* 113	CX614740	WASHER	2.3x7x0.13	ワッシャー	SEE1022839	
* 114	CX614750	WASHER	2.5x6x0.2	ワッシャー	SGE3600803	
* 115	CX614760	WASHER	2.6x4.7x0.2	ワッシャー	SGE3600701	
* 116	HX602890	LEAD	(BL)	リード線	SGE8400502	
* 117	HX602900	LEAD	(BU)	リード線	SGE8400602	
* 118	HX602910	LEAD	(BR)	リード線	SGE8400701	
* 119	HX602920	LEAD	(GL)	リード線	SGE8400301	
* 120	NX608140	MOTOR ASS'Y,ASSIST		アシストモーターASSY	SGE0500701	
* 131	AX610690	HOLDER (L)		ホルダーL	SGD1900901	
* 132	AX610700	HOLDER (R)		ホルダーR	SGD1900801	
* 133	AX610710	SPRING		コイルバネ	KGE103881A	
* 134	EA025050	PAN HEAD SCREW	2.5x5	FTナベ小ネジ	SEE3053501	
* 135	CX614770	BLIND PLATE		ブラインドプレート	SGD2700401	BL
* 135	CX614780	BLIND PLATE		ブラインドプレート	SGD2700402	T
* 137	VF248800	LED	SLF401C	LED	SEE561001	

* : New Parts (新規部品)

ランク : Japan only

Ref. NO.	PART NO.	Description	部品名	Remarks	Markets	ランク
138	LX604670	CONNECTOR ASS'Y	2P	コネクター付リード線	SEE2716311	
139	XX674490	DUMPER UNIT		ダンパーユニット	SIE9903001	
* 140	CX614790	HOLDER,CASSETTE		カセットホルダー	KGC103823D	BL
* 140	CX614800	HOLDER,CASSETTE		カセットホルダー	SGC2900602	T
142	CX614810	GUIDE R,CASSETTE		カセットガイドR	SGE2900101	
143	CX613820	GUIDE L,CASSETTE		カセットガイドL	SGE2900201	

* : New Parts (新規部品)

ランク : Japan only

REMOTE CONTROL TRANSMITTER

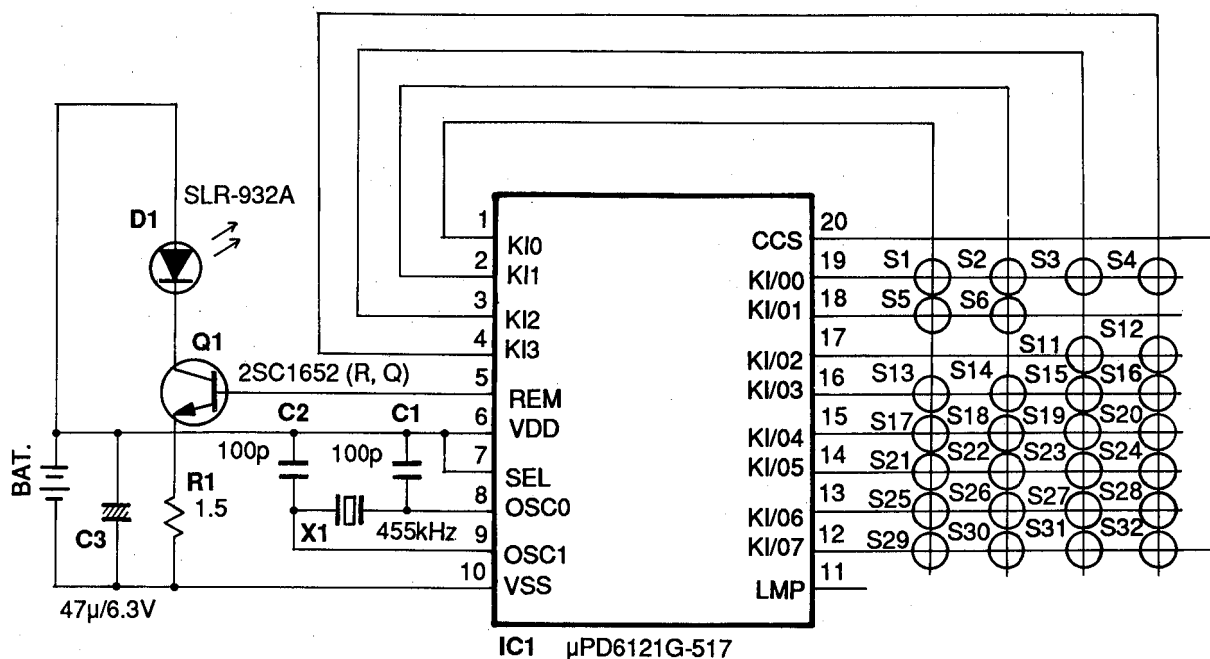

KEY No.

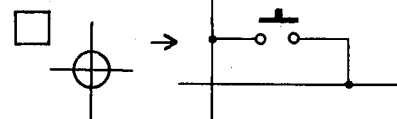

KEY NO.	DATA CODE								FUNCTION
	D0	D1	D2	D3	D4	D5	D6	D7	
1	0	0	0	0	0	0	0	0	PLAY
2	1	0	0	0	0	0	0	0	▶▶
3	0	1	0	0	0	0	0	0	◀◀
4	1	1	0	0	0	0	0	0	STOP
5	0	0	1	0	0	0	0	0	REC/PAUSE
6	1	0	1	0	0	0	0	0	REC MUTE
11	0	1	0	1	0	0	0	0	SEARCH ▶▶
12	1	1	0	1	0	0	0	0	SEARCH ◀◀
13	0	0	1	1	0	0	0	0	TAPE
14	1	0	1	1	0	0	0	0	COUNTER RESET
15	0	1	1	1	0	0	0	0	COUNTER MEMO
16	1	1	1	1	0	0	0	0	MONITOR
17	0	0	0	0	1	0	0	0	0
18	1	0	0	0	1	0	0	0	1
19	0	1	0	0	1	0	0	0	2
20	1	1	0	0	1	0	0	0	3
21	0	0	1	0	1	0	0	0	4
22	1	0	1	0	1	0	0	0	5
23	0	1	1	0	1	0	0	0	6
24	1	1	1	0	1	0	0	0	7
25	0	0	0	1	1	0	0	0	8
26	1	0	0	1	1	0	0	0	9
27	0	1	0	1	1	0	0	0	PROG
28	1	1	0	1	1	0	0	0	CLEAR
29	0	0	1	1	1	0	0	0	RUN
30	1	0	1	1	1	0	0	0	REMAIN
31	0	1	1	1	1	0	0	0	INTRO SCAN ▶
32	1	1	1	1	1	0	0	0	INTRO SCAN ◀
CUSTOM CODE	1	1	1	1	1	1	1	0	

KX-930

Parts List for Carbon Resistor

KX-930

Value	1/4W Type Part No.	1/6W Type Part No.	Value	1/4W Type Part No.	1/6W Type Part No.
1.0 Ω	HJ353100	HF853100	12KΩ	HJ357120	HF857120
1.8 "	HJ353180	*	15 "	HJ357150	HF857150
2.2 "	HJ353220	HF853220	18 "	HJ357180	HF857180
3.3 "	HJ353330	HF853330	22 "	HJ357220	HF857220
4.7 "	HJ353470	HF853470	27 "	HJ357270	HF857270
5.6 "	HJ353560	HF853560	33 "	HJ357330	HF857330
10 "	HJ354100	HF854100	39 "	HJ357390	HF857390
15 "	HJ354150	HF854150	47 "	HJ357470	HF857470
22 "	HJ354220	HF854220	56 "	HJ357560	HF857560
27 "	HJ354270	HF854270	68 "	HJ357680	HF857680
33 "	HJ354330	HF854330	82 "	HJ357820	HF857820
39 "	HJ354390	HF854390	91 "	HJ357910	HF857910
47 "	HJ354470	HF854470	100 "	HJ358100	HF858100
56 "	HJ354560	HF854560	120 "	HJ358120	HF858120
68 "	HJ354680	HF854680	150 "	HJ358150	HF858150
82 "	HJ354820	HF854820	180 "	HJ358180	HF858180
100 "	HJ355100	HF855100	220 "	HJ358220	HF858220
110 "	HJ355110	HF855110	270 "	HJ358270	HF858270
120 "	HJ355120	HF855120	330 "	HJ358330	HF858330
150 "	HJ355150	HF855150	390 "	HJ358390	HF858390
160 "	HJ355160	*	470 "	HJ358470	HF858470
180 "	HJ355180	HF855180	560 "	HJ358560	HF858560
220 "	HJ355220	HF855220	680 "	HJ358680	HF858680
270 "	HJ355270	HF855270	820 "	HJ358820	HF858820
330 "	HJ355330	HF855330	1.0MΩ	HJ359100	HF859100
390 "	HJ355390	HF855390	1.2 "	HJ359120	*
470 "	HJ355470	HF855470	1.5 "	HJ359150	HF859150
510 "	*	HF855510	1.8 "	HJ359180	HF859180
560 "	HJ355560	HF855560	2.2 "	HJ359220	HF859220
680 "	HJ355680	HF855680	3.3 "	HJ359330	HF859330
820 "	HJ355820	HF855820	3.9 "	HJ359390	*
910 "	HJ355910	HF855910	4.7 "	HJ359470	HF859470
1.0KΩ	HJ356100	HF856100			
1.2 "	HJ356120	HF856120			
1.5 "	HJ356150	HF856150			
1.8 "	HJ356180	HF856180			
2.0 "	HJ356200	HF856200			
2.2 "	HJ356220	HF856220			
2.4 "	HJ356240	HF856240			
2.7 "	HJ356270	HF856270			
3.0 "	HJ356300	HF856300			
3.3 "	HJ356330	HF856330			
3.6 "	HJ356360	HF856360			
3.9 "	HJ356390	HF856390			
4.7 "	HJ356470	HF856470			
5.1 "	HJ356510	HF856510			
5.6 "	HJ356560	HF856560			
6.8 "	HJ356680	HF856680			
8.2 "	HJ356820	HF856820			
9.1 "	HJ356910	HF856910			
10 "	HJ357100	HF857100			

