

STEREO POWER AMPLIFIER

M-60

SERVICE MANUAL

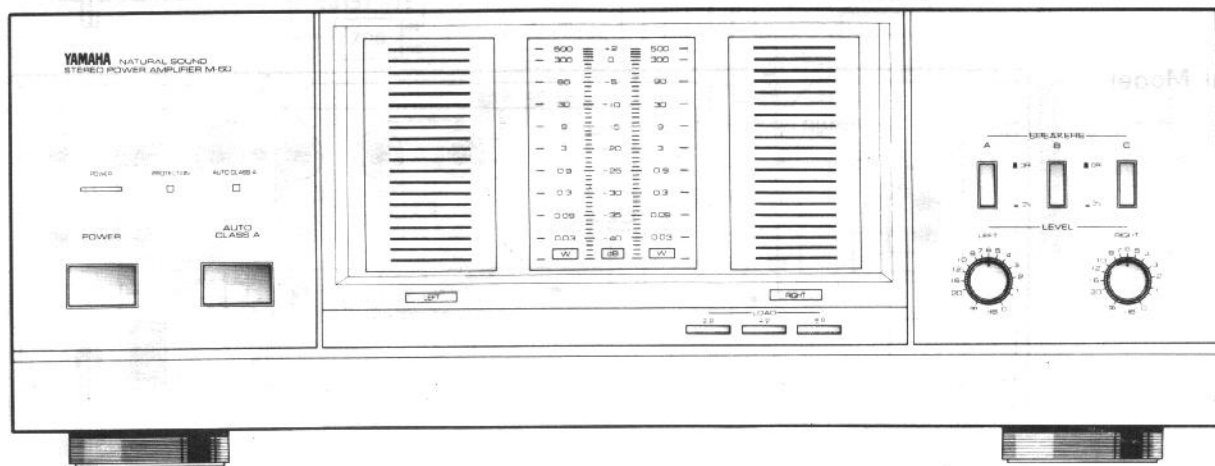

TO SERVICE PERSONNEL

1. Critical Components Information.

Components having special characteristics are marked \triangle and must be replaced with parts having specifications equal to those originally installed.

2. Leakage Current Measurement (For 120V Model Only).

When service has been completed, it is imperative that you verify that all exposed conductive surfaces are properly insulated from supply circuits.

- Meter impedance should be equivalent to 1500 ohm shunted by $0.15\mu\text{F}$.
- Leakage current must not exceed 0.5mA.
- Be sure to test for leakage with AC plug in both polarities.

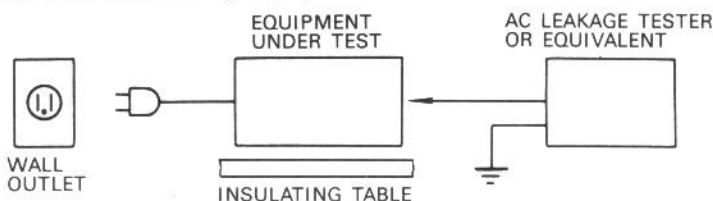

CONTENTS

| | | | |
|--------------------------------|---|---|----|
| REAR PANEL | 1 | P.C. BOARD ~ MAIN | 6 |
| BLOCK DIAGRAM | 2 | SCHEMATIC DIAGRAM ~ MAIN | 8 |
| SPECIFICATIONS | 2 | SCHEMATIC DIAGRAM ~ METER | 9 |
| INTERNAL VIEW | 3 | WIRING DIAGRAM | 9 |
| DISASSEMBLY INSTRUCTIONS | 3 | PARTS LIST ~ ELECTRIC | 10 |
| ADJUSTMENTS | 4 | EXPLODED VIEW ~ MECHANISM/CHASSIS | 14 |
| P.C. BOARD ~ METER | 5 | PARTS LIST ~ MECHANISM/CHASSIS | 16 |

SINCE 1887



YAMAHA

NIPPON GAKKI CO., LTD. HAMAMATSU, JAPAN

2.6K-781 ① Printed in Japan 84.7

PRINTED CIRCUIT BOARD PATTERN SIDE - MAIN CIRCUIT BOARD

INTERNAL VIEW

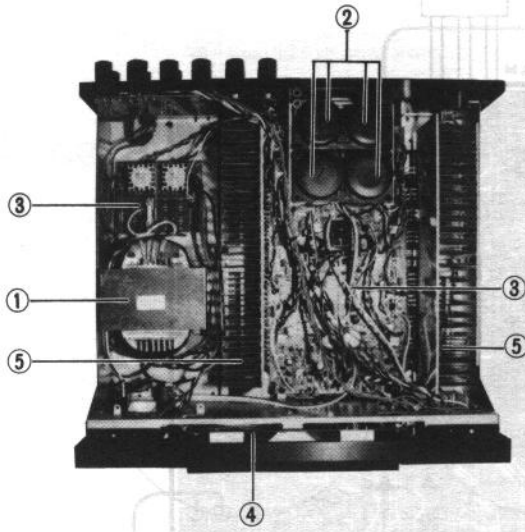

- ① Power Transformer
- ② Electrolytic Cap
- ③ Main P.C.B.
- ④ Meter P.C.B.
- ⑤ Heat Sink

ADJUSTMENTS

Before Adjustments

- Wait 2 minutes after power-ON to stabilize amplifier operation.
- Make sure that the main volume is minimum and set Auto-A switch to OFF.

| Step | Adjustments | Location | Test Equipment | Test point | Value |
|------|-------------------------------|---|---|--|----------|
| 1 | Idling adjustment | VR103(L-ch.) VR104(R-ch.) | D.C. V-meter Digital tester | Across emitter resistor (0.22Ω) of power transistor. R153,R155(L-ch.) R154,R156(R-ch.) | 10.0±1mV |
| 2 | Auto-A operation confirmation | Check that the voltage at each test point stated above increases when Auto-A switch is turned on. | | | 110±10mV |
| 3 | Meter Level adjustment | VR501(L-ch.) VR502(R-ch.) | (1) Set the load level of the meter at 2Ω position. (2) Adjust VR501 and VR502 so that 0dB of the meter lights up when the output is f=1KHz and V=34.5V. | | |

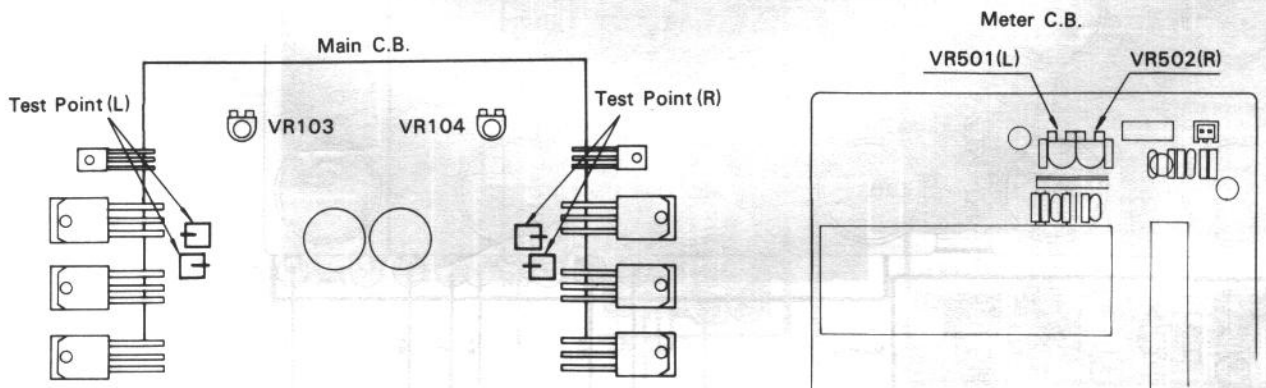

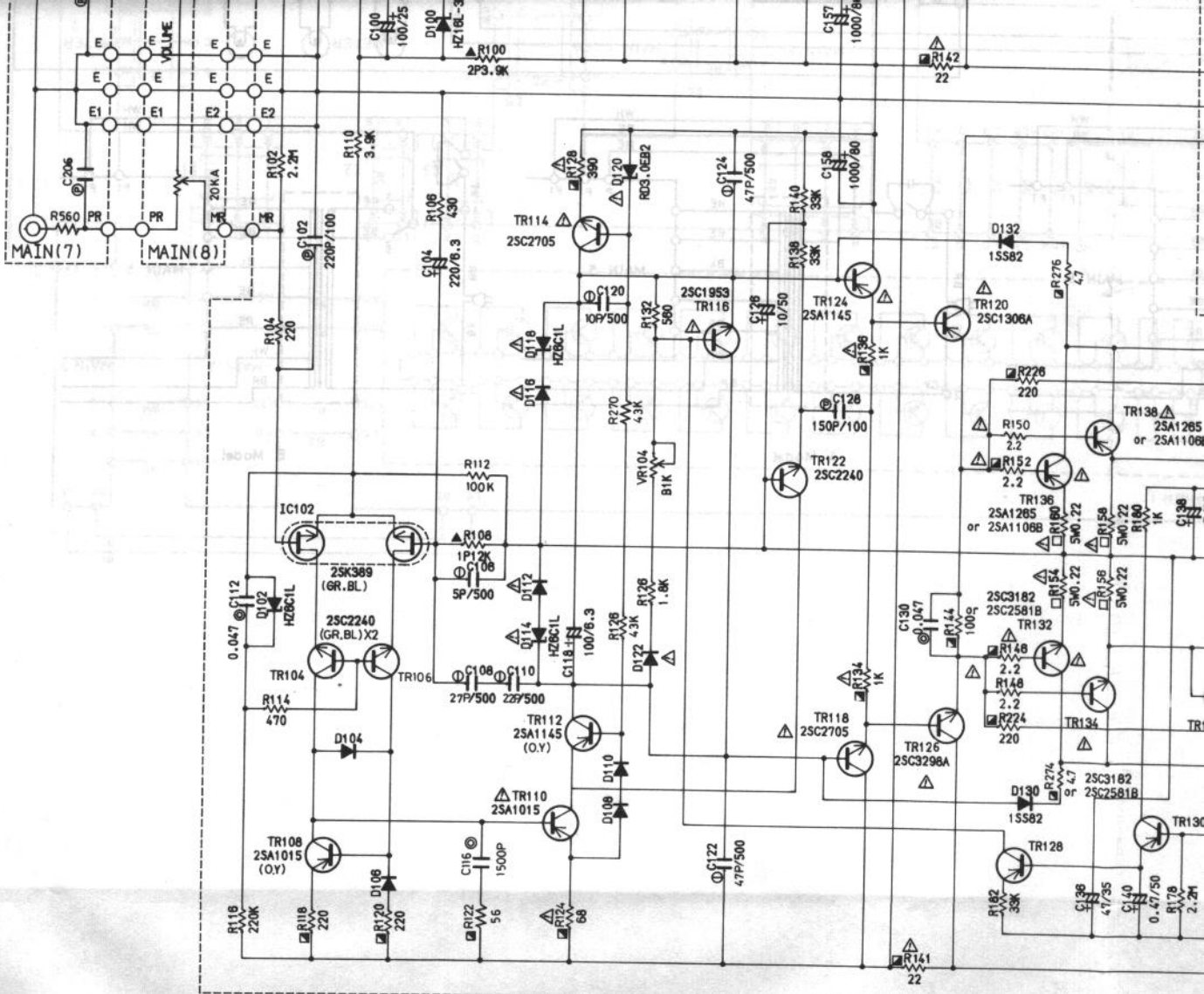



CAPACITOR

| REMARKS | PARTS NAME | |
|---------|------------------------------|---|
| NO MARK | ELECTROLYTIC CAPACITOR | # |
| NO MARK | CERAMIC CAPACITOR | |
| ⊙ | POLYESTEL FILM CAPACITOR | † |
| ○ | POLYSTYRENE FILM CAPACITOR | |
| ⊖ | MICA CAPACITOR | |
| ⊕ | POLYPROPYLENE FILM CAPACITOR | |

RESISTOR

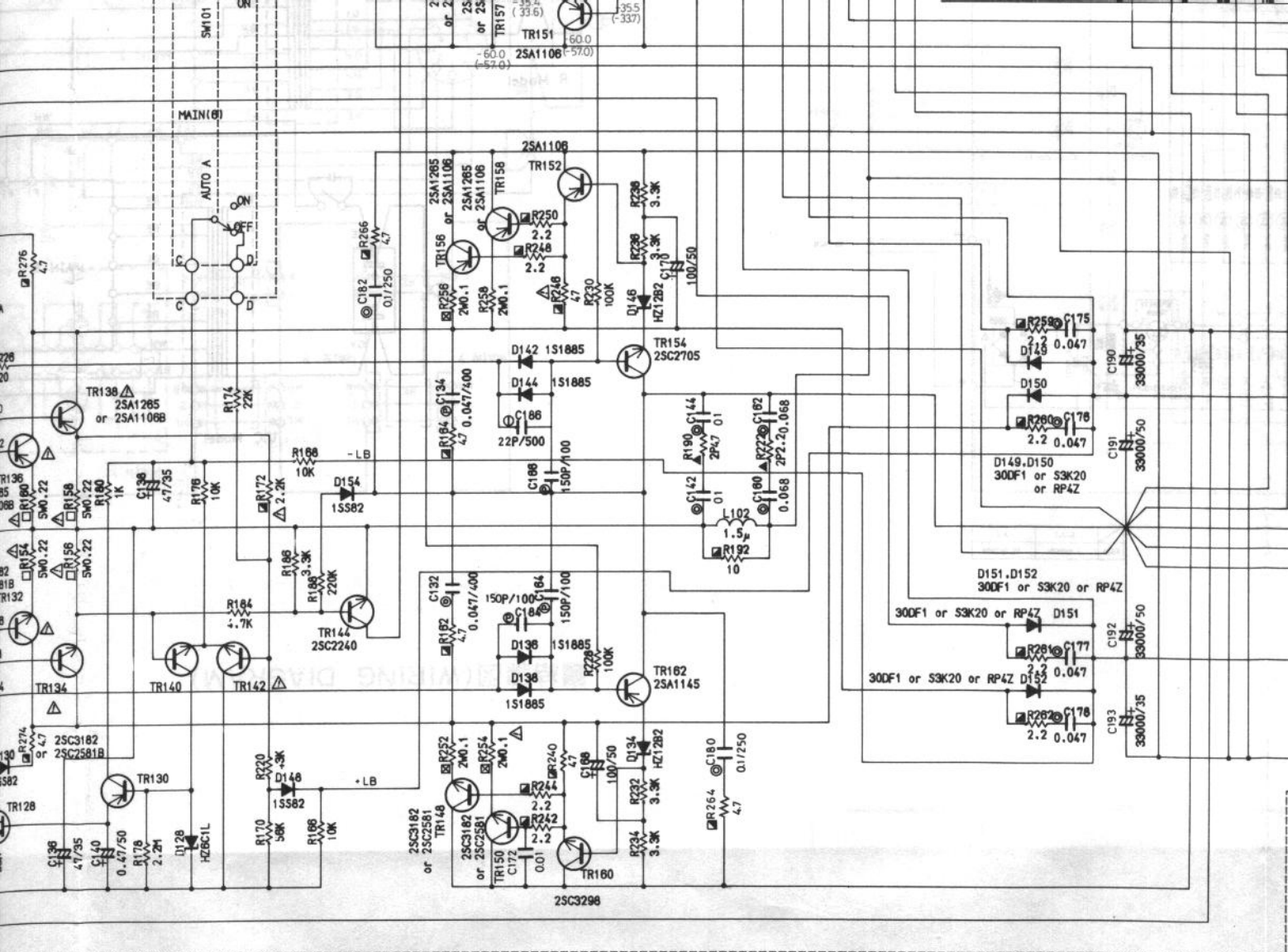
| REMARKS | PARTS NAME |
|---------|---------------------------------|
| NO MARK | CARBON FILM RESISTOR |
| △ | METAL OXIDE FILM RESISTOR |
| ▲ | METAL FILM RESISTOR |
| ⊠ | METAL PLATE RESISTOR |
| ⊞ | FIRE PROOF CARBON FILM RESISTOR |
| ⊗ | SEMI VARIABLE RESISTOR |

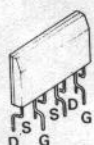
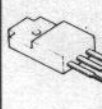
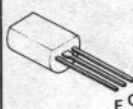
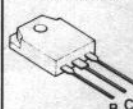
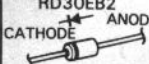
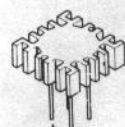
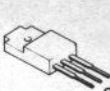

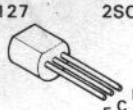
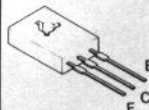
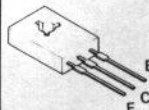
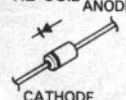
| | | | | | |
|--|--|--|--|--|---|
| <p>2SK389</p>  | <p>2SD1273</p>  | <p>2SB560</p>  | <p>2SA1265 2SC2581 2SC3182</p>  | <p>1S1555 1S1885 1S2473 30DF1 RP4Z RD30EB2</p>  | <p>D5FB20 1134B41</p>  |
| <p>2SA1306 2SC3289</p>  | <p>2SA1145 2SC2705</p>  | <p>2SA970 2SA1015 2SA1115 2SA1127</p>  | <p>2SB1815 2SC2240 2SC2603 2SC2634</p>  | <p>2SC1953 2SC3298</p>  | <p>HZ24-2 HZ16-3L HZ12-B2 HZ-6CIL</p>  |

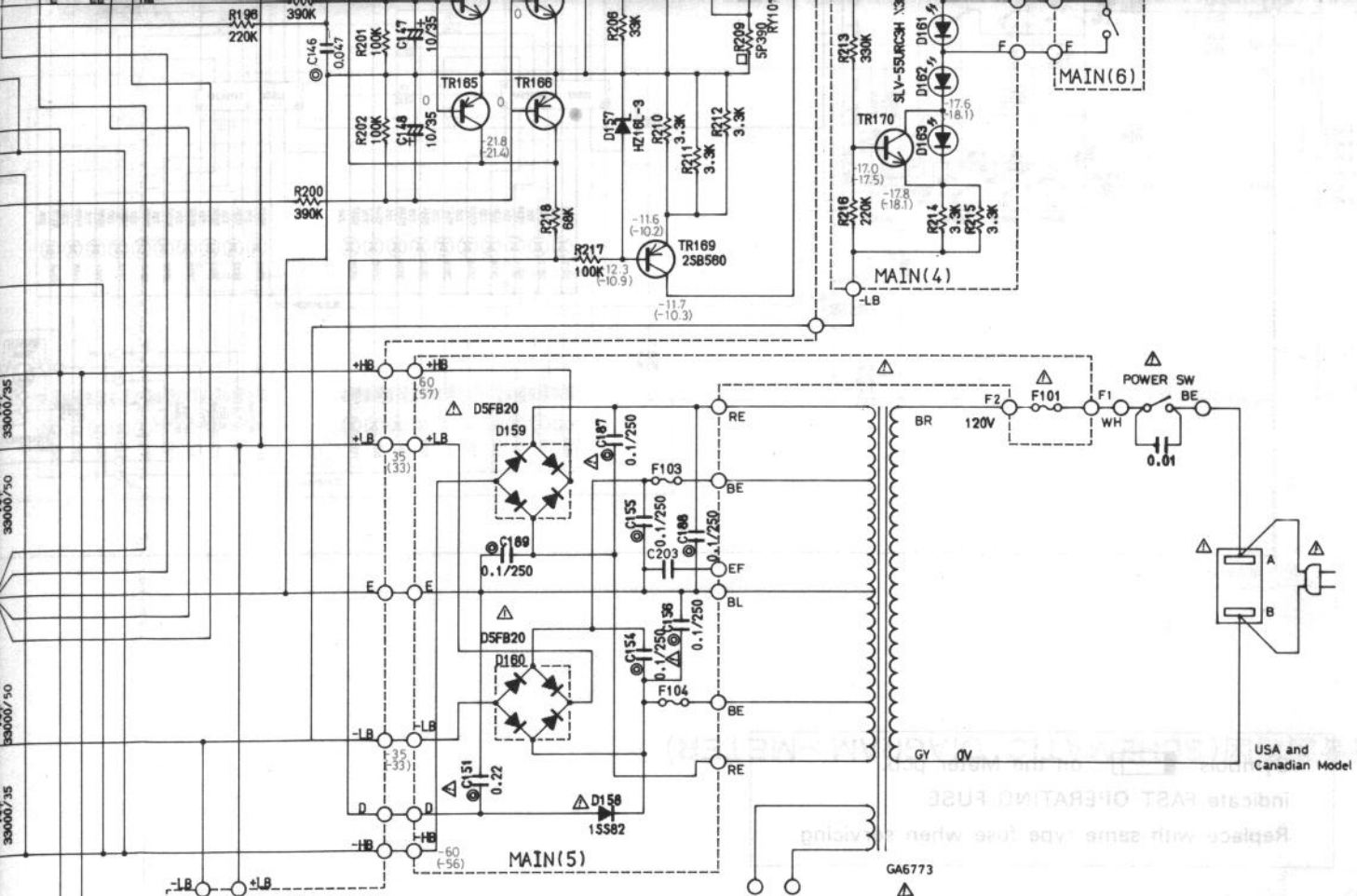

| AC IN | CONNECT (Terminal No.) | |
|-------|------------------------|-----|
| 100V | 5-4 | 2-1 |
| 120V | 6-5 | 3-2 |
| 220V | 7-1 | 8-4 |
| 240V | 7-6 | 8-3 |

(7-8) ... Ext. short

| | U.C | R | A.E |
|------------|---------|-----------|-------------|
| C154 | 0.1/250 | 0.1/250 | OPEN |
| C155 | OPEN | OPEN | 0.1/250 |
| C156 | OPEN | OPEN | 0.1/250 |
| C187 | 0.1/250 | 0.1/250 | OPEN |
| C188 | OPEN | OPEN | 0.1/250 |
| C189 | OPEN | OPEN | 0.1/250 |
| F101 | 15A250V | 15A250V | T8.3A250V |
| F102 | | T7.0A250V | |
| F103 | | | T8.3A250V |
| F104 | | | T8.3A250V |
| C201 - 203 | OPEN | OPEN | 0.01 |
| C195 - 200 | OPEN | OPEN | 2700P / 100 |

TO METER



to Meter PCB

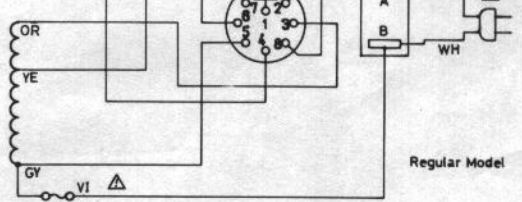
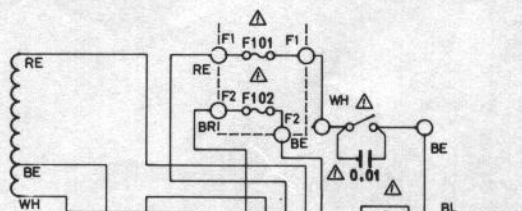
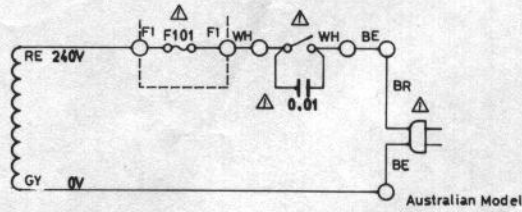
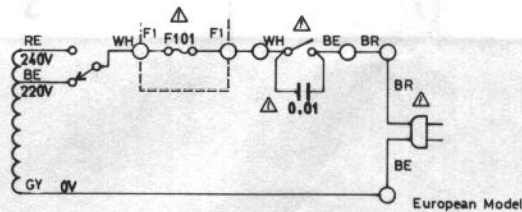

■総合回路図(SCHEMATIC DIAGRAM~MAIN)

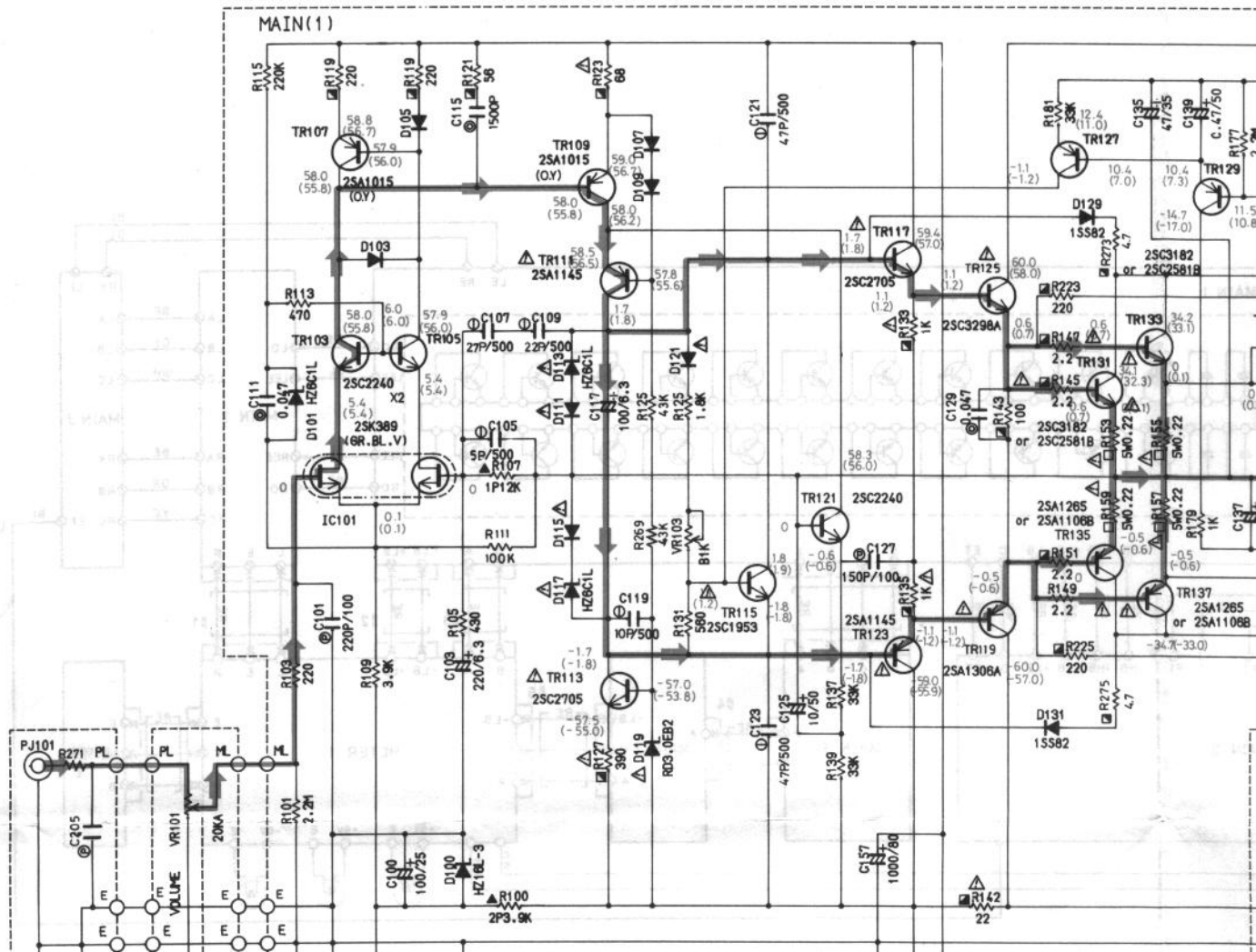

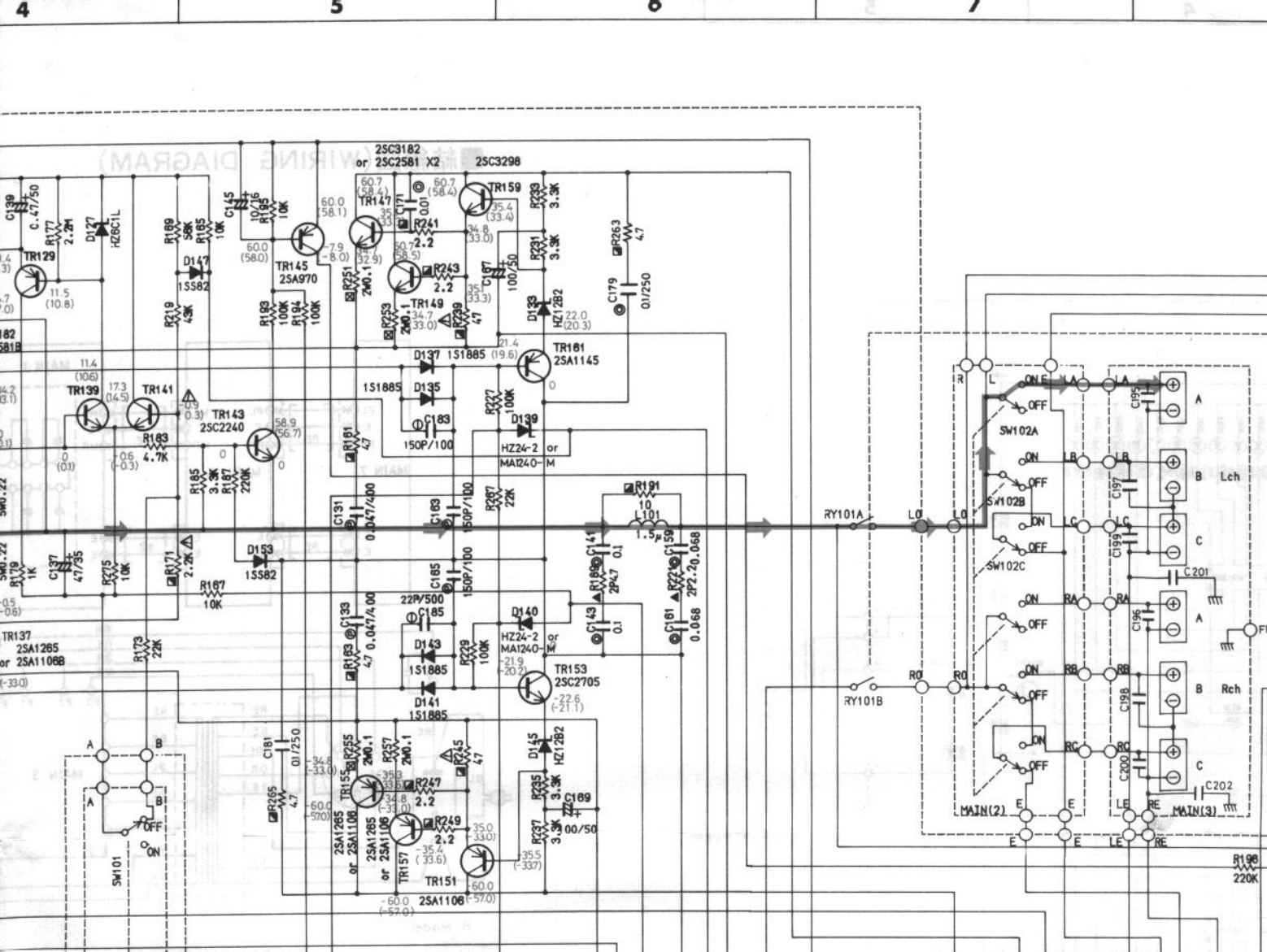

■ WARNING

Components having special characteristics are Marked  and must be replaced with parts having specifications equal to those originally installed.

- All voltage are measured with a 10M Ω /V DC electric volt meter.
- Schematic diagram is subject to change without notice.

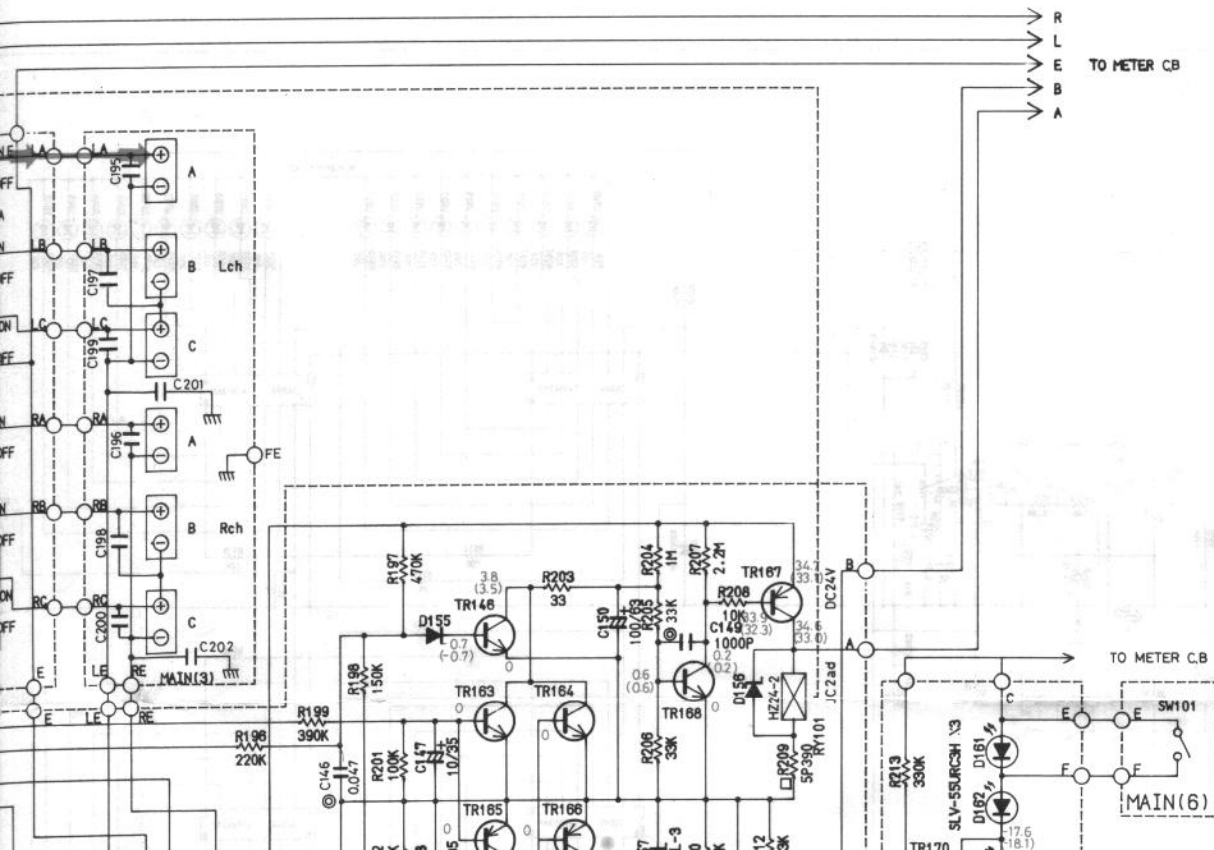

- Confirmation of the voltage switching operation.
 Terminals output : $f=1\text{KHz}$ 100W (load is 8Ω).
 Check that the wave form at $\pm\text{LP}$ and $\pm\text{RP}$
 terminals changes as shown below.

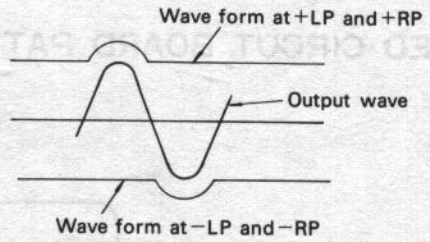

A B C D

PRINTED CIRCUIT BOARD PATTERN SIDE ~ METER CIRCUIT BOARD

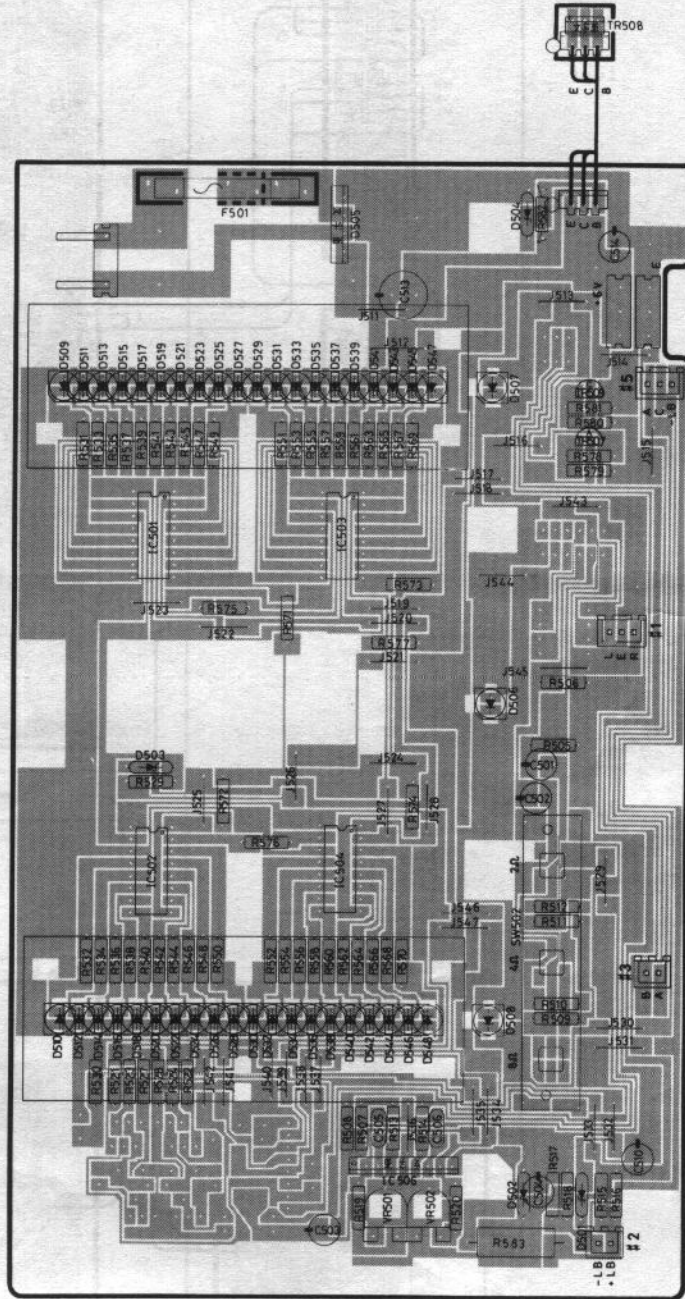

CSA

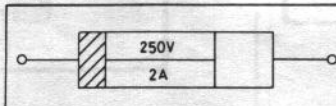

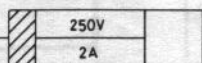
Symbols  on the Meter pcb indicate FAST OPERATING FUSE.

Replace with same type fuse when revicing.

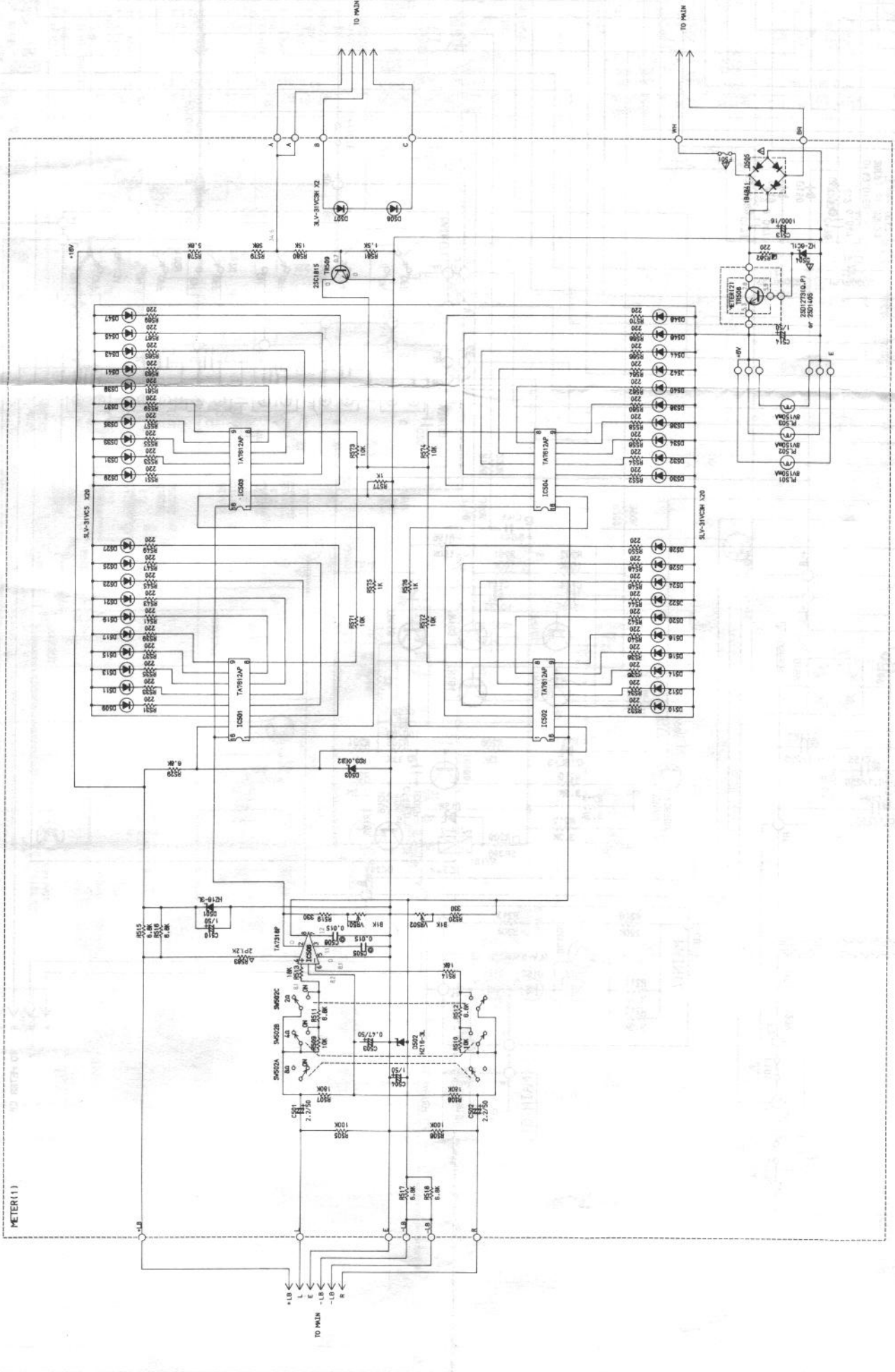

| | | | |
|-----|----------|-------------|-------------|
| REV | DATE | BY | CHKD |
| 1 | 10/10/00 | J. B. BROWN | T. J. BROWN |
| 2 | 10/10/00 | J. B. BROWN | T. J. BROWN |

PRINTED CIRCUIT BOARD PATTERN SIDE ~ MAIN CIRCUIT BOARD

1
2
3
4
5
6
6

Left
Level
Right
Input
Auto A
#4
Speakers
A
B
C

