

STEREO POWER AMPLIFIER

M-65

SERVICE MANUAL

FRONT PANEL

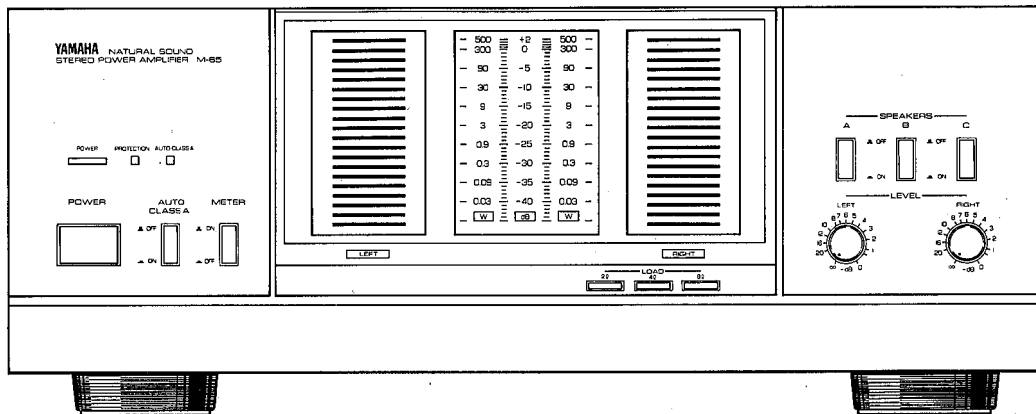

IMPORTANT NOTICE

This manual has been provided for the use of authorized Yamaha Retailers and their service personnel. It has been assumed that basic service procedures inherent to the industry, and more specifically Yamaha Products, are already known and understood by the users, and have therefore not been restated.

WARNING: Failure to follow appropriate service and safety procedures when servicing this product may result in personal injury, destruction of expensive components and failure of the product to perform as specified. For these reasons, we advise all Yamaha product owners that all service required should be performed by an authorized Yamaha Retailer or the appointed service representative.

IMPORTANT: The presentation or sale of this manual to any individual or firm does not constitute authorization, certification, recognition of any applicable technical capabilities, or establish a principle-agent relationship of any form.

The data provided is believed to be accurate and applicable to the unit(s) indicated on the cover. The research, engineering, and service departments of Yamaha are continually striving to improve Yamaha products. Modifications are, therefore, inevitable and specifications are subject to change without notice or obligation to retrofit. Should any discrepancy appear to exist, please contact the distributor's Service Division.

WARNING: Static discharges can destroy expensive components. Discharge any static electricity your body may have accumulated by grounding yourself to the ground buss in the unit (heavy gauge black wires connect to this buss).

IMPORTANT: Turn the unit OFF during disassembly and parts replacement. Recheck all work before you apply power to the unit.

CONTENTS

TO SERVICE PERSONNEL	1	ADJUSTMENT	5
SPECIFICATION	1	ADJUSTMENT POINTS	5
DIMENSIONS	1	WIRING ..	
REAR PANELS	2	PRINTED CIRCUIT BOARD (Pattern Side)	7~12
INTERNAL VIEW	3	IC BLOCK DIAGRAM	13
DISASSEMBLY PROCEDURE	3	SCHEMATIC DIAGRAM	14, 15
BLOCK DIAGRAM	4	PARTS LIST	16~23



■ TO SERVICE PERSONNEL

1. Critical Components Information.
Components having special characteristics are marked Δ and must be replaced with parts having specifications equal to those originally installed.
2. Leakage Current Measurement (For 120V Model Only).
When service has been completed, it is imperative that you verify that all exposed conductive surfaces are properly insulated from supply circuits.
 - Meter impedance should be equivalent to 1500 ohm shunted by 0.15 μ F.
 - Leakage current must not exceed 0.5mA.
 - Be sure to test for leakage with the AC plug in both polarities.

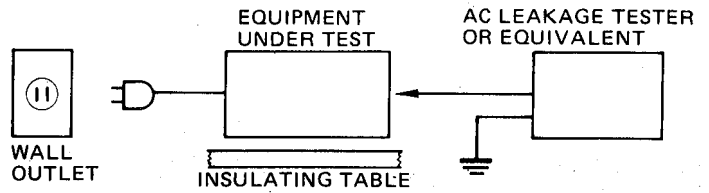

■ SPECIFICATIONS

● AUDIO SECTION

Minimum RMS Output Power Per Output Power Per Channel	
20 Hz ~ 20 kHz	
0.003% THD 8 ohms	170 W
0.007% 6 ohms	195 W
0.02% 4 ohms	230 W
Dynamic Power Per Channel	
8 ohms	255 W
6 ohms	315 W
4 ohms	380 W
2 ohms	450 W
DIN Standard Output Power Per Channel	
1 kHz (1% THD 4 ohms)	245 W (A.G.B.)
Dynamic Headroom	
8 ohms	1.76 dB (R.U.C.)
6 ohms	2.08 dB (R.U.C.)
4 ohms	2.18 dB (R.U.C.)
IEC Power	
1 kHz (0.01% THD) 8 ohms	185 W (A.G.B.)
6 ohms	220 W (A.G.B.)
4 ohms	250 W (A.G.B.)
Power Band Width	
8 ohms	10 kHz ~ 60 kHz
Damping Factor	
1 kHz 8 ohms	130 W
Input Sensitivity/Impedance	
MAIN IN	1.28 V/20 k Ω
Frequency Response	
MAIN IN	+0, -0.3 dB
Total Harmonic Distortion	
AUX/TAPE/TUNER (8 Ω)	
MAIN IN (85 W/8 Ω)	0.002%
Intermodulation Distortion	
AUX/TAPE/TUNER (8 ohms)	0.003%
Signal to Noise Ratio (IHF-A-Network)	
MAIN IN (Shorted)	127 dB
MAIN IN (5.1 k ohms terminated)	120 dB
Residual Noise (IHF-A-Network)	
	16 μ V
Channel Separation (Vol-30 dB)	
AUX/TAPE (1 kHz/10 kHz)	89 dB/70 dB
Power Supply	
	AC 120 V, 60 Hz (U.C.)
	AC 110/120/220/240V, 60/50 Hz (R)
Power Consumption	
	520 W, 680 VAW (U)
	650 W, 800 VAW (C)
	520 W (R)
	1150 W (A.G.B.)

AC Outlet	200 W (max)
Dimensions (W x H x D)	435 x 165 x 425 mm (17-1/8" x (6-1/2") x (16-3/4")
Weight	15 kg (33 lbs) (1.6 oz)

* Specifications subject to change without notice.

- (U) U.S.A. model
- (C) Canadian model
- (A) Australian model
- (G) European model
- (B) British model
- (R) Others model

■ DIMENSIONS

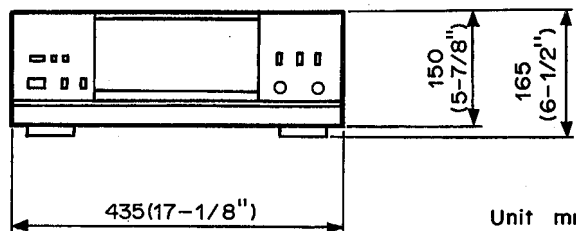
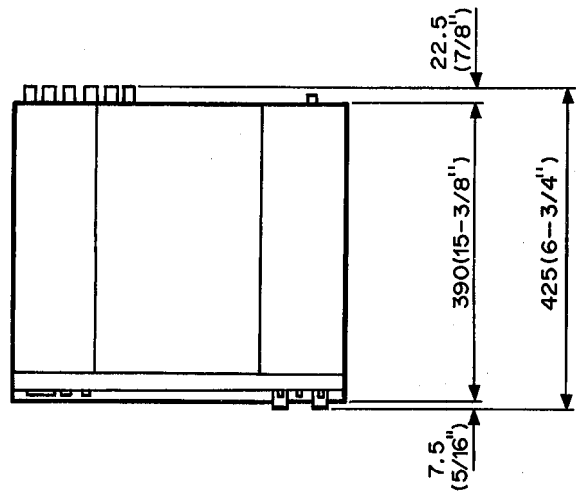

Unit mm (Inch)

■ REAR PANELS

● U.S.A. & Canadian models

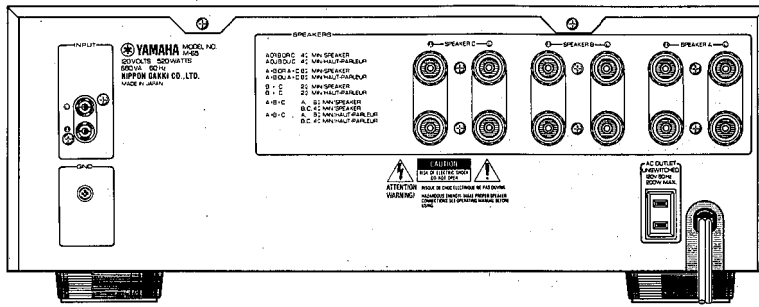

● European & British models

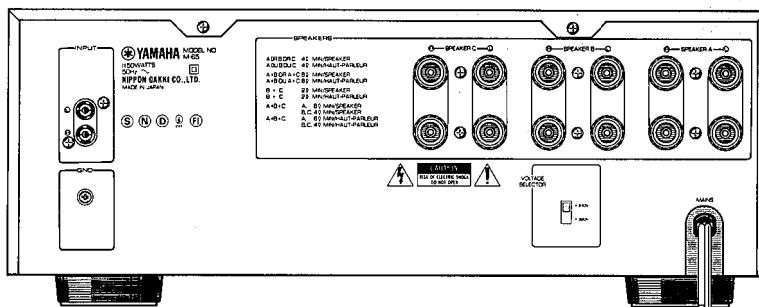

● Australian model

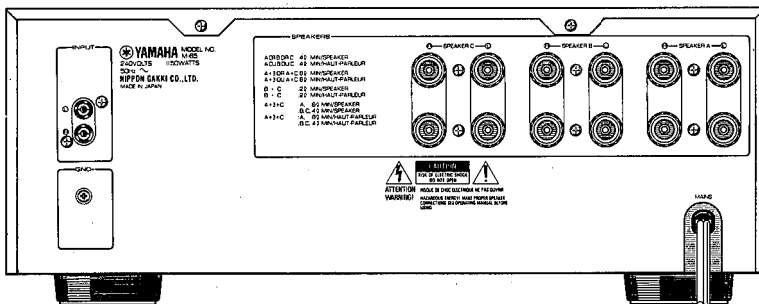

● Others model

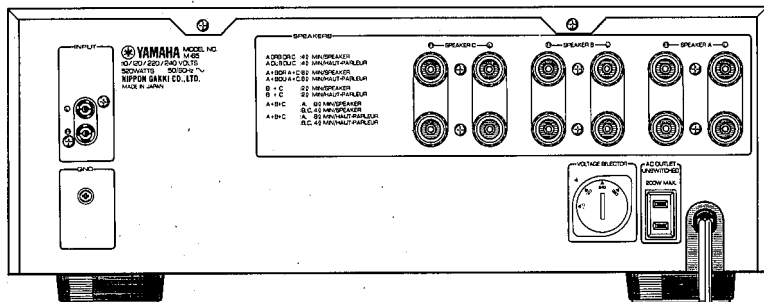

■ INTERNAL VIEW

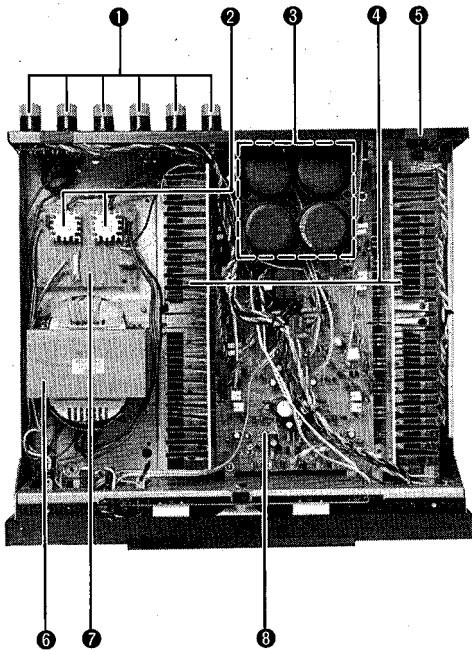

- ① SPEAKERS TERMINAL
- ② DIODE BRIDGE
- ③ ELECTROLYTIC CAP.
- ④ HEAT SINK
- ⑤ AC OUTLET
- ⑥ POWER TRANSFORMER
- ⑦ METER CIRCUIT BOARD
- ⑧ MAIN CIRCUIT BOARD

■ DISASSEMBLY PROCEDURES

1. Removal of Top Cover.
 - a. Remove 6 screws (①) in Fig. 1. and slide the Top Cover back.
2. Removal of Rear Panel.
 - a. Remove 16 screws (②) in Fig. 1.
3. Removal of Front Panel.
 - a. Remove 5 screws (③) in Fig. 1.
4. Removal of Bottom Cover.
 - a. Remove 6 screws (④) in Fig. 1. and Heat seat Removal.

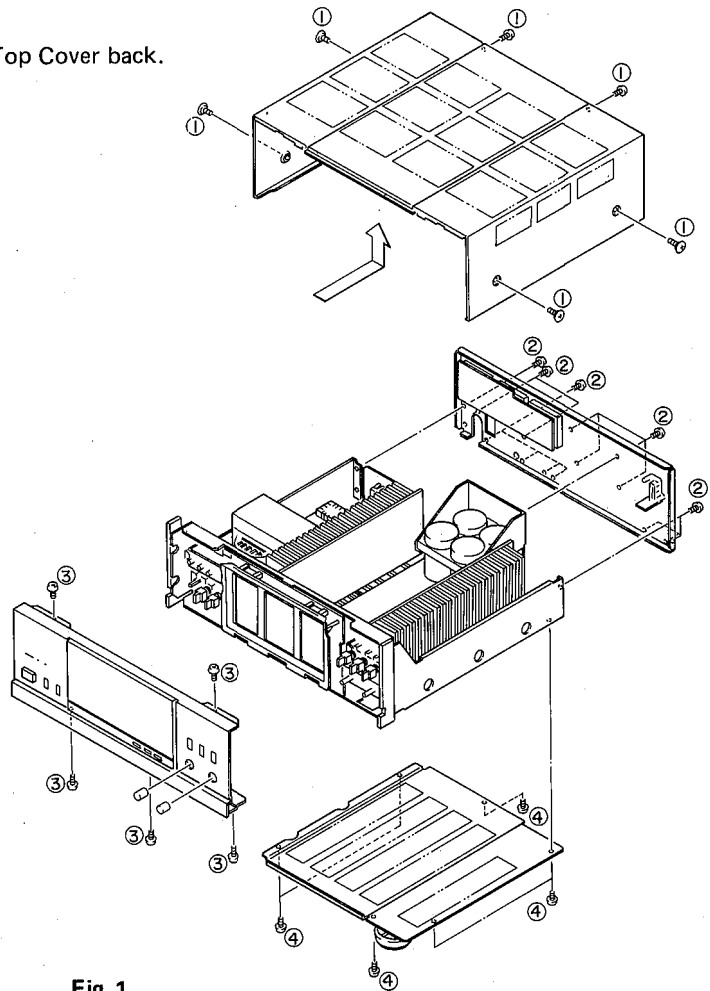
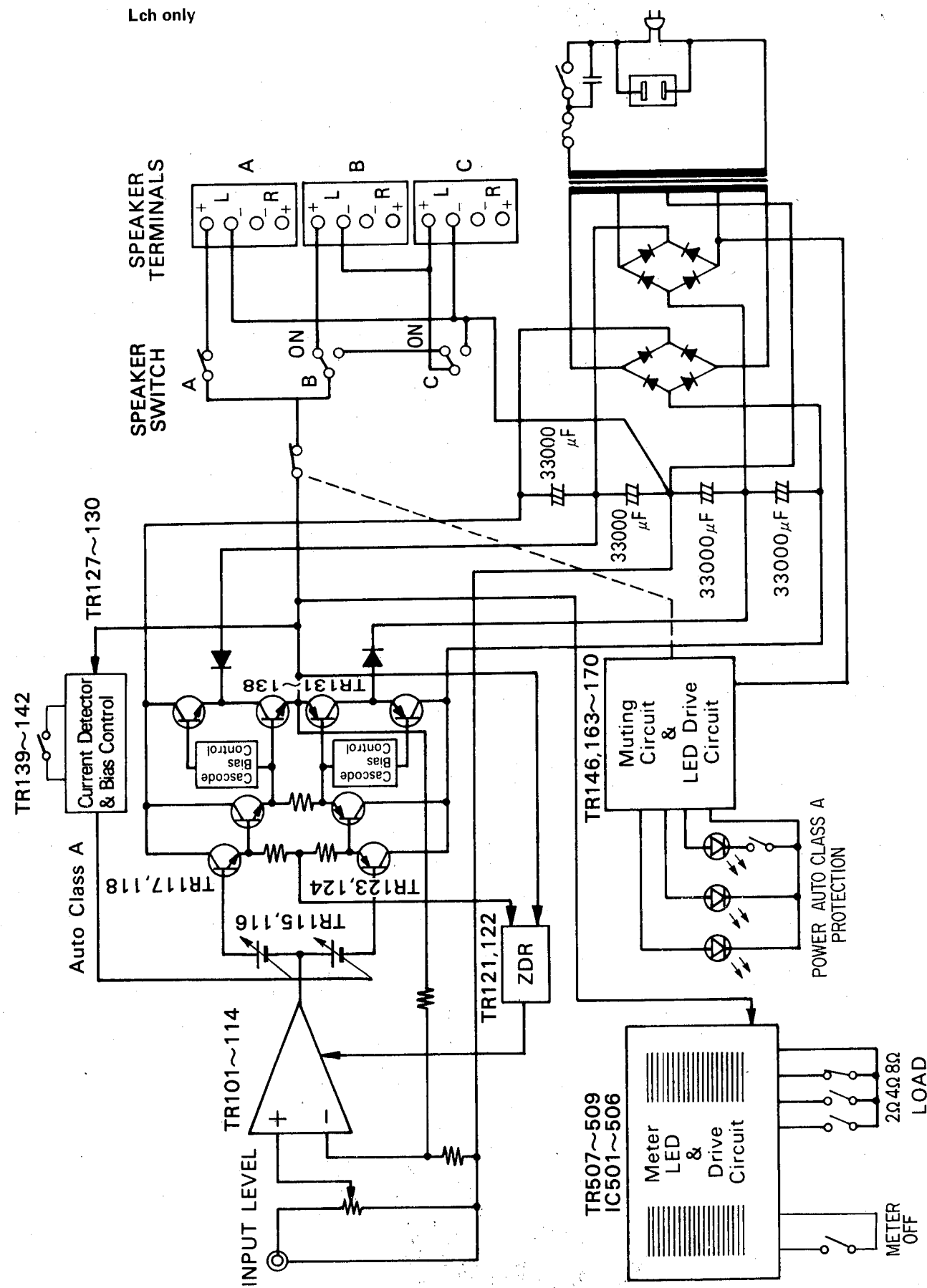

Fig. 1

■ BLOCK DIAGRAM



■ ADJUSTMENTS

No.	Item	Condition/Procedure	Check point	Adjustment/Confirmation	Reference
1	Idling adjustment	Before adjustment, leave M-65 about 2 minutes with: (a) Power switch: ON (b) Auto-Class switch: OFF (c) NO signal input	Voltage across R153, R155 -Lch R154, R156 -Rch	VR103 VR104	Adjust to 10 mV ± 1 mV DC R153-156: Emitter resistors of the power transistors (0.22 Ω)
2	Confirmation of Auto-Class A function	Auto-Class A switch: OFF → ON	Same as above	-	Confirmation increase of voltage more than 20 mV DC
3	Meter level adjustment	Meter load selector: 2 Ω Amplifier load: NO load or 8 Ω Signal freq.: 1 kHz			
		Speaker output voltage: 28.3 V	0 dB - LED	VR 501 (L) VR 502 (R)	Adjust to the lights up point
		Reduce the signal level 1 dB (to 25.2 V)		-	Confirm the 0 dB - LED fades out

■ ADJUSTMENT POINTS

MAIN P.C.B

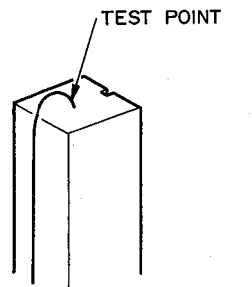
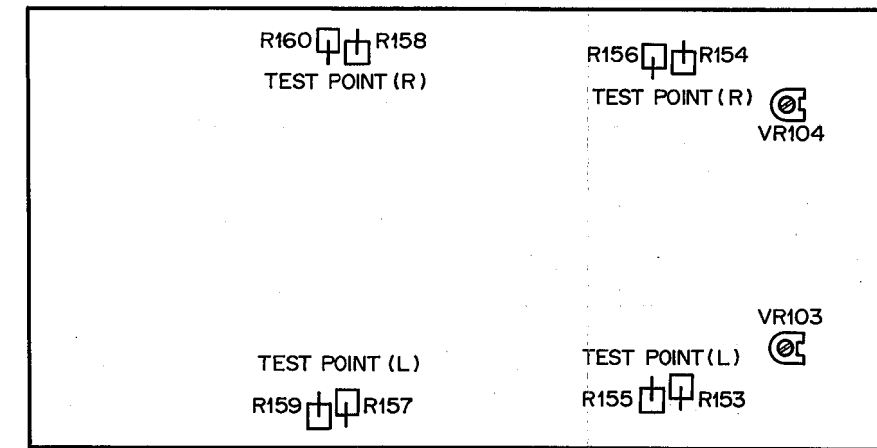

METER P.C.B

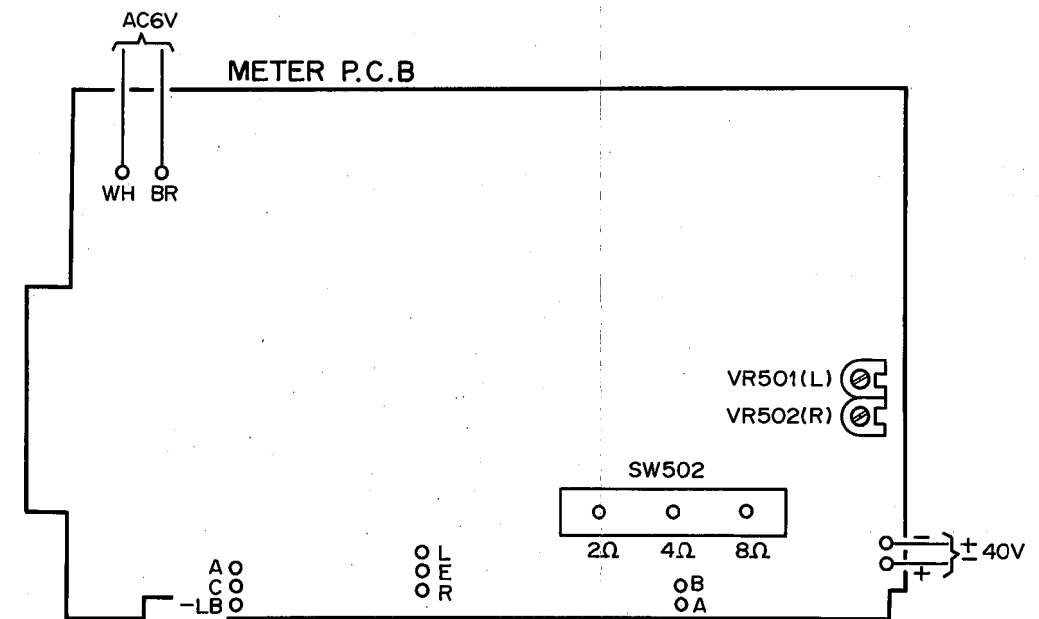

WIRING

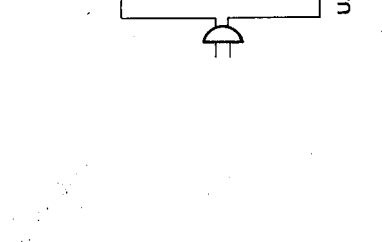
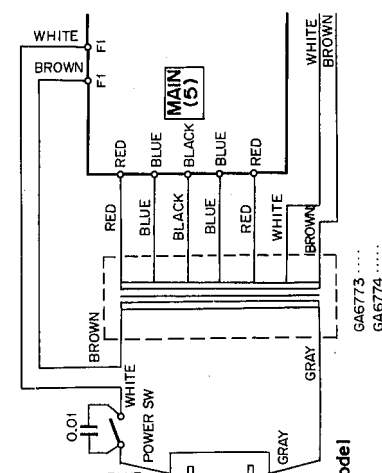
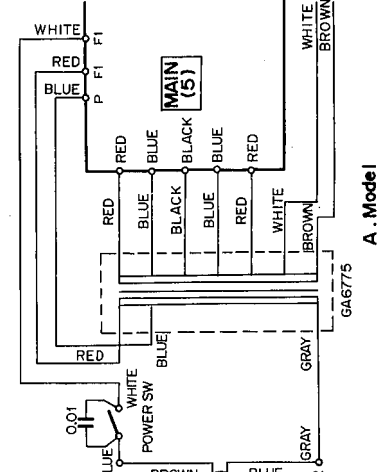
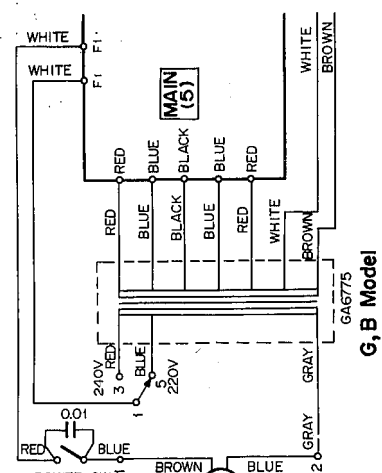
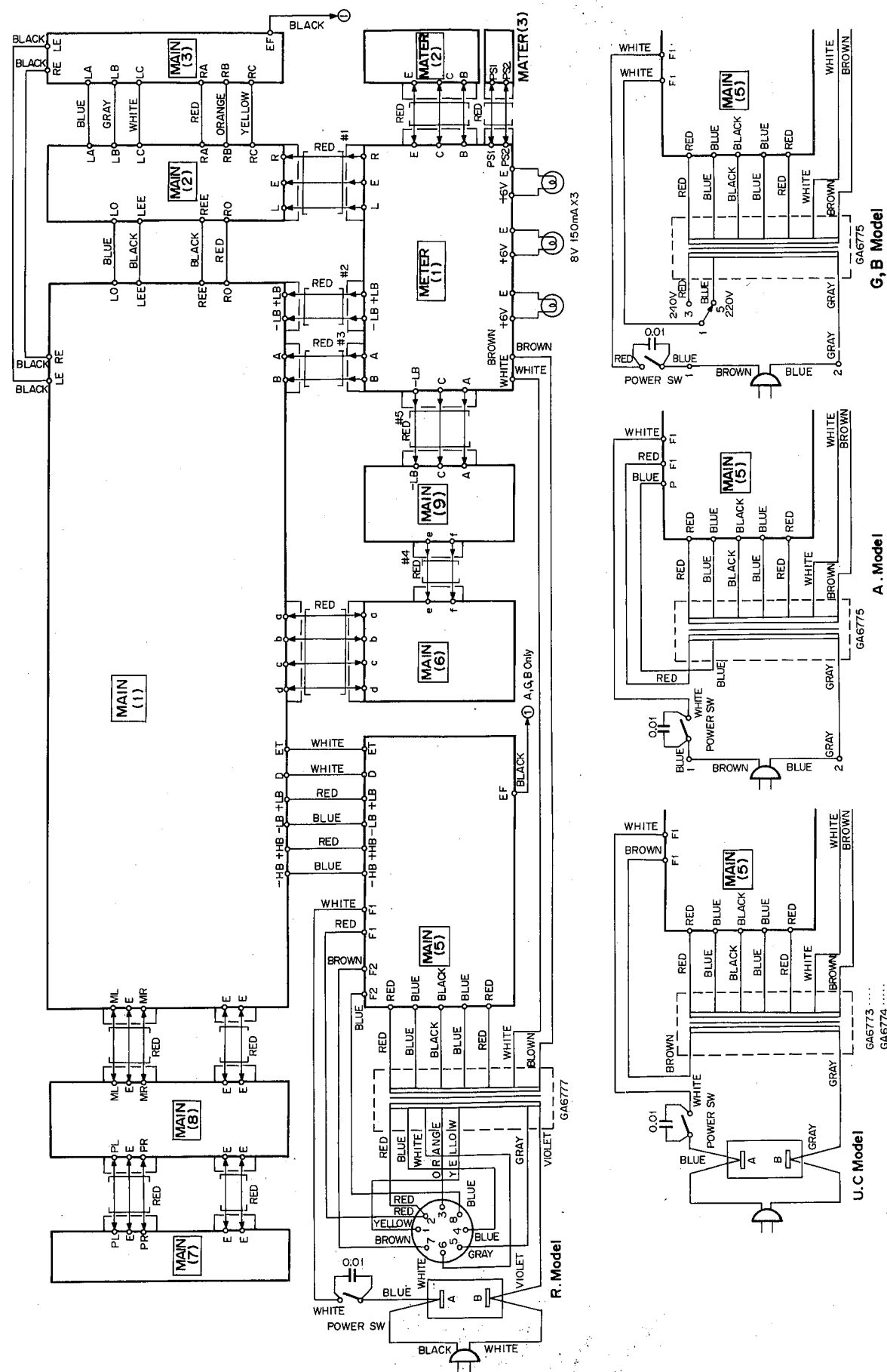

PRINTED CIRCUIT BOARD (Pattern Side)

Note
文字面 : Component Side

1
2
3
4
5
6
7

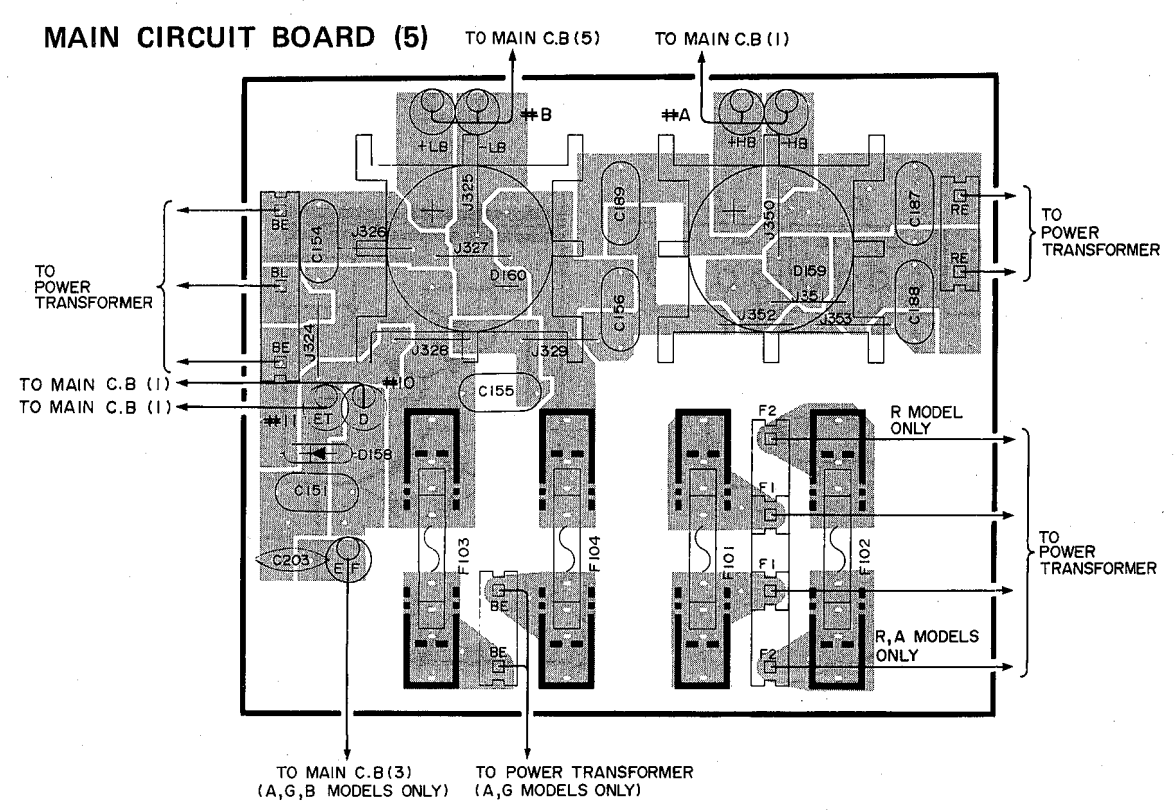

MAIN CIRCUIT BOARD (2)

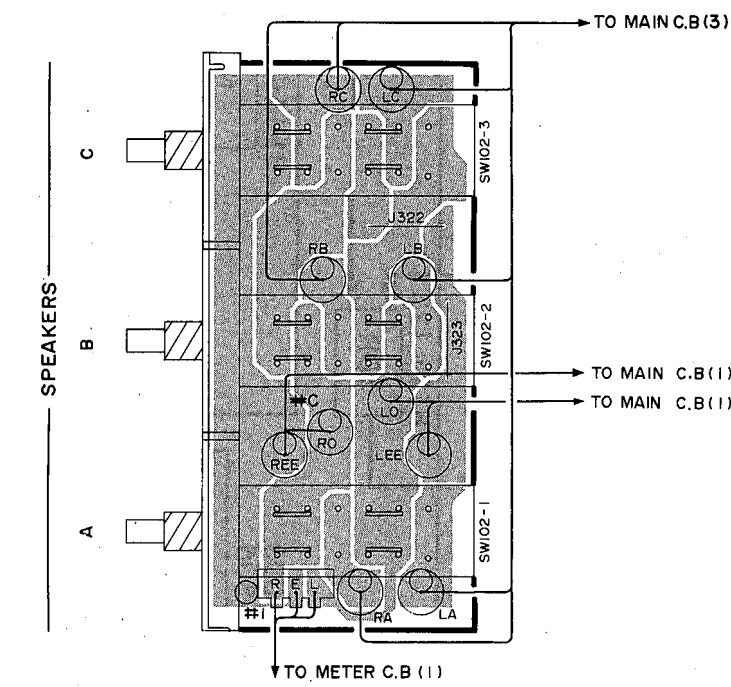

■ PRINTED CIRCUIT BOARD (Pattern Side) Note
文字面 : Component Side

MAIN CIRCUIT BOARD (1)

MAIN CIRCUIT BOARD (8)

MAIN CIRCUIT BOARD (7)

MAIN CIRCUIT BOARD (6)

1
2
3
4
5
6
7

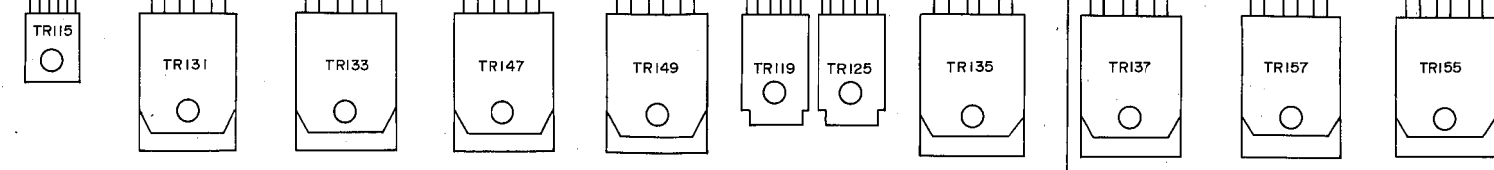
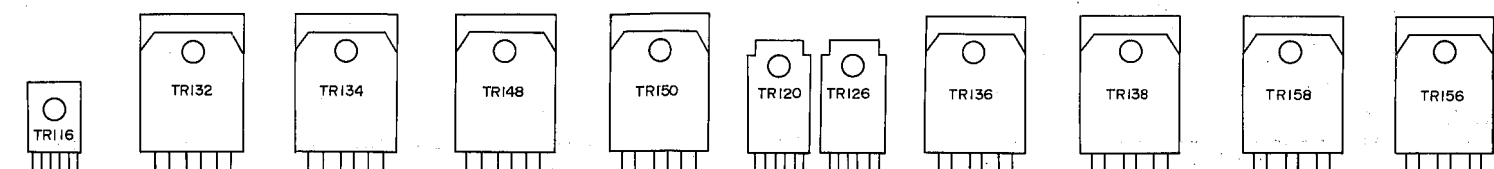
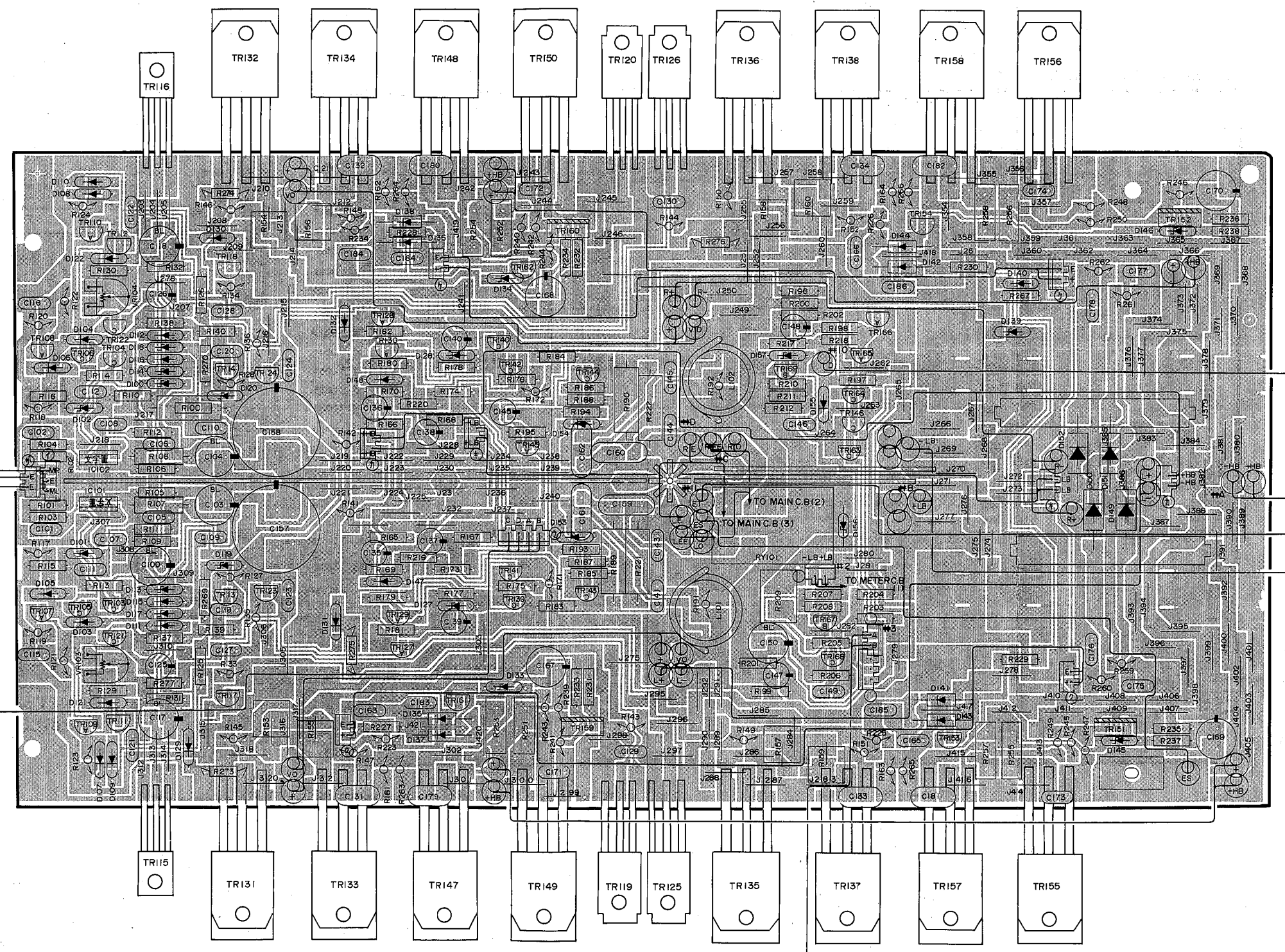
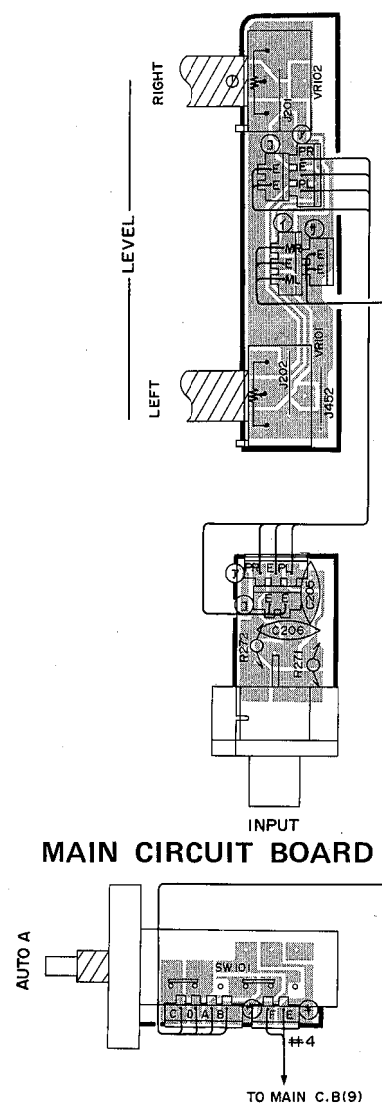

TO MAIN C.B (5)
TO MAIN C.B (5)
TO MAIN C.B (5)
TO MAIN C.B (5)
TO METER C.B (1)

A

B

C

D

E

F

G

H

I

M-65

PRINTED CIRCUIT BOARD (Pattern Side)

Note) 文字面: Component Side

1

2

3

4

5

6

7

10

METER CIRCUIT BOARD (1)

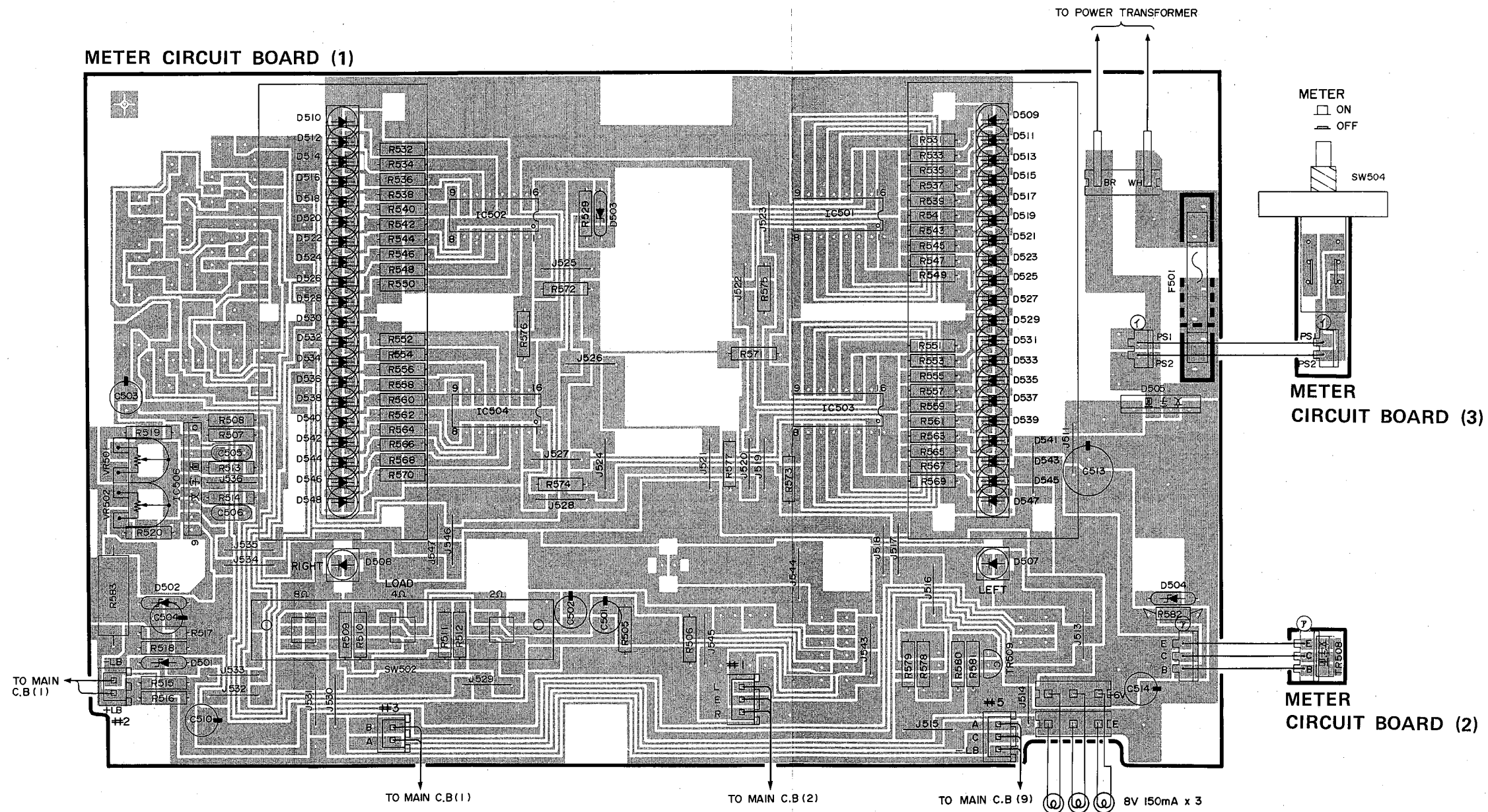

■ PRINTED CIRCUIT BOARD (Pattern Side) Note)
 文字面 : Component Side

1

MAIN CIRCUIT BOARD (3)

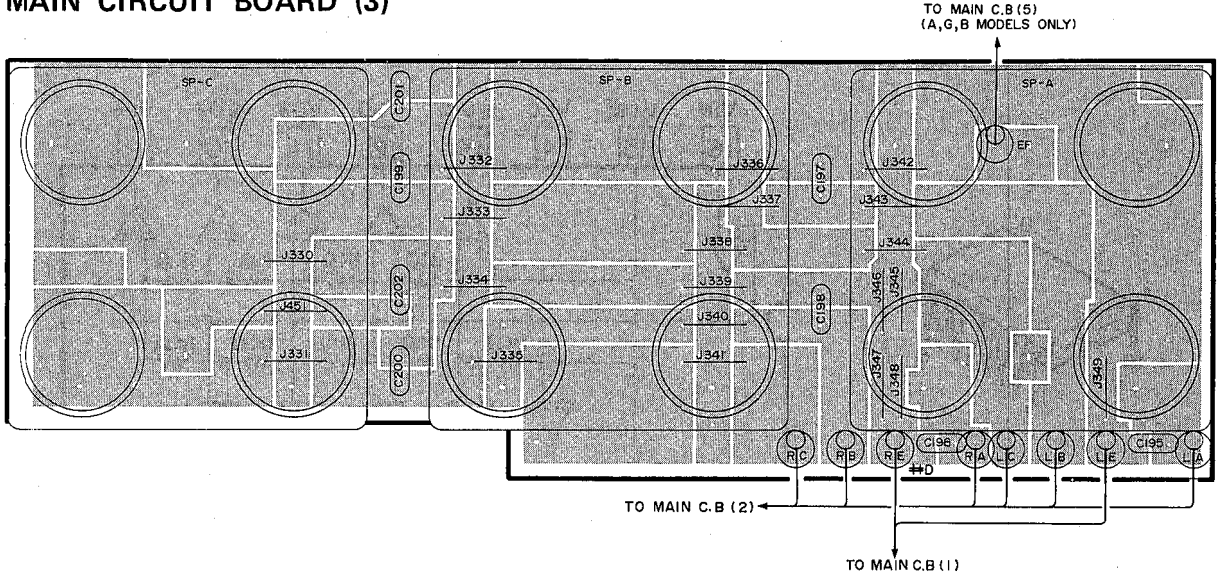

3

MAIN CIRCUIT BOARD (9)

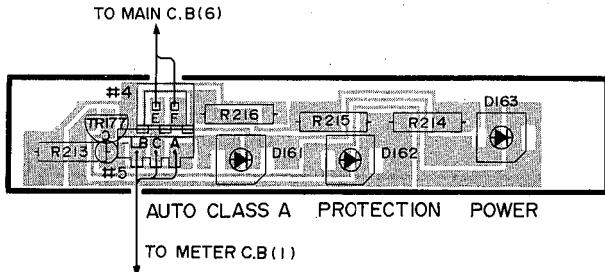

4

5

6

7

■ IC BLOCK DIAGRAM

IC501 ~ 504
TA7612AP

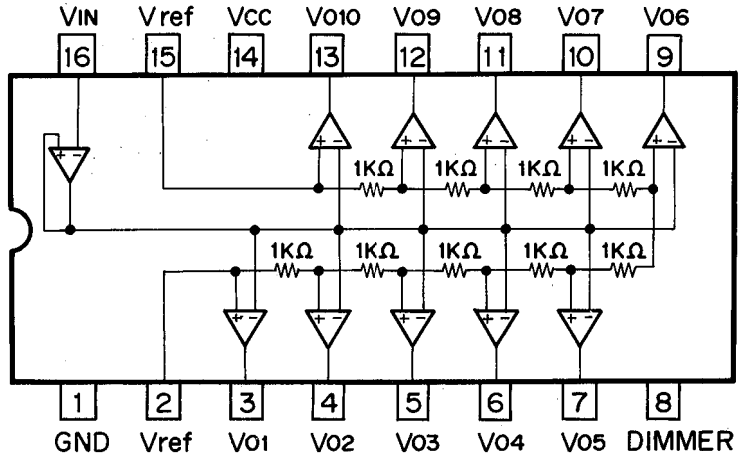
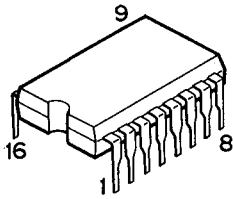

IC506
TA7318P

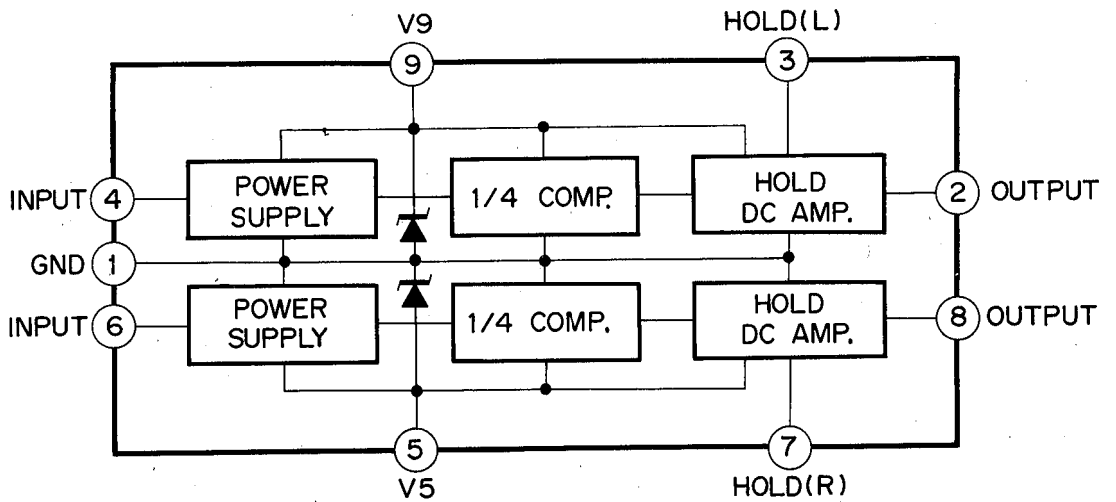
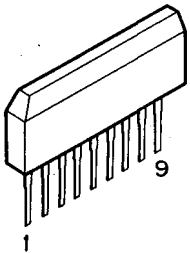

■ SCHEMATIC DIAGRAM

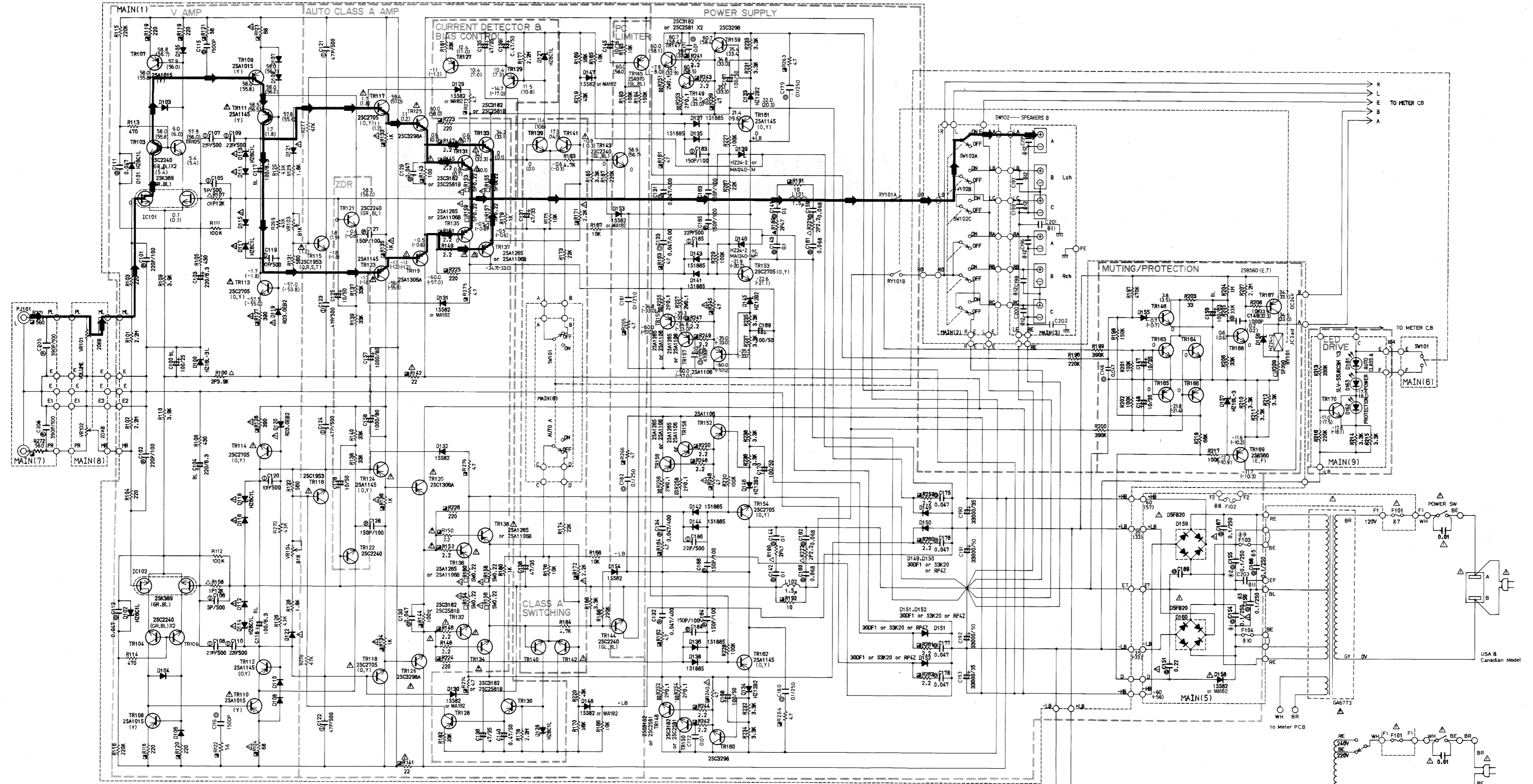

CAPACITOR

REMARKS	PARTS NAME
NO MARK	ELECTROLYTIC CAPACITOR
NO MARK	CERAMIC CAPACITOR
⊙	POLYESTER FILM CAPACITOR (MYLAR)
○	POLYSTYRENE FILM CAPACITOR
⊖	MICA CAPACITOR
Ⓟ	POLY PROPYLENE FILM CAPACITOR
●	SEMICONDUCTIVE CERAMIC CAPACITOR

RESISTOR

REMARKS	PARTS NAME
NO MARK	CARBON FILM RESISTOR (1/4W)
△	METAL OXIDE FILM RESISTOR
▲	METAL FILM RESISTOR
⊠	METAL PLATE RESISTOR
Ⓜ	FIRE PROOF CARBON FILM RESISTOR
Ⓢ	SEMENT MOLDED RESISTOR
Ⓟ	SEMI VARIABLE RESISTOR

3 marked

	U.C.	R	A, S, B
1	C154	0.1/250	OPEN
2	C155	OPEN	0.1/250
3	C156	OPEN	0.1/250
4	C187	0.1/250	OPEN
5	C188	OPEN	0.1/250
6	C189	OPEN	0.1/250
7	F101	15A250V	T6.3A250V
8	F102	T7.0A250V	
9	F103		T6.3A250V
10	F104		T6.3A250V
11	C200	OPEN	0.01
12	C195	OPEN	2K200P/100

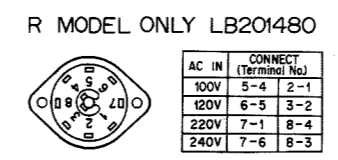

■ PIN CONNECTION DIAGRAM OF TRANSISTORS, DIODE AND ICS.

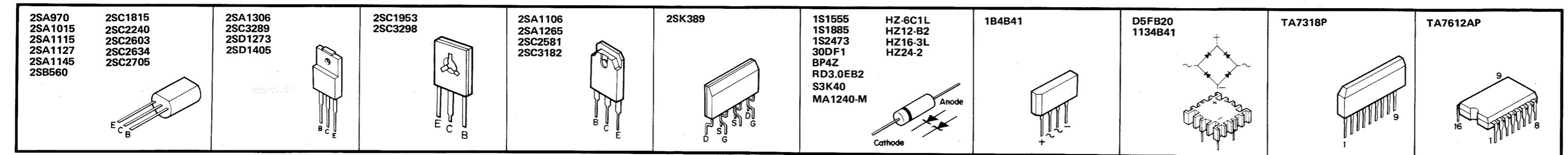

CAUTION

- Components having special characteristics are marked Δ and must be replaced with parts having specifications equal to those originally installed.
- All voltages are measured with a 10M Ω /V DC electric volt meter.
- Schematic diagram is subject to change without notice.

■ SCHEMATIC DIAGRAM

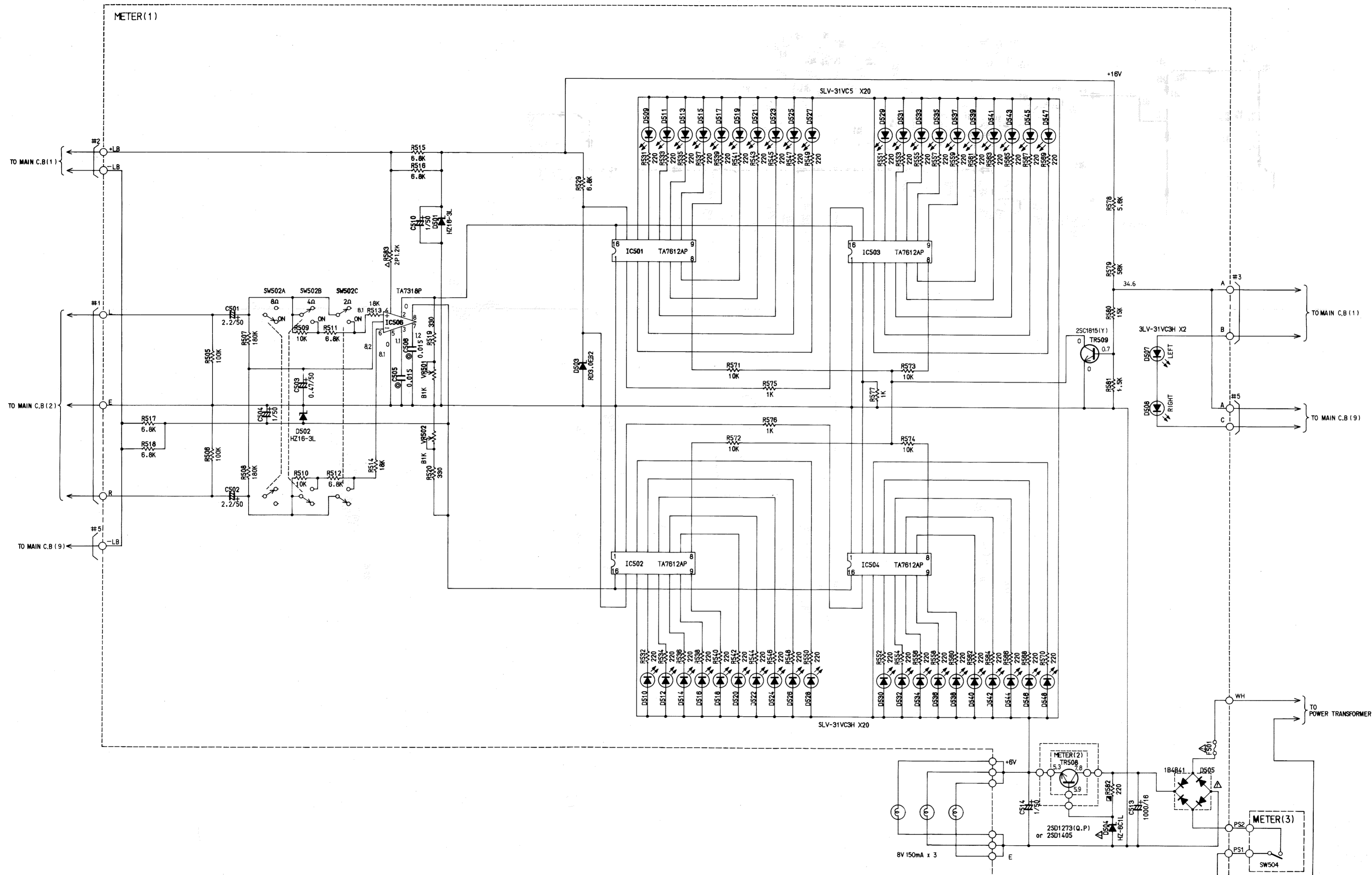

CAPACITOR	
REMARKS	PARTS NAME
NO MARK	ELECTROLYTIC CAPACITOR
NO MARK	CERAMIC CAPACITOR
⊙	POLYESTER FILM CAPACITOR (MYLAR)
○	POLYSTYRENE FILM CAPACITOR
Ⓜ	MICA CAPACITOR
Ⓟ	POLY PROPYLENE FILM CAPACITOR
●	SEMICONDUCTIVE CERAMIC CAPACITOR

RESISTOR	
REMARKS	PARTS NAME
NO MARK	CARBON FILM RESISTOR (1/4W)
△	METAL OXIDE FILM RESISTOR
▲	METAL FILM RESISTOR
⊠	METAL PLATE RESISTOR
■	FIRE PROOF CARBON FILM RESISTOR
□	SEMENT MOLDED RESISTOR
⊕	SEMI VARIABLE RESISTOR

CAUTION

- Components having special characteristics are marked Δ and must be replaced with parts having specifications equal to those originally installed.
- * All voltages are measured with a 10MS/V DC electric volt meter.
- * Schematic diagram is subject to change without notice.

	R.U.C	A.E
F501	2.0A250V	T2.0A250V

PARTS LIST

■ ELECTRICAL PARTS

■ WARNING

- Components having special characteristic are marked  and must be replaced with parts having specifications equal to those originally installed.
- Carbon resistors 1/4 W are not included in the ELECTRICAL PARTS list. For the parts No. of the carbon resistor, refer to P. 23.

Ref. No.	Part No.	Description	部 品 名	Remarks	Common Model	Markets	ランク
※	NA 09 01 70	Main Circuit Board Assy	メ イ ン シ ー ト			R	
※	NA 09 01 60	〃	〃			U.C	
※	NA 09 01 70	〃	〃			A.G.B	
	FC 36 46 80	Mylar Cap.	マ イ ラ ー コ ン	C159~162			
	FC 36 51 00	〃	〃	C141~144			
	UA 55 52 20	〃	〃	C151			
	FC 44 31 00	〃	〃	C149			
	UA 55 31 50	〃	〃	C115,116			
	FC 44 34 70	〃	〃	C173,174			
	FC 44 41 00	〃	〃	C171,172			
	FC 44 41 00	〃	〃	C201~203		A.G.B	
	FC 44 44 70	〃	〃	C111,112,129,130			
	FC 44 44 70	〃	〃	C146,175~178	Interchangeable		
	UA 25 44 70	〃	〃	〃			
	UT 45 21 50	Polypropylene Film Cap.	ポ リ プ ロ コ ン	C127,128,163~166 183,184			
	UT 65 22 20	〃	〃	C101,C102			
	UT 45 23 90	〃	〃	C205,206			
	UT 46 32 70	〃	〃	C195~200			
	FU 35 05 00	FE Mica Cap.	F E マ イ カ コ ン	C105,106			
	FU 35 11 00	〃	〃	C119,120			
	FU 35 12 20	〃	〃	C109,110,185,186			
	FU 35 12 70	〃	〃	C107,108			
	FU 35 14 70	〃	〃	C121~124			
	FZ 00 06 70	Metallized Mylar Cap.	M M コ ン	C131~134			
	FZ 00 46 60	〃	〃	C179~182			
	FZ 00 46 60	〃	〃	C154,187			
	FZ 00 46 60	〃	〃	C155,156,188,189			
	FZ 00 54 10	Electrolytic Cap.	ブ ラ ッ ク ゲ ー ト コ ン	C117,118,150			
	FZ 00 61 30	〃	〃	C103,104			
	FZ 00 61 40	〃	〃	C100			
	FZ 00 59 80	〃	オ ー デ ィ オ コ ン (UKJ)	C157,158			
	UH 13 71 00	〃	ケ ミ コ ン	C145			
※	UH 15 71 00	〃	〃	C147,148			
	UH 15 74 70	〃	〃	C135~138			
	UH 16 54 70	〃	〃	C139,140			
	UJ 16 71 00	〃	〃	C125,126			
※	UJ 16 81 00	〃	〃	C167~170			
	GD 90 05 20	Coil	ア ウ ト プ ッ ト コ イ ル	L101,102			
	HL 31 71 20	Metal Oxide Film Resistor	酸 金 抵 抗	R107,108			
	HL 32 32 20	〃	〃	R221,222			
	HL 32 34 70	〃	〃	R189,190			
	HL 32 63 90	〃	〃	R100			
※	VA 99 40 00	Potentiometer	可 変 抵 抗 器	VR101,102			
	HT 37 03 40	Pre-Set Potentiometer	半 固 定 抵 抗	VR103,104			
	HV 45 34 70	Flame Proof Carbon Resistor	不 燃 化 カ ー ボ ン 抵 抗	R273~276			
	HV 45 32 20	〃	〃	R145~182,241~244 247~250,259~262			
	HV 45 34 70	〃	〃	R161~164,263~266			
	HV 45 41 00	〃	〃	R191,192			

※New Parts (新規部品)

Ref. No.	Part No.	Description	部 品 名		Remarks	Common Model	Markets	ランク
	HV 45 42 20	Flame Proof Carbon Resistor	22Ω	1/4W	不燃化カーボン抵抗	R141,142		
	HV 45 44 70	//	47Ω	1/4W	//	R239,240,245,246		
	HV 45 45 60	//	56Ω	1/4W	//	R121,122		
	HV 45 46 80	//	68Ω	1/4W	//	R123,124		
	HV 45 51 00	//	100Ω	1/4W	//	R143,144		
	HV 45 52 20	//	220Ω	1/4W	//	R117~120,223~226		
	HV 45 53 90	//	390Ω	1/4W	//	R127,128		
	HV 45 55 60	//	560Ω	1/4W	//	R271,272		
	HV 45 61 00	//	1k	1/4W	//	R133~136		
	HV 45 62 20	//	2.2k	1/4W	//	R171,172		
	HZ 00 38 30	Metel Plate Resistr	0.1Ω	2W	金 属 板 抵 抗	R251~258		
	HZ 00 44 70	Cement Moulded Resistr	0.22Ω	5W	セ メ ン ト 抵 抗	R153~160		
	HZ 00 46 20	//	390Ω	5W	//	R209		
	iA 09 70 00	Transistor	2SA970(GR,BL)		ト ラ ン ジ ス タ	TR145		
	iA 10 15 71	//	2SA1015(Y)		//	TR107~110		
	iA 11 15 10	//	2SA1115(E,F)		//	TR127~130,165,166	Inter-changeable	
	iA 11 27 00	//	2SA1127(R,S,T)		//	//		
	iA 11 45 00	//	2SA1145(O,Y)		//	TR111,112,123,124 161,162		
	iA 13 06 40	//	2SA1306		//	TR151,152		
	iB 05 60 00	//	2SB560(E,F)		//	TR167,169		
	iC 22 40 00	//	2SC2240(GR,BL)		//	TR103~106 121,122,143,144		
	iC 26 03 10	//	2SC2603(E,F)		//	TR139~142,146 163,164,168,170	Inter-changeable	
	iC 26 34 00	//	2SC2634(R,S,T)		//	//		
	iC 27 05 00	//	2SC2705(O,Y)		//	TR113,114,117,118 153,154		
	iC 32 98 40	//	2SC3298		//	TR159,160		
	iE 10 45 00	FET	2SK389(GR,BL)		デュアル F E T	IC101,102		
	iF 00 06 70	Diode	1S2473		ダ イ オ ー ト	D103~112,115,116 121,122,155	Inter-changeable	
	iF 00 00 40	//	1S1555		//	//		
	iF 00 06 70	//	1S2473		//	D129~132,147,148 153,154,158	Inter-changeable	
	iF 00 00 40	//	1S1555		//	//		
	iF 00 19 40	Zener Diode	HZ24-2		ツェナーダイオード	D156		
	iF 00 19 40	//	HZ24-2		//	D139,140	Inter-changeable	
	iF 00 72 10	//	MA1240M		//	//		
	iF 00 15 10	//	HZ6C1L		//	D101,102,113,114 117,118,127,128		
	iF 00 20 80	//	HZ16-3L		//	D100,157		
	iF 00 35 50	//	HZ12B2		//	D133,134,145,146		
	iF 00 36 10	//	RD3,OEB2		//	D119,120		
	iF 00 44 40	LED	SLV-56URC3H		L E D	D161~163		
	iH 00 02 40	Diode	1S1885		ダ イ オ ー ト	D135~138,141~144		
	iH 00 09 60	//	30DF1		//	D149~152		
	iH 00 13 50	//	S3K40		//	//	Inter-changeable	
	iH 00 13 60	//	RP4Z		//	//		
	iH 00 11 30	//	D5FB20		//	D159,160		
	KA 80 46 20	Push Switch			プッシュスイッチ	SW102		
	VA 87 20 00	//			//	SW101		
	KB 00 07 70	Fuse	T6.3A	250V	ヒューズタイムラグ	F101	A,G,B	
	KB 00 13 80	//	15A	250V	// UL	//	R,U,C	
	KB 00 07 70	//	T6.3A	250V	// S	F103,104	A,G,B	

※New Parts (新規部品)

A

B

C

D

E

M-65

M-65

MECHANISM EXPLODED VIEW

1

2

3

4

5

6

7

20

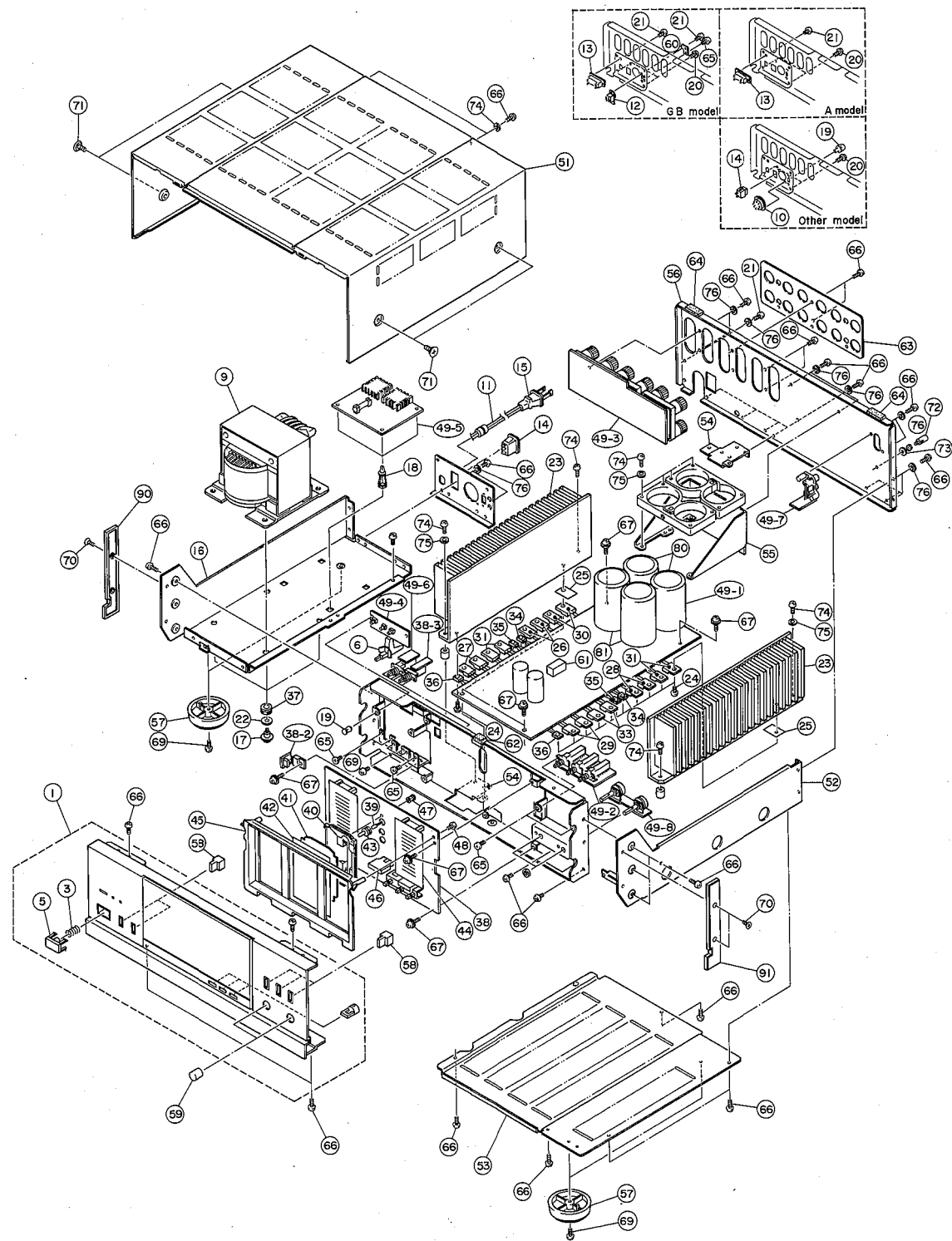

MECHANISM PARTS

Ref. No.	Part No.	Description	部品名	Remarks	Common Model	Markets	ランク
※ 1	NB 63 38 00	Panel Unit	パネルユニット				
2	NB 62 03 90	Sub Panel Ass'y	サブパネル Ass'y		M-60		
3	AA 62 20 80	Spring	スプリング		M-80		
4	CB 63 00 10	Reflector	リフレクター		C-80		
5	CB 63 03 50	Push Button	プッシュボタン	POWER	M-80		
6	KA 80 25 50	Push Switch	プッシュスイッチ	SDZ1P-A,TV-8	M-60	R,U,C	
7	CB 09 52 60	Cover	コンデンサーカバー	SS-23 5A/80A	//	A,G,B	
8	CB 64 46 70			HY-0105	//	A,G,B	
9	Fi 38 41 00	Ceramic Cap.	セラコン	0.01μF VA-1	//		
※ 9	GA 67 77 10	Power Transformer	電源トランス			R	△
※ //	GA 67 73 10					U	△
※ //	GA 67 74 10					C	△
※ //	GA 67 75 10					A,G,B	△
10	LB 20 14 80	Voltage Selector	電圧切換器	0211		R	
11	CB 62 01 90	Cord Stopper	コードストッパー	CM-22B		R,A	
12	CB 07 27 50			SR-4N-4		U,G,C,B	
13	KA 40 12 60	Slide Switch	スライドスイッチ	SS-12 5A/40A		G,B	
14	LA 00 29 50	2P Relay Terminal	2 P 中継端子台	MA0092A		A,G,B	
15	LB 20 30 60	AC OUTLET	AC アウトレット	S-i6498		R	
16	MG 00 16 30	Power Cord	電源コード	6A250V 2m		U,C	△
17	MG 00 23 80			13A125V 1.98m		A	△
18	MG 00 09 20			7.5A250V 2.5m		A	△
19	MG 00 14 90			7.5A250V 2.5m	Interchangeble	A	△
20	MG 00 23 10			7.5A250V 2m		A	△
21	MG 00 09 10			6A250V 2m		G,B	△
※ 16	AA 62 91 70	Side Frame(L)	サイドフレーム(L)				
17	AA 60 38 50	Special Screw	段付ネジ				
18	CB 63 07 40	Holder	ホルダー	PCB			
19	CB 06 88 80	Plastic Rivet	プラスチックリベット			R	
20	Ei 33 00 86	Bind Head Tapping	バインドヘッドタッピング	3×8 FCM3-BI			
21	ED 33 00 66	Binding Head Screw	鉄バインド小ネジ	3×6 FCM3-BI		A,G,B	
22	EV 20 31 06	Plain Washer	平座金	φ6-φ13 ZMC2-BI			
23	BA 09 01 00	Heat Sink	放熱板				
24	EZ 00 13 50	Cap Screw	鉄カップスクリュー	3×14(φ8) FCM3-BI			
25	VB 43 50 00	Radiation Sheet	放熱シート				
26	iA 11 06 40	Transistor	トランジスタ	2SA1106B	TR135~138	Inter-changeable	△
27	iA 12 65 30			2SA1265			△
28	iC 25 81 40			2SC2581B	TR131~134	Inter-changeable	△
29	iC 31 82 30			2SC3182			△
30	iA 11 06 00			2SA1106	TR155~158	Inter-changeable	△
31	iA 12 65 30			2SA1265			△
32	iC 25 81 00			2SC2581	TR147~150	Inter-changeable	△
33	iC 31 82 30			2SC3182			△
34	iA 13 06 10			2SA1306A	TR125,126		△
35	iC 32 98 10			2SC3298A	TR119,120		△
36	iC 19 53 50			2SC1953	TR115,116		△
37	CB 09 99 10	Rubber Cushion	防振ゴム				
※ 38	NA 09 01 30	Meter Circuit Board	メーターシート			R,U,C	
※ //	NA 09 01 40					A,G,B	
39	JB 00 11 00	Pilot Lamp	パイロットランプ	8V 150mA φ=300			

*New Parts (新規部品)

21

Ref. No.	Part No.	Description	部 品 名	Remarks	Common Model	Markets	ランク
40	CB:63:05:30	Lamp Reflector	ランプリフレクター		M-80		
41	CB:63:05:50	Diffusion Plate	拡 散 プ レ ー ト		//		
42	CB:63:03:30	Meter Circuit Board	メ ー タ ー シ ー ト		M-60		
43	CB:63:07:50	Lamp Cap.	ランブキャップ				
44	CB:63:03:40	Diffusion Film	拡 散 フ ィ ル ム		M-80		
45	CB:63:02:90	Meter Cover	メ ー タ ー カ バ ー				
46	CB:63:03:90	Reflector	リ フ レ ク タ ー				
47	CB:06:88:80	Plastic Rivet	No.1027 プラスチックリベット				
48	ED:33:01:06	Bind Head Tapping Screw	3×10 FCM3-B0 鉄バインドタッピンネジ	PACK			
※	NA:09:01:50	Main Circuit Board	メ イ ン シ ー ト			R	
※	// NA:09:01:60	//	//			U.C	
※	// NA:09:01:70	//	//			A.G.B	
80	FZ:00:59:60	Electrolytic Cap. Set	33000 μ F 35V ケミコンセット	C190,193 a pair			
81	FZ:00:59:90	//	33000 μ F 50V "	C191,192 a pair			
51	AA:62:19:80	Top Cover	ト ッ プ カ バ ー		M-80		
52	AA:62:20:10	Side Frame(R)	サ イ ド フ レ ー ム (R)		//		
53	AA:62:20:30	Bottom Cover	ボ ト ム カ バ ー		//		
54	AA:62:20:40	Stay for Radiator	ヒ ー ト シ ン ク ス テ ー		//		
55	AA:62:33:50	Capacitor Angle	ケ ミ コ ン 金 具		M-60		
56	AA:62:95:90	Rear Panel	リ ヤ パ ネ ル			R	
	// AA:62:96:00	//	//			U	
	// AA:62:96:10	//	//			A	
	// AA:62:96:20	//	//			G.B	
57	NB:62:03:20	Leg Ass'y	レ ッ グ Ass'y		M-80		
58	NB:62:04:60	Button Ass'y	ボ タ ン Ass'y		//		
59	BA:08:58:70	Knob	ツ マ ミ				
60	CB:60:14:40	Voltage Selection Stopper	V S ス ト ッ パ ー			G.B	
61	CB:63:07:60	Dumper	ダ ン パ ー (M)				
62	CB:60:13:40	Spacer	ス ペ ー サ ー				
63	CB:65:29:50	Sheet	シ ー ト				
64	CB:61:90:40	Rubber	押 え ゴ ム				
65	ED:33:00:66	Binding Head Screw	3×6 FCM3-BI 鉄バインド 小ネジ	PACK			
66	Ei:33:00:86	Binding Head Tapping Screw	3×8 FCM3-BI 鉄バインドタッピンネジ	PACK			
67	EK:36:50:80	BW Head Tapping Screw	3×8(ϕ 10) ZMC2-BI 鉄BWヘッドタッピンネジ				
68	EV:41:30:36	Toothed Lock Washer	ϕ 3 FCRM3-BI 鉄セムス平座金				
69	EK:33:00:30	BW Head Tapping Screw	3×10(ϕ 8)FCM3-BI 鉄BWヘッドタッピンネジ				
70	EB:34:01:00	Flat Head Screw	4×10 FCM3-BI 鉄 皿 小 ネ ジ				
71	AX:60:01:50	Screw	4×8 FCM3-BI 化 粧 ネ ジ				
72	EZ:00:14:00	Ground Terminal Screw	3×13.5 MFNi-II ア ー ス 端 子 ネ ジ				
73	EV:90:13:60	Toothed Lock Washer	3.6×10×0.8FNM3-3g 鉄セムス平座金				
	CB:06:92:50	Binding Tie	BK-1 インシュロックタイ				
74	EA:33:01:86	Pan Head Screw	3×18(ϕ 10) FCRM3-BI ナ ベ 小 ネ ジ	PACK			
75	EV:20:30:36	Plain Washer	ϕ 3 ZMC2-BI 平 座 金	PACK			
76	EV:41:30:36	Toothed Lock Washer	ϕ 3 FCRM3-BI 歯 付 座 金	PACK			
90	CB:63:03:70	Side Plate L	サ イ ド プ レ ー ト L		M-80		
91	CB:63:03:80	// R	// R		//		

*New Parts (新規部品)

Parts List for Carbon Resistor

Value	1/4W Type Part No.	1/6W Type Part No.	Value	1/4W Type Part No.	1/6W Type Part No.
1.0 Ω	HJ353100	※	12KΩ	HJ357120	HF857120
1.8 "	HJ353180	※	15 "	HJ357150	HF857150
2.2 "	HJ353220	HF853220	18 "	HJ357180	HF857180
3.3 "	HJ353330	HF853330	22 "	HJ357220	HF857220
4.7 "	HJ353470	HF853470	27 "	HJ357270	HF857270
5.6 "	HJ353560	HF853560	33 "	HJ357330	HF857330
10 "	HJ354100	HF854100	39 "	HJ357390	HF857390
15 "	HJ354150	HF854150	47 "	HJ357470	HF857470
22 "	HJ354220	HF854220	56 "	HJ357560	HF857560
27 "	HJ354270	HF854270	68 "	HJ357680	HF857680
33 "	HJ354330	HF854330	82 "	HJ357820	HF857820
39 "	HJ354390	HF854390	91 "	HJ357910	HF857910
47 "	HJ354470	HF854470	100 "	HJ358100	HF858100
56 "	HJ354560	HF854560	120 "	HJ358120	HF858120
68 "	HJ354680	HF854680	150 "	HJ358150	HF858150
82 "	HJ354820	HF854820	180 "	HJ358180	HF858180
100 "	HJ355100	HF855100	220 "	HJ358220	HF858220
110 "	HJ355110	HF855110	270 "	HJ358270	HF858270
120 "	HJ355120	HF855120	330 "	HJ358330	HF858330
150 "	HJ355150	HF855150	390 "	HJ358390	HF858390
160 "	HJ355160	※	470 "	HJ358470	HF858470
180 "	HJ355180	HF855180	560 "	HJ358560	HF858560
220 "	HJ355220	HF855220	680 "	HJ358680	HF858680
270 "	HJ355270	HF855270	820 "	HJ358820	HF858820
330 "	HJ355330	HF855330	1.0MΩ	HJ359100	HF859100
390 "	HJ355390	HF855390	1.2 "	HJ359120	※
470 "	HJ355470	HF855470	1.5 "	HJ359150	HF859150
510 "	※	HF855510	1.8 "	HJ359180	HF859180
560 "	HJ355560	HF855560	2.2 "	HJ359220	HF859220
680 "	HJ355680	HF855680	3.3 "	HJ359330	HF859330
820 "	HJ355820	HF855820	3.9 "	HJ359390	※
910 "	HJ355910	HF855910	4.7 "	HJ359470	※
1.0KΩ	HJ356100	HF856100			
1.2 "	HJ356120	HF856120			
1.5 "	HJ356150	HF856150			
1.8 "	HJ356180	HF856180			
2.0 "	HJ356200	HF856200			
2.2 "	HJ356220	HF856220			
2.4 "	HJ356240	HF856240			
2.7 "	HJ356270	HF856270			
3.0 "	HJ356300	HF856300			
3.3 "	HJ356330	HF856330			
3.6 "	HJ356360	HF856360			
3.9 "	HJ356390	HF856390			
4.7 "	HJ356470	HF856470			
5.1 "	HJ356510	HF856510			
5.6 "	HJ356560	HF856560			
6.8 "	HJ356680	HF856680			
8.2 "	HJ356820	HF856820			
9.1 "	HJ356910	HF856910			
10 "	HJ357100	HF857100			

1/4W Type

HJ35○○○○

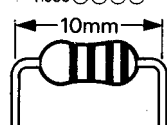

1/6W Type

HF85○○○○

