

MICRO COMPONENT SYSTEM MCR-E700

RDX-E700/NX-E700

SERVICE MANUAL

The MCR-E700 consists of the RDX-E700 and the NX-E700.
MCR-E700 は RDX-E700 と NX-E700 で構成されています。

IMPORTANT NOTICE

This manual has been provided for the use of authorized YAMAHA Retailers and their service personnel. It has been assumed that basic service procedures inherent to the industry, and more specifically YAMAHA Products, are already known and understood by the users, and have therefore not been restated.

WARNING: Failure to follow appropriate service and safety procedures when servicing this product may result in personal injury, destruction of expensive components, and failure of the product to perform as specified. For these reasons, we advise all YAMAHA product owners that any service required should be performed by an authorized YAMAHA Retailer or the appointed service representative.

IMPORTANT: The presentation or sale of this manual to any individual or firm does not constitute authorization, certification or recognition of any applicable technical capabilities, or establish a principle-agent relationship of any form.

The data provided is believed to be accurate and applicable to the unit(s) indicated on the cover. The research, engineering, and service departments of YAMAHA are continually striving to improve YAMAHA products. Modifications are, therefore, inevitable and specifications are subject to change without notice or obligation to retrofit. Should any discrepancy appear to exist, please contact the distributor's Service Division.

WARNING: Static discharges can destroy expensive components. Discharge any static electricity your body may have accumulated by grounding yourself to the ground buss in the unit (heavy gauge black wires connect to this buss).

IMPORTANT: Turn the unit OFF during disassembly and part replacement. Recheck all work before you apply power to the unit.

■ CONTENTS

TO SERVICE PERSONNEL	2-4	TRAY LOCK MODE / トレーロックモード	12
PREVENTION OF ELECTRO STATIC DISCHARGE	4	FACTORY RESET / ファクトリーリセット	12
LOCALE MANAGEMENT INFORMATION	5	PRINTED CIRCUIT BOARD	13-16
FRONT PANEL	6	BLOCK DIAGRAM	17
REMOTE CONTROL PANELS	6	SCHEMATIC DIAGRAM	18-23
REAR PANELS	7	RDX-E700 EXPLODED VIEW	24
SPECIFICATIONS / 参考仕様	8-9	RDX-E700 MECHANICAL PARTS	25-26
DIMENSIONS / 寸法図	9	NX-E700	27
INTERNAL VIEW / 各部名称	10	REMOTE CONTROL	28-29
RDX-E700 DISASSEMBLY PROCEDURES /			
RDX-E700分解手順	10-11		



このサービスマニュアルは、エコマーク認定の再生紙を使用しています。
This Service Manual uses recycled paper.

100991

© 2005 YAMAHA CORPORATION. All rights reserved.
This manual is copyrighted by YAMAHA and may not be copied or redistributed either in print or electronically without permission.



YAMAHA

YAMAHA CORPORATION
P.O.Box 1, Hamamatsu, Japan

05.11

■ TO SERVICE PERSONNEL

- Critical Components Information**
Components having special characteristics are marked Δ and must be replaced with parts having specifications equal to those originally installed.
- Leakage Current Measurement (For 120V Models Only)**
When service has been completed, it is imperative to verify that all exposed conductive surfaces are properly insulated from supply circuits.
 - Meter impedance should be equivalent to 1500 ohms shunted by 0.15 μ F.

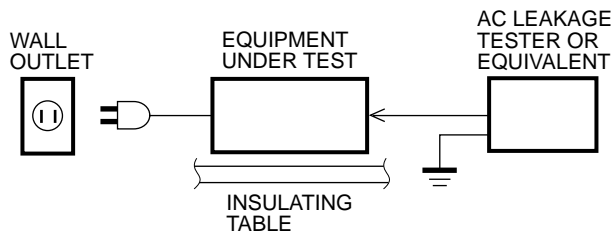

- Leakage current must not exceed 0.5mA.
- Be sure to test for leakage with the AC plug in both polarities.

WARNING: CHEMICAL CONTENT NOTICE!

The solder used in the production of this product contains LEAD. In addition, other electrical/electronic and/or plastic (where applicable) components may also contain traces of chemicals found by the California Health and Welfare Agency (and possibly other entities) to cause cancer and/or birth defects or other reproductive harm.

DO NOT PLACE SOLDER, ELECTRICAL/ELECTRONIC OR PLASTIC COMPONENTS IN YOUR MOUTH FOR ANY REASON WHATSOEVER!

Avoid prolonged, unprotected contact between solder and your skin! When soldering, do not inhale solder fumes or expose eyes to solder/flux vapor!

If you come in contact with solder or components located inside the enclosure of this product, wash your hands before handling food.

About Lead Free Solder / 無鉛ハンダについて

The P.C.B.s installed in this unit are soldered using the following solder.

本機に搭載されている基板のハンダ付けに使用されているハンダは下記の通りです。

	SIDE A / A 面	SIDE B / B 面
MPEG P.C.B.	Lead Free Solder / 無鉛ハンダ	Lead Free Solder / 無鉛ハンダ
FRONT P.C.B.	-	Lead Free Solder / 無鉛ハンダ
MAIN P.C.B.	Lead Free Solder / 無鉛ハンダ	Lead Free Solder / 無鉛ハンダ
POWER SUPPLY UNIT	-	Lead Free Solder / 無鉛ハンダ

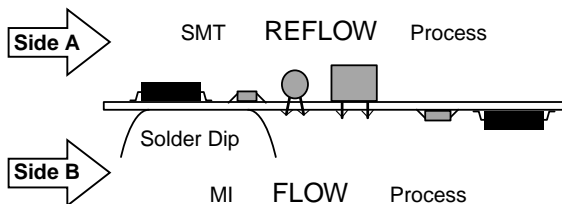

Among some types of lead free solder currently available, it is recommended to use one of the following types for the repair work.

- Sn + Ag + Cu (tin + silver + copper)
- Sn + Cu (tin + copper)
- Sn + Zn + Bi (tin + zinc + bismuth)

Caution:

- As the melting point temperature of the lead free solder is about 30°C to 40°C (50°F to 70°F) higher than that of the lead solder, be sure to use a soldering iron suitable to each solder.

無鉛ハンダにはいくつかの種類がありますが、修理時には下記のような無鉛ハンダの使用を推奨します。

- Sn+Ag+Cu (錫 + 銀 + 銅)
- Sn+Cu (錫 + 銅)
- Sn+Zn+Bi (錫 + 亜鉛 + ビスマス)

注意:

- 無鉛ハンダの融点温度は通常の鉛入りハンダに比べ30~40 程度高くなっていますので、それぞれのハンダに合ったハンダごてをご使用ください。

2. If lead solder must be used, be sure to remove lead free solder from each terminal section of the parts to be replaced and from the area around it completely before soldering, or make sure that the lead free solder and lead solder melt together fully.

WARNING: Laser Safety

This product contains a laser beam component. This component may emit invisible, as well as visible radiation, which may cause eye damage. To protect your eyes and skin from laser radiation, the following precautions must be used during servicing of the unit.

- 1) When testing and/or repairing any component within the product, keep your eyes and skin more than 30 cm away from the laser pick-up unit at all times. Do not stare at the laser beam at any time.
- 2) Do not attempt to readjust, disassemble or repair the laser pick-up, unless noted elsewhere in this manual.
- 3) CAUTION : Use of controls, adjustments or performance of procedures other than those specified herein may result in hazardous radiation exposure.

Laser Emitting conditions:

- 1) When the Top Cover is removed, and the STANDBY/ON SW is turned to the "ON" position, the laser component will emit a beam for several seconds to detect if a disc is present. During this time (5-10 sec.) the laser may radiate through the lens of the laser pick-up unit. Do not attempt any servicing during this period! If no disc is detected, the laser will stop emitting the beam. When a disc is loaded, you will not be exposed to any laser emissions.
- 2) The laser power level can be adjusted with the VR on the pick-up PWB, however, this level has been set by the factory prior to shipping from the factory. Do not adjust this laser level control unless instruction is provided elsewhere in this manual. Adjustment of this control can increase the laser emission level from the device.

Laser Diode Properties

Type:	Semiconductor laser GaAlAs
Wave length:	650 nm (DVD) 790 nm (VCD/CD)
Output Power:	1.45 mW (DVD) 1.13 mW (VCD/CD)
Beam divergence:	60 degree

2. 鉛入りハンダを使わざるを得ない場合は、あらかじめ交換する部品端子部やその周辺部の無鉛ハンダをすべて取り除くか、あるいは無鉛ハンダと鉛入りハンダが十分に溶けた状態となるようにハンダ付けしてください。

警告：レーザーの安全対策

本機はレーザー光線を放射する部品を搭載しています。この部品が放射するレーザー光線は目に損傷を起こします。このレーザー光線から目及び肌を保護するために、本機の修理作業中は下記の注意を厳守してください。

- 1) テスト時または修理時、目及び肌を光ピックアップから30cm以上離してください。いかなる場合もレーザー光線を見つめないでください。
- 2) 光ピックアップの再調整及び分解はしないでください。
- 3) このマニュアル上で指定されている以外の制御、調整、手順はレーザー光線を照射される結果を招く恐れがあります。

レーザー放射条件

- 1) トップカバーを取り外しSTANDBY/ONスイッチをONにすると、ディスク検知のため5～10秒間、光ピックアップからレーザー光線が放射されます。この間、修理はしないでください。ディスクが検知されなければ、レーザー光線の放射は停止します。ディスクがセットされている場合、ディスクで遮られるのでレーザー光線は修理担当者に届きません。
- 2) レーザーパワーレベルは光ピックアップ基板上のVRにより調整可能ですが、工場出荷前に調整セット済みなので、このVRは廻さないでください。このVRを廻すと装置からのレーザー光線の放射レベルが上がる恐れがあります。

レーザー

タイプ	半導体レーザー GaAlAs
波長	650 nm (DVD) 790 nm (VCD/CD)
出力	1.45 mW (DVD) 1.13 mW (VCD/CD)
ビーム広がり	60度

VARO! : AVATTAESSA JA SUOJALUKITUS OHITETTAESSA OLET ALTTIINA NÄKYMÄTTÖMÄLLE LASER-SÄTEILYLLE. ÄLÄ KATSO SÄTEESEEN.

WARNING! : OSYNLIG LASERSTRÅLNING NÄR DENNA DEL ÄR ÖPPNAD OCH SPÄRREN ÄR URKOPPLAD. BETRakta EJ STRÅLEN.

<p>CAUTION Use of controls or adjustments or performance of procedures other than those specified herein may result in hazardous radiation exposure.</p>
<p>AVERTISSEMENT L'utilisation de commandes et l'emploi de réglages ou de méthodes autres que ceux décrits ci-dessous, peuvent entraîner une exposition à un rayonnement dangereux.</p>
<p>VORSICHT Die Verwendung von Bedienelementen oder die Einstellung bzw. die Ausführung von anderen als in dieser Anleitung beschriebenen Vorgängen kann zu Gefährdung durch gefährliche Strahlung führen.</p>
<p>OBSERVERA Användning av reglage eller justeringar eller utförande av åtgärder på annat sätt än så som beskrivs häri kan resultera i farlig strålning.</p>
<p>ATTENZIONE L'uso di controlli, regolazioni, operazioni o procedure non specificati in questo manuale possono risultare in esposizione a radiazioni pericolose.</p>
<p>PRECAUCIÓN El uso de los controles, los ajustes o los procedimientos que no se especifican en este manual pueden causar una exposición peligrosa a la radiación.</p>
<p>LET OP Gebruik van bedieningsorganen, instellingen of procedures anders dan beschreven in dit document kan leiden tot blootstelling aan gevaarlijke stralen.</p>
<p>ПРЕДОСТЕРЕЖЕНИЕ Использование органов управления или произведение настроек или выполнение процедур, не указанных в данной инструкции, может отразиться на выделении опасной радиации.</p>

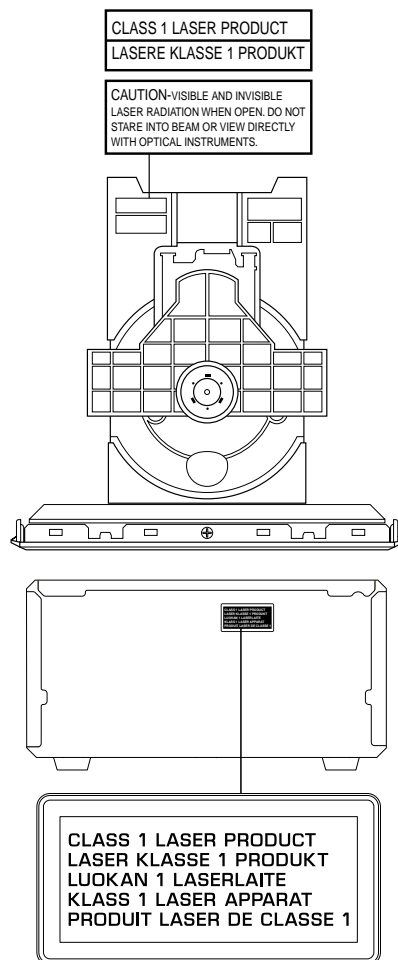

■ PREVENTION OF ELECTRO STATIC DISCHARGE

The laser diode in the DVD mechanism may be damaged due to static electricity from clothes or the human body. Use caution to prevent electro static damage when servicing or handling the DVD-mechanism.

1. Grounding for electro static damage prevention

Some devices, such as the DVD player, use an optical pickup (laser diode) that will be damaged by static electricity in the working environment. Only attempt service after ensuring that all grounding procedures have been completed.

1. Worktable grounding

Put a grounded conductive material (sheet) or iron sheet on the area where the optical pickup is placed.

2. Human body grounding

Use an anti-static wrist strap to discharge the static electricity from your body.

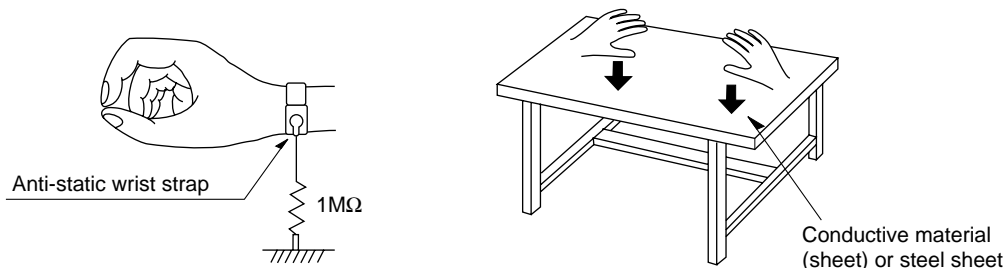

2. Handling Precautions for DVD mechanism

1. Handle the DVD mechanism gently, as it is an extremely high-precision assembly.
2. The flexible cable lines may break if an excessive force is applied to it. Use caution when handling the cable.
3. The semi-fixed resistor for laser power adjustment should not be adjusted. Do not turn the resistor.

■ LOCALE MANAGEMENT INFORMATION

Locale Management Information : This DVD player is designed and manufactured to respond to the Locale Management Information that is recorded on a DVD disc. If the Locale number described on the DVD disc does not correspond to the Locale number of this DVD player, this DVD player cannot play this disc.

This product incorporates copyright protection technology that is protected by method claims of certain U.S. patents and other intellectual property rights owned by Macrovision Corporation and other rights owners. Use of this copyright protection technology must be authorized by Macrovision Corporation, and is intended for home and other limited viewing uses only unless otherwise authorized by Macrovision Corporation. Reverse engineering or disassembly is prohibited.

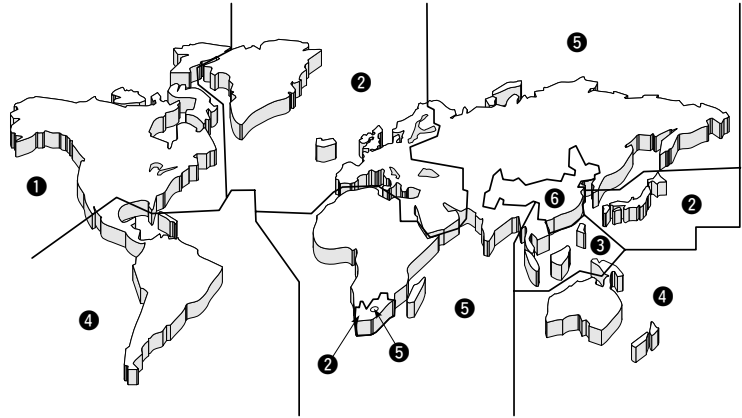

■ SYSTEM COMPOSITION / システム構成

The MCR-E700 consists of the RDX-E700 and the NX-E700.

▼ NX-E700

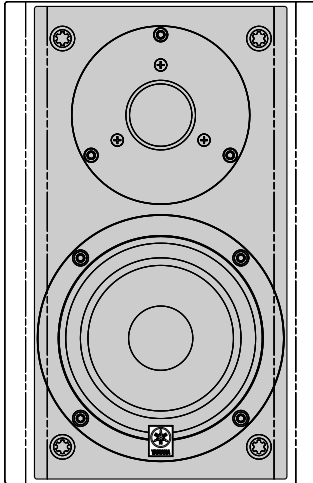

▼ NX-E700

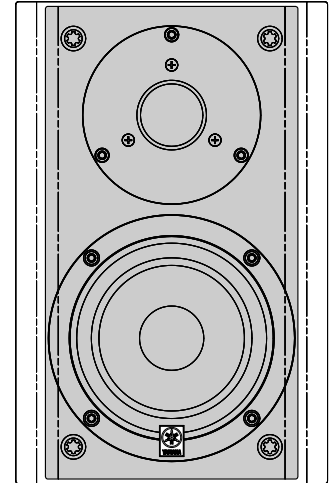

▼ RDX-E700

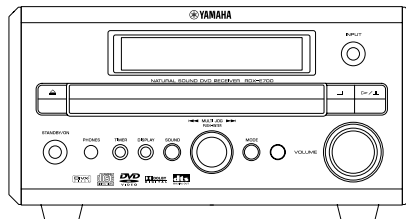

FRONT PANEL

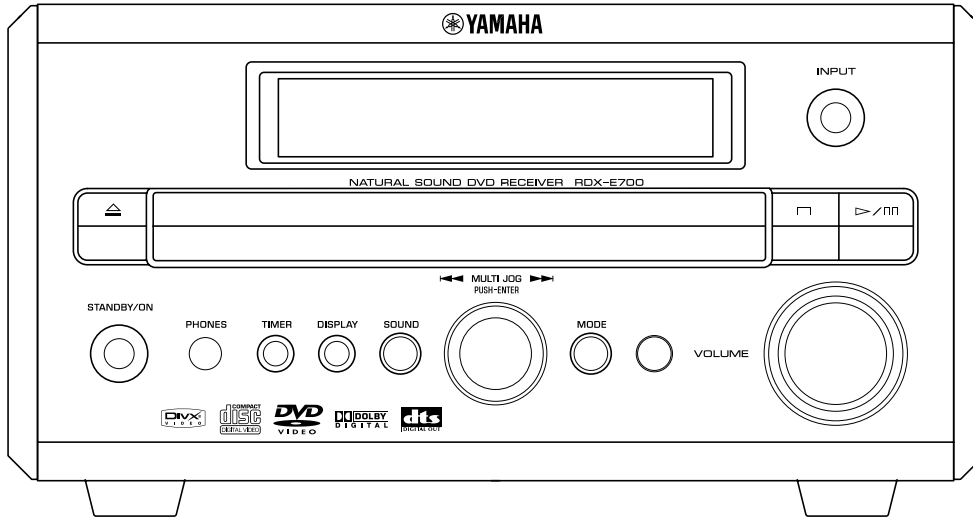

REMOTE CONTROL PANELS

▼ U, C, T, K, A, L, V, J models

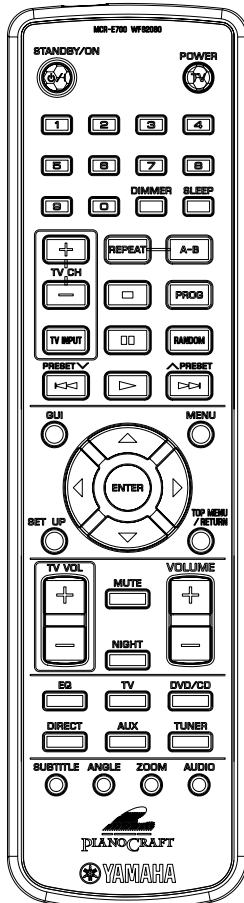

▼ B, G models

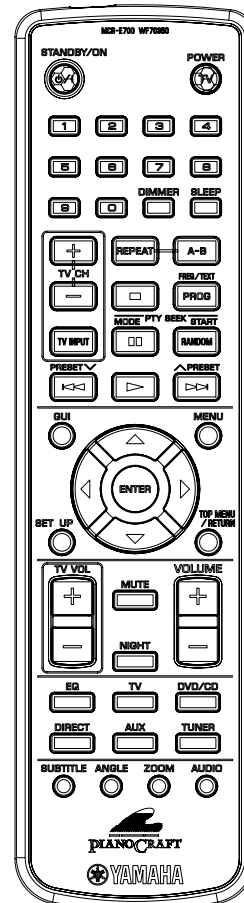

REAR PANELS

U, C models

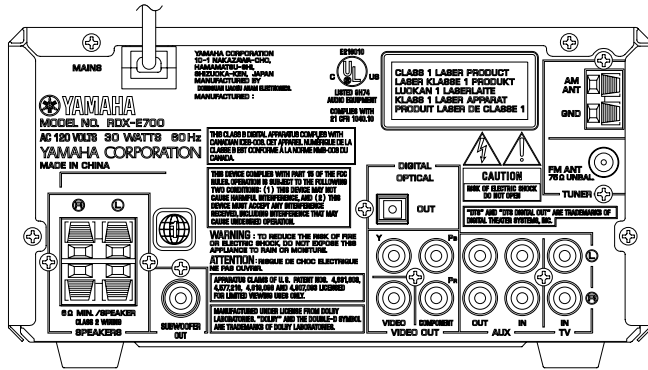

B, G models

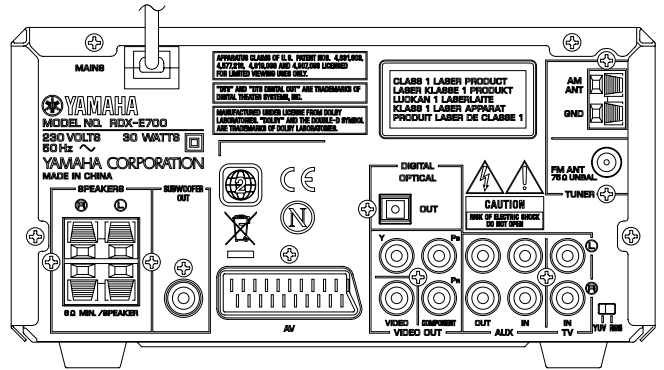

T model

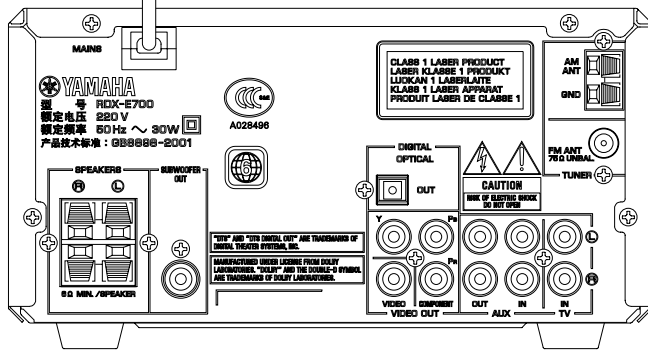

L model

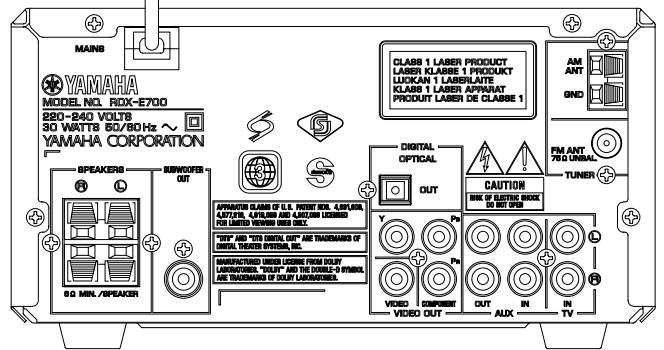

K model

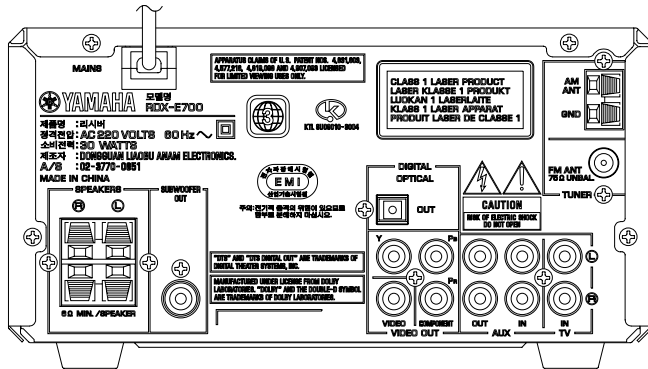

V model

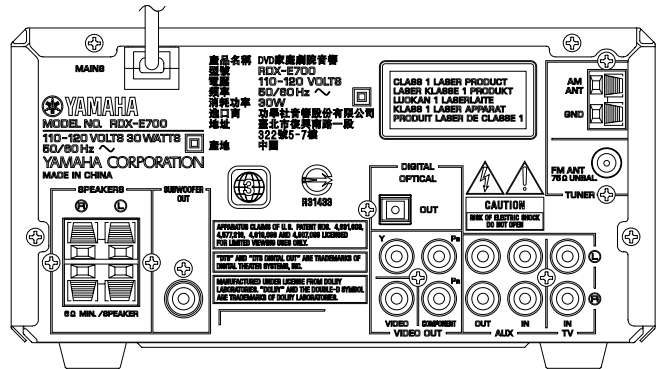

A model

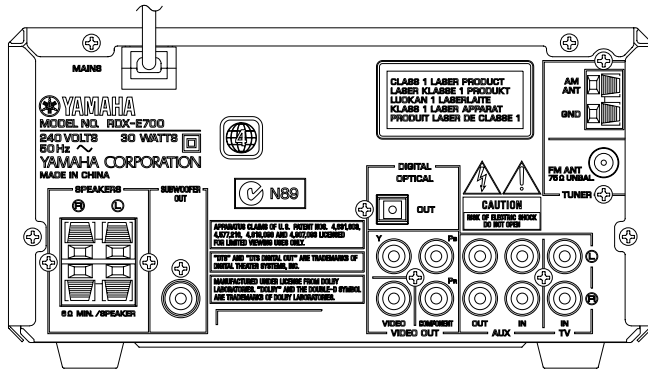

J model

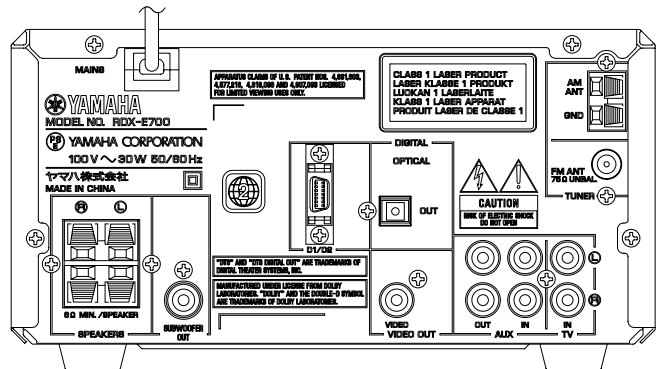

SPECIFICATIONS / 参考仕様

RDX-E700

AMPLIFIER SECTION / アンプ部

- **Minimum RMS output power per channel** (20 kHz Factory LPF) / 定格出力
(6 ohms, 1 kHz, 0.18% THD) 20 W + 20 W
- **Maximum RMS output power per channel** (20 kHz Factory LPF) / 実用最大出力
(6 ohms, 1 kHz, 10% THD) 30 W + 30 W
- **Total Harmonic Distortion** / 全高調波歪率
AUX etc (1 Channel Driven, 1 kHz) less than 0.08%
- **Input sensitivity/Impedance** (入力感度/インピーダンス)
AUX etc. 300 mV/47 k-ohms
- **Frequency Response** / 周波数特性
AUX etc. 10 Hz to 22 kHz \pm 3dB
- **Signal to Noise ratio** (S/N 比)
(20 kHz Factory LPF, IHF-A network, Shorted)
AUX etc (0 dB Input) 93 dB

VIDEO SECTION / ビデオ部

- **Video Signal Level** / ビデオ入力信号
Video 1 Vp-p/75 ohms
Component (Y/PB, PR) 1 Vp-p/0.7 Vp-p/75 ohms
Signal to Noise ratio 72 dB

TUNER SECTION / チューナー部

FM Section / FM チューナー部

- **Tuning Range** / 受信周波数範囲
U, C, T, K, A, B, G, L, V models 87.50 to 108.00 MHz
J model 76.0 to 108.0 MHz
- **Signal to Noise ratio** (Mono) (S/N 比) 75 dB
- **Sensitivity** (S/N 30 dB) / 感度(S/N 20dB) 1.0 μ V

AM Section / AM チューナー部

- **Tuning Range** / 受信周波数範囲
U, C models 530 to 1700 kHz
T, K, A, B, G, L, V, J models 522 to 1629 kHz
- **Signal to Noise ratio** (S/N 比) 32 dB
- **Sensitivity** (S/N 20 dB) / 感度(S/N 20dB) 700 μ V

CD/DVD PLAYER SECTION (CD/DVD レシーバー部)

- **Signal to Noise ratio** (S/N 比) 95 dB
- **Total Harmonic Distortion** / 全高調波歪率 0.007%
- **Separation** / セパレーション 90 dB

AUDIO FORMAT / オーディオ部

- Dolby Digital/MPEG decode (not decode DTS) / ドルビーデジタル/MPEG (DTS を除く)
- PCM DATA: 16 bit
- LPCM DATA: 20/24 bit
Fs: 44.1, 48 kHz support/88.2, 96 kHz downmix support /
Fs 44.1,48 kHz 対応 /88.2,96 kHz ダウンミック対応
- MP3: 32 kbps to 320 kbps, 16 kHz to 48 kHz sampling rate /
MP3:32 ~ 320 kbps 16 ~ 48 kHz サンプリングレート

- WMA: Up to 192 kbps (not support 32 kbps),
32 kHz, 44.1 kHz, 48 kHz sampling rate /
WMA:192 kbps まで (32 kbps を除く)
32,44.1,48 kHz サンプリングレート
- Support mono and stereo WMA/MP3 and VBR files /
WMA/MP3/VBR (モノラル/ステレオ)

GENERAL / 総合

Power Supply / 電源電圧

U, C models	AC 120 V, 60 Hz
T model	AC 220 V, 50 Hz
K model	AC 220 V, 60 Hz
A model	AC 240 V, 50 Hz
B, G models	AC 230 V, 50 Hz
L model	AC 220-240 V, 50/60 Hz
V model	AC 110-120 V, 50/60 Hz
J model	AC 100 V, 50/60 Hz

Power consumption / 消費電力

U, C, V, J models	0.9 W
T, K, B, G models	1.0 W
A, L models	1.1 W

Dimensions (W x H x D) / 外形寸法

	215 x 112.8 x 295.9 mm (8-7/16" x 4-7/16" x 11-5/8")
--	---

Weight / 質量

	2.65 kg (5 lbs. 13oz)
--	--------------------------

Finish / 仕上げ

Silver color	U, K, B, G, L, V, J models
Gold color	U, C, T, A, G, V models

Accessories / 付属品

	Remote control x 1
	Battery (size "AA", R06, UM-3) x 2
	AM loop antenna x 1
	Indoor FM antenna x 1
	Video pin cable x 1

* Specifications subject to change without prior notice.

U USA model
C Canadian model
T Chinese model
K Korean model
A Australian model
B British model
G European model
L Singapore model
V Tiwanes & Mexican models
J Japanese model

NX-E700

- **Type / 型式** 2-Way Bass Reflex Speaker System
Magnetic Shielding Type
2ウェイ・パスレス式 / 防磁型
- **Driver / スピーカーユニット**
 - Woofer 11 cm (4-1/2") Cone Type
 - Tweeter 2.5 cm (1") Dome Type
- **Frequency Response / 再生周波数帯域**
 - U, C, T, K, A, B, G, L, V models 60 Hz to 28 kHz (-10dB)
 - J model 60 Hz to 28 kHz (-10dB)
60 Hz to 80 kHz (-30dB)
- **Impedance / インピーダンス** 6 ohms
- **Nominal Input / 許容入力** 40 W
- **Maximum Input / 最大入力** 110 W
- **Sensitivity / 出力音圧レベル** 85 dB/2.83 V/m
- **Crossover Frequency / クロスオーバー周波数** 3 kHz
- **Input Terminal / 入力端子** Screw/Banana Type
- **Dimensions (W x H x D) / 寸法(幅 x 高さ x 奥行き)**
 - 165 mm x 255 mm x 183 mm
(6-1/2" x 10-1/16" x 7-3/16")
- **Weight / 質量** 3.4 kg (7 lbs 8 oz)
- **Finish / 仕上げ** Black
- **Accessories / 付属品** Speaker cable (4m) x 2

* Specifications subject to change without prior notice.



Manufactured under license from Dolby Laboratories.

"Dolby" and the double-D symbol are trademarks of Dolby Laboratories. ドルビーラボラトリーズからの実施権により製造されています。「ドルビー」及びダブルD記号は、ドルビーラボラトリーズの商標です。



"DTS" and "DTS DIGITAL OUT" are trademarks of Digital Theater Systems, Inc.

DTS および DTS Digital Out はデジタルシアターシステムズの登録商標です。



"DivX", "DivX Certified", and associated logos are trademarks of DivX Networks, Inc and are used under license.

DivX, DivX Certified およびそのロゴは DivX Networks Inc の商標であり、ライセンス承諾を得て使用されます。

MPEG Layer-3 audio decoding technology licensed from Fraunhofer IIS and Thomson multimedia.

MPEG-1 Audio Layer3 音声圧縮技術は、Fraunhofer IIS および THOMSON multimedia からライセンスを受けています。

■ DIMENSIONS / 寸法図

● RDX-E700

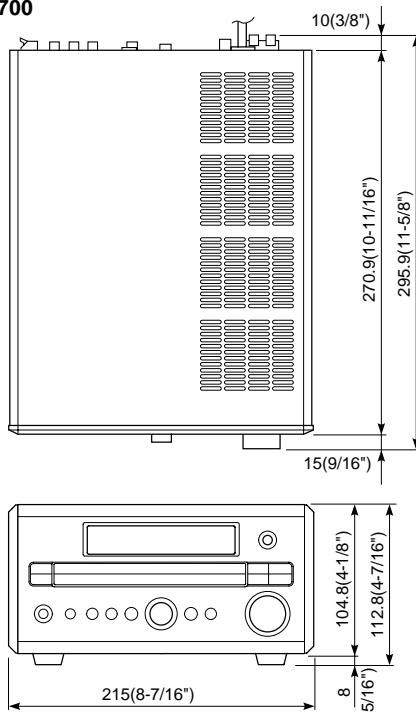

● NX-E700

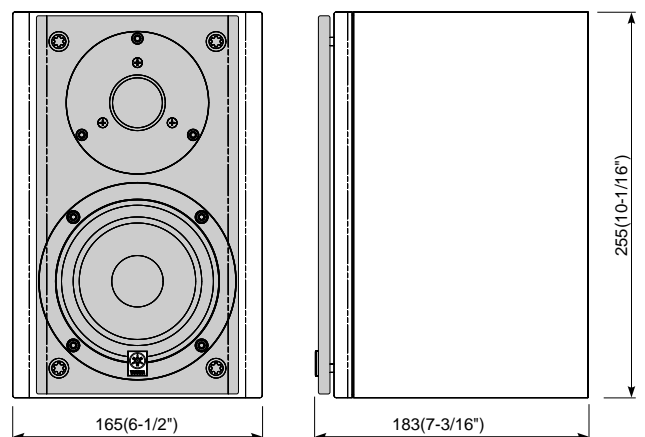

Unit : mm (inch)

INTERNAL VIEW / 各部名称

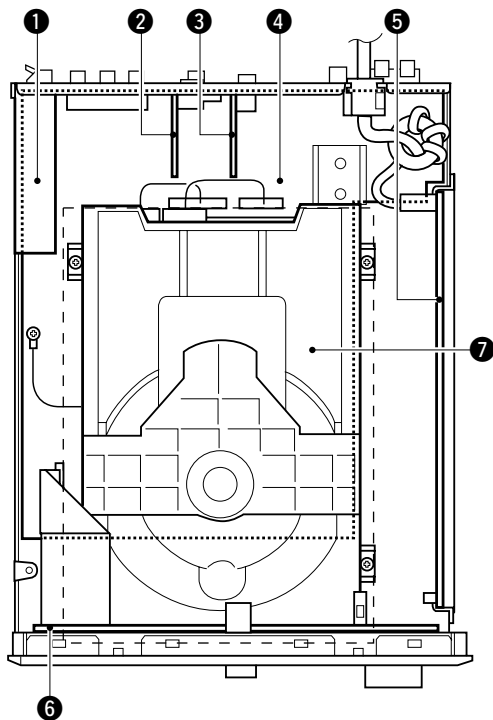

- ① AM/FM TUNER
- ② MAIN (2) P.C.B.
- ③ MAIN (3) P.C.B. (J model only)
- ④ MAIN (1) P.C.B.
- ⑤ POWER SUPPLY UNIT
- ⑥ FRONT P.C.B.
- ⑦ DVD MECHANISM ASS'Y

DISASSEMBLY PROCEDURES / RDX-E700分解手順

- Remove parts in disassembly order as numbered.
- Disconnect the power cable from the AC outlet.

1. Removal of Top Cover

- a. Remove 2 screws (①) and 4 screws (②). (Fig. 1)
- b. Slide the Top Cover rearward to remove it. (Fig. 1)

2. Removal of Front Panel Unit

- a. Open the tray, remove the door ornament and close the tray. (Fig. 1)
- b. Remove 4 screws (③). (Fig. 1)
- c. Remove connectors CN14. (Fig. 2)
- d. Remove 2 hooks and then slide the Front Panel Unit forward. (Fig. 2)

3. Removal of DVD Mechanism Ass'y

- a. Remove 4 screws (④) and a screw (⑤). (Fig. 1)
- b. Remove connectors CN11, CN12 and GND wire and then remove the DVD Mechanism Ass'y. (Fig. 2)

- 番号順に部品を取り外してください。
- AC電源コンセントから、電源コードを抜いてください。

1. トップカバーの外し方

- a. ①のネジ2本、②のネジ4本を外します。(Fig. 1)
- b. トップカバーを後方へスライドさせ取り外します。(Fig. 1)

2. フロントパネルユニットの外し方

- a. トレーを開き、ドア飾りを外し、トレーを閉じます。(Fig. 1)
- b. ③のネジ4本を外します。(Fig. 1)
- c. コネクターCN14を外します。(Fig. 2)
- d. フック2箇所を外し、フロントパネルユニットを前方へ引き出します。(Fig. 2)

3. DVDメカニズムASSYの外し方

- a. ④のネジ4本、⑤のネジ1本を外します。(Fig. 1)
- b. コネクターCN11、CN12、及びアース線を外し、DVDメカニズムASSYを取り外します。(Fig. 2)

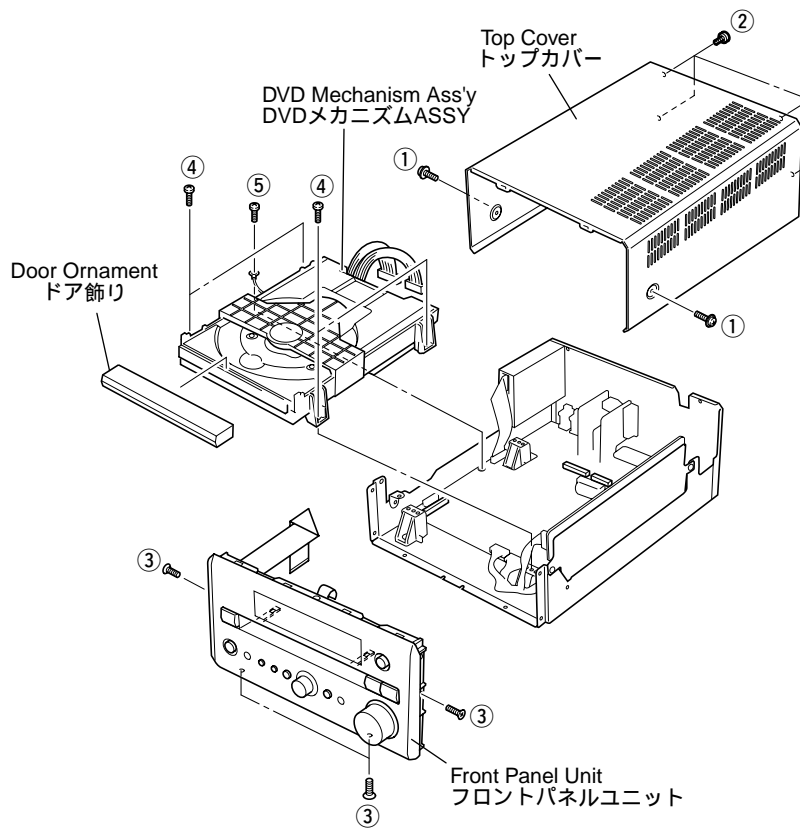

Fig. 1

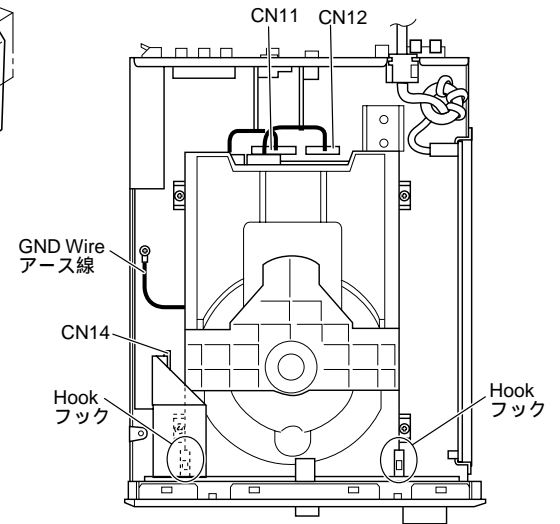

Fig. 2

● HOW TO MANUALLY EJECT THE TRAY

- Turn the unit bottom up.
- Turn the Loading Gear in the direction indicated with a screwdriver until the tray is ejected.
- Gently pull the tray out.

手動でトレイを開く方法

- 本機を上下反転します。
- トレイが出てくるまで、ドライバーでローディングギアを図に示す矢印の方向に回転します。
- トレイをそっと引き出します。

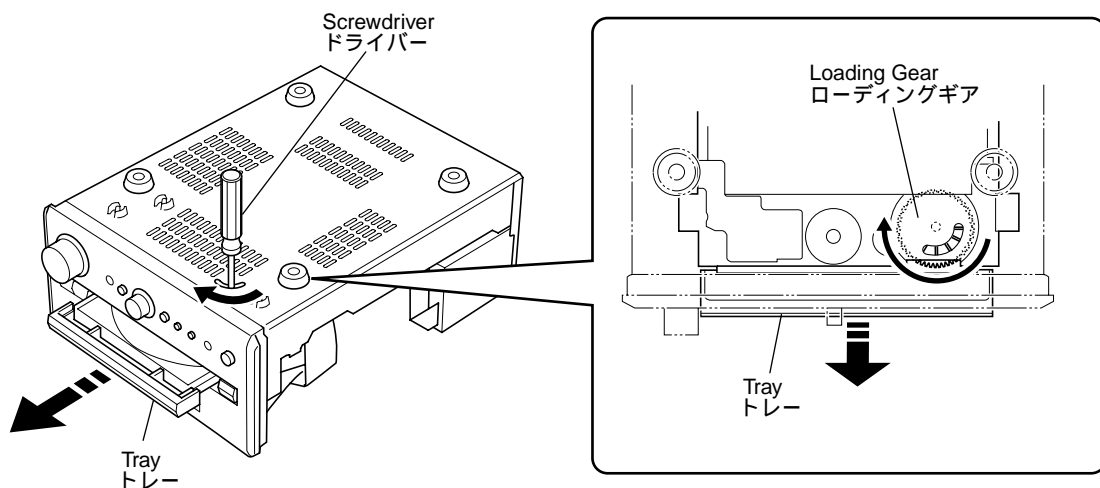

Fig. 3

■ TRAY LOCK MODE / トレーロックモード

In the TRAY LOCK mode, the tray open/close function is stopped temporarily.

● Setting Tray Lock mode

1. With the power turned off, while pressing the "TIMER" key and "MODE" key, keep pressing the "STANDBY/ON" key for 4 seconds or longer.
2. When the Tray Lock mode is set, "TRADE ON" is displayed which then returns to the normal display.

NOTE 1: Even after the Tray Lock mode is set, all functions remain the same as usual except the "open/close" key.

NOTE 2: If no disc is loaded in the tray, the Tray Lock mode is cancelled automatically.

● Canceling Tray Lock mode

1. With the power turned off, while pressing the "TIMER" key and "MODE" key, keep pressing the "STANDBY/ON" key for 4 seconds or longer.
2. When the Tray Lock mode is cancelled, "TRADE OFF" is displayed which then returns to the normal display.

トレーロックモードは、トレーのオープン/クローズ機能を一時的に停止する機能です。

トレーロックモードの起動

1. 電源オフの状態では、“TIMER”キーと“MODE”キーを押しながら“STANDBY/ON”キーを4秒間以上押し続けます。
2. トレーロックモードが起動し「TRADE ON」と表示した後、通常の表示に戻ります。

注1: トレーロックモード起動後、“オープン/クローズ”キー以外の操作は通常通り行うことができます。

注2: DISCがトレー上にセットされていない場合、トレーロックモードは自動的に解除されます。

トレーロックモードの解除

1. 電源オフの状態では、“TIMER”キーと“MODE”キーを押しながら“STANDBY/ON”キーを4秒間以上押し続けます。
2. トレーロックモードが解除され「TRADE OFF」と表示した後、通常の表示に戻ります。

■ FACTORY RESET / ファクトリーリセット

When any of the following conditions applies, perform the factory reset procedure to make setting of the DVD Mechanism Ass'y suitable for the destination region.

- The DVD Mechanism Ass'y (including MPEG P.C.B.) has been replaced.
- MPEG P.C.B. has been replaced.
- DVD firmware has been updated.

● Operation procedure

1. With the power turned off, while pressing the "SOUND" key and "MODE" key, keep pressing the "STANDBY/ON" key for 4 seconds or longer.
2. When the Service Mode is set, the software version information is displayed on the TV monitor screen connected to the main unit as shown below.

<Example>

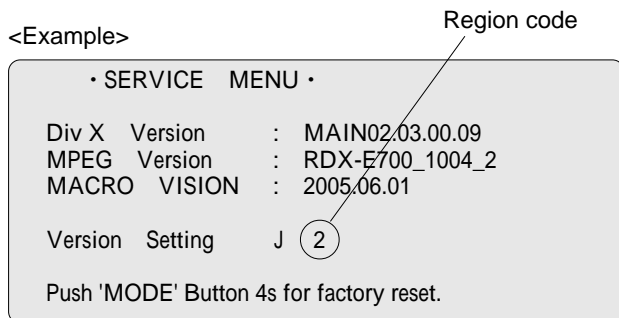

At the same time, the host software version is displayed of the main unit.

<Example>

050824-1

3. Keep pressing the "MODE" key for 4 seconds or longer. The display unit of the main unit repeats flashing and then the power is turned off automatically.

This completes the Factory Reset procedure.

下記の場合、DVDメカニズムASSYの仕向け地別設定を行うためにファクトリーリセットを行います。

- DVDメカニズムASSY(MPEG P.C.B.を含む)を交換した場合
- MPEG P.C.B.を交換した場合
- DVDファームウェアを更新した場合

操作方法

1. 電源オフの状態では、“SOUND”キーと“MODE”キーを押しながら“STANDBY/ON”キーを4秒間以上押し続けます。
2. サービスモードが起動した後、本機に接続したTVモニターの画面上にソフトウェアバージョン情報が下記のように表示されます。

<表示例>

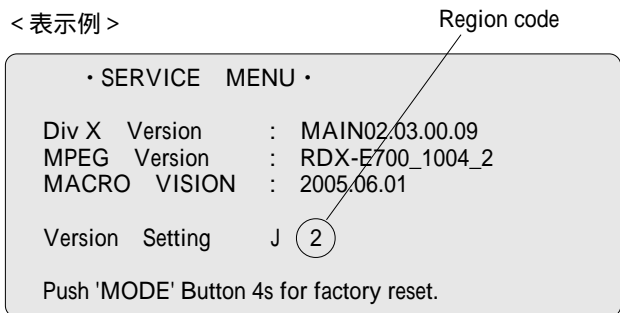

同時に本機の表示器にホストソフトウェアバージョンが表示されます。

<表示例>

050824-1

3. “MODE”キーを4秒間以上押し続けます。本機の表示器が点滅を繰り返した後、自動的に電源がOFFします。

以上の操作でファクトリーリセットは完了です。

PRINTED CIRCUIT BOARD
FOR INFORMATION ONLY (NO REPLACEMENT COMPONENT PARTS WILL BE AVAILABLE)

A

MPEG P.C.B.

(Side A) Lead Free Solder Used

DVD MECHANISM (OPEN/CLOSE) DVD MECHANISM (SPINDOLE & SLED)

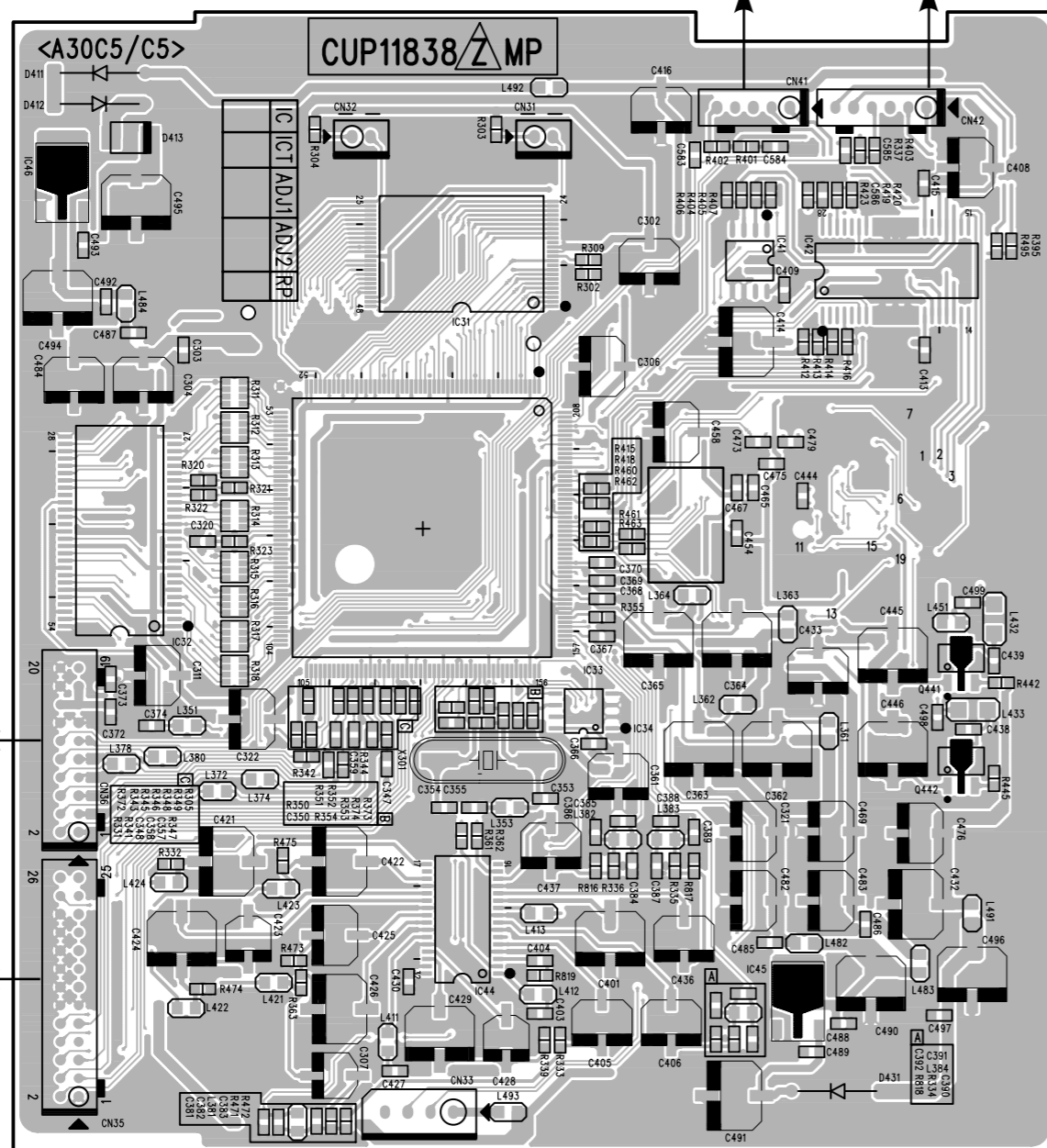

MPEG P.C.B.

(Side B) Lead Free Solder Used

DVD MECHANISM (PICK-UP)

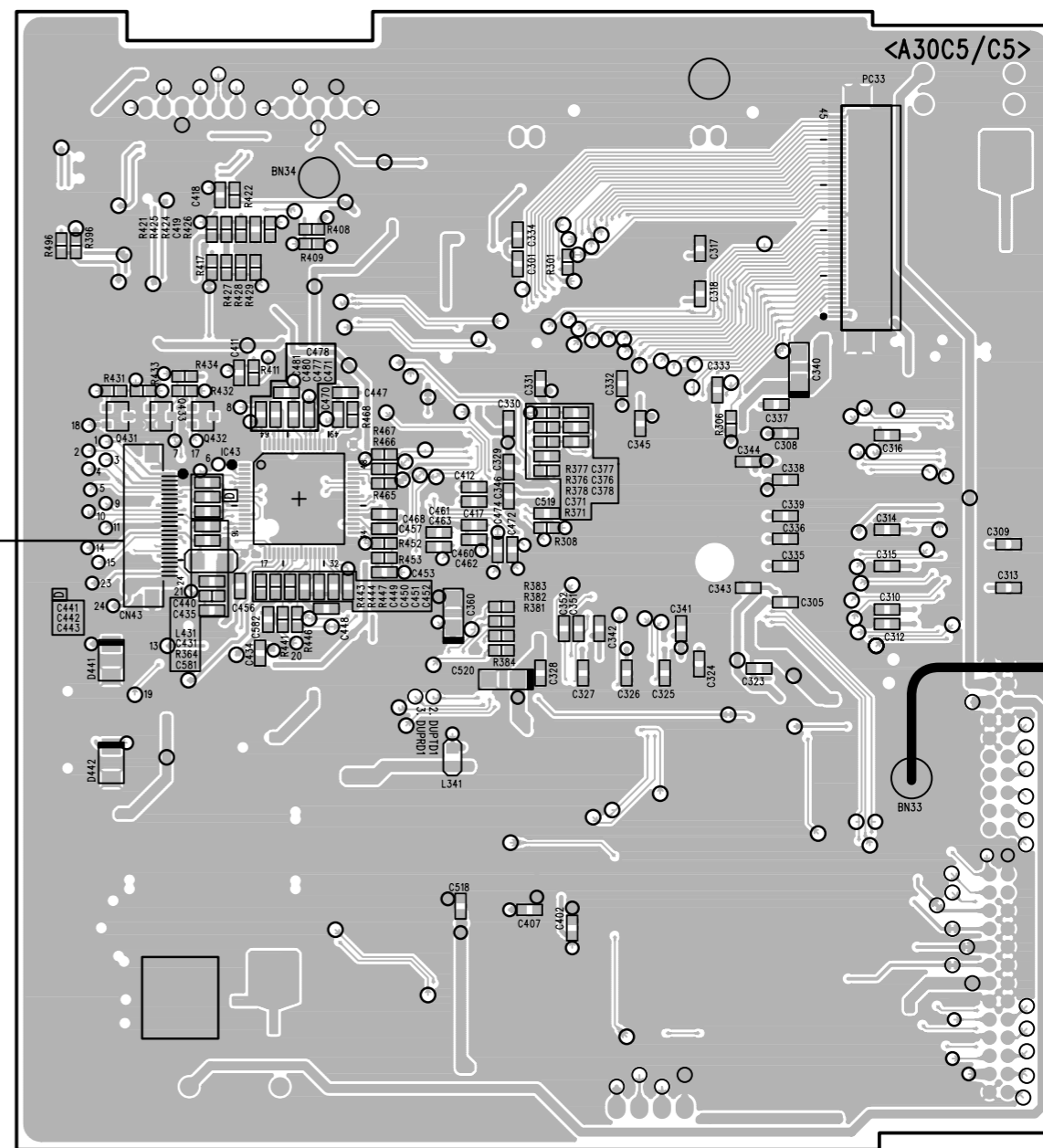

B

C

D

E

F

PRINTED CIRCUIT BOARD FOR INFORMATION ONLY (NO REPLACEMENT COMPONENT PARTS WILL BE AVAILABLE)

MAIN (2) P.C.B. (Side A) Lead Free Solder Used

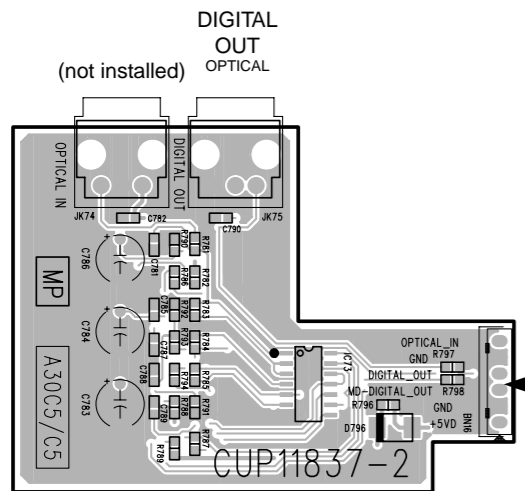

MAIN (1) P.C.B. (Side A) Lead Free Solder Used

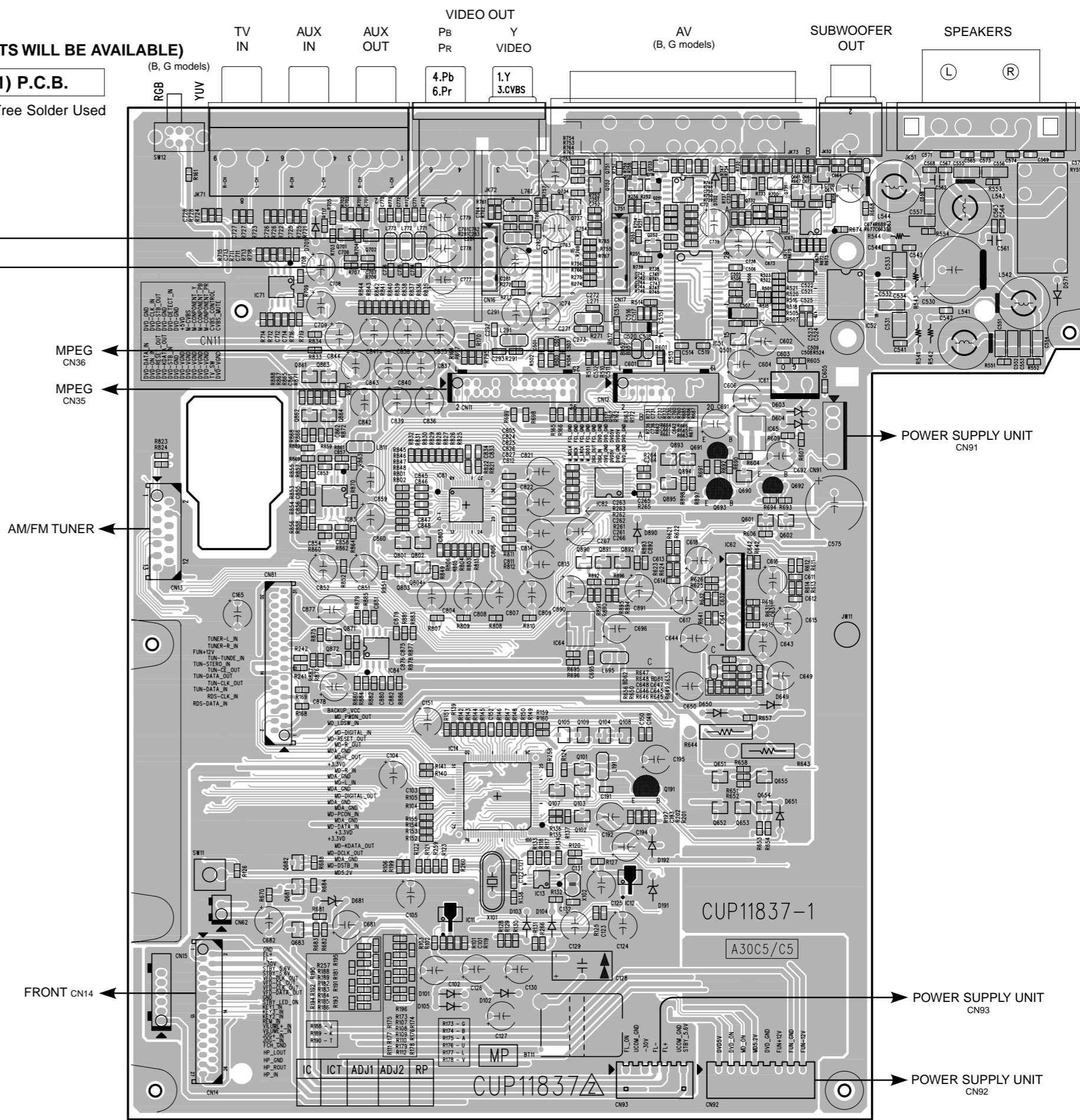

MAIN (3) P.C.B. (Side A)

J model

D1/D2

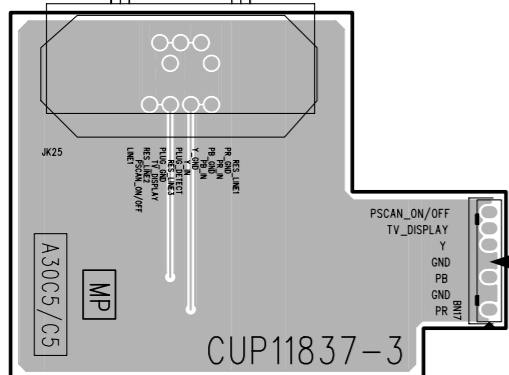

■ PRINTED CIRCUIT BOARD
 FOR INFORMATION ONLY (NO REPLACEMENT COMPONENT PARTS WILL BE AVAILABLE)

A

MAIN (1) P.C.B.
 (Side B) Lead Free Solder Used

MAIN (2) P.C.B.
 (Side B) Lead Free Solder Used

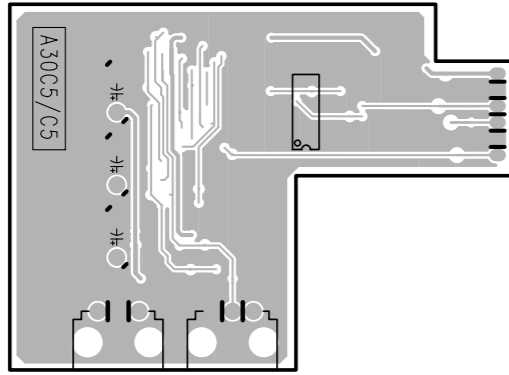

B

C

MAIN (3) P.C.B.
 (Side B) Lead Free Solder Used

● J model

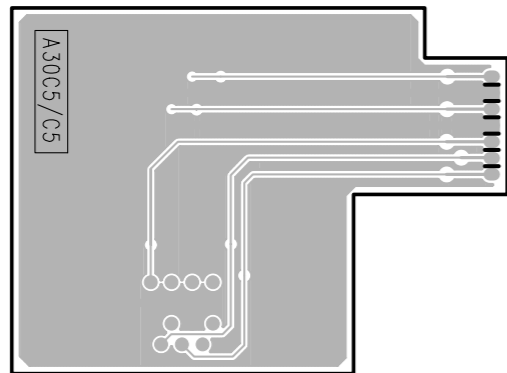

D

E

F

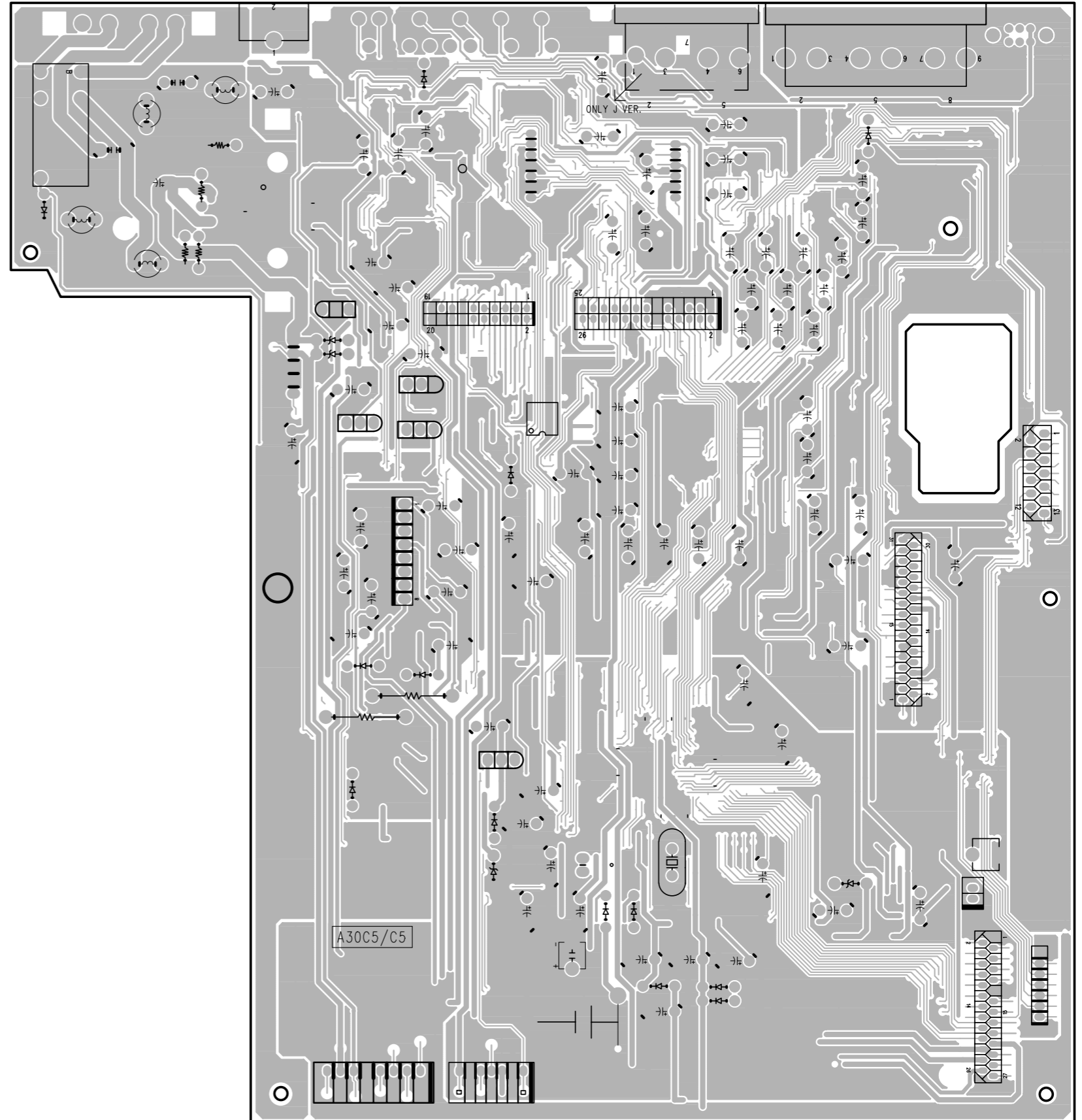

■ BLOCK DIAGRAM

A
B
C
D
E
F

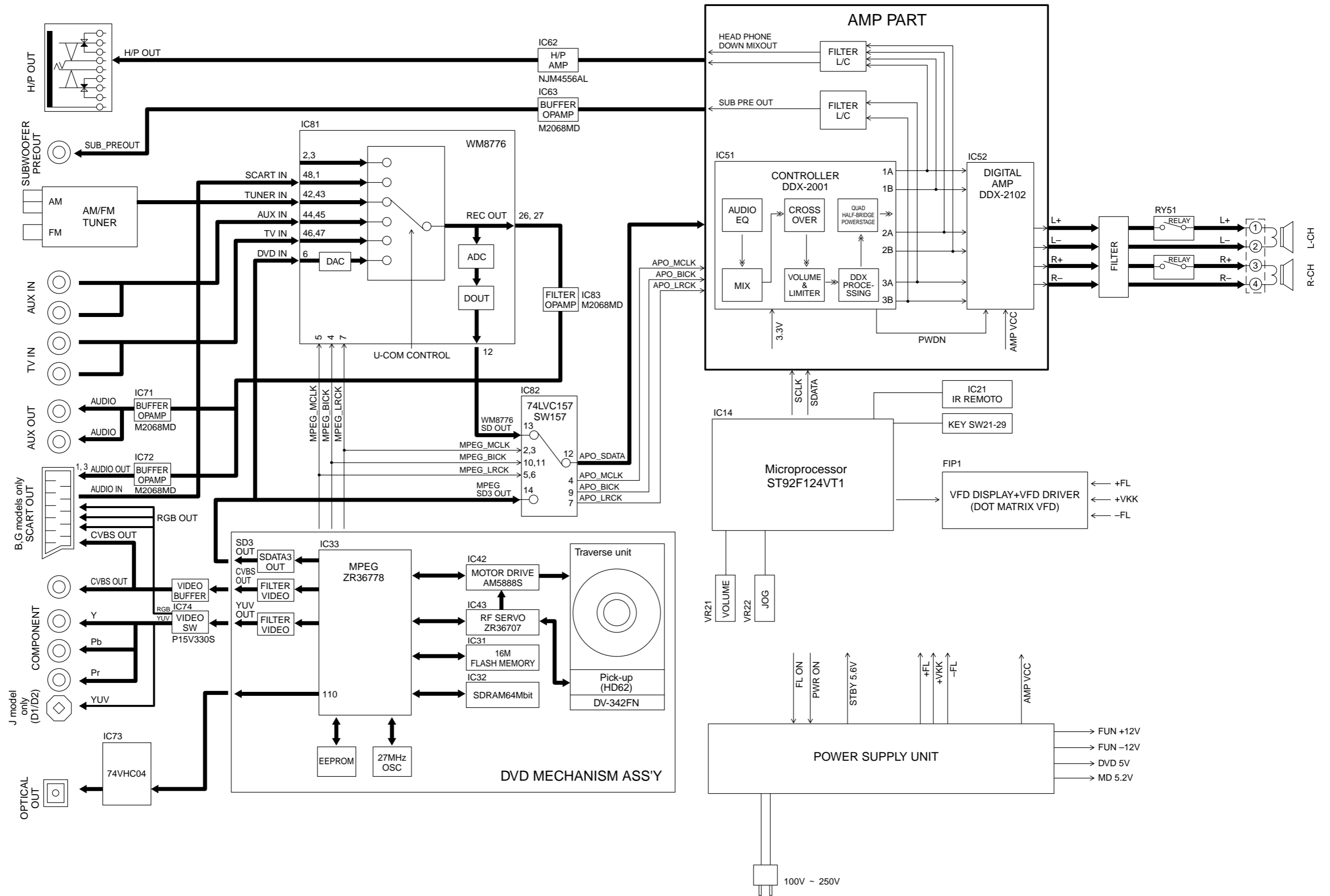

SCHEMATIC DIAGRAM (MPEG 1/2 (FRONT END)) FOR INFORMATION ONLY (NO REPLACEMENT COMPONENT PARTS WILL BE AVAILABLE)

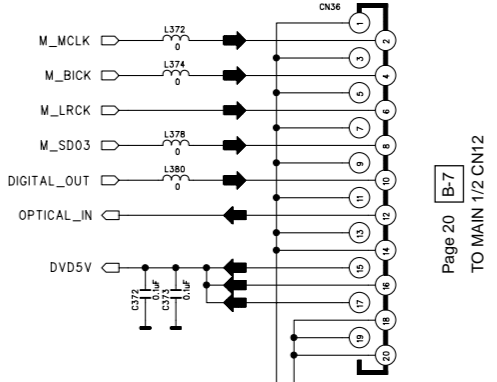
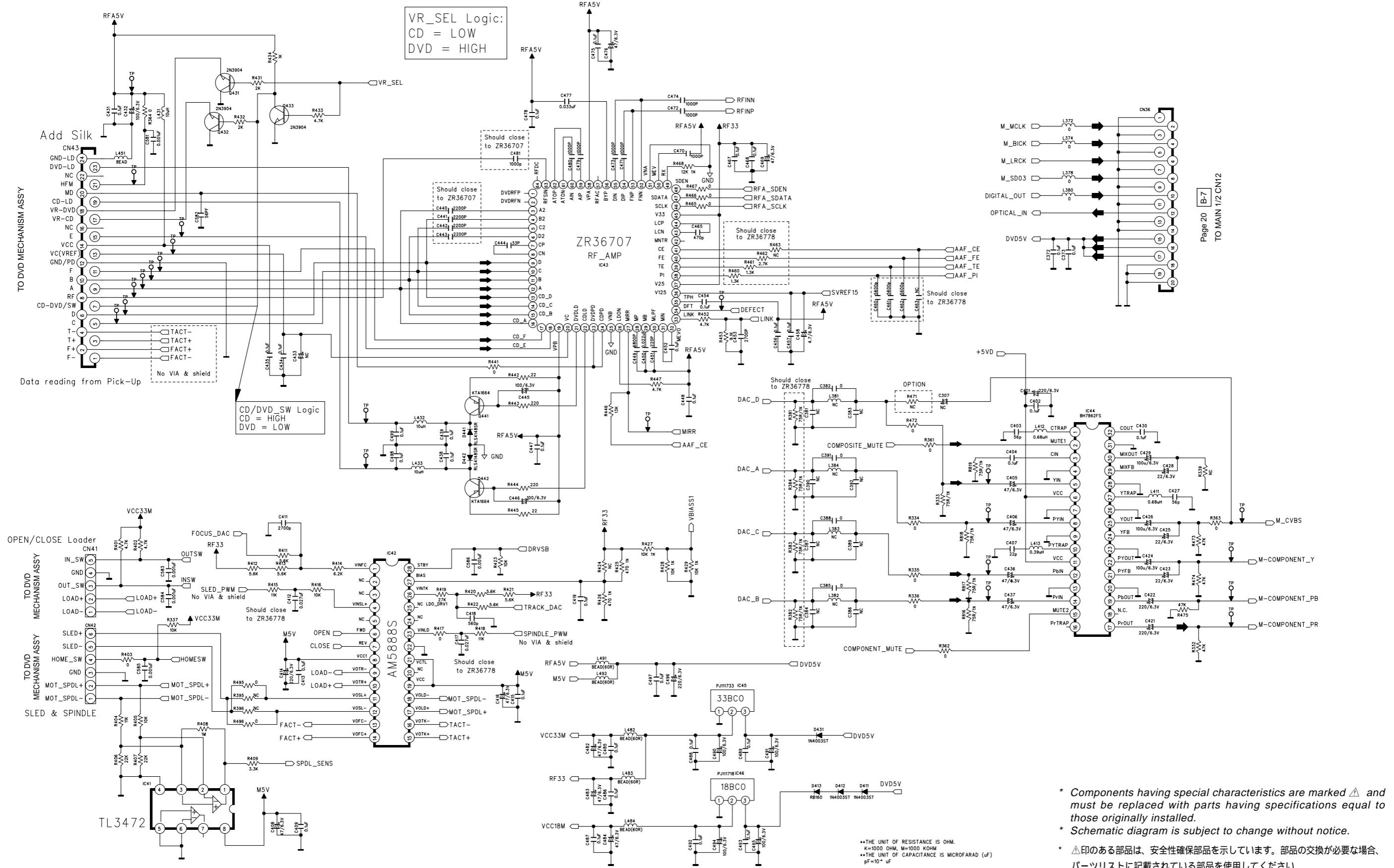

Page 20 B-7
TO MAIN 1/2 CN12

* Components having special characteristics are marked Δ and must be replaced with parts having specifications equal to those originally installed.

* Schematic diagram is subject to change without notice.

* Δ 印のある部品は、安全性確保部品を示しています。部品の交換が必要な場合、パーツリストに記載されている部品を使用してください。

* 本回路図は、標準回路図です。改良のため予告なく変更することがございます。

••THE UNIT OF RESISTANCE IS OHM.
K=1000 OHM, M=1000 KOHM
••THE UNIT OF CAPACITANCE IS MICROFARAD (μ F)
pF=10⁻¹² μ F

SCHEMATIC DIAGRAM (MPEG 2/2 (BACK END))
FOR INFORMATION ONLY (NO REPLACEMENT COMPONENT PARTS WILL BE AVAILABLE)

A
B
C
D
E
F

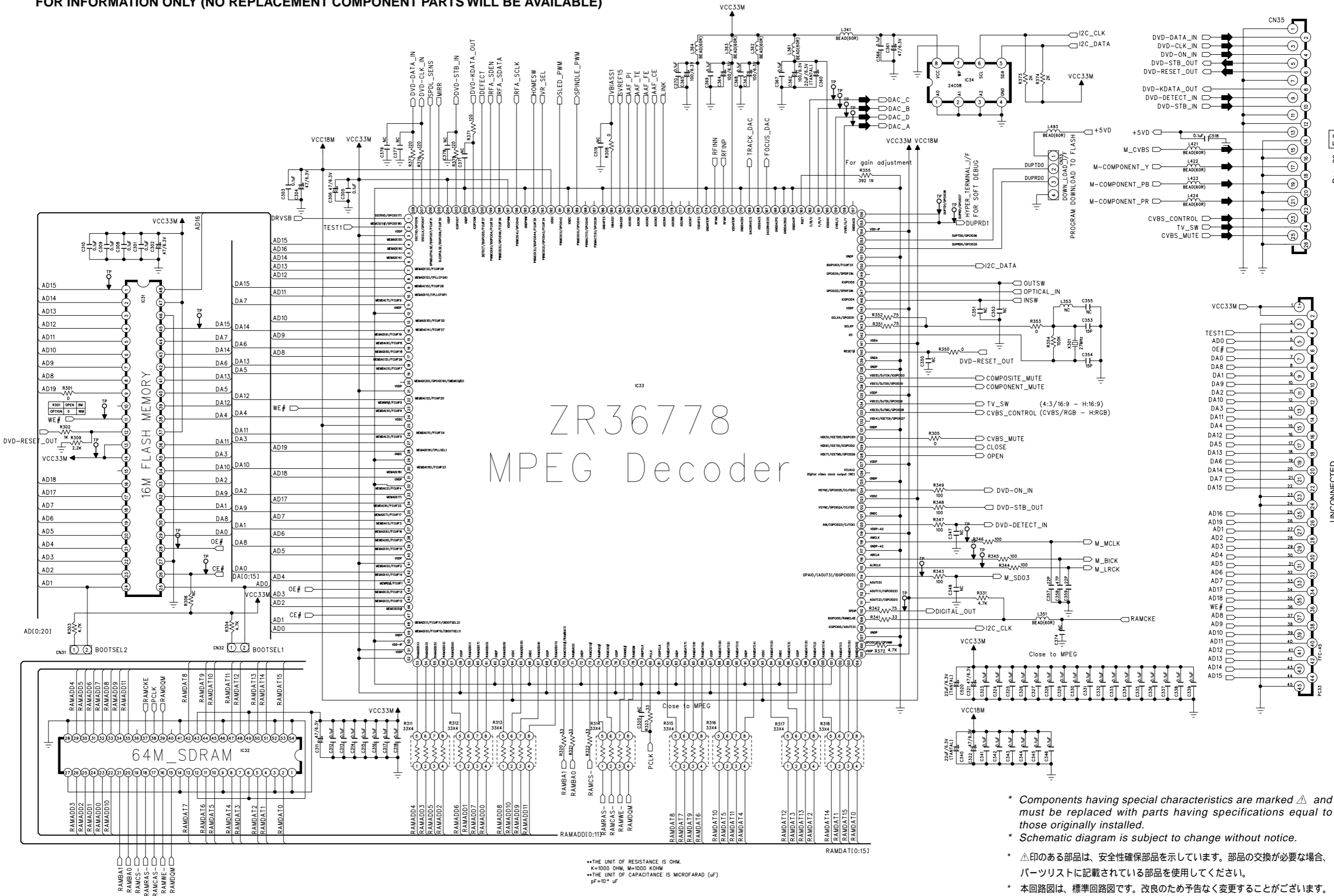

ZR36778
MPEG Decoder

* Components having special characteristics are marked Δ and must be replaced with parts having specifications equal to those originally installed.

* Schematic diagram is subject to change without notice.

* Δ 印のある部品は、安全性確保部品を示しています。部品の交換が必要な場合、パーツリストに記載されている部品を使用してください。

* 本回路図は、標準回路図です。改良のため予告なく変更することがございます。

••THE UNIT OF RESISTANCE IS OHM.
K=1000 OHM, M=1000 KOHM
••THE UNIT OF CAPACITANCE IS MICROFARAD (uF)
pF=10⁻⁶ uF

SCHEMATIC DIAGRAM (MAIN 1/2 (Microprocessor)) FOR INFORMATION ONLY (NO REPLACEMENT COMPONENT PARTS WILL BE AVAILABLE)

R795 FUN_GND->FD_GND R162 FCL_GND->FCH_GND R670 FUN_GND->FAN_GND
 R165 FUN_GND->MOD_GND R171 FV_GND->FCH_GND R711 FV_GND->FCH_GND
 R169 FUN_GND->MDA_GND R170 FA_GND->FCL_GND R608 AA_GND->AA_GND
 R165 DVD_GND->DVD_GND R163 FCL_GND->FCH_GND R609 AA_GND->AA_GND
 R166 DVD_GND->FV_GND R687 FUN_GND->FA_GND R688 AS_GND->FCH_GND
 R164 FUN_GND->FUN_GND R688 FUN_GND->FV_GND R689 AS_GND->FCH_GND
 R170 FA_GND->FCL_GND R689 FUN_GND->FCH_GND R172 DVD_GND->OCL_GND

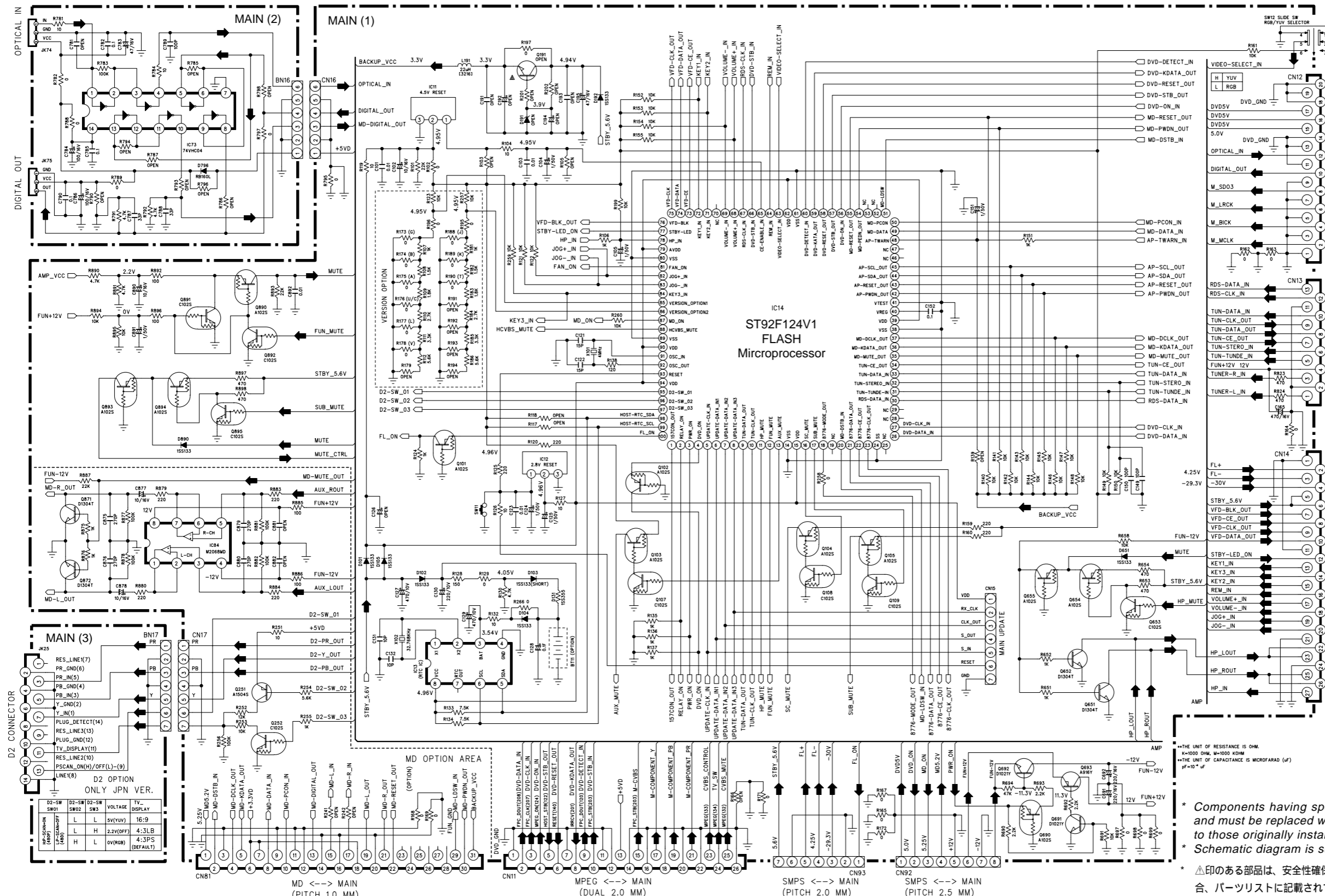

D2 CONNECTOR

D2-SW SW01	D2-SW SW02	D2-SW SW3	VOLTAGE	TV DISPLAY
L	L	H	5V(VU)	16:9
L	L	H	2.2V(OFF)	4:3LB
H	L	O(VCR)	0V(OVB)	4:3PS (DEFAULT)

D2 OPTION ONLY JPN VER.

D2-SW SW01	D2-SW SW02	D2-SW SW3	VOLTAGE	TV DISPLAY
L	L	H	5V(VU)	16:9
L	L	H	2.2V(OFF)	4:3LB
H	L	O(VCR)	0V(OVB)	4:3PS (DEFAULT)

* Components having special characteristics are marked Δ and must be replaced with parts having specifications equal to those originally installed.
 * Schematic diagram is subject to change without notice.
 * Δ 印のある部品は、安全性確保部品を示しています。部品の交換が必要な場合、パーツリストに記載されている部品を使用してください。
 * 本回路図は、標準回路図です。改良のため予告なく変更することがございます。

SCHEMATIC DIAGRAM (MAIN 2/2 (FUNCTION & AMP))
FOR INFORMATION ONLY (NO REPLACEMENT COMPONENT PARTS WILL BE AVAILABLE)

A
B
C
D
E
F

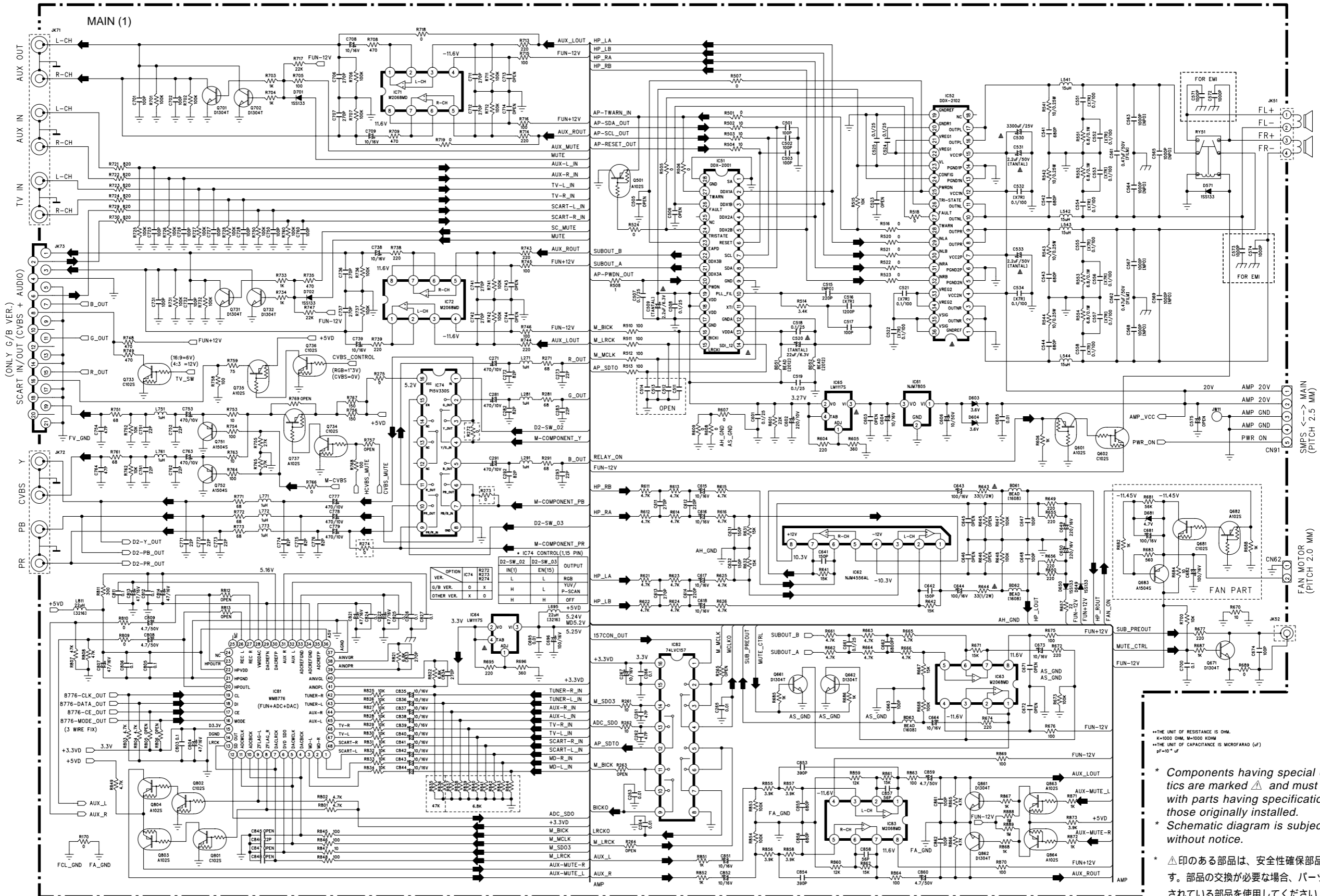

**THE UNIT OF RESISTANCE IS OHM.
 K=1000 OHM, M=1000 KOHM
 **THE UNIT OF CAPACITANCE IS MICROFARAD (UF)
 PF=10⁻⁶ UF

* Components having special characteristics are marked Δ and must be replaced with parts having specifications equal to those originally installed.
 * Schematic diagram is subject to change without notice.

* Δ 印のある部品は、安全性確保部品を示しています。部品の交換が必要な場合、パーツリストに記載されている部品を使用してください。
 * 本回路図は、標準回路図です。改良のため予告なく変更することがございます。

SWPS \leftarrow MAIN (PITCH 2.5 MM)
 CN91
 AMP 20V
 AMP 20V
 AMP GND
 AMP GND
 PWR ON
 CN91
 FAN MOTOR (PITCH 2.0 MM)
 CN62

SCHEMATIC DIAGRAM (FRONT)
FOR INFORMATION ONLY (NO REPLACEMENT COMPONENT PARTS WILL BE AVAILABLE)

Page 20 D-7
TO MAIN 1/2 CN14

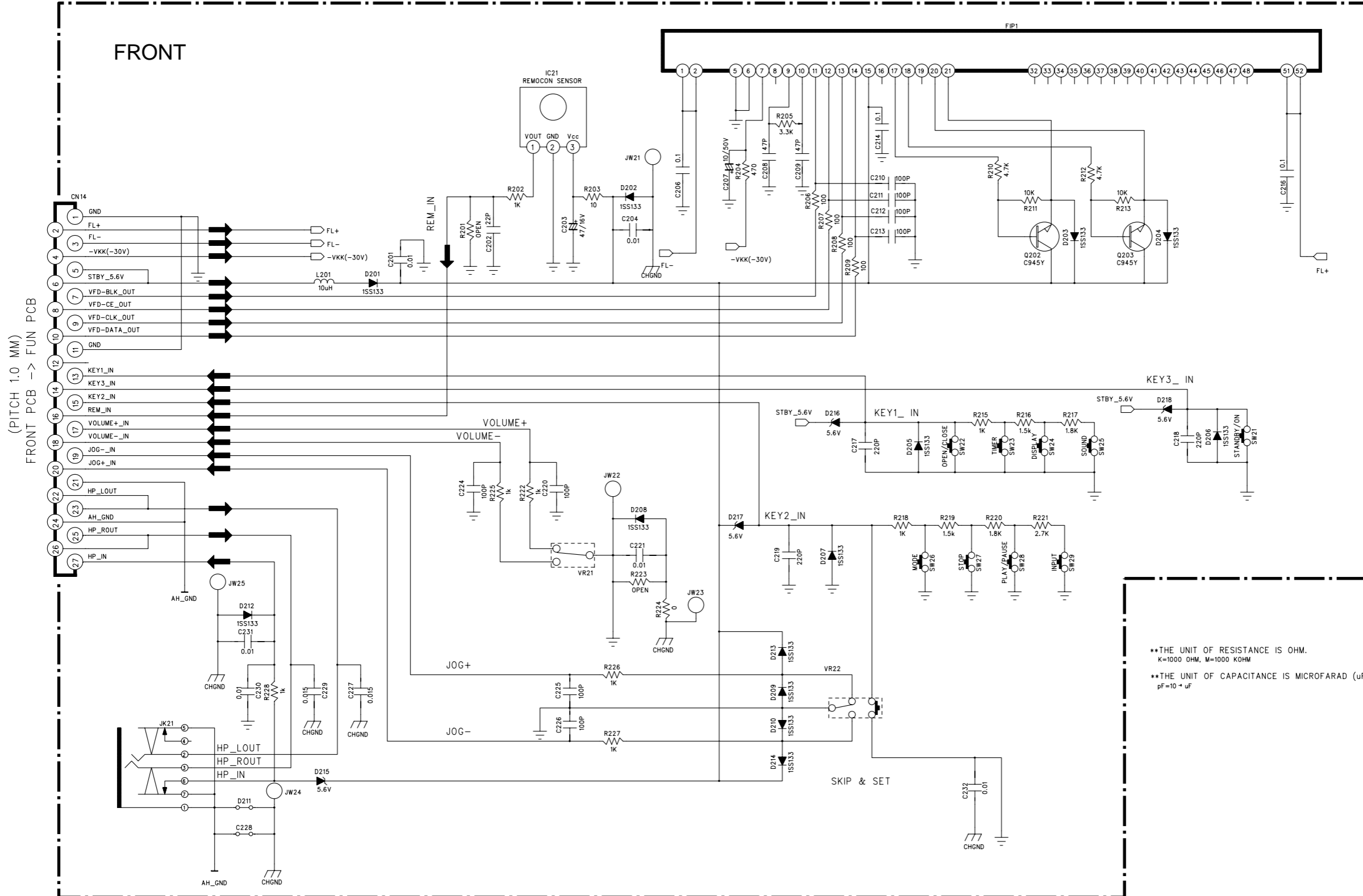

**THE UNIT OF RESISTANCE IS OHM.
K=1000 OHM, M=1000 KOHM
**THE UNIT OF CAPACITANCE IS MICROFARAD (uF)
pF=10⁻⁶ uF

- * Components having special characteristics are marked Δ and must be replaced with parts having specifications equal to those originally installed.
- * Schematic diagram is subject to change without notice.
- * Δ 印のある部品は、安全性確保部品を示しています。部品の交換が必要な場合、パーツリストに記載されている部品を使用してください。
- * 本回路図は、標準回路図です。改良のため予告なく変更することがございます。

SCHEMATIC DIAGRAM (POWER SUPPLY UNIT)
FOR INFORMATION ONLY (NO REPLACEMENT COMPONENT PARTS WILL BE AVAILABLE)

A
B
C
D
E
F

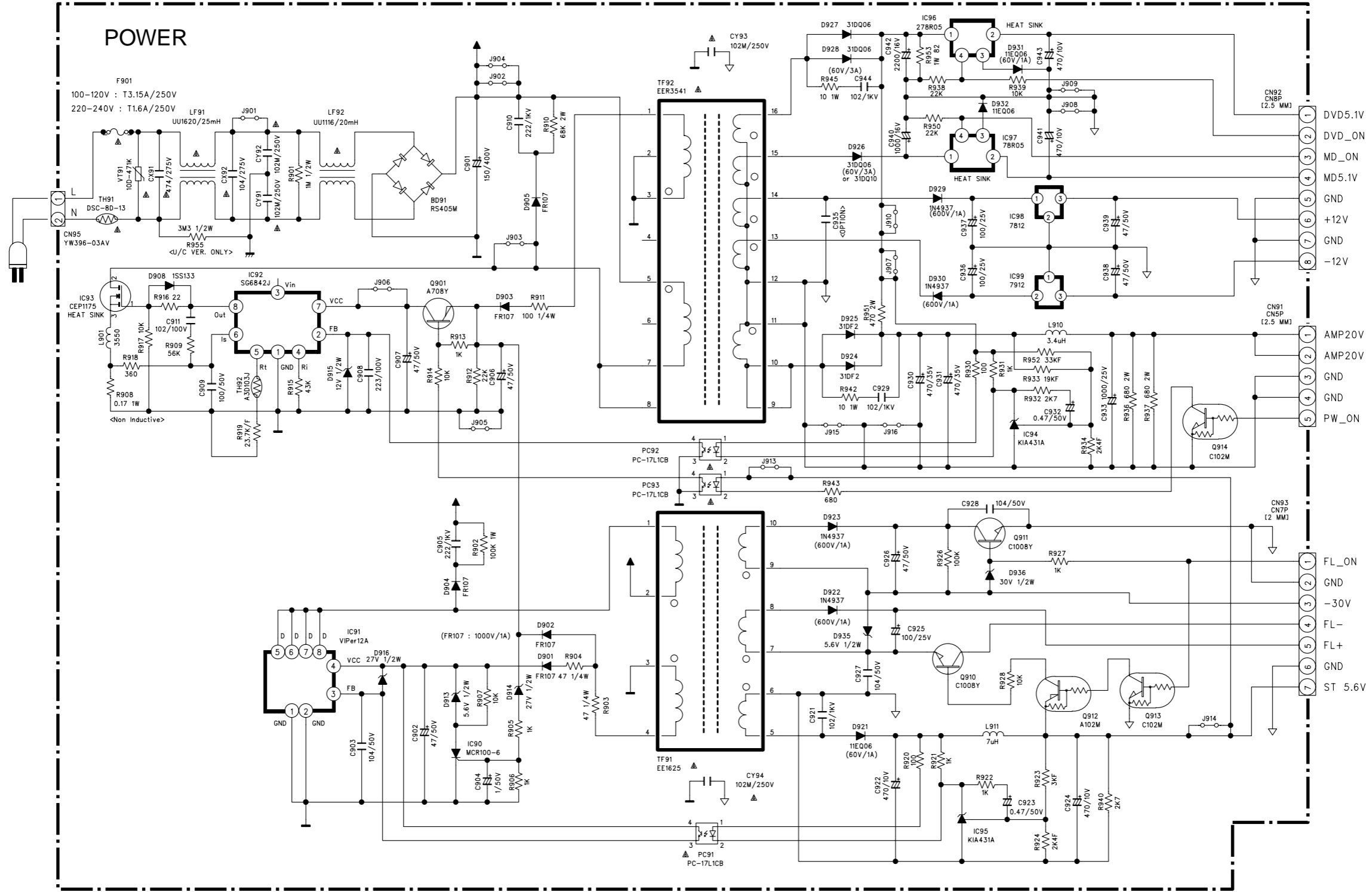

Page 20 TO MAIN 1/2 CN92

Page 21 TO MAIN 2/2 CN91

Page 20 TO MAIN 1/2 CN93

••THE UNIT OF RESISTANCE IS OHM.
 K=1000 OHM; M=1000 KOHM
 ••THE UNIT OF CAPACITANCE IS MICROFARAD (μF)
 pF=10⁻¹² μF

* Components having special characteristics are marked \triangle and must be replaced with parts having specifications equal to those originally installed.
 * Schematic diagram is subject to change without notice.
 * \triangle 印のある部品は、安全性確保部品を示しています。部品の交換が必要な場合、パーツリストに記載されている部品を使用してください。
 * 本回路図は、標準回路図です。改良のため予告なく変更することがございます。

RDX-E700/NX-E700

■ RDX-E700 EXPLODED VIEW

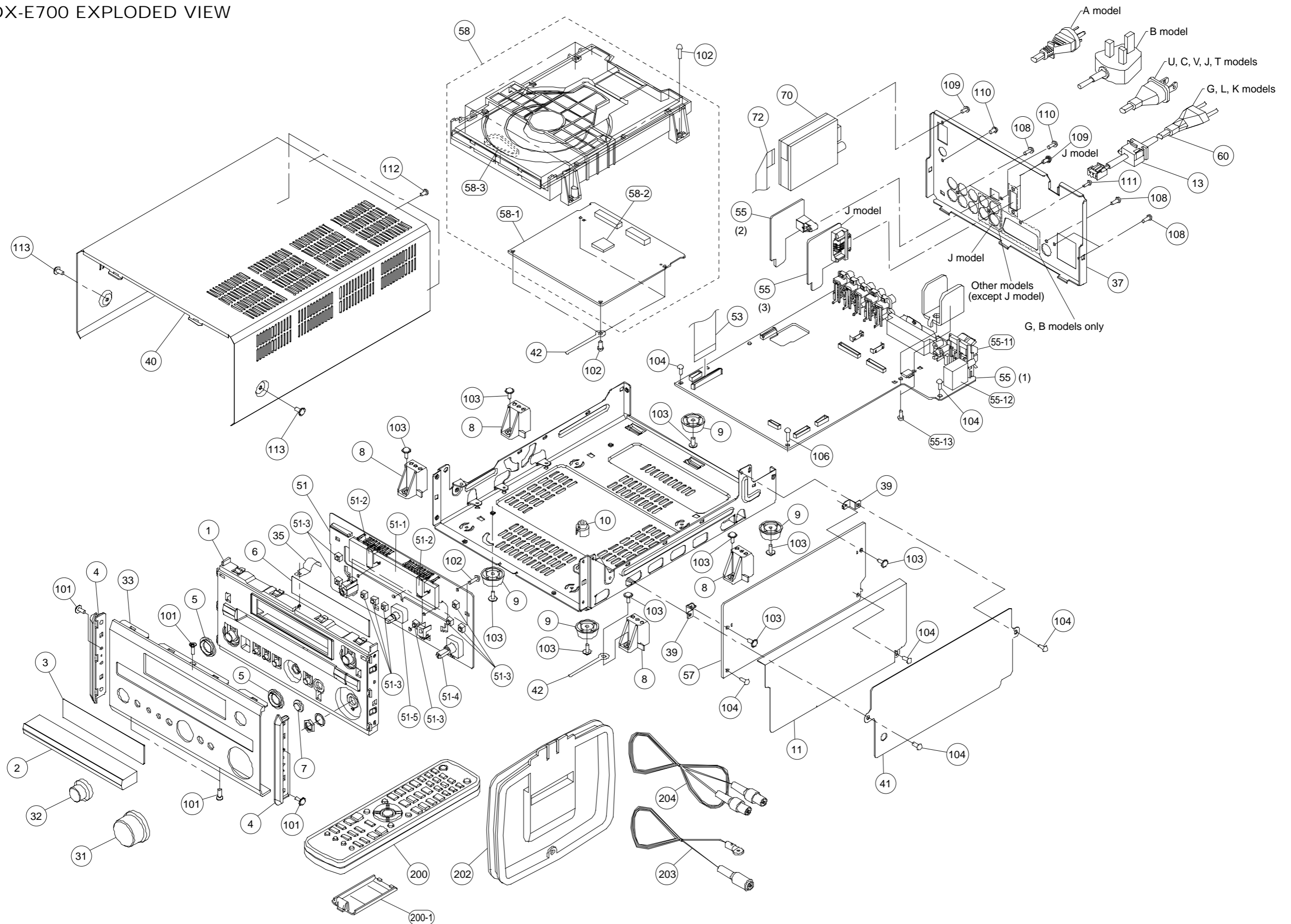

RDX-E700 MECHANICAL PARTS

Ref. No.	Part No.	Description	Remarks	Markets	部品名	Rank
* 1	AAX73990	SUB PANEL ASS'Y	GD	CGWRDXE700GD		サブパネル A S S Y
* 1	AAX74000	SUB PANEL ASS'Y	SI	CGWRDXE700SL		サブパネル A S S Y
* 2	AAX74070	DOOR ORNAMENT	GD	CGR1A384M9D6		ドア飾り
* 2	AAX74060	DOOR ORNAMENT	SI	CGR1A384M7G5		ドア飾り
* 3	AAX73750	FL WINDOW		CGU1A379Z		FLウィンドウ
* 4	AAX73980	SIDE BAR		CGR1A385		サイドバー
* 5	AAX74090	KNOB ORNAMENT	GD	CGR1A388M9D6		ノブ飾り
* 5	AAX74080	KNOB ORNAMENT	SI	CGR1A388M7G5		ノブ飾り
* 6	AAX73760	FL SHEET	GD	CMZ1A103Y		FLシート
* 6	AAX73770	FL SHEET	SI	CMZ1A103Z		FLシート
* 7	AAX73780	IR LENS		CGU1A380		IRレンズ
* 8	AAX74190	MECHA SUPPORT		CMH1A249		メカサポート
* 9	AAX74300	FOOT		CKL1A191		脚
* 10	AAX73910	SUPPORT/PCB		CHE170		サポート/PCB
* 11	AAX73950	INSULATOR		CMX1A177		インシュレータ
* 13	AAX73380	CORD STOPPER		KHR1A028		コードストッパー
* 31	AAX74160	VOLUME KNOB ASS'Y	GD	CGK1A113YA		ボリュームノブ A S S Y
* 31	AAX74170	VOLUME KNOB ASS'Y	SI	CGK1A113ZA		ボリュームノブ A S S Y
* 32	AAX74020	JOG KNOB ASS'Y	GD	CGK1A114YA		ジョグノブ A S S Y
* 32	AAX74030	JOG KNOB ASS'Y	SI	CGK1A114ZA		ジョグノブ A S S Y
* 33	AAX74150	FRONT PANEL	GD	CKM1A168ZC55		フロントパネル
* 33	AAX74140	FRONT PANEL	SI	CKM1A168ZC54		フロントパネル
* 35	AAX73940	EARTH PLATE		CMC2A214		アースプレート
* 37	AAX74210	REAR PANEL		CKF2A302Z	J	リアパネル
* 37	AAX74260	REAR PANEL		CKF3A302Y	UC	リアパネル
* 37	AAX74220	REAR PANEL		CKF3A302U	T	リアパネル
* 37	AAX74230	REAR PANEL		CKF3A302V	K	リアパネル
* 37	AAX74270	REAR PANEL		CKF3A302Z	A	リアパネル
* 37	AAX74200	REAR PANEL		CKF1A302Z	BG	リアパネル
* 37	AAX74250	REAR PANEL		CKF3A302X	L	リアパネル
* 37	AAX74240	REAR PANEL		CKF3A302W	V	リアパネル
* 39	AAX73920	BRACKET/PCB		CMD1A574		ブラケット/PCB
* 40	AAX74050	TOP COVER	GD	CKC1A167GD7		トップカバー
* 40	AAX74040	TOP COVER	SI	CKC1A167G33		トップカバー
* 41	AAX74010	SHIELD COVER		CMX1A179		シールドカバー
* 42	AAX73970	CABLE CLAMPER		KHE36-3		ケーブルクランパー
* 51	AAX73810	P.C.B. ASS'Y	FRONT	COP11836B		PCB フロント
* 51-1	AAX73730	FIP DISPLAY		HFLHCA-14SM14T		FIP表示器
* 51-2	AAX73740	FIP BRACKET		CMD1A572		FIPブラケット
* 51-3	AAX74630	TACT SWITCH	SKHV10910G	GST1A012ZT		タクトスイッチ
* 51-4	AAX74610	ENCODER VR		CSR2A036Z		エンコーダーVR
* 51-5	AAX74600	ENCODER SWITCH	EC12B24S2034ZZZ	HSR2A025Z		エンコーダーSW
* 53	AAX74740	FLEXIBLE FLAT CABLE	27P 180mm P=1.0	CWC1B4A27A180B		カード電線
* 55	AAX73850	P.C.B. ASS'Y	MAIN	COP11837J	J	PCB メイン
* 55	AAX73890	P.C.B. ASS'Y	MAIN	COP11837U	UC	PCB メイン
* 55	AAX73880	P.C.B. ASS'Y	MAIN	COP11837T	T	PCB メイン
* 55	AAX73860	P.C.B. ASS'Y	MAIN	COP11837K	K	PCB メイン
* 55	AAX73820	P.C.B. ASS'Y	MAIN	COP11837A	A	PCB メイン
* 55	AAX73830	P.C.B. ASS'Y	MAIN	COP11837B	B	PCB メイン
* 55	AAX73840	P.C.B. ASS'Y	MAIN	COP11837G	G	PCB メイン
* 55	AAX73870	P.C.B. ASS'Y	MAIN	COP11837L	L	PCB メイン
* 55	AAX73900	P.C.B. ASS'Y	MAIN	COP11837V	V	PCB メイン
* 55-11	AAX74620	SPEAKER TERMINAL	4P	CJJ5P014Z		スピーカターミナル

* New Parts (新規部品)

Ref. No.	Part No.	Description			Remarks	Markets	部品名	Rank
* 55-12	AAX74640	RELAY			HSL4A004ZU		リレー	
* 55-13	AAX74120	BIND HEAD B-TIGHT SCREW	3x8	MFZN2W3	CTB3+8J		バインドBタイトネジ	
△* 57	AAX73800	POWER SUPPLY UNIT			COP11839B		電源ユニット	
* 58	AAX73720	DVD MECHANISM ASS'Y			CJDRDXE700ZA		DVDメカニズムASSY	
* 58-1	AAX73790	P.C.B. ASS'Y		MPEG	CIP11838BSMD		P C B M P E G	
* 58-2	AAX73960	CUSHION			CHG1A306		クッション	
* 58-3	AAX74670	BELT			CHG1A330		ベルト	
△* 60	AAX74330	POWER CABLE	2m		CJA2J049ZA	J	電源コード	
△* 60	AAX74370	POWER CABLE	2m		CJA523FBUYA	UC	電源コード	
△* 60	AAX74350	POWER CABLE	2m		CJA2N047ZA	T	電源コード	
△* 60	AAX74320	POWER CABLE	2m		CJA2D073Z	K	電源コード	
△* 60	AAX74360	POWER CABLE	2m		CJA2S048ZA	A	電源コード	
△* 60	AAX73700	POWER CABLE	2m		CJA2E045ZA	B	電源コード	
△* 60	AAX74310	POWER CABLE	2m		CJA2B043ZA	GL	電源コード	
△* 60	AAX74340	POWER CABLE	2m		CJA2L072ZA	V	電源コード	
* 70	AAX74710	AM/FM TUNER			CNVMV016MA1-19	J	A M / F Mチューナー	
* 70	AAX74690	AM/FM TUNER			CNVMV014MA0-19	UCK	A M / F Mチューナー	
* 70	AAX74700	AM/FM TUNER			CNVMV014MA1-19	TALV	A M / F Mチューナー	
* 70	AAX74720	AM/FM TUNER			CNVMV114MA1-19	GB	A M / F Mチューナー	
* 72	AAX74730	FLEXIBLE FLAT CABLE	13P 100mm	P=1.25	CWC1B2A13B100B		カード電線	
* 101	AAX73520	FLAT HEAD B-TIGHT SCREW	3x8	MFZN2W3	CTS3+8G		皿Bタイトネジ	
* 102	AAX73540	BIND HEAD P-TIGHT SCREW	3x10	MFZN2W3	CTB3+10G		バインドPタイトネジ	
* 103	AAX73930	PW HEAD B-TIGHT SCREW	3x8-8	MFZN2W3	CTW3+8J		PWヘッドBタイトネジ	
* 104	AAX74110	BIND HEAD B-TIGHT SCREW	3x6	MFZN2W3	CTB3+6J		バインドBタイトネジ	
* 106	AAX74100	BIND HEAD B-TIGHT SCREW	3x12	MFZN2W3	CTB3+12J		バインドBタイトネジ	
* 108	AAX73550	BIND HEAD P-TIGHT SCREW	3x10	MFZN2B3	CTB3+10GFZ		バインドPタイトネジ	
* 109	AAX73560	BIND HEAD P-TIGHT SCREW	3x8	MFZN2B3	CTB3+8GFZ		バインドPタイトネジ	
* 110	AAX73510	BIND HEAD B-TIGHT SCREW	3x8	MFZN2B3	CTB3+8JFZ		バインドBタイトネジ	
* 111	AAX74380	SPECIAL SCREW			CHD1A055	GB	特殊ネジ	
* 112	AAX74110	BIND HEAD B-TIGHT SCREW	3x6	MFC2	CTB3+6JFC		バインドBタイトネジ	
* 113	AAX73930	PW HEAD B-TIGHT SCREW	3x8-8	MFC2	CTW3+8JFC		PWヘッドBタイトネジ	
		ACCESSORIES					付属品	
* 200	AAX74290	REMOTE CONTROL			CARTRDXE700U	JUCTKALV	リモコン	
* 200	AAX74280	REMOTE CONTROL			CARTRDXE700G	GB	リモコン	
200-1	AAX57560	BATTERY COVER	103RRS-141-07L		103RRS-141-07L		電池蓋	
* 202	AAX73180	AM LOOP ANTENNA			CSA1A020Z		A Mループアンテナ	
* 203	AAX73240	INDOOR FM ANTENNA			CSA1A018Z		F M簡易アンテナ	
* 204	AAX74130	VIDEO PIN CABLE BATTERY, MANGANESE	1P 1.5m YE 1pc UM3		CJS4M023Z		ビデオ用ピンケーブル 乾電池	

* New Parts (新規部品)

■ NX-E700

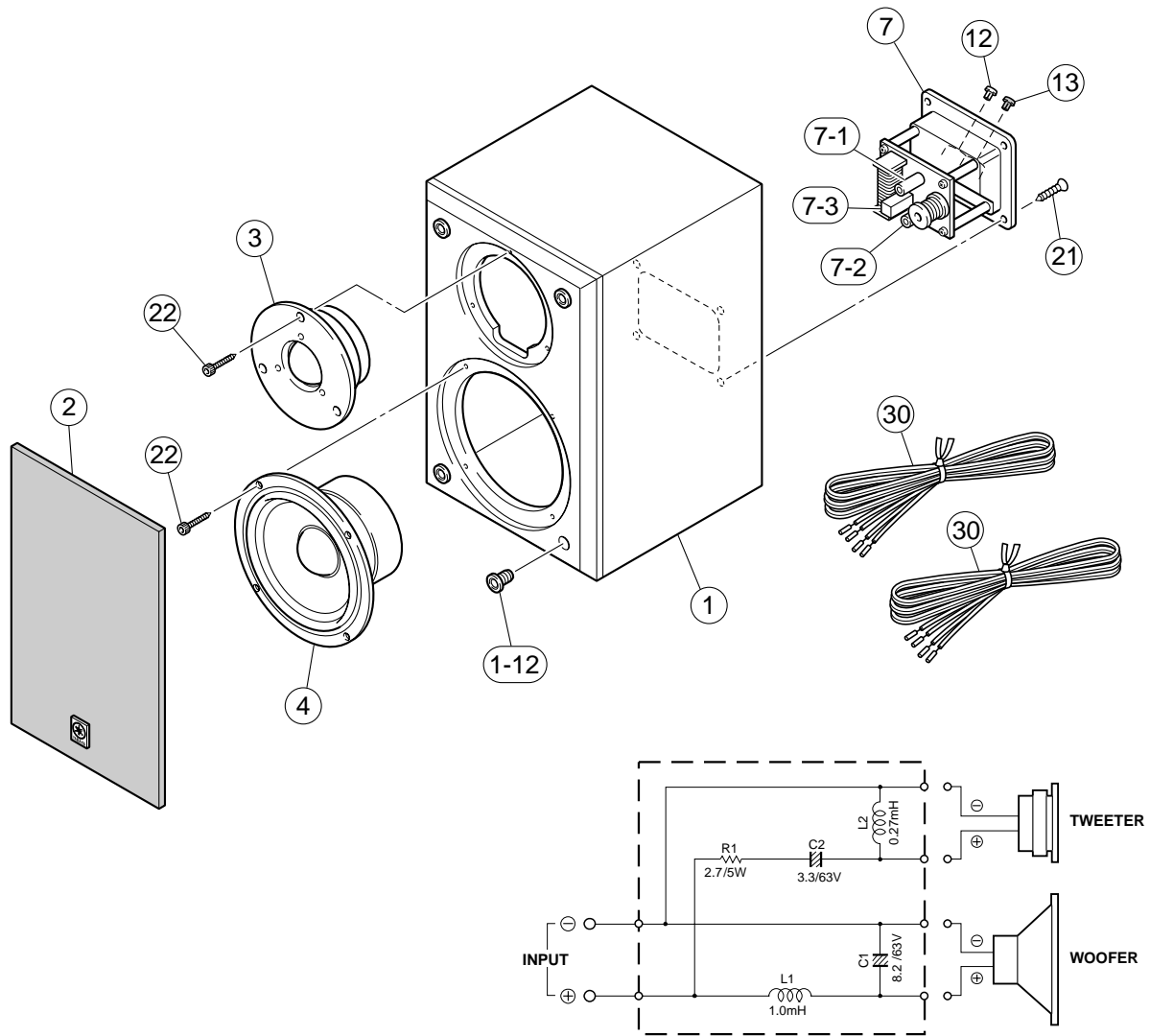

Ref. No.	Part No.	Description	Remarks	Markets	部品名	Rank
*	1	WG237700 CABINET ASS'Y	BL		キャビネットASSY	
*	2	WG237800 FRONT GRILLE ASS'Y			フロントグリルASSY	
*	3	XW275B00 DRIVER, TWEETER	2.5cm 5	JA05U3	スピーカーユニット	
*	4	XZ668C00 DRIVER, WOOFER	11cm 6	JA1151	スピーカーユニット	
	7	V9504600 NETWORK ASS'Y			ネットワークASSY	
	7-1	V6055400 ELECTROLYTIC CAP	8.2uF 63V		BPケミコン	04
	7-2	V6367500 ELECTROLYTIC CAP	3.3uF 63V		BPケミコン	
*	7-3	V9507500 CEMENT RESISTOR	2.7 5W		セメント抵抗	01
	12	V5361400 TERMINAL CAP	S06E RED		ターミナルキャップ	
	13	V5361500 TERMINAL CAP	S06E BLACK		ターミナルキャップ	
*	21	WE963200 FLAT HEAD WOOD SCREW	3.5x20 MFZN2B3		皿木ネジ	
	22	V9506100 HEXAGON HEAD WOOD SCREW	4x25 MFZN2BL		六角穴付き木ネジ	
	30	ACCESSORIES SPEAKER CABLE	4m 1pc		付属品 スピーカーケーブル	

* New Parts (新規部品)

REMOTE CONTROL

▼ U, C, T, K, A, L, V, J models

▼ B, G models

KEY NO. LAYOUT

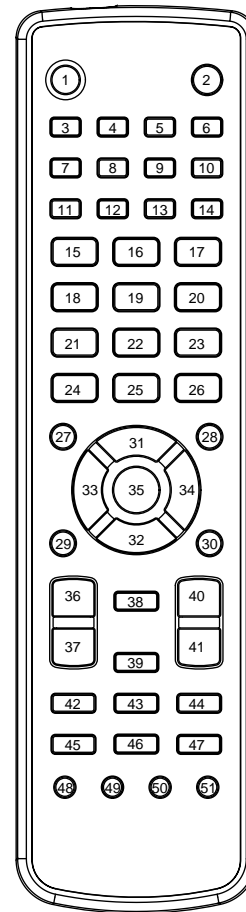
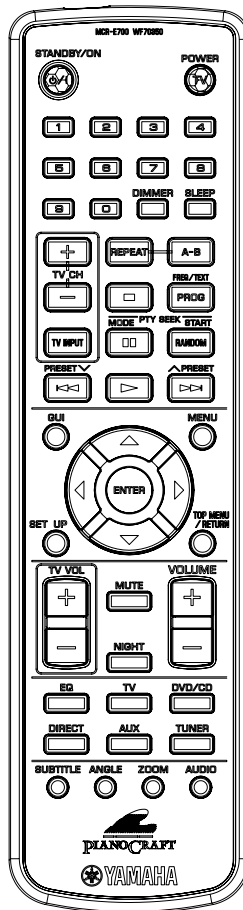
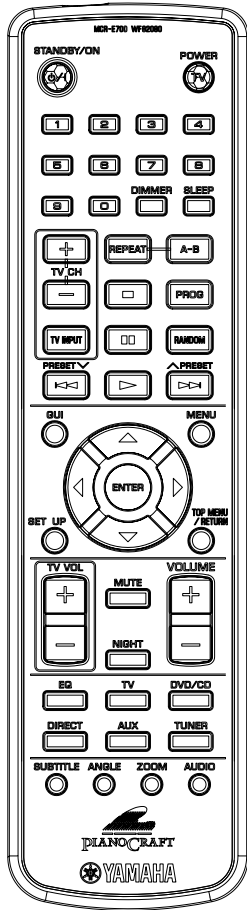

SCHEMATIC DIAGRAM

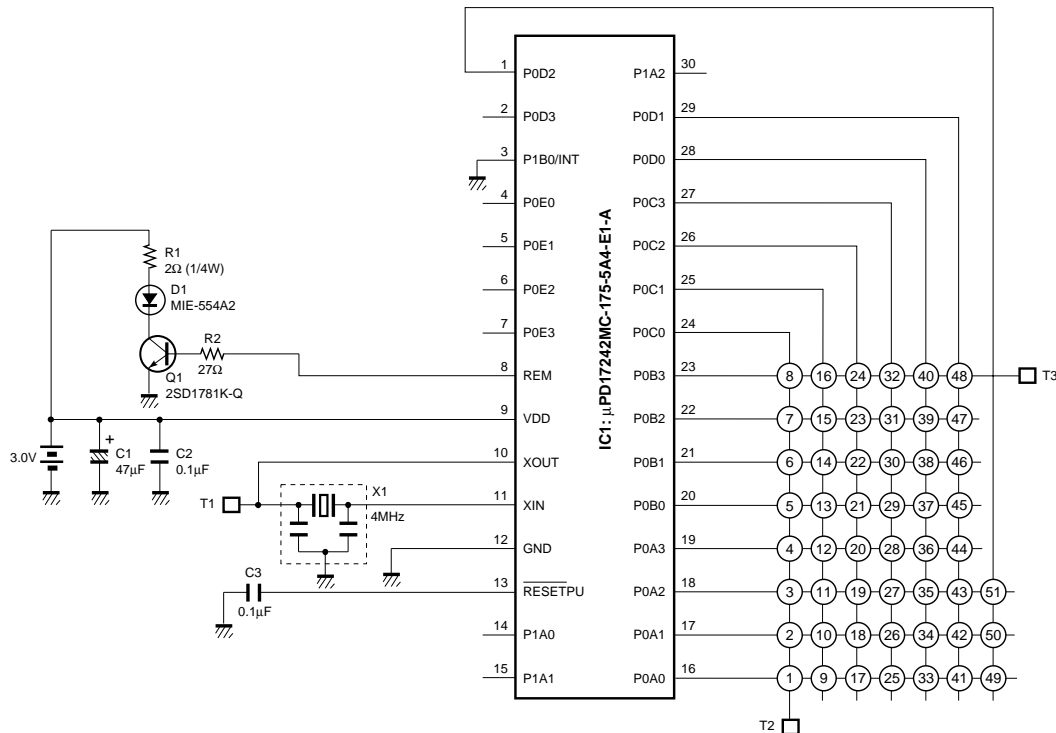

Key	Function	DVD/CD	TUNER	TV	AUX
1	STANDBY/ON	78-0F			
2	TV POWER	MBR TV POWER : 50-17			MBR CABLE /DBS POWER : 6-6F
3	1	7C-94	78-11	MBR TV (1) :50-0D	MBR CABLE /DBS (1) : 6-62
4	2	7C-95	78-12	MBR TV (2) :50-0E	MBR CABLE /DBS (2) : 6-63
5	3	7C-96	78-13	MBR TV (3) :50-0F	MBR CABLE /DBS (3) : 6-64
6	4	7C-97	78-14	MBR TV (4) :50-1C	MBR CABLE /DBS (4) : 6-65
7	5	7C-98	78-15	MBR TV (5) :50-1D	MBR CABLE /DBS (5) : 6-66
8	6	7C-99	78-16	MBR TV (6) :50-1E	MBR CABLE /DBS (6) : 6-67
9	7	7C-9A	78-17	MBR TV (7) :50-1F	MBR CABLE /DBS (7) : 6-69
10	8	7C-9B	78-18	MBR TV (8) :50-04	MBR CABLE /DBS (8) : 6-6A
11	9	7C-9C	78-19	MBR TV (9) :50-05	MBR CABLE /DBS (9) : 6-62
12	0	7C-93	78-10	MBR TV (0) :50-0C	MBR CABLE /DBS (0) : 6-61
13	DIMMER	7C-A9			
14	SLEEP	78-4F			
15	TV CH +	MBR TV CH + : 50-19			MBR CABLE /DBS CH + : 6-6C
16	REPEAT	7C-A3	N/A	N/A	N/A
17	A-B	7C-A4	N/A	N/A	N/A
18	TV CH -	MBR TV CH + : 50-18			MBR CABLE /DBS CH - : 6-6D
19	STOP	7C-85	N/A	N/A	N/A
20	PROG (FREQ/TXT)	7C-A0	78-81	N/A	N/A
21	TV INPUT	MBR TV INPUT : 50-09			
22	PAUSE (MODE)	7C-83	78-82	N/A	N/A
23	RANDOM (START)	7C-A1	78-83	N/A	N/A
24	SKIP - (PRESET -)	7C-B9	78-1C	N/A	N/A
25	PLAY	7C-82	N/A	N/A	N/A
26	SKIP + (PRESET +)	7C-BA	78-1B	N/A	N/A
27	GUI	7C-A6	N/A	N/A	N/A
28	MENU	7C-B2	N/A	N/A	MBR DBS MENU (CABLE : N/A) : N/A
29	SET UP	7C-A7	N/A	N/A	N/A
30	TOP MENU/RETURN	7C-B7	N/A	N/A	N/A
31		7C-B4	N/A	N/A	MBR DBS (CABLE : N/A) : N/A
32		7C-B3	N/A	N/A	MBR DBS (CABLE : N/A) : N/A
33		7C-B5	N/A	N/A	MBR DBS (CABLE : N/A) : N/A
34		7C-B6	N/A	N/A	MBR DBS (CABLE : N/A) : N/A
35	ENTER	7C-B8	N/A	N/A	MBR CABLE/DBS Enter : N/A
36	TV VOL +	MBR TV VOL + : 50-12			
37	TV VOL -	MBR TV VOL - : 50-15			
38	MUTE	78-9C			
39	NIGHT	78-8A			
40	VOLUME +	78-1E			
41	VOLUME -	78-1F			
42	EQ	78-5A			
43	T V	78-DF			
44	DVD/CD	78-4A			
45	DIRECT	78-50			
46	AUX	78-DE			
47	TUNER	78-4B			
48	SUBTITLE	7C-AA	N/A	N/A	N/A
49	ANGLE	7C-AE	N/A	N/A	N/A
50	ZOOM	7C-D7	N/A	N/A	N/A
51	AUDIO	7C-AD	N/A	N/A	N/A

In this table, the preset key code (MBR xxxx) is initial code.

表中のプリセットキーコード (MBR xxxx) は初期設定コードを示します。

RDX-E700/NX-E700

YAMAHA
