

MusicCAST 

DIGITAL AUDIO SERVER

MCX-1000

SERVICE MANUAL

The MusicCAST system consists of the MCX-1000, the MCX-A10 and the MCX-SP10.

This service manual is for the MCX-1000.

For the MCX-A10 and the MCX-SP10 service manual, please refer to the following publication number:

MCX-A10/MCX-SP10 100852

When accepting a repair order from the user, be sure to inform him/her that the data in HDD cannot be guaranteed. For the repair work, it is recommended to receive MCX-1000 and MCX-A10 as a set.

ミュージックキャストシステムはMCX-1000、MCX-A10およびMCX-SP10で構成されています。

このサービスマニュアルはMCX-1000用です。

MCX-A10およびMCX-SP10のサービスマニュアルは下記を参照してください。

MCX-A10/MCX-SP10 100852

修理依頼を受ける際、HDDのデータは保証できないことをお客様に伝えてください。

修理品はMCX-1000とMCX-A10をセットでお預かりすることを推奨します。

IMPORTANT NOTICE

This manual has been provided for the use of authorized YAMAHA Retailers and their service personnel.

It has been assumed that basic service procedures inherent to the industry, and more specifically YAMAHA Products, are already known and understood by the users, and have therefore not been restated.

WARNING: Failure to follow appropriate service and safety procedures when servicing this product may result in personal injury, destruction of expensive components, and failure of the product to perform as specified. For these reasons, we advise all YAMAHA product owners that any service required should be performed by an authorized YAMAHA Retailer or the appointed service representative.

IMPORTANT: The presentation or sale of this manual to any individual or firm does not constitute authorization, certification or recognition of any applicable technical capabilities, or establish a principle-agent relationship of any form.

The data provided is believed to be accurate and applicable to the unit(s) indicated on the cover. The research, engineering, and service departments of YAMAHA are continually striving to improve YAMAHA products. Modifications are, therefore, inevitable and specifications are subject to change without notice or obligation to retrofit. Should any discrepancy appear to exist, please contact the distributor's Service Division.

WARNING: Static discharges can destroy expensive components. Discharge any static electricity your body may have accumulated by grounding yourself to the ground buss in the unit (heavy gauge black wires connect to this buss).

IMPORTANT: Turn the unit OFF during disassembly and part replacement. Recheck all work before you apply power to the unit.



このサービスマニュアルは、エコマーク認定の再生紙を使用しています。
This Service Manual uses recycled paper.



■ CONTENTS

TO SERVICE PERSONNEL	2~4
PREVENTION OF ELECTRO STATIC DISCHARGE ...	5
FRONT PANEL	6
REAR PANELS	6~7
REMOTE CONTROL PANEL	7
SPECIFICATIONS	8~9
INTERNAL VIEW	9
DISASSEMBLY PROCEDURES / 分解手順	10~15
SERVICE PRECAUTIONS / サービス時の注意事項	16
UPDATING FIRMWARE / ファームウェアのアップデート	16~18
RECOVERY AFTER REPLACING HDD / HDD交換後のリカバリー	18~19
RECOVERY AFTER REPLACING MAIN P.C.B. / MAIN P.C.B.交換後のリカバリー	20~21
SERVICE MENU / サービスメニュー	21~22

ENTERING SYSTEM ID / システムIDの書き込み	23~24
TROUBLESHOOTING / トラブルシューティング	25~26
TEST MODE / テストモード	27~28
DISPLAY DATA	29
IC DATA	30~55
BLOCK DIAGRAM	56~57
PRINTED CIRCUIT BOARD	58~63
PIN CONNECTION DIAGRAM	64
SCHEMATIC DIAGRAM	65~73
PARTS LIST	75~89
REMOTE CONTROL	90
DIRECTION FOR USE SETUP GUIDE	90~93
QUICK MANUAL	94~112

■ TO SERVICE PERSONNEL

- Critical Components Information
Components having special characteristics are marked  and must be replaced with parts having specifications equal to those originally installed.
- Leakage Current Measurement (For 120V Models Only)
When service has been completed, it is imperative to verify that all exposed conductive surfaces are properly insulated from supply circuits.
 - Meter impedance should be equivalent to 1500 ohm shunted by 0.15 μ F.
 - Leakage current must not exceed 0.5mA.
 - Be sure to test for leakage with the AC plug in both polarities.

THE COMPACT DISC RECORDER SHOULD NOT BE ADJUSTED OR REPAIRED BY ANYONE EXCEPT PROPERLY QUALIFIED SERVICE PERSONNEL.



“CAUTION”

“F400: FOR CONTINUED PROTECTION AGAINST RISK OF FIRE, REPLACE ONLY WITH SAME TYPE 10A, 250V FUSE.”

CAUTION

F400: REPLACE WITH SAME TYPE 10A, 250V FUSE.

ATTENTION

F400: UTILISER UN FUSIBLE DE RECHANGE DE MEME TYPE DE 10A, 250V.

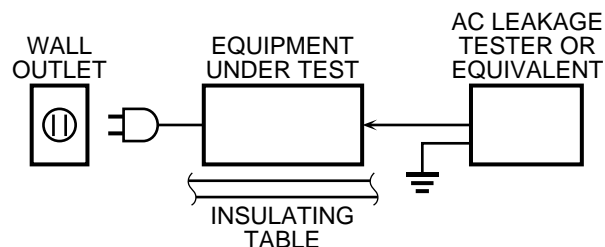

WARNING: CHEMICAL CONTENT NOTICE!

The solder used in the production of this product contains LEAD. In addition, other electrical/electronic and /or plastic (where applicable) components may also contain traces of chemicals found by the California Health and Welfare Agency (and possibly other entities) to cause cancer and/or birth defects or other reproductive harm.

DO NOT PLACE SOLDER, ELECTRICAL/ELECTRONIC OR PLASTIC COMPONENTS IN YOUR MOUTH FOR ANY REASON WHATSOEVER!

Avoid prolonged, unprotected contact between solder and your skin! When soldering, do not inhale solder fumes or expose eyes to solder/flux vapor!

If you come in contact with solder or components located inside the enclosure of this product, wash your hands before handling food.

WARNING: Laser Safety

This product contains a laser beam component. This component may emit invisible, as well as visible radiation, which may cause eye damage. To protect your eyes and skin from laser radiation, the following precautions must be used during servicing of the unit.

- 1) When testing and/or repairing any component within the product, keep your eyes and skin more than 30 cm away from the laser pick-up unit at all times. Do not stare at the laser beam at any time.
- 2) Do not attempt to readjust, disassemble or repair the laser pick-up, unless noted elsewhere in this manual.
- 3) CAUTION: Use of controls, adjustments or performance of procedures other than those specified herein may result in hazardous radiation exposure.

Laser Emitting conditions:

1. This device is a Class IIIb laser device.

Class IIIb means

With the protective case removed, exposure to the light output from the laser, either directly or reflected by a mirror, can cause harm to the eyes, but there is no danger to the eyes from exposure to dispersed reflected laser light. (Generally 0.5 W or less)

2. Always wear eyeglasses designed for protection against laser light.
3. Always wear gloves.
4. Have no reflective objects anywhere near this device.
5. Figure A shows from where in this device the laser is emitted.
6. When switching on the power to the device for the first time, always measure the laser power with a laser power meter and check that the power is no greater than the number of Watts in the specifications.
7. Never look directly at the laser light while the laser is emitting light.
8. Do not allow the laser light to shine directly on your skin while the laser is emitting light.

PROTECTION OF EYES FROM LASER BEAM DURING SERVICING

This set employs a laser. Therefore, be sure to carefully follow the instructions below when servicing.

1. Laser Diode Properties

- Material : GaAlAs
- Wavelength : 779-789 nm
- Emission Duration : Pulse
- Laser Output : DC erase mode max. 20mW (Continuous) *
Write mode max. 62mW *
(Max. Cycle 111 ns, Min. Cycle 30 ns at Max. Speed)

* This output is the value measured at the lens of the Laser Pickup Unit.

2. When checking the laser diode emission, keep your eyes more than 30 cm away from the objective lens.

CAUTION

Use of controls or adjustments or performance of procedures other than those specified herein may result in hazardous radiation exposure.

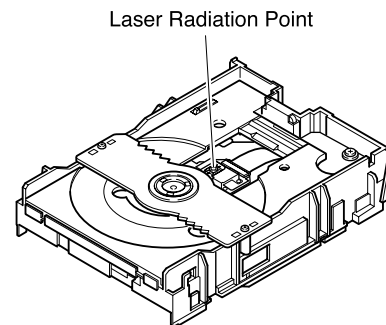

Figure A

CAUTION

Use of controls or adjustments or performance of procedures other than those specified herein may result in hazardous radiation exposure.

ATTENTION

L'emploi de commandes, de réglages ou un choix de procédures différents des spécifications de cette brochure peut entraîner une exposition à d'éventuelles radiations pouvant être dangereuses.

ACHTUNG

Die Verwendung von Bedienungselementen oder Einstellungen oder die Durchführung von Bedienungsvorgängen, die nicht in dieser Anleitung aufgeführt sind, kann zu einem Kontakt mit gefährlichen Laserstrahlen führen.

OBSERVERA

Användning av kontroller och justeringar eller genomförande av procedurer andra än de som specificeras i denna bok kan resultera i att du utsätter dig för farlig strålning.

ATTENZIONE

Uso di controlli o regolazioni o procedure non specificamente descritte può causare l'esposizione a radiazioni di livello pericoloso.

PRECAUCIÓN

El uso de los controles o los procedimientos de ajuste o utilización diferentes de los especificados en este manual pueden causar una exposición peligrosa a la radiación.

VOORZICHTIG

Gebruik van bedieningsorganen of instellingen, of uitvoeren van handelingen anders dan staan beschreven in deze handleiding kunnen leiden tot blootstelling aan gevaarlijke stralen.

VARO!

AVATTAESSA JA SUOJALUKITUS OHITETTAESSA OLET ALTTIINA NÄKYMÄTTÖMÄLLE LASERSÄTEILYLLE. ÄLÄ KATSO SÄTEESEEN.

WARNING!

OSYNLIG LASERSTRÅLNING NÄR DENNA DEL ÄR ÖPPNAD OCH SPÄRREN ÄR URKOPPLAD. BETRAKTA EJ STRÅLEN.

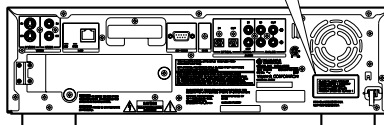
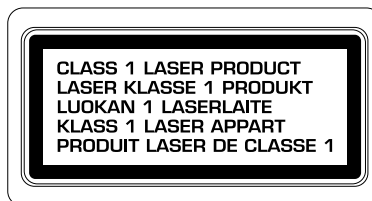

(U, C models)

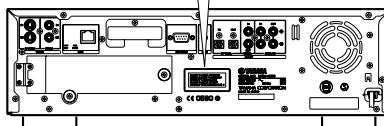
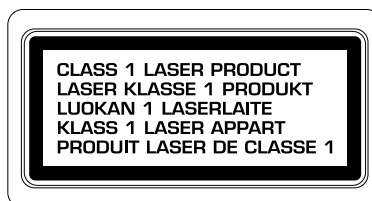

(B, G models)

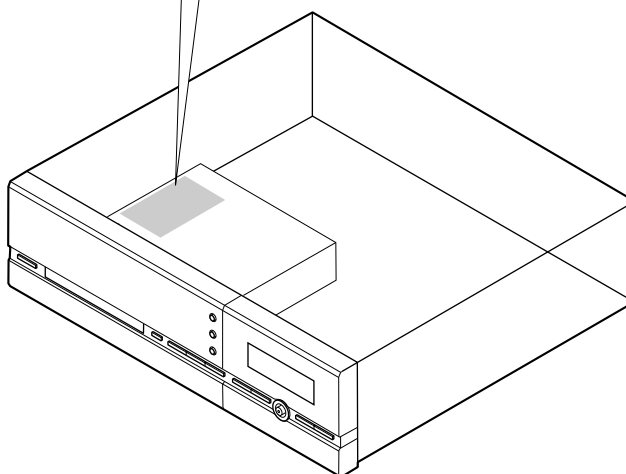

■ PREVENTION OF ELECTRO STATIC DISCHARGE

Some semiconductor (solid state) devices can be damaged easily by static electricity. Such components commonly are called Electrostatically Sensitive (ES) Devices. Examples of typical ES devices are integrated circuits and some field-effect transistors and semiconductor "chip" components. The following techniques should be used to help reduce the incidence of component damage caused by electro static discharge (ESD).

1. Immediately before handling any semiconductor component or semiconductor-equipped assembly, drain off any ESD on your body by touching a known earth ground. Alternatively, obtain and wear a commercially available discharging ESD wrist strap, which should be removed for potential shock reasons prior to applying power to the unit under test.
2. After removing an electrical assembly equipped with ES devices, place the assembly on a conductive surface such as aluminum foil, to prevent electrostatic charge buildup or exposure of the assembly.
3. Use only a grounded-tip soldering iron to solder or unsolder ES devices.
4. Use only an anti-static solder removal device. Some solder removal devices not classified as "anti-static (ESD protected)" can generate electrical charge sufficient to damage ES devices.
5. Do not use freon-propelled chemicals. These can generate electrical charges sufficient to damage ES devices.
6. Do not remove a replacement ES device from its protective package until immediately before you are ready to install it. (Most replacement ES devices are packaged with leads electrically shorted together by conductive foam, aluminum foil or comparable conductive material).
7. Immediately before removing the protective material from the leads of a replacement ES device, touch the protective material to the chassis or circuit assembly into which the device will be installed.

CAUTION: Be sure no power is applied to the chassis or circuit, and observe all other safety precautions.

8. Minimize bodily motions when handling unpackaged replacement ES devices. (Otherwise harmless motion such as the brushing together of your clothes fabric or the lifting of your foot from a carpeted floor can generate static electricity (ESD) sufficient to damage an ES device).

Grounding for electro static breakdown prevention

1. Human body grounding:
Use an anti static wrist strap to discharge the static electricity from your body.
2. Work table grounding:
Put a grounded conductive material (sheet) or iron sheet on the area where the optical pickup is placed.

Caution:

The static electricity of your clothes will not be grounded through the wrist strap. So take care not to let your clothes touch the optical pickup.

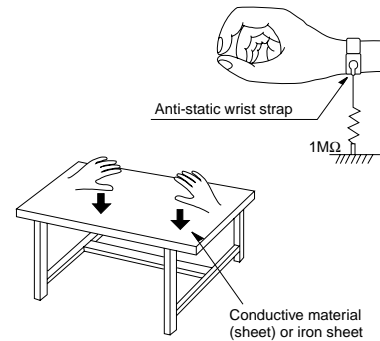

FRONT PANEL

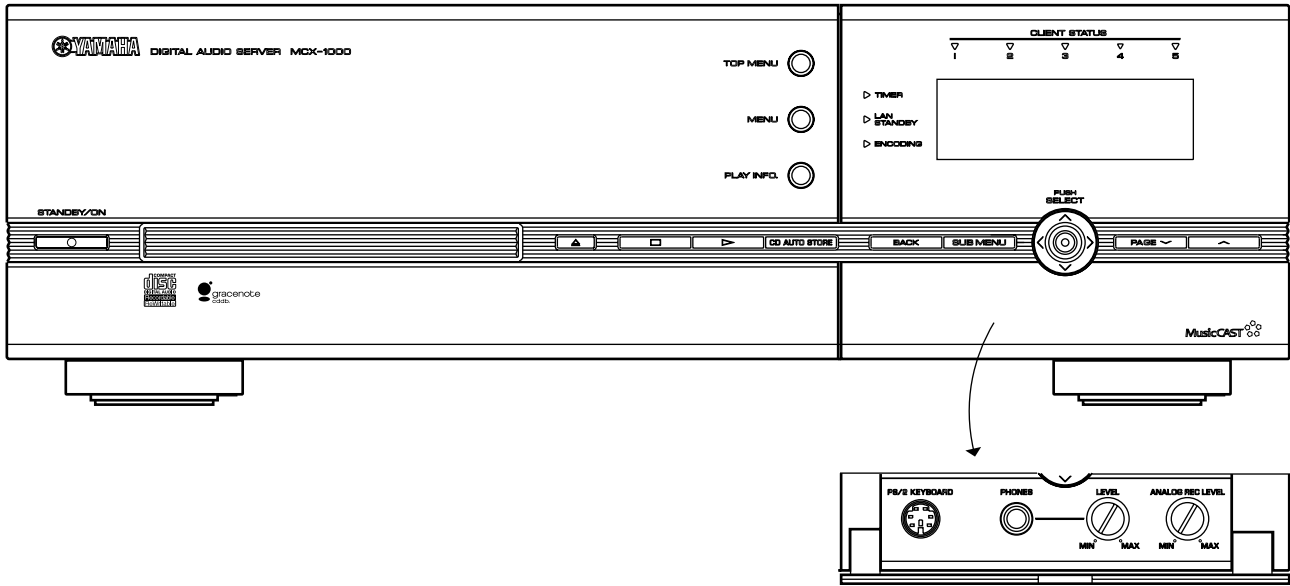

REAR PANELS

MCX-1000 (U, C models)

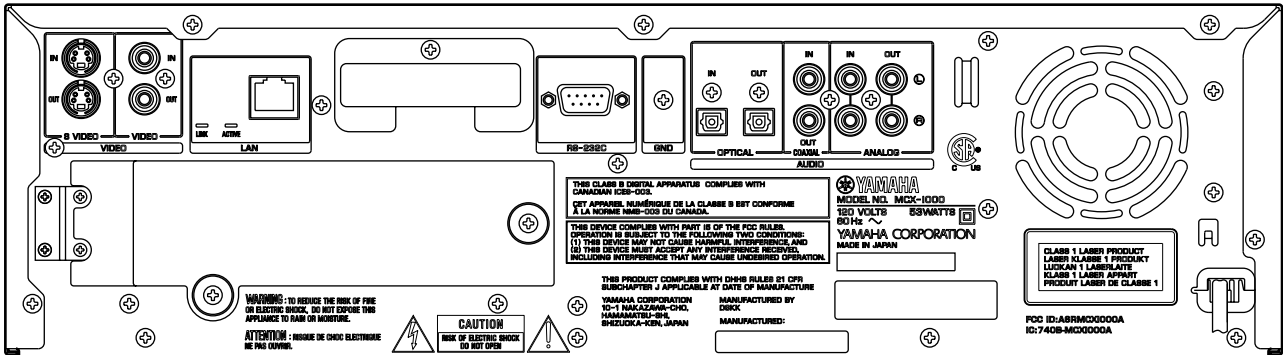

MCX-1000 (A model)

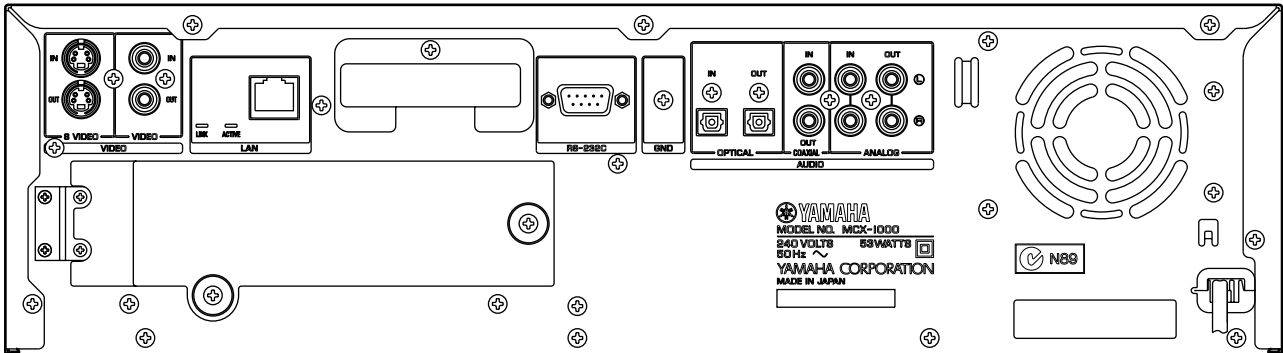

MCX-1000 (B, G models)

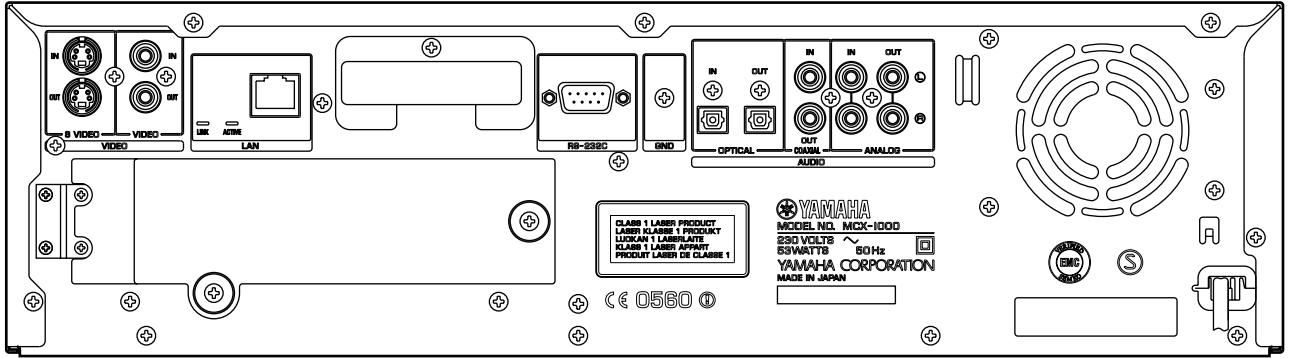

MCX-1000 (J model)

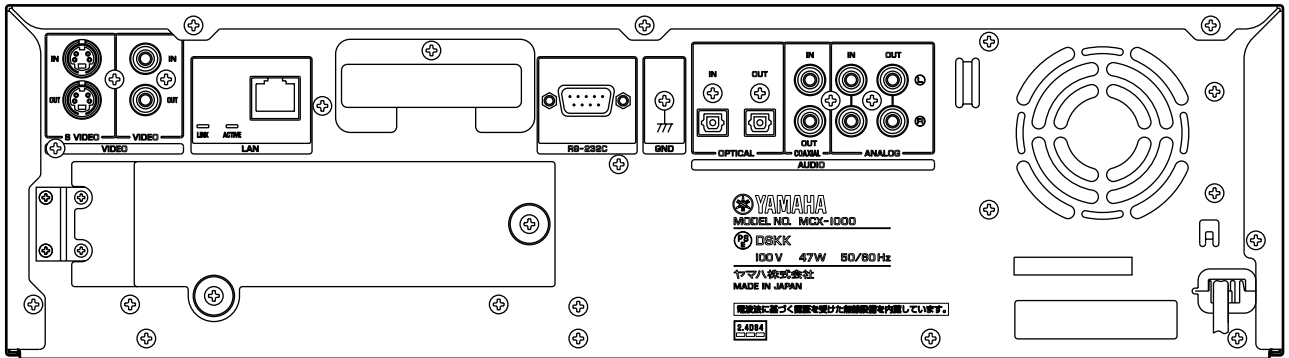

■ REMOTE CONTROL PANEL

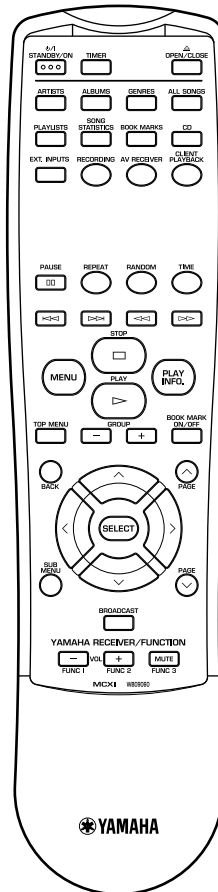

■ SPECIFICATIONS / 参考仕様

AUDIO PERFORMANCE / オーディオ性能

Frequency response 5 to 20,000 Hz, \pm 0.5 dB

S/N ratio / SN比 (EIAJ)

Playback 105 dB

Recording 92 dB

Total harmonic distortion / 歪率+雑音 (1 kHz)

Playback 0.004 %

Recording 0.006 %

Dynamic range / ダイナミックレンジ

Playback 99 dB

Recording 92 dB

INPUT/OUTPUT / 入出力仕様

LINE OUTPUT / ライン出力

Output level 2 Vrms

Output resistance 990 ohms

LINE INPUT / ライン入力

Input sensitivity 500 mVrms

Input impedance 23 k-ohms (REC LEVEL Max.)

DIGITAL OUTPUT / デジタル出力

Coaxial output level 0.5 Vp-p (75 ohms)

Optical output level -20 dBm

Sampling frequency 44.1 kHz

DIGITAL INPUT / デジタル入力

Coaxial input level 0.5 Vp-p (75 ohms)

Optical input level -20 dBm

Input gain (with Digital Volume) \pm 12 dB

Input gain (without Digital Volume) \pm 0 dB

Sampling frequency tolerance

..... 32 kHz, 44.1 kHz, 48 kHz and 96 kHz

HEADPHONE OUTPUT / ヘッドホン出力 (PHONES LEVEL MAX)

Output level (-20 dB, 150 ohms load) 330 mVrms

GENERAL / 一般仕様

Application disks / 対応ディスク

CD, CD-ROM (MP3 only), AUDIO CD-R, AUDIO CD-RW

MP3 formats / 対応MP3フォーマット

Disc that is produced in the ISO9660 Level 1 and 2 multi-session Juliet/Romeo format but unusable for packet write method.

Maximum number of folder layers is 8 and that of the files is 300.

The file extension is MP3 or mp3.

MPEG1 Layer 3 100% compression bit rate is applicable. With VBR, the time data and bit rate data may not be displayed correctly.

Based on ID3 Tag ver. 1.1

ISO9660 Level 1および2 マルチセッションJuliet/Romeoフォーマットで作成されたディスク。ただしバケットライトには非対応。

最大フォルダ階層は8。最大ファイル数は300

ファイルの拡張子はMP3またはmp3

MPEG1 Layer3全圧縮ビットレート対応。VBRは時刻情報、ビットレート情報が正しく表示されないことがあります。

ID3タグver 1.1準拠

HDD storage / HDD容量 80GB

LAN Interface / LANインターフェイス Ethernet 10/100 Base-T

Wireless Interface / 無線インターフェイス IEEE 802.11b

Power supply / 電源電圧

U, C models AC 120 V 60 Hz

A model AC 240 V 50 Hz

B, G models AC 230 V 50 Hz

J model AC 100 V 50/60 Hz

Power consumption / 消費電力

U, C, A, B, G models 53 W

J model 47 W

Standby power consumption / 待機電力

U, C models 3.3 W

A, B, G models 2.9 W

J model 4.1 W

Operating temperature / 動作温度 + 5 °C to + 35 °C

Max. dimensions / 最大寸法 (W x H x D)

..... 435 x 135.5 x 434.5 mm (17-1/8" x 4-9/16" x 16-5/16")

..... (include legs, knobs and antenna cover)

Weight / 質量 11.5 kg (17 lbs. 3 oz.)

Panel color / パネル色

Silver Color B, G, J models

Black Color U, C, A models

Accessories / 付属品

Remote Control x 1, Battery x 2, Optical Fiber Cable x 1, Audio Pin Cable x 1, Video Cable x 1

* Specifications are subject to change without notice due to product improvements.

※ 参考仕様および外観は予告なく変更されることがあります。

U U.S.A. model

A Australian model

G European model

C Canadian model

B British model

J Japanese model



"Music recognition technology and related data are provided by Gracenote and the Gracenote CDDB® Music Recognition ServiceSM. Gracenote is the industry standard in music recognition technology and related content delivery. For more information visit www.gracenote.com."

"CD and music-related data from Gracenote CDDB® Music Recognition ServiceSM © 2000, 2001, 2002 Gracenote. Gracenote CDDB Client Software © 2000, 2001, 2002 Gracenote. U.S. Patents Numbers #5,987,525; #6,061,680; #6,154,773, and other patents issued or pending.

CDDB is a registered trademark of Gracenote. The Gracenote logo and logotype, the Gracenote CDDB logo and logotype, and the "Powered by Gracenote CDDB" logo are trademarks of Gracenote. Music Recognition Service and MRS are service marks of Gracenote."

• DIMENSIONS

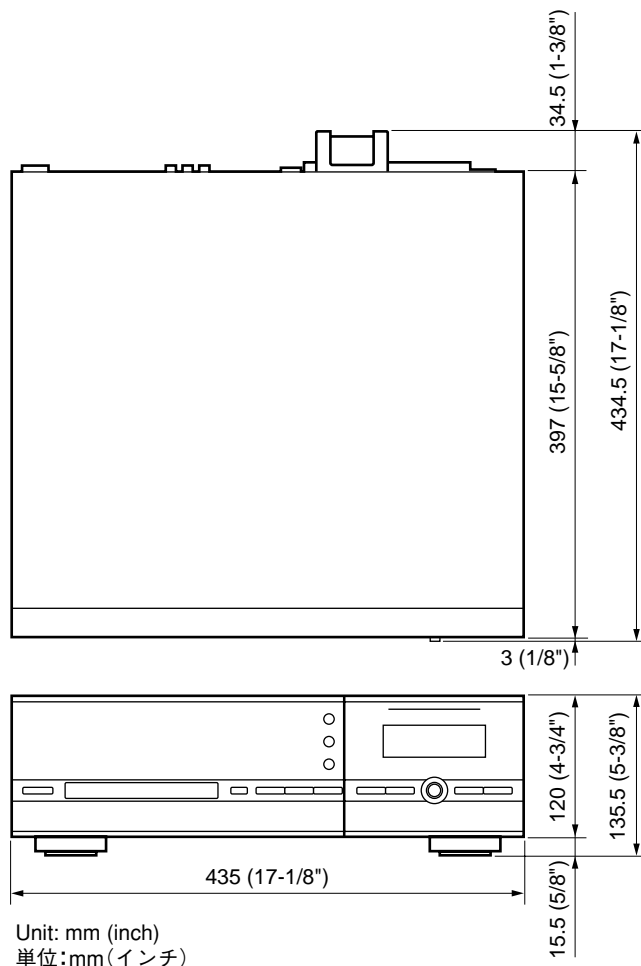

■ INTERNAL VIEW

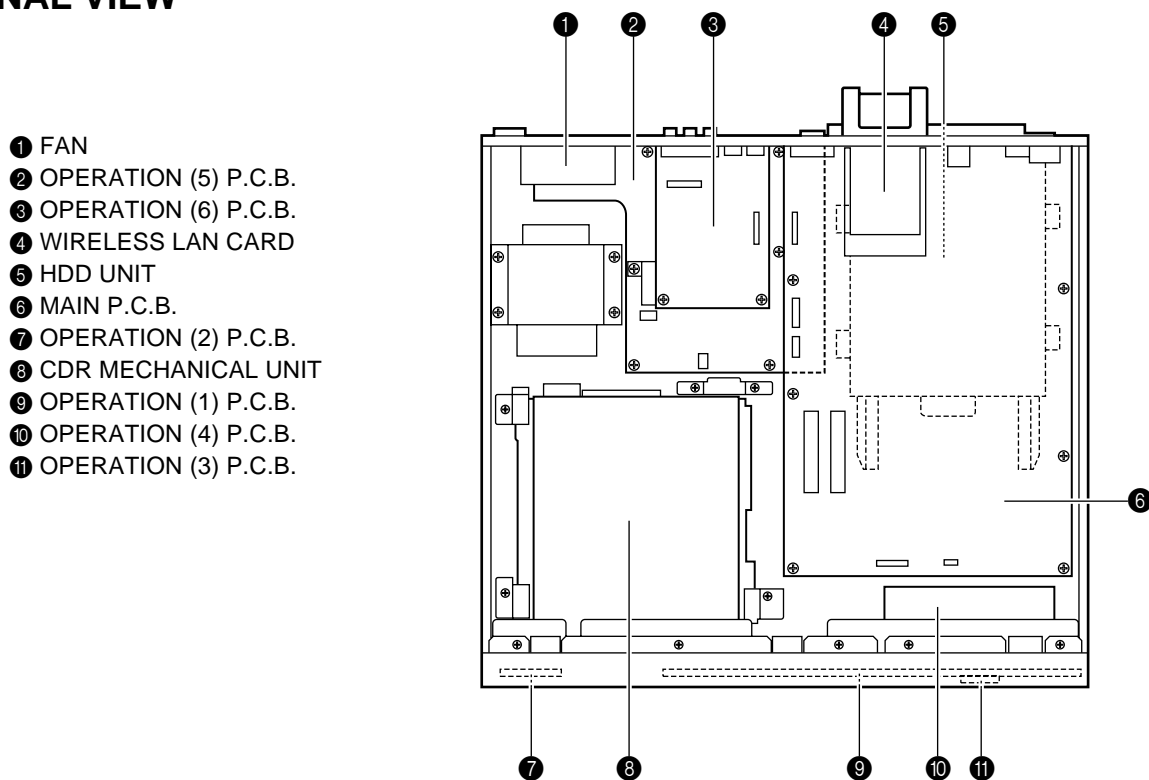

■ DISASSEMBLY PROCEDURES / 分解手順

(Remove parts in the order as numbered.)

(番号順に部品を取り外してください。)

CDR Mechanical Unit replacement

- The CDR mechanical unit must be replaced as a unit. None of its components can be supplied separately.
- When replacing the CDR mechanical unit, write down the following items.
 - Serial No. of the product and the symptom in detail
 - Mechanical serial No./mechanical shipping serial No. of the CDR mechanical unit
- When sending back the defective CDR mechanical unit for repair, send the whole unit.
- When sending back the defective CDR mechanical unit for repair, attach the disc that was used when the error occurred, if requested. However, Yamaha shall not be liable even if the data in the disc has become unreadable while the unit is being serviced/repared.
- When replacing the CDR mechanical unit, be sure to order a laser precaution label and a radiation sheet as spare parts and attach them to the new CDR mechanical unit. (Refer to the figure 4 and 5 in P11.)

CDRメカユニットの交換

- CDRメカユニットは、ユニット交換となります。小部品の部品供給はできません。
- CDRメカユニットを交換するときは、下記の事項を控えてください。
 - 本機の製造番号と詳しい症状
 - CDRメカユニットのメカ製番/メカ出荷製番
- 故障したCDRメカユニットは、修理の為にユニットごと返送してください。
- 修理依頼に際しては、必要に応じて、エラーが起きたときのディスクを添付するようお願いします。ただし、当社はサービス/修理中にディスクのデータが読み取れなくなってもその責務を負いません。
- CDRメカユニット交換の際には、レーザー注意文のラベルおよび放熱シートも部品発注して、新しいCDRメカユニットに貼り付けてください。(11ページのFig. 4および5参照)

1. Removal of Top Cover

- Turn off the power, wait for 10 seconds or longer and disconnect the Power Plug from the AC power outlet.
- Remove 4 screws (①) and 5 screws (②). (Fig. 1)
- Remove the Top Cover rearward while lifting it up. (Fig. 1)

1. トップカバーの取り外し

- 電源を切り、10秒以上待ってからAC電源コンセントから電源プラグを抜きます。
- ①のネジ4本、②のネジ5本を外します。(Fig. 1)
- トップカバーを持ち上げながら後方へ外します。(Fig. 1)

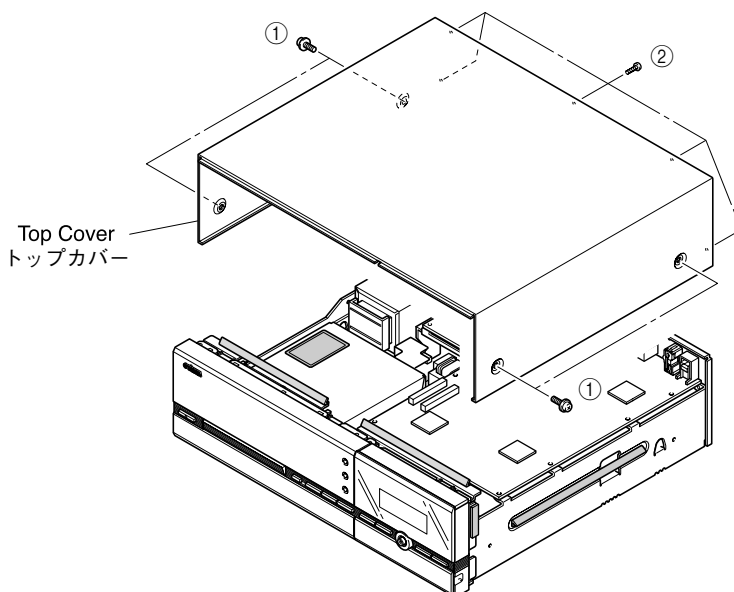

Fig. 1

2. Removal of CDR Mechanical Unit

- Remove 5 screws (③) and then remove each Stopper. (Fig. 3)
- Remove the CDR Mechanical Unit rearward while lifting it up. (Fig. 3)
- Disconnect the Power Cable and IDE Cable from the CDR Mechanical Unit. (Fig. 2)

2. CDRメカユニットの取り外し

- ③のネジ5本を外し、各ストッパーを外します。(Fig. 3)
- CDRメカユニットを持ち上げながら後方へ取り出します。(Fig. 3)
- CDRメカユニットから電源ケーブル、IDEケーブルを外します。(Fig. 2)

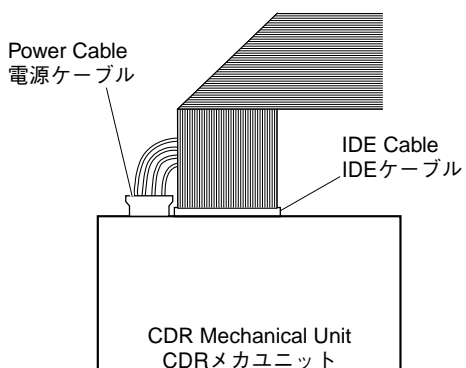

Fig. 2

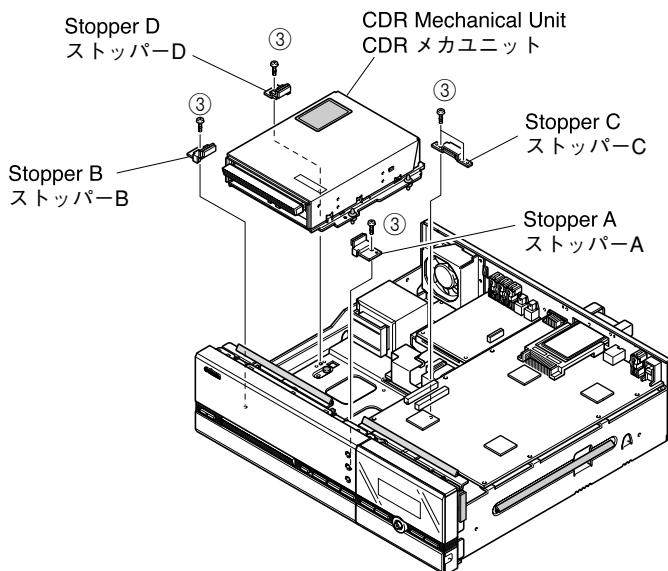

Fig. 3

3. Disassembly of CDR Mechanical Unit

- a. Remove 4 screws (④) and (⑤) respectively and then remove the Lower Frame. (Fig. 4)
- b. To open the Tray, move the Manual Eject Lever located on the bottom face. (Fig. 5)
- c. Remove the Lid upward. (Fig. 4)

3. CDRメカユニットの分解

- a. ④のネジ4本、⑤のネジ4本を外し、下フレームを外します。(Fig. 4)
- b. トレーを開ける場合は、底面のマニュアルイジェクトレバーを右へ動かして開きます。(Fig. 5)
- c. リッドを上方へ外します。(Fig. 4)

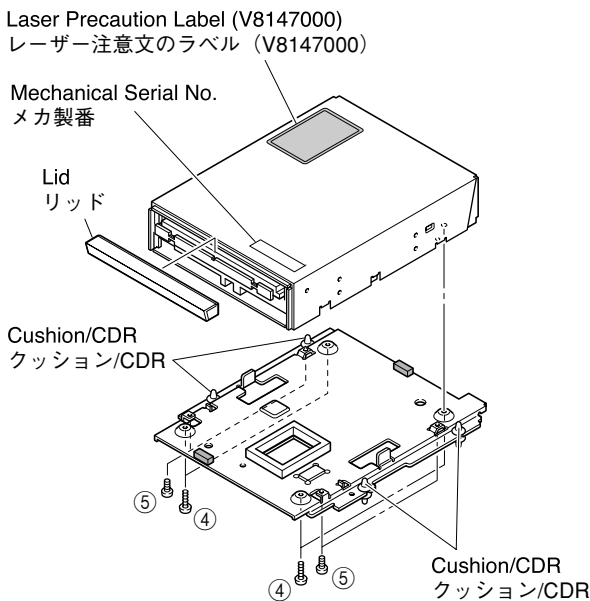

Fig. 4

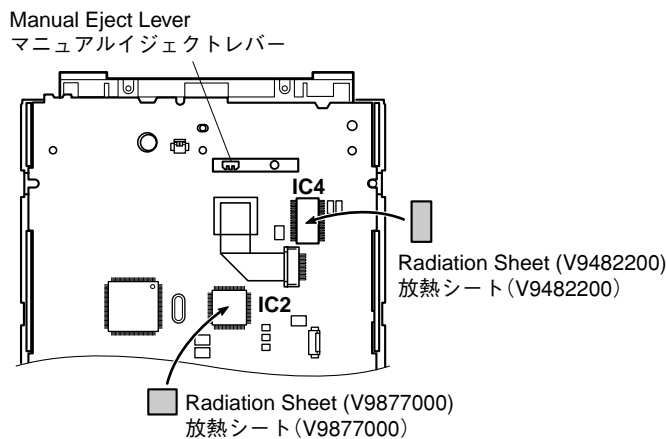

Fig. 5

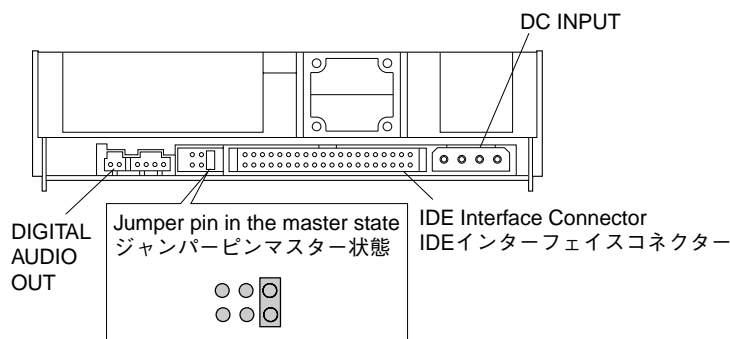

Fig. 6

4. Assembly of CDR Mechanical Unit

- Insert the jumper pin of the new CDR Mechanical Unit at the master position. (Fig. 6)
- Attach the Laser Precaution Label on the upper frame of the new CDR Mechanical Unit. (Fig. 4)
- Attach the Radiation Sheets to the IC2 and IC4 located on the bottom face of the new CDR Mechanical Unit. (Fig. 5)
- Fit the Lid to the new CDR Mechanical Unit. (Fig. 4)
- Install the Lower Frame and fix it with 4 screws (④) and (⑤) respectively. (Fig. 4)

5. Installation of CDR Mechanical Unit

- Connect the Power Cable and IDE Cable to the CDR Mechanical Unit. (Fig. 2)
- Install the CDR Mechanical Unit by inserting it from the rear. (Fig. 3)
At this time, check to make sure that 4 pieces of Cushion / CDR attached to the Lower Frame are fitted in the holes in the chassis properly. (Fig. 4)
- Using 5 screws (③), install each Stopper. (Fig. 3)

4. CDRメカユニットの交換

- 新しいCDRメカユニットのジャンパーピンを、マスターの位置に差し込みなおします。(Fig. 6)
- 新しいCDRメカユニットの上フレームに、レーザー注意文のラベルを貼り付けます。(Fig. 4)
- 新しいCDRメカユニットの底面にあるIC2およびIC4に、放熱シートを貼り付けます。(Fig. 5)
- 新しいCDRメカユニットにリッドをはめ込みます。(Fig. 4)
- ④のネジ4本、⑤のネジ4本で、下フレームを取り付けます。(Fig. 4)

5. CDRメカユニットの取り付け

- CDRメカユニットに電源ケーブル、IDEケーブルを接続します。(Fig. 2)
- CDRメカユニットを後方より差し込んで取り付けます。(Fig. 3)
このとき、下フレームに付いている4個のクッション/CDRがシャーシの穴に正しく入っていることを確認します。(Fig. 4)
- ③のネジ5本で、各ストッパーを取り付けます。(Fig. 3)

HDD replacement

- Loosen 2 screws (⑥) on the HDD Slot Door and open the HDD Slot Door. (Fig. 7)

HDDの交換

- リアパネルの⑥のネジ2本をゆるめ、HDDスロットドアを開きます。(Fig. 7)

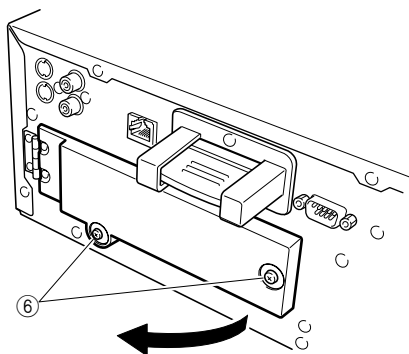

Fig. 7

- Disconnect the IDE Cable and Power Cable from the HDD. (Fig. 8)

- HDDからIDEケーブルと電源ケーブルを外します。(Fig. 8)

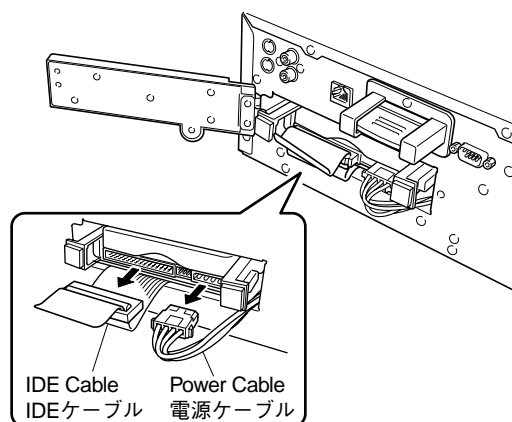
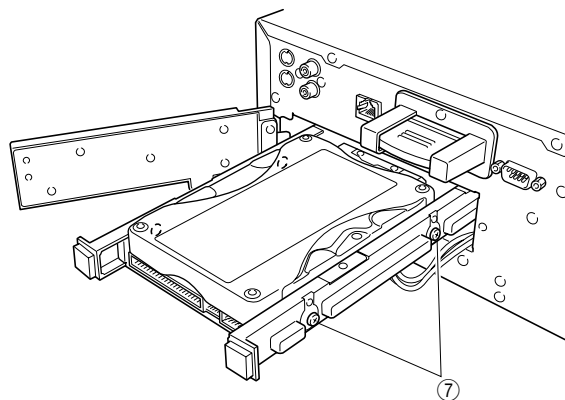

Fig. 8

- c. Pull out the HDD Tray. (Fig. 9)
- * Be careful not to hook the IDE Cable and the Power Cable over the HDD Tray.
 - * Do not apply the excessive force on the HDD Tray.
 - * Static electricity can damage the HDD. Be careful not to touch the terminal pins and the P.C.B..
- d. Loosen 4 screws (⑦) and then remove the HDD. (Fig. 9)
- c. HDDトレイを引き出します。(Fig. 9)
- ※ IDEケーブルや電源ケーブルをHDDトレイに引っかかないようご注意ください。
 - ※ HDDトレイを無理に引っ張ったり、過度の力を加えないでください。
 - ※ 静電気によりHDDが破損する場合がありますので、HDDのターミナルピンやP.C.B.に触れないようご注意ください。
- d. ⑦のネジ4本をゆるめ、HDDを取り外します。(Fig. 9)



(Screw are on the opposite side)
(反対側にもネジがあります。)

Fig. 9

- e. Set the plastic shunt of the new HDD to master. (Fig. 10)
- * It is necessary to set the HDD to MASTER or SLAVE when connecting the HDD to the component you plan to use. This unit is designed to operate HDD when it is set to MASTER. Usually, setting procedure is written on the HDD itself.
- e. 新しいHDDのショートピンを、マスターの状態にします。(Fig. 10)
- ※ IDE/ATAタイプのHDDはお使いになる機器と接続するときに、マスターまたはスレーブに設定する必要があります。本機で使用する場合は、マスターに設定すると作動するように設計されています。設定方法については、通常HDD本体に記載されています。

Example: When setting the STA380020ACE model

例: Seagate社製STA380020ACEの場合

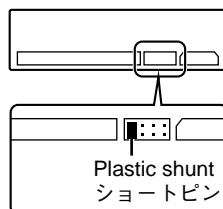

The HDD is set to MASTER by setting the plastic shunt at the first position from left of the jumper switch.

The HDD is set to SLAVE by setting no plastic shunt at any position of the jumper switch.

ジャンプスイッチの左端の位置にショートピンを差し込むと、マスターに設定されます。

ショートピンをどの位置にも差し込まないと、スレーブに設定されます。

Fig. 10

- f. Install a new HDD on the Tray using 4 screws (⑦). (Fig. 9)
- * HDD is a very sensitive device. Be careful not to give any shock to it.
- g. Push the HDD Tray and connect the IDE Cable and the Power Cable. (Fig. 11)
- * Make sure that the connectors are in the correct direction, and connect the cables securely.
 - * Static electricity can damage the HDD. Be careful not to touch the terminal pins and the circuit board.
 - * Do not apply excessive force on the HDD Tray.
- h. Close the HDD Slot Door and tighten the 2 screws (⑧) on the HDD Slot Door. (Fig. 12)

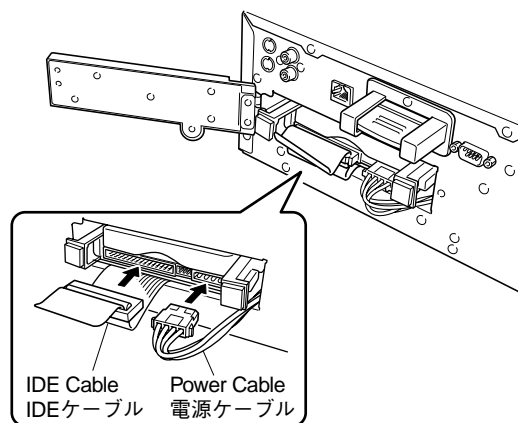

Fig. 11

- f. 新しいHDDをトレイに置き、⑦のネジ4本で固定します。(Fig. 9)
- ※ HDDは衝撃に弱い機器ですので、振動や衝撃を加えないようご注意ください。
- g. HDDトレイを奥に押し込み、IDEケーブルと電源ケーブルを差し込みます。(Fig. 11)
- ※ コネクターの向きが正しいか確認のうえ、しっかりと差し込んでください。
 - ※ 静電気によりHDDが破損する場合がありますので、HDDのターミナルピンやP.C.B.に触れないようご注意ください。
 - ※ HDDを無理に押し込んだり、過度の力を加えないでください。
- h. HDDスロットドアを閉じて、⑧のネジ2本をしめます。(Fig. 12)

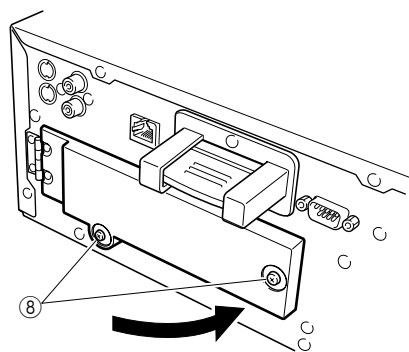

Fig. 12

P.C.B. operation check

- a. Remove the Top Cover. (Fig. 1)
- b. Disconnect the connector (CB603). (Fig. 13)
- c. Remove 1 screw (⑨) and disconnect the grounding wire. (Fig. 13)
- d. Remove 5 screws (⑩) and 5 screws (⑪). (Fig. 13)
- e. Remove the Front Panel Unit forward. (Fig. 13)

P.C.B.動作チェック

- a. トップカバーを取り外します。(Fig. 1)
- b. CB603を外します。(Fig. 13)
- c. ⑨のネジ1本を外し、アース線を外します。(Fig. 13)
- d. ⑩のネジ5本、⑪のネジ5本を外します。(Fig. 13)
- e. フロントパネルユニットを前方に外します。(Fig. 13)

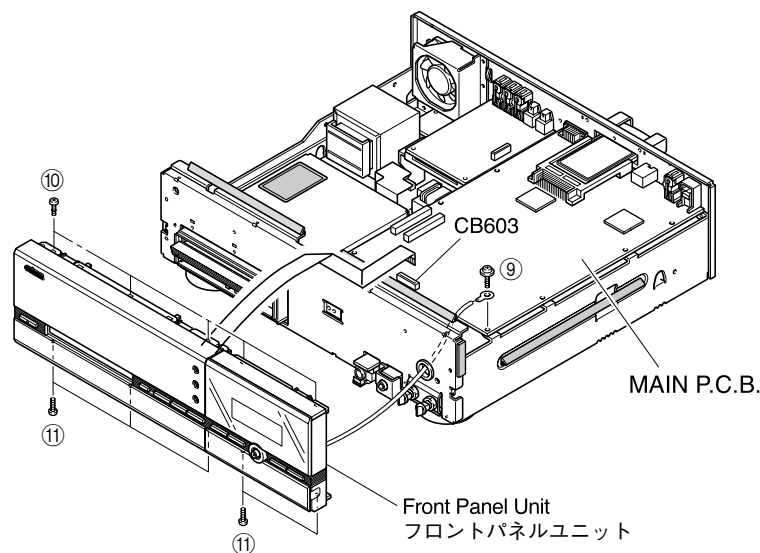

Fig. 13

- f. Remove screw (12) and then remove the Antenna Cover. (Fig. 14)
- g. Remove the Wireless LAN Card.
- h. Remove 3 screws (13) and 2 hexagonal nuts (14). (Fig. 14)
- i. Disconnect the connectors (CB222, CB223, CB301, CB601, CB602 and CB604). (Fig. 15)
- j. Remove 5 screws (15) and then remove the MAIN P.C.B. (Fig. 15)
- k. Remove 2 screws (16). (Fig. 16)
- l. Remove 2 screws (17) and then remove the Support. (Fig. 16)
- m. Remove Stopper (18). (Fig. 16)
- n. Remove 2 knobs. (Fig. 15)
- o. Remove 2 nuts (19) and then remove the OPERATION (4) P.C.B. (Fig. 16)
- p. Remove 4 screws (20). (Fig. 14)
- q. Remove 2 screws (21) and then remove the OPERATION (6) P.C.B. (Fig. 15)
- r. Install the Front Panel Unit.
- s. Spread cloth for insulation purpose and place the removed P.C.B. on it.
- t. Install the Wireless LAN Card.
- u. Reconnect all connectors that have been disconnected.
- v. Perform this check with the MAIN P.C.B. raised. (Fig. 17)

- f. ⑫のネジを外し、アンテナカバーを外します。(Fig. 14)
- g. 無線LANカードを外します。
- h. ⑬のネジ3本と⑭の六角ネジ2本を外します。(Fig. 14)
- i. CB222、CB223、CB301、CB601、CB602、CB604を外します。(Fig. 15)
- j. ⑮のネジ5本を外し、MAIN P.C.B.を外します。(Fig. 15)
- k. ⑯のネジ2本を外します。(Fig. 16)
- l. ⑰のネジ2本を外し、サポートを外します。(Fig. 16)
- m. ⑱のストッパーを外します。(Fig. 16)
- n. ノブ2個を外します。(Fig. 15)
- o. ⑲のナット2個を外し、OPERATION(4)P.C.B.を外します。(Fig. 16)
- p. ⑳のネジ4本を外します。(Fig. 14)
- q. ㉑のネジ2本を外し、OPERATION(6)P.C.B.を外します。(Fig. 15)
- r. フロントパネルを取り付けます。
- s. 絶縁用に布を敷き、取り外したP.C.B.を乗せます。
- t. 無線LANカードを取り付けます。
- u. 取り外したコネクタをすべて接続します。
- v. チェックはMAIN P.C.B.を立てた状態で行います。(Fig. 17)

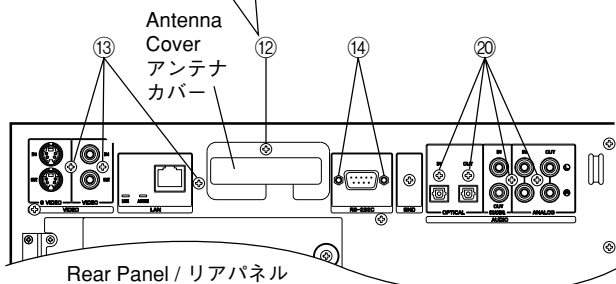
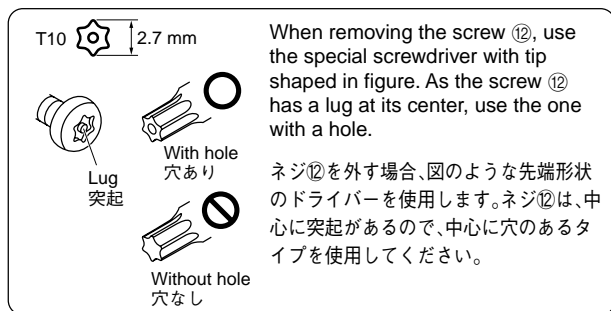

Fig. 14

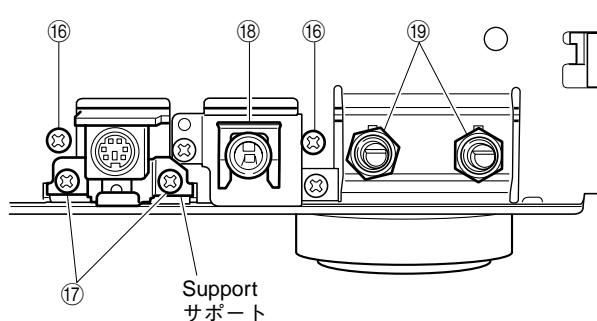

Fig. 16

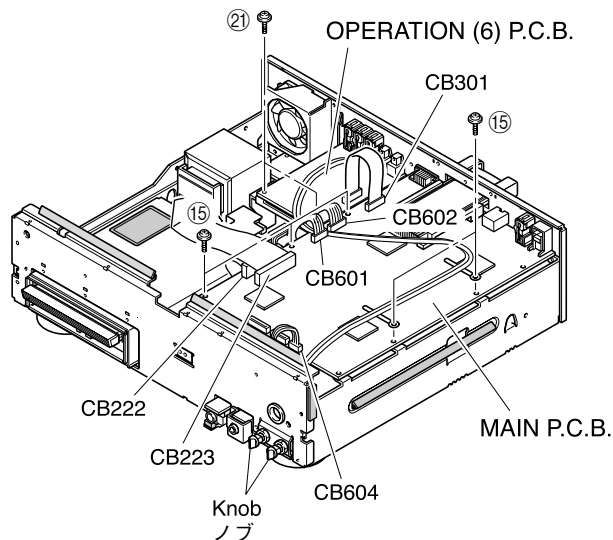

Fig. 15

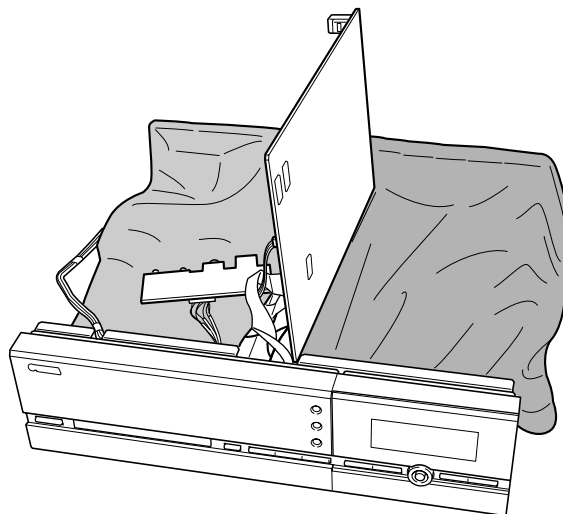

Fig. 17

■ SERVICE PRECAUTIONS／サービス時の注意事項

- When updating the firmware, refer to UPDATING FIRMWARE (p. 16 – 18).
 - After replacing the CDR mechanical unit, the CDR firmware must be updated.
For the details, refer to UPDATING FIRMWARE (p. 16 – 18).
 - After replacing the Sub CPU (IC602), the sub CPU firmware must be updated.
For the details, refer to UPDATING FIRMWARE (p. 16 – 18).
 - After replacing HDD, refer to RECOVERY AFTER REPLACING HDD (p. 18 – 19).
 - After replacing the Main P.C.B., refer to RECOVERY AFTER REPLACING MAIN P.C.B. (p. 20 – 21).
- ファームウェアのアップデートを行う場合
「ファームウェアのアップデート」(16～18ページ)を参照してください。
 - CDRメカユニットを交換した場合
CDRファームウェアのアップデートを行います。
詳しくは「ファームウェアのアップデート」(16～18ページ)を参照してください。
 - Sub CPU(IC602)を交換した場合
Sub CPUファームウェアのアップデートを行います。
詳しくは「ファームウェアのアップデート」(16～18ページ)を参照してください。
 - HDDを交換した場合
「HDD交換後のリカバリー」(18～19ページ)を参照してください。
 - メインP.C.B.を交換した場合
「メインP.C.B.交換後のリカバリー」(20～21ページ)を参照してください。

■ UPDATING FIRMWARE／ファームウェアのアップデート

Described below is the updating procedure used when:

- Updating the firmware only without replacing any part, and
- Updating the firmware after replacing the CDR mechanical unit or Sub CPU.

Recovery CD

Updating the firmware requires use of the recovery CD. The Recovery CD contains the following files. (The contents may vary.)

The release note (README.txt) includes the version of the firmware and the CRC value.

UP_RULES	MCX-1000 update operation specification file
MAIN.bin	MCX-1000 Main CPU firmware
S_SCPU.xxx	MCX-1000 Sub CPU firmware
S_FONE_XXX.BIN	MCX-1000 CRW-F1A firmware
AVA000.bin	MCX-1000 applicable AV Receiver list/function
FONTxxx	MCX-1000 GUI font
SKN1_XXXX	MCX-1000 image data
ECDDb.xxx	MCX-1000 CDDb relation data
CONFIG.GN	
BOOT0xx.bin	MCX-1000 testing firmware
CFIRM000.bin	MCX-A10 firmware
CFIRM001	
KENSA000.bin	MCX-A10 testing firmware
README.txt	Release note

下記の場合のアップデート手順について説明します。

- 部品交換を伴わずにアップデートのみを行う場合
- CDRメカユニットまたはSub CPUを交換後にアップデートを行う場合

リカバリーCD

ファームウェアのアップデートにはリカバリーCDを使用します。

リカバリーCDには下記のファイルが記録されています。(内容は変更されることがあります。)

リリースノート(README.txt)にはファームウェアのバージョンおよびCRCの値が記載されています。

UP_RULES	MCX-1000 update 動作規定ファイル
MAIN.bin	MCX-1000 Main CPU firmware
S_SCPU.xxx	MCX-1000 Sub CPU firmware
S_FONE_XXX.BIN	MCX-1000 CRW-F1A firmware
AVA000.bin	MCX-1000 対応 AV Receiver list / function
FONTxxx	MCX-1000 GUI font
SKN1_XXXX	MCX-1000 GUI 画像データ
ECDDb.xxx	MCX-1000 CDDb 関係データ
CONFIG.GN	
BOOT0xx.bin	MCX-1000検査用 firmware
CFIRM000.bin	MCX-A10用 firmware
CFIRM001	
KENSA000.bin	MCX-A10検査用 firmware
README.txt	リリースノート

なお、リカバリーCDの供給に関する詳細は、サービスニュースでお知らせします。

More information on supply of the recovery CD will be provided in the Service News.

Items required:

Recovery CD
TV monitor
Video cable

用意するもの

リカバリーCD
TVモニター
ビデオケーブル

Connection

Using the video cable, connect VIDEO OUT terminal of this unit to VIDEO input terminal of the TV monitor.

接続

本機のVIDEO OUTとTVモニターのVIDEO入力端子をビデオケーブルで接続します。

Operation Procedure

Perform following steps while watching the TV monitor screen and using the keys of the main unit.

- 1) Turn on the power.
- 2) The TOP MENU appears on the screen.
- 3) Using the "Controller" key, select the menu items as follows.
System Setup -> System Utility -> System Update
- 4) Press the "△" key to open the tray, set the recovery CD on it and then close it.
After reading the data, the version of each firmware is displayed as shown below.

操作手順

TVモニター画面を見ながら本体キーを使って操作します。

- 1) 電源を入れます。
- 2) TOP MENUが表示されます。
- 3) “コントローラー”キーを使いメニューを下記のように選択します。
System Setup → System Utility → System Update
- 4) “△”キーを押しトレイを開き、リカバリーCDをトレイに載せ、トレイを閉じます。
データ読み込み後、各ファームウェアのバージョンが表示されます。

Example) 例)

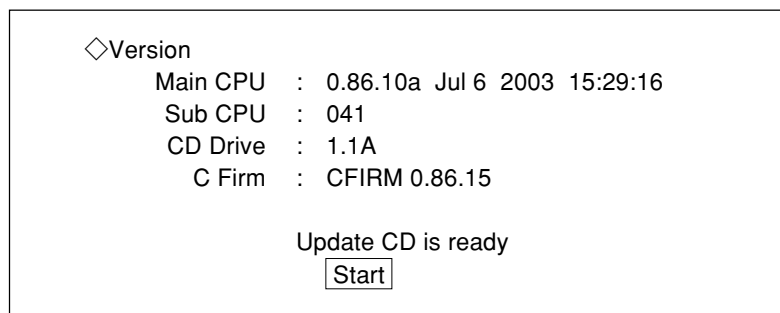

- 5) Press the "Controller" key.
After reading the data, the version updating menu is displayed and the 15-second count-down function starts at the same time.
- 5) “コントローラー”キーを押します。
データ読み込み後、バージョンアップメニューが表示され、同時に15秒のカウントダウンがスタートします。

<CD AUTO STORE> CD DRV SELECT : Updating of the CDR mechanism (F1A) is included.
CDRメカ (F1A) のアップデートを含みます。

<SUB MENU> SUB CPU SELECT : Updating of the Sub CPU is included.
Sub CPUのアップデートを含みます。

<BACK> BOTH SELECT : Updating of the CDR mechanism (F1A) and Sub CPU is included.
CDRメカ (F1A) およびSub CPUのアップデートを含みます。

<STOP> NORMAL

After replacing the CDR mechanical unit, press the "CD AUTO STORE" key.

After replacing the Sub CPU, press the "SUB MENU" key.

After replacing both CDR mechanical unit and Sub CPU, press the "BACK" key.

In the case other than the above, press the "□" key.

CDRメカユニットを交換した場合、“CD AUTO STORE”キーを押します。

Sub CPUを交換した場合、“SUB MENU”キーを押します。

CDRメカユニットとSub CPUの両方を交換した場合、“BACK”キーを押します。

上記以外の場合、“□”キーを押します。

If no key is pressed, "NORMAL" is automatically selected after counting down 15 seconds and the updating function is started.

After completion of the updating process, "EJECT & RESTART" or "SHUT OFF AC POWER" is displayed.

- 6) Execute restarting as described below.
 - a. When [EJECT & RESTART] is displayed, turn off and on the "STANDBY/ON" key.
 - b. When [SHUT OFF AC POWER] is displayed, keep pressing the "STANDBY/ON" key for 10 to 15 seconds and wait until resetting is completed. Upon completion of resetting, a clicking sound of the relay is heard and the CLIENT STATUS LED lights up from the left segment and right segment. Then, release the "STANDBY/ON" key within about 5 seconds.
- 7) After restarting, press the "△" key to open the tray, remove the recovery CD and close the tray.

なお、これらのキーが押されなければ、15秒のカウントダウン終了後、自動的に“NORMAL”が選択されてアップデートが開始されます。

アップデート終了後、EJECT & RESTARTまたはSHUT OFF AC POWERと表示されます。

- 6) 再起動します。
 - a. 「EJECT & RESTART」と表示された場合、「STANDBY/ON」キーをオフ、オンします。
 - b. 「SHUT OFF AC POWER」と表示された場合、「STANDBY/ON」キーを10～15秒押し続け、リセットされるまで待ちます。リセットがかかると「カチッ」というリレーの音がしてCLIENT STATUSのLEDが左右に順次点灯しますので5秒程度以内に指を離します。
- 7) 再起動後、「△」キーを押してトレイを開き、リカバリーCDを取り出し、トレイを閉じます。

■ RECOVERY AFTER REPLACING HDD/HDD交換後のリカバリー

Items required:

Recovery CD
TV monitor
Video cable

用意するもの

リカバリーCD
TVモニター
ビデオケーブル

Connection

Using the video cable, connect the VIDEO OUT terminal of this unit to the VIDEO input terminal of the TV monitor.

接続

本機のVIDEO OUTとTVモニターのVIDEO入力端子をビデオケーブルで接続します。

Operation Procedure

Perform following steps while watching the TV monitor screen and using the keys of the main unit.

操作手順

TVモニター画面を見ながら本体キーを使って操作します。

Case 1: When the installed HDD is a brand new one or the one used for the PC

- 1) Turn on the power.
- 2) [SET RECOVERY CD] appears on the screen.
- 3) Press the "△" key to open the tray, set the recovery CD on it and then close it.
The formatting function starts automatically. For menu selection while formatting, select NORMAL.
- 4) After formatting, execute restarting.
- 5) After restarting, press the "△" key and remove the recovery CD.

ケース1：新品またはパソコンで使用したHDDを取り付けた場合

- 1) 電源を入れます。
- 2) 「SET RECOVERY CD」と表示されます。
- 3) “△”キーを押してトレイを開き、リカバリーCDをトレイに載せ、トレイを閉じます。
自動的にFormatがスタートします。
なお、途中でのメニュー選択ではNORMALを選択します。
- 4) Format終了後、再起動します。
- 5) 再起動後、“△”キーを押してリカバリーCDを取り出します。

Case 2: When the installed HDD is the one used for other MCX-1000

- 1) Turn on the power.
- 2) The message as shown below is displayed.

ケース2：他のMCX-1000で使用したHDDを取り付けた場合

- 1) 電源を入れます。
- 2) 下記のように表示されます。

* HDD Error *
TurnOFF AC Power

- 3) While pressing and holding the "TOP MENU" key, wait for 1 second and press the "BACK" key.
- 4) [SET RECOVERY CD] appears on the screen.
- 5) Press the "△" key to open the tray, set the recovery CD on it and then close it.
The formatting function starts automatically. For menu selection, select NORMAL.
- 6) After formatting, execute restarting.
- 7) After restarting, press the "△" key and remove the recovery CD.

Case 3: When the installed HDD is the one previously used for the same MCX-1000

- 1) Turn on the power.
- 2) The [TOP MENU] appears on the screen.
- 3) While pressing the "TOP MENU" key, wait for 1 second and press the "BACK" key. This makes the hidden menu display mode start but there is no change in display in this stage.
- 4) Using the "Controller" key, select the menu items as follows.
System Setup -> System Utility -> Service Menu
-> Hard Drive Format

- 3) "TOP MENU"キーを押しながら離さずに1秒待った後、"BACK"キーを押します。
- 4) 「SET RECOVERY CD」と表示されます。
- 5) "△"キーを押してトレイを開き、リカバリーCDをトレイに載せ、トレイを閉じます。
自動的にFormatがスタートします。
なお、メニューはNORMALを選択します。
- 6) Format終了後、再起動します。
- 7) 再起動後、"△"キーを押してリカバリーCDを取り出します。

ケース3：過去にそのMCX-1000で使用したHDDを取り付けた場合

- 1) 電源を入れます。
- 2) 「TOP MENU」が表示されます。
- 3) "TOP MENU"キーを押しながら1秒待った後、"BACK"キーを押します。
これにより隠しメニュー表示モードが起動します。
ただし、この段階では表示に変化はありません。
- 4) "コントローラー"キーを使いメニュー画面を以下のように進めます。
System Setup → System Utility → Service Menu
→ Hard Drive Format

Hard Drive Format screen / Hard Drive Format画面表示

Are you sure you want to delete all HDD data ?	
Yes	Cancel

- 5) Using the "Controller" key, bring the cursor to "Yes" and press the "Controller" key.
- 6) [SET RECOVERY CD] appears on the screen.
- 7) Press the "△" key to open the tray, set the recovery CD on it and then close it.
The formatting function starts automatically. For menu selection, select "NORMAL".
- 8) After formatting, execute restarting.
- 9) After restarting, press the "△" key and remove the recovery CD.

- 5) "コントローラー"キーを使いカーソルを"Yes"に合わせて"コントローラー"キーを押します。
- 6) 「SET RECOVERY CD」と表示されます。
- 7) "△"キーを押してトレイを開き、リカバリーCDをトレイに載せ、トレイを閉じます。
自動的にFormatがスタートします。
なお、メニューは"NORMAL"を選択します。
- 8) Format終了後、再起動します。
- 9) 再起動後、"△"キーを押してリカバリーCDを取り出します。

■ RECOVERY AFTER REPLACING MAIN P.C.B./MAIN P.C.B.交換後のリカバリー

When the Main P.C.B. has been replaced, perform the recovery procedure as described below.

Use the same procedure also after replacing FLASH (IC108).

Items required:

Recovery CD
TV monitor
Video cable

Connection

Using the video cable, connect the VIDEO OUT terminal of this unit to the VIDEO input terminal of the TV monitor.

Operation Procedure

Perform following steps while watching the TV monitor screen and using the keys of the main unit.

Step 1

Update the firmware according to the following procedure

- a. Turn on the power.
- b. The error message as shown below is displayed.

Example) 例)

```
OSD VERSION MISMATCH
PROGRAM VERSION : 030505
BITMAP VERSION : 030611
INSERT OSD UPDATE CD
```

- c. Press the "△" key to open the tray, set the recovery CD on it and then close it.
The formatting function starts automatically.
- d. [READ ERROR] may appear but it is not necessary to do anything in this stage.
- e. After updating, press the "△" key and remove the recovery CD.
- f. Turn off the power.

Step 2

Enter the system ID.

For the details, refer to ENTERING SYSTEM ID (p. 23 – 24).

After entering the system ID, turn off the power, remove the jig P.C.B. and disconnect the connection cable.

Step 3

Install the firmware again.

For the details, refer to UPDATING FIRMWARE (p. 16 – 18).

Step 4

Reset the system according to the following procedure.

- a. Press the "TOP MENU" key. The [TOP MENU] is displayed.

メインP.C.B.を交換した場合、下記の手順でリカバリーを行います。

なお、FLASH(IC108)を交換した場合も同様です。

用意するもの

リカバリーCD
TVモニター
ビデオケーブル

接続

本機のVIDEO OUTとTVモニターのVIDEO入力端子をビデオケーブルで接続します。

操作手順

TVモニター画面を見ながら本体キーを使って操作します。

Step 1

ファームウェアをアップデートします。

- a. 電源を入れます。
- b. エラーメッセージが表示されます。

- c. “△”キーを押してトレイを開き、リカバリーCDをトレイに載せ、トレイを閉じます。
自動的にアップデートがスタートします。
- d. 「READ ERROR」が発生する場合がありますが、この段階では何もする必要はありません。
- e. アップデート終了後、“△”キーを押してリカバリーCDを取り出します。
- f. 電源を切ります。

Step 2

システムIDを書き込みます。

詳しくは、「システムIDの書き込み」(23～24ページ)を参照してください。

書き込み完了後、電源を切り、治具基板および接続ケーブルを外します。

Step 3

再び、ファームウェアをインストールします。

詳しくは「ファームウェアのアップデート」(16～18ページ)を参照してください。

Step 4

システムをリセットします。

- a. “TOP MENU”キーを押します。
「TOP MENU」が表示されます。

- b. Using the "Controller" key, select the menu items as follows.
System Setup -> System Utility -> System Reset
- c. Using the "Controller" key, bring the cursor to "Yes" and press the "Controller" key.
After resetting, the System Utility screen appears again.
- d. Turn the power OFF/ON.

- b. “コントローラー”キーを使ってメニュー画面を以下のように進めます。
System Setup → System Utility → System Reset
- c. “コントローラー”キーを使ってカーソルを“Yes”に合わせ“コントローラー”キーを押します。
リセット後、System Utility画面に戻ります。
- d. 電源をOFF/ONします。

■ SERVICE MENU / サービスメニュー

Items required

TV monitor
Video cable

用意するもの

TVモニター
ビデオケーブル

Connection

Using the video cable, connect the VIDEO OUT terminal of MCX-1000 to the VIDEO IN terminal of the TV monitor.

接続

MCX-1000のVIDEO OUTとTVモニターのVIDEO INをビデオケーブルで接続します。

Operation

Perform following steps while watching the TV monitor screen and using the keys of the main unit.

- 1) Turn on the power.
- 2) The [TOP MENU] appears on the screen.
- 3) While pressing and holding the "TOP MENU" key, wait for 1 second and press the "BACK" key. This makes the hidden menu display mode start but there is no change in display in this stage.
- 4) Using the "Controller" key, select the menu items as follows.

System Setup -> System Utility -> Service Menu

操作

TVモニター画面を見ながら本体キーを使って操作します。

- 1) 電源を入れます。
- 2) 「TOP MENU」が表示されます。
- 3) “TOP MENU”キーを押しながら離さずに1秒待った後、“BACK”キーを押します。
これにより隠しメニュー表示モードが起動します。
ただし、この段階では表示に変化はありません。
- 4) “コントローラー”キーを使いメニューを下記のように選択します。

System Setup → System Utility → Service Menu

Service Menu screen / サービスメニュー画面

- ◇ System Detail Version
 - ◇ System ID
 - ◇ Hard Drive Test (Experimental)
 - ◇ Hard Drive Format

Using the "Controller" key, select the menu item and press the "Controller" key. To return to the Service Menu screen, press the "BACK" key.

“コントローラー”キーを使いメニューを選び、“コントローラー”キーを押します。
表示後、“BACK”キーを押すとService Menu画面に戻ります。

System Detailed Version screen/System Detailed Version表示画面

Example) 例)

Main CPU	: 0.86.10a Jul 6 2003 15:29:16
Sub CPU	: 041
DSP	: MP3Pb17 MP3Eb03 MP3Rb03 DIAGa04
OSD	: 030611
FPGA	: B001
CD Drive	: 1.1A
CFirm	: CFIRM 0.86.15
CDDDB	: Revision 61
Boot PG Size	: 004D8960
Amp DB Size	: 00002CF9
Check Sum (CRC)	:

System ID screen/System ID表示画面

Example) 例)

System ID	: 33C203EC
MAC Address	: 00AODE1B0003
Country	: J (Japan)
Remained Re-write	: 14
Serial NO	: N010043Y0
Barcode	: 01004B00033

Hard Drive Format screen/Hard Drive Format 画面表示

Are you sure you want to delete all HDD data ?	
Yes	Cancel

For formatting, use the following procedure.

- Using the "Controller" key, bring the cursor to "Yes" and press the "Controller" key.
- [SET RECOVERY CD] appears on the display.
- Press the "△" key to open the tray, set the recovery CD on it and then close it.
The formatting function starts automatically. For menu selection, select NORMAL.
- After formatting, execute restarting.
- After restarting, press the "△" key and remove the recovery CD.

- To cancel the Service Menu display mode, turn off the power.

Formatする場合、以下の操作を行います。

- “コントローラー”キーを使いカーソルを“Yes”にあわせて“コントローラー”キーを押します。
- 「SET RECOVERY CD」と表示されます。
- “△”キーを押してトレイを開き、リカバリーCDをトレイに載せ、トレイを閉じます。
自動的にFormatがスタートします。
なお、メニューはNORMALを選択します。
- Format終了後、再起動します。
- 再起動後、“△”キーを押してリカバリーCDを取り出します。

- サービスメニュー表示モードを解除するには電源を切ります。

■ ENTERING SYSTEM ID / システムIDの書き込み

Preparation : Be sure to take the measure against static electricity before the work. (Refer to page 5)

Items required :

- IC writing jig (P.C.B. and 2P cable) : WA045500
- Flat cable 30P 250mm : WC028700

Setting and Connecting Jig

- 1) Turn off the power.
- 2) Remove the top cover.
- 3) Set the I/O selector (CB4) of the jig P.C.B. to +3.3V. (Fig. A)

Caution: Note that setting to +5V will damage the unit.

- 4) Set the DIP switch (SW1) of the jig P.C.B. (Fig. A)
- 5) Connect CB3 of the jig P.C.B. to CB606 of the MAIN P.C.B. with the cable (2P). (Fig. A)
- 6) Connect TE1 of the jig P.C.B. to CB101 of the MAIN P.C.B. with the flat cable (30P). (Fig. A)

Operation Procedure

Press the keys of the main unit for operation.

- 1) Turn on the power.
- 2) After about 8 seconds, "Serial No." is displayed in the 1st line and "N00000000" (9 figures) in the 2nd line.
- 3) Enter 9 alphanumeric characters represented as X in the serial number [SER.XXXXXXXXXX] found on the rear panel.

Note: The serial number is also found on the right side face of the main unit chassis. (Fig. B)

Inputting method :

The input number is displayed in the 2nd line and the figure being currently selected flashes.

Using "∧/∨" of the "Controller" key to increase/decrease the value and "</>" to shift the place, select the character to enter one by one.

- 4) Press the "PAGE ∨" key.
"Barcode No." is displayed in the 1st line and "00000000000" (11 figures) in the 2nd line.
- 5) Enter alphanumeric characters (11 figures) found under the barcode on the rear panel.
Use the same inputting method as described in Step 3).
At this time, be careful not to mix B with 8 and G with 6.
- 6) Press the "PAGE ∨" key.
"Country ID" is displayed in the 1st line and "J" in the 2nd line.
Using the "Controller" key, select one from "U, C, J, B, A and G".
- 7) Press the "PAGE ∨" key to change the input item and check if "Serial No.", "Barcode No." and "Country ID" are selected correctly.
- 8) Press the ">" key, and writing is executed.
- 9) After completion of writing the data, "Write OK" is displayed.

If there is an error in the input data, "Data NG" is displayed. In such case, press the "PAGE ∨" key, and the input display screen appears again. Then recheck the number on the rear panel and if an error is found,

準備 : 作業の前に必ず静電気対策を実施してください。(5ページ参照)

用意するもの :

- IC書き込み治具(基板+2Pケーブル) : WA045500
- フラットケーブル30P 250mm : WC028700

治具の設定及び接続

- 1) 電源を切ります。
- 2) トップカバーを外します。
- 3) 治具P.C.B.のI/Oセレクター(CB4)を+3.3Vに設定します。(Fig. A)
注意 : +5Vに設定した場合、MCX-1000の故障の原因になります。
- 4) 治具P.C.B.のディップスイッチ(SW1)を設定します。(Fig. A)
- 5) 治具P.C.B.のCB3とMAIN P.C.B.のCB606をケーブル(2P)で接続します。(Fig. A)
- 6) 治具P.C.B.のTE1とMAIN P.C.B.のCB101をフラットケーブル(30P)接続します。(Fig. A)

操作手順

本体のキーを押して操作します。

- 1) 電源を入れます。
- 2) 約8秒後、1行目「Serial No.」、2行目「N00000000」(9桁)と表示されます。
- 3) リアパネルに表示されているシリアルナンバー「SER.XXXXXXXXXX」のX部分の英数字(9桁)を入力します。
注意 : シリアルナンバーは本体シャーシ右側面にも表示されています。(Fig. B)
入力方法
2行目に入力する番号が表示され、現在選択している桁が点滅します。
“コントローラー”キーの“∧/∨”で値の増減、“</>”で桁の移動ができるので、一桁ずつ入力したい番号にあわせませす。
- 4) “PAGE ∨”キーを押します。
1行目「Barcode No.」、2行目「00000000000」(11桁)と表示されます。
- 5) リアパネルに表示されているバーコードの下の英数字(11桁)を入力します。
入力方法は、3)と同様です。
この時、Bと8、Gと6を読み間違えないように注意してください。
- 6) “PAGE ∨”キーを押します。
1行目「Country ID」、2行目「J」と表示されます。
“コントローラー”キーを使って、「U、C、J、B、A、G」の中から1つを選択します。
- 7) “PAGE ∨”キーを押し入力項目を切り替えて「Serial No.」、「Barcode No.」の数値、「Country ID」の仕向の選択が正しいか確認します。
- 8) “>”キーを押すと書き込みが行われます。
- 9) 書き込み完了後「Write OK」と表示されます。

入力されたデータに誤りがある場合、「Data NG」と表示されます。
この場合、“PAGE ∨”キーを押すと、再び入力表示に戻りますので、リアパネルの表示番号を再確認し、間違いがあれば再入力後、“>”キーを押します。

enter the correct data again and press the ">" key.
 If writing has failed, "Write failed" is displayed. In such case, turn off the power, perform the procedure of "Setting and connecting jig" all over again and then restart from Step 1).

- 10) After completion of writing the data, turn off the power.
- 11) Remove the jig P.C.B. and disconnect the connecting cable.
- 12) Install the top cover.

Caution:

The System ID can be rewritten up to 15 times.

書き込みに失敗した場合、「Write failed」と表示されます。

この場合、電源を切り、「治具の設定および接続」を最初からやり直した後、操作を1)からやり直します。

- 10) 書き込み完了後、電源を切ります。
- 11) 治具基板及び接続ケーブルを外します。
- 12) トップカバーを取り付けます。

注意：

System IDを書き換えできる回数は15回までです。

CB4 is to select the I/O voltage.
 On the MCX-1000 it is "+3.3V".
 CB4は、I/O電圧の選択用。
 MCX-1000の場合は+3.3V。

Set the DIP switch as shown in figure.
 DIPスイッチを図のように設定します。

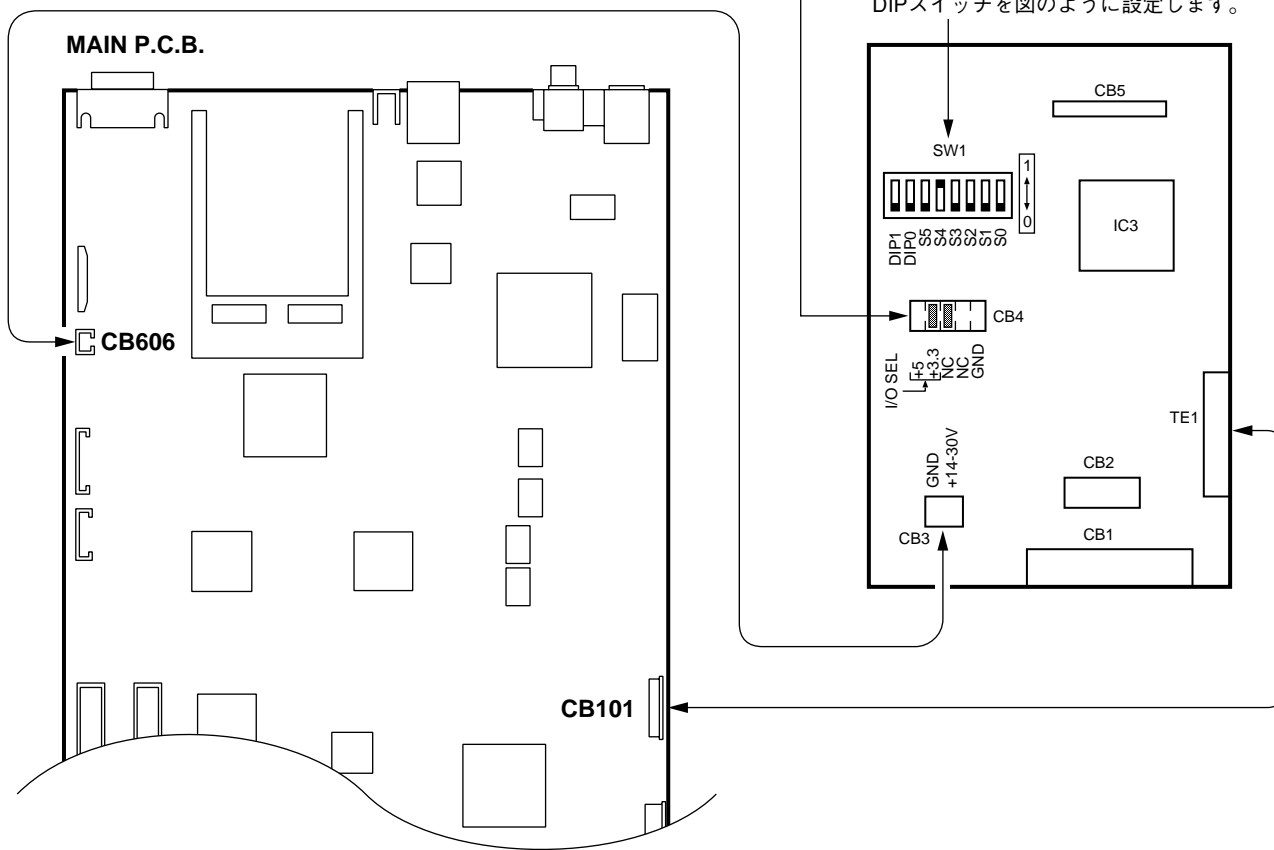

Fig. A

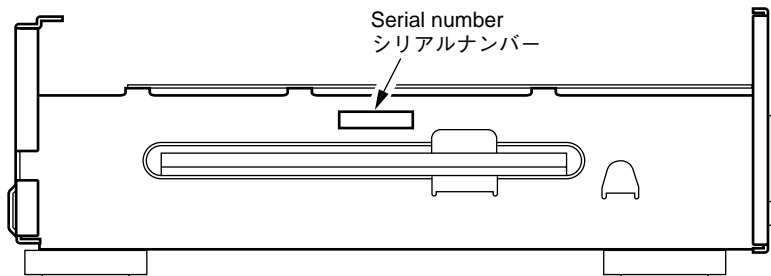
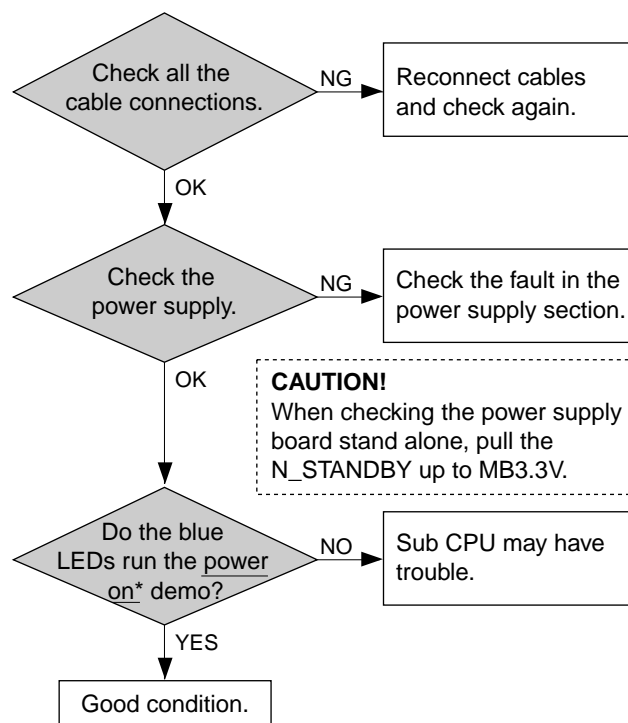

Fig. B

■ TROUBLESHOOTING / トラブルシューティング

When the power can't be turned on.



電源がONにできない場合

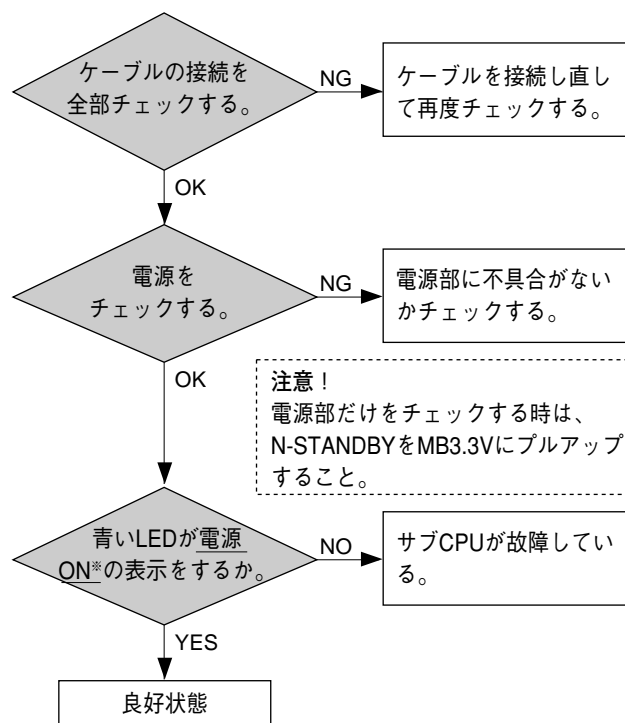

When [TOP MENU] can't be displayed.

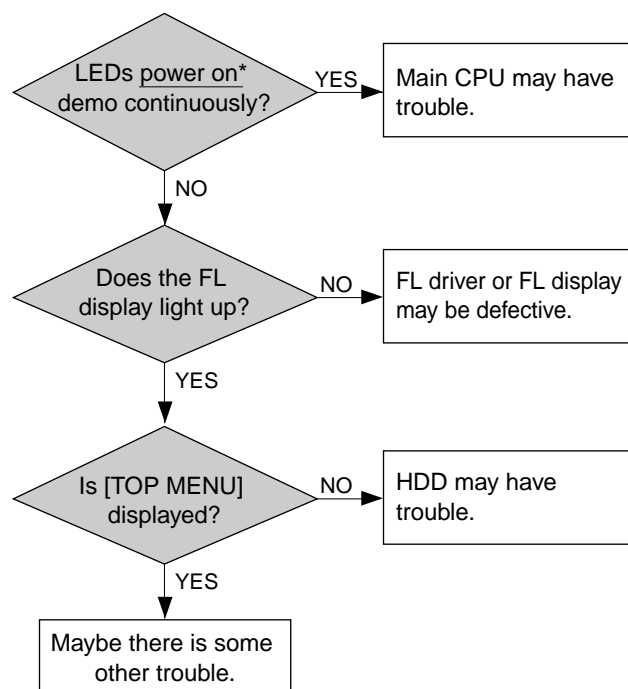

「TOP MENU」と表示されない場合

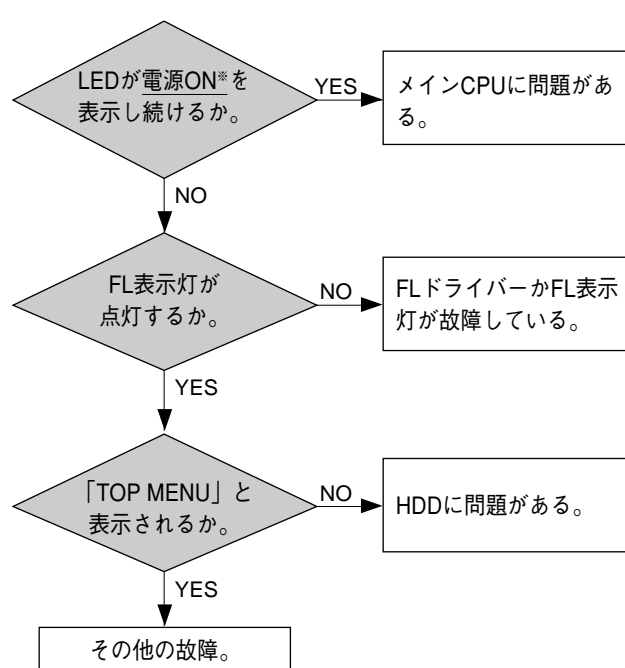

* The power ON display means blue LEDs lighting in the order of 1, 2, 3, 4, 5, 4, 3, 2, 1 repeatedly.

※ 電源ONの表示とは青色LEDが1、2、3、4、5、4、3、2、1(以下くり返し)のように表示を行うことを示します。

In case of Sub CPU trouble.

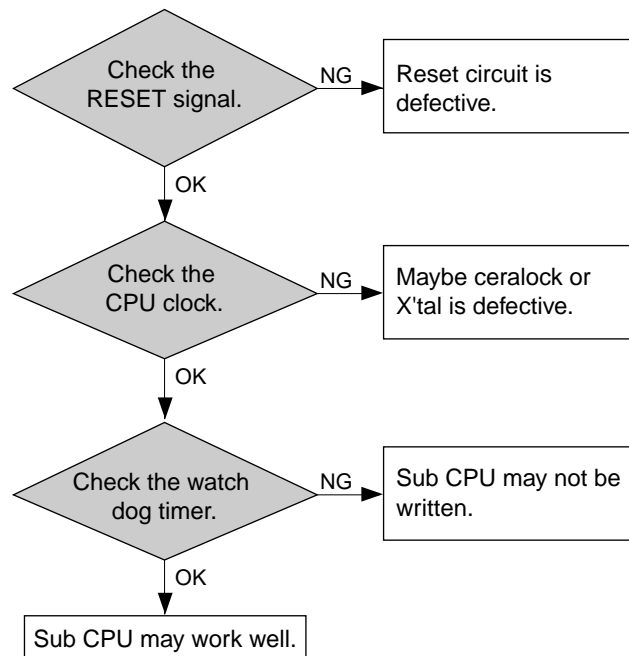

サブCPUが故障している場合

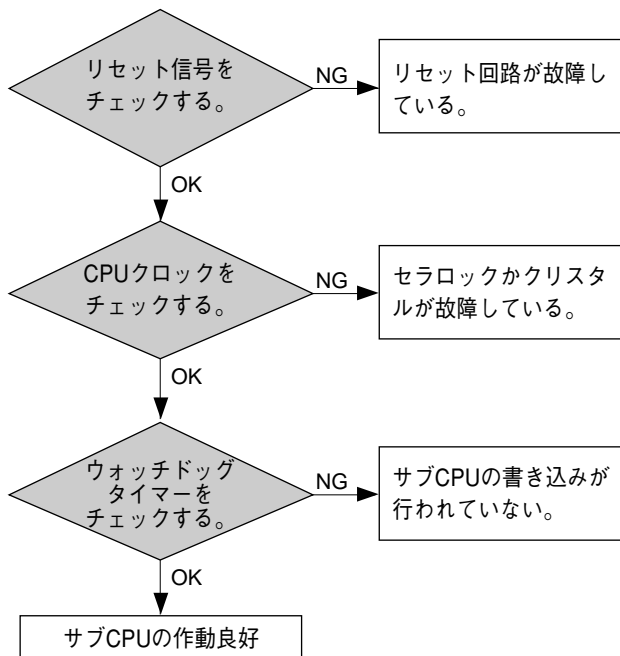

In case of MAIN CPU trouble.

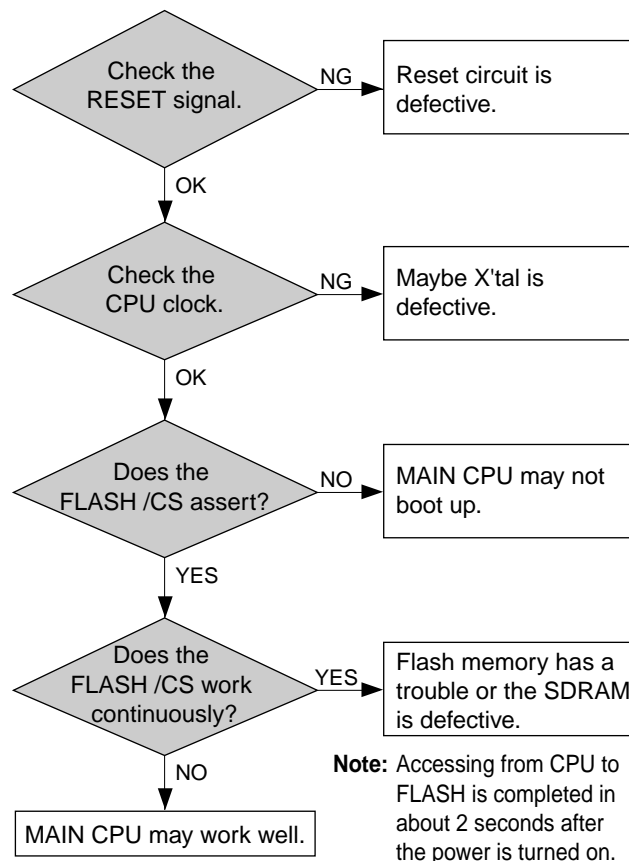

メインCPUが故障している場合

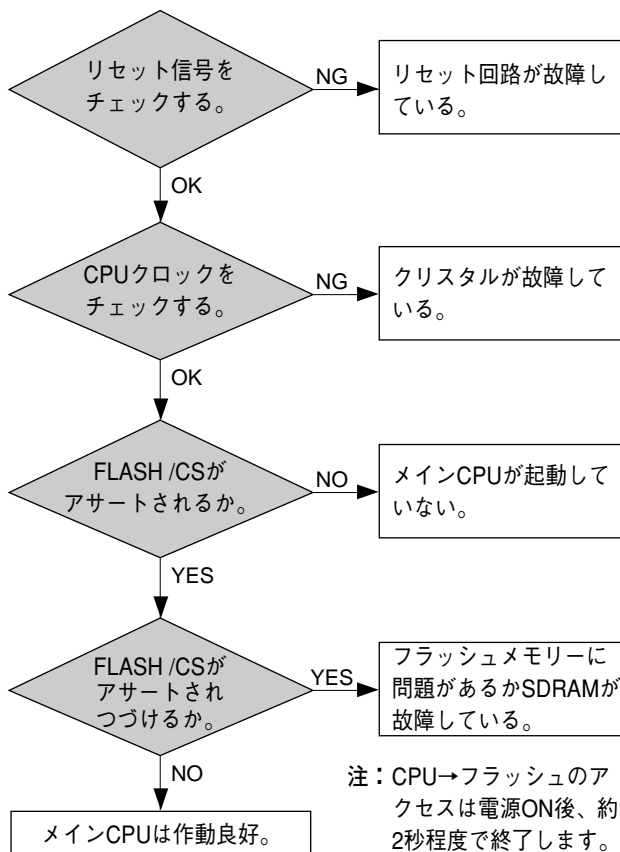

In case of other troubles.

- It's very difficult to find out other LSI's troubles because they are connected by the BUSes.
- However, if the trouble is caused by something other than the bus, it may be possible to find it by using the P.C.B. test mode.
 - Push "SUB MENU" key and "PAGE ∨" key at the same time and turn on the power.
 - Monitor the log using the terminal on PC.

その他のトラブルの場合

- その他のLSIまわりの不具合は、LSIがバス接続されているために発見することは非常に困難です。
- しかし、バス以外が原因となる不具合は、PCBテストモードを使用することで見つかる可能性があります。
 - “SUB MENU”キーと“PAGE∨”キーを同時に押して電源をONにする。
 - パソコンの端子を使ってログをモニターする。

■ TEST MODE / テストモード

Items required :

- CD player with digital output (optical/coaxial) terminal
- AV amplifier with digital input (optical/coaxial) terminal
- PS/2 key board
- Music CD
- Headphone
- Coaxial cable
- Optical cable

Operation Procedure :

Use the keys of the main unit for operation.

Starting Test Mode

While pressing the "SUB MENU" and "PAGE ^" keys simultaneously, connect the power cord to the AC power outlet. The CLIENT STATUS LED segments light up one after another.

After about 8 seconds, the Test mode starts up and "Final Test" is displayed.

1) Display

Press the "TOP MENU" key, and all segments of the FL display light up and the TIMER LED lights at the same time.

Press the "TOP MENU" key again, and the FL display turns off and the TIMER LED turns off at the same time.

2) FAN Control

Every time the "MENU" key is pressed, the FAN revolution speed changes in 3 steps (high speed, low speed, stop) and at the same time LAN STANDBY LED repeats on and off alternately. Also, the temperature in the main unit is displayed as FAN/Temp = XX.

These XX is in the range of the ambient temperature to 15°C higher than the ambient temperature.

Display	Fan revolution speed
FAN/Temp = XX FAN : high	High speed
Fan/TEMP = XX FAN : LOW	Low speed
FAN/Temp = XX FAN : STOP	Stop

3) PS/2 Key Board

Press the "PLAY INFO" key. Then, "PS/2 KB test" is displayed and at the same time the ENCODING LED lights up.

Letters or numbers input through the keyboard connected to the PS/2 terminal are displayed.

Caution:

Note that this unit uses settings for the Japanese keyboard. Therefore, use of a keyboard for any language other than Japanese may result in the display different from the inputted characters.

用意するもの :

- デジタル出力(光/同軸)を持ったCDプレーヤー
- デジタル入力(光/同軸)を持ったAVアンプ
- PS/2キーボード
- 音楽CD
- ヘッドホン
- 同軸ケーブル
- 光ケーブル

操作手順 :

本体のキーで操作します。

テストモード起動

"SUB MENU"キーと"PAGE ^"キーを押しながら、電源コードをACコンセントに接続します。

CLIENT STATUSのLEDが順次点灯します。

約8秒後、テストモードが起動し、「Final Test」が表示されます。

1) 表示

"TOP MENU"キーを押すとFLディスプレイが全灯し、同時にTIMER LEDが点灯します。

再び"TOP MENU"キーを押すとFLディスプレイが消灯し、同時にTIMERのLEDが消灯します。

2) FANコントロール

"MENU"キーを押す毎にFANの回転が3段階(高速、低速、停止)で切り替わり、同時にLAN STANDBY LEDが交互に点灯と消灯を繰り返します。また本体内部の温度をFAN/Temp = XXと表示します。

このXXはおよそ周囲温度以上～周囲温度+15°C以下の範囲となります。

表示	FAN回転
FAN/Temp = XX FAN: HIGH	高速回転
FAN/Temp = XX FAN: LOW	低速回転
FAN/Temp = XX FAN: STOP	停止

3) PS/2キーボード

"PLAY INFO."キーを押すと「PS/2 KB test」が表示され、同時にENCODINGのLEDが点灯します。

PS/2端子に接続したパソコン用キーボードから入力したアルファベットまたは数字が表示されます。

注意 :

日本語キーボードの設定になっていますので、日本語以外の言語のキーボードを使用した場合、入力した文字とは異なる表示をすることがあります。

4) Key operation

Press the "BACK", "SUB MENU", "PAGE ^", "PAGE v" and "CONTROLLER" keys. Then, each key name is displayed. Also, when the "CONTROLLER" key is pressed, the CLIENT STATUS LED lights up at the same time.

4) キー動作

“BACK”、“SUB MENU”、“PAGE ^”、“PAGE v”および“コントローラー”キーを押すと各キー名称が表示されます。また、“コントローラー”キーを押した時、同時にCLIENT STATUSのLEDが点灯します。

5) A/D converter

Press the "△" key. Then, "A/D conv. Test" is displayed. Play a music CD on the CD player, and check the reproduced sound through the headphone connected to the AV amplifier.

5) A/Dコンバータ

“△”キーを押すと「A/D conv. Test」が表示されます。CDプレーヤーで音楽CDを再生し、AVアンプに接続したヘッドホンで再生音を確認します。

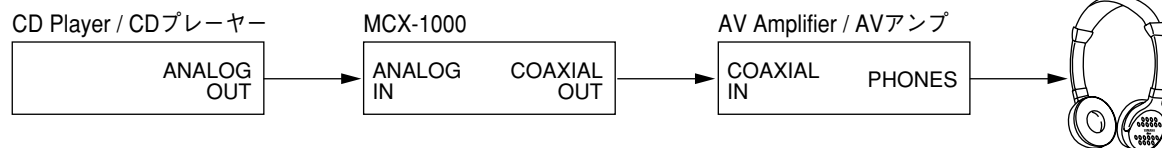

6) CODEC

Press the "□" key. Then, "CODEC1 test" is displayed. Play a music CD on the CD player, and check the reproduced sound through the headphone connected to the AV amplifier.

6) CODEC

“□”キーを押すと「CODEC1 test」が表示されます。CDプレーヤーで音楽CDを再生し、AVアンプに接続したヘッドホンで再生音を確認します。

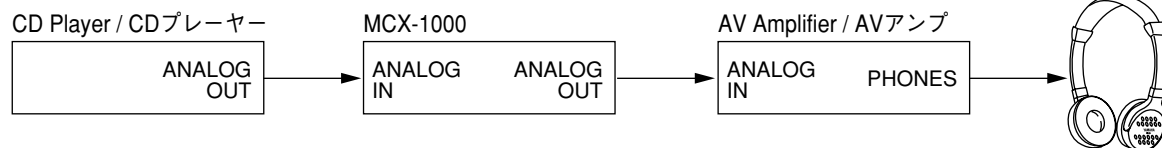

7) Optical input/output

Press the ">" key. Then, "OPTICAL check" is displayed. Play a music CD on the CD player, and check the reproduced sound through the headphone connected to the AV amplifier.

7) 光入出力

“>”キーを押すと「OPTICAL check」が表示されます。CDプレーヤーで音楽CDを再生し、AVアンプに接続したヘッドホンで、再生音を確認します。

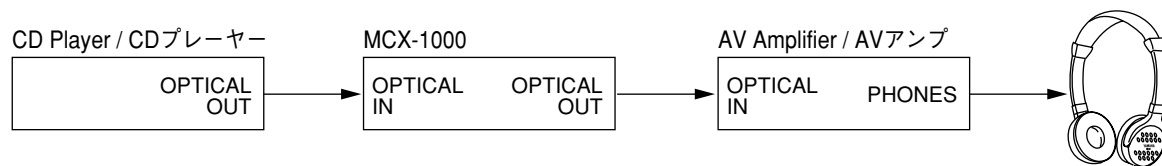

8) Coaxial input/output

Press the "CD AUTO STORE" key. Then, "COAXIAL check" is displayed. Play a music CD on the CD player, and check the reproduced sound through the headphone connected to the AV amplifier.

8) 同軸入出力

“CD AUTO STORE”キーを押すと「COAXIAL check」が表示されます。CDプレーヤーで音楽CDを再生し、AVアンプに接続したヘッドホンで、再生音を確認します。

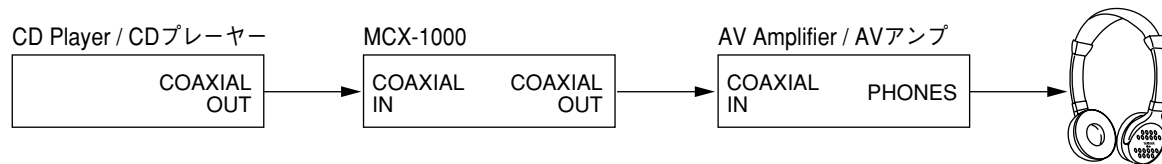

Canceling Test mode

After completion of testing, press the "STANDBY/ON" key to turn off the power.

テストモード解除

テスト終了後、“STANDBY/ON”キーを押して電源をオフにします。

DISPLAY DATA

● V100 : 162-MD-05GNA (V9876100)

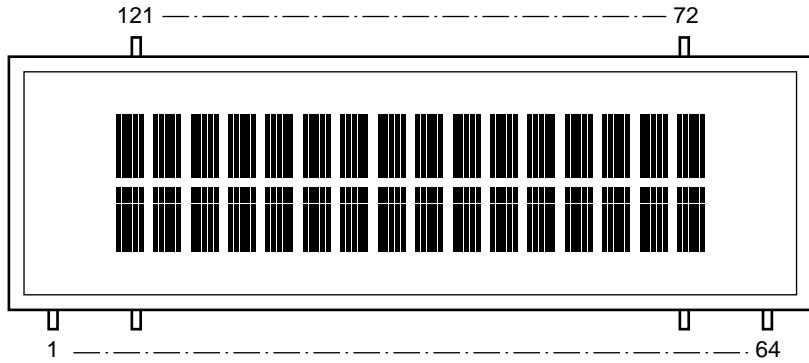

● PIN CONNECTION

Pin No.	128	127	126	125	124	123	122	121	120	119	118	117	116	115	114	113	112	111	110	109	108	107	106	105	104	103	102	101	100	99	98	97
Connection	NP	NP	NP	NP	NP	NP	NP	5-8A	4-8A	3-8A	2-8A	1-8A	5-7A	4-7A	3-7A	2-7A	1-7A	5-6A	4-6A	3-6A	2-6A	1-6A	5-5A	4-5A	3-5A	2-5A	1-5A	IC	1G	2G	3G	4G
Pin No.	96	95	94	93	92	91	90	89	88	87	86	85	84	83	82	81	80	79	78	77	76	75	74	73	72	71	70	69	68	67	66	65
Connection	5G	6G	7G	8G	1-1A	2-1A	3-1A	4-1A	5-1A	1-2A	2-2A	3-2A	4-2A	5-2A	1-3A	2-3A	3-3A	4-3A	5-3A	1-4A	2-4A	3-4A	4-4A	5-4A	NC	NP	NP	NP	NP	NP	NP	
Pin No.	1	2	3	4	5	6	7	8	9	10	11	12	13	14	15	16	17	18	19	20	21	22	23	24	25	26	27	28	29	30	31	32
Connection	F1	NP	F1	NP	F1	NP	NP	1-5B	2-5B	3-5B	4-5B	5-5B	1-6B	2-6B	3-6B	4-6B	5-6B	1-7B	2-7B	3-7B	4-7B	5-7B	1-8B	2-8B	3-8B	4-8B	5-8B	IC	9G	10G	11G	12G
Pin No.	33	34	35	36	37	38	39	40	41	42	43	44	45	46	47	48	49	50	51	52	53	54	55	56	57	58	59	60	61	62	63	64
Connection	13G	14G	15G	16G	5-4B	4-4B	3-4B	2-4B	1-4B	5-3B	4-3B	3-3B	2-3B	1-3B	5-2B	4-2B	3-2B	2-2B	1-2B	5-1B	4-1B	3-1B	2-1B	1-1B	NC	NP	NP	F2	NP	F2	NP	F2

Note : 1) F1, F2 Filament 2) NP No pin 3) DL Datum Line 4) 1G ~ 16G Grid 5) IC Internal connection

● GRID ASSIGNMENT

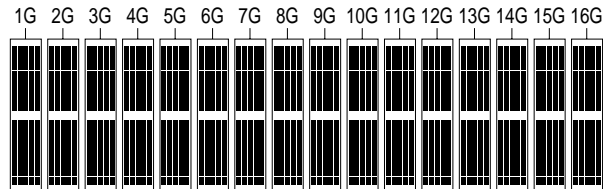

(A)	(B)
1-1 2-1 3-1 4-1 5-1	1-1 2-1 3-1 4-1 5-1
1-2 2-2 3-2 4-2 5-2	1-2 2-2 3-2 4-2 5-2
1-3 2-3 3-3 4-3 5-3	1-3 2-3 3-3 4-3 5-3
1-4 2-4 3-4 4-4 5-4	1-4 2-4 3-4 4-4 5-4
1-5 2-5 3-5 4-5 5-5	1-5 2-5 3-5 4-5 5-5
1-6 2-6 3-6 4-6 5-6	1-6 2-6 3-6 4-6 5-6
1-7 2-7 3-7 4-7 5-7	1-7 2-7 3-7 4-7 5-7
1-8 2-8 3-8 4-8 5-8	1-8 2-8 3-8 4-8 5-8
(UPPER)	(LOWER)
(1G - 16G)	

IC DATA

IC111 : HD6417709SF133 (MAIN P.C.B.)
μ-COM (CPU)

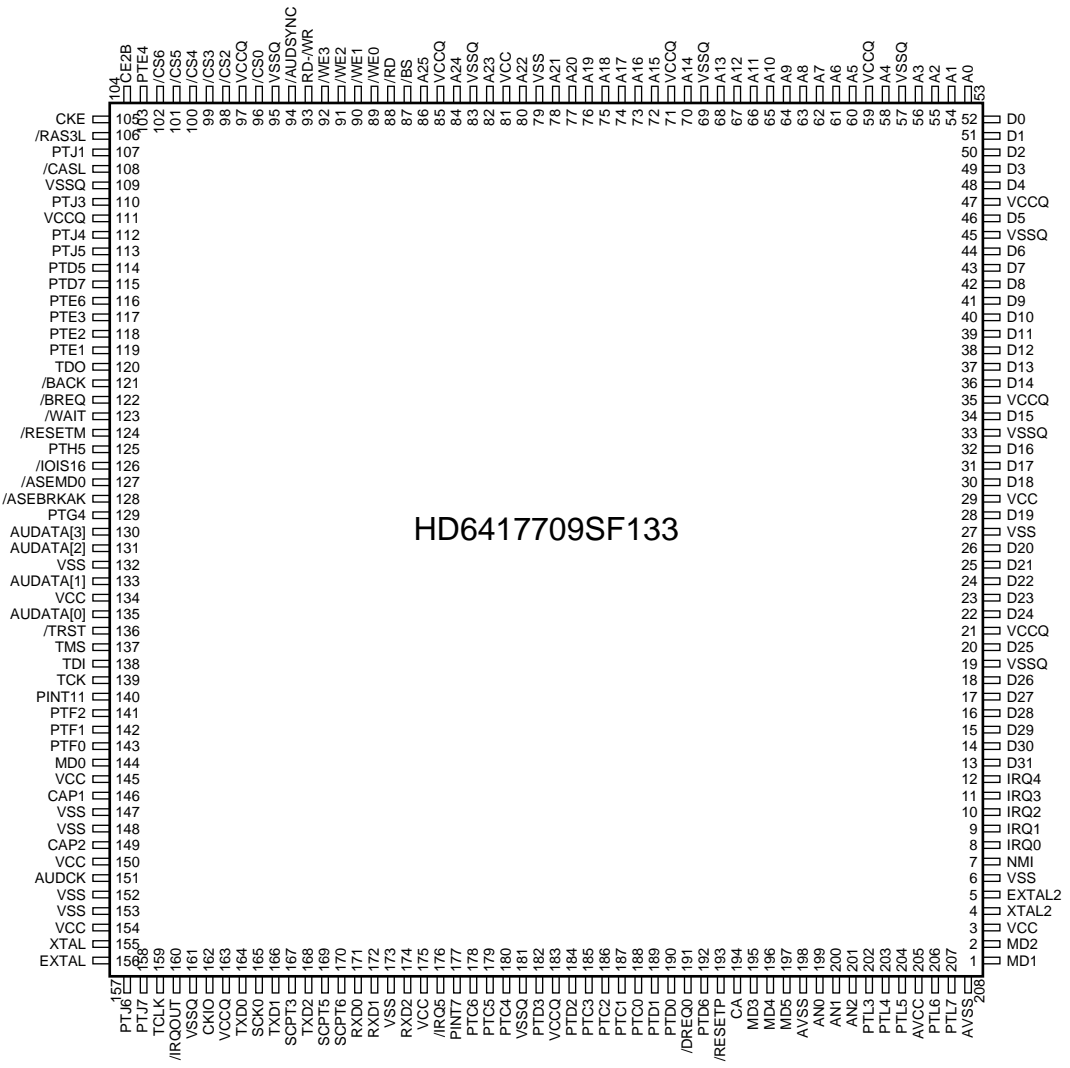

IC111 : HD6417709SF133 (MAIN P.C.B.)
 μ-COM (CPU)

Port	Pin No.	Port Function	Other Function	Signal Name	I/O	Logic	Function	Register Value	
A	23	PTA7(I/O)(Port)	D23(I/O)(Data Bus)	D23	I/O	—	Data Bus	PACR 0x0000	
	24	PTA6(I/O)(Port)	D22(I/O)(Data Bus)	D22	I/O	—	Data Bus		
	25	PTA5(I/O)(Port)	D21(I/O)(Data Bus)	D21	I/O	—	Data Bus		
	26	PTA4(I/O)(Port)	D20(I/O)(Data Bus)	D20	I/O	—	Data Bus		
	28	PTA3(I/O)(Port)	D19(I/O)(Data Bus)	D19	I/O	—	Data Bus		
	30	PTA2(I/O)(Port)	D18(I/O)(Data Bus)	D18	I/O	—	Data Bus		
	31	PTA1(I/O)(Port)	D17(I/O)(Data Bus)	D17	I/O	—	Data Bus		
	32	PTA0(I/O)(Port)	D16(I/O)(Data Bus)	D16	I/O	—	Data Bus		
	13	PTB7(I/O)(Port)	D31(I/O)(Data Bus)	D31	I/O	—	Data Bus		PBCR 0x0000
	14	PTB6(I/O)(Port)	D30(I/O)(Data Bus)	D30	I/O	—	Data Bus		
15	PTB5(I/O)(Port)	D29(I/O)(Data Bus)	D29	I/O	—	Data Bus			
16	PTB4(I/O)(Port)	D28(I/O)(Data Bus)	D28	I/O	—	Data Bus			
17	PTB3(I/O)(Port)	D27(I/O)(Data Bus)	D27	I/O	—	Data Bus			
18	PTB2(I/O)(Port)	D26(I/O)(Data Bus)	D26	I/O	—	Data Bus			
20	PTB1(I/O)(Port)	D25(I/O)(Data Bus)	D25	I/O	—	Data Bus			
22	PTB0(I/O)(Port)	D24(I/O)(Data Bus)	D24	I/O	—	Data Bus			
C	177	PTC7(I/O)(Port) PINT7(I)(INTC)	/MCS7(O)(BSC)	LAN_INT	— (Pull-up OFF)	Positive	Interrupts signal from LAN91C111	PCCR 0xD5F5 ->0xD555	
	178	PTC6(I/O)(Port) PINT6(I)(INTC)	/MCS6(O)(BSC)	HDD_N_RST	O	Negative	HDD reset signal		
	179	PTC5(I/O)(Port) PINT5(I)(INTC)	/MCS5(O)(BSC)	OPT_SEL	O	—	Digital input select (LOW: Optical HIGH: Coaxial)		
	180	PTC4(I/O)(Port) PINT4(I)(INTC)	/MCS4(O)(BSC)	TP	O	—	TP		
	185	PTC3(I/O)(Port) PINT3(I)(INTC)	/MCS3(O)(BSC)	IDE_N_PON	O	Negative	IDE drive power ON.		
	186	PTC2(I/O)(Port) PINT2(I)(INTC)	/MCS2(O)(BSC)	IDE_N_BE	O	Negative	IDE bus enable.		
	187	PTC1(I/O)(Port) PINT1(I)(INTC)	/MCS1(O)(BSC)	CDR_N_RST	O	Negative	CDR reset signal		
	188	PTC0(I/O)(Port) PINT0(I)(INTC)	/MCS0(O)(BSC)	CPU_N_RST	O	Negative	CPU reset signal		
	115	PTD7(I/O)(Port)	DACK1(O)(DMAC)	FLASH_N_VPP	O	Negative	Debug board connector (Flash sector protection release)		PDCR 0x6455
	192	PTD6(I)(Port)	/DREQ1(I)(DMAC)	TP	— (Pull-up ON)	—	TP		
114	PTD5(I/O)(Port)	DACK0(O)(DMAC)	SB_N_CS	O	Negative	Chip select signal for the jig.			
191	PTD4(I)(Port)	/DREQ0(I)(DMAC)	N_DRQ0	I	Negative	YGV619 DMA request			
182	PTD3(I/O)(Port)	/WAKEUP(O)(WTC)	SB_SCK	O	Positive	Serial clock for the jig.			
184	PTD2(I/O)(Port)	/RESETOUT(O)	SB_DATA	O	Positive	Serial data for the jig.			
189	PTD1(I/O)(Port)	DRACK(O)(DMAC)	SC_N_VPP	O	Negative	SubCPU VPP ON			
190	PTD0(I/O)(Port)	DRACK1(O)(DMAC)	SC_N_RST	O	Negative	SubCPU reset			

IC111 : HD6417709SF133 (MAIN P.C.B.)
 μ-COM (CPU)

Port	Pin No.	Port Function	Other Function	Signal Name	I/O	Logic	Function	Register Value
E	94	PTE7(I/O)(Port)	/AUDSYNC(O)(AUD)	N_AUDSYNC	O	Negative	For E10A	PECR 0x1154
	116	PTE6(I/O)(Port)		F_DATA	O	Positive	FPGA config DATA	
	104	PTE5(I/O)(Port)	/CE2B(O)(PCMCIA)	N_CE2B	O	Negative	PCMCIA : /CE2B signal	
	103	PTE4(I/O)(Port)	/CE2A(O)(PCMCIA)	FLDB_B_CS	O	Negative	FL Driver B synchronized serial chip select	
	117	PTE3(I/O)(Port)		FLDA_N_CS	O	Negative	FL Driver A synchronized serial chip select	
	118	PTE2(I/O)(Port)		SC_N_CS	O	Negative	SubCPU synchronized serial chip select	
	119	PTE1(I/O)(Port)	/RAS3U(O)(BSC)	CPU_MUTE	O	Positive	Audio muting signal	
	120	PTE0(I/O)(Port)	TDO(O)(H-UDI)	SH_TDO	O	Positive	For E10A	
	136	PTF7(I)(Port)	/TRST(I)(AUD, H-UDI)	SH_N_TRST	I	Negative	For E10A	
	137	PTF6(I)(Port)	TMS(I)(H-UDI)	SH_TMS	I	Positive	For E10A	
	138	PTF5(I)(Port)	TDI(I)(H-UDI)	SH_TDI	I	Positive	For E10A	
	F	139	PTF4(I)(Port)	TCK(I)(H-UDI)	SH_TCK	I	Positive	
140		PTF3(I)(Port)	/IRLS3(I)(INTC)	TP	I	—	TP	
141		PTF2(I)(Port)	/IRLS2(I)(INTC)	SB_BIT0	I	Positive	Input signal for the jig.	
142		PTF1(I)(Port)	/IRLS1(I)(INTC)	SB_DIP1	I	Positive	DIP_SW input for the jig.	
143		PTF0(I)(Port)	/IRLS0(I)(INTC)	SC_VGOOD	I	Positive	SubCPU power normality	
126		PTG7(I)(Port)	/IOIS16(I)(PCMCIA)	CPU_N_IOIS16	I	Negative	PCMCIA : /IOIS16	
127		PTG6(I)(Port)	/ASEMD0(I)(AUD,H-UDI)	N_ASEMD0	I	Negative	For E10A	
128		PTG5(I)(Port)	/ASEBRKAK(O)(AUD)	N_ASEBRAKA	O	Negative	For E10A	
129		PTG4(I)(Port)	CKIO2(O)(CPG)	TP	I	—	TP	
130		PTG3(I)(Port)	AUDATA3(O)(AUD)	AUDATA3	O	Positive	For E10A	
G	131	PTG2(I)(Port)	AUDATA2(O)(AUD)	AUDATA2	O	Positive	For E10A	PGCR 0x0200
	133	PTG1(I)(Port)	AUDATA1(O)(AUD)	AUDATA1	O	Positive	For E10A	
	135	PTG0(I)(Port)	AUDATA0(O)(AUD)	AUDATA0	O	Positive	For E10A	

IC111 : HD6417709SF133 (MAIN P.C.B.)
 μ-COM (CPU)

Port	Pin No.	Port Function	Other Function	Signal Name	I/O	Logic	Function	Register Value
H	159	PTH7(I/O)(Port)	TCLK(I/O)(Timer)	TP	O	-	TP	PHCR 0x4C00
	151	PTH6(I/O)(Port)	AUDCK(I)(AUD)	AUDCK	I	Positive	For E10A	
	125	PTH5(I/O)(Port)	/ADTRG(I)(ADC)	F_N_STATUS	I	Negative	FPGA config nSTATUS	
	12	PTH4(I/O)(Port)	IRQ4(I)(INTC)	PC_N_INT	I	Negative	Interrupts signal from PCMCIA	
	11	PTH3(I/O)(Port)	IRQ3(I)(INTC) /IRL3(I)(INTC)	HD_N_INT3	I	Negative	HD64480F IRL3	
	10	PTH2(I/O)(Port)	IRQ2(I)(INTC) /IRL2(I)(INTC)	HD_N_INT2	I	Negative	HD64480F IRL2	
	9	PTH1(I/O)(Port)	IRQ1(I)(INTC) /IRL1(I)(INTC)	HD_N_INT1	I	Negative	HD64480F IRL1	
	8	PTH0(I/O)(Port)	IRQ0(I)(INTC) /IRL0(I)(INTC)	HD_N_INT0	I	Negative	HD64480F IRL0	
	158	PTJ7(I/O)(Port)	STATUS1(O)(CPG)	DSP1_BSW	O	-	DSP1 bus swap (LOW: Through HIGH: Swap)	
	157	PTJ6(I/O)(Port)	STATUS0(O)(CPG)	DSP0_BSW	O	-	DSP0 bus swap (LOW: Through HIGH: Swap)	
J	113	PTJ5(I/O)(Port)		LED3	O	Positive	Debugg board connector	PJCR 0x5544
	112	PTJ4(I/O)(Port)		LED2	O	Positive	Debugg board connector	
	110	PTJ3(I/O)(Port)	/CASU(O)(BSC)	LED1	O	Positive	Debugg board connector	
	108	PTJ2(I/O)(Port)	/CASL(O)(BSC)	N_CASL	O	Negative	SDRAM : /CAS	
	107	PTJ1(I/O)(Port)		LED0	O	Positive	Debugg board connector	
	106	PTJ0(I/O)(Port)	/RAS3L(O)(BSC)	N_RAS3L	O	Negative	SDRAM : /RAS	
	92	PTK7(I/O)(Port)	/WE3(O)(BSC) /DMU0(O)(BSC) /ICIOWR(O)(BSC)	N_WE3	O	Negative	SDRAM : DQMUU PCMCIA : /ICIOWR	
	91	PTK6(I/O)(Port)	/WE2(O)(BSC) /DQMU0(O)(BSC) /ICIORD(O)(BSC)	N_WE2	O	Negative	SDRAM : DQMUU PCMCIA : /ICIORD	
	105	PTK5(I/O)(Port)	CKE(O)(BSC)	CKE	O	Positive	SDRAM : CKE	
	87	PTK4(I/O)(Port)	/BS(O)(BSC)	N_BS	O	Negative	Bus Start	
K	101	PTK3(I/O)(Port)	/CS5(O)(BSC) /CE1A(O)(BSC)	N_CS5	O	Negative	YG1619 chip select	PKCR 0x0000
	100	PTK2(I/O)(Port)	/CS4(O)(BSC)	N_CS4	O	Negative	LAN91C111 chip select	
	99	PTK1(I/O)(Port)	/CS3(O)(BSC)	N_CS3	O	Negative	SDRAM chip select	
	98	PTK0(I/O)(Port)	/CS2(O)(BSC)	N_CS2	O	Negative	ACDR3, DSP, HD64480F chip select	

IC111 : HD6417709SF133 (MAIN P.C.B.)
 μ-COM (CPU)

Port	Pin No.	Port Function	Other Function	Signal Name	I/O	Logic	Function	Register Value
L	207	PTL7(I)(Port)	AN7(I)(ADC) DA0(O)(DAC)	F_CONF_DONE	I	Positive	FPGA config CONF_DONE	PLCR 0xFF00
	206	PTL6(I)(Port)	AN6(I)(ADC) DA1(O)(DAC)	NTSC_N_PAL	I	—	NTSC/PAL select signal (LOW: PAL HIGH: NTSC)	
	204	PTL5(I)(Port)	AN5(I)(ADC)	DBG_DIP1	I	—	Debugg board connector (Reverse Boot)	
	203	PTL4(I)(Port)	AN4(I)(ADC)	DBG_DIP0	I	—	Debugg board connector	
	202	PTL3(I)(Port)	AN3(I)(ADC)		I	Negative	PS_N_STANDBY	
	201	PTL2(I)(Port)	AN2(I)(ADC)		I	—	AGND	
	200	PTL1(I)(Port)	AN1(I)(ADC)		I	—	AGND	
	199	PTL0(I)(Port)	AN0(I)(ADC)		I	—	AGND	
	176	SCPT7(I)(Port) IRQ5(I)(INTC)	/CTS2(I)(UART ch3) IRQ5(I)(INTC)	ACDR_N_INT	I (Pull-up OFF)	Negative	Interrupts signal from ACDP3	
	170	SCPT6(I/O)(Port)	/RTS2(O)(UART ch3)	TP	O	—	TP	
SCPT	169	SCPT5(I/O)(Port)	SCK2(I/O)(UART ch3)	F_DCLK	O	Negative	FPGA config DCLK	SCPCR 0x1440
	174	SCPT4(I)(Port)	RxD2(I)(UART ch3)	HOST_RXD2	I (RxD2)	—	AV AMP control RS232C RXD	
	168	SCPT4(O)(Port)	TxD2(O)(UART ch3)	HOST_TXD2	O (TxD2)	—	AV AMP control RS232C TXD	
	167	SCPT3(I/O)(Port)	SCK1(I/O)(UART ch2)	F_N_CONFIG	O	Negative	FPGA config nCONFIG	
	172	SCPT2(I)(Port)	RxD1(I)(UART ch2)	DBG_RXD1	I (RxD1)	—	Debugg board connector	
	166	SCPT2(O)(Port)	TxD1(O)(UART ch2)	DBG_TXD1	O (TxD1)	—	Debugg board connector	
	165	SCPT1(I/O)(Port)	SCK0(I/O)(UART ch1)	SH_SCK0	O (SCK0)	—	Synchronized serial clock	
	171	SCPT0(I)(Port)	RxD0(I)(UART ch1)	SH_RxD0	I (RxD0)	—	Synchronized serial RXD	
	164	SCPT0(O)(Port)	TxD0(O)(UART ch1)	SH_TxD0	O (TxD0)	—	Synchronized serial TXD	

Note: When SCPT0, 2, 4 is used as a port, it can be assigned only to either the input port or the output port.

IC222 : HD64480F (MAIN P.C.B.)
Bus Bridge LSI

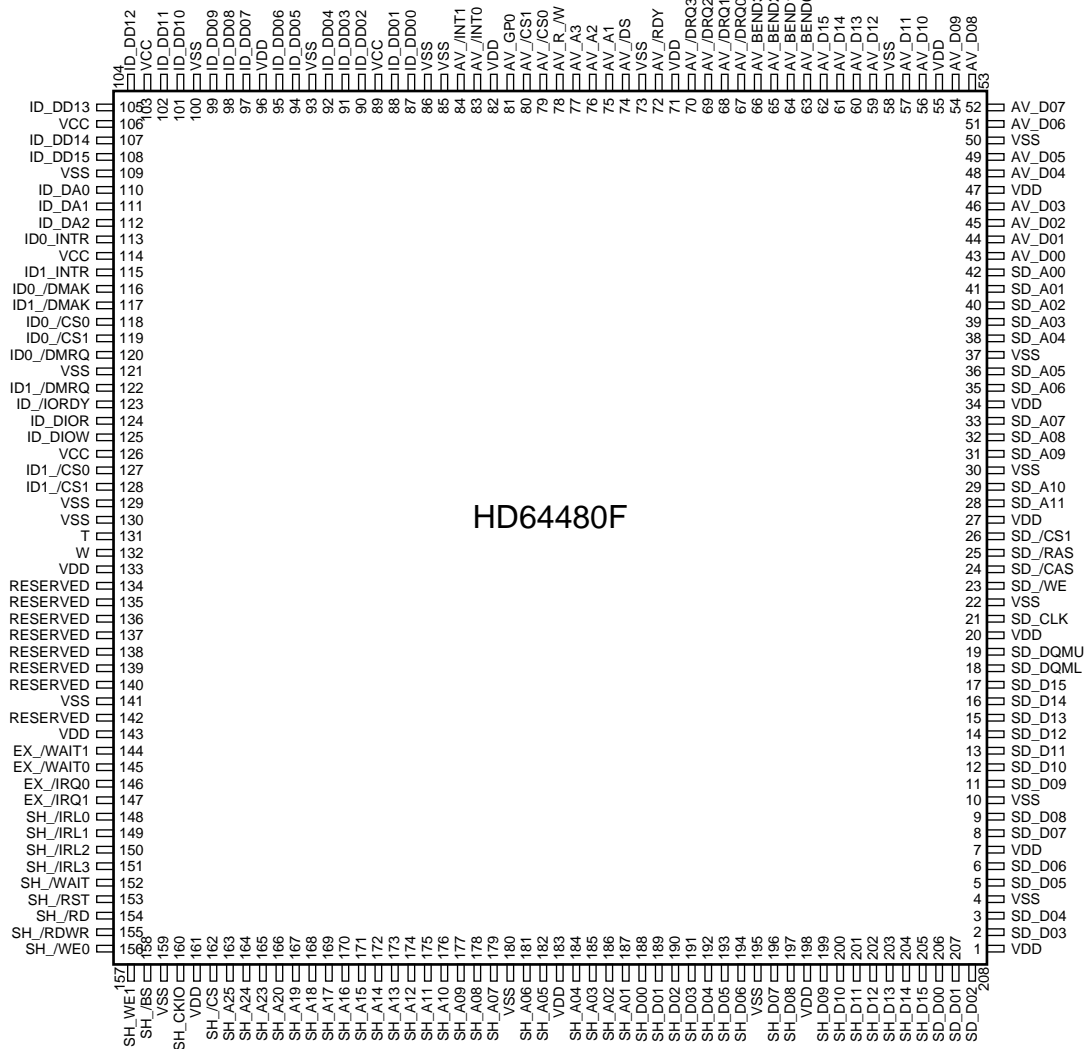

Pin No.	Signal Name	I/O	Active	Function	Buffer form
1	Vdd			+3.3V power supply	
2	SD_D03	I/O	H	SDRAM interface bus	LV-TTL(P-up)
3	SD_D04	I/O	H	SDRAM interface bus	LV-TTL(P-up)
4	Vss			GND	
5	SD_D05	I/O	H	SDRAM interface bus	LV-TTL(P-up)
6	SD_D06	I/O	H	SDRAM interface bus	LV-TTL(P-up)
7	Vdd			+3.3V power supply	
8	SD_D07	I/O	H	SDRAM interface bus	LV-TTL(P-up)
9	SD_D08	I/O	H	SDRAM interface bus	LV-TTL(P-up)
10	Vss			GND	
11	SD_D09	I/O	H	SDRAM interface bus	LV-TTL(P-up)
12	SD_D10	I/O	H	SDRAM interface bus	LV-TTL(P-up)
13	SD_D11	I/O	H	SDRAM interface bus	LV-TTL(P-up)
14	SD_D12	I/O	H	SDRAM interface bus	LV-TTL(P-up)
15	SD_D13	I/O	H	SDRAM interface bus	LV-TTL(P-up)

IC222 : HD64480F (MAIN P.C.B.)

Bus Bridge LSI

Pin No.	Signal Name	I/O	Active	Function	Buffer form
16	SD_D14	I/O	H	SDRAM interface bus	LV-TTL(P-up)
17	SD_D15	I/O	H	SDRAM interface bus	LV-TTL(P-up)
18	SD_DQML	O	H	SDRAM interface write mask	LV-TTL
19	SD_DQMU	O	H	SDRAM interface write mask	LV-TTL
20	Vdd			+3.3V power supply	
21	SD_CLK	O	H	SDRAM interface clock	LV-TTL
22	Vss			GND	
23	SD_/WE	O	L	SDRAM interface write enable	LV-TTL
24	SD_/CAS	O	L	SDRAM interface Colum Address Strobe	LV-TTL
25	SD_/RAS	O	L	SDRAM interface Raw Address Strobe	LV-TTL
26	SD_/CS1	O	L	SDRAM interface chip select	LV-TTL
27	Vdd			+3.3V power supply	
28	SD_A11	O	H	SDRAM interface address bus	LV-TTL
29	SD_A10	O	H	SDRAM interface address bus	LV-TTL
30	Vss			GND	
31	SD_A09	O	H	SDRAM interface address bus	LV-TTL
32	SD_A08	O	H	SDRAM interface address bus	LV-TTL
33	SD_A07	O	H	SDRAM interface address bus	LV-TTL
34	Vdd			+3.3V power supply	
35	SD_A06	O	H	SDRAM interface address bus	LV-TTL
36	SD_A05	O	H	SDRAM interface address bus	LV-TTL
37	Vss			GND	
38	SD_A04	O	H	SDRAM interface address bus	LV-TTL
39	SD_A03	O	H	SDRAM interface address bus	LV-TTL
40	SD_A02	O	H	SDRAM interface address bus	LV-TTL
41	SD_A01	O	H	SDRAM interface address bus	LV-TTL
42	SD_A00	O	H	SDRAM interface address bus	LV-TTL
43	AV_D00	I/O	H	AV extension bus data bus	LV-TTL(P-up)
44	AV_D01	I/O	H	AV extension bus data bus	LV-TTL(P-up)
45	AV_D02	I/O	H	AV extension bus data bus	LV-TTL(P-up)
46	AV_D03	I/O	H	AV extension bus data bus	LV-TTL(P-up)
47	Vdd			+3.3V power supply	
48	AV_D04	I/O	H	AV extension bus data bus	LV-TTL(P-up)
49	AV_D05	I/O	H	AV extension bus data bus	LV-TTL(P-up)
50	Vss			GND	
51	AV_D06	I/O	H	AV extension bus data bus	LV-TTL(P-up)
52	AV_D07	I/O	H	AV extension bus data bus	LV-TTL(P-up)
53	AV_D08	I/O	H	AV extension bus data bus	LV-TTL(P-up)
54	AV_D09	I/O	H	AV extension bus data bus	LV-TTL(P-up)
55	Vdd			+3.3V power supply	
56	AV_D10	I/O	H	AV extension bus data bus	LV-TTL(P-up)
57	AV_D11	I/O	H	AV extension bus data bus	LV-TTL(P-up)
58	Vss			GND	
59	AV_D12	I/O	H	AV extension bus data bus	LV-TTL(P-up)
60	AV_D13	I/O	H	AV extension bus data bus	LV-TTL(P-up)
61	AV_D14	I/O	H	AV extension bus data bus	LV-TTL(P-up)
62	AV_D15	I/O	H	AV extension bus data bus	LV-TTL(P-up)
63	AV_BEND0	O	H	AV extension bus forward block data complete	LV-TTL
64	AV_BEND1	O	H	AV extension bus forward block data complete	LV-TTL

IC222 : HD64480F (MAIN P.C.B.)
Bus Bridge LSI

Pin No.	Signal Name	I/O	Active	Function	Buffer form
65	AV_BEND2	O	H	AV extension bus forward block data complete	LV-TTL
66	AV_BEND3	O	H	AV extension bus forward block data complete	LV-TTL
67	AV_/DRQ0	I	L	AV extension bus forward data complete	LV-TTL(P-up)
68	AV_/DRQ1	I	L	AV extension bus forward data complete	LV-TTL(P-up)
69	AV_/DRQ2	I	L	AV extension bus forward data complete	LV-TTL(P-up)
70	AV_/DRQ3	I	L	AV extension bus forward data complete	LV-TTL(P-up)
71	Vdd			+3.3V power supply	
72	AV_/RDY	I	L	AV extension bus ready	LV-TTL
73	Vss			GND	
74	AV_/DS	O	L	AV extension bus data strobe	LV-TTL
75	AV_A1	O	H	AV extension bus address bus	LV-TTL
76	AV_A2	O	H	AV extension bus address bus	LV-TTL
77	AV_A3	O	H	AV extension bus address bus	LV-TTL
78	AV_R_/W	O	H	AV extension bus read/write	LV-TTL
79	AV_/CS0	O	L	AV extension bus chip select 0	LV-TTL
80	AV_/CS1	O	L	AV extension bus chip select 1	LV-TTL
81	AV_GPO	O	H	AV extension bus general output port	LV-TTL
82	Vdd			+3.3V power supply	
83	AV_/INT0	I	L	AV extension bus interrupted	LV-TTL(P-up)
84	AV_/INT1	I	L	AV extension bus interrupted	LV-TTL(P-up)
85	Vss			GND	
86	Vss			GND	
87	ID_DD00	I/O	H	ATA interface data bus	S-TTL(P-up)
88	ID_DD01	I/O	H	ATA interface data bus	S-TTL(P-up)
89	Vcc			+5V POWER SUPPLY (FOR ATA-3 INTERFACE)	
90	ID_DD02	I/O	H	ATA interface data bus	S-TTL(P-up)
91	ID_DD03	I/O	H	ATA interface data bus	S-TTL(P-up)
92	ID_DD04	I/O	H	ATA interface data bus	S-TTL(P-up)
93	Vss			GND	
94	ID_DD05	I/O	H	ATA interface data bus	S-TTL(P-up)
95	ID_DD06	I/O	H	ATA interface data bus	S-TTL(P-up)
96	Vdd			+3.3V power supply	
97	ID_DD07	I/O	H	ATA interface data bus	S-TTL(P-up)
98	ID_DD08	I/O	H	ATA interface data bus	S-TTL(P-up)
99	ID_DD09	I/O	H	ATA interface data bus	S-TTL(P-up)
100	Vss			GND	
101	ID_DD10	I/O	H	ATA interface data bus	S-TTL(P-up)
102	ID_DD11	I/O	H	ATA interface data bus	S-TTL(P-up)
103	Vcc			+5V POWER SUPPLY (FOR ATA-3 INTERFACE)	
104	ID_DD12	I/O	H	ATA interface data bus	S-TTL(P-up)
105	ID_DD13	I/O	H	ATA interface data bus	S-TTL(P-up)
106	Vcc			+5V POWER SUPPLY (FOR ATA-3 INTERFACE)	
107	ID_DD14	I/O	H	ATA interface data bus	S-TTL(P-up)
108	ID_DD15	I/O	H	ATA interface data bus	S-TTL(P-up)
109	Vss	GND			
110	ID_DA0	O	H	ATA interface address bus	TTL
111	ID_DA1	O	H	ATA interface address bus	TTL
112	ID_DA2	O	H	ATA interface address bus	TTL
113	ID0_INTR	I	H	ATA interface 0 interrupted request	S-TTL

IC222 : HD64480F (MAIN P.C.B.)

Bus Bridge LSI

Pin No.	Signal Name	I/O	Active	Function	Buffer form
114	Vcc			+5V POWER SUPPLY (FOR ATA-3 INTERFACE)	
115	ID1_INTR	I	H	ATA interface 1 interrupted request	S-TTL
116	ID0_DMAK	O	L	ATA interface 0 DMA acknowledge	TTL
117	ID1_DMAK	O	L	ATA interface 1 DMA acknowledge	TTL
118	ID0_CS0	O	L	ATA interface 0 chip select	TTL
119	ID0_CS1	O	L	ATA interface 0 chip select	TTL
120	ID0_DMRQ	I	H	ATA interface 0 DMA request	S-TTL
121	Vss			GND	
122	ID1_DMRQ	I	H	ATA interface 1 DMA request	S-TTL
123	ID_IORDY	I	H	ATA interface IORDY	S-TTL
124	ID_DIOR	O	L	ATA interface IOR	TTL
125	ID_DIOW	O	L	ATA interface IOW	TTL
126	Vcc			+5V POWER SUPPLY (FOR ATA-3 INTERFACE)	
127	ID1_CS0	O	L	ATA interface 1 chip select	TTL
128	ID1_CS1	O	L	ATA interface 1 chip select	TTL
129	Vss			GND	
130	Vss			GND	
131	T			Test (Connect to VSS)	
132	W			Test (Connect to VSS)	
133	Vdd			+3.3V power supply	
134	Reserved			Connect to GND	
135	Reserved			Connect to GND	
136	Reserved			Connect to GND	
137	Reserved			Connect to GND	
138	Reserved			NC	
139	Reserved			NC	
140	Reserved			NC	
141	Vss			GND	
142	Reserved			Connect to GND	
143	Vdd			+3.3V power supply	
144	EX_WAIT1	I	L	External wait input	LV-TTL(P-up)
145	EX_WAIT0	I	L	External wait input	LV-TTL(P-up)
146	EX_IRQ0	I	L	External interrupt input	LVS-TTL(P-up)
147	EX_IRQ1	I	L	External interrupt input	LVS-TTL(P-up)
148	SH_IRL0	O	L	SH interface External interrupt 0	LV-TTL
149	SH_IRL1	O	L	SH interface External interrupt 1	LV-TTL
150	SH_IRL2	O	L	SH interface External interrupt 2	LV-TTL
151	SH_IRL3	O	L	SH interface External interrupt 3	LV-TTL
152	SH_WAIT	O	L	SH interface wait	LV-TTL
153	SH_RST	I	L	SH interface reset	LVS-TTL
154	SH_RD	I	L	SH interface read strobe	LV-TTL
155	SH_RDWR	I	H	SH interface read/write	LV-TTL
156	SH_WE0	I	L	SH interface write enable 0	LV-TTL
157	SH_WE1	I	L	SH interface write enable 1	LV-TTL
158	SH_BS	I	L	SH interface bus start	LV-TTL
159	Vss			GND	
160	SH_CKIO	I	H	SH interface system clock	LV-CMOS
161	Vdd			+3.3V power supply	
162	SH_CS	I	L	SH interface chip select	LV-TTL

IC222 : HD64480F (MAIN P.C.B.)
Bus Bridge LSI

Pin No.	Signal Name	I/O	Active	Function	Buffer form
163	SH_A25	I	H	SH interface address bus	LV-TTL
164	SH_A24	I	H	SH interface address bus	LV-TTL
165	SH_A23	I	H	SH interface address bus	LV-TTL
166	SH_A20	I	H	SH interface address bus	LV-TTL
167	SH_A19	I	H	SH interface address bus	LV-TTL
168	SH_A18	I	H	SH interface address bus	LV-TTL
169	SH_A17	I	H	SH interface address bus	LV-TTL
170	SH_A16	I	H	SH interface address bus	LV-TTL
171	SH_A15	I	H	SH interface address bus	LV-TTL
172	SH_A14	I	H	SH interface address bus	LV-TTL
173	SH_A13	I	H	SH interface address bus	LV-TTL
174	SH_A12	I	H	SH interface address bus	LV-TTL
175	SH_A11	I	H	SH interface address bus	LV-TTL
176	SH_A10	I	H	SH interface address bus	LV-TTL
177	SH_A09	I	H	SH interface address bus	LV-TTL
178	SH_A08	I	H	SH interface address bus	LV-TTL
179	SH_A07	I	H	SH interface address bus	LV-TTL
180	Vss			GND	
181	SH_A06	I	H	SH interface address bus	LV-TTL
182	SH_A05	I	H	SH interface address bus	LV-TTL
183	Vdd			+3.3V power supply	
184	SH_A04	I	H	SH interface address bus	LV-TTL
185	SH_A03	I	H	SH interface address bus	LV-TTL
186	SH_A02	I	H	SH interface address bus	LV-TTL
187	SH_A01	I	H	SH interface address bus	LV-TTL
188	SH_D00	I/O	H	SH interface data bus	LV-TTL(P-up)
189	SH_D01	I/O	H	SH interface data bus	LV-TTL(P-up)
190	SH_D02	I/O	H	SH interface data bus	LV-TTL(P-up)
191	SH_D03	I/O	H	SH interface data bus	LV-TTL(P-up)
192	SH_D04	I/O	H	SH interface data bus	LV-TTL(P-up)
193	SH_D05	I/O	H	SH interface data bus	LV-TTL(P-up)
194	SH_D06	I/O	H	SH interface data bus	LV-TTL(P-up)
195	Vss			GND	
196	SH_D07	I/O	H	SH interface data bus	LV-TTL(P-up)
197	SH_D08	I/O	H	SH interface data bus	LV-TTL(P-up)
198	Vdd			+3.3V power supply	
199	SH_D09	I/O	H	SH interface data bus	LV-TTL(P-up)
200	SH_D10	I/O	H	SH interface data bus	LV-TTL(P-up)
201	SH_D11	I/O	H	SH interface data bus	LV-TTL(P-up)
202	SH_D12	I/O	H	SH interface data bus	LV-TTL(P-up)
203	SH_D13	I/O	H	SH interface data bus	LV-TTL(P-up)
204	SH_D14	I/O	H	SH interface data bus	LV-TTL(P-up)
205	SH_D15	I/O	H	SH interface data bus	LV-TTL(P-up)
206	SD_D00	I/O	H	SDRAM interface bus	LV-TTL(P-up)
207	SD_D01	I/O	H	SDRAM interface bus	LV-TTL(P-up)
208	SD_D02	I/O	H	SDRAM interface bus	LV-TTL(P-up)

IC301 : YDC130-F (MAIN P.C.B.)
ACDR3

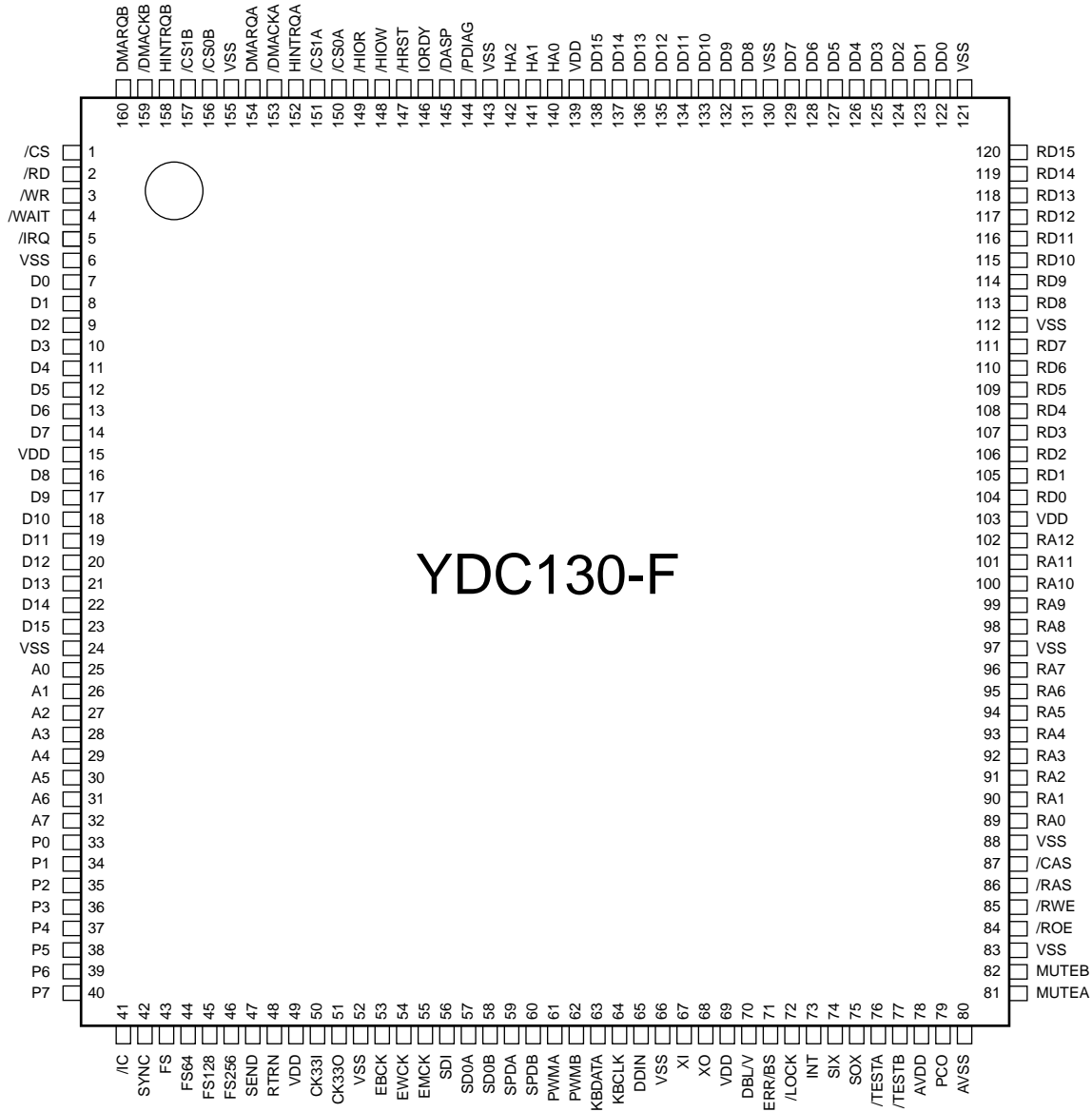

Pin No.	Terminal Name	I/O	DC Level	Function	
1	/CS	I	T	Microcomputer interface	Chip select input
2	/RD	I	T	Microcomputer interface	Read strobe input
3	/WR	I	T	Microcomputer interface	Write strobe input
4	/WAIT	OD	C	Wait output	
5	/IRQ	O	C	Interrupt request output	
6	VSS			GND	
7	D0	I/O	T/C	Microcomputer interface	Data bus
8	D1	I/O	T/C	Microcomputer interface	Data bus
9	D2	I/O	T/C	Microcomputer interface	Data bus
10	D3	I/O	T/C	Microcomputer interface	Data bus
11	D4	I/O	T/C	Microcomputer interface	Data bus
12	D5	I/O	T/C	Microcomputer interface	Data bus
13	D6	I/O	T/C	Microcomputer interface	Data bus

IC301 : YDC130-F (MAIN P.C.B.)
ACDR3

Pin No.	Terminal Name	I/O	DC Level	Function
14	D7	I/O	T/C	Microcomputer interface Data bus
15	VDD			+5V power supply
16	D8	I/O	T/C	Microcomputer interface Data bus
17	D9	I/O	T/C	Microcomputer interface Data bus
18	D10	I/O	T/C	Microcomputer interface Data bus
19	D11	I/O	T/C	Microcomputer interface Data bus
20	D12	I/O	T/C	Microcomputer interface Data bus
21	D13	I/O	T/C	Microcomputer interface Data bus
22	D14	I/O	T/C	Microcomputer interface Data bus
23	D15	I/O	T/C	Microcomputer interface Data bus
24	VSS			GND
25	A0	I	T	Microcomputer interface Data bus
26	A1	I	T	Microcomputer interface Data bus
27	A2	I	T	Microcomputer interface Data bus
28	A3	I	T	Microcomputer interface Data bus
29	A4	I	T	Microcomputer interface Data bus
30	A5	I	T	Microcomputer interface Data bus
31	A6	I	T	Microcomputer interface Data bus
32	A7	I	T	Microcomputer interface Data bus
33	P0	I+/O	T/C	General input/output port
34	P1	I+/O	T/C	General input/output port
35	P2	I+/O	T/C	General input/output port
36	P3	I+/O	T/C	General input/output port
37	P4	I+/O	T/C	General input/output port
38	P5	I+/O	T/C	General input/output port
39	P6	I+/O	T/C	General input/output port
40	P7	I+/O	T/C	General input/output port
41	/IC	I	T	Initial clear
42	SYNC	O	C	Synchronized signal output
43	FS	O\$C	fs	Clock output
44	FS64	O\$C	64fs	Clock output
45	FS128	O\$C	128fs	Clock output
46	FS256	O\$C	256fs	Clock output
47	SEND	O	C	Serial audio data output (send)
48	RTRN	I+	T	Serial audio data input (return)
49	VDD			+5V power supply
50	CK33I	I\$	C	33.8688MHz Clock input
51	CK33O	O\$	C	33.8688MHz Clock output (for charge couple)
52	VSS			GND
53	EBCK	I+	T	SRC bit clock input of input system When external DIR5 mode : serial data bit clock input
54	EWCK	I+	T	SRC word clock input of input system When external DIR5 mode : serial data word clock input
55	EMCK	I+	T	SRC system clock input of input system When external DIR5 mode : serial data master clock input
56	SDI	I	T	Serial audio data input
57	SDOA	O	C	Serial audio data output A
58	SDOB	O	C	Serial audio data output B
59	SPDA	O	C	Digital audio interface output A

IC301 : YDC130-F (MAIN P.C.B.)

ACDR3

Pin No.	Terminal Name	I/O	DC Level	Function
60	SPDB	O	C	Digital audio interface output B
61	PWMA	O	C	PWM waveform output A
62	PWMB	O	C	PWM waveform output B
63	KBDATA	I/OD	T/C	PS/2 interface data input/output
64	KBCLK	I/OD	T/C	PS/2 interface clock input/output
65	DDIN	IS	C	Digital audio interface input
66	VSS			GND
67	XI	I\$	C	24.576MHz clock input
68	XO	I\$	C	24.576MHz clock output (for charge couple)
69	VDD			+5V power supply
70	DBL/V	O	C	DIR5 rate clock output / Validity flag output When external DIR5 mode : Microcomputer interface Chip select output
71	ERR/BS	O	C	DIR5 data error detect output / Block start output When external DIR5 mode : Microcomputer interface Bit clock output
72	/LOCK	I/O	T/C	DIR5 PLL output When external DIR5 mode : User data input
73	INT	I/O	T/C	DIR5 interrupt output When external DIR5 mode : DIR5 interrupt input
74	SIX	I+	T	When external DIR5 mode : Microcomputer interface Data input
75	SOX	O	C	When external DIR5 mode : Microcomputer interface Data output
76	/TESTA	I+	T	Test terminal NC
77	/TESTB	I+	T	Test terminal NC
78	AVDD			+5V analog power supply
79	PCO	A		PLL filter connect terminal Connect 4700pF to GND
80	AVSS			GND (analog)
81	MUTEA	I+	T	Digital audio interface output A Mute
82	MUTEB	I+	T	Digital audio interface output B Mute
83	VSS			GND
84	/ROE	O	C	External RAM interface Read strobe output
85	/RWE	O	C	External RAM interface Write strobe output
86	/RAS	O	C	External RAM interface Row address strobe output
87	/CAS	O	C	External RAM interface Column address strobe output
88	VSS			GND
89	RA0	O	C	External RAM interface Address output
90	RA1	O	C	External RAM interface Address output
91	RA2	O	C	External RAM interface Address output
92	RA3	O	C	External RAM interface Address output
93	RA4	O	C	External RAM interface Address output
94	RA5	O	C	External RAM interface Address output
95	RA6	O	C	External RAM interface Address output
96	RA7	O	C	External RAM interface Address output
97	VSS			GND
98	RA8	O	C	External RAM interface Address output
99	RA9	O	C	External RAM interface Address output
100	RA10	O	C	External RAM interface Address output
101	RA11	O	C	External RAM interface Address output
102	RA12	O	C	External RAM interface Address output
103	VDD			+5V power supply
104	RD0	I/O	T/C	External RAM interface Data bus
105	RD1	I/O	T/C	External RAM interface Data bus
106	RD2	I/O	T/C	External RAM interface Data bus

IC301 : YDC130-F (MAIN P.C.B.)

ACDR3

Pin No.	Terminal Name	I/O	DC Level	Function	
107	RD3	I/O	T/C	External RAM interface	Data bus
108	RD4	I/O	T/C	External RAM interface	Data bus
109	RD5	I/O	T/C	External RAM interface	Data bus
110	RD6	I/O	T/C	External RAM interface	Data bus
111	RD7	I/O	T/C	External RAM interface	Data bus
112	VSS			GND	
113	RD8	I/O	T/C	External RAM interface	Data bus
114	RD9	I/O	T/C	External RAM interface	Data bus
115	RD10	I/O	T/C	External RAM interface	Data bus
116	RD11	I/O	T/C	External RAM interface	Data bus
117	RD12	I/O	T/C	External RAM interface	Data bus
118	RD13	I/O	T/C	External RAM interface	Data bus
119	RD14	I/O	T/C	External RAM interface	Data bus
120	RD15	I/O	T/C	External RAM interface	Data bus
121	VSS			GND	
122	DD0	I/O	T/C	IDE interface	Data bus
123	DD1	I/O	T/C	IDE interface	Data bus
124	DD2	I/O	T/C	IDE interface	Data bus
125	DD3	I/O	T/C	IDE interface	Data bus
126	DD4	I/O	T/C	IDE interface	Data bus
127	DD5	I/O	T/C	IDE interface	Data bus
128	DD6	I/O	T/C	IDE interface	Data bus
129	DD7	I/O	T/C	IDE interface	Data bus
130	VSS			GND	
131	DD8	I/O	T/C	IDE interface	Data bus
132	DD9	I/O	T/C	IDE interface	Data bus
133	DD10	I/O	T/C	IDE interface	Data bus
134	DD11	I/O	T/C	IDE interface	Data bus
135	DD12	I/O	T/C	IDE interface	Data bus
136	DD13	I/O	T/C	IDE interface	Data bus
137	DD14	I/O	T/C	IDE interface	Data bus
138	DD15	I/O	T/C	IDE interface	Data bus
139	VDD			+5V power supply	
140	HA0	O	C	IDE interface	Address output
141	HA1	O	C	IDE interface	Address output
142	HA2	O	C	IDE interface	Address output
143	VSS			GND	
144	/PDIAG	OD	C	IDE interface	Connecting check output
145	/DASP	OD	C	IDE interface	Active sleeve output
146	IORDY	I	T	IDE interface	Channel ready input
147	/HRST	OT	C	IDE interface	Reset output
148	/HIOW	OT	C	IDE interface	Write strobe output
149	/HIOR	OT	C	IDE interface	Read strobe output
150	/CS0A	OT	O	IDE interface	Chip select output A
151	/CS1A	OT	O	IDE interface	Chip select output A
152	HINTRQA	I	T	IDE interface	Interrupt request A
153	/DMACKA	OT	C	IDE interface	DMA acknowledge output A
154	DMARQA	I	T	IDE interface	DMA data request input A
155	VSS			GND	

IC301 : YDC130-F (MAIN P.C.B.)
ACDR3

Pin No.	Terminal Name	I/O	DC Level	Function	
156	/CS0B	OT	O	IDE interface	Chip select output B
157	/CS1B	OT	O	IDE interface	Chip select output B
158	HINTRQB	I	T	IDE interface	Interrupt request B
159	/DMACKB	OT	C	IDE interface	DMA acknowledge output B
160	DMARQB	I	T	IDE interface	DMA data request input B

I/O I : Input O : Output I/O : Bi-directional \$: Clock signal OT : Tri-state output
 + : Pull-up resistor built-in A : Analog terminal OD : Open drain
 DC C : CMOS level T : TTL level

IC402 : YGV619 (MAIN P.C.B.)
OSD

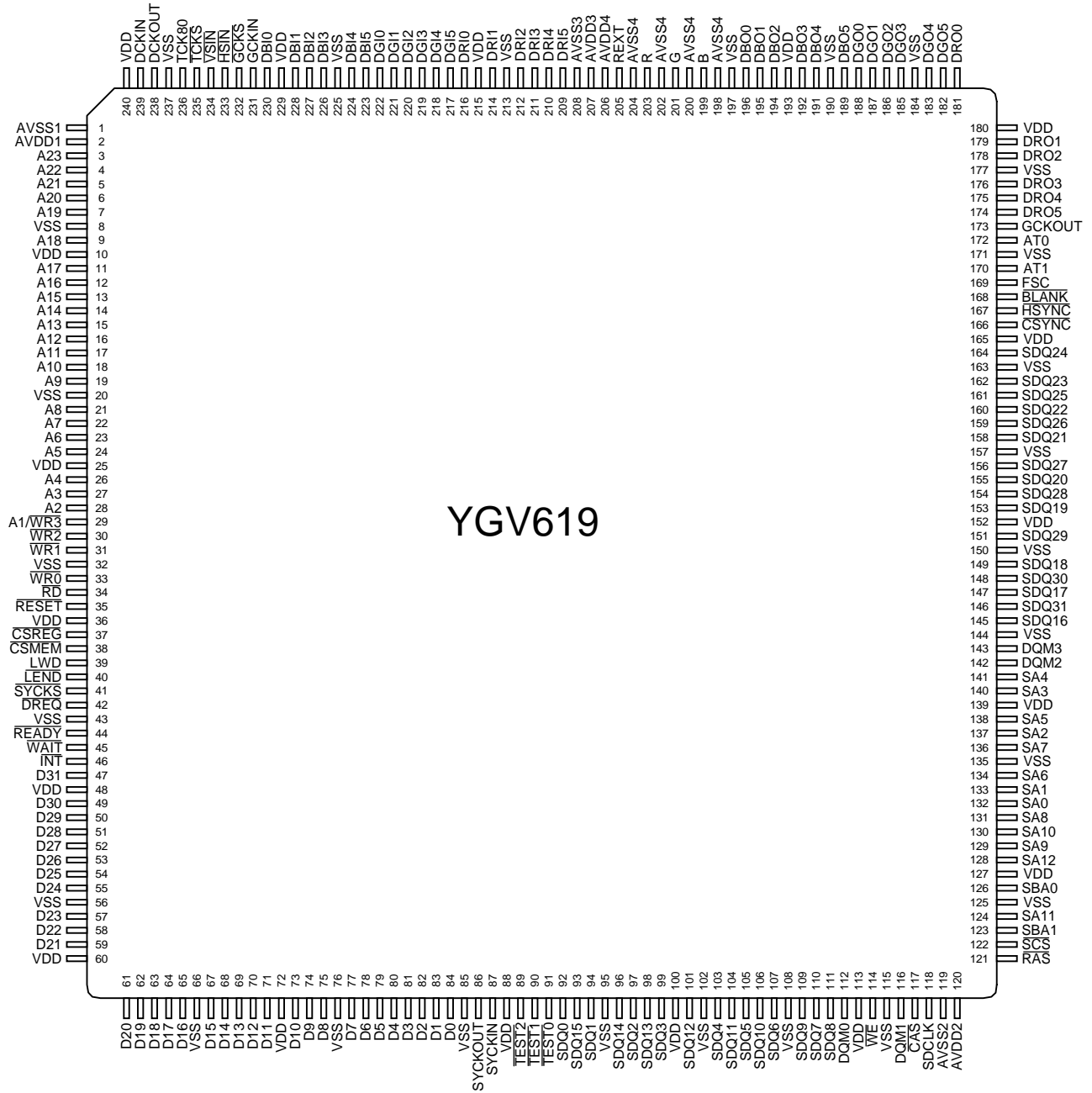

IC402 : YGV619 (MAIN P.C.B.)

OSD

Pin No.	Name	I/O Cell Type	Input		Output			Others attribute
			Level	5V tolerant	Level	5V tolerant	Buffer	
1	AVSS1							
2	AVDD1							
3	A23	I/O+	LVTTL	Yes	3.3V	Yes	4mA	Pull Up
4	A22	I/O+	LVTTL	Yes	3.3V	Yes	4mA	Pull Up
5	A21	I/O+	LVTTL	Yes	3.3V	Yes	4mA	Pull Up
6	A20	I/O+	LVTTL	Yes	3.3V	Yes	4mA	Pull Up
7	A19	I/O+	LVTTL	Yes	3.3V	Yes	4mA	Pull Up
8	VSS							
9	A18	I/O+	LVTTL	Yes	3.3V	Yes	4mA	Pull Up
10	VDD							
11	A17	I/O+	LVTTL	Yes	3.3V	Yes	4mA	Pull Up
12	A16	I/O+	LVTTL	Yes	3.3V	Yes	4mA	Pull Up
13	A15	I/O+	LVTTL	Yes	3.3V	Yes	4mA	Pull Up
14	A14	I/O+	LVTTL	Yes	3.3V	Yes	4mA	Pull Up
15	A13	I/O+	LVTTL	Yes	3.3V	Yes	4mA	Pull Up
16	A12	I/O+	LVTTL	Yes	3.3V	Yes	4mA	Pull Up
17	A11	I/O+	LVTTL	Yes	3.3V	Yes	4mA	Pull Up
18	A10	I/O+	LVTTL	Yes	3.3V	Yes	4mA	Pull Up
19	A9	I/O+	LVTTL	Yes	3.3V	Yes	4mA	Pull Up
20	VSS							
21	A8	I/O+	LVTTL	Yes	3.3V	Yes	4mA	Pull Up
22	A7	I	LVTTL	Yes				
23	A6	I	LVTTL	Yes				
24	A5	I	LVTTL	Yes				
25	VDD							
26	A4	I	LVTTL	Yes				
27	A3	I	LVTTL	Yes				
28	A2	I	LVTTL	Yes				
29	A1/WR3	I	LVTTL	Yes				
30	WR2	I+	LVTTL	Yes				Pull Up
31	WR1	I	LVTTL	Yes				
32	VSS							
33	WR0	I	LVTTL	Yes				
34	RD	I	LVTTL	Yes				
35	RESET	I\$	LVTTL	Yes				Schmitt Trigger Buffer
36	VDD							
37	CSREG	I	LVTTL	Yes				
38	CSMEM	I	LVTTL	Yes				
39	LWD	I+	LVTTL	Yes				Pull Up
40	LEND	I+	LVTTL	Yes				Pull Up
41	SYCKS	I+	LVTTL	Yes				Pull Up
42	DREQ	O			3.3V	No	4mA	
43	VSS							
44	READY	OT+			3.3V	Yes	4mA	Pull Up
45	WAIT	OT+			3.3V	Yes	4mA	Pull Up
46	INT	O			3.3V	No	4mA	
47	D31	I/O+	LVTTL	Yes	3.3V	Yes	4mA	Pull Up
48	VDD							
49	D30	I/O+	LVTTL	Yes	3.3V	Yes	4mA	Pull Up

IC402 : YGV619 (MAIN P.C.B.)
OSD

Pin No.	Name	I/O Cell Type	Input		Output			Others attribute
			Level	5V tolerant	Level	5V tolerant	Buffer	
50	D29	I/O+	LVTTL	Yes	3.3V	Yes	4mA	Pull Up
51	D28	I/O+	LVTTL	Yes	3.3V	Yes	4mA	Pull Up
52	D27	I/O+	LVTTL	Yes	3.3V	Yes	4mA	Pull Up
53	D26	I/O+	LVTTL	Yes	3.3V	Yes	4mA	Pull Up
54	D25	I/O+	LVTTL	Yes	3.3V	Yes	4mA	Pull Up
55	D24	I/O+	LVTTL	Yes	3.3V	Yes	4mA	Pull Up
56	VSS							
57	D23	I/O+	LVTTL	Yes	3.3V	Yes	4mA	Pull Up
58	D22	I/O+	LVTTL	Yes	3.3V	Yes	4mA	Pull Up
59	D21	I/O+	LVTTL	Yes	3.3V	Yes	4mA	Pull Up
60	VDD							
61	D20	I/O+	LVTTL	Yes	3.3V	Yes	4mA	Pull Up
62	D19	I/O+	LVTTL	Yes	3.3V	Yes	4mA	Pull Up
63	D18	I/O+	LVTTL	Yes	3.3V	Yes	4mA	Pull Up
64	D17	I/O+	LVTTL	Yes	3.3V	Yes	4mA	Pull Up
65	D16	I/O+	LVTTL	Yes	3.3V	Yes	4mA	Pull Up
66	VSS							
67	D15	I/O+	LVTTL	Yes	3.3V	Yes	4mA	Pull Up
68	D14	I/O+	LVTTL	Yes	3.3V	Yes	4mA	Pull Up
69	D13	I/O+	LVTTL	Yes	3.3V	Yes	4mA	Pull Up
70	D12	I/O+	LVTTL	Yes	3.3V	Yes	4mA	Pull Up
71	D11	I/O+	LVTTL	Yes	3.3V	Yes	4mA	Pull Up
72	VDD							
73	D10	I/O+	LVTTL	Yes	3.3V	Yes	4mA	Pull Up
74	D9	I/O+	LVTTL	Yes	3.3V	Yes	4mA	Pull Up
75	D8	I/O+	LVTTL	Yes	3.3V	Yes	4mA	Pull Up
76	VSS							
77	D7	I/O+	LVTTL	Yes	3.3V	Yes	4mA	Pull Up
78	D6	I/O+	LVTTL	Yes	3.3V	Yes	4mA	Pull Up
79	D5	I/O+	LVTTL	Yes	3.3V	Yes	4mA	Pull Up
80	D4	I/O+	LVTTL	Yes	3.3V	Yes	4mA	Pull Up
81	D3	I/O+	LVTTL	Yes	3.3V	Yes	4mA	Pull Up
82	D2	I/O+	LVTTL	Yes	3.3V	Yes	4mA	Pull Up
83	D1	I/O+	LVTTL	Yes	3.3V	Yes	4mA	Pull Up
84	D0	I/O+	LVTTL	Yes	3.3V	Yes	4mA	Pull Up
85	VSS							
86	SYCKOUT	O			3.3V	No		For crystal oscillator
87	SYCKIN	I	LVC MOS	No				For crystal oscillator and clock input
88	VDD							
89	TEST2	I	LVTTL	Yes				
90	TEST1	I	LVTTL	Yes				
91	TEST0	I	LVTTL	Yes				
92	SDQ0	I/O	LVTTL	Yes	3.3V	Yes	4mA	
93	SDQ15	I/O	LVTTL	Yes	3.3V	Yes	4mA	
94	SDQ1	I/O	LVTTL	Yes	3.3V	Yes	4mA	
95	VSS							
96	SDQ14	I/O	LVTTL	Yes	3.3V	Yes	4mA	
97	SDQ2	I/O	LVTTL	Yes	3.3V	Yes	4mA	
98	SDQ13	I/O	LVTTL	Yes	3.3V	Yes	4mA	

IC402 : YGV619 (MAIN P.C.B.)

OSD

Pin No.	Name	I/O Cell Type	Input		Output			Others attribute
			Level	5V tolerant	Level	5V tolerant	Buffer	
99	SDQ3	I/O	LVTTL	Yes	3.3V	Yes	4mA	
100	VDD							
101	SDQ12	I/O	LVTTL	Yes	3.3V	Yes	4mA	
102	VSS							
103	SDQ4	I/O	LVTTL	Yes	3.3V	Yes	4mA	
104	SDQ11	I/O	LVTTL	Yes	3.3V	Yes	4mA	
105	SDQ5	I/O	LVTTL	Yes	3.3V	Yes	4mA	
106	SDQ10	I/O	LVTTL	Yes	3.3V	Yes	4mA	
107	SDQ6	I/O	LVTTL	Yes	3.3V	Yes	4mA	
108	VSS							
109	SDQ9	I/O	LVTTL	Yes	3.3V	Yes	4mA	
110	SDQ7	I/O	LVTTL	Yes	3.3V	Yes	4mA	
111	SDQ8	I/O	LVTTL	Yes	3.3V	Yes	4mA	
112	DQM0	O			3.3V	No	4mA	
113	VDD							
114	WE	O			3.3V	No	4mA	
115	VSS							
116	DQM1	O			3.3V	No	4mA	
117	CAS	O			3.3V	No	4mA	
118	SDCLK	I/O	LVTTL	Yes	3.3V	Yes	8mA	
119	AVSS2							
120	AVDD2							
121	RAS	O			3.3V	No	4mA	
122	SCS	O			3.3V	No	4mA	
123	SBA1	O			3.3V	No	4mA	
124	SA11	O			3.3V	No	4mA	
125	VSS							
126	SBA0	O			3.3V	No	4mA	
127	VDD							
128	SA12	O			3.3V	No	4mA	
129	SA9	O			3.3V	No	4mA	
130	SA10	O			3.3V	No	4mA	
131	SA8	O			3.3V	No	4mA	
132	SA0	O			3.3V	No	4mA	
133	SA1	O			3.3V	No	4mA	
134	SA6	O			3.3V	No	4mA	
135	VSS							
136	SA7	O			3.3V	No	4mA	
137	SA2	O			3.3V	No	4mA	
138	SA5	O			3.3V	No	4mA	
139	VDD							
140	SA3	O			3.3V	No	4mA	
141	SA4	O			3.3V	No	4mA	
142	DQM2	O			3.3V	No	4mA	
143	DQM3	O			3.3V	No	4mA	
144	VSS							
145	SDQ16	I/O	LVTTL	Yes	3.3V	Yes	4mA	
146	SDQ31	I/O	LVTTL	Yes	3.3V	Yes	4mA	
147	SDQ17	I/O	LVTTL	Yes	3.3V	Yes	4mA	

IC402 : YGV619 (MAIN P.C.B.)
OSD

Pin No.	Name	I/O Cell Type	Input		Output			Others attribute
			Level	5V tolerant	Level	5V tolerant	Buffer	
148	SDQ30	I/O	LVTTL	Yes	3.3V	Yes	4mA	
149	SDQ18	I/O	LVTTL	Yes	3.3V	Yes	4mA	
150	VSS							
151	SDQ29	I/O	LVTTL	Yes	3.3V	Yes	4mA	
152	VDD							
153	SDQ19	I/O	LVTTL	Yes	3.3V	Yes	4mA	
154	SDQ28	I/O	LVTTL	Yes	3.3V	Yes	4mA	
155	SDQ20	I/O	LVTTL	Yes	3.3V	Yes	4mA	
156	SDQ27	I/O	LVTTL	Yes	3.3V	Yes	4mA	
157	VSS							
158	SDQ21	I/O	LVTTL	Yes	3.3V	Yes	4mA	
159	SDQ26	I/O	LVTTL	Yes	3.3V	Yes	4mA	
160	SDQ22	I/O	LVTTL	Yes	3.3V	Yes	4mA	
161	SDQ25	I/O	LVTTL	Yes	3.3V	Yes	4mA	
162	SDQ23	I/O	LVTTL	Yes	3.3V	Yes	4mA	
163	VSS							
164	SDQ24	I/O	LVTTL	Yes	3.3V	Yes	4mA	
165	VDD							
166	CSYNC	O			3.3V	No	4mA	
167	HSYNC	O			3.3V	No	4mA	
168	BLANK	O			3.3V	No	4mA	
169	FSC	O			3.3V	No	4mA	
170	AT1	O			3.3V	No	4mA	
171	VSS							
172	AT0	O			3.3V	No	4mA	
173	GCKOUT	O			3.3V	No	4mA	
174	DRO5	I/O	LVTTL	Yes	3.3V	Yes	4mA	
175	DRO4	I/O	LVTTL	Yes	3.3V	Yes	4mA	
176	DRO3	I/O	LVTTL	Yes	3.3V	Yes	4mA	
177	VSS							
178	DRO2	I/O	LVTTL	Yes	3.3V	Yes	4mA	
179	DRO1	I/O	LVTTL	Yes	3.3V	Yes	4mA	
180	VDD							
181	DRO0	I/O	LVTTL	Yes	3.3V	Yes	4mA	
182	DGO5	I/O	LVTTL	Yes	3.3V	Yes	4mA	
183	DGO4	I/O	LVTTL	Yes	3.3V	Yes	4mA	
184	VSS							
185	DGO3	I/O	LVTTL	Yes	3.3V	Yes	4mA	
186	DGO2	I/O	LVTTL	Yes	3.3V	Yes	4mA	
187	DGO1	I/O	LVTTL	Yes	3.3V	Yes	4mA	
188	DGO0	I/O	LVTTL	Yes	3.3V	Yes	4mA	
189	DBO5	I/O	LVTTL	Yes	3.3V	Yes	4mA	
190	VSS							
191	DBO4	I/O	LVTTL	Yes	3.3V	Yes	4mA	
192	DBO3	I/O	LVTTL	Yes	3.3V	Yes	4mA	
193	VDD							
194	DBO2	I/O	LVTTL	Yes	3.3V	Yes	4mA	
195	DBO1	I/O	LVTTL	Yes	3.3V	Yes	4mA	
196	DBO0	I/O	LVTTL	Yes	3.3V	Yes	4mA	

IC402 : YGV619 (MAIN P.C.B.)

OSD

Pin No.	Name	I/O Cell Type	Input		Output			Others attribute
			Level	5V tolerant	Level	5V tolerant	Buffer	
197	VSS							
198	AVSS4							
199	B	A						Analog
200	AVSS4							
201	G	A						Analog
202	AVSS4							
203	R	A						Analog
204	AVSS4							
205	REXT	A						Analog
206	AVDD4							
207	AVDD3							
208	AVSS3							
209	DRI5	I+	LVTTL	Yes				Pull Up
210	DRI4	I+	LVTTL	Yes				Pull Up
211	DRI3	I+	LVTTL	Yes				Pull Up
212	DRI2	I+	LVTTL	Yes				Pull Up
213	VSS							
214	DRI1	I+	LVTTL	Yes				Pull Up
215	VDD							
216	DRI0	I+	LVTTL	Yes				Pull Up
217	DGI5	I+	LVTTL	Yes				Pull Up
218	DGI4	I+	LVTTL	Yes				Pull Up
219	DGI3	I+	LVTTL	Yes				Pull Up
220	DGI2	I+	LVTTL	Yes				Pull Up
221	DGI1	I+	LVTTL	Yes				Pull Up
222	DGI0	I+	LVTTL	Yes				Pull Up
223	DBI5	I+	LVTTL	Yes				Pull Up
224	DBI4	I+	LVTTL	Yes				Pull Up
225	VSS							
226	DBI3	I+	LVTTL	Yes				Pull Up
227	DBI2	I+	LVTTL	Yes				Pull Up
228	DBI1	I+	LVTTL	Yes				Pull Up
229	VDD							
230	DBI0	I+	LVTTL	Yes				Pull Up
231	GCKIN	I	LVTTL	Yes				Clock input
232	GCKS	I+	LVTTL	Yes				Pull Up
233	HSIN	I+	LVTTL	Yes				Pull Up
234	VSIN	I+	LVTTL	Yes				Pull Up
235	TCKS	I+	LVTTL	Yes				Pull Up
236	TCK80	I	LVTTL	Yes				
237	VSS							
238	DCKOUT	O			3.3V	No		For crystal oscillator
239	DCKIN	I	LVC MOS	No				For crystal oscillator and clock input
240	VDD							

I : Input T : Tri-state

O : Output + : with pull up resistor

A : Analog \$: Schmitt Trigger Type Input Buffer

IC501 : LAN91C111 (MAIN P.C.B.)

Ethernet

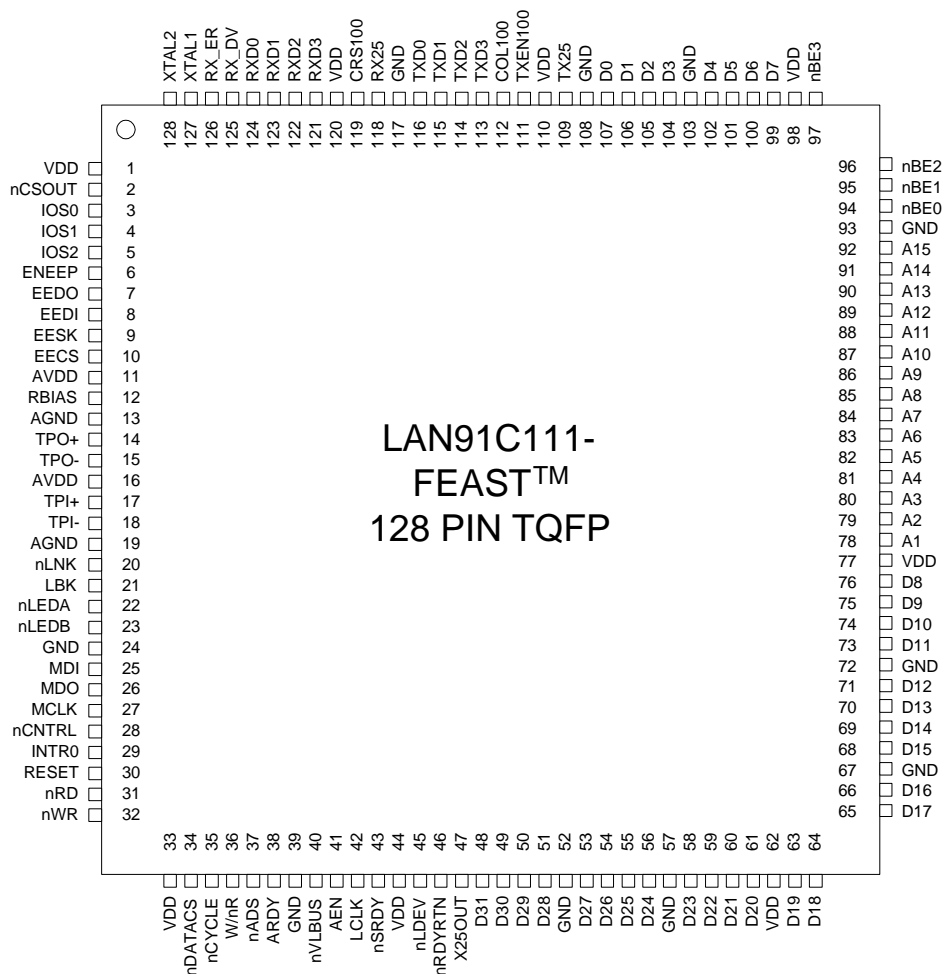

Pin No. TQFP	Name	Symbol	Buffer Type	Function
81-92	Address	A4-A15	I**	Input signal. This signal is double signed by LAN91C111 to determine access to the register of LAN91C111.
78-80	Address	A1-A3	I**	Input signal. Used by LAN91C111 to select of the internal register.
41	Address Enable	AEN	I**	Input signal. Used for approval of double signing of the address. The address can be double signed only when AEN is in the low state.
94-97	nByte Enable	nBE0-nBE3	I**	Input signal. Used to determine the register being accessed and the access width while accessing the register of LAN91C111. When nDATAcs is in the low state (burst accessing), nBE0 to nBE3 are ignored because 32-bit transmission is assumed.

IC501 : LAN91C111 (MAIN P.C.B.)

Ethernet

Pin No. TQFP	Name	Symbol	Buffer Type	Function
104-107, 99-102, 73-76, 68-71, 63-66, 58-61, 53-56, 48-51	Data Bus	D0-D31	I/O24**	Bidirectional signal. 32-bit data bus that is used to access the internal register of LAN91C111. The data bus has a weak internal pullup register. It is usable for direct connection with the system bus without external buffering. For the 16-bit system, only D0 to D15 are used.
30	Reset	RESET	IS**	Input signal. When this pin is in the high state, the controller executes resetting of the internal system (MAC and PHY). When this pin is in the high state, all registers are set to the default value and the controller reads the contents of the EEPROM device through the EEPROM interface (1). This input is not considered effective unless it is active for at least 100ns for filtering of glitches.
37	nAddress Strobe	nADS	IS**	Input signal. With the system that requires address latching, the rising edge of nADS indicates the time of A1, A15 and AEN latching. The internal functions of all LAN91C111 of A1, A15 and AEN are latched if there is no nLDEV decoding.
35	nCycle	nCYCLE	I**	Input signal. This active low signal is used to control the LAN91C111 EISA burst mode synchronous bus cycle.
36	Write/nREAD	W/nR	IS**	Input signal. Used to determine the direction of the synchronous cycle. When it is in the high state, the writing cycle is selected and when it is low, the reading cycle is selected.
40	NVLBus Access	nVLBUS	I with pullup**	Input signal. When it is in the low state, LAN91C111 synchronous bus interface is set for VL bus accessing. If not, LAN91C111 is set for EISA DMA burst accessing. It does not affect the asynchronous bus interface.
42	Local Bus Clock	LCLK	I**	Input signal. Used to interface the synchronous bus. The maximum frequency is 50MHz. For the EISA DMA burst mode, the maximum value is 8.33MHz.
38	Asynchronous Ready	ARDY	OD16	Open drain output signal. ARDY is usable for interfacing the asynchronous bus to expand accessing. Its rising (completion of accessing) edge is controlled by XTA 1 clock and so asynchronous with the host CPU, that is, bus clock.
43	nSynchronous Ready	nSRDY	O16	Output signal. This output is used for interfacing the synchronous bus at nVLBUS=0 to expand accessing. This signal is usually inactive and its falling edge indicates completion. This signal is synchronous with the bus clock LCLK.
46	nReady Return	nRDYRTN	I**	Input signal. This input is used to complete the synchronous reading cycle. In the EISA burst mode, it is picked up at the falling edge and the synchronous cycle continues until the EISA burst mode is adopted in the high state.

IC501 : LAN91C111 (MAIN P.C.B.)

Ethernet

Pin No. TQFP	Name	Symbol	Buffer Type	Function
29	Interrupt	INTR0	O24	Interrupt output signal. Used to cause interruption to the host on an event of a certain status. Caution: The selection bits which have been determined by the INT SEL 1-0 bit value in the configuration register are no more required but retained to keep interchangeability when the FEAST family is changed.
45	nLocal Device	nLDEV	O16	Output signal. This active low output is indicated when AEN is low and A4-A15 decoding to LAN91C111 is programmed to a higher byte of the base address register. n LDEV is a linked decode of an unlatched address and AEN signal.
31	nRead Strobe	nRD	IS**	Input signal. Used in the asynchronous bus interface.
32	nWrite Strobe	nWR	IS**	Input signal. Used in the asynchronous bus interface.
34	nData Path Chip Select	nDATACS	I with pullup**	Input signal. When nDATACS is in the low state, the data bus can be accessed regardless of selection of AEN, A1, A15 value and bank selection register. nDATACS provides interface to or from 32 bits of LAN9C111 at one time.
9	EEPROM Clock	EESK	O4	Output signal. Used when 4 μ sec clock transfers the data to or from the serial EEPROM.
10	EEPROM Select	EECS	O4	Output signal. It is chip select of serial EEPROM, used when forming and selecting the command of serial EEPROM.
7	EEPROM Data Out	EEDO	O4	Output signal. It is linked with D1 input (EEDI) of serial EEPROM.
8	EEPROM Data In	EEDI	I with Pulldown**	Input signal. It is linked with DO output (EEDO) of serial EEPROM.
3-5	I/O Base	IOS0- IOS2	I with pullup**	Input signal. It is possible to connect the external switch to make a selection among predefined EEPROM structures.
6	Enable EEPROM	ENEPP	I with pullup**	Input signal. It enables LAN91C111 to access serial EEPROM (in the high or open state). If EEPROM is not connected to LAN91C111, it must be grounded.
127,128	Crystal 1 Crystal 2	XTAL1	Icik	An external 25MHz crystal oscillator must be connected to these pins. When using the TTL clock, it should be connected to XTAL1 and XTAL2 should remain open.
1,33,44, 62,77, 98,110, 120	Power	VDD		+3.3V power supply pin.
11,16	Analog Power	AVDD		+3.3V analog power supply pin.

IC501 : LAN91C111 (MAIN P.C.B.)

Ethernet

Pin No. TQFP	Name	Symbol	Buffer Type	Function
24,39,52, 57,67,72, 93,103, 108,117	Ground	GND		Ground pin.
13,19	Analog Ground	AGND		Analog ground pin.
21	Loopback	LBK	O4	Output pin. It is effective when the LOOP bit is set (TCR bit 1).
20	nLink Status	nLNK	I with pullup**	Input signal. The general purpose port is used to transmit the LINK status (EPHSR bit 14).
28	nControl	nCNTRL	O12	General purpose control signal.
47	X25 Out	X25out	O12	25MHz output signal to external PHY.
111	Transit Enable 100 Mbps	TXEN100	O12	Output signal to MII PHY. It enables 100Mbps transmission.
119	Carrier Sense 100 Mbps	CRS100	I with pulldown**	Input signal from MII PHY. Wave form of bucket reception to be used when waiting for reception and restoring.
125	Receive Data Valid	RX_DV	I with pulldown**	Input signal from MII PHY. Wave form for receiving effective data, used to form reception data.
112	Collisio Detect 100 Mbps	COL100	i with pulldown**	Input signal from MII PHY. This is an input pin for collision detection.
113-116	Transmit Data	TXD0- TXD3	O12	Output signal. 4 bit data is transmitted to MII PHY.
109	Transmit Clock	TX25	I with pullup**	Input signal. The clock input from MII is transmitted. 4 bit rate clock (25 MHz for 100 Mbps and 2.5 Mbps for 10 Mbps)
118	Receive Clock	RX25	I with pullup**	Input signal. The clock input received from MII PHY. 4 bit rate clock (25 MHz for 100 Mbps or 2.5 Mbps for 10 Mbps).
121-124	Receive Data	RXD0- RXD3	I with pullup**	Input signal. 4 bits of the receiving data from MII PHY.
25	Management Data Input	MDI	I with pulldown**	MII management data input signal.
26	Management Data Output	MDO	O4	MII management data output signal.
27	Management Output	MCLK	O4	MII management clock.
126	Receive Error	RX_ER	I with pulldown**	For the input signal which indicates an error of the code detected by PHY. It is used to remove the bucket being received by LAN91C111. The error reported by this event has the same meaning as a faulty CRC. (Receive Status Word 13)

IC501 : LAN91C111 (MAIN P.C.B.)

Ethernet

Pin No. TQFP	Name	Symbol	Buffer Type	Function
2	nChip Select Output	nCSOUT	O4	For the output signal. Chip select is provided for mapping to the space of LAN91C111 with PHY function. It enables accessing the 8-bit lower address of LAN91C111 when BANK SELECTED is "7".
12	External Register	RBIAS	NA	For setting the transmission current. The output current for TP transmission output is set by the external resistor connected between this pin and GND.
14		TPO+	O/I	For output signal to transmit positive twist pair.
15		TPO-	O/I	For output signal to transmit negative twist pair.
17		TPI+	I/O	For output signal to receive positive twist pair.
18		TPI-	I/O	For input signal to receive negative twist pair.
22		nLEDA	OD16	For PHY LED output.
23		nLEDB	OD16	For PHY LED output.

Caution (1) When EEPROM is enabled.

This section describes each SM SC LAN91C111 signal in the detail. The signals are classified into function groups based on their related functions.

When the signal name starts with "n", it indicates that the signal is in the active low state and when no "n" there, it indicates the active high state of the signal.

"assert" or "assertion" indicates that the signal is effective regardless of whether the voltage level is high or low. "negata" or "negation" indicates that the signal is ineffective.

Also, "high-Z" indicates that the signal is in the tri-state.

"Undefined" means that the signal can be high, low, tri-state or intermediate level.

Buffer Types

O4	Output buffer with 2mA transmission side and 4mA reception side
O12	Output buffer with 6mA transmission side and 12mA reception side
O16	Output buffer with 8mA transmission side and 16mA reception side
O24	Output buffer with 12mA reception side and 24mA reception side
OD16	Open drain buffer with 16mA reception side
I/O4	Bidirectional buffer with 2mA transmission side and 4mA reception side
I/O24	Bidirectional buffer with 12mA transmission side and 24mA reception side
I/OD	Bidirectional open drain buffer with 4mA reception side
I	Input buffer
IS	Input buffer with Schmidt trigger hysteresis
Iclk	Clock input buffer
I/O	Difference input
O/I	Difference output
**	5V tolerant

■ BLOCK DIAGRAM

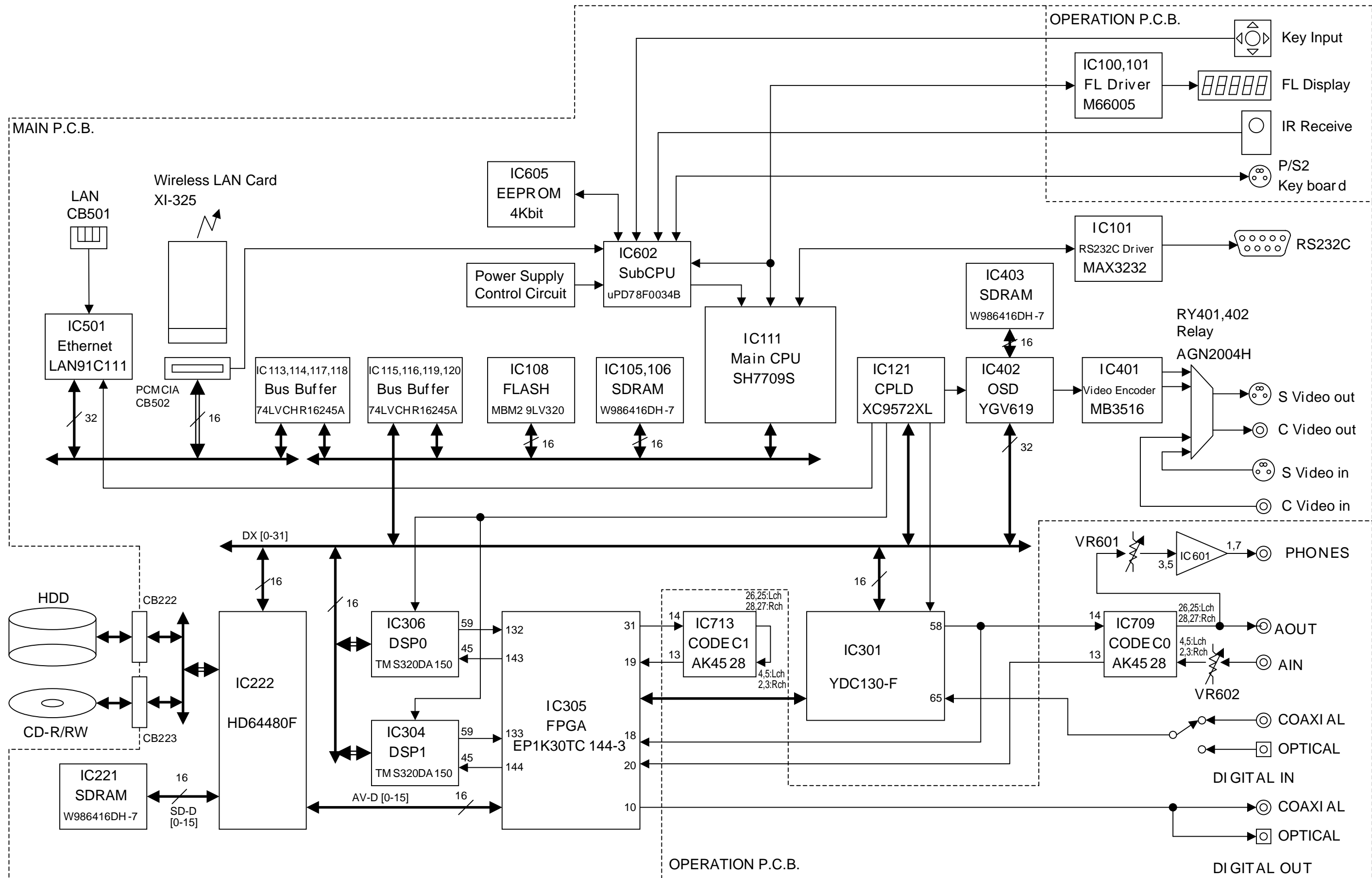

1 ■ BLOCK DIAGRAM

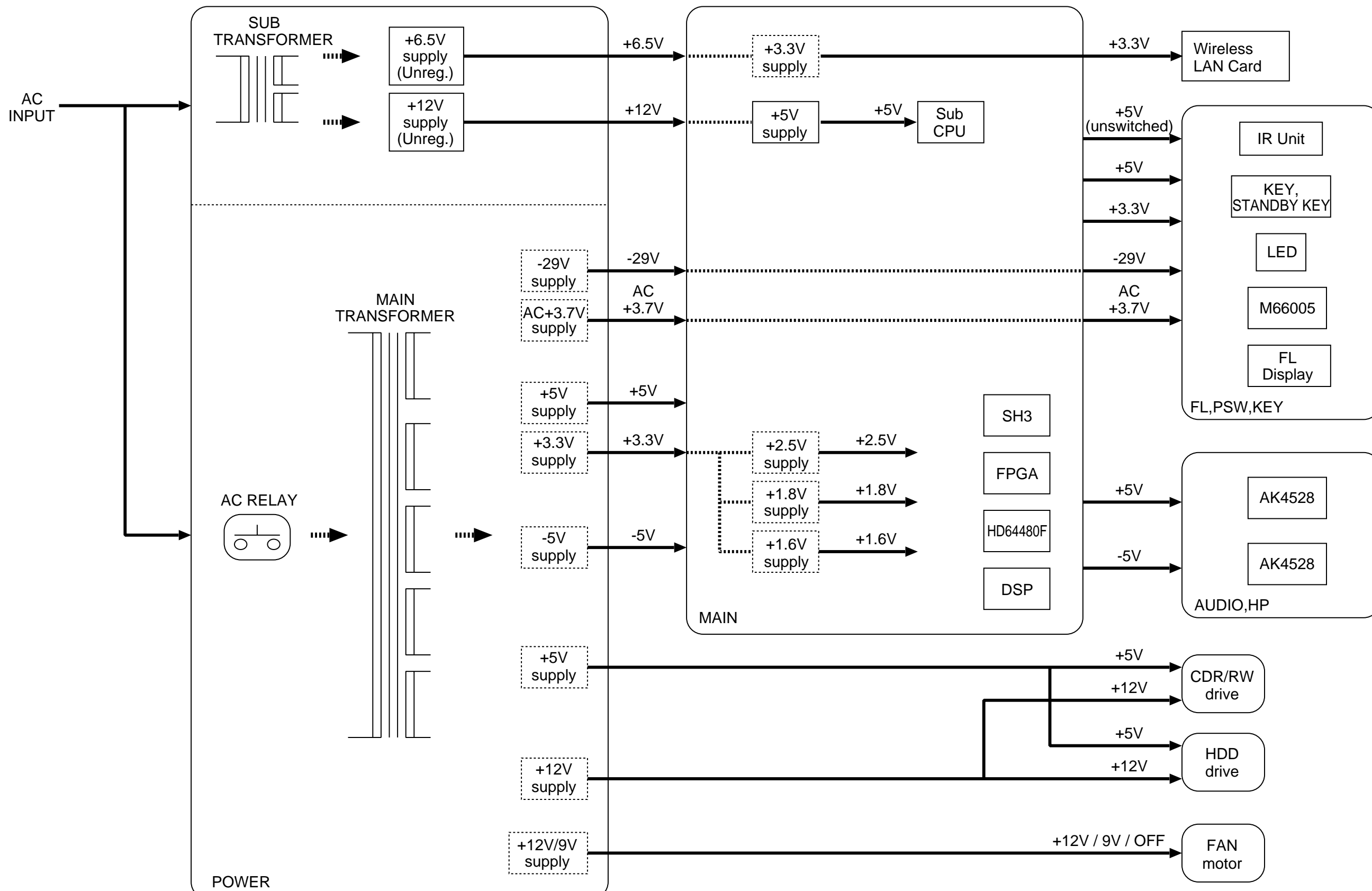

enable to power-off block

PRINTED CIRCUIT BOARD (Foil side)

MAIN P. C. B. (Lead Type Device)

Refer to "ENTERING SYSTEM ID" on pages 23 and 24.
「システムIDの書き込み」(23、24ページ)参照

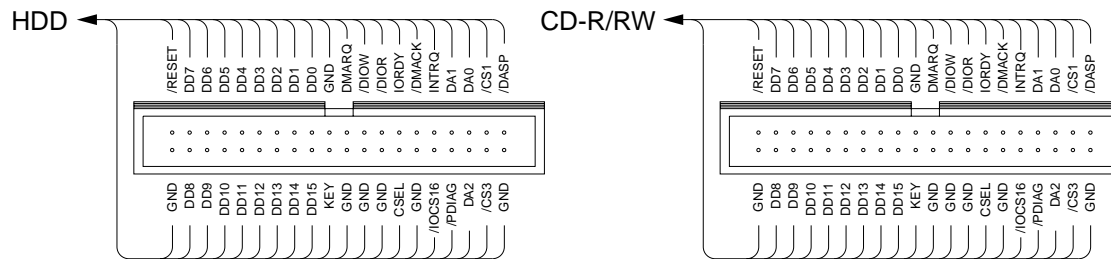

Semiconductor Location

Ref. No.	Location	Ref. No.	Location
D101	F5	IC310	E5
D301	D3	IC313	D3
D304	E3	IC314	E3
D401	B6	IC315	C3
D602	B3	IC401	B6
D603	D3	IC402	C6
D604	D3	IC403	C7
D605	D3	IC501	C5
D606	D3	IC601	D3
D607	D3	IC602	H4
D608	D3	IC603	E3
D610	H5	IC604	B3
D611	G4	IC605	H4
D615	H5	IC606	G4
IC101	B3	IC607	G5
IC103	G5	IC608	G6
IC104	G5	IC609	G5
IC107	F5	IC610	G5
IC108	G5	IC611	G5
IC109	F5	IC612	G4
IC110	F5	IC613	G5
IC111	G5	IC614	G4
IC115	E6	IC615	H5
IC116	E6	Q304	D3
IC119	D6	Q401	B7
IC120	D6	Q501	C3
IC121	F4	Q601	B3
IC122	F6	Q602	D3
IC222	G3	Q603	D3
IC224	H3	Q606	E3
IC225	H3	Q607	H5
IC301	D4	Q608	H5
IC302	E3	Q609	G4
IC303	E3	Q611	H5
IC304	E5	Q613	G4
IC305	F3		
IC306	E3		
IC307	D4		
IC308	D4		
IC309	E4		

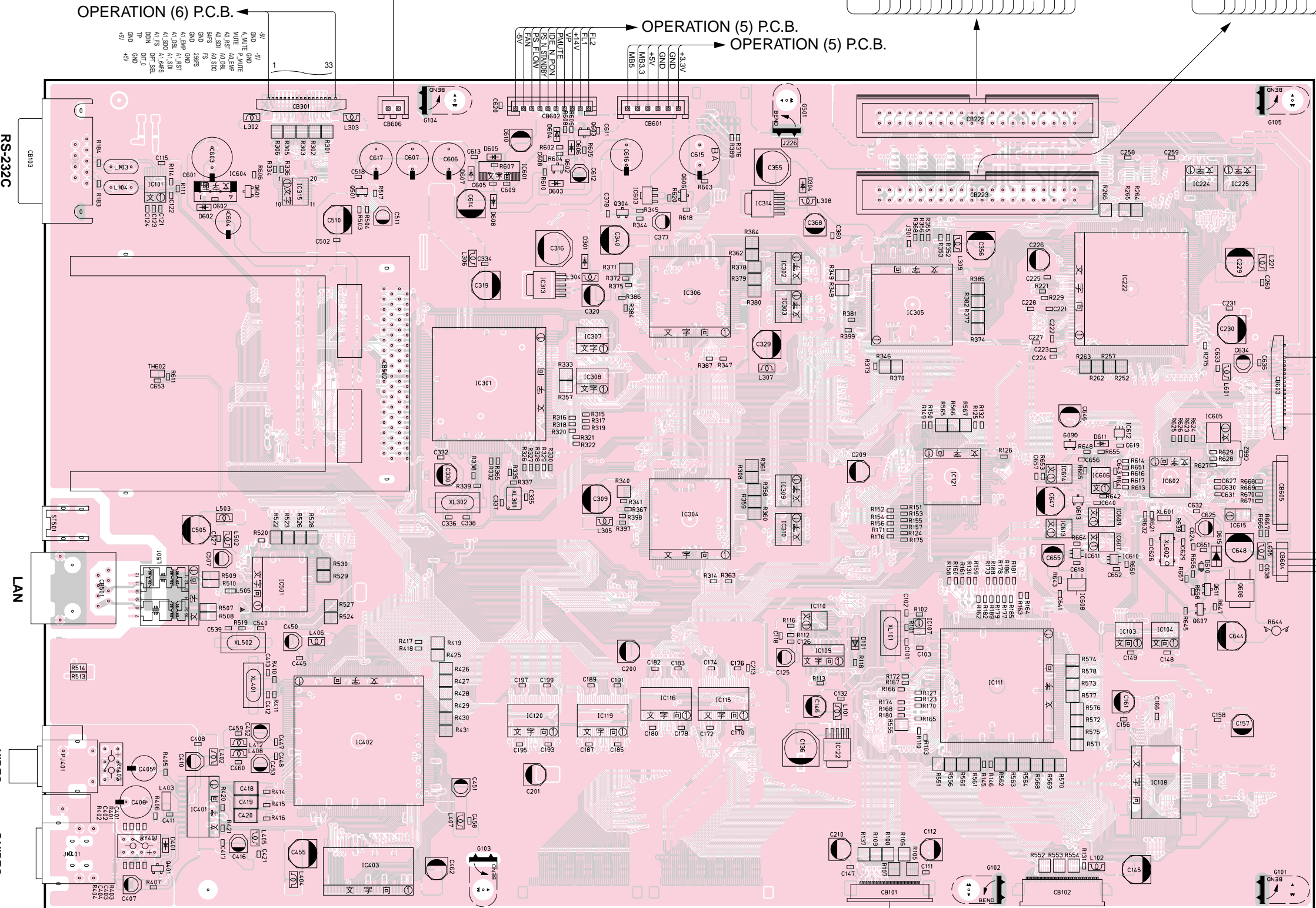

Refer to "ENTERING SYSTEM ID" on pages 23 and 24.
「システムIDの書き込み」(23、24ページ)参照

PRINTED CIRCUIT BOARD (Foil side)

OPERATION (1) P. C. B. (Lead Type Device)

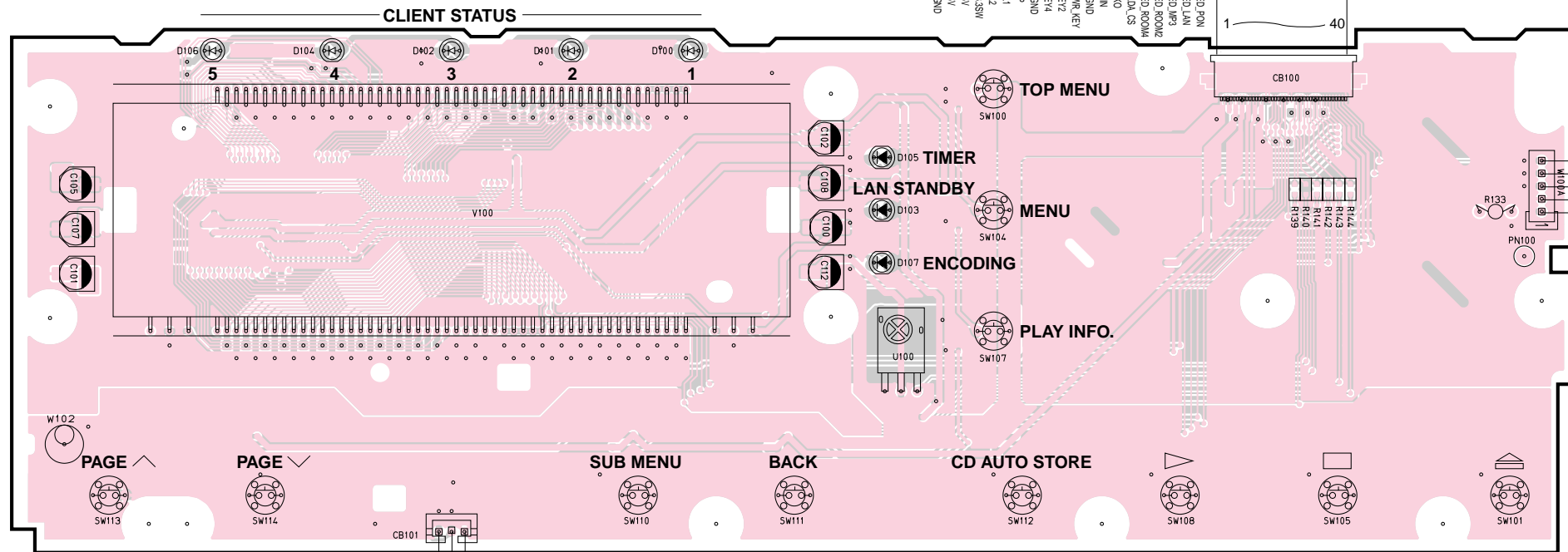

OPERATION (2) P. C. B. (Lead Type Device)

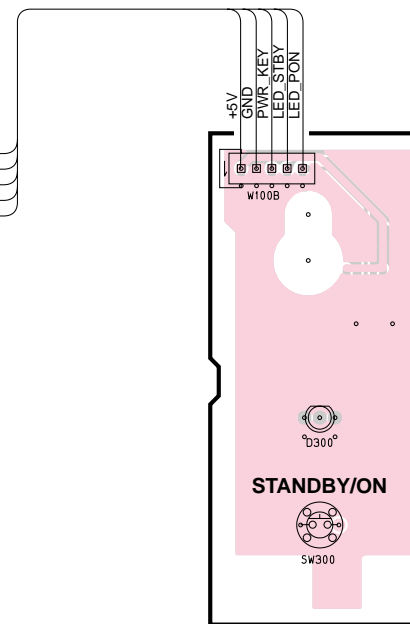

OPERATION (3) P. C. B. (Lead Type Device)

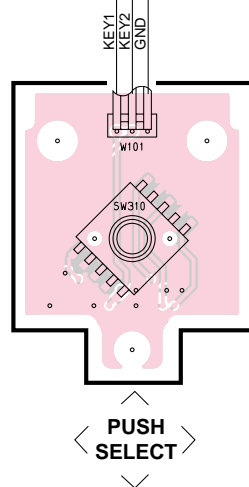

OPERATION (4) P. C. B. (Lead Type Device)

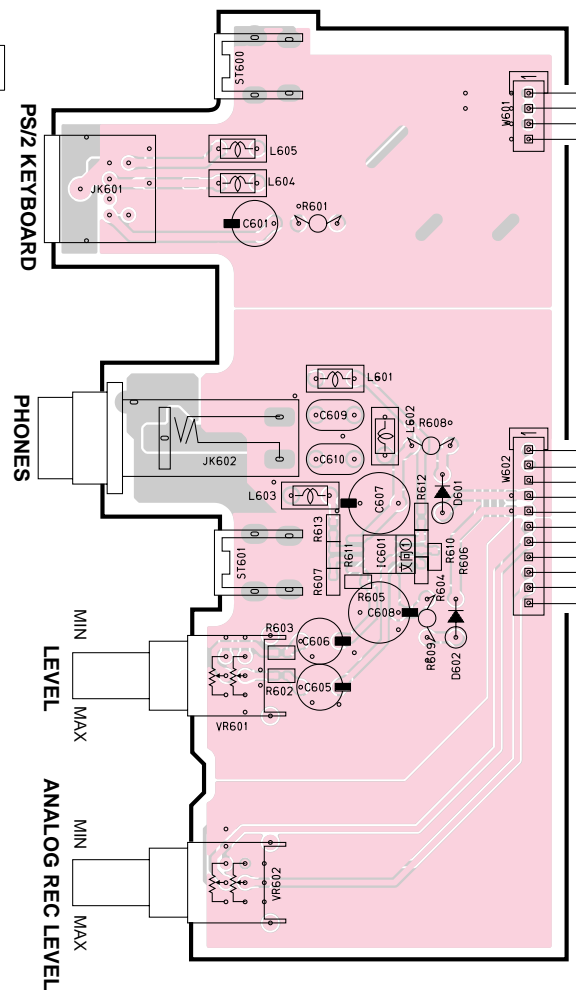

OPERATION (6) P.C.B.

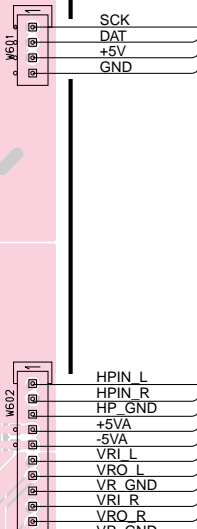

Semiconductor Location

Ref. No.	Location
D100	D2
D101	C2
D102	C2
D103	D2
D104	B2
D105	D2
D106	B2
D107	D3
D300	H3
D601	G5
D602	G6
IC601	F6

PRINTED CIRCUIT BOARD (Foil side)

OPERATION (1) P. C. B. (Surface Mount Device)

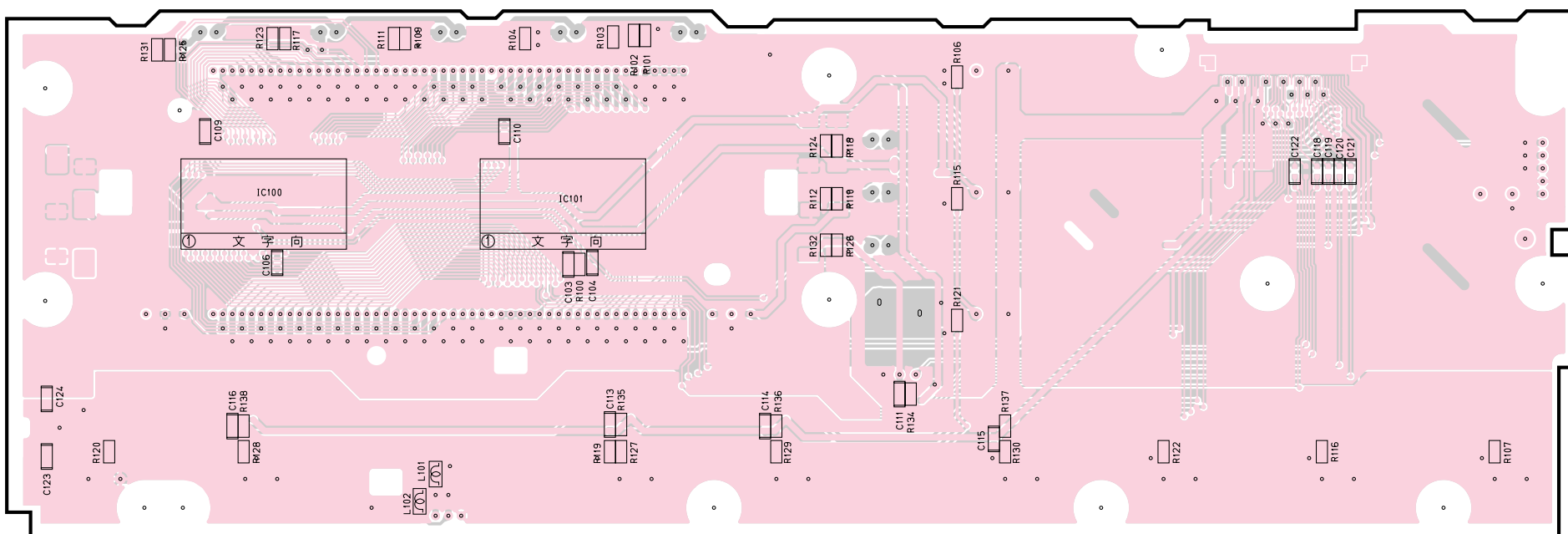

OPERATION (2) P. C. B. (Surface Mount Device)

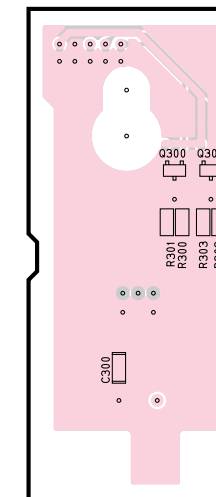

OPERATION (3) P. C. B. (Surface Mount Device)

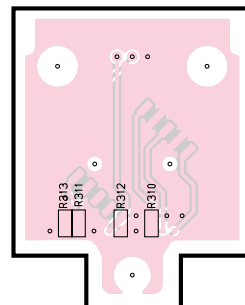

OPERATION (4) P. C. B. (Surface Mount Device)

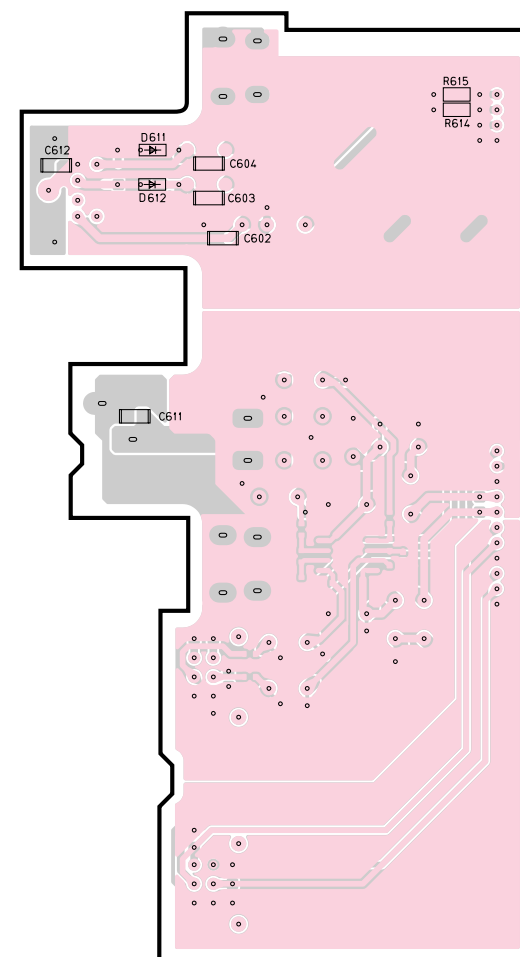

• Semiconductor Location

Ref. No.	Location
D611	E4
D612	E5
IC100	B2
IC101	C2
Q300	I3
Q301	I3

PRINTED CIRCUIT BOARD (Foil side)

• Semiconductor Location

Ref. No.	Location	Ref. No.	Location	Ref. No.	Location	Ref. No.	Location
D400	C5	D417	C3	IC400	F3	IC709	I5
D401	C6	D419	B5	IC401	C4	IC710	I5
D402	F3	D421	B5	IC402	C4	IC711	I6
D403	C6	D422	B5	IC403	C3	IC712	J5
D404	E4	D427	E2	IC404	C2	IC713	I5
D405	E3	D428	E2	IC405	E2	Q400	C5
D406	F3	D429	E5	IC701	H4	Q401	G3
D407	F3	D702	I6	IC702	H5	Q406	E2
D411	C4	D703	I6	IC703	H5	Q701	H4
D412	C3	D704	I6	IC705	H6	Q702	H4
D413	E3	D705	I6	IC706	H6	Q703	H4
D415	C5	D706	H6	IC707	H6	Q704	H4
D416	C5	D707	H6	IC708	H6	Q705	I6

OPERATION (5) P. C. B. (Lead Type Device)

FAN

MAIN P.C.B. ←

MAIN P.C.B. ←

HDD UNIT ←

CDR UNIT ←

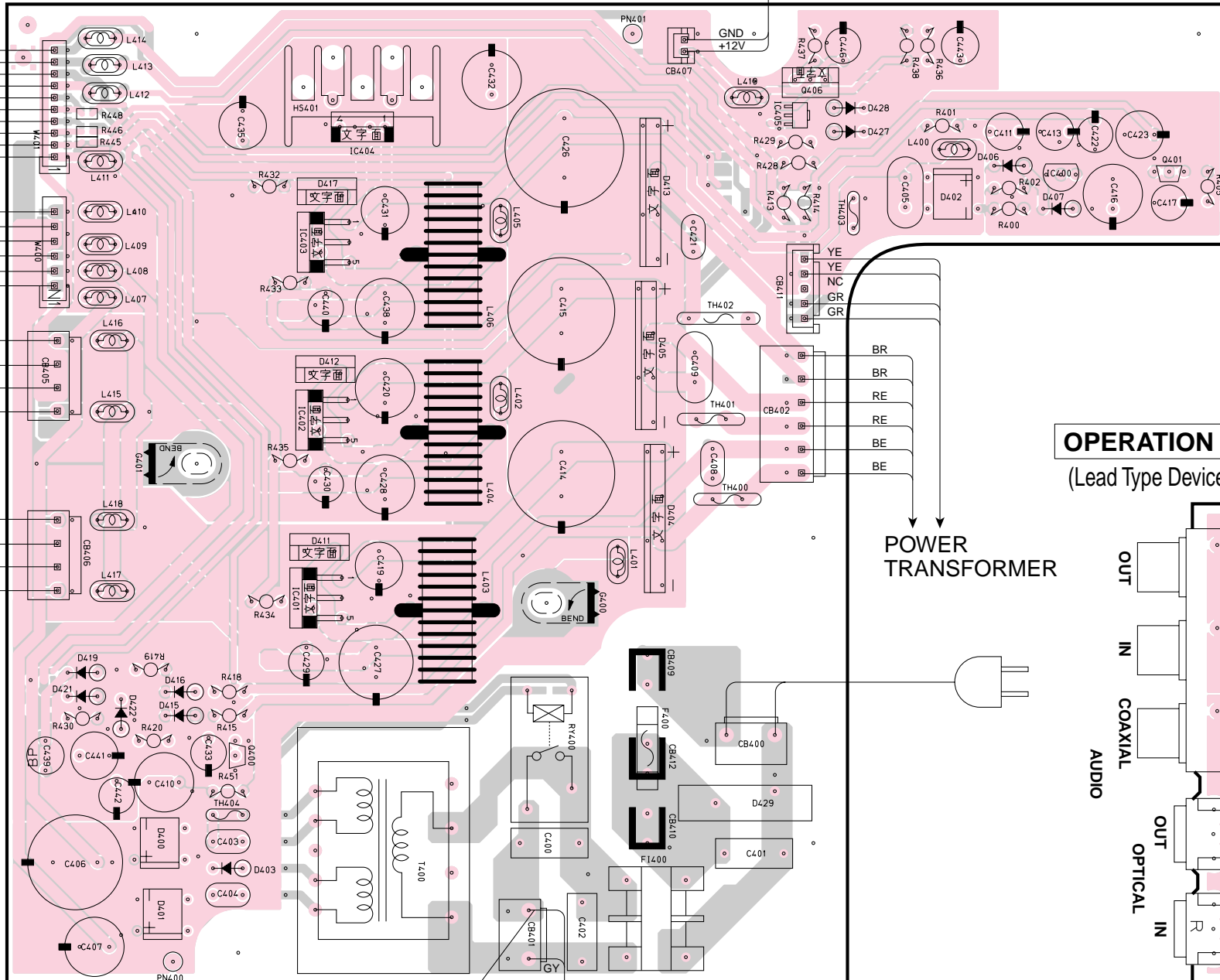

POWER TRANSFORMER

POWER TRANSFORMER

BR (U, C, J models)
BE (G, B models)
RE (A model)

OPERATION (6) P. C. B. (Lead Type Device)

OPERATION (4) P.C.B.

OUT
IN
COAXIAL
AUDIO
OUT
OPTICAL
IN

MAIN P.C.B. ←

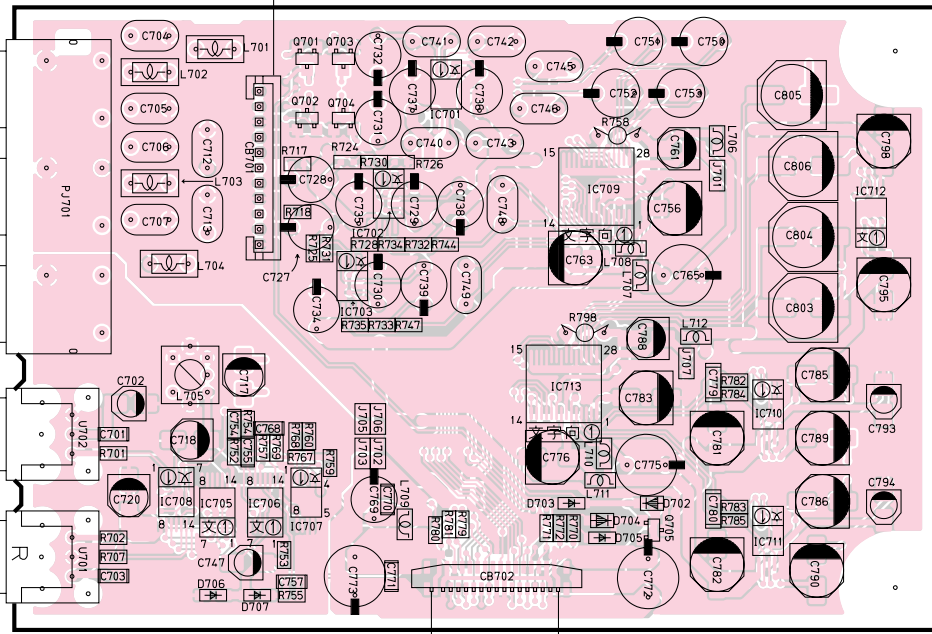

HPIN L
HPIN R
HP_GND
+5VA
-5VA
VRI L
VRO L
VR_GND
VRI R
VRO R
VR_GND

■ PIN CONNECTION DIAGRAM

• ICs

AK4528VF 	M5237ML 	NJM79L05A-T3 1: COMMON 2: IN 3: OUT	PQ05RD11 	NJM2100V NJM2904V(TE1) NJM4580V-TE2 μPC4570G2 AT24C04N-10SI-2.7 SN74AHC2GU04HDCTR SN74CBT3306PWR
M66005-0141AFP-280 	PQ1CG2032FZ 	SN74AHC02PWR SN74AHC08PWR SN74AHCU04PWR 74LCX14MTCX 74VHCT00AMTCX SN74LV08APWR SN74LV132APWR 	74LCX245MTCX 74VHCT245AMTCX 	
EP1K30TC144-3 	FST3383MTC MB3516APF-G-BND 	MBM29LV320BE90T 	M62703ML 	MAX3221CPW
PST572CMT-R 	PST600JM 	SN74AHC1G125DCKR SN74LVC1G17DCKR 	SN74LVC2G17DCKR 	NJM7805FA 3: IN 2: COM 1: OUT
μPD78F0034BGB-8EU 	W986416DH-7 	SN74LVCHR16245AGR 		
XC9572XL-10TQ100C 	TMS320DA150PG 	LAN91C111 	YDC130-F 	

HD6417709SF13 HD64480F 	YGV619
-------------------------------	------------

• Diodes

1N4002S MTZJ6.2B Anode Cathode	MA8051-M MA8056-M MA8300-L 1SS355 1SS380 MA8062-H UDZ4.7B 1SR154-400 MA732 Anode Cathode	TNR20V561K
D3SBA20 	S1NB20 	SF5S6

• Transistors

2SA933S 2SC1740S E C B	2SB1565 B C E
2SA1037K 2SA1037 2SD1938F DTA144EKA DTA143EK DTC114EKA DTC143EKA DTC144EKA 2SC2412K 2SC3326 C B E	2SD1760 B C E

SCHEMATIC DIAGRAM (MAIN: DMAC Block)

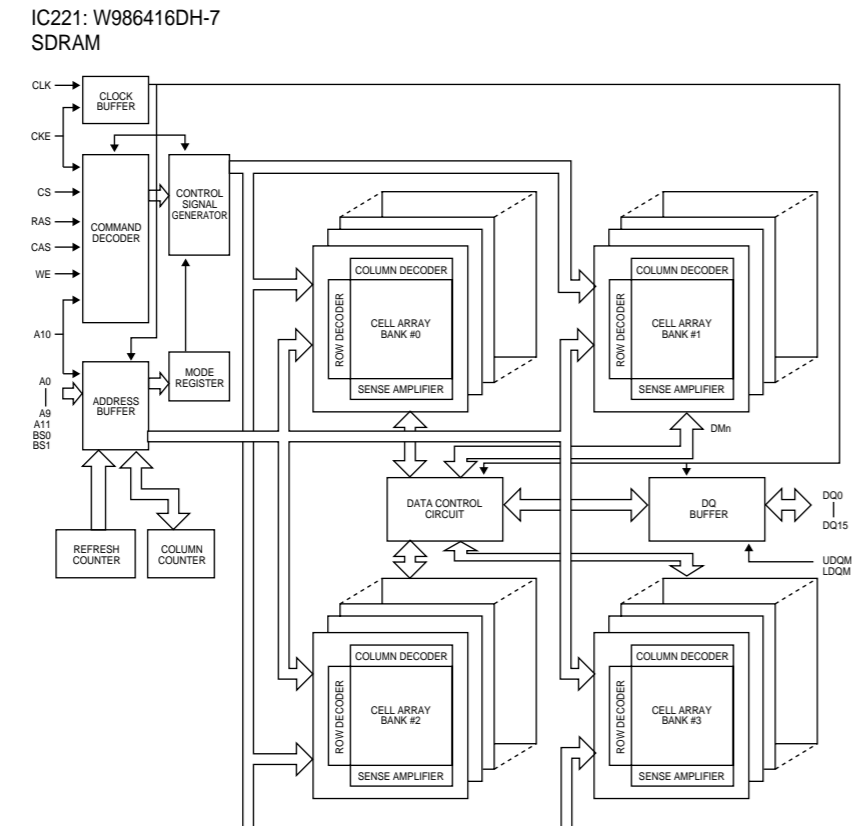
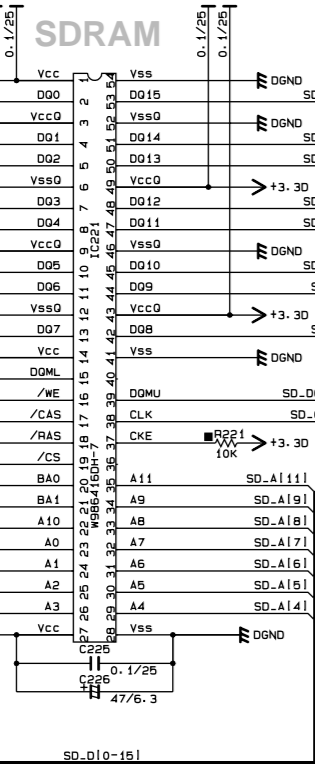
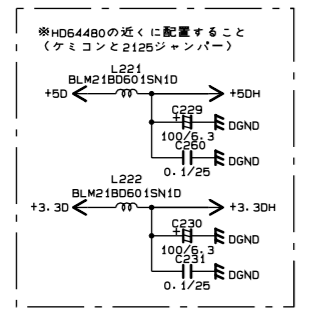
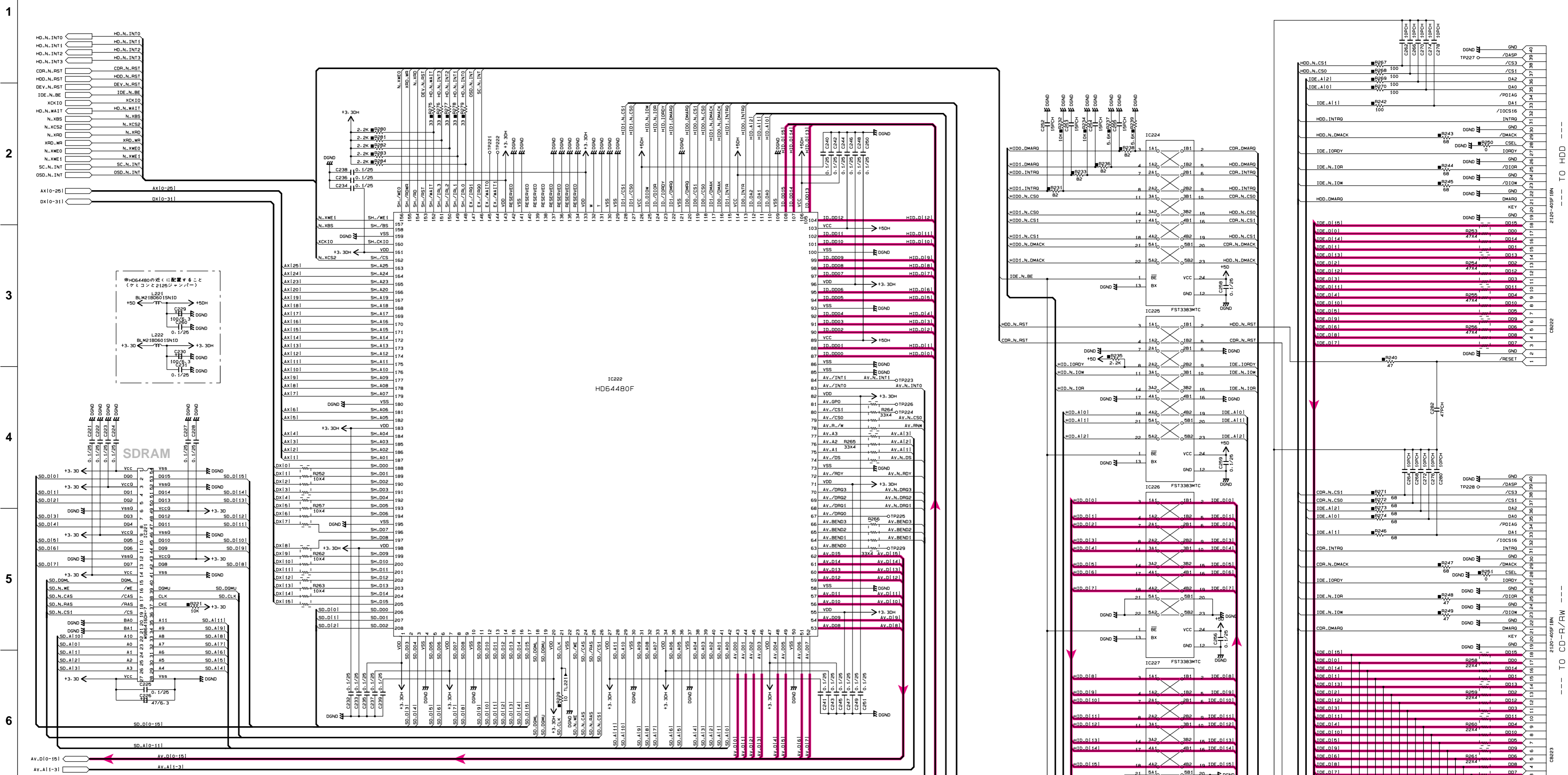

IC224-227: FST3383MTC 10-Bit Low Power Bus-Exchange Switch

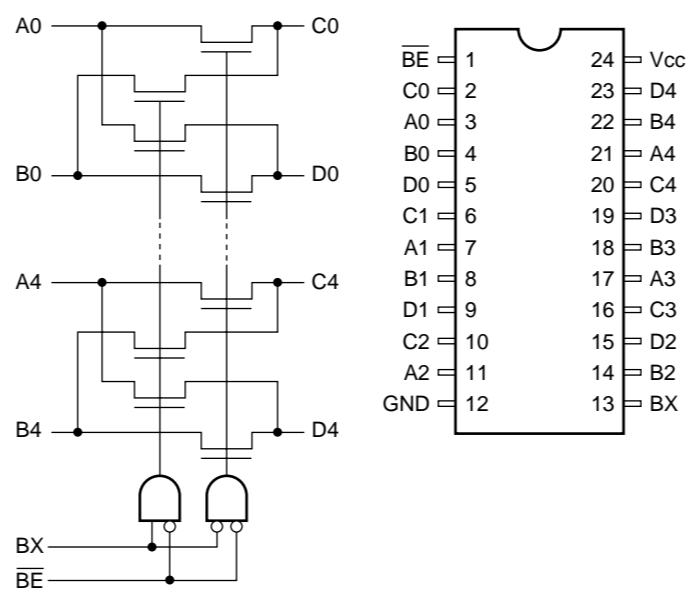

1
2
3
4
5
6
7
8
9

* All voltages are measured with a 10MΩ/V DC electronic voltmeter.
 * Components having special characteristics are marked with a triangle (▲) and must be replaced with parts having specifications equal to those originally installed.
 * Schematic diagram is subject to change without notice.

● 電圧は、内部抵抗10MΩの電圧計で測定したものです。
 ● ▲印のある部品は、安全性確保部品を示しています。部品の交換が必要な場合、パーツリストに記載されている部品を使用してください。
 ● 本回路図は標準回路図です。改良のため予告なく変更することがございます。

SCHEMATIC DIAGRAM (MAIN: SYSTEM Block)



FIGURE 71 (HZ) TO OPERATION (6)

FIGURE 71 (HZ) TO OPERATION (6)

FIGURE 71 (HZ) TO OPERATION (6)

FIGURE 71 (HZ) TO OPERATION (6)

FIGURE 71 (HZ) TO OPERATION (6)

FIGURE 71 (HZ) TO OPERATION (6)

- ★ All voltages are measured with a 10MΩ/2V DC electronic voltmeter.
- ★ Components having special characteristics are marked **!** and must be replaced with parts having specifications equal to those originally installed.
- ★ Schematic diagram is subject to change without notice.

- 電圧は、内部抵抗10MΩの電圧計で測定したものです。
- !印のある部品は、安全性確保部品を示しています。部品の交換が必要な場合、パーツリストに記載されている部品を使用してください。
- 本回路図は標準回路図です。改良のため予告なく変更することがございます。

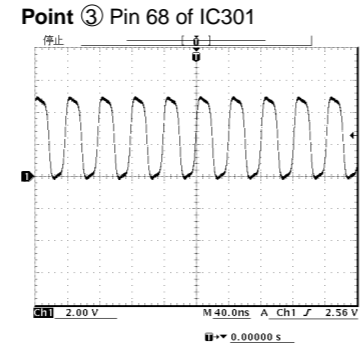
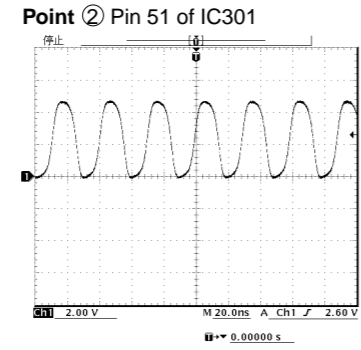

IC302-303, 307-310: FST3383MTC 10-Bit Low Power Bus-Exchange Switch

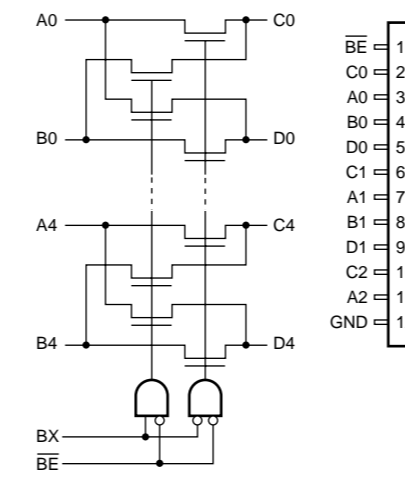

IC305: EP1K30TC144-3 FPGA

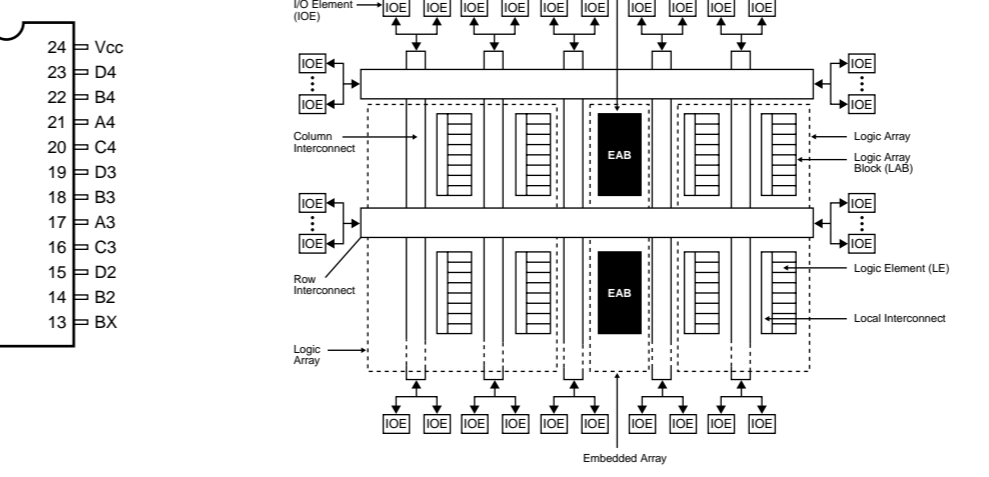

IC131: PQ070XZ5MZP Regulator

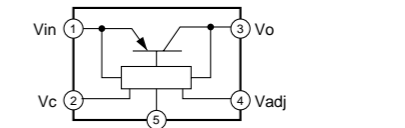

IC134: PQ025E5MZP Regulator

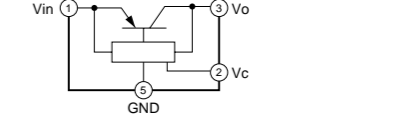

SCHEMATIC DIAGRAM (MAIN: CPU Block)

RESISTOR		CAPACITOR	
REMARKS	PARTS NAME	REMARKS	PARTS NAME
NO MARK	CARBON FILM RESISTOR (P#3)	NO MARK	ELECTROLYTIC CAPACITOR
△	CARBON FILM RESISTOR (P#10)	◎	TANTALUM CAPACITOR
□	METAL OXIDE FILM RESISTOR	⊖	CERAMIC TUBULAR CAPACITOR
○	METAL FILM RESISTOR	⊕	POLYESTER FILM CAPACITOR
◇	METAL PLATE RESISTOR	⊙	POLYETHYLENE FILM CAPACITOR
■	FILM PROOF CARBON FILM RESISTOR	⊖	MICA CAPACITOR
□	CEMENT MOUNTED RESISTOR	⊕	POLYPROPYLENE FILM CAPACITOR
◇	SEMI-VARIABLE RESISTOR	⊙	SEMICONDUCTIVE CERAMIC CAPACITOR
■	CHIP RESISTOR		

NOTICE (model)	
(J)	JAPAN
(U)	USA
(C)	CANADA
(R)	GENERAL
(I)	CHINA
(K)	KOREA
(A)	AUSTRALIA
(B)	BRITISH
(E)	EUROPE
(L)	SINGAPORE

IC110: 74LCX14MTCX Low Voltage Hex Inverter

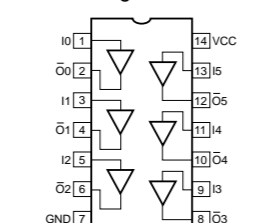

IC113-120: SN74LVCHR16245AGR 16-bit Bus Transceiver

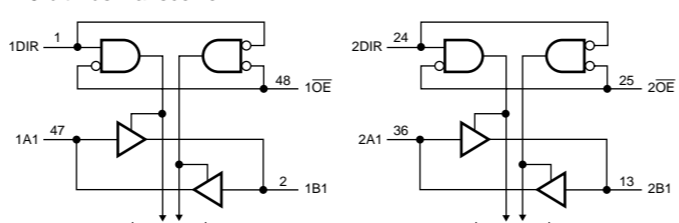

BUS BUFFER

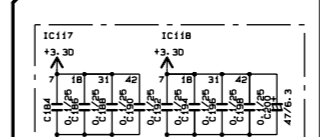
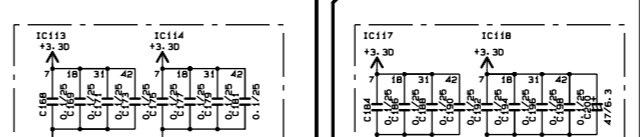

IC122: PQ018E201ZP Regulator

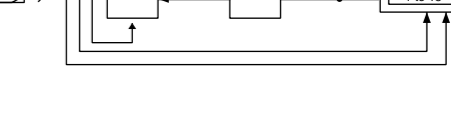
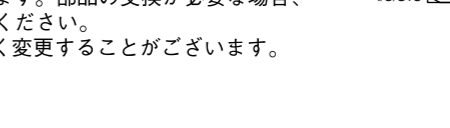
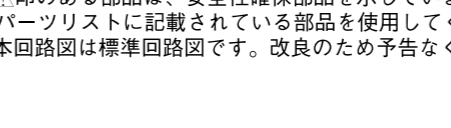
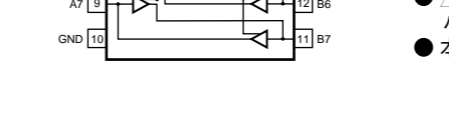
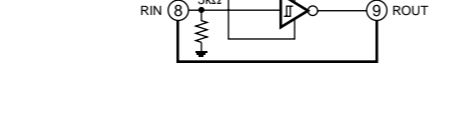
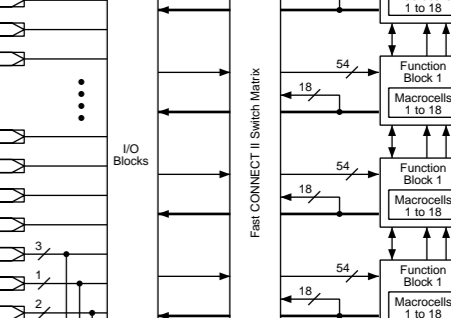
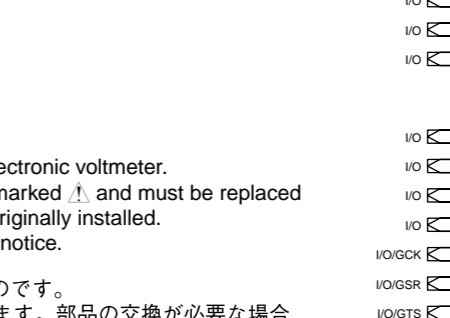
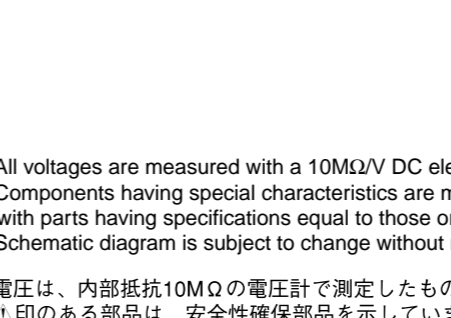
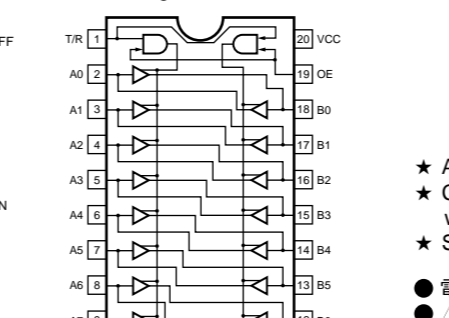
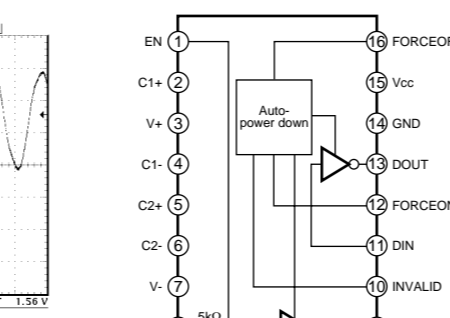
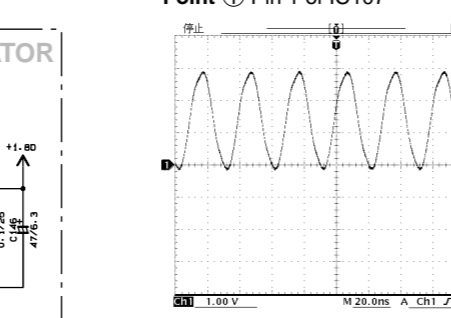
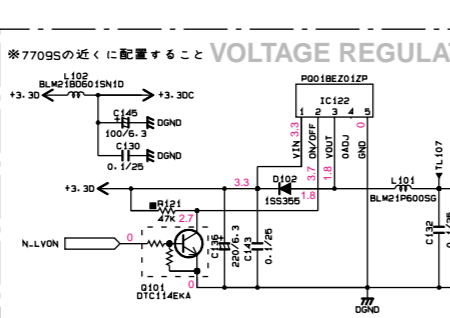
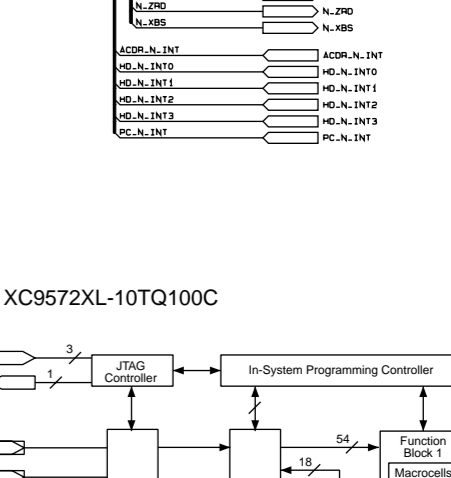
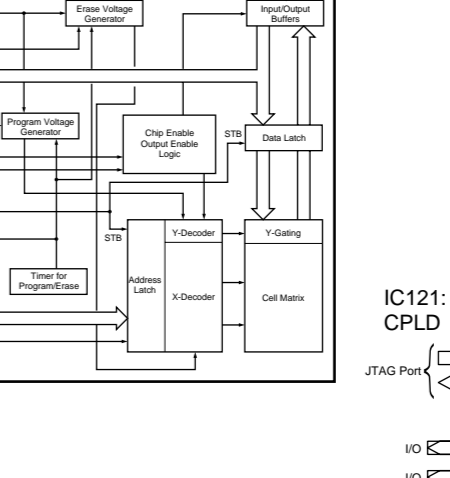
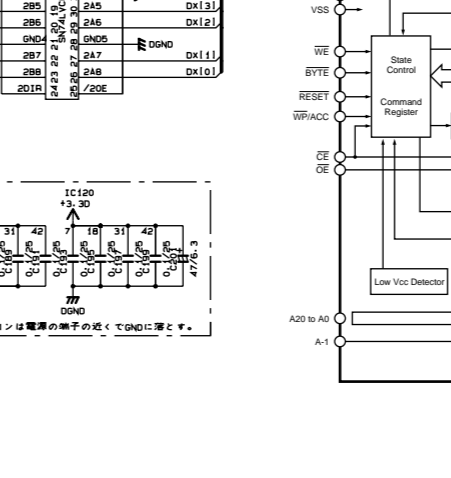
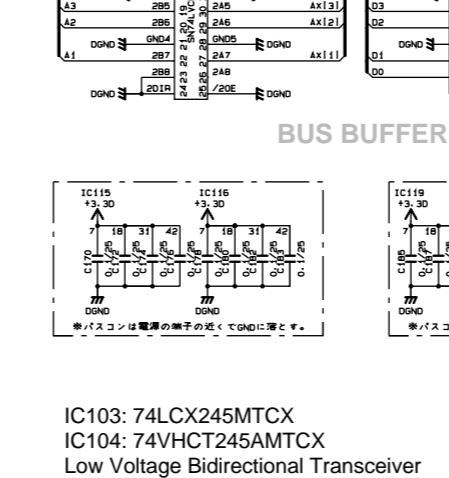
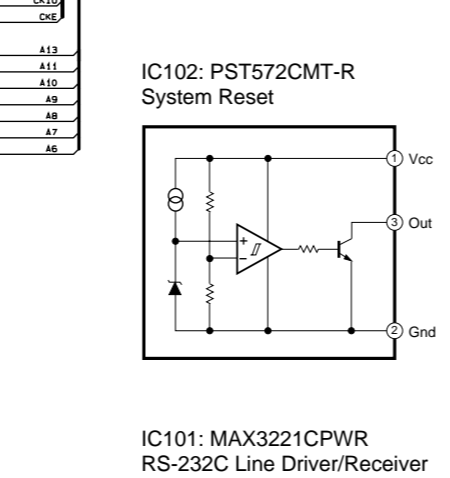
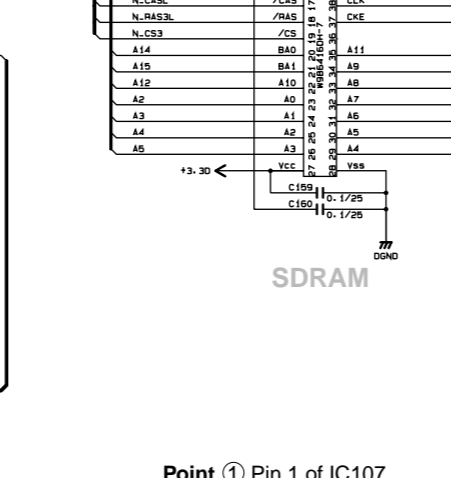
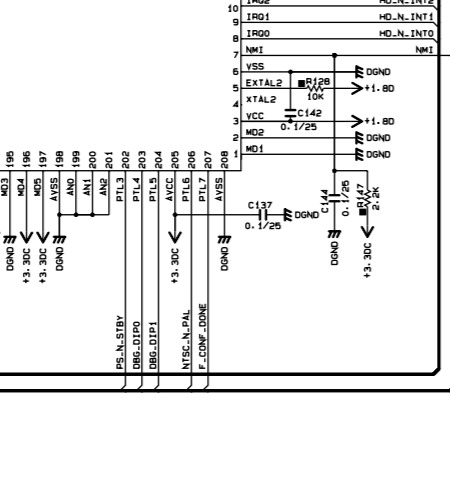
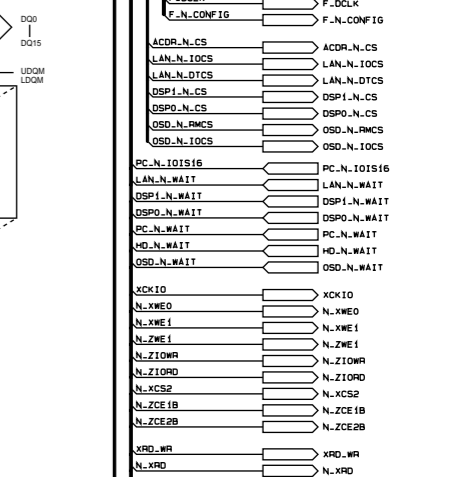
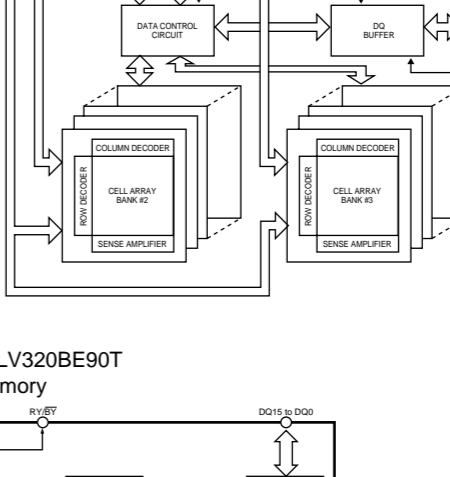
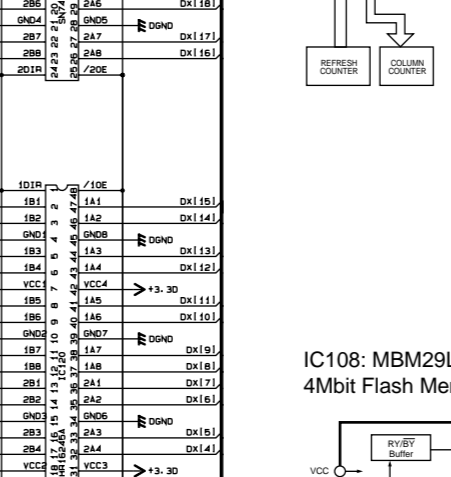
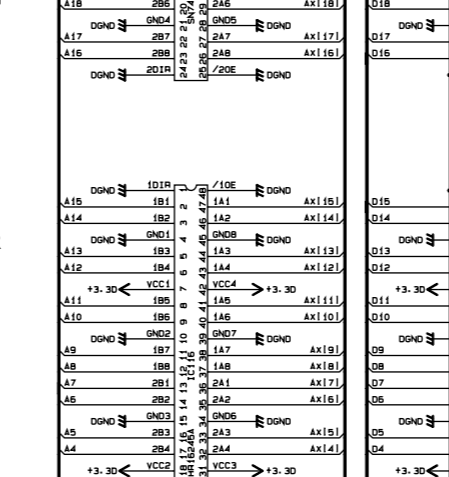
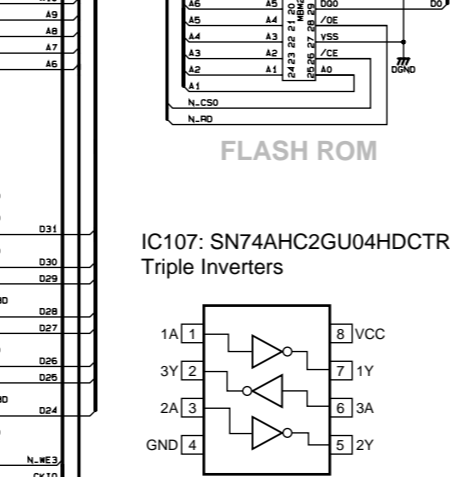
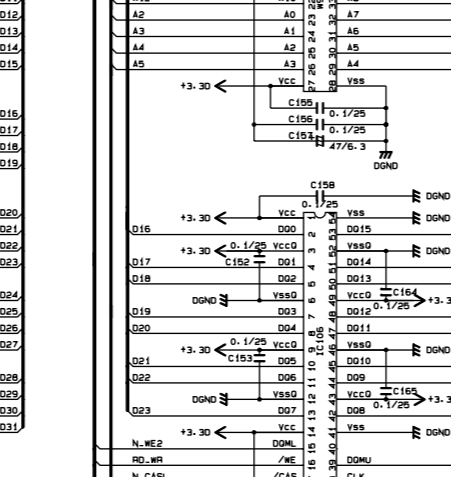
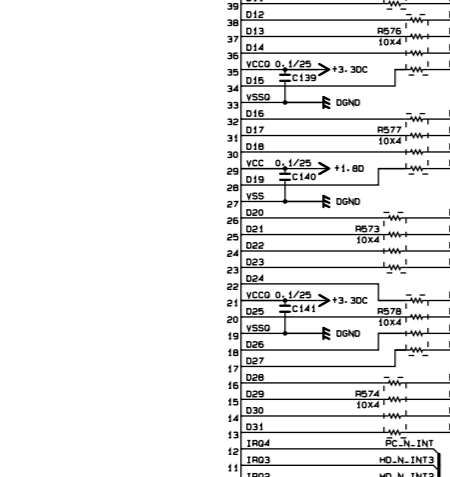
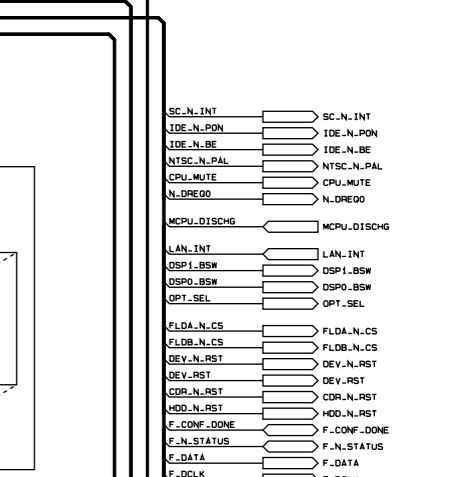
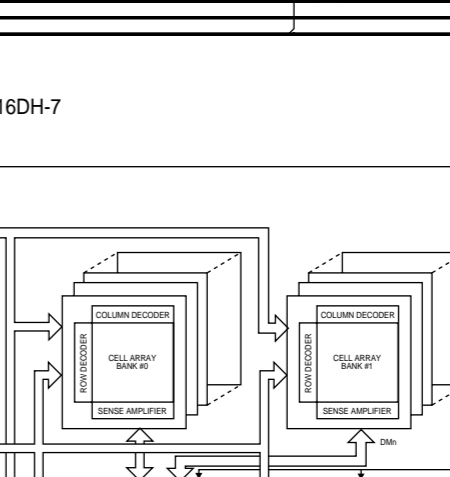
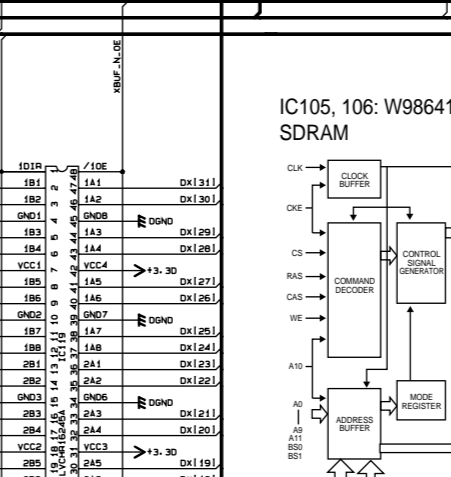
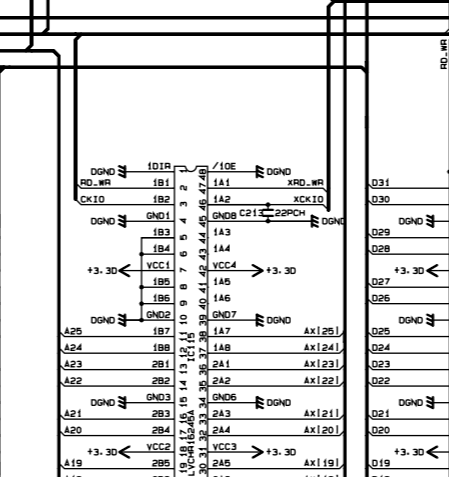
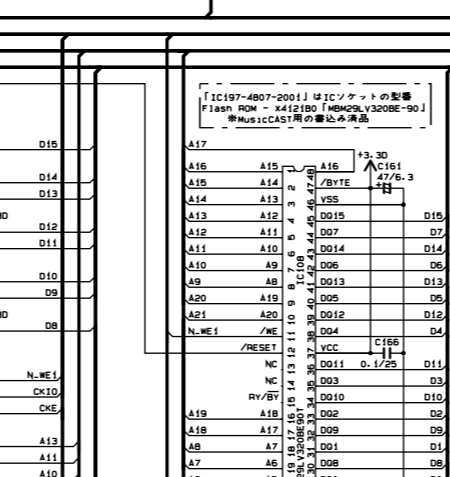
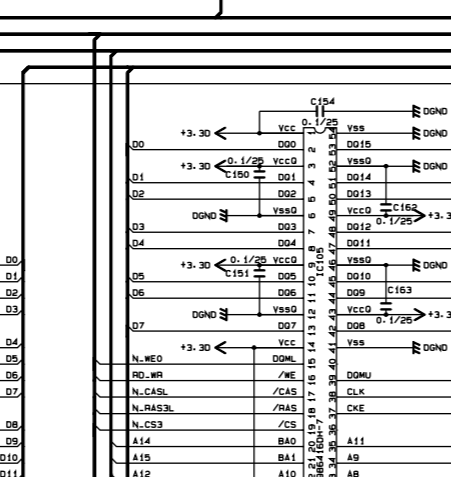
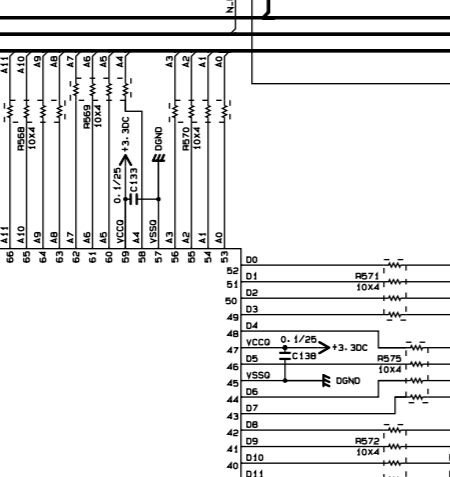
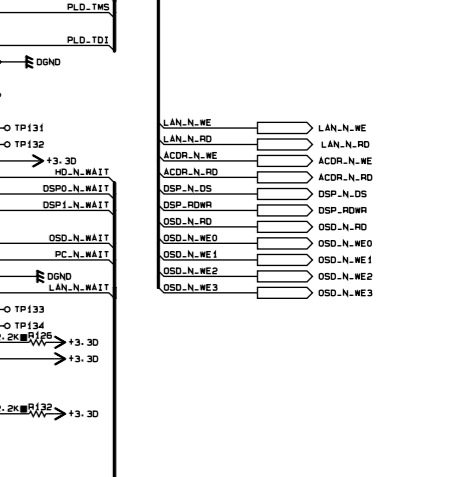
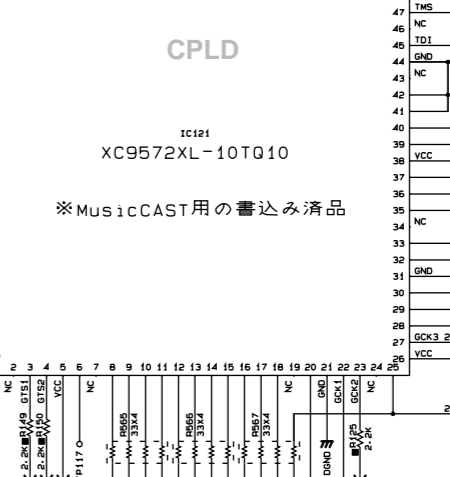
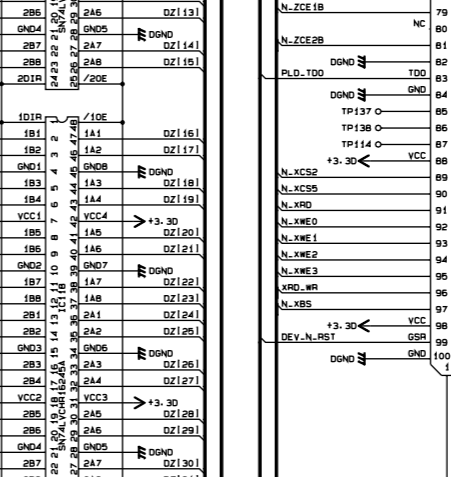
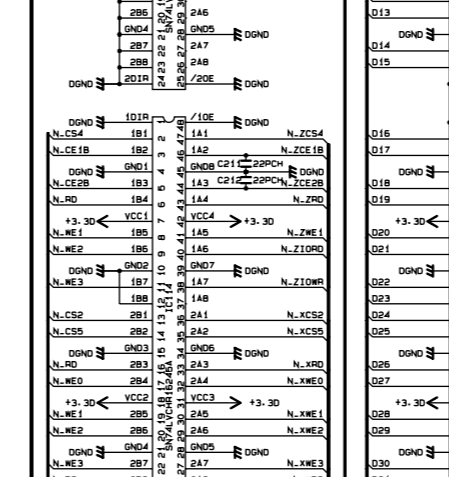
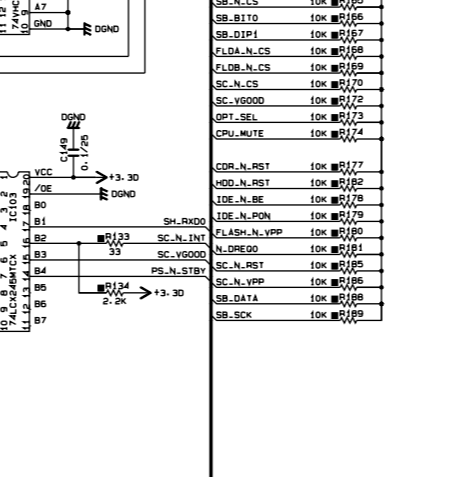
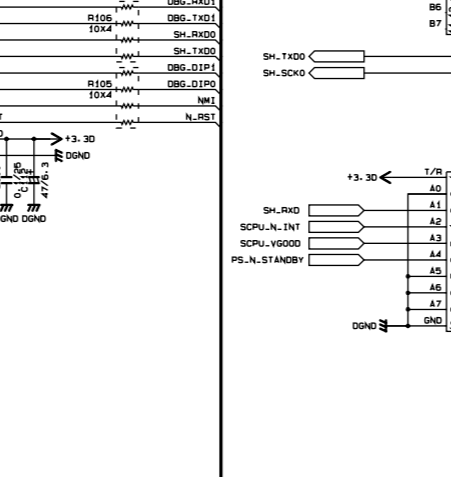
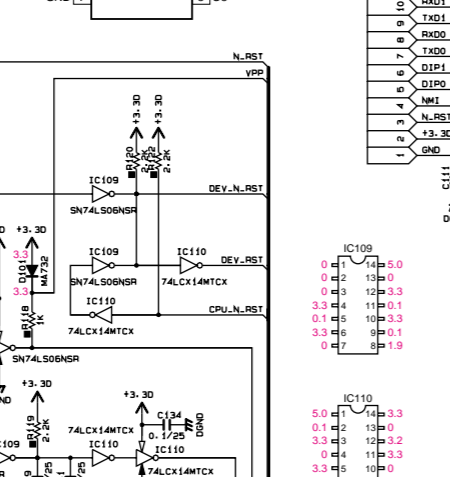
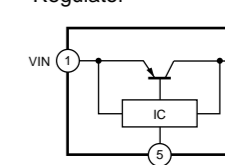

SCHEMATIC DIAGRAM (MAIN: Sub CPU Block)

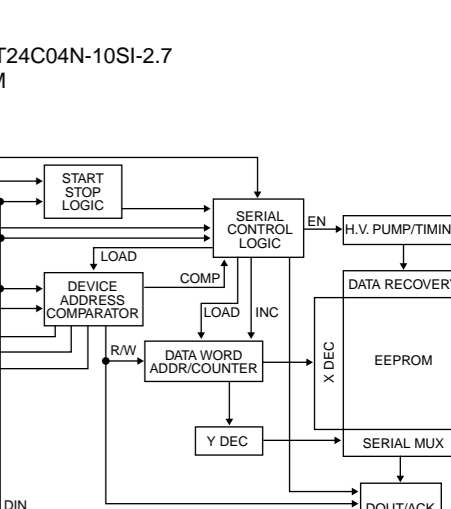
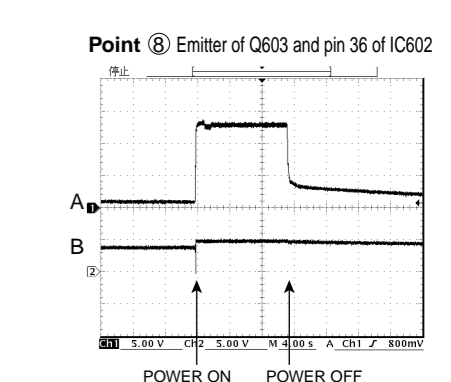
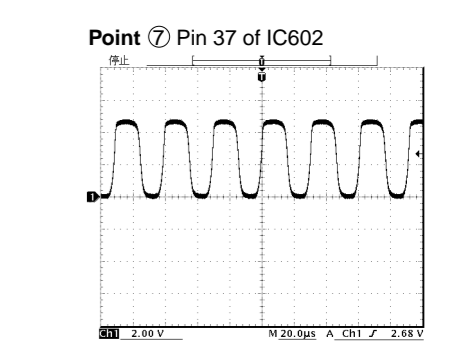
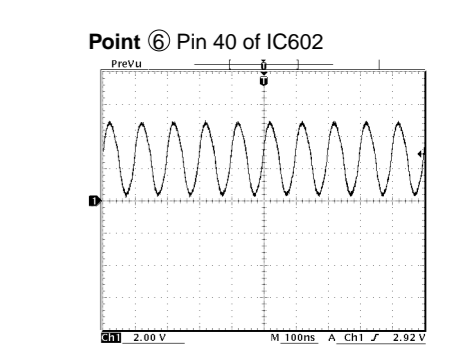
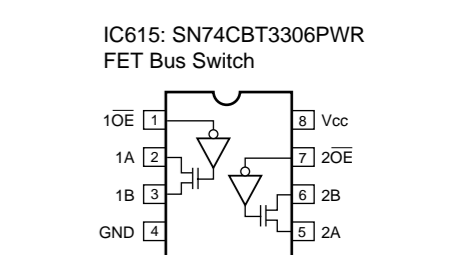
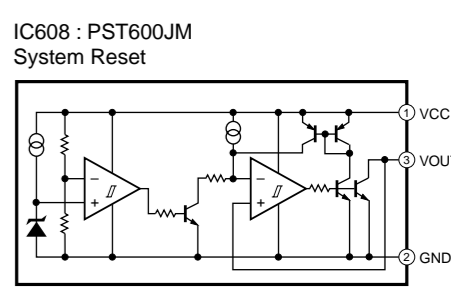
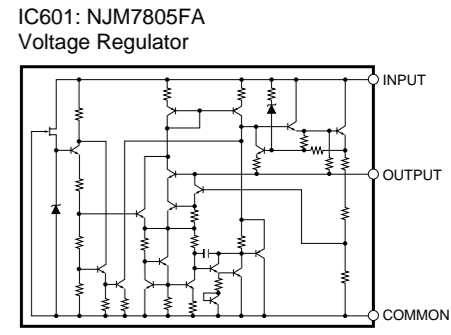
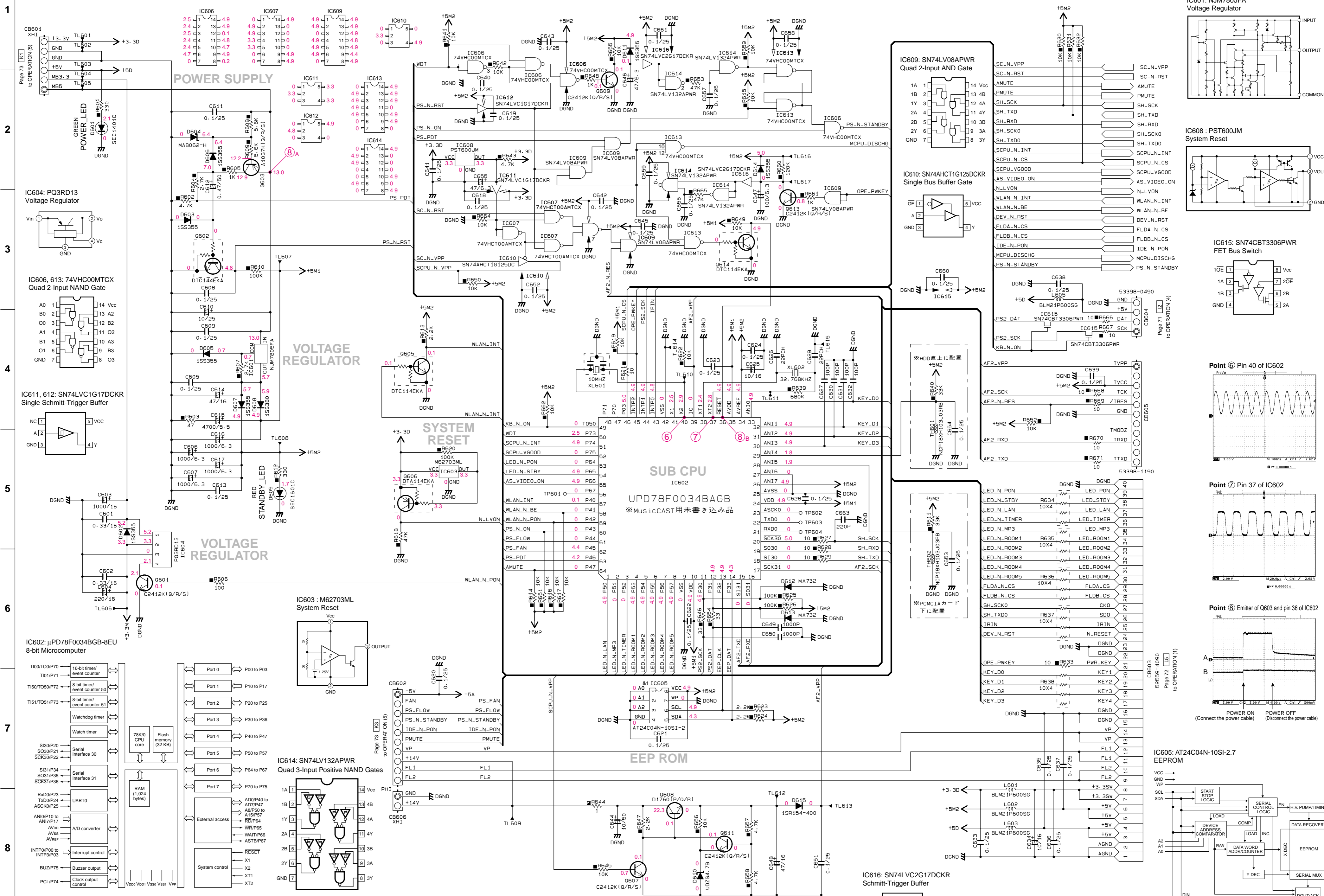

* All voltages are measured with a 10MΩ/V DC electronic voltmeter.
* Components having special characteristics are marked with a triangle and must be replaced with parts having specifications equal to those originally installed.
* Schematic diagram is subject to change without notice.

● 電圧は、内部抵抗10MΩの電圧計で測定したものです。
● ①印のある部品は、安全性確保部品を示しています。部品の交換が必要な場合、パーツリストに記載されている部品を使用してください。
● 本回路図は標準回路図です。改良のため予告なく変更することがございます。

Mark	Reference Parts Number	Parts Name
⊠1	IC605	AT24C04N-10SI-2.7 24LC04BT-1SN

SCHEMATIC DIAGRAM (MAIN: NETWORK Block)

Point ⑤ Pin 127 of IC501

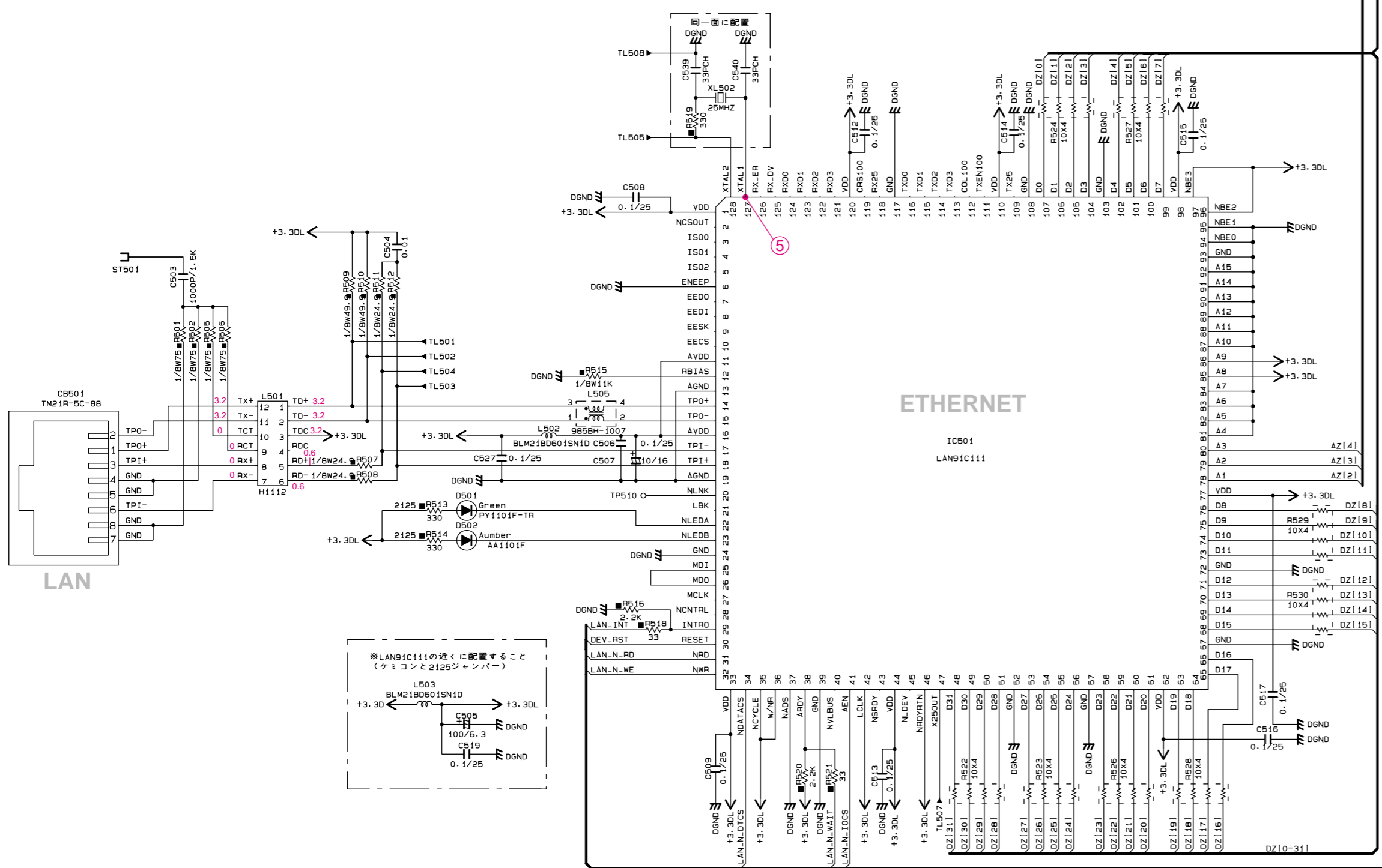
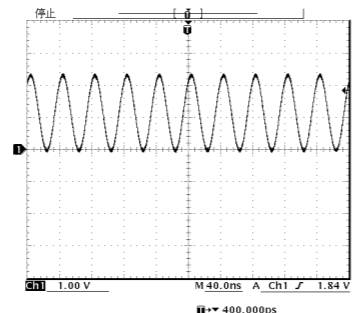

ETHERNET
IC501
LAN91C111

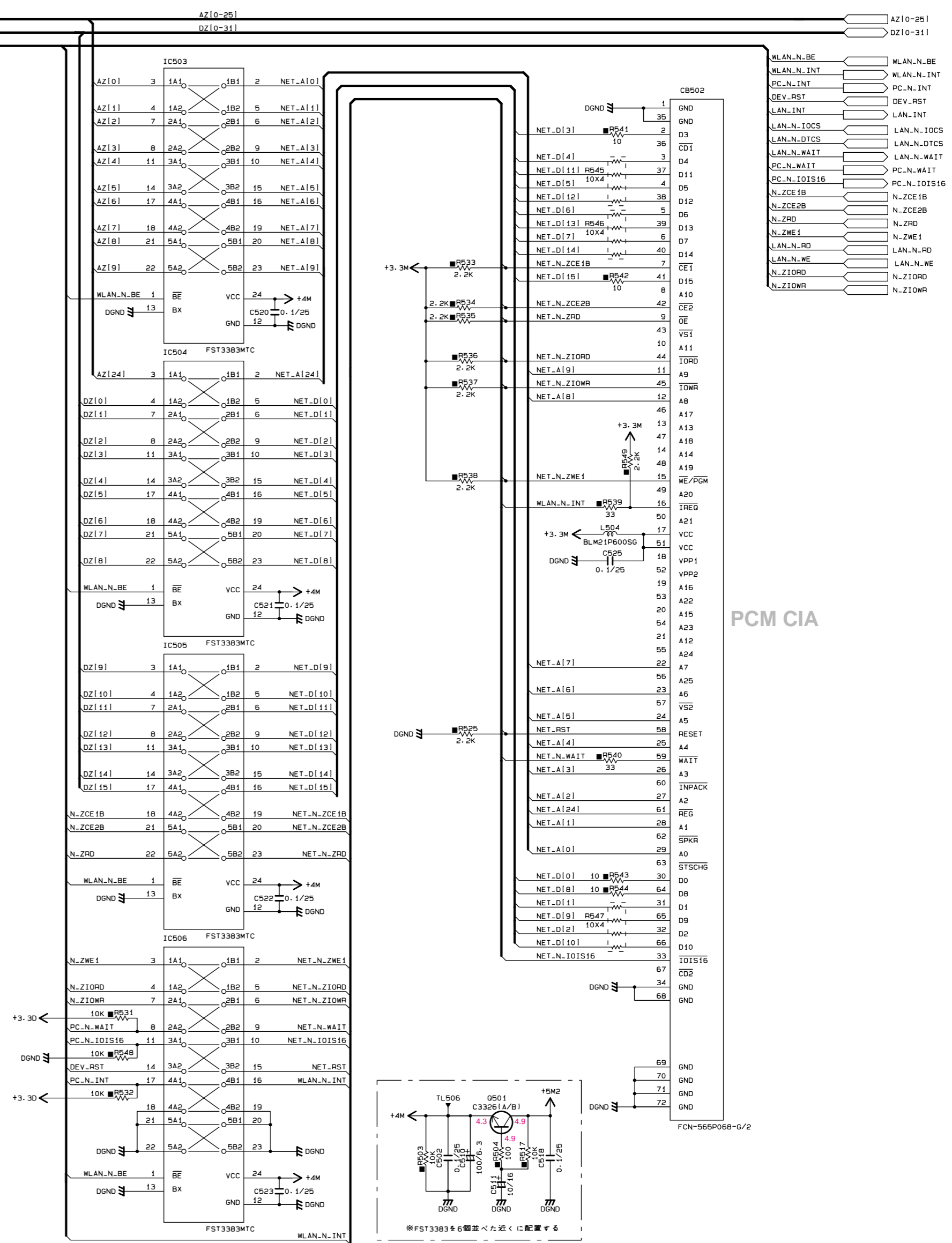

PCM CIA

LAN

IC503-506: FST3383MTC
10-Bit Low Power Bus-Exchange Switch

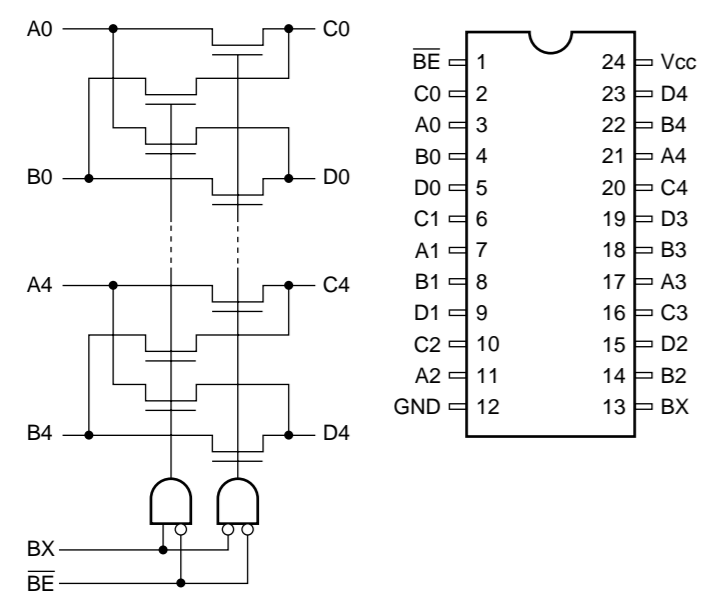

★ All voltages are measured with a 10MΩ/V DC electronic voltmeter.
★ Components having special characteristics are marked ⚠ and must be replaced with parts having specifications equal to those originally installed.
★ Schematic diagram is subject to change without notice.

● 電圧は、内部抵抗10MΩの電圧計で測定したものです。
● ⚠印のある部品は、安全性確保部品を示しています。部品の交換が必要な場合、パーツリストに記載されている部品を使用してください。
● 本回路図は標準回路図です。改良のため予告なく変更することがございます。

SCHEMATIC DIAGRAM (OPERATION 1/3)

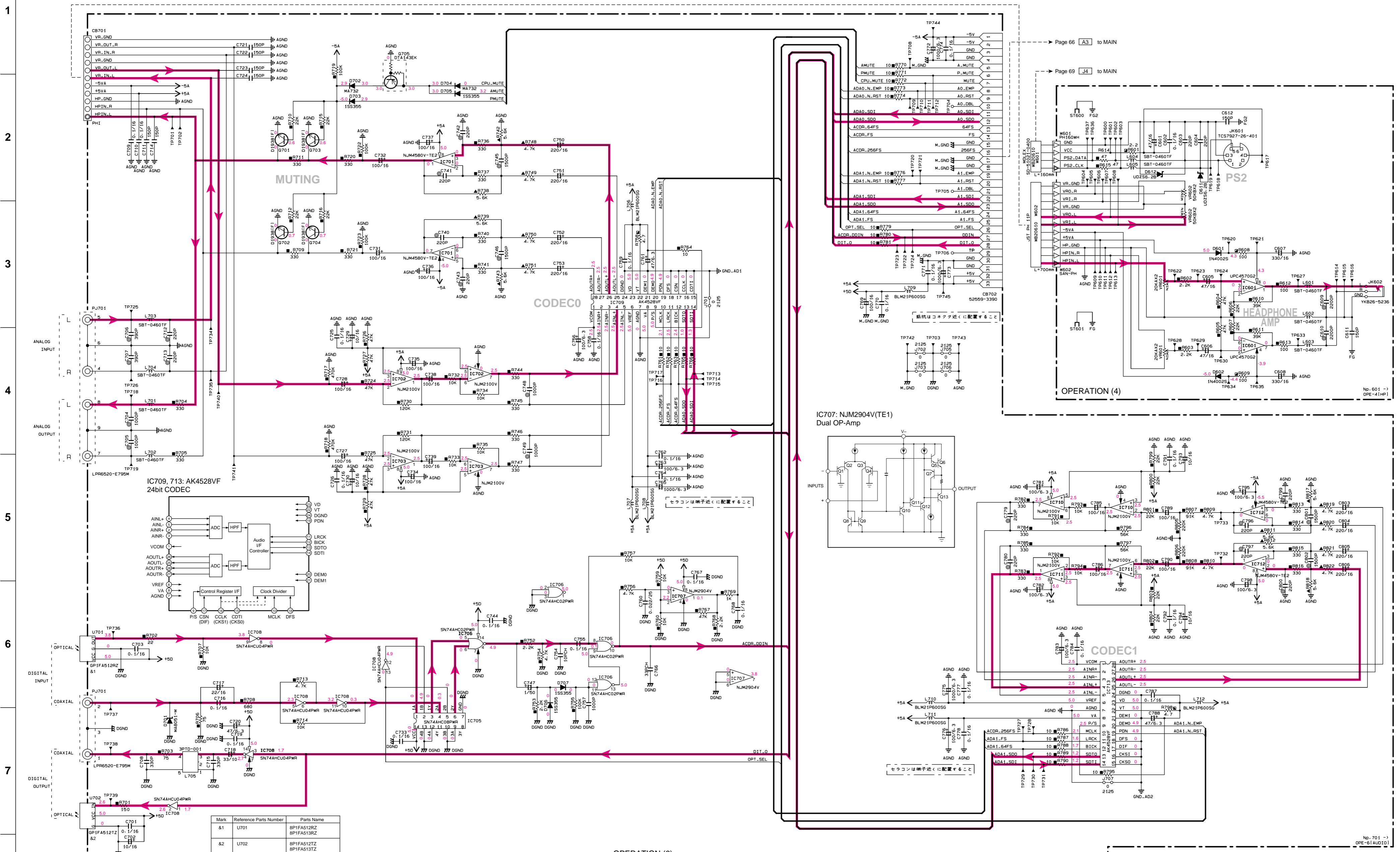

Mark	Reference	Parts Number	Parts Name
81	U701	8P1FA512RZ 8P1FA513RZ	
82	U702	8P1FA512TZ 8P1FA513TZ	

IC601: μPC4570G2
IC701, 712: NJM4580V-TE2
IC702, 703, 710, 711: NJM2100V
Dual OP-Amp

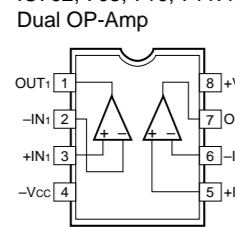

IC705: SN74AHC08PWR
Quad 2-Input AND Gate

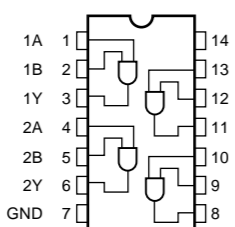

IC706: SN74AHC02PWR
Quad 2 Input NOR Gates

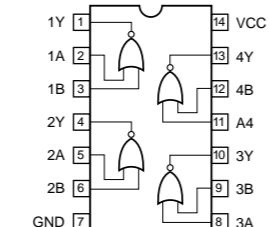

IC708: SN74AHC04PWR
Hex Inverters

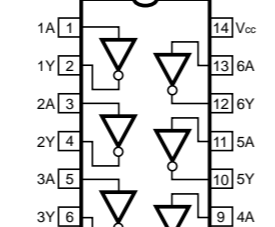

OPERATION (6)

IC707: NJM2904V(TE1)
Dual OP-Amp

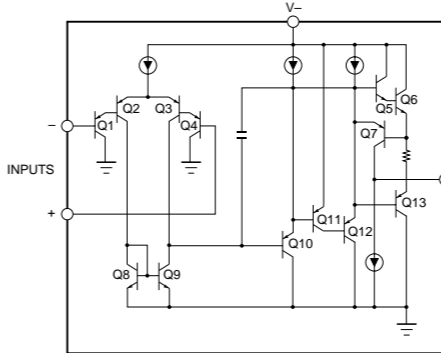

OPERATION (4)

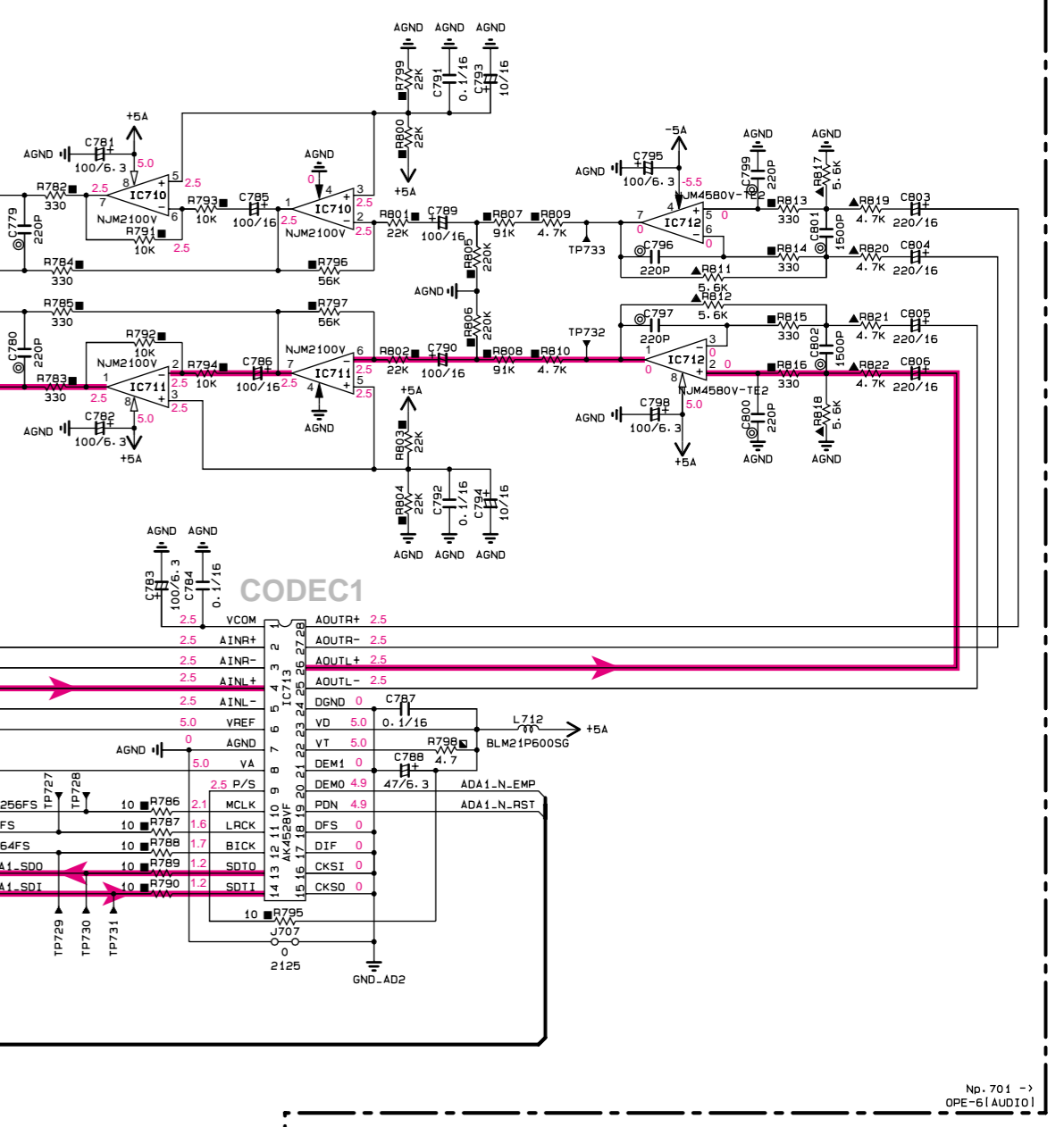

- ★ All voltages are measured with a 10MΩ/V DC electronic voltmeter.
 - ★ Components having special characteristics are marked with a triangle symbol and must be replaced with parts having specifications equal to those originally installed.
 - ★ Schematic diagram is subject to change without notice.
- 電圧は、内部抵抗10MΩの電圧計で測定したものです。
 ● 印のある部品は、安全性確保部品を示しています。部品の交換が必要な場合、パーツリストに記載されている部品を使用してください。
 ● 本回路図は標準回路図です。改良のため予告なく変更することがございます。

SCHEMATIC DIAGRAM (OPERATION 2/3)

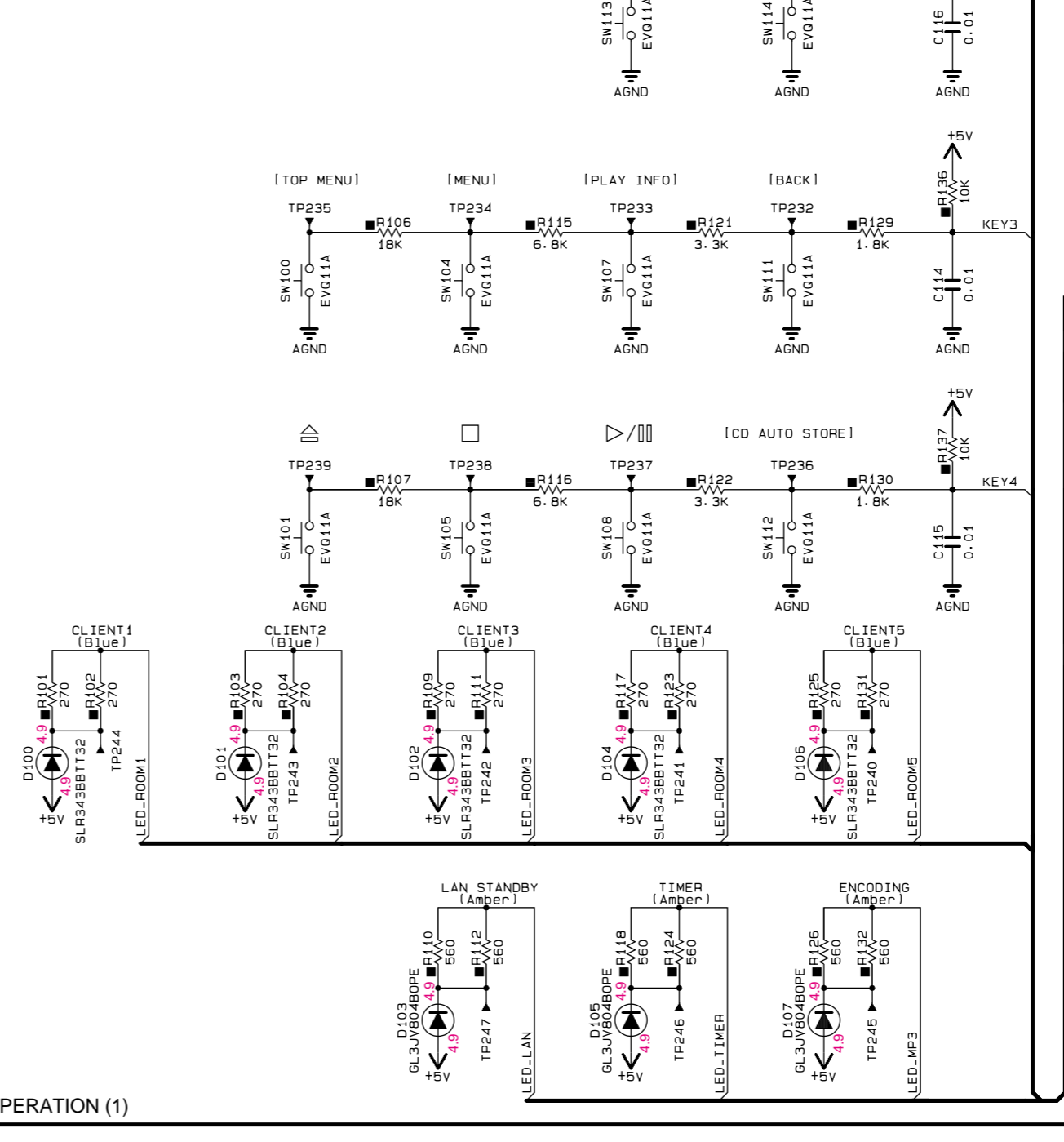
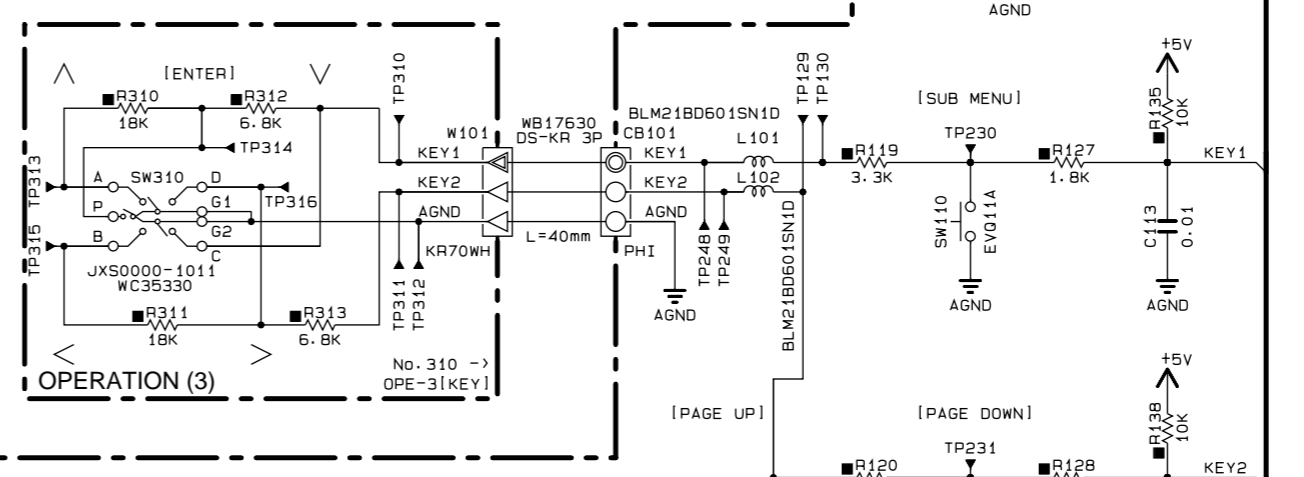
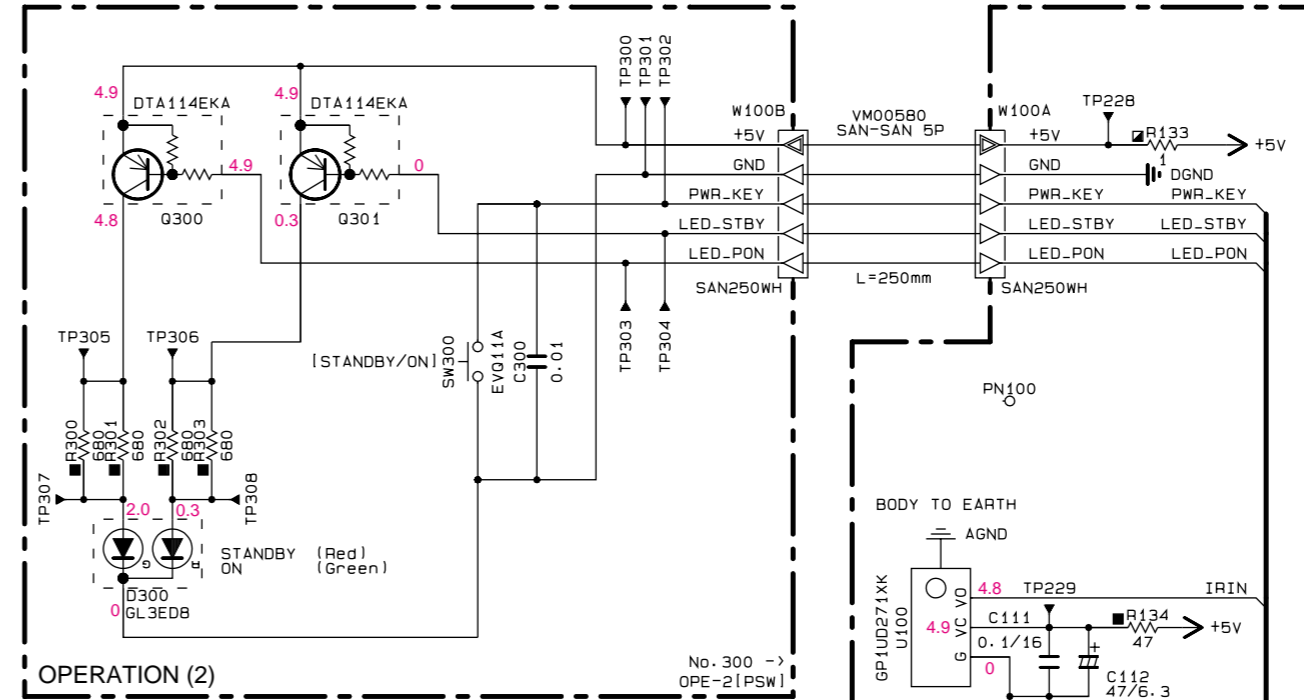
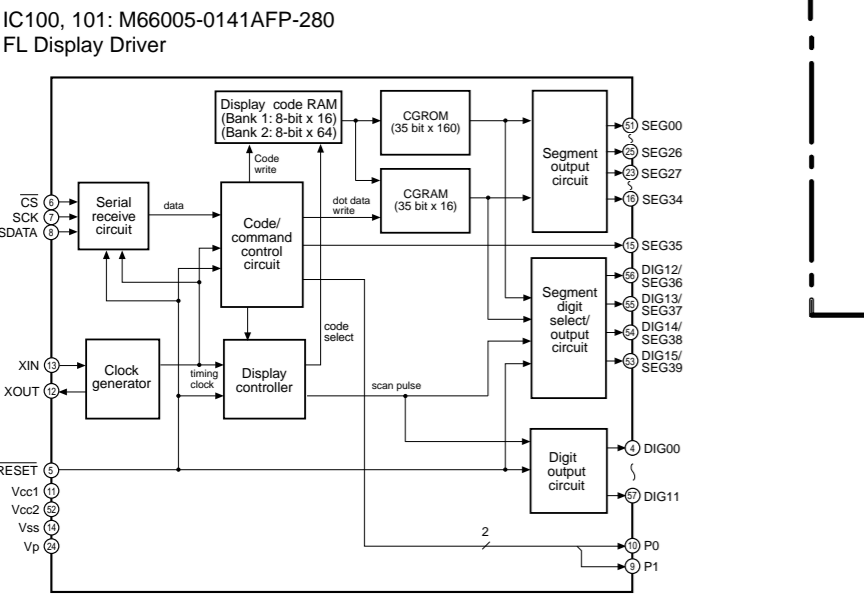
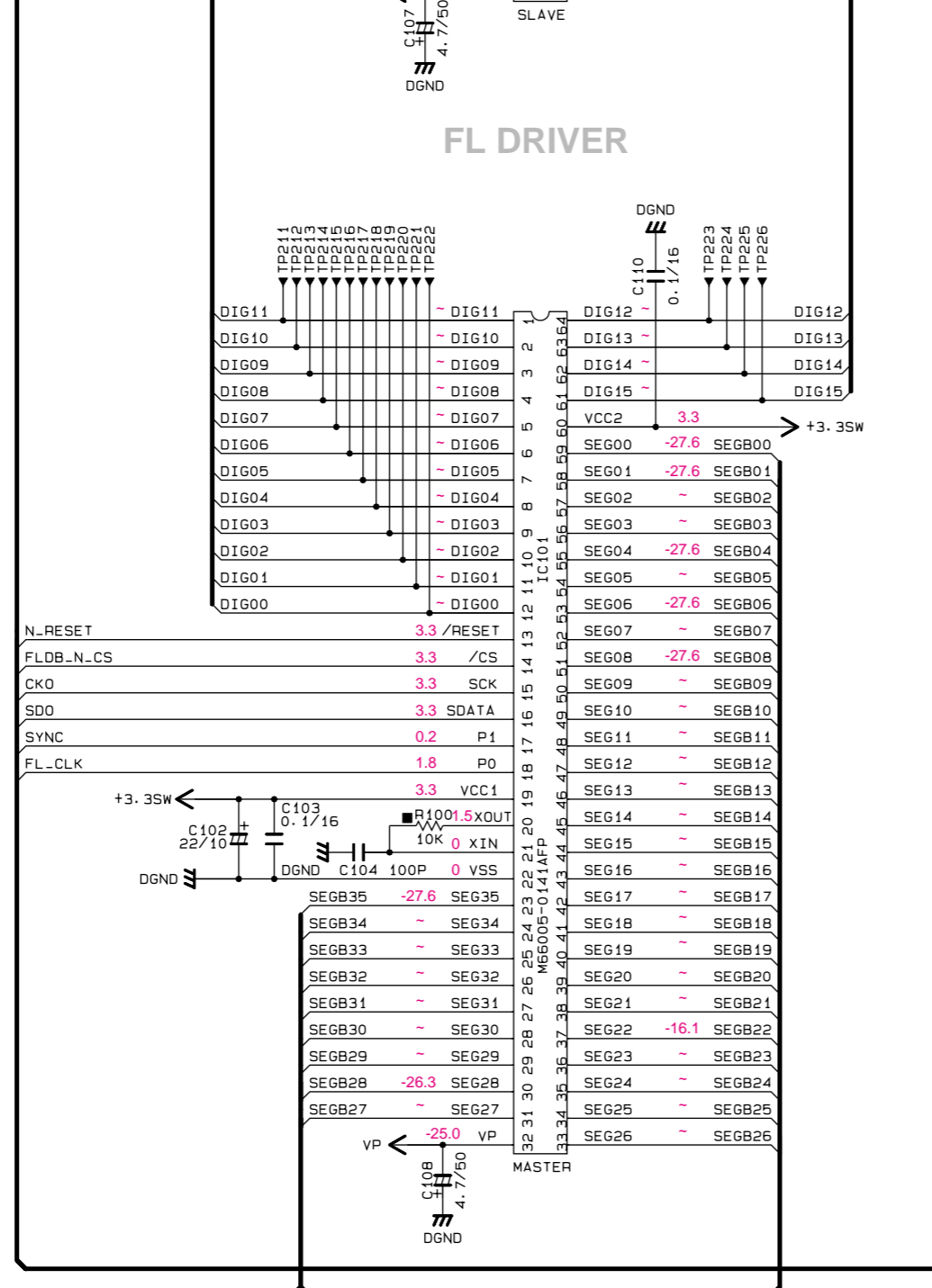
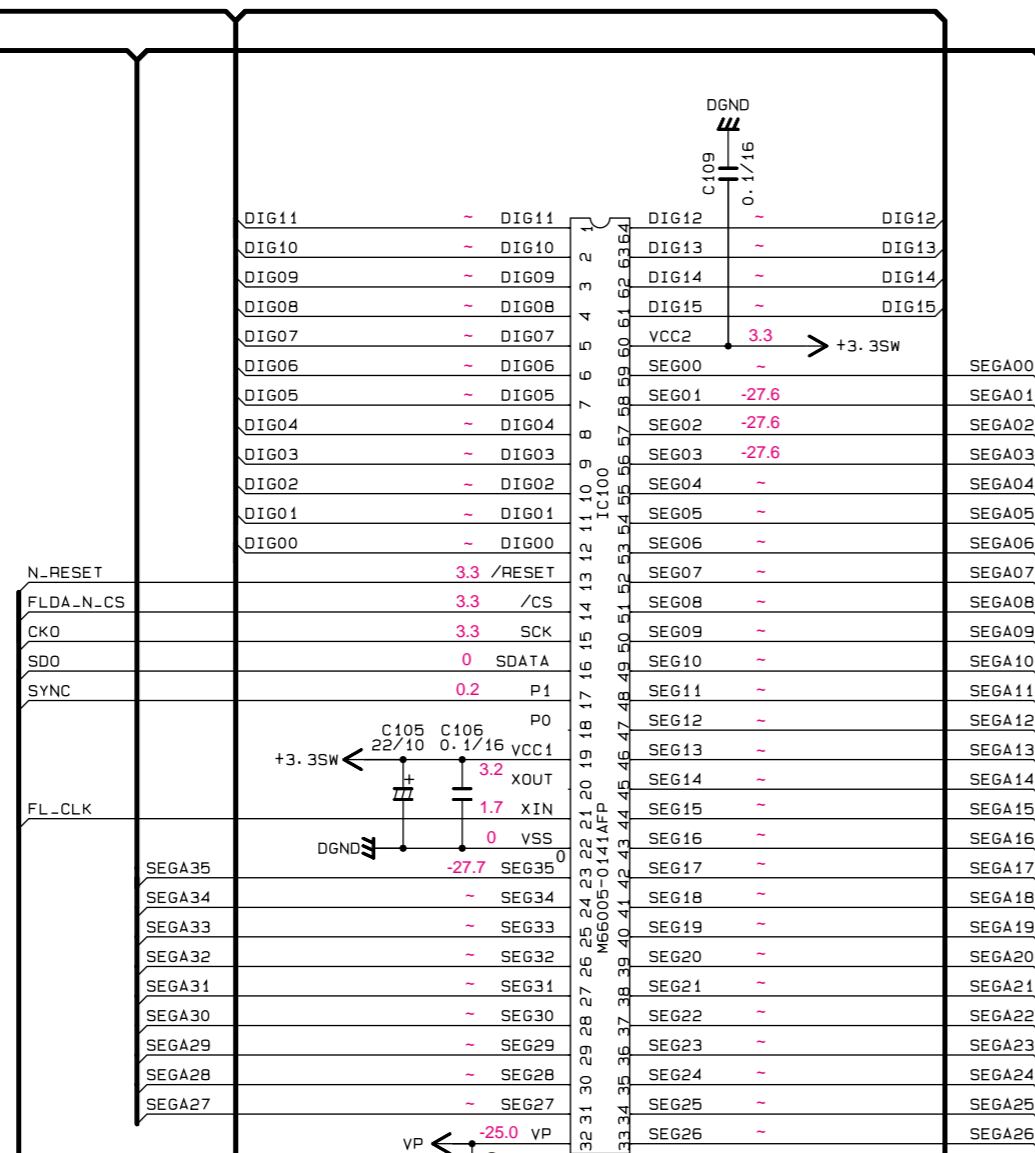
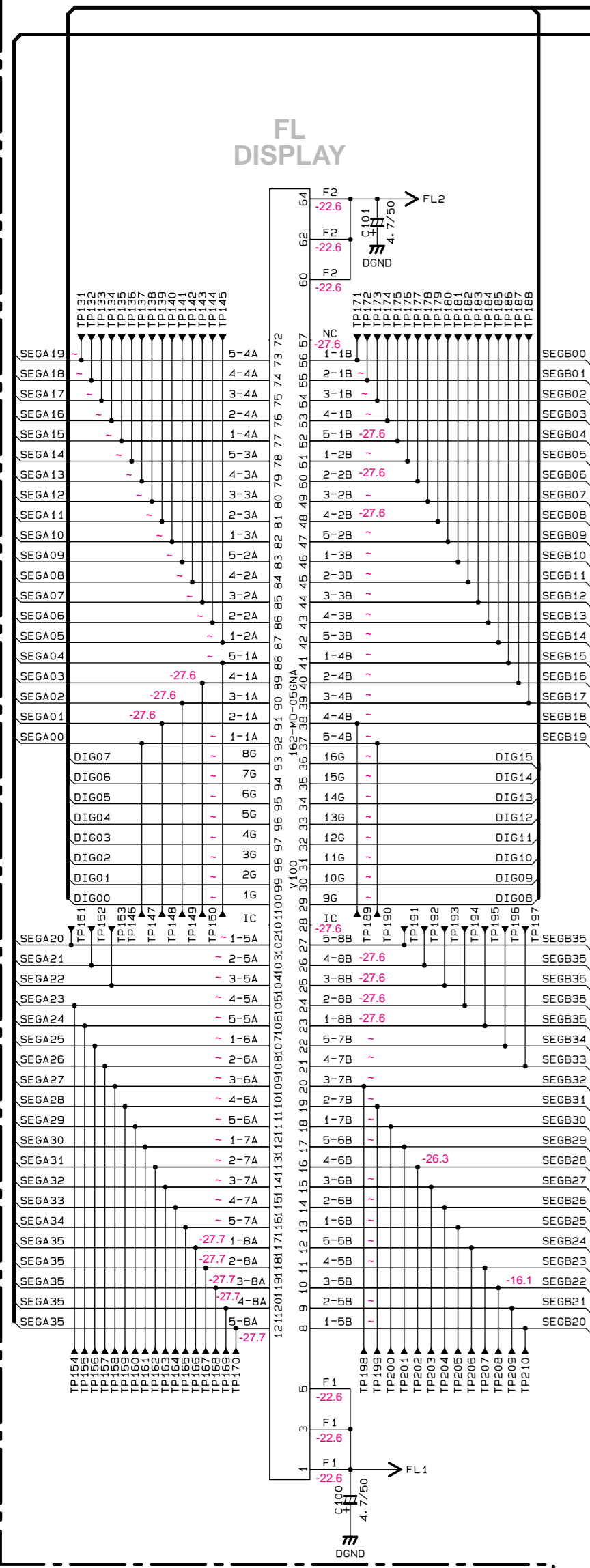

REMARKS	PARTS NAME
NO MARK	CARBON FILM RESISTOR (P=5)
☑	CARBON FILM RESISTOR (P=10)
△	METAL OXIDE FILM RESISTOR
▲	METAL FILM RESISTOR
⊠	METAL PLATE RESISTOR
⊞	FIRE PROOF CARBON FILM RESISTOR
⊞	CEMENT MOLDED RESISTOR
⊞	SEMI VARIABLE RESISTOR
⊞	CHIP RESISTOR

REMARKS	PARTS NAME
NO MARK	ELECTROLYTIC CAPACITOR
⊗	TANTALUM CAPACITOR
NO MARK	CERAMIC CAPACITOR
⊙	CERAMIC TUBULAR CAPACITOR
⊙	POLYESTER FILM CAPACITOR
⊙	POLYSTYRENE FILM CAPACITOR
⊙	MICA CAPACITOR
⊙	POLYPROPYLENE FILM CAPACITOR
⊙	SEMICONDUCTIVE CERAMIC CAPACITOR

NOTICE (model)
 (J)..... JAPAN
 (U)..... U.S.A
 (C)..... CANADA
 (R)..... GENERAL
 (T)..... CHINA
 (K)..... KOREA
 (A)..... AUSTRALIA
 (B)..... BRITISH
 (G)..... EUROPE
 (L)..... SINGAPORE

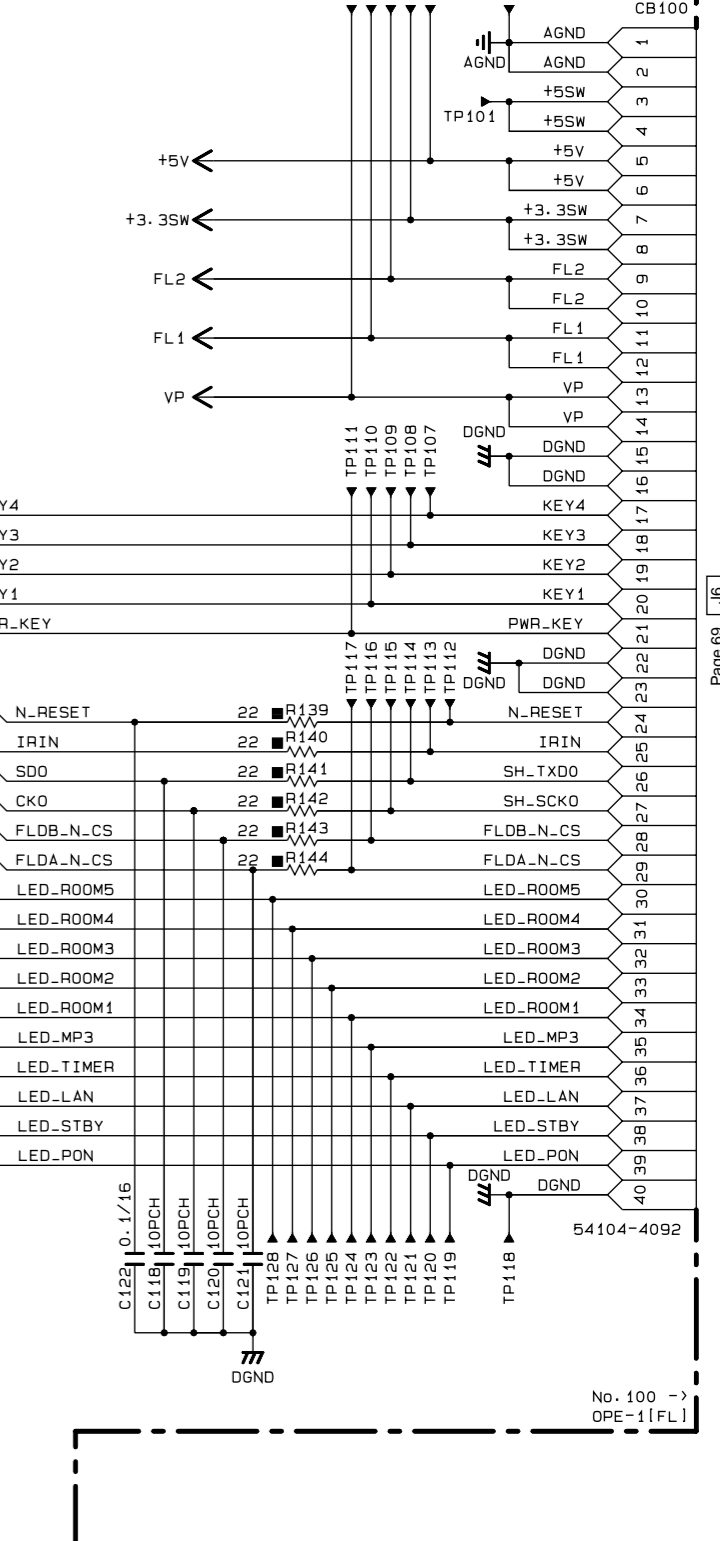

★ All voltages are measured with a 10MΩ/V DC electronic voltmeter.
 ★ Components having special characteristics are marked !, and must be replaced with parts having specifications equal to those originally installed.
 ★ Schematic diagram is subject to change without notice.
 ● 電圧は、内部抵抗10MΩの電圧計で測定したものです。
 ● !印のある部品は、安全性確保部品を示しています。部品の交換が必要な場合、パーツリストに記載されている部品を使用してください。
 ● 本回路図は標準回路図です。改良のため予告なく変更することがございます。

SCHEMATIC DIAGRAM (OPERATION 3/3)

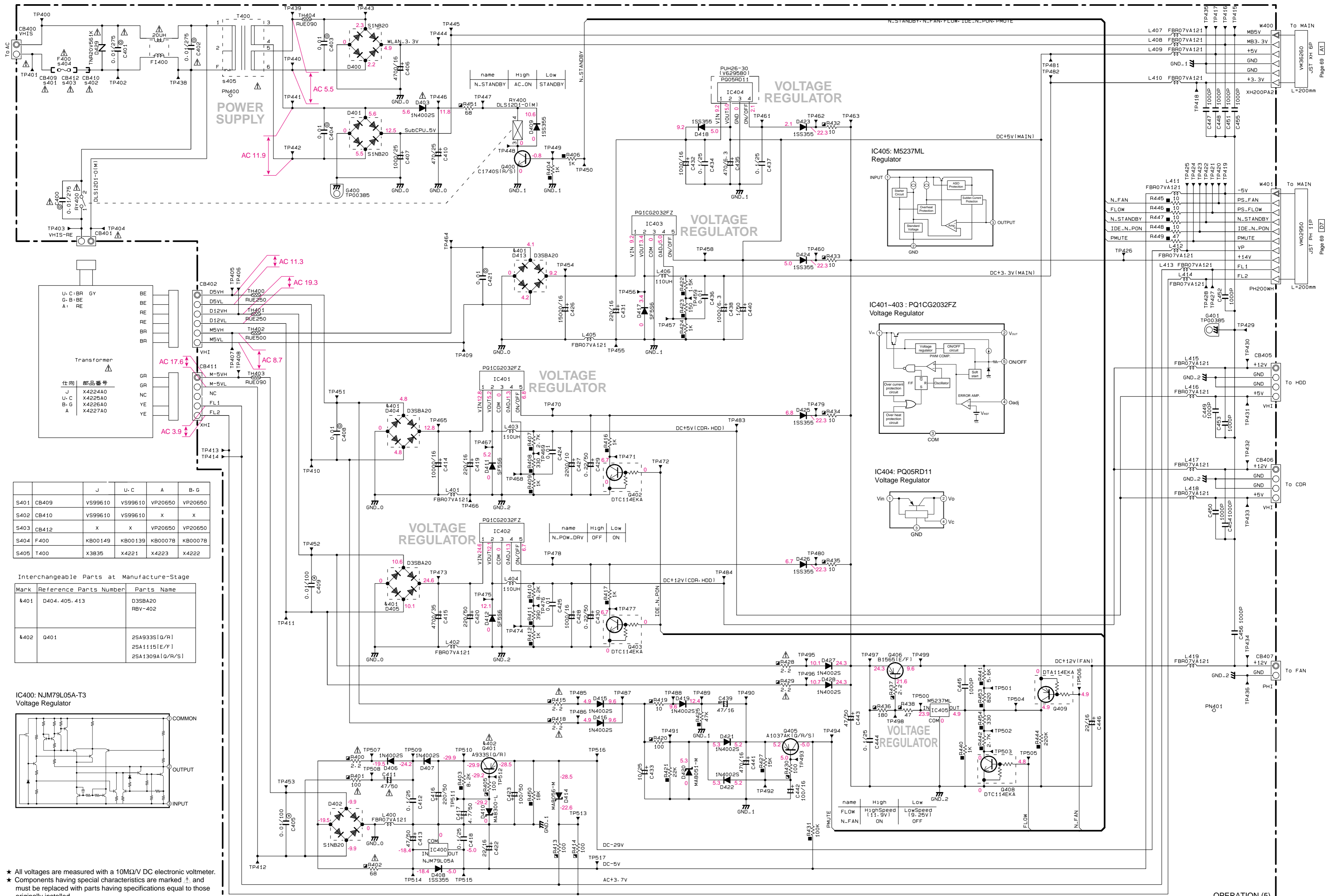

	J	U.C	A	B.G
S401	CB409	VS99610	VP20650	VP20650
S402	CB410	VS99610	X	X
S403	CB412	X	VP20650	VP20650
S404	F400	KB00149	KB00139	KB0007B
S405	T400	X3835	X4221	X4223

Interchangeable Parts at Manufacture-Stage

Mark	Reference Parts Number	Parts Name
k401	D404.405.413	D3SBA20 RBV-402
k402	0401	2SA933S1Q/R1 2SA1115E/F1 2SA1309A1Q/R/S1

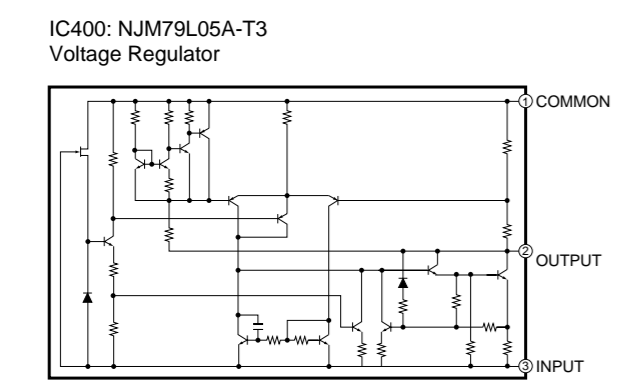

- * All voltages are measured with a 10MΩ/V DC electronic voltmeter.
- * Components having special characteristics are marked Δ and must be replaced with parts having specifications equal to those originally installed.
- * Schematic diagram is subject to change without notice.

- 電圧は、内部抵抗10MΩの電圧計で測定したものです。
- Δ 印のある部品は、安全性確保部品を示しています。部品の交換が必要な場合、パーツリストに記載されている部品を使用してください。
- 本回路図は標準回路図です。改良のため予告なく変更することがございます。

PARTS LIST

■ ELECTRICAL PARTS

■ WARNING

● Components having special characteristics are marked  and must be replaced with parts having specifications equal to those originally installed.

● 印のある部分は、安全確保部品を示しています。部品の交換が必要な場合、パーツリストに記載されている部品を使用してください。

● 部品価格ランクは、予告なく変更することがあります。

ABBREVIATIONS IN THIS LIST ARE AS FOLLOWS:

C.A.EL.CHP	: CHIP ALUMI.ELECTROLYTIC CAP	L.EMIT	: LIGHT EMITTING MODULE
C.CE	: CERAMIC CAP	LED.DSPLY	: LED DISPLAY
C.CE.ARRAY	: CERAMIC CAP ARRAY	LED.INFRD	: LED,INFRARED
C.CE.CHP	: CHIP CERAMIC CAP	MODUL.RF	: MODULATOR,RF
C.CE.ML	: MULTILAYER CERAMIC CAP	PHOT.CPL	: PHOTO COUPLER
C.CE.M.CHP	: CHIP MULTILAYER CERAMIC CAP	PHOT.INTR	: PHOTO INTERRUPTER
C.CE.SAFTY	: RECOGNIZED CERAMIC CAP	PHOT.RFLCT	: PHOTO REFLECTOR
C.CE.TUBLR	: CERAMIC TUBULAR CAP	PIN.TEST	: PIN,TEST POINT
C.CE.SMI	: SEMI CONDUCTIVE CERAMIC CAP	PLST.RIVET	: PLASTIC RIVET
C.EL	: ELECTROLYTIC CAP	R.ARRAY	: RESISTOR ARRAY
C.MICA	: MICA CAP	R.CAR.	: CARBON RESISTOR
C.ML.FLM	: MULTILAYER FILM CAP	R.CAR.CHP	: CHIP RESISTOR
C.MP	: METALLIZED PAPER CAP	R.CAR.FP	: FLAME PROOF CARBON RESISTOR
C.MYLAR	: MYLAR FILM CAP	R.FUS	: FUSABLE RESISTOR
C.MYLAR.ML	: MULTILAYER MYLAR FILM CAP	R.MTL.CHP	: CHIP METAL FILM RESISTOR
C.PAPER	: PAPER CAPACITOR	R.MTL.FLM	: METAL FILM RESISTOR
C.PLS	: POLYSTYRENE FILM CAP	R.MTL.OXD	: METAL OXIDE FILM RESISTOR
C.POL	: POLYESTER FILM CAP	R.MTL.PLAT	: METAL PLATE RESISTOR
C.POLY	: POLYETHYLENE FILM CAP	RSNR.CE	: CERAMIC RESONATOR
C.PP	: POLYPROPYLENE FILM CAP	RSNR.CRYS	: CRYSTAL RESONATOR
C.TNTL	: TANTALUM CAP	R.TW.CEM	: TWIN CEMENT FIXED RESISTOR
C.TNTL.CHP	: CHIP TANTALUM CAP	R.WW	: WIRE WOUND RESISTOR
C.TRIM	: TRIMMER CAP	SCR.BND.HD	: BIND HEAD B-TITE SCREW
CN	: CONNECTOR	SCR.BW.HD	: BW HEAD TAPPING SCREW
CN.BS.PIN	: CONNECTOR,BASE PIN	SCR.CUP	: CUP TITE SCREW
CN.CANNON	: CONNECTOR,CANNON	SCR.TERM	: SCREW TERMINAL
CN.DIN	: CONNECTOR,DIN	SCR.TR	: SCREW,TRANSISTOR
CN.FLAT	: CONNECTOR,FLAT CABLE	SUPRT.PCB	: SUPPORT,P.C.B.
CN.POST	: CONNECTOR,BASE POST	SURG.PRTCT	: SURGE PROTECTOR
COIL.MX.AM	: COIL,AM MIX	SW.TACT	: TACT SWITCH
COIL.AT.FM	: COIL,FM ANTENNA	SW.LEAF	: LEAF SWITCH
COIL.DT.FM	: COIL,FM DETECT	SW.LEVER	: LEVER SWITCH
COIL.MX.FM	: COIL,FM MIX	SW.MICRO	: MICRO SWITCH
COIL.OUTPT	: OUTPUT COIL	SW.PUSH	: PUSH SWITCH
DIOD.ARRAY	: DIODE ARRAY	SW.RT.ENC	: ROTARY ENCODER
DIODE.BRG	: DIODE BRIDGE	SW.RT.MTR	: ROTARY SWITCH WITH MOTOR
DIODE.CHP	: CHIP DIODE	SW.RT	: ROTARY SWITCH
DIODE.VAR	: VARACTOR DIODE	SW.SLIDE	: SLIDE SWITCH
DIOD.Z.CHP	: CHIP ZENER DIODE	TERM.SP	: SPEAKER TERMINAL
DIODE.ZENR	: ZENER DIODE	TERM.WRAP	: WRAPPING TERMINAL
DSCR.CE	: CERAMIC DISCRIMINATOR	THRMST.CHP	: CHIP THERMISTOR
FER.BEAD	: FERRITE BEADS	TR.CHP	: CHIP TRANSISTOR
FER.CORE	: FERRITE CORE	TR.DGT	: DIGITAL TRANSISTOR
FET.CHP	: CHIP FET	TR.DGT.CHP	: CHIP DIGITAL TRANSISTOR
FL.DSPLY	: FLUORESCENT DISPLAY	TRANS	: TRANSFORMER
FLTR.CE	: CERAMIC FILTER	TRANS.PULS	: PULSE TRANSFORMER
FLTR.COMB	: COMB FILTER MODULE	TRANS.PWR	: POWER TRANSFORMER ASS'Y
FLTR.LC.RF	: LC FILTER,EMI	TUNER.AM	: TUNER PACK,AM
GND.MTL	: GROUND PLATE	TUNER.FM	: TUNER PACK,FM
GND.TERM	: GROUND TERMINAL	TUNER.PK	: FRONT-ENDTUNER PACK
HOLDER.FUS	: FUSE HOLDER	VR	: ROTARY POTENTIOMETER
IC.PRTCT	: IC PROTECTOR	VR.MTR	: POTENTIOMETER WITH MOTOR
JUMPER.CN	: JUMPER CONNECTOR	VR.SW	: POTENTIOMETER WITH ROTARY SW
JUMPER.TST	: JUMPER,TEST POINT	VR.SLIDE	: SLIDE POTENTIOMETER
L.DTCT	: LIGHT DETECTING MODULE	VR.TRIM	: TRIMMER POTENTIOMETER

Note) Those parts marked with “#” are not included in the P.C.B. ass'y.

P.C.B. OPERATION

Schm Ref.	PART NO.	Description	Remarks	Markets	部 品 名	Rank	
*	WB160900	P. C. B.	OPERATION		J	P C B オペレーション	
*	WB161000	P. C. B.	OPERATION		UC	P C B オペレーション	
*	WB161100	P. C. B.	OPERATION		A	P C B オペレーション	
*	WB161200	P. C. B.	OPERATION		BG	P C B オペレーション	
*	CB100	V9927100	CN. BS. PIN	40P SE		F F Cコネクター	
	CB101	VB389900	CN. BS. PIN	3P		ベースピン	01
	CB400	VG879900	CN. BS. PIN	2P		ベースピン	01
*	CB401	VV487400	CN. BS. PIN	2P		ベースツキポスト	01
	CB402	LB932060	CN. BS. PIN	6P		ベースポスト	01
	CB405	LB932040	CN. BS. PIN	4P		ベースポスト	01
	CB406	LB932040	CN. BS. PIN	4P		ベースポスト	01
	CB407	VB389800	CN. BS. PIN	2P		ベースピン	01
▲	CB409	VS996100	HOLDER. FUS	EYF64BC	JUC	ヒューズクリップ	01
▲	CB409	VP206500	HOLDER. FUS	EYF-52BCT	ABG	ヒューズホルダー	01
▲	CB410	VS996100	HOLDER. FUS	EYF64BC	JUC	ヒューズクリップ	01
	CB411	LB918050	CN. BS. PIN	5P		ベース付ポスト	01
▲	CB412	VP206500	HOLDER. FUS	EYF-52BCT	ABG	ヒューズホルダー	01
	CB701	VB390700	CN. BS. PIN	11P		コネクタベースポスト	01
*	CB702	V9864300	CN. BS. PIN	33P TE		F F Cコネクタ	
▲	C400	V6185300	C. CE. SAFTY	0.01uF 275V		規格認定コン	
▲	C401	V6185300	C. CE. SAFTY	0.01uF 275V		規格認定コン	
▲	C402	V6185300	C. CE. SAFTY	0.01uF 275V		規格認定コン	
	C403	UA654100	C. MYLAR	0.01uF 50V		マイラーコン	01
	C404	UA654100	C. MYLAR	0.01uF 50V		マイラーコン	01
	C405	UT654100	C. PP	0.01uF 100V		P Pコン	01
	C406	UR739470	C. EL	4700uF 16V		ケミコン	02
	C407	UR849100	C. EL	1000uF 25V		ケミコン	01
	C408	UA654100	C. MYLAR	0.01uF 50V		マイラーコン	01
	C409	UT654100	C. PP	0.01uF 100V		P Pコン	01
	C410	UR868470	C. EL	470uF 50V		ケミコン	01
▲	C411	UR867470	C. EL	47uF 50V		ケミコン	01
	C413	UR867470	C. EL	47uF 50V		ケミコン	01
*	C414	WB807300	C. EL	10000uF 16V		ケミコン	
*	C415	WB807500	C. EL	4700uF 35V		ケミコン	
	C416	UR868220	C. EL	220uF 50V		ケミコン	
	C417	UR866470	C. EL	4.7uF 50V		ケミコン	01
*	C419	WB807100	C. EL	220uF 16V		ケミコン	
*	C420	WB807600	C. EL	220uF 50V		ケミコン	
	C421	UA654100	C. MYLAR	0.01uF 50V		マイラーコン	01
	C422	UR837220	C. EL	22uF 16V		ケミコン	01
	C423	UR868100	C. EL	100uF 50V		ケミコン	01
*	C426	WB807400	C. EL	15000uF 16V		ケミコン	
*	C427	WB807000	C. EL	2200uF 10V		ケミコン	
*	C428	WB807200	C. EL	1000uF 16V		ケミコン	
	C429	UR865220	C. EL	0.22uF 50V		ケミコン	01
	C430	UR865220	C. EL	0.22uF 50V		ケミコン	01
*	C431	WB807100	C. EL	220uF 16V		ケミコン	
*	C432	WB807200	C. EL	1000uF 16V		ケミコン	
	C433	UR847100	C. EL	10uF 25V		ケミコン	01
*	C435	WB806800	C. EL	470uF 6.3V		ケミコン	
*	C438	WB806900	C. EL	1000uF 6.3V		ケミコン	
	C439	UN837470	C. EL	47uF 16V		B Pケミコン	01
	C440	UR866100	C. EL	1uF 50V		ケミコン	01

* New Parts * 新規部品(マーク#の部品は、基板に含まれません)

P.C.B. OPERATION

Schm Ref.	PART NO.	Description	Remarks	Markets	部 品 名	Rank	
C441	UR838470	C. EL	470uF	16V		ケミコン	01
C442	UR838100	C. EL	100uF	16V		ケミコン	01
C443	UR867470	C. EL	47uF	50V		ケミコン	01
C446	UR837220	C. EL	22uF	16V		ケミコン	01
C601	UU137470	C. EL	47uF	16V		ケミコン	01
C605	UU137470	C. EL	47uF	16V		ケミコン	01
C606	UU137470	C. EL	47uF	16V		ケミコン	01
C607	UU138330	C. EL	330uF	16V		ケミコン FW	01
C608	UU138330	C. EL	330uF	16V		ケミコン FW	01
C609	UA653220	C. MYLAR	2200pF	50V		マイラーコン	01
C610	UA653220	C. MYLAR	2200pF	50V		マイラーコン	01
C704	UA653100	C. MYLAR	1000pF	50V		マイラーコン	03
C705	UA653100	C. MYLAR	1000pF	50V		マイラーコン	03
C706	UA652390	C. MYLAR	390pF	50V		マイラーコン	01
C707	UA652390	C. MYLAR	390pF	50V		マイラーコン	01
C712	UA652220	C. MYLAR	220pF	50V		マイラーコン	01
C713	UA652220	C. MYLAR	220pF	50V		マイラーコン	01
C727	UU138100	C. EL	100uF	16V		ケミコン	01
C728	UU138100	C. EL	100uF	16V		ケミコン	01
C729	UU137100	C. EL	10uF	16V		ケミコン	01
C730	UU137100	C. EL	10uF	16V		ケミコン	01
C731	UU138100	C. EL	100uF	16V		ケミコン	01
C732	UU138100	C. EL	100uF	16V		ケミコン	01
C734	UU138100	C. EL	100uF	16V		ケミコン	01
C735	UU138100	C. EL	100uF	16V		ケミコン	01
C736	UU138100	C. EL	100uF	16V		ケミコン	01
C737	UU138100	C. EL	100uF	16V		ケミコン	01
C738	UU138100	C. EL	100uF	16V		ケミコン	01
C739	UU138100	C. EL	100uF	16V		ケミコン	01
C740	UA652220	C. MYLAR	220pF	50V		マイラーコン	01
C741	UA652220	C. MYLAR	220pF	50V		マイラーコン	01
C742	UA652220	C. MYLAR	220pF	50V		マイラーコン	01
C743	UA652220	C. MYLAR	220pF	50V		マイラーコン	01
C745	UA653150	C. MYLAR	1500pF	50V		マイラーコン	01
C746	UA653150	C. MYLAR	1500pF	50V		マイラーコン	01
C748	UA653100	C. MYLAR	1000pF	50V		マイラーコン	03
C749	UA653100	C. MYLAR	1000pF	50V		マイラーコン	03
C750	UU138220	C. EL	220uF	16V		ケミコン FW	01
C751	UU138220	C. EL	220uF	16V		ケミコン FW	01
C752	UU138220	C. EL	220uF	16V		ケミコン FW	01
C753	UU138220	C. EL	220uF	16V		ケミコン FW	01
C765	UU119100	C. EL	1000uF	6.3V		ケミコン	01
C769	UU138100	C. EL	100uF	16V		ケミコン	01
C772	UU119100	C. EL	1000uF	6.3V		ケミコン	01
C773	UU119100	C. EL	1000uF	6.3V		ケミコン	01
C775	UU119100	C. EL	1000uF	6.3V		ケミコン	01
D100	WB965900	LED	BE SLR343BBTT32			L E D	
D101	WB965900	LED	BE SLR343BBTT32			L E D	
D102	WB965900	LED	BE SLR343BBTT32			L E D	
* D103	V5710700	LED	GL3JV804B0PE			L E D	01
D104	WB965900	LED	BE SLR343BBTT32			L E D	
* D105	V5710700	LED	GL3JV804B0PE			L E D	01
D106	WB965900	LED	BE SLR343BBTT32			L E D	

* New Parts * 新規部品(マーク#の部品は、基板に含まれません)

P.C.B. OPERATION

Schm Ref.	PART NO.	Description	Remarks	Markets	部 品 名	Rank
* D107	V5710700	LED	GL3JV804B0PE		LED	01
D300	VG197600	LED	GL3ED8		2色LED	01
D400	VR253700	DIODE.BRG	S1NB20 1A 200V		ダイブリッジ X 4	02
D401	VR253700	DIODE.BRG	S1NB20 1A 200V		ダイブリッジ X 4	02
D402	VR253700	DIODE.BRG	S1NB20 1A 200V		ダイブリッジ X 4	02
△ D403	VV307700	DIODE	1N4002S		ダイオード	01
D404	VN011300	DIODE.BRG	D3SBA20 4A 200V		ダイオード	03
D405	VN011300	DIODE.BRG	D3SBA20 4A 200V		ダイオード	03
D406	VV307700	DIODE	1N4002S		ダイオード	01
D407	VV307700	DIODE	1N4002S		ダイオード	01
D408	VT332900	DIODE	1SS355		ダイオード	01
D409	VT332900	DIODE	1SS355		ダイオード	01
* D410	VU999800	DIODE.ZENR	MA8300-L 29.0V		ツェナーダイオード	
D411	V6591700	DIODE	SF5S6		ダイオード	
D412	V6591700	DIODE	SF5S6		ダイオード	
D413	VN011300	DIODE.BRG	D3SBA20 4A 200V		ダイオード	03
D414	VU993000	DIODE.ZENR	MA8056-M 5.6V		ツェナーダイオード	01
D415	VV307700	DIODE	1N4002S		ダイオード	01
D416	VV307700	DIODE	1N4002S		ダイオード	01
D417	V6591700	DIODE	SF5S6		ダイオード	
D418	VT332900	DIODE	1SS355		ダイオード	01
D419	VV307700	DIODE	1N4002S		ダイオード	01
D420	VU992600	DIODE.ZENR	MA8051-M 5.1V		ツェナーダイオード	01
D421	VV307700	DIODE	1N4002S		ダイオード	01
D422	VV307700	DIODE	1N4002S		ダイオード	01
D423	VT332900	DIODE	1SS355		ダイオード	01
D424	VT332900	DIODE	1SS355		ダイオード	01
D425	VT332900	DIODE	1SS355		ダイオード	01
D426	VT332900	DIODE	1SS355		ダイオード	01
D427	VV307700	DIODE	1N4002S		ダイオード	01
D428	VV307700	DIODE	1N4002S		ダイオード	01
* △ D429	WB192100	VARIStOR	TNR20V561K		バリスタ	
D601	VV307700	DIODE	1N4002S		ダイオード	01
D602	VV307700	DIODE	1N4002S		ダイオード	01
D611	VU172100	DIODE.ZENR	UDZS6.2B 6.2V		ツェナーダイオード	01
D612	VU172100	DIODE.ZENR	UDZS6.2B 6.2V		ツェナーダイオード	01
D701	VU992600	DIODE.ZENR	MA8051-M 5.1V		ツェナーダイオード	01
D702	VQ721800	DIODE.CHP	MA732		チップ ダイオード	01
D703	VT332900	DIODE	1SS355		ダイオード	01
D704	VQ721800	DIODE.CHP	MA732		チップ ダイオード	01
D705	VT332900	DIODE	1SS355		ダイオード	01
D706	VT332900	DIODE	1SS355		ダイオード	01
D707	VT332900	DIODE	1SS355		ダイオード	01
△ F400	KB001490	FUSE	10A 250V	J	ヒューズ	01
△ F400	KB001390	FUSE	10A 250V	UC	ヒューズ	03
△ F400	KB000780	FUSE	T5.0A 250V	ABG	ヒューズ	02
Fi400	VH227500	FLTR	20uH SU10VD-10020		ラインフィルタ	03
* IC100	X4194A00	IC	M66005-0141AFP-280		IC	
* IC101	X4194A00	IC	M66005-0141AFP-280		IC	
IC400	XP264A00	IC	NJM79L05A-T3		IC	02
IC401	XY525A00	IC	PQ1CG2032FZ		電源 IC S I L	06
IC402	XY525A00	IC	PQ1CG2032FZ		電源 IC S I L	06
IC403	XY525A00	IC	PQ1CG2032FZ		電源 IC S I L	06

* New Parts * 新規部品(マーク#の部品は、基板に含まれません)

P.C.B. OPERATION

Schm Ref.	PART NO.	Description	Remarks	Markets	部 品 名	Rank
	IC404	XU814A00 IC	P005RD11 +5V 1.0A		電源 IC	03
*	IC405	XP154A00 IC	M5237ML 1.5-33V		電源 IC	02
	IC601	XF291A00 IC	uPC4570G2		IC	03
*	IC701	X2474A00 IC	NJM4580V-TE2		アンプ IC	01
*	IC702	X2538A00 IC	NJM2100V		アンプ IC SSOP	
*	IC703	X2538A00 IC	NJM2100V		アンプ IC SSOP	
*	IC705	X2713A00 IC	SN74AHC08PWR		ロジック IC	
*	IC706	X4201A00 IC	SN74AHC02PWR		ロジック IC	
*	IC707	XR532A00 IC	NJM2904V (TE1) DUAL		アンプ IC SSOP	02
*	IC708	X4200A00 IC	SN74AHC04PWR		ロジック IC	
	IC709	XY624A00 IC	AK4528VF		ADC&DAC IC	08
*	IC710	X2538A00 IC	NJM2100V		アンプ IC SSOP	
*	IC711	X2538A00 IC	NJM2100V		アンプ IC SSOP	
*	IC712	X2474A00 IC	NJM4580V-TE2		アンプ IC	01
	IC713	XY624A00 IC	AK4528VF		ADC&DAC IC	08
*	JK601	V2452000 JACK. DIN	6P TCS7927		ミニDIN端子	04
	JK602	V5129000 JACK. PHONE	YKB26-5236		ヘッドホンジャック	03
*	PJ701	V9909400 JACK. PIN	6P LPR6520-E795M		ピンジャック 6P	
	Q300	VV655000 TR. DGT	DTA114EKA		デジタルトランジスタ	01
	Q301	VV655000 TR. DGT	DTA114EKA		デジタルトランジスタ	01
	Q400	iC174020 TR	2SC1740S R, S		トランジスタ	01
△	Q401	iA093320 TR	2SA933S Q, R		トランジスタ	01
	Q402	VV655400 TR. DGT	DTC114EKA		デジタルトランジスタ	01
	Q403	VV655400 TR. DGT	DTC114EKA		デジタルトランジスタ	01
	Q405	VV556500 TR	2SA1037K Q, R, S		トランジスタ	01
	Q406	VS883300 TR	2SB1565 E, F		トランジスタ	02
	Q408	VV655400 TR. DGT	DTC114EKA		デジタルトランジスタ	01
	Q409	VV655000 TR. DGT	DTA114EKA		デジタルトランジスタ	01
	Q701	VZ725900 TR	2SD1938F S, T		トランジスタ	
	Q702	VZ725900 TR	2SD1938F S, T		トランジスタ	
	Q703	VZ725900 TR	2SD1938F S, T		トランジスタ	
	Q704	VZ725900 TR	2SD1938F S, T		トランジスタ	
	Q705	VC123900 TR. DGT	DTA1143EK		デジタルトランジスタ	03
	R133	HV753100 R. CAR. FP	1Ω 1/4W		不燃化カーボン抵抗	01
△	R400	HV753220 R. CAR. FP	2.2Ω 1/4W		不燃化カーボン抵抗	01
△	R401	HV755100 R. CAR. FP	100Ω 1/4W		不燃化カーボン抵抗	01
△	R402	HV754680 R. CAR. FP	68Ω 1/4W		不燃化カーボン抵抗	01
	R405	HV755100 R. CAR. FP	100Ω 1/4W		不燃化カーボン抵抗	01
	R413	HV755100 R. CAR. FP	100Ω 1/4W		不燃化カーボン抵抗	01
	R414	HV755100 R. CAR. FP	100Ω 1/4W		不燃化カーボン抵抗	01
△	R415	HV753220 R. CAR. FP	2.2Ω 1/4W		不燃化カーボン抵抗	01
△	R418	HV753220 R. CAR. FP	2.2Ω 1/4W		不燃化カーボン抵抗	01
	R419	HV754100 R. CAR. FP	10Ω 1/4W		不燃化カーボン抵抗	01
	R420	HV755100 R. CAR. FP	100Ω 1/4W		不燃化カーボン抵抗	01
△	R428	HV753220 R. CAR. FP	2.2Ω 1/4W		不燃化カーボン抵抗	01
△	R429	HV753220 R. CAR. FP	2.2Ω 1/4W		不燃化カーボン抵抗	01
	R430	HV755100 R. CAR. FP	100Ω 1/4W		不燃化カーボン抵抗	01
	R432	HV754100 R. CAR. FP	10Ω 1/4W		不燃化カーボン抵抗	01
	R433	HV754100 R. CAR. FP	10Ω 1/4W		不燃化カーボン抵抗	01
	R434	HV754100 R. CAR. FP	10Ω 1/4W		不燃化カーボン抵抗	01
	R435	HV754100 R. CAR. FP	10Ω 1/4W		不燃化カーボン抵抗	01
	R436	HV755180 R. CAR. FP	180Ω 1/4W		不燃化カーボン抵抗	01
	R437	HV753220 R. CAR. FP	2.2Ω 1/4W		不燃化カーボン抵抗	01

* New Parts * 新規部品 (マーク#の部品は、基板に含まれません)

P.C.B. OPERATION & P.C.B. MAIN

Schm Ref.	PART NO.	Description	Remarks	Markets	部 品 名	Rank
R438	HV754470	R. CAR. FP 47Ω 1/4W			不燃化カーボン抵抗	01
R451	HV754680	R. CAR. FP 68Ω 1/4W			不燃化カーボン抵抗	01
R601	HV753220	R. CAR. FP 2.2Ω 1/4W			不燃化カーボン抵抗	01
R608	HV755100	R. CAR. FP 100Ω 1/4W			不燃化カーボン抵抗	01
R609	HV755100	R. CAR. FP 100Ω 1/4W			不燃化カーボン抵抗	01
R758	HV753470	R. CAR. FP 4.7Ω 1/4W			不燃化カーボン抵抗	01
R798	HV753470	R. CAR. FP 4.7Ω 1/4W			不燃化カーボン抵抗	01
△ RY400	V6434900	RELAY DC DLS12D1-0(M)			リレー 12V TV-8	03
SW100	V4757100	SW. TACT EVQ11A			タクトSW	01
SW101	V4757100	SW. TACT EVQ11A			タクトSW	01
SW104	V4757100	SW. TACT EVQ11A			タクトSW	01
SW105	V4757100	SW. TACT EVQ11A			タクトSW	01
SW107	V4757100	SW. TACT EVQ11A			タクトSW	01
SW108	V4757100	SW. TACT EVQ11A			タクトSW	01
SW110	V4757100	SW. TACT EVQ11A			タクトSW	01
SW111	V4757100	SW. TACT EVQ11A			タクトSW	01
SW112	V4757100	SW. TACT EVQ11A			タクトSW	01
SW113	V4757100	SW. TACT EVQ11A			タクトSW	01
SW114	V4757100	SW. TACT EVQ11A			タクトSW	01
SW300	V4757100	SW. TACT EVQ11A			タクトSW	01
* SW310	WC353300	SW JXS0000-1011			マルチウエイスイッチ	
* △ T400	X3835A00	TRANS		J	サブトランス	
* △ T400	X4221A00	TRANS		UC	サブトランス	
* △ T400	X4223A00	TRANS		A	サブトランス	
* △ T400	X4222A00	TRANS		BG	サブトランス	
TH400	VV458000	SW RUE250 2.50A 30V			ポリスイッチ	03
TH401	VV458000	SW RUE250 2.50A 30V			ポリスイッチ	03
* TH402	VV458300	SW RUE500 5.00A 30V			ポリスイッチ	
TH403	VV457600	SW RUE090 0.90A 30V			ポリスイッチ	02
TH404	VV457600	SW RUE090 0.90A 30V			ポリスイッチ	02
U100	V8210200	L. DTCT GP1UD271XK			リモコン受光ユニット	03
U701	V7680700	CN. PHOT. SN 1P GP1FA512RZ			光ファイバ受信器	04
U702	V7680800	CN. PHOT. SN 1P GP1FA512TZ			光ファイバデータリンク	03
* V100	V9876100	FL. DSPLY 162-MD-05GNA			蛍光表示管	
VR601	VZ479400	VR A20KΩ			二連ロータリーVR	03
* VR602	WA049300	VR B 50.0K RK09L12A36			二連ロータリーVR	
* WA872700		SHEET			シート/FL	
* WA872600		SPACER. FL			スペーサ/FL	
* WB151400		CUSHION. FL			クッション/FL	
* VB659000		SCR. BND. HD 3x8 MFZN2BL			バインド小ネジ	01
* WB161300		P. C. B. MAIN		JUC	P C B メイン	
* WB161400		P. C. B. MAIN		ABG	P C B メイン	
* CB101	V9808500	CN. BS. PIN 30P SE			F F C F P C コネクタ	
* CB102	V8623300	CN. BS. PIN 36P SE			F F C コネクタ	
* CB103	V3768800	SOCKET 17LE-23090-28			コネクタソケット	03
CB222	V5739200	CN. BS. PIN 2120-40SF1BN			ピンヘッダー	
CB223	V5739200	CN. BS. PIN 2120-40SF1BN			ピンヘッダー	
* CB301	V9864300	CN. BS. PIN 33P TE			F F C コネクタ	
* CB501	WA245800	CN 8P TM21R-5C-88			モジュラーコネクタ	
* CB502	V7905000	CN FCN-565P068-G/224V			P C カードコネクタ	

* New Parts * 新規部品(マーク#の部品は、基板に含まれません)

P.C.B. MAIN

Schm Ref.	PART NO.	Description	Remarks	Markets	部 品 名	Rank
	CB601	LB918060 CN. BS. PIN	6P		ベース付ポスト	01
	CB602	VB390600 CN. BS. PIN	10P		コネクタベースポスト	01
*	CB603	V9978600 CN. BS. PIN	40P TE		F F Cコネクタ	
	CB604	V6929600 CN. BS. PIN	4P TE		ウェハー	01
*	CB605	WA029300 CN	11P TE		F F Cコネクター	
	CB606	LB918020 CN. BS. PIN	2P		ベース付ポスト	01
	C405	UU138220 C. EL	220uF 16V		ケミコン FW	01
	C406	UU119100 C. EL	1000uF 6.3V		ケミコン	01
*	C418	VR327400 C. MYLA. CHP	0.1uF 16V		チップマイラーコン	01
*	C419	VR327400 C. MYLA. CHP	0.1uF 16V		チップマイラーコン	01
*	C420	VR327400 C. MYLA. CHP	0.1uF 16V		チップマイラーコン	01
*	C503	V9878800 C. CE. M. CHP	1000pF		チップ積層セラコン	
	C603	UU139100 C. EL	1000uF 16V		ケミコン	01
	C604	UU138220 C. EL	220uF 16V		ケミコン FW	01
	C606	UU119100 C. EL	1000uF 6.3V		ケミコン	01
	C607	UU119100 C. EL	1000uF 6.3V		ケミコン	01
	C615	VF992600 C. EL	4700uF 5.5V		バックアップケミコン	02
	C616	UU119100 C. EL	1000uF 6.3V		ケミコン	01
	C617	UU119100 C. EL	1000uF 6.3V		ケミコン	01
	D101	V0721800 D10DE. CHP	MA732		チップ ダイオード	01
	D102	VT332900 D10DE	1SS355		ダイオード	01
	D301	VT332900 D10DE	1SS355		ダイオード	01
	D302	VT332900 D10DE	1SS355		ダイオード	01
	D304	VT332900 D10DE	1SS355		ダイオード	01
	D401	VT332900 D10DE	1SS355		ダイオード	01
*	D501	VU769000 LED. CHP	YE PY1101F-TR		チップ LED	
*	D502	V4998500 LED	ORANGE AA1101F		チップ LED	01
	D602	VT332900 D10DE	1SS355		ダイオード	01
	D603	VT332900 D10DE	1SS355		ダイオード	01
	D604	VU993500 D10DE. ZENR	MA8062-H 6.4V		ツェナーダイオード	01
	D605	VT332900 D10DE	1SS355		ダイオード	01
	D606	VT332900 D10DE	1SS355		ダイオード	01
	D607	VT332900 D10DE	1SS355		ダイオード	01
	D608	VV833200 D10DE	1SS380		ダイオード	01
	D610	VU171800 D10DE. ZENR	UDZ4.7B 4.7V		ツェナーダイオード	01
	D611	VT332900 D10DE	1SS355		ダイオード	01
	D612	V0721800 D10DE. CHP	MA732		チップ ダイオード	
	D613	V0721800 D10DE. CHP	MA732		チップ ダイオード	
	D614	VT332900 D10DE	1SS355		ダイオード	01
	D615	VT532500 D10DE	1SR154-400		ダイオード	01
*	IC101	X2757A00 IC	MAX3221CPWR		IC	
	IC102	XL122A00 IC	PST572CMT-R		IC	02
*	IC103	X0471A00 IC	74LCX245MTCX		ロジックIC	
	IC104	X0295A00 IC	74VHCT245AMTCX BUF		ロジックIC	03
*	IC105	XZ414B00 IC	W986416DH-7 DRAM		メモリIC 64M	08
*	IC106	XZ414B00 IC	W986416DH-7 DRAM		メモリIC 64M	08
*	IC107	X4061A00 IC	SN74AHC2GU04HDCR		ロジックIC	
*	IC108	X4121B00 IC	MBM29LV320BE90T		メモリIC	
	IC109	XP985A00 IC	SN74LS06NST-EL INV		IC	
*	IC110	X0477A00 IC	74LCX14MTCX		ロジックIC	
*	IC111	X2081A00 IC. CPU	HD6417709SF13		CPU/周辺IC	12
	IC113	XZ237A00 IC	SN74LVCHR16245AGR		ロジックIC DGG	04
	IC114	XZ237A00 IC	SN74LVCHR16245AGR		ロジックIC DGG	04

* New Parts * 新規部品(マーク#の部品は、基板に含まれません)

P.C.B. MAIN

Schm Ref.	PART NO.	Description	Remarks	Markets	部 品 名	Rank
IC115	XZ237A00	IC	SN74LVCHR16245AGR		ロジック IC D G G	04
IC116	XZ237A00	IC	SN74LVCHR16245AGR		ロジック IC D G G	04
IC117	XZ237A00	IC	SN74LVCHR16245AGR		ロジック IC D G G	04
IC118	XZ237A00	IC	SN74LVCHR16245AGR		ロジック IC D G G	04
IC119	XZ237A00	IC	SN74LVCHR16245AGR		ロジック IC D G G	04
IC120	XZ237A00	IC	SN74LVCHR16245AGR		ロジック IC D G G	04
* IC121	X4122B00	IC	XC9572XL-10TQ100C		デジタル IC	
IC122	X3401A00	IC	PQ018EZ01ZP 1.8V		電源 IC	03
* IC221	XZ414B00	IC	W986416DH-7 DRAM		メモリ IC 6 4 M	08
* IC222	X0285A00	IC	HD64480F		IC	
* IC224	X0122A00	IC	FST3383MTC		ロジック IC	
* IC225	X0122A00	IC	FST3383MTC		ロジック IC	
* IC226	X0122A00	IC	FST3383MTC		ロジック IC	
* IC227	X0122A00	IC	FST3383MTC		ロジック IC	
* IC301	X4123A00	IC	YDC130-F		IC デジタル	
* IC302	X0122A00	IC	FST3383MTC		ロジック IC	
* IC303	X0122A00	IC	FST3383MTC		ロジック IC	
* IC304	X3803A00	IC	TMS320DA150PG		ロジック IC	
* IC305	X4070A00	IC	EP1K30TC144-3		IC	
* IC306	X3803A00	IC	TMS320DA150PG		ロジック IC	
* IC307	X0122A00	IC	FST3383MTC		ロジック IC	
* IC308	X0122A00	IC	FST3383MTC		ロジック IC	
* IC309	X0122A00	IC	FST3383MTC		ロジック IC	
* IC310	X0122A00	IC	FST3383MTC		ロジック IC	
IC313	X3204A00	IC	PQ070XZ5MZP		電源 IC	03
IC314	XZ003A00	IC	PQ025EZ5MZP 2.5V		電源 IC Q F P	03
IC315	X0295A00	IC	74VHCT245AMTCX		IC	
* IC401	X2314A00	IC	MB3516APF-G-BND		IC	
* IC402	X2479A00	IC	YGV619		IC P Q F P	12
* IC403	XZ414B00	IC	W986416DH-7 DRAM		メモリ IC 6 4 M	08
* IC501	X2404A00	IC	LAN91C111		IC	13
* IC503	X0122A00	IC	FST3383MTC		ロジック IC	
* IC504	X0122A00	IC	FST3383MTC		ロジック IC	
* IC505	X0122A00	IC	FST3383MTC		ロジック IC	
* IC506	X0122A00	IC	FST3383MTC		ロジック IC	
IC601	XJ607A00	IC	NJM7805FA 5V		IC	02
* IC602	X3090A00	IC. CPU	UPD78F0034BGB-8EU		C P U / 周 辺 IC	
* IC603	X4151A00	IC	M62703ML		リセット IC	
IC604	XY045A00	IC	PQ3RD13 3.3V1A		電源 IC	03
* IC605	X4081A00	IC	AT24C04N-10S1-2.7		メモリ IC	
IC606	X3724A00	IC	74VHC00MTCX		ロジック IC	01
* IC607	X4150A00	IC	74VHCT00AMTCX		ロジック IC	
* IC608	X4451A00	IC	PST600JM		リセット IC	
* IC609	X4463A00	IC	SN74LV08APWR		ロジック IC	
* IC610	X4465A00	IC	SN74AHCT1G125DCKR		ロジック IC	
* IC611	X4453A00	IC	SN74LVC1G17DCKR		ロジック IC	
* IC612	X4453A00	IC	SN74LVC1G17DCKR		ロジック IC	
IC613	X3724A00	IC	74VHC00MTCX		ロジック IC	01
* IC614	X4464A00	IC	SN74LV132APWR		ロジック IC	
* IC615	X4503A00	IC	SN74CBT3306PWR		ロジック IC	
* IC616	X4454A00	IC	SN74LVC2G17DCKR		ロジック IC	
* JK401	V8210800	TERM. S	2P YKF51-5572		2 連 S 端子	04
* PJ401	V9909300	JACK. PIN	2P YE LPR6520		ピンジャック 2 P	

* New Parts * 新規部品(マーク#の部品は、基板に含まれません)

P.C.B. MAIN

Schm Ref.	PART NO.	Description	Remarks	Markets	部 品 名	Rank
Q101	VV655400	TR. DGT	DTC114EKA		デジタルトランジスタ	01
Q102	VV556400	TR	2SC2412K Q, R, S		トランジスタ	01
Q301	VV655400	TR. DGT	DTC114EKA		デジタルトランジスタ	01
Q302	VV655400	TR. DGT	DTC114EKA		デジタルトランジスタ	01
Q304	VD303700	TR	2SC3326 A, B		トランジスタ	01
Q401	VV655600	TR. DGT	DTC143EKA TP		デジタルトランジスタ	
Q501	VD303700	TR	2SC3326 A, B		トランジスタ	01
Q601	VV556400	TR	2SC2412K Q, R, S		トランジスタ	01
Q602	VV655700	TR. DGT	DTC144EKA		デジタルトランジスタ	01
Q603	iA103700	TR. CHP	2SA1037 Q, R, S		チップトランジスタ	01
Q605	VV655400	TR. DGT	DTC114EKA		デジタルトランジスタ	01
Q606	VV655000	TR. DGT	DTA114EKA		デジタルトランジスタ	01
Q607	VV556400	TR	2SC2412K Q, R, S		トランジスタ	01
* Q608	Vi334100	TR	2SD1760 F5 P, Q, R		トランジスタ	01
Q609	VV556400	TR	2SC2412K Q, R, S		トランジスタ	01
Q611	VV556400	TR	2SC2412K Q, R, S		トランジスタ	01
Q613	VV556400	TR	2SC2412K Q, R, S		トランジスタ	01
Q614	VV655400	TR. DGT	DTC114EKA		デジタルトランジスタ	01
* R422	Vi193900	R. MTL. CHP	390Ω 1/10W		チップ金被抵抗	01
R644	HV753100	R. CAR. FP	1Ω 1/4W		不燃化カーボン抵抗	01
RY401	V4785600	RELAY	DC AGN2004H		リレー 4.5V	05
RY402	V4785600	RELAY	DC AGN2004H		リレー 4.5V	05
ST501	BB071360	SCR. TERM	8.3x13		ネジ端子	01
* TH601	V9760200	THRMST. CHP	NCP18XH103J03RB		チップサーミスタ	
* TH602	V9760200	THRMST. CHP	NCP18XH103J03RB		チップサーミスタ	
* XL101	WB316300	RSNR. CRY	33.33MHz SMD-49		水晶振動子	
* XL301	WA624600	RSNR. CRY	33.8688MHz DSX531S		水晶振動子	
* XL302	VS167000	RSNR. CRY	24.576MHz SMD-49		水晶振動子	03
* XL401	WC061400	RSNR. CRY	14.31818MHz SMD-49	JUC	水晶振動子	03
* XL401	V6074900	RSNR. CRY	17.734475MHz	ABG	水晶振動子	03
* XL502	VZ540700	RSNR. CRY	25MHz SMD-49		水晶振動子	
* XL601	V9864200	RSNR. CE	10.0MHz		セラミック発振子	
* XL602	V9480700	RSNR. CRY	32.768KHz CM200S		水晶発振子	

* New Parts * 新規部品 (マーク#の部品は、基板に含まれません)

Chip Capacitors

Schm Ref.	PART NO.	Description	Remarks	Markets	部 品 名	Rank
	UF017470	C. EL. CHP	47uF 6.3V		チップケミコン	01
	UF018100	C. EL. CHP	100uF 6.3V		チップケミコン	01
	UF027220	C. EL. CHP	22uF 10V		チップケミコン	01
	UF027330	C. EL. CHP	33uF 10V		チップケミコン	01
	UF037100	C. EL. CHP	10uF 16V		チップケミコン	01
	UF037220	C. EL. CHP	22uF 16V		チップケミコン	01
	UF037470	C. EL. CHP	47uF 16V		チップケミコン	01
	UF038100	C. EL. CHP	100uF 16V		チップケミコン	01
*	UF047100	C. EL. CHP	10uF 25V		チップケミコン	01
*	UF065470	C. EL. CHP	0.47uF 50V		チップケミコン	01
	UF066100	C. EL. CHP	1uF 50V		チップケミコン	01
	UF066470	C. EL. CHP	4.7uF 50V		チップケミコン	01
*	UF067100	C. EL. CHP	10uF 50V		チップケミコン	01
	UF118220	C. EL. CHP	220uF 6.3V		チップケミコン	01
*	UF138220	C. EL. CHP	220uF 16V		チップケミコン	01
	US044220	C. CE. M. CHP	0.022uF 25V		チップセラコン	01
*	US060500	C. CE. CHP	5pF 50V		チップセラコン	01
	US061100	C. CE. M. CHP	10pF 50V		チップセラコン	01
	US061150	C. CE. CHP	15pF 50V		チップセラコン	01
	US061180	C. CE. CHP	18pF 50V		チップセラコン	01
	US061220	C. CE. M. CHP	22pF 50V		チップセラコン	01
	US061270	C. CE. M. CHP	27pF 50V		チップセラコン	01
	US061330	C. CE. M. CHP	33pF 50V		チップセラコン	01
	US061470	C. CE. M. CHP	47pF 50V		チップセラコン	01
	US062100	C. CE. M. CHP	100pF 50V		チップセラコン	01
	US062150	C. CE. CHP	150pF 50V		チップセラコン	01
	US062220	C. CE. CHP	220pF 50V		チップセラコン	01
	US062330	C. CE. M. CHP	330pF 50V		チップセラコン	01
	US062470	C. CE. M. CHP	470pF 50V		チップセラコン	01
	US063100	C. CE. M. CHP	1000pF 50V		チップセラコン	01
	US063470	C. CE. CHP	4700pF 50V		チップセラコン	01
	US064100	C. CE. M. CHP	0.01uF 50V		チップセラコン	01
	US135100	C. CE. CHP	0.1uF 16V		チップセラコン	01
	US135330	C. CE. CHP	0.33uF 16V		チップセラ (F)	01
	US145100	C. CE. CHP	0.1uF 25V		チップセラ (F)	01
*	VR328100	C. MYLA. CHP	220pF 50V		チップマイラーコン	
	VR329300	C. MYLA. CHP	0.0015uF 50V		チップマイラーコン	

* New Parts * 新規部品(マーク#の部品は、基板に含まれません)

Chip Resistors

Schm Ref.	PART NO.	Description	Remarks	Markets	部 品 名	Rank	
	RD255330	R. CHP	330Ω	1/10W		チップ抵抗	01
	RD350000	R. CHP	0Ω	1/16W		チップ抵抗	01
	RD354100	R. CHP	10Ω	1/16W		チップ抵抗	01
	RD354220	R. CHP	22Ω	1/16W		チップ抵抗	01
	RD354330	R. CHP	33Ω	1/16W		チップ抵抗	01
*	RD354360	R. CHP	36Ω	1/16W		チップ抵抗	01
	RD354470	R. CHP	47Ω	1/16W		チップ抵抗	01
	RD354680	R. CHP	68Ω	1/16W		チップ抵抗	01
	RD354750	R. CHP	75Ω	1/16W		チップ抵抗	01
	RD354820	R. CHP	82Ω	1/16W		チップ抵抗	01
	RD355100	R. CHP	100Ω	1/16W		チップ抵抗	01
	RD355150	R. CHP	150Ω	1/16W		チップ抵抗	01
	RD355220	R. CHP	220Ω	1/16W		チップ抵抗	01
	RD355270	R. CHP	270Ω	1/16W		チップ抵抗	01
	RD355330	R. CHP	330Ω	1/16W		チップ抵抗	01
	RD355390	R. CHP	390Ω	1/16W		チップ抵抗	01
	RD355470	R. CHP	470Ω	1/16W		チップ抵抗	01
	RD355560	R. CHP	560Ω	1/16W		チップ抵抗	01
	RD355680	R. CHP	680Ω	1/16W		チップ抵抗	01
	RD355820	R. CHP	820Ω	1/16W		チップ抵抗	01
	RD356100	R. CHP	1KΩ	1/16W		チップ抵抗	01
	RD356150	R. CHP	1.5KΩ	1/16W		チップ抵抗	01
	RD356180	R. CHP	1.8KΩ	1/16W		チップ抵抗	01
	RD356220	R. CHP	2.2KΩ	1/16W		チップ抵抗	01
	RD356270	R. CHP	2.7KΩ	1/16W		チップ抵抗	01
	RD356330	R. CHP	3.3KΩ	1/16W		チップ抵抗	01
	RD356470	R. CHP	4.7KΩ	1/16W		チップ抵抗	01
	RD356560	R. CHP	5.6KΩ	1/16W		チップ抵抗	01
	RD356680	R. CHP	6.8KΩ	1/16W		チップ抵抗	01
	RD356820	R. CHP	8.2KΩ	1/16W		チップ抵抗	01
	RD357100	R. CHP	10KΩ	1/16W		チップ抵抗	01
	RD357150	R. CHP	15KΩ	1/16W		チップ抵抗	01
	RD357180	R. CHP	18KΩ	1/16W		チップ抵抗	01
	RD357220	R. CHP	22KΩ	1/16W		チップ抵抗	01
	RD357330	R. CHP	33KΩ	1/16W		チップ抵抗	01
	RD357390	R. CHP	39KΩ	1/16W		チップ抵抗	01
	RD357470	R. CHP	47KΩ	1/16W		チップ抵抗	01
	RD357560	R. CHP	56KΩ	1/16W		チップ抵抗	01
	RD357910	R. CHP	91KΩ	1/16W		チップ抵抗	01
	RD358100	R. CHP	100KΩ	1/16W		チップ抵抗	01
	RD358120	R. CHP	120KΩ	1/16W		チップ抵抗	01
	RD358220	R. CHP	220KΩ	1/16W		チップ抵抗	01
	RD358470	R. CHP	470KΩ	1/16W		チップ抵抗	01
	RD358680	R. CHP	680KΩ	1/16W		チップ抵抗	01
	RD359100	R. CHP	1MΩ	1/16W		チップ抵抗	01
	RF356470	R. CHP	4.7KΩ	1/16W		チップ抵抗	01
	RF356560	R. CHP	5.6KΩ	1/16W		チップ抵抗	01
*	V9848700	R. CHP	24.9Ω	1/8W		チップ抵抗	01
*	V9848800	R. CHP	49.9Ω	1/8W		チップ抵抗	01
*	V9848900	R. CHP	75Ω	1/8W		チップ抵抗	01
*	V9849100	R. CHP	11KΩ	1/8W		チップ抵抗	01

* New Parts * 新規部品(マーク#の部品は、基板に含まれません)

MCX-1000

EXPLODED VIEW

T10 2.7 mm

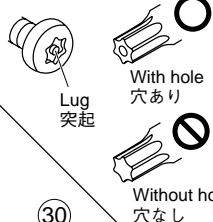

When removing the screw (137), use the special screwdriver with tip shaped in figure. As the screw (137) has a lug at its center, use the one with a hole.

ネジ(137)を外す場合、図のような先端形状のドライバーを使用します。ネジ(137)は、中心に突起があるので、中心に穴のあるタイプを使用してください。

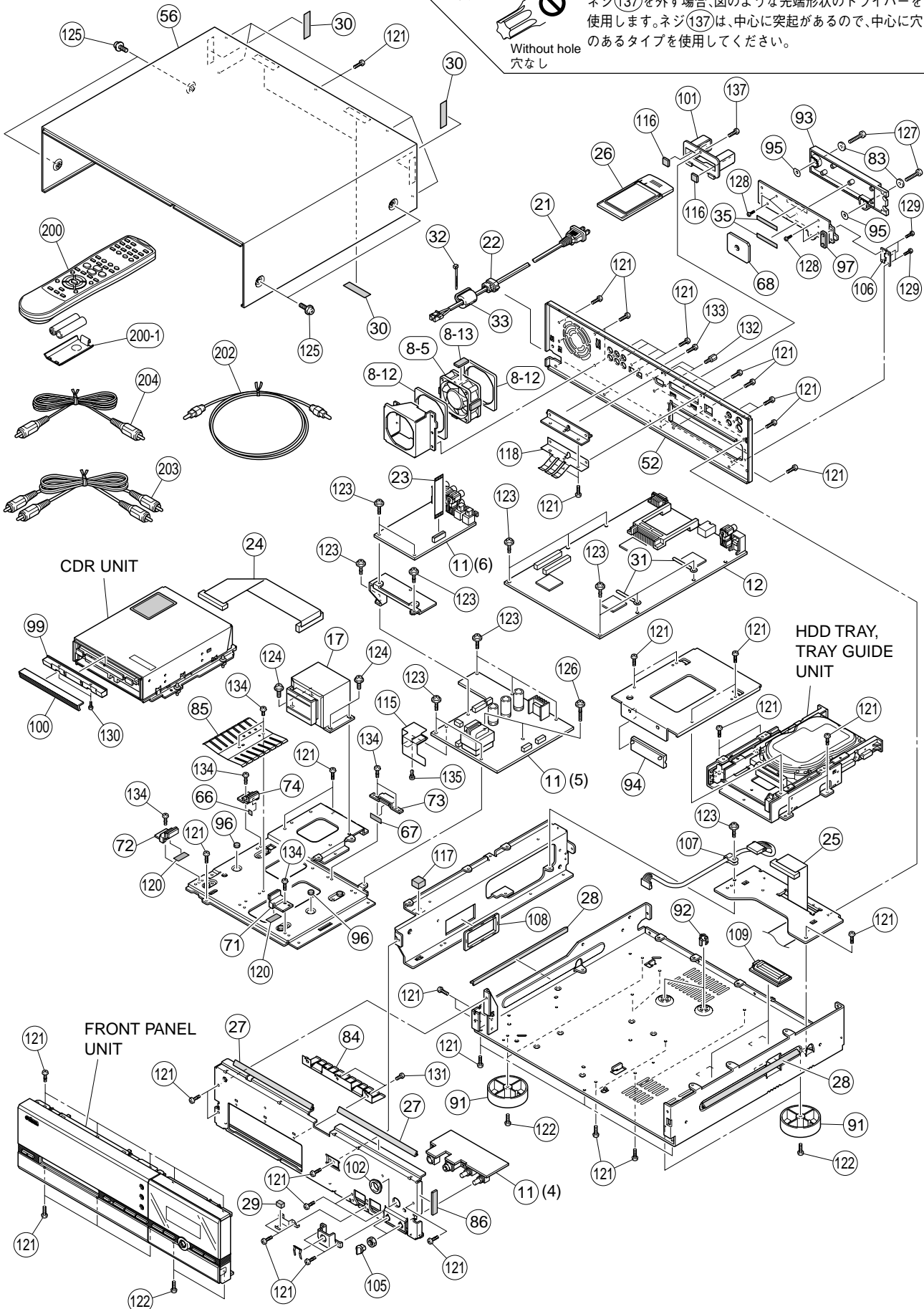

CDR UNIT

HDD TRAY, TRAY GUIDE UNIT

FRONT PANEL UNIT

1
2
3
4
5
6
7

MECHANICAL PARTS

Schm Ref.	PART NO.	Description	Remarks	Markets	部 品 名	Rank
8-5	V7719700	DC FAN MOTOR			DCファンモーター	09
8-12	V8080500	CUSHION/FAN			クッション/FAN	
8-13	V8080600	CUSHION/10x20			クッション/10X20	
* 11	WB160900	P.C.B. ASS'Y	OPERATION	J	PCB集成オペレーション	
* 11	WB161000	P.C.B. ASS'Y	OPERATION	UC	PCB集成オペレーション	
* 11	WB161100	P.C.B. ASS'Y	OPERATION	A	PCB集成オペレーション	
* 11	WB161200	P.C.B. ASS'Y	OPERATION	BG	PCB集成オペレーション	
* 12	WB161300	P.C.B. ASS'Y	MAIN	JUC	PCBメイン	
* 12	WB161400	P.C.B. ASS'Y	MAIN	ABG	PCBメイン	
* 17	X4224A00	POWER TRANSFORMER		J	電源トランス	
* 17	X4225A00	POWER TRANSFORMER		UC	電源トランス	
* 17	X4227A00	POWER TRANSFORMER		A	電源トランス	
* 17	X4226A00	POWER TRANSFORMER		BG	電源トランス	
* 21	VQ204100	POWER CABLE	2m	J	電源コード	05
* 21	WB930200	POWER CABLE	2m	UC	電源コード	
* 21	VP418300	POWER CABLE	2m	A	電源コード	06
* 21	WB247600	POWER CABLE	2m	B	電源コード	
* 21	VL238900	POWER CABLE	2m	G	電源コード	05
22	V2438700	CORD STOPPER	10P1		コードストッパー	02
* 23	WB176400	CONNECTOR, FLAT CABLE	33P 70mm P=0.5		バンカード C&C	
* 24	WB801000	CONNECTOR, FLAT CABLE	40P 560mm		フラットケーブル	
* 25	WB801100	CONNECTOR, FLAT CABLE	40P 260mm		フラットケーブル	
* 26	WB209700	WIRELESS LAN CARD	X1-325		無線LANカード	
* 27	WB835400	SOFT SHIELD	82-122-74008 L=170		ソフトシールド	
* 28	WB835500	SOFT SHIELD	82-122-74008 L=200		ソフトシールド	
* 29	WB835600	SOFT SHIELD	82-122-74021 L=10		ソフトシールド	
* 30	WB940700	CHO-FOIL	CCE W12.7xL50		コ・フォイル	
31	CB836200	BINDING TIE	S-70B		束線止め	02
32	CB069250	BINDING TIE	BK-1		束線止め	01
33	VV910400	FERRITE CORE	ZCAT3035-1330		クランプフィルタ	07
* 35	WC021000	SHIELD FINGER	H-100-00		シールドフィンガー	
* 52	WA867600	REAR PANEL		J	リヤパネル	
* 52	WA867700	REAR PANEL		UC	リヤパネル	
* 52	WA867800	REAR PANEL		A	リヤパネル	
* 52	WA868000	REAR PANEL		BG	リヤパネル	
* 56	WA867400	TOP COVER			トップカバー	
* 56	WA867500	TOP COVER			トップカバー	
* 66	WC373700	SPACER 4/81			スペーサー 4/81	
* 67	WC373800	SPACER 4/201			スペーサー 4/201	
* 68	WC373900	SHEET COVER			シートカバー	
71	V7880200	STOPPER/A			ストッパ/A	
* 72	WA869200	STOPPER/B			ストッパ/B	
* 73	WB150000	STOPPER/C			ストッパ/C	
* 74	WA869300	STOPPER/D			ストッパ/D	
83	V9478900	WASHER/REAR			ワッシャー/リア	
84	V8146700	EARTH PLATE/CENTER			アースプレート	03
85	V8146500	EARTH PLATE/BOTTOM			アースプレート	04
* 86	WB288700	DAMPER/FS			ダンパー/FS	
91	VQ780300	LEG	D60xH16		レッグ	01
92	VR264400	SPACER	H8		スペーサー	01
93	V9661800	COVER/REAR			カバー/リア	
94	V9569900	CUSHION/TRAY			クッション/トレイ	
95	V9597300	WASHER/A			ワッシャー/A	01
96	V7881000	DAMPER/D9			ダンパ/D9	

* New Parts * 新規部品(マーク#の部品は、基板に含まれません)

Schm Ref.	PART NO.	Description	Remarks	Markets	部 品 名	Rank
97	V9603200	CUSHION/REAR			クッション/REAR	
* 99	V6676900	LID A			リッドA	
* 100	WA871500	LID/COVER			リッド/カバー	
* 101	WA872000	COVER/ANT			カバー/ANT	
* 102	VV472600	BUSH	TB-1216		ブッシュ	
* 105	WA872200	KNOB		BL	ノブ	
* 105	WB151100	KNOB		SI	ノブ	
106	V9597900	HINGE	TH-TM-84 MFC2		ヒンジ	05
107	CB065520	NYLON CLAMP	NK-3N		ナイロンクランプ	01
* 108	WA046000	SQUARE BUSH	SB-6025		スクウェアブッシュ	03
* 109	WB209400	FCW CLAMP	FCW-52		FCW クランプ	
* 115	WB823500	SHEET/INSULATE			シート/絶縁	
* 116	WB823600	DAMPER/ANTENNA			ダンパー/アンテナ	
* 117	WB823700	DAMPER/MAIN			ダンパー/メイン	
* 118	WB941100	EARTH PLATE LAN			アースプレートLAN	
120	WC132000	SPACER/TO.5			スペーサー	
121	VN413300	BIND HEAD BONDING B-T. SCREW	3x8 MFZN2BL		ボンディングBタイトネジ	01
122	EP600250	BIND HEAD B-TIGHT SCREW	3x8 MFZN2Y		バインドBタイトネジ	01
123	VQ541700	PW HEAD B-TIGHT SCREW	3x8-8 MFC2		BWヘッドBタイトネジ	01
124	21991500	PW HEAD S-TIGHT SCREW	4x8-10 MFC2BL		PWヘッドSタイトネジ	01
125	21991500	PW HEAD S-TIGHT SCREW	4x8-10 MFC2BL	BL	PWヘッドSタイトネジ	01
125	VD069600	PW HEAD S-TIGHT SCREW	4x8-10 MFN133	SI	PWヘッドSタイトネジ	01
126	VT669400	PW HEAD B-TIGHT SCREW	3x15-8 MFC2		PWヘッドBタイトネジ	01
127	VH610100	BIND HEAD SCREW	3x14 MFZN2BL		バインド小ネジ	01
128	EP620160	BIND HEAD P-TIGHT SCREW	2.6x6 MFZN2BL		バインドPタイトネジ	01
129	V6534900	BIND HEAD S-TIGHT SCREW	2.6x5 MFZN2BL		バインドSタイト	
130	VG893800	BIND HEAD P-TIGHT SCREW	2x6 MFZN2BL		バインドPタイトネジ	01
131	EP600410	BIND HEAD S-TIGHT SCREW	3x6 MFZN2Y		バインドSタイトネジ	01
132	V3768900	SCREW, LOCK	17L-003C41		ロックネジ	01
133	VB748400	BIND HEAD SCREW	3x8 MFN133		バインド小ネジ	01
134	VE190700	BIND HEAD BONDING B-T. SCREW	3x6 MFC2BL		ボンディングBタイトネジ	01
* 135	WB586000	PL RUBBER RIVET	P3555B		ナイロンリベット	
* 137	WC186100	PAN HEAD TORX B-TIGHT SCREW	3x8 MFN133		ナベトルクスBタイトネジ	
		ACCESSORIES			付属品	
* 200	WB090600	REMOTE CONTROL	MCX1	RRS3000-5801LM	リモコン	
* 200-1	AAX51070	BATTERY COVER	103RRC-122-09R	103RRC-122-09R	電池蓋	
* 202	V5189700	OPTICAL FIBER CABLE	1m YAF11-0653		光ファイバケーブル	04
* 203	V8579800	AUDIO PIN CABLE	2P 1.5m RE/WH		ステレオピンケーブル	03
* 204	VE337100	VIDEO CABLE	1P 1.5m		映像ピンケーブル	04
		BATTERY, MANGANESE	R6DW		マンガン電池2PC	

* New Parts * 新規部品(マーク#の部品は、基板に含まれません)

FRONT PANEL UNIT

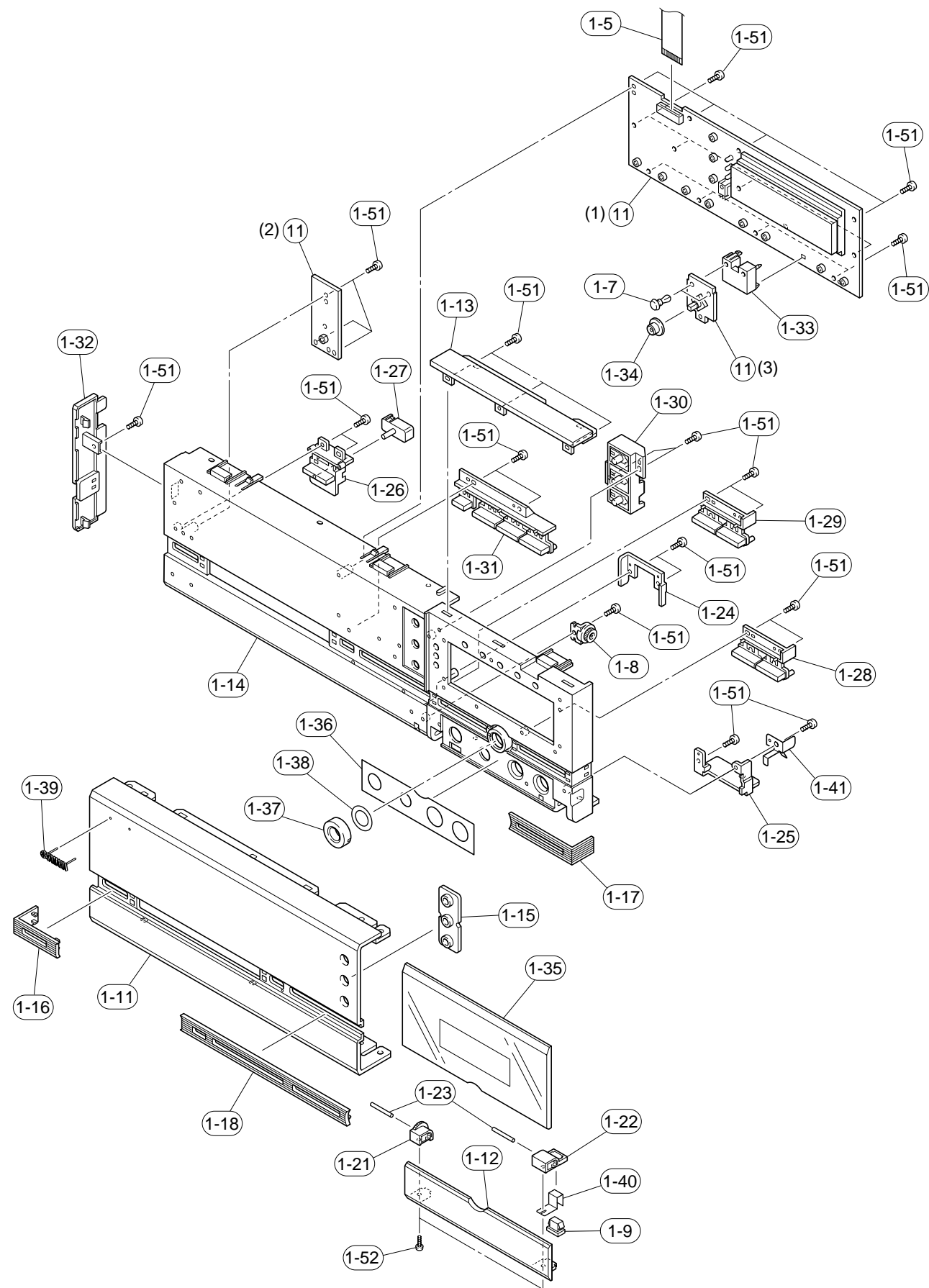

FRONT PANEL UNIT

Schm Ref.	PART NO.	Description	Remarks	Markets	部 品 名	Rank
* 1-5	WB854400	FFC/CABLE	40P 200mm		シールドバンカード	
* 1-7	WB586000	PL RUBBER RIVET	P3555B		ナイロンリベット	
* 1-8	WB215600	DAMPER/GEAR	002P-E		ダンパ/ギア	
* 1-9	V3073400	MAGNET CATCH	TL-248		マグネットキャッチ	04
* 1-11	WA869400	FRONT PANEL		BL	フロントパネル	
* 1-11	WA869500	FRONT PANEL		SI	フロントパネル	
* 1-12	WA869600	PANEL, LID		BL	パネル/リッド	
* 1-12	WA869700	PANEL, LID		SI	パネル/リッド	
* 1-13	WA869900	PLATE/TOP		BL	プレート/TOP	
* 1-13	WA870000	PLATE/TOP		SI	プレート/TOP	
* 1-14	WA870400	SUB PANEL		BL	サブパネル	
* 1-14	WA870600	SUB PANEL		SI	サブパネル	
* 1-15	WA871800	ESCUTCHEON		BL	エスカッション	
* 1-15	WA871900	ESCUTCHEON		SI	エスカッション	
* 1-16	WA871200	COVER/L			カバー/L	
* 1-17	WA871300	COVER/R			カバー/R	
* 1-18	WA871400	COVER/CENTER			カバー/CENTER	
* 1-21	WA872300	HINGE/L			ヒンジ/L	
* 1-22	WA872400	HINGE/R			ヒンジ/R	
* 1-23	WA870300	SHAFT			シャフト	
* 1-24	WA869000	STOPPER/SA			ストッパ/SA	
* 1-25	WA869100	STOPPER/SB			ストッパ/SB	
* 1-26	WA870800	BUTTON, 1P			ボタン/1P	
* 1-27	WA877700	LENS, LED			レンズ	
* 1-28	WA870900	BUTTON, 2P	R		ボタン/2P	
* 1-29	WA973500	BUTTON, 2P	L		ボタン/2P	
* 1-30	WA871000	BUTTON, 3P		BL	ボタン/3P	
* 1-30	WA973400	BUTTON, 3P		SI	ボタン/3P	
* 1-31	WA871100	BUTTON, 4P			ボタン/4P	
* 1-32	WA871600	PLATE SIDE		BL	プレートサイド	
* 1-32	WA871700	PLATE SIDE		SI	プレートサイド	
* 1-33	WA872500	SPACER, PCB			スペーサ/PCB	
* 1-34	WA872100	BUTTON/SELECT			ボタン/SELECT	
* 1-35	WA870700	WINDOW PANEL, LID			ウインドウ	
* 1-36	WA872800	SHEET, PS		BL	シート/P	
* 1-36	WB151200	SHEET, PS		SI	シート/P	
* 1-37	WA870100	BUTTON/CAP			ボタン/キャップ	
* 1-38	WB151300	SHEET/CAP			シート/CAP	
* 1-39	V6034100	EMBLEM			エンブレム	
* 1-40	WB820600	EARTH PLATE A			アースプレート A	
* 1-41	WB820700	EARTH PLATE B			アースプレート B	
1-51	EP630220	BIND HEAD P-TIGHT SCREW	3x8 MFZN2BL		バインドPタイトネジ	01
1-52	VZ518600	FLAT HEAD P-TIGHT SCREW	2.6x6 MFZN2BL		皿Pタイト	01
* 11	WB160900	P.C.B. ASS'Y	OPERATION	J	PCB集成オペレーション	
* 11	WB161000	P.C.B. ASS'Y	OPERATION	UC	PCB集成オペレーション	
* 11	WB161100	P.C.B. ASS'Y	OPERATION	A	PCB集成オペレーション	
* 11	WB161200	P.C.B. ASS'Y	OPERATION	BG	PCB集成オペレーション	

* New Parts * 新規部品(マーク#の部品は、基板に含まれません)

1 ■ HDD TRAY UNIT

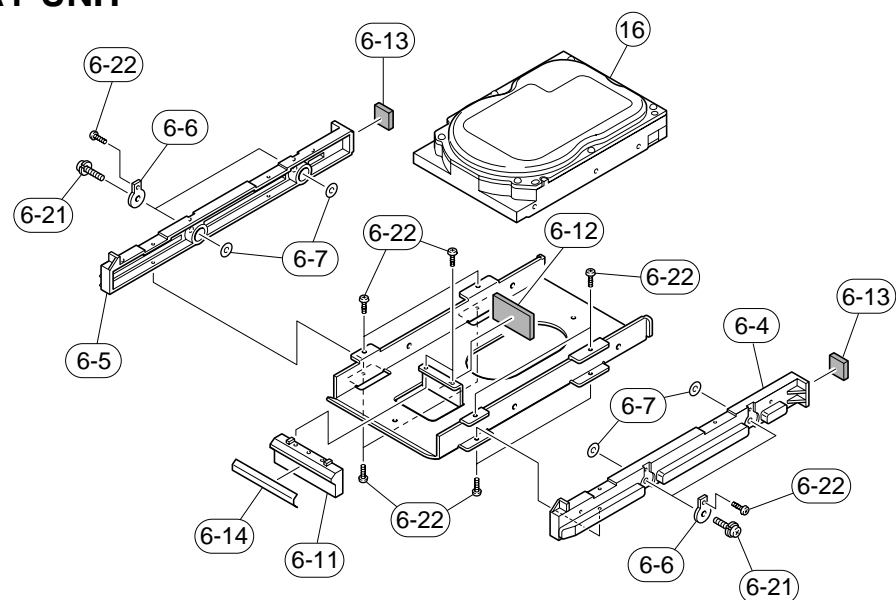

1 ■ HDD TRAY UNIT

Schm Ref.	PART NO.	Description	Remarks	Markets	部品名	Rank
6-4	V9479200	FRAME SIDE/R			フレーム サイド/R	01
6-5	V9479300	FRAME SIDE/L			フレーム サイド/L	01
6-6	V9478800	WASHER/SIDE			ワッシャー/サイド	
6-7	V9597400	WASHER/B			ワッシャー/B	01
6-11	V9569400	STOPPER			ストッパー/トレイ	
6-12	V9597500	DAMPER/BASE			ダンパー/BASE	
6-13	V9597700	DAMPER/TRAY			ダンパー/TRAY	
6-14	WB636600	SHEET/S			シート/S	
6-21	V9597800	PAN HEAD SCREW	6x32 MFZN2BL		十ナベ小ネジ	
6-22	VG893800	BIND HEAD P-TIGHT SCREW	2x6 MFZN2BL		バインドPタイトネジ	01
16	WA143300	HDD UNIT	3.5inch 80G		HDDユニット	45

* New Parts * 新規部品(マーク#の部品は、基板に含まれません)

2 ■ TRAY GUIDE UNIT

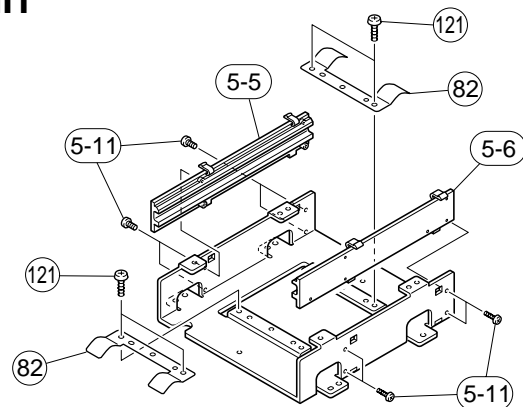

2 ■ TRAY GUIDE UNIT

Schm Ref.	PART NO.	Description	Remarks	Markets	部品名	Rank
5-5	V9479400	SUPPORT SIDE/R			サポート サイド/R	01
5-6	V9479500	SUPPORT SIDE/L			サポート サイド/L	01
5-11	VG893800	BIND HEAD P-TIGHT SCREW	2x6 MFZN2BL		バインドPタイトネジ	01
82	V9479000	EARTH PLATE			アースプレート	
121	VN413300	BIND HEAD BONDING B-T. SCREW	3x8 MFZN2BL		ボンディングBタイトネジ	01

* New Parts * 新規部品(マーク#の部品は、基板に含まれません)

3 ■ CDR UNIT

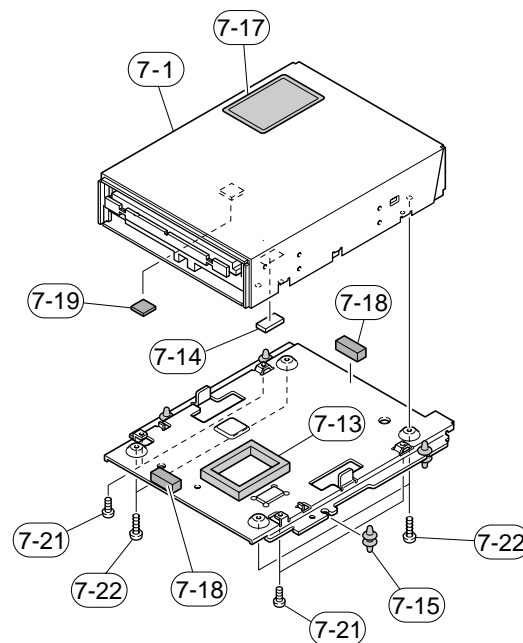

3 ■ CDR UNIT

Schm Ref.	PART NO.	Description	Remarks	Markets	部品名	Rank
7-1	WA875100	CDR MECHANICAL UNIT	CRW-F1AML		CDRメカユニット	
7-13	V6445800	PACKING/FFC			パッキン/FFC	
7-14	V9482200	HEAT SINK SHEET 8x16	INT-F1ML		放熱シート 8x16	01
7-15	V7881200	CUSHION/CDR			クッション/CDR	
7-17	V8147000	LABEL/LASER CAUTION			ラベル/レーザー	
7-18	V9844200	SOFT GASKET	UC-300279		ソフト ガasket	02
7-19	V9877000	HEAT SINK SHEET 16x16	INT-F1ML		放熱シート 16x16	
7-21	V6534900	BIND HEAD S-TIGHT SCREW	2.6x5 MFZN2BL		十バインドSタイト	
7-22	EP620100	BIND HEAD P-TIGHT SCREW	2.6x8 MFZN2Y		バインドPタイトネジ	01

* New Parts * 新規部品(マーク#の部品は、基板に含まれません)

■ REMOTE CONTROL

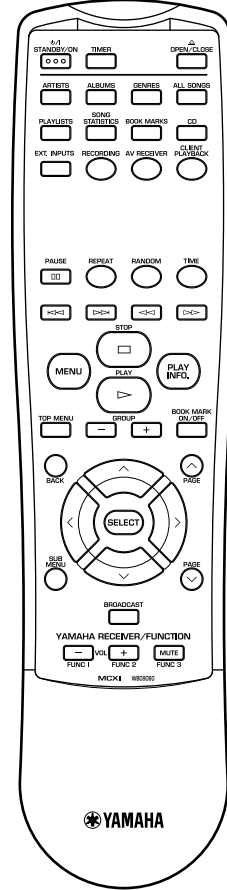
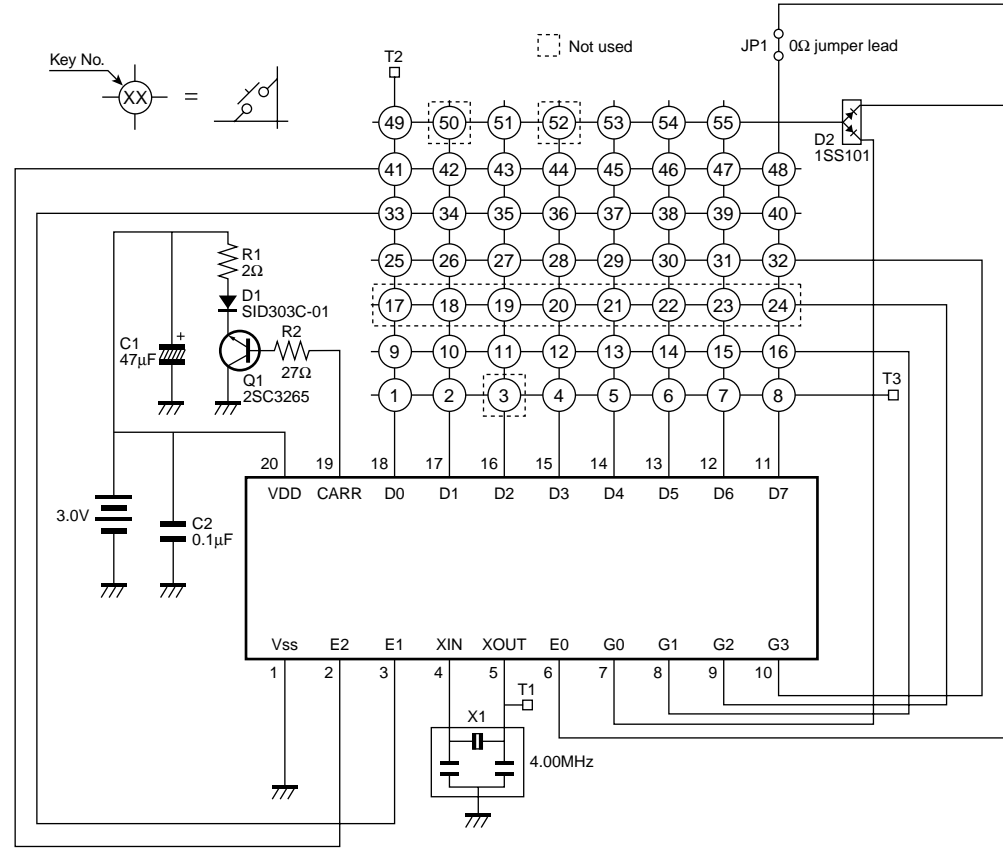

Custom Code: 80-37

Key No.	Key Name	Data Code	Key No.	Key Name	Data Code
1	STANDBY/ON \downarrow /I	20	32	\triangleright	27
2	TIMER	5F	33	\square	25
4	OPEN/CLOSE	21	34	MENU	51
5	ARTISTS \triangle	40	35	PLAY INFO.	4E
6	ALUBUMS	41	36	\triangleleft	22
7	GENRES	42	37	TOP MENU	50
8	ALL SONGS	43	38	GROUP -	2A
9	PLAYLISTS	44	39	GROUP +	2B
10	SONG STATISTICS	45	40	BOOK MARK ON/OFF	4F
11	BOOK MARKS	46	41	BACK	57
12	CD	47	42	PAGE \wedge	59
13	EXT. INPUTS	4B	43	\wedge	52
14	RECORDING	48	44	\leftarrow	54
15	AV RECEIVER	49	45	SELECT	56
16	CLIENT PLAYBACK	4A	46	\rightarrow	55
25	PAUSE \square	23	47	\vee	53
26	REPEAT	33	48	SUB MENU	58
27	RANDOM	32	49	PAGE \vee	5A
28	TIME	30	51	BROADCAST	31
29	\triangleleft	28	53	FUNC1	3E
30	\triangleright	29	54	FUNC2	3F
31	\triangle	26	55	FUNC3	3D

Setting up the MCX-1000

This document refers to the MCX-1000 DIGITAL AUDIO SERVER as the MusicCAST server and the MCX-A10 DIGITAL AUDIO TERMINAL as the MusicCAST client.

Carry out the procedures outlined in gray before attempting to use the MCX-1000.

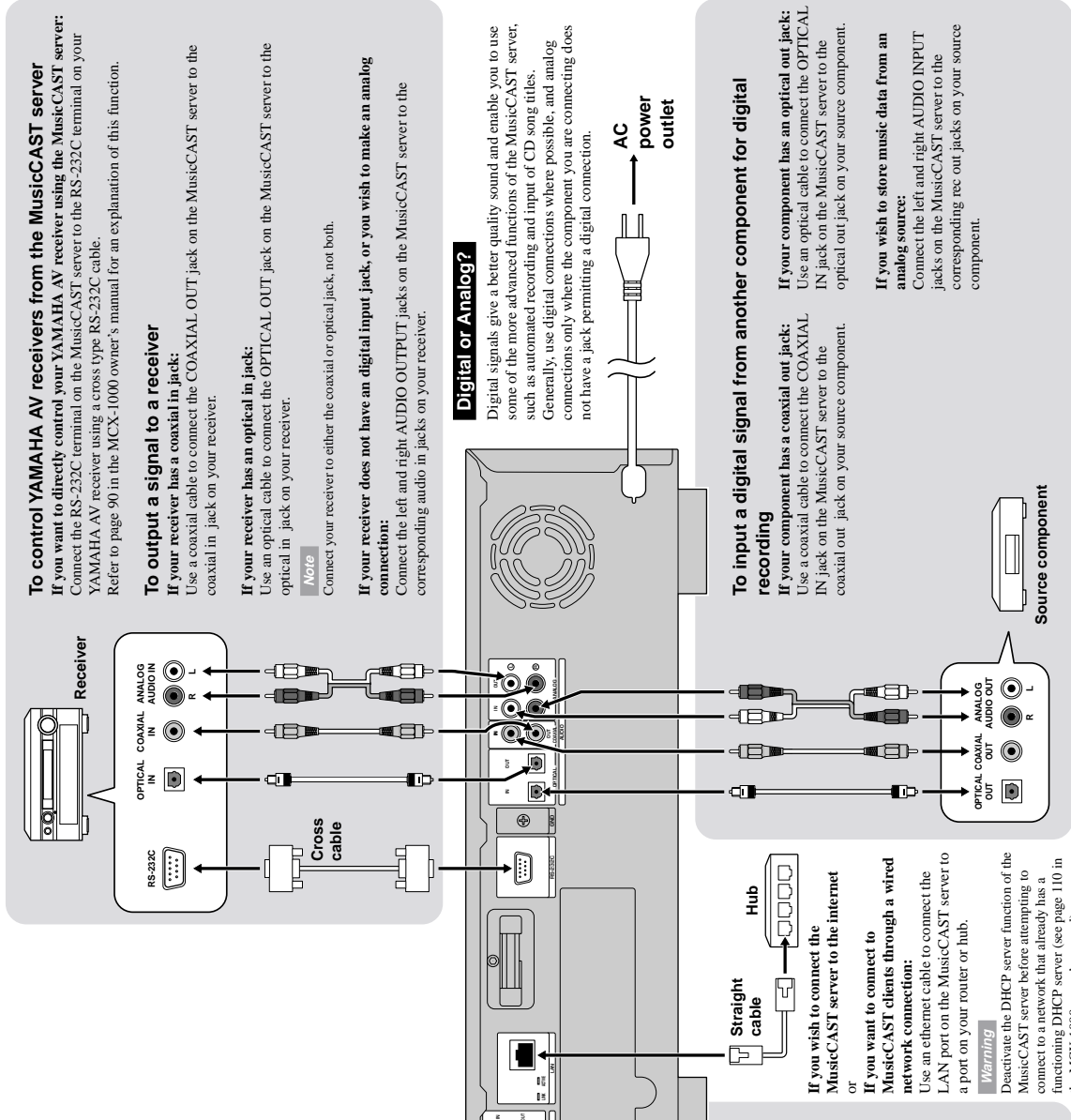
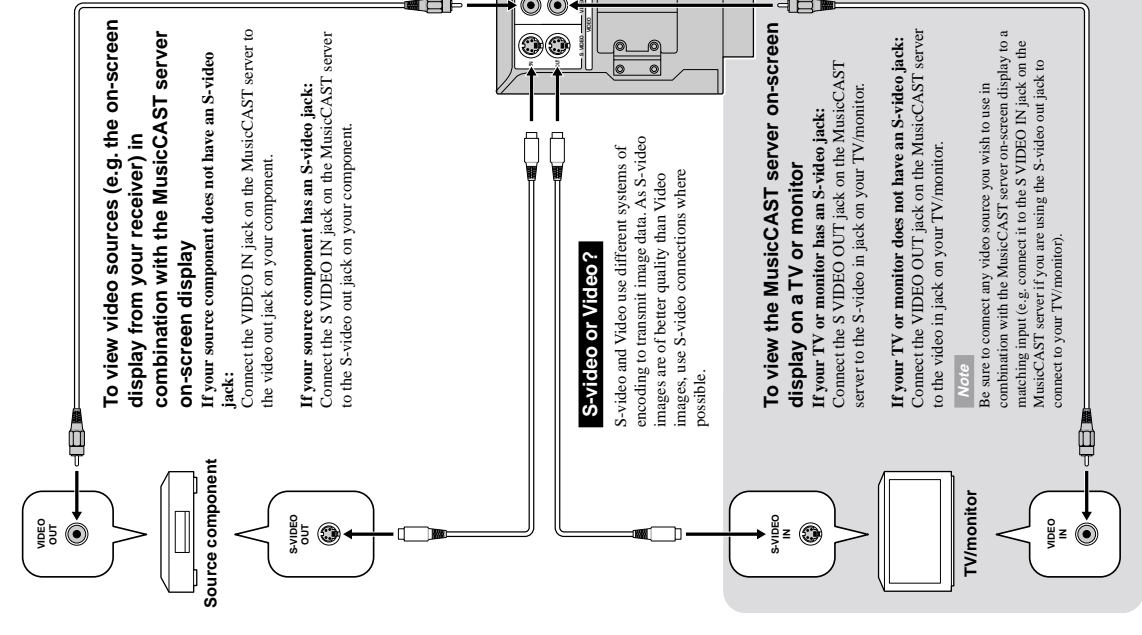

To control YAMAHA AV receivers from the MusicCAST server
 If you want to directly control your YAMAHA AV receiver using the MusicCAST server: Connect the RS-232C terminal on the MusicCAST server to the RS-232C terminal on your YAMAHA AV receiver using a cross type RS-232C cable. Refer to page 90 in the MCX-1000 owner's manual for an explanation of this function.

To output a signal to a receiver
 If your receiver has a coaxial in jack: Use a coaxial cable to connect the COAXIAL OUT jack on the MusicCAST server to the coaxial in jack on your receiver.
 If your receiver has an optical in jack: Use an optical cable to connect the OPTICAL OUT jack on the MusicCAST server to the optical in jack on your receiver.
Note
 Connect your receiver to either the coaxial or optical jack, not both.
 If your receiver does not have a digital input jack, or you wish to make an analog connection: Connect the left and right AUDIO OUTPUT jacks on the MusicCAST server to the corresponding audio in jacks on your receiver.

Digital or Analog?
 Digital signals give a better quality sound and enable you to use some of the more advanced functions of the MusicCAST server, such as automated recording and input of CD song titles. Generally, use digital connections where possible, and analog connections only where the component you are connecting does not have a jack permitting a digital connection.

To input a digital signal from another component for digital recording
 If your component has an optical out jack: Use an optical cable to connect the OPTICAL IN jack on the MusicCAST server to the optical out jack on your source component.
 If your component has a coaxial out jack: Use a coaxial cable to connect the COAXIAL IN jack on the MusicCAST server to the coaxial out jack on your source component.
Note
 If you wish to store music data from an analog source: Connect the left and right AUDIO INPUT jacks on the MusicCAST server to the corresponding rec out jacks on your source component.

To view the MusicCAST server on-screen display on a TV or monitor
 If your TV or monitor has an S-video jack: Connect the S VIDEO OUT jack on the MusicCAST server to the S-video in jack on your TV/monitor.
 If your TV or monitor does not have an S-video jack: Connect the VIDEO OUT jack on the MusicCAST server to the video in jack on your TV/monitor.
Note
 Be sure to connect any video source you wish to use in combination with the MusicCAST server on-screen display to a matching input (e.g. connect it to the S VIDEO IN jack on the MusicCAST server if you are using the S-video out jack to connect to your TV/monitor).
Warning
 Deactivate the DHCP server function of the MusicCAST server before attempting to connect to a network that already has a functioning DHCP server (see page 110 in the MCX-1000 owner's manual).

If you wish to connect the MusicCAST server to the internet
 or
If you want to connect to MusicCAST clients through a wired network connection:
 Use an ethernet cable to connect the LAN port on the MusicCAST server to a port on your router or hub.

Setting up the MCX-A10

Carry out the procedures outlined in gray before attempting to use the MCX-A10.

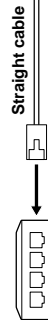

If you want to connect the MusicCAST client to a wired network

Use an ethernet cable to connect the LAN port on the MusicCAST client to a port on your hub.



If you want to input an audio signal from another component to the MusicCAST client

Connect the AUX IN jack on the MusicCAST client to the output jack on your component.

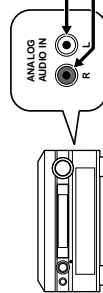

If you want to output an audio signal from the MusicCAST client to another component

Connect the left and right LINEOUT jacks on the MusicCAST client to the corresponding input jacks on your component.

The MusicCAST client will only output an analog signal.

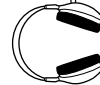

If you want to listen to the MusicCAST client through headphones

Connect your headphones to the PHONES jack. Output from the S.WOOFER jack and SPEAKER OUT terminals stops.

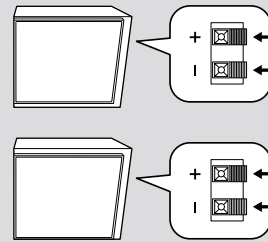

To connect the MusicCAST client to your speakers

You can connect the MusicCAST client to two speakers for stereo playback. Use a speaker cable to connect one of the negative (-) terminals on the MusicCAST client to the negative (-) terminal on one of your speakers.

Then connect the positive (+) terminal on the speaker to the matching positive (+) terminal on the MusicCAST client.

Repeat this operation for the other speaker. The speakers depicted are MCX-SP10 speakers designed specifically for use with the MCX-A10. You can also use the MCX-A10 in conjunction with other commercially available speakers.

Note

On the MCX-SP10 speakers, the red speaker terminals are positive, the black are negative.

To connect the MusicCAST client to AC power

Connect the AC power cable to the AC adaptor, then connect the AC adaptor to the DC IN 12V jack on the MusicCAST client. Finally, plug in the AC power cable to an AC outlet.

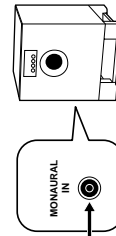
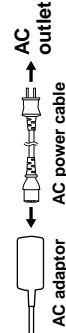

If you want to view the on-screen display using a TV/monitor

Connect the VIDEO OUT jack on the MusicCAST client to a video in jack on your TV/monitor.

If you want to connect the MusicCAST client to a subwoofer

Using the cable supplied, connect the S.WOOFER jack on the MusicCAST client to the input jack on your subwoofer.

Setting up the MusicCAST network

For a wireless connection

Place your MusicCAST client within approximately 30 meters of the MusicCAST server

Walls and obstructions placed between the distance over which they can achieve wireless network connections. The actual distance over which your MusicCAST components can make wireless connections may be reduced significantly depending on the layout and construction of the environment you are using them in.



30m or less

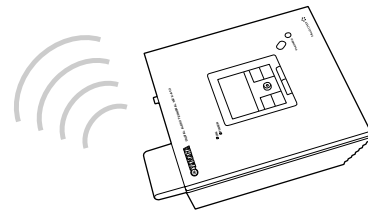

Note
Metal mounting racks may affect wireless network signals. Use wired network connections when mounting MusicCAST components in metal racks.

For a wired connection

Connect to components ①-④

Note
There is no specific order required for connection. The MusicCAST server can support simultaneous playback on up to seven MusicCAST client.

① MusicCAST server

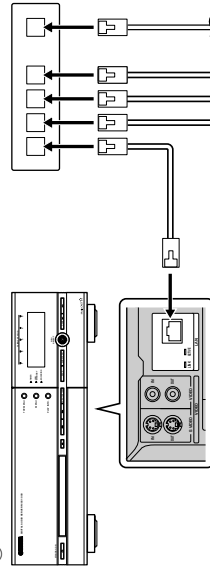

Caution

Deactivate the DHCP server function of the MusicCAST server before attempting to connect to a network that already has a functioning DHCP server (see page 110 in the MCX-1000 owner's manual).

Connect to your internet connection device

(eg: ADSL/Cable modem, ISDN terminal adapter, etc.)

② MusicCAST client

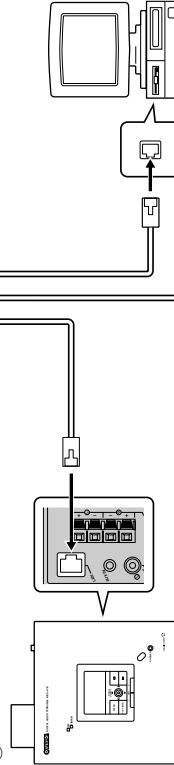

③ MusicCAST client

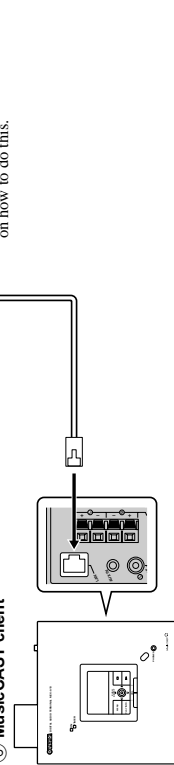

④ Personal Computer

You need to configure the router using a personal computer if you wish to connect to the internet. Consult the manual for your router for instructions on how to do this.

Sample network configurations

Standard wireless solution

Using internal wireless connection

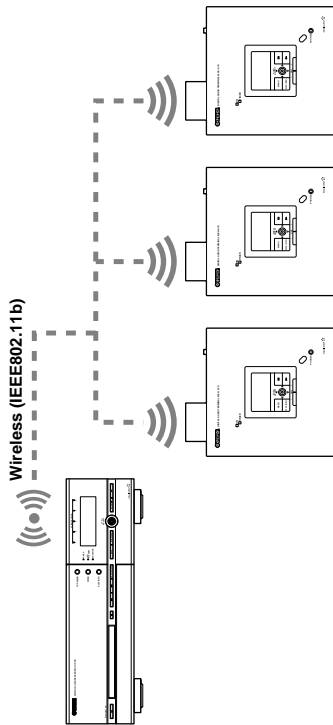

Use the Auto Configuration process described on page 12 in the quick manual to configure your MusicCAST components for the standard wireless solution.

Dual network solution

Wireless and wired connection to server

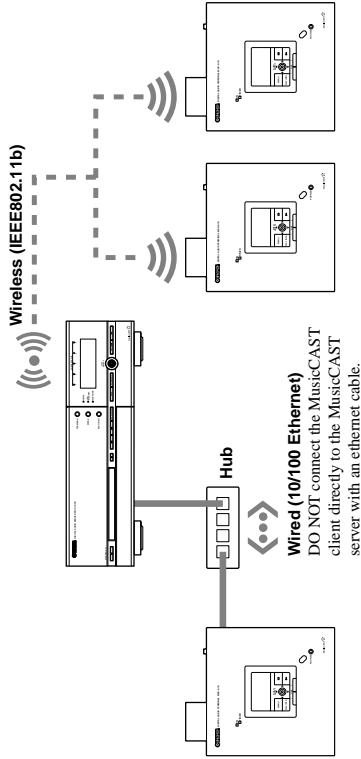

Use the Auto Configuration process described on page 12 in the quick manual to configure your components for a dual network solution.

Internet access solution

Used for updating CD recognition database

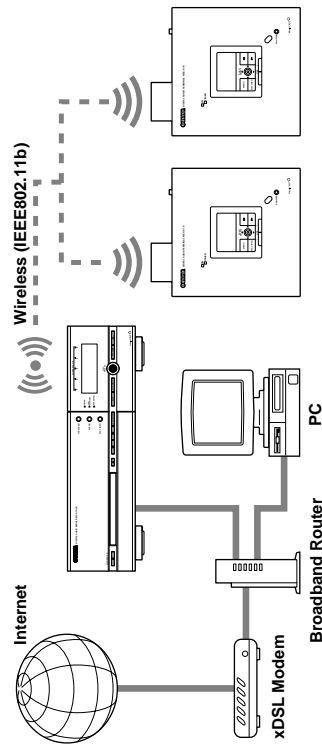

Use the Auto Configuration process described on page 12 in the quick manual to configure your components for an internet access solution.

Caution

Deactivate DHCP server function of the MusicCAST server before attempting to connect to a network that already has a functioning DHCP server (see page 110 in the MCX-1000 owner's manual).

Extended wireless solution

Used for expanding wireless coverage area

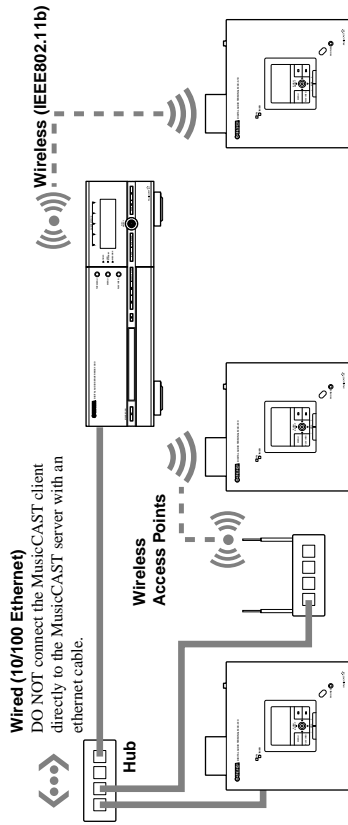

Configure all network settings manually for MusicCAST clients connecting via a wireless access point. Either configure your MusicCAST network to work without a WEP key (see page 111 in the MCX-1000 owner's manual) or set your wireless access terminal to use 128 bit WEP encryption (refer to the owner's manual for your wireless access terminal for instructions on how to do this).

About the Quick Manual

The Quick Manual is aimed at first time users of the MusicCAST system, and contains an easy to understand explanation of the general system functions. You can gain a basic understanding of how to use the MusicCAST system just by reading the Quick Manual.

The MusicCAST system provides a great many capabilities, ranging from the ability to store audio data from CDs and other sources, to the ability to simultaneously playback music in multiple different locations. This Quick Manual is divided into sections, each explaining how to correctly set and use a specific subset of the MusicCAST system functions. The sections in the Quick Manual are:

1. Configuring the MusicCAST network.
2. Storing CDs on the MusicCAST server.
3. Using the MusicCAST server to play back songs.
4. Using the MusicCAST client to play back songs recorded on the MusicCAST server.
5. A summary of the more advanced functions that the MusicCAST system provides.

Please refer to the MCX-1000 owner's manual or MCX-A10 owner's manual for more detailed explanations of the functions listed here, and of functions that are not covered in this quick manual.

This quick manual refers to the MCX-1000 DIGITAL AUDIO SERVER as the MusicCAST server and the MCX-A10 DIGITAL AUDIO TERMINAL as the MusicCAST client.

About the Quick Manual

The MusicCAST system

The MusicCAST system consists of two components which allow you to store music and play it back in multiple locations. You can store many of the CDs in your collection and play them back whenever you want, rather like a jukebox. The two components in the system are explained below.

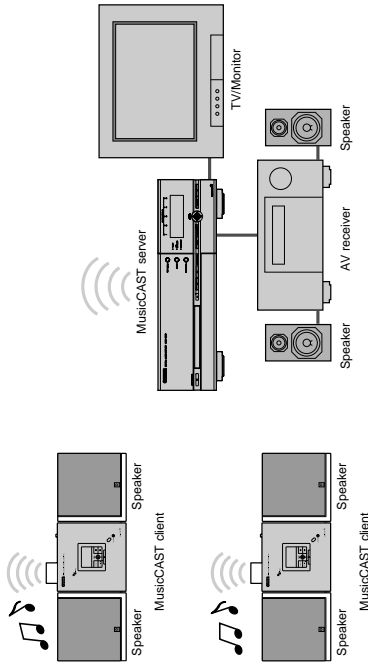

The MusicCAST Server

The MusicCAST server can store approximately 1,000 music CDs on its internal hard disk drive, which it can then playback, or distribute to MusicCAST clients for playback at a distance. It records the names of the songs, artist, album, and the music genre of the CD during the storage process, allowing easy access to the songs without requiring you to enter any data by hand. You can then use these criteria to look for and select songs for playback simply and quickly. You can also set the MusicCAST Server to play songs at random, repeat one particular song, or select from a number of other playback options.

VIEWID

The actual number of CDs the MusicCAST server can store depends on the format you choose to store songs in.

The MusicCAST Client

The MusicCAST client connects to the MusicCAST server, acting as a player for the songs stored on its hard disk drive. Since the MusicCAST client can connect to the MusicCAST server through a wireless connection, you can install it without installing any connecting cables. You can, for example, install a MusicCAST server in your living room, and MusicCAST clients in your bedroom and childrens' rooms, then and listen to the

music stored in the MusicCAST server from each location. The MusicCAST client allows you to search for songs in the same manner as the MusicCAST server, by selecting song, album, artist, or genre. Additionally, because the MusicCAST server is capable of connecting to up to 5 MusicCAST clients via wireless connections, or 7 MusicCAST clients via a combination of wired and wireless connections, you can play different songs on multiple MusicCAST clients at the same time.

NOTE

- The MusicCAST server is capable of distributing music to up to 7 MusicCAST clients simultaneously. Depending on factors such as the playback format you are using and the strength of the network signal available to MusicCAST clients connecting via wireless connections, it may be advisable to reduce the number of MusicCAST clients in your MusicCAST system if you encounter problems with playback.
- When using many MusicCAST clients simultaneously, the MusicCAST system is sensitive to changes or weakness in network signal strength. To ensure smooth playback select a low MP3 bitrate to store songs in (see page 121).
- Changes in the strength of the network signal, or a weak network signal, can easily affect playback of songs distributed to MusicCAST clients in PCM format over wireless network connections. If playback skips or pauses, set the MusicCAST server to distribute songs to MusicCAST clients in MP3 format.

About the Quick Manual

Operating the MusicCAST server

Use the remote control and the television connected to your MusicCAST server to carry out the procedures described in this Quick Manual.

If you connect your MusicCAST server to a television, you can easily search for CD titles, artist names, and other data on screen. You can also set all the other parameters used to operate the MusicCAST system from this on-screen display.

This Quick Manual assumes that you have connected your MusicCAST server to a TV/Monitor, and uses illustrations of the on-screen display to explain operations.

Most of the explanations in this manual center on using the remote control to operate MusicCAST components, but you can also access most functions directly from the MusicCAST server and client units. Refer to the illustrations provided with each explanation to check which keys or buttons are applicable for each step.

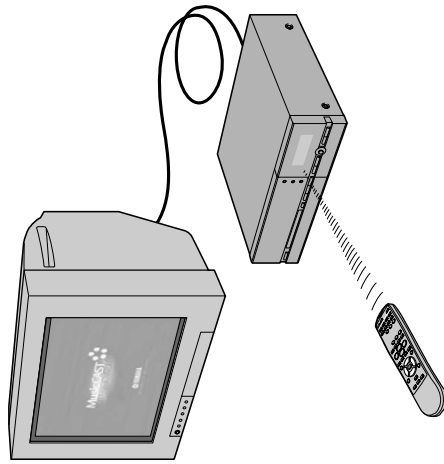

Using a TV/Monitor to view the MusicCAST server on-screen display

- 1 Insert the MusicCAST server plug into an AC outlet.
- 2 Press STANDBY/ON to switch the MusicCAST server power on.
The indicator on the STANDBY/ON button changes to green.
- 3 Turn the power of the TV/Monitor connected to the MusicCAST server on, and set it to display the MusicCAST video output (refer to your television manual for instructions on how to do this).

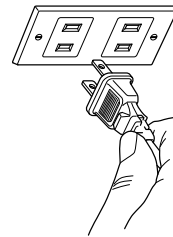

(U.S.A. model)

6

Getting started

Checking your system connections

You must connect your MusicCAST system correctly to fully use all of its functions. Follow the instructions in the attached "Setup guide" carefully when setting up your system.

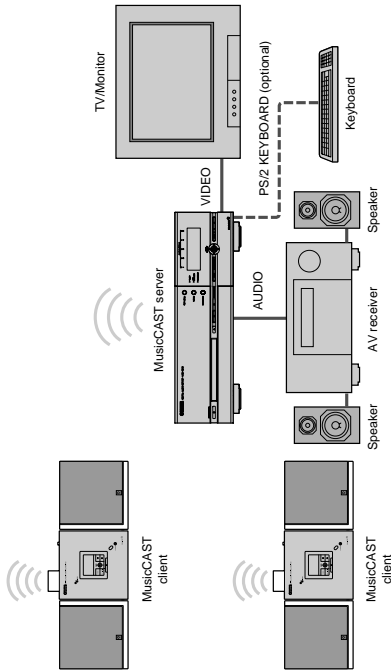

Getting started

Component check list

Check that you have the following connections and components in your MusicCAST system.

VIDEO

Not all of the items listed below are absolutely necessary. Check the comments provided for an explanation of the purpose of each component.

- MusicCAST client power
- MusicCAST client speakers
- MusicCAST server power
- TV/Monitor
- PS/2 keyboard (OPTIONAL)
- AV receiver, speakers
- MusicCAST server power
- Connect the MusicCAST server to an AC power outlet.
- You must connect speakers to the MusicCAST client if you wish to listen to music from it directly.
- For easy entry and editing of information such as album and song titles on the MusicCAST server.
- Connect all MusicCAST clients to an AC power outlet.
- Connect the MusicCAST server to an AC power outlet.

Allows full operation of MusicCAST server from the on-screen display.

Stores, plays back, and distributes songs stored on its internal hard disk drive.

Plays any of the songs stored in the MusicCAST server. MusicCAST clients are not capable of playback without a connection to a MusicCAST server.

You must connect speakers and an amplifier or AV receiver to the MusicCAST server if you wish to listen to music from it directly.

7

Getting started

Preparing the remote controls

Preparing the MusicCAST server remote control

- Inserting the batteries
- 1 Remove the cover on the underside of the remote control.
- 2 Insert two AA batteries into the battery compartment, checking that the positive (+) and negative (-) terminals on the batteries correspond to the polarity markings on the case.
- 3 Slide the cover back until it snaps into place.

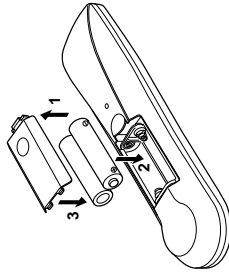

■ Using the remote control

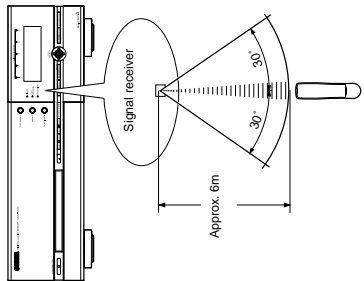

MEMO

- If using this remote control causes other equipment to malfunction, change the location of the equipment.
- Do not spill water or other liquids on the remote control.
- Do not store or leave the remote control in conditions of high temperature or humidity, such as near a stove, heater, or bath.
- Do not place the MusicCAST server in locations where the signal receiver will be in direct sunlight or near lighting equipment. The remote control may not function correctly in these conditions.

■ Battery replacement

If you find that the remote control must be used closer to the main unit than usual, the battery is weak. Replace the battery with new one.

■ Notes on batteries

- Please use AA size batteries.
- Do not use old batteries together with new ones.
- Do not use different types of batteries (such as alkaline and manganese batteries) together.
- Do not use rechargeable batteries.
- Remove the batteries from the remote control if you do not intend to use it for an extended period.
- If the battery leaks, dispose of it immediately. Avoid touching the leaked material or letting it come in contact with clothing, etc. Skin contact may cause burn. If it occurs, wash with water promptly and get medical attention.
- Do not connect the positive (+) and negative (-) terminals of any one-battery together.

Getting started

- If the battery leaks, dispose of it immediately. Avoid touching the leaked material or letting it come in contact with clothing, etc. Skin contact may cause burn. If it occurs, wash with water promptly and get medical attention.

■ Using the remote control

- Inserting the lithium batteries
- 1 Slide out the battery holder from the remote control by pushing into the hole in the holder with a ball-point pen, etc.
- 2 Place the battery in the holder, positive side upward.
- 3 Slide the holder into the remote control.

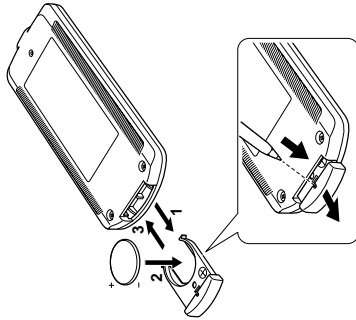

■ Battery replacement

If you find that the remote control must be used closer to the main unit than usual, the battery is weak. Replace the battery with new one.

■ Notes on the lithium battery

- Please take care when using the lithium battery as it may explode if mistreated.
- Never disassemble the battery.
 - Be sure the battery polarity is correct. If it is not installed correctly, it may cause fire or explosion.
 - Avoid placing the lithium battery or the remote control with the battery installed, in high temperature areas such as in direct sunlight.
 - Do not recharge the battery.
 - When replacing the battery, make sure to only use a CR2025 battery.
 - Keep the battery out of reach of children. If swallowed, get immediate medical help.
 - When disposing of the battery, insulate it with tape, etc. Never dispose of it in fire. Also, dispose of the battery according to local regulations.

MEMO

- If using this remote control causes other equipment to malfunction, change the location of the equipment.
- Do not spill water or other liquids on the remote control.
- Do not store or leave the remote control in conditions of high temperature or humidity, such as near a stove, heater, or bath.
- Do not place the MusicCAST client in locations where the signal receiver will be in direct sunlight or near lighting equipment. The remote control may not function correctly in these conditions.

Getting started

Connecting a keyboard to the MusicCAST server (OPTIONAL)

If you connect a keyboard to the MusicCAST server, you can enter and edit song and album titles directly, as well as other data and settings on your MusicCAST server. The MusicCAST system is compatible with any standard PS/2 style keyboard.

Connecting a keyboard to the MusicCAST server

- 1 If the MusicCAST server is turned on, press and hold **STANDBY/ON** for two seconds to place it in standby mode.
- 2 Disconnect the MusicCAST server from the AC power outlet.

NOTE

Disconnecting the MusicCAST server from AC power for more than one minute causes the internal clock in the MusicCAST server to become incorrect. Reset the date and time parameters to the correct settings (see page 118 in the MCX-1000 owner's manual for an explanation on how to do this).

- 3 Connect the keyboard jack to the **PS/2 KEYBOARD** input on the front panel of the MusicCAST server.
- 4 Reconnect the MusicCAST server to the AC power outlet.
- 5 Press **STANDBY/ON** to turn the MusicCAST server on.

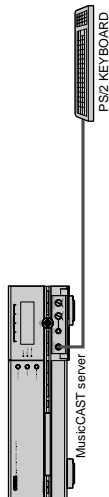

Setting the Keyboard parameters

Most of the explanations in this manual center on using the remote control to operate MusicCAST components, but you can also access most functions directly from the MusicCAST server and client units. Refer to the illustrations provided with each explanation to check which keys or buttons are applicable for each step.

- 1 Press **TOP MENU**. The Top Menu screen appears on the on-screen display.



10

Getting started

- 3 Use **^**/**v** to move the cursor to "Keyboard Type" and press **SELECT**. The Keyboard Type screen appears.



- 4 Use **^**/**<**/**>**/**v** to select the appropriate language from the menu.

Use the **^**/**<**/**>**/**v** to choose a setting and press **SELECT** to select it. Refer to the user manual for your keyboard to check its type and language.

- 5 Use **^**/**v** to move the cursor to "OK" and press **SELECT**.

The MusicCAST server confirms your settings and returns to the "System Setup" screen. Selecting "Cancel" cancels your settings and returns to the "System Setup" screen.

HINT

- Refer to page 22 for an explanation of how to enter characters.
- For a detailed explanation on character entry using a keyboard, see page 79 in the MCX-1000 owner's manual.

11

Configuring your MusicCAST network

Configuring your network

This quick manual describes how to use the Auto Configuration functionality of the MusicCAST system. For more detailed information on how to use the manual configuration options of the MusicCAST system refer to the sections on network configuration in the MusicCAST client and MCX-1000 owner's manuals.

Carry out the procedure described below to configure your MusicCAST system network settings using the Auto Configuration function. You can carry out Auto Configuration from multiple locations if necessary, but you may find it convenient to gather all of your MusicCAST components in one place for this procedure.

Using the Auto Configuration function

MusicCAST server

- 1 Press **TOP MENU**.

The Top Menu screen appears on the on-screen display of your MusicCAST server.



MusicCAST server

- 2 Use **↖↗** to move the cursor to "System Setup" and press **SELECT**.

The System Setup screen appears on the on-screen display of your MusicCAST server.



MusicCAST server

- 3 Use **↖↗** to move the cursor to "Network" and press **SELECT**.

The Network screen appears on the on-screen display of your MusicCAST server.



MusicCAST server

- 4 Use **↖↗** to move the cursor to "Auto Configuration" and press **SELECT**.

The following message appears on the on-screen display of your MusicCAST server.



Configuring your MusicCAST network

MusicCAST client

- 8 Use the controller on the MusicCAST client to move the cursor to "Network" and then press the controller.

The Network screen appears on the on-screen display of your MusicCAST client.



MusicCAST client

- 9 Use the controller on the MusicCAST client to move the cursor to "Auto Configuration" and press the controller.

The following screen appears on the on-screen display of your MusicCAST client.



MusicCAST client

- 10 Press **▶** to begin the Auto Configuration process.

The following screen appears on the on-screen display of your MusicCAST client.



- If the MusicCAST client finds more than one MusicCAST server it displays all the servers it finds on the on-screen display of your MusicCAST client.
- If the MusicCAST client does not find it more than one server it skips directly to step 11.



- Use the controller on the MusicCAST to move the cursor to the ID of the server you wish to select (the server ID is displayed on the Auto Configuration screen of the MusicCAST server on-screen display) and press it.

Storing CDs on the MusicCAST server

The first thing you should do to use your MusicCAST server is to store songs from a Music CD on its hard disk drive.

Why should I store CDs on the MusicCAST server?

The MusicCAST server can act as a CD player, playing a single CD at a time. However, it can also store large numbers of CDs on its hard disk drive, together with song, artist, and album titles, allowing easy access to the songs on your CDs whenever you want. You can select a song for playback just by choosing an artist, album, or genre name, and then choosing a song.

You can listen to any song stored on the MusicCAST server with a MusicCAST client, using the same simple method of selecting an artist, album, or genre.

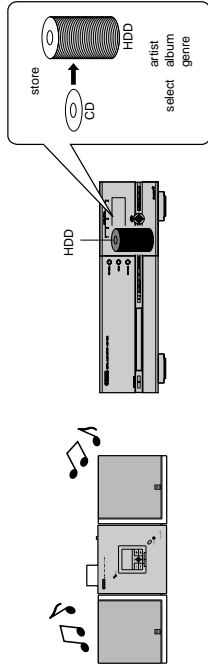

How does the MusicCAST server store songs from CDs?

When the MusicCAST server stores material in its internal hard disk drive, it also stores the relationships between the songs, genres, albums, and artists of the CDs you store. The diagram below depicts the relationships between these four groups.

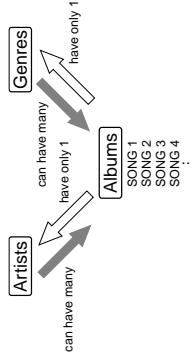

When you load a CD into the CD tray, the MusicCAST server attempts to find relevant information on the songs, genres, albums, and artists on the CD from its built-in Gracenote CDDB® database, or from the Internet-based Gracenote CDDB service.

VIDEO

- The MusicCAST server is set to access its built-in Gracenote CDDB database by default, and not to access the Internet-based Gracenote CDDB service. See page 119 in the MCX-1000 owner's manual for an explanation of how to change these settings.
- Provision of the Internet-based Gracenote CDDB database service is subject to termination without notice.
- Both the Internet-based and built-in Gracenote CDDB databases may occasionally display the wrong data, but you can edit this information by hand after you store the CD in the MusicCAST server hard disk drive (see page 21).
- If the Gracenote CDDB databases do not find any information about the CD you are storing, you can enter song, album, artist, and genre data by hand when storage is complete (see page 21).

Music recognition technology and related data are provided by Gracenote and the Gracenote CDDB Music Recognition ServiceSM. CDDB is a registered trademark of Gracenote. The Gracenote logo and logotype, the Gracenote CDDB logo and logotype, and the "Powered by Gracenote CDDB" logo are trademarks of Gracenote Music Recognition Service and MRS are service marks of Gracenote.

Configuring your MusicCAST network

11 The MusicCAST client attempts to connect to the MusicCAST server you select. The following screens appear on the MusicCAST client on-screen display in order:



MusicCAST server

12 The Client ID of the MusicCAST client you are attempting to configure appears on the on-screen display of the MusicCAST server.



MusicCAST server

13 Use \leftarrow / \rightarrow on the MusicCAST server remote control to move the cursor to "OK" on the on-screen display of your MusicCAST server and press SELECT.

The MusicCAST server restarts its network hardware. This will take five minutes at most. The following screen appears on the on-screen display of your MusicCAST client.



The Auto Configuration process is complete.

Storing CDs on the MusicCAST server

Loading a CD into the MusicCAST server

Load the CD you want to store into the MusicCAST server.

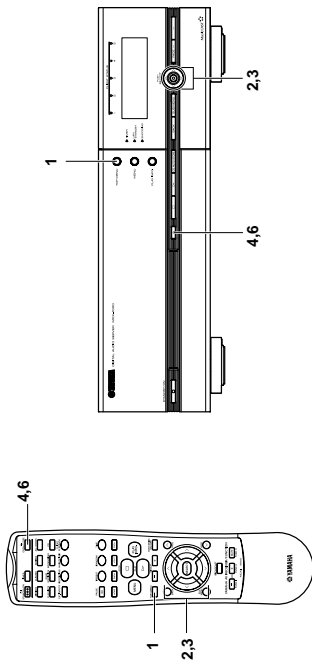

1 Press TOP MENU.

The Top Menu screen appears on the on-screen display.



2 Use \wedge/\vee to move the cursor to "Recording" and press SELECT.

The following screen appears on the on-screen display.



4 Press OPEN/CLOSE to open the disc tray.

5 Place the CD you wish to store in the MusicCAST server in the disc tray.

Place the CD in the tray label-side up, aligned with the grooves on the disc tray.

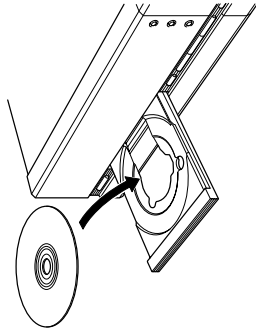

6 Press OPEN/CLOSE to close the disc tray.

When you load a CD, the MusicCAST server reads the type and volume of the CD, and then, if set to do so, looks for the names of the songs, album, artist, and genre of the CD in its built-in Gracenote CDDB database. This operation may take some time, during which the following screen appears on the on-screen display:



The CD content screen

When the MusicCAST has finished searching for information, it displays the following screen showing song, album, artist, and genre names.



The MusicCAST uses the following procedure to search for this data:

- 1 When data on the CD exists in the built-in Gracenote CDDB database of the MusicCAST server:
The MusicCAST server reads song titles, album, artist, and genre names from its database.
- 2 When the MusicCAST server does not find any relevant data, the following screen appears:



In this case, the MusicCAST server does not automatically store any information regarding the song titles, artist, album, or genre names. Lack of data makes searching for songs difficult, so you can enter it by hand after you store the CD. For more information, see page 21.

When the MusicCAST server does not find any data on your CD, it can connect to the Gracenote CDDB service via the Internet and download relevant data if it exists. For more information on this procedure, see page 119 of the MCX-1000 owner's manual.
Additionally, if your CD contains CD TEXT data, the MusicCAST server can utilize it for storage. For more information on this procedure, see page 23 of the MCX-1000 owner's manual.

Storing CDs on the MusicCAST server

Storing CDs automatically

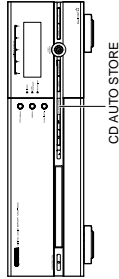

Use a simple, one-step procedure to store CDs on your MusicCAST server.

- 1 Load a CD into the MusicCAST server, and press CD AUTO STORE on the MusicCAST server.

- 2 The MusicCAST server stores all songs on the CD.

If it is able, the MusicCAST server stores any information it can obtain about the songs stored from its built-in Gracenote CDDB database.

If the MusicCAST server finds more than one match in its database a CD, it automatically selects an entry from those available and continues the storage process.

NOTE

If you use CDs that do not meet the CD standards described in the MCX-1000 owner's manual, the MusicCAST server may not operate properly.

Storing CDs on the MusicCAST server

Storing selected songs from a CD

Store a CD on the hard disk drive of the MusicCAST server.

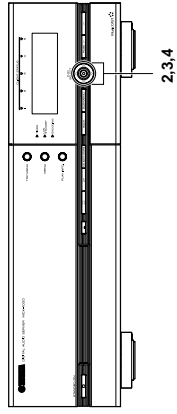
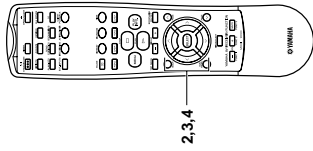

- 1 Follow the procedure described on page 16 to load a CD into the MusicCAST server and display its contents on the on-screen display.

- 2 Select the songs you want to store.

By default, the MusicCAST server selects all songs for storage. Use \blacktriangleleft \blacktriangleright to move the cursor to the checkboxes of the songs you do not wish to store, and press SELECT. The tick in the checkbox disappears.



The screen can display up to 10 songs. Use \blacktriangleleft \blacktriangleright to scroll the display if the CD contains more than 10 songs. Check that all of the songs you wish to store have ticks in their checkboxes.

Storing CDs on the MusicCAST server

- Use $\wedge / \vee / \leftarrow / \rightarrow$ to move the cursor to "Start" and press SELECT.

The MusicCAST server begins storing songs on its hard disk drive.

The following screen appears on the on-screen display during recording:



To stop this process press SELECT.

WARNING

Take care not to press SELECT in error, as this halts the storage process.

The MusicCAST server first stores the songs in PCM format, and then converts them into MP3 format, saving both copies on the hard disk drive (refer to the glossary for an explanation of PCM and MP3 formats). The conversion process takes a short time. If you set the MusicCAST server to store MP3 files only (see page 121 of the MCX-1000 owner's manual), it encodes all PCM files after this conversion is complete.

- When storage is complete, the following screen appears on the on-screen display:



Select one of the two options.

- To check the content you have just stored, select "Open stored album page".
 - To store another CD, select "Store another CD".
- The disc tray opens automatically. Place a new CD in the disc tray after removing the CD you have just stored, and repeat the storage procedure.

Storing CDs on the MusicCAST server

Entering CD information by hand

If the MusicCAST server cannot find any information such as song titles for the CD in its built-in Gracenote CDDB database when storing a CD, it does not store any title data with the songs. You can enter any missing data by hand to prevent difficulty in finding these songs later.

NOTE

You can also set the MusicCAST server to connect to the Internet-based Gracenote CDDB service (see page 115 in the MCX-1000 owner's manual).

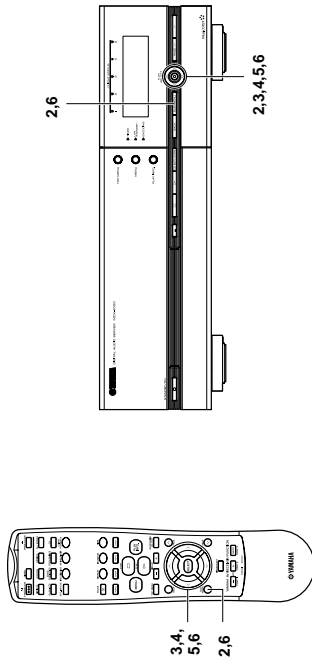

2,6

2,3,4,5,6

3,4,

5,6

2,6

3,4,

5,6

2,6

3,4,

5,6

2,6

- 1 If, after storing a CD, the MusicCAST server cannot find any information about it, the following screen appears on the on-screen display when you attempt to select it from the album playback screen.
- 2 Use $\wedge / \leftarrow / \rightarrow / \vee$ to move the cursor to a song name and press SUB MENU.

The Sub Menu appears:



Song names are listed as "Track 1", as shown above.

NOTE

The PCM and circular icons displayed here indicate that the MusicCAST server is currently encoding these tracks to MP3 format. These items may or may not appear on the on-screen display.

Listening from the MusicCAST server

You can listen to the songs that you store on the MusicCAST server using the process described on page 15.

MEMO

- If you wish to listen to music using the MusicCAST server without headphones, connect the MusicCAST server to an amplifier that is connected to speakers.
- Playback is impossible if you have not stored any songs on the hard disk drive. Carry out the procedures described on page 18, 19 to stored songs to the hard disk drive.

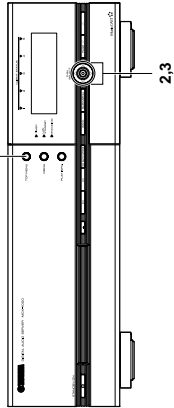
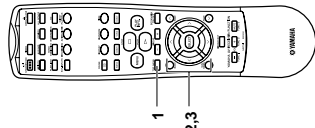

Listening from the MusicCAST server

Storing CDs on the MusicCAST server

3 Use \swarrow/\searrow to move the cursor to "Edit title" and press SELECT. The character entry screen appears:



4 Use \swarrow/\searrow to move the cursor to a character, and press SELECT.



You can use a PS/2 keyboard to enter characters directly if you have connected one to your MusicCAST server. In this case, the characters you enter appear in the character entry screen in the same manner as characters entered using on-screen entry. For a more detailed explanation, see page 78 of the MCX-1000 owner's manual.

NOTE

Disconnect the MusicCAST server from the AC outlet prior to connecting a PS/2 keyboard, and do not reconnect it to an AC outlet until you have finished connecting the PS/2 keyboard to the PS/2 ports on the front panel of the MusicCAST server.

5 When you finish entering characters, use \swarrow/\searrow to move the cursor to "OK" and press SELECT. If you wish to stop entry without changing the title, select "CANCEL".

6 Repeat steps 2-4 to enter all the song titles.

HINT

Song selection is even easier if you enter more data, such as artist, album, and genre names for the songs stored in the MusicCAST server.

Press SUB MENU on the artist, album, or genre screens to access the sub menu screens and use the same procedure as described here to edit names.

1 Press **DP MENU**.

The Top Menu screen appears on the on-screen display.



2 Use \swarrow/\searrow to move the cursor to the "Library" and press SELECT.

The Library screen appears on the on-screen display.



3 Use \swarrow/\searrow to move the cursor to a selection criteria and press SELECT.

Listening from the MusicCAST server

Selecting songs from an artist

- 1 Use **↖** to move the cursor to "Artists" and press **SELECT**.
The Artists screen appears on the on-screen display.

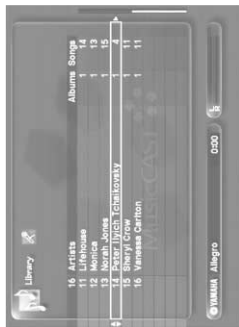

- 2 Use **↖** to move the cursor to an artist you want to listen to and press **SELECT**.
The albums of the artist you select appear on the on-screen display.



- 3 Use **↖** to move the cursor to an album and press **SELECT**.
The songs of the album you select appear on the on-screen display.



Listening from the MusicCAST server

Selecting songs from an album

- 1 Use **↖** to move the cursor to "Albums" and press **SELECT**.
The Albums screen appears on the on-screen display.



- 2 Use **↖** to move the cursor to the album you want to listen to and press **SELECT**.
The songs of the album you select appear on the on-screen display.



Selecting songs from a genre

- 1 Use **↖** to move the cursor to "Genre" and press **SELECT**.
The Genres screen appears on the on-screen display.

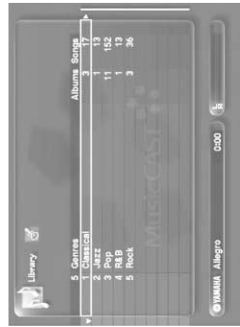

- 2 Use **↖** to move the cursor to a genre and press **SELECT**.
The albums in the genre you select appear on the on-screen display.



HINT

You can move directly to the Album menu by pressing ALBUMS.

- To stop playback
Press **□**.

- To halt playback temporarily
Press **⏸**. Press **⏸** again to resume playback.

Listening from the MusicCAST server



HINT

You can move directly to the Artists screen by pressing ARTISTS.

- To stop playback
Press **□**.

- To halt playback temporarily
Press **⏸**. Press **⏸** again to resume playback.

The Songs screen displays the format of each song in the column to the right of the column of song names.



Both PCM and MP3 versions of the song exist in the MusicCAST server hard disk drive.



The song is waiting to be encoded into MP3 format, after which the MusicCAST server will store both PCM and MP3 copies on its hard disk drive.



The song is waiting to be encoded into MP3 format, after which the MusicCAST server will delete the PCM copy from its hard disk drive.



Only the MP3 version of the song exists in the MusicCAST server hard disk drive.

Listening from the MusicCAST server

- Use **↖** to move the cursor to the album you want to listen to and press **SELECT**.
The songs of the album you select appear on the on-screen display.



Listening from the MusicCAST server

The Play Information screen

When you choose a song and press **SELECT**, information relevant to that song appears on the on-screen display. There are 2 information screens, which you access by pressing the **</>** keys. Press **PLAY INFO** to access this screen directly from other screens.



The Play Information screen displays the song title, and the artist, album, and genre to which it is linked. It also displays the status of the repeat (MCX-1000 owner's manual page 46) and random play (MCX-1000 owner's manual page 47) functions.

Selecting from the complete song list

- Use **↖** to move the cursor to "All Songs" and press **SELECT**.
All of the songs stored in the hard disk drive appear on the on-screen display in alphabetical order.



- Use **↖** to move the cursor to the song you want to listen to and press **SELECT**.

Playback of the selected song starts.
When playback of this song finishes, the MusicCAST server begins playback of the next song stored in alphabetical order in the MusicCAST server.
To return to the song list screen, press **BACK** to return to the song list screen.
To return to the Play Information screen again, press **PLAY INFO**.
For more information on the Play Information screen, see page 39 in the MCX-1000 owner's manual.

HINT
You can move directly to the song menu by pressing **ALL SONGS**.



This screen displays all of the songs in the group that the MusicCAST server is playing back. The content of this display depends on the method you use to select the song.

HINT
Press **BACK** or **MENU** to return to the list screen.

Listening from the MusicCAST server

Other useful playback functions

There are other methods of playback available on your MusicCAST server. For detailed explanations on the functions listed here refer to the appropriate page in the MCX-1000 owner's manual. Functions include:

- Playback only of those songs you like (Playlist, page 41)
You can make and store lists of songs, artists, albums, genres, and playlists stored in the MusicCAST server that you like, and then play the material contained in the lists.
- Repeat playback (Repeat, page 46)
Repeat playback of one song, or the songs from one album, artist, or genre.
- Playback of songs in random order. (Random, page 47)
You can playback songs from an album, artist, or genre in random order.
- Playback of songs or albums recorded or played back recently, or alternatively, those that the MusicCAST system plays most often. (Song statistics, page 55)
- You can use statistical information on recent playback and recording activities to select songs and albums for playback.
- Bookmark playback (Bookmark, page 53)
During playback, attach a mark to those songs that you like. You can then call up these songs for playback later.

Skipping playback groups

A playback group is the group selection criteria you use to select material for playback. For example, when you select album for playback, the playback group is set to "album", and when you select a genre for playback, the playback group becomes "genre". The playback group is displayed on the Play Information screen.

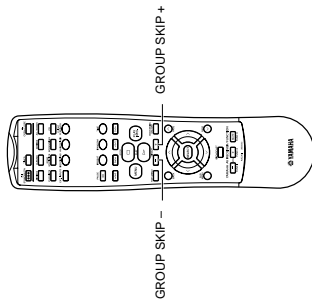

Use GROUP SKIP + and GROUP SKIP - on the remote control to skip between playback groups during playback. For example, press GROUP SKIP + during playback when the playback group is "album" to skip to the next album, and press GROUP SKIP - to skip to the previous album.

Skipping to a different song

Press **▶** to skip to the next song, or press **◀** once to return to the beginning of the currently playing song or twice to skip to the beginning of the previous song during playing or when playback is paused.

Searching forward or backward within a song

To search forward, press **▶▶**, and to search backward, press **◀◀**, during playback or when playback is paused.

Listening from the MusicCAST client

You can use the MusicCAST client to listen to songs stored on the MusicCAST server using the process described on page 15. Use album, artist, genres, or song names to search for songs you want to listen to. Refer to the MCX-A10 owner's manual for further information on how to use the MusicCAST client.

VIEW

- Configure the network settings on your MusicCAST client before attempting to playback music from it. See page 12 for an explanation of how to do this.
- Turn the MusicCAST server power on before attempting to playback material.

Check the client network connection

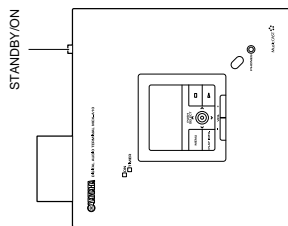

Press STANDBY/ON

Check that the network connection icon appears in the MusicCAST client on-screen display. One of the following three icons appears:

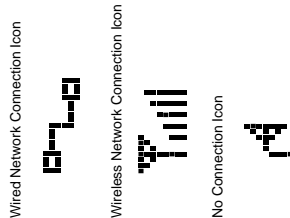

NOTE

If the MusicCAST client is in sleep mode press SLEEP on the remote control to turn the MusicCAST client on.

Listening from the MusicCAST client

For wireless connections, the network signal icon denotes the strength of the signal between the MusicCAST client and server, and only appears if the MusicCAST client and server network settings are configured correctly.

When the MusicCAST client is not receiving a signal from a MusicCAST server, the  icon appears. In this case, move the MusicCAST client closer to the MusicCAST server, and remove as many objects from between the two components as possible, until the display shows the wireless network connection icon. The bars on the right of the network connection icon indicate the strength of the network signal the MusicCAST client is receiving. The more bars displayed, the stronger the signal received.

When the network signal icon completely fails to display, you should connect the components using a network cable. Refer to the accompanying setup guide for more information. The wired network connection icon appears on the MusicCAST client on-screen display when the network settings are correctly configured.

VIEW

The MusicCAST client consumes a small amount of power even when it is in sleep or standby mode.

Listening from the MusicCAST client

Selecting songs from an artist

Use an artist name to look for a particular song.

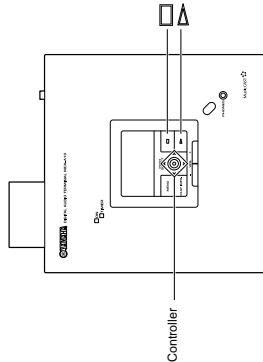
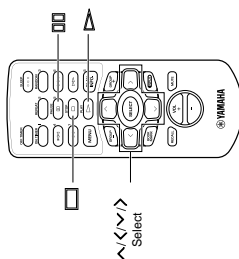

- 1 Press and hold **MENU** to return to the Top Menu screen.



- 2 Use  to move the cursor to "Play" and press **SELECT**.

The Play Menu screen appears on the on-screen display.



- 3 Use  to move the cursor to "Artists" and press **SELECT**.

The Artists screen appears on the on-screen display.



The artist names stored in the MusicCAST server are displayed alphabetically. The screen can display five artist names at a time. Use  to scroll the display up and down to display more names.

HINT

Move the cursor to an "Artists" and press  if you want to playback all of the songs on all of the albums assigned to this artist.

- 4 Use  to move the cursor to an artist and press **SELECT**.

The albums linked to this artist in the MusicCAST server appear in alphabetical order.

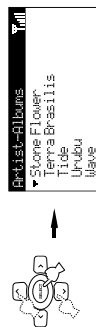

The screen can display five album names at once. Use  to scroll the display up and down to see more names.

HINT

Move the cursor to an album and press  if you want to playback all of the songs on all of the album.

- 5 Use  to move the cursor to an album and press **SELECT**.

The names of all the songs in the album appear.



Listening from the MusicCAST client

6 Use **^>/<** to move the cursor to the song and press **SELECT**.

Playback of the song you selected begins. When playback of the current song finishes, the next song on the album begins playing.

■ **To stop playback**

Press **□**.

■ **To halt playback temporarily**

Press **□□**. Press **□□** again to resume playback.



Press **<** to return to the previous screen. Press **PLAY INFO** during playback to display information on the current song on the on-screen display.

Listening from the MusicCAST client

Selecting songs from an album

Use an album name to look for a particular song.

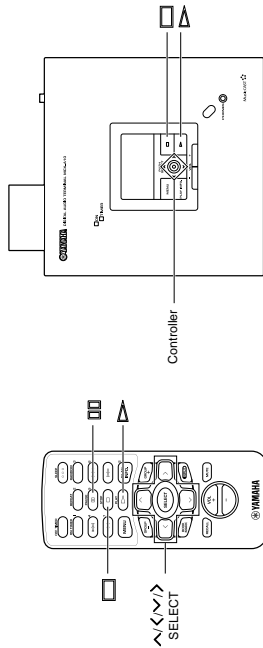

1 Press and hold **MENU** to return to the Top Menu screen.



2 Use **^>/<** to move the cursor to "Play" and press **SELECT**.

The Play Menu screen appears on the on-screen display.



3 Use **^>/<** to move the cursor to "Albums" and press **SELECT**.

The Albums screen appears on the on-screen display.



The albums stored in the MusicCAST server appear in alphabetical order. The screen can display five album names at a time. Use **^>/<** to scroll the display up and down to see more names.

Listening from the MusicCAST client



Move the cursor to an album and press **▶** if you want to playback all of the songs on all of the album.

4 Use **^>/<** to move the cursor to an album and press **SELECT**.

The names of all the songs in the album appear.



5 Use **^>/<** to move the cursor to a song and press **SELECT**.

Playback of the song you selected begins. When playback of the current song finishes, the next song on the album begins playing.

■ **To stop playback**

Press **□**.

■ **To halt playback temporarily**

Press **□□**. Press **□□** again to resume playback.



Press **<** to return to the previous screen. Press **PLAY INFO** during playback to display information on the current song on the on-screen display when viewing other screens.

Selecting songs from a genre

Use a genre to look for a particular song.

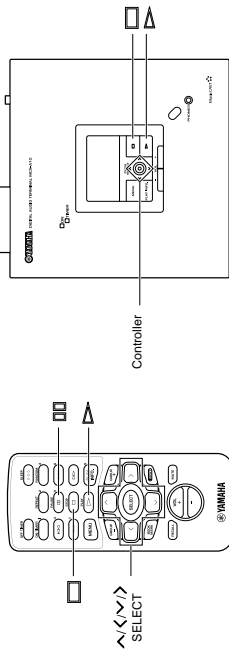

- 1 Press and hold **MENU** to return to the Top Menu screen.



Move the cursor to an genre and press **SELECT** if you want to playback all of the songs on all of the albums assigned to this genre.

- 4 Use **SELECT** to move the cursor to a genre and press **SELECT**.

The albums stored in the MusicCAST server appear in alphabetical order.

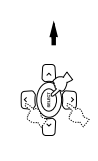

Use **SELECT** to scroll the display up and down to see more names.



Move the cursor to an album and press **SELECT** if you want to playback all of the songs on all of the album.

- 5 Use **SELECT** to move the cursor to an album and press **SELECT**.

The names of all the songs in the album appear.

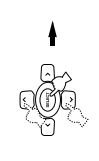

The genres stored in the MusicCAST server appear in alphabetical order. The screen can display five genre names at a time. Use **SELECT** to scroll the display up and down to see more names.

- 6 Use **SELECT** to move the cursor to a song and press **SELECT**.

Playback of the song you selected begins.

When playback of the current song finishes, the next song on the album begins playing.

- To stop playback

Press **STOP**.

- To halt playback temporarily

Press **PAUSE**. Press **PAUSE** again to resume playback.



Press **BACK** to return to the previous screen.

Press **INFO** during playback to display information on the current song on the on-screen display when viewing other screens.

Listening from the MusicCAST client

Selecting from the complete song list

Look for a particular song by name.

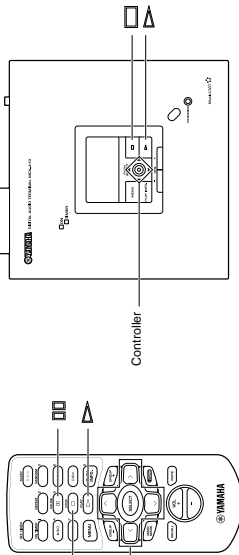

- 1 Press and hold MENU to return to the Top Menu screen.
 - ▶ Top Menu
 - ▶ Play
 - ▶ Recall Play
 - ▶ Edit Bookmark
 - ▶ Setup
 - ▶ Input
- 2 Use **↔** to move the cursor to "Play" and press SELECT.
 - ▶ Play Menu
 - ▶ Artists
 - ▶ Albums
 - ▶ Genres
 - ▶ All Songs
 - ▶ Playlists
- 4 Use **↔** to move the cursor to a song and press SELECT.
 - ▶ Play Menu
 - ▶ Play
 - ▶ Recall Play
 - ▶ Edit Bookmark
 - ▶ Setup
 - ▶ Input

Playback of the song you selected begins. When playback of the current song finishes, the next song in alphabetical order stored on the MusicCAST server begins playing.

 - To stop playback
Press **□**.
 - To halt playback temporarily
Press **□**. Press **□** again to resume playback.

HINT
Press **←** to return to the previous screen. Press **PLAY INFO** during playback to display information on the current song on the on-screen display when viewing other screens.

Listening from the MusicCAST client

Other useful playback functions

There are other methods of playback available on your MusicCAST client. For detailed explanations refer to the appropriate page in the MCX-A10 owner's manual. Functions include:

- Play only those songs you like (Playlist, page 41)
You can make and store lists of songs, albums, genres, and playlists stored in the MusicCAST server that you like, and then play the material contained in the lists.
- Repeat playback (Repeat, page 46)
Repeat playback of one song, or the songs from one album, artist, or genre.
- Playback of songs in random order. (Random, page 46)
You can playback songs from an album, artist, or genre in random order.
- Playback of songs or albums recorded or played back recently. (Song statistics, page 42)
You can use statistical information on recent playback and recording activities to select songs and albums for playback.
- Bookmark playback (Bookmark, page 43)
During playback, attach a mark to those songs that you like. You can then call up these songs for playback later.

Skipping playback groups

A playback group is the group selection criteria you use to select material for playback. For example, when you select album for playback, the playback group is set to "album", and when you select a genre for playback, the playback group becomes "genre". The playback group is displayed on the Play Information screen.

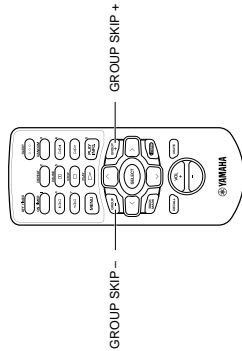

Use GROUP SKIP + and GROUP SKIP - on the remote control to skip between playback groups during playback. For example, press GROUP SKIP + during playback when the playback group is "album" to skip to the next album, and press GROUP SKIP - to skip to the previous album.



Listening from the MusicCAST client

Selecting from the complete song list

Look for a particular song by name.

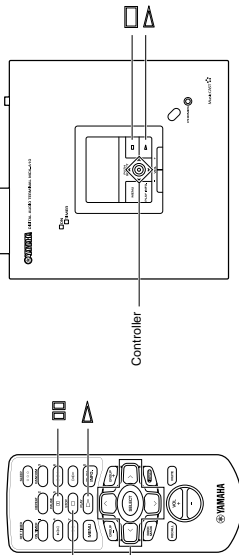

- 3 Use **↔** to move the cursor to "All Songs" and press SELECT.
 - ▶ All Songs screen
 - ▶ 7 Seconds
 - ▶ 9th & Herbie-in
 - ▶ Change Is Gonna Come
 - ▶ Felicitate
 - ▶ Thunder on Me

The songs stored in the MusicCAST server appear in alphabetical order. The screen can display five song names at a time. Use **↔** to scroll the display up and down to see more names.

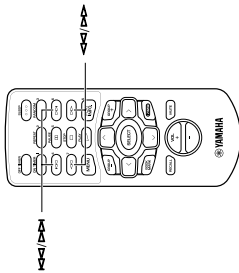

Skipping to a different song

Press **▶▶** to skip to the next song, or press **◀◀** once to return to the beginning of the currently playing song or twice to skip to the beginning of the previous song during playing.

Searching forward or backward within a song

To search forward, press **▶▶**, and to search backward, press **◀◀**, during playback. The MusicCAST client does not output any sound during these operations.

NOTE

You cannot skip or search through songs when playback is paused.

Advanced MusicCAST functions

The MusicCAST system has many other advanced capabilities which this Quick Manual does not attempt to explain. This section provides a brief summary of these functions and a page reference to the section of the MCX-1000 or MCX-A10 owner's manual where you can find a more in-depth explanation.

- **Making an Audio CD**
Use the MusicCAST server to make original CDs from the songs stored in on its hard disk drive.
See page 90 in the MCX-1000 owner's manual.
- **Duplicating CDs in your collection**
Use the MusicCAST server to make duplicates of Audio CDs in your collection. The CDs the MusicCAST server makes are only copyable in compliance with SCMS regulations (see page 136 in the MCX-1000 owner's manual for an explanation of SCMS).
See page 85 in the MCX-1000 owner's manual.
- **Controlling a YAMAHA AV receiver through an RS-232C connection**
Connect a YAMAHA AV receiver to the MusicCAST server with a cross-type RS-232C cable, and then use the MusicCAST server to change YAMAHA SURROUND PROGRAMS, alter volume settings, or switch the receiver between standby and power on modes.
See page 91 in the MCX-1000 owner's manual.
- **Controlling MusicCAST clients from a MusicCAST server**
Control playback on MusicCAST clients from a MusicCAST server.
See page 92 in the MCX-1000 owner's manual.
- **Using the Timer function to control recording and playback**
Use the Timer to automatically start and stop recording and playback on the MusicCAST server and clients at the time you designate.
See page 102 in the MCX-1000 owner's manual.
- **Using the MusicCAST server to playback Audio CDs**
Use the MusicCAST server as a standard CD player to playback CDs.
See page 48 in the MCX-1000 owner's manual.
- **Using the MusicCAST server to playback MP3 CDs**
Use the MusicCAST server to listen to MP3 CDs from your collection.
See page 52 in the MCX-1000 owner's manual.
- **Configuring the MusicCAST system network manually**
Manually configure the MusicCAST system network to suit your needs.
See page 108 in the MCX-1000 owner's manual and page 28 in the MCX-A10 owner's manual.
- **Viewing information on the data contained in the MusicCAST server**
View information on the current firmware version, MP3 encoding status, and data contained in the MusicCAST server.
See page 130 in the MCX-1000 owner's manual.
- **Connecting the MusicCAST server to an Internet-based Gracenote CDDB service**
Set the MusicCAST server to access an Internet-based Gracenote CDDB service whenever you load a CD into the disc tray, to gain information about the songs, artists, genres, and name of the CD.
See page 131 in the MCX-1000 owner's manual.
- **Recording music from external components**
Record audio material to the hard disk drive in the MusicCAST server from an external component connected to the MusicCAST server.
See page 26 in the MCX-1000 owner's manual.
- **Listening to radio stations using the MusicCAST client**
Use the MusicCAST client to listen to radio stations through a YAMAHA AV receiver connected to the MusicCAST server via a cross-type RS-232C cable. See page 49 in the MCX-A10 owner's manual.
- **Setting the date and time in the MusicCAST system**
In addition to using the internal clock and calendar to activate the Timer functions, the MusicCAST server uses date and time information to manage data stored in its hard disk drive. You can set the time and date yourself, or connect the MusicCAST server to a server on the Internet which will automatically update the MusicCAST server date and time settings.
See page 117 in the MCX-1000 owner's manual.
- **Advanced configuration utilities**
Set other miscellaneous parameters to enhance the performance of your MusicCAST system.
See page 115 in the MCX-1000 owner's manual.

Terms used in this manual

This manual uses a number of terms that, though not specific to the MusicCAST system, are not in general everyday use. In addition, some terms are used in a slightly unusual context. These words are listed alphabetically and in context below, along with an explanation of their meaning.

Playback

- **Album**
A collection of songs in the MusicCAST database assigned to a particular artist, and given a name. Each album is assigned to an artist. By default, each CD you store in the MusicCAST is stored as an Album.
- **Artist**
The item in the MusicCAST database to which albums are assigned. The artist of any CD you store in the MusicCAST is stored as the artist to the corresponding album (see album above).
- **Bookmark list**
A list of songs designated for easy retrieval using a MusicCAST client.
- **Genre**
The music type to which the albums stored in the MusicCAST are assigned. Examples include Jazz, Rock, and Classical.
- **Group**
The category which the MusicCAST component in. For example, if you play an album, then you are operating within the "album" category. If you playback a genre without selecting a specific song, you are operating within the "genre" category.
- **Playlist**
A list of songs, artists, albums, or genres you designate using the MusicCAST server for playback in a given sequence.
- **Song**
A single continuous track, equivalent to a single track from a CD, cassette, or other source, stored on the MusicCAST server.

Recording

- **CDDB**
The CDDB (Gracenote CDDB Music Recognition Service) is a database which you can access to gain information on the songs, artists, genre, and album names for music CDs.
- **CD TEXT**
Data encoded on some CDs which contains information on its song titles, album, artist, and genre names.
- **Encoding**
The process of converting PCM data stored from a CD into MP3 data.

- **CD-RW**
An abbreviation of Compact Disc Re-writable.
- **Controller**
The device on the front panel of the MusicCAST server and MusicCAST client used for entering data and navigating through the menus contained in these two components.
- **Front panel**
The panel on the front of MusicCAST server and MusicCAST client where the LCD display, controller, and various control keys are located.
- **Hard disk drive**
The component within your MusicCAST server that allows it to store the audio material from your CDs as data. Hard disk drive capacity is expressed in gigabytes, with a larger number denoting more storage capacity.
- **Hard disk**
See "Hard disk drive"
- **Hard drive**
See "Hard disk drive"
- **MusicCAST client**
The component in the MusicCAST system that allows you access to songs stored in the MusicCAST server for playback at a distance. Up to 7 MusicCAST clients can access the MusicCAST server at a time.
- **MusicCAST server**
The component in the MusicCAST system that you use to store and playback songs from CD. Other components in the MusicCAST system obtain song data from the MusicCAST server.
- **on-screen display**
The LCD display on the MusicCAST client or the display output to a TV or monitor connected to the MusicCAST server.
- **Remote control**
A handheld device for operating your MusicCAST components at a distance.

Software

- **Database**
An organized collection of data. The data is arranged in a logical manner so that it is easy to access, manage, and update.
- **Menu**
A display consisting of a multiple choice style list of options that you can choose from. Menus are displayed on the on-screen displays of the MusicCAST client and server.

Network connections

- **Connections**
The links between the components in your MusicCAST which allows them to exchange information. MusicCAST components can make both wired and wireless connections.
- **LAN cable**
A cable for connecting two components on a Local Area Network (LAN).
- **Network**
A collection of electronic components which share data and resources with one another.
- **Wireless LAN**
A network utilizing weak radio signals to share data between components.
- **Wired LAN**
A network utilizing LAN cables to share data between components.

Hardware

- **CD**
An abbreviation of Compact Disc. A small plastic disc: 12 cm (4.8 in) in diameter encoded with pre-stored data.
- **CD-R**
An abbreviation of Compact Disc Recordable. A small plastic disc identical to a CD in appearance, onto which a device such as the MusicCAST server can record data. The MusicCAST server can only use Audio type CDR media.