

MusicCAST 

DIGITAL AUDIO SERVER

MCX-2000

SERVICE MANUAL

When accepting a repair order from the user, be sure to inform him/her that the data in HDD cannot be guaranteed.

修理依頼を受ける際、HDDのデータは保証できないことをお客様に伝えてください。

IMPORTANT NOTICE

This manual has been provided for the use of authorized YAMAHA Retailers and their service personnel. It has been assumed that basic service procedures inherent to the industry, and more specifically YAMAHA Products, are already known and understood by the users, and have therefore not been restated.

WARNING: Failure to follow appropriate service and safety procedures when servicing this product may result in personal injury, destruction of expensive components, and failure of the product to perform as specified. For these reasons, we advise all YAMAHA product owners that any service required should be performed by an authorized YAMAHA Retailer or the appointed service representative.

IMPORTANT: The presentation or sale of this manual to any individual or firm does not constitute authorization, certification or recognition of any applicable technical capabilities, or establish a principle-agent relationship of any form.

The data provided is believed to be accurate and applicable to the unit(s) indicated on the cover. The research, engineering, and service departments of YAMAHA are continually striving to improve YAMAHA products. Modifications are, therefore, inevitable and specifications are subject to change without notice or obligation to retrofit. Should any discrepancy appear to exist, please contact the distributor's Service Division.

WARNING: Static discharges can destroy expensive components. Discharge any static electricity your body may have accumulated by grounding yourself to the ground buss in the unit (heavy gauge black wires connect to this buss).

IMPORTANT: Turn the unit OFF during disassembly and part replacement. Recheck all work before you apply power to the unit.

■ CONTENTS

TO SERVICE PERSONNEL	2~4	ENTERING SYSTEM ID / システムIDの書き込み	27~28
PREVENTION OF ELECTROSTATIC DISCHARGE	5	TROUBLESHOOTING	29
FRONT PANELS	6	トラブルシューティング	30
REAR PANELS	6~7	ERROR CODE AND RECOVERY /	
REMOTE CONTROL PANEL	8	エラーコードとリカバリー	31
SPECIFICATIONS	8~9	TEST MODE / テストモード	32~33
INTERNAL VIEW	9	IC DATA	34~41
DISASSEMBLY PROCEDURES / 分解手順	10~18	BLOCK DIAGRAM	43
SERVICE PRECAUTIONS /		PRINTED CIRCUIT BOARD	44~49
サービス時の注意事項	19	PIN CONNECTION DIAGRAM	50
UPDATING FIRMWARE /		SCHEMATIC DIAGRAM	51~62
ファームウェアのアップデート	19~20	PARTS LIST	63~76
RECOVERY AFTER REPLACING CD-R/RW DRIVE /		REMOTE CONTROL	77
CD-R/RWドライブ交換後のリカバリー	20	DIRECTION FOR USE	
RECOVERY AFTER REPLACING HDD /		Welcome to MusicCAST	78~81
HDD交換後のリカバリー	21~23	Preface	81~83
RECOVERY AFTER REPLACING MAIN P.C.B. /		Preparations and Setup	83~96
MAIN P.C.B.交換後のリカバリー	24	About Digital Recording with MusicCAST	96
SERVICE MENU / サービスメニュー	25~26	Glossary	97



このサービスマニュアルは、エコマーク認定の再生紙を使用しています。
This Service Manual uses recycled paper.

100958

© 2005 YAMAHA CORPORATION All rights reserved
This manual is copyrighted by YAMAHA and may not be copied or
redistributed either in print or electronically without permission



YAMAHA CORPORATION
P.O.Box 1, Hamamatsu, Japan

05 11

■ TO SERVICE PERSONNEL

1. Critical Components Information
Components having special characteristics are marked Δ and must be replaced with parts having specifications equal to those originally installed.
2. Leakage Current Measurement (For 120V Models Only)
When service has been completed, it is imperative to verify that all exposed conductive surfaces are properly insulated from supply circuits.
 - Meter impedance should be equivalent to 1500 ohms shunted by 0.15 μ F.
 - Leakage current must not exceed 0.5mA.
 - Be sure to test for leakage with the AC plug in both polarities.

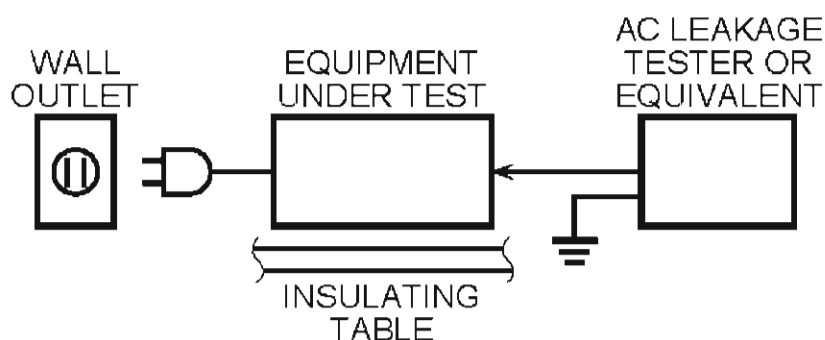

THE COMPACT DISC RECORDER SHOULD NOT BE ADJUSTED OR REPAIRED BY ANYONE EXCEPT PROPERLY QUALIFIED SERVICE PERSONNEL.

WARNING: CHEMICAL CONTENT NOTICE!

The solder used in the production of this product contains LEAD. In addition, other electrical/electronic and /or plastic (where applicable) components may also contain traces of chemicals found by the California Health and Welfare Agency (and possibly other entities) to cause cancer and/or birth defects or other reproductive harm.

DO NOT PLACE SOLDER, ELECTRICAL/ELECTRONIC OR PLASTIC COMPONENTS IN YOUR MOUTH FOR ANY REASON WHATSOEVER!

Avoid prolonged, unprotected contact between solder and your skin! When soldering, do not inhale solder fumes or expose eyes to solder/flux vapor!

If you come in contact with solder or components located inside the enclosure of this product, wash your hands before handling food.

About Lead Free Solder / 無鉛ハンダについて

The P.C.B.s installed in this unit are soldered using the following solder.

本機に搭載されている基板のハンダ付けに使用されているハンダは下記の通りです。

	Side A / A 面	Side B / B 面
MAIN P.C.B.	Lead Free Solder / 無鉛ハンダ	Lead Free Solder / 無鉛ハンダ
OPERATION P.C.B.	Lead Free Solder / 無鉛ハンダ	Lead Free Solder / 無鉛ハンダ

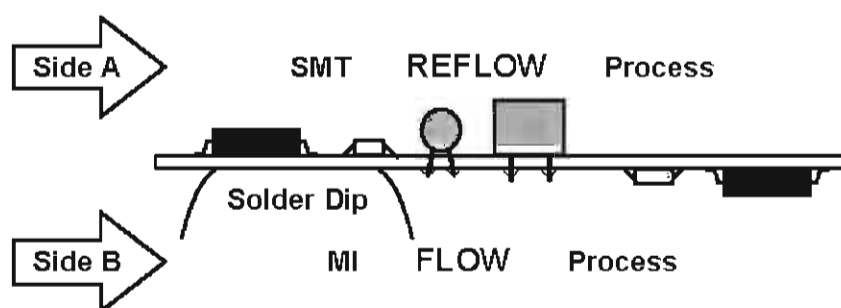

Among some types of lead free solder currently available, it is recommended to use one of the following types for the repair work.

- Sn + Ag + Cu (tin + silver + copper)
- Sn + Cu (tin + copper)
- Sn + Zn + Bi (tin + zinc + bismuth)

無鉛ハンダにはいくつかの種類がありますが、修理時には下記のような無鉛ハンダの使用を推奨します。

- Sn+Ag+Cu (錫+銀+銅)
- Sn+Cu (錫+銅)
- Sn+Zn+Bi (錫+亜鉛+ビスマス)

Caution:

1. As the melting point temperature of the lead free solder is about 30°C to 40°C (50°F to 70°F) higher than that of the lead solder, be sure to use a soldering iron suitable to each solder.
2. If lead solder must be used, be sure to remove lead free solder from each terminal section of the parts to be replaced and from the area around it completely before soldering, or make sure that the lead free solder and lead solder melt together fully.

注意:

- ① 無鉛ハンダの融点温度は通常の鉛入りハンダに比べ30～40°C程度高くなっていますので、それぞれのハンダに合ったハンダごてをご使用ください。
- ② 鉛入りハンダを使わざるを得ない場合は、あらかじめ交換する部品端子部やその周辺部の無鉛ハンダをすべて取り除くか、あるいは無鉛ハンダと鉛入りハンダが十分に溶けた状態となるようにハンダ付けしてください。

WARNING: Laser Safety

This product contains a laser beam component. This component may emit invisible, as well as visible radiation, which may cause eye damage. To protect your eyes and skin from laser radiation, the following precautions must be used during servicing of the unit.

- 1) When testing and/or repairing any component within the product, keep your eyes and skin more than 30 cm away from the laser pick-up unit at all times. Do not stare at the laser beam at any time.
- 2) Do not attempt to readjust, disassemble or repair the laser pick-up, unless noted elsewhere in this manual.
- 3) CAUTION: Use of controls, adjustments or performance of procedures other than those specified herein may result in hazardous radiation exposure.

Laser Emitting conditions:

1. This device is a Class IIIb laser device.

Class IIIb means

With the protective case removed, exposure to the light output from the laser, either directly or reflected by a mirror, can cause harm to the eyes, but there is no danger to the eyes from exposure to dispersed reflected laser light. (Generally 0.5 W or less)

2. Always wear eyeglasses designed for protection against laser light.
3. Always wear gloves.
4. Have no reflective objects anywhere near this device.
5. Figure A shows from where in this device the laser is emitted.
6. When switching on the power to the device for the first time, always measure the laser power with a laser power meter and check that the power is no greater than the number of Watts in the specifications.
7. Never look directly at the laser light while the laser is emitting light.
8. Do not allow the laser light to shine directly on your skin while the laser is emitting light.

PROTECTION OF EYES FROM LASER BEAM DURING SERVICING

This set employs a laser. Therefore, be sure to carefully follow the instructions below when servicing.

1. Laser Diode Properties

- Material : GaAlAs
- Wavelength : 780-787 nm
- Emission Duration : Pulse
- Laser Output : DC erase mode max. 12 mW (Continuous) *
Write mode max. 70 mW *
(Max. Cycle 98 ns, Min. Cycle 27 ns at Max. Speed)

* This output is the value measured at the lens of the Laser Pickup Unit.

2. When checking the laser diode emission, keep your eyes more than 30 cm away from the objective lens.

CAUTION

Use of controls or adjustments or performance of procedures other than those specified herein may result in hazardous radiation exposure.

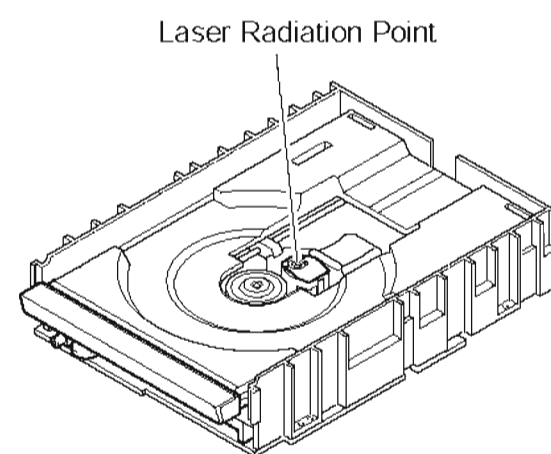
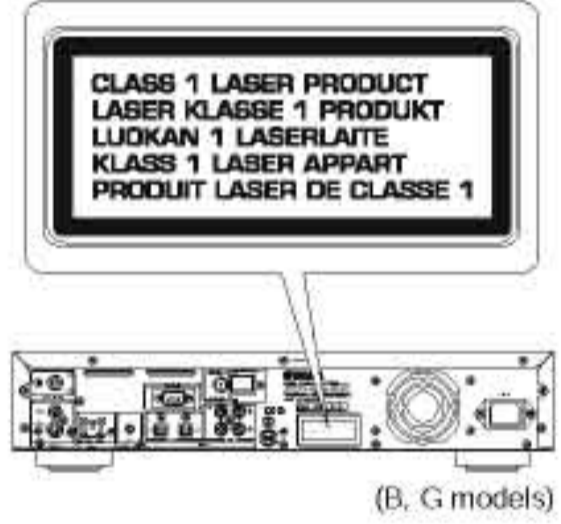
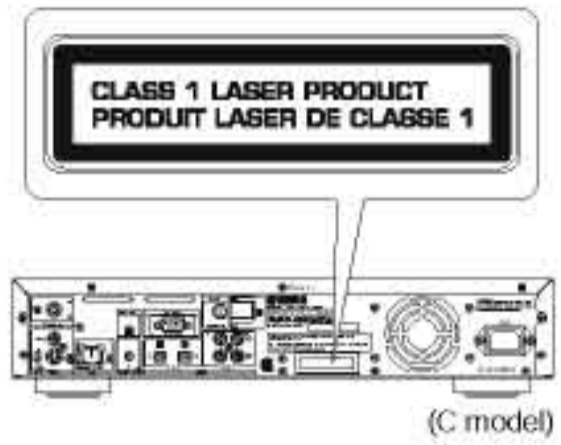

Figure A

<p>CAUTION Use of controls or adjustments or performance of procedures other than those specified herein may result in hazardous radiation exposure.</p>
<p>ATTENTION L'emploi de commandes, de réglages ou un choix de procédures différents des spécifications de cette brochure peut entraîner une exposition à d'éventuelles radiations pouvant être dangereuses.</p>
<p>ACHTUNG Die Verwendung von Bedienungselementen oder Einstellungen oder die Durchführung von Bedienungsvorgängen, die nicht in dieser Anleitung aufgeführt sind, kann zu einem Kontakt mit gefährlichen Laserstrahlen führen.</p>
<p>OBSERVERA Användning av kontroller och justeringar eller genomförande av procedurer andra än de som specificeras i denna bok kan resultera i att du utsätter dig för farlig strålning.</p>
<p>ATTENZIONE Uso di controlli o regolazioni o procedure non specificamente descritte può causare l'esposizione a radiazioni di livello pericoloso.</p>
<p>PRECAUCIÓN El uso de los controles o los procedimientos de ajuste o utilización diferentes de los especificados en este manual pueden causar una exposición peligrosa a la radiación.</p>
<p>VOORZICHTIG Gebruik van bedieningsorganen of instellingen, of uitvoeren van handelingen anders dan staan beschreven in deze handleiding kunnen leiden tot blootstelling aan gevaarlijke stralen.</p>

VARO!
AVATTAESSA JA SUOJALUKITUS OHITETTAESSA OLET ALTTIINA NÄKYMÄTTÖMÄLLE LASERSÄTEILYLLE. ÄLÄ KATSO SÄTEESEEN.

WARNING!
OSYNLIG LASERSTRÄLNING NÄR DENNA DEL ÄR ÖPPNAD OCH SPÄRREN ÄR URKOPPLAD. BETRakta EJ STRÄLEN.



CAUTION: CLASS 3B INVISIBLE LASER RADIATION WHEN OPEN/NOCD EXPOSURE TO THE BEAM.

VAROING: KLASSE 3B OSYNLIG LASERSTRÄLNING NÄR DENNA DEL ÄR ÖPPNAD. UNDVIK ATT UTSÄTTA DIG FÖR STRÄLLEN.

VARO! AVATTAESSA OLET ALTTIINA NÄKYMÄTTÖMÄLLE LUOKAN 3B LASERSÄTEILYLLE. ÄLÄ KATSO SÄTEESEEN.

ATTENTION: RADIATION LASER INVISIBLE DE CLASSE 3B QUAND OUVREZ. EVITEZ TOUT CONTACT AU FASCEAU.

ADVERTENCIA: CLASSE 3B OSYNLIG LASERSTRÄLNING NÄR DENNA DEL ÄR ÖPPNAD. UNDVIK ATT UTSÄTTA DIG FÖR STRÄLLEN.

VOORZICHTIG: NI OSYNLIG LASERSTRÄLNING NÄR DENNA DEL ÄR ÖPPNAD. UNDVIK ATT UTSÄTTA DIG FÖR STRÄLLEN.

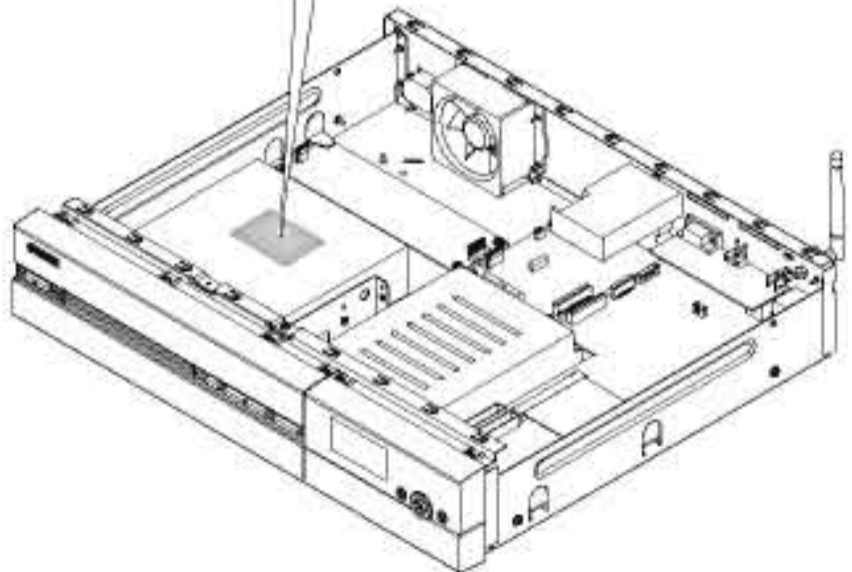

■ PREVENTION OF ELECTROSTATIC DISCHARGE

Some semiconductor (solid state) devices can be damaged easily by static electricity. Such components commonly are called Electrostatically Sensitive (ES) Devices. Examples of typical ES devices are integrated circuits and some field-effect transistors and semiconductor "chip" components. The following techniques should be used to help reduce the incidence of component damage caused by electro static discharge (ESD).

1. Immediately before handling any semiconductor component or semiconductor-equipped assembly, drain off any ESD on your body by touching a known earth ground. Alternatively, obtain and wear a commercially available discharging ESD wrist strap, which should be removed for potential shock reasons prior to applying power to the unit under test.
2. After removing an electrical assembly equipped with ES devices, place the assembly on a conductive surface such as aluminum foil, to prevent electrostatic charge buildup or exposure of the assembly.
3. Use only a grounded-tip soldering iron to solder or unsolder ES devices.
4. Use only an anti-static solder removal device. Some solder removal devices not classified as "anti-static (ESD protected)" can generate electrical charge sufficient to damage ES devices.
5. Do not use freon-propelled chemicals. These can generate electrical charges sufficient to damage ES devices.
6. Do not remove a replacement ES device from its protective package until immediately before you are ready to install it. (Most replacement ES devices are packaged with leads electrically shorted together by conductive foam, aluminum foil or comparable conductive material).
7. Immediately before removing the protective material from the leads of a replacement ES device, touch the protective material to the chassis or circuit assembly into which the device will be installed.
CAUTION: Be sure no power is applied to the chassis or circuit, and observe all other safety precautions.
8. Minimize bodily motions when handling unpackaged replacement ES devices. (Otherwise harmless motion such as the brushing together of your clothes fabric or the lifting of your foot from a carpeted floor can generate static electricity (ESD) sufficient to damage an ES device).

Grounding for electrostatic breakdown prevention

1. Human body grounding:
Use an anti static wrist strap to discharge the static electricity from your body.
2. Work table grounding:
Put a grounded conductive material (sheet) or iron sheet on the area where the optical pickup is placed.

Caution:

The static electricity of your clothes will not be grounded through the wrist strap. So take care not to let your clothes touch the optical pickup.

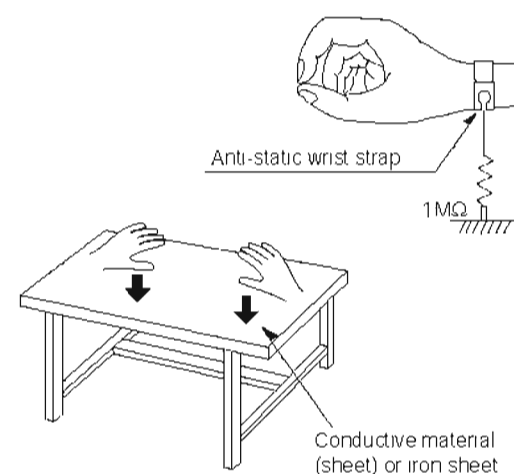

FRONT PANELS

U, C models

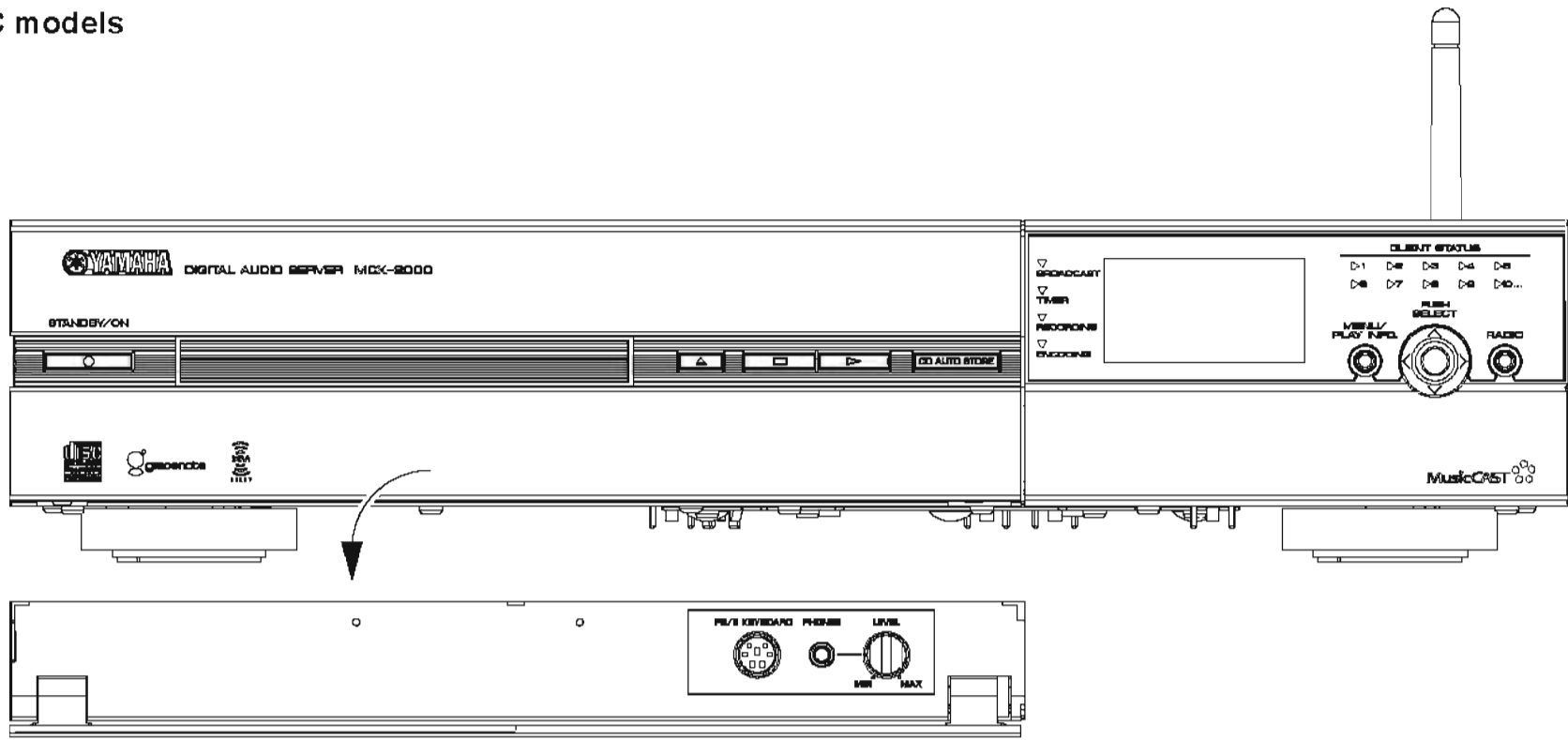

A, B, G, J models

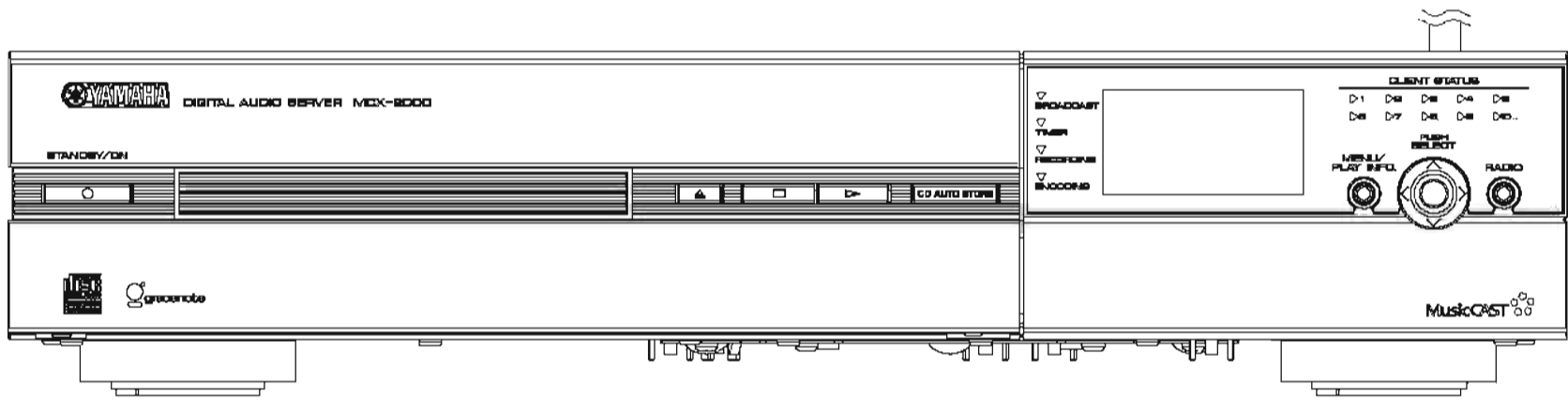

REAR PANELS

U model

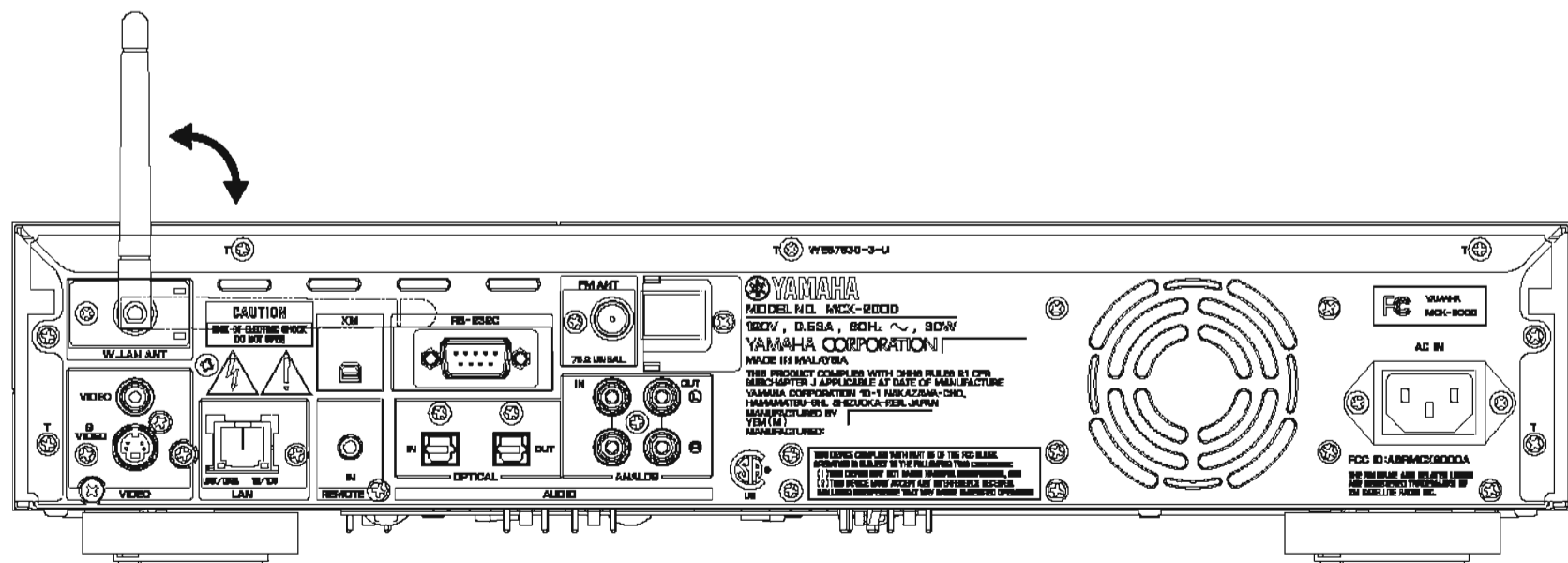

C model

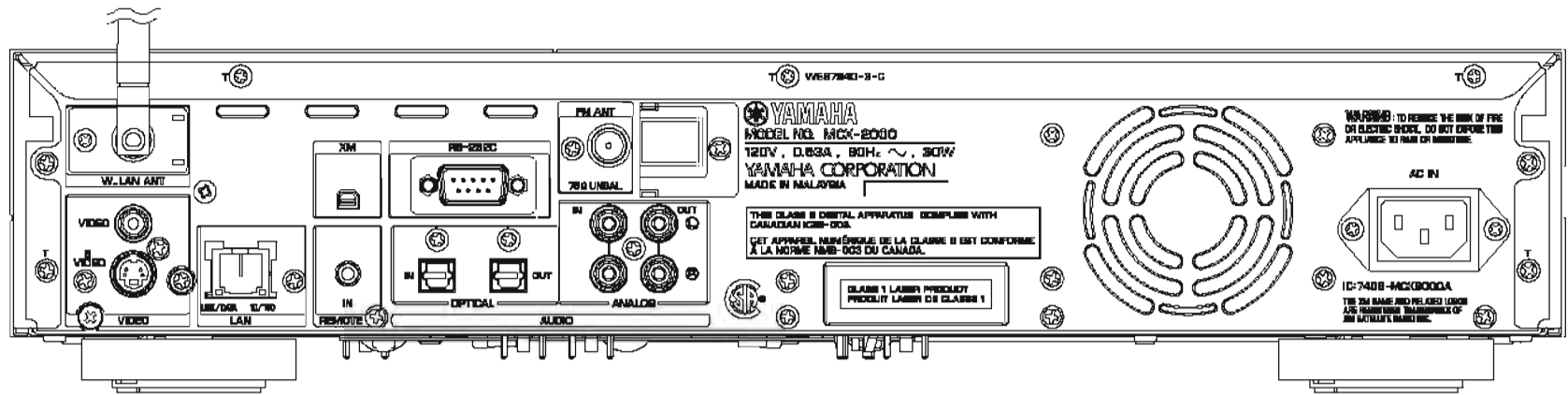

A model

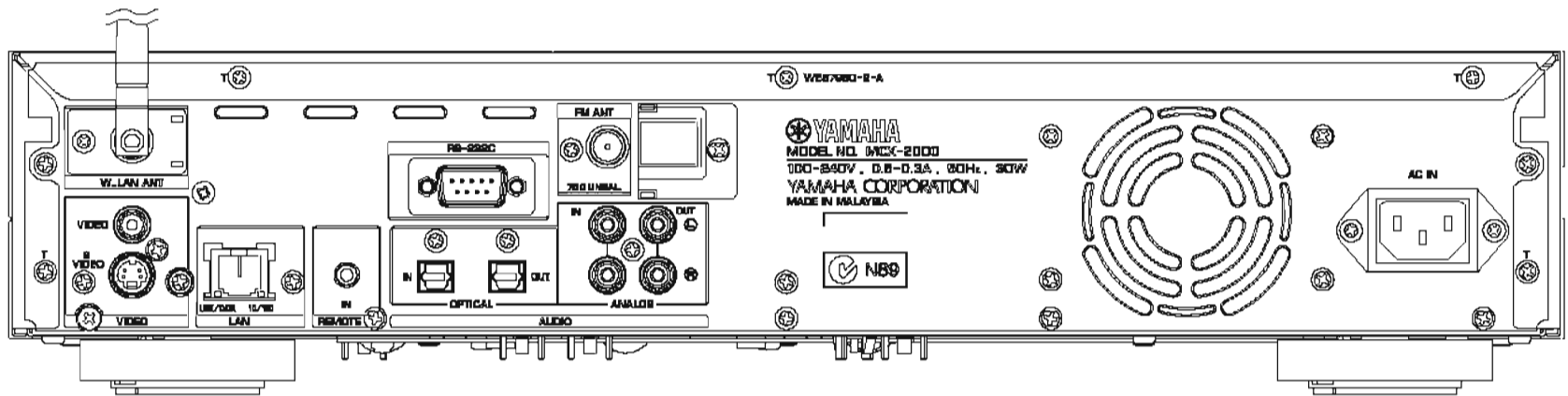

B, G models

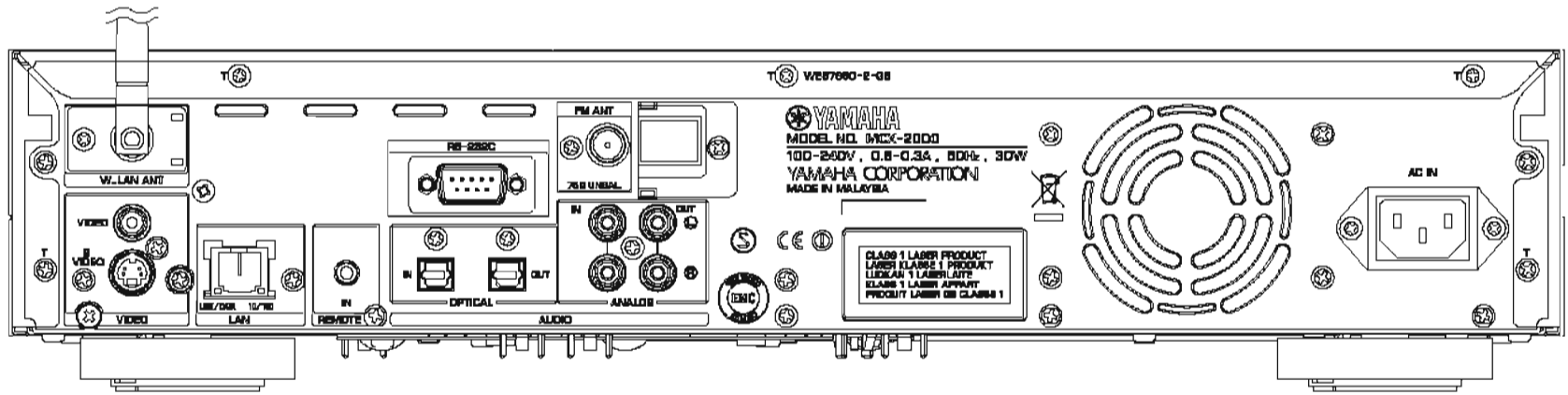

J model

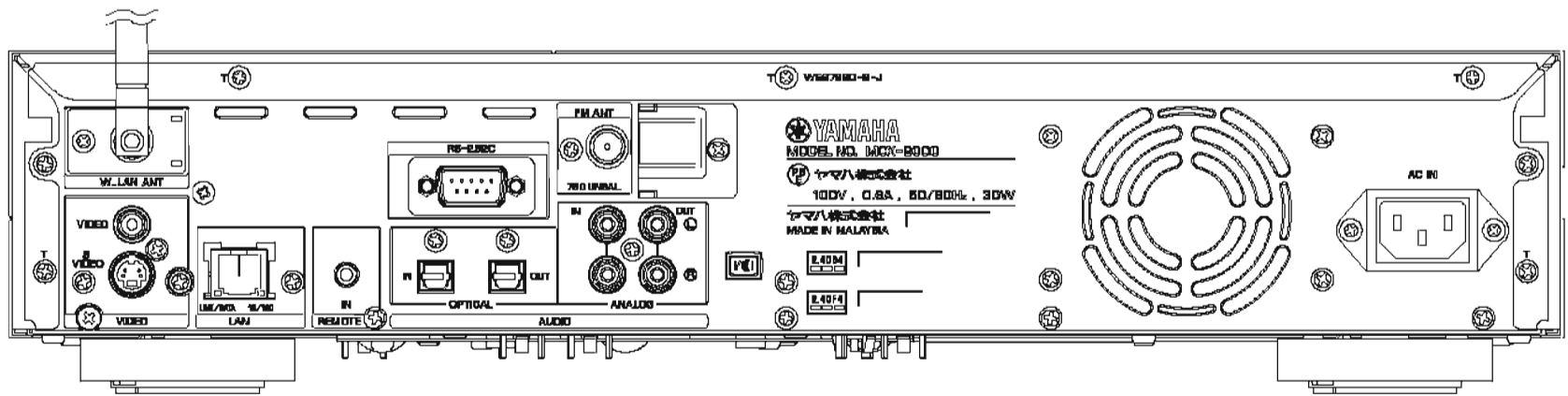

MCX-2000

REMOTE CONTROL PANEL

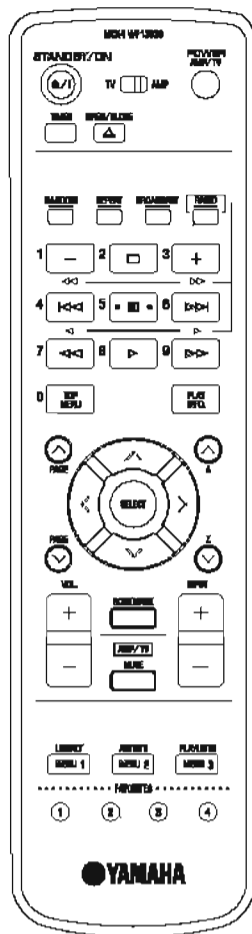

SPECIFICATIONS / 参考仕様

AUDIO PERFORMANCE / オーディオ性能

Output Level / 出力レベル (1 kHz, 0 dB)	2 ± 0.5 Vrms
Frequency Characteristics / 周波数特性 (EIAJ)	20 Hz to 20 kHz, ± 0.5 dB
Signal to Noise Ratio / S/N比 (EIAJ)	
Playback	100 dB or more
Recording	92 dB or more
Dynamic Range / ダイナミックレンジ (EIAJ)	
Playback	100 dB or more
Recording	92 dB or more
Total Harmonic Distortion / 歪率+雑音 (EIAJ)	
Playback	0.004 % or less
Recording	0.006 % or less

INPUT/OUTPUT / 入出力仕様

Line Output / ライン出力	
Output Level	2 Vrms
Output Resistance	600 ohms
Line Input / ライン入力	
Input Sensitivity	150 mVrms
Input Impedance	22 k-ohms
Digital Output / デジタル出力	
Optical Output Level	-20 dBm
Sampling Frequency	44.1 kHz
Digital Input / デジタル入力	
Optical Input Level	-20 dBm
Input Gain (with Digital Volume)	±12 dB
Input Gain (without Digital Volume)	±0 dB
Sampling Frequency Tolerance	32 kHz, 44.1 kHz, 48 kHz and 96 kHz
Headphone Output / ヘッドホン出力 (Phones Level Max.)	
Output Level (-20 dB, 150 ohms load)	430 mVrms

Video Output / ビデオ出力

Video Signal Level	1 Vp-p/75 ohms
S-Video Signal Level	
Y	1 Vp-p/75 ohms
C (U, C, J models)	0.286 Vp-p/75 ohms
C (A, B, G models)	0.3 Vp-p/75 ohms

FM TUNER / FMチューナー

Tuning Range / 受信周波数範囲

U, C models	87.5 to 107.9 MHz
A, B, G models	87.50 to 108.00 MHz
J model	76.0 to 90.0 MHz

Frequency Step / 周波数ステップ

U, C models	0.2 MHz
A, B, G models	0.05 MHz
J model	0.1 MHz

GENERAL / 一般仕様

Application Disks / 対応ディスク

..... CD, CD-ROM (MP3 only), AUDIO CD-R, AUDIO CD-RW

Support MP3 Format / 対応MP3フォーマット

The file extension is MP3 or mp3.
 MPEG1/ 2 Layer3 100% compression bit rate is applicable.
 Based on ID3 Tag ver. 1.1.
 ファイルの拡張子はMP3またはmp3
 MPEG1/ 2 Layer3全圧縮ビットレート対応
 ID3タグver 1.1準拠

HDD Capacity / HDD容量

..... 160 GB

LAN Interface / LANインターフェイス

..... Ethernet 10/100 Base-T

Wireless Interface / 無線インターフェイス

..... IEEE 802.11 b/g

Power Supply / 電源電圧

U, C models	AC 120 V, 60 Hz
A, B, G models	AC 100-240 V, 50 Hz
J model	AC 100 V, 50/60 Hz

Power consumption / 消費電力

Standby	5 W or less
CD Store	30 W

Operating Temperature / 動作温度

..... +5 °C to +35 °C

Weight / 質量 (without Package)

..... 6.6 kg (14 lbs. 9 oz.)

Maximum Dimensions / 最大寸法 (W x H x D)

..... 435 x 95.5 x 408.5 mm (17-1/8" x 3-3/4" x 16-1/16")

Panel Color / パネル色

Black Color	U, C, A, B, G, J models
Silver Color	J model
Titanium Color	B, G models

Accessories / 付属品

Remote Control x 1, Battery (Manganese) x 2, Optical Cable x 1, Audio Pin Cable x 1, Video Pin Cable x 1, Indoor FM Antenna x 1, Power Cable x 1, CAT-5 Straight Cable x 1, Upgrade CD-ROM x 1

* Specifications are subject to change without notice due to product improvements.

※ 参考仕様および外観は予告なく変更されることがあります。

U U.S.A. model	C Canadian model
A Australian model	B British model
G European model	J Japanese model



The XM name and related logos are registered trademarks of XM Satellite Radio Inc.

• DIMENSIONS

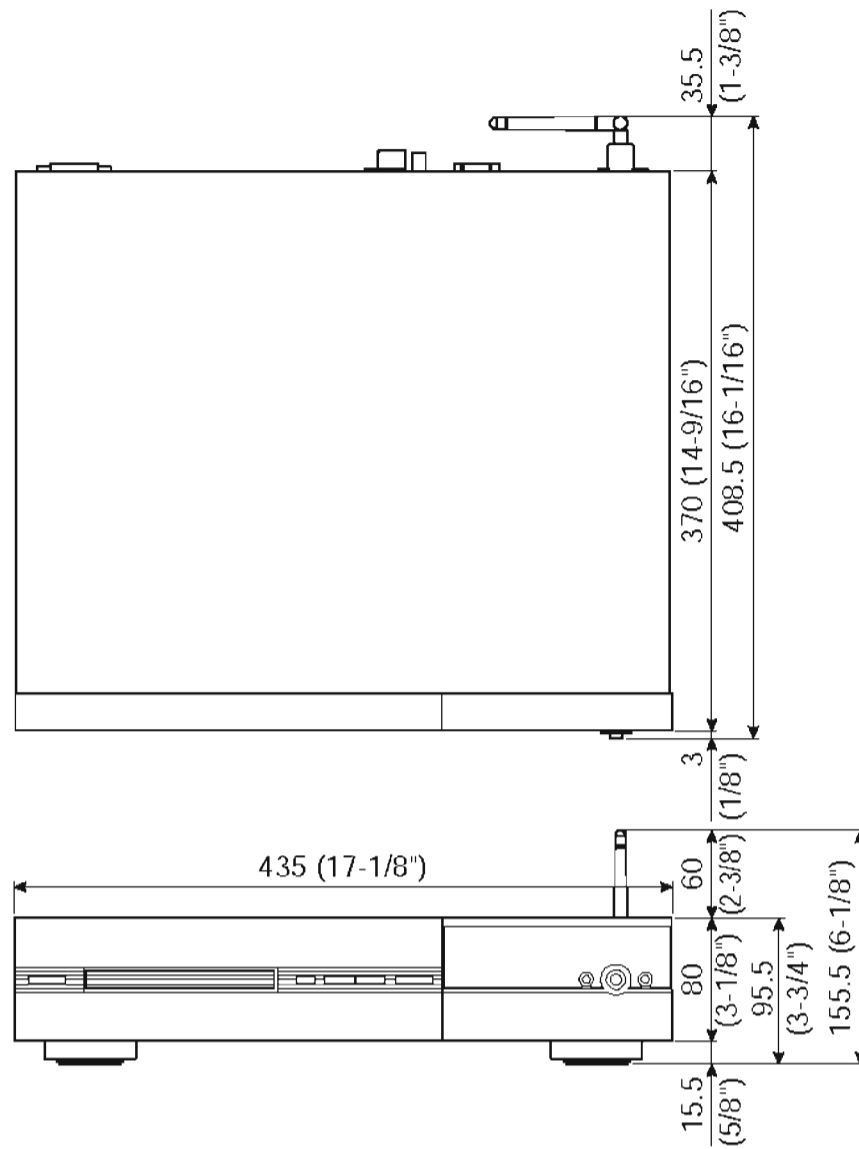

Unit: mm (inch)
 単位：mm(インチ)

■ INTERNAL VIEW

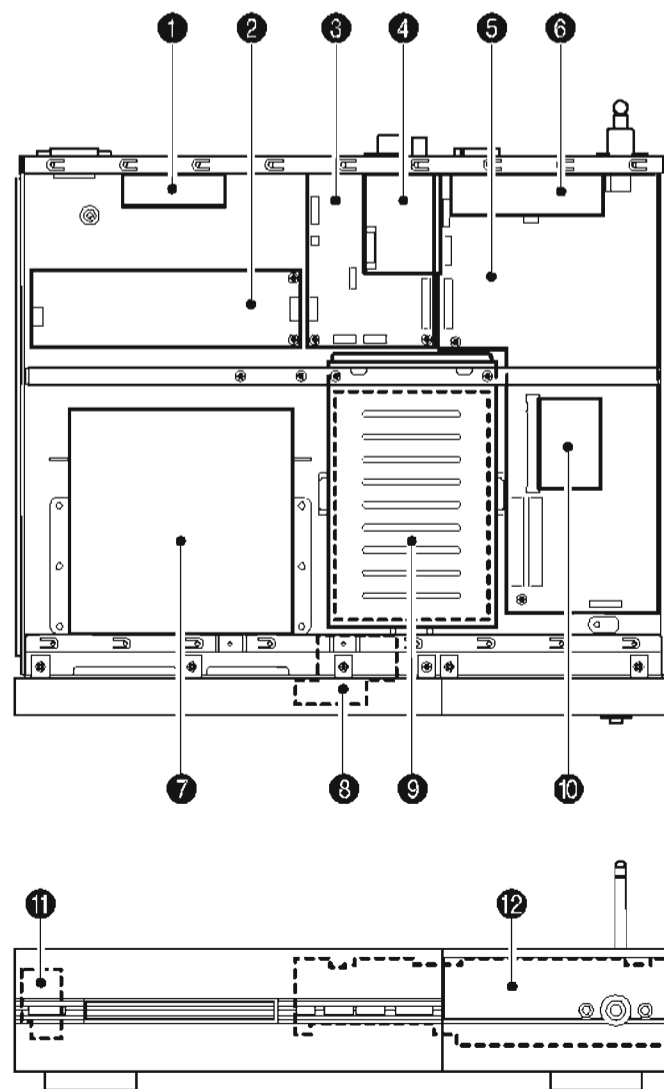

- ① DC FAN
- ② POWER SUPPLY UNIT
- ③ OPERATION (2) P.C.B.
- ④ FM / AM TUNER
- ⑤ MAIN (1) P.C.B.
- ⑥ MAIN (2) P.C.B.
- ⑦ CDR UNIT
- ⑧ OPERATION (3) P.C.B.
- ⑨ HDD UNIT
- ⑩ WIRELESS LAN CARD
- ⑪ OPERATION (4) P.C.B.
- ⑫ OPERATION (1) P.C.B.

■ DISASSEMBLY PROCEDURES / 分解手順

(Remove parts in the order as numbered.)

(番号順に部品を取り外してください。)

Disconnect the power cable from the AC power outlet.

AC電源コンセントから電源プラグを抜きます。

1. Removal of Top Cover

- a. Remove 4 screws (①), 4 screws (②) and 1 screw (③). (Fig. 1)
- b. Remove 1 screw (④). (Fig. 1)
- c. Remove the top cover rearward while lifting it up. (Fig. 1)

1. トップカバーの取り外し

- a. ①のネジ4本、②のネジ4本、③のネジ1本を外します。(Fig. 1)
- b. ④のネジ1本を外します。(Fig. 1)
- c. トップカバーを持ち上げながら後方へ外します。(Fig. 1)

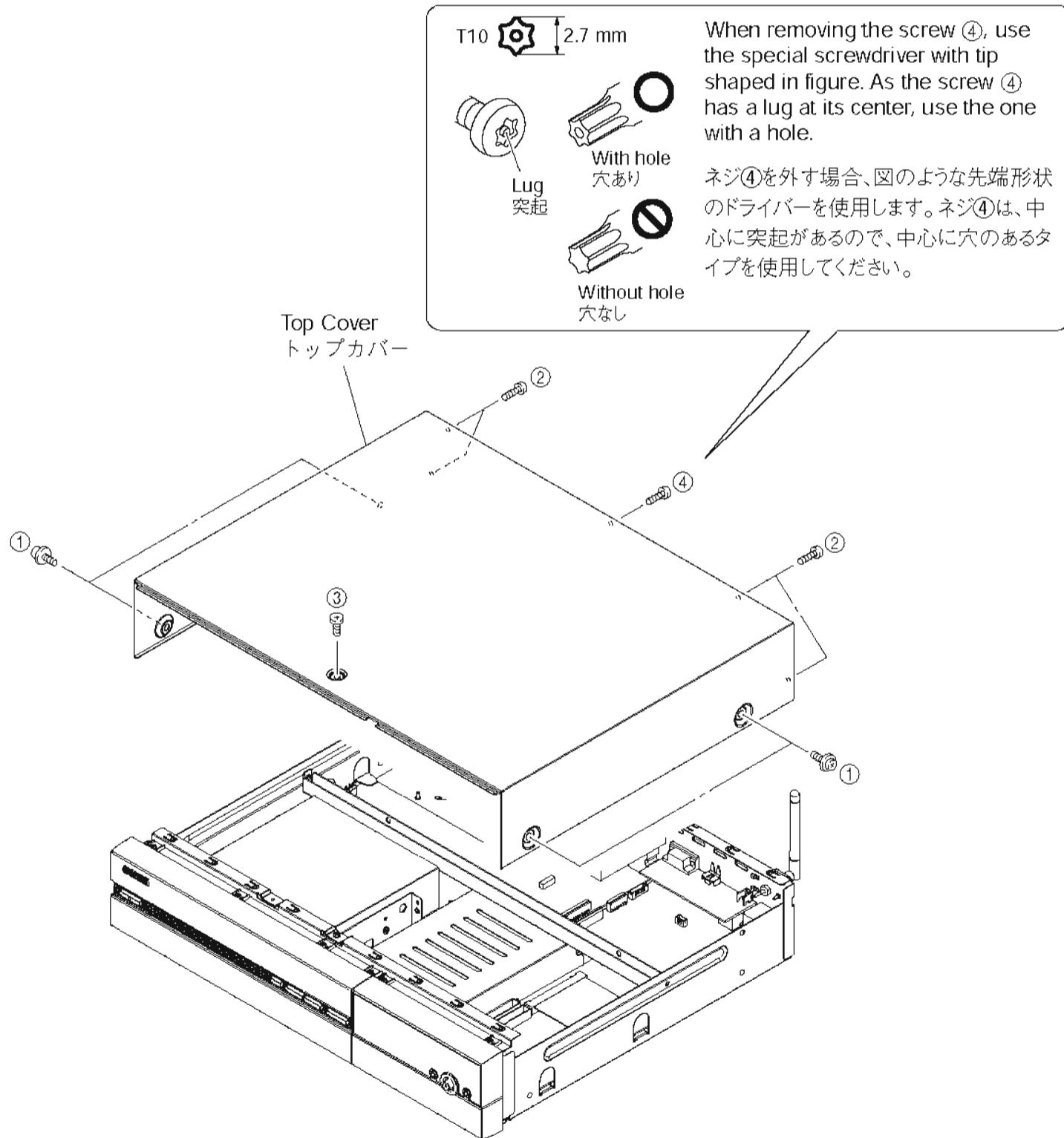

Fig. 1

*** Removal of Wireless LAN Module**

- a. Remove two Antenna connectors by using U.FL removing tool. (Fig. A)
- b. Expand the hook two places right and left, and detach wireless LAN module to the right. (Fig. A)

※ 無線LANモジュールの外し方

- a. U.FL引き抜き治具を使い、LANアンテナコネクタ2ヶ所を外します。(Fig. A)
- b. フック2ヶ所を左右にひろげ、無線LANモジュールを右方向に取り外します。(Fig. A)

* Be sure to connect the LAN antenna connector to the original position.

※ LANアンテナコネクタは必ず、元の位置に取り付けてください。

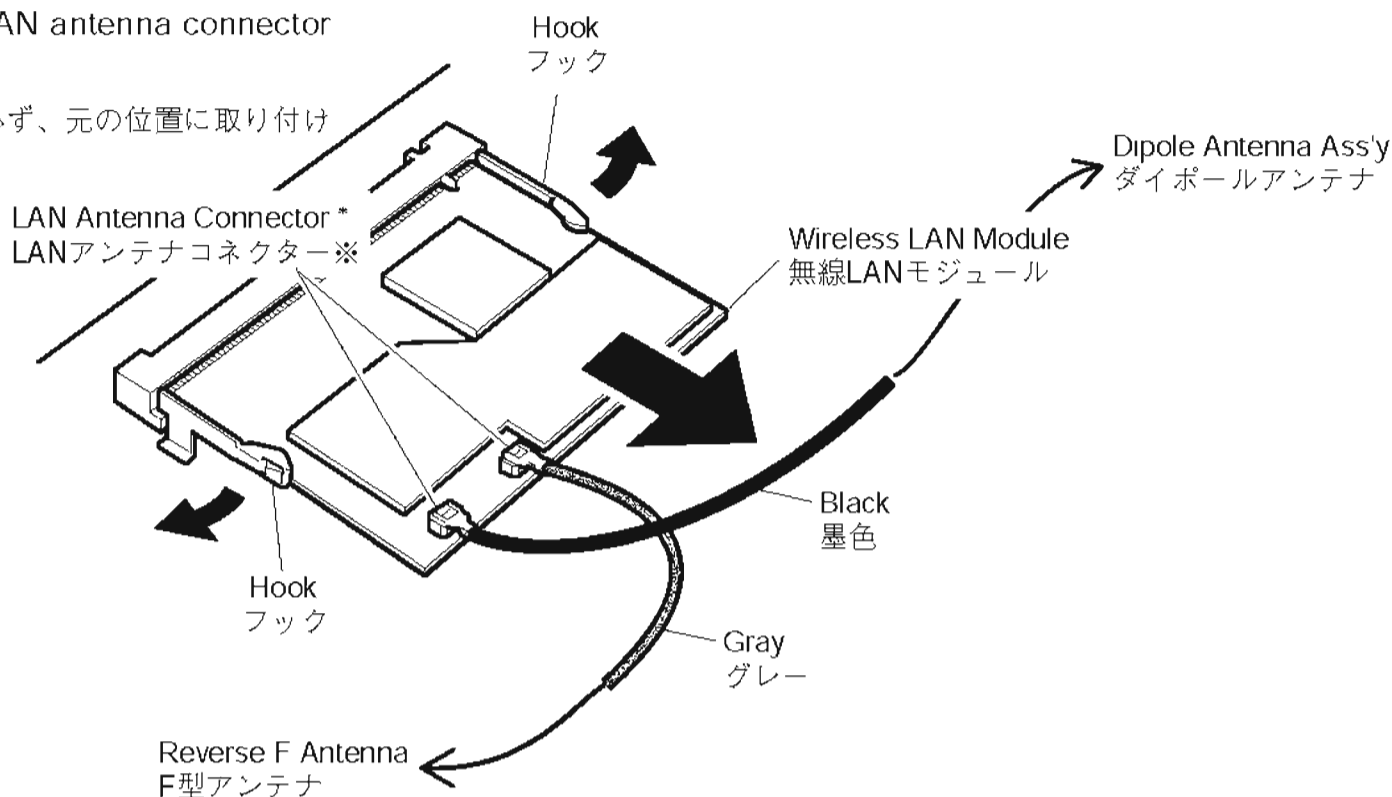
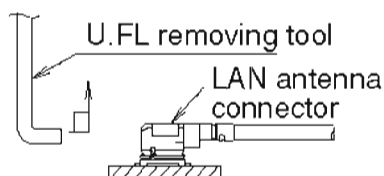

Fig. A

CAUTION !

- To remove the LAN antenna connector, use the U.FL removing tool. Hook the tip of this tool on the cover of the connector and pull it straight in the direction of the engaging axis of the connector.



Special removing tool

AAX72980: U.FL removing tool

- When installing the connector, insert it vertically with respect to the wireless LAN module as it is removed from the MAIN (1) P.C.B..
- The connector can be inserted and removed up to 5 times only.
- Be sure to connect the LAN antenna connector to the original position. (Fig. A)

注意 !

- LANアンテナコネクタを引き抜く場合は、U.FL引き抜き治具の先端部をコネクタふた部に引っ掛け、コネクタの嵌合軸に合わせ垂直に引き抜いてください。



専用引き抜き治具

AAX72980 : U.FL引き抜き治具

- コネクタ挿入時は、無線LANモジュールをMAIN(1) P.C.B.から取り外した状態で垂直に挿入してください。
- コネクタの挿抜は5回までとしてください。
- コネクタは必ず元の位置に取り付けてください。(Fig. A)

2. Removal of Front Panel Unit

- a. Remove 6 screws (⑤) and 6 screws (⑥). (Fig. 2)
- b. Remove CB901. (Fig. 2)
- c. Remove the front panel unit forward. (Fig. 2)

2. フロントパネルユニットの取り外し

- a. ⑤のネジ6本、⑥のネジ6本を外します。(Fig. 2)
- b. CB901を外します。(Fig. 2)
- c. フロントパネルユニットを前方に外します。(Fig. 2)

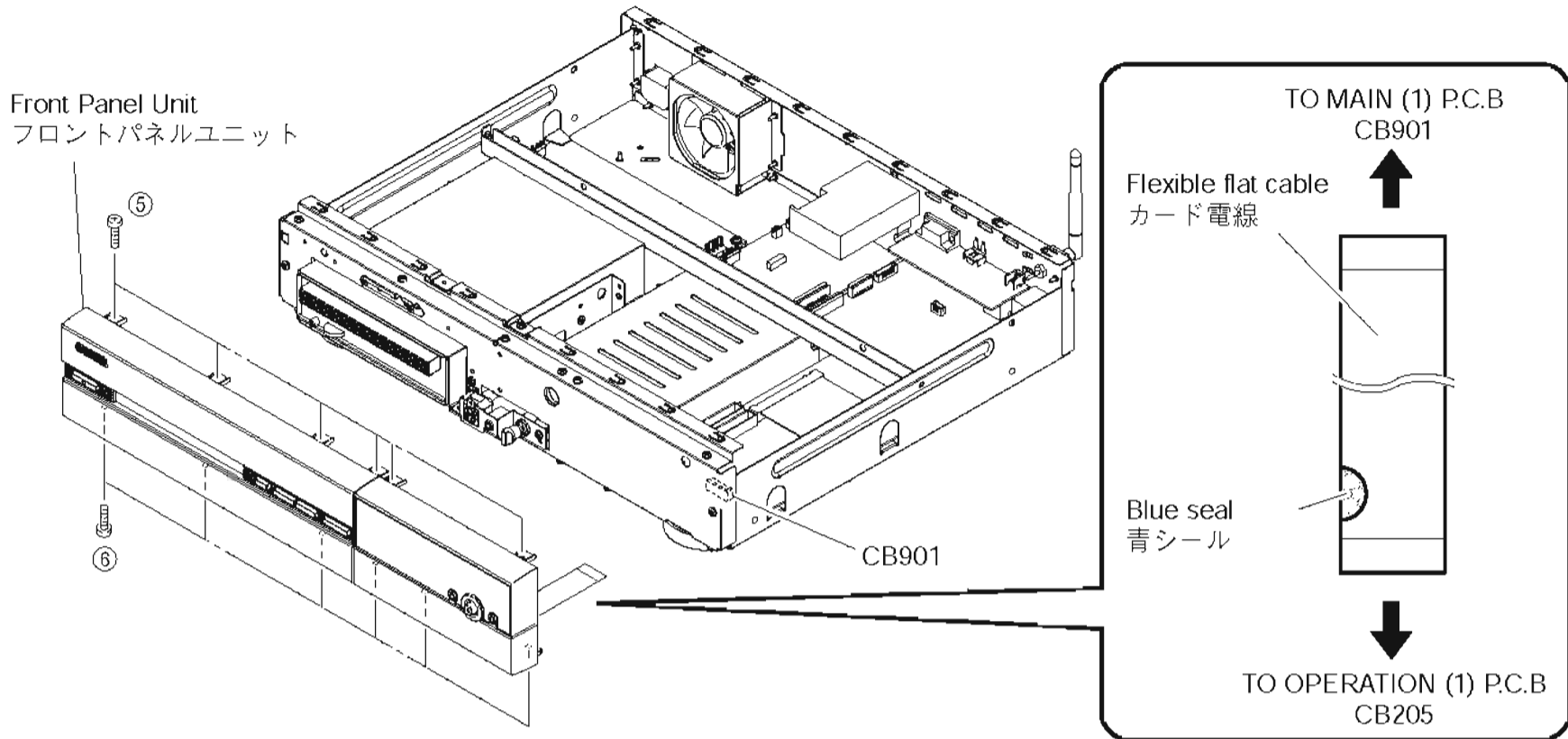

* Install the flexible flat cable with the blue seal being located CB205 side and left side.
 ※ このカード電線は青シールがCB205側かつ左側にくるように取り付けます。

Fig. 2

3. Removal of MAIN (1) and (2) P.C.B.

- a. Remove 6 screws (⑦). (Fig. 3)
- b. Remove the Angle/Chassis. (Fig. 3)
- c. Remove 1 screw (⑧) and 2 Jack screws (⑨). (Fig. 4)
- d. Remove CB850. (Fig. 5)
- e. Remove the MAIN (2) P.C.B..

3. MAIN(1)、(2)P.C.B.の取り外し

- a. ⑦のネジ6本を外します。(Fig. 3)
- b. アンクル/シャーシを取り外します。
- c. ⑧のネジ1本、⑨のジャックスクリュー2本を外します。(Fig. 4)
- d. CB850を外します。(Fig. 5)
- e. MAIN(2)P.C.B.を取り外します。

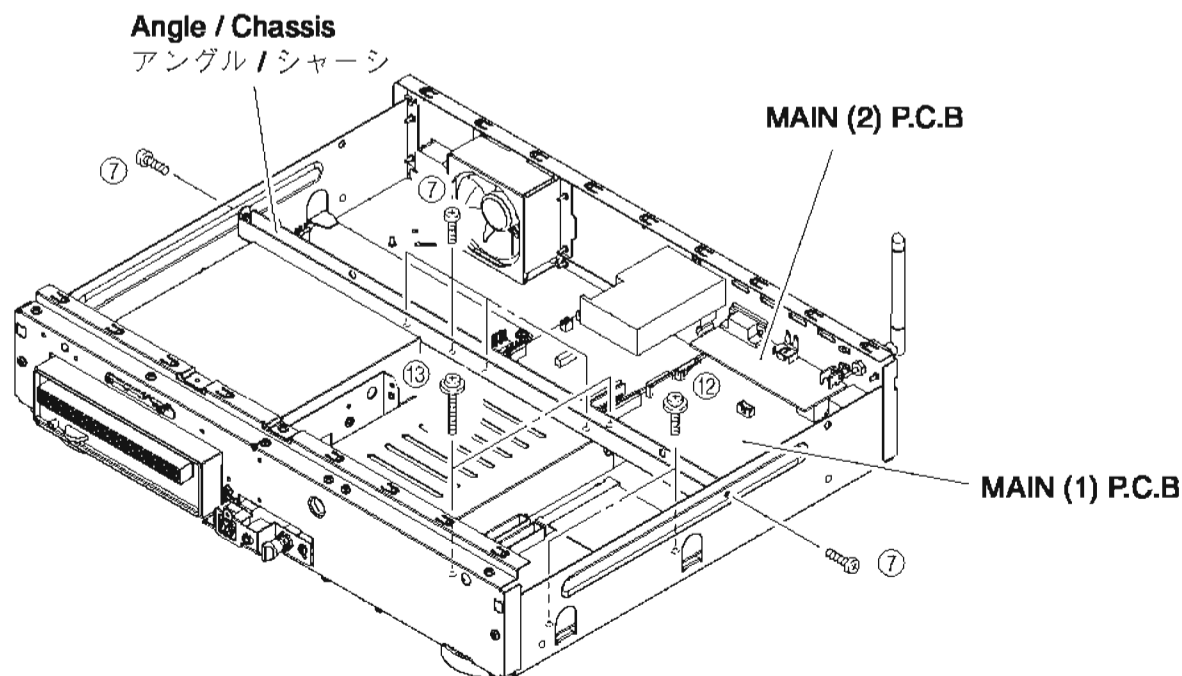

Fig. 3

- f. Remove 3 screws (⑩) and 3 screws (⑪). (Fig. 4)
- g. Remove 2 screws (⑫) and 2 screws (⑬). (Fig. 3)
- h. Remove CB201, CB501~CB504 and CB904. (Fig. 5)
- i. Remove the MAIN (1) P.C.B..

- f. ⑩のネジ3本、⑪のネジ3本を外します。(Fig. 4)
- g. ⑫のネジ2本、⑬のネジ2本を外します。(Fig. 3)
- h. CB201、CB501~CB504、CB904を外します。
(Fig. 5)
- i. MAIN (1) P.C.B.を取り外します。

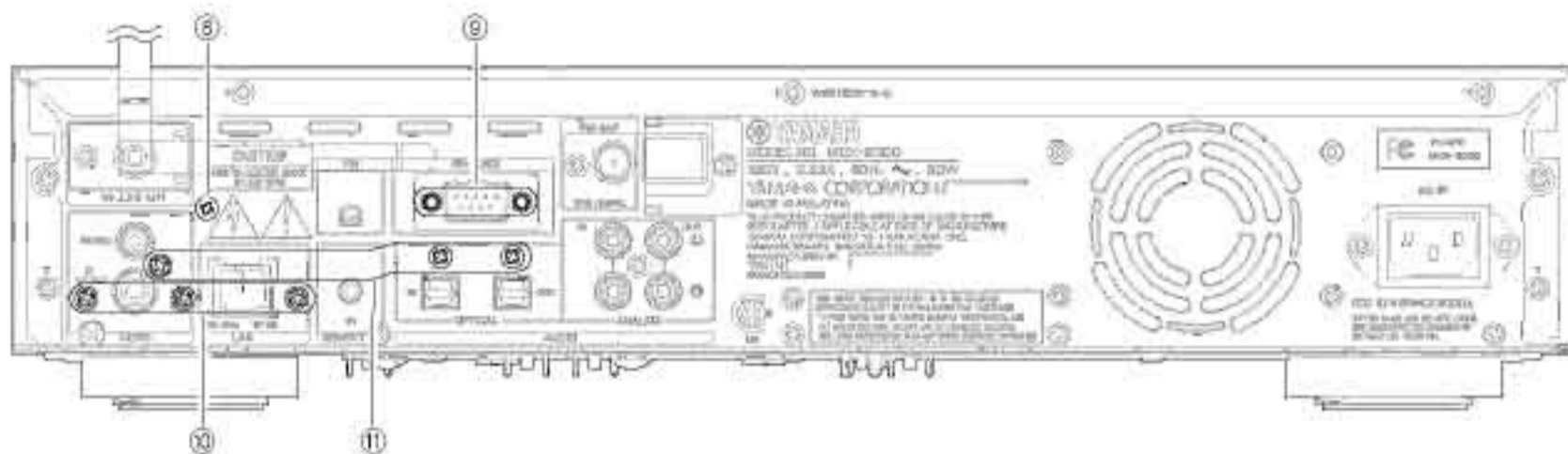

Fig. 4

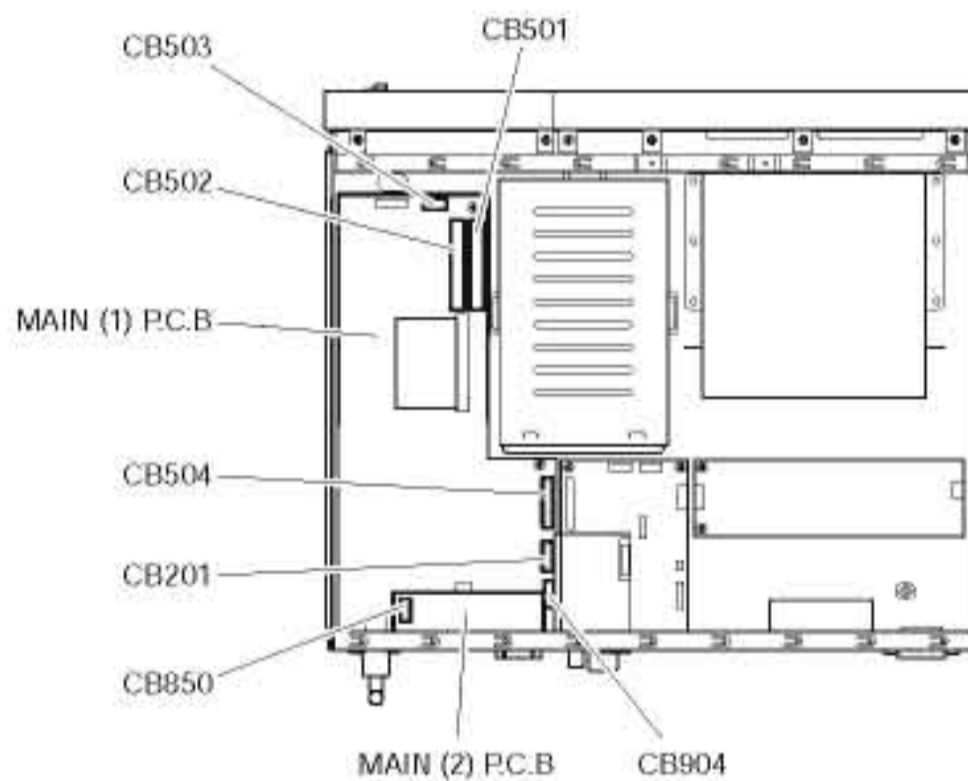

Fig. 5

When checking the P.C.B.:

- The cloth for insulation purpose on this unit, where P.C.B. is stood on it and checks it. (Fig. 6)
- Reconnect all cables (connectors) that have been disconnected.
Be sure to use the extension cable for servicing for the following section.
MAIN (1) P.C.B. CB504 – OPERATION (2) P.C.B. CB7:
WC028700 (30P 250mm P=0.5)
MAIN (1) P.C.B. CB901 – OPERATION (1) P.C.B. CB205:
MFA28160 (28P 160mm P=1.0)
- When connecting the cable, use care for the polarity.
- In this unit, the ground of MAIN (1) P.C.B. is connected to the Rear Panel. When MAIN (1) P.C.B. is removed from the Rear Panel, connect the ground to the rear panel or chassis, using a lead wire or the like. (Fig. 6)

P.C.B.チェックをする場合には

- 本機に絶縁用の布を敷き、その上にP.C.B.を立てた状態でチェックします。(Fig. 6)
- 外したケーブル(コネクタ)をすべて接続します。ただし次の区間は、サービス用延長ケーブルを使用してください。
MAIN(1)P.C.B. CB504 – OPERATION(2)P.C.B. CB7:
WC028700 (30P 250mm P=0.5)
MAIN(1)P.C.B. CB901 – OPERATION(1)P.C.B. CB205:
MFA28160 (28P 160mm P=1.0)
- ケーブルを接続する際、極性に注意してください。
- 本機ではMAIN(1)P.C.B.のアースがリアパネルに接続されています。MAIN(1)P.C.B.をリアパネルより取り外した場合は、リード線等でアースをリアパネルまたはシャーシに接続してください。(Fig. 6)

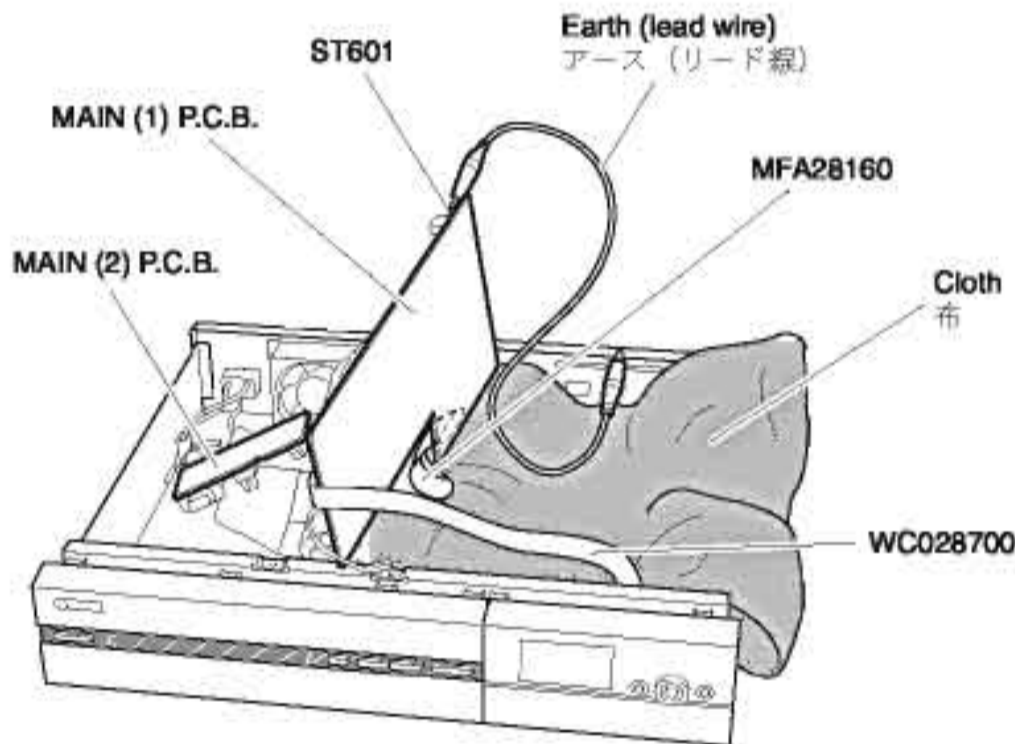

Fig. 6

4. Removal of CDR Unit

- Disconnect the power cable and IDE cable from the CDR unit. (Fig. 8)
- Remove 2 screws (14), 4 screws (15) and 1 screw (16). (Fig. 7)
- Remove the CDR unit rearward while lifting it up. (Fig. 7)
* The CDR unit is fixed with the hook in two places. (Fig. 7)

4. CDRユニットの取り外し

- CDRユニットから電源ケーブル、IDEケーブルを外します。(Fig. 8)
- 14のネジ2本、15のネジ4本、16のネジ1本を外します。(Fig. 7)
- 後方に持ち上げながらCDRユニットを取り外します。(Fig. 7)
* CDRユニットは2ヶ所のフックで固定されています。(Fig. 7)

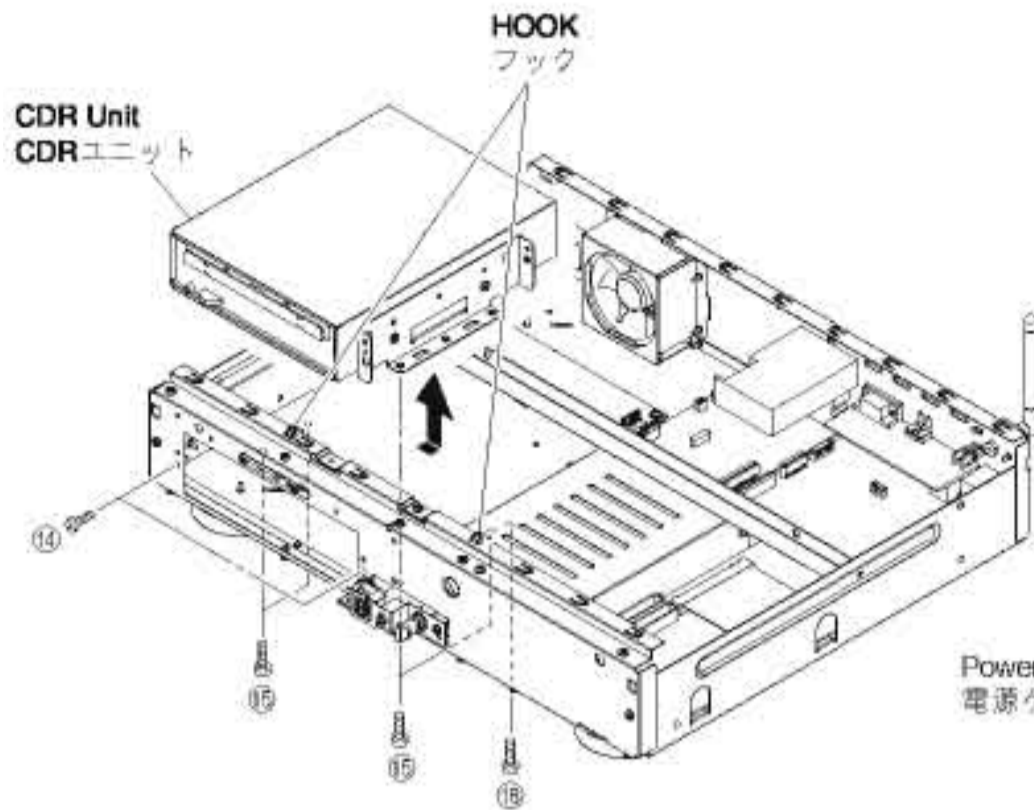

Fig. 7

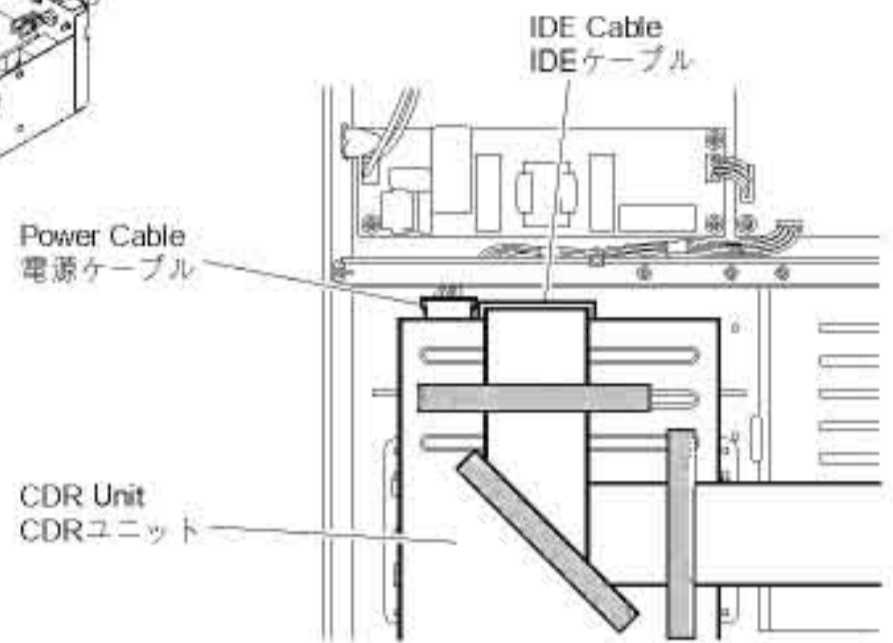

Fig. 8

5. Disassembly of CDR Unit

- a. Remove 6 screws (17) and then remove the Support CDR. (Fig. 9)
- b. Push the right side of the manual eject lever to open the tray and remove the lid upward. (Fig. 9, 10)

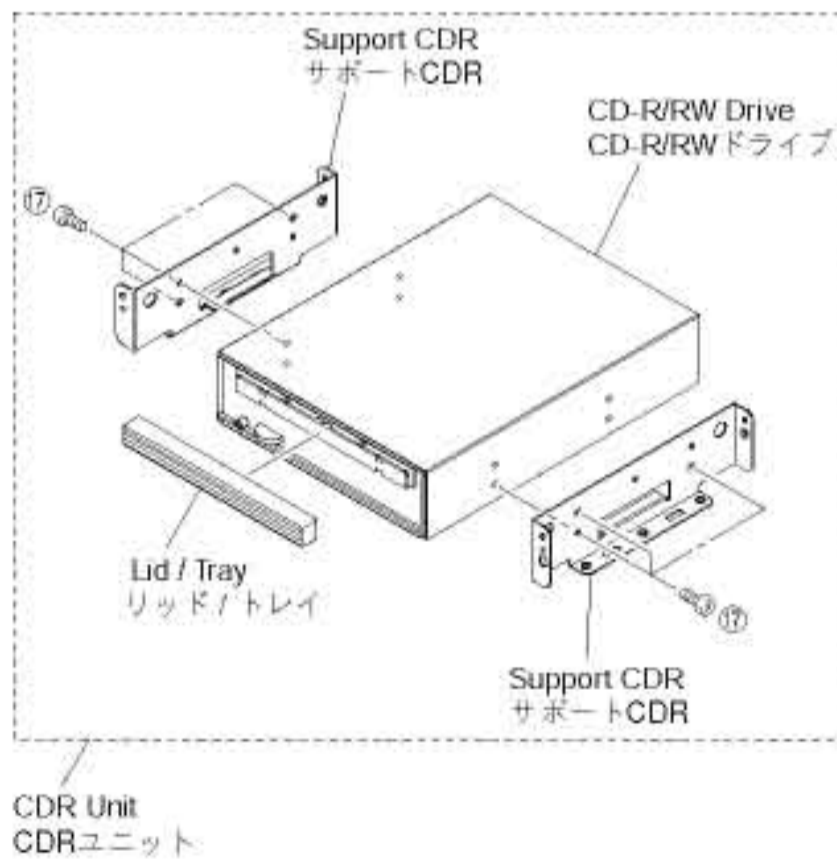

Fig. 9

5. CDRユニットの分解

- a. ⑰のネジ6本を外し、サポートCDRを外します。(Fig. 9)
- b. マニュアルイジェクトレバーの右側を押してトレイを開き、リッドを上方へ外します。(Fig. 9, 10)



Volume Control Manual Eject Lever
 ボリュームコントロール マニュアルイジェクトレバー

Note) To open the tray, push the right side (■ section) of the manual eject lever.

注) トレーを開く場合、マニュアルイジェクトレバーの右側(■部分)を押します。

Fig. 10

MCX-2000

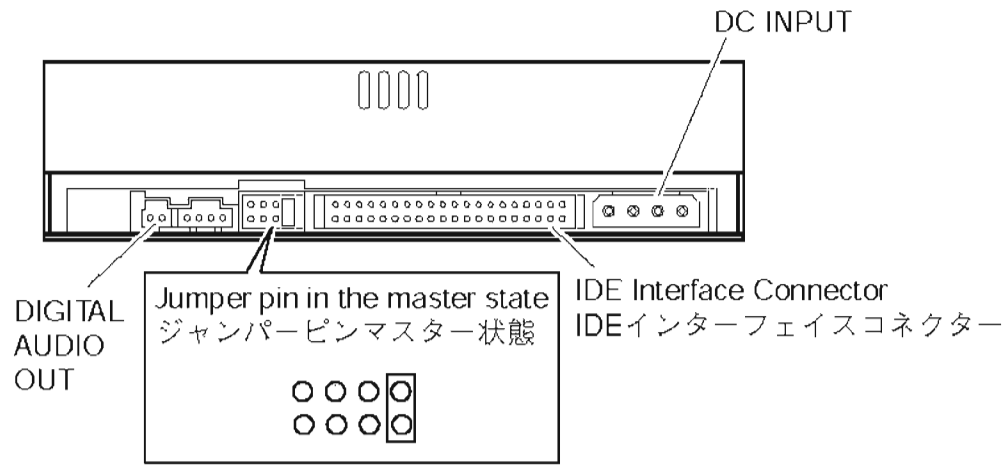

Fig. 11

6. Assembly of CDR Unit

- a. Set the plastic shunt of the new CD-R/RW drive to the master position. (Fig. 11)
- b. Set the Volume control to the minimum position (fully to the left). (Fig. 10)
- c. Push the right side of the manual eject lever to open the tray and install the lid. (Fig. 9, 10)
- d. Install the Support CDR using 6 screws marked (17). (Fig. 9)

6. CDRユニットの組立

- a. 新しいCD-R/RWドライブのショートピンを、マスターの位置に差し込みなおします。(Fig. 11)
- b. ボリュームコントロールを最小(左側一杯)に設定します。(Fig. 10)
- c. マニュアルイジェクトレバーの右側を押してトレイを開き、リッドを取り付けます。(Fig. 9, 10)
- d. 17のネジ6本でサポートCDRを取り付けます。(Fig. 9)

7. Installation of CDR Unit

- a. Connect the power cable and IDE cable to the CDR unit. (Fig. 8)
- b. Install the CDR unit. (Fig. 7)
- c. Install 2 screws (14), 4 screws (15) and 1 screw (16). (Fig. 7)

7. CDRユニットの取り付け

- a. CDRユニットに電源ケーブル、IDEケーブルを接続します。(Fig. 8)
- b. CDRユニットを取り付けます。(Fig. 7)
- c. 14のネジ2本、15のネジ4本、16のネジ1本。(Fig. 7)

HDD Replacement

- a. Remove 6 screws (18). (Fig. 12)
- b. Remove the Bottom Cover HDD. (Fig. 12)

HDDの交換

- a. 18のネジ6本を外します。(Fig. 12)
- b. ボトムカバーHDDを取り外します。(Fig. 12)

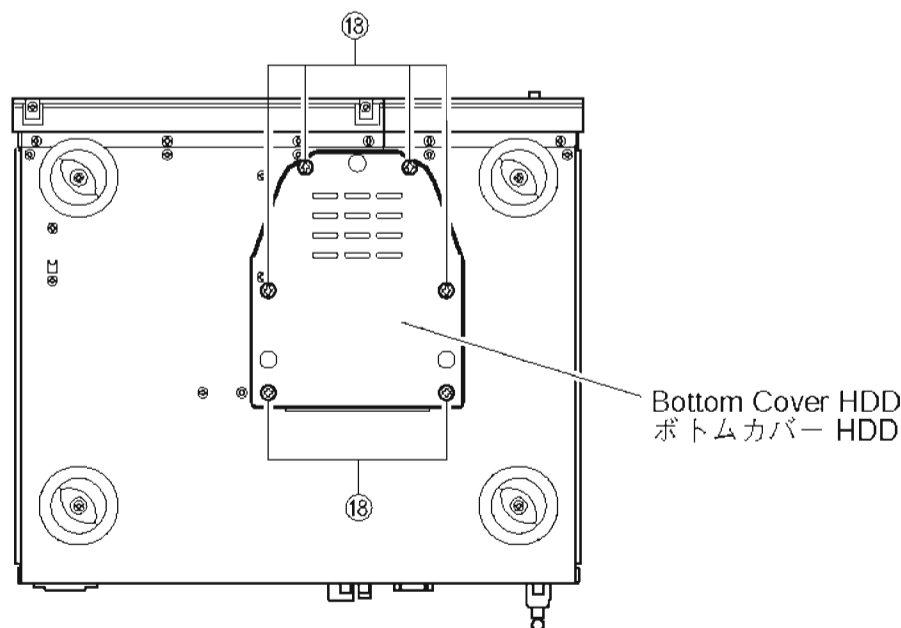

Fig. 12

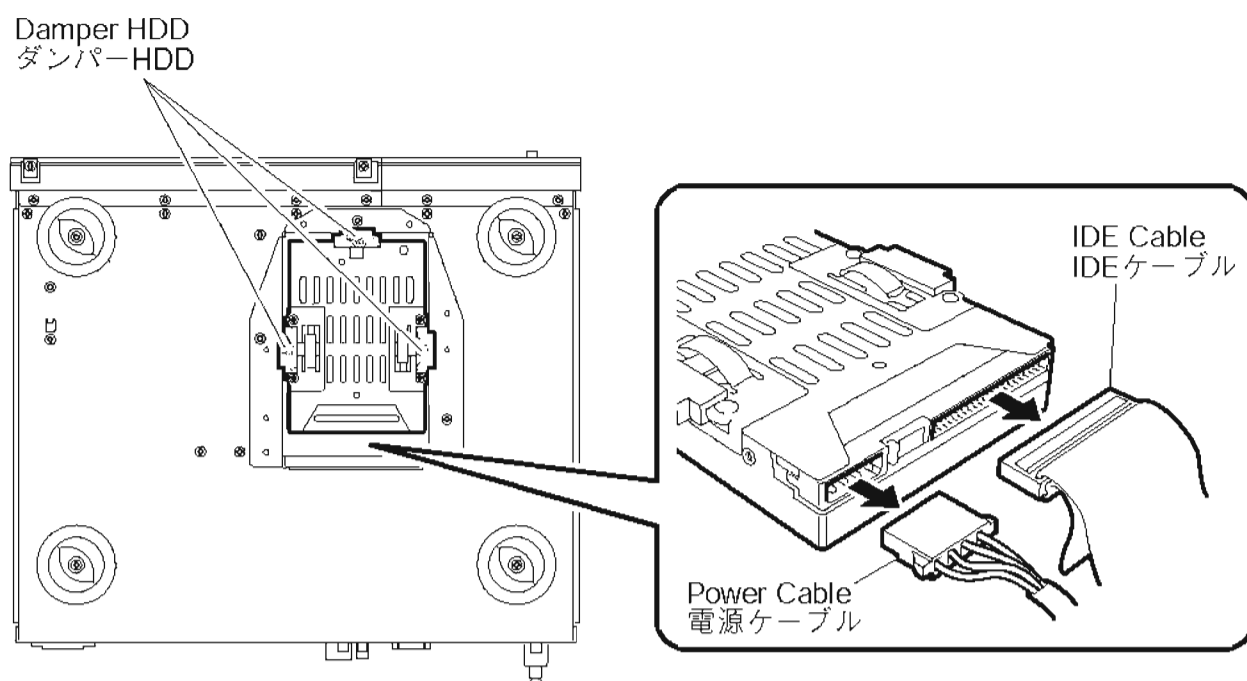

Fig. 13

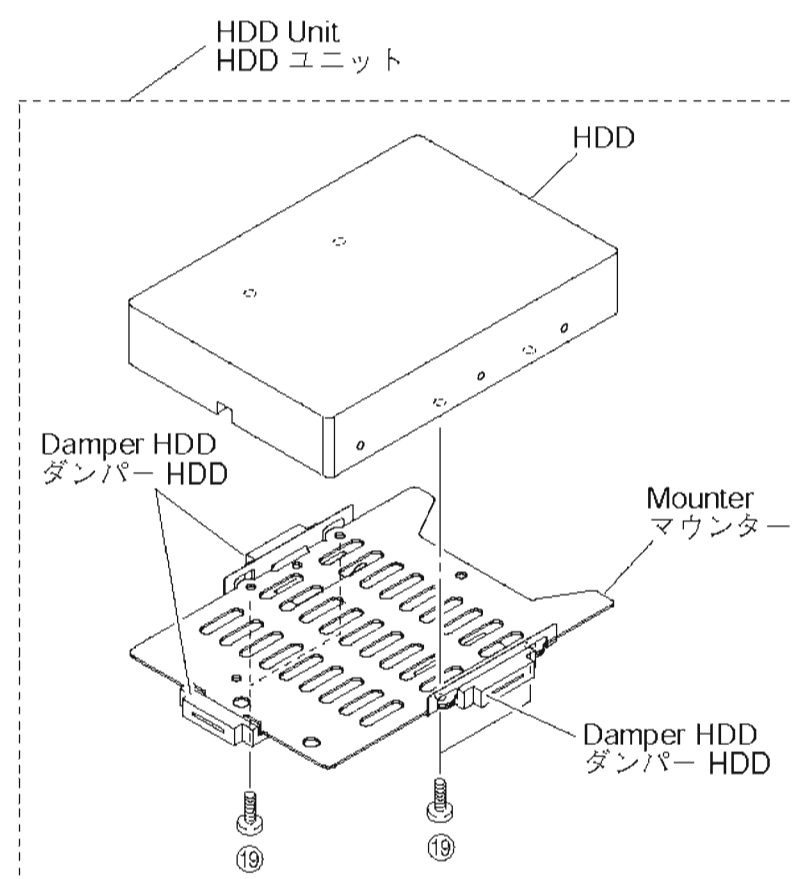
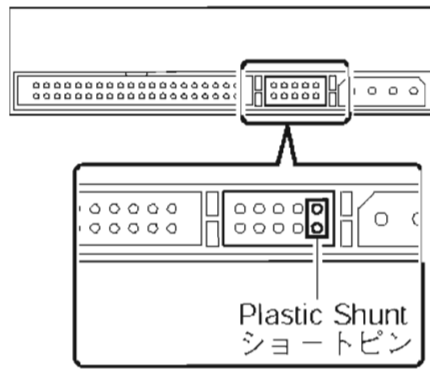

Fig. 14

- c. Disconnect the IDE cable and power cable from the HDD unit. (Fig. 13)
- d. Remove the HDD unit. (Fig. 13)
 - * The HDD unit is fixed by damper HDD in three places.
 - * Be careful not to hook the IDE cable and the power cable over the HDD tray.
 - * Static electricity can damage the HDD. Be careful not to touch the terminal pins and the P.C.B..
- e. Remove 4 screws (19). (Fig. 14)
- f. Remove the HDD. (Fig. 14)
- g. Set the plastic shunt of the new HDD to Cable select. (Fig. 15)
 - * It is necessary to set the HDD to MASTER, SLAVE or Cable select when connecting the HDD to the component you plan to use. This unit is designed to operate HDD when it is set to Cable select. Usually, setting procedure is written on the HDD itself.

- c. HDDユニットからIDEケーブルと電源ケーブルを外します。(Fig. 13)
- d. HDDユニットを取り外します。(Fig. 13)
 - * HDDユニットは3ヶ所のダンパーHDDで固定されています。
 - * IDEケーブルや電源ケーブルをHDDトレイに引っかけないようにご注意ください。
 - * 静電気によりHDDが破損する場合がありますので、HDDのターミナルピンやP.C.B.に触れないようにご注意ください。
- e. ⑲のネジ4本外します。(Fig. 14)
- f. HDDを取り外します。(Fig. 14)
- g. 新しいHDDのショートピンを、ケーブルセレクトに設定します。(Fig. 15)
 - * IDE/ATAタイプのHDDはお使いになる機器と接続するときに、マスターまたはスレーブまたはケーブルセレクトに設定する必要があります。本機で使用する場合は、ケーブルセレクトに設定すると作動するように設計されています。設定方法については、通常HDD本体に記載されています。

Example: When setting the WD1600BB model
 例: Western Digital社製WD1600BBの場合



The HDD is set to Cable select by setting the plastic shunt at the first position from right of the jumper switch.
 ジャンパースイッチの右から1番目の位置にショートピンを差し込むと、ケーブルセレクトに設定される

Example: When setting the ST3160021A model
 例: Seagate社製ST3160021Aの場合

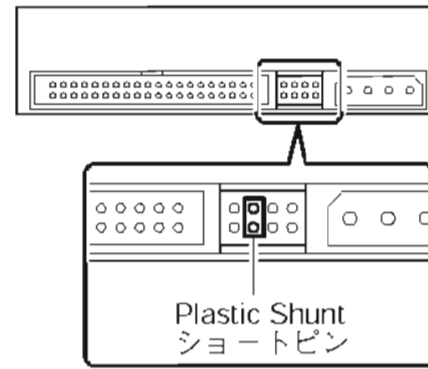

The HDD is set to Cable select by setting the plastic shunt at the second position from left of the jumper switch.
 ジャンパースイッチの左から2番目の位置にショートピンを差し込むと、ケーブルセレクトに設定される

Fig. 15

- h. Install a new HDD on the mounter using 4 screws (19) . (Fig. 14)
 - * HDD is a very sensitive device. Be careful not to give any shock to it.
- i. The IDE cable and power cable are inserted in the HDD unit. (Fig. 16)
 - * Make sure that the connectors are in the correct direction, and connect the cables securely.
 - * Static electricity can damage the HDD. Be careful not to touch the terminal pins and the circuit board.
- j. Install the HDD unit. (Fig. 16)
 - * The HDD unit is fixed by damper HDD in three places.
- k. Install the Bottom Cover HDD. (Fig. 12)
- l. Install 6 screws (18). (Fig. 12)

- h. 新しいHDDをマウンターに置き、19のネジ4本で固定します。(Fig. 14)
 - * HDDは衝撃に弱い機器ですので、振動や衝撃を加えないようにご注意ください。
- i. HDDユニットにIDEケーブル、電源ケーブルを差し込みます。(Fig. 16)
 - * コネクタの向きが正しいか確認のうえ、しっかりと差し込んでください。
 - * 静電気によりHDDが破損する場合がありますので、HDDのターミナルピンやP.C.B.に触れないようにご注意ください。
- j. HDDユニットを取り付けます。(Fig. 16)
 - * HDDユニットは3ヶ所のダンパーHDDで固定されています。
- k. ボトムカバーHDDを取り付けます。(Fig. 12)
- l. 18のネジ6本をしめます。(Fig. 12)

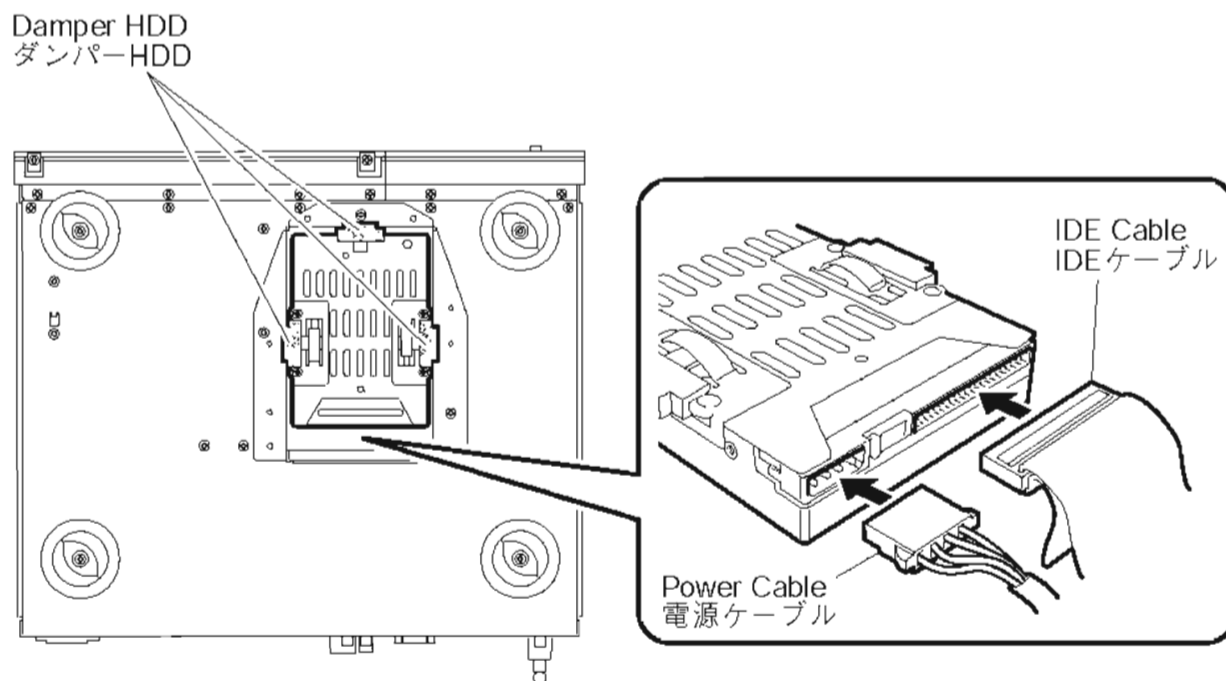

Fig. 16

■ SERVICE PRECAUTIONS / サービス時の注意事項

1. When updating the firmware only without replacing any part, refer to "UPDATING FIRMWARE". (p. 19~20)
 2. After replacing the CD-R/RW Drive, refer to "RECOVERY AFTER REPLACING CD-R/RW DRIVE". (p. 20)
 3. After replacing HDD, refer to "RECOVERY AFTER REPLACING HDD". (p. 21~23)
 4. After replacing the Main P.C.B., refer to "RECOVERY AFTER REPLACING MAIN P.C.B.". (p. 24)
1. 部品交換を伴わずにファームウェアのアップデートのみを行う場合
「ファームウェアのアップデート」(19~20ページ)を参照してください。
 2. CD-R/RWドライブを交換した場合
「CD-R/RWドライブ交換後のリカバリー」(20ページ)を参照してください。
 3. HDDを交換した場合
「HDD交換後のリカバリー」(21~23ページ)を参照してください。
 4. メインP.C.B.を交換した場合
「メインP.C.B.交換後のリカバリー」(24ページ)を参照してください。

■ UPDATING FIRMWARE / ファームウェアのアップデート

Updating the firmware requires use of the Update CD.

* More information on supply of the Update CD will be provided in the Service News.

ファームウェアのアップデートにはアップデートCDを使用します。

※ アップデートCDの供給に関する詳細は、サービスニュースでお知らせします。

• Items required

Update CD

• 用意するもの
アップデートCD

• Operation Procedure

Perform following steps while watching the display screen of the main unit and using the keys of the main unit.

• 操作手順
本体の表示画面を見ながら本体キーを使って操作します。

- 1) Turn on the power.
- 2) The [TOP MENU] is displayed.
- 3) Press the "△" key to open the tray, set the Update CD on the tray and then close the tray.
- 4) Using the "Cursor Controller" key, select the menu items as follows.
[Setup]
→ [System Utilities]
→ [System Update]
- 5) Press the "Cursor Controller >" key.
- 6) Using the "Cursor Controller" key, select the [Start].
The updating function starts.

- 1) 電源を入れます。
- 2) [トップメニュー]が表示されます。
- 3) "△"キーを押してトレイを開き、アップデートCDをトレイに載せ、トレイを閉じます。
- 4) "カーソルコントローラー"キーを使いメニューを下記のように選択します。
[システム設定]
→ [システムユーティリティ]
→ [システムのアップデート]
- 5) "カーソルコントローラー >"キーを押します。
- 6) "カーソルコントローラー"キーを使い、[開始]を選択します。
アップデートが開始します。

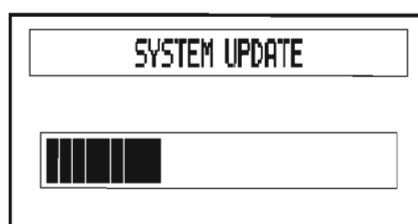

During downloading / 書き込み中

After updating, the message as shown below is displayed.

アップデート終了後、下記のように表示されます。

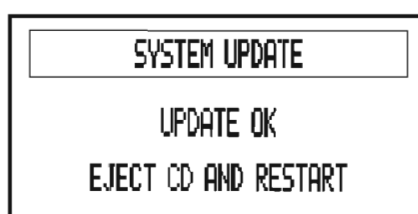

- 7) Press the “△” key to open the tray, remove the Update CD and close the tray.
- 8) Press “STANDBY/ON” key to restart.
- 9) Confirm the version of the firmware.
Using the “Cursor Controller” key, select the menu items as follows.

[Setup]
→ [System Utilities]
→ [System Information]
→ [Version]

When the displayed firmware version is the same as the firmware version recorded in the Update CD, the procedure is completed.

- 10) Press the “STANDBY/ON” key to turn off the power.

- 7) “△”キーを押してトレイを開き、アップデートCDを取り出し、トレイを閉じます。
- 8) “STANDBY/ON”キーを押して再起動します。
- 9) ファームウェアのバージョンを確認します。
“カーソルコントローラー”キーを使いメニューを下記のように選択します。

[システム設定]→[システム]
→[システムユーティリティ]
→[システム情報]
→[バージョン]

表示されたファームウェアのバージョンと、アップデートCDに記載されているファームウェアのバージョンが同様になれば完了です。

- 10) “STANDBY/ON”キーを押して、電源をOFFします。

RECOVERY AFTER REPLACING CD-R/RW DRIVE / CD-R/RWドライブ交換後のリカバリー

After replacing the CD-R/RW drive, perform the recovery procedure as described below.

• Items required

Rescue CD

• Operation Procedure

Perform following steps while watching the display screen of the main unit and using the keys of the main unit.

- 1) Turn on the power.
The message as shown below is displayed.

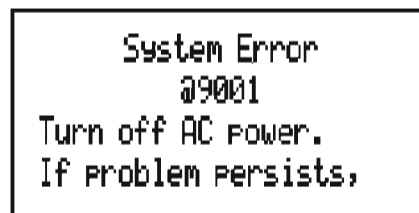

- 2) Press the “△” key to open the tray, set the Rescue CD on the tray and then close the tray.
The updating function starts automatically.

- 3) After updating, the message as shown below is displayed.

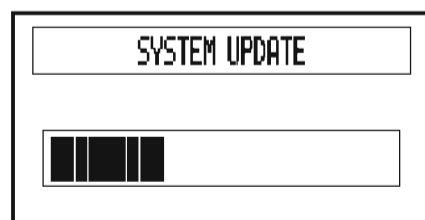

During downloading / 書き込み中



CD-R/RWドライブを交換した場合、下記の手順でリカバリーを行います。

• 用意するもの

Rescue CD

• 操作手順

本体の表示画面を見ながら本体キーを使って操作します。

- 1) 電源を入れます。
下記のように表示されます。

- 2) “△”キーを押してトレイを開き、Rescue CDをトレイに載せ、トレイを閉じます。
自動的にアップデートがスタートします。

- 3) アップデート終了後、下記のように表示されます。

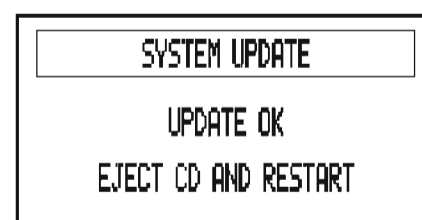

- 4) Press the “△” key to open the tray, remove the Rescue CD and close the tray.

- 5) Press the “STANDBY/ON” key.
The power to the main unit is turned OFF and then turned ON automatically.

- 4) “△”キーを押してトレイを開き、Rescue CDを取り出し、トレイを閉じます。

- 5) “STANDBY/ON”キーを押します。
本体の電源はOFF後、自動的にONします。

■ RECOVERY AFTER REPLACING HDD / HDD交換後のリカバリー

After replacing the HDD, perform the recovery procedure as described below.

• Items required

FORMAT and Recovery CD (HDD is formatted.)
Rescue CD (HDD is not formatted.)

• Operation Procedure

Perform following steps while watching the display screen of the main unit and using the keys of the main unit.

HDDを交換した場合、下記の手順でリカバリーを行います。

• 用意するもの

FORMAT and Recovery CD (HDDをフォーマットします。)
Rescue CD (HDDをフォーマットしません。)

• 操作手順

本体の表示画面を見ながら本体キーを使って操作します。

Case 1

- When a brand new HDD is installed.
- When an HDD used for a PC or other MCX-2000 is installed.

Note) In this case, for the purpose of copyright protection, HDD cannot be used unless all the data recorded in it is erased.

- 1) Turn on the power.
The message as shown below is displayed.

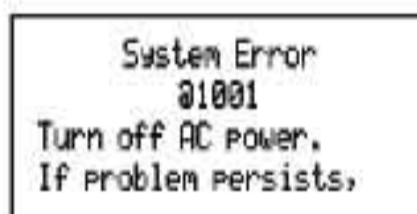

- 2) Press the "△" key to open the tray, set the FORMAT and Recovery CD on the tray and then close the tray.
Note) The data recorded in HDD is completely erased. The updating function starts automatically.

- 3) After updating, the message as shown below is displayed.

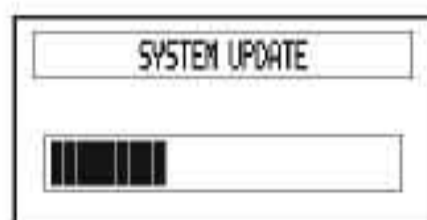

During downloading / 書き込み中

- 4) Press the "△" key to open the tray, remove the FORMAT and Recovery CD and close the tray.
- 5) Press the "STANDBY/ON" key.
The power to the main unit is turned OFF and then turned ON automatically.

ケース1

- 新品のHDDを取り付けた場合
- パソコンまたは他のMCX-2000で使ったHDDを取り付けた場合
注)この場合、著作権保護のためにHDDに記録されたデータをすべて消さない限り使用することはできません。

- 1) 電源を入れます。
下記のように表示されます。

- 2) "△"キーを押してトレイを開き、FORMAT and Recovery CDをトレイに載せ、トレイを閉じます。
注)HDDに記録されたデータはすべて消去されます。自動的にアップデートがスタートします。

- 3) アップデート終了後、下記のように表示されます。

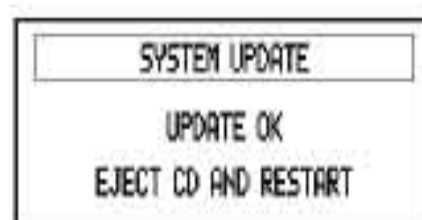

- 4) "△"キーを押してトレイを開き、FORMAT and Recovery CDを取り出し、トレイを閉じます。
- 5) "STANDBY/ON"キーを押します。
本体の電源はOFF後、自動的にONします。

Case 2

- When the installed HDD is the one previously used for the same MCX-2000

Turn on the power.
"A" or "B" is displayed as shown below.

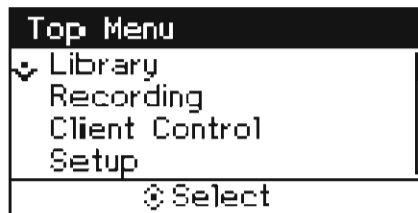

"A"

ケース2

- 過去にそのMCX-2000で使用したHDDを取り付けた場合

電源を入れます。
下記のように、"A"または"B"が表示されます。

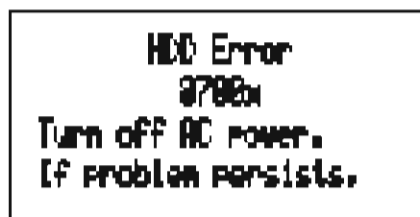
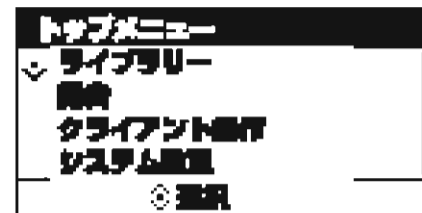

"B"

When A is displayed

- When formatting HDD is not needed
The main unit is available as it is.
 - When formatting HDD is needed
Note) The data recorded in HDD is completely erased.
- Press the "≡" key to open the tray, set the FORMAT and Recovery CD on the tray and then close the tray.
 - Using the "Cursor Controller" key, select the menu items as follows.

[Setup]
→ [System Utilities]
→ [System Update]

- Press the "Cursor Controller >" key.
- Using the "Cursor Controller" key, select the [Start].
The updating function starts.
- After updating, the message as shown below is displayed.

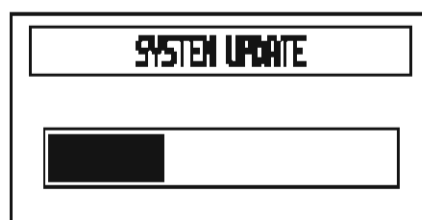

During downloading / 書き込み中



表示Aの場合

- HDDをフォーマットしない場合
本機はそのまま使用できます。
 - HDDをフォーマットする場合
注) HDDに記録されたデータはすべて消去されます。
- "≡"キーを押してトレイを開き、FORMAT and Recovery CDをトレイに載せ、トレイを閉じます。
 - "カーソルコントローラー"キーを使いメニューを下記のように選択します。
- [システム設定]
→ [システムユーティリティ]
→ [システムのアップデート]
- "カーソルコントローラー >"キーを押します。
 - "カーソルコントローラー"キーを使い、[開始]を選択します。
アップデートがスタートします。
 - アップデート終了後、下記のように表示されます。



- Press the "≡" key to open the tray, remove the FORMAT and Recovery CD and close the tray.
- Press the "STANDBY/ON" key.
The power to the main unit is turned OFF and then turned ON automatically.

- "≡"キーを押してトレイを開き、FORMAT and Recovery CDを取り出し、トレイを閉じます。
- "STANDBY/ON"キーを押します。
本体の電源はOFF後、自動的にONします。

When B is displayed• **When formatting HDD is not needed**

Use the Rescue CD.

• **When formatting HDD is needed**

Use the FORMAT and Recovery CD.

Note) The data recorded in HDD is completely erased.

- 1) Press the "△" key to open the tray, set the Rescue CD or FORMAT and Recovery CD on the tray and then close the tray.

The updating function starts automatically.

- 2) After updating, the message as shown below is displayed.

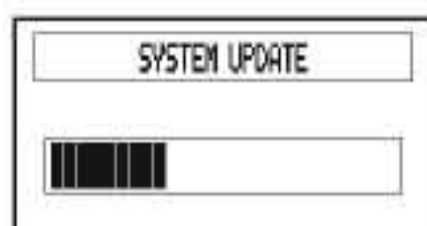

During downloading / 書き込み中

- 3) Press the "△" key to open the tray, remove the Rescue CD or FORMAT and Recovery CD and close the tray.

- 4) Press the "STANDBY/ON" key.

The power to the main unit is turned OFF and then turned ON automatically.

表示Bの場合

- HDDをフォーマットしない場合
Rescue CDを使用します。

- HDDをフォーマットする場合
FORMAT and Recovery CDを使用します。

注) HDDに記録されたデータはすべて消去されます。

- 1) "△"キーを押してトレイを開き、Rescue CDまたは、FORMAT and Recovery CDをトレイに載せ、トレイを閉じます。

自動的にアップデートがスタートします。

- 2) アップデート終了後、下記のように表示されます。

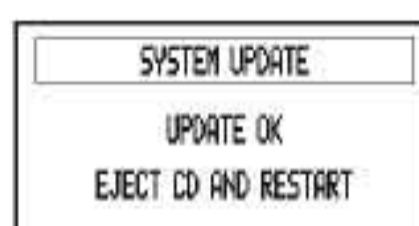

- 3) "△"キーを押してトレイを開き、Rescue CDまたはFORMAT and Recovery CDを取り出し、トレイを閉じます。

- 4) "STANDBY/ON"キーを押します。

本体の電源はOFF後、自動的にONします。

■ RECOVERY AFTER REPLACING MAIN P.C.B. / MAIN P.C.B.交換後のリカバリー

After replacing the Main P.C.B., perform the recovery procedure as described below.

• Items required

System ID write Utility CD
Rescue CD

• Operation Procedure

Perform following steps while watching the display screen of the main unit and using the keys of the main unit.

Step 1

Install the System ID write Utility.

- 1) Turn on the power.

The message as shown below is displayed.

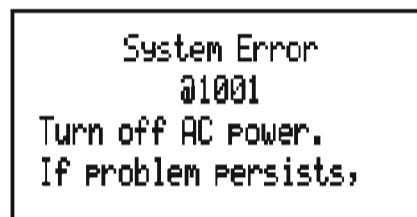

- 2) Press the “△” key to open the tray, set the System ID write Utility CD on the tray and then close the tray. The Installing function starts automatically.
- 3) After Installing, press the “△” key to open the tray, and remove the System ID write Utility CD and close the tray.
- 4) Press the “STANDBY/ON” key to turn off the power.

Step 2

Enter the system ID.

For the details, refer to “ENTERING SYSTEM ID” (p. 27~28).

After entering the system ID, turn off the power, remove the jig P.C.B. and disconnect the connection cable.

Step 3

Install the firmware.

For the details, refer to “RECOVERY AFTER REPLACING HDD, Case 2, When B is displayed, • When HDD is not formatted” (p. 23).

Step 4

Reset the system.

- 1) Press the “MENU” key.

The [TOP MENU] is displayed.

- 2) Using the “Cursor Controller” key, select the menu items as follows.

[Setup]

→ [System Utilities]

→ [System Reset]

- 3) Using the “Cursor Controller” key, bring the cursor to “Yes” and press the “Cursor Controller” key. After resetting, the [System Reset] screen is displayed.
- 4) Press the “STANDBY/ON” key to turn off the power.

メインP.C.B.を交換した場合、下記の手順でリカバリーを行います。

• 用意するもの

System ID write Utility CD
Rescue CD

• 操作手順

本体の表示画面を見ながら本体キーを使って操作します。

Step 1

システムID書き換えユーティリティをインストールします。

- 1) 電源を入れます。

下記のように表示されます。

- 2) “△”キーを押してトレイを開き、System ID write Utility CDをトレイに載せ、トレイを閉じます。自動的にインストールがスタートします。
- 3) インストール終了後、“△”キーを押してトレイを開き System ID write Utility CDを取り出し、トレイを閉じます。
- 4) “STANDBY/ON”キーを押し、電源をOFFします。

Step 2

システムIDを書き込みます。

詳しくは、「システムIDの書き込み」(27~28ページ)を参照してください。

書き込み完了後、電源を切り、治具基板および接続ケーブルを外します。

Step 3

ファームウェアをインストールします。

詳しくは「HDD交換後のリカバリー、ケース2、表示Bの場合、• HDDをフォーマットしない場合」(23ページ)を参照してください。

Step 4

システムを初期化します。

- 1) “MENU”キーを押します。

[トップメニュー]が表示されます。

- 2) “カーソルコントローラー”キーを使いメニューを下記のように選択します。

[システム設定]

→[システムユーティリティ]

→[システム設計の初期化]

- 3) “カーソルコントローラー”キーを使ってカーソルを“開始”に合わせ“カーソルコントローラー”キーを押します。リセット後、[システム設計の初期化]画面に戻ります。
- 4) “STANDBY/ON”キーを押し、電源をOFFします。

■ SERVICE MENU / サービスメニュー

• Items required

TV monitor
Video cable

• Connection

Using the video cable, connect the VIDEO OUT terminal of main unit to the VIDEO IN terminal of the TV monitor.

• Operation Procedure

Perform following steps while watching the TV monitor screen and using the keys of the main unit.

- 1) Turn on the power.
- 2) The [TOP MENU] is displayed.
- 3) Using the "Cursor Controller" key, select the [Setup] menu.
- 4) Press the "△" key to open the tray.
- 5) With the tray opened, press the "□" key three times, and the "Cursor Controller >" key once.
The [Service Menu] is displayed.

Service Menu screen

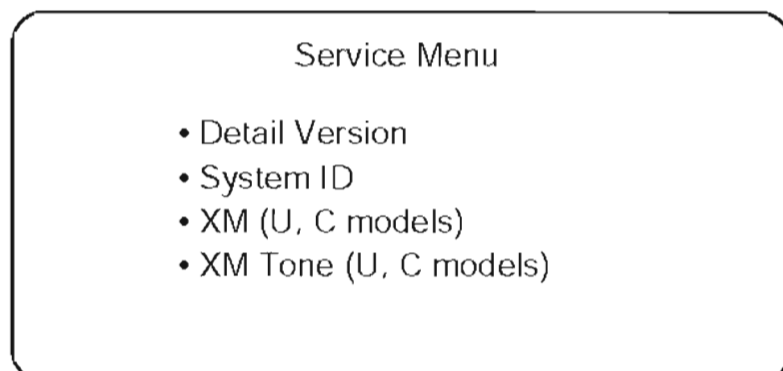

- 6) Using the "Cursor Controller" key, select the menu item and press the "Cursor Controller" key.
Selected menu is displayed.
- 7) To return to the [Setup] screen, press the "Cursor Controller <" key.
- 8) To return to the [Service Menu] screen, press the "Cursor Controller <" key.

• 用意するもの

TVモニター
ビデオケーブル

• 接続

本機のVIDEO OUTとTVモニターのVIDEO INをビデオケーブルで接続します。

• 操作手順

TVモニター画面を見ながら本体キーを使って操作します。

- 1) 電源を入れます。
- 2) [トップメニュー]が表示されます。
- 3) "カーソルコントローラー"キーを使い[システム設定]を選択します。
- 4) "△"キーを押してトレイを開きます。
- 5) トレーを開いたままの状態、"□"キーを3回、"カーソルコントローラー >"キーを1回押します。
[サービスメニュー]が表示されます。

サービスメニュー画面

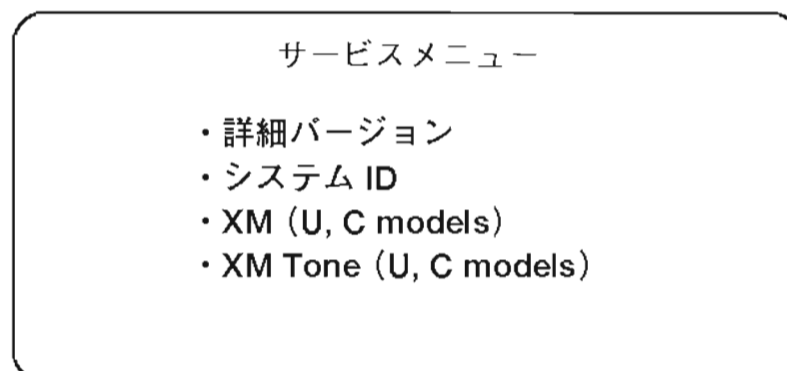

- 6) "カーソルコントローラー"キーを使いメニューを選び、"カーソルコントローラー"キーを押します。
選ばれたメニューが表示されます。
- 7) "カーソルコントローラー <"キーを押すと[システム設定]画面に戻ります。
- 8) "カーソルコントローラー <"キーを押すと[サービスメニュー]画面に戻ります。

Detail Version screen / 詳細バージョン画面

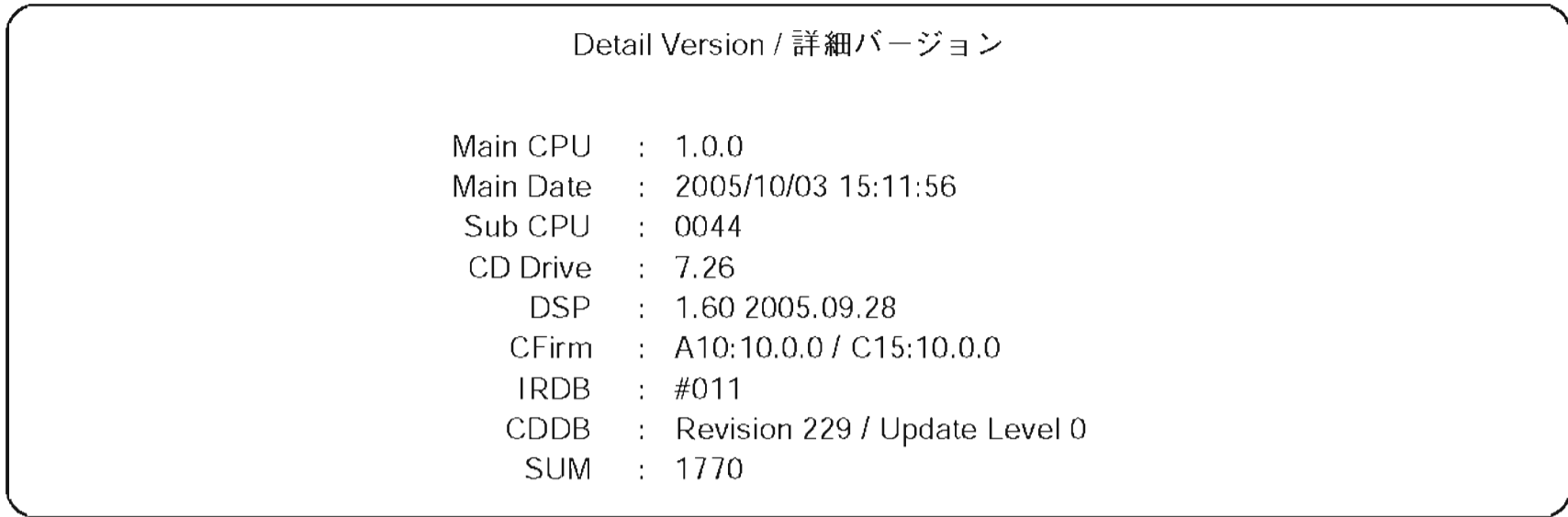

* Numeric values in the figure example are for reference. ※ 図中の数値は参考例です。

System ID screen / システム ID画面

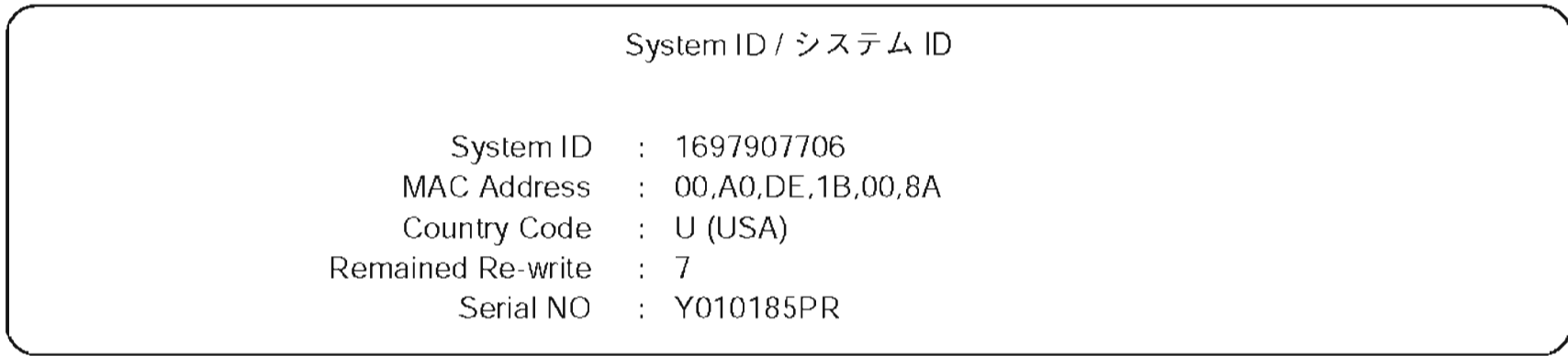

* Numeric values in the figure example are for reference. ※ 図中の数値は参考例です。

XM screen (U, C models)

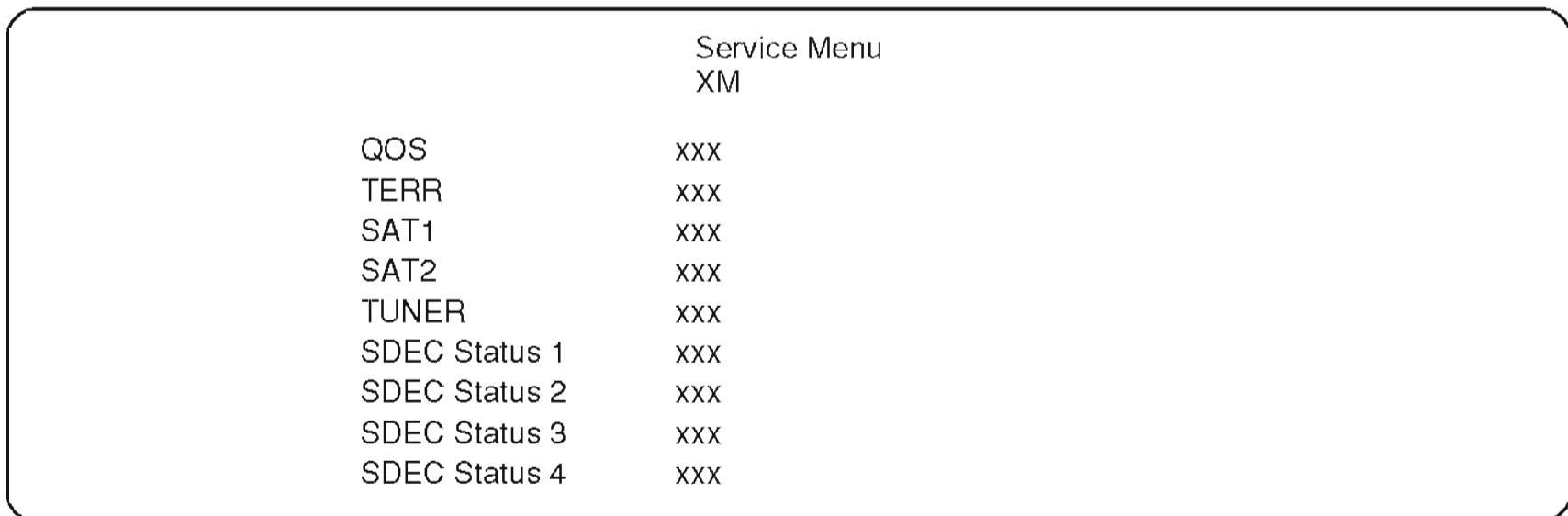

* Numeric values in the figure example are for reference. ※ 図中の数値は参考例です。

XM Tone (U, C models)
Test tone is output.

XM tone (U, C models)
テストトーンを出力します。

■ ENTERING SYSTEM ID / システムIDの書き込み

Preparation Be sure to take the measure against static electricity before the work. (Refer to p. 5)

Items required

IC writing jig (P.C.B. and 2P cable) : WA045500

* This 2P cable is not used.

Flat cable 30P 250mm : WC028700

Setting and Connecting Jig

- 1) Turn off the power and disconnect the power cable from the AC outlet.
- 2) Remove the top cover.
- 3) Set the I/O selector (CB4) of the jig P.C.B. to +3.3V. (Fig. A)
Caution: Note that setting to +5V will damage the unit.
- 4) Set the DIP switch (SW1) of the jig P.C.B. (Fig. A)
- 5) Connect TE1 of the jig P.C.B. to CB303 of the MAIN P.C.B. with the flat cable (30P). (Fig. A)

Operation Procedure

Perform following steps while watching the display screen of the main unit and using the keys of the main unit.

- 1) Turn on the power.
- 2) After about 10 seconds, "SER No. : XXXXXXXXX" is displayed in the 1st line and "Destination : U" in the 2nd line.
- 3) Enter 9 alphanumeric characters represented as X in the serial number [SER.XXXXXXXXX] found on the rear panel.
Note: The serial number is also found in a main unit chassis inside bottom. (Fig. B)
Inputting method :
The input number is displayed in the first line and the cursor is displayed under the currently selected digit. Using "▲/▼" of the "Cursor Controller" key to increase/decrease the value and "</>" to shift the place, select the character to enter one by one.
- 4) Using the "RADIO" key, select one from "U, A, G, B, C and J".
- 5) Check if "SER No." and "Destination" are selected correctly.
- 6) Press the "▶" key, and writing is executed.
- 7) After completion of writing the data, "System ID Write OK" is displayed.
If writing has failed, "System ID Write NG" is displayed. In such case, turn off the power, perform the procedure of "Setting and connecting jig" all over again and then restart from Step 1.
- 8) After completion of writing the data, turn off the power.
- 9) Remove the jig P.C.B. and disconnect the connecting cable.
- 10) Install the top cover.

Caution

The System ID can be rewritten up to 15 times.

準備 作業の前に必ず静電気対策を実施してください。(5ページ参照)

用意するもの

IC書き込み治具(基板+2Pケーブル) : WA045500

* この2Pケーブルは使用しません。

フラットケーブル30P 250mm : WC028700

治具の設定及び接続

- 1) 電源を切り、電源コードをACコンセントから抜きます。
- 2) トップカバーを外します。
- 3) 治具P.C.B.のI/Oセレクター(CB4)を+3.3Vに設定します。(Fig. A)
注意：+5Vに設定した場合、MCX-2000の故障の原因になります。
- 4) 治具P.C.B.のディップスイッチ(SW1)を設定します。(Fig. A)
- 5) 治具P.C.B.のTE1とMAIN P.C.B.のCB303をフラットケーブル(30P)接続します。(Fig. A)

操作手順

本体の表示画面を見ながら本体キーを使って操作します。

- 1) 電源を入れます。
- 2) 約10秒後、1行目「SER No. : XXXXXXXXX」、2行目「Destination : U」と表示されます。
- 3) リアパネルに表示されているシリアルナンバー「SER.XXXXXXXXX」のX部分の英数字(9桁)を入力します。
注意：シリアルナンバーは本体シャーシ内側底面にも表示されています。(Fig. B)
入力方法：
1行目に入力する番号が表示され、現在選択している桁の下にカーソルが表示されます。
“カーソルコントローラー”キーの“▲/▼”で値の増減、“</>”で桁の移動ができます。
1桁ずつ入力したい番号にあわせませす。
- 4) “RADIO”キーを使って、「U、A、G、B、C、J」の中から1つを選択します。
- 5) 「SER No.」、「Destination」の仕向の選択が正しいか確認します。
- 6) “▶”キーを押すと書き込みが行われます。
- 7) 書き込み完了後「System ID Write OK」と表示されます。
書き込みに失敗した場合、「System ID Write NG」と表示されます。
この場合、電源を切り、「治具の設定および接続」を最初からやり直した後、操作手順1からやり直します。
- 8) 書き込み完了後、電源を切ります。
- 9) 治具基板及び接続ケーブルを外します。
- 10) トップカバーを取り付けます。

注意

System IDを書き換えできる回数は15回までです。

CB4 is to select the I/O voltage.
 On the MCX-2000 it is "+3.3V".
 CB4は、I/O電圧の選択用。
 MCX-2000の場合は+3.3V。

Set the DIP switch as shown in figure.
 DIPスイッチを図のように設定します。

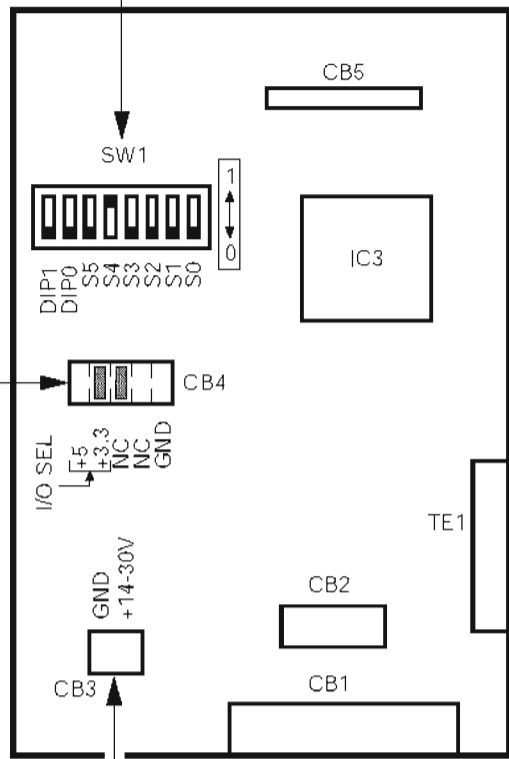

* This 2P cable is not used.
 * この2Pケーブルは使用しません

Fig. A

Flat Cable 30P/
 フラットケーブル 30P

MAIN P.C.B.

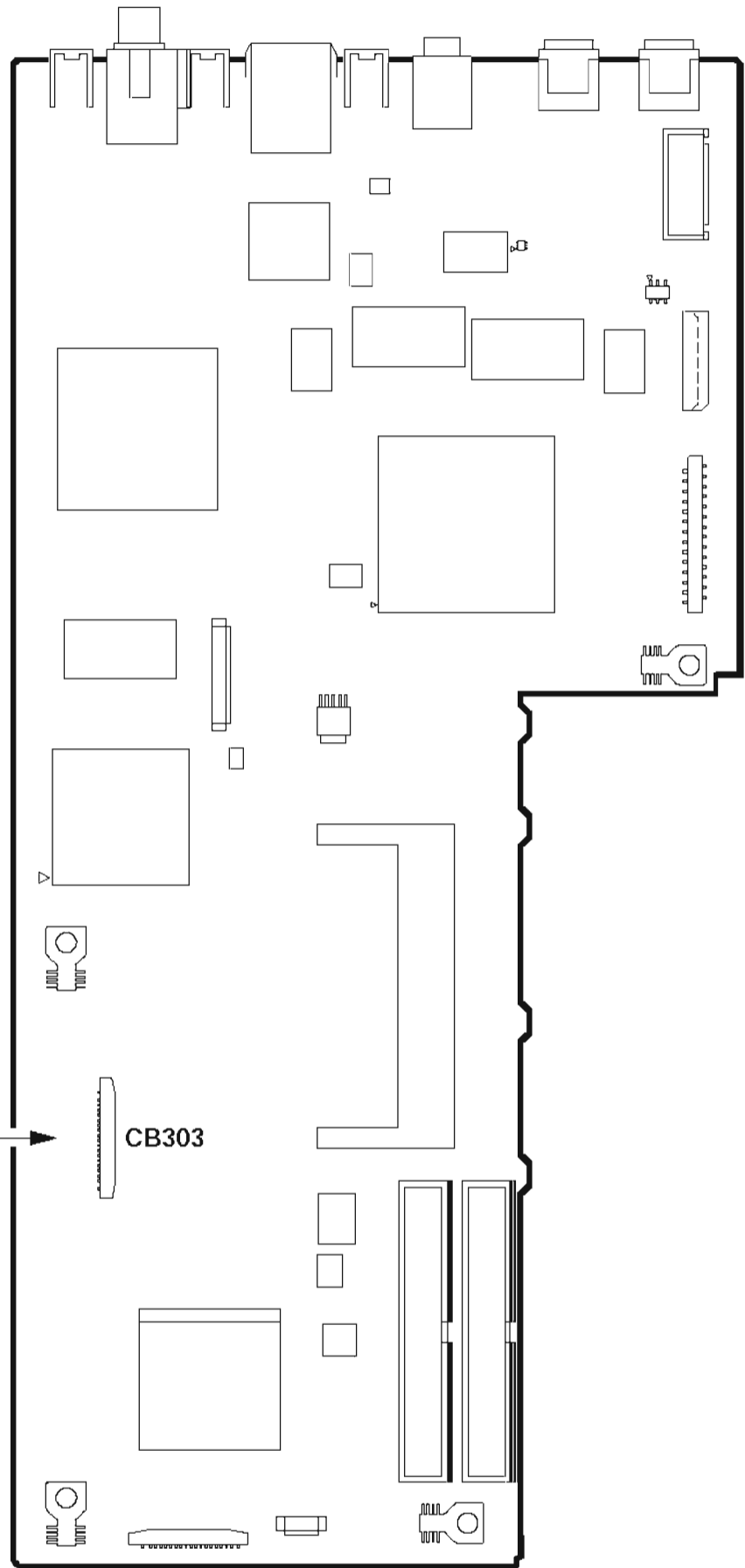

Serial Number
 シリアルナンバー

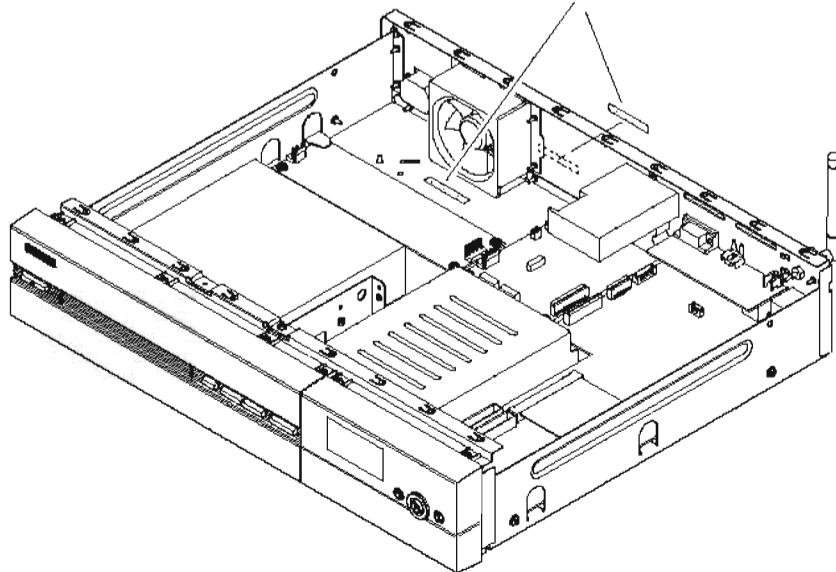
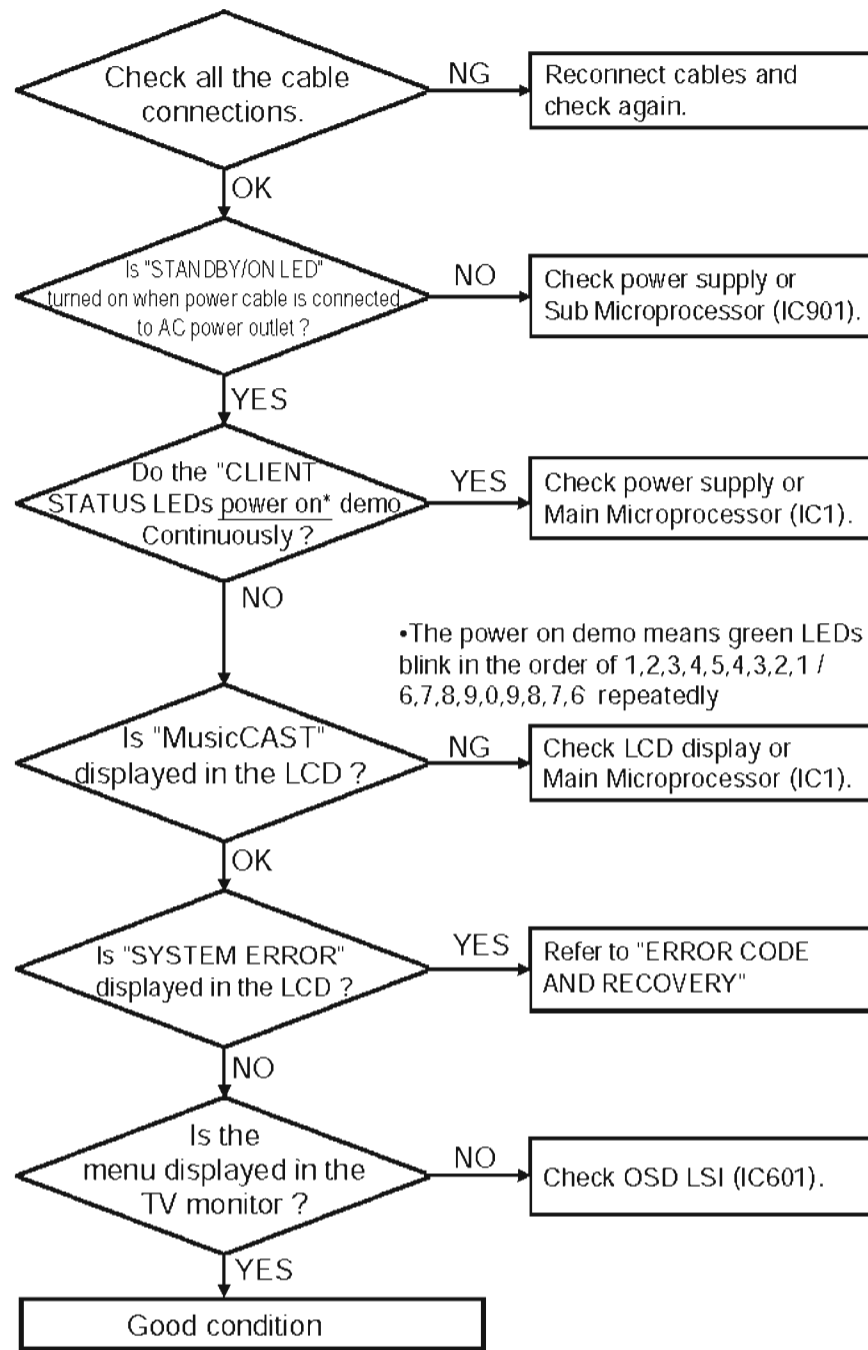

Fig. B

■ TROUBLESHOOTING

When the power can't be turned on.



The check of a power supply.

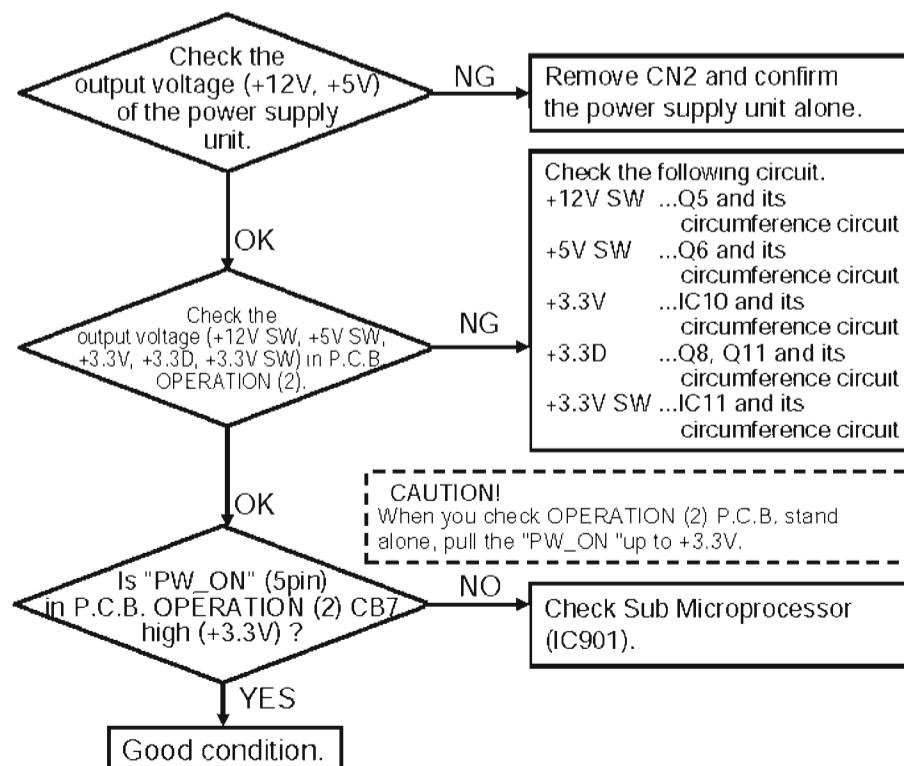

The check of Sub Microprocessor (IC901).

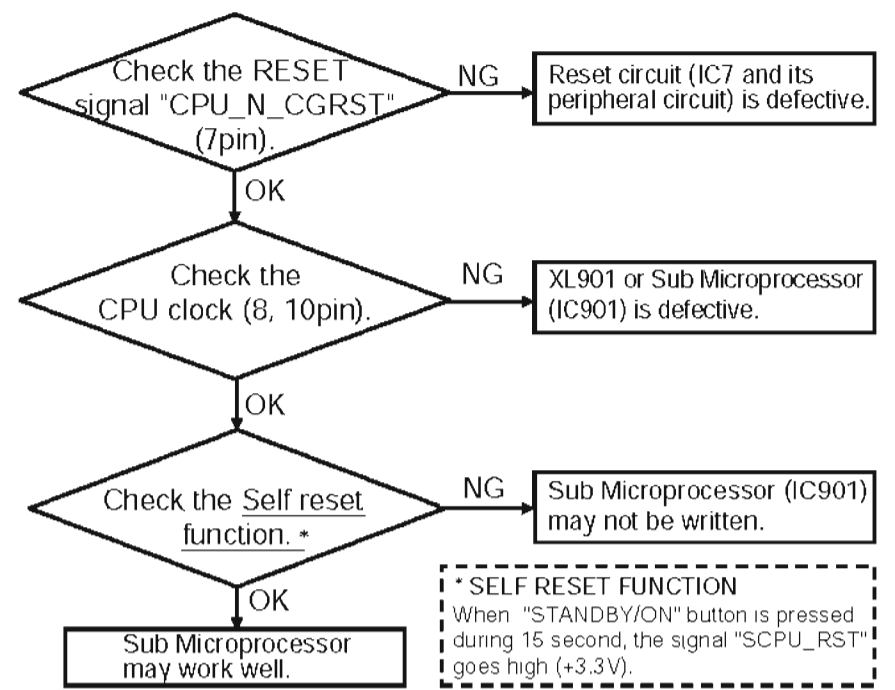

The check of Main Microprocessor (IC1).

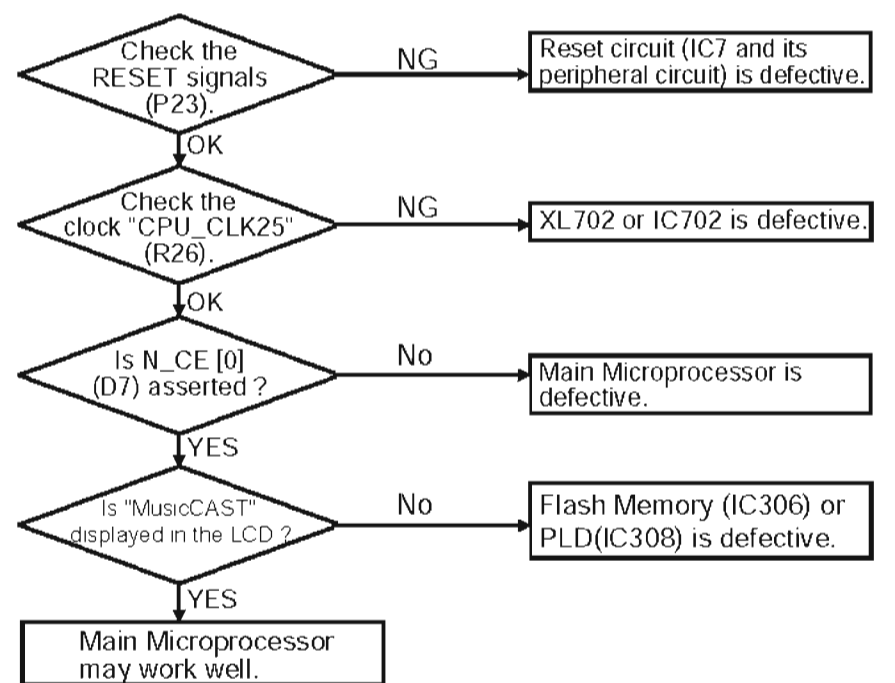

■ トラブルシューティング

電源がONにできない場合

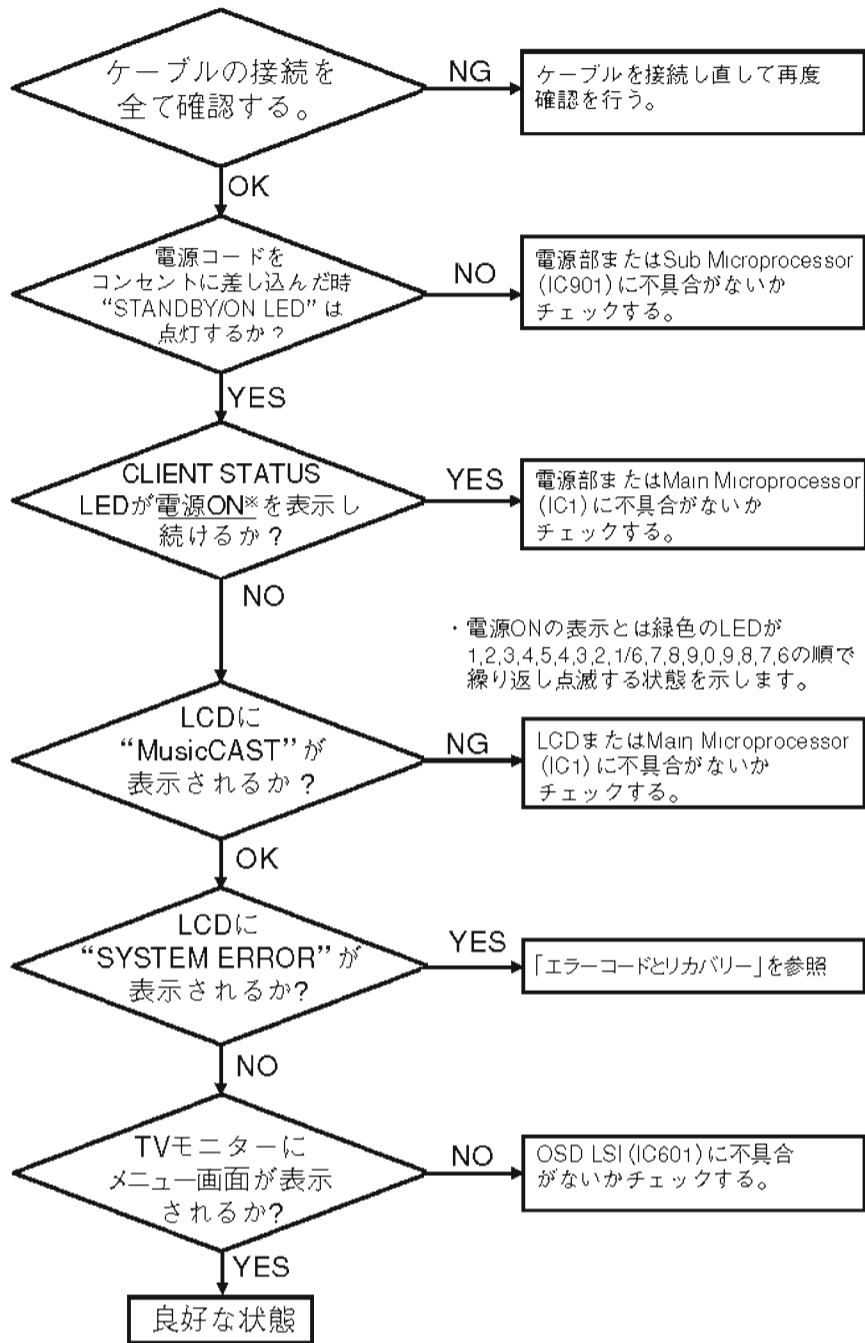

電源部の確認

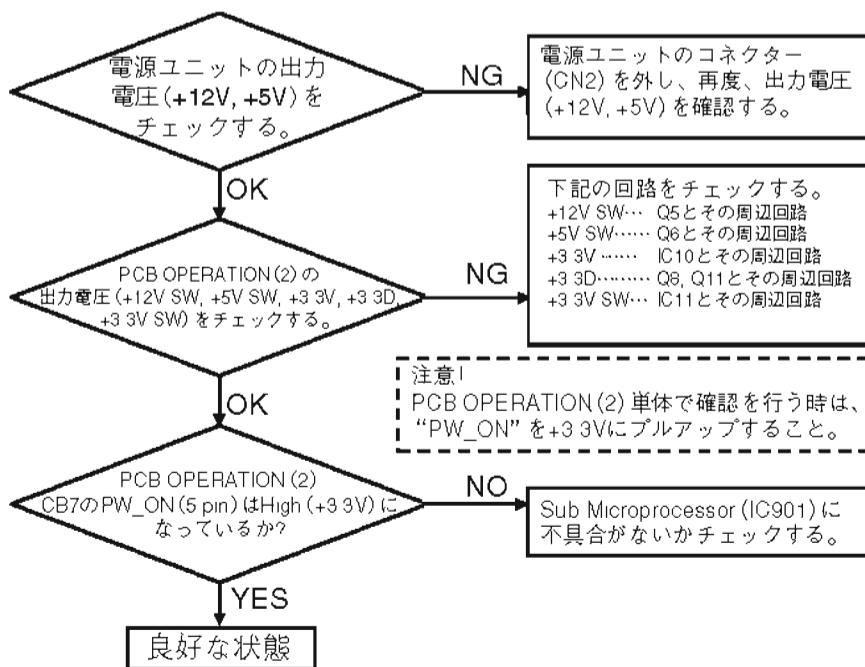

Sub Microprocessor (IC901) の確認

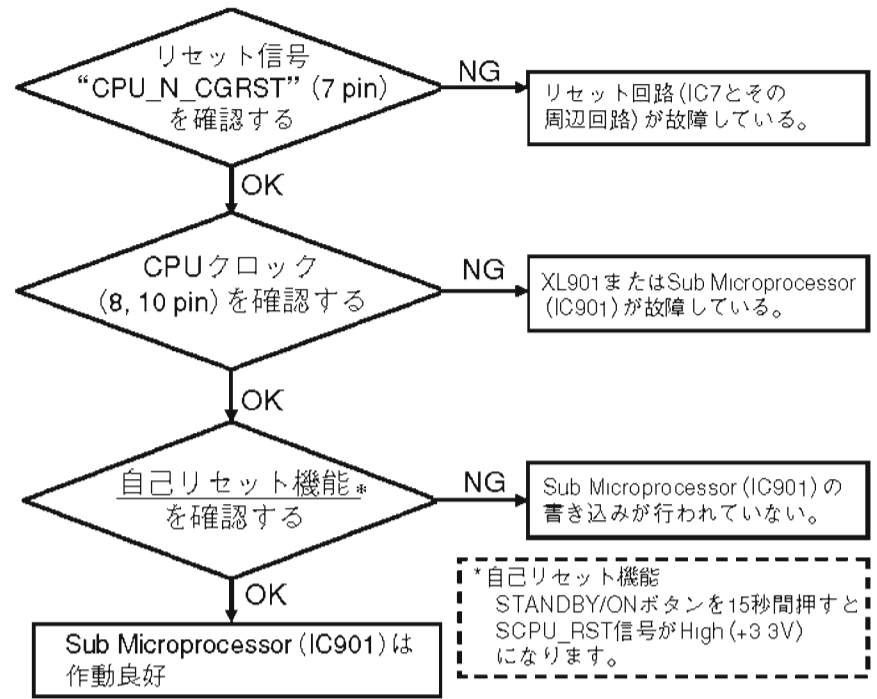

Main Microprocessor (IC1) の確認

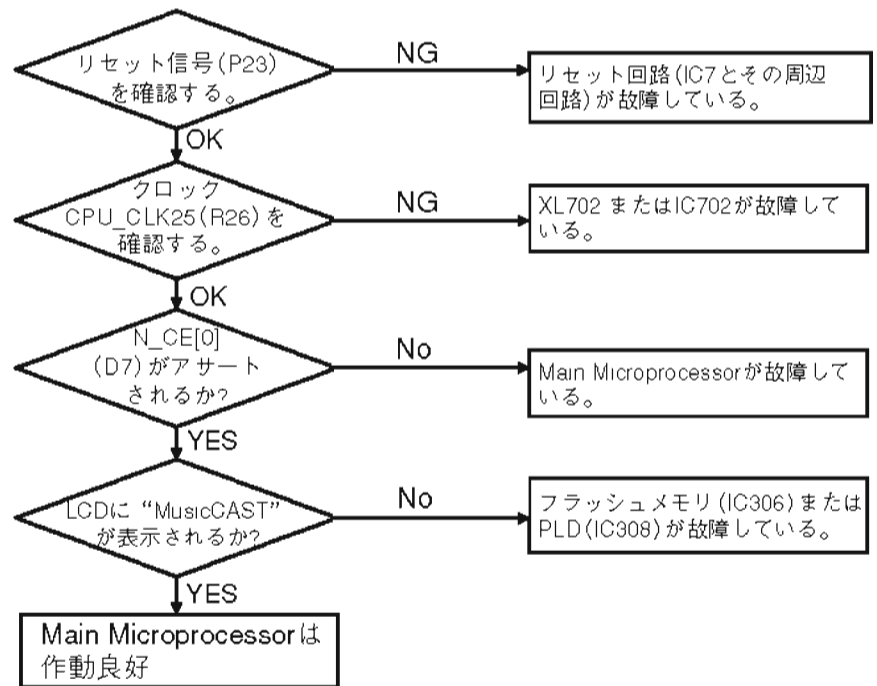

MCX-2000

■ ERROR CODE AND RECOVERY / エラーコードとリカバリー

When a critical error occurs in this unit, the following error message is displayed on a LCD display.

本機に致命的なエラーが発生した場合、表示画面に下記のエラーメッセージが表示されます。

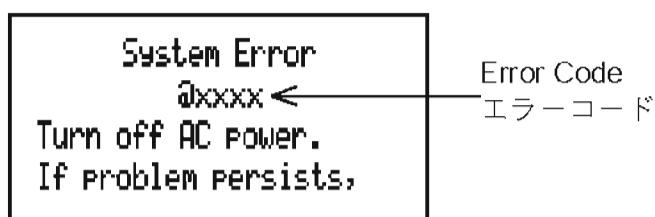

Error Code Table

Error Code	Contents of Error	Recovery
@0000, @1001	The P.C.B. MAIN's system ID is different from the HDD's system ID.	Refer to "RECOVERY AFTER REPLACING MAIN P.C.B."
@2001	HDD has broken. (Access non-ability etc.)	Check the HDD and its cables. Refer to "RECOVERY AFTER REPLACING HDD".
@2003	HDD has broken. (Database has an error.)	
@2004	HDD has broken. (Partition 0)	
@2005	HDD has broken. (Partition 1)	
@2006	HDD has broken. (Partition 2)	
@2007	HDD has broken. (Partition 3...Musical piece management information)	
@2008	HDD has broken. (Partition 4...Musical piece main part)	
@3001	Cable network initialization error.	
@3002	Wireless LAN Module initialization error.	
@4001	The initialization error of a voice control part (IC501 YDC131).	Check the IC501 YDC131. (MAIN P.C.B.)
@4002	IC401 TMS320D610A initialization error.	Check the IC401 TMS320D610A. (MAIN P.C.B.)
@5001	Data base read failure for AV Receiver control.	Refer to "RECOVERY AFTER REPLACING HDD".
@6001	An error of the serial communications department for communication with Sub Microprocessor (remote control / panel key control).	Check the Main Microprocessor and Sub Microprocessor in the MAIN P.C.B..
@6002	The error of Sub Microprocessor (remote control / panel key control).	
@7001	OSD database (FONT) read failure.	Refer to "RECOVERY AFTER REPLACING HDD".
@7002	OSD database (OSD) read failure.	
@7003	OSD database (JIM) read failure.	
@7004	The shortage of an OSD database file.	
@9001	CD-R/RW Drive cannot be recognized.	Refer to "RECOVERY AFTER REPLACING CD-R/RW Drive".

エラーコード一覧

Error Code	エラー内容	リカバリー
@0000, @1001	System IDがHDDとメイン基板で異なる。	「メインP.C.B.交換後のリカバリー」を参照してください。
@2001	HDDが壊れている(アクセス不能など)	HDDまたは接続ケーブルをチェックしてください。 「HDD交換後のリカバリー」を参照してください。
@2003	HDDが壊れている(データベースにエラーがある)	
@2004	HDDが壊れている(パーティション0)	
@2005	HDDが壊れている(パーティション1)	
@2006	HDDが壊れている(パーティション2)	
@2007	HDDが壊れている(パーティション3 ... 楽曲管理情報)	
@2008	HDDが壊れている(パーティション4 ... 楽曲本体)	
@3001	有線ネットワーク初期化エラー	
@3002	無線LANモジュール初期化エラー	
@4001	音声制御部(IC501 YDC131)の初期化エラー	メインPCBのIC501(YDC131)をチェックしてください。
@4002	IC401(TMS320D610A)初期化エラー	メインPCBのIC401(TMS320D610A)をチェックしてください。
@5001	AV Receiver 制御用データベース読み込み失敗	「HDD交換後のリカバリー」を参照してください。
@6001	Sub Microprocessor(リモコン/パネルキー制御)との通信のためのシリアル通信部のエラー	メインPCBのMain MicroprocessorまたはSub Microprocessorをチェックしてください。
@6002	Sub Microprocessor(リモコン/パネルキー制御)のエラー	
@7001	OSDデータベース(FONT)読み込み失敗	「HDD交換後のリカバリー」を参照してください。
@7002	OSDデータベース(OSD)読み込み失敗	
@7003	OSDデータベース(JIM)読み込み失敗	
@7004	OSDデータベースファイル不足	
@9001	CD-R/RWドライブが認識できない	「CD-R/RWドライブ交換後のリカバリー」を参照してください。

■ TEST MODE / テストモード

Items required

- CD player with digital output (optical/coaxial) terminal
- AV amplifier with digital input (optical/coaxial) terminal
- Music CD
- Headphone
- Optical cable x 2
- Stereo pin cable
- TV monitor
- VIDEO cable

Connection

Using the video cable, connect the VIDEO OUT terminal of main unit to the VIDEO IN terminal of the TV monitor.

Operation Procedure

Perform following steps while watching the TV monitor screen and using the keys of the main unit.

Starting Test Mode

While pressing the "MENU" and "CD AUTO STORE" keys simultaneously, connect the power cable to the AC power outlet. The CLIENT STATUS LED segments light up one after another.

After about 10 seconds, the Test mode starts up and "Final Test" is displayed as follows.

用意するもの

- デジタル出力(光/同軸)を持ったCDプレーヤー
- デジタル入力(光/同軸)を持ったAVアンプ
- 音楽CD
- ヘッドホン
- 光ケーブル×2
- ステレオピンケーブル
- TVモニター
- ビデオケーブル

接続

本機のVIDEO OUTとTVモニターのVIDEO INをビデオケーブルで接続します。

操作手順

TVモニター画面を見ながら本体キーを使って操作します。

テストモード起動

"MENU"キーと"CD AUTO STORE"キーを押しながら、電源コードをACコンセントに接続します。CLIENT STATUSのLEDが順次点灯します。約10秒後、テストモードが起動し、下記のように表示されます。

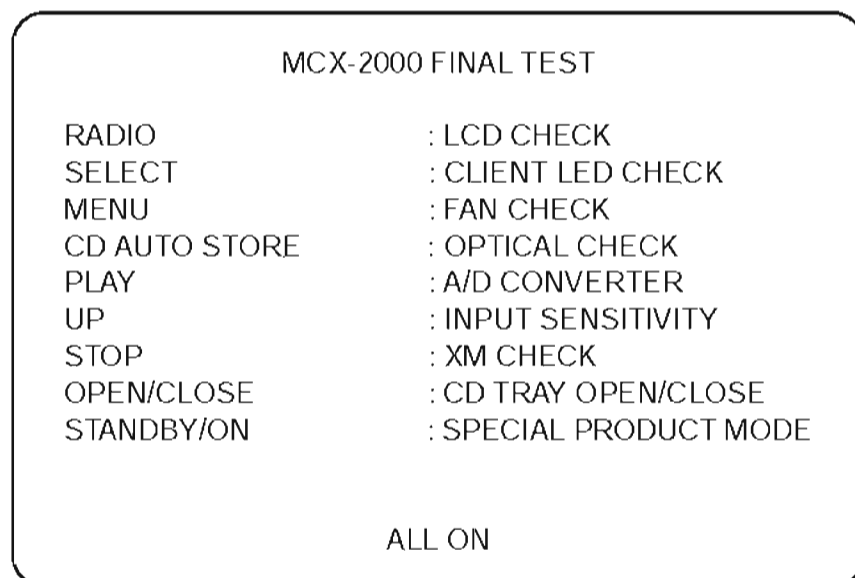

TV monitor's displayed / TVモニター画面

- 1) Display
Press the "RADIO" key, and all segments of the LCD display light up. Press the "RADIO" key again, and the LCD display turns off.
- 2) CLIENT STATUS LED Display
Press the "Cursor Controller" key, and all segments of the CLIENT STATUS LED light up. Press the "Cursor Controller" key again, and all segments of the CLIENT STATUS LED turns off.
- 3) FAN Control
Press the "MENU" key, and FAN operates and BROADCAST LED lights at the same time. Also, the temperature in the main unit is displayed as XX°C. These XX is in the range of the ambient temperature to 15°C higher than the ambient temperature.

- 1) 表示
"RADIO"キーを押すとLCDディスプレイが全灯します。再び"RADIO"キーを押すとLCDディスプレイが消灯します。
- 2) CLIENT STATUS LED表示
"カーソルコントローラー"キーを押すとCLIENT STATUS LEDが全て点灯します。再び"カーソルコントローラー"キーを押すとCLIENT STATUS LEDが全て消灯します。
- 3) FANコントロール
"MENU"キーを押すとFANが動作し、同時にBROADCAST LEDが点灯します。また本体内部の温度をXX°Cと表示します。このXXはおよそ周囲温度以上～周囲温度+15°C以下の範囲となります。

4) Optical Input/Output

Press the "CD AUTO STORE" key. Then, "OPTICAL IN/OUT check" is displayed and the TIMER LED lights at the same time.

Play a music CD on the CD player, and check the reproduced sound through the headphone connected to the AV amplifier.

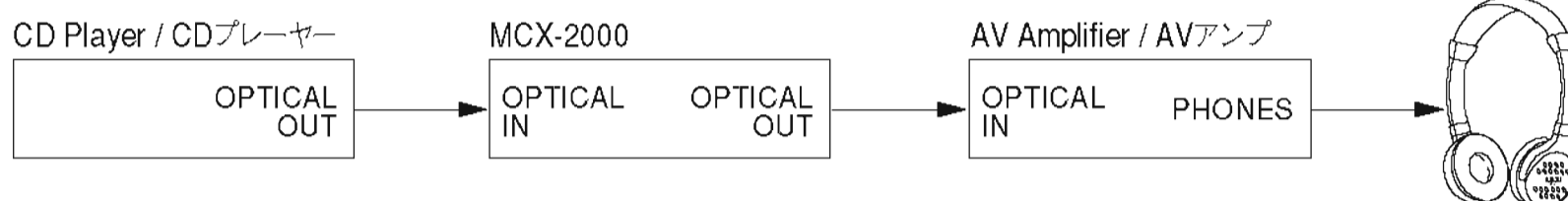

4) 光入出力

“CD AUTO STORE”キーを押すと「OPTICAL IN/OUT check」が表示されます。同時に、TIMER LEDが点灯します。

CDプレーヤーで音楽CDを再生し、AVアンプに接続したヘッドホンで、再生音を確認します。

5) A/D Converter

Press the ">" key. Then, "A/D Converter" is displayed and the RECORDING LED lights at the same time.

Play a music CD on the CD player, and check the reproduced sound through the headphone connected to the AV amplifier.

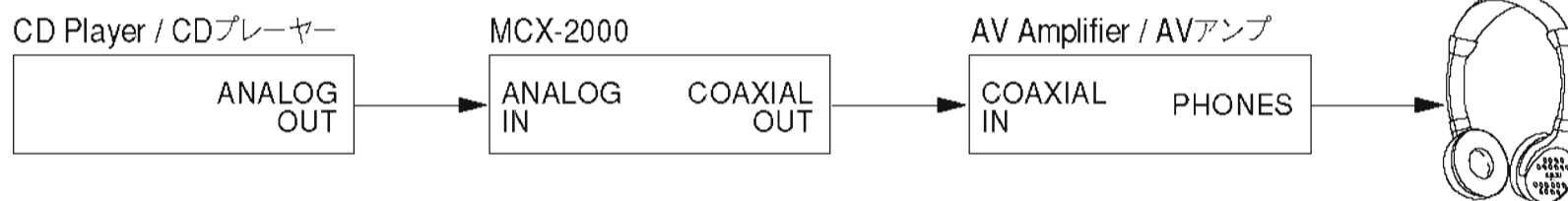

5) A/Dコンバータ

“>”キーを押すと「A/D Converter」が表示されます。同時に、RECORDING LEDが点灯します。

CDプレーヤーで音楽CDを再生し、AVアンプに接続したヘッドホンで再生音を確認します。

Canceling Test mode

After completion of testing, perform the following operations.

- Press the "BOOK MARK" key of remote control. Top menu is displayed.
- Press and hold the "STANDBY/ON" key.
- Release the "STANDBY/ON" key if all LED (CLIENT STATUS, BROADCAST, TIMER, RECORDING, ENCODING) of a Front Panel lights up. And then the power is turned off.

テストモード解除

テスト終了後、以下の操作を行います。

- リモコンの“BOOK MARK”キーを押します。トップメニューが表示されます。
- “STANDBY/ON”キーを押し続けます。
- フロントパネルのすべてのLED (CLIENT STATUS、BROADCAST、TIMER、RECORDING、ENCODING) が点灯したら“STANDBY/ON”キーを離します。すると電源が切れます。

■ IC DATA

IC1 : TMPR4938XBG-300 (MAIN P.C.B.)
MAIN Microprocessor

* No replacement part available. / サービス部品供給なし

Pin No.	Pin Name	Signal Name	I/O	Logic	Pull Up/Down	Block	Function
R26	MASTERCLK	CPU_CLK25	I	-	-	CG	Master clock 25MHz input
K1	RESET#	CPU_N_RST	I	Neg	-	Reset	Reset
P23	CGRESET#	CPU_N_CGRST	I	Neg	-	Reset	CG Reset
*	ADDR0~19	AD[0:19]	O	-	-	Address	Address
*	D0~31	D[0:63]	I/O	-	-	Data	Data Bus
L1	SYSCLK	SYSCLK	O	-	-	CG	System Clock
C4	ACK#/READY	ZREADY	I	Pos	PU(1.0K)	EBUSC	Ready
AE5	SWE#	N_SWE	O	Neg	-	EBUSC	Write Enable
M1	OE#	N_OE	O	Neg	-	EBUSC	Output Enable
C5	ACE#	N_ACE	O	Neg	-	EBUSC	Address Clock Enable
D7	CE0#	N_CE[0]	O	Neg	-	EBUSC	Chip Enable 0 (IC1 Flash Memory)
C7	CE1#	N_CE[1]	O	Neg	-	EBUSC	Chip Enable 1 (no use)
C6	CE2#	N_CE[2]	O	Neg	-	EBUSC	Chip Enable 2 (LCD)
B6	CE3#	N_CE[3]	O	Neg	-	EBUSC	Chip Enable 3 (IC308 PLD)
A6	CE4#	N_CE[4]	O	Neg	-	EBUSC	Chip Enable 4 (IC501 MCAP)
A5	CE5#	N_CE[5]	O	Neg	-	EBUSC	Chip Enable 5 (IC601 OSD IO)
B4	CE6#	N_CE[6]	O	Neg	-	EBUSC	Chip Enable 6 (IC601 OSD RAM)
A4	CE7#	N_CE[7]	O	Neg	-	EBUSC	Chip Enable 7 (IC401 DSP)
A9	BWE0#	N_BWE[0]	O	Neg	-	EBUSC	Byte Write Enable 1
A10	BWE1#	N_BWE[1]	O	Neg	-	EBUSC	Byte Write Enable 2
B10	BWE2#	N_BWE[2]	O	Neg	-	EBUSC	Byte Write Enable 3
C10	BWE3#	N_BWE[3]	O	Neg	-	EBUSC	Byte Write Enable 4
F4	NMI#	Not Assigned	I	Neg	PU(10K)	IRC	NonMaskable Interrupt (no use)
F3	INT0	MCAP_N_ZINT	I	Neg	PU(2.2K)	IRC	External Interrupt Request 0 (IC501 MCAP)
F2	INT1	SCPU_N_INT	I	Neg	PU(10K)	IRC	External Interrupt Request 1 (IC901 Sub Microprocessor)
F1	INT2	PCI_N_INT	I	Neg	PU(2.2K)	IRC	External Interrupt Request 2 (CB801 miniPCI)
G3	INT3	D2C_N_ZINT	I	Neg	PU(2.2K)	IRC	External Interrupt Request 3 (IC401 DSP)
G1	INT5	OSD_N_ZINT	I	Neg	PU(2.2K)	IRC	External Interrupt Request 4 (IC601 OSD)
AF14	SDCLK0	SDCLK[0]	O	-	-	SDRAMC	SDRAM Controller Clock 0
AF19	SDCLK1	SDCLK[1]	O	-	-	SDRAMC	SDRAM Controller Clock 1 (feedback clock)
AF13	SDCLK2	SDCLK[2]	O	-	-	SDRAMC	SDRAM Controller Clock 2
AF17	SDCLK3	Not Assigned	O	-	-	SDRAMC	SDRAM Controller Clock 3 (no use)
AF15	SDCKLIN	SDCLK[1]	I	-	-	SDRAMC	SDRAM Feedback Clock Input
AD17	CKE	CKE	O	Pos	-	SDRAMC	Clock Enable
AE7	RAS#	N_RAS	O	Neg	-	SDRAMC	Row Address Strobe
AF4	CAS#	N_CAS	O	Neg	-	SDRAMC	Column Address Strobe
AC7	SDCS0	SDCS[0]	O	Neg	-	SDRAMC	Synchronous Memory Device Chip Select 0
AD7	SDCS1	Not Assigned	O	-	-	SDRAMC	Synchronous Memory Device Chip Select 1 (no use)
AE17	SDCS2	Not Assigned	O	-	-	SDRAMC	Synchronous Memory Device Chip Select 2 (no use)
AB18	SDCS3	Not Assigned	O	-	-	SDRAMC	Synchronous Memory Device Chip Select 3 (no use)
AB6	DQM0	DQM[0]	O	Pos	-	SDRAMC	Data Mask 0
AE6	DQM1	DQM[1]	O	Pos	-	SDRAMC	Data Mask 1
AC18	DQM2	DQM[2]	O	Pos	-	SDRAMC	Data Mask 2
AE19	DQM3	DQM[3]	O	Pos	-	SDRAMC	Data Mask 3
AD6	DQM4	DQM[4]	O	Pos	-	SDRAMC	Data Mask 4
AF6	DQM5	DQM[5]	O	Pos	-	SDRAMC	Data Mask 5
AD18	DQM6	DQM[6]	O	Pos	-	SDRAMC	Data Mask 6
AB20	DQM7	DQM[7]	O	Pos	-	SDRAMC	Data Mask 7
AE5	WE#	N_WE	O	Neg	-	SDRAMC	Write Enable

IC1 : TMPR4938XBG-300 (MAIN P.C.B.)
MAIN Microprocessor

* No replacement part available. / サービス部品供給なし

Pin No.	Pin Name	Signal Name	I/O	Logic	Pull Up/Down	Block	Function
G2	E0RXER	MII_RXERR	I	Pos	-	ETHERC0	Receive Error indicator input
AD3	E0RXD0	MII_RXD[0]	I	-	-	ETHERC0	receive data 0
AF3	E0RXD1	MII_RXD[1]	I	-	-	ETHERC0	receive data 1
AC20	E0TXD0	MII_TXD[0]	O	-	-	ETHERC0	Transmit data 0
AB21	E0TXD1	MII_TXD[1]	O	-	-	ETHERC0	Transmit data 1
AE3	E0RXD2	MII_RXD[2]	I	-	-	ETHERC0	receive data 2
AE4	E0RXD3	MII_RXD[3]	I	-	-	ETHERC0	receive data 3
AE20	E0TXD2	MII_TXD[2]	O	-	-	ETHERC0	Transmit data 2
AD21	E0TXD3	MII_TXD[3]	O	-	-	ETHERC0	Transmit data 3
B2	E0CRS	MII_CRD	I	Pos	-	ETHERC0	Carrier sense signal
B1	E0TXEN	MII_TXEN	O	Pos	-	ETHERC0	Transmit Enable
A7	E0MDIO	MII_MDIO	I/O	-	-	ETHERC0	Management data bi-directional signal
J2	E0TXER	MII_TXERR	O	Pos	-	ETHERC0	Transmit Error indicator
J3	E0MDC	MII_MDC	O	-	-	ETHERC0	Management data clock output
E6	E0COL	MII_COL	I	Pos	-	ETHERC0	Collision detection signal
J4	E0RXCLK	MII_RXCLK	I	-	-	ETHERC0	Receive Clock
J5	E0RXDV	MII_RXDVAL	I	Pos	-	ETHERC0	Receive data valid signal
B9	E0TXCLK	MII_TXCLK	I	-	-	ETHERC0	Transmit Clock
*	PCIAD0~31	PCI_AD[0:31]	I/O	-	-	PCIC	PCI Address and Data
H26	PCICLK0	PCI_CLK[0]	O	-	-	PCIC	PCI Clock 0
J26	PCICLK1	Not Assigned		-	-	PCIC	PCI Clock 1 (no use)
K26	PCICLK2	Not Assigned		-	-	PCIC	PCI Clock 2 (no use)
L26	PCICLK3	PCI_CLK[3]	O	-	-	PCIC	PCI Clock 3 (feedback clock)
M26	PCICLK4	Not Assigned		-	-	PCIC	PCI Clock 4 (no use)
N26	PCICLK5	Not Assigned		-	-	PCIC	PCI Clock 5 (no use)
P26	PCICLKIN	PCI_CLK[3]	I	-	-	PCIC	PCI Feedback Clock
A20	CBE0	PCI_CBE[0]	I/O	Pos	-	PCIC	PCI command and Byte Enable 0
B22	CBE1	PCI_CBE[1]	I/O	Pos	-	PCIC	PCI command and Byte Enable 1
A26	CBE2	PCI_CBE[2]	I/O	Pos	-	PCIC	PCI command and Byte Enable 2
F23	CBE3	PCI_CBE[3]	I/O	Pos	-	PCIC	PCI command and Byte Enable 3
J25	GNT0#	PCI_GNT[0]	O	Pos	PU(10K)	PCIC	PCI Grant 0
K24	GNT1#	PCI_GNT[1]	O	Pos	PU(10K)	PCIC	PCI Grant 1
L25	GNT2#	PCI_GNT[2]	O	Pos	PU(10K)	PCIC	PCI Grant 2
M25	GNT3#	PCI_GNT[3]	O	Pos	PU(10K)	PCIC	PCI Grant 3
K25	REQ0#	PCI_REQ[0]	I	Pos	PU(10K)	PCIC	PCI Request 0
L22	REQ1#	PCI_REQ[1]	I	Pos	PU(10K)	PCIC	PCI Request 1
L24	REQ2#	PCI_REQ[2]	I	Pos	PU(10K)	PCIC	PCI Request 2
M24	REQ3#	PCI_REQ[3]	I	Pos	PU(10K)	PCIC	PCI Request 3
F24	IDSEL	Not Assigned	I	Pos	PD(4.7K)	PCIC	PCI Initialization Device Select
B25	FRAME#	PCI_N_FRAME	I/O	Neg	PU(10K)	PCIC	PCI Cycle Frame
D24	TRDY#	PCI_N_TRDY	I/O	Neg	PU(10K)	PCIC	PCI Target Ready
A25	IRDY#	PCI_N_IRDY	I/O	Neg	PU(10K)	PCIC	PCI Initiator Ready
B24	STOP#	PCI_N_STOP	I/O	Neg	PU(10K)	PCIC	PCI Stop
C24	DEVSEL#	PCI_N_DEVSEL	I/O	Neg	PU(10K)	PCIC	PCI Device Select
C22	PAR	PCI_N_PAR	I/O	-	-	PCIC	PCI Parity
B23	PERR#	PCI_N_PERR	I/O	Neg	PU(10K)	PCIC	PCI Data Parity Error
D22	SERR#	PCI_N_SERR	I/O	Neg	PU(10K)	PCIC	PCI System Error
C23	LOCK#	PCI_N_LOCK	I	Neg	PU(10K)	PCIC	PCI Lock
N22	PME	Not Assigned	I	Pos	PU(10K)	PCIC	PCI Power Management Event
D20	M66EN	Not Assigned	O	-	-	PCIC	PCI Bus 66MHz Clock Enable
A12	DO	Not Assigned	O	-	-	PCIC	PCI EEPROM DataOut

IC1 : TMPR4938XBG-300 (MAIN P.C.B.)
 MAIN Microprocessor

* No replacement part available. / サービス部品供給なし

Pin No.	Pin Name	Signal Name	I/O	Logic	Pull Up/Down	Block	Function
A15	CS	Not Assigned	O	-	-	PCIC	PCI EEPROM Chip Select
A14	SK	Not Assigned	O	-	-	PCIC	PCI EEPROM Serial Clock
A11	DI	Not Assigned	I	-	PU(10K)	PCIC	PCI EEPROM Data In
A1	PIO1	SCPU_CS	O	Pos	PU(10K)	PIO	PIO[1] Sub Microprocessor Chip Select
C2	PIO4	PCI_N_RST	O	Neg	PU(4.7K)	PIO	PIO[4] PCI Reset
C1	PIO5	PLD_N_RST	O	Neg	PU(4.7K)	PIO	PIO[5] PLD Reset
D3	PIO6	DBG_DIP0	I	Pos	PD(4.7K)	PIO	PIO[6] Service Board DIP0
D1	PIO7	DBG_DIP1	I	Pos	PD(4.7K)	PIO	PIO[7] Service Board DIP1
M2	WDRST	Not Assigned	O	Pos	-	TMR	Watchdog Reset
E2	TIMER0	Not Assigned	O	-	-	TMR	Timer Output 0
E3	TIMER1	Not Assigned	O	-	-	TMR	Timer Output 1
E1	TCLK	Not Assigned	I	-	PU(10K)	TMR	External Timer Clock
A2	SPICLK	SCPU_SCK	I/O	-	-	SPI	SPI Clock
A8	SPIOUT	SCPU_RXD	O	-	-	SPI	SPI Data Output
B9	SPIN	SCPU_TXD	I	-	-	SPI	SPI Data Input
G4	RXD0	CPU_RXD	I	-	-	SIO	SIO Receive Data
H1	TXD0	CPU_TXD	O	-	-	SIO	SIO Transmit Data
H3	CTS0#	Not Assigned	I	Neg	PU(10K)	SIO	SIO Clear to Send
H2	RTS0#	Not Assigned	O	Neg	-	SIO	SIO Request to Send
J1	SCLK	Not Assigned	I	-	PU(10K)	SIO	External Serial Clock
E11	DMAREQ0	Not Assigned	I	Pos	PU(10K)	DMAC	DMA Request 0
C8	DMAREQ3	Not Assigned	I	Pos	PU(10K)	DMAC	DMA Request 3
D11	DMAACK0	Not Assigned	O	Pos	-	DMAC	DMA Acknowledge 0
B7	DMAACK3	Not Assigned	O	Pos	-	DMAC	DMA Acknowledge 3
E9	DMADONE#	Not Assigned	I/O	Neg	PU(10K)	DMAC	DMA Done
E16	TRST#	EJTAG_N_TRST	I	Neg	PD(2.2K)	EJTAG	Test Reset Input
C11	TDI	EJTAG_TDI	I	-	PU(2.2K)	EJTAG	JTAG Test Data Input
B11	TCK	EJTAG_TCK	I	-	PU(2.2K)	EJTAG	JTAG Test Clock Input
C12	TMS	EJTAG_TMS	I	-	PU(2.2K)	EJTAG	JTAG Test Mode Select Input
B12	DCLK	EJTAG_DCKL	O	-	-	EJTAG	Debug Clock
B13	TDO/TPCO	EJTAG_TDO	O	-	-	EJTAG	JTAG Test Data Output
E13	TPC1	EJTAG_TPC1	O	0	-	EJTAG	PC Trace Output 1
D13	TPC2	EJTAG_TPC2	O	0	-	EJTAG	PC Trace Output 2
C13	TPC3	EJTAG_TPC3	O	0	-	EJTAG	PC Trace Output 3
A7	PCST0	EJTAG_PCST[0]	O	-	-	EJTAG	PC Trace Status Information 0
C16	PCST1	EJTAG_PCST[1]	O	-	-	EJTAG	PC Trace Status Information 1
B16	PCST2	EJTAG_PCST[2]	O	-	-	EJTAG	PC Trace Status Information 2
A16	PCST3	EJTAG_PCST[3]	O	-	-	EJTAG	PC Trace Status Information 3
C15	PCST4	EJTAG_PCST[4]	O	-	-	EJTAG	PC Trace Status Information 4
B15	PCST5	EJTAG_PCST[5]	O	-	-	EJTAG	PC Trace Status Information 5
E14	PCST6	EJTAG_PCST[6]	O	-	-	EJTAG	PC Trace Status Information 6
C14	PCST7	EJTAG_PCST[7]	O	-	-	EJTAG	PC Trace Status Information 7
B14	PCST8	EJTAG_PCST[8]	O	-	-	EJTAG	PC Trace Status Information 8
D5	BYAPALL#	Not Assigned	I	Neg	PU(33K)	CG	Bypass PLL
K3	HALTDOZE	Not Assigned	O	Pos	-	CG	Hat/Doze State Output
K2	TEST0#	Not Assigned	I	Neg	-	TEST	Test Mode Setting 0
L5	TEST1#	Not Assigned	I	Neg	-	TEST	Test Mode Setting 1
L4	TEST2#	Not Assigned	I	Neg	-	TEST	Test Mode Setting 2
L3	TEST3#	Not Assigned	I	Neg	-	TEST	Test Mode Setting 3
L2	TEST4#	Not Assigned	I	Neg	-	TEST	Test Mode Setting 4

* PD : Pull Down / PU : Pull Up

IC308 : LC4064V-75TN100C (MAIN P.C.B.)
PLDs

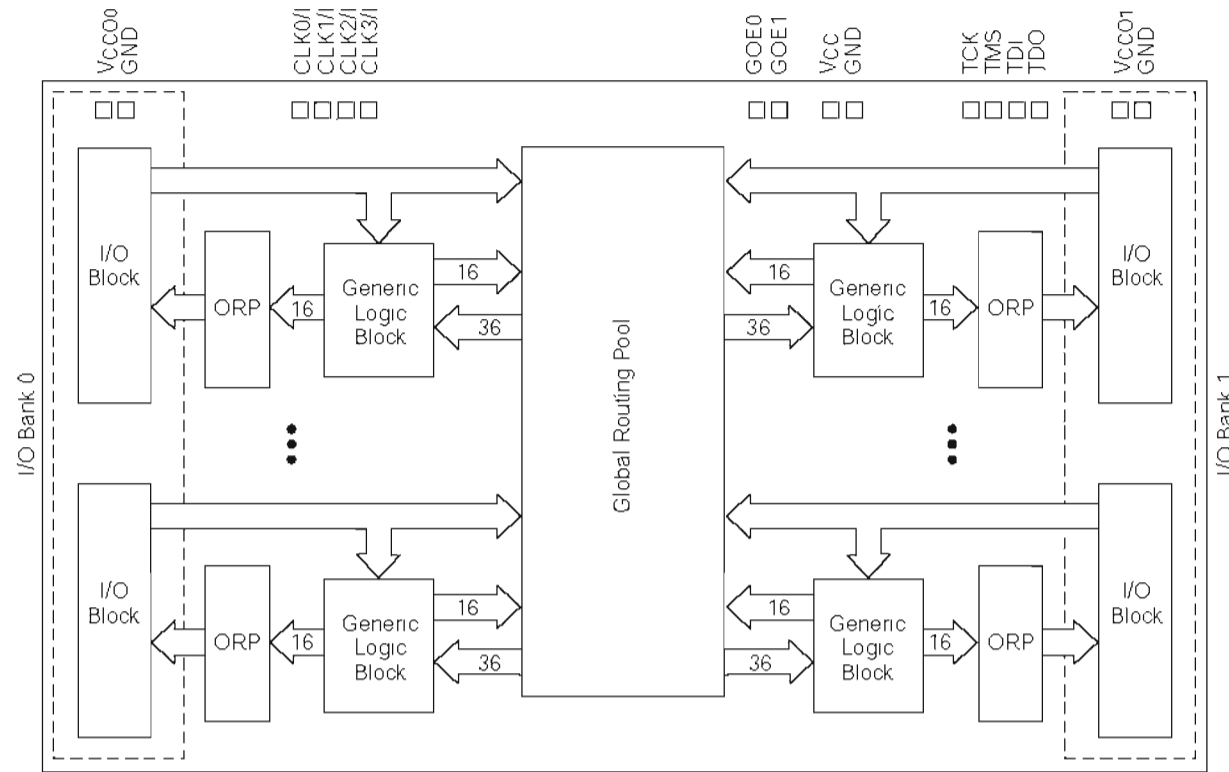

Pin No.	Pin Name	Signal Name	I/O	Logic	Pull Up/Down	Comment
1	GND	GND	-	-	-	
2	TDI	PLD_TDI	I	-	PU(2.2k)	JTAG TDI
3	A8	AX[0]	I	-	-	Address Bus
4	A9	AX[1]	I	-	-	Address Bus
5	A10	AX[2]	I	-	-	Address Bus
6	A11	AX[12]	I	-	-	Address Bus
7	GND	GND	-	-	-	
8	A12	AX[13]	I	-	-	Address Bus
9	A13	AX[14]	I	-	-	Address Bus
10	A14	ACC_ON	O	Pos	PD(2.2k)	Busbuffer Output Enable Control
11	A15	BUSDIR	O	Pos	PD(2.2k)	Busbuffer Direction Control
12	AI	+3.3D_SW	I	-	-	(no use)
13	VCC0	+3.3D_SW	-	-	-	
14	B15	DX[7]	I/O	-	-	Data Bus
15	B14	DX[6]	I/O	-	-	Data Bus
16	B13	DX[5]	I/O	-	-	Data Bus
17	B12	DX[4]	I/O	-	-	Data Bus
18	GND	GND	-	-	-	
19	B11	DX[3]	I/O	-	-	Data Bus
20	B10	DX[2]	I/O	-	-	Data Bus
21	B9	DX[1]	I/O	-	-	Data Bus
22	B8	DX[0]	I/O	-	-	Data Bus
23	I	+3.3D_SW	I	-	-	(no use)
24	TCK	PLD_TCK	I	-	PD(2.2k)	JTAG TCK
25	VCC	+3.3D_SW	-	-	-	
26	GND	GND	-	-	-	
27	I	GND	-	-	-	(no use)
28	B7	LDC_D[7]	I/O	-	-	LCD Data Bus
29	B6	LDC_D[6]	I/O	-	-	LCD Data Bus
30	B5	LDC_D[5]	I/O	-	-	LCD Data Bus

IC308 : LC4064V-75TN100C (MAIN P.C.B.)
PLDs

Pin No.	Pin Name	Signal Name	I/O	Logic	Pull Up/Down	Comment
31	B4	LDC_D[4]	I/O	-	-	LCD Data Bus
32	GND	GND	-	-	-	
33	VCCO	+3.3D_SW	-	-	-	
34	B3	LDC_D[3]	I/O	-	-	LCD Data Bus
35	B2	LDC_D[2]	I/O	-	-	LCD Data Bus
36	B1	LDC_D[1]	I/O	-	-	LCD Data Bus
37	B0	LDC_D[0]	I/O	-	-	LCD Data Bus
38	CLK1/I	+3.3D_SW	I	-	-	(no use)
39	CLK2/I	+3.3D_SW	I	-	-	(no use)
40	VCC	+3.3D_SW	-	-	-	
41	C0		O	-	-	(no use)
42	C1	C2D_N_INT	O	Neg	PU(2.2k)	Interrupt from Microprocessor to DSP
43	C2	AD_CS3	O	Pos	-	ADC Chip Select
44	C3	DA_CSA3	O	Pos	-	DAC (IC5) Chip Select
45	VCCO	+3.3D_SW	-	-	-	
46	GND	GND	-	-	-	
47	C4	DA_CSB3	O	Pos	-	DAC (IC6) Chip Select
48	C5	ADA_SCK3	O	-	-	ADC/DAC Serial Clock
49	C6	ADA_SDI3	O	-	-	ADC/DAC Serial Data
50	C7	DA_LAT3	O	-	-	DAC (IC6) Latch
51	GND	GND	-	-	-	
52	TMS	PLD_TMS	I	-	-	JTAG TMS
53	C8	SOFT_MUTE	O	Pos	-	DAC (IC5) Mute Control
54	C9	DEV_N_RST	O	Pos	PU(2.2k)	Peripheral Device Reset
55	C10	FLASH_N_VPP	O	Neg	PU(2.2k)	Flash Memory Erase Control
56	C11	LCD_BL_L	O	Pos	PD(2.2k)	LCD Back Light Control
57	GND	GND	-	-	-	
58	C12	XM_N_RST	O	Neg	-	XM Reset
59	C13	LCD_BL_H	O	Pos	PD(2.2k)	LCD Back Light Control
60	C14		O	-	-	(no use)
61	C15		O	-	-	(no use)
62	I	+3.3D_SW	-	-	-	(no use)
63	VCCO	+3.3D_SW	-	-	-	
64	D15		O	-	-	(no use)
65	D14		O	-	-	(no use)
66	D13		O	-	-	(no use)
67	D12	TUN_DO	I	-	-	Tuner Data Input
68	GND	GND	-	-	-	
69	D11	RDS_DO	I	-	PU(2.2k)	RDS Data Input
70	D10	OSD_SEL	I	-	-	NTSC/PAL appreciation
71	D9	TUN_N_STEREO5	I	Neg	PU(2.2k)	Tuner Stereo Signal
72	D8	TUN_N_TUNED5	I	Neg	PU(2.2k)	Tuner Tuned Signal
73	I	+3.3D_SW	I	-	-	(no use)
74	TDO	PLD_TDO	O	-	-	JTAG TDO
75	VCC	+3.3D_SW	-	-	-	
76	GND	GND	-	-	-	
77	I	GND	I	-	-	(no use)
78	D7	DSP_N_RST	O	-	PU(2.2k)	DSP Reset
79	D6	DSP_N_HRDY	I	Neg	-	DSP Ready Input
80	D5	READY	O	Pos	-	Ready Output

IC308 : LC4064V-75TN100C (MAIN P.C.B.)
PLDs

Pin No.	Pin Name	Signal Name	I/O	Logic	Pull Up/Down	Comment
81	D4	LCD_RS	O	Pos	-	LCD Register Select
82	GND	GND	-	-	-	
83	VCCO	+3.3D_SW	-	-	-	
84	D3	LCD_N_CE	O	Neg	-	LCD Chip Enable
85	D2	AX[22]	O	-	-	Upper Address Output
86	D1	AX[21]	O	-	-	Upper Address Output
87	DO/GOE1	AX[20]	O	-	-	Upper Address Output
88	CLK3/I	+3.3D_SW	I	-	-	(no use)
89	CLK0/I	ZSYSCLK	I	-	-	System Clock Input
90	VCC	+3.3D_SW	-	-	-	
91	A0/GOE0	N_ZCE[2]	I	Neg	-	Chip Enable 2 (for LCD)
92	A1	LCD_N_OE	O	Neg	-	LCD Output Enable
93	A2	LCD_N_WE	O	Neg	-	LCD Write Enable
94	A3	N_ZCE[3]	I	Neg	-	Chip Enable 3 (for PLD)
95	VCCO	+3.3D_SW	-	-	-	
96	GND	GND	-	-	-	
97	A4	PLD_N_OE	I	Neg	-	PLD Output Enable
98	A5	PLD_N_WE	I	Neg	-	PLD Write Enable
99	A6	N_ZACE	I	Neg	-	Address Clock Enable
100	A7	PLD_N_ZRST	I	Neg	-	PLD Reset Input

* PD : Pull Down / PU : Pull Up

IC901 : M30262F6GP-U5 (MAIN P.C.B.)
 16-Bit Microprocessor (SUB Microprocessor)

* No replacement part available. / サービス部品供給なし

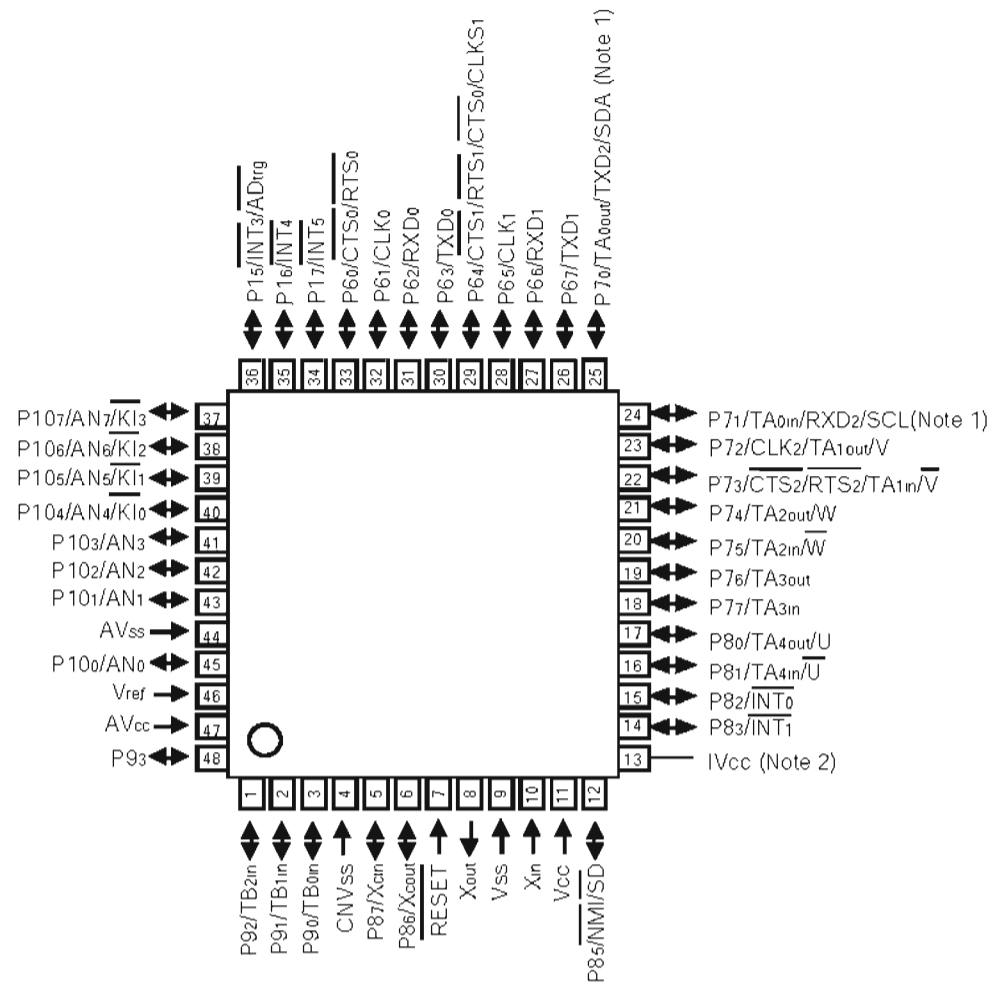

Note 1. this pin is N channel open-drain output pins.
 Note 2. Leave this pin open.

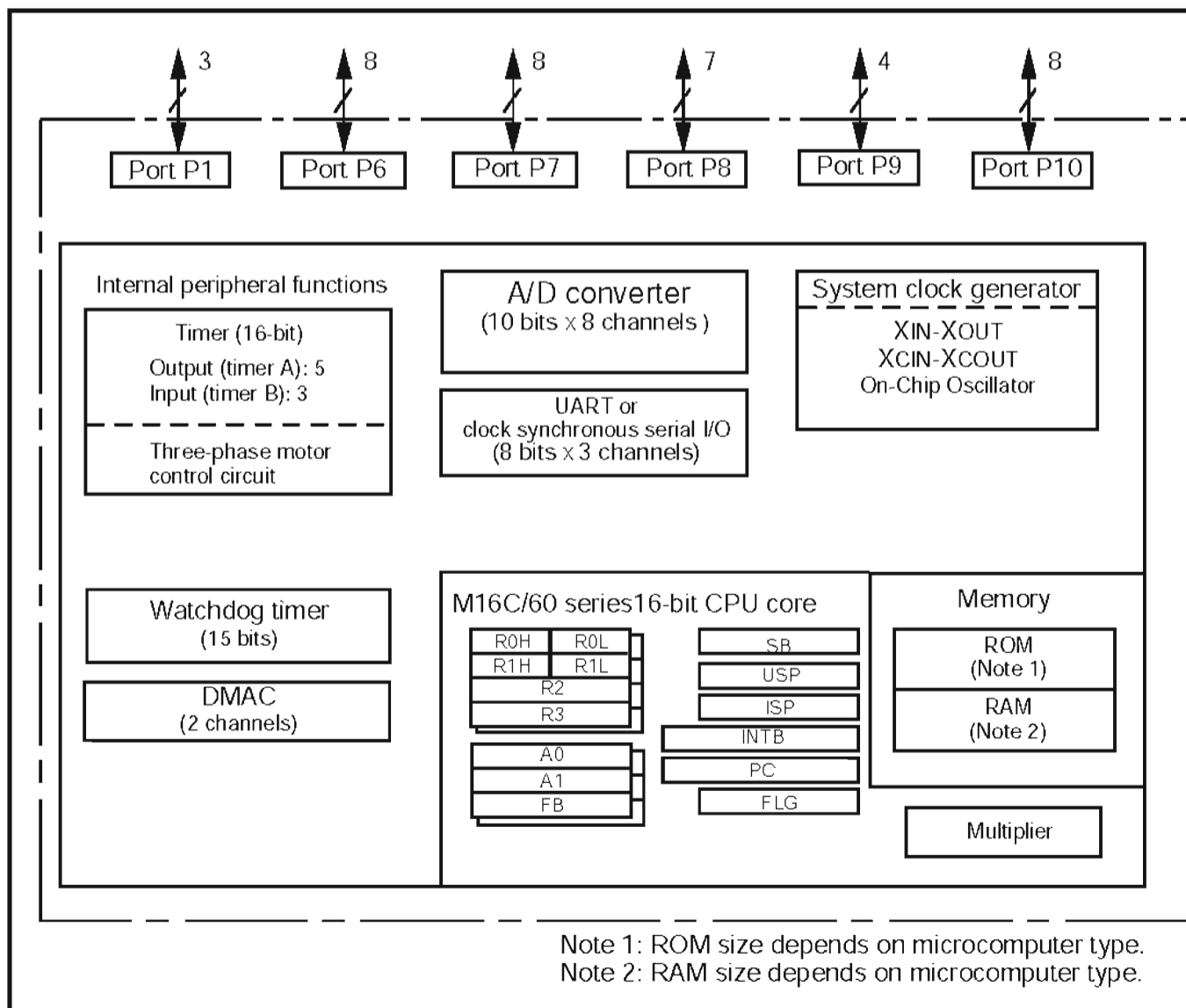

Note 1: ROM size depends on microcomputer type.
 Note 2: RAM size depends on microcomputer type.

IC901 : M30262F6GP-U5 (MAIN P.C.B.)
16-Bit Microprocessor (SUB Microprocessor)

* No replacement part available. / サービス部品供給なし

Pin No.	Pin Name	Function	Signal Name	I/O	Logic	Pull Up/Down	Comment
1	TB2in	Timer	IR_IN	I	-	-	IR Input from Front Panel
2	P91	I/O	PW_N_ON	O	Neg	PD(10K)	Standby Control
3	P90	I/O	RTC_WR	O	Pos	-	RTC Write Enable
4	CNVss	GND	VSS	-	-	-	
5	P87	I/O	RTC_CE	O	Pos	-	RTC Chip Enable
6	P86	I/O	SCPU_N_INT	O	Neg	PU(10K)	Interrupt from SUB Microprocessor to MAIN Microprocessor
7	/RESET	Reset	SCPU_N_RST	I	Neg	-	Reset Input
8	Xout	Clock		O	-	-	Clock Input
9	Vss	GND	VSS	-	-	-	
10	Xin	Clock		I	-	-	Clock Output
11	Vcc	Vcc	+3.3D	-	-	-	
12	P85/NMI	I/O	DBG_LED[0]	O	Pos	PU(10K)	Service Board LED0
13	IVCC			-	-	-	(no use)
14	P83	I/O	DBG_LED[2]	O	Pos	PD(10K)	Service Board LED2
15	P82	I/O	DBG_LED[3]	O	Pos	PD(10K)	Service Board LED3
16	P81	I/O	SCPU_PSCK	O	-	PU(10K)	RTC, LEDC Serial Clock
17	P80	I/O	SCPU_PDAT	I/O	-	PU(10K)	RTC, LEDC Serial Data
18	P77	I/O	SCPU_CS	I	Pos	PD(10K)	SPI Chip Select
19	P76	I/O	DBG_LED[1]	O	Pos	PD(10K)	Service Board LED4
20	P75	I/O	HP_MUTE	O	Pos	PU(10K)	HeadPhone Mute Control
21	P74	I/O	CPU_MUTE	O	Pos	PU(10K)	CPU_MUTE Control
22	P73	I/O	LED_N_CLR	O	Neg	-	LEDC Clear
23	P72	I/O	LED_N_STB	O	Neg	-	LEDC Strobe
24	RXD2	Serial IO	SCPU_RXD2	I	-	PD(10K)	XM Control Receive Data
25	TXD2	Serial IO	SCPU_TXD2	O	-	-	XM Control Trancemit Data
26	TXD1	Serial IO	SCPU_TXD1	O	-	-	RS232C Trancemit Data
27	RXD1	Serial IO	SCPU_RXD1	I	-	PU(10K)	RS232C Receive Data
28	CLK1	Serial IO	W_SCLK	O	-	-	ROM Writer Clock
29	P64	I/O	W_BUSY	O	-	-	ROM Writer Busy
30	TXD0	Serial IO	SCPU_TXD0	O	-	-	Trancemit Data to MAIN Microprocessor
31	RXD0	Serial IO	SCPU_RXD0	I	-	PU(10K)	Receive Data from MAIN Microprocessor
32	CLK0	Serial IO	SCPU_SCLK	O	-	PU(10K)	Serial Clock
33	P60	I/O	FAN_ON	O	Pos	PD(10K)	FAN Control
34	P17	I/O	SCPU_RST	O	Pos	PD(10K)	System Reset Control
35	P16	I/O	SB_DIP1	I	Pos	PU(10K)	Service Board DIP1
36	P15	I/O	IR_IN2	I	-	-	IR Input from Rear Panel
37	P107	I/O	SB_CS	O	Pos	-	Service Board Chip Select
38	P106	I/O	SB_SCK	O	-	-	Service Board Serial Clock
39	P105	I/O	SB_DO	O	-	-	Service Board Serial Data Output
40	P104	I/O	SB_DI	I	-	PU(10K)	Service Board Serial Data Input
41	AN3	AD	WLAN_TH	I	-	-	Thermistor Input
42	AN2	AD	KEY_D3	I	-	-	OPE KEY 3
43	AN1	AD	KEY_D2	I	-	-	OPE KEY 2
44	Avss	Analog GND	GND	-	-	-	
45	AN0	AD	KEY_D1	I	-	-	OPE KEY 1
46	VREF	Reference	+3.3D	I	-	-	
47	Avcc	Analog GND	+3.3D	-	-	-	
48	P93	I/O		O	-	-	(no use)

* PD : Pull Down / PU : Pull Up

Key Input (A-D) Pull-Up Resistance 10 k-Ohms

Ohm	0	+1.8k	+3.3k	+6.8k	+18k
V	-0.3	~0.8	~1.5	~2.1	~2.5
KEY1 (AN0, 45 pin)	RADIO	SELECT >	PUSH SELECT (ENTER)	SELECT <	-
KEY2 (AN1, 43 pin)	MENU/ PLAY INFO.	SELECT △	SELECT ▽	-	-
KEY3 (AN2, 42 pin)	CD AUTO STORE	PLAY/PAUSE	STOP	EJECT	STANDBY/ON

MEMO

A large empty rectangular frame with a double-line border, intended for writing a memo. The frame is centered on the page and occupies most of the vertical space below the header.

MCX-2000

BLOCK DIAGRAM

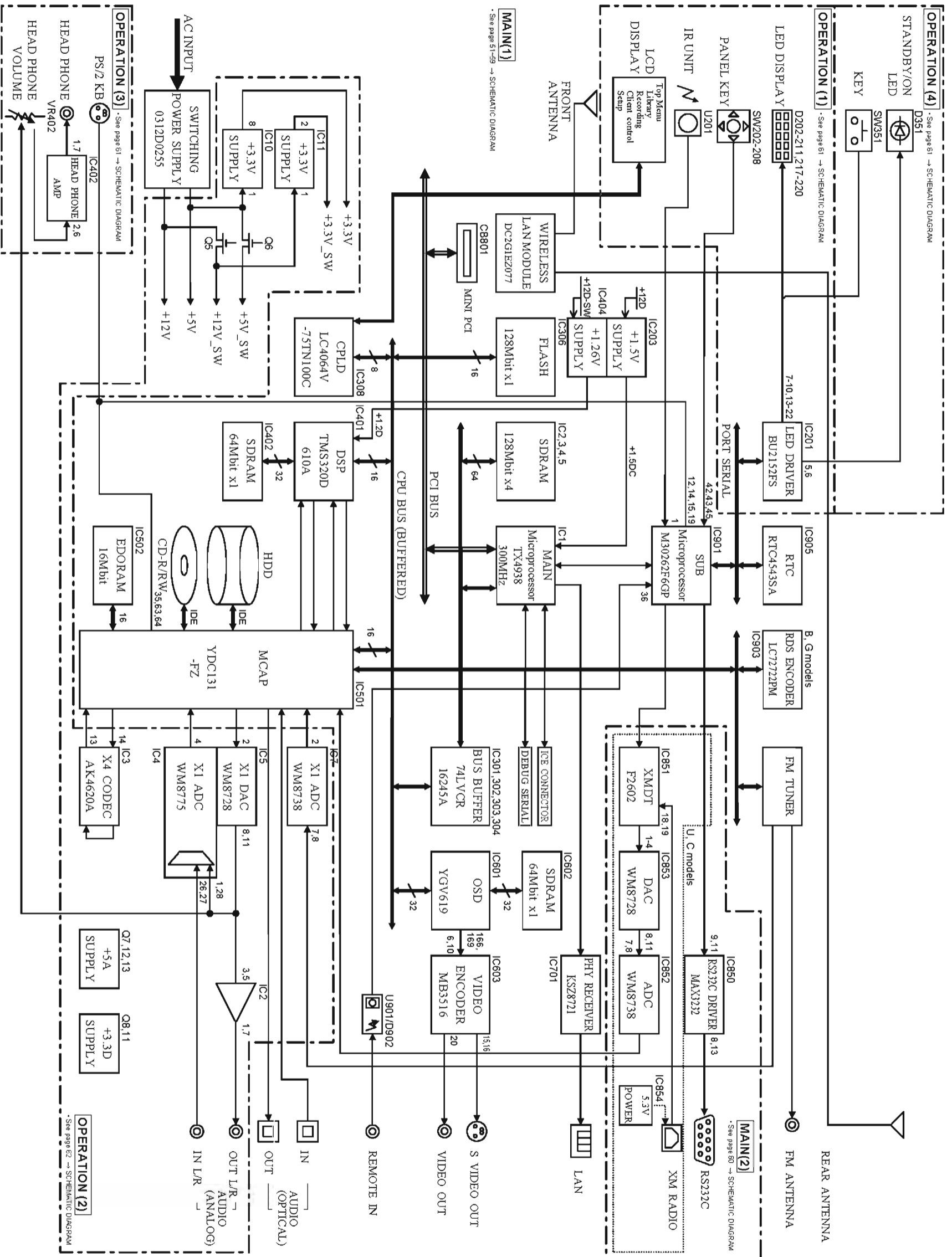

1
2
3
4
5
6
7

A B C D E F G H I J

■ PRINTED CIRCUIT BOARD

MAIN (1) P.C.B. (Side A) Lead Free Solder Used

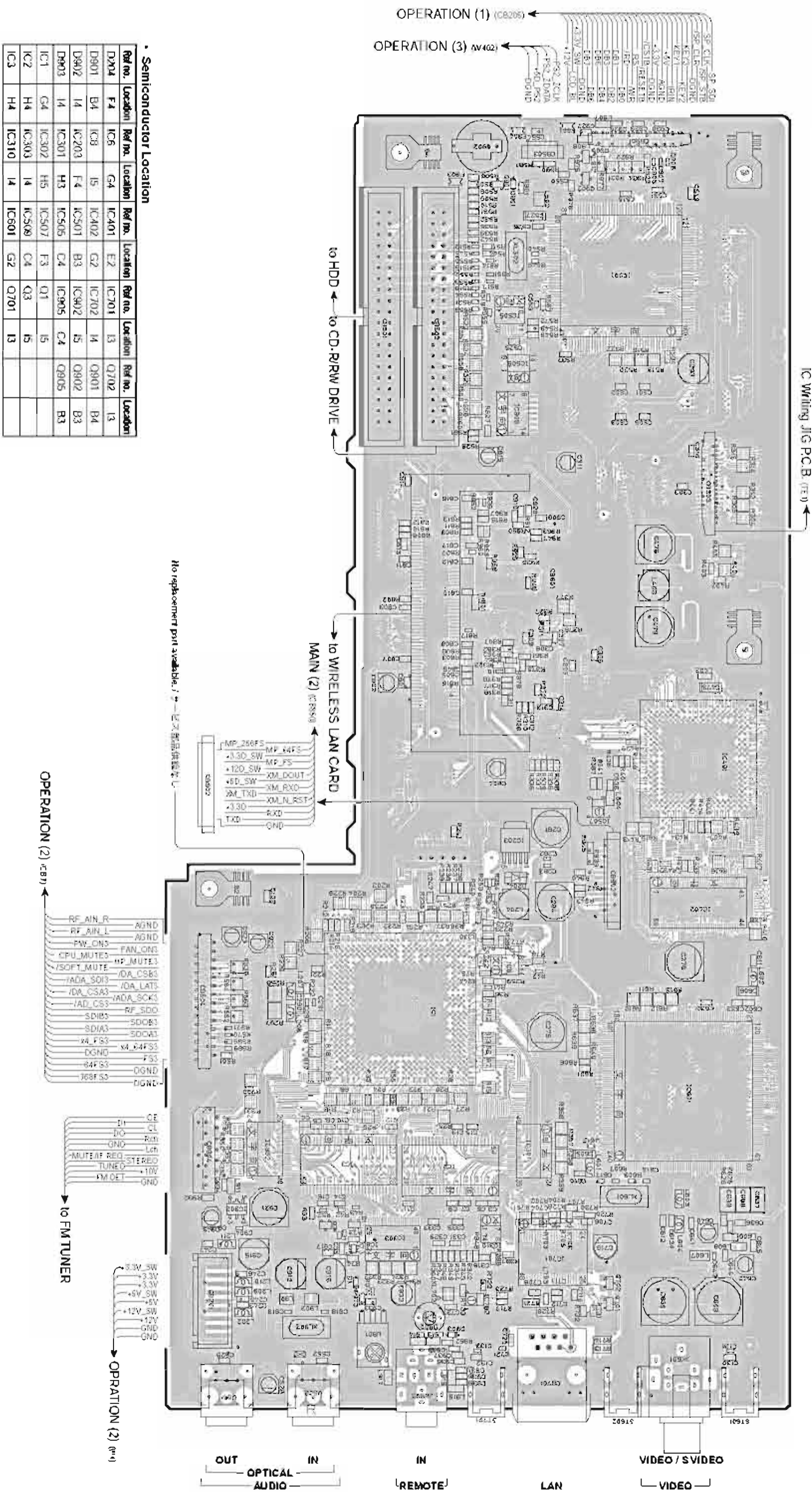

• Semiconductor Location

Ref no.	Location	Ref no.	Location	Ref no.	Location	Ref no.	Location	Ref no.	Location
D204	F4	IC6	G4	IC401	E2	IC701	I3	Q702	I3
D801	B4	IC3	I5	IC402	G2	IC702	I4	Q901	B4
D902	I4	IC203	F4	IC501	B3	IC802	I5	Q902	B3
D903	I4	IC301	H3	IC505	C4	IC905	C4	Q905	B3
IC1	G4	IC302	H5	IC507	F3	Q1	I5		
IC2	H4	IC303	I4	IC509	C4	Q3	I5		
IC3	H4	IC310	I4	IC601	G2	Q701	I3		

1 ■ PRINTED CIRCUIT BOARD

MAIN (1) P.C.B. (Side B) Lead Free Solder Used

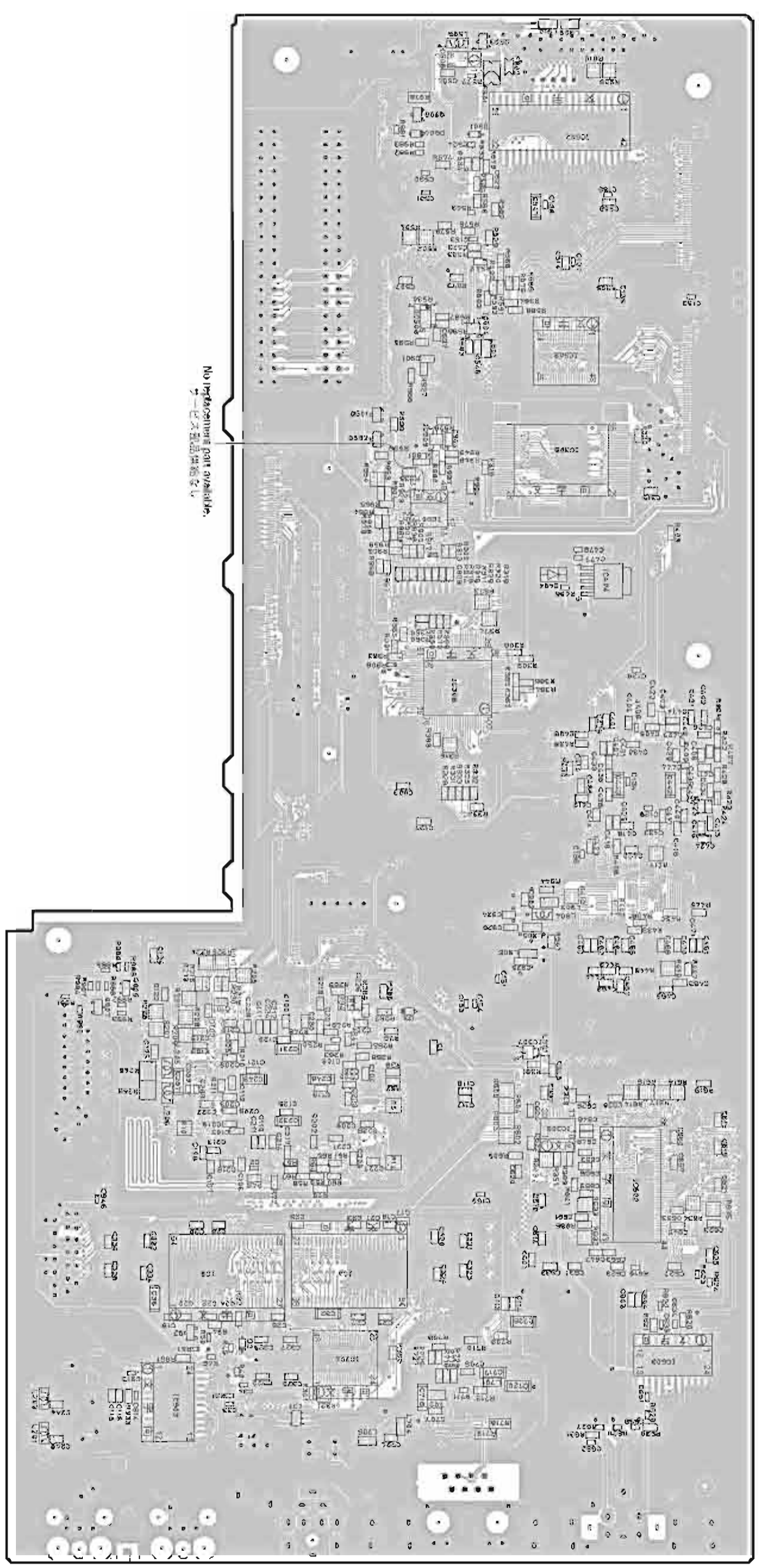

• Semiconductor Location

Ref no.	Location	Ref no.	Location	Ref no.	Location	Ref no.	Location	Ref no.	Location
D1	I5	IC4	H4	IC307	G3	IC505	B3	IC908	D4
D2	I5	IC5	H4	IC308	E3	IC506	C4	Q2	I5
D3	G4	IC7	H5	IC404	E3	IC602	G2	Q503	B3
D4/D4	E3	IC304	I4	IC502	B3	IC603	I2	Q806	B4
D501	B3	IC306	G3	IC503	C3	IC901	D4	Q807	G5
D904	B4	IC306	D3	IC504	C3	IC903	I5	Q808	G6

A B C D E F G H I J

1

2

3

4

5

6

7

1 ■ PRINTED CIRCUIT BOARD

MAIN (2) P.C.B. (Side A) Lead Free Solder Used

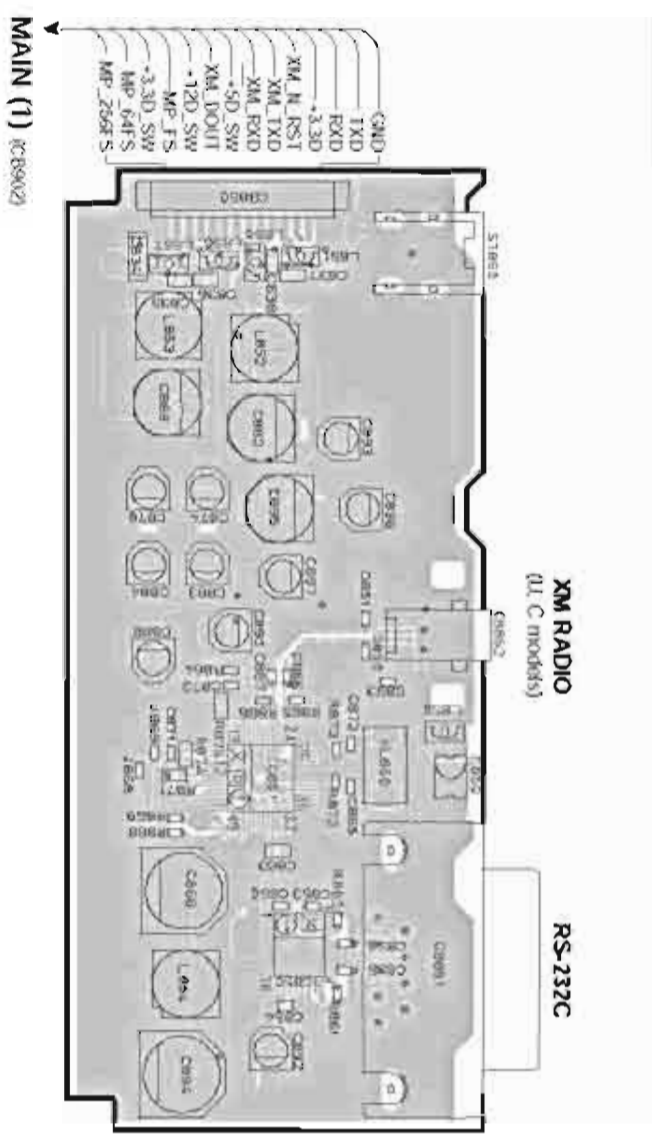

MAIN (2) P.C.B. (Side B) Lead Free Solder Used

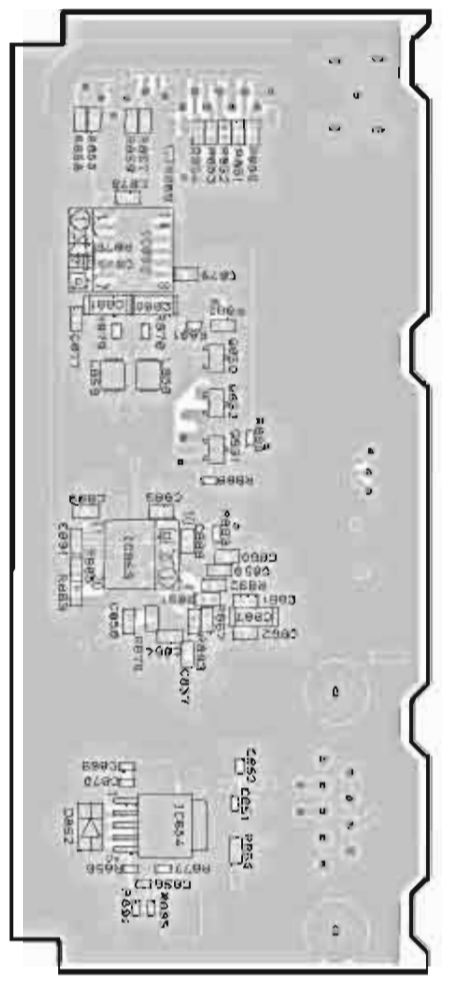

Circuit No.	U.C	A	J	R.G
C546	○	X	X	X
C835, 836, 838	○	X	X	X
C803, 924, 926	○	X	X	X
C912, 915, 916	X	X	X	○
C913, 914	X	X	X	○
C917	X	X	X	○
C918, 919	X	X	X	○
C18852	○	X	X	X
IC504	○	X	X	○
IC903	X	X	X	○
L501	○	X	X	X
L855-857	○	X	X	X
L901, 902	X	X	X	○
L903, 905	○	X	X	X
L904	○	X	X	X
RB47, 503	○	X	X	X
RB32	X	X	X	○
RB33	X	X	X	○
RB51	X	X	X	○
RB30-945	○	X	X	X
XL902	X	X	X	○

X : NOT USED
○ : USED / APPLICABLE

• Semiconductor Location

Ref. no.	Location	Ref. no.	Location	Ref. no.	Location
D850	C3	IC851	D3	Q851	C8
D851	C3	IC852	B6	Q852	C6
D852	D6	IC853	D6		
D853	C3	IC854	D6		
IC850	D3	Q850	C6		

1 ■ PRINTED CIRCUIT BOARD

OPERATION (1) P.C.B. (Side A) Lead Free Solder Used

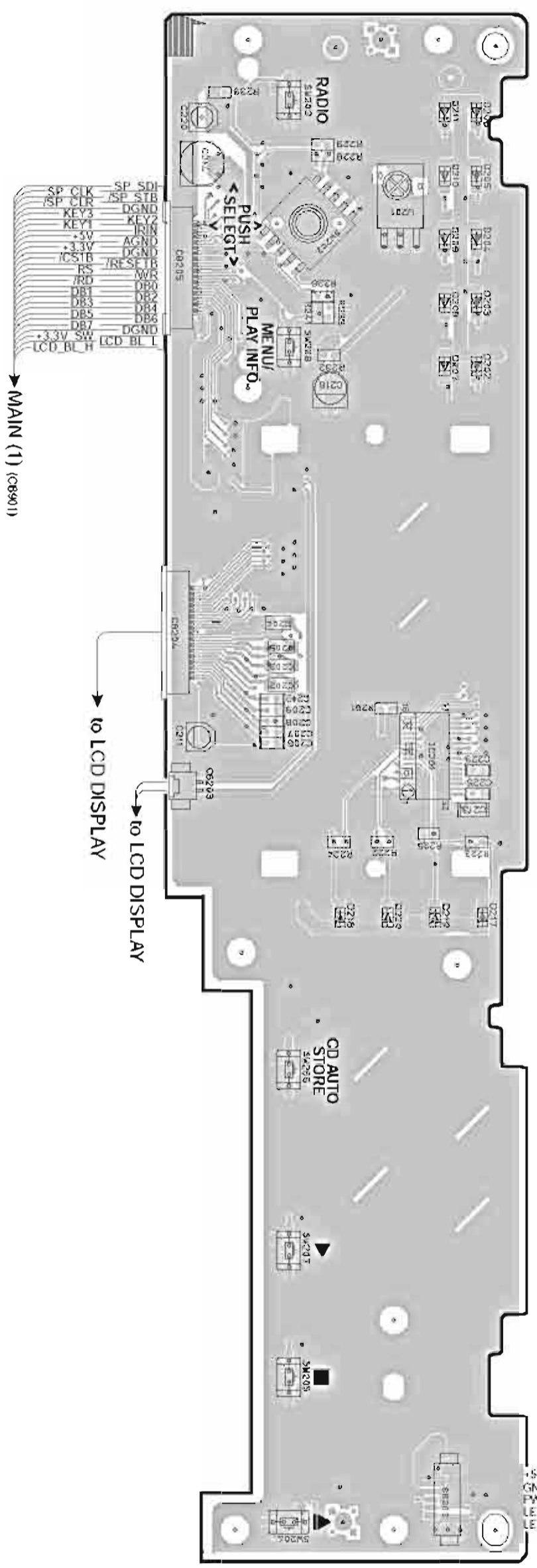

OPERATION (4) (CR3311)
+5V
GND
PWR_KEY
LED_STBY
LED_PON

OPERATION (1) P.C.B. (Side B) Lead Free Solder Used

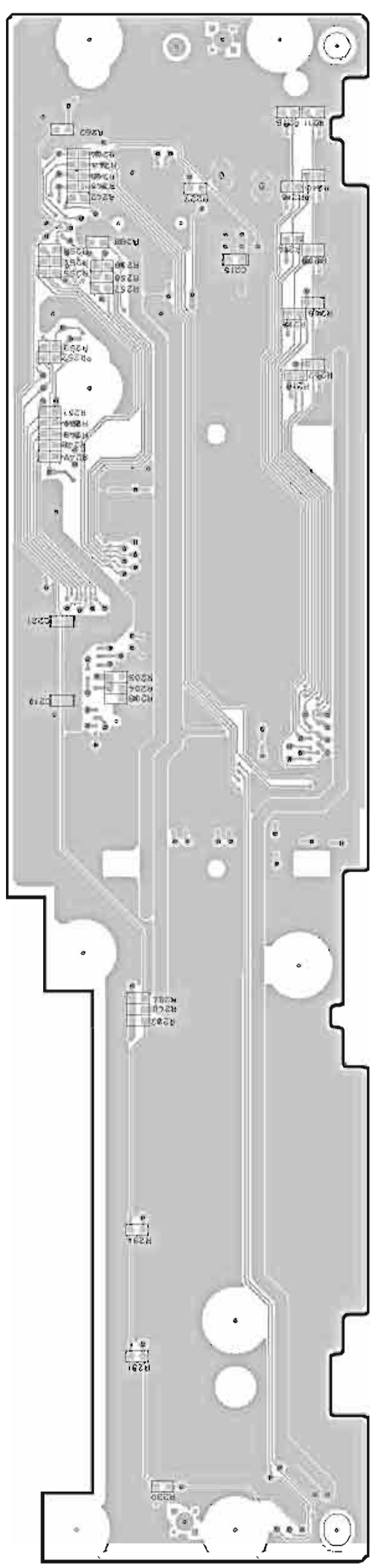

• Semiconductor Location

Ref No.	Location
D202	C2
D203	C2
D204	B2
D205	B2
D206	B2
D207	C2
D208	C2
D209	B2
D210	B2
D211	B2
D217	F2
D218	F3
D219	F2
D220	F2
IC201	E2

■ PRINTED CIRCUIT BOARD

OPERATION (2) P.C.B. (Side A) Lead Free Solder Used

OPERATION (2) P.C.B. (Side B) Lead Free Solder Used

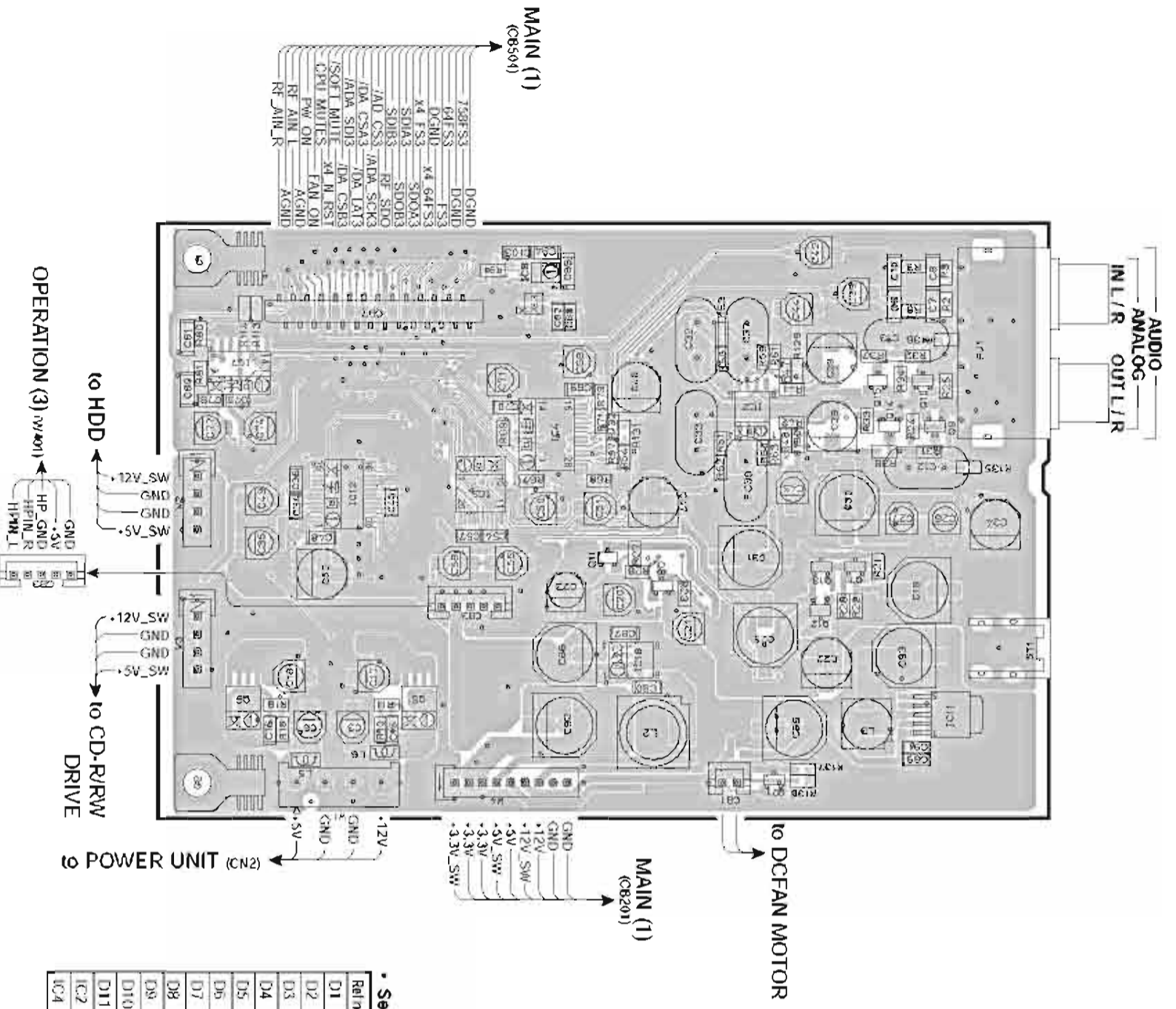

• Semiconductor Location

Ref.no	Location	Ref.no	Location	Ref.no	Location	Ref.no	Location
D1	I3	IC5	C5	Q9	C3		
D2	I3	IC7	C6	Q10	C3		
D3	I3	IC8	B4	Q11	D4		
D4	I4	IC10	D4	Q12	D3		
D5	I4	IC11	D3	Q13	D3		
D6	J3	IC12	C5	Q14	C3		
D7	I4	Q1	J3	Q15	C3		
D8	E3	Q3	J6	Q16	I3		
D9	E4	Q4	J6	Q17	H3		
D10	I5	Q5	D5	Q18	H3		
D11	I6	Q6	D6	Q19	I5		
IC2	C4	Q7	D3	Q20	I5		
IC4	C4	Q8	D4	Q21	E3		

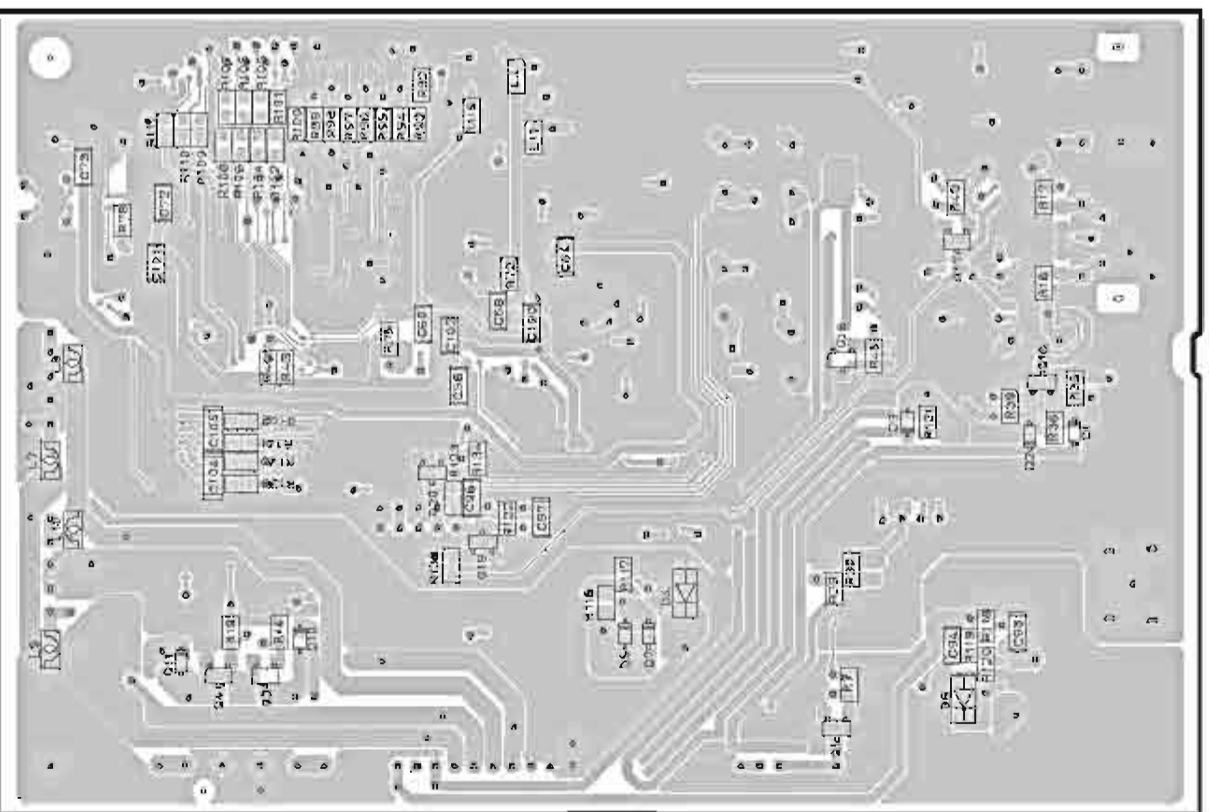

1 ■ PRINTED CIRCUIT BOARD

OPERATION (3) P.C.B. (Side A) Lead Free Solder Used

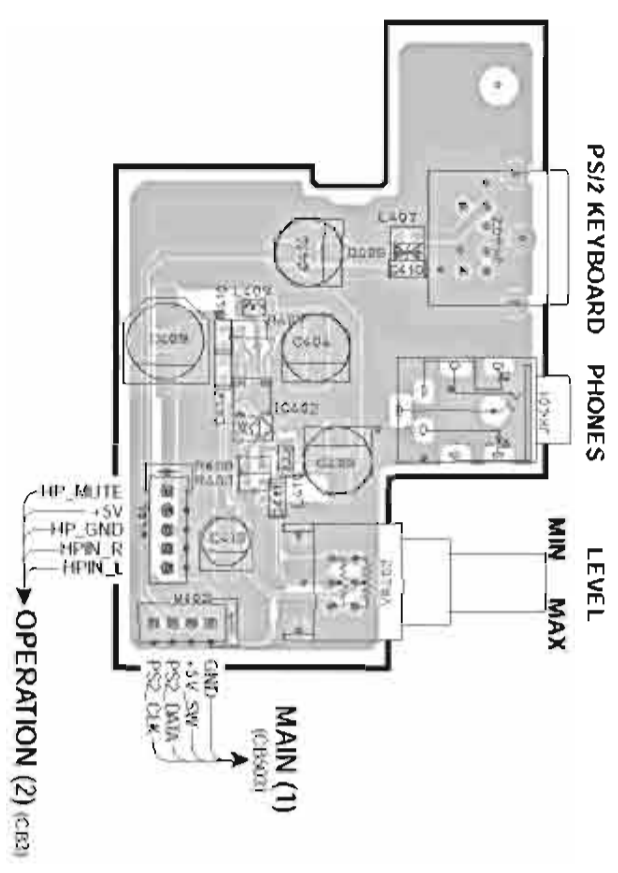

OPERATION (4) P.C.B. (Side A) Lead Free Solder Used

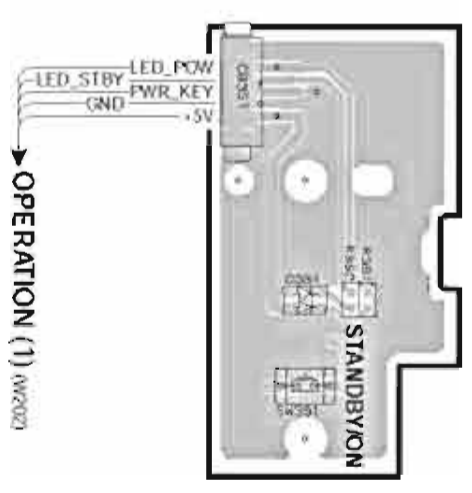

OPERATION (3) P.C.B. (Side B) Lead Free Solder Used



OPERATION (4) P.C.B. (Side B) Lead Free Solder Used

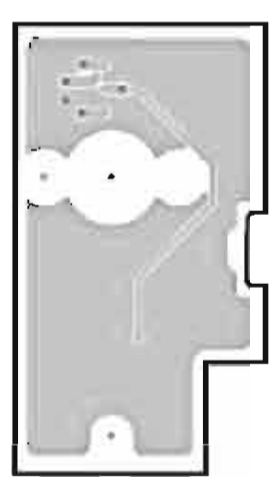

• Semiconductor Location

Part No.	Location
D351	C2
D401	B6
D402	C6
D403	E5
D404	F5
D405	B2
IC402	B3

■ PIN CONNECTION DIAGRAM

• ICS

BD45285G SN74LVC1G125DCKR SN74LVC1G08DCKR	SN74LVC2G17DCKR	NJM2370U10	POICZ4IH2Z	SN74LVC2G08DCKR
POICX12H2ZP SN74C8T3306PW/R SN74AHC3G004HDCTR NJM215M1E1 NJM3114AV	RTC4543SA	74LCX00MTCX WM8738	SN74LVC32APWR SN74LVC74APWR	
MAX3221C/PWR	SN74LVC245APWR WM8728	MB3516APF-G-BND	LC72722PM	
WM8775	AK4620A	WM884CC2EH-7		
BU2152FS	M30262FCP	MSM511616SF-60J3R1	SN74LVC16245A	
W9812G6DH-7	LC4084V-75TN100C	YDC131FZ		
TC98FVM7B2ATG65				

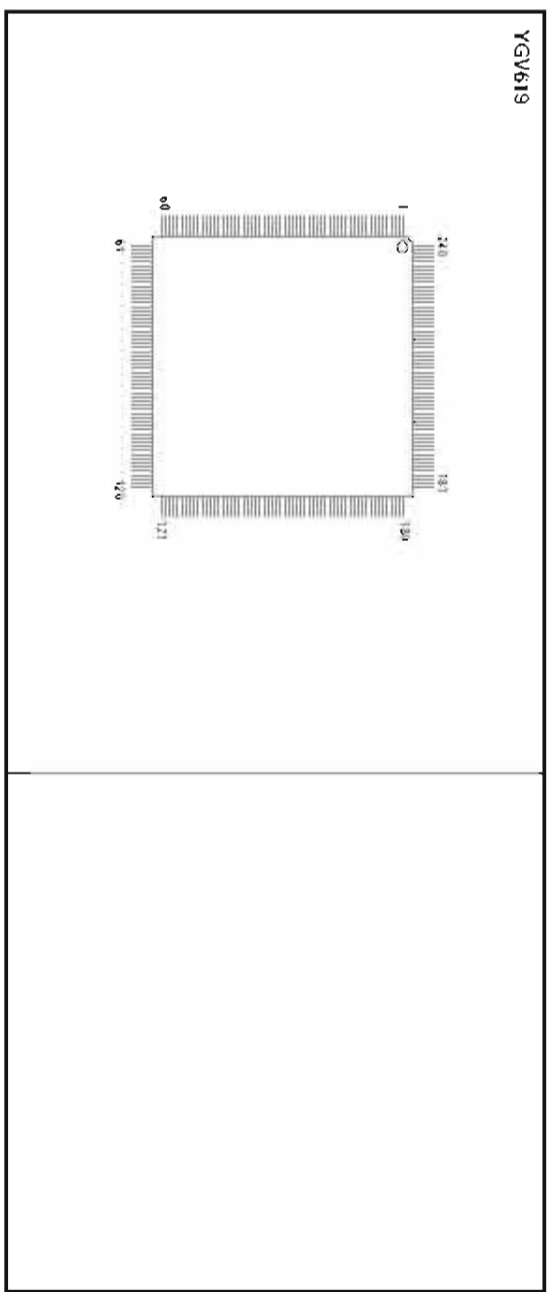

• Diodes

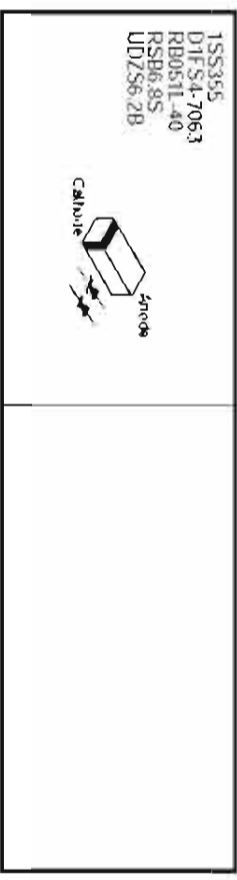

• Transistors

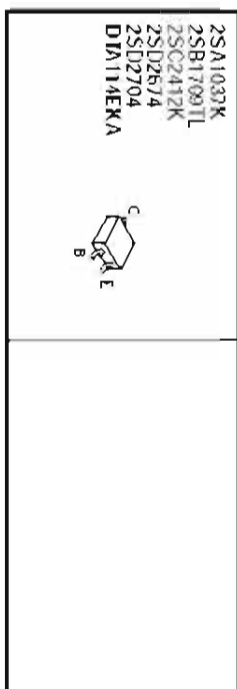

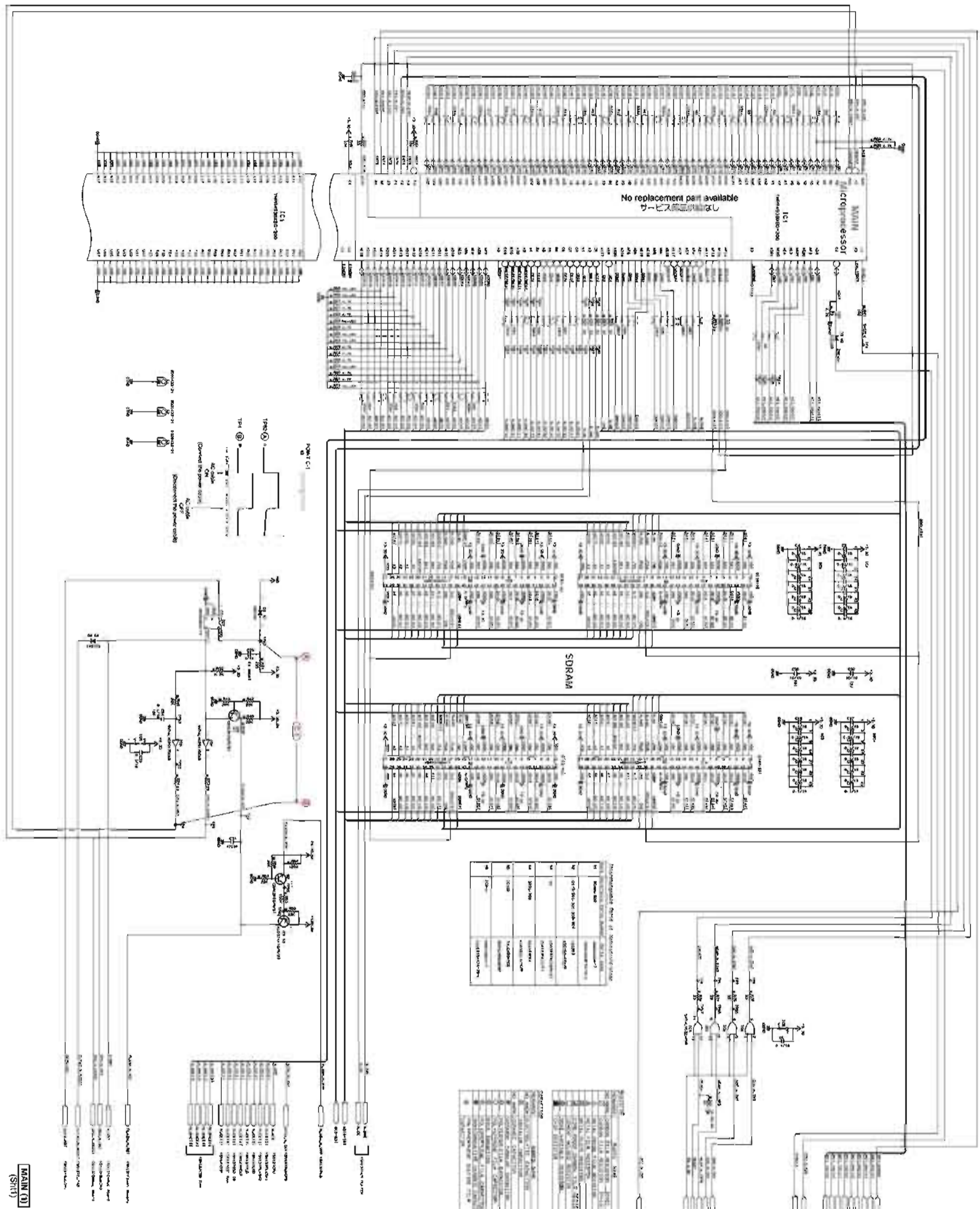

Microprocessor Pinout Table:

Pin No.	Symbol	Function
1	NC	No connection
2	NC	No connection
3	NC	No connection
4	NC	No connection
5	NC	No connection
6	NC	No connection
7	NC	No connection
8	NC	No connection
9	NC	No connection
10	NC	No connection
11	NC	No connection
12	NC	No connection
13	NC	No connection
14	NC	No connection
15	NC	No connection
16	NC	No connection
17	NC	No connection
18	NC	No connection
19	NC	No connection
20	NC	No connection
21	NC	No connection
22	NC	No connection
23	NC	No connection
24	NC	No connection
25	NC	No connection
26	NC	No connection
27	NC	No connection
28	NC	No connection
29	NC	No connection
30	NC	No connection
31	NC	No connection
32	NC	No connection
33	NC	No connection
34	NC	No connection
35	NC	No connection
36	NC	No connection
37	NC	No connection
38	NC	No connection
39	NC	No connection
40	NC	No connection
41	NC	No connection
42	NC	No connection
43	NC	No connection
44	NC	No connection
45	NC	No connection
46	NC	No connection
47	NC	No connection
48	NC	No connection
49	NC	No connection
50	NC	No connection
51	NC	No connection
52	NC	No connection
53	NC	No connection
54	NC	No connection
55	NC	No connection
56	NC	No connection
57	NC	No connection
58	NC	No connection
59	NC	No connection
60	NC	No connection
61	NC	No connection
62	NC	No connection
63	NC	No connection
64	NC	No connection
65	NC	No connection
66	NC	No connection
67	NC	No connection
68	NC	No connection
69	NC	No connection
70	NC	No connection
71	NC	No connection
72	NC	No connection
73	NC	No connection
74	NC	No connection
75	NC	No connection
76	NC	No connection
77	NC	No connection
78	NC	No connection
79	NC	No connection
80	NC	No connection
81	NC	No connection
82	NC	No connection
83	NC	No connection
84	NC	No connection
85	NC	No connection
86	NC	No connection
87	NC	No connection
88	NC	No connection
89	NC	No connection
90	NC	No connection
91	NC	No connection
92	NC	No connection
93	NC	No connection
94	NC	No connection
95	NC	No connection
96	NC	No connection
97	NC	No connection
98	NC	No connection
99	NC	No connection
100	NC	No connection

IC2-5: WB61250M-7 2M x 4 Banks x 16M SDRAM

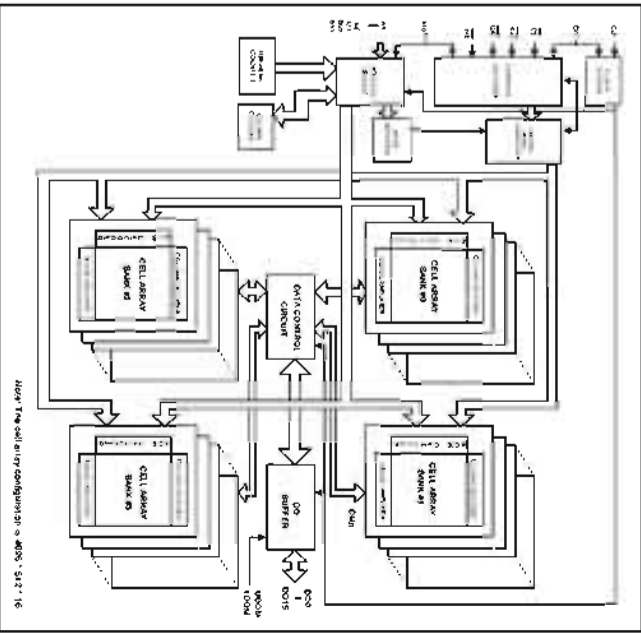

1. All voltages are measured with a 10kΩ/DC electronic voltmeter.
 2. Components having special characteristics are marked Δ and must be replaced with parts having specifications equal to those originally installed.
 3. Schematic diagram is subject to change without notice.

● 電圧は、10kΩの電子抵抗で測定したものです。● 特別な特性を有する部品は、△印を付し、必ず同等の規格品で交換してください。● 回路図は予告なく変更することがあります。

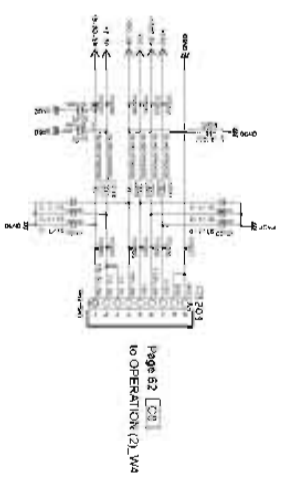
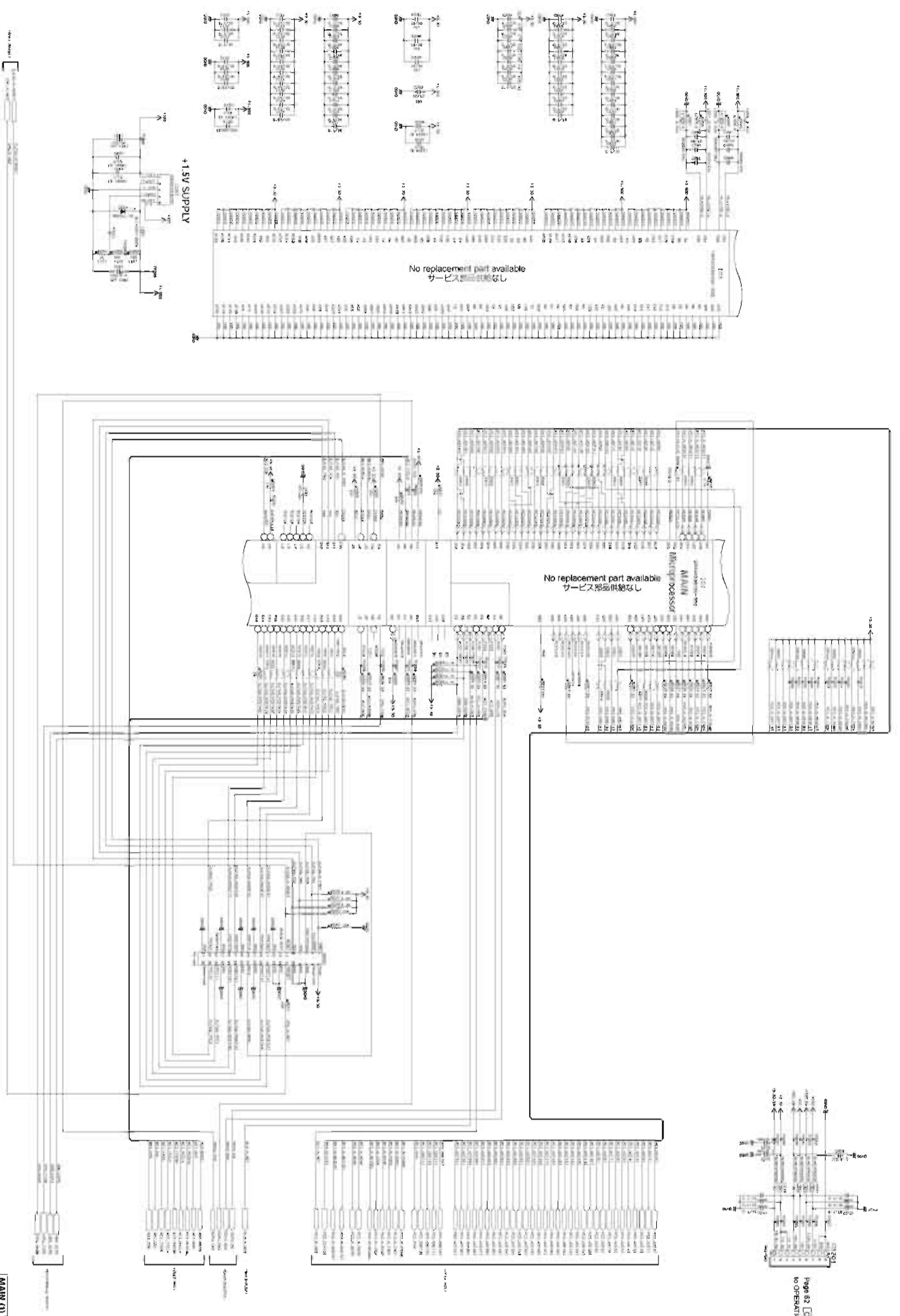

IC2003 P01CZ41H2Z
 Chopper Regulators

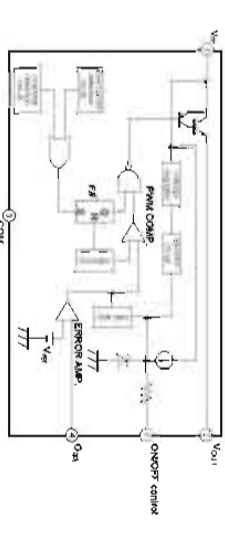

* All voltages are measured with a 10KΩV DC electronic voltmeter.
 * Components having special characteristics are marked Δ and must be replaced with parts having specifications equal to those originally installed.
 * Schematic diagrams are subject to change without notice.

● 電圧は、10KΩV DCの電圧計で測定します。
 ● Δ印のある部品は、特殊性能部品を示しています。部品の交換が必要の場合は、Δ印のある部品と同等の性能部品を同じくしてください。
 ● 本図面は仕様変更図です。改訂のため予告なく変更することがあります。

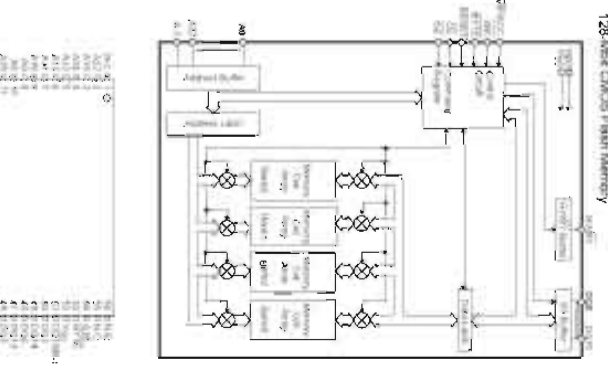
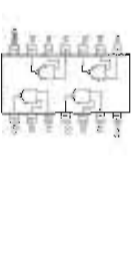
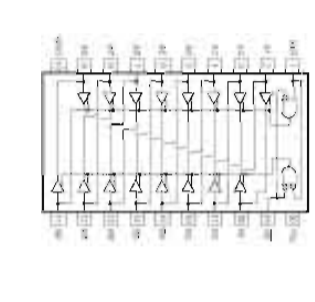
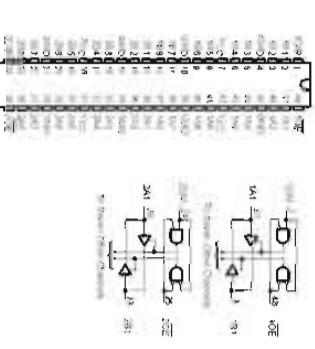
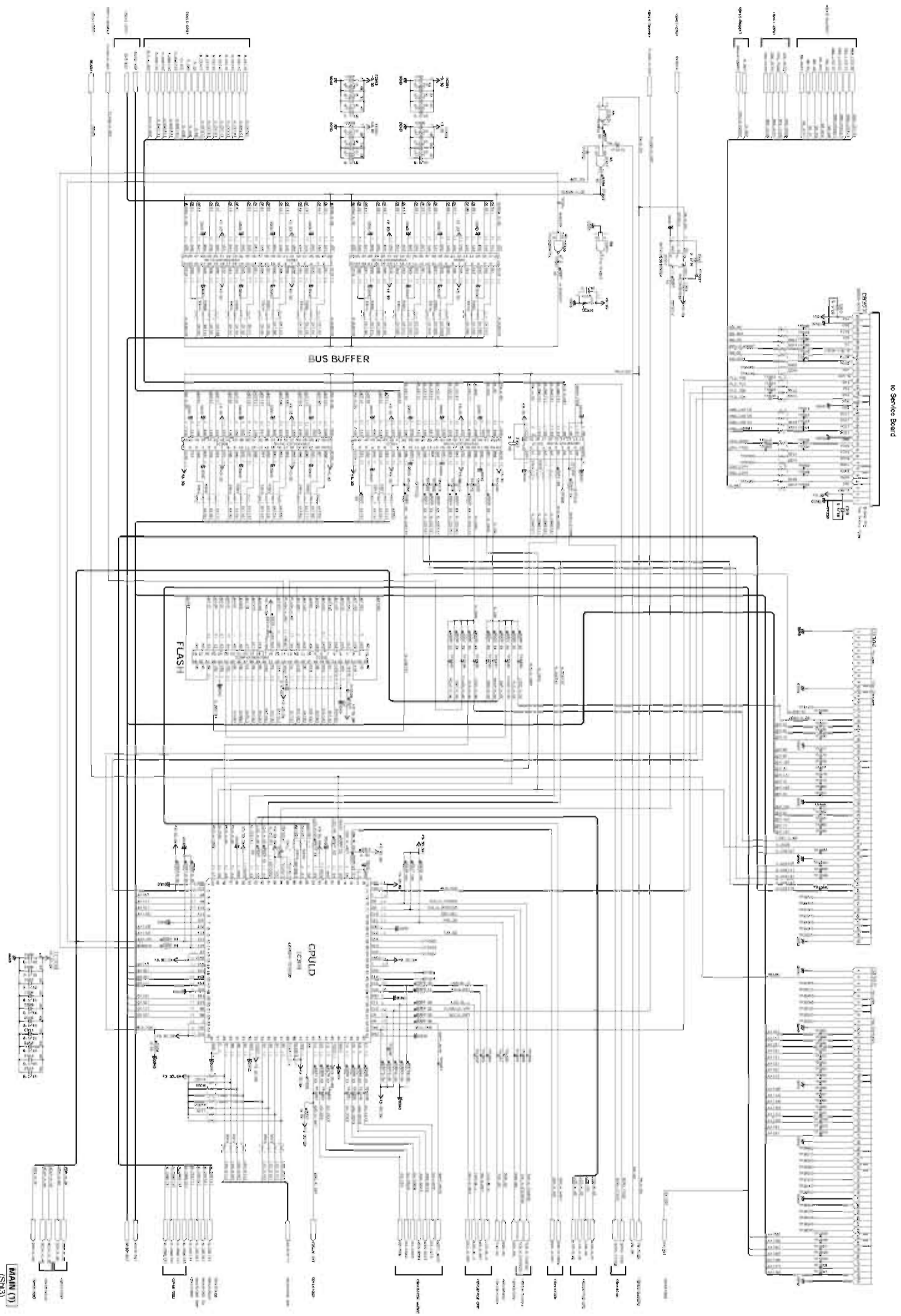

MAIN (1)
(S1/3)

1	2	3	4	5	6	7	8	9	10	11	12	13	14	15	16	17	18	19	20	21	22	23	24
1	2	3	4	5	6	7	8	9	10	11	12	13	14	15	16	17	18	19	20	21	22	23	24

* All voltages are measured with a 10MΩVDC electronic load meter.
 * Components having special characteristics are marked (A) and must be replaced with parts having specifications equal to those originally installed.
 * Schematic diagram is subject to change without notice.
 ● 測定は、片側接地 (GND) の電圧計で測定したものです。
 ● 丸印のある部品は、特殊な特性を有しています。製品の交換が容易な場合、パーツリストに記載されている部品を交換してください。
 ● 本図は、将来の改良に備えて、仕様の異なる部品に置き換えることができます。

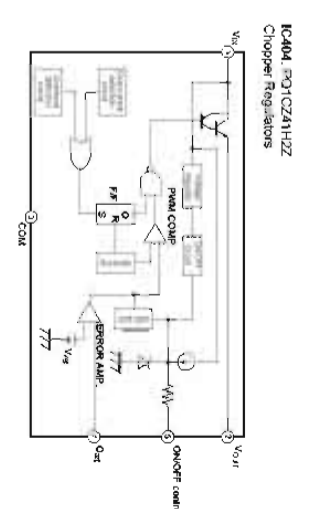
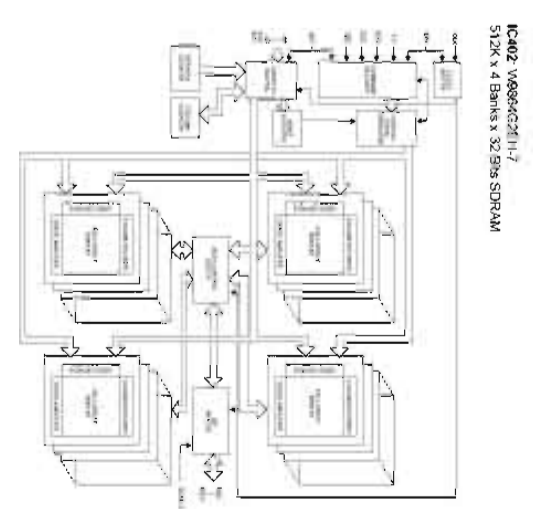
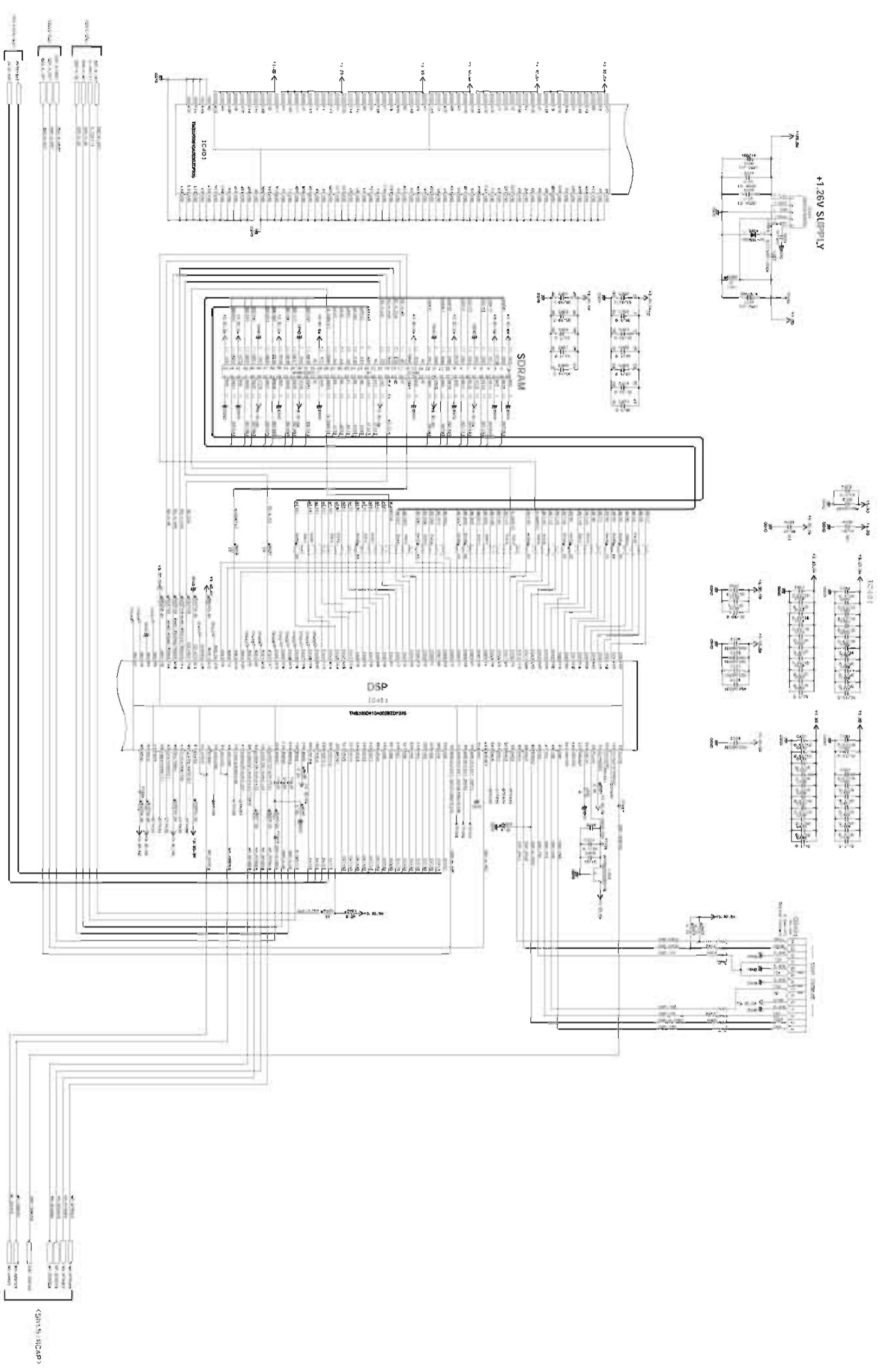

* All voltages are measured with a 10kΩV/DC electronic volt meter.
 * Components having special characteristics are marked Δ and must be replaced with parts having specifications equal to those originally specified.
 * Schematic diagrams is subject to change without notice.

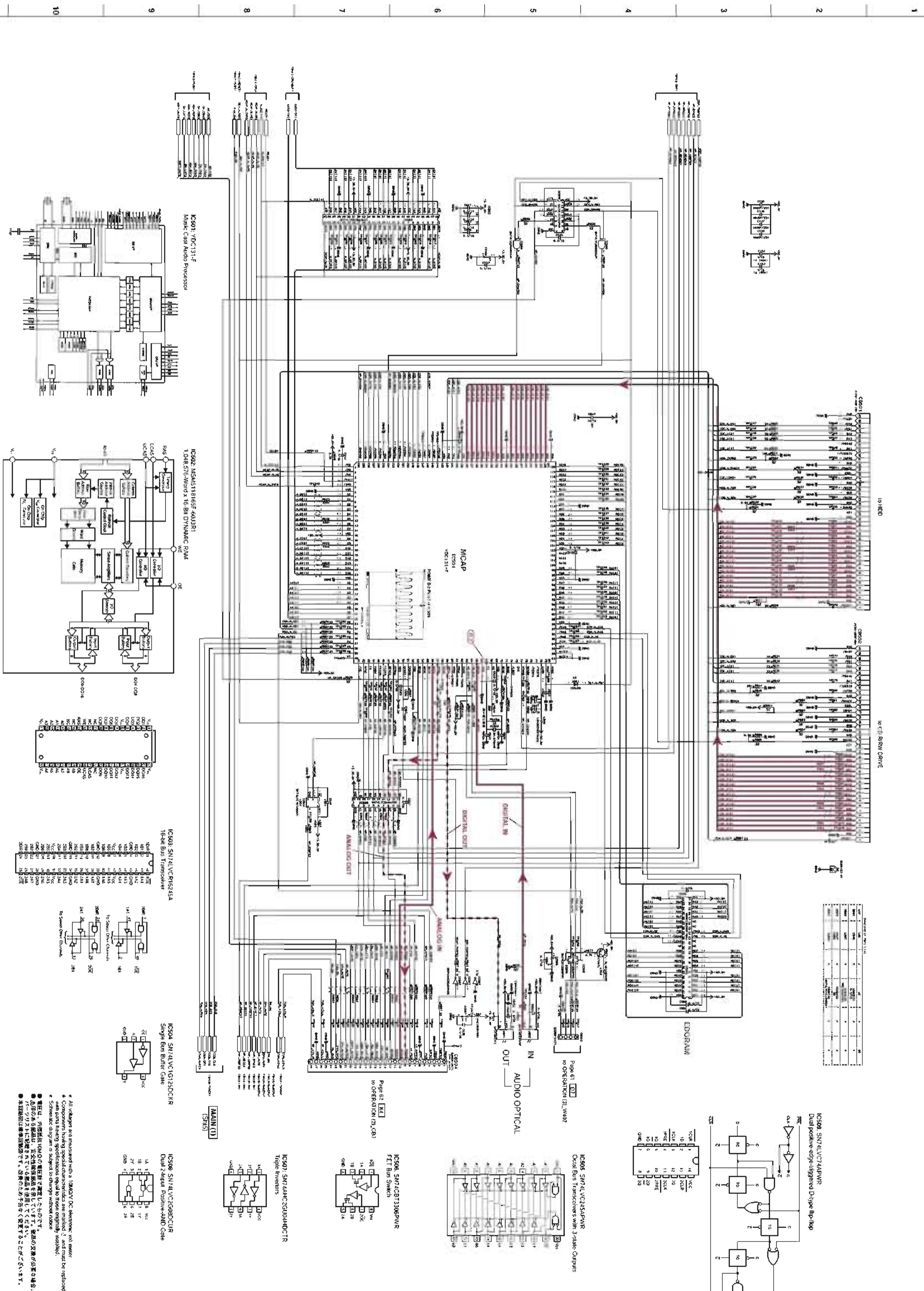

Pin 1 to 16

Pin	Signal	Level
1	VCC	5V
2	NC	-
3	NC	-
4	NC	-
5	NC	-
6	NC	-
7	NC	-
8	NC	-
9	NC	-
10	NC	-
11	NC	-
12	NC	-
13	NC	-
14	NC	-
15	NC	-
16	NC	-

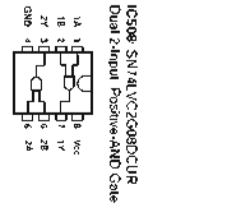
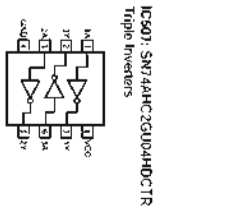
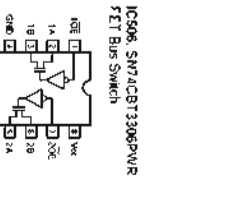
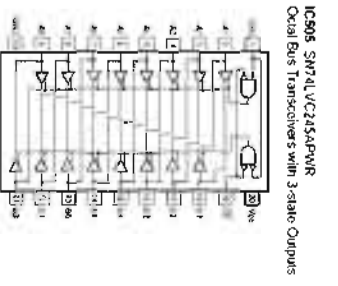
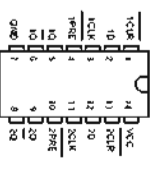
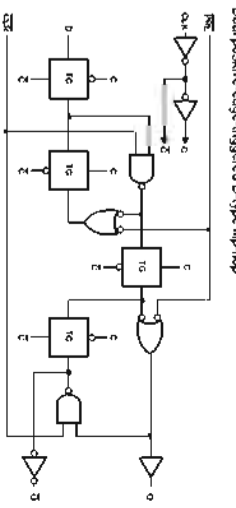

* All voltages are measured with a 10kΩV DC electronic voltmeter.
* Component handling specifications are marked "L" and must be replaced with parts having specifications equal to those originally specified.
* Schematic diagram is subject to change without notice.
● 電圧は、10kΩV DC 電圧計で測定したものです。
● 部品は、取り扱いの規格が同等以上の部品で置き換えることができます。
● 回路図は、仕様変更を伴って変更される場合がございます。

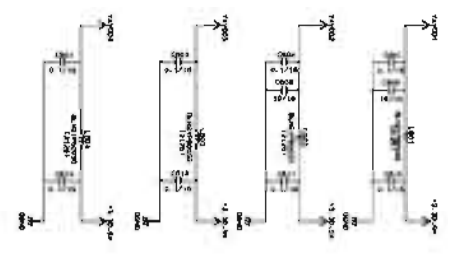
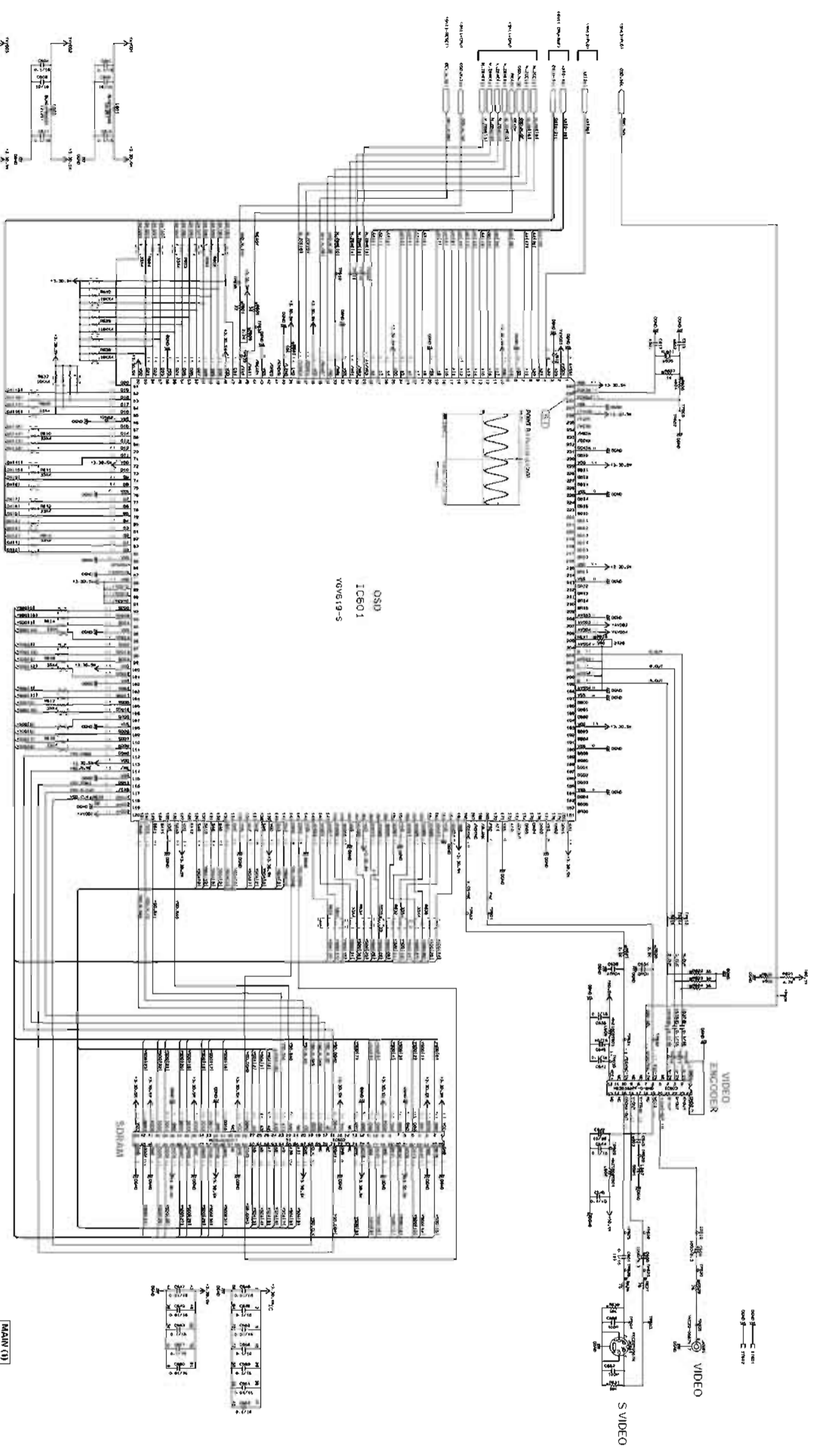

DISCRETE PART LIST

QTY	REF	DESCRIPTION	VALUE	UNIT
1	100	RES	10K	Ω
1	101	RES	100K	Ω
1	102	RES	1K	Ω
1	103	RES	10K	Ω
1	104	RES	100K	Ω
1	105	RES	1K	Ω
1	106	RES	10K	Ω
1	107	RES	100K	Ω
1	108	RES	1K	Ω
1	109	RES	10K	Ω
1	110	RES	100K	Ω
1	111	RES	1K	Ω
1	112	RES	10K	Ω
1	113	RES	100K	Ω
1	114	RES	1K	Ω
1	115	RES	10K	Ω
1	116	RES	100K	Ω
1	117	RES	1K	Ω
1	118	RES	10K	Ω
1	119	RES	100K	Ω
1	120	RES	1K	Ω
1	121	RES	10K	Ω
1	122	RES	100K	Ω
1	123	RES	1K	Ω
1	124	RES	10K	Ω
1	125	RES	100K	Ω
1	126	RES	1K	Ω
1	127	RES	10K	Ω
1	128	RES	100K	Ω
1	129	RES	1K	Ω
1	130	RES	10K	Ω
1	131	RES	100K	Ω
1	132	RES	1K	Ω
1	133	RES	10K	Ω
1	134	RES	100K	Ω
1	135	RES	1K	Ω
1	136	RES	10K	Ω
1	137	RES	100K	Ω
1	138	RES	1K	Ω
1	139	RES	10K	Ω
1	140	RES	100K	Ω
1	141	RES	1K	Ω
1	142	RES	10K	Ω
1	143	RES	100K	Ω
1	144	RES	1K	Ω
1	145	RES	10K	Ω
1	146	RES	100K	Ω
1	147	RES	1K	Ω
1	148	RES	10K	Ω
1	149	RES	100K	Ω
1	150	RES	1K	Ω
1	151	RES	10K	Ω
1	152	RES	100K	Ω
1	153	RES	1K	Ω
1	154	RES	10K	Ω
1	155	RES	100K	Ω
1	156	RES	1K	Ω
1	157	RES	10K	Ω
1	158	RES	100K	Ω
1	159	RES	1K	Ω
1	160	RES	10K	Ω
1	161	RES	100K	Ω
1	162	RES	1K	Ω
1	163	RES	10K	Ω
1	164	RES	100K	Ω
1	165	RES	1K	Ω
1	166	RES	10K	Ω
1	167	RES	100K	Ω
1	168	RES	1K	Ω
1	169	RES	10K	Ω
1	170	RES	100K	Ω
1	171	RES	1K	Ω
1	172	RES	10K	Ω
1	173	RES	100K	Ω
1	174	RES	1K	Ω
1	175	RES	10K	Ω
1	176	RES	100K	Ω
1	177	RES	1K	Ω
1	178	RES	10K	Ω
1	179	RES	100K	Ω
1	180	RES	1K	Ω
1	181	RES	10K	Ω
1	182	RES	100K	Ω
1	183	RES	1K	Ω
1	184	RES	10K	Ω
1	185	RES	100K	Ω
1	186	RES	1K	Ω
1	187	RES	10K	Ω
1	188	RES	100K	Ω
1	189	RES	1K	Ω
1	190	RES	10K	Ω
1	191	RES	100K	Ω
1	192	RES	1K	Ω
1	193	RES	10K	Ω
1	194	RES	100K	Ω
1	195	RES	1K	Ω
1	196	RES	10K	Ω
1	197	RES	100K	Ω
1	198	RES	1K	Ω
1	199	RES	10K	Ω
1	200	RES	100K	Ω

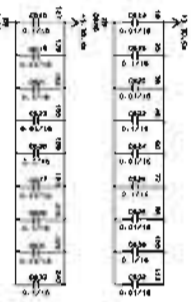

IC602: VG964G/147
 512K X 4 Banks X 32 Bits SDRAM

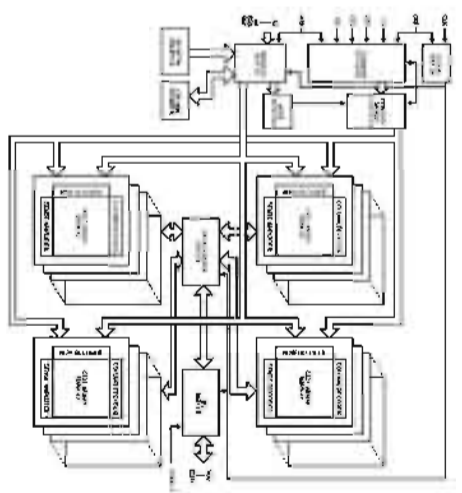

MAIN (1)
 (SM6)

IC603: MB3516APF G-RND
 RGB Encoder

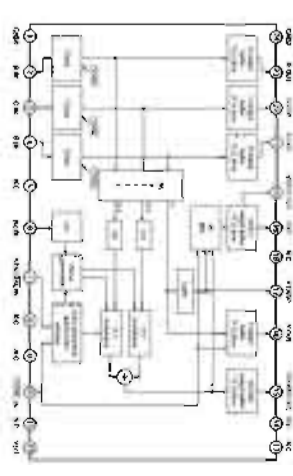

* All voltages are measured with a 10kΩV DC impedance, with meter.
 * Components having special characteristics are marked with asterisk and must be replaced with parts having specifications equal to those originally specified.
 * Schematic diagram is subject to change without notice.

● 電圧は、10kΩV DCの電圧計で測定したものです。
 ● 特別な特性を有する部品は、*で示されています。部品の交換が必要の場合は、元の部品と同等の部品を交換してください。
 ● 回路図は無断で変更される場合があります。

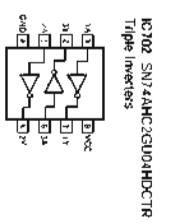
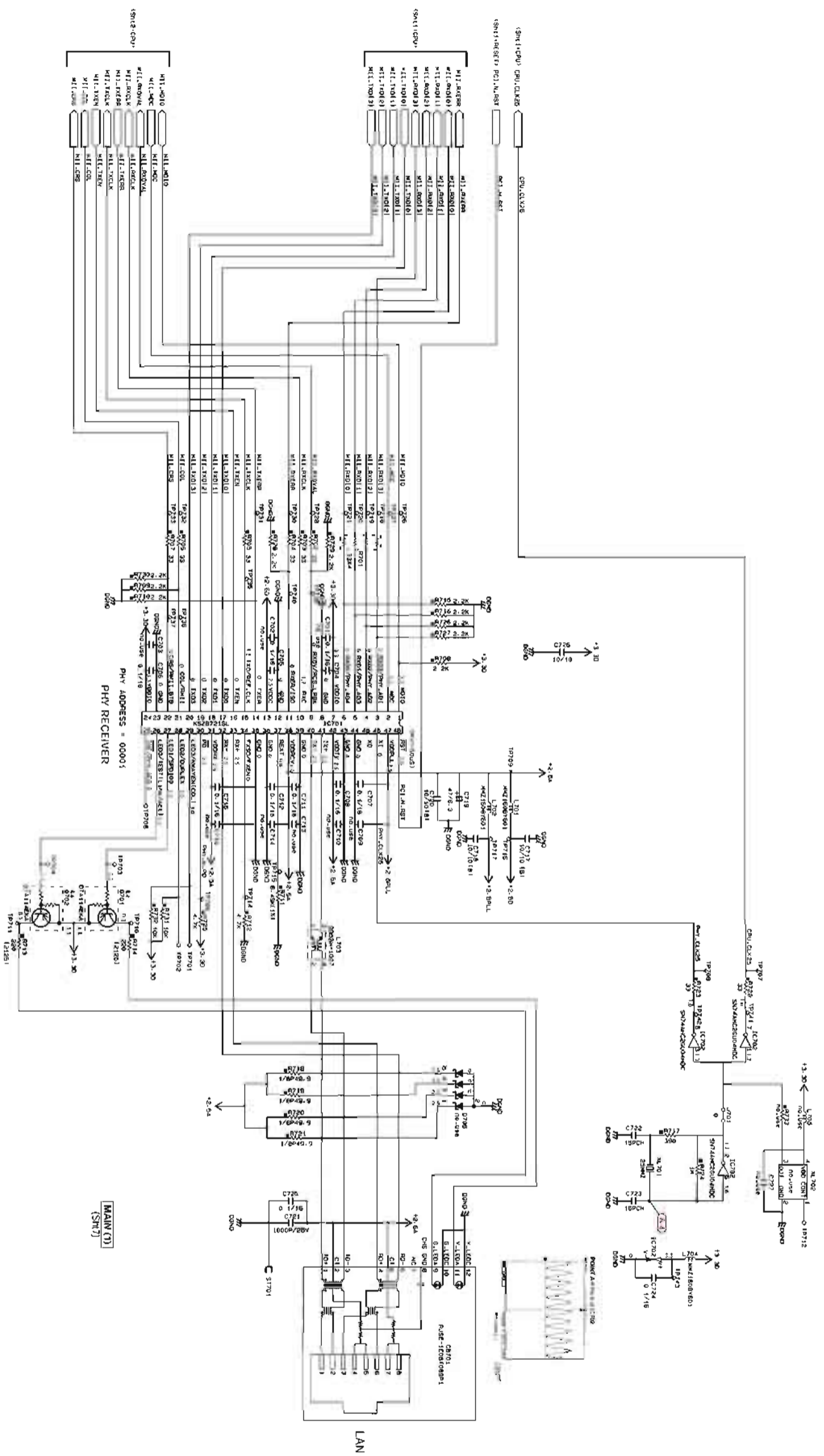

* All dimensions are measured with a 100KV D.C. detector. not meter.
 * Components having special characteristics are marked "L" and must be replaced
 with parts having specifications equal to those originally specified.
 * Schematic diagram is subject to change without notice.
 ● 単位は、国際単位 (SI) の単位に準拠して示されています。
 ● 特殊な特性を有する部品は「L」でマークされ、同等の規格品で置き換える必要
 があります。
 ● システムに組み立てられている部品は、図面に示されているものと異なることが
 あります。
 ● 本図は、図面更新の都合により、変更される場合があります。

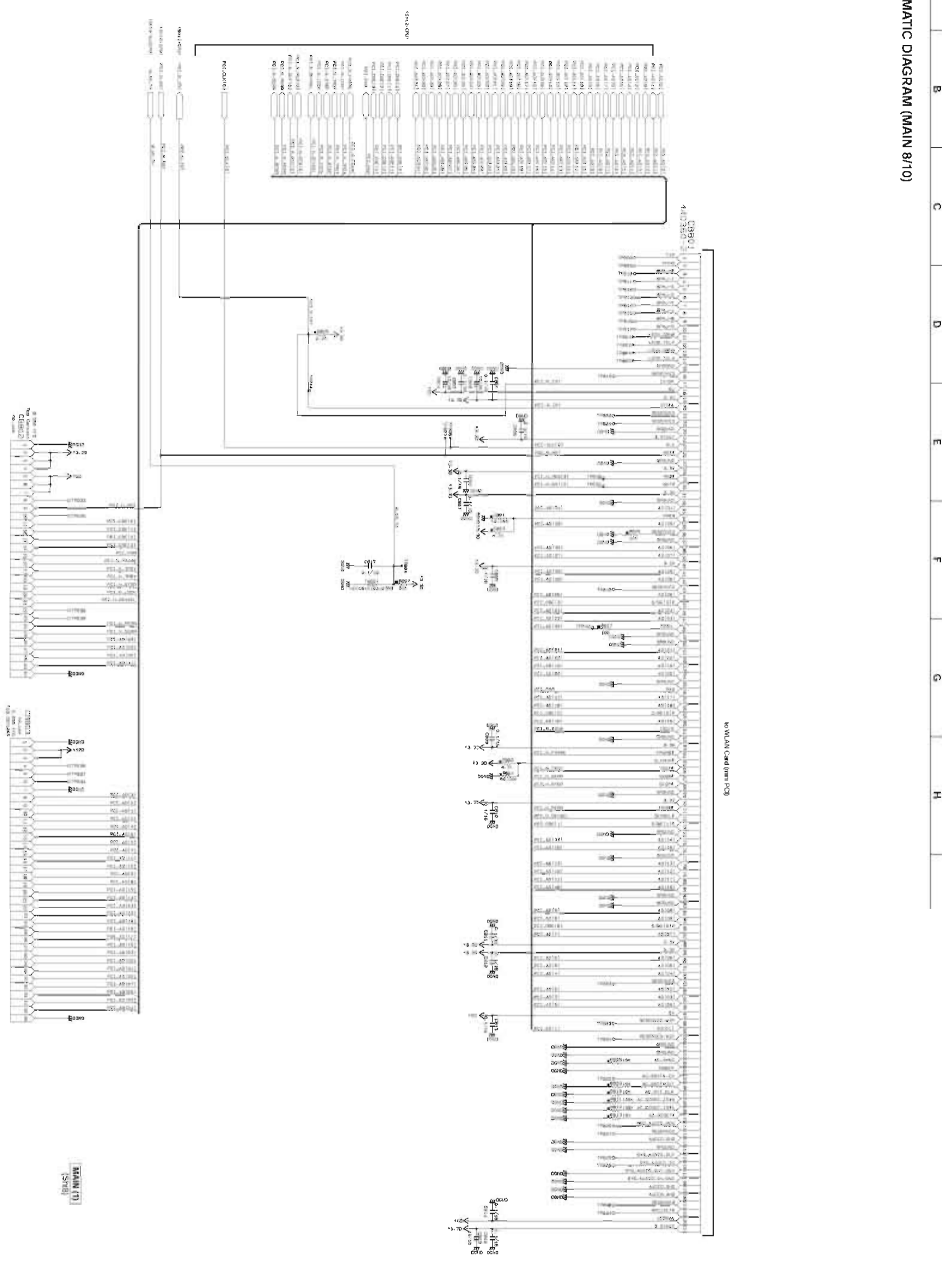

* All voltages are measured with a 10MΩV DC detector, volt meter.
 * Component's having special characteristics, are marked / and have to replaced with parts having specifications equal to those originally installed.
 * Schematic diagram is subject to change without notice.
 ● 電圧は、10MΩVの電圧計で測定したものです。
 ● 特別な特性を有する部品は、斜線/で示されています。部品の交換が必要の場合は、元の部品と同等の仕様を有する部品に交換してください。
 ● 本図面は仕様変更の対象となります。変更のありか不明な点もありません。

DATA SHEET PART LIST

NO.	QTY	DESCRIPTION	REVISION
1	1	IC850: MAX3221C/PWR	1
2	1	IC852: WM8738	1
3	1	IC853: WM8728	1
4	1	IC854: PD1C21HZZ	1
5	1	IC855: MAX3221C/PWR	1
6	1	IC856: MAX3221C/PWR	1
7	1	IC857: MAX3221C/PWR	1
8	1	IC858: MAX3221C/PWR	1
9	1	IC859: MAX3221C/PWR	1
10	1	IC860: MAX3221C/PWR	1
11	1	IC861: MAX3221C/PWR	1
12	1	IC862: MAX3221C/PWR	1
13	1	IC863: MAX3221C/PWR	1
14	1	IC864: MAX3221C/PWR	1
15	1	IC865: MAX3221C/PWR	1
16	1	IC866: MAX3221C/PWR	1
17	1	IC867: MAX3221C/PWR	1
18	1	IC868: MAX3221C/PWR	1
19	1	IC869: MAX3221C/PWR	1
20	1	IC870: MAX3221C/PWR	1

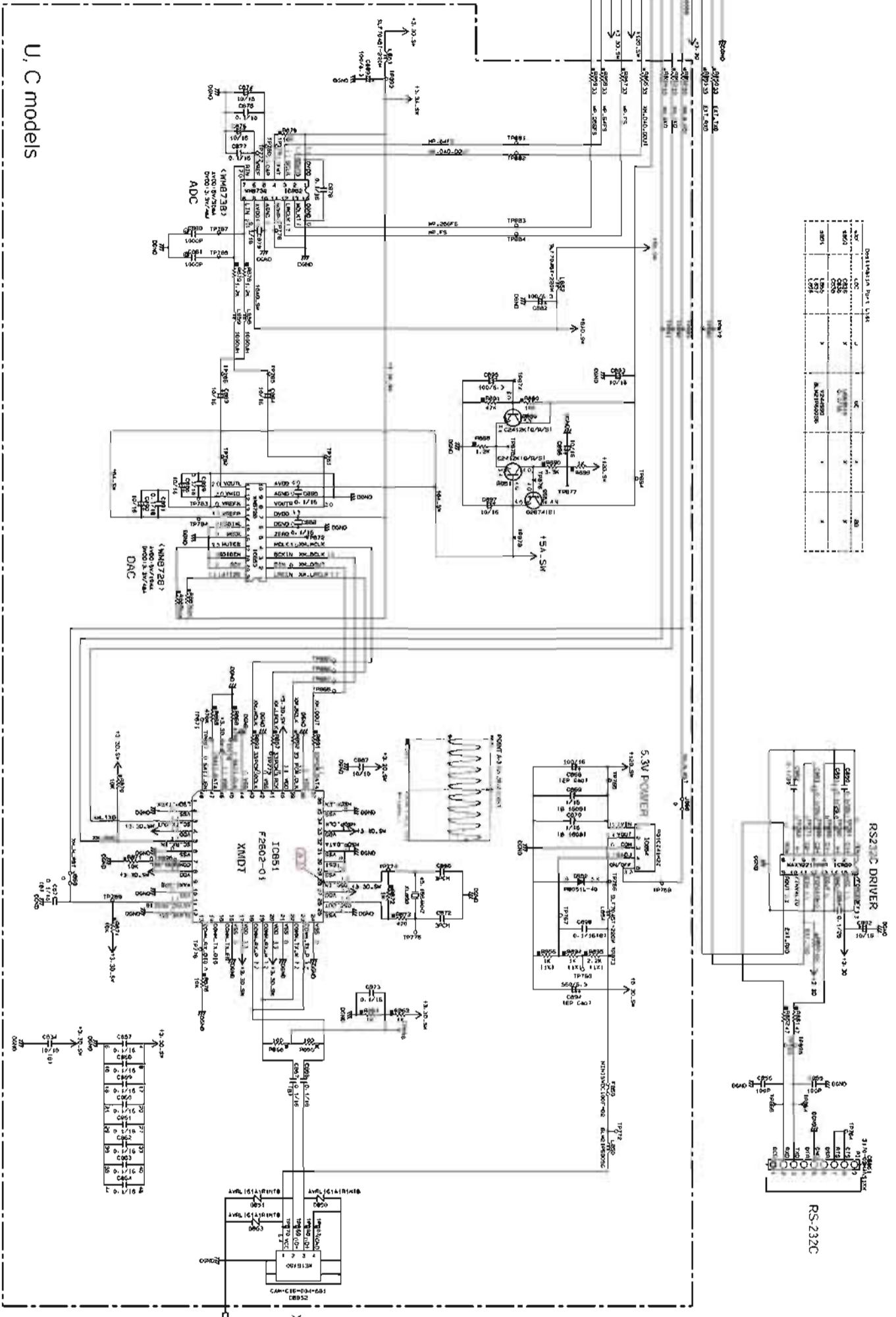

MAIN (2) (SH10)

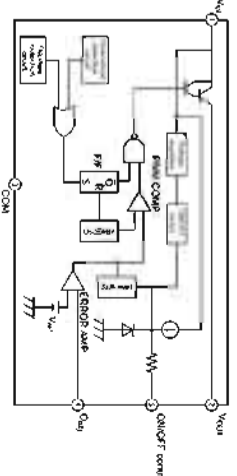
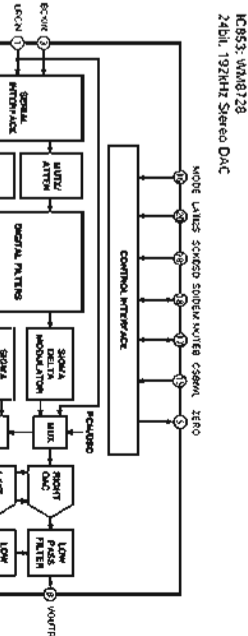
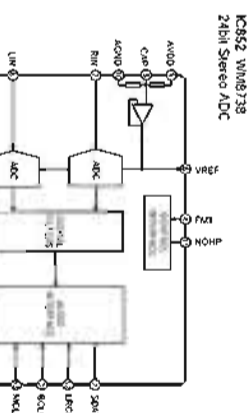
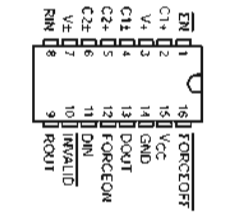
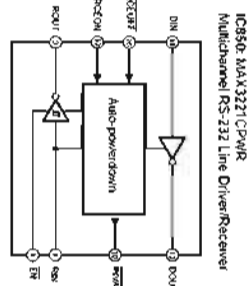

* All voltages are measured with a 10kΩV DC impedance, with noise.
 * Components having special characteristics are marked Δ and must be replaced with parts having specifications equal to those originally specified.
 * Schematic diagram is subject to change without notice.
 ● 電圧は、10kΩV DCの電圧計で測定したものです。
 ● Δ印のある部品は、特別な特性を有する部品を指して示されています。元の仕様と同等の部品で交換してください。
 ● 本図面は、無条件に変更される可能性があります。

NO.	REVISION	DATE	BY	REASON
1	INITIAL			
2	REVISION			
3	REVISION			
4	REVISION			
5	REVISION			
6	REVISION			
7	REVISION			
8	REVISION			
9	REVISION			
10	REVISION			

NO.	REVISION	DATE	BY	REASON
1	INITIAL			
2	REVISION			
3	REVISION			
4	REVISION			
5	REVISION			
6	REVISION			
7	REVISION			
8	REVISION			
9	REVISION			
10	REVISION			

NO.	REVISION	DATE	BY	REASON
1	INITIAL			
2	REVISION			
3	REVISION			
4	REVISION			
5	REVISION			
6	REVISION			
7	REVISION			
8	REVISION			
9	REVISION			
10	REVISION			

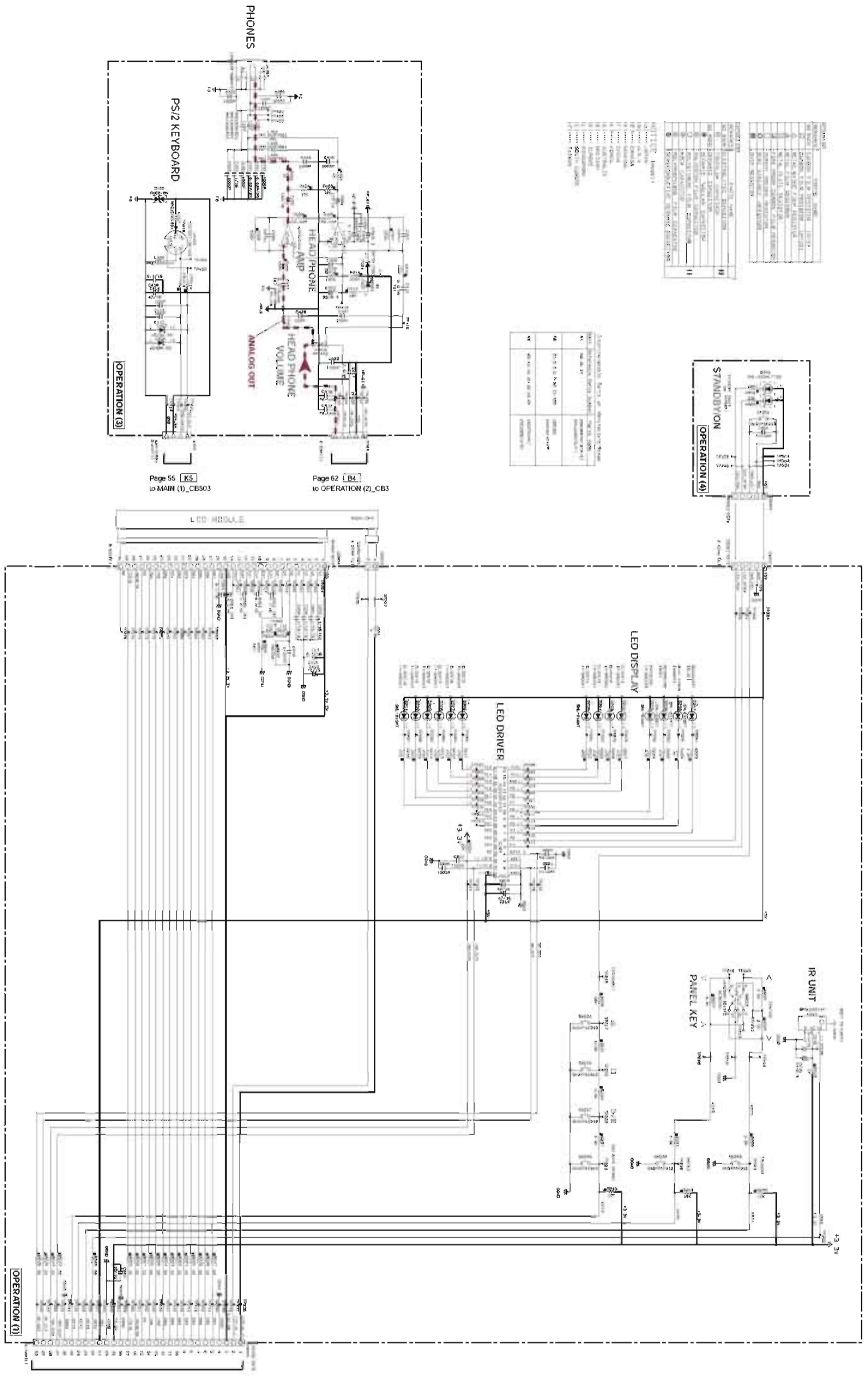

Page 59 (1/2)
to MAIN (1)_CB801

Page 55 (KS)
to MAIN (1)_CB503

Page 62 (B4)
to OPERATION (2)_CB3

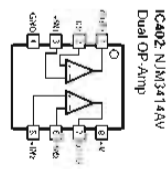
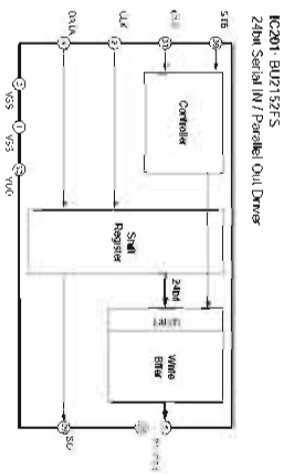

* All chipjags are measured with a 100kV DC electronic volt meter
 * Components having special characteristics are marked A, and must be replaced with parts having specifications equal to those originally installed
 * Schematic diagram is subject to change without notice.
 ● 測定は、片抵抗値10kΩの電圧計で測定したものです。
 ● A印のある部品は、特別な特性を有しています。製品の交換が必要の場合、パーツリストに記載されている部品を使用してください。
 ● 本図は、仕様変更により変更される場合があります。交換のため予告なく変更することがあります。

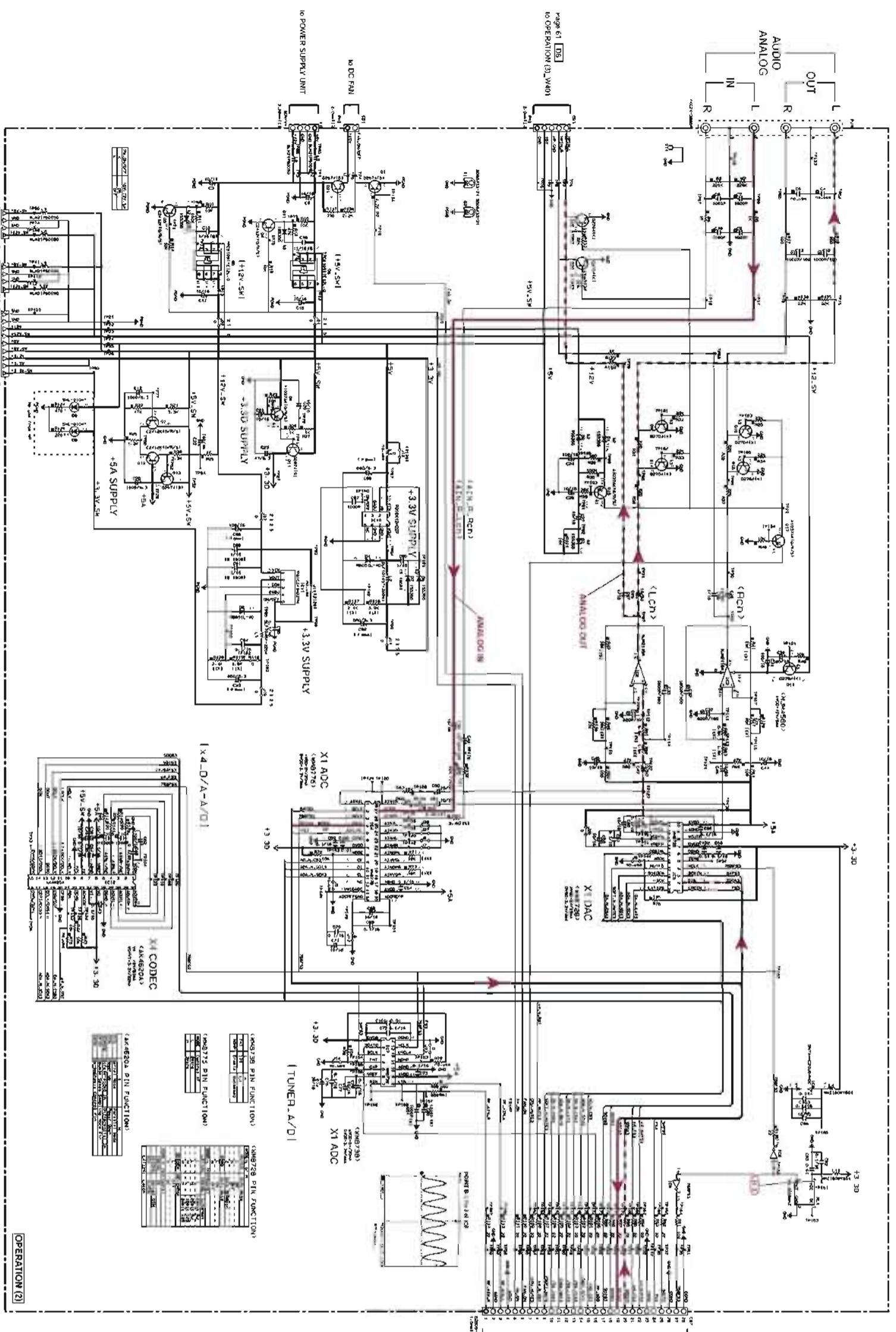

Page 61 (2) 10 OPERATION (2) WH01

Page 52 (2) 10 H00 10 CD-R/RW 10 MAIN (1) CB201

IC1: WM8775 24-bit 96kHz ADC

IC2: WM8728 24-bit 192kHz Stereo DAC

IC3: AK4620A 24-bit 192kHz Audio CODEC

* All voltages are measured with a 10MΩV.D.C. impedance, with meter with parts having specifications equal to those originally installed.
 † Schematic diagram is subject to change without notice.
 ● 電圧は、10MΩV.D.C.の電圧計で測定したものです。
 ● 元の部品規格は、同等の規格品に交換して構いません。
 ● 回路図は変更される場合があります。ご了承ください。

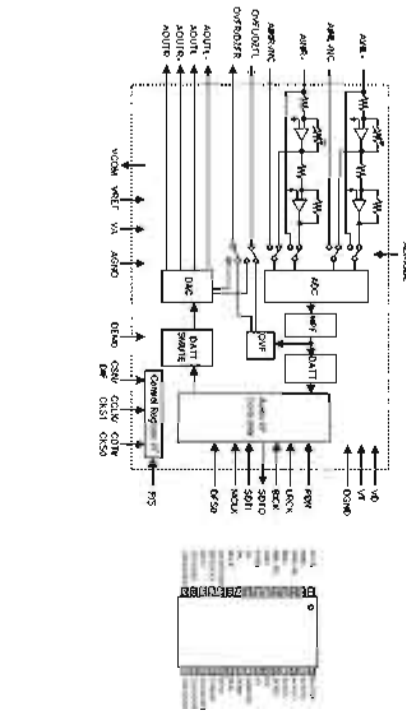
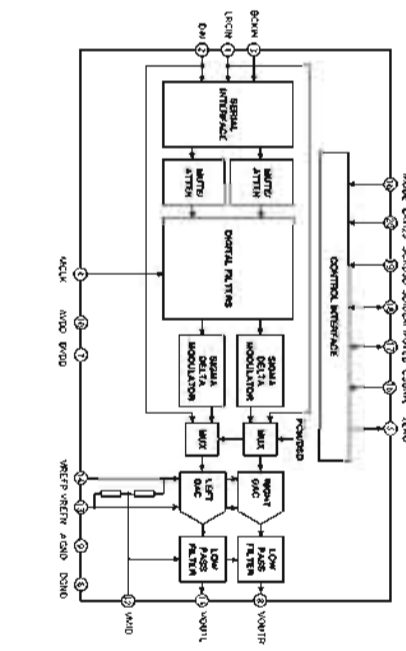
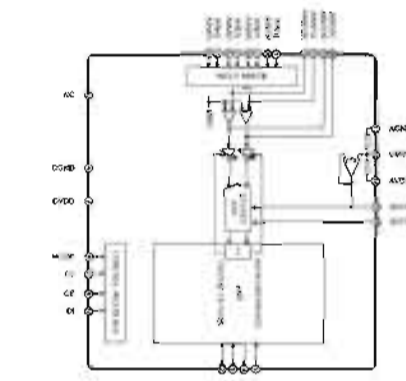

Page 55 (2) 10 MAIN (1) CB304

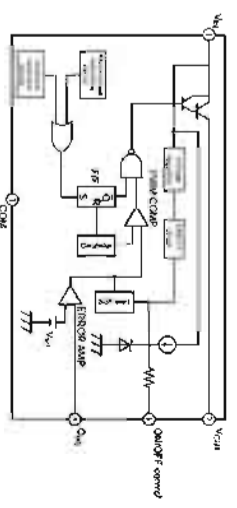
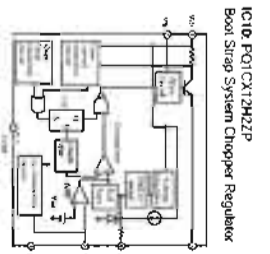
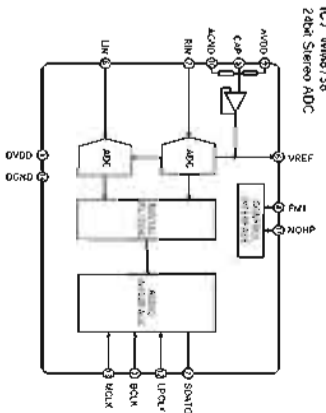
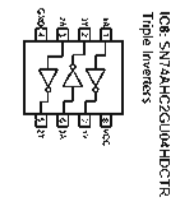
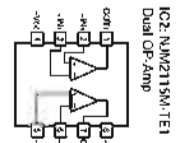

PARTS LIST

■ ELECTRICAL PARTS

■ WARNING

- Components having special characteristics are marked \triangle and must be replaced with parts having specifications equal to those originally installed.
- \triangle 印のある部分は、安全確保部品を示しています。部品の交換が必要な場合、パーツリストに記載されている部品を使用してください。
- 部品価格ランクは、予告なく変更することがあります。

ABBREVIATIONS IN THIS LIST ARE AS FOLLOWS:

C.A.EL.CHP	: CHIP ALUMI.ELECTROLYTIC CAP	L.EMIT	: LIGHT EMITTING MODULE
C.CE	: CERAMIC CAP	LED.DSPLY	: LED DISPLAY
C.CE.ARRAY	: CERAMIC CAP ARRAY	LED.INFRD	: LED,INFRARED
C.CE.CHP	: CHIP CERAMIC CAP	MODUL.RF	: MODULATOR,RF
C.CE.ML	: MULTILAYER CERAMIC CAP	PHOT.CPL	: PHOTO COUPLER
C.CE.M.CHP	: CHIP MULTILAYER CERAMIC CAP	PHOT.INTR	: PHOTO INTERRUPTER
C.CE.SAFTY	: RECOGNIZED CERAMIC CAP	PHOT.RFLCT	: PHOTO REFLECTOR
C.CE.TUBLR	: CERAMIC TUBULAR CAP	PIN.TEST	: PIN,TEST POINT
C.CE.SMI	: SEMI CONDUCTIVE CERAMIC CAP	PLST.RIVET	: PLASTIC RIVET
C.EL	: ELECTROLYTIC CAP	R.ARRAY	: RESISTOR ARRAY
C.MICA	: MICA CAP	R.CAR.	: CARBON RESISTOR
C.ML.FLM	: MULTILAYER FILM CAP	R.CAR.CHP	: CHIP RESISTOR
C.MP	: METALLIZED PAPER CAP	R.CAR.FP	: FLAME PROOF CARBON RESISTOR
C.MYLAR	: MYLAR FILM CAP	R.FUS	: FUSABLE RESISTOR
C.MYLAR.ML	: MULTILAYER MYLAR FILM CAP	R.MTL.CHP	: CHIP METAL FILM RESISTOR
C.PAPER	: PAPER CAPACITOR	R.MTL.FLM	: METAL FILM RESISTOR
C.PLS	: POLYSTYRENE FILM CAP	R.MTL.OXD	: METAL OXIDE FILM RESISTOR
C.POL	: POLYESTER FILM CAP	R.MTL.PLAT	: METAL PLATE RESISTOR
C.POLY	: POLYETHYLENE FILM CAP	RSNR.CE	: CERAMIC RESONATOR
C.PP	: POLYPROPYLENE FILM CAP	RSNR.CRY	: CRYSTAL RESONATOR
C.TNTL	: TANTALUM CAP	R.TW.CEM	: TWIN CEMENT FIXED RESISTOR
C.TNTL.CHP	: CHIP TANTALUM CAP	R.CEMENT	: CEMENT RESISTOR
C.TRIM	: TRIMMER CAP	SCR.BND.HD	: BIND HEAD B-TITE SCREW
CN	: CONNECTOR	SCR.BW.HD	: BW HEAD TAPPING SCREW
CN.BS.PIN	: CONNECTOR,BASE PIN	SCR.CUP	: CUP TITE SCREW
CN.CANNON	: CONNECTOR,CANNON	SCR.TERM	: SCREW TERMINAL
CN.DIN	: CONNECTOR,DIN	SCR.TR	: SCREW,TRANSISTOR
CN.FLAT	: CONNECTOR,FLAT CABLE	SUPRT.PCB	: SUPPORT,P.C.B.
CN.POST	: CONNECTOR,BASE POST	SURG.PRTCT	: SURGE PROTECTOR
COIL.MX.AM	: COIL,AM MIX	SW.TACT	: TACT SWITCH
COIL.AT.FM	: COIL,FM ANTENNA	SW.LEAF	: LEAF SWITCH
COIL.DT.FM	: COIL,FM DETECT	SW.LEVER	: LEVER SWITCH
COIL.MX.FM	: COIL,FM MIX	SW.MICRO	: MICRO SWITCH
COIL.OUTPT	: OUTPUT COIL	SW.PUSH	: PUSH SWITCH
DIOD.ARRAY	: DIODE ARRAY	SW.RT.ENC	: ROTARY ENCODER
DIODE.BRG	: DIODE BRIDGE	SW.RT.MTR	: ROTARY SWITCH WITH MOTOR
DIODE.CHP	: CHIP DIODE	SW.RT	: ROTARY SWITCH
DIODE.VAR	: VARACTOR DIODE	SW.SLIDE	: SLIDE SWITCH
DIOD.Z.CHP	: CHIP ZENER DIODE	TERM.SP	: SPEAKER TERMINAL
DIODE.ZENR	: ZENER DIODE	TERM.WRAP	: WRAPPING TERMINAL
DSCR.CE	: CERAMIC DISCRIMINATOR	THRMST.CHP	: CHIP THERMISTOR
FER.BEAD	: FERRITE BEADS	TR.CHP	: CHIP TRANSISTOR
FER.CORE	: FERRITE CORE	TR.DGT	: DIGITAL TRANSISTOR
FET.CHP	: CHIP FET	TR.DGT.CHP	: CHIP DIGITAL TRANSISTOR
FL.DSPLY	: FLUORESCENT DISPLAY	TRANS	: TRANSFORMER
FLTR.CE	: CERAMIC FILTER	TRANS.PULS	: PULSE TRANSFORMER
FLTR.COMB	: COMB FILTER MODULE	TRANS.PWR	: POWER TRANSFORMER ASS'Y
FLTR.LC.RF	: LC FILTER,EMI	TUNER.AM	: TUNER PACK,AM
GND.MTL	: GROUND PLATE	TUNER.FM	: TUNER PACK,FM
GND.TERM	: GROUND TERMINAL	TUNER.PK	: FRONT-ENDTUNER PACK
HOLDER.FUS	: FUSE HOLDER	VR	: ROTARY POTENTIOMETER
IC.PRTCT	: IC PROTECTOR	VR.MTR	: POTENTIOMETER WITH MOTOR
JUMPER.CN	: JUMPER CONNECTOR	VR.SW	: POTENTIOMETER WITH ROTARY SW
JUMPER.TST	: JUMPER,TEST POINT	VR.SLIDE	: SLIDE POTENTIOMETER
L.DTCT	: LIGHT DETECTING MODULE	VR.TRIM	: TRIMMER POTENTIOMETER

P.C.B. OPERATION

Ref. No	Part No.	Description	Remarks	Markets	部 品 名	Rank
*	WF416100	P. C. B.	OPERATION		P C B オペレーション	
	CB1	VB389800	CN. BS. PIN	2P	ベースピン	01
	CB3	VB390100	CN. BS. PIN	5P	ベースピン	01
*	CB7	WC199800	CN	52808 28P TE	F F C / F P C コネクター	02
*	CB202	VQ992600	CN	5P 53261-0590	コネクター P=1. 2 5	01
	CB203	VQ992300	CN	53261-0290 2PIN	コネクター P=1. 2 5	01
	CB204	V9808500	CN	30P SE	F F C F P C コネクター	02
	CB205	V9887300	CN	30P TE	F F C F P C コネクター	02
*	CB351	VQ992600	CN	5P 53261-0590	コネクター P=1. 2 5	01
	C3	UF037100	C. EL. CHP	10uF 16V	チップケミコン	01
	C6	UF037100	C. EL. CHP	10uF 16V	チップケミコン	01
	C7-10	VR329100	C. POLY. CHP	1000pF 50V	チップマイラーコン	01
	C12-13	WE101700	C. PP	1000pF 100V	P P コン	
	C15-16	WD176300	C. CE. CHP	1uF 16V K	チップセラコン	01
	C17-18	UF037100	C. EL. CHP	10uF 16V	チップケミコン	01
*	C19	WF467000	C. EL. CHP	1000uF 6. 3V	チップケミコン	
	C20-21	UF037100	C. EL. CHP	10uF 16V	チップケミコン	01
	C22	UF038100	C. EL. CHP	100uF 16V	チップケミコン	01
	C23	UF017470	C. EL. CHP	47uF 6. 3V	チップケミコン	01
	C24	UF038100	C. EL. CHP	100uF 16V	チップケミコン	01
*	C25	WF467000	C. EL. CHP	1000uF 6. 3V	チップケミコン	
	C26-27	UF037100	C. EL. CHP	10uF 16V	チップケミコン	01
	C28-29	WC895000	C. EL. CHP	10uF 50V	チップケミコン	01
	C30-31	UF038100	C. EL. CHP	100uF 16V	チップケミコン	01
	C32-33	WE101700	C. PP	1000pF 100V	P P コン	
	C34	US135100	C. CE. CHP	0. 1uF 16V	チップセラコン	01
	C35	UF037100	C. EL. CHP	10uF 16V	チップケミコン	01
	C36	US135100	C. CE. CHP	0. 1uF 16V	チップセラコン	01
*	C37-38	WE101600	C. PP	820pF 100V	P P コン	01
	C39	UF037100	C. EL. CHP	10uF 16V	チップケミコン	01
	C42	UF037100	C. EL. CHP	10uF 16V	チップケミコン	01
	C43	US135100	C. CE. CHP	0. 1uF 16V	チップセラコン	01
	C44-45	UF037100	C. EL. CHP	10uF 16V	チップケミコン	01
	C46-47	WC895000	C. EL. CHP	10uF 50V	チップケミコン	01
	C48	US135100	C. CE. CHP	0. 1uF 16V	チップセラコン	01
	C49-51	UF037100	C. EL. CHP	10uF 16V	チップケミコン	01
	C52	UF038100	C. EL. CHP	100uF 16V	チップケミコン	01
	C54	US135100	C. CE. CHP	0. 1uF 16V	チップセラコン	01
	C55	UF037100	C. EL. CHP	10uF 16V	チップケミコン	01
	C56-57	US135100	C. CE. CHP	0. 1uF 16V	チップセラコン	01
	C58	UF037100	C. EL. CHP	10uF 16V	チップケミコン	01
	C59-60	US135100	C. CE. CHP	0. 1uF 16V	チップセラコン	01
	C64	US135100	C. CE. CHP	0. 1uF 16V	チップセラコン	01
	C68	UF037100	C. EL. CHP	10uF 16V	チップケミコン	01
	C69-70	US135100	C. CE. CHP	0. 1uF 16V	チップセラコン	01
	C71	UF037100	C. EL. CHP	10uF 16V	チップケミコン	01
	C72-73	US135100	C. CE. CHP	0. 1uF 16V	チップセラコン	01
	C74	UF037100	C. EL. CHP	10uF 16V	チップケミコン	01
	C75	US135100	C. CE. CHP	0. 1uF 16V	チップセラコン	01
	C77	UF037100	C. EL. CHP	10uF 16V	チップケミコン	01
	C78	US135100	C. CE. CHP	0. 1uF 16V	チップセラコン	01
	C80-81	VR329100	C. POLY. CHP	1000pF 50V	チップマイラーコン	01
	C82	US135100	C. CE. CHP	0. 1uF 16V	チップセラコン	01
	C83	US064100	C. CE. CHP	0. 01uF 50V B	チップセラコン	01
	C84	US135100	C. CE. CHP	0. 1uF 16V	チップセラコン	01

* New Parts * 新規部品

P.C.B. OPERATION

Ref. No	Part No.	Description	Remarks	Markets	部 品 名	Rank
	C85	WD758300 C.CE. CHP	10uF 10V		チップセラコン	01
*	C86	WE475900 C.EL	560uF 6.3V		ケミコン	02
	C87	US063100 C.CE. CHP	1000pF 50V B		チップセラコン	01
*	C88	WE477600 C.EL	100uF 16V		ケミコン	02
	C89-91	WD176300 C.CE. CHP	1uF 16V K		チップセラコン	01
*	C92-93	WE475900 C.EL	560uF 6.3V		ケミコン	02
	C94-95	US135100 C.CE. CHP	0.1uF 16V		チップセラコン	01
	C96-97	WD176300 C.CE. CHP	1uF 16V K		チップセラコン	01
	C100-103	US064100 C.CE. CHP	0.01uF 50V B		チップセラコン	01
	C104-105	VR329100 C.POLY. CHP	1000pF 50V		チップマイラーコン	01
*	C202-205	WF456400 C.CE. M. CHP	4.7uF 16V		チップ積層セラコン	
	C206-209	WD176300 C.CE. CHP	1uF 16V K		チップセラコン	01
	C210	US135100 C.CE. CHP	0.1uF 16V		チップセラコン	01
	C211	UF037100 C.EL. CHP	10uF 16V		チップケミコン	01
	C212	WD176300 C.CE. CHP	1uF 16V K		チップセラコン	01
	C213	WD758300 C.CE. CHP	10uF 10V		チップセラコン	01
	C214	UF037470 C.EL. CHP	47uF 16V		チップケミコン	01
	C215	US135100 C.CE. CHP	0.1uF 16V		チップセラコン	01
	C216	UF017470 C.EL. CHP	47uF 6.3V		チップケミコン	01
	C220	UF037100 C.EL. CHP	10uF 16V		チップケミコン	01
	C221	US135100 C.CE. CHP	0.1uF 16V		チップセラコン	01
	C223	US063100 C.CE. CHP	1000pF 50V B		チップセラコン	01
	C225	US063100 C.CE. CHP	1000pF 50V B		チップセラコン	01
	C401-402	US044220 C.CE. CHP	0.022uF 25V B		チップセラコン	01
	C403	WD176300 C.CE. CHP	1uF 16V K		チップセラコン	01
	C404-405	UF038100 C.EL. CHP	100uF 16V		チップケミコン	01
	C406	US135100 C.CE. CHP	0.1uF 16V		チップセラコン	01
	C409	UF118470 C.EL. CHP	470uF 6.3V		チップケミコン	01
	C410	US135100 C.CE. CHP	0.1uF 16V		チップセラコン	01
	C411-412	US035100 C.CE. CHP	0.1uF 16V B		チップセラコン	01
	C413	UF017330 C.EL. CHP	33uF 6.3V		チップケミコン	01
	C414	UF037470 C.EL. CHP	47uF 16V		チップケミコン	01
	C415-416	US062220 C.CE. CHP	220pF 50V B		チップセラコン	01
	C417	US035100 C.CE. CHP	0.1uF 16V B		チップセラコン	01
	C420-423	US063100 C.CE. CHP	1000pF 50V B		チップセラコン	01
	C426	US063100 C.CE. CHP	1000pF 50V B		チップセラコン	01
	C429-432	US063100 C.CE. CHP	1000pF 50V B		チップセラコン	01
	D1-3	VT332900 DIODE	1SS355		ダイオード	01
*	D4	WE351200 DIODE	RB051L-40		ショットキダイオード	
	D5	VT332900 DIODE	1SS355		ダイオード	01
*	D6	WE351200 DIODE	RB051L-40		ショットキダイオード	
	D7	VT332900 DIODE	1SS355		ダイオード	01
	D10-11	VT332900 DIODE	1SS355		ダイオード	01
*	D202-211	VS345500 LED. CHP	SML-010MTT87(M, N)		チップLED	01
*	D217	WE351400 LED. CHP	SML011BBT BE		チップLED	
*	D218	VS345500 LED. CHP	SML-010MTT87(M, N)		チップLED	01
*	D219	WE526500 LED. CHP	SML-011YTT YE		チップLED	
*	D220	VS345400 LED	SML-010VT RED 3020		チップLED アカ	01
*	D351	WF459600 LED	SML-020MLTT86		2色発光LED	
*	D401	VS597500 DIODE. CHP	D1FS4-7063 TP		チップダイオード	01
	D402	VT332900 DIODE	1SS355		ダイオード	01
	D403-404	VU172100 DIODE. ZENR	UDZS6.2B 6.2V		ツェナーダイオード	01
	D405	WC413300 DIODE. ZENR	RSB6.8S 6.8V		ツェナーダイオード	01
	G1-2	WB438000 TERM. GND	M4 SD00433-21		アース端子	
	IC2	X3852A00 IC	NJM2115M-TE1 OPAMP		アンプIC DMP	01

* New Parts * 新規部品

P.C.B. OPERATION & P.C.B. MAIN

Ref. No	Part No.	Description	Remarks	Markets	部 品 名	Rank
* IC4	X6069A00	IC	WM8775		A/Dコンバーター	
* IC5	X6071A00	IC	WM8728		D/Aコンバーター	
* IC7	X6189A00	IC	WM8738		A/Dコンバーター	
IC8	X4061A00	IC	SN74AHC2GU04HDCR		ロジックIC	01
* IC10	X6188A00	IC	PQ1CX12H2ZP		電源IC	
* IC11	X5172A00	IC	PQ1CZ41H2Z		電源IC	
* IC12	X7030A00	IC	AK4620AVF-E2		IC	
IC201	X4510A00	IC	BU2152FS		IC	
* IC402	XV978A00	IC	NJM3414AV OP AMP		アンプIC	
* JK401	WF101400	JACK. MNI	LGS6516-0505FC		ミニジャック	
JK402	V2452000	JACK. DIN	6P TCS7927		ミニDIN端子	04
PJ1	V2612400	JACK. PIN	4P		ピンジャック	04
* Q1	WD045600	TR	2SD2674 S		トランジスタ	
Q3-4	VV556400	TR	2SC2412K Q, R, S		トランジスタ	01
Q5-6	WD541300	FET	TPC8109 TP		FET	03
Q7	VV556400	TR	2SC2412K Q, R, S		トランジスタ	01
Q8	VV556500	TR	2SA1037K Q, R, S		トランジスタ	01
Q9-10	WC883400	TR	2SD2704 K		トランジスタ	
* Q11	WD045600	TR	2SD2674 S		トランジスタ	
Q12	VV556400	TR	2SC2412K Q, R, S		トランジスタ	01
* Q13	WD045600	TR	2SD2674 S		トランジスタ	
Q14-15	WC883400	TR	2SD2704 K		トランジスタ	
Q16-17	VV556500	TR	2SA1037K Q, R, S		トランジスタ	01
Q18-20	WC883400	TR	2SD2704 K		トランジスタ	
* Q21	WD045600	TR	2SD2674 S		トランジスタ	
ST1	V4040500	SCR. TERM	M3		スクリュー/ターミナル	01
SW202	WC353300	SW	JXS0000-1011		マルチウエイスイッチ	04
SW203-208	WD166000	SW. TACT	SKQYPAE010		タクト SW	
SW351	WD166000	SW. TACT	SKQYPAE010		タクト SW	
U201	WA422400	L. DTCT	GP1UD261XK		リモコン受光ユニット	03
* VR402	WF130400	VR	A 20K RK09L12B0C1P		二連ロータリーVR	
* XL1	WG131200	RESONATOR	33.8688M DS0321SV		水晶発振器	
*	WF415700	P. C. B.	MAIN		PCB メイン	
*	WF415800	P. C. B.	MAIN	J	PCB メイン	
*	WF415900	P. C. B.	MAIN	UC	PCB メイン	
*	WF416000	P. C. B.	MAIN	A	PCB メイン	
				BG	PCB メイン	
CB201	VT389000	CN. BS. PIN	9P		ベース付ポスト	01
CB303	WB182500	CN. BS. PIN	52559 30P TE		FFCコネクタ	
CB501-502	V5739200	CN. BS. PIN	2120-40SF1BN		ピンヘッダー	
CB503	V6929600	CN. BS. PIN	4P TE		ウェハー	01
* CB504	WC199800	CN	52808 28P TE		FFC/FPCコネクタ	02
* CB701	WE997200	CN	RJSE-1E08T089P1		LANコネクタ	
* CB801	WE155000	SOCKET	440360 124P SE		ミニPCIソケット	
* CB850	WB186300	CN	53398 14P TE		FFCコネクタ	
CB851	V6509500	SOCKET	9P SE 3170		コネクタソケット	04
* CB852	WE161800	CN	CAM-C16 4P SE	UC	シリアルバスコネクタ	
CB901	WB182500	CN. BS. PIN	52559 30P TE		FFCコネクタ	
* CB902	WB186300	CN	53398 14P TE		FFCコネクタ	
CB904	VM923600	CN. BS. PIN	13P		FFCコネクタ	01
C1	US635100	C. CE. CHP	0.1uF 16V		チップセラコン	01
C2	US061100	C. CE. CHP	10pF 50V B		チップセラコン	01
C3-4	US635100	C. CE. CHP	0.1uF 16V		チップセラコン	01

* New Parts * 新規部品

P.C.B. MAIN

Ref. No	Part No.	Description	Remarks	Markets	部 品 名	Rank
C5-6	US634100	C.CE. CHP	0.01uF 16V		チップセラコン	01
C7-18	US635100	C.CE. CHP	0.1uF 16V		チップセラコン	01
C19-20	US634100	C.CE. CHP	0.01uF 16V		チップセラコン	01
C21-30	US635100	C.CE. CHP	0.1uF 16V		チップセラコン	01
C31	US063470	C.CE. CHP	4700pF 50V B		チップセラコン	01
C32	WD758300	C.CE. CHP	10uF 10V		チップセラコン	01
C33	WD176300	C.CE. CHP	1uF 16V K		チップセラコン	01
C34	US035100	C.CE. CHP	0.1uF 16V B		チップセラコン	01
C35	US635100	C.CE. CHP	0.1uF 16V		チップセラコン	01
C36	WD758300	C.CE. CHP	10uF 10V		チップセラコン	01
C100	US635100	C.CE. CHP	0.1uF 16V		チップセラコン	01
C101	US634100	C.CE. CHP	0.01uF 16V		チップセラコン	01
C102-111	US635100	C.CE. CHP	0.1uF 16V		チップセラコン	01
C112-113	US634100	C.CE. CHP	0.01uF 16V		チップセラコン	01
C114-115	US635100	C.CE. CHP	0.1uF 16V		チップセラコン	01
C116	US634100	C.CE. CHP	0.01uF 16V		チップセラコン	01
C117	US635100	C.CE. CHP	0.1uF 16V		チップセラコン	01
C118-127	US634100	C.CE. CHP	0.01uF 16V		チップセラコン	01
* C128-129	WD760500	C.CE. M. CHP	1000pF 25V		チップ積層セラコン	
C130	US635100	C.CE. CHP	0.1uF 16V		チップセラコン	01
* C131	WD760500	C.CE. M. CHP	1000pF 25V		チップ積層セラコン	
C132	US634100	C.CE. CHP	0.01uF 16V		チップセラコン	01
* C133-138	WD760500	C.CE. M. CHP	1000pF 25V		チップ積層セラコン	
C150-154	WD176300	C.CE. CHP	1uF 16V K		チップセラコン	01
* C155-156	WD760500	C.CE. M. CHP	1000pF 25V		チップ積層セラコン	
C201-202	US635100	C.CE. CHP	0.1uF 16V		チップセラコン	01
C203	US634100	C.CE. CHP	0.01uF 16V		チップセラコン	01
C204	US635100	C.CE. CHP	0.1uF 16V		チップセラコン	01
C205-206	US634100	C.CE. CHP	0.01uF 16V		チップセラコン	01
C207-230	US635100	C.CE. CHP	0.1uF 16V		チップセラコン	01
C231-232	WD758300	C.CE. CHP	10uF 10V		チップセラコン	01
C242-247	US635100	C.CE. CHP	0.1uF 16V		チップセラコン	01
C248-249	WD758300	C.CE. CHP	10uF 10V		チップセラコン	01
* C275-276	WE475900	C.EL	560uF 6.3V		ケミコン	02
* C281	WE477600	C.EL	100uF 16V		ケミコン	02
C282-283	WD176300	C.CE. CHP	1uF 16V K		チップセラコン	01
* C284	WE475900	C.EL	560uF 6.3V		ケミコン	02
C287	WD758300	C.CE. CHP	10uF 10V		チップセラコン	01
* C288	WD760500	C.CE. M. CHP	1000pF 25V		チップ積層セラコン	
C289	WD760600	C.CE. CHP	0.082uF 25V		チップセラコン	01
C290	WD758300	C.CE. CHP	10uF 10V		チップセラコン	01
* C291	WD760500	C.CE. M. CHP	1000pF 25V		チップ積層セラコン	
C292	WD760600	C.CE. CHP	0.082uF 25V		チップセラコン	01
C293	UF018100	C.EL. CHP	100uF 6.3V		チップケミコン	01
C303	US635100	C.CE. CHP	0.1uF 16V		チップセラコン	01
C305-316	US635100	C.CE. CHP	0.1uF 16V		チップセラコン	01
C318	US635100	C.CE. CHP	0.1uF 16V		チップセラコン	01
C320-335	US635100	C.CE. CHP	0.1uF 16V		チップセラコン	01
C337	US635100	C.CE. CHP	0.1uF 16V		チップセラコン	01
C345	US635100	C.CE. CHP	0.1uF 16V		チップセラコン	01
C401	US635100	C.CE. CHP	0.1uF 16V		チップセラコン	01
C402-405	US634100	C.CE. CHP	0.01uF 16V		チップセラコン	01
C406-409	US635100	C.CE. CHP	0.1uF 16V		チップセラコン	01
C410-411	US634100	C.CE. CHP	0.01uF 16V		チップセラコン	01
C412	US635100	C.CE. CHP	0.1uF 16V		チップセラコン	01

* New Parts * 新規部品

P.C.B. MAIN

Ref. No	Part No.	Description	Remarks	Markets	部 品 名	Rank
C413-414	US634100	C. CE. CHP	0.01uF 16V		チップセラコン	01
C415-416	US635100	C. CE. CHP	0.1uF 16V		チップセラコン	01
C417	US634100	C. CE. CHP	0.01uF 16V		チップセラコン	01
C418-420	US635100	C. CE. CHP	0.1uF 16V		チップセラコン	01
C421-422	US634100	C. CE. CHP	0.01uF 16V		チップセラコン	01
C423	US635100	C. CE. CHP	0.1uF 16V		チップセラコン	01
C424	US634100	C. CE. CHP	0.01uF 16V		チップセラコン	01
C425-430	US635100	C. CE. CHP	0.1uF 16V		チップセラコン	01
C431-432	US634100	C. CE. CHP	0.01uF 16V		チップセラコン	01
C433-435	US635100	C. CE. CHP	0.1uF 16V		チップセラコン	01
C436-437	US634100	C. CE. CHP	0.01uF 16V		チップセラコン	01
C438-440	US635100	C. CE. CHP	0.1uF 16V		チップセラコン	01
C442-443	WD758300	C. CE. CHP	10uF 10V		チップセラコン	01
* C445	WD760500	C. CE. M. CHP	1000pF 25V		チップ積層セラコン	
C460-461	US634100	C. CE. CHP	0.01uF 16V		チップセラコン	01
C462	US635100	C. CE. CHP	0.1uF 16V		チップセラコン	01
C463-464	US634100	C. CE. CHP	0.01uF 16V		チップセラコン	01
C465-468	US635100	C. CE. CHP	0.1uF 16V		チップセラコン	01
C469-470	US634100	C. CE. CHP	0.01uF 16V		チップセラコン	01
C471	US635100	C. CE. CHP	0.1uF 16V		チップセラコン	01
C473	WD758300	C. CE. CHP	10uF 10V		チップセラコン	01
C474	US635100	C. CE. CHP	0.1uF 16V		チップセラコン	01
* C476	WE477600	C. EL	100uF 16V		ケミコン	02
C477-478	WD176300	C. CE. CHP	1uF 16V K		チップセラコン	01
* C479	WE475900	C. EL	560uF 6.3V		ケミコン	02
C501-505	US635100	C. CE. CHP	0.1uF 16V		チップセラコン	01
C507-508	US635100	C. CE. CHP	0.1uF 16V		チップセラコン	01
C514-515	US635100	C. CE. CHP	0.1uF 16V		チップセラコン	01
C522-523	US635100	C. CE. CHP	0.1uF 16V		チップセラコン	01
C524	US063470	C. CE. CHP	4700pF 50V B		チップセラコン	01
C525-526	US635100	C. CE. CHP	0.1uF 16V		チップセラコン	01
C527	WD758300	C. CE. CHP	10uF 10V		チップセラコン	01
C528	UF037100	C. EL. CHP	10uF 16V		チップケミコン	01
C529	US635100	C. CE. CHP	0.1uF 16V		チップセラコン	01
C530-531	US061180	C. CE. CHP	18pF 50V B		チップセラコン	01
C536-537	US635100	C. CE. CHP	0.1uF 16V		チップセラコン	01
C546	US635100	C. CE. CHP	0.1uF 16V	UC	チップセラコン	01
C547	WD758300	C. CE. CHP	10uF 10V		チップセラコン	01
C549-552	US635100	C. CE. CHP	0.1uF 16V		チップセラコン	01
C553	US062100	C. CE. CHP	100pF 50V B		チップセラコン	01
C554	US635100	C. CE. CHP	0.1uF 16V		チップセラコン	01
C601-604	US635100	C. CE. CHP	0.1uF 16V		チップセラコン	01
C605-606	WD758300	C. CE. CHP	10uF 10V		チップセラコン	01
C609	UF119100	C. EL. CHP	1000uF 6.3V		チップケミコン	02
C610-613	US635100	C. CE. CHP	0.1uF 16V		チップセラコン	01
C614	US634100	C. CE. CHP	0.01uF 16V		チップセラコン	01
C615	US635100	C. CE. CHP	0.1uF 16V		チップセラコン	01
C616	US061220	C. CE. CHP	22pF 50V B	JUC	チップセラコン	01
C616	US061150	C. CE. CHP	15pF 50V B	ABG	チップセラコン	01
C617	US061200	C. CE. CHP	20pF 50V B	JUC	チップセラコン	01
C617	US061100	C. CE. CHP	10pF 50V B	ABG	チップセラコン	01
C618	US635100	C. CE. CHP	0.1uF 16V		チップセラコン	01
C619-620	US634100	C. CE. CHP	0.01uF 16V		チップセラコン	01
C621-622	US635100	C. CE. CHP	0.1uF 16V		チップセラコン	01
C623-624	US634100	C. CE. CHP	0.01uF 16V		チップセラコン	01

* New Parts * 新規部品

MCX-2000

P.C.B. MAIN

Ref. No	Part No.	Description	Remarks	Markets	部 品 名	Rank	
C625-626	US635100	C. CE. CHP	0. 1uF	16V		チップセラコン	01
C627-628	US634100	C. CE. CHP	0. 01uF	16V		チップセラコン	01
C629-630	US635100	C. CE. CHP	0. 1uF	16V		チップセラコン	01
C631-632	US634100	C. CE. CHP	0. 01uF	16V		チップセラコン	01
C633	US635100	C. CE. CHP	0. 1uF	16V		チップセラコン	01
C634	US060500	C. CE. CHP	5pF	50V B		チップセラコン	01
C635	US061470	C. CE. CHP	47pF	50V B		チップセラコン	01
C636	US635100	C. CE. CHP	0. 1uF	16V		チップセラコン	01
* C637-639	WB580600	C. MYLA. CHP	0. 1uF	16V		チップマイラーコン	
C640	UF037100	C. EL. CHP	10uF	16V		チップケミコン	01
C641	US635100	C. CE. CHP	0. 1uF	16V		チップセラコン	01
C642	UF037100	C. EL. CHP	10uF	16V		チップケミコン	01
C643	US061270	C. CE. CHP	27pF	50V B	JUC	チップセラコン	01
C643	US061180	C. CE. CHP	18pF	50V B	ABG	チップセラコン	01
C644-645	US635100	C. CE. CHP	0. 1uF	16V		チップセラコン	01
C646-647	US634100	C. CE. CHP	0. 01uF	16V		チップセラコン	01
C648	US635100	C. CE. CHP	0. 1uF	16V		チップセラコン	01
C649	US634100	C. CE. CHP	0. 01uF	16V		チップセラコン	01
C650	UF119100	C. EL. CHP	1000uF	6. 3V		チップケミコン	02
C651	US035100	C. CE. CHP	0. 1uF	16V B		チップセラコン	01
C652	US634100	C. CE. CHP	0. 01uF	16V		チップセラコン	01
C653	US635100	C. CE. CHP	0. 1uF	16V		チップセラコン	01
C656-657	US635100	C. CE. CHP	0. 1uF	16V		チップセラコン	01
C658	US062100	C. CE. CHP	100pF	50V B		チップセラコン	01
C659	US635100	C. CE. CHP	0. 1uF	16V		チップセラコン	01
C660-661	US634100	C. CE. CHP	0. 01uF	16V		チップセラコン	01
C662	US062100	C. CE. CHP	100pF	50V B		チップセラコン	01
C663	US635100	C. CE. CHP	0. 1uF	16V		チップセラコン	01
C704-708	US635100	C. CE. CHP	0. 1uF	16V		チップセラコン	01
C711-712	US635100	C. CE. CHP	0. 1uF	16V		チップセラコン	01
C715	US635100	C. CE. CHP	0. 1uF	16V		チップセラコン	01
C717-718	WD758300	C. CE. CHP	10uF	10V		チップセラコン	01
C719	UF017470	C. EL. CHP	47uF	6. 3V		チップケミコン	01
C720	WD758300	C. CE. CHP	10uF	10V		チップセラコン	01
* C721	WD760500	C. CE. M. CHP	1000pF	25V		チップ積層セラコン	
C724	US635100	C. CE. CHP	0. 1uF	16V		チップセラコン	01
C725	US635100	C. CE. CHP	0. 1uF	16V		チップセラコン	01
C726	WD758300	C. CE. CHP	10uF	10V		チップセラコン	01
C727	US635100	C. CE. CHP	0. 1uF	16V		チップセラコン	01
C801	US635100	C. CE. CHP	0. 1uF	16V		チップセラコン	01
C802	UF037100	C. EL. CHP	10uF	16V		チップケミコン	01
C803	US635100	C. CE. CHP	0. 1uF	16V		チップセラコン	01
C804	UF037100	C. EL. CHP	10uF	16V		チップケミコン	01
C805-814	US635100	C. CE. CHP	0. 1uF	16V		チップセラコン	01
C815	UF037100	C. EL. CHP	10uF	16V		チップケミコン	01
C816-817	US635100	C. CE. CHP	0. 1uF	16V		チップセラコン	01
C834	WD758300	C. CE. CHP	10uF	10V	UC	チップセラコン	01
C835-836	US635100	C. CE. CHP	0. 1uF	16V	UC	チップセラコン	01
C837	US635100	C. CE. CHP	0. 1uF	16V		チップセラコン	01
C838	US635100	C. CE. CHP	0. 1uF	16V	UC	チップセラコン	01
C850-854	US145100	C. CE. CHP	0. 1uF	25V		チップセラコン	01
C855-856	US062100	C. CE. CHP	100pF	50V B		チップセラコン	01
C857-864	US635100	C. CE. CHP	0. 1uF	16V	UC	チップセラコン	01
C865	US060300	C. CE. CHP	3pF	50V B	UC	チップセラコン	01
C866-867	US035100	C. CE. CHP	0. 1uF	16V B	UC	チップセラコン	01

* New Parts * 新規部品

P.C.B. MAIN

Ref. No	Part No.	Description	Remarks	Markets	部 品 名	Rank	
*	C868	WE477600 C. EL	100uF 16V		UC	ケミコン	02
	C869-870	WD176300 C. CE. CHP	1uF 16V K		UC	チップセラコン	01
	C871	US035100 C. CE. CHP	0.1uF 16V B		UC	チップセラコン	01
	C872	US060300 C. CE. CHP	3pF 50V B		UC	チップセラコン	01
	C873	US035100 C. CE. CHP	0.1uF 16V B		UC	チップセラコン	01
	C874	UF037100 C. EL. CHP	10uF 16V		UC	チップケミコン	01
	C875	US635100 C. CE. CHP	0.1uF 16V		UC	チップセラコン	01
	C876	UF037100 C. EL. CHP	10uF 16V		UC	チップケミコン	01
	C877-879	US635100 C. CE. CHP	0.1uF 16V		UC	チップセラコン	01
	C880-881	VR329100 C. POLY. CHP	1000pF 50V		UC	チップマイラーコン	01
	C882	UF018100 C. EL. CHP	100uF 6.3V		UC	チップケミコン	01
	C883-884	UF037100 C. EL. CHP	10uF 16V		UC	チップケミコン	01
	C885	US635100 C. CE. CHP	0.1uF 16V		UC	チップセラコン	01
	C886	UF037100 C. EL. CHP	10uF 16V		UC	チップケミコン	01
	C887	WD758300 C. CE. CHP	10uF 10V		UC	チップセラコン	01
	C888	US635100 C. CE. CHP	0.1uF 16V		UC	チップセラコン	01
	C889	UF018100 C. EL. CHP	100uF 6.3V		UC	チップケミコン	01
	C890	UF037100 C. EL. CHP	10uF 16V		UC	チップケミコン	01
	C891	US635100 C. CE. CHP	0.1uF 16V		UC	チップセラコン	01
	C892	UF037100 C. EL. CHP	10uF 16V			チップケミコン	01
	C893	UF037100 C. EL. CHP	10uF 16V		UC	チップケミコン	01
*	C894	WE475900 C. EL	560uF 6.3V		UC	ケミコン	02
	C895	UF018100 C. EL. CHP	100uF 6.3V		UC	チップケミコン	01
	C896-897	UF037100 C. EL. CHP	10uF 16V		UC	チップケミコン	01
	C898	US035100 C. CE. CHP	0.1uF 16V B		UC	チップセラコン	01
	C899	US635100 C. CE. CHP	0.1uF 16V		UC	チップセラコン	01
	C901	US635100 C. CE. CHP	0.1uF 16V			チップセラコン	01
	C902	WD292000 C. CE. CHP	0.047F 5.5V			ダイナキャパシタ	05
	C903	US635100 C. CE. CHP	0.1uF 16V		UC	チップセラコン	01
	C904	WD176300 C. CE. CHP	1uF 16V K			チップセラコン	01
	C905-907	US062100 C. CE. CHP	100pF 50V B			チップセラコン	01
	C908-910	US635100 C. CE. CHP	0.1uF 16V			チップセラコン	01
	C911	UF037100 C. EL. CHP	10uF 16V			チップケミコン	01
	C912	UF037470 C. EL. CHP	47uF 16V		BG	チップケミコン	01
	C913-914	US062330 C. CE. CHP	330pF 50V B		BG	チップセラコン	01
	C915	UF037470 C. EL. CHP	47uF 16V		BG	チップケミコン	01
	C916	UF037470 C. EL. CHP	47uF 16V		BG	チップケミコン	01
	C917	US635100 C. CE. CHP	0.1uF 16V		BG	チップセラコン	01
	C918	US061220 C. CE. CHP	22pF 50V B		BG	チップセラコン	01
	C919	US061220 C. CE. CHP	22pF 50V B		BG	チップセラコン	01
	C920	US635100 C. CE. CHP	0.1uF 16V			チップセラコン	01
*	C921	WE477600 C. EL	100uF 16V			ケミコン	02
	C922-923	UF037100 C. EL. CHP	10uF 16V			チップケミコン	01
	C924	US635100 C. CE. CHP	0.1uF 16V		UC	チップセラコン	01
	C925	US635100 C. CE. CHP	0.1uF 16V			チップセラコン	01
	C926	US635100 C. CE. CHP	0.1uF 16V		UC	チップセラコン	01
	C927-930	US635100 C. CE. CHP	0.1uF 16V			チップセラコン	01
	C931	US663100 C. CE. CHP	1000pF 50V			チップセラコン	
	C932	UF017470 C. EL. CHP	47uF 6.3V			チップケミコン	01
	C933-934	US635100 C. CE. CHP	0.1uF 16V			チップセラコン	01
	C935-937	US663100 C. CE. CHP	1000pF 50V			チップセラコン	
	C938-939	US634100 C. CE. CHP	0.01uF 16V			チップセラコン	01
	C944	US635100 C. CE. CHP	0.1uF 16V			チップセラコン	01
	C945	UF037100 C. EL. CHP	10uF 16V			チップケミコン	01
	D1-3	VT332900 DIODE	1SS355			ダイオード	01

* New Parts * 新規部品

MCX-2000

P.C.B. MAIN

Ref. No	Part No.	Description	Remarks	Markets	部 品 名	Rank
* D204	WE351200	DIODE	RB051L-40		ショットキダイオード	
* D404	WE351200	DIODE	RB051L-40		ショットキダイオード	
D501	VT332900	DIODE	1SS355		ダイオード	01
D850-851	WE674800	DIODE	AVRL161A1R1NTB	UC	チップバリスタ	01
* D852	WE351200	DIODE	RB051L-40	UC	ショットキダイオード	
D853	WE674800	DIODE	AVRL161A1R1NTB	UC	チップバリスタ	01
D901	VT332900	DIODE	1SS355		ダイオード	01
D902	V2598200	LED	SIR-505ST		LED	
D903-904	VT332900	DIODE	1SS355		ダイオード	01
F850	V2429100	SW. POLY	SMDC100-02	UC	ポリスイッチ	02
G1-4	WB438000	TERM. GND	M4 SD00433-21		アース端子	
* IC2-5	X6720A00	IC	EDS1216AATA-75-E		メモリIC	
* IC6	X5405A00	IC	SN74LVC32APWR OR		ロジックIC	01
* IC7	X6218A00	IC	BD45285G RESET		リセットIC	
IC8	X4454A00	IC	SN74LVC2G17DCKR		ロジックIC	01
* IC203	X5172A00	IC	PQ1CZ41H2Z		電源IC	
* IC301-304	X5733A00	IC	SN74LVCR16245A		ロジックIC	
IC305	XZ287A00	IC	SN74LVC245APWR		ロジックIC	02
* IC306	X6766A00	IC	TC58FVM7B2ATG65		メモリIC 128M	18
IC307	X3801A00	IC	SN74LVC1G125DCKR		ロジックIC	01
* IC308	X6654A00	IC	LC4064V-75TN100C		IC デジタル	05
* IC310	X5406A00	IC	SN74LVC00APWR NAND		ロジックIC	
* IC401	X5756A00	IC	TMS320D610A003BZDP225		CPU/周辺IC	
IC402	X0176B00	IC	W9864G2EH-7 SDRAM		メモリIC	08
* IC404	X5172A00	IC	PQ1CZ41H2Z		電源IC	
* IC501	X6655A00	IC	YDC131-F		IC デジタル	
* IC502	X2812A00	IC	MSM5118165F-60J3R1		メモリIC 16M	08
* IC503	X5733A00	IC	SN74LVCR16245A		ロジックIC	
IC504	X3801A00	IC	SN74LVC1G125DCKR	UC	ロジックIC	01
IC505	XZ287A00	IC	SN74LVC245APWR		ロジックIC	02
IC506	X4503A00	IC	SN74CBT3306PWR		ロジックIC	03
IC507	X4061A00	IC	SN74AHC2GU04HDCTR		ロジックIC	01
IC508	X4119A00	IC	SN74LVC2G08DCUR		ロジックIC	01
IC509	X5731A00	IC	SN74LVC74APWR		ロジックIC	02
IC601	X2479A00	IC	YGV619		IC PQFP	12
IC602	X0176B00	IC	W9864G2EH-7 SDRAM		メモリIC	08
IC603	X2314A00	IC	MB3516APF-G-BND		IC	04
* IC701	X5621A00	IC	KSZ8721SL		IC, デジタル	05
IC702	X4061A00	IC	SN74AHC2GU04HDCTR		ロジックIC	01
IC850	X2757A00	IC	MAX3221CPWR		IC	04
* IC851	X6227B00	IC	F2602E-01	UC	CPU/周辺IC	
* IC852	X6189A00	IC	WM8738	UC	A/Dコンバーター	
* IC853	X6071A00	IC	WM8728	UC	D/Aコンバーター	
* IC854	X5172A00	IC	PQ1CZ41H2Z	UC	電源IC	
* IC902	X7027A00	IC	NJM2370U10 (TE1)		電源IC	
IC903	X0082A00	IC	LC72722PM	BG	IC SOP	
IC905	X2548A00	IC	RTC-4543SA RTC		CPU/周辺IC	04
IC909	X5896A00	IC	SN74LVC1G08DCKR		ロジックIC	01
J868-869		R. CHP	0Ω 1/16W J	UC	チップ抵抗	
* JK601	WF152700	CN	JACK YKC22-0567N		2連ビデオコネクタ	
* JK902	WF884500	JACK. MNI	LGS6507-1000FC		ミニジャック	
L402	V6246100	C. CHP	NFM3DCC223R1H3L		エミフィル チップ	01
Q1-2	VV556400	TR	2SC2412K Q, R, S		トランジスタ	01
Q3	VV556500	TR	2SA1037K Q, R, S		トランジスタ	01
* Q503	WE408000	TR	2SB1709TL		トランジスタ	

* New Parts * 新規部品

MCX-2000

P.C.B. MAIN

Ref. No	Part No.	Description	Remarks	Markets	部 品 名	Rank	
Q701-702	VV655000	TR. DGT	DTA114EKA			デジタルトランジスタ	01
Q850-851	VV556400	TR	2SC2412K Q, R, S		UC	トランジスタ	01
* Q852	WD045600	TR	2SD2674 S		UC	トランジスタ	
Q901-902	VV556400	TR	2SC2412K Q, R, S			トランジスタ	01
Q905	VV556400	TR	2SC2412K Q, R, S			トランジスタ	01
* Q906	WE408000	TR	2SB1709TL			トランジスタ	
Q907-908	VV556400	TR	2SC2412K Q, R, S			トランジスタ	01
R547		R. CHP	33Ω 1/16W J	0510 LEAD FREE	UC	チップ抵抗	
R583		R. CHP	33Ω 1/16W J	0510 LEAD FREE	UC	チップ抵抗	
R608		R. CHP	680Ω 1/16W J	0816	JUC	チップ抵抗	
R608		R. CHP	470Ω 1/16W J	0816	ABG	チップ抵抗	
R626		R. CHP	10KΩ 1/16W J	0510 LEAD FREE	JUC	チップ抵抗	
R626		R. CHP	33Ω 1/16W J	0510 LEAD FREE	ABG	チップ抵抗	
R852-855		R. CHP	33Ω 1/16W J	0510 LEAD FREE	UC	チップ抵抗	
R856		R. CHP	1.0KΩ 1/16W F	0816 LEAD FREE	UC	チップ抵抗	
R857-859		R. CHP	33Ω 1/16W J	0510 LEAD FREE	UC	チップ抵抗	
R863-864		R. CHP	1KΩ 1/16W J	0816	UC	チップ抵抗	
R865-866		R. CHP	100Ω 1/16W J	0816	UC	チップ抵抗	
R867		R. CHP	33Ω 1/16W J	0510 LEAD FREE	UC	チップ抵抗	
R868-869		R. CHP	470KΩ 1/16W J	0816	UC	チップ抵抗	
R870-871		R. CHP	10KΩ 1/16W J	0510 LEAD FREE	UC	チップ抵抗	
R872		R. CHP	1MΩ 1/16W J	0816	UC	チップ抵抗	
R873		R. CHP	470Ω 1/16W J	0816	UC	チップ抵抗	
R874-876		R. CHP	10KΩ 1/16W J	0510 LEAD FREE	UC	チップ抵抗	
R878-879		R. CHP	1.2KΩ 1/16W J	0816	UC	チップ抵抗	
R880		R. CHP	10KΩ 1/16W J	0510 LEAD FREE	UC	チップ抵抗	
R881		R. CHP	47KΩ 1/16W J	0816	UC	チップ抵抗	
R883		R. CHP	10KΩ 1/16W J	0510 LEAD FREE	UC	チップ抵抗	
R885		R. CHP	10KΩ 1/16W J	0510 LEAD FREE	UC	チップ抵抗	
R888		R. CHP	1.2KΩ 1/16W J	0816	UC	チップ抵抗	
R889		R. CHP	1KΩ 1/16W J	0816	UC	チップ抵抗	
R890		R. CHP	3.3KΩ 1/16W J	0816	UC	チップ抵抗	
R891-893		R. CHP	33Ω 1/16W J	0510 LEAD FREE	UC	チップ抵抗	
R894		R. CHP	1.0KΩ 1/16W F	0816 LEAD FREE	UC	チップ抵抗	
R895		R. CHP	2.2KΩ 1/16W F	0816 LEAD FREE	UC	チップ抵抗	
R932		R. CHP	33Ω 1/16W J	0510 LEAD FREE	BG	チップ抵抗	
R933		R. CHP	100K 1/16W J	0510 LEAD FREE	BG	チップ抵抗	
R939-945		R. CHP	33Ω 1/16W J	0510 LEAD FREE	UC	チップ抵抗	
R951		R. CHP	33Ω 1/16W J	0510 LEAD FREE	BG	チップ抵抗	
ST601-602	V4040500	SCR. TERM	M3			スクリュー/ターミナル	01
ST701	V4040500	SCR. TERM	M3			スクリュー/ターミナル	01
ST850	V4040500	SCR. TERM	M3			スクリュー/ターミナル	01
TH801	V9760200	THRMST. CHP	NCP18XH103J03RB			チップサーミスタ	01
U501	WB920900	CN. PHOT. SN	1P GP1FA513TZ0F			光ファイバデータ端子	03
U502	WB547900	CN. PHOT. SN	1P GP1FA513RZ0F			光ファイバ受信器	03
U901	WA422400	L. DTCT	GP1UD261XK			リモコン受光ユニット	03
XL502	VS167000	RSNR. CRYST	24.576MHz SMD-49			水晶振動子	03
XL601	WC061400	RSNR. CRYST	14.31818MHz SMD-49		JUC	水晶振動子	
XL601	V6074900	RSNR. CRYST	17.734475MHz		ABG	水晶振動子	03
XL702	WE917700	RESONATOR	25.0MHz			水晶発振器	04
* XL850	WE436500	RSNR. CRYST	45.1584M DSX840GA		UC	水晶振動子	
* XL901	WC522900	RSNR. CE	CSTCE20M0V51-R0			セラミック振動子	01
* XL902	WF152800	RSNR. CRYST	4.332MHZ SMD49		BG	水晶振動子	

* New Parts * 新規部品

Chip Resistors

● The chip resistor is not supplied as a replacement part.
 * When a chip resistor is necessary, use the following part
 AAX60720: CHIP RESISTOR SAMPLE BOOK

● チップ抵抗はサード部品として供給しません。
 ※ チップ抵抗が必要な場合は、下記の部品をご利用ください。
 AAX60720: CHIP RESISTOR SAMPLE BOOK

Ref. No	Part No.	Description	Remarks	Markets	部 品 名	Rank
	R, CHP	10Ω	1.25x2		チップ抵抗	
	R, CHP	33Ω	1.25x2		チップ抵抗	
	R, CHP	220Ω	1.25x2		チップ抵抗	
	R, CHP	2.2kΩ	1.25x2		チップ抵抗	
	R, CHP	0Ω	0816		チップ抵抗	
	R, CHP	22Ω	0816		チップ抵抗	
	R, CHP	36Ω	0816		チップ抵抗	
	R, CHP	47Ω	0816		チップ抵抗	
	R, CHP	75Ω	0816		チップ抵抗	
	R, CHP	82Ω	0816		チップ抵抗	
	R, CHP	100Ω	0816		チップ抵抗	
	R, CHP	220Ω	0816		チップ抵抗	
	R, CHP	330Ω	0816		チップ抵抗	
	R, CHP	470Ω	0816		チップ抵抗	
	R, CHP	680Ω	0816		チップ抵抗	
	R, CHP	1kΩ	0816		チップ抵抗	
	R, CHP	1.2kΩ	0816		チップ抵抗	
	R, CHP	1.8kΩ	0816		チップ抵抗	
	R, CHP	2.2kΩ	0816		チップ抵抗	
	R, CHP	3.3kΩ	0816		チップ抵抗	
	R, CHP	4.7kΩ	0816		チップ抵抗	
	R, CHP	5.6kΩ	0816		チップ抵抗	
	R, CHP	6.8kΩ	0816		チップ抵抗	
	R, CHP	10kΩ	0816		チップ抵抗	
	R, CHP	18kΩ	0816		チップ抵抗	
	R, CHP	22kΩ	0816		チップ抵抗	
	R, CHP	47kΩ	0816		チップ抵抗	
	R, CHP	100kΩ	0816		チップ抵抗	
	R, CHP	180kΩ	0816		チップ抵抗	
	R, CHP	220kΩ	0816		チップ抵抗	
	R, CHP	470kΩ	0816		チップ抵抗	
	R, CHP	1MΩ	0816		チップ抵抗	
	R, CHP	33Ω	LEAD FREE		チップ抵抗	
	R, CHP	2.2kΩ	LEAD FREE		チップ抵抗	
	R, CHP	4.7kΩ	LEAD FREE		チップ抵抗	
	R, CHP	10kΩ	LEAD FREE		チップ抵抗	
	R, CHP	100k	LEAD FREE		チップ抵抗	
	R, CHP	100Ω	LEAD FREE		チップ抵抗	
	R, CHP	390Ω	LEAD FREE		チップ抵抗	
	R, CHP	1.0kΩ	LEAD FREE		チップ抵抗	
	R, CHP	1.8kΩ	LEAD FREE		チップ抵抗	
	R, CHP	2.2kΩ	LEAD FREE		チップ抵抗	
	R, CHP	2.4kΩ	LEAD FREE		チップ抵抗	
	R, CHP	3.9kΩ	LEAD FREE		チップ抵抗	
	R, CHP	5.6kΩ	LEAD FREE		チップ抵抗	
	R, CHP	10kΩ	LEAD FREE		チップ抵抗	
	R, CHP	22kΩ	LEAD FREE		チップ抵抗	
	R, CHP	100kΩ	LEAD FREE		チップ抵抗	
	R, CHP	510kΩ	LEAD FREE		チップ抵抗	
	R, CHP	49.9Ω	1/8W		チップ抵抗	
	R, CHP	5.6Ω	1/3W		チップ抵抗	
	R, CAR, CHP	6.49kΩ	1/10W F		チップ抵抗	

* New Parts * 新部品

Parts List for Carbon Resistors

Value	1/4W Type Part No.	1/6W Type Part No.	Value	1/4W Type Part No.	1/6W Type Part No.
1.0 Ω	HJ35 3100	HF85 3100	10 kΩ	HF45 7100	HF45 7100
1.8 Ω	HJ35 3180	*	11 kΩ	HF45 7110	HF45 7110
2.2 Ω	HJ35 3220	HF85 3220	12 kΩ	HJ35 7120	HF85 7120
3.3 Ω	HJ35 3330	HF85 3330	13 kΩ	HF45 7130	HF45 7130
4.7 Ω	HJ35 3470	HF85 3470	15 kΩ	HF45 7150	HF45 7150
5.6 Ω	HJ35 3560	HF85 3560	18 kΩ	HF45 7180	HF45 7180
10 Ω	HF45 4100	HF45 4100	22 kΩ	HF45 7220	HF45 7220
15 Ω	HJ35 4150	HF85 4150	24 kΩ	HF45 7240	HF45 7240
22 Ω	HF45 4220	HF45 4220	27 kΩ	HJ35 7270	HF85 7270
27 Ω	HJ35 4270	HF85 4270	30 kΩ	HF45 7300	HF45 7300
33 Ω	HF45 4330	HF45 4330	33 kΩ	HF45 7330	HF45 7330
39 Ω	HJ35 4470	HF85 4390	36 kΩ	HF45 7360	HF45 7360
47 Ω	HF45 4470	HF45 4470	39 kΩ	HF45 7390	HF45 7390
56 Ω	HF45 4560	HF45 4560	47 kΩ	HF45 7470	HF45 7470
68 Ω	HF45 4680	HF45 4680	51 kΩ	HF45 7510	HF45 7510
75 Ω	HF45 4750	HF45 4750	56 kΩ	HF45 7560	HF45 7560
82 Ω	HF45 4820	HF45 4820	62 kΩ	HF45 7620	HF45 7620
91 Ω	HF45 4910	HF45 4910	68 kΩ	HF45 7680	HF45 7680
100 Ω	HF45 5100	HF45 5100	82 kΩ	HF45 7820	HF45 7820
110 Ω	HJ35 5110	HF85 5110	91 kΩ	HF45 7910	HF45 7910
120 Ω	HF45 5120	HF45 5120	100 kΩ	HF45 8100	HF45 8100
150 Ω	HF45 5150	HF45 5150	110 kΩ	HF45 8110	HF45 8110
160 Ω	HJ35 5160	*	120 kΩ	HF45 8120	HF45 8120
180 Ω	HF45 5180	HF45 5180	150 kΩ	HF45 8150	HF45 8150
200 Ω	HF45 5200	HF45 5200	180 kΩ	HF45 8180	HF45 8180
220 Ω	HF45 5220	HF45 5220	220 kΩ	HJ35 8220	HF85 8220
270 Ω	HF45 5270	HF45 5270	270 kΩ	HF45 8270	HF45 8270
330 Ω	HF45 5330	HF45 5330	300 kΩ	HF45 8300	HF45 8300
390 Ω	HF45 5390	HF45 5390	330 kΩ	HF45 8330	HF45 8330
430 Ω	HF45 5430	HF45 5430	390 kΩ	HJ35 8390	HF85 8390
470 Ω	HF45 5470	HF45 5470	470 kΩ	HF45 8470	HF45 8470
510 Ω	HF45 5510	HF45 5510	560 kΩ	HJ35 8560	HF85 8560
560 Ω	HF45 5560	HF45 5560	680 kΩ	HJ35 8680	HF85 8680
680 Ω	HF45 5680	HF45 5680	820 kΩ	HJ35 8820	HF85 8820
820 Ω	HF45 5820	HF45 5820	1.0 MΩ	HF45 9100	HF45 9100
910 Ω	HF45 5910	HF45 5910	1.2 MΩ	HJ35 9120	*
1.0 kΩ	HF45 6100	HF45 6100	1.5 MΩ	HJ35 9150	HF85 9150
1.2 kΩ	HF45 6120	HF45 6120	1.8 MΩ	HJ35 9180	HF85 9180
1.5 kΩ	HF45 6150	HF45 6150	2.2 MΩ	HJ35 9220	HF85 9220
1.8 kΩ	HF45 6180	HF45 6180	3.3 MΩ	HJ35 9330	HF85 9330
2.0 kΩ	HJ35 6200	HF85 6200	3.9 MΩ	HJ35 9390	*
2.2 kΩ	HF45 6220	HF45 6220	4.7 MΩ	HJ35 9470	HF85 9470
2.4 kΩ	HJ35 6240	HF85 6240			
2.7 kΩ	HF45 6270	HF45 6270			
3.0 kΩ	HF45 6300	HF45 6300			
3.3 kΩ	HF45 6330	HF45 6330			
3.6 kΩ	HJ35 6360	HF85 6360			
3.9 kΩ	HF45 6390	HF45 6390			
4.7 kΩ	HF45 6470	HF45 6470			
5.1 kΩ	HF45 6510	HF45 6510			
5.6 kΩ	HF45 6560	HF45 6560			
6.8 kΩ	HF45 6680	HF45 6680			
8.2 kΩ	HF45 6820	HF45 6820			
9.1 kΩ	HF45 6910	HF45 6910			

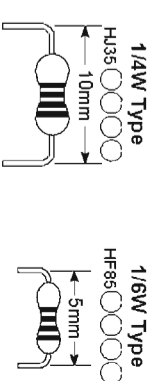

* : Not available

EXPLODED VIEW

T10 5.7mm

 When removing the screw (29), use the special screwdriver with tip shaped in figure. As the screw (29) has a flange at its center, use the one with a hole.
 この(29)を外す場合は、図のような先端形状のドライバーを使用します。この(29)は、中心に突起があるため、中心に穴のあるドライバーを使用してください。

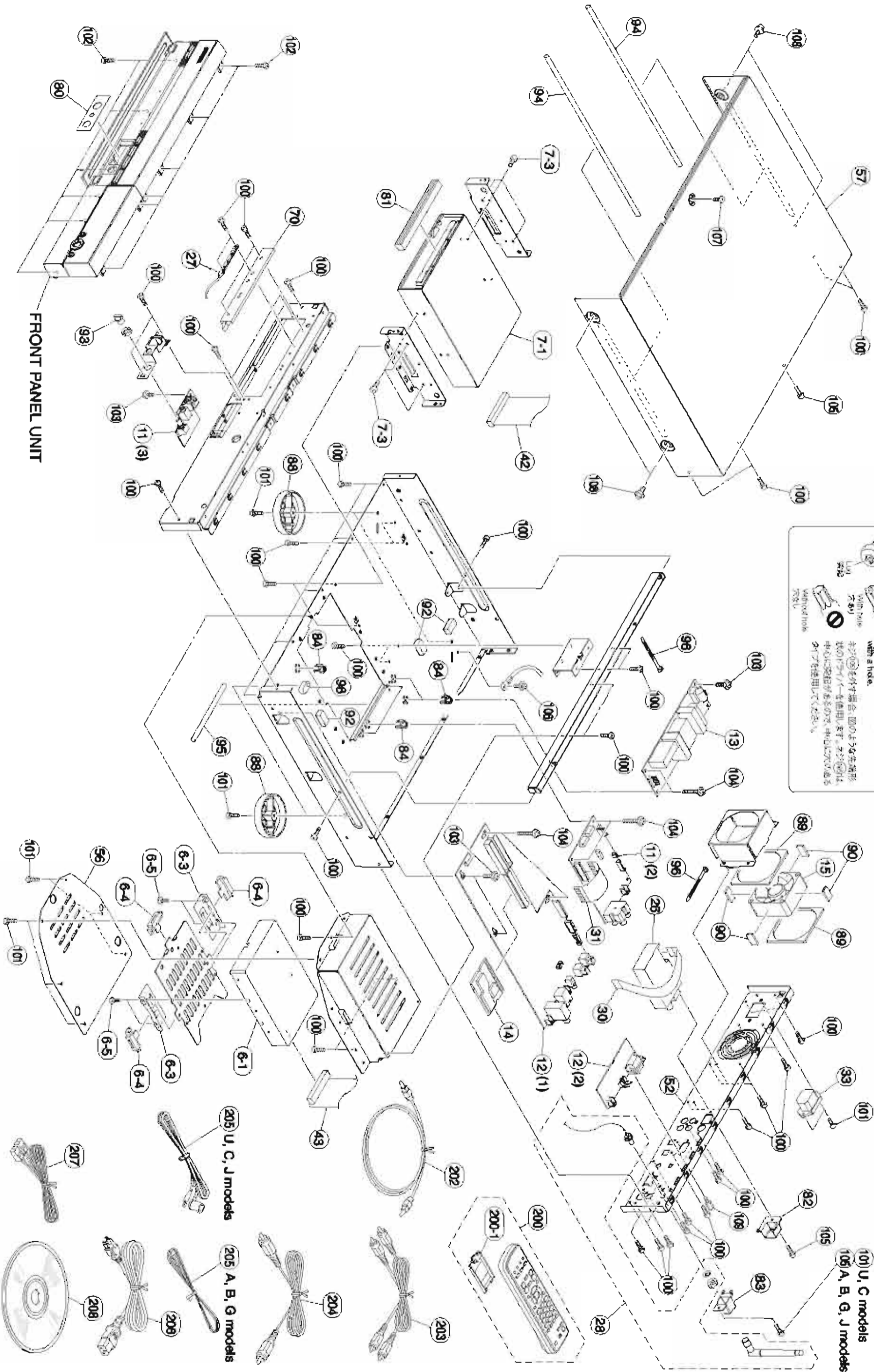

FRONT PANEL UNIT

205 U, C, J models

205 A, B, G models

101 U, C models
106 A, B, G, J models

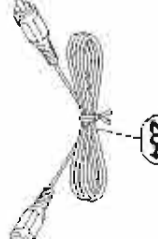
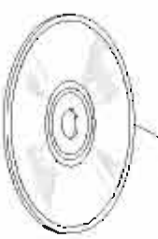

MECHANICAL PARTS

Ref. No	Part No.	Description	Remarks	Markets	部 品 名	Rank
* 6-1	WD209200	HEAD DISC DRIVE	3.5inch 160GB		ハードディスク	
* 6-3	WE81700	EARTH PLATE HDD			アースプレートHDD	
* 6-4	WE83500	DAMPER HDD			ダンパーHDD	
* 6-5	WE78600	DISH HEAD SCREW (INCH SIZE)	UN#6-32-5 M#ZM2K3		DISHヘッド小ネジ	
* 7-1	WE785100	CD-R/RW DRIVE	PX-W5232TA/70BPy		CD-R/RWドライブ	
* 7-3	WE774000	BLIND HEAD SCREW	3x6 M#ZM2K3		バインドヘッドネジ	
* 11	WE416100	P.C.B. ASSY	OPERATION	J	PCBオペレーション	
* 12	WE415700	P.C.B. ASSY	MAIN	J	PCBメイン	
* 12	WE415800	P.C.B. ASSY	MAIN	J	PCBメイン	
* 12	WE415900	P.C.B. ASSY	MAIN	A	PCBメイン	
* 12	WE416000	P.C.B. ASSY	MAIN	BG	PCBメイン	
* 13	WE424000	POWER SUPPLY UNIT			電源ユニット	
* 14	WE419800	WIREFLESS LAN MODULE	DC3G1E2077		無線LANモジュール	
* 15	V7719700	DC FAN MOTOR	DC D06T-12TL07 (EX)		DCファンモーター	
* 26	WB423900	AM/FM TUNER	ENK9047050	J	AM/FM チューナー	
* 26	WB424000	AM/FM TUNER	ENK9067090	JC	AM/FM チューナー	
* 26	WB424100	AM/FM TUNER	ENK9077110	ABG	AM/FM チューナー	
* 27	WF302000	REVERES F ANTENNA	WA-0-0452		反転F型アンテナ	
* 28	WF819300	DIPOLE ANTENNA ASS'Y	ANT0432-16B/S-U-B		ダイポールアンテナ	
* 30	ME113120	FLEXIBLE FLAT CABLE	13P 120mm P=1.25		カード電線 C&C	
* 31	ME28060	FLEXIBLE FLAT CABLE	28P 60mm P=1.0		カード電線	
* 33	WF423700	CONNECTOR ASS'Y	2P 250mm AC INLET		コネクタASSY	
* 42	WF427200	CONNECTOR FLAT CABLE	80P 400mm P=2.0		フラットケーブル	
* 43	WF427300	CONNECTOR FLAT CABLE	80P 280mm P=2.0		フラットケーブル	
* 52	WE79200	REAR PANEL		J	リヤパネル	
* 52	WE79300	REAR PANEL		U	リヤパネル	
* 52	WE79400	REAR PANEL		C	リヤパネル	
* 52	WE79500	REAR PANEL		A	リヤパネル	
* 52	WE79600	REAR PANEL		BG	リヤパネル	
* 56	WE880500	BOTTOM COVER HDD			ボトムカバーHDD	
* 57	WE880600	TOP COVER			トップカバー	
* 57	WE880700	TOP COVER		BL	トップカバー	
* 70	WF697900	EARTH PLATE/FR		TI, SI	アースプレート/FR	
* 80	WE882900	SHEET JACK		BL	シート/ジャック	
* 80	WE883000	SHEET JACK		TI	シート/ジャック	
* 80	WE883000	SHEET JACK		SI	シート/ジャック	
* 81	WE883600	LID TRAY			リッド/トレイ	
* 82	WE883700	COVER AM ANTENNA			カバー/AM_ANT	
* 83	WE883800	COVER LOD ANTENNA			カバー/ロッドANT	
* 84	VR264400	SPACER	H8		スペーサー	
* 88	V0780300	LEG	D60XH16		レッグ	
* 89	V8080500	CUSHION FAN			クッション/FAN	
* 90	V8080600	CUSHION 10X20			クッション/10X20	
* 92	VY977200	SPACER	10x20 t8		スペーサー	
* 93	WF534800	KNOB HP		BL	ノブ/HP	
* 93	WF534900	KNOB HP		TI	ノブ/HP	
* 93	WF535000	KNOB HP		SI	ノブ/HP	
* 94	WG096600	SOFT SHIELD	SHS3-050050 L=315		ソフトシールド	
* 95	WG096700	SOFT SHIELD	SHS3-010050 L=110		ソフトシールド	
* 96	VU590000	BLINDING TIE	CBTD001B		ブラインドタイ	
* 98	V7993800	DAMPER SCREW			ダンパー/スクリュー	
* 100	WE774100	BLIND HEAD B-TIGHT SCREW	3x8 M#ZM2B3		バインドヘッドBタイトネジ	
* 101	WE774300	BLIND HEAD B-TIGHT SCREW	3x8 M#ZM2K3		バインドヘッドBタイトネジ	
* 102	WE774400	BLIND HEAD B-TIGHT SCREW	3x8 M#ZM2B3		バインドヘッドBタイトネジ	
* 103	YH365800	PW HEAD B-TIGHT SCREW	3x6-8 M#C2		PWヘッドBタイトネジ	
* 104	Y7699400	PW HEAD B-TIGHT SCREW	3x15-8 M#C2		PWヘッドBタイトネジ	

* New Parts * 新規部品

Ref. No	Part No.	Description	Remarks	Markets	部 品 名	Rank
* 105	WC186100	PIN HEAD TORX B-TIGHT SCREW	3x8 M#N133		トルクスチボットネジ	
* 105	WE774700	BLIND HEAD S-TIGHT SCREW	4x10 M#ZM2K3		バインドヘッドSタイトネジ	
* 107	WE200500	DISH HEAD B-TIGHT SCREW	3x6 M#N13BL		DISHヘッドBタイトネジ	
* 108	21991500	PW HEAD S-TIGHT SCREW	4x8-10 M#C2BL		PWヘッドSタイトネジ	
* 108	VD069800	PW HEAD S-TIGHT SCREW	4x8-10 M#N133		PWヘッドSタイトネジ	
* 109	V6509600	JACK SCREW	SS6-A47511848		ジャックスクリュー	
* 200	WF138300	ACCESSORIES			付属品	
* 200-1	AAK57560	REMOTE CONTROL	MCX-4		リモコン	
* 202	V9156100	BATTERY COVER	103RRS-141-07L		電池蓋	
* 203	VS381600	OPTICAL CABLE	00L171-16066 0.6m 1pc		光ケーブル	
* 204	V6508900	AUDIO PIN CABLE	2P 1.0m RE/WH 1pc		ビデオ用ピンケーブル	
* 205	V6267000	VIDEO PIN CABLE	1P 1.5m YE 1pc		FEM簡易アンテナ	
* 205	V0147100	INDOOR FM ANTENNA	1.4m 1pc	JUC	FEM簡易アンテナ	
* 206	WF42100	POWER CABLE	2m 1pc	ABG	電源コード	
* 206	WF424200	POWER CABLE	2m 1pc	J	電源コード	
* 206	WF424300	POWER CABLE	2m 1pc	JC	電源コード	
* 206	WF424500	POWER CABLE	2m 1pc	A	電源コード	
* 206	WF424600	POWER CABLE	2m 1pc	B	電源コード	
* 207	WG136900	CAT-5 STRAIGHT CABLE	8P 2m SHILED 1pc	G	電源コード	
* 208	X6772400	CD-ROM	1pc		CAT5ストレートケーブル	
* 208		BATTERY MANGANESE	R0DW 2pcs		CD-ROM	
* 208		BATTERY			マンガン電池 2PCS	
* 208		SERVICE TOOLS				
* 208	AAK72980	U.FL REMOVING TOOL	U.FL-IP-N-2		サービスマニュアル	
* 208	WA045500	IC WRING JIG (42P CABLE)			U.FL引き抜き治具	
* 208	WC028700	FLEXIBLE FLAT CABLE	30P 250mm P=0.5		IC書き込み治具	
* 208	ME428160	FLEXIBLE FLAT CABLE	28P 160mm P=1.0		カード電線	
* 208					カード電線	

* New Parts * 新規部品

FRONT PANEL UNIT

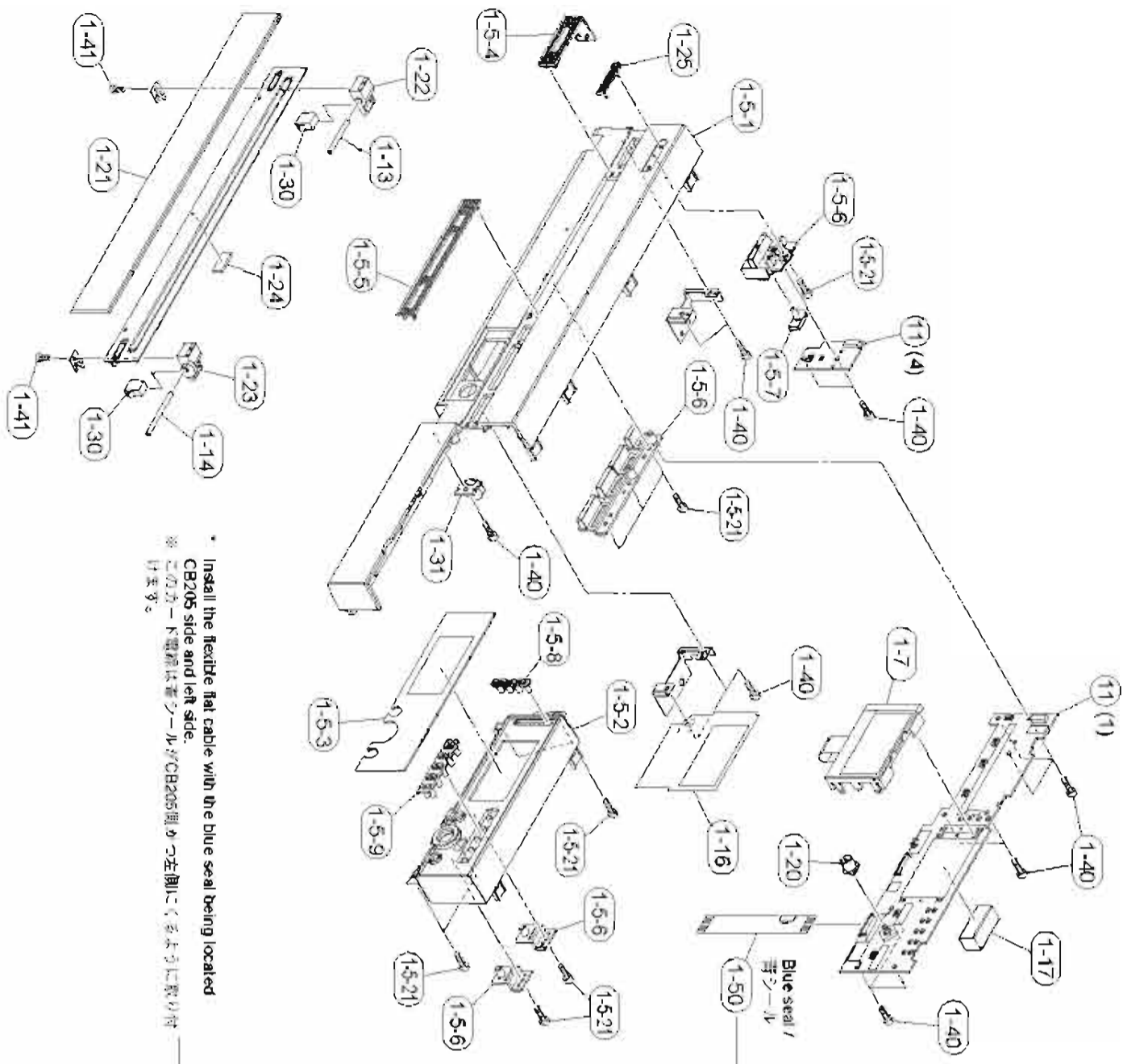

Ref. No.	Part No.	Description	Remarks	Markets	部品名	Rank
1-5-1	WE881890	FRONT PANEL-L	BL		フロントパネル-L	
1-5-1	WE881900	FRONT PANEL-L	TI		フロントパネル-L	
1-5-1	WF120100	FRONT PANEL-L	SI		フロントパネル-L	
1-5-2	WE882000	FRONT PANEL-R			フロントパネル-R	
1-5-3	WE882100	SHEET WINDOW			シートウィンドウ	
1-5-4	WE882200	COVER L			カバーL	
1-5-5	WE882300	COVER R			カバーR	
1-5-6	WE882400	BUTTON OPE			ボタン OPE	
1-5-7	WE882500	LENS POWER			レンズ 10P	
1-5-8	WE988000	LENS 4P			レンズ 4P	
1-5-9	WE988100	LENS TOP			レンズ TOP	
1-5-21	WF266600	BLIND HEAD P-TIGHT SCREW			バインドヘッドタイトネジ	
1-7	WF423900	LCD DISPLAY			液晶ディスプレイ	
1-13	WE881500	SHAFT LID-L			シャフト リッド-L	
1-14	WE987800	SHAFT LID-R			シャフト リッド-R	
1-16	WE697700	LANTH PLATE LCD			ランタンプレート LCD	
1-17	WE9096100	SOFT SHIELD			ソフトシールド	
1-20	WE882800	BUTTON STICK			ボタンスティック	
1-21	WE883100	LID PALET	BL		リッド パレット	
1-21	WE440900	LID PALET	BL	4BG	リッド パレット	
1-21	WE883200	LID PALET	TI		リッド パレット	
1-21	WF120300	LID PALET	SI		リッド パレット	
1-22	WE883300	HINKE L			ヒンジL	
1-23	WE883400	HINKE R			ヒンジR	
1-24	V2126000	DAMPER			ダンパー	
1-25	V6034100	SOLEEN			ソール	
1-30	V9073400	MAGNET CATCH			マグネットキャッチ	
1-31	WE215600	DAMPER GEAR			ダンパーギア	
1-40	WE976600	BLIND HEAD P-TIGHT SCREW			バインドヘッドタイトネジ	
1-41	WE973700	BLIND HEAD P-TIGHT SCREW			バインドヘッドタイトネジ	
1-50	WE477500	REXIBLE FLAT CABLE			カーネルケーブル	
11	WE416100	P.C.B. ASSY			P.C.B.アッセンション	

1 New Parts * 新部品

■ REMOTE CONTROL

• MCX4

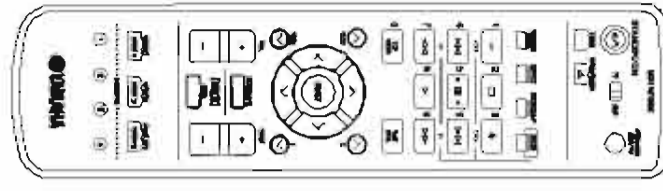

• KEY NO. LAYOUT



• SCHEMATIC DIAGRAM

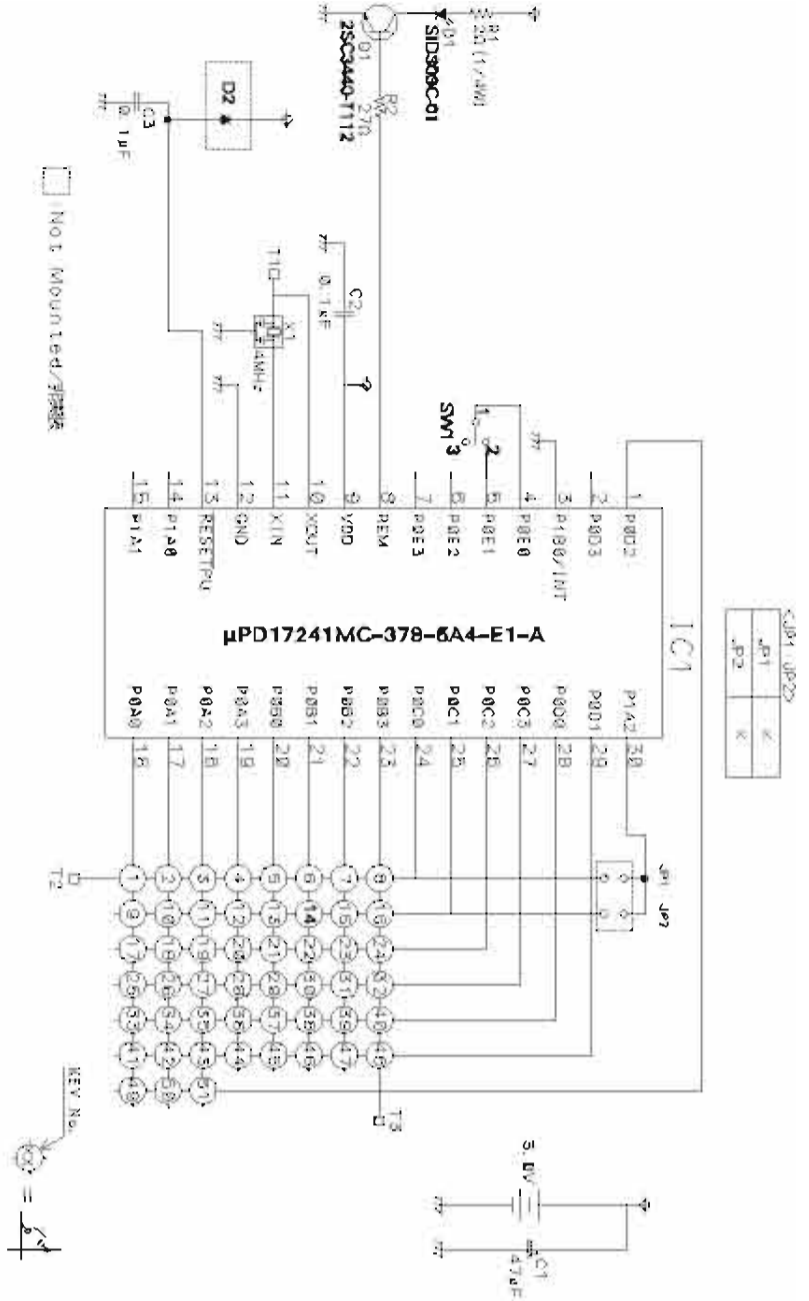

Key No.	Function	SW : AMP		SW : TV	
		Custom	Data	Custom	Data
1	STANDBY/ON	80-37	20	←	
2	POWER AMP/TV	80-37	3A	50-AF	17
3	TIMER	80-37	5F	←	
4	OPEN/CLOSE	80-37	21	←	
5	-	80-37	24	←	
6	-	80-37	35	←	
7	-	80-37	36	←	
8	-	80-37	37	←	
9	-	80-37	38	←	
10	-	80-37	39	←	
11	RANDOM	80-37	32	←	
12	REPEAT	80-37	33	←	
13	BROADCAST	80-37	31	←	
14	RADIO	80-37	34	←	
15	- / 1	80-37	2A	←	
16	□ / 2	80-37	25	←	
17	+ / 3	80-37	2B	←	
18	◀ / 4	80-37	2B	←	
19	▢ / 5	80-37	23	←	
20	▶ / 6	80-37	29	←	
21	◀ / 7	80-37	26	←	
22	▷ / 8	80-37	22	←	
23	▷ / 9	80-37	27	←	
24	TOP MENU / 0	80-37	50	←	
25	-	80-37	5E	←	
26	PLAY INFO	80-37	4E	←	

Key No.	Function	SW : AMP		SW : TV	
		Custom	Data	Custom	Data
27	PAGE (up)	80-37	59	←	
28	A (up)	80-37	57	←	
29	PAGE (down)	80-37	5A	←	
30	Z (down)				
31	CURSOR (up)	80-37	52	←	
32	CURSOR (down)	80-37	53	←	
33	CURSOR (left)	80-37	54	←	
34	CURSOR (right)	80-37	55	←	
35	SELECT	80-37	56	←	
36	VOL +	80-37	3F	50-AF	12
37	VOL -	80-37	3E	50-AF	15
38	BOOKMARK	80-37	4F	←	
39	MUTE (AMP/TV)	80-37	3D	50-AF	08
40	INPUT +	80-37	3C	50-AF	09
41	INPUT -	80-37	3B	50-AF	09
42	-	80-37	5B	←	
43	-	80-37	5C	←	
44	-	80-37	5D	←	
45	LIBRARY / MENU 1	80-37	43	←	
46	ARTISTS / MENU 2	80-37	40	←	
47	PLAYLISTS / MENU 3	80-37	44	←	
48	FAVORITES 1	80-37	2C	←	
49	FAVORITES 2	80-37	2D	←	
50	FAVORITES 3	80-37	2E	←	
51	FAVORITES 4	80-37	2F	←	

Welcome to MusicCAST

MusicCAST is a new, convenient home audio network featuring playback of digital music streams. It consists of a MCX-2000 music server and its dedicated clients (MCX-A10 or MCX-C15, sold separately). With all your music sources—including CDs and radio broadcasts—brought together in a single server unit, each person in the house can enjoy their own music, anytime, on demand.

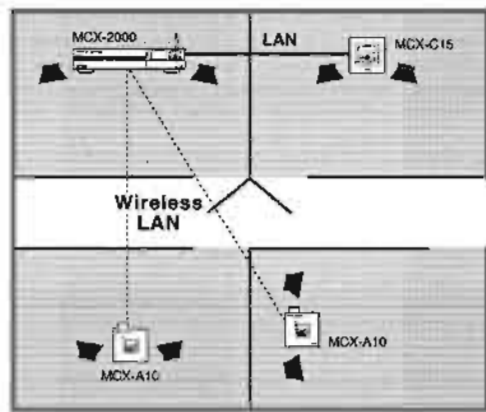

This guide helps you in quickly setting up your new MCX-2000 and client devices, building your own MusicCAST network—and tapping into a whole new world of music listening enjoyment.

NOTE Each page number (page 200) in this guide indicates that you can see a detailed explanation on that page of the separate Owner's Manual.

Preparing Items

Find and take out the following items from the MusicCAST product packages. (See Owner's Manual for a complete list of supplied items.)

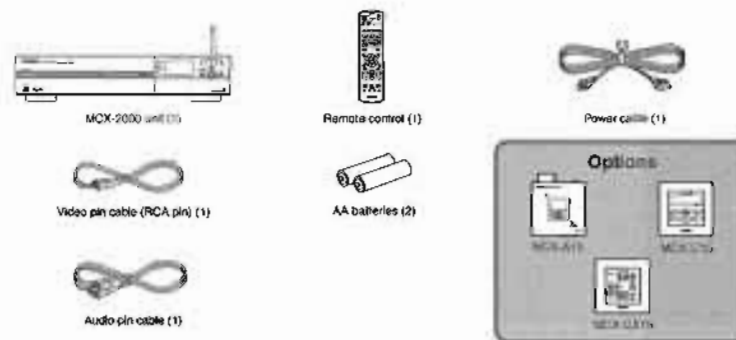

NOTE If you're using an MCX-C15, also prepare a network hub and two network cables (CAT5 straight cables) for connecting with the MCX-2000.

Connecting with Peripheral Devices

Connect the MCX-2000 and its clients, as well as any other desired peripherals as shown in the following illustrations.

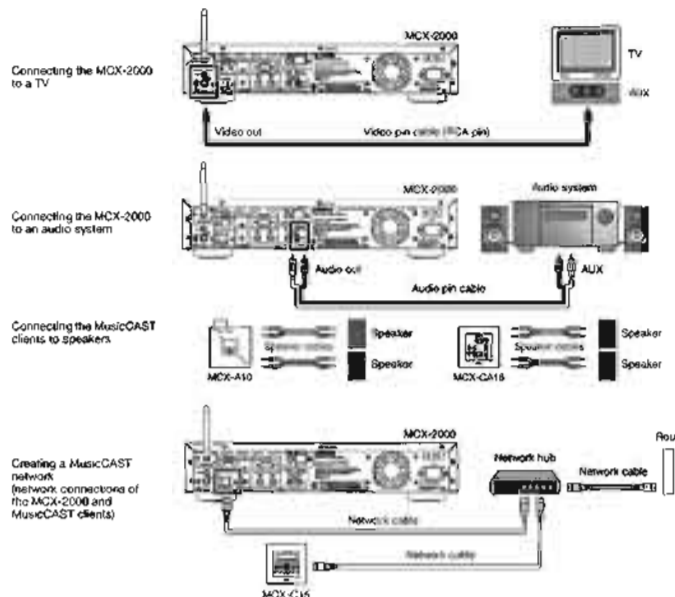

Remote Control Features and Operations

You can use the supplied remote control to perform most of the MCX-2000 operations (such as selecting a menu item or determining a setting value). Prepare the remote control before operations.

Setting Batteries

Set batteries inside the remote control as shown below.

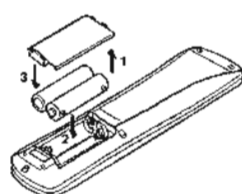

- 1 Remove the bottom cover of the remote control.
- 2 Set two AA batteries (supplied) in appropriate directions, according to the illustration in the compartment.
- 3 Slide the cover until it snaps into place.

NOTE If the remote control doesn't work well, the batteries may be weak. Replace them with two new AA batteries. Always handle batteries appropriately, according to the safety precautions at the beginning of this manual.

Powering Up

Turn on your TV and switch it to external input (connected to the MCX-2000 video output). When you turn on the MCX-2000, your TV will show the initial "MusicCAST" splash screen, followed automatically by the Easy Setup screen.

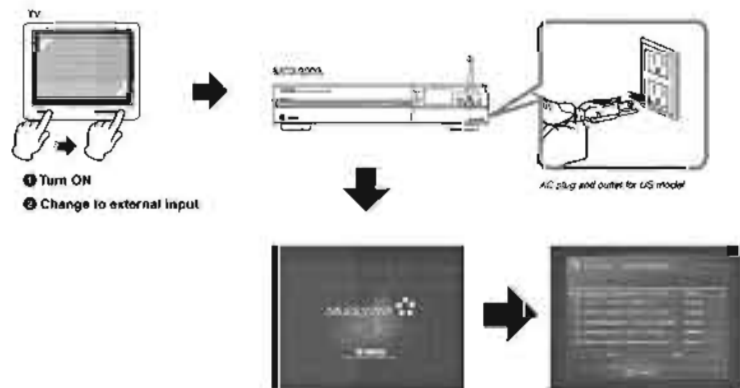

NOTE The MCX-2000 is designed to show the Easy Setup screen when you first turn on the unit (after connecting). If the Easy Setup screen doesn't appear, check the TV and set the TV to the external input. When the Top Menu screen is shown on the TV, use the remote control to move the highlight selection above to Setup (the last item of Top Menu), and press the SELECT button. Then, from the Setup menu screen, select Easy Setup. Scroll down in the display if it is not visible.

Creating a MusicCAST Network

The Easy Setup feature lets you quickly create a MusicCAST network. There are several types of MusicCAST networks. Here we explain how to configure the most basic network that's comprised of a single MCX-2000 server and one or more clients.

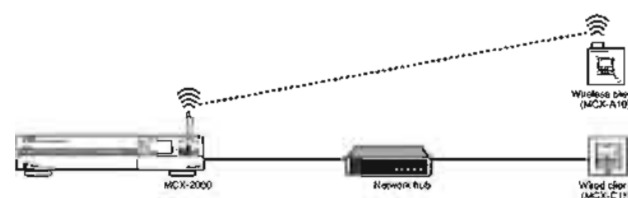

NOTE Your clients and network hub should be turned off at this point. Turn them on later when you're asked to do so in the Easy Setup process.

1 With Easy Setup, you can quickly and easily configure your desired MusicCAST network just by following the simple on-screen instructions (page 27). To create a network comprised of an MCX-2000 with clients, specify the options listed below. When the proper settings have been made, a simple diagram of your system appears in the display.

Enter the following settings:

- **Language:** Select a language used for screen messages.
- **Date and Time:** Set the current date and time.
- **System configuration selection:** Select "Use the MCX-2000 in conjunction with MCX-A10/C15 clients".
- **Network connection selection:** Select "Connect to a network containing MusicCAST components only".
- **Network settings configuration:** Select "Automatic configuration".

After you've made these settings, a diagram of the specified MusicCAST system (in this case, a MusicCAST-only network with the MCX-2000 and clients) is shown in the display.

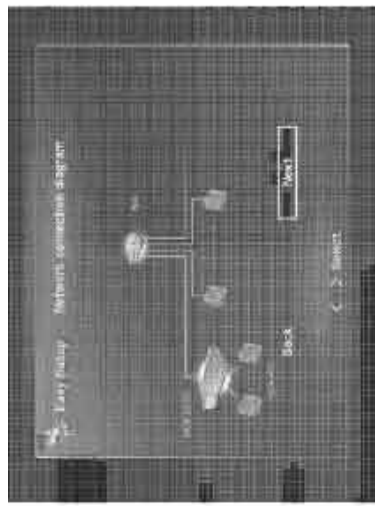

NOTE To select a displayed item, move the highlight on it using the up or down arrow button, and then press the SELECT button. The SELECT button also lets you alternately select and deselect a radio button. When you specify a value, use the up or down arrow button to display a desired value, and then press the SELECT button (page 19).

From the next screen, you will need to operate the MCX-2000 and each client to configure the MusicCAST network.

2 Turn on each client as instructed in the on-screen message. If you're using a network hub for wired clients, you should turn on the hub at this time. When you're ready, go to the next screen.

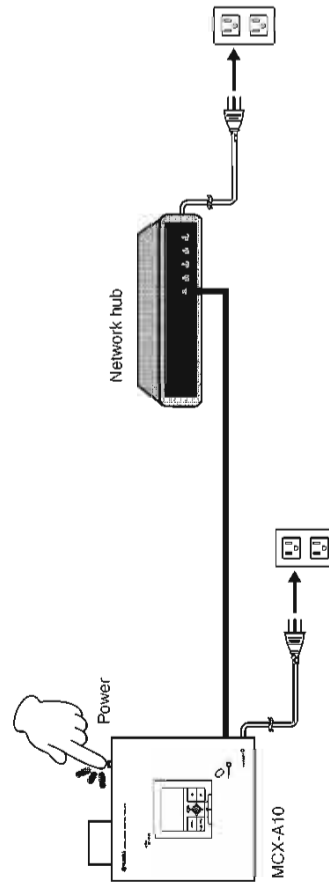

3 Following the screen message, start Auto Configuration on each client. Use the front-panel cursor controller to select Top Menu > Setup > Network > Auto Configuration, and then press the PLAY button. The clients start searching for the music server (MCX-2000).

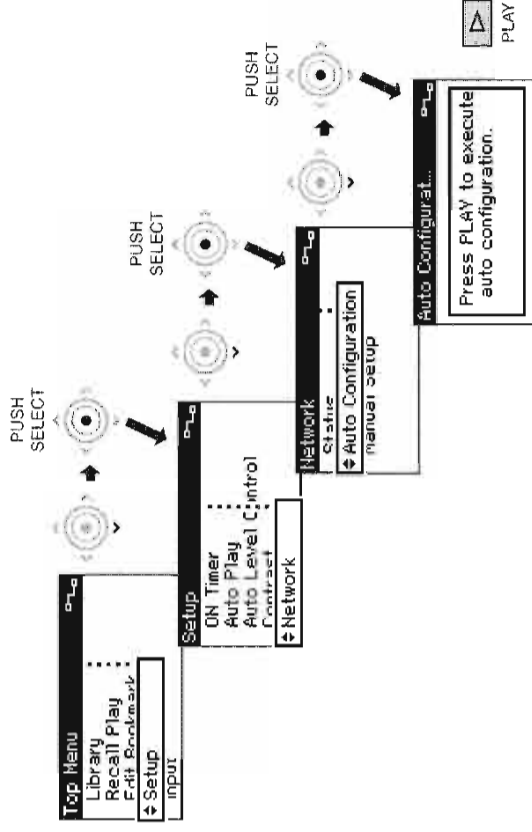

NOTE You can use the cursor controller on a client's front panel in the same way as the cursor controller on the MCX-2000 remote control. Push the center stick upward, downward, leftward or rightward as you press the up, down, left or right arrow button on the remote control. When you press this stick vertically, it works the same as pressing the SELECT button. In addition, you can go back to the previous screen by pushing the stick leftward.

4 When you go to the next Easy Setup screen, the MCX-2000 starts searching for any available clients.



NOTE Don't touch or operate any clients until their IDs appear in the above screen and are successfully registered to the MCX-2000.

5 When the screen shows all clients (IDs) you are using, go to the next screen for updating their firmware. This process is necessary to use them with the MCX-2000. On each client, select Top Menu > Setup > System > System Update, and then press the PLAY button.



When the firmware update is complete, each client displays the above message and automatically restarts itself. When you go to the next screen, you can see the updated firmware version.



NOTE The firmware version on your clients may be more recent than the one shown above. In addition, the client firmware version doesn't always match that of the MCX-2000.

NOTE Each version number may be different from your MCX-2000.

6 Go to the next screen, and select "Confirm" to complete the Easy Setup process. Your MusicCAST network has been successfully created.

Streaming Music

To begin music streaming over the MusicCAST network, you'll first need to prepare your audio sources (music) on the MCX-2000 music server. The MCX-2000 can stream several types of audio sources to the clients. Here, we'll explain how to record songs from a music CD and deliver them to the clients.

1 Press the OPEN/CLOSE button on the remote control and open the CD tray. Set a music CD with its label side facing up.

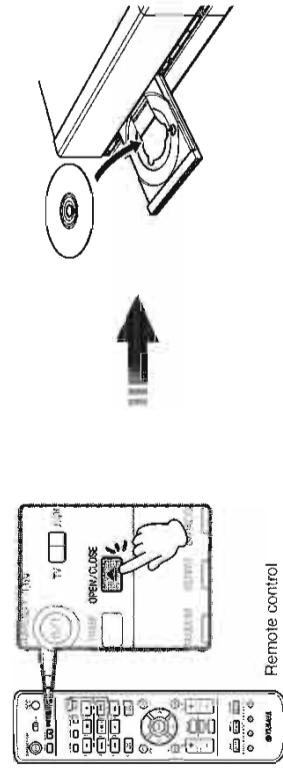

2 Press the CD AUTO STORE button on the MCX-2000 front panel (the tray will close automatically). The RECORDING indicator (at the left of the front panel display) lights in red, followed by the ENCODING indicator lighting in green.

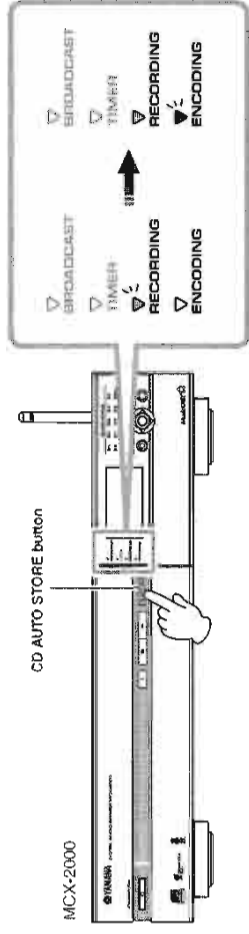

NOTE The RECORDING indicator lights up while the MCX-2000 is importing CD songs in (uncompressed) PCM format. The ENCODING indicator lights up while the MCX-2000 is encoding PCM songs to MP3 format. Naturally, these indicators go off a first-in, first-out basis during the import process.

3 When the RECORDING indicator goes off, indicating that your CD songs have been successfully imported to the MCX-2000, select Top Menu > Library > Music Archive.

When "All Songs" is selected:

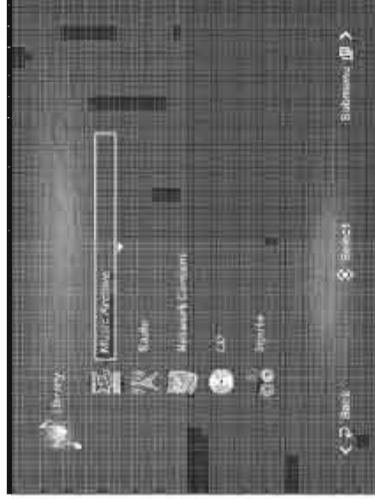

4 Move the highlight to one of the first four menu items (Artists, Albums, Genres or All Songs) and press the SELECT button. You can view the artist name, album title, genre or a list of songs from the music CD you just imported.

When "All Songs" is selected:

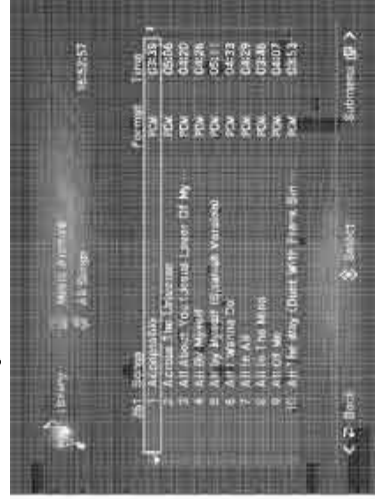

NOTE If the music CD is a recent release or a private, self-made CD, generic song information may be shown (such as unknown artist, album, etc.). If this happens, you can enter the relevant information manually (page 75).

- From one of your clients, select Top Menu > Library > Music Archive. You can see the same menu items — Artists, Albums, Genres and All Songs as found in the MCX-2000 screen. Select one of them and confirm the client display also shows the artist name, album title, genre or a list of songs from the music CD you just imported on the MCX-2000.

When "All Songs" is selected

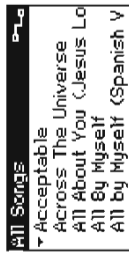

NOTE If the display on a client is dimmed and shows the current time, press the controller stick. The client will 'wake up' and restart the network connection with the MCX-2000 (page 14).

- From the menu items in the client screens, select a song and start playback. (Move the triangle icon to the left of a song title, and then press the controller stick or PLAY button.)

NOTE You can adjust the playback volume using the VOL +/- buttons on the client front panel.

This is the basic procedure for music streaming over the MusicCAST network. If you have two or more clients, you can play different songs on them. The MCX-2000 also supports multitasking, allowing you to continue importing other music CDs by repeating steps 1 to 3 above, or select and play a different song on the MCX-2000, even while delivering different music to each client.

Preface

Thank you and congratulations on your purchase of the Yamaha MCX-2000 Digital Audio Server!

The MCX-2000 is a music server that enhances the concept of MusicCAST, a digital music delivery method over a personal network.

MusicCAST delivers a new listening style for the digital era. It allows you to record various audio sources, including music CDs, onto the music server, and enjoy streamed playback on a client device (MCX-A10 or MCX-C15, sold separately) placed anywhere in your home, using wired and wireless computer networking technologies.

There are many ways to use the MusicCAST network and the MCX-2000 music server.

Use the MCX-2000 to collect and centralize all music sources in your home. Then, simply place a client device in every room of your house—instead of buying a separate stereo or audio set for each of your family members. This setup lets each member of the family enjoy their own favorite music—in any room at the same time. Naturally, the music server can also be set to stream the same music to each client, so that you can walk around your house and have the same music play no matter where you go.

The MCX-2000 has other great features. It can also stream music or audio programs from the built-in FM radio tuner anywhere in your home via the MusicCAST network. Locally on the MCX-2000, you can also enjoy Internet radio programs. You can also use the MCX-2000 to record audio content from old analog tapes. Once recorded, they can be streamed via the MusicCAST network and burned onto CD-R/RW media for storage purposes, together with songs from music CDs.

The above are just a few examples to show how you can use the MusicCAST network and the MCX-2000 music server. You'll find additional ones throughout this manual, too—so, keep the manual in a safe place and read it thoroughly in order to get the most out of your new MCX-2000.

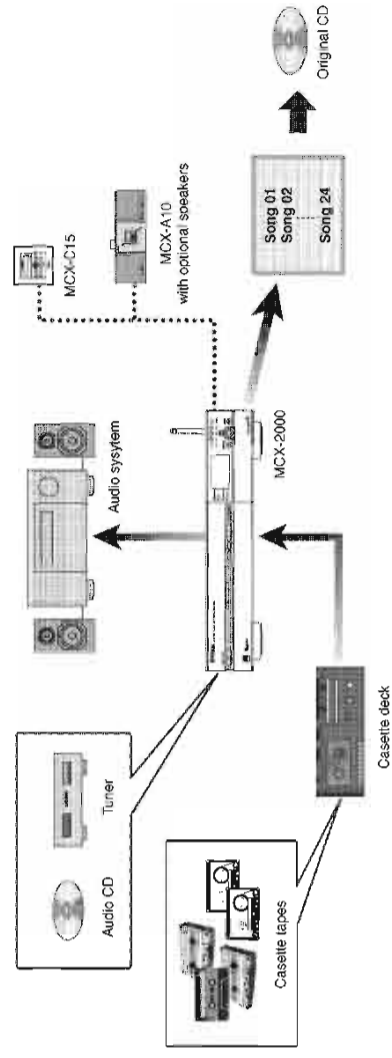

What's Included

The MCX-2000 product package contains the following items. When you open the box, first check they have all been included. If something is missing, please contact the dealer from whom you purchased the product.

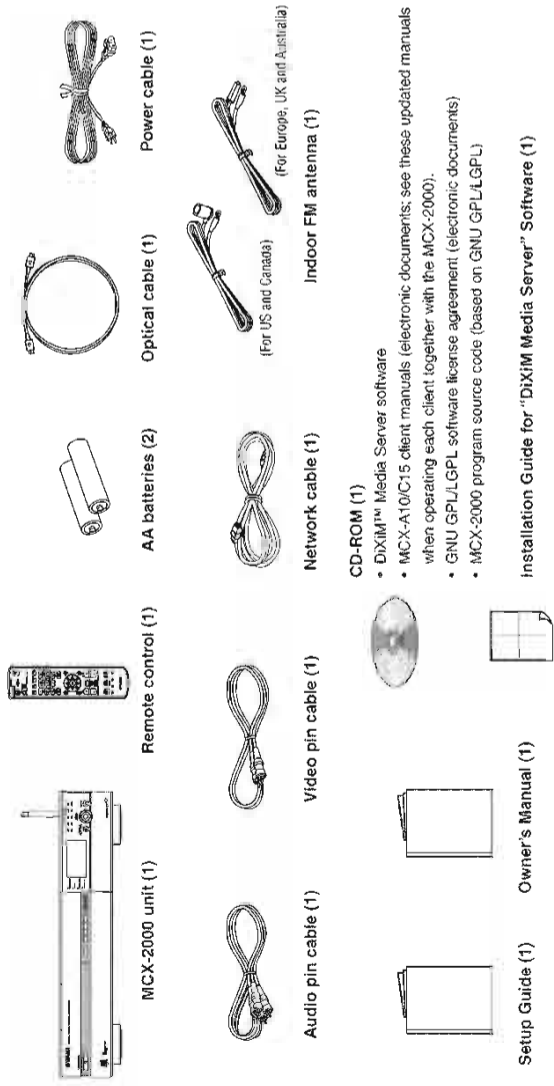

Feature Overview

Designed to be a comprehensive, ultimate audio center for your home, the MCX-2000 incorporates a wide variety of features and functions. Here, we'll take a look at some of ways you can use these features.

Audio Playback Functions

The MCX-2000 lets you play a wide variety of audio sources, including commercial music CDs, your own original MP3 CDs (CD-ROM), external audio signals, and radio programs from the built-in FM tuner. You can also listen to audio content stored on your Windows computer if you connect the MCX-2000 to your computer network (LAN). Since the MCX-2000 can access the internet through your computer network, you can even enjoy music from your favorite internet radio stations. When you play these audio sources on the main MCX-2000 itself, connect a speaker system (power amplifier and speakers, or powered speakers) to the unit.

- Playing Archived Music (page 46)
- Playing a CD (page 51)
- Listening to FM Radio (page 54)
- Listening to Internet Radio (page 59)
- Playing External Audio Signals (page 63)
- Playing Audio Content on the Computer (page 64)

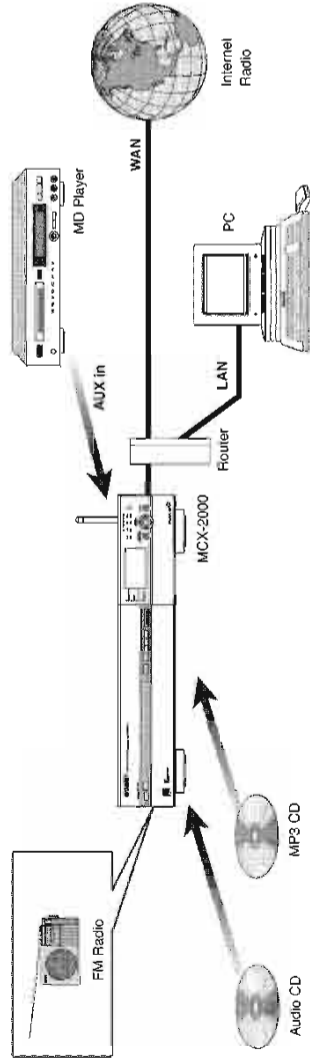

Audio Recording Functions

The MCX-2000 incorporates a large-capacity 160GB hard disk drive, allowing up to 200 hours of digital recording in linear PCM format (16-bit/44.1kHz) or up to 2,000 hours in MP3 format (160kbps bit rate). Recordable audio sources include commercial music CDs, external audio signals, and radio programs from the built-in FM tuner.

- Recording Songs from a Music CD (page 66)
- Recording from FM Radio (page 69)
- Recording External Audio Signals (page 69)

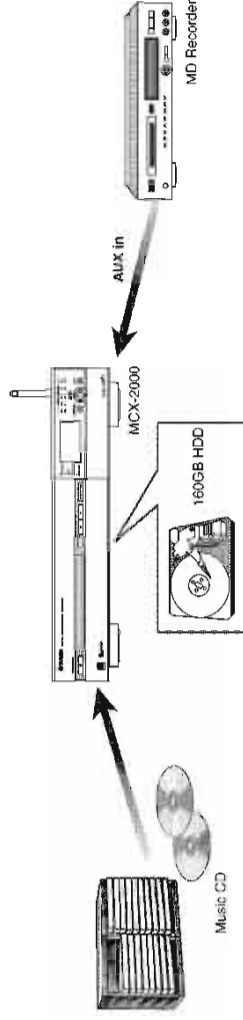

Music Archiving Functions

When recording audio sources, you can add information to each song—such as the song title, artist name, album name and genre—then store it to the music archive in the MCX-2000 hard drive. This information can then be used to find specific songs you want to play. Because the MCX-2000 incorporates a special song database system (based on Gracenote CDDB®), this information will be set automatically if your songs are from popular music CDs. Other useful functions include Playlist and Bookmark, letting you create custom song lists appropriate to specific occasions (such as parties, morning 'wake-up' music, etc.) and allowing you to mark your favorite tunes for quick access.

- Adding a Bookmark to a Song (page 50)
- Typing Text Characters (page 75)
- Editing Titles (page 77)
- Changing Song Attributes (page 77)
- Using a Playlist (page 82)
- Registering an Internet Radio Station (page 84)

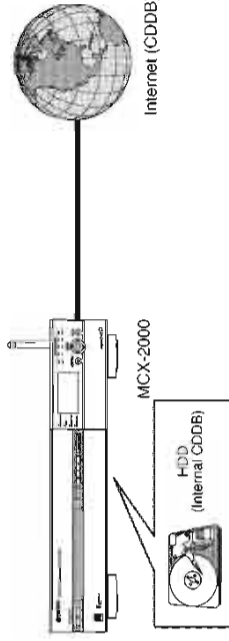

CD Recording Functions

This function lets you create a music mix CD of your own selections by arranging archived songs in your favorite order. You can also use this function to duplicate existing music CDs, allowing you to copy your personal mixes to CD and give it to your friends.

- Recording Archived Songs to a CD (page 73)
- Duplicating a Music CD (page 71)



Music Streaming Functions

Once songs are archived (recorded) on the MCX-2000 hard drive, you can stream them to up to 15 clients via the MusicCAST network. The MCX-2000 can deliver the same music to each client simultaneously (broadcast) or can also deliver different songs to different clients at the same time, at the request of each client. In addition, the MCX-2000 supports remote control of clients via the MusicCAST network, allowing you to operate them without having to go to each unit individually.

- MusicCAST as an Integrated Music Delivery System (page 66)
- Operating a Client Remotely (page 67)

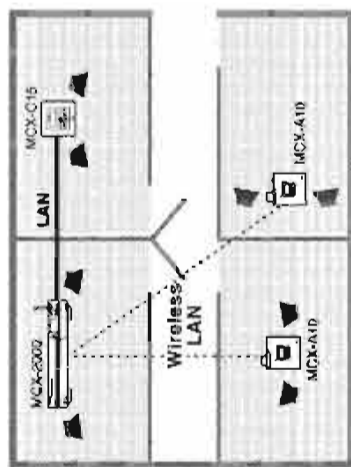

Timer Function

The MCX-2000 and clients incorporate a timer that enables song playback at a specified time. You can program up to ten playback timer instances for each MusicCAST device.

- Setting the Timer Playback (page 88)
- Using the Timer Playback (page 97)

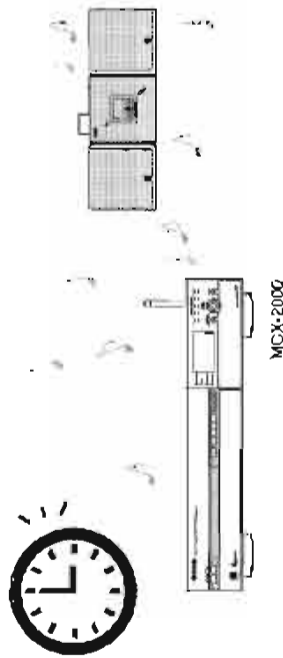

Connecting External Devices

Connect all relevant devices referring to the section "Panel Descriptions" (page 7) and the setup illustration below. Make sure each device is turned off before making connections.

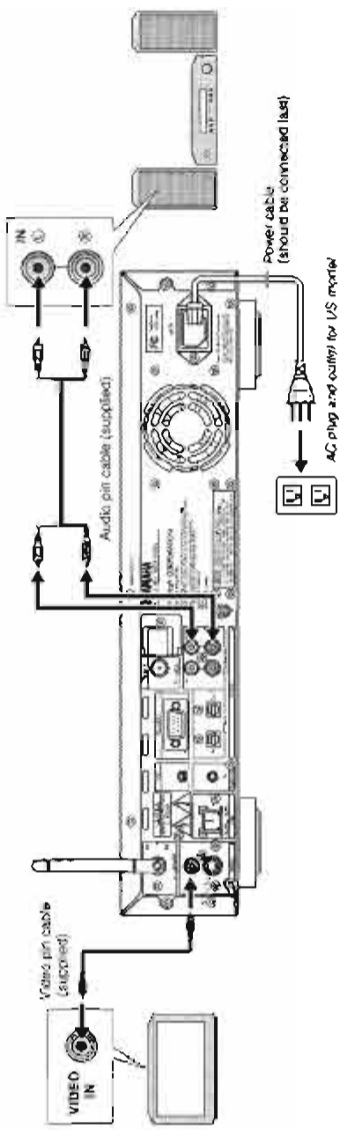

- The MCX-2000 is designed to connect to a TV monitor for easy operation. Though you can still operate the unit while viewing its front panel display, a large TV display offers more operation information at a time.
- The MCX-2000 accepts a generic PS/2 keyboard. This enables faster, more convenient operation than the remote control or front-panel buttons, especially when you edit song information or other text data.
- The MCX-2000 is designed to become active immediately after the power cable is connected to the AC power source. Make sure to connect to the AC power source only in the last step after all other devices are connected.

Connecting to the AC Power

When relevant external devices are all connected, turn on these devices first, and then connect the MCX-2000 power cable to the AC power source.

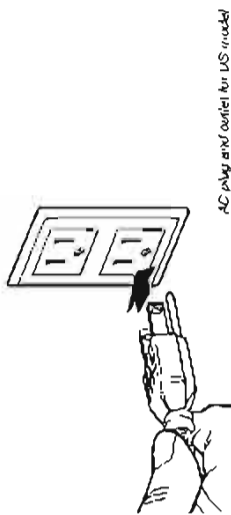

The front panel STANDBY/ON button indicator will light up in green. On the TV monitor, switch the video input source to the MCX-2000 video output (VIDEO or S-VIDEO). If the following screen is shown on the TV display, connection to the TV monitor has been successful.

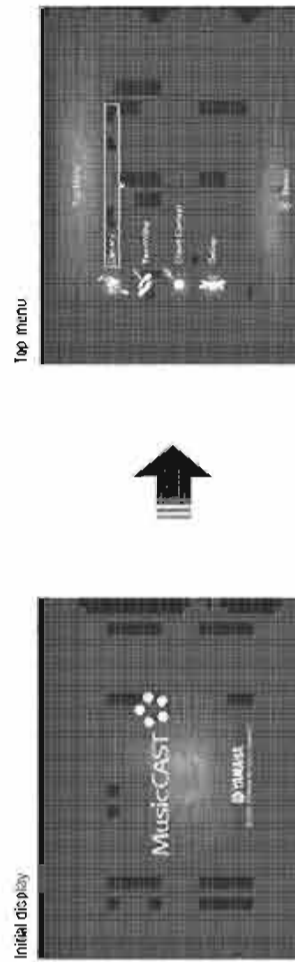

You can call up any necessary operation by selecting a menu item from the Top Menu. In addition, when you turn on the MCX-2000 for the first time after purchase, or after the system reset operation (page 103), the Easy Setup screen (page 27) will appear instead of the Top Menu screen.



NOTE If the indicator light of the STANDBY/ON button turns amber or red, press the button to continue working on the MCX-2000. The unit is designed to automatically go into an energy saving mode if no operations have been performed for a while. Read the following column for more information.

Operation Modes on the MCX-2000

The MCX-2000 has no switch to completely turn the unit off. When you connect the MCX-2000 to the AC power source, the front panel STANDBY/ON button indicator lights up in green and the MCX-2000 enters active mode. In this mode, you can record or play an audio source while viewing the built-in display or the TV monitor.

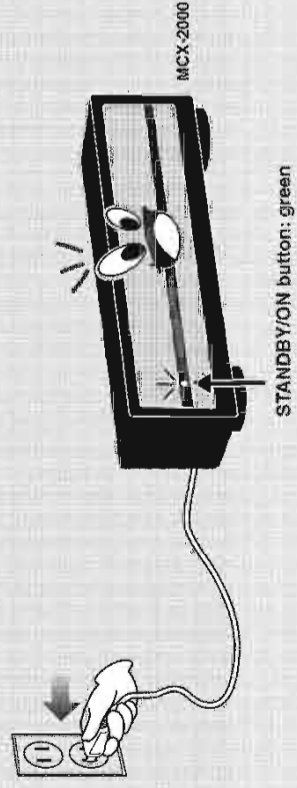

When you press the STANDBY/ON button on the remote control or the unit's front panel, the front panel STANDBY/ON button indicator light turns amber, and then the MCX-2000 enters sleep mode. In this mode, the MCX-2000 stops showing a screen on the TV monitor and built-in display, waiting for a client request or your remote control operation.

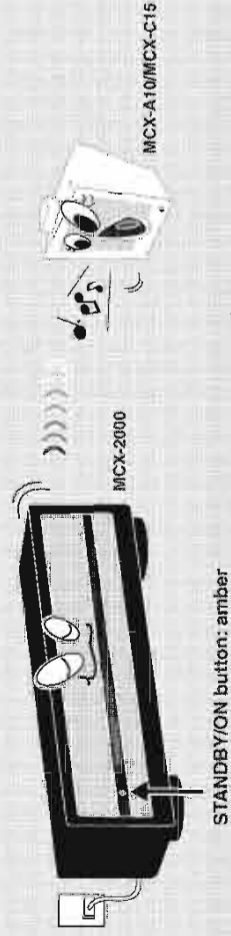

When you press the power switch on a client, it immediately establishes a network connection with the MCX-2000 and enters active mode. (The corresponding CLIENT STATUS indicator lights up on the MCX-2000.) The client shows Top Menu in the built-in display, and gets ready to play a streamed song from the MCX-2000.

As mentioned above, even in sleep mode, the MCX-2000 can still respond to a request from any registered client. This is because the MCX-2000 maintains network connections with clients. As long as network connections are maintained, the MCX-2000 can continue streaming music to clients. In fact, clients can continue playing a streamed song if the MCX-2000 later enters sleep mode.



If you hold down the STANDBY/ON button for more than 3 seconds when the MCX-2000 is in active or sleep mode, the indicator light turns red and the MCX-2000 enters standby mode, where the unit consumes less power. In standby mode, network activities between the MCX-2000 and clients stop. (All CLIENT STATUS indicators go off on the MCX-2000.) In this process, all active clients also enter sleep mode (Remote Sleep). They stop playing a streamed song (because of no network connection with the MCX-2000), and show the current time in the display without backlight. In sleep mode, clients wait for your operation and can awake the MCX-2000 to resume music streaming.

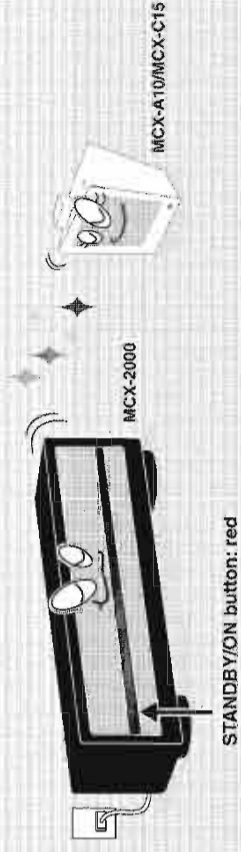

Let's say, standby mode is deep sleep. When a client sends a request, the MCX-2000 in standby mode notices it and enters lighter sleep mode. (The STANDBY/ON indicator light turns amber.) Otherwise, you can press the STANDBY/ON button to completely awake the MCX-2000 and make it enter active mode. (The STANDBY/ON indicator light turns green.) But, when the MCX-2000 directly enters active mode from standby mode, it first must re-establish network connections with clients, taking more time to resume network activities or music streaming.

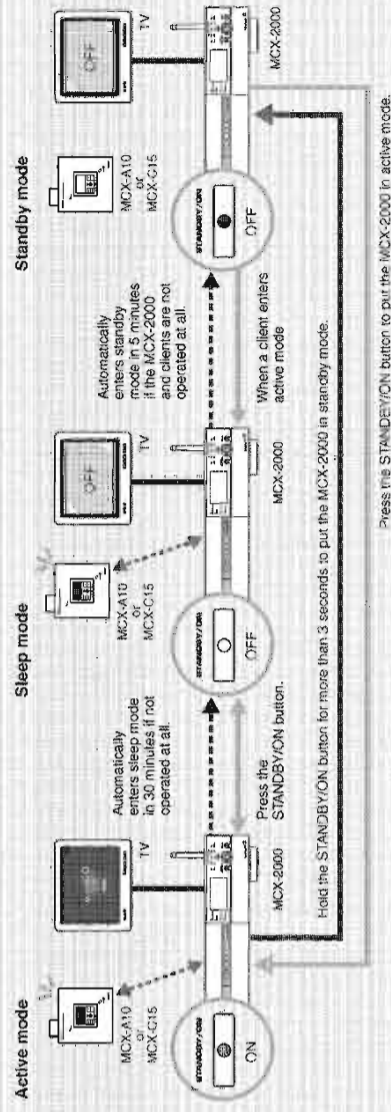

NOTE The MCX-2000 enters standby mode if it's been idle (with no operation on the unit or no network activities) for one hour. Press the STANDBY/ON button to put the MCX-2000 in active mode.

Configuring Your MusicCAST Network

After connecting necessary devices and cables to the MCX-2000 music server and clients (optional MCX-A10 or MCX-C15, or both), you can now configure a MusicCAST network customized for your specific needs. The MusicCAST network uses standard wired and wireless PC networking technologies, and the MCX-2000 allows both wired and wireless connections at the same time. The unit can also connect to the Internet and an existing computer network, enabling exceptionally flexible configuration of your MusicCAST network. In this section, we'll explain some network basics and give some configuration examples for different purposes. Examine these and see which MusicCAST network is best for you.

NOTE The MCX-2000 incorporates the Easy Setup feature (page 27) that helps you configure the best MusicCAST network for your environment. Since configuring a MusicCAST network requires some knowledge about computer networking, we recommend using Easy Setup for optimum results. When you configure a MusicCAST network for the first time, you need to manually operate the MCX-2000 and clients. For this reason, regardless of where each client is finally to be placed, bring the MCX-2000 and all of its clients together in one place to make these processes easier.

Network Basics

You can easily configure a MusicCAST network using the built-in networking features of the MCX-2000 and clients. The more you learn here about basic networking mechanism and terms, the more you will get out of your MusicCAST systems. Take the time to read this section carefully before configuring your MusicCAST network.

The MCX-2000 finds each client (or each client finds the music server) using a unique address assigned to the companion. This address is called *IP address* and is similar to the physical address of your house. We'll take this analogy a little bit farther and compare the server-client network relationship to the communication between you and your neighbor friend living on the same street.

An IP address is comprised of a *network address* and a *host address*, which are comparable to your street address and home address. The MCX-2000 can only communicate with clients that live on the same street (or have the same network address). Naturally, they are separate entities, and so each has its own unique host address in the same network.

If the MCX-2000 and its clients have a slightly different network address (or, in other words, have a different street, town, city or country name), they are no longer neighbors living on the same street.

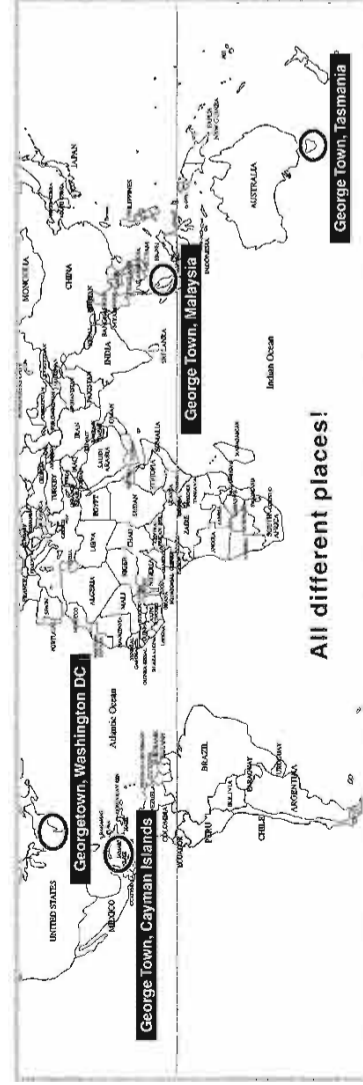

Fortunately, the MCX-2000 and its clients are designed to automatically have the same network address (factory settings). So, the first step of configuring a MusicCAST network is easily cleared. In other words, they are designed to live on the same street. The second step is to determine and assign a unique host address to each of them.

During automatic configuration of a MusicCAST network, the MCX-2000 utilizes a technique called DHCP (Dynamic Host Configuration Protocol) to assign a unique IP address to each client (DHCP server feature) and define where they are in the MusicCAST network. Once the music server and clients have a unique address in the MusicCAST network, they can find each other, and music streaming and other network communication becomes possible.

Configuration of a MusicCAST-only network

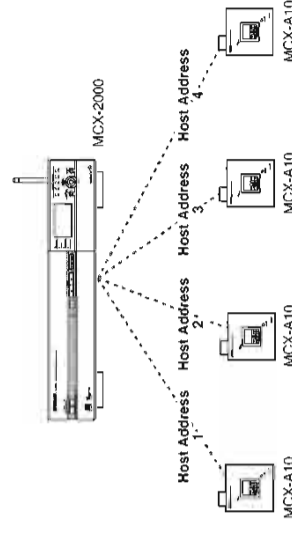

If you want to use the MCX-2000 for listening to music stored on a Windows PC, or if you want to connect the MCX-2000 to the Internet, you need to set the same network address to the Windows PC, the MCX-2000 and its clients. Once you do this, your MusicCAST network becomes integrated into your PC network.

You can easily create this integrated network. If your PC network is already connected to the Internet, simply connect the MCX-2000 to the PC network hub using a standard network cable. In this configuration, the MCX-2000 and its clients are automatically assigned a unique host address from the DHCP server in the PC network. As a result, your Windows PC, the MCX-2000 and its clients all belong to the same LAN.

Configuration of a MusicCAST network for PC network and Internet access

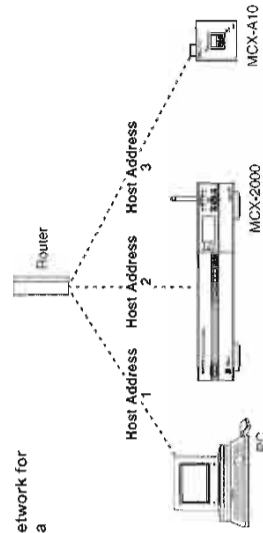

The DHCP server in your PC network might be a dedicated DHCP server (PC running DHCP server software). For most customers, the easiest way to deploy a DHCP service for a personal network is to use an equivalent feature of a commercial router product. (You may already have one for broadband Internet access.) The router is a dedicated device that sends and receives necessary information between networks while limiting unnecessary information or blocking unauthorized access from one network to another. Standard router products also offer a DHCP server feature.

Now perhaps you understand the basics of computer networks. The above two examples are typical (and among the easiest) configurations of your MusicCAST network. Of course, you can create other configurations based on your networking needs. In the following sections, we'll explain how to configure your MusicCAST network based on the above two examples.

NOTE You cannot set up the MCX-2000 (MusicCAST network) to directly connect to the Internet. Always use a router to bridge your MusicCAST network and the Internet.

Configuring a MusicCAST-only Network

The simplest and easiest way is to network the MCX-2000 and its clients in a wireless configuration. In a wireless MusicCAST network, the MCX-2000 can stream music to up to five clients within a range of 30 meters from the server. This is ideal for most houses, since the MusicCAST network can extend to any room without using a single network cable. With the wireless setup, you don't need to place the MCX-2000 and clients on the same floor. However, if there is an obstacle that blocks radio signals between the MCX-2000 and clients, music streaming may fall even though the devices are theoretically placed closely enough.

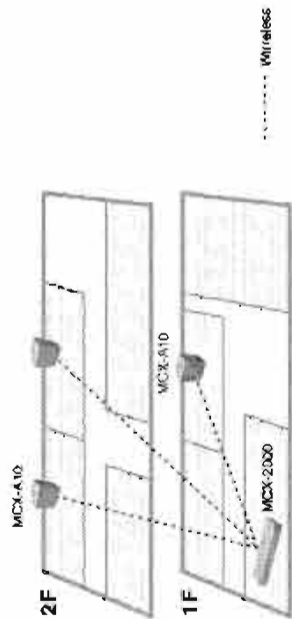

If you are planning to use the MusicCAST systems in a multi-floor shop (for example, in building larger than a family house), you may want to connect more clients using network cables. In addition to the five wireless clients, the MCX-2000 can support up to ten wired clients at the same time. The server can stream a different song to each client, or broadcast the same music to several clients. You can use these functions to create different moods in different rooms by streaming separate music to clients on each floor, all the while broadcasting the same music to maintain a unified image for the shop. You can even use the timer playback feature (page 97) to stream the same audio message to all clients at the specified time while they normally play different music.

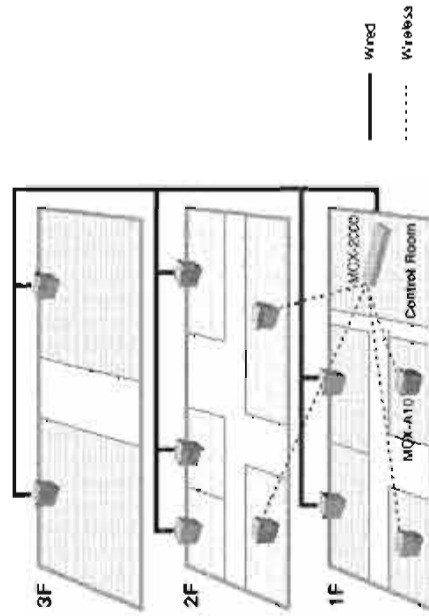

These two MusicCAST networks are easily configured using Easy Setup (page 27).

Configuring a MusicCAST Network for PC Network and Internet Access

Recently, many people are enjoying music using their computers. If you're managing a music collection on a Windows PC, you can also listen to songs from the collection on the MCX-2000. To enable this, just start networking between that PC and the MCX-2000 (page 31). If you already have a home network, simply connect the MCX-2000 to that network using a standard network cable. Next, install the supplied software application to the music PC, open the application, and you're ready to go. When you select "Network Content" for audio sources on the MCX-2000, the unit automatically locates the music PC in the network and displays a list of songs from the PC music collection. Simply select a song you want to listen from the list, and start playback (page 64). Once the MCX-2000 and PC is networked, you can also edit song data for the music archive on the MCX-2000 using a standard web browser on a computer in the PC network (page 76).

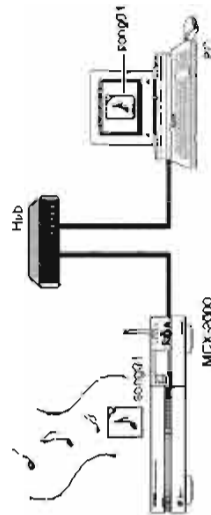

As a computer user, you're maybe using the Internet, or maybe sharing a broadband Internet connection with two or more computers in the same PC network. If this applies to you, we recommend to configure your MusicCAST network so that the MCX-2000 can access the Internet via your PC network (page 31). In this configuration, you can broadcast an Internet radio program to multiple clients (page 69), automatically get the latest song data from the online CDDB database, and regularly set accurate time to the MCX-2000 and clients using a public time server (page 91).

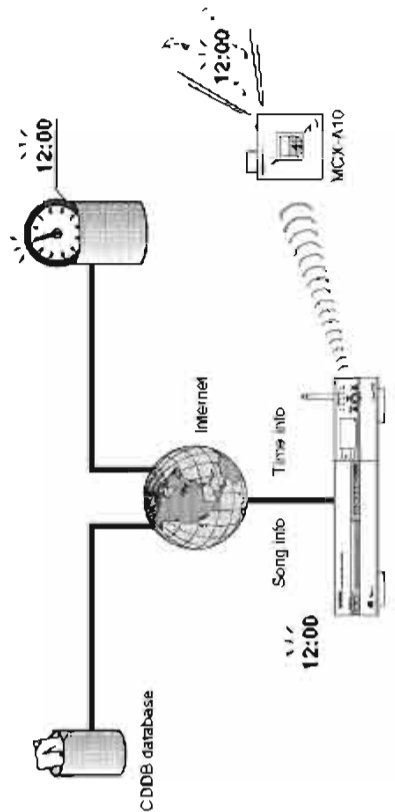

These two MusicCAST networks are easily configured using Easy Setup (page 27).

Using Easy Setup

You have many options to set up the MCX-2000 (setting parameters), and they serve as switch or data to make the MCX-2000 the best music server for you. So, you need to understand what each parameter does and set it up appropriately to create your MusicCAST network as purposed. You can manually set up all parameters one by one, but it's so painful. That's why we've prepared the Easy Setup feature as one of menu items. Using Easy Setup, you can set up the MCX-2000 quickly and create a purposed MusicCAST network very easily.

NOTE The front panel display doesn't show the Easy Setup screens. Operate the MCX-2000 watching your TV monitor that's connected to the MCX-2000 video output.

- 1 Press the TOP MENU button on the remote control, and select Top Menu > Setup > Easy Setup.

NOTE Skip this operation when you turn on the MCX-2000 for the first time after purchase, or after the system reset operation (page 103) because the Easy Setup screen will appear instead of the Top Menu screen.

- 2 In the first screen, you're asked to select a language used for menus and messages. Move the selection (highlight) to your desired language and press the SELECT button. (Turn on its radio button.)



- 3 When you go the next screen, you can see notes on Easy Setup. Read notes and, if you're ready, go to the next screen.



As above, Easy Setup lets you configure the MCX-2000 interactively. Simply continue selecting your preferred option(s) in each screen. And, you'll complete necessary settings for your MusicCAST network. We introduce several Easy Setup screens on the following pages. For details, see the guide messages shown in each Easy Setup screen.

Easy Setup Overview

Date and Time

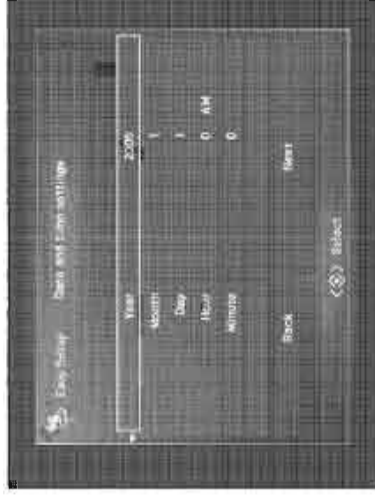

Move the highlight to a parameter you want to edit, and press the SELECT button. Scroll and display a desired value, and determine it using the SELECT button.

NOTE The MCX-2000 can get an accurate time from a public time server on the Internet (page 91).

MusicCAST System Configuration



Select from Stand-alone (no MusicCAST network) or Together with Clients (to enable music streaming).

Network Connection (stand-alone, without clients)



Select from No Connection (no PC or Internet access) or Existing Network (to enable PC or Internet access).

NOTE When using the MCX-2000 solely without clients, PC and Internet, Easy Setup finishes with this screen.

Network Connection (with clients)



Select from MusicCAST Only (no PC or Internet access) or PC Network Integration (to enable PC or Internet access).

Network Configuration

Available network configuration options may vary according to your selections.



Select from Automatic (with Internet access), Automatic (without Internet access) or Manual. It's recommended to select one of the Automatic settings (depending on your need) if you're unfamiliar with networking.

NOTE If you select Manual, Easy Setup finishes with this screen. You need to set up your MCX-2000 and MusicCAST network parameters manually. See "Manual Configuration of a MusicCAST Network" (page 35) for details.

While you answer these questions, Easy Setup determines network configurations you need. Unless you select to manually configure network parameters, Easy Setup finally shows a diagram of required physical network connections. (Your diagram may be different from the following ones.)

For the MCX-2000 to access the Internet via an existing PC network

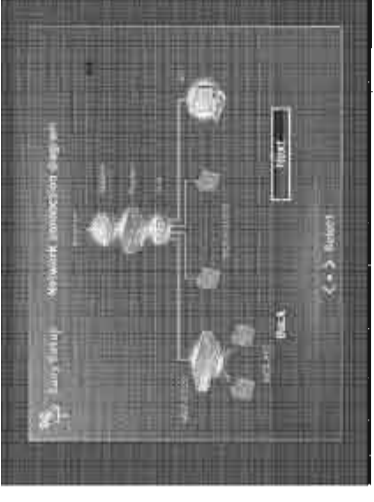

According to the diagram, connect the MCX-2000 Ethernet port to the network hub (or the one equipped with your router) using a standard network cable (CAT5 straight cable). Also, connect all wired clients (using a network cable for each) to the network hub connected to the MCX-2000.

NOTE When you have specified to use the MCX-2000 as a stand-alone unit with PC or Internet access, Easy Setup finishes after setting up network parameters.

For automatic configuration of a MusicCAST network



Consecutively, Easy Setup lets you register clients (page 32) and update their firmware (page 45). Easy Setup finishes when these processes are all complete.

Automatic Configuration of a MusicCAST Network

Your MusicCAST network is created when you register clients to the MCX-2000. Once this process is complete, the MCX-2000 and clients can quickly resume network connections even after you reconnect their power cable or awake the MCX-2000 from standby mode (page 14).

NOTE This section describes the procedure of Client Registration that is also available as a final step of Easy Setup (page 27). Though we explain here the procedure starting from the menu item selection, the registration process is identical. So, read this section as supplemental information when using Easy Setup.

Configuration examples:

MusicCAST-only network (without Internet access)

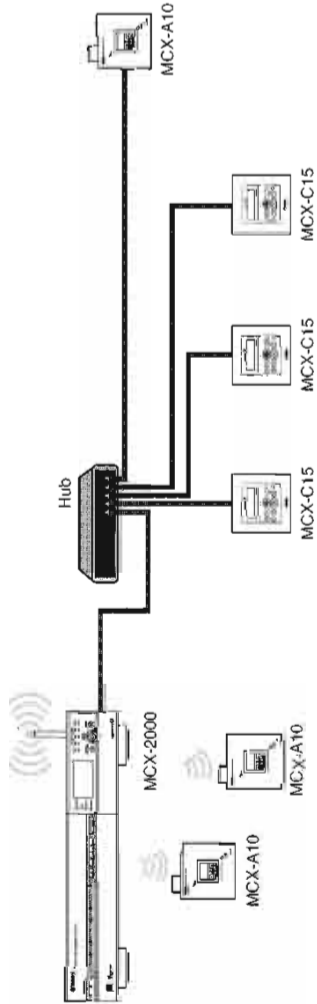

MusicCAST network integrated into a PC network (with Internet access)

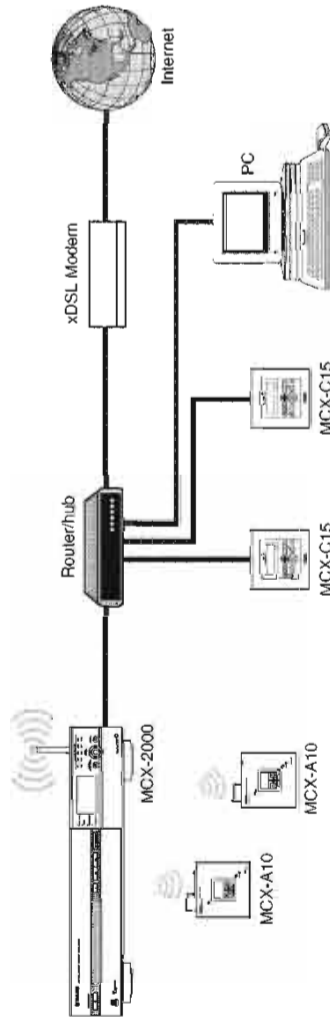

NOTE When you configure a MusicCAST network for the first time, you need to manually operate the MCX-2000 and clients. For this reason, regardless of where each client is finally to be placed, bring the MCX-2000 and all of its clients together in one place to make these procedures easier.

Preparation on the MCX-2000

- 1 Select Top Menu > Setup > Network.

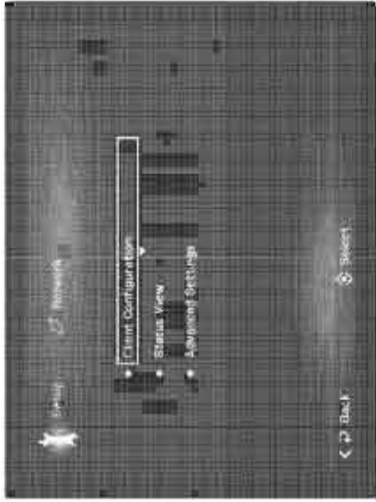

- 2 From the Network menu, select Client Registration > Auto Configuration.

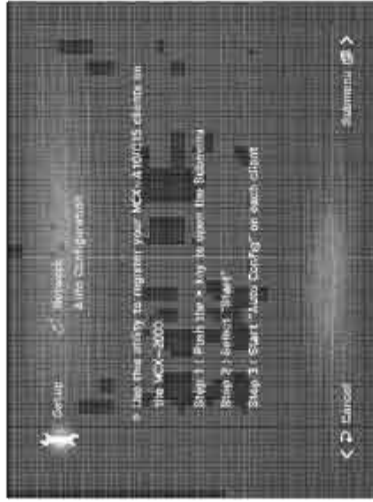

- 3 Open the Submenu in the Auto Configuration screen. Select Start from the menu.

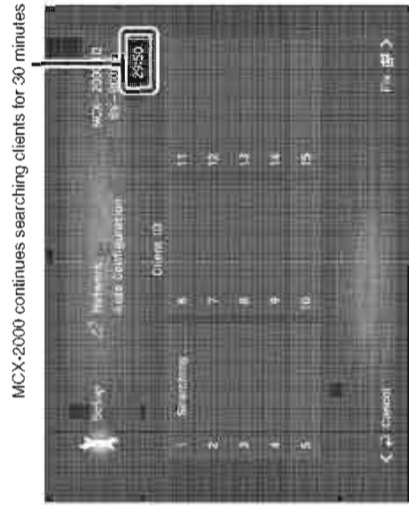

When the MCX-2000 starts searching available clients, register them within 30 minutes. With this screen shown on the MCX-2000, go and prepare each client.

NOTE When you see the "Cannot confirm IP address" message in the screen, there is no external DHCP server that assigns IP addresses to the MCX-2000 and MusicCAST clients. In this case, the MCX-2000 automatically enters DHCP Server mode (page 37). Simply select OK in the dialog box to continue auto configuration. Select Cancel if you want to set up an external DHCP server. Auto Configuration is canceled.

Preparation on Each Client

- 1 Turn on the client.
The front panel display lights up, showing the initial screen, followed by a "Connecting..." message.
NOTE If the client display shows the current time without backlight, it's in sleep mode. If this is the case, press the center stick of the cursor controller. The client wakes up and shows the above message.
- 2 The "Connecting..." message indicates the client is searching a MusicCAST server to establish a network connection. At this point, however, we have not completed any network configuration. So, when the client display shows a network icon, push the controller stick upward or downward to cancel the message. The client stops searching.



NOTE The wireless network icon doesn't appear on the MCX-C15 that supports only wired networking.

- 3 From Top Menu, select Setup > Network > Manual Setup > DHCP. Make sure the DHCP is enabled (ON).



- 4 Push the controller stick leftward twice to go back to the Network screen. Select Auto Configuration (Top Menu > Setup > Network > Auto Configuration).

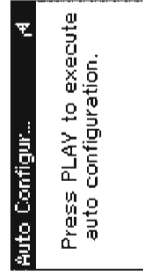

With this screen shown on each client, you can start automatic configuration of a MusicCAST network.

Automatic Registration of Clients

Before configuring a MusicCAST network through automatic Client Registration, be sure to connect any wired clients to the network hub connected to the MCX-2000. (If you want to integrate your MusicCAST network into an existing PC network, connect both the MCX-2000 and wired clients to the PC network hub.)

- 1 On each client, press the front panel Play button as the Auto Configuration screen is shown. Notice the client display shows the following messages in a short period.

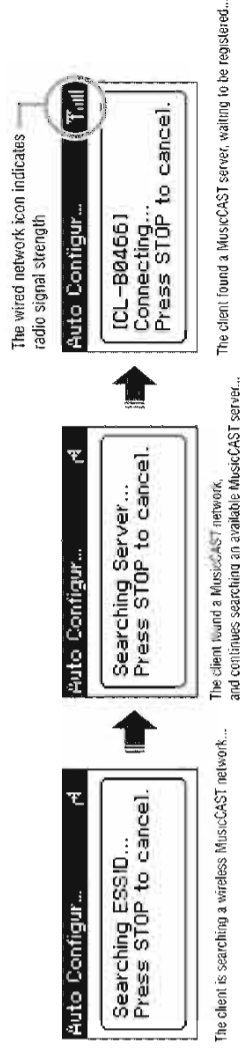

- 2 As soon as the client display shows its ID (CL-XXXXX: a 5-digit unique number to each client), the MCX-2000 will also show the same client ID in the registration screen.

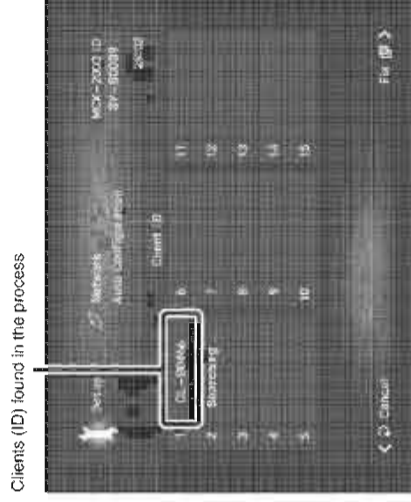

NOTE Each client display continues showing "Press STOP to cancel" during the registration process. If you press the Stop button, the registration process for that client will be canceled. Normally, you don't need to operate clients after you pressed the Play button in step 2.

- 3 When the MCX-2000 found all clients, open the Submenu (Fix) in the registration screen. Select OK from the menu. The MCX-2000 shows "Saving..." and registers the clients it found. Each client display shows "Complete!" for a second.
Now that the MCX-2000 and each client recognized and memorized each other, your MusicCAST network is successfully created. Go to Applications section (page 46) and enjoy MusicCAST.

NOTE When networked with the MCX-2000 for the first time, your clients must be updated before actual use (page 45).

Manual Configuration of a MusicCAST Network

There may be a case you need to assign a fixed IP address to the MCX-2000 and clients to integrate a MusicCAST network into a PC network that has no DHCP server. You can solve it by manually configure some or all of network parameters of the MCX-2000 and clients. We explain here several points you should remember when configuring a MusicCAST network manually.

Configuration example:

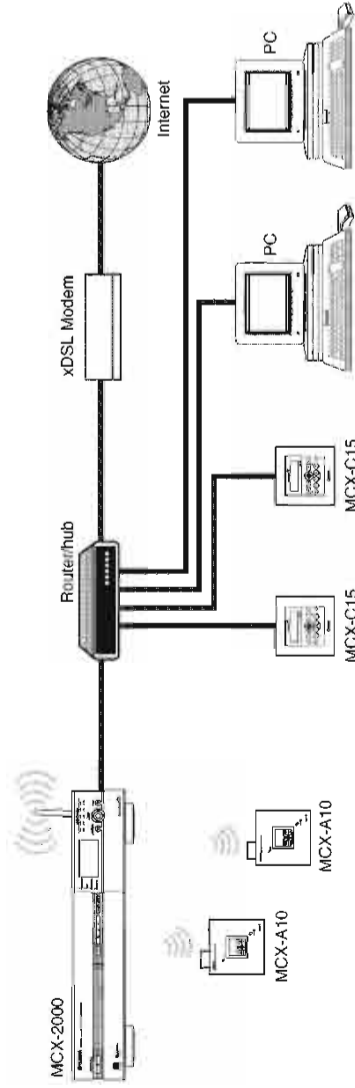

NOTE Though the MCX-2000 has two physical network ports (wired and wireless), these ports internally share a single (identical) IP address. So, you cannot use these ports for two separate network connections. In addition, the MCX-2000 doesn't support music streaming to a remote client over the router (Internet). Always use the MCX-2000, its clients and a PC that's used to communicate with the MCX-2000 within the same network (LAN).

Checking Out Parameter Values

Before manually setting up the MCX-2000 and clients, check out the following values for MusicCAST and PC network integration:

- IP addresses (unique values, not used with other devices in the PC network)
- Subnet mask (the same value as used with other devices in the PC network)
- Gateway (router IP address; essential to connect the MCX-2000 to the Internet)
- DNS server (name server IP address; at least one DNS server is necessary to specify an NTP server (page 91) with its domain name for retrieving accurate time for the MCX-2000 date and time settings)

Network parameter values shown above are very important for successful networking. You must consider how your MusicCAST network is configured for your specific need, and define each parameter value to set up your network as purposed. It's recommended to write down your network plan with appropriate values in the following chart.

System Unique Information	Server/Client ID	MCX-2000	Client (1)	Client (2)	Client (3)	Client (4)
Setting Method	DHCP Server / DHCP Client / Manual	DHCP Server / DHCP Client / Manual	DHCP Client / Manual	DHCP Client / Manual	DHCP Client / Manual	DHCP Client / Manual
IP Address (when DHCP is disabled)		(Specify a valid IP address below with Manual.)	(Specify a valid IP address below with Manual.)	(Specify a valid IP address below with Manual.)	(Specify a valid IP address below with Manual.)	(Specify a valid IP address below with Manual.)
Subnet Mask	
Gateway Address	
Primary DNS	
Secondary DNS	
NTP Server (only when used) (Server domain name when DNS is specified; Server IP address when DNS is not specified.)						
ESS ID (up to 13 ASCII characters)						
WEP Key (up to 13 ASCII characters)						
Channel						

NOTE If you have more than 4 clients, copy the blank chart above and substitute the appropriate client numbers as needed.

Settings on the MCX-2000

- 1 Select Top Menu > Setup > Network > Advanced Settings.

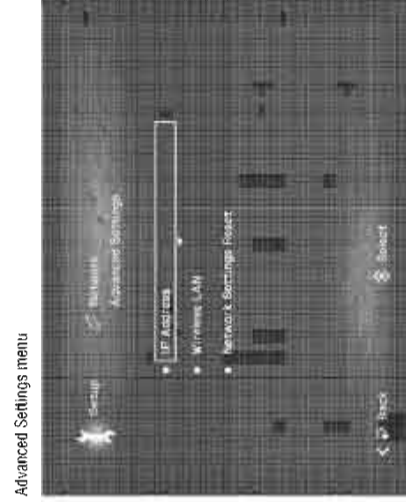

- 2 From the above menu, select IP Address or Wireless LAN as needed, and set up the relevant parameters shown in the screen.

NOTE If you reconfigure your MusicCAST network because you have changed the target PC network configurations, you may want to clear existing MCX-2000 network settings using the Network Settings Reset command from the above menu (page 100).

IP Address

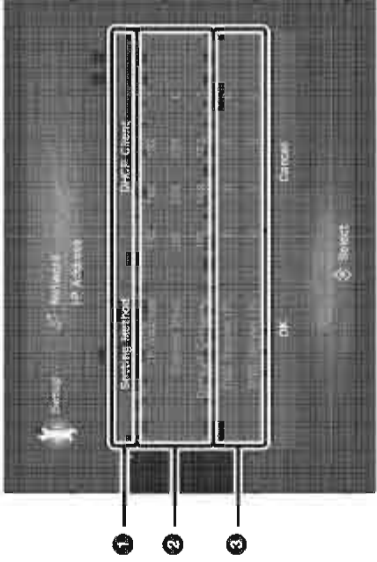

1 Setting Method

Specifies a DHCP operation of the MCX-2000. When the MCX-2000 has a 'wired' connection to a PC network and finds a DHCP server there, it enters DHCP Client mode and gets an IP address from the server. (Accordingly, clients will also get an IP address from the same server.) If the MCX-2000 finds no DHCP server in the connected network, it automatically enters DHCP Server mode. (Clients will get an IP address from the MCX-2000.) Because of this scheme, you normally don't need to change this setting as long as you want to automatically configure a series of network parameters. Select Manual if you really need them to set up manually.

NOTE When you select Manual, you must assign each of the MCX-2000 and clients a unique IP address conforming to the connected PC network (page 23).

2 IP Address, Subnet Mask, Default Gateway

When selecting DHCP Server or Manual for Setting Method, specify an IP address within the network address of the connected PC network. Among these three parameters, only IP Address takes a 'unique' value to the MCX-2000. Subnet Mask and Default Gateway should take the same values with a PC that's manually configured to access the Internet via the connected network. Default Gateway normally takes an IP address set to the router LAN port (supposing the router WAN port is connected to a broadband modem).

3 DNS Server (P), DNS Server (S)

When selecting DHCP Server or Manual for Setting Method, specify IP addresses of primary (P) and secondary (S) DNS servers provided from your Internet service provider. These values (at least one) are necessary if you use URL to specify an Internet resource (server) available to the MCX-2000, such as a public NTP server to get accurate date and time (page 91). If you specify such a resource using the IP address, you can leave these values blank.

When you complete necessary settings, select OK at the bottom of the screen. When the "Network rebooting..." message is shown and your settings are stored, you will return to the Advanced Settings menu.

Wireless LAN

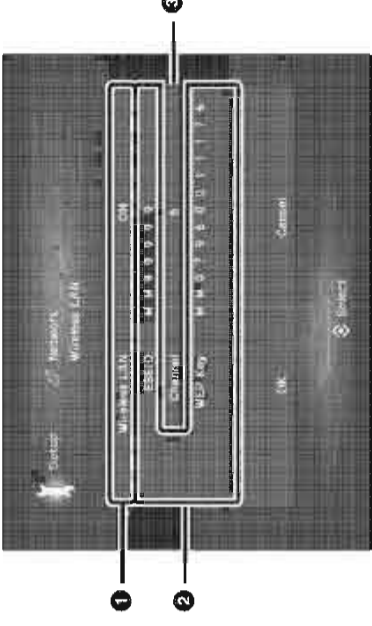

1 Wireless LAN

If you use the wireless functions in your MusicCAST network (or you have a client wirelessly communicating with the MCX-2000), specify ON to enable the wireless access point feature built into the MCX-2000.

2 ESS ID, WEP Key

ESS ID is a name of the wireless network configured by the MCX-2000 wireless access point feature, and WEP Key is a password for clients to log onto the network. If you're using a wireless access point for PC networking, MusicCAST clients only connect to the wireless access point created by MusicCAST servers including the MCX-2000. Since each MusicCAST server is preconfigured with unique ESS ID and WEP Key values, you normally don't need to change them.

NOTE The MCX-2000 supports a 104-bit WEP key (precisely, a 128-bit long key with initialization data), which is equivalent to 13-ASCII characters. If your 'password' is less than 13 characters, the MCX-2000 will internally complement it. In addition, the MCX-2000 doesn't support hexadecimal WEP keys.

3 Channel

The Channel parameter is used to avoid radio interference between the MCX-2000 and a device that uses the same 2.4 GHz radio signal range (such as microwave oven, wireless handset, or other wireless access point). You don't need to change the Channel value unless you're experiencing a problem such as interrupted playback of streamed music or unstable wireless networking.

When you complete necessary settings, select OK at the bottom of the screen. When the "Network rebooting..." message is shown and your settings are stored, you will return to the Advanced Settings menu.

NOTE If you want to access the MCX-2000 from a wireless computer to edit names or titles (page 73), install a wireless access point in your PC network. The wireless access point feature built into the MCX-2000 is available only for MusicCAST clients registered to the MCX-2000 (through automatic or manual configuration).

Settings on Each Client

- 1 Turn on the client.

The front panel display lights up, showing the initial screen, followed by a "Connecting..." message.

NOTE If the client display shows the current time without backlight, it's in sleep mode. If this is the case, press the center stick of the cursor controller. The client wakes up and shows the above message.

- 2 The "Connecting..." message indicates the client is searching a MusicCAST server to establish a network connection. At this point, however, we have not completed any network configuration. So, when the client display shows a network icon, push the controller stick upward or downward to cancel the message. The client stops searching.

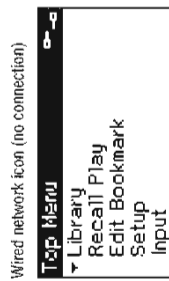
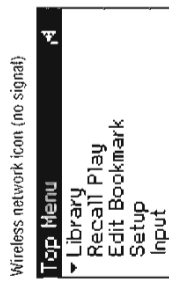

NOTE The wireless network icon doesn't appear on the MCX-C15 that supports only wired networking.

- 3 From Top Menu, select Setup > Network > Manual Setup.



From the above menu, select a parameter and set it up as needed.

NOTE You may perhaps choose manual configuration of network parameters just because you want to opt on top of your MusicCAST network. It's however, not so practical with MusicCAST clients. They're designed to get appropriate parameter values during automatic registration process (page 31), so manual configuration should be done to "edit" retrieved settings according to your special needs.

Mode



Specify how this client can connect to a MusicCAST network. With Wireless, its wireless network port is only enabled, disabling its wired (Ethernet) network port. With Auto, the client connects to the MCX-2000 via either active network port (factory setting). When using the wireless port, the ESS ID and WEP Key parameters should be configured according to the target MCX-2000 server.

When you select and determine a value, the "Press PLAY to system restart, STOP to cancel." message is shown. If you press the front panel Play button, the client will restart to enable the change. Press the front panel Stop button to abort your change. Push the controller stick leftward to go back to the Manual Setup menu.

NOTE Wired-only clients (MCX-C15) don't have this parameter.

Server ID

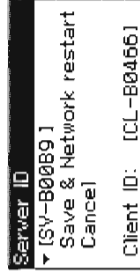

Specify the target MCX-2000 with its ID (SV-XXXXX: a 5-digit unique number to each server). You can confirm the MCX-2000 server ID on your TV monitor, by selecting Top Menu > Setup > Network > Client Configuration > Manual Configuration. You can also confirm client IDs in the MCX-2000 screen if you previously performed the automatic registration (page 34). Client IDs will be required later in manual registration process (page 43), so it's recommended to write them down in your setup chart (page 36) at this point.

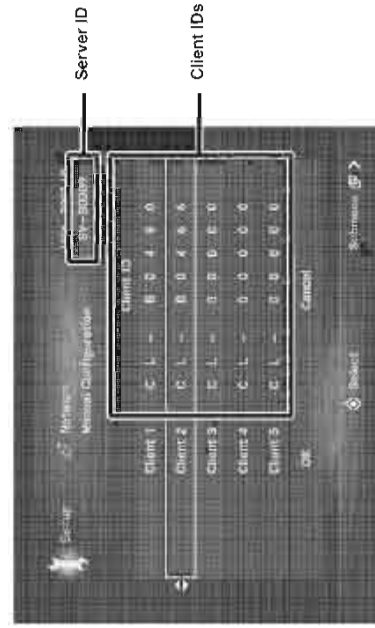

When you have finished, select and determine Save & Network Restart. When the "Please wait." message is shown and your setting is stored, you will go back to the Manual Setup menu. If you abort your change, select Cancel or push the controller stick leftward.

DHCP



Specify ON to automatically get an IP address from the MCX-2000 or a DHCP server (or an equivalent router function) in your PC network (factory setting), or OFF to manually specify on this client. When you select OFF, you need to specify appropriate values to the IP Address and Subnet Mask parameters.

When you select either value, the "Please wait." message is shown. When your setting is stored, you will go back to the Manual Setup menu.

IP Address

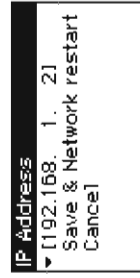

Specify an IP address within the same network address as the target MCX-2000. This value must be unique and shouldn't duplicate the one used for the MCX-2000, other MusicCAST clients or devices in the target PC network. The specified IP address only works when the DHCP parameter is set to OFF (when this client doesn't get an IP address from the MCX-2000 or a DHCP server in your PC network).

When you have finished, select and determine Save & Network Restart. When the "Please wait." message is shown and your setting is stored, you will go back to the Manual Setup menu. If you abort your change, select Cancel or push the controller stick leftward.

Subnet Mask



Specify the same subnet mask value as the target MCX-2000. The specified subnet mask value only works when the DHCP parameter is set to OFF (when this client doesn't get an IP address from the MCX-2000 or a DHCP server in your PC network).

When you have finished, select and determine Save & Network Restart. When the "Please wait." message is shown and your setting is stored, you will go back to the Manual Setup menu. If you abort your change, select Cancel or push the controller stick leftward.

ESS ID

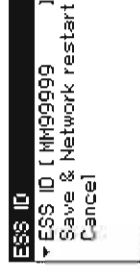

Specify the ESS ID for the wireless network created by the target MCX-2000. You can confirm the MCX-2000 ESS ID, by selecting Top Menu > Setup > Network > Advanced Settings > Wireless LAN.

When you have finished, select and determine Save & Network Restart. When the "Please wait." message is shown and your setting is stored, you will go back to the Manual Setup menu. If you abort your change, select Cancel or push the controller stick leftward.

NOTE Wired-only clients (MCX-C15) don't have this parameter.

WEP Key

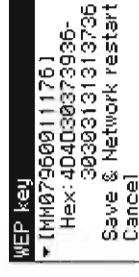

Specify the WEP key for the wireless network created by the target MCX-2000. You can confirm the MCX-2000 WEP key, by selecting Top Menu > Setup > Network > Advanced Settings > Wireless LAN. In addition, you can also view the WEP key in hexadecimal (HEX) in the client display (just for confirmation).

When you have finished, select and determine Save & Network Restart. When the "Please wait." message is shown and your setting is stored, you will go back to the Manual Setup menu. If you abort your change, select Cancel or push the controller stick leftward.

NOTE Wired-only clients (MCX-C15) don't have this parameter.

Manual Registration of Clients

Unlike automatic registration (page 34), configuring a MusicCAST network through manual registration is completed with setup on the MCX-2000 only.

- 1 Select Top Menu > Setup > Network.

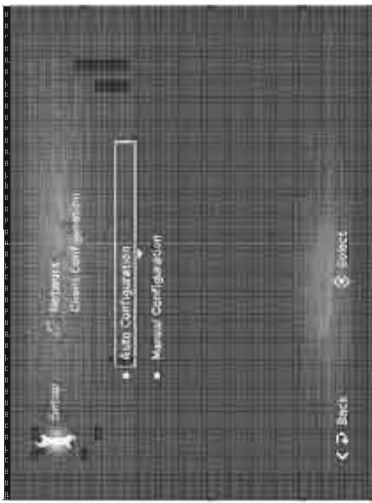

- 2 From the Network menu, select Client Configuration > Manual Configuration.

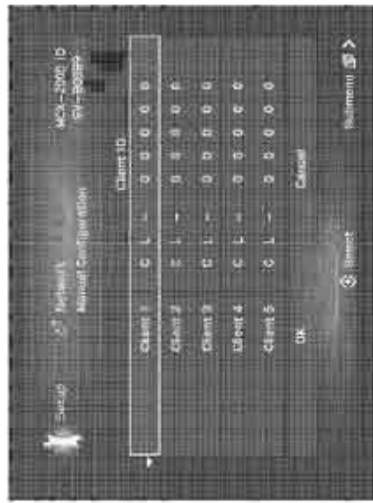

- 3 Input each client ID to one of the Client 1 to Client 15 columns (up to 15 units), while viewing the setup chart. You can input your client ID to any column. (Client numbers correspond to the front panel CLIENT STATUS indicators.)



Move the highlight (selection) using the up and down arrow buttons on the cursor controller, press the SELECT button to select a column. Input a 5-digit ID number after "CL-". Use the left and right arrow buttons to move between digits, and the up and down arrow buttons to select a character. When you've finished, press the SELECT button to determine it.

NOTE While you're moving the highlight (not actually editing), you can access the Submenu. The Reset this Client command lets you reset the ID number in the current column to an initial value (CL-00000). The Reset all Clients command lets you clear all clients currently registered to the MCX-2000, resetting all ID numbers at a time. You can also use the Change Client order command to arrange the order of listed clients. Changing the client order resets each client name to the default (Client #). So, be sure if you've renamed them in the Client Control screen (page 87).

- 4 When you have finished specifying all of your clients, select OK at the bottom of the screen. After showing the "Network rebooting..." message, the MCX-2000 restarts itself attempting to create a MusicCAST network with registered clients. Confirm your manual registration has been successful in the next section.

Confirming Network Status

During and after manual registration, your MusicCAST clients don't show any message like "Complete," in automatic registration. So, you need to confirm they're successfully registered and able to communicate with the MCX-2000 over the network.

- 1 Make sure each registered client is turned on.
- 2 On the MCX-2000, select Top Menu > Client Control for the following screen.

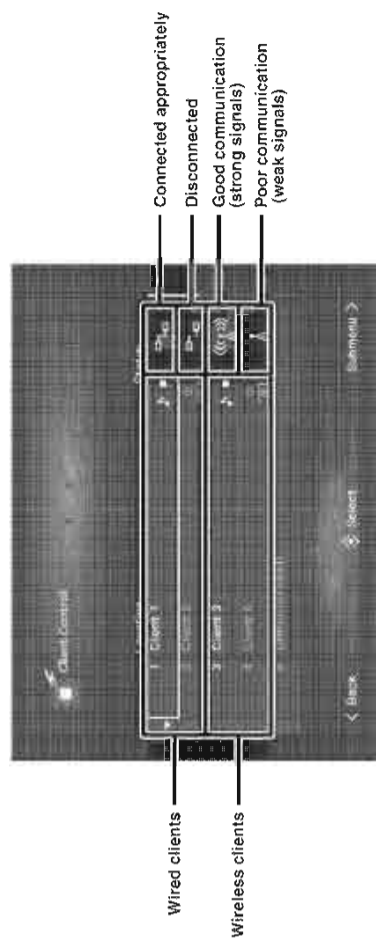

In this screen, you can view the current status of your MusicCAST network (connected clients). When the network icon in the Status column is an appropriate one, the MCX-2000 and that client is well communicating over the MusicCAST network.

NOTE If a wireless client is shown with weak signals, it might be caused by how and where you placed that client. If you start music streaming from the MCX-2000 and experience a problem such as interrupted playback, consider relocating it or connecting to the MCX-2000 using a network cable. If a client is obviously turned on (active), but shown with a "no signal" wireless icon or a "disconnected" wired icon, you might have misconfigured. Check the network settings with your setup chart.

When the MCX-2000 and each client are well communicating, your MusicCAST network has successfully been created. Go to Applications section (page 46) and enjoy MusicCAST.

NOTE When networked with the MCX-2000 for the first time, your clients must be updated before actual use (page 46).

Updating Client Firmware

To fully enjoy music streaming over a MusicCAST network, you must first update all of your MusicCAST clients to match up to the latest features the MCX-2000 delivers. Update each client firmware in the following procedure. (You don't need to operate the MCX-2000.)

NOTE If you already updated the client firmware using Easy Setup, this process isn't necessary.

- 1 Select Top Menu > Setup > System > System Update.



- 2 With the above screen shown, press the front panel Play button.



Your client receives the latest firmware from the MCX-2000, and then updates the content in its flash memory. During the update process, the client display shows several messages. When the "Update OK" message is finally shown, your client restarts itself.

- 3 When the client establishes a network connection with the MCX-2000 and shows the Top Menu screen, the update process is complete. If you're using two or more clients, repeat the above procedure.

NOTE We endeavor to keep our products better. When a future version of the MCX-2000 firmware is available, first update your MCX-2000 with the specified procedure (page 103), and then update your client firmware with the above procedure.

About Digital Recording with MusicCAST

Rules of Digital Recording

SCMS-Serial Copy Management System

As a digital audio component, this unit conforms with the Serial Copy Management System (SCMS) standards. The Serial Copy Management System restricts copies made by recording digital signals to first-generation copies only. The digital program sources that have been recorded cannot be digitally recorded again.

There are two rules as follows:

Rule 1

Digital sources such as commercially available CDs can be copied digitally onto other recordable digital media with this unit (a first-generation digital copy). However, the first generation digital copy cannot be copied digitally any further.

Rule 2

The source that was recorded via the **ANALOG IN** jacks can be copied digitally onto other recordable digital media (a first-generation digital copy). However, the first generation digital copy cannot be copied digitally any further. The server automatically detects whether it is able to store a CD digitally on its hard disk drive (the default setting is to store digitally).

Source sampling rate conversion

- Digital input of this unit supports sampling frequencies of 32 kHz, 44.1 kHz, 48 kHz, and 96 kHz. This unit converts these inputs to 44.1 kHz, 16-bit digital signals and records them onto the HDD, or a CD-R or CD-RW disc.
- Analog input is also converted to the same digital signal to be recorded.
- This unit outputs the signals at the sampling frequency of 44.1 kHz, 16-bit from its digital output.

Recording of non-audio signals

- This unit is designed exclusively for recording audio signals. Recording is only possible for audio signals.
- When a CD with CD-TEXT is recorded from an external CD player, CD-TEXT cannot be copied even if it is not copy protected. To copy CD-TEXT, select the CD-TEXT option when you store a CD on the hard disk drive of the server.
- If the digital signals contain graphic data such as CD graphics, the non-audio signals will not be recorded.
- It is not possible to record from non-audio sources such as CD-ROM or DVD.
- For the above reasons you may encounter difficulty storing CD-TEXT. We recommend using the internal Griacenote CDDB Music Recognition Service as a source of information when storing CDs.

Notes on the MusicCast system

Number of recordable discs and tracks and their length

- The server can record up to 99 songs to a CD-R or CD-RW.
- The server can store up to 1000 songs in an album.
- Once the maximum number of tracks has been recorded to a disc or album, no further recording is possible, even if space for recording is available.
- The minimum length of one track is 4 seconds. The maximum length of one track is 99 minutes 59 seconds for the HDD.
- The MusicCAST can store up to 10000 albums and 65,000 songs. However the number of albums you can create is also limited by the availability of space on the hard disk drive.
- When recording on a CD-R or CD-RW disc, a 2-second silence is automatically added to the beginning of the first track. Therefore the actual total recordable time will be 2 seconds shorter than the total recordable time of a CD-R or CD-RW disc.

Glossary

This manual uses a number of terms that, though not specific to the MusicCAST system, are not in general everyday use. In addition, some terms are used in a slightly unusual context. These words are listed alphabetically and in context below, along with an explanation of their meaning.

Playback

MP3 format

A data format used to store music on the hard disk drive in the server. MP3 files take roughly one tenth of the space that PCM files take to store the same song. However, sound quality is not as good as that of PCM files, and the server cannot record MP3 files to a CD-R.

PCM format

A data format used to store music on the hard disk drive in the server. PCM files provide CD quality audio playback but require a lot of space on the hard disk drive.

Storing

Copying the tracks on a CD onto the hard disk drive in the server.

Album

A collection of songs in the MusicCAST database assigned to a particular artist, and given a name. Each album is assigned to an artist. By default, each CD you store in the server stored as an Album.

Artist

The item in the MusicCAST database to which albums are assigned. The artist of any CD you store in the MusicCAST is stored as the artist to the corresponding album (see album above).

Bookmark list

A list of songs you have designated for easy retrieval.

Genre

The music type to which the albums stored in the server are assigned. Examples include Jazz, Rock, and Classical.

Group

The category which you are operating your MusicCAST component in. For example, if you play an album without selecting a song, then you are operating within the "album" category. If you play a genre without selecting a song, you are operating within the "genre" category.

Playlist

A list of songs you designate using the server for playback in a given sequence.

Song

A single continuous track, equivalent to a single track from a CD, cassette, or other source, stored on the server.

Recording

CDDB

The CDDB (Gracenote CDDB Music Recognition Service) is a database which you can access to gain information on the songs, artists, genre, and album names for music CDs.

CD-TEXT

Data encoded on some CDs which contains information on its song titles, album, artist, and genre names.

Encoding

The process of converting PCM data stored from a CD into MP3 data.

Subnet mask

A number identifying the group within a network to which a particular component belongs.

TCP/IP

An abbreviation of Transmission Control Protocol/Internet Protocol, a system of coding information that allows it to be shared efficiently on a network.

WEP

An abbreviation of Wired Equivalent Privacy. This system encrypts data transferred between the components on a wireless network. Components with the same encryption key can share data with each other, but components without this key cannot.

Wireless LAN

A network utilizing weak radio signals to share data between components.

Wired LAN

A network utilizing network cables to share data between components.

Hardware

CD

An abbreviation of Compact Disc. A small plastic disc 12 cm (4.8 in) in diameter encoded with pre-stored data.

CD-R

An abbreviation of Compact Disc Recordable. A small plastic disc identical to a CD in appearance, onto which a device such as the server can record data. The server can only record to Audio type CD-R media.

CD-RW

An abbreviation of Compact Disc Re-writable.

Client

See "Digital Audio Terminal".

Controller

The device on the front panel of the server and client used for entering data and navigating through the menus contained in these two components.

Digital Audio Server

The component in the MusicCAST system that you use to store and playback songs. Other components in the MusicCAST system obtain song data from the server.

Digital Audio Terminal

The component in the MusicCAST system that allows access to songs stored in the server for playback at a distance. Up to 7 Digital Audio Terminals (clients) can access the server at once.

Front panel

The panel on the front of the server and client with the LCD display, controller and various control keys are located.

Hard disk drive

The component within your server used to store the audio material from your CDs as data. Hard disk drive capacity is expressed in gigabytes, with a larger number denoting more storage capacity.

Remote control

A handheld device for operating your MusicCAST components from a distance.

Server

See "Digital Audio Server".

Software

Database

The organized collection of data stored on the hard disk drive in your server. The data is arranged in a logical manner so that it is easy to access, manage, and update.

Menu

A display consisting of a multiple choice style list of options that you can choose from. Menus are displayed on the on-screen displays of the client and server.

On-screen display

The LCD display on the client or the display output to a TV or monitor connected to the server.

MCX-2000

