

DIGITAL AUDIO TERMINAL/SPEAKER SYSTEM MCX-A10/MCX-SP10

SERVICE MANUAL

The MusicCAST system consists of the MCX-1000, the MCX-A10 and the MCX-SP10.

This service manual is for the MCX-A10 and the MCX-SP10. For the MCX-1000 service manual, please refer to the following publication number:

ミュージックキャストシステムはMCX-1000、MCX-A10及びMCX-SP10で構成されています。

このサービスマニュアルはMCX-A10及びMCX-SP10用です。MCX-1000のサービスマニュアルは下記を参照してください。

MCX-1000

100851

MCX-1000

100851

When accepting a repair request from the user, be sure to let him/her know that the stored HDD data cannot be guaranteed.

For the repair work, it is recommended to receive MCX-1000 and MCX-A10 as a set.

修理依頼を受ける際、HDDのデータは保証できないことをお客様に伝えてください。

修理品はMCX-1000とMCX-A10をセットでお預かりすることを推奨します。

IMPORTANT NOTICE

This manual has been provided for the use of authorized YAMAHA Retailers and their service personnel. It has been assumed that basic service procedures inherent to the industry, and more specifically YAMAHA Products, are already known and understood by the users, and have therefore not been restated.

WARNING: Failure to follow appropriate service and safety procedures when servicing this product may result in personal injury, destruction of expensive components, and failure of the product to perform as specified. For these reasons, we advise all YAMAHA product owners that any service required should be performed by an authorized YAMAHA Retailer or the appointed service representative.

IMPORTANT: The presentation or sale of this manual to any individual or firm does not constitute authorization, certification or recognition of any applicable technical capabilities, or establish a principle-agent relationship of any form.

The data provided is believed to be accurate and applicable to the unit(s) indicated on the cover. The research, engineering, and service departments of YAMAHA are continually striving to improve YAMAHA products. Modifications are, therefore, inevitable and specifications are subject to change without notice or obligation to retrofit. Should any discrepancy appear to exist, please contact the distributor's Service Division.

WARNING: Static discharges can destroy expensive components. Discharge any static electricity your body may have accumulated by grounding yourself to the ground buss in the unit (heavy gauge black wires connect to this buss).

IMPORTANT: Turn the unit OFF during disassembly and part replacement. Recheck all work before you apply power to the unit.



このサービスマニュアルは、エコマーク認定の再生紙を使用しています。
This Service Manual uses recycled paper.



■ CONTENTS

TO SERVICE PERSONNEL	2
FRONT PANEL	3
REMOTE CONTROL PANEL	3
SIDE PANELS	3
SPECIFICATIONS / 参考仕様	4
INTERNAL VIEW	5
DISASSEMBLY PROCEDURES /	
分解手順	6-8
RECOVERY AFTER REPLACING CORE P.C.B. /	
CORE P.C.B.交換後のリカバリー	9
UPDATING FIRMWARE /	
ファームウェアのアップデート	9-12

ENTERING SYSTEM ID /	
システムIDの書き込み	13-15
TROUBLESHOOTING	16-21
TEST MODE / テストモード	22-24
IC DATA	25-33
PIN CONNECTION DIAGRAM	33
BLOCK DIAGRAM	34
POWER SUPPLY BLOCK DIAGRAM	35
PRINTED CIRCUIT BOARD	36-40
SCHEMATIC DIAGRAM	41-42
PARTS LIST	43-55
REMOTE CONTROL	56

■ TO SERVICE PERSONNEL

1. Critical Components Information
Components having special characteristics are marked \triangle and must be replaced with parts having specifications equal to those originally installed.
 2. Leakage Current Measurement (For 120V Models Only)
When service has been completed, it is imperative to verify that all exposed conductive surfaces are properly insulated from supply circuits.
- Meter impedance should be equivalent to 1500 ohm shunted by 0.15 μ F.

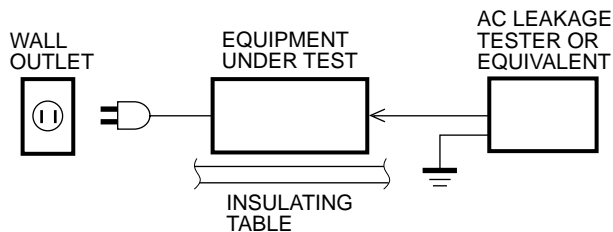

- Leakage current must not exceed 0.5mA.
- Be sure to test for leakage with the AC plug in both polarities.

WARNING: CHEMICAL CONTENT NOTICE!

The solder used in the production of this product contains LEAD. In addition, other electrical/electronic and/or plastic (where applicable) components may also contain traces of chemicals found by the California Health and Welfare Agency (and possibly other entities) to cause cancer and/or birth defects or other reproductive harm.

DO NOT PLACE SOLDER, ELECTRICAL/ELECTRONIC OR PLASTIC COMPONENTS IN YOUR MOUTH FOR ANY REASON WHATSOEVER!

Avoid prolonged, unprotected contact between solder and your skin! When soldering, do not inhale solder fumes or expose eyes to solder/flux vapor!

If you come in contact with solder or components located inside the enclosure of this product, wash your hands before handling food.

WARNING: Lithium batteries are dangerous because they can be exploded by improper handling. Observe the following precautions when handling or replacing lithium batteries.

- Leave lithium battery replacement to qualified service personnel.
- Always replace with batteries of the same type.
- When installing on the PC board by soldering, solder using the connection terminals provided on the battery cells. Never solder directly to the cells. Perform the soldering as quickly as possible.
- Never reverse the battery polarities when installing.
- Do not short the batteries.
- Do not attempt to recharge these batteries.
- Do not disassemble the batteries.
- Never heat batteries or throw them into fire.

ADVARSEL!

Lithiumbatteri —Eksplodingsfare ved fejlagtig håndtering. Udskiftning må kun ske med batteri af samme fabrikat og type. Levér det brugte batteri tilbage til leverandøren.

VARNING

Explosionsfara vid felaktigt batteribyte. Använd samma batterityp eller an ekvivalent typ som rekommenderas av apparattillverkaren. Kassera använt batteri enligt fabrikantens instruktion.

VAROITUS

Paristo voi räjähtää, jos se on virheellisesti asennettu. Vaihda paristo ainoastaan laitevalmistajan suosittelemaan tyyppiin. Hävitä käytetty paristo valmistajan ohjeiden mukaisesti.

■ FRONT PANEL

▼ MCX-A10

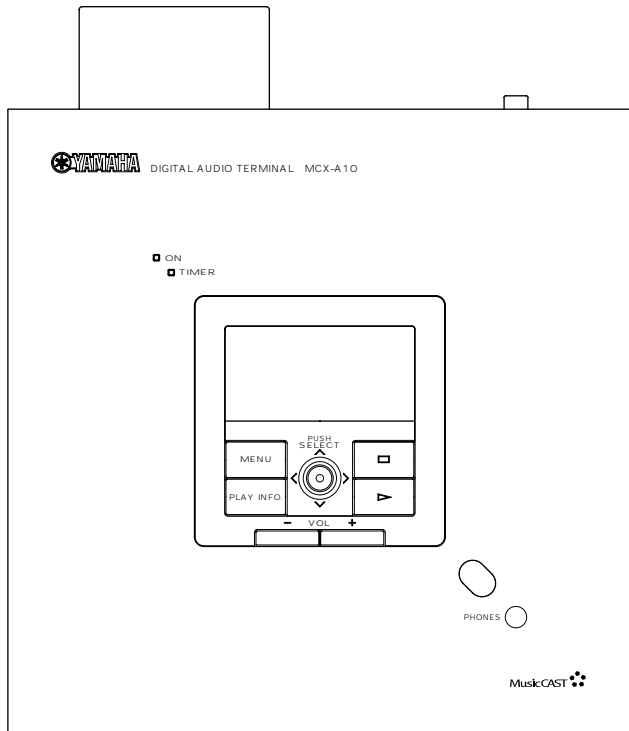

■ REMOTE CONTROL PANEL

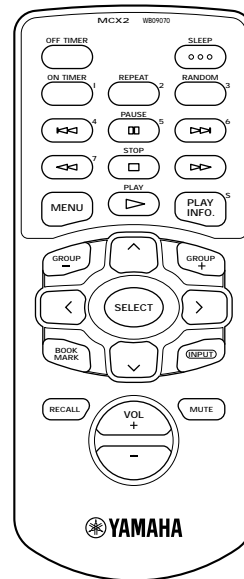

■ SIDE PANELS

▼ MCX-A10 (U, C, A, B, G models)

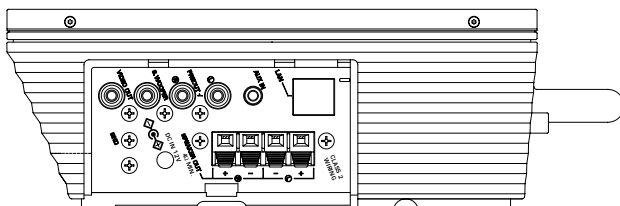

▼ MCX-A10 (J model)

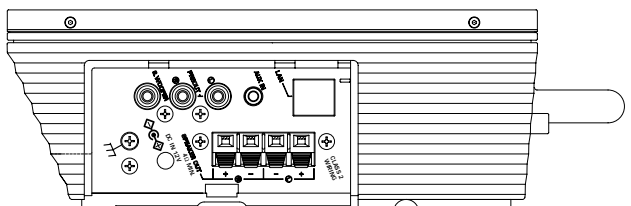

■ SPECIFICATIONS / 参考仕様

● MCX-A10

■ GENERAL / 一般

Playback Data Format / 再生データフォーマット

MP3 (all clients), Linear PCM (selected one client)

Power Supply / 電源電圧 AC 100V to 240V, 50/60Hz

Power Consumption / 消費電力 40W

Standby Power Consumption / 待機時消費電力

U, C models 0.7W

A, B, G models 1.1W

J model 0.5W

Operating Temperature / 動作温度 +5°C to +35°C

Weight (without AC adaptor) / 質量 2.0 kg (4 lbs 6 oz)

Max. Dimensions (W x H x D) / 最大寸法

210 x 244.5 x 79 mm

(8-1/4" x 9-15/16" x 3-1/8")

Panel Color / パネル色 Silver

Accessory / 付属品 Remote Control, Lithium Battery

AC Adaptor, Power Cable

Audio Pin Cable

Video Pin Cable (U, C, A, B, G)

Subwoofer Cable

Stand

■ AUDIO PERFORMANCE / オーディオ性能

Frequency Characteristics / 周波数特性

20Hz to 20kHz, ±0.5dB (EIAJ)

Signal to Noise Ratio / SN比 100dB or more (EIAJ)

Dynamic Range / 再生ダイナミックレンジ

90dB or more (EIAJ)

THD + Noise / 歪率 + ノイズ 0.008% or less (EIAJ)

■ INPUT/OUTPUT / 入出力

Input Sensitivity / 入力感度

AUX IN 300mVrms

Output Level / 出力レベル

LINEOUT (1kHz, 0dB) 2Vrms

SUBWOOFER (Volume MAX, 50Hz, 300mV input) 1Vrms

PHONES (Phones level MAX, -20dB, 150Ω load) 650mVrms

Maximum Power (EIAJ) / 実用最大出力

(4Ω, 1kHz, 10% THD) 17W + 17W or 18W (1ch)

● MCX-SP10

Type / 型式

2-way Bass Reflex Magnetic Shielding Type

Driver / スピーカーユニット

Woofer 10 cm (4") Cone Type

Tweeter 2.5 cm (1") Dome Type

Impedance / インピーダンス 4 Ω

Frequency Response / 再生周波数帯域 100 Hz to 27 kHz

Nominal Input / 許容入力 20 W

Sensitivity / 出力音圧レベル 89 dB/2.83 V/m

Dimensions (W x H x D) / 外形寸法

210 x 210 x 79 mm

(8-5/16" x 8-5/16" x 3-1/8")

Weight / 質量

1.2 kg (2 lbs 10 oz) x 2

Accessory / 付属品

Speaker cable (5 m) x 2

Pad

* Specifications subject to change without prior notice.

U USA model

C Canadian model

A Australian model

B British model

G European model

J Japanese model

DIMENSIONS / 寸法図

▼ MCX-A10

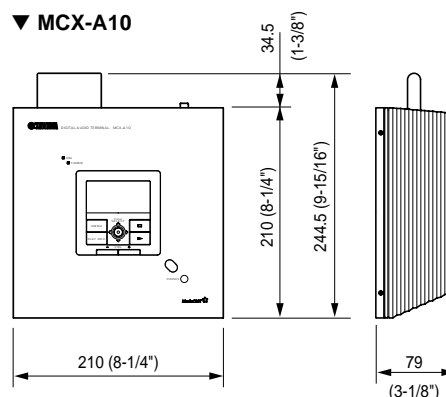

▼ MCX-SP10

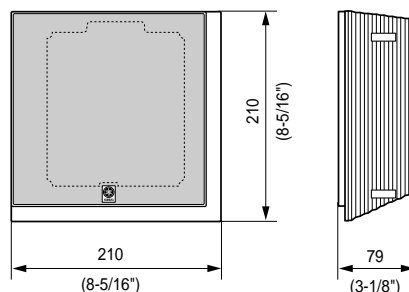

Unit : mm (inch)

INTERNAL VIEW

▼ Bottom View

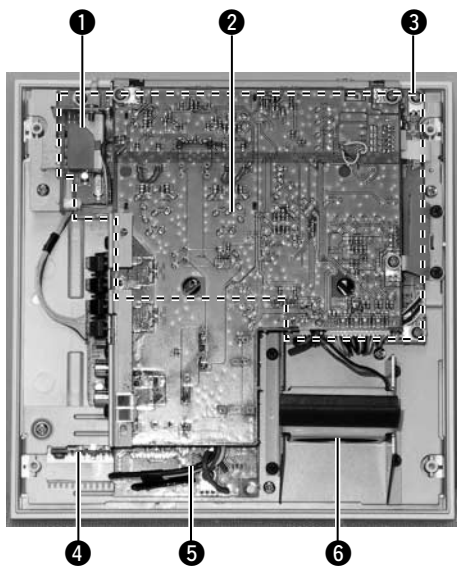

- ❶ D-AMP (5) P.C.B.
- ❷ D-AMP (1) P.C.B.
- ❸ CORE P.C.B.
- ❹ D-AMP (4) P.C.B.
- ❺ D-AMP (6) P.C.B.
- ❻ FAN UNIT
- ❼ D-AMP (2) P.C.B.
- ❽ D-AMP (3) P.C.B.
- ❾ LCD
- ❿ FRONT PANEL UNIT

▼ Top View

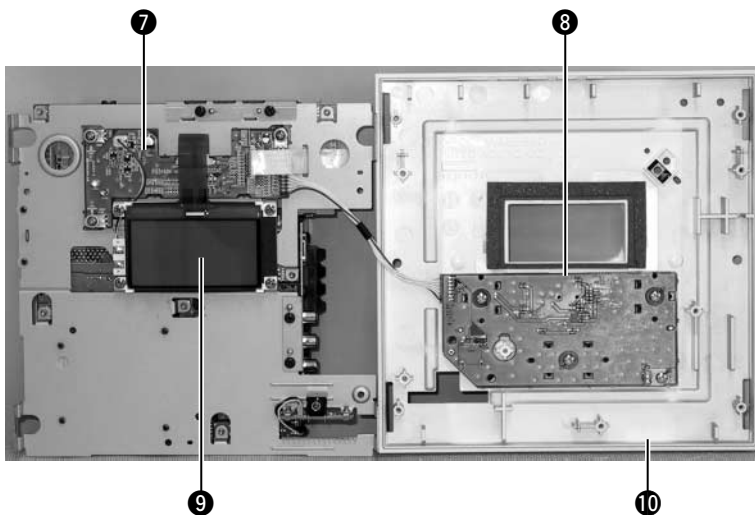

■ DISASSEMBLY PROCEDURES / 分解手順

(Remove parts in the order as numbered.)

(番号順に部品を取り外してください。)

1. Removal of Rear Cover

1. リアカバーの外し方

- a. Spread soft cloth on the table and place MCX-A10 upside down on it.
- b. Remove the Side Cover. (Fig. 1)
- c. Using the special screw driver, remove 1 screw marked [①] and then remove the LAN Cover. (Fig. 1)
- d. Remove LAN card and STANDBY/ON knob.
- e. Remove 4 screws marked [②]. (Fig. 1)
- f. Remove the rear cover.

- a) 机上に柔らかい布を敷き、その上にMCX-A10を上下反転して置きます。
- b) サイドカバーを外します。(Fig. 1)
- c) 特殊ドライバーを使って①のネジ1本を外し、LANカバーを外します。(Fig. 1)
- d) LANカード及びSTANDBY/ONノブを外します。
- e) ②のネジ4本を外します。(Fig. 1)
- f) リアカバーを外します。

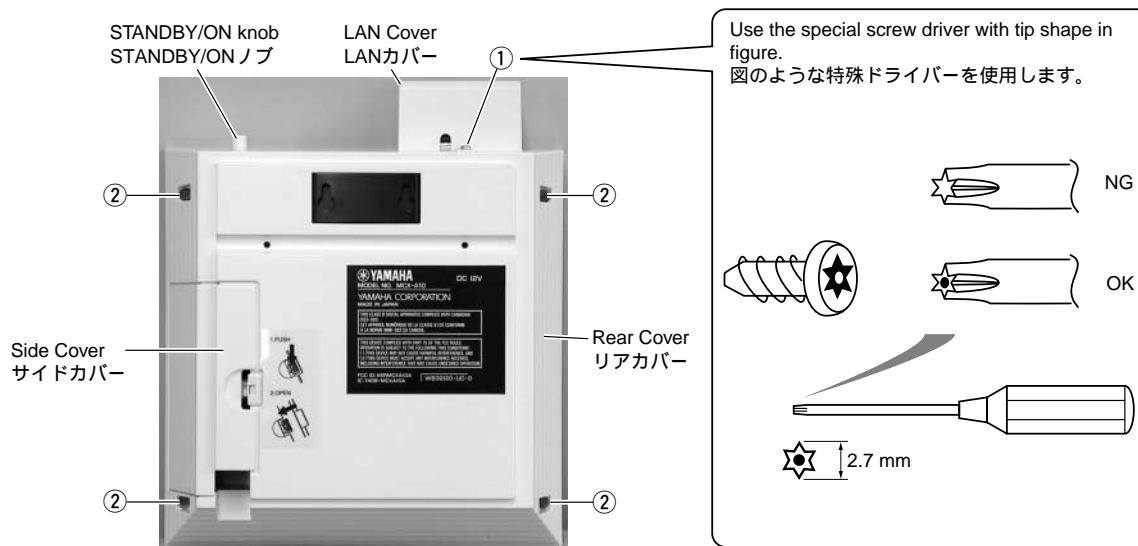

Fig. 1

2. Removal of Front Panel Unit

2. フロントパネルユニットの外し方

- a. Remove 5 screws marked [③]. (Fig. 2)
- b. Using the 1.5mm allen wrench, remove 4 screws marked [④]. (Fig. 2)

- a) ③のネジ5本を外します。(Fig. 2)
- b) 1.5 mm 六角レンチを使って④のネジ4本を外します。(Fig. 2)

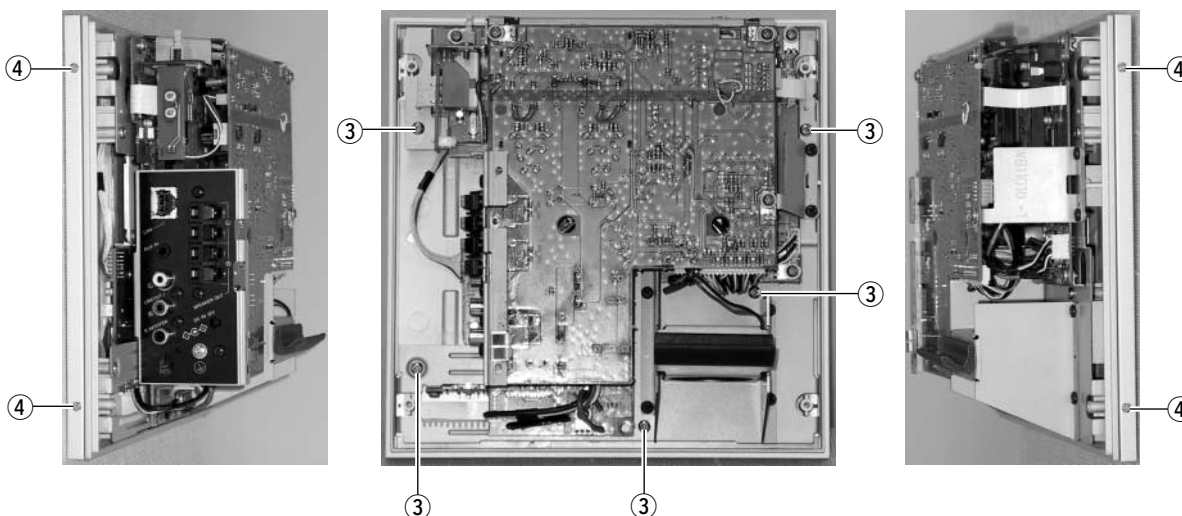

Fig. 2

- c. Lift the main unit side and remove CB401. (Fig. 3)
- d. Remove the front panel unit.

- c) 本体側を持ち上げ、CB401を外します。(Fig. 3)
- d) フロントパネルユニットを外します。

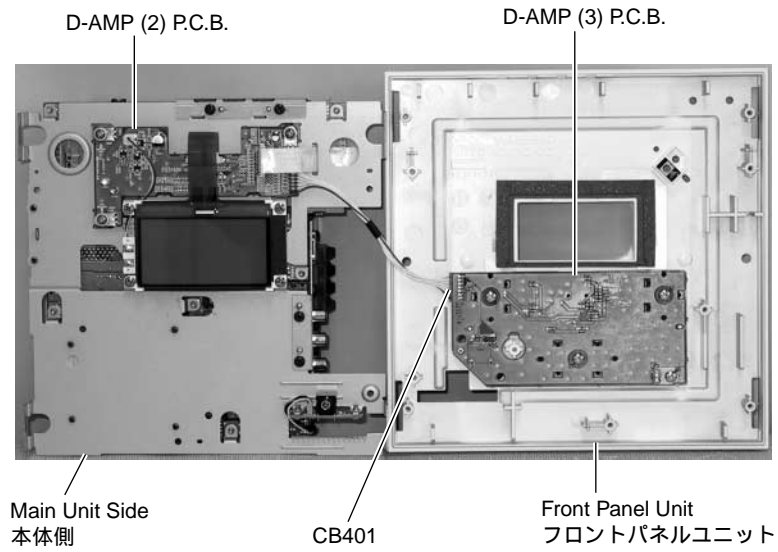

Fig. 3

3. Removal of FAN Unit

- a. Remove 4 screws marked [⑤]. (Fig. 4)
- b. Remove CB706 and the FAN unit can be removed. (Fig. 4)

- 3. FANユニットの外し方
- a) ⑤のネジ4本を外します。(Fig. 4)
- b) CB706を外し、FANユニットを外します。(Fig. 4)

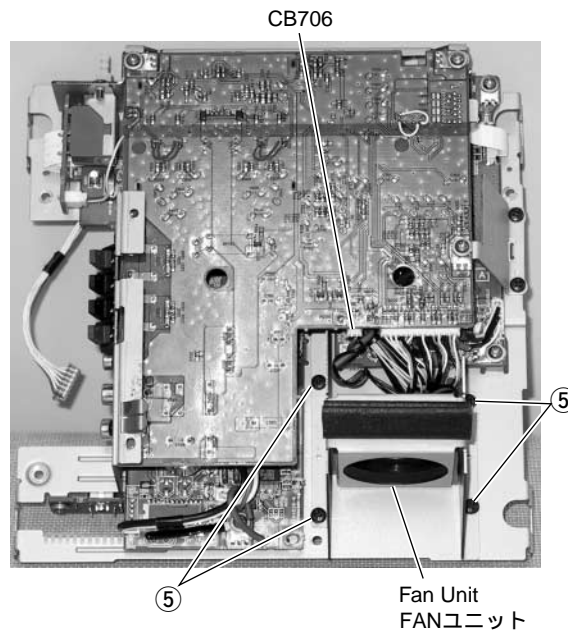

Fig. 4

4. Removal of D-AMP (1) P.C.B. and D-AMP (5) P.C.B.

- Remove 3 screws marked [⑥] and 3 screws marked [⑦]. (Fig. 5)
- Remove 2 screws marked [⑧]. (Fig. 6)
- Remove CB652. (Fig. 5)
- Remove D-AMP (1) P.C.B. and D-AMP (5) P.C.B.

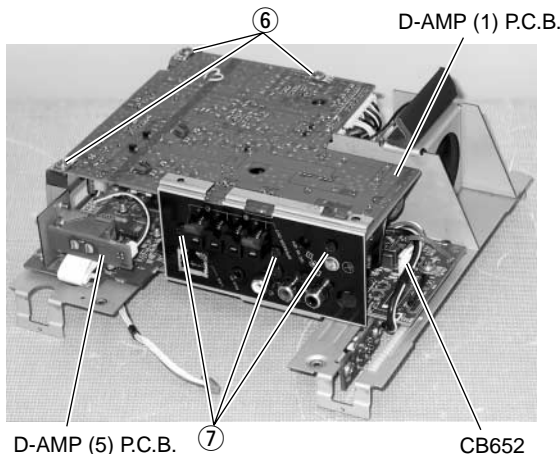

Fig. 5

4. D-AMP (1) P.C.B.及びD-AMP (5) P.C.B.の外し方

- ⑥のネジ3本、⑦のネジ3本を外します。(Fig. 5)
- ⑧のネジ2本を外します。(Fig. 6)
- CB652を外します。(Fig. 5)
- D-AMP (1) P.C.B.及びD-AMP (5) P.C.B.を外します。

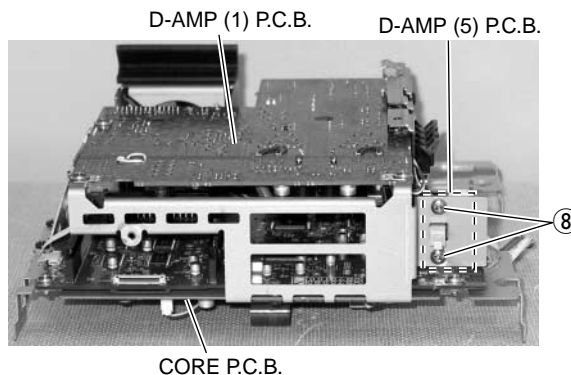

Fig. 6

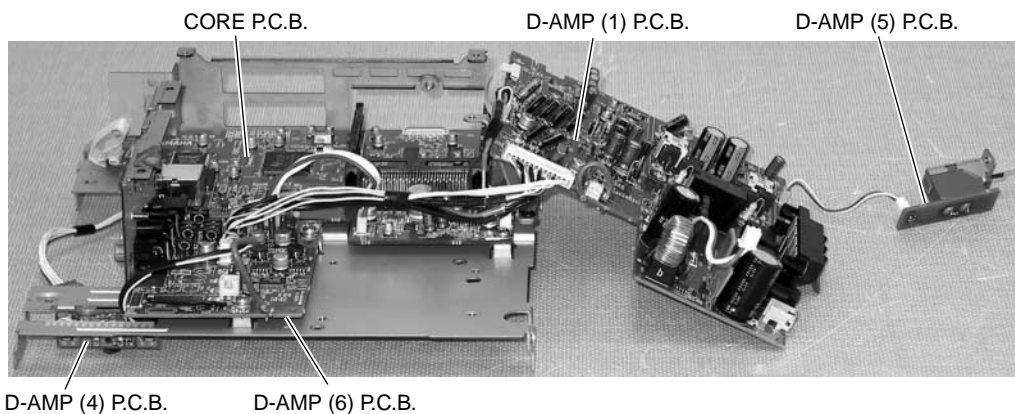

Fig. 7

When checking the P.C.B. :

Install D-AMP (1) P.C.B. and D-AMP (5) P.C.B. as originally installed and connect CB652 which was disconnected during disassembly. (Fig. 5)

With the removed front panel unit placed beside the main unit, connect CB401. (Fig. 3)

The operation can be checked with the FAN unit removed as it is.

CAUTION

As the speaker output of this unit is BTL connected, the grounding side of any measuring device to be connected to the speaker terminal must be floated.

P.C.B.チェックをする場合には

D-AMP (1) P.C.B.及びD-AMP (5) P.C.B.は元通りに取り付けます。分解時に外したCB652を接続します。(Fig. 5)

外したフロントパネルユニットは本体の横に置き、CB401を接続します。(Fig. 3)

FANユニットは外したままで、動作チェックに支障はありません。

注意

本機のスピーカー出力はBTL接続になっていますので、スピーカー端子に接続する測定器のアース側はフローティングが必要です。

■ RECOVERY AFTER REPLACING CORE P.C.B. / CORE P.C.B.交換後のリカバリー

After replacing the CORE P.C.B. or IC11, perform the recovery procedure as follows.

- 1) Enter the system ID.
For the details, refer to ENTERING SYSTEM ID (p. 13-15).
- 2) Update the firmware.
For the details, refer to UPDATING FIRMWARE (p. 9-12).
- 3) Reset the system as follows.
 - a. Keep pressing the "TOP MENU" key for 2 seconds, and the TOP MENU is displayed.
 - b. Using the "CONTROLLER" key, select the menu items as follows.
Setup System System reset
 - c. The System Reset screen appears.
 - d. Press the "PLAY" key.
This resets MCX-A10 and restores the factory setting of parameters. The power to MCX-A10 is turned OFF/ON automatically.

CORE P.C.B.またはIC11を交換した場合、下記の手順でリカバリーを行います。

- 1) システムIDの書き込みを行います。
詳しくは「システムIDの書き込み」(13～15ページ)を参照してください。
- 2) ファームウェアのアップデートを行います。
詳しくは「ファームウェアのアップデート」(9～12ページ)を参照してください。
- 3) システムリセットを行います。
 - a. "TOP MENU"キーを2秒間押し続けます。
TOP MENUが表示されます
 - b. "コントローラー"キーを使ってメニューを下記のように選択します。
Setup System System Reset
 - c. System Reset画面が表示されます。
 - d. "PLAY"キーを押します。
MCX-A10はリセットされ工場出荷時のパラメータに戻ります。
MCX-A10は自動的に電源がOFF/ONされます。

■ UPDATING FIRMWARE / ファームウェアのアップデート

After replacing CORE P.C.B. or IC11, the firmware must be updated.

For updating the firmware, use the recovery CD and execute it via the network from MCX-1000.

The detailed information regarding supply of the recovery CD will be provided in Service News.

Items required

Recovery CD
MCX-1000
Ethernet Hub
CAT-5 Straight Cable, 2 pcs
TV monitor
Video cable

Preparation

Execute updating of MCX-1000 in advance.
For the details, refer to UPDATING FIRMWARE in the MCX-1000 Service Manual.

CORE P.C.B.またはIC11を交換した場合、ファームウェアのアップデートが必要です。

ファームウェアのアップデートはリカバリーCDを使用し、MCX-1000からネットワークを経由して行います。なお、リカバリーCDの供給に関する詳細は、サービスニュースでお知らせします。

用意するもの

リカバリーCD
MCX-1000
Ethernet Hub
CAT-5 ストレートケーブル 2本
TVモニター
ビデオケーブル

準備

あらかじめMCX-1000をアップデートします。
詳しくはMCX-1000サービスマニュアルの「ファームウェアのアップデート」を参照してください。

Connection

Make connections as shown below.

接続

図のように接続します。

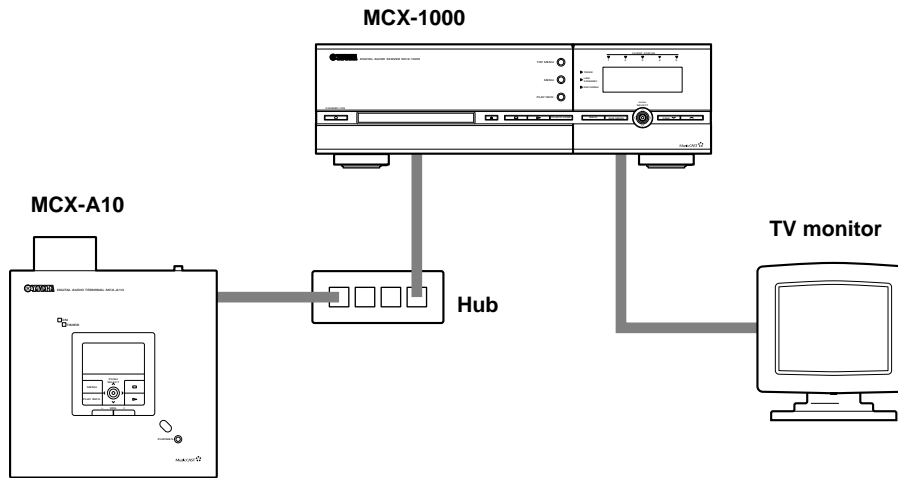
**Operation**

To operate MCX-1000, use the keys of the main unit while watching the TV monitor screen.

To operate MCX-A10, use the keys of the main unit while watching the screen of the main unit.

操作

MCX-1000はTVモニター画面を見ながら本体キーを使って操作します。

MCX-A10は本体の表示画面を見ながら本体キーを使って操作します。

- 1) Turn on the power to MCX-1000 and MCX-A10.
- 2) Reset MCX-1000.
 - a. Press the "TOP MENU" key. Then the TOP MENU is displayed.
 - b. Using the "CONTROLLER" key, select the menu items as follows.
System Setup System Utility System Reset
 - c. Using the "CONTROLLER" key, set the cursor to "Yes" and press the "CONTROLLER" key.
 - d. After resetting, the System Utility screen appears again.
 - e. Turn the power to MCX-1000 OFF/ON.
- 3) Reset MCX-A10.
 - a. Keep pressing the "TOP MENU" key for 2 seconds, and TOP MENU is displayed.
 - b. Using the "CONTROLLER" key, select the menu items as follows.
Setup System System Reset
 - c. Press the "PLAY" key.
After resetting, the power is turned OFF/ON automatically.

- 1) MCX-1000とMCX-A10の電源を入れます。
- 2) MCX-1000をリセットします。
 - a. "TOP MENU"キーを押します。
TOP MENUが表示されます
 - b. "コントローラー"キーを使ってメニューを下記のように選択します。
System Setup System Utility System Reset
 - c. "コントローラー"キーを使って" Yes "に合わせ"コントローラー"キーを押します。
 - d. リセット後、System Utility画面に戻ります。
 - e. MCX-1000の電源をOFF/ONします。
- 3) MCX-A10をリセットします。
 - a. "TOP MENU"キーを2秒間押し続けます。
TOP MENUが表示されます
 - b. "コントローラー"キーを使ってメニューを下記のように選択します。
Setup System System Reset
 - c. "PLAY"キーを押します。
リセット後、自動的に電源がOFF/ONされます。

- 4) Connect MCX-1000 and MCX-A10 as a network.

Operation of MCX-1000

- a. Press the "TOP MENU" key.
The TOP MENU screen appears.
- b. Using the "CONTROLLER" key, select the menu items as follows.
System Setup Network Auto Configuration
Then, cautionary message is displayed.
- c. Press the "CONTROLLER" key.
This sets MCX-1000 in the Auto Configuration mode.

Operation of MCX-A10

- d. Keep pressing the "TOP MENU" key for 2 seconds, and the TOP MENU appears.
- e. Using the "CONTROLLER" key, select the menu items as follows.
Setup Network Auto Configuration
Then the message as shown below appears.
Press PLAY to execute
auto configuration.
- f. Press the "PLAY" key, and the message as shown below appears.
Searching ESSID ••• ..
Press STOP to cancel.
- g. MCX-A10 attempts connection with MCX-1000 and a message appears as follows.
Searching Server ••• ..
Press STOP to cancel.

Example [CL-B0402]
 Connecting •••
 Press STOP to cancel.

Operation of MCX-1000

- h. The ID of MCX-A10 to be connected is displayed.
- i. Using the "CONTROLLER" key, set the cursor to "OK" and press the "CONTROLLER" key. This completes connection of MCX-1000 and MCX-A10 as a network.

- 4) MCX-1000とMCX-A10をネットワークで接続します。

MCX-1000の操作

- a. " TOP MENU "キーを押します。
TOP MENU画面が表示されます
- b. " コントローラー "キーを使ってメニューを下記のように選択します。
System Setup Network Auto Configuration
注意メッセージが表示されます。
- c. " コントローラー "キーを押します。
これによりMCX-1000はAuto Configurationモードに入ります。

MCX-A10の操作

- d. " TOP MENU "キーを2秒間押し続けます。
TOP MENUが表示されます
- e. " コントローラー "キーを使ってメニューを下記のように選択します。
Setup Network Auto Configuration
次のメッセージが表示されます。
Press PLAY to execute
auto configuration.
- f. " PLAY "キーを押します。次のメッセージが表示されます。
Serching ESSID ••• ..
Press STOP to cancel.
- g. MCX-A10はMCX-1000との接続を試みます。
次のメッセージが表示されます。
Serching Server ••• ..
Press STOP to cancel.

例 [CL-B0402]
 Connecting •••
 Press STOP to cancel.

MCX-1000の操作

- h. 接続しようとしているMCX-A10のIDが表示されます。
- i. " コントローラー "キーを使って" OK "に合わせ" コントローラー "キーを押します。
MCX-1000とMCX-A10がネットワークで接続されます。

5) Update the MCX-A10 firmware according to the following procedure.

Step 1

Before updating, check the existing version of the firmware and write it down.

- a. Using the "CONTROLLER" key, select the menu items as follows.

Setup System Information.

The information screen as shown below appears.

Example	Version:	0.84. 1
	Date:	2003/06/20 19:52:41

Write down the version number.

- b. Using "<" of the "CONTROLLER" key, restore the System screen.

Step 2

Perform the following updating procedure.

- a. Using the "CONTROLLER" key, set the cursor to "System Update" and press the "CONTROLLER" key. The System Update screen appears.
- b. Press the "PLAY" key. After updating, MCX-A10 is restarted automatically.

Step 3

After updating, check the version of the firmware as described in Step 1.

Example	Version:	0.86. 15
	Date:	2003/07/05 21:00:25

5) MCX-A10のFirmwareのアップデートを行います。

Step 1

アップデート前に現Firmwareバージョンを確認、メモします。

- a. "コントローラー"キーを使ってメニューを下記のように選択します。

Setup System Information
Information画面が表示されます。

例	Version:	0. 84. 1
	Date:	2003/06/20 19:52:41

Versionナンバーをメモします。

- b. "コントローラー"キーの"<"を使ってSystem画面に戻します。

Step 2

アップデートを行います。

- a. "コントローラー"キーを使ってカーソルを"System Update"に合わせ"コントローラー"キーを押します。System Update画面が表示されます。
- b. "PLAY"キーを押します。Update後、自動的に再起動します。

Step 3

アップデート後にFirmwareバージョンを確認します。操作はStep 1と同様です。

例	Version:	0. 86. 15
	Date:	2003/07/05 21:00:25

■ ENTERING SYSTEM ID / システムIDの書き込み

After replacing the CORE P.C.B. or IC11, the system ID must be entered.

CORE P.C.B.またはIC11を交換した場合、システムIDを書き込む必要があります。

Preparation: Take the measure against static electricity before the work.

準備：作業の前に必ず静電気対策を実施してください。

Items required:

IC Writing Jig (P.C.B. + 2P cable) : WA045500

用意するもの：

IC書き込み治具(基板 + 2Pケーブル) : WA045500

Note) This 2P cable is not used.

注)この2Pケーブルは使用しません

Flat Cable 30P 250mm : WC028700

フラットケーブル 30P 250mm : WC028700

DC Stabilized Power Supply

DC安定化電源

Soldering Iron

ハンダゴテ

Wire (50cm), 2 pcs

線材 50cm 2本

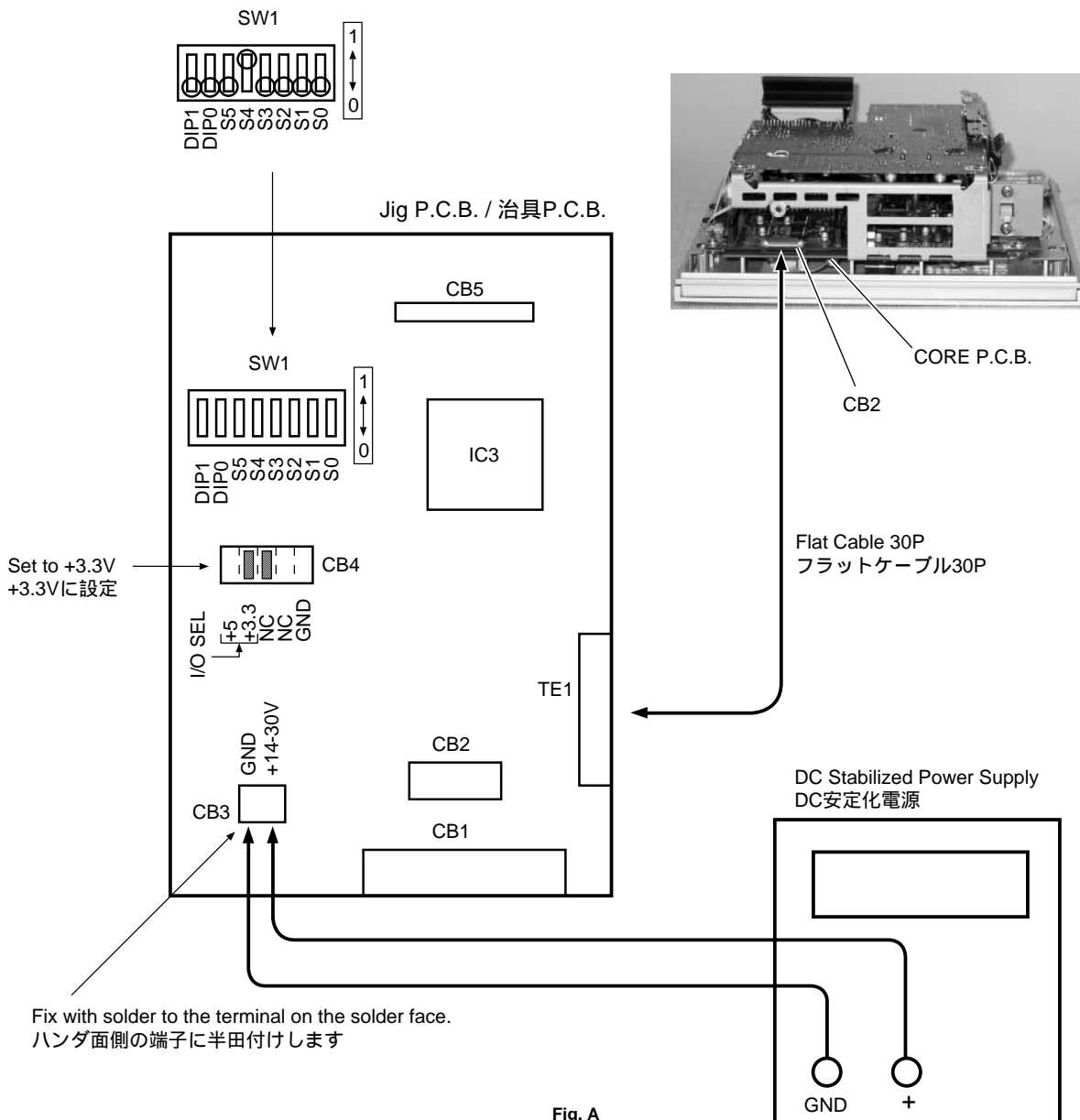

Setting and connecting jig

- 1) Turn off the power.
- 2) Remove the rear cover.
(Refer to DISASSEMBLY PROCEDURES.)
- 3) Set the I/O selector (CB4) of the jig P.C.B. to +3.3V. (Fig. A)
Caution: Note that setting to +5V will damage the unit.
- 4) Set the DIP switch (SW1) of the jig P.C.B. (Fig. A)
- 5) Connect TE1 of the jig P.C.B. and CB2 of the CORE P.C.B. with a flat cable (30P). (Fig. A)
- 6) Connect the +14-30V terminal of CB3 on the jig P.C.B. and the + output terminal of the DC stabilized power supply with a wire. (Fig. A)
- 7) Connect the GND terminal of CB3 on the jig P.C.B. and the GND terminal of the DC stabilized power supply with a wire. (Fig. A)

Operation procedure

Use the keys of the main unit for operation.

- 1) Press the "STANDBY/ON" switch of MCX-A10 to turn on the power.
- 2) Turn on the DC stabilized power supply and set the output voltage to + 15V.
- 3) After about 6 seconds, the system ID manual mode screen appears.

Example / 例

```
SYSTEM ID MANUAL MODE
Serial: N0XXXXXX0
Barcode: 01000000000
Country: J
```

- 4) Press the "CONTROLLER" key and the System ID input screen appears.

```
**Write system ID
Serial: N0XXXXXX0
Barcode: 01000000000
Country: J
Save
Cancel
```

- 5) Using the "CONTROLLER" key, set the cursor to ID and press the "CONTROLLER" key. Then the currently selected digit flashes.

Using the "CONTROLLER" key, enter 9 alphanumeric characters represented as X in [SER.XXXXXXXXXX].

治具の設定及び接続

- 1) 電源を切ります。
- 2) リアカバーを外します。(分解手順を参照)
- 3) 治具P.C.B.のI/Oセレクター(CB4)を+3.3Vに設定します。(Fig. A)
注意:+5Vに設定した場合、故障の原因になります。
- 4) 治具P.C.B.のディップスイッチ(SW1)を設定します。(Fig. A)
- 5) 治具P.C.B.のTE1とCORE P.C.B.のCB2をフラットケーブル(30P)接続します。(Fig. A)
- 6) 治具P.C.B.のCB3の+14-30V端子とDC安定化電源の+出力端子を線材で接続します。(Fig. A)
- 7) 治具P.C.B.のCB3のGND端子とDC安定化電源のGND端子を線材で接続します。(Fig. A)

操作手順

本体キーを使って操作します。

- 1) MCX-A10の"STANDBY/ON"スイッチを押して電源を入れます。
- 2) DC安定化電源の電源を入れ、出力電圧を+15Vに設定します。
- 3) 約6秒後、システムIDマニュアルモード画面が表示されます。

- 4) "コントローラー"キーを押します。
System ID入力画面が表示されます。

- 5) "コントローラー"キーを使いカーソルをIDに合わせ、"コントローラー"キーを押します。
現在選択している桁が点滅します。
"コントローラー"キーを使いリアパネルに表示されているシリアル「SER.XXXXXXXXXX」のX部分の英数字(9桁)を入力します。

How to enter characters:

Using \wedge / \vee of the "CONTROLLER" key to increase/decrease the value and $<$ / $>$ to shift the place, select the character to enter one by one.

Note: The serial numbers are also displayed on the sub-panel. (Fig. B)

- 6) Press the "CONTROLLER" key.
- 7) Using the "CONTROLLER" key, set the cursor to MAC and press the "CONTROLLER" key. Then the currently selected digit flashes.
Using the "CONTROLLER" key, enter 11 alphanumeric characters under the bar code indicated on the rear panel.
Use the same method as in Step 5) to enter characters.
Caution: At this time, be careful not to mix B with 8 and G with 6.
- 8) Press the "CONTROLLER" key.
- 9) Using the "CONTROLLER" key, set the cursor to Country and press the "CONTROLLER" key.
Also, using the "CONTROLLER" key, select one from [U, C, J, B, A and G].
- 10) Press the "CONTROLLER" key.
- 11) Using the "CONTROLLER" key, set the cursor to Save and press the "CONTROLLER" key.
- 12) After writing is completed, the SYSTEM ID MANUAL MODE screen appears.

Note: The System ID can be rewritten up to 15 times.

入力方法

"コントローラー"キーの \wedge / \vee で値の増減、 $<$ / $>$ で桁の移動が行えるので、一桁ずつ入力したい番号にあわせてます。

注：シリアルNOはサブパネルにも表示してあります。(Fig. B)

- 6) "コントローラー"キーを押します。
- 7) "コントローラー"キーを使いカーソルをMACに合わせ"コントローラー"を押します。
現在選択している桁が点滅します。
"コントローラー"キーを使いリアパネルに表示されているバーコードの下の英数字(11桁)を入力します。
入力方法は5)と同様です。
注意:この時、Bと8、Gと6を間違えないように注意してください。
- 8) "コントローラー"キーを押します。
- 9) "コントローラー"キーを使いカーソルをCountryに合わせ"コントローラー"を押します。
"コントローラー"キーを使い「U、C、J、B、A、G」の中から1つを選択します。
- 10) "コントローラー"キーを押します。
- 11) "コントローラー"キーを使いカーソルをSaveに合わせ、"コントローラー"キーを押します。
- 12) 書き込みが行われた後、SYSTEM ID MANUAL MODE画面が表示されます。
注：System IDを書き換えできるのは15回までです。

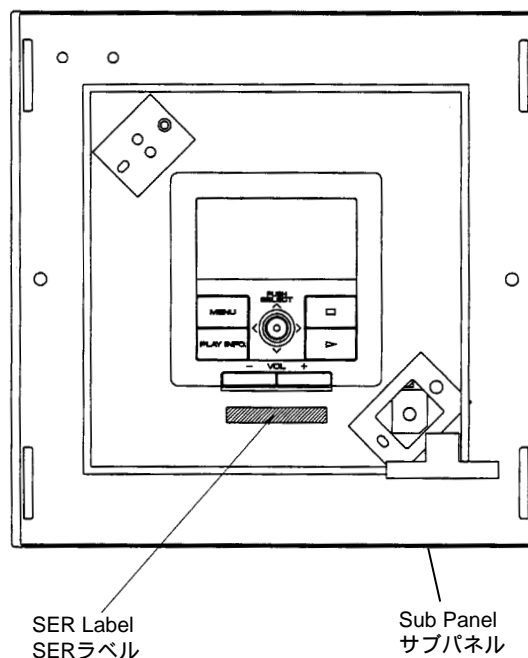
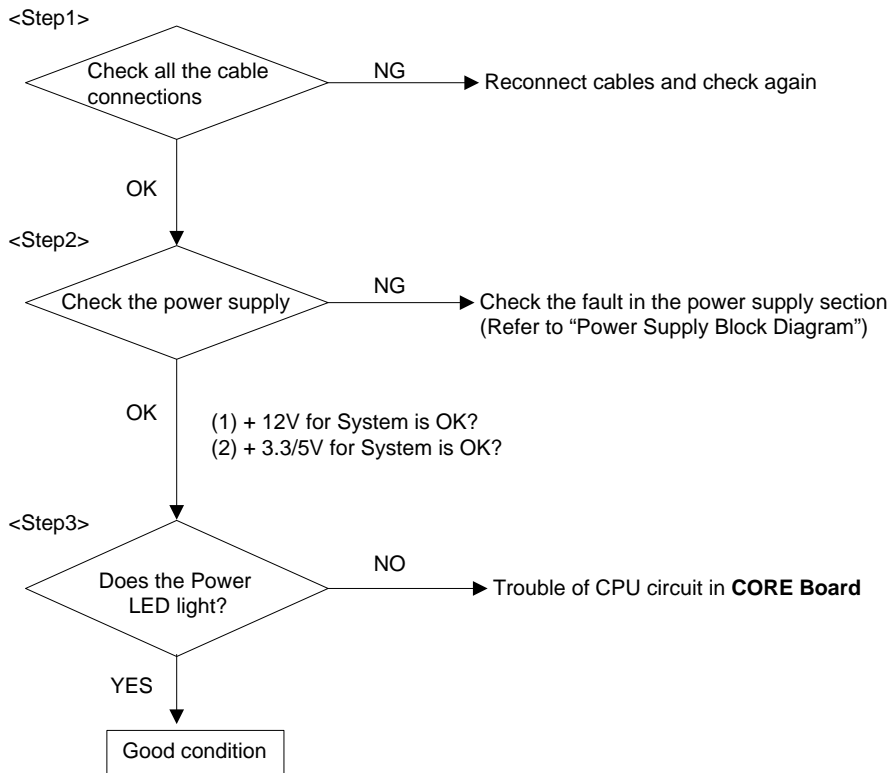

Fig. B

■ TROUBLESHOOTING

● When the power can't be turned on.



● When "TOP MENU" can't be displayed.

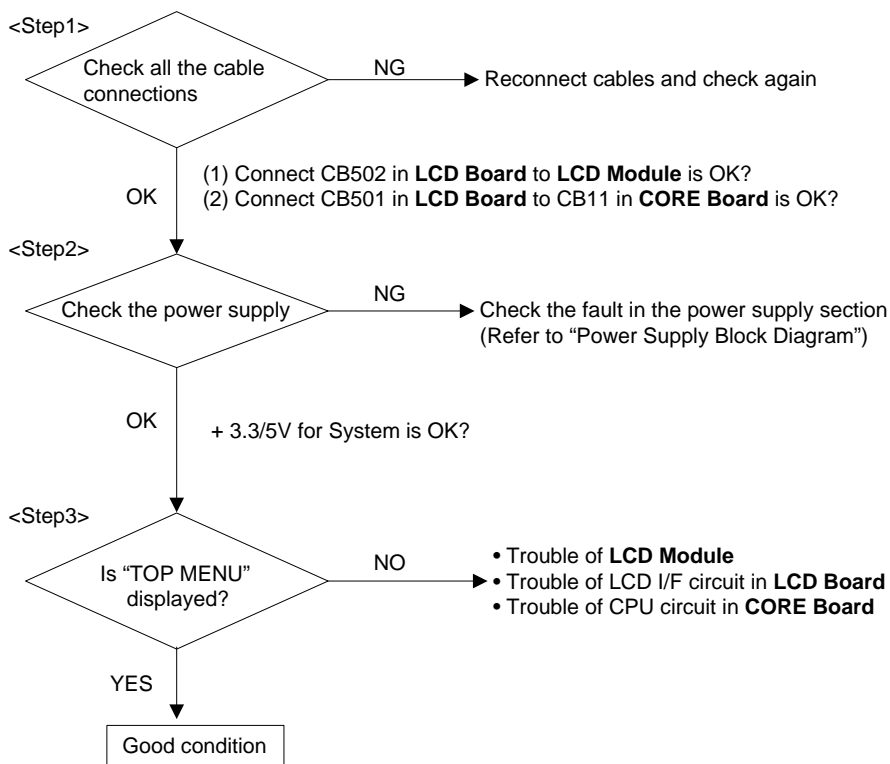

電源がONにできない場合

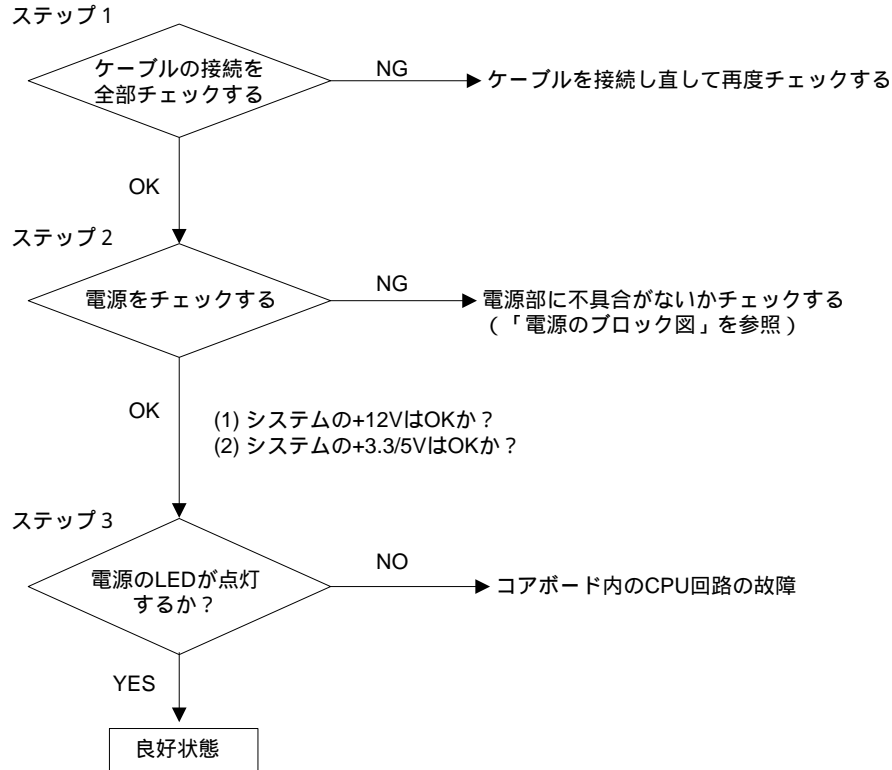

“TOP MENU”と表示されない場合

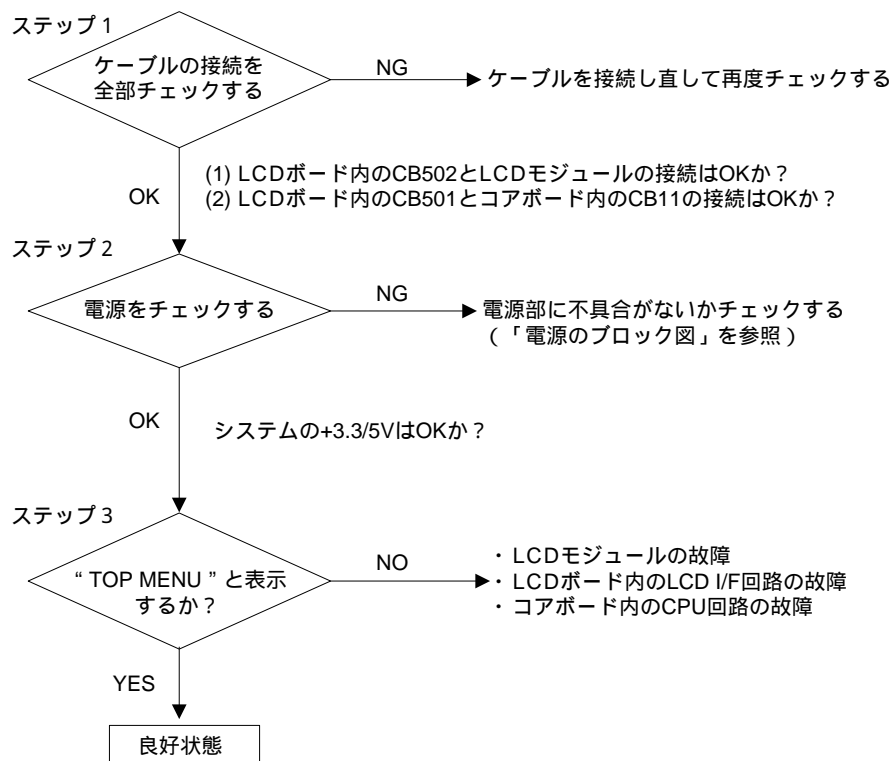

● When the unit is uncontrollable with the controller and buttons.

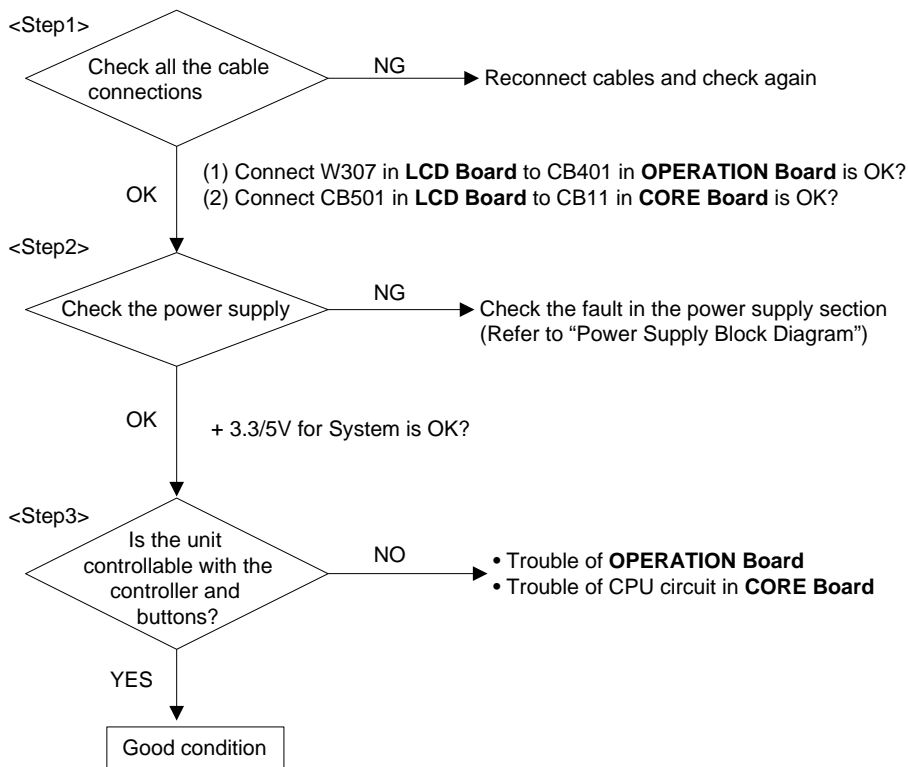

● When the unit is uncontrollable with the remote control.

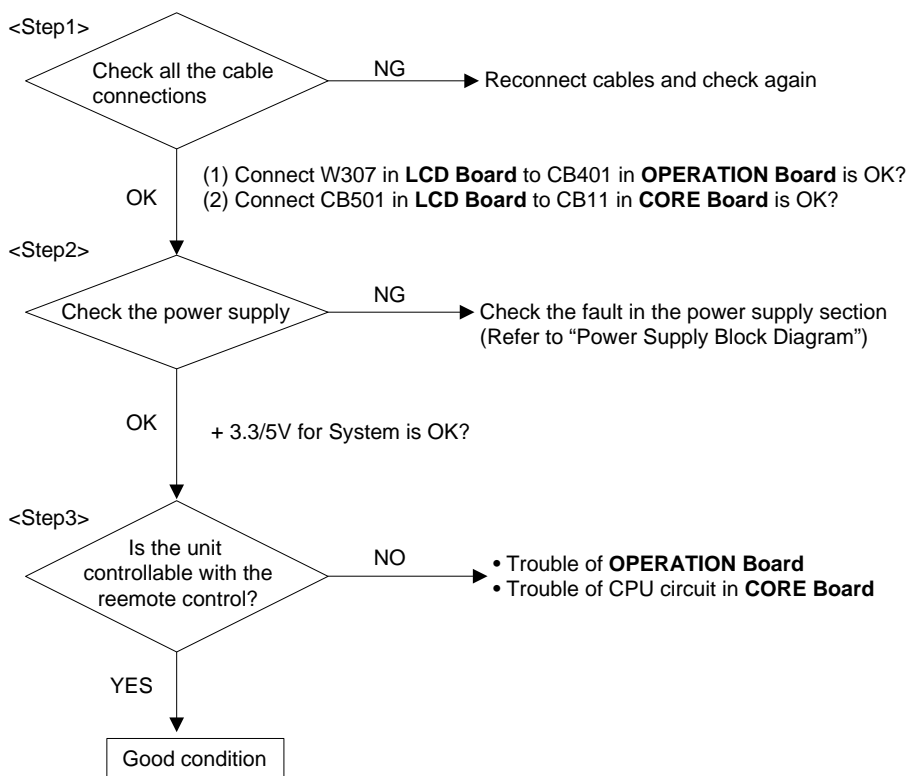

コントローラーでもボタンでも操作できない場合

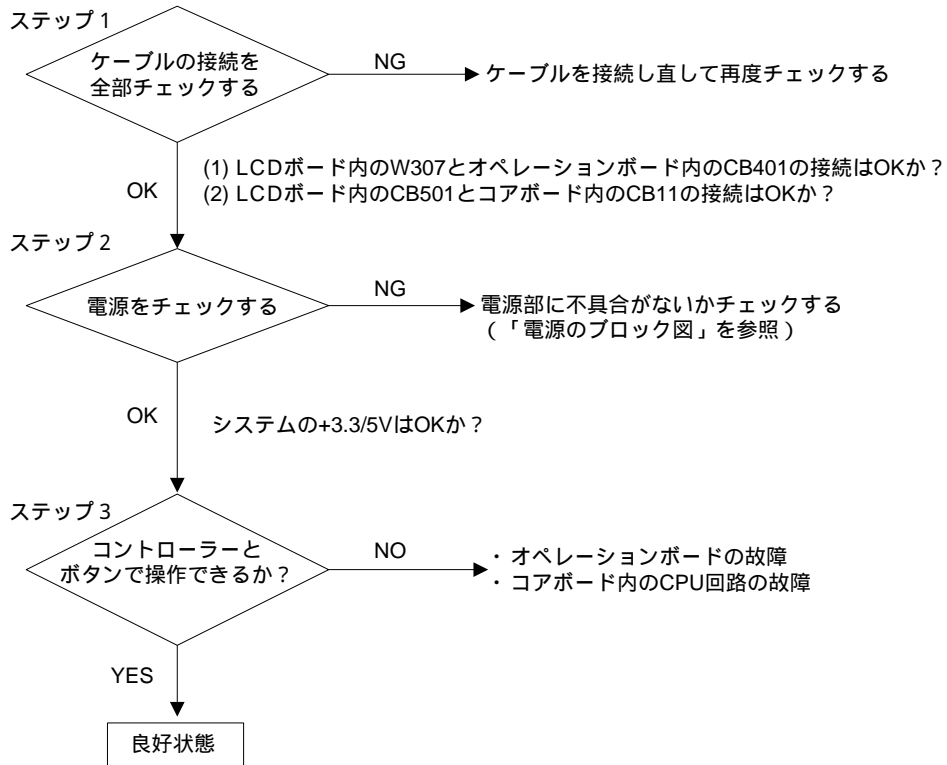

リモコンで操作できない場合

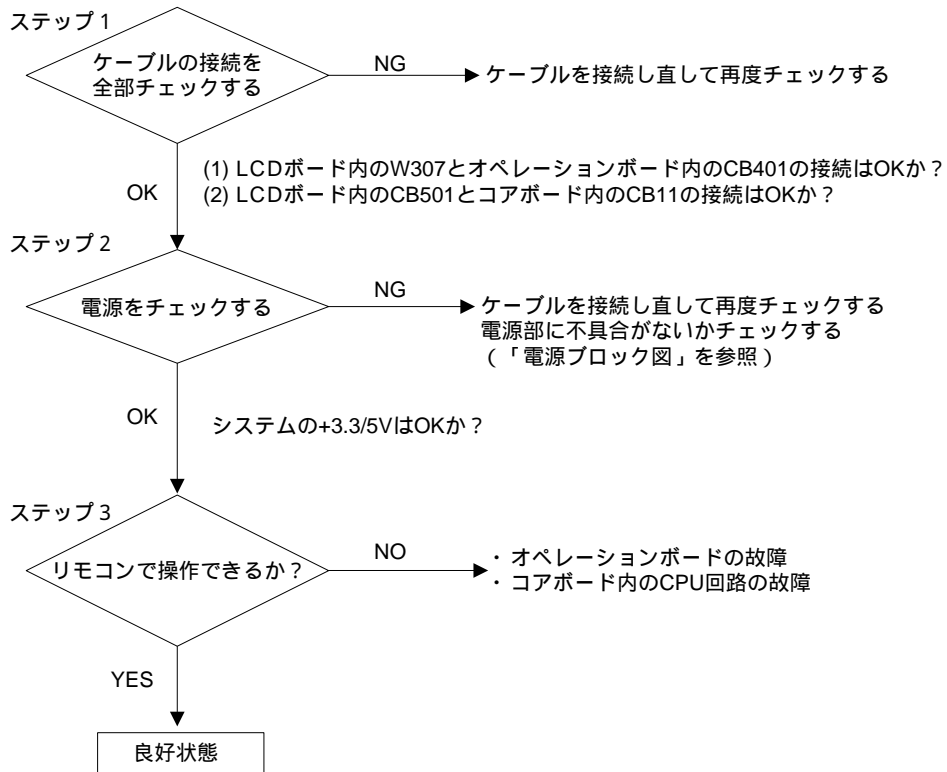

● When the unit can't play music.

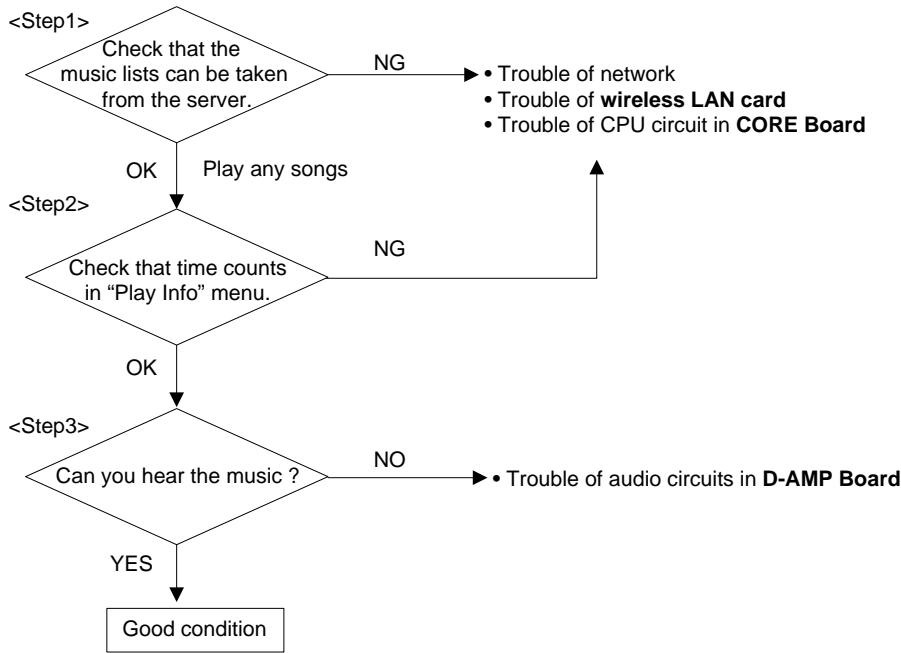

● In case of CPU trouble on CORE Board

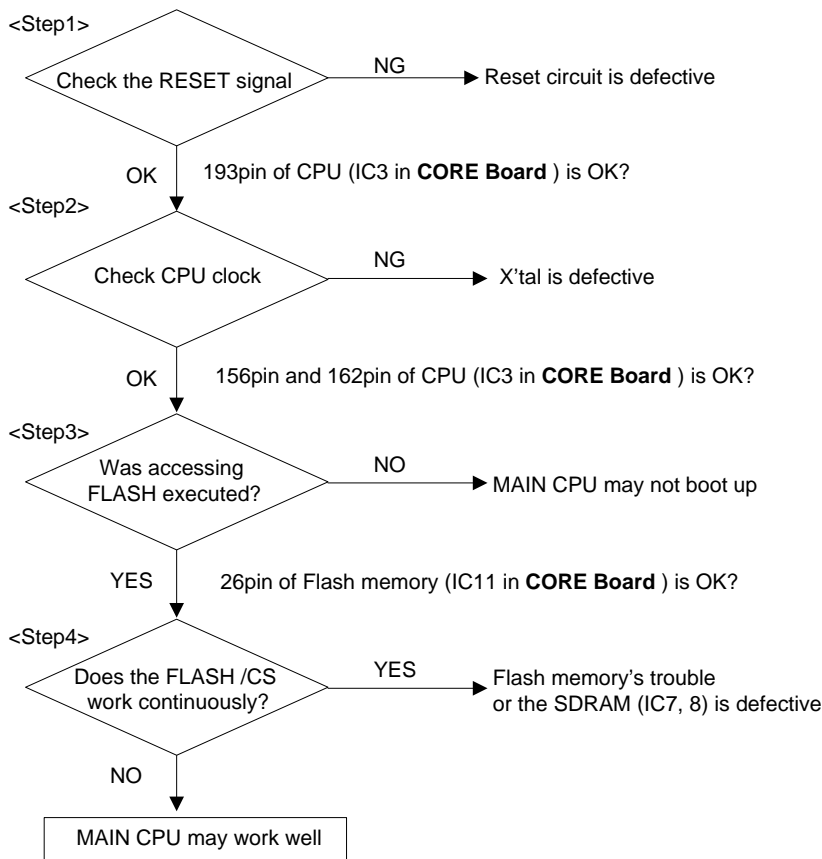

● In case of other troubles

- It is very difficult to find any other trouble around LSI because LSI is connected using the bus.
- However, if the trouble cause is not in the bus but something else, it may be possible to find it by using the TEST mode.
- Push TOP MENU & PLAY at the same time and power on.
- Monitor the log using LCD on MCX- A10.

曲がかからない場合

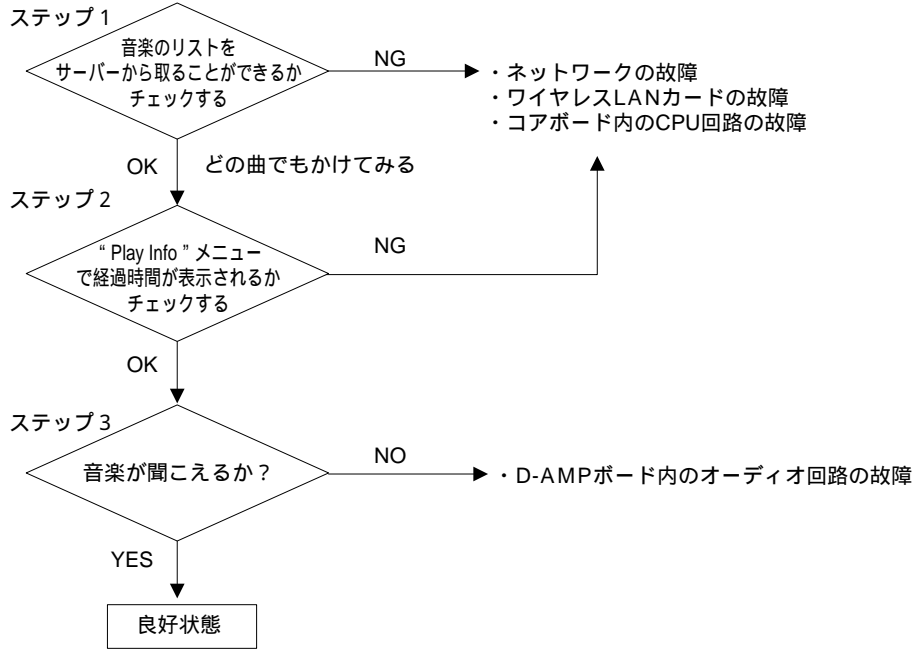

コアボード内のCPUが故障の場合

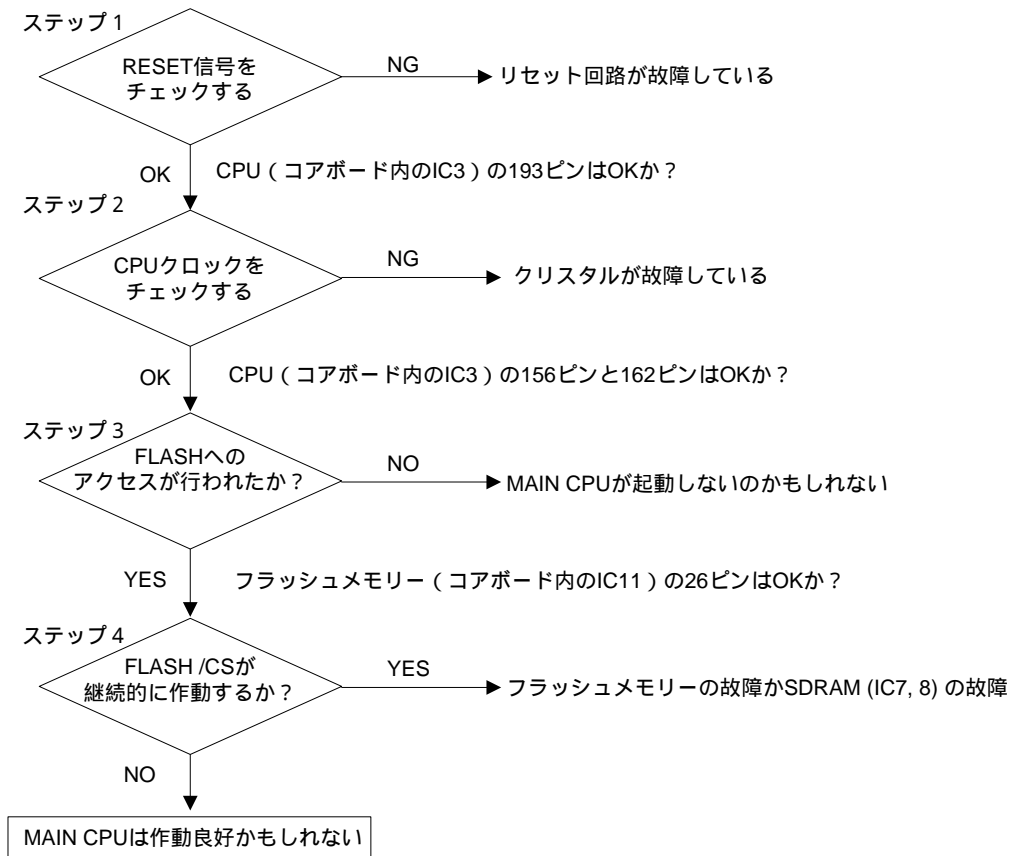

その他のトラブルの場合

- ・ その他のLSI周りの不具合は、LSIがバス接続されているために発見することは非常に困難です。
- ・ しかし、バス以外が原因となる不具合はPCBテストモードを使用すれば見つかる可能性があります。
 - TOP MENUとPLAYを同時に押して電源をONにします。
 - MCX-A10のLCDを使ってログをモニターします。

■ TEST MODE / テストモード

Items required

CD player
Music CD
Audio pin, mini-cable
Headphone
Oscilloscope
Level meter
Distortion gauge

準備するもの

CDプレーヤー
音楽CD
オーディオピン-ミニケーブル
ヘッドホン
オシロスコープ
レベルメーター
歪率計

Operation Procedure

Use the keys of the main unit for operation.

操作手順

本体キーを使って操作します。

< Stating Test Mode >

- 1) While pressing the "MENU" and "STOP" keys, press the "STANDBY/ON" key and immediately release the "MENU" and "STOP" keys.
- 2) The test mode starts up and Final Ass'y Test Menu appears on the display.

Note: Keeping the "MENU" and "STOP" keys pressed continuously in Step 1) above blackens the entire display. In such case, press the "PLAY" key and then the "MENU" key so that Final Ass'y Test Menu appears on the display.

< テストモード起動 >

- 1) "MENU"キーと"STOP"キーを押しながら"STANDBY/ON"キーを押した後すみやかに"MENU"キーと"STOP"キーから指を離します。
- 2) テストモードが起動しFinal Ass'y Test Menuが表示されます。

注: 1)で"MENU"キーと"STOP"キーを押し続けると全黒表示になります。この場合、"PLAY"キーを押し次に"MENU"キーを押すと、Final Ass'y Test Menuが表示されます。

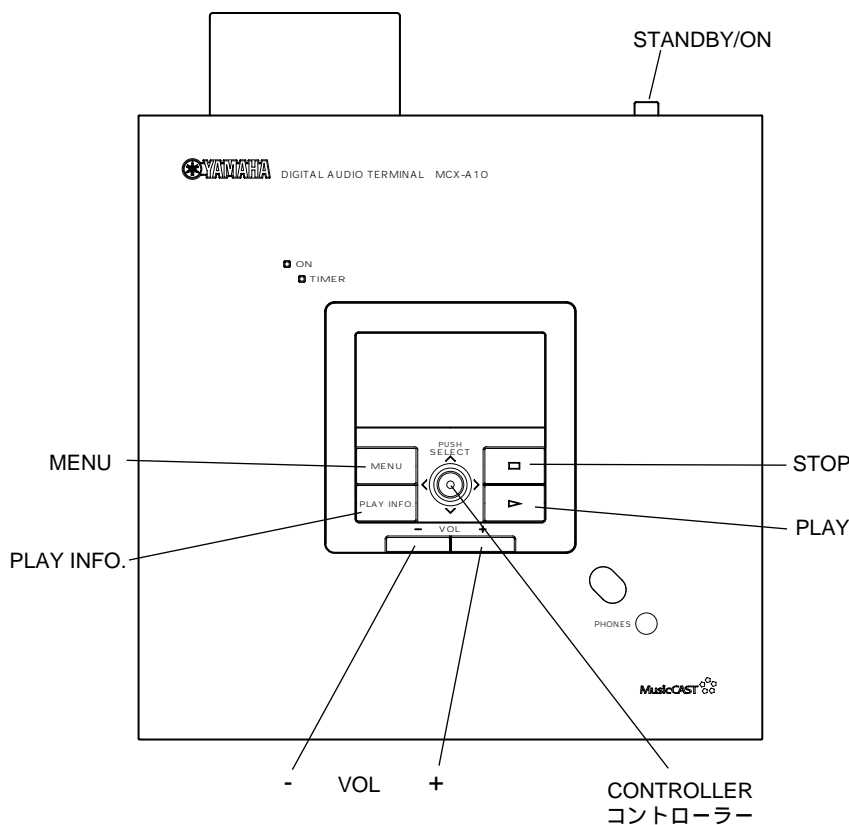

```
Final Ass'y Test Menu
<<Push Panel Keys >>
[MENU]MUTE [STOP]LCD
[INFO]FAN [PLAY]EXT.IN
[VOL-]JP.AMP [VOL+]DAC
[SELECT]Key & Temp
```

Note)

As the sound output level in the test mode is high, check it very carefully when listening by using the head phone.

注)テストモードでの音声出力レベルは高いのでヘッドホンで音を聞く場合には、充分注意してください。

1) MUTE

Press the "MENU" key, and the muting function of the audio output and video output turns on and a half of the ON LED turns on at the same time.

Press the "MENU" key again, and the muting function of the audio output and video output turns off and the entire ON LED turns on at the same time.

2) FAN Control

Each time the "PLAY INFO" key is pressed, the fan speed changes among 3 steps (high speed, low speed, stop) and the brightness of the TIMERE LED changes at the same time.

Display / 表示	FAN speed / FAN回転	Brightness of TIMER LED
FAN SPEED HIGH	High speed / 高速回転	Full / 全灯
FAN SPEED LOW	Low speed / 低速回転	Half / 半灯
FAN OFF	Stop / 停止	Off / 消灯

3) Temperature Detection

Press the "CONTROLLER" key, and the internal temperature of the main unit is displayed. This temperature is within the approximate range of higher than the ambient temperature and lower than the ambient temperature plus 15°C.

4) LCD Display

Every time the "STOP" key is pressed, the LCD lighting changes among 4 modes.

5) External Input

Press the "PLAY" key, and Ext. Input Test screen appears. Using the CD player, play the music CD to check the play-back sound through the headphone. At this time, check the sound level very carefully as the output level of the headphone is high. Move the cursor with the "CONTROLLER" key to check that the play-back sound changes accordingly.

1) MUTE

"MENU"キーを押すとオーディオ出力とビデオ出力のミュートがONし、同時にON LEDが半灯します。

再び"MENU"キーを押すとオーディオ出力とビデオ出力のミュートがOFFし、同時にON LEDが全灯します。

2) FANコントロール

"PLAY INFO."キーを押す毎に、FANの回転が3段階(高速、低速、停止)で切り替わり、同時にTIMER LEDの明るさが切り替わります。

3) 温度検出

"コントローラー"キーを押すと本体の内部温度が表示されます。温度はおよそ周囲温度以上～周囲温度+15以下の範囲となります。

4) LCD表示

"STOP"キーを押す毎に、LCDの点灯状態が4つのモードに切り替わります。

5) 外部入力

"PLAY"キーを押すとExt. Input Test 画面が表示されます。CDプレーヤーで音楽CDを再生し、ヘッドホンで再生音を確認します。この時、ヘッドホン出力レベルが高いので充分注意してください。"コントローラー"キーを使いカーソルを移動し、再生音の変化を確認します。

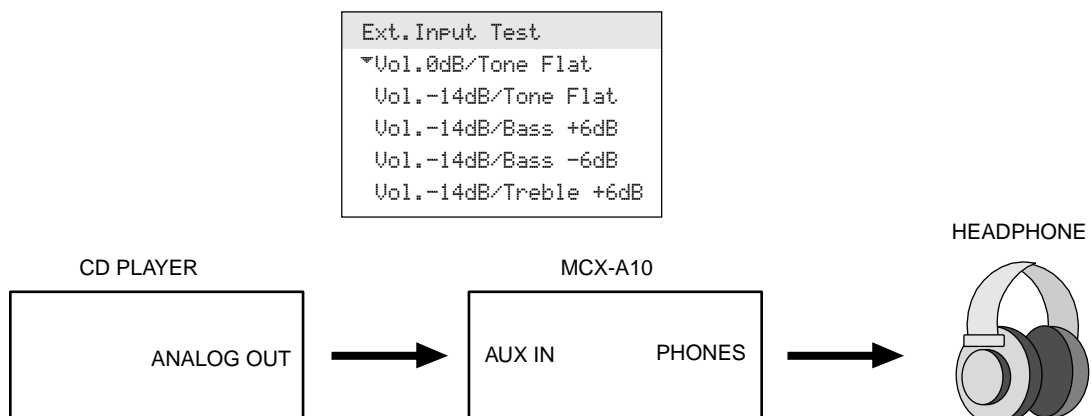

6) DAC Test

Press the "VOL +" key, and the DAC Test screen appears. Then, the built-in signal generator outputs the signals.

Move the cursor with the "CONTROLLER" key to check the output level, distortion factor, SN and frequency response.

6) DACテスト

"VOL +"キーを押すとDAC Test画面が表示されます。MCX-A10に内蔵された信号発生器からの信号が出力されます。

"コントローラー"キーを使いカーソルを移動し、出力レベル、歪率、SN、周波数特性を確認します。

DAC Test
▼DSP 1kHz 0dB
DSP Sound Off
DSP 1kHz -20.0dB
DSP 10kHz -20.0dB
DSP 50Hz -20.0dB

Check Items

- Output level (2 ± 0.2 Vrms), T.H.D. + Noise (0.01% or less)
- SN ratio (100dB or more)
- Output level (200 ± 20 mVrms)
- Frequency response (Output level at 1kHz, -20.0 dB \pm 1.0dB)
- Frequency response (Output level at 1kHz, -20.0 dB \pm 1.0dB)

確認事項

- 出力レベル(2 ± 0.2 Vrms)、歪率 + ノイズ(0.01%)
- SN比 (100dB)
- 出力レベル(200 ± 20 mVrms)
- 周波数特性(1kHz -20.0dBでの出力レベル \pm 1.0dB)
- 周波数特性(1kHz -20.0dBでの出力レベル \pm 1.0dB)

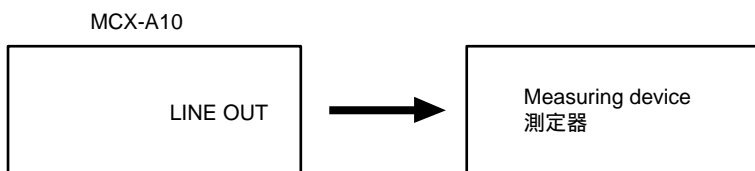

■ IC DATA

IC3 : HD6417709SF100
32 bit μ-COM (CPU)

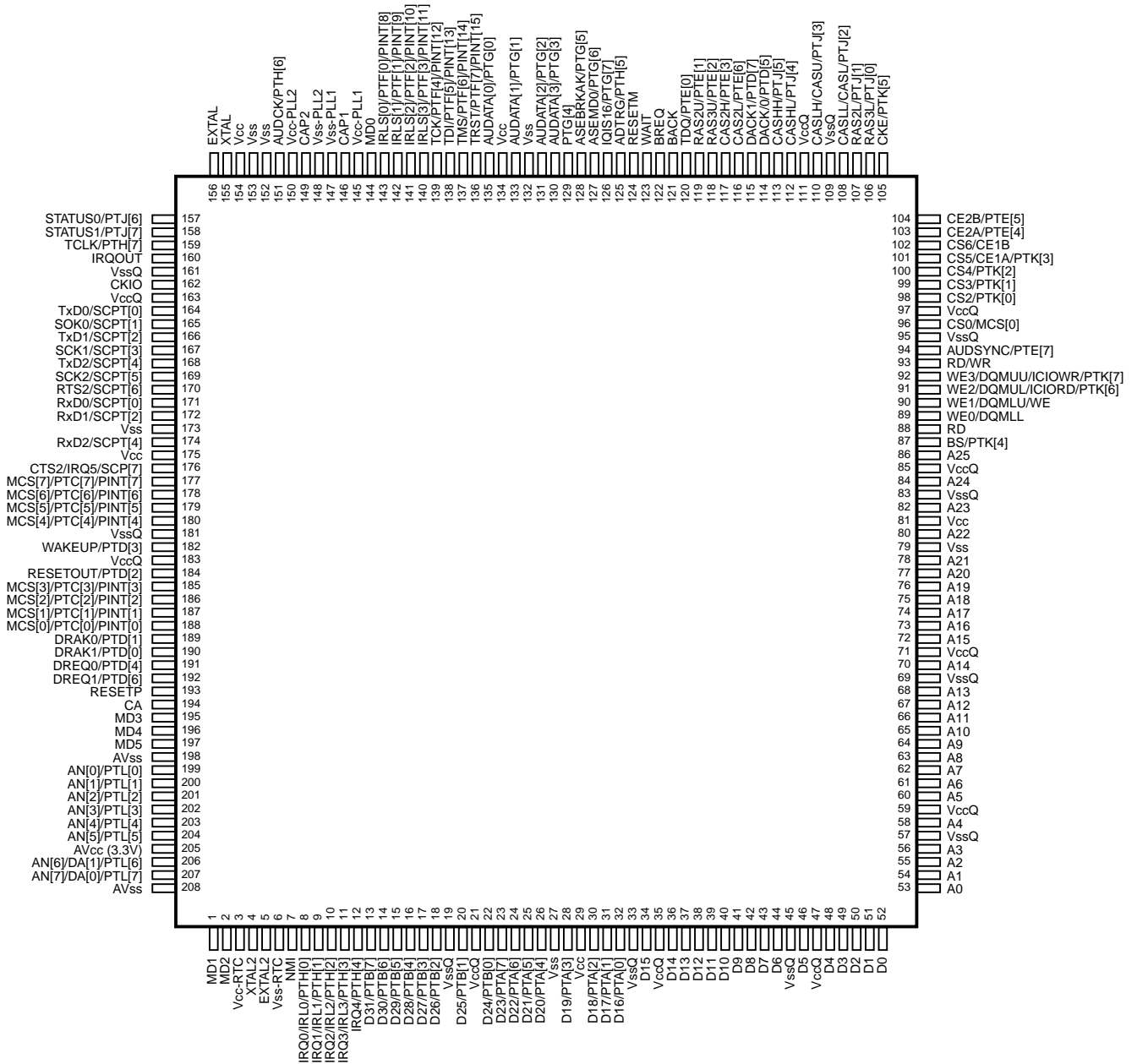

MCX-A10/
MCX-SP10

IC3 : HD6417709SF100
32 bit μ -COM (CPU)

Pin No.	Pin Name	I/O	Function	Pin No.	Pin Name	I/O	Function
1	MD1	I	Clock mode setting	56	A3	O	Address bus
2	MD2	I	Clock mode setting	57	VssQ	-	Power supply for input/output (0V)
3	Vcc-RTC	-	Power supply for RTC (+1.7DC)	58	A4	O	Address bus
4	XTAL2	O	Crystal oscillator terminal for built-in RTC	59	VccQ	-	Power supply for input/output (3.3V)
5	EXTAL2	I	Crystal oscillator terminal for built-in RTC	60	A5	O	Address bus
6	Vss-RTC	-	Power supply for RTC (0V)	61	A6	O	Address bus
7	NMI	I	Non maskable interrupt request	62	A7	O	Address bus
8	D2SH_N_INT0	I	Interrupt request from DSP	63	A8	O	Address bus
9	D2SH_N_INT1	I	Interrupt request from DSP	64	A9	O	Address bus
10	-	I	-	65	A10	O	Address bus
11	-	I	-	66	A11	O	Address bus
12	PC_N_INT	I	Interrupt request from PCMCIA	67	A12	O	Address bus
13	D31	I/O	Data bus	68	A13	O	Address bus
14	D30	I/O	Data bus	69	VssQ	-	Power supply for input/output (0V)
15	D29	I/O	Data bus	70	A14	O	Address bus
16	D28	I/O	Data bus	71	VccQ	-	Power supply for input/output (3.3V)
17	D27	I/O	Data bus	72	A15	O	Address bus
18	D26	I/O	Data bus	73	A16	O	Address bus
19	VssQ	-	Power supply for input/output (0V)	74	A17	O	Address bus
20	D25	I/O	Data bus	75	A18	O	Address bus
21	VccQ	-	Power supply for input/output (3.3V)	76	A19	O	Address bus
22	D24	I/O	Data bus	77	A20	O	Address bus
23	D23	I/O	Data bus	78	A21	O	Address bus
24	D22	I/O	Data bus	79	Vss	-	Power supply (0V)
25	D21	I/O	Data bus	80	A22	O	Address bus
26	D20	I/O	Data bus	81	Vcc	-	Power supply (+1.7DC)
27	Vss	-	Power supply (0V)	82	A23	O	Address bus
28	D19	I/O	Data bus	83	VssQ	-	Power supply for input/output (0V)
29	Vcc	-	Power supply (1.7DC)	84	A24	O	Address bus
30	D18	I/O	Data bus	85	VccQ	-	Power supply for input/output (3.3V)
31	D17	I/O	Data bus	86	A25	O	Address bus
32	D16	I/O	Data bus	87	N_BS	O	Bus cycle start signal
33	VssQ	-	Power supply for input/output (0V)	88	N_RD	O	Read strobe
34	D15	I/O	Data bus	89	N_WE0	O	D7 - D0 select signal
35	VccQ	-	Power supply for input/output (3.3V)	90	N_WE1	O	D15 - D8 select signal
36	D14	I/O	Data bus	91	N_WE2	O	D23 - D16 select signal
37	D13	I/O	Data bus	92	N_WE3	O	D31 - D24 select signal
38	D12	I/O	Data bus	93	RD_WR	O	Read/write
39	D11	I/O	Data bus	94	N_AUDSYNC	O	AUD cycle
40	D10	I/O	Data bus	95	VssQ	-	Power supply for input/output (0V)
41	D9	I/O	Data bus	96	N_CS0	O	Chip select 0
42	D8	I/O	Data bus	97	VccQ	-	Power supply for input/output (3.3V)
43	D7	I/O	Data bus	98	N_CS2	O	Chip select 2
44	D6	I/O	Data bus	99	N_CS3	O	Chip select 3
45	VssQ	-	Power supply for input/output (0V)	100	N_CS4	O	Chip select 4
46	D5	I/O	Data bus	101	N_CS5	O	Chip select 5
47	VccQ	-	Power supply for input/output (3.3V)	102	N_CE1B	O	Chip select 6
48	D4	I/O	Data bus	103	LCD_BL	O	LCD control signal
49	D3	I/O	Data bus	104	N_CE2B	O	Card enable for area 6PCMCIA
50	D2	I/O	Data bus	105	CKE	O	CK enable (SDRAM)
51	D1	I/O	Data bus	106	N_RAS3L	O	RAS for lower 32M/64M byte address (SDRAM)
52	D0	I/O	Data bus	107	LED0	O	For debugging
53	A0	O	Address bus	108	N_CASL	O	CAS for lower 32M/64M byte address (SDRAM)
54	A1	O	Address bus	109	VssQ	-	Power supply for input/output (0V)
55	A2	O	Address bus	110	LINE_MUTE	O	Mute control signal

IC3 : HD6417709SF100
32 bit μ -COM (CPU)

Pin No.	Pin Name	I/O	Function	Pin No.	Pin Name	I/O	Function
111	VccQ	-	Power supply for input/output (3.3V)	166	DBG_TxD1	O	Serial transmission data 1
112	FAN9V	O	FAN control signal	167	EQ_CE	O	Tone control signal
113	N_FAN	O	FAN control signal	168	LED_TIMER1	O	Timer LED control signal
114	SB_N_CS	O	Control signal for service board	169	VOL_N_CS	O	Electronic volume control signal
115	FLASH_N_VPP	O	Flash rewrite control signal	170	N_OSDMUTE	O	Video output control signal
116	SP_ON	O	Speaker control signal	171	SH_RxD0	I	Serial reception data 0
117	SW_MUTE	O	Sub woofer control signal	172	DBG_RxD1	I	Serial reception data 1
118	LED_TIMER0	O	TIMER LED control signal	173	Vss	-	Power supply (0V)
119	CPU_MUTE	O	Mute control signal	174	-	I	-
120	SH_TD0	O	Test data output	175	Vcc	-	Power supply (+1.7DC)
121	-	O	-	176	LAN_N_ACT	I	Cable LAN active signal
122	-	I	-	177	DACDAMP_N_PDN	O	DAC/DAMP control signal
123	PLD_N_WAIT	I	Hardware wait signal	178	DAC_N_CS	O	DAC control signal
124	N_RESETM	I	Manual reset request	179	DACVOLOSD_CK	O	Control signal for DAC/electronic volume/ OSD
125	-	I	-	180	DACVOLOSD_DI	O	Control signal for DAC/electronic volume/ OSD
126	CPU_N_IOIS16	I	16 bit input/output for area 6	181	VssQ	-	Power supply for input/output (0V)
127	N_ASEMD0	I	ASE mode	182	EPRSB_CK	O	EEPROM/control signal for service board
128	N_ASEBRKAK	O	ASE break acknowledge	183	VccQ	-	Power supply for input/output (3.3V)
129	-	I	-	184	EPRSB_DI	I/O	EEPROM/control signal for service board
130	AUDATA3	O	AUD data	185	DSP0_N_COM1	O	Control signal for DSP
131	AUDATA2	O	AUD data	186	DSP0_N_COM0	O	Control signal for DSP
132	Vss	-	Power supply (0V)	187	DSP0_N_RST	O	Reset signal for DSP
133	AUDATA1	O	AUD data	188	CPU_N_RST	O	Soft reset signal
134	Vcc	-	Power supply (+1.7DC)	189	OSD_N_CS	O	Control signal for OSD
135	AUDATA0	O	AUD data	190	DSP0_BSW	O	Bus switch select signal
136	SH_N_TRST	I	Test reset	191	LAN_N_LINK	I	Cable LAN link signal
137	SH_TMS	I	Test mode switch	192	HPDET	I	Headphone detect signal
138	SH_TDI	I	Test data input	193	N_RESETP	I	Power on reset request
139	SH_TCK	I	Test clock	194	CA	I	Chip active/hardware standby request
140	LAN_INT	I	Interrupt request from cable LAN	195	MD3	I	Bus width setting for area 0
141	SB_BIT0	I	Control signal for service board	196	MD4	I	Bus width setting for area 0
142	SB_DIP1	I	Control signal for service board	197	MD5	I	Endian setting
143	HARDINFO	I	Hardware information	198	AVss	-	Analog power supply (0V)
144	MD0	I	Clock mode setting	199	KEY0	I	Key input signal
145	Vcc-PLL1	-	Power supply for PLL1 (+1.7DC)	200	KEY1	I	Key input signal
146	CAP1	-	External capacity terminal for PLL1	201	KEY2	I	Key input signal
147	Vss-PLL1	-	Power supply for PLL1 (0V)	202	TEMP	I	Temperature control signal
148	Vss-PLL2	-	Power supply for PLL2 (0V)	203	DBG_DIP0	I	Control signal for debugging board
149	CAP2	-	External capacity terminal for PLL2	204	DBG_DIP1	I	Control signal for debugging board
150	Vcc-PLL2	-	Power supply for PLL2 (+1.7DC)	205	AVcc	-	Analog power supply (3.3V)
151	AUDCK	I	AUD clock	206	CLKCNT	O	Clock control signal
152	Vss	-	Power supply (0V)	207	N_PROT	I	System protect signal
153	Vss	-	Power supply (0V)	208	AVss	-	Analog power supply (0V)
154	Vcc	-	Power supply (+1.7DC)				
155	-	O	-				
156	EXTAL	I	External clock/ Crystal oscillator terminal				
157	EQ_DI	O	Tone control signal				
158	EQ_CK	O	Tone control signal				
159	IRIN	I	Remote control signal input				
160	-	O	-				
161	VssQ	-	Power supply for input/output (0V)				
162	CKIO	O	System clock output				
163	VccQ	-	Power supply for input/output (3.3V)				
164	SH_TxD0	O	Serial transmission data 0				
165	N_PWRSLP	O	Power LED control signal				

IC901 : LAN91C111-NE
Ethernet

MCX-A10/
MCX-SP10

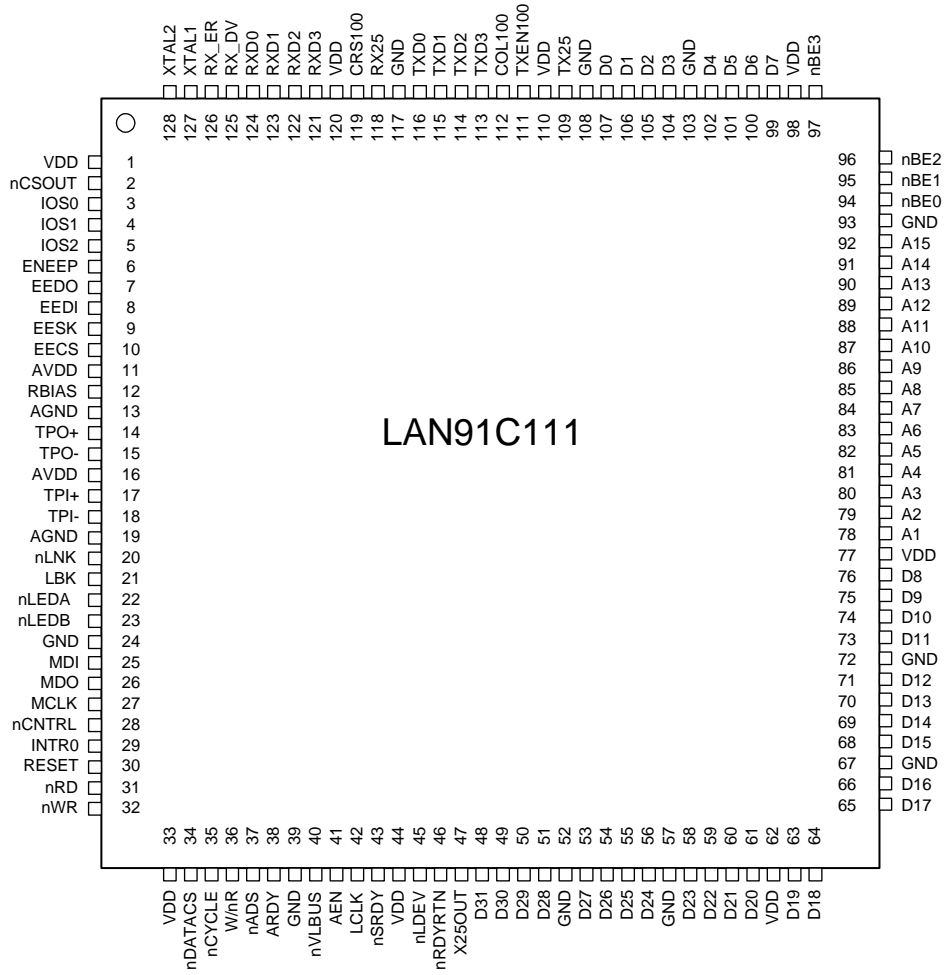

IC901 : LAN91C111-NE
Ethernet

Pin No.	Symbol	Name	Buffer Type	Function
81-92	A4-A15	Address	I **	Input signal. This signal is double signed by LAN91C111 to determine access to the register of LAN91C111.
78-80	A1-A3	Address	I **	Input signal. This signal is used by LAN91C111 for selection of the internal register.
41	AEN	Address Enable	I **	Input signal. This signal is used for approval of double signing of the address. The address can be double signed only when AEN is in the low state.
94-97	nBE0-nBE3	nByte Enable	I **	Input signal. This signal is used to determine the register being accessed and the access width while accessing the register of LAN91C111. When nDATACS is in the low state (burst accessing), nBE0 - nBE3 are ignored because 32-bit transmission is assumed.
104-107, 99-102, 73-76, 68-71, 63-66, 58-61, 53-56, 48-51	D0-D31	Data Bus	I/O24 **	Bidirectional signal. It is a 32-bit data bus that is used to access the internal register of LAN91C111. The data bus has a weak internal pullup register. It is usable for direct connection with the system bus without external buffering. For the 16-bit system, only D0-D15 are used.
30	RESET	Reset	IS **	Input signal. When this pin is in the high state, the controller executes resetting of the internal system (MAC and PHY). When this pin is in the high state, all registers are set to the default value and the controller reads the contents of the EEPROM device through the EEPROM interface (1). This input is not considered effective unless it is active for at least 100ns for filtering of glitches.
37	nADS	nAddress Strobe	IS **	Input signal. With the system that requires address latching, the rising edge of nADS indicates the time of A1-A15 and AEN latching. The internal functions of all LAN91C111 of A1-A15 and AEN are latched if there is no nLDEV decoding.
35	nCYCLE	nCycle	I **	Input signal. This active low signal is used to control the LAN91C111 EISA burst mode synchronous bus cycle.
36	W/nR	Write/nREAD	IS **	Input signal. This signal determines the direction of the synchronous cycle. When it is in the high state, the writing cycle is selected and when it is low, the reading cycle is selected.
40	nVLBUS	NVLBus Access	I with pullup **	Input signal. When this signal is in the low state, LAN91C111 synchronous bus interface is set for VL bus accessing. If not, LAN91C111 is set for EISA DMA burst accessing. It does not affect the asynchronous bus interface.
42	LCLK	Local Bus Clock	I **	Input signal. This signal is used to interface the synchronous bus. The maximum frequency is 50MHz. With the EISA DMA burst mode, the maximum value is 8.33MHz.
38	ARDY	Asynchronous Ready	OD16	Open drain output signal. ARDY is usable for interfacing with the asynchronous bus to expand accessing. Its rising (completion of accessing) edge is controlled by XTA 1 clock and so asynchronous with the host CPU, that is, bus clock.
43	nSRDY	nSynchronous Ready	O16	Output signal. This output is used for interfacing the synchronous bus at nVLBUS=0 to expand accessing. This signal is usually inactive and its falling edge indicates completion. This signal is synchronous with the bus clock LCLK.
46	nRDYRTN	nReady Return Interrupt	I **	Input signal. This input is used to complete the synchronous reading cycle. In the EISA burst mode, it is picked up at the falling edge and the synchronous cycle continues until the EISA burst mode is adopted in the high state.

Pin No.	Symbol	Name	Buffer Type	Function
29	INTR0	nLocal Device	O24	Interrupt output signal. This signal is used to cause interruption to the host on an event of a certain status. Caution: The selection bits which have been determined by the INT SEL 1-0 bit value in the configuration register are no more required but retained to keep interchangeability when the FEAST family is changed.
45	nLDEV	nRead Strobe	O16	Output signal. This active low output is indicated when AEN is low and A4-A15 decoding to LAN91C111 is programmed to a higher byte of the base address register. n LDEV is a linked decode of an unlatched address and AEN signal.
31	nRD	nWrite Strobe	IS **	Input signal. This signal is used in the asynchronous bus interface.
32	nWR	nData Path	IS **	Input signal. This signal is used in the asynchronous bus interface.
34	nDATACS	Chip Select	I with pullup **	Input signal. When n DATACS is in the low state, the data bus can be accessed regardless of selection of AEN, A1 - A15 value and bank selection register. n DATACS provides interface to or from 32 bits of LAN9C111at one time.
9	EESK	EEPROM Clock	O4	Output signal. It is used when 4 _sec clock transfers the data to or from the serial EEPROM.
10	EECS	EEPROM Select	O4	Output signal. It is chip select of serial EEPROM, used when forming and selecting the command of serial EEPROM.
7	EEDO	EEPROM Data Out	O4	Output signal. It is linked with D1 input (EEDI) of serial EEPROM.
8	EEDI	EEPROM Data In	I with pulldown **	Input signal. It is linked with DO output (EEDO) of serial EEPROM.
3-5	IOS0-IOS2	I/O Base	I with pullup **	Input signal. It is possible to connect the external switch to make a selection among predefined EEPROM structures.
6	ENEEP	Enable EEPROM	I with pullup **	Input signal. It enables LAN91C111 to access serial EEPROM (in the high or open state). If EEPROM is not connected to LAN91C111, it must be grounded.
127, 128	XTAL1 XTAL2	Crystal 1 Crystal 2	Iclk	An external 25MHz crystal oscillator must be connected to these pins. When using the TTL clock, it should be connected to XTAL1 and XTAL2 should remain open.
1, 33, 44, 62, 77, 98, 110, 120	VDD	Power		+3.3V power supply pin.
11, 16	AVDD	Analog Power		+3.3V analog power supply pin.
24, 39, 52, 57, 67, 72, 93, 103, 108, 117	GND	Ground		Ground pin.
13, 19	AGND	Analog Ground		Analog ground pin.
21	LBK	Loopback	O4	Output pin. It is effective when the LOOP bit is set (TCR bit 1).
20	nLNK	nLink Status	I with pullup **	Input signal. The general purpose port is used to transmit the LINK status (EPHSR bit 14).
28	nCNTRL	nControl	O12	General purpose control signal.
47	X25out	X25 Out	O12	25MHz output signal to external PHY.
111	TXEN100	Transit Enable100 Mbps	O12	Output signal to MII PHY. It enables 100Mbps transmission.
119	CRS100	Carrier Sense 100 Mbps	I with pulldown **	Input signal from MII PHY. Wave form of bucket reception to be used when waiting for reception and restoring.
125	RX_DV	Receive Data Valid	I with pulldown **	Input signal from MII PHY. Wave form for receiving effective data, used to form reception data.
112	COL100	Collisio Detect 100 Mbps	I with pulldown **	Input signal from MII PHY. This is an input pin for collision detection.
113-116	TXD0-TXD3	Transmit Data	O12	Output signal. 4 bit data is transmitted to MII PHY.

Pin No.	Symbol	Name	Buffer Type	Function
109	TX25	Transmit Clock	I with pullup **	Input signal. The clock input from MII is transmitted. 4 bit rate clock (25 MHz for 100 Mbps and 2.5 Mbps for 10 Mbps)
118	RX25	Receive Clock	I with pullup **	Input signal. The clock input from MII PHY is received. 4 bit rate clock (25 MHz for 100 Mbps and 2.5 Mbps for 10 Mbps)
121-124	RXD0-RXD3	Receive Data	I with pullup **	Input signal. 4 bits of the receiving data from MII PHY.
25	MDI	Management Data Input	I with pulldown **	MII management data input signal.
26	MDO	Management Data Output	O4	MII management data output signal.
27	MCLK	Management Clock	O4	MII management clock.
126	RX_ER	Receive Error	I with pulldown **	This pin is for the input signal which indicates an error of the code detected by PHY. It is used to remove the bucket being received by LAN91C111. The error reported by this event has the same meaning as a faulty CRC. (Receive Status Word 13)
2	nCSOUT	nChip Select Output	O4	This pin is for the output signal. Chip select is provided for mapping to the space of LAN91C111 with PHY function. It enables accessing the 8-bit lower address of LAN91C111 when BANK SELECTED is "7".
12	RBIAS	External Register	NA	This pin is for setting the transmission current. The output current for TP transmission output is set by the external resistor connected between this pin and GND.
14	TPO+		O/I	This pin is for output signal to transmit positive twist pair.
15	TPO-		O/I	This pin is for output signal to transmit negative twist pair.
17	TPI+		I/O	This pin is for output signal to receive positive twist pair.
18	TPI-		I/O	This pin is for input signal too receive negative twist pair.
22	nLEDA		OD16	This pin is for PHY LED output.
23	nLEDB		OD16	This pin is for PHY LED output.

SIGNAL DESCRIPTION PARAMETERS

Presence of "n" at the beginning of a signal indicates that the signal is in the active low state and its absence indicates the active high state of the signal.

"assert" or "assertion" indicates that the signal is effective regardless whether the voltage level is high or low. "negata" or "negation" indicates that the signal is ineffective. Also, "high-Z" indicates that the signal is in the tri-state.

"Undefined" means that the signal can be high, low, tri-state or intermediate level.

Buffer Types

- O4 Output buffer with 2mA transmission side and 4mA reception side
- O12 Output buffer with 6mA transmission side and 12mA reception side
- O16 Output buffer with 8mA transmission side and 16mA reception side
- O24 Output buffer with 12mA transmission side and 24mA reception side
- OD16 Open drain buffer with 16mA reception side
- I/O4 Bidirectional buffer with 2mA transmission side and 4mA reception side
- I/O24 Bidirectional buffer with 12mA transmission side and 24mA reception side
- I/OD Bidirectional open drain buffer with 4mA reception side
- I Input buffer
- IS Input buffer with Schmidt trigger hysteresis
- Iclk Clock input buffer
- I/O Difference input
- O/I Difference output
- ** 5V trylant

IC601 : LC74781-9844 (U model)

IC601 : LC74782-9866 (C, A, B, G models)

On-screen Display Controller

MCX-A10/
MCX-SP10

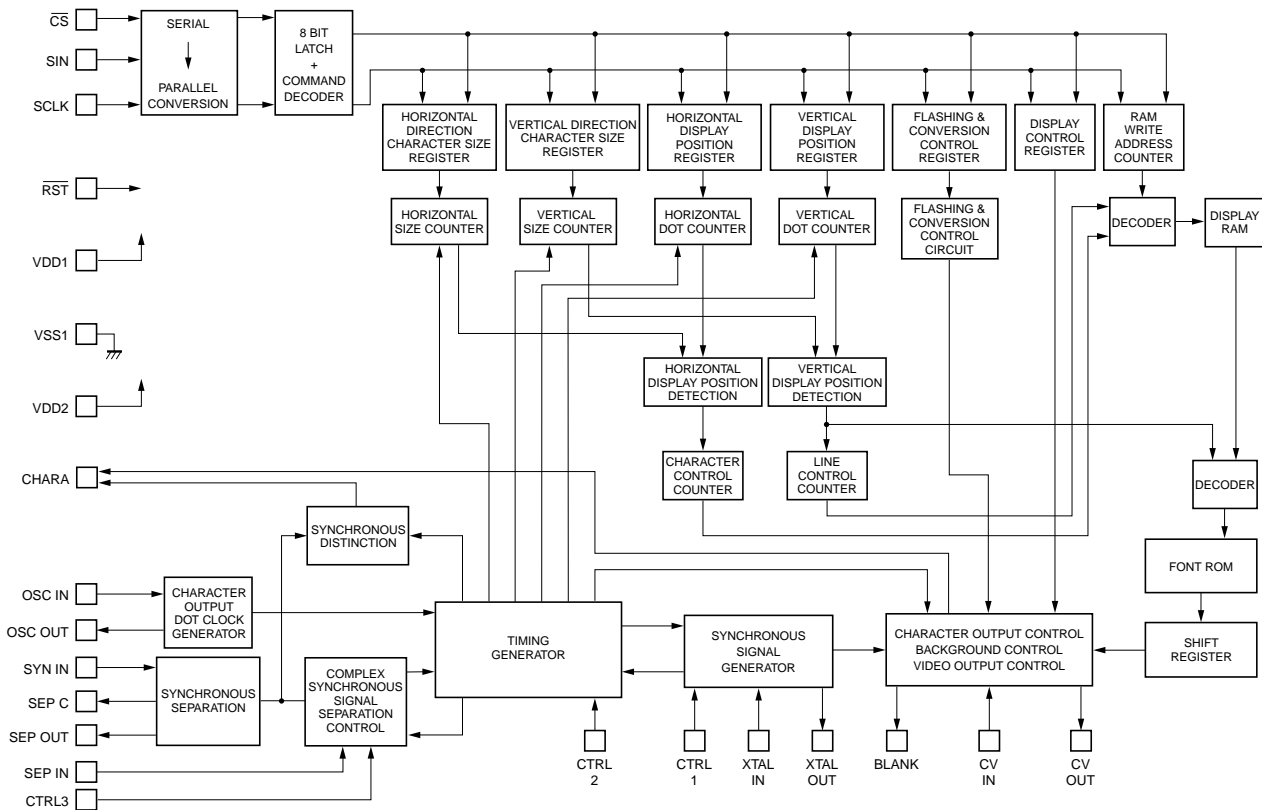
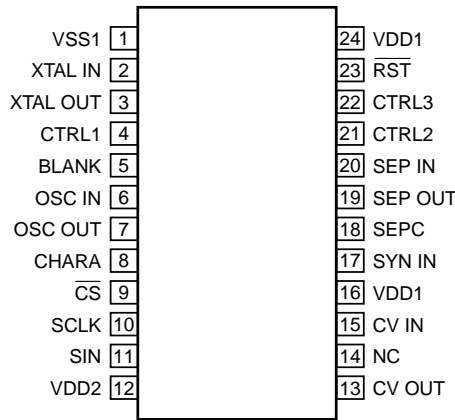

IC601 : LC74781-9844 (U model)
IC601 : LC74782-9866 (C, A, B, G models)
On-screen Display Controller

Pin No.	Symbol	Terminal name	Function
1	VSS1	Ground terminal	Connection to GND (Digital system ground terminal)
2	XTAL IN	Crystal oscillation terminal	Terminal to connect the crystal of the crystal oscillator for internal synchronous signal generation and a capacitor or to input an external clock. (2fsc or 4fsc)
3	XTAL OUT		
4	CTRL1	Crystal oscillation input switching terminal	Switching terminal between the mode to input a clock externally and the mode for crystal oscillation. [L] = Crystal oscillation, [H] = External clock input
5	BLANK	Blank output terminal	Terminal to output the blank signal (character and bordering OR signal) (MOD0 : complex synchronous signal output at [H]). When resetting (RST terminal = [L]), a crystal oscillation clock is output (but not when resetting by the command).
6	OSC IN	LC oscillation terminal	Terminal to connect the coil of the oscillator for character output dot clock generation and a capacitor.
7	OSC OUT		
8	CHARA	Character output terminal	Terminal to output a character signal (MOD0 : It becomes an output terminal to judge the external synchronous signal at [H] and outputs the result after judging existence of the external synchronous signal. When a synchronous signal exists, [H] is output.) When resetting (RST terminal = [L]), a dot clock (LC oscillation) is output (but it is not output when reset by the command.)
9	/CS	Enable input terminal	Serial data input enable input terminal. The serial data input becomes enable at [L]. A pull-up resistor is built in (hysteresis input).
10	SCLK	Clock input terminal	Input terminal of clock for serial data input. A pull-up resistor is built in (hysteresis input).
11	SIN	Data input terminal	Serial data input terminal. A pull-up resistor is built in (hysteresis input).
12	VDD2	Power supply terminal	Power supply terminal for complex image signal level adjustment (Power supply for analog system)
13	CV OUT	Video signal output terminal	Output terminal for complex image signal.
14	NC		Connected to GND or unconnected.
15	CV IN	Video signal input terminal	Input terminal for complex image signal.
16	VDD1	Power supply terminal	Power supply terminal (+5V : power supply for digital system)
17	SYN IN	Synchronous separation circuit input terminal	Video signal input terminal of the built-in synchronous separation circuit (When the built-in synchronous separation circuit is not used, it becomes a horizontal synchronous signal input or a complex synchronous signal input.)
18	SEP C	Synchronous separation circuit bias voltage terminal	Terminal to monitor built-in synchronous separation circuit bias voltage.
19	SEP OUT	Complex synchronous signal output terminal	Terminal to output a complex synchronous signal of built-in synchronous separation circuit ([H] when internally synchronized at MOD1 : [H], [L] output when externally synchronized) (When the built-in synchronous separation circuit is not used, SYNIN input signal is output.)
20	SEP IN	Vertical synchronous signal input terminal	Terminal to input a vertical synchronous signal by integrating the output signal of SEPOUT terminal. Connect the integration circuit between SEPOUT terminals. Fix it to VDD1 when not used.
21	CTRL2	NTSC/PAL-M switching input terminal	Pin setting has a priority over switching of NTSC/PAL/PAL-M/PAL-N method. The NTSC method is selected after [L]= reset. NTSC/PAL/PAL-M/PAL-N method setting by a command is effective. [H] = PAL-M method.
22	CTRL3	SEPIN input control terminal	Terminal to control whether or not to input VSYNC signal into SEPIN input terminal. [L] = VSYNC inputted, [H] = VSYNC not inputted.
23	/RST	Reset input terminal	System reset input terminal. A pull-up resistor is built in (hysteresis input).
24	VDD1	Power supply terminal (+5V)	Power supply terminal (+5V : power supply for digital system)

PIN CONNECTION DIAGRAM

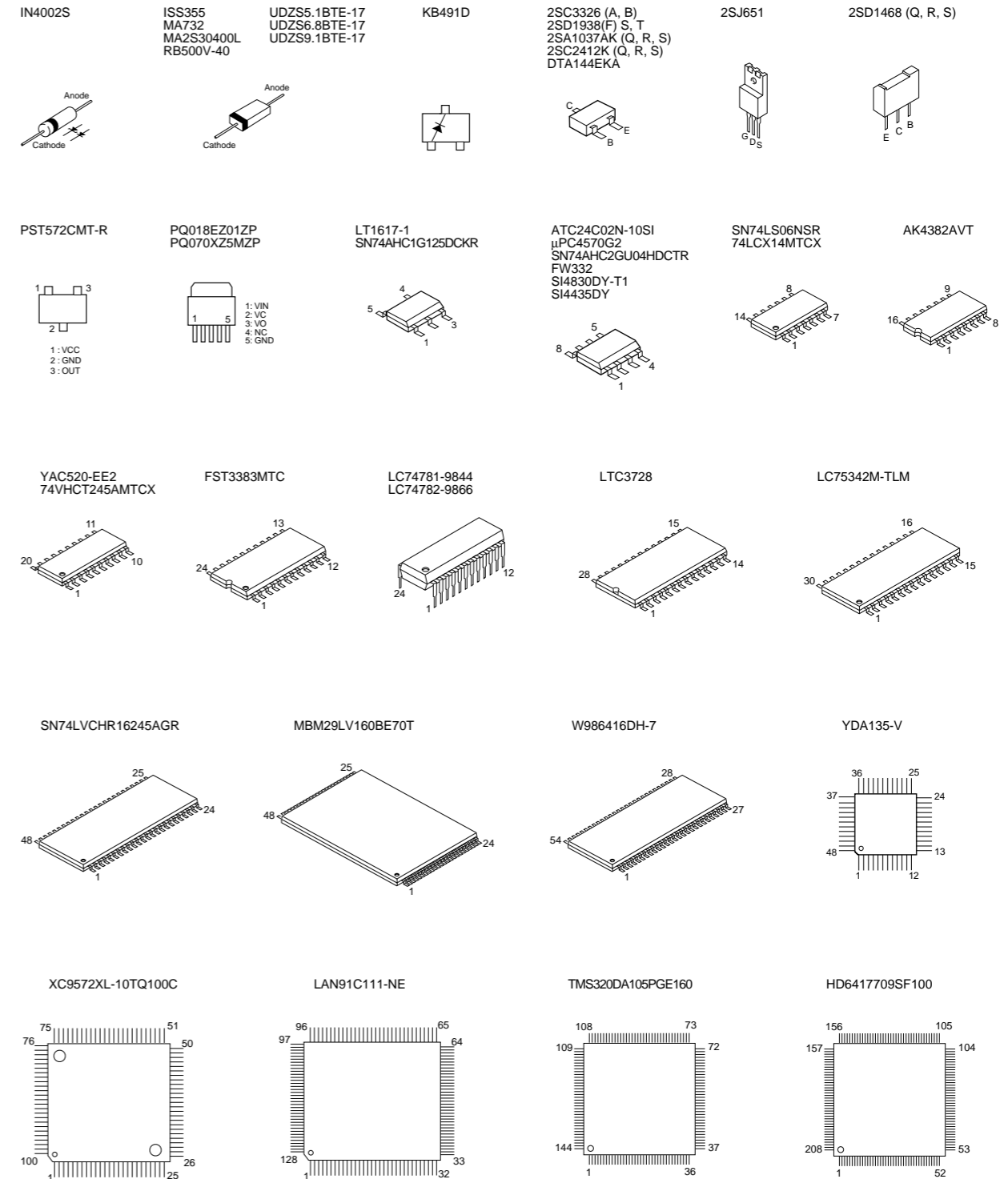

■ BLOCK DIAGRAM

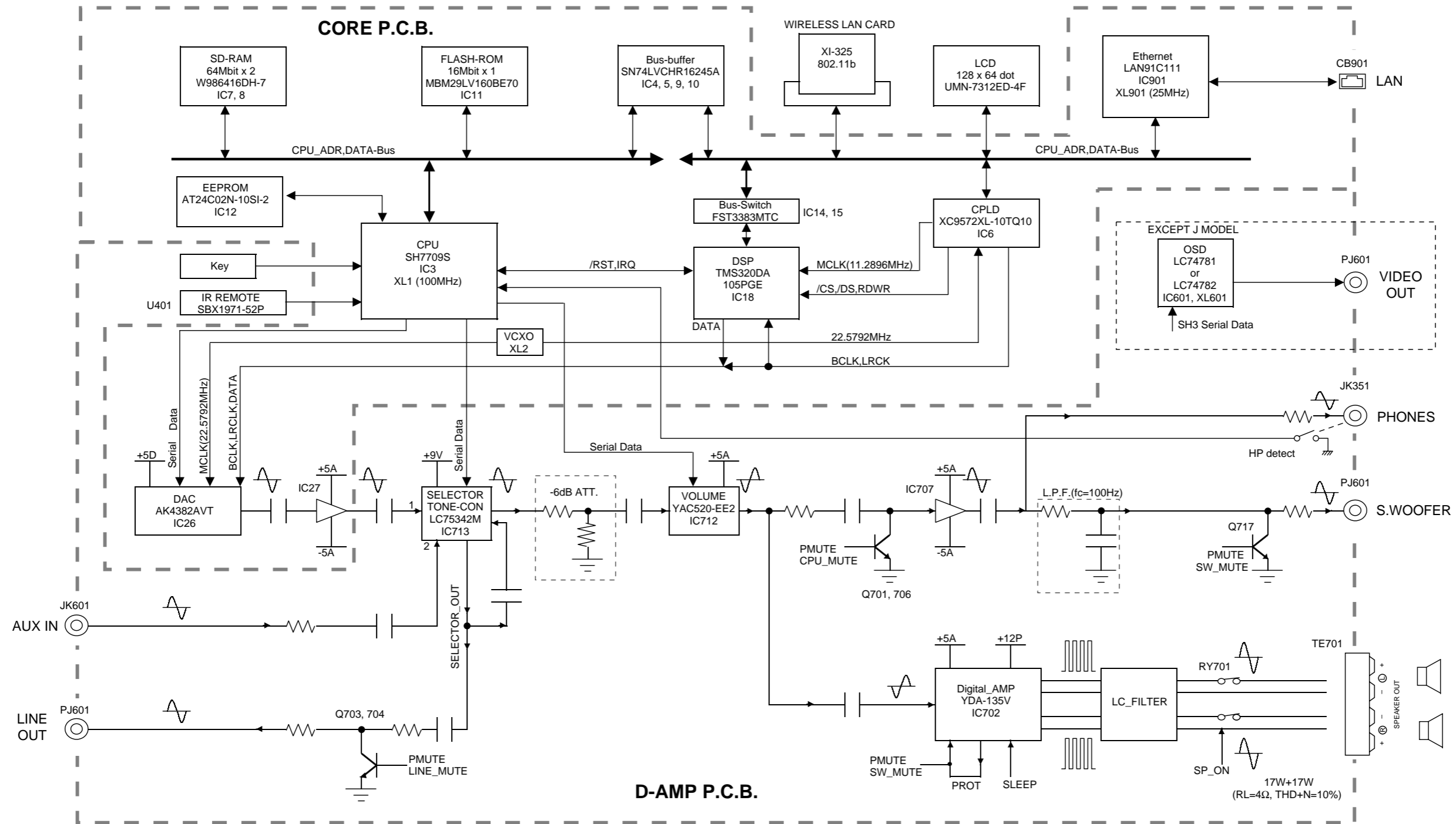

■ POWER SUPPLY BLOCK DIAGRAM

1

2

3

4

5

6

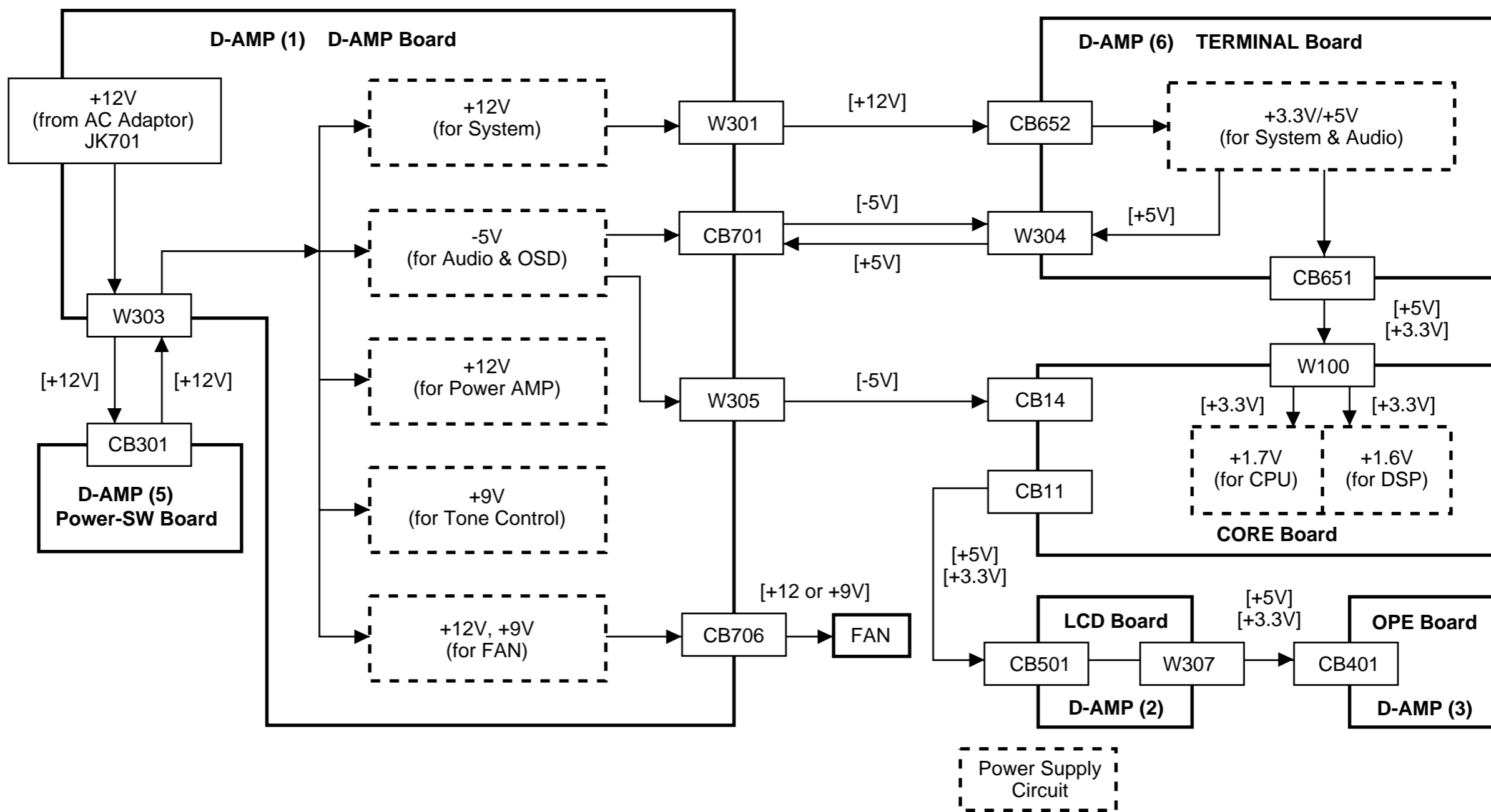

PRINTED CIRCUIT BOARD (Foil side)

Point ① (Pin 6 of IC21)

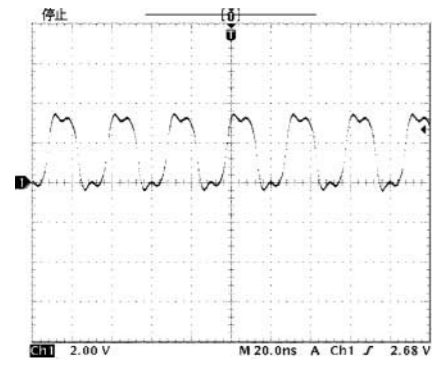

Point ② (Pin 1 of IC22)

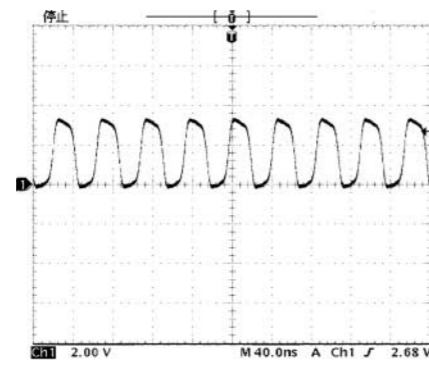

Point ④ (Pin 128 of IC901)

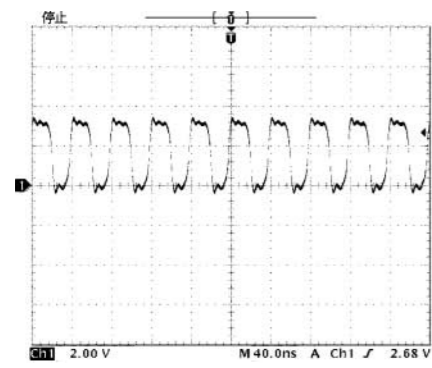

NOTE)
The CORE P.C.B. actually has a six-layer pattern structure (part face pattern, internal pattern 1, internal pattern 2, internal pattern 3, internal pattern 4 and solder face pattern) but it is shown as "part face pattern + solder face pattern" in this diagram.

NOTE)
CORE P.C.B.は、6層パターン構造（部品面パターン、内層1パターン、内層2パターン、内層3パターン、内層4パターン、ハンダ面パターン）ですが、本図のCORE P.C.B.は、部品面パターン+ハンダ面パターンを表記しております。

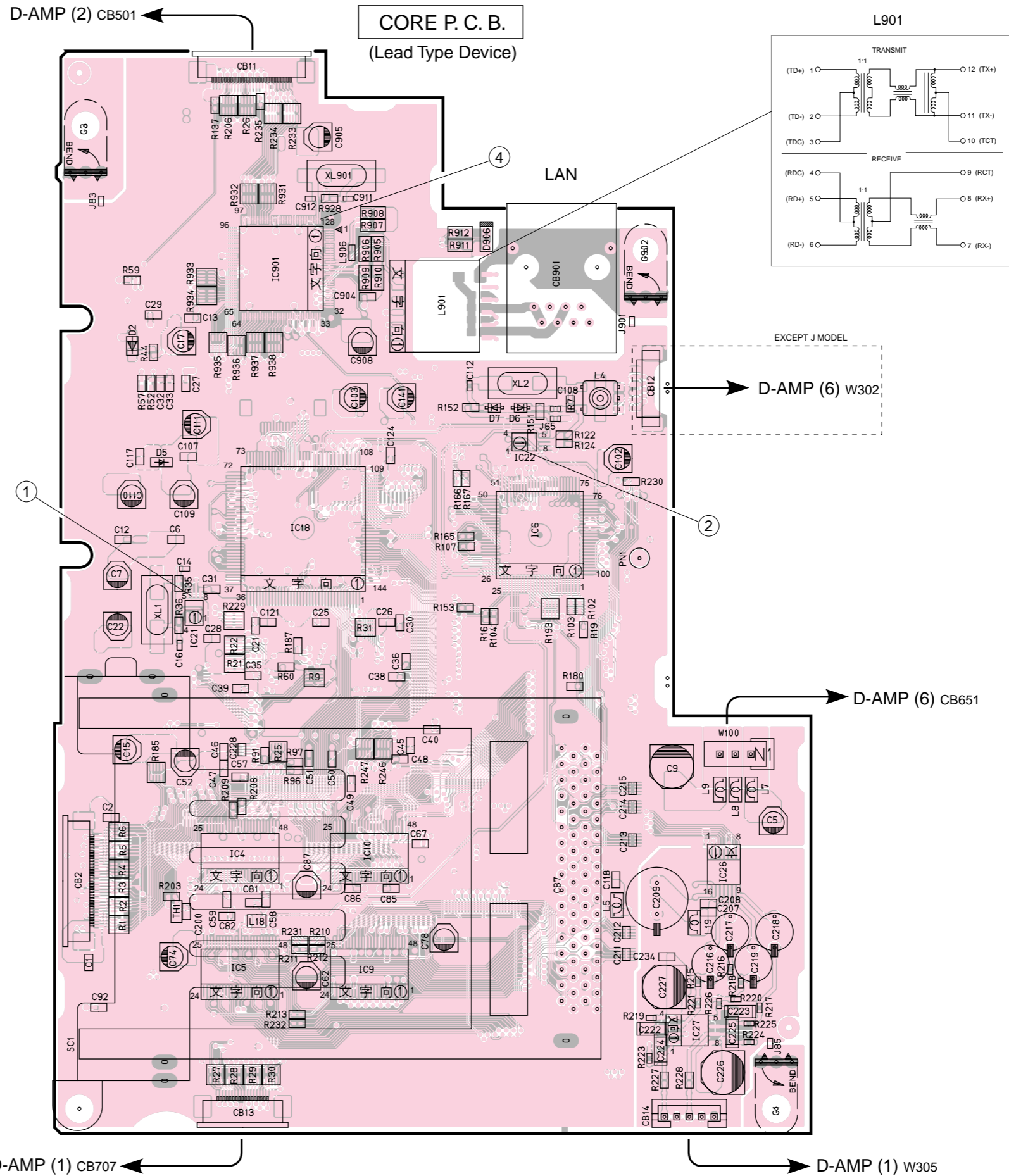

PRINTED CIRCUIT BOARD (Foil side)

1

Point ③

CH 1 : Pin 1 of IC2
CH 2 : Pin 3 of IC2

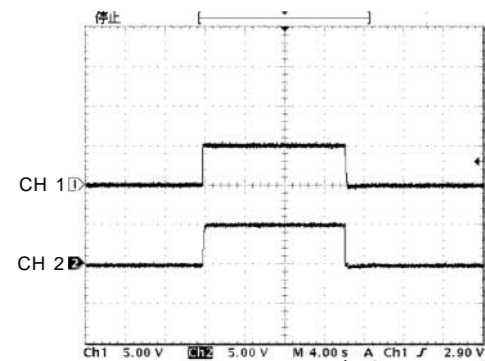

AC CORD ON
(Connect the AC adaptor)

AC CORD OFF
(Disconnect the AC adaptor)

Point ③

CH 1 : Pin 1 of IC2
CH 2 : Pin 3 of IC2

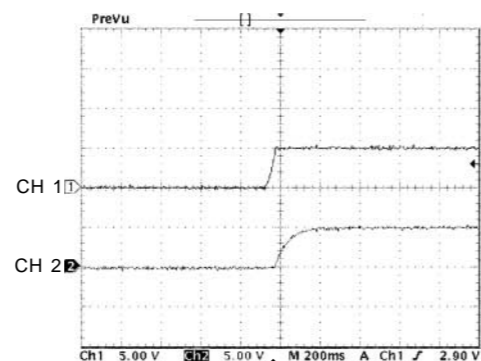

AC CORD ON
(Connect the AC adaptor)

2

3

4

5

NOTE)

The CORE P.C.B. actually has a six-layer pattern structure (part face pattern, internal pattern 1, internal pattern 2, internal pattern 3, internal pattern 4 and solder face pattern) but it is shown as "part face pattern + solder face pattern" in this diagram.

NOTE)

CORE P.C.B.は、6層パターン構造（部品面パターン、内層1パターン、内層2パターン、内層3パターン、内層4パターン、ハンダ面パターン）ですが、本図のCORE P.C.B.は、部品面パターン+ハンダ面パターンを表記しております。

6

CORE P. C. B.
(Surface Mount Device)

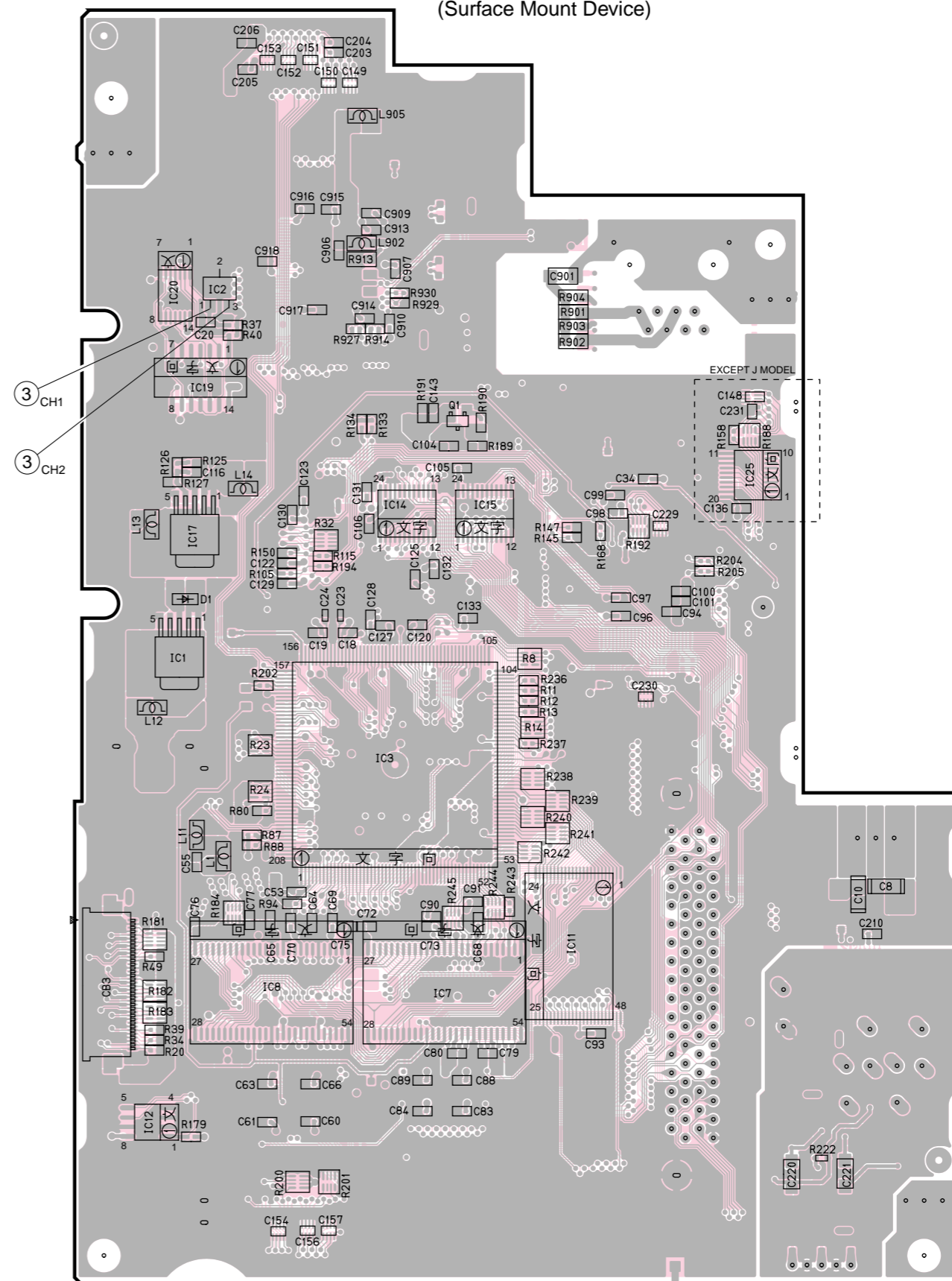

PRINTED CIRCUIT BOARD (Foil side)

D-AMP (1) P. C. B.
(Lead Type Device)

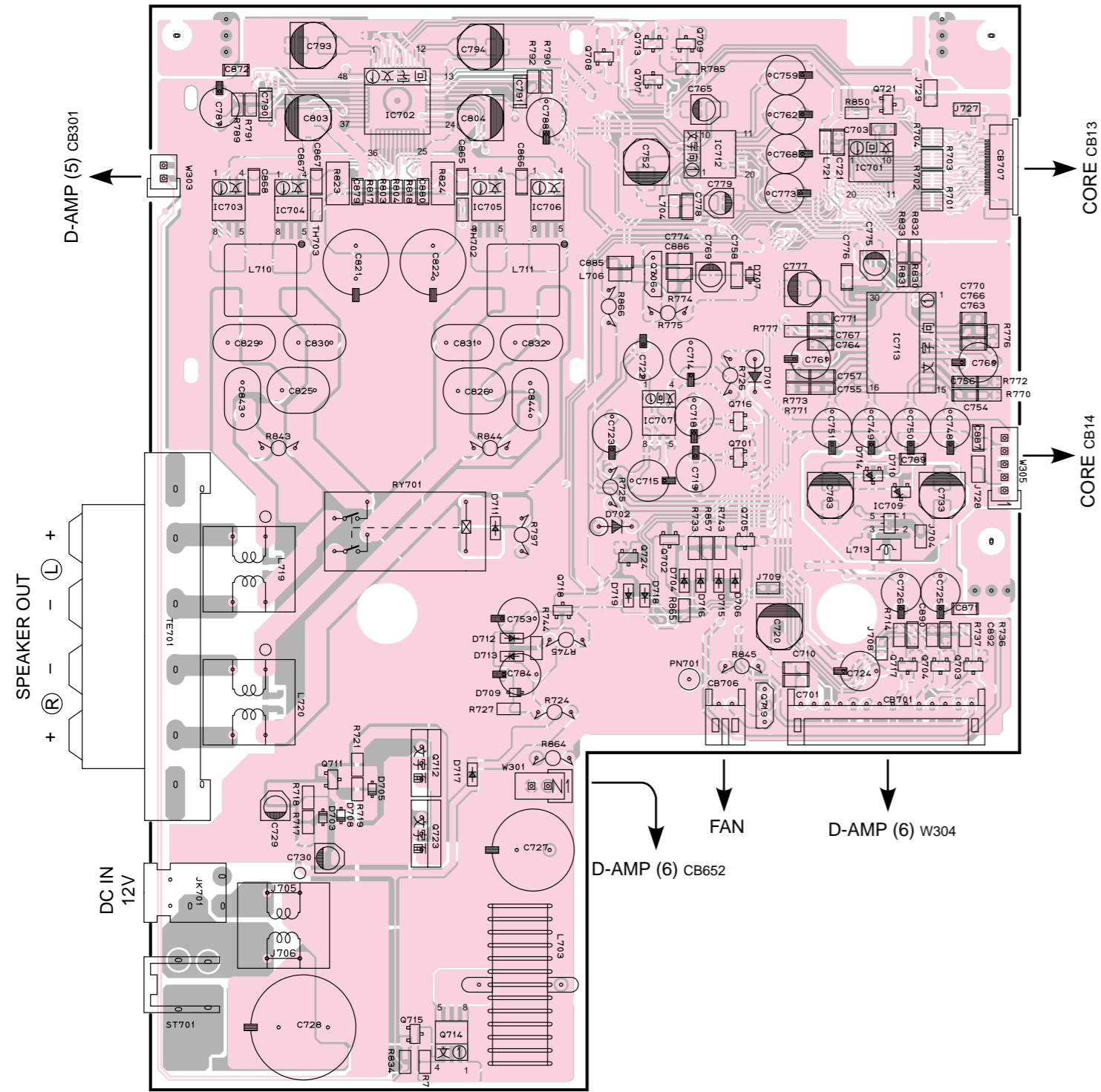

D-AMP (1) P. C. B.
(Surface Mount Device)

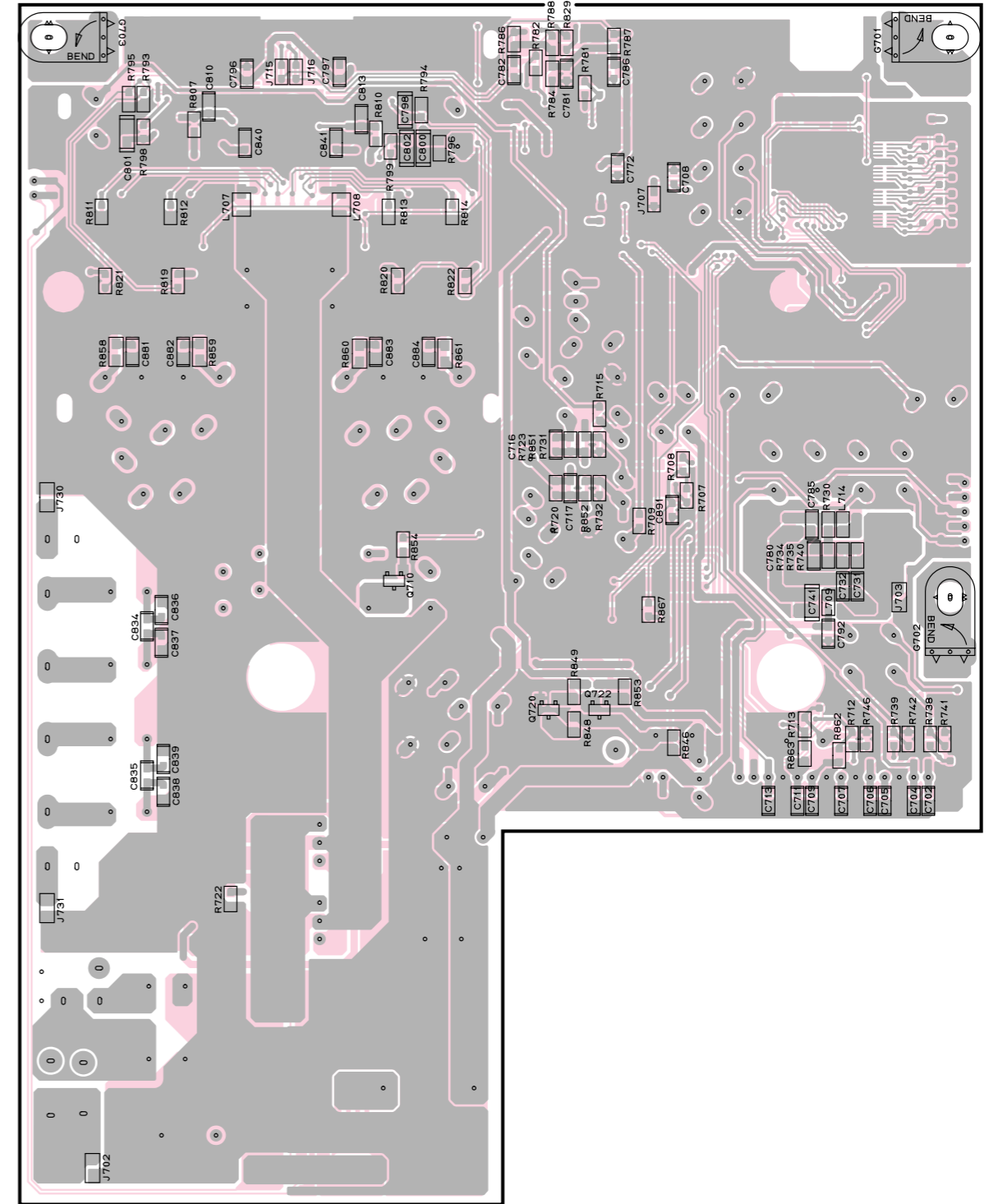

PRINTED CIRCUIT BOARD (Foil side)

1

D-AMP (3) P.C.B.
(Lead Type Device)

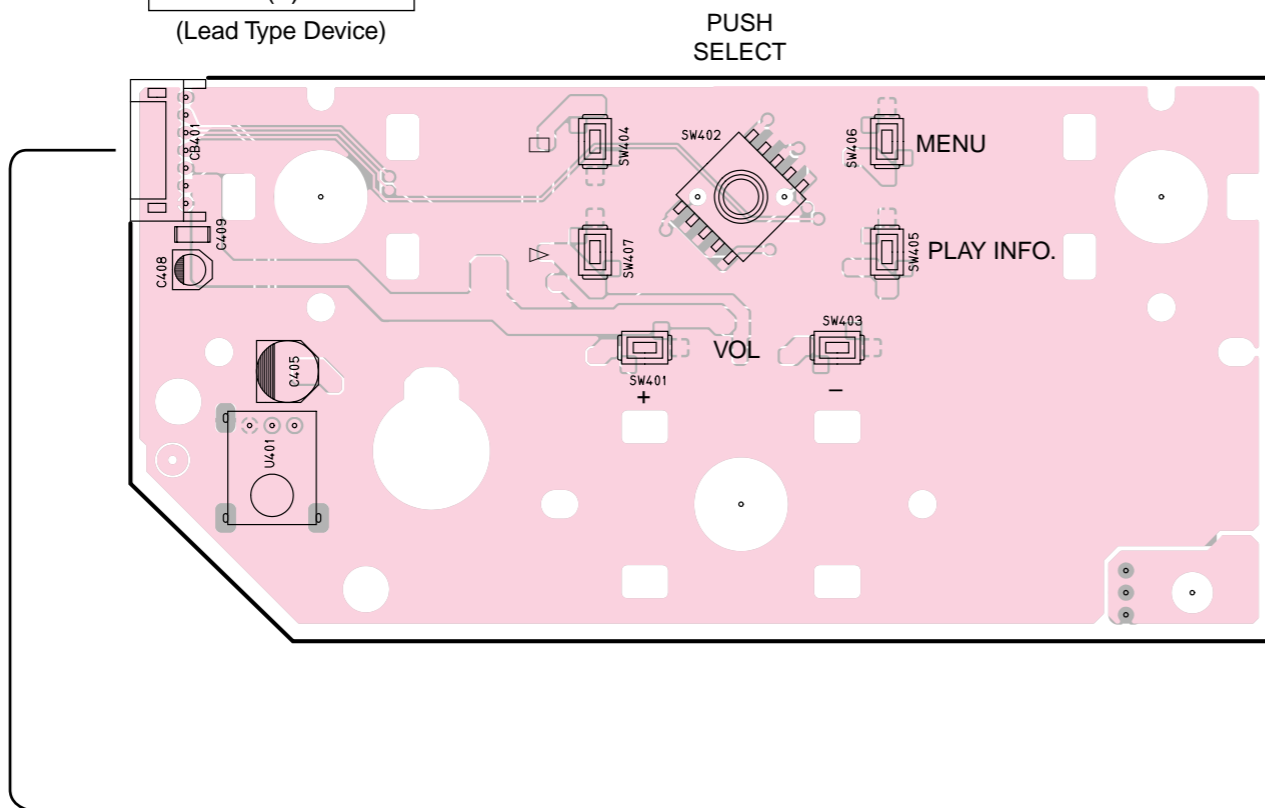

2

3

D-AMP (3) P.C.B.
(Surface Mount Device)

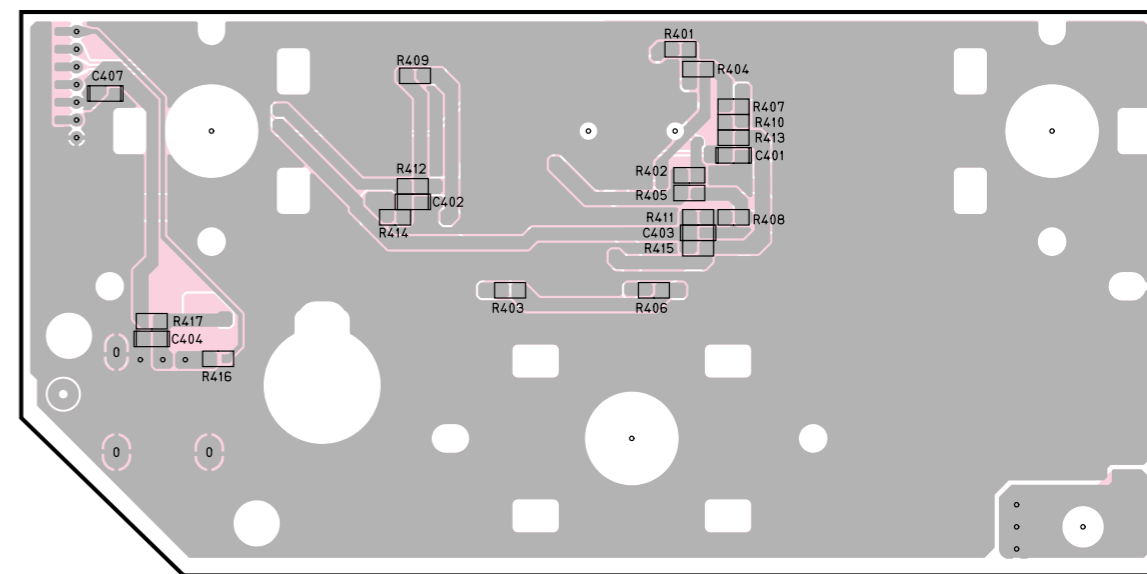

4

D-AMP (2) P.C.B.
(Lead Type Device)

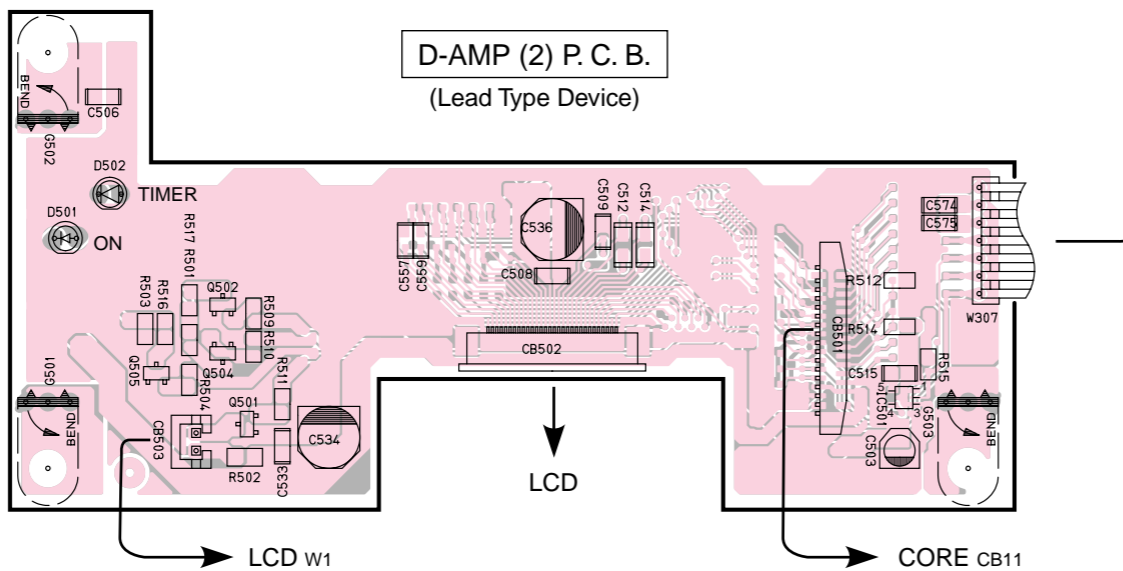

5

D-AMP (2) P.C.B.
(Surface Mount Device)

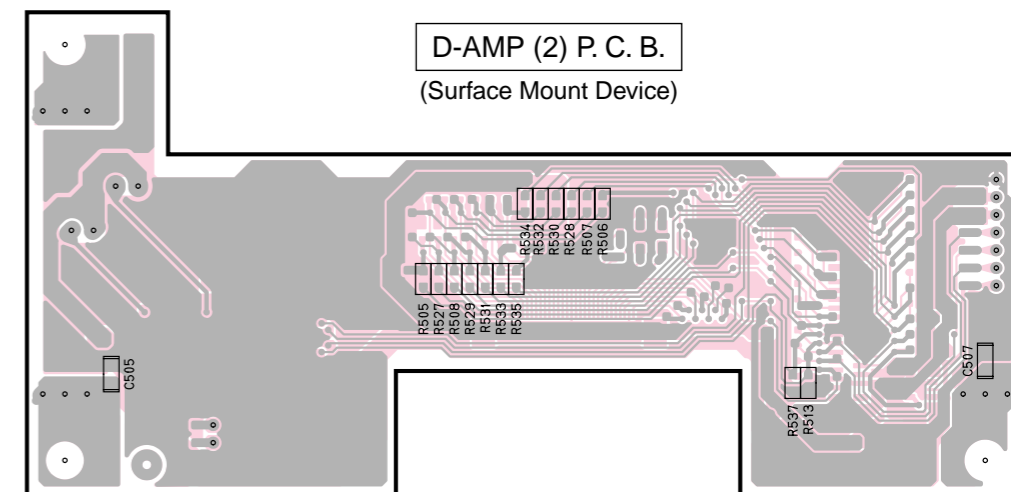

6

PRINTED CIRCUIT BOARD (Foil side)

D-AMP (4) P. C. B.
(Lead Type Device)

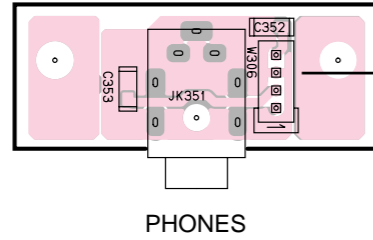

D-AMP (4) P. C. B.
(Surface Mount Device)

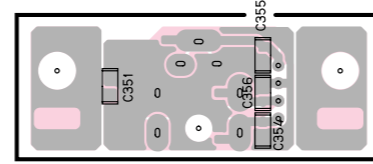

D-AMP (5) P. C. B.
(Lead Type Device)

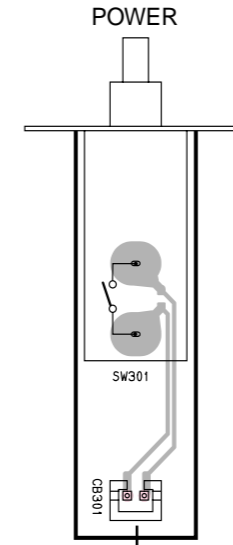

D-AMP (1) W303

D-AMP (5) P. C. B.
(Surface Mount Device)

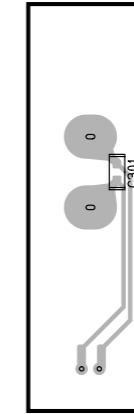

Point ⑤ (Pin 2 of IC601)

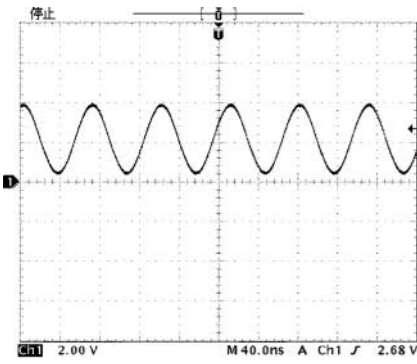

D-AMP (6) P. C. B.
(Lead Type Device)

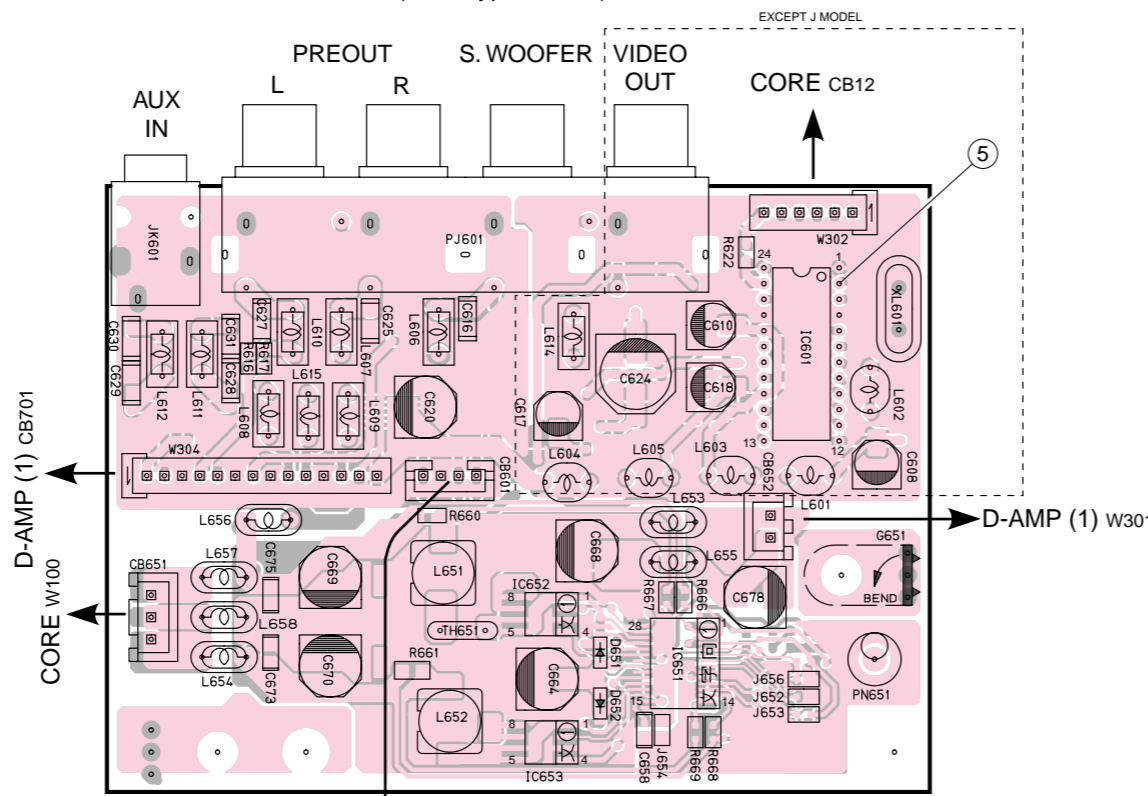

D-AMP (6) P. C. B.
(Surface Mount Device)

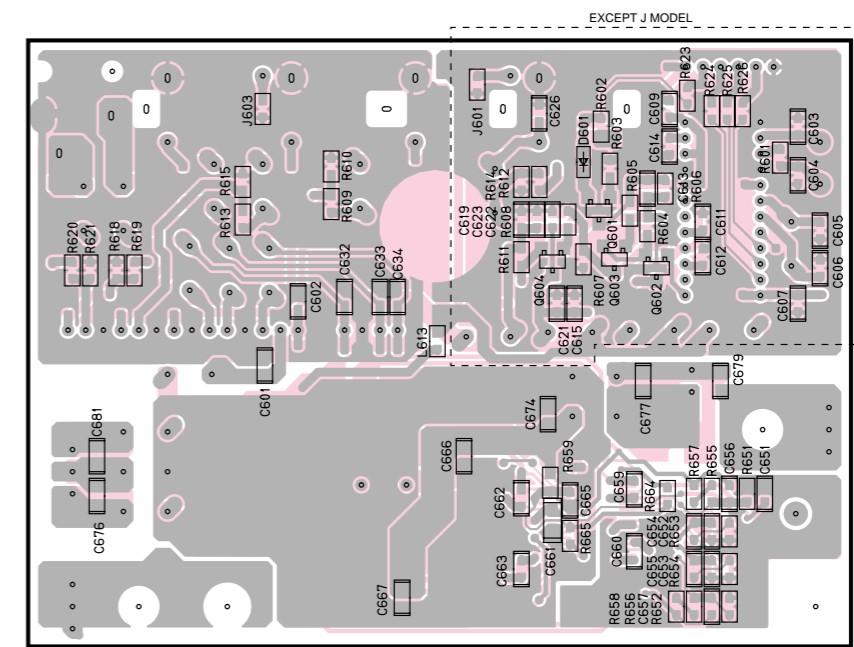

SCHEMATIC DIAGRAM (CORE)

Point ① (Pin 6 of IC21)

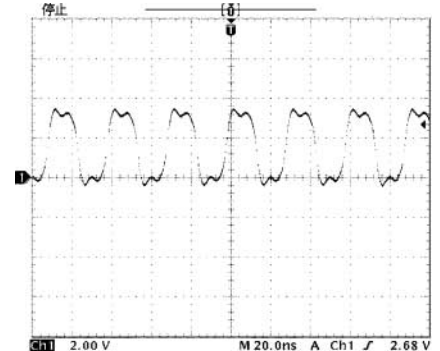

Point ② (Pin 1 of IC22)

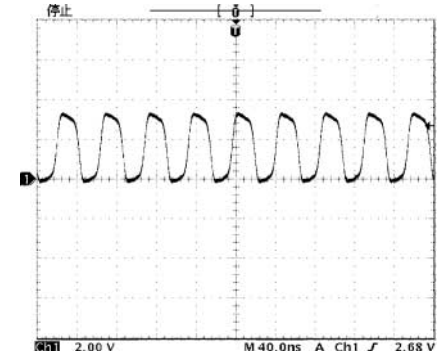

Point ③ CH 1 : Pin 1 of IC2 CH 2 : Pin 3 of IC2

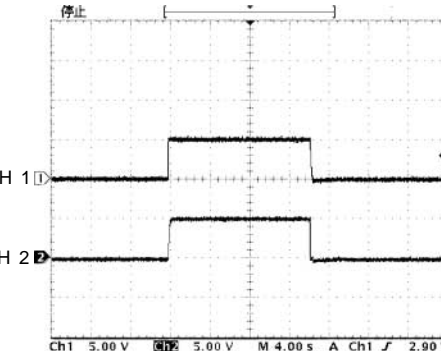

Point ④ (Pin 128 of IC901)

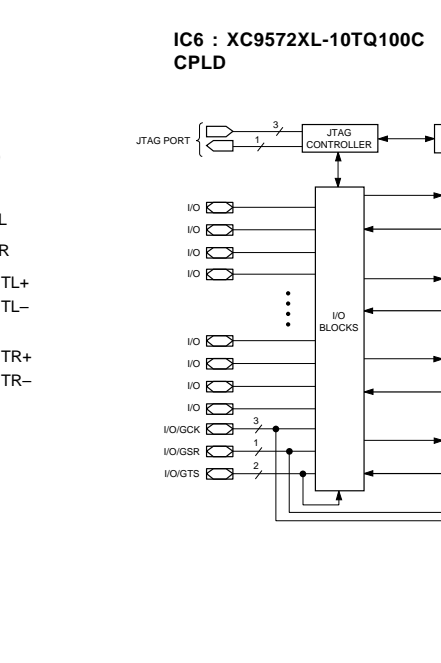
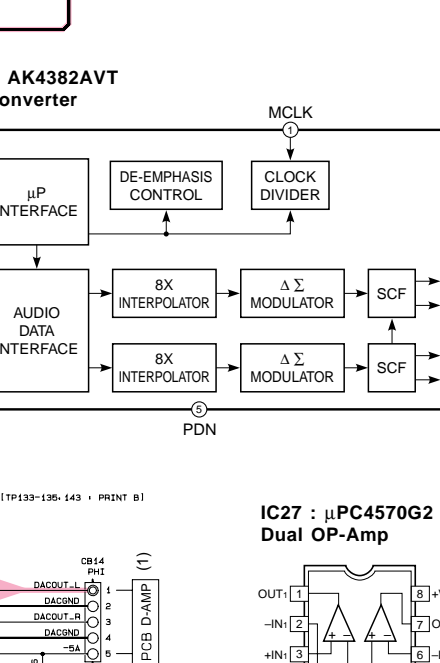
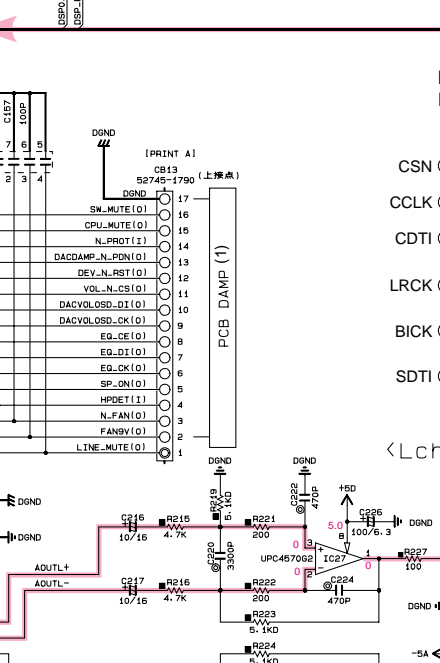
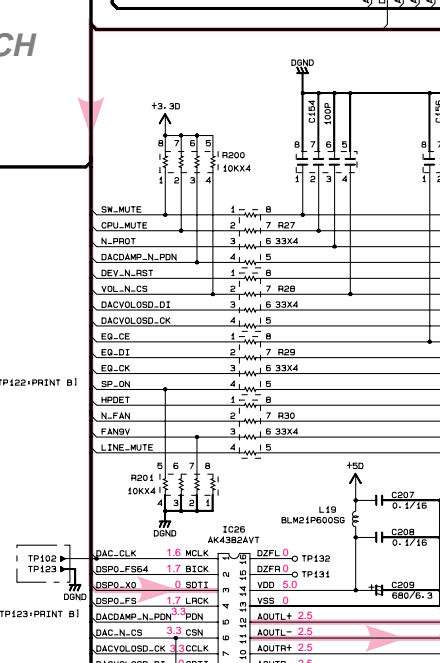
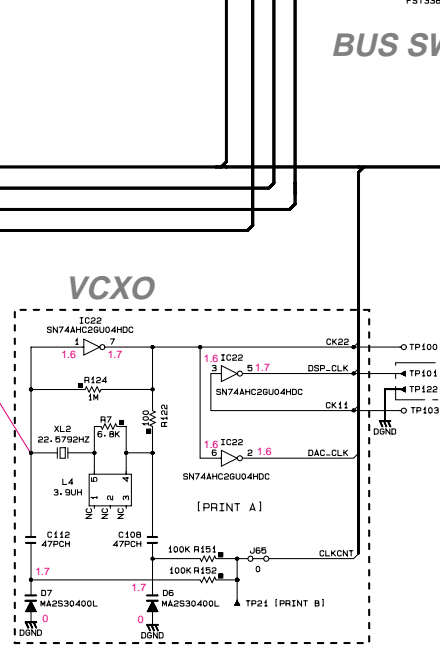
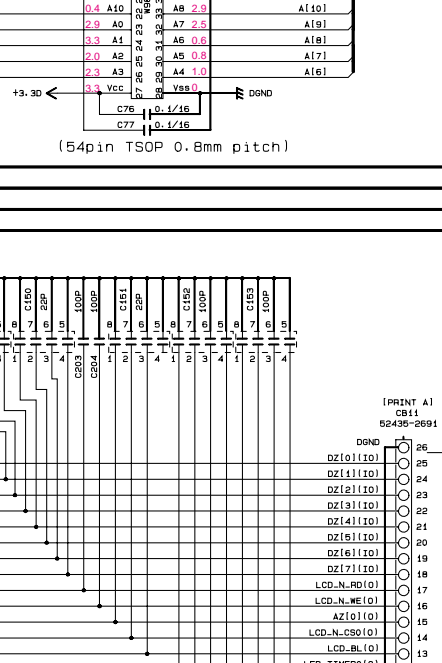
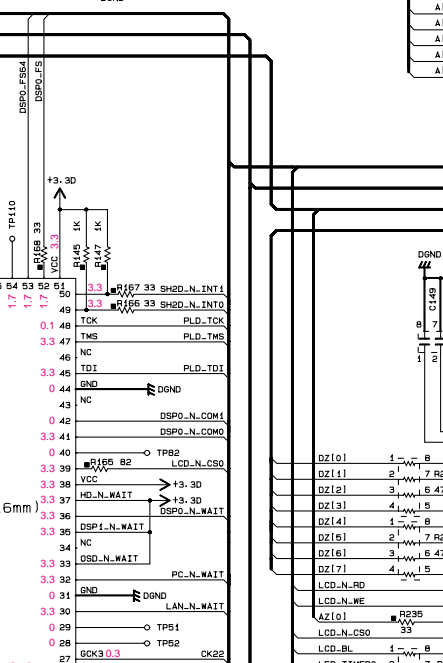
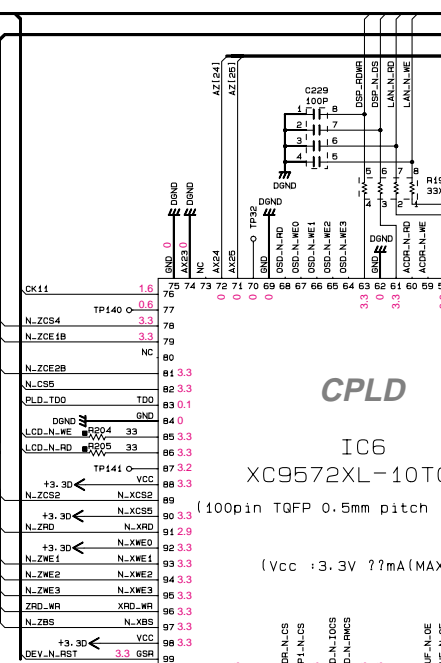
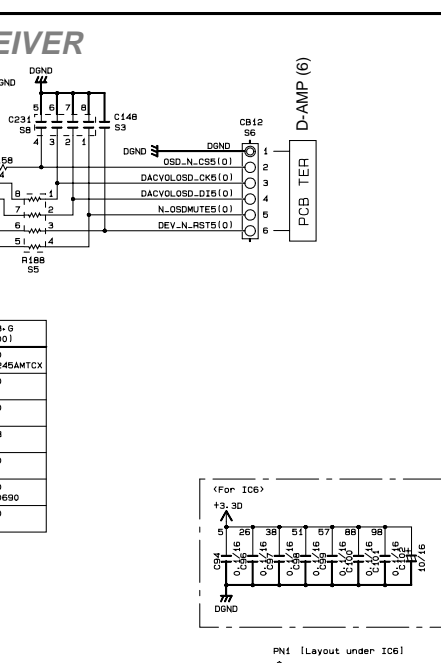
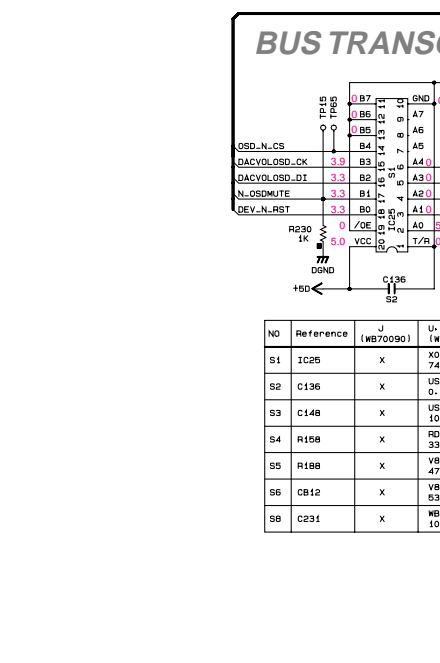
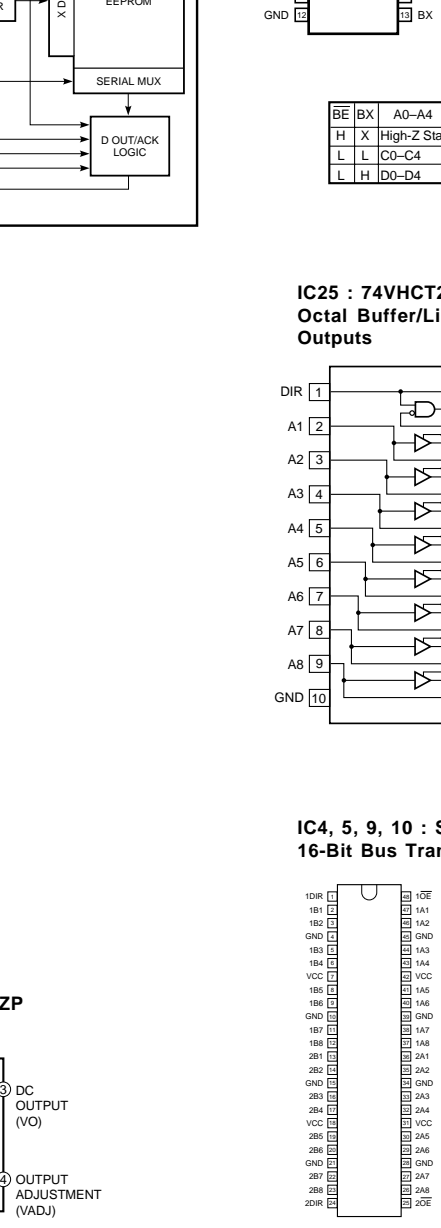
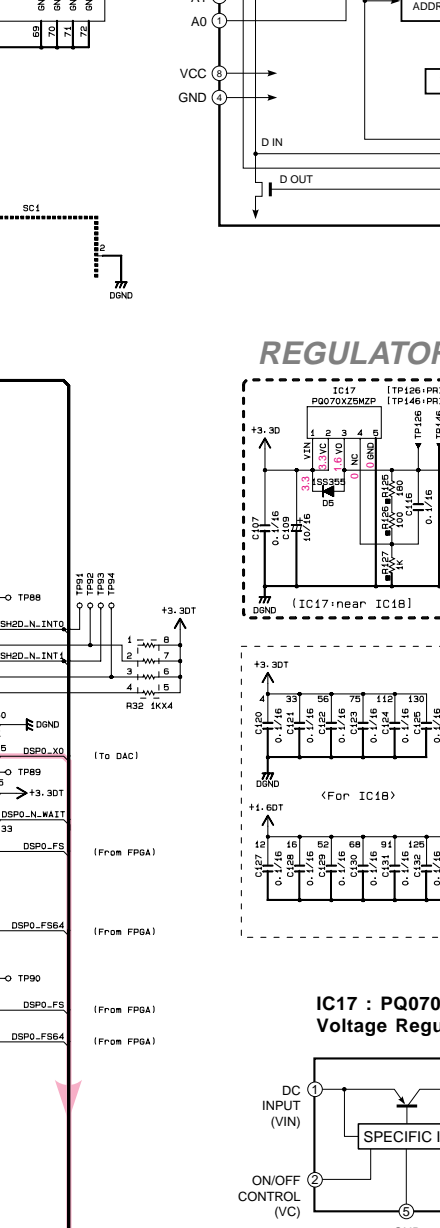
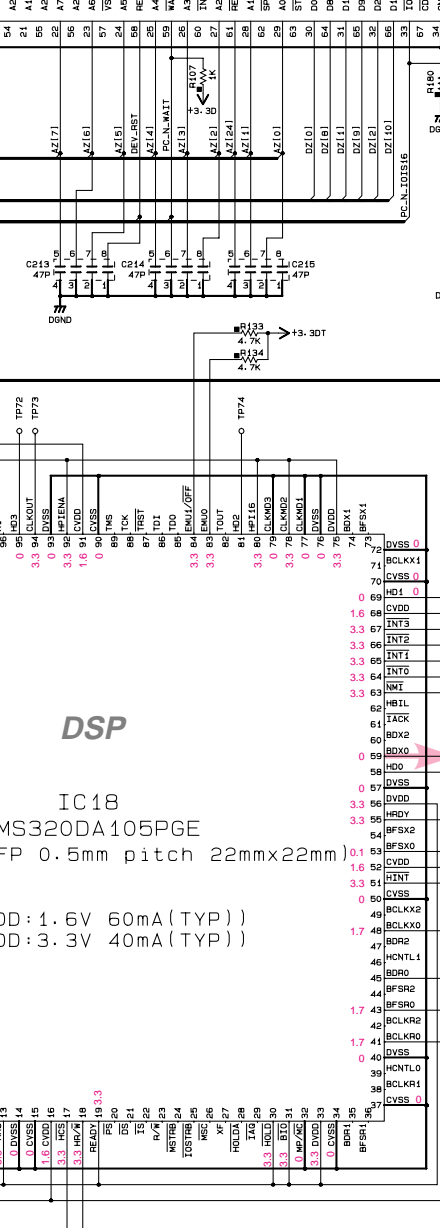
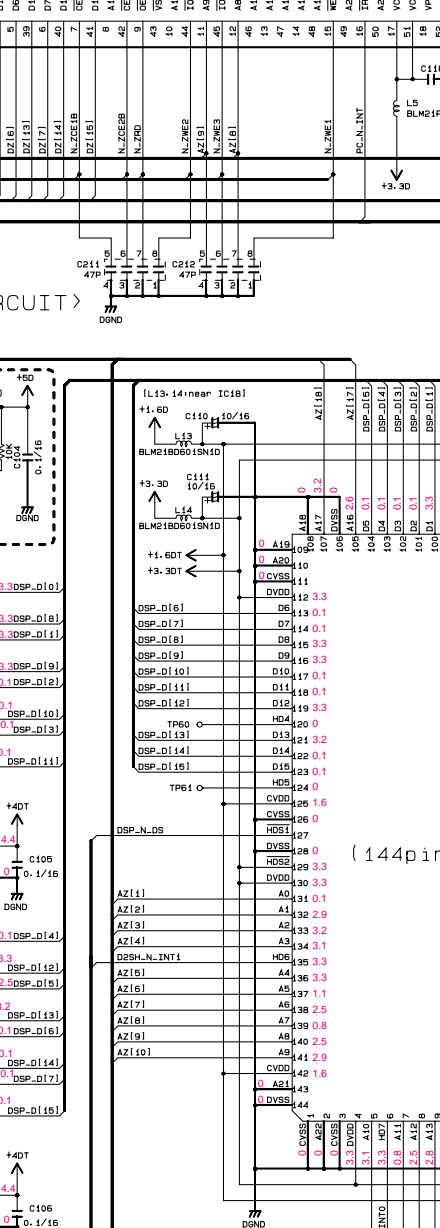
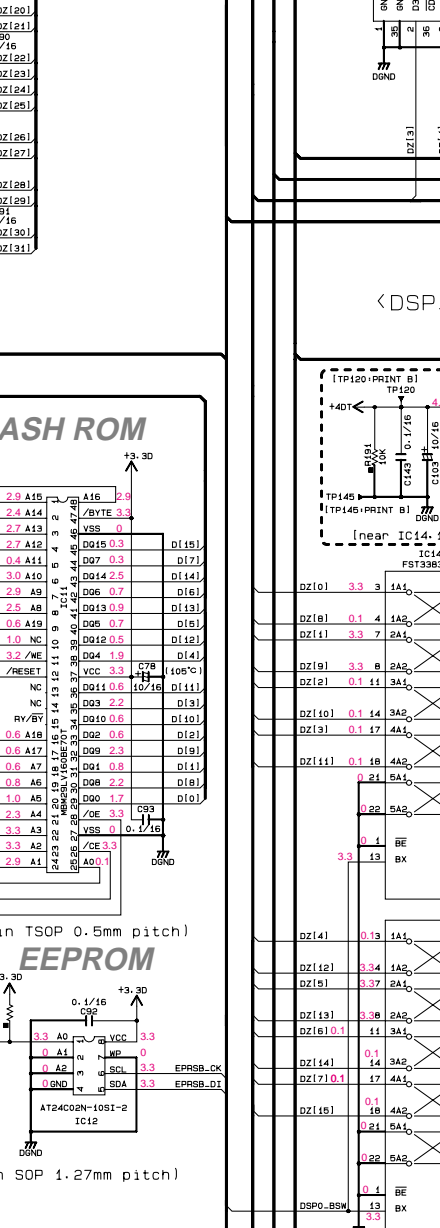
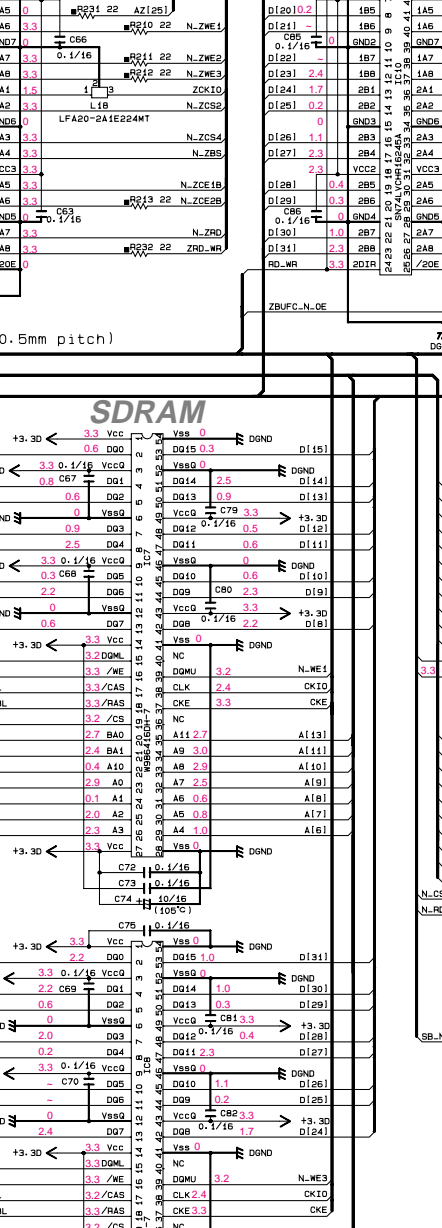
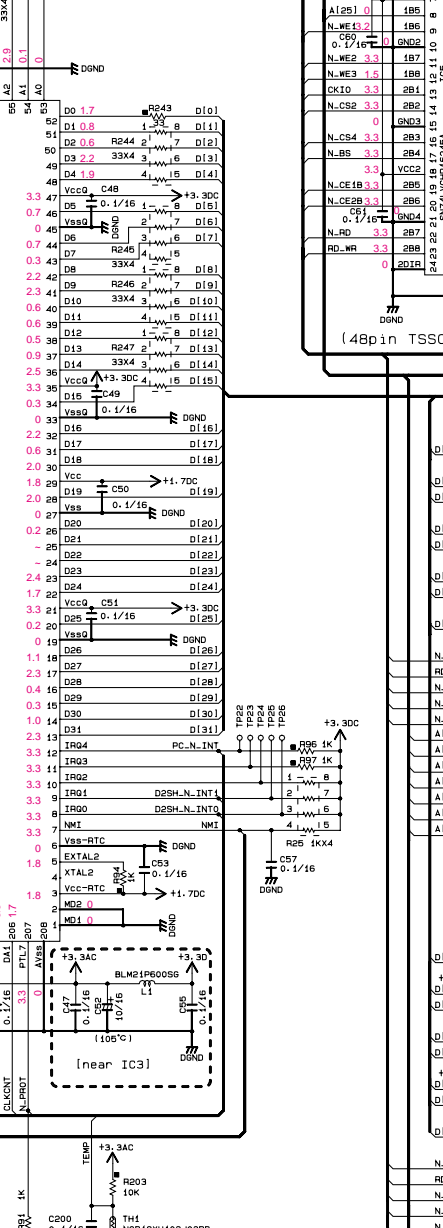
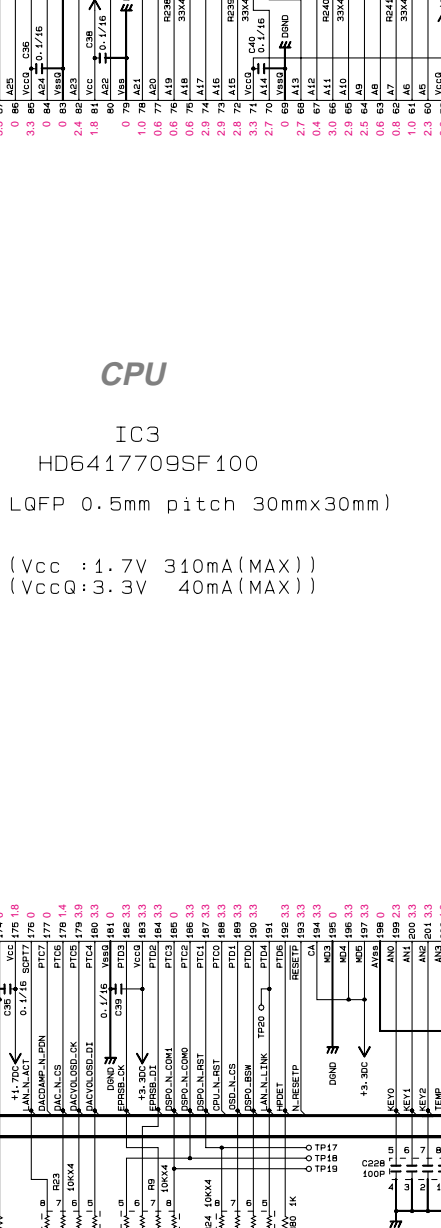
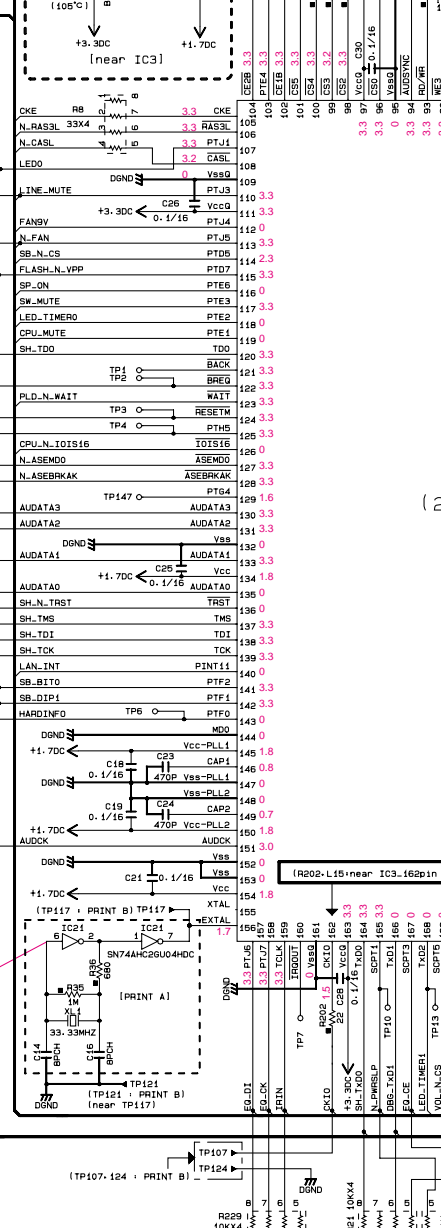
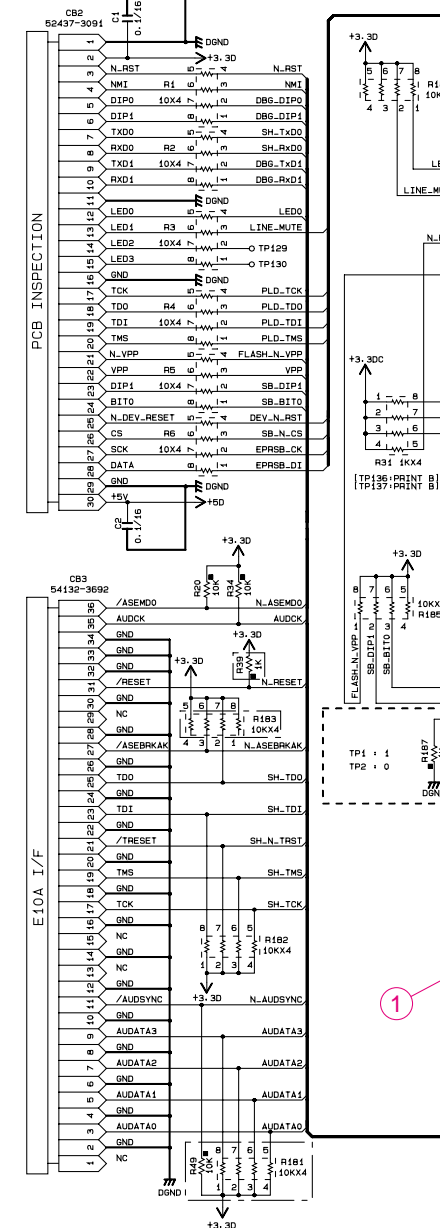
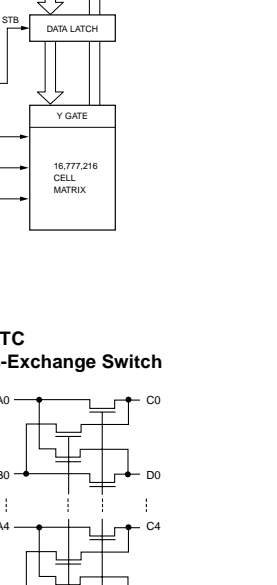
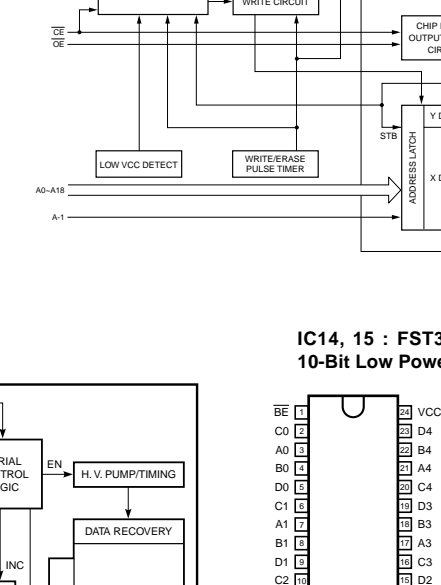
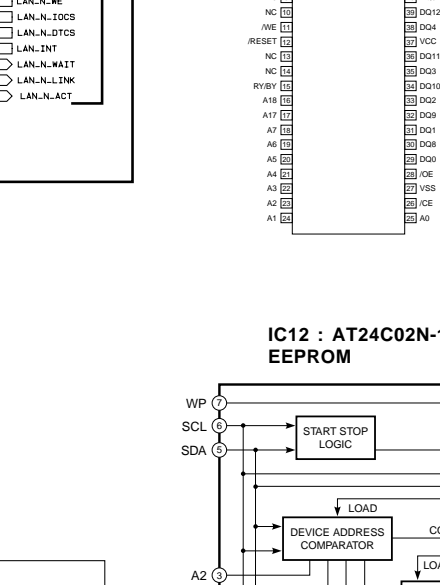
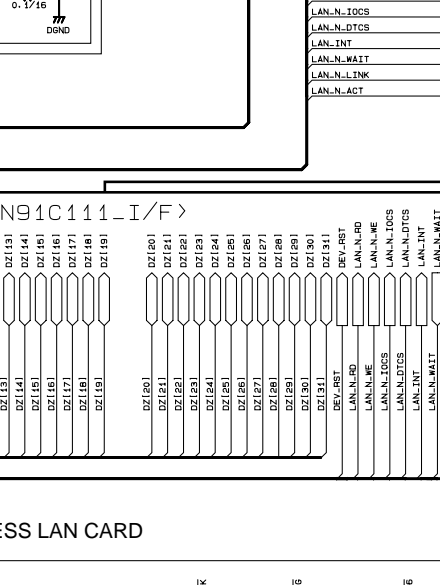
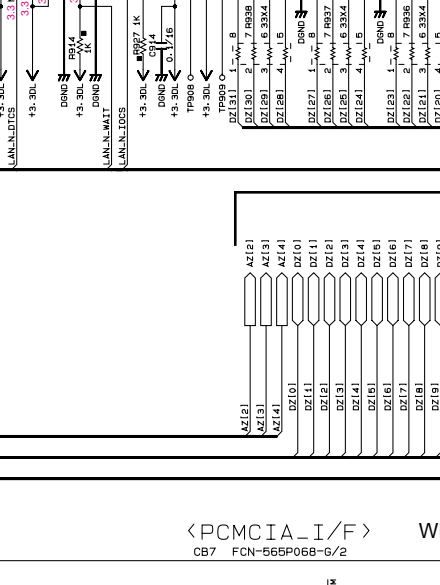
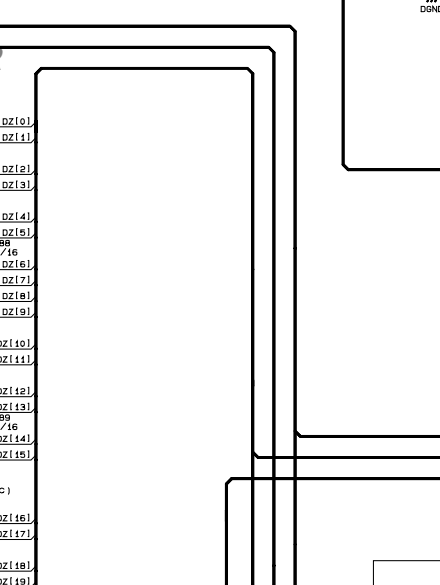
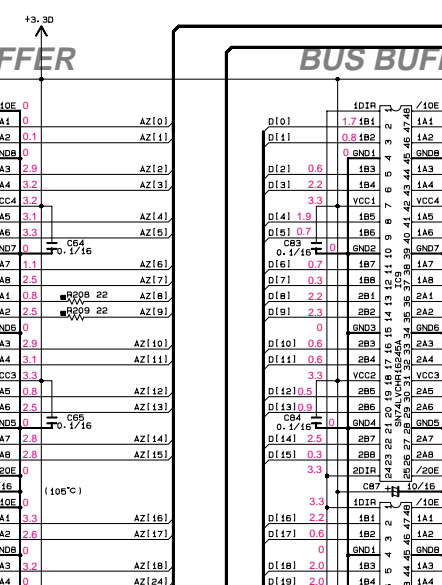
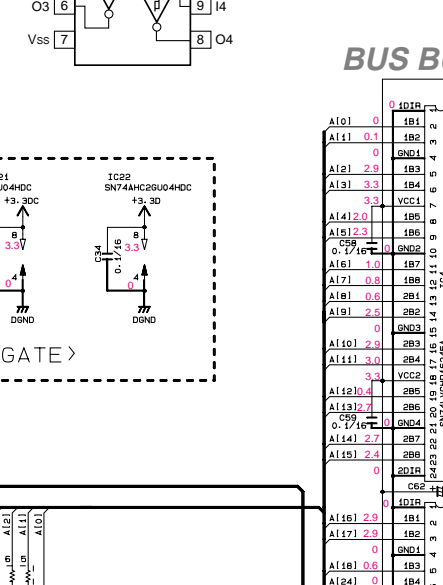
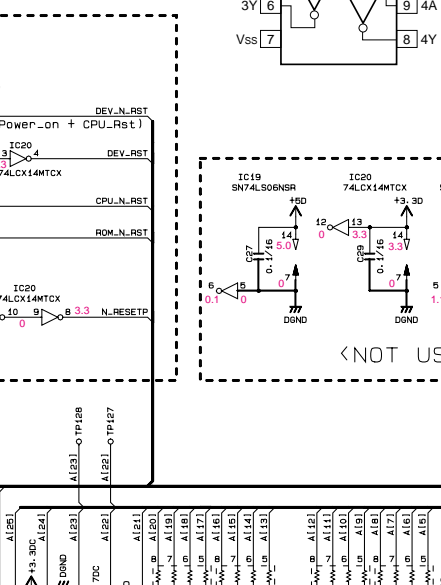
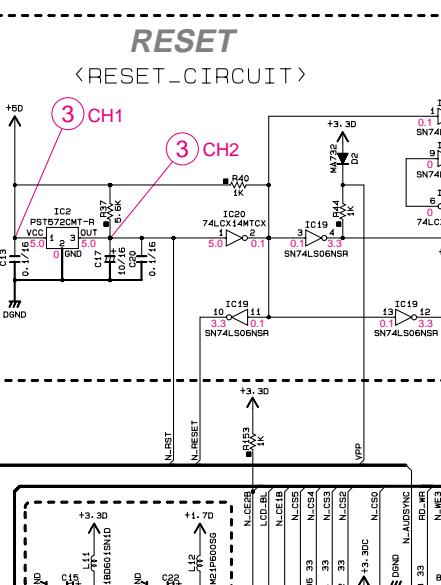
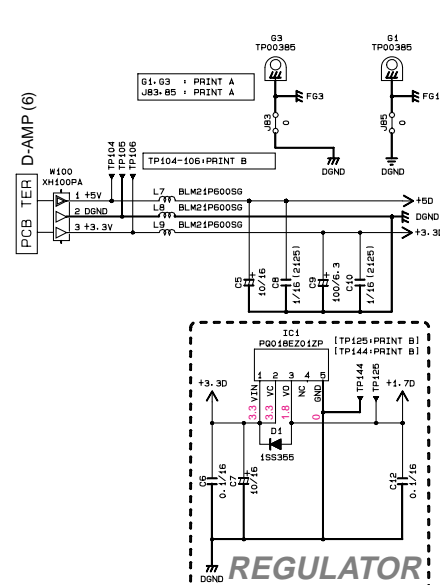
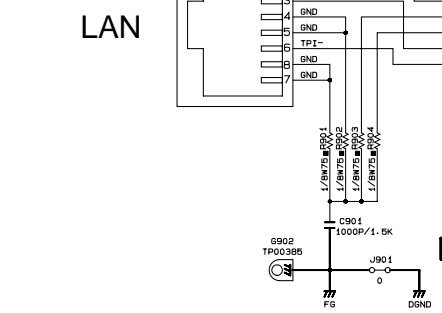
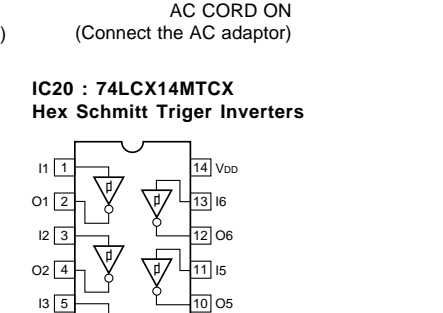
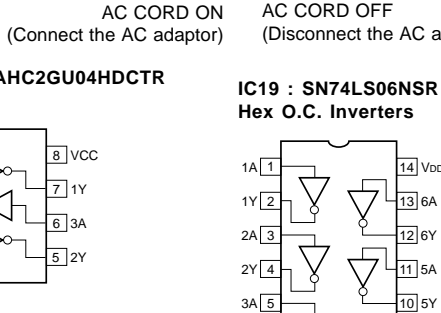
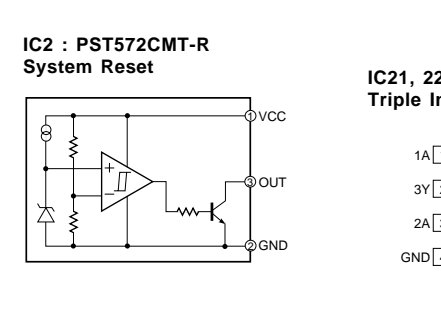
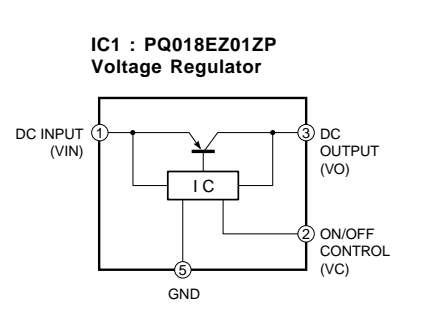
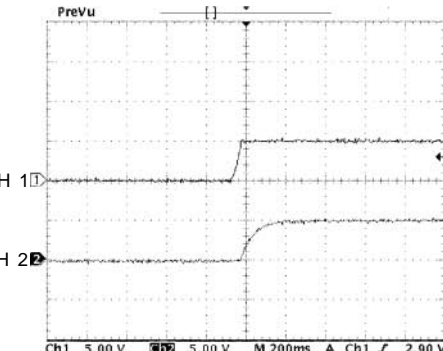

Table with 3 columns: REFERENCE, PARTS NAME, and REMARKS. Lists various components like resistors, capacitors, and ICs.

Table with 3 columns: REFERENCE, PARTS NAME, and REMARKS. Lists various components like resistors, capacitors, and ICs.

Table with 3 columns: REFERENCE, PARTS NAME, and REMARKS. Lists various components like resistors, capacitors, and ICs.

Table with 3 columns: REFERENCE, PARTS NAME, and REMARKS. Lists various components like resistors, capacitors, and ICs.

Table with 3 columns: REFERENCE, PARTS NAME, and REMARKS. Lists various components like resistors, capacitors, and ICs.

Table with 3 columns: REFERENCE, PARTS NAME, and REMARKS. Lists various components like resistors, capacitors, and ICs.

Table with 3 columns: REFERENCE, PARTS NAME, and REMARKS. Lists various components like resistors, capacitors, and ICs.

Table with 3 columns: REFERENCE, PARTS NAME, and REMARKS. Lists various components like resistors, capacitors, and ICs.

Table with 3 columns: REFERENCE, PARTS NAME, and REMARKS. Lists various components like resistors, capacitors, and ICs.

Table with 3 columns: REFERENCE, PARTS NAME, and REMARKS. Lists various components like resistors, capacitors, and ICs.

All voltages are measured with a 10MΩ/V DC electronic volt meter. Components having special characteristics are marked Δ and must be replaced with parts having specifications equal to those originally installed. Schematic diagram is subject to change without notice.

SCHEMATIC DIAGRAM (D-AMP)

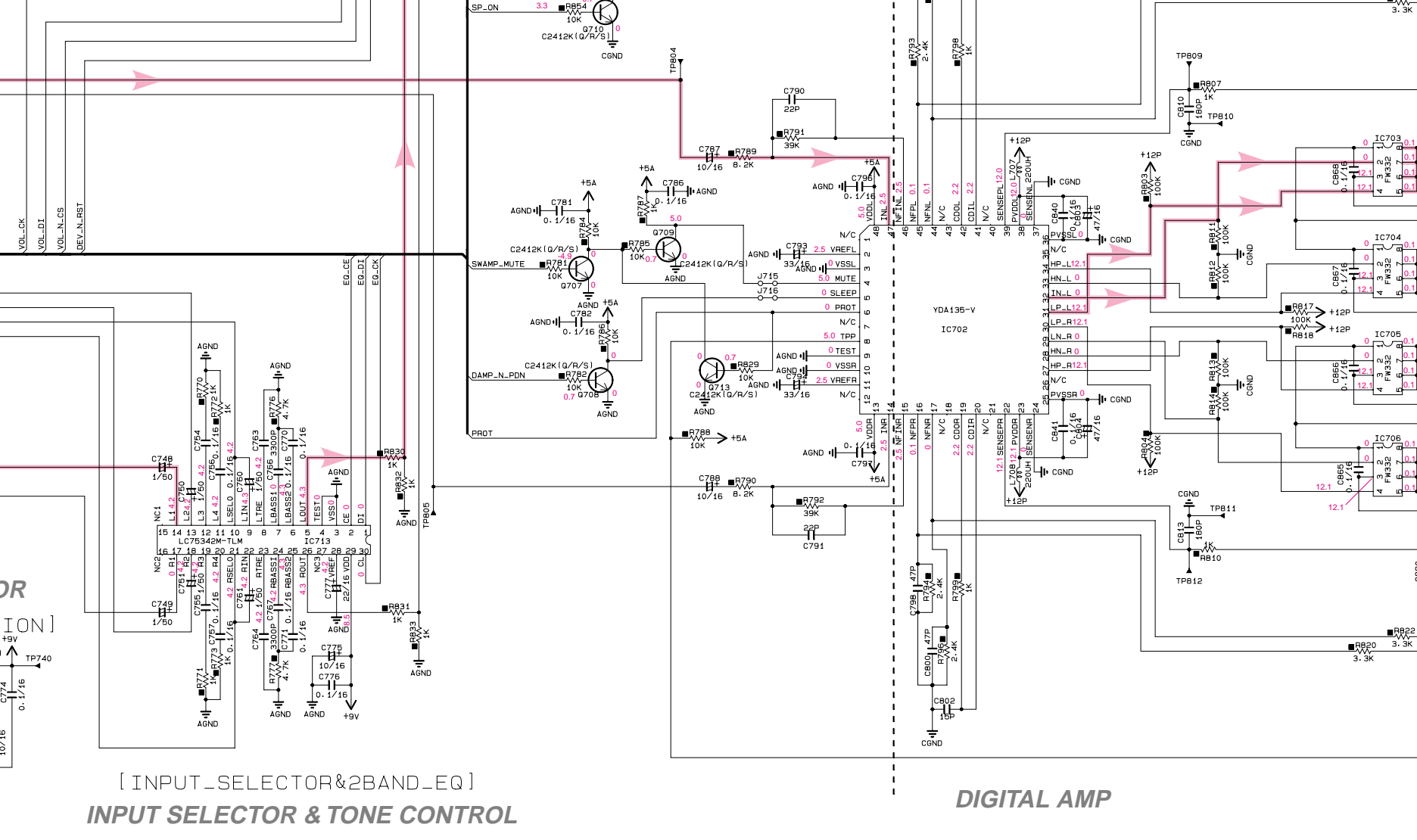
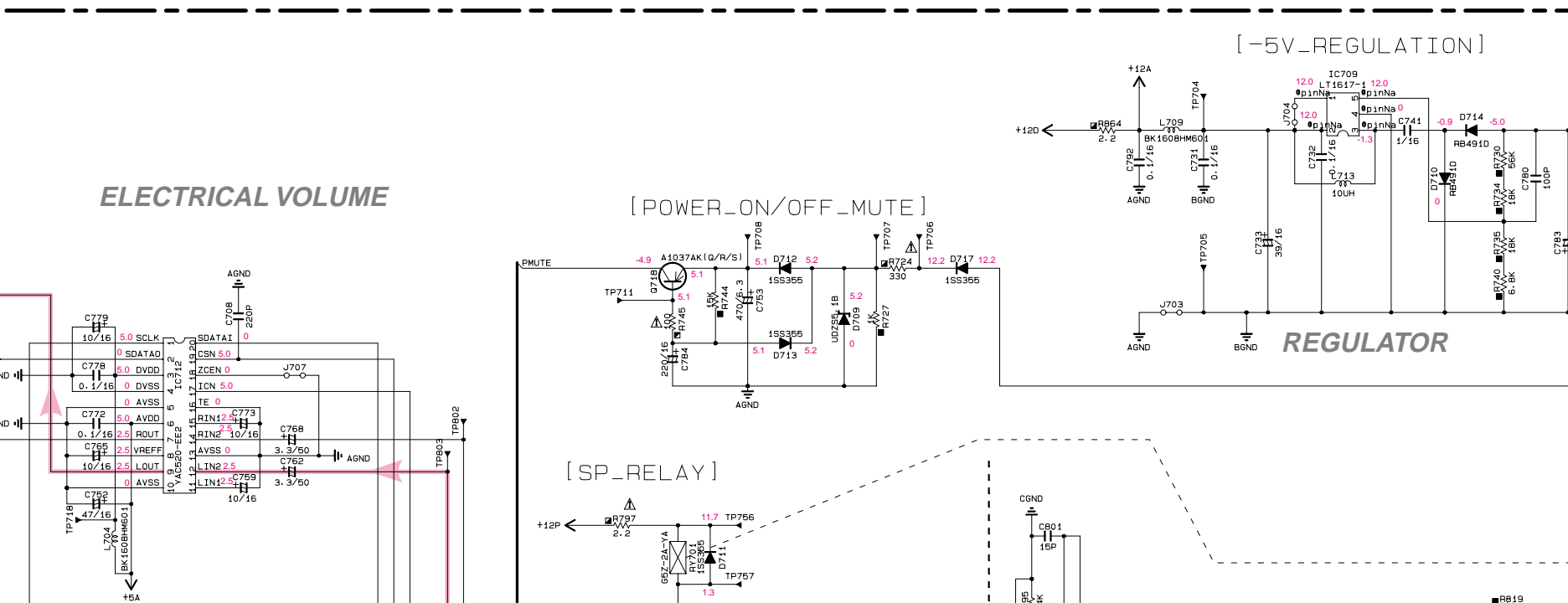
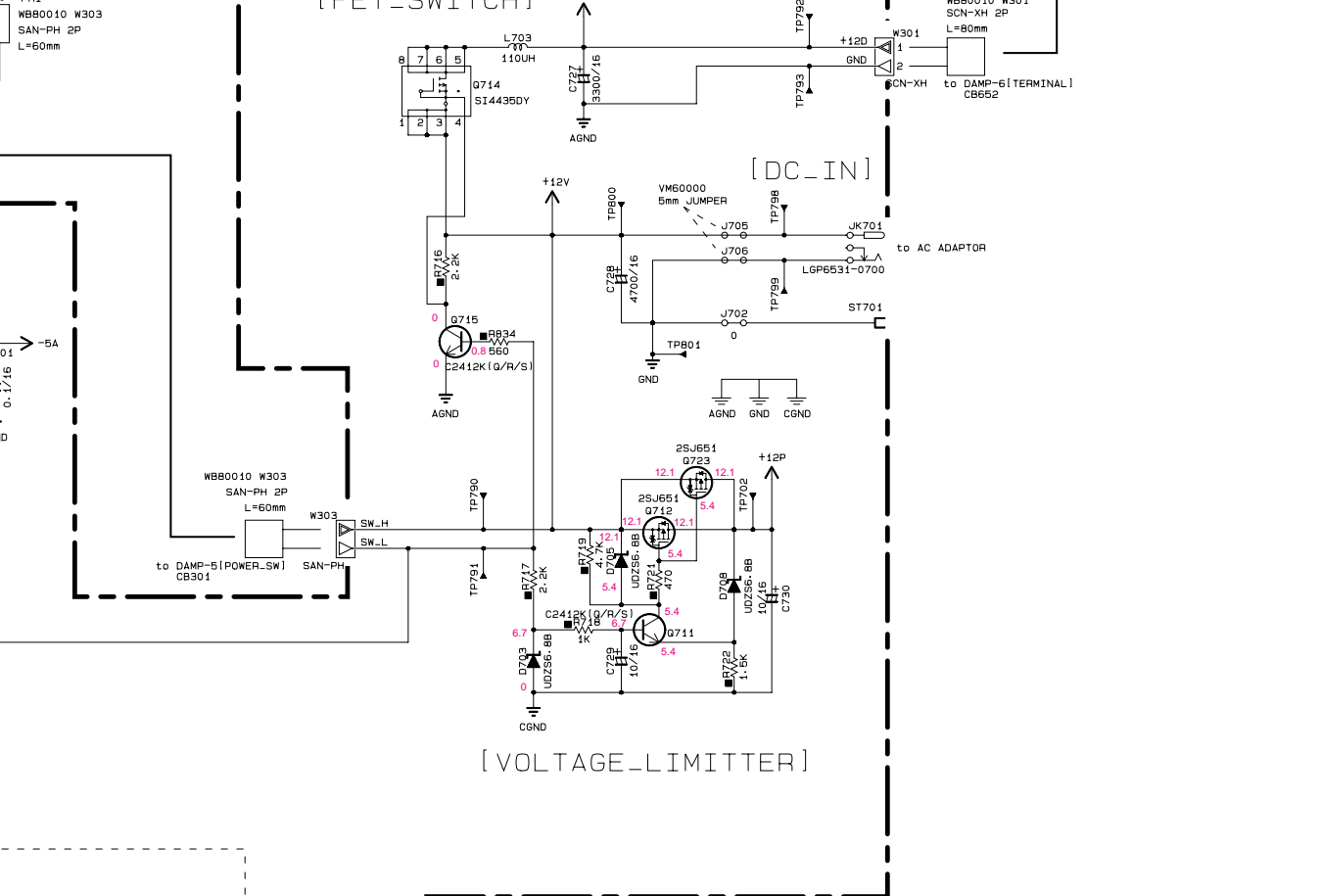
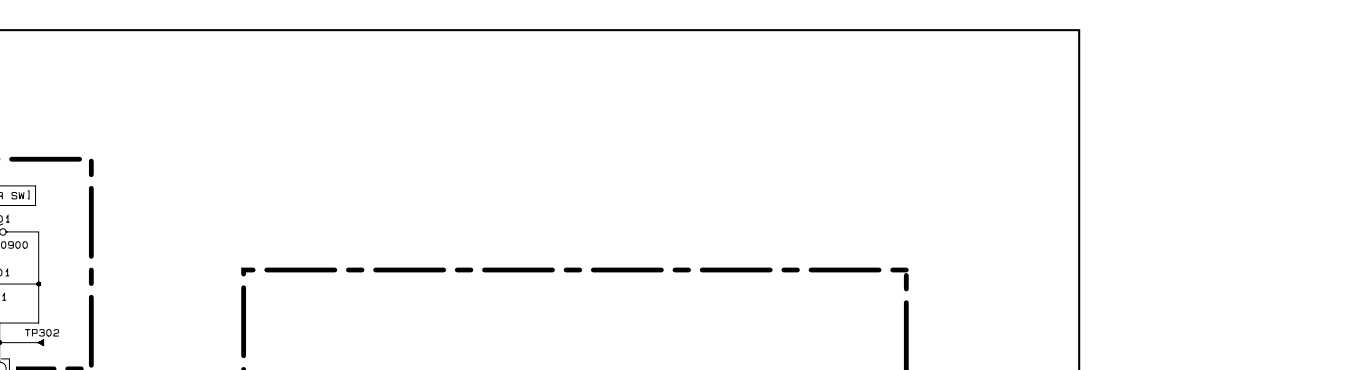
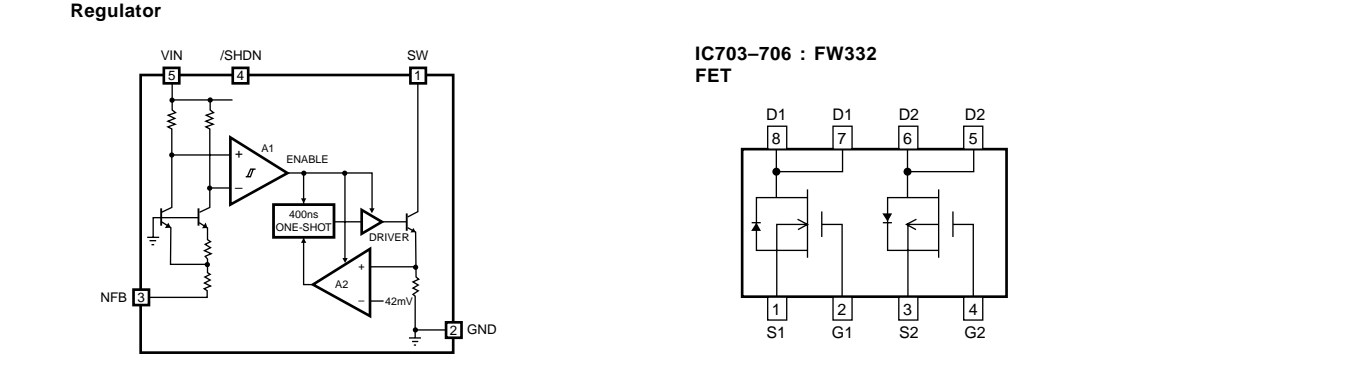
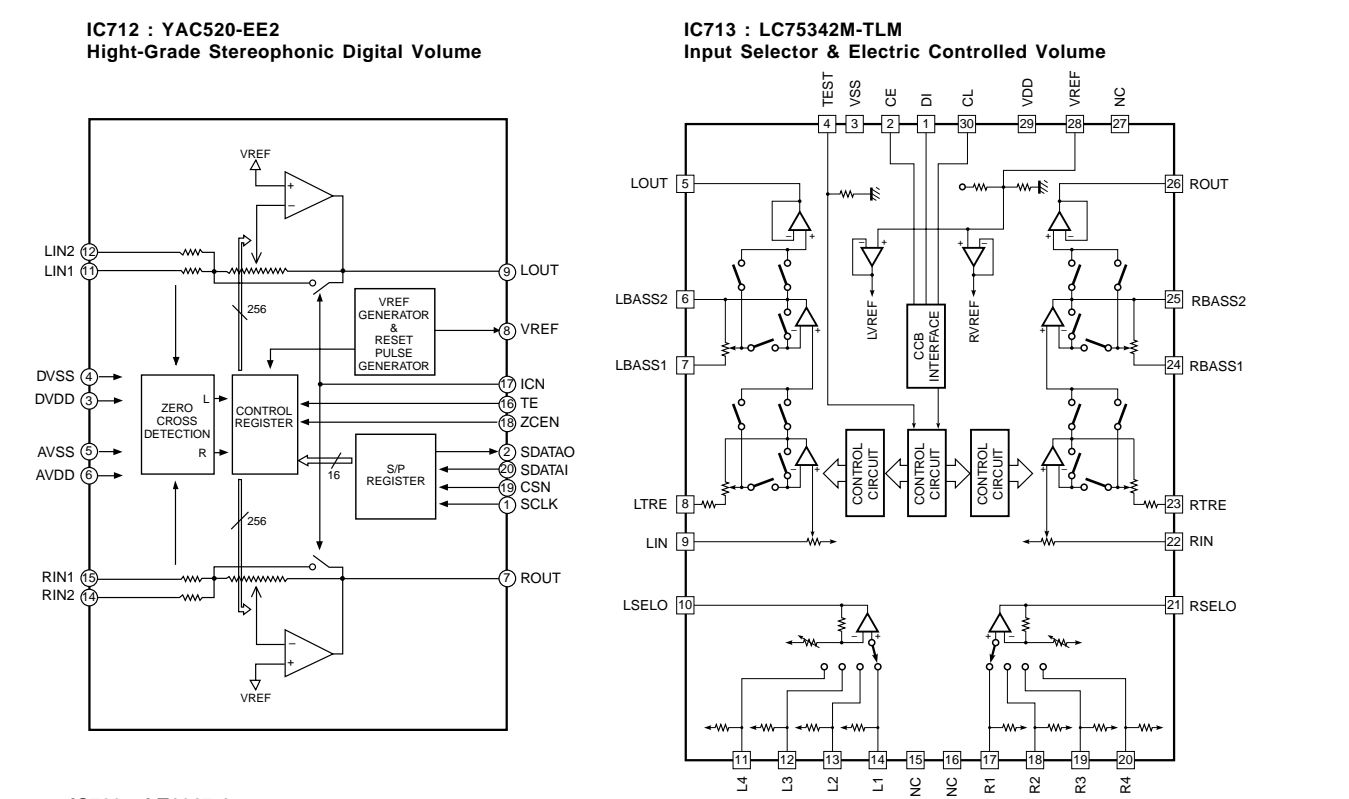
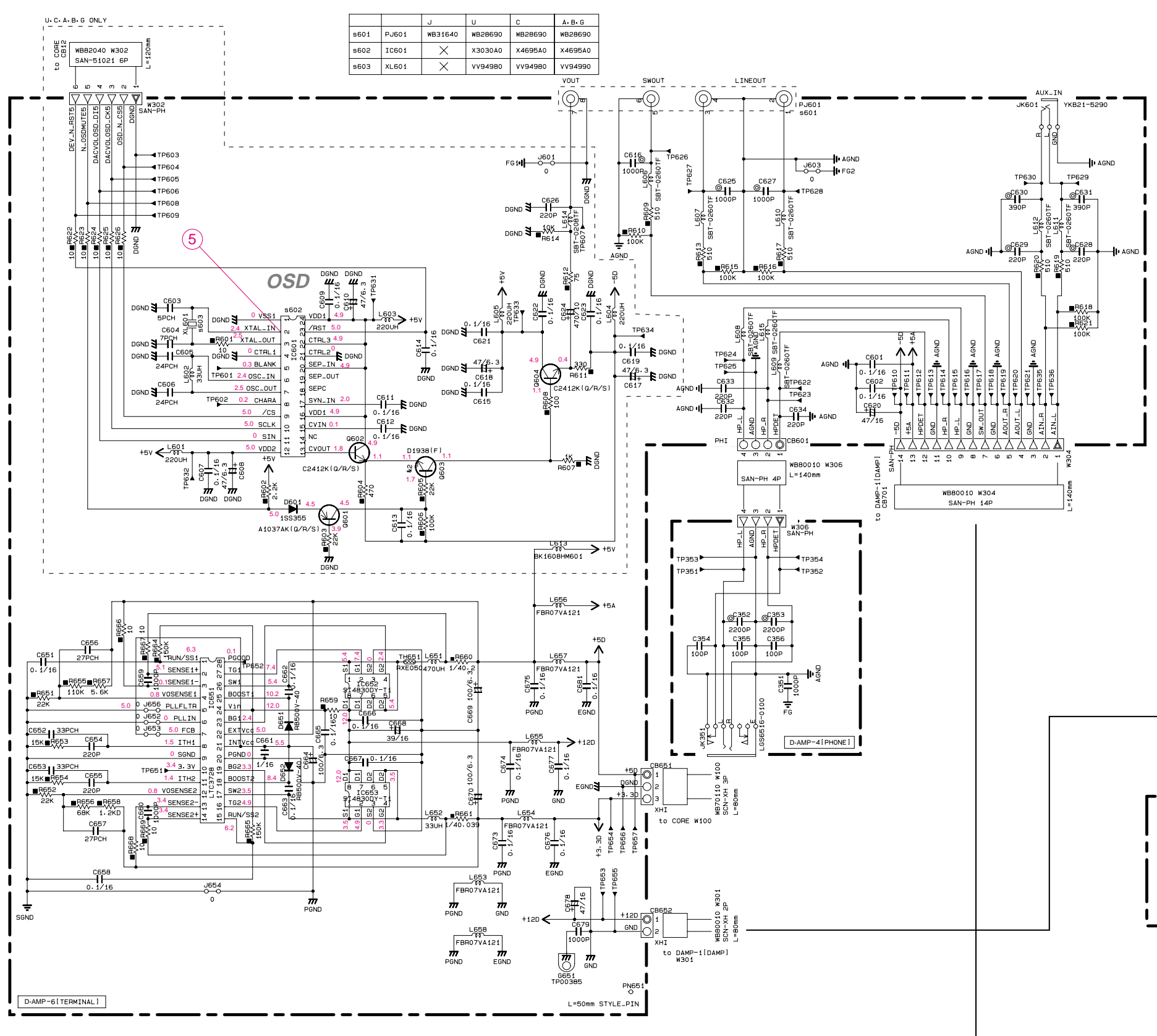
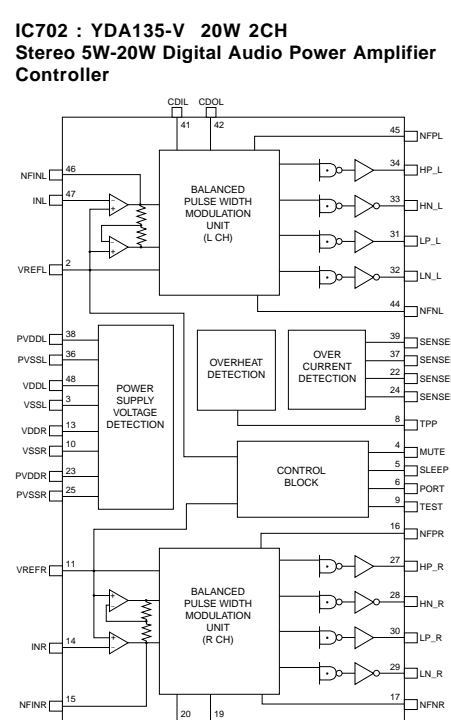
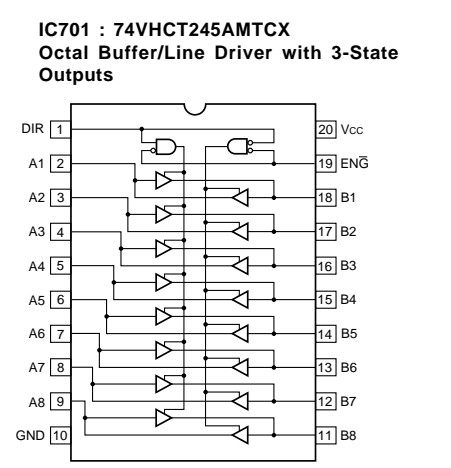
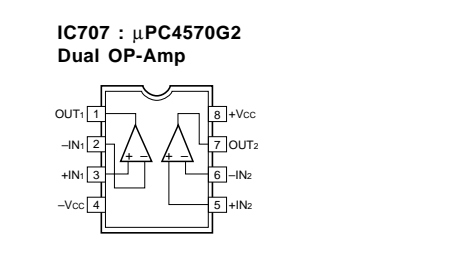
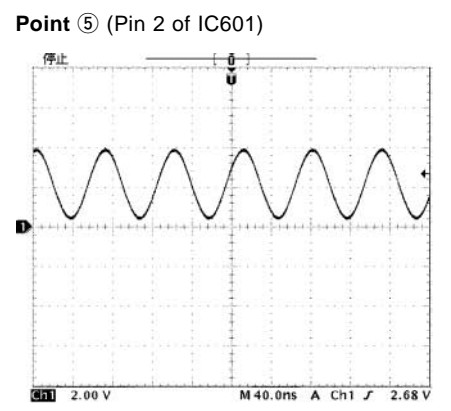
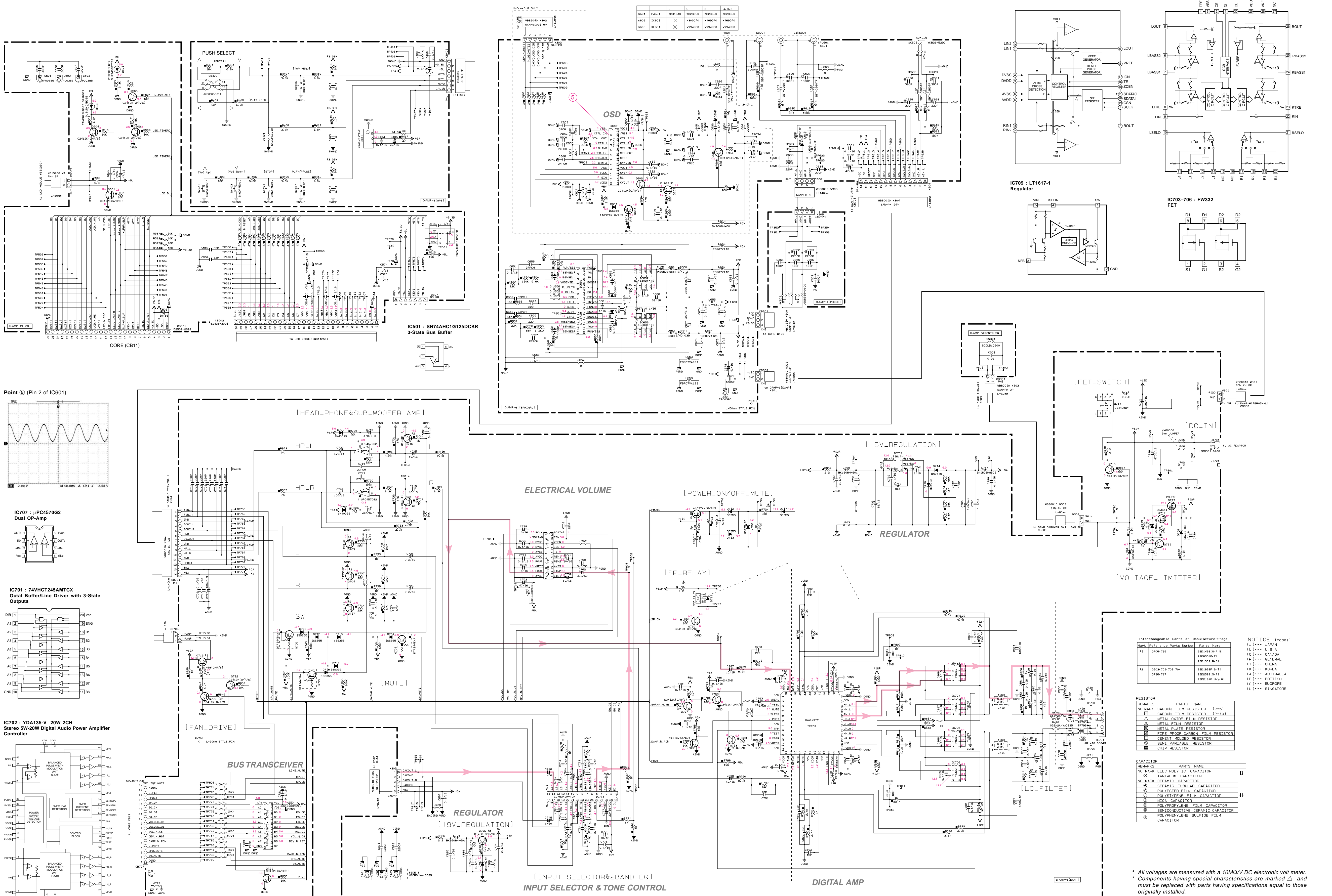

Mark	Reference Parts Number	Parts Name	Interchangeable Parts at Manufacture-Stage	NOTICE (code)
01	0706-719	2001480(b-r-s)	(J)..... JAPAN	(U)..... U.S.A
		20009916-1	(U)..... U.S.A	(C)..... CANADA
		20010018-5	(R)..... GENERAL	(T)..... CHINA
		20019987(b-1)	(A)..... AUSTRALIA	(B)..... BRITISH
		20011410-v-1	(E)..... EUROPE	(L)..... SINGAPORE

REMARKS	PARTS NAME	[DWS]
NO MARK	CARBON FILM RESISTOR	[R]
NO MARK	CARBON FILM RESISTOR (P-10)	[R]
NO MARK	METAL OXIDE FILM RESISTOR	[R]
NO MARK	METAL FILM RESISTOR	[R]
NO MARK	METAL PLATE RESISTOR	[R]
NO MARK	FILM PROOF CARBON FILM RESISTOR	[R]
NO MARK	CEMENT MOLDED RESISTOR	[R]
NO MARK	SEMIVARIABLE RESISTOR	[R]
NO MARK	GHIP RESISTOR	[R]

REMARKS	PARTS NAME	[DWS]
NO MARK	ELECTROLYTIC CAPACITOR	[E]
NO MARK	TANTALUM CAPACITOR	[E]
NO MARK	CERAMIC CAPACITOR	[C]
NO MARK	CERAMIC TUBULAR CAPACITOR	[C]
NO MARK	POLYESTER FILM CAPACITOR	[C]
NO MARK	POLYSTYRENE FILM CAPACITOR	[C]
NO MARK	MICA CAPACITOR	[C]
NO MARK	POLYPROPYLENE FILM CAPACITOR	[C]
NO MARK	SEMICONDUCTIVE CERAMIC CAPACITOR	[C]
NO MARK	POLYPHENYLENE SULFIDE FILM CAPACITOR	[C]

* All voltages are measured with a 10MΩ/V DC electronic volt meter.
 * Components having special characteristics are marked Δ and must be replaced with parts having specifications equal to those originally installed.
 * Schematic diagram is subject to change without notice.

PARTS LIST

■ ELECTRICAL PARTS

■ WARNING

- Components having special characteristics are marked \triangle and must be replaced with parts having specifications equal to those originally installed.
- For the capacitor not found in the list, refer to the schematic diagram.

\triangle 印のある部分は、安全確保部品を示しています。部品の交換が必要な場合、パーツリストに記載されている部品を使用してください。
リストに記載されていないコンデンサは、回路図を参照してください。

ABBREVIATIONS IN THIS LIST ARE AS FOLLOWS :

C.A.EL.CHP	: CHIP ALUMI. ELECTROLYTIC CAP	L.DTCT	: LIGHT DETECTING MODULE
C.CE	: CERAMIC CAP	L.EMIT	: LIGHT EMITTING MODULE
C.CE.ARRAY	: CERAMIC CAP ARRAY	LED.DSPLY	: LED DISPLAY
C.CE.CHP	: CHIP CERAMIC CAP	LED.INFRD	: LED, INFRARED
C.CE.ML	: MULTILAYER CERAMIC CAP	MODUL.RF	: MODULATOR, RF
C.CE.M.CHP	: CHIP MULTILAYER CERAMIC CAP	PHOT.CPL	: PHOTO COUPLER
C.CE.SAFTY	: RECOGNIZED CERAMIC CAP	PHOT.INTR	: PHOTO INTERRUPTER
C.CE.TUBLR	: CERAMIC TUBULAR CAP	PHOT.RFLCT	: PHOTO REFLECTOR
C.CE.SMI	: SEMI CONDUCTIVE CERAMIC CAP	PIN.TEST	: PIN, TEST POINT
C.EL	: ELECTROLYTIC CAP	PLST.RIVET	: PLASTIC RIVET
C.MICA	: MICA CAP	R.ARRAY	: RESISTOR ARRAY
C.ML.FLM	: MULTILAYER FILM CAP	R.CAR	: CARBON RESISTOR
C.MP	: METALLIZED PAPER CAP	R.CAR.CHP	: CHIP RESISTOR
C.MYLAR	: MYLAR FILM CAP	R.CAR.FP	: FLAME PROOF CARBON RESISTOR
C.MYLAR.ML	: MULTILAYER MYLAR FILM CAP	R.FUS	: FUSABLE RESISTOR
C.PAPER	: PAPER CAPACITOR	R.MTL.CHP	: CHIP METAL FILM RESISTOR
C.PLS	: POLYSTYRENE FILM CAP	R.MTL.FLM	: METAL FILM RESISTOR
C.POL	: POLYESTER FILM CAP	R.MTL.OXD	: METAL OXIDE FILM RESISTOR
C.POLY	: POLYETHYLENE FILM CAP	R.MTL.PLAT	: METAL PLATE RESISTOR
C.PP	: POLYPROPYLENE FILM CAP	RSNR.CE	: CERAMIC RESONATOR
C.TNTL	: TANTALUM CAP	RSNR.CRYS	: CRYSTAL RESONATOR
C.TNTL.CHP	: CHIP TANTALUM CAP	R.TW.CEM	: TWIN CEMENT FIXED RESISTOR
C.TRIM	: TRIMMER CAP	R.WW	: WIRE WOUND RESISTOR
CN	: CONNECTOR	SCR.BND.HD	: BIND HEAD B-TITE SCREW
CN.BS.PIN	: CONNECTOR, BASE PIN	SCR.BW.HD	: BW HEAD TAPPING SCREW
CN.CANNON	: CONNECTOR, CANNON	SCR.CUP	: CUP TITE SCREW
CN.DIN	: CONNECTOR, DIN	SCR.TERM	: SCREW TERMINAL
CN.FLAT	: CONNECTOR, FLAT CABLE	SCR.TR	: SCREW, TRANSISTOR
CN.POST	: CONNECTOR, BASE POST	SUPRT.PCB	: SUPPORT, P.C.B.
COIL.MX.AM	: COIL, AM MIX	SURG.PRTCT	: SURGE PROTECTOR
COIL.AT.FM	: COIL, FM ANTENNA	SW.TACT	: TACT SWITCH
COIL.DT.FM	: COIL, FM DETECT	SW.LEAF	: LEAF SWITCH
COIL.MX.FM	: COIL, FM MIX	SW.LEVER	: LEVER SWITCH
COIL.OUTPT	: OUTPUT COIL	SW.MICRO	: MICRO SWITCH
DIOD.ARRAY	: DIODE ARRAY	SW.PUSH	: PUSH SWITCH
DIODE.BRG	: DIODE BRIDGE	SW.RT.ENC	: ROTARY ENCODER
DIODE.CHP	: CHIP DIODE	SW.RT.MTR	: ROTARY SWITCH WITH MOTOR
DIODE.SHOT	: SCHOTTKY BARRIER DIODE	SW.RT	: ROTARY SWITCH
DIODE.VAR	: VARACTOR DIODE	SW.SLIDE	: SLIDE SWITCH
DIOD.Z.CHP	: CHIP ZENER DIODE	TERM.SP	: SPEAKER TERMINAL
DIODE.ZENR	: ZENER DIODE	TERM.WRAP	: WRAPPING TERMINAL
DSCR.CE	: CERAMIC DISCRIMINATOR	THRMST.CHP	: CHIP THERMISTOR
FER.BEAD	: FERRITE BEADS	TR.CHP	: CHIP TRANSISTOR
FER.CORE	: FERRITE CORE	TR.DGT	: DIGITAL TRANSISTOR
FET.CHP	: CHIP FET	TR.DGT.CHP	: CHIP DIGITAL TRANSISTOR
FL.DSPLY	: FLUORESCENT DISPLAY	TRANS	: TRANSFORMER
FLTR.CE	: CERAMIC FILTER	TRANS.PULS	: PULSE TRANSFORMER
FLTR.COMB	: COMB FILTER MODULE	TRANS.PWR	: POWER TRANSFORMER ASS'y
FLTR.LC.RF	: LC FILTER, EMI	TUNER.AM	: TUNER PACK, AM
GND.MTL	: GROUND PLATE	TUNER.FM	: TUNER PACK, FM
GND.TERM	: GROUND TERMINAL	TUNER.PK	: FRONT-END TUNER PACK
HOLDER.FUS	: FUSE HOLDER	VR	: ROTARY POTENTIOMETER
IC.PRTCT	: IC PROTECTOR	VR.MTR	: POTENTIOMETER WITH MOTOR
JUMPER.CN	: JUMPER CONNECTOR	VR.SW	: POTENTIOMETER WITH ROTARY SW
JUMPER.TST	: JUMPER, TEST POINT	VR.SLIDE	: SLIDE POTENTIOMETER
		VR.TRIM	: TRIMMER POTENTIOMETER

P.C.B. D-AMP

MCX-A10/
MCX-SP10

Ref. No.	PART NO.	Description	Remarks	Markets	部品名	Rank
*	WB698000	P.C.B.	D-AMP		J P C B D - A M P	
*	WB698100	P.C.B.	D-AMP		U P C B D - A M P	
*	WB886100	P.C.B.	D-AMP		C P C B D - A M P	
*	WB701600	P.C.B.	D-AMP		ABG P C B D - A M P	
	CB301	VB389800	CN.BS.PIN	2P		ベースピン 01
	CB401	VB858600	CN.BS.PIN	7P		ベースピン 01
*	CB501	WA538700	CN.BS.PIN	26P TE		F F C コネクタ
*	CB502	V9887300	CN	30P TE		F F C F P C コネクタ
	CB503	VB389800	CN.BS.PIN	2P		ベースピン 01
	CB601	VB390000	CN.BS.PIN	4P		ベースピン 01
*	CB651	LB918030	CN.BS.PIN	3P		ベース付ポスト 01
	CB652	LB918020	CN.BS.PIN	2P		ベース付ポスト 01
*	CB701	VH904200	CN.BS.PIN	14P		コネクタベースポスト 01
	CB706	VB858100	CN.BS.PIN	2P		コネクタベースポスト 01
*	CB707	V9890600	CN	17P SE		F F C / F P C コネクタ
*	C352	VR329500	C.MYLA.CHP	0.0022uF 50V		チップマイラー 01
*	C353	VR329500	C.MYLA.CHP	0.0022uF 50V		チップマイラー 01
*	C616	VR329100	C.POLY.CHP	1000pF 50V		チップマイラーコン 01
*	C625	VR329100	C.POLY.CHP	1000pF 50V		チップマイラーコン 01
*	C627	VR329100	C.POLY.CHP	1000pF 50V		チップマイラーコン 01
	C628	VR328100	C.MYLA.CHP	220pF 50V		チップマイラーコン 01
	C629	VR328100	C.MYLA.CHP	220pF 50V		チップマイラーコン 01
*	C630	VR328500	C.MYLA.CHP	390pF 50V		チップマイラーコン 01
*	C631	VR328500	C.MYLA.CHP	390pF 50V		チップマイラーコン 01
*	C664	WB070900	C.EL	100uF 6.3V		ケミコン
*	C668	WB638100	C.EL	39uF 16V		ケミコン
*	C669	WB070900	C.EL	100uF 6.3V		ケミコン
*	C670	WB070900	C.EL	100uF 6.3V		ケミコン
*	C714	UU118470	C.EL	470uF 6.3V		ケミコン F W
*	C715	UU118470	C.EL	470uF 6.3V		ケミコン F W
	C718	UU137100	C.EL	10uF 16V		ケミコン 01
	C719	UU137100	C.EL	10uF 16V		ケミコン 01
	C722	UU138100	C.EL	100uF 16V		ケミコン 01
	C723	UU138100	C.EL	100uF 16V		ケミコン 01
	C724	UU166100	C.EL	1uF 50V		ケミコン 01
	C725	UU166220	C.EL	2.2uF 50V		ケミコン 01
	C726	UU166220	C.EL	2.2uF 50V		ケミコン 01
*	C727	UR839330	C.EL	3300uF 16V		ケミコン
*	C728	UR839470	C.EL	4700uF 16V		ケミコン 03
*	C733	WB638100	C.EL	39uF 16V		ケミコン
	C748	UU166100	C.EL	1uF 50V		ケミコン 01
	C749	UU166100	C.EL	1uF 50V		ケミコン 01
	C750	UU166100	C.EL	1uF 50V		ケミコン 01
	C751	UU166100	C.EL	1uF 50V		ケミコン 01
*	C753	UU118470	C.EL	470uF 6.3V		ケミコン F W
	C759	UU137100	C.EL	10uF 16V		ケミコン 01
	C760	UU166100	C.EL	1uF 50V		ケミコン 01
	C761	UU166100	C.EL	1uF 50V		ケミコン 01
	C762	UU166330	C.EL	3.3uF 50V		ケミコン 01
	C768	UU166330	C.EL	3.3uF 50V		ケミコン 01
	C773	UU137100	C.EL	10uF 16V		ケミコン 01
*	C783	WB070900	C.EL	100uF 6.3V		ケミコン
	C784	UU138220	C.EL	220uF 16V		ケミコン F W 01

* New Parts (新規部品)

P.C.B. D-AMP

Ref. No.	PART NO.	Description	Remarks	Markets	部品名	Rank
C787	UU137100	C.EL	10uF 16V		ケミコン	01
C788	UU137100	C.EL	10uF 16V		ケミコン	01
C790	UB051220	C.CE.M.CHP	22pF 50V		チップ積層セラコン	01
C791	UB051220	C.CE.M.CHP	22pF 50V		チップ積層セラコン	01
C798	UB051470	C.CE.M.CHP	47pF 50V		チップ積層セラコン	01
C800	UB051470	C.CE.M.CHP	47pF 50V		チップ積層セラコン	01
C801	UB051150	C.CE.M.CHP	15pF 50V		チップ積層セラコン	01
C802	UB051150	C.CE.M.CHP	15pF 50V		チップ積層セラコン	01
* C821	WB564400	C.EL	1000uF 16V		ケミコン	
* C822	WB564400	C.EL	1000uF 16V		ケミコン	
C825	UA655560	C.MYLAR	0.56uF 50V		マイラーコン	01
C826	UA655560	C.MYLAR	0.56uF 50V		マイラーコン	01
C829	UA655150	C.MYLAR	0.15uF 50V		マイラーコン	01
C830	UA655150	C.MYLAR	0.15uF 50V		マイラーコン	01
C831	UA655150	C.MYLAR	0.15uF 50V		マイラーコン	01
C832	UA655150	C.MYLAR	0.15uF 50V		マイラーコン	01
C843	UA654150	C.MYLAR	0.015uF 50V		マイラーコン	01
C844	UA654150	C.MYLAR	0.015uF 50V		マイラーコン	01
D501	WB965900	LED	BE SLR343BBTT32		LED	03
D502	V7446400	LED	GL3JS404B0SE		LED	
D601	VT332900	DIODE	1SS355	UCABG	ダイオード	01
D651	V2376600	DIODE.SHOT	RB500V-40		ショットキーダイオード	01
D652	V2376600	DIODE.SHOT	RB500V-40		ショットキーダイオード	01
D701	VV307700	DIODE	1N4002S		ダイオード	01
D702	VV307700	DIODE	1N4002S		ダイオード	01
D703	VU172200	DIODE.ZENR	UDZ6.8B 6.8V		ツェナーダイオード	01
D704	VT332900	DIODE	1SS355		ダイオード	01
D705	VU172200	DIODE.ZENR	UDZ6.8B 6.8V		ツェナーダイオード	01
D706	VT332900	DIODE	1SS355		ダイオード	01
D707	VU172500	DIODE.ZENR	UDZS9.1B		ツェナーダイオード	01
D708	VU172200	DIODE.ZENR	UDZ6.8B 6.8V		ツェナーダイオード	01
D709	VU171900	DIODE.ZENR	UDZ5.1B 5.1V		ツェナーダイオード	01
* D710	V2574400	DIODE.SHOT	RB491D		ショットキーダイオード	01
D711	VT332900	DIODE	1SS355		ダイオード	01
D712	VT332900	DIODE	1SS355		ダイオード	01
D713	VT332900	DIODE	1SS355		ダイオード	01
* D714	V2574400	DIODE.SHOT	RB491D		ショットキーダイオード	01
D715	VT332900	DIODE	1SS355		ダイオード	01
D716	VT332900	DIODE	1SS355		ダイオード	01
D717	VT332900	DIODE	1SS355		ダイオード	01
D718	VT332900	DIODE	1SS355		ダイオード	01
D719	VT332900	DIODE	1SS355		ダイオード	01
* IC501	X3764A00	IC	SN74AHC1G125DCKR		ロジックIC	01
IC601	X3030A00	IC	LC74781-9844	U	IC DIP	07
* IC601	X4695A00	IC	LC74782-9866	CABG	IC	
* IC651	X4488A00	IC	LTC3728 DC/DC		電源IC	
* IC652	WB566000	FET	SI4830DY-T1		FET	
* IC653	WB566000	FET	SI4830DY-T1		FET	
IC701	X0295A00	IC	74VHCT245AMTCX BUF		ロジックIC	03
* IC702	X3947A00	IC	YDA135-V 20W 2CH		アンプ QFP	
* IC703	WA809100	FET	FW332		FET	
* IC704	WA809100	FET	FW332		FET	
* IC705	WA809100	FET	FW332		FET	

* New Parts (新規部品)

P.C.B. D-AMP

Ref. No.	PART NO.	Description	Remarks	Markets	部品名	Rank
* IC706	WA809100	FET	FW332		F E T	
IC707	XF291A00	IC	uPC4570G2		I C	03
* IC709	X3179A00	IC	LT1617-1		電源 I C S O P	
IC712	XZ545A00	IC	YAC520-EE2		I C	04
IC713	XY935A00	IC	LC75342M-TLM		I C S O P	05
* JK351	WB071300	JACK.MNI	LGS6516-0100		ミニジャック	
JK601	Vi435500	JACK.MNI	YKB21-5130		ミニジャック	01
* JK701	V9856700	JACK	LGP6531-0700		D C 電源ジャック	
* PJ601	WB316400	JACK.PIN	3P YKC21-4538N	J	ピンジャック 3 P	
* PJ601	WB286900	JACK.PIN	4P YKC21-4542N	UCABG	ピンジャック 4 P	
Q501	VV556400	TR	2SC2412K Q,R,S		トランジスタ	01
Q502	VV556400	TR	2SC2412K Q,R,S		トランジスタ	01
Q504	VV556400	TR	2SC2412K Q,R,S		トランジスタ	01
Q505	VV556400	TR	2SC2412K Q,R,S		トランジスタ	01
Q601	VV556500	TR	2SA1037K Q,R,S	UCABG	トランジスタ	01
Q602	VV556400	TR	2SC2412K Q,R,S	UCABG	トランジスタ	01
Q603	VZ725900	TR	2SD1938F S,T	UCABG	トランジスタ	
Q604	VV556400	TR	2SC2412K Q,R,S	UCABG	トランジスタ	01
Q701	VZ725900	TR	2SD1938F S,T		トランジスタ	
Q702	VV655300	TR.DGT	DTA144EKA		デジタルトランジスタ	01
Q703	VZ725900	TR	2SD1938F S,T		トランジスタ	
Q704	VZ725900	TR	2SD1938F S,T		トランジスタ	
Q705	VV655300	TR.DGT	DTA144EKA		デジタルトランジスタ	01
Q706	VA710000	TR	2SD1468		トランジスタ	01
Q707	VV556400	TR	2SC2412K Q,R,S		トランジスタ	01
Q708	VV556400	TR	2SC2412K Q,R,S		トランジスタ	01
Q709	VV556400	TR	2SC2412K Q,R,S		トランジスタ	01
Q710	VV556400	TR	2SC2412K Q,R,S		トランジスタ	01
Q711	VV556400	TR	2SC2412K Q,R,S		トランジスタ	01
* Q712	WB291600	FET	2SJ651		F E T	
Q713	VV556400	TR	2SC2412K Q,R,S		トランジスタ	01
* Q714	V2570300	FET	SI4435DY		F E T	03
Q715	VV556400	TR	2SC2412K Q,R,S		トランジスタ	01
Q716	VZ725900	TR	2SD1938F S,T		トランジスタ	
Q717	VZ725900	TR	2SD1938F S,T		トランジスタ	
Q718	VV556500	TR	2SA1037K Q,R,S		トランジスタ	01
Q719	VA710000	TR	2SD1468		トランジスタ	01
Q720	VV556400	TR	2SC2412K Q,R,S		トランジスタ	01
Q721	VV556400	TR	2SC2412K Q,R,S		トランジスタ	01
Q722	VV556400	TR	2SC2412K Q,R,S		トランジスタ	01
* Q723	WB291600	FET	2SJ651		F E T	
Q724	VV655300	TR.DGT	DTA144EKA		デジタルトランジスタ	01
△ R724	HV755330	R.CAR.FP	330	1/4W	不燃化カーボン抵抗	01
R725	HV755100	R.CAR.FP	100	1/4W	不燃化カーボン抵抗	01
R726	HV755100	R.CAR.FP	100	1/4W	不燃化カーボン抵抗	01
△ R745	HV755100	R.CAR.FP	100	1/4W	不燃化カーボン抵抗	01
△ R775	HV755100	R.CAR.FP	100	1/4W	不燃化カーボン抵抗	01
△ R797	HV753220	R.CAR.FP	2.2	1/4W	不燃化カーボン抵抗	01
R843	VP939500	R.MTL.FLM	1	1W	金属被膜抵抗	01
R844	VP939500	R.MTL.FLM	1	1W	金属被膜抵抗	01
△ R845	HV755100	R.CAR.FP	100	1/4W	不燃化カーボン抵抗	01
R864	HV753220	R.CAR.FP	2.2	1/4W	不燃化カーボン抵抗	01
R866	HV753220	R.CAR.FP	2.2	1/4W	不燃化カーボン抵抗	01

* New Parts (新規部品)

P.C.B. D-AMP & CORE

MCX-A10/
MCX-SP10

Ref. No.	PART NO.	Description	Remarks	Markets	部品名	Rank
* RY701	VK881200	RELAY	DC G5Z-2A-YA		リレー 12V	04
* SW301	WB070700	SW.PUSH	SDDL10900 J.U.C.S		ブッシュSW	
SW401	V2174700	SW.TACT	SKQDPAE010		タクトSW	01
SW402	WC353300	SW	JXS0000-1011		マルチウエイスイッチ	04
SW403	V2174700	SW.TACT	SKQDPAE010		タクトSW	01
SW404	V2174700	SW.TACT	SKQDPAE010		タクトSW	01
SW405	V2174700	SW.TACT	SKQDPAE010		タクトSW	01
SW406	V2174700	SW.TACT	SKQDPAE010		タクトSW	01
SW407	V2174700	SW.TACT	SKQDPAE010		タクトSW	01
* TE701	V7408800	TERM.SP	LQR1410-0004M		スピーカターミナル 4P	
* TH651	VV216100	PROTECTOR	RXE050 0.50A 60V		ボリスイッチ	03
* TH702	WB965500	THRMST.CHP	PRF18BE471QB1RB		チップサーミスタ	
* TH703	WB965500	THRMST.CHP	PRF18BE471QB1RB		チップサーミスタ	
* U401	V3853900	L.DTCT	SBX1971-52P		リモコン受光ユニット	03
XL601	VV949800	RSNR.CRYS	14.31818MHz	UC	水晶振動子	03
* XL601	WC044100	RSNR.CRYS	17.734475MHz	ABG	水晶振動子	
*	WB700900	P.C.B.	CORE	J	P C B コア	
*	WB701000	P.C.B.	CORE	UCABG	P C B コア	
CB2	V9808500	CN	30P SE		F F C F P C コネクタ	02
CB3	V8623300	CN.BS.PIN	36P SE		F F C コネクタ	02
CB7	V7905000	CN	FCN-565P068-G/224V		P C カードコネクタ	07
* CB11	V9887400	CN	26P TE		F F C F P C コネクタ	
* CB12	V8929500	CN.BS.PIN	6P TE	UCABG	ウェハー	
* CB13	V9890600	CN	17P SE		F F C / F P C コネクタ	
CB14	VB390100	CN.BS.PIN	5P		ベースピン	01
CB901	WA245800	CN	8P TM21R-5C-88		モジュラーコネクタ	05
* C209	WB564500	C.EL	680uF 6.3V		ケミコン	
C216	UU137100	C.EL	10uF 16V		ケミコン	01
C217	UU137100	C.EL	10uF 16V		ケミコン	01
C218	UU137100	C.EL	10uF 16V		ケミコン	01
C219	UU137100	C.EL	10uF 16V		ケミコン	01
* C220	VS030500	C.MYLA.CHP	3300pF 50V		チップマイラーコン	
* C221	VS030500	C.MYLA.CHP	3300pF 50V		チップマイラーコン	
* C222	VR328600	C.MYLA.CHP	470pF 50V		チップマイラーコン	01
* C223	VR328600	C.MYLA.CHP	470pF 50V		チップマイラーコン	01
* C224	VR328600	C.MYLA.CHP	470pF 50V		チップマイラーコン	01
* C225	VR328600	C.MYLA.CHP	470pF 50V		チップマイラーコン	01
C901	V9878800	C.CE.M.CHP	1000pF		チップ積層セラコン	01
D1	VT332900	DIODE	1SS355		ダイオード	01
D2	VQ721800	DIODE.CHP	MA732		チップ ダイオード	01
D5	VT332900	DIODE	1SS355		ダイオード	01
D6	V3616900	DIODE.VAR	MA2S30400L		バリキャップ	01
D7	V3616900	DIODE.VAR	MA2S30400L		バリキャップ	01
* D906	WB636800	LED	SML-521MDWT86		2色 LED	
IC1	X3401A00	IC	PQ018EZ01ZP 1.8V		電源 I C	03
IC2	XL122A00	IC	PST572CMT-R		I C	02
* IC3	X3276A00	IC.CPU	HD6417709SF100B		I C / C P U	
IC4	XZ237A00	IC	SN74LVCHR16245AGR		ロジック I C D G G	04
IC5	XZ237A00	IC	SN74LVCHR16245AGR		ロジック I C D G G	04
* IC6	X4764A00	IC	XC9572XL-10TQ100C		デジタル I C	

* New Parts (新規部品)

P.C.B. CORE

Ref. No.	PART NO.	Description	Remarks	Markets	部品名	Rank
IC7	XZ414B00	IC	W986416DH-7 DRAM		メモリ IC 64M	08
IC8	XZ414B00	IC	W986416DH-7 DRAM		メモリ IC 64M	08
IC9	XZ237A00	IC	SN74LVCHR16245AGR		ロジック IC DGG	04
IC10	XZ237A00	IC	SN74LVCHR16245AGR		ロジック IC DGG	04
* IC11	X4230C00	IC	MBM29LV160BE70T		メモリ IC	
* IC12	X4082A00	IC	AT24C02N-10SI-2.7		メモリ IC	
IC14	X0122A00	IC	FST3383MTC		ロジック IC	03
IC15	X0122A00	IC	FST3383MTC		ロジック IC	03
IC17	X3204A00	IC	PQ070XZ5MZP		電源 IC	03
* IC18	X3802A00	IC	TMS320DA105PGE160		ロジック IC	
IC19	XP985A00	IC	SN74LS06NST-EL INV		IC	
IC20	X0477A00	IC	74LCX14MTCX		ロジック IC	01
IC21	X4061A00	IC	SN74AHC2GU04HDCTR		ロジック IC	01
IC22	X4061A00	IC	SN74AHC2GU04HDCTR		ロジック IC	01
IC25	X0295A00	IC	74VHCT245AMTCX BUF	UCABG	ロジック IC	03
IC26	X0661A00	IC	AK4382AVT		IC	07
IC27	XF291A00	IC	uPC4570G2		IC	03
IC901	X2404A00	IC	LAN91C111		IC	13
* L18	WB289600	FLTR.LC.RF	LFA20-2A1E224MT		E M I フィルター	
Q1	VD303700	TR	2SC3326 A,B		トランジスタ	01
* R125	RA155180	R.MTL.CHP	180 1/16W		チップ金被抵抗	
* R126	RA155100	R.MTL.CHP	100 1/16W		チップ金被抵抗	
* R127	RA156100	R.MTL.CHP	1K 1/16W		チップ金被抵抗	
* SC1	WB926500	PLATE.GND			アースプレート	
TH1	V9760200	THRMST.CHP	NCP18XH103J03RB		チップサーミスタ	01
XL1	WB316300	RSNR.CRYS	33.33MHz SMD-49		水晶振動子	03
* XL2	WB963500	RSNR.CRYS	22.5792MHz		水晶振動子	
XL901	VZ540700	RSNR.CRYS	25MHz SMD-49		水晶振動子	03

* New Parts (新規部品)

CHIP CAPACITORS

Ref. No.	PART NO.	Description	Remarks	Markets	部品名	Rank
	UF017470	C.EL.CHP 47uF 6.3V			チップケミコン	01
	UF018100	C.EL.CHP 100uF 6.3V			チップケミコン	01
	UF037100	C.EL.CHP 10uF 16V			チップケミコン	01
	UF037220	C.EL.CHP 22uF 16V			チップケミコン	01
*	UF037330	C.EL.CHP 33uF 16V			チップケミコン	01
*	UF037470	C.EL.CHP 47uF 16V			チップケミコン	01
*	UF128470	C.EL.CHP 470uF 10V			チップケミコン	02
	WB568300	C.EL.CHP 10uF 16V			チップケミコン	
	UB446100	C.CE.CHP 1uF 16V			チップセラコン	01
*	US060400	C.CE.CHP 4pF 50V			チップセラ (C H)	
	US060700	C.CE.CHP 7pF 50V			チップセラコン	01
	US060800	C.CE.CHP 8pF 50V			チップセラコン	01
	US061240	C.CE.CHP 24pF 50V			チップセラ (C H)	01
	US061270	C.CE.M.CHP 27pF 50V			チップセラコン	01
	US061330	C.CE.M.CHP 33pF 50V			チップセラコン	01
	US061470	C.CE.M.CHP 47pF 50V			チップセラコン	01
	US062100	C.CE.M.CHP 100pF 50V			チップセラコン	01
	US062180	C.CE.CHP 180P 50V			チップセラコン	01
	US062220	C.CE.CHP 220pF 50V			チップセラコン	01
	US062470	C.CE.M.CHP 470pF 50V			チップセラコン	01
	US063100	C.CE.M.CHP 1000pF 50V			チップセラコン	01
	US063220	C.CE.M.CHP 2200pF 50V			チップセラコン	01
	US063330	C.CE.M.CHP 3300pF 50V			チップセラ (B)	01
	US063470	C.CE.CHP 4700pF 50V			チップセラコン	01
	US064100	C.CE.M.CHP 0.01uF 50V			チップセラコン	01
	US064150	C.CE.M.CHP 0.015uF 50V			チップセラコン	01
	US135100	C.CE.CHP 0.1uF 16V			チップセラコン	01
*	US634100	C.CE.CHP 0.01uF 16V			チップセラ (B)	
*	US635100	C.CE.CHP 0.1uF 16V			チップセラ (F)	01
*	US662100	C.CE.CHP 100pF 50V			チップセラ (C H)	

* New Parts (新規部品)

MCX-A10/
MCX-SP10

CHIP RESISTOR

Ref. No.	PART NO.	Description	Remarks	Markets	部品名	Rank
*	RD253680	R. CHP 6.8 1/16W			チップ抵抗	
	RD254100	R. CHP 10 1/10W			チップ抵抗	01
	RD255330	R. CHP 330 1/10W			チップ抵抗	01
	RD350000	R. CHP 0 1/16W			チップ抵抗	01
	RD354100	R. CHP 10 1/16W			チップ抵抗	01
	RD354220	R. CHP 22 1/16W			チップ抵抗	01
	RD354470	R. CHP 47 1/16W			チップ抵抗	01
	RD354750	R. CHP 75 1/16W			チップ抵抗	01
	RD355100	R. CHP 100 1/16W			チップ抵抗	01
	RD355330	R. CHP 330 1/16W			チップ抵抗	01
	RD355470	R. CHP 470 1/16W			チップ抵抗	01
	RD355510	R. CHP 510 1/16W			チップ抵抗	01
	RD355560	R. CHP 560 1/16W			チップ抵抗	01
	RD356100	R. CHP 1K 1/16W			チップ抵抗	01
	RD356150	R. CHP 1.5K 1/16W			チップ抵抗	01
	RD356180	R. CHP 1.8K 1/16W			チップ抵抗	01
	RD356220	R. CHP 2.2K 1/16W			チップ抵抗	01
	RD356330	R. CHP 3.3K 1/16W			チップ抵抗	01
	RD356470	R. CHP 4.7K 1/16W			チップ抵抗	01
	RD356680	R. CHP 6.8K 1/16W			チップ抵抗	01
	RD357100	R. CHP 10K 1/16W			チップ抵抗	01
	RD357150	R. CHP 15K 1/16W			チップ抵抗	01
	RD357180	R. CHP 18K 1/16W			チップ抵抗	01
	RD357220	R. CHP 22K 1/16W			チップ抵抗	01
	RD357470	R. CHP 47K 1/16W			チップ抵抗	01
	RD358100	R. CHP 100K 1/16W			チップ抵抗	01
	RD358150	R. CHP 150K 1/16W			チップ抵抗	01
*	RD454220	R. CHP 22 1/16W			チップ抵抗	
*	RD454330	R. CHP 33 1/16W			チップ抵抗	
*	RD454820	R. CHP 82 1/16W			チップ抵抗	
*	RD455100	R. CHP 100 1/16W			チップ抵抗	
*	RD455330	R. CHP 330 1/16W			チップ抵抗	
*	RD455680	R. CHP 680 1/16W			チップ抵抗	
*	RD456100	R. CHP 1K 1/16W			チップ抵抗	
*	RD456220	R. CHP 2.2K 1/16W			チップ抵抗	
*	RD456470	R. CHP 4.7K 1/16W			チップ抵抗	
*	RD456560	R. CHP 5.6K 1/16W			チップ抵抗	
*	RD456680	R. CHP 6.8K 1/16W			チップ抵抗	
*	RD457100	R. CHP 10K 1/16W			チップ抵抗	
*	RD458100	R. CHP 100K 1/16W			チップ抵抗	
*	RD459100	R. CHP 1M 1/16W			チップ抵抗	
	RF455200	R. CHP 200 1/16W			チップ抵抗	01
	RF456100	R. CHP 1.0K 1/16W			チップ抵抗	
	RF456120	R. CHP 1.2K 1/16W			チップ抵抗	
*	RF456240	R. CHP 2.4K 1/16W			チップ抵抗	
	RF456330	R. CHP 3.3K 1/16W			チップ抵抗	
	RF456470	R. CHP 4.7K 1/16W			チップ抵抗	
*	RF456510	R. CHP 5.1K 1/16W			チップ抵抗	01
	RF456560	R. CHP 5.6k 1/16W			チップ抵抗	
	RF456680	R. CHP 6.8K 1/16W			チップ抵抗	
	RF456820	R. CHP 8.2K 1/16W			チップ抵抗	
	RF457100	R. CHP 10K 1/16W			チップ抵抗	
	RF457150	R. CHP 15K 1/16W			チップ抵抗	01

* New Parts (新規部品)

CHIP RESISTOR

Ref. No.	PART NO.	Description	Remarks	Markets	部品名	Rank
	RF457180	R.CHP 18K 1/16W			チップ抵抗	
	RF457220	R.CHP 22K 1/16W			チップ抵抗	
*	RF457390	R.CHP 39K 1/16W			チップ抵抗	
	RF457470	R.CHP 47K 1/16W			チップ抵抗	
*	RF457560	R.CHP 56K 1/16W			チップ抵抗	
*	RF457680	R.CHP 68K 1/16W			チップ抵抗	
*	RF458110	R.CHP 110K 1/16W			チップ抵抗	
*	RF458120	R.CHP 120K 1/16W			チップ抵抗	
	V9848700	R.CHP 24.9 1/8W			チップ抵抗	01
	V9848800	R.CHP 49.9 1/8W			チップ抵抗	01
	V9848900	R.CHP 75 1/8W			チップ抵抗	01
	V9849100	R.CHP 11K 1/8W			チップ抵抗	01
*	WB000400	R.CHP 0.05 1W			チップ抵抗	
*	WB565800	R.CHP 0.039 1/4W			チップ抵抗	
*	WB565900	R.CHP 0.2 1/4W			チップ抵抗	

MCX-A10/
MCX-SP10

* New Parts (新規部品)

MCX-A10/MCX-SP10

1 ■ EXPLODED VIEW (MCX-A10)

When removing screw (78), use the special screw driver with tip shape in figure.

ネジ(78)を外す場合、図のような先端形状のドライバーを使用します。

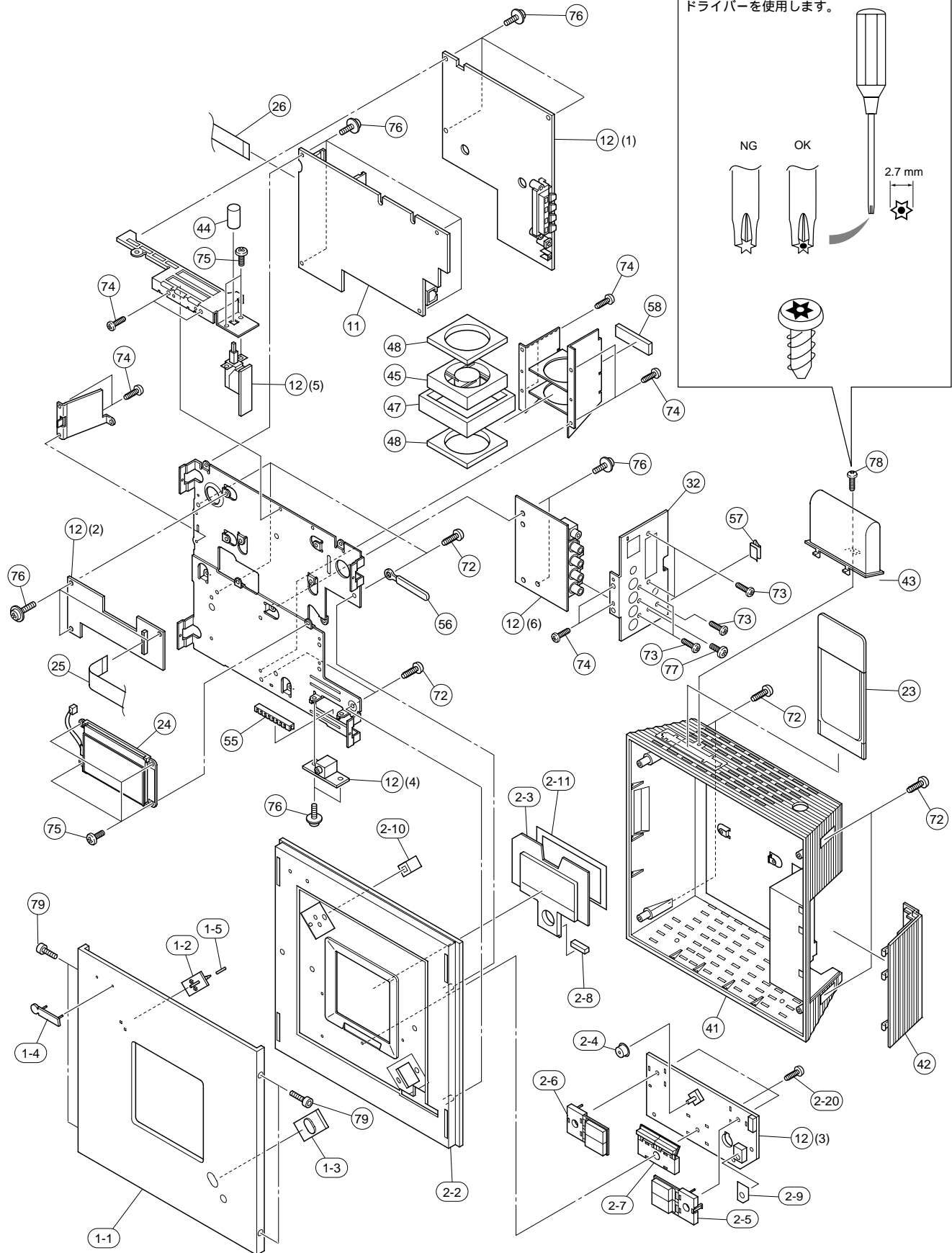
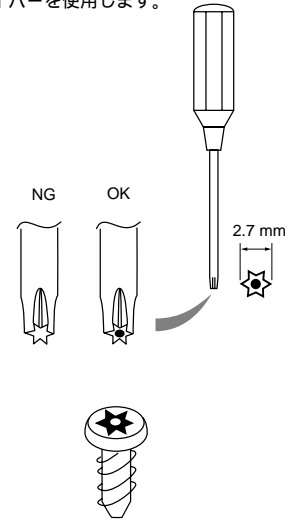

MECHANICAL PARTS (MCX-A10)

Ref. No.	PART NO.	Description	Remarks	Markets	部品名	Rank
* 1-1	WB089900	FRONT PANEL			フロントパネル	
* 1-2	WA860500	LENS, LED			レンズ	
* 1-3	WA860600	REFLECTOR			リフレクター	
1-4	V6034100	EMBLEM			エンブレム	
* 1-5	WB997800	DAMPER 10/2/T1			ダンパー 10 / 2 / 1	
* 2-2	WA858800	SUB PANEL	SILVER		サブパネル	
* 2-3	WA859200	WINDOW PANEL, LID			ウインドウ	
* 2-4	WA860300	KNOB/STICK			ノブ / STICK	
* 2-5	WB173600	BUTTON A/R ASS'Y			ボタン A R ASSY	
* 2-6	WB173700	BUTTON A/L ASS'Y			ボタン A L ASSY	
* 2-7	WB173500	BUTTON B ASS'Y			ボタン B ASSY	
* 2-8	WB211600	DAMPER 5.5/4/17			ダンパー 5 . 5 / 4 /	
* 2-9	WB321800	SHEET/IRDA			シート / IRDA	
* 2-10	WB997900	SHEET/LED			シート / LED	
* 2-11	WC252400	SPACER/LCD			スペーサ / LCD	
2-20	WA231700	BIND HEAD P-TIGHT SCREW	3x8 MFNI33		+ バインド P タイト	01
* 11	WB700900	P.C.B. ASS'Y	CORE	J	P C B コア	
* 11	WB701000	P.C.B. ASS'Y	CORE	UCABG	P C B コア	
* 12	WB698000	P.C.B. ASS'Y	D-AMP	J	P C B D - AMP	
* 12	WB698100	P.C.B. ASS'Y	D-AMP	U	P C B D - AMP	
* 12	WB886100	P.C.B. ASS'Y	D-AMP	C	P C B D - AMP	
* 12	WB701600	P.C.B. ASS'Y	D-AMP	ABG	P C B D - AMP	
* 23	WB209700	WIRELESS LAN CARD	XI-325		無線 LAN カード	
* 24	WB112500	LCD	UMN-7312ED-4F		液晶ディスプレイ	
* 25	WB802200	FLEXIBLE FLAT CABLE	26P 110mm P=0.5		カード電線	
* 26	WB802300	FLEXIBLE FLAT CABLE	17P 50mm P=0.5		カード電線	
* 32	WB329800	SIDE PANEL		J	サイドパネル	
* 32	WB109700	SIDE PANEL		UCABG	サイドパネル	
* 41	WA859100	REAR COVER	SILVER		リヤカバー	
* 42	WB107900	SIDE COVER			サイドカバー	
* 43	WC043300	COVER/LAN			カバー / LAN	
* 44	WA860400	KNOB/SW			ノブ / SW	
* 45	WB818200	DC FAN MOTOR	F412R-12LLB-14		DC ファンモーター	
* 47	WB792200	CUSHION/FAN A			クッション / ファン A	
* 48	WB792300	CUSHION/FAN B			クッション / ファン B	
* 55	VR492900	BUSH	KG-008		ブッシュ	01
56	CB836200	BINDING TIE	S-70B		束線止め	02
* 57	WB988600	SHIELD FINGERS	F-312-00		シールドフィンガー	
* 58	WB978600	SOFT SHIELD	UC-300281T L=50		ソフトシールド	
72	WA231700	BIND HEAD P-TIGHT SCREW	3x8 MFNI33		+ バインド P タイト	01
73	VN413300	BIND HEAD BONDING B-T. SCREW	3x8 MFZN2BL		ボンディング B タイトネジ	01
74	VE190700	BIND HEAD BONDING B-T. SCREW	3x6 MFC2BL		ボンディング B タイトネジ	01
* 75	EG330040	BIND HEAD SCREW	3x6 MFZN2Y		バインド小ネジ	01
76	VH365800	PW HEAD B-TIGHT SCREW	3x6-8 MFC2		PW ヘッド B タイトネジ	01
77	VB748400	BIND HEAD SCREW	3x8 MFNI33		バインド小ネジ	01
* 78	WC186100	PAN HEAD TORX B-TIGHT SCREW	3x8 MFNI33		ナベトルクス B タイトネジ	
* 79	WB320300	HEX SOCKET HEAD BOLT	M2x5 MFNI33		六角穴付きボルト	

* New Parts (新規部品)

Ref. No.	PART NO.	Description	Remarks	Markets	部品名	Rank
		ACCESSORIES				
* 200	WB090700	REMOTE CONTROL	MCX2		付属品	
* 200-1	AAX30940	BATTERY HOLDER	103RRS-129-50L		リモコン	
△* 202	WB753700	AC ADAPTOR	LSE0107A1240		電池ホルダー	
△* 203	WB753300	POWER CABLE	2m	J	ACアダプター	
△* 203	WB753400	POWER CABLE	2m	UC	電源コード	
△* 203	WB820500	POWER CABLE	2m	A	電源コード	
△* 203	WB753500	POWER CABLE	2m	B	電源コード	
△* 203	WB753600	POWER CABLE	2m	G	電源コード	
* 204	WB216800	AUDIO PIN CABLE	2P 1.5m RE/WH		ステレオピンケーブル	
* 205	WB216700	VIDEO PIN CABLE	1P 1.5m YE	UCABG	ビデオ用ピンケーブル	
* 206	WB216600	SUBWOOFER CABLE	2P 1.5m BL		サブウーハーケーブル	
* 207	WB428300	STAND	with 2 screws		スタンド	
		LITHIUM BATTERY	CR2025		リチウム電池	

* New Parts (新規部品)

Remote control

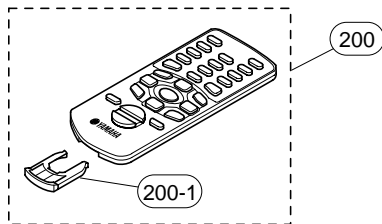

Lithium battery



Video pin cable

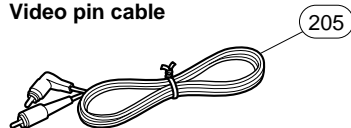

AC adaptor (LSE0107A1240)

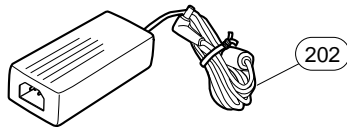

Subwoofer cable

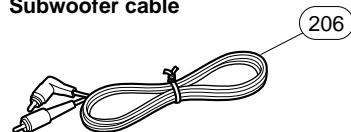

AC power cable

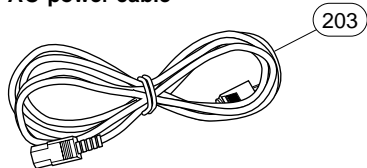

Stand

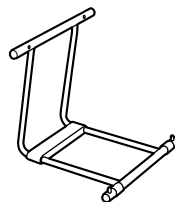

Audio pin cable

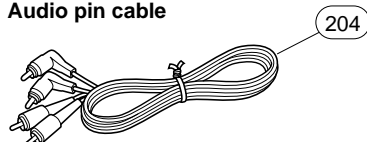

Screw 3 x 10



1 ■ EXPLODED VIEW (MCX-SP10)

1

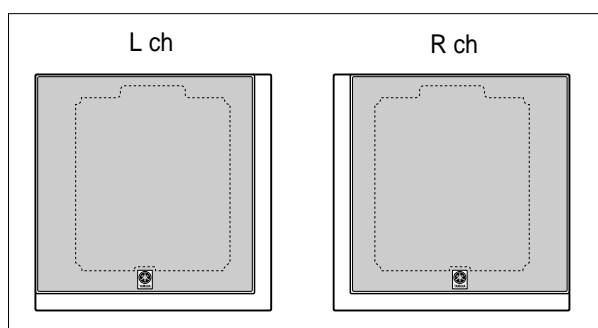

2

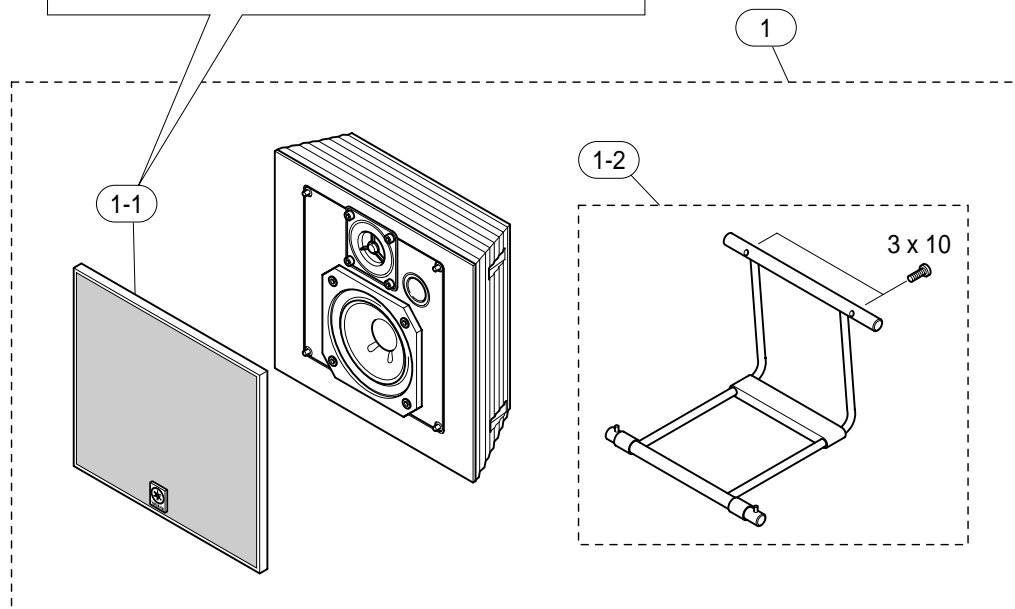

3

4

5

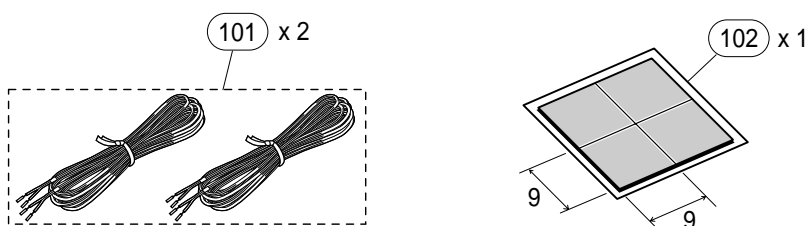

6

Ref. No.	PART NO.	Description	Remarks	Markets	部品名	Rank
		MCX-SP10				
* 1	AAX51880	SPEAKER SYSTEM	L+R/set	CP11YM022002	スピーカシステム	
* 1-1	AAX51890	FRONT GRILLE ASS'Y	L	BHBKYM022001	フロントグリルASS'Y	
* 1-1	AAX51900	FRONT GRILLE ASS'Y	R	BHBKYM022002	フロントグリルASS'Y	
* 1-2	WB428300	STAND	with 2 screws		スタンド	
		ACCESSORIES			付属品	
* 101	AAX51870	SPEAKER CABLE	5m 1pc	DX2024201001	スピーカケーブル	
* 102	AAX51910	PAD	9x9 t2 4pcs/set	JD4011000015	防振パッド	

7

* New Parts (新規部品)

MCX-A10/MCX-SP10

REMOTE CONTROL

SCHEMATIC DIAGRAM

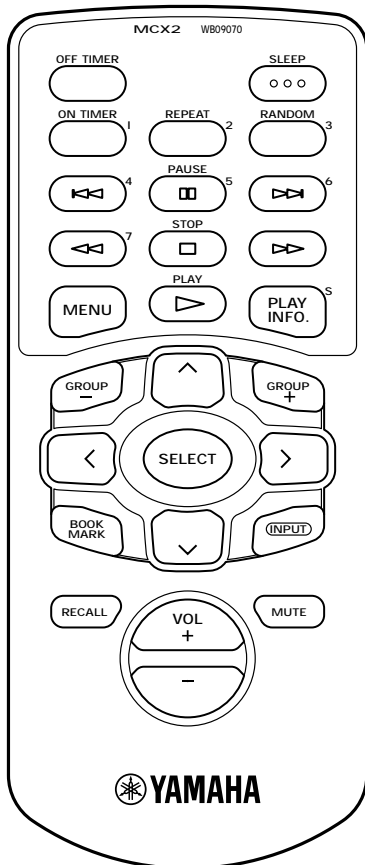
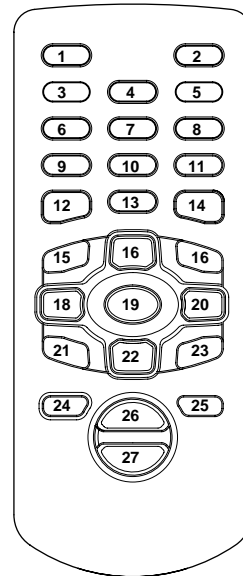
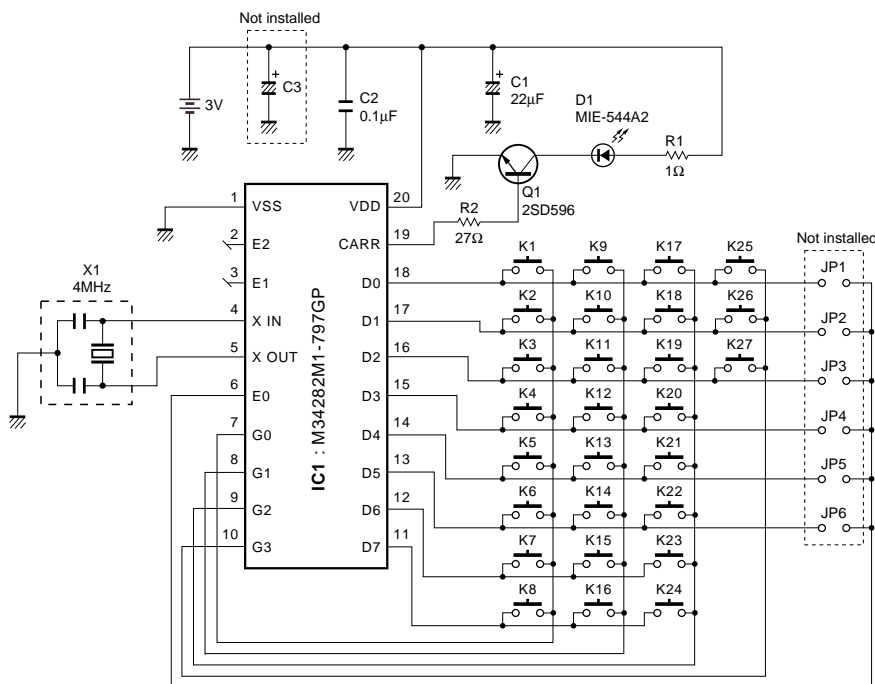

Custom Code : 80-37

Key No.	Function	Data
1	SLEEP	BE
2	STANDBY/ON	80
3	TIMER	BF
4	REPEAT	93
5	RANDOM	92
6	SKIP -	88
7	PAUSE	83
8	SKIP +	89
9	SCAN -	86
10	STOP	85
11	SCAN +	87
12	MENU	B1
13	PLAY	82
14	PLAY INF.	AE
15	GROUP -	8A
16	CURSOR UP	B2
17	GROUP +	8B
18	CURSOR LEFT	B4
19	SELECT	B6
20	CURSOR RIGHT	B5
21	BOOKMARK	91
22	CURSOR DOWN	B3
23	INPUT	98
24	RECALL	---
25	MUTE	9D
26	VOL +	9F
27	VOL -	9E
24+3	RECALL CLIENT1	A0
24+4	RECALL CLIENT2	A1
24+5	RECALL CLIENT3	A2
24+6	RECALL CLIENT4	A3
24+7	RECALL CLIENT5	A4
24+8	RECALL CLIENT6	A5
24+9	RECALL CLIENT7	A6
24+10	RECALL CLIENT8	A7
24+11	RECALL CLIENT9	A8
24+12	RECALL CLIENT10	A9
24+14	RECALL SERVER	AA