

# MINIDISC RECORDER

# MDX-595

## SERVICEMANUAL

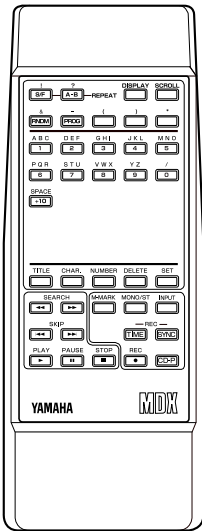
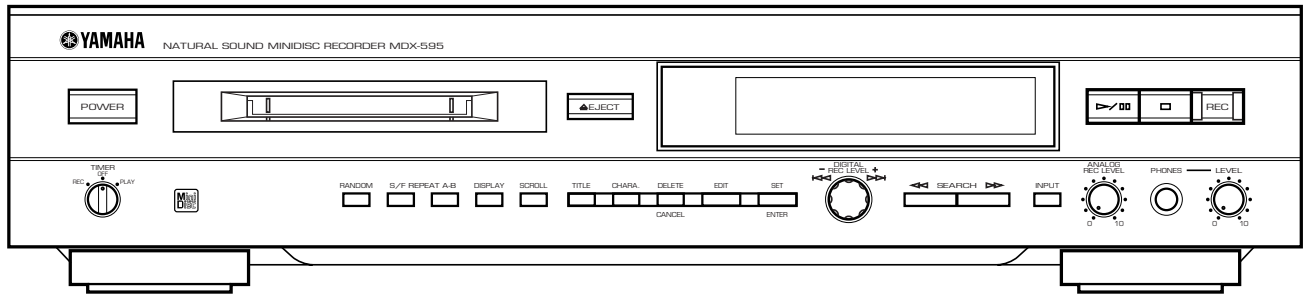

### IMPORTANT NOTICE

This manual has been provided for the use of authorized YAMAHA Retailers and their service personnel. It has been assumed that basic service procedures inherent to the industry, and more specifically YAMAHA Products, are already known and understood by the users, and have therefore not been restated.

**WARNING:** Failure to follow appropriate service and safety procedures when servicing this product may result in personal injury, destruction of expensive components and failure of the product to perform as specified. For these reasons, we advise all YAMAHA product owners that all service required should be performed by an authorized YAMAHA Retailer or the appointed service representative.

**IMPORTANT:** The presentation or sale of this manual to any individual or firm does not constitute authorization, certification or recognition of any applicable technical capabilities, or establish a principle-agent relationship of any form.

The data provided is believed to be accurate and applicable to the unit(s) indicated on the cover. The research, engineering, and service departments of YAMAHA are continually striving to improve YAMAHA products. Modifications are, therefore, inevitable and specifications are subject to change without notice or obligation to retrofit. Should any discrepancy appear to exist, please contact the distributor's Service Division.

**WARNING:** Static discharges can destroy expensive components. Discharge any static electricity your body may have accumulated by grounding yourself to the ground buss in the unit (heavy gauge black wires connect to this buss).

**IMPORTANT:** Turn the unit OFF during disassembly and parts replacement. Recheck all work before you apply power to the unit.

### CONTENTS

TO SERVICE PERSONNEL .....	1~2
REAR PANELS .....	2
SPECIFICATIONS .....	3
INTERNAL VIEW .....	4
DISASSEMBLY PROCEDURES .....	4~8
ADJUSTMENT & TEST MODE .....	9~16
SPECIAL TEST MODE .....	17
ERROR DISPLAY .....	18~19
TROUBLESHOOTING .....	20~24

IC DATA .....	25~34
BLOCK DIAGRAM .....	35~37
TEST POINT WAVEFORMS .....	38~39
PRINTED CIRCUIT BOARD .....	40~47
SCHEMATIC DIAGRAM .....	48~51
PARTS LIST .....	52~64
GREASE APPLICATION DIAGRAM .....	65
REMOTE CONTROL TRANSMITTER .....	66



このサービスマニュアルは、エコマーク認定の再生紙を使用しています。  
This Service Manual uses recycled paper.



## ■ TO SERVICE PERSONNEL

1. Critical Components Information.  
Components having special characteristics are marked ⚠ and must be replaced with parts having specifications equal to those originally installed.
2. Leakage Current Measurement (For 120V Models Only).  
When service has been completed, it is imperative to verify that all exposed conductive surfaces are properly insulated from supply circuits.
  - Meter impedance should be equivalent to 1500 ohm shunted by 0.15μF.
  - Leakage current must not exceed 0.5mA.
  - Be sure to test for leakage with the AC plug in both polarities.

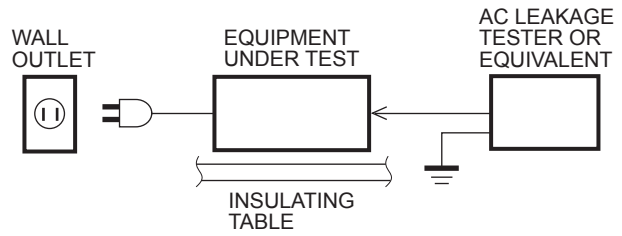

**CAUTION:** USE OF CONTROLS OR ADJUSTMENTS OR PERFORMANCE OF PROCEDURES OTHER THAN THOSE SPECIFIED HEREIN MAY RESULT IN HAZARDOUS RADIATION EXPOSURE.

THE MINI DISC RECORDER SHOULD NOT BE ADJUSTED OR REPAIRED BY ANYONE EXCEPT PROPERLY QUALIFIED SERVICE PERSONNEL.

### Laser Diode Properties

Material:	GaAIAs
Wavelength:	785 nm
Pulse time:	Read mode ...0.8 mW Continuous
	Write mode ...max 10 mW 0.5S
	min cycle 1.5S
	Repetition

## WARNING: CHEMICAL CONTENT NOTICE!

The solder used in the production of this product contains LEAD. In addition, other electrical/electronic and/or plastic (where applicable) components may also contain traces of chemicals found by the California Health and Welfare Agency (and possibly other entities) to cause cancer and/or birth defects or other reproductive harm.

DO NOT PLACE SOLDER, ELECTRICAL/ELECTRONIC OR PLASTIC COMPONENTS IN YOUR MOUTH FOR ANY REASON WHATSOEVER!

Avoid prolonged, unprotected contact between solder and your skin! When soldering, do not inhale solder fumes or expose eyes to solder/flux vapor!

If you come in contact with solder or components located inside the enclosure of this product, wash your hands before handling food.

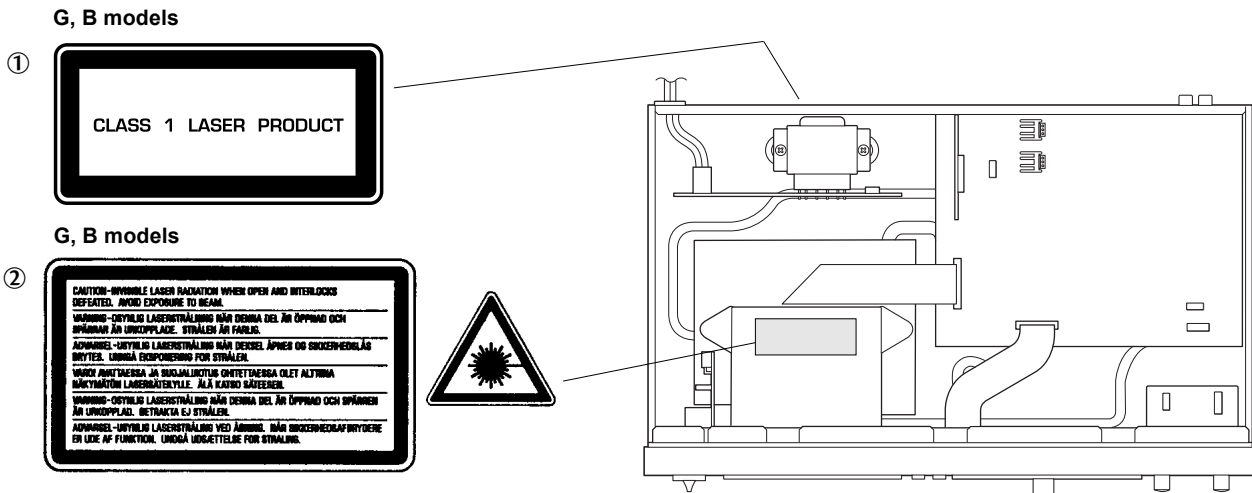

**English**

- ① THIS PRINTING (SEE POSITION SHOWN IN THE ILLUSTRATION) INFORMS THE USER THAT THE APPARATUS CONTAINS A LASER COMPONENT.
- ② THIS LABEL (SEE POSITION SHOWN IN THE ILLUSTRATION) WARNS THAT ANY FURTHER PROCEDURE WILL BRING THE USER INTO EXPOSURE WITH THE LASER BEAM.

CAUTION : USE OF CONTROLS, ADJUSTMENTS OR PERFORMANCE OF PROCEDURES OTHER THAN THOSE SPECIFIED HEREIN, MAY RESULT IN HAZARDOUS RADIATION EXPOSURE.

**Swedish**

- ① DENNA MÄRKNING (SE FIGUR) UPPLYSER OM ATT DET I APPARATEN INGÅR EN LASERKOMPONENT AV TYP KLAS 1.
- ② VARNINGSMÄRKNING (SE FIGUR) FÖR STRÅLNING. INGREPP I APPARATEN BÖR ENDAST FÖRETAGAS AV FACKMAN MED KÄNNEDOM OM LASER. APPARATEN INNEHÅLLER EN LASERKOMPONENT SOM AVGER STRÅLNING ÖVERSTIGANDE GRÄNSEN FÖR LASERKLASS 1.

VARNING : OSYNLIG LASERSTRÅLNING NÄR DENNA DEL ÄR ÖPPNAD OCH SPÄRREN ÄR URKOPPLAD. STIRRA EJ I STRÅLEN OCH BETRakta EJ STRÅLEN GENOM OPTISKT INSTRUMENT.

**Danish**

- ① DETTE MÆRKAT ER ANBRAGT SOM VIST I ILLUSTRATIONEN FOR AT ADVARE BRUGEREN OM AT APPARATET INDEHOLDER EN LASERKOMPONENT.
- ② DETTE MÆRKAT OM LASEREN ER ANBRAGT PÅ APPARATET SOM EN OPLYSNING OM AT APPARATET INDEHOLDER ET LASERKOMPONENT.

ADVARSEL : USYNLIG LASERSTRÅLING VED ÅBNING, NÅR SIKKERHEDSAFBRYDERE ER UDE AF FUNKTION. SE IKKE IND I STRÅLEN-HELLER IKKE MED OPTISKE INSTRUMENTER.

ADVARSEL : USYNLIG LASERSTRÅLING NÅR DEKSEL ÅPNES OG SIKKERHEDSLÅS BRYTES. STIRR IKKE INN I STRÅLEN ELLER SE DIREKTE MED OPTISKE INSTRUMENTER.

**Finnish**

VARO! :  
AVATTAESSA JA SUOJALUKITUS OHITETTAESSA OLET ALTTIINA NÄKYMÄTTÖMÄLLE LASER-SÄTEILYLLE. ÄLÄ TUIJOTA SÄTEESEEN ÄLÄKÄ KATSO SITÄ OPTISEN LAITTEEN LÄPI.

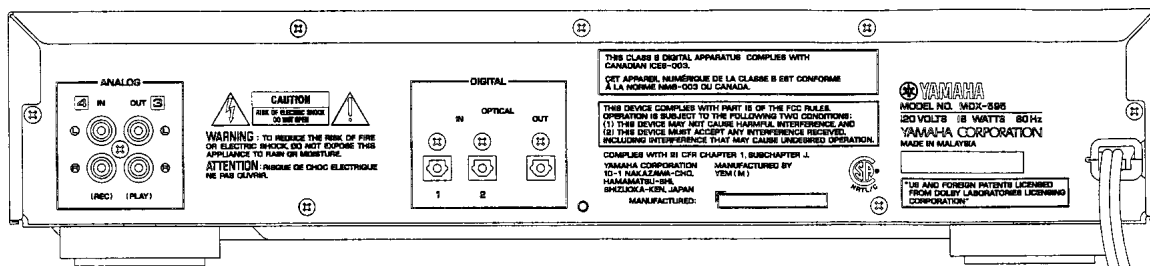
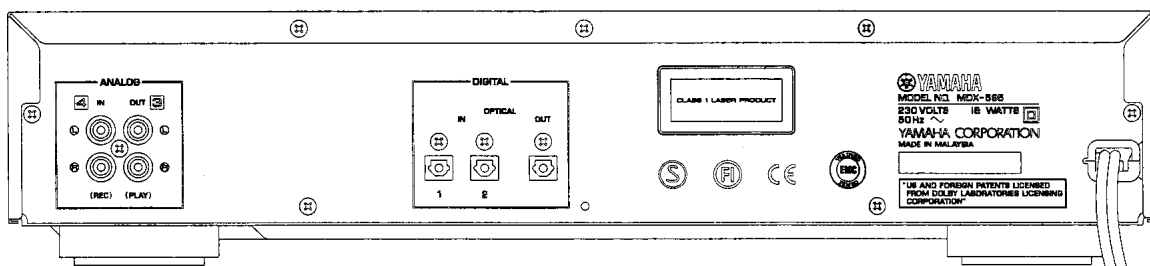
**REAR PANELS****▼ U model****▼ G, B models**

## ■ SPECIFICATIONS

### Digital audio system

**System**

MiniDisc digital audio system

**Disc**

MiniDisc

**Recording method**

Magnetic field variation overwrite

**Reading method**

Non-contact optical pickup (using semiconductor laser)

**Laser**

Semiconductor laser

**Laser Diode Properties**

Material: GaAlAs

Wavelength: 785 nm

Pulse time:

Read mode ... 0.8 mW Continuous

Write mode ... max 10 mW 0.5S

min cycle 1.5S

Repetition

**Record/playback time**

Max. 80 minutes

80 minutes (stereo)

160 minutes (mono)

**Revolutions**

Approx. 400~900 rpm (CLV)

**Error Correction**

ACIRC (Advanced Cross Interleave Reed-solomon Code)

**Sampling frequency**

44.1 kHz (32 kHz and 48 kHz signals converted to 44.1 kHz for recording)

**Coding**

ATRAC (Adaptive TRansform Acoustic Coding)

**Modulation system**

EFM (Eight-to-Fourteen Modulation)

**Number of channels**

2 (stereo) or 1 (mono, for extended recording)

**Frequency Response**

5 ~ 20,000 Hz  $\pm$ 0.5 dB

**Signal-to-Noise Ratio**

More than 99 dB during playback

**Wow and Flutter**

Below measurable limit

### Inputs

**LINE IN (REC)**

Type: pin jack

Input impedance: greater than 56 k-ohms

Standard input level: 300 mV

**DIGITAL IN (OPTICAL) 1/2**

Type: square optical connector jack

### Outputs

**LINE OUT (PLAY)**

Type: pin jack

Standard output level:  $2.0 \pm 0.5$  Vrms

**DIGITAL OUT (OPTICAL)**

Type: square optical connector jack

**PHONES**

Standard output level

(Input 150 ohms shorted, - 20 dB):  $300 \pm 60$  mV

### GENERAL

**Power Supplies**

U model 120 V, 60 Hz

G, B models 230 V, 50 Hz

**Power Consumption**

20 W

**Dimensions (W x H x D)**

435 x 96 x 288 mm (17-1/8" x 3-3/4" x 11-5/16")

**Weight**

4.1 kg (9 lbs. 1 oz.)

**Accessories**

Remote Control.... 1

Audio cord... 2

Optical cord... 1

Batteries (size AA, R6, UM-3).... 2

Specifications subject to change without notice.

**U : USA model**

**B : British model**

**G : European model**

\* US and foreign patents licensed from Dolby Laboratories Licensing Corporation.

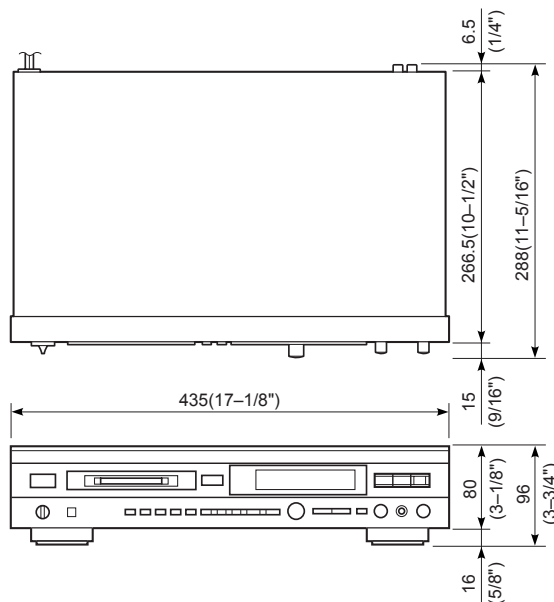

Units : mm (inch)

## INTERNAL VIEW

- ① POWER TRANSFORMER
- ② P.C.B. DIGITAL
- ③ P.C.B. MAIN (1)
- ④ POWER SWITCH
- ⑤ MD MECHANISM UNIT
- ⑥ P.C.B. MAIN (2)

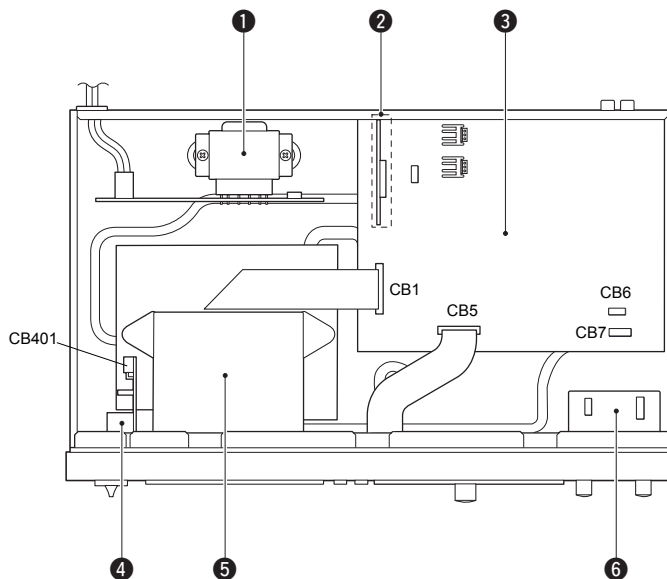

## DISASSEMBLY PROCEDURES

(Remove parts in disassembly order as numbered.)

### 1. Removal of Top Cover

- a. Remove 4 screws (①) and 3 screw (②) in Fig. 1.

### 2. Removal of Front Panel

- a. Remove 4 connectors.
  - CB5, CB6, CB7, CB401
- b. Remove 3 screws (③) and 2 screws (④) in Fig. 1.

### 3. Removal of MD Mechanism Unit

- a. Remove 1 connector.
  - CB1
- b. Remove 4 screws (⑤) in Fig. 1.
- c. Remove 4 screws (⑥) in Fig. 2.
- d. Remove 2 screws (⑦) in Fig. 2.
- e. Remove 2 screws (⑧) in Fig. 2.

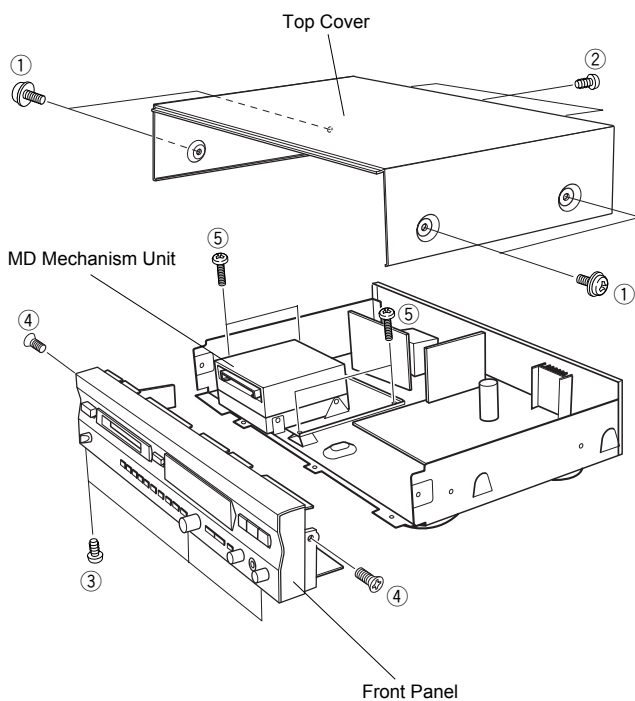

Fig. 1

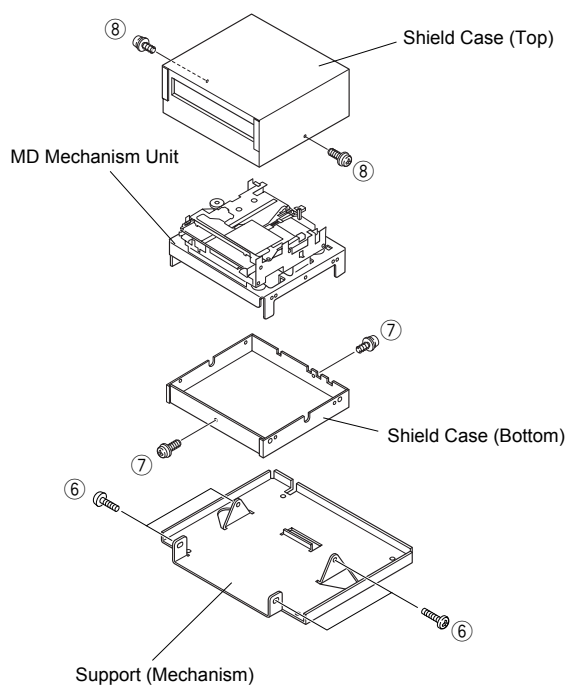

Fig. 2

## Disassembly of MD Mechanical Unit

Remove the MD mechanical unit according to Steps 1 ~ 3 of the disassembly procedure (page 4).

### Removal of MD Main P.C.B. (Fig. 3)

1. Remove 4 screws (Q1).
2. Remove 6 connectors (Q2).

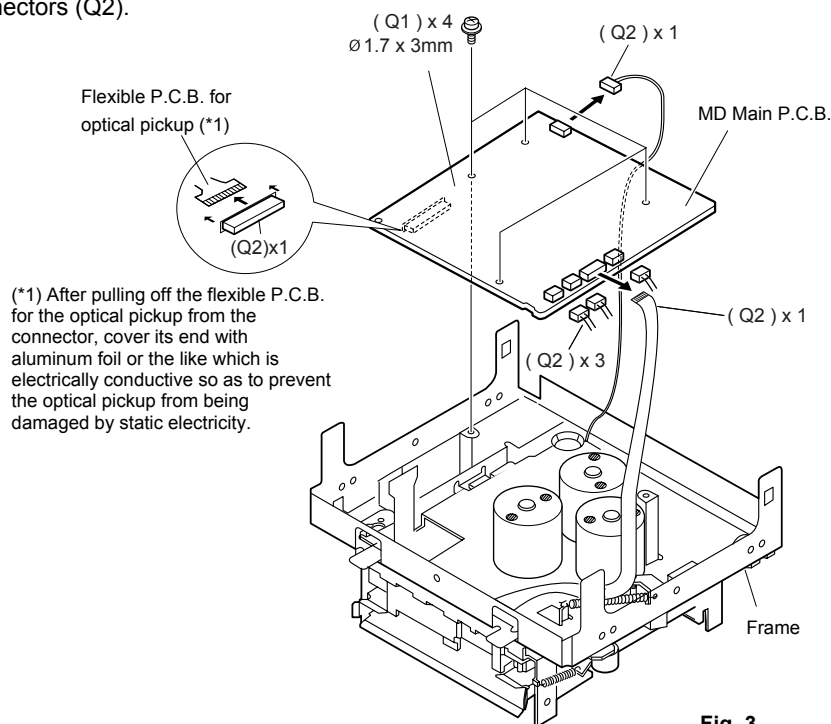

Fig. 3

### Removal of MD Mechanism (Fig.4)

1. Remove 4 screws (R1).

**Caution**

Almost the entire surface of the cartridge holder is coated with oil. When removing the mechanism, hold it at the rear end (where marked with arrows in the figure) and avoid touching the oiled surface.

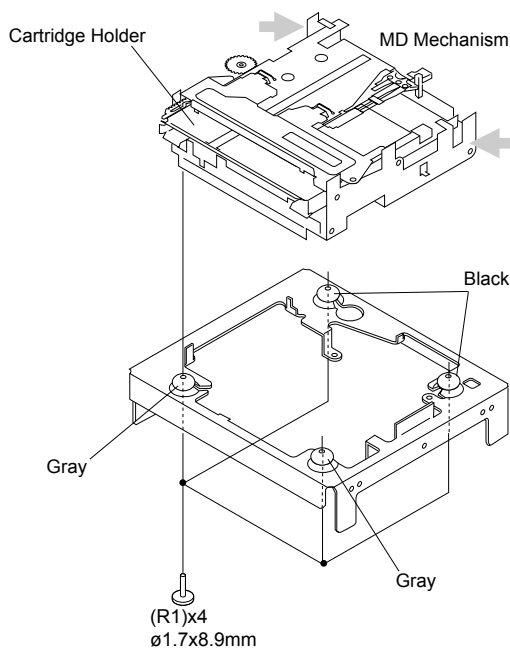

Fig. 4

### Removal of Magnetic Head (Fig.5)

1. Remove a screw (A1).

**Caution**

- a. When removing the magnetic head, hold its base and do not touch the magnetic head itself or the leaf spring.
- b. Place the magnetic head upside down.
- c. Use special care so as not to cause any damage to the magnetic head when installing it.

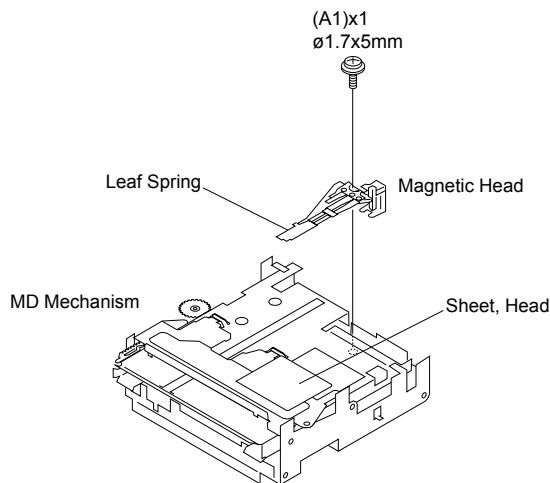

Fig. 5

### Removal of Cartridge Holder (Fig.6)

1. Open the roller arm lever in the arrow direction and move the clamber lever to the rear.
  2. With a +5V voltage (\*2) applied to the red line side of the blue connector of the loading motor, push the rack gear in the arrow direction until the cam plate lever clicks.
- (\*2) A +5V voltage can be obtained from the pluspol (D6.5/5V) of C3 and the ground terminal of the Main P.C.B.
3. Remove a screw (B1 and B2, 1 each) from the holder arm and remove the cartridge holder by moving it to the left.

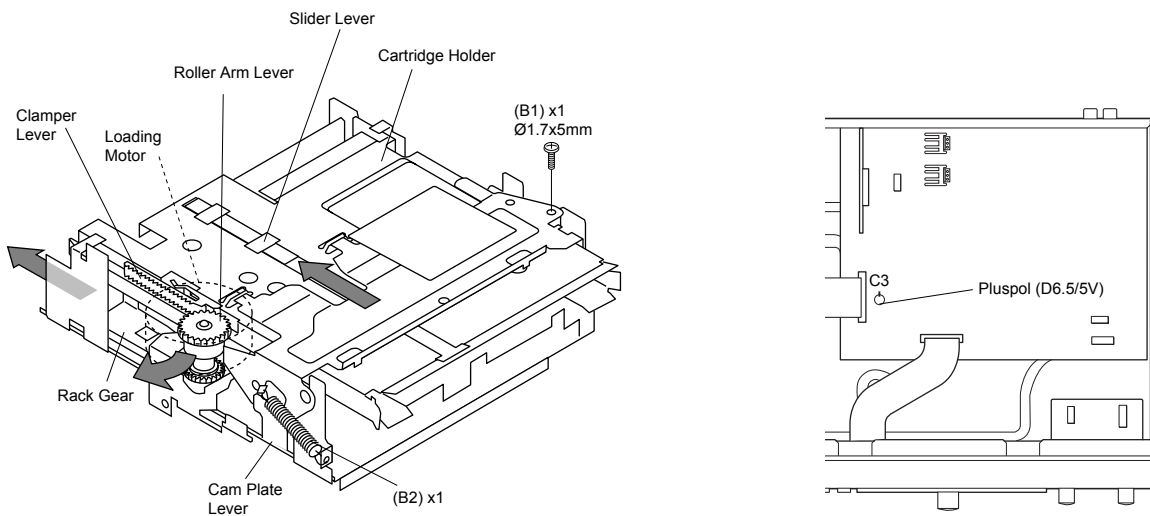

Fig.6

#### Caution

Be careful so that oil does not get on the clamber lever which contacts the roller of the roller arm lever.

#### Installation of Cartridge Holder

- To install the cartridge holder, the rack of the mechanism must be lowered toward the rear.
- While pushing the roller arm lever outward, push in the slider lever.
- Apply a +5V voltage to the loading motor (until clicking sound is heard) and push in the rack gear.
- With the slider lever and the rack gear installed as described above, fit the cartridge holder as shown in the figure and tighten screws.

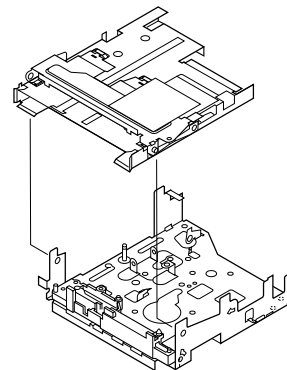

**Removal of Mechanism SW P.C.B. (Fig.7)**

- Once the mechanism switch P.C.B. is removed, it will be necessary to perform "Adjustment of Lead-in Switch Position". (See page 13.)

1. Remove 2 screws (E1) and then remove the Mechanism SW P.C.B.

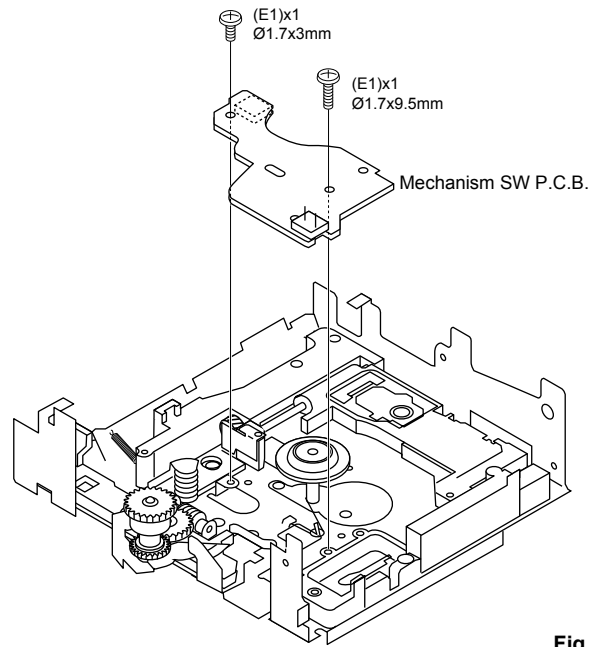

**Fig.7**

**Installation of Mechanism SW P.C.B.**

- Set the mechanism to the eject mode by applying -5V to the loading motor.
- Install the mechanism SW P.C.B. so that the boss fits in the hole in it.
- Push the lead switch on the mechanism SW P.C.B. toward the optical pickup side (so that looseness in the boss hole is eliminated).
- Tighten screws and apply thread lock.
- Measure the lead-in switch position. (See page 13.) (Enter the result in EEPROM.)

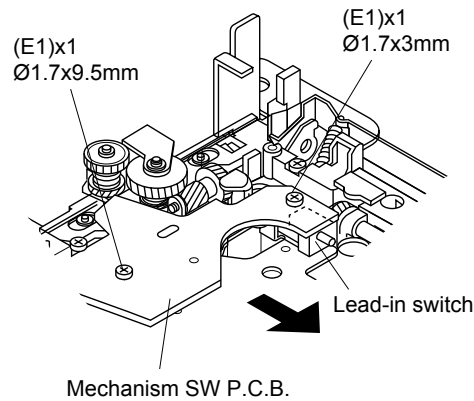

**Removal of Sled Motor/Loading Motor (Fig.8)**

1. Remove 4 screws (D1) and then remove the sled motor/loading motor.

**Caution**

Use care so as not to cause any damage to the gear.  
(The damaged gear will cause abnormal noise to occur while searching.)

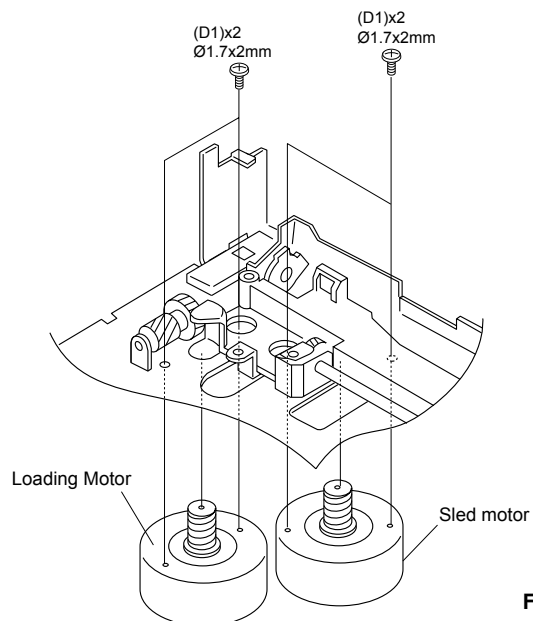

**Fig. 8**



### Removal of Spindle Motor (Fig.9)

- Once the spindle motor is removed, it will be necessary to perform "Pickup Rating". (See page 14.)

- Remove 3 screws (C1).
- Remove the spindle motor by moving it in the arrow direction.

#### Caution

- Be careful not to scratch the gear.  
(Scratched gear will produce noises during searching.)
- As the turn-table is magnetized, keep foreign objects from being attracted.

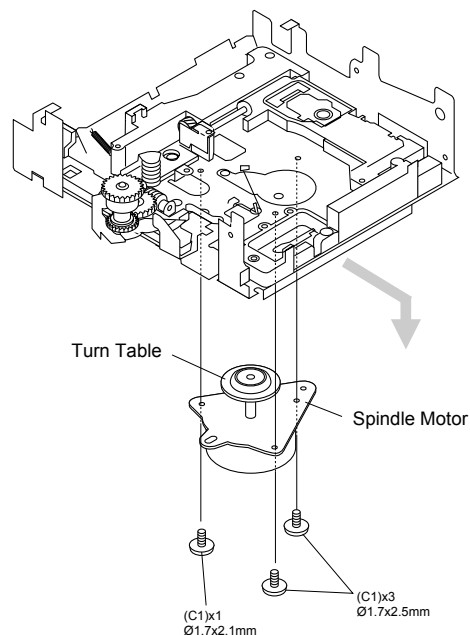

Fig.9

### Removal of Optical Pickup Head (Fig.10 and Fig.11)

- Remove 3 screws (F1).

#### Caution

- Use care so as not to cause any damage to the gear.  
(The damaged gear will cause abnormal noise to occur while searching.)

- Remove a screw (F2).  
The leaf spring (A) attached to the P.U. will be reused when replacing the pickup. It is not supplied with the optical pickup.
- Using tweezers or the like, pull the PU shaft from the base a little. Pull only enough to allow the pickup to come off. If it is pulled off completely, the oil on the shaft will be scraped off.

**Be sure to keep oil on the shaft!**

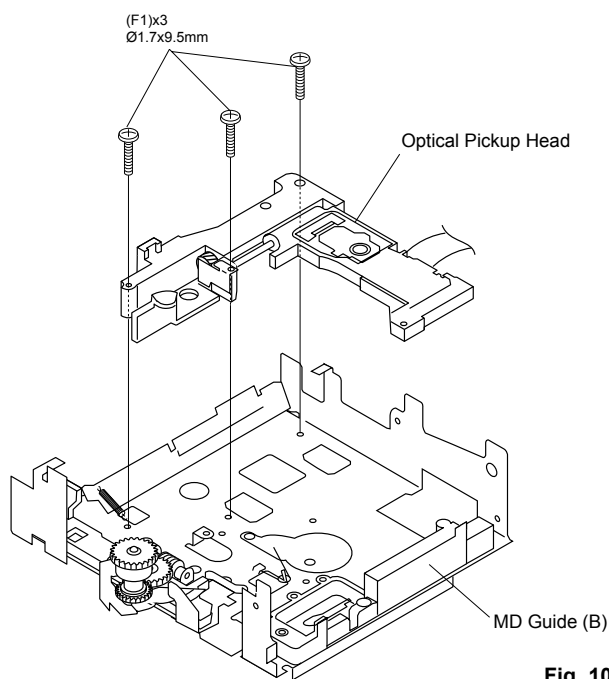

Fig. 10

### Assembly of Optical Pickup

- When installing the pickup to the MD guide (A), be sure to tighten the leaf spring (A) with it.
- When installing the pickup to the MD mechanism, fit the pickup into the MD guide (B) first, match the boss of the MD guide (A) and its hole in the chassis and tighten them with a screw.

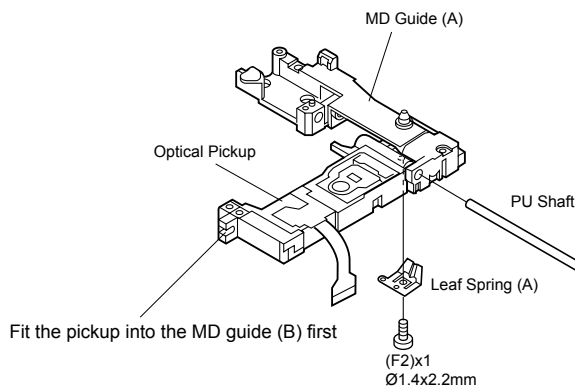

Fig. 11

## ■ ADJUSTMENT & TEST MODE

### Preparation before Adjustment

#### ● Test disc

Type	Test disc
High reflecting disc	TDYS1 (SONY) [for reproduction] (P/No. TX945850)
Low reflecting disc	Commercially available mini disc for recording
Low reflecting disc	MMD-318 [for pre-adjustment] (P/No. AAX04890)

#### ● Extension cable (see connection diagram on page 14.)

Type	Part No.
1. Extension P.C.B. for servicing	TX946230
2. 2-pin extension connector for servicing	TX946200
3. 6-pin extension connector for servicing	TX946210
4. 5-pin flat cable for servicing	TX946190
5. 28-pin flat cable for servicing	TX946220

## TEST MODE

### 1. How to set to the test mode

- 1) Press the POWER button while pressing the SET/ENTER button and the PLAY/PAUSE button.

Version of microprocessor on display (about 1 second)

```
t s m 1 3 * * e * *
```

Version of EEPROM protect data (from 01)

Version of microprocessor ROM (from 01)

“EJECT” on display

- 2) Load either a disc for reproduction or a disc for recording.

“AUT VOBI” on display

This completes setting to the test mode.

### 2. How to set to each mode

Every time the DISPLAY button is pressed, the mode changes. (For operation of each mode, refer to the section describing each mode.)

->AUTO pre-adjustment -> AUTO adjustment -> RESULT preparation -> RESULT -> MANUAL pre-adjustment -> MANUAL adjustment -> EEPROM setting

**Caution)** The AUTO pre-adjustment and AUTO adjustment modes are used for adjustment during servicing. Other modes are used when checking the specific measured values and adjusted values or when changing the set value and the adjusted value. Note that use of other modes will rewrite RAM and EEPROM.

### 3. How to cancel test mode

- 1) Finish the AUTO pre-adjustment and AUTO adjustment. (“COMPLETE” appears on the display)
- 2) Press the REC button. (“TEST END” appears on the display)
- 3) Eject the disc by pressing the EJECT button.
- 4) Turn off the power.

● When using a new combination of a mechanical pickup and an MD P.C.B. after a repair or for some other reason, make sure to set to the TEST mode and perform AUTO pre-adjustment and AUTO adjustment according to the following procedure.

- 1) Set to the TEST mode and perform AUTO pre-adjustment and AUTO adjustment.
- 2) Cancel the TEST mode by pressing the REC button. (Writing into EEPROM starts from here.)
- 3) Eject the disc by pressing the EJECT button.
- 4) Turn off the power.

## Description of TEST modes

<b>1. AUTO pre-adjustment mode</b> [ _AUT_YOBI _]	Automatic pre-adjustment is performed. (Grating adjustment mode after this adjustment.) Adjusted values are output by using the interface.
<b>2. AUTO adjustment mode</b> [ AUTO_AJST _]	Automatic adjustment is performed. Adjusted values are output by using the interface. Continuous reproduction is performed. (Error rate on display, jump test)
<b>3. RESULT preparation mode</b> [ _RST_YOBI _]	Not used (Do not use this function as it is not for servicing)
<b>4. RESULT mode (main adjustment)</b> [ _RESULT _ _]	Not used (Do not use this function as it is not for servicing)
<b>5. MANUAL pre-adjustment mode</b> [ _MNU_YOBI _]	Not used (Do not use this function as it is not for servicing)
<b>6. MANUAL adjustment mode</b> [ _MNU_AJST _]	Not used (Do not use this function as it is not for servicing)
<b>7. EEPROM setting mode</b> [ EEPROM_SET ]	Various factors of the digital servo function are changed manually. Each servo function is turned on independently. The voltage is measured at the temperature detect terminal and the standard value is set.
<b>8. TEST-PLAY mode</b> [ TEST_PLAY _]	Continuous reproduction from the specified address is performed. C1 error rate is measured and ADIP error rate is measured.
<b>9. TEST-REC mode</b> [ TEST_REC _ _]	Continuous recording from the specified address is performed.
<b>10. INNER mode</b> [ _ _INNER _ _]	The position where the INNER switch is turned ON is measured.
<b>11. EJECT mode</b> [ _ _EJECT _ _]	To TEMP setting (of EEPROM setting) To CONTROL setting (of EEPROM setting) Laser power setting (record/reproduction power) is performed.

## 1. AUTO pre-adjustment mode Low reflecting disc (MMD-318) only

Step	Setting method	Remark	Display
1	Set the Test mode to STOP.	No disc is loaded.	[ EJECT ]
2	Load a disc.	Auto pre-adjustment menu	[ LOADING ] [ _AUT_YOBI _]
3	Press the SET/ENTER button once. Grating adjustment is performed and adjusted values are output. Adjustment is completed.	Auto pre-adjustment is started after sliding to the innermost track. “ *** ” changes in the following order during automatic adjustment. HAo -> RFg -> SAg -> SBg -> PTG -> PCH -> GTG -> GCH -> RCG -> SEG -> RFG -> SAG -> HAO -> HEO -> TCO -> LAO Proceed to Step 4 when adjustment is OK. Proceed to Step 5 when adjustment is NG.	[ *** : _ _ _ _ _ ]  [ _ COMPLETE _ ] [ Can't _ ADJ. ]
4	When adjustment is OK, press the DELETE/CANCEL button.	The display returns to the AUTO pre-adjustment menu.	[ _AUT_YOBI _]
5	When adjustment is NG, press the DELETE/CANCEL button.	There is an abnormality at the adjusted point such as HAO. Refer to “Troubleshooting”. (page 20)	[ Can't _ ADJ. ]

**2. AUTO adjustment mode**

Step	Setting method	Remark	Display
1	Set the TEST mode to STOP.	No disc is loaded.	[ EJECT ]
2	Load a disc. Press the DISPLAY button once.	AUTO pre-adjustment menu AUTO adjustment menu	[ LOADING ] [ _ AUT _ YOBI _ ] [ AUTO _ AJST _ ]
3	Press the SET/ENTER button once. Adjusted values are output. Adjustment is completed.	Automatic pre-adjustment is started after sliding to the innermost track. “ *** ” changes in the following order when a high reflecting disc (disc for reproduction) is used. PEG -> HAG “ *** ” changes in the following order when a low reflecting disc (disc for recording) is used. PEG -> LAG -> GCG -> GEG -> LAG Proceed to Step 4 when adjustment is OK. Proceed to Step 5 when adjustment is NG.	[ *** : _ _ _ _ _ ]  [ _ COMPLETE _ ] [ Can't _ ADJ. ]
4	When adjustment is OK, press the SET/ENTER button.	Continuous reproduction (bit section) (Address + C1 error display) Continuous reproduction (group section) (Address + C1 error display)	[ s XXXX c YYYY ] [ a XXXX c YYYY ]
5	Press the INPUT button. Press the DELETE/CANCEL button.	Continuous reproduction (group section) (Address + ADIP error display) Display returns to the AUTO adjustment menu display.	[ a XXXX a YYYY ] [ AUTO _ AJST _ ]
6	When adjustment is NG, press the DELETE/CANCEL button.	There is an abnormality at the adjusted point such as PEG. Refer to “Troubleshooting”. (page 20)	[ Can't _ ADJ. ]

Note) \*\*\* : Adjustment name, XXXX: Address, YYYY: Measured value

**8. TEST-PLAY mode**

(Use this mode to check that the playback function is provided at the specified address.)

Step	Setting method	Remark	Display
1	Load a disc.	AUTO pre-adjustment menu	[ _ AUT _ YOBI _ ]
2	Press the TITLE button.	TEST-PLAY menu	[ TEST _ PLAY _ ]
3	Press the INPUT button. Press the SET/ENTER button.	ADDRESS setting (The initial value of the target address is displayed.) Set the search output to “H” while searching and back to “L” when continuous reproduction is started.	[ ADRES _ 0050 ]
4	Continuous reproduction (bit section) Continuous reproduction (group section)	(Address + C1 error display) (Address + C1 error display)	[ s XXXX c YYYY ] [ a XXXX c YYYY ]
5	Press the INPUT button. Continuous reproduction (group section)	(Address + ADIP error display)	[ a XXXX a YYYY ]
6	Press the DELETE/CANCEL button.	TEST-PLAY menu	[ TEST _ PLAY _ ]

- Every time the TITLE button is pressed in the address setting mode, the address changes in the order of 0050-> 03C0 -> 0700 -> 08A0 -> 0050 -> —
- Pressing the DISPLAY button in the TEST-PLAY menu changes to the AUTO pre-adjustment menu.

## 9. TEST-REC mode

Use a disc for confirmation of recording function. (It is used to check the REC function at the specified address.)

Step	Setting method	Remark	Display
1	Load a disc.	AUTO pre-adjustment menu	[ _AUT_ VOBI _ ]
2	Press the TITLE button twice.	TEST-REC menu	[ TEST_REC _ ]
3	Press the SET/ENTER button.	ADDRESS setting (The initial value of the address is displayed.)	[ a0050 _ Pw ZZ ]
4	Press the SET/ENTER button.	Set the search output to "H" while searching and back to "L" when continuous reproduction is started. Continuous recording	[ a XXXX _ Pw ZZ ]
5	Press the DELETE/CANCEL button.	TEST-REC menu	[ TEST_REC _ ]

- Every time the TITLE button is pressed in the address setting mode, the address changes in the order of 0050-> 03C0 -> 0700 -> 08A0 -> 0050 -> —
- Pressing the DISPLAY button in the TEST-REC menu changes to the AUTO pre-adjustment menu.

## 10. INNER mode

Step	Setting method	Remark	Display
1	Load a disc.	AUTO pre-adjustment menu	[ _AUT_ VOBI _ ]
2	Press the CHARA. button.	INNER menu	[ _ _ INNER _ _ ]
3	Press the SET/ENTER button.	INNER switch position is measured. (Both SUBQ address and C1 error are displayed.)	[ s XXXX c YYYY ]
4	Press the DELETE/CANCEL button.	INNER menu	[ _ _ INNER _ _ ]

- Pressing the DISPLAY button in the INNER menu changes to the AUTO pre-adjustment menu.

## 11. EJECT mode

Step	Setting method	Remark	Display
1	EJECT status in the TEST mode	EJECT menu (No disc is loaded.)	[ _ _ EJECT _ _ ]
2	Press the INPUT button.	Maximum power output status	[ xPw _ _ _ _ _ ]
3	Press the INPUT button.	Recording power output status	[ rPw _ _ _ _ _ ]
4	Press the INPUT button.	Reproduction power output status	[ pPw _ _ _ _ _ ]
5	Press the TITLE edit button.	To TEMP setting of EEPROM setting (Refer to TEMP setting of EEPROM.)	
6	Press the CHARA. button.	To CONTROL setting of EEPROM setting (Refer to CONTROL setting of EEPROM.)	
7	Press the DELETE/CANCEL button.	EJECT menu	[ _ _ EJECT _ _ ]

### ● Confirmation of pick-up laser power

Recording and reproduction can be checked by using the laser power meter. However it should be used for checking only because there is variation in its measurement.

When the measured value is excessively deviated from the reference value, replace the pick-up.

Reference value (measured at room temperature of 25 °C)

During reproduction (ppw) :  $0.72 \pm 0.1$  mW

During recording :  $5.5 \pm 0.5$  mW

Note : Be very careful when using the laser power meter. The laser beam would cause damage to your eye if exposed to it directly.

● **Lead-in switch position measurement mode**

Load a TDYS1 disc for reproduction (high reflecting disc).

Note) Adjust the position of the lead-in switch to FF85 ~ FFD2.

1. Loosen 2 screws (A) fixing the mechanism switch P.C.B.
2. Retighten screws while pushing the mechanism switch P.C.B. in the arrow (-) direction and then measure the position of the lead-in switch again. After adjusting the position, tighten 2 screws (A) securely. (Fig.12)

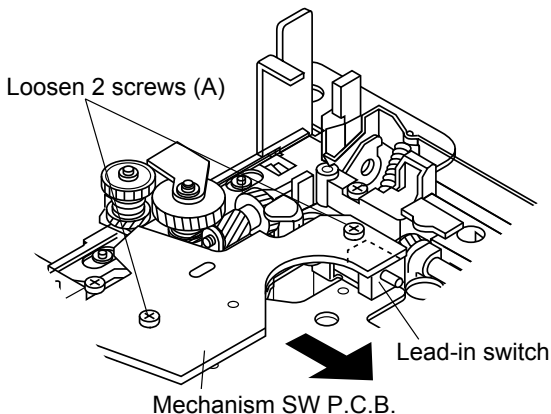

Note) Apply thread lock to 2 screws on the P.C.B. after tightening them.

Fig.12

● **Forced rotation of loading motor**

It is possible to force the loading motor to rotate by turning the jog dial when the microprocessor version (t.sm13\*\*\*e\*\*\*) of the test mode or EJECT appears on display. (This is used when the disc cannot be ejected.)

\* To obtain the microprocessor version on display When a disc is loaded, “ \_AUT \_YDBI \_ ” appears on display. Press the DELETE/CANCEL key in this state, and the microprocessor version will appear.

● **Confirmation of magnetic head installation position**

- After replacing the magnetic head and the optical pick-up, be sure to confirm their installation positions.
  - To facilitate adjustment of their installation positions, bring the optical pick-up to the center position and follow the procedure described below.
1. Push down the up-shift arm of the magnetic head with a finger to raise the magnetic head.
  2. Looking at the unit from above, check if the magnetic head matches with the optical pick-up objective lens.
  3. Check to ensure that the magnetic head moves up and down smoothly.

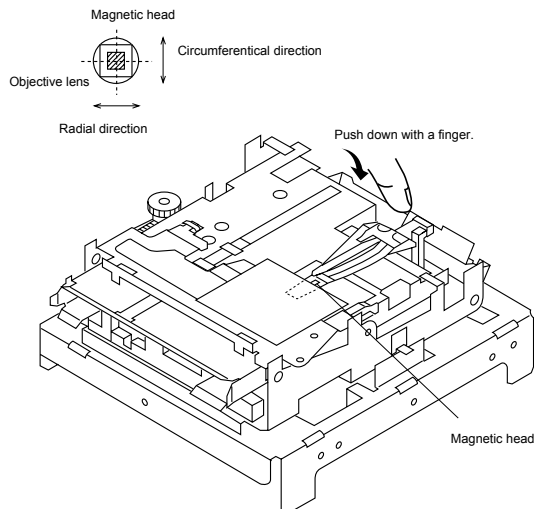

## MECHANISM ADJUSTMENT

When making adjustment, be sure to connect an extension cable for servicing and an expansion P.C.B. as shown in Fig. 16.

### 1. Optical pickup rating inspection method

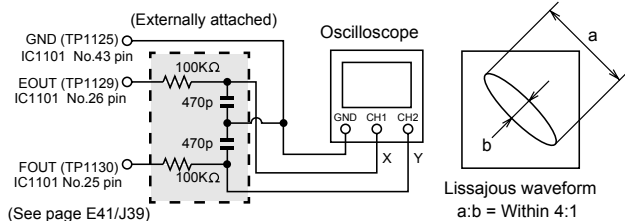
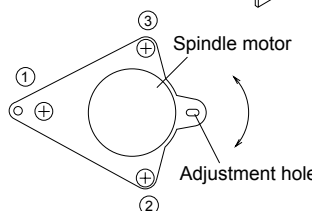
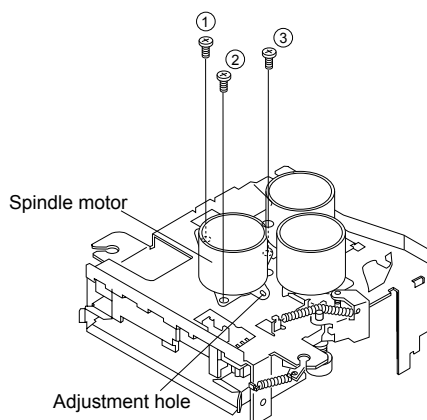

Fig. 13

After performing automatic adjustment in the AUTO mode selected from the test mode by using a high reflecting MD disc (COMPLETE status on display), adjust the EOUT to FOUT Lissajous waveform (x-y).

1. Loosen 3 screws of the spindle motor a little and make adjustment while watching the Lissajous waveform.
2. After adjustment, tighten screws in the order of (①), (②) and (③).



Check the Lissajous waveform while adjusting the installation position by using a screwdriver in the adjustment hole in the spindle motor.

Fig. 14

### 2. Jitter verification method

After performing automatic adjustment in the AUTO mode selected from the test mode by using a low reflecting MD disc, confirm the jitter in the pit continuous reproduction mode and the groove continuous reproduction mode.

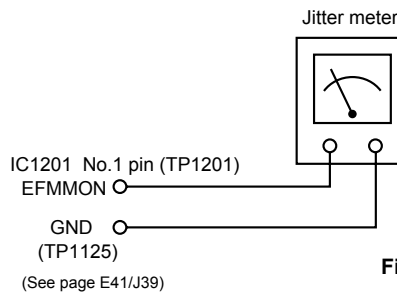

Fig. 15

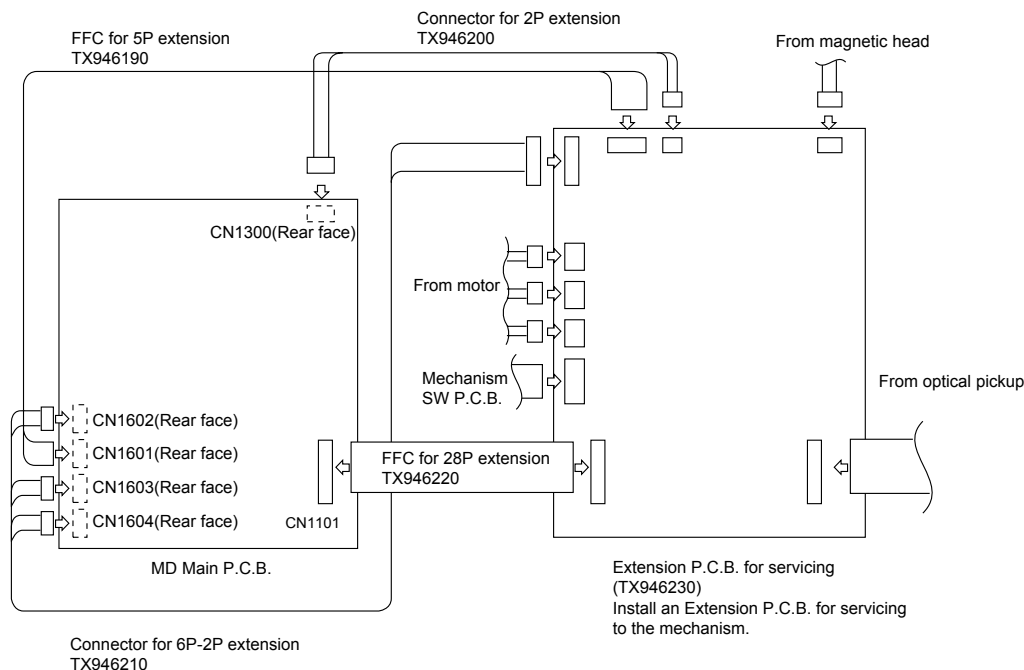

Fig. 16





● Slide setting

Item on display	Set value
SLG	3B H
SL2	18 H
SLDLIM	7F H
SLDLEV	12 H
SLKLVk	50 H
SLKLVt	3A H
SLKLVm	50 H

● Control setting

Item on display	Set value
CONTROL1	80 H
CONTROL2	02 H
SPKLEV <sub>m</sub>	26 H
ADJTTM	14 H
HDEQAD	92 H
LDEQAD	8F H
GDEQAD	8D H
HDEQBC	8C H
LDEQBC	8F H
GDEQBC	8D H
HALSG	21 H
LALSG	21 H
GALSG	11 H
HALSOFS	FF H
LALSOFS	00 H
GALSOFS	00 H

● Adjust setting

Item on display	Set value
COK	A0 H
FAT	C0 H
TAT	3E H
CAT	20 H
FAB	64 H
STR	0A H
SFS	0D H
STC	0D H

EE-PROM SETTING MODE TRANSITION DIAGRAM

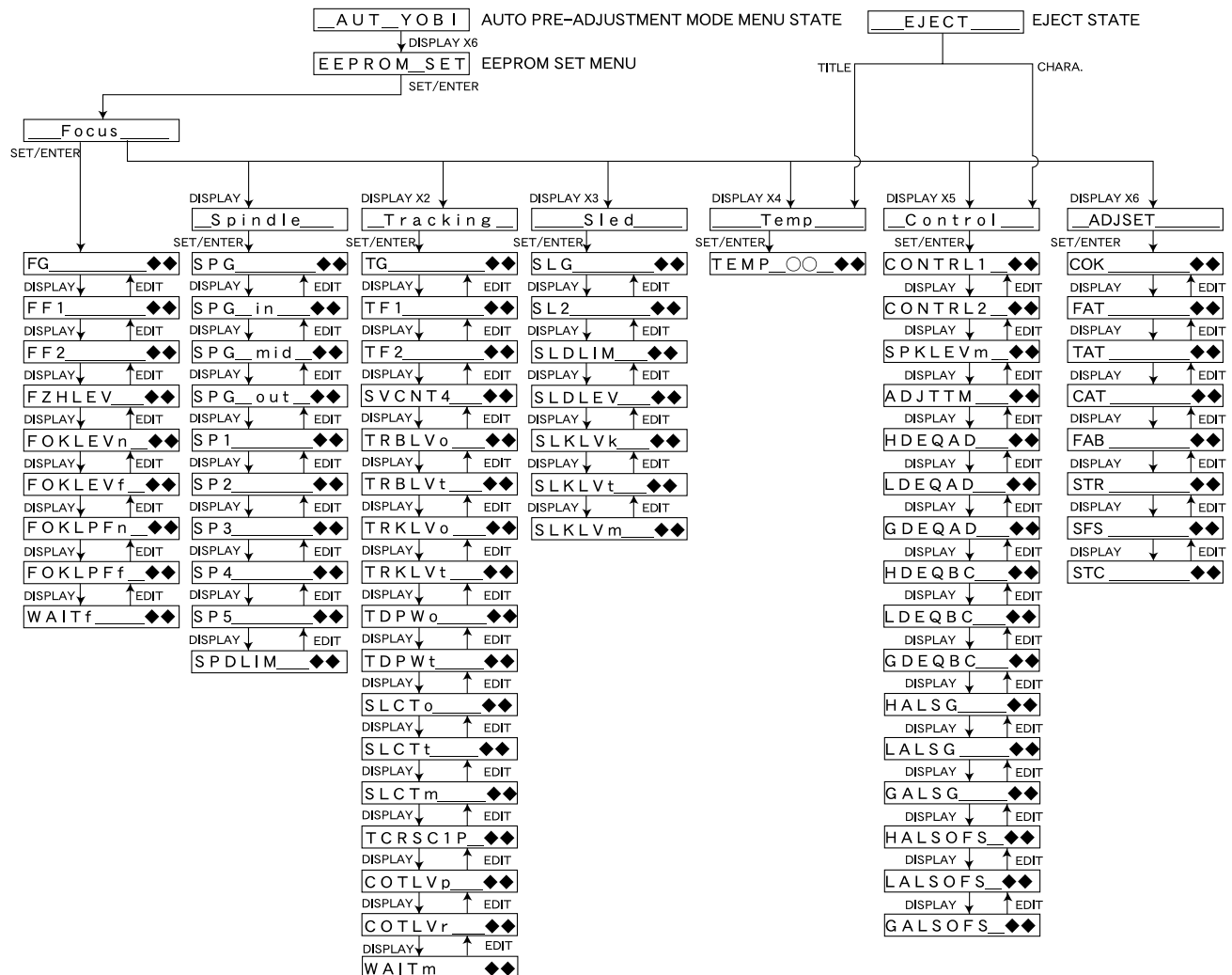

Note) To return to the SUB MENU or MAIN MENU display of the test mode, press the DELETE/CANCEL button.

## ■ SPECIAL TEST MODE

### ● How to set to the special test mode

Press the POWER button while pressing the SET/ENTER button and the STOP button. Then all the indicators will light up.

### ● Operation procedure

Every time the SET/ENTER button is pressed, lighting of indicators and items on the display change as follows.

- 1) All indicators light up.
- 2) All indicators turn off.
- 3) Segments not sharing the border light up.
- 4) Above segments turn off and other segments light up.
- 5) The date when the software was entered appears on the display.
- 6) The version of the micro processor appears on the display. [ CPU Ver:TP01 ]
- 7) The time of auto-marking appears on the display. [ AM Time :C8h ]
- 8) The analog level of auto-marking appears on the display. [ AM Lv1\_A:24h ]
- 9) The digital level of auto-marking appears on the display. [ AM Lv1\_D:1Ah ]
- 10) Write/read check for EEPROM appears on the display. [ EE W/R Check ]

When the INPUT button is pressed at this point, whether the micro processor executed data write/read function into EEPROM or not is checked.

If [OK] appears on the display and the pin 6 of IC6 is at "H", the check result is satisfactory.

[NG] is displayed when there is an error while writing or reading the data.

In such a case, check EEPROM (IC7).

### ● How to cancel the special mode

Press the STOP button, and the mode will change from the special test mode to the product mode and the data in RAM will be cleared.

Note : Turning off the power will cancel the special test mode but will not clear the data in RAM.

Data to write in EEPROM (IC7)	Initial settings
INPUT mode	ANALOG
REPEAT mode	OFF
RANDOM mode	OFF
PROGRAM mode	OFF
REC mode (STEREO/MONO)	STEREO
AUTO MARK/MANUAL	AUTO ("MANUAL" does not light up.)
DISPLAY mode	DISC TITLE

## ■ ERROR DISPLAY

Error on display	Description	Countermeasure
Can't REC	<ul style="list-style-type: none"> <li>• DEFECT occurred 10 times continuously during REC-PLAY.</li> <li>• Recordable cluster became "0" due to occurrence of DEFECT during REC-PLAY.</li> <li>• REC mode cannot be set for 20 seconds even after repeated try of reading the read disabled address.</li> </ul>	<ul style="list-style-type: none"> <li>• Check that the disc is free from scratch, dust, finger print, black spot, etc. and that decentering, face deflection, etc. are not excessive.</li> </ul>
Can't Copy	<ul style="list-style-type: none"> <li>• One of the following judgments has been made depending on the channel status of the digital signal inputted from D-IN during REC-PAUSE or REC-PLAY.</li> <li>(1) Other than audio</li> <li>(2) Other than civil purpose</li> <li>(3) Copy NG due to reversed COPY bit of CD</li> </ul>	<ul style="list-style-type: none"> <li>• Check if the CD is a copy inhibited on (e.g., CD-R, etc.)</li> </ul>
DIGin Unlock	<ul style="list-style-type: none"> <li>• Either of the following symptoms occurred for the digital signal inputted from D-IN during REC-PAUSE or REC-PLAY.</li> <li>(1) Digital IN PLL is unlocked.</li> <li>(2) Locked under conditions other than FS=44.1kHz.</li> </ul>	<ul style="list-style-type: none"> <li>• Check that the D-IN signal line is free from abnormality.</li> </ul>
TOC Full	<ul style="list-style-type: none"> <li>• No space is left to register music No and character data (song name, disc name, etc.) while the REC-PLAY function is used.</li> <li>• No recordable space is left when trying to activate the REC-PAUSE function.</li> </ul>	<ul style="list-style-type: none"> <li>• Use a disc for recording and reproduction with a space left to register UTOC.</li> </ul>
UTOC ERR R	<ul style="list-style-type: none"> <li>• "FTNO &gt; LTNO" occurred.</li> <li>• "FTNO = 0 or 1" occurred.</li> <li>• UTOC recorded in the disc could not be read.</li> </ul>	<ul style="list-style-type: none"> <li>• As an abnormality exists in the UTOC data, use another disc.</li> </ul>
UTOC ERR A	<ul style="list-style-type: none"> <li>• "Start address &gt; end address" occurred.</li> </ul>	
UTOC ERR L0 ~ 4	<ul style="list-style-type: none"> <li>• Any one of the UTOC0 ~ 4 data was looped.</li> </ul>	
Not Audio	<ul style="list-style-type: none"> <li>• Data not for audio purpose is recorded in the track mode of TNO which is currently selected.</li> </ul>	<ul style="list-style-type: none"> <li>• Select another TNO or use another disc.</li> </ul>
Disc Full	<ul style="list-style-type: none"> <li>• No recordable space is left when trying to activate the REC-PAUSE function.</li> </ul>	<ul style="list-style-type: none"> <li>• Use another disc for recording with a recordable space left.</li> </ul>
Playback MD	<ul style="list-style-type: none"> <li>• The loaded disc was for reproduction only when trying to activate the REC-PAUSE function or trying to edit.</li> </ul>	<ul style="list-style-type: none"> <li>• As the loaded disc is for reproduction only, use a disc for recording.</li> </ul>
Protected	<ul style="list-style-type: none"> <li>• Recording of editing was attempted while the data protector of the disc for recording and reproduction is set to the data protected state.</li> <li>• Editing the track subject to write protect function was attempted by using the data written in UTOC.</li> </ul>	<ul style="list-style-type: none"> <li>• Try again with the data protector set to the original position.</li> <li>• As the track to be edited is write protected, try again with another track.</li> </ul>

Error on display	Description	Countermeasure
Can' t Edit	<ul style="list-style-type: none"> <li>Editing conditions were not satisfied with respect to each editing function.</li> </ul>	<ul style="list-style-type: none"> <li>Wrong operation procedure was used. Try again by using the correct procedure.</li> </ul>
TMP Over!!	<ul style="list-style-type: none"> <li>The temperature in the set (MD unit) went up excessively high due to occurrence of some abnormality.</li> </ul>	<ul style="list-style-type: none"> <li>Check according to troubleshooting.</li> <li>Check the temperature of the area where the unit is used.</li> </ul>
DISC ERR R DISC ERR S DISC ERR W	<ul style="list-style-type: none"> <li>The data was not correct or it was not possible to read it correctly.</li> <li>Recording the music data failed as an abnormality occurred while recording it.</li> </ul>	<ul style="list-style-type: none"> <li>Use another disc as there is an abnormality in TOC or UTOC data or the disc has a scratch or other faulty condition.</li> </ul>
TOC ERR S TOC ERR R	<ul style="list-style-type: none"> <li>The TOC data was not correct.</li> <li>It was not possible to read the TOC data.</li> </ul>	<ul style="list-style-type: none"> <li>The TOC data recorded in the disc is not in compliance with the MD standard.</li> <li>Use another disc as the disc has a scratch or other faulty condition.</li> </ul>
U TOC W ERR	<ul style="list-style-type: none"> <li>It was not possible to rewrite UTOC correctly and an abnormality occurred while rewriting it.</li> </ul>	<ul style="list-style-type: none"> <li>Use another disc as the disc has a scratch or other faulty condition.</li> </ul>
FOCUS ERR	<ul style="list-style-type: none"> <li>The disc was loaded but it was not possible to draw in FOCUS.</li> </ul>	<ul style="list-style-type: none"> <li>Check that the disc is free from scratch, dust, finger print, black spot, etc. and that decentering, face deflection, etc. are not excessive.</li> </ul>
BLANK DISC	<ul style="list-style-type: none"> <li>The total number of TNO and NAME characters was "0" as a result of reading UTOC.</li> </ul>	<ul style="list-style-type: none"> <li>Check if the disc is recordable by actually recording.</li> </ul>
TOC W ERROR	<ul style="list-style-type: none"> <li>UTOC can be read but cannot be rewritten.</li> </ul>	<ul style="list-style-type: none"> <li>Check if the recording head contacts properly and if wiring from the circuit board to the recording head is free from breakage.</li> </ul>
EEPROM ERROR	<ul style="list-style-type: none"> <li>The EEPROM data is not correct</li> </ul>	<ul style="list-style-type: none"> <li>Try again after resetting and if still NG, replace EEPROM.</li> </ul>

### Mechanism Error

Error on display	Description
MECHA_ERR2_*	The head fails to move up.
MECHA_ERR3_*	The head fails to move down.

HINF (IC1401 No.97 pin)

* = E Eject completed position	< 1.3 V
* = M Horizontal midway position	> 3.06 V
* = L Load completed position	1.853 ~ 2.48 V
* = D Head down position	1.3 ~ 1.853 V

## ■ TROUBLESHOOTING

### When MD fails to operate

When the objective lens of the optical pickup becomes dirty, MD may fail to operate. Clean the objective lens first and check MD for reproduction function. If it still fails to operate, check according to the following flow charts. Contaminant on the pickup lens such as dust and a foreign matter may cause the pickup to skip or the TOC (content of the selection) not to be displayed. Check if the lens is clean before making adjustments. If the lens is dirty, clean it as follows.

- Turn off the power. Dampen the lens cleaning paper with a small amount of isopropyl alcohol and wipe the lens with it, using care not to cause any damage to the lens. Be sure not to touch the lens with your hand directly.

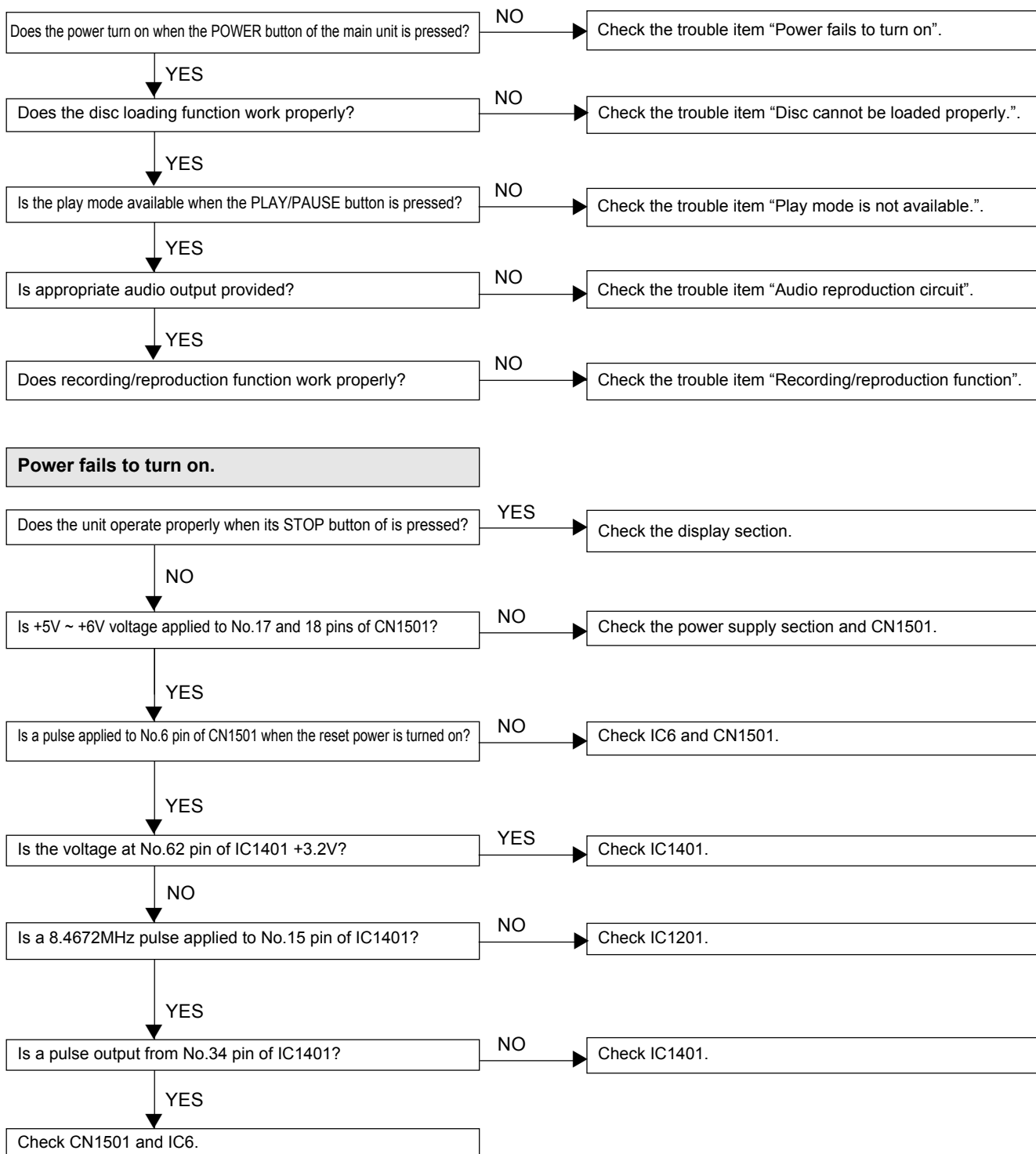

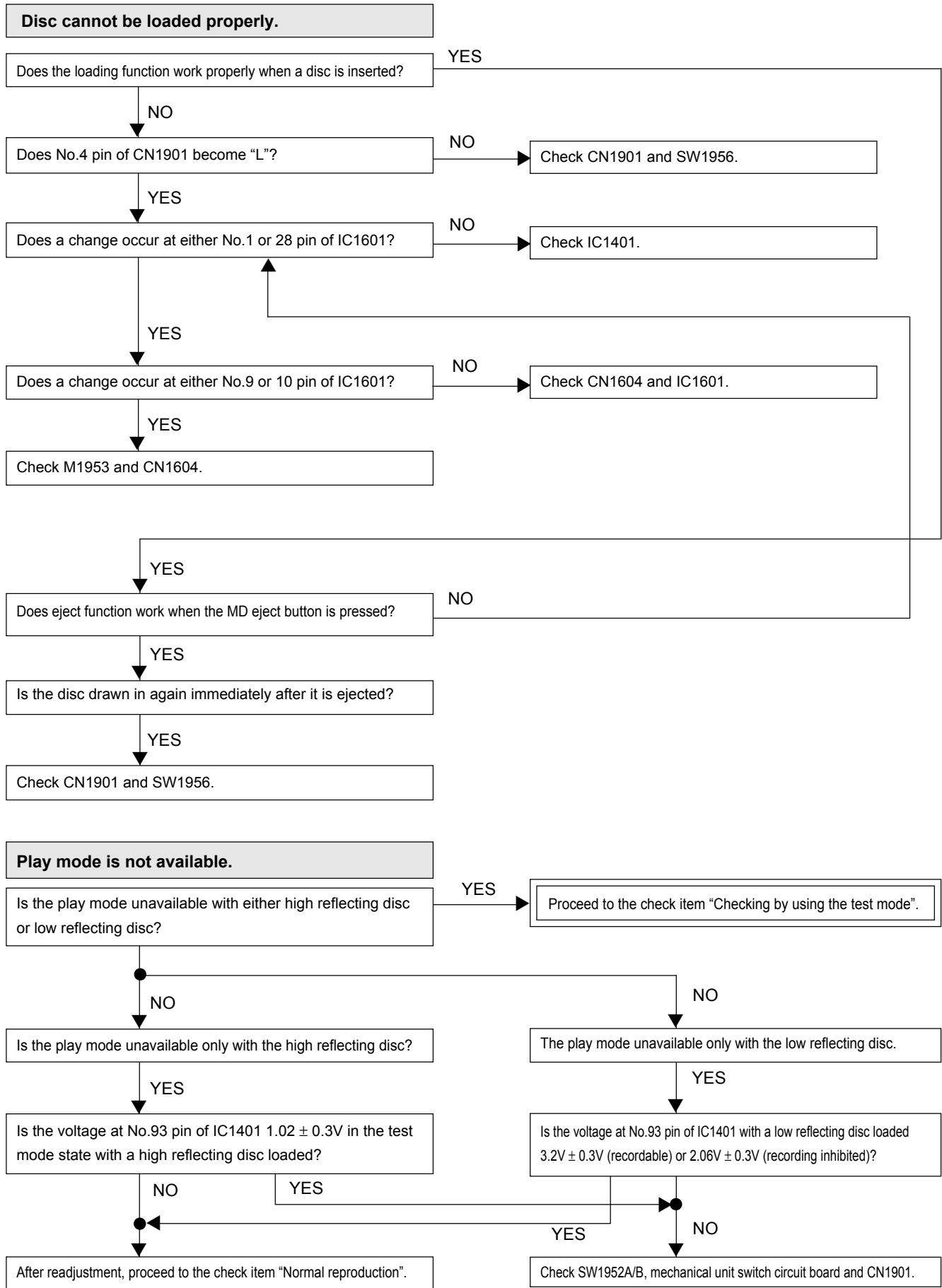

**Normal reproduction**

Applicable when the E2-PROM value has been confirmed as normal in the test mode

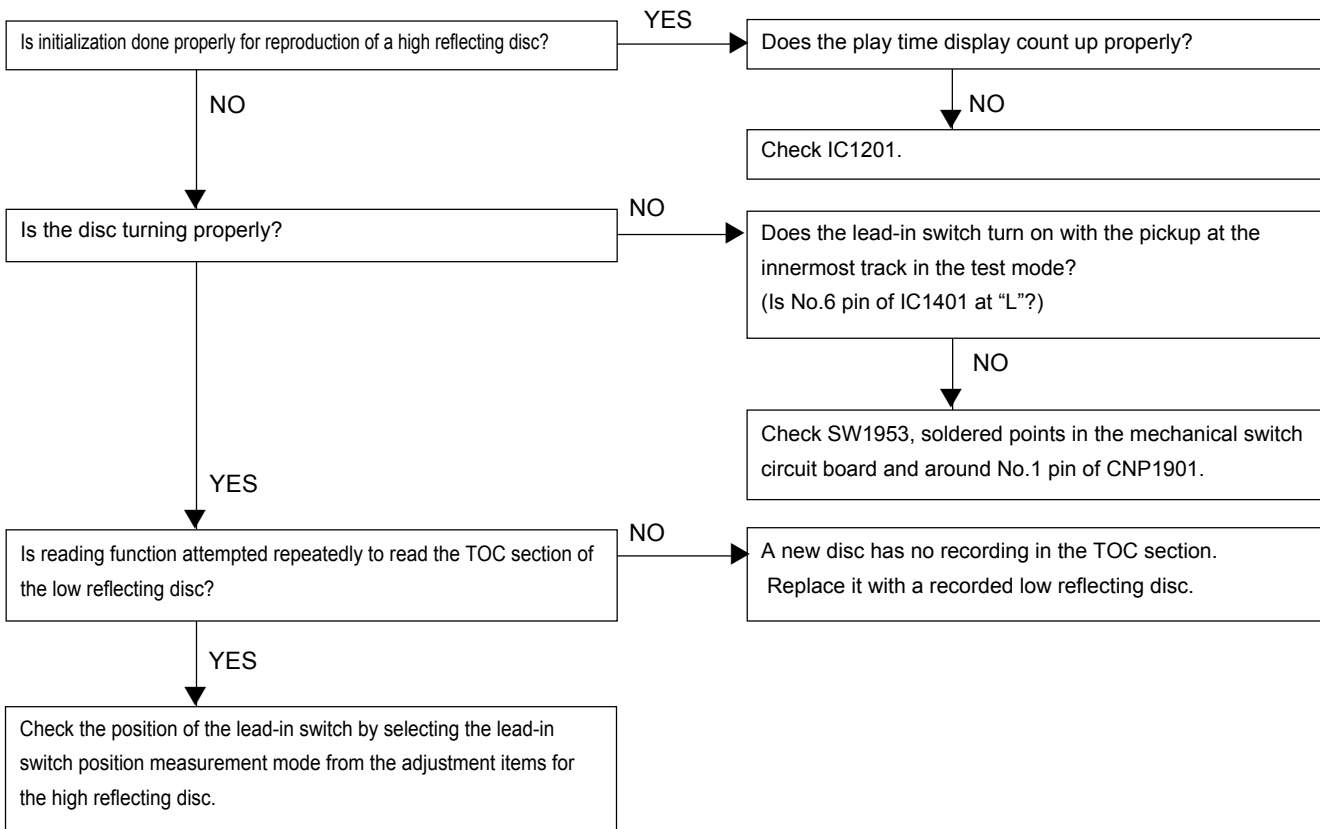

**Audio reproduction circuit**

Applicable when no sound is produced although the play time display counts up properly during reproduction in the normal mode

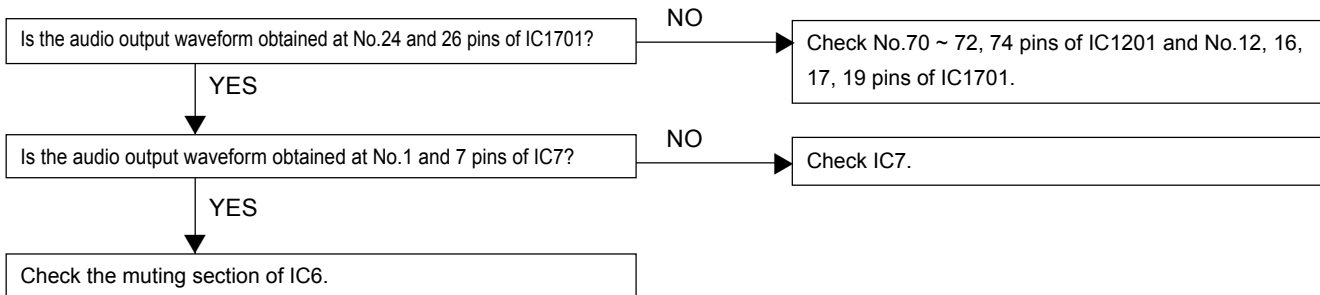

**Recording/reproduction function**

Load a low reflection disc and after confirming the audio output in the normal reproduction mode, execute recording/reproduction.

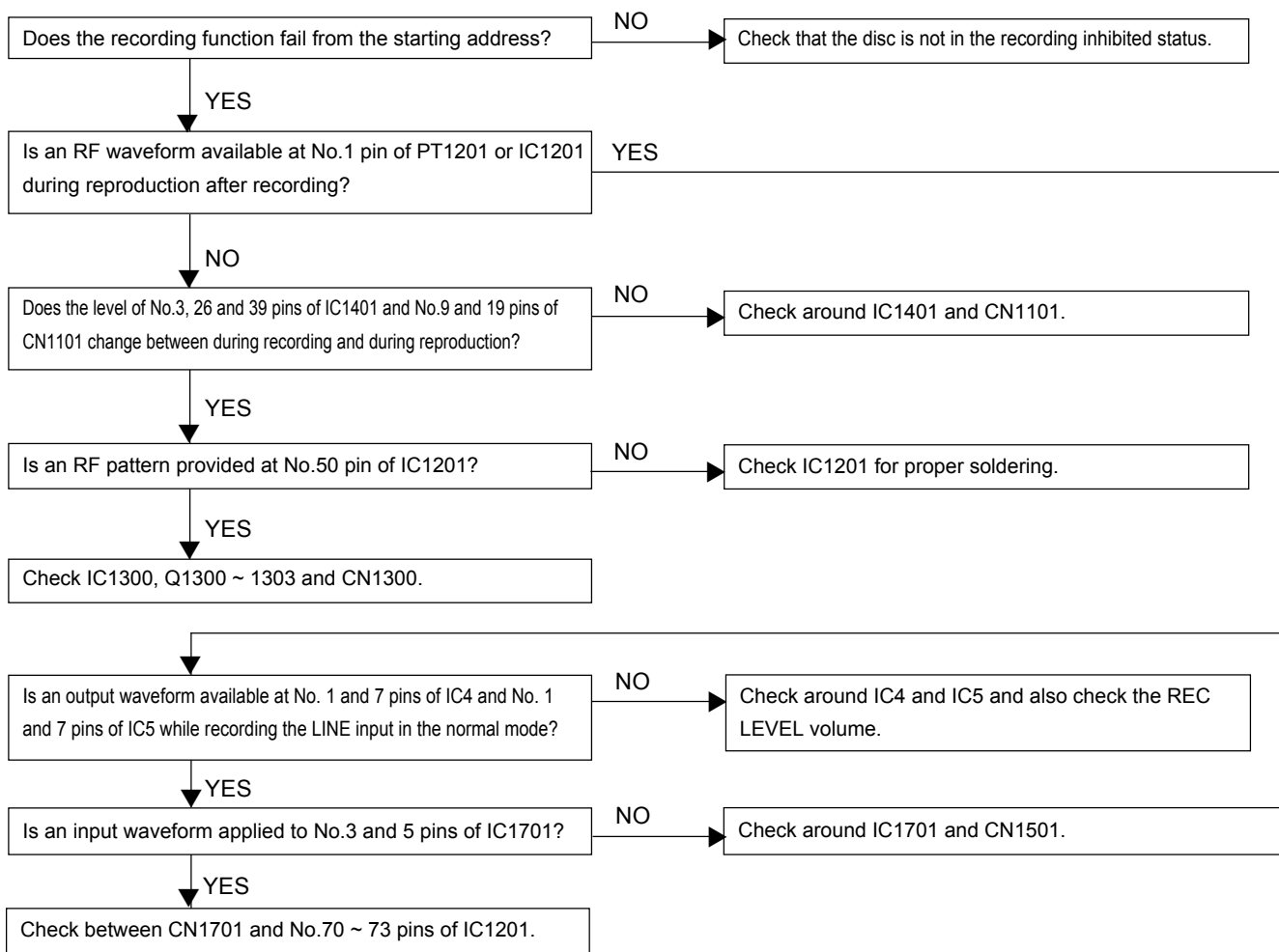

**Focus servo function does not work.**

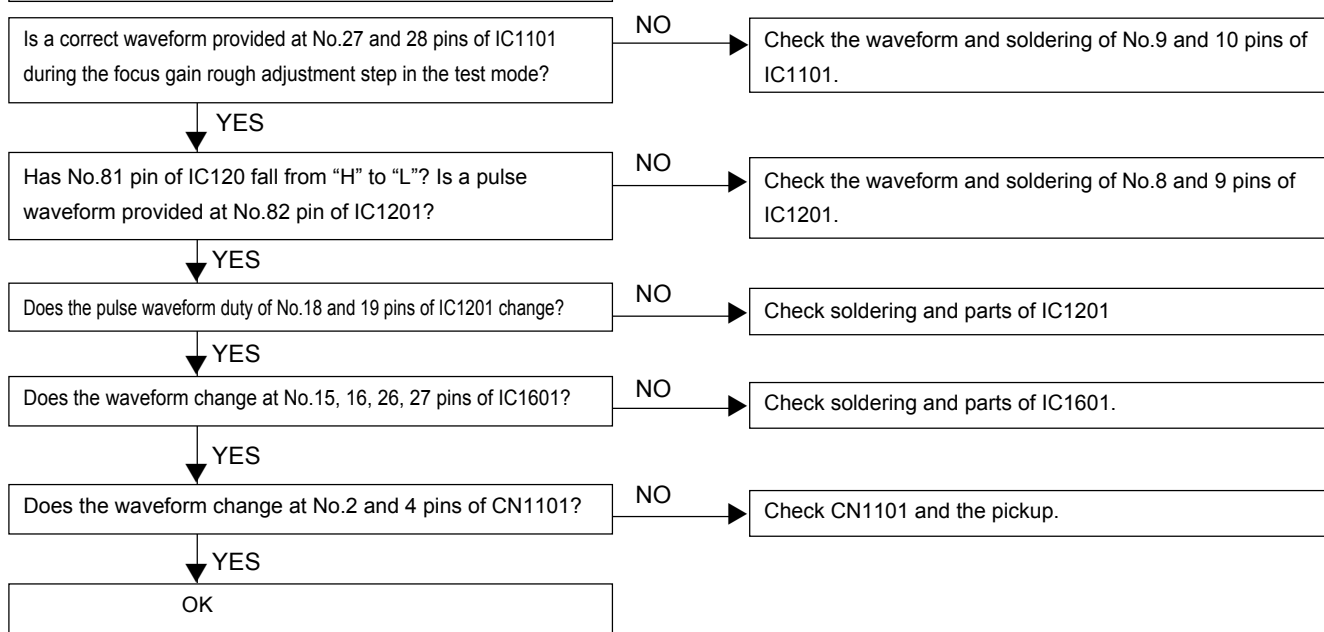



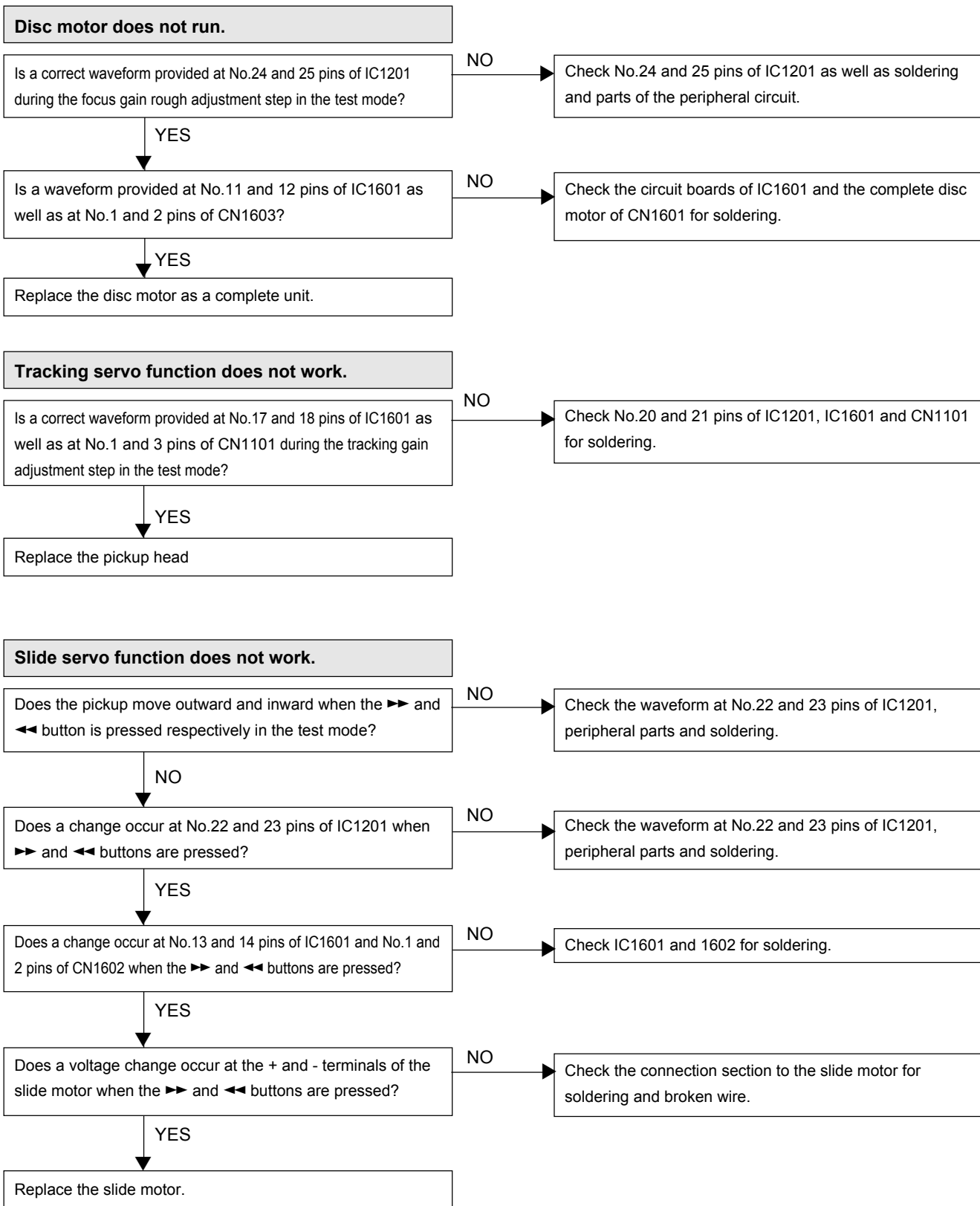

■ IC DATA

IC1101 : IR3R55  
RF Signal Processing

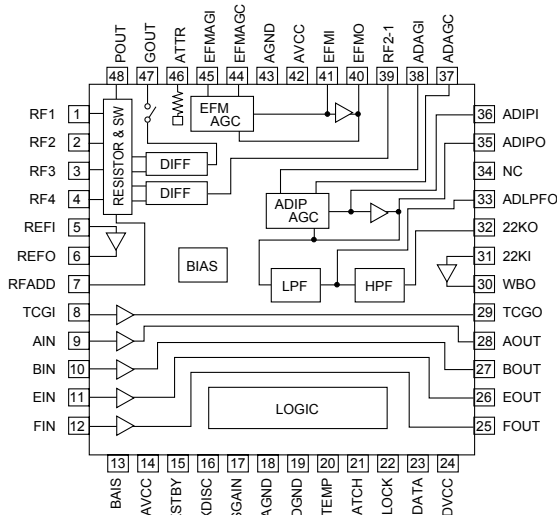

No.	Pin Name	Function
1	RF1	RF signal input terminal 1 to input RF signal output from pickup
2	RF2	RF signal input terminal 2 to input RF signal output from pickup
3	RF3	RF signal input terminal 3 to input RF signal output from pickup
4	RF4	RF signal input terminal 4 to input RF signal output from pickup
5	REFI	Amplifier input terminal for reference voltage
6	REFO	Amplifier output terminal for reference voltage
7	RFADD	Output terminal for added resistance of RF1 ~ 4
8	TCGI	Amplifier input terminal for track cross detect signal when in groove section
9	AIN	Amplifier (focus servo system) reverse input terminal for servo signal
10	BIN	Amplifier (focus servo system) reverse input terminal for servo signal
11	EIN	Amplifier (tracking servo system) reverse input terminal for servo signal
12	FIN	Amplifier (tracking servo system) reverse input terminal for servo signal
13	BIAS	Bias input terminal
14	AVCC	Power supply terminal for analog section
15*	VSTBY	Output terminal for logic signal (Inverse STBY signal is output.)
16*	XDISC	Output terminal for logic signal (Inverse DISC signal is output.)
17*	XSGAIN	Output terminal for logic signal (Inverse SGAIN signal is output.)
18	AGND	Ground terminal for analog section
19	DGND	Ground terminal for digital section
20	DTEMP	Chip temperature detect terminal
21	LATCH	Input terminal for latch signal
22	CLOCK	Input terminal for clock signal
23	DATA	Input terminal for serial data
24	DVCC	Power supply terminal for digital section
25	FOUT	Amplifier (tracking servo system) output terminal for servo signal
26	EOUT	Amplifier (tracking servo system) output terminal for servo signal
27	BOUT	Amplifier (focus servo system) output terminal for servo signal
28	AOUT	Amplifier (focus servo system) output terminal for servo signal
29	TCGO	Amplifier output terminal for track cross detect signal when in groove section
30	WBO	Comparator output terminal to make ADIP signal into binary value
31	22KI	Comparator input terminal to make ADIP signal into binary value
32	22KO	HPF amplifier output terminal for ADIP signal
33*	ADLPFO	LPF amplifier output terminal for ADIP signal
34*	NC	NC
35	ADIPO	Pre-amplifier output terminal for ADIP signal
36	ADIPi	AGC amplifier output terminal for ADIP signal
37	ADAGC	AGC smooth capacitor connecting terminal for ADIP signal
38	ADAGI	AGC amplifier input terminal for ADIP signal
39	RF2-1	RF1, RF2 differential signal
40	EFMO	Pre-amplifier output terminal for RF signal
41*	EFMI	AGC amplifier output terminal for RF signal
42	AVCC	Power supply terminal for analog section
43	AGND	Ground terminal for analog section
44	EFMAGC	AGC smooth capacitor connecting terminal for EFM signal
45	EFMAGI	AGC amplifier input terminal for EFM signal
46*	ATTR	Terminal to attenuate 47, 48 pin output signal
47	GOUT	Output terminal for RF1+RF2-RF3-RF4 signal when in groove section
48	POUT	Output terminal for added resistance of RF1 ~ 4 when in pit section

The \* marked terminal is a terminal which is not connected externally (open terminal).

IC1201 : LR376484

ATRAC Encoder/Decoder

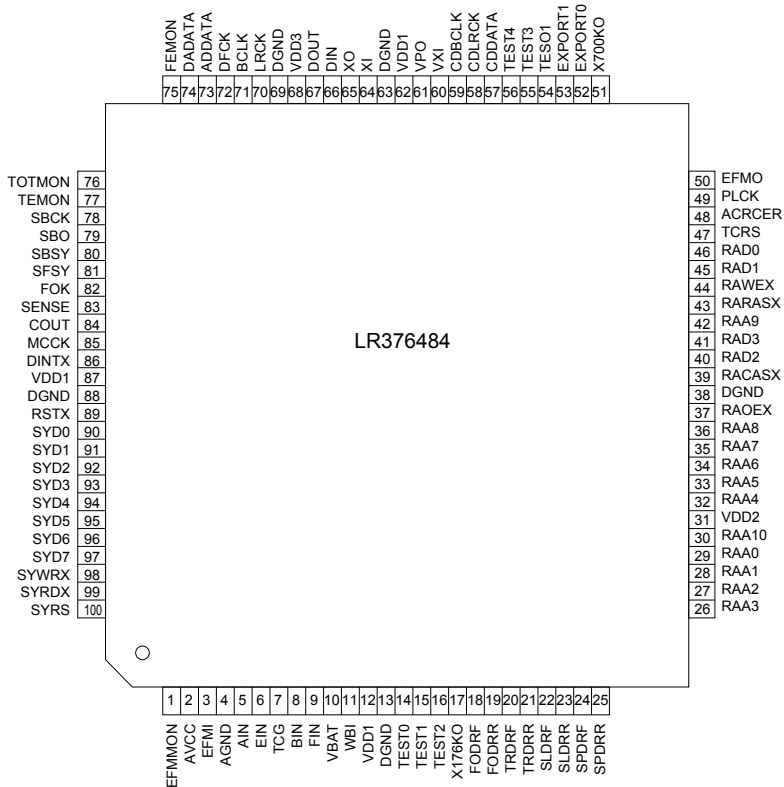

No.	Pin Name	I/O	Function
1*	EFMMON	O	EFM monitor output
2	AVCC		Power supply terminal for analog section
3	EFMI	I	Input terminal for EFM signal from RF amplifier
4	AGND		Ground terminal for analog section
5	AIN	I	Focus error signal A
6	EIN	I	Tracking error signal E
7	TCG	I	Tracking cross signal
8	BIN	I	Focus error signal B
9	FIN	I	Tracking error signal F
10	VBAT	I	Power supply voltage detect signal for constant voltage servo
11	WBI	I	ADIP wobble signal
12	VDD1		Power supply terminal for digital section
13	DGND		Digital ground terminal
14,15	TEST0,TEST1	I	Test input terminal, connected to GND when in normal use
16	TEST2	I	Test input terminal, to select encode/decode/servo mode or ATRAC mode. Connected to GND in normal use
17	X176KO	O	Clock output. f=176.4KHz (4fs)
18	FODRF	O	Focus servo forward output. PWM
19	FODRR	O	Focus servo reverse output. PWM
20	TRDRF	O	Tracking servo forward output. PWM
21	TRDRR	O	Tracking servo reverse output. PWM
22	SLDRF	O	Slide servo forward output. PWM
23	SLDRR	O	Slide servo reverse output. PWM
24	SPDRF	O	Spindle servo forward output or spindle serve output. PWM
25	SPDRR	O	Spindle servo reverse output or switching of spindle rotation forward/reverse
26	RAA3	O	Address output to external D-RAM. ADR3
27	RAA2	O	Address output to external D-RAM. ADR2
28	RAA1	O	Address output to external D-RAM. ADR1
29	RAA0	O	Address output to external D-RAM. ADR0 (LSB)
30*	RAA10	O	Address output to external D-RAM. ADR10 (MSB)
31	VDD2		Power supply terminal for DRAM interface
32	RAA4	O	Address output to external D-RAM. ADR4
33	RAA5	O	Address output to external D-RAM. ADR5
34	RAA6	O	Address output to external D-RAM. ADR6

The \* marked terminal is a terminal which is not connected externally (open terminal).

## IC1201 : LR376484

## ATRAC Encoder/Decoder

No.	Pin Name	I/O	Function
35	RAA7	O	Address output to external D-RAM. ADR7
36	RAA8	O	Address output to external D-RAM. ADR8
37	RAOEX	O	Data output enable signal output to external D-RAM
38	DGND		Ground terminal for digital section
39	RACASX	O	Column address strobe signal output to external D-RAM
40	RAD2	I/O	Data input/output with external D-RAM. D2
41	RAD3	I/O	Data input/output with external D-RAM. D3 (MSB)
42	RAA9	O	Address output to external D-RAM. ADR9
43	RARASX	O	Low address strobe signal output to external D-RAM
44	RAWEX	O	Data write enable signal output to external D-RAM
45	RAD1	I/O	Data input/output with external D-RAM. D1
46	RAD0	I/O	Data input/output with external D-RAM. D0 (LSB)
47*	TCRS	O	Track cross signal
48*	ACRCER	O	CRC error flag monitor output of ADIP
49*	PLCK	O	EFM PLL clock output during reproduction
50	EFM0	O	EFM signal output during recording and C1F (C1 error flag) monitor output during reproduction
51*	X700KO	O	Clock output. f=705.6KHz. No clock output when RSTX=0.
52*	EXPORT0	O	Microprocessor expansion output port 0
53*	EXPORT1	O	Microprocessor expansion output port 1
54*	TESO1	O	Microprocessor expansion output port 2 when switching PLLLR.
55	TEST3	I/O	Microprocessor expansion output port 3 when switching PLLOSC.
56	TEST4	I/O	Microprocessor expansion output port 4 when switching EXTCLK.
57	CDDATA	I/O	CD data input for high speed dubbing. Microprocessor expansion output port 5 when switching.
58	CDLRCK	I/O	CD LR clock input for high speed dubbing. Microprocessor expansion output port 6 when switching.
59	CDBCLK	I/O	CD bit clock input for high speed dubbing. Microprocessor expansion output port 7 when switching.
60	VXI	I	PLL clock input for variable pitch.
61*	VPO	O	PLL phase error output for variable pitch.
62	VDD1		Power supply terminal for digital section
63	DGND		Ground terminal for digital section
64	XI	I	Oscillation circuit input. 33.8688MHz
65	XO	O	Oscillation circuit output. 33.8688MHz
66	DIN	I	Digital input signal
67	DOUT	O	Digital output signal
68	VDD3		Power supply terminal for internal PLL
69	DGND		Ground terminal for digital section
70	LRCK	O	Output terminal for switching music data to Lch, Rch
71	BCLK	O	Shift clock for music data
72	DFCK	O	Clock for AD/DA converter digital filter. 256Fs
73	ADDATA	I	Voice data input
74	DADATA	O	Voice data output
75*	FEMON	O	Focus error signal monitor output
76*	TOTMON	O	Total signal monitor output
77*	TEMON	O	Tracking error signal monitor output
78	SBCK	I	DIN sub-code reading clock. EIAJ CP-309 format
79	SBO	O	DIN sub-code serial data. EIAJ CP-309 format.
80	SBSY	O	DIN sub-code block synchronous signal. EIAJ CP-309 format.
81	SFSY	O	DIN sub-code frame synchronous signal. EIAJ CP-309 format.
82	FOK	O	Focus OK detect signal. "0": focus OK
83	SENSE	O	Servo state detect signal. "1": Auto move, auto jump, auto focus being drawn in
84	COUT	O	Track cross signal output
85	MCCK	O	Clock output for microprocessor. Clock output also when RSTX=0
86	DINTX	O	Output terminal used to request interrupt into system control interface.
87	VDD1		Power supply terminal for digital section
88	DGND		Ground terminal for digital section
89	RSTX	I	Chip reset input. Reset at "L" (Note)
90	SYD0	I/O	Data bus terminal of system control interface (LSB)
91 ~ 96	SYD1 ~ SYD6	I/O	Data bus terminal of system control interface.
97	SYD7	I/O	Data bus terminal of system control interface. (MSB)
98	SYWRX	I	Input terminal for register write pulse of system control interface
99	SYRDX	I	Input terminal for register read pulse of system control interface
100	SYRS	I	Input terminal for register selection of system control interface

The \* marked terminal is a terminal which is not connected externally (open terminal).

(Note) Set RSTX to "L" when or after turning on the power supply.

## IC1401 : iX0290AW

## MD System Microprocessor

No.	Pin Name	I/O	Function
1*	NX	O	Input/output port P96
2	SBCK	O	Input/output port P95
3	LDVAR	O	LDVAR (Laser power adjustment output)
4*	ADIS	O	ADJS (for automatic adjustment step check)
5	SFSY	O	Input/output port P92
6	LOADIN	I	LD SW CK input (interrupt input only when used individually)
7	ERROR	I	ERR input (UNLOCK of monitor PLL)
8	BYTE	I	GND
9	CNVss	I	GND
10	STID OUT	O	ST-ID output
11	SEACH OUT	O	MD search output
12	RESET	I	RESET input
13*	NC		Clock output
14	Vss		GND
15	MCCK	I	EXTAL (8.4672MHz)
16	Vcc		+3.15V
17	P85	I	Input/output port P85
18	DINT	I	DINT (interrupt input from MD•LSI)
19	DSENSE	I	DSENSE (servo sense input from MD•LSI)
20	ST-ID	I	ST-ID input (MD-ON)
21	SERCH	I	CD search input (Synchro REC interrupt input)
22	MDRSW	O	MD RSW output
23*	FSW	I	FSW1 (SW for power frequency switching)
24	VARI-PSW	O	Corresponding measure to variable pitch, provided (H)/ not provided (L)
25	P-DOWN	I	P-DOWN (power failure detect)
26	HD ON	O	HDON (Magnetic head current ON/OFF output)
27	LD+	O	LD+ (Loading motor + control output)
28	LD-	O	LD- (Loading motor - control output)
29	CIN	I	CIN (Track count signal input)
30	INNER	I	INN SW (Inner SW detect input)
31	DATA	O	R-DATA
32	LATCH	O	R-LATCH
33	CLOCK	O	R-CLK
34	DSTB	O	DSTB (System control communication possible and communication being executed)
35	MD DATA	O	MD DATA (MD data output)
36	K DATA	I	K DATA (System control data input)
37	DSCK	I	DSCK (System control communication clock input)
38	4M/16M	I	4M/16M DRAM select input
39	R/P	O	R/P output (REC/PLAY switching)
40	FOK	I	FOK (Focus servo state monitor input)
41	PLL SEL	O	Input/output port P55
42	S2	O	S2 output
43	S1	O	S1 output
44	SYRS	O	SYRS (MD-LSI register select signal output)
45	SYRD	O	SYRD (MD-LSI read signal output)
46	SYWR	O	SYWR (MD-LSI write signal output)
47	SYS D7	I/O	SYS D7 (Data bus 7)
48	SYS D6	I/O	SYS D6 (Data bus 6)
49	SYS D5	I/O	SYS D5 (Data bus 5)
50	SYS D4	I/O	SYS D4 (Data bus 4)
51	SYS D3	I/O	SYS D3 (Data bus 3)
52	SYS D2	I/O	SYS D2 (Data bus 2)
53	SYS D1	I/O	SYS D1 (Data bus 1)
54	SYS D0	I/O	SYS D0 (Data bus 0)

The \* marked terminal is a terminal which is not connected externally (open terminal).

## IC1401 : iX0290AW

## MD System Microprocessor

No.	Pin Name	I/O	Function
55*	P37/A15	O	Input/output port P37
56*	P36	O	Input/output port P36
57*	P35	O	Input/output port P35
58	EEPROM	O	EEPROM (E2PROM protect cancel)
59	EPCS	O	EPCS (E2PROM chip selector output)
60	EEPDATA	I/O	EEPDATA (E2PROM serial data output)
61	EEPCLK	O	EEPCLK (E2PROM serial clock output)
62	Vcc	I	+3.15V
63*	P30	O	Input/output port P30
64	GND		GND
65	L3 DATA	O	L3 DATA (soft serial communication, 2 modes provided, LSB first)
66	L3 MODE	O	L3 MODE (soft serial communication, 2 modes provided, LSB first)
67	L3 CLK	O	L3 CLK (soft serial communication, 2 modes provided, LSB first)
68*	P24	O	Input/output port P24
69*	P23	O	Input/output port P23
70	PCNT0	O	PCNT0 output
71*	PCNT1	O	Input/output port
72	LD ON	O	LDON output (H: ON)
73	A/B	O	ANLPTR output
74	SBSY	O	ADPON output (for CK)
75*	DAP ON	O	DAPON output (for CK)
76*	DFS0	O	DFS0 output
77*	DFS1	O	DFS1 output
78	DIG EX	O	DIG EX output (for CK)
79	DIG CD	O	DIG CD OUTPUT (for CK)
80	XRST	O	XRST (system reset output)
81*	AD MUTE	O	ADMUTE output (for CK)
82*	EMPH	O	EMPHA output (for CK)
83*	DAMUT	O	DAMUTE output (for CK)
84	MUTE	O	MUTE output
85	DOUTM	O	DOUTM output (for CK)
86	TEST2	I	TEST2 (special mode select 2)
87	TEST1	I	TEST1 (special mode select 1)
88	TEST0	I	TEST0 (special mode select 0)
89	AVCK3	I	AVCK3 (special mode monitor input)
90	AVCK2	I	AVCK2 (AD/DA section 3.1V monitor input)
91	AVCK1	I	AVCK1 (DOUT section 5V monitor input)
92	DTEMP	I	DTEMP (temperature detect input)
93	MINF	I	MINF (for each disc type/REC input)
94	TEST K1	I	TEST K1 (test key input 1)
95	TEST K2	I	TEST K2 (test key input 2)
96	GND		GND
97	HINF	I	HINF (mechanical unit position/head position)
98	VREF		+3.15V
99	AVcc		+3.15V
100	S80	I	Input/output port

The \* marked terminal is a terminal which is not connected externally (open terminal).

**IC6 : M30622M8-xxxFP**  
**Main System Microprocessor**

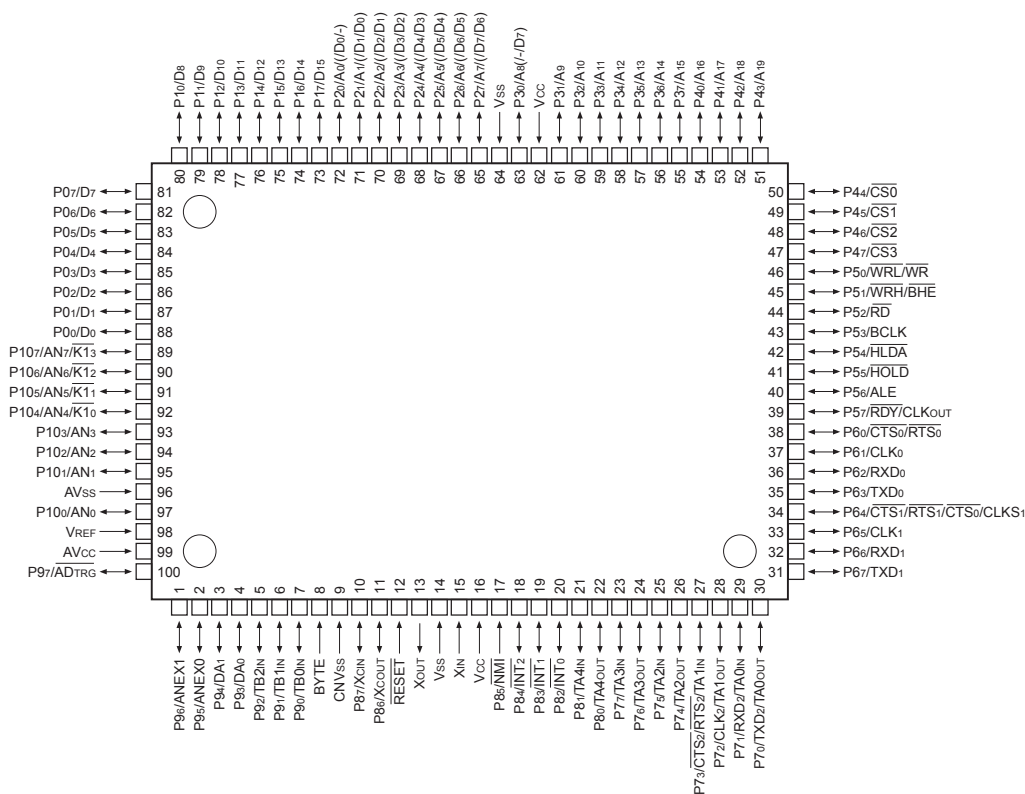

No.	Port	I/O	Name	Function
1	P96/ANEX1	O	CDI	Data to DEQ
2	P95/ANEX0	O	XCLK	Clock to DEQ
3	P94/DA1	I	LDCKN	Lock flag input for DIR
4	P93/DA0	O	DSELB	Digital input switching
5	P92/TB2in	O	DSELA	Digital input switching
6	P91/TB1in	O	/MUTE	LINE MUTE
7	P90/TB0in			Unused (GND)
8	BYTE	I	GND	
9	CNVss	I	GND	
10	P87/Xcin	I/O		Unused (GND)
11	P86/Xcout	I/O		Unused (GND)
12	/RESET	I	/RES	Reset input
13	Xout	O	XOUT	Ceramic lock 10MHz
14	Vss	I	GND	GND level input
15	Xin	I	XIN	Ceramic lock 10MHz
16	Vcc	I	VCC	Microprocessor power supply input
17	P85//NMI	I	PU	PU to Vcc
18	P84//INT2	I	DSTB	MD strobe input
19	P83//INT1	I	/PDN	Power failure detect (Power down)
20	P82//INT0	I	REM	Remote controller input
21	P81//TA4in	I/O		Unused (GND)
22	P80//TA4out	I/O		Unused (GND)
23	P77//TA3in	I/O		Unused (GND)
24	P76//TA3out	I/O		Unused (GND)
25	P75//TA2in	I/O		Unused (GND)
26	P74//TA2out	O	6.5/5V	MD unit power supply switching
27	P73//TA1in	O		Unused (GND)
28	P72//TA1out	O	SCL	Clock to EEPROM
29	P71//TA0in	I	SDI	Data input for EEPROM
30	P70//TA0out	O	SDO	Data to EEPROM
31	P67//Tx/D1	O	FLDAT	Data to FL driver
32	P66//Rx/D1	O	/FLCE	CE FL driver
33	P65//CLK1	O	FLCLK	Clock FL data
34	P64//CTS	O	/FLRES	Reset FL driver

## IC6 : M30622M8-xxxFP

## Main System Microprocessor

No.	Port	I/O	Name	Function
35	P63/TxD0	O	KDATA	MD key data
36	P62/RxD0	I	MDDATA	MD data input
37	P61/CLK0	O	DSCK	MD clock output
38	P60/CTS0,/RTS0	O	MD-ST	MD start (MD-ON)
39	P57//RDY,CLKout	O	/MD-RES	MD reset output
40	P56/ALE	I/O		Unused (GND)
41	P55//HOLD	I/O	SEARCH	Synchro REC signal
42	P54//HLDA	O	PDOWN	Used at MD unit power failure
43	P53/BCLK	I/O		Unused (GND)
44	P52//RD	I/O		Unused (GND)
45	P51//WRH,/BHE	I/O		Unused (GND)
46	P50//WRL,/WR	I/O		Unused (GND)
47	P47//CS3	I/O	CG/CSG	Unused (pull up)
48	P46//CS2	I/O		Unused (pull up)
49	P45//CS1	I	Ver	Destination input
50	P44//CS0	I	/LOADIN	H-L: DISC IN
51	P43/A19	I/O		Unused (GND)
52	P42/A18	I/O		Unused (GND)
53	P41/A17	I/O		Unused (GND)
54	P40/A16	I/O		Unused (GND)
55	P37/A15	I/O		Unused (GND)
56	P36/A14	I/O		Unused (GND)
57	P35/A13	I/O		Unused (GND)
58	P34/A12	I/O		Unused (GND)
59	P33/A11	I/O		Unused (GND)
60	P32/A10	I/O		Unused (GND)
61	P31/A9	I/O		Unused (GND)
62	Vcc	I	VCC	Microprocessor power supply input
63	P30/A8	I/O		Unused (GND)
64	Vss	I	GND	GND level input
65	P27/A7	I/O		Unused (GND)
66	P26/A6	I/O		Unused (GND)
67	P25/A5	I/O		Unused (GND)
68	P24/A4	I/O		Unused (GND)
69	P23/A3	I/O		Unused (GND)
70	P22/A2	I/O		Unused (GND)
71	P21/A1	I/O		Unused (GND)
72	P20/A0	I/O		Unused (GND)
73	P17/D15	I/O		Unused (GND)
74	P16/D14	I/O		Unused (GND)
75	P15/D13	I/O		Unused (GND)
76	P14/D12	I/O		Unused (GND)
77	P13/D11	I/O		Unused (GND)
78	P12/D10	I/O		Unused (GND)
79	P11/D9	I/O		Unused (GND)
80	P10/D8	I/O		Unused (GND)
81	P07/D7	I	DIG1	DEQ (/OVF)
82	P06/D6	I/O	DIG2	Unused (NC)
83	P05/D5	I/O	DIG3	Unused (NC)
84	P04/D4	I	TREC	Timer SW input
85	P03/D3	I	TPLY	Timer SW input
86	P02/D2	I/O		Unused (GND)
87	P01/D1	I	JOG2	JOG input 2
88	P00/D0	I	JOG1	JOG input 1
89	P107/AN7	O	/DEQRES	Rest DEQ
90	P106/AN6	O	/DITRES	Rest DIT
91	P105/AN5	I	ERRD	Data error flag input for DIR
92	P104/AN4	O	/DIRRES	Reset DIR
93	P103/AN3	O	/CRS	Serial rest DEQ
94	P102/AN2	I	KEY3	KEY input 3
95	P101/AN1	I	KEY2	KEY input 2
96	AVss	I	GND	GND level input for AD
97	P100/AN0	I	KEY1	KEY input 1
98	Vref	I	VREF	Reference voltage input for AD
99	AVcc	I	ADVCC	Power supply terminal for AD
100	P97//ADTRG	O	DITMUTE	Mute output to DIT



**IC703 : YM3436DK**  
**DIR (Digital Format Interface Receiver)**

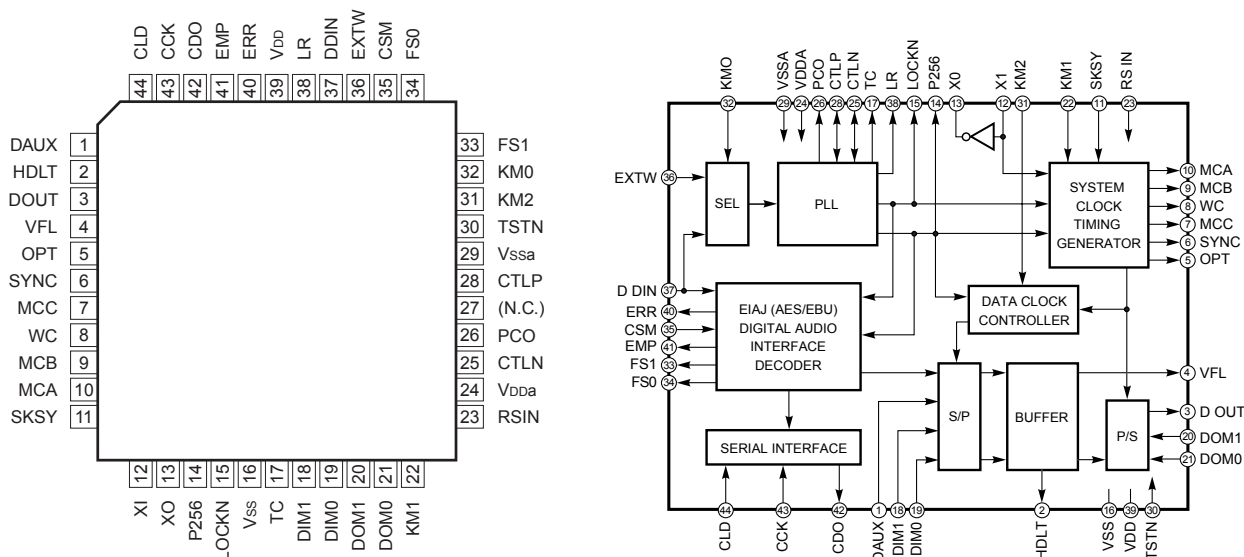

Pin No.	Pin Name	I/O	Function	Pin No.	Pin Name	I/O	Function
1	DAUX	I	Auxiliary input for audio data	26	PCO	O	PLL phase comparison output
2	HDLT	O	Asynchronous buffer operation flag	27	(NC)		
3	DOUT	O	Audio data output	28	CTLP	I	VCO control input P
4	VFL	O	Parity flag output	29	Vssa		VCO section power (GND)
5	OPT	O	Fs x 1 Synchronous output signal for DAC	30	TSTN	I	Test terminal. Open for normal use
6	SYNC	O	Fs x 1 Synchronous output signal for DSP	31	KM2	I	Clock mode switching input 2
7	MCC	O	Fs x 64Bit clock output	32	KM0	I	Clock mode switching input 0
8	WC	O	Fs x 1Word clock output	33	FS1	O	Channel status sampling frequency display output 1
9	MCB	O	Fs x 128Bit clock output	34	FS0	O	Channel status sampling frequency display output 0
10	MCA	O	Fs x 256Bit clock output	35	CSM	I	Channel status output method selection
11	SKSY	I	Clock synchronization control input	36	EXTW	I	External synchronous auxiliary input word clock
12	XI	I	Crystal oscillator connection or external clock input	37	DDIN	I	EIAJ (AES/EBU) data input
13	XO	O	Crystal oscillator connection	38	LR	O	PLL word clock output
14	P256	O	VCO oscillating clock connection	39	Vdd		Logic section power (+5V)
15	LOCKN	O	PLL lock flag	40	ERR	O	Data error flag output
16	Vss		Logic section power (GND)	41	EMP	O	Channel status emphasis control code output
17	TC	O	PLL time constant switching output	42	CD0	O	3-wire type microcomputer interface data output
18	DIM1	I	Data input mode selection	43	CCK	I	3-wire type microcomputer interface clock input
19	DIM0	I	Data input mode selection	44	CLD	I	3-wire type microcomputer interface load input
20	DOM1	I	Data output mode selection				
21	DOM0	I	Data output mode selection				
22	KM1	I	Clock mode switching input 1				
23	RSTN	I	System reset input				
24	Vdda		VCO section power (+5V)				
25	CTLN	I	VCO control input N				

**IC704 : YM6104**  
**DEQ (Digital Equalizer)**

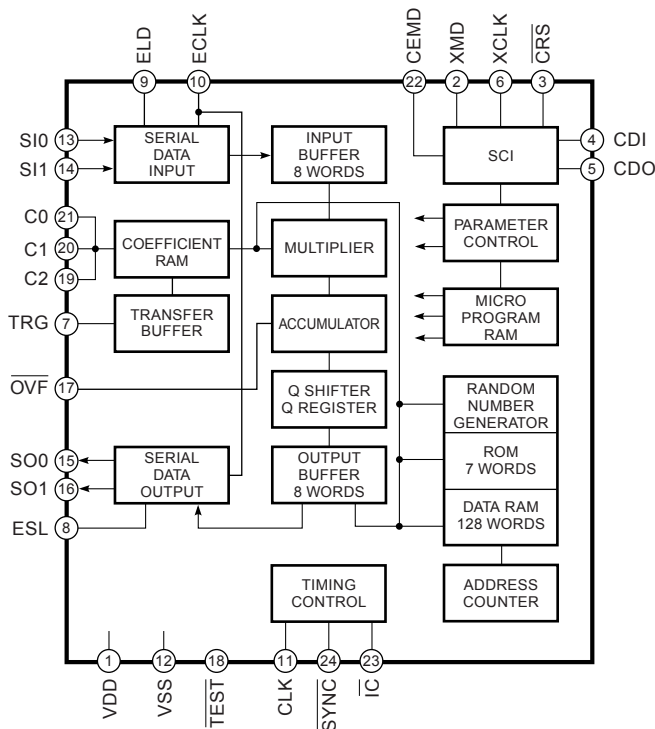

Pin No.	Pin Name	I/O	Function
1	VDD	I	+5V power supply
2	XMD	I	Switches CDI input to either synchronous mode (1 : 1) "L" or asynchronous mode (Start-stop synchronous system 16 : 1) "H"
3	CRS	I	Initializes SCI interface
4	CDI	I	SCI input for setting micro program, factor and control register
5	CDO	O	SCI output for setting micro program, factor and control register
6	XCLK	I	Input-output clock for CDI and CDO
7	TRG	I	Determines parameter transfer timing from transfer buffer to factor RAM when external trigger is selected
8	ESL	I	Enters output timing into SO0 and SO1 when EXT clock is selected
9	ELD	I	Enters input timing into SI0 and SI1 when EXT clock is selected
10	ECLK	I	Enters input-output clock for SI0, SO0 and SO1 when EXT clock is selected
11	CLK	I	Master clock input
12	VSS	I	Ground
13, 14	SI0, SI1	I	16 bits serial input
15, 16	SO0, SO1	O	16 bits serial output
17	OVF	O	Over flow detect
18	TEST	I	Used for testing Usually connected to +5V
19	C2/Sign	O	Outputs bit 2 of factor RAM while delaying it by 1 bit. Used as a timing signal Monitors sign bit of accumulator by setting test Reg (When factor RAM is used as a timing signal, effective bit number of factor decreases)
20	C1/TESTM	O	Outputs bit 1 of factor RAM while delaying it by 1 bit. Used as a timing signal Switches to test output of multiplier by setting test Reg
21	CO	O	Outputs bit 2 of factor RAM while delaying it by 1 bit. Can be used as a timing signal
22	CEMD	I	Turns OFF CE of SCI input CE ON : "H" CE OFF : "L"
23	IC	I	Initializes DEQ operation
24	Sync	I	Synchronous signal of system

## IC705 : YM3437C-FE2

## DIT (Digital Audio Interface Signal Transmitter)

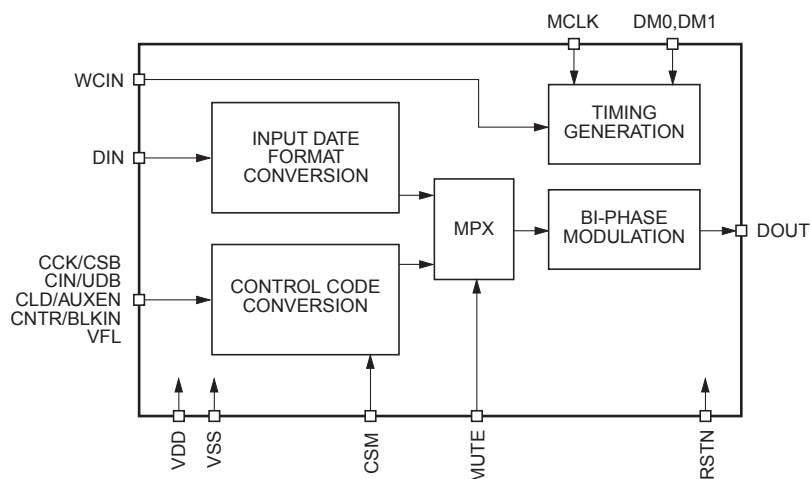
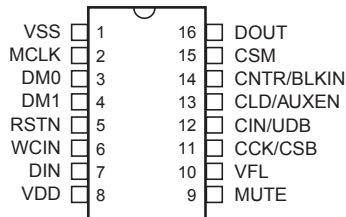

Pin No.	Pin Name	I/O	Function
1	VSS	–	Ground
2	MCLK	I	Master clock input (128fs)
3	DM0	I	Data input mode select 0
4	DM1	I	Data input mode select 1
5	RSTN	I	System reset input (“ L ” active)
6	WCIN	I	Word clock input
7	DIN	I	Audio data input
8	VDD	–	+ 5V power supply
9	MUTE	I	DOUT output muting control input (when “ H ”, muted audio data)
10	VFL	I	Validity flag input
11	CCK/CSB	I	CSM = “ L ” ; C, U bit data input serial clock CSM = “ H ” ; C bit data input
12	CIN/USB	I	CSM = “ L ” ; C, U bit data input serial data CSM = “ H ” ; U bit data input
13	CLD/AUXEN	I	CSM = “ L ” ; C, U bit data input word clock CSM = “ H ” ; 24-bit output at “ H ” (AUX bit used)
14	CNTR/BLKIN	I	CSM = “ L ” ; Local sample address reset input CSM = “ H ” ; Block start clock
15	CSM	I	Control code input mode select (“ L ” ; Asynchronous mode “ H ” ; Synchronous mode)
16	DOUT	O	Digital audio interface signal output

■ BLOCK DIAGRAM (MD)

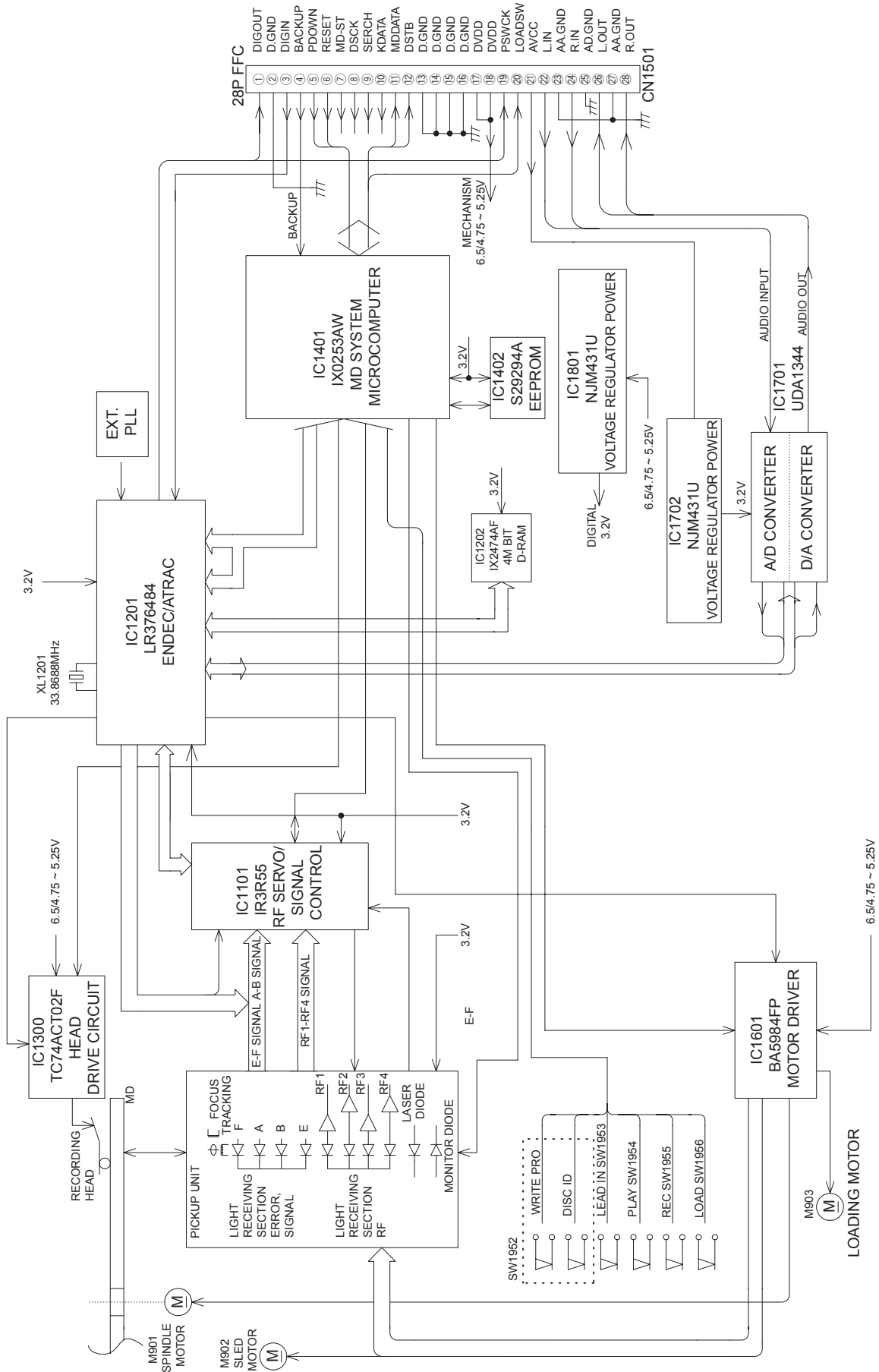



TEST POINT WAVEFORM

1  
2  
3  
4  
5  
6

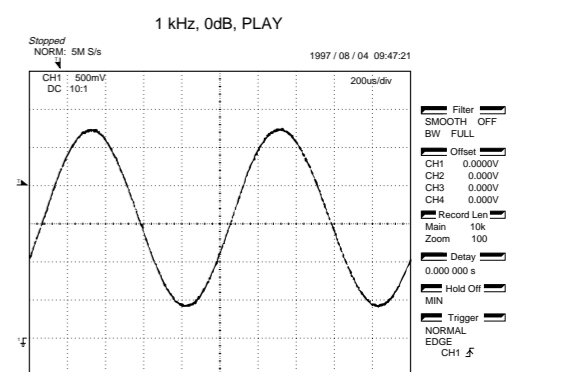
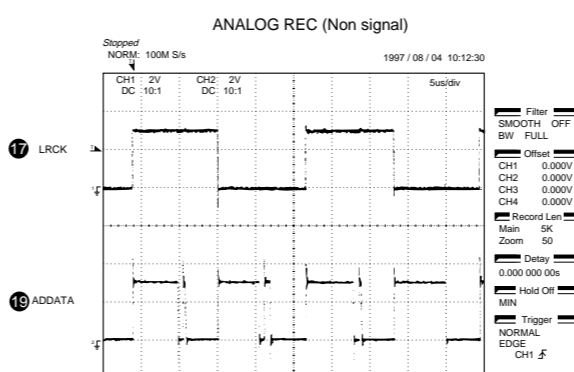
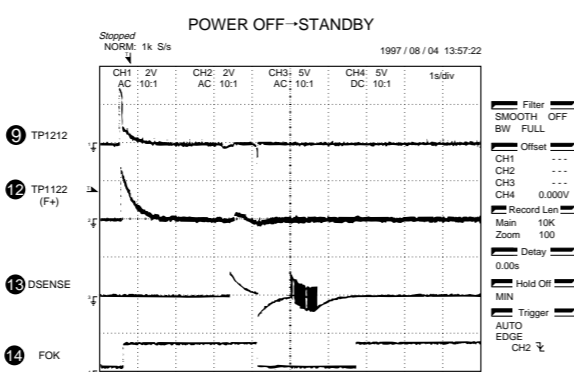
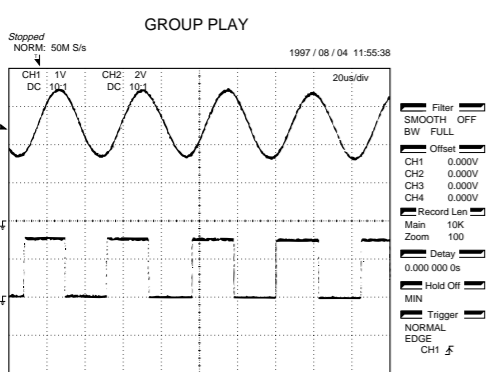
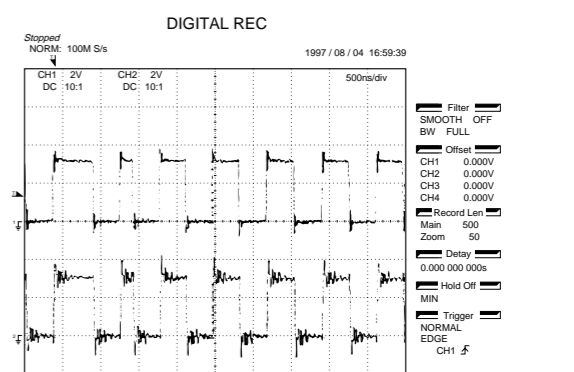
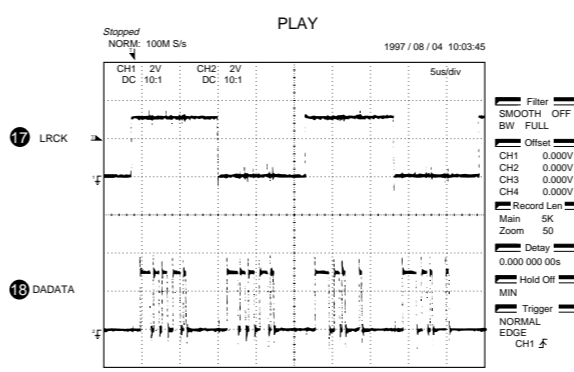
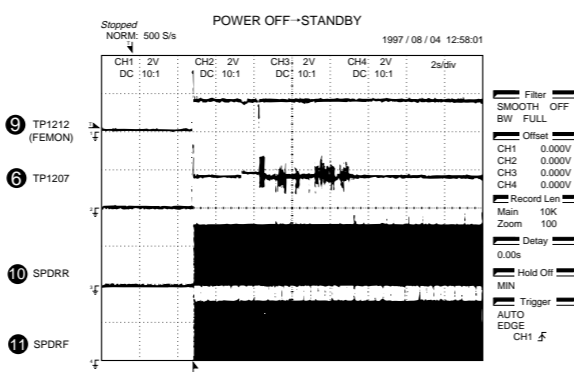
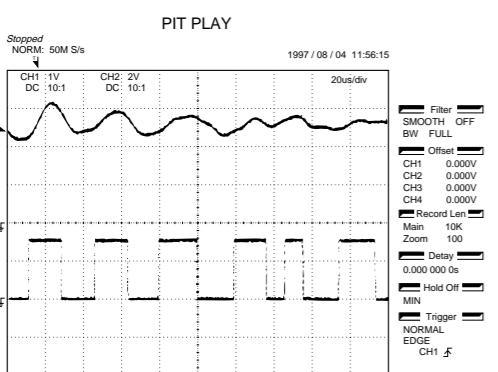
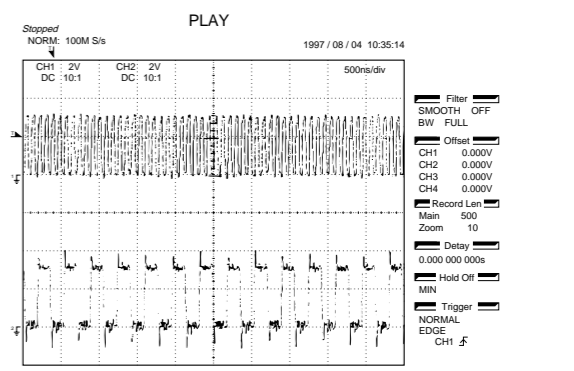
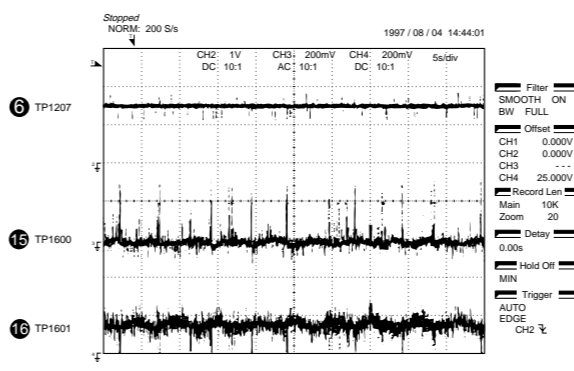
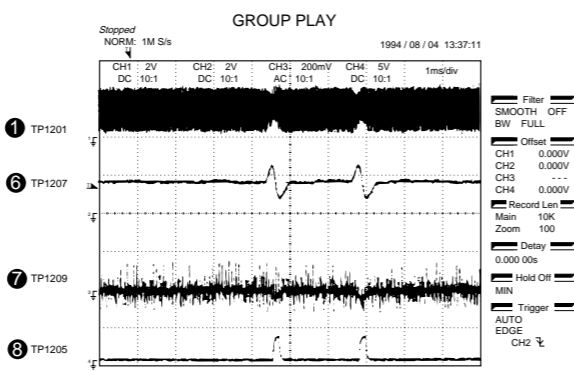
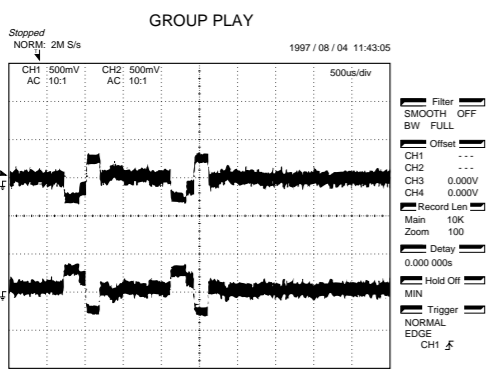
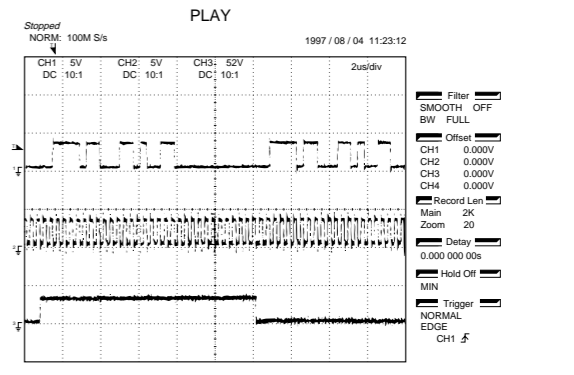
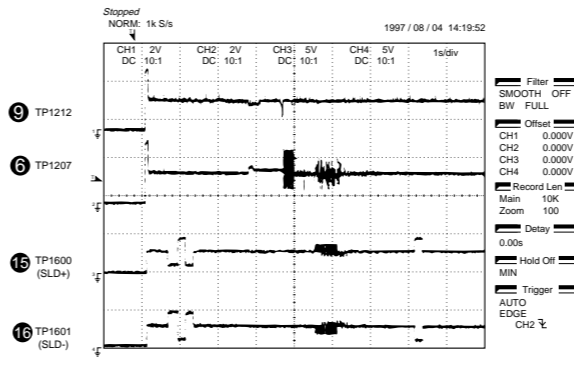
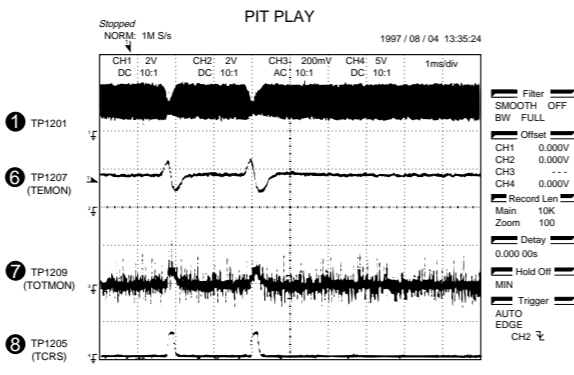
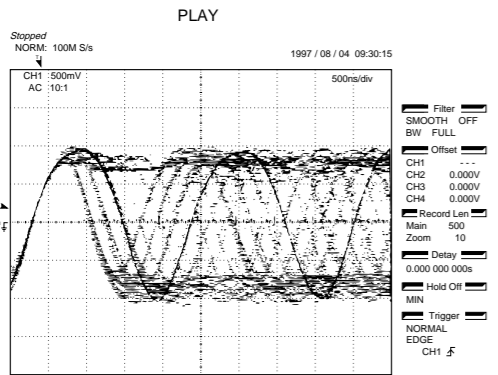

# PRINTED CIRCUIT BOARD (Foil side)

Note : ⑥ ~ ⑨

Connect an oscilloscope to the test points (⑥ ~ ⑨) through a filter as shown below.

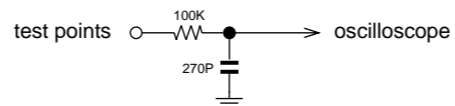

MD MAIN PWB-A (TOP VIEW)

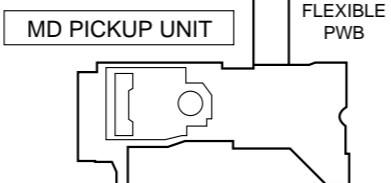
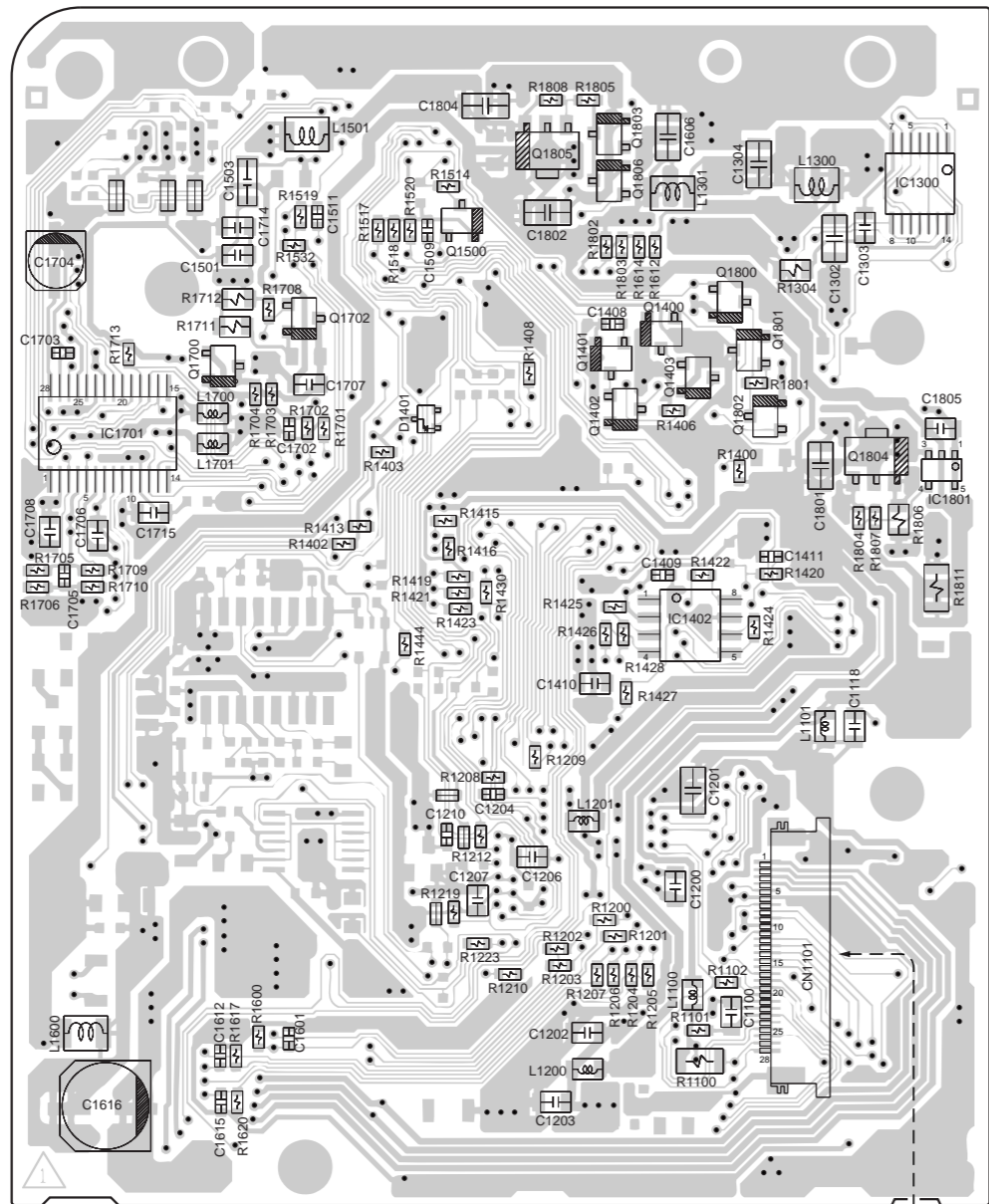

① to ②④ : TEST POINT WAVEFORMS (See page E38/J36)

MD MAIN PWB-A (BOTTOM VIEW)

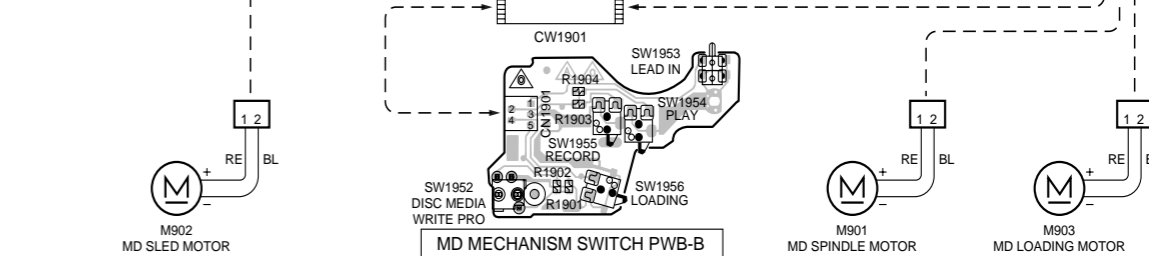
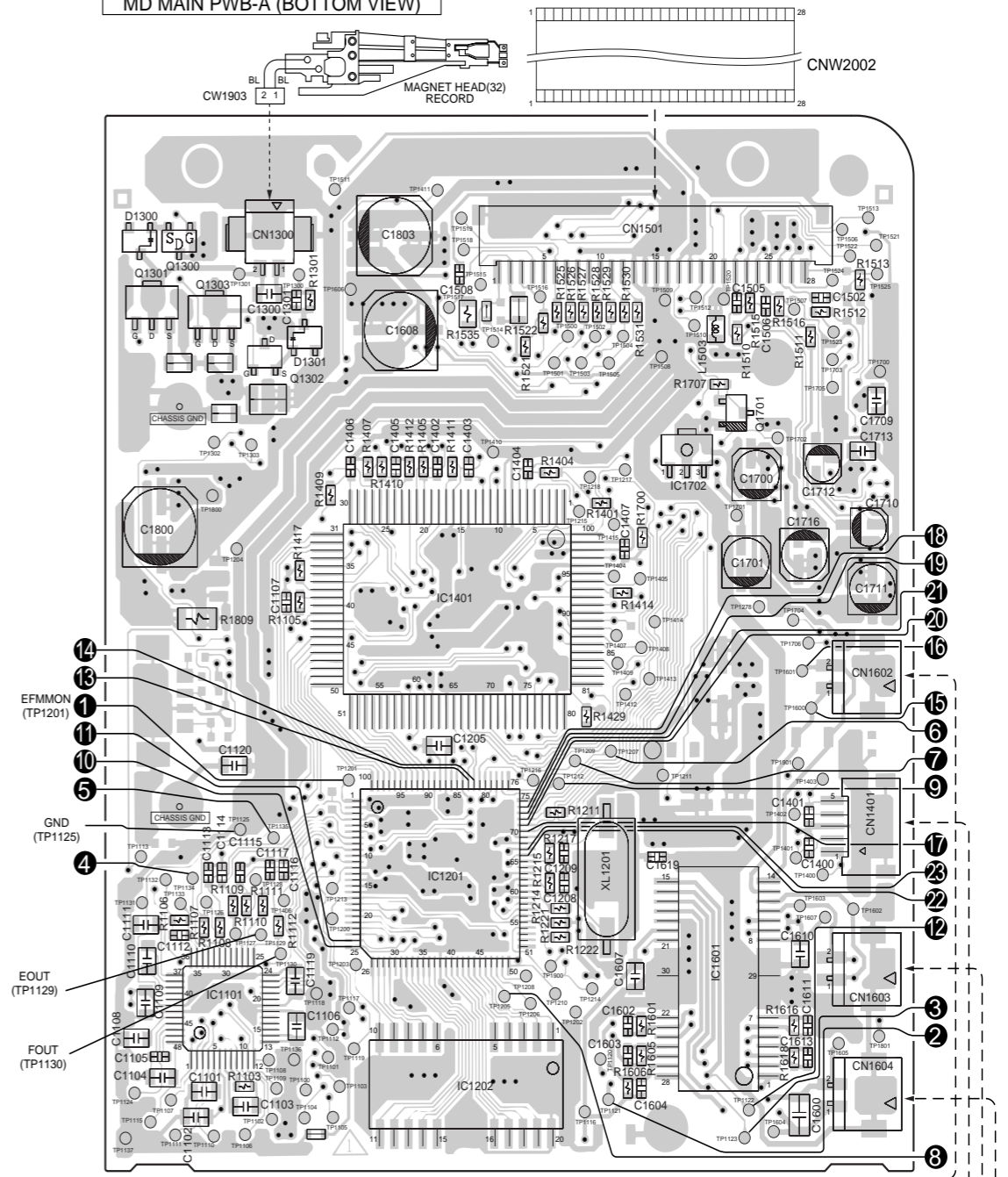

PRINTED CIRCUIT BOARD (Foil side)

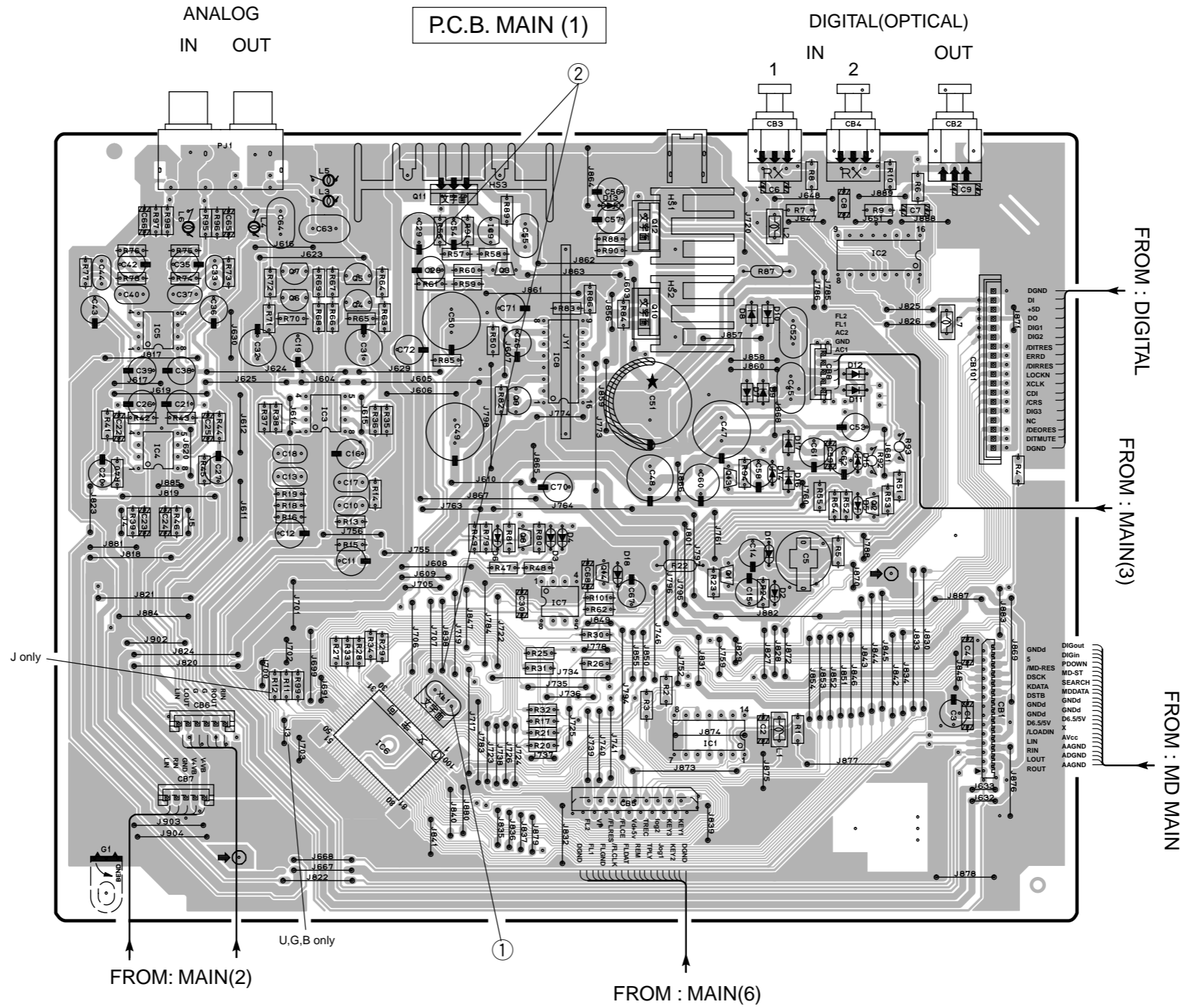

Point ① (Pin 13 of IC6)  
 V : 2V/div H : 50 nsec/div  
 DC range 1 : 1 probe

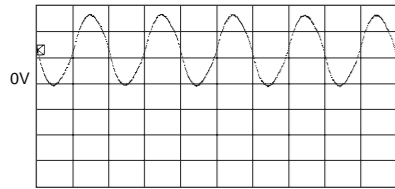

Point ②  
 (CH1 : Pin 12 of IC6) V : 2V/div CH1  
 (CH2 : Collector of Q11) V : 2V/div CH2  
 H : 2 sec/div DC range 1 : 1 probe

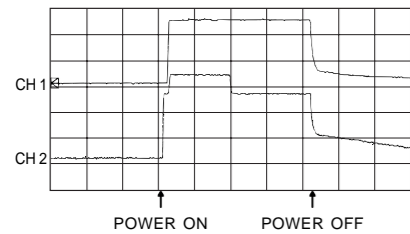







SCHEMATIC DIAGRAM

1 to 24 : TEST POINT WAVEFORMS (See page E38/J36)

MD MAIN PWB-A

Note : 6 ~ 9  
Connect an oscilloscope to the test points (6 ~ 9) through a filter as shown below.

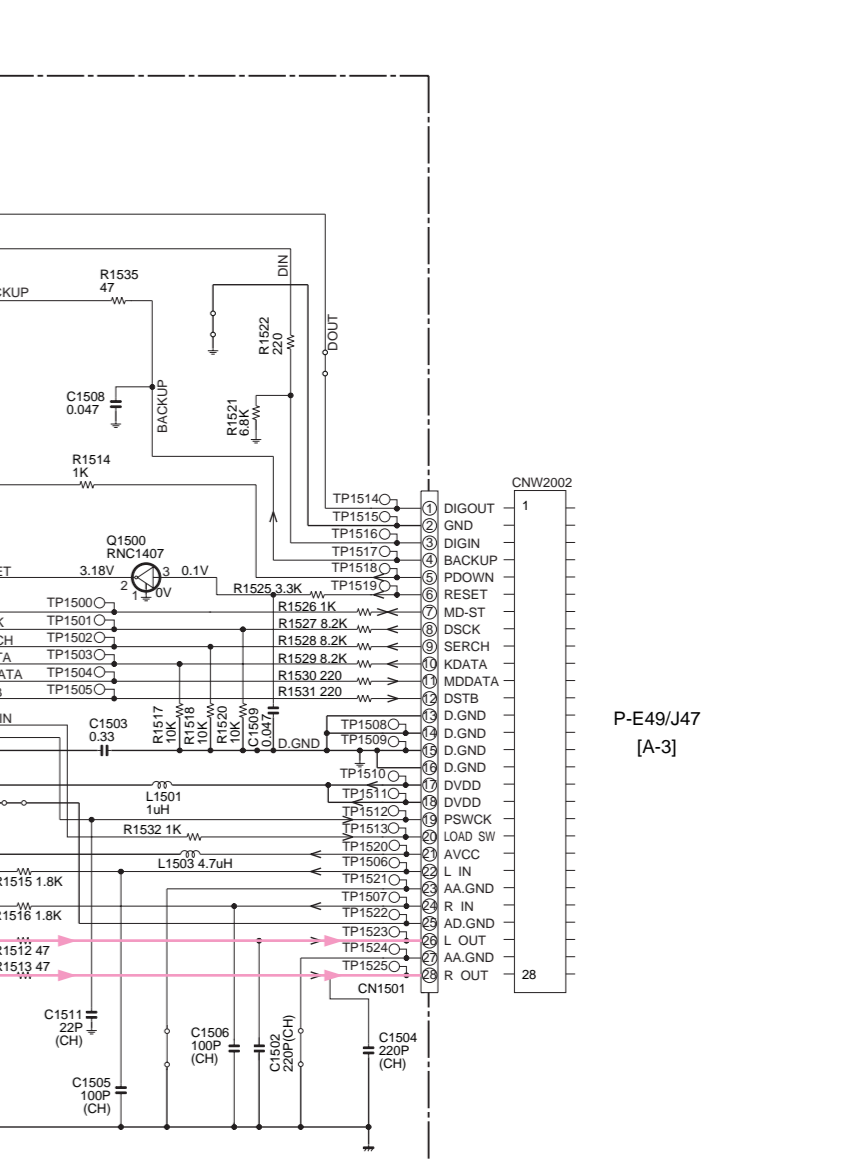
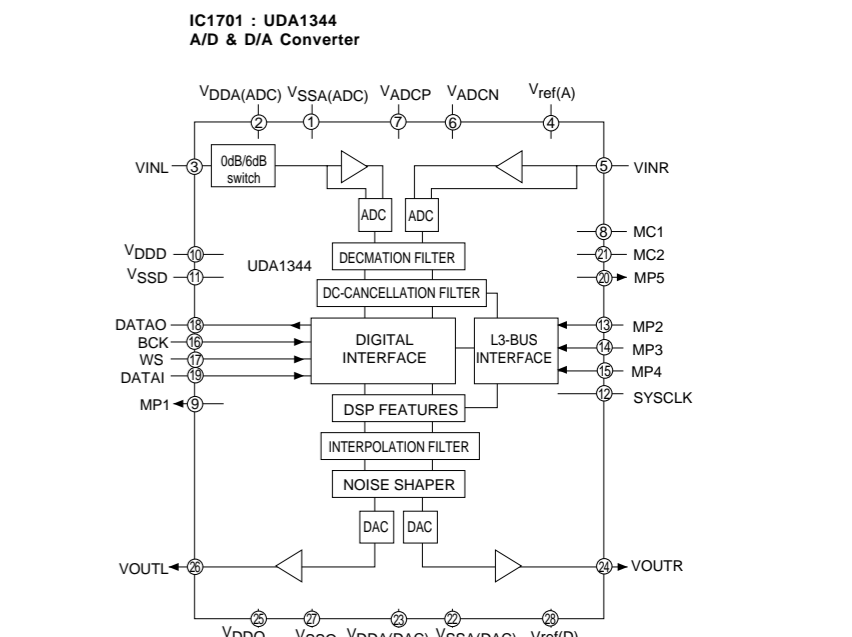
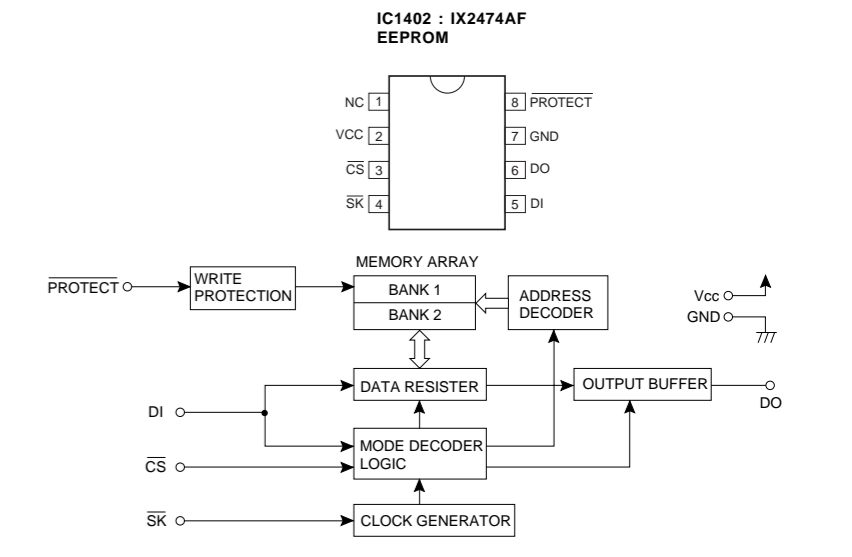
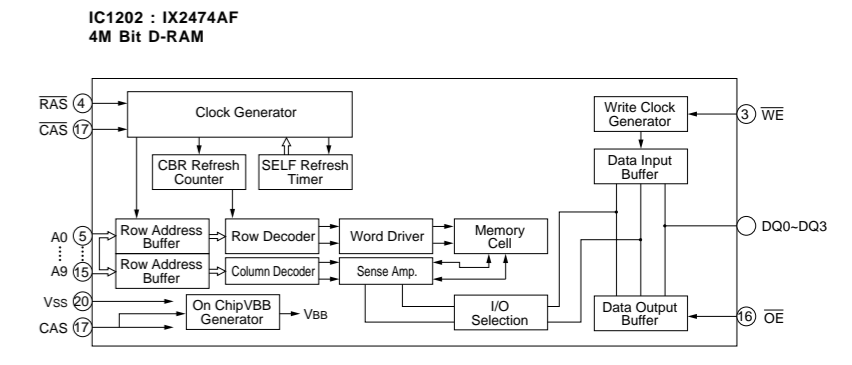
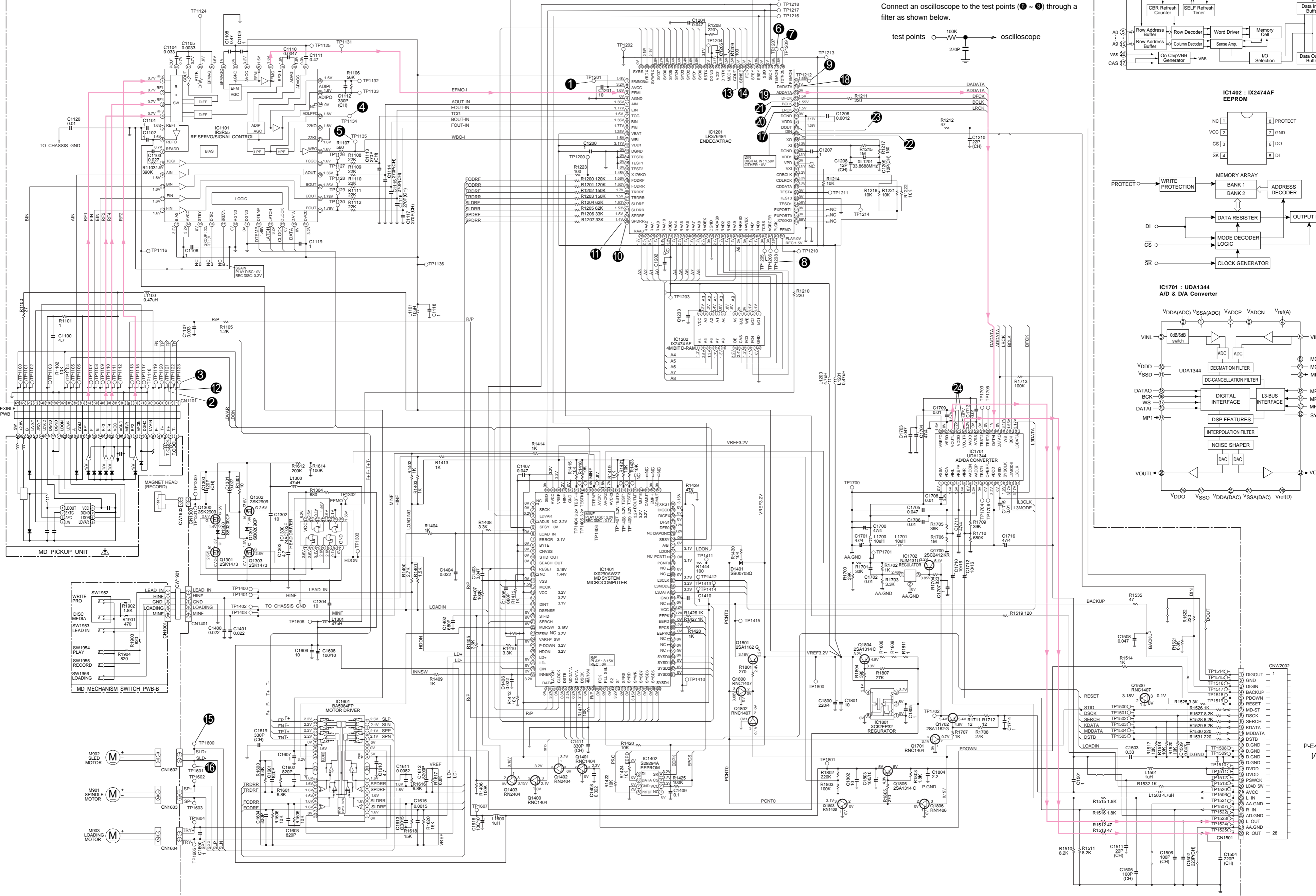
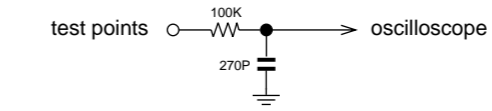

All voltages are measured with a 10MΩ/DC electric volt meter.  
Components having special characteristics are marked Δ and must be replaced with parts having specifications equal to those originally installed.  
Schematic diagram is subject to change without notice.

SCHEMATIC DIAGRAM

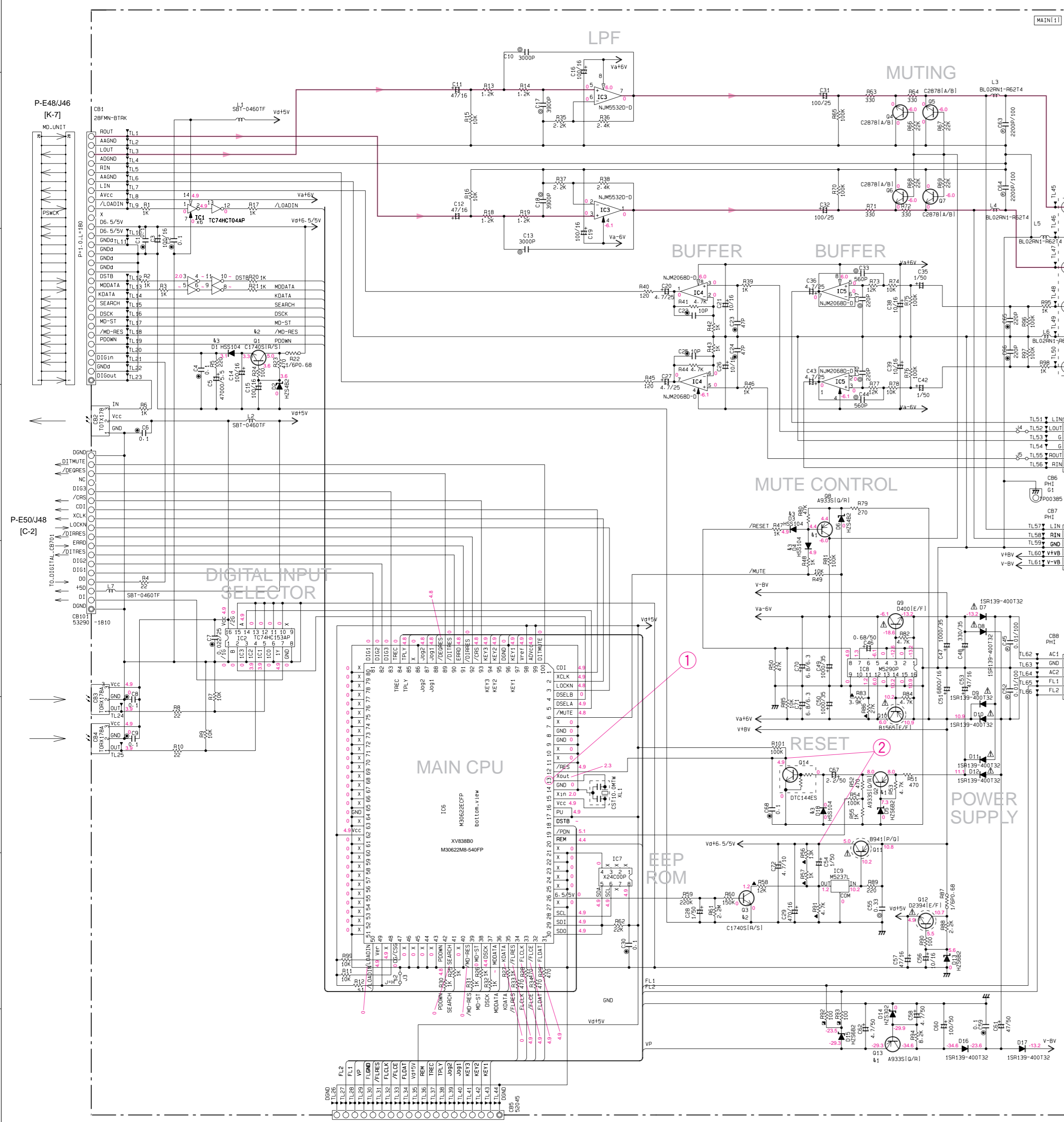

NOTICE (model1)  
 (J)..... JAPANESE  
 (U)..... U. S. A  
 (C)..... CANADIAN  
 (R)..... GENERAL  
 (A)..... AUSTRALIAN  
 (B)..... BRITISH  
 (G)..... EUROPEAN  
 (T)..... CHINA  
 (L)..... SINGAPORE

RESISTOR

REMARKS	PARTS NAME
NO MARK	CARBON FILM RESISTOR (P=5)
□	CARBON FILM RESISTOR (P=10)
△	METAL OXIDE FILM RESISTOR
△	METAL FILM RESISTOR
□	METAL PLATE RESISTOR
⊠	FIRE PROOF CARBON FILM RESISTOR
□	CEMENT MOLDED RESISTOR
⊠	SEMI VARIABLE RESISTOR
■	CHIP RESISTOR

CAPACITOR

REMARKS	PARTS NAME
NO MARK	ELECTROLYTIC CAPACITOR
⊗	TANTALUM CAPACITOR
NO MARK	CERAMIC CAPACITOR
●	CERAMIC TUBULAR CAPACITOR
○	POLYESTER FILM CAPACITOR
○	POLYSTYRENE FILM CAPACITOR
○	MICA CAPACITOR
○	POLYPROPYLENE FILM CAPACITOR
○	SEMICONDUCTIVE CERAMIC CAPACITOR

Interchangeable Parts at Manufacture-Stage

Mark	Reference Parts Number	Parts Name
k1	02-B-13	2S4933S(Q/R) 2S4115S(E/F) 2S41309A(G/R/S)
k2	01-3	2SC1740S(I/R/S) 2SC2603I(E/F) 2SC331A(I/G/R/S)
k3	D1-3-4-1B	HSS104 ISS133 ISS176
k4		
k5		

IC3 : NJM5532M  
 IC4 : NJM2068D-D  
 Dual OP-Amp

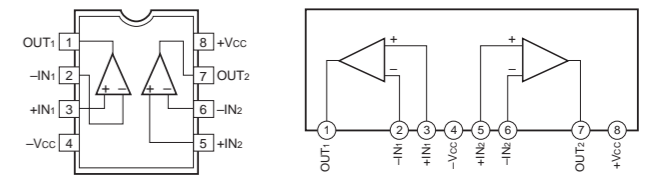

IC1 : TC74HC04AP  
 Hex Inverters

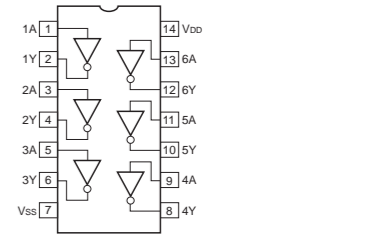

IC2 : TC74HC153AP  
 Dual 4 to 1 Data Selectors

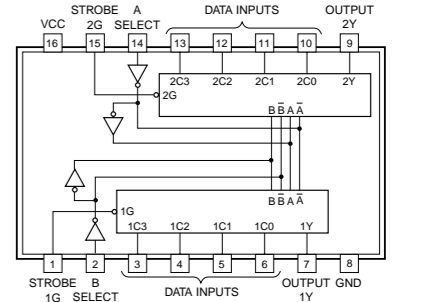

INPUTS OUTPUT

SELECT	STROBE	Y
B A	H G	L
X X	L L	C0
L H	L L	C1
H L	L L	C2
H H	L L	C3

IC7 : X24C00P  
 Electrically Erasable PROM

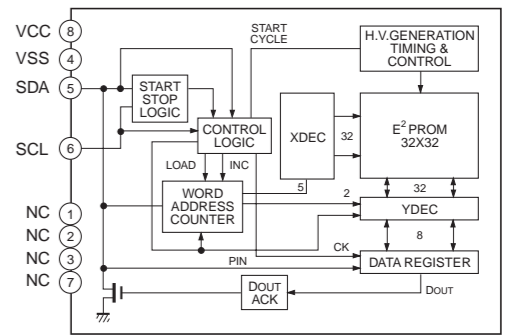

IC8 : M5290P  
 Constant-Voltage Tracking Supply with Reset

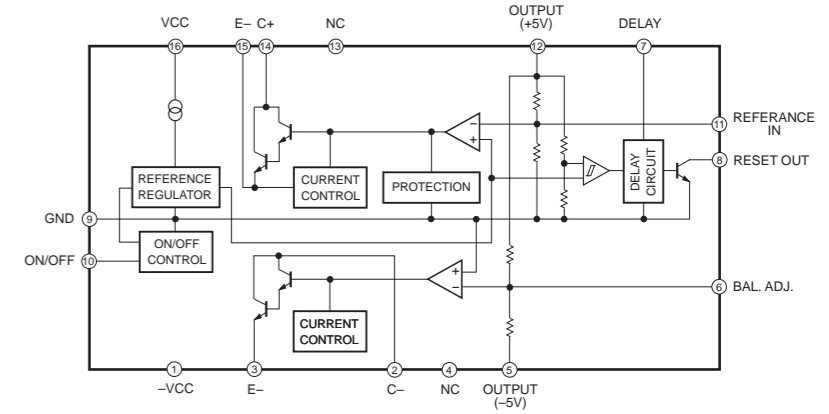

Point ① (Pin 13 of IC6)  
 V : 2V/div H : 50 nsec/div  
 DC range 1 : 1 probe

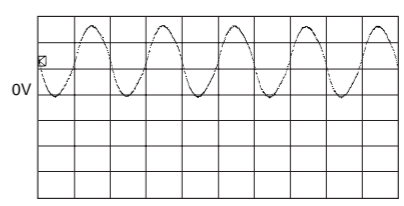

Point ② (CH1 : Pin 12 of IC6  
 CH2 : Collector of Q11)  
 V : 2V/div CH1  
 V : 2V/div CH2  
 H : 2 sec/div DC range 1 : 1 probe

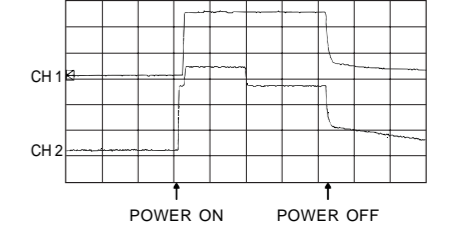

	J	U	B-G	LAST
1	R12	HF45710	X X	R 101
2	J3	X	W50000 W50000	C 68
3	T301	XT873 XUB05 XT874		D 14
4				L 7
5				IC 9

\* All voltages are measured with a 10MΩ/DC electric volt meter.  
 \* Components having special characteristics are marked △ and must be replaced with parts having specifications equal to those originally installed.  
 \* Schematic diagram is subject to change without notice.

SCHEMATIC DIAGRAM

REMARKS	PARTS NAME	Symbol
NO MARK	ELECTROLYTIC CAPACITOR	
⊗	TANTALUM CAPACITOR	
NO MARK	CERAMIC CAPACITOR	
●	CERAMIC TUBULAR CAPACITOR	
⊙	POLYESTER FILM CAPACITOR	
○	POLYSTYRENE FILM CAPACITOR	
⊖	MICA CAPACITOR	
⊕	POLYPROPYLENE FILM CAPACITOR	
⊗	SEMICONDUCTIVE CERAMIC CAPACITOR	

REMARKS	PARTS NAME	Symbol
NO MARK	CARBON FILM RESISTOR (P=5)	
⊠	CARBON FILM RESISTOR (P=10)	
△	METAL OXIDE FILM RESISTOR	
▲	METAL FILM RESISTOR	
⊞	METAL PLATE RESISTOR	
⊞	FIRE PROOF CARBON FILM RESISTOR	
⊞	CEMENT VARIABLE RESISTOR	
⊞	SEMI VARIABLE RESISTOR	
⊞	CHIP RESISTOR	

NOTICE (mode1)  
 (J)..... JAPANESE  
 (U)..... U. S. A  
 (C)..... CANADIAN  
 (R)..... GENERAL  
 (A)..... AUSTRALIAN  
 (B)..... BRITISH  
 (G)..... EUROPEAN  
 (T)..... CHINA  
 (L)..... SINGAPORE

Interchangeable Parts at Manufacture-Stage

Mark	Reference Parts Number	Parts Name
41	0701	25C1740S1R/S1 25C26031E/F1 25C3311A10/R/S1
42	IC701	NJM2904M NJM2904G

IC701 : NJM2904M-T1  
Dual OP-Amp

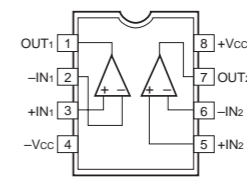

IC706 : TC74VHC04F  
Hex Inverters

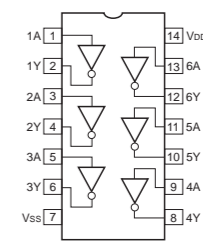

IC702 : HD74HC02FPEL  
Quad 2 Input NOR

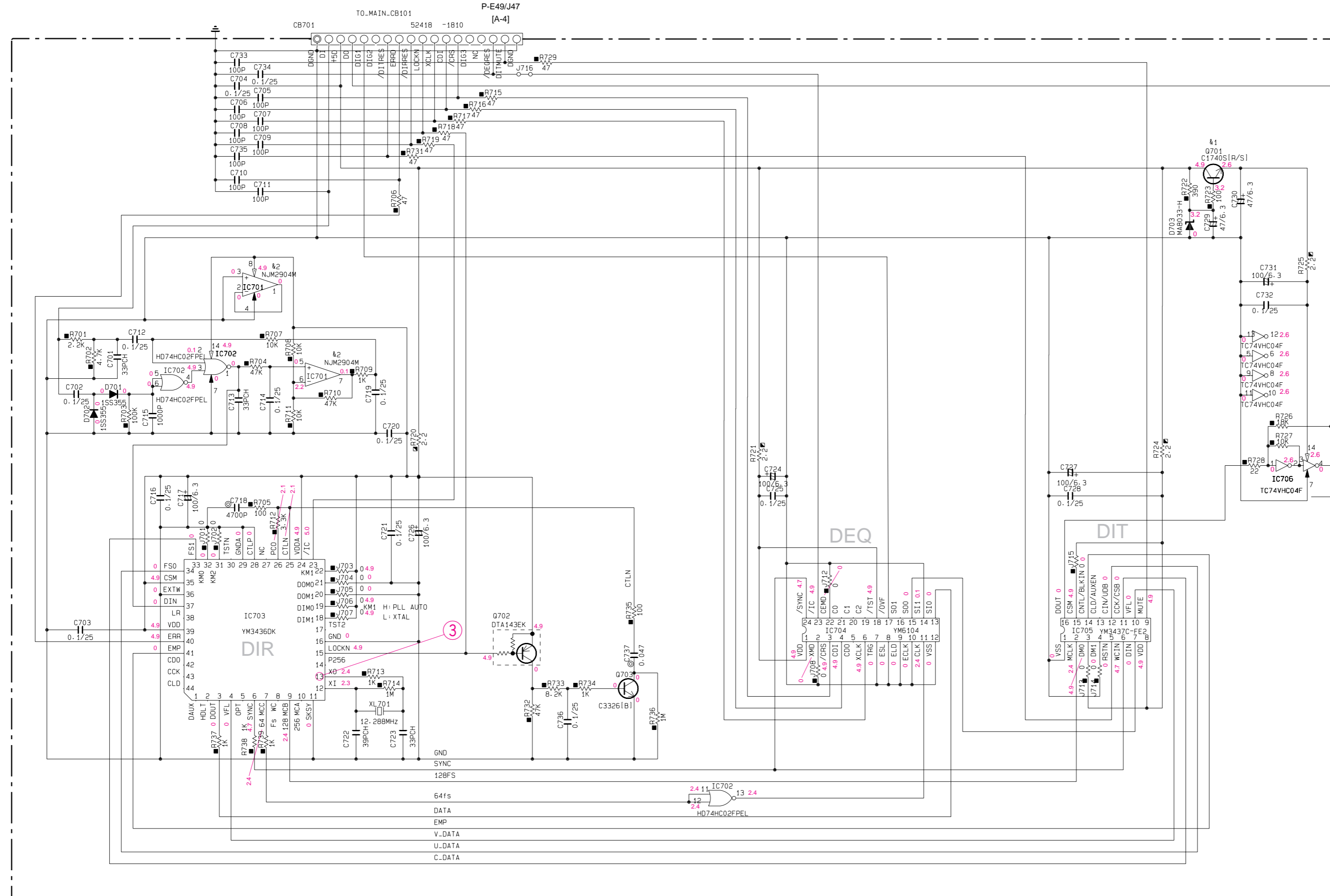
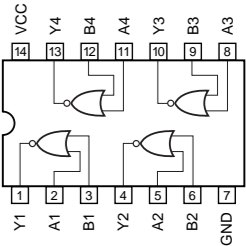

Point ③ (Pin 13 of IC703)  
 V : 2V/div H : 50 nsec/div  
 DC range 1 : 1 probe

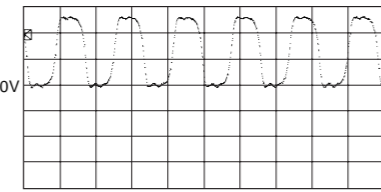

\* All voltages are measured with a 10MΩ/DC electric volt meter.  
 \* Components having special characteristics are marked △ and must be replaced with parts having special characteristics equal to those originally installed.  
 \* Schematic diagram is subject to change without notice.

SCHEMATIC DIAGRAM

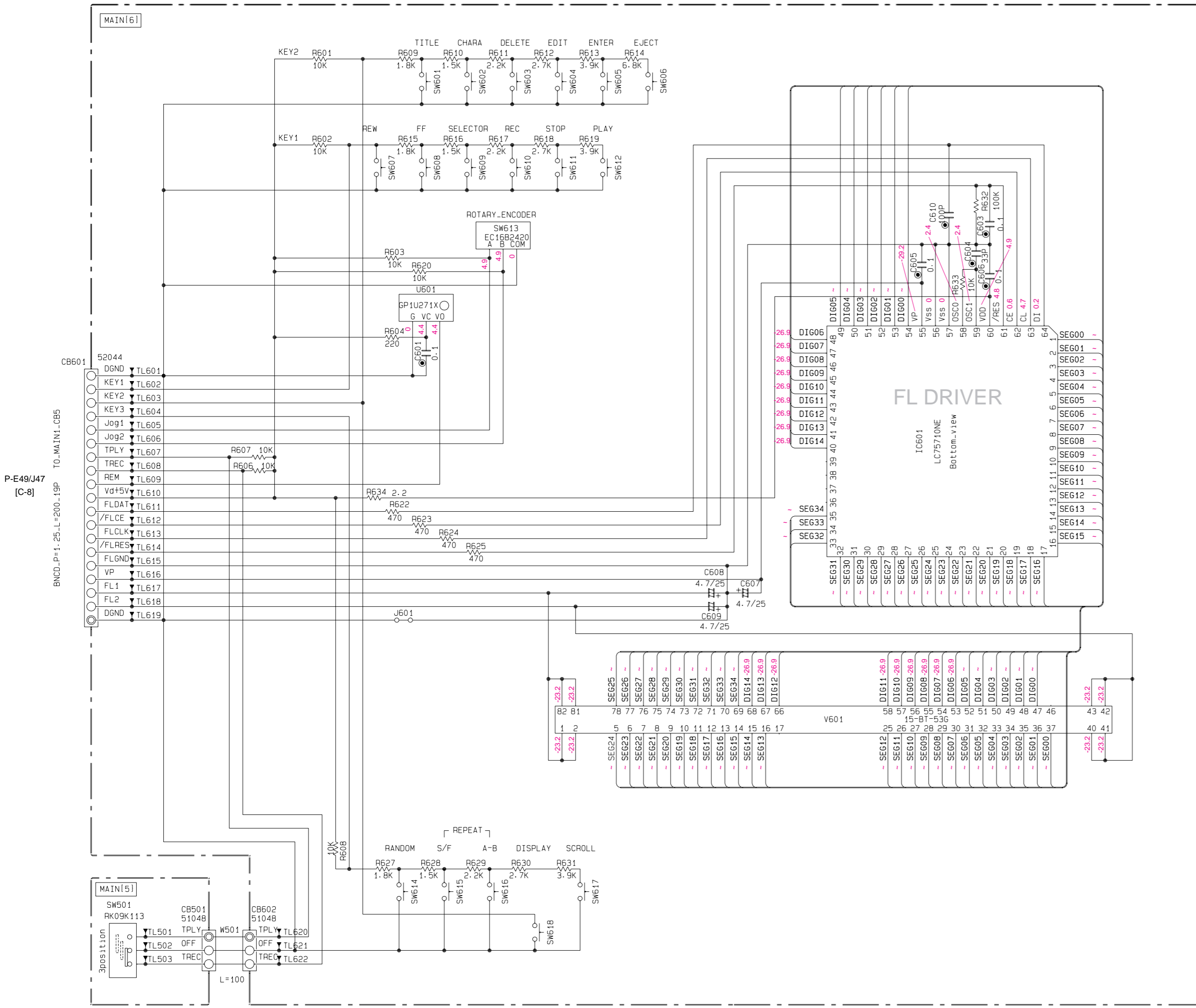

P-E49/J47 [C-8]
BNC-D\_P=1.25, L=200.19P TO\_MAIN1\_CB5

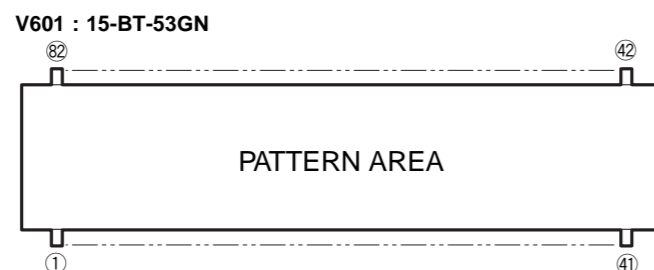

Table with 2 columns: PIN NO. and CONNECTION. It lists connections for pins 1 through 44, including filament (F1, F2), no extend pins (NX), datum lines (P1-P35), and no pins (NP).

Table with 2 columns: PIN NO. and CONNECTION. It lists connections for pins 15G through 14G, including analog/digital, disc track, total, remain, random, and repeat signals.

NOTICE (mode1)
(J)..... JAPANESE
(U)..... U.S.A
(C)..... CANADIAN
(R)..... GENERAL
(A)..... AUSTRALIAN
(B)..... BRITISH
(G)..... EUROPEAN
(T)..... CHINA
(L)..... SINGAPORE

Table with 2 columns: REMARKS and PARTS NAME. It lists resistor types such as Carbon Film Resistor, Metal Oxide Film Resistor, Metal Film Resistor, Metal Plate Resistor, Fire Proof Carbon Film Resistor, Cement Molded Resistor, Semi Variable Resistor, and Chip Resistor.

Table with 2 columns: REMARKS and PARTS NAME. It lists capacitor types such as Electrolytic Capacitor, Tantalum Capacitor, Ceramic Capacitor, Polyester Film Capacitor, Polystyrene Film Capacitor, Mica Capacitor, Polypropylene Film Capacitor, and Semiconductive Ceramic Capacitor.

IC601 - LC75710NE FL Driver

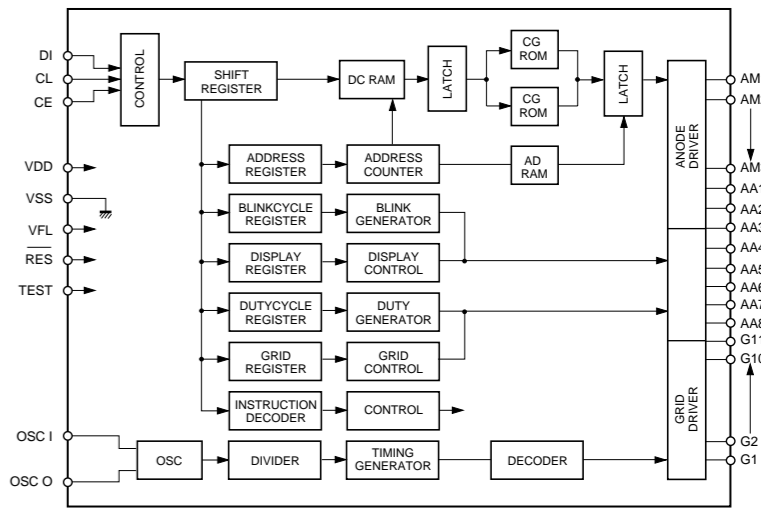
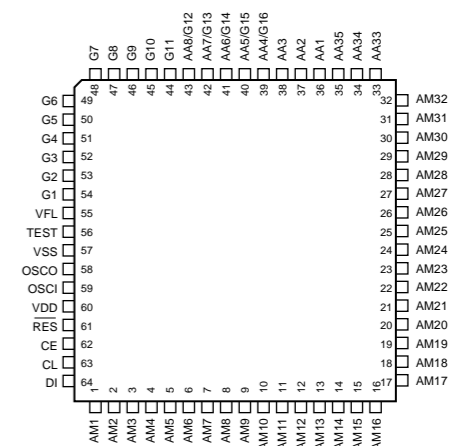

ANODE CONNECTION

Table with 4 columns: P, 1G, 2G, 3G-14G, 15G. It lists anode connections for pins P1 through P35, including manual, random, and repeat signals.

All voltages are measured with a 10MΩ/DC electric volt meter.
Components having special characteristics are marked Δ and must be replaced with parts having specifications equal to those originally installed.
Schematic diagram is subject to change without notice.

# PARTS LIST

## ■ ELECTRICAL PARTS

### ■ WARNING

Components having special characteristics are marked  $\triangle$  and must be replaced with parts having specifications equal to those originally installed.

- Carbon resistors (1/6W or 1/4W) are not included in the ELECTRICAL PARTS List. For the part Nos. of the carbon resistors, refer to the last page.

### ABBREVIATIONS IN THIS LIST ARE AS FOLLOWS :

C.A.EL.CHP	: CHIP ALUMI. ELECTROLYTIC CAP	L.EMIT	: LIGHT EMITTING MODULE
C.CE	: CERAMIC CAP	LED.DSPLY	: LED DISPLAY
C.CE.ARRAY	: CERAMIC CAP ARRAY	LED.INFRD	: LED, INFRARED
C.CE.CHP	: CHIP CERAMIC CAP	MODUL.RF	: MODULATOR, RF
C.CE.ML	: MULTILAYER CERAMIC CAP	PHOT.CPL	: PHOTO COUPLER
C.CE.M.CHP	: CHIP MULTILAYER CERAMIC CAP	PHOT.INTR	: PHOTO INTERRUPTER
C.CE.SAFY	: RECOGNIZED CERAMIC CAP	PHOT.RFLCT	: PHOTO REFLECTOR
C.CE.TUBLR	: CERAMIC TUBULAR CAP	PIN.TEST	: PIN, TEST POINT
C.CE.SMI	: SEMI CONDUCTIVE CERAMIC CAP	PLST.RIVET	: PLASTIC RIVET
C.EL	: ELECTROLYTIC CAP	R.ARRAY	: RESISTOR ARRAY
C.MICA	: MICA CAP	R.CAR	: CARBON RESISTOR
C.ML.FLM	: MULTILAYER FILM CAP	R.CAR.CHP	: CHIP RESISTOR
C.MP	: METALLIZED PAPER CAP	R.CAR.FP	: FLAME PROOF CARBON RESISTOR
C.MYLAR	: MYLAR FILM CAP	R.FUS	: FUSABLE RESISTOR
C.MYLAR.ML	: MULTILAYER MYLAR FILM CAP	R.MTL.CHP	: CHIP METAL FILM RESISTOR
C.PAPER	: PAPER CAPACITOR	R.MTL.FLM	: METAL FILM RESISTOR
C.PLS	: POLYSTYRENE FILM CAP	R.MTL.OXD	: METAL OXIDE FILM RESISTOR
C.POL	: POLYESTER FILM CAP	R.MTL.PLAT	: METAL PLATE RESISTOR
C.POLY	: POLYETHYLENE FILM CAP	RSNR.CE	: CERAMIC RESONATOR
C.PP	: POLYPROPYLENE FILM CAP	RSNR.CRYS	: CRYSTAL RESONATOR
C.TNTL	: TANTALUM CAP	R.TW.CEM	: TWIN CEMENT FIXED RESISTOR
C.TNTL.CHP	: CHIP TANTALUM CAP	R.WW	: WIRE WOUND RESISTOR
C.TRIM	: TRIMMER CAP	SCR.BND.HD	: BIND HEAD B-TITE SCREW
CN	: CONNECTOR	SCR.BW.HD	: BW HEAD TAPPING SCREW
CN.BS.PIN	: CONNECTOR, BASE PIN	SCR.CUP	: CUP TITE SCREW
CN.CANNON	: CONNECTOR, CANNON	SCR.TERM	: SCREW TERMINAL
CN.DIN	: CONNECTOR, DIN	SCR.TR	: SCREW, TRANSISTOR
CN.FLAT	: CONNECTOR, FLAT CABLE	SUPRT.PCB	: SUPPORT, P.C.B.
CN.POST	: CONNECTOR, BASE POST	SURG.PRTCT	: SURGE PROTECTOR
COIL.MX.AM	: COIL, AM MIX	SW.TACT	: TACT SWITCH
COIL.AT.FM	: COIL, FM ANTENNA	SW.LEAF	: LEAF SWITCH
COIL.DT.FM	: COIL, FM DETECT	SW.LEVER	: LEVER SWITCH
COIL.MX.FM	: COIL, FM MIX	SW.MICRO	: MICRO SWITCH
COIL.OUTPT	: OUTPUT COIL	SW.PUSH	: PUSH SWITCH
DIOD.ARRAY	: DIODE ARRAY	SW.RT.ENC	: ROTARY ENCODER
DIODE.BRG	: DIODE BRIDGE	SW.RT.MTR	: ROTARY SWITCH WITH MOTOR
DIODE.CHP	: CHIP DIODE	SW.RT	: ROTARY SWITCH
DIODE.VAR	: VARACTOR DIODE	SW.SLIDE	: SLIDE SWITCH
DIOD.Z.CHP	: CHIP ZENER DIODE	TERM.SP	: SPEAKER TERMINAL
DIODE.ZENR	: ZENER DIODE	TERM.WRAP	: WRAPPING TERMINAL
DSCR.CE	: CERAMIC DISCRIMINATOR	THRMST.CHP	: CHIP THERMISTOR
FER.BEAD	: FERRITE BEADS	TR.CHP	: CHIP TRANSISTOR
FER.CORE	: FERRITE CORE	TR.DGT	: DIGITAL TRANSISTOR
FET.CHP	: CHIP FET	TR.DGT.CHP	: CHIP DIGITAL TRANSISTOR
FL.DSPLY	: FLUORESCENT DISPLAY	TRANS	: TRANSFORMER
FLTR.CE	: CERAMIC FILTER	TRANS.PULS	: PULSE TRANSFORMER
FLTR.COMB	: COMB FILTER MODULE	TRANS.PWR	: POWER TRANSFORMER ASS'y
FLTR.LC.RF	: LC FILTER ,EMI	TUNER.AM	: TUNER PACK, AM
GND.MTL	: GROUND PLATE	TUNER.FM	: TUNER PACK, FM
GND.TERM	: GROUND TERMINAL	TUNER.PK	: FRONT-END TUNER PACK
HOLDER.FUS	: FUSE HOLDER	VR	: ROTARY POTENTIOMETER
IC.PRTCT	: IC PROTECTOR	VR.MTR	: POTENTIOMETER WITH MOTOR
JUMPER.CN	: JUMPER CONNECTOR	VR.SW	: POTENTIOMETER WITH ROTARY SW
JUMPER.TST	: JUMPER, TEST POINT	VR.SLIDE	: SLIDE POTENTIOMETER
L.DTCT	: LIGHT DETECTING MODULE	VR.TRIM	: TRIMMER POTENTIOMETER

**Note)** Those parts marked with “#” are not included in the P.C.B. ass'y.

**P.C.B. MAIN**

Schm Ref.	PART NO.	Description	
*	V3548300	P.C.B.	MAIN(U)
*	V3548400	P.C.B.	MAIN(BG)
CB1	V3733000	CN	28P
CB2	VT707200	L.EMIT	TOTX178
CB3	VT620100	L.DTCT	TORX178A
CB4	VT620100	L.DTCT	TORX178A
* CB5	VQ047400	CN.BS.PIN	19P
CB6	VB390200	CN.BS.PIN	6P
CB7	VB390100	CN.BS.PIN	5P
CB8	VB390100	CN.BS.PIN	5P
* CB101	VQ963900	CN.BS.PIN	18P
CB301	VG879900	CN.BS.PIN	2P
* CB401	VP245600	CN	2P
CB501	Vi878100	CN.BS.PIN	3P
* CB601	VQ044900	CN.BS.PIN	19P
CB602	Vi878100	CN.BS.PIN	3P
C1	VJ599100	C.CE.TUBLR	0.1uF 50V
C2	VJ599100	C.CE.TUBLR	0.1uF 50V
C3	UR838100	C.EL	100uF 16V
C4	VJ599100	C.CE.TUBLR	0.1uF 50V
C5	VU545000	C.EL	47000uF 5.5V
C6	VJ599100	C.CE.TUBLR	0.1uF 50V
C7	VG280100	C.CE.TUBLR	0.022uF 25V
C8	VJ599100	C.CE.TUBLR	0.1uF 50V
C9	VJ599100	C.CE.TUBLR	0.1uF 50V
C10	UA353300	C.MYLAR	3000pF 50V
* C11	VQ083000	C.EL	47uF 16V
* C12	VQ083000	C.EL	47uF 16V
C13	UA353300	C.MYLAR	3000pF 50V
C14	UR838100	C.EL	100uF 16V
C15	UR838100	C.EL	100uF 16V
C16	VG287600	C.EL	100uF 25V
C17	UA953390	C.MYLAR	3900pF 50V
C18	UA953390	C.MYLAR	3900pF 50V
C19	VG287600	C.EL	100uF 25V
* C20	UR846470	C.EL	4.7uF 25V
C21	UR837100	C.EL	10uF 16V
C22	VF466600	C.CE.TUBLR	10pF 50V
C23	VF466700	C.CE.TUBLR	47pF 50V
C24	VF466700	C.CE.TUBLR	47pF 50V
C25	VF466600	C.CE.TUBLR	10pF 50V
C26	UR837100	C.EL	10uF 16V
* C27	UR846470	C.EL	4.7uF 25V
C28	UR866100	C.EL	1uF 50V
C29	UR838470	C.EL	470uF 16V
C30	VJ599100	C.CE.TUBLR	0.1uF 50V
C31	VQ569900	C.EL	100uF 25V
C32	VQ569900	C.EL	100uF 25V
C33	UA952560	C.MYLAR	560pF 50V
C35	UR866100	C.EL	1uF 50V
* C36	UR846470	C.EL	4.7uF 25V
C37	UA952220	C.MYLAR	220pF 50V
C38	UR837100	C.EL	10uF 16V

\* New Parts

Schm Ref.	PART NO.	Description	
C39	UR837100	C.EL	10uF 16V
C40	UA952220	C.MYLAR	220pF 50V
C42	UR866100	C.EL	1uF 50V
* C43	UR846470	C.EL	4.7uF 25V
C44	UA952560	C.MYLAR	560pF 50V
C45	VK534100	C.PP	0.01uF 100V
C46	UR865680	C.EL	0.68uF 50V
* C47	VG289800	C.EL	1000uF 50V
* C48	VG289600	C.EL	330uF 35V
* C49	VG289800	C.EL	1000uF 50V
* C50	VG289800	C.EL	1000uF 50V
C51	VR420400	C.EL	6800uF 16V
C52	VK534100	C.PP	0.01uF 100V
C53	UR837470	C.EL	47uF 16V
C54	UR866100	C.EL	1uF 50V
* C55	VR169000	C.MYLAR.ML	ECQ-V1H334JL3
C56	UR837100	C.EL	10uF 16V
C57	UR837470	C.EL	47uF 16V
C58	UR866470	C.EL	4.7uF 50V
C59	VJ599100	C.CE.TUBLR	0.1uF 50V
C60	UR868100	C.EL	100uF 50V
C61	UR867470	C.EL	47uF 50V
C62	UR866470	C.EL	4.7uF 50V
C63	VL883800	C.PP	2200pF 100V
C64	VL883800	C.PP	2200pF 100V
C65	VG278400	C.CE.TUBLR	220pF 50V
C66	VG278400	C.CE.TUBLR	220pF 50V
C67	UR866220	C.EL	2.2uF 50V
C68	VJ599100	C.CE.TUBLR	0.1uF 50V
C70	VR498100	C.EL	6.8uF 6.3V
C71	VR498100	C.EL	6.8uF 6.3V
C72	V3694000	C.EL	4.7uF 10V
C201	UR838330	C.EL	330uF 16V
C202	UR837100	C.EL	10uF 16V
C203	VJ599100	C.CE.TUBLR	0.1uF 50V
C204	VJ599100	C.CE.TUBLR	0.1uF 50V
C205	UR837100	C.EL	10uF 16V
C206	VJ599100	C.CE.TUBLR	0.1uF 50V
C207	UR838330	C.EL	330uF 16V
⚠ C301	VS741700	C.CE.SAFTY	0.01uF 275V
⚠ C302	VS741700	C.CE.SAFTY	0.01uF 275V
⚠ C401	VS741700	C.CE.SAFTY	0.01uF 275V
C601	VJ599100	C.CE.TUBLR	0.1uF 50V
C603	VJ599100	C.CE.TUBLR	0.1uF 50V
C604	VG277000	C.CE.TUBLR	33pF 50V
C605	VJ599100	C.CE.TUBLR	0.1uF 50V
C606	VJ599100	C.CE.TUBLR	0.1uF 50V
C607	UM406470	C.EL	4.7uF 50V
C608	UM406470	C.EL	4.7uF 50V
C609	UM406470	C.EL	4.7uF 50V
C610	VF466800	C.CE.TUBLR	100pF 50V
D1	VD631600	DIODE	1SS133,176,HSS104
* D2	VM973800	DIODE.ZENR	HZS4B2TD 4.0V

\* New Parts



P.C.B. MAIN

Schm Ref.	PART NO.	Description
D3	VD631600	DIODE 1SS133,176,HSS104
D4	VD631600	DIODE 1SS133,176,HSS104
D5	VM974400	DIODE.ZENR HZS6B2TD 6.0V
* D6	VM973800	DIODE.ZENR HZS4B2TD 4.0V
△ D7	VU264100	DIODE 1SR139-400
△ D8	VU264100	DIODE 1SR139-400
△ D9	VU264100	DIODE 1SR139-400
△ D10	VU264100	DIODE 1SR139-400
△ D11	VU264100	DIODE 1SR139-400
△ D12	VU264100	DIODE 1SR139-400
D13	VM974400	DIODE.ZENR HZS6B2TD 6.0V
D14	VM976500	DIODE.ZENR HZS302TD 30V
D15	VM974400	DIODE.ZENR HZS6B2TD 6.0V
D16	VU264100	DIODE 1SR139-400
D17	VU264100	DIODE 1SR139-400
D18	VD631600	DIODE 1SS133,176,HSS104
D201	VU264100	DIODE 1SR139-400
D202	VU264100	DIODE 1SR139-400
G1	VR463400	TERM.GND D3.5 TP00385
* HS1	VR110000	HEAT.SINK UOT-16CS25
* HS2	VR110000	HEAT.SINK UOT-16CS25
* HS3	VZ901000	HEAT.SINK OSH-1743-L50-SPL
* IC1	XA830A00	IC TC74HCT04AP INV
* IC2	iR015300	IC TC74HC153AP MPX
IC3	XA673A00	IC NJM5532D-D
IC4	XA987A00	IC NJM2068D-D
IC5	XA987A00	IC NJM2068D-D
* IC6	XV838C00	IC M30622M8-565FP CPU
* IC7	XM683A00	IC X24C00P
IC8	XD201A00	IC M5290P
* IC9	XQ667A00	IC M5237L
IC201	XG938A00	IC BA15218N
IC601	XR188A00	IC LC75710NE FLD
* JK201	V2086700	JACK.PHONE YKB21-5236
L1	VD473700	COIL 60uH
L2	VD473700	COIL 60uH
* L3	GE300610	FER.BEAD BL02RN1-R62T4
* L4	GE300610	FER.BEAD BL02RN1-R62T4
* L5	GE300610	FER.BEAD BL02RN1-R62T4
* L6	GE300610	FER.BEAD BL02RN1-R62T4
L7	VD473700	COIL 60uH
L202	Vi491100	FER.CORE BP53RB19012080M
L203	VD473700	COIL 60uH
L204	VD473700	COIL 60uH
L205	VD473700	COIL 60uH
L301	Vi491100	FER.CORE BP53RB19012080M
△* L302	VH227500	FLTR 20uH SU10VD-10020
* PJ1	V3007700	JACK.PIN 4P
Q1	iC174020	TR 2SC1740S R,S
Q2	iA093320	TR 2SA933S Q,R
Q3	iC174020	TR 2SC1740S R,S
Q4	iC287820	TR 2SC2878 A,B
Q5	iC287820	TR 2SC2878 A,B

\* New Parts

Schm Ref.	PART NO.	Description
Q6	iC287820	TR 2SC2878 A,B
Q7	iC287820	TR 2SC2878 A,B
Q8	iA093320	TR 2SA933S Q,R
△ Q9	iD040040	TR 2SD400
△ Q10	VS883300	TR 2SB1565 E,F
△ Q11	VC141900	TR 2SB941 P,Q
△ Q12	VS883400	TR 2SD2394 E,F
Q13	iA093320	TR 2SA933S Q,R
Q14	VG722000	TR.DGT DTC144ES
R22	Vi868300	R.FUS 0.68Ω 1/6W
* R56	VP441700	R.MTL.FLM 13KΩ 1/4W
* R57	VP439000	R.MTL.FLM 1KΩ 1/4W
* R58	VP441600	R.MTL.FLM 12KΩ 1/4W
* R83	VP440400	R.MTL.FLM 3.9KΩ 1/4W
* R86	VP442400	R.MTL.FLM 27KΩ 1/4W
R87	Vi868300	R.FUS 0.68Ω 1/6W
* R91	VP440600	R.MTL.FLM 4.7KΩ 1/4W
R92	HV755100	R.CAR.FP 100Ω 1/4W
R93	HV755100	R.CAR.FP 100Ω 1/4W
R201	HV755100	R.CAR.FP 100Ω 1/4W
R214	HV755100	R.CAR.FP 100Ω 1/4W
△* SW401	VZ364100	SW.PUSH SDDL1-A2-F-1
* SW501	VZ364300	SW.RT RK09K113
SW601	VG392900	SW.TACT SKHVAA
SW602	VG392900	SW.TACT SKHVAA
SW603	VG392900	SW.TACT SKHVAA
SW604	VG392900	SW.TACT SKHVAA
SW605	VG392900	SW.TACT SKHVAA
SW606	VG392900	SW.TACT SKHVAA
SW607	VG392900	SW.TACT SKHVAA
SW608	VG392900	SW.TACT SKHVAA
SW609	VG392900	SW.TACT SKHVAA
SW610	VG392900	SW.TACT SKHVAA
SW611	VG392900	SW.TACT SKHVAA
SW612	VG392900	SW.TACT SKHVAA
* SW613	VR021100	SW.RT.ENC EC16B242040SA
SW614	VG392900	SW.TACT SKHVAA
SW615	VG392900	SW.TACT SKHVAA
SW616	VG392900	SW.TACT SKHVAA
SW617	VG392900	SW.TACT SKHVAA
SW618	VG392900	SW.TACT SKHVAA
△* T301	XT874A00	TRANS.PWR (BG)
△* T301	XU805A00	TRANS.PWR (U)
△* TH301	VT865700	POSISTOR PTH8L14AR0R5M1C030
△* TH302	VT865700	POSISTOR PTH8L14AR0R5M1C030
U601	VU591000	L.DTCT GP1U271X
* V601	V3200000	FL.DSPLY 15-BT-53G
VR201	V3703700	VR A20KΩ
VR202	V3703700	VR A20KΩ
XL1	VQ791000	RSNR.CE 10MHz
	VB966900	CN IMSA-6024
	BB071360	SCR.TERM 8.3x13
	V3747500	SUPRT

\* New Parts

## P.C.B. MAIN

Schm Ref.	PART NO.	Description		
	VR519500	SHEET		
	V3747400	SPACER.FL	T4x6x18	
	EG330030	SCR.BND.HD	3x6	FCRM3-BL
*	V3548500	P.C.B.	DIGITAL	
* CB701	VQ962100	CN.BS.PIN	18P	
C701	VJ900700	C.CE.M.CHP	33pF	50V
C702	UB245100	C.CE.M.CHP	0.1uF	25V
C703	UB245100	C.CE.M.CHP	0.1uF	25V
C704	UB245100	C.CE.M.CHP	0.1uF	25V
C705	UB052100	C.CE.M.CHP	100pF	50V
C706	UB052100	C.CE.M.CHP	100pF	50V
C707	UB052100	C.CE.M.CHP	100pF	50V
C708	UB052100	C.CE.M.CHP	100pF	50V
C709	UB052100	C.CE.M.CHP	100pF	50V
C710	UB052100	C.CE.M.CHP	100pF	50V
C711	UB052100	C.CE.M.CHP	100pF	50V
C712	UB245100	C.CE.M.CHP	0.1uF	25V
C713	VJ900700	C.CE.M.CHP	33pF	50V
C714	UB245100	C.CE.M.CHP	0.1uF	25V
C715	UB013100	C.CE.M.CHP	1000pF	50V
C716	UB245100	C.CE.M.CHP	0.1uF	25V
C717	UM388100	C.EL	100uF	10V
C718	UA953470	C.MYLAR	4700pF	50V
C719	UB245100	C.CE.M.CHP	0.1uF	25V
C720	UB245100	C.CE.M.CHP	0.1uF	25V
C721	UB245100	C.CE.M.CHP	0.1uF	25V
C722	VJ900900	C.CE.M.CHP	39pF	50V
C723	VJ900700	C.CE.M.CHP	33pF	50V
C724	UM388100	C.EL	100uF	10V
C725	UB245100	C.CE.M.CHP	0.1uF	25V
C726	UM388100	C.EL	100uF	10V
C727	UM388100	C.EL	100uF	10V
C728	UB245100	C.CE.M.CHP	0.1uF	25V
C729	UM387470	C.EL	47uF	16V
C730	UM387470	C.EL	47uF	16V
C731	UM388100	C.EL	100uF	10V
C732	UB245100	C.CE.M.CHP	0.1uF	25V
C733	UB052100	C.CE.M.CHP	100pF	50V
C734	UB245100	C.CE.M.CHP	0.1uF	25V
C735	UB052100	C.CE.M.CHP	100pF	50V
C736	UB245100	C.CE.M.CHP	0.1uF	25V
C737	UA954470	C.MYLAR	0.047uF	50V
D701	VT332900	DIODE	1SS355	
D702	VT332900	DIODE	1SS355	
D703	VU990900	DIODE.ZENR	MA8033-H	3.4V
IC701	XR038A00	IC	NJM2904M	OP AMP
IC702	XL091A00	IC	HD74HC02	FPEL NOR
IC703	XG948E00	IC	YM3436DK	
* IC704	XE788A00	IC	YM6104	
IC705	XW060A00	IC	YM3437C	FE2

\* New Parts

Schm Ref.	PART NO.	Description		
* IC706	XM332A00	IC	TC74VHC04F	EL INV
Q701	iC174020	TR	2SC1740S	R,S
* Q702	VC123900	TR.DGT	DTA143EK	
* Q703	VG730700	TR.CHP	2SC3326	B
R720	HV753220	R.CAR.FP	2.2Ω	1/4W
R721	HV753220	R.CAR.FP	2.2Ω	1/4W
R724	HV753220	R.CAR.FP	2.2Ω	1/4W
R725	HV753220	R.CAR.FP	2.2Ω	1/4W
XL701	Vi552000	RSNR.CRYS	12.288MHz	
	BB071360	SCR.TERM	8.3x13	
	RD250000	R.CAR.CHP	0Ω	1/10W
	RD254220	R.CAR.CHP	22Ω	1/10W
	RD254470	R.CAR.CHP	47Ω	1/10W
	RD255100	R.CAR.CHP	100Ω	1/10W
	RD255390	R.CAR.CHP	390Ω	1/10W
	RD256100	R.CAR.CHP	1KΩ	1/10W
	RD256220	R.CAR.CHP	2.2KΩ	1/10W
	RD256330	R.CAR.CHP	3.3KΩ	1/10W
	RD256470	R.CAR.CHP	4.7KΩ	1/10W
	RD256820	R.CAR.CHP	8.2KΩ	1/10W
	RD257100	R.CAR.CHP	10KΩ	1/10W
	RD257180	R.CAR.CHP	18KΩ	1/10W
	RD257470	R.CAR.CHP	47KΩ	1/10W
	RD258100	R.CAR.CHP	100KΩ	1/10W
	RD259100	R.CAR.CHP	1MΩ	1/10W

\* New Parts

## P.C.B. MD MAIN

Schm				
Ref.	PART NO.	Description	Remarks	
*	AAX02260	P.C.B.	MAIN	92LPWB2976MDSS
* C1100	AAX02530	C.CHP	4.7uF 10V	RCKZ0003AWZZ
* C1101	AAX02750	C.CHP	1uF 6.3V	VCKYTV0JB105K
* C1102	AAX02770	C.CHP	1uF 16V	VCKYTV1CF105K
* C1103	AAX02800	C.CHP	0.027uF 50V	VCKYTV1HB273K
* C1104	AAX02810	C.CHP	0.033uF 50V	VCKYTV1HB333K
* C1105	AAX02690	C.CHP	3300pF 50V	VCKYCY1HB332K
* C1106	AAX02750	C.CHP	1uF 6.3V	VCKYTV0JB105K
* C1107	AAX02650	C.CHP	0.033uF 16V	VCKYCY1CB333K
* C1108	AAX02760	C.CHP	0.47uF 16V	VCKYTV1CB474K
* C1109	AAX02750	C.CHP	1uF 6.3V	VCKYTV0JB105K
* C1110	AAX02820	C.CHP	4700pF 50V	VCKYTV1HB472K
* C1111	AAX02760	C.CHP	0.47uF 16V	VCKYTV1CB474K
* C1112	AAX02590	C.CHP	330pF 50V	VCCCCY1HH331J
* C1113	AAX02580	C.CHP	270pF 50V	VCCCCY1HH271J
* C1114	AAX02580	C.CHP	270pF 50V	VCCCCY1HH271J
* C1115	AAX02580	C.CHP	270pF 50V	VCCCCY1HH271J
* C1116	AAX02580	C.CHP	270pF 50V	VCCCCY1HH271J
* C1117	AAX02580	C.CHP	270pF 50V	VCCCCY1HH271J
* C1118	AAX02780	C.CHP	1uF 16V	VCKYTV1CF105Z
* C1119	AAX02750	C.CHP	1uF 6.3V	VCKYTV0JB105K
* C1120	AAX02830	C.CHP	0.01uF 50V	VCKYTV1HF103Z
* C1200	AAX02780	C.CHP	1uF 16V	VCKYTV1CF105Z
* C1201	AAX02520	C.CHP	10uF 10V	RCKZ0002AWZZ
* C1202	AAX02780	C.CHP	1uF 16V	VCKYTV1CF105Z
* C1203	AAX02780	C.CHP	1uF 16V	VCKYTV1CF105Z
* C1204	AAX02660	C.CHP	0.047uF 16V	VCKYCY1CB473K
* C1205	AAX02780	C.CHP	1uF 16V	VCKYTV1CF105Z
* C1206	AAX02790	C.CHP	1200pF 50V	VCKYTV1HB122K
* C1207	AAX02780	C.CHP	1uF 16V	VCKYTV1CF105Z
* C1208	AAX02550	C.CHP	12pF 50V	VCCCCY1HH120J
* C1209	AAX02550	C.CHP	12pF 50V	VCCCCY1HH120J
* C1210	AAX02560	C.CHP	22pF 50V	VCCCCY1HH220J
* C1300	AAX02600	C.CHP	120pF 50V	VCCCTV1HH121J
* C1301	AAX02640	C.CHP	0.027uF 16V	VCKYCY1CB273K
* C1302	AAX02520	C.CHP	10uF 10V	RCKZ0002AWZZ
* C1303	AAX02530	C.CHP	4.7uF 10V	RCKZ0003AWZZ
* C1304	AAX02520	C.CHP	10uF 10V	RCKZ0002AWZZ
* C1400	AAX02630	C.CHP	0.022uF 16V	VCKYCY1CB223K
* C1401	AAX02630	C.CHP	0.022uF 16V	VCKYCY1CB223K
* C1402	AAX02700	C.CHP	680pF 50V	VCKYCY1HB681K
* C1403	AAX02660	C.CHP	0.047uF 16V	VCKYCY1CB473K
* C1404	AAX02630	C.CHP	0.022uF 16V	VCKYCY1CB223K
* C1405	AAX02700	C.CHP	680pF 50V	VCKYCY1HB681K
* C1406	AAX02630	C.CHP	0.022uF 16V	VCKYCY1CB223K
* C1407	AAX02660	C.CHP	0.047uF 16V	VCKYCY1CB473K
* C1408	AAX02630	C.CHP	0.022uF 16V	VCKYCY1CB223K
* C1409	AAX02670	C.CHP	0.1uF 25V	VCKYCY1EF104Z
* C1410	AAX02780	C.CHP	1uF 16V	VCKYTV1CF105Z
* C1411	AAX02590	C.CHP	330pF 50V	VCCCCY1HH331J
* C1501	AAX02780	C.CHP	1uF 16V	VCKYTV1CF105Z
* C1502	AAX02570	C.CHP	220pF 50V	VCCCCY1HH221J
* C1503	AAX02720	C.CHP	0.33uF 16V	VCKYTV1CF105Z

\* New Parts

Schm				
Ref.	PART NO.	Description	Remarks	
* C1504	AAX02570	C.CHP	220pF 50V	VCCCCY1HH221J
* C1505	AAX02540	C.CHP	100pF 50V	VCCCCY1HH101J
* C1506	AAX02540	C.CHP	100pF 50V	VCCCCY1HH101J
* C1508	AAX02660	C.CHP	0.047uF 16V	VCKYCY1CB473K
* C1509	AAX02660	C.CHP	0.047uF 16V	VCKYCY1CB473K
* C1511	AAX02560	C.CHP	22pF 50V	VCCCCY1HH220J
* C1600	AAX02730	C.CHP	1uF 16V	VCKYTV1CF105Z
* C1601	AAX02610	C.CHP	820pF 50V	VCCSCY1HL821J
* C1602	AAX02610	C.CHP	820pF 50V	VCCSCY1HL821J
* C1603	AAX02610	C.CHP	820pF 50V	VCCSCY1HL821J
* C1604	AAX02610	C.CHP	820pF 50V	VCCSCY1HL821J
* C1606	AAX02520	C.CHP	10uF 10V	RCKZ0002AWZZ
* C1607	AAX02780	C.CHP	1uF 16V	VCKYTV1CF105Z
* C1608	AAX02490	C.EL.CHP	100uF 10V	VCEAPS107AF1A
* C1610	AAX02530	C.CHP	4.7uF 10V	RCKZ0003AWZZ
* C1611	AAX02710	C.CHP	8200pF 50V	VCKYCY1HB822K
* C1612	AAX02710	C.CHP	8200pF 50V	VCKYCY1HB822K
* C1613	AAX02680	C.CHP	1500pF 50V	VCKYCY1HB152K
* C1615	AAX02680	C.CHP	1500pF 50V	VCKYCY1HB152K
* C1616	AAX02490	C.EL.CHP	100pF 10V	VCEAPS107AF1A
* C1619	AAX02590	C.CHP	330pF 50V	VCCCCY1HH331J
* C1700	AAX02510	C.EL.CHP	47uF 4V	VCEAPS476AF0G
* C1701	AAX02510	C.EL.CHP	47uF 4V	VCEAPS476AF0G
* C1702	AAX02620	C.CHP	0.01uF 16V	VCKYCY1CB103K
* C1703	AAX02660	C.CHP	0.047uF 16V	VCKYCY1CB473K
* C1704	AAX02510	C.EL.CHP	47uF 4V	VCEAPS476AF0G
* C1705	AAX02660	C.CHP	0.047uF 16V	VCKYCY1CB473K
* C1706	AAX02830	C.CHP	0.01uF 50V	VCKYTV1HF103Z
* C1707	AAX02780	C.CHP	1uF 16V	VCKYTV1CF105Z
* C1708	AAX02830	C.CHP	0.01uF 50V	VCKYTV1HF103Z
* C1709	AAX02830	C.CHP	0.01uF 50V	VCKYTV1HF103Z
* C1710	AAX02480	C.EL.CHP	10uF 16V	RCEZ1620AFZZ
* C1711	AAX02510	C.EL.CHP	47uF 4V	VCEAPS476AF0G
* C1712	AAX02480	C.EL.CHP	10uF 16V	RCEZ1620AFZZ
* C1713	AAX02830	C.CHP	0.01uF 50V	VCKYTV1HF103Z
* C1714	AAX02780	C.CHP	1uF 16V	VCKYTV1CF105Z
* C1715	AAX02830	C.CHP	0.01uF 50V	VCKYTV1HF103Z
* C1716	AAX02510	C.EL.CHP	47uF 4V	VCEAPS476AF0G
* C1800	AAX02500	C.EL.CHP	220uF 4V	VCEAPS227AF0G
* C1801	AAX02520	C.CHP	10uF 10V	RCKZ0002AWZZ
* C1802	AAX02520	C.CHP	10uF 10V	RCKZ0002AWZZ
* C1803	AAX02490	C.EL.CHP	100pF 10V	VCEAPS107AF1A
* C1804	AAX02740	C.CHP	2.2uF 16V	VCKYTV1CF225Z
* C1805	AAX02780	C.CHP	1uF 16V	VCKYTV1CF105Z
* CN1101	AAX01400	CN.PLUG	28P	QCNCWY028AFZZ
* CN1300	AAX01380	CN.PLUG	2P	QCNCM891BAFZZ
* CN1401	AAX01390	CN.PLUG	5P	QCNCWXC05AFZZ
* CN1501	AAX01410	CN.PLUG	28P	QCNCWZ028AFZZ
* CN1602	AAX01350	CN.PLUG	2P	QCNCM890BAF02
* CN1603	AAX01370	CN.PLUG	2P	QCNCM890BAFZZ
* CN1604	AAX01360	CN.PLUG	2P	QCNCM890BAF06
* CW1901	AAX01340	CN.FLT	5P	QCNCWN1042AWZZ
* CW1903	AAX02360	CN.BS.PIN	2P	QCNCWN1044AWZZ

\* New Parts

P.C.B. MD MAIN

Schm				
Ref.	PART NO.	Description	Remarks	
* D1300	AA02470	DIODE	SB0209CP	VHDSB0209CP1
* D1301	AA02470	DIODE	SB0209CP	VHDSB0209CP1
* D1401	AA02460	DIODE	SB00703Q	VHDSB00703Q1
* IC1101	AA02180	IC	IR3R55	VHIIIR3R55//1
* IC1201	AA04880	IC	LR376484	VHILR3764841
* IC1202	AA02150	IC	IX2474AF	RHIX2474AFZZ
* IC1300	AA02160	IC	74ACT02F	VHI74ACT02F1
* IC1401	AA02140	IC	IX0290AW	RHIX0290AWZZ
* IC1402	AA02200	IC	S29294A	VHIS29294A/1
* IC1601	AA02170	IC	BA5984FP	VHIBA5984FP1
* IC1701	AA02210	IC	UDA1344	VHIUDA1344/1
* IC1702	AA02190	IC	NJM431U	VHINJM431U/1
* IC1801	AA02220	IC	XC62EP32	VHIXC62EP321
* L1100	AA02230	IC	0.47uH	VPBNNR47K0000
* L1101	AA02330	COIL	10uH	VPBNN100K0000
* L1200	AA02340	COIL	4.7uH	VPBNN47K0000
* L1201	AA02230	COIL	0.47uH	VPBNNR47K0000
* L1300	AA02350	COIL	47uH	VPNM470K0000
* L1301	AA02350	COIL	47uH	VPNM470K0000
* L1501	AA02320	COIL	1uH	RCILZ0016AWZZ
* L1503	AA02340	COIL	4.7uH	VPBNN47K0000
* L1600	AA02320	COIL	1uH	RCILZ0016AWZZ
* L1700	AA02330	COIL	10uH	VPBNN100K0000
* L1701	AA02330	COIL	10uH	VPBNN100K0000
* Q1300	AA02100	FET	2SK2909	VS2SK2909//1
* Q1301	AA02090	FET	2SK1473	VS2SK1473//1
* Q1302	AA02100	FET	2SK2909	VS2SK2909//1
* Q1303	AA02090	FET	2SK1473	VS2SK1473//1
* Q1400	AA02890	TR	RNC1404	VSRNC1404//1
* Q1401	AA02890	TR	RNC1404	VSRNC1404//1
* Q1402	AA02880	TR	RN2404	VSRN2404//1
* Q1403	AA02880	TR	RN2404	VSRN2404//1
* Q1500	AA02900	TR	RNC1407	VSRNC1407//1
* Q1700	AA02860	TR	2SC2412KR	VS2SC2412KR1
* Q1701	AA02890	TR	RNC1404	VSRNC1404//1
* Q1702	AA02840	TR	2SA1162G	VS2SA1162G/1
* Q1800	AA02900	TR	RNC1407	VSRNC1407//1
* Q1801	AA02840	TR	2SA1162G	VS2SA1162G/1
* Q1802	AA02900	TR	RNC1407	VSRNC1407//1
* Q1803	AA02870	TR	RN1406	VSRN1406//1
* Q1804	AA02850	TR	2SA1314C	VS2SA1314C/1
* Q1805	AA02850	TR	2SA1314C	VS2SA1314C/1
* Q1806	AA02870	TR	RN1406	VSRN1406//1
* R1100	AA03080	R.CAR.CHP	27Ω 1/8W	VRSTQ2BB270J
* R1101	AA01880	R.CAR.CHP	1Ω 1/16W	VRSCY1JB1R0J
* R1102	AA01760	R.CAR.CHP	10KΩ 1/16W	VRSCY1JB103J
* R1103	AA02020	R.CAR.CHP	390KΩ 1/16W	VRSCY1JB394J
* R1105	AA01810	R.CAR.CHP	1.2KΩ 1/16W	VRSCY1JB122J
* R1106	AA02060	R.CAR.CHP	56KΩ 1/16W	VRSCY1JB563J
* R1107	AA02050	R.CAR.CHP	560Ω 1/16W	VRSCY1JB561J
* R1108	AA01910	R.CAR.CHP	22KΩ 1/16W	VRSCY1JB223J
* R1109	AA01910	R.CAR.CHP	22KΩ 1/16W	VRSCY1JB223J
* R1110	AA01910	R.CAR.CHP	22KΩ 1/16W	VRSCY1JB223J

\* New Parts

Schm				
Ref.	PART NO.	Description	Remarks	
* R1111	AA01910	R.CAR.CHP	22KΩ 1/16W	VRSCY1JB223J
* R1112	AA01910	R.CAR.CHP	22KΩ 1/16W	VRSCY1JB223J
* R1113	AA01710	R.CAR.CHP	0Ω 1/16W	VRSCY1JB000J
* R1200	AA01820	R.CAR.CHP	120KΩ 1/16W	VRSCY1JB124J
* R1201	AA01820	R.CAR.CHP	120KΩ 1/16W	VRSCY1JB124J
* R1202	AA01860	R.CAR.CHP	150KΩ 1/16W	VRSCY1JB154D
* R1203	AA01860	R.CAR.CHP	150KΩ 1/16W	VRSCY1JB154D
* R1204	AA02070	R.CAR.CHP	62KΩ 1/16W	VRSCY1JB623J
* R1205	AA02070	R.CAR.CHP	62KΩ 1/16W	VRSCY1JB623J
* R1206	AA01990	R.CAR.CHP	33KΩ 1/16W	VRSCY1JB333J
* R1207	AA01990	R.CAR.CHP	33KΩ 1/16W	VRSCY1JB333J
* R1208	AA01900	R.CAR.CHP	220Ω 1/16W	VRSCY1JB221J
* R1209	AA01730	R.CAR.CHP	100Ω 1/16W	VRSCY1JB101J
* R1210	AA01900	R.CAR.CHP	220Ω 1/16W	VRSCY1JB221J
* R1211	AA01900	R.CAR.CHP	220Ω 1/16W	VRSCY1JB221J
* R1212	AA02030	R.CAR.CHP	47Ω 1/16W	VRSCY1JB470J
* R1214	AA01760	R.CAR.CHP	10KΩ 1/16W	VRSCY1JB103J
* R1215	AA01790	R.CAR.CHP	1MΩ 1/16W	VRSCY1JB105J
* R1216	AA01710	R.CAR.CHP	0Ω 1/16W	VRSCY1JB000J
* R1217	AA01830	R.CAR.CHP	150Ω 1/16W	VRSCY1JB151J
* R1219	AA01760	R.CAR.CHP	10KΩ 1/16W	VRSCY1JB103J
* R1220	AA01710	R.CAR.CHP	0Ω 1/16W	VRSCY1JB000J
* R1221	AA01760	R.CAR.CHP	10KΩ 1/16W	VRSCY1JB103J
* R1222	AA01760	R.CAR.CHP	10KΩ 1/16W	VRSCY1JB103J
* R1223	AA01730	R.CAR.CHP	100Ω 1/16W	VRSCY1JB101J
* R1224	AA01710	R.CAR.CHP	0Ω 1/16W	VRSCY1JB000J
* R1300	AA03090	R.CAR.CHP	0Ω 1/10W	VRSTV2AB000J
* R1301	AA01720	R.CAR.CHP	10Ω 1/16W	VRSCY1JB100J
* R1302	AA03090	R.CAR.CHP	0Ω 1/10W	VRSTV2AB000J
* R1303	AA03060	R.CAR.CHP	0Ω 1/8W	VRSTQ2BB000J
* R1304	AA03150	R.CAR.CHP	680Ω 1/10W	VRSTV2AB681J
* R1400	AA01940	R.CAR.CHP	2.7KΩ 1/16W	VRSCY1JB272J
* R1401	AA01840	R.CAR.CHP	1.5KΩ 1/16W	VRSCY1JB152J
* R1402	AA01750	R.CAR.CHP	1KΩ 1/16W	VRSCY1JB102J
* R1403	AA01750	R.CAR.CHP	1KΩ 1/16W	VRSCY1JB102J
* R1404	AA01750	R.CAR.CHP	1KΩ 1/16W	VRSCY1JB102J
* R1405	AA01980	R.CAR.CHP	3.3KΩ 1/16W	VRSCY1JB332J
* R1406	AA01780	R.CAR.CHP	100KΩ 1/16W	VRSCY1JB104J
* R1407	AA01780	R.CAR.CHP	100KΩ 1/16W	VRSCY1JB104J
* R1408	AA01980	R.CAR.CHP	3.3KΩ 1/16W	VRSCY1JB332J
* R1409	AA01750	R.CAR.CHP	1KΩ 1/16W	VRSCY1JB102J
* R1410	AA01980	R.CAR.CHP	3.3KΩ 1/16W	VRSCY1JB332J
* R1411	AA01750	R.CAR.CHP	1KΩ 1/16W	VRSCY1JB102J
* R1412	AA01760	R.CAR.CHP	10KΩ 1/16W	VRSCY1JB103J
* R1413	AA01750	R.CAR.CHP	1KΩ 1/16W	VRSCY1JB102J
* R1414	AA01750	R.CAR.CHP	1KΩ 1/16W	VRSCY1JB102J
* R1415	AA01760	R.CAR.CHP	10KΩ 1/16W	VRSCY1JB103J
* R1416	AA01760	R.CAR.CHP	10KΩ 1/16W	VRSCY1JB103J
* R1417	AA01760	R.CAR.CHP	10KΩ 1/16W	VRSCY1JB103J
* R1419	AA01760	R.CAR.CHP	10KΩ 1/16W	VRSCY1JB103J
* R1420	AA01760	R.CAR.CHP	10KΩ 1/16W	VRSCY1JB103J
* R1421	AA01760	R.CAR.CHP	10KΩ 1/16W	VRSCY1JB103J
* R1422	AA01760	R.CAR.CHP	10KΩ 1/16W	VRSCY1JB103J

\* New Parts

**P.C.B. MD MAIN & OTHER**

Schm				
Ref.	PART NO.	Description	Remarks	
* R1423	AAX01760	R.CAR.CHP	10KΩ	1/16W VRSCY1JB103J
* R1424	AAX01760	R.CAR.CHP	10KΩ	1/16W VRSCY1JB103J
* R1425	AAX01780	R.CAR.CHP	100KΩ	1/16W VRSCY1JB104J
* R1426	AAX01750	R.CAR.CHP	1KΩ	1/16W VRSCY1JB102J
* R1427	AAX01750	R.CAR.CHP	1KΩ	1/16W VRSCY1JB102J
* R1428	AAX01750	R.CAR.CHP	1KΩ	1/16W VRSCY1JB102J
* R1429	AAX02040	R.CAR.CHP	47KΩ	1/16W VRSCY1JB473J
* R1430	AAX01760	R.CAR.CHP	10KΩ	1/16W VRSCY1JB103J
* R1444	AAX01730	R.CAR.CHP	100Ω	1/16W VRSCY1JB101J
* R1510	AAX03050	R.CAR.CHP	8.2KΩ	1/16W VRSCY1JB822J
* R1511	AAX03050	R.CAR.CHP	8.2KΩ	1/16W VRSCY1JB822J
* R1512	AAX02030	R.CAR.CHP	47Ω	1/16W VRSCY1JB470J
* R1513	AAX02030	R.CAR.CHP	47Ω	1/16W VRSCY1JB470J
* R1514	AAX01750	R.CAR.CHP	1KΩ	1/16W VRSCY1JB102J
* R1515	AAX01870	R.CAR.CHP	1.8KΩ	1/16W VRSCY1JB182J
* R1516	AAX01870	R.CAR.CHP	1.8KΩ	1/16W VRSCY1JB182J
* R1517	AAX01760	R.CAR.CHP	10KΩ	1/16W VRSCY1JB103J
* R1518	AAX01760	R.CAR.CHP	10KΩ	1/16W VRSCY1JB103J
* R1518	AAX01760	R.CAR.CHP	10KΩ	1/16W VRSCY1JB103J
* R1519	AAX01800	R.CAR.CHP	120Ω	1/16W VRSCY1JB121J
* R1520	AAX01760	R.CAR.CHP	10KΩ	1/16W VRSCY1JB103J
* R1521	AAX03020	R.CAR.CHP	6.8KΩ	1/16W VRSCY1JB682J
* R1522	AAX01900	R.CAR.CHP	220Ω	1/16W VRSCY1JB221J
* R1523	AAX01710	R.CAR.CHP	0Ω	1/16W VRSCY1JB000J
* R1525	AAX01980	R.CAR.CHP	3.3KΩ	1/16W VRSCY1JB332J
* R1526	AAX01750	R.CAR.CHP	1KΩ	1/16W VRSCY1JB102J
* R1527	AAX03050	R.CAR.CHP	8.2KΩ	1/16W VRSCY1JB822J
* R1528	AAX03050	R.CAR.CHP	8.2KΩ	1/16W VRSCY1JB822J
* R1529	AAX03050	R.CAR.CHP	8.2KΩ	1/16W VRSCY1JB822J
* R1530	AAX01900	R.CAR.CHP	220Ω	1/16W VRSCY1JB221J
* R1531	AAX01900	R.CAR.CHP	220Ω	1/16W VRSCY1JB221J
* R1532	AAX01750	R.CAR.CHP	1KΩ	1/16W VRSCY1JB102J
* R1535	AAX03130	R.CAR.CHP	47Ω	1/10W VRSTV2AB470J
* R1536	AAX03090	R.CAR.CHP	0Ω	1/10W VRSTV2AB000J
* R1537	AAX03090	R.CAR.CHP	0Ω	1/10W VRSTV2AB000J
* R1538	AAX03090	R.CAR.CHP	0Ω	1/10W VRSTV2AB000J
* R1539	AAX03090	R.CAR.CHP	0Ω	1/10W VRSTV2AB000J
* R1600	AAX02080	R.CAR.CHP	6.8KΩ	1/16W VRSCY1JB682D
* R1601	AAX02080	R.CAR.CHP	6.8KΩ	1/16W VRSCY1JB682D
* R1605	AAX01760	R.CAR.CHP	10KΩ	1/16W VRSCY1JB103J
* R1606	AAX01760	R.CAR.CHP	10KΩ	1/16W VRSCY1JB103J
* R1612	AAX01890	R.CAR.CHP	200KΩ	1/16W VRSCY1JB204D
* R1614	AAX01770	R.CAR.CHP	100KΩ	1/16W VRSCY1JB104D
* R1616	AAX03020	R.CAR.CHP	6.8KΩ	1/16W VRSCY1JB682J
* R1617	AAX03020	R.CAR.CHP	6.8KΩ	1/16W VRSCY1JB682J
* R1618	AAX01850	R.CAR.CHP	15KΩ	1/16W VRSCY1JB153J
* R1620	AAX01850	R.CAR.CHP	15KΩ	1/16W VRSCY1JB153J
* R1700	AAX02010	R.CAR.CHP	39KΩ	1/16W VRSCY1JB393J
* R1701	AAX01960	R.CAR.CHP	30KΩ	1/16W VRSCY1JB303J
* R1702	AAX01740	R.CAR.CHP	1KΩ	1/16W VRSCY1JB102D
* R1703	AAX01970	R.CAR.CHP	3.3KΩ	1/16W VRSCY1JB332D
* R1704	AAX03040	R.CAR.CHP	820Ω	1/16W VRSCY1JB821J
* R1705	AAX02010	R.CAR.CHP	39KΩ	1/16W VRSCY1JB393J

\* New Parts

Schm				
Ref.	PART NO.	Description	Remarks	
* R1706	AAX01790	R.CAR.CHP	1MΩ	1/16W VRSCY1JB105J
* R1707	AAX01750	R.CAR.CHP	1KΩ	1/16W VRSCY1JB102J
* R1708	AAX01950	R.CAR.CHP	27KΩ	1/16W VRSCY1JB273J
* R1709	AAX02010	R.CAR.CHP	39KΩ	1/16W VRSCY1JB393J
* R1710	AAX03030	R.CAR.CHP	680KΩ	1/16W VRSCY1JB684J
* R1711	AAX03100	R.CAR.CHP	12Ω	1/10W VRSTV2AB120J
* R1712	AAX03100	R.CAR.CHP	12Ω	1/10W VRSTV2AB120J
* R1713	AAX01780	R.CAR.CHP	100KΩ	1/16W VRSCY1JB104J
* R1801	AAX01930	R.CAR.CHP	270Ω	1/16W VRSCY1JB271J
* R1802	AAX01920	R.CAR.CHP	220K	1/16W VRSCY1JB224D
* R1803	AAX01770	R.CAR.CHP	100KΩ	1/16W VRSCY1JB104D
* R1804	AAX02000	R.CAR.CHP	390Ω	1/16W VRSCY1JB391J
* R1805	AAX01930	R.CAR.CHP	270Ω	1/16W VRSCY1JB271J
* R1806	AAX03120	R.CAR.CHP	1Ω	1/10W VRSTV2AB1R0J
* R1807	AAX01950	R.CAR.CHP	27KΩ	1/16W VRSCY1JB273J
* R1808	AAX01870	R.CAR.CHP	1.8KΩ	1/16W VRSCY1JB182J
* R1809	AAX03070	R.CAR.CHP	1Ω	1/8W VRSTQ2BB1R0J
* R1811	AAX03070	R.CAR.CHP	1Ω	1/8W VRSTQ2BB1R0J
* R1811	AAX03070	R.CAR.CHP	1Ω	1/8W VRSTQ2BB1R0J
* XL1201	AAX01660	RSNR.CRYS		RCRSC0001AWZZ
* CN1901	AAX02450	CN.SOKT	5P	QCNCW037EAWZZ
* R1901	AAX03140	R.CAR.CHP	470Ω	1/10W VRSTV2AB471J
* R1902	AAX03110	R.CAR.CHP	1.8KΩ	1/10W VRSTV2AB182J
* R1903	AAX03160	R.CAR.CHP	820Ω	1/10W VRSTV2AB821J
* R1904	AAX03160	R.CAR.CHP	820Ω	1/10W VRSTV2AB821J
* SW1952	AAX02410	SW		QSWP0006AWZZ
* SW1953	AAX02400	SW		QSWM0157AFZZ
* SW1954	AAX02380	SW		QSWM0002AWZZ
* SW1955	AAX02380	SW		QSWM0002AWZZ
* SW1956	AAX02390	SW		QSWM0156AFZZ
* AAX01420		P.W.B.	MECHANISM	QPWBF0400AWZZ

\* New Parts

MDX-595

# 1 EXPLODED VIEW

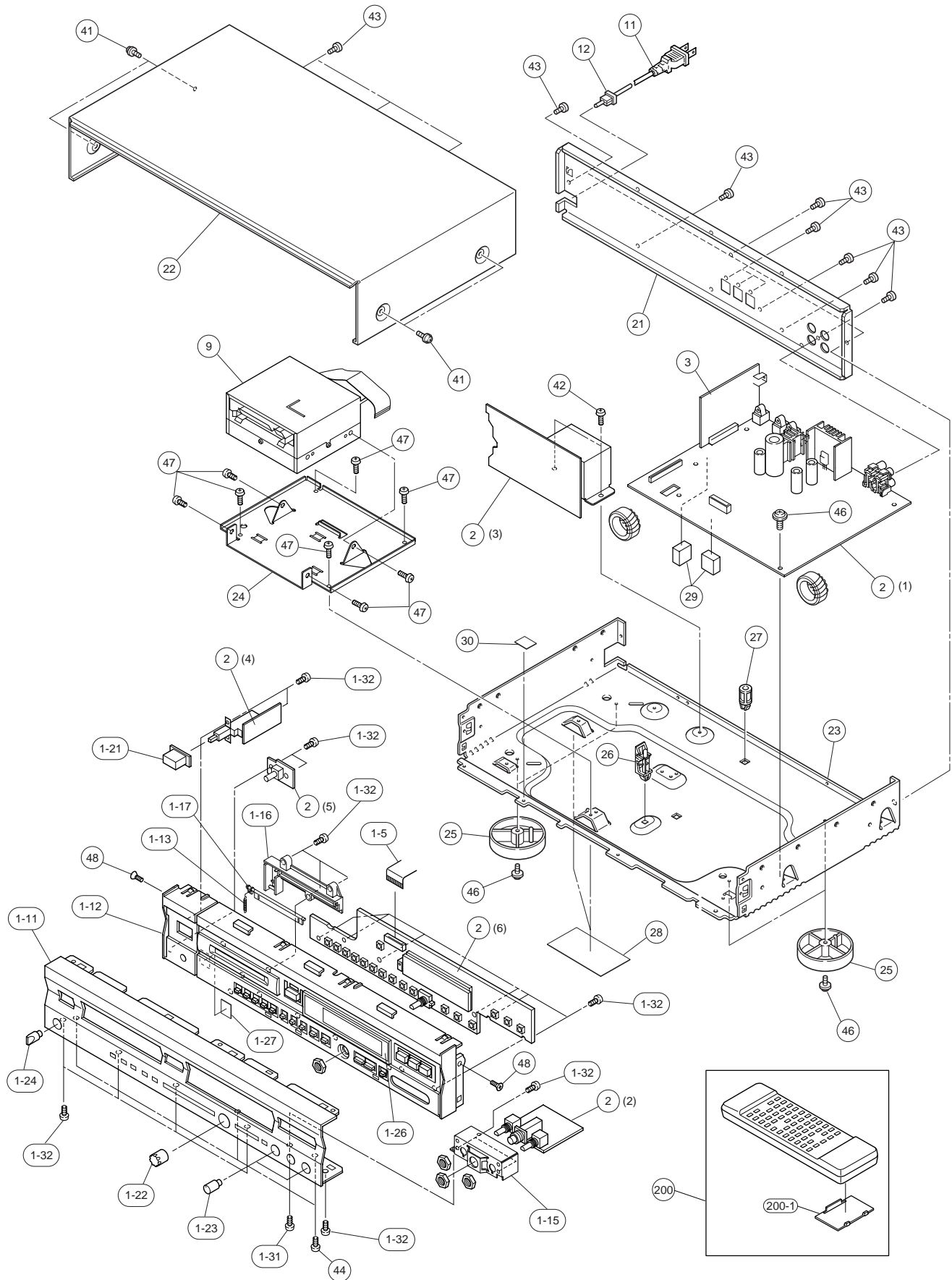

MECHANICAL PARTS

Ref. No.	PART NO.	Description	Remarks	Markets
* 1-5	MF119200	FLEXIBLE FLAT CABLE	19P 200mm	
* 1-11	V3080200	FRONT PANEL		BL
* 1-11	V3080300	FRONT PANEL		TI
* 1-12	V3080600	PANEL, SUB		BL
* 1-12	V3080700	PANEL, SUB		TI
* 1-13	V3082300	SPRING		
* 1-15	V3081800	SUPPORT, VR		
* 1-16	V3082200	GRILL, LID		BL
* 1-16	V3204800	GRILL, LID		TI
* 1-17	V3080800	LID, MD		BL
* 1-17	V3080900	LID, MD		TI
1-21	VZ494400	BUTTON	11x22	BL
1-21	VZ494500	BUTTON	11x22	TI
* 1-22	V2047400	KNOB	D14ED	BL
* 1-22	V2047500	KNOB	D14ED	TI
* 1-23	V3322700	KNOB, ED		BL
* 1-23	V3322800	KNOB, ED		TI
1-24	VR308400	KNOB, VR	D10	BL
* 1-24	VU114800	KNOB, VR	D10	TI
* 1-26	V3081500	WINDOW PANEL, LID		
1-27	V2269200	DAMPER	T1x13x13	
1-31	VN413300	BIND HEAD BONDING B-T. SCREW	3x8 MFZN2-BL	
* 1-32	EP630290	BIND HEAD P-TITE SCREW	3x6 FCRM3-BL	
* 2	V3548300	P.C.B. ASS'Y	MAIN	(U)
* 2	V3548400	P.C.B. ASS'Y	MAIN	(BG)
* 3	V3548500	P.C.B. ASS'Y	DIGITAL	
* 9	V3098100	MD RECORDER UNIT	MDM-98A	
△ 11	V2363800	POWER CORD ASS'Y		(U)
△ 11	VN363700	POWER CORD ASS'Y		(G)
△ 11	VV437300	POWER CORD ASS'Y		(B)
12	V2438700	CORD STOPPER	#10P1	
* 21	V3079900	REAR PANEL		(U)
* 21	V3080000	REAR PANEL		(BG)
* 22	VZ151900	TOP COVER		BL
* 22	VZ152000	TOP COVER		TI
* 23	VZ151800	CHASSIS, MAIN	ALL	
* 24	V3081700	SUPPORT, MECH		
25	VQ780300	LEG	D60xH16	
* 26	V3205000	CARD EDGE SPACER	KGES-18	
27	VU981200	SUPPORT, P.C.B.	No.3596	
28	VS037900	SHEET, TRAY	B	
* 29	V2113100	SPACER		
30	V2269200	DAMPER	T1x13x13	
41	21991500	PW HEAD S-TITE SCREW	4x8-10 FCRM3-BL	BL
41	VH313200	BW HEAD S-TITE SCREW	4x8-10 FNM3-BL	TI
* 42	V2728500	BIND HEAD S-TITE SCREW	4x7 MFZN2-BL	
43	VN413300	BIND HEAD BONDING B-T. SCREW	3x8 MFZN2-BL	
44	VE190700	BIND HEAD BONDING B-T. SCREW	3x6 FCRM3-BL	
46	EL300650	PW HEAD B-TITE SCREW	3x8-8 FCRM3-BL	
* 47	EP600530	BIND HEAD S-TITE SCREW	3x8 ZMC2-BL	
* 48	VF378100	FLAT HEAD SCREW	3x6 ZMC2-Y	

\* New Parts

Ref. No.	PART NO.	Description	Remarks	Markets
* 200	VZ480500	ACCESSORIES		
* 200-1	CX680450	REMOTE CONTROL TRANSMITTER		
	V3541900	LID		
	VY952200	OPTICAL CABLE	1P	
		PIN-PLUG CORD	2P 1.0m	
		BATTERY, MANGANESE	SUM-3,AA,R06	

\* New Parts

1 ■ EXPLODED VIEW (MD Mechanism Unit)

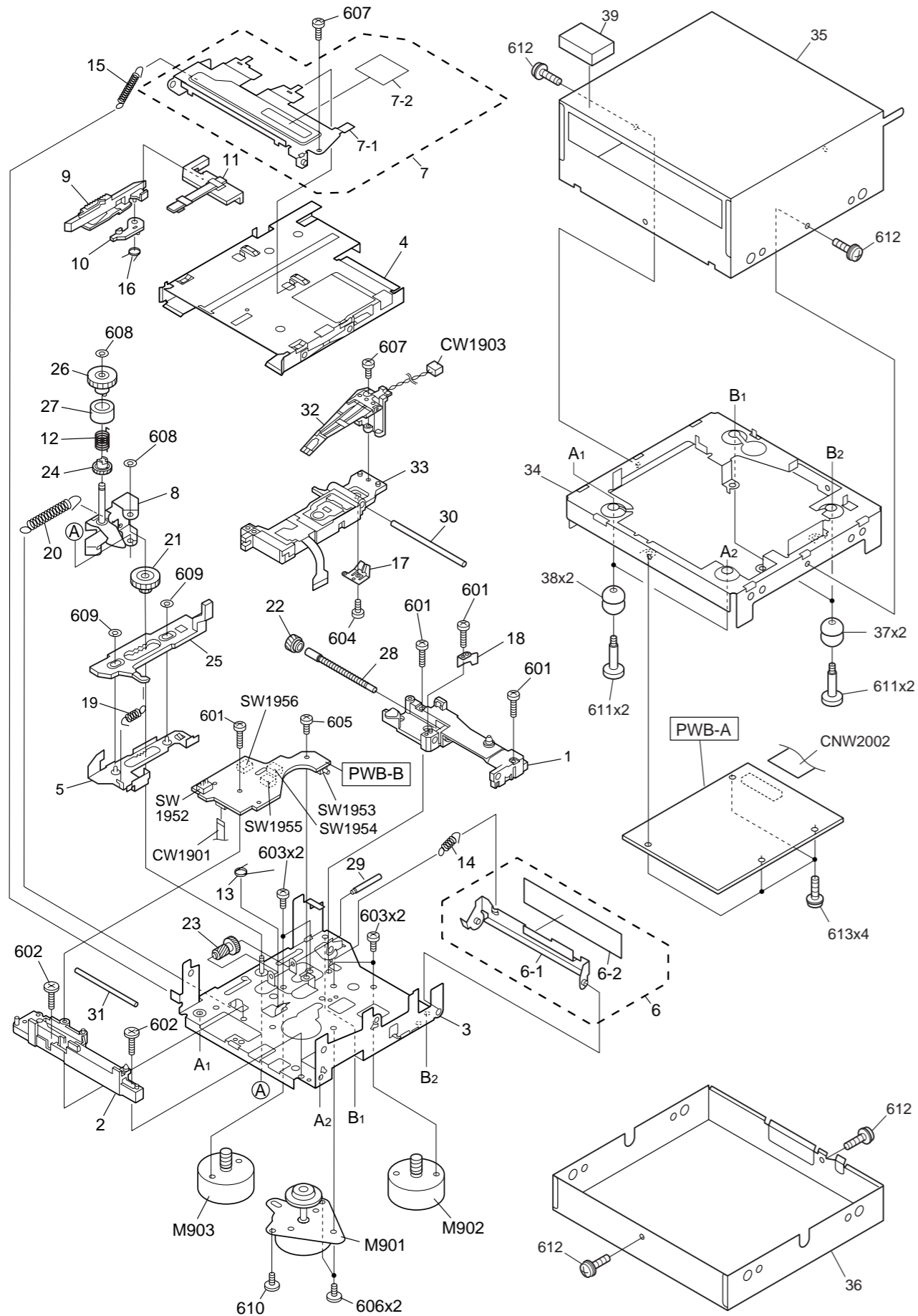

1 ■ MECHANICAL PARTS (MD Mechanism Unit)

Ref. No.	PART NO.	Description	Remarks	Markets
*	V3098100	MD RECORDER UNIT		V3098100
* 1	AAX02240	MD GUIDE	A	LANGF0033AWZZ
* 2	AAX02250	MD GUIDE	B	LANGF0034AWZZ
* 3	AAX02930	DRIVE CHASSIS		LCHSM0080AWM1
* 4	AAX02270	CARTRIDGE HOLDER		LHLDX3004AWM1
* 5	AAX02280	CAM PLATE LEVER		MLEVF0036AWM1
* 6	AAX02130	SHIFT ARM ASSY	HA	MLEVF0025AWM1
* 6-1	AAX02120	SHIFT ARM	HA	MLEVF0025AWZZ
* 6-2	AAX01510	SHEET, LEAD PROTECTION		PSHEP0026AWZZ
* 7	AAX01480	HOLDER ARM ASSY		MLEVF0037AWM2
* 7-1	AAX01460	HOLDER ARM		MLEVF0037AWM1
* 7-2	AAX01440	SHEET, HEAD PROTECTION		PSHEP0024AWZZ
* 8	AAX01600	ROLLER ARM LEVER		MLEVF0030AWM1
* 9	AAX02310	CLUTCH LEVER		MLEVP0075AWZZ
* 10	AAX02290	CATCH		MLEVP0076AWZZ
* 11	AAX02440	SLIDER LEVER		MLEVP0077AWZZ
* 12	AAX01590	SPRING, ROLLER HOLDER		MSPRD0103AWFJ
* 13	AAX02430	SPRING, SPIN		MSPRD0105AWFJ
* 14	AAX02370	SPRING, SHIFT ARM		MSPRD1318AFFJ
* 15	AAX01470	SPRING, HOLDER ARM		MSPRD1319AFFJ
* 16	AAX02300	SPRING, CATCH		MSPRD1334AFFJ
* 17	AAX01680	SPRING, LEAF	A	MSPRP0015AWFJ
* 18	AAX02950	SPRING, DRIVE SHAFT		MSPRP0017AWFJ
* 19	AAX01500	SPRING, RACK		MSPRT0018AWFJ
* 20	AAX01570	SPRING, ROLLER		MSPRT1566AFFJ
* 21	AAX01540	LOADING GEAR	B	NGERH0066AWZZ
* 22	AAX02920	DRIVE GEAR		NGERH0067AWZZ
* 23	AAX01530	LOADING GEAR	A	NGERH0068AWZZ
* 24	AAX01560	ROLLER GEAR		NGERH0084AWZZ
* 25	AAX01490	RACK GEAR		NGERR0002AWZZ
* 26	AAX01580	ROLLER HOLDER		NROLP0010AWZZ
* 27	AAX02910	TRANSFER ROLLER		NROLR0001AWZZ
* 28	AAX02940	DRIVING SHAFT		NSFTD0005AWFT
* 29	AAX01520	LOADING GEAR SHAFT		NSFTM0017AWFW
* 30	AAX01310	PICKUP SLIDE SHAFT		MSFTM0277AFFW
* 31	AAX01320	PICKUP GUIDE SHAFT		NSFTM0278AFFW
* 32	AAX01640	MAGNETIC HEAD		RCILH0108AFZZ
* 33	AAX01630	OPTICAL PICKUP		RCTR8190AFZZ
* 34	AAX01450	BASE FRAME		LANGK0092AWFW
* 35	AAX01650	UPPER COVER		PCOVS3021AWFW
* 36	AAX01670	BOTTOM COVER		PCOVS3022AWFW
* 37	AAX01700	RUBBER, UNTI-VIBRATION	A	PCUSG0672AFSA
* 38	AAX01690	RUBBER, UNTI-VIBRATION	B	PCUSG0672AFSB
* 39	AAX01430	CUSHION, HEAD		PCUSS0041AWZZ
* 601	AAX02960	SCREW	M1.7x9.5	LXBZ0030AWZZ
* 602	AAX02970	SCREW	M1.7x7.5	LXBZ0031AWZZ
* 603	AAX02980	SCREW	M1.7x2	LXBZ0032AWZZ
* 604	AAX03000	SCREW	M1.4x2.2	LXBZ0804AFF
* 605	AAX03010	SCREW	M1.7x3	LXBZ0846AFZZ
* 606	AAX01260	SCREW	M1.7x2.5	LXBZ0851AFZZ
* 607	AAX01280	SCREW	M1.7x5	LXBZ0883AFZZ
* 608	AAX01610	WASHER	1.5x3.2x0.5	LXWZ9268AFZZ

\* New Parts



Ref. No.	PART NO.	Description	Remarks	Markets
* 609	AAX01620	WASHER	1.2x3x0.2	LXWZ9269AFZZ
* 610	AAX02990	SCREW	M1.7x2.1	LXBZ0036AWZZ
* 611	AAX01270	SCREW	M1.7x8.9	LXBZ0852AFFD
* 612	AAX01290	SCREW	M2x4	XBPSD20P04K00
* 613	AAX01300	SCREW	M1.7x3	XSPSN17P03K00
* CNW2002	AAX02110	MD FLAT CABLE	28P	QCWNW6763AFM1
* M901	AAX02420	MOTOR, SPINDLE		RMOTV0012AWZZ
* M902	AAX01330	MOTOR, FEED		RMOTV0013AWM2
* M903	AAX01550	MOTOR, LOAD		RMOTV0014AWM1

\* New Parts

MDX-595

# GREASE APPLICATION DIAGRAM

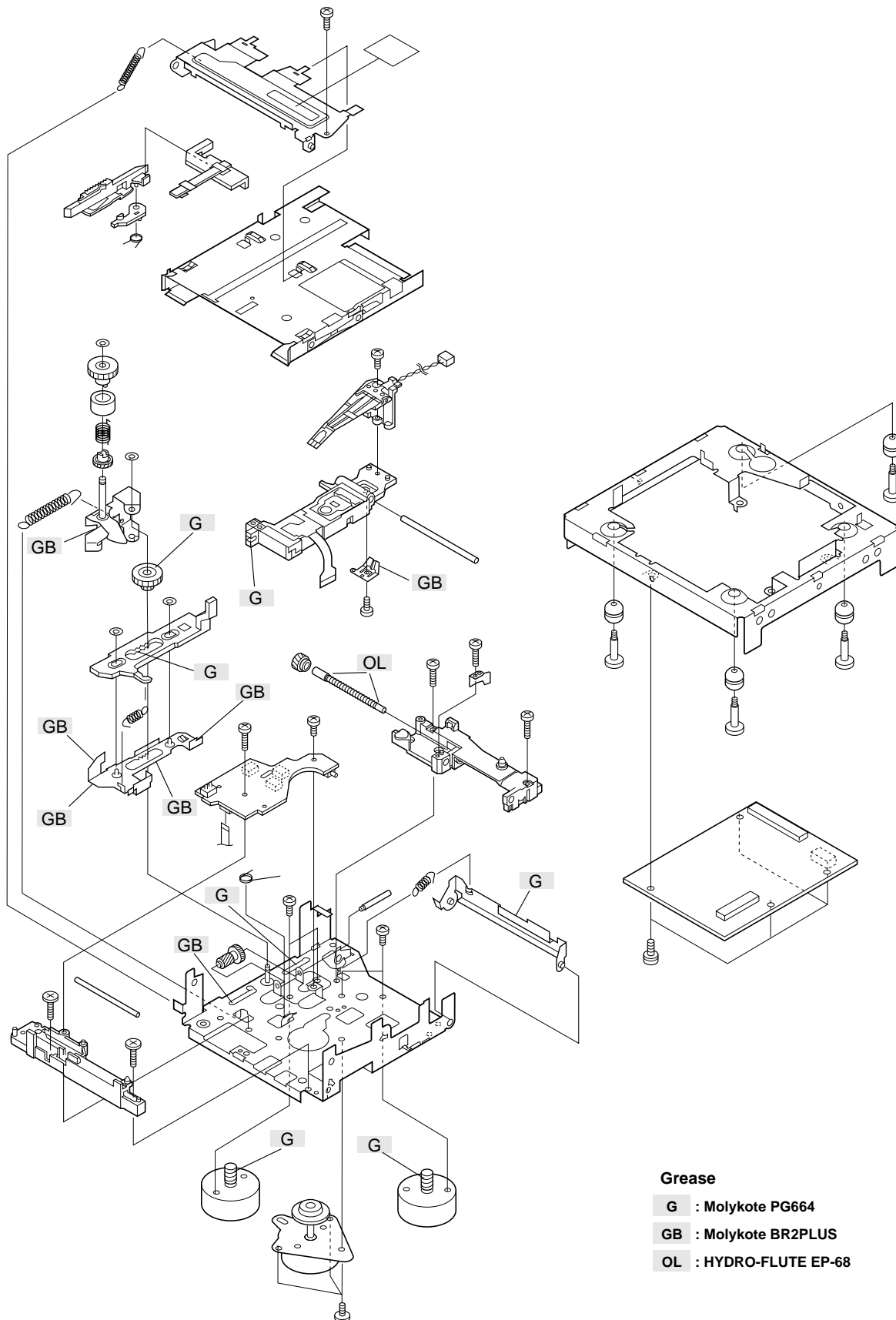

1

# REMOTE CONTROL TRANSMITTER

## ■ SCHEMATIC DIAGRAM

2

3

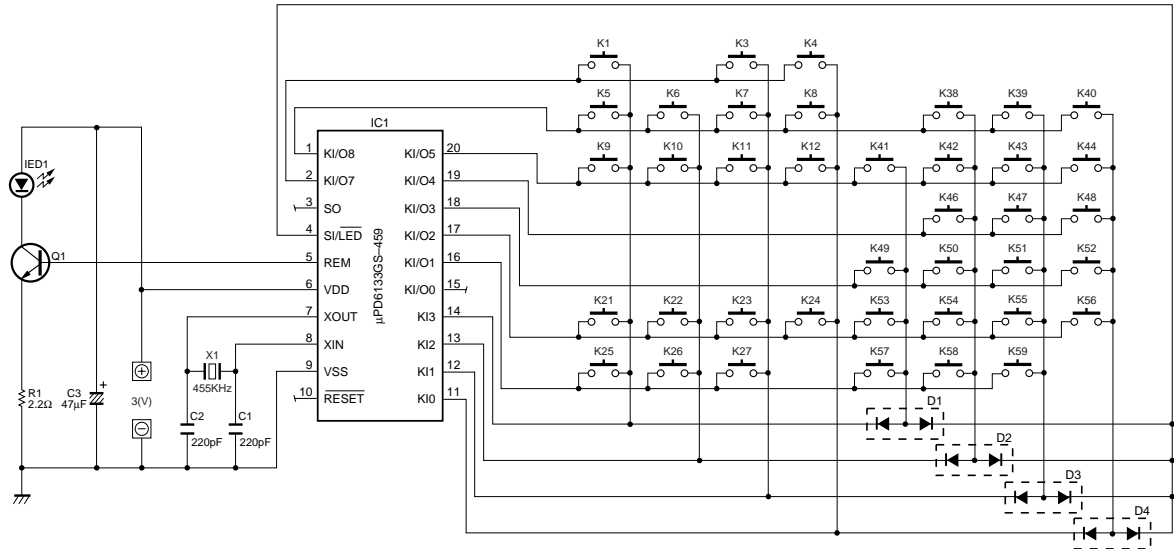

4

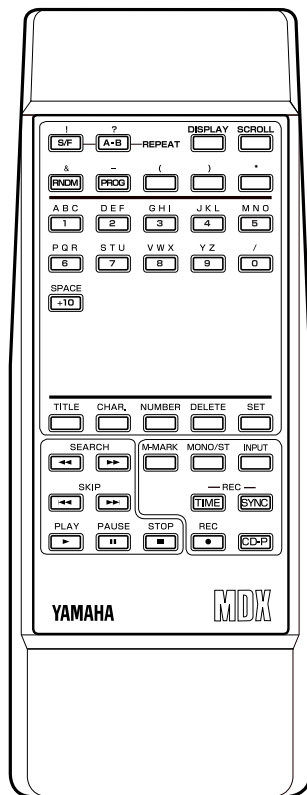

5

6

Key No.	FUNCTION	CUSTOM (HEX)	DATA (HEX)
1	A-B	79	82
2		79	B6
3	DISPLAY	79	A5
4	SCROLL	79	A6
5	2	79	86
6	3	79	87
7	4	79	88
8	5	79	89
9	7	79	8B
10	8	79	8C
11	9	79	8D
12	0	79	8E
13		79	B5
14		79	9D
15		79	9E
16		79	9F
17		79	94
18		79	95
19		79	96
20		79	97
21	SEARCH <<<	79	AC
22	SEARCH >>>	79	AD
23	M-MARK	79	B3
24	MONO/ST	79	B4
25	INPUT	79	A7
26	REC SYNC	79	B2
27	CD-P	79	02
28		79	B7
29		79	B8
30		79	B9

Key No.	FUNCTION	CUSTOM (HEX)	DATA (HEX)
31		79	BA
32		79	BB
33		79	98
34		79	99
35		79	9A
36		79	9B
37		79	9C
38	TITLE	79	A0
39	CHAR	79	A1
40	NUMBER	79	A2
41	DELETE	79	A4
42	SET	79	A3
43	SKIP <<	79	AB
44	SKIP >>	79	AE
45		79	B1
46	REC TIME	79	B0
47	PLAY >	79	A8
48	PAUSE	79	A9
49	STOP □	79	AA
50	REC ○	79	AF
51	S / F	79	81
52	RNDM	79	83
53	PRGM	79	84
54	(	79	91
55	)	79	90
56	*	79	92
57	1	79	85
58	6	79	8A
59	+10	79	8F
60		79	93

7

CUSTOM CODE							
HEX	C0	C1	C2	C3	C4	C5	C6 C7
79	1	0	0	1	1	1	1 0

# Parts List for Carbon Resistors

Value	1/4W Type Part No.	1/6W Type Part No.	Value	1/4W Type Part No.	1/6W Type Part No.
1.0 Ω	HJ35 3100	HF85 3100	10 kΩ	HF45 7100	HF45 7100
1.8 Ω	HJ35 3180	*	11 kΩ	HF45 7110	HF45 7110
2.2 Ω	HJ35 3220	HF85 3220	12 kΩ	HJ35 7120	HF85 7120
3.3 Ω	HJ35 3330	HF85 3330	13 kΩ	HF45 7130	HF45 7130
4.7 Ω	HJ35 3470	HF85 3470	15 kΩ	HF45 7150	HF45 7150
5.6 Ω	HJ35 3560	HF85 3560	18 kΩ	HF45 7180	HF45 7180
10 Ω	HF45 4100	HF45 4100	22 kΩ	HF45 7220	HF45 7220
15 Ω	HJ35 4150	HF85 4150	24 kΩ	HF45 7240	HF45 7240
22 Ω	HF45 4220	HF45 4220	27 kΩ	HJ35 7270	HF85 7270
27 Ω	HJ35 4270	HF85 4270	30 kΩ	HF45 7300	HF45 7300
33 Ω	HF45 4330	HF45 4330	33 kΩ	HF45 7330	HF45 7330
39 Ω	HJ35 4470	HF85 4390	36 kΩ	HF45 7360	HF45 7360
47 Ω	HF45 4470	HF45 4470	39 kΩ	HF45 7390	HF45 7390
56 Ω	HF45 4560	HF45 4560	47 kΩ	HF45 7470	HF45 7470
68 Ω	HF45 4680	HF45 4680	51 kΩ	HF45 7510	HF45 7510
75 Ω	HF45 4750	HF45 4750	56 kΩ	HF45 7560	HF45 7560
82 Ω	HF45 4820	HF45 4820	62 kΩ	HF45 7620	HF45 7620
91 Ω	HF45 4910	HF45 4910	68 kΩ	HF45 7680	HF45 7680
100 Ω	HF45 5100	HF45 5100	82 kΩ	HF45 7820	HF45 7820
110 Ω	HJ35 5110	HF85 5110	91 kΩ	HF45 7910	HF45 7910
120 Ω	HF45 5120	HF45 5120	100 kΩ	HF45 8100	HF45 8100
150 Ω	HF45 5150	HF45 5150	110 kΩ	HF45 8110	HF45 8110
160 Ω	HJ35 5160	*	120 kΩ	HF45 8120	HF45 8120
180 Ω	HF45 5180	HF45 5180	150 kΩ	HF45 8150	HF45 8150
200 Ω	HF45 5200	HF45 5200	180 kΩ	HF45 8180	HF45 8180
220 Ω	HF45 5220	HF45 5220	220 kΩ	HJ35 8220	HF85 8220
270 Ω	HF45 5270	HF45 5270	270 kΩ	HF45 8270	HF45 8270
330 Ω	HF45 5330	HF45 5330	300 kΩ	HF45 8300	HF45 8300
390 Ω	HF45 5390	HF45 5390	330 kΩ	HF45 8330	HF45 8330
430 Ω	HF45 5430	HF45 5430	390 kΩ	HJ35 8390	HF85 8390
470 Ω	HF45 5470	HF45 5470	470 kΩ	HF45 8470	HF45 8470
510 Ω	HF45 5510	HF45 5510	560 kΩ	HJ35 8560	HF85 8560
560 Ω	HF45 5560	HF45 5560	680 kΩ	HJ35 8680	HF85 8680
680 Ω	HF45 5680	HF45 5680	820 kΩ	HJ35 8820	HF85 8820
820 Ω	HF45 5820	HF45 5820	1.0 MΩ	HF45 9100	HF45 9100
910 Ω	HF45 5910	HF45 5910	1.2 MΩ	HJ35 9120	*
1.0 kΩ	HF45 6100	HF45 6100	1.5 MΩ	HJ35 9150	HF85 9150
1.2 kΩ	HF45 6120	HF45 6120	1.8 MΩ	HJ35 9180	HF85 9180
1.5 kΩ	HF45 6150	HF45 6150	2.2 MΩ	HJ35 9220	HF85 9220
1.8 kΩ	HF45 6180	HF45 6180	3.3 MΩ	HJ35 9330	HF85 9330
2.0 kΩ	HJ35 6200	HF85 6200	3.9 MΩ	HJ35 9390	*
2.2 kΩ	HF45 6220	HF45 6220	4.7 MΩ	HJ35 9470	HF85 9470
2.4 kΩ	HJ35 6240	HF85 6240			
2.7 kΩ	HF45 6270	HF45 6270			
3.0 kΩ	HF45 6300	HF45 6300			
3.3 kΩ	HF45 6330	HF45 6330			
3.6 kΩ	HJ35 6360	HF85 6360			
3.9 kΩ	HF45 6390	HF45 6390			
4.7 kΩ	HF45 6470	HF45 6470			
5.1 kΩ	HF45 6510	HF45 6510			
5.6 kΩ	HF45 6560	HF45 6560			
6.8 kΩ	HF45 6680	HF45 6680			
8.2 kΩ	HF45 6820	HF45 6820			
9.1 kΩ	HF45 6910	HF45 6910			

**1/4W Type**

HJ35 ○○○○

10mm

**1/4W Type**

HF45 ○○○○

**1/6W Type**

HF85 ○○○○

5mm