

# MULTITRACK CASSETTE RECORDER

# MT8X

## SERVICE MANUAL



MT8X

### ■ CONTENTS (目次)

SPECIFICATIONS (総合仕様).....	2/4
PANEL LAYOUT (パネルレイアウト).....	6
DIMENSIONS (寸法図).....	10
CIRCUIT BOARD LAYOUT (ユニットレイアウト).....	11
DISASSEMBLY PROCEDURE (分解手順).....	13
LSI PIN DESCRIPTION (LSI端子機能表).....	19
IC BLOCK DIAGRAM (ICブロック図).....	20
CIRCUIT BOARDS (シート基板図).....	22
CASSETTE MECHANISM ADJUSTMENT PROCEDURE (MECHANICAL) (カセットメカニズム調整手順).....	41/57
GENERAL ADJUSTMENT PROCEDURE FOR MT8X (ELECTRICAL) (MT8X総合調整手順(電気)).....	47/62
REGARDING SPECIAL MODE (TEST PROGRAM) (特殊モード(テストプログラム)).....	55/70
POT & COIL LAYOUT (調整用ボリューム、コイルレイアウト).....	72
PARTS LIST	
BLOCK DIAGRAM (ブロックダイアグラム)	
CONNECTION (結線図)	
OVERALL CIRCUIT DIAGRAM (総回路図)	

## IMPORTANT NOTICE

This manual has been provided for the use of authorized Yamaha Retailers and their service personnel. It has been assumed that basic service procedures inherent to the industry, and more specifically Yamaha Products, are already known and understood by the users, and have therefore not been restated.

**WARNING:** Failure to follow appropriate service and safety procedures when servicing this product may result in personal injury, destruction of expensive components and failure of the product to perform as specified. For these reasons, we advise all Yamaha product owners that all service required should be performed by an authorized Yamaha Retailer or the appointed service representative.

**IMPORTANT:** The presentation or sale of this manual to any individual or firm does not constitute authorization, certification, recognition of any applicable technical capabilities, or establish a principle-agent relationship of any form.

The data provided is believed to be accurate and applicable to the unit(s) indicated on the cover. The research, engineering, and service departments of Yamaha are continually striving to improve Yamaha products. Modifications are, therefore, inevitable and changes in specification are subject to change without notice or obligation to retrofit. Should any discrepancy appear to exist, please contact the distributor's Service Division.

**WARNING:** Static discharges can destroy expensive components. Discharge any static electricity your body may have accumulated by grounding yourself to the ground buss in the unit (heavy gauge black wires connect to this buss).

**IMPORTANT:** Turn the unit OFF during disassembly and parts replacement. Recheck all work before you apply power to the unit.

## WARNING: CHEMICAL CONTENT NOTICE!

The solder used in the production of this product contains LEAD. In addition, other electrical/electronic and/or plastic (where applicable) components may also contain traces of chemicals found by the California Health and Welfare Agency (and possibly other entities) to cause cancer and/or birth defects or other reproductive harm.

**DO NOT PLACE SOLDER, ELECTRICAL/ELECTRONIC OR PLASTIC COMPONENTS IN YOUR MOUTH FOR ANY REASON WHAT SO EVER!**

Avoid prolonged, unprotected contact between solder and your skin! When soldering, do not inhale solder fumes or expose eyes to solder/flux vapor!

If you come in contact with solder or components located inside the enclosure of this product, wash your hands before handling food.

### ■ WARNING

Components having special characteristics are marked  and must be replaced with parts having specifications equal to those originally installed.

印の部品は、安全を維持するために重要な部品です。交換する場合は、安全のため必ず指定の部品をご使用下さい。

**SPECIFICATIONS**

**MODEL** 8-track/8-channel one way recording and playback cassette recorder with mixer

<b>TAPE TRANSPORT</b>	Tape Type	CrO <sub>2</sub> (Bias: HIGH; EQ: 70 μs)
	Track Configuration	8-track/8-channel one way recording and playback
	Heads	8-channel Permalloy rec/play head x 1 8-channel ferrite erase head x 1
	Motor	DC servo motor for capstan x 1 DC motor for reel x 1 DC motor for mechanism control x 1
	Tape Speed	9.5 cm/sec.
	Pitch Control	Approx. ±12%
	Wow & Flutter	0.08% WRMS or less
	Rewind Time	Approx. 95 sec. at normal speed (for C-60 tape) Approx. 75 sec. at high speed (for C-60 tape)

**ELECTRICAL SPECIFICATIONS:** 0 dB = 0.775 Vr.m.s.

<No. of I/O Jacks>

MIC/LINE x 4 CH1 - 4	INSERT I/O x 2 CH1 - 2	LINE x 3 CH5 - 7
LINE L/MONO, R x 1 CH8	AUX RETURN L/MONO, R x 2	2TR IN L, R x 1
AUX SEND x 2	STEREO OUT L,R x 1	MONITOR OUT L, R x 1
TAPE OUT x 8 CH1 - 8	PHONES L,R x 1	

**CONNECTORS**

MIC/LINE 1 - 4	Input Impedance 10 kΩ Min. Input Level -56 dB (gain control, ch. fader max.) Max. Input Level +10 dB (gain control min., headroom margin)	Rated Input Level -10 dB to -50 dB (ch. fader nominal)
INSERT IN 1, 2	Input Impedance 10 kΩ Min. Input Level -16 dB (ch. fader max.)	Rated Input Level -10 dB
LINE 5 - 8	Input Impedance 10 kΩ Min. Input Level -16 dB (ch. fader max.)	Rated Input Level -10 dB (ch. fader nominal)
AUX RETURN L/R 1, 2	Input Impedance 20 kΩ Min. Input Level -16 dB (AUX RTN LEVEL control max.)	Rated Input Level -10 dB (AUX RTN LEVEL control nominal)
2TR IN L, R	Input Impedance 10 kΩ Min. Input Level -16 dB	Rated Input Level -10 dB (MONITOR/PHONES control nominal)
INSERT OUT 1, 2	Output Impedance 100 Ω Rated Output Level -10 dB (at 10 kΩ load)	Rated Load Impedance 10 kΩ or more
AUX SEND 1, 2	Output Impedance 1 kΩ Rated Output Level -10 dB (at 10 kΩ load)	Rated Load Impedance 10 kΩ or more
STEREO OUT L, R	Output Impedance 1 kΩ Rated Output Level -10 dB (at 10 kΩ load)	Rated Load Impedance 10 kΩ or more
MONITOR OUT L, R	Output Impedance 1 kΩ Rated Output Level -10 dB (at 10 kΩ load)	Rated Load Impedance 10 kΩ or more
TAPE OUT 1 - 8	Output Impedance 100 Ω Rated Output Level -10 dB (at 10 kΩ load)	Rated Load Impedance 10 kΩ or more
PHONES	Rated Load Impedance 8-40 Ω	Max. Output Level 100 mW (at 40 Ω load)

**MIXER**

Frequency Response (At Rated Input and Output)

20 Hz – 20 kHz  $\pm 1$  dB

MIC IN-STEREO OUT  
 LINE IN-STEREO OUT  
 LINE IN-PHONES OUT

Noise level (12.7 kHz: 6 dB/oct. L.P.F)

Signal process noise: -115 dB/Rs = 150  $\Omega$

STEREO OUT: -80 dB/CH, optimum position of the Master Fader

S/N Ratio (At Rated Input and Output Levels)

68 dB/IHF-A MIC IN-STEREO OUT (GAIN TRIM MAX.)

70 dB/IHF-A LINE IN-STEREO OUT (GAIN TRIM MIN.)

Distortion (1 kHz, At Rated Input and Output)

0.3 %/30 kHz L.P.F MIC IN-STEREO OUT (GAIN TRIM MAX.)

0.05 %/30 kHz L.P.F LINE IN-STEREO OUT (GAIN TRIM MIN.)

Equalizer

LOW/SHELVING	Standard Frequency 100 Hz	Variable Range $\pm 12$ dB
MID/PEAKING	Standard Frequency 1 kHz	Variable Range $\pm 12$ dB
HIGH/SHELVING	Standard Frequency 10 kHz	Variable Range $\pm 12$ dB

**RECORDER**

(4 track simultaneous recording)

Overall Frequency Response 50 Hz – 14 kHz  $\pm 3$  dB (dbx NR OFF)

Overall S/N ratio 80 dB/IHA-F (dbx NR ON), (At distortion level of 3 %)

Overall Distortion 2 % (400 Hz, -10 dB)

Overall channel separation 60 dB (1 kHz, -10 dB, dbx NR ON)  
 (between adjacent channels)

Erasure Rate 55 dB (1 kHz, 0 dB)

Noise Reduction dbx NR (SYNC position: TR8 = OFF)

**GENERAL**

Control Jacks PUNCH I/O (FC4 or FC5)

REMOTE CONTROL (RCM1)

Power Requirements U.S. & Canadian Models: 120 V AC, 60 Hz

UK Model: 240 V AC, 50 Hz

General Model: 230 V AC, 50 Hz

Power Consumption 40 W

Dimensions (WxHxD) 489 mm X 129 mm X 390 mm (19 - 1/4" X 5 - 1/16" X 15 - 3/8")

Weight 7.0 kg (15 lbs. 6 oz.)

Accessory AC power cord, cotton swab

\* dbx is a trademark of dbx Incorporated.

0 dB = 0.775 Vr.m.s.

## ■ 総合仕様

形式: ミキサー付8トラック8チャンネル片道録音/再生カセットレコーダー

機構部:	使用テープ	C-46 ~ 90 カセットテープ CrO <sub>2</sub> (TypeII) 専用
	トラック形式	8トラック/8チャンネル片道録音/再生
	ヘッド構成	8チャンネル録音/再生:ハードパーマロイ×1 8チャンネル消去:フェライト×1
	モーター	DCサーボモーター キャプスタン用×1 DCモーター リール用×1 DCモーター メカニズムコントロール用×1
	テープ速度	9.5 cm/sec.
	ピッチコントロール	約±12%
	ワウフラッター	0.08% W.RMS以下
	早巻き時間	約95秒 ノーマル (C-60 テープ) 約75秒 高速 (C-60 テープ)

電気部: 0dB=0.775Vrms

《入出力チャンネル数》

MIC/LINE×4 CH1 ~ 4	INSERT I/O ×2 CH1 ~ 2	LINE ×3 CH5 ~ 7
LINE L/MONO,R ×1 CH8	AUX RETURN L/MONO,R ×2	2TR IN L,R ×1
AUX SEND ×2	STEREO OUT L,R ×1	MONITOR OUT L,R ×1
TAPE OUT ×8 CH1 ~ 8	PHONES L,R ×1	

仕様:

MIC/LINE 1 ~ 4	入力インピーダンス 10 kΩ	規定入力レベル -10dB ~ -50dB (CH FADER 規定位置) 最小入力レベル -56dB (GAIN TRIM, CH FADER MAX.) 最大入力レベル +10dB (GAIN TRIM MIN. ヘッドルームマージン)
INSERT IN 1,2	入力インピーダンス 10 kΩ	規定入力レベル -10dB 最小入力レベル -16dB (CH FADER MAX.)
LINE 5 ~ 8	入力インピーダンス 10 kΩ	規定入力レベル -10dB (CH FADER 規定位置) 最小入力レベル -16dB (CH FADER MAX.)
AUX RETURN L/R 1,2	入力インピーダンス 20 kΩ	規定入力レベル -10dB (AUX RETURN VOLUME 規定位置) 最小入力レベル -16dB (AUX RETURN VOLUME MAX.)
2TR IN L,R	入力インピーダンス 10 kΩ	規定入力レベル -10dB (MONITOR/PHONES VOLUME 規定位置) 最小入力レベル -16dB
INSERT OUT 1,2	出力インピーダンス 100 Ω	規定負荷インピーダンス 10 kΩ 以上 規定出力レベル -10dB (10 kΩ 負荷時)
AUX SEND 1,2	出力インピーダンス 1k Ω	規定負荷インピーダンス 10 kΩ 以上 規定出力レベル -10dB (10 kΩ 負荷時)
STEREO OUT L,R	出力インピーダンス 1k Ω	規定負荷インピーダンス 10 kΩ 以上 規定出力レベル -10dB (10 kΩ 負荷時)
MONITOR OUT L,R	出力インピーダンス 1k Ω	規定負荷インピーダンス 10 kΩ 以上 規定出力レベル -10dB (10 kΩ 負荷時)
TAPE OUT 1~8	出力インピーダンス 100 Ω	規定負荷インピーダンス 10 kΩ 以上 規定出力レベル -10dB (10 kΩ 負荷時)
PHONES	規定負荷インピーダンス 8 ~ 40 Ω	最大出力レベル 100mW (40 Ω 負荷時)

# MT8X

## ミキサー部

周波数特性 (規定入出力時)

20Hz ~ 20kHz  $\pm \frac{1}{4}$  dB

MIC IN—STEREO OUT  
LINE IN—STEREO OUT  
LINE IN—PHONES OUT

ノイズレベル (12.7kHz -6dB/oct. L.P.F)

入力換算ノイズ -115dB/Rs=150Ω

STEREO OUT -80dB/CH, MASTER FADER 規定位置

S/N (規定入力、規定出力レベル位置)

68dB/IHF-A MIC IN-STEREO OUT (GAIN TRIM MAX.)

70dB/IHF-A LINE IN-STEREO OUT (GAIN TRIM MIN.)

歪率 (1kHz, 規定入出力時) 0.3%/30kHz L.P.F MIC IN-STEREO OUT (GAIN TRIM MAX.)

0.05%/30kHz L.P.F LINE IN-STEREO OUT (GAIN TRIM MIN.)

イコライザー

LOW/SHELVING

基準周波数 100Hz 可変範囲  $\pm 12$ dB

MID/PEAKING

基準周波数 1kHz 可変範囲  $\pm 12$ dB

HIGH/SHELVING

基準周波数 10kHz 可変範囲  $\pm 12$ dB

## レコーダー部

(4トラック同時録音)

総合周波数特性 50Hz  $\pm \frac{3}{5}$  dB ~ 14kHz  $\pm \frac{3}{5}$  dB (dbx NR OFF)

総合S/N 80dB/IHF-A (dbx NR ON)、歪率3%レベル

総合歪率 2% (400Hz, -10dB レベル)

総合チャンネルセパレーション 60dB (1kHz, -10dB レベル dbx NR ON)

(隣接チャンネル間)

消去率 55dB (1kHz, 0dB レベル)

ノイズ・リダクション dbx NR (SYNC POSITION : Tr 8=OFF)

## その他

操作端子 PUNCH I/O (FC4またはFC5)  
REMOTE CONTROL (RCM1)

電源 AC100V 50/60Hz

消費電力 35W

最大外形寸法 489(W)×129(H)×390(D)

重量 7.0 Kg

付属品 電源コード、綿棒

## オプション

インサクションケーブル YIC025/YIC050/YIC070

# PANEL LAYOUT (パネルレイアウト)

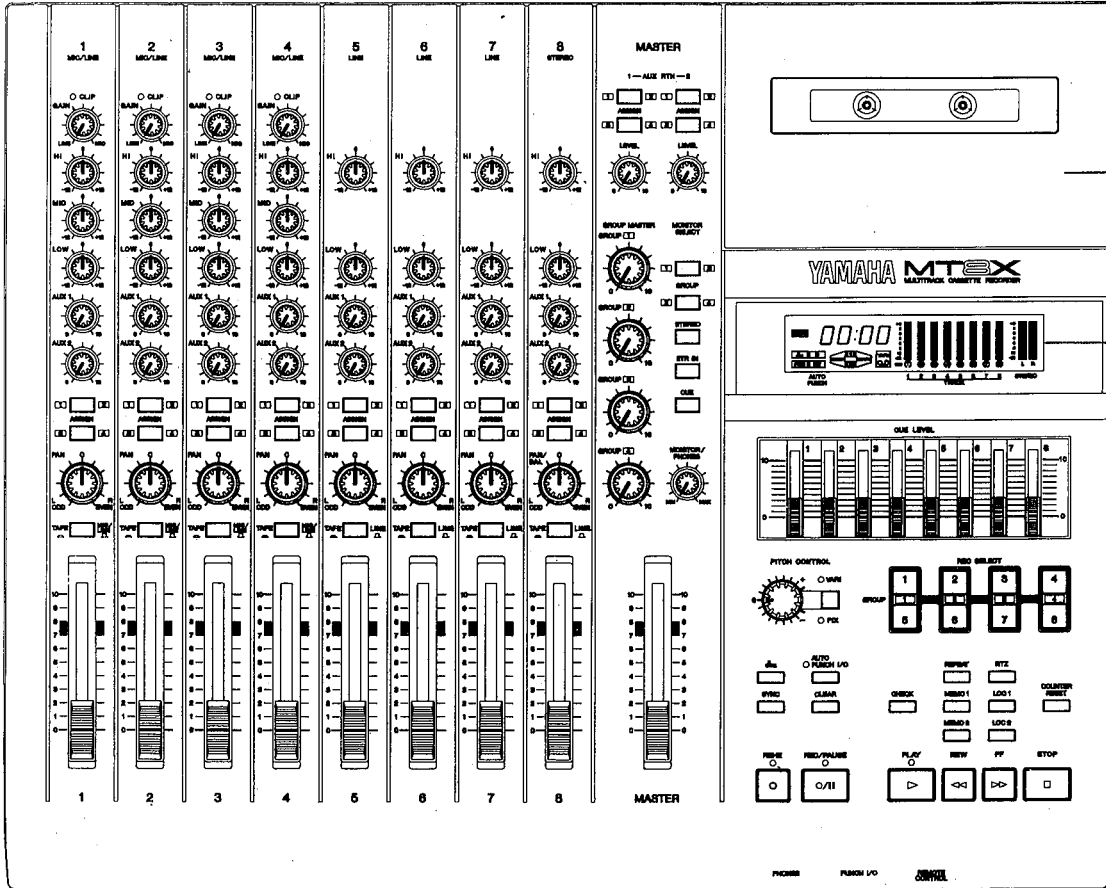

● MIXER(ミキサー部)

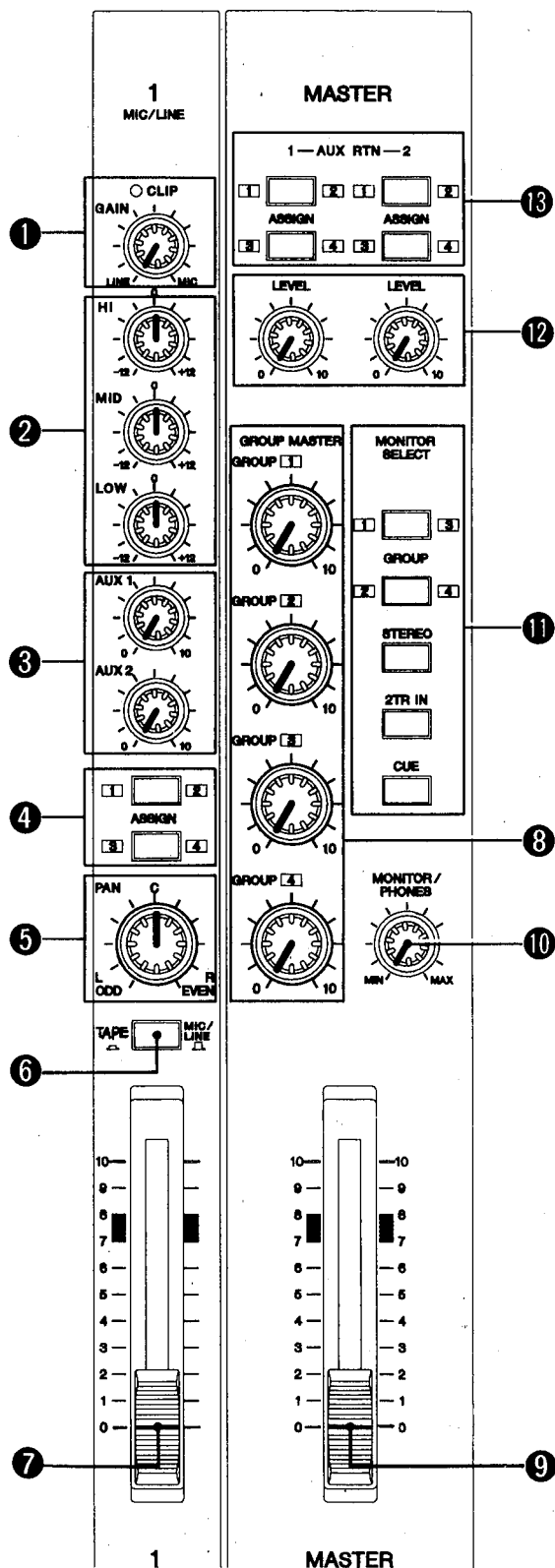

- ① GAIN Control and CLIP Indicator
- ② Equalizer Controls
- ③ AUX 1 and 2 Controls
- ④ ASSIGN Switches
- ⑤ PAN Control
- ⑥ Input Selector Switch
- ⑦ Channel Fader
- ⑧ GROUP MASTER Controls
- ⑨ STEREO Fader
- ⑩ MONITOR/PHONES Control
- ⑪ MONITOR SELECT Switches
- ⑫ AUX RTN LEVEL Controls
- ⑬ AUX RTN ASSIGN Switches

- ① GAINコントロールツマミ,CLIPインジケータ
- ② イコライザーツマミ
- ③ AUX1,2コントロールツマミ
- ④ ASSIGNスイッチ
- ⑤ PAN(パンポット)コントロールツマミ
- ⑥ 入力セレクトスイッチ
- ⑦ チャンネルフェーダー
- ⑧ GROUP MASTERコントロールツマミ
- ⑨ ステレオフェーダー
- ⑩ MONITOR/PHONESコントロールツマミ
- ⑪ MONITOR SELECTスイッチ
- ⑫ AUX RTN LEVELコントロールツマミ
- ⑬ AUX RTN ASSIGNスイッチ



● RECORDER(レコーダー部)

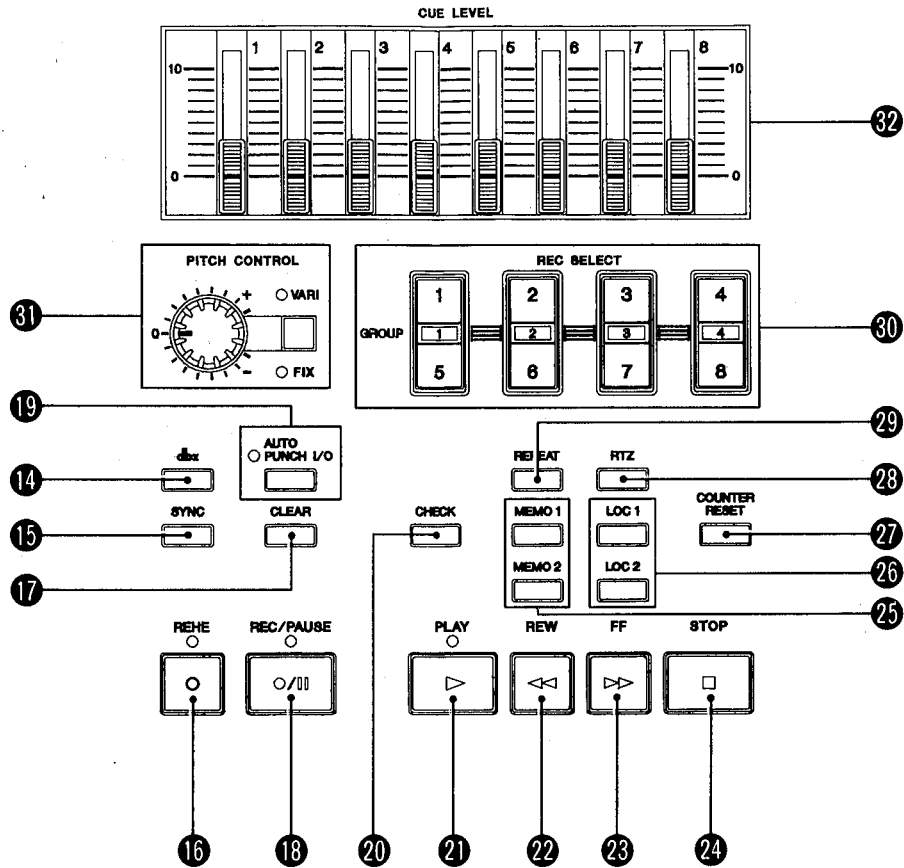

- |   |                                 |
|---|---------------------------------|
| ⑭ dbx Switch                                  | ⑭ dbxキー                         |
| ⑮ SYNC Switch                                 | ⑮ SYNCキー                        |
| ⑯ REHE Button Indicator                       | ⑯ REHEキー,インジケーター                |
| ⑰ CLEAR Button                                | ⑰ CLEARキー                       |
| ⑱ REC/PAUSE Button and Indicator              | ⑱ REC/PAUSEキー,インジケーター           |
| ⑲ AUTO PUNCH I/O Button and Indicator         | ⑲ AUTO PUNCH I/Oキー,インジケーター      |
| ⑳ CHECK Button                                | ⑳ CHECKキー                       |
| ㉑ PLAY Button and Indicator                   | ㉑ PLAYキー,インジケーター                |
| ㉒ REW Button                                  | ㉒ REWキー                         |
| ㉓ FF Button                                   | ㉓ FFキー                          |
| ㉔ STOP Button                                 | ㉔ STOPキー                        |
| ㉕ MEMO 1 and 2 Buttons                        | ㉕ MEMO 1,2キー                    |
| ㉖ LOC 1 and LOC 2 Buttons                     | ㉖ LOC 1,2キー                     |
| ㉗ COUNTER RESET Button                        | ㉗ COUNTER RESETキー               |
| ㉘ RTZ Button                                  | ㉘ RTZキー                         |
| ㉙ REPEAT Button                               | ㉙ REPEATキー                      |
| ㉚ REC SELECT Switches                         | ㉚ REC SELECTキー                  |
| ㉛ PITCH Control (Knob, Switch and Indicators) | ㉛ PITCH CONTROLツマミ,スイッチ,インジケーター |
| ㉜ CUE LEVEL Controls                          | ㉜ CUE LEVELコントロール               |
| ㉝ Cassette Compartment                        | ㉝ カセットホルダー                      |

MT8X

● DISPLAY(ディスプレイ部) ⑧

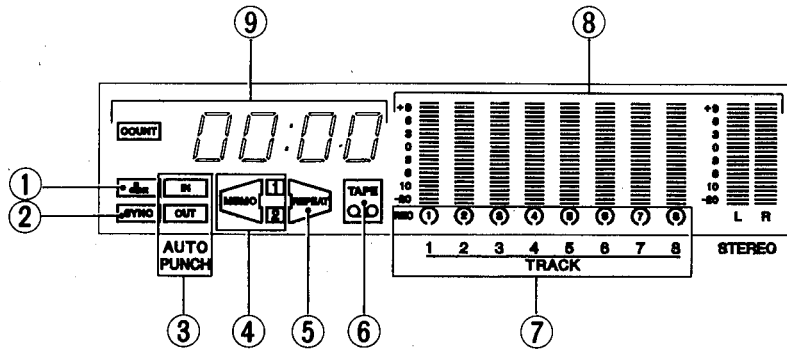

- ① dbx Indicator
- ② SYNC Indicator
- ③ Automatic Punch-in/out Indicator
- ④ MEMO 1 and 2 Indicators
- ⑤ REPEAT Indicator
- ⑥ TAPE Indicator
- ⑦ REC Select Indicators
- ⑧ Level Meter
- ⑨ Tape Counter

- ① dbxインジケータ
- ② SYNCインジケータ
- ③ AUTO PANCH IN, OUTインジケータ
- ④ MEMO 1,2インジケータ
- ⑤ REPEATインジケータ
- ⑥ TAPEインジケータ
- ⑦ REC SELECTインジケータ
- ⑧ レベルメータ
- ⑨ テープカウンタ

● FRONT PANEL (フロントパネル部)

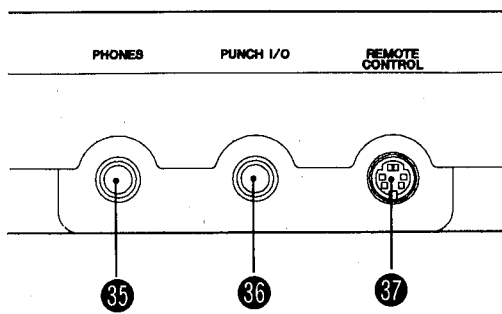

- ⑤ PHONES Jack
- ⑥ PUNCH I/O Jack
- ⑦ REMOTE CONTROL Jack

- ⑤ PHONES端子
- ⑥ PUNCH I/O端子
- ⑦ REMOTE CONTROL端子

● REAR PANEL (リアパネル部)

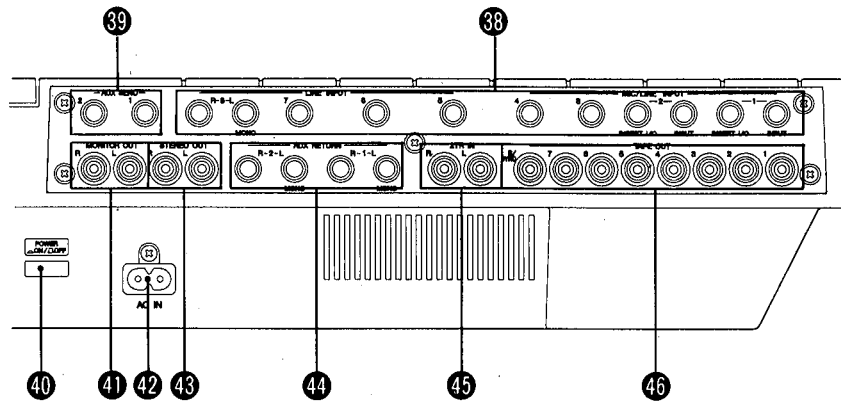

- ③⑧ MIC/LINE INPUT, LINE INPUT and INSERT I/O Jacks
- ③⑨ AUX SEND 1 and 2 Jacks
- ④⑩ POWER Switch
- ④① MONITOR OUT Jacks
- ④② AC IN Socket
- ④③ STEREO OUT Jacks
- ④④ AUX RETURN 1 and 2 Jacks
- ④⑤ 2TR IN Jacks
- ④⑥ TAPE OUT Jacks (1-8/SYNC)

- ③⑧ MIC/LINE INPUT LINE INPUT, INSERT I/O端子
- ③⑨ AUX SEND 1,2端子
- ④⑩ POWERスイッチ
- ④① MONITOR OUT端子
- ④② AC INソケット
- ④③ STEREO OUT端子
- ④④ AUX RETURN端子
- ④⑤ 2TN IN端子
- ④⑥ TAPE OUT端子(1~8/SYNC)

■ DIMENSIONS (寸法図)

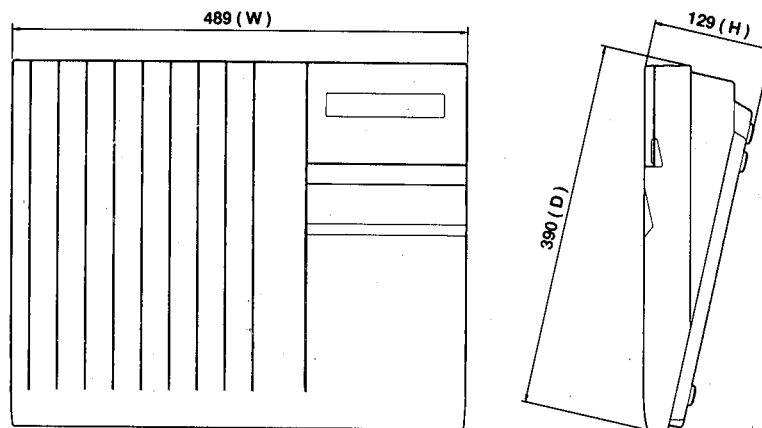

# ■ CIRCUIT BOARD LAYOUT (ユニットレイアウト)

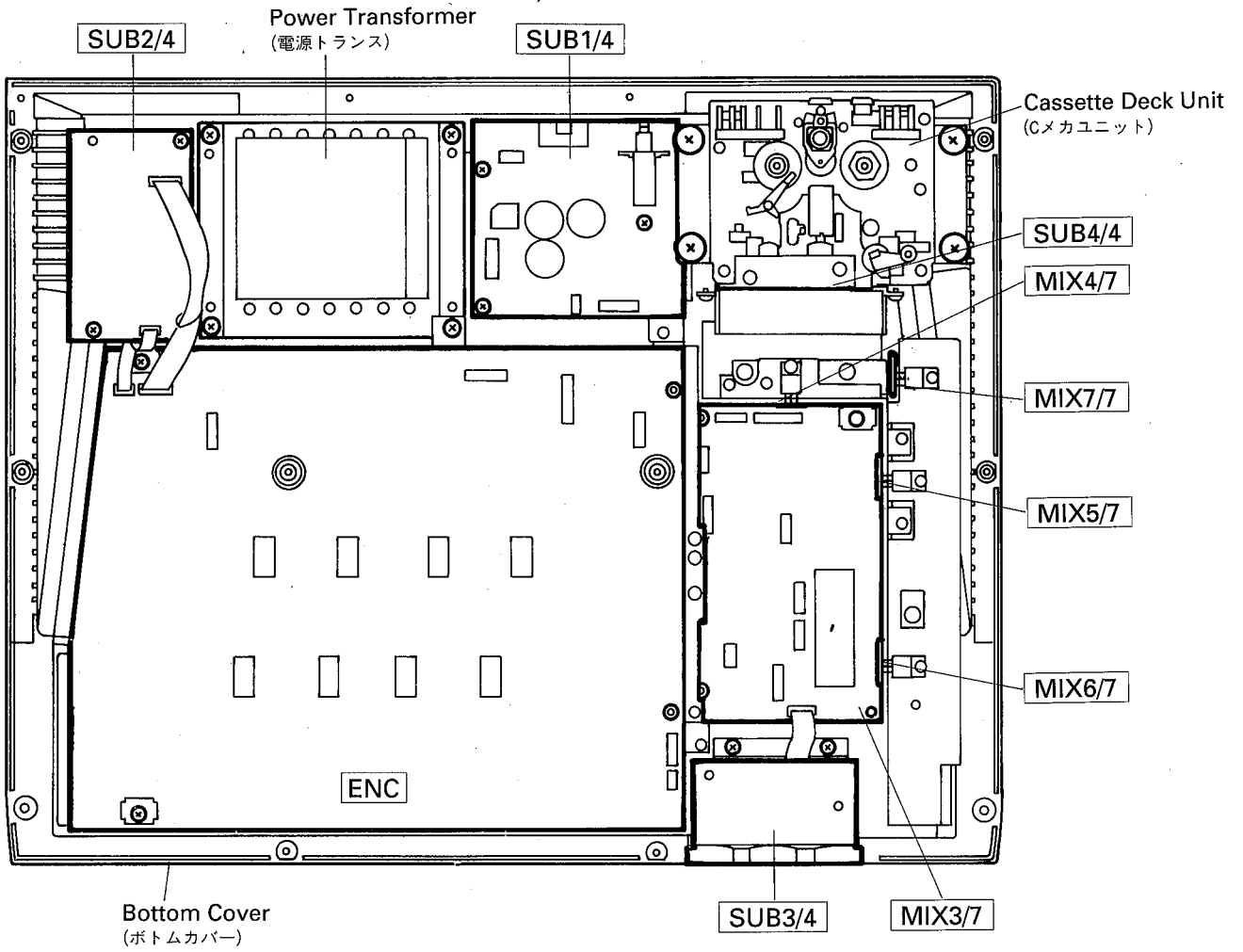

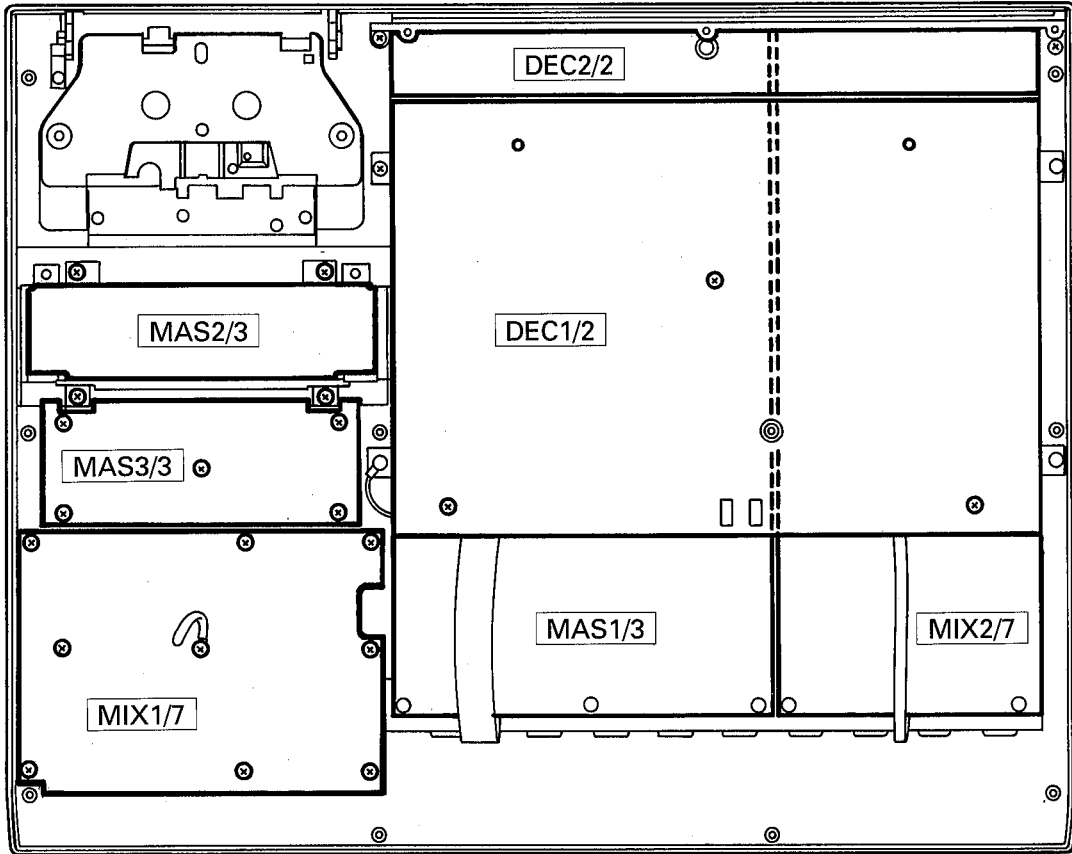

Top Cover  
(トップカバー)

# DISASSEMBLY PROCEDURE (分解手順)

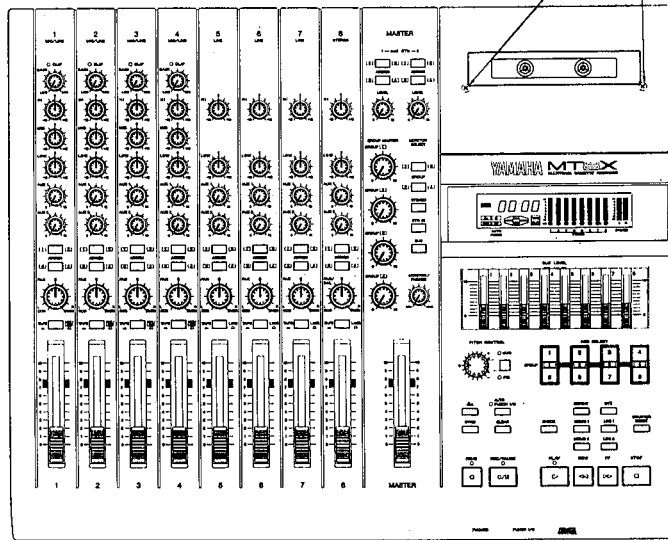
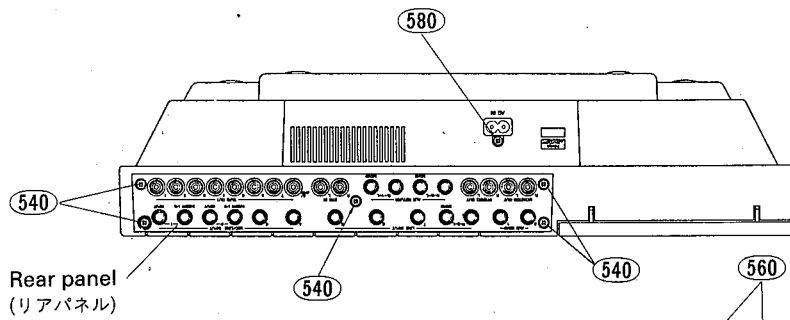

Bottom cover assembly  
(ボトムカバー-Ass'y)

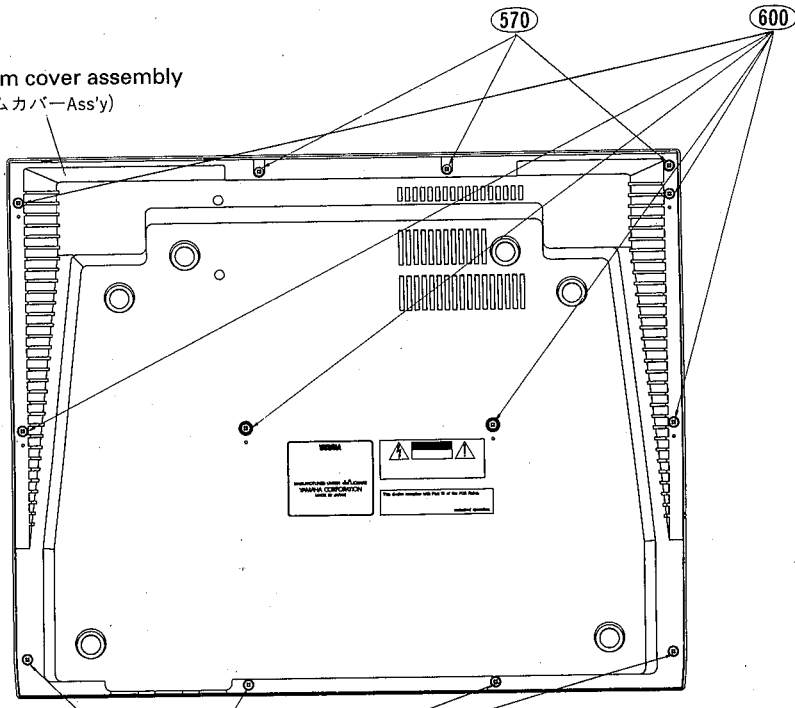

- (540) :SCREW (段付ネジ) FCM3-BL (VQ032200)
- (560) :BIND HEAD SCREW (+バインド小ネジ) 3.0×6 FCM3BL (EG330030)
- (570) :BIND HEAD TAPPING SCREW-B (+バインドBタイト) 3.0×8 FCM3BL (EP600830)
- (580) :BIND HEAD TAPPING SCREW-P (+バインドPタイト) 3.0×10 FCM3BL (EP600910)
- (590) :BIND HEAD TAPPING SCREW-P (+バインドPタイト) 3.0×16 FCM3BL (VD016800)
- (600) :BIND HEAD TAPPING SCREW-P (+バインドPタイト) 3.0×35 FCM3BL (VQ032700)

(Fig. 1)

MT8X

## 1. Bottom Cover Assembly Removal

- 1-1. Remove the three (3) screws marked (570), the four (4) screws marked (590), the six (6) screws marked (600) and the two (2) screws marked (560), then the bottom cover assembly can be removed. (Fig.1)

## 2. ENC Circuit Board Removal

- 2-1. Remove the bottom cover assembly. (see procedure 1)  
 2-2. Remove the two (2) plastic rivets marked (630A). (Fig.2)  
 2-3. Remove the two (2) screws marked (580A), then the ENC circuit board can be removed. (Fig.2)

## 3. MIX-3/7 Circuit Board Removal

- 3-1. Remove the bottom cover assembly. (see procedure 1)  
 3-2. Remove the three (3) plastic rivets marked (630B). (Fig.2)  
 3-3. Remove the screw marked (580B), then the MIX-3/7 circuit board can be removed. (Fig.2)

## 4. SUB-1/4 Circuit Board Removal

- 4-1. Remove the bottom cover assembly. (see procedure 1)  
 4-2. Remove the screw marked (580). (Fig.1)  
 4-3. Remove the three (3) screws marked (580C), then the SUB-1/4 circuit board can be removed. (Fig.2)

## 1. ボトムカバー-Ass'yの外し方

- 1-1 (570) のネジを3本、(590) のネジを4本、(600) のネジを6本、(560) のネジ2本を外し、ボトムカバー-Ass'yを外します。(図1)

## 2. ENCシートの外し方

- 2-1 ボトムカバー-Ass'yを外します。(1項参照)  
 2-2 (630A) のプラリベット2本を外します。(図2)  
 2-3 (580A) のネジ2本を外し、ENCシートを外します。(図2)

## 3. MIX-3/7シートの外し方

- 3-1 ボトムカバー-Ass'yを外します。(1項参照)  
 3-2 (630B) のプラリベット3本を外します。(図2)  
 3-3 (580B) のネジ1本を外し、MIX-3/7シートを外します。(図2)

## 4. SUB-1/4シートの外し方

- 4-1 ボトムカバー-Ass'yを外します。(1項参照)  
 4-2 AC IN端子を止めている (580) のネジ1本を外します。(図1)  
 4-3 (580C) のネジ3本を外し、SUB-1/4シートを外します。(図2)

**5. SUB-2/4 Circuit Board Removal**

- 5-1. Remove the bottom cover assembly. (see procedure 1)
- 5-2. Remove the two (2) screws marked (580D), then the SUB-2/4 circuit board can be removed. (Fig.2)

**5. SUB-2/4シートの外し方**

- 5-1 ボトムカバー-Ass'yを外します。(1項参照)
- 5-2 (580D)のネジ2本を外し、SUB-2/4シートを外します。(図2)

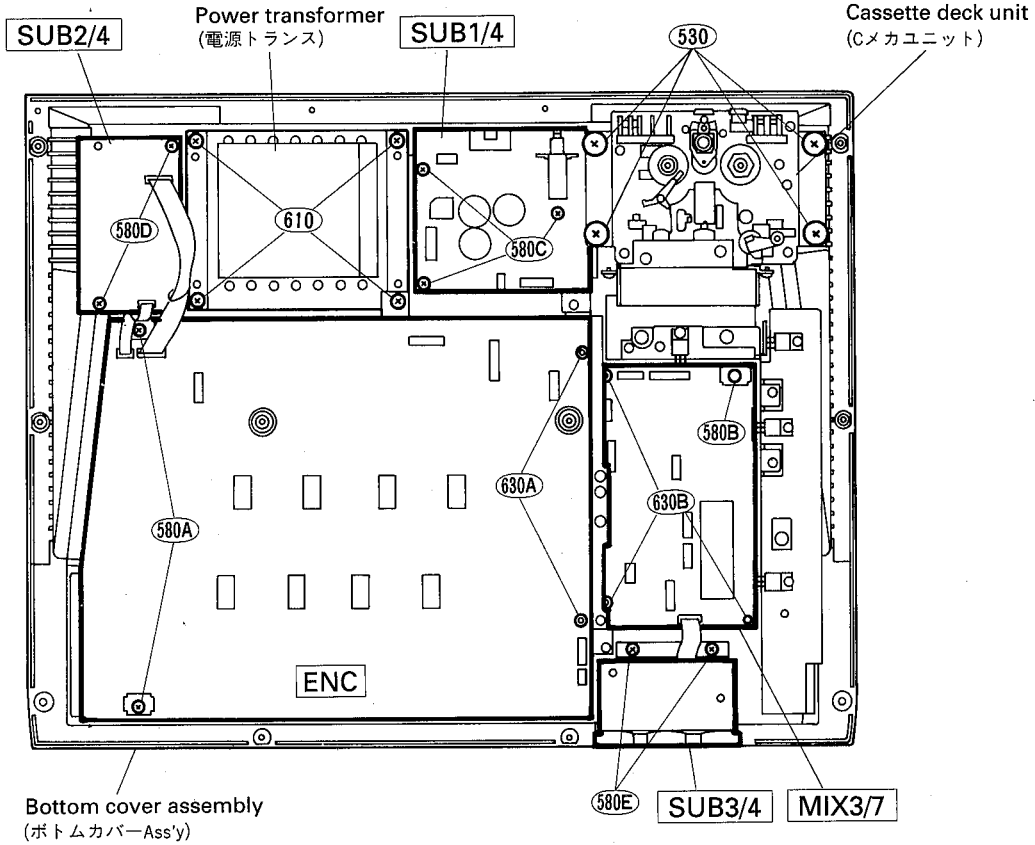

- (530) :SCREW(段付ネジ) ZMC2-Y (VQ031900)
- (580) :BIND HEAD TAPPING SCREW-P (+バインドPタイト) 3.0×10 FCM3BL (EP600910)
- (610) :BIND HEAD TAPPING SCREW-P (+バインドPタイト) 4.0×12 FCM3BL (VB744600)

(Fig. 2)

**6. SUB-3/4 Circuit Board Removal**

- 6-1. Remove the bottom cover assembly. (see procedure 1)
- 6-2. Remove the two (2) screws marked (580E) (Fig.2)
- 6-3. Remove the two (2) plastic rivets marked (630), then the SUB-3/4 circuit board can be removed. (Fig.3)

**6. SUB-3/4シートの外し方**

- 6-1 ボトムカバー-Ass'yを外します。(1項参照)
- 6-2 (580E)のネジ2本を外します。(図2)
- 6-3 (630)のプラリベット2本を外し、SUB-3/4シートを外します。(図3)

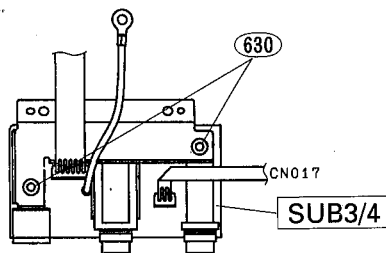

(Fig. 3)

MT8X



**7. SUB-4/4 Circuit Board Removal**

- 7-1. Remove the bottom cover assembly. (see procedure 1)
- 7-2. Remove the four (4) screws marked (530), then the cassette deck unit can be removed. (Fig.2)
- 7-3. To remove the shield plate, remove the two (2) screws marked (555). (Fig.4)
- 7-4. Remove the two (2) plastic rivets marked (630), then the SUB-4/4 circuit board can be removed. (Fig.4)

**7. SUB-4/4シートの外し方**

- 7-1 ボトムカバーAss'yを外します。(1項参照)
- 7-2 (530)のネジ4本を外し、Cメカユニットを外します。(図2)
- 7-3 (555)のネジ2本を外し、Cメカユニットからシールドプレートを外します。(図4)
- 7-4 (630)のプラリベット2本を外し、SUB-4/4シートを外します。(図4)

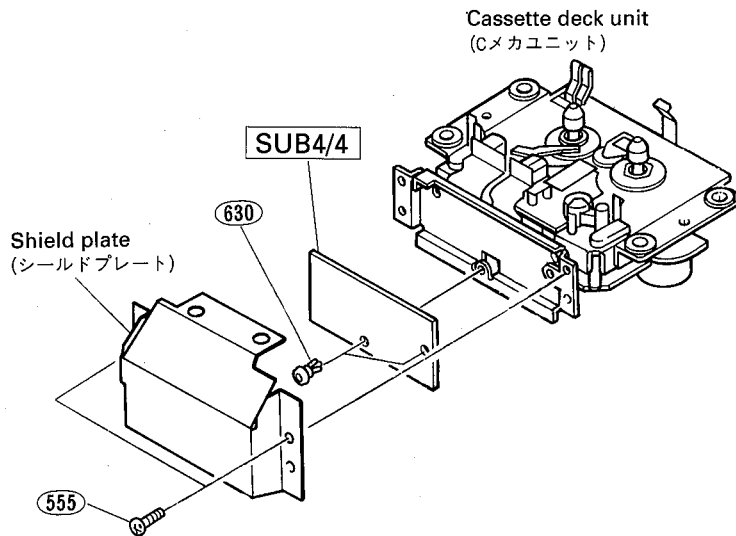

(555) : BIND HEAD TAPPING SCREW-B (+バインドBタイト) 3.0×5 ZMC2-Y (VQ030800)

(Fig. 4)

**8. Power Transformer Removal**

- 8-1. Remove the bottom cover assembly. (see procedure 1)
- 8-2. Remove the four (4) screws marked (610), then the power transformer can be removed with the holder. (Fig.2)
- 8-3. To remove the holder, remove the four (4) screws marked (620). (Fig.5)

**8. 電源トランスの外し方**

- 8-1 ボトムカバーAss'yを外します。(1項参照)
- 8-2 (610)のネジ4本を外します。(図2)
- 8-3 (620)のネジ4本を外し、ホルダーから電源トランスを外します。(図5)

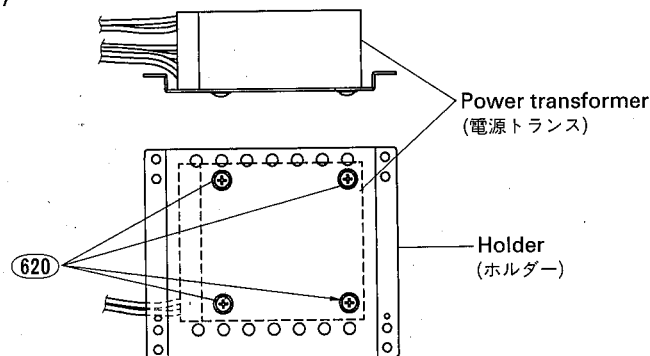

(620) : SELF TAPPING SCREW-S (カップSタイト) 4.0×8 FNM3-BL (VE460600)

(Fig. 5)

**9. DEC-1/2 Circuit Board Removal**

- 9-1. Remove the bottom cover assembly. (see procedure 1)
  - 9-2. Remove the three (3) screws marked (600) and the two (2) plastic rivets marked (630), then the shield sheet can be removed. (Fig.6)
  - 9-3. Remove the DEC-1/2 circuit board from the two (2) spacers marked (470). (Fig.6)
- \* DEC-1/2 circuit board is directly connected to the MIX-2/7 and the MAS-1/3 with the connector CN109 and CN110.

**9. DEC-1/2シートの外し方**

- 9-1 ボトムカバーAss'yを外します。(1項参照)
  - 9-2 (600)のネジ3本と(630)のプラリベット2本を外し、シールドシートを外します。(図6)
  - 9-3 (470)のスペーサー2ヶ所を外し、DEC-1/2シートを真上に引き抜きます。(図6)
- 注)DEC-1/2シートは、CN109とCN110でMIX-2/7シートとMAS-1/3シートに直接接続されています。

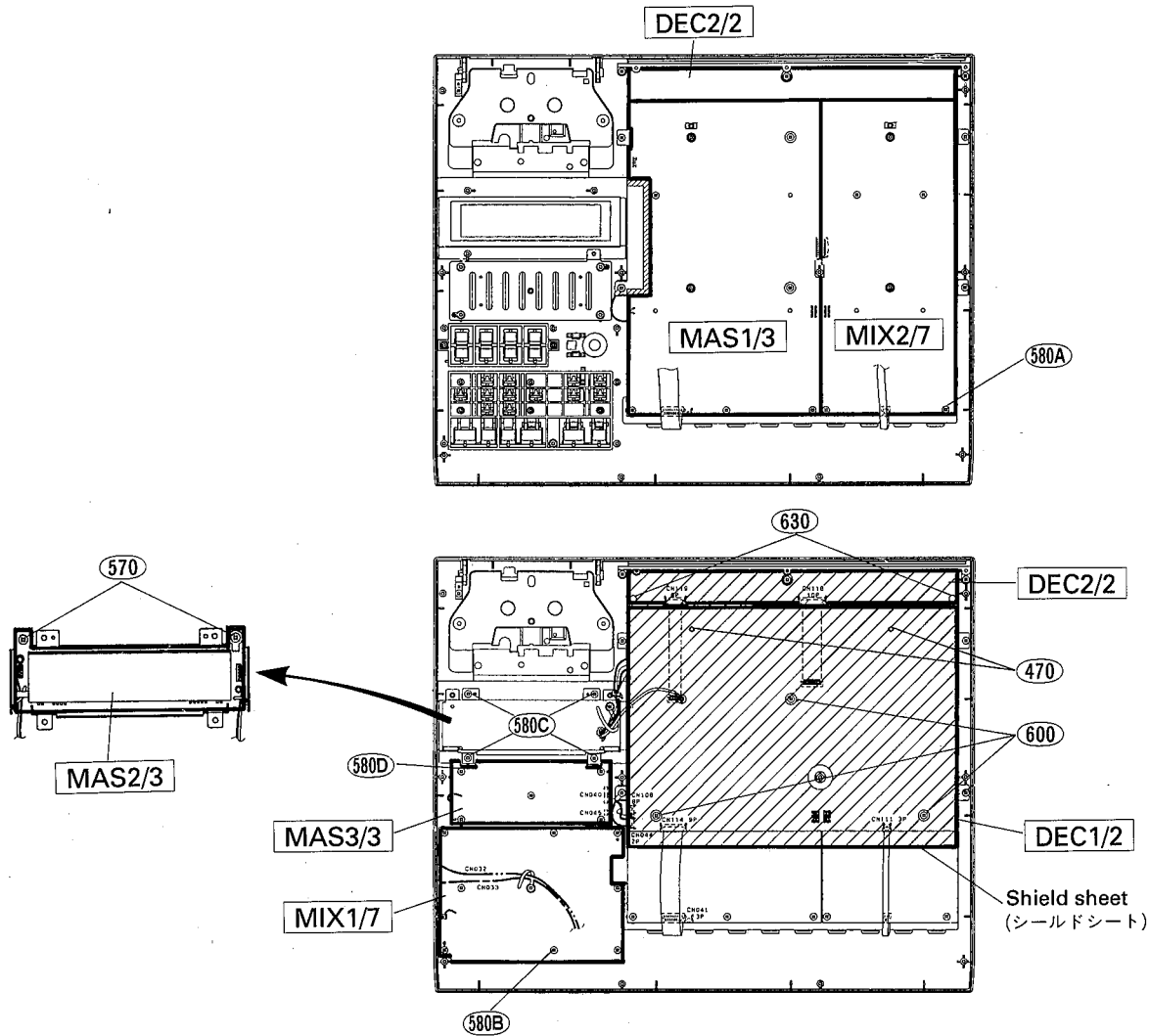

(Fig. 6) (570) : BIND HEAD TAPPING SCREW-B (+バインドBタイト) 3.0×8 FCM3BL (EP600830)  
 (580) : BIND HEAD TAPPING SCREW-P (+バインドPタイト) 3.0×10 FCM3BL (EP600910)  
 (600) : BIND HEAD TAPPING SCREW-P (+バインドPタイト) 3.0×35 FCM3BL (VQ032700)

**10. DEC-2/2, MAS-1/3 and MIX-2/7 Circuit Board Removal**

- 10-1. Pull out the knobs in channel input section.
- 10-2. To remove the rear panel, remove the five (5) screws marked (540). (Fig.1)
- 10-3. Remove the bottom cover assembly. (see procedure 1)
- 10-4. Remove the DEC-1/2 circuit board. (see procedure 9)

**10. DEC-2/2シート、MAS-1/3シート、MIX-2/7シートの外し方**

- 10-1 ミキサー部のツマミを全て外します。
- 10-2 (540)のネジ5本を外し、リヤパネルを外します。(図1)
- 10-3 ボトムカバーAss'yを外します。(1項参照)
- 10-4 DEC-1/2シートを外します。(9項参照)

- 10-5. Remove the seventeen (17) screws marked (580A) . (Fig.6)
- 10-6. To remove the two (2) stays, remove the ten (10) hexagonal nuts marked [510]. (Fig.7)
- 10-7. Remove the seventeen (17) u-shaped holders marked (500) and the seven (7) screws marked (575) , then the sub chassis can be removed. (Fig.7)
- 10-8. Disconnect CN120, then the DEC-2/2 circuit board can be removed.
- 10-9. Disconnect CN036, then the MAS-1/3 circuit board and MIX-2/7 circuit board can be removed. (Fig.7)

**11. MIX-1/7 Circuit Board Removal**

- 11-1. Pull out the pitch control knob.
- 11-2. Remove the bottom cover assembly. (see procedure 1)
- 11-3. Remove the nine (9) screws marked (580B) , then the MIX-1/7 circuit board can be removed. (Fig.6)

**12. MAS-2/3 Circuit Board Removal**

- 12-1. Remove the bottom cover assembly. (see procedure 1)
- 12-2. Remove the four (4) screws marked (580C) . (Fig.6)
- 12-3. Remove the two (2) screws marked (570) , then the MAS-2/3 circuit board can be removed. (Fig.6)

**13. MAS-3/3 Circuit Board Removal**

- 13-1. Pull out the cue level knobs and the spacers.
- 13-2. Remove the bottom cover assembly. (see procedure 1)
- 13-3. Remove the five (5) screws marked (580D) , then the MAS-3/3 circuit board can be removed. (Fig.6)

- 10-5 (580A) のネジ17本を外します。(図6)
- 10-6 (510) の特殊六角ナット10ヶを外し、ステー2本を外します。(図7)
- 10-7 (500) のU字金具17ヶと (575) のネジ7本を外し、サブシャーシを外します。(図7)
- 10-8 DEC-2/2シートのCN120をMAS-1/3シートから引き抜き、DEC-2/2シートを外します。
- 10-9 MIX-2/7シートのCN036を外すと、MAS-1/3シートとMIX-2/7シートが外れます。(図7)

**11. MIX-1/7シートの外し方**

- 11-1 PITCH CONTROLのつまみを外します。
- 11-2 ボトムカバー-Ass'yを外します。(1項参照)
- 11-3 (580B) のネジ9本を外し、MIX-1/7シートを外します。(図6)

**12. MAS-2/3シートの外し方**

- 12-1 ボトムカバー-Ass'yを外します。(1項参照)
- 12-2 (580C) のネジ4本を外します。(図6)
- 12-3 (570) のネジ2本を外し、ステーからMAS-2/3シートを外します。(図6)

**13. MAS-3/3シートの外し方**

- 13-1 CUE LEVELのつまみとスペーサーを外します。
- 13-2 ボトムカバー-Ass'yを外します。(1項参照)
- 13-3 (580D) のネジ5本を外し、MAS-3/3シートを外します。(図6)

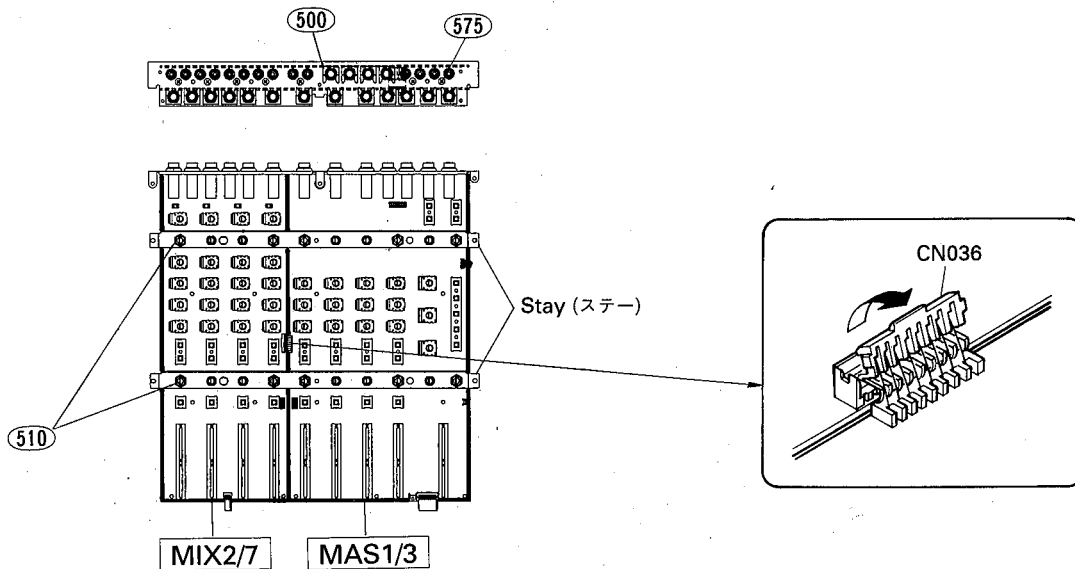

(Fig. 7)

(575): BONDING HEAD TAPPING SCREW (ボンディングBタイト) 3.0×8 FCM3BL (EZ000620)

**LSI PIN DESCRIPTION (LSI端子機能表)**

● M38022M2SP (XM267A00) CPU

PIN NO.	NAME	I/O	FUNCTION	PIN NO.	NAME	I/O	FUNCTION												
1	VCC	I		41	SW	I	Punch I/O "L": Unplugged, "H": plugged Not use												
2	VR	I		42	-														
3	AVSS	I		43	FF	O	Reel motor speed control <table border="1"> <tr> <th>Pin</th> <th>PLAY</th> <th>FF</th> <th>igh FF</th> </tr> <tr> <td>43,FF</td> <td>"H"</td> <td>"L"</td> <td>"L"</td> </tr> <tr> <td>44,PLAY</td> <td>"L"</td> <td>"H"</td> <td>"L"</td> </tr> </table>	Pin	PLAY	FF	igh FF	43,FF	"H"	"L"	"L"	44,PLAY	"L"	"H"	"L"
Pin	PLAY	FF	igh FF																
43,FF	"H"	"L"	"L"																
44,PLAY	"L"	"H"	"L"																
4	1, 2	I	A/D Track 1, 2	44	PLAY	O													
5	3, 4	I	A/D Track 3, 4																
6	5, 6	I	A/D Track 5, 6																
7	7, 8	I	A/D Track 7, 8																
8	L, R	I	A/D Stereo out L, R																
9	Key 1	I	A/D Key 1																
10	Key 2	I	A/D Key 2																
11	Key 3	I	A/D Key 3	45	RMR	O	Reel motor direction control <table border="1"> <tr> <th rowspan="2">PIN</th> <th colspan="2">Direction</th> </tr> <tr> <th>FF</th> <th>REW</th> </tr> <tr> <td>45, RMR</td> <td>"L"</td> <td>"H"</td> </tr> <tr> <td>46, RMF</td> <td>"H"</td> <td>"L"</td> </tr> </table>	PIN	Direction		FF	REW	45, RMR	"L"	"H"	46, RMF	"H"	"L"	
PIN	Direction																		
	FF	REW																	
45, RMR	"L"	"H"																	
46, RMF	"H"	"L"																	
12	PLAY	O	LED (Play)	46	RMF	O													
13	REC	O	LED (Rec/Pause)																
14	RH	O	LED (Rehe)																
15	P, I/O	O	LED (Auto punch I/O)																
16	CTR	O	A/D Select "L": Meter CH1, 3, 5, key B, D "H": Meter CH2, 4, 6, 8, key A, C																
17	CL	I/O	Chip Select (to M66008)																
18	CLK	O	Clock (to M66008)	47	AM -	O	Assist motor control												
19	DATA	O	Data (to M66008)	48	AM +	O													
20	CLK	O	Clock (to MSC1164)	49	I/O	I	Condition of foot switch "L": off, "H": on												
21	DIN	O	Din (to MSC 1164)	50	P.DET	I													
22	LS	O	Latch strove (to MSC1164)	51	SW2	I	Detection of power Off												
23	CL	O	Clear (to MSC1164)	52	SW1	I													
24	-		Not use	53	REC	I	Detection of cassette mechanical unit position "L": Recording possible, "H": Recording impossible												
25	SYNC	O	Analog switch control "L": SYNC on																
26	CNVSS	I	Ground	54	HS	I	"L": Tape equipped, "H": Tape not equipped												
27	RESET	I	Reset																
28	DBX	O	dBx "L": on, "H": off	55	RPT	I	Detection of reel pulse PRT: Take up side RPS: Supply side												
29	CUE	O	Not use	56	RPS	I													
30	X1	I	Clock	57	PB. MUTE1	O	Play back mute control "L": Other than play back condition "H": In recording condition												
31	XO	O																	
32	VSS	O	Ground	58	PB. MUTE2	O													
33	R. MUTE1	O	Recording mute control "L": Other than recording condition "H": Recording condition	59	PB. MUTE3	O													
34	R. MUTE2	O																	
35	R. MUTE3	O																	
36	R. MUTE4	O																	
37	BIAS1	O	Bias oscillating control "L": Other than recording condition "H": Recording condition	60	PB. MUTE4	O													
38	BIAS2	O																	
39	BIAS3	O																	
40	BIAS4	O																	

\*1 A/D DATA (METER)

Segment	-20	-10	-6	-3	0	+3	+6	+10
Voltage [V]	0.353	0.598	0.753	0.859	1.00	1.164	1.353	1.568

\*2 A/D DATA (KEY)

KEY	A	4	8	RESET	STOP	FF	REW	-	-
	B	3	7	RTZ	LOC2	MONO2	PLAY	-	-
C	2	6	LOC1	MONO1	CLEAR	SYNC	REC/PAUSE	-	
D	1	5	REPEAT	CHECK	AUTO I/O	dbx	REHE	-	
Voltage [V]	0.0	0.69	1.43	2.21	2.87	3.63	4.31	5.0	

● M66008P (XM266A00) EXP. I/O

PIN NO.	NAME	I/O	FUNCTION	PIN NO.	NAME	I/O	FUNCTION
1	DO	-	Not used	13	D12	O	Encode/Decode (CH4) Encode/Decode (CH3) Encode/Decode (CH2) Encode/Decode (CH1)
2	DI	I	Data	14	D11	O	
3	CLK	I	Clock	15	D10	O	
4	CS	I	Chip select	16	D 9	O	
5	VCC	I	Power supply	17	D 8	O	Monitor select (CH8) Monitor select (CH7) Monitor select (CH6) Monitor select (CH5) Monitor select (CH4) Monitor select (CH3) Monitor select (CH2) Monitor select (CH1)
6	S	I	Set in	18	D 7	O	
7	GND	I	Ground	19	D 6	O	
8	D16	O	Encode/Decode (CH8)	20	D 5	O	
9	D15	O	Encode/Decode (CH7)	21	D 4	O	
10	D14	O	Encode/Decode (CH6)	22	D 3	O	
11	D13	O	Encode/Decode (CH5)	23	D 2	O	
12	GND	O	Ground	24	D 1	O	

"L": Recording signal  
"H": play back signal

Whether to return played back sound to mixer input  
"L" Level: Not to be returned (being recorded)  
"H" Level: To be returned (being played back)

● MSC1164 (XM255A00) FL DRIVER

PIN NO.	NAME	I/O	FUNCTION	PIN NO.	NAME	I/O	FUNCTION
1	-			17		O	Driver
2	-			18		O	
3	DO	O	Data output	19		O	
4	LS	I	Latch strove	20		O	
5	CL	I	Clear	21		O	
6	+5		Power supply	22		O	
7		O		23		O	
8		O		24		O	
9		O		25		O	
10		O		26		O	
11		O	Driver	27	+32		Power supply (Driver)
12		O		28	GND		
13		O		29	CLK	I	Clock
14		O		30	DI	I	Data input
15		O		31	-		
16		O		32	-		

● AN6292NK (XJ637A00) Dual dbx NR

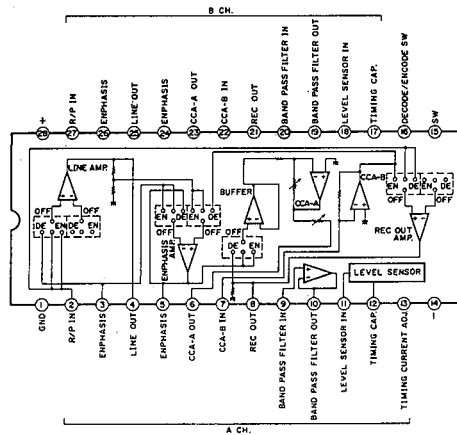

■ IC BLOCK DIAGRAM (ICブロック図)

- NJM2068S-D (XE322A00)
- NJM4558S (IG076800)
- NJM4560S (IG121800)
- μPC4570HA (XB247A00)  
Dual Operational Amplifier

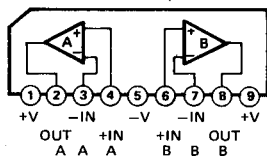

- BU4053B (IG149000)  
Triple 2-Ch.  
Multiplexer/Demultiplexer

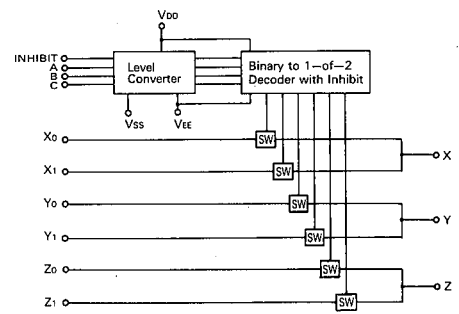
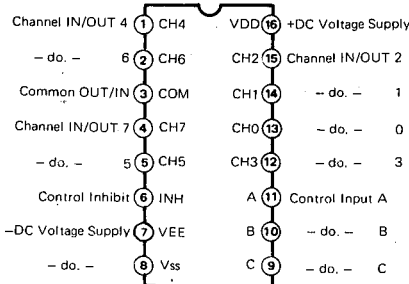

INHIBIT	Control				channel "ON"
	C	B	A		
L	L	L	L	L	Z0, Y0, X0
L	L	L	L	H	Z0, Y0, X1
L	L	L	H	L	Z0, Y1, X0
L	L	L	H	H	Z0, Y1, X1
L	H	L	L	L	Z1, Y0, X0
L	H	L	L	H	Z1, Y0, X1
L	H	L	H	L	Z1, Y1, X0
L	H	L	H	H	Z1, Y1, X1
H	X	X	X		NONE

● **BU4551B (XI929A00)**  
 Quad 2 Channel  
 Analog Multiplexer/Demultiplexer

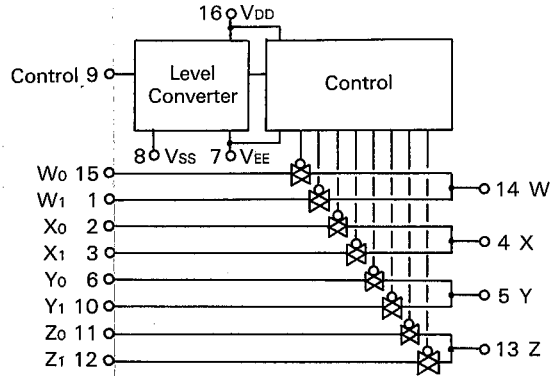
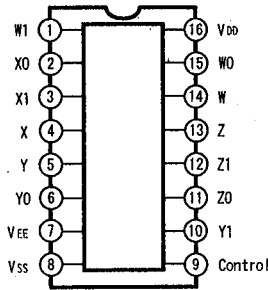

Control	ON
0	W <sub>0</sub> X <sub>0</sub> Y <sub>0</sub> Z <sub>0</sub>
1	W <sub>1</sub> X <sub>1</sub> Y <sub>1</sub> Z <sub>1</sub>

● **LA6515 (XI250A00)**  
 Operational Amplifier

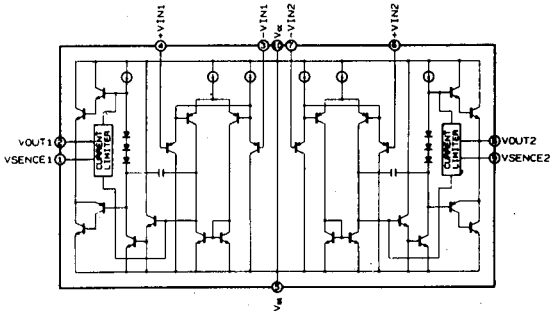

● **BA6138 (IG074900)**  
 (1/2W Power of Compressor Amp.)

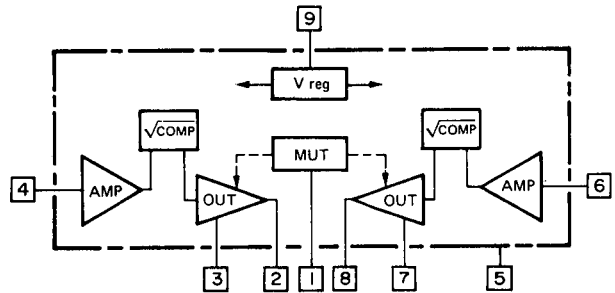

● **LB1649 (XA299A00)**  
 Motor Driver

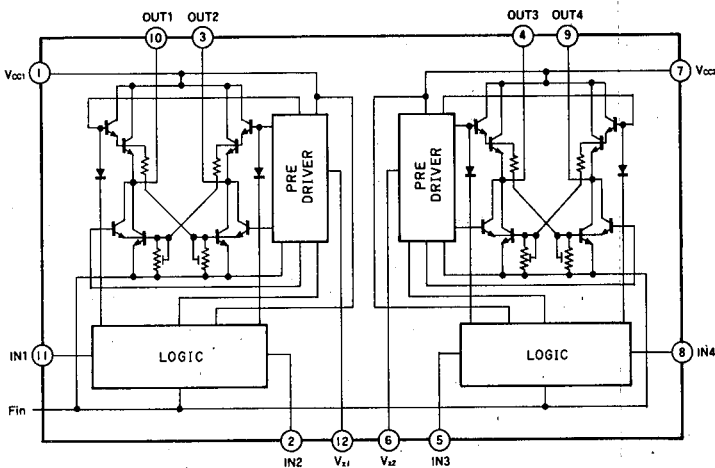

● **LC4966 (IG149300)**  
 Quad Analog Switch

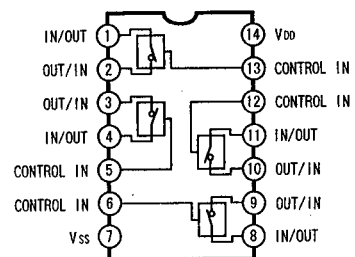

## ■ CASSETTE MECHANISM ADJUSTMENT PROCEDURE (MECHANICAL)

adjustment procedure for magnetic head of cassette mechanism after replacement should be performed according to the following procedure. If only Rec/PB head is adjusted, skip the steps marked \* and go to the next ones

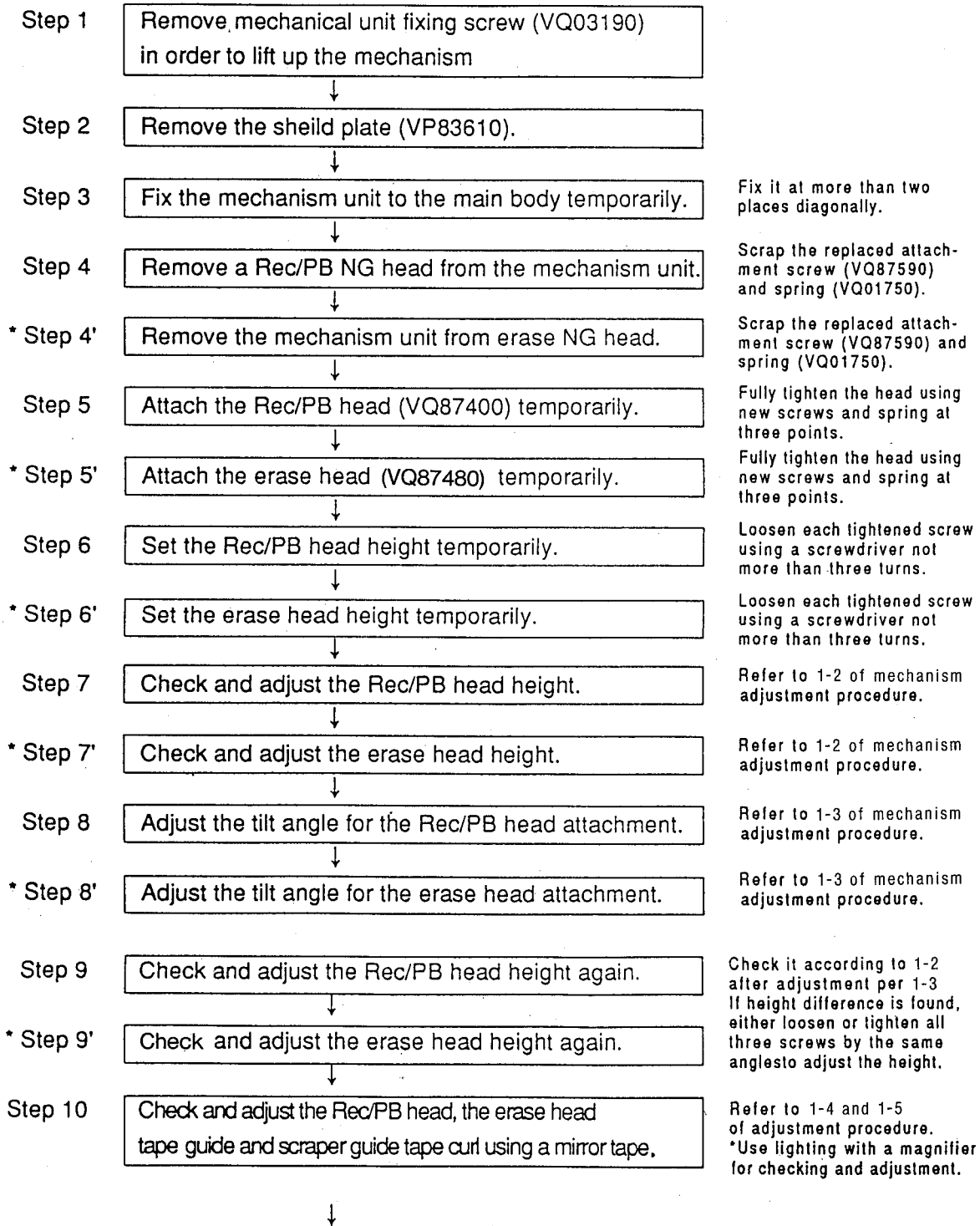

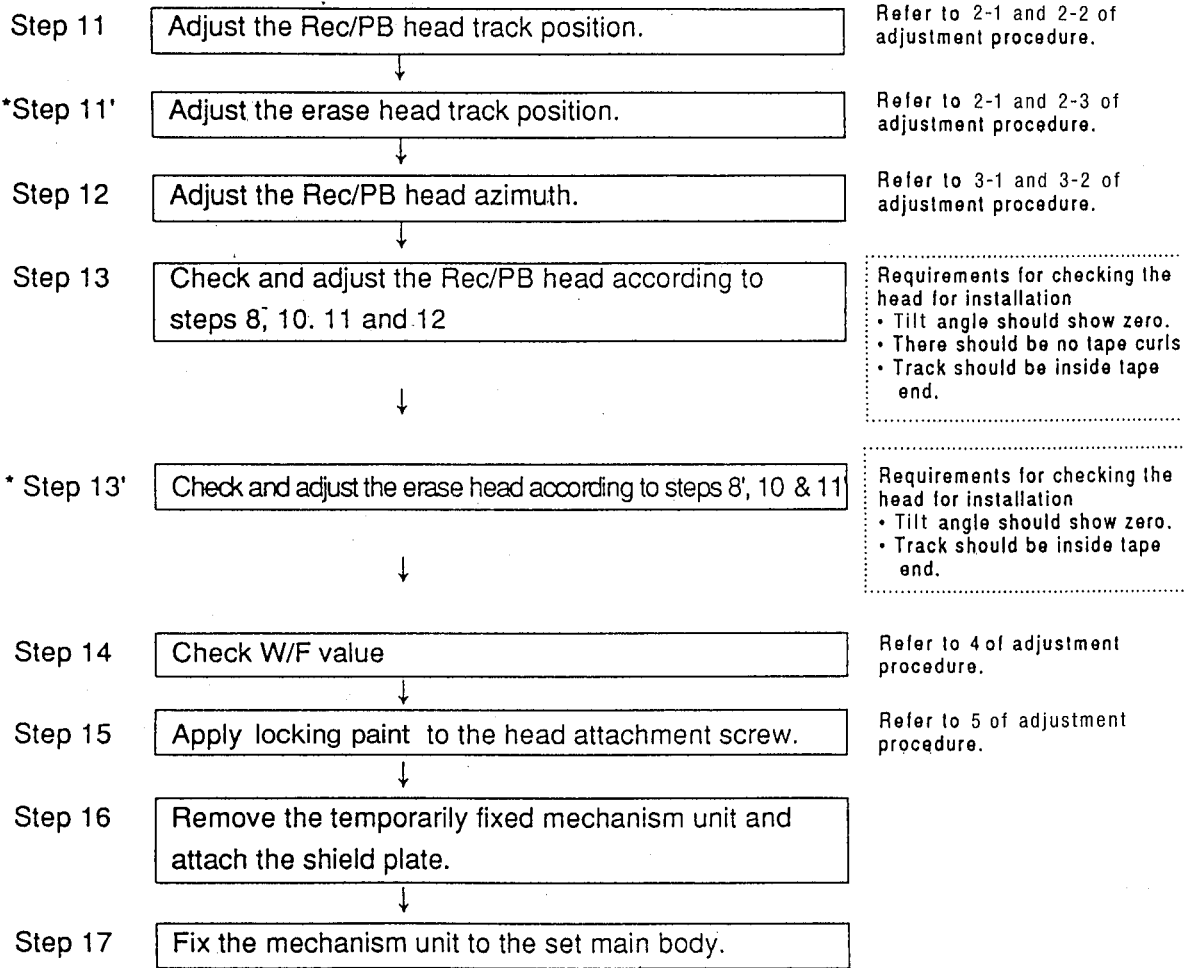

1. Checking the Tape for Running

- 1-1. Connect the wire material from mechanism unit pin 7 and pin 11 to the driving tool of the mechanism.
- 1-2. Place the gauge plate on the mechanism unit and put the unit in the PLAY condition; then, adjust the head height for attachment while setting it with the head tape guide.

Note) Adjust the height by applying the check bars to the head guide so as not to damage the head.

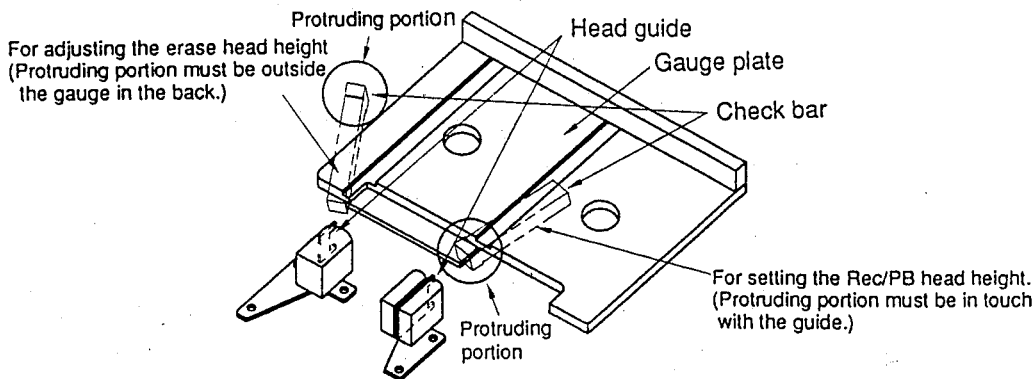



1-3. Tilt angle setting

- 1) Put the gauge plate on the mechanism.
- 2) While holding the gauge plate lightly by hand to prevent it from moving, push in the dial tilt gauge.
- 3) Turn the tilt adjusting screw until the reading of the gauge comes to zero when fully pushed in. (Adjusting range should be within one graduation.)

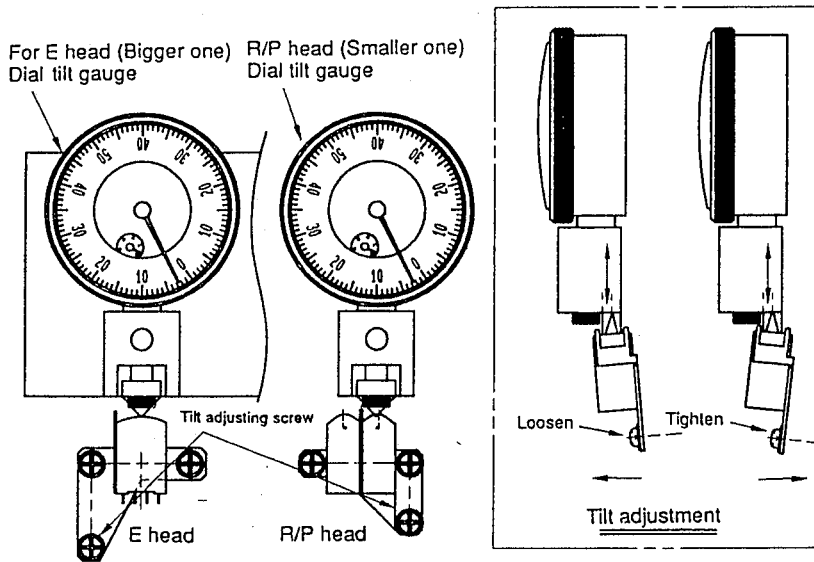

Note) Set the dial gauge using the tilt calibration gauge so that right angle becomes zero before inspection.

1-4. Apply a mirror tape (SONY. MC112C) and start the operation of the mechanism (PLAY).

1-5. Check the tape for curls and make fine adjustment of the head height.

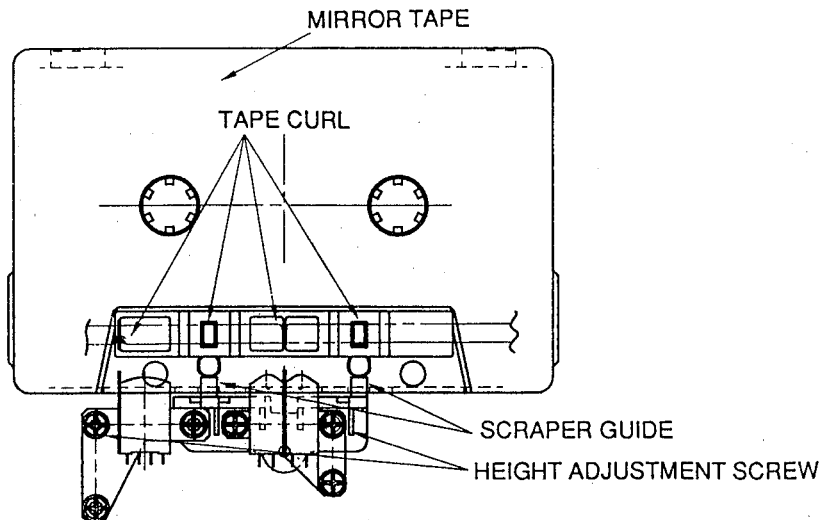

MT8X

.Any tape curls should not be allowed in the mechanism. Check the unit and replace parts as necessary.

.If any tape curl is found as shown in the above figure, turn the attachment adjusting screws at three points on R/P head by the same angle so that no tape curl appears on the mechanism.

Note) The screw is designed to give a vertical movement of 0.25mm by one turn.

.After adjustment, check the unit using the tilt gauge.

2. Checking and adjusting the tape and E&R/P head track position

2-1. Set a test tape (ABEX, SCC-2219 mirror leader tape) to the mechanism.

2-2. Checking the R/P head track

.Check that the tape protrudes from the core portion (especially the center gap) of the channels at both upper and lower ends, and no center channel (3Tr, 6Tr) protrudes from the center line.

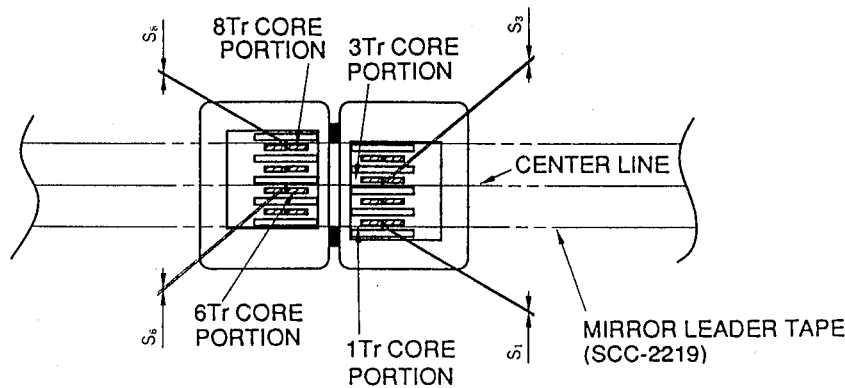

$S8$  and  $S1 > 0$  (Target ... 1/4 of core width)

$S6$ ,  $S3 > 0$  (Target ... 2/5 of core width)

.If the above conditions are not satisfied, adjust according to the following.

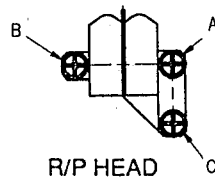

.Adjust  $S8$  and  $S6$  using B screw.

.Adjust  $S1$  and  $S3$  using A screw and C screw by turning them by the same angle.

.If adjustment is necessary for a greater width, perform the tilt angle setting as shown in 1-3.

.If core protrusion can not be helped to the extent that no tape curl occurs, replace the head.

2-3. Checking the E head track tape touch

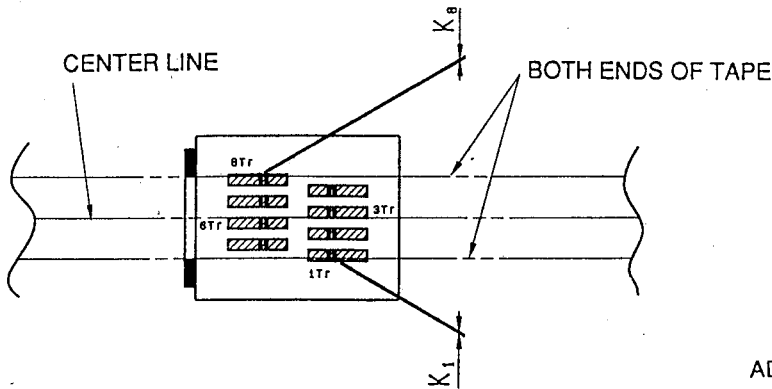

. Adjust the head height using the adjustment screw as shown to the right so that the center line comes and that the surfaces of 3Tr core and 6Tr and K1 and K8 become almost flush.

. Check that the tape touch bulking is perpendicular to the tape within the tape guide portion during tape running. If the bulking is excessive, adjust it using the tilt adjustment screw so that the tape touch becomes perpendicular to the tape.

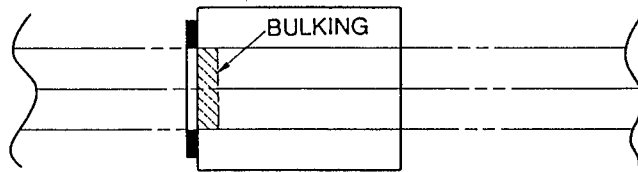
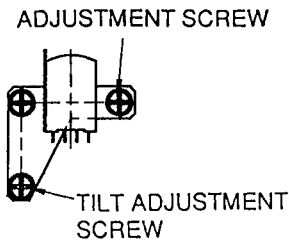

. Check that there are no pin holes or flaws in the E head.

3. R/P head azimuth adjustment

3-1. Set a test tape (ABEX, TCC-151, 6.3kHz - 12.6 Hz at double speed) to the mechanism, and switch on (PLAY) the mechanism.

3-2. Inspect and adjust the mechanism so that the R/P head 2Tr output becomes maximum or as specified. If the azimuth output is insufficient, adjust the azimuth adjustment screw, A screw and C screw.

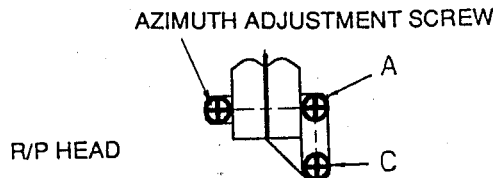

MT8X

4. Checking W/F value

Set a test tape (ABEX, TCW-211 or equivalent--- For double speed, 3kHz 0dB tap e) to the mechanism, and play it to measure the W/F value.

.Measurement is preferably made where the tape is wound 2/3 to 3/4 from the beginning.

.Specification W/F value  $\leq$  0.06. (WRMS for double speed)

5. Apply locking paint to the head attachment screw

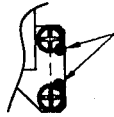

As shown to the left, apply locking paint at six points of the screw area for the seat and head attaching plate, except for the head area.

6. Set the ground assembly and shield plate/head as illustrated below by using +bind B tightening screw  $\varnothing 3 \times 5$ . Tightening torque should be 5 to 8 kgcm.

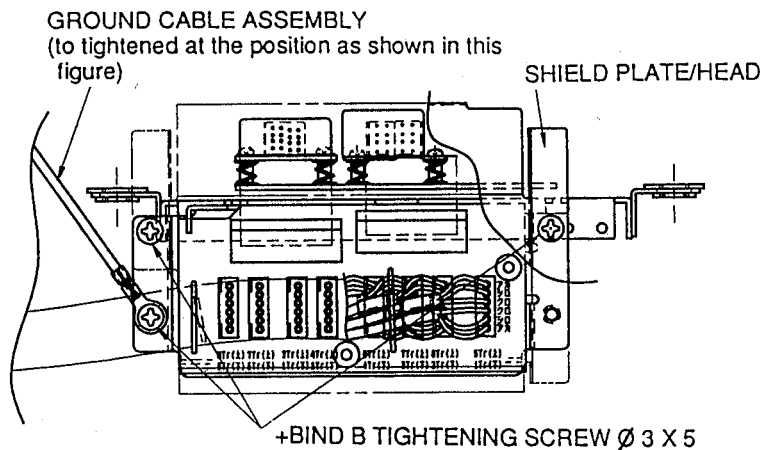

7. Checking Erase Rate

7-1. Connect the mechanism unit to the Rec/PB circuit tool.

7-2. Cross Erasure Verification

After recording in 2Tr, the lowering of the play back output level 2Tr after 1 Tr and 3 Tr erase should be 1dB/7.5kHz max.

7-3. Erase ratio

When the respective recording is done for for each Tr, the erase ratio should be:

60dB/1kHz, B.P.F. or more

MT8X

## ■ GENERAL ADJUSTMENT PROCEDURE FOR MT8X (ELECTRICAL)

Items for Adjustment      No. of Adjustment

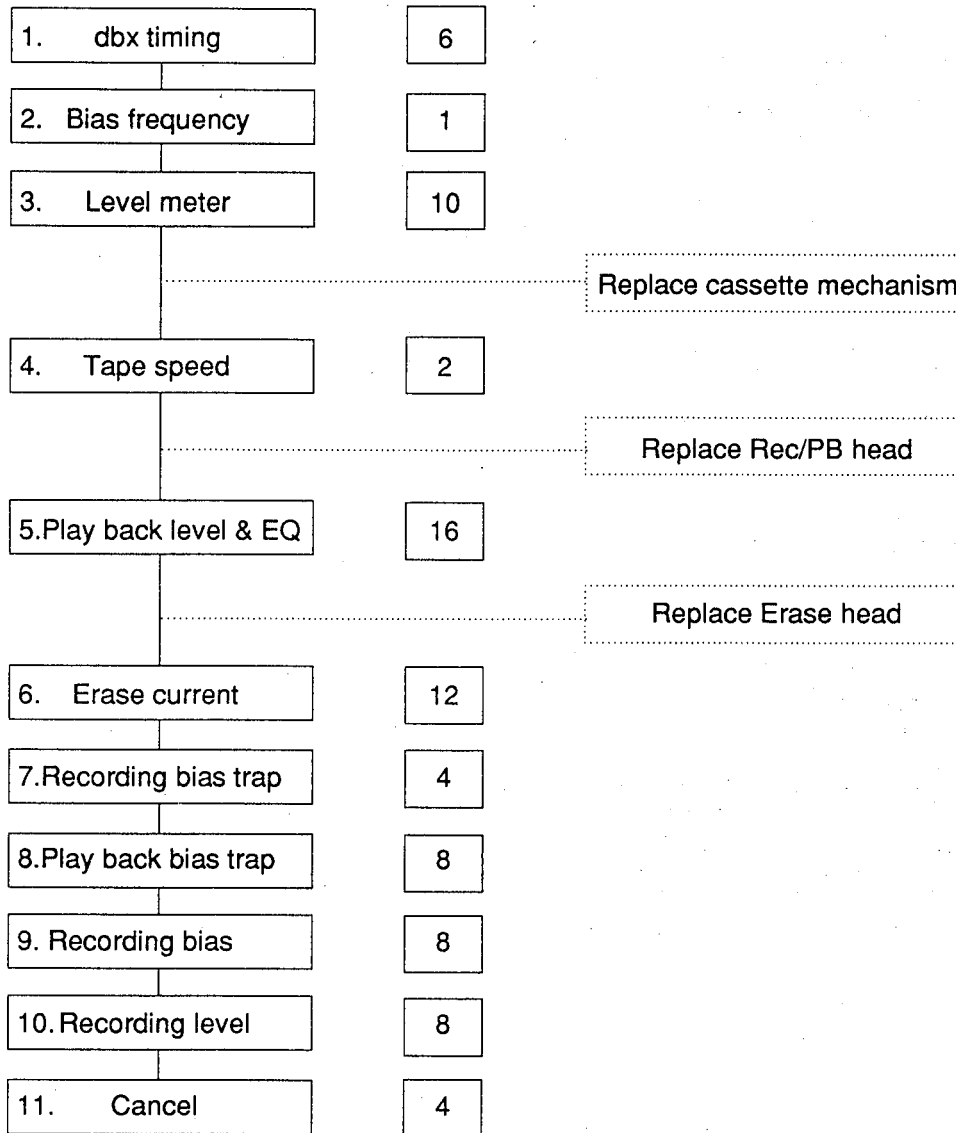

### 1. dbx Timing Adjustment

Adjustment points    DEC VR101 (CH 1.2)  
                           DEC VR301 (CH 3.4)  
                           DEC VR501 (CH 5.6)  
                           DEC VR701 (CH 7.8)

ENC VR206 (GROUP 1.2)  
 ENC VR406 (GROUP 3.4)

Check points        DEC CN101 (CH 1.2)  
                           DEC CN102 (CH 3.4)  
                           DEC CN103 (CH 5.6)  
                           DEC CN104 (CH 7.8)

	ENC CN203 (GROUP 1.2)	
	ENC CN403 (GROUP 3.4)	
Target value	18.4 + 0.2mV	
Measuring meter	DC millibar meter	
Tape	Not needed	
Adjustment	Connect the measuring meter at the test point and adjust by each VR.	
Remarks	Each connector	Pin (1) (+) Pin (2) (-)

## 2. Bias frequency

Adjustment point	SUB L101
Check point	SUB C101 both ends (▲:HOT)
Target value	85 + 1KHz
Measuring meter	Frequency counter
Tape	Not specified
Adjustment	Turn the master coil core in the recording condition of GROUP 1.
Remarks	Use of the test mode [1] makes the adjustment possible without equipping the tape.

## 3. Level meter

Adjustment points	DEC VR102 (CH 1) DEC VR202 (CH 2) DEC VR302 (CH 3) DEC VR402 (CH 4) DEC VR502 (CH 5) DEC VR602 (CH 6) DEC VR702 (CH 7) DEC VR802 (CH 8) DEC VR103 (CH L) DEC VR104 (CH R)
Check point	Level meter display
Target value	Glowing of 0dB segment
Measuring meter	• AC voltmeter • Oscillator

Tape	Not specified
Adjustment	<ul style="list-style-type: none"> <li>• Frequency 1KHz</li> <li>• Output TAPE OUT (CH1 - 8) Stereo out (L.R.)</li> </ul> <p>When each output is -10.5dBm, adjust for each VR. (At TAPE OUT, REC/PAUSE)</p>
Remarks	<p>Use of the test mode [1] makes the adjustment possible without the tape being equipped.</p> <p>Use of the test mode [3] makes the release of PEEK HOLD possible.</p>

**4. Tape speed**

Adjustment points	MIX VR002 (FIX) MIX VR001 (VARI)
Check point	TAPE OUT (CH 1 or 8)
Target value	FIX : 3000 + 15Hz VARI: $\pm 0.2\%$ (for FIX)
Measuring meter	Frequency counter
Tape	Test tape: Equivalent of A.BEX TCW-211
Adjustment	With the test tape being played back, adjust for each VR.
Remarks	

**5. Play back (Sound reproducing) level & EQ**

Adjustment points	<p>ENC VR103 (CH1 P.B. LEVEL) ENC VR102 (CH1 P.B. EQ)</p> <p>ENC VR203 (CH2 P.B. LEVEL) ENC VR202 (CH2 P.B. EQ)</p> <p>ENC VR303 (CH3 P.B. LEVEL) ENC VR302 (CH3 P.B. EQ)</p> <p>ENC VR403 (CH4 P.B. LEVEL) ENC VR402 (CH4 P.B. EQ)</p> <p>ENC VR503 (CH5 P.B. LEVEL) ENC VR502 (CH5 P.B. EQ)</p> <p>ENC VR603 (CH6 P.B. LEVEL) ENC VR602 (CH6 P.B. EQ)</p> <p>ENC VR703 (CH7 P.B. LEVEL) ENC VR702 (CH7 P.B. EQ)</p>
-------------------	---

ENC VR 803 (CH8 P.B. LEVEL)  
 ENC VR 802 (CH8 P.B. EQ)

Check point TAPE OUT CH 1 - 8

Target value • P.B. LEVEL -10 + 0.5dBm  
 • P.B. EQ -20 + 1.0dBm

Measuring meter AC voltmeter

Tape • P.B. LEVEL Equivalent of A.BEX TCC-121  
 • P.B. EQ Equivalent of A.BEX TCC-151

Adjustment With the test tape being played back, adjust for each VR.

NOTE: After adjusting EQ, recheck LEVEL.

Remarks

**6. Erasing current**

Adjustment points SUB L101 (SLAVE COIL)  
 ENC L101 (CH 1 VARIABLE COIL)  
 ENC L501 (CH 5 VARIABLE COIL)

SUB L201 (SLAVE COIL)  
 ENC L201 (CH 2 VARIABLE COIL)  
 ENC L601 (CH 6 VARIABLE COIL)

SUB L301 (SLAVE COIL)  
 ENC L301 (CH 3 VARIABLE COIL)  
 ENC L701 (CH 7 VARIABLE COIL)

SUB L401 (SLAVE COIL)  
 ENC L401 (CH 4 VARIABLE COIL)  
 ENC L801 (CH 8 VARIABLE COIL)

Check points CH 1 TP101 - TP103 (GND)  
 CH 5 TP501 - TP103 (GND)

CH 2 TP201 - TP203 (GND)  
 CH 6 TP601 - TP203 (GND)

CH 3 TP301 - TP303 (GND)  
 CH 7 TP701 - TP303 (GND)

CH 4 TP401 - TP403 (GND)  
 CH 8 TP801 - TP403 (GND)

Target value 60 mA

Measuring meter AC Voltmeter



Tape	Not specified
Adjustment	<p>Adjust for each GROUP in REC/PLAY, with other GROUPs off.</p> <p>(1) Adjust the erase current to the max point with SLAVE COIL.</p> <p>(2) Adjust the erase current to the max point with VARIABLE COIL.</p> <p>In this case, if the erase current is:</p> <p>1&gt;62mA: adjust to 62mA by turning the SLAVE COIL counterclockwise and return to (2).</p> <p>1&lt;62mA: adjust to 62mA by turning the SLAVE COIL clockwise and return to (2). If more than 62mA cannot be reached, adjust to the maximum and return to (2).</p> <p>1=62mA: adjust to 60mA by turning the VARIABLE COIL clockwise.</p> <p>(3) Change CH in GROUP and adjust to 60mA by turning the VARIABLE COIL</p>
Remarks	Use of test mode [1] makes the adjustment possible without equipping the tape.

#### 7. Remarksng bias trap

Adjustment points	<p>ENC FI 103 (GROUP 1)</p> <p>ENC FI 203 (GROUP 2)</p> <p>ENC FI 303 (GROUP 3)</p> <p>ENC FI 403 (GROUP 4)</p>
Check points	<p>GROUP 1 TP102 - TP104 (GND)</p> <p>GROUP 2 TP202 - TP104 (GND)</p> <p>GROUP 3 TP302 - TP304 (GND)</p> <p>GROUP 4 TP402 - TP304 (GND)</p>
Target value	Minimum [Ref: 30mA or so]
Measuring meter	AC voltmeter or oscilloscope
Tape	Not specified
Adjustment	Adjust with each coil in order for AC voltage to be maximum in the recording condition.
Remarks	Use of the test mode [1] makes the adjustment possible without equipping the tape.

#### 8. Play back (Sound reproducing) bias trap

Adjustment points	<p>ENC FI 101 (CH 1)</p> <p>ENC FI 201 (CH 2)</p> <p>ENC FI 301 (CH 3)</p> <p>ENC FI 401 (CH 4)</p> <p>ENC FI 501 (CH 5)</p> <p>ENC FI 601 (CH 6)</p> <p>ENC FI 701 (CH 7)</p> <p>ENC FI 801 (CH 8)</p>
-------------------	---

Check points	CH 1 R114 (▲ mark) - TP204 (GND) CH 2 R214 (▲ mark) - TP404 (GND) CH 3 R314 (▲ mark) - TP204 (GND) CH 4 R414 (▲ mark) - TP404 (GND) CH 5 R514 (▲ mark) - TP204 (GND) CH 6 R614 (▲ mark) - TP404 (GND) CH 7 R714 (▲ mark) - TP204 (GND) CH 8 R814 (▲ mark) - TP404 (GND)
Target value	Minimu [Ref: 100mV or so]
Measuring meter	AC voltmeter or oscilloscope
Tape	Not specified
Adjustment	Adjust for each coil in order for AC voltage of play back CH in the same GROUP to be minimum in the recording condition.
Remarks	Use of the test mode [1] makes the adjustment possible without equipping the tape.

### 9. Recording bias

Adjustment points	ENC VR101 (CH 1) ENC VR201 (CH 2) ENC VR301 (CH 3) ENC VR401 (CH 4) ENC VR501 (CH 5) ENC VR601 (CH 6) ENC VR701 (CH 7) ENC VR801 (CH 8)
Check point	TAPE OUT (CH 1 - 8)
Target value	$\pm 0.5\text{dB}$ (for 1KHz)
Measuring meter	• AC voltmeter • Oscillator
Tape	Alignment tape TDK AC-513
Adjustment	Record/play back signals of 1KHz and 10KHz -30dBm at TAPE OUT and adjust for the same level at each VR. See *1.
Remarks	Check the bias current value for each CH. Reference bias value [ $I_b$ ]: 550 $\mu\text{A}$ See *2

### 10. Recording Level

Adjustment points	ENC VR104 (CH 1) ENC VR204 (CH 2) ENC VR304 (CH 3)
-------------------	--

	ENC VR404 (CH 4) ENC VR504 (CH 5) ENC VR604 (CH 6) ENC VR704 (CH 7) ENC VR804 (CH 8)
Check point	TAPE OUT (CH 1 - 8)
Target value	±0.5dB
Measuring meter	• AC voltmeter • Oscillator
Tape	Alignment tape TDK AC-513
Adjustment	Record/play back signals of 1KHz -10dBm at TAPE OUT and adjust for the same level at each VR. See *1
Remarks	See *2.

**11. Cancel**

Adjustment points	ENC VR105 (GROUP 1) ENC VR205 (GROUP 2) ENC VR305 (GROUP 3) ENC VR405 (GROUP 4)
Check point	TAPE OUT (CH 1 - 8)
Target value	Minimum
Measuring meter	• AC voltmeter • Oscillator
Tape	Not needed.
Adjustment	Adjust at each VR in order for leakage to the adjoining CH to be minimum in the recording condition of 2KHz/-10dBm.  NOTE:For adjustment, use combinations of GROUP and adjoining CH that will develop frequent leakage.  1→2(5→6), 2→3(6→7), 3→4(7→8), 4→3(8→7) 2→1(6→5), 3→2(7→6)
Remarks	Use the test mode [1]

MT8X

\*1 Adjusting recording bias [ $I_B$ ] and recording level [ $I_S$ ]

Either may be the first to adjust. However, as the sensitivity may depend on the bias value, be sure to check the recording level at the end.

[Often due to a variance in the bias characteristic (of the head)]

1. Re-adjust the sensitivity if it changes (0.5dB or more) subsequent to the adjustment of the bias.

2. Check the distortion ratio.

If it is out of specification, re-adjust the recording bias to satisfy the specified value (1.8%).

\* If the recording bias is re-adjusted after the first adjustment because of a deteriorated distortion ratio, rec/PB f characteristic is changed. The make it flat, there is no alternative but to re-adjust the PB EQ.

• In the case of +1dB for (10KHz) for the recording bias adjustment:

Re-adjust the PB EQ to -21dBm.

• In the case of -1dB for 10KHz) for the recording bias adjustment:

Re-adjust the PB EQ to -19dBm.

3. If the PB EQ is re-adjusted, re-check the rec/PB f characteristic.

\*2 Adjusting by temporary adjustment of bias current [ $I_S$ ]

(1) Adjust [ $I_B$ ] to 550 $\mu$ A.	Both ends of R101 (CH 1)
	Both ends of R201 (CH 2)
(Adjust for each CH in the recording condition of no signals.)	Both ends of R301 (CH 3)
	Both ends of R401 (CH 4)
	Both ends of R501 (CH 5)
	Both ends of R601 (CH 6)
	Both ends of R701 (CH 7)
	Both ends of R801 (CH 8)

(2) Adjust the recording level.

(3) Adjust the recording bias.

## ■ REGARDING SPECIAL MODE (TEST PROGRAM)

[Entering into Each Mode]

The following chart shows combinations for entry into each mode. If the power source is switched on while these combinations of keys are pressed, the respective modes can be entered into.

Key Combination	Mode
<i>PLAY + TRACK1</i>	Cassette Mecha Check
<i>RESET + TRACK1</i>	All Segment Light On
<i>CLEAR + TRACK1</i>	No Peak Hold
<i>REC/PAUSE+TRACK1</i>	Rec return
<i>RTZ + TRACK1</i>	Full Repeat

\*Release: Turn POWER OFF except for "All Segment Lights On."

### 1. Cassette Mecha Check Mode

If this mode is entered into, the REMAIN blinks on the FL tube, indicating that the mode is not a normal one. Mechanical operation is possible without the tape being equipped. Naturally, the REC operation is possible as well. (Note that the AUTO STOP will not be operated when the tape is equipped.)

### 2. All Segment Light On Mode

This is the mode that enables all segments on the FL tube and all LEDs to light. A push on the REST key enables a return to the normal model.

Since scanning is being carried out as in normal operation, the illumination of the FL will not be increased only in this model.

### 3. No Peak Hold Mode

Peak hold operation will not be implemented.  
Operations other than in the peak hold mode are all the same.

### 4. Rec Return Mode

If the REW key is pressed while the recording is done, the tape is rewound to the recording start point and then stops.  
Operations (e.g. REPEAT, LOCATE, PUNCH I/O, etc.) other than this are not guaranteed.

### 5. Full Repeat Mode

If this mode is entered into, TRACK 1 of FL goes off (normally, on), indicating that the mode is not a normal one. If the tape end is reached during play back, the tape will be automatically rewound, causing the tape to play back from the beginning. Unless the STOP key and others are pressed, REPEAT PLAY is implemented. No other than this (recording, etc.) can be guaranteed.

**MT8X TRACK FORMAT [REFERENCE]**

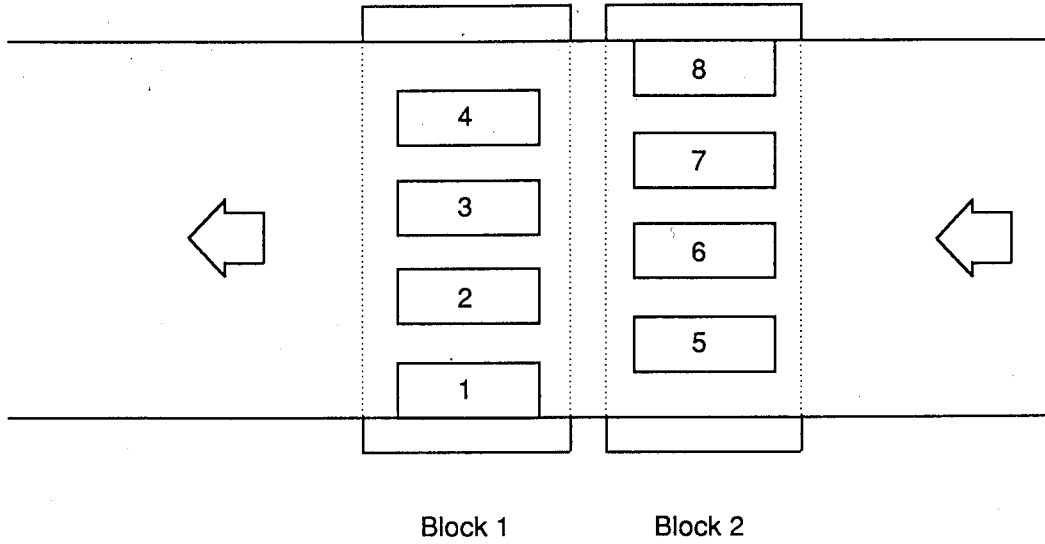

\* In MT8X, "ajoining channels" mean that they are adjacent to each other in the same block on the head. For instance, track 4 and 5 cannot be called ajoining channels.

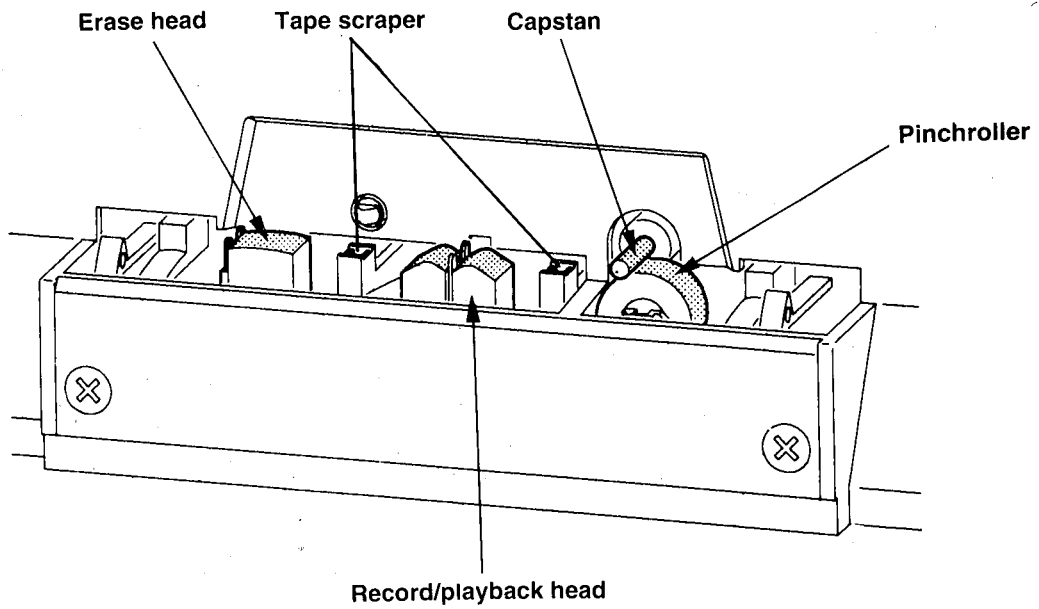

MT8X

■ カセットメカニズム調整手順

カセットメカニズムの磁気ヘッドを交換取付け再調整する場合、以下の手順に従って調整して下さい。尚、録再ヘッドのみの調整では\*印のステップを省略して先のステップに進んで下さい。

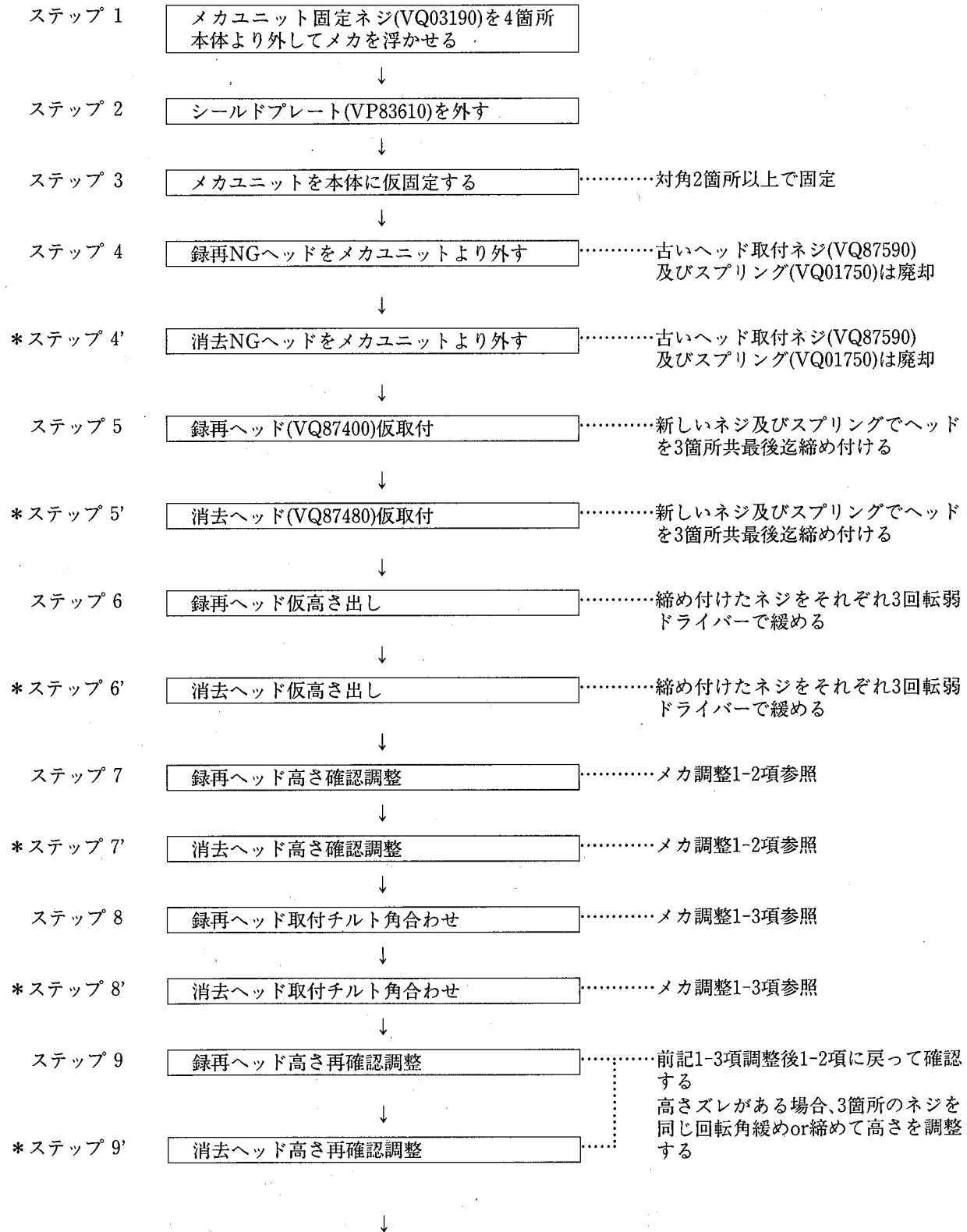

MT8X

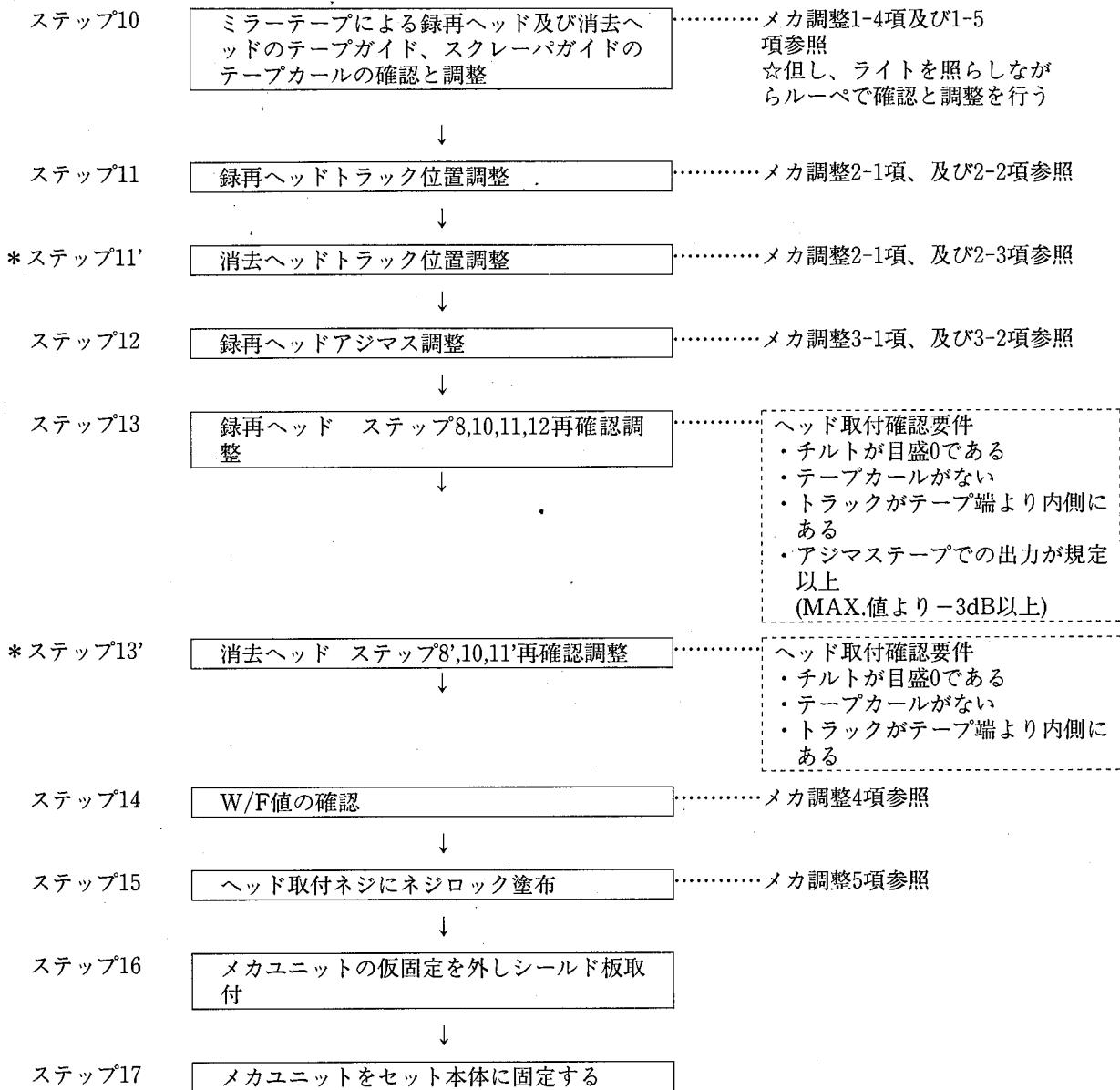

1. テープ走行の確認

1-1.メカ駆動治具に、メカユニットから出ている7ピンと11ピンの線材を接続します。

1-2.メカユニットにゲージプレートに乗せた後、メカユニットを[PLAY]状態にし、チェックバーをヘッドのテープガイドに合わせながら、ヘッドの高さを調整して取付けます。

注) ヘッドを傷つけないように、チェックバーをヘッドガイドに当てて高さを調整します。

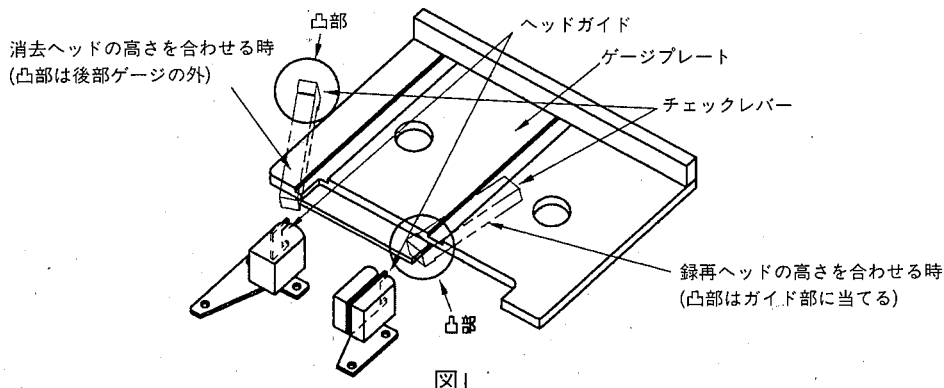



1-3. チルト角の調整

- 1) ゲージプレートにメカユニットを乗せます。
- 2) ゲージプレートを浮かさないように、手で軽く押さえながら、ダイヤルチルトゲージを押し込んでいきます。
- 3) 押し切ったときのゲージの値を読み取り、[0]になるようにチルト調整ネジを回します。(調整範囲 --- 1目盛以内)

注) ダイヤルゲージは、検査前にチルト校正ゲージで直角=0目盛に合わせておいて下さい。



図2

1-4. ミラーテープ (SONY、MC112C) を装着して、メカユニットを[PLAY]状態にします。

1-5. テープカールの確認と、ヘッドの高さを微調整します。

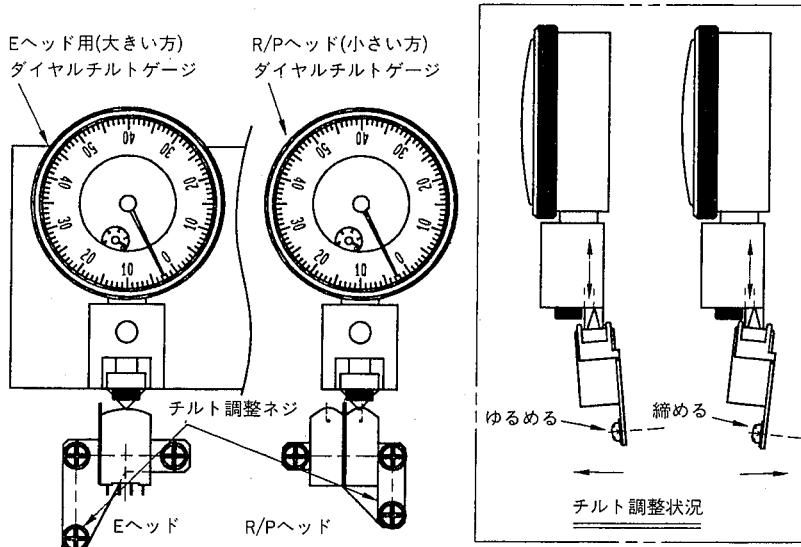

図3

- ・スクレーパーガイドに、テープカールが確認された場合、メカユニットとしてNGのため、ユニットの見直しと交換を行う必要があります。
  - ・上図のように、テープカールが確認された場合、消去ヘッド、録/再ヘッドの各3個所の取付調整ネジを同一回転角まわして上下させ、テープカールのない位置に調整します。
- 注) ネジは、1回転で0.25mmの高さが上下します。
- ・調整後、チルトゲージにて再確認を行います。

2. テープと消去&録/再ヘッドのトラック位置の確認と調整

2-1. テストテープ(ABEX、SCC-2219ミラーリーダーテープ)をメカユニットに装着します。

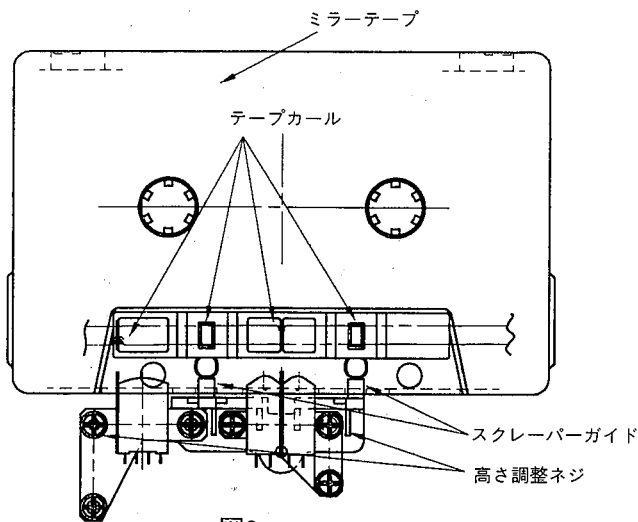
2-2. 録/再ヘッドのトラック確認

- ・ヘッド上下の端チャンネル(1Tr、8Tr)のコア部分(特に中心ギャップ部分)がテープよりはみ出していないこと、及び中央チャンネル(3Tr、6Tr)がセンターラインよりはみ出していないことを確認します。



図4

S8及びS1 $\geq$ 0 (狙い目・・・コア幅の1/4) ———— を確認します  
 S6、S3 $\geq$ 0 (狙い目・・・コア幅の2/5) ————

- ・もし、上記条件が満たされていない場合は、以下の調整を行います。
  - ・S8、S6を合わせるときは、Bネジを調整します。
  - ・S1、S3を合わせるときは、AネジとCネジを同一量だけ調整します。

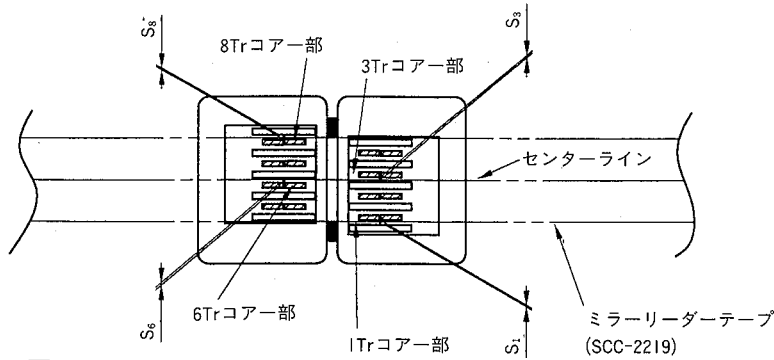

図5

※調整の幅が大きいときは、1-3のチルト角の調整を再度行います。

※テープカールしない範囲で、どうしてもコアがはみ出る場合は、ヘッドを交換する必要があります。

2-3. 消去ヘッドのトラック確認とテープタッチ確認

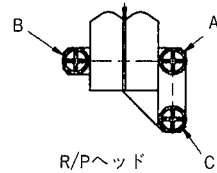

図6



図7

- ・センターラインが3Trコアと6Trコアの端面にくるように、またK1とK8がほぼ等しくなるように右図の調整ネジでヘッドの高さを調整します。
- ・走行中、テープガイド部分のテープタッチのふくらみが垂直になるように確認し、ひどい場合はチルト調整ネジで垂直になるように調整します。

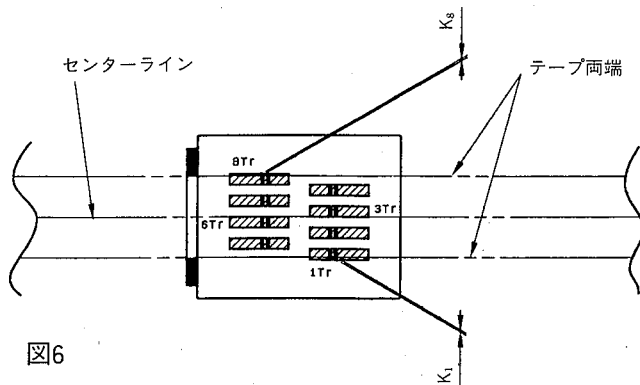

図8

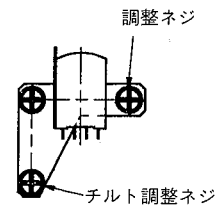
- ・消去ヘッドにピンホールや傷などがないことも合わせて確認します。

3. 録/再ヘッドのアジスマ調整

3-1. テストテープ(ABEX、TCC-151、6.3kHz- 倍速時 12.6kHz)をメカユニットに装着して、メカユニットを[PLAY]状態にします。

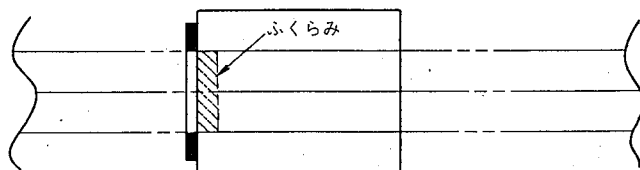
3-2. 録/再ヘッドの2Trの出力がMAX。又は、所定の出力となるように検査調整を行います。アジマス出力不足の場合は、アジマス調整ネジ及びA、Cネジを調整します。



図9

4. W/F値の確認

テストテープ(ABEX、TCW-211又は同等品 --- 倍速用3kHz 0dBテープ)をメカユニットに装着して、メカユニットを[PLAY]状態にしてW/F値を測定します。

- ・テープは、テープの巻き始めより2/3~3/4巻き取った位置に設定します。
- ・スペック W/F値 $\leq$ 0.06 (WRMS. 倍速時)

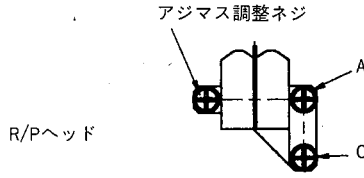
5. ヘッド取付けネジにネジロックを塗布します。

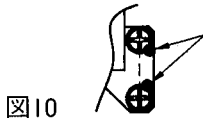

左図のように、ネジの頭を避けてネジ座とヘッド取付板に重なるように調整ネジ6本にネジロックを塗布します。

6. アース線Ass'y及びシールドプレート/ヘッドを下図のように+バインドBタイトネジ $\phi$ 3 $\times$ 5にて取付けます。 締付けトルク --- 5~8kgcm



図11

7. 消去率の確認

7-1. メカユニットを録音・再生回路治具に接続します。

7-2. クロス消去の検証

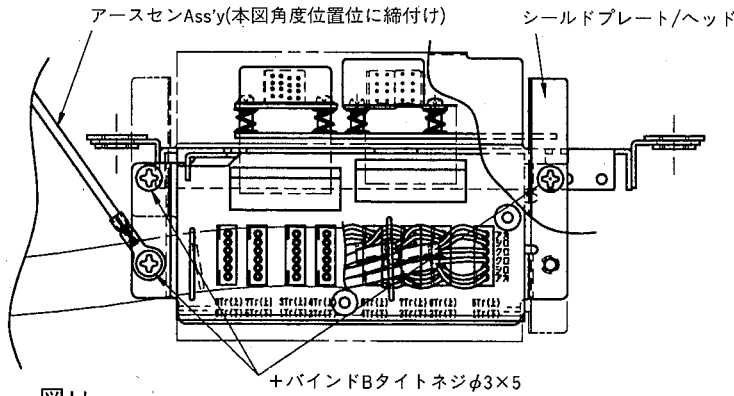
2Trに録音した後、1・3Tr消去時の2Trの再生レベルのダウンが1dB/7.5kHz以下のことを確認します。

7-3. 消去率

各Trを個別に録音・再生を行ったときの消去率は、60dB/1kHz、B.P.F. --- 以上のことを確認します。

■ MT8X総合調整手順(電気)

調整項目	調整数
1. dbxタイミング	6
2. バイアス周波数	1
3. レベルメーター	10
----- カセットメカ交換 -----	
4. テープスピード	2
----- 録再ヘッド交換 -----	
5. 再生レベル&EQ	16
----- 消去ヘッド交換 -----	
6. 消去電流	12
7. 録音バイアストラップ	4
8. 再生バイアストラップ	8
9. 録音バイアス	8
10. 録音レベル	8
11. キャンセル	4

1. dbxタイミング調整

調整箇所	シートDEC VR101(CH 1,2)
	シートDEC VR301(CH 3,4)
	シートDEC VR501(CH 5,6)
	シートDEC VR701(CH 7,8)
	シートENC VR206(GROUP 1,2)
	シートENC VR406(GROUP 3,4)

チェックポイント	シートDEC CN101(CH 1,2) シートDEC CN102(CH 3,4) シートDEC CN103(CH 5,6) シートDEC CN104(CH 7,8)  シートENC CN203(GROUP 1,2) シートENC CN403(GROUP 3,4)
目的値	18.4±0.2mV
測定器	DCミリバル計
テープ	不要
調整方法	テストポイントに測定器を接続、各VRにて調整します
備考	各コネクタ PIN①(+) PIN②(-)

## 2. バイアス周波数

調整箇所	シートSUB L101
チェックポイント	シートSUB C101両端(▲印 HOT)
目的値	85±1KHz
測定器	周波数カウンタ
テープ	指定無し
調整方法	GROUP1の録音状態で、マスターコイルのコアを回す
備考	テストモード[1]使用により、テープ装着しなくても可能

## 3. レベルメーター

調整箇所	シートDEC VR102(CH 1) シートDEC VR202(CH 2) シートDEC VR302(CH 3) シートDEC VR402(CH 4) シートDEC VR502(CH 5) シートDEC VR602(CH 6) シートDEC VR702(CH 7) シートDEC VR802(CH 8) シートDEC VR103(CH L) シートDEC VR104(CH R)
チェックポイント	レベルメーター表示
目的値	0dBセグメント点燈
測定器	・ AC VOLTMETER ・ OSCILLATOR

テープ	指定無し
調整方法	<ul style="list-style-type: none"> <li>・周波数 1KHz</li> <li>・出力 TAPE OUT(CH1~8) STEREO OUT(L,R)</li> </ul> 各出力が-10.5dBmの時、各VRで調整します (TAPE OUTの時は、REC/PAUSE状態)
備考	テストモード[1]使用により、テープ装着しなくても可能 テストモード[3]使用により、PEEK HOLD解除が可能

#### 4. テープスピード

調整箇所	シートMIX VR002(FIX) シートMIX VR001(VARI)
チェックポイント	TAPE OUT(CH1 or 8)
目的値	FIX:3000±15Hz VARI:±0.2%(FIXに対し)
測定器	周波数カウンター
テープ	テストテープ:A・BEX TCW-211相当品
調整方法	テストテープ再生状態にて、各VRで調整します
備考	

#### 5. 再生レベル&EQ

調整箇所	シートENC VR103(CH1 P.B LEVEL) シートENC VR102(CH1 P.B EQ)  シートENC VR203(CH2 P.B LEVEL) シートENC VR202(CH2 P.B EQ)  シートENC VR303(CH3 P.B LEVEL) シートENC VR302(CH3 P.B EQ)  シートENC VR403(CH4 P.B LEVEL) シートENC VR402(CH4 P.B EQ)  シートENC VR503(CH5 P.B LEVEL) シートENC VR502(CH5 P.B EQ)  シートENC VR603(CH6 P.B LEVEL) シートENC VR602(CH6 P.B EQ)  シートENC VR703(CH7 P.B LEVEL) シートENC VR702(CH7 P.B EQ)  シートENC VR803(CH8 P.B LEVEL) シートENC VR802(CH8 P.B EQ)
------	--

チェックポイント	TAPE OUT CH1~8
目的値	・ P.B LEVEL $-10 \pm 0.5 \text{dBm}$ ・ P.B EQ $-20 \pm 1.0 \text{dBm}$
測定器	AC VOLTMETER
テープ	・ P.B LEVEL A・ BEX TCC-121 相当品 ・ P.B EQ A・ BEX TCC-151 相当品
調整方法	テストテープ再生状態にて、各VRで調整します 注) EQ調整後、LEVELを再確認して下さい
備考	dBX "OFF"

## 6. 消去電流

調整箇所	シートSUB L101(SLAVE COIL) シートENC L101(CH 1 VARIABLE COIL) シートENC L501(CH 5 VARIABLE COIL)  シートSUB L201(SLAVE COIL) シートENC L201(CH 2 VARIABLE COIL) シートENC L601(CH 6 VARIABLE COIL)  シートSUB L301(SLAVE COIL) シートENC L301(CH 3 VARIABLE COIL) シートENC L701(CH 7 VARIABLE COIL)  シートSUB L401(SLAVE COIL) シートENC L401(CH 4 VARIABLE COIL) シートENC L801(CH 8 VARIABLE COIL)
チェックポイント	CH 1 TP101-TP103(GND) CH 5 TP501-TP103(GND)  CH 2 TP201-TP203(GND) CH 6 TP601-TP203(GND)  CH 3 TP301-TP303(GND) CH 7 TP701-TP303(GND)  CH 4 TP401-TP403(GND) CH 8 TP801-TP403(GND)
目的値	60mA
測定器	AC VOLTMETER
テープ	指定無し
調整方法	REC PLAY状態で各GROUP毎行い、他GROUPはOFF ①.SLAVE COILにて消去電流を最大ポイントに調整します ②.VARIABLE COILにて消去電流を最大ポイントに調整します この時の消去電流が

I>62mAの場合、SLAVE COILを左に回し62mAに調整し②へ戻ります  
 I<62mAの場合、SLAVE COILを右に回し62mAに調整し②へ戻ります  
 62mA上がらない場合は最大に調整し②へ戻ります  
 I=62mAの場合、VARIABLE COILを右に回し60mAに調整します  
 ③.GROUP内のCHを変え、VARIABLE COILを右に回し60mAに調整します

備考 テストモード[1]使用により、テープ装着しなくても可能

## 7. 録音バイアストラップ

調整箇所	シートENC FI103(GROUP 1) シートENC FI203(GROUP 2) シートENC FI303(GROUP 3) シートENC FI403(GROUP 4)
チェックポイント	GROUP 1 TP102-TP104(GND) GROUP 2 TP202-TP104(GND) GROUP 3 TP302-TP304(GND) GROUP 4 TP402-TP304(GND)
目的値	最小[参考値:30mV前後]
測定器	AC VOLTMETER or OSCILOSCOPE
テープ	指定無し
調整方法	録音状態でAC電圧が最小になる様、各コイルで調整します
備考	テストモード[1]使用により、テープ装着しなくても可能

## 8. 再生バイアストラップ

調整箇所	シートENC FI101(CH 1) シートENC FI201(CH 2) シートENC FI301(CH 3) シートENC FI401(CH 4) シートENC FI501(CH 5) シートENC FI601(CH 6) シートENC FI701(CH 7) シートENC FI801(CH 8)
チェックポイント	CH 1 R114(▲印)-TP204(GND) CH 2 R214(▲印)-TP404(GND) CH 3 R314(▲印)-TP204(GND) CH 4 R414(▲印)-TP404(GND) CH 5 R514(▲印)-TP204(GND) CH 6 R614(▲印)-TP404(GND) CH 7 R714(▲印)-TP204(GND) CH 8 R814(▲印)-TP404(GND)
目的値	最小[参考値:100mV前後]



測定器	AC VOLTMETER or OSCILOSCOPE
テープ	指定無し
調整方法	録音状態で、同一GROUP再生CHのAC電圧が最小になる様、各コイルで調整します ※全GROUP録音状態で良い
備考	テストモード[1]使用により、テープ装着しなくても可能

## 9. 録音バイアス

調整箇所	シートENC VR101(CH 1) シートENC VR201(CH 2) シートENC VR301(CH 3) シートENC VR401(CH 4) シートENC VR501(CH 5) シートENC VR601(CH 6) シートENC VR701(CH 7) シートENC VR801(CH 8)
チェックポイント	TAPE OUT(CH1~8)
目的値	±0.5dB(1KHzに対して)
測定器	・ AC VOLTMETER ・ OSCILLATOR
テープ	アライメントテープ TDK AC-513
調整方法	TAPE OUTで1KHz,10KHz,-30dBmの信号を録再し、同一レベルになる様各VRで調整します ※1参照
備考	バイアス電流値を観測する場合は、各CH毎に実施して下さい 参考バイアス値[I <sub>B</sub> ]:550μA ※2参照

## 10. 録音レベル

調整箇所	シートENC VR104(CH 1) シートENC VR204(CH 2) シートENC VR304(CH 3) シートENC VR404(CH 4) シートENC VR504(CH 5) シートENC VR604(CH 6) シートENC VR704(CH 7) シートENC VR804(CH 8)
------	--

チェックポイント	TAPE OUT(CH1~8)
目的値	±0.5dB
測定器	・ AC VOLTMETER ・ OSCILLATOR
テープ	アライメントテープ TDK AC-513
調整方法	TAPE OUTで1KHz, -10dBmの信号を録再し、-10dBmになる様各VRで調整します ※1参照
備考	※2参照

## 11. キャンセル

調整箇所	シートENC VR105(GROUP 1) シートENC VR205(GROUP 2) シートENC VR305(GROUP 3) シートENC VR405(GROUP 4)
チェックポイント	TAPE OUT(CH1~8)
目的値	最小
測定器	・ AC VOLTMETER ・ OSCILLATOR
テープ	不要
調整方法	2KHz/-10dBmの録音状態で、隣接CHへの漏れが最小になる様に各VRで調整します 注) 調整は、GROUP内と隣接CHで漏れの多い組み合わせで行って下さい 1→2(5→6), 2→3(6→7), 3→4(7→8), 4→3(8→7) 2→1(6→5), 3→2(7→6)
備考	テストモード[1]使用

### ※1 録音バイアス[ $I_B$ ],録音レベル[ $I_S$ ]調整について

どちらを先に調整しても良いが、バイアス値により感度が変化する場合がある為、最後に必ず録音レベルの確認を実施して下さい。

[バイアス特性(ヘッド)のバラツキによるものが多い]

1. バイアス調整後、感度が(0.5dB以上)変化したら感度を再調整します。
2. 歪率を確認する。

スペック外れの場合は、規格値(1.8%以上)を満足するよう録音バイアスを再調整します。

※録音バイアス調整後、歪率悪化の為録音バイアス再調整した場合、録再f特は変化しています。

フラットにするには、再生EQを再調整して下さい。

- ・録音バイアス調整で(10KHzが)+1dBの場合:再生EQを-21dBmに再調整します
  - ・録音バイアス調整で(10KHzが)-1dBの場合:再生EQを-19dBmに再調整します
3. 再生EQを再調整した場合、録再f特を再確認して下さい。

※ 2 バイアス電流 $[I_B]$ 仮調整による調整方法

①.  $[I_B]$ を $550\mu A$ に調整します

(無信号録音状態にて各CH毎に実施)

R101 両端(CH 1)  
R201 両端(CH 2)  
R301 両端(CH 3)  
R401 両端(CH 4)  
R501 両端(CH 5)  
R601 両端(CH 6)  
R701 両端(CH 7)  
R801 両端(CH 8)

②. 録音レベル調整を行います

③. 録音バイアス調整を行います

## ■ 特殊モード (テストプログラム)

### 【各モードへの入り方】

下に各モードに入る為の組合せを示します。下記のキーを押しながら電源を入れることにより、それぞれのモードに入ります。尚キーはMT8X本体のキーを指し、リモートコントローラーのキーではありません。

キーの組合せ	モード
PLAY+TRACK1	Cassette Mecha Check
RESET+TRACK1	All Segment Light On
CLEAR+TRACK1	No Peak Hold
REC/PAUSE+TRACK1	Rec Return
RTZ+TRACK1	Full Repeat

#### 1. Cassette Mecha Check Mode

このモードに入るとFL管のREMAINが点滅し、通常モードでないことを示します。

テープを装着しなくてもメカ動作が可能、もちろんREC動作も出来ます。(テープ装着時、AUTO STOP動作しないので注意して下さい)ヘッドクリーニング時、修理調整時に使用します。

#### 2. All Segment Light On Mode

FL管の全セグメント、及び各LEDを全て点燈させるモード。RESETキーを押すことによって通常モードに戻ることが出来ます。動作確認用

通常の動作と同じくスキャンをしているので、このモードだけFLの輝度が上がることはありません。

#### 3. No Peak Hold MODE

レベルメータのピークホールド処理を行わない。

ピークホールド以外は、通常と全く同じ動作。動作確認用

#### 4. Rec Return MODE

録音中にREWキーが押されると、録音開始点まで巻戻してSTOPします。

これ以外(REPEAT,LOCATE,PUNCH I/O等)の動作は保証しません。

修理、調整時に使用します。

#### 5. Full Repeat Mode

このモードに入るとFLのTRACK 1が消燈し(通常は点燈)、通常モードでないことを示します。

再生中にテープエンドまで来た場合、自動的に巻戻しテープの最初でPLAYします。

STOPキー等が押されない限り、REPEAT PLAYを行います。これ以外(録音等)の動作は保証しません。修理、調整時に使用します。

※解除方法：All Segment Light On以外は電源をOFFすると解除できます。

**MT8X TRACK FORMAT [REFERENCE]**

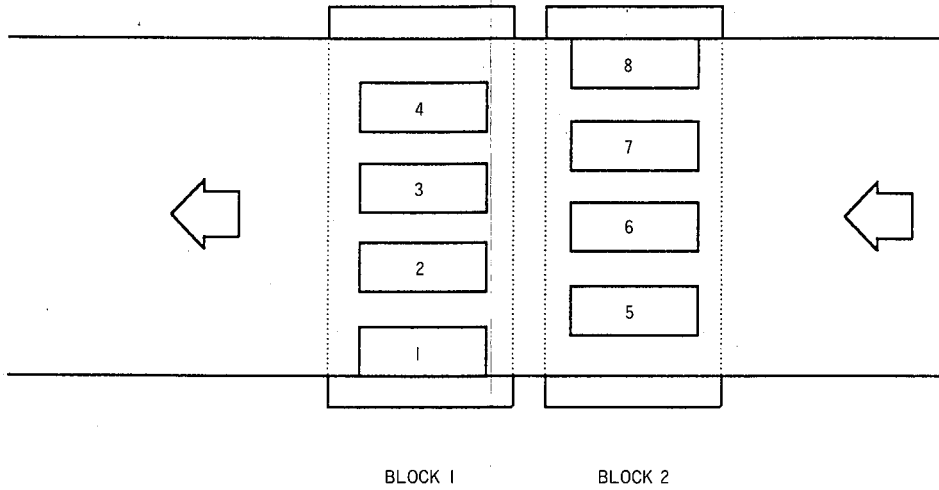

※MT8Xで隣接チャンネルとは、ヘッド上でブロック内でのことを言います。  
従って、トラック4と5は隣接チャンネルとは言いません。

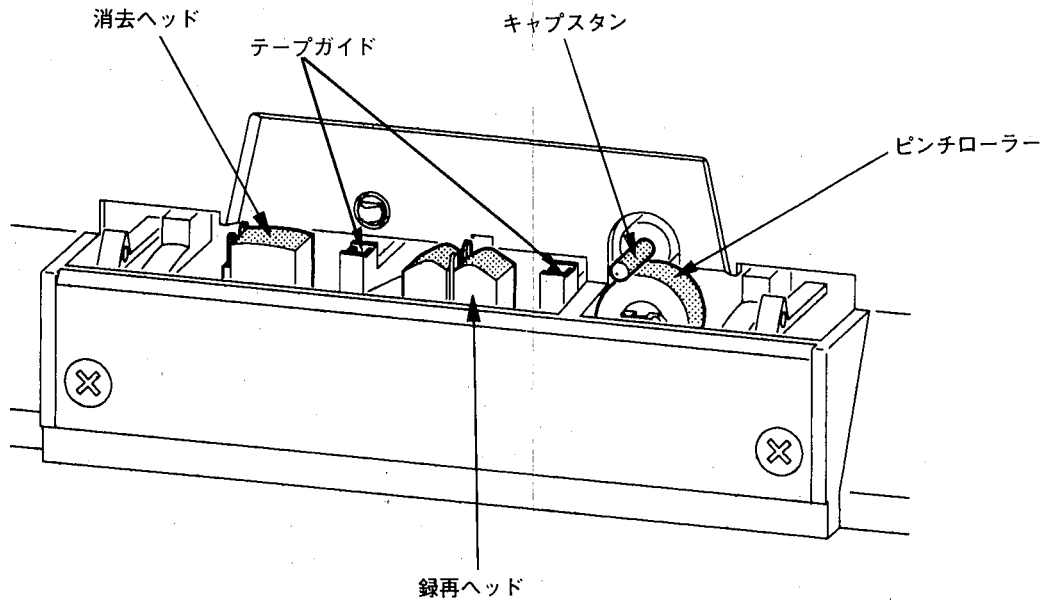

■ POT & COIL LAYOUT (調整用ボリューム、コイルレイアウト)

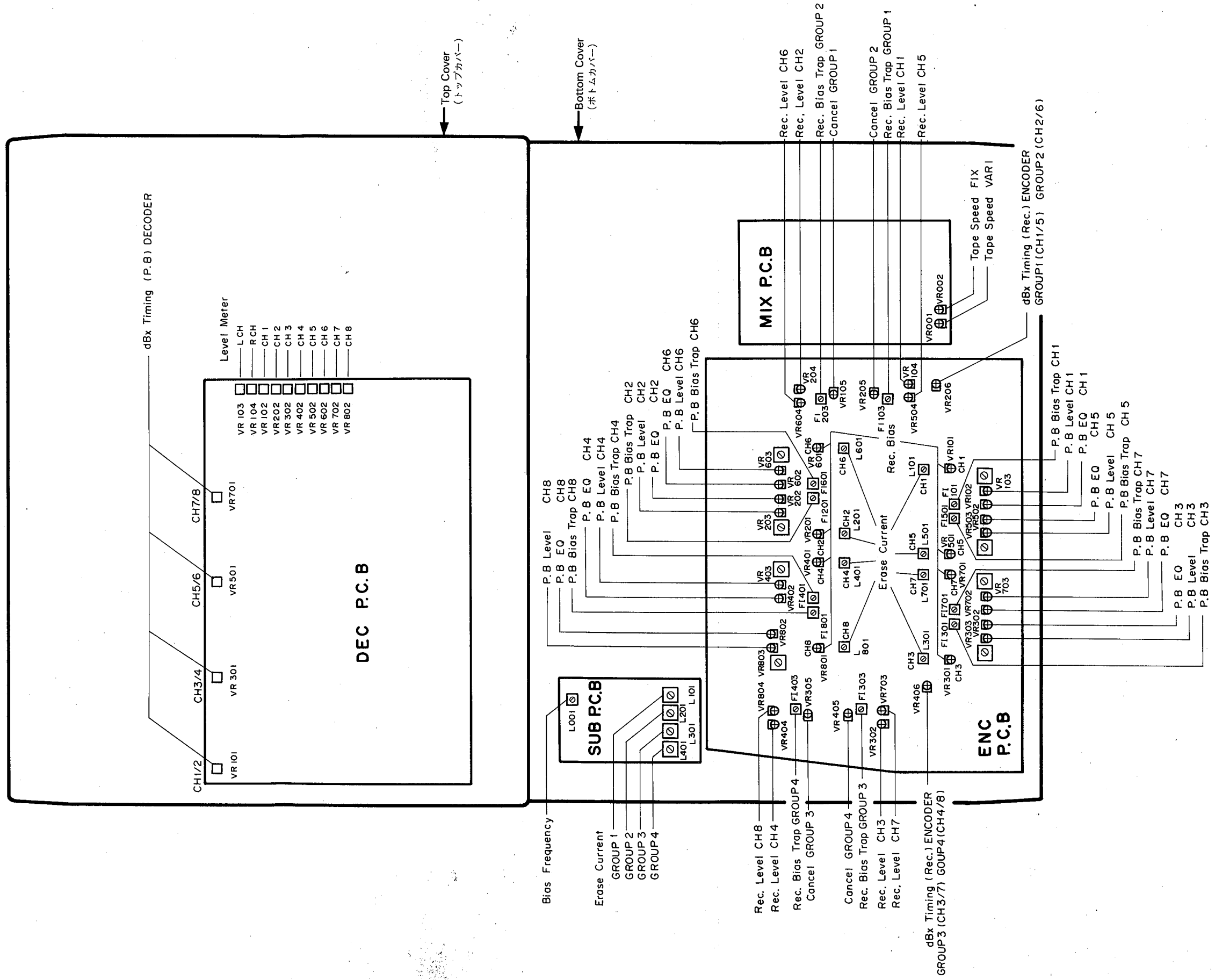

MT8X

**CIRCUIT BOARDS (シート基板図)**

● MIX Circuit Board

**MIX 1/7**

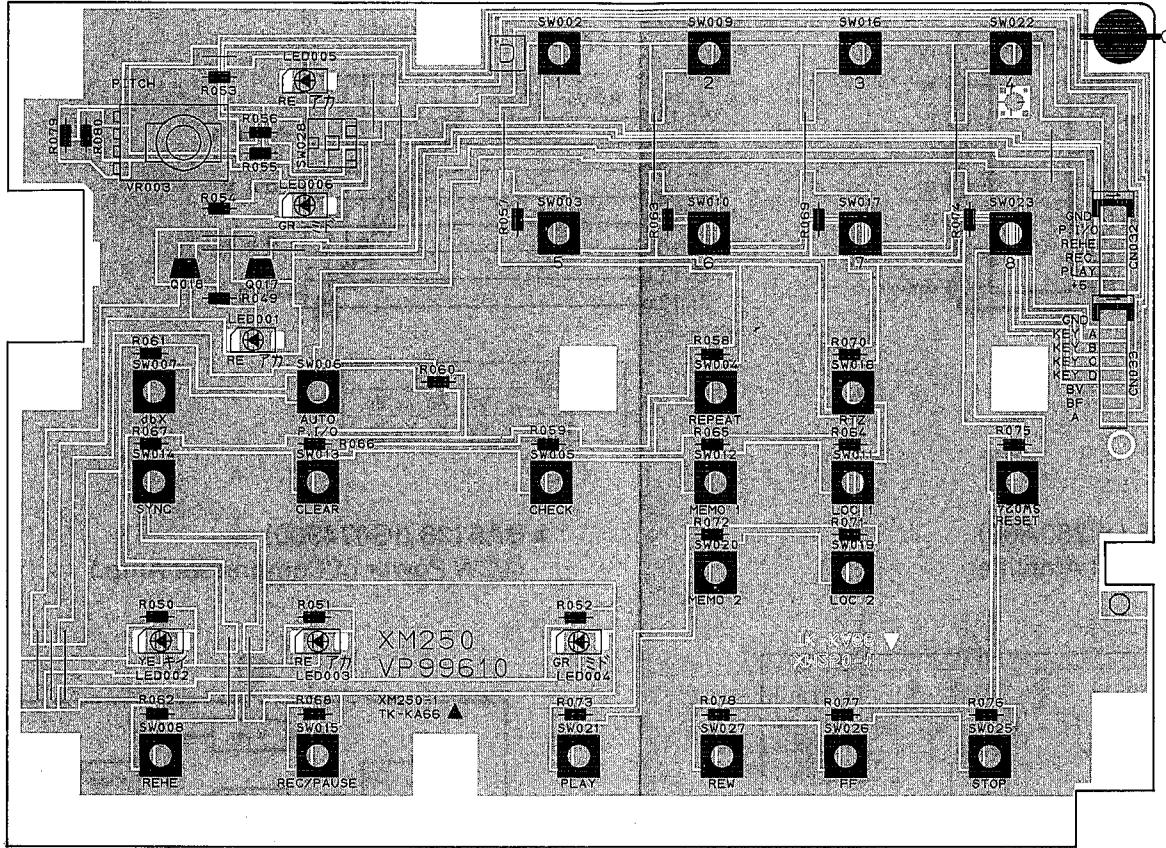

Components side (部品側)

**MIX 3/7**

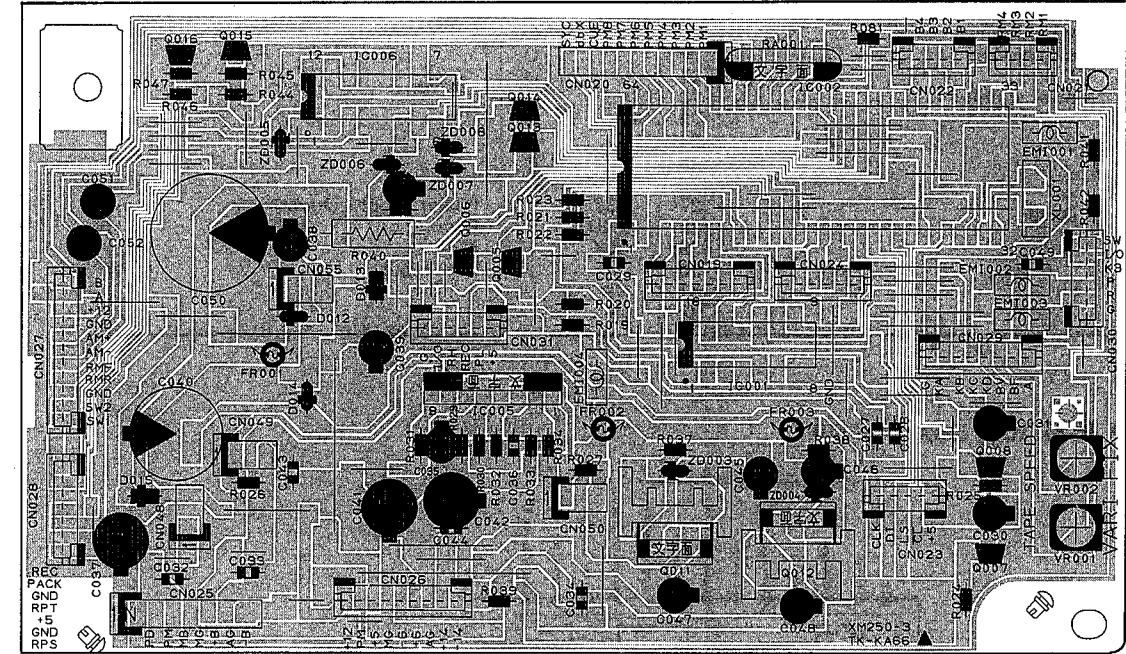

Components side (部品側)

**MIX 4/7**

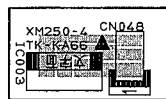

Components side (部品側)

**MIX 5/7**

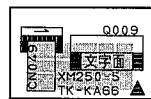

Components side (部品側)

**MIX 6/7**

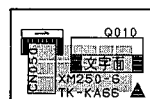

Components side (部品側)

**MIX 7/7**

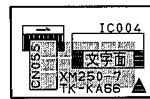

Components side (部品側)

**Notes**

- CIRCUIT BOARD : MIX XM250D0  
 CIRCUIT BOARD : MIX 1/7 (NX812220)  
 CIRCUIT BOARD : MIX 2/7 (NX812230)  
 CIRCUIT BOARD : MIX 3/7 (NX812240)  
 CIRCUIT BOARD : MIX 4/7 (NX812250)  
 CIRCUIT BOARD : MIX 5/7 (NX812260)  
 CIRCUIT BOARD : MIX 6/7 (NX812270)  
 CIRCUIT BOARD : MIX 7/7 (NX812280)
1. CAP.  
 C110, 111, 210, 211 : 0.0220 50V J (UA654220)  
 310, 311, 410, 411 : 1800P 50V J (UA653180)  
 C112, 212, 312, 412 : 0.0120 50V J (UA654120)  
 C116, 216, 316, 416 : 7500P 50V J (UA353750)  
 C119, 219, 319, 419 :

2. CERAMIC TUBULAR CAP.-SL  
 C105, 205, 305, 405 : 22P 50V J (VG276600)  
 C115, 215, 315, 415 : 10P 50V J (VF466600)  
 C124, 224, 324, 424 : 15P 50V J (VG276200)

3. CERAMIC TUBULAR CAP.-B  
 C101, 201, 301, 401 : 220P 50V K (VG278400)  
 C103, 104, 114, 117 : 123, 203, 204, 214  
 217, 223, 303, 304  
 314, 317, 323, 403  
 404, 414, 417, 423 : 100P 50V K (VF466800)  
 C118, 218, 318, 418 : 150P 50V K (VG278200)

4. CERAMIC TUBULAR CAP.-F  
 C27~29, 36, 43, 44 : 0.022 25V Z (VG280100)  
 49, 107, 207, 307 : 0.1 50V Z (VJ599100)  
 407 :  
 C32~34 :

5. ELECTROLYTIC CAP.  
 C30 : 4.700 25.0V (VG288400)  
 C31, 35 : 1.00 50.0V (VG290500)  
 C37 : 100.00 16.0V (VG287600)  
 C38, 102, 108, 109 : 10.00 25.0V (VG288500)  
 121, 202, 208, 209 : 100.00 10.0V (VG286800)  
 221, 302, 308, 309 : 3300 6.3V (VK179300)  
 402, 408, 409 : 100.00 25.0V (VG288900)  
 C39, 47, 48 : 47.00 10.0V (VG286700)  
 C40 : 4700 16.0V (VK180700)  
 C41, 42 : 7.00 16.0V (VG287500)  
 C45, 46, 128, 228 : 0.22 50.0V (UM415220)  
 328, 428 : 10.00 25.0V (UM407100)  
 C50 : 100.00 16.0V (UI538100)  
 C106, 206, 306, 406 : 7.00 16.0V (VG287500)  
 C113, 213, 313, 413 : 0.22 50.0V (UM415220)  
 C120, 122, 125, 220 : 222, 225, 320, 321  
 322, 325, 420, 421 : 10.00 25.0V (UM407100)  
 422, 425 : 100.00 16.0V (UI538100)  
 C126, 127 :

6. ELECTROLYTIC CAP.-BP  
 C51, 52 : 1.00 50.0V (UK866100)

7. CARBON RESISTOR  
 R19, 52, 54 : 270.0 1/4 J (HF455270)  
 R20, 31, 32, 49, 51 : 560.0 1/4 J (HF455560)  
 53 :  
 R21~23, 25, 79~81 : 102, 117, 120, 123  
 202, 217, 220, 302 : 10.0K 1/4 J (HF457100)  
 317, 320, 323, 402 : 10.0K 1/4 J (HF457100)  
 417, 420 :  
 R24, 37, 38, 105 : 1.0K 1/4 J (HF456100)  
 205, 305, 405 :

- R26, 27, 106, 206 : 220.0 1/4 J (HF455220)  
 306, 406 : 22.0K 1/4 J (HF457220)  
 R29, 56 : 3.3K 1/4 J (HF456330)  
 R30, 55 : 15.0K 1/4 J (HF457150)  
 R33, 34 :  
 R39, 104, 107, 122 : 100.0K 1/4 J (HF458100)  
 124, 126, 204, 207 : 1.6K 1/4 J (HF456160)  
 224, 226, 304, 307 : 2.4K 1/4 J (HF456240)  
 322, 324, 326, 404 : 4.7K 1/4 J (HF456470)  
 407, 424, 426 : 51.0K 1/4 J (HF457510)  
 R41, 57, 63, 69, 74 : 1.6K 1/4 J (HF456160)  
 R42, 58, 64, 70, 75 : 2.4K 1/4 J (HF456240)  
 R44, 46 : 4.7K 1/4 J (HF456470)  
 R45, 47 : 51.0K 1/4 J (HF457510)  
 R50, 101, 201, 301 : 470.0 1/4 J (HF455470)  
 401 :  
 R59, 65, 71, 76, 116 : 3.9K 1/4 J (HF456390)  
 216, 316, 416 :  
 R60, 66, 72, 77, 128 : 129, 228, 229, 328  
 329, 428, 429 : 5.6K 1/4 J (HF456560)  
 R61, 67, 73, 78 : 13.0K 1/4 J (HF457130)  
 R62, 68 : 36.0K 1/4 J (HF457360)  
 R103, 121, 203, 221 : 100.0 1/4 J (HF455100)  
 321, 421 : 150.0K 1/4 J (HF458150)  
 R108, 208, 308, 408 : 270.0K 1/4 J (HF458270)  
 R109, 209, 309, 409 :  
 R110, 113, 210, 213 : 12.0K 1/4 J (HF457120)  
 310, 313, 410, 413 : 8.2K 1/4 J (HF456820)  
 R111, 211, 311, 411 : 39.0K 1/4 J (HF457390)  
 R112, 212, 312, 412 : 9.1K 1/4 J (HF456910)  
 R114, 214, 314, 414 : 470.0K 1/4 J (HF458470)  
 R115, 215, 315, 415 : 18.0K 1/4 J (HF457180)  
 R118, 119, 218, 219 : 91.0K 1/4 J (HF457910)  
 318, 319, 418, 419 :  
 R125, 225, 325, 425 :  
 R127, 130~136, 227 : 230~236, 327, 330  
 331~336, 427, 430 : 33.0K 1/4 J (HF457330)  
 431~436 :

MIX 2/7

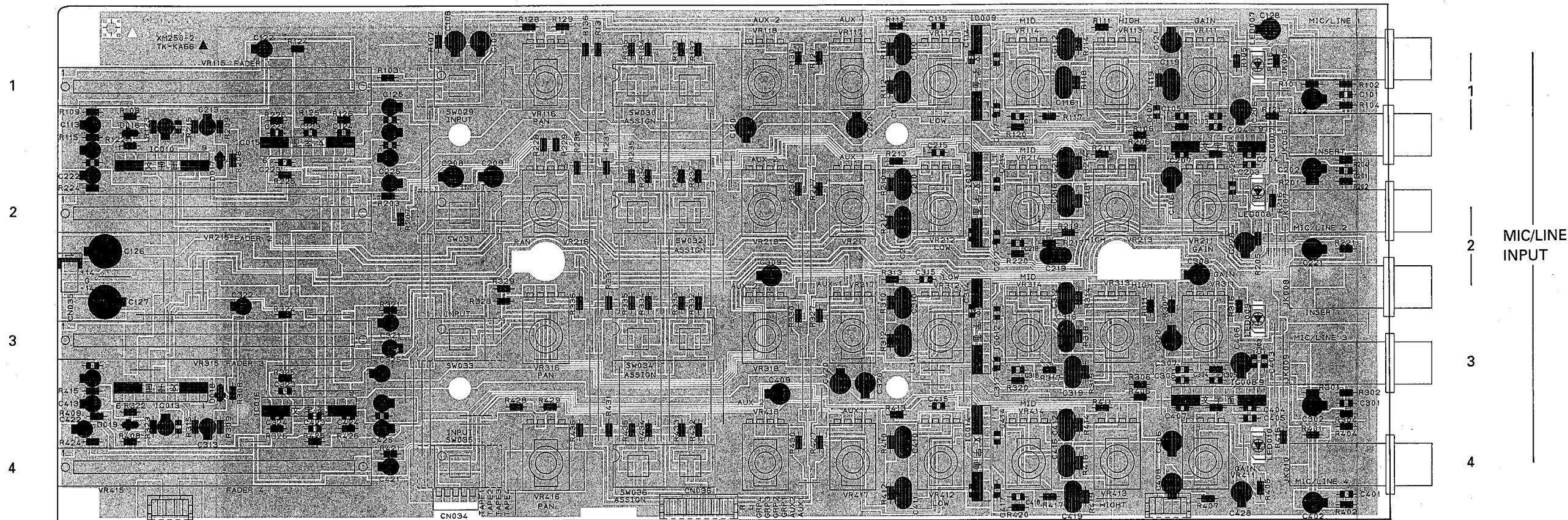

Components side (部品側)

- 8. METAL OXIDE FILM RESISTOR  
R40: 18.0 1W J (HL214180)
- 9. FUSE RESISTOR  
FR 1: 4.7 1/4 J (VE009700)  
FR 2, 3: 10.0 1/4 G (VK186600)
- 10. RESISTOR ARRAY  
RA 1: RGLE8X103J (VF771900)
- 11. IC  
IC 1: BU4551B (XI929A00) ANALOG SWITCH  
IC 2: M38022M2SP (XM709A00) CPU  
IC 3: NJM7812FA (XJ608A00) REGULATOR +12V  
IC 4: NJM78M05FA (XJ604A00) REGULATOR +5V  
IC 5: M5230L (XB382A00) REGULATOR  
IC 6: LB1649 (XA299A00) MOTOR DRIVER  
IC 7, 8: NJM2068S-D (XE322A00) OP AMP  
IC 9~16: NJM4558S (IG076800) OP AMP
- 12. TACT SWITCH  
SW 2-27: SKH-VBA005A (VG392900)
- 13. PUSH SWITCH  
SW28: SPPH23 (VQ036800) VARI/FIX  
SW29, 31, 33, 35: SPEC12 (VQ035600) ASSIGN  
SW30, 32, 34, 36: SPEC21 2 (VQ035700) TAPE, MIC/LINE
- 14. PHONE JACK  
JK 5, 7, 9, 10: YKB21-5011 (VD430000) MIC/LINE  
JK 6, 8: YKB21-5166 (VP599800) INSERT
- 15. EMI FILTER  
EMI 1~4: LS MT Y223NB (FZ006970)
- 16. CERAMIC RESONATOR  
XL 1: CST8.00MTW (VJ802400)

- 17. TRIMMER POTENTIOMETER  
VR 1, 2: B 6.8K 3P (VQ033000)
- 18. SLIDE POT.  
VR115, 215, 315  
415: 10.0K (VQ030400) FADER1-4
- 19. VARIABLE RESISTOR  
VR 3: B 10.0K (VQ032500) PITCH  
VR111, 211, 311  
411: A 100.0K (VQ032400) GAIN  
VR112, 114, 212  
213, 214, 312  
313, 314, 412  
414: B 50.0K (VQ031400) LOW, MID, HIGH  
VR113, 413: B 50.0K (VQ031500) HIGH  
VR116, 416: B 10.0K (VQ031000) PAN  
VR117, 118, 217  
218, 317, 318  
417, 418: A 10.0K (VQ031200) AUX1, 2  
VR216, 316: B 10.0K (VQ030900) PAN
- 20. TRANSISTOR  
Q 7, 15, 16: 2SC2603 E, F (IC260320)  
Q 9, 12: 2SB1274 R, S (VC614000)  
Q 10, 11: 2SD1913 R, S (VC407900)
- 21. DIODE  
D12, 14, 16~19: 1SS133 T-77 (IF004600)  
D13, 15: 1SR139-100 T-32 (VH770800)
- 22. ZENER DIODE  
ZD 3, 4, 7: MTZ J 7.5B 7.5V (VG438600)  
ZD 5, 6: MTZ J 9.1C 9.1V (VG439300)  
ZD 8: MTZ J 4.3A 4.3V (VG436700)
- 23. LED  
LED 1, 3, 5, 7~10: SLR-34URC3H3 RE (IF008730)  
LED 2: SLR-34YC3H3 YE (VE067000)  
LED 4, 6: SLR-34MC3H3 GR (IF008740)

- 24. DIGITAL TRANSISTOR  
Q 8: DTC143XS TP (VD488500)  
Q 5, 6, 17, 18: DTA114ES (VD678500)  
Q 13, 14: DTC114ES (VD678700)
- 25. CONNECTOR HOUSING  
CN34: 52084 5P TE (VP600000) to DEC-CN109  
CN36: FJ 8P (VK217100) to MAS-CN39
- 26. BASE PIN IN STICK  
CN19: PH 7P TE (VD005000) to DEC-CN115  
CN21: PH 4P TE (VD004700) to ENC-CN106  
CN22: PH 5P TE (VD004800) to ENC-CN108  
CN23: PH 5P TE (VD004800) to MAS-CN47  
CN24: PH 6P TE (VD004900) to DEC-CN113  
CN26: PH 9P TE (VD005200) to ENC-CN113  
CN27: PH 11P TE (VG699700) to CASSETTE  
CN28: PH 7P TE (VD005000) to CASSETTE  
CN29: PH 8P TE (VD005100) to MIX-CN33  
CN30: PH 6P TE (VD004900) to SUB-CN18  
CN31: PH 6P TE (VD004900) to MIX-CN32
- 27. CONNECTOR ASSEMBLY  
CN20: 11P 200L (VQ051000) to ENC-CN110  
CN25: 7P 140L (VQ051700) to SUB-CN3
- 28. PH CONNECTOR ASSEMBLY  
CN35: 3P 120mm B&C (VB708400) to DEC-CN111  
CN48: 3P 70mm B&B (VB692900) to MIX-CN48  
CN49: 3P 100mm B&B (VB693000) to MIX-CN49  
CN50: 3P 140mm B&B (VB693200) to MIX-CN50  
CN55: 3P 100mm B&B (VB693000) to MIX-CN55
- 29. B&C CONNECTOR ASSEMBLY  
CN32: PH328 6P 350 (VM023000) to MIX-CN31  
CN33: PH362 8P 350 (VM026400) to MIX-CN29



● MAS Circuit Board

MAS 1/3

AUX SEND

2

1

R

8

L

7

LINE INPUT

6

5

MASTER

8

7

6

5

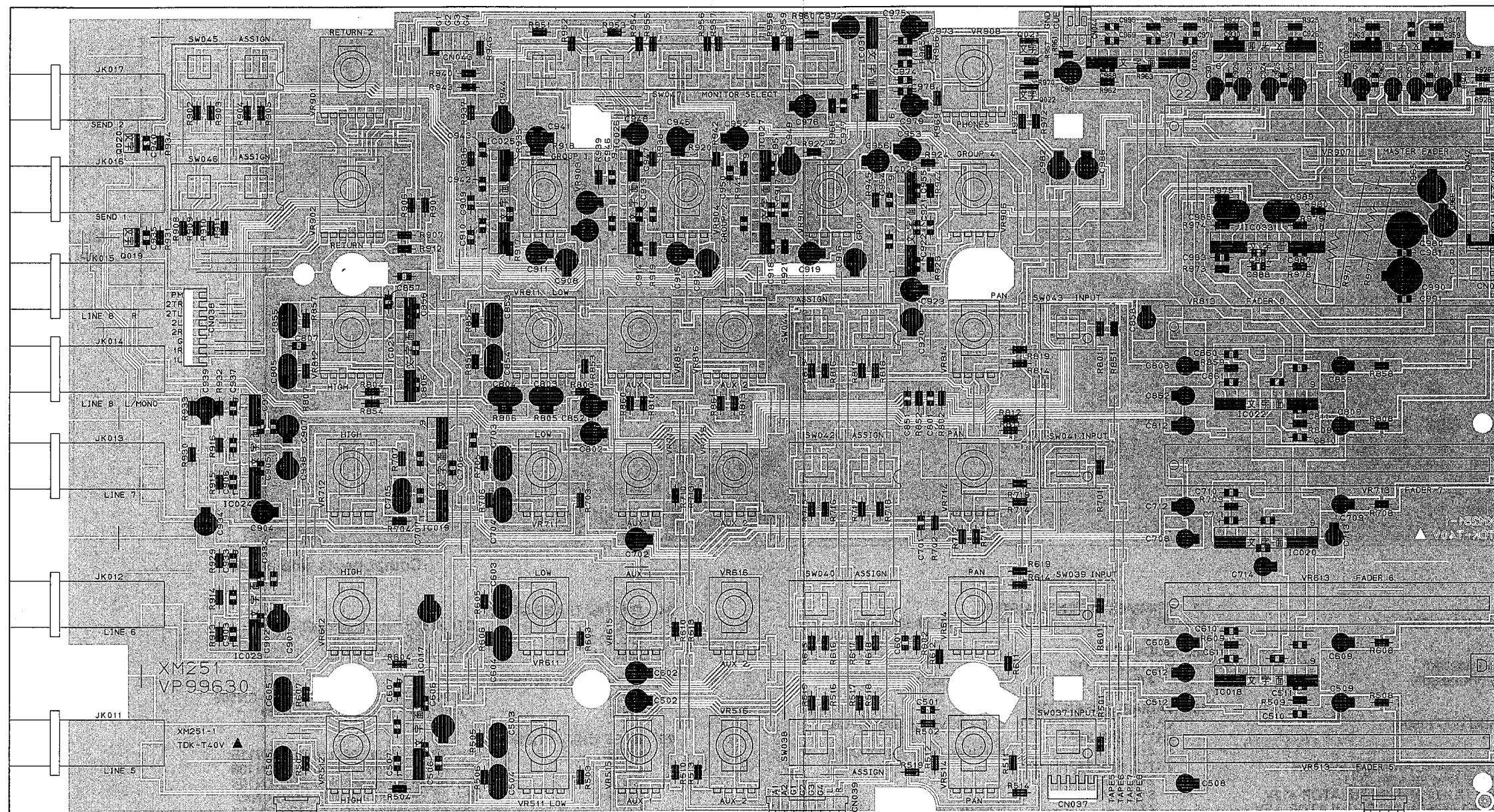

Components side (部品側)

MT8X

MAS 2/3

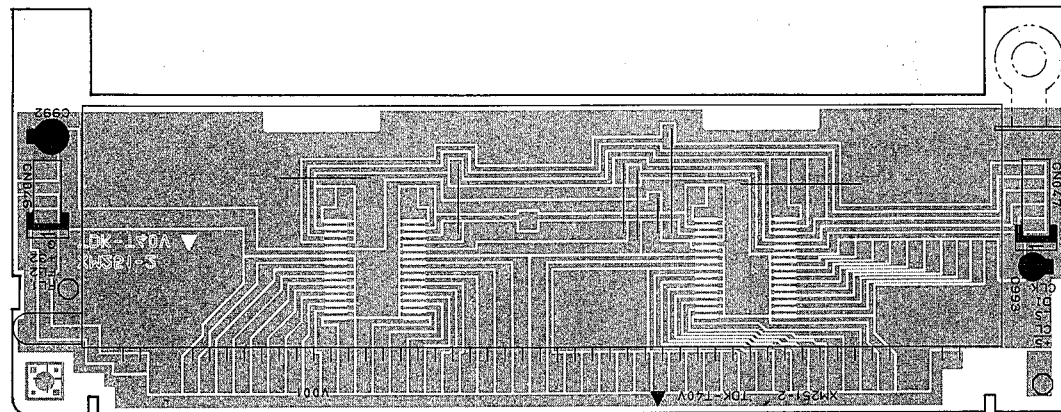

Components side (部品側)

MAS 3/3

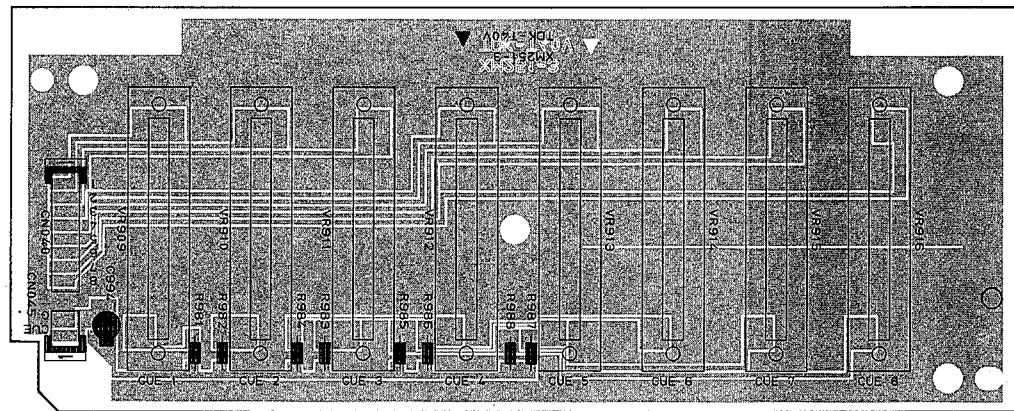

Components side (部品側)

Notes)

CIRCUIT BOARD : MAS XM251D0  
 CIRCUIT BOARD : MAS 1/3 (NX812290)  
 CIRCUIT BOARD : MAS 2/3 (NX812300)  
 CIRCUIT BOARD : MAS 3/3 (NX812310)

1. MYLAR CAP.  
 C503, 504, 603, 604  
 703, 704, 803, 804  
 853, 854: 0.0220 50V J (UA654220)  
 C505, 605, 705, 805  
 855: 1800P 50V J (UA653180)  
 C985, 989: 0.1000 50V J (UA655100)
2. CERAMIC TUBULAR CAP.-SL  
 C507, 607, 707, 807  
 857: 10P 50V J (VF466600)  
 C511, 611, 711, 811  
 861, 926, 930, 973  
 977: 15P 50V J (VG276200)  
 C903, 906, 959, 963: 50V J (VG276400)  
 C910, 914, 918, 922: 50V J (VG277200)  
 C933, 937: 56P 50V J (VG277500)  
 C943, 947, 951, 955: 27P 50V J (VG276800)  
 C968: 68P 50V J (VG277000)  
 C970, 983, 987: 33P 50V J (VG277000)

3. CERAMIC TUBULAR CAP.-B  
 C501, 601, 701, 801  
 851: 220P 50V K (VG278400)  
 C506, 510, 606, 610  
 706, 710, 806, 810  
 856, 860, 902, 905  
 909, 913, 917, 921  
 925, 929, 932, 936  
 942, 946, 950, 954  
 958, 962, 969, 971  
 974, 978, 984, 988  
 995: 100P 50V K (VF466800)
4. CERAMIC TUBULAR CAP.-F  
 C935, 940, 981, 991: 0.022 25V Z (VG280100)
5. ELECTROLYTIC CAP.  
 C502, 602, 702, 802  
 852, 901, 904, 908  
 911, 912, 915, 916  
 919, 920, 923, 934  
 939, 941, 944, 945  
 948, 949, 952, 953  
 956, 967, 972, 975  
 976, 979, 982, 986: 10.00 25.0V (VG288500)  
 C508, 509, 512, 608  
 609, 612, 708, 709  
 712~714, 808, 809  
 812, 858, 859, 862  
 907, 924, 927, 928  
 931, 938, 957, 961  
 993, 994: 10.00 25.0V (UM407100)  
 C960, 964: 22.00 25.0V (UM407220)  
 C965, 966: 100.00 16.0V (UI538100)  
 C980, 990: 330.00 16.0V (VG287800)  
 C992: 10.00 50.0V (UI567100)
6. CARBON RESISTOR  
 R501, 601, 701, 801  
 851, 930, 931, 933  
 934, 966, 967, 969  
 970, 989: 1.0K 1/4 J (HF456100)  
 R502, 602, 702, 802  
 852: 470.0K 1/4 J (HF458470)  
 R503, 506, 603, 606  
 703, 706, 803, 806  
 853, 856: 12.0K 1/4 J (HF457120)  
 R504, 604, 704, 804  
 854: 6.8K 1/4 J (HF456680)  
 R505, 605, 705, 805  
 855, 917, 919, 921  
 923, 926, 928: 39.0K 1/4 J (HF457390)  
 R507, 607, 707, 807  
 857: 9.1K 1/4 J (HF456910)  
 R508, 608, 708, 808  
 858, 955, 956, 959  
 960, 964, 973, 978: 47.0K 1/4 J (HF457470)  
 R509, 609, 709, 809  
 859, 925, 927, 936  
 939, 942, 945, 948  
 950, 961, 965, 968: 100.0K 1/4 J (HF458100)  
 R510, 513~519, 610  
 613~619, 710, 713  
 714~719, 810, 813  
 814~819, 860, 861  
 901~912: 33.0K 1/4 J (HF457330)  
 R511, 512, 611, 612  
 711, 712, 811, 812: 5.6K 1/4 J (HF456560)  
 R913, 015, 947, 949: 82.0K 1/4 J (HF457820)  
 R914, 916, 929, 932: 27.0K 1/4 J (HF457270)  
 R918, 920, 922, 924  
 951~954, 962, 963  
 981~988: 22.0K 1/4 J (HF457220)  
 R935, 938, 941, 944: 56.0K 1/4 J (HF457560)  
 R937, 940, 943, 946: 220.0 1/4 J (HF455220)  
 R957, 958: 68.0K 1/4 J (HF457680)  
 R972, 976: 15.0K 1/4 J (HF457150)  
 R974, 979: 4.7 1/4 J (HF453470)  
 R975, 980: 2.2 1/4 J (HF453220)
7. METAL OXIDE FILM RESISTOR  
 R971: 100.0 2W J (HL225100)  
 R977: 120.0 2W J (HL225120)
8. IC  
 IC17~32: NJM4558S (IG076800) OP AMP  
 IC33: LA6515 (XI250A00) OP AMP  
 IC34, 35: MSC1164 (XM255A00) FL. DRIVER
9. FLUORESCENT DISPLAY  
 V 1: FV593G (VP599200)
10. PUSH SWITCH  
 SW37, 39, 41, 43: SPEC12 (VQ035600) TAPE, MIC/LINE  
 SW38, 40, 42, 44~46: SPEC21 2 (VQ035700) ASSIGN  
 SW47: SPEC52 (VQ035800) MONI. SELECT
11. PHONE JACK  
 JK11~17: YKB21-5011 (VD430000) INPUT, AUX SEND
12. SLIDE POT.  
 VR513, 613, 713: A 10.0K (VQ030400) FADER5-7  
 VR813, 907: A 10.0K (VQ030600) FADER8, MAS. FADER  
 VR909~916: A 10.0K (VQ030300) CUE1-8
13. VARIABLE RESISTOR  
 VR511, 611, 612  
 711, 712: B 50.0K (VQ031400) LOW, HIGH  
 VR512: B 50.0K (VQ031500) HIGH  
 VR514, 814: B 10.0K (VQ031000) PAN  
 VR515, 516, 615  
 616, 715, 716  
 903~906: A 10.0K (VQ031200) AUX1, 2, GROUPE MAS.  
 B 10.0K (VQ030900) PAN  
 VR811: B 50.0K (VQ032300) LOW  
 VR812: B 50.0K (VQ053800) HIGH  
 VR815, 816: A 10.0K (VQ031700) AUX1, 2  
 VR901: A 20.0K (VQ032100) LEVEL  
 VR902: A 20.0K (VQ032000) LEVEL  
 VR908: A 10.0K (VQ031800) PHONES
14. TRANSISTOR  
 Q19~22: 2SD1915(F) S, T (VK432900)
15. CN39: FJ 8P (VL548500) to MIX-CN36
16. BASE POST CONNECTOR  
 CN41: PH 3P SE (VB858200) to SUB-CN17  
 CN44: PH 2P SE (VB858100) to MAS-CN45
17. CONNECTOR HOUSING  
 CN37: 52084 5P TE (VP600000) to DEC-CN110  
 CN38: 52084 8P TE (VP600300) to DEC-CN120
18. PH CONNECTOR ASSEMBLY  
 CN42: 9P 120mm B&C (VB718600) to DEC-CN114  
 CN45: 2P 70mm B&C (VB706500) to MAS-CN44
19. B&C CONNECTOR ASSEMBLY  
 CN40: PH353 8P 70 (VM025500) to DEC-CN108  
 CN43: PH296 4P 450 (VM019800) to ENC-CN107  
 CN46: PH293 4P 300 (VM019500) to SUB-CN4  
 CN47: PH314 5P 500 (VM021600) to MIX-CN23

● DEC Circuit Board

DEC 1/2

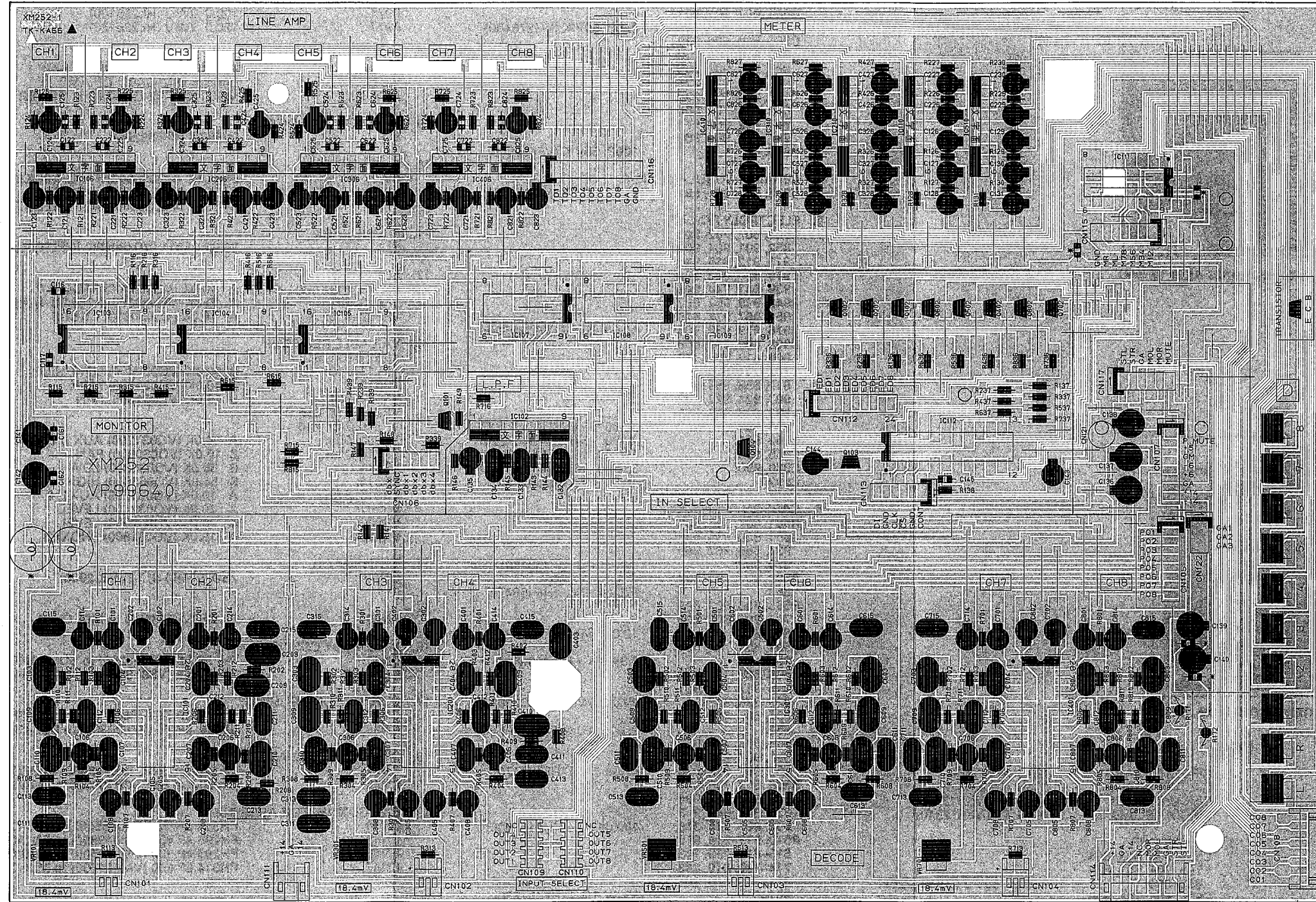

Components side (部品側)

MT8X

DEC 2/2

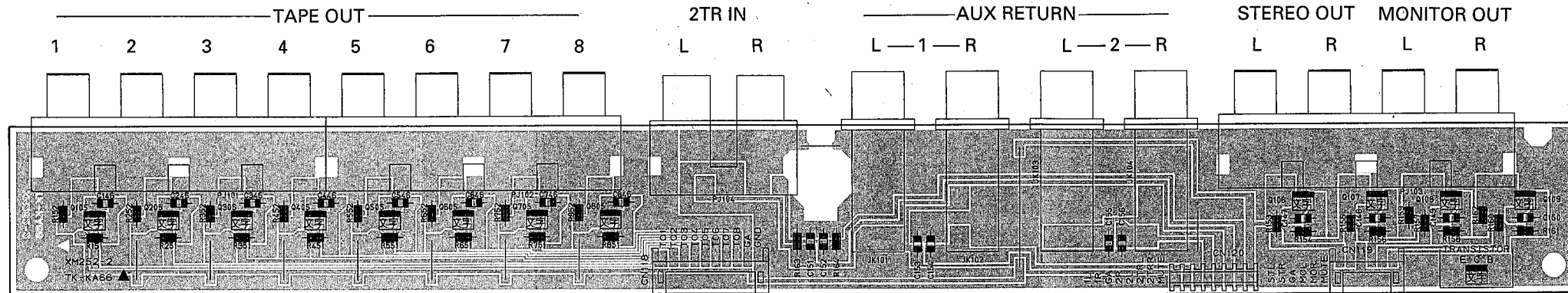

Components side (部品側)

Notes)

<p>CIRCUIT BOARD : DEC XM252D0                  CIRCUIT BOARD : DEC 1/2 (NX812320)                  CIRCUIT BOARD : DEC 2/2 (NX812330)</p> <p>1. MYLAR CAP.                  C103, 109, 110, 203                  209, 210, 303, 309                  310, 403, 409, 410                  503, 509, 510, 603                  609, 610, 703, 709                  710, 803, 809, 810:                  C104, 115, 204, 215                  304, 315, 404, 415                  504, 515, 604, 615                  704, 715, 804, 815:                  C107, 207, 307, 407                  507, 607, 707, 807:                  C111, 112, 211, 212                  311, 312, 411, 412                  511, 512, 611, 612                  711, 712, 811, 812:                  C113, 213, 313, 413                  513, 613, 713, 813:                  C132:                  C133:                  C134:</p> <p>2. CERAMIC TUBULAR CAP.-B                  C122, 222, 322, 422                  522, 622, 722, 822:                  C124, 224, 324, 424                  524, 624, 724, 824:                  C151~156:</p> <p>3. CERAMIC TUBULAR CAP.-F                  C116, 117, 146~150                  246, 346, 446, 546                  646, 746, 846:                  C145, 161, 162:</p> <p>4. ELECTROLYTIC CAP.                  C101, 105, 108, 126                  129, 201, 205, 208                  226, 229, 301, 305                  308, 326, 401, 405                  408, 426, 501, 505                  508, 526, 601, 605                  608, 626, 701, 705                  708, 726, 801, 805                  808, 826:                  C102, 125, 202, 225                  302, 325, 402, 425                  502, 525, 602, 625                  702, 725, 802, 825:                  C106, 206, 306, 406                  506, 606, 706, 806:</p>	<p>DEC XM252D0                  DEC 1/2 (NX812320)                  DEC 2/2 (NX812330)</p> <p>0.1000 50V J (UA655100)</p> <p>1800P 50V J (UA653180)</p> <p>0.0330 50V J (UA654330)</p> <p>3300P 50V J (UA653330)</p> <p>330P 50V J (UA652330)                  4700P 50V J (UA353470)                  0.0200 50V J (UA654200)                  3900P 50V J (UA353390)</p> <p>100P 50V K (VF466800)</p> <p>150P 50V K (VG278200)                  220P 50V K (VG278400)</p> <p>0.022 25V Z (VG280100)                  0.1 50V Z (VJ599100)</p> <p>22.00 25.0V (VG288600)</p> <p>47.00 25.0V (VG288800)</p> <p>0.33 50.0V (VG290200)</p>	<p>C114, 127, 130, 214                  227, 230, 314, 327                  414, 427, 514, 527                  614, 627, 714, 727                  814, 827:                  C121, 123, 128, 131                  221, 223, 321, 323                  328, 421, 423, 521                  523, 528, 621, 623                  721, 723, 728, 821                  823:                  C135, 143:                  C136-142:                  C144:</p> <p>5. CARBON RESISTOR                  R107, 207, 307, 407                  507, 607, 707, 807:                  R112, 113, 151, 153                  154-162, 212, 251                  312, 313, 351, 412                  451, 512, 513, 551                  512, 651, 712, 713                  751, 812, 851:                  R115, 121, 124, 139                  142, 146, 147, 152                  215, 221, 224, 239                  252, 315, 321, 324                  339, 325, 415, 421                  424, 439, 452, 515                  521, 524, 552, 615                  621, 624, 652, 715                  721, 724, 752, 815                  821, 824, 852:                  R116, 141, 144, 145                  216, 316, 416, 516                  716:                  R122, 222, 322, 422                  522, 622, 722, 822:                  R123, 223, 323, 423                  523, 623, 723, 823:                  R125, 225, 325, 425                  525, 625, 725, 825:                  R126, 129, 226, 229                  326, 426, 526, 626                  726, 826:                  R127, 130, 227, 230                  327, 427, 527, 627                  727, 827:                  R128, 131, 328, 528                  728:                  R136-138, 143, 148                  149, 236, 237, 336                  337, 436, 437, 536                  537, 636, 637, 736                  737, 836:                  R163, 164:</p> <p>2.20 50.0V (VG290600)</p> <p>10.00 25.0V (VG288500)                  1.00 50.0V (VG290500)                  100.00 25.0V (VG288900)                  4.700 25.0V (VG288400)</p> <p>1.0M 1/4 J (HF459100)</p> <p>1.0K 1/4 J (HF456100)</p> <p>10.0K 1/4 J (HF457100)                  6.8K 1/4 J (HF456680)                  12.0K 1/4 J (HF457120)                  100.0 1/4 J (HF455100)                  330.0K 1/4 J (HF458330)                  22.0 1/4 J (HF454220)                  150.0 1/4 J (HF455150)</p> <p>47.0K 1/4 J (HF457470)                  15.0K 1/4 J (HF457150)</p>	<p>6. FLAME PROOF C. RESISTOR                  R171, 172: 3.3 1/4 J (HV753330)</p> <p>7. METAL FILM RESISTOR                  R101, 201, 301, 401                  501, 601, 701, 801:                  R102, 104, 202, 204                  302, 304, 402, 404                  502, 504, 602, 604                  702, 704, 802, 804:                  R103, 203, 303, 403                  503, 603, 703, 803:                  R105, 205, 305, 405                  505, 605, 705, 805:                  R106, 110, 206, 210                  306, 310, 406, 410                  506, 510, 606, 610                  706, 710, 806, 810:                  R108, 208, 308, 408                  508, 608, 708, 808:                  R109, 209, 309, 409                  509, 609, 709, 809:                  R111, 211, 311, 411                  511, 611, 711, 811:</p> <p>1.0K 1/4 F (VP439000)                  3.9K 1/4 F (VP440400)                  10.0K 1/4 F (VP441400)</p> <p>33.0K 1/4 F (VP442600)                  91.0K 1/4 F (VP443700)                  4.7K 1/4 F (VP440600)                  6.8K 1/4 F (VP441000)</p> <p>8. IC                  IC111:                  IC101, 201, 301                  401:                  IC102:                  IC103~105, 107                  108, 109:                  IC106, 206, 306                  406:                  IC110, 210, 310, 410                  510:                  IC112:</p> <p>BU4551B (X1929A00) ANALOG SWITCH                  AN6292NK (XJ637A00) dbx                  NJM4558S (IG076800) OP AMP                  BU4053B (IG149000) MULTIPLEXER                  NJM4560S (IG121800) OP AMP                  BA6138 (IG074900) COMPRESSOR                  M66008P (XM266A00) EXP. I/O</p> <p>9. PIN JACK                  PJ101, 102:                  PJ103:                  PJ104:</p> <p>YKC21-3115 (VQ032800) TAPE OUT                  YKC21-3041 (VP599400) ST OUT, MONI. OUT                  YKC21-3045 (VM725600) AUX RETURN</p> <p>10. PHONE JACK                  JK101~104:</p> <p>YKB21-5011 (VD430000) AUX RETURN</p> <p>11. TRIMMER POTENTIOMETER                  VR101, 301, 501                  701:                  VR102~104, 202                  302, 402, 502                  602, 702, 802:</p> <p>B 4.7K 3P EVN (VJ808900)                  B 10.0K 3P EVN (VJ809100)</p> <p>12. TRANSISTOR                  Q105~109, 205, 305                  405, 505, 605, 705                  805:</p> <p>2SD1915(F) S, T (VK432900)</p>	<p>13. DIGITAL TRANSISTOR                  Q101, 103: DTC114ES (VD678700)                  Q102, 104, 202, 302                  402, 502, 602, 702                  802: DTA124ES TP (VH257100)</p> <p>14. BASE POST CONNECTOR                  CN101: PH 2P SE (VB858100) No Connection                  CN102: PH 2P SE (VB858100) No Connection                  CN103: PH 2P SE (VB858100) No Connection                  CN104: PH 2P SE (VB858100) No Connection                  CN108: PH 8P SE (VB858700) to MAS-CN40                  CN111: PH 3P SE (VB858200) to MIX-CN35                  CN114: PH 9P SE (VB858800) to MAS-CN42                  CN118: PH 10P SE (VB858900) to DEC-CN116                  CN119: PH 6P SE (VB858500) to DEC-CN117</p> <p>15. CONNECTOR WAFER                  CN109: 53064 5P TE (VP601100) to MIX-CN34                  CN110: 53064 5P TE (VP601100) to MAS-CN37                  CN120: 53064 8P TE (VP601400) to MAS-CN38</p> <p>16. CONNECTOR ASSEMBLY                  CN113: DEC I/O EXP. to MIX-CN24                  CN121: DEC GND</p> <p>17. PH CONNECTOR ASSEMBLY                  CN116: 10P 70mm B&amp;C (VB720100) to DEC-CN118                  CN117: 6P 120mm B&amp;C (VB713500) to DEC-CN119</p> <p>18. B&amp;C CONNECTOR ASSEMBLY                  CN105: PH365 8P 500 (VM026700) to ENC-CN109                  CN106: PH334 6P 650 to ENC-CN111                  CN107: PH362 8P 350 (VM026400) to ENC-CN114                  CN112: PH380 9P 400 (VM028200) to ENC-CN112                  CN115: PH346 7P 400 (VM024800) to MIX-CN19                  CN122: PH277 3P 350 to ENC-CN116</p>
--	--	--	---	--

● ENC Circuit Board

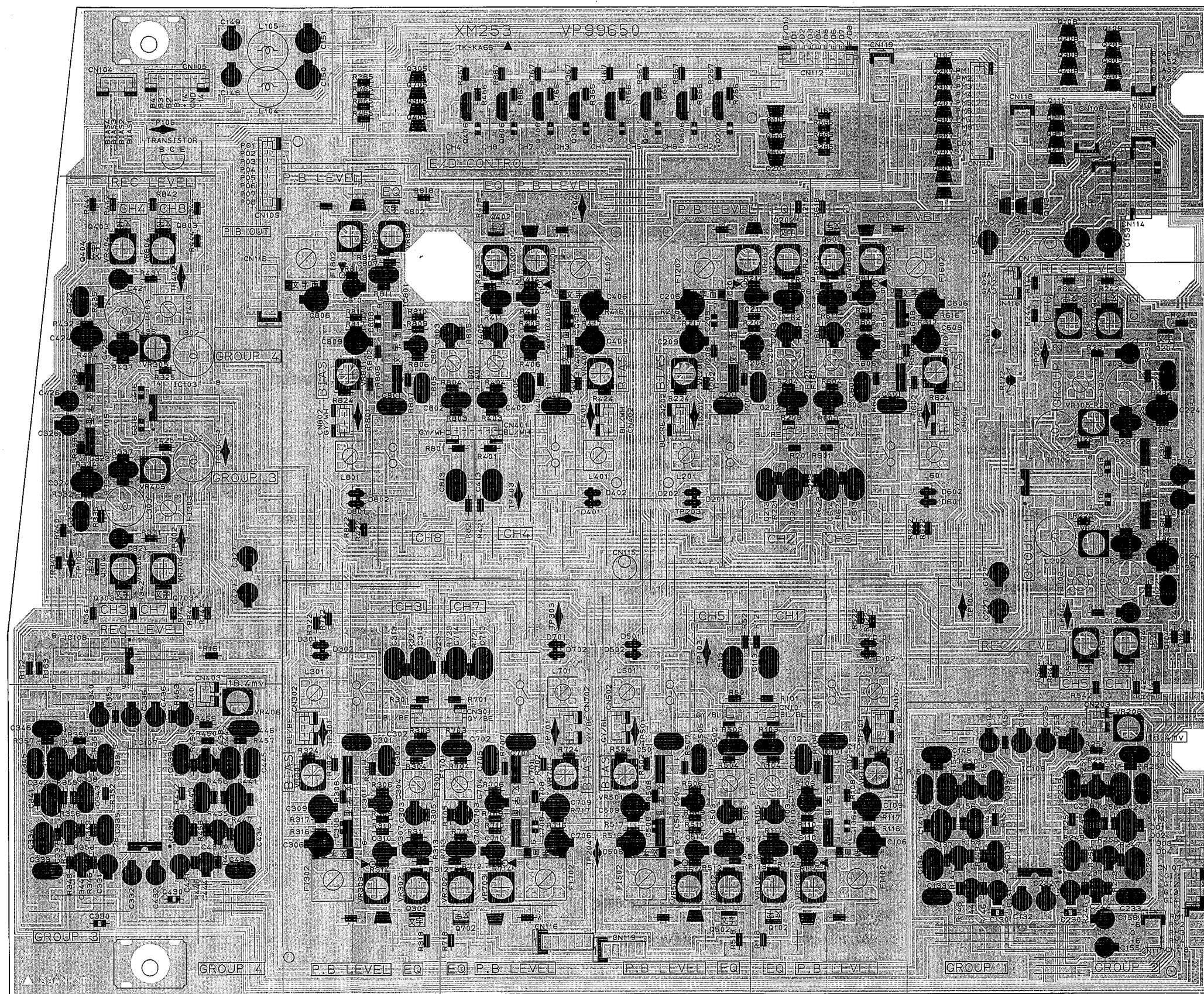

Components side (部品側)

MT8X

Notes)

- CIRCUIT BOARD : ENC (VP996500) XM253D0
- MYLAR CAP.  
C101, 201, 301, 401  
501, 601, 701, 801: 220P 50V J (UA652220)  
C102, 105, 202, 205  
302, 305, 402, 405  
502, 505, 602, 605  
702, 705, 802, 805: 820P 50V J (UA652820)  
C107, 207, 307, 407  
507, 607, 707, 807: 0.0220 50V J (UA654220)  
C113, 213, 214, 313  
314, 413, 513, 613  
614, 713, 714, 813: 0.2200 50V J (UA655220)  
C122, 222, 322, 422: 2400P 50V J (UA653240)  
C123, 223, 323, 423: 4700P 50V J (UA653470)  
C124, 224, 324, 424: 0.2700 50V J (UA655270)  
C133, 135, 233, 235  
333, 335, 433, 435: 1800P 50V J (UA653180)  
C134, 141, 142, 234  
241, 242, 334, 341  
342, 434, 441, 442: 0.1000 50V J (UA655100)  
C139, 239, 339, 439: 0.0330 50V J (UA654330)  
C143, 145, 243, 245  
343, 345, 443, 445: 3300P 50V J (UA653330)  
C146, 246, 346, 446: 330P 50V J (UA652330)
  - CERAMIC TUBULAR CAP.-B  
C108, 208, 308, 408  
508, 608, 708, 808: 100P 50V K (VF466800)
  - CERAMIC TUBULAR CAP.-X  
C130, 230, 330, 430: 3900P 16V N (VG279700)
  - CERAMIC TUBULAR CAP.-F  
C116, 152, 216, 316  
416: 0.022 25V Z (VG280100)
  - ELECTROLYTIC CAP.  
C103, 121, 203, 221  
303, 321, 403, 421  
503, 603, 703, 803: 10.00 25.0V (VE018300)  
C104, 204, 304, 404  
504, 604, 704, 804: 100.00 6.3V (VG286200)  
C106, 109, 206, 209  
306, 309, 406, 409  
506, 509, 606, 609  
706, 709, 806, 809: 47.00 16.0V (VE017800)  
C110, 126, 137, 157  
210, 226, 237, 310  
326, 337, 410, 426  
437, 510, 610, 710  
810: 10.00 25.0V (VG288500)  
C127, 132, 155, 156  
227, 232, 327, 332  
427, 432: 47.00 25.0V (VG288800)  
C131, 136, 140, 231  
236, 240, 331, 336  
340, 431, 436, 440: 22.00 25.0V (VG288600)  
C138, 238, 338, 438: 0.33 50.0V (VG290200)  
C144, 244, 344, 444: 2.20 50.0V (VG290600)  
C148, 149, 153, 154:  
C150, 151: 100.00 25.0V (VG288900)  
330.00 16.0V (VG287800)
  - COIL  
L101, 201, 301, 401  
501, 601, 701, 801: 1.2mH (VP764300)  
L102, 202, 302, 402: 47mH(473S) (VQ522800)  
L103, 203, 303, 403: 39mH(393S) (VR012700)  
L104, 105: 1mH 260mA (VP764400)

- CARBON RESISTOR  
R101, 104, 121, 201  
204, 221, 223, 301  
304, 321, 323, 401  
404, 421, 501, 504  
521, 601, 604, 621  
623, 701, 704, 721  
723, 801, 804, 821: 10.0 1/4 J (HF454100)  
R102, 202, 302, 402  
502, 602, 702, 802: 33.0K 1/4 J (HF457330)  
R103, 139, 165, 203  
239, 265, 303, 339  
365, 403, 439, 465  
503, 565, 603, 665  
703, 765, 803, 865: 100.0K 1/4 J (HF458100)  
R105, 109, 205, 209  
305, 309, 405, 409  
505, 509, 605, 609  
705, 709, 805, 809: 22.0K 1/4 J (HF457220)  
R106, 206, 306, 406  
506, 606, 706, 806: 68.0 1/4 J (HF454680)  
R107, 108, 131, 207  
208, 231, 307, 308  
331, 407, 408, 431  
507, 508, 607, 608  
707, 708, 807, 808: 4.7K 1/4 J (HF456470)  
R110, 210, 310, 410  
510, 610, 710, 810: 330.0 1/4 J (HF455330)  
R111, 211, 311, 411  
511, 611, 711, 811: 120.0K 1/4 J (HF458120)  
R112, 124, 212, 224  
312, 324, 412, 424  
512, 524, 612, 624  
712, 724, 812, 824: 1.0 1/4 J (HF453100)  
R113, 161, 162, 213  
313, 413, 513, 613  
713, 813: 47.0K 1/4 J (HF457470)  
R114, 125, 148, 158  
214, 225, 248, 258  
259, 314, 325, 348  
358, 414, 425, 448  
458, 459, 514, 614  
714, 814: 1.0K 1/4 J (HF456100)  
R116, 117, 216, 217  
316, 317, 416, 417  
516, 517, 616, 617  
716, 717, 816, 817: 220.0 1/4 J (HF455220)  
R118, 137, 141, 167  
218, 237, 241, 267  
318, 337, 341, 367  
418, 437, 441, 467  
518, 567, 618, 667  
718, 767, 818, 867: 2.2K 1/4 J (HF456220)  
R122, 222, 322, 422  
522, 622, 722, 822: 22.0 1/4 J (HF454220)  
R132, 232, 332, 432: 15.0K 1/4 J (HF457150)  
R134, 234, 334, 434: 30.0K 1/4 J (HF457300)  
R135, 235, 335, 435: 1.5K 1/4 J (HF456150)  
R136, 236, 336, 436: 1.8K 1/4 J (HF456180)  
R140, 240, 340, 440: 6.8K 1/4 J (HF456680)  
R142, 144, 166, 242  
244, 266, 342, 344  
366, 442, 444, 466  
542, 544, 566, 642  
644, 666, 742, 744  
766, 842, 844, 866: 10.0K 1/4 J (HF457100)  
R153, 253, 353, 453: 1.0M 1/4 J (HF459100)  
R163: 39.0K 1/4 J (HF457390)
- FLAME PROOF C. RESISTOR  
R171, 172: 4.7 1/4 J (HV753470)

- METAL FILM RESISTOR  
R146, 246, 346, 446: 4.3K 1/4 F (VP440500)  
R147, 247, 347, 447  
550, 250, 350, 450: 1.0K 1/4 F (VP439000)  
R149, 149, 349, 449: 3.9K 1/4 F (VP440400)  
R151, 251, 351, 451: 10.0K 1/4 F (VP441400)  
R152, 252, 352, 452  
555, 255, 355, 455: 33.0K 1/4 F (VP442600)  
R154, 254, 354, 454: 4.7K 1/4 F (VP440600)  
R156, 256, 356, 456: 6.8K 1/4 F (VP441000)  
R157, 257, 357, 457: 91.0K 1/4 F (VP443700)
- IC  
IC101, 201, 301  
401, 501, 601  
701, 801: NJM2068S-D (XE322A00) OP AMP  
IC102, 103: LC4966 (IG149300) ANALOG SWITCH  
IC104, 105: UPC4570HA (XB247A00) OP AMP  
IC106, 107: AN6292NK (XJ637A00) dbx  
IC108: BU4053B (IG149000) MULTIPLEXER
- RELAY  
RY101, 201, 301  
401, 501, 601  
701, 801: DC RY 12W-OH-K (VM640200)
- LC FILTER  
F1101, 201, 301  
401, 501, 601  
701, 801: 85k BP (VP764800)  
F1102, 202, 302  
402, 502, 602  
702, 802: 16k LPF (VR121000)  
F1103, 203, 303  
403: 85k (VQ033400)
- TRIMMER POTENTIOMETER  
VR101, 201, 301  
401, 501, 601  
701, 801: B 150.0K 3P (VJ694300)  
VR102, 202, 302  
402, 502, 602  
702, 802: B 3.3K 3P (VJ693300)  
VR103, 203, 303  
403, 503, 603  
703, 803: B 10.0K 3P (VJ693600)  
VR104, 204, 304  
404, 504, 604  
704, 804: B 22.0K 3P (VJ693800)  
VR105, 205, 305  
405: B 4.7K 3P (VJ693400)
- TRANSISTOR  
Q102~104, 202~204  
302~304, 402~404  
502, 503, 602, 603  
702, 703, 802, 803: 2SD1915(F) S, T (VK432900)  
Q106, 206, 306, 406  
506, 606, 706, 806: 2SD1858 TV2 Q, R (VE613400)
- DIODE  
D101, 102, 201, 202  
301, 302, 401, 402  
501, 502, 601, 602  
701, 702, 801, 802: 1SS133 T-77 (IF004600)
- DIGITAL TRANSISTOR  
Q105, 107, 108, 110  
112, 113, 205, 207  
208, 210, 305, 307  
308, 310, 405, 407  
408, 410, 505, 507  
605, 607, 705, 707  
805, 807: DTA124ES TP (VH257100)  
Q109, 114, 209, 309  
409: DTC114ES (VD678700)

- BASE PIN IN STICK  
CN101: PH 6P TE (VD004900) to SUB-CN11  
CN102: PH 3P TE (VD004600) to SUB-CN7  
CN104: PH 4P TE (VD004700) to SUB-CN15  
CN105: PH 7P TE (VD005000) to SUB-CN16  
CN107: PH 4P TE (VD004700) to MAS-CN43  
CN109: PH 8P TE (VD005100) to DEC-CN105  
CN110: PH 11P TE (VG699700) to MIX-CN20  
CN111: PH 6P TE (VD004900) to DEC-CN106  
CN112: PH 9P TE (VD005200) to DEC-CN112  
CN114: PH 8P TE (VD005100) to DEC-CN107  
CN116: PH 3P TE (VD004600) to DEC-CN122  
CN201: PH 6P TE (VD004900) to SUB-CN12  
CN202: PH 3P TE (VD004600) to SUB-CN9  
CN203: PH 2P TE (VD004500) No Connection  
CN301: PH 6P TE (VD004900) to SUB-CN13  
CN302: PH 3P TE (VD004600) to SUB-CN7  
CN401: PH 6P TE (VD004900) to SUB-CN14  
CN402: PH 3P TE (VD004600) to SUB-CN9  
CN403: PH 2P TE (VD004500) No Connection  
CN502: PH 3P TE (VD004600) to SUB-CN8  
CN602: PH 3P TE (VD004600) to SUB-CN10  
CN702: PH 3P TE (VD004600) to SUB-CN8  
CN802: PH 3P TE (VD004600) to SUB-CN10
- CONNECTOR ASSEMBLY  
CN115: ENC GND  
CN120: ENC PB OUT
- B&C CONNECTOR ASSEMBLY  
CN106: PH30 5P 250 (VM021100) to MIX-CN21  
CN108: PH29 4P 250 (VM019400) to MIX-CN22  
CN113: PH37 9P 100 (VM027300) to MIX-CN26  
CN117: PH42 3P 250 (VM002400)  
CN118: PH59 4P 250 (VM004100)  
CN119: PH80 5P 450 (VM006200)

● SUB Circuit Board

SUB 1/4

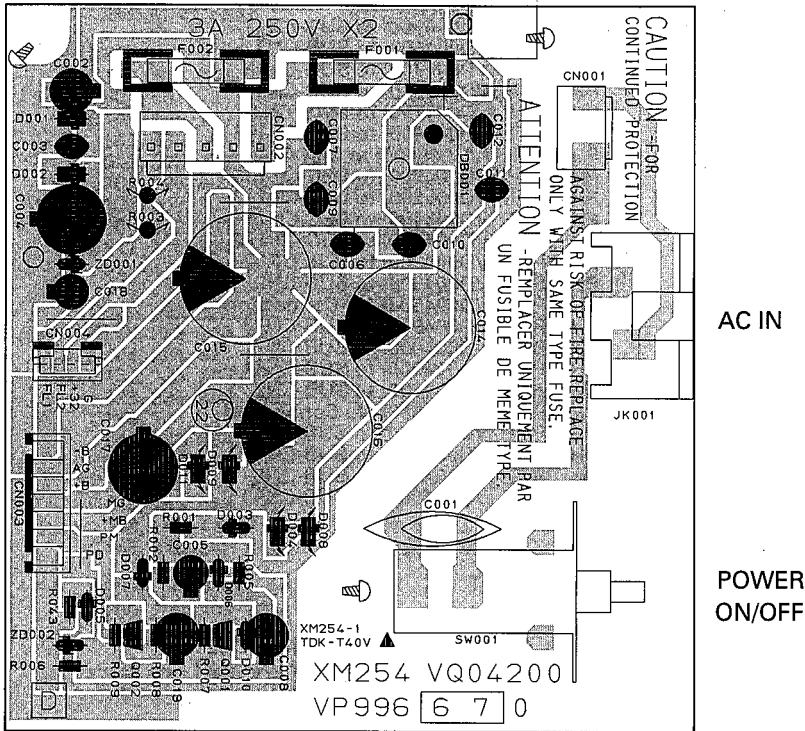

Components side (部品側)

SUB 2/4

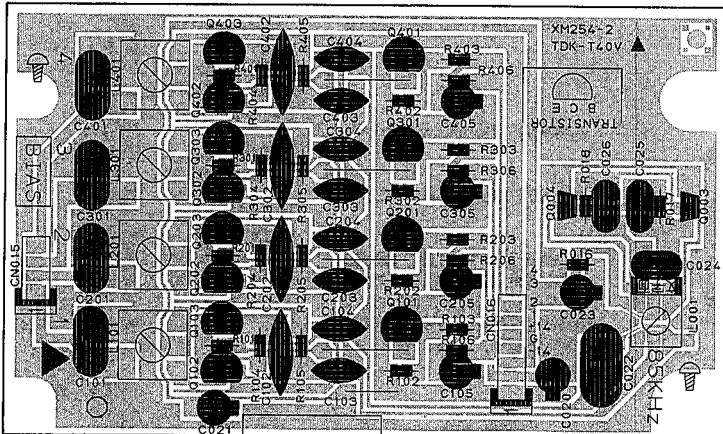

Components side (部品側)





## Notes)

- |                            |                               |                           |  |
|----------------------------|-------------------------------|---------------------------|--|
| CIRCUIT BOARD :            | SUB XM254D0                   | 10. PUSH SWITCH           |  |
| CIRCUIT BOARD :            | SUB 1/4 (NX812340) J          | SW 1:                     | ESB82 TV-3 (VQ040100) POWER            |
| CIRCUIT BOARD :            | SUB 1/4 (NX812350) U, C, V    |                           |  |
| CIRCUIT BOARD :            | SUB 1/4 (NX812360) H, B, W    | 11. FUSE                  |  |
| CIRCUIT BOARD :            | SUB 2/4 (NX812370)            | F 1, 2:                   | 3.00A (KB003590) J, U, C, V            |
| CIRCUIT BOARD :            | SUB 3/4 (NX812380)            | F1, 2:                    | 2.00A (KB003070) H, B, W               |
| CIRCUIT BOARD :            | SUB 4/4 (NX812390)            |                           |  |
| 1. MYLAR CAP.              |                               | 12. PHONE JACK            |  |
| C24:                       | 4700P 50V J (UA653470)        | JK 2:                     | YKB21-5009 (VL080300) PHONES           |
| C25, 26:                   | 1000P 50V J (UA653100)        | JK 3:                     | YKB21-5076 (VL080500) PUNCH I/O        |
| 2. POLYPROPYLENE FILM CAP. |                               | 13. AC INLET              |  |
| C22:                       | 1000P 100V J (UT653100)       | JK 1:                     | M1779-B (VL327300) J, H, B, W          |
| C101, 201, 301, 401:       | 5600P 100V J (UT653560)       | JK 1:                     | M1770-A (VI042900) U, C, V             |
| 3. CERAMIC CAP.            |                               | 14. DIN JACK              |  |
| C 1:                       | 0.01 250V (VA891300) J        | JK 4:                     | 8P CMS 5008 (VL105500) REMOTE CONTROL  |
| C 1:                       | 0.010 400V (FI384100) U, C, V |                           |  |
|                            |                               |                           |  |
| C102, 202, 302, 402:       | 150P 50V J (VA777500)         | 15. FUSE HOLDER           | EYF-52BC (VP206500)                    |
| C103, 104, 203, 204        |                               |                           |  |
| 303, 304, 403, 404:        | 100P 50V J (VA761800)         |                           |  |
| 4. CERAMIC CAP.-F          |                               | 16. TRANSISTOR            |  |
| C 3, 6, 7, 9, 10, 11       |                               | Q 1, 3, 4:                | 2SC2603 E, F (IC260320)                |
| 12:                        | 0.0100 50V Z (FG644100)       | Q 2:                      | 2SA933S Q, R (IA093320)                |
|                            |                               | Q101, 201, 301, 401:      | 2SC2878 A, B (IC287820)                |
|                            |                               | Q102, 103, 202, 203       |  |
|                            |                               | 302, 303, 402, 403:       | 2SC1318 R, S (VQ032900)                |
| 5. CERAMIC TUBULAR CAP.-F  |                               | 17. DIODE                 |  |
| C19:                       | 0.022 25V Z (VG280100)        | D 1, 2:                   | 1SR139-100 T-32 (VH770800)             |
| C54-56:                    | 0.1 50V Z (VJ599100)          | D 3, 5-7, 10:             | 1SS133 T-77 (IF004600)                 |
|                            |                               | D 4, 8, 9, 11:            | 1SR139-100 T-62 (VH801600)             |
| 6. ELECTROLYTIC CAP.       |                               | 18. DIODE STACK           |  |
| C 2, 13:                   | 100.00 25.0V (VG288900)       | DB 1:                     | S4VB20 2.6A 200 (IH001090)             |
| C 4:                       | 220.00 50.0V (UJ868220)       |                           |  |
| C 5:                       | 4.700 25.0V (VG288400)        |                           |  |
| C 8:                       | 220.00 6.3V (VG286300)        |                           |  |
| C14-16:                    | 4700 25.0V (VK181300)         |                           |  |
| C17:                       | 470.00 25.0V (UJ848470)       |                           |  |
| C18, 21:                   | 10.00 50.0V (VG290900)        |                           |  |
| C20, 23:                   | 10.00 25.0V (VG288500)        |                           |  |
|                            |                               |                           |  |
| C105, 205, 305, 405:       | 4.70 50.0V (VG290800)         | 19. ZENER DIODE           |  |
| 7. COIL                    |                               | ZD 1:                     | MTZ J 4.7C 4.7V (VG437200)             |
| L 1:                       | 85KHZ P-P (VP764500)          | ZD 2:                     | MTZ J 5.1A 5.1V (VG437300)             |
| L101, 201, 301, 401:       | 85KHZ (VP769100)              |                           |  |
| 8. CARBON RESISTOR         |                               | 20. BASE POST CONNECTOR   |  |
| R 1, 6:                    | 1.0K 1/4 J (HF456100)         | CN 1:                     | VA 2P TE (VG879900) to P.T. primary    |
| R 2:                       | 4.7K 1/4 J (HF456470)         | CN 2:                     | VH 5P TE (LB932050) to P.T. secondary  |
| R 5:                       | 47.0K 1/4 J (HF457470)        | CN 3:                     | XH 7P TE (LB918070) to MIX-CN25        |
| R 7:                       | 27.0K 1/4 J (HF457270)        |                           |  |
| R 8:                       | 1.8K 1/4 J (HF456180)         | 21. BASE PIN IN STICK     |  |
| R 9, 103, 203, 303         |                               | CN 4:                     | PH 4P TE (VD004700) to MAS-CN46        |
| 403:                       | 10.0K 1/4 J (HF457100)        | CN 7:                     | PH 6P TE (VD004900) to ENC-CN102, 302  |
| R10:                       | 3.9K 1/4 J (HF456390)         | CN 8:                     | PH 6P TE (VD004900) to ENC-CN502, 702  |
| R11:                       | 5.6K 1/4 J (HF456560)         | CN 9:                     | PH 6P TE (VD004900) to ENC-CN202, 402  |
| R12:                       | 13.0K 1/4 J (HF457130)        | CN10:                     | PH 6P TE (VD004900) to ENC-CN602, 802  |
| R13:                       | 36.0K 1/4 J (HF457360)        | CN11:                     | PH 6P TE (VD004900) to ENC-CN101       |
| R16, 101, 201, 301         |                               | CN12:                     | PH 6P TE (VD004900) to ENC-CN201       |
| 401:                       | 100.0 1/4 J (HF455100)        | CN13:                     | PH 6P TE (VD004900) to ENC-CN301       |
| R17, 18:                   | 220.0K 1/4 J (HF458220)       | CN14:                     | PH 6P TE (VD004900) to ENC-CN401       |
| R43:                       | 2.7K 1/4 J (HF456270)         |                           |  |
| R102, 202, 302, 402:       | 22.0K 1/4 J (HF457220)        | 22. BASE PIN              |  |
| R104, 105, 204, 205        |                               | CN 5:                     | FPC 16P SE (VP534700) to ERACE HEAD    |
| 304, 305, 404, 405:        | 470.0K 1/4 J (HF458470)       | CN 6:                     | FPC 16P SE (VP534700) to REC/PLAY HEAD |
| R106, 206, 306, 406:       | 33.0K 1/4 J (HF457330)        |                           |  |
| 9. FLAME PROOF C. RESISTOR |                               | 23. PH CONNECTOR ASSEMBLY |  |
| R 3, 4:                    | 100.0 1/4 J (HV755100)        | CN15:                     | 4P 70mm B&C (VB709900) to ENC-CN104    |
| R14, 15:                   | 39.0 1/4 J (HV754390)         | CN16:                     | 7P 120mm B&C (VB715200) to ENC-CN105   |
|                            |                               | CN17:                     | 3P 300mm B&C (VB709000) to MAS-CN41    |
|                            |                               | CN18:                     | 6P 70mm B&C (VB713300) to MIX-CN30     |

■ BLOCK DIAGRAM (ブロックダイアグラム)

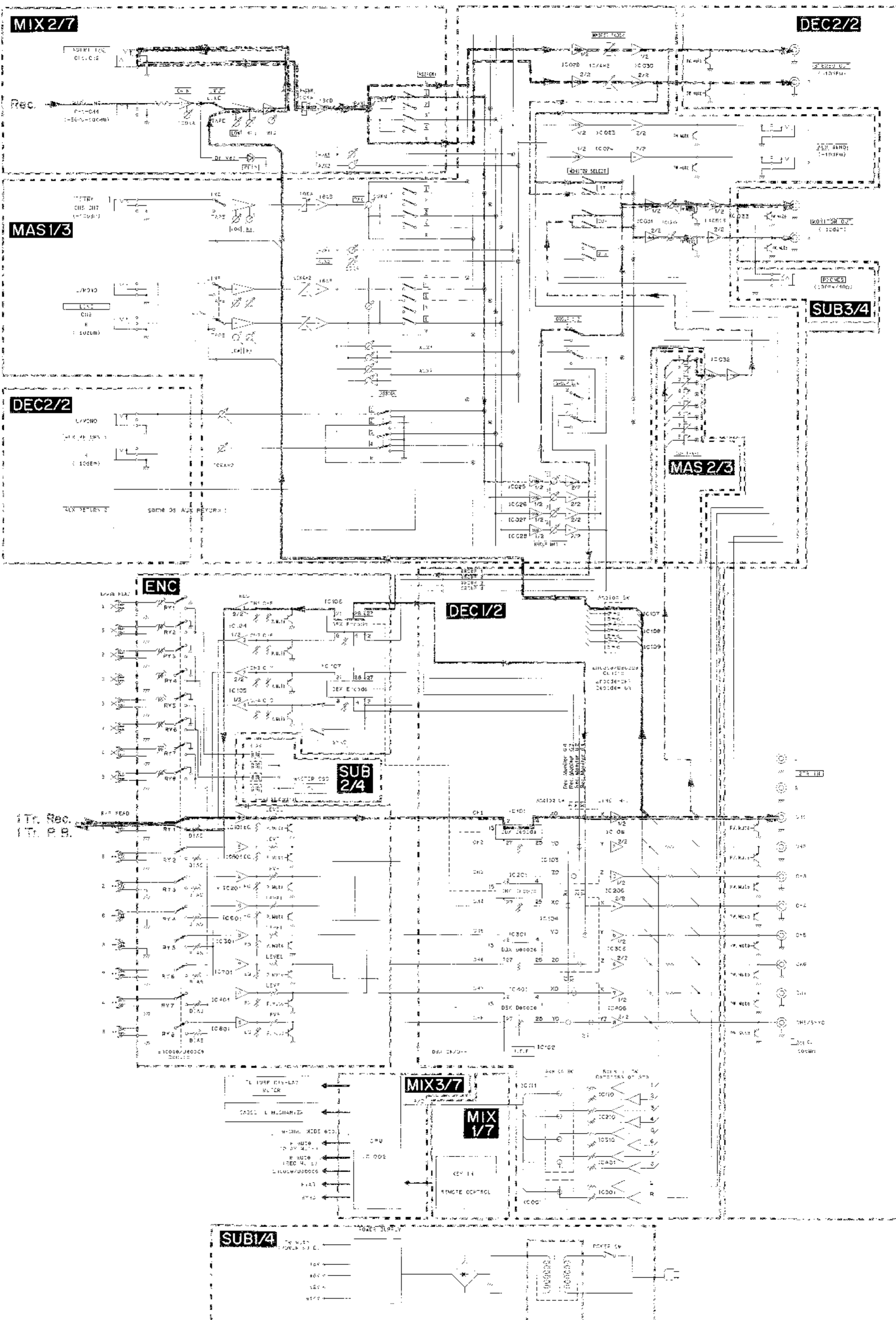



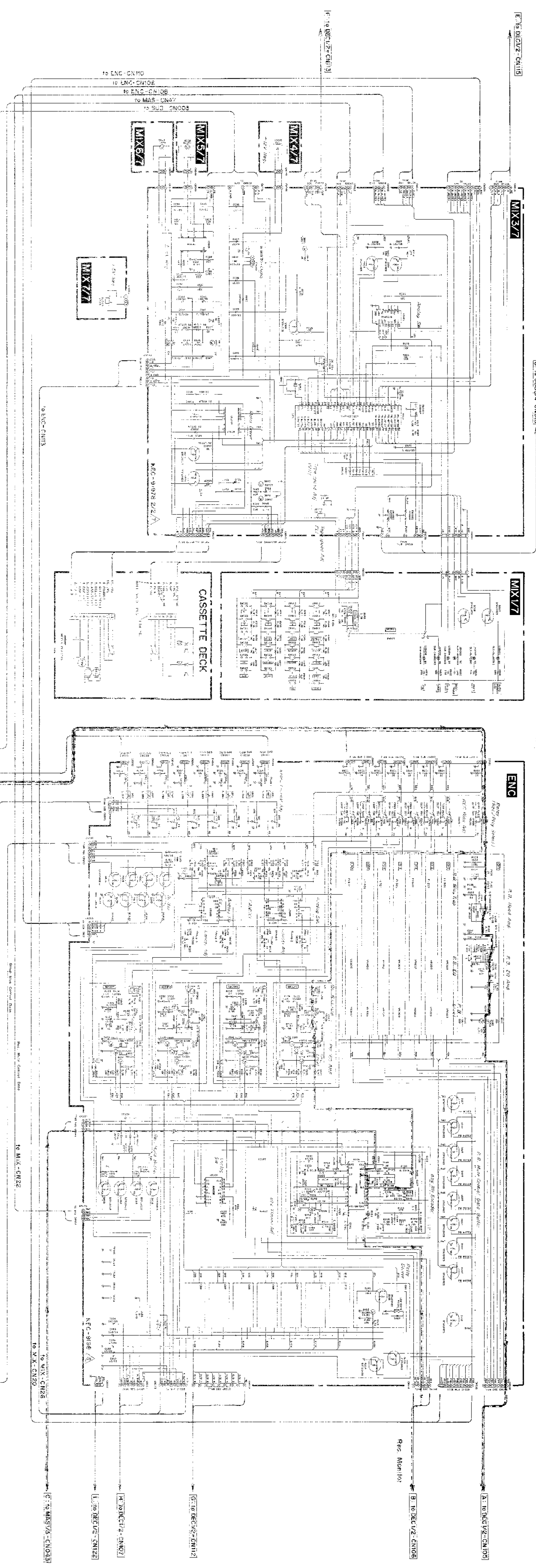

★WARNING  
 本機は高電圧部を有する。修理の際は、必ず電源を切り、静電気を除去してから作業を行ってください。また、修理の際は、必ず取扱説明書をお読みください。また、修理の際は、必ず取扱説明書をお読みください。

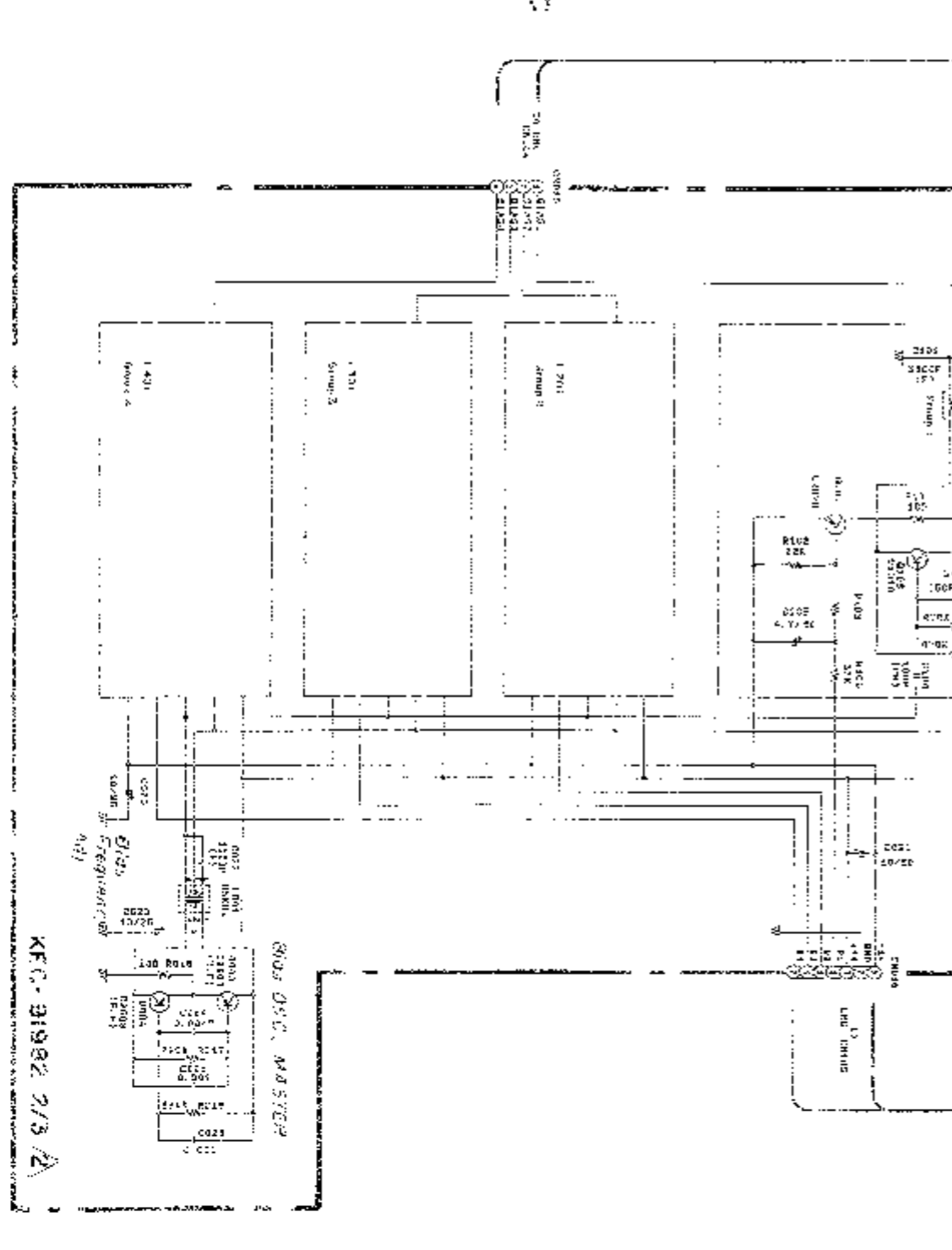
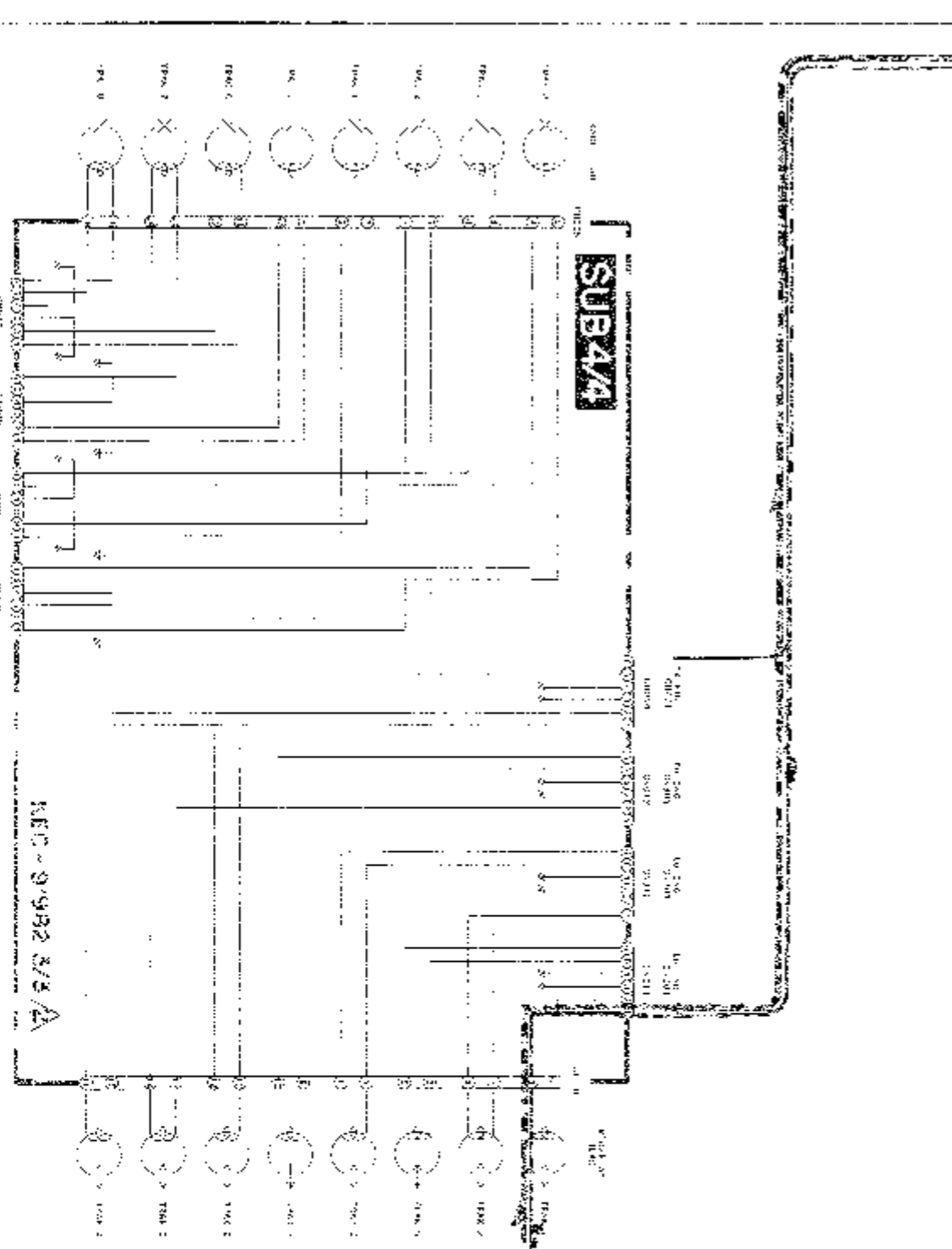
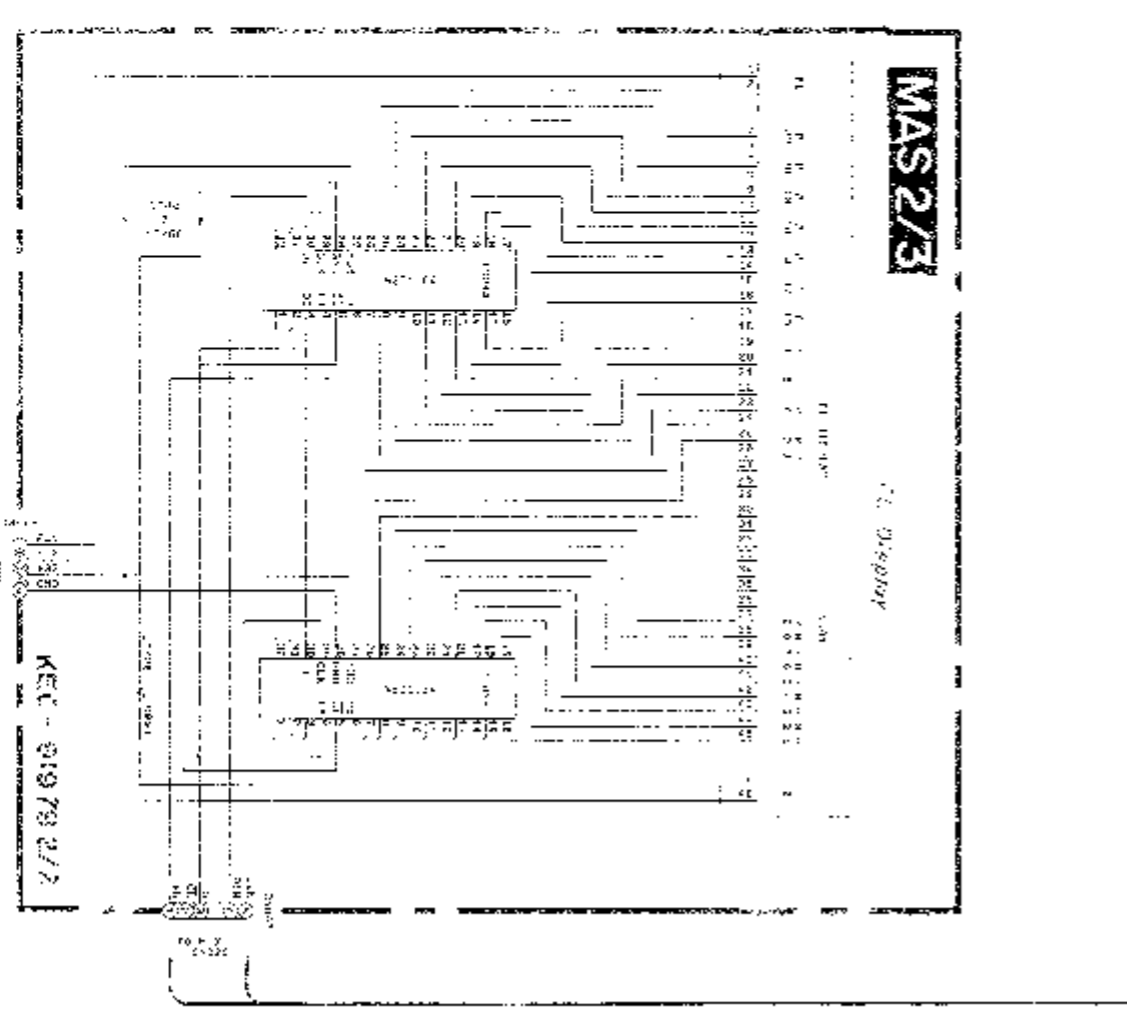
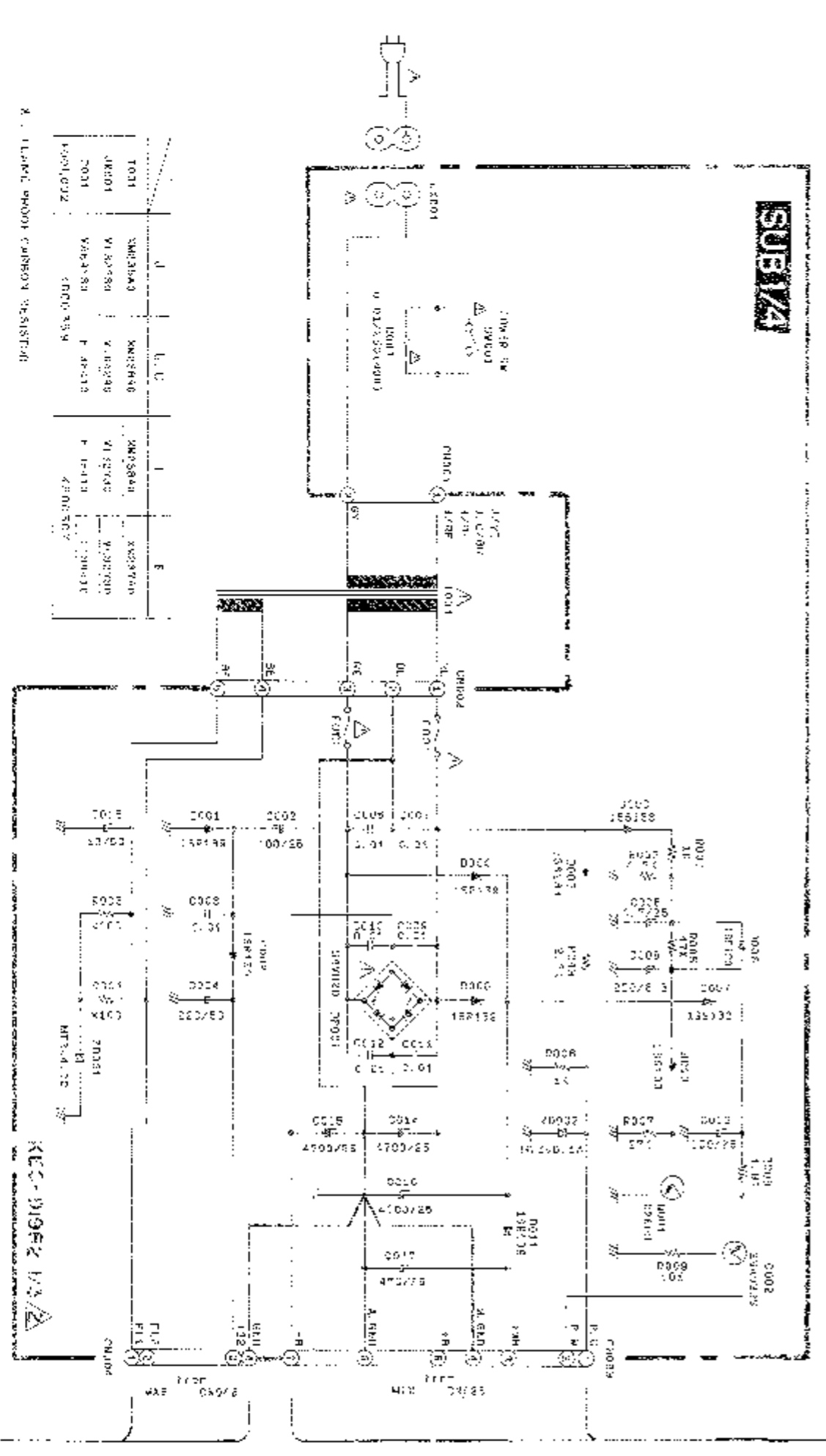

- 部品表
- | 部品名 | 値   | 部品名  | 値   |
|-----|-----|------|-----|
| R1  | 10k | R51  | 10k |
| R2  | 10k | R52  | 10k |
| R3  | 10k | R53  | 10k |
| R4  | 10k | R54  | 10k |
| R5  | 10k | R55  | 10k |
| R6  | 10k | R56  | 10k |
| R7  | 10k | R57  | 10k |
| R8  | 10k | R58  | 10k |
| R9  | 10k | R59  | 10k |
| R10 | 10k | R60  | 10k |
| R11 | 10k | R61  | 10k |
| R12 | 10k | R62  | 10k |
| R13 | 10k | R63  | 10k |
| R14 | 10k | R64  | 10k |
| R15 | 10k | R65  | 10k |
| R16 | 10k | R66  | 10k |
| R17 | 10k | R67  | 10k |
| R18 | 10k | R68  | 10k |
| R19 | 10k | R69  | 10k |
| R20 | 10k | R70  | 10k |
| R21 | 10k | R71  | 10k |
| R22 | 10k | R72  | 10k |
| R23 | 10k | R73  | 10k |
| R24 | 10k | R74  | 10k |
| R25 | 10k | R75  | 10k |
| R26 | 10k | R76  | 10k |
| R27 | 10k | R77  | 10k |
| R28 | 10k | R78  | 10k |
| R29 | 10k | R79  | 10k |
| R30 | 10k | R80  | 10k |
| R31 | 10k | R81  | 10k |
| R32 | 10k | R82  | 10k |
| R33 | 10k | R83  | 10k |
| R34 | 10k | R84  | 10k |
| R35 | 10k | R85  | 10k |
| R36 | 10k | R86  | 10k |
| R37 | 10k | R87  | 10k |
| R38 | 10k | R88  | 10k |
| R39 | 10k | R89  | 10k |
| R40 | 10k | R90  | 10k |
| R41 | 10k | R91  | 10k |
| R42 | 10k | R92  | 10k |
| R43 | 10k | R93  | 10k |
| R44 | 10k | R94  | 10k |
| R45 | 10k | R95  | 10k |
| R46 | 10k | R96  | 10k |
| R47 | 10k | R97  | 10k |
| R48 | 10k | R98  | 10k |
| R49 | 10k | R99  | 10k |
| R50 | 10k | R100 | 10k |

Connector Assembly for CASSETTE DECK

SUB 4/4	Cable		Tube	
	(U)	(L)	(U)	(L)
CN007	GY	BL	BL	BL
CN008	GY	SE	RE	RE
CN009	GY	RE	RE	SE
CN010	GY	BL	WH	WH
CN011	BL	BL	WH	RE
CN012	R	RI	RF	BL
CN013	GY	GY	SE	RE
CN014	GY	GY	WH	RE

	For Erase		For Reu/P S	
	Cable	Tube	Cable	Tube
CH.1	BL	BL	BL	RI
CH.5	GY	BL	GY	BL
CH.2	R	RF	RI	RE
CH.6	GY	RE	GY	RI
CH.3	BL	SE	BL	SE
CH.4	GY	RF	GY	SE
CH.7	BL	WH	BL	WH
CH.8	GY	WH	GY	WH

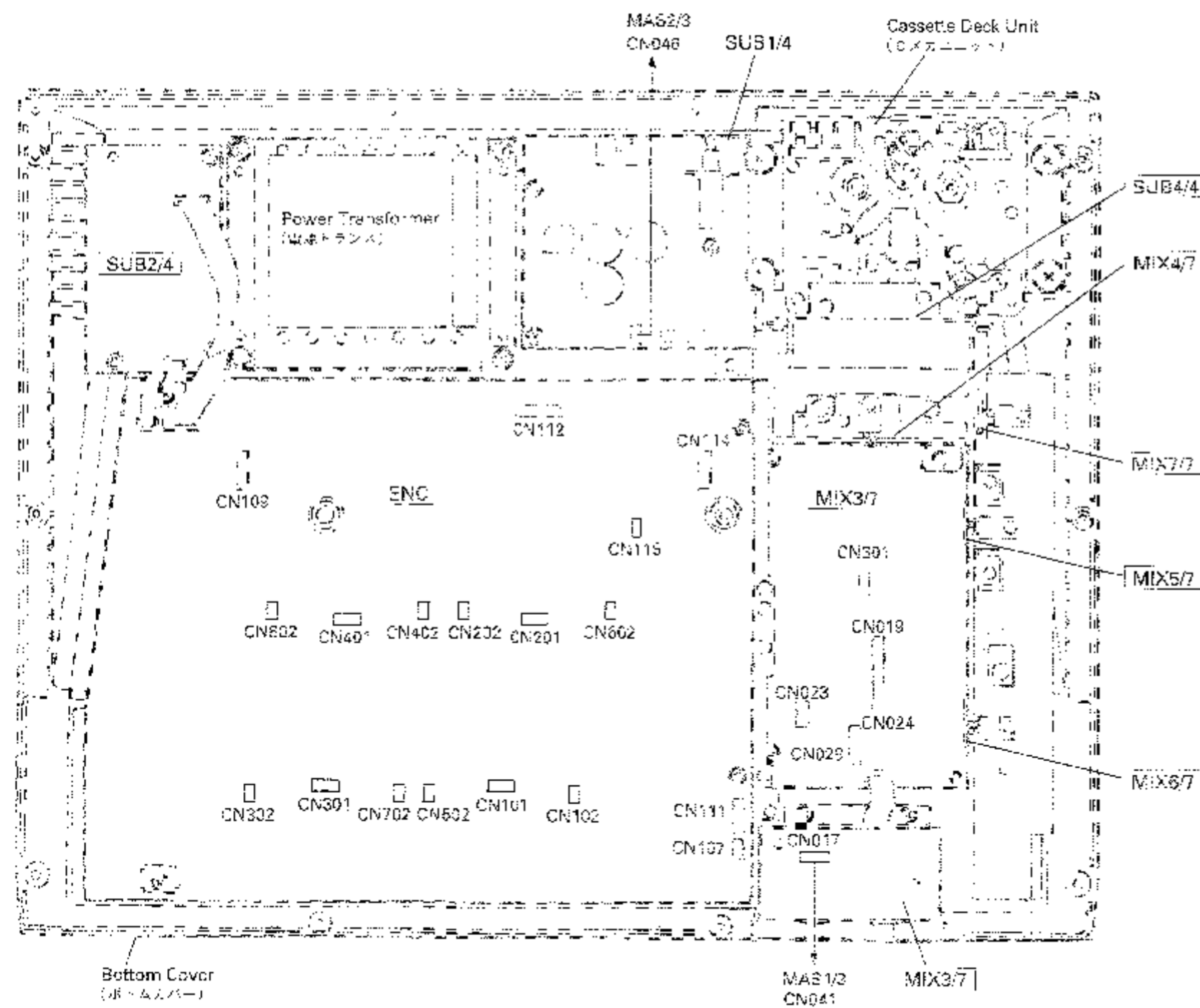
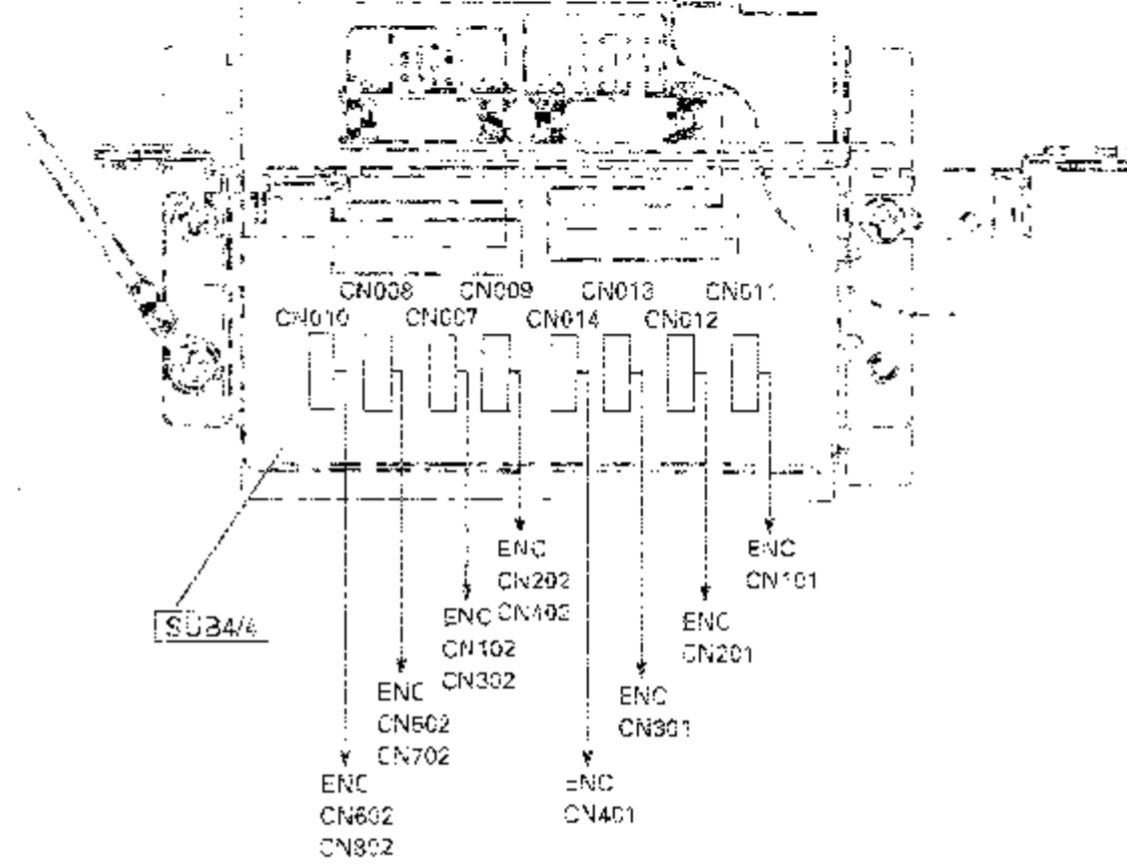

MIX

CN-No.	Destination
MIX3/7-CN019 (2)	DEC1/2-CN116
MIX3/7-CN020 (1)	ENC-CN110
MIX3/7-CN021 (1)	ENC-CN108
MIX3/7-CN022 (4)	ENC-CN108
MIX3/7-CN023 (3)	MAS2/3-CN047
MIX3/7-CN024 (5)	DEC1/2-CN114
MIX3/7-CN025 (7)	SUB1/4-CN003
MIX3/7-CN026 (5)	ENC-CN115
MIX3/7-CN027 (1)	CASSETTE DECK
MIX3/7-CN028 (2)	CASSETTE DECK
MIX3/7-CN029 (3)	MIX1/7-CN033
MIX3/7-CN030 (5)	SUB3/4-CN018
MIX3/7-CN031 (5)	MIX1/7-CN032
MIX3/7-CN032 (5)	MIX3/7-CN020
MIX3/7-CN033 (5)	DEC1/2-CN118
MIX3/7-CN034 (5)	DEC1/2-CN118
MIX3/7-CN035 (5)	DEC1/2-CN118
MIX3/7-CN036 (5)	MIX3/7-CN024
MIX3/7-CN037 (5)	ENC-CN105
MIX3/7-CN038 (5)	ENC-CN105
MIX3/7-CN039 (5)	MIX3/7-CN022
MIX3/7-CN040 (5)	ENC-CN107
MIX3/7-CN041 (5)	ENC-CN107
MIX3/7-CN042 (5)	ENC-CN107
MIX3/7-CN043 (5)	ENC-CN107
MIX3/7-CN044 (5)	ENC-CN107
MIX3/7-CN045 (5)	ENC-CN107
MIX3/7-CN046 (5)	ENC-CN107
MIX3/7-CN047 (5)	ENC-CN107
MIX3/7-CN048 (5)	ENC-CN107
MIX3/7-CN049 (5)	ENC-CN107
MIX3/7-CN050 (5)	ENC-CN107
MIX3/7-CN051 (5)	ENC-CN107
MIX3/7-CN052 (5)	ENC-CN107
MIX3/7-CN053 (5)	ENC-CN107

# MULTITRACK CASSETTE RECORDER

# MT8X

# PARTS LIST

## ■ CONTENTS (目次)

ELECTRICAL PARTS (電気部品).....	1
OVERALL ASSEMBLY (総組立).....	10
TOP COVER UNIT (トップカバーユニット).....	14
CASSETTE DECK UNIT (Cメカユニット).....	16
CASSETTE DECK ASSEMBLY (Cメカ Ass'y).....	18
ACCESSORIES (付属品).....	21
SERVICE PARTS (サービスパーツ).....	21

## Notes DESTINATION ABBREVIATIONS

A : Australian model	J : Japanese model
B : British model	M : South African model
C : Canadian model	Q : South-east Asia model
D : German model	U : U.S.A. model
E : European model	V : General export model (110V)
F : French model	W : General export model (220V)
G : Belgian model	X : General export model
H : North European model	Y : Export model
I : Indonesian model	

## ■ WARNING

Components having special characteristics are marked  $\Delta$  and must be replaced with parts having specifications equal to those originally installed.

$\Delta$ 印の部品は、安全を維持するために重要な部品です。交換する場合は、安全のため必ず指定の部品をご使用下さい。

- The numbers with "pc." or "pcs" in "Remarks" show quantities for each unit.
- The parts with "—" in "Part No." are not available as spare parts.
- 部品価格ランクは、変更になることがあります。
- Remarks欄に記されている数字は、使用個数です。
- 部品No.が"—"の部品は、サービス用部品として準備されておりません。

**ELECTRICAL PARTS (電気部品)**

Ref.	Part No.	Description		部品名	Remarks	ランク
	--	<ELECTRICAL PARTS>		<電気部品>	MT8X	
*	NX812220	CIRCUIT BOARD	MIX	MIXシート	(VP99610)	
*	NX812230	CIRCUIT BOARD	MIX 1/7	MIX 1 / 7 シート		
*	NX812240	CIRCUIT BOARD	MIX 2/7	MIX 2 / 7 シート		
			MIX 3/7	MIX 3 / 7 シート		
*	NX812250	CIRCUIT BOARD	MIX 4/7	MIX 4 / 7 シート		
*	NX812260	CIRCUIT BOARD	MIX 5/7	MIX 5 / 7 シート		
*	NX812270	CIRCUIT BOARD	MIX 6/7	MIX 6 / 7 シート		
*	NX812280	CIRCUIT BOARD	MIX 7/7	MIX 7 / 7 シート		
	--	CIRCUIT BOARD	MAS	MASシート	(VP99630)	
*	NX812290	CIRCUIT BOARD	MAS 1/3	MAS 1 / 3 シート		
*	NX812300	CIRCUIT BOARD	MAS 2/3	MAS 2 / 3 シート		
*	NX812310	CIRCUIT BOARD	MAS 3/3	MAS 3 / 3 シート		
*	--	CIRCUIT BOARD	DEC	DECシート	(VP99640)	
*	NX812320	CIRCUIT BOARD	DEC 1/2	DEC 1 / 2 シート		
*	NX812330	CIRCUIT BOARD	DEC 2/2	DEC 2 / 2 シート		
*	VP996500	CIRCUIT BOARD	ENC	ENCシート		
	--	CIRCUIT BOARD	SUB	SUBシート	J (VP99660)	
	--	CIRCUIT BOARD	SUB	SUBシート	U,C,V (VP99670)	
	--	CIRCUIT BOARD	SUB	SUBシート	H,B,W (VQ04200)	
*	NX812340	CIRCUIT BOARD	SUB 1/4	SUB 1 / 4 シート	J	
*	NX812350	CIRCUIT BOARD	SUB 1/4	SUB 1 / 4 シート	U,C,V	
*	NX812360	CIRCUIT BOARD	SUB 1/4	SUB 1 / 4 シート	H,B,W	
*	NX812370	CIRCUIT BOARD	SUB 2/4	SUB 2 / 4 シート		
*	NX812380	CIRCUIT BOARD	SUB 3/4	SUB 3 / 4 シート		
*	NX812390	CIRCUIT BOARD	SUB 4/4	SUB 4 / 4 シート		
	--	CIRCUIT BOARD	MIX	MIXシート	(VP99610)	
*	NX812220	CIRCUIT BOARD	MIX 1/7	MIX 1 / 7 シート		
*	NX812230	CIRCUIT BOARD	MIX 2/7	MIX 2 / 7 シート		
*	NX812240	CIRCUIT BOARD	MIX 3/7	MIX 3 / 7 シート		
*	NX812250	CIRCUIT BOARD	MIX 4/7	MIX 4 / 7 シート		
*	NX812260	CIRCUIT BOARD	MIX 5/7	MIX 5 / 7 シート		
*	NX812270	CIRCUIT BOARD	MIX 6/7	MIX 6 / 7 シート		
*	NX812280	CIRCUIT BOARD	MIX 7/7	MIX 7 / 7 シート		
	UA353750	MYLAR CAP.	7500P 50V J	マイラーコン		01
	UA653180	MYLAR CAP.	1800P 50V J	マイラーコン		01
	UA654120	MYLAR CAP.	0.0120 50V J	マイラーコン		01
	UA654220	MYLAR CAP.	0.0220 50V J	マイラーコン		01
	VF466600	CERAMIC TUBULAR CAP.-SL	10P 50V J	円筒セラ (SL)		01
	VF466800	CERAMIC TUBULAR CAP.-B	100P 50V K	円筒セラ (B)		01
	VG276200	CERAMIC TUBULAR CAP.-SL	15P 50V J	円筒セラ (SL)		01
	VG276600	CERAMIC TUBULAR CAP.-SL	22P 50V J	円筒セラ (SL)		01
	VG278200	CERAMIC TUBULAR CAP.-B	150P 50V K	円筒セラ (B)		01
	VG278400	CERAMIC TUBULAR CAP.-B	220P 50V K	円筒セラ (B)		01
	VG280100	CERAMIC TUBULAR CAP.-F	0.022 25V Z	円筒セラ (F)		01
	VJ599100	CERAMIC TUBULAR CAP.-F	0.1 50V Z	円筒セラ (F)		01
*	UI538100	ELECTROLYTIC CAP.	100.00 16.0V	ケミコン		01
*	UM407100	ELECTROLYTIC CAP.	10.00 25.0V	ケミコン		01
*	UM415220	ELECTROLYTIC CAP.	0.22 50.0V	ケミコン		01
	VG286700	ELECTROLYTIC CAP.	47.00 10.0V	ケミコン RA-2		01
	VG286800	ELECTROLYTIC CAP.	100.00 10.0V	ケミコン RA-2		01
	VG287500	ELECTROLYTIC CAP.	47.00 16.0V	ケミコン RA-2		01
	VG287600	ELECTROLYTIC CAP.	100.00 16.0V	ケミコン RA-2		01
	VG288400	ELECTROLYTIC CAP.	4.700 25.0V	ケミコン RA-2		01
	VG288500	ELECTROLYTIC CAP.	10.00 25.0V	ケミコン RA-2		01
	VG288900	ELECTROLYTIC CAP.	100.00 25.0V	ケミコン RA-2		01
	VG290500	ELECTROLYTIC CAP.	1.00 50.0V	ケミコン RA-2		01
*	VK179300	ELECTROLYTIC CAP.	3300 6.3V	ケミコン AU		02
*	VK180700	ELECTROLYTIC CAP.	4700 16.0V	ケミコン AU		03
	UK866100	ELECTROLYTIC CAP.-BP	1.00 50.0V	BPケミコン		01
	HF455100	CARBON RESISTOR	100.0 1/4 J	カーボン抵抗		01
	HF455220	CARBON RESISTOR	220.0 1/4 J	カーボン抵抗		01
	HF455270	CARBON RESISTOR	270.0 1/4 J	カーボン抵抗		01
	HF455470	CARBON RESISTOR	470.0 1/4 J	カーボン抵抗		01
	HF455560	CARBON RESISTOR	560.0 1/4 J	カーボン抵抗		01
	HF456100	CARBON RESISTOR	1.0K 1/4 J	カーボン抵抗		01
	HF456160	CARBON RESISTOR	1.6K 1/4 J	カーボン抵抗		01
	HF456240	CARBON RESISTOR	2.4K 1/4 J	カーボン抵抗		01
	HF456330	CARBON RESISTOR	3.3K 1/4 J	カーボン抵抗		01

\*New Parts (新規部品)

ランク:Japan only

MT8X

Ref.	Part No.	Description	部品名	Remarks	ランク
	HF456390	CARBON RESISTOR	3.9K 1/4 J	カーボン抵抗	01
	HF456470	CARBON RESISTOR	4.7K 1/4 J	カーボン抵抗	01
	HF456560	CARBON RESISTOR	5.6K 1/4 J	カーボン抵抗	01
	HF456820	CARBON RESISTOR	8.2K 1/4 J	カーボン抵抗	01
	HF456910	CARBON RESISTOR	9.1K 1/4 J	カーボン抵抗	01
	HF457100	CARBON RESISTOR	10.0K 1/4 J	カーボン抵抗	01
	HF457120	CARBON RESISTOR	12.0K 1/4 J	カーボン抵抗	01
	HF457130	CARBON RESISTOR	13.0K 1/4 J	カーボン抵抗	01
	HF457150	CARBON RESISTOR	15.0K 1/4 J	カーボン抵抗	01
	HF457180	CARBON RESISTOR	18.0K 1/4 J	カーボン抵抗	01
	HF457220	CARBON RESISTOR	22.0K 1/4 J	カーボン抵抗	01
	HF457330	CARBON RESISTOR	33.0K 1/4 J	カーボン抵抗	01
	HF457360	CARBON RESISTOR	36.0K 1/4 J	カーボン抵抗	01
	HF457390	CARBON RESISTOR	39.0K 1/4 J	カーボン抵抗	01
	HF457510	CARBON RESISTOR	51.0K 1/4 J	カーボン抵抗	01
	HF457910	CARBON RESISTOR	91.0K 1/4 J	カーボン抵抗	01
	HF458100	CARBON RESISTOR	100.0K 1/4 J	カーボン抵抗	01
	HF458150	CARBON RESISTOR	150.0K 1/4 J	カーボン抵抗	01
	HF458270	CARBON RESISTOR	270.0K 1/4 J	カーボン抵抗	01
	HF458470	CARBON RESISTOR	470.0K 1/4 J	カーボン抵抗	01
*	HL214180	METAL OXIDE FILM RESISTOR	18.0 1W J	酸化金属膜抵抗	01
	VE009700	FUSE RESISTOR	4.7 1/4 J	ヒューズ抵抗	01
	VK186600	FUSE RESISTOR	10.0 1/4 G	ヒューズ抵抗	01
	VF771900	RESISTOR ARRAY	RGLE8X103J	抵抗アレイ	01
	IG076800	IC	NJM4558S	IC	03
	XE322A00	IC	NJM2068S-D	IC	02
	XB382A00	IC	M5230L	IC	03
	XJ604A00	IC	NJM78M05FA	IC	02
	XJ608A00	IC	NJM7812FA	IC	02
	XI929A00	IC	BU4551B	IC	02
	XA299A00	IC	LB1649	IC	05
	XM709A00	IC	M38022M2SP	IC	13
	VG392900	TACT SWITCH	SKH-VBA005A	タクトスイッチ	01
	VQ035600	PUSH SWITCH		プッシュスイッチ	03
	VQ036800	PUSH SWITCH	SPPH23	プッシュスイッチ	03
	VQ035700	PUSH SWITCH	SPEC21 2	プッシュスイッチ	04
	VB966900	PIN	IMSA-6024	スタイルピン	01
	VD430000	PHONE JACK	YKB21-5011	ホーンコネクタ	02
	VP599800	PHONE JACK	YKB21-5166	ホーンジャック	03
	VK217100	CONNECTOR HOUSING	FJ 8P	FJ-リセブタクル	01
	VD004700	BASE PIN IN STICK	PH 4P TE	ベースピン	01
	VD004800	BASE PIN IN STICK	PH 5P TE	ベースピン	01
	VD004900	BASE PIN IN STICK	PH 6P TE	ベースピン	01
	VD005000	BASE PIN IN STICK	PH 7P TE	ベースピン	01
	VD005100	BASE PIN IN STICK	PH 8P TE	ベースピン	01
	VD005200	BASE PIN IN STICK	PH 9P TE	ベースピン	01
	VG699700	BASE PIN IN STICK	PH 11P TE	ベースピン	01
	VP600000	CONNECTOR HOUSING	52084 5P TE	コネクタハウジング	01
	FZ006970	EMI FILTER	LS MT Y223NB	LCフィルタ	02
	VJ802400	CERAMIC RESONATOR	CST8.00MTW	セラミック振動子	01
	VQ033000	TRIMMER POTENTIOMETER	B 6.8K 3P	半固定ボリューム	01
	VQ030400	SLIDE POT.	A 10.0K	スライドボリューム	04
	VQ030900	VARIABLE RESISTOR	B 10.0K	ロータリーボリューム	02
	VQ031000	VARIABLE RESISTOR	B 10.0K	ロータリーボリューム	03
	VQ031200	VARIABLE RESISTOR	A 10.0K	ロータリーボリューム	02
	VQ031400	VARIABLE RESISTOR	B 50.0K	ロータリーボリューム	02
	VQ031500	VARIABLE RESISTOR	B 50.0K	ロータリーボリューム	03
	VQ032400	VARIABLE RESISTOR	A 100.0K	ロータリーボリューム	02
	VQ032500	VARIABLE RESISTOR	B 10.0K	ロータリーボリューム	02
	VC614000	TRANSISTOR	2SB1274 R,S	トランジスタ	02
	IC260320	TRANSISTOR	2SC2603 E,F	トランジスタ	01
	VC407900	TRANSISTOR	2SD1913 R,S	トランジスタ	01
	IF004600	DIODE	1SS133 T-77	ダイオード	01
	VH770800	DIODE	1SR139-100 T-32	ダイオード	01
	VG436700	ZENER DIODE	MTZ J 4.3A 4.3V	ツェナーダイオード	01
	VG438600	ZENER DIODE	MTZ J 7.5B 7.5V	ツェナーダイオード	01
	VG439300	ZENER DIODE	MTZ J 9.1C 9.1V	ツェナーダイオード	01
	IF008730	LED	SLR-34URC3H3 RE	LEDフック付き	02
	IF008740	LED	SLR-34MC3H3 GR	LEDフック付き	01
	VE067000	LED	SLR-34YC3H3 YE	LED	01

\*New Parts (新規部品)



Ref.	Part No.	Description	部品名	Remarks	ランク
	VD488500	DIGITAL TRANSISTOR	DTC143XS TP	デジタルトランジスタ	03
	VD678500	DIGITAL TRANSISTOR	DTA114ES	デジタルトランジスタ	03
	VD678700	DIGITAL TRANSISTOR	DTC114ES	デジタルトランジスタ	03
*	VP836300	HOLDER	PCB	ホルダー	03
*	VQ051000	CONNECTOR ASSEMBLY	11P 200L	束線	06
	VQ051700	CONNECTOR ASSEMBLY	7P 140L	束線	05
	VP944700	HEAT SINK	UOT-10C25-SPL	ヒートシンク	02
	VB692900	PH CONNECTOR ASSEMBLY	3P 70mm B&B	PHコネクタ Assy	02
*	VB693000	PH CONNECTOR ASSEMBLY	3P 100mm B&B	PHコネクタ Assy	02
*	VB693200	PH CONNECTOR ASSEMBLY	3P 140mm B&B	PHコネクタ Assy	02
	VB708400	PH CONNECTOR ASSEMBLY	3P 120mm B&C	PHコネクタ Assy	02
*	VM023000	B&C CONNECTOR ASSEMBLY	PH328 6P 350	B & Cコネクタ-Assy	05
*	VM026400	B&C CONNECTOR ASSEMBLY	PH362 8P 350	B & Cコネクタ-Assy	06
	--	CIRCUIT BOARD	MAS	M A S シート	(VP99630)
*	NX812290	CIRCUIT BOARD	MAS 1/3	M A S 1 / 3 シート	
*	NX812300	CIRCUIT BOARD	MAS 2/3	M A S 2 / 3 シート	
*	NX812310	CIRCUIT BOARD	MAS 3/3	M A S 3 / 3 シート	
	UA653180	MYLAR CAP.	1800P 50V J	マイラーコン	01
	UA654220	MYLAR CAP.	0.0220 50V J	マイラーコン	01
	UA655100	MYLAR CAP.	0.1000 50V J	マイラーコン	01
	VF466600	CERAMIC TUBULAR CAP.-SL	10P 50V J	円筒セラ (SL)	01
	VF466800	CERAMIC TUBULAR CAP.-B	100P 50V K	円筒セラ (B)	01
*	VG276200	CERAMIC TUBULAR CAP.-SL	15P 50V J	円筒セラ (SL)	01
	VG276400	CERAMIC TUBULAR CAP.-SL	18P 50V J	円筒セラ (SL)	01
	VG276800	CERAMIC TUBULAR CAP.-SL	27P 50V J	円筒セラ (SL)	01
	VG277000	CERAMIC TUBULAR CAP.-SL	33P 50V J	円筒セラ (SL)	01
	VG277200	CERAMIC TUBULAR CAP.-SL	39P 50V J	円筒セラ (SL)	01
	VG277500	CERAMIC TUBULAR CAP.-SL	56P 50V J	円筒セラ (SL)	01
	VG277700	CERAMIC TUBULAR CAP.-SL	68P 50V J	円筒セラ (SL)	01
	VG278400	CERAMIC TUBULAR CAP.-B	220P 50V K	円筒セラ (B)	01
	VG280100	CERAMIC TUBULAR CAP.-F	0.022 25V Z	円筒セラ (F)	01
	UI538100	ELECTROLYTIC CAP.	100.00 16.0V	ケミコン	01
	UM407100	ELECTROLYTIC CAP.	10.00 25.0V	ケミコン	01
	UM407220	ELECTROLYTIC CAP.	22.00 25.0V	ケミコン	01
*	UI567100	ELECTROLYTIC CAP.	10.00 50.0V	ケミコン	01
	VG287800	ELECTROLYTIC CAP.	330.00 16.0V	ケミコン	01
	VG288500	ELECTROLYTIC CAP.	10.00 25.0V	ケミコン	01
	HF453220	CARBON RESISTOR	2.2 1/4 J	カーボン抵抗	01
	HF453470	CARBON RESISTOR	4.7 1/4 J	カーボン抵抗	01
	HF455220	CARBON RESISTOR	220.0 1/4 J	カーボン抵抗	01
	HF456100	CARBON RESISTOR	1.0K 1/4 J	カーボン抵抗	01
	HF456560	CARBON RESISTOR	5.6K 1/4 J	カーボン抵抗	01
	HF456680	CARBON RESISTOR	6.8K 1/4 J	カーボン抵抗	01
	HF456910	CARBON RESISTOR	9.1K 1/4 J	カーボン抵抗	01
	HF457120	CARBON RESISTOR	12.0K 1/4 J	カーボン抵抗	01
	HF457150	CARBON RESISTOR	15.0K 1/4 J	カーボン抵抗	01
	HF457220	CARBON RESISTOR	22.0K 1/4 J	カーボン抵抗	01
	HF457270	CARBON RESISTOR	27.0K 1/4 J	カーボン抵抗	01
	HF457330	CARBON RESISTOR	33.0K 1/4 J	カーボン抵抗	01
	HF457390	CARBON RESISTOR	39.0K 1/4 J	カーボン抵抗	01
	HF457470	CARBON RESISTOR	47.0K 1/4 J	カーボン抵抗	01
	HF457560	CARBON RESISTOR	56.0K 1/4 J	カーボン抵抗	01
	HF457680	CARBON RESISTOR	68.0K 1/4 J	カーボン抵抗	01
	HF457820	CARBON RESISTOR	82.0K 1/4 J	カーボン抵抗	01
	HF458100	CARBON RESISTOR	100.0K 1/4 J	カーボン抵抗	01
*	HF458470	CARBON RESISTOR	470.0K 1/4 J	カーボン抵抗	01
*	HL225100	METAL OXIDE FILM RESISTOR	100.0 2W J	酸化金属被膜抵抗	01
*	HL225120	METAL OXIDE FILM RESISTOR	120.0 2W J	酸化金属被膜抵抗	01
	IG076800	IC	NJM4558S	IC	03
	OP AMP				
*	XI250A00	IC	LA6515	IC	03
*	XM255A00	IC	MSC1164	IC	07
*	VP599200	FLUORESCENT DISPLAY	FV593G	蛍光表示管	11
*	VQ035600	PUSH SWITCH		プッシュスイッチ	03
*	VQ035700	PUSH SWITCH	SPEC21 2	プッシュスイッチ	04
*	VQ035800	PUSH SWITCH	SPEC52	プッシュスイッチ	06
	VB966900	PIN	IMSA-6024	スタイルピン	01
	VD430000	PHONE JACK	YKB21-5011	ホンコネクタ	02
*	VL548500	PLUG	FJ 8P	FJ ショートプラグ	01
*	VB858100	BASE POST CONNECTOR	PH 2P SE	コネクタベースポスト	01

MT8X

Ref.	Part No.	Description	部品名	Remarks	ランク	
* * * * *	VB858200 VP600000 VP600300 VQ030300 VQ030400	BASE POST CONNECTOR CONNECTOR HOUSING CONNECTOR HOUSING SLIDE POT. SLIDE POT.	PH 3P SE 52084 5P TE 52084 8P TE A 10.0K A 10.0K	コネクタベースポスト コネクタハウジング コネクタハウジング スライドボリューム スライドボリューム	CUE 1-8 FADER 5-7	01 01 02 03 04
* * * * *	VQ030600 VQ030900 VQ031000 VQ031200 VQ031400	SLIDE POT. VARIABLE RESISTOR VARIABLE RESISTOR VARIABLE RESISTOR VARIABLE RESISTOR	A 10.0K B 10.0K B 10.0K A 10.0K B 50.0K	二連スライドボリューム ロータリーボリューム ロータリーボリューム ロータリーボリューム ロータリーボリューム	FADERS, M.FADER PAN CH.6,7 PAN CH.5,8 AUX 1,2, G.MAS LOW,HIGH	04 02 03 02 02
* * * * *	VQ031500 VQ031700 VQ031800 VQ032000 VQ032100	VARIABLE RESISTOR VARIABLE RESISTOR VARIABLE RESISTOR VARIABLE RESISTOR VARIABLE RESISTOR	B 50.0K A 10.0K A 10.0K A 20.0K A 20.0K	ロータリーボリューム 二連ロータリーボリューム 二連ロータリーボリューム 二連ロータリーボリューム 二連ロータリーボリューム	HIGH CH.5 AUX 1,2 PHONES LEVEL RTN1 LEVEL RTN2	03 03 03 03 03
* * * * *	VQ032300 VQ053800 VK432900 VP836400 --	VARIABLE RESISTOR VARIABLE RESISTOR TRANSISTOR HOLDER CONNECTOR ASSEMBLY	B 50.0K B 50.0K 2SD1915(F) S,T FL REMOTE CONTROL	二連ロータリーボリューム 二連ロータリーボリューム トランジスタ ホルダ 線材 A s s y	LOW CH.8 HIGH CH.8  (VQ04360)	03 03 01 05
* * * * *	BB066290 VB706500 VB718600 VM019500 VM019800	WASHER PH CONNECTOR ASSEMBLY PH CONNECTOR ASSEMBLY B&C CONNECTOR ASSEMBLY B&C CONNECTOR ASSEMBLY	4.5 CR-3020 2P 70mm B&C 9P 120mm B&C PH293 4P 300 PH296 4P 450	アースワッシャー PHコネクタ A s s y PHコネクタ A s s y B & C コネクタ-Assy B & C コネクタ-Assy		01 01 03 05 05
* * * * *	VM021600 VM025500 -- NX812320	B&C CONNECTOR ASSEMBLY B&C CONNECTOR ASSEMBLY CIRCUIT BOARD CIRCUIT BOARD	PH314 5P 500 PH353 8P 70 DEC DEC 1/2	B & C コネクタ-Assy B & C コネクタ-Assy D E C シート D E C 1 / 2 シート	(VP99640)	05 05
* * * * *	NX812330 UA353390 UA353470 UA652330 UA653180	CIRCUIT BOARD MYLAR CAP. MYLAR CAP. MYLAR CAP. MYLAR CAP.	DEC 2/2 3900P 50V J 4700P 50V J 330P 50V J 1800P 50V J	D E C 2 / 2 シート マイラーコン マイラーコン マイラーコン マイラーコン		01 01 01 01
* * * * *	UA653330 UA654200 UA654330 UA655100 VF466800	MYLAR CAP. MYLAR CAP. MYLAR CAP. MYLAR CAP. CERAMIC TUBULAR CAP.-B	3300P 50V J 0.0200 50V J 0.0330 50V J 0.1000 50V J 100P 50V K	マイラーコン マイラーコン マイラーコン マイラーコン 円筒セラ (B)		01 01 01 01 01
* * * * *	VG278200 VG278400 VG280100 VJ599100 VG288400	CERAMIC TUBULAR CAP.-B CERAMIC TUBULAR CAP.-B CERAMIC TUBULAR CAP.-F CERAMIC TUBULAR CAP.-F ELECTROLYTIC CAP.	150P 50V K 220P 50V K 0.022 25V Z 0.1 50V Z 4.700 25.0V	円筒セラ (B) 円筒セラ (B) 円筒セラ (F) 円筒セラ (F) ケミコン R A - 2		01 01 01 01 01
* * * * *	VG288500 VG288600 VG288800 VG288900 VG290200	ELECTROLYTIC CAP. ELECTROLYTIC CAP. ELECTROLYTIC CAP. ELECTROLYTIC CAP. ELECTROLYTIC CAP.	10.00 25.0V 22.00 25.0V 47.00 25.0V 100.00 25.0V 0.33 50.0V	ケミコン R A - 2 ケミコン R A - 2 ケミコン R A - 2 ケミコン R A - 2 ケミコン R A - 2		01 01 01 01 01
* * * * *	VG290500 VG290600 HF454220 HF455100 HF455150	ELECTROLYTIC CAP. ELECTROLYTIC CAP. CARBON RESISTOR CARBON RESISTOR CARBON RESISTOR	1.00 50.0V 2.20 50.0V 22.0 1/4 J 100.0 1/4 J 150.0 1/4 J	ケミコン R A - 2 ケミコン R A - 2 カーボン抵抗 カーボン抵抗 カーボン抵抗		01 01 01 01 01
* * * * *	HF456100 HF456680 HF457100 HF457120 HF457150	CARBON RESISTOR CARBON RESISTOR CARBON RESISTOR CARBON RESISTOR CARBON RESISTOR	1.0K 1/4 J 6.8K 1/4 J 10.0K 1/4 J 12.0K 1/4 J 15.0K 1/4 J	カーボン抵抗 カーボン抵抗 カーボン抵抗 カーボン抵抗 カーボン抵抗		01 01 01 01 01
* * * * *	HF457470 HF458100 HF458330 HF459100 HV753330	CARBON RESISTOR CARBON RESISTOR CARBON RESISTOR CARBON RESISTOR FLAME PROOF C. RESISTOR	47.0K 1/4 J 100.0K 1/4 J 330.0K 1/4 J 1.0M 1/4 J 3.3 1/4 J	カーボン抵抗 カーボン抵抗 カーボン抵抗 カーボン抵抗 不燃化カーボン抵抗		01 01 01 01 01
* * * * *	VP439000 VP440400 VP440500 VP440600 VP441000	METAL FILM RESISTOR METAL FILM RESISTOR METAL FILM RESISTOR METAL FILM RESISTOR METAL FILM RESISTOR	1.0K 1/4 F 3.9K 1/4 F 4.3K 1/4 F 4.7K 1/4 F 6.8K 1/4 F	金属被膜抵抗 金属被膜抵抗 金属被膜抵抗 金属被膜抵抗 金属被膜抵抗		

\*New Parts (新規部品)

ランク: Japan only

Ref.	Part No.	Description	部品名	Remarks	ランク	
* ** *	VP441400 VP442600 VP443700 IG074900 IG076800	METAL FILM RESISTOR METAL FILM RESISTOR METAL FILM RESISTOR IC IC	10.0K 1/4 F 33.0K 1/4 F 91.0K 1/4 F BA6138 NJM4558S	金属被膜抵抗 金属被膜抵抗 金属被膜抵抗 IC IC	COMPRESSOR OP AMP	01 04 03
*	IG121800 XI929A00 XJ637A00 IG149000 XM266A00	IC IC IC IC IC	NJM4560S BU4551B AN6292NK BU4053B M66008P	IC IC IC IC IC	OP AMP ANALOG SWITCH dbx MULTIPLEXER EXP I/O	05 02 07 03 05
* ** *	VB966900 VM725600 VP599400 VQ032800 VD430000	PIN PIN JACK PIN JACK PIN JACK PHONE JACK	IMSA-6024 YKC21-3045 YKC21-3041 YKC21-3115 YKB21-5011	スタイルピン ピンジャック 2P ピンジャック 3P ピンジャック 4P ホンコネクタ	AUX RETURN ST OUT, MO.OUT TEPE OUT AUX RETURN	01 02 03 03 02
	VB858100 VB858200 VB858500 VB858700 VB858800	BASE POST CONNECTOR BASE POST CONNECTOR BASE POST CONNECTOR BASE POST CONNECTOR BASE POST CONNECTOR	PH 2P SE PH 3P SE PH 6P SE PH 8P SE PH 9P SE	コネクタベースポスト コネクタベースポスト コネクタベースポスト コネクタベースポスト コネクタベースポスト		01 01 01 01 01
* ** ** ** *	VB858900 VP601100 VP601400 VJ808900 VJ809100	BASE POST CONNECTOR CONNECTOR WAFER CONNECTOR WAFER TRIMMER POTENTIOMETER TRIMMER POTENTIOMETER	PH 10P SE 53064 5P TE 53064 8P TE B 4.7K 3P EVN B 10.0K 3P EVN	コネクタベースポスト コネクタウェハー コネクタウェハー 半固定ボリューム 半固定ボリューム		01 01 02 01 01
	VK432900 VH257100 VD678700 -- --	TRANSISTOR DIGITAL TRANSISTOR DIGITAL TRANSISTOR CONNECTOR ASSEMBLY CONNECTOR ASSEMBLY	2SD1915(F) S,T DTA124ES TP DTC114ES DEC I/O EXP. DEC GND	トランジスタ デジタルトランジスタ デジタルトランジスタ 線材 Assy 線材 Assy	(VQ14680) (VQ59910)	01 01 03
* ** ** *	VB713500 VB720100 -- -- VM024800	PH CONNECTOR ASSEMBLY PH CONNECTOR ASSEMBLY B&C CONNECTOR ASSEMBLY B&C CONNECTOR ASSEMBLY B&C CONNECTOR ASSEMBLY	6P 120mm B&C 10P 70mm B&C PH277 3P 350 PH334 6P 650 PH346 7P 400	PHコネクタ Assy PHコネクタ Assy B&Cコネクタ Assy B&Cコネクタ Assy B&Cコネクタ Assy	(VM01790) (VM02360)	03 03 05
* ** ** *	VM026400 VM026700 VM028200 VP996500	B&C CONNECTOR ASSEMBLY B&C CONNECTOR ASSEMBLY B&C CONNECTOR ASSEMBLY CIRCUIT BOARD	PH362 8P 350 PH365 8P 500 PH380 9P 400 ENC	B & C コネクタ Assy B & C コネクタ Assy B & C コネクタ Assy ENCシート		06 06 06
* **	UA652220 UA652330 UA652820 UA653180 UA653240	MYLAR CAP. MYLAR CAP. MYLAR CAP. MYLAR CAP. MYLAR CAP.	220P 50V J 330P 50V J 820P 50V J 1800P 50V J 2400P 50V J	マイラーコン マイラーコン マイラーコン マイラーコン マイラーコン		01 01 01 01 03
	UA653330 UA653470 UA654220 UA654330 UA655100	MYLAR CAP. MYLAR CAP. MYLAR CAP. MYLAR CAP. MYLAR CAP.	3300P 50V J 4700P 50V J 0.0220 50V J 0.0330 50V J 0.1000 50V J	マイラーコン マイラーコン マイラーコン マイラーコン マイラーコン		01 01 01 01 01
	UA655220 UA655270 VF466800 VG279700 VG280100	MYLAR CAP. MYLAR CAP. CERAMIC TUBULAR CAP.-B CERAMIC TUBULAR CAP.-X CERAMIC TUBULAR CAP.-F	0.2200 50V J 0.2700 50V J 100P 50V K 3900P 16V N 0.022 25V Z	マイラーコン マイラーコン 円筒セラ (B) 円筒セラ (X) 円筒セラ (F)		01 01 01 01 01
	VE017800 VE018300 VG286200 VG287800 VG288500	ELECTROLYTIC CAP. ELECTROLYTIC CAP. ELECTROLYTIC CAP. ELECTROLYTIC CAP. ELECTROLYTIC CAP.	47.00 16.0V 10.00 25.0V 100.00 6.3V 330.00 16.0V 10.00 25.0V	ケミコン DUORE ケミコン DUORE ケミコン RA-2 ケミコン RA-2 ケミコン RA-2		01 01 01 01 01
	VG288600 VG288800 VG288900 VG290200 VG290600	ELECTROLYTIC CAP. ELECTROLYTIC CAP. ELECTROLYTIC CAP. ELECTROLYTIC CAP. ELECTROLYTIC CAP.	22.00 25.0V 47.00 25.0V 100.00 25.0V 0.33 50.0V 2.20 50.0V	ケミコン RA-2 ケミコン RA-2 ケミコン RA-2 ケミコン RA-2 ケミコン RA-2		01 01 01 01 01
* ** ** *	VQ522800 VR012700 VP764300 VP764400 HF453100	COIL COIL COIL COIL CARBON RESISTOR	47mH (473S) 39mH (393S) 1mH 1mH 260mA 1.0 1/4 J	固定コイル 固定コイル コイル チョークコイル カーボン抵抗		02 02 02 01

Ref.	Part No.	Description	部品名	Remarks	ランク
	HF454100	CARBON RESISTOR	10.0 1/4 J	カーボン抵抗	01
	HF454220	CARBON RESISTOR	22.0 1/4 J	カーボン抵抗	01
	HF454680	CARBON RESISTOR	68.0 1/4 J	カーボン抵抗	01
	HF455220	CARBON RESISTOR	220.0 1/4 J	カーボン抵抗	01
	HF455330	CARBON RESISTOR	330.0 1/4 J	カーボン抵抗	01
	HF456100	CARBON RESISTOR	1.0K 1/4 J	カーボン抵抗	01
	HF456150	CARBON RESISTOR	1.5K 1/4 J	カーボン抵抗	01
	HF456180	CARBON RESISTOR	1.8K 1/4 J	カーボン抵抗	01
	HF456220	CARBON RESISTOR	2.2K 1/4 J	カーボン抵抗	01
	HF456470	CARBON RESISTOR	4.7K 1/4 J	カーボン抵抗	01
	HF456680	CARBON RESISTOR	6.8K 1/4 J	カーボン抵抗	01
	HF457100	CARBON RESISTOR	10.0K 1/4 J	カーボン抵抗	01
	HF457150	CARBON RESISTOR	15.0K 1/4 J	カーボン抵抗	01
	HF457220	CARBON RESISTOR	22.0K 1/4 J	カーボン抵抗	01
	HF457300	CARBON RESISTOR	30.0K 1/4 J	カーボン抵抗	01
	HF457330	CARBON RESISTOR	33.0K 1/4 J	カーボン抵抗	01
	HF457390	CARBON RESISTOR	39.0K 1/4 J	カーボン抵抗	01
	HF457470	CARBON RESISTOR	47.0K 1/4 J	カーボン抵抗	01
	HF458100	CARBON RESISTOR	100.0K 1/4 J	カーボン抵抗	01
	HF458120	CARBON RESISTOR	120.0K 1/4 J	カーボン抵抗	01
	HF459100	CARBON RESISTOR	1.0M 1/4 J	カーボン抵抗	01
	HV753470	FLAME PROOF C. RESISTOR	4.7 1/4 J	カーボン抵抗	01
	VP439000	METAL FILM RESISTOR	1.0K 1/4 F	金属被膜抵抗	
	VP440400	METAL FILM RESISTOR	3.9K 1/4 F	金属被膜抵抗	
	VP440500	METAL FILM RESISTOR	4.3K 1/4 F	金属被膜抵抗	
	VP440600	METAL FILM RESISTOR	4.7K 1/4 F	金属被膜抵抗	
	VP441000	METAL FILM RESISTOR	6.8K 1/4 F	金属被膜抵抗	
	VP441400	METAL FILM RESISTOR	10.0K 1/4 F	金属被膜抵抗	
	VP442600	METAL FILM RESISTOR	33.0K 1/4 F	金属被膜抵抗	
	VP443700	METAL FILM RESISTOR	91.0K 1/4 F	金属被膜抵抗	01
	XB247A00	IC	UPC4570HA	IC	OP AMP
	XE322A00	IC	NJM2068S-D	IC	OP AMP
	IG149300	IC	LC4966	IC	
	XJ637A00	IC	AN6292NK	IC	dbx
	IG149000	IC	BU4053B	IC	MULTIPLEXER
	VM640200	RELAY	DC RY 12W-0H-K	リレー	
	VN010200	PIN	VN01020	リードピン	01
	VD004500	BASE PIN IN STICK	PH 2P TE	ベースピン	01
	VD004600	BASE PIN IN STICK	PH 3P TE	ベースピン	01
	VD004700	BASE PIN IN STICK	PH 4P TE	ベースピン	01
	VD004900	BASE PIN IN STICK	PH 6P TE	ベースピン	01
	VD005000	BASE PIN IN STICK	PH 7P TE	ベースピン	01
	VD005100	BASE PIN IN STICK	PH 8P TE	ベースピン	01
	VD005200	BASE PIN IN STICK	PH 9P TE	ベースピン	01
	VG699700	BASE PIN IN STICK	PH 11P TE	ベースピン	01
	VP764800	LC FILTER	85KHZ BP	バイアストラップ	02
	VQ033400	LC FILTER		バイアストラップ	02
	VR121000	LC FILTER	16KHZ LPF	ローパスフィルター	
	VJ693300	TRIMMER POTENTIOMETER	B 3.3K 3P	半固定ボリューム	01
	VJ693400	TRIMMER POTENTIOMETER	B 4.7K 3P	半固定ボリューム	01
	VJ693600	TRIMMER POTENTIOMETER	B 10.0K 3P	半固定ボリューム	01
	VJ693800	TRIMMER POTENTIOMETER	B 22.0K 3P	半固定ボリューム	01
	VJ694300	TRIMMER POTENTIOMETER	B 150.0K 3P	半固定ボリューム	02
	VE613400	TRANSISTOR	2SD1858 TV2 Q,R	トランジスタ	01
	VK432900	TRANSISTOR	2SD1915(F) S,T	トランジスタ	01
	IF004600	DIODE	1SS133 T-77	ダイオード	01
	VH257100	DIGITAL TRANSISTOR	DTA124ES TP	デジタルトランジスタ	01
	VD678700	DIGITAL TRANSISTOR	DTC114ES	デジタルトランジスタ	03
	VP836300	HOLDER	PCB	ホルダー	03
	--	CONNECTOR ASSEMBLY	ENC GND	線材 Assy	(VQ05610)
	--	CONNECTOR ASSEMBLY	ENC PB OUT	線材 Assy	(VQ21210)
	VM002400	B&C CONNECTOR ASSEMBLY	PH42 3P 250	B & B コネクタ - Assy	04
	VM004100	B&C CONNECTOR ASSEMBLY	PH59 4P 250	B & B コネクタ - Assy	05
	VM006200	B&C CONNECTOR ASSEMBLY	PH80 5P 450	B & B コネクタ - Assy	05
	VM019400	B&C CONNECTOR ASSEMBLY	PH29 4P 250	B & C コネクタ - Assy	05
	VM021100	B&C CONNECTOR ASSEMBLY	PH30 5P 250	B & C コネクタ - Assy	05
	VM027300	B&C CONNECTOR ASSEMBLY	PH37 9P 100	B & C コネクタ - Assy	05
	--	CIRCUIT BOARD	SUB	SUB シート	J (VP99660)
	--	CIRCUIT BOARD	SUB	SUB シート	U,C,V (VP99670)

\*New Parts (新規部品)

ランク: Japan only

Ref.	Part No.	Description	部品名	Remarks	ランク
*	--	CIRCUIT BOARD	SUB	H, B, W (VQ04200)	
*	NX812340	CIRCUIT BOARD	SUB 1/4	J	
*	NX812350	CIRCUIT BOARD	SUB 1/4	J, C, V	
*	NX812360	CIRCUIT BOARD	SUB 1/4	H, B, W	
*	NX812370	CIRCUIT BOARD	SUB 2/4		
*	NX812380	CIRCUIT BOARD	SUB 3/4		
*	NX812390	CIRCUIT BOARD	SUB 4/4		
*	UA653100	MYLAR CAP.	1000P 50V J		03
*	UA653470	MYLAR CAP.	4700P 50V J		01
*	UT653100	POLYPROPYLENE FILM CAP.	1000P 100V J		01
	UT653560	POLYPROPYLENE FILM CAP.	5600P 100V J		01
	VA761800	CERAMIC CAP.	100P 50V J		01
	VA777500	CERAMIC CAP.	150P 50V J		01
	FG644100	CERAMIC CAP.-F	0.0100 50V Z		01
	VG280100	CERAMIC TUBULAR CAP.-F	0.022 25V Z		01
	VJ599100	CERAMIC TUBULAR CAP.-F	0.1 50V Z		01
	UJ848470	ELECTROLYTIC CAP.	470.00 25.0V		01
	UJ868220	ELECTROLYTIC CAP.	220.00 50.0V		01
	VG286300	ELECTROLYTIC CAP.	220.00 6.3V		01
	VG288400	ELECTROLYTIC CAP.	4.700 25.0V		01
	VG288500	ELECTROLYTIC CAP.	10.00 25.0V		01
	VG288900	ELECTROLYTIC CAP.	100.00 25.0V		01
	VG290800	ELECTROLYTIC CAP.	4.70 50.0V		01
	VG290900	ELECTROLYTIC CAP.	10.00 50.0V		01
	VK181300	ELECTROLYTIC CAP.	4700 25.0V		03
*	VA891300	CERAMIC CAP.	0.01 250V	J	01
*	FI384100	CERAMIC CAP.	0.010 400V	U, C, V, H, B, W	01
*	VP764500	COIL	85KHZ P-P		02
*	VP769100	COIL	85KHZ		02
*	HF455100	CARBON RESISTOR	100.0 1/4 J		01
	HF456100	CARBON RESISTOR	1.0K 1/4 J		01
	HF456180	CARBON RESISTOR	1.8K 1/4 J		01
	HF456270	CARBON RESISTOR	2.7K 1/4 J		01
	HF456390	CARBON RESISTOR	3.9K 1/4 J		01
	HF456470	CARBON RESISTOR	4.7K 1/4 J		01
	HF456560	CARBON RESISTOR	5.6K 1/4 J		01
	HF457100	CARBON RESISTOR	10.0K 1/4 J		01
	HF457130	CARBON RESISTOR	13.0K 1/4 J		01
	HF457220	CARBON RESISTOR	22.0K 1/4 J		01
	HF457270	CARBON RESISTOR	27.0K 1/4 J		01
	HF457330	CARBON RESISTOR	33.0K 1/4 J		01
	HF457360	CARBON RESISTOR	36.0K 1/4 J		01
	HF457470	CARBON RESISTOR	47.0K 1/4 J		01
	HF458220	CARBON RESISTOR	220.0K 1/4 J		01
	HF458470	CARBON RESISTOR	470.0K 1/4 J		01
*	HV754390	FLAME PROOF C. RESISTOR	39.0 1/4 J		01
*	HV755100	FLAME PROOF C. RESISTOR	100.0 1/4 J		01
*	VQ040100	PUSH SWITCH	ESB82 TV-3		03
*	KB003590	FUSE	3.00A	POWER	01
*	KB003070	FUSE	2.00A	J, U, C, V	01
	VB966900	PIN	IMSA-6024	H, B, W	01
	VL080300	PHONE JACK	YKB21-5009		01
	VL080500	PHONE JACK	YKB21-5076	PHONES	01
	VL327300	AC INLET	M1779-B	PUNCH I/O	02
	VI042900	AC INLET	M1770-A	J, H, B, W	02
	VL105500	DIN JACK	8P CMS 5008	U, C, V	02
	LB918070	BASE POST CONNECTOR	XH 7P TE		01
	LB932050	BASE POST CONNECTOR	VH 5P TE		01
	VD004700	BASE PIN IN STICK	PH 4P TE		01
	VD004900	BASE PIN IN STICK	PH 6P TE		01
*	VG879900	ASE POST CONNECTOR	VA 2P TE		01
*	VP534700	BASE PIN	FPC 16P SE		03
	VP206500	FUSE HOLDER	EYF-52BC		01
	IA093320	TRANSISTOR	2SA933S Q, R		01
	IC260320	TRANSISTOR	2SC2603 E, F		01
*	IC287820	TRANSISTOR	2SC2878 A, B		01
*	VQ032900	TRANSISTOR	2SC1318 R, S		01
	IF004600	DIODE	1SS133 T-77		01
	VH770800	DIODE	1SR139-100 T-32		01
	VH801600	DIODE	1SR139-100 T-62		01

Ref.	Part No.	Description	部品名	Remarks	ランク	
△	IH001090 VG437200 VG437300 -- --	DIODE STACK ZENER DIODE ZENER DIODE CONNECTOR ASSEMBLY CONNECTOR ASSEMBLY	S4VB20 2.6A 200 MTZ J 4.7C 4.7V MTZ J 5.1A 5.1V REMOTE CONTROL GND	ダイオードスタック ツェナーダイオード ツェナーダイオード 線材 A s s y 線材 A s s y	(VQ04360) (VQ04370)	04 01 01
*	VB709000 VB709900 VB713300 VB715200	PH CONNECTOR ASSEMBLY PH CONNECTOR ASSEMBLY PH CONNECTOR ASSEMBLY PH CONNECTOR ASSEMBLY	3P 300mm B&C 4P 70mm B&C 6P 70mm B&C 7P 120mm B&C	PHコネクタ A s s y PHコネクタ A s s y PHコネクタ A s s y PHコネクタ A s s y		02 02 03 03
*	△ △ △ △ △	XM235B00 XM236B00 XM237B00 XM238B00 MG002110	POWER TRANSFORMER POWER TRANSFORMER POWER TRANSFORMER POWER TRANSFORMER AC CORD	電源トランス 電源トランス 電源トランス 電源トランス 7A VFF 1.8M	J U,C,V B H,W J	14 14 14 14 04
△ △ △ △ △	VE368000 VQ206300 MG002150 VE368500 VM683700	AC CORD AC CORD AC CORD AC CORD AC CORD	3A 125V 1.8M UC 7A 2.0M SPT-2 2.5A 1A250V 1.8M 1A B	電源コード 電源コード 電源コード 電源コード 電源コード	J U,C,V H,W H,W B	03 05 05 05 10



OVERALL ASSEMBLY (総組立)

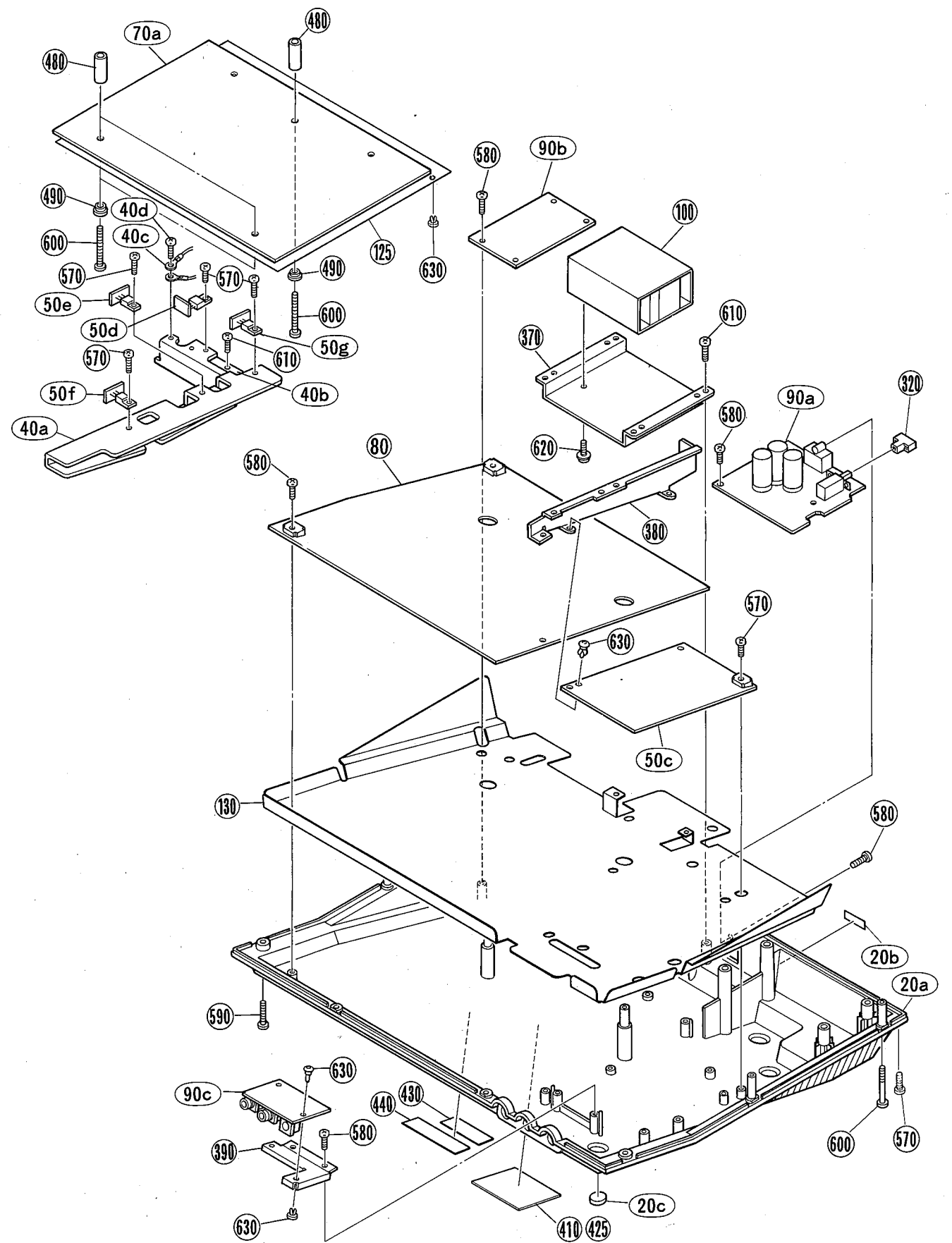
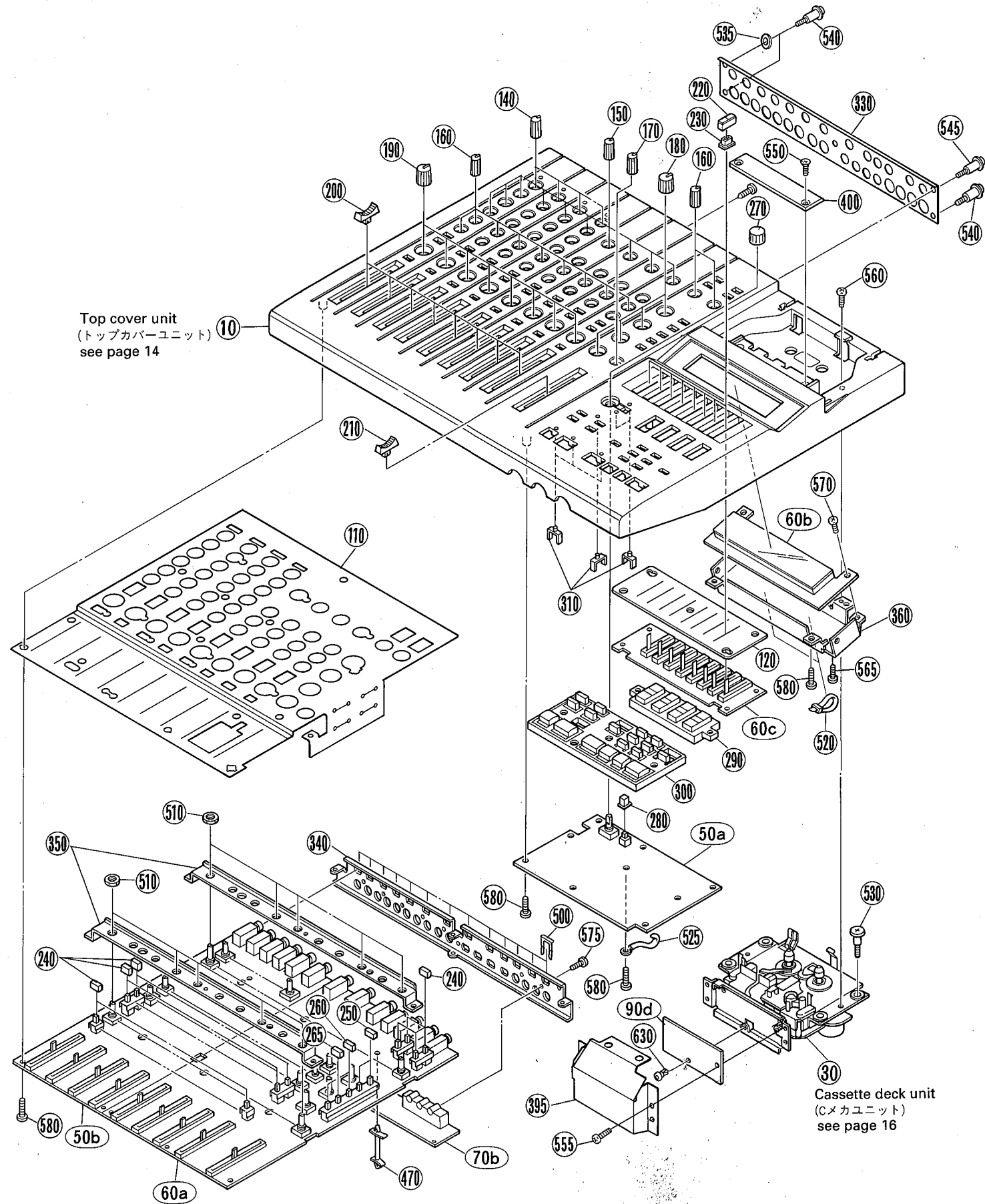



Ref.	Part No.	Description	部品名	Remarks	ランク
10	--	<OVERALL ASSEMBLY> TOP COVER UNIT	<総組立> トップカバーユニット	MT8X	
20	--	BOTTOM COVER ASSEMBLY	ボトムカバーアッセンブリ	(VQ03110)	
* 20a	VP830500	BOTTOM COVER	ボトムカバー	(VP94390)	
* 20b	VQ258600	SHEET	シート		03
			POWER		
* 20c	VQ411300	LEG	レッグ	6pcs	
* 30	VQ024400	CASSETTE DECK UNIT	Cメカユニット		
40	--	RADIATOR UNIT	ラジエータユニット	(VQ03130)	
40a	--	RADIATOR	ラジエータ	(VP83970)	
40b	--	HOLDER, RADIATOR	ホルダー/ラジエータ	(VP94910)	
40c	--	GNG WIRE AEEMBLY	アース線アッセンブリ	(VQ02940)	
40d	EP600830	BIND HEAD TAPPING SCREW-B	3.0X8 FCM3BL バインドヘッドタッピングネジ	7pcs	01
50	--	CIRCUIT BOARD	MIX	(VP99610)	
* 50a	NX812220	CIRCUIT BOARD	MIX 1/7	MIX 1 / 7 シート	
* 50b	NX812230	CIRCUIT BOARD	MIX 2/7	MIX 2 / 7 シート	
* 50c	NX812240	CIRCUIT BOARD	MIX 3/7	MIX 3 / 7 シート	
* 50d	NX812250	CIRCUIT BOARD	MIX 4/7	MIX 4 / 7 シート	
* 50e	NX812260	CIRCUIT BOARD	MIX 5/7	MIX 5 / 7 シート	
* 50f	NX812270	CIRCUIT BOARD	MIX 6/7	MIX 6 / 7 シート	
* 50g	NX812280	CIRCUIT BOARD	MIX 7/7	MIX 7 / 7 シート	
60	--	CIRCUIT BOARD	MAS	(VP99630)	
* 60a	NX812290	CIRCUIT BOARD	MAS 1/3	MAS 1 / 3 シート	
* 60b	NX812300	CIRCUIT BOARD	MAS 2/3	MAS 2 / 3 シート	
* 60c	NX812310	CIRCUIT BOARD	MAS 3/3	MAS 3 / 3 シート	
70	--	CIRCUIT BOARD	DEC	(VP99640)	
* 70a	NX812320	CIRCUIT BOARD	DEC 1/2	DEC 1 / 2 シート	
* 70b	NX812330	CIRCUIT BOARD	DEC 2/2	DEC 2 / 2 シート	
* 80	VP996500	CIRCUIT BOARD	ENC	ENC シート	
90	--	CIRCUIT BOARD	SUB	J (VP99660)	
90	--	CIRCUIT BOARD	SUB	U, C, V (VP99670)	
90	--	CIRCUIT BOARD	SUB	H, B, W (VQ04200)	
* 90a	NX812340	CIRCUIT BOARD	SUB 1/4	SUB 1 / 4 シート	
* 90a	NX812350	CIRCUIT BOARD	SUB 1/4	SUB 1 / 4 シート	J
* 90a	NX812360	CIRCUIT BOARD	SUB 1/4	SUB 1 / 4 シート	U, C, V
* 90b	NX812370	CIRCUIT BOARD	SUB 2/4	SUB 2 / 4 シート	H, B, W
* 90c	NX812380	CIRCUIT BOARD	SUB 3/4	SUB 3 / 4 シート	
* 90d	NX812390	CIRCUIT BOARD	SUB 4/4	SUB 4 / 4 シート	
* 100	XM235B00	POWER TRANSFORMER	電源トランス	J	14
* 100	XM236B00	POWER TRANSFORMER	電源トランス	U, C, V	14
* 100	XM237B00	POWER TRANSFORMER	電源トランス	B	14
* 100	XM238B00	POWER TRANSFORMER	電源トランス	H, W	14
* 110	VP826200	SHIELD PLATE	MIX.	シールドプレート	10
* 120	VP826300	SHIELD PLATE	MONI.	シールドプレート	06
* 125	VQ524100	SHIELD SHEET	DEC	シールドシート	
* 130	VP826400	SHIELD PLATE	BOTTOM	シールドプレート	10
* 140	VP826500	KNOB	GY	ノブ	GAIN
* 150	VP826600	KNOB	GR	ノブ	HI, MID, LOW
* 160	VP826700	KNOB	BE	ノブ	AUX1, AUX2
* 170	VP826800	KNOB	OR	ノブ	MON. / PHO.
* 180	VP826900	KNOB	GY	ノブ	GROUP1-4
* 190	VP827000	KNOB	PK	ノブ	PAN
* 200	VP827500	KNOB	GY	ノブ	FADER1-8
* 210	VP827600	KNOB	OR	ノブ	MASTER
* 220	VP827800	KNOB	OR	スライドツマミ	CUE LEVEL
* 230	VP910000	SPACER		スペーサ	8pcs
* 240	VP827100	KNOB	BL/GY	プッシュツマミ	ASSIGN
* 250	VP827200	KNOB	BL/GR	プッシュツマミ	GROUP
* 260	VP827400	KNOB	BL/RE	プッシュツマミ	STEREO, CUE
* 265	VP827300	KNOB	BL/OR	プッシュツマミ	2TR IN
* 270	VP827900	KNOB		ノブ	PITCH
* 280	VP828000	BUTTON		ボタン	PITCH
* 290	VP828100	BUTTON		ボタン	REC SELECT
* 300	VP828200	BUTTON		ボタン	OPARATION
* 310	VP828400	LENS		レンズ	6pcs
* 320	VL415300	BUTTON		ボタン	POWER
* 330	VP830200	REAR PANEL		リヤパネル	
340	--	SUB CHASSIS	REAR	サブシャーシ	(VP83470)
350	--	STAY		ステー	(VP83490)
360	--	STAY	FL	ステー	(VP83500)
370	--	HOLDER	P.T.	ホルダー	(VP83510)

\*New Parts (新規部品)

Ref.	Part No.	Description	部品名	Remarks	ランク
380	--	HOLDER	ホルダー	(VP83520)	
390	--	HOLDER	ホルダー	(VP83530)	
* 395	VP836100	SHIELD PLATE	シールドプレート		05
* 400	VP835400	PLATE	プレート		08
410	--	LABEL	ラベル	J (VP82910)	
410	--	LABEL	ラベル	U,C,V (VP82930)	
410	--	LABEL	ラベル	H,W (VP82950)	
425	--	LABEL	ラベル	B (VP82970)	
430	--	LABEL	ラベル	U (VA03930)	
			CAUTION	UCHW (VQ26900)	
440	--	LABEL	ラベル	U,C,V (VL20810)	
* 470	VQ031600	SPACER	スペーサ		03
480	VP489300	BUSHING	ブッシュ		03
* 490	VP834800	COLLAR	カラー		03
500	VI549000	U-SHAPED HOLDER	U字金具	17pcs	01
510	VJ388000	HEXAGONAL NUT	9 ZMC2BL	特殊六角ナット	10pcs
520	CB069250	CORD BINDER	BK-1	インシュロックタイ	01
525	CB836200	CORD BINDER	S-70B	束線止め	02
* 530	VQ031900	SCREW	ZMC2-Y	段付ネジ/Cメカ	4pcs
535	ET700060	SPRING WASHER	2 5.0 ZMC2BL	バネ座金	1pc.
* 540	VQ032200	SCREW	FCM3-BL	段付ネジ/リヤ	5pcs
545	EX802760	TOOTHED LOCK WASHER	5.0 ZMC2BL	歯付き座金内歯形	1pc.
* 550	VQ032600	PAN HEAD TAPPING SCREW-P	3.0X8 FNM33G	+皿Pタイト	2pcs
* 555	VQ030800	BIND HEAD TAPPING SCREW-B	3.0X5 ZMC2-Y	+バインドBタイト	3pcs
560	EG330030	BIND HEAD SCREW	3.0X6 FCM3BL	+バインド小ネジ	2pcs
565	VA078100	BIND HEAD TAPPING SCREW-S	3.0X5 ZMC2Y	+バインドSタイト	1pc.
570	EP600830	BIND HEAD TAPPING SCREW-B	3.0X8 FCM3BL	+バインドBタイト	15pcs
575	EZ000620	BONDING HEAD TAPPING SCREW	3.0X8 FCM3BL	ボンディングBタイト	7pcs
580	EP600910	BIND HEAD TAPPING SCREW-P	3.0X10 FCM3BL	+バインドPタイト	50pcs
* 590	VD016800	BIND HEAD TAPPING SCREW-P	3.0X16 FCM3BL	+バインドPタイト	4pcs
* 600	VQ032700	BIND HEAD TAPPING SCREW-P	3.0X35 FCM3BL	+バインドPタイト	9pcs
* 610	VB744600	BIND HEAD TAPPING SCREW-P	4.0X12 FCM3BL	+バインドPタイト	7pcs
* 620	VE460600	SELF TAPPING SCREW-S	4.0X8 FNM3-BL	カップSタイト	4pcs
630	CB605620	PLASTIC RIVET		プラリベット	8pcs
640	--	GND WIRE ASSEMBLY		アース線 Assy	(VQ02940)
650	--	PH CONNECTOR ASSEMBLY		PHコネクター-Assy	(VQ02950)
660	--	PH CONNECTOR ASSEMBLY		PHコネクター-Assy	(VQ02960)
670	--	PH CONNECTOR ASSEMBLY		PHコネクター-Assy	(VQ02970)
680	--	PH CONNECTOR ASSEMBLY		PHコネクター-Assy	(VQ02980)
690	--	PH CONNECTOR ASSEMBLY		PHコネクター-Assy	(VQ02990)
700	--	PH CONNECTOR ASSEMBLY		PHコネクター-Assy	(VQ03000)
710	--	PH CONNECTOR ASSEMBLY		PHコネクター-Assy	(VQ03010)
720	--	PH CONNECTOR ASSEMBLY		PHコネクター-Assy	(VQ03020)

MT8X

■ TOP COVER UNIT (トップカバーユニット)

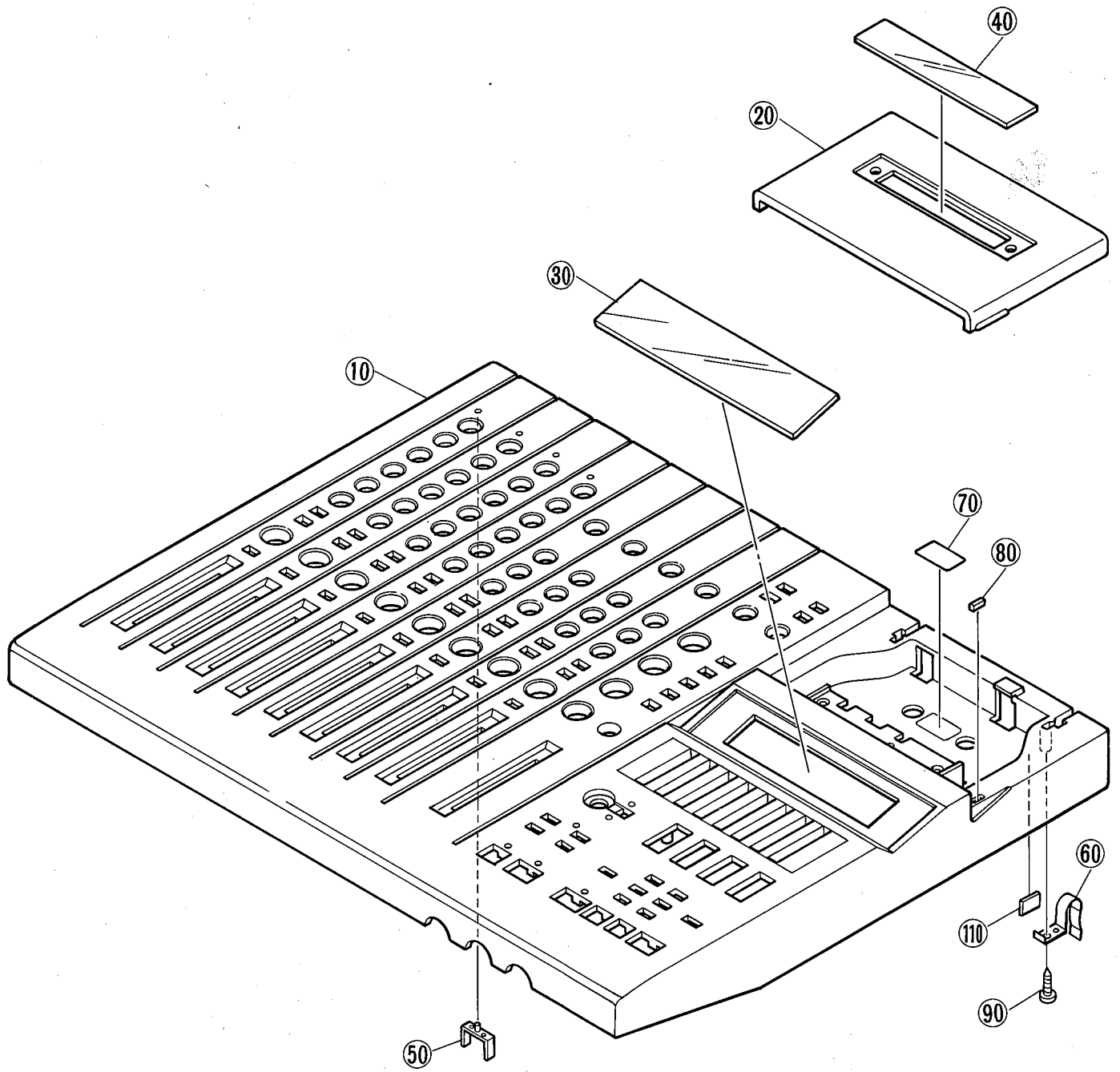

MT8X



■ CASSETTE DECK UNIT (Cメカユニット)

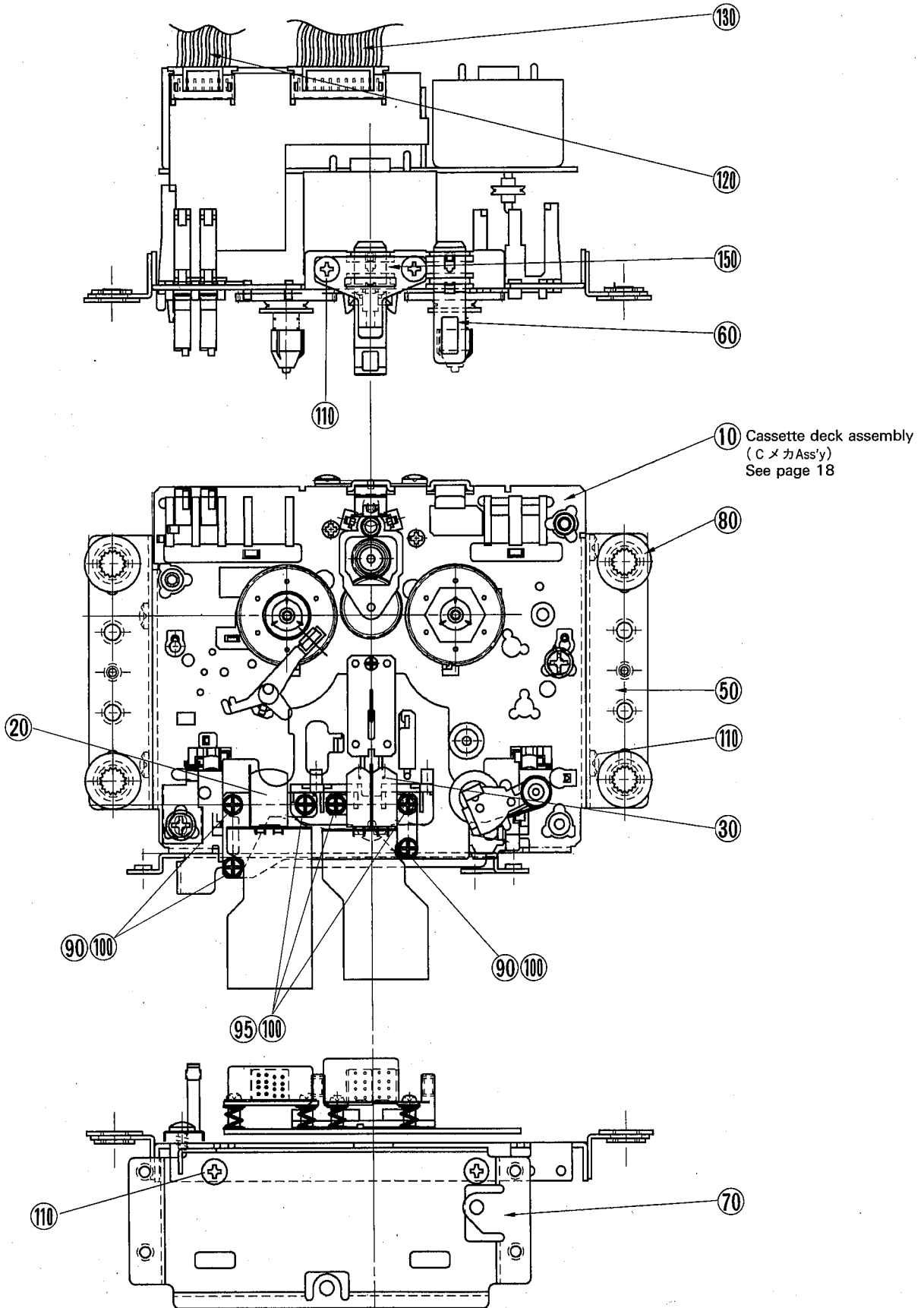



■ CASSETTE DECK ASSEMBLY (CメカAss'y)

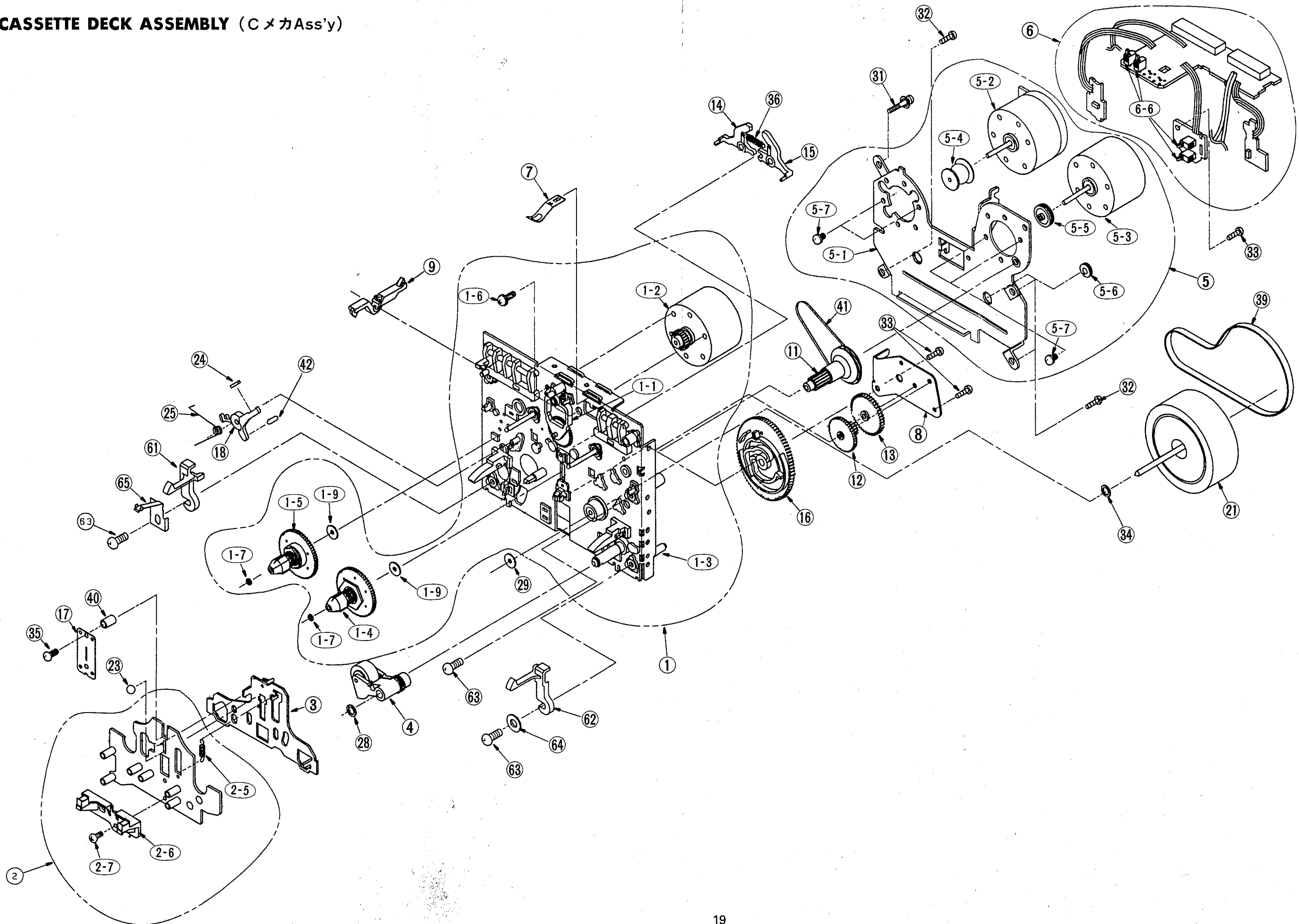

MT8X





**ACCESSORIES (付属品)**

Ref.	Part No.	Description	部品名	Remarks	ランク
	--	<ACCESSORIES> COTTON SWAB		MT8X (VR09440) (VQ57800)	
⚠	MG002110	PLANNING SHEET	MT8X		
⚠	VE368000	AC CORD	7A VFF 1.8M	電源コード	J 04
		AC CORD	3A 125V 1.8M	電源コード	J 03
⚠	VQ206300	AC CORD	UC 7A 2.0M SPT-2	電源コード	U,C,V 05
⚠	MG002150	AC CORD	2.5A	電源コード	H,W 05
⚠	VE368500	AC CORD	1A250V 1.8M	電源コード	H,W 05
⚠	VM683700	AC CORD	1A B	電源コード	B 10

\*New Parts (新規部品)

ランク:Japan only

**SERVICE PARTS (サービスパーツ)**

Ref.	Part No.	Description	部品名	Remarks	ランク
	TX800500	<SERVICE PARTS> HEAD ALIGNMENT JIG SET	MT8X	MT8X	
* 1a	--	CHECK BAR		ヘッドアライメントジグセット	
* b	--	DIAL-TYPE TILT GAUGE		チェックバー	HEAD HEIGHT
* 1c	--	DIAL TYPE TILT GAUGE		ダイヤルチルトゲージ	E HEAD TILT
				ダイヤルチルトゲージ	R/P HEAD TILT
* 1d	--	GAUGE PLATE		ゲージプレート	HEAD ALIGNMENT
* 1e	--	90° /91° ANGLE JIG		90° /91° 校正治具	HEAD ALIGNMENT
* 2	TX911100	MIRROR TAPE	12um	ミラーテープ	SONY MC112C 16
* 3	TX800370	MIRROR LEADER TAPE	MT8X	ミラーリーダーテープ	A·BEX SCC-2219 25
* 4	TX911550	WOW & FLUTTER TAPE	9.5cm/s 3kHz 0dB	ワウフラッターテープ	A·BEX TCW-211 21
* 5	TX800460	AZIMUTH TAPE	4.8cm/s6.3kHz-10dB	アジマステープ	A·BEX TCC-151 18
* 6	TX911840	LEVEL TAPE	4.8cm/s315kHz -4dB	レベルテープ	A·BEX TCC-121 19
* 7	TX911750	REFERENCE TAPE	SA-C60 (Cr02) Type II	リファレンステープ	TDK AC-513 08
* 8	VB712400	EXTENSION CABLE	5P B&C 300mm	延長ケーブル	PANEL - BOTTOM 02
* 9	VB714100	EXTENSION CABLE	6P B&C 300mm	延長ケーブル	PANEL - BOTTOM 03
* 10	VB717700	EXTENSION CABLE	8P B&C 400mm	延長ケーブル	PANEL - BOTTOM 03
* 11	VB710500	EXTENSION CABLE	4P B&C 400mm	延長ケーブル	FL DIS. - POWER 02
* 12	VB709200	EXTENSION CABLE	3P B&C 400mm	延長ケーブル	HP.JACK - MAS 02
* 13	NX812880	ERASE HEAD A'SSY	MT8X	EヘッドA s s y	
* 13a	VQ874800	ERASE HEAD		消去ヘッド	1pc.
* 13b	VQ875900	SCREW	HEAD	セレクションネジ	3pcs
* 13c	VQ017500	SPRING	HEAD	スプリング	
* 13d	VR164700	SPRING	HEAD A	スプリング	1pc.
* 14	NX812870	REC/PLAYBACK HEAD A'SSY	MT8X	R/PヘッドA s s y	
* 14a	VQ874000	REC/PLAYBACK HEAD		録音/再生ヘッド	1pc.
* 14b	VQ875900	SCREW	HEAD	セレクションネジ	3pcs
* 14c	VQ017500	SPRING	HEAD	スプリング	
* 14d	VR164700	SPRING	HEAD A	スプリング	2pcs

\*New Parts (新規部品)

ランク:Japan only