

TONE GENERATOR

ML128

SERVICE MANUAL

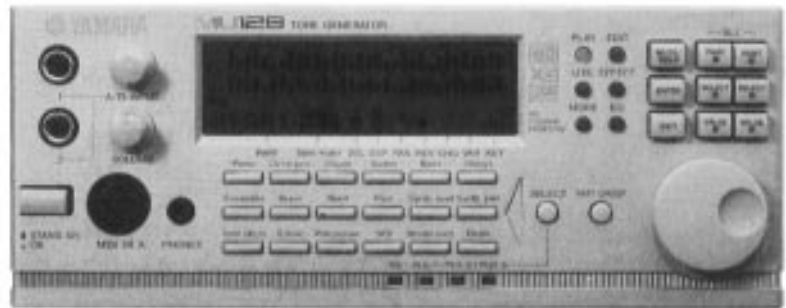

■ CONTENTS

PANEL LAYOUT	3
SPECIFICATIONS	4
CIRCUIT BOARD LAYOUT	6
WIRING & BLOCK DIAGRAM	7
DISASSEMBLY PROCEDURE	8
CIRCUIT BOARDS	11
LSI PIN DESCRIPTION	13
IC BLOCK DIAGRAM	15
TEST PROGRAM	18
INITIALIZE	26
ERROR MESSAGES	28
CONNECTING CABLES	29
MIDI IMPLEMENTATION CHART	30
PARTS LIST	
OVERALL CIRCUIT DIAGRAM	

IMPORTANT NOTICE

This manual has been provided for the use of authorized Yamaha Retailers and their service personnel. It has been assumed that basic service procedures inherent to the industry, and more specifically Yamaha Products, are already known and understood by the users, and have therefore not been restated.

WARNING: Failure to follow appropriate service and safety procedures when servicing this product may result in personal injury, destruction of expensive components and failure of the product to perform as specified. For these reasons, we advise all Yamaha product owners that all service required should be performed by an authorized Yamaha Retailer or the appointed service representative.

IMPORTANT: This presentation or sale of this manual to any individual or firm does not constitute authorization, certification, recognition of any applicable technical capabilities, or establish a principal-agent relationship of any form.

The data provided is believed to be accurate and applicable to the unit(s) indicated on the cover. The research engineering, and service departments of Yamaha are continually striving to improve Yamaha products. Modifications are, therefore, inevitable and changes in specification are subject to change without notice or obligation to retrofit. Should any discrepancy appear to exist, please contact the distributor's Service Division.

WARNING: Static discharges can destroy expensive components. Discharge any static electricity you may have accumulated by grounding yourself to the ground buss in the unit (heavy gauge black wires connect to this buss).

IMPORTANT: Turn the unit OFF during disassembly and parts replacement. Recheck all work before you apply power to the unit.

WARNING: CHEMICAL CONTENT NOTICE!

The solder used in the production of this product contains LEAD. In addition, other electrical / electronic and / or plastic (where applicable) components may also contain traces of chemicals found by the California Health and Welfare Agency (and possibly other entities) to cause cancer and / or birth defects or other reproductive harm.

DO NOT PLACE SOLDER, ELECTRICAL / ELECTRONIC OR PLASTIC COMPONENTS IN YOUR MOUTH FOR ANY REASON WHAT SO EVER!

Avoid prolonged, unprotected contact between solder and your skin! When soldering, do not inhale solder fumes or expose eyes to solder / flux vapor!

If you come in contact with solder or components located inside the enclosure of this product, wash your hands before handling food.

LITHIUM BATTERY HANDLING

This product uses a lithium battery for memory back-up.

WARNING: Lithium batteries are dangerous because they can be exploded by improper handling. Observe the following precautions when handling or replacing lithium batteries.

- Leave lithium battery replacement to qualified service personnel.
- Always replace with batteries of the same type.
- When installing on the PC board by soldering, solder using the connection terminals provided on the battery cells. Never solder directly to the cells. Perform the soldering as quickly as possible.
- Never reverse the battery polarities when installing.
- Do not short the batteries.
- Do not attempt to recharge these batteries.
- Do not disassemble the batteries.
- Never heat batteries or throw them into fire.

ADVARSEL!

Lithiumbatteri—Eksplussionsfare ved fejlagtig håndtering. Udskiftning må kun ske med batteri af samme fabrikat og type. Levér det brugte batteri tilbage til leverandøren.

WARNING

Explosionsfara vid felaktigt batteribyte. Använd samma batterityp eller en ekvivalent typ som rekommenderas av apparattillverkaren. Kassera använt batteri enligt fabrikantens instruktion.

VAROITUS

Paristo voi räjähtää, jos se on virheellisesti asennettu. Vaihda paristo ainoastaan laitevalmistajan suosittelemaan tyyppiin. Hävitä käytetty paristo valmistajan ohjeiden mukaisesti.

The following information complies with Dutch Official Gazette 1995. 45; ESSENTIALS OF ORDER ON THE COLLECTION OF BATTERIES.

- Please refer to the disassembly procedure for the removal of Back-up Battery.
- Leest u voor het verwijderen van de backup batterij deze beschrijving.

■ WARNING

Components having special characteristics are marked  and must be replaced with parts having specification equal to those originally installed.

■ PANEL LAYOUT

● Front Panel

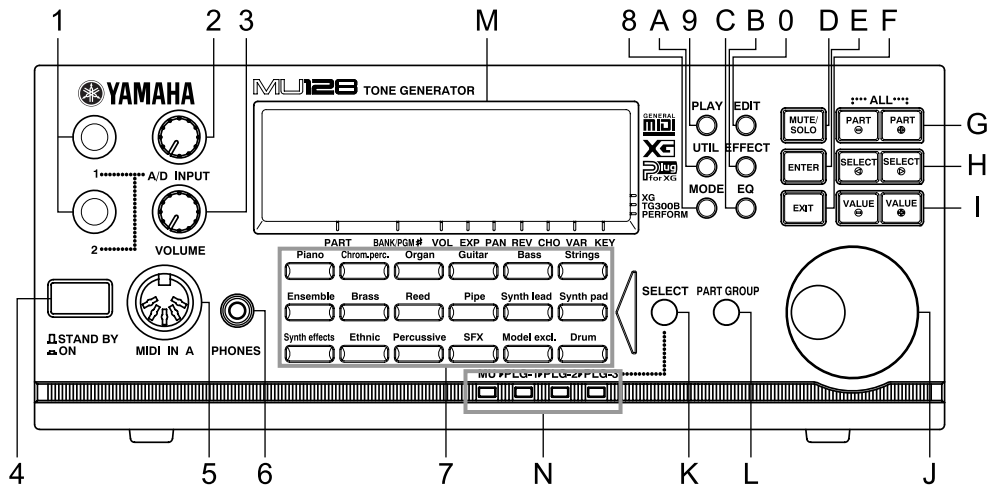

- | | |
|--------------------------------------|------------------------------------|
| 1. A/D INPUT1,2 jacks | A. UTIL (UTILITY) button |
| 2. A/D INPUT VOLUME control | B. EFFECT button |
| 3. VOLUME control | C. EQ button |
| 4. STAND BY/ON switch (Power Switch) | D. MUTE/SOLO button |
| 5. MIDI IN A (front panel) | E. ENTER button |
| 6. PHONES jack | F. EXIT button |
| 7. Voice Category buttons | G. PART \ominus/\oplus buttons |
| 8. MODE button | H. SELECT \ominus/\oplus buttons |
| 9. PLAY button | I. VALUE \ominus/\oplus buttons |
| 0. EDIT button | J. Data dial |
| | K. SELECT button |
| | L. PART GROUP button |
| | M. Display |
| | N. LEDs |

● Rear Panel

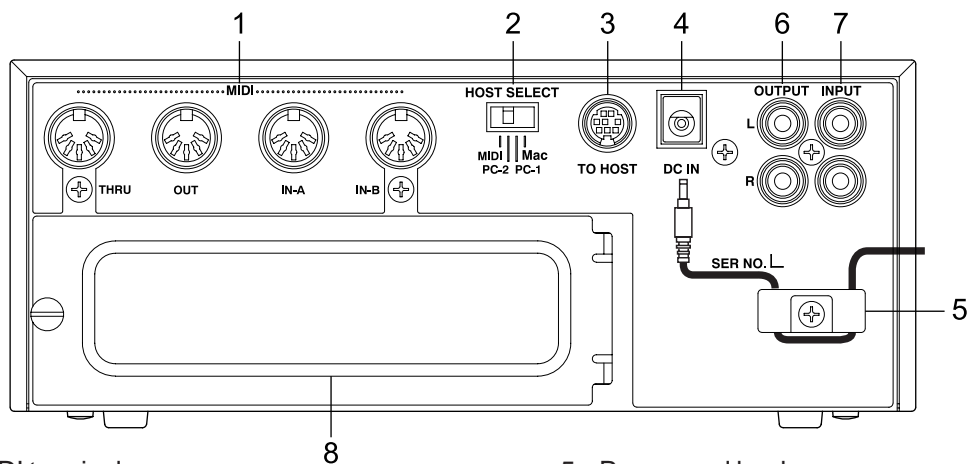

- | | |
|-----------------------|-----------------------------------|
| 1. MIDI terminals | 5. Power cord hook |
| 2. HOST SELECT switch | 6. OUTPUT L,R jacks (Left,Right) |
| 3. TO HOST terminals | 7. INPUT L,R jacks (Left,Right) |
| 4. DC IN terminals | 8. XG Plug-in board expansion bay |

■ SPECIFICATIONS

1. FUNCTION

Tone generation Method	AWM2 (Advanced Wave Memory 2)
Maximum Simultaneous Polyphony	128-note
Sound Module Modes	XG, TG300B and Performance
Multi-timbral Capacity	64-part (on 64 MIDI channels; with dynamic Voice allocation)
Effects	Seven sections of multi-effects: Reverb(12 Types), Chorus(14 Types),Variation (70 Types), Insertion 1/2 (43 Types),Multi EQ(4 Types), and Part EQ (1 Type)
Interface	Direct connection to host computer port (RS-232C,RS-422); MIDI terminals allow connection to MIDI sequencer or MIDI controller.

2. COMPONENT

Internal Voice	Normal Voice	Total	1342
		XG	1099
		TG300B	664
	Drum Voice	Total	47
		XG	37
		TG300B	10
Performance Programs	Up to four Voices plus all effect settings can be memorized to a Performance.		
	Preset Programs		100
	User Programs		100
Effects	Reverb		12 Types
	Chorus		14 Types
	Variation		70 Types
	Insertion 1/2		43 Types
	Multi EQ		5 Types

3. DISPLAY

LCD	Custom back-lit LCD
LED	10

4. CONTROLS

[PLAY]	[UTIL]	[MODE]
[EDIT]	[EFFECT]	[EQ]
[MUTE/SOLO]	[ENTER]	[EXIT]
[PART \ominus]	[PART \oplus]	
[SELECT \blacktriangleleft]	[SELECT \blacktriangleright]	
[VALUE \ominus]	[VALUE \oplus]	
HOST SELECT		
STAND BY/ON		
VOLUME		
A/D INPUT VOLUME		
[SELECT]	[PART GROUP]	
[Piano][Chrom.perc.][Organ][Guitar][Bass][Strings][Ensemble][Brass][Reed][Pipe][Synth lead]		
[Synth pad][Synth effects][Ethnic][Percussive][SFX][Model excl.][Drum]		

5. JACKS and TERMINALS

Front panel:PHONES jack (stereo mini pin), A/D INPUT 1, 2, jacks (1/4" mono), MIDI IN-A terminal

Rear panel:INPUT L, R jacks (Left,Right), OUTPUT L, R jacks (Left,Right), DC IN jack, TO HOST terminal, HOST SELECT switch, MIDI IN-A/B, MIDI OUT, and MIDI THRU terminals, XG Plug-in board expansion bay

6. POWER SUPPLY

Yamaha PA-6 AC Adaptor (included)

7. DIMENSIONS (W X D X H)

219.5(W)X229.5(D)X91.1(H)[mm] (8-5/8"X9"X3-1/2")

8. WEIGHT

1.9Kg(4 lbs., 3 oz.)

9. SUPPLIED ACCESSORIES

Owner's Manual, Sound List Book & MIDI Data Book

AC Adaptor (PA-6)

CD-ROM(XG tools)

10. OPTIONAL ACCESSORIES

XG Plug-in board

Virtual Acoustic Plug-in Board PLG100-VL

Vocal Harmony Plug-in Board PLG100-VH

Advanced DX/TX Plug-in Board PLG100-DX

11. OUTPUT LEVEL

Refer to the TEST 14 &15 of the "TEST PROGRAM" on page 22 & 23.

CIRCUIT BOARD LAYOUT

- Front View

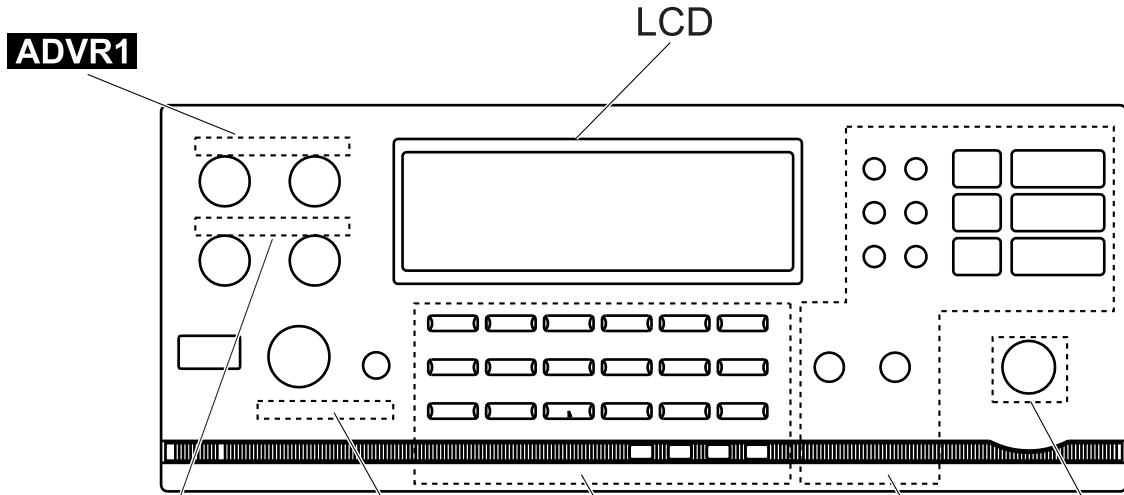

- Bottom View

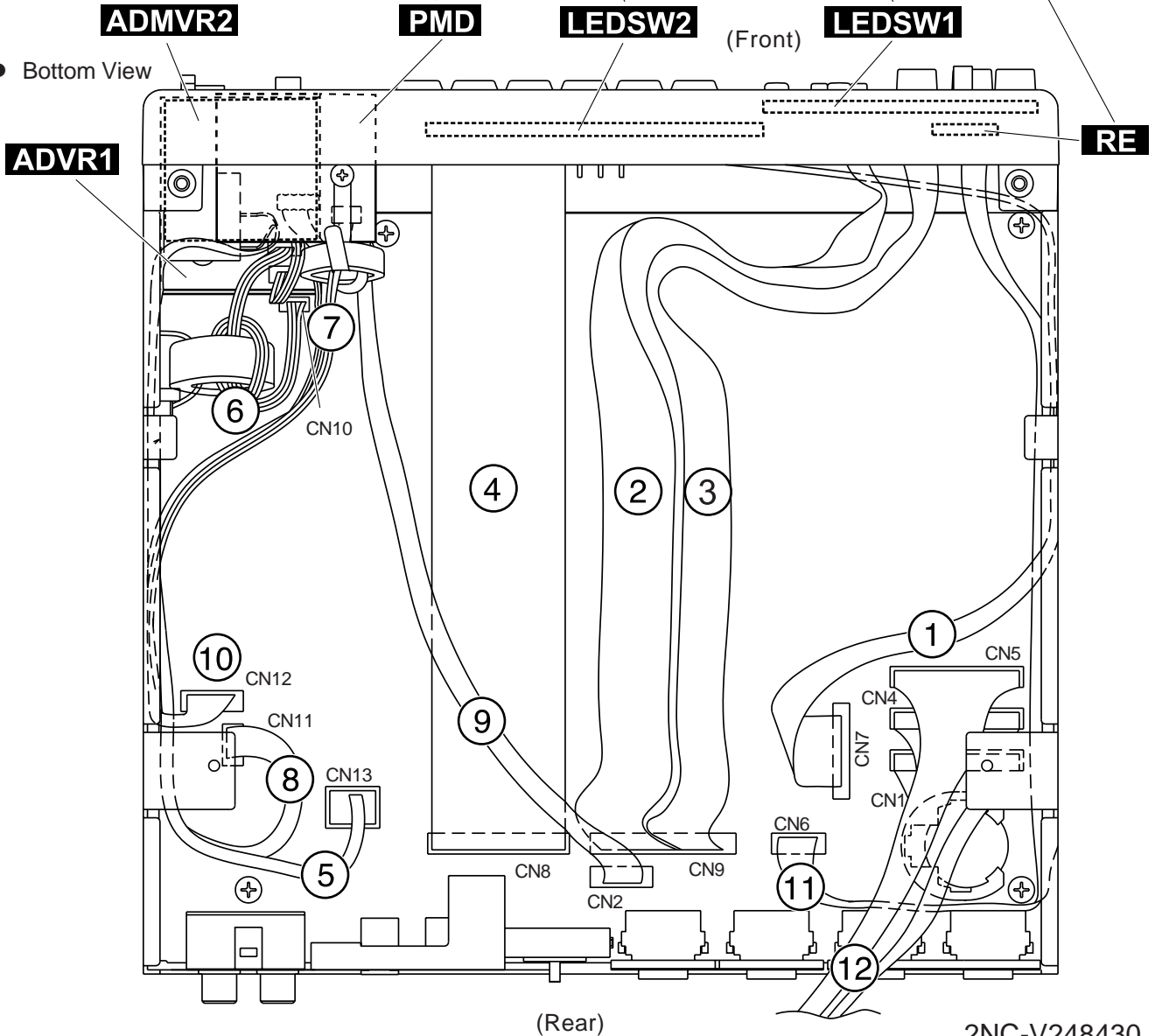

WIRING

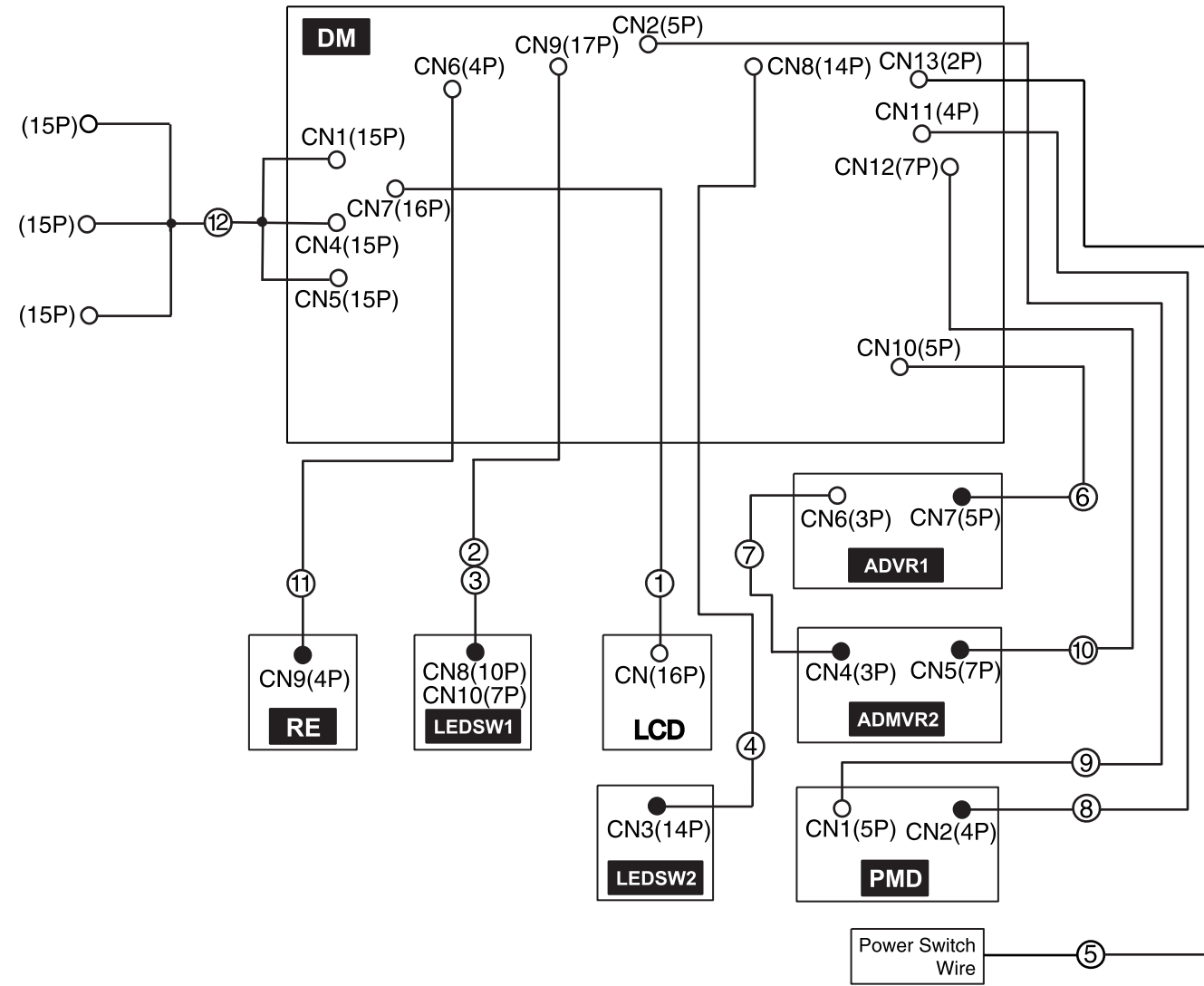

● indicates board-in connectors.
○ indicates connectors in general.

REF. NO.	PART NO.	WIRE NO.	REMARKS	DESTINATION	SPARE PARTS	P/L
①	VT020800	LCD	16P	DM-CN7	LCD	○ P.5 (250)
②	V234440	SW1	10P/L300	DM-CN9	LED SW1-CN8	× PNJ (20)
③	V234450	SW2	7P/L300	DM-CN9	LED SW1-CN10	× PNJ (30)
④	V234520	SW3	14P/L250	DM-CN8	LED SW2-CN3	× PNJ (40)
⑤	V2482700	PSW	2P	DM-CN13	P.SW	○
⑥	V234410	AD IN	5P/L100	DM-CN10	ADVR1-CN7	× PNJ (CN7)
⑦	V234390	AD	3P/L100	ADVR1-CN6	ADMVR2-CN4	× PNJ (CN4)
⑧	V234470	HP	4P/L250	DM-CN11	PMD-CN2	× PNJ (CN2)
⑨	V234460	MIDI	5P/L250	DM-CN2	PMD-CN1	× PNJ (60)
⑩	V234420	VR	7P/L180	DM-CN12	ADMVR2-CN5	× PNJ (CN5)
⑪	V234430	RE	4P/L300	DM-CN6	RE-CN9	× PNJ (70)
⑫	V2927700	PSR	15PX3/L300	DM-CN1,4,5	Plug-in board	○ DM (50)

NOTE: REF. NO. is indicated in CIRCUIT BOARD LAYOUT figures in page 6.
REF NO. 2-4 and NO. 6-11 are not available as spare parts, and REF NO.1, 5 and 12 are available as spare parts.
P/L indicates the reference page or the seat name and the location of each parts list.

BLOCK DIAGRAM

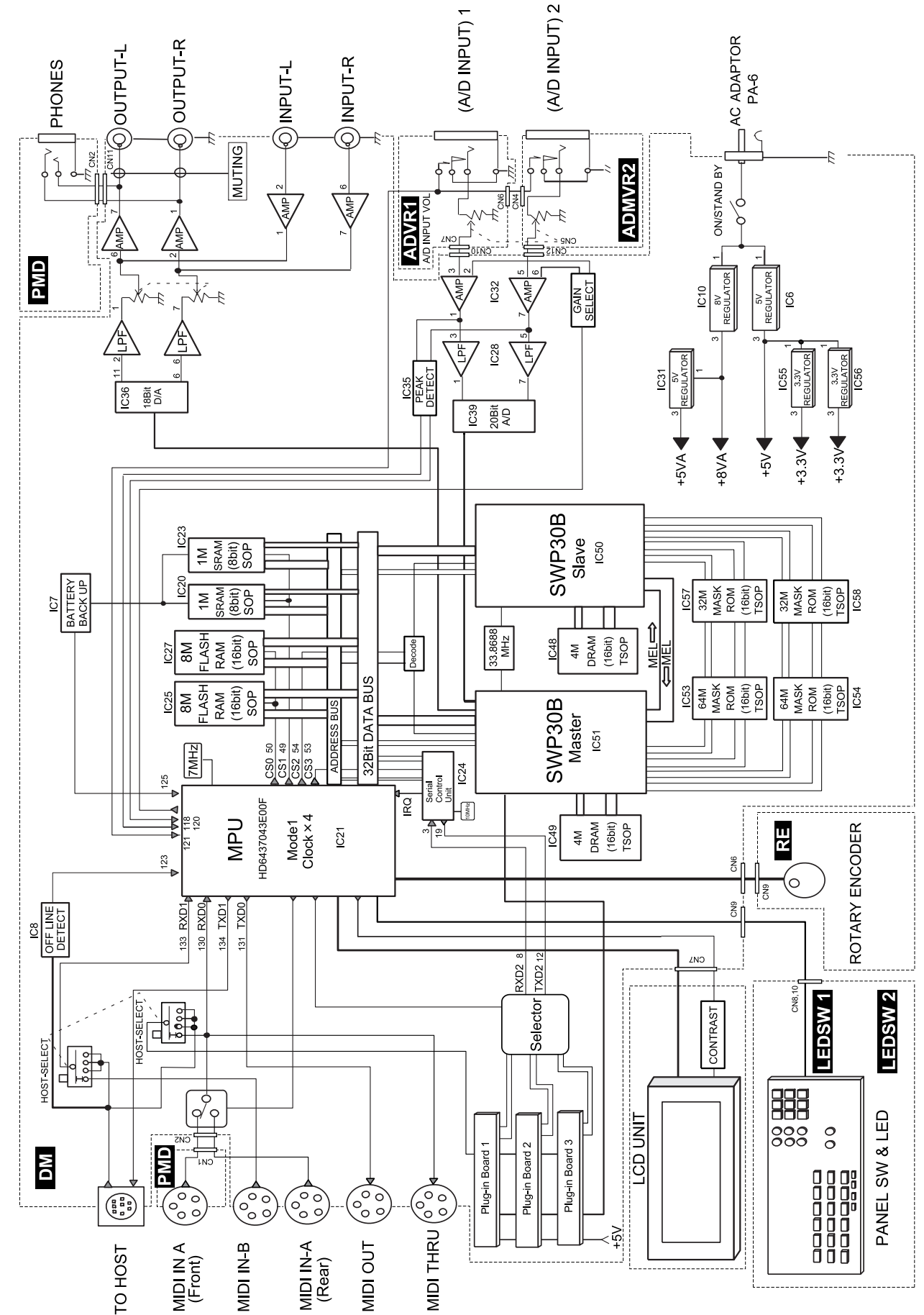

DISASSEMBLY PROCEDURE

1. Bottom Assembly

- 1-1 Remove the four (4) screws marked [60], the two (2) screws marked [70] and the two (2) screws marked [80]. The bottom assembly can then be removed. (Fig. 1)

* When assembling the bottom assembly, tighten the screws in the order shown in the figure below.

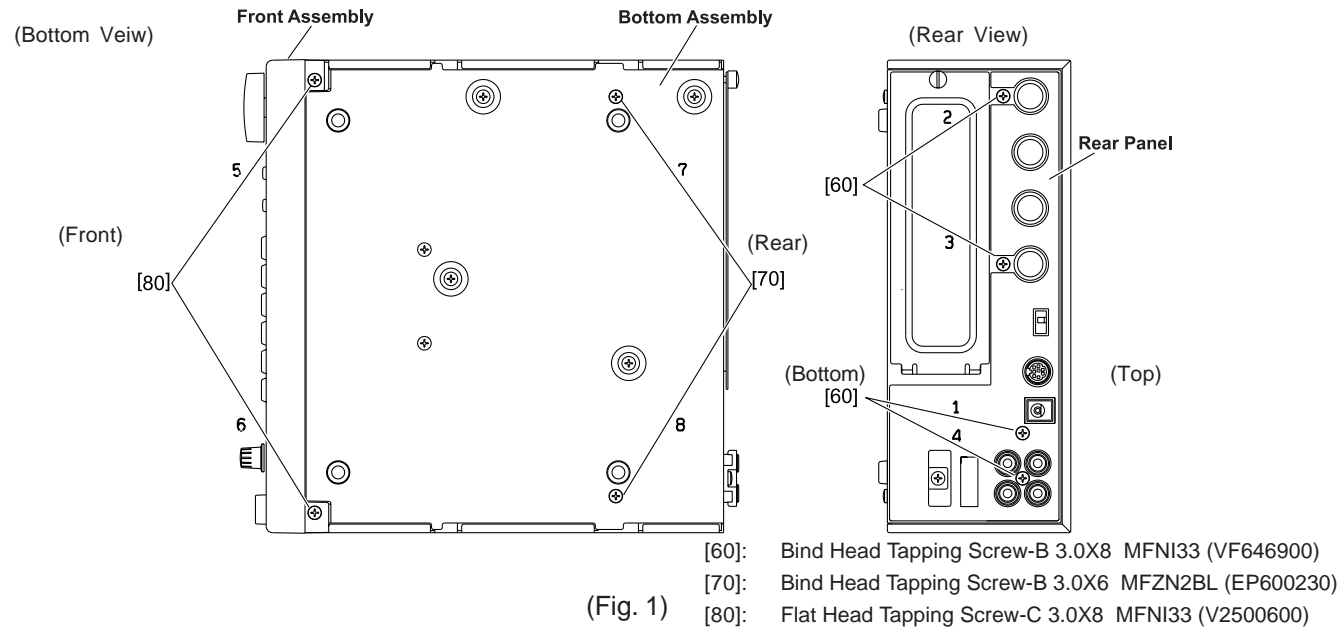

(Fig. 1)

2. Top Assembly

- 2-1 Remove the bottom assembly. (See Procedure 1.)
 2-2 Remove the A/D INPUT knob.
 2-3 Remove the two (2) screws marked [30]. The Top Assembly can then be removed. (Fig. 2)

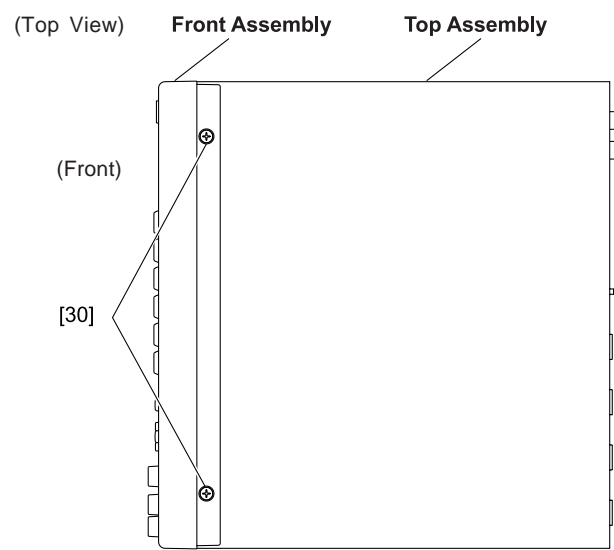

[30]: Flat Head Tapping Screw-C 3.0X8 MFNI33 (V2500600)
 (Fig. 2)

3. DM Circuit Board and ADVR1 Circuit Board

- 3-1 Remove the bottom assembly. (See Procedure 1.)
 3-2 Remove the Top assembly. (See Procedure 2.)
 3-3 Remove the four(4) screws marked [T40a]. The DM circuit board can then be removed. (Fig. 3)
 3-4 Remove the two(2) screws marked [T40b]. The ADVR1 circuit board can then be removed. (Fig. 3)
 3-5 Melt the solder on the four(4) points marked [A] in figure 6-2 and remove the rear shield. (Fig. 3)

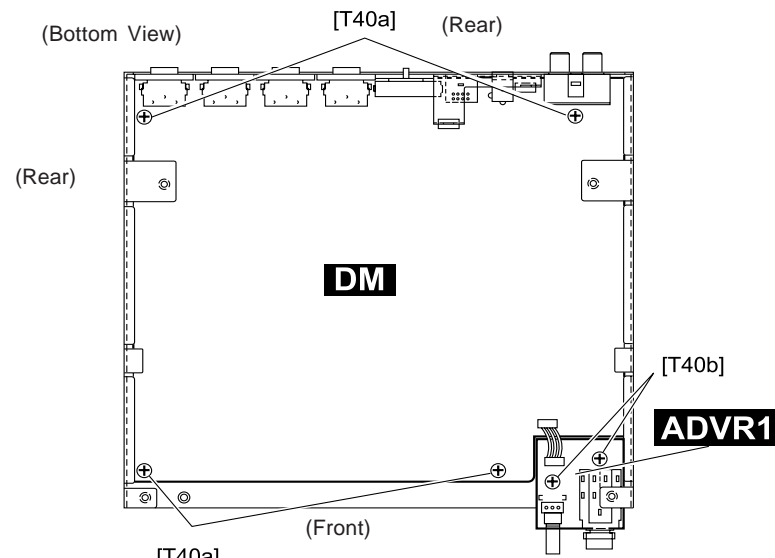

[T40a]: Bind Head Tapping Screw-B 3.0X6 MFZN2BL (EP600230)
 (Fig. 3)

4. LEDSW1 Circuit Board and LEDSW2 Circuit Board and LCD and RE Circuit Board

- 4-1 Remove the bottom assembly. (See Procedure 1.)
 4-2 Remove the two (2) screws marked [30]. The front assembly can then be removed. (Fig. 2)
 4-3 Remove the five (5) screws marked [100]. The LEDSW1 circuit board can then be removed. (Fig. 4)
 4-4 Remove the four (4) screws marked [80A]. The LEDSW2 circuit board can then be removed. (Fig. 4)
 4-5 Remove the four (4) screws marked [80B]. The LED can then be removed. (Fig. 4)
 4-6 Remove the two (2) screws marked [120] and the encoder knob. The RE circuit board can then be removed. (Fig. 4)

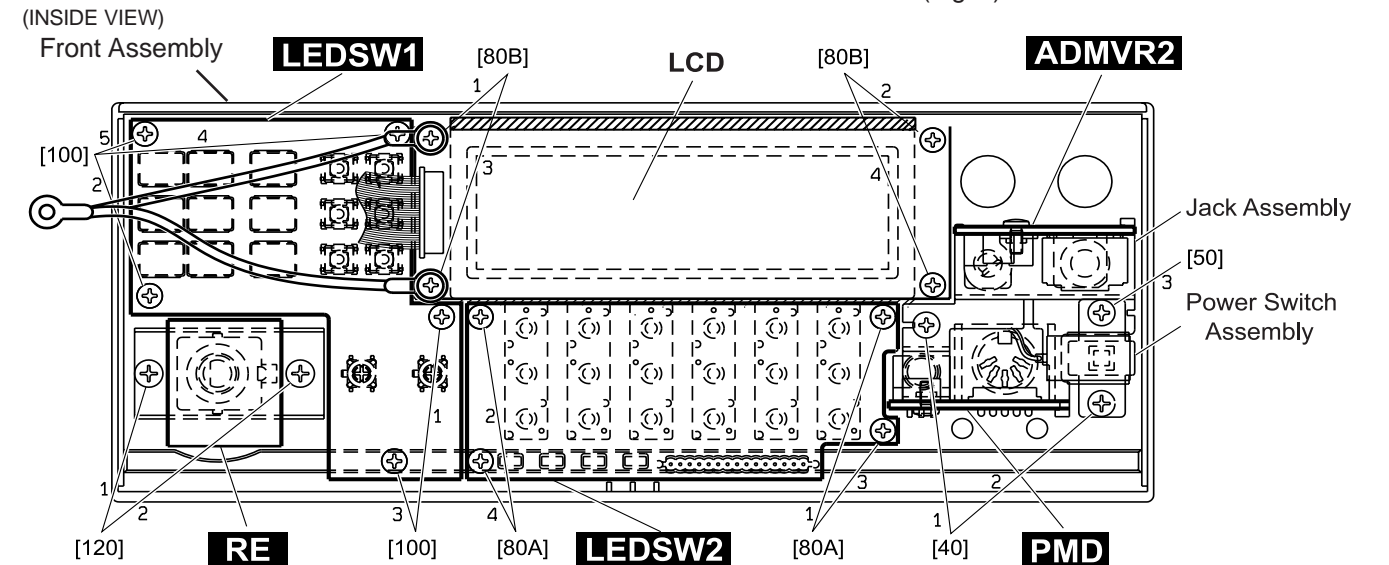

[40]: Bind Head Tapping Screw-B 3.0X6 MFZN2BL (EP600230) [100]: Bind Head Tapping Screw-B 2.6X6 MFZN2Y (VC069600)
 [50]: Bind Head Tapping Screw-B 2.6X10 MFZN2Y (VD791000) [120]: Bind Head Tapping Screw-B 3.0X6 MFZN2BL (EP600230)
 [80]: Bind Head Tapping Screw-B 2.6X10 MFZN2Y (VD791000) (Fig. 4)

5. PSW Connector Assembly, PMD Circuit Board and ADMVR2 Circuit Board

- 5-1 Remove the bottom assembly. (See Procedure 1.)
 5-2 Remove the front assembly. (See Procedure 4-2.)
 5-3 Remove the volume knob.
 5-4 Remove the two (2) screws marked [40] and the screw marked [50]. The PSW connector assembly and the JACK assembly can then be removed. (Fig. 4)
 5-5 Remove the two (2) screws marked [20d]. The PMD circuit board, the ADMVR2 circuit board and the front shield can then be removed. (Fig. 5)
 5-6 Remove the front shield marked [50] from the PMD circuit board. (Fig. 5)

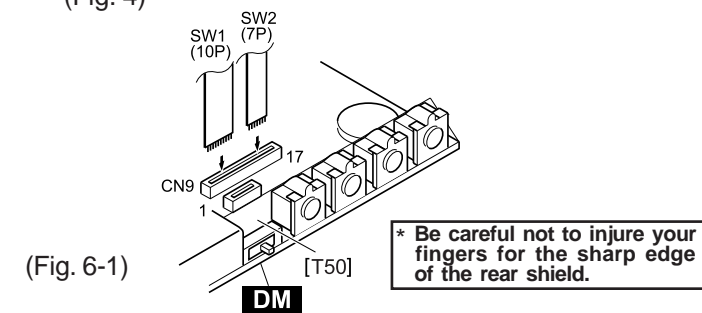

* Connection of the cable bundles to the CN9 of the DM circuit board is shown in Fig 6-1.

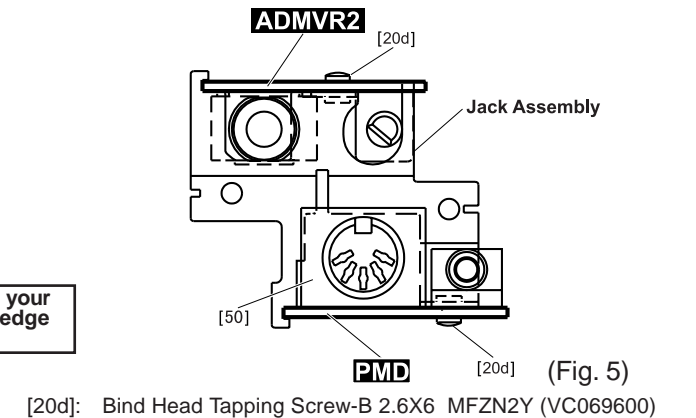

[20d]: Bind Head Tapping Screw-B 2.6X6 MFZN2Y (VC069600)
 (Fig. 5)

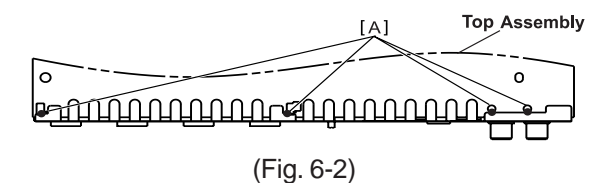
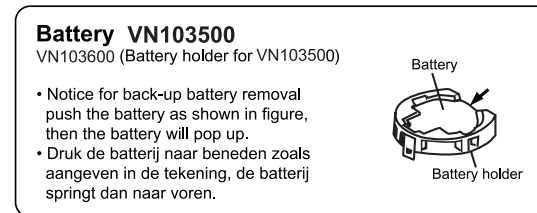

(Fig. 6-2)

● Installing the Plug-in Board

1. Turn off the power switches of the MU128 and any connected devices. Also remove all connected cables from the MU128, and unplug the power adaptor.
 - When installing/uninstalling an XG Plug-in board, make sure to let the installed board(s) cool down for a while after turning the power switch off.
 - Make sure to unplug the power adaptor from the MU128 before installing/uninstalling the board. Attempting to install/uninstall the board while power adaptor is still connected may damage the board and/or the MU128.

2. Remove the large screw from the expansion bay cover on the rear panel, and remove the cover (as shown below).
 - Since the screw is tightened securely at the factory, you may need to use a screwdriver to loosen it at first, so that it can be fastened and removed simply by using your fingers.

3. Remove the XG Plug-in board from its protective packaging.

Before handling the XG Plug-in board, make sure to discharge any static electricity from your body or clothes by touching a grounded metal surface. Also be careful not to touch any parts or connectors of the board.

4. Insert the board along the guide rails about two-thirds of the way inside the MU128, with the connector side face down and toward you (as shown below). Make sure to insert it slowly and gently, keeping the edges of the board inside the proper guide rails, as shown in the illustration. With keeping the board in place, plug in one of the three cable connectors to the connector on the XG Plug-in board. Any one of the cable connectors can be used.

The logical board assignment in the MU128 (PLG-1 -3) is set automatically to the following order: 1) PLG100-VL, 2) PLG100-DX, 3) PLG100-VH.

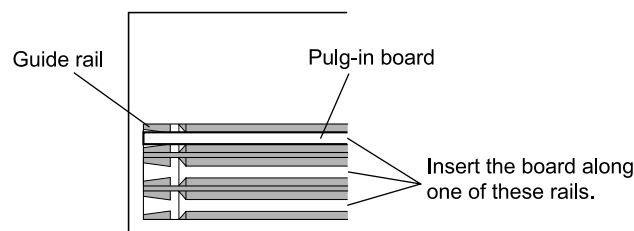

Carefully plug in the cable connector to the XG Plug-in connector as shown below, matching the two notches on the cable connector with the sockets on the board. Firmly press the connectors together until they lock.

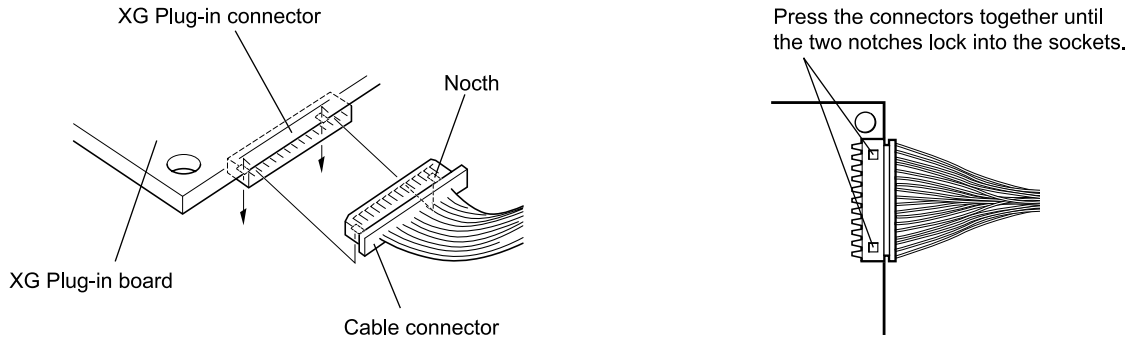

5. Slowly and gently insert the rest of the XG Plug-in board into the expansion bay.

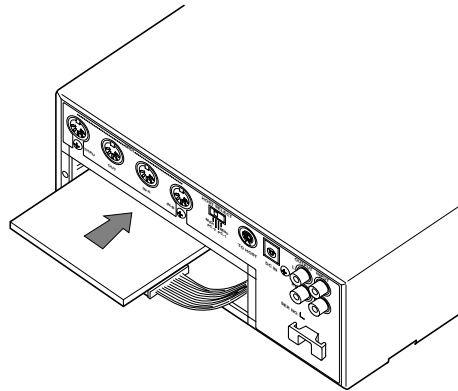

6. Replace the cover with the screw you removed in step #2.

Latch the hinges on the cover to the inside of the expansion bay and secure the cover to the rear panel with the screw. Press the cover down with your hand for the sponge cushion on the back of the cover to hold the installed board(s) securely in place.

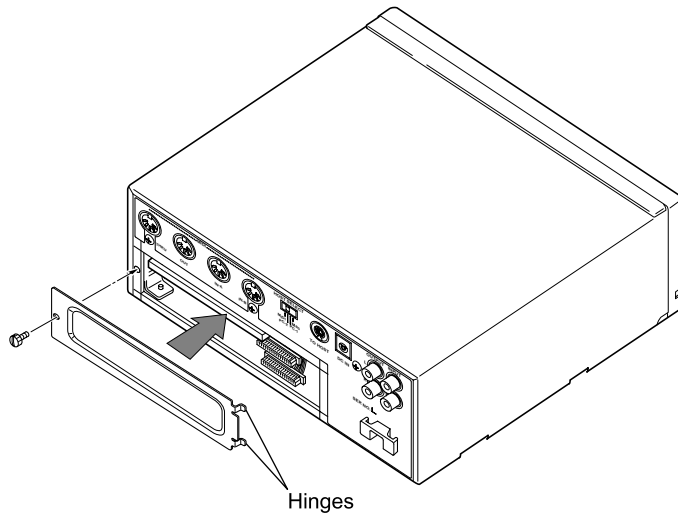

■ CIRCUIT BOARDS

• DM Circuit Board

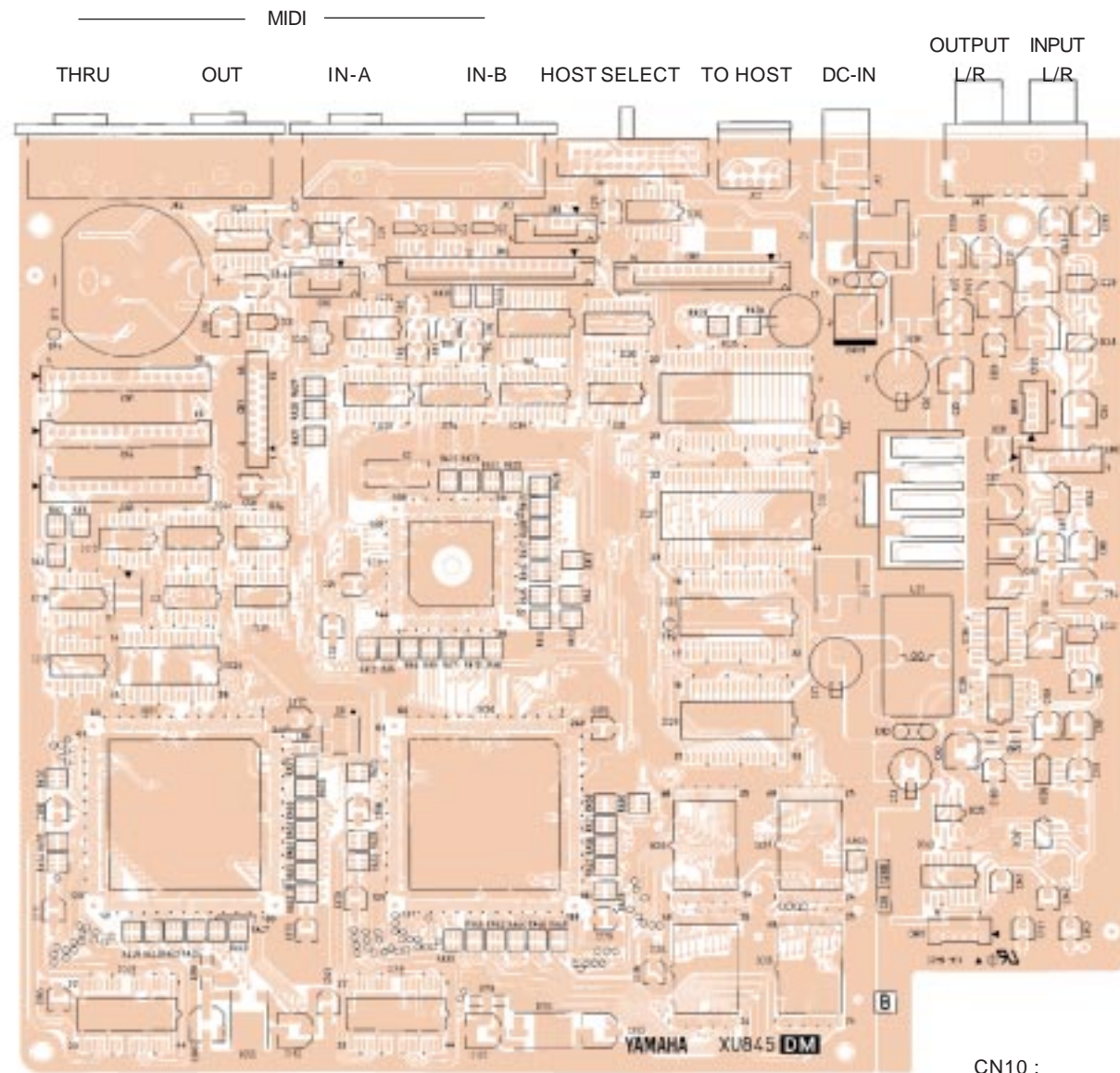

- CN2 : to PMD-CN1
- CN9 : to LEDSW1-CN8 to LEDSW1-CN10
- CN8 : to LEDSW2-CN3
- CN6 : to RE-CN9
- CN1,4,5 : to Plug in board
- CN7 : to LCD

- CN13 : to Power SW Assembly
- CN11 : to PMD-CN2
- CN12 : to ADMVR2-CN5

CN10 : to ADVR1-CN7

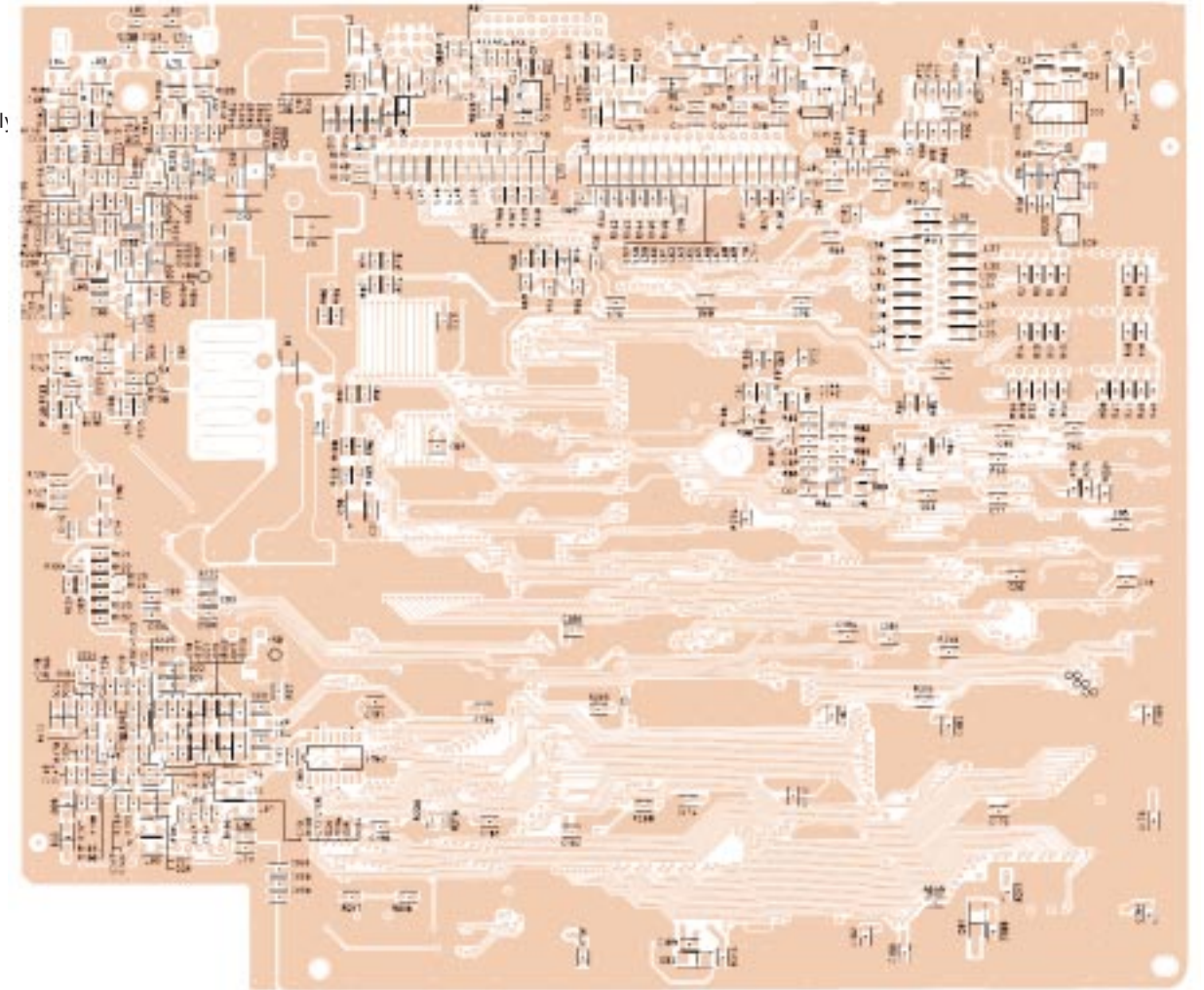

● Connection of the cable bundles to the CN9 of the DM circuit board is shown right.

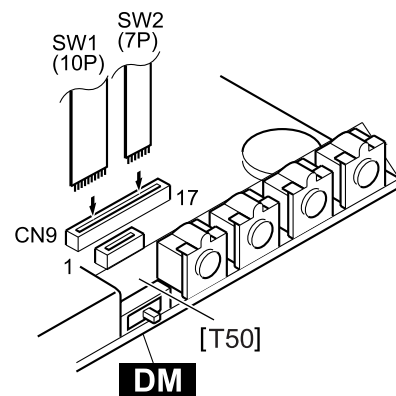

Component side

Battery VN103500

VN103600 (Battery holder for VN103500)

- Notice for back-up battery removal push the battery as shown in figure, then the battery will pop up.
- Druk de batterij naar beneden zoals aangeven in de tekening, de batterij springt dan naar voren.

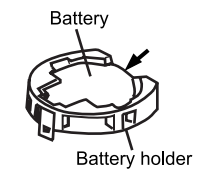

Pattern side

2NA1-V227130

Note : See parts list for details of circuit board component parts.

• LEDSW1 Circuit Board

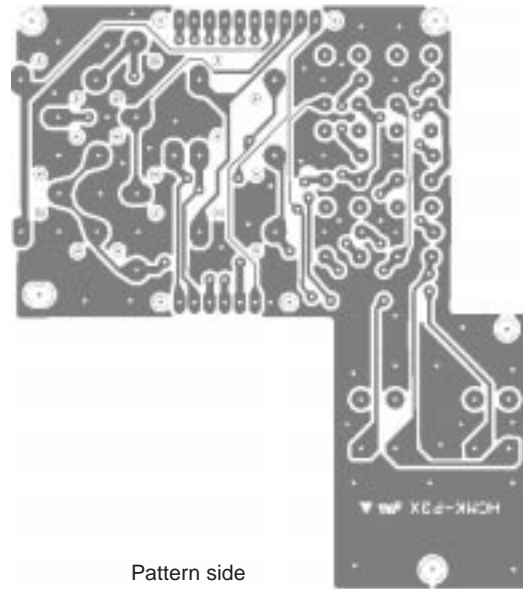
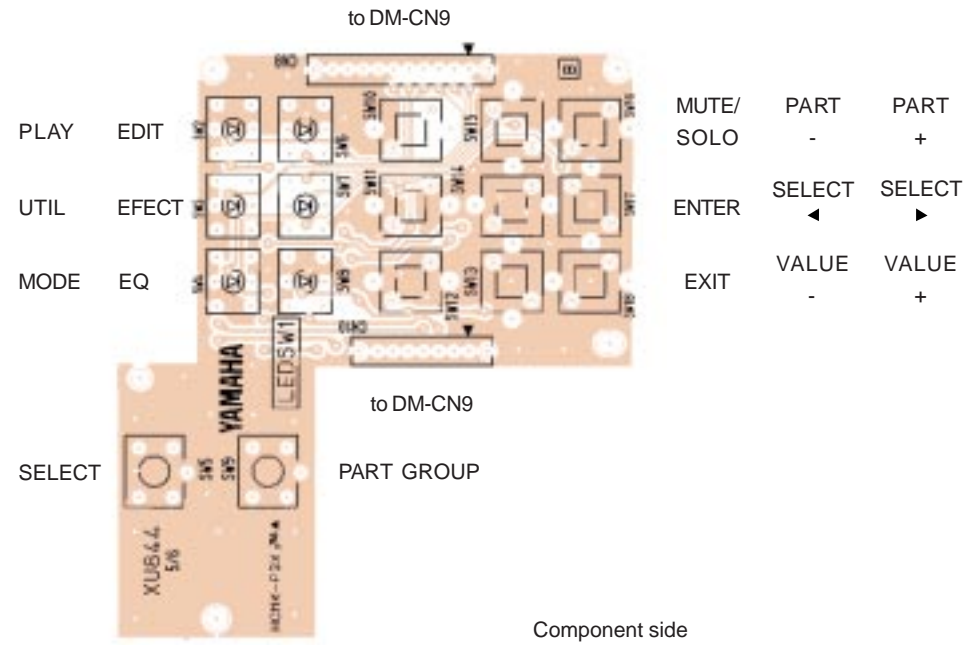

• RE Circuit Board

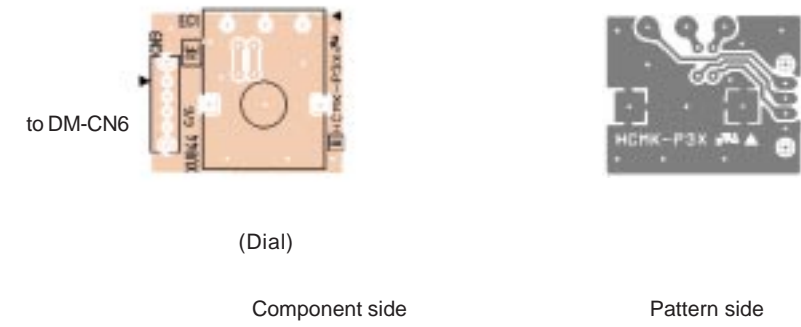

• LEDSW2 Circuit Board

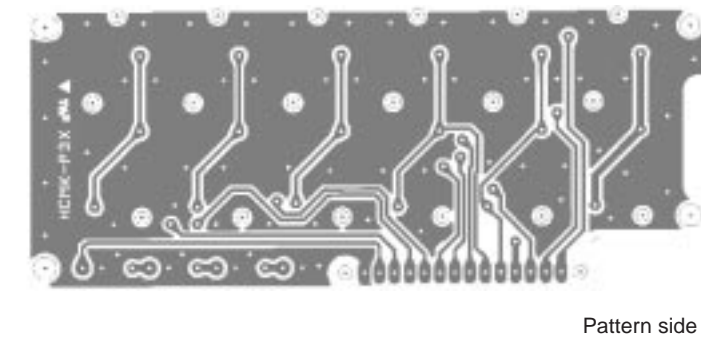
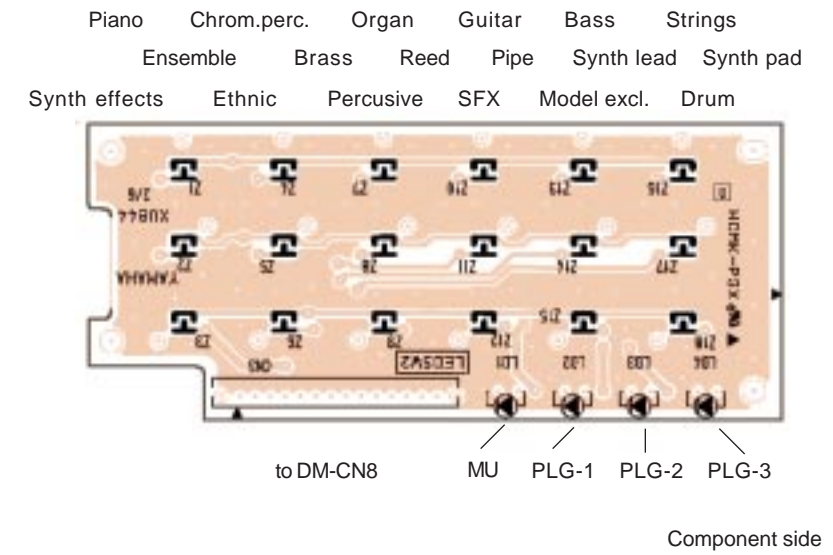

Note : See parts list for details of circuit board component parts.

• ADVR1 Circuit Board

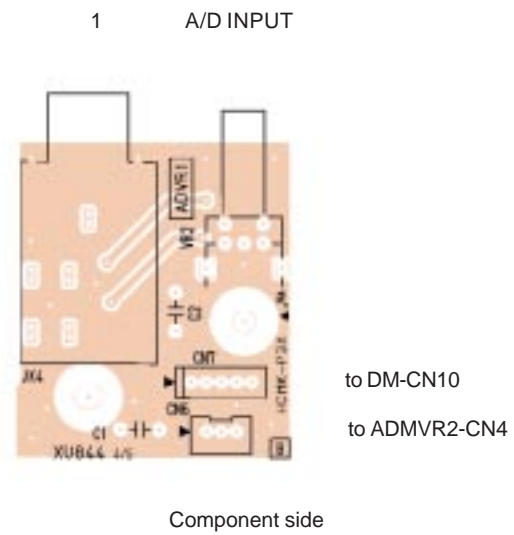

• ADMVR2 Circuit Board

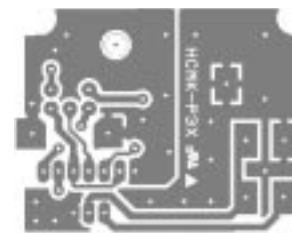
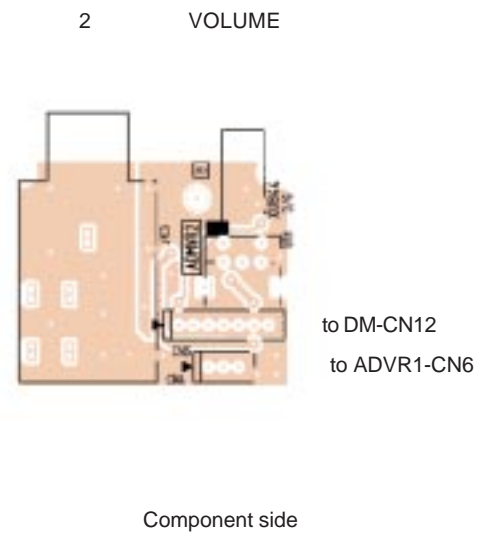

• PMD Circuit Board

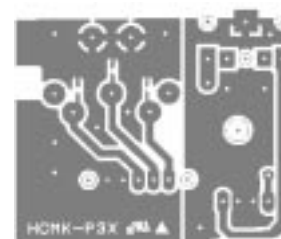
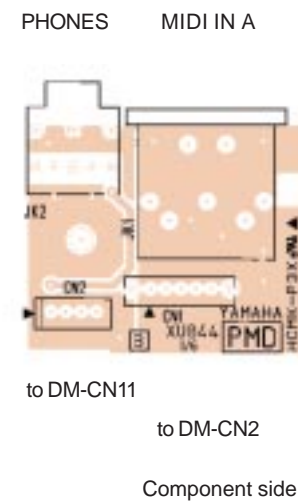

■ LSI PIN DESCRIPTION

● HD6437043E00F (XS936A00) CPU

PIN NO.	NAME	I/O	FUNCTION	PIN NO.	NAME	I/O	FUNCTION	
1	/WRHH	O	HH write	73	D15	I/O	Data bus	
2	PE14	I/O	Port E	74	D14	I/O		
3	/WRHL	O	NC	75	D13	I/O		
4	PA21	I	Flash/WE write check (RY/BY)	76	D12	I/O	Power supply	
5	PE15	I/O	LCD, SW, LED Data control (DB7)	77	VCC	-		
6	VSS	I	Ground	78	D11	I/O	Data bus	
7	A0	I	Address bus	79	VSS	-	Ground	
8	A1	O						
9	A2	O						
10	A3	O						
11	A4	O	Power supply	81	D9	I/O	Data bus	
12	VCC	-						
13	A5	O	Address bus	82	D8	I/O	Data bus	
14	VSS	-	Ground	83	D7	I/O		
15	A6	O	Power supply	84	D6	I/O	Power supply	
16	A7	O						
17	A8	O						
18	A9	O						
19	A10	O	Address bus	85	VCC	-	Power supply	
20	A11	O						
21	A12	O						
22	A13	O						
23	A14	O	Power supply	86	D5	I/O	Data bus	
24	A15	O						
25	A16	O						
26	VCC	-						
27	A17	O	Address bus	87	VSS	-	Ground	
28	VSS	-	Ground	88	D4	I/O	Data bus	
29	PA20	O	LED control	89	D3	I/O		
30	PA19	O	NC	90	D2	I/O		
31	PB2	O	PB select (SW1)	91	D1	I/O		
32	PB3	O	PB select (SW2)	92	D0	I/O	Ground	
33	PA18	O	SW data read (SWD)	93	VSS	-		
34	PB4	O	PB select (SW3)	94	XTAL	-	Crystal oscillator	
35	VSS	-	Ground	95	MD3	-	Mode select	
36	PB5	O	PB select (SW4)	96	EXTAL	-	Crystal oscillator	
37	A18	O	Address bus	97	MD2	-	Mode select	
38	A19	O						
39	A20	O						
40	VCC	-						
41	A21	O	Address bus	98	NMI	-	Non-maskable interrupt	
42	VSS	-	Ground	99	VCC	-	Power supply	
43	/RD	O	Read	100	PA16	I	Rotary encoder (REB)	
44	/WDTOVF	-	NC	101	PA17	I	Rotary encoder (REA)	
45	D31	I/O	Data bus	102	MD1	-	Mode select	
46	D30	I/O	Data bus	103	MD0	-	Mode select	
47	/WRH	O	High write	104	PLLVCC	-	PLL power supply	
48	/WRL	O	Low write	105	PLLCAP	-	PLL capacitor	
49	/CS1	O	Chip select for SRAM	106	PLLVSS	-	PLL ground	
50	/CS0	O	Chip select for system Rom	107	PA15	O	Rotary encoder (RER)	
51	PA9	O	PB select (SW6)	108	/RES	-	Reset	
52	PA8	O	PB select (SW5)	109	PE0	O	LCD control (LCD-R/W)	
53	/CS3	O	Chip select for serial interface	110	PE1	O	NC	
54	/CS2	O	Chip select for SWP30	111	PE2	O	LCD control (LCD-RS)	
55	VSS	-	Ground	112	VCC	-	Power supply	
56	D29	I/O	Data bus	113	PE3	O	Latch for reset (LCREAD)	
57	D28	I/O						
58	D27	I/O						
59	D26	I/O						
60	D25	I/O	Ground	114	PE4	O	LCD control (LCD-E)	
61	VSS	-						
62	D24	I/O	Data bus	115	PE5	O	1M clock for mac.	
63	VCC	-	Power supply	116	PE6	O	Clock for PB serial (SICLK)	
64	D23	I/O	Data bus	117	VSS	-	Ground	
65	D22	I/O						
66	D21	I/O						
67	D20	I/O						
68	D19	I/O	Ground	118	AN0	I	A/D input level (R)	
69	D18	I/O						
70	D17	I/O	Ground	119	AN1	I	A/D input level (L)	
71	VSS	-						
72	D16	I/O		Data bus	120	AN2	I	A/D jack check
					121	AN3	I	Host sw position
				122	AN4	I	Off-line detection	
				123	AN5	I	Analog ground	
				124	AVSS	-	Battery check	
				125	AN6	I	Model check	
				126	AN7	I	A/D reference voltage	
				127	AVREF	I	Analog power supply	
				128	AVCC	I	Ground	
				129	VSS	-	MIDI-IN	
				130	RXD0	I	MIDI-OUT	
				131	TXD0	I	Serial ready for PB	
				132	/IRQ0	I	MIDI-IN	
				133	RXD1	I	MIDI-OUT	
				134	TXD1	O	Power supply	
				135	VCC	-	MIDI-IN A front/rear select	
				136	PA5	O	SW strobe (SWS)	
				137	PE7	O	LCD, SW, LED data control (DB0)	
				138	PE8	I/O	LCD, SW, LED data control (DB1)	
				139	PE9	I/O	LCD, SW, LED data control (DB2)	
				140	PE10	I/O	Ground	
				141	VSS	-	LCD, SW, LED data control (DB3)	
				142	PE11	I/O	LCD, SW, LED data control (DB4)	
				143	PE12	I/O	LCD, SW, LED data control (DB5)	
				144	PE13	I/O		

● TC203C760HF-002 (XS725A00) SWP30B (AWM Tone Generator coped with MEG) Standard Wave Processor

PIN NO.	NAME	I/O	FUNCTION	PIN NO.	NAME	I/O	FUNCTION		
1	VSS		(Ground)	121	VSS		(Ground)		
2	CA0	I	Address bus of internal register	122	HMD0	I/O	Wave memory data bus (Upper 16 bits)		
3	CA1	I		123	HMD1	I/O			
4	CA2	I		124	HMD2	I/O			
5	CA3	I		125	HMD3	I/O			
6	CA4	I		126	HMD4	I/O			
7	CA5	I		127	HMD5	I/O			
8	CA6	I		128	HMD6	I/O			
9	CA7	I		129	HMD7	I/O			
10	CA8	I		130	HMD8	I/O			
11	CA9	I		131	HMD9	I/O			
12	CA10	I	132	HMD10	I/O				
13	CA11	I	133	HMD11	I/O				
14	VSS		(Ground)	134	HMD12	I/O			
15	CD0	I/O	Data bus of internal register	135	HMD13	I/O	(Ground)		
16	CD1	I/O		136	HMD14	I/O			
17	CD2	I/O		137	HMD15	I/O			
18	CD3	I/O		138	VSS				
19	CD4	I/O		139	HMA0	O			
20	CD5	I/O		140	HMA1	O			
21	CD6	I/O		141	HMA2	O			
22	CD7	I/O		142	HMA3	O			
23	CD8	I/O		143	HMA4	O			
24	CD9	I/O		144	HMA5	O			
25	CD10	I/O	145	HMA6	O				
26	CD11	I/O	146	HMA7	O				
27	CD12	I/O	147	HMA8	O				
28	CD13	I/O	148	HMA9	O				
29	CD14	I/O	149	HMA10	O				
30	VDD		(Power supply)	150	VDD		(Power supply)		
31	VSS		(Ground)	151	VSS		(Ground)		
32	CD15	I/O	Chip select Write strobe Read strobe	152	HMA11	O	Wave memory address bus		
33	CSN	I		153	HMA12	O			
34	WRN	I		154	HMA13	O			
35	RDN	I		155	HMA14	O			
36	VDD			(Power supply)	156	HMA15		O	
37	SYSH0	O		157	HMA16	O			
38	SYSH1	O		158	HMA17	O			
39	SYSH2	O		159	HMA18	O			
40	SYSH3	O		160	HMA19	O			
41	SYSH4	O		161	HMA20	O			
42	SYSH5	O	162	HMA21	O				
43	SYSH6	O	163	HMA22	O				
44	SYSH7	O	164	HMA23	O				
45	KONO0	O	165	HMA24	O				
46	KONO1	O	166	VSS		(Ground)			
47	KONO2	O	167	MRASN	O	RAS when DRAM(s) is connected to wave memory			
48	KONO3	O	168	MCASN	O	CAS when DRAM(s) is connected to wave memory			
49	VSS		(Ground)	169	MOEN	O	Wave memory output enable		
50	SYSL0	I/O	NSYS/LNSYS upper 16 bits output	170	MWEN	O	Wave memory write enable		
51	SYSL1	I/O		171	VSS		(Ground)		
52	SYSL2	I/O		172	LMD0	I/O	Wave memory data bus (Lower 16 bits)		
53	SYSL3	I/O		173	LMD1	I/O			
54	SYSL4	I/O		174	LMD2	I/O			
55	SYSL5	I/O		175	LMD3	I/O			
56	SYSL6	I/O		176	LMD4	I/O			
57	SYSL7	I/O		177	LMD5	I/O			
58	KONI0	I		178	LMD6	I/O			
59	KONI1	I		179	LMD7	I/O			
60	VDD		(Power supply)	180	VDD			(Power supply)	
61	VSS		(Ground)	181	VSS			(Ground)	
62	KONI2	I	182	LMD8	I/O	Wave memory data bus (Lower data memory)			
63	KONI3	I	183	LMD9	I/O				
64	DAC0	O	184	LMD10	I/O				
65	DAC1	O	185	LMD11	I/O				
66	WCLK	O	186	LMD12	I/O				
67	MEL00	O	187	LMD13	I/O				
68	MEL01	O	188	LMD14	I/O				
69	MEL02	O	189	LMD15	I/O				
70	MEL03	O	190	VSS			(Ground)		
71	MEL04	O	191	LMA0	O		Wave memory address bus (Lower data memory)		
72	MEL05	O	192	LMA1	O				
73	MEL06	O	193	LMA2	O				
74	MEL07	O	194	LMA3	O				
75	VDD		(Power supply)	195	LMA4	O			
76	ADLR	O	ADC word clock	196	LMA5	O			
77	MELI0	I	197	LMA6	O				
78	MELI1	I	198	LMA7	O				
79	MELI2	I	199	LMA8	O				
80	MELI3	I	200	LMA9	O				
81	MELI4	I	201	LMA10	O				
82	MELI5	I	202	LMA11	O				
83	MELI6	I	203	VSS		(Ground)			
84	MELI7	I	204	LMA12	O	Wave memory address bus (Lower data memory)			
85	VSS		(Ground)	205	LMA13		O		
86	RCASN	O	DRAM column address strobe (RAS signal)	206	LMA14		O		
87	RA8	O	207	LMA15	O				
88	RA7	O	208	LMA16	O				
89	RA6	O	209	LMA17	O				
90	VDD		(Power supply)	210	VDD			(Power supply)	
91	VSS		(Ground)	211	VSS			(Ground)	
92	RA5	O	DRAM address bus	212	LMA18		O	Wave memory address bus (Lower data memory)	
93	RA4	O		213	LMA19		O		
94	RA3	O		214	LMA20	O			
95	RA2	O		215	LMA21	O			
96	RA1	O		216	LMA22	O			
97	RA0	O		217	LMA23	O			
98	RRASN	O		DRAM row address strobe (RAS signal)	218	LMA24	O		
99	RWEN	O		DARM write enable	219	VSS			(Ground)
100	VSS			(Ground)	220	SYO	O		Sync. signal for master clock
101	RD7	I/O		DRAM data bus	221	SYOD	O		Sync. signal for HCLK/QCLK
102	RD6	I/O	222		QCLK	O	1/12 master clock (64Fs)		
103	RD5	I/O	223		HCLK	O	1/8 master clock (128Fs)		
104	RD4	I/O	224		CK256	O	1/3 master clock (256Fs)		
105	RD3	I/O	225		SYSCLK	O	1/2 master clock (384Fs)		
106	RD2	I/O	226		VDD		(Power supply)		
107	RD1	I/O	227		SYI	I	Sync. clock		
108	RD0	I/O	228		MCLKI	I	Master clock input		
109	VSS		(Ground)		229	MCLKO	O	Master clock output	
110	RD17	I/O	230		VDD		(Power supply)		
111	RD16	I/O	231	XIN	I	Crystal osc. input			
112	RD15	I/O	232	XOUT	O	Crystal osc. output			
113	RD14	I/O	233	VSS		(Ground)			
114	RD13	I/O	234	ICN	I	Initial clear			
115	RD12	I/O	235	CHIP2	I	2 chips mode enable			
116	RD11	I/O	236	SLAVE	I	Master/Slave select when 2 chips mode			
117	RD10	I/O	237	TESTON	I	Test pin			
118	RD9	I/O	238	ACIN	I				
119	RD8	I/O	239	DCTEST	I				
120	VDD		(Power supply)	240	VDD		(Power supply)		

● **μPD63200GS-E1 (XP867A00) DAC (Digital to Analog Converter)**

PIN NO.	NAME	I/O	FUNCTION	PIN NO.	NAME	I/O	FUNCTION
1	4/8FS	I	4/8 Fs selection	9	R. REF		Channel R voltage reference
2	D. GND		Digital ground	10	L. REF		Channel L voltage reference
3	16/8 BIT	I	16 bit/8 bit selection	11	L. OUT	O	Channel L output
4	D. VDD		Digital power supply	12	A. GND		Analog ground
5	A. GND		Analog ground	13	LRCX/WD	I	Left/right check, Word clock
6	R. OUT	O	Channel R output	14	LR/RSI	I	Left/right selection, Channel R series input
7	A. VDD		Analog power supply	15	SI/LSI	I	Series input/Channel L series input
8	A. VDD			16	CLK	I	Clock

● **μPD71051GU-10-E2 (XS762A00) Serial Controller**

PIN NO.	NAME	I/O	FUNCTION	PIN NO.	NAME	I/O	FUNCTION
1	D2	I/O	Data bus	15	TxRDY	O	Transmit ready
2	D3	I/O	Data bus	16	SYNC/BRK	I/O	Synch. receiver/break
3	RxDATA	I	Receive data	17	/CTS	I	MODEM control
4	GND	-	Ground	18	TxEMP	O	Transmitter empty
5	D4	I/O	Data bus	19	TxDATA	O	Transmit data
6	D5	I/O		20	CLK	I	Main clock
7	D6	I/O		21	RESET	I	Reset
8	D7	I/O		22	/DSR	I	MODEM control
9	/TxCLK	I	Transmitter clock	23	/RTS	O	
10	/WR	I	Write control	24	/DTR	O	Receive clock
11	/CS	I	Chip select	25	/RxCLK	I	
12	C//D	I		26	VDD	-	Power supply (+5V)
13	/RD	I	Read control	27	D0	I/O	Data bus
14	RxRDY	O	Receive ready	28	D1	I/O	Data bus

● **PCM1800 (XU770A00) A/D Converter**

PIN NO.	NAME	I/O	FUNCTION	PIN NO.	NAME	I/O	FUNCTION
1	VINL	I	Analog input (L ch.)	13	LRCK	I/O	Sampling clock input/output
2	VREF1		Reference 1 decoupling cap.	14	BCK	I/O	Bit clock input/output
3	REFCOM		Reference decoupling common	15	DOUT	O	Audio data output
4	VREF2		Reference 2 decoupling cap.	16	SYSCK	I	System clock input
5	VINR	I	Analog input (R ch.)	17	DGND		Digital ground
6	RSTB	I	Reset input active "L"	18	VDD		Power supply +5V
7	BYPAS	I	LCF bypass control	19	CINNRR		Anti-aliasing filter cap. (-) R ch.
8	FMT0	I	Audio data format 0	20	CINPR		Anti-aliasing filter cap. (+) R ch.
9	FMT1	I	Audio data format 1	21	CINNL		Anti-aliasing filter cap. (-) L ch.
10	MODE0	I	Master/Slave mode selection 0	22	CINPL		Anti-aliasing filter cap. (+) L ch.
11	MODE1	I	Master/Slave mode selection 1	23	VCC		Analog power supply
12	FSYNC	I/O	Frame sync. input/output	24	AGND		Analog ground

■ **IC BLOCK DIAGRAM**

● **TC74HC14AF-TP1 (XD657A00)**
Hex Inverter

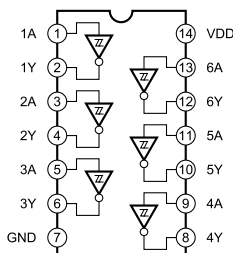

● **SC7SU04FEL (XI348A00)**
Inverter

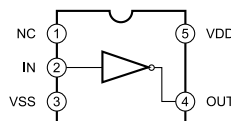

● **TC7W14FU (XN883A00)**
Triple Inverter

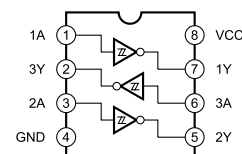

- **TC74HCU04AF-TP1** (XD660A00)
Hex Inverter

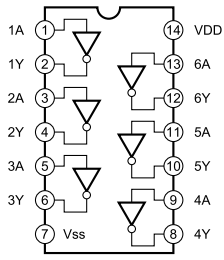

- **TC74HC4050AF-T1** (XI 299A00)
Hex Buffer/Converter

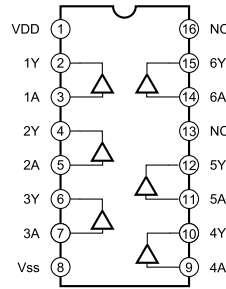

- **TC74S66F** (XR682A00)
Bilateral Switch

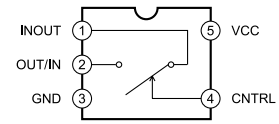

- **TC74HC4066AF-T1** (XG385A00)
Quad Bilateral Analog Switch

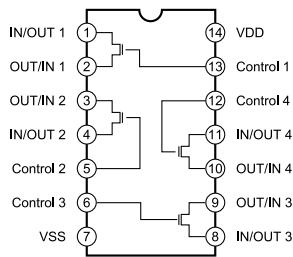

- **TC7S32F** (XM588A00)
OR

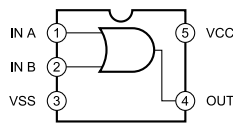

- **TC74HC32F-T1** (XD599A00)
Quad 2 Input OR

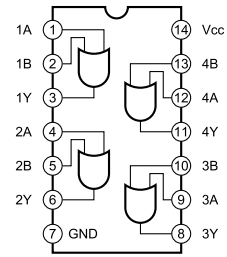

- **TC74HC126AF** (XS776A00)
Bus Buffer

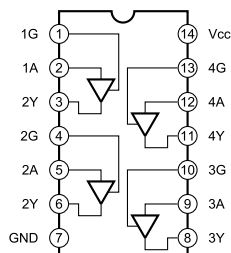

- **TC4W53F** (XL545A00)
DUAL 2-channel Multiplexer/Demultiplexer

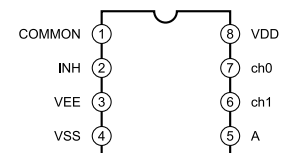
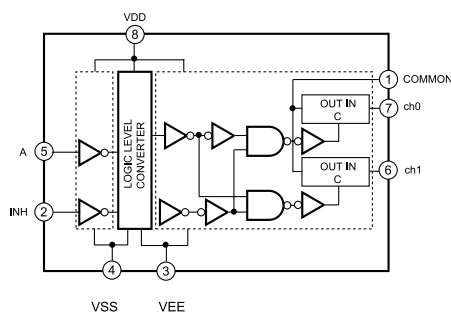

- **MC34051MEL** (XP881A00)
- **M5M34051FP** (XV103A00)
Line Transceiver

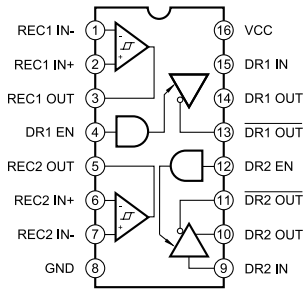

- **NJU7660M-T1** (XP596A00)
DC/DC Voltage Converter

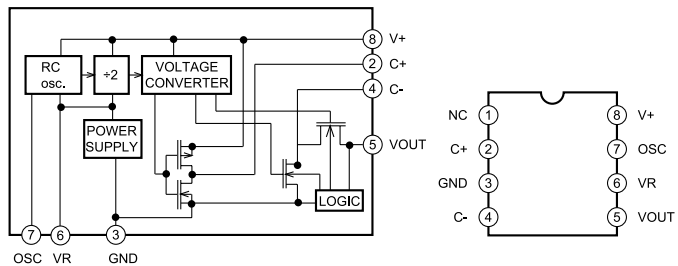

- μ **PC4570G2** (XF291A00)
- **NJM4556AMT1** (XQ138A00)
Dual Operational Amplifier

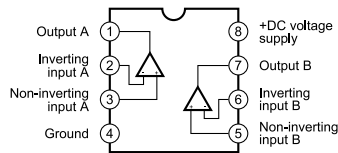

- **TC74HC74AF** (XP003A00)
Dual D-Type Flip-Flop

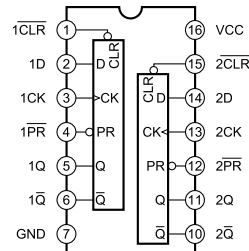

INPUTS				OUTPUTS	
PR	CLR	CK	D	Q	Q̄
H	L	X	X	H	L
L	H	X	X	L	H
L	L	X	X	H	H
H	H	↑	L	H	L
H	H	↑	H	L	H
H	H	L	X	Q ₀	Q ₀

- **SN74HC273NSR** (XH223A00)
Octal D-Type Flip-Flop

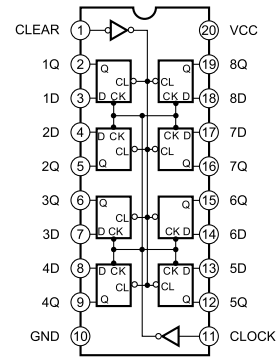

- **TC74HC245F-T1** (XD603A00) • **HD74LVC139FPEL** (XS048A00) • **TC74HC4051AF-TP** (XR056A00)
Octal 3-State Bus Transceiver Dual 2 to 4 Demultiplexer Triple 2-channel Multiplexer /Demultiplexer

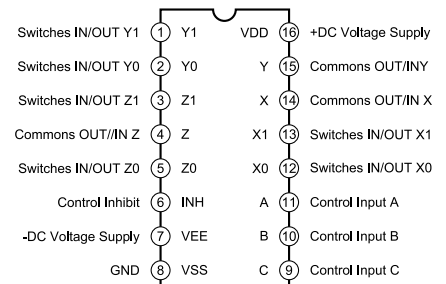
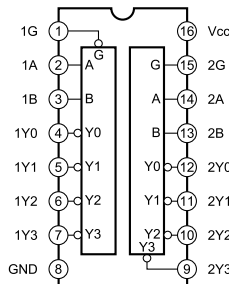
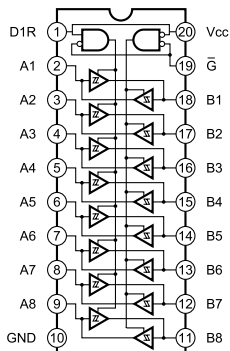

TEST PROGRAM

Preparations

The following measuring instruments and jigs are required for testing the equipment

Measuring instruments:

Low-frequency oscillator (Distortion factor: 0.1 % or less), Frequency counter, Oscilloscope (Input impedance: 1 MΩ or more), Level meter (JIS-C curve), Analog currugated analyzer, Keyboard amplifier

Jigs: MIDI cable, PB (plug-in board)

Test number	Test title
A	TEST ENTRY
B	STARTING THE TESTS
1	SRAM
2	BATTERY
3	LCD DOT BLINK AND CONTRAST
4	LED
5	SWITCHES
6	DIAL
7	MIDI 1 A Front
8	MIDI 2 A Rear
9	MIDI 3 B
10	MIDI 4
11	HOST SELECT
12	TO HOST
13	WAVE ROM
14	1 kHz OUTPUT (L) SIGNAL SOUND
15	1 kHz OUTPUT (R) SIGNAL SOUND
16	A/D INPUT HIGH
17	A/D INPUT LOW
18	SDP AND DRM
19	CHECKING THE 128 SIGNAL SOUNDS
20	PB1 NAME
21	PB1 RAM
22	PB1 MIDI IN
23	PB1 MEL
24	PB2 NAME
25	PB2 RAM
26	PB2 MIDI IN
27	PB2 MEL
28	PB3 NAME
29	PB3 RAM
30	PB3 MIDI IN
31	PB3 MEL
32	FACTORY SETTINGS
33	EXIT

Note 1: For tests 20 to 23, the plug-in board should be connected to the CN5 of the DM sheet on the equipment before turning ON the power supply.

Note 2: For tests 24 to 27, the plug-in board should be connected to the CN4 of the DM sheet on the equipment before turning ON the power supply.

Note 3: For tests 28 to 31, the plug-in board should be connected to the CN1 of the DM sheet on the equipment before turning ON the power supply.

The tests shown below need not be conducted as part of the inspection of MU128.

- 21 PB1 RAM
- 25 PB2 RAM
- 29 PB3 RAM

A. TEST ENTRY

To turn ON the equipment, press the STAND BY/ON button while pressing the PLAY and MUTE/SOLO buttons at one time.

MU128 TEST MODE
 Ver#.# #-##-##

Ver #.# # shows the version number of the product program ROM.

Precautions before starting the test

Before starting a test immediately after the end of the assembly or battery replacement, press STAND BY/ON while pressing the UTIL and ENTER buttons at one time. This step will change the inputted values over to the factory settings.

B. Starting the tests

Press the SELECT / button and select the test numbers desired. Then press the ENTER button. The tests with their numbers selected will be then conducted in sequence.

When the ENTER button is pressed without any test numbers selected, the tests listed will be conducted in numerical order, starting with the "1. SRAM" test.

When the test being conducted is finished without any problems, ok will appear and the next test will be conducted automatically. If the next test is not conducted automatically, refer to "Ending the test" for each item.

The screen for selecting the test number desired will be indicated by pressing the EXIT button, whether the equipment fails in the test being conducted or not.)

If an error occurs during the "5.SWITCHES" test, however, refer to "Ending the test".

1. SRAM

01 RAM

Write/read the data in the SRAM field and check/verify the data.

All the SRAM data will be saved.

Displaying the test result

OK

01 RAM
ok

NG

01 RAM
err

2. BATTERY

02 BATTERY

The battery voltage is checked by the A/D of the CPU (IC 21). Make sure that the voltage is in the range from 2.9 to 3.4 V.

Displaying the test result

OK

02 BATTERY
ok

NG

02 BATTERY err

3. LCD DOT BLINK AND CONTRAST

Visually check to see if all of the white dots of the LCD are highlighted black.
Also check to see if the back light is lit properly. Then press the [SELECT] button and make sure that the contrast is changed in eight stages.

Ending the test
Press the [ENTER] button. You will then go to the next test.

4. LED

04 LED

Make sure that the LEDs are lit in order of [MU], [PLG-1], [PLG-2], [PLG-3], [PLAY], [UTIL], [MODE], [EDIT], [EFFECT], and [EQ]. Also make sure that all of the LEDs are then lit and extinguished.

Ending the test
Press the [ENTER] button. You will then go to the next test.

5. SWITCHES

05 SWITCH [Piano]

[TURN ON/OFF] the panel switches from [Piano] to [Value \oplus in] accordance with the switch name displayed on the LCD.

When the above step is done, a specific sound is heard if the switch being tested is in its normal condition. You will then go to the test of the next switch.
If the switch being tested fails in the test, you will not go to the test of the next switch even though you press the switch directed on the LCD.

Displaying the test result
OK

05 SWITCH ok

NG None

Ending the test
When the test of the switches from [Piano] to [Value \oplus] has been finished, you will go to the next test. If you think that the switch being tested has fails in the test, turn OFF the equipment once and restart the test.

6. DIAL

06 DIAL Right 0-10=00

Make that the dial is working properly. Slowly turn the dial clockwise until a value of 10 is obtained for "00" on the LCD. When the value 10 is obtained, the next item illustrated below will appear.

06 DIAL Left 0-10=00

Slowly turn the dial counterclockwise until a value of 10 is obtained for "00" on the LCD.

Displaying the test result
OK

06 DIAL ok

NG

06 DIAL err

7. MIDI 1 A Front

Use a MIDI cable and connect the MIDI IN A (front) connector to the MIDI OUT connector. Then conduct the test.
Before starting the test, select MIDI under HOST SELECT.

07 MIDI 1A Front

The test pattern (AA 50 5F) will be sent from MIDI OUT and received by MIDI IN (front). The result of the test pattern received will then be judged.

Displaying the test result
OK

07 MIDI 1A Front ok

NG

07 MIDI 1A Front err

8. MIDI 2 A Rear

Use a MIDI cable and connect the MIDI IN A (rear) connector to the MIDI OUT connector. Then conduct the test.
Before starting the test, select MIDI under HOST SELECT.

08 MIDI 2A Rear

The test pattern (AA 50 5F) will be sent from MIDI OUT and received by MIDI IN A (rear). The result of the test pattern received will then be judged.

Displaying the test result
OK

08 MIDI 2A Rear ok

NG

08 MIDI 2A Rear err

9. MIDI 3 B

Use a MIDI cable and connect the MIDI IN B connector to the MIDI OUT connector. Then perform the test. Before starting the test, select MIDI under HOST SELECT.

09 MIDI 3 B

The test pattern (AA 50 5F) will be sent from MIDI OUT and received by MIDI IN B. The result of the test pattern received will then be judged.

Displaying the test result

OK 09 MIDI 3 B ok

NG 09 MIDI 3 B err

10. MIDI 4

Use two MIDI cables and connect the MIDI IN A (rear) and MIDI IN B connectors to the MIDI OUT and MIDI THRU connectors respectively. Then perform the test. Before starting the test, select MIDI the HOST SELECT.

10 MIDI 4

The test pattern (AA 50 5F) will be sent from MIDI OUT and received by MIDI IN A. The data output from MIDI THRU will be received by MIDI IN B. The result of the test pattern and data received will be judged.

Displaying the test result

OK 10 MIDI 4 ok

NG 10 MIDI 4 err

11. HOST SELECT

11 HOST SELECT
Mac ZZZ-YYY= XXX

(ZZZ=Lower limit, YYY=Upperlimit, XX= Measured value)

Change MAC over to PC-1, PC-2, and MIDI in sequence under HOST SELECT in accordance with the host name displayed on the LCD and make sure that the switch is functioning properly.

Displaying the test result

OK 11 HOST SELECT ok

NG None

12. TO HOST TX/RX

12 TO HOST

The test is for factory inspection before shipment. The test will not be performed here. Testing without a test-specific jig will result in an error. To eliminate any error, refer to "B. Starting the tests."

13. WAVE ROM

13 WAVE ROM

Read and verify four WAVE ROM data through SWP30.

Displaying the test result

OK 13 WAVE ROM ok

NG 13 WAVE ROM IC xx err

(xx : IC number with an error)

14. 1 kHz OUTPUT (L) sound

14 OUTPUT L 1 kHz

Make sure that the proper signals are being output from OUTPUT (L) and PHONES (L).

Note 4:

Insert the plugs into the OUTPUT (L, R) and PHONES terminals and measure the frequency, waveform and level of individual signals output. Before starting the measurement, make sure that the plug is not inserted into the AD/ INPUT terminal. Also set the master volume at maximum.

Check items

OUTPUT (L) : 1 kHz +/- 3 Hz, Sine wave,
+3.0 dBm +/- 2 dB (Load: 10 k ohm)
Distortion factor 0.25 % or less

OUTPUT (R) : -80 dBm or less

PHONES (L) : 1 kHz +/- 3 Hz, Sine wave,
-4.0 dBm +/- 2 dB (Load: 33 ohm)
Distortion factor 0.5 % or less

PHONES (R) : -65 dBm or less

Ending the test

Press the [ENTER] button. You will then go to the next test.

15. 1 kHz OUTPUT (R) SOUND

15 OUTPUT R 1 kHz

Make sure that the proper signals are being output from OUTPUT (R) and PHONES (R).

Use the same settings as specified in Note 4 for test 14.

Check items

- OUTPUT (L) : -80 dBm or less
- OUTPUT (R) : 1 kHz +/- 3 Hz, Sine wave, +3.0 dBm +/- 2 dB (Load: 10 k ohm) Distortion factor 0.25 % or less
- PHONES (L) : -65 dBm or less
- PHONES (R) : 1 kHz +/- 3 Hz, Sine wave, -4.0 dBm +/- 2 dB (Load: 33 ohm) Distortion factor 0.5 % or less

Ending the test

Press the [ENTER] button. You will then go to the next test.

16. A/D INPUT HIGH

16 INPUT HIGH

When HIGH is displayed on the side of INPUT in the INPUT GAIN field, make sure that the signal input in the A/D INPUT field changes according to the INPUT VOLUME value and is output from OUTPUT. In addition, input a signal at a specified level into the A/D INPUT field and make sure that the level meter lamp on the LCD is lit.

Note 5:

Insert the plugs into the OUTPUT (L, R) and PHONES terminals and measure the frequency, waveform and level of individual signals output. Before starting the measurement, set the master volume at maximum.

Check items

Input the sine wave data ---- 39.0 dBm, 1 kHz, distortion factor : 0.1 or less --- In the A/D INPUT(L) field (with the cable coming from the A/D INPUT (R) terminal connected to the ground terminal).

When A/D INPUT VOLUME is set at maximum, make sure that the specified values shown below are obtained for OUTPUT (L) and (R).

- OUTPUT (L) : +4 dBm +/- 2 dB (Load: 10 k ohm) Distortion factor 0.25 % or less
- OUTPUT (R) : -65 dBm or less

When A/D INPUT VOLUME is set at minimum, make sure that the specified value shown below is obtained

for OUTPUT (L).

- OUTPUT (L) : -70 dBm or less

Input the sine wave data ---- 39.0 dBm, 1 kHz, distortion factor : 0.1 or less --- in the AD INPUT (R) field (with the cable coming from the A/D INPUT (L) terminal connected to the ground terminal).

When A/D INPUT VOLUME is set at maximum, make sure that the specified values shown below are obtained for OUTPUT (L) and (R).

- OUTPUT (L) : -65 dBm or less
- OUTPUT (R): +4 dBm +/- 2 dB (Load: 10 k ohm) Distortion factor 0.25 % or less

When A/D INPUT VOLUME is set at minimum, make sure that the specified value shown below is obtained for OUTPUT (R).

- OUTPUT (R): -70 dBm or less

Set A/D INPUT VOLUME at maximum. When the inputting the sine wave data----33.0 dBm and 1 kHz in the AD INPUT(L) field, make sure that the level meter lamp on the LCD is lit.

Ending the test

Press the [ENTER] button. You will then go to the next test.

17. A/D INPUT LOW

17 INPUT LOW

When LOW is displayed on the side of INPUT in the INPUT GAIN field, make sure that the signal input in the A/D INPUT field changes according to the INPUT VOLUME value and is output from OUTPUT. In addition, input a signal at a specified level into the A/D INPUT field and make sure that the level meter lamp on the LCD is lit.

Use the same settings as specified in Note 6 for test 16.

Check items

Input the sine wave data----15.0 dBm, 1 kHz, distortion factor : 0.1 or less---in the AD INPUT(L) field (with the cable coming from the A/D INPUT (R) terminal connected to the ground terminal).

When A/D INPUT VOLUME is set at maximum, make sure that the specified values shown below are obtained for OUTPUT (L) and (R).

- OUTPUT (L) : +4 dBm +/- 2 dB (Load: 10 k ohm) Distortion factor 0.25 % or less
- OUTPUT (R): -60 dBm or less

When A/D INPUT VOLUME is set at minimum, make sure that the specified value shown below is obtained for OUTPUT (L).

- OUTPUT (L) :-72 dBm or less

Input the sine wave data of -15.0 dBm, 1 kHz, distortion factor : 0.1 or less --- in the AD INPUT (R) field (with the cable coming from the A/D INPUT (L) terminal connected to the ground terminal).

When A/D INPUT VOLUME is set at maximum, make sure that the specified values shown below are obtained for OUTPUT (L) and (R).

- OUTPUT (L) :-67 dBm or less
- OUTPUT (R) :+4.0 dBm +/- 22 dB (Load: 10 k ohm)

Distortion factor 0.25 % or less
 When A/D INPUT VOLUME is set at minimum, make sure that the specified value shown below is obtained for OUTPUT (R).
 OUTPUT (R) : -72 dBm or less

Set A/D INPUT VOLUME at maximum. When the inputting the sine wave data -9.0 dBm and 1 kHz in the AD INPUT (L) field, make sure that all the level meter lamps on the LCD are lit.

Ending the test
 Press the [ENTER] button. You will then go to the next test.

18. DSP AND DRAM

18 DSP & DRAM

Measure the frequency, waveform and level of individual signals output from the OUTPUT (L, R) terminals and make sure that the proper signals are being input. Before starting the measurement, make sure that the plug is not inserted into the AD/ INPUT terminal. Also set the master volume at maximum. Observe the situation for at least two seconds.

Check items
 OUTPUT (L) : 1 kHz +/- 3.0 Hz, Sine wave, +3.5 dBm +/- 2 dB (Load: 10 k ohm)
 Distortion factor 0.25 % or less
 OUTPUT (R): 1 kHz +/- 3.0 Hz, Sine wave, +3.5 dBm +/- 2 dB (Load: 10 k ohm)
 Distortion factor 0.25 % or less

Ending the test
 Press the [ENTER] button. You will then go to the next test.

19. CHECKING THE 128 SIGNAL SOUNDS

19 128ch OUT

An audible signal is produced for channels 1 to 64 from OUTPUT (L) and for channels 65 to 128 from OUTPUT (R).

The audible signal is produced 64 times for approximate 0.3 seconds at intervals of approx. 0.1 second. Make sure that the proper audible signal is heard for each of the 128 channels. Also make sure that the sine wave being output has the proper waveform. (L ch = 1 kHz, R ch = 2 kHz)
 Before starting the test, set the master volume at maximum at the time. During the test, the following information will appear on the LCD:

19 128ch OUT
 Lch=xx Rch=xx

(xx : Channel number with the audible signal being produced.)

Ending the test
 Press the [ENTER] button. You will then go to the next test.

20. PB1 NAME

Note 1: For test 20 to 23, connect the PB (plug-in board) to the CN 5 of the DM sheet in the equipment before turning ON the equipment.

20 PB1 NAME

A request for the board name and version is sent from the MU to the PB through the MU-PB communications signal line. The information obtained from the PB is then displayed on the LCD. Make sure that the communications signal line for the CN 5 of the DM sheet is functioning properly and check the board name and version.

Displaying the test result

OK 20 PB1 NAME
 PLG100-(VL) VX.XX

(X.XX = Version number)

NG 20 PB1 NAME
 err

(If no information is returned from the PB.)

21. PB1 RAM

21 PB1 RAM

Check the RAM of the PB connected to the CN 5 of the DM sheet.

Displaying the test result

OK 21 PB1 RAM
 ok

NG 21 PB1 RAM
 err

22. PB1 MIDI IN

22 PB1 MIDI IN

Check the MIDI IN of the PB connected to the CN 5 of the DM sheet.

Use a MIDI cable and connect the MIDI IN A (Rear) connector to the MIDI OUT connector. Then conduct the test.
 Before starting the test, select MIDI under HOST SELECT.

Displaying the test result

OK 22 PB1 MIDI IN
 ok

NG

22 PB1 MIDI IN err

23. PB1 MEL

23 PB1 MEL

Perform the tests 1 to 3 described below and make sure that the proper signal is being output from OUTPUT (L, R).

(Details)

The signal input into A/D INPUT is output from the CN5-MEL OUT of MU128 and a request for the audible signal is made to the PB. The sound source PB then outputs a 1 kHz sine wave from MEL OUT. The effect PB then outputs the input signal from MEL OUT. The MU128 then outputs the sine wave input into CN5-MEL IN from OUTPUT.

1. Testing the MU128

Make sure that the MEL IN/OUT of the CN5 is functioning properly.

2. Testing the sound source PB (PLG100-VL, SG, etc.)

Make sure that the sound source section and the MEL OUT are functioning properly.

3. Testing the effect PB (PLG100-VH)

Make sure that the effect section and the MEL IN/OUT are functioning properly.

Insert the plugs into the OUTPUT (L, R) and PHONES terminals and measure the frequency, waveform and level of each signal output. Set the VOLUME and A/D INPUT VOLUME at maximum.

Check items

When the sine wave data---1 kHz and -15dBm---are input into A/D INPUT (L), make sure the following specified values are obtained for OUTPUT (L):

OUTPUT (L):

- 1 kHz +/- 3 Hz, 4.0 dBm +/- 2 dBm (PLG100-VH),
- 1 kHz +/- 3 Hz, 3.2 dBm +/- 2 dBm (PLG100-VL),
- 1 kHz +/- 3 Hz, 2.0 dBm +/- 2 dBm (PLG100-VS),
- 1 kHz +/- 3 Hz, 0.8 dBm +/- 2 dBm (PLG100-XG)

Ending the test

Press the [ENTER] button. You will then go to the next test.

When testing the MU128, use PLG100-VH.

24. PB2 NAME

Note 2: For tests 24 to 27, connect the PB to the CN4 before turning ON the equipment.

24 PB2 NAME

A request for the board name and version is sent from the MU to the PB through the MU-PB communications signal line. The information obtained from the PB is then displayed on the LCD. Make sure that the

communications signal line for the CN 4 is functioning properly and check the board name and version.

Displaying the test result

OK

24 PB2 NAME PLG100-VL VX.XX

(X.XX = Displaying the test result)

NG

24 PB2 NAME err

(If no information is returned from the PB.)

25. PB2 RAM

25 PB2 RAM

Check the RAM of the PB connected to the CN 4 of the DM sheet.

Displaying the test result

OK

25 PB2 RAM ok

NG

25 PB2 RAM err

26. PB2 MIDI IN

26 PB2 MIDI IN

Check the MIDI IN of the PB connected to the CN 4 of the DM sheet.

Use a MIDI cable and connect the MIDI IN A (Rear) connector to the MIDI OUT connector. Then conduct the test.

Before starting the test, select MIDI under HOST SELECT.

Displaying the test result

OK

26 PB2 MIDI IN ok

NG

26 PB2 MIDI IN err

27. PB2 MEL

27 PB2 MEL

Perform the tests 1 to 3 described below and make sure that the proper signal is being output from OUTPUT (L, R).

(Details)

The signal input into AD INPUT is output from the CN4-MEL OUT of MU128 and a request for the audible signal is made to the PB. The sound source PB then outputs a 1 kHz sine wave from MEL OUT. The effect PB (PLB-100VH) then outputs the input signal from MEL OUT. The MU128 then outputs the sine wave input into CN4-MEL IN from OUTPUT.

1. Testing the MU128
Make sure that the MEL IN/OUT of the CN4 is functioning properly.
2. Testing the sound source PB (PLG100-VL, DX, etc.)
Make sure that the sound source section and the MEL OUT are functioning properly.
3. Testing the effect PB (PLG100-VH)
Make sure that the effect section and the MEL IN/OUT are functioning properly.

Insert the plugs into the OUTPUT (L, R) terminals and measure the frequency, waveform and level of each signal output. Set VOLUME and A/D INPUT VOLUME at maximum.

Check items

When the sin wave data---1 kHz and -15dBm---are input into A/D INPUT (L), make sure the following specified values are obtained for OUTPUT (L).

OUTPUT (L):

- 1 kHz +/- 3 Hz, 4.0 dBm +/- 2 dBm (PLG100-VH),
- 1 kHz +/- 3 Hz, 3.2 dBm +/- 2 dBm (PLG100-VL),
- 1 kHz +/- 3 Hz, 2.0 dBm +/- 2 dBm (PLG100-VS),
- 1 kHz +/- 3 Hz, 0.8 dBm +/- 2 dBm (PLG100-XG)

Ending the test

Press the [ENTER] button. You will then go to the next test.

When testing the MU128, use PLG100-VH.

Note 3: For tests 28 to 31, connect the PB to the CN1 before turning ON the equipment.

28. PB3 NAME

28 PB3 NAME

A request for the board name and version is sent from the MU to the PB through the MU-PB communications signal line. The information obtained from the PB is then displayed on the LCD. Make sure that the communications signal line for the CN 1 of the DM sheet is functioning properly and check the board name and version.

Displaying the test result

OK

28 PB3 NAME
PLG100-VL
VX.XX

(X.XX = Version number)

NG

28 PB3 NAME
err

(If no information is returned from the PB.)

29. PB3 RAM

29 PB3 RAM

Check the RAM of the PB connected to the CN 1 of the DM sheet.

Displaying the test result

OK

29 PB3 RAM
ok

NG

29 PB3 RAM
err

30. PB3 MIDI IN

30 PB3 MIDI IN

Check the MIDI IN of the PB connected to the CN 1 of the DM sheet.

Use a MIDI cable and connect the MIDI IN A (Rear) connector to the MIDI OUT connector. Then conduct the test.

Before starting the test, select MIDI under HOST SELECT.

Displaying the test result

OK

30 PB3 MIDI IN
ok

NG

30 PB3 MIDI IN
err

31. PB3 MEL

31 PB3 MEL

Perform the tests 1 to 3 described next and make sure that the proper signal is being output from OUTPUT (L, R).

(Details)

The signal input into A/D INPUT is output from the CN1-MEL OUT of MU128 and a request for the audible signal is made to the PB.

The sound source PB then outputs a 1 kHz sine wave from MEL OUT. The effect PB (PLG-100VH) then outputs the input signal from MEL OUT.

The MU 128 then outputs the sine wave input into CN1-MEL IN from OUTPUT.

1. Testing the MU128

Make sure that the MEL IN/OUT of the CN1 is functioning properly.

2. Testing the sound source PB (PLG100-VL, DX, etc)
Make sure that the sound source section and the MEL OUT are functioning properly.
3. Testing the effect PB (PLG100-VH)
Make sure that the effect section and the MEL IN/OUT are functioning properly.

Insert the plugs into the OUTPUT (L, R) terminals and measure the frequency, waveform and level of each signal output. Set VOLUME and A/D INPUT VOLUME at maximum.

Check items

When the sine wave data---1 kHz and -15 dBm---are input into A/D INPUT (L), make sure the following specified values are obtained for OUTPUT (L).

OUTPUT (L):

- 1 kHz +/- 3 Hz, 4.0 dBm +/-2 dBm (PLG100-VH),
- 1 kHz +/- 3 Hz, 3.2 dBm +/-2 dBm (PLG100-VL),
- 1 kHz +/- 3 Hz, 2.0 dBm +/-2 dBm (PLG100-VS),
- 1 kHz +/- 3 Hz, 0.8 dBm +/-2 dBm (PLG100-XG)

32. FACTORY SETTINGS

32 FACTORY SET

When the [ENTER] button is pressed, the individual data will be changed to the factory settings and you will exit the test mode.

When pressing the [EXIT] button, you will return to the screen for selecting the desired test numbers without changing the data to the factory settings.

33. EXIT

33 EXIT

When pressing the [ENTER] button, you will exit the test mode and enter the play mode.

When pressing the [EXIT] button, you will return to the screen for selecting the desired test numbers.

When you exit the test mode and enter the play mode, make sure that the noise level for each of the terminals.

- OUTPUT (L) : -88 dBm or less
- OUTPUT (R) : -88 dBm or less
- PHONES (L) : -88 dBm or less
- PHONES (R) : -88 dBm or less

■ INITIALIZE

The Initialize functions allow you to restore the factory settings of the MU128.

1. From the Utility mode menu, press the [SELECT ◀/▶] button to select [INITIAL]

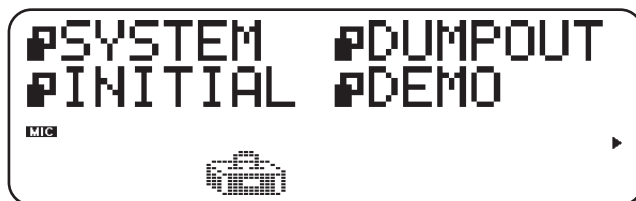

2. Press the [ENTER] button.



3. Press the [SELECT ◀/▶] button to select the type of data to be initialized.

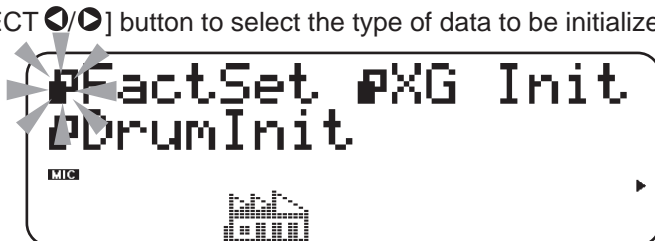

4. Press the [ENTER] button, then "Are you sure ?" appears in the display.

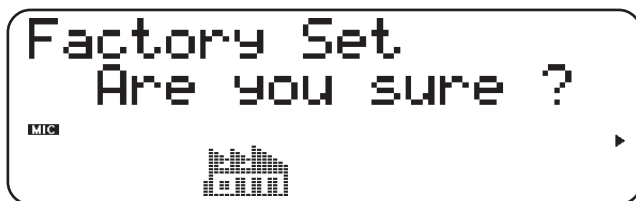

5. Press the [ENTER] button to execute the operation.
When the operation is completed. The MU128 will then return to the Initialize menu 3.

To cancel the operation, press the [EXIT] button. The MU128 will then return to the Initialize menu.

- Since the Initialize functions replace existing data, you should save any and all important settings to a data storage device or YAMAHA MDF3 before executing these functions.
- Selecting Sound Module Mode also replaces existing data.

1 Fact Set (Factory Settings)

This restores the original factory settings, including Multi, Performance, Effect, Equalizer and System Setup, of the MU128.

2 XG Init (XG Initialize) (Its parameter will be available when Sound Module mode XG is currently selected.)

3 GM Init (GM Initialize) (Its parameter will be available when Sound Module mode TG300B is currently selected.)

This restores the settings below.

Multi Part Control

Multi All Part Control

Multi Part Edit

Effect

Equalizer

Performance mode settings cannot be initialized.

4 PFMInit (Performance Initialize) (Its parameter will be available when Sound Module mode PFM is currently selected.)

This restores Performance Edit Buffer.

Performance internal memory cannot be initialized.

5 DrumInit (Drum Initialize) (Its parameter will be available when Sound Module mode XG or TG300B is currently selected.)

This restores Drum Setup (DrumS1~4).

Select a Drum Setup (DrumS1~4) to be initialized by using [VALUE  / ] buttons or the dial.

■ ERROR MESSAGES

Battery Low!	The battery voltage (for internal memory backup) may be too low. Replace the battery with the new one.
Check Sum ERROR!	The checksum of the received System Exclusive message is incorrect. Check the size of the checksum of the message and transmitting again.
HOST Is Offline!	This message appears when the host computer is not turned on, the connecting cable is not properly connected, or the sequencing software is not active.
Illegal Data!	A data error resulted during reception of MIDI messages. Try transmitting the data again, or turn the MU128 off and back on again.
MIDI Buffer Full!	Too much MIDI data is being received by the MU128 at one time. Reduce the amount of data being sent to the MU128.
No Parameter	The selected parameter cannot be displayed with the show MIDI Data function.
No RecallPerform!	This message appears if you use the Recall function in the Performance Edit mode when there is no edited performance data to be recalled.
Not Available	Drum Voices cannot be selected when the Sound Module mode is set to "PFM."
Not Available with PLG	The selected XG Plug-in board does not have Voice for the selected Voice category.
PB Com ERROR!	<ul style="list-style-type: none"> An error occurred in the communication between the MU128 and the XG Plug-in board. Turn off the power and check that the board is properly installed. The XG Plug-in board was unable to process incoming MIDI data, probably because too much data was received too quickly. If possible, avoid sending unnecessary data and reduce the amount of data sent to the MU128.
Rcv CH Is OFF!	The selected parameter for use with the Show MIDI Data function cannot be converted to a MIDI message value since the Receive Channel for the Part is off. Set the Receive Channel to an appropriate value.
Select BANK Or PGM# First	This message appears if you use the Show MIDI Data function when the Sound Module mode is set to "PFM" and both the bank number and program number are selected by the cursors. (The Show MIDI Data function cannot display both values simultaneously.) Move the cursor to one parameter or the other (bank number or program number) and use the Show MIDI Data function to check each value individually.
Select drumS1 • 4 When You Edit	This message appears if you attempt to edit a Drum Voice for a Part whose Part mode has been set to "drum." Set the part mode to one of the drum setups ("drumS1-S4") in order to edit the Drum Voice.
SysEx Adrs ERROR!	The data of the received System Exclusive message is incorrect. Check the address of the message and try transmitting again.
SysEx Data ERROR!	The data of the received System Exclusive message is incorrect. Check the data of the message (as to whether it requires an MSB or LSB header) and try transmitting again.
SysEx Size ERROR!	The data of the received System Exclusive message is incorrect. Check the size of the message and try transmitting again.
This Parameter Isn' t Excl Data	The selected parameter cannot be displayed with the Show MIDI Data function.

CONNECTING CABLES

Connecting to an Apple Macintosh Serise Computer

Apple Macintosh peripheral cable (M0197). Maximum length 2 meters.

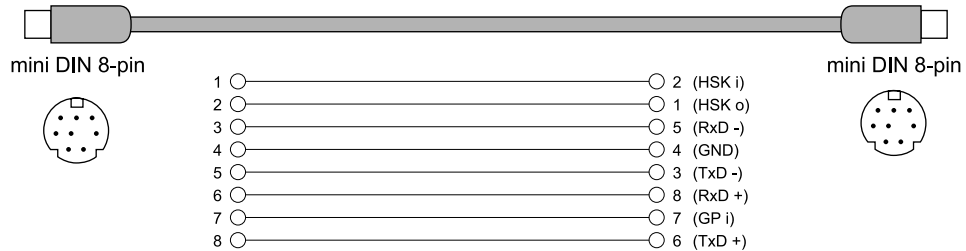

Connecting to an IBM-PC/AT Serise Computer

PC-1

8-pin MINI DIN to D-SUB 25-pin cable. If your PC-1 type computer has a 9-pin serial port, use the PC-2 type cable. Maximum length 1.8 meters.

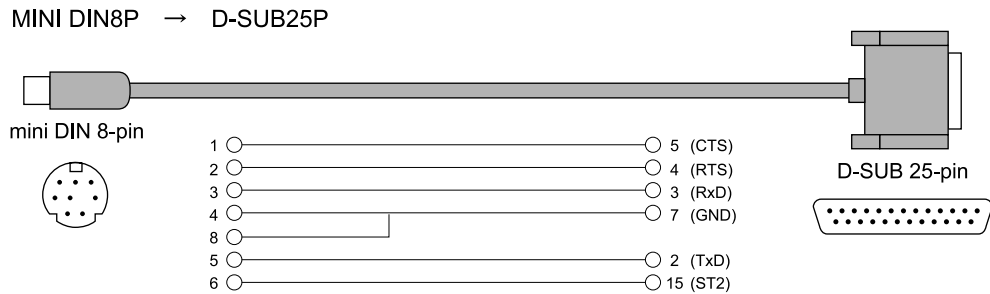

PC-2

8-pin MINI DIN to D-SUB 9-pin cable. Maximum length 1.8 meters

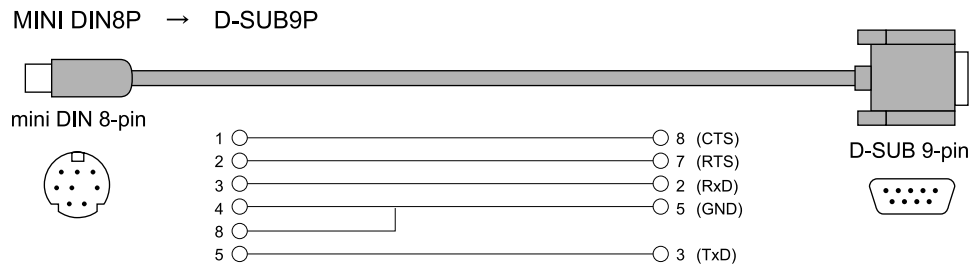

Connector Pin Number

mini DIN 8-pin

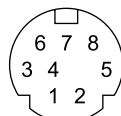

D-SUB 25-pin

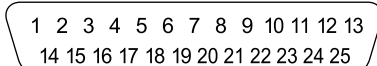

D-SUB 9-pin

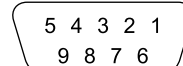

Function ...	Transmitted	Recognized	Remarks
Basic Default Channel Changed	x x	1 - 16 1 - 16	
Mode Default Messages Altered	x x *****	3 3, 4 (m=1) *2 x	
Note Number : True voice	x *****	0 - 127 0 - 127	
Velocity Note ON Note OFF	x x	o 9nH,v=1-127 x	
After Touch Key's Ch's	x x	o *1 o *1	
Pitch Bender	x	o 0-24 semi *1	
Control Change	0,32 x 1,5,7,10,11 x 6,38 x 64-67 x 71-74 x 84 x 91,93,94 x 96-97 x 98-99 x 100-101 x	o *1 o *1 o *1 o *1 o *1 o *1 o *1 o *1 o *1 o *1	Bank Select Data Entry Sound Controller Portamento Cntrl Effect Depth RPN Inc,Dec NRPN LSB,MSB RPN LSB,MSB
Prog Change : True #	x *****	o 0 - 127	
System Exclusive	o *3	o *3	
Common : Song Pos. : Song Sel. : Tune	x x x	x x x	
System Real Time :Clock :Commands	x x	x x	
Aux Mes- sages :All Sound Off :Reset All Cntrls :Local ON/OFF :All Notes OFF :Active Sense :Reset	x x x x x x	o(120,126,127) o(121) x o(123-125) o x	
Notes:*1 receive if switch is on. *2 m is always treated as "1" regardless of its value. *3 transmit/receive if exclusive switch is on.			

TONE GENERATOR MU128 PARTS LIST

■ CONTENTS

OVERALL ASSEMBLY	2
FRONT ASSEMBLY	4
ELECTRICAL PARTS	6

Note) DESTINATION ABBREVIATIONS

J : Japanese model	A : Australian model
U : U.S. model	E : European model
C : Canadian model	D : German model
X : General model	B : British model
M : South African model	I : Indonesian model
H : North European model	O : Chinese model

■ WARNING

Components having special characteristics are marked \triangle and must be replaced with parts having specifications equal to those originally installed.

- The numbers in "QTY" shows quantities for each unit.
- The parts with "–" in "Part No." are not available as spare parts.

OVERALL ASSEMBLY

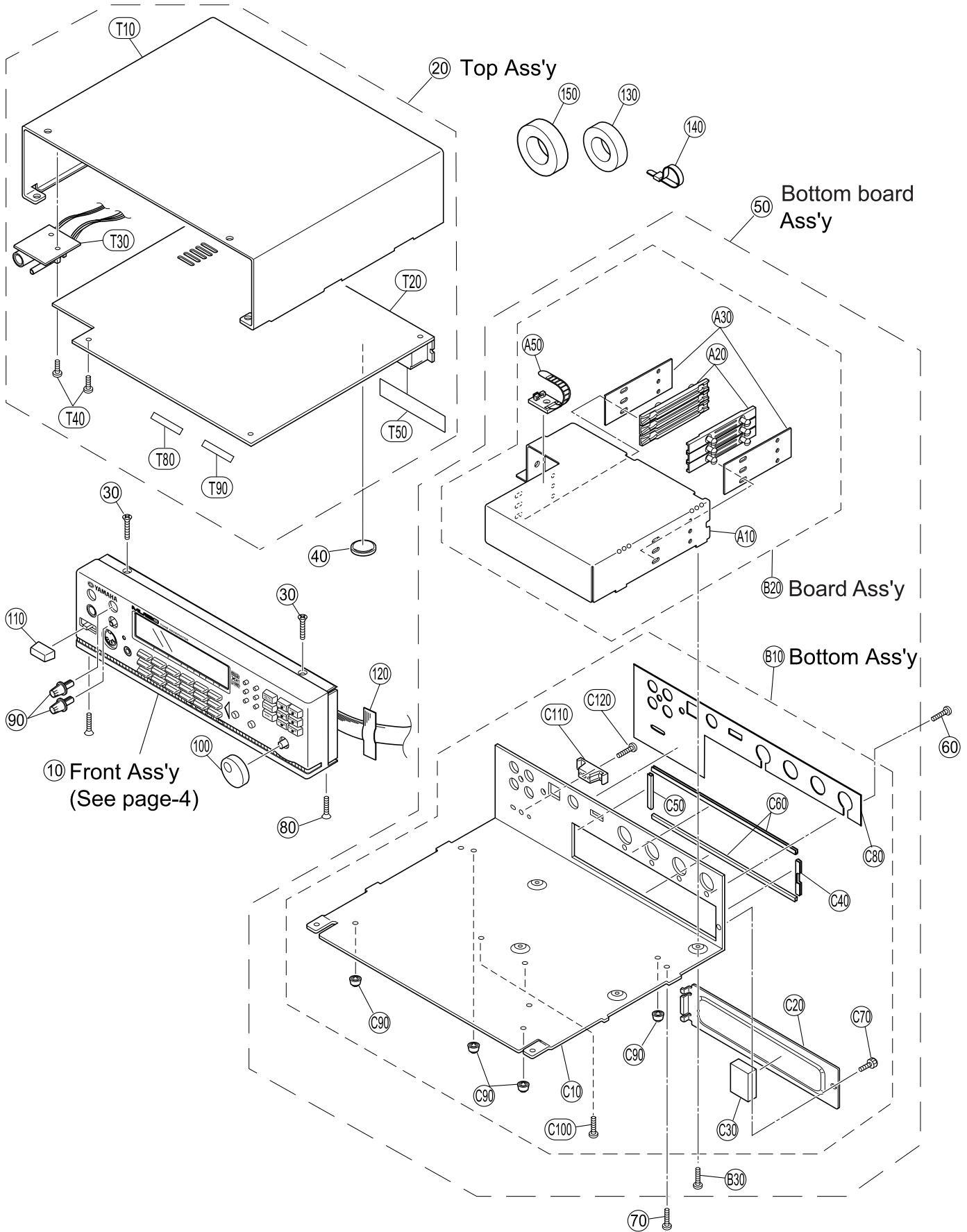

REF NO.	PART NO.	DESCRIPTION		REMARKS	QTY	RANK
10	--	OVERALL ASSEMBLY		MU128		
20	--	Front assembly		(V248540)		
30	V2500600	Flat Head Tapping Screw-C	3.0X8 MFNI33			
40	VN103500	Lithium Battery	CR2032		2	03
* 50	V2485600	Bottom board assembly		(V248560)		
60	VF646900	Bind Head Tapping Screw-B	3.0X8 MFNI33		4	01
70	EP600230	Bind Head Tapping Screw-B	3.0X6 MFZN2BL		2	01
80	V2500600	Flat Head Tapping Screw-C	3.0X8 MFNI33		2	
90	V2476000	Knob, VR		A/D INPUT,VOLUME	2	03
100	V2500700	Knob, Encoder	XG	Dial		04
110	V2493500	Knob, Power Switch		ON/STAND BY		03
120	VA126100	Adhesive Tape	12X50		4	03
130	VC362700	Ferrite Core	FR25/15/12-1400L		2	04
140	CB069250	Cord Holder	BK-1			01
* 150	V3221500	Ferrite Core	HF40T22X6.5X14			
	--	Top Assembly		(V248560)		
T10	V2486100	Top Cover				11
T20	V2271300	Circuit Board	DM			
T30	V2369700	Circuit Board	ADVR1			
T40	EP600230	Bind Head Tapping Screw-B	3.0X6 MFZN2BL		6	01
* T50	V3197600	Rear Shield				
* T80	V3298500	Contact Tape L				
* T90	V3314700	Contact Tape S			2	
	--	Bottom Board Assembly		(V248560)		
B10	--	Bottom Assembly		(V248630)		13
B20	--	Board Assembly		(V248640)		
B30	EP600230	Bind Head Tapping Screw-B	3.0X6 MFZN2BL		4	01
	V2486300	Bottom board Assembly				13
C10	--	Bottom cover		(V247620)		
C20	V2564100	Cover				07
C30	--	Sponge, Cover		(V248650)		
C40	--	Edge Cover A		(V248660)		
C50	--	Edge Cover B		(V248670)		
C60	--	Edge Cover C		(V248680)	2	
C70	V2517100	Screw	3.0X6			
C80	--	Rear Panel Sheet		(V248690)		
C90	V2487000	Foot	FF-013		4	03
C100	VB659000	Bind Head Screw	3.0X8 MFZN2BL		2	01
C110	VC407100	Cord Column				02
C120	VF646900	Bind Head Tapping Screw-B	3.0X8 MFNI33			01
	--	Board Assembly		(V248640)		
A10	--	Angle, Board		(V248620)		
A20	V2487100	Guide Rail	GR-80S	(V247670)	6	04
A30	--	Rail Spacer			2	
A50	VF852500	UL Clamp	UL-13G			02
		ACCESSORIES				
△	VZ089200	AC Adapter	PA-6	J		16
△	VZ282000	AC Adapter	PA-6 UL,CSA	U		
△	VZ089300	AC Adapter	PA-6 CE	E		15
	--	Magneto Optical Disk	12cm XGW	J	(XV030B0)	
	--	Magneto Optical Disk	12cm	U,E,W	(XV598A0)	

* : New parts

RANK : Japan only

FRONT ASSEMBLY

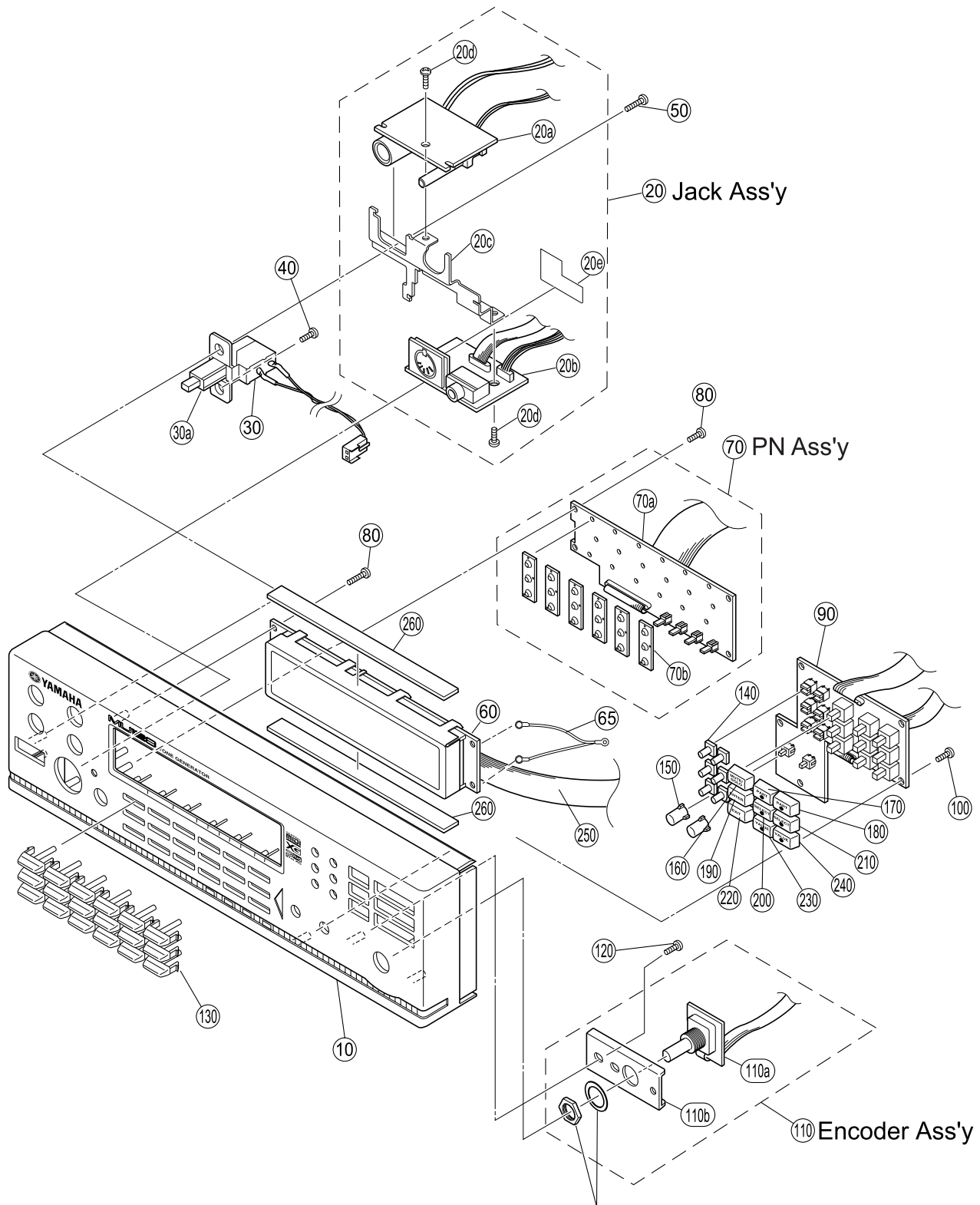

These parts pertain to the encoder (110a).

REF NO.	PART NO.	DESCRIPTION		REMARKS	QTY	RANK
10	--	Front assembly		MU128 (V248540)		11
20	--	Front Panel				
20a	V2369800	Jack assembly		(V248580)		
20b	V2369800	Circuit Board	ADMVR2			
20c	V2476500	Circuit Board	PMD			
20d	V2476500	Holder, Jack				05
20e	VC069600	Bind Head Tapping Screw-B	2.6X6 MFZN2Y		2	01
30	V3298600	Front Shield				
30a	V2482700	Power Switch Assembly				07
40	VC843500	Push Switch	SDDL1216A J.U.C.S			03
50	EP600230	Bind Head Tapping Screw-B	3.0X6 MFZN2BL		2	01
60	VD791000	Bind Head Tapping Screw-B	2.6X10 MFZN2Y			01
65	VS609700	LCD	DM113Z-5BL3			19
70	V3394300	GND Wire	LCD-DM			
70a	--	PN Assembly		(V248950)		
70a	V2369100	Circuit Board	LEDSW2			
70b	V2475900	Rubber Switch		Piano,Chrom.perc.,Organ, Guitar,Bass,Strings, Brass,Ensemble,Reed, Pipe,Synth lead, Synth pad,Synth effects, Ethnic,Percussive,SFX, Model excl.,Drum	6	03
80	VD791000	Bind Head Tapping Screw-B	2.6X10 MFZN2Y		8	01
90	V2369200	Circuit board	LEDSW1			
100	VC069600	Bind Head Tapping Screw-B	2.6X6 MFZN2Y		5	01
110	--	Encoder Assembly		Dial (V248600)		
110a	V2369600	Circuit Board	RE			
110b	VY794600	Angle, Encoder				03
120	EP600230	Bind Head Tapping Screw-B	3.0X6 MFZN2BL		2	01
130	V2493600	Button, VR			18	03
140	VM825700	Bitton, Mode	CBX-T3	PLAY,EDIT,UTIL,EFFECT, MODE,EQ SELECT,PART GROUP MUTE/SOLO	6	03
150	V2495300	OP Button			2	03
160	V2495800	Key top button	MS			04
170	V2495900	Key top button	P-	PART-		04
180	V2496100	Key top button	P+	PART+		04
190	V2496200	Key top button	EN	ENTER		04
200	V2496400	Key top button	S-	SELECT<		04
210	V2496500	Key top button	S+	SELECT>		04
220	V2496600	Key top button	EX	EXIT		04
230	V2496700	Key top button	V-	VALUE-		04
240	V2496800	Key top button	V+	VALUE+		04
250	VT020800	Cable, LCD	BNCD-P=1-L-16-250			03
260	--	LCD Sponge		(V295970)	2	

* : New parts

RANK : Japan only

ELECTRICAL PARTS

REF NO.	PART NO.	DESCRIPTION		REMARKS	QTY	RANK
		ELECTRICAL PARTS		MU128		
	V2369700	Circuit Board	ADVR1	(XU844B0)		
	V2369800	Circuit Board	ADMVR2	(XU844B0)		
	V2271300	Circuit Board	DM	(XU845B0)		
	V2369200	Circuit board	LEDSW1	(XU844B0)		
	V2369100	Circuit Board	LEDSW2	(XU844B0)		
	V2369000	Circuit Board	PMD	(XU844B0)		
	V2369600	Circuit Board	RE	(XU844B0)		
	V2271300	Circuit Board	DM	(XU845B0)		
20	EG330360	Bind Head Screw	3.0X6 MFZN2BL			01
30	VV488200	Holder, Jack				03
40	IL000690	Insulation Sheet	CSSX-G509			01
50	V2927700	Power Switch Assembly	15PX3L=300			08
BT1	VN103600	Battery Holder	CR2032			03
C1	UB044100	Monolithic Ceramic Cap.	F 0.010 50V Z			01
-3	UB044100	Monolithic Ceramic Cap.	F 0.010 50V Z			01
C4	UB052100	Monolithic Ceramic Cap.	SL 100P 50V J			01
C5	VR331500	Miller cap. (chip)	0.1000 50V J			01
C7	UR849100	Electrolytic Cap.	1000 25.0V			01
C8	UF037100	Electrolytic Cap. (chip)	10 16V			01
C9	UB245100	Monolithic Ceramic Cap.	F 0.100 25V Z			01
C10	UR848470	Electrolytic Cap.	470.00 25.0V			01
C11	UB245100	Monolithic Ceramic Cap.	F 0.100 25V Z			01
-13	UB245100	Monolithic Ceramic Cap.	F 0.100 25V Z			01
C14	UB044100	Monolithic Ceramic Cap.	F 0.010 50V Z			01
C15	VR331500	Miller cap. (chip)	0.1000 50V J			01
C16	UF066470	Electrolytic Cap. (chip)	4.7 50V			01
C17	UR839100	Electrolytic Cap.	1000 16.0V			01
C18	UB245100	Monolithic Ceramic Cap.	F 0.100 25V Z			01
C21	UB245100	Monolithic Ceramic Cap.	F 0.100 25V Z			01
C22	UF038100	Electrolytic Cap. (chip)	100 16V			01
C23	UR838470	Electrolytic Cap.	470.00 16.0V			01
C24	UB245100	Monolithic Ceramic Cap.	F 0.100 25V Z			01
C25	UF038100	Electrolytic Cap. (chip)	100 16V			01
C26	UB245100	Monolithic Ceramic Cap.	F 0.100 25V Z			01
C28	UB245100	Monolithic Ceramic Cap.	F 0.100 25V Z			01
C29	UF037100	Electrolytic Cap. (chip)	10 16V			01
C30	UB245100	Monolithic Ceramic Cap.	F 0.100 25V Z			01
C31	UB245100	Monolithic Ceramic Cap.	F 0.100 25V Z			01
C32	UF037100	Electrolytic Cap. (chip)	10 16V			01
C33	VD989700	Tantalum Capacitor	4.70 16V M			03
C34	UF037220	Electrolytic Cap. (chip)	22 16V			01
C35	UB013220	Monolithic Ceramic Cap.	B 2200P 50V K			01
C36	UB245100	Monolithic Ceramic Cap.	F 0.100 25V Z			01
C37	UF037220	Electrolytic Cap. (chip)	22 16V			01
C38	UB245100	Monolithic Ceramic Cap.	F 0.100 25V Z			01
C39	UB044100	Monolithic Ceramic Cap.	F 0.010 50V Z			01
C40	UB044100	Monolithic Ceramic Cap.	F 0.010 50V Z			01
C41	UB245100	Monolithic Ceramic Cap.	F 0.100 25V Z			01
C42	UB044100	Monolithic Ceramic Cap.	F 0.010 50V Z			01
C43	UB245100	Monolithic Ceramic Cap.	F 0.100 25V Z			01
C44	UB044100	Monolithic Ceramic Cap.	F 0.010 50V Z			01
C45	UB245100	Monolithic Ceramic Cap.	F 0.100 25V Z			01
C46	UF037100	Electrolytic Cap. (chip)	10 16V			01
C47	UB245100	Monolithic Ceramic Cap.	F 0.100 25V Z			01
C48	UB044100	Monolithic Ceramic Cap.	F 0.010 50V Z			01
C49	UB044100	Monolithic Ceramic Cap.	F 0.010 50V Z			01
C50	UF037100	Electrolytic Cap. (chip)	10 16V			01
C51	UB012470	Monolithic Ceramic Cap.	B 470P 50V K			01
C52	UB051270	Monolithic Ceramic Cap.	SL 27P 50V J			01
C53	UB051270	Monolithic Ceramic Cap.	SL 27P 50V J			01
C54	UF037100	Electrolytic Cap. (chip)	10 16V			01
C55	UB245100	Monolithic Ceramic Cap.	F 0.100 25V Z			01
C56	UB245100	Monolithic Ceramic Cap.	F 0.100 25V Z			01
C57	UB245100	Monolithic Ceramic Cap.	F 0.100 25V Z			01
C59	UB245100	Monolithic Ceramic Cap.	F 0.100 25V Z			01
C60	UB245100	Monolithic Ceramic Cap.	F 0.100 25V Z			01
-62	UB245100	Monolithic Ceramic Cap.	F 0.100 25V Z			01
C63	VQ686200	Monolithic Ceramic Cap.	F 1.0 16V Z			01

* : New parts

RANK : Japan only

REF NO.	PART NO.	DESCRIPTION		REMARKS	QTY	RANK
C64	VQ686200	Monolithic Ceramic Cap.	F 1.0 16V Z			01
C65	UB245100	Monolithic Ceramic Cap.	F 0.100 25V Z			01
C66	UB245100	Monolithic Ceramic Cap.	F 0.100 25V Z			01
C67	UF037470	Electrolytic Cap. (chip)	47 16V			01
C68	UB245100	Monolithic Ceramic Cap.	F 0.100 25V Z			01
C69	UB245100	Monolithic Ceramic Cap.	F 0.100 25V Z			01
C70	UF037470	Electrolytic Cap. (chip)	47 16V			01
C71	UB051470	Monolithic Ceramic Cap.	SL 47P 50V J			01
C72	UB051470	Monolithic Ceramic Cap.	SL 47P 50V J			01
C73	UB245100	Monolithic Ceramic Cap.	F 0.100 25V Z			01
-77	UB245100	Monolithic Ceramic Cap.	F 0.100 25V Z			01
C78	VQ686200	Monolithic Ceramic Cap.	F 1.0 16V Z			01
C79	VQ686200	Monolithic Ceramic Cap.	F 1.0 16V Z			01
C80	UB245100	Monolithic Ceramic Cap.	F 0.100 25V Z			01
C81	UF037470	Electrolytic Cap. (chip)	47 16V			01
-83	UF037470	Electrolytic Cap. (chip)	47 16V			01
C84	UF038100	Electrolytic Cap. (chip)	100 16V			01
C85	UB245100	Monolithic Ceramic Cap.	F 0.100 25V Z			01
C86	UB245100	Monolithic Ceramic Cap.	F 0.100 25V Z			01
C87	UF066470	Electrolytic Cap. (chip)	4.7 50V			01
C88	UF066470	Electrolytic Cap. (chip)	4.7 50V			01
C89	UB245100	Monolithic Ceramic Cap.	F 0.100 25V Z			01
C90	UB245100	Monolithic Ceramic Cap.	F 0.100 25V Z			01
C91	UB013680	Monolithic Ceramic Cap.	B 6800P 50V K			01
C92	UB013680	Monolithic Ceramic Cap.	B 6800P 50V K			01
C93	UB012470	Monolithic Ceramic Cap.	B 470P 50V K			01
C94	UF037470	Electrolytic Cap. (chip)	47 16V			01
C95	UB245100	Monolithic Ceramic Cap.	F 0.100 25V Z			01
-97	UB245100	Monolithic Ceramic Cap.	F 0.100 25V Z			01
C98	UF037100	Electrolytic Cap. (chip)	10 16V			01
C99	UF066470	Electrolytic Cap. (chip)	4.7 50V			01
C100	UB012470	Monolithic Ceramic Cap.	B 470P 50V K			01
C101	UF066470	Electrolytic Cap. (chip)	4.7 50V			01
C102	UB052270	Monolithic Ceramic Cap.	SL 270P 50V J			01
C103	UB052270	Monolithic Ceramic Cap.	SL 270P 50V J			01
C104	UB245100	Monolithic Ceramic Cap.	F 0.100 25V Z			01
-106	UB245100	Monolithic Ceramic Cap.	F 0.100 25V Z			01
C107	UB013680	Monolithic Ceramic Cap.	B 6800P 50V K			01
C108	UB013680	Monolithic Ceramic Cap.	B 6800P 50V K			01
C109	UF066100	Electrolytic Cap. (chip)	1 50V			01
C110	UB245100	Monolithic Ceramic Cap.	F 0.100 25V Z			01
C111	UF066100	Electrolytic Cap. (chip)	1 50V			01
C112	UB052180	Monolithic Ceramic Cap.	SL 180P 50V J			01
C113	UB245100	Monolithic Ceramic Cap.	F 0.100 25V Z			01
C114	UB245100	Monolithic Ceramic Cap.	F 0.100 25V Z			01
C115	UB052100	Monolithic Ceramic Cap.	SL 100P 50V J			01
C116	UB052100	Monolithic Ceramic Cap.	SL 100P 50V J			01
C117	UB245100	Monolithic Ceramic Cap.	F 0.100 25V Z			01
C118	UB052180	Monolithic Ceramic Cap.	SL 180P 50V J			01
C119	UB013330	Monolithic Ceramic Cap.	B 3300P 50V K			01
C120	UB245100	Monolithic Ceramic Cap.	F 0.100 25V Z			01
C121	UB245100	Monolithic Ceramic Cap.	F 0.100 25V Z			01
C122	UB052100	Monolithic Ceramic Cap.	SL 100P 50V J			01
C123	UB052100	Monolithic Ceramic Cap.	SL 100P 50V J			01
C124	UB013330	Monolithic Ceramic Cap.	B 3300P 50V K			01
C125	UB013120	Monolithic Ceramic Cap.	B 1200P 50V K			01
C126	UB245100	Monolithic Ceramic Cap.	F 0.100 25V Z			01
C127	UB013120	Monolithic Ceramic Cap.	B 1200P 50V K			01
C128	UF037220	Electrolytic Cap. (chip)	22 16V			01
C129	UF037220	Electrolytic Cap. (chip)	22 16V			01
C130	UF138220	Electrolytic Cap. (chip)	220 16V UUR1C2			01
C131	UF138220	Electrolytic Cap. (chip)	220 16V UUR1C2			01
C132	UB245100	Monolithic Ceramic Cap.	F 0.100 25V Z			01
C133	UB051470	Monolithic Ceramic Cap.	SL 47P 50V J			01
C134	UB051470	Monolithic Ceramic Cap.	SL 47P 50V J			01
C135	UB052100	Monolithic Ceramic Cap.	SL 100P 50V J			01
C136	UB052100	Monolithic Ceramic Cap.	SL 100P 50V J			01
C137	UB013100	Monolithic Ceramic Cap.	B 1000P 50V K			01
C138	UB013100	Monolithic Ceramic Cap.	B 1000P 50V K			01
C139	UF066470	Electrolytic Cap. (chip)	4.7 50V			01

* : New parts

RANK : Japan only

REF NO.	PART NO.	DESCRIPTION		REMARKS	QTY	RANK
C140	UF066470	Electrolytic Cap. (chip)	4.7 50V			01
C141	UF066100	Electrolytic Cap. (chip)	1 50V			01
C142	UF066100	Electrolytic Cap. (chip)	1 50V			01
C143	UB245100	Monolithic Ceramic Cap.	F 0.100 25V Z			01
-145	UB245100	Monolithic Ceramic Cap.	F 0.100 25V Z			01
C146	UB052100	Monolithic Ceramic Cap.	SL 100P 50V J			01
C147	UB052100	Monolithic Ceramic Cap.	SL 100P 50V J			01
C148	UB012470	Monolithic Ceramic Cap.	B 470P 50V K			01
C149	UB012470	Monolithic Ceramic Cap.	B 470P 50V K			01
C150	UB245100	Monolithic Ceramic Cap.	F 0.100 25V Z			01
C151	UF065220	Electrolytic Cap. (chip)	0.22 50V			01
C152	UF065220	Electrolytic Cap. (chip)	0.22 50V			01
C153	UB013220	Monolithic Ceramic Cap.	B 2200P 50V K			01
C154	UB013220	Monolithic Ceramic Cap.	B 2200P 50V K			01
C155	UB044100	Monolithic Ceramic Cap.	F 0.010 50V Z			01
C156	UB044100	Monolithic Ceramic Cap.	F 0.010 50V Z			01
C157	UF038100	Electrolytic Cap. (chip)	100 16V			01
C158	VQ686200	Monolithic Ceramic Cap.	F 1.0 16V Z			01
-160	VQ686200	Monolithic Ceramic Cap.	F 1.0 16V Z			01
C161	UF037100	Electrolytic Cap. (chip)	10 16V			01
C162	UB245100	Monolithic Ceramic Cap.	F 0.100 25V Z			01
C163	UF037100	Electrolytic Cap. (chip)	10 16V			01
C164	UB245100	Monolithic Ceramic Cap.	F 0.100 25V Z			01
C165	UF037100	Electrolytic Cap. (chip)	10 16V			01
C166	UF037100	Electrolytic Cap. (chip)	10 16V			01
C167	UB245100	Monolithic Ceramic Cap.	F 0.100 25V Z			01
C168	UF037100	Electrolytic Cap. (chip)	10 16V			01
C169	UB245100	Monolithic Ceramic Cap.	F 0.100 25V Z			01
C170	UF037100	Electrolytic Cap. (chip)	10 16V			01
C171	UF037100	Electrolytic Cap. (chip)	10 16V			01
C172	UB245100	Monolithic Ceramic Cap.	F 0.100 25V Z			01
-175	UB245100	Monolithic Ceramic Cap.	F 0.100 25V Z			01
C176	UF037100	Electrolytic Cap. (chip)	10 16V			01
C177	UF037100	Electrolytic Cap. (chip)	10 16V			01
-179	UF037100	Electrolytic Cap. (chip)	10 16V			01
C180	UB245100	Monolithic Ceramic Cap.	F 0.100 25V Z			01
-183	UB245100	Monolithic Ceramic Cap.	F 0.100 25V Z			01
C184	UB044100	Monolithic Ceramic Cap.	F 0.010 50V Z			01
C185	UB245100	Monolithic Ceramic Cap.	F 0.100 25V Z			01
C186	UF037470	Electrolytic Cap. (chip)	47 16V			01
C187	UF037470	Electrolytic Cap. (chip)	47 16V			01
C188	UB245100	Monolithic Ceramic Cap.	F 0.100 25V Z			01
-191	UB245100	Monolithic Ceramic Cap.	F 0.100 25V Z			01
C192	UF037470	Electrolytic Cap. (chip)	47 16V			01
C193	UF037470	Electrolytic Cap. (chip)	47 16V			01
C194	UB245100	Monolithic Ceramic Cap.	F 0.100 25V Z			01
C195	UB245100	Monolithic Ceramic Cap.	F 0.100 25V Z			01
C196	UF037100	Electrolytic Cap. (chip)	10 16V			01
C197	UB245100	Monolithic Ceramic Cap.	F 0.100 25V Z			01
C198	UB245100	Monolithic Ceramic Cap.	F 0.100 25V Z			01
CN2	VK024900	Wire Trap	52147 5P TE			01
CN6	VK024800	Wire Trap	52147 4P TE			01
CN7	VS666700	Connector	SLW 16P TE			02
CN8	VK025800	Wire Trap	52147 14P TE			01
CN9	VF667700	Wire Trap	52147 17P TE			01
CN10	VB390100	Connector Base Post	PH- 5P TE			01
CN11	VB390000	Connector Base Post	PH- 4P TE			01
CN12	VB390300	Connector Base Post	PH- 7P TE			01
CN13	LB932020	Base Post Connector	VH- 2P TE			01
D1	V2330500	Diode	DE5S4M			03
D2	VB493900	Diode	MA221			01
-6	VB493900	Diode	MA221			01
D7	VS201100	Diode	D1F60			01
D8	VB493900	Diode	MA221			01
-10	VB493900	Diode	MA221			01
D11	V2330500	Diode	DE5S4M			03
D12	VS201100	Diode	D1F60			01
D13	VB493900	Diode	MA221			01
-30	VB493900	Diode	MA221			01
D31	VS201100	Diode	D1F60			01

* : New parts

RANK : Japan only

REF NO.	PART NO.	DESCRIPTION		REMARKS	QTY	RANK
D32	VS201100	Diode	D1F60			01
D33	VB493900	Diode	MA221			01
D34	VB493900	Diode	MA221			01
IC1	XD657A00	IC	TC74HC14AF-TP1	SOP		02
IC2	VN686000	Photo Coupler	PC410T			04
-4	VN686000	Photo Coupler	PC410T			04
IC5	XI299A00	IC	TC74HC4050AF-T1	BUFFER		02
IC6	XT442A00	IC	SI-8050S	REGULATOR +5V		05
IC7	XR682A00	IC	TC7S66F	BILATERAL SWITCH		01
IC8	XD657A00	IC	TC74HC14AF-TP1	INVERTER		02
IC9	XM588A00	IC	TC7S32F	OR		01
IC10	XV063A00	IC	UPC2908T-E1	REGULATOR +8V		03
IC11	XI686A00	IC	M62021FP	RESET		04
IC12	XD599A00	IC	TC74HC32F-T1	OR		01
IC13	XD657A00	IC	TC74HC14AF-TP1	SOP		02
IC14	XS776A00	IC	TC74HC126AF	BUS BUFFER		02
IC15	XL545A00	IC	TC4W53F	ANALOG SW		02
IC16	XP881A00	IC	MC34051MEL	LINE TRANSCEIVER		05
IC16	XV103A00	IC	M5M34051FP	LINE TRANSCEIVER		05
IC17	XI348A00	IC	SC7SU04FEL	INVERTER		01
IC18	XD660A00	IC	TC74HCU04AF-TP1	INVERTER		01
IC19	XD657A00	IC	TC74HC14AF-TP1	SOP		02
IC20	XS681A00	IC	M5M51008BFP-70LLT	SRAM		11
IC21	XS936A00	IC	HD6437043E00F	CPU		11
IC22	XP596A00	IC	NJU7660M-T1	DC-DC CONVERTER		05
IC23	XS681A00	IC	M5M51008BFP-70LLT	SRAM		11
IC24	XS762A00	IC	UPD71051GU-10-E2	SERIAL CONTROL		06
* IC25	XV224B00	IC	450V105	FLASH ROM		
IC26	XR056A00	IC	TC74HC4051AF-TP	MULTIPLEXER		02
* IC27	XV217B00	IC	450V105	FLASH ROM		
IC28	XF291A00	IC	UPC4570G2	OP AMP		03
IC29	XF291A00	IC	UPC4570G2	OP AMP		03
IC30	XP003A00	IC	TC74HC74AF	D-F/F		01
IC31	XJ598A00	IC	NJM78L05UA	REGULATOR +5V		02
IC32	XF291A00	IC	UPC4570G2	OP AMP		03
IC33	XD603A00	IC	TC74HC245F-T1	TRANSCEIVER		04
IC34	XH223A00	IC	SN74HC273NSR	D-FF		01
IC35	XF291A00	IC	UPC4570G2	OP AMP		03
IC36	XP867A00	IC	UPD63200GS-E1	D/A CONVERTER		07
IC37	XH223A00	IC	SN74HC273NSR	D-FF		01
IC38	XH223A00	IC	SN74HC273NSR	D-FF		01
IC39	XU770A00	IC	PCM1800E/2K	A/D CONVERTER		07
IC40	XQ138A00	IC	NJM4556AMT1	SOP		03
IC41	XF291A00	IC	UPC4570G2	OP AMP		03
IC42	XF291A00	IC	UPC4570G2	OP AMP		03
IC43	XG385A00	IC	TC74HC4066AF-T1	BILATERAL SWITCH		02
IC44	XS776A00	IC	TC74HC126AF	BUS BUFFER		02
IC45	XN883A00	IC	TC7W14FU	INVERTER		02
IC48	XS438A00	IC	M5M44260CTP-7	DRAM 70NS		16
IC48	XU462A00	IC	MSM514260C-60TS-K	DRAM 70NS		16
IC49	XS438A00	IC	M5M44260CTP-7	DRAM 70NS		16
IC49	XU462A00	IC	MSM514260C-60TS-K	DRAM 70NS		16
IC50	XS725A00	IC	TC203C760HF-002	SWP30B		19
IC51	XS725A00	IC	TC203C760HF-002	SWP30B		19
IC52	XS048A00	IC	HD74LVC139FPEL	DECODER		03
IC53	XV364A00	IC	64M	WAVE ROM (1-L)		11
IC54	XV365A00	IC	64M	WAVE ROM (1-H)		11
IC55	XS516A00	IC	UPC2933T-E1	REGURATOR +3.3V		03
IC56	XS516A00	IC	UPC2933T-E1	REGURATOR +3.3V		03
IC57	XV366A00	IC	32M	WAVE ROM (2-L)		09
IC58	XV376A00	IC	32M	WAVE ROM (2-H)		09
EM1	VR193800	LC Filter	STF-104ZB-TBM			01
EM2	VR193800	LC Filter	STF-104ZB-TBM			01
EM3	VT332800	EMI Filter (chip)	NFM41P11C204			01
-9	VT332800	EMI Filter (chip)	NFM41P11C204			01
JK1	VJ207400	DC-IN Jack	16V DC 3A HEC2305	DC IN		01
JK2	VM761000	DIN Connector	DIN 8P MD-S810	TO HOST		03
JK3	VJ885500	DIN Connector	3P YKF51-5054	MIDI IN-A,MIDI IN-B		04
JK4	VJ885500	DIN Connector	3P YKF51-5054	MIDI THRU,MIDI OUT		04
JK5	VM725900	Pin Jack	YKC21-3282	OUTPUT L/R,INPUT L/R		02

* : New parts

RANK : Japan only

REF NO.	PART NO.	DESCRIPTION	REMARKS	QTY	RANK
K1	V2330700	Heat Sink	PUE 26-30		05
L1	VG238200	LC Filter	PLT2003C		04
L2	VL139800	Chip Solid inductance	BLM31A700SPT 70ohm		01
-4	VL139800	Chip Solid inductance	BLM31A700SPT 70ohm		01
L5	VR243700	Chip Inductance	56U LEM2520 T 560J		01
L6	VL139800	Chip Solid inductance	BLM31A700SPT 70ohm		01
L7	VR243700	Chip Inductance	56U LEM2520 T 560J		01
L8	VL139800	Chip Solid inductance	BLM31A700SPT 70ohm		01
-10	VL139800	Chip Solid Inductance	BLM31A700SPT 70ohm		01
L11	VR243700	Chip Inductance	56U LEM2520 T 560J		01
L12	VR243700	Chip Inductance	56U LEM2520 T 560J		01
L13	VL139800	Chip Solid Inductance	BLM31A700SPT 70ohm		01
L14	VR243700	Chip Inductance	56U LEM2520 T 560J		01
-19	VR243700	Chip Inductance	56U LEM2520 T 560J		01
L20	VL139800	Chip Solid Inductance	BLM31A700SPT 70ohm		01
-22	VL139800	Chip Solid Inductance	BLM31A700SPT 70ohm		01
L23	VZ875300	Coil	HP-032J		06
L24	VL139800	Chip Solid Inductance	BLM31A700SPT 70ohm		01
-39	VL139800	Chip Solid Inductance	BLM31A700SPT 70ohm		01
L40	VR243700	Chip Inductance	56U LEM2520 T 560J		01
L41	VR243700	Chip Inductance	56U LEM2520 T 560J		01
L42	VL139800	Chip Solid Inductance	BLM31A700SPT 70ohm		01
-72	VL139800	Chip Solid Inductance	BLM31A700SPT 70ohm		01
L73	VR243700	Chip Inductance	56U LEM2520 T 560J		01
-78	VR243700	Chip Inductance	56U LEM2520 T 560J		01
L79	VL139600	Chip Solid Inductance	BLM21B050SPT 5ohm		01
L80	VR243700	Chip Inductance	56U LEM2520 T 560J		01
L81	VR243700	Chip Inductance	56U LEM2520 T 560J		01
L82	VL139600	Chip Solid Inductance	BLM21B050SPT 5ohm		01
L83	VR243700	Chip Inductance	56U LEM2520 T 560J		01
L84	VR243700	Chip Inductance	56U LEM2520 T 560J		01
L85	VL139600	Chip Solid Inductance	BLM21B050SPT 5ohm		01
L86	VL139600	Chip Solid Inductance	BLM21B050SPT 5ohm		01
L87	VR243700	Chip Inductance	56U LEM2520 T 560J		01
L88	VL139800	Chip Solid Inductance	BLM31A700SPT 70ohm		01
L89	VL139600	Chip Solid Inductance	BLM21B050SPT 5ohm		01
L90	VL139600	Chip Solid Inductance	BLM21B050SPT 5ohm		01
R1	RD255100	Carbon Resistor (chip)	100.0 0.1 J		01
-17	RD255100	Carbon Resistor (chip)	100.0 0.1 J		01
R18	RD255100	Carbon Resistor (chip)	100.0 0.1 J		01
R19	RD255220	Carbon Resistor (chip)	220.0 0.1 J		01
R20	RD257100	Carbon Resistor (chip)	10.0K 0.1 J		01
R21	RD255220	Carbon Resistor (chip)	220.0 0.1 J		01
-26	RD255220	Carbon Resistor (chip)	220.0 0.1 J		01
R29	RD254560	Carbon Resistor (chip)	56.0 0.1 J		01
R30	RD257220	Carbon Resistor (chip)	22.0K 0.1 J		01
R31	RD254560	Carbon Resistor (chip)	56.0 0.1 J		01
R32	RD255100	Carbon Resistor (chip)	100.0 0.1 J		01
R33	RD257100	Carbon Resistor (chip)	10.0K 0.1 J		01
R34	RD255100	Carbon Resistor (chip)	100.0 0.1 J		01
R35	RD257100	Carbon Resistor (chip)	10.0K 0.1 J		01
R36	RD257100	Carbon Resistor (chip)	10.0K 0.1 J		01
R37	RD255100	Carbon Resistor (chip)	100.0 0.1 J		01
R38	RD257100	Carbon Resistor (chip)	10.0K 0.1 J		01
R39	RD255100	Carbon Resistor (chip)	100.0 0.1 J		01
-42	RD255100	Carbon Resistor (chip)	100.0 0.1 J		01
R43	RD256100	Carbon Resistor (chip)	1.0K 0.1 J		01
R44	RD256100	Carbon Resistor (chip)	1.0K 0.1 J		01
R45	RD256100	Carbon Resistor (chip)	1.0K 0.1 J		01
R46	RD255100	Carbon Resistor (chip)	100.0 0.1 J		01
R47	RD255100	Carbon Resistor (chip)	100.0 0.1 J		01
R48	RD257220	Carbon Resistor (chip)	22.0K 0.1 J		01
R49	RD256100	Carbon Resistor (chip)	1.0K 0.1 J		01
R50	RD256100	Carbon Resistor (chip)	1.0K 0.1 J		01
R51	RD257220	Carbon Resistor (chip)	22.0K 0.1 J		01
R52	RD256470	Carbon Resistor (chip)	4.7K 0.1 J		01
R53	RD257220	Carbon Resistor (chip)	22.0K 0.1 J		01
-56	RD257220	Carbon Resistor (chip)	22.0K 0.1 J		01
R57	RD257100	Carbon Resistor (chip)	10.0K 0.1 J		01
R58	RD257100	Carbon Resistor (chip)	10.0K 0.1 J		01

* : New parts

RANK : Japan only

REF NO.	PART NO.	DESCRIPTION		REMARKS	QTY	RANK
R59	RD257220	Carbon Resistor (chip)	22.0K 0.1 J			01
R60	RD257100	Carbon Resistor (chip)	10.0K 0.1 J			01
-63	RD257100	Carbon Resistor (chip)	10.0K 0.1 J			01
R64	RD257220	Carbon Resistor (chip)	22.0K 0.1 J			01
-66	RD257220	Carbon Resistor (chip)	22.0K 0.1 J			01
R67	RD255680	Carbon Resistor (chip)	680.0 0.1 J			01
R68	RD258680	Carbon Resistor (chip)	680.0K 0.1 J			01
R69	RD255680	Carbon Resistor (chip)	680.0 0.1 J			01
R71	RD250000	Carbon Resistor (chip)	0.0 0.0 J			01
R72	RD256240	Carbon Resistor (chip)	2.4K 0.1 J			01
R73	RD256300	Carbon Resistor (chip)	3.0K 0.1 J			01
R74	RD250000	Carbon Resistor (chip)	0.0 0.0 J			01
R75	RD259100	Carbon Resistor (chip)	1.0M 0.1 J			01
R76	RD256330	Carbon Resistor (chip)	3.3K 0.1 J			01
R77	RD256360	Carbon Resistor (chip)	3.6K 0.1 J			01
R79	RD256470	Carbon Resistor (chip)	4.7K 0.1 J			01
-82	RD256470	Carbon Resistor (chip)	4.7K 0.1 J			01
R84	RD257220	Carbon Resistor (chip)	22.0K 0.1 J			01
R85	RD257100	Carbon Resistor (chip)	10.0K 0.1 J			01
R86	RD250000	Carbon Resistor (chip)	0.0 0.0 J			01
R88	RD256160	Carbon Resistor (chip)	1.6K 0.1 J			01
R89	RD255470	Carbon Resistor (chip)	470.0 0.1 J			01
R91	RD256100	Carbon Resistor (chip)	1.0K 0.1 J			01
R92	RD256200	Carbon Resistor (chip)	2.0K 0.1 J			01
R93	RD257220	Carbon Resistor (chip)	22.0K 0.1 J			01
R94	RD257220	Carbon Resistor (chip)	22.0K 0.1 J			01
R95	RD250000	Carbon Resistor (chip)	0.0 0.0 J			01
R96	RD250000	Carbon Resistor (chip)	0.0 0.0 J			01
R98	RD256100	Carbon Resistor (chip)	1.0K 0.1 J			01
R99	RD258100	Carbon Resistor (chip)	100.0K 0.1 J			01
R100	RD258100	Carbon Resistor (chip)	100.0K 0.1 J			01
R101	RD256100	Carbon Resistor (chip)	1.0K 0.1 J			01
R102	RD256100	Carbon Resistor (chip)	1.0K 0.1 J			01
R103	RD255220	Carbon Resistor (chip)	220.0 0.1 J			01
R104	RD256330	Carbon Resistor (chip)	3.3K 0.1 J			01
R105	RD255680	Carbon Resistor (chip)	680.0 0.1 J			01
R106	RD257100	Carbon Resistor (chip)	10.0K 0.1 J			01
R107	RD257220	Carbon Resistor (chip)	22.0K 0.1 J			01
R110	RD250000	Carbon Resistor (chip)	0.0 0.0 J			01
R111	RD154470	Carbon Resistor (chip)	47.0 1/4 J			01
-114	RD154470	Carbon Resistor (chip)	47.0 1/4 J			01
R115	RD257360	Carbon Resistor (chip)	36.0K 0.1 J			01
R116	RD257360	Carbon Resistor (chip)	36.0K 0.1 J			01
R117	RD257150	Carbon Resistor (chip)	15.0K 0.1 J			01
R118	RD257150	Carbon Resistor (chip)	15.0K 0.1 J			01
R119	RD155470	Carbon Resistor (chip)	470.0 1/4 J			01
R120	RD255100	Carbon Resistor (chip)	100.0 0.1 J			01
R121	RD257100	Carbon Resistor (chip)	10.0K 0.1 J			01
R125	RD256680	Carbon Resistor (chip)	6.8K 0.1 J			01
R126	RD256270	Carbon Resistor (chip)	2.7K 0.1 J			01
R127	RD257100	Carbon Resistor (chip)	10.0K 0.1 J			01
R128	RD256680	Carbon Resistor (chip)	6.8K 0.1 J			01
R130	RD256470	Carbon Resistor (chip)	4.7K 0.1 J			01
R131	RD257220	Carbon Resistor (chip)	22.0K 0.1 J			01
R133	RD257120	Carbon Resistor (chip)	12.0K 0.1 J			01
R134	RD257120	Carbon Resistor (chip)	12.0K 0.1 J			01
R135	RD256470	Carbon Resistor (chip)	4.7K 0.1 J			01
R136	RD256680	Carbon Resistor (chip)	6.8K 0.1 J			01
R137	RD256470	Carbon Resistor (chip)	4.7K 0.1 J			01
R138	RD256680	Carbon Resistor (chip)	6.8K 0.1 J			01
R139	RD255270	Carbon Resistor (chip)	270.0 0.1 J			01
-146	RD255270	Carbon Resistor (chip)	270.0 0.1 J			01
R147	RD256470	Carbon Resistor (chip)	4.7K 0.1 J			01
R148	RD256470	Carbon Resistor (chip)	4.7K 0.1 J			01
R149	RD256100	Carbon Resistor (chip)	1.0K 0.1 J			01
R150	RD256100	Carbon Resistor (chip)	1.0K 0.1 J			01
R151	RD256470	Carbon Resistor (chip)	4.7K 0.1 J			01
R152	RD256470	Carbon Resistor (chip)	4.7K 0.1 J			01
R153	RD257100	Carbon Resistor (chip)	10.0K 0.1 J			01
R154	RD257100	Carbon Resistor (chip)	10.0K 0.1 J			01

* : New parts

RANK : Japan only

REF NO.	PART NO.	DESCRIPTION		REMARKS	QTY	RANK
R155	RD256820	Carbon Resistor (chip)	8.2K 0.1 J			01
R156	RD256820	Carbon Resistor (chip)	8.2K 0.1 J			01
R157	RD257240	Carbon Resistor (chip)	24.0K 0.1 J			01
R158	RD257240	Carbon Resistor (chip)	24.0K 0.1 J			01
R159	RD257100	Carbon Resistor (chip)	10.0K 0.1 J			01
-161	RD257100	Carbon Resistor (chip)	10.0K 0.1 J			01
R162	RD256820	Carbon Resistor (chip)	8.2K 0.1 J			01
R163	RD256820	Carbon Resistor (chip)	8.2K 0.1 J			01
R164	RD257240	Carbon Resistor (chip)	24.0K 0.1 J			01
R165	RD257240	Carbon Resistor (chip)	24.0K 0.1 J			01
R166	RD255470	Carbon Resistor (chip)	470.0 0.1 J			01
R167	RD255470	Carbon Resistor (chip)	470.0 0.1 J			01
R168	RD257100	Carbon Resistor (chip)	10.0K 0.1 J			01
R169	RD257100	Carbon Resistor (chip)	10.0K 0.1 J			01
R170	RD257120	Carbon Resistor (chip)	12.0K 0.1 J			01
R172	RD257100	Carbon Resistor (chip)	10.0K 0.1 J			01
-176	RD257100	Carbon Resistor (chip)	10.0K 0.1 J			01
R177	RD258100	Carbon Resistor (chip)	100.0K 0.1 J			01
R178	RD258100	Carbon Resistor (chip)	100.0K 0.1 J			01
R179	RD257100	Carbon Resistor (chip)	10.0K 0.1 J			01
R180	RD257100	Carbon Resistor (chip)	10.0K 0.1 J			01
R181	RD154470	Carbon Resistor (chip)	47.0 1/4 J			01
R182	RD256100	Carbon Resistor (chip)	1.0K 0.1 J			01
R183	RD154470	Carbon Resistor (chip)	47.0 1/4 J			01
R184	RD256100	Carbon Resistor (chip)	1.0K 0.1 J			01
R185	RD257100	Carbon Resistor (chip)	10.0K 0.1 J			01
R186	RD257100	Carbon Resistor (chip)	10.0K 0.1 J			01
R187	RD258100	Carbon Resistor (chip)	100.0K 0.1 J			01
R188	RD258100	Carbon Resistor (chip)	100.0K 0.1 J			01
R189	RD256330	Carbon Resistor (chip)	3.3K 0.1 J			01
R190	RD257100	Carbon Resistor (chip)	10.0K 0.1 J			01
R191	RD257100	Carbon Resistor (chip)	10.0K 0.1 J			01
R192	RD256330	Carbon Resistor (chip)	3.3K 0.1 J			01
R193	RD256100	Carbon Resistor (chip)	1.0K 0.1 J			01
R194	RD256100	Carbon Resistor (chip)	1.0K 0.1 J			01
-196	RD256100	Carbon Resistor (chip)	1.0K 0.1 J			01
R197	RD256100	Carbon Resistor (chip)	1.0K 0.1 J			01
R198	RD258100	Carbon Resistor (chip)	100.0K 0.1 J			01
R199	RD256100	Carbon Resistor (chip)	1.0K 0.1 J			01
R200	RD258100	Carbon Resistor (chip)	100.0K 0.1 J			01
R201	RD254100	Carbon Resistor (chip)	10.0 0.1 J			01
R202	RD255150	Carbon Resistor (chip)	150.0 0.1 J			01
R203	RD254680	Carbon Resistor (chip)	68.0 0.1 J			01
R204	RD257470	Carbon Resistor (chip)	47.0K 0.1 J			01
R205	RD258100	Carbon Resistor (chip)	100.0K 0.1 J			01
R206	RD257220	Carbon Resistor (chip)	22.0K 0.1 J			01
R208	RD254680	Carbon Resistor (chip)	68.0 0.1 J			01
R209	RD254680	Carbon Resistor (chip)	68.0 0.1 J			01
R210	RD257470	Carbon Resistor (chip)	47.0K 0.1 J			01
R213	RD254680	Carbon Resistor (chip)	68.0 0.1 J			01
R214	RD254680	Carbon Resistor (chip)	68.0 0.1 J			01
R215	RD257100	Carbon Resistor (chip)	10.0K 0.1 J			01
R216	RD257100	Carbon Resistor (chip)	10.0K 0.1 J			01
R217	RD250000	Carbon Resistor (chip)	0.0 0.0 J			01
R219	RD250000	Carbon Resistor (chip)	0.0 0.0 J			01
R221	RD255680	Carbon Resistor (chip)	680.0 0.1 J			01
R224	RD257220	Carbon Resistor (chip)	22.0K 0.1 J			01
R225	RD257100	Carbon Resistor (chip)	10.0K 0.1 J			01
RA1	RE047220	Resistor Array	22KX4			01
-5	RE047220	Resistor Array	22KX4			01
RA6	RE044000	Resistor Array (chip)	0X4			01
-10	RE044000	Resistor Array (chip)	0X4			01
RA11	RE047220	Resistor Array	22KX4			01
-13	RE047220	Resistor Array	22KX4			01
RA14	RE044000	Resistor Array (chip)	0X4			01
-20	RE044000	Resistor Array (chip)	0X4			01
RA21	RE044680	Resistor Array	68X4			01
RA22	RE044000	Resistor Array (chip)	0X4			01
-25	RE044000	Resistor Array (chip)	0X4			01
RA26	RE044680	Resistor Array	68X4			01

* : New parts

RANK : Japan only

REF NO.	PART NO.	DESCRIPTION		REMARKS	QTY	RANK
RA27	RE044680	Resistor Array	68X4			01
RA28	RE046470	Resistor Array	4.7KX4			01
RA29	RE046470	Resistor Array	4.7KX4			01
RA30	RE047100	Resistor Array	10KX4			01
RA31	RE047100	Resistor Array	10KX4			01
RA32	RE044680	Resistor Array	68X4			01
-63	RE044680	Resistor Array	68X4			01
SW1	VQ665200	Slide Switch	SSSF144-S06N-0			03
TA1	VQ248400	Transistor Array	TD62783AF			04
TR2	VD303700	Transistor	2SC3326 A,B TE85R			01
TR3	VD456900	Transistor	2SCDTC143XK			01
-8	VD456900	Transistor	2SCDTC143XK			01
TR9	VD303700	Transistor	2SC3326 A,B TE85R			01
TR10	VD303700	Transistor	2SC3326 A,B TE85R			01
TR11	VJ927200	Transistor	2SA1162 O,Y			01
X1	V2330600	Ceramic Resonator	CSTCC10.0MG0H6-TC			01
X2	VV762900	Quartz Crystal Unit	7M SMD-49			03
X3	VV335600	Quartz Crystal Unit	33.8688M DSO751S			06
ZD1	VU171500	Zener Diode	UDZ 3.6BTE-17 3.6V			01
	V2369700	Circuit Board	ADVR1	(XU844B0)		
	V2369800	Circuit Board	ADMVR2	(XU844B0)		
	V2369200	Circuit board	LEDSW1	(XU844B0)		
	V2369100	Circuit Board	LEDSW2	(XU844B0)		
	V2369000	Circuit Board	PMD	(XU844B0)		
	V2369600	Circuit Board	RE	(XU844B0)		
10	V2493700	LED Spacer	H=4.5			03
20	--	Connector Assembly	10P L=300	(V234440)		
30	--	Connector Assembly	7P L=300	(V234450)		
40	--	Connector Assembly	14P L=250	(V234520)		
60	--	Connector Assembly	5P L=250	(V234460)		
70	--	Connector Assembly	4P L=300	(V234430)		
CN1	VI878300	Cable Holder	51048 5P TE			01
CN2	--	Connector Assembly	L=250	(V234470)		
CN3	VI879200	Cable Holder	51048 14P TE			01
CN4	--	Connector Assembly	L=100	(V234390)		
CN5	--	Connector Assembly	L=180	(V234420)		
CN6	VB389900	Connector Base Post	PH- 3P TE			01
CN7	--	Connector Assembly	L=100	(V234410)		
CN8	VI878800	Cable Holder	51048 10P TE			01
CN9	VI878200	Cable Holder	51048 4P TE			01
CN10	VI878500	Cable Holder	51048 7P TE			01
EC1	VU481300	Encoder	REB161 PVB 15F	Dial		03
JK1	V2240900	DIN Connector	5P TCS5031-454151	MIDI IN A		03
JK2	VM552100	Phone Jack	HSJ0912-01-01	PHONES		02
JK3	VT160000	Phone Jack	YKB26-5218	2		05
JK4	VT160000	Phone Jack	YKB26-5218	1		05
LD1	V2483600	LED	GL8EG42	MU,PLG-1,PLG-2		01
-4	V2483600	LED	GL8EG42	PLG-3		01
SW2	VK701100	Push Switch	SKHQFN GREEN	PLAY,UTIL,MODE		02
-4	VK701100	Push Switch	SKHQFN GREEN			02
SW5	VN121700	Push Switch	SKHPPP	SELECT		01
SW6	VK701100	Push Switch	SKHQFN GREEN	EDIT,EFFECT,EQ		02
-8	VK701100	Push Switch	SKHQFN GREEN			02
SW9	VN121700	Push Switch	SKHPPP	PART GROUP		01
SW10	KA906550	Push Switch	KEC10901	MUTE/SOLO,ENTER,EXIT,		02
-18	KA906550	Push Switch	KEC10901	VALUE-,SELECT<,PART-		02
VR1	V2293000	Rotary Variable Resistor	A10K X2 RK09K12A0	VOLUME		03
VR2	V2292900	Rotary Variable Resistor	A50K X2 RK09K12A0	A/D INPUT		03
	VN103500	Lithium Battery	CR2032			03
	VS609700	LCD	DM113Z-5BL3			19
	VC843500	Push Switch	SDDL1216A J.U.C.S			03

* : New parts

RANK : Japan only

MU128 OVERALL CIRCUIT DIAGRAM 1/2

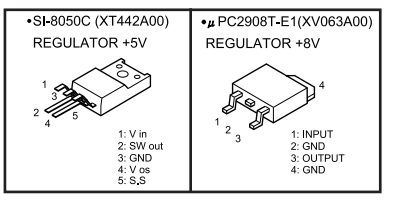
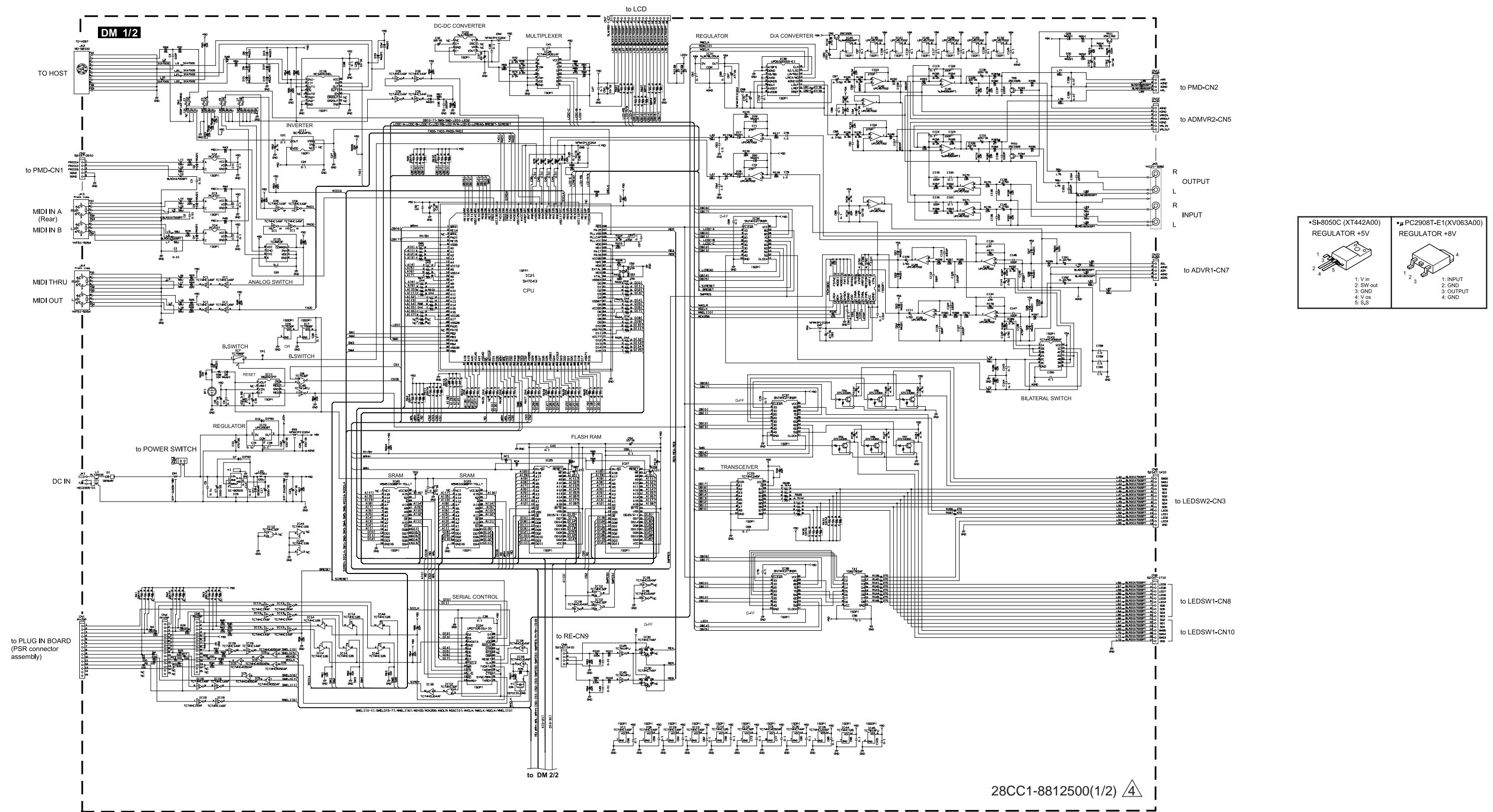

Note: See parts list for details of circuit board component parts.

MU128 OVERALL CIRCUIT DIAGRAM 2/2

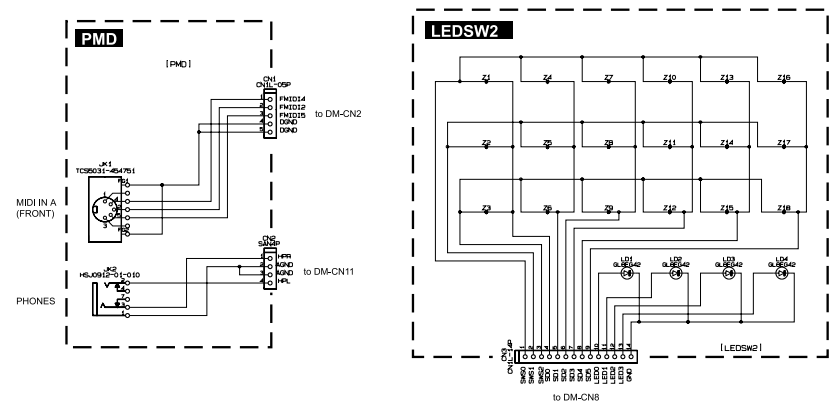
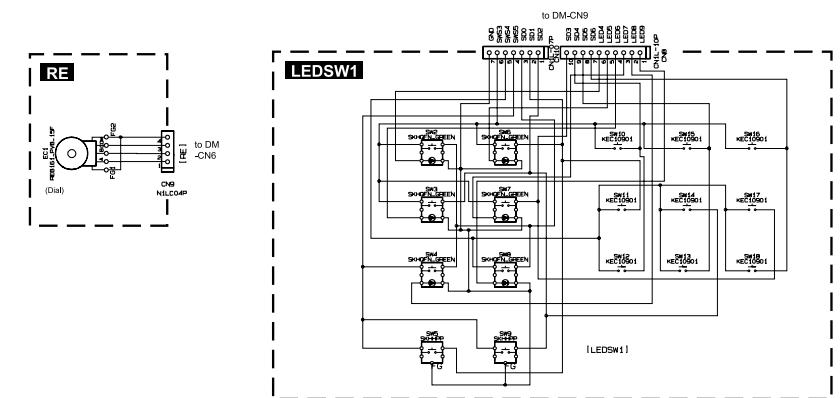
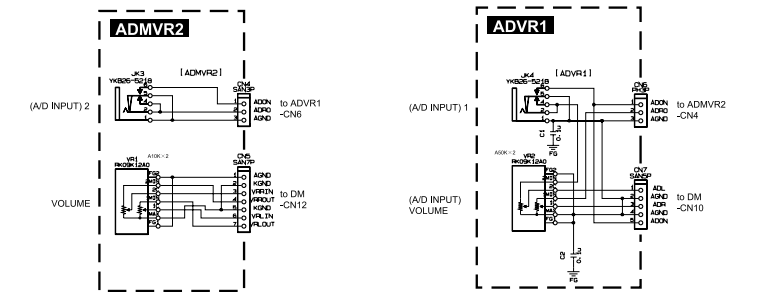
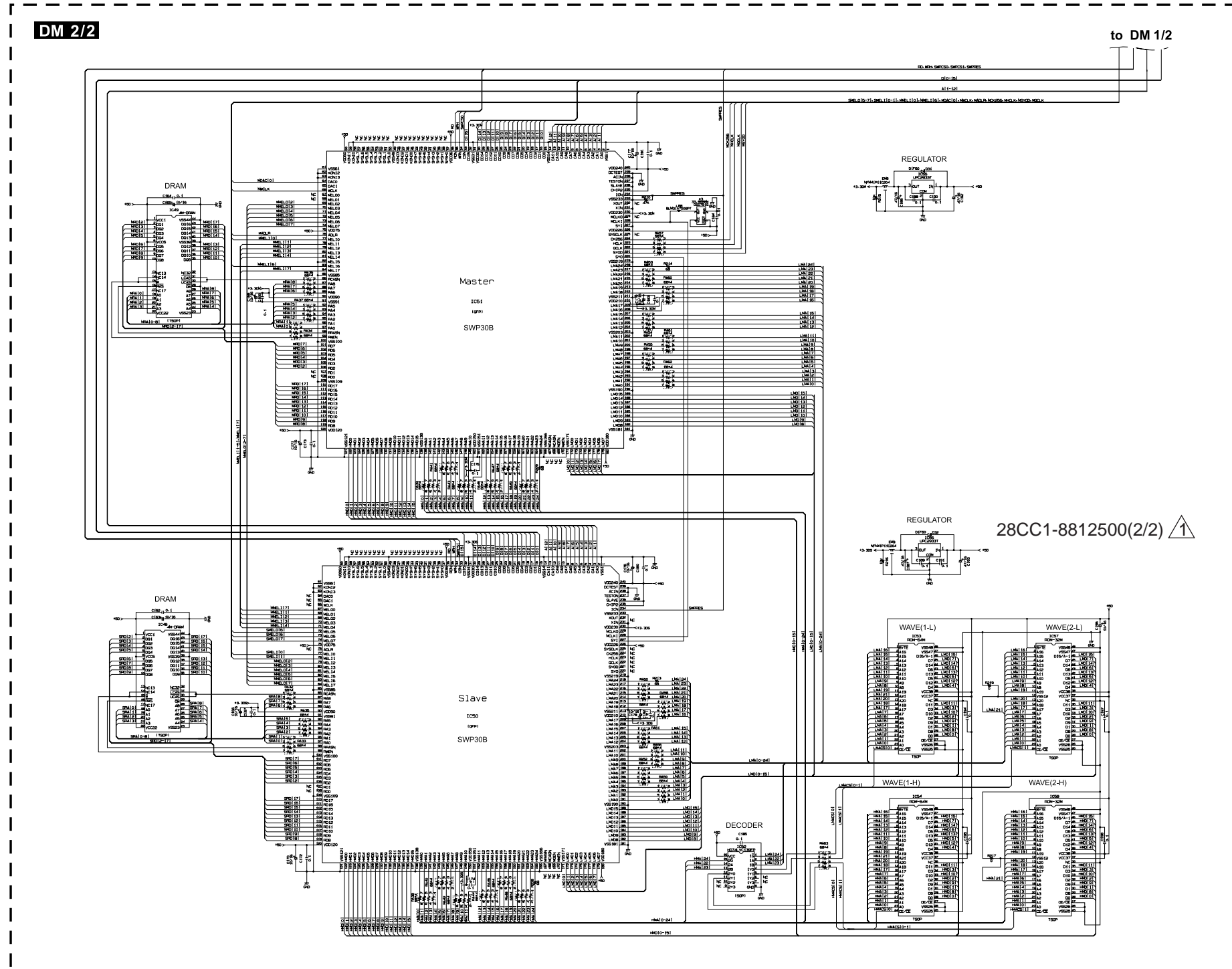

Note: See parts list for details of circuit board component parts.

- ADMVR2 : 28CC1-8812502
- RE : 28CC1-8812502
- PMD : 28CC1-8812502
- ADVR1 : 28CC1-8812502
- LED SW1 : 28CC1-8812502
- LED SW2 : 28CC1-8812502