

YAMAHA TONE GENERATOR MU90R SERVICE MANUAL



■ CONTENTS (目次)

SPECIFICATIONS (総合仕様)	2/3
PANEL LAYOUT (パネルレイアウト)	4
CIRCUIT BOARD LAYOUT (ユニットレイアウト)	5
BLOCK DIAGRAM (ブロックダイアグラム)	6
DISASSEMBLY PROCEDURE (分解手順)	7
LSI PIN DESCRIPTION (LSI端子機能表)	11
IC BLOCK DIAGRAM (ICブロック図)	14
TEST PROGRAM (テストプログラム)	16/25
MIDI/COMPUTER CONNECTING CABLES (コンピュータ接続ケーブルについて)	22/31
ERROR MESSAGES (エラーメッセージ)	23/32
INITIALIZE (イニシャライズ)	24/33
MIDI DATA FORMAT (MIDIデータフォーマット)	34
EFFECT PROGRAM LIST (エフェクトプログラムリスト)	57
EFFECT PARAMETER LIST (エフェクトパラメータリスト)	63
MIDI IMPLEMENTATION CHART	70
CIRCUIT BOARDS (シート基板図)	72
OVERALL CIRCUIT DIAGRAM (総回路図)	75
PARTS LIST	

IMPORTANT NOTICE

This manual has been provided for the use of authorized Yamaha Retailers and their service personnel. It has been assumed that basic service procedures inherent to the industry, and more specifically Yamaha Products, are already known and understood by the users, and have therefore not been restated.

WARNING: Failure to follow appropriate service and safety procedures when servicing this product may result in personal injury, destruction of expensive components and failure of the product to perform as specified. For these reasons, we advise all Yamaha product owners that all service required should be performed by an authorized Yamaha Retailer or the appointed service representative.

IMPORTANT: This presentation or sale of this manual to any individual or firm does not constitute authorization, certification, recognition of any applicable technical capabilities, or establish a principal-agent relationship of any form.

The data provided is believed to be accurate and applicable to the unit(s) indicated on the cover. The research engineering, and service departments of Yamaha are continually striving to improve Yamaha products. Modifications are, therefore, inevitable and changes in specification are subject to change without notice or obligation to retrofit. Should any discrepancy appear to exist, please contact the distributor's Service Division.

WARNING: Static discharges can destroy expensive components. Discharge any static electricity you body may have accumulated by grounding yourself to the ground buss in the unit (heavy gauge black wires connect to this buss.)

IMPORTANT: Turn the unit OFF during disassembly and parts replacement. Recheck all work before you apply power to the unit.

LITHIUM BATTERY HANDLING

This product uses a lithium battery for memory back-up.

WARNING: Lithium batteries are dangerous because they can be exploded by improper handling. Observe the following precautions when handling or replacing lithium batteries.

- Leave lithium battery replacement to qualified service personnel.
- Always replace with batteries of the same type.
- When installing on the PC board by soldering, solder using the connection terminals provided on the battery cells. Never solder directly to the cells. Perform the soldering as quickly as possible.
- Never reverse the battery polarities when installing.
- Do not short the batteries.
- Do not attempt to recharge these batteries.
- Do not disassemble the batteries.
- Never heat batteries or throw them into fire.

ADVARSEL!

Lithiumbatteri-Eksplosionsfare ved fejlagtig håndtering. Udskiftning må kun ske med batteri af samme fabrikat og type. Levér det brugte batteri tilbage til leverandøren.

VARNING

Explosionsfara vid felaktigt batteribyte. Använd samma batterityp eller en ekvivalent typ som rekommenderas av apparattillverkaren. Kassera använt batteri enligt fabrikantens instruktion.

VAROITUS

Paristo voi räjähtää, jos se on virheellisesti asennettu. Vaihda paristo ainoastaan laitevalmistajan suosittelemaan tyyppiin. Hävitä käytetty paristo valmistajan ohjeiden mukaisesti.

The following information complies with Dutch Official Gazette 1995. 45; ESSENTIALS OF ORDER ON THE COLLECTION OF BATTERIES.

- Please refer to the disassembly procedure for the removal of Back-up Battery.
- Leest u voor het verwijderen van de backup batterij deze beschrijving.

WARNING: CHEMICAL CONTENT NOTICE!

The solder used in the production of this product contains LEAD. In addition, other electrical/electronic and/or plastic (where applicable) components may also contain traces of chemicals found by the California Health and Welfare Agency (and possibly other entities) to cause cancer and/or birth defects or other reproductive harm.

DO NOT PLACE SOLDER, ELECTRICAL/ELECTRONIC OR PLASTIC COMPONENTS IN YOUR MOUTH FOR ANY REASON WHATSOEVER!

Avoid prolonged, unprotected contact between solder and your skin! When soldering, do not inhale solder fumes or expose eyes to solder/flux vapor!

If you come in contact with solder or components located inside the enclosure of this product, wash your hands before handling food.

■ WARNING

Components having special characteristics are marked Δ and must be replaced with parts having specification equal to those originally installed.

Δ 印の商品は、安全を維持するために重要な部品です。交換する場合は、安全のため必ず指定の部品をご使用下さい。

SPECIFICATIONS

Controls

VOLUME control; A/D INPUT level control; Mode select buttons: PLAY, UTIL (UTILITY), MODE, EDIT, EFFECT, EQ; other buttons: MUTE/SOLO, ENTER, EXIT, PART \ominus/\oplus , SELECT \odot/\bullet , VALUE \ominus/\oplus ; data dial; POWER button

Jacks and Terminals

Front panel: PHONES jack (1/4"), A/D INPUT 1, 2 jacks (1/4"), Rear panel: INDIVIDUAL OUTPUT 1, 2 jacks; OUTPUT R, L/MONO jacks (Right, Left/Mono); DC IN jack; TO HOST terminal; HOST SELECT switch; MIDI IN A/B, MIDI OUT, and MIDI THRU terminals

Computer/MIDI Interface

Direct connection to host computer port (RS-232C, RS-422) with optional cables (CCJ-PC1, CCJ-PC1, CCJ-MAC); MIDI terminals allow connection to MIDI sequencer or MIDI controller

Data Transfer (Baud) Rate

MIDI — 31,250 bps (bits per second)
 Mac — 31,250 bps
 PC-1 — 31,250 bps
 PC-2 — 38,400 bps

Power Supply

Yamaha PA-3B AC Adaptor (included)

Dimensions (W x D x H)

483 x 229 x 44 mm (19" x 9" x 1-3/4")

Weight

2.4 kg (5 lbs., 5 oz.)

Included Accessories

Owner's Manual, Yamaha PA-3B AC Adaptor

Output Level

Refer to the TEST PROGRAM section of this manual.

Tone Generation Method

AWM2 (Advanced Wave Memory 2)

Maximum Simultaneous Polyphony

64-note

Sound Module Modes

XG (Extended General MIDI), TG300B, C/M, and Performance

Multi-timbral Capacity

32-Part (on 32 MIDI channels; with element reserve priority for later notes and dynamic Voice allocation)

Internal Voice/Program Structure

Normal Programs

Total Voices 779
 XG mode 586
 TG300B mode 614
 C/M mode 128 (Parts 1 — 9), 64 (Parts 11 — 16)

Drum Programs

Total Programs 30
 XG mode 20
 TG300B mode 10
 C/M mode 1

Performance Programs

Up to four Voices plus all effect settings can be memorized to a Performance.

Preset Programs 100
 User Programs 100

Effects

Five sections of multi-effects: Reverb (12 Types), Chorus (14 Types), Variation (62 Types), Insertion 1, 2 (43 Types), and EQ (4 Types)

Demo Song

1 (not editable, stored in ROM)

Display

Custom back-lit LCD

■ 総合仕様

1. 機能

音源	AWM2音源
最大同時発音数	64音
サウンドモジュールモード	XG, TG300B (GM-B), C/M, Performance
発音方式	32チャンネル・マルチティンバー エレメントリザーブ付後着優先、DVA
エフェクター	6基搭載 リバーブ、コーラス、バリエーション、インサーション1,2、イコライザー
インターフェース機能	別売ケーブル (CCJ-PC1, CCJ-PC2, CCJ-MAC, CCJ-PCINF) にてRS-232C、RS-422ポートと直接接続可能 MIDIシーケンサー、MIDIキーボードに接続可能

2. 内部構成

音色数	ノーマル音色	トータル	779
		XG	586
		TG300B	614
		C/M	128 (Tr.1-9), 64 (Tr.11-16)
	ドラム音色	トータル	30
		XG	20
		TG300B	10
		C/M	1
エフェクター種類	パフォーマンス プリセット	4レイヤーまで可能、エフェクトもメモリー	
			100
	インターナル		100
		リバーブ	12
	コーラス		14
		バリエーション	62
	インサーション1,2		各43
		イコライザー	4

3. ディスプレイ

LCD	カスタムLCD (バックライト付)
LED	6個 (スイッチに内蔵)

4. 操作子

[PLAY]	[UTIL]	[MODE]
[EDIT]	[EFFECT]	[EQ]
[MUTE/SOLO]	[ENTER]	[EXIT]
[PART+]	[PART-]	
[SELECT+]	[SELECT-]	
[VALUE+]	[VALUE-]	
HOST SELECT (リアパネル)		
POWERスイッチ (電源スイッチ)		
VOLUMEつまみ (マスターボリューム)		
A/D INPUT VOLUMEつまみ (インプットボリューム)		

5. 接続端子

TO HOST(MINI DIN)	
MIDI IN-A	
MIDI IN-B	
MIDI OUT	
MIDI THRU	
PHONES (ステレオ標準ジャック)	
OUTPUT L, R (ステレオ標準ジャック)	定格出力: +5db (10kΩ負荷時) 出力インピーダンス1kΩ
A/D INPUT1,2 (モノラル標準ジャック)	定格入力: (Mic) -36db 入力インピーダンス33kΩ [Mic] (Line) -11.5db 入力インピーダンス33kΩ [Line]
INDIV OUTPUT1,2 (モノラル標準ジャック)	
DC IN	

6. 電源

ACアダプター (PA-3B)

7. 外形寸法

483 (W) × 229 (D) × 44 (H) [mm]

8. 重量

2.4Kg

9. 付属品

取扱説明書セット
ACアダプター (PA-3B)

10. 出力レベル

本サービスマニュアルの“テストプログラム”の項目を参照して下さい。

■ PANEL LAYOUT (パネルレイアウト)

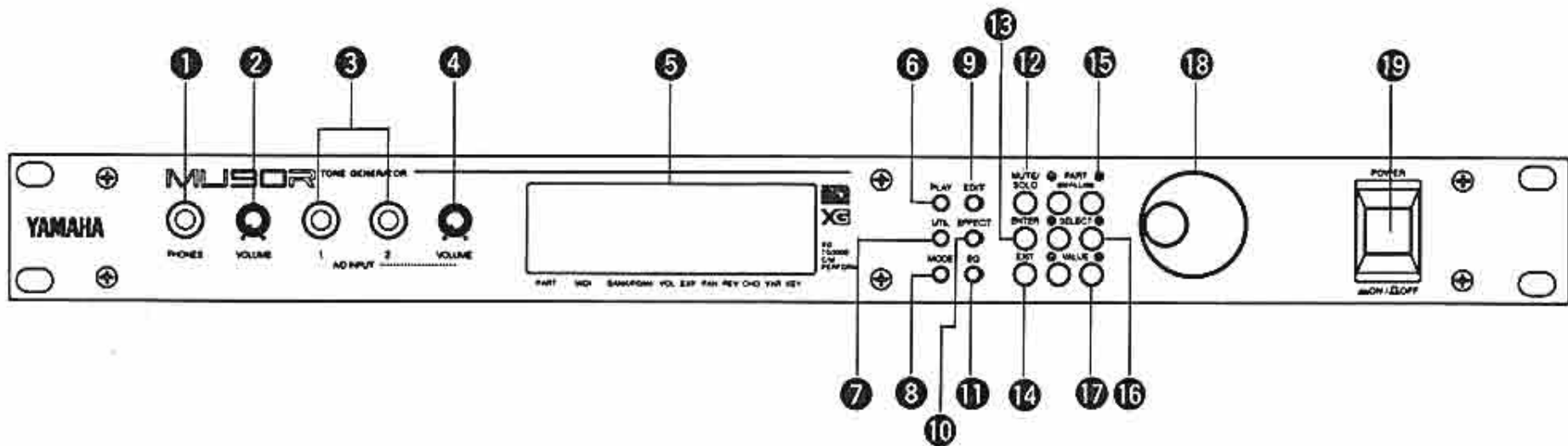

- ① PHONES jack
- ② VOLUME control
- ③ A/D INPUT 1, 2 jacks
- ④ A/D INPUT level control
- ⑤ Display
- ⑥ PLAY button
- ⑦ UTIL (UTILITY) button
- ⑧ MODE button
- ⑨ EDIT button
- ⑩ EFFECT button
- ⑪ EQ button
- ⑫ MUTE/SOLO button
- ⑬ ENTER button
- ⑭ EXIT button
- ⑮ PART \ominus/\oplus buttons
- ⑯ SELECT $\blacktriangleleft/\blacktriangleright$ buttons
- ⑰ VALUE \ominus/\oplus buttons
- ⑱ DATA dial
- ⑲ POWER switch

- ① PHONES (ヘッドフォン) 端子
- ② VOLUME (ボリューム) 端子
- ③ A/D INPUT (A/Dインプット) 1, 2端子
- ④ A/D INPUT VOLUME (A/Dインプットボリューム) つまみ
- ⑤ ディスプレイ
- ⑥ PLAY (プレイ) ボタン
- ⑦ UTIL (ユーティリティ) ボタン
- ⑧ MODE (モード) ボタン
- ⑨ EDIT (エディット) ボタン
- ⑩ EFFECT (エフェクト) ボタン
- ⑪ EQ (イコライザー) ボタン
- ⑫ MUTE/SOLO (ミュート/ソロ) ボタン
- ⑬ ENTER (エンター)
- ⑭ EXIT (エグジット) ボタン
- ⑮ PART (パート) ボタン
- ⑯ SELECT (セレクト) ボタン
- ⑰ VALUE (バリュー) ボタン
- ⑱ ダイアル
- ⑲ POWER (パワー) スイッチ

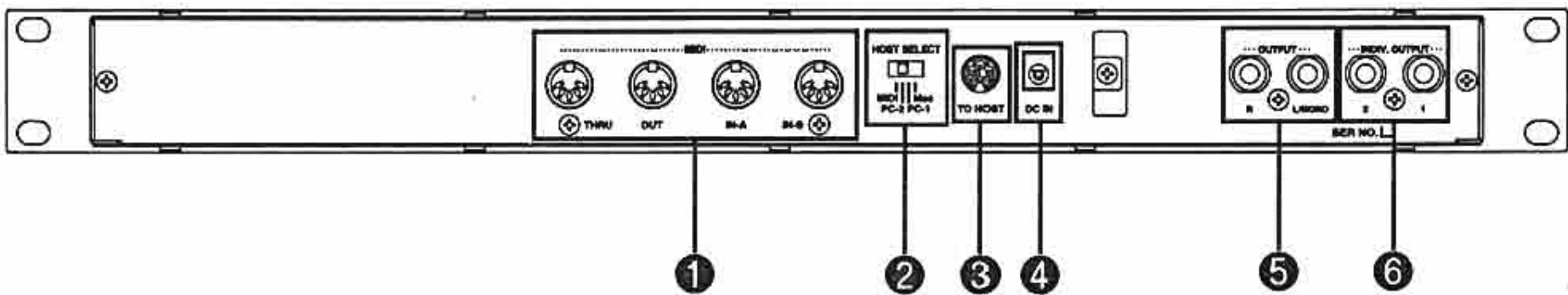

- ① MIDI THRU, MIDI OUT and MIDI IN A/B terminals
 - MIDI THRU
 - MIDI OUT
 - MIDI IN-A
 - MIDI IN-B
- ② HOST SELECT switch
- ③ TO HOST terminal
- ④ DC IN jack
- ⑤ OUTPUT L, R jacks
- ⑥ INDIV. OUTPUT 1, 2 jacks

- ① MIDI (ミディ) 端子
 - MIDI THRU (スルー) 端子
 - MIDI OUT (アウト) 端子
 - MIDI IN-A (イン-A) 端子
 - MIDI IN-B (イン-B) 端子
- ② HOST SELECT (ホストセレクト) スイッチ
- ③ TO HOST (トゥーホスト) 端子
- ④ DC IN (ディーシーイン) 端子
- ⑤ OUTPUT (アウトプット) 端子
- ⑥ INDIV. OUTPUT (インディビデュアルアウトプット) 端子

■ CIRCUIT BOARD LAYOUT (ユニットレイアウト)

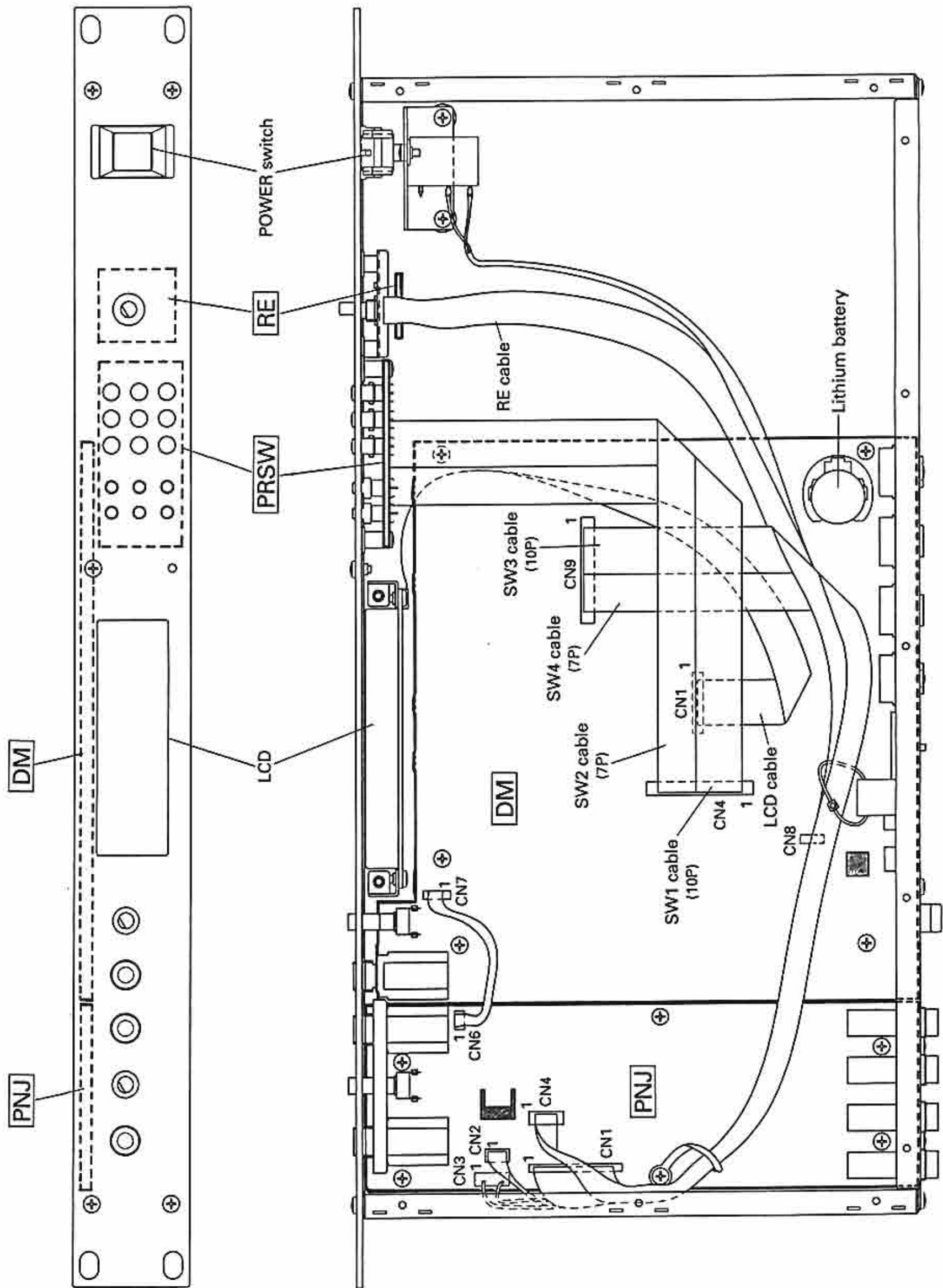

■ BLOCK DIAGRAM (ブロックダイアグラム)

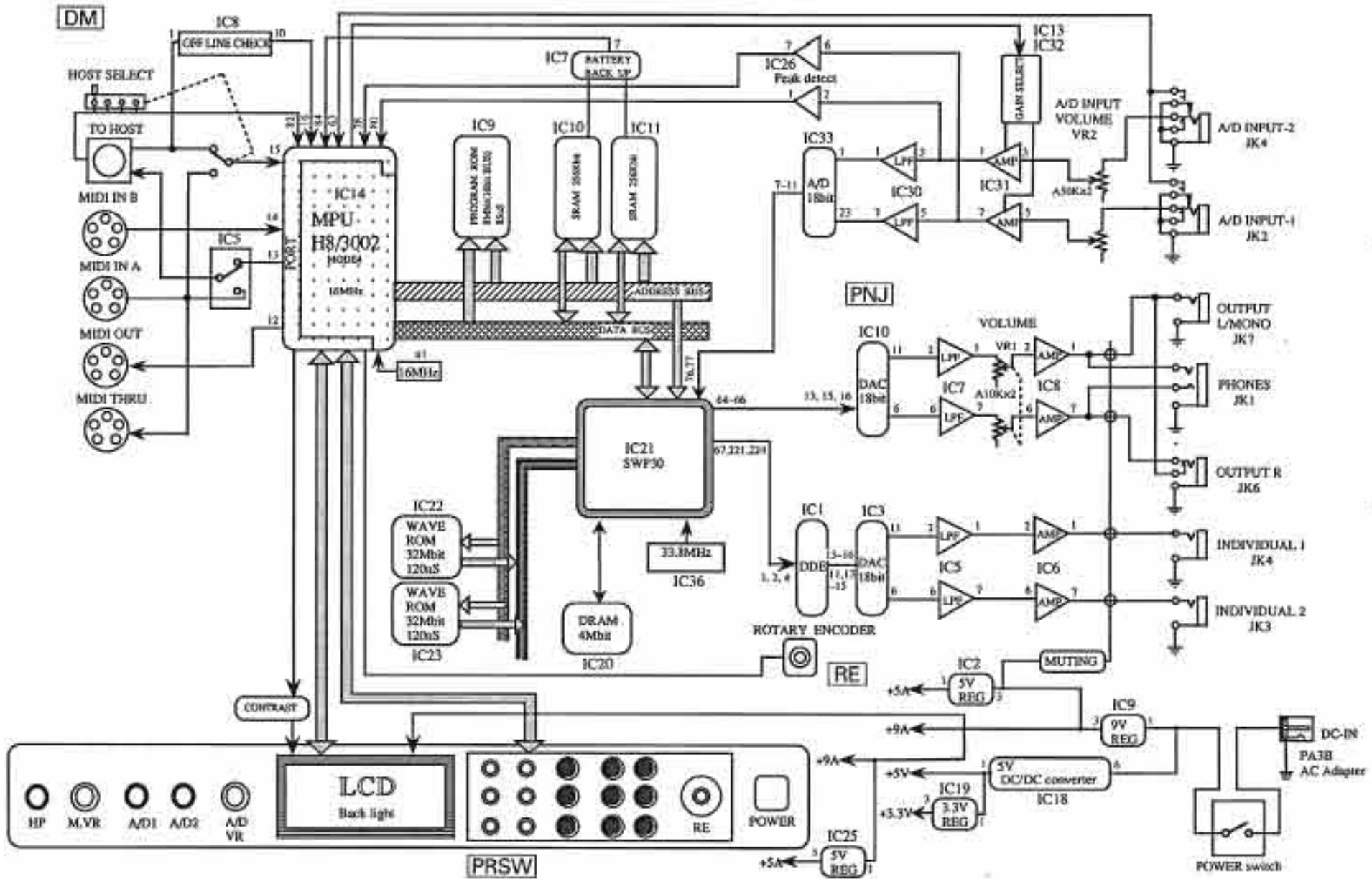

28CA1-8811556

MU90R

■ DISASSEMBLY PROCEDURE (分解手順)

- 1 Bottom Assembly
 - 1-1 Remove the eleven (11) screws marked [200] and the screw marked [150A]; remove the bottom assembly. (Fig. 1)
 - 1-2 [200]のネジ11本と[150A]のネジ1本を外して、ボトム Ass'yを外します。(図1)

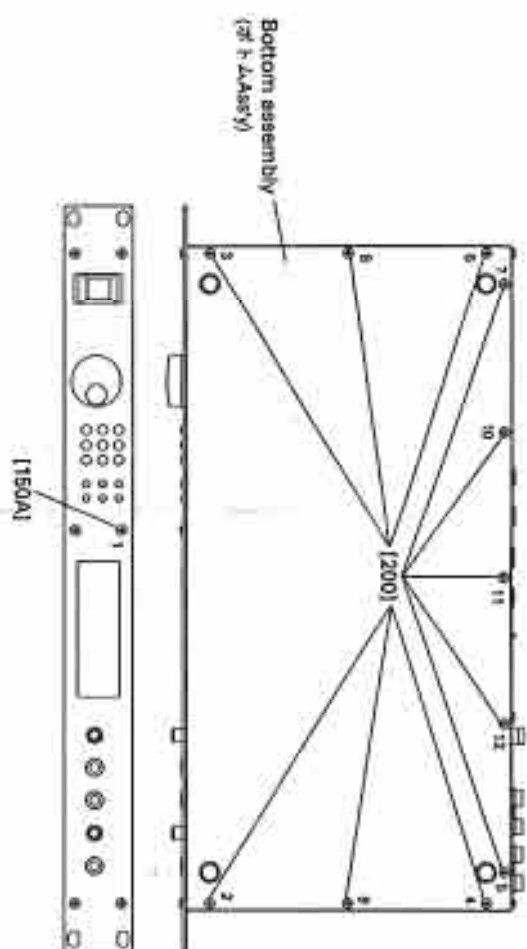

[200]: Bind Head Tapping Screw-B 3.0X6 MFZN2BL (EP600230) + バックアップ電池 (Fig. 1)

- 2 Rear Panel Assembly
 - 2-1 Remove the bottom assembly. (See procedure 1)
 - 2-2 Remove the ten (10) screws marked [80] and the two (2) screws marked [90]; remove the rear panel assembly. (Fig. 2)
 - 2-1 リアパネル Ass'yを外します。(1項参照)
 - 2-2 [80]のネジ10本と[90]のネジ2本を外して、リアパネル Ass'yを外します。(図2)

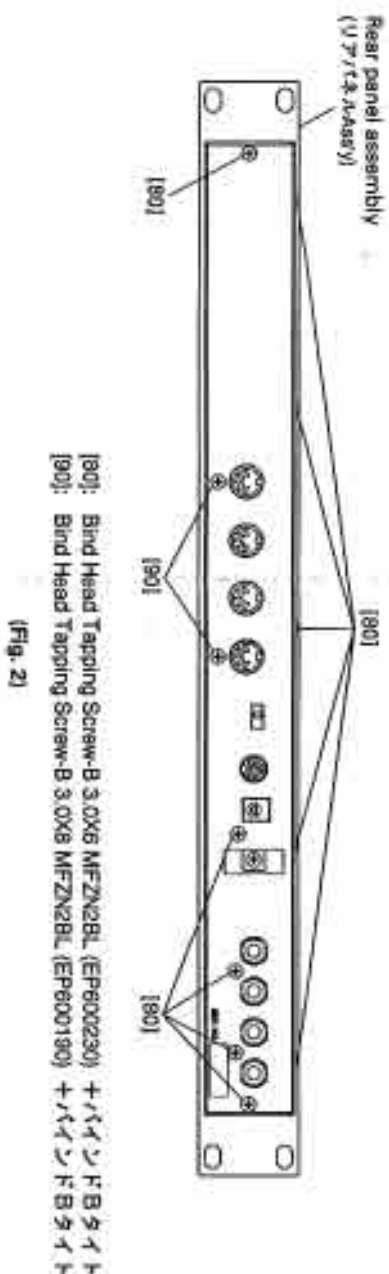

[80]: Bind Head Tapping Screw-B 3.0X6 MFZN2BL (EP600230) + バックアップ電池
 [90]: Bind Head Tapping Screw-B 3.0X6 MFZN2BL (EP600180) + バックアップ電池 (Fig. 2)

MU90R

- 3 DM Circuit Board**
- 3-1 Remove the bottom assembly. (See procedure 1)
 - 3-2 Remove the rear panel assembly. (See procedure 2)
 - 3-3 Remove the five (5) screws marked [60A]; remove the DM circuit board. (Fig. 3)
- * Pull off the A/D INPUT VOLUME knob from the DM circuit board.
 - * The cables plugged into the connectors CN4 and CN9, should be inserted as shown in Figure 4 and 5.
- 4 PNU Circuit Board**
- 4-1 Remove the bottom assembly. (See procedure 1)
 - 4-2 Remove the rear panel assembly. (See procedure 2)
 - 4-3 Remove the six (6) screws marked [60B]; remove the PNU circuit board. (Fig. 3)
- * Pull off the VOLUME knob from the PNU circuit board.

Battery VS246400
VS246300(Battery holder for VS246400)

- * Notice for back-up battery removal
Push against the holder hook, then the battery will pop up.
- * Druk tegen de houder, de batterij springt dan naar voren.

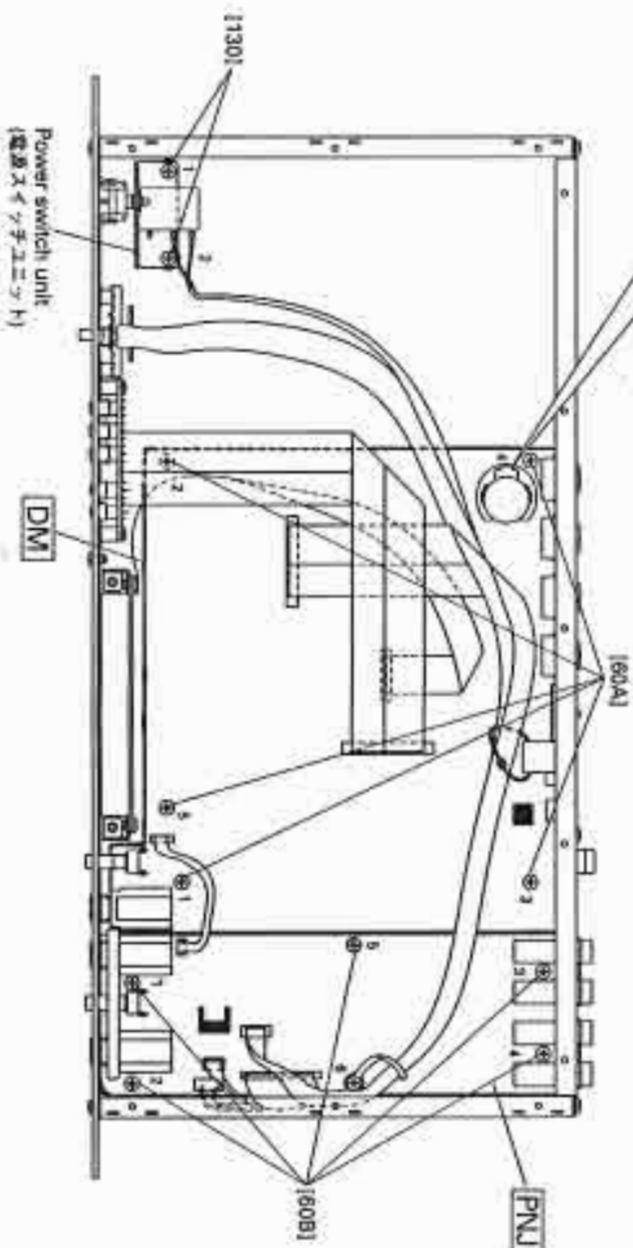



[60]: Bind Head Tapping Screw-B 3.0X6 MFN2BL (EP600230) +バインドヘッドタイト
[130]: Bind Head Tapping Screw-B 3.0X6 MFN2BL (EP600230) +バインドヘッドタイト

(Fig. 3)

- 3 DMシート**
- 3-1 ボトム Assy を外します。(1項参照)
 - 3-2 リアパネル Assy を外します。(2項参照)
 - 3-3 [60A]のネジ5本を外して、DMシートを外します。(図3)
- * 1 DMシートからインタフェクトツマミを引き抜きます。
 - * 2 また、CN4とCN9の束線は図4、図5のように取り付けて下さい。
- 4 PNUシート**
- 4-1 ボトム Assy を外します。(1項参照)
 - 4-2 リアパネル Assy を外します。(2項参照)
 - 4-3 [60B]のネジ6本を外して、PNUシートを外します。(図3)
- * PNUシートからインタフェクトツマミを引き抜きます。

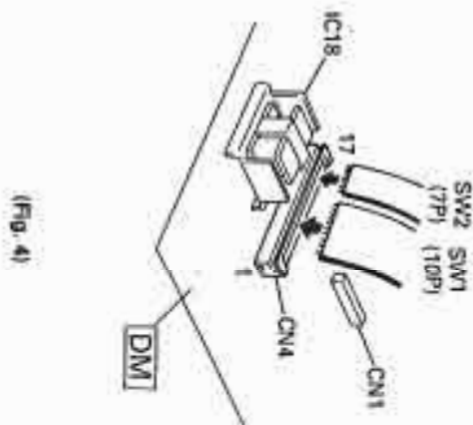
* The lithium battery is not a part of the DM circuit board. (リチウム電池は、DMシートの構成部品ではありません。)



(Fig. 4)

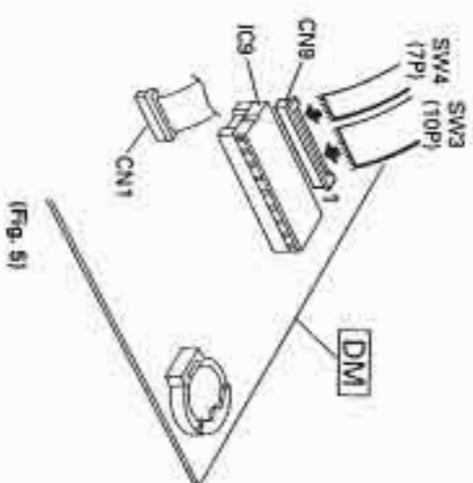

(Fig. 5)

- 5 LCD Display**
- 5-1 Remove the bottom assembly. (See procedure 1)
 - 5-2 Remove the two (2) screws marked [110] on the top cover; remove the LCD display. (Fig. 6)
- 6 Power Switch Unit**
- 6-1 Remove the bottom assembly. (See procedure 1)
 - 6-2 Remove the two (2) screws marked [130]; remove the power switch unit. (Fig. 3)
- 7 Front Panel Assembly**
- 7-1 Remove the bottom assembly. (See procedure 1)
 - 7-2 Remove the five (5) screws marked [150B]; remove the front panel assembly. (Fig. 6)

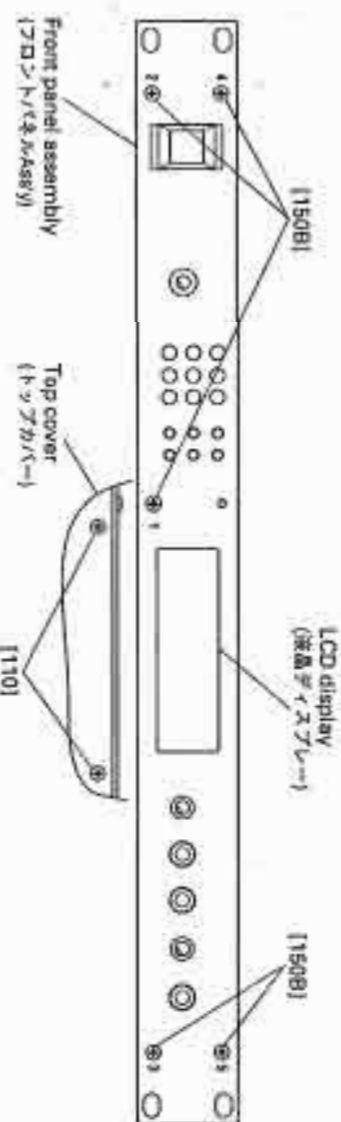

[110]: Bind Head Tapping Screw-B 3.0X6 MFN2BL (EP600230) +バインドヘッドタイト
[150]: Bind Head Tapping Screw-B 3.0X6 MFN2BL (EP600230) +バインドヘッドタイト

(Fig. 6)

- 5 液晶ディスプレイ**
- 5-1 ボトム Assy を外します。(1項参照)
 - 5-2 トップカバーの[110]のネジ2本を外して、液晶ディスプレイを外します。(図6)
- 6 電源スイッチユニット**
- 6-1 ボトム Assy を外します。(1項参照)
 - 6-2 [130]のネジ2本を外して、電源スイッチユニットを外します。(図3)
- 7 フロントパネルアッシー**
- 7-1 ボトム Assy を外します。(1項参照)
 - 7-2 [150B]のネジ5本を外して、フロントパネル Assy を外します。(図6)

8 Encoder Assembly

- 8-1 Remove the bottom assembly. (See procedure 1)
- 8-2 Remove the front panel assembly. (See procedure 7)
- 8-3 Remove the encoder knob.
- 8-4 Remove the two (2) screws marked [F80]; remove the encoder assembly. (Fig. 7)

9 PRSW Circuit Board

- 9-1 Remove the bottom assembly. (See procedure 1)
 - 9-2 Remove the front panel assembly. (See procedure 7)
 - 9-3 Remove the four (4) screws marked [F60]; remove the PRSW circuit board. (Fig. 7)
- Pull off the OP and MODE buttons from the PRSW circuit board.

8 エンコーダー Ass'y

- 8-1 ボトム Ass'y を外します。(1項参照)
- 8-2 フロントパネル Ass'y を外します。(7項参照)
- 8-3 エンコーダーツマミを外します。
- 8-4 [F80]のネジ 2本を外して、エンコーダー Ass'y を外します。(図 7)

9 PRSW シート

- 9-1 ボトム Ass'y を外します。(1項参照)
 - 9-2 フロントパネル Ass'y を外します。(7項参照)
 - 9-3 [F60]のネジ 4本を外し、PRSW シートを外します。(図 7)
- * PRSW シートから、モードボタンと OP ボタンを外します。

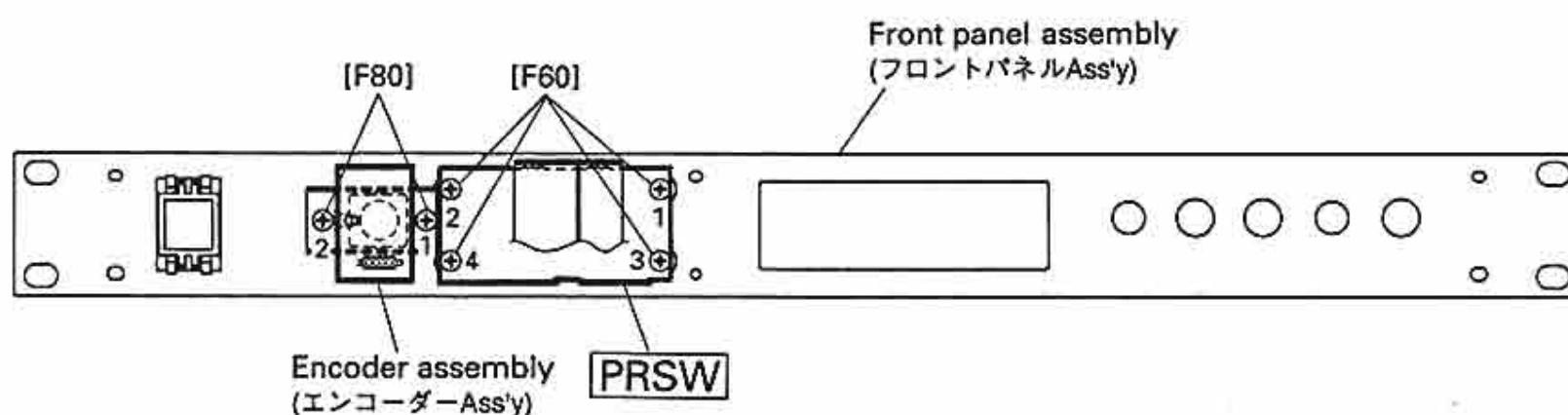

[F60]: Bind Head Tapping Screw-B 3.0X6 MFZN2BL (EP600230) + バインド B タイト
 [F80]: Bind Head Tapping Screw-B 3.0X6 MFZN2BL (EP600230) + バインド B タイト

(Fig. 7)

Note: When you reassemble these parts, you should tighten the screws in the order described in the figure.

注: これらの部品を組み付けるときは、図中に示した順序でネジを締めて下さい。

■ LSI PIN DESCRIPTION (LSI端子機能表)

● HD6413002F16 (XP691A00) CPU

PIN NO.	NAME	I/O	FUNCTION	PIN NO.	NAME	I/O	FUNCTION	
1	VCC		Power supply (+5 V)	51	A14	O	Address bus	
2	PB0	I/O	LCD/SW/LCD contrast/LED1 data	52	A15	O		
3	PB1	I/O	LCD/SW/LCD contrast/LED2 data	53	A16	O		
4	PB2	I/O	LCD/SW/LCD contrast/LED3 data	54	A17	O		
5	PB3	I/O	LCD/SW/LCD contrast/LED4 data	55	A18	O		
6	PB4	I/O	LCD/SW/LED5 data,HOST control	56	A19	O	Ground	
7	PB5	I/O	LCD/SW/LED6 data	57	VSS	-		
8	PB6//DREQ0	I/O	LCD/SW/ADG2 control data, SW strove	58	P60//WAIT	O	Port 6 /Wait (Not used)	
9	PB7//DREQ1	I/O	LCD/SW/ADG1 control data, SW strove	59	P61//BREQ	O	SWP30 reset control	
10	/RES0	O	Reset output (N.C.)	60	P62//BACK	I	FLag for A/D input	
11	VSS	-	Ground	61	φ	O	System clock (N.C.)	
12	P90/TXD0	O	MIDI-OUT (serial data)	62	/STBY	I	Stand-by mode signal	
13	P91/TXD1	O	Host (serial data)	63	/RES	I	Reset	
14	P92/RXD0	O	MIDI-IN B (serial data)	64	NMI	I	Non-maskable interrupt	
15	P93/RXD1	O	Host or MIDI-IN A (serial data)	65	VSS	-	Ground	
16	P94/SCK0	I	Off line detection	66	EXTAL	I	Crystal oscillator	
17	P95/SCK1	I/O	Not used	67	XTAL	I	Crystal oscillator	
18	P40/D0	I/O	Port 4/Data bus	68	VCC	-	Power supply (+5 V)	
19	P41/D1	I/O						
20	P42/D2	I/O						
21	P43/D3	I/O						
22	VSS	-	Ground	69	/AS	O	Address strove (N.C.)	
23	P44/D4	I/O	Port 4/Data bus	70	/RD	O	Read strove	
24	P45/D5	I/O						
25	P46/D6	I/O						
26	P47/D7	I/O						
27	D8	I/O	Data bus	71	/HWR	O	High write	
28	D9	I/O						
29	D10	I/O						
30	D11	I/O						
31	D12	I/O						
32	D13	I/O						
33	D14	I/O						
34	D15	I/O	Power supply (+5 V)	72	/LWR	O	Low write	
35	VCC	-		N.C.	73	MD0	I	Mode select (mode 1~4)
36	A0	O	Address bus	74	MD1	I		
37	A1	O						
38	A2	O						
39	A3	O						
40	A4	O						
41	A5	O						
42	A6	O						
43	A7	O	Ground	75	MD2	I		
44	VSS	-		Power supply (+5 V)	76	AVCC	-	Power supply for ADC
45	A8	O		N.C.	77	VREF	I	Reference voltage for ADC
46	A9	O		Address bus	78	P70//AN0	I	Analog input level (R)
47	A10	O						
48	A11	O						
49	A12	O						
50	A13	O						
					79	P71//AN1	I	Not used
					80	P72//AN2	I	Analog input level (L)
				81	P73//AN3	I	Not used	
				82	P74//AN4	I	Host switching position detection	
				83	P75//AN5	I	Not used	
				84	P76//AN6	I	Battery voltage check	
				85	P77//AN7	I	Not used	
				86	AVSS	-	Ground for ADC	
				87	P80//RFRSH	I	Level interruption	
				88	P81//CS3	O	Not used	
				89	P82//CS2	O	SWP30 chip select 2	
				90	P83//CS1	O	SRAM chip select 1	
				91	P84//CS0	O	Syatem ROM chip select 0	
				92	VSS	-	Ground	
				93	PA0	O	A/D gain,Host select,LCD contrast data latch	
				94	PA1	O	LCD register select control	
				95	PA2	O	1 MHz clock output for Macintosh	
				96	PA3	O	LED/SW strove data latch	
				97	PA4	O	SW data read control	
				98	PA5	O	LCD enable control	
				99	PA6	O	LCD R/W control	
				100	PA7	O	Not used	

• TC203C760HF-001 (XR738A00) SWP30 (AWM Tone Generator coped with MEG) Standard Wave Processor

PIN NO.	NAME	I/O	FUNCTION	PIN NO.	NAME	I/O	FUNCTION	
1	VSS		(Ground)	121	VSS		(Ground)	
2	CA0		Address bus of internal register	122	HMD0	I/O	Wave memory data bus (Upper data memory)	
3	CA1			123	HMD1	I/O		
4	CA2			124	HMD2	I/O		
5	CA3			125	HMD3	I/O		
6	CA4			126	HMD4	I/O		
7	CA5			127	HMD5	I/O		
8	CA6			128	HMD6	I/O		
9	CA7			129	HMD7	I/O		
10	CA8			130	HMD8	I/O		
11	CA9			131	HMD9	I/O		
12	CA10			132	HMD10	I/O		
13	CA11		133	HMD11	I/O			
14	VSS		(Ground)	134	HMD12	I/O		
15	CD0	I/O	Data bus of internal register	135	HMD13	I/O		
16	CD1	I/O		136	HMD14	I/O		
17	CD2	I/O		137	HMD15	I/O		
18	CD3	I/O		138	VSS		(Ground)	
19	CD4	I/O		139	HMA0	O	Wave memory address bus (Upper 16 bits)	
20	CD5	I/O		140	HMA1	O		
21	CD6	I/O		141	HMA2	O		
22	CD7	I/O		142	HMA3	O		
23	CD8	I/O		143	HMA4	O		
24	CD9	I/O		144	HMA5	O		
25	CD10	I/O		145	HMA6	O		
26	CD11	I/O		146	HMA7	O		
27	CD12	I/O		147	HMA8	O		
28	CD13	I/O		148	HMA9	O		
29	CD14	I/O	149	HMA10	O			
30	VDD		(Power supply)	150	VSS		(Ground)	
31	VSS		(Ground)	151	VDD		(Power supply)	
32	CD15	I/O	Chip select Write strobe Read strobe	152	HMA11	O	Wave memory address bus (Upper 16 bits)	
33	/CS	I		153	HMA12	O		
34	/WR	I		154	HMA13	O		
35	/RD	I		155	HMA14	O		
36	VDDS			(Power supply)	156	HMA15		O
37	SYSH0	O		157	HMA16	O		
38	SYSH1	O		158	HMA17	O		
39	SYSH2	O		159	HMA18	O		
40	SYSH3	O		160	HMA19	O		
41	SYSH4	O		161	HMA20	O		
42	SYSH5	O	162	HMA21	O			
43	SYSH6	O	163	HMA22	O			
44	SYSH7	O	164	HMA23	O			
45	KONO0	O	Key on data	165	HMA24	O	Wave memory address bus (Lower data memory)	
46	KONO1	O		166	VSS			(Ground)
47	KONO2	O		167	/MRAS	O		RAS when DRAM(s) is connected to wave memory
48	KONO3	O	(Ground)	168	/MCAS	O		CAS when DRAM(s) is connected to wave memory
49	VSS		(Ground)	169	/MOE	O		Wave memory output enable
50	SYSL0	I/O	NSYS/LNSYS upper 16 bits	170	/MWE	O		Wave memory write enable
51	SYSL1	I/O		171	VSS			(Ground)
52	SYSL2	I/O		172	LMD0	I/O		Wave memory data bus (Lower data memory)
53	SYSL3	I/O		173	LMD1	I/O		
54	SYSL4	I/O		174	LMD2	I/O		
55	SYSL5	I/O		175	LMD3	I/O		
56	SYSL6	I/O		176	LMD4	I/O		
57	SYSL7	I/O		177	LMD5	I/O		
58	KONI0	I	178	LMD6	I/O			
59	KONI1	I	179	LMD7	I/O			
60	VDDS		(Power supply)	180	VDDS		(Power supply)	
61	VSS		(Ground)	181	VSS		(Ground)	
62	KONI2	I	DAC output	182	LMD8	I/O	Wave memory data bus (Lower data memory)	
63	KONI3	I		183	LMD9	I/O		
64	DAC0	O	DAC0/DAC1 word clock	184	LMD10	I/O		
65	DAC1	O		185	LMD11	I/O		
66	WCLK	O		186	LMD12	I/O		
67	MELO0	O		187	LMD13	I/O		
68	MELO1	O		188	LMD14	I/O		
69	MELO2	O		189	LMD15	I/O		
70	MELO3	O		190	VSS			(Ground)
71	MELO4	O		191	LMA0	O		Wave memory address bus (Lower data memory)
72	MELO5	O		192	LMA1	O		
73	MELO6	O		193	LMA2	O		
74	MELO7	O		194	LMA3	O		
75	VDDS			(Power supply)	195	LMA4	O	
76	ADLR	O		ADC word clock	196	LMA5	O	
77	MELI0	I		MEL wave data input	197	LMA6	O	
78	MELI1	I	198		LMA7	O		
79	MELI2	I	199		LMA8	O		
80	MELI3	I	200		LMA9	O		
81	MELI4	I	201		LMA10	O		
82	MELI5	I	202		LMA11	O		
83	MELI6	I	203		VSS		(Ground)	
84	MELI7	I	204		LMA12	O		
85	VSS		(Ground)	205	LMA13	O		
86	/RCAS	O	DRAM column address strobe	206	LMA14	O		
87	RA8	O		207	LMA15	O		
88	RA7	O		208	LMA16	O		
89	RA6	O		209	LMA17	O		
90	VDD			(Power supply)	210	VDD		(Power supply)
91	VSS			(Ground)	211	VSS		(Ground)
92	RA5	O		DRAM address bus	212	LMA18	O	
93	RA4	O			213	LMA19	O	
94	RA3	O			214	LMA20	O	
95	RA2	O			215	LMA21	O	
96	RA1	O	216		LMA22	O		
97	RA0	O	217		LMA23	O		
98	/RRAS	O	218		LMA24	O		
99	/RWE	O	219		VSS		(Ground)	
100	VSS		(Ground)	220	SYO	O	Sync. signal for master clock	
101	RD7	I/O	DRAM data bus	221	SYOD	O	Sync. signal for HCLK/QCLK	
102	RD6	I/O		222	QCLK	O	1/12 master clock (64Fs)	
103	RD5	I/O		223	HCLK	O	1/6 master clock (128Fs)	
104	RD4	I/O		224	CK256	O	1/3 master clock (256Fs)	
105	RD3	I/O		225	SYSCCLK	O	1/2 master clock (384Fs)	
106	RD2	I/O		226	VDDS		(Power supply)	
107	RD1	I/O		227	SYI	I	Sync. clock	
108	RD0	I/O		228	MCLKI	I	Master clock input	
109	VSS			(Ground)	229	MCLKO	O	Master clock output
110	RD17	I/O		DRAM data bus	230	VDD		(Power supply)
111	RD16	I/O			231	XIN	I	Crystal osc. input
112	RD15	I/O	232		XOUT	O	Crystal osc. output	
113	RD14	I/O	233		VSS		(Ground)	
114	RD13	I/O	234		/IC	I	Initial clear	
115	RD12	I/O	235		CHIP2	I	2 chips mode enable	
116	RD11	I/O	236		SLAVE	I	Master/Slave select when 2 chips mode	
117	RD10	I/O	237		/TESTO	I	Test pin	
118	RD9	I/O	238		/ACI	I		
119	RD8	I/O	239		DCTEST	I		
120	VDDS		(Power supply)		240	VDDS		(Power supply)

• **LC7886M-TRM (XQ209A00) ADC** (Analog to Digital Converter)

PIN NO.	NAME	I/O	FUNCTION	PIN NO.	NAME	I/O	FUNCTION
1	ADIN1	I	CH1 analog input	13	DGND		Digital GND
2	VH		Reference voltage "H"	14	TSTOUT	I	} Test pin (Connected to digital GND)
3	AVDD		Analog power supply	15	TEST1	I	
4	VR1		CH1 (VH+VL)/2 Reference voltage	16	TEST2	I	
5	TEST3	I	Test pin (Connected to analog GND)	17	TEST4	I	
6	AVDD		Analog power supply	18	TEST6	I	
7	FORM	I	When FORM="H", LRCK="L": CH1, LRCK="H": CH2 When FORM="L", LRCK="H": CH1, LRCK="L": CH2	19	AGND		Analog GND
8	IFDA	I	"H":18 bit digital data, "L":16 bit digital data,	20	TEST5	I	Test pin (Connected to analog GND)
9	LRCK	I	CH1/CH2 select	21	VR2		CH2 (VH+VL)/2 Reference voltage
10	BCLK	I	Bit clock	22	VL		Reference voltage "L"
11	ADDATA	O	Data output	23	ADIN2	I	CH2 analog input
12	DVDD		Digital power supply	24	AGND		Analog GND

• **μPD63200GS-E1 (XP867A00) DAC** (Digital to Analog Converter)

PIN NO.	NAME	I/O	FUNCTION	PIN NO.	NAME	I/O	FUNCTION
1	4/8F	I	4/8 Fs selection	9	R. REF		Channel R voltage reference
2	D. GND		Digital ground	10	L. REF		Channel L voltage reference
3	16 BIT	I	16 bit/18 bit selection	11	L. OUT	O	Channel L output
4	D. VDD		Digital power supply	12	A. GND		Analog ground
5	A. GND		Analog ground	13	WDCK	I	Word clock
6	R. OUT	O	Channel R output	14	RSI	I	Channel R series input
7	A. VDD		} Analog power supply	15	SI/LSI	I	Series input/Channel L series input
8	A. VDD			16	CLK	I	Clock

• **JG541023 (XM326A00) DDE1** (DAC Dynamic Range Enhancer)

PIN NO.	NAME	I/O	FUNCTION	PIN NO.	NAME	I/O	FUNCTION
1	CLK	I	Master clock	9	SH 0	O	N.C.
2	SYW	I	Sync signal	10	SH 1	O	N.C.
3	MIN 1	I	Signal input	11	LE	O	Latch enable for DAC
4	MIN 0	I	Signal input	12	VDD		
5	VSS			13	DACO 0	O	Output (DAC)
6	SEL 1	I	Mode select	14	DACO 1	O	Output (DAC)
7	SEL 0	I	Mode select	15	DCLK	O	Clock for DAC
8	SUP	I	1 bit shift up input	19	ICN	I	Initial clear

■ IC BLOCK DIAGRAM (ICブロック図)

- **SN74HC14AF-TP1 (XD657A00)** Hex Inverter
- **SN74HC74NSR (XC726A00)** Dual D-Type Flip-Flop
- **TC74HC245F-T1 (XD603A00)** Octal 3-State Bus Transceiver

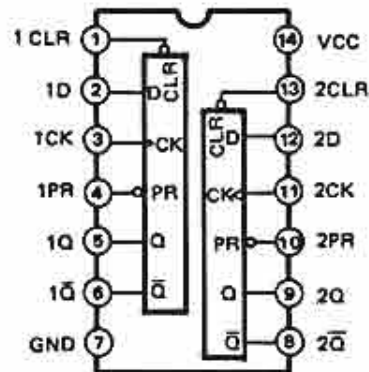
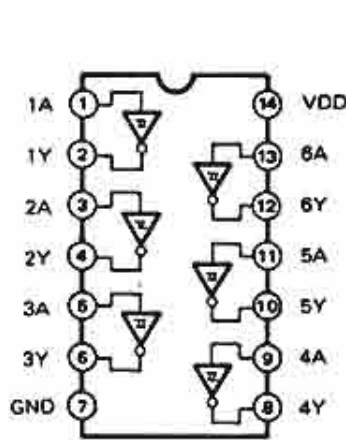

INPUTS				OUTPUTS	
PR	CLR	CLK	D	Q	Q̄
L	H	X	X	H	L
H	L	X	X	L	H
L	L	X	X	H	H
H	H	↑	H	H	L
H	H	↑	L	L	H
H	H	L	X	Q ₀	Q̄ ₀

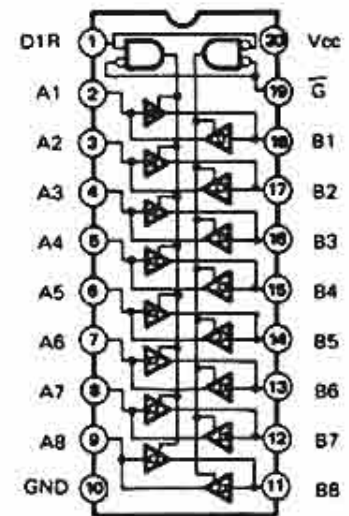

- **SN74HC273NSR (XH223A00)** Octal D-Type Flip Flop
- **TC74HC4051AF (XJ623A00)** Triple 2-channel Multiplexer /Demultiplexer
- **MC34051MEL (XP881A00)** Dual EIA-422/423 Line Transceiver

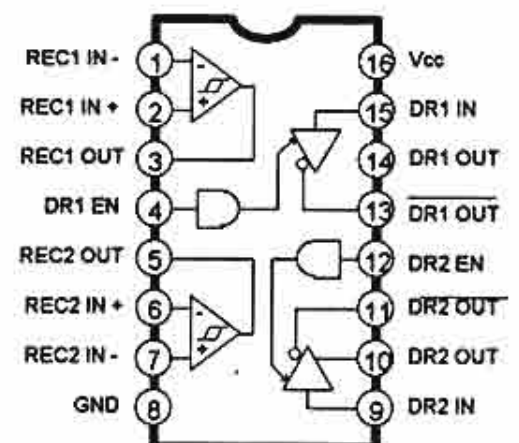
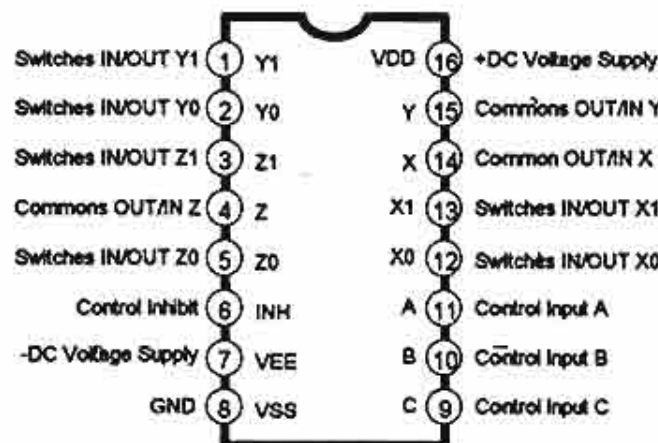
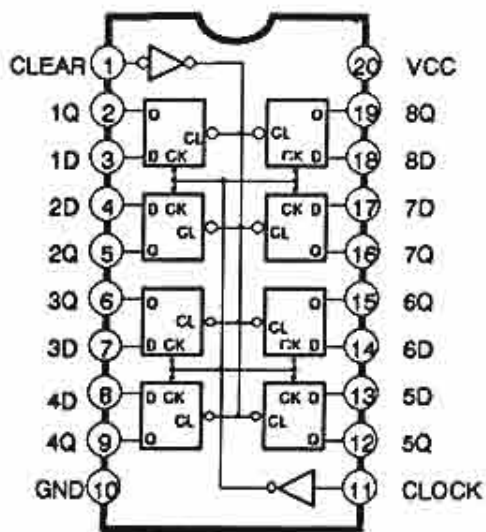

- **TC74HC4066AF-T1 (XG385A00)** Quad Bilateral Analog Switch
- **SC7SU04FER (XI348A00)** Inverter
- **TC7W14F (XR336A00)** Triple Inverter

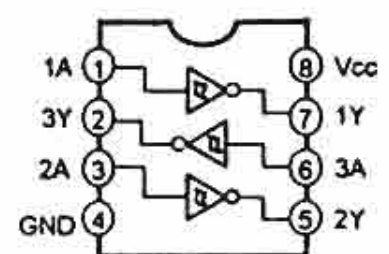
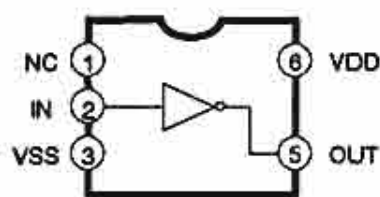
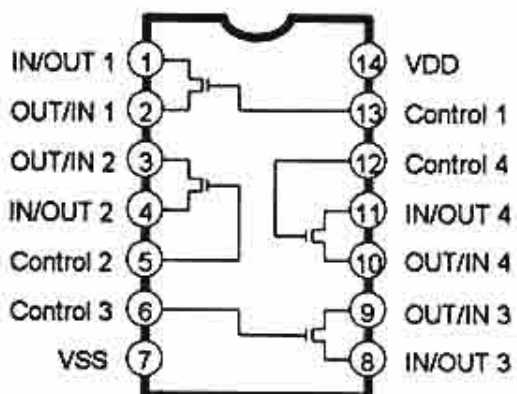

- **TC7S32F (XM588A00)**
OR

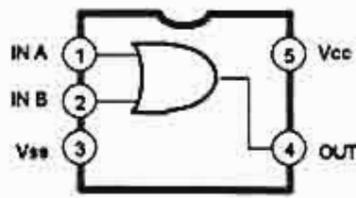

- **μPC4570G2 (XF291A00)**
- **NJM4556AMT1 (XQ138A00)**
Dual Operational Amplifier

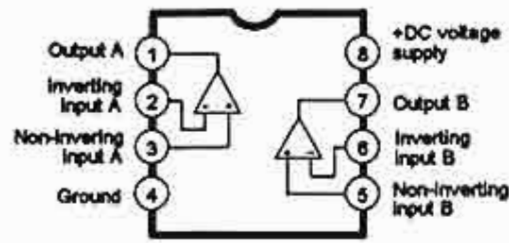

- **NJU7660M-T1 (XP596A00)**
DC/DC Voltage Converter

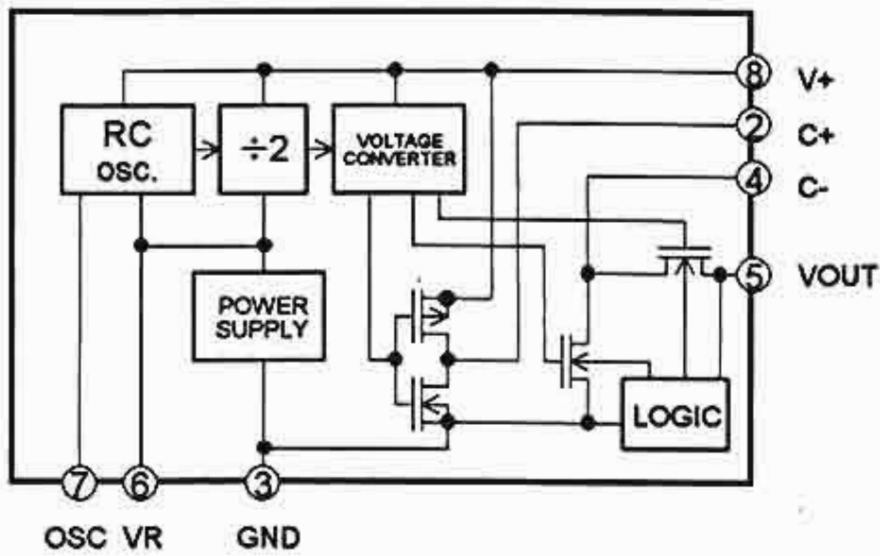

- **TC4W53F (XL545A00)**
Dual 2-channel Multiplexer
/Demultiplexer

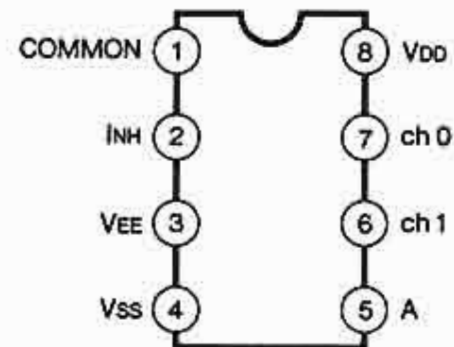
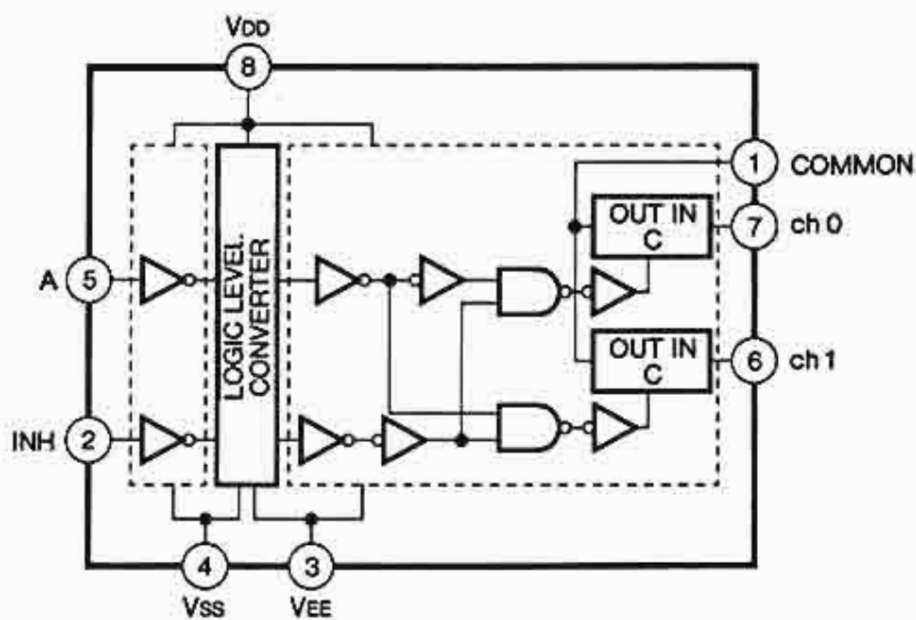

TEST PROGRAM

PREPARATIONS

The following measuring instruments and jigs are necessary during the test.

Measuring instruments:

Audio signal generator, Oscilloscope, Amplifier/Speaker system, etc.

Jigs: MIDI cables, etc.

No.	Test	Remarks
A	TEST ENTRY	
B	PROCEEDING THROUGH THE TEST AND SELECTION WHEN AN ERROR IS DETECTED	
1	SYSTEM RAM	SRAM Read/Write
2	BATTERY	A/D check on CPU
3	LCD ALL-DOTS ON	
4	SWITCH & LED	Switch ON/OFF & LED ON/OFF
5	DIAL	Dial function
6	MIDI 1	Connect MIDI IN A to MIDI OUT
7	MIDI 2	Connect MIDI IN B to MIDI OUT
8	HOST SELECT	Slide HOST SELECT
9	TO HOST TX/RX	Factory use
10	WAVE ROM	Wave ROM Read
11	1 kHz OUTPUT(L)	Using measuring instruments
12	1 kHz OUTPUT(R)	Using measuring instruments
13	1 kHz INDIV. 1 OUTPUT	Using measuring instruments
14	1 kHz INDIV. 2 OUTPUT	Using measuring instruments
15	INPUT HIGH	Using measuring instruments
16	INPUT LOW	Using measuring instruments
17	DSP & DRAM	Using measuring instruments
18	64 SOUNDS OUTPUT	By listening
19	FACTORY SETTINGS	
20	EXIT	

A. HOW TO ENTER THE TEST PROGRAM

While pressing the [PLAY] and [MUTE/SOLO] buttons, turn the MU90R POWER switch on.

When the test program is initiated, the version of the program ROM will appear on the LCD.

MU90R TEST MODE
Ver#. ## ##-###-##

(Where ### is the version number)

After displaying the version message shown above, the following display will appear.

01 RAM

You should perform the factory settings before any test, when you replace a circuit board or the backup battery. The factory settings are performed by pressing the [UTIL] and [ENTER] buttons while turning the MU90R POWER switch on.

B. PROCEEDING THROUGH THE TESTS

When you enter the test program, the following display will appear.

01 RAM

Use the [SELECT >] and [SELECT <] buttons to move through the various tests of the test program. After you have selected the test, press [ENTER] to start the test in succession from that number.

If you press [ENTER] without selecting the test, the system will start the test from "1. RAM" test.

TEST SELECTION WHEN AN ERROR IS DETECTED

In each test, if an NG (No Good) error is detected, press [EXIT]. The MU90R will wait for the entry of a test number.

TEST 1. SRAM TEST

01 RAM

The Write/Read check for SRAM (IC 10 and IC 11) will be performed automatically on the following address.

IC 10, IC 11 : 200000h - 20FFFFh (16-bits data bus)

DISPLAY OF TEST RESULT

OK 01 RAM ok

NG 01 RAM err

TEST END

If the test is OK, OK will be displayed and the test will end and proceed to the next test. If NG is detected during the test, refer to section B, "PROCEEDING THROUGH THE TESTS". All SRAM data is preserved.

TEST 2. BATTERY TEST

02 BATTERY

This test checks that the voltage of the battery is greater than 2.8 V and less than 3.5 V.

DISPLAY OF TEST RESULTS

OK 02 BATTERY ok

NG 02 BATTERY err

TEST END

If the test is OK, OK will be displayed and the test will end and proceed to the next test. If NG is detected during the test, refer to section B, "PROCEEDING THROUGH THE TESTS".

TEST 3. LCD - ALL DOTS "ON" TEST

Check that all dots of the LCD change to black. After checking the back light, you should press [SELECT] to control the LCD contrast in eight (8) steps.

TEST END

Press [ENTER] to end the test. The MU90R will proceed to enter the following test.

If you press [EXIT], the MU90R will wait for the entry of the test number.

TEST 4. SWITCH & LED TEST

04 SWITCH & LED

Press the panel switches consecutively from the [PLAY] button to the button [VALUE+], according to the order indicated by the LCD. At this time, you should check that the LED [PLAY] though [EQ] switches light up.

04 SWITCH & LED
[ENTER]

(E.g. when checking [ENTER])

If the switch is OK, a beep will sound and you should proceed to test the next switch. If the wrong switch is pressed, the program does not proceed and no sound will be heard.

DISPLAY OF TEST RESULTS

OK 04 SW & LED ok

NG (No change in display)

TEST END

When the button [VALUE+] is pressed, if the test is OK, the test will end and proceed to the next test. If an error is detected during the test, you should turn the POWER off.

TEST 5. DIAL

05 DIAL

This test checks that the dial function works properly.

Press [ENTER]. The LCD will indicate "RIGHT 0-10=00". Rotate the dial clockwise until LCD indicates the number "10". Then the LCD will indicates "LEFT 0-10=00". Rotate the dial counter-clockwise until LCD indicates the number "10".

If the test result is OK, the test proceed to the next test. If an error is detected, the program does not proceed.

DISPLAY OF TEST RESULTS

OK 05 DIAL ok

NG 05 DIAL err

TEST END

If the test is OK, OK will be displayed and the test will end and proceed to the next test. If NG is detected during the test, refer to section B, "PROCEEDING THROUGH THE TESTS".

TEST 6. MIDI TEST 1

06 MIDI 1

After connecting the [MIDI IN A] to the [MIDI OUT] and the [MIDI THRU] to the [MIDI IN B] via MIDI cables, execute the test. The [HOST SELECT] switch must be set at the [MIDI] during the test.

DISPLAY OF TEST RESULTS

OK MIDI 1 ok

NG MIDI 1 err

TEST END

The test automatically proceeds to the next test if the test is OK. If NG is detected during the test, refer to section B, "PROCEEDING THROUGH THE TESTS".

TEST 7. MIDI TEST 2

07 MIDI 2

After connecting the [MIDI IN A] to the [MIDI OUT] and the [MIDI THRU] to the [MIDI IN B] via MIDI cables, execute the test. The [HOST SELECT] switch must be set at the [MIDI] during the test.

DISPLAY OF TEST RESULTS

OK MIDI 2 ok

NG MIDI 2 err

TEST END

The test automatically proceeds to the next test if the test is OK. If NG is detected during the test, refer to section B, "PROCEEDING THROUGH THE TESTS".

TEST 8. HOST SELECT SWITCH TEST

08 HOST SELECT
MIDI ZZ--YY=XX

Change the [HOST SELECT] switch from [Mac] through [MIDI], according to the order indicated by the LCD.

08 HOST SELECT
PC2 ZZ--YY=XX

(Where ZZ: minimum value, YY: maximum value, XX: current value)

If an unexpected code is received, the system will not proceed to test the next step. Check that OK is displayed at each position of the HOST SELECT switch.

Decision value MIDI: 0 V~0.6 V
 PC2: 1.25 V~2.1 V
 PC1: 2.8 V~3.7 V
 MAC: 4.7 V~5 V

DISPLAY OF TEST RESULTS

OK

08 HOST SELECT
ok

TEST END

When the HOST SELECT switch is set at [MIDI], if the test is OK, the test will end and proceed to the next test.

During the test, if you press [EXIT], the MU90R will wait for the entry of the test number.

If NG is detected during the test, refer to section B, "PROCEEDING THROUGH THE TESTS".

TEST 9. TO HOST TX/RX

09 TO HOST

This test is utilized by the factory and it is not intended for field service use.

DISPLAY OF TEST RESULTS

OK

09 TO HOST
ok

NG

09 TO HOST
err

TEST END

When this test is initiated without a jig for checking, an error will occur. You should refer to section B, "PROCEEDING THROUGH THE TESTS".

TEST 10. WAVE ROM TEST

10 WAVE ROM

The Read/Verify check for WAVE ROM (IC 22 and IC 23 via the SWP20-LSI will be performed automatically.

DISPLAY OF TEST RESULTS

OK

10 WAVE ROM
ok

NG

10 WAVE ROM
err

TEST END

If the test is OK, OK will be displayed and the test will end. If NG is detected during the test, refer to section B, "PROCEEDING THROUGH THE TESTS".

TEST 11. 1 kHz SOUND OUTPUT (L) TEST

11 OUTPUT L 1 kHz

Check that the correct signal is output from the OUTPUT (L) and the PHONES (L) jacks.

Insert the appropriate phone plug into the OUTPUT (L, R) and the PHONES jacks and check the output.

If necessary, verify the frequency, output waveform, output level, and THD of the OUTPUT (L, R) and PHONES output using a frequency counter, oscilloscope, AC voltmeter (with 12.47 kHz filter) and distortion meter. If a plug is inserted to the A/D INPUT, it must be pulled out. The VOLUME control must be set at maximum for this check.

ITEMS TO CHECK

Listed below are the specifications and conditions of the OUTPUT (L, R) and the PHONES outputs during this test.

OUTPUT(L) : 1 kHz \pm 3 Hz, sine wave, +3.0 dBm \pm 2 dB (10 k Ω load), distortion 0.25 % or less

OUTPUT(R) : less than -80 dBm

PHONES(L) : 1 kHz \pm 3 Hz, sine wave, -4.5 dBm \pm 2 dB (33 Ω load), distortion 0.5 % or less

PHONES(R) : less than -65 dBm

If the plug connected to the OUTPUT (R) is pulled out:

OUTPUT(L) : -2.0 dBm \pm 2 dB

TEST END

Press [ENTER] to end the test. The MU90R will automatically proceed to the next test.

If you press [EXIT], the MU90R will wait for the entry of the test number.

TEST 12. 1 kHz SOUND OUTPUT (R) TEST

12 OUTPUT R 1 kHz

Check that the correct signal is output from the OUTPUT (R) and the PHONES (R) jacks.

Insert the appropriate phone plug into the OUTPUT (L, R) and the PHONES jacks and check the output.

If necessary, verify the frequency, output waveform, output level, and THD of the OUTPUT (L, R) and PHONES output using a frequency counter, oscilloscope, AC voltmeter (with 12.47 kHz filter) and distortion meter. If a plug is inserted to the A/D INPUT, it must be pulled out. The VOLUME control must be set at maximum for this check.

ITEMS TO CHECK

Listed below are the specifications and conditions of the OUTPUT (L, R) and the PHONES outputs during this test.

OUTPUT(L) : less than -80 dBm

OUTPUT(R) : 1 kHz \pm 3 Hz, sine wave, +3.0 dBm \pm 2 dB (10 k Ω load), distortion 0.25 % or less
 PHONES(L) : less than -65 dBm
 PHONES(R) : 1 kHz \pm 3 Hz, sine wave, -4.5 dBm \pm 2 dB (33 Ω load), distortion 0.5 % or less

TEST END

Press [ENTER] to end the test. The MU90R will automatically proceed to the next test.

If you press [EXIT], the MU90R will wait for the entry of the test number.

TEST 13. INDIV. 1 1 kHz SOUND OUTPUT TEST

13 INDIVOUT1 1 kHz

Check that the correct signal is output from INDIV. 1 OUTPUT.

Insert the appropriate phone plug into the INDIV. 1 OUTPUT and check the output.

If necessary, verify the frequency, output waveform, output level, and THD of the INDIV. 1 OUTPUT output using a frequency counter, oscilloscope, AC voltmeter (with 12.47 kHz filter) and distortion meter. If a plug is inserted to the A/D INPUT, it must be pulled out.

ITEMS TO CHECK

Listed below are the specifications and conditions of the INDIV. 1 OUTPUT outputs during this test.

INDIV. 1 OUTPUT : 1 kHz \pm 3 Hz, sine wave, +4.0 dBm \pm 2 dB (10 k Ω load), distortion 0.25 % or less

INDIV. 2 OUTPUT : less than -80 dBm

TEST END

Press [ENTER] to end the test. The MU90R will automatically proceed to the next test.

If you press [EXIT], the MU90R will wait for the entry of the test number.

TEST 14. INDIV. 2 1 kHz SOUND OUTPUT TEST

14 INDIVOUT2 1 kHz

Check that the correct signal is output from INDIV. 2 OUTPUT.

Insert the appropriate phone plug into the INDIV. 2 OUTPUT and check the output.

If necessary, verify the frequency, output waveform, output level, and THD of the INDIV. 1 OUTPUT output using a frequency counter, oscilloscope, AC voltmeter (with 12.47 kHz filter) and distortion meter. If a plug is inserted to the A/D INPUT, it must be pulled out.

ITEMS TO CHECK

Listed below are the specifications and conditions of

the INDIV. 1 OUTPUT outputs during this test.

INDIV. 1 OUTPUT : less than -80 dBm

INDIV. 2 OUTPUT : 1 kHz \pm 3 Hz, sine wave, +4.0 dBm \pm 2 dB (10 k Ω load), distortion 0.25 % or less

TEST END

Press [ENTER] to end the test. The MU90R will automatically proceed to the next test.

If you press [EXIT], the MU90R will wait for the entry of the test number.

TEST 15. INPUT HIGH TEST

15 INPUT HIGH

Apply a signal to [A/D INPUT], and check that the signal obtained at [OUTPUT] is controlled in gain with the A/D INPUT.

Check that the level meters on the LCD light up when the provided signal is applied to [INPUT].

Insert the appropriate phone plug into the OUTPUT (L, R) and the PHONES jacks and check the output.

If necessary, verify the frequency, output waveform, output level, and THD of the OUTPUT (L, R) and PHONES output using a frequency counter, oscilloscope, AC voltmeter (with 12.47 kHz filter) and distortion meter. The VOLUME control must be set at maximum for this check.

ITEMS TO CHECK

Listed below are the specifications and conditions of the OUTPUT (L, R) outputs during this test.

When a sine wave signal of -36.0 dBm, 1 kHz is applied to A/D INPUT (L), and A/D INPUT is set at maximum, and A/D INPUT (R) is connected to the ground:

OUTPUT(L) : +5 dBm \pm 2 dB (10k Ω load), distortion 0.5 % or less

OUTPUT(R) : less than -48 dBm

When a sine wave signal of -36.0 dBm, 1 kHz is applied to A/D INPUT (R), and A/D INPUT is set at maximum, and A/D INPUT (L) is connected to the ground:

OUTPUT(L) : less than -48 dBm

OUTPUT(R) : +5 dBm \pm 2 dB (10k Ω load), distortion 0.5 % or less

When a sine wave signal of -36.0 dBm, 1 kHz is applied to A/D INPUT (L), and A/D INPUT is set at minimum, and A/D INPUT (R) is connected to the ground:

OUTPUT(L) : less than -66 dBm

When a sine wave signal of -36.0 dBm, 1 kHz is applied to A/D INPUT (R), and A/D INPUT is set at minimum, and A/D INPUT (L) is connected to the ground:

OUTPUT(R) : less than -66 dBm

Check that the level meters on the LCD will light up,

when the sine wave of $-29.0 \text{ dBm} \pm 2 \text{ dB}$, 1 kHz is applied to the A/D INPUT (L).

TEST END

Press [ENTER] to end the test, the MU90R will automatically proceed to the next test.

If you press [EXIT], the MU90R will wait for the entry of the test number.

TEST 16. INPUT LOW TEST

16 INPUT LOW

Apply the signal to [A/D INPUT], and check that the signal obtained at [OUTPUT] is controlled in gain with A/D INPUT.

Check that the level meters on the LCD will light up when the provided signal is applied to [INPUT].

Insert the appropriate phone plug into the OUTPUT (L, R) and the PHONES jacks and check the output.

If necessary, verify the frequency, output waveform, output level, and THD of the OUTPUT (L, R) and PHONES output using a frequency counter, oscilloscope, AC voltmeter (with 12.47 kHz filter) and distortion meter. The VOLUME control must be set at maximum for this check.

ITEMS TO CHECK

Listed below are the specifications and conditions of the OUTPUT (L, R) outputs during this test.

When the sine wave signal of -11.5 dBm , 1 kHz is applied it A/D INPUT (L) and A/D INPUT is set at maximum, and A/D INPUT (R) is connected to the ground:

OUTPUT(L) : $+5 \text{ dBm} \pm 2 \text{ dB}$ (10k Ω load),
distortion 0.5 % or less

OUTPUT(R) : less than -60 dBm

When the sine wave signal of -11.5 dBm , 1 kHz is applied to A/D INPUT (R), and A/D INPUT is set at maximum, and A/D INPUT (L) is connected to the ground:

OUTPUT(L) : less than -60 dBm

OUTPUT(R) : $+5 \text{ dBm} \pm 2 \text{ dB}$ (10k Ω load),
distortion 0.5 % or less

When the sine wave signal of -11.5 dBm , 1 kHz is applied to AD/INPUT(L) and A/D INPUT is set at minimum, and A/D INPUT (R) is connected to the ground:

OUTPUT(L) : less than -65 dBm

When the sine wave signal of -11.5 dBm , 1 kHz is applied to A/D INPUT (R), and A/D INPUT is set at minimum, and A/D INPUT (L) is connected to the ground:

OUTPUT(R) : less than -65 dBm

Check that the level meters on the LCD will light up, when the sine wave of $-6 \text{ dBm} \pm 2 \text{ dB}$, 1 kHz is applied to the A/D INPUT (R).

TEST END

Press [ENTER] to end the test, the MU90R will automatically proceed to the next test.

If you press [EXIT], the MU90R will wait for the entry of the test number.

TEST 17. DSP & DRAM TEST

17 DSP&DRAM

Check that the correct signal is output from OUTPUT (L) jack.

Insert the appropriate phone plug into the OUTPUT (L) jack and check the output.

If necessary, verify the frequency, output waveform, output level, and THD of the OUTPUT (L, R) and the PHONES output using a frequency counter, oscilloscope, AC voltmeter (with 12.47 kHz filter) and distortion meter. If a plug is inserted to A/D INPUT, it must be disconnected. The VOLUME control must be set at maximum for this check.

ITEMS TO CHECK

Listed below are the specifications and conditions of the OUTPUT (L) output during this test.

OUTPUT(L) : 1 kHz $\pm 3.0 \text{ Hz}$, sine wave, $+4 \text{ dBm} \pm 2 \text{ dB}$ (10 k Ω load), distortion 0.25 % or less

TEST END

Press [ENTER] to end the test, the MU90R will automatically proceed to the next test.

If you press [EXIT], the MU90R will wait for the entry of the test number.

TEST 18. 64 SOUNDS OUTPUT TEST

18 64ch OUT

Check that the correct sine wave signals from channel 1 to channel 32 are output from the OUTPUT (L) and channel 33 through channel 64 are output from the OUTPUT (R).

If necessary, verify the output waveform using an oscilloscope (L channel: 1 kHz, R channel: 2 kHz).

The VOLUME control must be set at maximum for this check. While sounding, the LCD will display the following message.

18 64ch OUT
Lch=xx Rch=xx

(Where xx: currently sounded channel)

TEST END

Press [ENTER] to end the test, the MU90R will automatically proceed to the next test.

If you press [EXIT], the MU90R will wait for the entry of the test number.

TEST 19. FACTORY SETTINGS

19 FACTORY SET

This test is used to initialize the data to the factory settings.

If you press [ENTER], the factory preset data will be restored, the MU90R will exit the test, and then enter to play mode.

If you press [EXIT], they will not be restored.

TEST 20. EXIT TEST PROGRAM

20 EXIT

When [ENTER] is pressed, the MU90R will exit the test program and then enter to play mode.

To remain in the test program, press [EXIT], then the MU90R will wait for the entry of the test number.

You should check that the noise levels are as follows, after the MU90R has quit the test program.

- OUTPUT (L): less than -88 dBm
- OUTPUT (R): less than -88 dBm
- PHONES (L): less than -88 dBm
- PHONES (R): less than -88 dBm

MIDI/COMPUTER CONNECTING CABLES

MIDI

Standard MIDI cable. Maximum length 15 meters.



Mac

Apple Macintosh Peripheral cable (M0197). Maximum length 2 meters.

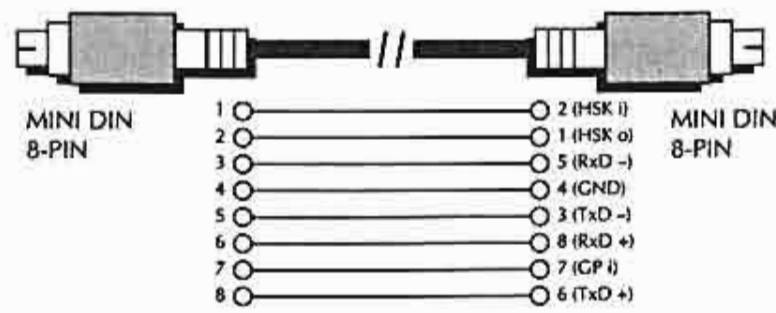

PC-1

8-pin MINI DIN to D-SUB 25-pin cable. If your PC-1 type computer has a 9-pin serial port, use the PC-2 type cable. Maximum length 1.8 meters.

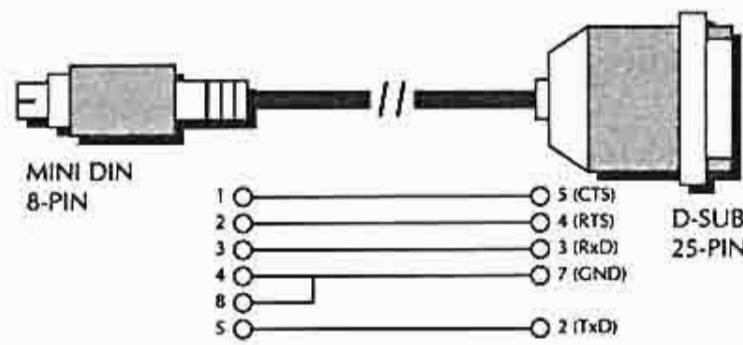

PC-2

8-pin MINI DIN to D-SUB 9-pin cable. Maximum length 1.8 meters.

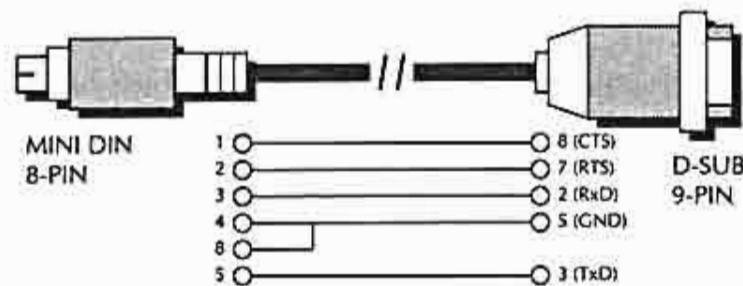

■ ERROR MESSAGES

Battery Low!

The battery voltage (for internal memory backup) may be too low. Bring the unit to your local Yamaha dealer or any other authorized Yamaha service personnel.

Illegal Data!

A data error resulted during reception of MIDI messages. Try transmitting the data again, or turn the MU90R off and back on again.

MIDI Buffer Full!

Too much MIDI data is being received by the MU90R at one time. Reduce the amount of data being sent to the MU90R.

HOST is OffLine!

This message appears when the host computer is not turned on, the connecting cable is not properly connected, or the sequencing software is not active.

SysEx Adrs ERROR!

The data of the received System Exclusive message is incorrect. Check the address of the message and try transmitting again.

SysEx Data ERROR!

The data of the received System Exclusive message is incorrect. Check the data of the message (as to whether it requires an MSB or LSB header) and try transmitting again.

SysEx Size ERROR!

The data of the received System Exclusive message is incorrect. Check the size of the message and try transmitting again.

Check Sum ERROR!

The checksum of the received System Exclusive message is incorrect. Check the checksum of the message and try transmitting again.

This Parameter isn't Excl Data

The selected parameter has no System Exclusive value and cannot be displayed with the Show Exclusive function.

No Parameter

The selected parameter for use with the Show Exclusive function does not exist as a valid parameter.

Rcv CH is OFF!

The selected parameter for use with the Show Exclusive function cannot be converted to a MIDI message value since the Receive Channel for the Part is off. Set the Receive Channel to an appropriate value.

INITIALIZE

The Initialize functions allow you to restore the factory settings of the MU90R.

NOTE
 Since the Initialize functions replace existing data, you should save any and all important settings to a MIDI data storage device before using these functions.

Operation

- 1 Press the UTIL button and select "INITIAL," then press the ENTER button.



- 2 From the Initialize menu, select the type of data to be initialized: Factory Settings (FactSet), selected Sound Module mode (XGInit, GM Init, C/MInit, PFMInit) or Drum (DrumInit). Then, press the ENTER button to call up the selected data dump.



Factory Settings (FactSet)



This restores the original factory settings of the MU90R.

Selected Sound Module Mode:

Extended General MIDI (XGInit)



General MIDI (GM Init)



Computer Music (C/MInit)



Performance (PFMInit)



One of the four parameters above will be available, depending on the currently selected Sound Module mode: XG, TG300B, C/M or PFM. Initializing this parameter restores the original settings for the selected mode.

- NOTES**
- For the PFMInit setting, only the currently selected Performance will be initialized.
 - For XGInit and GM Init, the initialized settings are the same as when the MU90R is reset upon receiving an XG System On or GM System On message.

Drum (DrumInit)



Range: DrumS1 — DrumS4

This restores the original drum settings for the selected Drum Setup S1 — S4. (Use the VALUE \ominus/\oplus buttons or data dial to select the desired Drum Setup.)

NOTE
 This parameter is not available when the MU90R is set to Performance mode.

- 3 From the "Are you sure?" prompt, press the ENTER button to execute the operation, or press the EXIT button to cancel it and return to the previous display.

An "Executing..." message appears in the display during the operation. When the operation is completed, the MU90R returns to the Initialize menu.

■ テストプログラム

準備

測定条件: 本体をテストする場合は、次の測定器や治具が必要です。

測定器: 低周波発振器、アナログ波形測定機、キーボードアンプなど

治具: MIDI ケーブル、HOST チェック治具など

テスト 番号	表題	判定条件など
A	テストエントリー	
B	テストの進め方および NG のときのテストの進め方	
1	SYSTEM RAM	SRAM READ/WRITE
2	BATTERY	CPU の A/D チェック
3	LCD ドットとコントラスト	全白、全黒の反転
4	スイッチと LED	スイッチ ON/OFF、LED ON/OFF
5	DIAL	ダイヤルを回転する
6	MIDI 1	MIDI IN A と MIDI OUT を接続します
7	MIDI 2	MIDI IN B と MIDI OUT を接続します
8	HOST SELECT	HOST SELECT スイッチを切り替えます
9	TO HOST TX/RX	HOST チェック治具を接続します
10	WAVE ROM	WAVE ROM READ
11	1 kHz OUTPUT(L) 発音	計測
12	1 kHz OUTPUT(R) 発音	計測
13	1 kHz INDIV. 1 発音	計測
14	1 kHz INDIV. 2 発音	計測
15	INPUT HIGH	計測
16	INPUT LOW	計測
17	エフェクト&DRAM	計測
18	64 音発音	聴感
19	ファクトリーセット	
20	EXIT	

A. テストエントリー

[PLAY] ボタンと[MUTE/SOLO] ボタンを押しながら、MU90R の電源を ON します。

```
MU90R TEST MODE
Ver#. ## ##-###-##
```

しばらくすると、以下の表示がされます。

```
01 RAM
```

Ver#.## は、製品プログラム ROM のバージョン番号です。

テストを進めるときの注意事項

組み立て上がり直後、またはバッテリー交換直後からテストを始めるときは、[UTIL] ボタンと[ENTER] ボタンを押しながら電源を入れることによってファクトリーセットを行い、その後でテストを実行して下さい。

B. テストの進め方

テストにエントリーすると、次の画面が表示されます。

```
01 RAM
```

SELECT キーによりテスト番号を選択し、[ENTER] を押し、押されたテスト番号から順に自動的にテ

ストが実行されます。

何も選択せずに[ENTER] を押し、"01 RAM" より、テストナンバー順に自動的にテストが実行されます。エラーが発生した場合は、エラー表示を行ってテストは止まります。

NG と判断したときのテストの進め方

各テストにおいて NG と判断した場合は、[EXIT] を押し、テスト番号の選択画面となります。

ただし、"04 SW & LED" のテスト中にエラーが発生した場合は、電源を切ってテストを終了して下さい。

1. SRAM

```
01 RAM
```

次の SRAM 領域に、データ "A5" をライト/リードしてペリファイチェックを行います。

IC10, IC11 = h'200000 ~ h'20FFFF (16-bit Data Bus)

判定結果の表示

```
OK 01 RAM
                                ok
```

```
NG 01 RAM
                                err
```

テストの終了方法

OK のときは、OK が表示されて次のテストに進みます。テスト途中で、NG と判断した場合の処理方法は、" B. テストの進め方" を参照して下さい。また、SRAM のすべてのデータは保存されます。

2. BATTERY

```
02 BATTERY
```

バッテリー電圧が、CPU(IC 11) の A/D によりチェックされた内容が、2.9 V ~ 3.4 V の範囲にあることを確認します。

判定結果の表示

```
OK 02 BATTERY
                                ok
```

```
NG 02 BATTERY
                                err
```

テストの終了方法

OK のときは、OK が表示されて次のテストに進みます。テスト途中で、NG と判断した場合の処理方法は、" B. テストの進め方" を参照して下さい。

3. LCD ドットブリンクとコントラスト

LCD の全ドットが、白から黒に反転することを目で見て確認します。また、バックライトが正しく点灯していることを確認したら、[SELECT]キーを押して、コントラストが8段階に切り替わることを確認します。

テストの終了方法

[ENTER]を押すとテストは終了し、次のテストへ進みます。

[EXIT]を押すとテストは終了し、テスト番号の選択画面となります。

4. スイッチと LED

04 SWITCH & LED

[PLAY]から[VALUE+]までのパネルスイッチを以下のようなLCDの表示に従ってON/OFFします。

このとき、LCDに表示されているスイッチのLEDが点灯していることを確認した後、スイッチを押してスイッチが正常に動作することを確認します。

04 SWITCH & LED
[ENTER]

([ENTER]スイッチのチェックの場合)

スイッチチェックの順序を下図に示します。

[PLAY] → [UTIL] → [MODE] → [EDIT] → [EFFECT] → [EQ] → [MUTE/SOLO] → [ENTER] → [EXIT] → [PART -] → [SELECT -] → [VALUE -] → [PART +] → [SELECT +] → [VALUE +]

LCDの表示に従ってスイッチをON/OFFしたとき、スイッチが正常の場合"ポーッ"と発音して次のスイッチにテストが進みます。

NGの場合、LCDに指示されたスイッチを押しても、次のスイッチのテストに進みません。

判定結果の表示

OK 04 SW & LED ok

NG なし

テストの終了方法

[VALUE+]までのチェックすると、次のテストに進みます。テスト途中でNGと判断した場合は、一度電源を切ってテストをやり直して下さい。

5. DIAL

05 DIAL

ダイヤルを回して正しく動作することを確認します。

LCDの表示に従って、値が"10"になるまでダイヤルを右に回します。次に値が"10"になるまでダイヤルを左に回します。正常の場合は、次のテストにすすみます。NGの場合は、LCDに"err"が表示され次のテストに進みません。

判定結果の表示

OK 05 DIAL ok

NG 05 DIAL err

テストの終了方法

OKのときは、OKが表示されて次のテストに進みます。テスト途中で、NGと判断した場合の処理方法は、"B.テストの進め方"を参照して下さい。

6. MIDI 1

MIDI IN A 端子と MIDI OUT 端子、そして MIDI THRU 端子と MIDI IN B 端子を MIDI ケーブルで接続した後、テストを実行します。このとき、HOST SELECTはMIDIにセットしておきます。

06 MIDI 1

MIDI OUT 端子からテストパターン(AA 50 5F)を送って MIDI IN A 端子で受信した結果で判定します。

判定結果の表示

OK MIDI 1 ok

NG MIDI 1 err

テストの終了方法

OKのときは、OKが表示されて次のテストに進みます。テスト途中で、NGと判断した場合の処理方法は、"B.テストの進め方"を参照して下さい。

7. MIDI 2

MIDI IN A 端子と MIDI OUT 端子、そして MIDI THRU 端子と MIDI IN B 端子を MIDI ケーブルで接続した後、テストを実行します。

このとき、HOST SELECTはMIDIにセットしておきます。

07 MIDI 2

MIDI OUT 端子からテストパターン(AA 50 5F)を送って MIDI IN A 端子で受信し、MIDI THRU 端子から出力されたデータを MIDI IN B 端子で受信した結果で判定します。

判定結果の表示

OK

MIDI 2	ok
--------	----

NG

MIDI 2	err
--------	-----

テストの終了方法

OK のときは、OK が表示されて次のテストに進みます。テスト途中で、NG と判断した場合の処理方法は、" B. テストの進め方" を参照して下さい。

8. HOST SELECT

08 HOST SELECT MIDI ZZ--YY=XX

(ZZ = 下限値、YY = 上限値、XX = 測定値)

LCD の表示に従って、[Mac]から[PC-1]→[PC-2]→[MIDI]の順に HOST SELECT スイッチを切り替え、スイッチが正しく働くことを確認します。

08 HOST SELECT PC2 ZZ--YY=XX

(*[PC2]に切り替え要求中)

正しい DATA が来るまでは無限ループとなります。

判定値 MIDI: 0 V~0.6 V
PC2: 1.25 V~2.1 V
PC1: 2.8 V~3.7 V
MAC: 4.7 V~5 V

LCD の表示に従ってスイッチを切り替えたとき、全て OK となることを確認します。

判定結果の表示

OK

08 HOST SELECT	ok
----------------	----

テストの終了方法

[MIDI]までチェックすると OK が表示され、テストは次に進みます。テストの途中で[EXIT]を押すと、テストを終了してテスト番号の選択画面となります。テスト途中で、NG と判断した場合の処理方法は、" B. テストの進め方" を参照して下さい。

9. TO HOST TX/RX

09 TO HOST

このテストは、工場出荷検査用のテストです。ここでは、実行しません。

このテストは、TO HOST IN/OUT の動作確認をテストパターン(AA 50 5F)により行います。

判定結果の表示

OK

09 TO HOST	ok
------------	----

NG

09 TO HOST	err
------------	-----

テストの終了方法

テスト用の治具なしでテストを実行すると、エラーが発生します。処理方法は、" B. テストの進め方" を参照して下さい。

10. WAVE ROM

10 WAVE ROM

SWP20 を介して 4 つの WAVE ROM のデータをリード/ベリファイします。

判定結果の表示

OK

10 WAVE ROM	ok
-------------	----

NG

10 WAVE ROM	err
-------------	-----

テストの終了方法

OK のときは、OK が表示されて次のテストに進みます。テスト途中で、NG と判断した場合の処理方法は、" B. テストの進め方" を参照して下さい。

11. 1 kHz OUTPUT (L)発音

11 OUTPUT L 1 kHz

OUTPUT(L)端子および PHONES(L)端子より、正常な信号が出力されていることを確認します。

OUTPUT(L, R)端子、PHONES(L, R)端子共にプラグを差し込み、各出力の周波数、出力波形、出力レベルを観測・測定します。このとき、A/D INPUTには、プラグが差し込まれていないこと。また、マスターボリュームは MAX とします。

チェック項目

OUTPUT(L): 1 kHz ±3 Hz、SIN 波、+3.0 dBm±2 dB (負荷 10 k Ω)、歪率 0.25 %以下

OUTPUT(R): -80 dBm 以下

PHONES(L): 1 kHz ±3 Hz、SIN 波、-4.5 dBm±2 dB (負荷 33 Ω)、歪率 0.5 %以下

PHONES(R): -65 dBm 以下

OUTPUT (R)のプラグを抜いたとき

OUTPUT(L): -2.0 dBm±2 dB

テストの終了方法

[ENTER]を押すと、テストは次に進みます。
[EXIT]を押すと、テスト番号の選択画面となります。

12. 1 kHz OUTPUT (R)発音

12 OUTPUT R 1 kHz

OUTPUT(R)端子および PHONES(R)端子より、正常な信号が出力されていることを確認します。

OUTPUT(L, R)端子、PHONES(L, R)端子共にプラグを差し込み、各出力の周波数、出力波形、出力レベルを観測・測定します。このとき、A/D INPUTには、プラグが差し込まれていないこと。

また、マスターボリュームはMAXとします。

チェック項目

OUTPUT(L): -80 dBm以下
OUTPUT(R): 1 kHz \pm 3 Hz、SIN波、+3.0 dBm \pm 2 dB
(負荷 10 k Ω)、歪率 0.25 %以下
PHONES(L): -65 dBm以下
PHONES(R): 1 kHz \pm 3 Hz、SIN波、-4.5 dBm \pm 2 dB
(負荷 33 Ω)、歪率 0.5 %以下

テストの終了方法

[ENTER]を押すと、テストは次に進みます。
[EXIT]を押すと、テスト番号の選択画面となります。

13. INDIVOUT 1 1 kHz 発音

13 INDIVOUT 1 1 kHz

INDIV. OUTPUT 1 端子より、正常な信号が出力されていることを確認します。

INDIV. OUTPUT 1 端子にプラグを差し込み、出力の周波数、出力波形、出力レベルを観測・測定します。このとき、A/D INPUTには、プラグが差し込まれていないこと。

チェック項目

INDIV. OUTPUT 1: 1 kHz \pm 3 Hz、SIN波、+4.0 dBm \pm 2 dB
(負荷 10 k Ω)、歪率 0.25 %以下
INDIV. OUTPUT 2: -80 dBm以下

テストの終了方法

[ENTER]を押すと、テストは次に進みます。
[EXIT]を押すと、テスト番号の選択画面となります。

14. INDIVOUT 2 1 kHz 発音

14 INDIVOUT 2 1 kHz

INDIV. OUTPUT 2 端子より、正常な信号が出力されていることを確認します。

INDIV. OUTPUT 2 端子にプラグを差し込み、出力の周波数、出力波形、出力レベルを観測・測定します。このとき、A/D INPUTには、プラグが差し込まれていないこと。

チェック項目

INDIV. OUTPUT 1: -80 dBm以下
INDIV. OUTPUT 2: 1 kHz \pm 3 Hz、SIN波、+4.0 dBm \pm 2 dB
(負荷 10 k Ω)、歪率 0.25 %以下

テストの終了方法

[ENTER]を押すと、テストは次に進みます。
[EXIT]を押すと、テスト番号の選択画面となります。

15. INPUT HIGH

15 INPUT HIGH

INPUT GAIN が HIGH のときに、A/D INPUT 端子に入力した信号が、INPUT VOLUME によりゲインが変化し、OUTPUT 端子より出力されることを確認します。また、規定のレベルの信号を A/D INPUT 端子に入力することにより、LCD のレベルメータが点灯することを確認します。

OUTPUT(L, R)端子と PHONES(L, R)端子共にプラグを差し込み、各出力の周波数、出力波形、出力レベルを観測・測定します。

このとき、マスターボリュームはMAXとします。

チェック項目

A/D INPUT(L)端子に-36.0 dBm、1 kHz の SIN 波を入力(A/D INPUT(R)端子はグラウンドに接続)し、INPUT VOLUME を MAX としたとき
OUTPUT(L): +5 dBm \pm 2 dB (負荷 10k Ω)、歪率 0.5 %以下
OUTPUT(R): -48 dBm以下

A/D INPUT(R)端子に-36.0 dBm、1 kHz の SIN 波を入力(A/D INPUT(L)端子はグラウンドに接続)し、INPUT VOLUME を MAX としたとき
OUTPUT(L): -48 dBm以下
OUTPUT(R): +5 dBm \pm 2 dB (負荷 10 k Ω)、歪率 0.5%以下

A/D INPUT(L)端子に-36.0 dBm、1 kHz の SIN 波を入力(A/D INPUT(R)端子はグラウンドに接続)し、INPUT VOLUME を MIN としたとき
OUTPUT(L): -66 dBm以下

A/D INPUT(R)端子に-36.0 dBm、1 kHz の SIN 波を入力(A/D INPUT(L)端子はグラウンドに接続)し、INPUT VOLUME を MIN としたとき
OUTPUT(R): -66 dBm以下

INPUT VOLUME を MAX とし、A/D INPUT(L)端子に -29.0 dBm±2 dB、1 kHz の SIN 波を入力したとき、LCD のレベルメータが点灯することを確認します。

テストの終了方法

[ENTER]を押すと、テストは次に進みます。
[EXIT]を押すと、テスト番号の選択画面となります。

16. INPUT LOW

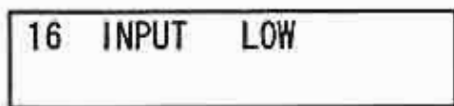

INPUT GAIN が LOW のときに、A/D INPUT 端子に入力した信号が、INPUT VOLUME によりゲインが変化し、OUTPUT 端子より出力されることを確認します。また、規定のレベルの信号を A/D INPUT 端子に入力することにより、LCD のレベルメータが点灯することを確認します。

OUTPUT(L, R)端子と PHONES(L, R)端子共にプラグを差し込み、各出力の周波数、出力波形、出力レベルを観測・測定します。

このとき、マスターボリュームは MAX とします。

チェック項目

A/D INPUT(L)端子に-11.5 dBm、1 kHz の SIN 波を入力(A/D INPUT(R)端子はグラウンドに接続)し、INPUT VOLUME を MAX としたとき

OUTPUT(L) : +5 dBm±2 dB (負荷 10k Ω)、歪率 0.5 %以下

OUTPUT(R) : -60 dBm 以下

A/D INPUT(R)端子に-11.5 dBm、1 kHz の SIN 波を入力(A/D INPUT(L)端子はグラウンドに接続)し、INPUT VOLUME を MAX としたとき

OUTPUT(L) : -60 dBm 以下

OUTPUT(R) : +5.0 dBm±2 dB (負荷 10 k Ω)、歪率 0.5% 以下

A/D INPUT(L)端子に-11.5 dBm、1 kHz の SIN 波を入力(A/D INPUT(R)端子はグラウンドに接続)し、INPUT VOLUME を MIN としたとき

OUTPUT(L) : -65 dBm 以下

A/D INPUT(R)端子に-11.5 dBm、1 kHz の SIN 波を入力(A/D INPUT(L)端子はグラウンドに接続)し、INPUT VOLUME を MIN としたとき

OUTPUT(R) : -65 dBm 以下

INPUT VOLUME を MAX とし、A/D INPUT(R)端子に-6.0 dBm±2 dB、1 kHz の SIN 波を入力したとき、LCD のレベルメータが全て点灯することを確認します。

テストの終了方法

[ENTER]を押すと、テストは次に進みます。
[EXIT]を押すと、テスト番号の選択画面となります。

17. エフェクトと DRAM

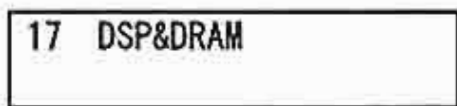

OUTPUT(L)端子から出力される信号の周波数、出力波形、出力レベルを観測・測定し、正常な信号が出力されていることを確認します。このとき、A/D INPUT には、プラグが差し込まれていないこと。また、マスターボリュームは MAX とします。なお、最低でも 2 秒以上は観測して下さい。

チェック項目

OUTPUT(L) : 1 kHz ±3.0 Hz、SIN 波、+4.0 dBm±2 dB(負荷 10 k Ω)、歪率 0.25 %以下

テストの終了方法

[ENTER]を押すと、テストは次に進みます。
[EXIT]を押すと、テスト番号の選択画面となります。

18. 64 音発音

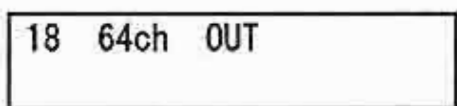

OUTPUT(L)端子からは、1 チャンネルから 32 チャンネルまでの信号が発音されます。また、OUTPUT(R)端子からは、33 チャンネルから 64 チャンネルまでの信号が発音されます。

発音時間は約 0.3 秒、間隔が約 0.1 秒で 32 回繰り返し発音されますので、聴感で 64 の発音チャンネルが正常に発音されていることを確認します。

また、出力波形が正常なサイン波であることを確認します。(Lch = 1 kHz、Rch = 2 kHz)

このとき、マスターボリュームは MAX とします。テスト中、LCD には以下のように表示されます。

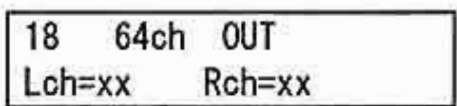

(xx : 現在発音しているチャンネル番号)

テストの終了方法

[ENTER]を押すと、テストは次に進みます。
[EXIT]を押すと、テスト番号の選択画面となります。

19. ファクトリーセット

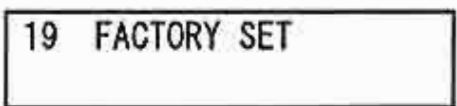

[ENTER]を押すと各データはファクトリーセットされて工場出荷データとなり、テストモードから抜けます。
[EXIT]を押すと、ファクトリーセットは実行されず EXIT します。

20. EXIT

20 EXIT

[ENTER]を押すと、テストモードから抜けて、プレイモードになります。

[EXIT]を押すと、テスト番号の選択画面となります。

テストモードを抜けプレイモードになったらとき、ノイズレベルが次の条件を満たすことを確認して下さい。

OUTPUT(L) : -88 dBm 以下

LINE OUT(R) : -88 dBm 以下

PHONES(L) : -88 dBm 以下

PHONES(R) : -88 dBm 以下

■ コンピュータ接続ケーブルについて

NEC PC-9800/9821 シリーズとの接続

mini DIN 8-pin → D-SUB 25-pin (YAMAHA CCJ-PC1、CCJ-PC1NFまたは同等品)

MINI DIN8P → D-SUB25P

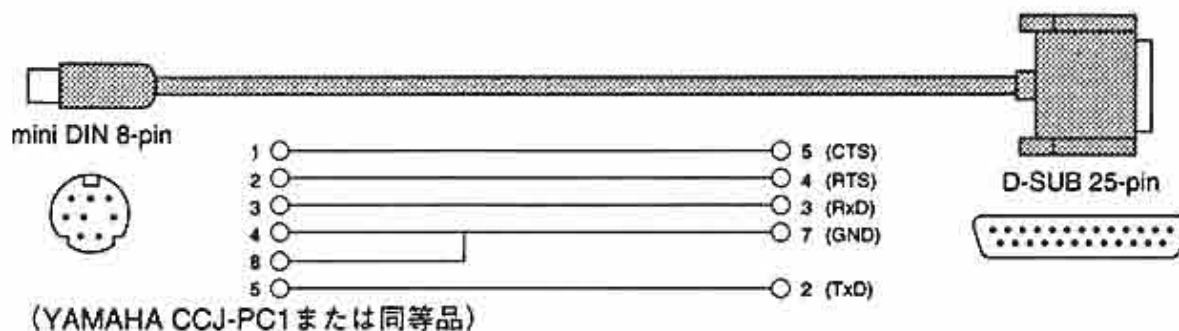

Apple Macintosh シリーズとの接続

システムベリフェラル - 8 ケーブル (YAMAHA CCJ-MAC または同等品)

Apple社システムベリフェラル - 8 ケーブル [M0197]

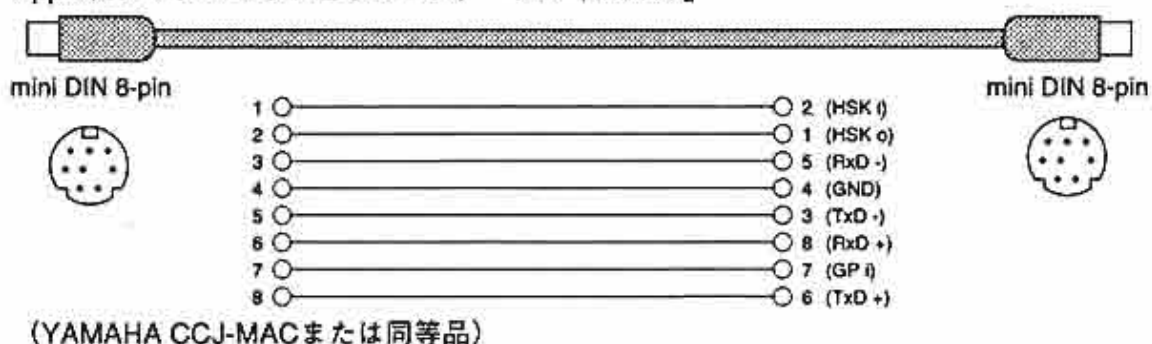

IBM PC/AT シリーズとの接続

mini DIN 8-pin → D-SUB 9-pin (YAMAHA CCJ-PC2 または同等品)

MINI DIN8P → D-SUB9P

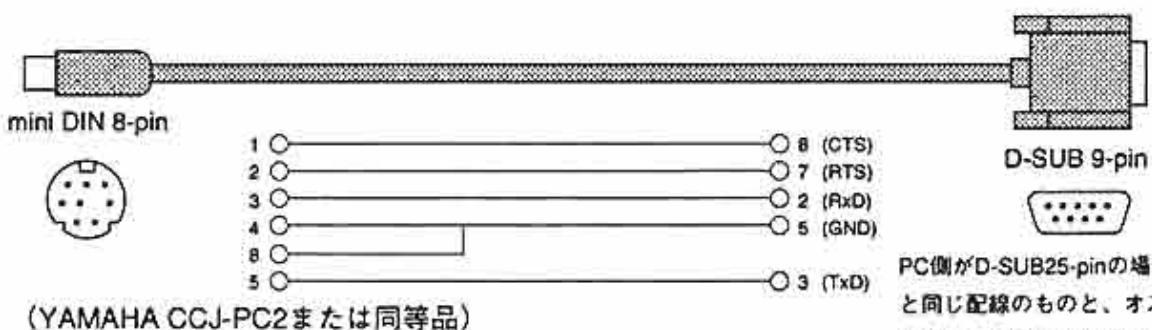

PC側がD-SUB25-pinの場合はPC-9800シリーズと同じ配線のもの、オス、メス変換プラグアダプターを併せて使用してください。

Macintoshはアップルコンピュータ社の商標です。

PC-9801/9821は日本電気株式会社の商標です。

IBM-PC/ATは、インターナショナルビジネスマシーン社の商標です。

その他、本書に記載されている会社名および商品名等は、各社の登録商標および商標です。

■ エラーメッセージ

Battery Low!

内蔵バッテリーが消耗しています。
お買い上げのお店か、お近くのヤマハ電気音響製品サービス拠点にご連絡ください。

Illegal Data!

MIDI受信中にデータエラーが発生しました。もう一度送信してみてください。

MIDI Buffer Full!

大量のMIDI情報を短時間に受信したため、処理できませんでした。
不要なMIDI情報はなるべく送らないようにしてください。

HOST is OffLine!

コンピューターの電源が切れているか、ケーブルが正しく接続されていません。
ケーブルを確認して、コンピューター側のドライバーやMIDIアプリケーションが正しく機能しているか確認してください。

SysEx Adrs ERROR!

受信したシステムエクスクルーシブメッセージのアドレスが違います。
送信データのアドレスを確認してください。

SysEx Data ERROR!

受信したシステムエクスクルーシブメッセージのデータが違います。
送信データの内容(MSB、LSBが必要なデータかなど)を確認してください。

SysEx Size ERROR!

受信したシステムエクスクルーシブメッセージのサイズが違います。
送信データのサイズを確認してください。

Check Sum ERROR!

受信したシステムエクスクルーシブメッセージのチェックサムが違います。
送信データのチェックサムを確認してください。

This Parameter isn't Excl Data

ショーエクスクルーシブで見ようとしたパラメーターはエクスクルーシブ情報に変換できません。

No Parameter

ショーエクスクルーシブまたはショーコントロールチェンジで見ようとしたパラメーターは有効なパラメーターではありません。

Rcv CH is OFF!

ショーコントロールで見ようとしたパラメーターはパートのレシーブチャンネルがOFFになっているためMIDI情報に変換できません。レシーブチャンネルを設定してください。



- ・ MU90R内部の設定を工場出荷状態などの一定の初期状態に戻します。

イニシャルイズでの操作



1. ユーティリティメニューで[SELECT ●/●]ボタンを押して、「INITIAL」にカーソルを移動します。

- ▼ 「INITIAL」が点滅状態になります。



2. [ENTER]ボタンを押します。

- ▼ イニシャルイズに入り、メニューが表示されます。



3. [SELECT ●/●]ボタンを押して、イニシャルイズしたい項目を選びます。

- ▼ イニシャルイズしたい項目が点滅状態になります。

4. [ENTER]ボタンを押します。

- ▼ イニシャルイズの確認画面になります。



5. [ENTER]ボタンを押して、イニシャルイズを実行します。

- ▼ イニシャルイズが終了すると、自動的にイニシャルイズのメニューに戻ります。

- ・ 中止したいときは[EXIT]ボタンを押します。

イニシャルイズを実行すると、メモリーやバッファアワーの中に入っているMU90Rのデータは消えてしまいます。大切なデータはあらかじめヤマハMIDIデータファアライアーMDF2などに保存してください。



■ イニシャルイズ

イニシャルイズの種類

イニシャルイズの種類	機能
FactSet 1. (ファクトリーセット)	マルチ、パフォーマンス、エフェクト、EQを含むすべての設定を工場出荷状態に戻します。
XG Init 2. (XGイニシャルイズ)	マルチの設定をXGモードの初期状態に戻します。
GM Init 3. (GMイニシャルイズ)	マルチの設定をTG300Bモードの初期状態に戻します。
C/M Init 4. (C/Mイニシャルイズ)	マルチの設定をC/Mモードの初期状態に戻します。
PFM Init 5. (パフォーマンスイニシャルイズ)	パフォーマンスのバッファアワーを初期状態に戻します。インターナルメモリーは初期化されません。
Drum Init 6. (ドラムイニシャルイズ)	drumS1～drumS4のドラムセットアップの設定を初期化します。

・ サウンドモジュールモードの設定により、イニシャルイズの種類が異なります。

イニシャルイズの種類の詳細

(1) FactSet(ファクトリーセット)

【解説】

- ・ マルチ、パフォーマンス、エフェクト、イコライザー、システムセットアップを含むすべての内部設定を工場出荷状態に戻します。

(2) XG Init(XGイニシャルイズ)

【解説】

- ・ マルチパートコントロール、マルチオールパートコントロール、マルチパートエディット、エフェクト、イコライザーの設定をXGモードの初期状態に戻します。

- ・ マルチ以外の設定は初期化されません。

- ・ このメニューは、サウンドモジュールモードにXGが選択されているときだけ表示されます。

(3) GM Init(GMイニシャルイズ)

【解説】

- ・ マルチパートコントロール、マルチオールパートコントロール、マルチパートエディット、エフェクト、イコライザーの設定をTG300Bモードの初期状態に戻します。

- ・ マルチ以外の設定は初期化されません。

- ・ このメニューは、サウンドモジュールモードにTG300Bが選択されているときだけ表示されます。

(4) C/M Init(C/Mイニシャルイズ)

【解説】

- ・ マルチパートコントロール、マルチオールパートコントロール、マルチパートエディット、エフェクト、イコライザーの設定をC/Mモード初期状態に戻します。

- ・ マルチ以外の設定は、初期化されません。

- ・ このメニューは、サウンドモジュールモードにC/Mが選択されているときだけ表示されます。

(5) PFM Init(パフォーマンスイニシャルイズ)

【解説】

- ・ パフォーマンスエディットバッファアワーを初期状態に戻します。

- ・ パフォーマンスを最初から作りたいたいときに使用する機能です。

- ・ このイニシャルイズでは、パフォーマンスのインターナルメモリーは初期化されません。

- ・ このメニューは、サウンドモジュールモードにPFMが選択されているときだけ表示されます。

(6) Drum Init(ドラムイニシャルイズ)

【解説】

- ・ ドラムセットアップ(drumS1～S4)の設定を初期化します。

- ・ 初期化するドラムセットアップ(DrumS1～S4)を[VALUE ●/●]ボタンまたはダイヤルで選択することができます。

- ・ このメニューは、サウンドモジュールモードにXG、TG300B、C/Mが選択されているときに表示されます。

【参考】

- ・ サウンドモジュールモードを切り替えたときも、ここでの各イニシャルイズと同様に初期化されます。

MIDI DATA FORMAT (MIDIデータフォーマット)

1. Channel messages

1.1 Note-on / Note-off

These are messages which convey keyboard performance data.
 Range of received notes = C-2 ...G8
 Velocity range = 1...127 (Velocity is received only for note-on)

When the Multi Part parameter Rcv NOTE MESSAGE = OFF, that part is not received.
 For Drum parts*, key-off is not received when the Drum Setup parameter Rcv NOTE OFF = OFF.
 For Drum parts, key-on is not received when the Drum Setup parameter Rcv NOTE ON = OFF.

* Drum Part indicates that the Multi Part parameter PART MODE is DRUM or DRUMS1...4.

1.2 Control Changes

These messages convey controller operations such as for volume and pan.
 The function is distinguished by the control number (Ctrl#).
 When the Multi Part parameter Rcv CONTROL CHANGE = OFF, that part will not receive control changes.

1.2.1 Bank Select

These messages select the voice bank.

Control#	Parameter	Data Range
0	Bank Select MSB	0,64, 126, 127 (Normal voice,SFX voice, SFX kit, Drum kit)
32	Bank Select LSB	0...127

Bank Select processing is suspended until a Program Change message is received, and when a voice from a different voice bank is to be selected, Bank Select and a program change message must be transmitted as a set, in the order of Bank Select MSB, LSB, and Program Change.

Bank Select is not received when Sound Module Mode = C/M.

1.2.2 Modulation

In general this message controls the depth at which vibrato is applied, but the depth of the following seven effects can be controlled.

The effect of these messages can be changed by the following parameters.

- Multi Part Parameter
 1. MW PITCH CONTROL
 2. MW FILTER CONTROL
 3. MW AMPLITUDE CONTROL
 4. MW LFO PMOD DEPTH
 5. MW LFO FMOD DEPTH
 6. MW LFO AMOD DEPTH
- Effect1 Parameter
 7. MW VARIATION CONTROL DEPTH
(Valid when Variation Effect is assigned to a part as an Insertion effect.)

With the initial settings, the LFO Pitch Modulation (PMOD) effect will apply.

Control#	Parameter	Data Range
0	Modulation	0...127

When the Multi Part parameter Rcv MODULATION = OFF, that part will not receive Modulation.

If the receiving channel is a drum part, effects 5 and 6 will not apply.

1.2.3 Portamento Time

This message controls the way in which portamento (see 1.2.9) is applied.

Control#	Parameter	Data Range
5	Portamento Time	0...127

When Portamento = ON, this adjusts the speed of the pitch change.
 A value of 0 is the shortest portamento time, and 127 is the longest portamento time.
 If the receiving channel is a drum part, Portamento Time is not received.

1.2.4 Data Entry

This message sets the value of the parameter specified by RPN (see 1.2.22) or NRPN (see 1.2.21).

Control#	Parameter	Data Range
6	Data Entry MSB	0...127
38	Data Entry LSB	0...127

1.2.5 Main Volume

This message control the volume of each part.
 (Use it to adjust the volume balance of each part.)

Control#	Parameter	Data Range
7	Main Volume	0...127

If the Multi Part parameter Rcv VOLUME = OFF, that part will not receive Main Volume.
 0 is silence, 127 is maximum volume.

1.2.6 Panpot

This message controls the stereo location of the sound of each part.

Control#	Parameter	Data Range
10	Pan	0...64...127

If the Multi Part parameter Rcv PAN = OFF, that part will not receive Panpot.
 0 is left, 64 is center, 127 is right.

1.2.7 Expression

This message controls the dynamics of each part.
 (Use it to create volume changes during a song.)

Control#	Parameter	Data Range
11	Expression	0...127

If the Multi Part parameter Rcv EXPRESSION = OFF, that part will not receive Expression.

1.2.8 Hold1

This message controls sustain pedal on/off.

Control#	Parameter	Data Range
64	Hold1	0...63,64...127 (OFF, ON)

When ON, the currently-sounding notes will be sustained even after note-off is received.
 If the Multi Part parameter Rcv HOLD1 = OFF, that part will not receive Hold1.

1.2.9 Portamento

This message controls portamento pedal on/off.

Control#	Parameter	Data Range
64	Portamento	0...63,64...127 (OFF, ON)

When ON, the pitch will smoothly change from one note to the next. The time over which the pitch change occurs is adjusted by Portamento Time (see 1.2.3). If the Multi Part parameter MONO/POLY MODE = MONO, turning Portamento = ON will also cause the sound to be smoothly connected (legato).

If any of the following Multi Part parameter settings apply, that part will not receive Portamento.

- Rcv PORTAMENTO = OFF
- PART MODE = DRUM, DRUMS1...4

1.2.10 Sostenuto

This message controls sostenuto pedal on/off.

Control#	Parameter	Data Range
66	Sostenuto	0...63,64...127 (OFF, ON)

When sostenuto is turned on while a note is sounding, that note will continue sustaining until sostenuto is turned off.

If the following Multi Part parameter setting applies, that part will not receive Sostenuto.

- Rcv SOSTENUTO = OFF

1.2.11 Soft Pedal

This message controls soft pedal on/off.

Control#	Parameter	Data Range
67	Soft Pedal	0...63,64...127 (OFF, ON)

When ON, the sound will be softer.
 If any of the following Multi Part parameter settings apply, that part will not receive Soft Pedal.

- Rcv SOFT PEDAL = OFF
- PART MODE = DRUM, DRUMS1...4

1.2.12 Harmonic Content

This message adjusts the resonance of the filter that is specified by the sound.

Control#	Parameter	Data Range
71	Harmonic Content	0...64...127 (-64...0...+63)

Since this is a relative change parameter, it specifies an increase or decrease centered at 64.

Higher values will produce a more distinctive sound.
 For some sounds, the effective range may be narrower than the settable range.

1.2.13 Release Time

This message adjusts the EG Release Time specified by the sound.

Control#	Parameter	Data Range
72	Release Time	0...64...127 (-64...0...+63)

Since this is a relative change parameter, it specifies an increase or decrease centered at 64. Higher values will lengthen the release which occurs after note-off.

1.2.14 Attack Time

This message adjusts the EG Attack Time specified by the sound.

Control#	Parameter	Data Range
73	Attack Time	0...64...127 (-64...0...+63)

Since this is a relative change parameter, it specifies an increase or decrease centered at 64. Higher values will make the attack more gradual, and lower values will make the attack more sharp.

1.2.15 Brightness

This message adjusts the low pass filter cutoff frequency specified by the sound.

Control#	Parameter	Data Range
74	Brightness	0...64...127 (-64...0...+63)

Since this is a relative change parameter, it specifies an increase or decrease centered at 64. Lower values will produce a more mellow sound. For some sounds, the effective range may be narrower than the settable range.

1.2.16 Portamento Control

This message specifies the key source number for portamento (the key number from which portamento will start). The portamento source key is specified as 0...127. When Portamento Control is received, the currently sounding pitch will change at a speed of Portamento Time 0 to the key of the next note-on that is received on the same channel.

Control#	Parameter	Data Range
84	Portamento Control	0...127 (C-2...G8)

This is received even if Rcv PORTAMENTO = OFF.

1.2.17 Effect1 Depth (Reverb Send Level)

This message specifies the send level for the reverb effect.

Control#	Parameter	Data Range
91	Effect1 Depth	0...127

Higher values will produce a deeper reverb. The result of the value will depend on the state of the reverb effect.

1.2.18 Effect3 Depth (Chorus Send Level)

This message specifies the send level for the chorus effect.

Control#	Parameter	Data Range
93	Effect3 Depth	0...127

Higher values will produce more modulation and spaciousness. The result of the value will depend on the state of the chorus effect.

1.2.19 Effect4 Depth (Variation Effect Send Level)

This message specifies the send level for the variation effect.

Control#	Parameter	Data Range
94	Effect4 Depth	0...127

However, this is not received if the Variation Effect parameter Variation Connection = 0 (Insertion).

1.2.20 Data Increment / Decrement (for RPN)

This message increases or decreases the value of the parameter specified by RPN (see 1.2.22) in units of 1.

Control#	Parameter	Data Range
96	RPN Increment	--
97	RPN Decrement	--

The data byte is ignored.

1.2.21 NRPN (Non-registered Parameter Number)

These messages are used to set parameters such as vibrato, filter, EG, or drum setup etc. The parameter is specified by transmitting a NRPN MSB and NRPN LSB, and subsequently Data Entry (see 1.2.4) is used to set the value of the specified parameter.

Control#	Parameter	Data Range
98	NRPN LSB	0...127
99	NRPN MSB	0...127

When the Multi Part parameter Rcv NRPN = OFF, NRPN for that part will not be received. The following NRPN messages can be received.

NRPN	Data Entry*1	Parameter name and range of values
MSB LSB	MSB LSB	
01H 08H	mm -- *2	Vibrato Rate mm : 00H - 40H - 7FH (-64...0...+63)
01H 09H	mm --	Vibrato Depth mm : 00H - 40H - 7FH (-64...0...+63)
01H 0AH	mm -- *3	Vibrato Delay mm : 00H - 40H - 7FH (-64...0...+63)
01H 20H	mm --	Low Pass Filter Cutoff Frequency mm : 00H - 40H - 7FH (-64...0...+63)
01H 21H	mm --	Low Pass Filter Resonance mm : 00H - 40H - 7FH (-64...0...+63)
01H 24H	mm --	High Pass Filter Cutoff Frequency mm : 00H - 40H - 7FH (-64...0...+63)
01H 30H	mm -- *4	EQ Bass Gain mm : 00H - 40H - 7FH (-64...0...+63)
01H 31H	mm -- *4	EQ Treble Gain mm : 00H - 40H - 7FH (-64...0...+63)
01H 34H	mm -- *4	EQ Bass Frequency mm : 04H - 28H (32...2.0k[Hz])
01H 35H	mm -- *4	EQ Treble Frequency mm : 1CH - 3AH (500...16.0k[Hz])
01H 63H	mm --	EG Attack Time mm : 00H - 40H - 7FH (-64...0...+63)
01H 64H	mm --	EG Decay Time mm : 00H - 40H - 7FH (-64...0...+63)
01H 66H	mm --	EG Release Time mm : 00H - 40H - 7FH (-64...0...+63)
14H rr	mm --	Drum Low Pass Filter Cutoff Frequency rr : drum instrument note number mm : 00H - 40H - 7FH (-64...0...+63)
15H rr	mm --	Drum Low Pass Filter Resonance rr : drum instrument note number mm : 00H - 40H - 7FH (-64...0...+63)
16H rr	mm --	Drum EG Attack Rate rr : drum instrument note number mm : 00H - 40H - 7FH (-64...0...+63)
17H rr	mm --	Drum EG Decay Rate rr : drum instrument note number mm : 00H - 40H - 7FH (-64...0...+63) Applies to both Decay 1 and 2
18H rr	mm --	Drum Instrument Pitch Coarse rr : drum instrument note number mm : 00H - 40H - 7FH (-64...0...+63)
19H rr	mm --	Drum Instrument Pitch Fine rr : drum instrument note number mm : 00H - 40H - 7FH (-64...0...+63)
1AH rr	mm --	Drum Instrument Level rr : drum instrument note number mm : 00H - 7FH (0...maximum)
1CH rr	mm --	Drum Instrument Panpot rr : drum instrument note number mm : 00H,01H-40H-7FH (RND, L63...C...R63)
1DH rr	mm --	Drum Instrument Reverb Send Level rr : drum instrument note number mm : 00H - 7FH (0...maximum)
1EH rr	mm --	Drum Instrument Chorus Send Level rr : drum instrument note number mm : 00H - 7FH (0...maximum)
1FH rr	mm --	Drum Instrument Variation Send Level rr : drum instrument note number mm : 00H - 7FH (0...maximum) when Variation Connection = SYSTEM mm : 00H, 01H-7FH(OFF,ON) when Variation Connection = INSERTION

24H rr	mm --	Drum High Pass Filter Cutoff Frequency mm : 00H - 40H - 7FH (-64...0...+63)
30H rr	mm --	Drum EQ Bass Gain mm : 00H - 40H - 7FH (-64...0...+63)
31H rr	mm --	Drum EQ Treble Gain mm : 00H - 40H - 7FH (-64...0...+63)
34H rr	mm --	Drum EQ Bass Frequency mm : 04H - 28H (32...2.0k[Hz])
35H rr	mm --	Drum EQ Treble Frequency mm : 1CH - 3AH (500...16.0k[Hz])

MSB 14H-35H (for drum) is received when the Multi Part parameter PART MODE = DRUMS1...4.

- *1 See 1.2.4
- *2 '-' indicates that the value is ignored.
- *3 Adjusts the time at which the vibrato effect begins after a note is played. Lower values will cause the effect to begin applying sooner, and higher values will cause the effect to begin applying later. This has no effect when Bank Select MSB=127 is selected.
- *4 This has no effect when the Multi Part parameter PART MODE = DRUM or DRUMS1...4.

1.2.22 RPN (Registered Parameter Number)

These messages make part settings such as Pitch Bend Sensitivity and Tuning. The RPN MSB and RPN LSB are transmitted to specify the parameter which is to be controlled, and subsequently Data Entry (see 1.2.4) is used to set the value of the specified parameter.

Control#	Parameter	Data Range
100	RPN LSB	0...127
101	RPN MSB	0...127

If the Multi Part parameter Rcv RPN = OFF, that part will not receive this message.

The following RPN messages can be received.

RPN	Data Entry *1	
MSB LSB	MSB LSB	Parameter name and range of values
00H 00H	mm -- *2	Pitch Bend Sensitivity mm:00H - 18H (0...+24 semitones) Set in semitone units up to two octaves
00H 01H	mm ll	Fine Tuning mm ll: 00H 00H -100 cents : mm ll: 40H 00H0 cents : mm ll: 7FH 7FH +100 cents [Note] After mm ll: 00H 7FH (= -87.5) cents comes 01H 00H (= -87.4 cents)
00H 02H	mm --	Coarse Tuning mm:28H - 40H - 58H (-24...0...+24 semitones)
7FH 7FH	-- --	RPN Null Puts the RPN and NRPN numbers in an un-set condition. The internal setting values will not change.

- *1 Refer to 1.2.4.
- *2 '--' indicates that the setting value is ignored.

1.2.23 Assignable Controller

By specifying a control change number of 0...95 for a part, you can control the way in which an effect is applied.

For each part, this instrument allows two control change numbers to be specified: AC1 and AC2.

The following parameters specify the effects that are controlled by AC1 and AC2.

- Multi Part Parameter
 1. AC1,AC2 PITCH CONTROL
 2. AC1,AC2 FILTER CONTROL
 3. AC1,AC2 AMPLITUDE CONTROL
 4. AC1,AC2 LFO PMOD DEPTH
 5. AC1,AC2 LFO FMOD DEPTH
 6. AC1,AC2 LFO AMOD DEPTH
- Effect Parameter
 7. AC1,AC2 VARIATION CONTROL DEPTH
(Valid when Variation Effect is assigned to a part as Insertion.)

The AC1 control change number is specified by the Multi Part parameter or A/D Part parameter AC1 CONTROLLER NUMBER.

The AC2 control change number is specified by the Multi Part parameter or A/D Part parameter AC2 CONTROLLER NUMBER.

1.3 Channel Mode messages

These messages specify the basic operation of each part.

1.3.1 All Sound Off

Silences all currently sounding notes on the corresponding channel. However the status of channel messages such as Note-on or Hold On is preserved.

Control#	Parameter	Data Range
120	All Sound Off	0

1.3.2 Reset All Controllers

The values of the following controllers will change.

Controller	Value
Pitch Bend Change	+/-0 (center)
Channel Pressure	0 (off)
Polyphonic Key Pressure	0 (off)
Modulation	0 (off)
Expression	127 (maximum)
Hold	0 (off)
Portamento	0 (off)
Sostenuto	0 (off)
Soft Pedal	0 (off)
Portamento Control	Reset the Portamento Source Note Number that was received
RPN	Number un-set, internal data will not change.
NRPN	Number un-set, internal data will not change.

The following data will not change

Program Change, Bank Select MSB/LSB, Volume, Pan, Effect Send Levels 1/3/4, and the value of parameters which were set using RPN and NRPN.

Control#	Parameter	Data Range
121	Reset All Controllers	0

1.3.3 All Note Off

Turns off all notes which are currently "note-on" for the corresponding channel. However if Hold1 or Sostenuto are ON, the notes will continue sounding until these are turned off.

Control#	Parameter	Data Range
123	All Note Off	0

1.3.4 Omni Off

Performs the same processing as when All Note Off is received.

Control#	Parameter	Data Range
124	Omni Off	0

1.3.5 Omni On

Performs the same processing as when All Sound Off is received.

Control#	Parameter	Data Range
125	Omni On	0

1.3.6 Mono

Performs the same processing as when All Sound Off is received, and if the value (mono number) is within the range of 0...16, sets the corresponding channel to Mode4* (m=1).

Control#	Parameter	Data Range
126	Mono	0...16

* Mode4 is when only the messages of the specified channel are received, and notes are sounded monophonically.

1.3.7 Poly

Performs the same processing as when All Note Off is received, and sets the corresponding channel to Mode3*.

Control#	Parameter	Data Range
127	Poly	0

* Mode3 is when only the messages of the specified channel are received, and notes are sounded polyphonically.

1.4 Program Change

This message selects sounds.
 This changes the program number of the receiving channel. If the voice bank is also to be changed, transmit this message together with the Bank Select message (see 1.2.1).
 If the Multi Part parameter Rcv PROGRAM CHANGE = OFF, that part will not receive Program Change messages.
 If Sound Module Mode = C/M, the Drum Part will not receive Program Change messages.

1.5 Pitch Bend

This message conveys pitch bend operations.
 In general this message modifies the pitch of a part, but it can also control the depth of the following seven effects.
 The result of this message can be changed by the following parameters.

- Multi Part Parameter
 1. BEND PITCH CONTROL
 2. BEND FILTER CONTROL
 3. BEND AMPLITUDE CONTROL
 4. BEND LFO PMOD DEPTH
 5. BEND LFO FMOD DEPTH
 6. BEND LFO AMOD DEPTH
- Effect1 Parameter
 7. BEND VARIATION CONTROL DEPTH
 (Valid when Variation Effect is assigned to a part as Insertion.)

By default this will function as Pitch Control.
 If the receive channel is a drum part, effects 5 and 6 will not apply.
 If the Multi Part parameter Rcv PITCH BEND CHANGE = OFF, that part will not receive Pitch Bend messages.

1.6 Channel Aftertouch

This message conveys the force with which the keyboard is pressed after notes are played (for an entire MIDI channel).
 The pressure can be controlled for each part. This message will create changes in the currently-sounding notes.
 The effect of this message can be specified by the following parameters.

- Multi Part Parameter
 1. CAT PITCH CONTROL
 2. CAT FILTER CONTROL
 3. CAT AMOLITUDE CONTROL
 4. CAT LFO PMOD DEPTH
 5. CAT LFO FMOD DEPTH
 6. CAT LFO AMOD DEPTH
- Effect1 Parameter
 7. CAT VARIATION CONTROL DEPTH
 (Valid when Variation Effect is assigned to a part as Insertion.)

By default there will be no effect.
 If the receive channel is a drum part, effects 5 and 6 will not apply.
 If the Multi Part parameter Rcv CHANNEL AFTER TOUCH = OFF, that part will not receive Channel Aftertouch messages.

1.7 Polyphonic Aftertouch

This message conveys the force with which a key is pressed after a note is played (for an individual note).
 The pressure can be controlled independently for each note. This message will create changes in the currently-sounding note.
 The effect of this message can be specified by the following Multi Part parameters.

1. PAT PITCH CONTROL
2. PAT FILTER CONTROL
3. PAT AMPLITUDE CONTROL
4. PAT LFO PMOD DEPTH
5. PAT LFO FMOD DEPTH
6. PAT LFO AMOD DEPTH

By default there will be no effect.
 The effect will apply to note numbers 36...97.
 In the case of the following Multi Part parameter settings, that part will not receive Polyphonic Aftertouch messages.

- Rcv CHANNEL AFTER TOUCH = OFF
- PART MODE = DRUM, DRUMSL...4

2. System Exclusive messages

2.1 Parameter change

This instrument uses the following parameter changes.

- [UNIVERSAL REALTIME MESSAGE]
 - 1) Master Volume
- [UNIVERSAL NON REALTIME MESSAGE]
 - 1) General MIDI System On
 - 2) Identity Request (INQUIRY MESSAGE)
 - 3) Identity Reply (INQUIRY MESSAGE)
- [XG PARAMETER CHANGE]
 - 1) XG System on
 - 2) XG System parameter change
 - 3) Multi Effect1 parameter change
 - 4) Multi EQ parameter change
 - 5) Multi Effect2 parameter change
 - 6) Display parameter change
 - 7) Multi Part parameter change
 - 8) AD Part parameter change
 - 9) AD System parameter change
 - 10) Drums Setup parameter change
- [MU80 NATIVE PARAMETER CHANGE]
 - 1) System parameter change
 - 2) Remote switch
- [MU90,MU90R NATIVE PARAMETER CHANGE]
 - 1) Current Performance parameter change
- [Other]
 - 1) Master tuning
 - 2) TG300 System parameter change
 - 3) TG300 Multi Effect parameter change
 - 4) TG300 Multi Part parameter change

2.1.1 Universal realtime messages

2.1.1.1 Master Volume

11110000	FOH	= Exclusive status
01111111	7FH	= Universal Real Time
01111111	7FH	= ID of target device
0000100	04H	= Sub-ID #1=Device Control Mes sage
0000001	01H	= Sub-ID #2=Master Volume
* 0sssssss	SSH	= Volume LSB
0ttttttt	TTH	= Volume MSB
11110111	F7H	= End of Exclusive
or		
11110000	FOH	= Exclusive status
01111111	7FH	= Universal Real Time
0xxxxnnn	XNH	= Device Number, xxx = don't care
0000100	04H	= Sub-ID #1=Device Control Message
0000001	01H	= Sub-ID #2=Master Volume
0sssssss	SSH	= Volume LSB
0ttttttt	TTH	= Volume MSB
11110111	F7H	= End of Exclusive

When this is received, the Volume MSB will be reflected in the System parameter MASTER VOLUME.

* This indicates that SSH is the hexadecimal expression of the binary 0sssssss. The same applies for other cases.

2.1.2 Universal non-realtime messages

2.1.2.1 General MIDI System On

11110000	FOH	= Exclusive status
01111110	7EH	= Universal Non-Real Time
01111111	7FH	= ID of target device
00001001	09H	= Sub-ID #1=General MIDI Message
0000001	01H	= Sub-ID #2=General MIDI On
11110111	F7H	= End of Exclusive
or		
11110000	FOH	= Exclusive status
01111110	7EH	= Universal Non-Real Time
0xxxxnnn	XNH	= N:Device Number, X:don't care
00001001	09H	= Sub-ID #1=General MIDI Message
0000001	01H	= Sub-ID #2=General MIDI On
11110111	F7H	= End of Exclusive

When this message is received, the SOUND MODULE MODE will be set to XG, and all settings except for MIDI Master Tuning will be reset to their default values.
 However in the following cases this is not received.

- SOUND MODULE MODE = C/M
- When the XG Model System parameter (see table 2-2) Rcv GM EXCLUSIVE MESSAGE=OFF.

Since approximately 50 ms is required to execute this message, an appropriate interval must be left before the next message.

2.1.2.2 Identity Request

11110000	F0H	= Exclusive status
01111110	7EH	= Universal Non-Real Time
0mmmmmm	MMH	= Device Number
00000110	06H	= Sub-ID #1=General Information
00000001	01H	= Sub-ID #2=Identity Request
11110111	F7H	= End of Exclusive

When this message is received, this instrument will transmit the following 2.1.2.3 Identity Reply message.

2.1.2.3 Identity Reply

11110000	F0H	= Exclusive status
01111110	7EH	= Universal Non-Real Time
0mmmmmm	MMH	= Device Number
00000110	06H	= Sub-ID #1=General Information
00000010	02H	= Sub-ID #2=Identity Reply
01000011	43H	= YAMAHA ID
00000000	00H	= Device Family Code LSB
		MU90R ID #1
01000001	41H	= Device Family Code MSB
		MU90R ID #2
01010010	52H	= Device Number Code LSB
		MU90R ID #3
00000010	02H	= Device Number Code MSB
		MU90R ID #4
00000000	00H	
00000000	00H	
00000000	00H	
00000001	01H	= Tone Generator Code=XG
11110111	F7H	= End of Exclusive

When this instrument receives a 2.1.2.2 Identity Request message, it will transmit this message.

2.1.3 XG Parameter Change

This message sets XG-related parameters. One parameter can be modified by each message. The message format is as follows.

11110000	F0H	Exclusive status
01000011	43H	YAMAHA ID
0001nnnn	1NH	N:device Number
01001100	4CH	Model ID
0ggggggg	GGH	Address High
0mmmmmm	MMH	Address Mid
01111111	LLH	Address Low
0sssssss	SSH	Data
:	:	
11110111	F7H	End of Exclusive

For parameters with a data size of 2 or 4, the corresponding number of data bytes will be transmitted.

2.1.3.1 XG System On

11110000	F0H	Exclusive status
01000011	43H	YAMAHA ID
0001nnnn	1NH	N:device Number
01001100	4CH	Model ID
00000000	00H	Address High
00000000	00H	Address Mid
01111110	7EH	Address Low
00000000	00H	Data
11110111	F7H	End of Exclusive

When On is received, SOUND MODULE MODE will be set to XG. Since approximately 50 ms is required to execute this message, an appropriate interval must be left before the next message.

2.1.3.2 XG System parameter change

This message sets the XG SYSTEM block (see tables <1-1> and <1-2>).

2.1.3.3 Multi Effect1 parameter change

This message sets the MULTI EFFECT1 block (see tables <1-1> and <1-4>).

2.1.3.4 Multi EQ parameter change

This message sets the MULTI EQ block (see tables <1-1> and <1-5>).

2.1.3.5 Multi Effect2 parameter change

This message sets the MULTI EFFECT2 block (see tables <1-1> and <1-6>).

2.1.3.6 Display parameter change

This message sets the DISPLAY block (see tables <1-1> and <1-7>).

2.1.3.7 Multi Part parameter change

This message sets the MULTI PART block (see tables <1-1> and <1-8>).

2.1.3.8 AD Part parameter change

This message sets the AD PART block (see tables <1-1> and <1-9>).

2.1.3.9 AD Part parameter change

This message sets the AD SYSTEM block (see tables <1-1> and <1-10>).

2.1.3.10 Drums Setup parameter change

This message sets the DRUMS SETUP block (see tables <1-1> and <1-11>).

2.1.4 MU80 Native parameter changes

These messages set parameters unique to the MU80. One parameter can be modified by each message. The message format is as follows.

11110000	F0H	Exclusive status
01000011	43H	YAMAHA ID
0001nnnn	1NH	N:Device Number
01001001	49H	Model ID
0ggggggg	GGH	Address High
0mmmmmm	MMH	Address Mid
01111111	LLH	Address Low
0vvvvvvv	VVH	Data
:	:	
11110111	F7H	End of Exclusive

For parameters with a data size of 2 or 4, the corresponding number of data bytes will be transmitted.

2.1.4.1 System parameter change

This message sets the SYSTEM block (see tables <2-1> and <2-2>).

2.1.4.2 Remote switch

This message sets the REMOTE SWITCH block (see tables <2-1> and <2-3>).

2.1.5 MU90/MU90R Native parameter changes

These messages set parameters unique to the MU90/MU90R. One parameter can be modified by each message. The message format is as follows.

11110000	F0H	Exclusive status
01000011	43H	YAMAHA ID
0001nnnn	1NH	N:Device Number
01011001	59H	Model ID
0ggggggg	GGH	Address High
0mmmmmm	MMH	Address Mid
01111111	LLH	Address Low
0vvvvvvv	VVH	Data
:	:	
11110111	F7H	End of Exclusive

For parameters with a data size of 2 or 4, the corresponding number of data bytes will be transmitted.

2.1.5.1 Current Performance parameter change

This message sets the CURRENT PERFORMANCE block (see tables <3-1> and <3-2>).

2.1.6 Other parameter changes

2.1.6.1 Master Tuning

This message simultaneously modifies the pitch of all channels.

11110000	F0H	Exclusive status
01000011	43H	YAMAHA ID
0001nnnn	1NH	N:device Number
00100111	27H	Model ID
00110000	30H	Address High
00000000	00H	Address Mid
00000000	00H	Address Low
0mmmmmm	MMH	Master Tune MSB
01111111	LLH	Master Tune LSB
0xxxxxxx	XXH	don't care
11110111	F7H	End of Exclusive

Normally the XG SYSTEM parameter MASTER TUNE should be used (see table <1-2>).

2.2 Bulk Dump

This instrument uses the following bulk dumps.

[XG BULK DUMP]

- 1) XG System bulk dump
- 2) System Information bulk dump
- 3) Multi Effect1 bulk dump
- 4) Multi EQ bulk dump
- 5) Multi Effect2 bulk dump
- 6) Multi Part bulk dump
- 7) AD Part bulk dump
- 8) Drums Setup bulk dump

[MU80 NATIVE BULK DUMP]

- 1) System bulk dump
- 2) MU80, MU50 Internal Performance bulk dump

[MU90, MU90R NATIVE BULK DUMP]

- 1) Internal Performance bulk dump

2.2.1 XG Bulk Dump

These messages set XG-related parameters. Unlike parameter changes, a single message can set multiple parameters. The message format is as follows.

11110000	F0H	Exclusive status
01000011	43H	YAMAHA ID
0000nnnn	0NH	N:Device Number
01001100	4CH	Model ID
0sssssss	SSH	ByteCountMSB
0ttttttt	TTH	ByteCountLSB
0ggggggg	GGH	Address High
0mmmmmm	MMH	Address Mid
01111111	LLH	Address Low
0vvvvvvv	VVH	Data
:	:	:
0kkkkkkk	KKH	Check-sum
11110111	F7H	End of Exclusive

Address and Byte Count are given in tables 1-n. Byte Count indicates the total size of the data in tables 1-n.

Bulk Dump and Dump Request messages are received when the beginning of the block is specified as the address.

"Block" indicates the unit size of the data string included in the total size in tables 1-n. Check sum is the value which produces a lower 7 bits of 0 when the Start Address, Byte Count, and the Check Sum itself are added.

2.2.1.1 XG System bulk dump

This message sets the XG SYSTEM block (see tables <1-1> and <1-2>).

2.2.1.2 System Information bulk dump

This message indicates the contents of the SYSTEM INFORMATION block (see tables <1-1> and <1-3>).

This message is transmitted in response to a dump request, but will be ignored if it is received.

2.2.1.3 Multi Effect 1 bulk dump

This message sets the MULTI EFFECT1 block (see tables <1-1> and <1-4>).

2.2.1.4 Multi EQ bulk dump

This message sets the MULTI EQ block (see tables <1-1> and <1-5>).

2.2.1.5 Multi Effect 2 bulk dump

This message sets the MULTI EFFECT2 block (see tables <1-1> and <1-6>).

2.2.1.6 Multi Part bulk dump

This message sets the MULTI PART block (see tables <1-1> and <1-8>).

2.2.1.7 A/D Part bulk dump

This message sets the A/D PART block (see tables <1-1> and <1-9>).

2.2.1.8 Drums Setup bulk dump

This message sets the DRUMS SETUP block (see tables <1-1> and <1-11>).

2.2.2 MU80 Native bulk dump

These messages set parameters unique to the MU80. Unlike parameter changes, a single message can set multiple parameters.

11110000	F0H	Exclusive status
01000011	43H	YAMAHA ID
0000nnnn	0NH	N:Device Number
01001001	49H	Model ID
0sssssss	SSH	ByteCountMSB
0ttttttt	TTH	ByteCountLSB
0ggggggg	GGH	Address High
0mmmmmm	MMH	Address Mid
01111111	LLH	Address Low
0vvvvvvv	VVH	Data
:	:	:
0kkkkkkk	KKH	Check-sum
11110111	F7H	End of Exclusive

The details are the same for 2.2.1 XG Bulk Dump. However for the address, byte count and block, refer to tables 2-n.

2.2.2.1 System bulk dump

This message sets the SYSTEM block (see tables <2-1> and <2-2>).

2.2.2.2 MU80/MU50 Internal Performance bulk dump

This message is in MU80/MU50 data format. It sets the INTERNAL PERFORMANCE block (see tables <2-1> and <2-4>).

2.2.3 MU90/MU90R Native bulk dump

This message sets parameters that are unique to the MU90/MU90R. Unlike parameter changes, a single message can set multiple parameters.

11110000	F0H	Exclusive status
01000011	43H	YAMAHA ID
0000nnnn	0NH	N:Device Number
01011001	59H	Model ID
0sssssss	SSH	ByteCountMSB
0ttttttt	TTH	ByteCountLSB
0ggggggg	GGH	Address High
0mmmmmm	MMH	Address Mid
01111111	LLH	Address Low
0vvvvvvv	VVH	Data
:	:	:
0kkkkkkk	KKH	Check-sum
11110111	F7H	End of Exclusive

The details are the same for 2.2.1 XG Bulk Dump. However for the address, byte count and block, refer to tables 3-n.

2.2.3.1 Internal Performance bulk dump

This message sets the INTERNAL PERFORMANCE block (see tables <3-1> and <3-3>).

2.3 Parameter Request

These messages request that parameter values be transmitted. The transmitted data will be in the format of parameter change messages (see 2.1.3 and 2.1.4).

2.3.1 XG parameter request

This message requests that XG parameter settings be transmitted. The transmitted data will be in the format of an XG Parameter Change (see 2.1.3).

11110000	F0H	Exclusive status
01000011	43H	YAMAHA ID
0011nnnn	3NH	N:device Number
01001100	4CH	Model ID
0ggggggg	GGH	Address High
0mmmmmm	MMH	Address Mid
01111111	LLH	Address Low
11110111	F7H	End of Exclusive

2.3.2 MU80 Native parameter request

This message requests that parameters unique to the MU80 be transmitted. The transmitted data will be in the format of an XG Model Native Parameter Change (see 2.1.4).

11110000	F0H	Exclusive status
01000011	43H	YAMAHA ID
0011nnnn	3NH	N:Device Number
01001001	49H	Model ID
0ggggggg	GGH	Address High
0mmmmmm	MMH	Address Mid
01111111	LLH	Address Low
11110111	F7H	End of Exclusive

2.3.3 MU90/MU90R Native parameter request

This message requests that parameters unique to the MU90/MU90R be transmitted. The transmitted data will be in the format of a MU90/MU90R Native Parameter Change (see 2.1.4).

11110000	F0H	Exclusive status
01000011	43H	YAMAHA ID
0011nnnn	3NH	N:Device Number
01011001	59H	Model ID
0ggggggg	GGH	Address High
0mmmmmm	MMH	Address Mid
01111111	LLH	Address Low
11110111	F7H	End of Exclusive

2.4 Dump Request

These messages request that parameter values of the specified block be transmitted. The transmitted data will be in bulk dump format.

2.4.1 XG dump request

This message requests that all parameter values of the specified block of XG parameters be transmitted. The transmitted data will be in XG Bulk Dump format (see 2.2.1).

11110000	F0H	Exclusive status
01000011	43H	YAMAHA ID
0010nnnn	2NH	N:device Number
01001100	4CH	Model ID
0ggggggg	GGH	Address High
0mmmmmm	MMH	Address Mid
01111111	LLH	Address Low
11110111	F7H	End of Exclusive

The address is valid if the beginning of the block is specified. Transmission/reception of dump requests cannot be turned off by a MIDI switch other than Exclusive = off.

2.4.2 MU80 Native dump request

This message requests that all parameter values of the specified block of MU80 native parameters be transmitted. The transmitted data will be in MU80 Native Bulk Dump format (see 2.2.2).

11110000	F0H	Exclusive status
01000011	43H	YAMAHA ID
0010nnnn	2NH	N:Device Number
01001001	49H	Model ID
0ggggggg	GGH	Address High
0mmmmmm	MMH	Address Mid
01111111	LLH	Address Low
11110111	F7H	End of Exclusive

Details are the same as 2.4.1 XG Bulk Dump Request.

2.4.2 MU90/MU90R Native dump request

This message requests that all parameter values of the specified block of MU90/MU90R native parameters be transmitted. The transmitted data will be in MU90/MU90R Native Bulk Dump format (see 2.2.3).

11110000	F0H	Exclusive status
01000011	43H	YAMAHA ID
0010nnnn	2NH	N:Device Number
01011001	59H	Model ID
0ggggggg	GGH	Address High
0mmmmmm	MMH	Address Mid
01111111	LLH	Address Low
11110111	F7H	End of Exclusive

Details are the same as 2.4.1 XG Bulk Dump Request.

3. Realtime messages**3.1 Active Sensing**

a) Transmission
Not transmitted.

b) Reception

Once FE has been received, if no MIDI messages are received for an interval of approximately 300 msec, the same processing will be performed as when ALL SOUND OFF, ALL NOTE OFF, and RESET ALL CONTROLLERS are received, and the instrument will return to a status of never having received FE.

<Table 1-1>

Parameter Base Address
MODEL ID = 4C

Parameter	Address			Description
	(H)	(M)	(L)	
XG SYSTEM	00	00	00	System
	00	00	7D	Drum setup Reset
	00	00	7E	XG System On
	00	00	7F	All Parameter Reset
INFORMATION	01	00	00	System Information
EFFECT 1	02	01	00	Effect1(Reverb,Chorus,Variation)
	02	40	00	Multi EQ
EFFECT 2	03	00	00	Insertion Effect 1
	03	01	00	Insertion Effect 2
DISPLAY	06	00	00	Display Letter
	07	00	00	Display Bit Map
MULTI PART	08	00	00	Multi Part 1
	:	:	:	:
	08	0F	00	Multi Part 16
	08	10	00	Multi Part 17
MULTI PART (additional)	:	:	:	:
	08	1F	00	Multi Part 32
	0A	00	00	Multi Part 1
	0A	0F	00	Multi Part 16
A/D PART	0A	10	00	Multi Part 17
	:	:	:	:
	0A	1F	00	Multi Part 32
A/D SYSTEM	10	00	00	A/D Part 1
	10	01	00	A/D Part 2
DRUM	11	00	00	A/D System
DRUM	30	0D	00	Drum Setup 1
	31	0D	00	Drum Setup 2
	32	0D	00	Drum Setup 3
	33	0D	00	Drum Setup 4

Address	Parameter
3n 0D 00	note number 13
3n 0E 00	note number 14
:	:
3n 5B 00	note number 91

<Table 1-2>

MIDI Parameter Change table (XG SYSTEM)

Address (H)	Size (H)	Data (H)	Parameter	Description	Initial value (H)
00 00 00	4	00 - 0F	MASTER TUNE	-102.4...0...+102.3[cent]	00 04 00 00
01		00 - 0F		1st bit3-0→bit15-12	
02		00 - 0F		2nd bit3-0→bit11-8	
03		00 - 0F		3rd bit3-0→bit7-4	
		00 - 0F		4th bit3-0→bit3-0	
04	1	00 - 7F	MASTER VOLUME	0...127	7F
05	1	00 - 7F	MASTER ATTENUATOR	0...127	00
06	1	28 - 58	TRANSPOSE	-24...0...+24[semitones]	40
7D	1	N	DRUM SETUP RESET	N: Drum setup number(receive only)	--
7E	1	00	XG SYSTEM ON	00=XG system ON (receive only)	--
7F	1	00	ALL PARAMETER RESET	00=ON (receive only)	--
TOTAL SIZE		07			

<Table 1-3>

MIDI Parameter Change table (SYSTEM INFORMATION)

Address (H)	Size (H)	Data (H)	Parameter	Description
01 00 00	E	20 - 7F	Model Name 1	32...127(ASCII CHARACTER)
:	:	:	:	:
0D		20 - 7F	Model Name 14	32...127(ASCII CHARACTER)
0E	1	00 - 7F	XG Level 1	
0F	1	00 - 7F	XG Level 2	
TOTAL SIZE		10		

Transmitted in response to a dump request, but not received.

<Table 1-4>

MIDI Parameter Change table (EFFECT 1)

Address (H)	Size (H)	Data (H)	Parameter	Description	Initial value (H)
02 01 00	2	00 - 7F	REVERB TYPE MSB	Refer to the Effect Program List	01(=HALL1)
		00 - 7F	REVERB TYPE LSB	"	00
02	1	00 - 7F	REVERB PARAMETER 1	"	12(depends on reverb type)
03	1	00 - 7F	REVERB PARAMETER 2	"	0A("")
04	1	00 - 7F	REVERB PARAMETER 3	"	08("")
05	1	00 - 7F	REVERB PARAMETER 4	"	0D("")
06	1	00 - 7F	REVERB PARAMETER 5	"	31("")
07	1	00 - 7F	REVERB PARAMETER 6	"	00("")
08	1	00 - 7F	REVERB PARAMETER 7	"	00("")
09	1	00 - 7F	REVERB PARAMETER 8	"	00("")
0A	1	00 - 7F	REVERB PARAMETER 9	"	00("")
0B	1	00 - 7F	REVERB PARAMETER 10	"	00("")
0C	1	00 - 7F	REVERB RETURN	-∞dB...0dB...+6dB(0...96...127)	40
0D	1	01 - 7F	REVERB PAN	L63...C...R63	40
TOTAL SIZE 0E					
02 01 10	1	00 - 7F	REVERB PARAMETER 11	Refer to the Effect Parameter List	00(depends on reverb type)
11	1	00 - 7F	REVERB PARAMETER 12	"	04("")
12	1	00 - 7F	REVERB PARAMETER 13	"	32("")
13	1	00 - 7F	REVERB PARAMETER 14	"	08("")
14	1	00 - 7F	REVERB PARAMETER 15	"	40("")
15	1	00 - 7F	REVERB PARAMETER 16	"	00("")
TOTAL SIZE 6					
02 01 20	2	00 - 7F	CHORUS TYPE MSB	Refer to the Effect Program List	41(=CHORUS1)
		00 - 7F	CHORUS TYPE LSB	"	00
22	1	00 - 7F	CHORUS PARAMETER 1	"	06(depends on chorus type)
23	1	00 - 7F	CHORUS PARAMETER 2	"	36("")
24	1	00 - 7F	CHORUS PARAMETER 3	"	4D("")
25	1	00 - 7F	CHORUS PARAMETER 4	"	6A("")
26	1	00 - 7F	CHORUS PARAMETER 5	"	00("")
27	1	00 - 7F	CHORUS PARAMETER 6	"	1C("")
28	1	00 - 7F	CHORUS PARAMETER 7	"	40("")
29	1	00 - 7F	CHORUS PARAMETER 8	"	2E("")
2A	1	00 - 7F	CHORUS PARAMETER 9	"	40("")
2B	1	00 - 7F	CHORUS PARAMETER 10	"	40("")
2C	1	00 - 7F	CHORUS RETURN	-∞dB...0dB...+6dB(0...96...127)	40
2D	1	01 - 7F	CHORUS PAN	L63...C...R63(1...64...127)	40
2E	1	00 - 7F	SEND CHORUS TO REVERB	-∞dB...0dB...+6dB(0...96...127)	00
TOTAL SIZE 0F					
02 01 30	1	00 - 7F	CHORUS PARAMETER 11	Refer to the Effect Parameter List	2E(depends on chorus type)
31	1	00 - 7F	CHORUS PARAMETER 12	"	40("")
32	1	00 - 7F	CHORUS PARAMETER 13	"	0A("")
33	1	00 - 7F	CHORUS PARAMETER 14	"	00("")
34	1	00 - 7F	CHORUS PARAMETER 15	"	00("")
35	1	00 - 7F	CHORUS PARAMETER 16	"	00("")
TOTAL SIZE 6					
02 01 40	2	00 - 7F	VARIATION TYPE MSB	Refer to the Effect Program List	05(=DELAY L,C,R)
		00 - 7F	VARIATION TYPE LSB	"	00
42	2	00 - 7F	VARIATION PARAMETER 1 MSB	"	1A(depends on variation type)
		00 - 7F	VARIATION PARAMETER 1 LSB	"	05("")
44	2	00 - 7F	VARIATION PARAMETER 2 MSB	"	0D("")
		00 - 7F	VARIATION PARAMETER 2 LSB	"	03("")
46	2	00 - 7F	VARIATION PARAMETER 3 MSB	"	27("")
		00 - 7F	VARIATION PARAMETER 3 LSB	"	08("")
48	2	00 - 7F	VARIATION PARAMETER 4 MSB	"	27("")
		00 - 7F	VARIATION PARAMETER 4 LSB	"	08("")
4A	2	00 - 7F	VARIATION PARAMETER 5 MSB	"	00("")
		00 - 7F	VARIATION PARAMETER 5 LSB	"	4A("")
4C	2	00 - 7F	VARIATION PARAMETER 6 MSB	"	00("")
		00 - 7F	VARIATION PARAMETER 6 LSB	"	64("")
4E	2	00 - 7F	VARIATION PARAMETER 7 MSB	"	00("")
		00 - 7F	VARIATION PARAMETER 7 LSB	"	0A("")
50	2	00 - 7F	VARIATION PARAMETER 8 MSB	"	00("")
		00 - 7F	VARIATION PARAMETER 8 LSB	"	00("")
52	2	00 - 7F	VARIATION PARAMETER 9 MSB	"	00("")
		00 - 7F	VARIATION PARAMETER 9 LSB	"	00("")
54	2	00 - 7F	VARIATION PARAMETER 10 MSB	"	00("")
		00 - 7F	VARIATION PARAMETER 10 LSB	"	20("")
56	1	00 - 7F	VARIATION RETURN	-∞dB...0dB...+6dB(0...96...127)	40
57	1	01 - 7F	VARIATION PAN	L63...C...R63(1...64...127)	40
58	1	00 - 7F	SEND VARIATION TO REVERB	-∞dB...0dB...+6dB(0...96...127)	00
59	1	00 - 7F	SEND VARIATION TO CHORUS	-∞dB...0dB...+6dB(0...96...127)	00
5A	1	00 - 01	VARIATION CONNECTION	INSERTION , SYSTEM	00
5B	1	00 - 7F	VARIATION PART NUMBER	Part 1...32(0...31)	7F
				AD1, AD2(64, 65)	
				OFF(127)	
5C	1	00 - 7F	MW VARIATION CONTROL DEPTH	-64...0...+63	40
5D	1	00 - 7F	BEND VARIATION CONTROL DEPTH	-64...0...+63	40
5E	1	00 - 7F	CAT VARIATION CONTROL DEPTH	-64...0...+63	40
5F	1	00 - 7F	AC1 VARIATION CONTROL DEPTH	-64...0...+63	40
60	1	00 - 7F	AC2 VARIATION CONTROL DEPTH	-64...0...+63	40
TOTAL SIZE 21					

02 01 70	1	00 - 7F	VARIATION PARAMETER 11	Refer to the Effect Parameter List	00(depends on variation type)
71	1	00 - 7F	VARIATION PARAMETER 12	"	3C("")
72	1	00 - 7F	VARIATION PARAMETER 13	"	1C("")
73	1	00 - 7F	VARIATION PARAMETER 14	"	40("")
74	1	00 - 7F	VARIATION PARAMETER 15	"	2E("")
75	1	00 - 7F	VARIATION PARAMETER 16	"	40("")
TOTAL SIZE 6					

<Table 1-5>

MIDI Parameter Change table (MULTI EQ)

Address (H)	Size (H)	Data (H)	Parameter	Description	Initial value (H)
02 40 00	1	00 - 04	EQ TYPE	flat, jazz, pops, rock, classic	00
01	1	34 - 4C	EQ GAIN1	-12...0...+12[dB]	40(depends on EQ type)
02	1	04 - 28	EQ FREQUENCY1	32...2.0k[Hz]	0C("")
03	1	01 - 78	EQ Q1	0.1...12.0	07("")
04	1	00 - 01	EQ SHAPE1	shelving , peaking	00("")
05	1	34 - 4C	EQ GAIN2	-12...0...+12[dB]	40("")
06	1	0E - 36	EQ FREQUENCY2	100...10.0k[Hz]	1C("")
07	1	01 - 78	EQ Q2	0.1...12.0	07("")
08	1		NOT USED		--
09	1	34 - 4C	EQ GAIN3	-12...0...+12[dB]	40("")
0A	1	0E - 36	EQ FREQUENCY3	100...10.0k[Hz]	22("")
0B	1	01 - 78	EQ Q3	0.1...12.0	07("")
0C	1		NOT USED		--
0D	1	34 - 4C	EQ GAIN4	-12...0...+12[dB]	40("")
0E	1	0E - 36	EQ FREQUENCY4	100...10.0k[Hz]	2E("")
0F	1	01 - 78	EQ Q4	0.1...12.0	07("")
10	1		NOT USED		--
11	1	34 - 4C	EQ GAIN5	-12...0...+12[dB]	40("")
12	1	1C - 3A	EQ FREQUENCY5	0.5k...16.0k[Hz]	34("")
13	1	01 - 78	EQ Q5	0.1...12.0	07("")
14	1	00 - 01	EQ SHAPE5	shelving , peaking	00("")

TOTAL SIZE 15

<Table 1-6>

MIDI Parameter Change table (EFFECT 2)

Address (H)	Size (H)	Data (H)	Parameter	Description	Initial value (H)
03 00 00	2	00 - 7F	INSERTION EFFECT1 TYPE MSB	Refer to the Effect Program List	49(=DISTORTION)
		00 - 7F	INSERTION EFFECT1 TYPE LSB	"	00
02	1	00 - 7F	INSERTION EFFECT1 PARAMETER1	"	28(depends on insertion effect1 type)
03	1	00 - 7F	INSERTION EFFECT1 PARAMETER2	"	14("")
04	1	00 - 7F	INSERTION EFFECT1 PARAMETER3	"	48("")
05	1	00 - 7F	INSERTION EFFECT1 PARAMETER4	"	35("")
06	1	00 - 7F	INSERTION EFFECT1 PARAMETER5	"	40("")
07	1	00 - 7F	INSERTION EFFECT1 PARAMETER6	"	00("")
08	1	00 - 7F	INSERTION EFFECT1 PARAMETER7	"	2B("")
09	1	00 - 7F	INSERTION EFFECT1 PARAMETER8	"	4A("")
0A	1	00 - 7F	INSERTION EFFECT1 PARAMETER9	"	0A("")
0B	1	00 - 7F	INSERTION EFFECT1 PARAMETER10	"	7F("")
0C	1	00 - 7F	INSERTION EFFECT1 PART NUMBER	Part1...32(0...31) AD1, AD2(64, 65) OFF(127)	7F
0D	1	00 - 7F	MW INSERTION CONTROL DEPTH	-64...0...+63	40
0E	1	00 - 7F	BEND INSERTION CONTROL DEPTH	-64...0...+63	40
0F	1	00 - 7F	CAT INSERTION CONTROL DEPTH	-64...0...+63	40
10	1	00 - 7F	AC1 INSERTION CONTROL DEPTH	-64...0...+63	40
11	1	00 - 7F	AC2 INSERTION CONTROL DEPTH	-64...0...+63	40

TOTAL SIZE 12

20	1	00 - 7F	INSERTION EFFECT1 PARAMETER11	Refer to the Effect Parameter List	78(depends on insertion effect1 type)
21	1	00 - 7F	INSERTION EFFECT1 PARAMETER12	"	00("")
22	1	00 - 7F	INSERTION EFFECT1 PARAMETER13	"	00("")
23	1	00 - 7F	INSERTION EFFECT1 PARAMETER14	"	00("")
24	1	00 - 7F	INSERTION EFFECT1 PARAMETER15	"	00("")
25	1	00 - 7F	INSERTION EFFECT1 PARAMETER16	"	00("")

TOTAL SIZE 6

30	2	00 - 7F	INSERTION EFFECT1 PARAMETER1 MSB	Refer to the Effect Parameter List	00(depends on insertion effect1 type)
		00 - 7F	INSERTION EFFECT1 PARAMETER1 LSB	"	28(")
32	2	00 - 7F	INSERTION EFFECT1 PARAMETER2 MSB	"	00(")
		00 - 7F	INSERTION EFFECT1 PARAMETER2 LSB	"	14(")
34	2	00 - 7F	INSERTION EFFECT1 PARAMETER3 MSB	"	00(")
		00 - 7F	INSERTION EFFECT1 PARAMETER3 LSB	"	48(")
36	2	00 - 7F	INSERTION EFFECT1 PARAMETER4 MSB	"	00(")
		00 - 7F	INSERTION EFFECT1 PARAMETER4 LSB	"	35(")
38	2	00 - 7F	INSERTION EFFECT1 PARAMETER5 MSB	"	00(")
		00 - 7F	INSERTION EFFECT1 PARAMETER5 LSB	"	40(")
3A	2	00 - 7F	INSERTION EFFECT1 PARAMETER6 MSB	"	00(")
		00 - 7F	INSERTION EFFECT1 PARAMETER6 LSB	"	00(")
3C	2	00 - 7F	INSERTION EFFECT1 PARAMETER7 MSB	"	00(")
		00 - 7F	INSERTION EFFECT1 PARAMETER7 LSB	"	2B(")
3E	2	00 - 7F	INSERTION EFFECT1 PARAMETER8 MSB	"	00(")
		00 - 7F	INSERTION EFFECT1 PARAMETER8 LSB	"	4A(")
40	2	00 - 7F	INSERTION EFFECT1 PARAMETER9 MSB	"	00(")
		00 - 7F	INSERTION EFFECT1 PARAMETER9 LSB	"	0A(")
42	2	00 - 7F	INSERTION EFFECT1 PARAMETER10 MSB	"	00(")
		00 - 7F	INSERTION EFFECT1 PARAMETER10 LSB	"	7F(")

TOTAL SIZE 14

When using an EFFECT TYPE for which MSB is not required, the parameters of addresses 02-0B are received, and the parameters of addresses 30-42 are not received.
 When using an EFFECT TYPE for which MSB is required, the parameters of addresses 30-42 are received, and the parameters of addresses 02-0B are not received.

For bulk transmission which includes EFFECT TYPE data, the parameters of addresses 02-0B will always be transmitted. However for an EFFECT TYPE which requires MSB, the parameters of addresses 02-0B are not received when bulk data is received.

03 01 00	2	00 - 7F	INSERTION EFFECT2 TYPE MSB	Refer to the Effect Program List	49(=DISTORTION)
		00 - 7F	INSERTION EFFECT2 TYPE LSB	"	00
02	1	00 - 7F	INSERTION EFFECT2 PARAMETER1	"	28(depends on insertion effect2 type)
03	1	00 - 7F	INSERTION EFFECT2 PARAMETER2	"	14(")
04	1	00 - 7F	INSERTION EFFECT2 PARAMETER3	"	48(")
05	1	00 - 7F	INSERTION EFFECT2 PARAMETER4	"	35(")
06	1	00 - 7F	INSERTION EFFECT2 PARAMETER5	"	40(")
07	1	00 - 7F	INSERTION EFFECT2 PARAMETER6	"	00(")
08	1	00 - 7F	INSERTION EFFECT2 PARAMETER7	"	2B(")
09	1	00 - 7F	INSERTION EFFECT2 PARAMETER8	"	4A(")
0A	1	00 - 7F	INSERTION EFFECT2 PARAMETER9	"	0A(")
0B	1	00 - 7F	INSERTION EFFECT2 PARAMETER10	"	7F(")
0C	1	00 - 7F	INSERTION EFFECT2 PART NUMBER	Part1...32(0...31) AD1, AD2(64, 65) OFF(127)	7F
0D	1	00 - 7F	MW INSERTION CONTROL DEPTH	-64...0...+63	40
0E	1	00 - 7F	BEND INSERTION CONTROL DEPTH	-64...0...+63	40
0F	1	00 - 7F	CAT INSERTION CONTROL DEPTH	-64...0...+63	40
10	1	00 - 7F	AC1 INSERTION CONTROL DEPTH	-64...0...+63	40
11	1	00 - 7F	AC2 INSERTION CONTROL DEPTH	-64...0...+63	40

TOTAL SIZE 12

20	1	00 - 7F	INSERTION EFFECT2 PARAMETER11	Refer to the Effect Parameter List	78(depends on insertion effect2 type)
21	1	00 - 7F	INSERTION EFFECT2 PARAMETER12	"	00(")
22	1	00 - 7F	INSERTION EFFECT2 PARAMETER13	"	00(")
23	1	00 - 7F	INSERTION EFFECT2 PARAMETER14	"	00(")
24	1	00 - 7F	INSERTION EFFECT2 PARAMETER15	"	00(")
25	1	00 - 7F	INSERTION EFFECT2 PARAMETER16	"	00(")

TOTAL SIZE 6

30	2	00 - 7F	INSERTION EFFECT2 PARAMETER1 MSB	Refer to the Effect Parameter List	00(depends on insertion effect2 type)
		00 - 7F	INSERTION EFFECT2 PARAMETER1 LSB	"	28(")
32	2	00 - 7F	INSERTION EFFECT2 PARAMETER2 MSB	"	00(")
		00 - 7F	INSERTION EFFECT2 PARAMETER2 LSB	"	14(")
34	2	00 - 7F	INSERTION EFFECT2 PARAMETER3 MSB	"	00(")
		00 - 7F	INSERTION EFFECT2 PARAMETER3 LSB	"	48(")
36	2	00 - 7F	INSERTION EFFECT2 PARAMETER4 MSB	"	00(")
		00 - 7F	INSERTION EFFECT2 PARAMETER4 LSB	"	35(")
38	2	00 - 7F	INSERTION EFFECT2 PARAMETER5 MSB	"	00(")
		00 - 7F	INSERTION EFFECT2 PARAMETER5 LSB	"	40(")
3A	2	00 - 7F	INSERTION EFFECT2 PARAMETER6 MSB	"	00(")
		00 - 7F	INSERTION EFFECT2 PARAMETER6 LSB	"	00(")
3C	2	00 - 7F	INSERTION EFFECT2 PARAMETER7 MSB	"	00(")
		00 - 7F	INSERTION EFFECT2 PARAMETER7 LSB	"	2B(")
3E	2	00 - 7F	INSERTION EFFECT2 PARAMETER8 MSB	"	00(")
		00 - 7F	INSERTION EFFECT2 PARAMETER8 LSB	"	4A(")
40	2	00 - 7F	INSERTION EFFECT2 PARAMETER9 MSB	"	00(")
		00 - 7F	INSERTION EFFECT2 PARAMETER9 LSB	"	0A(")
42	1	00 - 7F	INSERTION EFFECT2 PARAMETER10 MSB	"	00(")
		00 - 7F	INSERTION EFFECT2 PARAMETER10 LSB	"	7F(")

TOTAL SIZE 14

When using an EFFECT TYPE for which MSB is not required, the parameters of addresses 02-0B are received, and the parameters of addresses 30-42 are not received.
 When using an EFFECT TYPE for which MSB is required, the parameters of addresses 30-42 are received, and the parameters of addresses 02-0B are not received.

For bulk transmission which includes EFFECT TYPE data, the parameters of addresses 02-0B will always be transmitted. However for an EFFECT TYPE which requires MSB, the parameters of addresses 02-0B are not received when bulk data is received.

<Table 1-7>

MIDI Parameter Change table (DISPLAY DATA)

Address (H)	Size (H)	Data (H)	Parameter	Description	Initial value (H)
06 00 00	20	20 - 7F	DISPLAY LETTER Data1	32...127(ASCII CHARACTER)	--
:			:	:	:
1F			DISPLAY LETTER Data32	32...127(ASCII CHARACTER)	--
TOTAL SIZE	20				
07 00 00	30	00 - 7F	DISPLAY BITMAP Data1 *	0...127	--
:			:	:	:
2F			DISPLAY BITMAP Data48	0...127	--
TOTAL SIZE	30				

* How DISPLAY BITMAP data and the screen display are related
 In the horizontal direction, seven pixels form one byte of data.
 To display a pixel, set its data bit to 1. To turn off the pixel, set its data bit to 0.
 This data is arranged in the screen as follows.

	b7	b6	b5	b4	b3	b2	b1	b0		b7	b6	b5	b4	b3	b2	b1	b0		b7	b6	b5	b4	b3	b2	b1	b0	(“b” indicates “bit”)
Data1	0	*	*	*	*	*	*	*	Data17	0	*	*	*	*	*	*	*	Data33	0	*	*	-	-	-	-	-	
Data2									Data18									Data34									
Data3									Data19									Data35									
Data4									Data20									Data36									
Data5									Data21									Data37									
Data6									Data22									Data38									
Data7									Data23									Data39									
Data8									Data24									Data40									
Data9									Data25									Data41									
Data10									Data26									Data42									
Data11									Data27									Data43									
Data12									Data28									Data44									
Data13									Data29									Data45									
Data14									Data30									Data46									
Data15									Data31									Data47									
Data16									Data32									Data48									

Only bit 6 and bit 5 are used for Data33-Data48.

Bitmap data can also be received just for a specific pixel. In this case, the other pixels will display their previous status. Display Data parameter changes can transmit data continuously from a desired location.

<Table 1-8>

MIDI Parameter Change table (MULTI PART)

Address (H)	Size (H)	Data (H)	Parameter	Description	Initial value (H)
08 nn 00	1	00 - 40	ELEMENT RESERVE	0...64	part 10, 26=0 other parts =2
nn 01	1	00 - 7F	BANK SELECT MSB	0...127	part 10, 26=7F other parts=0
nn 02	1	00 - 7F	BANK SELECT LSB	0...127	00
nn 03	1	00 - 7F	PROGRAM NUMBER	1...128	00
nn 04	1	00-1F,7F	Rev CHANNEL	A1...A16, B1...B16, OFF	Part No.
nn 05	1	00 - 01	MONO/POLY MODE	MONO , POLY	01
nn 06	1	00 - 02	SAME NOTE NUMBER KEY ON ASSIGN	SINGLE, MULTI, INST(for DRUM)	01
nn 07	1	00 - 05	PART MODE	NORMAL, DRUM, DRUMS1...4	Part 10=2, Part 26=4 other parts=0
nn 08	1	28 - 58	NOTE SHIFT	-24...0...+24[semitones]	40
nn 09	2	00 - 0F	DETUNE	-12.8...0...+12.7[Hz]	08 00
nn 0A		00 - 0F		1st bit3-0→bit7-4 2nd bit3-0→bit3-0	
nn 0B	1	00 - 7F	VOLUME	0...127	64
nn 0C	1	00 - 7F	VELOCITY SENSE DEPTH	0...127	40
nn 0D	1	00 - 7F	VELOCITY SENSE OFFSET	0...127	40
nn 0E	1	00 - 7F	PAN	RND, L63...C...R63	40
nn 0F	1	00 - 7F	NOTE LIMIT LOW	C-2...G8	00
nn 10	1	00 - 7F	NOTE LIMIT HIGH	C-2...G8	7F
nn 11	1	00 - 7F	DRY LEVEL	0...127	7F
nn 12	1	00 - 7F	CHORUS SEND	0...127	00
nn 13	1	00 - 7F	REVERB SEND	0...127	28
nn 14	1	00 - 7F	VARIATION SEND	0...127	00
nn 15	1	00 - 7F	VIBRATO RATE	-64...0...+63	40
nn 16	1	00 - 7F	VIBRATO DEPTH	-64...0...+63	40
nn 17	1	00 - 7F	VIBRATO DELAY	-64...0...+63	40
nn 18	1	00 - 7F	LOW PASS FILTER CUTOFF FREQUENCY	-64...0...+63	40
nn 19	1	00 - 7F	LOW PASS FILTER RESONANCE	-64...0...+63	40
nn 1A	1	00 - 7F	EG ATTACK TIME	-64...0...+63	40
nn 1B	1	00 - 7F	EG DECAY TIME	-64...0...+63	40
nn 1C	1	00 - 7F	EG RELEASE TIME	-64...0...+63	40
nn 1D	1	28 - 58	MW PITCH CONTROL	-24...0...+24[semitones]	40
nn 1E	1	00 - 7F	MW LOW PASS FILTER CONTROL	-9600...0...+9450[cent]	40
nn 1F	1	00 - 7F	MW AMPLITUDE CONTROL	-100...0...+100[%]	40
nn 20	1	00 - 7F	MW LFO PMOD DEPTH	0...127	0A

nn 74	1		NOT USED		--
nn 75	1		NOT USED		--
nn 76	1	04 - 28	EQ BASS FREQUENCY	32...2.0k[Hz]	0C
nn 77	1	1C - 3A	EQ TREBLE FREQUENCY	500...16.0k[Hz]	36
nn 78	1		NOT USED		--
nn 79	1		NOT USED		--
nn 7A	1		NOT USED		--
nn 7B	1		NOT USED		--
nn 7C	1		NOT USED		--
nn 7D	1		NOT USED		--
nn 7E	1		NOT USED		--
nn 7F	1		NOT USED		--
TOTAL SIZE	0C				

0A nn 10	1	00, 08, 28, 29	OUTPUT SELECT	0:stereo out, 8:indiv1+2 40:indiv1,41:indiv2	0
----------	---	----------------	---------------	---	---

TOTAL SIZE 1
When data other than the above is received, 0: Stereo Out will be selected.

0A nn 20	1	00 - 7F	HIGH PASS FILTER CUTOFF FREQUENCY	-64...0...+63	40
nn 21	1		NOT USED		--
TOTAL SIZE	2				

nn = PART NUMBER

In the case of the DRUM PART, there will be no effect for the following parameters.

- BANK SELECT LSB
- MONO/POLY MODE
- SCALE TUNING
- PORTAMENTO
- PITCH EG
- FILTER MODURATION DEPTH(FMOD DEPTH)
- AMPLITUDE MODURATION DEPTH(AMOD DEPTH)
- OUTPUT SELECT

<Table 1-9>

MIDI Parameter Change table (A/D PART)

Address (H)	Size (H)	Data (H)	Parameter	Description	Initial value (H)
10 0n 00	1	00 - 01	INPUT GAIN	MIC , LINE	00
01	1	00 - 7F	BANK SELECT MSB	0...127	00
02	1	00 - 7F	BANK SELECT LSB	0...127	00
03	1	00 - 7F	PROGRAM NUMBER	1...128	00
04	1	00-1F, 7F	Rcv CHANNEL	A1...A16,B1...B16, OFF	7F
05	1		NOT USED		--
06	1		NOT USED		--
07	1		NOT USED		--
08	1		NOT USED		--
09	1		NOT USED		--
0A	1		NOT USED		--
0B	1	00 - 7F	VOLUME	0...127	00
0C	1		NOT USED		--
0D	1		NOT USED		--
0E	1	01 - 7F	PAN	L63...C...R63	40
0F	1		NOT USED		--
10	1		NOT USED		--
11	1	00 - 7F	DRY LEVEL	0...127	7F
12	1	00 - 7F	CHORUS SEND	0...127	00
13	1	00 - 7F	REVERB SEND	0...127	00
14	1	00 - 7F	VARIATION SEND	0...127	00
TOTAL SIZE	15				

10 0n 30	1		NOT USED		--
31	1		NOT USED		--
32	1	00 - 01	Rcv PROGRAM CHANGE	OFF , ON	00
33	1	00 - 01	Rcv CONTROL CHANGE	OFF , ON	01
34	1		NOT USED		--
35	1	00 - 01	MUTE	ON, OFF	01
36	1		NOT USED		--
37	1		NOT USED		--
38	1		NOT USED		--
39	1	00 - 01	Rcv VOLUME	OFF , ON	01
3A	1	00 - 01	Rcv PAN	OFF , ON	01
3B	1	00 - 01	Rcv EXPRESSION	OFF , ON	01
3C	1		NOT USED		--
3D	1		NOT USED		--
3E	1		NOT USED		--
3F	1		NOT USED		--
40	1	00 - 01	Rcv BANK SELECT	OFF , ON	00
41	1		NOT USED		--
42	1		NOT USED		--
43	1		NOT USED		--
44	1		NOT USED		--
45	1		NOT USED		--
46	1		NOT USED		--
47	1		NOT USED		--
48	1		NOT USED		--
49	1		NOT USED		--
4A	1		NOT USED		--

MU90R

nn 21	1	00-7F	MW LFO FMOD DEPTH	0...127	00
nn 22	1	00-7F	MW LFO AMOD DEPTH	0...127	00
nn 23	1	28-58	BEND PITCH CONTROL	-24...0...+24[semitones]	42
nn 24	1	00-7F	BEND LOW PASS FILTER CONTROL	-9600...0...+9450[cent]	40
nn 25	1	00-7F	BEND AMPLITUDE CONTROL	-100...0...+100[%]	40
nn 26	1	00-7F	BEND LFO PMOD DEPTH	0...127	00
nn 27	1	00-7F	BEND LFO FMOD DEPTH	0...127	00
nn 28	1	00-7F	BEND LFO AMOD DEPTH	0...127	00
TOTAL SIZE 29					
nn 30	1	00-01	Rcv PITCH BEND	OFF, ON	01
nn 31	1	00-01	Rcv CH AFTER TOUCH(CAT)	OFF, ON	01
nn 32	1	00-01	Rcv PROGRAM CHANGE	OFF, ON	01
nn 33	1	00-01	Rcv CONTROL CHANGE	OFF, ON	01
nn 34	1	00-01	Rcv POLY AFTER TOUCH(PAT)	OFF, ON	01
nn 35	1	00-01	Rcv NOTE MESSAGE	OFF, ON	01
nn 36	1	00-01	Rcv RPN	OFF, ON	01
nn 37	1	00-01	Rcv NRPN	OFF, ON	XGmode=01, GMmode=00
nn 38	1	00-01	Rcv MODURATION	OFF, ON	01
nn 39	1	00-01	Rcv VOLUME	OFF, ON	01
nn 3A	1	00-01	Rcv PAN	OFF, ON	01
nn 3B	1	00-01	Rcv EXPRESSION	OFF, ON	01
nn 3C	1	00-01	Rcv HOLD1	OFF, ON	01
nn 3D	1	00-01	Rcv PORTAMENTO	OFF, ON	01
nn 3E	1	00-01	Rcv SOSTENUTO	OFF, ON	01
nn 3F	1	00-01	Rcv SOFT PEDAL	OFF, ON	01
nn 40	1	00-01	Rcv BANK SELECT	OFF, ON	XGmode=01, GMmode=00
nn 41	1	00-7F	SCALE TUNING C	-64...0...+63[cent]	40
nn 42	1	00-7F	SCALE TUNING C#	-64...0...+63[cent]	40
nn 43	1	00-7F	SCALE TUNING D	-64...0...+63[cent]	40
nn 44	1	00-7F	SCALE TUNING D#	-64...0...+63[cent]	40
nn 45	1	00-7F	SCALE TUNING E	-64...0...+63[cent]	40
nn 46	1	00-7F	SCALE TUNING F	-64...0...+63[cent]	40
nn 47	1	00-7F	SCALE TUNING F#	-64...0...+63[cent]	40
nn 48	1	00-7F	SCALE TUNING G	-64...0...+63[cent]	40
nn 49	1	00-7F	SCALE TUNING G#	-64...0...+63[cent]	40
nn 4A	1	00-7F	SCALE TUNING A	-64...0...+63[cent]	40
nn 4B	1	00-7F	SCALE TUNING A#	-64...0...+63[cent]	40
nn 4C	1	00-7F	SCALE TUNING B	-64...0...+63[cent]	40
nn 4D	1	28-58	CAT PITCH CONTROL	-24...0...+24[semitones]	40
nn 4E	1	00-7F	CAT LOW PASS FILTER CONTROL	-9600...0...+9450[cent]	40
nn 4F	1	00-7F	CAT AMPLITUDE CONTROL	-100...0...+100[%]	40
nn 50	1	00-7F	CAT LFO PMOD DEPTH	0...127	00
nn 51	1	00-7F	CAT LFO FMOD DEPTH	0...127	00
nn 52	1	00-7F	CAT LFO AMOD DEPTH	0...127	00
nn 53	1	28-58	PAT PITCH CONTROL	-24...0...+24[semitones]	40
nn 54	1	00-7F	PAT LOW PASS FILTER CONTROL	-9600...0...+9450[cent]	40
nn 55	1	00-7F	PAT AMPLITUDE CONTROL	-100...0...+100[%]	40
nn 56	1	00-7F	PAT LFO PMOD DEPTH	0...127	00
nn 57	1	00-7F	PAT LFO FMOD DEPTH	0...127	00
nn 58	1	00-7F	PAT LFO AMOD DEPTH	0...127	00
nn 59	1	00-5F	AC1 CONTROLLER NUMBER	0...95	10
nn 5A	1	28-58	AC1 PITCH CONTROL	-24...0...+24[semitones]	40
nn 5B	1	00-7F	AC1 LOW PASS FILTER CONTROL	-9600...0...+9450[cent]	40
nn 5C	1	00-7F	AC1 AMPLITUDE CONTROL	-100...0...+100[%]	40
nn 5D	1	00-7F	AC1 LFO PMOD DEPTH	0...127	00
nn 5E	1	00-7F	AC1 LFO FMOD DEPTH	0...127	00
nn 5F	1	00-7F	AC1 LFO AMOD DEPTH	0...127	00
nn 60	1	00-5F	AC2 CONTROLLER NUMBER	0...95	11
nn 61	1	28-58	AC2 PITCH CONTROL	-24...0...+24[semitones]	40
nn 62	1	00-7F	AC2 LOW PASS FILTER CONTROL	-9600...0...+9450[cent]	40
nn 63	1	00-7F	AC2 AMPLITUDE CONTROL	-100...0...+100[%]	40
nn 64	1	00-7F	AC2 LFO PMOD DEPTH	0...127	00
nn 65	1	00-7F	AC2 LFO FMOD DEPTH	0...127	00
nn 66	1	00-7F	AC2 LFO AMOD DEPTH	0...127	00
nn 67	1	00-01	PORTAMENTO SWITCH	OFF, ON	00
nn 68	1	00-7F	PORTAMENTO TIME	0...127	00
nn 69	1	00-7F	PITCH EG INITIAL LEVEL	-64...0...+63	40
nn 6A	1	00-7F	PITCH EG ATTACK TIME	-64...0...+63	40
nn 6B	1	00-7F	PITCH EG RELEASE LEVEL	-64...0...+63	40
nn 6C	1	00-7F	PITCH EG RELEASE TIME	-64...0...+63	40
nn 6D	1	01-7F	VELOCITY LIMIT LOW	1...127	01
nn 6E	1	01-7F	VELOCITY LIMIT HIGH	1...127	7F
TOTAL SIZE 3F					
nn 70	1		NOT USED		--
nn 71	1		NOT USED		--
nn 72	1	00-7F	EQ BASS GAIN	-12 - +12[dB]	40
nn 73	1	00-7F	EQ TREBLE GAIN	-12 - +12[dB]	40
TOTAL SIZE 4					

4B	1		NOT USED		--
4C	1		NOT USED		--
4D	1		NOT USED		--
4E	1		NOT USED		--
4F	1		NOT USED		--
50	1		NOT USED		--
51	1		NOT USED		--
52	1		NOT USED		--
53	1		NOT USED		--
54	1		NOT USED		--
55	1		NOT USED		--
56	1		NOT USED		--
57	1		NOT USED		--
58	1		NOT USED		--
59	1	00 - 5F	AC1 CONTROLLER NUMBER	0...95	10
5A	1		NOT USED		--
5B	1		NOT USED		--
5C	1		NOT USED		--
5D	1		NOT USED		--
5E	1		NOT USED		--
5F	1		NOT USED		--
60	1	00 - 5F	AC2 CONTROLLER NUMBER	0...95	11
TOTAL SIZE 31					

n:A/D Part number(0 - 1)

<Table 1-10>

MIDI Parameter Change table (A/D System)

Address (H)	Size (H)	Data (H)	Parameter	Description	Initial value (H)
11 00 00	1	00 - 01	A/D1.2 MONO/STEREO MODE	MONO/STEREO	00
TOTAL SIZE 1					

<Table 1-11>

MIDI Parameter Change table (DRUM SETUP)

Address (H)	Size (H)	Data (H)	Parameter	Description	Initial value (H)
3n rr 00	1	00 - 7F	PITCH COARSE	-64...0...+63	40
01	1	00 - 7F	PITCH FINE	-64...0...+63[cent]	40
02	1	00 - 7F	LEVEL	0...127	depend on the note
03	1	00 - 7F	ALTERNATE GROUP	OFF,1...127	"
04	1	00 - 7F	PAN	RND,L63...C...R63	"
05	1	00 - 7F	REVERB SEND	0...127	"
06	1	00 - 7F	CHORUS SEND	0...127	"
07	1	00 - 7F	VARIATION SEND	0...127	7F
08	1	00 - 01	KEY ASSIGN	SINGLE , MULTI	00
09	1	00 - 01	Rcv NOTE OFF	OFF , ON	depend on the note
0A	1	00 - 01	Rcv NOTE ON	OFF , ON	01
0B	1	00 - 7F	LOW PASS FILTER CUTOFF FREQUENCY	-64...0...63	40
0C	1	00 - 7F	LOW PASS FILTER RESONANCE	-64...0...63	40
0D	1	00 - 7F	EG ATTACK RATE	-64...0...63	40
0E	1	00 - 7F	EG DECAY1 RATE	-64...0...63	40
0F	1	00 - 7F	EG DECAY2 RATE	-64...0...63	40
TOTAL SIZE 10					

3n rr 20	1	00 - 7F	EQ BASS GAIN	-12 - +12[dB]	40
21	1	00 - 7F	EQ TREBLE GAIN	-12 - +12[dB]	40
22	1		NOT USED		--
23	1		NOT USED		--
24	1	04 - 28	EQ BASS FREQUENCY	32...2.0k[Hz]	0C
25	1	1C - 3A	EQ TREBLE FREQUENCY	500...16.0k[Hz]	36
26	1		NOT USED		--
27	1		NOT USED		--
28	1		NOT USED		--
29	1		NOT USED		--
2A	1		NOT USED		--
2B	1		NOT USED		--
2C	1		NOT USED		--
2D	1		NOT USED		--
TOTAL SIZE 0E					

3n rr 40	1	00, 08, 28, 29	OUTPUT SELECT	0:stereo out, 8:indiv1+2 40:indiv1,41:indiv2	0
----------	---	----------------	---------------	---	---

TOTAL SIZE 1

When data other than the above is received, 0: Stereo Out will be selected.

3n rr 50	1	00 - 7F	HIGH PASS FILTER CUTOFF FREQUENCY	-64...0...63	40
51	1		NOT USED		--
TOTAL SIZE 2					

3n rr 60	1	30 - 50	VELOCITY SENSE PITCH	-16...0...16	depend on the note
61	1	30 - 50	VELOCITY SENSE LPF CUTOFF	-16...0...16	"
TOTAL SIZE 2					

MU90R

n:Drum Setup Number(0 - 3)
rr:note number(0D - 5B)

The MU90 will initialize all Drum Setup data in the following cases.
When XG SYSTEM ON is received
When GM SYSTEM ON is received
When DRUM SETUP RESET is received (in XG mode)

[Note]

When a program change is received by a part to which a Drum Setup is assigned, the assigned Drum Setup will be initialized.
If the same Drum Setup is assigned to two or more parts, changes in Drum Setup parameters (including program changes) will be reflected in all parts to which it is assigned.

<Table 2-1>

Parameter Base Address
MODEL ID = 49

Parameter	Address			Description
	(H)	(M)	(L)	
MU80 SYSTEM	00	00	00	System
REMOTE SWITCH	0A	00	00	Remote Switch
MU80 INTERNAL PERFORMANCE	30	00	00	#1 Common
	30	:	:	:
	30	63	00	#100 Common
	31	00	00	#1 Part1
	31	:	:	:
	31	63	00	#100 Part1
	32	00	00	#1 Part2
	32	:	:	:
	32	63	00	#100 Part2
	33	00	00	#1 Part3
	33	:	:	:
	33	63	00	#100 Part3
34	00	00	#1 Part4	
34	:	:	:	
34	63	00	#100 Part4	

MU80 Performance Common INT

Address	(H)	Parameter
30	pp 00	System
	pp 20	Effect
	pp 70	EQ

pp: Performance#

<Table 2-2>

MIDI Parameter Change table (SYSTEM)

Address (H)	Size (H)	Data (H)	Parameter	Description	Initial value (H)
00 00 00	1	00 - 01	MUTE LOCK	OFF , ON	00
01	1	00 - 01	AD LOCK	OFF , ON	00
02	1	00 - 01	EQ LOCK	OFF , ON	00
03	1	00 - 01	Rcv GM EXCLUSIVE MESSAGE	OFF , ON	01
04	1	00 - 01	Rcv BANK SELECT	OFF , ON	01
05	1	00 - 04	BULK OUT INTERVAL TIME	50, 100, 150, 200, 300	02
06	1	00 - 10	PERFORMANCE SYSTEM CHANNEL	1...16, all	00
07	1	28 - 58	PERFORMANCE SYSTEM TRANSPOSE	-24...0...+24[semitone]	40
08	1	00 - 07	LCD CONTRAST	1...8	01
09	1	00 - 07	MULTI PORT NUMBER for MIDI OUT	1...8	00
TOTAL SIZE 0A					
00 00 10	1	00 - 01	DRUM EDIT Rcv NOTE	OFF , ON	01
TOTAL SIZE 1					
00 00 11	1	00 - 01	OUTPUT SELECT LOCK	OFF , ON	00
TOTAL SIZE 1					

<Table 2-3>

MIDI Parameter Change table (REMOTE SWITCH)

Address (H)	Size (H)	Data (H)	Parameter	Description	Initial value (H)
0A 00 00	1	00-01	PLAY SWITCH	OFF , ON	--
01	1	00-01	UTIL SWITCH	OFF , ON	--
02	1	00-01	MODE SWITCH	OFF , ON	--
03	1	00-01	EDIT SWITCH	OFF , ON	--
04	1	00-01	EFFECT SWITCH	OFF , ON	--
05	1	00-01	EQ SWITCH	OFF , ON	--
06	1	00-01	MUTE/SOLO SWITCH	OFF , ON	--
07	1	00-01	ENTER SWITCH	OFF , ON	--
08	1	00-01	EXIT SWITCH	OFF , ON	--
09	1	00-01	PART- SWITCH	OFF , ON	--
0A	1	00-01	SELECT- SWITCH	OFF , ON	--
0B	1	00-01	VALUE- SWITCH	OFF , ON	--
0C	1	00-01	PART+ SWITCH	OFF , ON	--
0D	1	00-01	SELECT+ SWITCH	OFF , ON	--
0E	1	00-01	VALUE+ SWITCH	OFF , ON	--
TOTAL SIZE 0F					

<Table 2-4>

MIDI Parameter Change table (MU80, MU50 INTERNAL PERFORMANCE)

Address (H)	Size (H)	Data (H)	Parameter	Description	Initial value (H)
30 pp 00	0C	20 - 7F	PERFORMANCE NAME	32...127(ASCII CHARACTER)	depends on performance number
pp 0C	01	00 - 7F	PERFORMANCE VOLUME	0...127	"
pp 0D	01	01 - 7F	PERFORMANCE PAN	L63...C...R63(1...64...127)	"
pp 0E	01	00 - 60	ACI CC NUMBER	0...95, CAT(96)	"
pp 0F	01	00 - 01	A/D INPUT	OFF , ON	"
TOTAL SIZE 10					

MU90R

30	pp 20	2	00-7F	REVERB TYPE MSB	Refer to the Effect Program List	depends on performance number
	pp 21		00-7F	REVERB TYPE LSB	"	"
	pp 22	1	00-7F	REVERB PARAMETER 1	"	"
	pp 23	1	00-7F	REVERB PARAMETER 2	"	"
	pp 24	1	00-7F	REVERB PARAMETER 3	"	"
	pp 25	1	00-7F	REVERB PARAMETER 4	"	"
	pp 26	1	00-7F	REVERB PARAMETER 5	"	"
	pp 27	1	00-7F	REVERB RETURN	-∞dB...0dB...+6dB(0...96...127)	"
	pp 28	1	01-7F	REVERB PAN	L63...C...R63	"
	pp 29	2	00-7F	CHORUS TYPE MSB	Refer to the Effect Program List	"
	pp 2A		00-7F	CHORUS TYPE LSB	"	"
	pp 2B	1	00-7F	CHORUS PARMETER 1	"	"
	pp 2C	1	00-7F	CHORUS PARMETER 2	"	"
	pp 2D	1	00-7F	CHORUS PARMETER 3	"	"
	pp 2E	1	00-7F	CHORUS PARMETER 4	"	"
	pp 2F	1	00-7F	CHORUS PARMETER 5	"	"
	pp 30	1	00-7F	CHORUS RETURN	-∞dB...0dB...+6dB(0...96...127)	"
	pp 31	1	01-7F	CHORUS PAN	L63...C...R63	"
	pp 32	1	00-7F	SEND CHORUS TO REVERB	-∞dB...0dB...+6dB(0...96...127)	"
	pp 33	2	00-7F	VARIATION TYPE MSB	Refer to the Effect Program List	"
	pp 34		00-7F	VARIATION TYPE LSB	"	"
	pp 35	2	00-7F	VARIATION PARMETER 1 MSB	"	"
	pp 36		00-7F	VARIATION PARMETER 1 LSB	"	"
	pp 37	2	00-7F	VARIATION PARMETER 2 MSB	"	"
	pp 38		00-7F	VARIATION PARMETER 2 LSB	"	"
	pp 39	2	00-7F	VARIATION PARMETER 3 MSB	"	"
	pp 3A		00-7F	VARIATION PARMETER 3 LSB	"	"
	pp 3B	2	00-7F	VARIATION PARMETER 4 MSB	"	"
	pp 3C		00-7F	VARIATION PARMETER 4 LSB	"	"
	pp 3D	2	00-7F	VARIATION PARMETER 5 MSB	"	"
	pp 3E		00-7F	VARIATION PARMETER 5 LSB	"	"
	pp 3F	2	00-7F	VARIATION PARMETER 10 MSB	"	"
	pp 40		00-7F	VARIATION PARMETER 10 LSB	"	"
	pp 41	1	00-7F	VARIATION RETURN	-∞dB...0dB...+6dB(0...96...127)	"
	pp 42	1	01-7F	VARIATION PAN	L63...C...R63(1...64...127)	"
	pp 43	1	00-7F	SEND VARIATION TO REVERB	-∞dB...0dB...+6dB(0...96...127)	"
	pp 44	1	00-7F	SEND VARIATION TO CHORUS	-∞dB...0dB...+6dB(0...96...127)	"
	pp 45	1	00-7F	ACI VARIATION CONTROL DEPTH	0...127	"
	pp 46	1	00-01	VARIATION CONNECTION	INSERTION , SYSTEM	"
	pp 47	1	00-03,7F	VARIATION PART	Part1...4(0...3) AD1, AD2(64, 65) OFF(127)	"
	pp 48	2	00-7F	INSERTION EFFECT 1 TYPE MSB	Refer to the Effect Program List	"
	pp 49		00-7F	INSERTION EFFECT 1 TYPE LSB	"	"
	pp 4A	1	00-7F	INSERTION EFFECT 1 PARAMETER1	"	"
	pp 4B	1	00-7F	INSERTION EFFECT 1 PARAMETER2	"	"
	pp 4C	1	00-7F	INSERTION EFFECT 1 PARAMETER3	"	"
	pp 4D	1	00-7F	INSERTION EFFECT 1 PARAMETER4	"	"
	pp 4E	1	00-7F	INSERTION EFFECT 1 PARAMETER5	"	"
	pp 4F	1	00-7F	INSERTION EFFECT 1 PARAMETER10	"	"
	pp 50	1	00-7F	INSERTION EFFECT 1 PART	Part1...4(0...3) AD1, AD2(64, 65) OFF(127)	"
TOTAL SIZE		31				
30	pp 70	1	00 - 04	EQ TYPE	flat,jazz,pops,rock,concert	depends on performance number
	pp 71	1	34 - 4C	EQ GAIN1	-12...0...+12[dB]	"
	pp 72	1	34 - 4C	EQ GAIN2	-12...0...+12[dB]	"
	pp 73	1	34 - 4C	EQ GAIN3	-12...0...+12[dB]	"
	pp 74	1	34 - 4C	EQ GAIN4	-12...0...+12[dB]	"
	pp 75	1	34 - 4C	EQ GAIN5	-12...0...+12[dB]	"
TOTAL SIZE		06				
3n	pp 00	1	00 - 7F	PROGRAM NUMBER	1...128	depends on performance number
3n	pp 01	1	00 - 7F	BANK SELECT	0...127 (Refer to the XG voice map)	"
3n	pp 02	1	00 - 7F	VOLUME	0...127	"
3n	pp 03	1	00, 01 - 7F	PAN	RND, L63...C...R63	"
3n	pp 04	1	00 - 7F	DRY SEND LEVEL	0...127	"
3n	pp 05	1	00 - 7F	CHORUS SEND	0...127	"
3n	pp 06	1	00 - 7F	REVERB SEND	0...127	"
3n	pp 07	1	00 - 7F	VARIATION SEND	0...127	"
3n	pp 08	1	28 - 58	NOTE SHIFT	-24...0...+24[semitones]	"
3n	pp 09	1	00 - 7F	LOW PASS FILTER CUTOFF FREQUENCY	-64...0...+63	"
3n	pp 0A	1	00 - 7F	LOW PASS FILTER RESONANCE	-64...0...+63	"
3n	pp 0B	1	00 - 7F	EG ATTACK TIME	-64...0...+63	"
3n	pp 0C	1	00 - 7F	EG DECAY TIME	-64...0...+63	"
3n	pp 0D	1	00 - 7F	EG RELEASE TIME	-64...0...+63	"
3n	pp 0E	1	00 - 7F	VIBRATO RATE	-64...0...+63	"
3n	pp 0F	1	00 - 7F	VIBRATO DEPTH	-64...0...+63	"
3n	pp 10	1	00 - 7F	VIBRATO DELAY	-64...0...+63	"
3n	pp 11	2	00 - 0F	DETUNE	-12.8...0...+12.7[Hz]	"
					1st bit3-0→bit7-4 2nd bit3-0→bit3-0	"
					1st bit6 : OFF,ON(0,1) 1st bit5 : MONO,POLY(0,1)	"
					1st bit4 : OFF,ON(0,1)	"
3n	pp 13	1	00 - 7F	PITCH EG INITIAL LEVEL	0...127	"
3n	pp 14	1	00 - 7F	PITCH EG ATTACK TIME	0...127	"
3n	pp 15	1	00 - 7F	PITCH EG RELEASE LEVEL	0...127	"
3n	pp 16	1	00 - 7F	PITCH EG RELEASE TIME	0...127	"
3n	pp 17	1	00 - 7F	MW LFO PMOD DEPTH *	0...127	"

3n pp 18	1	00 - 7F	MW LFO FMOD DEPTH *	0...127	"
3n pp 19	1	28 - 58	PITCH BEND CONTROL *	-24...0...+24[semitones]	"
3n pp 1A	1	00 - 7F	AC1 LOW PASS FILTER CONTROL *	-64...0...63	"
3n pp 1B	1	00 - 7F	AC1 AMPLITUDE CONTROL *	-100...0...+100[%]	"
3n pp 1C	1	00 - 7F	VELOCITY SENSE DEPTH	0...127	"
3n pp 1D	1	00 - 7F	VELOCITY SENSE OFFSET	0...127	"
3n pp 1E	1	00 - 7F	NOTE LIMIT LOW	C-2...G8	"
3n pp 1F	1	00 - 7F	NOTE LIMIT HIGH	C-2...G8	"
3n pp 20	1	00 - 7F	PORTAMENTO TIME *	0...127	"
3n pp 21	1	01 - 7F	VELOCITY LIMIT LOW	1...127	"
3n pp 22	1	01 - 7F	VELOCITY LIMIT HIGH	1...127	"
TOTAL SIZE 23					

n: performance part number (01-04)

pp: performance number (00-63)

For parameters marked by an *, only the data of n=1 is received as common data, and the data of n=2-4 is not received.

<Table 3-1>

Parameter Base Address
MODEL ID = 59

Parameter	Address			Description
	(H)	(M)	(L)	
CURRENT PERFORMANCE	09	00	00	Part1
	09	01	00	Part2
	09	02	00	Part3
	09	03	00	Part4
	0B	00	00	Common
	0C	00	00	Insertion1 Effect
	0C	01	00	Insertion2 Effect
INTERNAL PERFORMANCE	30	00	00	#1 Part1
	:	:	:	:
	30	63	00	#100 Part1
	31	00	00	#1 Part2
	:	:	:	:
	31	63	00	#100 Part2
	32	00	00	#1 Part3
	:	:	:	:
	32	63	00	#100 Part3
	33	00	00	#1 Part4
	:	:	:	:
	33	63	00	#100 Part4
	40	00	00	#1 Common
	:	:	:	:
	40	63	00	#100 Common
	50	00	00	#1 Insertion1 Effect
	:	:	:	:
50	63	00	#100 Insertion1 Effect	
51	00	00	#1 Insertion2 Effect	
:	:	:	:	
51	63	00	#100 Insertion2 Effect	

Address	(H)	Parameter
0B	00 00	System
	00 20	Effect
	00 70	EQ

Address	(H)	Parameter
40	pp 00	System
	pp 20	Effect
	pp 70	EQ

pp: Performance#

<Table 3-2>

MIDI Parameter Change table (CURRENT PERFORMANCE)

Address (H)	Size (H)	Data (H)	Parameter	Description	Initial value (H)
09 0n 00	1	00 - 7F	PROGRAM NUMBER	1...128	depends on performance number
0n 01	1	00 - 7F	BANK SELECT	0...127 (Refer to the XG voice map)	"
0n 02	1	00 - 7F	VOLUME	0...127	"
0n 03	1	00 - 7F	PAN	RND,L63...C...R63(0, 1...64...127)	"
0n 04	1	00 - 7F	DRY SEND LEVEL	0...127	"
0n 05	1	00 - 7F	CHORUS SEND	0...127	"
0n 06	1	00 - 7F	REVERB SEND	0...127	"
0n 07	1	00 - 7F	VARIATION SEND	0...127	"
0n 08	1	28 - 58	NOTE SHIFT	-24...0...+24[semitones]	"
0n 09	1	00 - 01	Rev NOTE MESSAGE(MUTE)	OFF, ON(0, 1)	"
0n 0A	1	00 - 7F	LOW PASS FILTER CUTOFF FREQUENCY	-64...0...+63	"
0n 0B	1	00 - 7F	LOW PASS FILTER RESONANCE	-64...0...+63	"
0n 0C	1	00 - 7F	EG ATTACK TIME	-64...0...+63	"
0n 0D	1	00 - 7F	EG DECAY TIME	-64...0...+63	"
0n 0E	1	00 - 7F	EG RELEASE TIME	-64...0...+63	"
0n 0F	1	00 - 7F	VIBRATO RATE	-64...0...+63	"
0n 10	1	00 - 7F	VIBRATO DEPTH	-64...0...+63	"
0n 11	1	00 - 7F	VIBRATO DELAY	-64...0...+63	"
0n 12	2	00 - 0F	DETUNE	-12.8...0...+12.7[Hz]	"
0n 13		00 - 0F		1st bit3-0→bit7-4 2nd bit3-0→bit3-0	"
0n 14	1	00 - 7F	PITCH EG INITIAL LEVEL	-64...0...+63	"
0n 15	1	00 - 7F	PITCH EG ATTACK TIME	-64...0...+63	"
0n 16	1	00 - 7F	PITCH EG RELEASE LEVEL	-64...0...+63	"
0n 17	1	00 - 7F	PITCH EG RELEASE TIME	-64...0...+63	"
0n 18	1	00 - 01	MONO/POLY MODE	MONO, POLY(0, 1)	"
0n 19	1	00 - 7F	VELOCITY SENSE DEPTH	0...127	"
0n 1A	1	00 - 7F	VELOCITY SENSE OFFSET	0...127	"
0n 1B	1	00 - 7F	NOTE LIMIT LOW	C-2...G8(0...127)	"
0n 1C	1	00 - 7F	NOTE LIMIT HIGH	C-2...G8(0...127)	"
0n 1D	1	01 - 7F	VELOCITY LIMIT LOW	1...127	"
0n 1E	1	01 - 7F	VELOCITY LIMIT HIGH	1...127	"
0n 1F	1	00 - 7F	EQ BASS	-64...0...+63(-12 - +12[dB])	"
0n 20	1	00 - 7F	EQ TREBLE	-64...0...+63(-12 - +12[dB])	"
0n 21	1	04 - 28	EQ BASS frequency	32...2.0k[Hz]	"
0n 22	1	1C - 3A	EQ TREBLE frequency	500...16.0k[Hz]	"
0n 23	1	00 - 7F	HIGH PASS FILTER CUTOFF FREQUENCY	-64...0...+63	"

TOTAL SIZE 24

0B 00 00	0C	20 - 7F	PERFORMANCE NAME	32...127(ASCII CHARACTER)	depends on performance number
	0C	01	PERFORMANCE VOLUME	0...127	"
	0D	01	PERFORMANCE PAN	L63...C...R63	"
	0E	01	AC1 CC NUMBER	0...95.CAT	"
	0F	01	A/D INPUT	OFF , ON	"
	10	01	MW LFO PMOD DEPTH	0...127	"
	11	01	MW LFO FMOD DEPTH	0...127	"
	12	01	BEND PITCH CONTROL	-24...0...+24[semitones]	"
	13	01	AC1 LOW PASS FILTER CONTROL	-64 ...0...+63	"
	14	01	AC1 AMPLITUDE CONTROL	-64 ...0...+63	"
	15	01	AC1 LFO FMOD DEPTH	0...127	"
	16	01	PORTAMENTO SWITCH	OFF , ON(0, 1)	"
	17	01	PORTAMENTO TIME	0...127	"
TOTAL SIZE		18			

0B 00 20	2	00-7F	REVERB TYPE MSB	Refer to the Effect Program List	depends on performance number
		00-7F	REVERB TYPE LSB	"	"
	1	00-7F	REVERB PARAMETER 1	"	"
	1	00-7F	REVERB PARAMETER 2	"	"
	1	00-7F	REVERB PARAMETER 3	"	"
	1	00-7F	REVERB PARAMETER 4	"	"
	1	00-7F	REVERB PARAMETER 5	"	"
	1	00-7F	REVERB RETURN	-∞dB...0dB...+6dB(0...96...127)	"
	1	01-7F	REVERB PAN	L63...C...R63	"
	2	00-7F	CHORUS TYPE MSB	Refer to the Effect Program List	"
		00-7F	CHORUS TYPE LSB	"	"
	1	00-7F	CHORUS PARAMETER 1	"	"
	1	00-7F	CHORUS PARAMETER 2	"	"
	1	00-7F	CHORUS PARAMETER 3	"	"
	1	00-7F	CHORUS PARAMETER 4	"	"
	1	00-7F	CHORUS PARAMETER 5	"	"
	1	00-7F	CHORUS RETURN	-∞dB...0dB...+6dB(0...96...127)	"
	1	01-7F	CHORUS PAN	L63...C...R63(1...64...127)	"
	1	00-7F	SEND CHORUS TO REVERB	-∞dB...0dB...+6dB(0...96...127)	"
	2	00-7F	VARIATION TYPE MSB	Refer to the Effect Program List	"
		00-7F	VARIATION TYPE LSB	"	"
	2	00-7F	VARIATION PARAMETER 1 MSB	"	"
		00-7F	VARIATION PARAMETER 1 LSB	"	"
	2	00-7F	VARIATION PARAMETER 2 MSB	"	"
		00-7F	VARIATION PARAMETER 2 LSB	"	"
	2	00-7F	VARIATION PARAMETER 3 MSB	"	"
		00-7F	VARIATION PARAMETER 3 LSB	"	"
	2	00-7F	VARIATION PARAMETER 4 MSB	"	"
		00-7F	VARIATION PARAMETER 4 LSB	"	"
	2	00-7F	VARIATION PARAMETER 5 MSB	"	"
		00-7F	VARIATION PARAMETER 5 LSB	"	"
	2	00-7F	VARIATION PARAMETER 10 MSB	"	"
		00-7F	VARIATION PARAMETER 10 LSB	"	"
	1	00-7F	VARIATION RETURN	-∞dB...0dB...+6dB(0...96...127)	"
	1	01-7F	VARIATION PAN	L63...C...R63	"
	1	00-7F	SEND VARIATION TO REVERB	-∞dB...0dB...+6dB(0...96...127)	"
	1	00-7F	SEND VARIATION TO CHORUS	-∞dB...0dB...+6dB(0...96...127)	"
	1	00-7F	AC1 VARIATION CONTROL DEPTH	0...127	"
	1	00-01	VARIATION CONNECTION	INSERTION , SYSTEM	"
	1	00-7F	VARIATION PART	Part1...4(0...3) AD1, AD2(64, 65) OFF(127)	"
TOTAL SIZE		28			

0B 00 70	1	00 - 04	EQ TYPE	flat,jazz,pops,rock,concert	depends on performance number
	1	34 - 4C	EQ GAIN1	-12...0...+12[dB]	"
	1	34 - 4C	EQ GAIN2	-12...0...+12[dB]	"
	1	34 - 4C	EQ GAIN3	-12...0...+12[dB]	"
	1	34 - 4C	EQ GAIN4	-12...0...+12[dB]	"
	1	34 - 4C	EQ GAIN5	-12...0...+12[dB]	"
TOTAL SIZE		06			

0C 00 00	2	00-7F	INSERTION EFFECT 1 TYPE MSB	Refer to the Effect Program List	depends on performance number
		00-7F	INSERTION EFFECT 1 TYPE LSB	"	"
	2	00-7F	INSERTION EFFECT 1 PARAMETER1 MSB	"	"
		00-7F	INSERTION EFFECT 1 PARAMETER1 LSB	"	"
	2	00-7F	INSERTION EFFECT 1 PARAMETER2 MSB	"	"
		00-7F	INSERTION EFFECT 1 PARAMETER2 LSB	"	"
	2	00-7F	INSERTION EFFECT 1 PARAMETER3 MSB	"	"
		00-7F	INSERTION EFFECT 1 PARAMETER3 LSB	"	"
	2	00-7F	INSERTION EFFECT 1 PARAMETER4 MSB	"	"
		00-7F	INSERTION EFFECT 1 PARAMETER4 LSB	"	"
	2	00-7F	INSERTION EFFECT 1 PARAMETERS5 MSB	"	"
		00-7F	INSERTION EFFECT 1 PARAMETERS5 LSB	"	"
	2	00-7F	INSERTION EFFECT 1 PARAMETER10 MSB	"	"
		00-7F	INSERTION EFFECT 1 PARAMETER10 LSB	"	"
	1	00-7F	INSERTION EFFECT 1 PART	Part1...4(0...3) AD1, AD2(64, 65) OFF(127)	"
TOTAL SIZE		0F			

0C 01 (X)	2	(X)-7F	INSERTION EFFECT 2 TYPE MSB	Refer to the Effect Program List	depends on performance number
01		(X)-7F	INSERTION EFFECT 2 TYPE LSB	"	"
02	2	00-7F	INSERTION EFFECT 2 PARAMETER1 MSB	"	"
03		(X)-7F	INSERTION EFFECT 2 PARAMETER1 LSB	"	"
04	2	00-7F	INSERTION EFFECT 2 PARAMETER2 MSB	"	"
05		(X)-7F	INSERTION EFFECT 2 PARAMETER2 LSB	"	"
06	2	00-7F	INSERTION EFFECT 2 PARAMETER3 MSB	"	"
07		00-7F	INSERTION EFFECT 2 PARAMETER3 LSB	"	"
08	2	00-7F	INSERTION EFFECT 2 PARAMETER4 MSB	"	"
09		00-7F	INSERTION EFFECT 2 PARAMETER4 LSB	"	"
0A	2	00-7F	INSERTION EFFECT 2 PARAMETER5 MSB	"	"
0B		00-7F	INSERTION EFFECT 2 PARAMETER5 LSB	"	"
0C	2	00-7F	INSERTION EFFECT 2 PARAMETER10 MSB	"	"
0D		00-7F	INSERTION EFFECT 2 PARAMETER10 LSB	"	"
0E	1	00-7F	INSERTION EFFECT 2 PART	Part1...4(0...3) AD1, AD2(64, 65) OFF(127)	"

TOTAL SIZE 0F

<Table 3-3>

MIDI Parameter Change table (INTERNAL PERFORMANCE)

Address (H)	Size (H)	Data (H)	Parameter	Description	Initial value (H)
3n pp 00	1	00 - 7F	PROGRAM NUMBER	1...128	depends on performance number
3n pp 01	1	00 - 7F	BANK SELECT	0...127 (Refer to the XCi voice map)	"
3n pp 02	1	00 - 7F	VOLUME	0...127	"
3n pp 03	1	00, 01 - 7F	PAN	RND, L63...C...R63	"
3n pp 04	1	00 - 7F	DRY SEND LEVEL	0...127	"
3n pp 05	1	00 - 7F	CHORUS SEND	0...127	"
3n pp 06	1	00 - 7F	REVERB SEND	0...127	"
3n pp 07	1	00 - 7F	VARIATION SEND	0...127	"
3n pp 08	1	28 - 58	NOTE SHIFT	-24...0...+24[semitones]	"
3n pp 09	1	00 - 7F	LOW PASS FILTER CUTOFF FREQUENCY	-64...0...+63	"
3n pp 0A	1	00 - 7F	LOW PASS FILTER RESONANCE	-64...0...+63	"
3n pp 0B	1	00 - 7F	EG ATTACK TIME	-64...0...+63	"
3n pp 0C	1	00 - 7F	EG DECAY TIME	-64...0...+63	"
3n pp 0D	1	00 - 7F	EG RELEASE TIME	-64...0...+63	"
3n pp 0E	1	00 - 7F	VIBRATO RATE	-64...0...+63	"
3n pp 0F	1	00 - 7F	VIBRATO DEPTH	-64...0...+63	"
3n pp 10	1	00 - 7F	VIBRATO DELAY	-64...0...+63	"
3n pp 11	2	00 - 0F	DETUNE	-12.8...0...+12.7[Hz]	"
3n pp 12		00 - 7F		1st bit3-0→bit7-4 2nd bit3-0→bit3-0	"
			Rev NOTE MESSAGE	1st bit6 : OFF,ON(0,1)	"
			MONO/POLY MODE	1st bit5 : MONO,POLY(0,1)	"
3n pp 13	1	00 - 7F	PITCH EG INITIAL LEVEL	0...127	"
3n pp 14	1	00 - 7F	PITCH EG ATTACK TIME	0...127	"
3n pp 15	1	00 - 7F	PITCH EG RELEASE LEVEL	0...127	"
3n pp 16	1	00 - 7F	PITCH EG RELEASE TIME	0...127	"
3n pp 17	1	00 - 7F	VELOCITY SENSE DEPTH	0...127	"
3n pp 18	1	00 - 7F	VELOCITY SENSE OFFSET	0...127	"
3n pp 19	1	00 - 7F	NOTE LIMIT LOW	C-2...G8	"
3n pp 1A	1	00 - 7F	NOTE LIMIT HIGH	C-2...G8	"
3n pp 1B	1	01 - 7F	VELOCITY LIMIT LOW	1...127	"
3n pp 1C	1	01 - 7F	VELOCITY LIMIT HIGH	1...127	"
3n pp 1D	1	00 - 7F	EQ BASS	-64...0...+63(-12 - +12[dB])	"
3n pp 1E	1	00 - 7F	EQ TREBLE	-64...0...+63(-12 - +12[dB])	"
3n pp 1F	1	04 - 28	EQ BASS frequency	32...2.0k[Hz]	"
3n pp 20	1	1C - 3A	EQ TREBLE frequency	500...16.0k[Hz]	"
3n pp 21	1	00 - 7F	HIGH PASS FILTER CUTOFF FREQUENCY	-64...0...+63	"

TOTAL SIZE 22

n: performance part number (00-03)
pp:performance number (00-63)

40 pp 00	0C	20 - 7F	PERFORMANCE NAME	32...127(ASCII CHARACTER)	depends on performance number
pp 0C	01	00 - 7F	PERFORMANCE VOLUME	0...127	"
pp 0D	01	01 - 7F	PERFORMANCE PAN	L63...C...R63(1...64...127)	"
pp 0E	01	00 - 60	AC1 CC NUMBER	0...95,CAT	"
pp 0F	01	00 - 01	A/D INPUT	OFF , ON	"
pp 10	01	00 - 7F	MW LFO PMOD DEPTH	0...127	"
pp 11	01	00 - 7F	MW LFO FMOD DEPTH	0...127	"
pp 12	01	28 - 58	BEND PITCH CONTROL	-24...0...+24[semitones]	"
pp 13	01	00 - 7F	AC1 FILTER CONTROL	-64...0...+63	"
pp 14	01	00 - 7F	AC1 AMPLITUDE CONTROL	-100...0...+100[%]	"
pp 15	01	00 - 7F	AC1 LFO FMOD DEPTH	0...127	"
pp 16	01	00 - 01	PORTAMENTO SWITCH	OFF , ON(0, 1)	"
pp 17	01	00 - 7F	PORTAMENTO TIME	0...127	"

TOTAL SIZE 18

40	pp 20	2	00-7F	REVERB TYPE MSB	Refer to the Effect Program List	depends on performance number
	pp 21		00-7F	REVERB TYPE LSB	"	"
	pp 22	1	00-7F	REVERB PARAMETER 1	"	"
	pp 23	1	00-7F	REVERB PARAMETER 2	"	"
	pp 24	1	00-7F	REVERB PARAMETER 3	"	"
	pp 25	1	00-7F	REVERB PARAMETER 4	"	"
	pp 26	1	00-7F	REVERB PARAMETER 5	"	"
	pp 27	1	00-7F	REVERB RETURN	-∞dB...0dB...+6dB(0...96...127)	"
	pp 28	1	01-7F	REVERB PAN	L63...C...R63	"
	pp 29	2	00-7F	CHORUS TYPE MSB	Refer to the Effect Program List	"
	pp 2A		00-7F	CHORUS TYPE LSB	"	"
	pp 2B	1	00-7F	CHORUS PARAMETER 1	"	"
	pp 2C	1	00-7F	CHORUS PARAMETER 2	"	"
	pp 2D	1	00-7F	CHORUS PARAMETER 3	"	"
	pp 2E	1	00-7F	CHORUS PARAMETER 4	"	"
	pp 2F	1	00-7F	CHORUS PARAMETER 5	"	"
	pp 30	1	00-7F	CHORUS RETURN	-∞dB...0dB...+6dB(0...96...127)	"
	pp 31	1	01-7F	CHORUS PAN	L63...C...R63	"
	pp 32	1	00-7F	SEND CHORUS TO REVERB	-∞dB...0dB...+6dB(0...96...127)	"
	pp 33	2	00-7F	VARIATION TYPE MSB	Refer to the Effect Program List	"
	pp 34		00-7F	VARIATION TYPE LSB	"	"
	pp 35	2	00-7F	VARIATION PARAMETER 1 MSB	"	"
	pp 36		00-7F	VARIATION PARAMETER 1 LSB	"	"
	pp 37	2	00-7F	VARIATION PARAMETER 2 MSB	"	"
	pp 38		00-7F	VARIATION PARAMETER 2 LSB	"	"
	pp 39	2	00-7F	VARIATION PARAMETER 3 MSB	"	"
	pp 3A		00-7F	VARIATION PARAMETER 3 LSB	"	"
	pp 3B	2	00-7F	VARIATION PARAMETER 4 MSB	"	"
	pp 3C		00-7F	VARIATION PARAMETER 4 LSB	"	"
	pp 3D	2	00-7F	VARIATION PARAMETER 5 MSB	"	"
	pp 3E		00-7F	VARIATION PARAMETER 5 LSB	"	"
	pp 3F	2	00-7F	VARIATION PARAMETER 10 MSB	"	"
	pp 40		00-7F	VARIATION PARAMETER 10 LSB	"	"
	pp 41	1	00-7F	VARIATION RETURN	-∞dB...0dB...+6dB(0...96...127)	"
	pp 42	1	01-7F	VARIATION PAN	L63...C...R63(1...64...127)	"
	pp 43	1	00-7F	SEND VARIATION TO REVERB	-∞dB...0dB...+6dB(0...96...127)	"
	pp 44	1	00-7F	SEND VARIATION TO CHORUS	-∞dB...0dB...+6dB(0...96...127)	"
	pp 45	1	00-7F	AC1 VARIATION CONTROL DEPTH	0...127	"
	pp 46	1	00-01	VARIATION CONNECTION	INSERTION , SYSTEM	"
	pp 47	1	00-03,7F	VARIATION PART	Part1...4(0...3) AD1, AD2(64, 65) OFF(127)	"
TOTAL SIZE		28				

40	pp 70	1	00 - 04	EQ TYPE	flat,jazz,pops,rock,concert	depends on performance number
	pp 71	1	34 - 4C	EQ GAIN1	-12...0...+12[dB]	"
	pp 72	1	34 - 4C	EQ GAIN2	-12...0...+12[dB]	"
	pp 73	1	34 - 4C	EQ GAIN3	-12...0...+12[dB]	"
	pp 74	1	34 - 4C	EQ GAIN4	-12...0...+12[dB]	"
	pp 75	1	34 - 4C	EQ GAIN5	-12...0...+12[dB]	"
TOTAL SIZE		06				

50	pp 00	2	00-7F	INSERTION EFFECT 1 TYPE MSB	Refer to the Effect Program List	depends on performance number
	pp 01		00-7F	INSERTION EFFECT 1 TYPE LSB	"	"
	pp 02	2	00-7F	INSERTION EFFECT 1 PARAMETER1 MSB	"	"
	pp 03		00-7F	INSERTION EFFECT 1 PARAMETER1 LSB	"	"
	pp 04	2	00-7F	INSERTION EFFECT 1 PARAMETER2 MSB	"	"
	pp 05		00-7F	INSERTION EFFECT 1 PARAMETER2 LSB	"	"
	pp 06	2	00-7F	INSERTION EFFECT 1 PARAMETER3 MSB	"	"
	pp 07		00-7F	INSERTION EFFECT 1 PARAMETER3 LSB	"	"
	pp 08	2	00-7F	INSERTION EFFECT 1 PARAMETER4 MSB	"	"
	pp 09		00-7F	INSERTION EFFECT 1 PARAMETER4 LSB	"	"
	pp 0A	2	00-7F	INSERTION EFFECT 1 PARAMETERS5 MSB	"	"
	pp 0B		00-7F	INSERTION EFFECT 1 PARAMETERS5 LSB	"	"
	pp 0C	2	00-7F	INSERTION EFFECT 1 PARAMETER10 MSB	"	"
	pp 0D		00-7F	INSERTION EFFECT 1 PARAMETER10 LSB	"	"
	pp 0E	1	00-7F	INSERTION EFFECT 1 PART	Part1...4(0...3) AD1, AD2(64, 65) OFF(127)	"
TOTAL SIZE		0F				

51	pp 00	2	00-7F	INSERTION EFFECT 2 TYPE MSB	Refer to the Effect Program List	depends on performance number
	pp 01		00-7F	INSERTION EFFECT 2 TYPE LSB	"	"
	pp 02	2	00-7F	INSERTION EFFECT 2 PARAMETER1 MSB	"	"
	pp 03		00-7F	INSERTION EFFECT 2 PARAMETER1 LSB	"	"
	pp 04	2	00-7F	INSERTION EFFECT 2 PARAMETER2 MSB	"	"
	pp 05		00-7F	INSERTION EFFECT 2 PARAMETER2 LSB	"	"
	pp 06	2	00-7F	INSERTION EFFECT 2 PARAMETER3 MSB	"	"
	pp 07		00-7F	INSERTION EFFECT 2 PARAMETER3 LSB	"	"
	pp 08	2	00-7F	INSERTION EFFECT 2 PARAMETER4 MSB	"	"
	pp 09		00-7F	INSERTION EFFECT 2 PARAMETER4 LSB	"	"
	pp 0A	2	00-7F	INSERTION EFFECT 2 PARAMETER5 MSB	"	"
	pp 0B		00-7F	INSERTION EFFECT 2 PARAMETER5 LSB	"	"
	pp 0C	2	00-7F	INSERTION EFFECT 2 PARAMETER10 MSB	"	"
	pp 0D		00-7F	INSERTION EFFECT 2 PARAMETER10 LSB	"	"
	pp 0E	1	00-7F	INSERTION EFFECT 2 PART	Part1...4(0...3) AD1, AD2(64, 65) OFF(127)	"
TOTAL SIZE		0F				

EFFECT PROGRAM LIST (エフェクトプログラムリスト)

MU90R A/D INPUT PRESET

BANK LSB	Source	Preset Name	input gain	var type	A/D1	A/D2	PGM CNG# = 0	1	2	3	4	5	6	7	8	9	10	11	12	
0	MIC	Mic	mic	.	Off	mic	Chorus+Reverb	Chorus	Reverb	Chorus	Chorus	Chorus+Reverb	Karaoke1	Karaoke2	Karaoke3	Echo	Vocal	Studio	Oct Up	Oct Down
1	GUITAR (注1)	Guitar	mic	.	Off	mic	Chorus+Reverb	Chorus	Reverb	Chorus	Chorus	Chorus+Reverb	Karaoke1	Karaoke2	Karaoke3	Echo	Funk Gtr	Tremolo	Phaser	5th Guitar
2	KEYBOARD	Keyboard	line	.	Off	line	Chorus+Reverb	Chorus	Reverb	Chorus	Chorus	Chorus+Reverb	Phaser EP	Pan EP	Wah Clavi	Rotary Orgn	Synth Str	Synth Pad	Synth Lead	SFX
3	AUDIO (注2)	Audio	line	.	Off	line	Chorus+Reverb	Chorus	Reverb	Chorus	Chorus	Chorus+Reverb	Phaser EP	Pan EP	Wah Clavi	Rotary Orgn	Synth Str	Synth Pad	Synth Lead	SFX
18	STEREO KEYBOARD (注3)	Keyboard	line	.	Off	line	Chorus+Reverb	Chorus	Reverb	Chorus	Chorus	Chorus+Reverb	Phaser EP	Pan EP	Wah Clavi	Rotary Orgn	Synth Str	Synth Pad	Synth Lead	SFX
19	STEREO AUDIO (注3)	Audio	line	.	Off	line	Chorus+Reverb	Chorus	Reverb	Chorus	Chorus	Chorus+Reverb	Phaser EP	Pan EP	Wah Clavi	Rotary Orgn	Synth Str	Synth Pad	Synth Lead	SFX

(Note 1) The input may be distorted depending on the guitar that you use. Make adjustments using either the A/D INPUT VOLUME or the volume of your guitar.

(Note 2) For AUDIO, A/D1 is panned to the left channel, and A/D2 is panned to the right channel.

(Note 3) The stereo setting can be selected only for A/D1.

The A/D1 and A/D2 inputs are handled as the left and right channels respectively of a stereo signal.

REVERB

No.	MSB	LSB	Effect Type	Features
0	00H	00H	NO EFFECT	Effect is off
1	01H	00H	HALL 1	Reverb simulating the reverberance of a hall
2	01H	01H	HALL 2	"
3	02H	00H	ROOM 1	Reverb simulating the reverberance of a room
4	02H	01H	ROOM 2	"
5	02H	02H	ROOM 3	"
6	03H	00H	STAGE 1	Reverb suitable for solo instruments
7	03H	01H	STAGE 2	"
8	04H	00H	PLATE	Reverb simulating a metal plate reverb device
9	10H	00H	WHITE ROOM	Unique short reverb with a slight initial delay
10	11H	00H	TUNNEL	Simulation of a cylindrical space extending to left and right
11	12H	00H	CANYON	Simulation of an imaginary sound space extending without limits
12	13H	00H	BASEMENT	Reverb with unique resonance after a slight initial delay

CHORUS

No.	MSB	LSB	Effect Type	Features
0	00H	00H	NO EFFECT	Effect is off
1	41H	00H	CHORUS 1	Standard chorus effect. Gives the sound a natural spaciousness.
2	41H	01H	CHORUS 2	"
3	41H	02H	CHORUS 3	"
4	41H	08H	CHORUS 4	"
5	42H	00H	CELESTE 1	This effect uses a three-phase LFO to create modulation and spaciousness
6	42H	01H	CELESTE 2	"
7	42H	02H	CELESTE 3	"
8	42H	08H	CELESTE 4	"
9	43H	00H	FLANGER 1	An effect reminiscent of a jet airplane
10	43H	01H	FLANGER 2	"
11	43H	08H	FLANGER 3	"
12	44H	00H	SYMPHONIC	Additional stages are added to the modulation of CELESTE
13	57H	00H	ENSEMBLE DETUNE	A chorus effect without modulation created by adding a slightly pitch-shifted sound
14	48H	00H	PHASER 1	Adds modulation by cyclically changing the phase

VARIATION

No.	MSB	LSB	Effect Type	Features
0	00H	00H	NO EFFECT	Effect is off
1	01H	00H	HALL 1	Reverb simulating the reverberance of a hall
2	01H	01H	HALL 2	"
3	02H	00H	ROOM 1	Reverb simulating the reverberance of a room
4	02H	01H	ROOM 2	"
5	02H	02H	ROOM 3	"
6	03H	00H	STAGE 1	Reverb suitable for solo instruments
7	03H	01H	STAGE 2	"
8	04H	00H	PLATE	Reverb simulating a metal plate reverb unit
9	10H	00H	WHITE ROOM	Unique short reverb with a slight initial delay
10	11H	00H	TUNNEL	Simulation of a cylindrical space extending to left and right
11	12H	00H	CANYON	Simulation of an imaginary sound space extending without limits
12	13H	00H	BASEMENT	Reverb with unique resonance after a slight initial delay
13	05H	00H	DELAY L,C,R	An effect which generates three delays: L, R and C (center)
14	06H	00H	DELAY L,R	An effect which generates two delays, L and R, and provides two feedback delays
15	07H	00H	ECHO	Two delays (L and R) and independent feedback for L and R
16	08H	00H	CROSS DELAY	This effect crosses the feedback of two delays
17	09H	00H	ER 1	An effect which produces only the early reflections of reverb
18	09H	01H	ER 2	"
19	0AH	00H	GATE REVERB	Simulation of gated reverb
20	0BH	00H	REVERSE GATE	Simulation of gated reverb played backward
21	14H	00H	KARAOKE 1	Echo for karaoke
22	14H	01H	KARAOKE 2	"
23	14H	02H	KARAOKE 3	"
24	41H	00H	CHORUS 1	Standard chorus effect. Adds natural spaciousness.
25	41H	01H	CHORUS 2	"
26	41H	02H	CHORUS 3	"
27	41H	08H	CHORUS 4	"
28	42H	00H	CELESTE 1	An effect which uses a 3-phase LFO to add modulation and spaciousness
29	42H	01H	CELESTE 2	"
30	42H	02H	CELESTE 3	"
31	42H	08H	CELESTE 4	"
32	43H	00H	FLANGER 1	An effect reminiscent of a jet airplane
33	43H	01H	FLANGER 2	"
34	43H	08H	FLANGER 3	"
35	44H	00H	SYMPHONIC	Additional stages are added to the modulation of CELESTE
36	57H	00H	ENSEMBLE DETUNE	A chorus effect without modulation created by adding a slightly pitch-shifted sound
37	58H	00H	AMBIENCE	An effect that blurs the location of the sound to add spatial width
38	45H	00H	ROTARY SPEAKER	Simulation of a rotary speaker. AC1 (assignable controller 1) etc. can be used to control the speed of rotation.
39	56H	00H	2WAY ROTARY SPEAKER	Simulation of a rotary speaker. AC1 (assignable controller 1) etc. can be used to control the speed of rotation.

40	46H	00H	TREMOLO	An effect which cyclically modulates the volume
41	47H	00H	AUTO PAN	An effect which cyclically moves the sound left/right and front/back
42	48H	00H	PHASER 1	Cyclically changes the phase to add modulation
43	48H	08H	PHASER 2	"
44	49H	00H	DISTORTION	Adds a hard-edged distortion. A noise gate is provided, making this suitable for use with A/D input as well.
45	49H	01H	COMP+DISTORTION	Since a compressor is provided in the initial stage, even distortion is produced regardless of the input level.
46	4AH	00H	OVER DRIVE	Adds mild distortion. A noise gate is provided, making this suitable for use with A/D input as well.
47	4BH	00H	AMP SIMULATOR	Simulates a guitar amp. A noise gate is provided, making this suitable for use with A/D input as well.
48	4CH	00H	3BAND EQ(MONO)	Mono EQ with low, mid and high equalization
49	4DH	00H	2BAND EQ(STEREO)	Stereo EQ with low and high equalization. Ideal for the drum part.
50	4EH	00H	AUTO WAH(LFO)	Cyclically changes the center frequency of a wah filter. Can be used with AC1 etc. as a pedal wah.
51	4EH	01H	AUTO WAH+DIST	The output of AUTO WAH is distorted by DISTORTION. Can be used with AC1 etc. as a pedal wah.
52	4EH	02H	AUTO WAH+ODRV	The output of AUTO WAH is distorted by OVERDRIVE. Can be used with AC1 etc. as a pedal wah.
53	52H	00H	TOUCH WAH 1	The level of the input will modify the center frequency of the wah filter. Can be used with AC1 etc. as a pedal wah.
54	52H	01H	TOUCH WAH+DIST	The output of TOUCH WAH is distorted by DISTORTION. Can be used with AC1 etc. as a pedal wah.
55	52H	02H	TOUCH WAH+ODRV	The output of TOUCH WAH is distorted by OVERDRIVE. Can be used with AC1 etc. as a pedal wah.
56	52H	08H	TOUCH WAH 2	The level of the input will modify the center frequency of the wah filter. Can be used with AC1 etc. as a pedal wah.
57	50H	00H	PITCH CHANGE 1	This effect changes the pitch of the input signal.
58	50H	01H	PITCH CHANGE 2	"
59	51H	00H	AURAL EXCITER®	This effect adds new overtones to the input signal to make it stand out.
60	53H	00H	COMPRESSOR	Limits the output when the input signal exceeds a specified level. Can also add a sense of attack to the sound.
61	54H	00H	NOISE GATE	Gates the input when the input signal falls below a specified level. Effective when you wish to suppress noise from the A/D input.
62	55H	00H	VOICE CANCEL	Attenuates the vocal part of a recording on CD etc.
63	40H	00H	THRU	Bypass without applying an effect

Aural Exciter ® is a registered trademark of Aphex Corporation.

INSERTION1,2

No.	MSB	LSB	Effect Type	Features
0	40H	00H	THRU	Bypass without applying an effect
1	01H	00H	HALL 1	Reverb simulating the reverberance of a hall
2	01H	01H	HALL 2	"
3	02H	00H	ROOM 1	Reverb simulating the reverberance of a room
4	02H	01H	ROOM 2	"
5	02H	02H	ROOM 3	"
6	03H	00H	STAGE 1	Reverb suitable for solo instruments
7	03H	01H	STAGE 2	"
8	04H	00H	PLATE	Reverb simulating a metal plate reverb unit
9	05H	00H	DELAY L,C,R	An effect which generates three delays: L, R and C (center)
10	06H	00H	DELAY L,R	An effect which generates two delays, L and R, and provides two feedback delays
11	07H	00H	ECHO	Two delays (L and R) and independent feedback for L and R
12	08H	00H	CROSS DELAY	This effect crosses the feedback of two delays
13	14H	00H	KARAOKE 1	Echo for karaoke
14	14H	01H	KARAOKE 2	"
15	14H	02H	KARAOKE 3	"
16	41H	00H	CHORUS 1	Standard chorus effect. Adds natural spaciousness.
17	41H	01H	CHORUS 2	"
18	41H	02H	CHORUS 3	"
19	41H	08H	CHORUS 4	"
20	42H	00H	CELESTE 1	An effect which uses a 3-phase LFO to add modulation and spaciousness
21	42H	01H	CELESTE 2	"
22	42H	02H	CELESTE 3	"
23	42H	08H	CELESTE 4	"
24	43H	00H	FLANGER 1	An effect reminiscent of a jet airplane
25	43H	01H	FLANGER 2	"
26	43H	08H	FLANGER 3	"
27	44H	00H	SYMPHONIC	Additional stages are added to the modulation of CELESTE
28	57H	00H	ENSEMBLE DETUNE	A chorus effect without modulation created by adding a slightly pitch-shifted sound
29	45H	00H	ROTARY SPEAKER	Simulation of a rotary speaker. AC1 (assignable controller 1) etc. can be used to control the speed of rotation.
30	46H	00H	TREMOLO	An effect which cyclically modulates the volume
31	47H	00H	AUTO PAN	An effect which cyclically moves the sound left/right and front/back
32	48H	00H	PHASER 1	Cyclically changes the phase to create modulation
33	49H	00H	DISTORTION	Adds a hard-edged distortion
34	4AH	00H	OVER DRIVE	Adds mild distortion
35	4BH	00H	AMP SIMULATOR	Simulates a guitar amp
36	4CH	00H	3BAND EQ(MONO)	Mono EQ with low, mid and high equalization
37	4DH	00H	2BAND EQ(STEREO)	Stereo EQ with low and high equalization. Ideal for the drum part.
38	4EH	00H	AUTO WAH(LFO)	Cyclically changes the center frequency of a wah filter. Can be used with AC1 etc. as a pedal wah.
39	52H	00H	TOUCH WAH 1	The level of the input will modify the center frequency of the wah filter. Can be used with AC1 etc. as a pedal wah.
40	52H	08H	TOUCH WAH 2	The level of the input will modify the center frequency of the wah filter. Can be used with AC1 etc. as a pedal wah.
41	51H	00H	AURAL EXCITER®	This effect adds new overtones to the input signal to make it stand out.
42	53H	00H	COMPRESSOR	Limits the output when the input signal exceeds a specified level. Can also add a sense of attack to the sound.
43	54H	00H	NOISE GATE	Gates the input when the input signal falls below a specified level. Effective when you wish to suppress noise from the A/D input.

Aural Exciter ® is a registered trademark of Aphex Corporation.

REVERB TYPE

TYPE MSB		TYPE LSB				
DEC	HEX	00	01	02	...	08
000	0	NO EFFECT				
001	1	HALL 1	HALL 2			
002	2	ROOM 1	ROOM 2	ROOM 3		
003	3	STAGE 1	STAGE 2			
004	4	PLATE				
005	5	NO EFFECT				
:	:	:				
015	F	NO EFFECT				
016	10	WHITE ROOM				
017	11	TUNNEL				
018	12	CANYON				
019	13	BASEMENT				
020	14	NO EFFECT				
:	:	:				
127	7F	NO EFFECT				

NO EFFECT
Same as basic effects (LSB=00)

CHORUS TYPE

TYPE MSB		TYPE LSB				
DEC	HEX	00	01	02	...	08
000	0	NO EFFECT				
001	1	NO EFFECT				
:	:	:				
064	40	NO EFFECT				
065	41	CHORUS 1	CHORUS 2	CHORUS 3		CHORUS 4
066	42	CELESTE 1	CELESTE 2	CELESTE 3		CELESTE 4
067	43	FLANGER 1	FLANGER 2			FLANGER 3
068	44	SYMPHONIC				
069	45	NO EFFECT				
:	:	:				
071	47	NO EFFECT				
072	48	PHASER 1				
073	49	NO EFFECT				
:	:	:				
086	56	NO EFFECT				
087	57	ENSEMBLE DETUNE				
088	58	NO EFFECT				
:	:	:				
127	7F	NO EFFECT				

NO EFFECT
Same as basic effects (LSB=00)

VARIATION TYPE (0-63)

TYPE MSB		TYPE LSB				
DEC	HEX	00	01	02	...	08
000	0	NO EFFECT				
001	1	HALL 1	HALL 2			
002	2	ROOM 1	ROOM 2	ROOM 3		
003	3	STAGE 1	STAGE 2			
004	4	PLATE				
005	5	DELAY L,C,R				
006	6	DELAY L,R				
007	7	ECHO				
008	8	CROSS DELAY				
009	9	ER 1	ER 2			
010	A	GATE REVERB				
011	B	REVERSE GATE				
012	C	NO EFFECT or THRU				
:	:	:				
015	F	NO EFFECT or THRU				
016	10	WHITE ROOM				
017	11	TUNNEL				
018	12	CANYON				
019	13	BASEMENT				
020	14	KARAOKE 1	KARAOKE 2	KARAOKE 3		
021	15	NO EFFECT or THRU				
:	:	:				
063	3F	NO EFFECT or THRU				

NO EFFECT (for SYS) or THRU (for INS)
Same as basic effects (LSB=00)

VARIATION TYPE (64-127)

TYPE MSB		TYPE LSB					
DEC	HEX	00	01	02	...	08	
064	40	THRU					
065	41	CHORUS 1	CHORUS 2	CHORUS 3		CHORUS 4	
066	42	CELESTE 1	CELESTE 2	CELESTE 3		CELESTE 4	
067	43	FLANGER 1	FLANGER 2			FLANGER 3	
068	44	SYMPHONIC					
069	45	ROTARY SPEAKER					
070	46	TREMOLO					
071	47	AUTO PAN					
072	48	PHASER 1				PHASER 2	
073	49	DISTORTION	COMP+DISTORTION				
074	4A	OVER DRIVE					
075	4B	AMP SIMULATOR					
076	4C	3-BAND EQ					
077	4D	2-BAND EQ					
078	4E	AUTO WAH(LFO)	AUTO WAH+DIST	AUTO WAH+OVERDRIVE			
079	4F	THRU					
080	50	PITCH CHANGE	PITCH CHANGE2				
081	51	AURAL EXCITER®					
082	52	TOUCH WAH 1	TOUCH WAH+DIST	TOUCH WAH+OVERDRIVE		TOUCH WAH 2	
083	53	COMPRESSOR					
084	54	NOISE GATE					
085	55	VOICE CANCEL					
086	56	2WAY ROTARY SPEAKER					
087	57	ENSEMBLE DETUNE					
088	58	AMBIENCE					
089	59	THRU					
:	:	:					
127	7F	THRU					

THRU
Same as basic effects (LSB=00)

INSERTION EFFECT TYPE

TYPE MSB		TYPE LSB					
DEC	HEX	00	01	02	...	08	
000	0	THRU					
001	1	HALL 1	HALL 2				
002	2	ROOM 1	ROOM 2	ROOM 3			
003	3	STAGE 1	STAGE 2				
004	4	PLATE					
005	5	DELAY L,C,R					
006	6	DELAY L,R					
007	7	ECHO					
008	8	CROSS DELAY					
009	9	THRU					
:	:	:					
019	13	THRU					
020	14	KARAOKE 1	KARAOKE 2	KARAOKE 3			
021	15	THRU					
:	:	:					
063	3F	THRU					
064	40	THRU					
065	41	CHORUS 1	CHORUS 2	CHORUS 3		CHORUS 4	
066	42	CELESTE 1	CELESTE 2	CELESTE 3		CELESTE 4	
067	43	FLANGER 1	FLANGER 2			FLANGER 3	
068	44	SYMPHONIC					
069	45	ROTARY SPEAKER					
070	46	TREMOLO					
071	47	AUTO PAN					
072	48	PHASER 1					
073	49	DISTORTION					
074	4A	OVER DRIVE					
075	4B	AMP SIMULATOR					
076	4C	3BAND EQ					
077	4D	2-BAND EQ					
078	4E	AUTO WAH(LFO)					
079	4F	THRU					
080	50	THRU					
081	51	AURAL EXCITER®					
082	52	TOUCH WAH 1				TOUCH WAH 2	
083	53	COMPRESSOR					
084	54	NOISE GATE					
085	55	THRU					
086	56	THRU					
087	57	ENSEMBLE DETUNE					
088	58	THRU					
:	:	:					
127	7F	THRU					

THRU
Same as basic effects (LSB=(X))

Aural Exciter ® is a registered trademark of Aphex Corporation.

EFFECT PARAMETER LIST (エフェクトパラメータリスト)

HALL1,HALL2
ROOM1,ROOM2,ROOM3
STAGE1,STAGE2
PLATE (reverb, variation, insertion1,2 block)

No.	Parameter	Display	Value	See Table	Control
1	Reverb Time	0.3~30.0s	0-69	table#4	
2	Diffusion	0~10	0-10		
3	Initial Delay	0~63	0-63	table#5	
4	HPF Cutoff	Thru~8.0kHz	0-52	table#3	
5	LPF Cutoff	1.0k~Thru	34-60	table#3	
6					
7					
8					
9					
10	Dry/Wet	D63>W - D=W - D<W63	1-127		●
11	Rev Delay	0~63	0-63	table#5	
12	Density	0~4 (reverb, variation block) 0~2 (insertion1,2 block)	0-4		
13	Er/Rev Balance	E63>R - E=R - E<R63	1-127		
14	High Damp	0.1~1.0	1-10		
15	Feedback Level	-63~+63	1-127		
16					

DELAY L,C,R (variation, insertion1,2 block)

No.	Parameter	Display	Value	See Table	Control
1	Lch Delay	0.1~1486.0ms (variation block) 0.1~742.9ms (insertion1,2 block)	1-14860 1-7429		
2	Rch Delay	0.1~1486.0ms (variation block) 0.1~742.9ms (insertion1,2 block)	1-14860 1-7429		
3	Cch Delay	0.1~1486.0ms (variation block) 0.1~742.9ms (insertion1,2 block)	1-14860 1-7429		
4	Feedback Delay	0.1~1486.0ms (variation block) 0.1~742.9ms (insertion1,2 block)	1-14860 1-7429		
5	Feedback Level	-63~+63	1-127		
6	Cch Level	0~127	0-127		
7	High Damp	0.1~1.0	1-10		
8					
9					
10	Dry/Wet	D63>W - D=W - D<W63	1-127		●
11					
12					
13	EQ Low Frequency	32Hz~2.0kHz	4-40	table#3	
14	EQ Low Gain	-12~+12dB	52-76		
15	EQ High Frequency	500Hz~16.0kHz	28-58	table#3	
16	EQ High Gain	-12~+12dB	52-76		

ECHO (variation, insertion1,2 block)

No.	Parameter	Display	Value	See Table	Control
1	Lch Delay1	0.1~743.0ms (variation block) 0.1~371.4ms (insertion1,2 block)	1-7430 1-3714		
2	Lch Feedback Level	-63~+63	1-127		
3	Rch Delay1	0.1~743.0ms (variation block) 0.1~371.4ms (insertion1,2 block)	1-7430 1-3714		
4	Rch Feedback Level	-63~+63	1-127		
5	High Damp	0.1~1.0	1-10		
6	Lch Delay2	0.1~743.0ms (variation block) 0.1~371.4ms (insertion1,2 block)	1-7430 1-3714		
7	Rch Delay2	0.1~743.0ms (variation block) 0.1~371.4ms (insertion1,2 block)	1-7430 1-3714		
8	Delay2 Level	0~127	0-127		
9					
10	Dry/Wet	D63>W - D=W - D<W63	1-127		●
11					
12					
13	EQ Low Frequency	32Hz~2.0kHz	4-40	table#3	
14	EQ Low Gain	-12~+12dB	52-76		
15	EQ High Frequency	500Hz~16.0kHz	28-58	table#3	
16	EQ High Gain	-12~+12dB	52-76		

EARLY REF1,EARLY REF2 (variation block)

No.	Parameter	Display	Value	See Table	Control
1	Type	S-H, L-H, Rdm, Rvs, Plt, Spr	0-5		
2	Room Size	0.1~7.0	0-44	table#6	
3	Diffusion	0~10	0-10		
4	Initial Delay	0~63	0-63	table#5	
5	Feedback Level	-63~+63	1-127		
6	HPF Cutoff	Thru~8.0kHz	0-52	table#3	
7	LPF Cutoff	1.0k~Thru	34-60	table#3	
8					
9					
10	Dry/Wet	D63>W - D=W - D<W63	1-127		●
11	Liveness	0~10	0-10		
12	Density	0~3	0-3		
13	High Damp	0.1~1.0	1-10		
14					
15					
16					

WHITE ROOM
TUNNEL
CANYON
BASEMENT (reverb, variation block)

No.	Parameter	Display	Value	See Table	Control
1	Reverb Time	0.3~30.0s	0-69	table#4	
2	Diffusion	0~10	0-10		
3	Initial Delay	0~63	0-63	table#5	
4	HPF Cutoff	Thru~8.0kHz	0-52	table#3	
5	LPF Cutoff	1.0k~Thru	34-60	table#3	
6	Width	0.5~10.2m	0-37	table#11	
7	Height	0.5~20.2m	0-73	table#11	
8	Depth	0.5~30.2m	0-104	table#11	
9	Wall Vary	0~30	0-30		
10	Dry/Wet	D63>W - D=W - D<W63	1-127		●
11	Rev Delay	0~63	0-63	table#5	
12	Density	0~4	0-4		
13	Er/Rev Balance	E63>R - E=R - E<R63	1-127		
14	High Damp	0.1~1.0	1-10		
15	Feedback Level	-63~+63	1-127		
16					

DELAY L,R (variation, insertion1,2 block)

No.	Parameter	Display	Value	See Table	Control
1	Lch Delay	0.1~1486.0ms (variation block) 0.1~742.9ms (insertion1,2 block)	1-14860 1-7429		
2	Rch Delay	0.1~1486.0ms (variation block) 0.1~742.9ms (insertion1,2 block)	1-14860 1-7429		
3	Feedback Delay 1	0.1~1486.0ms (variation block) 0.1~742.9ms (insertion1,2 block)	1-14860 1-7429		
4	Feedback Delay 2	0.1~1486.0ms (variation block) 0.1~742.9ms (insertion1,2 block)	1-14860 1-7429		
5	Feedback Level	-63~+63	1-127		
6	High Damp	0.1~1.0	1-10		
7					
8					
9					
10	Dry/Wet	D63>W - D=W - D<W63	1-127		●
11					
12					
13	EQ Low Frequency	32Hz~2.0kHz	4-40	table#3	
14	EQ Low Gain	-12~+12dB	52-76		
15	EQ High Frequency	500Hz~16.0kHz	28-58	table#3	
16	EQ High Gain	-12~+12dB	52-76		

CROSS DELAY (variation, insertion1,2 block)

No.	Parameter	Display	Value	See Table	Control
1	L->R Delay	0.1~743.0ms (variation block) 0.1~371.4ms (insertion1,2 block)	1-7430 1-3714		
2	R->L Delay	0.1~743.0ms (variation block) 0.1~371.4ms (insertion1,2 block)	1-7430 1-3714		
3	Feedback Level	-63~+63	1-127		
4	Input Select	L,R,L&R	0-2		
5	High Damp	0.1~1.0	1-10		
6					
7					
8					
9					
10	Dry/Wet	D63>W - D=W - D<W63	1-127		●
11					
12					
13	EQ Low Frequency	32Hz~2.0kHz	4-40	table#3	
14	EQ Low Gain	-12~+12dB	52-76		
15	EQ High Frequency	500Hz~16.0kHz	28-58	table#3	
16	EQ High Gain	-12~+12dB	52-76		

GATE REVERB
REVERSE GATE (variation block)

No.	Parameter	Display	Value	See Table	Control
1	Type	TypeA,TypeB	0-1		
2	Room Size	0.1~20.0	0-127	table#6	
3	Diffusion	0~10	0-10		
4	Initial Delay	0~127	0-127	table#5	
5	Feedback Level	-63~+63	1-127		
6	HPF Cutoff	Thru~8.0kHz	0-52	table#3	
7	LPF Cutoff	1.0k~Thru	34-60	table#3	
8					
9					
10	Dry/Wet	D63>W - D=W - D<W63	1-127		●
11	Liveness	0~10	0-10		
12	Density	0~3	0-3		
13	High Damp	0.1~1.0	1-10		
14					
15					
16					

KARAOKE1,2,3 (variation, insertion1,2 block)

No.	Parameter	Display	Value	See Table	Control
1	Delay Time	0-127	0-127	table#7	
2	Feedback Level	-63~+63	1-127		
3	HPF Cutoff	Thru~8.0kHz	0-52	table#3	
4	LPF Cutoff	1.0k~Thru	34-60	table#3	
5					
6					
7					
8					
9					
10	Dry/Wet	D63>W - D=W - D<W63	1-127		●
11					
12					
13					
14					
15					
16					

FLANGER1,2,3 (chorus, variation, insertion1,2 block)

No.	Parameter	Display	Value	See Table	Control
1	LFO Frequency	0.00Hz~39.7Hz	0-127	table#1	
2	LFO Depth	0-127	0-127		
3	Feedback Level	-63~+63	1-127		
4	Delay Offset	0-63	0-63	table#2	
5					
6	EQ Low Frequency	32Hz~2.0kHz	4-40	table#3	
7	EQ Low Gain	-12~+12dB	52-76		
8	EQ High Frequency	500Hz~16.0kHz	28-58	table#3	
9	EQ High Gain	-12~+12dB	52-76		
10	Dry/Wet	D63>W - D=W - D<W63	1-127		●
11	EQ Mid Frequency	100Hz~10.0kHz (variation block)	14-54	table#3	
12	EQ Mid Gain	-12~+12dB (variation block)	52-76		
13	EQ Mid Width	1.0~12.0 (variation block)	10-120		
14	LFO Phase Difference	-180~+180deg	4-124	resolution=3deg.	
15					
16					

ENSEMBLE DETUNE (chorus, variation, insertion1,2 block)

No.	Parameter	Display	Value	See Table	Control
1	Detune	-50~+50cent	14-114		
2	Lch Init Delay	0-127	0-127	table#2	
3	Rch Init Delay	0-127	0-127	table#2	
4					
5					
6					
7					
8					
9					
10	Dry/Wet	D63>W - D=W - D<W63	1-127		●
11	EQ Low Frequency	32Hz~2.0kHz (variation, insertion1,2 block)	4-40	table#3	
12	EQ Low Gain	-12~+12dB (variation, insertion1,2 block)	52-76		
13	EQ High Frequency	500Hz~16.0kHz (variation, insertion1,2 block)	28-58	table#3	
14	EQ High Gain	-12~+12dB (variation, insertion1,2 block)	52-76		
15					
16					

ROTARY SPEAKER (variation, insertion1,2 block)

No.	Parameter	Display	Value	See Table	Control
1	LFO Frequency	0.00Hz~39.7Hz	0-127	table#1	●
2	LFO Depth	0-127	0-127		
3					
4					
5					
6	EQ Low Frequency	32Hz~2.0kHz	4-40	table#3	
7	EQ Low Gain	-12~+12dB	52-76		
8	EQ High Frequency	500Hz~16.0kHz	28-58	table#3	
9	EQ High Gain	-12~+12dB	52-76		
10	Dry/Wet	D63>W - D=W - D<W63	1-127		
11	EQ Mid Frequency	100Hz~10.0kHz (variation block)	14-54	table#3	
12	EQ Mid Gain	-12~+12dB (variation block)	52-76		
13	EQ Mid Width	1.0~12.0 (variation block)	10-120		
14					
15					
16					

CHORUS1,2,3,4

CELESTE1,2,3,4 (chorus, variation, insertion1,2 block)

No.	Parameter	Display	Value	See Table	Control
1	LFO Frequency	0.00Hz~39.7Hz	0-127	table#1	
2	LFO Depth	0-127	0-127		
3	Feedback Level	-63~+63	1-127		
4	Delay Offset	0-127	0-127	table#2	
5					
6	EQ Low Frequency	32Hz~2.0kHz	4-40	table#3	
7	EQ Low Gain	-12~+12dB	52-76		
8	EQ High Frequency	500Hz~16.0kHz	28-58	table#3	
9	EQ High Gain	-12~+12dB	52-76		
10	Dry/Wet	D63>W - D=W - D<W63	1-127		●
11	EQ Mid Frequency	100Hz~10.0kHz (variation block)	14-54	table#3	
12	EQ Mid Gain	-12~+12dB (variation block)	52-76		
13	EQ Mid Width	1.0~12.0 (variation block)	10-120		
14					
15	Input Mode	mono/stereo	0-1		
16					

SYMPHONIC (chorus, variation, insertion1,2 block)

No.	Parameter	Display	Value	See Table	Control
1	LFO Frequency	0.00Hz~39.7Hz	0-127	table#1	
2	LFO Depth	0-127	0-127		
3	Delay Offset	0-127	0-127	table#2	
4					
5					
6	EQ Low Frequency	32Hz~2.0kHz	4-40	table#3	
7	EQ Low Gain	-12~+12dB	52-76		
8	EQ High Frequency	500Hz~16.0kHz	28-58	table#3	
9	EQ High Gain	-12~+12dB	52-76		
10	Dry/Wet	D63>W - D=W - D<W63	1-127		●
11	EQ Mid Frequency	100Hz~10.0kHz (variation block)	14-54	table#3	
12	EQ Mid Gain	-12~+12dB (variation block)	52-76		
13	EQ Mid Width	1.0~12.0 (variation block)	10-120		
14					
15					
16					

AMBIENCE (variation block)

No.	Parameter	Display	Value	See Table	Control
1	Delay Time	0-127	0-127	table#2	
2	Output Phase	normal/invers	0-1		
3					
4					
5					
6	EQ Low Frequency	32Hz~2.0kHz	4-40	table#3	
7	EQ Low Gain	-12~+12dB	52-76		
8	EQ High Frequency	500Hz~16.0kHz	28-58	table#3	
9	EQ High Gain	-12~+12dB	52-76		
10	Dry/Wet	D63>W - D=W - D<W63	1-127		●
11					
12					
13					
14					
15					
16					

2WAY ROTARY SPEAKER (variation block)

No.	Parameter	Display	Value	See Table	Control
1	Rotor Speed	0.0Hz~39.7Hz	0-127	table#1	●
2	Drive Low	0-127	0-127		
3	Drive High	0-127	0-127		
4	Low/High	L63>H - L=H - L<H63	1-127		
5					
6	EQ Low Frequency	32Hz~2.0kHz	4-40	table#3	
7	EQ Low Gain	-12~+12dB	52-76		
8	EQ High Frequency	500Hz~16.0kHz	28-58	table#3	
9	EQ High Gain	-12~+12dB	52-76		
10					
11	Crossover Frequency	100Hz~10.0kHz	14-54	table#3	
12	Mic L-R Angle	0deg~180deg	0-60	resolution=3deg.	
13					
14					
15					
16					

TREMOLO (variation, insertion1,2 block)

No.	Parameter	Display	Value	See Table	Control
1	LFO Frequency	0.00Hz~39.7Hz	0-127	table#1	●
2	AM Depth	0~127	0-127		
3	PM Depth	0~127	0-127		
4					
5					
6	EQ Low Frequency	32Hz~2.0kHz	4-40	table#3	
7	EQ Low Gain	-12~+12dB	52-76		
8	EQ High Frequency	500Hz~16.0kHz	28-58	table#3	
9	EQ High Gain	-12~+12dB	52-76		
10					
11	EQ Mid Frequency	100Hz~10.0kHz (variation block)	14-54	table#3	
12	EQ Mid Gain	-12~+12dB (variation block)	52-76		
13	EQ Mid Width	1.0~12.0 (variation block)	10-120		
14	LFO Phase Difference	-180~+180deg	4-124	resolution=3deg.	
15	Input Mode	mono/stereo	0-1		
16					

AUTO PAN (variation, insertion1,2 block)

No.	Parameter	Display	Value	See Table	Control
1	LFO Frequency	0.00Hz~39.7Hz	0-127	table#1	●
2	L/R Depth	0~127	0-127		
3	F/R Depth	0~127	0-127		
4	PAN Direction	L<->R.L->R.L<-R.Lturn. Rturn,L/R	0-5		
5					
6	EQ Low Frequency	32Hz~2.0kHz	4-40	table#3	
7	EQ Low Gain	-12~+12dB	52-76		
8	EQ High Frequency	500Hz~16.0kHz	28-58	table#3	
9	EQ High Gain	-12~+12dB	52-76		
10					
11	EQ Mid Frequency	100Hz~10.0kHz (variation block)	14-54	table#3	
12	EQ Mid Gain	-12~+12dB (variation block)	52-76		
13	EQ Mid Width	1.0~12.0 (variation block)	10-120		
14					
15					
16					

PHASER 1 (chorus, variation, insertion1,2 block)

No.	Parameter	Display	Value	See Table	Control
1	LFO Frequency	0.00Hz~39.7Hz	0-127	table#1	
2	LFO Depth	0~127	0-127		
3	Phase Shift Offset	0~127	0-127		
4	Feedback Level	-63~+63	1-127		
5					
6	EQ Low Frequency	32Hz~2.0kHz	4-40	table#3	
7	EQ Low Gain	-12~+12dB	52-76		
8	EQ High Frequency	500Hz~16.0kHz	28-58	table#3	
9	EQ High Gain	-12~+12dB	52-76		
10	Dry/Wet	D63>W - D=W - D<W63	1-127		●
11	Stage	4,5,6 (chorus, insertion1,2 block) 4~12 (variation block)	4-6 4-12		
12	Diffusion	mono/stereo	0-1		
13					
14					
15					
16					

PHASER 2 (variation block)

No.	Parameter	Display	Value	See Table	Control
1	LFO Frequency	0.00Hz~39.7Hz	0-127	table#1	
2	LFO Depth	0~127	0-127		
3	Phase Shift Offset	0~127	0-127		
4	Feedback Level	-63~+63	1-127		
5					
6	EQ Low Frequency	32Hz~2.0kHz	4-40	table#3	
7	EQ Low Gain	-12~+12dB	52-76		
8	EQ High Frequency	500Hz~16.0kHz	28-58	table#3	
9	EQ High Gain	-12~+12dB	52-76		
10	Dry/Wet	D63>W - D=W - D<W63	1-127		●
11	Stage	3,4,5,6	3-6		
12					
13	LFO Phase Difference	-180deg~+180deg	4-124	resolution=3deg.	
14					
15					
16					

DISTORTION

OVERDRIVE (variation, insertion1,2 block)

No.	Parameter	Display	Value	See Table	Control
1	Drive	0~127	0-127		●
2	EQ Low Frequency	32Hz~2.0kHz	4-40	table#3	
3	EQ Low Gain	-12~+12dB	52-76		
4	LPF Cutoff	1.0k~Thru	34-60	table#3	
5	Output Level	0~127	0-127		
6					
7	EQ Mid Frequency	100Hz~10.0kHz	14-54	table#3	
8	EQ Mid Gain	-12~+12dB	52-76		
9	EQ Mid Width	1.0~12.0	10-120		
10	Dry/Wet	D63>W - D=W - D<W63	1-127		
11	Edge(Clip Curve)	0~127	0-127	mild-sharp	
12					
13					
14					
15					
16					

COMP+DIST (variation block)

No.	Parameter	Display	Value	See Table	Control
1	Drive	0~127	0-127		●
2	EQ Low Frequency	32Hz~2.0kHz	4-40	table#3	
3	EQ Low Gain	-12~+12dB	52-76		
4	LPF Cutoff	1.0k~Thru	34-60	table#3	
5	Output Level	0~127	0-127		
6					
7	EQ Mid Frequency	100Hz~10.0kHz	14-54	table#3	
8	EQ Mid Gain	-12~+12dB	52-76		
9	EQ Mid Width	1.0~12.0	10-120		
10	Dry/Wet	D63>W - D=W - D<W63	1-127		
11	Edge(Clip Curve)	0~127	0-127	mild-sharp	
12	Attack	1ms~40ms	0-19	table#8	
13	Release	10ms~680ms	0-15	table#9	
14	Threshold	-48dB~-6dB	79-121		
15	Ratio	1.0~20.0	0-7	table#10	
16					

AMP SIMULATOR (variation, insertion1,2 block)

No.	Parameter	Display	Value	See Table	Control
1	Drive	0~127	0-127		●
2	AMP Type	Off.Stack.Combo.Tube	0-3		
3	LPF Cutoff	1.0k~Thru	34-60	table#3	
4	Output Level	0~127	0-127		
5					
6					
7					
8					
9					
10	Dry/Wet	D63>W - D=W - D<W63	1-127		
11	Edge(Clip Curve)	0~127	0-127	mild-sharp	
12					
13					
14					
15					
16					

3BAND EQ(MONO) (variation, insertion1,2 block)

No.	Parameter	Display	Value	See Table	Control
1	EQ Low Gain	-12~+12dB	52-76		
2	EQ Mid Frequency	100Hz~10.0kHz	14-54	table#3	
3	EQ Mid Gain	-12~+12dB	52-76		
4	EQ Mid Width	1.0~12.0	10-120		
5	EQ High Gain	-12~+12dB	52-76		
6	EQ Low Frequency	50Hz~2.0kHz	8-40	table#3	
7	EQ High Frequency	500Hz~16.0kHz	28-58	table#3	
8					
9					
10					
11					
12					
13					
14					
15	Input Mode	mono/stereo	0-1		
16					

2BAND EQ(STEREO) (variation, insertion1,2 block)

No.	Parameter	Display	Value	See Table	Control
1	EQ Low Frequency	32Hz~2.0kHz	4-40	table#3	
2	EQ Low Gain	-12~+12dB	52-76		
3	EQ High Frequency	500Hz~16.0kHz	28-58	table#3	
4	EQ High Gain	-12~+12dB	52-76		
5					
6					
7					
8					
9					
10					
11					
12					
13					
14					
15					
16					

AUTO WAH (variation, insertion1,2 block)

No.	Parameter	Display	Value	See Table	Control
1	LFO Frequency	0.00Hz~39.7Hz	0-127	table#1	
2	LFO Depth	0~127	0-127		
3	Cutoff Frequency Offset	0~127	0-127		●
4	Resonance	1.0~12.0	10-120		
5					
6	EQ Low Frequency	32Hz~2.0kHz	4-40	table#3	
7	EQ Low Gain	-12~+12dB	52-76		
8	EQ High Frequency	500Hz~16.0kHz	28-58	table#3	
9	EQ High Gain	-12~+12dB	52-76		
10	Dry/Wet	D63>W - D=W - D<W63	1-127		
11	Drive	0~127	0-127		
12					
13					
14					
15					
16					

**AUTO WAH+DIST
AUTO WHA+ODRV (variation block)**

No.	Parameter	Display	Value	See Table	Control
1	LFO Frequency	0.00Hz~39.7Hz	0-127	table#1	
2	LFO Depth	0~127	0-127		
3	Cutoff Frequency Offset	0~127	0-127		●
4	Resonance	1.0~12.0	10-120		
5					
6	EQ Low Frequency	32Hz~2.0kHz	4-40	table#3	
7	EQ Low Gain	-12~+12dB	52-76		
8	EQ High Frequency	500Hz~16.0kHz	28-58	table#3	
9	EQ High Gain	-12~+12dB	52-76		
10	Dry/Wet	D63>W - D=W - D<W63	1-127		
11	Drive	0~127	0-127		
12	EQ Low Gain (distortion)	-12~+12dB	52-76		
13	EQ Mid Gain (distortion)	-12~+12dB	52-76		
14	LPF Cutoff	1.0kHz~thru	34-60	table#3	
15	Output Level	0~127	0-127		
16					

**TOUCH WAH 1 (variation, insertion1,2 block)
TOUCH WAH+DIST (variation block)**

No.	Parameter	Display	Value	See Table	Control
1	Sensitive	0~127	0-127		
2	Cutoff Frequency Offset	0~127	0-127		●
3	Resonance	1.0~12.0	10-120		
4					
5					
6	EQ Low Frequency	32Hz~2.0kHz	4-40	table#3	
7	EQ Low Gain	-12~+12dB	52-76		
8	EQ High Frequency	500Hz~16.0kHz	28-58	table#3	
9	EQ High Gain	-12~+12dB	52-76		
10	Dry/Wet	D63>W - D=W - D<W63	1-127		
11	Drive	0~127	0-127		
12					
13					
14					
15					
16					

**TOUCH WAH 2 (variation, insertion1,2 block)
TOUCH WAH+ODRV (variation block)**

No.	Parameter	Display	Value	See Table	Control
1	Sensitive	0~127	0-127		
2	Cutoff Frequency Offset	0~127	0-127		●
3	Resonance	1.0~12.0	10-120		
4					
5					
6	EQ Low Frequency	32Hz~2.0kHz	4-40	table#3	
7	EQ Low Gain	-12~+12dB	52-76		
8	EQ High Frequency	500Hz~16.0kHz	28-58	table#3	
9	EQ High Gain	-12~+12dB	52-76		
10	Dry/Wet	D63>W - D=W - D<W63	1-127		
11	Drive	0~127	0-127		
12	EQ Low Gain (distortion)	-12~+12dB	52-76		
13	EQ Mid Gain (distortion)	-12~+12dB	52-76		
14	LPF Cutoff	1.0kHz~thru	34-60	table#3	
15	Output Level	0~127	0-127		
16					

PITCH CHANGE 1 (variation block)

No.	Parameter	Display	Value	See Table	Control
1	Pitch	-24~+24	40-88		
2	Initial Delay	0~127	0-127	table#7	
3	Fine 1	-50Hz~+50Hz	14-114		
4	Fine 2	-50Hz~+50Hz	14-114		
5	Feedback Level	-99~+99%	1-127		
6					
7					
8					
9					
10	Dry/Wet	D63>W - D=W - D<W63	1-127		●
11	Pan 1	L63~R63	1-127		
12	Output Level 1	0~127	0-127		
13	Pan 2	L63~R63	1-127		
14	Output Level 2	0~127	0-127		
15					
16					

PITCH CHANGE 2 (variation block)

No.	Parameter	Display	Value	See Table	Control
1	Pitch	-24~+24	40-88		
2	Initial Delay	0~127	0-127	table#7	
3	Fine 1	-50~+50cent	14-114		
4	Fine 2	-50~+50cent	14-114		
5	Feedback Level	-99~+99%	1-127		
6					
7					
8					
9					
10	Dry/Wet	D63>W - D=W - D<W63	1-127		●
11	Pan 1	L63~R63	1-127		
12	Output Level 1	0~127	0-127		
13	Pan 2	L63~R63	1-127		
14	Output Level 2	0~127	0-127		
15					
16					

**AURAL EXCITER®
(variation, insertion1,2 block)**

No.	Parameter	Display	Value	See Table	Control
1	HPF Cutoff	500Hz~16.0kHz	28-58	table#3	●
2	Drive	0~127	0-127		
3	Mix Level	0~127	0-127		
4					
5					
6					
7					
8					
9					
10					
11					
12					
13					
14					
15					
16					

Aural Exciter® is a registered trademark of Aphex Corporation.

COMPRESSOR (variation, insertion1,2 block)

No.	Parameter	Display	Value	See Table	Control
1	Attack	1~40ms	0-19	table#8	
2	Release	10~680ms	0-15	table#9	
3	Threshold	-48~-6dB	79-121		
4	Ratio	1.0~20.0	0-7	table#10	
5	Output Level	0~127	0-127		
6					
7					
8					
9					
10					
11					
12					
13					
14					
15					
16					

NOISE GATE (variation, insertion1,2 block)

No.	Parameter	Display	Value	See Table	Control
1	Attack	1~40ms	0-19	table#8	
2	Release	10~680ms	0-15	table#9	
3	Threshold	-72~-30dB	55-97		
4	Output Level	0~127	0-127		
5					
6					
7					
8					
9					
10					
11					
12					
13					
14					
15					
16					

VOICE CANCELAR (variation block)

No.	Parameter	Display	Value	See Table	Control
1					
2					
3					
4					
5					
6					
7					
8					
9					
10					
11	Low Adjust	0~26	0-26		
12	High Adjust	0~26	0-26		
13					
14					
15					
16					

Explanation of effect parameters

Parameter name	Effect types in which the parameter exists	Explanation of parameter
AM Depth	TREMOLO	Depth of volume modulation
AMP Type	AMP SIMULATOR	Select the amp type to be simulated
Attack	COMPRESSOR type NOISE GATE	Time until when the compressor begins to take effect Time until when the gate begins to open
Cch Delay	DELAY L,C,R	Delay length of center channel
Cch Level	DELAY L,C,R	Volume of center channel
Crossover Frequency	2WAY ROTARY SPEAKER	Crossover frequency between the high frequency speaker and the low frequency speaker
Cutoff Frequency Offset	WAH type	Frequency offset value which will control the wah filter
Delay Offset	CHORUS type	Offset value of delay modulation
Delay Time	KARAOKE 1,2,3 AMBIENCE	Interval between repeats of the karaoke echo Delay length
Delay2 Level	ECHO	Volume of the second delay
Density	REVERB type, EARLY REF type	Density of the reflections. Higher values produce greater density.
Depth	REVERB type	Depth of the room to be simulated
Detune	ENSEMBLE DETUNE	Amount of pitch shift
Diffusion	REVERB type, EARLY REF type, PHASER	Controls the amount of spread
Drive	DISTORTION type AURAL EXCITER	The degree of distortion The degree to which the exciter effect is applied
Drive High	2WAY ROTARY SPEAKER	Depth of the modulation caused by the rotation of the low frequency speaker
Drive Low	2WAY ROTARY SPEAKER	Depth of the modulation caused by the rotation of the high frequency speaker
Dry/Wet	All types	Balance between dry sound and effect sound
Edge (Clip Curve)	DISTORTION type	Curve of distortion character (sharp (127) distorts suddenly, and mild (0) distorts gradually)
EQ High Frequency	All types	Frequency at which the EQ will boost/cut the high range
EQ High Gain	All types	Amount of gain with which the EQ will boost/cut the high range
EQ Low Frequency	All types	Frequency at which the EQ will boost/cut the low range
EQ Low Gain	All types	Amount of gain with which the EQ will boost/cut the low range
EQ Mid Frequency	All types	Frequency at which the EQ will boost/cut the mid range
EQ Mid Gain	All types	Amount of gain with which the EQ will boost/cut the mid range
EQ Mid Width	All types	Width of the area at which the EQ will boost/cut the mid range
Er/Rev Balance	REVERB type	Level balance between the early reflections and the reverb sound
F/R Depth	AUTO PAN	Depth of front/back panning (valid when PAN Direction=Lturn, Rturn)
Feedback Delay	DELAY L,C,R	Length of feedback delay
Feedback Delay 1	DELAY L, R	Length of feedback delay 1
Feedback Delay 2	DELAY L, R	Length of feedback delay 2
Feedback Level	REVERB type DELAY type, EARLY REF type, PITCH CHANGE type KARAOKE type CHORUS type, FLANGER type PHASER type	Amount of feedback for the initial delay Amount of feedback Setting for delay repeats Level at which the delayed output is returned to the input (negative values invert the phase) Level at which the output of the phaser is returned to the input (negative values invert the phase)
Fine 1	PITCH CHANGE type	Fine pitch setting for first unit
Fine 2	PITCH CHANGE type	Fine pitch setting for second unit
Height	REVERB type	Height of the room to be simulated
High Adjust	VOICE CANCELAR	Adjust the upper limit of the mid-range frequencies to be attenuated
High Damp	REVERB type, DELAY type, EARLY REF type	Adjust the decay of the high frequencies (smaller values will cause high frequencies to decay more rapidly)
HPF Cutoff	REVERB type, EARLY REF type, KARAOKE type, AURAL EXCITER	Frequency at which the high pass filter will cut the low range
Initial Delay	REVERB type EARLY REF type PITCH CHANGE type	Delay time until the early reflections Length of delay until the ER (Gate Reverb) sounds Delay length
Input Mode	All types	Mono/stereo switch for the input
Input Select	CROSS DELAY	Select the input
L/R Depth	AUTO PAN	Depth of left/right panning
L->R Delay	CROSS DELAY	Delay time from left (input) to right (output)
Lch Delay	DELAY type	Delay length of the left channel
Lch Delay 1	ECHO	First delay length of the left channel
Lch Delay 2	ECHO	Second delay length of the left channel
Lch Feedback Level	ECHO	Feedback amount of the left channel
Lch Init Delay	ENSEMBLE DETUNE	Length of left channel delay
LFO Depth	CHORUS type, FLANGER type, SYMPHONIC type ROTARY SPEAKER PHASER type WAH type	Frequency of delay modulation Modulation depth caused by speaker rotation Depth of phase modulation Depth to which wah filter is controlled
LFO Frequency	CHORUS type, FLANGER type, SYMPHONIC ROTARY SPEAKER TREMOLO AUTO PAN PHASER type WAH type	Frequency of delay modulation Frequency at which the speaker rotates Modulation frequency Auto pan frequency Frequency of phase modulation Frequency at which wah filter is controlled
LFO Phase Difference	PHASER type, FLANGER type	L/R phase difference between modulation waveforms (At 0 deg (=64) there is no phase difference.)
Liveness	EARLY REF type	ER decay. Lower values produce faster decay.
Low Adjust	VOICE CANCELAR	Adjust the lower limit of the mid-range that will be attenuated
Low/High	2WAY ROTARY SPEAKER	Volume balance between the high range speaker and the low range speaker
LPF Cutoff	All types	Frequency at which the low pass filter will cut the high range
Mic L-R Angle	2WAY ROTARY SPEAKER	L/R angle of the mics which will pick up the output
Mix Level	AURAL EXCITER	Level of the effect sound which will be mixed into the dry sound
Output Level	All types	Output level
Output Level 1	PITCH CHANGE type	Output level of first unit
Output Level 2	PITCH CHANGE type	Output level of second unit
Output Phase	AMBIENCE	Exchange the L/R phase of the effect sound
Pan 1	PITCH CHANGE type	PAN of first unit
Pan 2	PITCH CHANGE type	PAN of second unit
PAN Direction	AUTO PAN	Type of auto pan (L<->R is sine wave, L/R is square wave)
Phase Shift Offset	PHASER type	Offset value of phase modulation
Pitch	PITCH CHANGE type	Pitch setting in semitone steps

PM Depth	TREMOLO	Depth of delay modulation
R->L Delay	CROSS DELAY	Delay time from right (input) to left (output)
Ratio	COMPRESSOR type	Compression ratio of the compressor
Rch Delay	DELAY type	Delay length of the right channel
Rch Delay 1	ECHO	First delay length of the right channel
Rch Delay 2	ECHO	Second delay length of the right channel
Rch Feedback Level	ECHO	Feedback amount of the right channel
Rch Init Delay	ENSEMBLE DETUNE	Length of right channel delay
Release	COMPRESSOR type NOISE GATE	Time until when the compressor effect is removed Time until when the gate is closed
Resonance	WAH type	Bandwidth of the wah filter
Rev Delay	REVERB type	Delay time from the early reflections until the reverb sound
Reverb Time	REVERB type	Length of reverb
Room Size	EARLY REF type	ER will become longer as the size of the room (this value) increases
Rotor Speed	2WAY ROTARY SPEAKER	Frequency at which the speaker rotates
Sensitive	WAH type	Sensitivity with which the wah filter will respond to changes in the input
Stage	PHASER type	Number of stages in the phase shifter
Threshold	COMPRESSOR type NOISE GATE	Input level at which the effect begins to apply Input level at which the gate begins to open
Type	EARLY REF type	Select the type
Wall Vary	REVERB type	Condition of the walls of the room being simulated (higher values produce more random reflections)
Width	REVERB type	Width of the room being simulated

Note (The types such as "REVERB type" referred to in the above table include the following effects.)

CHORUS type	CHORUS1, CHORUS2, CHORUS3, CHORUS4, CELESTE1, CELESTE2, CELESTE3, CELESTE4,
COMPRESSOR type	COMPRESSOR, COMP+DIST
DELAY type	DELAY L,C,R, DELAY L,R, ECHO, CROSS DELAY
DISTORTION type	DISTORTION, OVERDRIVE, AMP SIMULATOR, AUTO WAH+DIST, AUTO WAH+ODRV, TOUCH WAH+DIST, TOUCH WAH+ODRV, COMP+DIST
EARLY REF type	EARLY REF1, EARLY REF2, GATE REVERB, REVERSE GATE
FLANGER type	FLANGER1, FLANGER2, FLANGER3
KARAOKE type	KARAOKE1, KARAOKE2, KARAOKE3
PHASER type	PHASER1, PHASER2
PITCH CHANGE type	PITCH CHANGE1, PITCH CHANGE2
REVERB type	HALL1, HALL2, ROOM1, ROOM2, ROOM3, STAGE1, STAGE2, PLATE, WHITE ROOM, TUNNEL, CANYON, BASEMENT
WAH type	AUTO WAH, AUTO WAH+DIST, AUTO WAH+ODRV, TOUCH WAH1, TOUCH WAH2, TOUCH WAH+DIST, TOUCH WAH+ODRV

YAMAHA [Tone Generator]
 Model MU90R MIDI Implementation Chart

Date :16-DEC-1996
 Version : 1.0

Function ...	Transmitted	Recognized	Remarks
Basic Default Channel Changed	x x	1 - 16 1 - 16	
Mode Default Messages Altered	x x *****	3 3,4 (m = 1) *2 x	
Note Number : True voice	x *****	0 - 127 0 - 127	
Velocity Note ON Note OFF	x x	o 9nH, v=1-127 x	
After Touch Key's Ch's	x x	o *1 o *1	
Pitch Bend	x	o 0-24 semi *1	
Control Change	0,32 x 1,5,7,10,11 x 6,38 x 64-67 x 71-74 x 84 x 91,93,94 x 96-97 x 98-99 x 100-101 x 120 x 121 x	o *1 o *1 o *1 o *1 o *1 o *1 o *1 o *1 o *1 o *1 o *1 o	Bank Select Data Entry Sound Controller Portamento Cntrl Effect Depth RPN Inc,Dec NRPN LSB,MSB RPN LSB,MSB All Sound Off Reset All Cntrls
Prog Change : True #	x *****	o 0 - 127	
System Exclusive	o *3	o *3	
System : Song Pos. : Song Sel. Common : Tune	x x x	x x x	
System :Clock Real Time :Commands	x x	x x	
Aux :Local ON/OFF :All Notes OFF Mes- :Active Sense sages:Reset	x x x x	x o(123-127) o x	

Notes: *1 ; receive if switch is on.
 *2 ; m is always treated as "1" regardless of its value.
 *3 ; transmit/receive if exclusive switch is on.

Mode 1 : OMNI ON, POLY Mode 2 : OMNI ON, MONO o : Yes
 Mode 3 : OMNI OFF, POLY Mode 4 : OMNI OFF, MONO x : No

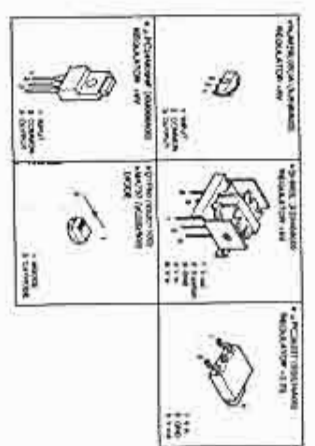
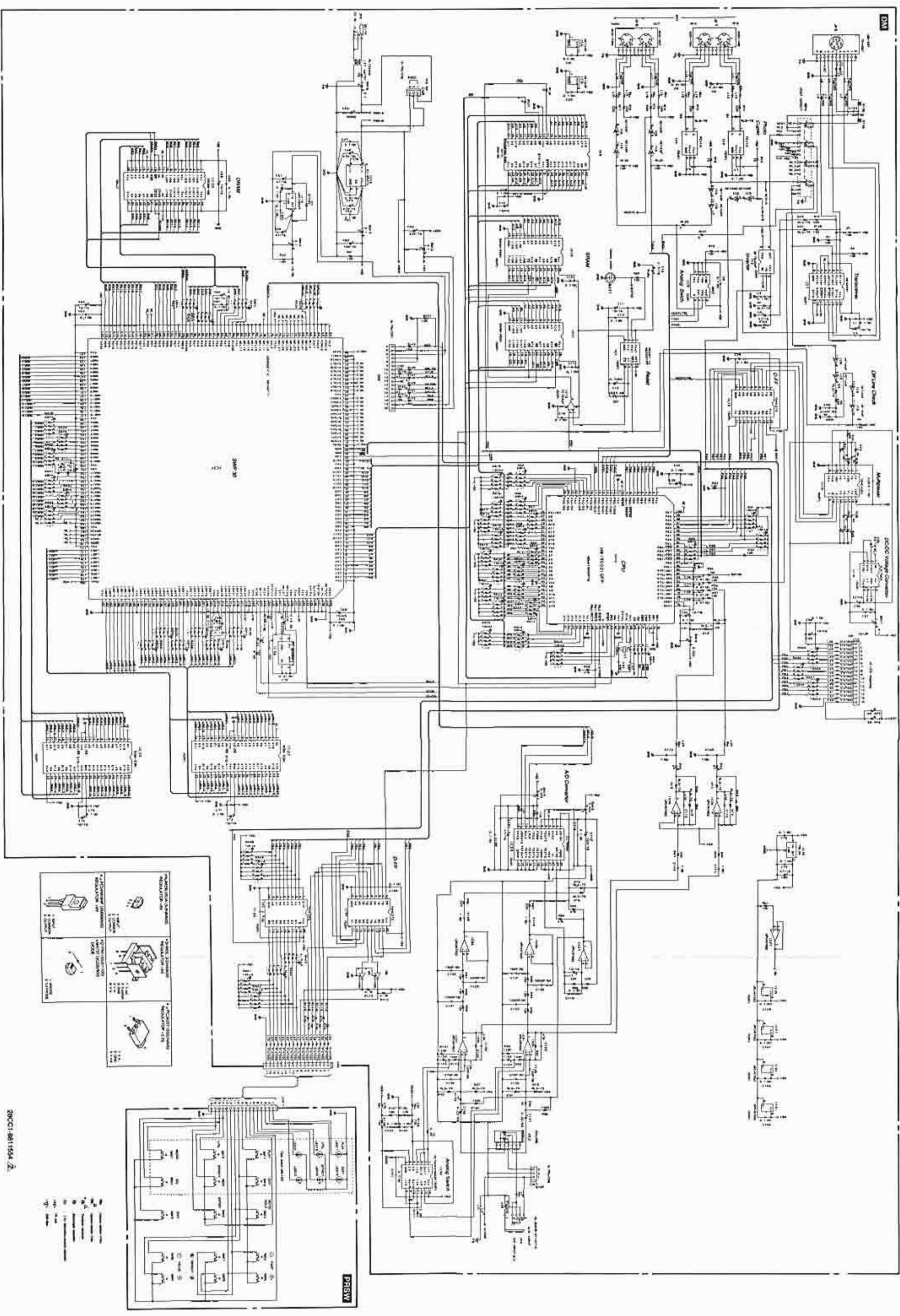

280C1-881154 A

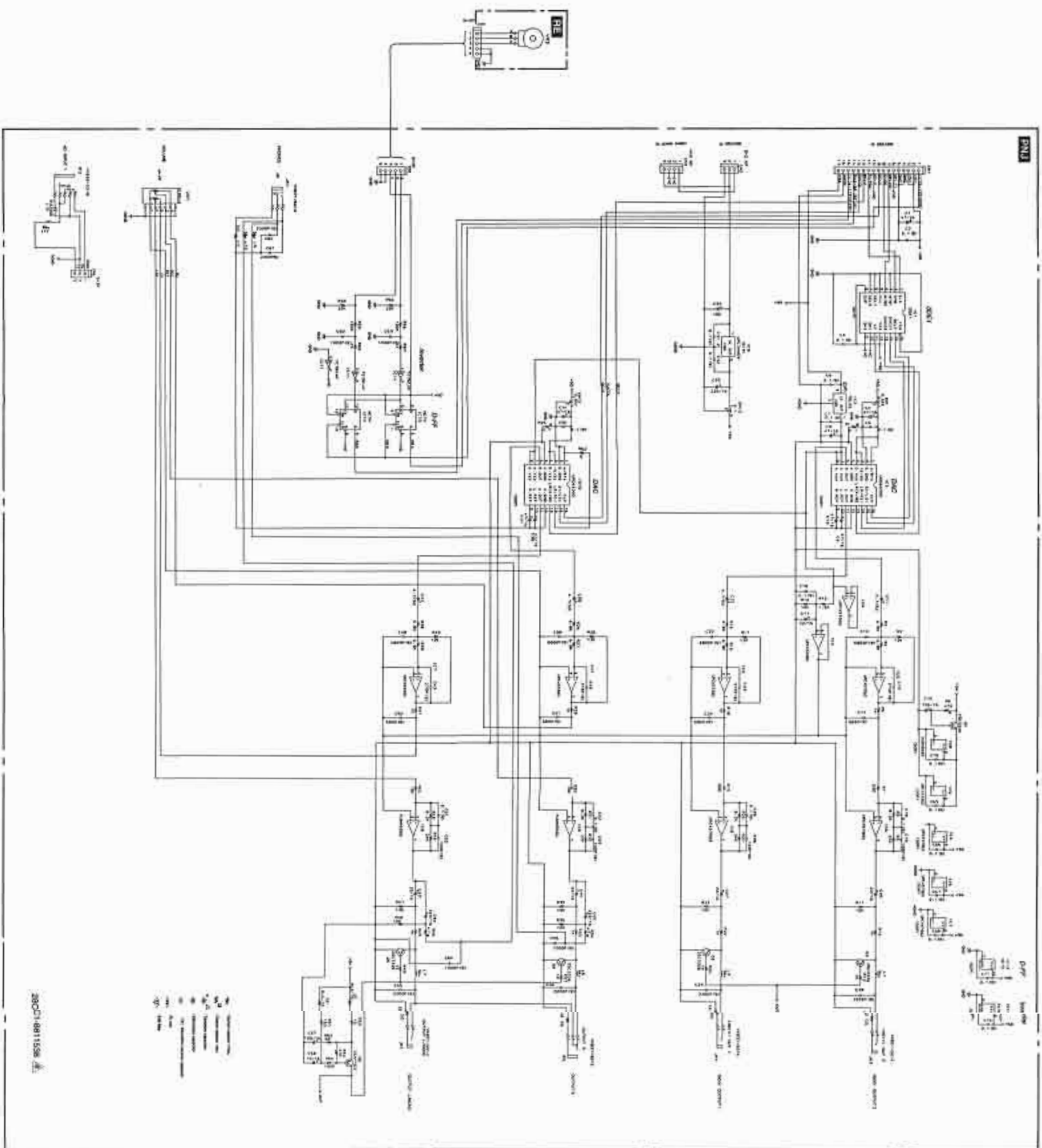

Symbol	Description	Symbol	Description
1	250V 100W LAMP	10	250V 100W HEATER
2	250V 100W HEATER	11	250V 100W HEATER
3	250V 100W HEATER	12	250V 100W HEATER
4	250V 100W HEATER	13	250V 100W HEATER
5	250V 100W HEATER	14	250V 100W HEATER
6	250V 100W HEATER	15	250V 100W HEATER
7	250V 100W HEATER	16	250V 100W HEATER
8	250V 100W HEATER	17	250V 100W HEATER
9	250V 100W HEATER	18	250V 100W HEATER
10	250V 100W HEATER	19	250V 100W HEATER
11	250V 100W HEATER	20	250V 100W HEATER
12	250V 100W HEATER	21	250V 100W HEATER
13	250V 100W HEATER	22	250V 100W HEATER
14	250V 100W HEATER	23	250V 100W HEATER
15	250V 100W HEATER	24	250V 100W HEATER
16	250V 100W HEATER	25	250V 100W HEATER
17	250V 100W HEATER	26	250V 100W HEATER
18	250V 100W HEATER	27	250V 100W HEATER
19	250V 100W HEATER	28	250V 100W HEATER
20	250V 100W HEATER	29	250V 100W HEATER
21	250V 100W HEATER	30	250V 100W HEATER
22	250V 100W HEATER	31	250V 100W HEATER
23	250V 100W HEATER	32	250V 100W HEATER
24	250V 100W HEATER	33	250V 100W HEATER
25	250V 100W HEATER	34	250V 100W HEATER
26	250V 100W HEATER	35	250V 100W HEATER
27	250V 100W HEATER	36	250V 100W HEATER
28	250V 100W HEATER	37	250V 100W HEATER
29	250V 100W HEATER	38	250V 100W HEATER
30	250V 100W HEATER	39	250V 100W HEATER
31	250V 100W HEATER	40	250V 100W HEATER
32	250V 100W HEATER	41	250V 100W HEATER
33	250V 100W HEATER	42	250V 100W HEATER
34	250V 100W HEATER	43	250V 100W HEATER
35	250V 100W HEATER	44	250V 100W HEATER
36	250V 100W HEATER	45	250V 100W HEATER
37	250V 100W HEATER	46	250V 100W HEATER
38	250V 100W HEATER	47	250V 100W HEATER
39	250V 100W HEATER	48	250V 100W HEATER
40	250V 100W HEATER	49	250V 100W HEATER
41	250V 100W HEATER	50	250V 100W HEATER
42	250V 100W HEATER	51	250V 100W HEATER
43	250V 100W HEATER	52	250V 100W HEATER
44	250V 100W HEATER	53	250V 100W HEATER
45	250V 100W HEATER	54	250V 100W HEATER
46	250V 100W HEATER	55	250V 100W HEATER
47	250V 100W HEATER	56	250V 100W HEATER
48	250V 100W HEATER	57	250V 100W HEATER
49	250V 100W HEATER	58	250V 100W HEATER
50	250V 100W HEATER	59	250V 100W HEATER
51	250V 100W HEATER	60	250V 100W HEATER
52	250V 100W HEATER	61	250V 100W HEATER
53	250V 100W HEATER	62	250V 100W HEATER
54	250V 100W HEATER	63	250V 100W HEATER
55	250V 100W HEATER	64	250V 100W HEATER
56	250V 100W HEATER	65	250V 100W HEATER
57	250V 100W HEATER	66	250V 100W HEATER
58	250V 100W HEATER	67	250V 100W HEATER
59	250V 100W HEATER	68	250V 100W HEATER
60	250V 100W HEATER	69	250V 100W HEATER
61	250V 100W HEATER	70	250V 100W HEATER
62	250V 100W HEATER	71	250V 100W HEATER
63	250V 100W HEATER	72	250V 100W HEATER
64	250V 100W HEATER	73	250V 100W HEATER
65	250V 100W HEATER	74	250V 100W HEATER
66	250V 100W HEATER	75	250V 100W HEATER
67	250V 100W HEATER	76	250V 100W HEATER
68	250V 100W HEATER	77	250V 100W HEATER
69	250V 100W HEATER	78	250V 100W HEATER
70	250V 100W HEATER	79	250V 100W HEATER
71	250V 100W HEATER	80	250V 100W HEATER
72	250V 100W HEATER	81	250V 100W HEATER
73	250V 100W HEATER	82	250V 100W HEATER
74	250V 100W HEATER	83	250V 100W HEATER
75	250V 100W HEATER	84	250V 100W HEATER
76	250V 100W HEATER	85	250V 100W HEATER
77	250V 100W HEATER	86	250V 100W HEATER
78	250V 100W HEATER	87	250V 100W HEATER
79	250V 100W HEATER	88	250V 100W HEATER
80	250V 100W HEATER	89	250V 100W HEATER
81	250V 100W HEATER	90	250V 100W HEATER
82	250V 100W HEATER	91	250V 100W HEATER
83	250V 100W HEATER	92	250V 100W HEATER
84	250V 100W HEATER	93	250V 100W HEATER
85	250V 100W HEATER	94	250V 100W HEATER
86	250V 100W HEATER	95	250V 100W HEATER
87	250V 100W HEATER	96	250V 100W HEATER
88	250V 100W HEATER	97	250V 100W HEATER
89	250V 100W HEATER	98	250V 100W HEATER
90	250V 100W HEATER	99	250V 100W HEATER
91	250V 100W HEATER	100	250V 100W HEATER

STONE GENERATOR

MU90R

PARTS LIST

■ CONTENTS (目次)

OVERALL ASSEMBLY (総組立)	1
ELECTRICAL PARTS (電気部品)	3~6

Note) DESTINATION ABBREVIATIONS

J : Japanese model	A : Australian model
U : U.S.A. model	E : European model
C : Canadian model	D : German model
X : General model	B : British model
M : South African model	I : Indonesian model
H : North European model	O : Chinese model

- The numbers in "QTY" shows quantities for each unit.
- The parts with "--" in "Parts No." are not available as spare parts.
- 部品価格ランクは、変更になることがあります。
- QTY 欄に記されている数字は、各ユニット当たりの使用個数です
- 部品 No.が "--" の部品は、サービス用部品として準備されていません。

OVERALL ASSEMBLY (総組立)

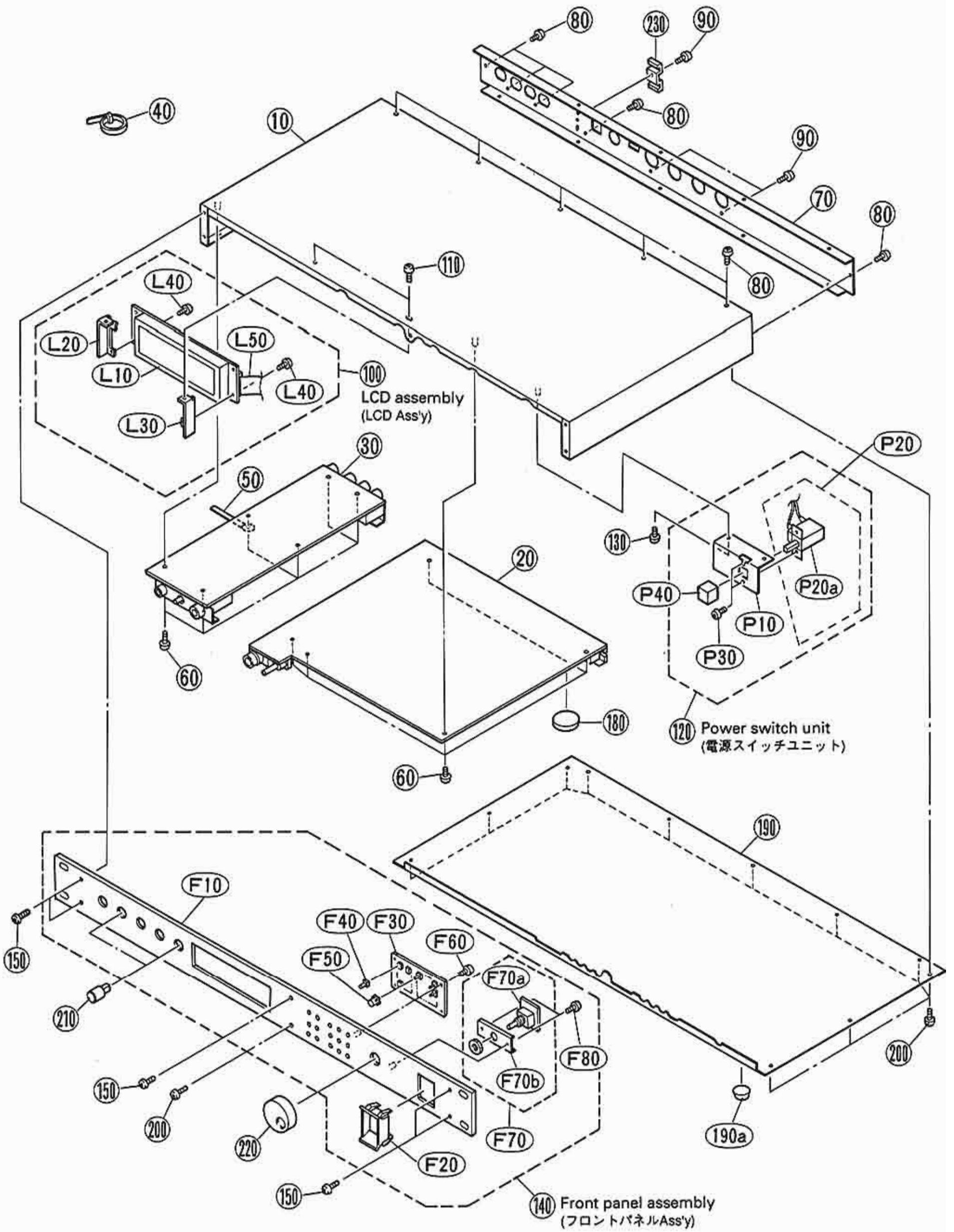

REF NO.	PART NO.	DESCRIPTION		部 品 名	REMARKS	QTY	ランク
		OVERALL ASSEMBLY		総 組 立	MU90R		
• 10	VV978300	Top Cover		ト ッ プ カ バ ー 印 刷 品			
• 20	VV501300	Circuit Board	DM	D M シ ー ト	(XS214B0)		
• 30	VV501500	Circuit Board	PNJ	P N J シ ー ト	(XS679C0)		
• 40	CB069250	Cord Holder	BK-1	イ ン シ ュ ロ ッ ク タ イ			01
50	CB502030	Cord Binder	S-75B	束 線 止 め			01
• 60	EP600230	Bind Head Tapping Screw-B	3.0X6 MFZN2BL	+ バ イ ン ド B タ イ ト		11	01
• 70	VV978500	Rear Panel Assembly		リ ア パ ネ ル A s s ' y			
• 80	EP600230	Bind Head Tapping Screw-B	3.0X6 MFZN2BL	+ バ イ ン ド B タ イ ト		10	01
• 90	EP600190	Bind Head Tapping Screw-B	3.0X8 MFZN2BL	+ バ イ ン ド B タ イ ト		3	01
100	—	LCD Assembly		L C D A s s ' y	(VV97880)		
110	EP600230	Bind Head Tapping Screw-B	3.0X6 MFZN2BL	+ バ イ ン ド B タ イ ト		2	01
120	—	Power Switch Unit		電 源 ス イ ッ チ ユ ニ ッ ト	(VV97890)		
130	EP600230	Bind Head Tapping Screw-B	3.0X6 MFZN2BL	+ バ イ ン ド B タ イ ト		2	01
140	—	Front Panel Assembly		フ ロ ン ト パ ネ ル A s s ' y	(VV97900)		
150	EP600230	Bind Head Tapping Screw-B	3.0X6 MFZN2BL	+ バ イ ン ド B タ イ ト		5	01
180	VS246400	Lithium Battery	CR2450	リ チ ウ ム 電 池			03
• 190	VV978400	Bottom Assembly		ボ ト ム A s s ' y			
190a	CB037120	Foot		フ ッ ト		4	03
200	EP600230	Bind Head Tapping Screw-B	3.0X6 MFZN2BL	+ バ イ ン ド B タ イ ト		12	01
210	VM825600	Input Knob		イ ン プ ッ ト ツ マ ミ		2	03
220	VS052100	Knob, Encoder		エ ン コ ー ダ ー ツ マ ミ			04
230	VC407100	Cord Column		D C コ ー ド コ ラ ム			02
	—	LCD ASSEMBLY		L C D A s s ' y	(VV97880)		
• L10	VS609700	LCD	DM113Z-5BL3	液 晶 デ ィ ス プ レ イ			19
• L20	VV979400	LCD Angle L		L C D ア ン グ ル L			
• L30	VV979500	LCD Angle R		L C D ア ン グ ル R			
• L40	EP600230	Bind Head Tapping Screw-B	3.0X6 MFZN2BL	+ バ イ ン ド B タ イ ト		2	01
• L50	VT020800	LCD Cable	BNCD-P=1-L-16-250	L C D ケ ー ブ ル			03
	—	Power Switch Unit		電 源 ス イ ッ チ ユ ニ ッ ト	(VV97890)		
• P10	VV979600	Holder, Power Switch		P S W ア ン グ ル	(VV43840)		
P20	—	Connector Assembly	PS	P S 束 線			
P20a	VP691000	Push Switch	SDDL1	プ ッ シ ュ S W	POWER SWITCH		03
P30	EG330360	Bind Head Screw	3.0X6 MFZN2BL	+ バ イ ン ド 小 ネ ジ		2	01
P40	VL812900	Power Switch Knob		電 源 ス イ ッ チ ノ ブ			03
	—	Front Panel Assembly		フ ロ ン ト パ ネ ル A s s ' y	(VV97900)		
• F10	VV979100	Front Panel		フ ロ ン ト パ ネ ル 印 刷 品			
F20	VL813000	Escutcheon, Power Switch		P S W エ ス カ ッ シ ョ ン			03
• F30	VV501400	Circuit Board	PRSW	P R S W シ ー ト	(XS214B0)		
F40	VM825700	Mode Button		モ ー ド ボ タ ン	PLAY,UTIL,MODE,EDIT,EQ	6	03
F50	VM825800	OP Button		O P ボ タ ン	EFFECT MUTE/SOLO,ENTER,EXIT	9	03
F60	EP600230	Bind Head Tapping Screw-B	3.0X6 MFZN2BL	+ バ イ ン ド B タ イ ト		4	01
F70	—	Encoder Assembly		エ ン コ ー ダ A s s ' y	(VY84050)	4	
• F70a	VV501600	Circuit Board	RE	R E シ ー ト	(XS679C0)		
F70b	—	Angle, Encoder		エ ン コ ー ダ ア ン グ ル	(VY79460)		
F80	EP600230	Bind Head Tapping Screw-B	3.0X6 MFZN2BL	+ バ イ ン ド B タ イ ト		3	01
		ACCESSORIES		付 属 品			
	VT368600	AC Adapter	PA-3B JP	A C ア ダ プ タ ー	J		09
	VT368700	AC Adapter	PA-3B UC	A C ア ダ プ タ ー	UC		
	VT368800	AC Adapter	PA-3B CEE	A C ア ダ プ タ ー	E		08

* New Parts (新規部品)

ランク : Japan only

ELECTRICAL PARTS (電気部品)

REF NO.	PART NO.	DESCRIPTION	部 品 名	REMARKS	QTY	ランク
		ELECTRICAL PARTS	電 気 部 品	MU90R		
	VV501300	Circuit Board	DM	(XS214B0)		
	VV501500	Circuit Board	PNJ	(XS679C0)		
	VV501400	Circuit Board	PRSW	(XS214B0)		
	VV501600	Circuit Board	RE	(XS679C0)		
	VV501300	Circuit Board	DM	(XS214B0)		
	XF291A00	IC	UPC4570G2	OP AMP		03
	XJ598A00	IC	NJM78L05UA	REGULATOR +5V		02
	XS346A00	IC	SI-8501L	REGULATOR +5V 1.0A		07
	XS516A00	IC	UPC2933T	REGULATOR +3.3V		03
	XP596A00	IC	NJU7660M-T1	DC-DC CONVERTER		05
	XD603A00	IC	TC74HC245F-T1	BUS TRANSCEIVER		04
	XD657A00	IC	TC74HC14AF-TP1	HEX INVERTER		02
	XG385A00	IC	TC74HC4066AF-T1	ANALOG SWITCH		02
	XH223A00	IC	SN74HC273NSR	D-FF		01
	XI348A00	IC	SC7SU04FEL	INVERTER		01
	XJ623A00	IC	TC74HC4051AF	MULTIPLEXER		02
	XL545A00	IC	TC4W53F	ANALOG SWITCH		02
	XM588A00	IC	TC7S32F	OR		01
	XP881A00	IC	MC34051MEL	LINE TRANSCEIVER		05
	XP691A00	IC	HD6413002F16	CPU		10
	XR738A00	IC	TC203C760HF-001	SWP30		20
	XN279C00	IC	M5M5256DFP-70LL	SRAM 256K		07
	XR978A00	IC	M5M44260CJ-7	DRAM 4M		16
	XS518A00	IC	KM23C32000AG-4J	WAVE ROM 1 MASK ROM 32M		13
	XS743A00	IC	KM23C32000AG-5J	WAVE ROM 2 MASK ROM 32M		13
	XT023A00	IC	M27C800-10	EPROM		
	XI686A00	IC	M62021FP	RESET		04
	XQ209A00	IC	LC7886M-TRM	A/D CONVETER		09
	VD456900	Transistor	2SCDTC143XK	ト ラ ン ジ ス タ		01
	VB493900	Diode	MA221	ダ イ オ ー ド		01
	VB797600	Diode	RLS-73	ダ イ オ ー ド		01
	VQ282500	Diode	MA737	ダ イ オ ー ド		02
	VS201100	Diode	D1F60	ダ イ オ ー ド		01
	VU171500	Zener Diode	UDZ 3.6BTE-17 3.6V	ツ ェ ナ ー ダイ オ ー ド		01
	VN686000	Photo Coupler	PC410T	フ ォ ト カ プ ラ		04
	VR903700	Photo Coupler	HCPL-M600	フ ォ ト カ プ ラ		04
	UB012470	Monolithic Ceramic Cap.	B 470P 50V K	チ ッ プ 積 層 セ ラ コ ン		01
	UB013120	Monolithic Ceramic Cap.	B 1200P 50V K	チ ッ プ 積 層 セ ラ コ ン		01
	UB013220	Monolithic Ceramic Cap.	B 2200P 50V K	チ ッ プ 積 層 セ ラ コ ン		01
	UB013330	Monolithic Ceramic Cap.	B 3300P 50V K	チ ッ プ 積 層 セ ラ コ ン		01
	UB051330	Monolithic Ceramic Cap.	SL 33P 50V J	チ ッ プ 積 層 セ ラ コ ン		01
	UB051470	Monolithic Ceramic Cap.	SL 47P 50V J	チ ッ プ 積 層 セ ラ コ ン		01
	UB052100	Monolithic Ceramic Cap.	SL 100P 50V J	チ ッ プ 積 層 セ ラ コ ン		01
	UB052180	Monolithic Ceramic Cap.	SL 180P 50V J	チ ッ プ 積 層 セ ラ コ ン		01
	UB044100	Monolithic Ceramic Cap.	F 0.010 50V Z	チ ッ プ 積 層 セ ラ コ ン		01
	UB245100	Monolithic Ceramic Cap.	F 0.100 25V Z	チ ッ プ 積 層 セ ラ コ ン		01
	VQ686200	Monolithic Ceramic Cap.	F 1.0 16V Z	チ ッ プ 積 層 セ ラ コ ン		01
	UI565220	Electrolytic Cap.	0.22 50.0V	ケ ミ コ ン		01
	UJ837100	Electrolytic Cap.	10.00 16.0V	ケ ミ コ ン		01
	UJ837220	Electrolytic Cap.	22.00 16.0V	ケ ミ コ ン		01
	UJ837470	Electrolytic Cap.	47.00 16.0V	ケ ミ コ ン		01
	UJ838100	Electrolytic Cap.	100.00 16.0V	ケ ミ コ ン		01
	UJ838220	Electrolytic Cap.	220.00 16.0V	ケ ミ コ ン		01
	UJ848220	Electrolytic Cap.	220.00 25.0V	ケ ミ コ ン		01
	UJ866100	Electrolytic Cap.	1.00 50.0V	ケ ミ コ ン		01
	UJ866470	Electrolytic Cap.	4.70 50.0V	ケ ミ コ ン		01
	VH339600	Electrolytic Cap.	470.00 16.0V	ケ ミ コ ン R S		01
	VH340500	Electrolytic Cap.	470.00 25.0V	ケ ミ コ ン R S		01
	FP736470	Tantalum Cap.	4.70 16V M	タ ン タ ル コ ン		01
	VR243700	Chip Inductance	56U LEM2520 T 560J	巻 線 チ ッ プ イ ン ダ ク タ		01
	VD303400	Monolithic Ceramic Cap.	1.0 16V Z	チ ッ プ 積 層 セ ラ コ ン		01
	VL139800	Chip Inductance	BLM31A700SPT 70ohm	チ ッ プ ソ リ ッ ド イ ン ダ ク タ		01
	RD150000	Carbon Resistor (chip)	0.0 1/4 J	チ ッ プ 抵 抗		01
	RD154470	Carbon Resistor (chip)	47.0 1/4 J	チ ッ プ 抵 抗		01
	RD154680	Carbon Resistor (chip)	68.0 1/4 J	チ ッ プ 抵 抗		01
	RD250000	Carbon Resistor (chip)	0.0 0.0 J	チ ッ プ 抵 抗		01
	RD254470	Carbon Resistor (chip)	47.0 0.1 J	チ ッ プ 抵 抗		01
	RD254560	Carbon Resistor (chip)	56.0 0.1 J	チ ッ プ 抵 抗		01

* New Parts (新規部品)

ランク : Japan only

REF NO.	PART NO.	DESCRIPTION	部 品 名	REMARKS	QTY	ランク
	RD255100	Carbon Resistor (chip)	100.0 0.1 J	チ ッ プ 抵 抗		01
	RD255220	Carbon Resistor (chip)	220.0 0.1 J	チ ッ プ 抵 抗		01
	RD255470	Carbon Resistor (chip)	470.0 0.1 J	チ ッ プ 抵 抗		01
	RD255680	Carbon Resistor (chip)	680.0 0.1 J	チ ッ プ 抵 抗		01
	RD256100	Carbon Resistor (chip)	1.0K 0.1 J	チ ッ プ 抵 抗		01
	RD256160	Carbon Resistor (chip)	1.6K 0.1 J	チ ッ プ 抵 抗		01
	RD256200	Carbon Resistor (chip)	2.0K 0.1 J	チ ッ プ 抵 抗		01
	RD256220	Carbon Resistor (chip)	2.2K 0.1 J	チ ッ プ 抵 抗		01
	RD256240	Carbon Resistor (chip)	2.4K 0.1 J	チ ッ プ 抵 抗		01
	RD256300	Carbon Resistor (chip)	3.0K 0.1 J	チ ッ プ 抵 抗		01
	RD256330	Carbon Resistor (chip)	3.3K 0.1 J	チ ッ プ 抵 抗		01
	RD256360	Carbon Resistor (chip)	3.6K 0.1 J	チ ッ プ 抵 抗		01
	RD256470	Carbon Resistor (chip)	4.7K 0.1 J	チ ッ プ 抵 抗		01
	RD257100	Carbon Resistor (chip)	10.0K 0.1 J	チ ッ プ 抵 抗		01
	RD257220	Carbon Resistor (chip)	22.0K 0.1 J	チ ッ プ 抵 抗		01
	RD257240	Carbon Resistor (chip)	24.0K 0.1 J	チ ッ プ 抵 抗		01
	RD257360	Carbon Resistor (chip)	36.0K 0.1 J	チ ッ プ 抵 抗		01
	RD257470	Carbon Resistor (chip)	47.0K 0.1 J	チ ッ プ 抵 抗		01
	RD258100	Carbon Resistor (chip)	100.0K 0.1 J	チ ッ プ 抵 抗		01
	RD258120	Carbon Resistor (chip)	120.0K 0.1 J	チ ッ プ 抵 抗		01
	RD258680	Carbon Resistor (chip)	680.0K 0.1 J	チ ッ プ 抵 抗		01
	RD259100	Carbon Resistor (chip)	1.0M 0.1 J	チ ッ プ 抵 抗		01
	RE044680	Resistor Array	68X4	抵 抗 ア レ イ		01
	RE045100	Resistor Array	100X4	抵 抗 ア レ イ		01
	RE046470	Resistor Array	.7KX4	抵 抗 ア レ イ		01
	RE047100	Resistor Array	10KX4	抵 抗 ア レ イ		01
	FZ006970	LC Filter	LS MT Y223NB	L C フィルター E M I		02
	VG238200	LC Filter	PLT2003C	L C フィルター E M I		04
	VR193800	LC Filter	STF-104ZB-TBM	L C フィルター E M I		01
	VP864900	Quartz Crystal Unit	16M SMD-49	水 晶 振 動 子		04
	VV345500	Quartz Crystal Unit	DOC-49S5	水 晶 発 振 器		05
	VV444400	Quartz Crystal Unit	SG-531PTJ	水 晶 発 振 器		01
	VD456900	Transistor	2SCDTC143XK	ト ラ ン ジ ス タ		01
	VB493900	Diode	MA221	ダ イ オード		01
	VB797600	Diode	RLS-73	ダ イ オード		01
	VQ282500	Diode	MA737	ダ イ オード		02
	VS201100	Diode	D1F60	ダ イ オード		01
	VU171500	Zener Diode	UDZ 3.6BTE-17 3.6V	ツェナーダイオード		01
	VN686000	Photo Coupler	PC410T	フ ォ ト カ プ ラ		04
	VR903700	Photo Coupler	HCPL-M600	フ ォ ト カ プ ラ		04
VR2	VS666800	Rotary Variable Resistor	RK09K12A0A6CA	二 連 ロータリー V R	A50KX2 A/D INPUT VOLUME	03
SW16	VQ665200	Slide Switch	SSSF144-S06N-0	ス ラ イ ド S W	HOST SELECT	03
CN1	VS666700	Connector	SLW-16P TE	コ ネ ク タ	to LCD ass'y	02
CN4	VF667700	Connector	52147-17P TE	コ ネ ク タ	to PRSW-CN11	01
CN7	VB389900	Connector Base Post	PH- 3P TE	コネクタベースポスト	to PNJ-CN6	01
CN8	LB918030	Base Post Connector	XH- 3P TE	ベースツキポスト	to PNJ-CN2	01
CN9	VF667700	Connector	52147-17P TE	コ ネ ク タ	to PNJ-CN1	01
JK4	VT160000	Phone Jack, MONAURAL	YKB26-5218	ホ ー ン ジャック	A/D INPUT 2	05
JK5	VM761000	DIN Connector	DIN-8P MD-S810	複 合 コネクタ	TO HOST	03
JK6	VJ207400	DC-IN Connector	16V DC 3A HEC2305	D C ジャック	DC-IN	01
JK7	VJ885500	DIN Connector	3P YKF51-5054	D I N コネクタ	MIDI IN A/B	04
JK8	VJ885500	DIN Connector	3P YKF51-5054	D I N コネクタ	MIDI OUT/THRU	04
	VK863100	IC Socket	DICF-42CS-E	I C ソケット		03
	VS246300	Battery Holder	CR2450BH	バ ッ テ リー ホルダー		03
	VV488200	Holder, Jack	#A0311	J K ア ン グ ル		
	—	Connector Assembly	SW1 10P	S W 1 束 線	(VV43790)	
	—	Connector Assembly	SW2 7P	S W 2 束 線	(VV43820)	
	VV501500	Circuit Board	PNJ	P N J シ ー ト	(XS679C0)	
	XF291A00	IC	UPC4570G2	I C	OP AMP	03
	XQ138A00	IC	NJM4556AMT1	I C	OP AMP	03
	XM927A00	IC	AN78L05-(TA)	I C	REGULATOR +5V	01
	XM968B00	IC	UPC24M09AHF	I C	REGULATOR +9V	03
	XC726A00	IC	SN74HC74NSR	I C	D-FF	01
	XR336A00	IC	TC7W14F	I C	INVERTER	02
	XM326A00	IC	JG541023	I C	DDE1	04
	XP867A00	IC	UPD63200GS-E1	I C	D/A CONVETER	07
	XP867A00	IC	UPD63200GS-E1	I C	D/A CONVERTER	07
	VJ927200	Transistor	2SA1162 O,Y	ト ラ ン ジ ス タ		01
	VD303700	Transistor	2SC3326 A,B TE85R	ト ラ ン ジ ス タ		01

* New Parts (新規部品)

ランク : Japan only

REF NO.	PART NO.	DESCRIPTION	部 品 名	REMARKS	QTY	ランク
	VB797600	Diode	RLS-73	ダイオード		01
	UB012270	Monolithic Ceramic Cap.	B 270P 50V K	チップ積層セラコン		01
	UB013100	Monolithic Ceramic Cap.	B 1000P 50V K	チップ積層セラコン		01
	UB013220	Monolithic Ceramic Cap.	B 2200P 50V K	チップ積層セラコン		01
	UB013680	Monolithic Ceramic Cap.	B 6800P 50V K	チップ積層セラコン		01
	UB052100	Monolithic Ceramic Cap.	SL 100P 50V J	チップ積層セラコン		01
	UB245100	Monolithic Ceramic Cap.	F 0.100 25V Z	チップ積層セラコン		01
	UJ866100	Electrolytic Cap.	1.00 50.0V	ケミコン		01
	UJ837100	Electrolytic Cap.	10.00 16.0V	ケミコン		01
	UJ837220	Electrolytic Cap.	22.00 16.0V	ケミコン		01
	UJ837470	Electrolytic Cap.	47.00 16.0V	ケミコン		01
	UJ838100	Electrolytic Cap.	100.00 16.0V	ケミコン		01
	UJ838220	Electrolytic Cap.	220.00 16.0V	ケミコン		01
	UJ866470	Electrolytic Cap.	4.70 50.0V	ケミコン		01
	VR243700	Chip Inductance	56U LEM2520 T 560J	巻線チップインダクタ		01
	RD150000	Carbon Resistor (chip)	0.0 1/4 J	チップ抵抗		01
	VL139800	Chip Inductance	BLM31A700SPT 70ohm	チップソリッドインダクタ		01
	RD153470	Carbon Resistor (chip)	4.7 1/4 J	チップ抵抗		01
	RD154470	Carbon Resistor (chip)	47.0 1/4 J	チップ抵抗		01
	RD155470	Carbon Resistor (chip)	470.0 1/4 J	チップ抵抗		01
	RD250000	Carbon Resistor (chip)	0.0 0.0 J	チップ抵抗		01
	RD254100	Carbon Resistor (chip)	10.0 0.1 J	チップ抵抗		01
	RD254680	Carbon Resistor (chip)	68.0 0.1 J	チップ抵抗		01
	RD255150	Carbon Resistor (chip)	150.0 0.1 J	チップ抵抗		01
	RD256100	Carbon Resistor (chip)	1.0K 0.1 J	チップ抵抗		01
	RD256150	Carbon Resistor (chip)	1.5K 0.1 J	チップ抵抗		01
	RD256680	Carbon Resistor (chip)	6.8K 0.1 J	チップ抵抗		01
	RD256820	Carbon Resistor (chip)	8.2K 0.1 J	チップ抵抗		01
	RD257100	Carbon Resistor (chip)	10.0K 0.1 J	チップ抵抗		01
	RD257120	Carbon Resistor (chip)	12.0K 0.1 J	チップ抵抗		01
	RD257220	Carbon Resistor (chip)	22.0K 0.1 J	チップ抵抗		01
	RD257240	Carbon Resistor (chip)	24.0K 0.1 J	チップ抵抗		01
	RD257470	Carbon Resistor (chip)	47.0K 0.1 J	チップ抵抗		01
	RD258100	Carbon Resistor (chip)	100.0K 0.1 J	チップ抵抗		01
	VV483200	Rotary Variable Resistor	A10KX2 RK09K12A0	二連ロータリーVR	VOLUME(PHONES)	
	FZ006970	LC Filter	LS MT Y223NB	LCフィルターEM I		02
	VR193800	LC Filter	STF-104ZB-TBM	LCフィルターEM I		01
	VC362700	Ferrite Core	FR25/15/12-1400L	フェライトコア		04
CN1	VI879500	Cable Holder	51048-17P TE	ケーブルホルダー	to DM-CN9	01
CN2	—	Connector Assembly	DC	DC 束線	to DM-CN8 (VV43860)	
CN3	LB918040	Base Post Connector	XH- 4P TE	ベースツキポスト	to power switch	01
CN4	VK024900	Wire Trap	52147- 5P TE	ワイヤートラップ	to RE-CN7	01
CN6	—	Connector Assembly	ADIN	ADIN 束線	to DM-CN7 (VV95090)	
JK1	VE382300	Phone Jack	YKB21-5010	ホンコネクタ	PHONES	01
JK2	VT160000	Phone Jack	YKB26-5218	ホンジャック	A/D INPUT 1	05
JK3	VC687500	Phone Jack	YKB21-5014	ホンコネクタ (黒)	INDIV. 2	01
JK4	VC687500	Phone Jack	YKB21-5014	ホンコネクタ (黒)	INDIV. 1	01
JK6	VB312600	Phone Jack	YKB21-5012	ホンコネクタ (黒)	OUTPUT R	02
JK7	VC687500	Phone Jack	YKB21-5014	ホンコネクタ (黒)	OUTPUT L/MONO	01
	VV916900	Holder, Jack		JKアングル		
	VF891900	Jack Angle		JACKアングル		02
	VA078900	Jumper Wire	0.55	ジャンパー線		
	CB069250	Cord Holder	BK-1	インシュロックタイ		01
	—	Connector Assembly	SW4 7P	SW 4 束線	(VV94490)	
	—	Connector Assembly	SW3 10P	SW 3 束線	(VV94480)	
	—	Connector Assembly	RE 5P	RE ケーブル	(VV43850)	
	VV501400	Circuit Board	PRSW	PRS W シート	(XS214B0)	
SW17	VK701100	Push Switch	SKHQFN GREEN	プッシュ SW	PLAY	02
SW18	VK701100	Push Switch	SKHQFN GREEN	プッシュ SW	EDIT	02
SW19	VK701100	Push Switch	SKHQFN GREEN	プッシュ SW	UTIL	02
SW20	VK701100	Push Switch	SKHQFN GREEN	プッシュ SW	EFFECT	02
SW21	VK701100	Push Switch	SKHQFN GREEN	プッシュ SW	MODE	02
SW22	VK701100	Push Switch	SKHQFN GREEN	プッシュ SW	EQ	02
SW23	VN121700	Push Switch	SKHHPP	プッシュ SW	MUTE/SOLO	01
SW24	VN121700	Push Switch	SKHHPP	プッシュ SW	PART -	01
SW25	VN121700	Push Switch	SKHHPP	プッシュ SW	PART +	01
SW26	VN121700	Push Switch	SKHHPP	プッシュ SW	ENTER	01
SW27	VN121700	Push Switch	SKHHPP	プッシュ SW	SELECT <	01
SW28	VN121700	Push Switch	SKHHPP	プッシュ SW	SELECT >	01

* New Parts (新規部品)

ランク : Japan only

REF NO.	PART NO.	DESCRIPTION	部 品 名	REMARKS	QTY	ランク
SW29	VN121700	Push Switch	SKHHPP	プ ッ シ ュ S W	EXIT	01
SW30	VN121700	Push Switch	SKHHPP	プ ッ シ ュ S W	VALUE -	01
SW31	VN121700	Push Switch	SKHHPP	プ ッ シ ュ S W	VALUE +	01
CN11	V1879500	Cable Holder	51048-17P TE	ケ ー ブ ル ホ ル ダ ー	to DM-CN4	01
	VV501600	Circuit Board	RE	R E シ ー ト	(XS679C0)	
	VU481300	Rotary Encoder	EVQ VCN F02 24B	1 4 形 エ ン コ ー ダ		03
CN7	V1878300	Cable Holder	51048- 5P TE	ケ ー ブ ル ホ ル ダ ー	to PNJ-CN4	01
	VS246400	Lithium Battery	CR2450	リ チ ウ ム 電 池		03
	VS609700	LCD	DM113Z-5BL3	液 晶 デ ィ ス プ レ イ		19
	VP691000	Push Switch	SDDL B1	プ ッ シ ュ S W	POWER SWITCH	03

* New Parts (新規部品) ランク : Japan only