

HOME THEATER SPEAKER SYSTEM NS-P320

SERVICE MANUAL

NS-P320

The NS-P320 is composed of the NS-M104, the NS-C104, the NS-E104 and the SW-P201. The NS-M104, the NS-C104 and the NS-E104 loudspeakers are not field serviceable and must be replaced as complete units.

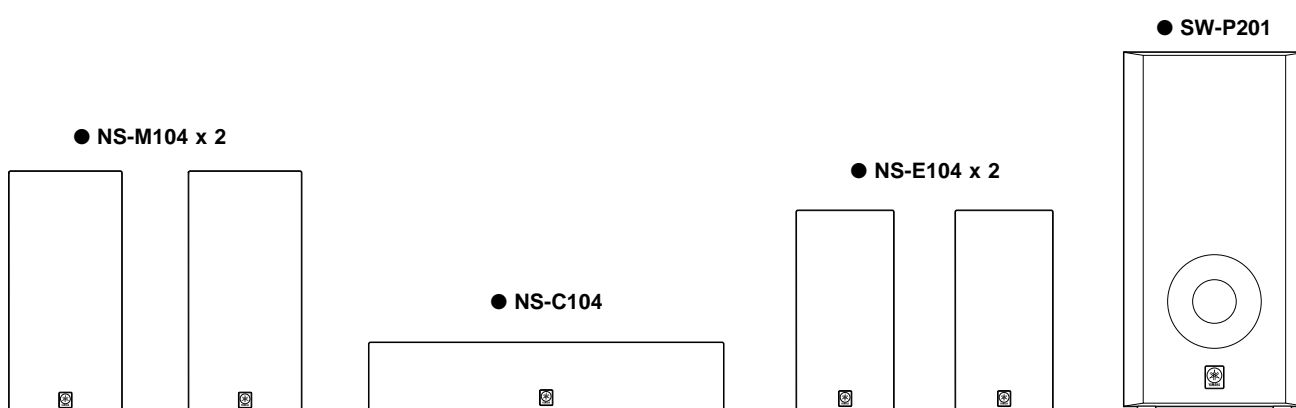

IMPORTANT NOTICE

This manual has been provided for the use of authorized YAMAHA Retailers and their service personnel. It has been assumed that basic service procedures inherent to the industry, and more specifically YAMAHA Products, are already known and understood by the users, and have therefore not been restated.

WARNING: Failure to follow appropriate service and safety procedures when servicing this product may result in personal injury, destruction of expensive components, and failure of the product to perform as specified. For these reasons, we advise all YAMAHA product owners that any service required should be performed by an authorized YAMAHA Retailer or the appointed service representative.

IMPORTANT: The presentation or sale of this manual to any individual or firm does not constitute authorization, certification or recognition of any applicable technical capabilities, or establish a principle-agent relationship of any form.

The data provided is believed to be accurate and applicable to the unit(s) indicated on the cover. The research, engineering, and service departments of YAMAHA are continually striving to improve YAMAHA products. Modifications are, therefore, inevitable and specifications are subject to change without notice or obligation to retrofit. Should any discrepancy appear to exist, please contact the distributor's Service Division.

WARNING: Static discharges can destroy expensive components. Discharge any static electricity your body may have accumulated by grounding yourself to the ground buss in the unit (heavy gauge black wires connect to this buss).

IMPORTANT: Turn the unit OFF during disassembly and part replacement. Recheck all work before you apply power to the unit.

CONTENTS

TO SERVICE PERSONNEL	1
SW-P201 REAR PANELS	1 – 2
SPECIFICATIONS	3
SW-P201 DISASSEMBLY PROCEDURES	4
SW-P201 BLOCK DIAGRAM	5

SW-P201 PRINTED CIRCUIT BOARD	6 – 7
SW-P201 SCHEMATIC DIAGRAM	8
PARTS LIST	9 – 13
PARTS LIST FOR CARBON RESISTORS	14



このサービスマニュアルは、エコマーク認定の再生紙を使用しています。
This Service Manual uses recycled paper.



■ TO SERVICE PERSONNEL

1. Critical Components Information
Components having special characteristics are marked \triangle and must be replaced with parts having specifications equal to those originally installed.
 2. Leakage Current Measurement (For 120V Models Only)
When service has been completed, it is imperative to verify that all exposed conductive surfaces are properly insulated from supply circuits.
- Meter impedance should be equivalent to 1500 ohm shunted by 0.15 μ F.

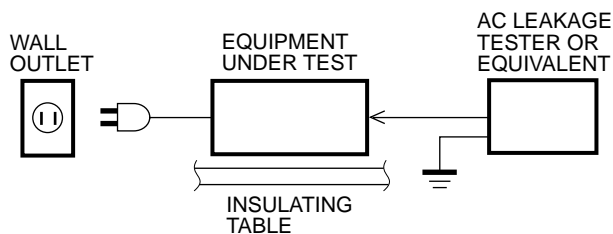

- Leakage current must not exceed 0.5mA.
- Be sure to test for leakage with the AC plug in both polarities.

WARNING: CHEMICAL CONTENT NOTICE!

The solder used in the production of this product contains LEAD. In addition, other electrical/electronic and/or plastic (where applicable) components may also contain traces of chemicals found by the California Health and Welfare Agency (and possibly other entities) to cause cancer and/or birth defects or other reproductive harm.

DO NOT PLACE SOLDER, ELECTRICAL/ELECTRONIC OR PLASTIC COMPONENTS IN YOUR MOUTH FOR ANY REASON WHATSOEVER!

Avoid prolonged, unprotected contact between solder and your skin! When soldering, do not inhale solder fumes or expose eyes to solder/flux vapor!

If you come in contact with solder or components located inside the enclosure of this product, wash your hands before handling food.

■ SW-P201 REAR PANELS

▼ SW-P201 U, C models

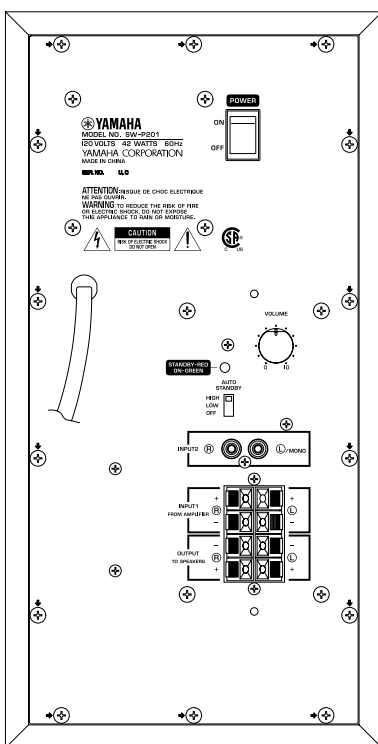

▼ SW-P201 B,G models

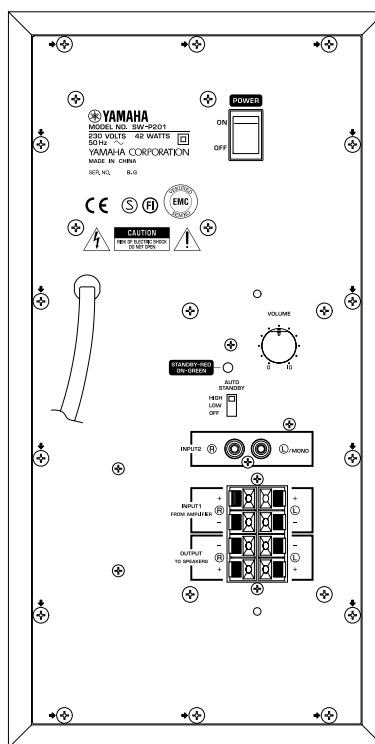

▼ SW-P201 A model

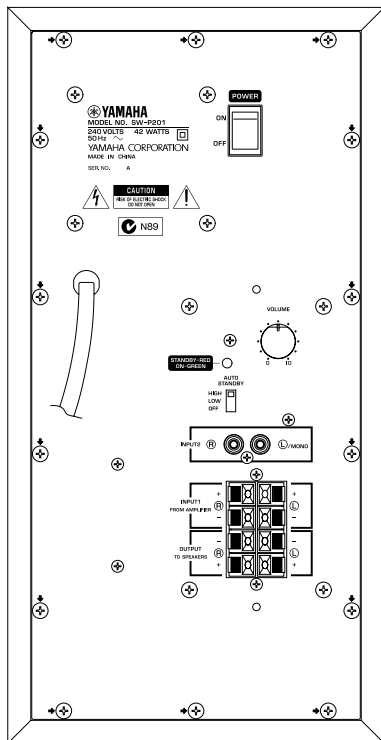

▼ SW-P201 R model

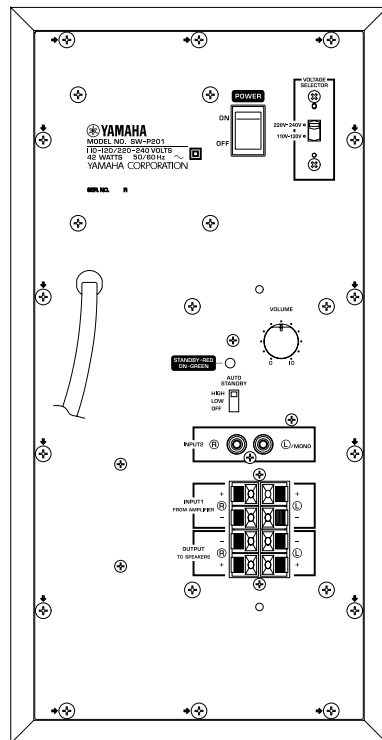

▼ SW-P201 K model

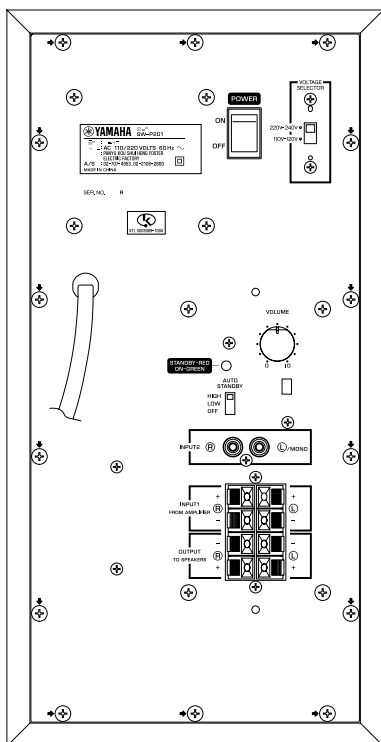

NS-P320

■ SPECIFICATIONS

■ NS-M104

Type 2-way bass-reflex speaker system
Magnetic shielding type

Driver 12 cm (4-3/4") cone woofer
2.5 cm (1") balanced dome tweeter

Impedance 6 ohms

Frequency Response 65 Hz to 28 kHz

Nominal Input Power 50 W

Maximum Input Power 160 W

Sensitivity 89 dB/2.83 V/m

Dimensions (W X H X D) 140 x 300 x 167 mm
(5-1/2" x 11-13/16" x 6-9/16")

Weight 1.9 kg (4 lbs. 3 oz)

Finish Black color (U, C, R, A, B, G)
Silver color (U, C, R, K, A, B, G)

■ NS-C104

Type 2-way bass-reflex speaker system
Magnetic shielding type

Driver 7 cm (2-3/4") cone woofer x 3
1.5 cm (5/8") tweeter

Impedance 6 ohms

Frequency Response 95 Hz to 20 kHz

Nominal Input Power 70 W

Maximum Input Power 180 W

Sensitivity 91 dB/2.83 V/m

Dimensions (W X H X D) 440 x 85 x 122 mm
(17-5/16" x 3-5/16" x 4-13/16")

Weight 1.7 kg (3 lbs. 11 oz)

Finish Black color (U, C, R, A, B, G)
Silver color (U, C, R, K, A, B, G)

■ NS-E104

Type Full-range bass-reflex speaker system
Magnetic shielding type

Driver 10 cm (4") cone woofer

Impedance 6 ohms

Frequency Response 110 Hz to 20 kHz

Nominal Input Power 30 W

Maximum Input Power 110 W

Sensitivity 91 dB/2.83 V/m

Dimensions (W X H X D) 120 x 250 x 92 mm
(4-3/4" x 9-13/16" x 3-5/8")

Weight 1.1 kg (2 lbs. 6 oz)

Finish Black color (U, C, R, A, B, G)
Silver color (U, C, R, K, A, B, G)

■ SW-P201

Type Advanced Yamaha Active Servo Technology

Driver 16 cm (6-5/16") cone woofer (JA1678)
Magnetic shielding type

Amplifier Output 50 W/5 ohms

Frequency Response 30 Hz to 200 Hz (-10 db)

Power Supply

U, C models AC120V, 60 Hz

A model AC240V, 50 Hz

B, G models AC230V, 50 Hz

R, K models AC110-120/220-240V, 50/60 Hz

Power Consumption 42 W
(In the standby mode: 6W)

Dimensions (W x H x D) 200 x 395 x 384 mm
(7-7/8" x 15-9/16" x 15-1/8")

Weight 9.3 kg (20 lbs. 8oz)

Finish Black color (U, C, R, A, B, G)
Silver color (U, C, R, K, A, B, G)

■ ACCESSORIES

Pin Cord (3 m) x 1

Speaker Cable (15 m) x 2

Speaker Cable (4 m) x 3

Fastener x 4

Pad x 8

* Specifications subject to change without notice.

U USA model
C Canadian model
A Australian model
B British model
G European model
R General model
K Korea model

● DIMENSION

● NS-M104

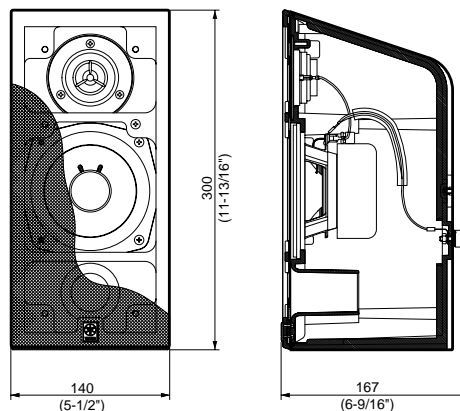

● NS-C104

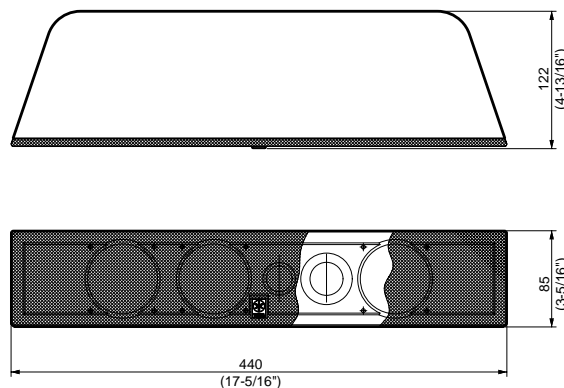

Units : mm (inch)

● NS-E104

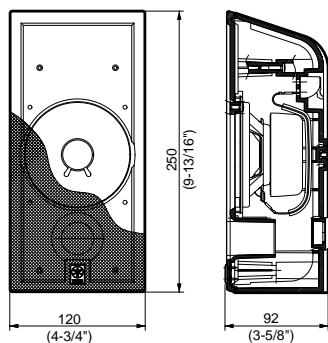

● SW-P201

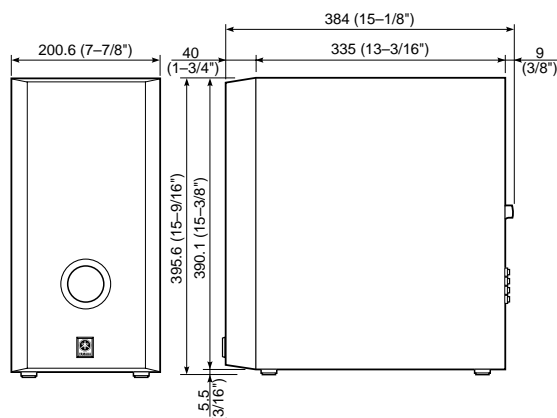

Units : mm (inch)

SW-P201 DISASSEMBLY PROCEDURES

(Remove parts in the order as numbered.)

1. Removal of Front Grille

The front grille is fixed to the cabinet with dowels at 6 locations.

- * As a screwdriver (for slotted head screw) is used for removal, use special care not to cause damage to the cabinet.
- a. Using the screwdriver inserted in the gap between the front grille and the cabinet (bottom side first), push up the front grille.
- b. Remove the front grille by lifting it up.

When installing the Front Grille, apply quick-drying bond to the dowels and then fit them into dowel holes for secure installation. (The Front Grille will come off easily if its dowels are fitted into dowel holes only.)

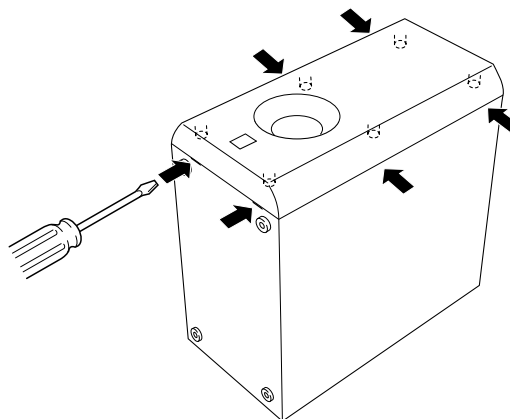

Fig. 1

2. Removal of Rear Panel

Remove 14 screws (①) in Fig. 2.

- * Arrow marks (⇒) are printed to identify the screws to be removed.
- * When assembling the Rear Panel, check to ensure that the packing is not damaged so as to prevent air leakage from occurring.

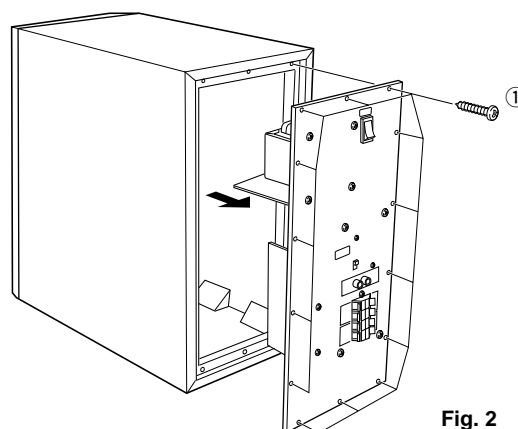
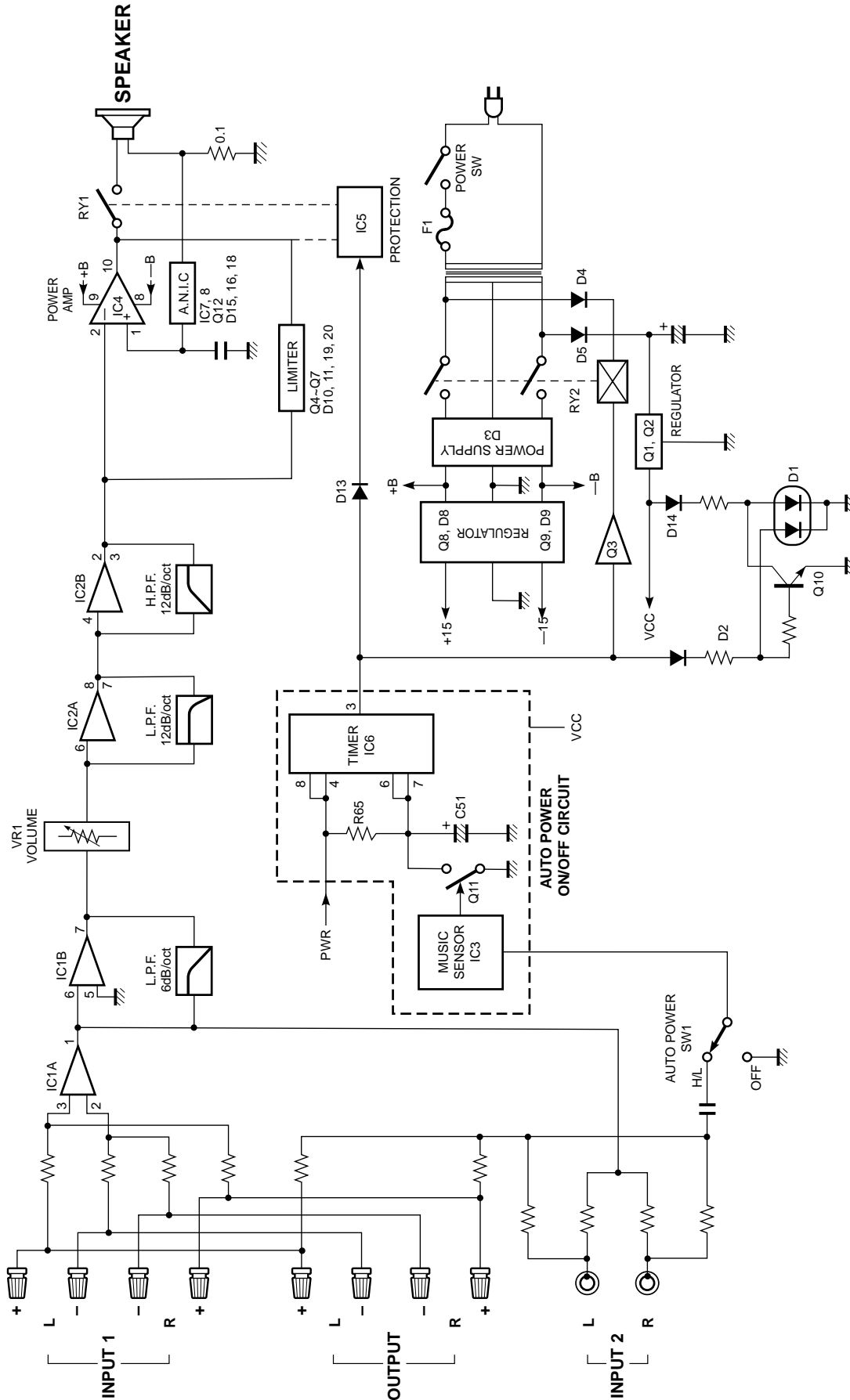

Fig. 2

SW-P201 BLOCK DIAGRAM

NS-P320



1 ■ SW-P201 PRINTED CIRCUIT BOARD (Component side)

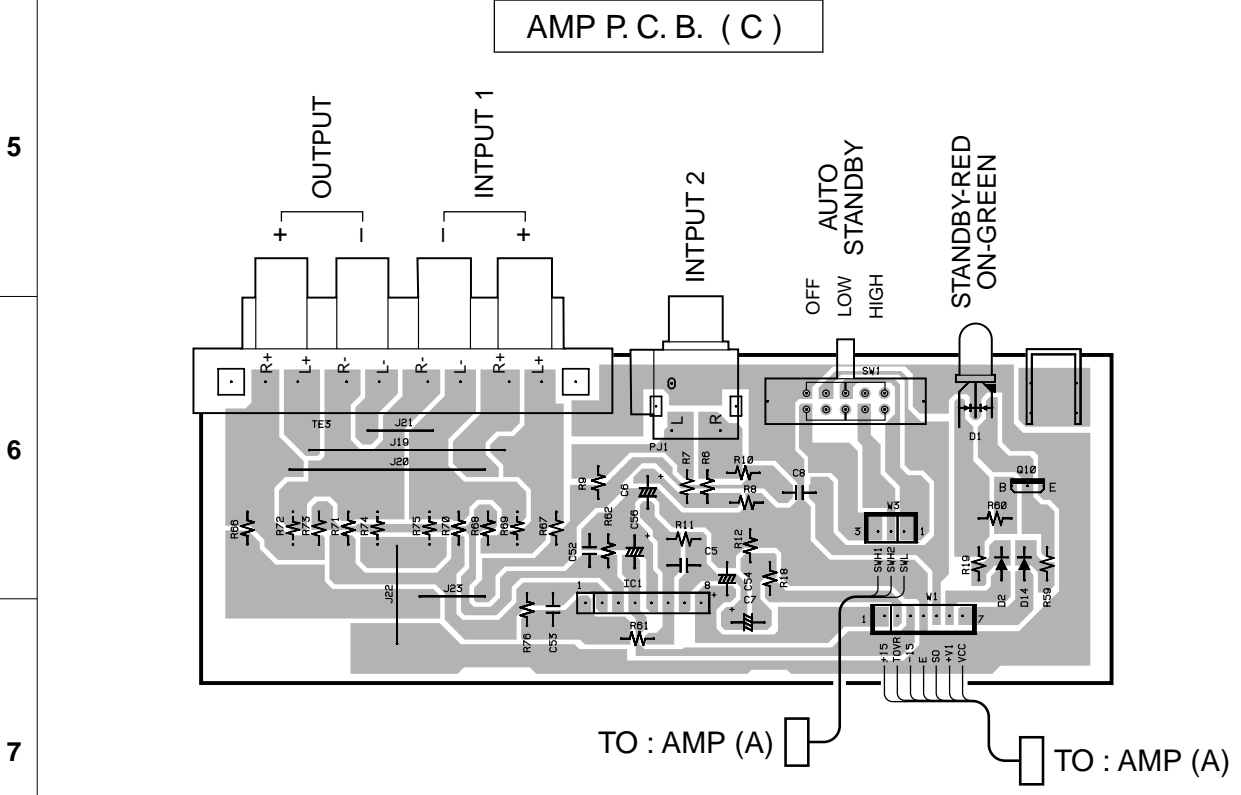
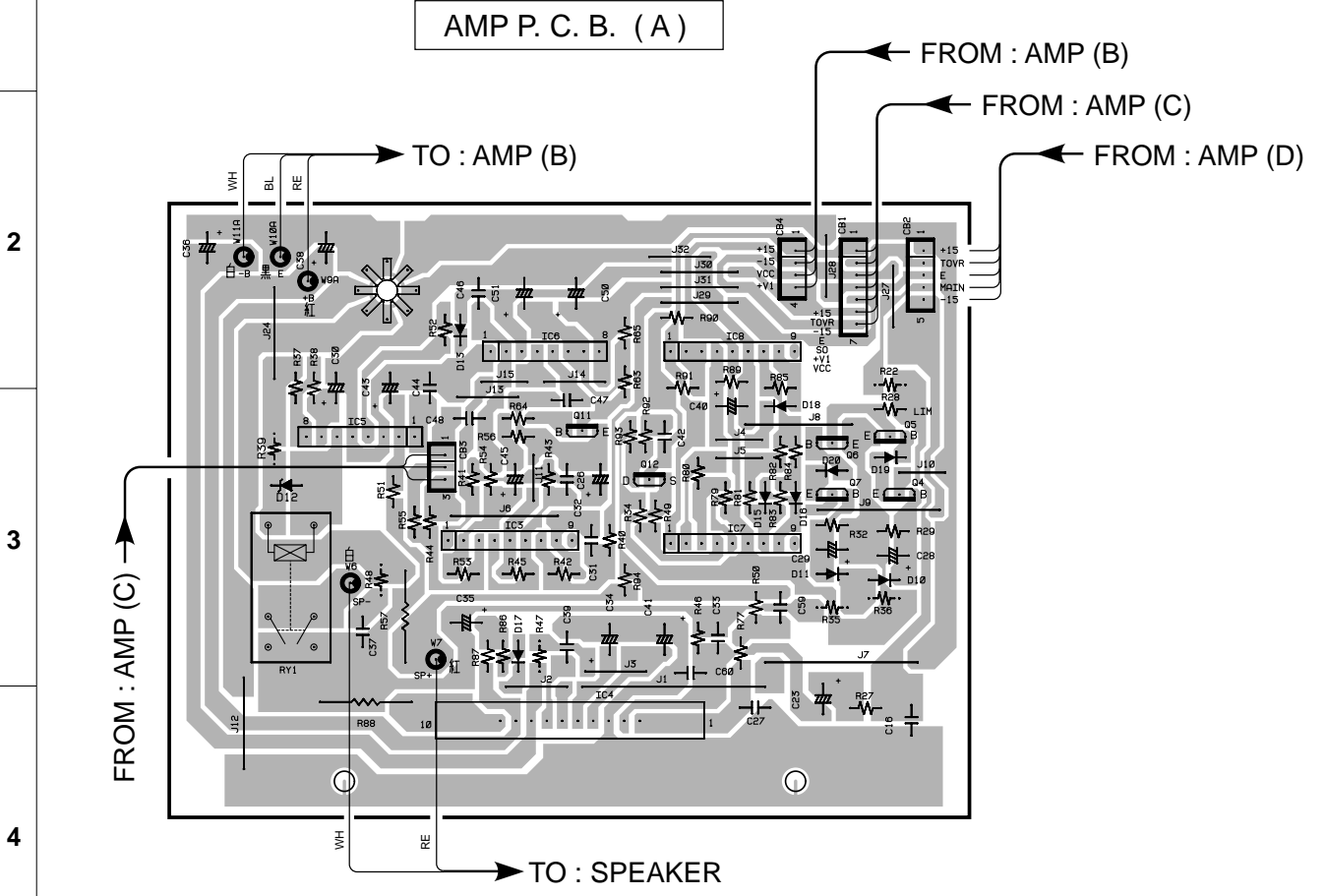

NS-P320

SW-P201 PRINTED CIRCUIT BOARD (Component side)

AMP P. C. B. (B)

R, K only

VOLTAGE SELECTOR

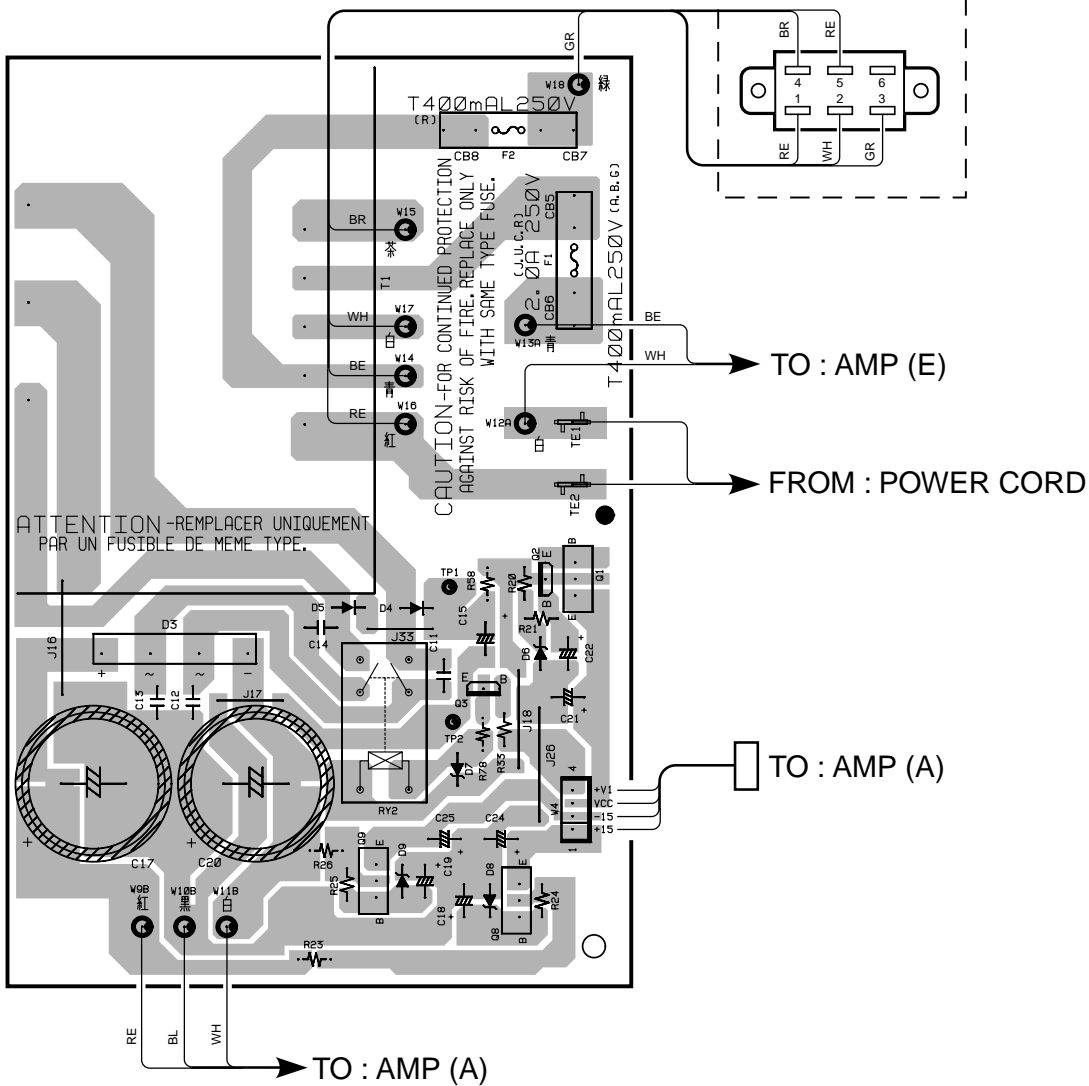

AMP P. C. B. (D)

AMP P. C. B. (E)

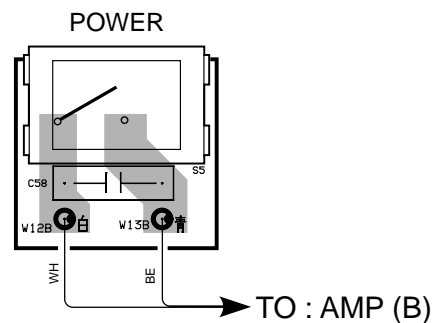
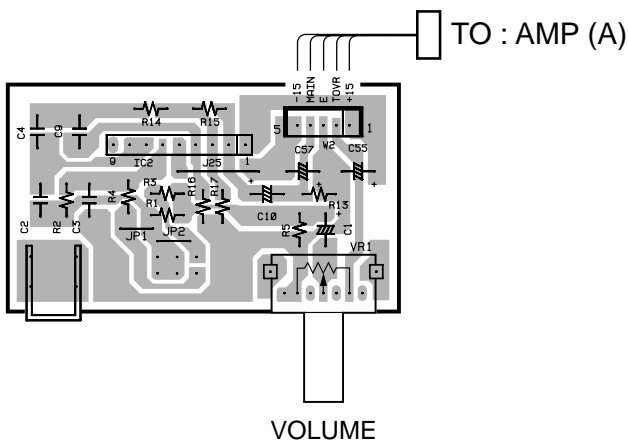

SW-P201 SCHEMATIC DIAGRAM

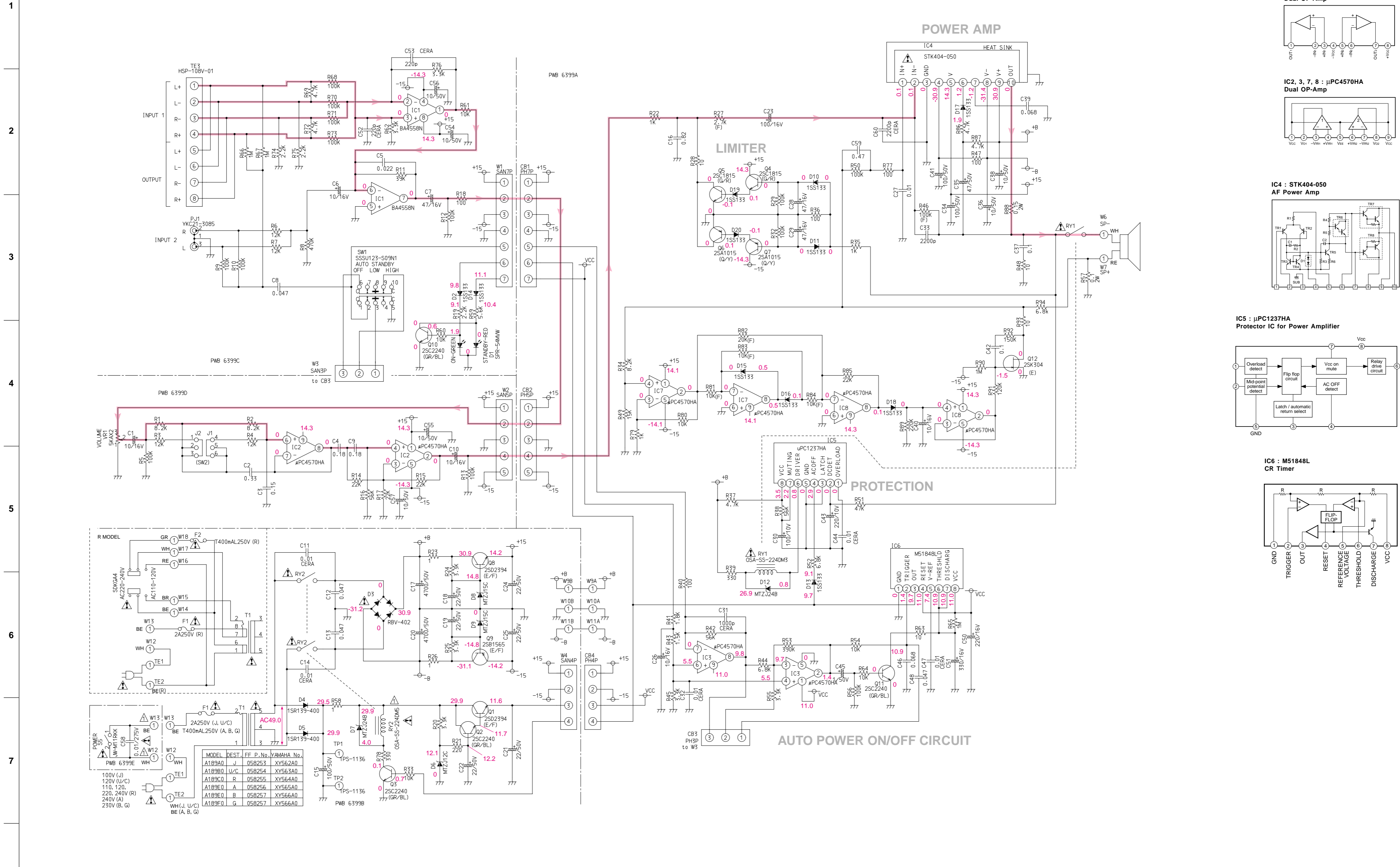

IC1 : BA4558N Dual OP-Amp

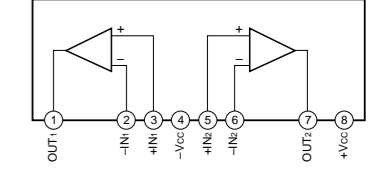

IC2, 3, 7, 8 : μPC4570HA Dual OP-Amp

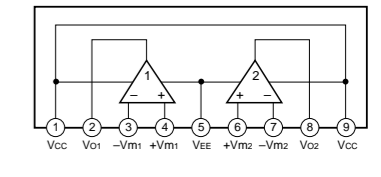

IC4 : STK404-050 AF Power Amp

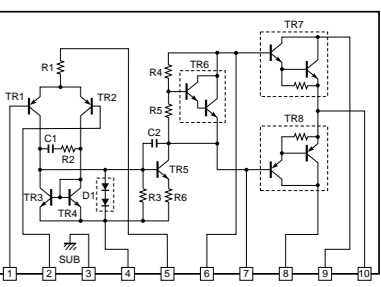

IC5 : μPC1237HA Protector IC for Power Amplifier

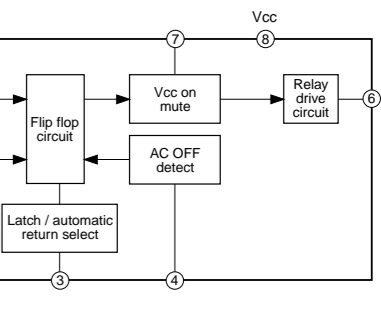

IC6 : M51848L CR Timer

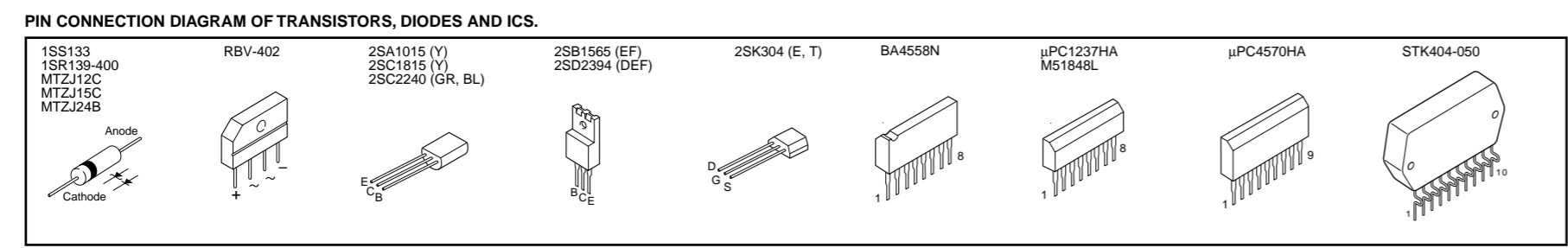
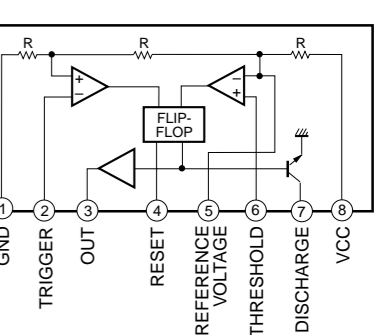

* All voltage are measured with a 10MΩ/V DC electric volt meter.
 * Components having special characteristics are marked Δ and must be replaced with parts having specifications equal to those originally installed.
 * Schematic diagram is subject to change without notice.

PARTS LIST

■ ELECTRICAL PARTS

■ WARNING

Components having special characteristics are marked \triangle and must be replaced with parts having specifications equal to those originally installed.

- Carbon resistors (1/6W or 1/4W) are not included in the ELECTRICAL PARTS List. For the parts No. of the carbon resistors, refer to last page.

ABBREVIATIONS IN THIS LIST ARE AS FOLLOWS :

C.A.EL.CHP	: CHIP ALUMI. ELECTROLYTIC CAP	L.EMIT	: LIGHT EMITTING MODULE
C.CE	: CERAMIC CAP	LED.DSPLY	: LED DISPLAY
C.CE.ARRAY	: CERAMIC CAP ARRAY	LED.INFRD	: LED, INFRARED
C.CE.CHP	: CHIP CERAMIC CAP	MODUL.RF	: MODULATOR, RF
C.CE.ML	: MULTILAYER CERAMIC CAP	PHOT.CPL	: PHOTO COUPLER
C.CE.M.CHP	: CHIP MULTILAYER CERAMIC CAP	PHOT.INTR	: PHOTO INTERRUPTER
C.CE.SAFTY	: RECOGNIZED CERAMIC CAP	PHOT.RFLCT	: PHOTO REFLECTOR
C.CE.TUBLR	: CERAMIC TUBULAR CAP	PIN.TEST	: PIN, TEST POINT
C.CE.SMI	: SEMI CONDUCTIVE CERAMIC CAP	PLST.RIVET	: PLASTIC RIVET
C.EL	: ELECTROLYTIC CAP	R.ARRAY	: RESISTOR ARRAY
C.MICA	: MICA CAP	R.CAR	: CARBON RESISTOR
C.ML.FLM	: MULTILAYER FILM CAP	R.CAR.CHP	: CHIP RESISTOR
C.MP	: METALLIZED PAPER CAP	R.CAR.FP	: FLAME PROOF CARBON RESISTOR
C.MYLAR	: MYLAR FILM CAP	R.FUS	: FUSABLE RESISTOR
C.MYLAR.ML	: MULTILAYER MYLAR FILM CAP	R.MTL.CHP	: CHIP METAL FILM RESISTOR
C.PAPER	: PAPER CAPACITOR	R.MTL.FLM	: METAL FILM RESISTOR
C.PLS	: POLYSTYRENE FILM CAP	R.MTL.OXD	: METAL OXIDE FILM RESISTOR
C.POL	: POLYESTER FILM CAP	R.MTL.PLAT	: METAL PLATE RESISTOR
C.POLY	: POLYETHYLENE FILM CAP	RSNR.CE	: CERAMIC RESONATOR
C.PP	: POLYPROPYLENE FILM CAP	RSNR.CRYS	: CRYSTAL RESONATOR
C.TNTL	: TANTALUM CAP	R.TW.CEM	: TWIN CEMENT FIXED RESISTOR
C.TNTL.CHP	: CHIP TANTALUM CAP	R.WW	: WIRE WOUND RESISTOR
C.TRIM	: TRIMMER CAP	SCR.BND.HD	: BIND HEAD B-TITE SCREW
CN	: CONNECTOR	SCR.BW.HD	: BW HEAD TAPPING SCREW
CN.BS.PIN	: CONNECTOR, BASE PIN	SCR.CUP	: CUP TITE SCREW
CN.CANNON	: CONNECTOR, CANNON	SCR.TERM	: SCREW TERMINAL
CN.DIN	: CONNECTOR, DIN	SCR.TR	: SCREW, TRANSISTOR
CN.FLAT	: CONNECTOR, FLAT CABLE	SUPRT.PCB	: SUPPORT, P.C.B.
CN.POST	: CONNECTOR, BASE POST	SURG.PRTCT	: SURGE PROTECTOR
COIL.MX.AM	: COIL, AM MIX	SW.TACT	: TACT SWITCH
COIL.AT.FM	: COIL, FM ANTENNA	SW.LEAF	: LEAF SWITCH
COIL.DT.FM	: COIL, FM DETECT	SW.LEVER	: LEVER SWITCH
COIL.MX.FM	: COIL, FM MIX	SW.MICRO	: MICRO SWITCH
COIL.OUTPT	: OUTPUT COIL	SW.PUSH	: PUSH SWITCH
DIOD.ARRAY	: DIODE ARRAY	SW.RT.ENC	: ROTARY ENCODER
DIODE.BRG	: DIODE BRIDGE	SW.RT.MTR	: ROTARY SWITCH WITH MOTOR
DIODE.CHP	: CHIP DIODE	SW.RT	: ROTARY SWITCH
DIODE.VAR	: VARACTOR DIODE	SW.SLIDE	: SLIDE SWITCH
DIOD.Z.CHP	: CHIP ZENER DIODE	TERM.SP	: SPEAKER TERMINAL
DIODE.ZENR	: ZENER DIODE	TERM.WRAP	: WRAPPING TERMINAL
DSCR.CE	: CERAMIC DISCRIMINATOR	THRMST.CHP	: CHIP THERMISTOR
FER.BEAD	: FERRITE BEADS	TR.CHP	: CHIP TRANSISTOR
FER.CORE	: FERRITE CORE	TR.DGT	: DIGITAL TRANSISTOR
FET.CHP	: CHIP FET	TR.DGT.CHP	: CHIP DIGITAL TRANSISTOR
FL.DSPLY	: FLUORESCENT DISPLAY	TRANS	: TRANSFORMER
FLTR.CE	: CERAMIC FILTER	TRANS.PULS	: PULSE TRANSFORMER
FLTR.COMB	: COMB FILTER MODULE	TRANS.PWR	: POWER TRANSFORMER ASS'y
FLTR.LC.RF	: LC FILTER, EMI	TUNER.AM	: TUNER PACK, AM
GND.MTL	: GROUND PLATE	TUNER.FM	: TUNER PACK, FM
GND.TERM	: GROUND TERMINAL	TUNER.PK	: FRONT-END TUNER PACK
HOLDER.FUS	: FUSE HOLDER	VR	: ROTARY POTENTIOMETER
IC.PRTCT	: IC PROTECTOR	VR.MTR	: POTENTIOMETER WITH MOTOR
JUMPER.CN	: JUMPER CONNECTOR	VR.SW	: POTENTIOMETER WITH ROTARY SW
JUMPER.TST	: JUMPER, TEST POINT	VR.SLIDE	: SLIDE POTENTIOMETER
L.DTCT	: LIGHT DETECTING MODULE	VR.TRIM	: TRIMMER POTENTIOMETER

Note) Those parts marked with “#” are not included in the P.C.B. ass'y.

SW-P201 P.C.B. AMP

Schm Ref.	PART NO.	Description	Remarks
	AAX14790	P. C. B.	AMP (UC) 330571
	AAX14800	P. C. B.	AMP (RK) 330572
	AAX14810	P. C. B.	AMP (ABG) 330573
C1	UR837100	C. EL	10uF 16V 066833
C2	UA655330	C. MYLAR	0.33uF 50V 044570
C3	UA655150	C. MYLAR	0.15uF 50V 065292
C4	UA655180	C. MYLAR	0.18uF 50V 065297
C5	XX707860	C. POL	0.022uF 50V 064984
C6	UR837100	C. EL	10uF 16V 066833
C7	UR837470	C. EL	47uF 16V 066963
C8	UA654470	C. MYLAR	0.047uF 50V 064987
C9	UA655180	C. MYLAR	0.18uF 50V 065297
C10	UR837100	C. EL	10uF 16V 066833
C11	FG644100	C. CE	0.01uF 50V 065452
C12	UA654470	C. MYLAR	0.047uF 50V 064987
C13	UA654470	C. MYLAR	0.047uF 50V 064987
C14	FG644100	C. CE	0.01uF 50V 065452
C15	UJ668100	C. EL	100uF 50V 058262
C16	UA655820	C. MYLAR	0.82uF 50V 051719
C17	VG892500	C. EL	4700uF 50V 066742
C18	Ui367220	C. EL	22uF 50V 058261
C19	Ui367220	C. EL	22uF 50V 058261
C20	VG892500	C. EL	4700uF 50V 066742
C21	Ui367220	C. EL	22uF 50V 058261
C22	Ui367220	C. EL	22uF 50V 058261
C23	UR838100	C. EL	100uF 16V 066840
C24	Ui367220	C. EL	22uF 50V 058261
C25	Ui367220	C. EL	22uF 50V 058261
C26	UR837100	C. EL	10uF 16V 066833
C27	UA354100	C. MYLAR	0.01uF 50V 064981
C28	UR837470	C. EL	47uF 16V 066963
C29	UR837470	C. EL	47uF 16V 066963
C30	FX606590	C. EL	100uF 10V 058260
C31	FG613100	C. CE	1000pF 50V 065385
C32	FG644100	C. CE	0.01uF 50V 065452
C33	XX707850	C. POL	0.0022uF 50V 065055
C34	UJ668100	C. EL	100uF 50V 058262
C35	UJ667470	C. EL	47uF 50V 058259
C36	FX607210	C. EL	10uF 50V 058258
C37	UA655100	C. MYLAR	0.1uF 50V 065269
C38	FX607210	C. EL	10uF 50V 058258
C39	UA654680	C. MYLAR	0.068uF 50V 064989
C40	UR837100	C. EL	10uF 16V 066833
C41	UJ668100	C. EL	100uF 50V 058262
C42	UA655100	C. MYLAR	0.1uF 50V 065269
C43	VE117600	C. EL	220uF 10V 066900
C44	FG644100	C. CE	0.01uF 50V 065452
C45	VG290500	C. EL	1uF 50V 066870
C46	UA654680	C. MYLAR	0.068uF 50V 064989
C47	FG644100	C. CE	0.01uF 50V 065452
C48	UA654470	C. MYLAR	0.047uF 50V 064987
C50	UR838220	C. EL	220uF 16V 045291
C51	VG287800	C. EL	330uF 16V 045312

* New Parts

Schm Ref.	PART NO.	Description	Remarks
C52	UG412220	C. CE	220pF 50V 065404
C53	UG412220	C. CE	220pF 50V 065404
C54	FX607210	C. EL	10uF 50V 058258
C55	FX607210	C. EL	10uF 50V 058258
C56	FX607210	C. EL	10uF 50V 058258
C57	FX607210	C. EL	10uF 50V 058258
C58	VS741700	C. POL	0.01uF 275V 065262
C59	UA655470	C. MYLAR	0.47uF 50V 044631
C60	UG413220	C. CE	0.0022uF 50V 065407
CB5	VP206500	HOLDER . FUS	EYF-52BCT 074277
CB6	VP206500	HOLDER . FUS	EYF-52BCT 074277
CB7	VP206500	HOLDER . FUS	EYF-52BCT(R) 074277
CB8	VP206500	HOLDER . FUS	EYF-52BCT(R) 074277
D1	AAX13500	LED	LED SPR-54MWWF 070008
D2	iF004600	D IODE	1SS133 069460
D3	VC971500	D IODE . BRG	RBV-402 4.0A 200V 069612
D4	VU264100	D IODE	1SR139-400 069536
D5	VU264100	D IODE	1SR139-400 069536
D6	VG440300	D IODE . ZENR	MTZJ12C 12V 069172
D7	VG442500	D IODE . ZENR	MTZJ24B 069220
D8	VG440800	D IODE . ZENR	MTZJ15B 15V 069190
D9	VG440800	D IODE . ZENR	MTZJ15B 15V 069190
D10	iF004600	D IODE	1SS133 069460
D11	iF004600	D IODE	1SS133 069460
D12	VG442500	D IODE . ZENR	MTZJ24B 069220
D13	iF004600	D IODE	1SS133 069460
D14	iF004600	D IODE	1SS133 069460
D15	iF004600	D IODE	1SS133 069460
D16	iF004600	D IODE	1SS133 069460
D17	iF004600	D IODE	1SS133 069460
D18	iF004600	D IODE	1SS133 069460
D19	iF004600	D IODE	1SS133 069460
D20	iF004600	D IODE	1SS133 069460
F1	AAX13570	FUSE	2A 250V(UCR) 058991
F1	KB000660	FUSE	400mA 250V(ABG) 075126
F2	KB000660	FUSE	400mA 250V(RK) 075126
IC1	AAX13480	IC	BA4558N 044472
IC2	XB247A00	IC	uPC4570HA 070111
IC3	XB247A00	IC	uPC4570HA 070111
IC4	AAX13490	IC	STK404-050 AF 058246
IC5	XF663A00	IC	uPC1237HA 070293
IC6	XP741A00	IC	M51848L 070916
IC7	XB247A00	IC	uPC4570HA 070111
IC8	XB247A00	IC	uPC4570HA 070111
PJ1	AAX13580	JACK . PIN	2P YKC21-3085 058243
Q1	VS883400	TR	2SD2394 D, E, F 068968
Q2	AAX12590	TR	2SC2240 GR BL 073532
Q3	AAX12590	TR	2SC2240 GR BL 073532
Q4	iC1815M0	TR	2SC1815 Y, GR 068741
Q5	iC1815M0	TR	2SC1815 Y, GR 068741
Q6	iA101590	TR	2SA1015 O, Y 068587
Q7	iA101590	TR	2SA1015 O, Y 068587
Q8	VS883400	TR	2SD2394 D, E, F 068968

* New Parts

SW-P201 P.C.B. AMP

Schm Ref.	PART NO.	Description	Remarks
Q9	VS883300	TR	2SB1565 E, F 044140
Q10	AAX12590	TR	2SC2240 GR BL 073532
Q11	AAX12590	TR	2SC2240 GR BL 073532
Q12	AAX09180	FET	2SK304 E 051061
R23	AAX11950	R. CAR. FP	1 1/4W 084665
R26	AAX11950	R. CAR. FP	1 1/4W 084665
R27	VH005800	R. MTL. FLM	2.7K 1/4W 068203
R35	AAX11880	R. CAR. FP	1K 1/4W 044454
R36	AAX11860	R. CAR. FP	100 1/4W 044153
R39	HV454820	R. CAR. FP	82 1/4W 044149
R46	VH009600	R. MTL. FLM	100K 1/4W 068149
R47	AAX11860	R. CAR. FP	100 1/4W 044153
R48	AAX11870	R. CAR. FP	10 1/4W 044452
R57	AAX13640	R. METAL	0.1 2W 045244
R58	AAX11950	R. CAR. FP	1 1/4W 084665
R69	HV456470	R. CAR. FP	4.7K 1/4W 044152
R72	HV456470	R. CAR. FP	4.7K 1/4W 044152
R74	HV456220	R. CAR. FP	2.2K 1/4W 044209
R75	HV456220	R. CAR. FP	2.2K 1/4W 044209
R78	HV455330	R. CAR. FP	330 1/4W
R81	VP441400	R. MTL. FLM	10K 1/4W 068279
R82	AAX09780	R. MTL. FLM	20K 1/4W 068187
R83	VP441400	R. MTL. FLM	10K 1/4W 068279
R84	VP441400	R. MTL. FLM	10K 1/4W 068279
R88	AAX13650	R. METAL	0.15 2W 058287
RY1	VU161600	RELAY	OSA-SS-224-DM3 079766
RY2	VW272600	RELAY	OSA-SS-224-DM5 079770
SW1	VD179500	SW. SLIDE	SSSU123-S09N1 044160
TE1	XX707320	PIN	IPS-5007 064821
TE2	XX707320	PIN	IPS-5007 064821
TE3	AAX13530	TERM. SP	8P 044223
VR1	V2515500	VR	A5K 058244
	BB070700	GND. MTL	075884

* New Parts

Schm Ref.	PART NO.	Description	Remarks

* New Parts

NS-P320

NS-P320

SW-P201 EXPLODED VIEW

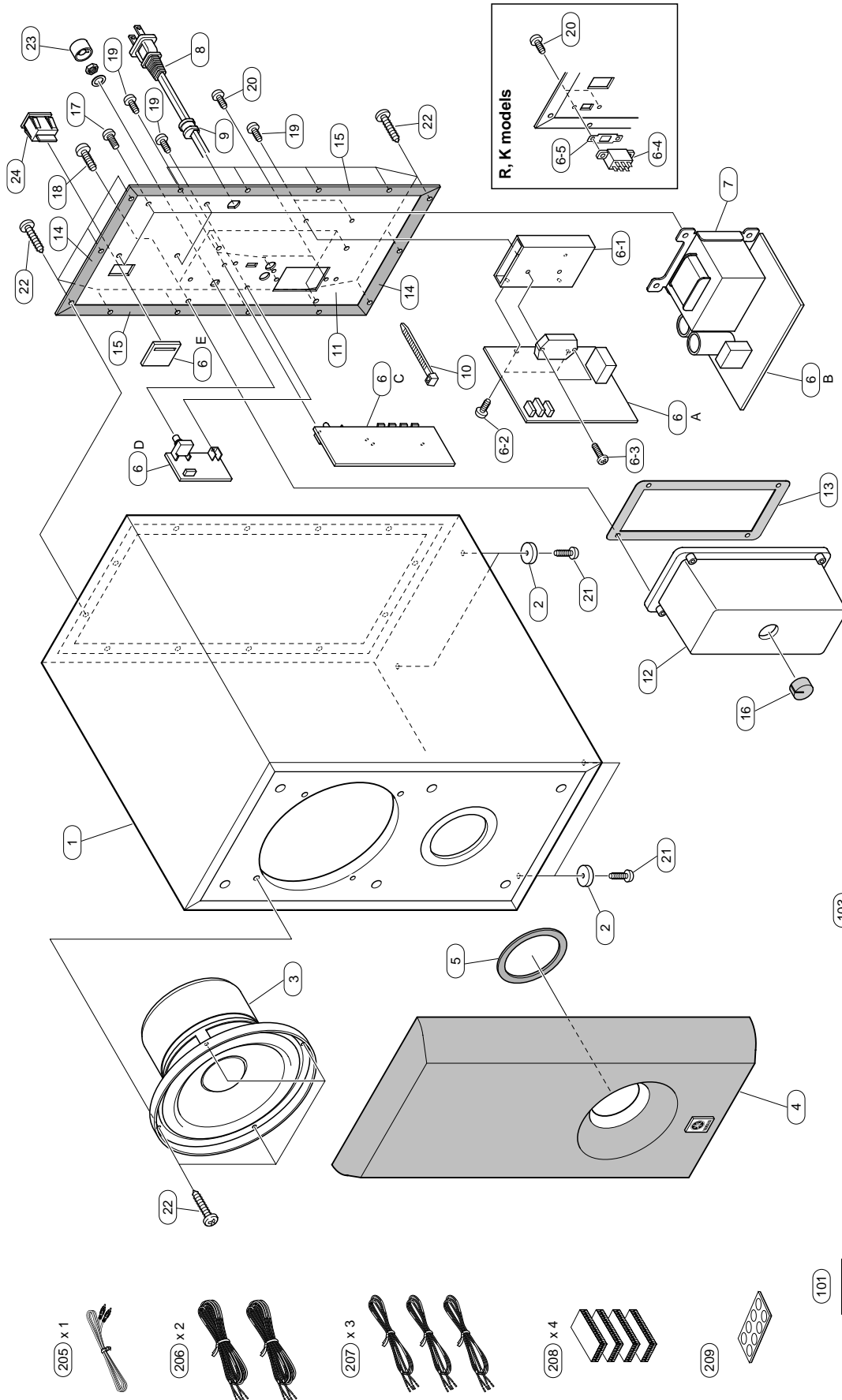

Removal of Front Grille of NS-M104

Insert a knife or the like into the gaps near 6 bosses to separate them gradually. During this work, keep the gap at the center a little larger than the upper and lower gaps, taking the warp into account.

NS-M104, NS-C104 & NNS-E104 requires replacement as a unit. Components cannot be supplied as individually.

■ SW-P201 MECHANICAL PARTS

Ref. No.	PART NO.	Description	Remarks	Markets
1	AA13510	ENCLOSURE	BLACK	058581
1	AA123520	ENCLOSURE	SILVER	337936
2	AA12290	FOOT		055357
3	XY559A00	SPEAKER	16cm JA1678	058529
4	AA13590	FRONT GRILLE ASS'Y	BLACK	058579
4	AA123590	FRONT GRILLE ASS'Y	BLACK GRAY	337280
4	AA119530	FRONT GRILLE ASS'Y	SILVER	332028
5	AA112930	SEAL		056813
6	AA114790	P.C.B. ASS'Y	AMP	330571
6	AA114800	P.C.B. ASS'Y	AMP	330572
6	AA114810	P.C.B. ASS'Y	AMP	330573
6- 1	AA113560	HEATSINK		058265
6- 2	EP600250	BIND HEAD B-TITE SCREW	3x8 MFZN2Y	075636
6- 3	AA113540	BIND HEAD B-TITE SCREW	3x15 ZC	075644
△ 6- 4	VE962600	SLIDE SWITCH	SDKGA4(R)	084733
△ 6- 5	AA113660	CUSHION, SWITCH		084851
△ 7	AA113630	POWER TRANSFORMER		058254
△ 7	AA113770	POWER TRANSFORMER		058255
△ 7	AA113780	POWER TRANSFORMER		058256
△ 7	AA113790	POWER TRANSFORMER		058257
△ 8	AA113760	POWER CORD		050166
△ 8	AA113750	POWER CORD		044483
△ 8	VZ163800	POWER CORD		076131
△ 8	VZ163900	POWER CORD		076130
△ 8	VZ164000	POWER CORD		076128
△* 8	V8012900	POWER CORD		352474
9	AA112230	CUSHION STOPPER	SR-4	078519
10	CB069250	BINDING TIE	BK-1	080558
11	AA113710	REAR PANEL		058276
11	AA113720	REAR PANEL		058278
11	AA113730	REAR PANEL		058279
11	AA113740	REAR PANEL		058280
12	AA113610	MOLD COVER		044183
13	AA113520	CUSHION C		044416
14	AA112910	SEAL		055433
15	AA112920	SEAL		058018
16	AA109370	CUSHION BUSH		084849
17	EK396010	BIND HEAD S-TITE SCREW	4x8 MFC2BL	075180
18	VB744600	BIND HEAD P-TITE SCREW	4x12 MFC2BL	075196
19	AA109630	BIND HEAD B-TITE SCREW	3x8 BL B	075243
20	AA109640	BIND HEAD P-TITE SCREW	3x10 BL	075321
21	AA112130	BIND HEAD TAPPING SCREW	M3.5x16	021404
22	AA112120	BIND HEAD TAPPING SCREW	M4x20	021385
23	AA113600	VOLUME KNOB		044179
△ 24	AA113550	POWER SWITCH	ROCKER JW-M11RK	058288
* 101	AA130530	MAIN SPEAKER SYSTEM	NS-M104 BLACK 1pc	350136
* 101	AA130540	MAIN SPEAKER SYSTEM	NS-M104 SILVER 1pc	350137
* 101-1	AA130510	FRONT GRILLE ASS'Y	BLACK for NS-M104	350162
* 101-1	AA130520	FRONT GRILLE ASS'Y	SILVER for NS-M104	350997
* 102	AA130480	CENTER SPEAKER SYSTEM	NS-C104 BLACK 1pc	350134
* 102	AA130490	CENTER SPEAKER SYSTEM	NS-C104 SILVER 1pc	350135
* 103	AA130550	REAR SPEAKER SYSTEM	NS-E104 BLACK 1pc	350138
* 103	AA130560	REAR SPEAKER SYSTEM	NS-E104 SILVER 1pc	350139
		ACCESSORIES		
205	AA113690	PIN CORD	1P 3m 1pc	019075
206	AA112220	SPEAKER CORD	15m 2pcs/set	055751
207	AA113670	SPEAKER CORD	4m 3pcs/set	058602
* 208	AA130500	FASTENER TAPE	30x25.5 1pair	353654
* 209	AA130470	CUSHION	M10 8pcs/set	353646

* New Parts

Parts List for Carbon Resistors

Value	1/4W Type Part No.	1/6W Type Part No.	Value	1/4W Type Part No.	1/6W Type Part No.
1.0 Ω	HJ35 3100	HF85 3100	10 kΩ	HF45 7100	HF45 7100
1.8 Ω	HJ35 3180	*	11 kΩ	HF45 7110	HF45 7110
2.2 Ω	HJ35 3220	HF85 3220	12 kΩ	HJ35 7120	HF85 7120
3.3 Ω	HJ35 3330	HF85 3330	13 kΩ	HF45 7130	HF45 7130
4.7 Ω	HJ35 3470	HF85 3470	15 kΩ	HF45 7150	HF45 7150
5.6 Ω	HJ35 3560	HF85 3560	18 kΩ	HF45 7180	HF45 7180
10 Ω	HF45 4100	HF45 4100	22 kΩ	HF45 7220	HF45 7220
15 Ω	HJ35 4150	HF85 4150	24 kΩ	HF45 7240	HF45 7240
22 Ω	HF45 4220	HF45 4220	27 kΩ	HJ35 7270	HF85 7270
27 Ω	HJ35 4270	HF85 4270	30 kΩ	HF45 7300	HF45 7300
33 Ω	HF45 4330	HF45 4330	33 kΩ	HF45 7330	HF45 7330
39 Ω	HJ35 4470	HF85 4390	36 kΩ	HF45 7360	HF45 7360
47 Ω	HF45 4470	HF45 4470	39 kΩ	HF45 7390	HF45 7390
56 Ω	HF45 4560	HF45 4560	47 kΩ	HF45 7470	HF45 7470
68 Ω	HF45 4680	HF45 4680	51 kΩ	HF45 7510	HF45 7510
75 Ω	HF45 4750	HF45 4750	56 kΩ	HF45 7560	HF45 7560
82 Ω	HF45 4820	HF45 4820	62 kΩ	HF45 7620	HF45 7620
91 Ω	HF45 4910	HF45 4910	68 kΩ	HF45 7680	HF45 7680
100 Ω	HF45 5100	HF45 5100	82 kΩ	HF45 7820	HF45 7820
110 Ω	HJ35 5110	HF85 5110	91 kΩ	HF45 7910	HF45 7910
120 Ω	HF45 5120	HF45 5120	100 kΩ	HF45 8100	HF45 8100
150 Ω	HF45 5150	HF45 5150	110 kΩ	HF45 8110	HF45 8110
160 Ω	HJ35 5160	*	120 kΩ	HF45 8120	HF45 8120
180 Ω	HF45 5180	HF45 5180	150 kΩ	HF45 8150	HF45 8150
200 Ω	HF45 5200	HF45 5200	180 kΩ	HF45 8180	HF45 8180
220 Ω	HF45 5220	HF45 5220	220 kΩ	HJ35 8220	HF85 8220
270 Ω	HF45 5270	HF45 5270	270 kΩ	HF45 8270	HF45 8270
330 Ω	HF45 5330	HF45 5330	300 kΩ	HF45 8300	HF45 8300
390 Ω	HF45 5390	HF45 5390	330 kΩ	HF45 8330	HF45 8330
430 Ω	HF45 5430	HF45 5430	390 kΩ	HJ35 8390	HF85 8390
470 Ω	HF45 5470	HF45 5470	470 kΩ	HF45 8470	HF45 8470
510 Ω	HF45 5510	HF45 5510	560 kΩ	HJ35 8560	HF85 8560
560 Ω	HF45 5560	HF45 5560	680 kΩ	HJ35 8680	HF85 8680
680 Ω	HF45 5680	HF45 5680	820 kΩ	HJ35 8820	HF85 8820
820 Ω	HF45 5820	HF45 5820	1.0 MΩ	HF45 9100	HF45 9100
910 Ω	HF45 5910	HF45 5910	1.2 MΩ	HJ35 9120	*
1.0 kΩ	HF45 6100	HF45 6100	1.5 MΩ	HJ35 9150	HF85 9150
1.2 kΩ	HF45 6120	HF45 6120	1.8 MΩ	HJ35 9180	HF85 9180
1.5 kΩ	HF45 6150	HF45 6150	2.2 MΩ	HJ35 9220	HF85 9220
1.8 kΩ	HF45 6180	HF45 6180	3.3 MΩ	HJ35 9330	HF85 9330
2.0 kΩ	HJ35 6200	HF85 6200	3.9 MΩ	HJ35 9390	*
2.2 kΩ	HF45 6220	HF45 6220	4.7 MΩ	HJ35 9470	HF85 9470
2.4 kΩ	HJ35 6240	HF85 6240			
2.7 kΩ	HF45 6270	HF45 6270			
3.0 kΩ	HF45 6300	HF45 6300			
3.3 kΩ	HF45 6330	HF45 6330			
3.6 kΩ	HJ35 6360	HF85 6360			
3.9 kΩ	HF45 6390	HF45 6390			
4.7 kΩ	HF45 6470	HF45 6470			
5.1 kΩ	HF45 6510	HF45 6510			
5.6 kΩ	HF45 6560	HF45 6560			
6.8 kΩ	HF45 6680	HF45 6680			
8.2 kΩ	HF45 6820	HF45 6820			
9.1 kΩ	HF45 6910	HF45 6910			

1/4W Type

HJ35 ○○○○

10mm

1/6W Type

HF45 ○○○○

HF85 ○○○○

5mm