

# HOME THEATER SOUND SYSTEM DVX-S120

# DVR-S120/NX-P120

## SERVICE MANUAL

The DVX-S120 is composed of the DVR-S120 and the NX-P120.

DVX-S120 は DVR-S120 と NX-P120 で構成されています。

### IMPORTANT NOTICE

This manual has been provided for the use of authorized YAMAHA Retailers and their service personnel. It has been assumed that basic service procedures inherent to the industry, and more specifically YAMAHA Products, are already known and understood by the users, and have therefore not been restated.

**WARNING:** Failure to follow appropriate service and safety procedures when servicing this product may result in personal injury, destruction of expensive components, and failure of the product to perform as specified. For these reasons, we advise all YAMAHA product owners that any service required should be performed by an authorized YAMAHA Retailer or the appointed service representative.

**IMPORTANT:** The presentation or sale of this manual to any individual or firm does not constitute authorization, certification or recognition of any applicable technical capabilities, or establish a principle-agent relationship of any form.

The data provided is believed to be accurate and applicable to the unit(s) indicated on the cover. The research, engineering, and service departments of YAMAHA are continually striving to improve YAMAHA products. Modifications are, therefore, inevitable and specifications are subject to change without notice or obligation to retrofit. Should any discrepancy appear to exist, please contact the distributor's Service Division.

**WARNING:** Static discharges can destroy expensive components. Discharge any static electricity your body may have accumulated by grounding yourself to the ground buss in the unit (heavy gauge black wires connect to this buss).

**IMPORTANT:** Turn the unit OFF during disassembly and part replacement. Recheck all work before you apply power to the unit.

## CONTENTS

TO SERVICE PERSONNEL .....	2-4
PREVENTION OF ELECTRO STATIC DISCHARGE .....	4
LOCALE MANAGEMENT INFORMATION .....	5
SYSTEM COMPOSITION / システム構成 .....	5
FRONT PANELS .....	6-7
REMOTE CONTROL PANELS .....	7
REAR PANELS .....	8-9
SPECIFICATIONS / 参考仕様 .....	10-12
INTERNAL VIEW .....	13
DVR-S120 DISASSEMBLY PROCEDURES /	
DVR-S120分解手順 .....	14-18
NX-SW120 DISASSEMBLY PROCEDURES /	
NX-SW120分解手順 .....	19-20

DVR-S120 SELF DIAGNOSIS FUNCTION (DIAG) /	
DVR-S120自己診断機能(ダイアグ) .....	21-43
DISPLAY DATA .....	44-45
IC DATA .....	46-55
DVR-S120 ADJUSTMENT / DVR-S120調整 .....	56
DVR-S120 BLOCK DIAGRAM .....	57-59
DVR-S120 PRINTED CIRCUIT BOARD .....	60-68
NX-SW120 PRINTED CIRCUIT BOARD .....	69
DVR-S120 SCHEMATIC DIAGRAM .....	70-79
NX-SW120 SCHEMATIC DIAGRAM .....	80
PARTS LIST .....	81-97
REMOTE CONTROL .....	98



このサービスマニュアルは、エコマーク認定の再生紙を使用しています。  
This Service Manual uses recycled paper.



## ■ TO SERVICE PERSONNEL

### 1. Critical Components Information

Components having special characteristics are marked  $\triangle$  and must be replaced with parts having specifications equal to those originally installed.

### 2. Leakage Current Measurement (For 120V Models Only)

When service has been completed, it is imperative to verify that all exposed conductive surfaces are properly insulated from supply circuits.

- Meter impedance should be equivalent to 1500 ohm shunted by 0.15 $\mu$ F.

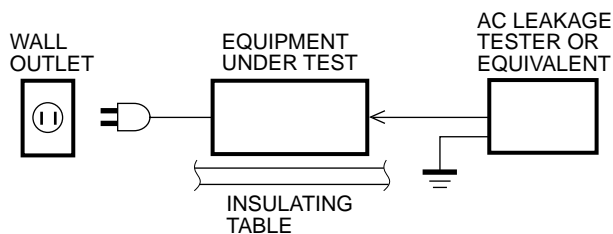

- Leakage current must not exceed 0.5mA.
- Be sure to test for leakage with the AC plug in both polarities.

## WARNING: CHEMICAL CONTENT NOTICE!

The solder used in the production of this product contains LEAD. In addition, other electrical/electronic and/or plastic (where applicable) components may also contain traces of chemicals found by the California Health and Welfare Agency (and possibly other entities) to cause cancer and/or birth defects or other reproductive harm.

**DO NOT PLACE SOLDER, ELECTRICAL/ELECTRONIC OR PLASTIC COMPONENTS IN YOUR MOUTH FOR ANY REASON WHATSOEVER!**

Avoid prolonged, unprotected contact between solder and your skin! When soldering, do not inhale solder fumes or expose eyes to solder/flux vapor!

If you come in contact with solder or components located inside the enclosure of this product, wash your hands before handling food.

## About lead-free solder / 無鉛ハンダについて

The foil side of MAIN P.C.B. and SUB P.C.B. used for the DVR-S120 are soldered with lead-free soldering material which is an alloy of Sn+Ag+Cu (tin + silver + copper).

For the soldering points other than the above, lead solder is used.

Among some types of lead-free solder currently available, it is recommended to use one of the following types for the repair work.

- Sn + Ag + Cu (tin + silver + copper)
- Sn + Cu (tin + copper)
- Sn + Zn + Bi (tin + zinc + bismuth)

### Caution:

1. As the melting point temperature of the lead-free solder is about 30°C to 40°C (50°F to 70°F) higher than that of the lead solder, be sure to use a soldering iron suitable to each solder.
2. If lead solder must be used, be sure to remove lead-free solder from each terminal section of the parts to be replaced and from the area around it completely before soldering, or make sure that the lead-free solder and lead solder melt together fully.

DVR-S120 に使用されている MAIN 基板および SUB 基板のハンダ面のハンダ付けには、Sn+Ag+Cu (錫+銀+銅)の合金である無鉛ハンダが使用されています。

なお、上記以外のハンダ付けには鉛入りハンダが使用されています。

無鉛ハンダにはいくつかの種類がありますが、修理時には下記のような無鉛ハンダの使用を推奨します。

- Sn+Ag+Cu (錫+銀+銅)
- Sn+Cu (錫+銅)
- Sn+Zn+Bi (錫+亜鉛+ビスマス)

### 注意:

1. 無鉛ハンダの融点温度は通常の鉛入りハンダに比べ30～40 程度高くなっていますので、それぞれのハンダに合ったハンダごてをご使用ください。
2. 鉛入りハンダを使わざるを得ない場合は、あらかじめ交換する部品端子部やその周辺部の無鉛ハンダをすべて取り除くか、あるいは無鉛ハンダと鉛入りハンダが十分に溶けた状態となるようにハンダ付けしてください。

## WARNING: Laser Safety

This product contains a laser beam component. This component may emit invisible, as well as visible radiation, which may cause eye damage. To protect your eyes and skin from laser radiation, the following precautions must be used during servicing of the unit.

- 1) When testing and/or repairing any component within the product, keep your eyes and skin more than 30 cm away from the laser pick-up unit at all times. Do not stare at the laser beam at any time.
- 2) Do not attempt to readjust, disassemble or repair the laser pick-up, unless noted elsewhere in this manual.
- 3) CAUTION : Use of controls, adjustments or performance of procedures other than those specified herein may result in hazardous radiation exposure.

## Laser Emitting conditions:

- 1) When the Top Cover is removed, and the STANDBY/ON SW is turned to the "ON" position, the laser component will emit a beam for several seconds to detect if a disc is present. During this time (5-10 sec.) the laser may radiate through the lens of the laser pick-up unit. Do not attempt any servicing during this period! If no disc is detected, the laser will stop emitting the beam. When a disc is loaded, you will not be exposed to any laser emissions.
- 2) The laser power level can be adjusted with the VR on the pick-up PWB, however, this level has been set by the factory prior to shipping from the factory. Do not adjust this laser level control unless instruction is provided elsewhere in this manual. Adjustment of this control can increase the laser emission level from the device.

### Laser Diode Properties

Type:	Semiconductor laser GaAIAs
Wave length:	650 nm (DVD) 790 nm (VCD/CD)
Output Power:	1.45 mW (DVD) 1.31 mW (VCD/CD)
Beam divergence:	60 degree

## 警告：レーザーの安全対策

本機はレーザー光線を放射する部品を搭載しています。この部品が放射するレーザー光線は目に損傷を起こします。このレーザー光線から目及び肌を保護するために、本機の修理作業中は下記の注意を厳守してください。

- 1) テスト時または修理時、目及び肌を光ピックアップから30cm以上離してください。いかなる場合もレーザー光線を見つめないでください。
- 2) 光ピックアップの再調整及び分解はしないでください。
- 3) このマニュアル上で指定されている以外の制御、調整、手順はレーザー光線を照射される結果を招く恐れがあります。

## レーザー放射条件

- 1) トップカバーを取り外しSTANDBY/ONスイッチをONにすると、ディスク検知のため5～10秒間、光ピックアップからレーザー光線が放射されます。この間、修理はしないでください。  
ディスクが検知されなければ、レーザー光線の放射は停止します。ディスクがセットされている場合、ディスクで遮られるのでレーザー光線は修理担当者には届きません。
- 2) レーザーパワーレベルは光ピックアップ基板上のVRにより調整可能ですが、工場出荷前に調整セット済みなので、このVRは廻さないでください。このVRを廻すと装置からのレーザー光線の放射レベルが上がる恐れがあります。

### レーザー

タイプ	半導体レーザー GaAIAs
波長	650 nm (DVD) 790 nm (VCD/CD)
出力	1.45 mW (DVD) 1.31 mW (VCD/CD)
ビーム広がり	60 度

VARO! : AVATTAESSA JA SUOJALUKITUS OHITETTAESSA OLET ALTTIINA NÄKYMÄTTÖMÄLLE LASER-SÄTEILYLLE. ÄLÄ KATSO SÄTEESEEN.

VARNING! : OSYNLIG LASERSTRÅLNING NÄR DENNA DEL ÄR ÖPPNAD OCH SPÄRREN ÄR URKOPPLAD. BETRAKTA EJ STRÅLEN.

## WARNING

The use of optical instruments with this product will increase eye hazard.

Repair handling should take place as much as possible with a disc loaded inside the player.

U, C, R, T, K, G, B, L, A models



The label is put on the bottom side of the unit.

U, C, R, T, K, G, B, L, A models

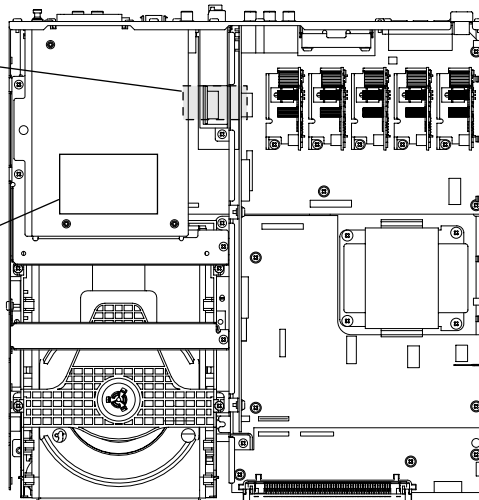
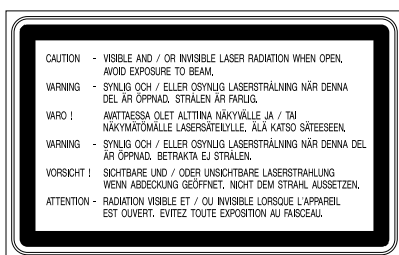

## ■ PREVENTION OF ELECTRO STATIC DISCHARGE

The laser diode in the traverse unit (optical pickup) may be damaged due to static electricity from clothes or the human body. Use caution to prevent electrostatic damage when servicing or handling the laser diode.

### 1. Grounding for electrostatic damage prevention

Some devices, such as the DVD player, use an optical pickup (laser diode) that will be damaged by static electricity in the working environment. Only attempt service after ensuring that all grounding procedures have been completed.

#### 1. Worktable grounding

Put a grounded conductive material (sheet) or iron sheet on the area where the optical pickup is placed.

#### 2. Human body grounding

Use an anti-static wrist strap to discharge the static electricity from your body.

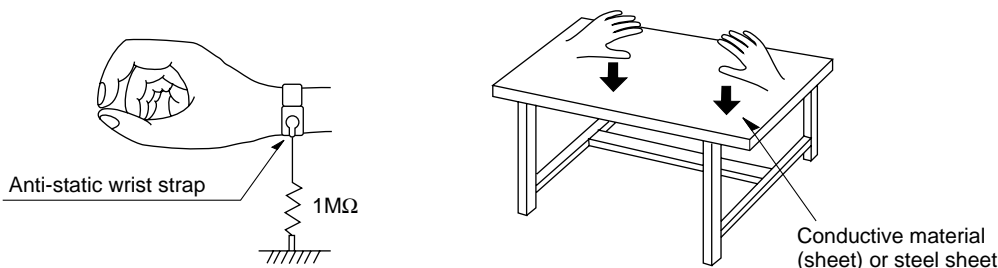

### 2. Handling of the optical pickup

- To prevent damage to the optical pickup replacement parts during transportation and before installation, both ends of the laser diode are short-circuited. After installing the new part, remove the short circuit according to the correct procedure in this service manual.
- Do not use a tester to check the laser diode in the optical pickup. The power supply in the tester will damage the laser diode.

### 3. Handling Precautions for the Traverse Unit (Optical Pickup)

- Handle the traverse unit (optical pickup) gently, as it is an extremely high-precision assembly.
- The flexible cable lines may break if an excessive force is applied to it. Use caution when handling the cable.
- The semi-fixed resistor for laser power adjustment should not be adjusted. Do not turn the resistor.

## ■ LOCALE MANAGEMENT INFORMATION

Locale Management Information : This DVD player is designed and manufactured to respond to the Locale Management Information that is recorded on a DVD disc. If the Locale number described on the DVD disc does not correspond to the Locale number of this DVD player, this DVD player cannot play this disc.

This product incorporates copyright protection technology that is protected by method claims of certain U.S. patents and other intellectual property rights owned by Macrovision Corporation and other rights owners. Use of this copyright protection technology must be authorized by Macrovision Corporation, and is intended for home and other limited viewing uses only unless otherwise authorized by Macrovision Corporation. Reverse engineering or disassembly is prohibited.

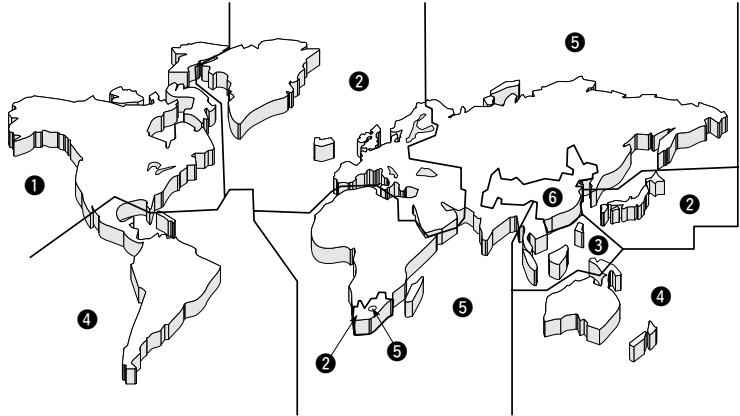

## ■ SYSTEM COMPOSITION / システム構成

The DVX-S120 is composed of the DVR-S120 and the NX-P120.

**DVR-S120**

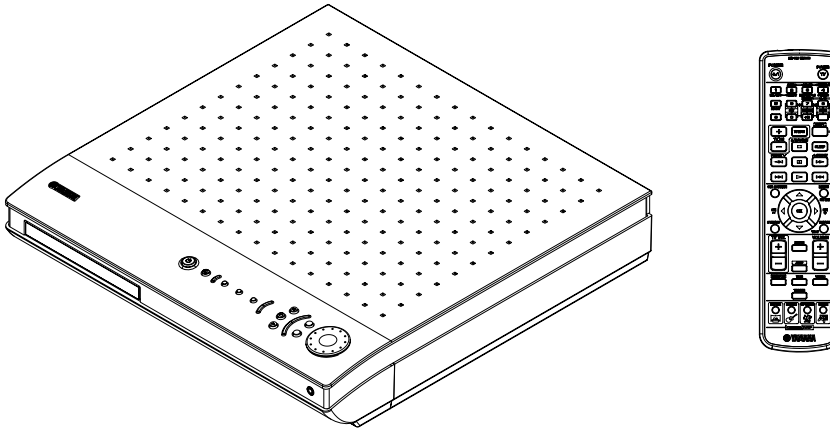

**NX-P120**

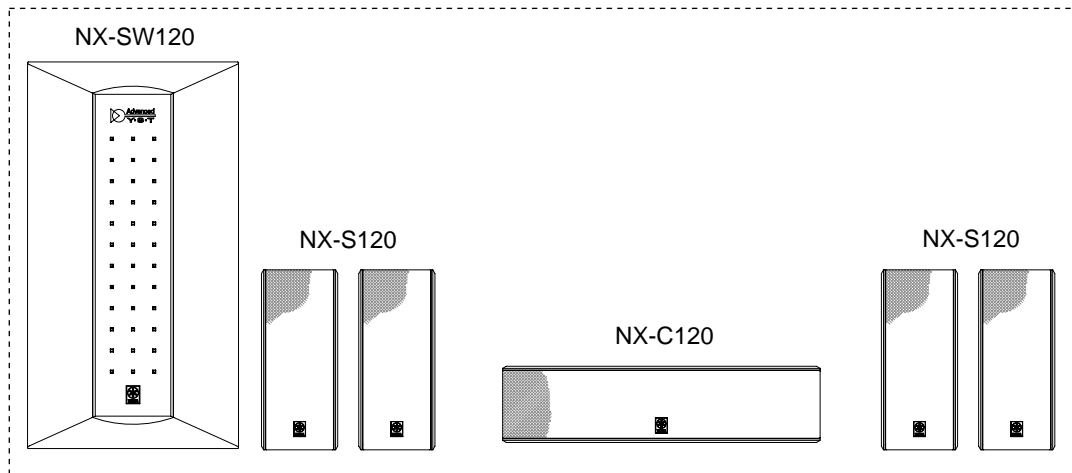

# FRONT PANELS

## ▼ DVR-S120

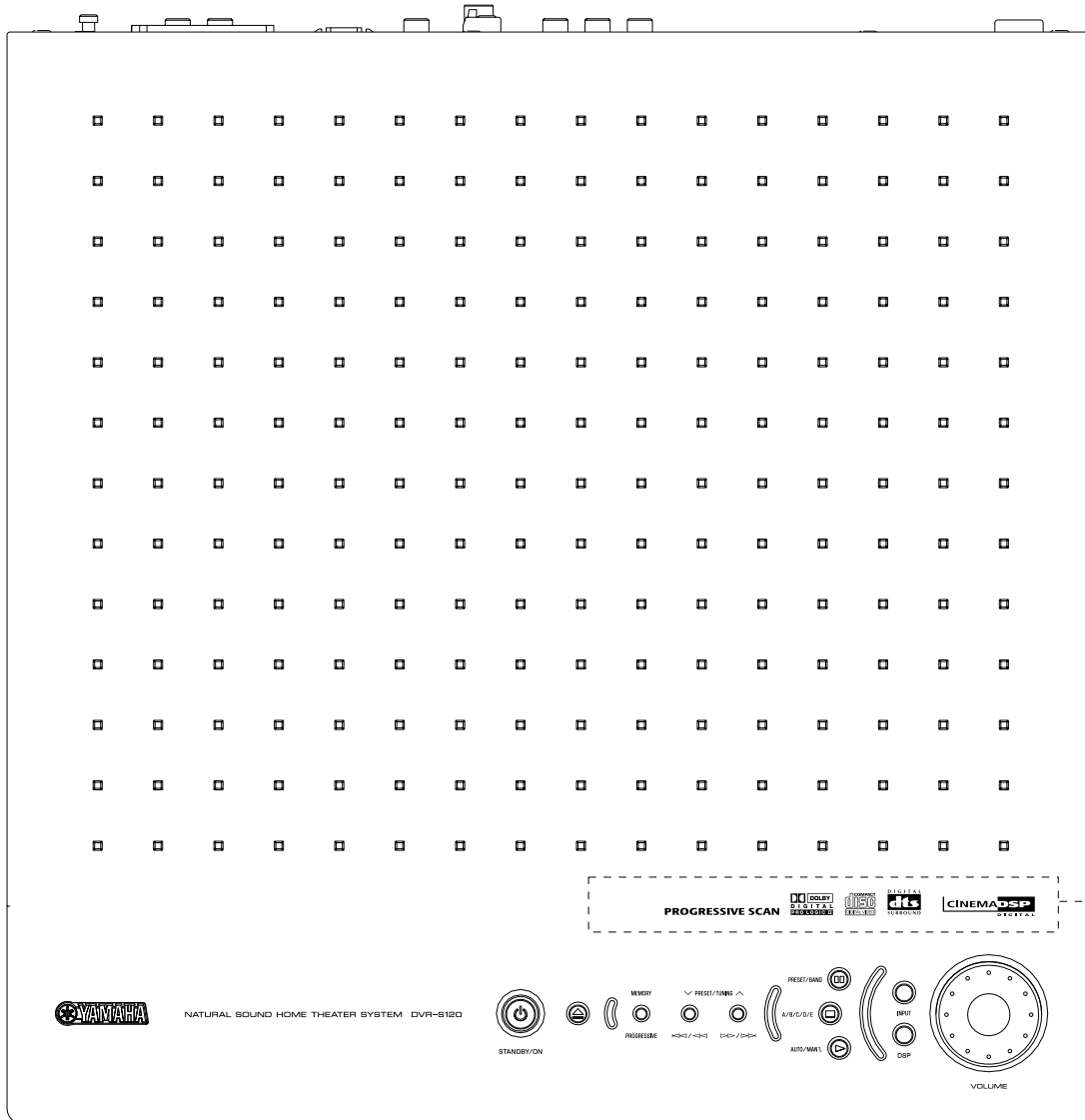
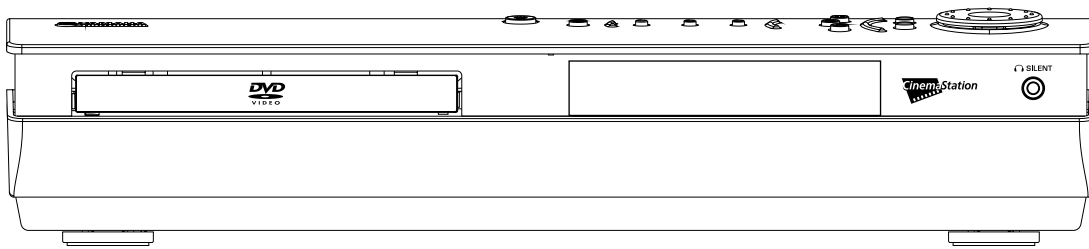

### U, C, R, T, K, L, A models



### B, G models



### J model



▼ NX-SW120

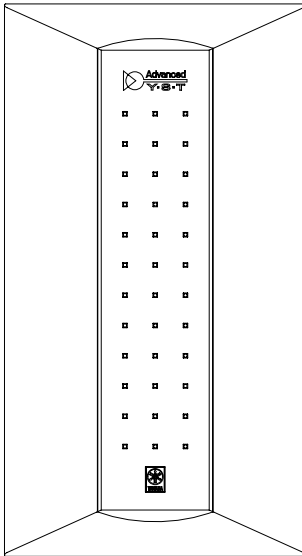

▼ NX-C120

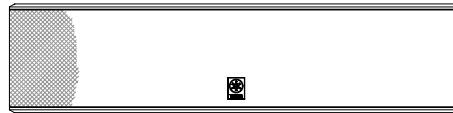

▼ NX-S120

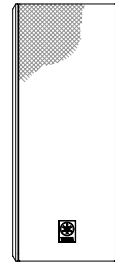

■ REMOTE CONTROL PANELS

▼ J model

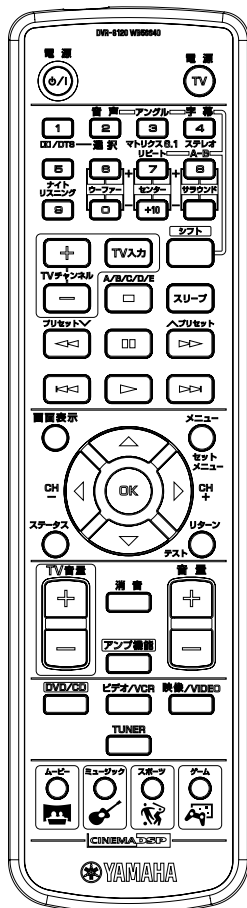

▼ U, C, R, T, K, L, A models

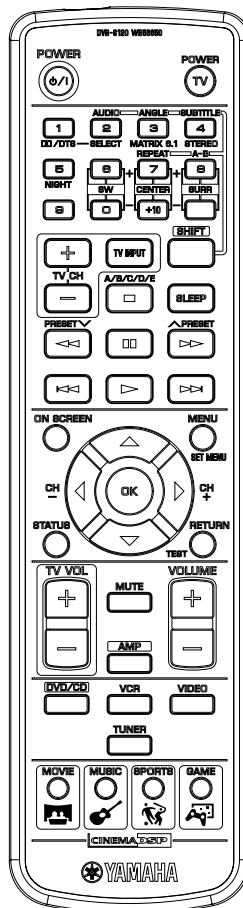

▼ B, G models

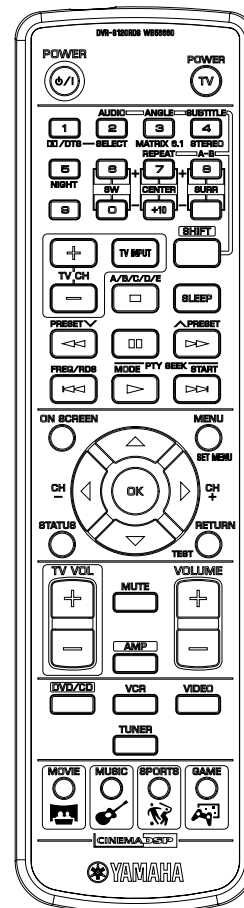

## REAR PANELS

### ▼ DVR-S120 (U, C, R, T, K, L, A models)

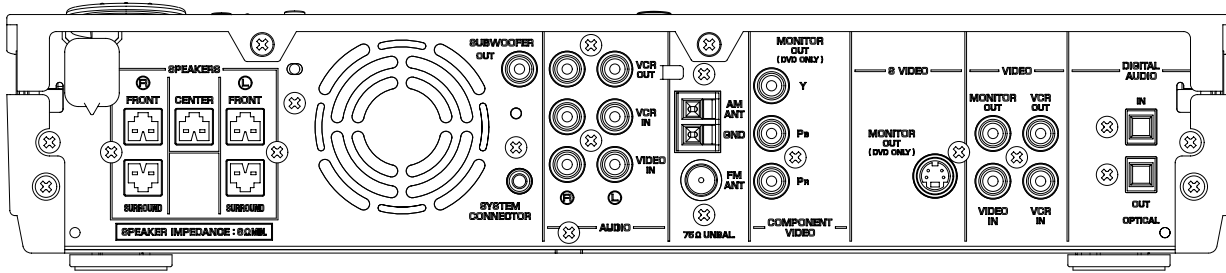

### ▼ DVR-S120 (B, G models)

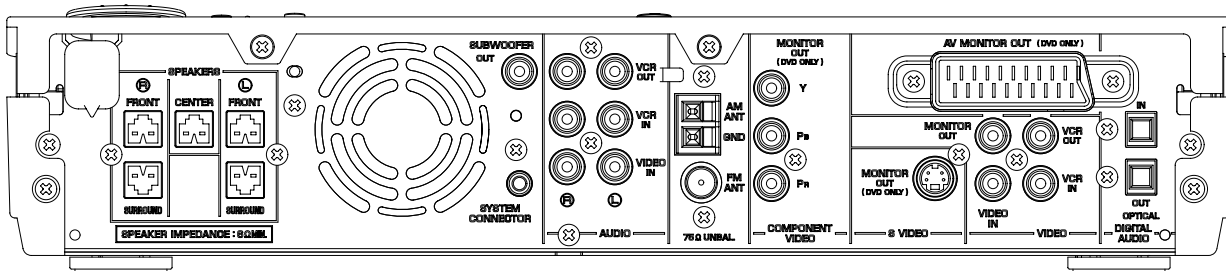

### ▼ DVR-S120 (J model)

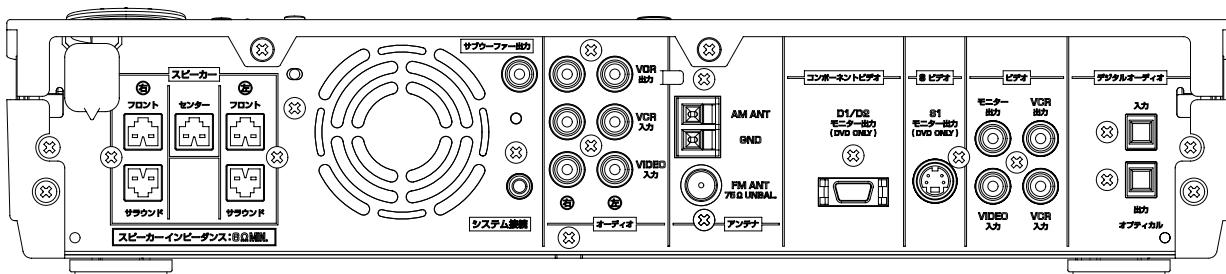

### ▼ NX-S120

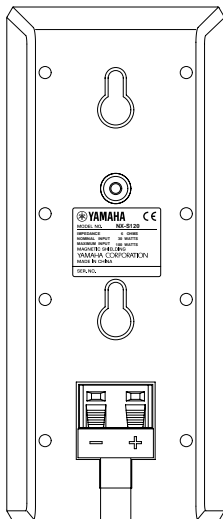

### ▼ NX-C120

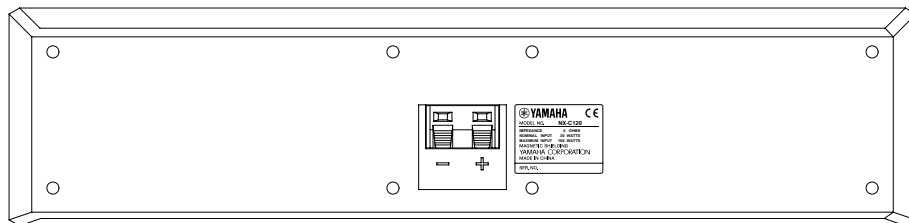



▼ NX-SW120 (U, C models)

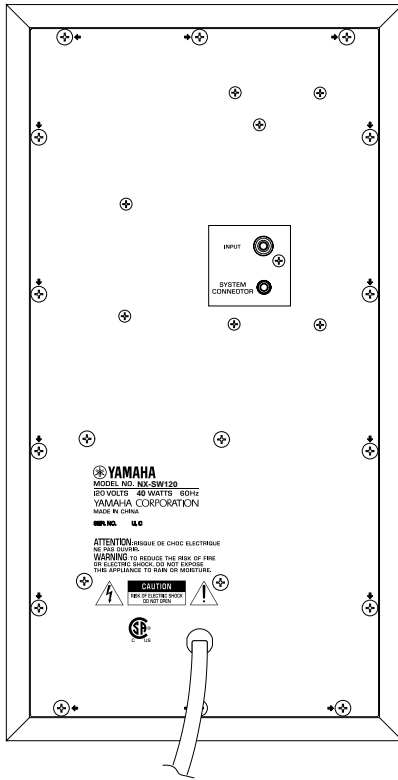

▼ NX-SW120 (R, L, T, K models)

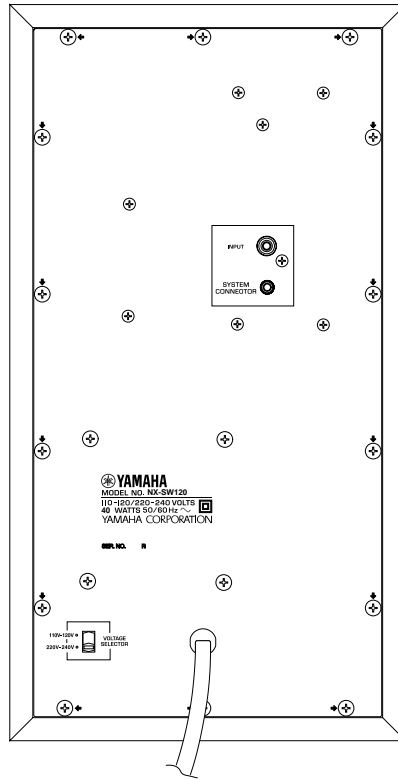

▼ NX-SW120 (B, G models)

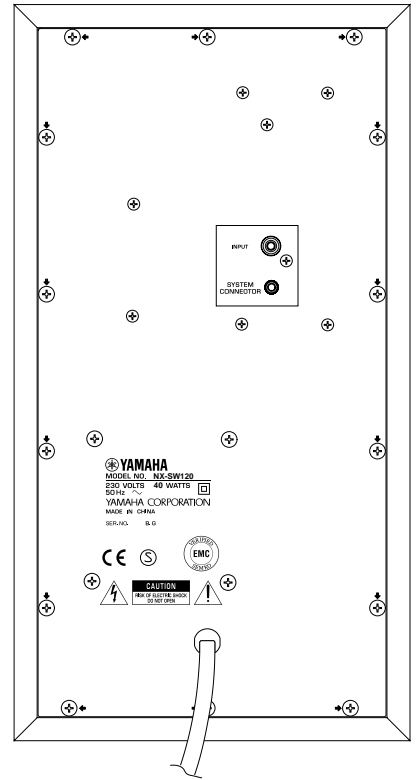

▼ NX-SW120 (A model)

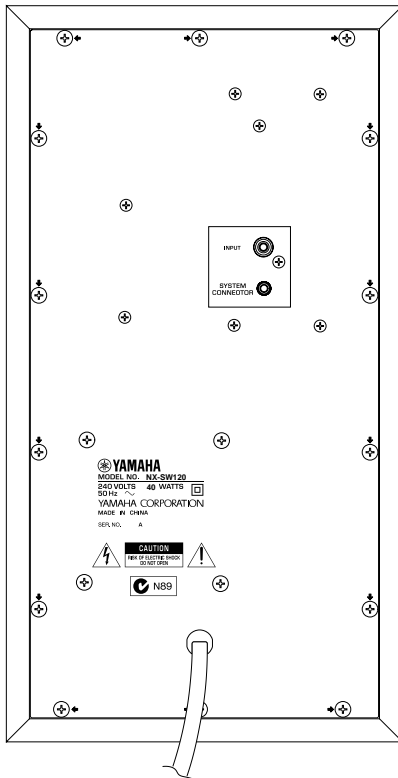

▼ NX-SW120 (J model)

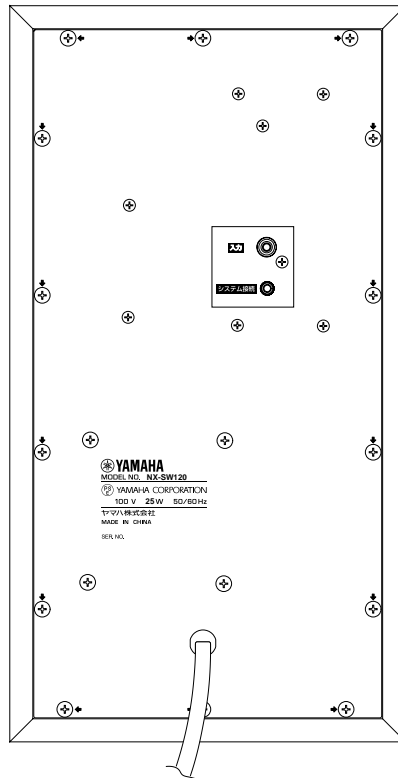

## ■ SPECIFICATIONS / 参考仕様

### DVR-S120

#### AMPLIFIER SECTION / オーディオ部

Input Sensitivity/Impedance / 入力感度/インピーダンス	
VCR, VIDEO	200 mV/47 kΩ
Maximum Input Signal / 最大許容入力	
VCR, VIDEO (1kHz, 0.5 % THD)	2.2 V
Output Level/Impedance / 出力電圧/インピーダンス (when 1 kHz, 200 mV is input)	
REC OUT	200 mV/1.2 kΩ
PRE OUT (FRONT L/R, CENTER, REAR L/R)	1V
PRE OUT (SUBWOOFER/FRONT SP Small, 50Hz)	4V
Frequency Response / 周波数特性	
REC OUT (FRONT L/R, 20 Hz to 20 kHz)	0/-1 dB
Signal to Noise Ratio (IHF-A Network) / S/N比	
VCR, VIDEO (REC OUT, Input shorted, 200mV)	90 dB
Minimum RMS Output Power / 定格出力	
FRONT L/R (6 Ω, 1 kHz, 0.9% THD)	45 W/ch
CENTER (6 Ω, 1 kHz, 0.9% THD)	45 W
SURROUND L/R (6 Ω, 1 kHz, 0.9% THD)	45 W/ch
U, C Only	
FRONT L/R (6 Ω, 20 Hz to 20 kHz, 0.9% THD)	45 W/ch
CENTER (6 Ω, 20 Hz to 20 kHz, 0.9% THD)	45 W
SURROUND L/R (6 Ω, 20 Hz to 20 kHz, 0.9% THD)	45 W/ch
Maximum Power (EIAJ) / 実用最大出力	
FRONT L/R (6 Ω, 1 kHz, 10% THD)	55 W/ch
CENTER (6 Ω, 1 kHz, 10% THD)	55 W
SURROUND L/R (6 Ω, 1 kHz, 10% THD)	55 W/ch
Total Harmonic Distortion / 全高調波歪率	
FRONT L/R (1 kHz, 20 W, SP OUT)	0.05 %

#### VIDEO SECTION (VCR, VIDEO) / ビデオ部

Video Signal Type / ビデオ信号方式	NTSC/PAL
Video Signal Level / ビデオ信号	
Video	1 Vp-p/75 Ω
S-Video	
Y	1 Vp-p/75 Ω
C	0.286 Vp-p/75 Ω
Maximum Input Level / 最大許容入力	
VCR, VIDEO	1.5 Vp-p
Signal to Noise Ratio / S/N比	
Monitor Out	50 dB
Frequency Response / 周波数帯域	
Monitor Out (5 Hz to 10 MHz)	
Video	0/-3 dB
S-Video	0/-3 dB

#### TUNER SECTION / チューナー部

FM Tuning Range / FM受信周波数範囲	
U, C, K models	87.5 to 107.9 MHz
A, B, G models	87.50 to 108.00 MHz
L, R models	87.5 to 108.0 MHz
J model	87.50 to 108.00 MHz
J model	76.0 to 90.0 MHz
AM Tuning Range / AM受信周波数範囲	
U, C, K models	530 to 1710 kHz

A, B, G, J models	531 to 1611 kHz
L, R models	530 to 1710 kHz
	531 to 1611 kHz

#### DVD SECTION / DVD部

Output Level / 出力レベル	
REC OUT	
DVD/VIDEO, CD/CD-DA (1 kHz, 0 dB)	2 ± 0.3 V
Video Output / 映像信号出力	1 Vp-p/75 Ω
Y Output/S-Video Output / Y出力/S映像出力	1 Vp-p/75 Ω
C Output/S-Video Output / C出力/S映像出力	
U, C, R, J models	0.286 Vp-p/75 Ω
K, L, A, B, G models	0.3 Vp-p/75 Ω
Y Output/Component Video Output / Y出力/コンポーネント出力	
Except J model	1.0 Vp-p/75 Ω
Pb Output/Component Video Output / Pb出力/コンポーネント出力	
Except J model	0.7 Vp-p/75 Ω
Pr Output/Component Video Output / Pr出力/コンポーネント出力	
Except J model	0.7 Vp-p/75 Ω

#### GENERAL / 総合

Power Supply / 電源電圧	
U, C models	AC 120 V, 60 Hz
R model	AC 110-120 V, 50 Hz
K model	AC 220 V, 60 Hz
L model	AC 220-240 V, 50 Hz
A model	AC 240 V, 50 Hz
G, B models	AC 230 V, 50 Hz
J model	AC 100 V, 50/60 Hz
Power Consumption / 消費電力	
J model	95 W
Except J model	85 W
Standby Power Consumption / 待機時消費電力	
U, C, A, K, B, G, J models	0.4 W
R, L models	0.5 W
Dimensions (W x H x D) / 寸法 (幅 x 高さ x 奥行き)	
	360 x 75 x 370.2 mm
	(14-3/16" x 2-15/16" x 14-9/16")
Weight / 質量	6.4 kg (14 lbs 1 oz)
Accessories / 付属品	
	Remote Control x 1
	Battery (size "UM-3", "R06") x 2
	Indoor FM antenna x 1
	AM loop antenna x 1
	Video Pin Cable (1.5m) x 1
	Speaker Cable (Front, Center: 5 m) x 3
	Speaker Cable (Surround: 15 m) x 2

\* Specifications subject to change without notice.

U	..... USA model
C	..... Canadian model
A	..... Australian model
B	..... British model
G	..... European model
R	..... General model
T	..... Chinese model
K	..... Korean model
L	..... Singapore model
J	..... Japanese model

## NX-P120

### ● NX-S120

**Type / 型式** ..... Full Range Acoustic Suspension  
Magnetic Shielding Type

**Driver / スピーカーユニット**  
..... 5 cm (2") Cone Magnetic Shielding Type x 2

**Frequency Response / 再生周波数帯域**  
..... 100 Hz to 25 kHz

**Impedance / インピーダンス** ..... 6 Ω

**Nominal Input / 許容入力** ..... 30 W

**Maximum Input / 最大入力** ..... 100 W

**Sensitivity / 出力音圧レベル** ..... 86 dB/2.83 V/m

**Input Terminal / 入力端子** ..... Push Type

**Dimensions (W x H x D) / 寸法 幅 × 高さ × 奥行き**  
..... 72 mm x 170 mm x 108 mm  
(2-13/16" x 6-11/16" x 4-1/4")

**Weight / 質量** ..... 0.9 kg (2 lbs.)

**Finish / 仕上げ** ..... Silver or White Painted

**Accessories / 付属品** ..... Nonskid Pads x 16  
Mounting Bracket x 4, Screws x 4

**Appropriate Speaker Stand / 適応スピーカースタンド** ... SPS-80

**Appropriate Speaker Bracket / 適応ブラケット** ... SPM-8S

### ● NX-C120

**Type / 型式** ..... Full Range Acoustic Suspension  
Magnetic Shielding Type

**Driver / スピーカーユニット**  
..... 5 cm (2") Cone Magnetic Shielding Type x 2

**Frequency Response / 再生周波数帯域**  
..... 100 Hz to 25 kHz

**Impedance / インピーダンス** ..... 6 Ω

**Nominal Input / 許容入力** ..... 30 W

**Maximum Input / 最大入力** ..... 100 W

**Sensitivity / 出力音圧レベル** ..... 86 dB/2.83 V/m

**Input Terminal / 入力端子** ..... Push Type

**Dimensions (W x H x D) / 寸法 幅 × 高さ × 奥行き**  
..... 300 mm x 72 mm x 105 mm  
(11-13/16" x 2-13/16" x 4-1/8")

**Weight / 質量** ..... 1.1 kg (2 lbs. 6 oz.)

**Finish / 仕上げ** ..... Silver or White Painted

**Accessories / 付属品** ..... Fasteners x 2

### ● NX-SW120

**Type / 型式** ..... Advanced Yamaha Active Servo Technology

**Output Power / 出力** ..... 50 W (100 Hz, 5 Ω, 10 % THD)

**Dynamic Power / ダイナミックパワー** ..... 100 W, 5 Ω

**Input Impedance / 入力インピーダンス** ... INPUT (PJ): 12 kΩ

**Frequency Response / 再生周波数帯域** .... 30 Hz to 200 Hz

**Driver / スピーカーユニット** ..... 16 cm (6-1/2") cone  
Magnetic Shielding Type

**Input Section / 入力部**

INPUT ..... RCA Pin Jack

SYSTEM CONNECTOR ..... Mono Mini Jack

**Power Supply / 電源**

U, C models ..... AC 120 V, 60 Hz

R, T, K, L models .. AC 110-120/220-240 V, 50/60 Hz

A model ..... AC 240 V, 50 Hz

B, G models ..... AC 230 V, 50 Hz

J model ..... AC 100 V, 50/60 Hz

**Power Consumption / 消費電力**

U, C, A, B, G, R, T, K, L models ..... 40 W

J model ..... 25 W

**Dimensions (W x H x D) / 寸法 幅 × 高さ × 奥行き**  
..... 200 mm x 365 mm x 390 mm  
(7-7/8" x 14-7/20" x 15-5/16")

**Weight / 質量** ..... 8.4 kg (18 lbs. 8 oz.)

**Finish / 仕上げ** ..... Silver

**Accessories / 付属品** ..... Subwoofer Cable (5m) x 1  
System Control Cable (5m) x 1  
Nonskid Pad x 4

\* Specifications subject to change without notice.

U ..... USA model  
C ..... Canadian model  
A ..... Australian model  
B ..... British model  
G ..... European model  
R ..... General model  
T ..... Chinese model  
K ..... Korean model  
L ..... Singapore model  
J ..... Japanese model



Manufactured under license from Dolby Laboratories.  
 "Dolby", "Pro Logic" and the double-D symbol are trademarks of  
 Dolby Laboratories.

ドルビーラボラトリーズからの実施権により製造されています。  
 「ドルビー」、「PRO LOGIC」およびダブルD記号  は、ドル  
 ビーラボラトリーズの商標です。



"DTS" and "DTS Digital Surround" are registered trademarks of  
 Digital Theater Systems, Inc.

DTS およびDTS デジタルサラウンドはデジタルシアターシステム  
 ズの登録商標です。



AAC ロゴマーク  はドルビーラボラトリーズの登録商標です。

"SILENT CINEMA" is a trademark of YAMAHA CORPORATION.  
 「サイレントシアター / SILENT THEATER」はヤマハ株式会社の  
 登録商標です。

**DIMENSIONS / 寸法図**

● **DVR-S120**

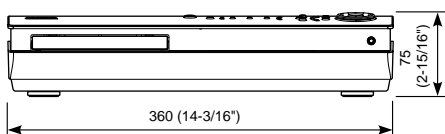
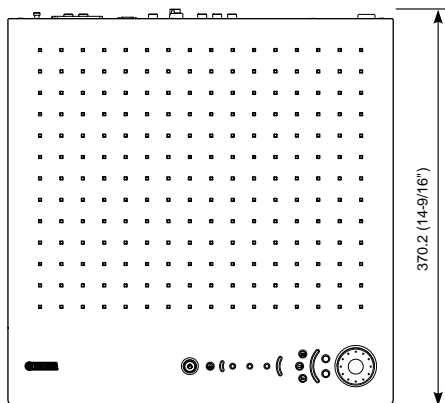

● **NX-SW120**

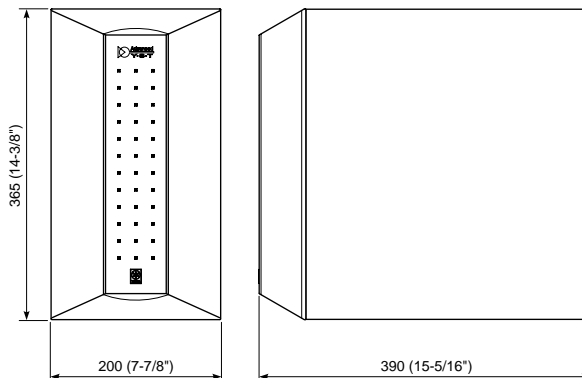

● **NX-C120**

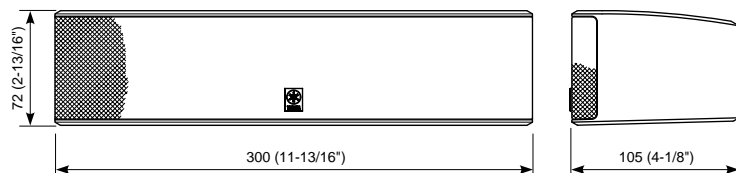

● **NX-S120**

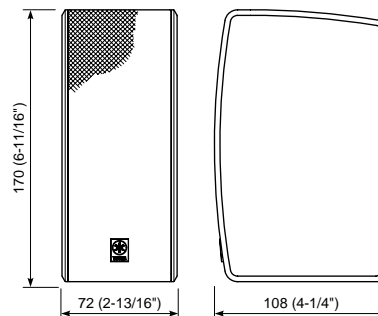

Unit : mm (inch)

## INTERNAL VIEW

### ▼ DVR-S120

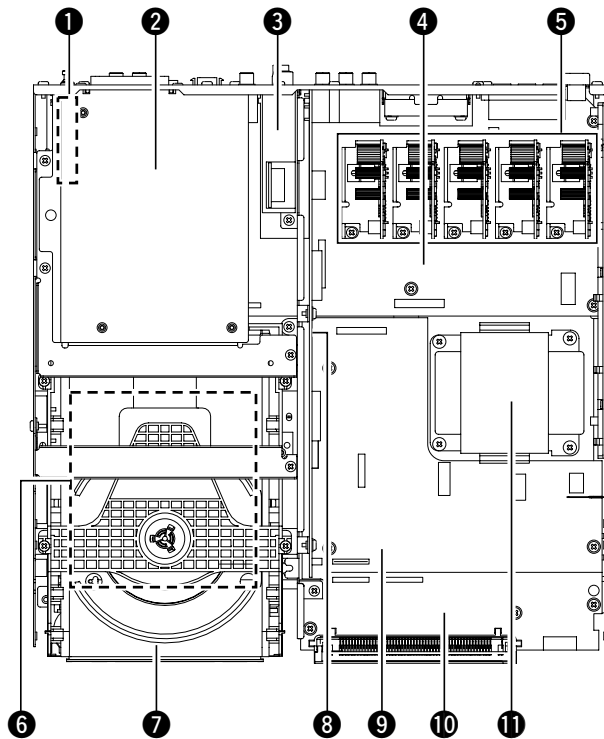

- ① SUB (3) P.C.B.
- ② DVD P.C.B.
- ③ AM/FM TUNER
- ④ MAIN (1) P.C.B.
- ⑤ D-AMP MODULE
- ⑥ DIGITAL P.C.B.
- ⑦ DVD MECHANISM
- ⑧ MAIN (2) P.C.B.
- ⑨ SUB (1) P.C.B.
- ⑩ MAIN (3) P.C.B.
- ⑪ POWER TRANSFORMER

### ▼ NX-SW120

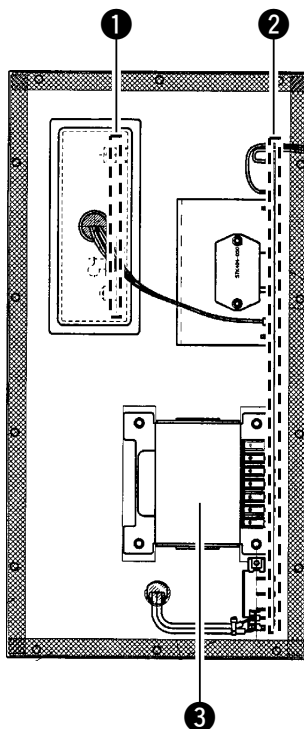

- ① MAIN (2) P.C.B.
- ② MAIN (1) P.C.B.
- ③ POWER TRANSFORMER

## ■ DVR-S120 DISASSEMBLY PROCEDURES / DVR-S120分解手順

(Remove parts in disassembly order as numbered.)

(番号順に部品を取り外してください。)

### 1. Removal of Side Cover L/R

- Remove 1 screw ( ① ) in Fig. 1.
- Lift the Side Cover L at the rear and move it rear-ward slantingly.
- Remove 1 screw ( ② ) in Fig. 1.
- Lift the Side Cover R at the rear and move it rear-ward slantingly.

### 1. サイドカバーL/Rの外し方

- ①のネジ1本を外します。( Fig. 1 )
- サイドカバーLを後方へスライドさせ取り外します。
- ②のネジ1本を外します。( Fig. 1 )
- サイドカバーRを後方へスライドさせ取り外します。

### 2. Removal of Bottom Cover

- Remove 2 screws ( ③ ) in Fig. 2.
- Spread soft cloth and place this unit upside down on it.
- Remove 4 screws ( ④ ) in Fig. 2.
- Release 1 hook and remove the Bottom Cover toward the Front Panel side in Fig. 2.

### 2. ボトムカバーの外し方

- ③のネジ2本を外します。( Fig. 2 )
- 柔らかい布を敷いた上に、本機を上下反転して置きます。( Fig. 2 )
- ④のネジ4本を外します。( Fig. 2 )
- フック1ヶ所を外し、ボトムカバーをフロントパネル側に外します。( Fig. 2 )

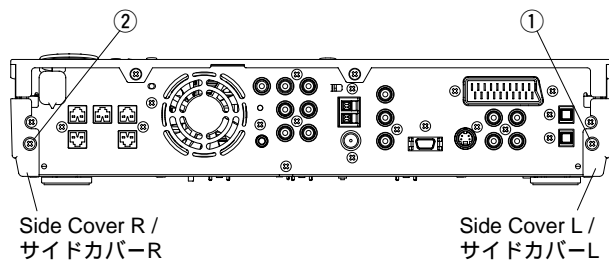
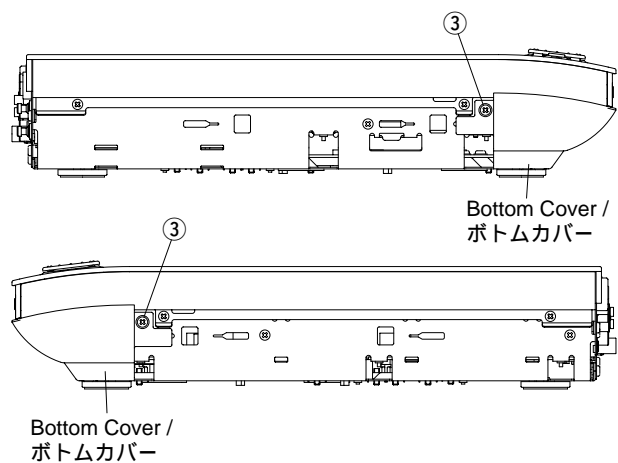

Fig. 1



#### ● Bottom view

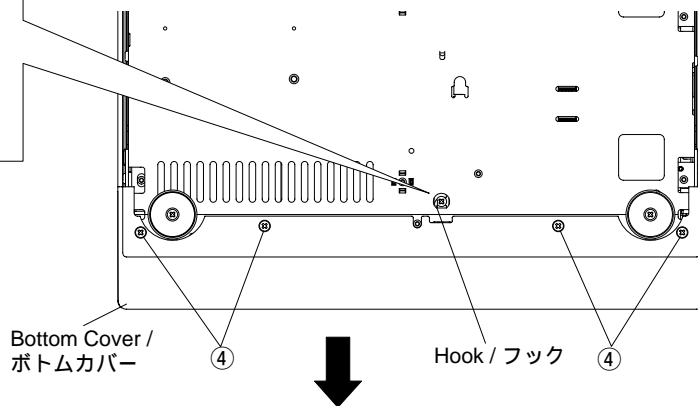
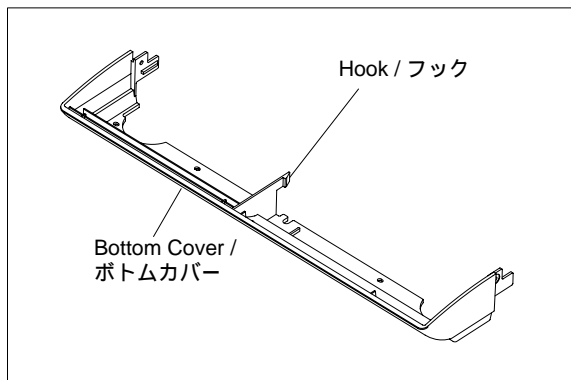

Fig. 2

### ● HOW TO MANUALLY EJECT THE TRAY

- Remove the Side Cover L/R.
- Remove the Bottom Cover.
- Move the slider in the direction indicated.
- Gently pull the tray out.

### ● 手動でトレイを開く方法

- サイドカバーL/Rを外します。
- ボトムカバーを外します。
- スライダを矢印の方向に動かします。
- トレイをそっと引き出します。

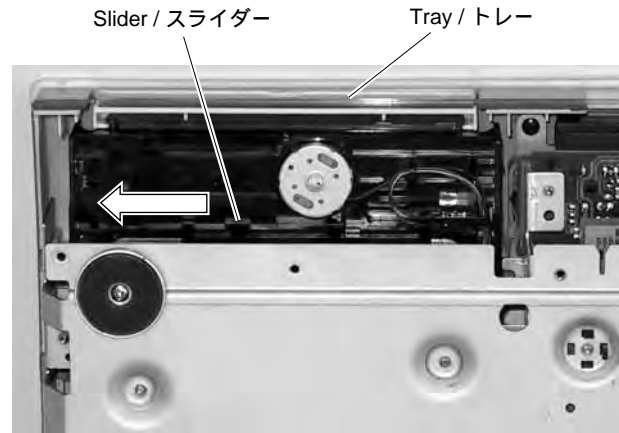

### 3. Removal of Top Unit

- Remove 1 screw ( ⑤ ) in Fig. 3.
- Turn this unit again to set it upside up.
- Remove 6 screws ( ⑥ ) and 2 screws ( ⑦ ) in Fig. 4.
- Remove connectors CB222 and CB278 in Fig. 4.
- Remove the Top Unit.

### 3. トップユニットの外し方

- ⑤のネジ1本を外します。( Fig. 3 )
- 再び、本機を上下反転して置きます。
- ⑥のネジ6本、⑦のネジ2本を外します。( Fig. 4 )
- コネクタCB222、CB278を外します。( Fig. 4 )
- トップユニットを外します。

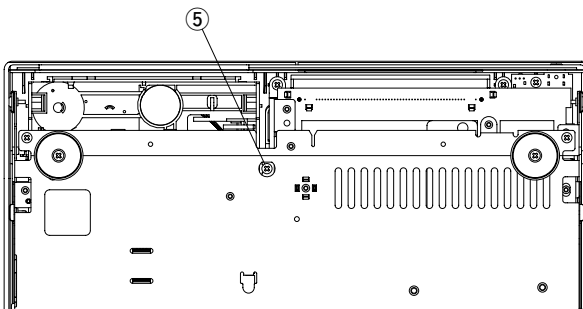

Fig. 3

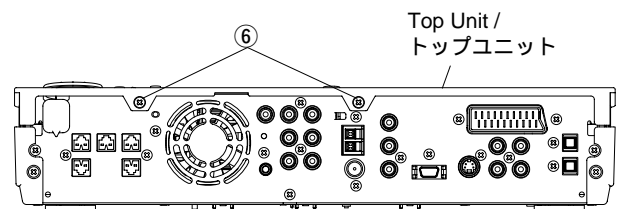
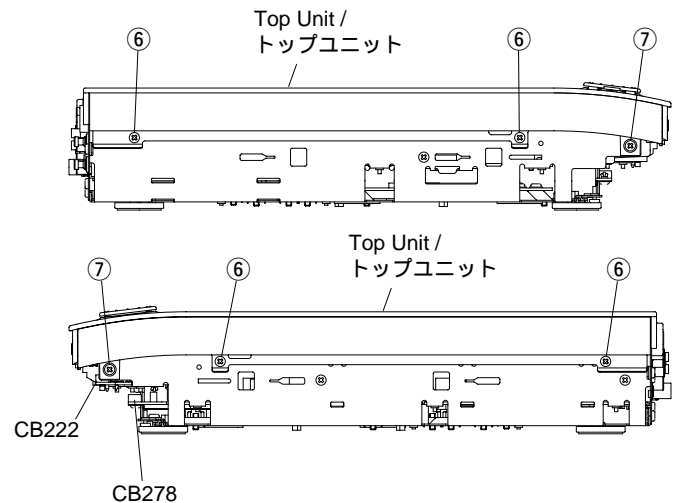

Fig. 4

**4. Removal of DVD Mechanism**

- a. Remove 2 screws ( ⑧ ) and then remove the Top Frame in Fig. 5.
- b. Remove 3 screws ( ⑨ ) in Fig. 5.
- c. Remove 2 screws ( ⑩ ) in Fig. 5. (G, B only)
- d. Remove the DVD support and the DVD P.C.B. in Fig. 5.
- e. Remove connectors 1601, 1603, 1615, 1618, 1619 and 1620 in Fig. 6.
- f. Remove connector CB3 in Fig. 7.
- g. Remove 4 screws ( ⑪ ) and then remove the DVD Mechanism in Fig. 7.

**4. DVDメカニズムの外し方**

- a. ⑧のネジ2本を外し、トップフレームを外します。( Fig. 5 )
- b. ⑨のネジ3本を外します。( Fig. 5 )
- c. ⑩のネジ2本を外します。( G, B only ) ( Fig. 5 )
- d. DVDサポート & DVD P.C.B.を外します。( Fig. 5 )
- e. コネクター1601、1603、1615、1618、1619、1620を外します。( Fig. 6 )
- f. コネクターCB3を外します。( Fig. 7 )
- g. ⑪のネジ4本を外し、DVDメカニズムを外します。( Fig. 7 )

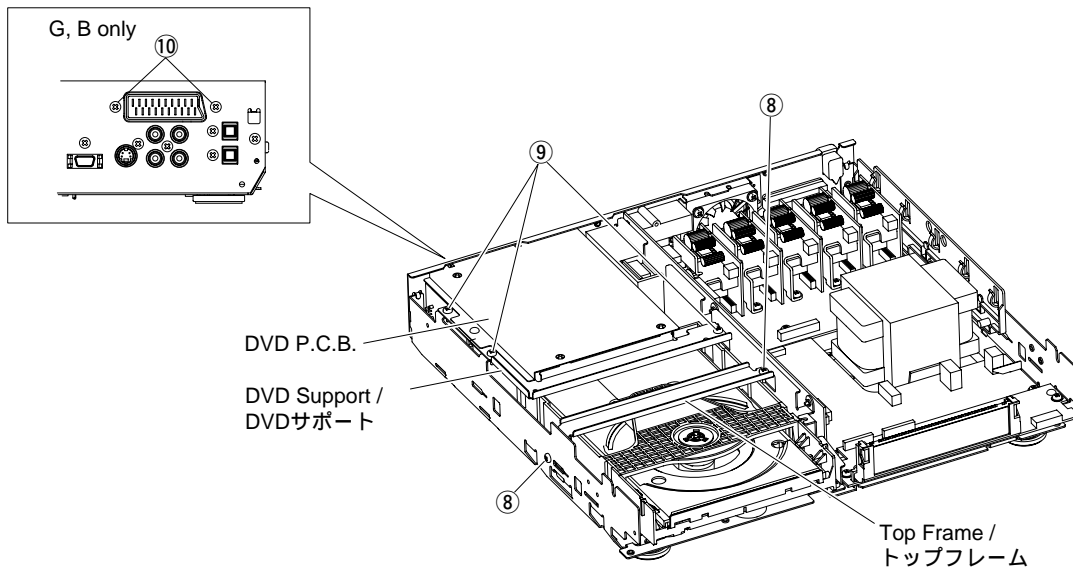

Fig. 5

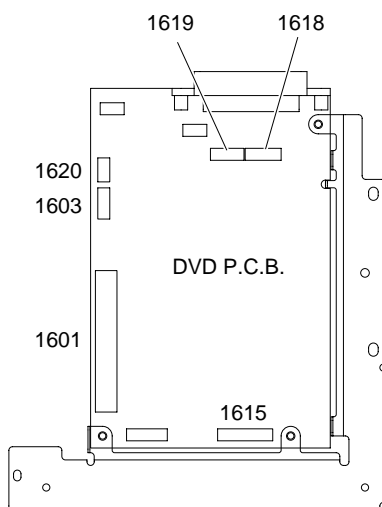

Fig. 6

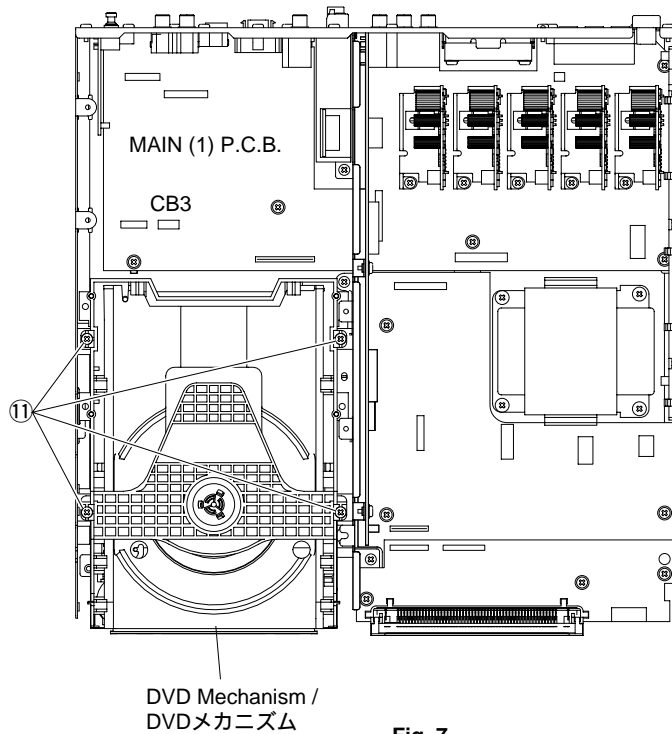

Fig. 7



### 5. Removal of DIGITAL P.C.B.

- a. Remove connectors CB374, CB375 and CB378 in Fig. 8.
- b. Remove 4 screws ( ⑫ ) and then remove the DIGITAL P.C.B. in Fig. 8.

### 6. Removal of D-Amp Module

Remove 5 screws ( ⑬ ) and then remove the D-Amp Modules in Fig. 8.

### 7. Removal of MAIN (3) P.C.B.

- a. Remove connectors CB221 and CB224 in Fig. 8.
- b. Remove 3 screws ( ⑭ ) and 1 push rivet ( ⑮ ) and then remove the MAIN (3) P.C.B. in Fig. 8.

### 8. Removal of AM/FM Tuner

Remove 2 screws ( ⑯ ) and then remove the AM/FM Tuner in Fig. 8.

### 5. DIGITAL P.C.B.の外し方

- a. コネクターCB374、CB375、CB378を外します。( Fig. 8 )
- b. ⑫のネジ4本を外し、DIGITAL P.C.B.を外します。( Fig. 8 )

### 6. D-AMPモジュールの外し方

⑬のネジ5本を外し、D-アンプモジュールを外します。( Fig. 8 )

### 7. MAIN (3) P.C.B.の外し方

- a. コネクターCB221、CB224を外します。( Fig. 8 )
- b. ⑭のネジ3本、⑮のプッシュリベット1本を外し、MAIN (3) P.C.B.を外します。( Fig. 8 )

### 8. AM/FMチューナーの外し方

⑯のネジ2本を外し、AM/FMチューナーを外します。( Fig. 8 )

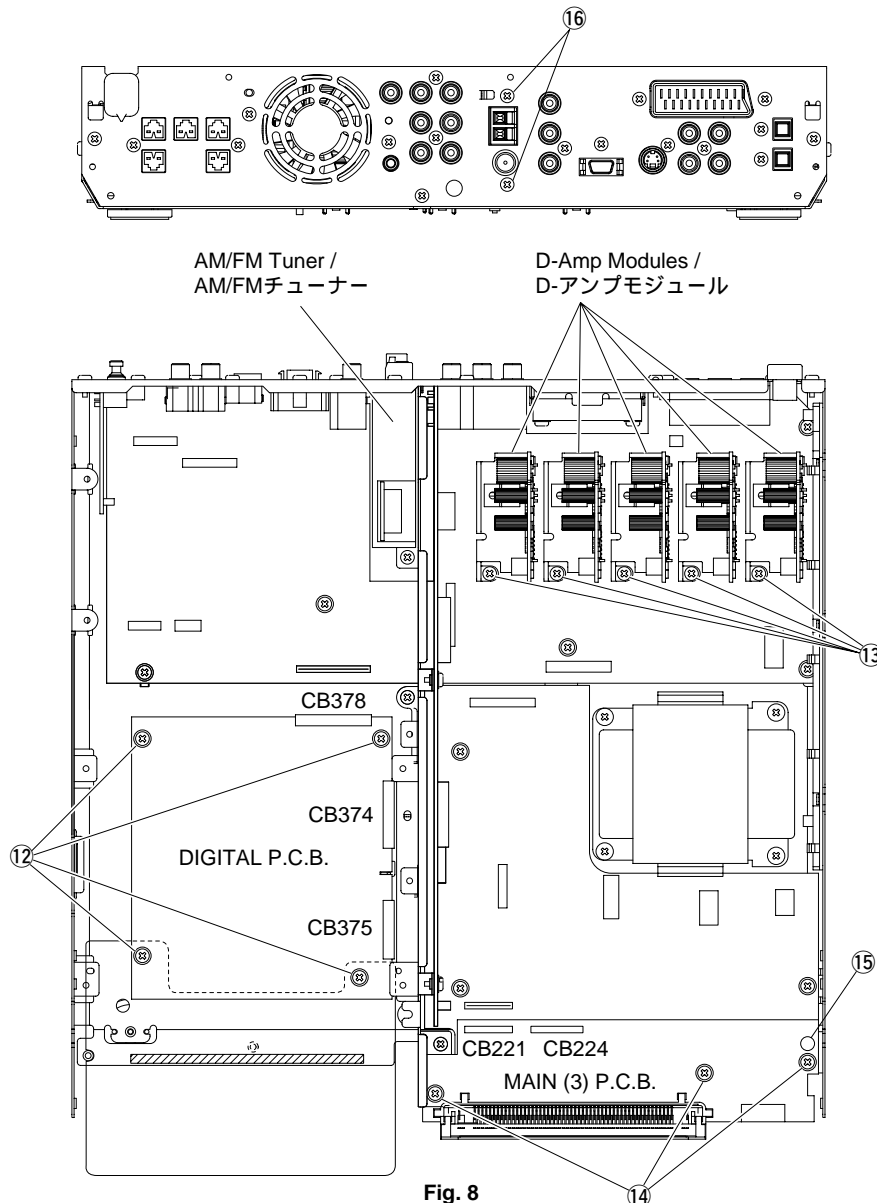

Fig. 8

**9. Removal of MAIN (2) & SUB (1) P.C.B.**

- a. Remove 2 screws ( 17 ) in Fig. 9.
- b. Remove 3 screws ( 18 ) and then remove the Shield in Fig. 9.
- c. Remove 2 screws ( 19 ) in Fig. 9.
- d. Remove 2 screws ( 20 ) and 1 screw ( 21 ) in Fig. 9.
- e. Remove connectors CB2, CB124, CB275, CB276 and CB277 in Fig. 9.
- f. Remove the MAIN (2) & SUB (1) P.C.B. in Fig. 9.

**10. Removal of MAIN (1) P.C.B.**

- a. Remove 2 screws ( 22 ) and then remove the Power Cable Support in Fig. 9.
- b. Remove 3 screws ( 23 ) and 2 screws ( 24 ) in Fig. 9.
- c. Remove connector CB17 in Fig. 9.
- d. Remove 3 screws ( 25 ) in Fig. 9.
- e. Remove the MAIN (1) P.C.B. with the Rear Panel attached to it in Fig. 9.

**9. MAIN (2) & SUB (1) P.C.B.の外し方**

- a. 17のネジ2本を外します。( Fig. 9 )
- b. 18のネジ3本を外し、シールドを外します。( Fig. 9 )
- c. 19のネジ2本を外します。( Fig. 9 )
- d. 20のネジ2本、21のネジ1本を外します。( Fig. 9 )
- e. コネクターCB2、CB124、CB275、CB276、CB277を外します。( Fig. 9 )
- f. MAIN (2) & SUB (1) P.C.B.を外します。( Fig. 9 )

**10. MAIN (1) P.C.B.の外し方**

- a. 22のネジ2本を外し、パワーコードサポートを外します。( Fig. 9 )
- b. 23のネジ3本、24のネジ2本を外します。( Fig. 9 )
- c. コネクターCB17を外します。( Fig. 9 )
- d. 25のネジ3本を外します。( Fig. 9 )
- e. リアパネルが付いた状態でMAIN (1) P.C.B.を外します。( Fig. 9 )

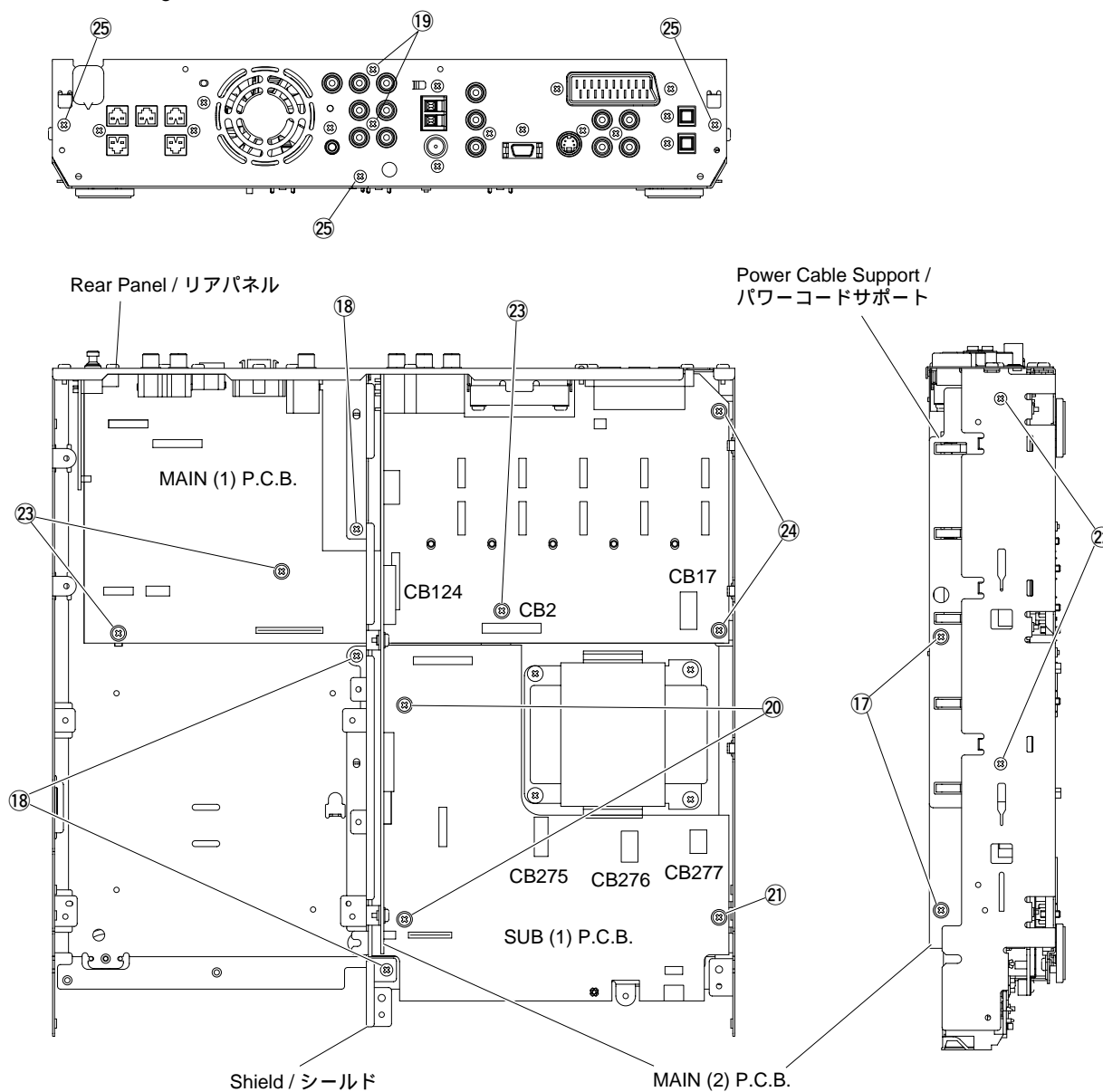
**Fig. 9**

## ■ NX-SW120 DISASSEMBLY PROCEDURES / NX-SW120分解手順

(Remove parts in disassembly order as numbered.)

(番号順に部品を取り外してください。)

### 1. Removal of Front Grille

**The Front Grille is fixed to the cabinet with dowels at 6 locations. As a screwdriver (for slotted head screw) is used for removal, use special care not to cause damage to the cabinet.**

- Using the screwdriver inserted in the gap between the Front Grille and the cabinet (bottom side first), push up the Front Grille.
- Remove the Front Grille by lifting it up.

\* **When installing the Front Grille, apply quick-drying bond to the dowels and then fit them into dowel holes for secure installation. (The Front Grille will come off easily if its dowels are fitted into dowel holes only.)**

### 2. Removal of Rear Panel

Remove 14 screws ( ① ) in Fig. 2.

\* **Arrow marks ( ⇒ ) are printed to identify the screws to be removed.**

\* **When assembling the Rear Panel, check to ensure that the packing is not damaged so as to prevent air leakage from occurring.**

### 1. フロントグリルの外し方

フロントグリルは6箇所のダボで固定されています。取り外しの際、本体に傷が付かないよう十分注意してください。

- 底側からマイナスドライバー等を差し込み、フロントグリルを押し上げます。(Fig. 1)
- 徐々に上面へマイナスドライバー等で押し上げて、フロントグリルを外します。

\* 取り付け時には、フロントグリルのダボに速乾ボンドなどを塗って差し込み、固定してください。(フロントグリルを差し込むだけでは、簡単にはずれてしまいます。)

### 2. リアパネルの外し方

①のネジ14本を外し、リアパネルを取り出します。

(Fig. 2)

\* 取り外すネジの箇所には矢印(マーク)が印刷されています。

\* 組み立ての際は、パッキングの損傷など無いことを確認し、エア漏れが発生しないように組み立ててください。

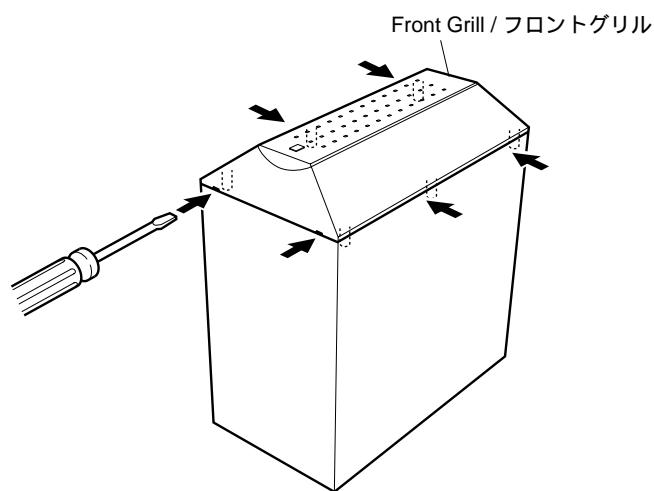

Fig. 1

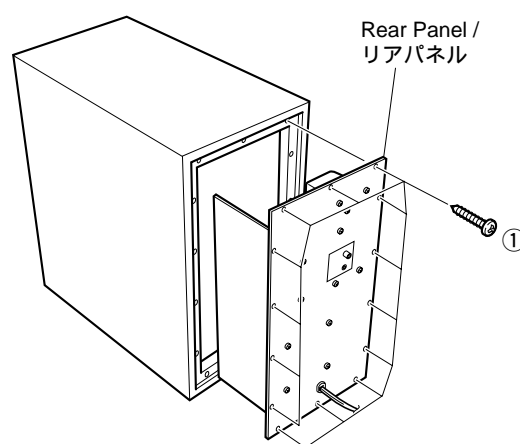

Fig. 2

When checking the P.C.B.:

Turn on the power to NX-SW120 according to the following procedure.

- Short between the terminals of RY2 (relay).
- Connect the power cable to the AC power outlet.

P.C.B.動作チェックをする場合

下記の方法により NX-SW120 に電源を投入します。

- RY2 (リレー) の端子間をショートします。
- 電源コードを AC 電源コンセントに接続します。

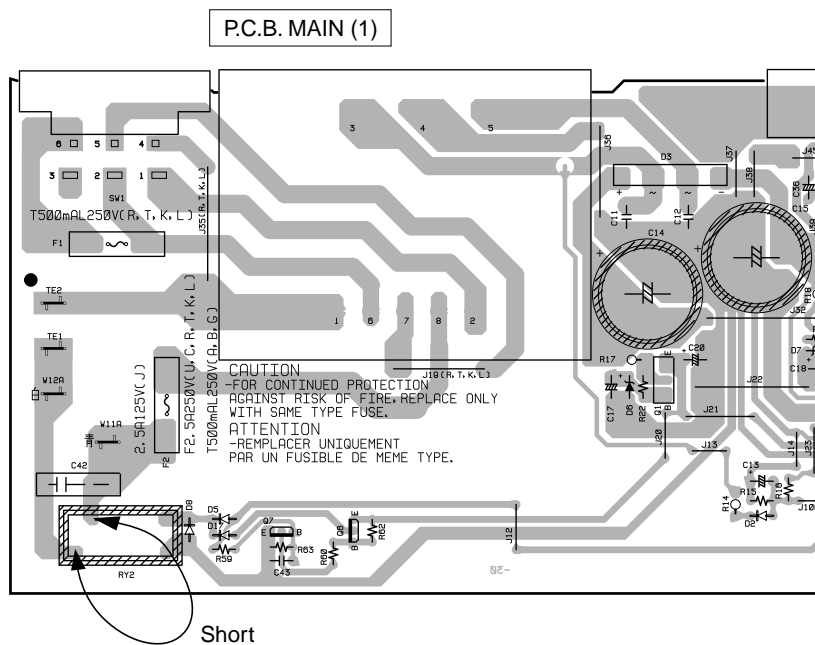

Short between these terminals for the P.C.B. check.

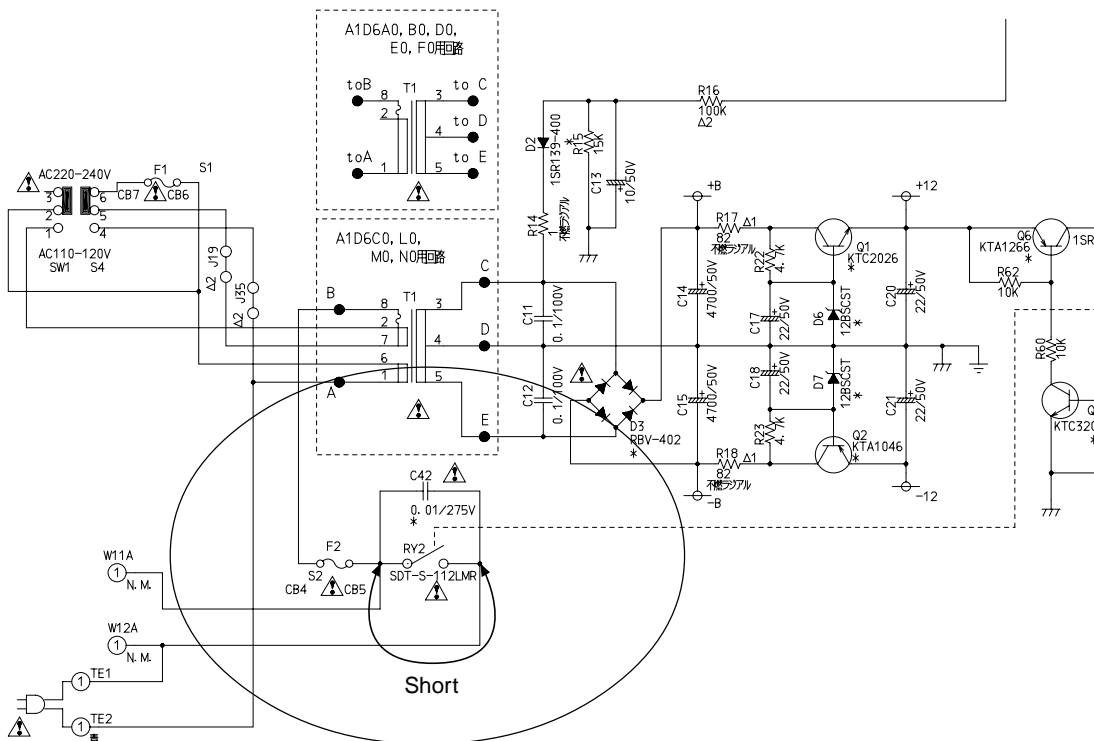

## ■ DVR-S120 SELF DIAGNOSIS FUNCTION (DIAG) / DVR-S120自己診断機能(ダイアグ)

This product has a built-in self diagnosis function (DIAG) to facilitate inspection, measurement and determination of a faulty item, if any. There are 14 DIAG menu items, each having sub-menu items.

Listed in the table below are menu items and sub-menu items. (Start-up and operation of DIAG menu are executed by using the main unit.)

本機には、検査、測定、不良個所の発見を目的にした自己診断機能(ダイアグ)があります。

ダイアグメニューは14個あり、そのそれぞれにサブメニューがあります。

下表はメニュー一覧です。

(ダイアグのメニュー操作は本体で行います。)

No.	DIAG menu	Sub-menu
1	DSP THROUGH	1. ANALOG BYPASS
		2. YSS 0dB
		3. YSS Front 0dB
		4. YSS FULL BIT
		5. YSS FULL BIT F
2	RAM THROUGH	RAM 0dB
3	PRO LOGIC /	1. PRO LOGIC I
		2. PRO LOGIC II
4	SPEAKERS SET	1. MAIN: SMALL 0dB
		2. CENTER: NONE
		3. LFE/BASS: MAIN
		4. Front Mix: 5ch
5	MARGIN CHECK	1. MAIN 12 dB margin
		2. MAIN 18 dB margin
6	DISPLAY CHECK	1. VFD CHECK (Initial display / 初期表示)
		2. VFD DISP OFF (All segments OFF / 全セグメント消灯)
		3. VFD DISP ALL (All segments ON 100% / 全セグメント点灯 100%)
		4. VFD DIMMER (All segments ON 50% / 全セグメント点灯 50%)
		5. CHECKED PATTERN (ON in lattice / 格子状点灯)
7	MANUAL TEST	1. TEST ALL
		2. TEST FRONT L
		3. TEST CENTER
		4. TEST FRONT R
		5. TEST SUR. R
		6. TEST SUR. L
		7. TEST LFE
8	FACTORY PRESET	1. PRESET INHIBITED (memory initialization inhibited / メモリーの初期化禁止)
		2. PRESET RESERVED (memory initialized / メモリーの初期化)
9	AD DATA CHECK /FAN TEST	1. PS (protection)
		2. PANEL KEY
		3. FAN OUT/THM
		4. FAN DRIVE TEST: HIGH
		5. FAN DRIVE TEST: MID
		6. FAN DRIVE TEST: LOW
10	IF STATUS	1. INSIDE STATUS 1
		2. INSIDE STATUS 2
		3. INSIDE STATUS 3
		4. CHANNEL STATUS 1
		5. CHANNEL STATUS 2
		6. CHANNEL STATUS 3
		7. CHANNEL STATUS 4
		8. CHANNEL STATUS 5

No.	DIAG menu	Sub-menu
		9. BSI (YSS) 1
		10. BSI (YSS) 2
		11. BSI (YSS) 3
		12. BSI (YSS) 4
		13. BSI (CS) 1
		14. BSI (CS) 2
		15. BSI (CS) 3
		16. BSI (CS) 4
		17. BSI (CS) 5
		18. YSS938-1
		19. YSS938-2
		20. YSS938-3
		21. CS49329
		22. Mute Trigger
11	DSP RAM CHECK	1. YSS938 BUS CHECK
		2. PLD/CS BUS CHECK
12	SOFT SWITCH	1. SW MODE: PCB/SOFT
		2. MODEL SETTING
		3. TUNER DESTINATION
		4. TUNER EXIST
		5. RDS EXIST
		6. VIDEO FORMAT
13	ROM VERSION/CHECK SUM/ PORT	1. VERSION
		2. CHECK SUM ALL
		3. PORT
		4. AAC PORT
14	ROM CORRECTION/ CHECK SUM	1. SOFT DATE
		2. ROM CORRECTION: EXIST/NOT
		3. ROM CORRECTION CHECK SUM DISP
		4. ROM CORRECTION REMOCON RECEIVE
		5. REMOCON CODE DISP
		6. Protection History
		7. UCD CLOCK LOW/HIGH
		8. ASPECT Lo/Mid/Hi

## ● Starting DIAG

While pressing the "A/B/C/D/E" key on the main unit, press the "STANDBY/ON" key until the FL display lights up. Within 4 seconds after that, press the "PRESET/BAND" key to start the DIAG function.

## ダイアグの起動

本体の "A/B/C/D/E" キーを押しながら "STANDBY/ON" キーを押し、表示点灯後4秒以内に "PRESET/BAND" キーを押すとダイアグが起動します。

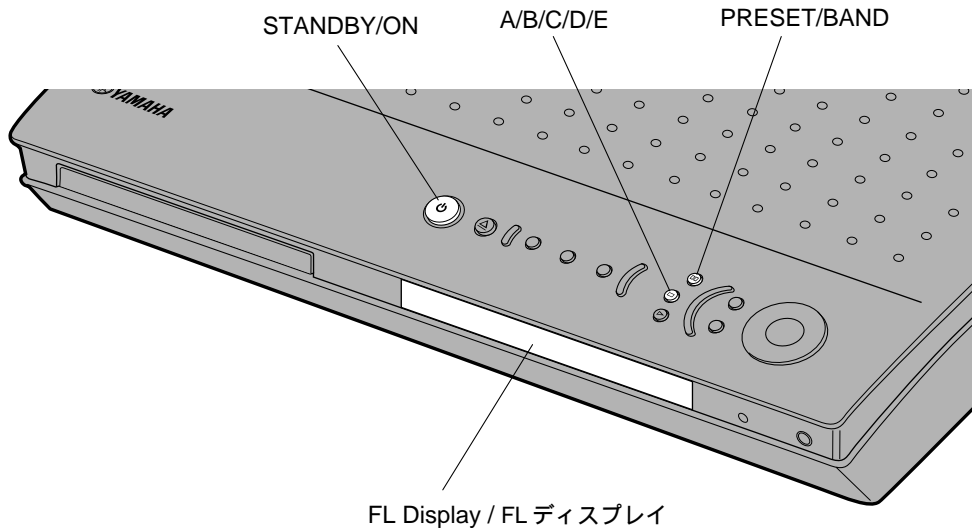

\* *In the DIAG mode, all the protection functions other than the excess current detect function are canceled, and the "SLEEP" segment of the FL display of the main unit flashes. Please note, therefore, that no protection function works even when a dangerous situation occurs while using the DIAG mode.*

ダイアグモードでは過電流検出以外のプロテクション動作が解除されます。  
このモードでは本体 FL ディスプレイの "SLEEP" が点滅します。  
以後、ダイアグ中、危険な状態でもプロテクション動作が働きませんので注意してください。

## ● Canceling DIAG

**1** Before canceling DIAG, execute setting for PRESET of DIAG menu No.8 (Memory initialization inhibited or Memory initialized).

\* *In order to keep the user memory stored, be sure to select PRESET INHIBITED (Memory initialization inhibited). Protection history will remain in memory.*

**2** Turn off the power by pressing the "STANDBY/ON" key of the main unit.

## ダイアグの解除

- 1** ダイアグを解除する前に、ダイアグメニュー No. 8 の FACTORY PRESET (メモリーの初期化禁止/またはメモリーの初期化) の設定をします。  
ユーザーメモリーを保持したい場合は、必ず PRESET INHIBITED (メモリー初期化禁止) を選択してください。
- 2** 本体の "STANDBY/ON" キーを押し、パワーオフにします。

## ● Display provided when DIAG started

On the FL display of the main unit, an opening message (including the version and the protection history) appears for a few seconds followed by the diagnostic menu display of ANALOG BYPAS.

## ダイアグ起動時の表示

本体FLディスプレイには、オープニング(プロテクション履歴/バージョン)が表示され、数秒後にダイアグメニュー表示(ANALOG BYPAS)となります。

### When there is no history of protection function:

プロテクション履歴が無い場合:

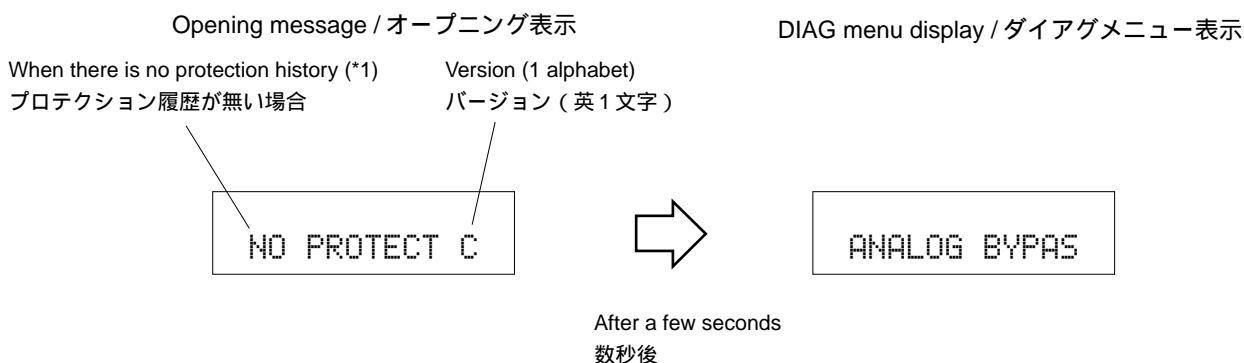

### When there is a history of protection function:

The FL display appears as shown below depending on the type of the protection function.

プロテクション履歴がある場合:

プロテクションの種類によって下記の表示が現れます。

The protection function worked due to excessive current through the amplifier. Causes could be a short at the speaker terminal or a defect in the amplifier.

I PROTECT C

スピーカーをショートさせた時などが原因で、プロテクションが働いたことを示します。

The protection function worked due to a DC voltage appearing at the speaker terminal. A cause could be a defect in the amplifier.

DC PROTECT C

アンプの故障でスピーカーに直流電圧が掛かるなどが原因で、プロテクションが働いたことを示します。

The protection function worked due to an AC overload. A cause could be a shorted secondary wire of the transformer.

AC PROTECT C

トランスの二次巻き線がショートしたときなどが原因で、プロテクションが働いたことを示します。

The protection function worked due to the temperature limit being exceeded. Causes could be poor ventilation or a defect related to the thermal sensor.

TMP PRT:000 C

温度制限を越えた原因で、プロテクションが働いたことを示します。



The protection function worked due to a defect or overload in the power supply (but not related to the DVD). If the power is turned on with the abnormality unsolved, the protection function works in about 1 second to turn off the power.

```
PS PRT:000 C
```

電源 (DVD関連以外) による原因で、プロテクションが働いたことを示します。異常状態のままパワーオンすると、約1秒後にプロテクションが掛かり、電源が切れます。

The protection function worked due to a defect or overload in the DVD power supply. If the power is turned on with the abnormality unsolved, the protection function works in about 1 second to turn off the power.

```
PS2 PRT:000 C
```

電源 (DVD関連) による原因で、プロテクションが働いたことを示します。異常状態のままパワーオンすると、約1秒後にプロテクションが掛かり、電源が切れます。

TMP PRT, PS PRT and PS2 PRT displays include the abnormal A/D value in %. Concerning this value, refer to DIAG menu No.9 AD DATA CHECK described on page 36.

TMP PRT表示、PS PRT表示、PS2 PRT表示には、異常状態のA/D値を%表示します。

この値に関しては、後述のダイアグメニューNo. 9 AD DATA CHECK(36ページ)を参照してください。

#### ● History of protection function

When the protection function has worked, its history is stored in memory with a backup. Even if no abnormality is noted while servicing the unit, an abnormality which has occurred previously can be defined as long as the backup data has been stored.

The history of the protection function is cleared when DIAG is cancelled by selecting PRESET RESERVED (Memory initialized) of DIAG menu No.8 or by selecting Prt Hist < DEL (Protection history deletion reserved) of sub-menu 6 of DIAG menu No.14 and the backup data is erased.

#### プロテクションの履歴

プロテクションが働いた場合、履歴をバックアップして記憶しています。サービスのときに異常が認められなくても、バックアップが残っていれば、お客様のところで起きた異常を区別できます。

プロテクションの履歴は、ダイアグメニュー No.8 で PRESET RESERVED(メモリーの初期化)を選んでダイアグを解除した場合や、ダイアグメニューNo.14のサブメニュー6でPrt Hist <DEL(プロテクション履歴削除の予約)を選んでダイアグ解除した場合、バックアップが消えたときにはクリアされます。

#### ● Display during menu operation

During the DIAG operation, the function at work is indicated on the FL indicator. The contents displayed during the function operation are shown for each step.

#### メニュー動作中の表示

ダイアグ中、本体のFLディスプレイに動作中の機能が表示されます。機能動作中の表示内容については、後述の機能詳細で記述します。

## ● Operation procedure of DIAG menu and SUB-MENU

There are 14 MENU items and some SUB-MENU items as well.

### DIAG menu selection

Main unit: PRESET TUNING  $\vee$  (forward)/ $\wedge$  (reverse) key

### SUB-MENU selection

Main unit: DSP (forward) key

## ダイアグメニューとサブメニューの操作

ダイアグにはNo.1～14のメニューがあり、さらにいくつかのサブメニューがあります。

ダイアグメニューの選択

本体 : PRESET TUNING  $\vee$  (順送り)  $\wedge$  (逆送り) キー

サブメニューの選択

本体 : DSP (順送り) キー

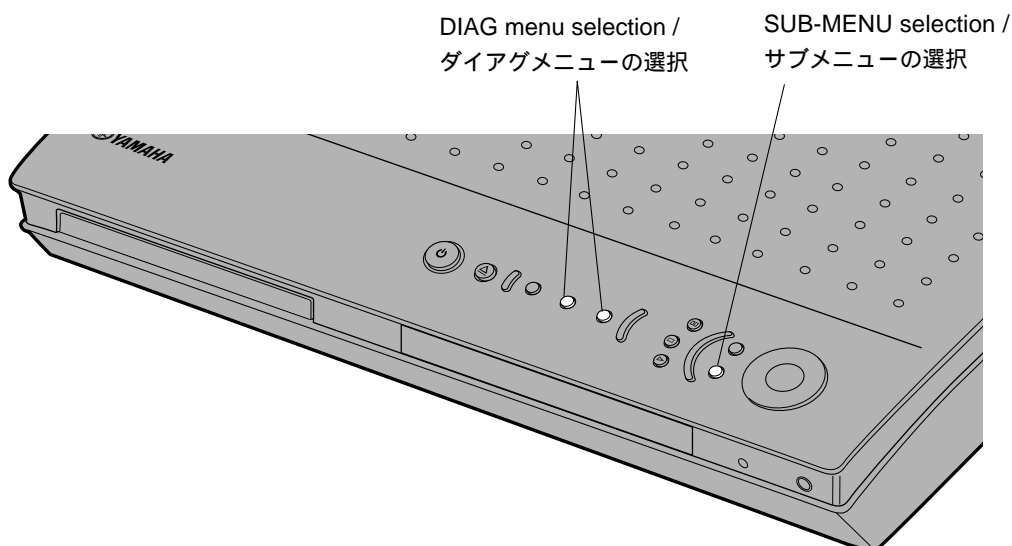

## ● Functions available during DIAG

In addition to the DIAG menu, the functions listed below are available:

- Input selection
- Center/Surround/Sub-woofer level adjustment
- Muting
- Power on/off operation
- Master volume

\* **Functions related to the tuner and the set menu are not available.**

\* **It is possible to confirm Menu No.10 "IF STATUS" while keeping the signal process (operation status) of each DIAG menu by using the INPUT MODE key of the main unit.**

### ダイアグ中の機能

ダイアグメニューの他に以下の機能が動作します。

- インプット切り換え
- センター/サラウンド/サブウーファーレベル調整
- ミューティング
- パワーオン・オフ操作
- マスターボリューム

\* チューナー関連、セットメニュー関連は機能しません。

\* 本体INPUTモードキーにより、各ダイアグメニューの信号処理(動作状態)を維持したままメニューNo. 10 "IF STATUS"の確認ができます。

## ● Initial settings used to start DIAG function

The following initial settings are used when starting the DIAG function:

(When the DIAG function is canceled, the settings before starting DIAG will be restored.)

- Input : VIDEO 1
- Master volume : 56 (-40dB)
- Effect level : 0dB
- Audio mute : OFF
- Speaker settings : LARGE /BASS OUT = BOTH
- DIAG menu : ANALOG BYPASS

### ダイアグ開始時の初期設定

ダイアグ開始時の初期設定は、下記の設定になります。また、これらの設定は、ダイアグ解除時にはダイアグ開始前の状態に戻ります。

- インプット : VIDEO 1
- マスターボリューム : 56 (-40dB)
- エフェクトレベル : 0dB
- オーディオミュート : オフ
- スピーカー設定 : LARGE / BASS OUT = BOTH
- ダイアグメニュー : ANALOG BYPASS

## Details of DIAG menu

With full-bit output specified in some modes, it is possible to execute 0dBFS output without head margin in each channel.

### 1. DSP THROUGH

Main DSP of YSS938 is selected for MAIN L/R output.

### ANALOG BYPASS

- The signal for L/R is output as it is without passing through the DSP section.

## ダイアグメニュー詳細

一部のモードでフルビット指定することで、各チャンネルのヘッドマージンを廃して 0dBFS 出力することが可能です。

### 1. DSP THROUGH

MAIN L/R 出力には YSS938 の Main DSP が選択されます。

### ANALOG BYPASS

- L/R は、DSP 部を通らずにそのまま出力されます。

### ANALOG BYPAS

Input level	Volume	SPEAKERS OUT (1KHz)			SUBWOOFER (50 Hz)
		FRONT L/R	CENTER	SURROUND L/R	
Both ch, -20 dBm	-10 dB	+22.3 dBm	- ∞	- ∞	- ∞

### YSS 0dB

- The signal is output including the head margin.  
Head margin:  
Main L/R: 0dBFS, Center: 0dBFS,  
RL/RR: -12dBFS, SWFR: Add L/R signal at -20dBFS.

### YSS 0dB

- ヘッドマージンを含んで出力されます。  
ヘッドマージン：  
Main L/R: 0dBFS、Center: 0dBFS、  
RL/RR: 12dBFS、SWFR: L/R を 20dBfs にて加算

### YSS 0dB

Input level	Volume	SPEAKERS OUT (1KHz)			SUBWOOFER (50 Hz)
		FRONT L/R	CENTER	SURROUND L/R	
Both ch, -20 dBm	-10 dB	+18.0 dBm	+17.5 dBm	+18.2 dBm	- 4.8 dBm

### YSS Front 0dB

- The front CH signal including the head margin is output at the main CH.  
Head margin:  
Main L/R: 0dBFS, Center: 0dBFS,  
RL/RR: -12dBFS, SWFR: Add L/R signal at -20dBFS.

### YSS Front 0dB

- ヘッドマージンを含んでフロント CH をメイン CH に出力されます。  
ヘッドマージン：  
Main L/R: 0dBFS、Center: 0dBFS、  
RL/RR: 12dBFS、SWFR: L/R を 20dBfs にて加算

### YSS Front0dB

Input level	Volume	SPEAKERS OUT (1KHz)			SUBWOOFER (50 Hz)
		FRONT L/R	CENTER	SURROUND L/R	
Both ch, -20 dBm	-10 dB	+18.0 dBm	- ∞	- ∞	- ∞

**YSS FULL BIT**

- The signal is output in digital full bit without including the head margin. The SWFR signal is output but not in digital full bit.

**YSS FULL BIT**

- ヘッドマージンを含まず、デジタルフルビットで出力されます。SWFR は出力されますが、デジタルフルビットではありません。

YSS FULL BIT

Input level	Volume	SPEAKERS OUT (1KHz)			SUBWOOFER (50 Hz)
		FRONT L/R	CENTER	SURROUND L/R	
Both ch, -20 dBm	-10 dB	+18.0 dBm	+17.5 dBm	+18.2 dBm	- 4.8 dBm

**YSS FULL BIT F**

- The front CH signal is output in digital full bit at the main CH.

**YSS FULL BIT F**

- フロントCHがメインCHに、デジタルフルビットで出力されます。

FULL BIT F

Input level	Volume	SPEAKERS OUT (1KHz)			SUBWOOFER (50 Hz)
		FRONT L/R	CENTER	SURROUND L/R	
Both ch, -20 dBm	-10 dB	+18.0 dBm	- ∞	- ∞	- ∞

**DSP THROUGH  
YSS (Analog)**

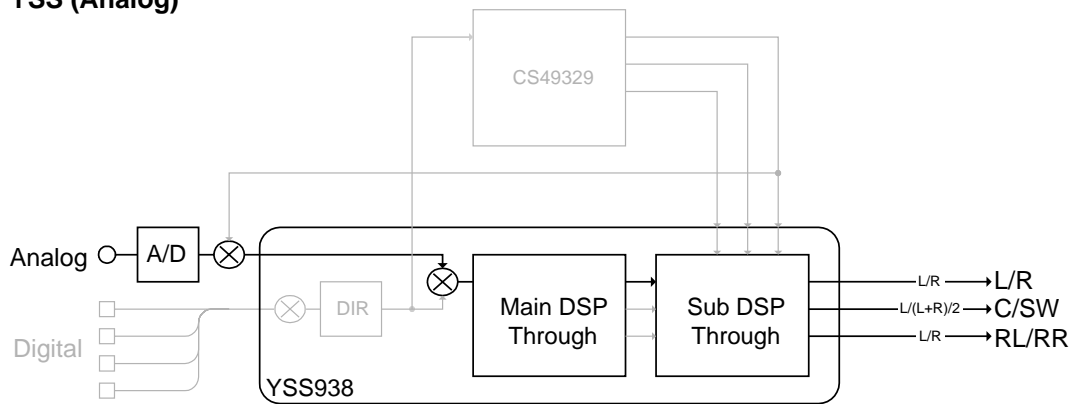

(Shaded items not used in this example)

**2. RAM THROUGH**

This function is for YSS938 only.

Only the CT signal is output through the Sub DSP – DRAM.

**2. RAM THROUGH**

YSS938 のみの動作です。

CT のみ が Sub DSP - DRAM 経由で出力されます。

RAM 0dB

RAM 0dB

RAM 0dB

Input level	Volume	SPEAKERS OUT (1KHz)			SUBWOOFER (50 Hz)
		FRONT L/R	CENTER	SURROUND L/R	
Both ch, -20 dBm	-10 dB	- ∞	+17.5 dBm	- ∞	- ∞

**RAM THROUGH  
(Auto)**

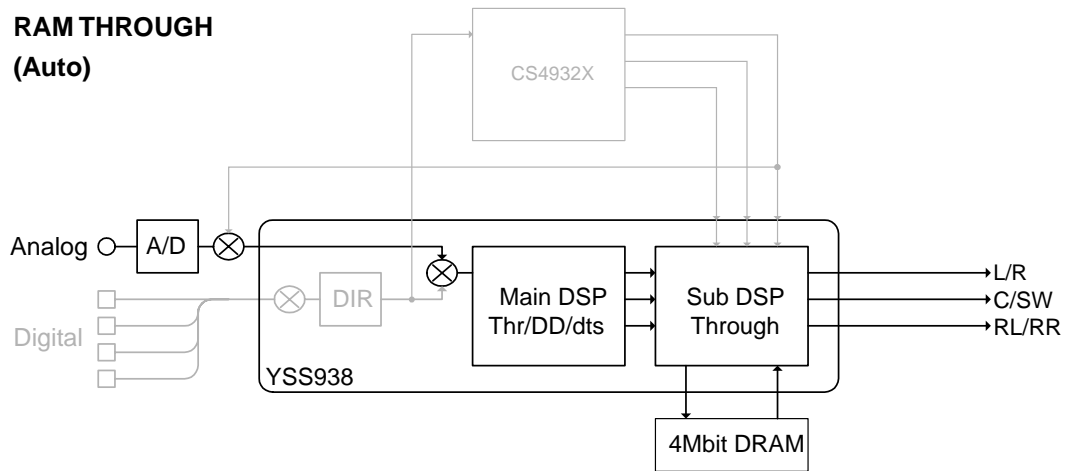

(Shaded items not used in this example)

### 3. PRO LOGIC

The L/C/R/RL/RR signals undergo the Pro-Logic processing and C/RL/RR signals are output through Sub DSP-DRAM. Main DSP is selected for MAIN L/R output.

Using the sub-menu, it is possible to select PRO LOGIC I, II (Movie). The Auto Input Balance function is always off.

When the Dolby Digital Multi input is used, the function is the same as in the Dolby Digital Normal mode.

The LFE signal is not output when decoding in the PRO LOGIC I, II mode.

### 3. PRO LOGIC

L/C/R/RL/RR は YSS938 によりプロロジック処理され、C/RL/RR は Sub DSP DRAM 経由で出力されます。MAIN L/R 出力には Main DSP が選択されます。

サブメニューで PRO LOGIC I、II (Movie) を選択可能です。常時 Auto Input Balance off です。

AAC 入力時は CS49329 でデコード後、L/R はプロロジック処理されます。(J model のみ)

Dolby Digital Multi 入力時は、通常の Dolby Digital Normal と同じ動作をします。

PRO LOGIC I、II デコード時は、LFE は出力されません。

#### PRO LOGIC I

#### PRO LOGIC I

PRO LOGIC I

Input level	Volume	SPEAKERS OUT (1KHz)			SUBWOOFER (50 Hz)
		FRONT L/R	CENTER	SURROUND L/R	
Each ch, -20 dBm	-10 dB	+18.0 dBm	- ∞	- ∞	- ∞
Both ch, -20 dBm	-10 dB	- ∞	+20.4 dBm	- ∞	- ∞

#### PRO LOGIC II

#### PRO LOGIC II

PRO LOGIC II

Input level	Volume	SPEAKERS OUT (1KHz)			SUBWOOFER (50 Hz)
		FRONT L/R	CENTER	SURROUND L/R	
Each ch, -20 dBm	-10 dB	+18.0 dBm	- ∞	- ∞	- ∞
Both ch, -20 dBm	-10 dB	- ∞	+20.4 dBm	- ∞	- ∞

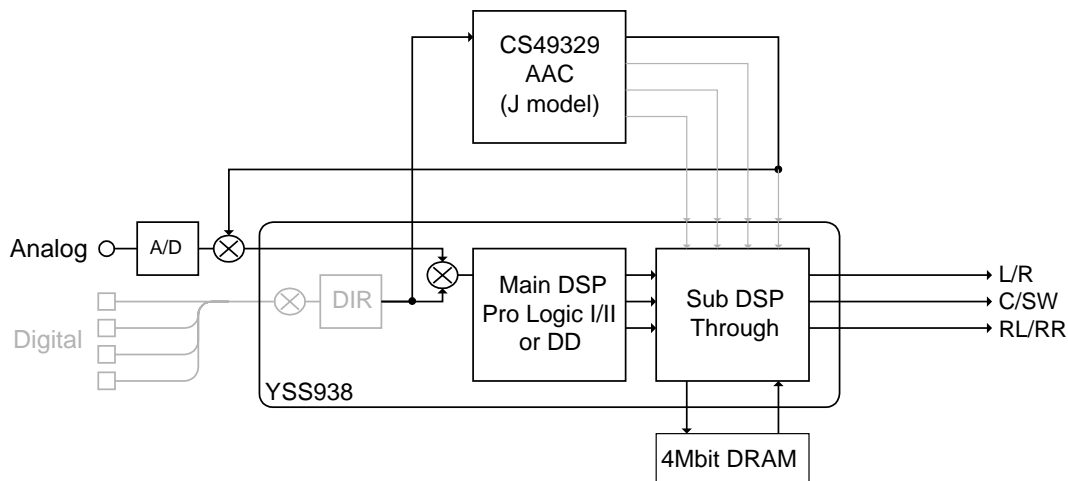

(Shaded items not used in this example)

#### 4. SPEAKERS SET

The input signal is automatically identified and switched in the priority order of dts → DOLBY DIGITAL → AAC → PCM AUDIO → Analog (A/D) according to the signal detection. The signals output from the DSP block are the same as 1. DSP THROUGH: YSS 0dB.

#### 4. SPEAKERS SET

入力は信号検出によって、dts DOLBY DIGITAL AAC PCM AUDIO アナログ(A/D)の優先順で自動判別切り換えされます。DSP部からは、No. 1 DSP THROUGHのYSS 0dBと同様の信号が出力されます。

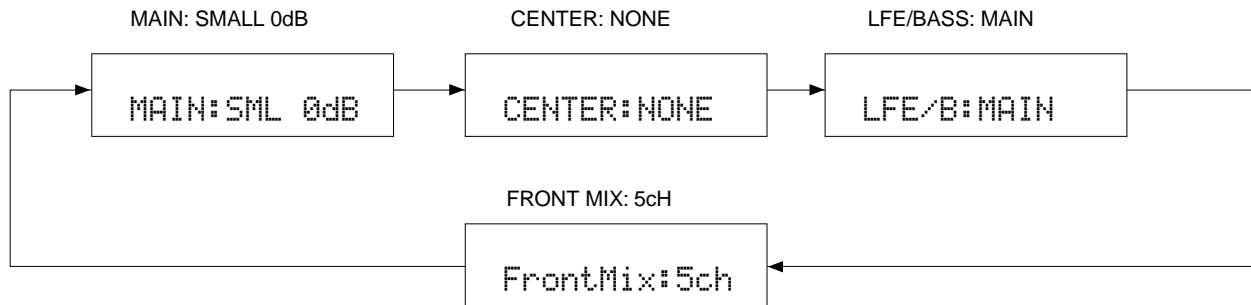

The analog switch settings for each sub-menu are as shown in the table below.

各サブメニューにおけるアナログスイッチの設定は以下の通りです。

Sub-menu	CENTER SP	REAR SP	MAIN SP	MAIN LEVEL	LFE/BASS
1 MAIN: SMALL 0dB	LARGE	LARGE	SMALL	0dB	SWFR
2 CENTER: NONE	NONE	LARGE	LARGE	0dB	BOTH
3 LFE/BASS: MAIN	SMALL	SMALL	LARGE	0dB	MAIN
4 FRONT MIX: 5cH	LARGE	LARGE	LARGE	0dB	BOTH

**LARGE:** This mode is used with a speaker with high bass reproduction performance (a large unit). Full bandwidth signals are output.  
**SMALL:** This mode is used with a speaker with low bass reproduction performance (a small unit). The signals of 90Hz or less are mixed into the channel specified by LFE/BASS.  
**NONE:** This mode is used with no center speaker. The center content is reduced by 3dB and distributed to MAIN L/R.

**LARGE :** 低音再生能力の高い(ユニットの大きい)スピーカーを使用するモードです。全帯域が出力されます。  
**SMALL :** 低音再生能力の低い(ユニットの小さい)スピーカーを使用するモードです。90Hz以下がLFE/BASSで指定したチャンネルにミックスされます。  
**NONE :** スピーカーを使用しないモードです。センター成分は 3dB されて、MAIN L/R に振り分けられます。

Sub-menu	Input level	Volume	SPEAKERS OUT (1KHz)			SUBWOOFER (50 Hz)
			FRONT L/R	CENTER	SURROUND L/R	
1 MAIN: SMALL 0dB	1kHz, Both ch, -20 dBm	-10 dB	+18.0 dBm	- ∞	- ∞	- ∞
2 CENTER: NONE	1kHz, Both ch, -20 dBm	-10 dB	- ∞	+17.5 dBm	- ∞	- ∞
3 LFE/BASS: MAIN	50Hz, Both ch, -20 dBm	-10 dB	- ∞	- ∞	- ∞	- ∞
4 FRONT MIX: 5cH	1kHz, Both ch, -20 dBm	-10 dB	+18.0 dBm	- ∞	- ∞	- ∞

**5. MARGIN CHECK**

The signal is output including the head margin.

**5. MARGIN CHECK**

ヘッドマージンを含んで出力されます。

**MAIN 12dB MARGIN**

**MAIN 12dB MARGIN**

MAIN 12dB

Input level	Volume	SPEAKERS OUT (1KHz)			SUBWOOFER (50 Hz)
		FRONT L/R	CENTER	SURROUND L/R	
1kHz, Both ch, -20 dBm	-10 dB	+5.8 dBm	- ∞	- ∞	- ∞

**MAIN 18dB MARGIN**

**MAIN 18dB MARGIN**

MAIN 18dB

Input level	Volume	SPEAKERS OUT (1KHz)			SUBWOOFER (50 Hz)
		FRONT L/R	CENTER	SURROUND L/R	
1kHz, Both ch, -20 dBm	-10 dB	-0.2 dBm	- ∞	- ∞	- ∞

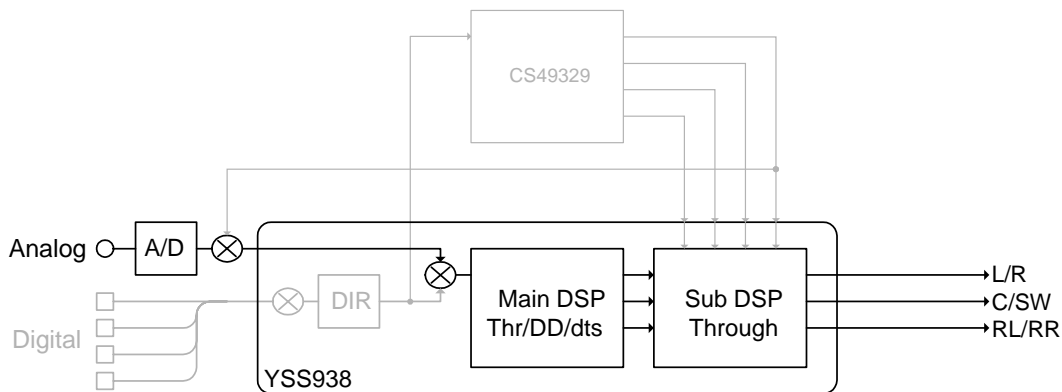

(Shaded items not used in this example)



## 6. DISPLAY CHECK

This program is used to check the FL display section. The display condition varies as shown below according to the sub-menu operation. The signals are processed using EFFECT OFF (The L/R signal is output using ANALOG MAIN BYPASS.)

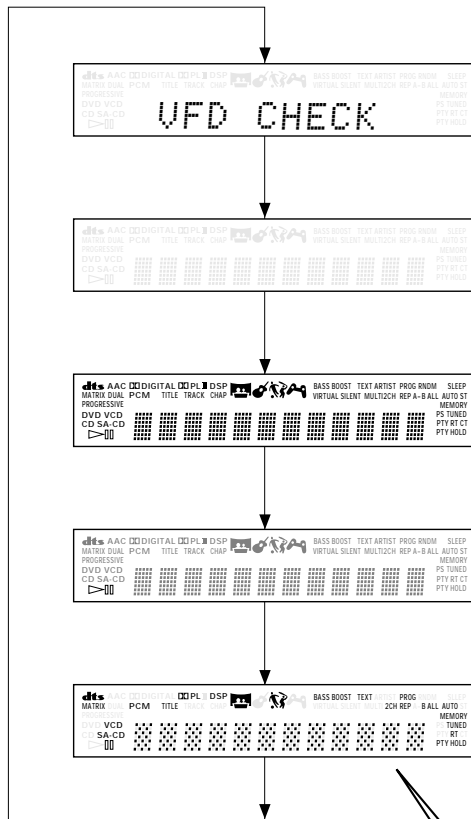

## 6. DISPLAY CHECK

FL 表示部のチェックプログラムです。サブメニュー操作により、表示状態が以下のように変わります。信号処理はEFFECT OFF( ANALOG MAIN BYPASSでL/Rを出力)です。

### Initial display /

初期表示

### All segments OFF /

全セグメント消灯

### All segments ON (dimmer 100%) /

全セグメント点灯 (ディマー 100%)

### All segments ON (dimmer 50%) /

全セグメント点灯 (ディマー 50%)

### Lighting of segments in lattice /

セグメント格子状点灯

### Lighting in lattice / 格子状点灯



Short / ショート



Normal / 正常

Segment conditions of the FL driver and the FL tube are checked by turning ON and OFF all segments. Next, the operation of the FL driver is checked by using the dimmer control. Then a short between segments next to each other is checked by turning ON and OFF all segments alternately (in lattice). (In the above example, the segments in the second row from the top are shorted.)

全セグメント消灯・全セグメント点灯によりFLドライバー、FL管のセグメントの不良を確認します。次に、ディマーコントロールによってFLドライバーの動作チェックを行います。さらに全セグメントを交互(格子状)に点灯/消灯することで、隣り合うセグメントのショートをチェックします。

## 7. MANUAL TEST

The noise generator built into the DSP outputs the test noise through the channels specified by the sub-menu.

The noise frequency for LFE is 35 to 250 Hz. Other than that, the center frequency is 800Hz.

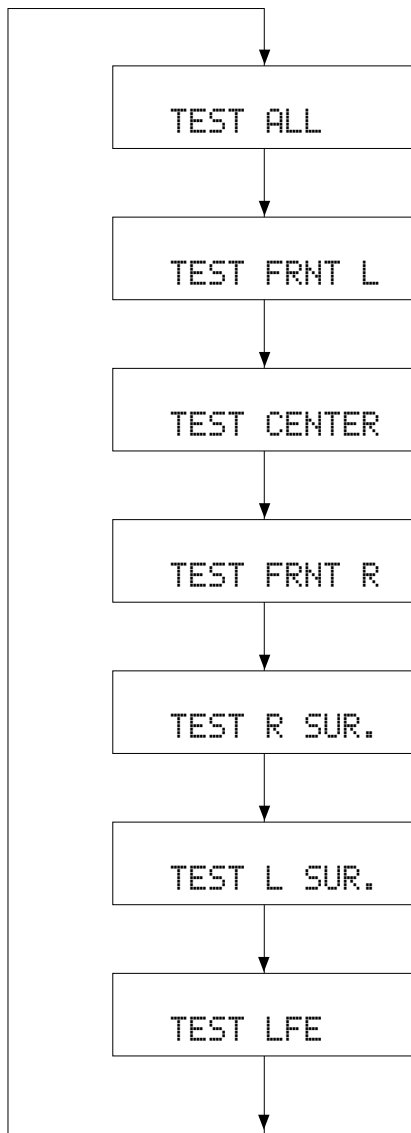

## 7. MANUAL TEST

DSP 内蔵のノイズ発生回路によって、サブメニューで指定したチャンネルへテストノイズを出力します。

LFE用のノイズ周波数は35 ~ 250Hz、それ以外は中心周波数800Hzとなります。

### TEST ALL

Noise is output from all channels except SUB WOOFER.  
SUB WOOFER 以外の全チャンネルからノイズを出力

### TEST FRONT L

Noise is output from the FRONT L channel.  
FRONT L チャンネルからノイズを出力

### TEST CENTER

Noise is output from the CENTER channel.  
CENTER チャンネルからノイズを出力

### TEST FRONT R

Noise is output from the FRONT R channel.  
FRONT R チャンネルからノイズを出力

### TEST R SURROUND

Noise is output from the SURROUND R channel.  
SURROUND R チャンネルからノイズを出力

### TEST L SURROUND

Noise is output from the SURROUND L channel.  
SURROUND L チャンネルからノイズを出力

### TEST LFE

Noise is output from the SUB WOOFER channel.  
SUB WOOFER チャンネルからノイズを出力

### 8. FACTORY PRESET

This menu is used to reserve and inhibit initialization of the back-up RAM. The signals are processed using EFFECT OFF. (The L/R signal is output using ANALOG MAIN BY-PASS.)

### 8. FACTORY PRESET

バックアップ用RAM(音場プログラムのパラメーターやセットメニュー内容等)の初期化を予約/禁止します。信号処理はEFFECT OFFと同じです(ANALOG MAIN BY-PASSで、L/Rを出力)。

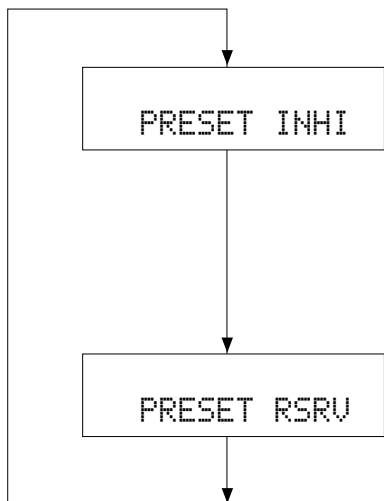

#### PRESET INHIBIT (Initialization inhibited) / PRESET INHIBIT(初期化禁止)

RAM initialization is not executed. Select this sub-menu to protect the values set by the user.

**Note: The protection history will not be erased using PRESET INHIBIT.**

RAMの初期化は行われません。ユーザーの設定値を保護するときは、こちらを選択してください。

#### PRESET RESERVED (Initialization reserved) / PRESET RESERVED(初期化予約)

Initialization of the back-up RAM is reserved. (Actually, initialization is executed the next time that the power is turned on.) Select this sub-menu to reset to the original factory settings or to reset the RAM. Use PRESET RESERVED to erase the protection history.

バックアップRAMの初期化が予約されます。(実際に初期化されるのは、次回の電源投入時です。)工場出荷時やRAMをリセットしたいときは、こちらを選択してください。

**CAUTION: Before setting to the PRESET RESERVED, write down the existing preset memory content of the Tuner in a table as shown below. (This is because setting to the PRESET RESERVED will cause the user memory content to be erased.)**

注意：PRESET RESERVEDを選んで初期化をする前に、チューナーのユーザーメモリー内容を下表に書き写してください。(初期化をすると、ユーザーメモリーの内容は消えてしまいます。)

Preset group	P1	P2	P3	P4	P5	P6	P7	P8
A								
B								
C								
D								
E								

#### ● PRESET STATIONS / プリセット局

STATION		FM FACTORY PRESET DATA (MHz)				STATION		AM FACTORY PRESET DATA (kHz)	
PAGE	NO.	U, C	R, T, K, L, G, B, A	J	PAGE	NO.	U, C, R, T, K	L, G, B, A, J	
A/C/E	1	87.5	87.50	76.0	B/D	1	630	630	
	2	90.1	90.10	83.0		2	1080	1080	
	3	95.1	95.10	84.0		3	1440	1440	
	4	98.1	98.10	86.0		4	530	531	
	5	107.9	108.00	90.0		5	1710	1611	
	6	88.1	88.10	78.0		6	900	900	
	7	106.1	106.10	88.0		7	1350	1350	
	8	107.9	108.00	82.1		8	1400	1404	

## 9. AD DATA CHECK/FAN TEST

This menu is used to display the A/D conversion value of the terminals which detect the panel keys of the main unit and protection functions in % using the sub-menu. During signal processing, the condition before execution is maintained.

When K0 menu is selected, keys become non-operable due to detection of the values of all keys.

However, it is possible to advance to the next sub-menu by turning the VOLUME of the main unit. When using this function, note that turning the VOLUME more than 2 clicks will cause the volume value to change.

*\*The figures in the diagram are given as reference only.*

### PS/PS2 (protection detection)

**PS:** Value of power supply voltage protection other than DVD (Normal value: 49 to 60)

**P2:** Value of power supply voltage protection related to DVD (Normal value: 46 to 70)

If PS or P2 is out of the normal value range, the protection function works to turn off the power after 1 second.

## 9. AD DATA CHECK/FAN TEST

本体パネルキー、プロテクションなどを検出している端子のA/D変換の値を、サブメニューで%表示します。信号処理は実行前の状態を維持します。

K0のメニューにすると、全キーの値を検出するためキー操作はできなくなりますが、本体のVOLUMEを回すことにより、次のサブメニューに進めることができます。このとき2クリック以上回すと、ボリューム値が変化するので注意してください。

図中の数値は参考例です。

### PS/PS2 (プロテクションの検出)

**PS:** DVD以外の電源電圧プロテクションの値 (正常値49 ~ 60)

**P2:** DVD関連の電源電圧プロテクションの値 (正常値46 ~ 70)

PS、P2は正常値を外れるとプロテクションが働き、電源オフされます。

PS:057P2:055

### K0 (Panel key of main unit)

A/D of the key fails to function properly when the standard value is deviated. In this case, check the constant of partial pressure resistor, solder condition, etc. Refer to table 1.

### K0 (本体パネルキー)

キーのA/Dは基準値から外れると、正常な動きをしません。Table 1 をご覧になり、各キーの分圧抵抗の定数、ハンダ不良等の確認をしてください。

K0:100%

[Table 1]

Display (%)	K0
0 - 5	STOP
6 - 15	SKIP/SEARCH -
16 - 25	SKIP/SEARCH +
26 - 35	PAUSE
36 - 45	DSP
46 - 55	INPUT
56 - 65	PLAY
66 - 75	PROGRESSIVE
76 - 85	OPEN

**TH/Fa (temperature detection/fan drive level)**

**TH:** 500% display of the voltage based on the temperature detected value. Reference voltage : 5V  
(Normal value: 1 to 318)

**Fa:** Current fan drive level on the left and the past fan drive history on the right.

## TH/Fa( 温度検出/ファン駆動レベル)

**TH:** 温度検出値で電圧の500 %表示、基準電圧は5V  
( 正常値1 ~ 318 )

**Fa:** 左側は現在のファン駆動レベル、右側は過去のファン駆動履歴

```
TH:125Fa:_/_
```

**FAN DRIVE TEST  
HIGH**

FAN DRIVE TEST ( ファン駆動テスト )  
HIGH : ファン駆動強

```
FanTest:HIGH
```

**FAN DRIVE TEST  
MID**

FAN DRIVE TEST ( ファン駆動テスト )  
MID : ファン駆動中

```
FanTest:MID
```

**FAN DRIVE TEST  
LOW**

FAN DRIVE TEST ( ファン駆動テスト )  
LOW : ファン駆動弱

```
FanTest:LOW
```

### 10. IF STATUS (Input function status)

Using the sub-menu, the status data is displayed one after another in the hexadecimal notation.

During signal processing, the status before execution of this menu is maintained.

\* **Numeric values in the figure example are for reference.**

#### IS1 (Internal status):

Indicates the status information of the microprocessor.

### 10. IF STATUS

サブメニュー操作により、以下のステータス情報を順次 16 進数で表示します。信号処理は、本メニュー実行前の状態を維持します。

図中の数値は参考例です。

#### IS 1 (内部ステータス)

マイコンのステータス情報を表示します。

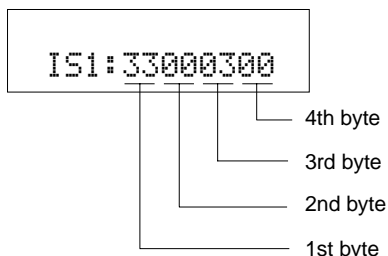

#### <1st byte>

Digital input/output setting value  
Upper 4 bits: REC OUT selected /  
lower 4 bits: INPUT selected

Value	Choice	Preset name
0	NONE	
1	NONE	
2	DIGITAL	DVD/CD
3	OPT	VIDEO
4	NONE	
6	NONE	
8	NONE	
9	NONE	

#### <第1バイト>

デジタル入出力設定値  
上位4bit REC OUT 選択 /  
下位4bit INPUT 選択

#### <2nd byte>

Fs information of reproduction signal

#### <第2バイト>

再生信号のFs情報

Display	00	01	02	03	04	05	06	0A	0B	0C	0D
<b>Fs (kHz)</b>	Analog	32	44.1	48	64	88.2	96	Unknown NRM	Unknown DBL	Unknown QUAD	Not defined

#### <3rd byte>

Audio code mode information of reproduction signal

#### <第3バイト>

再生信号のオーディオコードモード情報

Display	00	01	02	03	04	05	06	07	08	09	0A	0B	0C	0D
<b>Audio Code</b>	MULTI MONO	1+1	1/0	2/0	3/0	2/1	3/1	2/2	3/2	2/3	3/3	OVER 6.1	MULTI PCE	Unknown

#### <4th byte>

Format information of reproduction signal

#### <第4バイト>

再生信号のフォーマット情報

Display	Signal format
00	Analog (Unlock)
01	Incorrect digital (*1)
10	PCM Audio
20	Digital Data
21	IEC1937 Data
22	None PCM
23	Unknown
50	dts

Display	Signal format
51	Red dts
54	dts-ES MATRIX
58	dts-ES DISCRETE
5C	dts-ES (Both flag)
60	AAC
C0	Dolby Digital
C1	D.D. Karaoke
C4	D.D.6.1 (D.D.EX)

(\*1): Analog processing used for digital reproduction is not possible because of a commercial bit or 4-ch audio reason.

(\*1): 業務用ビットや4ch オーディオなどの理由で、デジタル再生できずアナログ処理されます。

**IS2-3 (Internal status):** (Not used in this model)

IS2 3(内部ステータス)(使用しません)

IS2:780101

IS3:01011001

**CS1-5:** Indicates channel status information of the input signal (IEC60958). (Not used in this model)

CS 1 5: 入力信号のIEC60958 チャンネルステータス情報を表示します。(使用しません)

CS1:FFFFFFFF

CS5:FFFFFFFF

**BY1-4:** Indicates information of the bit stream included in the DOLBY DIGITAL signal. (Not used in this model)

BY1 4: DOLBY DIGITAL 信号に含まれるビットストリームインフォメーション情報を表示します。(使用しません)

BY1:FFFFFFFF

BY4:FFFFFFFF

**BC1-5:** Indicates information of the bit stream included in the dts signal. (Not used in this model)

BC1 5: dts 信号に含まれるビットストリームインフォメーション情報を表示します。(使用しません)

BC1:000000FF

BC5:E1

**YS1-3:** Indicates device status information of YSS938 (IC379). (Not used in this model)

YS1 3: YSS938( IC379 )のデバイスステータス情報を表示します。(使用しません)

*\* The numeric value in the figure is an example for reference.*

図中数値は参考例です。

YS1:A6820043

YS2:00000000

YS3:600660D1

**CS:** CS49329 Unsolicited Messages (AUTODETECT\_RESPONSE) (Not used in this model)

CS: CS49329 Unsolicited Messages (AUTODETECT\_RESPONSE) (使用しません)

CS :000020

**MTT:** Mute Trigger (Not used in this model)

MTT: Mute Trigger(使用しません)

MTT:00060000

## 11. DSP RAM CHECK

This menu is used to self-diagnose whether or not the bus connection for the YSS938 and the external RAM is made properly.

During signal processing, the status before execution of this menu is maintained.

The address bus and the data bus are checked and the connection condition is displayed.

When no error is detected, "NoEr" appears on display.

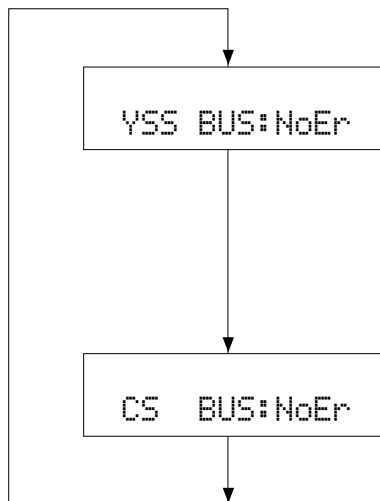

## 11. DSP RAM CHECK

YSS938と外付けRAMとのバス接続の正否を自己診断します。信号処理は、このメニューを実行する前の状態を維持します。アドレスバス、データバスのチェックを行い、接続正否を表示します。

エラーが検出されなかった場合は、“ NoEr ”と表示されます。

### YSS938 BUS CHECK

Display	Description
WAIT	Bus is being checked.
NoEr	No error detected.
DATA	Data bus shorted or open.
RSCS	/RAS or /CAS shorted, or open.
ADDR	Address bus shorted or open.

### PLD/SRAM BUS CHECK

Display	Description
WAIT	Bus is being checked.
NoEr	No error detected.
EDxx	Data bus shorted or open. (xx: 00-07)
EAXx	Address bus shorted or open. (xx: 00-0E)



## 12. SOFT SW

This menu is used to confirm the function settings on P.C.B..

## 12. SOFT SW

P.C.B. 上の機能設定を確認する機能です。

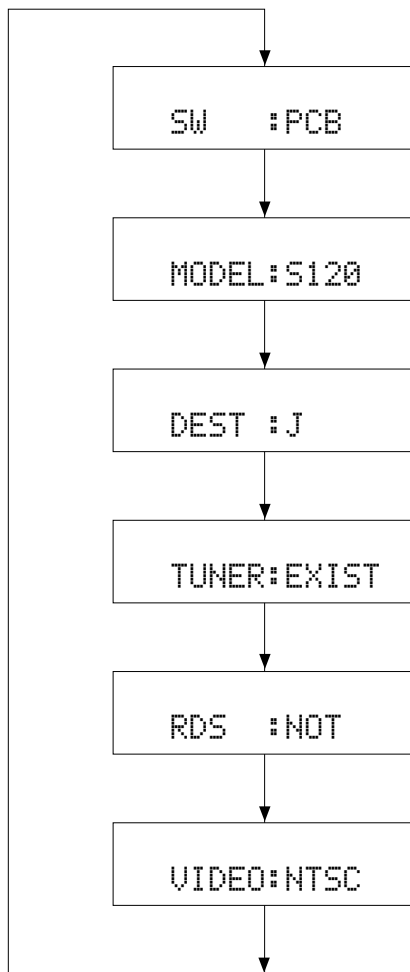

### SW MODE:

Select PCB. Do not select SOFT.

PCBを選択してください。SOFTには設定しないでください。

### MODEL SETTING:

Select S120. Do not select S200.

S120を選択してください。S200には設定しないでください。

### TUNER DESTINATION:

J, UC, AGTK or RL can be confirmed.

J、UC、AGTK、RLのいずれかを確認できます。

### TUNER:

NOT or EXIST can be confirmed.

NOTまたはEXISTを確認できます。

### RDS:

NOT or EXIST can be confirmed.

NOTまたはEXISTを確認できます。

### VIDEO FORMAT:

NTSC or PAL can be confirmed.

NTSCまたはPALを確認できます。

### 13. MICROPROCESSOR INFORMATION

The version, checksum and the port specified by the microprocessor are displayed. The signal is processed using EFFECT OFF. The checksum is obtained by adding the data at every 8 bits for each program area and expressing the result as a 4-figure hexadecimal data.

### 13. マイコン情報

サブメニューは4つあります。プログラムのバージョン、チェックサム、マイコンの指定ポートを表示します。信号はエフェクトOFFです。チェックサムは、プログラムエリア別にデータを8ビットごとに加算していき、4桁の16進データで現したものです。

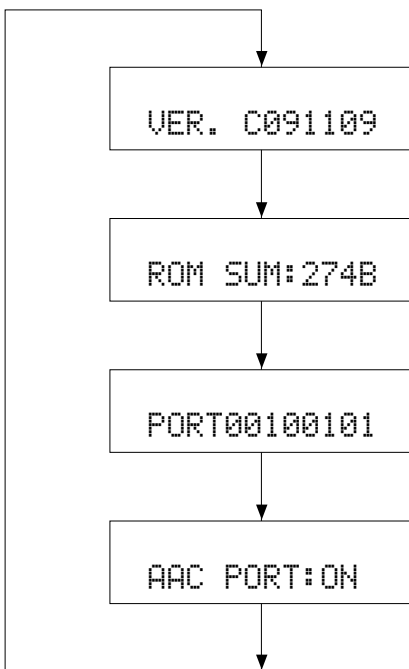

**Version / バージョン情報**

Release 1 digit / Main version 2 digit / DSP version 2 digit / DVD version 2 digit

**Checksum / チェックサム表示**

A: All area

**Check of port setting for judging microprocessor function**

マイコンの機能判定用ポート設定確認

**Display of AAC function detection port state**

AAC 機能検出ポート状態表示

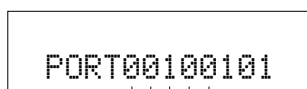

- Tuner mode 0 (\*1)
- Tuner mode 1 (\*1)
- Tuner with (1) / without (0)
- RDS with (1) / without (0)
- VIDEO format: PAL (1) / NTSC (0)

\*1 (Tuner mode)

Tuner mode 1	Tuner mode 0	Tuner frequency
0	0	AM: 531-1611kHz/9kHz FM: 76.0-90.0MHz/100kHz
1	0	AM: 531-1611kHz/9kHz FM: 87.50-108.00MHz/50kHz
0	1	AM: 530-1710kHz/10kHz FM: 87.5-107.9MHz/200kHz
1	1	AM: 531-1611kHz/9kHz FM: 87.50-108.00MHz/50kHz

## 14. Other Information

## 14. その他の情報

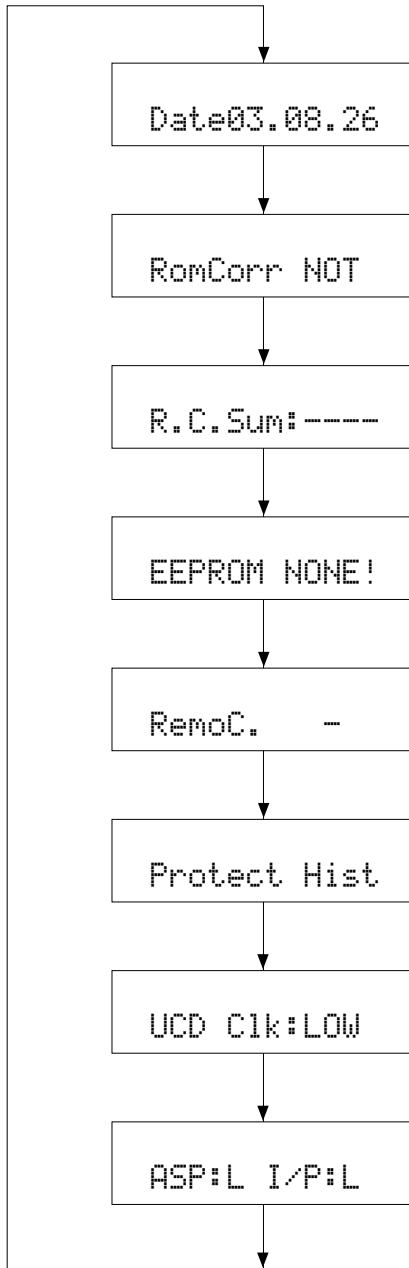
**Soft Date / ソフトの日付**

**Rom Correction Exit, Not / ROM コレクションデータの有無**  
(Not used in this model) / (使用しません)

**Rom Correction Check Sum Display /**  
ROM コレクションエリアのチェックサム  
(Not used in this model) / (使用しません)

**Rom Correction Remote Control Receive**  
ROM コレクションデータのリモコン受信  
(Not used in this model) / (使用しません)

**Remote Control Code Display / リモコン受信コード表示**  
Remote control received code can be checked. / リモコン受信コードが  
確認できます。

**Protect History Delete**  
プロテクション履歴削除の予約 / 解除  
Reservation/cancellation can be selected by pressing A/B/C/D/E button.  
A/B/C/D/E ボタンにより予約・解除が選択できます。

**Forced output of UCD clock / UCD クロックの強制出力**  
HIGH or LOW can be selected by using the A/B/C/D/E key.  
A/B/C/D/E ボタンにより HIGH/LOW の切り替えができます。

**Forced output of aspect, interlace/progressive port**  
アスペクト、インターレース / プロGRESSIVEポートの強制出力  
H, M or L can be selected by using the A/B/C/D/E key.  
A/B/C/D/E ボタンにより H/M/L の切り替えができます。

## ■ DISPLAY DATA

V221 : 14-BT-80GNKF (WB452200)

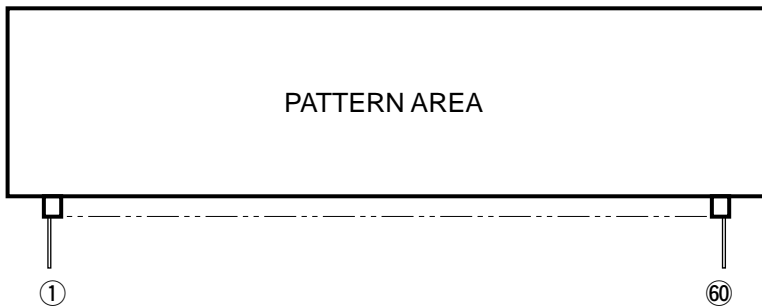

### ● PIN CONNECTION

Pin No.	1	2	3	4	5	6	7	8	9	10	11	12	13	14	15	16	17	18	19	20	21	22	23	24	25	26	27	28	29	30
Connection	F1	NX	NP	NP	1G	2G	3G	4G	5G	6G	7G	8G	9G	10G	11G	12G	13G	14G	NX	NX	NX	P35	P34	P33	P32	P31	P30	P29	P28	P27

Pin No.	31	32	33	34	35	36	37	38	39	40	41	42	43	44	45	46	47	48	49	50	51	52	53	54	55	56	57	58	59	60
Connection	P26	P25	P24	P23	P22	P21	P20	P19	P18	P17	P16	P15	P14	P13	P12	P11	P10	P9	P8	P7	P6	P5	P4	P3	P2	P1	NP	NP	NX	F2

**Note** 1) F1, F2 ..... Filament      3) NX ..... No extend pin      5) 1G~14G ..... Grid  
 2) NP ..... No Pin      4) P1~P35 ..... Datum Line

### ● GRID ASSIGNMENT

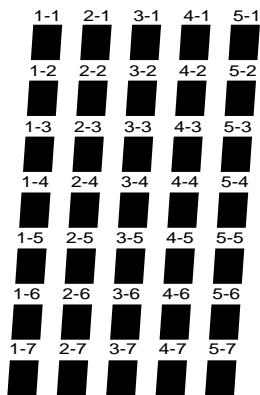
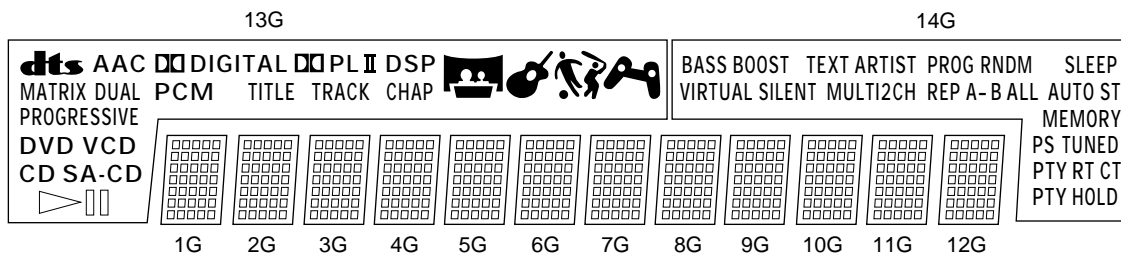





(1G~12G)



(13G)

## ● ANODE CONNECTION

	1G ~ 12G	13G	14G
P1	1-1	S1	SLEEP
P2	2-1	S2	AUTO
P3	3-1	S3	ST
P4	4-1	S4	MEMORY
P5	5-1	CHAP	PS
P6	1-2	DSP	TUNED
P7	2-2	TRACK	PTY
P8	3-2	 PL	RT
P9	4-2	II	CT
P10	5-2	TITLE	PTY HOLD
P11	1-3	 DIGITAL	VIRTUAL
P12	2-3	PCM	BASS BOOST
P13	3-3	AAC	SILENT
P14	4-3		TEXT
P15	5-3	DUAL	MULTI
P16	1-4	MATRIX	2CH
P17	2-4	PROGRESSIVE	ARTIST
P18	3-4	VCD	REP
P19	4-4	DVD	A-
P20	5-4	SA-CD	B
P21	1-5	CD	ALL
P22	2-5		PROG
P23	3-5		RNDM
P24	4-5	-	-
P25	5-5	-	-
P26	1-6	-	-
P27	2-6	-	-
P28	3-6	-	-
P29	4-6	-	-
P30	5-6	-	-
P31	1-7	-	-
P32	2-7	-	-
P33	3-7	-	-
P34	4-7	-	-
P35	5-7	-	-

## ■ IC DATA

### IC381 : M30624FGAFP (DIGITAL P.C.B.)

#### Main CPU

No.	Name	Port	I/O	Function
1	P96	SOUT4	OUT	(Pull-down resistor required)
2	P95	CLK4	OUT	(Pull-down resistor required)
3	P94	DA1	D-A OUT	FAN D-A OUT (FAN) [0 ~ VCC]
4	P93	DA0	OUT	(Pull-down resistor required)
5	P92	SOUT3	S-OUT	[SDM] YSS938 DATA OUT (Serial I/O-3)
6	P91	SIN3	S-IN	[SDD] YSS938 DATA IN (Serial I/O-3)
7	P90	CLK3	S-CLK	[SCK] YSS938 CLK OUT (Serial I/O-3)
8	BYTE	-	-	Connect to VSS (GND)
9	CNVSS	-	-	Connect to VSS (GND) via Resistor (5.1k-ohms) [For flash writing: Vcc]
10	P87	CMOS	OUT	(Pull-down resistor required)
11	P86	CMOS	OUT	(Pull-down resistor required)
12	/RESET	-	-	RESET [L: RESET]
13	XOUT	-	-	16MHz OUT (with built-in feedback resistor)
14	VSS	-	-	GND
15	XIN	-	-	16MHz IN (with built-in feedback resistor)
16	VCC	-	-	Power supply, +5V
17	P85	/NMI	IN	Connect to Vcc via Resistor (10 k-ohms) (NMI function unused)
18	P84	/INT2	INT-IN	Digital AMP I Protect (ERR) [H: Error]
19	P83	/INT1	INT-IN	[INT938] YSS938 IPINT/MUTE/DIR
20	P82	/INT0	IN	Communication with DVD sub-microprocessor / READY IN (Pull-down resistor required) [L: READY]
21	P81	TA4IN	IN	DC Protect (DC_PRT) [L: when in abnormal state]
22	P80	TA4OUT	T-OUT	Digital AMP CLOCK OUT (380KHz/421KHz) [L: Self-excited, Pulse: Separately excited]
23	P77	TA3IN	IN	HEAD PHONE Detect (Pull-up resistor required) [H: being used]
24	P76	TA3OUT	OUT	Sub-microprocessor 8MHz OUT
25	P75	TA2IN	OUT	Digital AMP Enable OUT [L: Stop, H: Operation]
26	P74	TA2OUT	OUT	[/ICD] YSS938 /DA /AD /CODEC /DEM OUT
27	P73	/CTS2	OUT	[CSY] YSS938 CE OUT
28	P72	CLK2	S-CLK	CLK for communication with DVD sub-microprocessor (Serial I/O-2)
29	P71	RXD2	S-IN	RxD for communication with DVD sub-microprocessor (Serial I/O-2)
30	P70	TXD2	S-OUT	TxD for communication with DVD sub-microprocessor [Pull-up resistor N-OD required] (Serial I/O-2)
31	P67	TXD1	S-OUT	(DATA OUT to EEPROM)/DATA OUT to Flash Writer (Serial I/O-1)
32	P66	RXD1	S-IN	(DATA IN from EEPROM)/DATA IN from Flash Writer (Serial I/O-1)
33	P65	CLK1	S-CLK	(CLK OUT to EEPROM)/CLK IN from Flash Writer (Serial I/O-1)
34	P64	/CTS1	OUT	TUNER MUTE/Busy OUT to Flash Writer
35	P63	TXD0	S-OUT	FL Driver TxD (FL_TXD) (Serial I/O-0)
36	P62	RXD0	IN	CS-DSP INT
37	P61	CLK0	S-CLK	FL Driver CLOCK OUT (FL_CLK) (Serial I/O-0)
38	P60	/CTS0	OUT	IRQ OUT for communication with DVD sub-microprocessor [H: Request]
39	P57	CLKOUT	OUT	[CSR] CS493x TxD
40	P56	ALE	IN	[CST] CS493x RxD
41	P55	/HOLD	IN	Connect to VSS (GND) via Resistor (10 k-ohms) (For Flash Writing: L)
42	P54	/HLDA	OUT	[CSC] CS493x CLOCK OUT
43	P53	BCLK	OUT	[/CSCS] CS493x CS OUT
44	P52	/RD	OUT	[/ICCS] CS493x RESET OUT
45	P51	/WRH	OUT	[/CSPLD] DIG EXTERNAL IC CE OUT (when using PLD)
46	P50	/WRL	IN	Connect to Vcc via Resistor (10 k-ohms) [L when resetting : Sub-microprocessor 8MHz OUT at power OFF] (For Flash Writing: H)
47	P47	/CS3	OUT	DVD sub-microprocessor reset (Pull-down resistor required) [L: Reset]
48	P46	/CS2	OUT	(CS OUT to EEPROM) (Pull-down resistor required) [H: DATA Transfer]
49	P45	/CS1	OUT	Power Relay Output (POW-RY) [H: ON]
50	P44	/CS0	OUT	FL Driver RESET (Light OFF) OUT (FL-ON)
51	P43	CMOS	OUT	PLL/RDS IC TxD (PLL/RDS_TXD)
52	P42	-	IN	PLL IC RxD IN (TU_Dat_o)
53	P41	CMOS	OUT	PLL/RDS IC CLOCK (PLL/RDS_CLK)
54	P40	CMOS	OUT	FL Driver CE OUT (FL-CE) [L: Address, H: Data]
55	P37	CMOS	OUT	S Terminal Mute OUT
56	P36	CMOS	OUT	Component Mute OUT
57	P35	-	IN	TUNER STATION IN (STATION) (Pull-up resistor required) [L: Station provided]
58	P34	CMOS	OUT	(Pull-down resistor required)
59	P33	CMOS	OUT	PLL/RDS IC Chip Enable OUT (PLL/RDS_CE) [L: Address, H: Data]

## IC381 : M30624FGAFP (DIGITAL P.C.B.)

## Main CPU

No.	Name	Port	I/O	Function
60	P32	-	IN	RDS IC RxD (RDS_RXD) (Pull-up resistor required)
61	P31	CMOS	OUT	(Pull-down resistor required)
62	VCC	-	-	Power supply, +5V
63	P30	CMOS	OUT	(Pull-down resistor required)
64	VSS	-	-	GND
65	P27	CMOS	OUT	Aspect Select WIDE 2 (S terminal switching)
66	P26	CMOS	OUT	Aspect Select WIDE 1 (S terminal switching)
67	P25	CMOS	OUT	D Terminal Control OUT (P/I) [L: Interlace, H: Progressive]
68	P24	CMOS	OUT	VIDEO Selector D (MUTE2)
69	P23	CMOS	OUT	VIDEO Selector C (MUTE1)
70	P22	CMOS	OUT	VIDEO Selector B (V_SEL_B)
71	P21	CMOS	OUT	VIDEO Selector A (V_SEL_A)
72	P20	CMOS	OUT	(Pull-down resistor required)
73	P17	/INT5	INT-IN	Remote Control IN (REMOTE)
74	P16	/INT4	INT-IN	Standby SW IN [H: ON]
75	P15	/INT3	INT-IN	Power Down DETECT INT IN (PW_DN) [L: POWER DOWN]
76	P14	CMOS	OUT	Full MUTE (+ HP Muting available) OUT [L: MUTE]
77	P13	CMOS	OUT	Sub-woofer Mute OUT [L: MUTE]
78	P12	CMOS	OUT	(Pull-down resistor required)
79	P11	CMOS	OUT	(Pull-down resistor required)
80	P10	CMOS	OUT	(Pull-down resistor required)
81	P07	CMOS	OUT	Input Select/Electronic Volume IC CLOCK (BD3842FS/BD3815KS 2-wire serial) (CKBD)
82	P06	CMOS	OUT	Input Select/Electronic Volume IC DATA (BD3842FS/BD3815KS 2-wire serial) (DTBD)
83	P05	CMOS	OUT	HP MUTE OUT [L: MUTE]
84	P04	-	IN	Rotary Encoder B (ROT-2) (Pull-up resistor required)
85	P03	-	IN	Rotary Encoder A (ROT-1) (Pull-up resistor required)
86	P02	CMOS	OUT	(Pull-down resistor required)
87	P01	CMOS	OUT	(Pull-down resistor required)
88	P00	CMOS	OUT	
89	P107	AN7	A-D IN	Destination Select Input [0 ~ VREF]
90	P106	AN6	IN	TUNER STEREO Detect IN (Pull-up resistor required)
91	P105	AN5	A-D IN	(Pull-up at 100 k-ohms) [0 ~ VREF]
92	P104	AN4	A-D IN	Key AD Input 0 (KEY0) [0 ~ VREF]
93	P103	AN3	A-D IN	Temperature Detect (Thermistor) IN (for driving FAN) (YHM-M) [0 ~ VREF]
94	P102	AN2	A-D IN	Power Voltage Detect 1 (V Protect) IN (V1-PRT) [0 ~ VREF]
95	P101	AN1	IN	AC Power Voltage Detect (AC Protect) IN (AC-PRT) [H: when in abnormal state]
96	AVSS	-	-	Connect to VSS (GND)
97	P100	AN0	OUT	Power Voltage Detect 2 (V2 Protect) IN (V2-PRT) [0 ~ VREF]
98	VREF	-	-	A-D, D-A Reference Voltage Input [ ~ VCC]
99	AVCC	-	-	Connect to VCC Terminal (+5V)
100	P97	SIN4	IN	(Used as Design Test Port) (Pull-down resistor required)

## ● KEY INPUT (A-D) PULL UP RESISTOR 10kΩ

Ω	0	+1.2k	+1.2k	+1.8k	+2.7k	+3.3k	+4.7k	+8.2k	+18k	+47k
V	0 ~ 0.25	~ 0.75	~ 1.25	~ 1.75	~ 2.25	~ 2.75	~ 3.25	~ 3.75	~ 4.25	~ 4.75
KEY 0 (92pin)	STOP A/B/C/D/E	SKIP/SEARCH - PRESET/TUNING -	SKIP/SEARCH + PRESET/TUNING +	PAUSE PRESET/BAND	DSP +	INPUT +	PLAY AUTO/MAN'L	PROGRESSIVE MEMORY	OPEN	NO KEY

## ● TUNER MARKET &amp; DVD REGION SELECT IN (89 pin, A-D) PULL UP RESISTOR 10kΩ

Ω	4.3k	6.8k	10k	15k	24k	39k	91k	∞ (pull-up only)
V	1.25 ~ 1.75	~ 2.25	~ 2.75	~ 3.25	~ 3.75	~ 4.25	~ 4.75	4.75 ~ 5
Market	T	K	L (9K/50K) (10K/100K)	R (9K/50K) (10K/100K)	A	U, C	B, G	J
Region	6	3	3	3	4	1	2	2

**IC383 : M38517FGFP (DIGITAL P.C.B.)  
SUB CPU**

No.	Name	Port	I/O	Function
1	VCC	-	-	Power supply, +5V
2	VREF	-	-	A-D, D-A Reference Voltage Input [ ~ VCC]
3	AVSS	-	-	Connect to Vss (GND)
4	P44	INT3	OUT	(Pull-down resistor required)
5	P43	INT2	OUT	(Pull-down resistor required)
6	P42	INT1	INT-IN	Interrupt Request from Main Microprocessor [H: IRQ]
7	P41	INT0	IN	Connect to Vcc (+5V) via Resistor (10 k-ohms) [For Flash Writing: Vcc]
8	P40	CMOS	OUT	(Pull-down resistor required)
9	P27	/RDY1	OUT	BUSY OUT to Flash Writer
10	P26	SCLK1	S-CLK	CLK IN from Flash Writer (Serial I/O-1)
11	P25	TxD1	S-OUT	DATA OUT to Flash Writer (Serial I/O-1)
12	P24	RxD1	S-IN	DATA IN from Flash Writer (Serial I/O-1)
13	P23	SCL1	N-OUT	IIC SCL (Communication with DVD Module) [Pull-up resistor required] (Serial I/O-I2C)
14	P22	SDA1	N-OUT	IIC SDA (Communication with DVD Module) [Pull-up resistor required] (Serial I/O-I2C)
15	CNVSS	-	-	Connect to Vss (GND) via Resistor (5.1 k-ohms) [For Flash Writing: Vcc]
16	P21	CMOS	OUT	(Pull-down resistor required)
17	P20	CMOS	OUT	(Pull-down resistor required)
18	/RESET	-	-	RESET (Test land required) [L: RESET]
19	XIN	-	-	8MHz IN (with built-in feedback resistor)
20	XOUT	-	-	8MHz OUT (with built-in feedback resistor)
21	VSS	-	-	GND
22	P17	CMOS	IN/OUT	General purpose I/O P17 (Pull-down resistor required)
23	P16	CMOS	IN/OUT	General purpose I/O P16 (Pull-down resistor required)
24	P15	CMOS	IN/OUT	General purpose I/O P15 (Pull-down resistor required)
25	P14	CMOS	IN/OUT	General purpose I/O P14 (Pull-down resistor required)
26	P13	CMOS	IN/OUT	General purpose I/O P13 (Pull-down resistor required)
27	P12	CMOS	IN/OUT	General purpose I/O P12 (Pull-down resistor required)
28	P11	CMOS	IN/OUT	General purpose I/O P11 (Pull-down resistor required)
29	P10	CMOS	IN/OUT	General purpose I/O P10 (Pull-down resistor required)
30	P07	CMOS	OUT	DVD Unit Power Supply 3 OUT [H: ON]
31	P06	CMOS	OUT	DVD Unit Power Supply 2 OUT [H: ON]
32	P05	CMOS	OUT	DVD Unit Power Supply 1 OUT (Pull-down resistor required)
33	P04	CMOS	OUT	(Pull-down resistor required)
34	P03	SRDY2	OUT	RDY OUT to Main Microprocessor (Serial I/O-2)
35	P02	SCLK2	S-CLK	CLK IN from Main Microprocessor (Serial I/O-2)
36	P01	SOUT2	S-OUT	DATA OUT to Main Microprocessor (Serial I/O-2)
37	P00	SIN2	S-IN	DATA IN from Main Microprocessor (Serial I/O-2)
38	P34	CMOS	OUT	(Pull-down resistor required)
39	P33	CMOS	OUT	(Pull-down resistor required)
40	P32	CMOS	OUT	(Pull-down resistor required)
41	P31	CMOS	OUT	(Pull-down resistor required)
42	P30	AN0	A-D IN	Key AD Input for TEST [0 ~ VREF]



IC379 : YSS938 (DIGITAL P.C.B.)  
 DSP

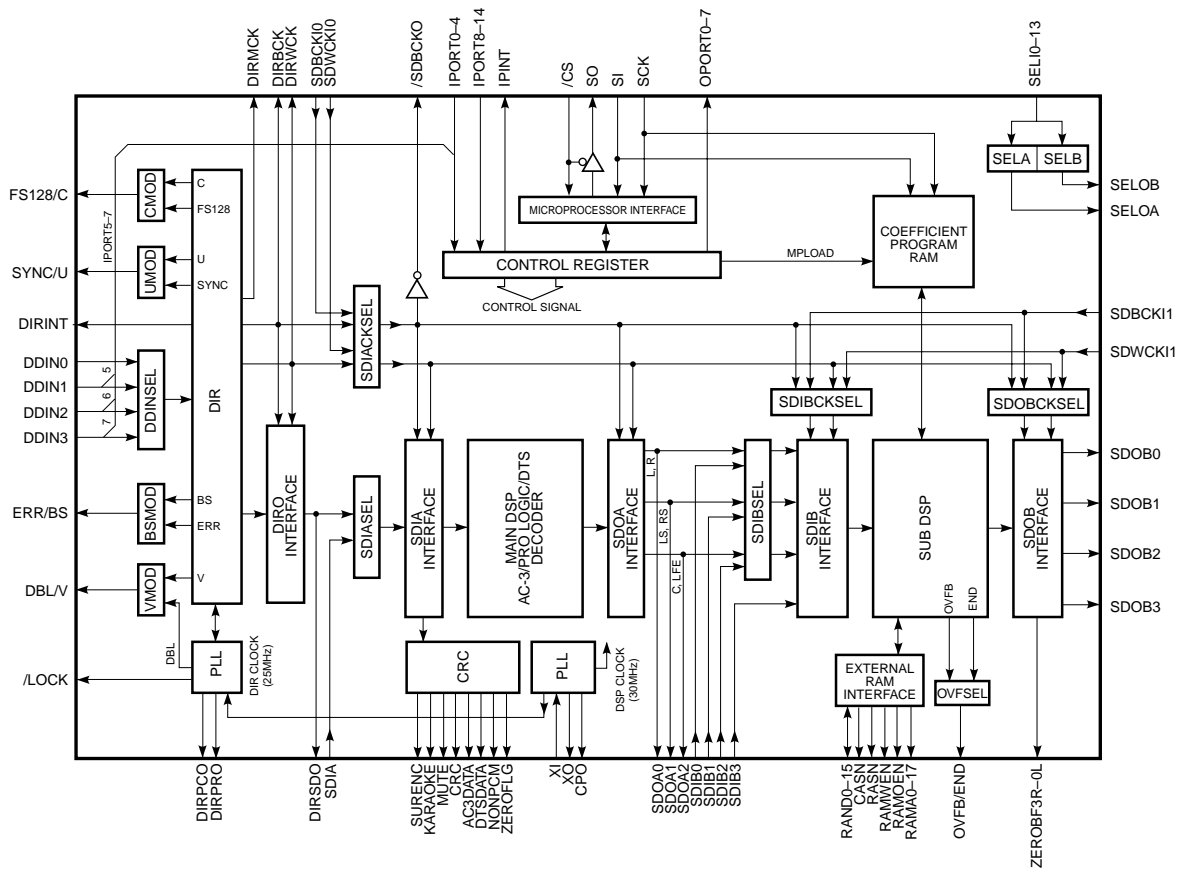
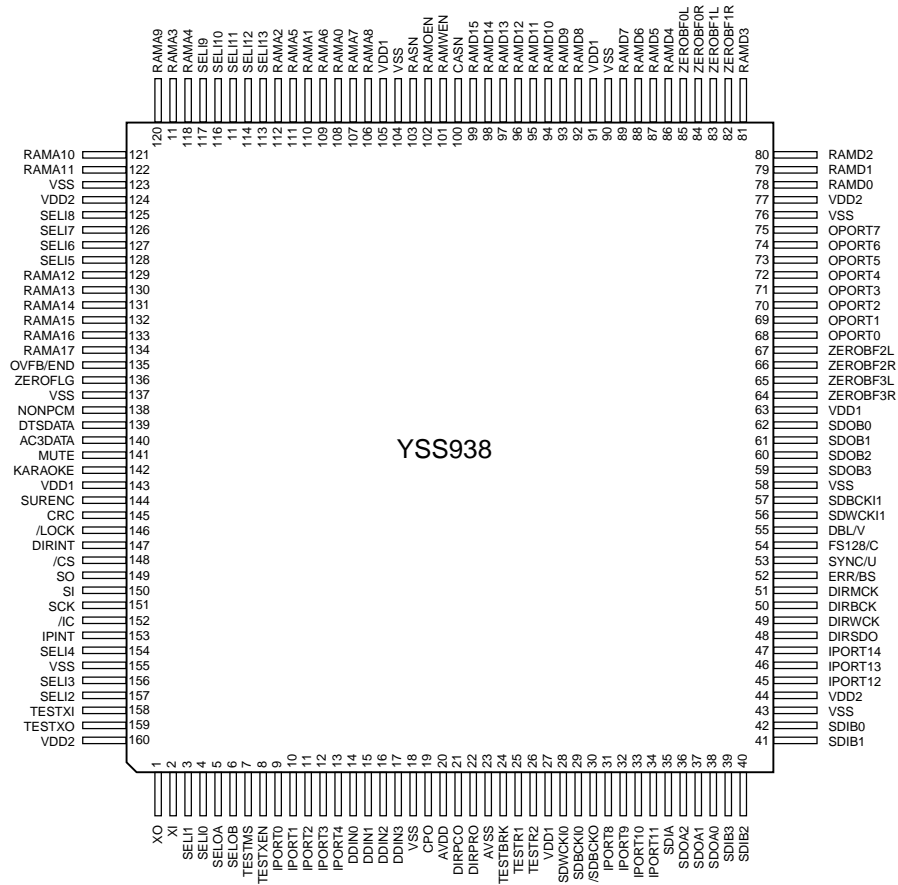

**IC379 : YSS938 (DIGITAL P.C.B.)****DSP**

No.	Name	I/O	Function
1	XO	O	Crystal oscillator connecting terminal
2	XI	I	Crystal oscillator connecting terminal (24.576MHz )
3	SEL1	I+	Built-in selector input 1 (Unconnected)
4	SEL10	I+	Built-in selector input 0 (GND)
5	SELOA	O+	Built-in selector output A (ISEL)
6	SELOB	O+	Built-in selector output B (RSEL)
7	TESTMS	I+	Test terminal (unconnected)
8	TESTXEN	I+	Test terminal (unconnected)
9	IPORT0	I+	General purpose input terminal (Pull down)
10	IPORT1	I+	General purpose input terminal (GND)
11	IPORT2	I+	General purpose input terminal (GND)
12	IPORT3	I+	General purpose input terminal (GND)
13	IPORT4	I+	General purpose input terminal (GND)
14	DDIN0	Is	DIR: Digital audio interface data input terminal 0 (ISEL)
15	DDIN1	Is	DIR: Digital audio interface data input terminal 1/General purpose input terminal (Pull down)
16	DDIN2	Is	DIR: Digital audio interface data input terminal 2/General purpose input terminal (Pull down)
17	DDIN3	Is	DIR: Digital audio interface data input terminal 3/General purpose input terminal (Pull down)
18	VSS		Ground terminal
19	CPO	A	PLL filter connecting terminal
20	AVDD		+3.3V power terminal (for DIR)
21	DIRPCO	A	DIR: PLL filter connecting terminal
22	DIRPRO	A	DIR: PLL filter connecting terminal
23	AVSS		Ground terminal (for DIR)
24	TESTBRK	I+	Test terminal (Unconnected)
25	TESTR1	I+	PLL initialization signal input terminal for DSP (/ICD)
26	TESTR2	I+	Test terminal (Unconnected)
27	VDD1		+3.3V power terminal (for terminal section)
28	SDWCKI0	I+	Word clock input terminal for SDIA, SDOA, SDIB, SDOB interface (Unconnected)
29	SDBCKI0	I+	Bit clock input terminal for SDIA, SDOA, SDIB, SDOB interface (Unconnected)
30	/SDBCK0	O	DIRBCK or SDBCKI0 invert clock output terminal (Unconnected)
31	IPORT8	I+	IPINT general purpose input terminal
32	IPORT9	I+	IPINT general purpose input terminal
33	IPORT10	I+	IPINT general purpose input terminal (NONPCM)
34	IPORT11	I+	IPINT general purpose input terminal (NONPCM)
35	SDIA	I	AC-3/DTS bit stream (or PCM) data input terminal to Main DSP
36	SDOA2	O	PCM output terminal from Main DSP (C/LFE output) (Unconnected)
37	SDOA1	O	PCM output terminal from Main DSP (LS/RS output) (Unconnected)
38	SDOA0	O	PCM output terminal from Main DSP (L/R output) (Unconnected)
39	SDIB3	I+	PCM input terminal 3 to Sub DSP
40	SDIB2	I+	PCM input terminal 2 to Sub DSP
41	SDIB1	I+	PCM input terminal 1 to Sub DSP
42	SDIB0	I+	PCM input terminal 0 to Sub DSP
43	VSS		Ground terminal
44	VDD2		+2.5V power terminal (for internal circuit)
45	IPORT12	I+	IPINT general purpose input terminal (F_MUTE)
46	IPORT13	I+	IPINT general purpose input terminal (DIRINT)
47	IPORT14	I+	IPINT general purpose input terminal (Unconnected)
48	DIRSDO	O	AC-3/DTS bit stream (or PCM) data output terminal from DIR
49	DIRWCK	O	DIR: Serial data word clock (fs) output terminal (WCK)
50	DIRBCK	O	DIR: Serial data bit clock (64fs) output terminal (BCK)
51	DIRMCK	O	DIR: Serial data master clock (256fs or 128fs) output terminal (MCK)
52	ERR/BS	O	DIR: Data error detect output/block start output terminal (Unconnected)
53	SYNC/U	O	DIR: Serial data synchronous timing output/user data output terminal (Unconnected)
54	FS128/C	O	DIR: Serial data master clock 128fs output/channel status output terminal (Unconnected)
55	DBL/V	O	DIR: Double rate clock output/validity flag output terminal (Unconnected)

## IC379 : YSS938 (DIGITAL P.C.B.)

## DSP

No.	Name	I/O	Function
56	SDWCKI1	I+	Word clock input terminal for SDIB, SDOB interface (Unconnected)
57	SDBCKI1	I+	Bit clock input terminal for SDIB, SDOB interface (Unconnected)
58	VSS		Ground terminal
59	SDOB3	O	PCM output terminal from Sub DSP
60	SDOB2	O	PCM output terminal from Sub DSP
61	SDOB1	O	PCM output terminal from Sub DSP
62	SDOB0	O	PCM output terminal from Sub DSP
63	VDD1		+3.3V power terminal (for terminal section)
64	ZEROBF3R	O+	SDOB3 Rch zero flag output terminal (Unconnected)
65	ZEROBF3L	O+	SDOB3 Lch zero flag output terminal (Unconnected)
66	ZEROBF2R	O+	SDOB2 Rch zero flag output terminal (Unconnected)
67	ZEROBF2L	O+	SDOB2 Lch zero flag output terminal (Unconnected)
68	OPORT0	O	General purpose output terminal (SMUTE)
69	OPORT1	O	General purpose output terminal (Unconnected)
70	OPORT2	O	General purpose output terminal (/ICCDC)
71	OPORT3	O	General purpose output terminal (DFS)
72	OPORT4	O	General purpose output terminal (Unconnected)
73	OPORT5	O	General purpose output terminal (Unconnected)
74	OPORT6	O	General purpose output terminal (MEMACS)
75	OPORT7	O	General purpose output terminal (Unconnected)
76	VSS		Ground terminal
77	VDD2		+2.5V power terminal (for internal circuit)
78	RAMD0	I+/O	Sub DSP: External memory data terminal 0
79	RAMD1	I+/O	Sub DSP: External memory data terminal 1
80	RAMD2	I+/O	Sub DSP: External memory data terminal 2
81	RAMD3	I+/O	Sub DSP: External memory data terminal 3
82	ZEROBF1R	O+	SDOB1 Rch zero flag output terminal (Unconnected)
83	ZEROBF1L	O+	SDOB1 Lch zero flag output terminal (Unconnected)
84	ZEROBF0R	O+	SDOB0 Rch zero flag output terminal (Unconnected)
85	ZEROBF0L	O+	SDOB0 Lch zero flag output terminal (Unconnected)
86	RAMD4	I+/O	Sub DSP: External memory data terminal 4
87	RAMD5	I+/O	Sub DSP: External memory data terminal 5
88	RAMD6	I+/O	Sub DSP: External memory data terminal 6
89	RAMD7	I+/O	Sub DSP: External memory data terminal 7
90	VSS		Ground terminal
91	VDD1		+3.3V power terminal (for terminal section)
92	RAMD8	I+/O	Sub DSP: External memory data terminal 8
93	RAMD9	I+/O	Sub DSP: External memory data terminal 9
94	RAMD10	I+/O	Sub DSP: External memory data terminal 10
95	RAMD11	I+/O	Sub DSP: External memory data terminal 11
96	RAMD12	I+/O	Sub DSP: External memory data terminal 12
97	RAMD13	I+/O	Sub DSP: External memory data terminal 13
98	RAMD14	I+/O	Sub DSP: External memory data terminal 14
99	RAMD15	I+/O	Sub DSP: External memory data terminal 15
100	CASN	O	Sub DSP: Column address strobe output terminal for external DRAM
101	RAMWEN	O	Sub DSP: Write enable terminal for external memory
102	RAMOEN	O	Sub DSP: Output enable terminal for external memory
103	RASN	O	Sub DSP: Low address strobe output terminal for external DRAM
104	VSS		Ground terminal
105	VDD1		+3.3V power terminal (for terminal section)
106	RAMA8	O	Sub DSP: External memory address terminal 8
107	RAMA7	O	Sub DSP: External memory address terminal 7
108	RAMA0	O	Sub DSP: External memory address terminal 0
109	RAMA6	O	Sub DSP: External memory address terminal 6
110	RAMA1	O	Sub DSP: External memory address terminal 1

**IC379 : YSS938 (DIGITAL P.C.B.)****DSP**

No.	Name	I/O	Function
111	RAMA5	O	Sub DSP: External memory address terminal 5
112	RAMA2	O	Sub DSP: External memory address terminal 2
113	SEL13	I+	Built-in selector input 13 (Unconnected)
114	SEL12	I+	Built-in selector input 12 (Unconnected)
115	SEL11	I+	Built-in selector input 11 (Unconnected)
116	SEL10	I+	Built-in selector input 10 (Unconnected)
117	SEL9	I+	Built-in selector input 9 (Unconnected)
118	RAMA4	O	Sub DSP: External memory address terminal 4
119	RAMA3	O	Sub DSP: External memory address terminal 3
120	RAMA9	O	Sub DSP: External memory address terminal 9 (Unconnected)
121	RAMA10	O	Sub DSP: External memory address terminal 10 (Unconnected)
122	RAMA11	O	Sub DSP: External memory address terminal 11 (Unconnected)
123	VSS		Ground terminal
124	VDD2		+2.5V power terminal (for internal circuit)
125	SEL8	I+	Built-in selector input 8 (Unconnected)
126	SEL7	I+	Built-in selector input 7 (GND)
127	SEL6	I+	Built-in selector input 6 (Unconnected)
128	SEL5	I+	Built-in selector input 5 (Unconnected)
129	RAMA12	O	Sub DSP: External memory address terminal 12 (Unconnected)
130	RAMA13	O	Sub DSP: External memory address terminal 13 (Unconnected)
131	RAMA14	O	Sub DSP: External memory address terminal 14 (Unconnected)
132	RAMA15	O	Sub DSP: External memory address terminal 15 (Unconnected)
133	RAMA16	O	Sub DSP: External memory address terminal 16 (Unconnected)
134	RAMA17	O	Sub DSP: External memory address terminal 17 (Unconnected)
135	OVFB/END	O	Sub DSP: Overflow/program end detect terminal (Unconnected)
136	ZEROF LG	O	Main DSP: Zero flag output terminal (Unconnected)
137	VSS		Ground terminal
138	NONPCM	O	Main DSP: Non-PCM data detect terminal
139	DTSDATA	O	Main DSP: DTS data detect terminal (Unconnected)
140	AC3DATA	O	Main DSP: AC3 data detect terminal (Unconnected)
141	MUTE	O	Main DSP: Auto mute detect terminal (F_MUTE)
142	KARAOKE	O	Main DSP: AC3 KARAOKE data detect terminal (Unconnected)
143	VDD1		+3.3V power terminal (for terminal section)
144	SURENC	O	Main DSP: AC-3 2/0 mode Dolby surround encode input detect terminal (Unconnected)
145	CRC	O	Main DSP: AC3 CRC error detect terminal (Unconnected)
146	/LOCK	O	DIR: PLL lock detect terminal (Unconnected)
147	DIRINT	O	DIR: Interrupt output terminal
148	/CS	Is	Microprocessor interface chip select input terminal (CSY)
149	SO	Ot	Microprocessor interface data output terminal
150	SI	Is	Microprocessor interface data input terminal (SDM)
151	SCK	Is	Microprocessor interface clock input terminal (YSSCK)
152	/IC	Is	Initial clear input terminal (/ICD)
153	IPINT	O+	Interrupt output terminal by IPORT 8-14
154	SEL14	I+	Built-in selector input 4 (Unconnected)
155	VSS		Ground terminal
156	SEL13	I+	Built-in selector input 3 (OPTA)
157	SEL12	I+	Built-in selector input 2 (SPDIF)
158	TESTXI	I	Test terminal (should be always connected to VSS)
159	TESTXO	O	Test terminal (Unconnected)
160	VDD2		+2.5V power terminal (for internal circuit)

Is: Schmidt trigger input terminal

I+: Input terminal with pull-up resistor

O: digital output terminal

O+: Tri-state digital output terminal

A: Analog terminal

IC372 : XC9572XL-10Q100C (DIGITAL P.C.B.) ..... J only

PLD

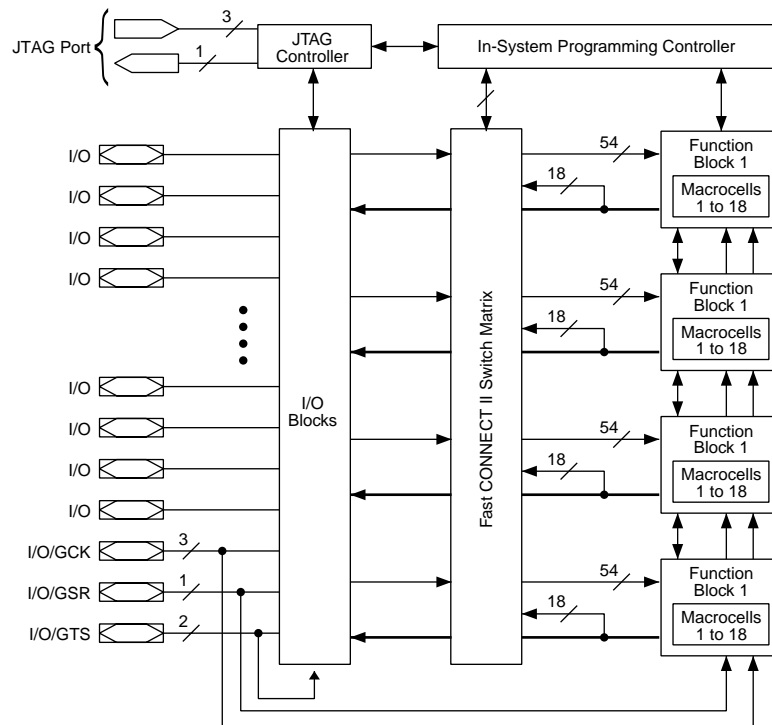
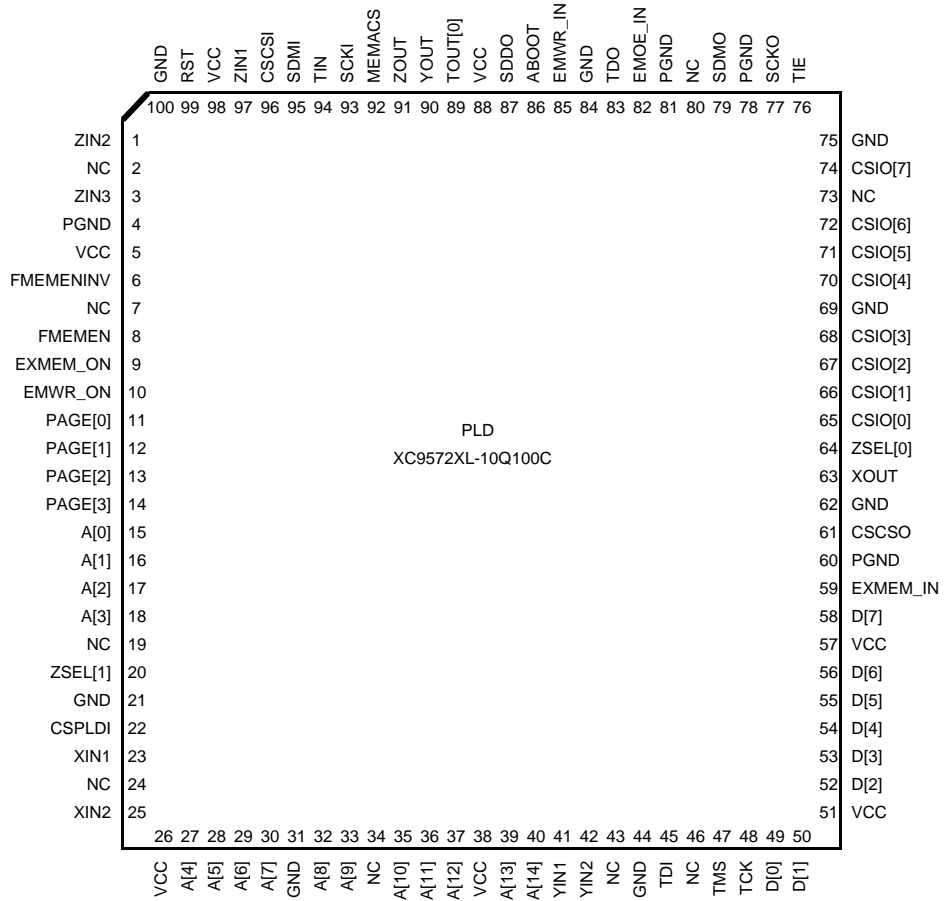

## IC372 : XC9572XL-10Q100C (DIGITAL P.C.B.) ..... J only

## PLD

NO.	端子名	信号線名称	I/O	機能
1	ZIN2		IN	MAIN DAC "SDATA" 用 セクタ入力端子 : AUDATA0 (GND)
2	N.C.			N.C.
3	ZIN3		IN	MAIN DAC "SDATA" 用 セクタ入力端子 : SDOA0 (GND)
4	PGND			電源 (0V)
5	VCC			電源 (+3.3V)
6	FMEMENINV	FMEINV	OUT	SRAM チップセレクト
7	N.C.			N.C.
8	FMEMEN		OUT	Flash Memory チップセレクト (未接続)
9	EXMEM_ON	/EMOE	OUT	外部メモリ用 Output Enable 出力
10	EMWR_ON	/EMWE	OUT	外部メモリ用 Write Enable 出力
11	PAGE[0]		OUT	Flash Memory Page Select (上位アドレスバスに接続) (未接続)
12	PAGE[1]		OUT	Flash Memory Page Select (上位アドレスバスに接続) (未接続)
13	PAGE[2]		OUT	Flash Memory Page Select (上位アドレスバスに接続) (未接続)
14	PAGE[3]		OUT	Flash Memory Page Select (上位アドレスバスに接続) (未接続)
15	A[0]	EMA[0]	OUT	外部メモリアクセス用アドレスバス
16	A[1]	EMA[1]	OUT	外部メモリアクセス用アドレスバス
17	A[2]	EMA[2]	OUT	外部メモリアクセス用アドレスバス
18	A[3]	EMA[3]	OUT	外部メモリアクセス用アドレスバス
19	N.C.			N.C.
20	ZSEL[1]		IN	MAIN DAC "SDATA" 用 セクタ制御信号入力端子 (未接続) 00 : zout = GND 10 : zout = AUDATA0 01 : zout = SDOB3 11 : zout = SDOA0
21	GND			電源 (0V)
22	CSPLDI	/CSPLD	IN	PLD 用チップセレクト (Low アクティブ)
23	XIN1	SDAO	IN	YSS938 "SDIB0" 用 セクタ入力端子 : SDAO(ADC 出力信号)
24	N.C.			N.C.
25	XIN2	SDIB0	IN	YSS938 "SDIB0" 用 セクタ入力端子 : AUDATA0(tout 出力)
26	VCC			電源 (+3.3V)
27	A[4]	EMA[4]	OUT	外部メモリアクセス用アドレスバス
28	A[5]	EMA[5]	OUT	外部メモリアクセス用アドレスバス
29	A[6]	EMA[6]	OUT	外部メモリアクセス用アドレスバス
30	A[7]	EMA[7]	OUT	外部メモリアクセス用アドレスバス
31	GND			電源 (0V)
32	A[8]	EMA[8]	OUT	外部メモリアクセス用アドレスバス
33	A[9]	EMA[9]	OUT	外部メモリアクセス用アドレスバス
34	N.C.			N.C.
35	A[10]	EMA[10]	OUT	外部メモリアクセス用アドレスバス
36	A[11]	EMA[11]	OUT	外部メモリアクセス用アドレスバス
37	A[12]	EMA[12]	OUT	外部メモリアクセス用アドレスバス
38	VCC			電源 (+3.3V)
39	A[13]	EMA[13]	OUT	外部メモリアクセス用アドレスバス
40	A[14]	EMA[14]	OUT	外部メモリアクセス用アドレスバス
41	YIN1	DIRSDO	IN	CS49329 "SDATAN" 用 セクタ入力端子 : DIRSDO
42	YIN2	SDOA0	IN	CS49329 "SDATAN" 用 セクタ入力端子 : SDOA0
43	N.C.			N.C.
44	GND			電源 (0V)
45	TDI			Test Data In
46	N.C.			N.C.
47	TMS			Test Mode Select
48	TCK			Test Clock
49	D[0]	EMD[0]	I/O	外部メモリアクセス用 Data バス
50	D[1]	EMD[1]	I/O	外部メモリアクセス用 Data バス
51	VCC			電源 (+3.3V)
52	D[2]	EMD[2]	I/O	外部メモリアクセス用 Data バス
53	D[3]	EMD[3]	I/O	外部メモリアクセス用 Data バス

## IC372 : XC9572XL-10Q100C (DIGITAL P.C.B.) ..... J only

## PLD

NO.	端子名	信号線名称	I/O	機能
54	D[4]	EMD[4]	I/O	外部メモリアクセス用 Data バス
55	D[5]	EMD[5]	I/O	外部メモリアクセス用 Data バス
56	D[6]	EMD[6]	I/O	外部メモリアクセス用 Data バス
57	VCC			電源 (+3.3V)
58	D[7]	EMD[7]	I/O	外部メモリアクセス用 Data バス
59	EXMEM_IN	/EXM2	IN	External Memory OUT Enable from CS49329
60	PGND			電源 (0V)
61	CSCSO	/CSCS3	OUT	CS49329 用チップセレクト出力 (cscsi のスルー)
62	GND			電源 (0V)
63	XOUT	SDIA	OUT	YSS938 “ SDIA ” 用 セレクタ出力端子
64	ZSEL[0]		IN	MAIN DAC “ SDATA ” 用 セレクタ制御信号入力端子 00 : zout = GND 01 : zout = SDOB3 (未接続)
65	CSIO[0]	GPIO[0]	I/O	CS49329 GPIO バス
66	CSIO[1]	GPIO[1]	I/O	CS49329 GPIO バス
67	CSIO[2]	GPIO[2]	I/O	CS49329 GPIO バス
68	CSIO[3]	GPIO[3]	I/O	CS49329 GPIO バス
69	GND			電源 (0V)
70	CSIO[4]	GPIO[4]	I/O	CS49329 GPIO バス
71	CSIO[5]	GPIO[5]	I/O	CS49329 GPIO バス
72	CSIO[6]	GPIO[6]	I/O	CS49329 GPIO バス
73	N.C.			N.C.
74	CSIO[7]	GPIO[7]	I/O	CS49329 GPIO バス
75	GND			電源 (0V)
76	PGND			電源 (0V)
77	SCKO	SCKCL	OUT	DSP デバイス(CS49329/YSS938)への Serial Clock 出力
78	PGND			電源 (0V)
79	SDMO	SDMIN	OUT	DSP デバイス(CS49329/YSS938)への Serial Data 出力
80	N.C.			N.C.
81	PGND			電源 (0V)
82	EMOE_IN	/EMOE2	IN	External Memory Enable(latch clock) from CS49329
83	TDO			Test Data Out
84	GND			電源 (0V)
85	EMWR_IN	/EMWE2	IN	EXternal Memory Write Enable from CS49329
86	ABOOT		OUT	CS49329 Auto Boot 用出力 (Low or Hi-z 出力) (未接続)
87	SDDO	SDDO	OUT	PLD からマイコンへの Serial Data 出力。 Read Data 送信時以外は Hi-Z
88	VCC			電源 (+3.3V)
89	TOUT[0]	/CSRST	OUT	CS49329 “ RESET ” のスルー出力端子。
90	YOUT		OUT	CS49329 “ SDATAN ” 用 セレクタ出力端子 (未接続)
91	ZOUT		OUT	MAIN DAC “ SDATA ” 用 セレクタ出力端子 (未接続)
92	MEMACS	MEMACS	IN	マイコンシリアルモード切替え信号入力 (H : マイコン serial をメモリアクセスに使用)
93	SCKI	CSC	IN	マイコンからの Serial Clock 入力
94	TIN	/ICCS	IN	CS49329 “ RESET ” の入力端子。信号は、スルーで tout 端子から出力される。
95	SDMI	SDM	IN	マイコンからの Serial Data 入力
96	CSCSI	/CSCS	IN	CS49329 用チップセレクト信号入力
97	ZIN1		IN	MAIN DAC “ SDATA ” 用 セレクタ入力端子 (GND)
98	VCC			電源 (+3.3V)
99	RST	/ICD	IN	PLD システムリセット (Low リセット)
100	GND			電源 (0V)

## ■ DVR-S120 ADJUSTMENT / DVR-S120調整

### ■ Condition

- Start adjustment 5 sec or more after the power is turned on.
- Headphones are not plugged in.
- No input signal.

### ■ DC Offset Adjustment

Adjust the potentiometer on each D-Amp Module so that the DC voltage becomes  $0 \pm 10$  mV at each speaker output.

### ■ 条件

- 電源を入れてから5秒間以上経過後に調整を始めます。
- ヘッドホンは差し込みません。
- 無信号

### ■ DC オフセット調整

各スピーカー出力端子のDC電圧が  $0 \pm 10$  mVになるように、各D-アンプモジュールの半固定VRを調整します。

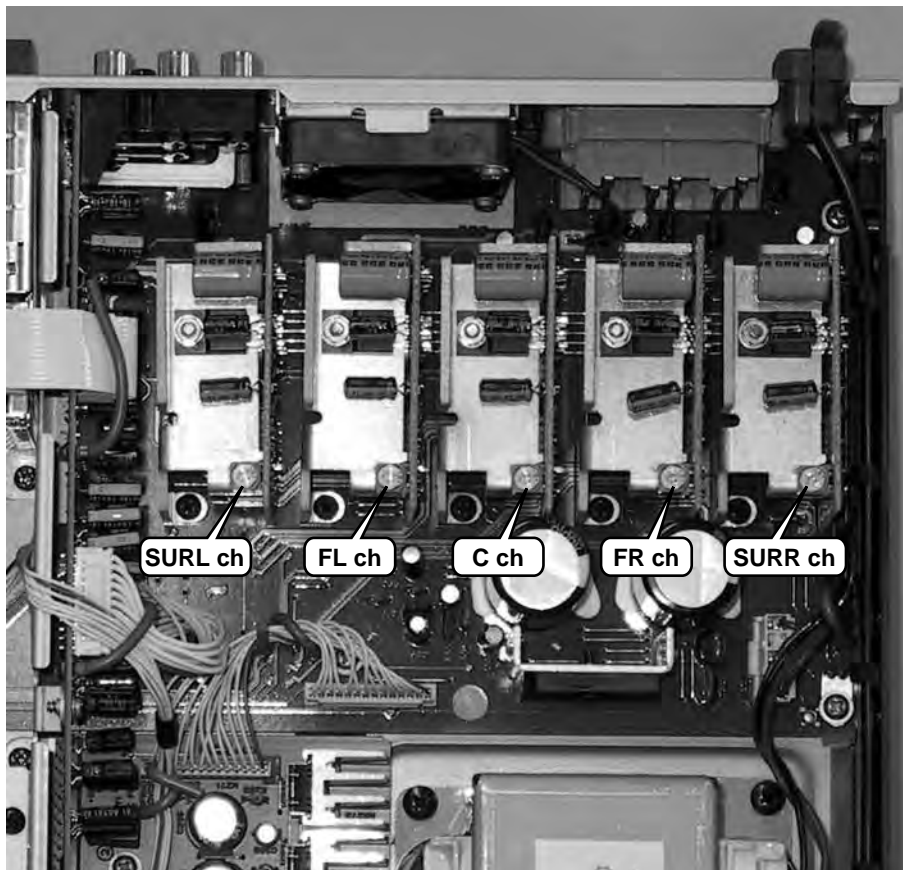



■ DVR-S120 BLOCK DIAGRAM / ブロックダイアグラム

1

2

3

4

5

6

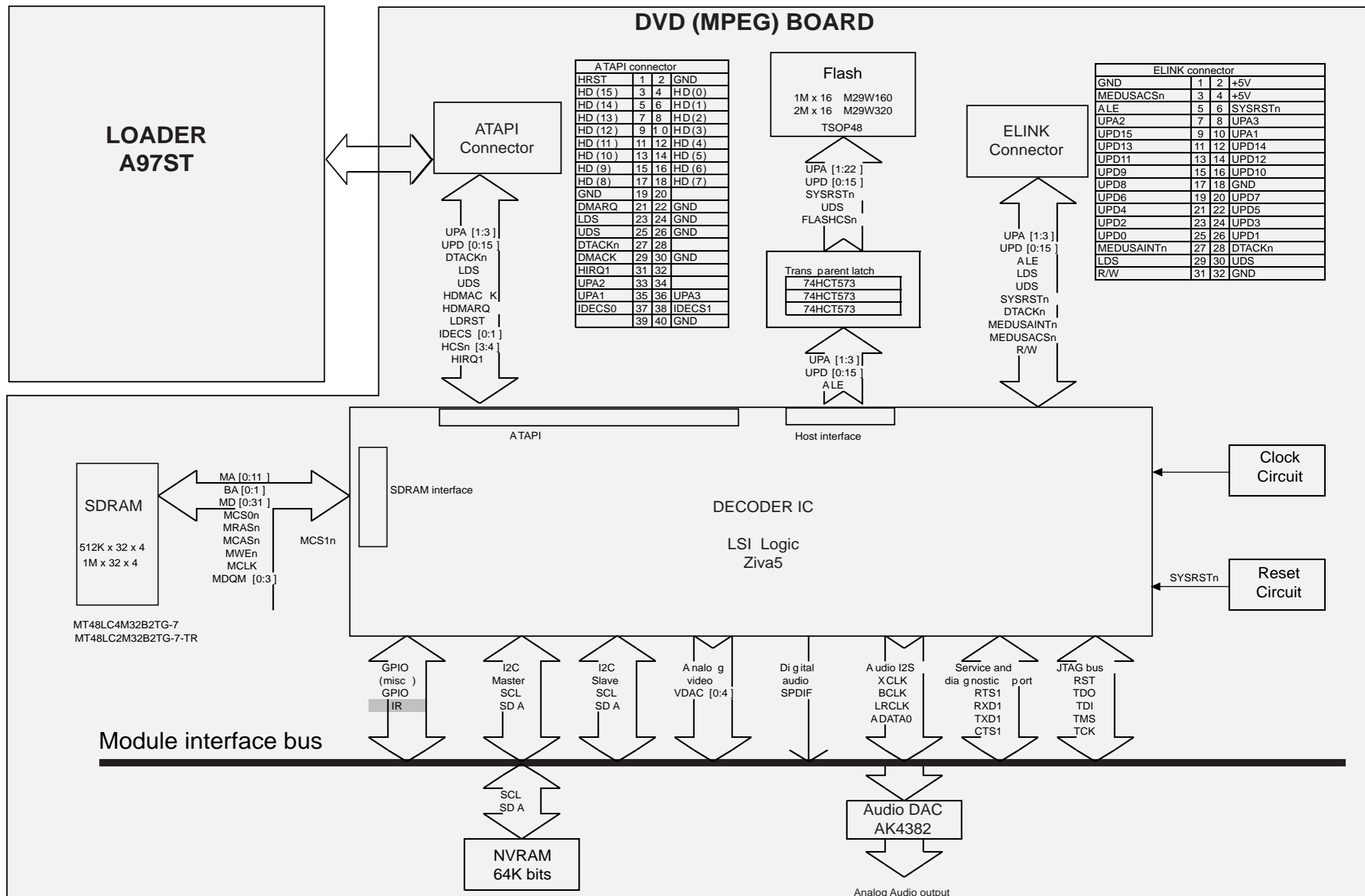

■ DVR-S120 BLOCK DIAGRAM / ブロックダイアグラム

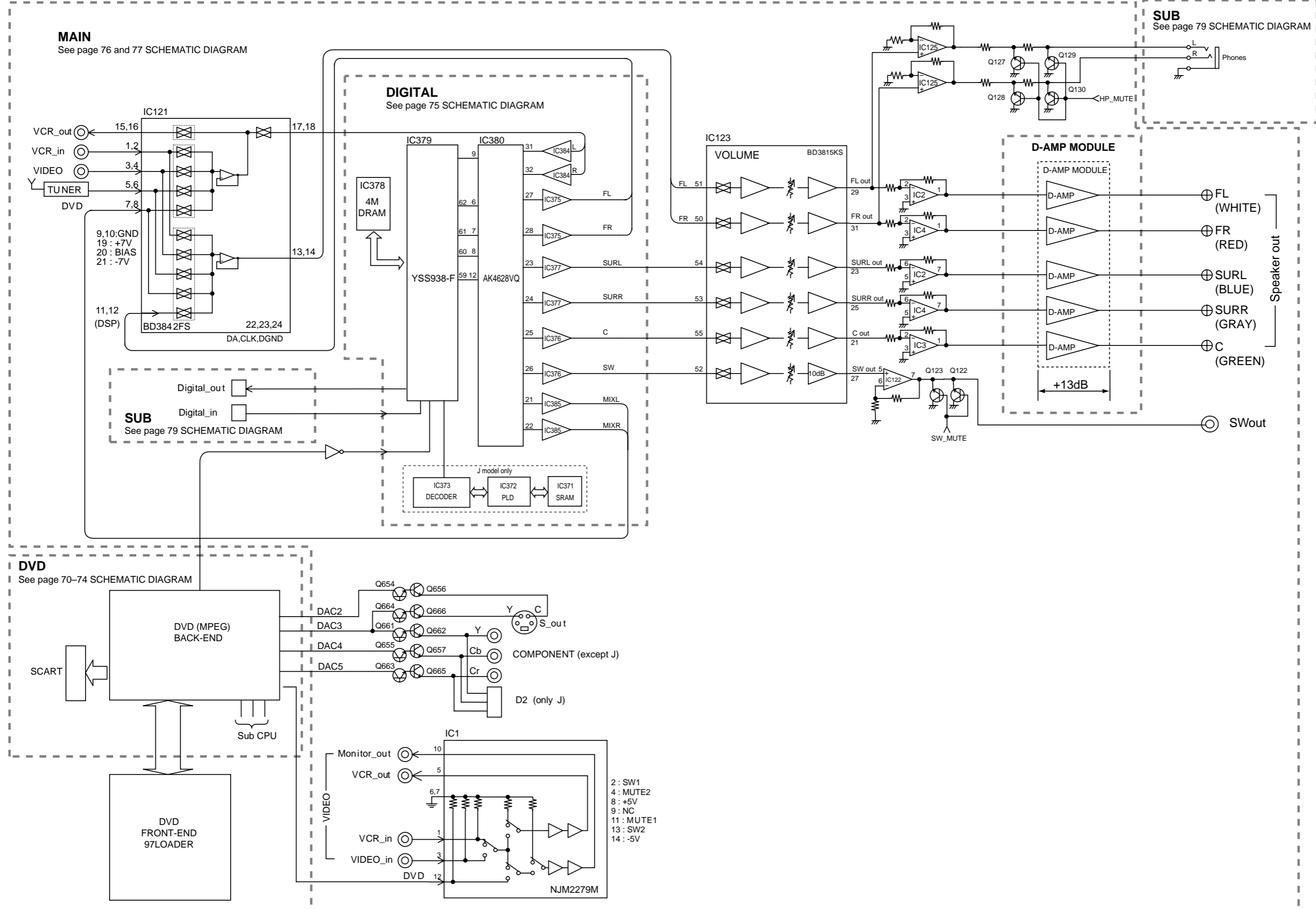

# DVR-S120 BLOCK DIAGRAM / ブロックダイアグラム

1

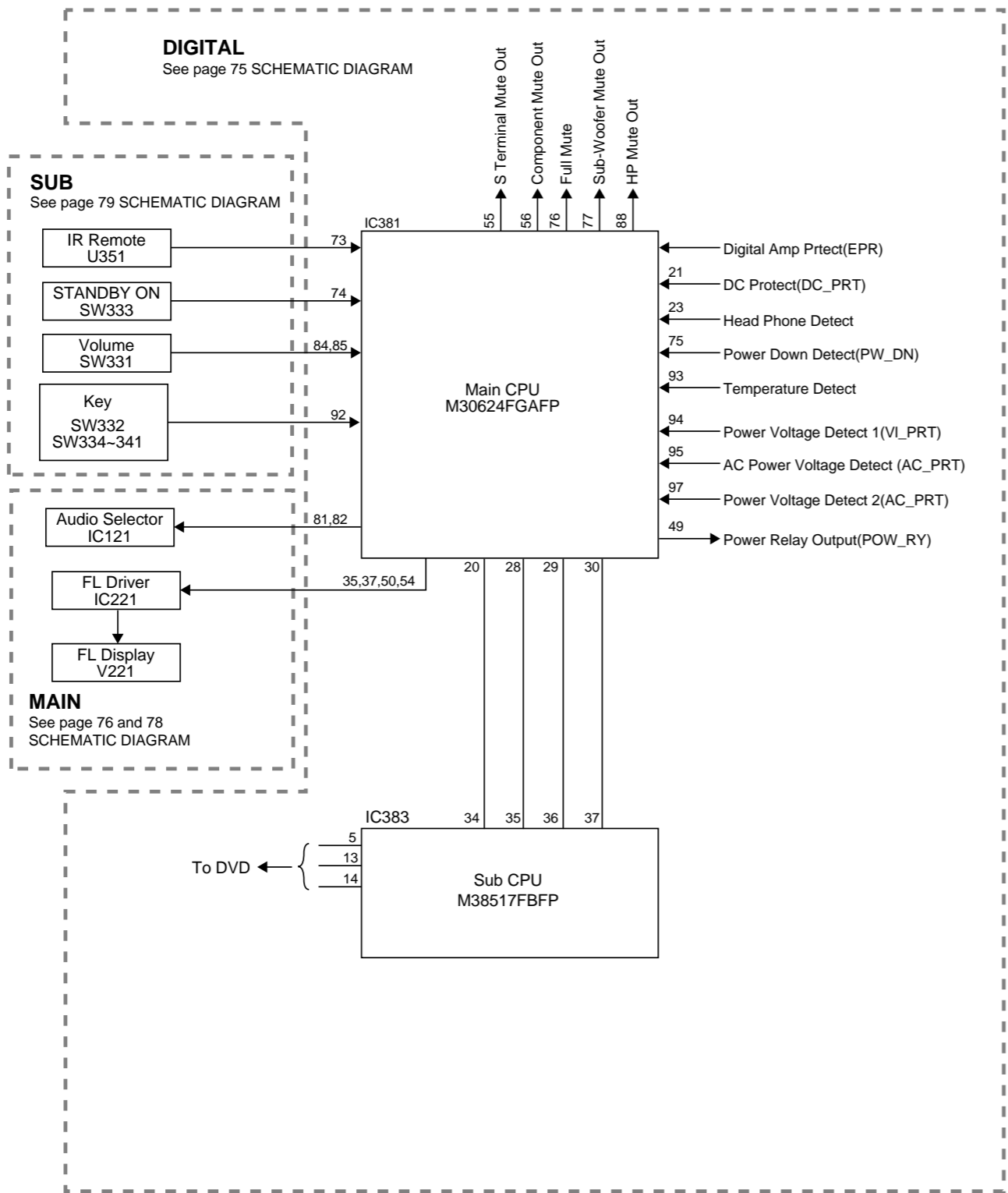

2

3

4

5

6

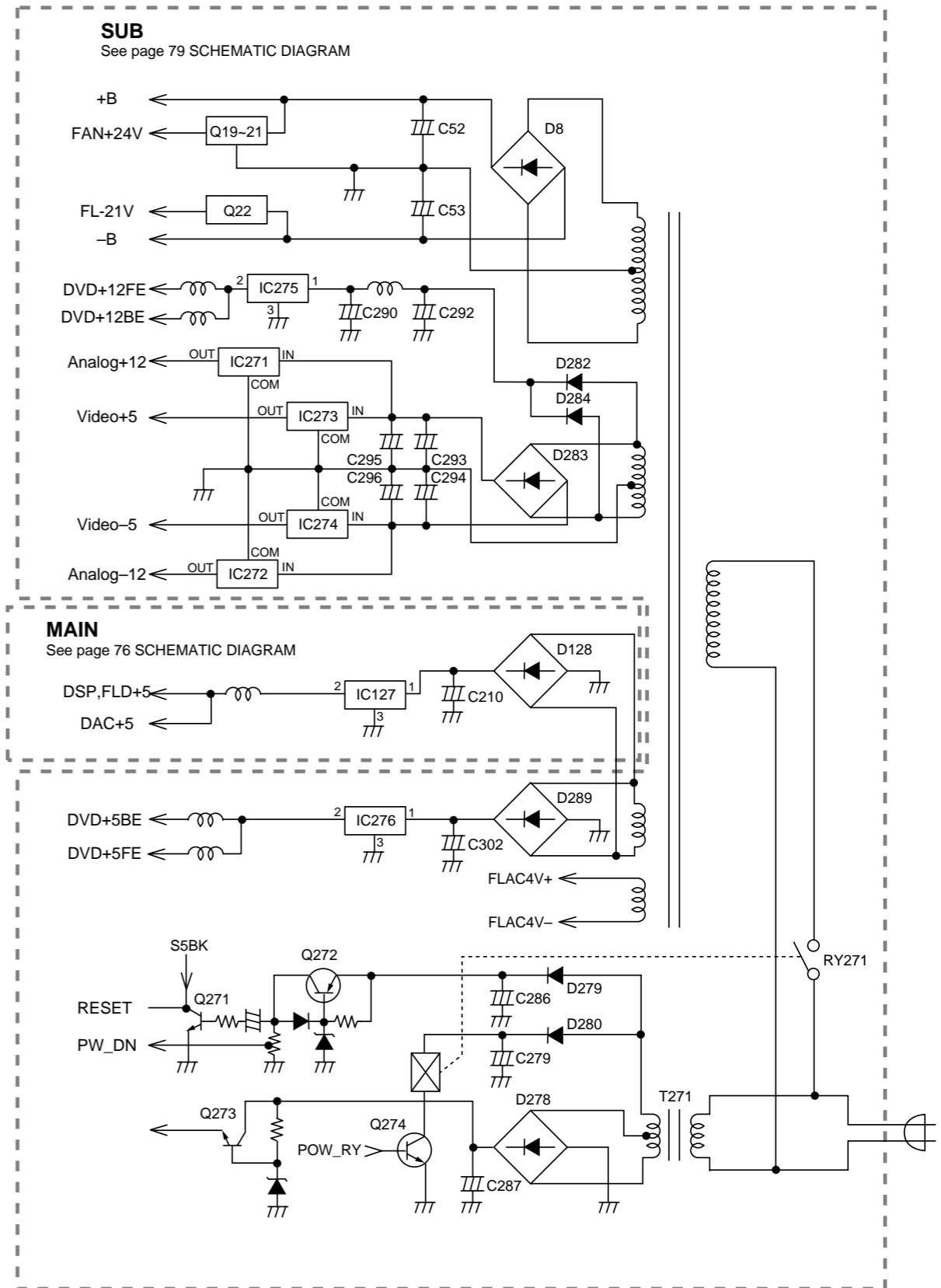

**DVR-S120**

**DVR-S120 PRINTED CIRCUIT BOARD**

**DVD Component Side**

The first digit of a component indicates the component type.

1xxx : Connector    3xxx : Resistor    5xxx : Coil    7xxx : IC, Transistor, FET  
 2xxx : Capacitor    4xxx : SMD jumper    6xxx : Diode    9xxx : Wire jumper

1600 B1	1619 E8	2723 C7	2771 D7	2800 F7	2817 E7	2850 G9	2869 B7	2893 F3	2908 F7	3611 C5	3635 C2	3648 C6	3665 E3	3682 D9	3716 G2	3741 D7	3760 E9	3776 C7	3799 C6	3811 F7
1601 A2	1620 B9	2752 A8	2783 D7	2801 F7	2818 E7	2852 E9	2870 B7	2895 A8	2909 F6	3612 D7	3636 C4	3653 F4	3666 E4	3685 B2	3717 G1	3747 B8	3763 C8	3777 B7	3800 C6	3812 E6
1602 B4	1621 B9	2759 D9	2785 D7	2802 F7	2819 E8	2853 G9	2871 E1	2896 B8	2910 F7	3613 C5	3637 B2	3654 A8	3667 E3	3686 C2	3718 H1	3748 B8	3764 C9	3778 B8	3801 E6	3813 F7
1603 A7	2612 B8	2760 B8	2786 D7	2803 F8	2821 A9	2854 F9	2873 G2	2900 E6	2911 F7	3614 D7	3639 B1	3655 B8	3668 F4	3698 B5	3719 H1	3750 B8	3765 B9	3779 B8	3802 E6	3814 F8
1605 C1	2663 B5	2761 C8	2787 D7	2806 G7	2822 G1	2855 F9	2881 F6	2901 E7	2912 G6	3615 D6	3640 C1	3658 F4	3673 E9	3699 A5	3720 G2	3751 B8	3766 B8	3780 B8	3803 D7	3815 F8
1606 F9	2683 B7	2762 D7	2790 F7	2808 G7	2823 G9	2856 E9	2883 F2	2902 D7	2913 G7	3616 D6	3641 C5	3659 F4	3674 E9	3700 B6	3721 H2	3752 C7	3770 C8	3781 G8	3804 E8	3816 F8
1608 B10	2690 C1	2763 C8	2792 F7	2809 G7	2824 B1	2857 F9	2884 E2	2903 E6	2914 G7	3617 D6	3642 C2	3660 C4	3675 E9	3704 G4	3722 G2	3753 D7	3771 C7	3784 C7	3805 D8	3817 F8
1610 A8	2691 D1	2765 C7	2793 F7	2810 G7	2825 F9	2859 E9	2886 F3	2904 E7	2915 B8	3618 C6	3644 B2	3661 D4	3676 E9	3712 G8	3723 E8	3754 D7	3772 C8	3785 E8	3806 D8	3818 F8
1611 A6	2692 D1	2766 B8	2794 F7	2811 G8	2838 B9	2862 H2	2888 E3	2905 E7	2916 C8	3630 C6	3645 B5	3662 D4	3677 E9	3713 F8	3724 D2	3757 C7	3773 C8	3786 E8	3807 D8	3820 F8
1615 E1	2693 D1	2769 B8	2795 F8	2814 E7	2840 D8	2866 E1	2890 F6	2906 E7	3603 C5	3633 B5	3646 A9	3663 D4	3678 C8	3714 F8	3725 D2	3758 D7	3774 C7	3787 F8	3808 D8	3821 F6
1618 F8	2694 D1	2770 C7	2798 F7	2816 E7	2848 E8	2867 E2	2892 H7	2907 F7	3604 C5	3634 B5	3647 A9	3664 E4	3680 B8	3715 E8	3734 B7	3759 C7	3775 C7	3788 F8	3810 E8	3822 E6

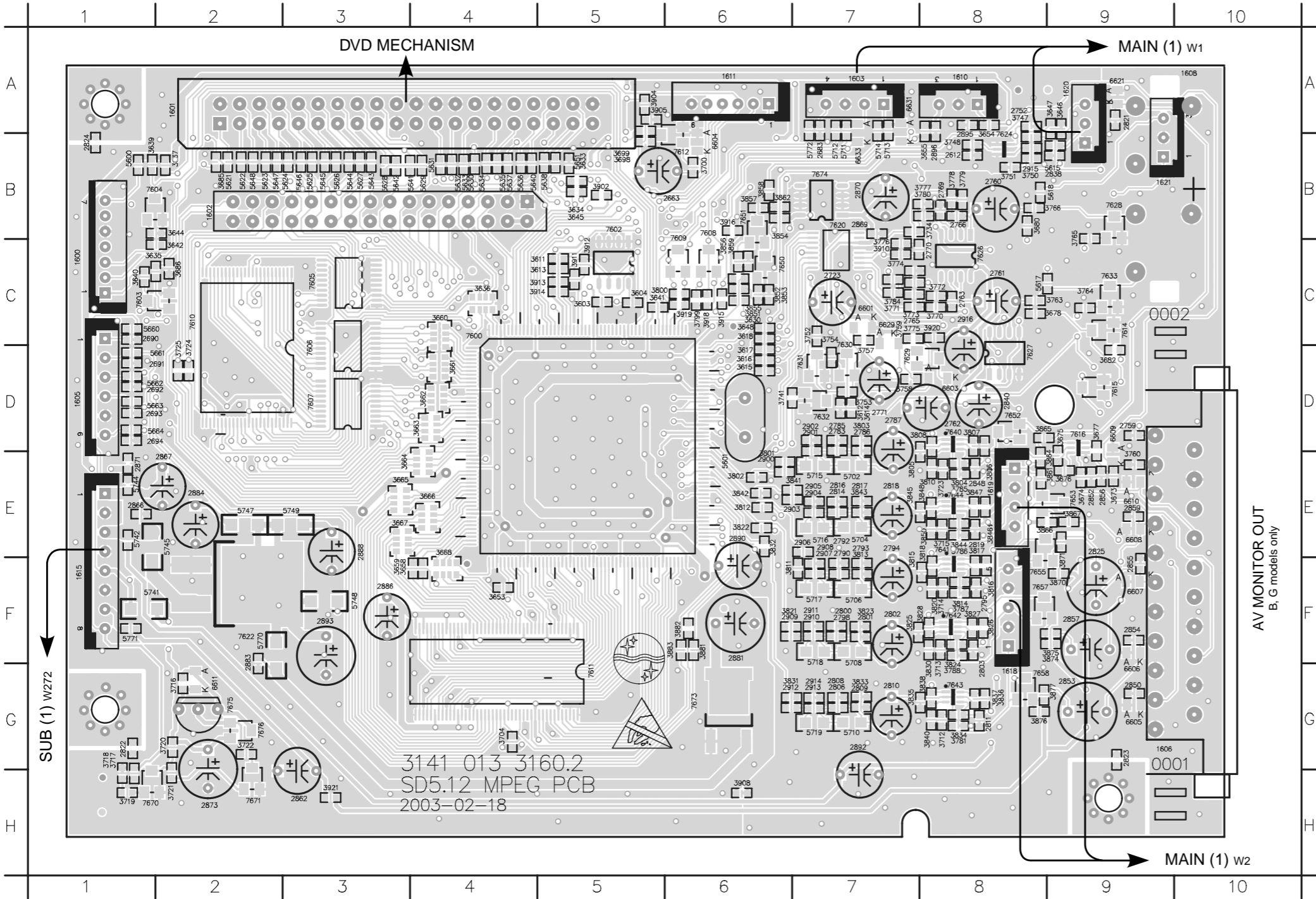

3823 F7	3881 F6	5645 B3	6631 B7
3824 F8	3882 F6	5646 B3	6633 B7
3825 F7	3883 F6	5647 B2	7600 D4
3826 F8	3902 B5	5648 B2	7602 C5
3827 F8	3904 A5	5651 B5	7603 C2
3828 F8	3905 A5	5660 C1	7604 B1
3830 F8	3908 H6	5661 D1	7605 C3
3831 G6	3910 C7	5662 D1	7606 D3
3832 E6	3911 C5	5663 D1	7607 D3
3833 G7	3912 C5	5664 D1	7608 C6
3834 G8	3913 C5	5702 E7	7609 C6
3835 G8	3914 C5	5704 E7	7610 C3
3836 G8	3915 C6	5706 F7	7611 F5
3837 G8	3916 B6	5708 F7	7612 B6
3838 G8	3918 C6	5710 G7	7614 C9
3840 G8	3919 C6	5711 B7	7615 D9
3841 E6	3920 C8	5712 B7	7616 E9
3842 E6	3921 H3	5713 B7	7620 B7
3843 E7	5600 B1	5714 B7	7622 F2
3844 E8	5601 D6	5715 E7	7624 B8
3845 E8	5615 B9	5716 E7	7626 B8
3846 E8	5617 C9	5717 F7	7627 D8
3847 E8	5618 B8	5718 F7	7628 B9
3848 E8	5621 B2	5719 G7	7629 D7
3850 E8	5622 B2	5741 F1	7630 D7
3851 C6	5623 B2	5742 E1	7631 D7
3852 C6	5624 B3	5744 E1	7632 D7
3853 C6	5625 B3	5745 E1	7633 C9
3854 B6	5626 B3	5747 E2	7640 D8
3855 C6	5627 B3	5748 F3	7641 F8
3856 C6	5628 B3	5749 E2	7642 F8
3857 B6	5629 B4	5770 F2	7643 G8
3858 B6	5630 B4	5771 F1	7644 E8
3859 C6	5631 B4	5772 B7	7650 C6
3861 E8	5632 B4	6601 C7	7651 C6
3862 B6	5633 B4	6603 D8	7652 D8
3864 E8	5634 B4	6604 B6	7653 E8
3865 D8	5635 B4	6605 G9	7655 F8
3866 E9	5636 B4	6606 F9	7657 F8
3867 E9	5637 B4	6607 F9	7658 G8
3870 F9	5638 B5	6608 E9	7670 H1
3871 E9	5640 B4	6609 D9	7671 H2
3874 F8	5641 B4	6610 E9	7673 G6
3875 F8	5642 B3	6611 G2	7674 B7
3876 G8	5643 B3	6621 A9	7675 G2
3877 G8	5644 B3	6629 C7	7676 G2

■ DVR-S120 PRINTED CIRCUIT BOARD

**DVR-S120**

The first digit of a component indicates the component type.

1xxx : Connector    3xxx : Resistor    5xxx : Coil    7xxx : IC, Transistor, FET  
 2xxx : Capacitor    4xxx : SMD jumper    6xxx : Diode    9xxx : Wire jumper

**DVD Copper Side**

2601	C1	2609	C2	2622	E6	2630	D5	2638	D5	2661	D2	2671	F4	2681	B7	2833	B7	2877	D6	3626	D6	3649	C4	3694	C2	3819	F8	3888	D6	3897	C7	3917	C6	5753	D5
2602	C3	2613	C5	2623	D5	2631	E4	2639	D4	2662	D3	2672	G5	2754	E9	2839	A10	2878	D6	3627	D6	3650	D6	3696	C2	3829	F8	3889	B6	3898	C7	5602	C8	5755	E6
2603	D3	2614	C4	2624	D6	2632	E4	2640	D4	2664	B4	2673	G4	2755	C9	2841	C8	2879	D6	3628	D6	3651	D2	3701	B6	3839	G8	3890	B7	3899	C7	5665	E6	5756	E6
2604	D3	2617	D6	2625	D4	2633	E5	2641	C4	2665	B4	2676	F5	2756	B9	2849	B10	2880	F6	3629	D6	3652	D2	3737	C7	3849	E8	3891	H6	3901	G6	5666	E6	5757	D5
2605	D6	2618	D6	2626	D4	2634	E4	2642	E5	2667	F4	2677	F4	2757	D8	2861	F1	2889	E3	3631	C6	3669	D6	3762	C9	3860	E8	3893	F6	3903	B5	5667	E6	5758	D5
2606	D6	2619	E6	2627	E4	2635	F6	2643	E4	2668	F4	2678	F4	2764	C8	2864	F2	2891	E6	3632	C6	3679	C1	3767	B9	3880	C8	3894	B8	3906	F4	5750	E6	6630	C6
2607	D6	2620	E6	2628	E5	2636	E5	2644	C5	2669	G4	2679	F4	2767	C8	2868	G7	3606	C6	3638	C2	3681	D9	3769	D9	3884	C8	3895	B8	3907	F4	5751	D5	6632	A7
2608	C6	2621	E6	2629	E5	2637	D6	2645	D6	2670	G4	2680	F5	2768	C8	2874	B7	3608	C6	3643	C1	3692	C2	3809	D8	3885	C8	3896	E6	3909	G6	5752	D5	6634	B7

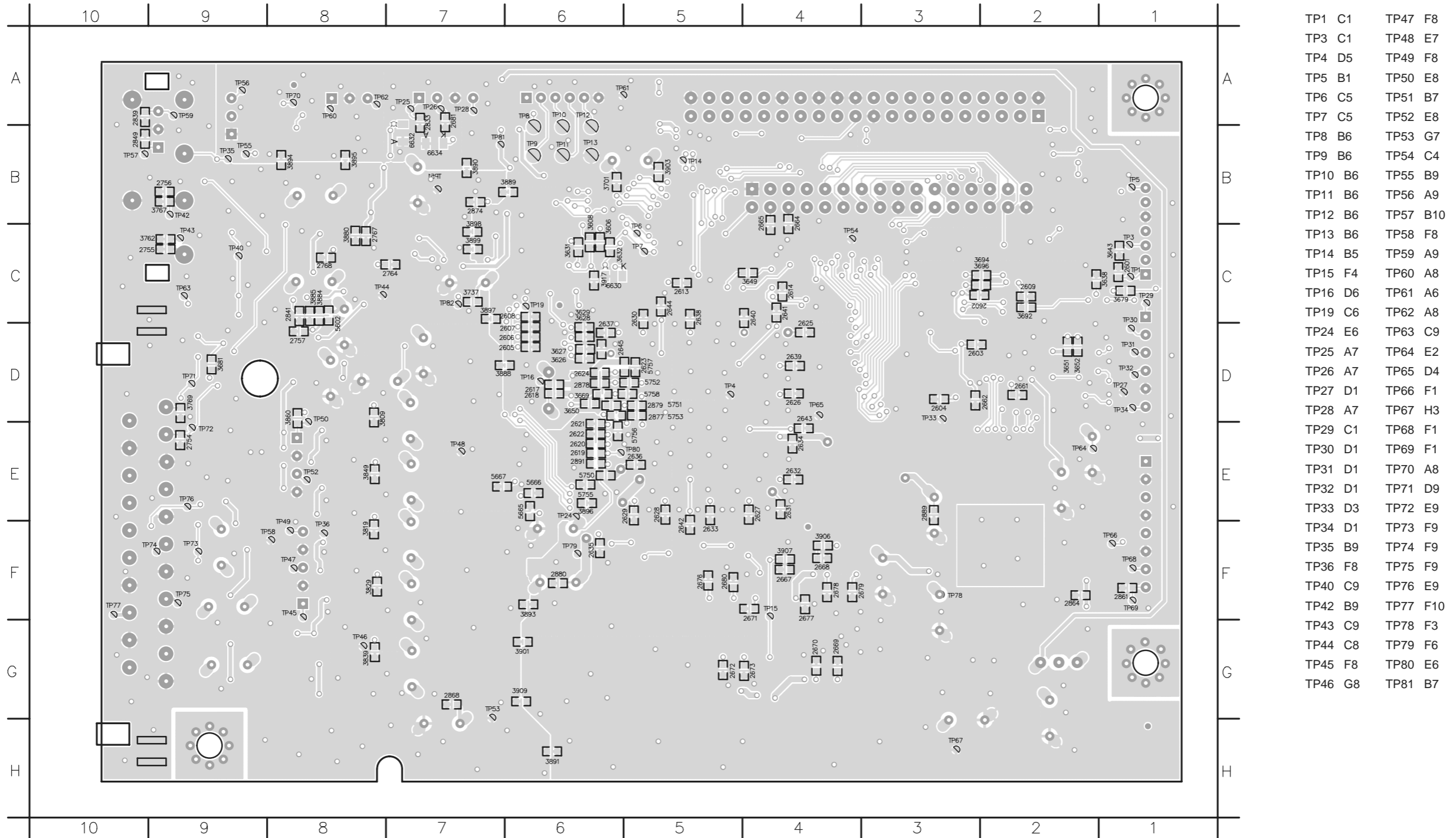

■ DVR-S120 PRINTED CIRCUIT BOARD (Foil side)

DVR-S120

DIGITAL P. C. B.  
(Lead Type Device)

DIGITAL P. C. B.  
(Surface Mount Device)

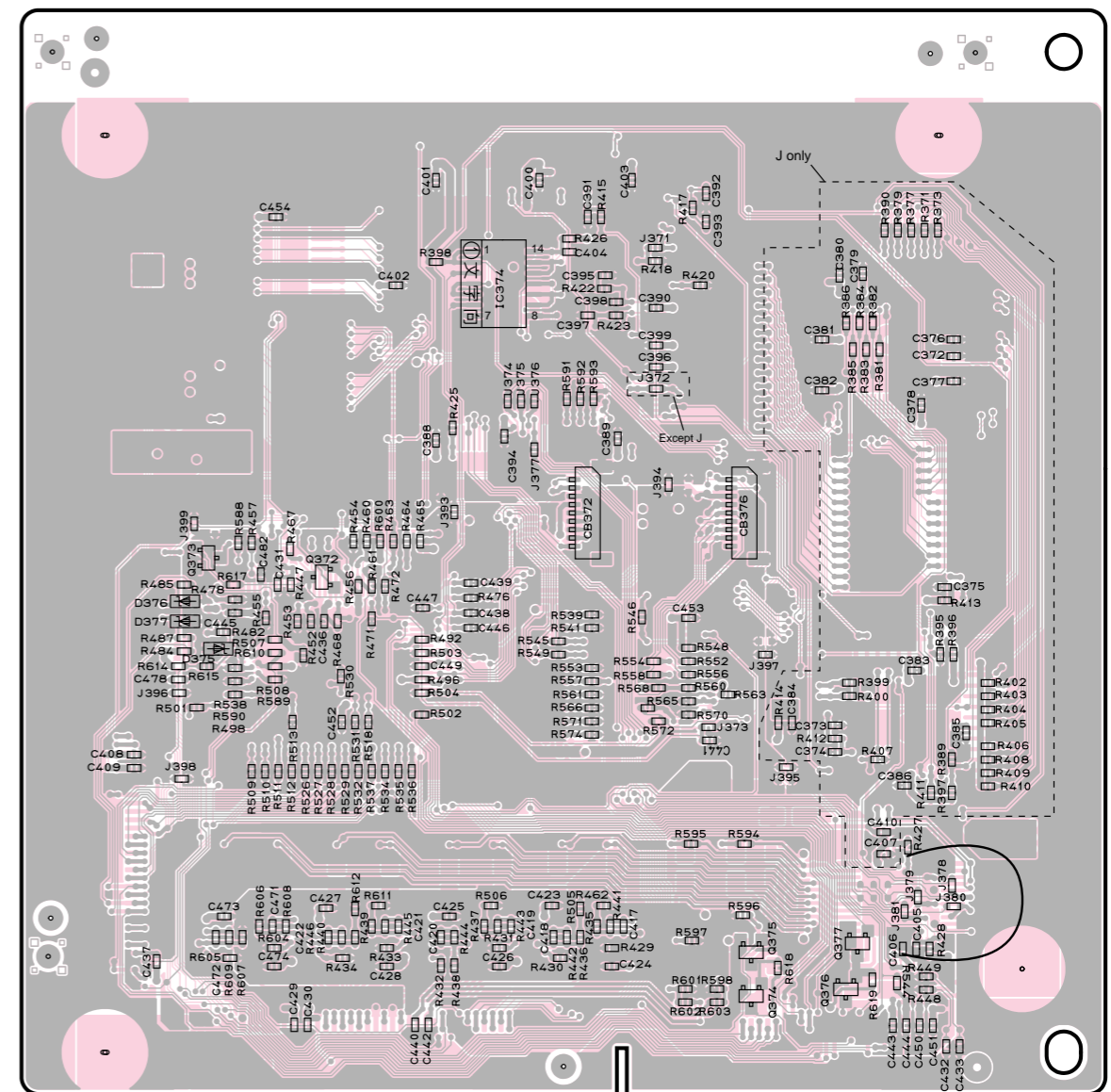
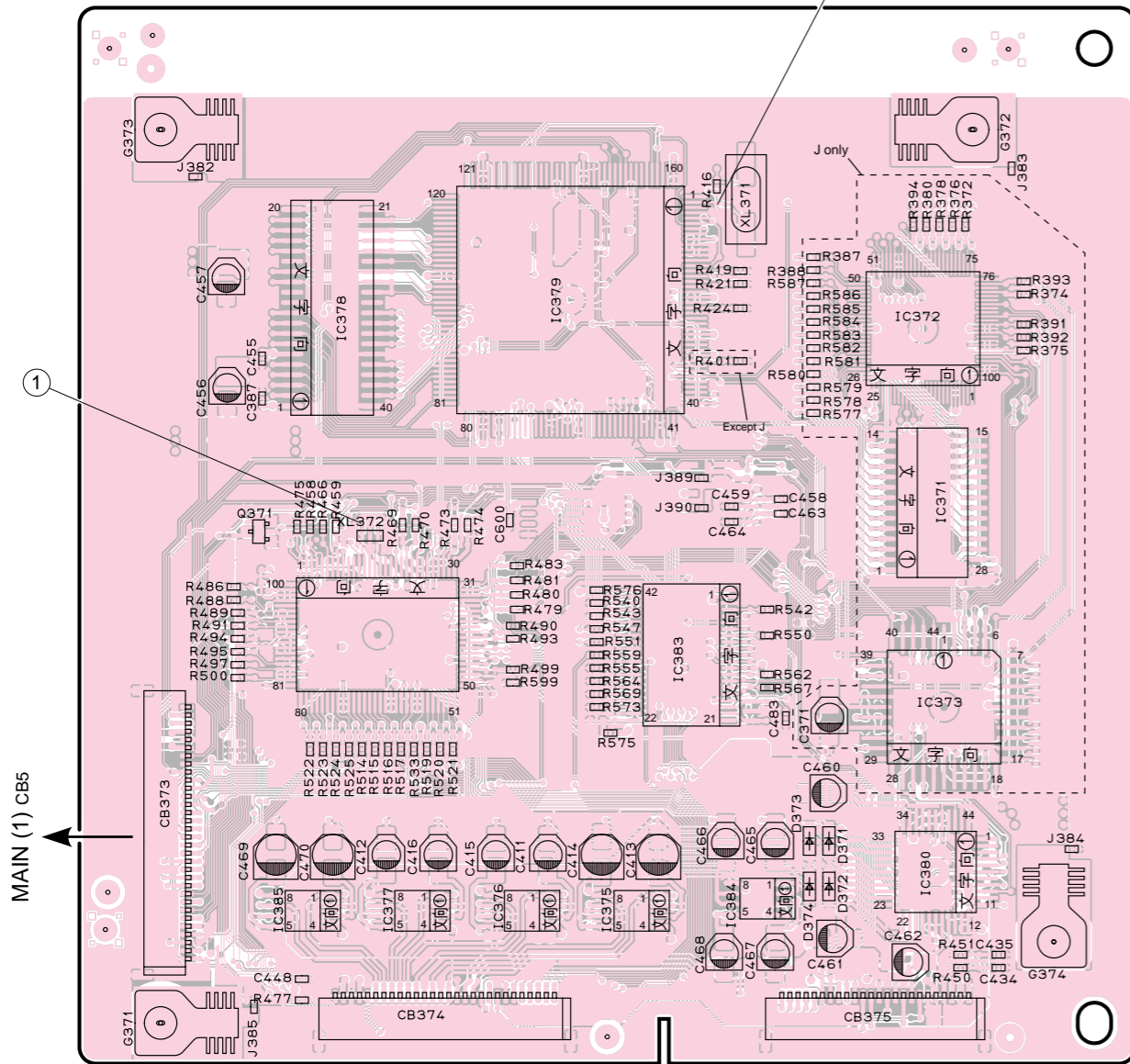



DVR-S120 PRINTED CIRCUIT BOARD (Foil side)

DVR-S120

MAIN (1) P.C.B.  
(Lead Type Device)

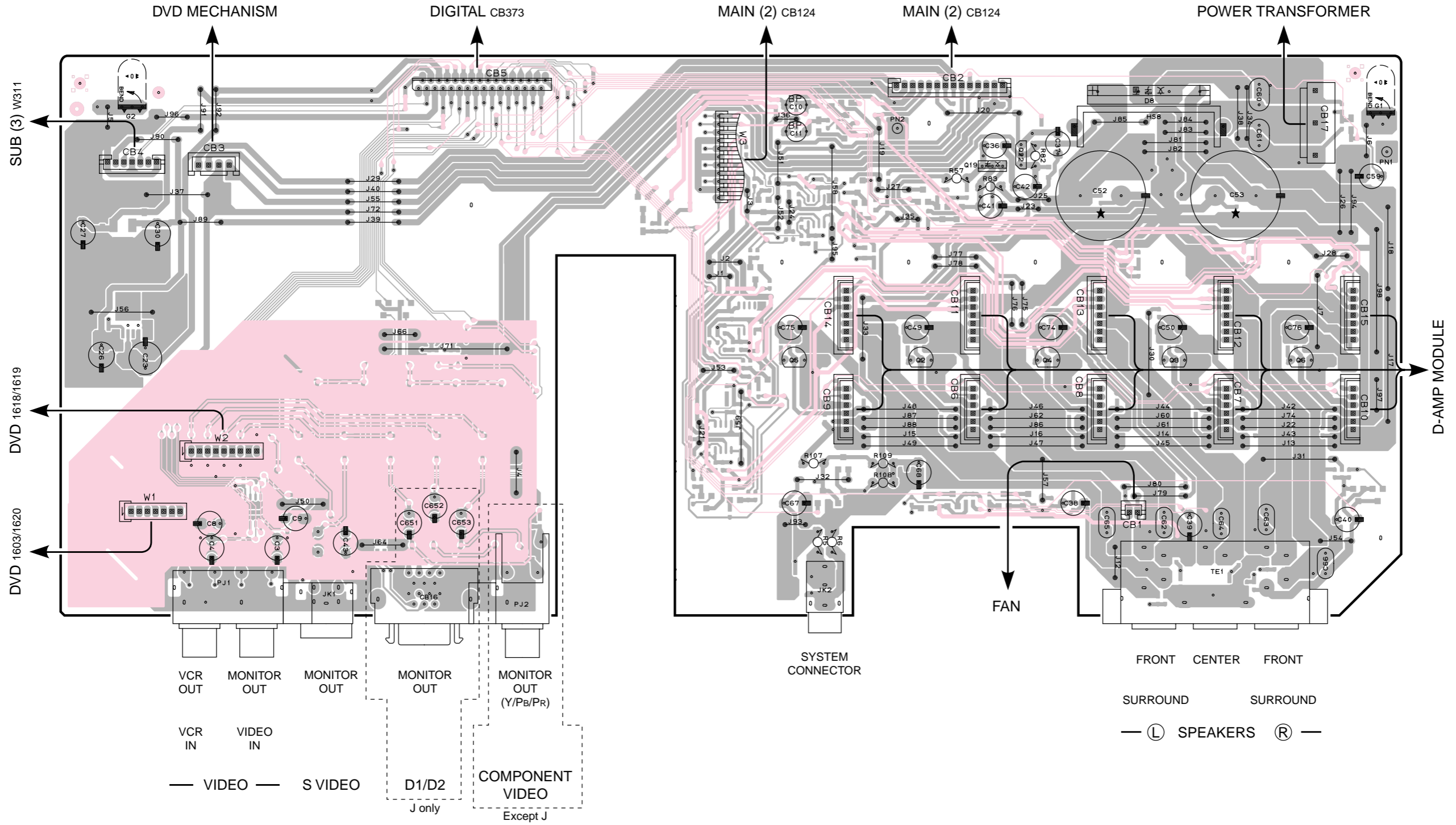



■ DVR-S120 PRINTED CIRCUIT BOARD (Foil side)

DVR-S120

MAIN (1) P. C. B.  
(Surface Mount Device)

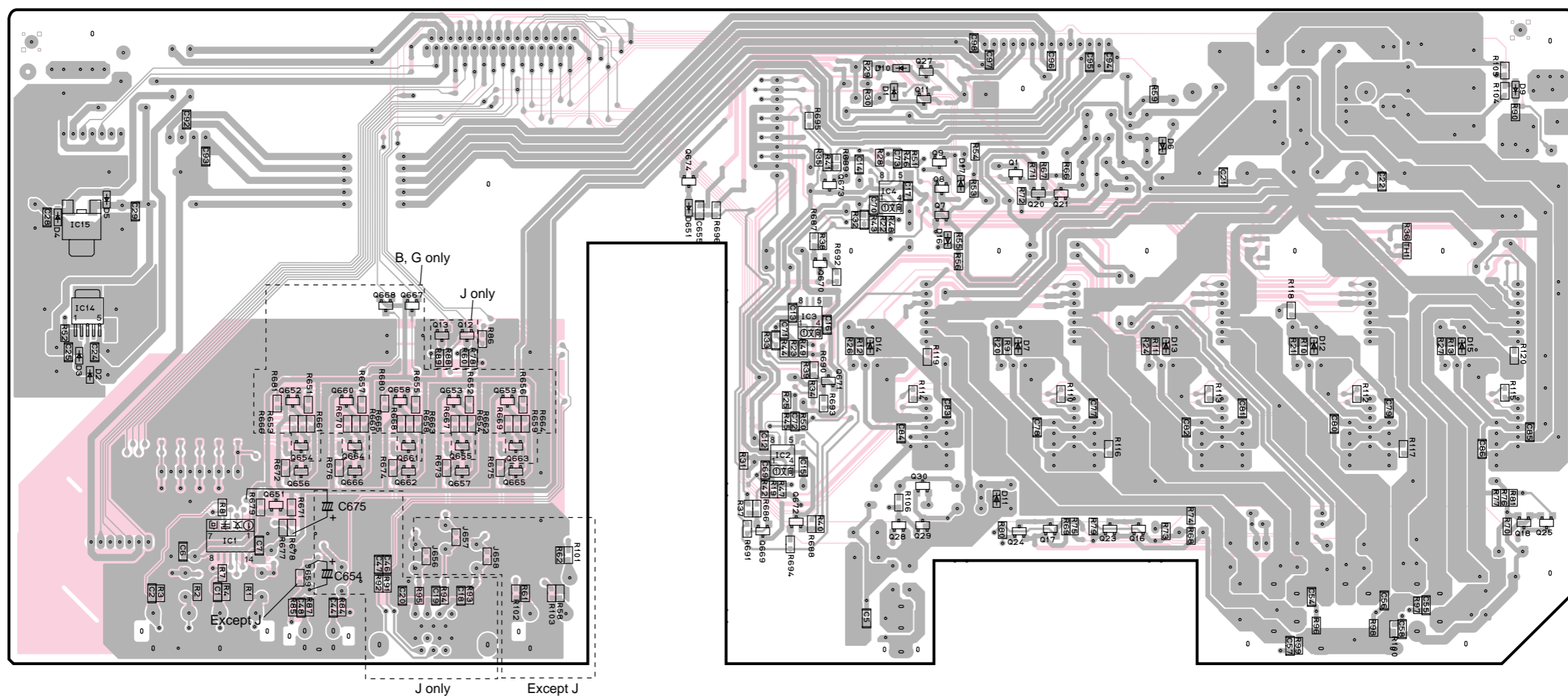

MAIN (3) P. C. B.  
(Lead Type Device)

SUB (4) W351

MAIN (3) P. C. B.  
(Surface Mount Device)

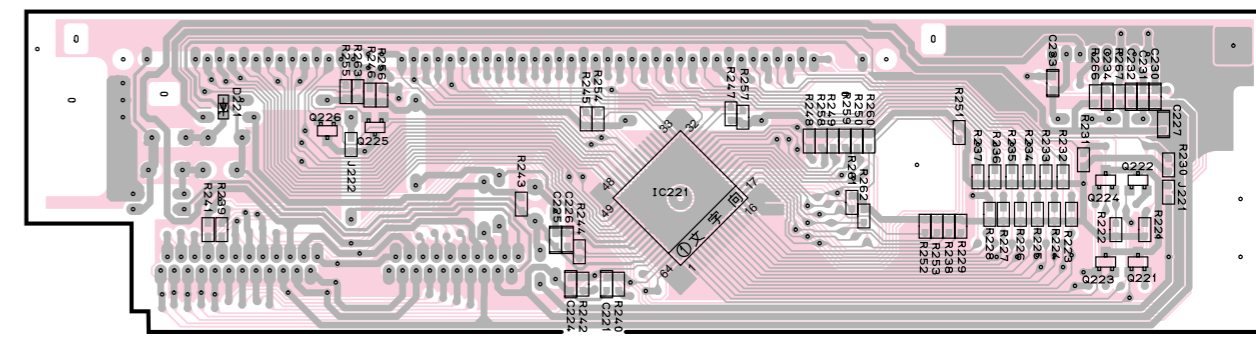
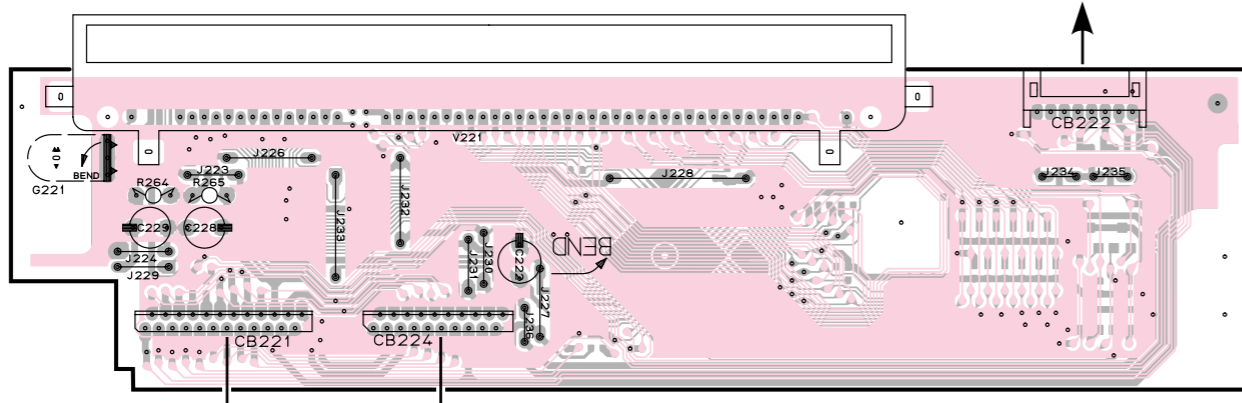

DIGITAL CB375    SUB (1) CB274

1  
2  
3  
4  
5  
6



■ DVR-S120 PRINTED CIRCUIT BOARD (Foil side)

DVR-S120

1  
2  
3  
4  
5  
6

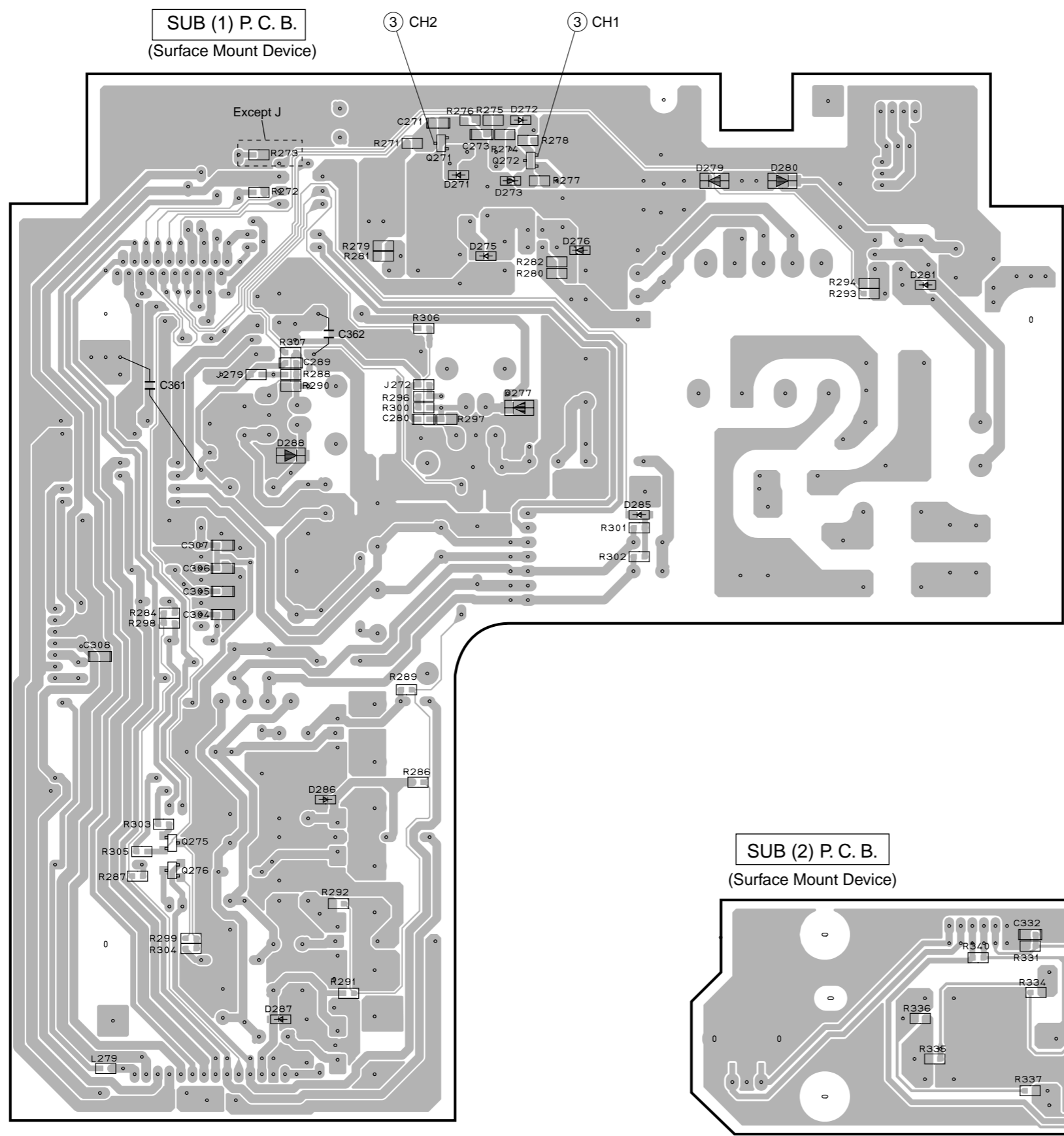

SUB (1) P. C. B.  
(Surface Mount Device)

③ CH2

③ CH1

Point ③  
CH 1 : Emitter of Q272  
CH 2 : Collector of Q271

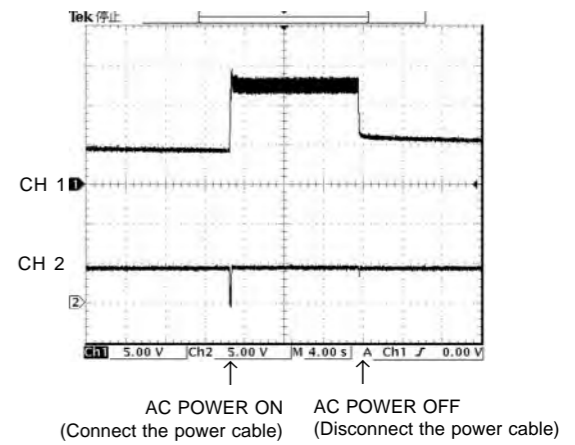

SUB (2) P. C. B.  
(Surface Mount Device)

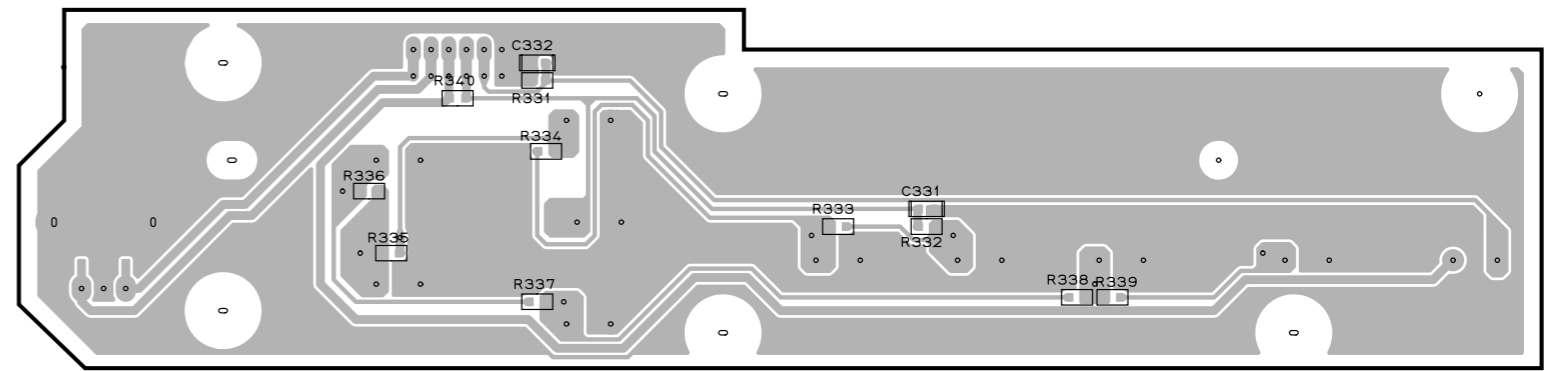

■ DVR-S120 PRINTED CIRCUIT BOARD (Foil side)

DVR-S120

1

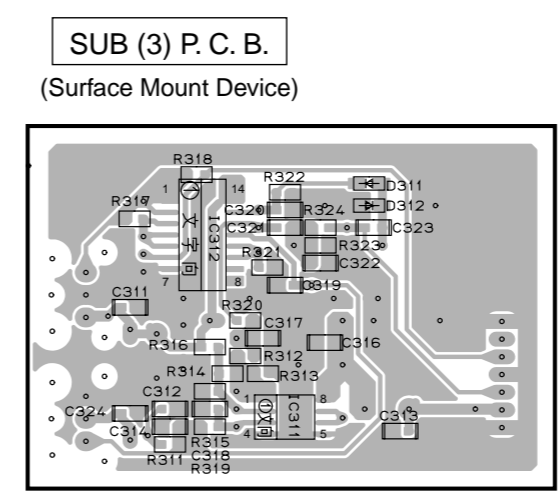
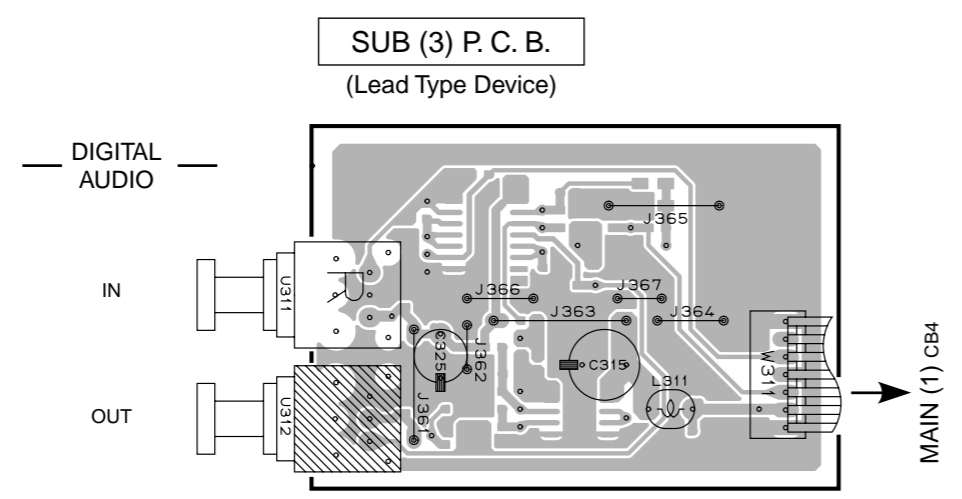

2

3

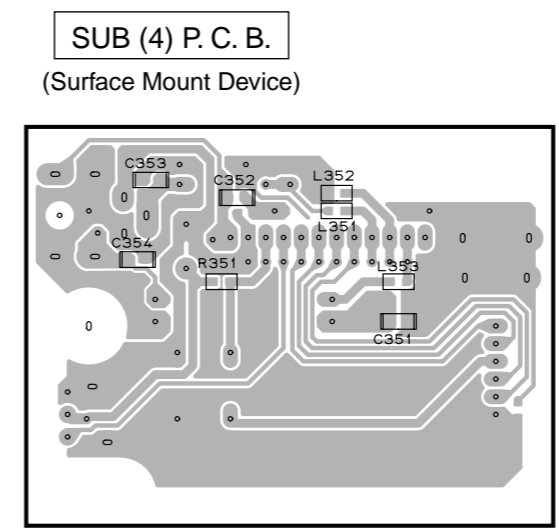
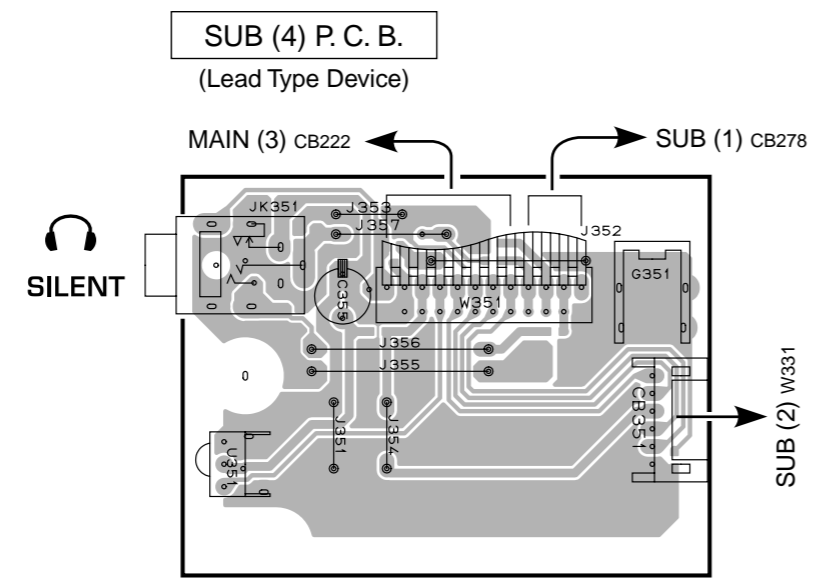

4

5

6

■ NX-SW120 PRINTED CIRCUIT BOARD

NX-SW120

1

P.C.B. MAIN (1)

2

3

4

5

6

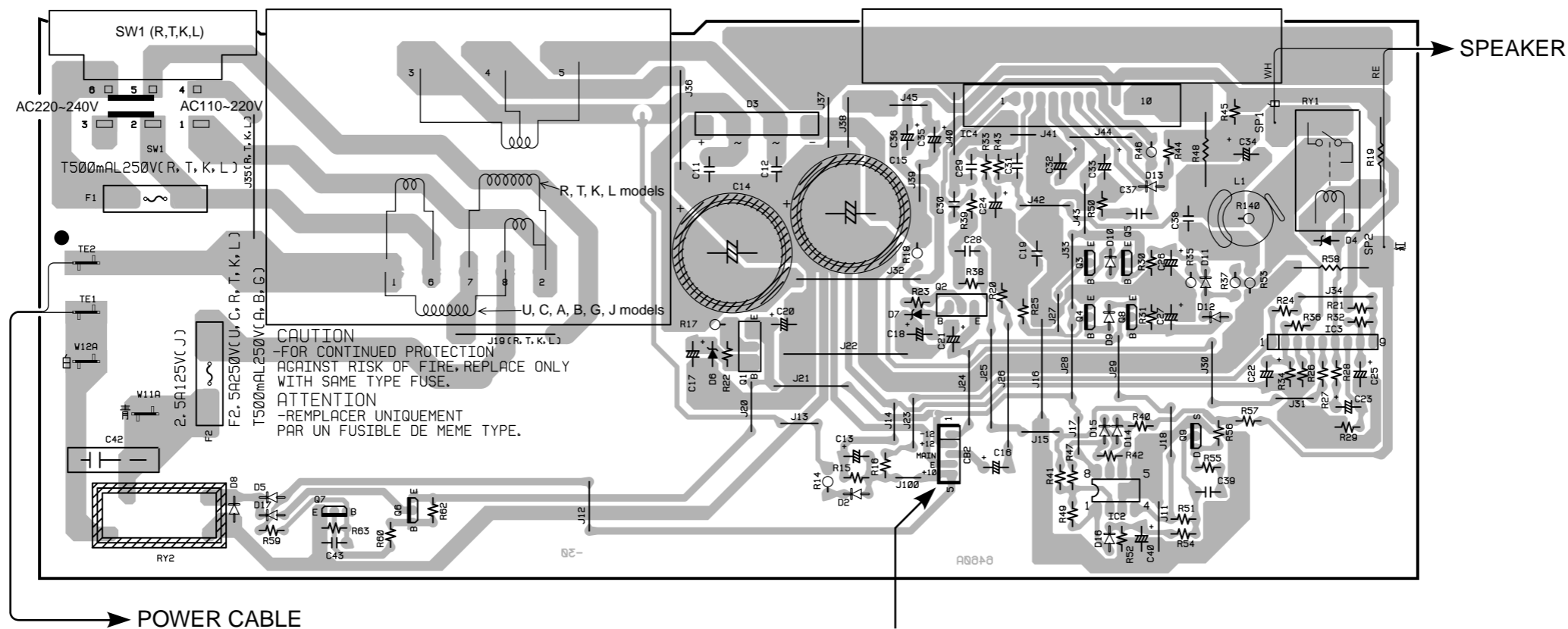

P.C.B. MAIN (2)

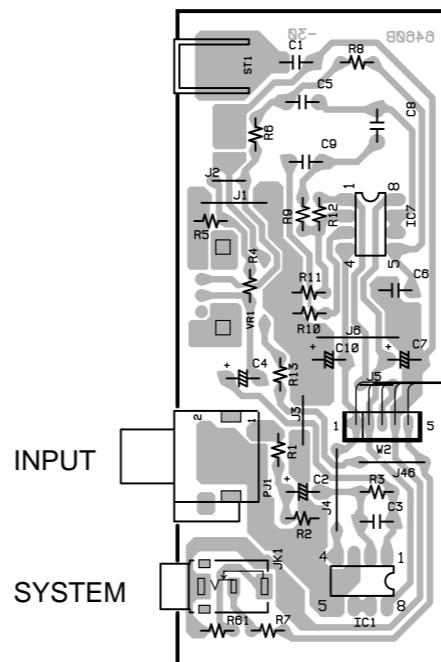

■ DVR-S120 SCHEMATIC DIAGRAM (DVD 1/5)

The first digit of a component indicates the component type.

- 1xxx : Connector    3xxx : Resistor    5xxx : Coil    7xxx : IC, Transistor, FET
- 2xxx : Capacitor    4xxx : SMD jumper    6xxx : Diode    9xxx : Wire jumper

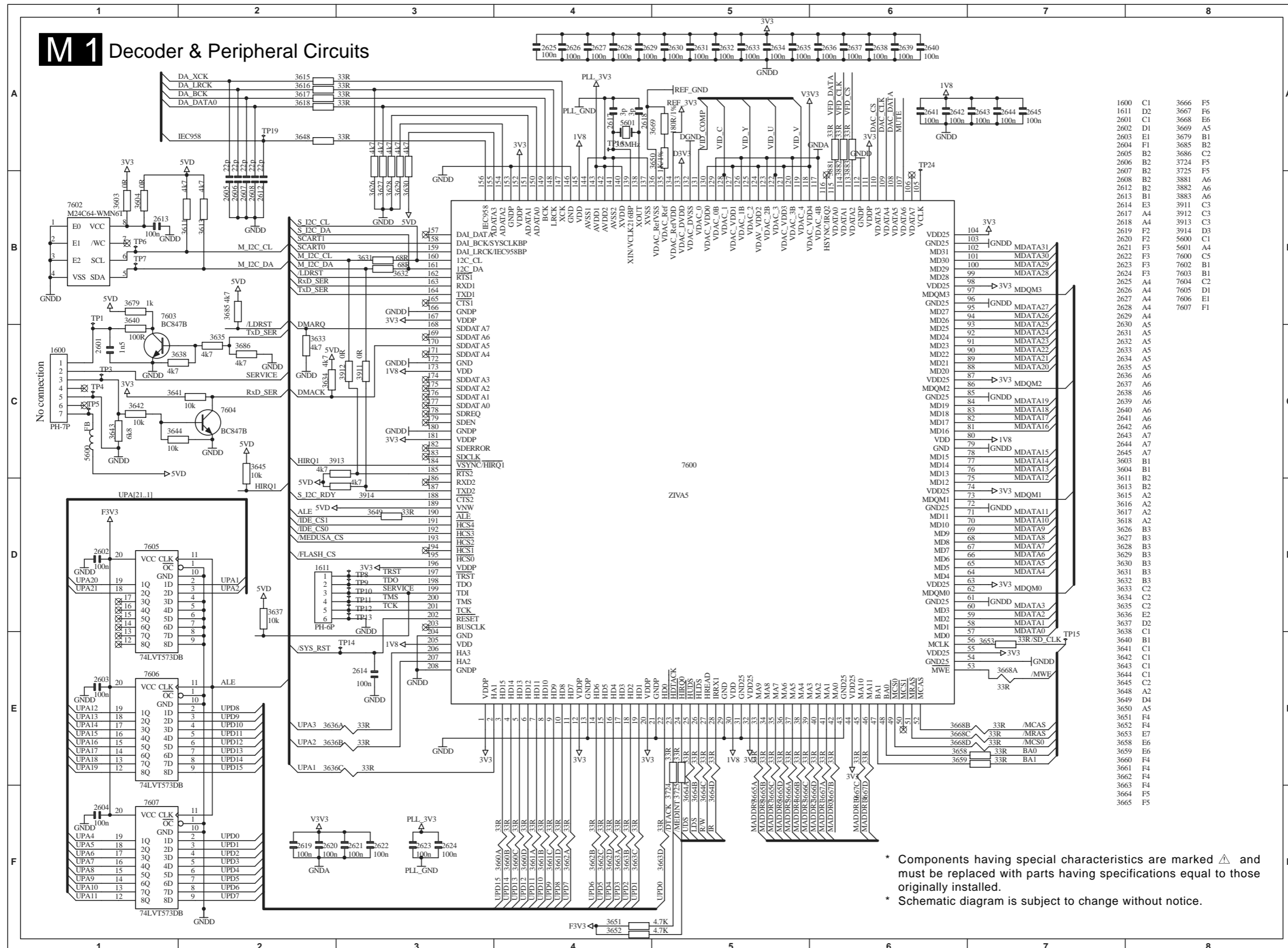

\* Components having special characteristics are marked  $\Delta$  and must be replaced with parts having specifications equal to those originally installed.  
 \* Schematic diagram is subject to change without notice.

■ DVR-S120 SCHEMATIC DIAGRAM (DVD 2/5)

The first digit of a component indicates the component type.

- 1xxx : Connector    3xxx : Resistor    5xxx : Coil    7xxx : IC, Transistor, FET
- 2xxx : Capacitor    4xxx : SMD jumper    6xxx : Diode    9xxx : Wire jumper

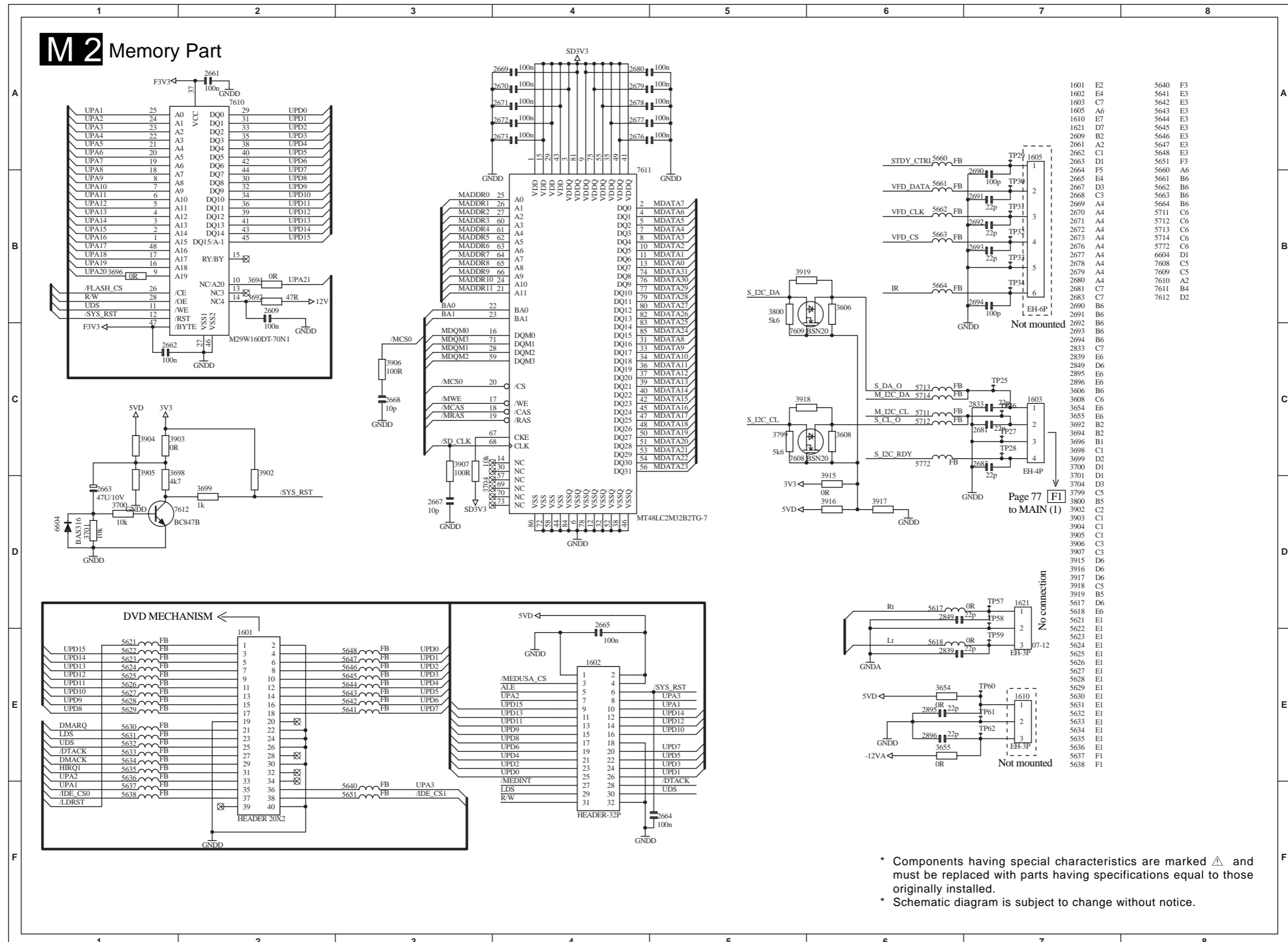

\* Components having special characteristics are marked  $\Delta$  and must be replaced with parts having specifications equal to those originally installed.  
 \* Schematic diagram is subject to change without notice.

■ DVR-S120 SCHEMATIC DIAGRAM (DVD 3/5)

The first digit of a component indicates the component type.

1xxx : Connector    3xxx : Resistor    5xxx : Coil    7xxx : IC, Transistor, FET

2xxx : Capacitor    4xxx : SMD jumper    6xxx : Diode    9xxx : Wire jumper

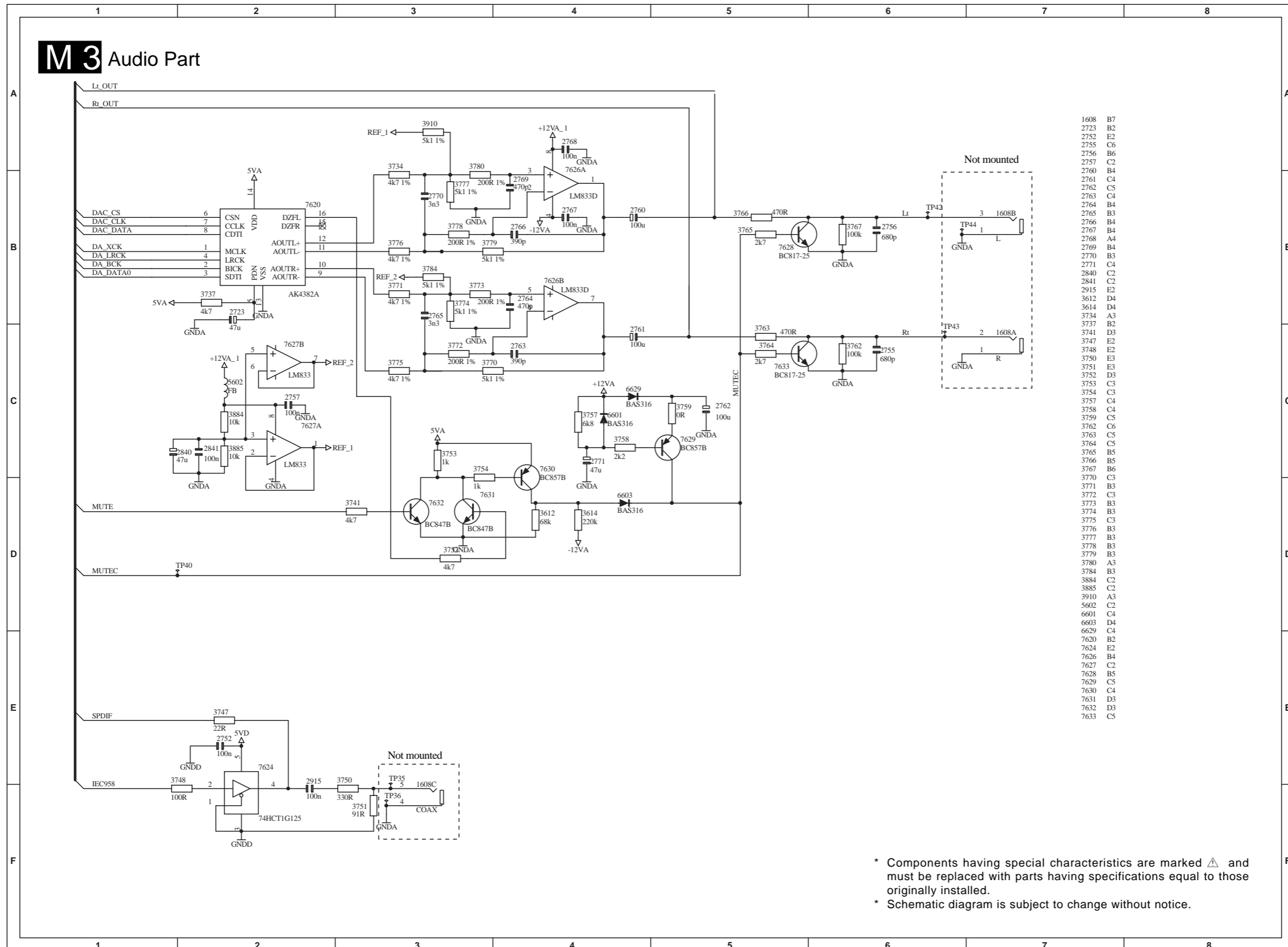



■ DVR-S120 SCHEMATIC DIAGRAM (DVD 4/5)

The first digit of a component indicates the component type.

- 1xxx : Connector    3xxx : Resistor    5xxx : Coil    7xxx : IC, Transistor, FET
- 2xxx : Capacitor    4xxx : SMD jumper    6xxx : Diode    9xxx : Wire jumper

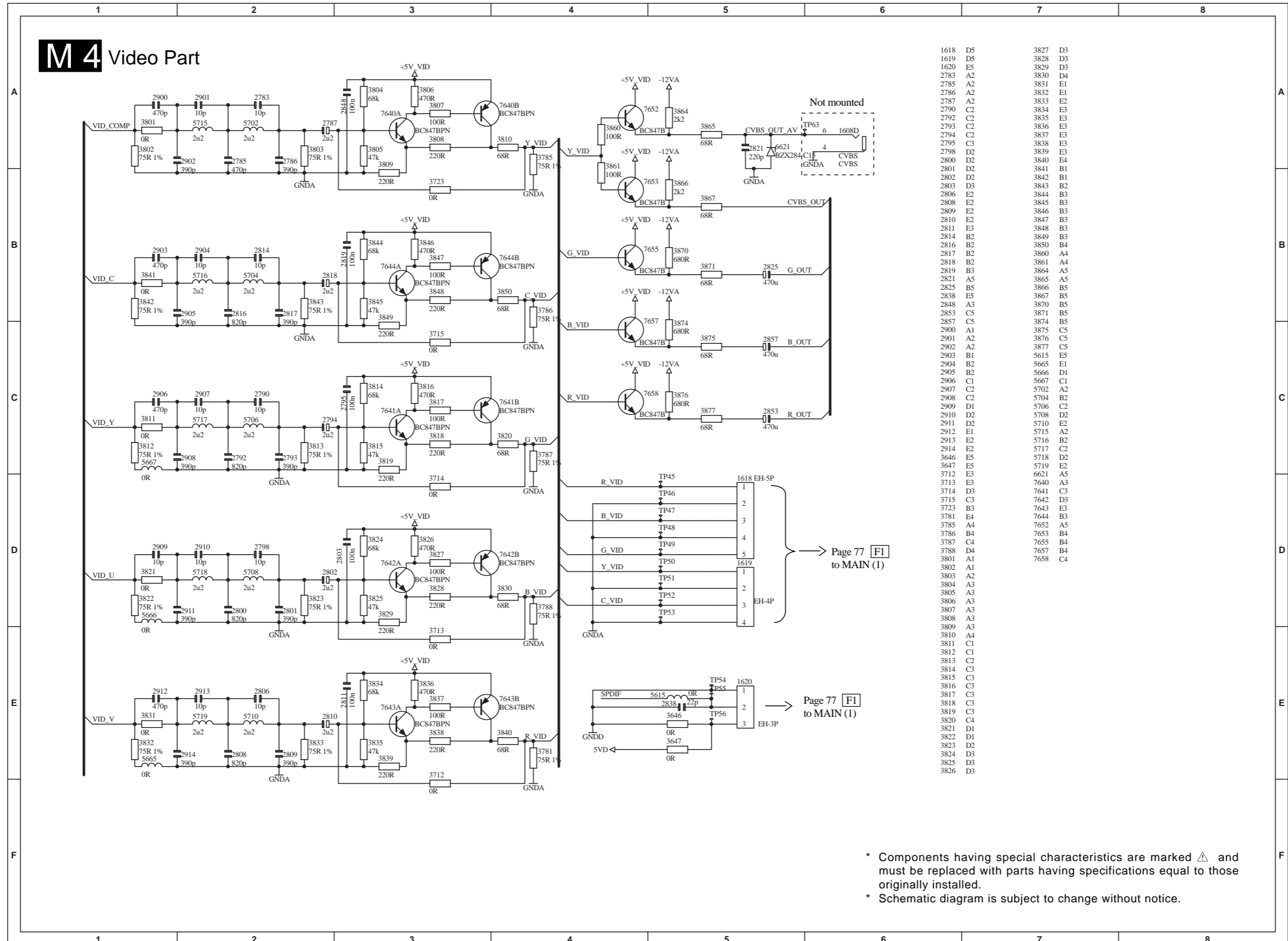

\* Components having special characteristics are marked  $\Delta$  and must be replaced with parts having specifications equal to those originally installed.  
 \* Schematic diagram is subject to change without notice.

■ DVR-S120 SCHEMATIC DIAGRAM (DVD 5/5)

The first digit of a component indicates the component type.

1xxx : Connector    3xxx : Resistor    5xxx : Coil    7xxx : IC, Transistor, FET  
 2xxx : Capacitor    4xxx : SMD jumper    6xxx : Diode    9xxx : Wire jumper

**M5** Power & Scart port

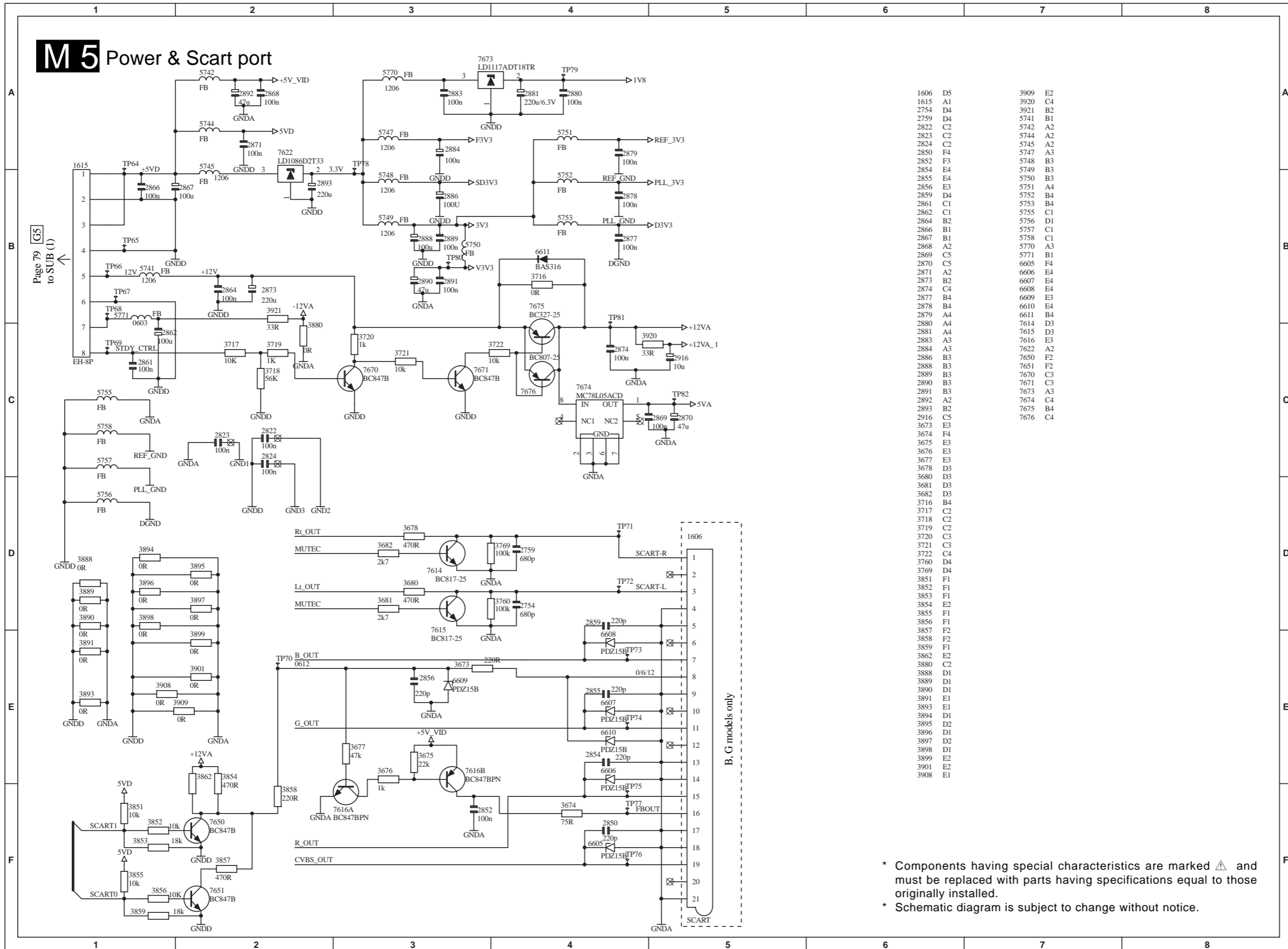

1606	D5	3909	E2
1615	A1	3920	C4
2754	D4	3921	B2
2759	D4	5741	B1
2822	C2	5742	A2
2823	C2	5744	A2
2824	C2	5745	A2
2850	F4	5747	A3
2852	F3	5748	B3
2854	E4	5749	B3
2855	E4	5750	B3
2856	E3	5751	A4
2859	D4	5752	B4
2861	C1	5753	B4
2862	C1	5755	C1
2864	B2	5756	D1
2866	B1	5757	C1
2867	B1	5758	C1
2868	A2	5770	A3
2869	C5	5771	B1
2870	C5	6605	F4
2871	A2	6606	E4
2873	B2	6607	E4
2874	C4	6608	E4
2877	B4	6609	E3
2878	B4	6610	E4
2879	A4	6611	B4
2880	A4	7614	D3
2881	A4	7615	D3
2883	A3	7616	E3
2884	A3	7622	A2
2886	B3	7650	F2
2888	B3	7651	F2
2889	B3	7670	C3
2890	B3	7671	C3
2891	B3	7673	A3
2892	A2	7674	C4
2893	B2	7675	B4
2916	C5	7676	C4
3673	E3		
3674	F4		
3675	E3		
3676	E3		
3677	E3		
3678	D3		
3680	D3		
3681	D3		
3682	D3		
3716	B4		
3717	C2		
3718	C2		
3719	C2		
3720	C3		
3721	C3		
3722	C4		
3760	D4		
3769	D4		
3851	F1		
3852	F1		
3853	F1		
3854	E2		
3855	F1		
3856	F1		
3857	F2		
3858	F2		
3859	F1		
3862	E2		
3880	C2		
3888	D1		
3889	D1		
3890	D1		
3891	E1		
3893	E1		
3894	D1		
3895	D2		
3896	D1		
3897	D2		
3898	D1		
3899	E2		
3901	E2		
3908	E1		

\* Components having special characteristics are marked  $\Delta$  and must be replaced with parts having specifications equal to those originally installed.  
 \* Schematic diagram is subject to change without notice.

DVR-S120 SCHEMATIC DIAGRAM (DIGITAL)

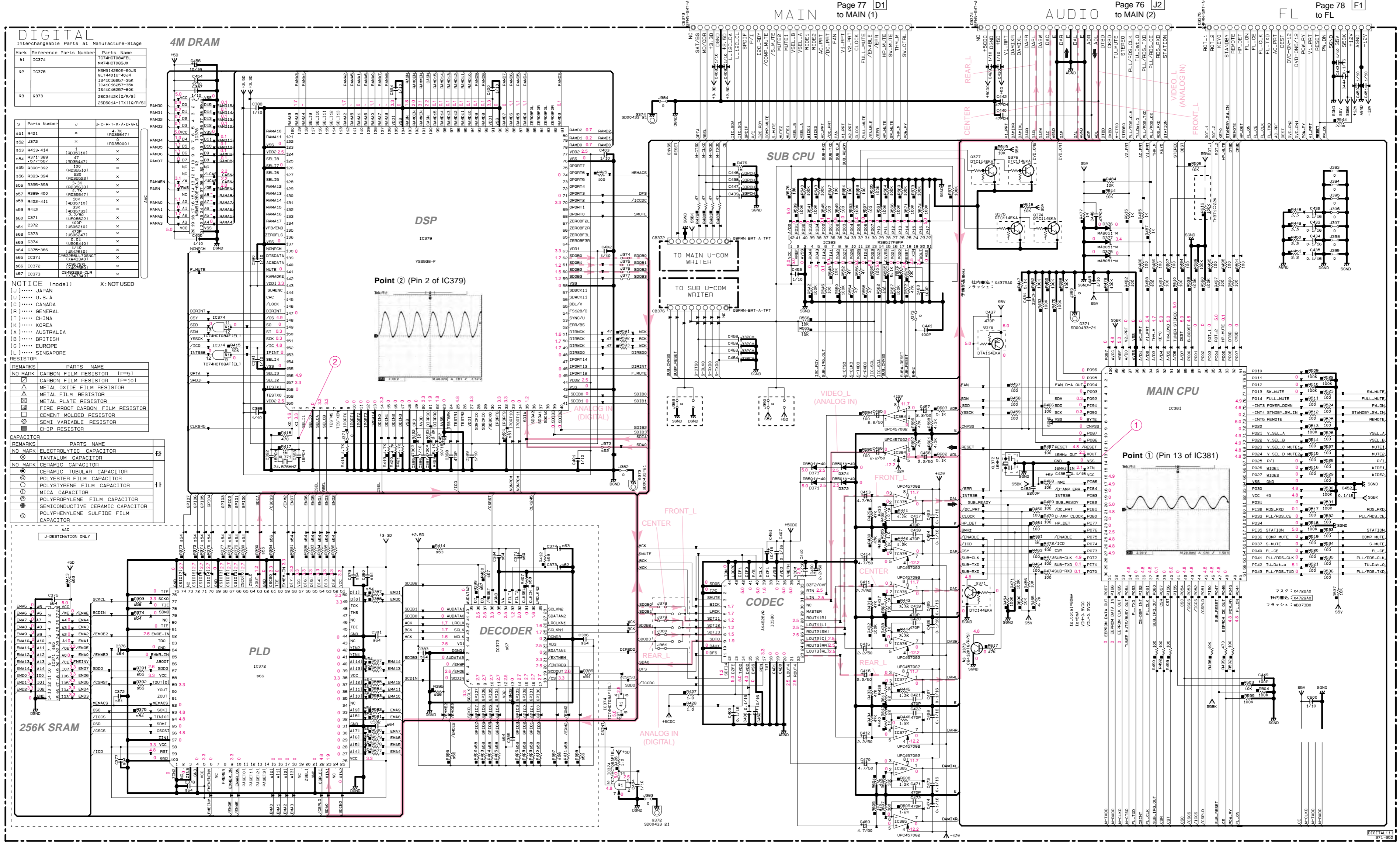

**DIGITAL**  
Interchangeable Parts at Manufacture-Stage

Mark	Reference Parts Number	Parts Name
K1	IC374	TC74HCT08AFEL Hex Inverter
K2	IC378	MSM514260E-60JS 4Mbit DRAM
K3	IC373	CS49329-CLR Audio Decoder

**NOTICE** (mode1) X: NOT USED

(J)..... JAPAN  
(U)..... U.S.A  
(C)..... CANADA  
(R)..... GENERAL  
(T)..... CHINA  
(K)..... KOREA  
(A)..... AUSTRALIA  
(B)..... BRITISH  
(G)..... EUROPE  
(L)..... SINGAPORE

**REMARKS** PARTS NAME

NO MARK CARBON FILM RESISTOR (P=5)  
CARBON FILM RESISTOR (P=10)  
METAL OXIDE FILM RESISTOR  
METAL FILM RESISTOR  
METAL PLATE RESISTOR  
FIRE PROOF CARBON FILM RESISTOR  
CEMENT MOLDED RESISTOR  
SEMI VARIABLE RESISTOR  
CHIP RESISTOR

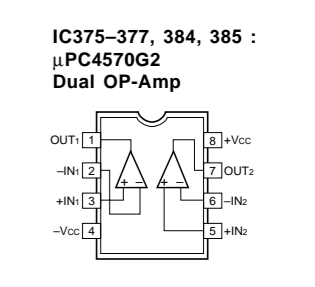
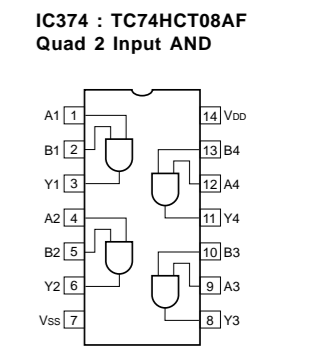
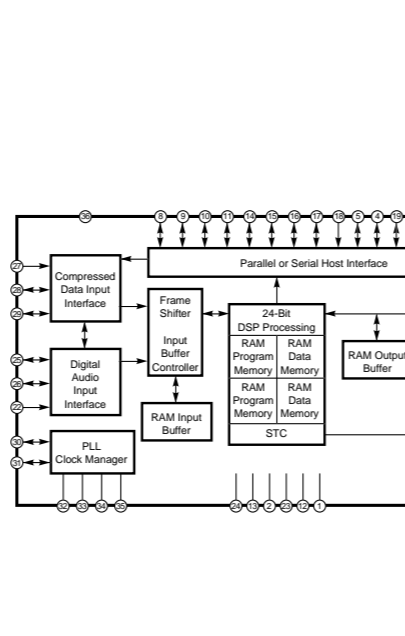
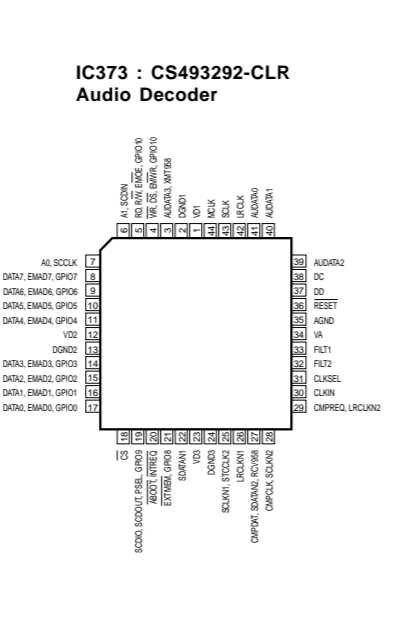
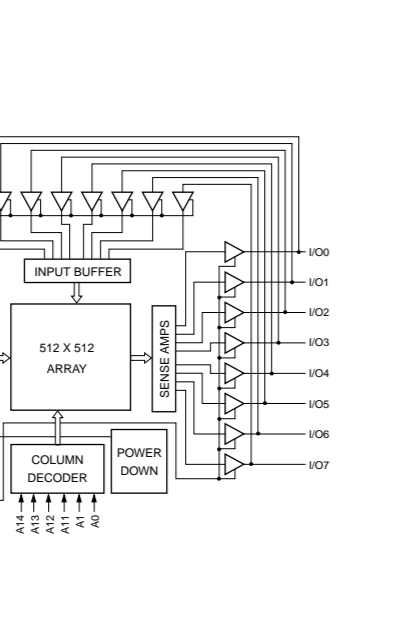
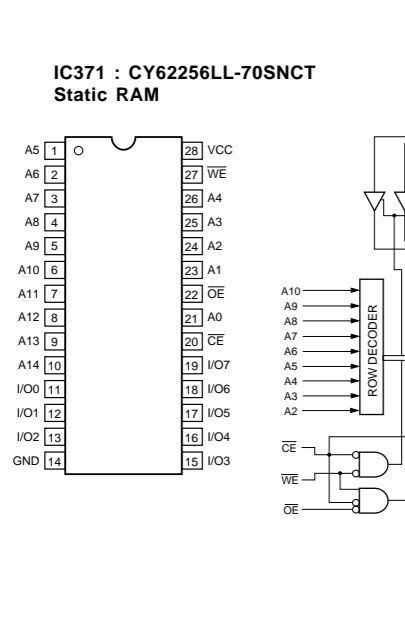

\* All voltages are measured with a 10MΩ/V DC electronic volt meter.  
\* Components having special characteristics are marked Δ and must be replaced with parts having specifications equal to those originally installed.  
\* Schematic diagram is subject to change without notice.

DVR-S120 SCHEMATIC DIAGRAM (MAIN 1/3)

AUDIO

Reference No	UCRTRAL	B-G
s21	IC124	X X LC72722PM X008240
s22	XL121	X X 4.332MHz V393090
s23	Q124	X X C2412K10/R/S1 V195840
s24	D122	X X MAB056-M V99300
s25	L121, 122	X X BLM1880601SN10 V308340
s26	C142	X X 33/16 UR83733
s27	C149	X X 47/16 UR83747
s28	C144	X X 2.2/50 UR86622
s29	C147, 150	X X 330P US06233
s30	C153, 161	X X 27PCH US06127
s31	C166, 151	X X 0.1/16 US13510
s32	R151	X X 3.3K RD35633
s33	R157	X X 100K RD35810
s34	R160	X X RD35647
s35	R211	X X 100 RD35510

Mark	Reference Parts Number	Parts Name
k21	Q126	2SA1037AK(G/R/S1)
		2SA1235A(E/F)

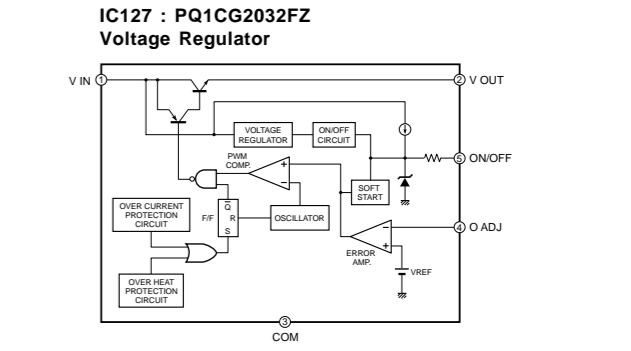
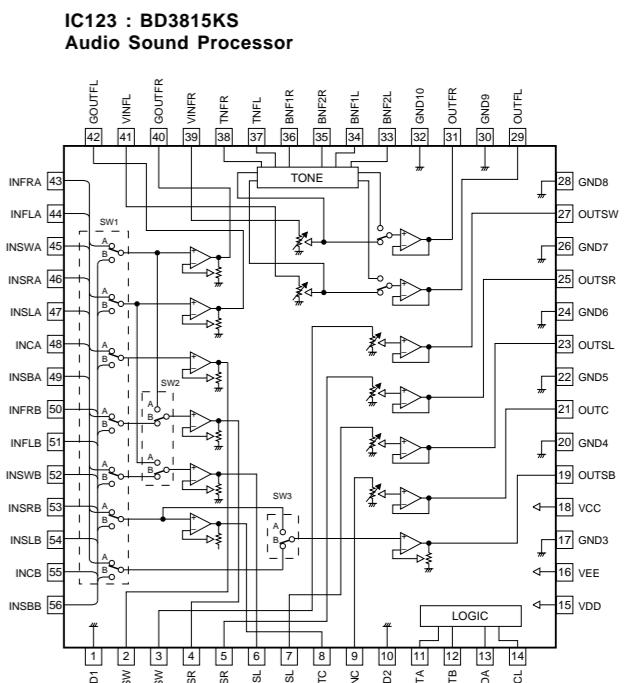
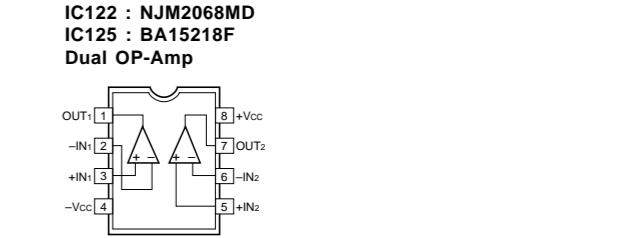
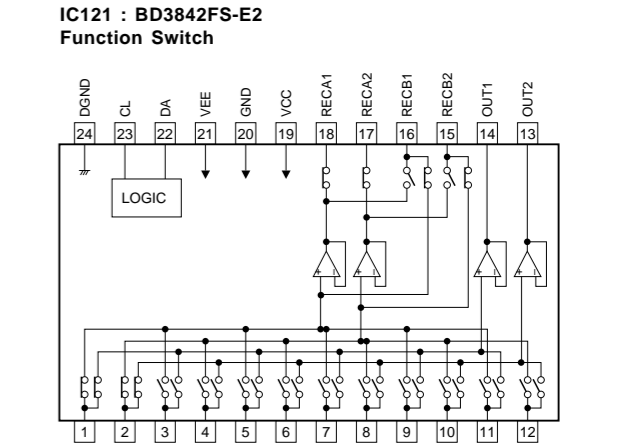
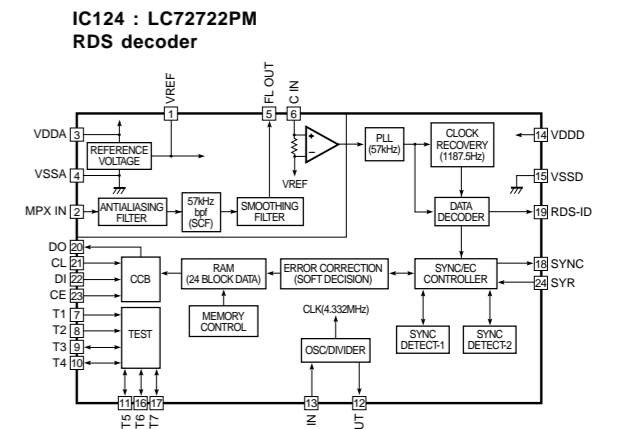
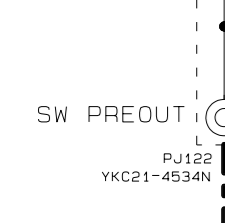
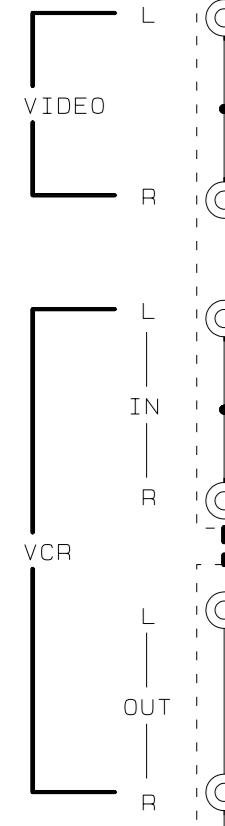
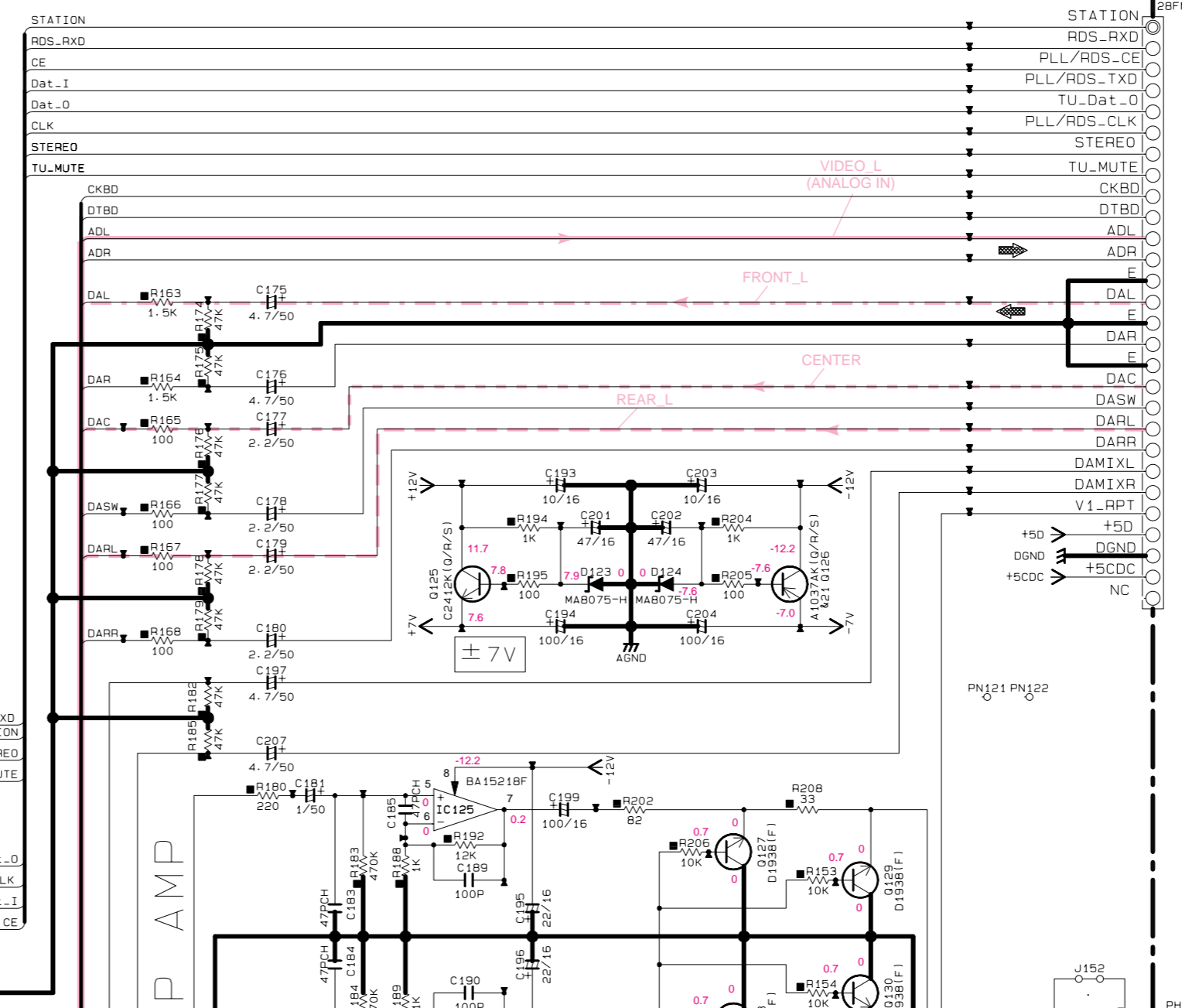
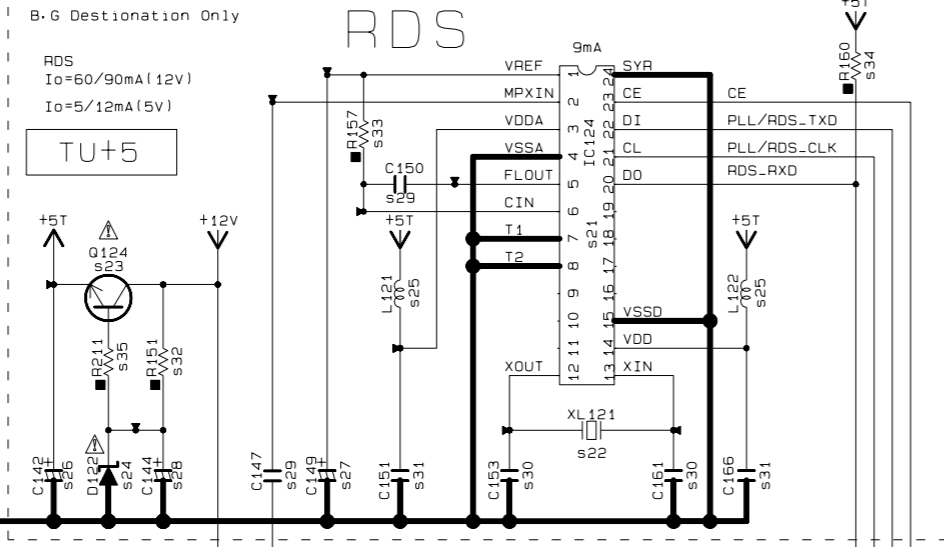

Page 75 to DIGITAL

Page 79 to SUB (1)

Page 77 to MAIN (1)

Page 79 to SUB (1)

\* All voltages are measured with a 10MΩ/V DC electronic volt meter.  
 \* Components having special characteristics are marked Δ and must be replaced with parts having specifications equal to those originally installed.  
 \* Schematic diagram is subject to change without notice.

■ DVR-S120 SCHEMATIC DIAGRAM (MAIN 2/3)

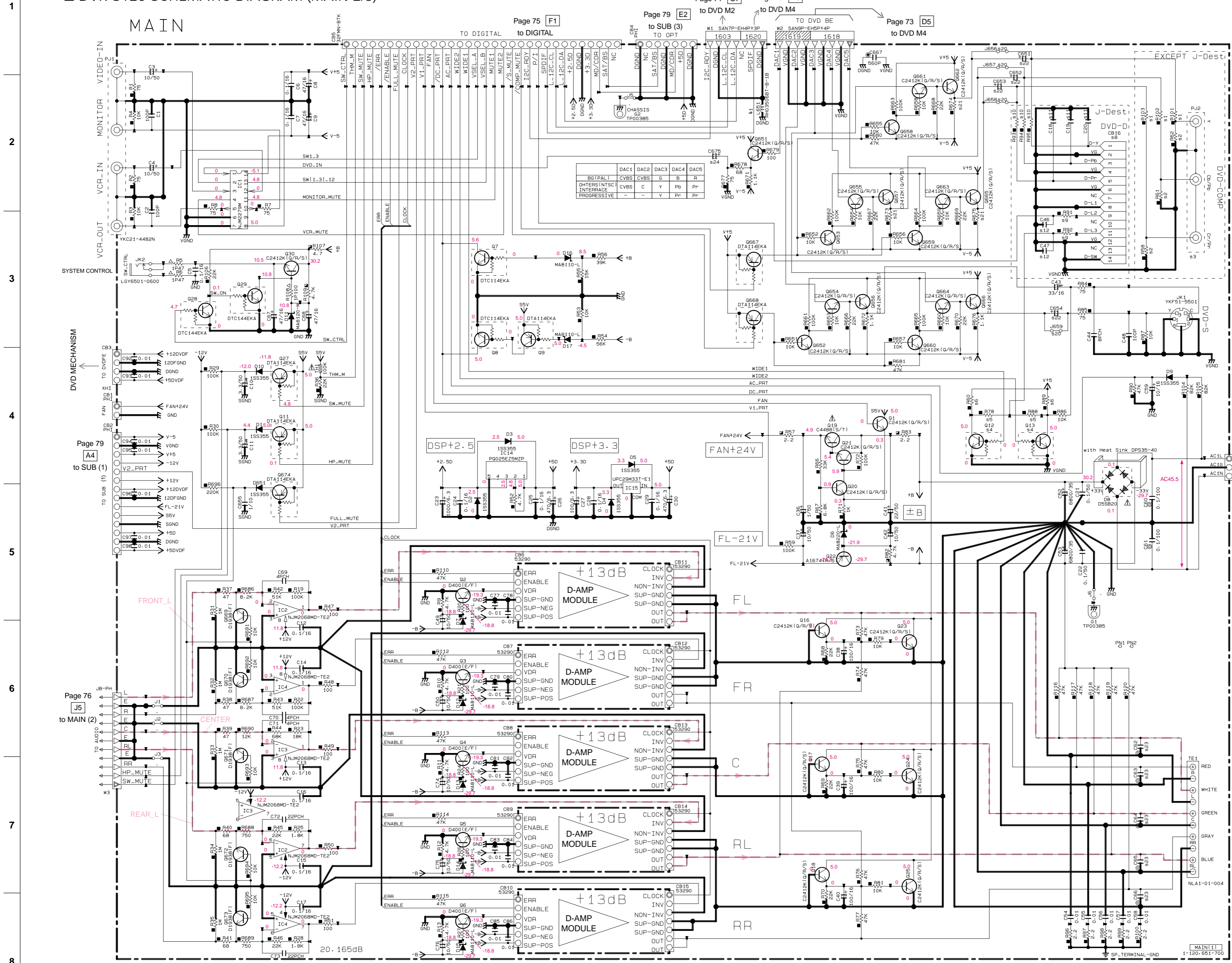

Reference No	J	UCRTKAL	BG
s1 R101-103	X	75 (RD35475)	75 (RD35475)
s2 R58-61-62	X	100K (RD35810)	100K (RD35810)
s3 PJ2	X	YKC21-4195N (WB38530)	YKC21-4195N (WB38530)
s4 Q12-13	X	DTC114EKA (VV6540)	X
s5 R78-88	X	25K (RD35722)	X
s6 R60-89	X	2.2K (RD35622)	X
s7			
s8 CB16	X	YKF45-3004 (V768410)	X
s9 R91-92	X	100 (RD35610)	X
s10 R93-95	X	100 (RD35610)	X
s11 C18-20	X	BRCH (UB06080)	X
s12 C46-47	X	0.01 (UB06410)	X
s13			
s14			
s15			
s16			
s17			
s18			
s19			
s20 J656-659	X	0 (RD35000)	0 (RD35000)
s21 R673-675	X	560 (RD35556)	1.1K (RD35611)
s22 C651-654	X	470/10 (URB347)	X
s23 C62-66	X	0.01 (UA65410)	0.047 (UA65447)
s24 C675	X	5.2/20 (URB6622)	X

Interchangeable Parts at Manufacture-Stage

Mark	Reference Parts Number	Parts Name
△1	L651	RH03506B1-B-1B BL02RN1R2P1A

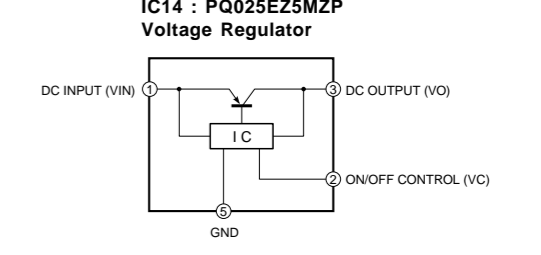
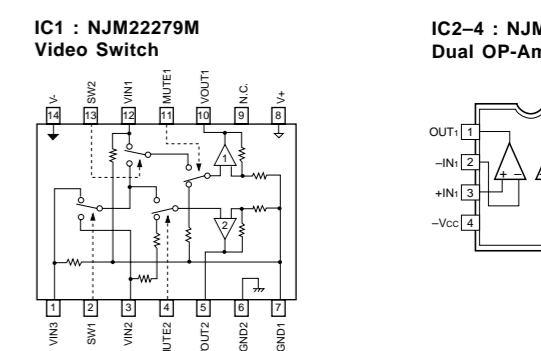
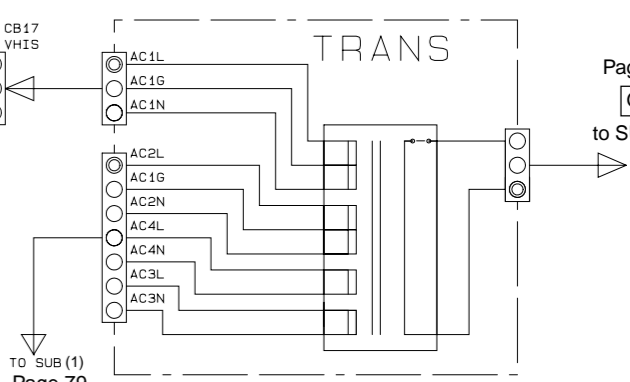

\* All voltages are measured with a 10MΩ/V DC electronic volt meter.  
 \* Components having special characteristics are marked △ and must be replaced with parts having specifications equal to those originally installed.  
 \* Schematic diagram is subject to change without notice.

DVR-S120 SCHEMATIC DIAGRAM (MAIN 3/3)

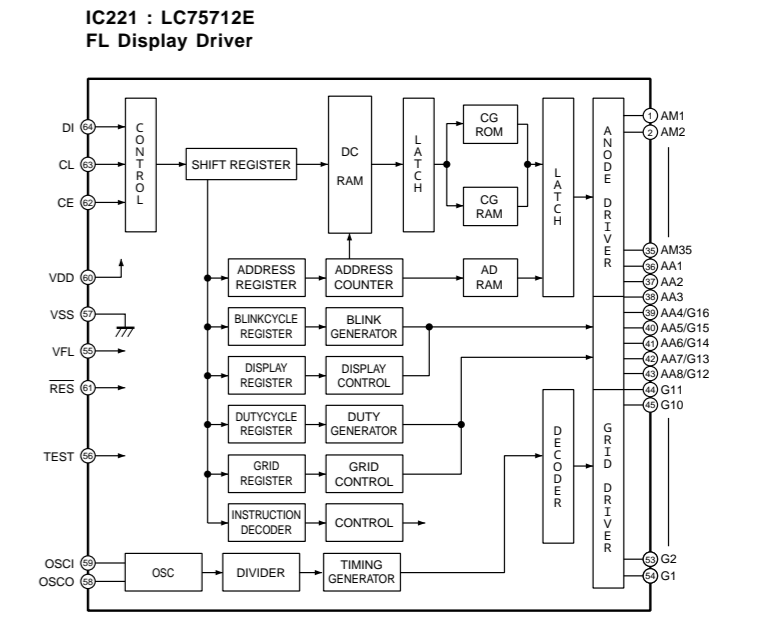
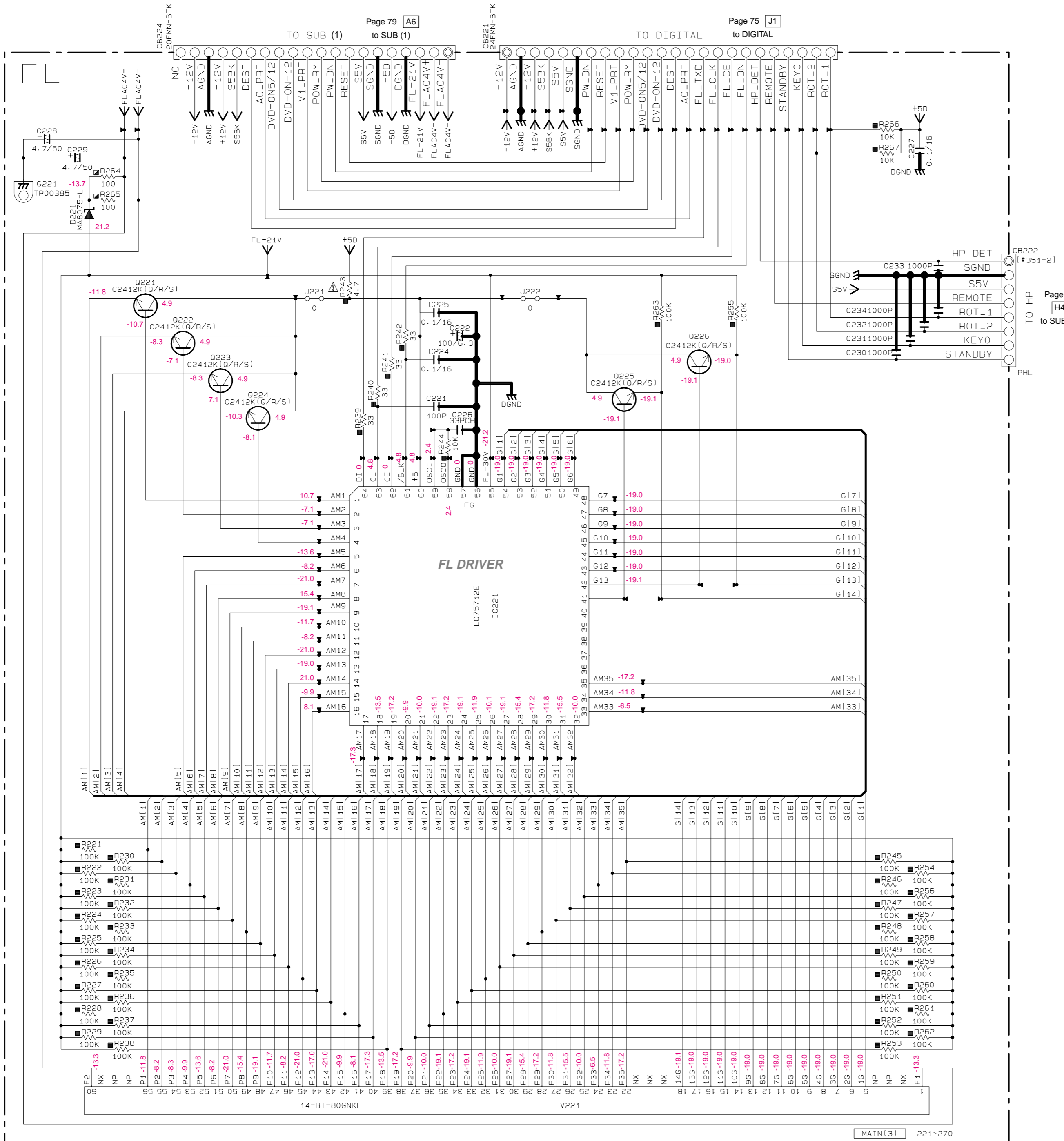

\* All voltages are measured with a 10MΩ/V DC electronic volt meter.  
 \* Components having special characteristics are marked Δ and must be replaced with parts having specifications equal to those originally installed.  
 \* Schematic diagram is subject to change without notice.

DVR-S120 SCHEMATIC DIAGRAM (SUB)

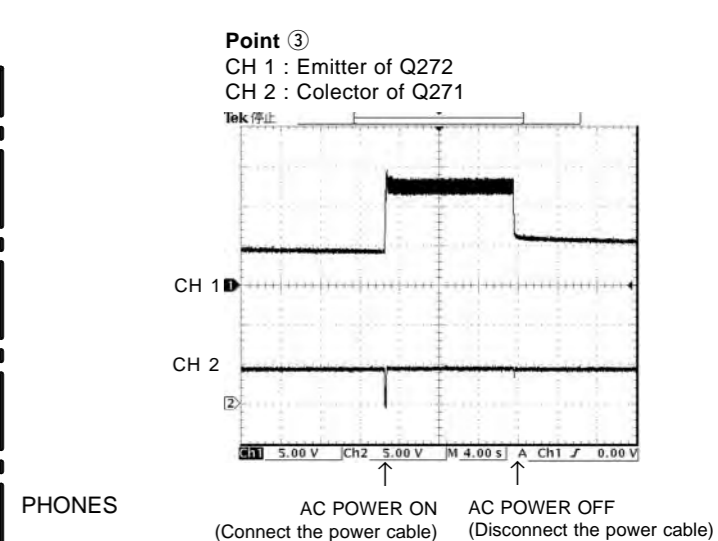
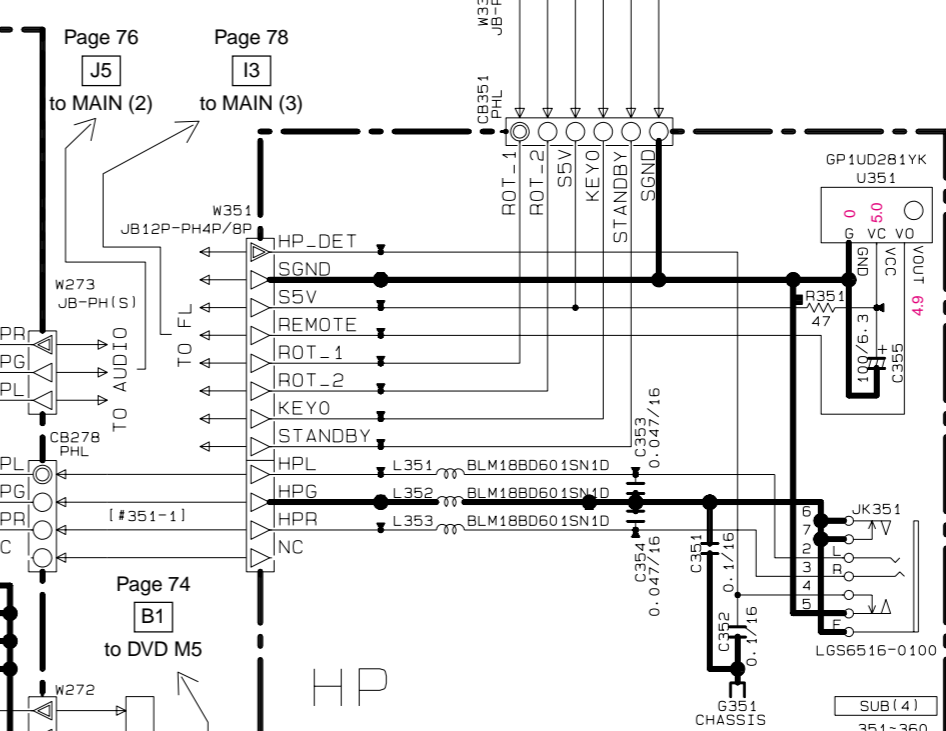
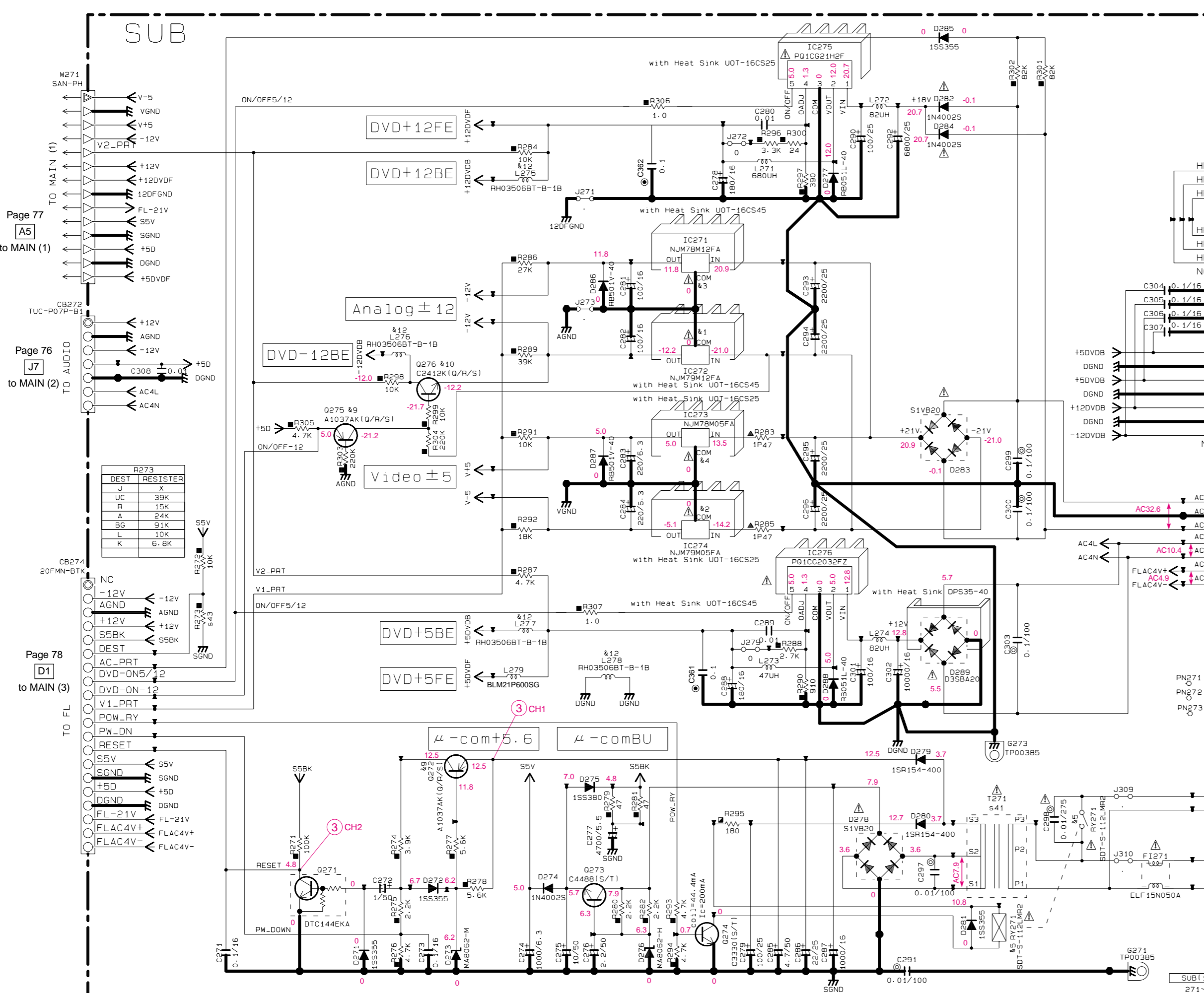
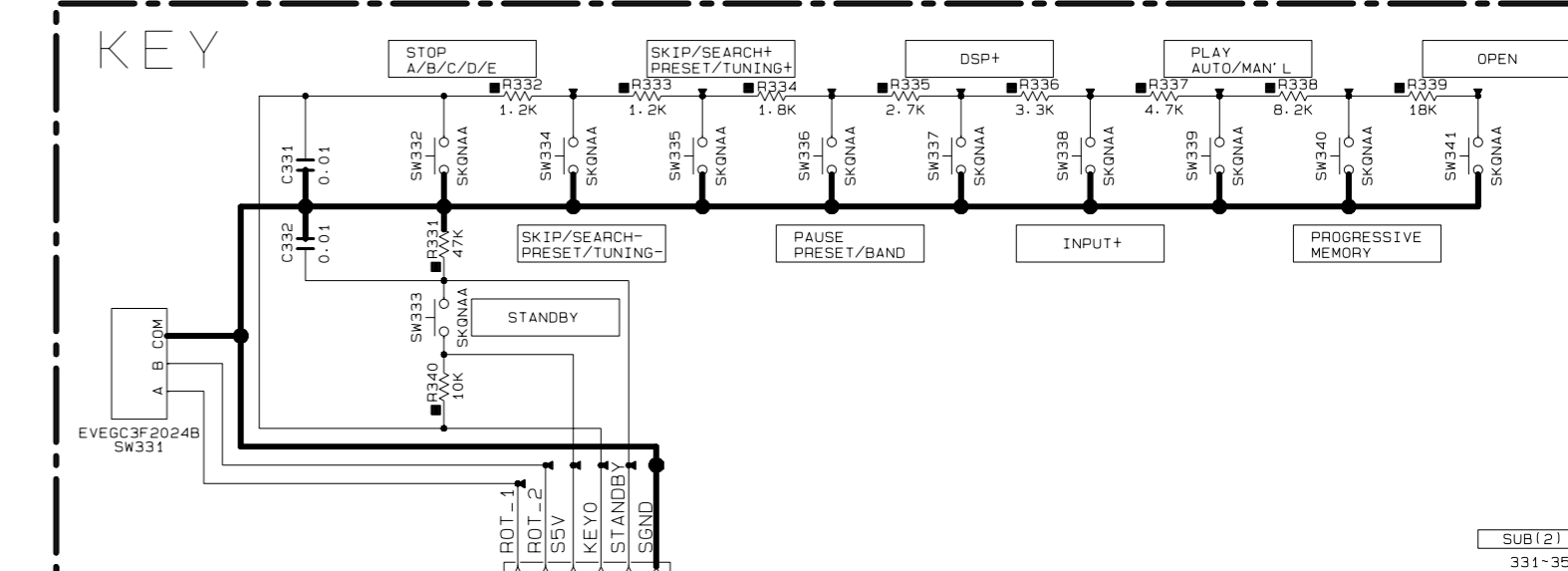
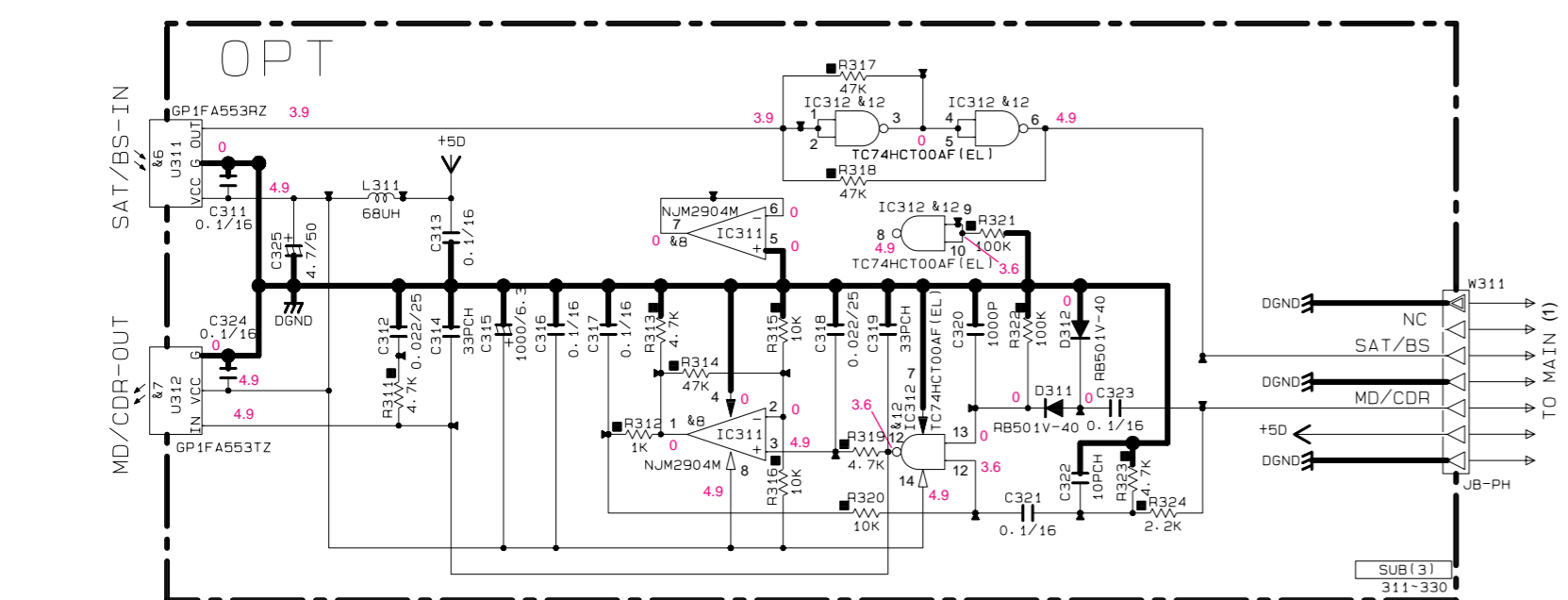
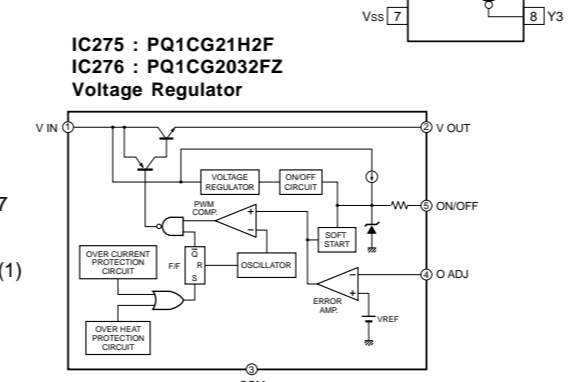
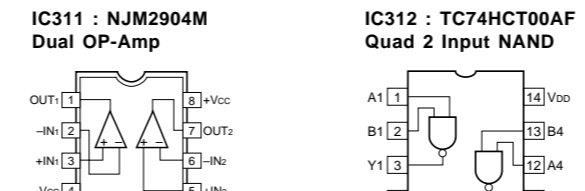

Interchangeable Parts at Manufacture-Stage

Mark	Reference Parts Number	Parts Name
k1	IC272	NJM79M12FA AN79M12F
k2	IC274	NJM79M05FA AN79M05F
k3	IC271	NJM7812FA AN78M12F
k4	IC273	NJM78M05FA AN78M05F
k5	RY271	SDT-S-112LMR2 DL51201-0[M]
k6	U311	GP1FA553RZ TORX179
k7	U312	GP1FA553TZ TOTX179
k8	IC311	NJM2904M NJM2904G
k9	Q272-275	2SA1037AK(Q/R/S) 2SA1235AIE[F]
k10	Q276	2SC2412K(Q/R/S) 2SD601A(Q/R/S)
k11	IC312	TC74HCT00AF MM74HCT00SJK
k12	L275-278	RH03506BT-B-1B BL02RM1R2P1A

Reference No	J	U.C	R	T	K	A	B.G	L
s41	T271	X2490 (X2490A0)	X2491 (X2491A0)	X4434 (X4434A0)	X2948 (X2948A0)	X2493 (X2493A0)	X2494 (X2494A0)	X2948 (X2948A0)
s42								
s43	R273	X	39K (RD35739)	15K (RD35715)	4.3K (RD35643)	6.8K (RD35668)	24K (RD35724)	91K (RD35791)
s44								

X: NOT USED

\* All voltages are measured with a 10MΩV DC electronic volt meter.  
 \* Components having special characteristics are marked Δ and must be replaced with parts having specifications equal to those originally installed.  
 \* Schematic diagram is subject to change without notice.

■ NX-SW120 SCHEMATIC DIAGRAM

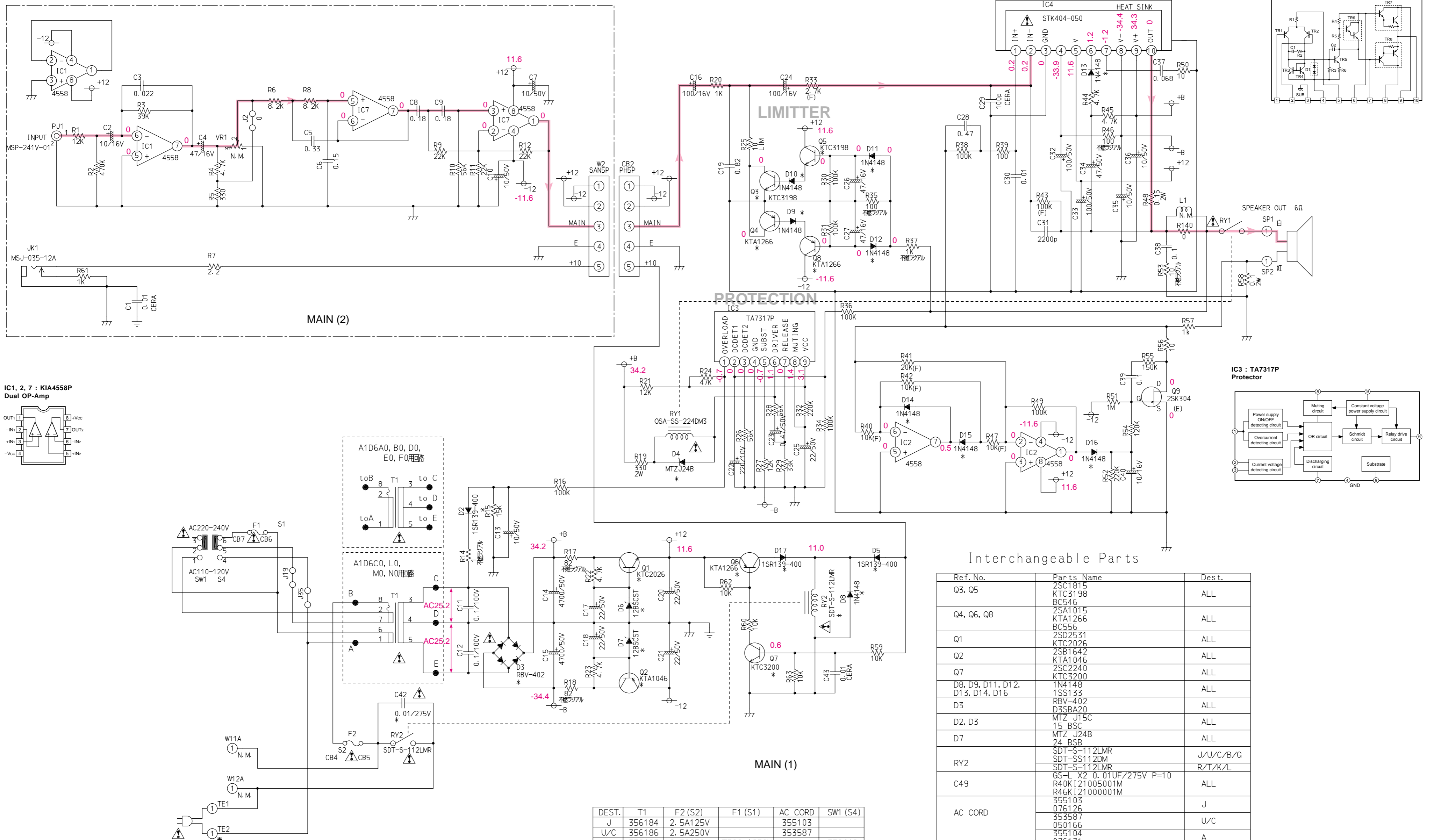

IC1, 2, 7 : KIA4558P Dual OP-Amp

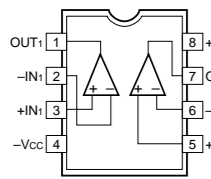

A1D6A0, B0, D0, E0, F0用回路

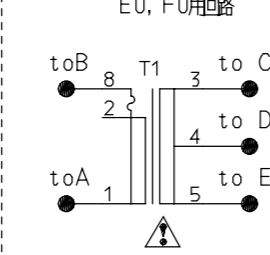

A1D6C0, L0, M0, N0用回路

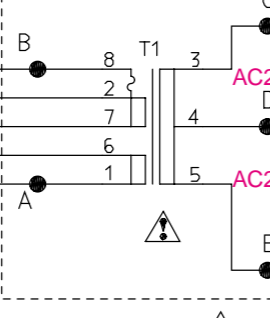

MAIN (1)

DEST.	T1	F2 (S2)	F1 (S1)	AC CORD	SW1 (S4)
J	356184	2. 5A125V		355103	
U/C	356186	2. 5A250V		353587	
R	356187	2. 5A250V	T500mA250V	378708	336446
A	356188	T500mA250V		355104	
B	356189	T500mA250V		360577	
G	356189	T500mA250V		355106	
K	356187	2. 5A250V	T500mA250V	357511	336446
T	356187	2. 5A250V	T500mA250V	356321	336446
L	356187	2. 5A250V	T500mA250V	355106	336446

Interchangeable Parts

Ref. No.	Parts Name	Dest.
Q3, Q5	2SC1815 KTC3198 BC546	ALL
Q4, Q6, Q8	2SA1015 KTA1266 BC556	ALL
Q1	2SD2531 KTC2026	ALL
Q2	2SB1642 KTA1046	ALL
Q7	2SC2240 KTC3200	ALL
D8, D9, D11, D12, D13, D14, D16	1N4148 1SS133	ALL
D3	RBV-402 D3SBA20	ALL
D2, D3	MTZ J15C 15 BSC	ALL
D7	MTZ J24B 24 BSB	ALL
RY2	SDT-S-112LMR SDT-SS112DM SDT-S-112LMR	J/U/C/B/G R/T/K/L
C49	GS-L X2 0.01UF/275V P=10 R40K I21005001M R46K I21000001M	ALL
AC CORD	355103 076126	J
	353587 050166	U/C
	355104 076131	A
	355105 360577 076130	B
	355106 076128	G
	357511 352474	K

IC4 : STK404-050 Power Amp

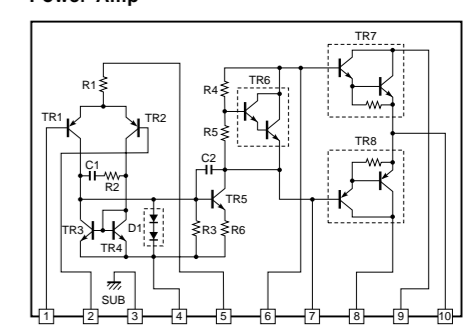

IC3 : TA7317P Protector

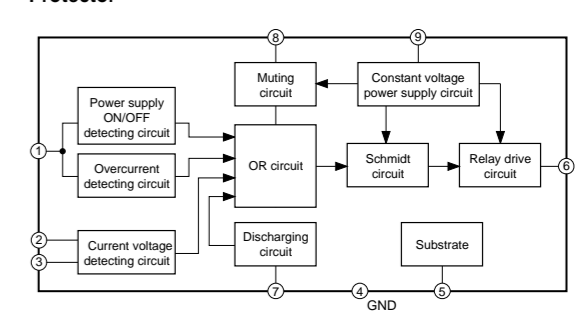

\* All voltages are measured with a 10MΩ/V DC electronic volt meter.  
 \* Components having special characteristics are marked Δ and must be replaced with parts having specifications equal to those originally installed.  
 \* Schematic diagram is subject to change without notice.



# PARTS LIST

## ■ ELECTRICAL PARTS

### ■ WARNING

- Components having special characteristics are marked  $\triangle$  and must be replaced with parts having specifications equal to those originally installed.

$\triangle$ 印のある部分は、安全確保部品を示しています。部品の交換が必要な場合、パーツリストに記載されている部品を使用してください。

### ABBREVIATIONS IN THIS LIST ARE AS FOLLOWS :

C.A.EL.CHP	: CHIP ALUMI. ELECTROLYTIC CAP	L.DTCT	: LIGHT DETECTING MODULE
C.CE	: CERAMIC CAP	L.EMIT	: LIGHT EMITTING MODULE
C.CE.ARRAY	: CERAMIC CAP ARRAY	LED.DSPLY	: LED DISPLAY
C.CE.CHP	: CHIP CERAMIC CAP	LED.INFRD	: LED, INFRARED
C.CE.ML	: MULTILAYER CERAMIC CAP	MODUL.RF	: MODULATOR, RF
C.CE.M.CHP	: CHIP MULTILAYER CERAMIC CAP	PHOT.CPL	: PHOTO COUPLER
C.CE.SAFTY	: RECOGNIZED CERAMIC CAP	PHOT.INTR	: PHOTO INTERRUPTER
C.CE.TUBLR	: CERAMIC TUBULAR CAP	PHOT.RFLCT	: PHOTO REFLECTOR
C.CE.SMI	: SEMI CONDUCTIVE CERAMIC CAP	PIN.TEST	: PIN, TEST POINT
C.EL	: ELECTROLYTIC CAP	PLST.RIVET	: PLASTIC RIVET
C.MICA	: MICA CAP	R.ARRAY	: RESISTOR ARRAY
C.ML.FLM	: MULTILAYER FILM CAP	R.CAR	: CARBON RESISTOR
C.MP	: METALLIZED PAPER CAP	R.CAR.CHP	: CHIP RESISTOR
C.MYLAR	: MYLAR FILM CAP	R.CAR.FP	: FLAME PROOF CARBON RESISTOR
C.MYLAR.ML	: MULTILAYER MYLAR FILM CAP	R.FUS	: FUSABLE RESISTOR
C.PAPER	: PAPER CAPACITOR	R.MTL.CHP	: CHIP METAL FILM RESISTOR
C.PLS	: POLYSTYRENE FILM CAP	R.MTL.FLM	: METAL FILM RESISTOR
C.POL	: POLYESTER FILM CAP	R.MTL.OXD	: METAL OXIDE FILM RESISTOR
C.POLY	: POLYETHYLENE FILM CAP	R.MTL.PLAT	: METAL PLATE RESISTOR
C.PP	: POLYPROPYLENE FILM CAP	RSNR.CE	: CERAMIC RESONATOR
C.TNTL	: TANTALUM CAP	RSNR.CRYS	: CRYSTAL RESONATOR
C.TNTL.CHP	: CHIP TANTALUM CAP	R.TW.CEM	: TWIN CEMENT FIXED RESISTOR
C.TRIM	: TRIMMER CAP	R.WW	: WIRE WOUND RESISTOR
CN	: CONNECTOR	SCR.BND.HD	: BIND HEAD B-TITE SCREW
CN.BS.PIN	: CONNECTOR, BASE PIN	SCR.BW.HD	: BW HEAD TAPPING SCREW
CN.CANNON	: CONNECTOR, CANNON	SCR.CUP	: CUP TITE SCREW
CN.DIN	: CONNECTOR, DIN	SCR.TERM	: SCREW TERMINAL
CN.FLAT	: CONNECTOR, FLAT CABLE	SCR.TR	: SCREW, TRANSISTOR
CN.POST	: CONNECTOR, BASE POST	SUPRT.PCB	: SUPPORT, P.C.B.
COIL.MX.AM	: COIL, AM MIX	SURG.PRTCT	: SURGE PROTECTOR
COIL.AT.FM	: COIL, FM ANTENNA	SW.TACT	: TACT SWITCH
COIL.DT.FM	: COIL, FM DETECT	SW.LEAF	: LEAF SWITCH
COIL.MX.FM	: COIL, FM MIX	SW.LEVER	: LEVER SWITCH
COIL.OUTPT	: OUTPUT COIL	SW.MICRO	: MICRO SWITCH
DIOD.ARRAY	: DIODE ARRAY	SW.PUSH	: PUSH SWITCH
DIODE.BRG	: DIODE BRIDGE	SW.RT.ENC	: ROTARY ENCODER
DIODE.CHP	: CHIP DIODE	SW.RT.MTR	: ROTARY SWITCH WITH MOTOR
DIODE.SHOT	: SCHOTTKY BARRIER DIODE	SW.RT	: ROTARY SWITCH
DIODE.VAR	: VARACTOR DIODE	SW.SLIDE	: SLIDE SWITCH
DIOD.Z.CHP	: CHIP ZENER DIODE	TERM.SP	: SPEAKER TERMINAL
DIODE.ZENR	: ZENER DIODE	TERM.WRAP	: WRAPPING TERMINAL
DSCR.CE	: CERAMIC DISCRIMINATOR	THRMST.CHP	: CHIP THERMISTOR
FER.BEAD	: FERRITE BEADS	TR.CHP	: CHIP TRANSISTOR
FER.CORE	: FERRITE CORE	TR.DGT	: DIGITAL TRANSISTOR
FET.CHP	: CHIP FET	TR.DGT.CHP	: CHIP DIGITAL TRANSISTOR
FL.DSPLY	: FLUORESCENT DISPLAY	TRANS	: TRANSFORMER
FLTR.CE	: CERAMIC FILTER	TRANS.PULS	: PULSE TRANSFORMER
FLTR.COMB	: COMB FILTER MODULE	TRANS.PWR	: POWER TRANSFORMER ASS'y
FLTR.LC.RF	: LC FILTER, EMI	TUNER.AM	: TUNER PACK, AM
GND.MTL	: GROUND PLATE	TUNER.FM	: TUNER PACK, FM
GND.TERM	: GROUND TERMINAL	TUNER.PK	: FRONT-END TUNER PACK
HOLDER.FUS	: FUSE HOLDER	VR	: ROTARY POTENTIOMETER
IC.PRTCT	: IC PROTECTOR	VR.MTR	: POTENTIOMETER WITH MOTOR
JUMPER.CN	: JUMPER CONNECTOR	VR.SW	: POTENTIOMETER WITH ROTARY SW
JUMPER.TST	: JUMPER, TEST POINT	VR.SLIDE	: SLIDE POTENTIOMETER
		VR.TRIM	: TRIMMER POTENTIOMETER

## DVR-S120 P.C.B. DIGITAL &amp; MAIN

Ref. No.	PART NO.	Description	Remarks	Markets	部品名	Rank
*	WB852800	P.C.B.	DIGITAL	J	P C B デジタル	
*	WB852900	P.C.B.	DIGITAL	UCRTKABGL	P C B デジタル	
* CB372	WC195900	CN	9P TE FMN		F M Nコネクタ	
* CB373	WA903200	CN	32P SE FMN		F M Nコネクタ	
* CB374	WA902800	CN	28P SE FMN		F M Nコネクタ	
* CB375	WA902400	CN	24P SE FMN		F M Nコネクタ	
* CB376	WC195900	CN	9P TE FMN		F M Nコネクタ	
D371	VV220700	DIODE.SHOT	RB501V-40		ショットキーダイオード	
D372	VV220700	DIODE.SHOT	RB501V-40		ショットキーダイオード	
D373	VV220700	DIODE.SHOT	RB501V-40		ショットキーダイオード	
D374	VV220700	DIODE.SHOT	RB501V-40		ショットキーダイオード	
D375	VU992600	DIODE.ZENR	MA8051-M 5.1V		ツェナーダイオード	
D376	VU992600	DIODE.ZENR	MA8051-M 5.1V		ツェナーダイオード	
D377	VU992600	DIODE.ZENR	MA8051-M 5.1V		ツェナーダイオード	
* G371	WB438000	TERM.GND	M4 SD00433-21		アース端子	
* G372	WB438000	TERM.GND	M4 SD00433-21		アース端子	
* G373	WB438000	TERM.GND	M4 SD00433-21		アース端子	
* G374	WB438000	TERM.GND	M4 SD00433-21		アース端子	
IC371	XW433A00	IC	CY62256LL-70SNCT	J	メモリ IC 256K	05
* IC372	X4075B00	IC	XC9572XL-10Q100C	J	IC	
IC373	X3473A00	IC	CS493292-CLR	J	IC	
IC374	XZ012A00	IC	TC74HCT08AF(EL)		ロジック IC SOP	01
IC375	XF291A00	IC	uPC4570G2		IC	03
IC376	XF291A00	IC	uPC4570G2		IC	03
IC377	XF291A00	IC	uPC4570G2		IC	03
IC378	XV077B00	IC	MSM514260E-60JS		メモリ IC 4M	
IC379	X0238B00	IC	YSS938		IC	
* IC380	X3807A00	IC	AK4628VQ		IC	
* IC381	X4729A00	IC.CPU	M30624FGAFP	EPROM WRITTEN	IC	
* IC383	X4379A00	IC.CPU	M38517F8FP	EPROM WRITTEN	IC	
IC384	XF291A00	IC	uPC4570G2		IC	03
IC385	XF291A00	IC	uPC4570G2		IC	03
Q371	VV655700	TR.DGT	DTC144EKA		デジタルトランジスタ	01
Q372	VV655000	TR.DGT	DTA114EKA		デジタルトランジスタ	
Q373	VV556400	TR	2SC2412K Q,R,S		トランジスタ	
Q374	VV655400	TR.DGT	DTC114EKA		デジタルトランジスタ	
Q375	VV655400	TR.DGT	DTC114EKA		デジタルトランジスタ	
Q376	VV655400	TR.DGT	DTC114EKA		デジタルトランジスタ	
Q377	VV655400	TR.DGT	DTC114EKA		デジタルトランジスタ	
XL371	V3625700	RSNR.CRYS	24.576MHz		水晶振動子	
* XL372	WB440500	RSNR.CE	CSTCE16MOV53-R0		セラミック発振子	
*	WB851700	P.C.B.	MAIN	J	P C B メイン	
*	WB851800	P.C.B.	MAIN	UCRTKAL	P C B メイン	
*	WB851900	P.C.B.	MAIN	BG	P C B メイン	
CB1	VB389800	CN.BS.PIN	2P		ベースピン	01
CB2	VE352600	CN.BS.PIN	14P		コネクタベースポスト	01
CB3	VL844800	CN.BS.PIN	4P		ベース付ポスト	01
CB4	VB390300	CN.BS.PIN	7P		ベースピン	01
* CB5	V2283600	CN.BS.PIN	32P TE FMN		F F Cコネクタ	
CB6	VQ962700	CN.BS.PIN	6P		ウエハー	

\* New Parts (新規部品)

**Note)** Those parts marked with “#” are not included in the P.C.B. ass'y. (マーク#の部品は、基板に含まれません)

## DVR-S120 P.C.B. MAIN

Ref. No.	PART NO.	Description	Remarks	Markets	部品名	Rank
CB7	VQ962700	CN.BS.PIN	6P		ウエハー	
CB8	VQ962700	CN.BS.PIN	6P		ウエハー	
CB9	VQ962700	CN.BS.PIN	6P		ウエハー	
CB10	VQ962700	CN.BS.PIN	6P		ウエハー	
CB11	VQ962800	CN.BS.PIN	7P		ウエハー	
CB12	VQ962800	CN.BS.PIN	7P		ウエハー	
CB13	VQ962800	CN.BS.PIN	7P		ウエハー	
CB14	VQ962800	CN.BS.PIN	7P		ウエハー	
CB15	VQ962800	CN.BS.PIN	7P		ウエハー	
CB16	V7684100	CM	14P SE YKF SERIES	J	D端子コネクタ	
CB17	VT637800	CN.BS.PIN	3P		ベースツキポスト	
CB121	VM923600	CN.BS.PIN	13P		F F Cコネクタ	01
* CB122	WA894700	CN	28P TE FMN		F M Nコネクタ	
CB123	VB389900	CN.BS.PIN	3P		ベースピン	01
CB124	VB390700	CN.BS.PIN	11P		コネクタベースポスト	01
CB125	V7827400	SOCKET	7P TE TUC SERIES		コネクタソケット	
* CB221	V2329900	CN.BS.PIN	24P TE FMN		F F Cコネクタ	
CB222	VB858700	CN.BS.PIN	8P		ベースピン	01
CB224	V7667200	CN.BS.PIN	20P TE		F F Cコネクタ	
C3	UR867100	C.EL	10uF 50V		ケミコン	
C4	UR867100	C.EL	10uF 50V		ケミコン	
C8	UR837470	C.EL	47uF 16V		ケミコン	01
C9	UR837470	C.EL	47uF 16V		ケミコン	01
C10	UN866330	C.EL	3.3uF 50V		B Pケミコン	
C11	UN866330	C.EL	3.3uF 50V		B Pケミコン	
C23	UR819100	C.EL	1000uF 6.3V		ケミコン	01
C26	UR818470	C.EL	470uF 6.3V		ケミコン	
C27	UR818100	C.EL	100uF 6.3V		ケミコン	01
C30	UR818470	C.EL	470uF 6.3V		ケミコン	
C36	UR866100	C.EL	1uF 50V		ケミコン	01
C37	UR867100	C.EL	10uF 50V		ケミコン	
C38	UR838100	C.EL	100uF 16V		ケミコン	01
C39	UR838100	C.EL	100uF 16V		ケミコン	01
C40	UR838100	C.EL	100uF 16V		ケミコン	01
C41	UR867220	C.EL	22uF 50V		ケミコン	01
C42	UR867100	C.EL	10uF 50V		ケミコン	
C43	UN837330	C.EL	33uF 16V		ケミコン	01
C49	UR867100	C.EL	10uF 50V		ケミコン	
C50	UR867100	C.EL	10uF 50V		ケミコン	
* C52	WB824000	C.EL	6800uF 35V		ケミコン F W	
* C53	WB824000	C.EL	6800uF 35V		ケミコン F W	
C59	UR837100	C.EL	10uF 16V		ケミコン	01
C60	VT898000	C.MYLAR	0.1uF 100V		マイラーコン	01
C61	VT898000	C.MYLAR	0.1uF 100V		マイラーコン	01
C62	UA654100	C.MYLAR	0.01uF 50V		マイラーコン	01
C63	UA654100	C.MYLAR	0.01uF 50V		マイラーコン	01
C64	UA654100	C.MYLAR	0.01uF 50V		マイラーコン	01
C65	UA654100	C.MYLAR	0.01uF 50V		マイラーコン	01
C66	UA654100	C.MYLAR	0.01uF 50V		マイラーコン	01
C67	UR837470	C.EL	47uF 16V		ケミコン	01
C68	UR837470	C.EL	47uF 16V		ケミコン	01
C74	UR867100	C.EL	10uF 50V		ケミコン	
C75	UR867100	C.EL	10uF 50V		ケミコン	

\* New Parts (新規部品)

**Note)** Those parts marked with “#” are not included in the P.C.B. ass'y. (マーク#の部品は、基板に含まれません)

## DVR-S120 P.C.B. MAIN

Ref. No.	PART NO.	Description	Remarks	Markets	部品名	Rank	
C76	UR867100	C.EL	10uF	50V		ケミコン	
C122	UR837330	C.EL	33uF	16V		ケミコン	01
C129	UR866220	C.EL	2.2uF	50V		ケミコン	
C131	UR837100	C.EL	10uF	16V		ケミコン	01
C132	UR837100	C.EL	10uF	16V		ケミコン	01
C133	UR837330	C.EL	33uF	16V		ケミコン	01
C138	UR837100	C.EL	10uF	16V		ケミコン	01
C142	UR837330	C.EL	33uF	16V	BG	ケミコン	01
C144	UR866220	C.EL	2.2uF	50V	BG	ケミコン	
C148	UR866220	C.EL	2.2uF	50V		ケミコン	
C149	UR837470	C.EL	47uF	16V	BG	ケミコン	01
C152	UR837100	C.EL	10uF	16V		ケミコン	01
C154	UR837100	C.EL	10uF	16V		ケミコン	01
C155	UR837100	C.EL	10uF	16V		ケミコン	01
C156	UR837100	C.EL	10uF	16V		ケミコン	01
C157	UA653470	C.MYLAR	4700pF	50V		マイラーコン	01
C158	UA653470	C.MYLAR	4700pF	50V		マイラーコン	01
C159	UR837100	C.EL	10uF	16V		ケミコン	01
C160	UA655100	C.MYLAR	0.1uF	50V		マイラーコン	01
C162	UA655100	C.MYLAR	0.1uF	50V		マイラーコン	01
C163	UR837100	C.EL	10uF	16V		ケミコン	01
C164	UA655100	C.MYLAR	0.1uF	50V		マイラーコン	01
C165	UA655100	C.MYLAR	0.1uF	50V		マイラーコン	01
C170	UR866470	C.EL	4.7uF	50V		ケミコン	01
C171	UR866470	C.EL	4.7uF	50V		ケミコン	01
C172	UR866220	C.EL	2.2uF	50V		ケミコン	
C173	UR866220	C.EL	2.2uF	50V		ケミコン	
C174	UR866220	C.EL	2.2uF	50V		ケミコン	
C175	UR866470	C.EL	4.7uF	50V		ケミコン	01
C176	UR866470	C.EL	4.7uF	50V		ケミコン	01
C177	UR866220	C.EL	2.2uF	50V		ケミコン	
C178	UR866220	C.EL	2.2uF	50V		ケミコン	
C179	UR866220	C.EL	2.2uF	50V		ケミコン	
C180	UR866220	C.EL	2.2uF	50V		ケミコン	
C181	UR866100	C.EL	1uF	50V		ケミコン	01
C182	UR866100	C.EL	1uF	50V		ケミコン	01
C186	UR866470	C.EL	4.7uF	50V		ケミコン	01
C187	VT898000	C.MYLAR	0.1uF	100V		マイラーコン	01
C191	UR866470	C.EL	4.7uF	50V		ケミコン	01
C192	V7409000	C.EL	180uF	16V		ケミコン	
C193	UR837100	C.EL	10uF	16V		ケミコン	01
C194	UR838100	C.EL	100uF	16V		ケミコン	01
C195	UR837220	C.EL	22uF	16V		ケミコン	01
C196	UR837220	C.EL	22uF	16V		ケミコン	01
C197	UR866470	C.EL	4.7uF	50V		ケミコン	01
C199	UR838100	C.EL	100uF	16V		ケミコン	01
C200	UR838100	C.EL	100uF	16V		ケミコン	01
C201	UR837470	C.EL	47uF	16V		ケミコン	01
C202	UR837470	C.EL	47uF	16V		ケミコン	01
C203	UR837100	C.EL	10uF	16V		ケミコン	01
C204	UR838100	C.EL	100uF	16V		ケミコン	01
C207	UR866470	C.EL	4.7uF	50V		ケミコン	01
C208	UR838100	C.EL	100uF	16V		ケミコン	01

\* New Parts (新規部品)

**Note)** Those parts marked with “#” are not included in the P.C.B. ass'y. (マーク#の部品は、基板に含まれません)

## DVR-S120 P.C.B. MAIN

Ref. No.	PART NO.	Description	Remarks	Markets	部品名	Rank
C210	UR73A100	C.EL	10000uF 16V		ケミコン	
C222	UM388100	C.EL	100uF 10V		ケミコン	01
C228	UR866470	C.EL	4.7uF 50V		ケミコン	01
C229	UR866470	C.EL	4.7uF 50V		ケミコン	01
D1	VT332900	DIODE	1SS355		ダイオード	
D2	VT332900	DIODE	1SS355		ダイオード	
D3	VT332900	DIODE	1SS355		ダイオード	
D4	VT332900	DIODE	1SS355		ダイオード	
D5	VT332900	DIODE	1SS355		ダイオード	
* D6	VU998600	DIODE.ZENR	MA8220-L 21.3V		ツェナーダイオード	
D7	VU995700	DIODE.ZENR	MA8110-L 10.7V		ツェナーダイオード	
△ D8	VN011400	DIODE.BRG	D5SB20 5A 200V		ダイオード	
D9	VT332900	DIODE	1SS355		ダイオード	
D10	VT332900	DIODE	1SS355		ダイオード	
D11	VU996200	DIODE.ZENR	MA8120-M 12.0V		ツェナーダイオード	
D12	VU995700	DIODE.ZENR	MA8110-L 10.7V		ツェナーダイオード	
D13	VU995700	DIODE.ZENR	MA8110-L 10.7V		ツェナーダイオード	
D14	VU995700	DIODE.ZENR	MA8110-L 10.7V		ツェナーダイオード	
D15	VU995700	DIODE.ZENR	MA8110-L 10.7V		ツェナーダイオード	
D16	VU995700	DIODE.ZENR	MA8110-L 10.7V		ツェナーダイオード	
D17	VU995700	DIODE.ZENR	MA8110-L 10.7V		ツェナーダイオード	
△ D121	VU995700	DIODE.ZENR	MA8110-L 10.7V		ツェナーダイオード	
△ D122	VU993000	DIODE.ZENR	MA8056-M 5.6V	BG	ツェナーダイオード	
D123	VU994300	DIODE.ZENR	MA8075-H 7.7V		ツェナーダイオード	
D124	VU994300	DIODE.ZENR	MA8075-H 7.7V		ツェナーダイオード	
D126	V6267600	DIODE	RB051L-40		ダイオード	
△ D128	V4269600	DIODE.BRG	D2SBA20 1.5A 200V		ダイオ - ドブリツジ	
D221	VU994100	DIODE.ZENR	MA8075-L 7.3V		ツェナーダイオード	
D651	VT332900	DIODE	1SS355		ダイオード	
* IC1	X4239A00	IC	NJM2279M		IC	
IC2	X3505A00	IC	NJM2068MD-TE2		アンプIC SOP	
IC3	X3505A00	IC	NJM2068MD-TE2		アンプIC SOP	
IC4	X3505A00	IC	NJM2068MD-TE2		アンプIC SOP	
IC14	XZ003A00	IC	PQ025EZ5MZP 2.5V		電源IC QFP	
IC15	XU965A00	IC	uPC29M33T-E1 3.3V		電源IC	
* IC121	X4258A00	IC	BD3842FS-E2		IC	
IC122	X3505A00	IC	NJM2068MD-TE2		アンプIC SOP	
IC123	X3546A00	IC	BD3815KS		IC	
IC124	X0082A00	IC	LC72722PM	BG	IC SOP	
IC125	XS377A00	IC	BA15218F OP AMP		アンプIC	
△ IC127	XY525A00	IC	PQ1CG2032FZ		電源IC SIL	
IC221	XV160A00	IC	LC75712E FLD		ロジックIC フラット	
JK1	VS867300	CN.DIN	4P YKF51-5501		DINコネクタ	
JK2	VJ726800	JACK.MNI			モノラルミニジャック	01
* PJ1	WB320900	JACK.PIN	4P YKC21-4482N		ピンジャック 4P	
* PJ2	WB385300	JACK.PIN	3P YKC21-4195N	UCRTKABGL	ピンジャック 3P	
* PJ121	WB320800	JACK.PIN	4P YKC21-4084N		ピンジャック 4P	
* PJ122	WB385400	JACK.PIN	3P YKC21-4534N		ピンジャック 3P	
Q1	VV556400	TR	2SC2412K Q,R,S		トランジスタ	
Q2	iD040040	TR	2SD400		トランジスタ	01
Q3	iD040040	TR	2SD400		トランジスタ	01
Q4	iD040040	TR	2SD400		トランジスタ	01
Q5	iD040040	TR	2SD400		トランジスタ	01

\* New Parts (新規部品)

**Note)** Those parts marked with "#" are not included in the P.C.B. ass'y. (マーク#の部品は、基板に含まれません)

## DVR-S120 P.C.B. MAIN

Ref. No.	PART NO.	Description	Remarks	Markets	部品名	Rank
Q6	iD040040	TR	2SD400		トランジスタ	01
Q7	VV655400	TR.DGT	DTC114EKA		デジタルトランジスタ	01
Q8	VV655400	TR.DGT	DTC114EKA		デジタルトランジスタ	01
Q9	VV655000	TR.DGT	DTA114EKA		デジタルトランジスタ	
Q11	VV655000	TR.DGT	DTA114EKA		デジタルトランジスタ	
Q12	VV655400	TR.DGT	DTC114EKA	J	デジタルトランジスタ	01
Q13	VV655400	TR.DGT	DTC114EKA	J	デジタルトランジスタ	01
Q16	VV556400	TR	2SC2412K Q,R,S		トランジスタ	
Q17	VV556400	TR	2SC2412K Q,R,S		トランジスタ	
Q18	VV556400	TR	2SC2412K Q,R,S		トランジスタ	
△ Q19	VP872700	TR	2SC4488 S,T		トランジスタ	
Q20	VV556400	TR	2SC2412K Q,R,S		トランジスタ	
Q21	VV556400	TR	2SC2412K Q,R,S		トランジスタ	
Q22	VG805300	TR	2SA1674 R,S		トランジスタ	
Q23	VV556400	TR	2SC2412K Q,R,S		トランジスタ	
Q24	VV556400	TR	2SC2412K Q,R,S		トランジスタ	
Q25	VV556400	TR	2SC2412K Q,R,S		トランジスタ	
Q27	VV655000	TR.DGT	DTA114EKA		デジタルトランジスタ	
Q28	VV655700	TR.DGT	DTC144EKA		デジタルトランジスタ	01
Q29	VV655700	TR.DGT	DTC144EKA		デジタルトランジスタ	01
Q30	VV556400	TR	2SC2412K Q,R,S		トランジスタ	
△ Q121	VP872700	TR	2SC4488 S,T		トランジスタ	
Q122	VZ725900	TR	2SD1938F S,T		トランジスタ	
Q123	VZ725900	TR	2SD1938F S,T		トランジスタ	
△ Q124	VV556400	TR	2SC2412K Q,R,S	BG	トランジスタ	
Q125	VV556400	TR	2SC2412K Q,R,S		トランジスタ	
Q126	VV556500	TR	2SA1037K Q,R,S		トランジスタ	
Q127	VZ725900	TR	2SD1938F S,T		トランジスタ	
Q128	VZ725900	TR	2SD1938F S,T		トランジスタ	
Q129	VZ725900	TR	2SD1938F S,T		トランジスタ	
Q130	VZ725900	TR	2SD1938F S,T		トランジスタ	
Q221	VV556400	TR	2SC2412K Q,R,S		トランジスタ	
Q222	VV556400	TR	2SC2412K Q,R,S		トランジスタ	
Q223	VV556400	TR	2SC2412K Q,R,S		トランジスタ	
Q224	VV556400	TR	2SC2412K Q,R,S		トランジスタ	
Q225	VV556400	TR	2SC2412K Q,R,S		トランジスタ	
Q226	VV556400	TR	2SC2412K Q,R,S		トランジスタ	
Q651	VV556400	TR	2SC2412K Q,R,S		トランジスタ	
Q652	VV556400	TR	2SC2412K Q,R,S		トランジスタ	
Q653	VV556400	TR	2SC2412K Q,R,S		トランジスタ	
Q654	VV556400	TR	2SC2412K Q,R,S		トランジスタ	
Q655	VV556400	TR	2SC2412K Q,R,S		トランジスタ	
Q656	VV556400	TR	2SC2412K Q,R,S		トランジスタ	
Q657	VV556400	TR	2SC2412K Q,R,S		トランジスタ	
Q658	VV556400	TR	2SC2412K Q,R,S		トランジスタ	
Q659	VV556400	TR	2SC2412K Q,R,S		トランジスタ	
Q660	VV556400	TR	2SC2412K Q,R,S		トランジスタ	
Q661	VV556400	TR	2SC2412K Q,R,S		トランジスタ	
Q662	VV556400	TR	2SC2412K Q,R,S		トランジスタ	
Q663	VV556400	TR	2SC2412K Q,R,S		トランジスタ	
Q664	VV556400	TR	2SC2412K Q,R,S		トランジスタ	
Q665	VV556400	TR	2SC2412K Q,R,S		トランジスタ	
Q666	VV556400	TR	2SC2412K Q,R,S		トランジスタ	

\* New Parts (新規部品)

**Note)** Those parts marked with “#” are not included in the P.C.B. ass'y. (マーク#の部品は、基板に含まれません)

## DVR-S120 P.C.B. MAIN &amp; SUB

Ref. No.	PART NO.	Description	Remarks	Markets	部品名	Rank	
Q667	VV655000	TR. DGT	DTA114EKA		デジタルトランジスタ		
Q668	VV655000	TR. DGT	DTA114EKA		デジタルトランジスタ		
Q669	VZ725900	TR	2SD1938F S,T		トランジスタ		
Q670	VZ725900	TR	2SD1938F S,T		トランジスタ		
Q671	VZ725900	TR	2SD1938F S,T		トランジスタ		
Q672	VZ725900	TR	2SD1938F S,T		トランジスタ		
Q673	VZ725900	TR	2SD1938F S,T		トランジスタ		
Q674	VV655000	TR. DGT	DTA114EKA		デジタルトランジスタ		
R5	VP940200	R. MTL. OXD	47 1W		酸化金属被膜抵抗	01	
R6	VP940200	R. MTL. OXD	47 1W		酸化金属被膜抵抗	01	
R57	HV753220	R. CAR. FP	2.2 1/4W		不燃化カーボン抵抗	01	
R82	HV756470	R. CAR. FP	4.7K 1/4W		不燃化カーボン抵抗	01	
R83	HV753220	R. CAR. FP	2.2 1/4W		不燃化カーボン抵抗	01	
R107	HV753470	R. CAR. FP	4.7 1/4W		不燃化カーボン抵抗	01	
R108	VP940400	R. CAR. FP	100 1W		不燃化カーボン抵抗	01	
R109	HV756470	R. CAR. FP	4.7K 1/4W		不燃化カーボン抵抗	01	
R264	HV755100	R. CAR. FP	100 1/4W		不燃化カーボン抵抗	01	
R265	HV755100	R. CAR. FP	100 1/4W		不燃化カーボン抵抗	01	
* TE1	WB244100	TERM. SP	NLA1-01-004		スピーカー端子		
TH1	V7962300	THRMST. CHP	NCP18WF104J03RB		チップサーミスタ		
* V221	WB452200	FL. DSPLY	14-BT-80GNKF		蛍光表示管		
XL121	V3930900	RSNR. CRYST	4.332MHz	BG	水晶振動子		
	V6955200	SHEET	W=35	JUCRTKA	保護シート		
	WB552400	SHEET		BG	シート / F L		
	EP600140	SCR. BND. HD	3x10 MFZN2BL		バインド B タイトネジ	01	
	EG330360	SCR. BND. HD	3x6 MFZN2BL		バインド小ネジ	01	
* * * * *	WB852000	P. C. B.	SUB	J	P C B 集成 サブ		
	WB852100	P. C. B.	SUB	UC	P C B 集成 サブ		
	WB852200	P. C. B.	SUB	R	P C B 集成 サブ		
	WB852300	P. C. B.	SUB	T	P C B 集成 サブ		
	WB852400	P. C. B.	SUB	K	P C B 集成 サブ		
	WB852500	P. C. B.	SUB	A	P C B 集成 サブ		
	WB852600	P. C. B.	SUB	BG	P C B 集成 サブ		
	WB852700	P. C. B.	SUB	L	P C B 集成 サブ		
△ *	CB272	V7825700	CN	7P TE TUC SERIES		コネクタプラグ	
	CB274	V7667200	CN. BS. PIN	20P TE		F F C コネクタ	
	CB275	VL845100	CN. BS. PIN	7P		ベース付ポスト	01
△ *	CB276	VT807100	CN. BS. PIN	2P		ベースポスト	
△	CB277	VG879900	CN. BS. PIN	2P		ベースピン	01
	CB278	VB858300	CN. BS. PIN	4P		コネクタベースポスト	01
	CB351	VB858500	CN. BS. PIN	6P		ベースピン	01
	C272	UM416100	C. EL	1uF 50V		ケミコン	01
	C274	UR819100	C. EL	1000uF 6.3V		ケミコン	01
	C275	UM417100	C. EL	10uF 50V		ケミコン	01
	C276	UM416220	C. EL	2.2uF 50V		ケミコン	01
	C277	VF992600	C. EL	4700uF 5.5V		バックアップケミコン	
	C278	V7409000	C. EL	180uF 16V		ケミコン	
	C279	UR848100	C. EL	100uF 25V		ケミコン	
	C281	UR838100	C. EL	100uF 16V		ケミコン	01
	C282	UR838100	C. EL	100uF 16V		ケミコン	01

\* New Parts (新規部品)

Note) Those parts marked with "#" are not included in the P.C.B. ass'y. (マーク#の部品は、基板に含まれません)

## DVR-S120 P.C.B. SUB

Ref. No.	PART NO.	Description	Remarks	Markets	部品名	Rank
C283	UR818100	C.EL	100uF 6.3V		ケミコン	01
C284	UR818100	C.EL	100uF 6.3V		ケミコン	01
C285	UM416470	C.EL	4.7uF 50V		ケミコン	01
C286	UM407220	C.EL	22uF 25V		ケミコン	01
C287	UR839100	C.EL	1000uF 16V		ケミコン	
C288	V7409000	C.EL	180uF 16V		ケミコン	
C290	UR848100	C.EL	100uF 25V		ケミコン	
C291	VR325100	C.MYLAR	0.01uF 100V		マイラーコン	
C292	UR749680	C.EL	6800uF 25V		ケミコン	
C293	UR749220	C.EL	2200uF 25V		ケミコン	
C294	UR749220	C.EL	2200uF 25V		ケミコン	
C295	UR749220	C.EL	2200uF 25V		ケミコン	
C296	UR749220	C.EL	2200uF 25V		ケミコン	
C297	VR325100	C.MYLAR	0.01uF 100V		マイラーコン	
C298	V6185300	C.CE.SAFTY	0.01uF 275V		規格認定コン	
C299	VR325400	C.MYLAR	0.1uF 100V		マイラーコン	01
C300	VR325400	C.MYLAR	0.1uF 100V		マイラーコン	01
C301	UR838100	C.EL	100uF 16V		ケミコン	01
C302	UR73A100	C.EL	10000uF 16V		ケミコン	
C303	VT898000	C.MYLAR	0.1uF 100V		マイラーコン	01
C315	UR819100	C.EL	1000uF 6.3V		ケミコン	01
C325	UR866470	C.EL	4.7uF 50V		ケミコン	01
C355	UM388100	C.EL	100uF 10V		ケミコン	01
D271	VT332900	DIODE	1SS355		ダイオード	
D272	VT332900	DIODE	1SS355		ダイオード	
D273	VU993400	DIODE.ZENR	MA8062-M 6.2V		ツェナーダイオード	
D274	VV307700	DIODE	1N4002S		ダイオード	
D275	VV833200	DIODE	1SS380		ダイオード	
D276	VU993500	DIODE.ZENR	MA8062-H 6.4V		ツェナーダイオード	
D277	V6267600	DIODE	RB051L-40		ダイオード	
△ D278	VQ379300	DIODE.BRG	S1VB20 1A 200V		ダイオード	02
D279	VT532500	DIODE	1SR154-400		ダイオード	01
D280	VT532500	DIODE	1SR154-400		ダイオード	01
D281	VT332900	DIODE	1SS355		ダイオード	
△ D282	VV307700	DIODE	1N4002S		ダイオード	
△ D283	VQ379300	DIODE.BRG	S1VB20 1A 200V		ダイオード	02
△ D284	VV307700	DIODE	1N4002S		ダイオード	
D285	VT332900	DIODE	1SS355		ダイオード	
D286	VV220700	DIODE.SHOT	RB501V-40		ショットキーダイオード	
D287	VV220700	DIODE.SHOT	RB501V-40		ショットキーダイオード	
D288	V6267600	DIODE	RB051L-40		ダイオード	
△ D289	VN011300	DIODE.BRG	D3SBA20 4A 200V		ダイオード	03
D311	VV220700	DIODE.SHOT	RB501V-40		ショットキーダイオード	
D312	VV220700	DIODE.SHOT	RB501V-40		ショットキーダイオード	
* Fi271	WC362100	FLTR	ELF15N050A		ラインフィルター	
G351	V4040500	SCR.TERM	M3		スクリュー/ターミナル	
△ IC271	XJ602A00	IC	NJM78M12FA		IC	02
△ IC272	XD343A00	IC	NJM79M12FA		IC	03
△ IC273	XJ604A00	IC	NJM78M05FA		IC	02
△ IC274	XE436A00	IC	NJM79M05FA		IC	03
△ IC275	XY455A00	IC	PQ1CG21H2F SW		電源 IC S I L	
△ IC276	XY525A00	IC	PQ1CG2032FZ		電源 IC S I L	
IC311	XRO38A00	IC	NJM2904M OP AMP		IC	

\* New Parts (新規部品)

**Note)** Those parts marked with “#” are not included in the P.C.B. ass'y. (マーク#の部品は、基板に含まれません)



## DVR-S120 P.C.B. SUB &amp; DVD

Ref. No.	PART NO.	Description	Remarks	Markets	部品名	Rank	
IC312	XY120A00	IC	TC74HCT00AF(EL) NA			ロジック IC SOP	
JK351	WB071300	JACK.MNI	LGS6516-0100			ミニジャック	
Q271	VV655700	TR.DGT	DTC144EKA			デジタルトランジスタ	01
Q272	VV556500	TR	2SA1037K Q,R,S			トランジスタ	
Q273	VP872700	TR	2SC4488 S,T			トランジスタ	
Q274	VC218900	TR	2SC3330 R,S,T			トランジスタ	01
Q275	VV556500	TR	2SA1037K Q,R,S			トランジスタ	
Q276	VV556400	TR	2SC2412K Q,R,S			トランジスタ	
* R283	WB785300	R.MTL.OXD	56 1W			酸化金属被膜抵抗	
* R285	WB785300	R.MTL.OXD	56 1W			酸化金属被膜抵抗	
R295	HV755180	R.CAR.FP	180 1/4W			不燃化カーボン抵抗	01
* R300	RD354240	R.CAR.CHP	24 1/16W			チップ抵抗	
△ RY271	V6017400	RELAY	DC SDT-S-112LMR2			リレー 12V	
* SW331	WA876500	SW.RT.ENC	EVEGC3F2024B			ロータリーエンコーダ	
SW332	VV020300	SW.TACT	SKQNAA			タクトSW	01
SW333	VV020300	SW.TACT	SKQNAA			タクトSW	01
SW334	VV020300	SW.TACT	SKQNAA			タクトSW	01
SW335	VV020300	SW.TACT	SKQNAA			タクトSW	01
SW336	VV020300	SW.TACT	SKQNAA			タクトSW	01
SW337	VV020300	SW.TACT	SKQNAA			タクトSW	01
SW338	VV020300	SW.TACT	SKQNAA			タクトSW	01
SW339	VV020300	SW.TACT	SKQNAA			タクトSW	01
SW340	VV020300	SW.TACT	SKQNAA			タクトSW	01
SW341	VV020300	SW.TACT	SKQNAA			タクトSW	01
△ T271	X2490A00	TRANS.PWR		J		サブトランス	
△ T271	X2491A00	TRANS.PWR		UC		サブトランス	
△ * T271	X4434A00	TRANS		R		サブトランス	
△ T271	X2948A00	TRANS.PWR		TKL		サブトランス	
△ T271	X2493A00	TRANS.PWR		A		サブトランス	
△ T271	X2494A00	TRANS.PWR		BG		サブトランス	
U311	WB001400	CN.PHOT.SN	1P GP1FA553RZ			光ファイバ受信器	
U312	WB001600	CN.PHOT.SN	1P GP1FA553TZ			光ファイバリンク	
* U351	WB437900	L.DTCT	GP1UD281YK			リモコン受光ユニット	
	EP600140	SCR.BND.HD	3x10 MFZN2BL			バインドBタイトネジ	01
	EG330360	SCR.BND.HD	3x6 MFZN2BL			バインド小ネジ	01
* * * * *	WB876500	P.C.B.	DVD (SD5.12P)		JUCRTKA	DVD BOARD	
* * * * *	WB876600	P.C.B.	DVD (SD5.12P)		BG	DVD BOARD	
1606	AAX29760	TERM.SCART	21P	2422 025 12352	BG	スカート端子	
2663	UR837470	C.EL	47uF 16V			ケミコン	01
2723	UR837470	C.EL	47uF 16V			ケミコン	01
2760	UR837470	C.EL	47uF 16V			ケミコン	01
2761	UR837470	C.EL	47uF 16V			ケミコン	01
2762	UR848100	C.EL	100uF 25V			ケミコン	
2771	UR837470	C.EL	47uF 16V			ケミコン	01
2787	UR866220	C.EL	2.2uF 50V			ケミコン	
2794	UR866220	C.EL	2.2uF 50V			ケミコン	
2802	UR866220	C.EL	2.2uF 50V			ケミコン	
2810	UR866220	C.EL	2.2uF 50V			ケミコン	
2818	UR866220	C.EL	2.2uF 50V			ケミコン	
2840	UR848100	C.EL	100uF 25V			ケミコン	

\* New Parts (新規部品)

Note) Those parts marked with "#" are not included in the P.C.B. ass'y. (マーク#の部品は、基板に含まれません)

## DVR-S120 P.C.B. DVD

Ref. No.	PART NO.	Description	Remarks	Markets	部品名	Rank	
2853	UR848470	C.EL	470uF	25V		ケミコン	01
2855	UR848470	C.EL	470uF	25V		ケミコン	01
2857	UR848470	C.EL	470uF	25V		ケミコン	01
2862	UR848100	C.EL	100uF	25V		ケミコン	
2867	UR848100	C.EL	100uF	25V		ケミコン	
2870	UR837470	C.EL	47uF	16V		ケミコン	01
2873	UR848220	C.EL	220uF	25V		ケミコン	
2881	UR848220	C.EL	220uF	25V		ケミコン	
2884	UR848100	C.EL	100uF	25V		ケミコン	
2886	UR848100	C.EL	100uF	25V		ケミコン	
2888	UR848100	C.EL	100uF	25V		ケミコン	
2890	UR837470	C.EL	47uF	16V		ケミコン	01
2892	UR837470	C.EL	47uF	16V		ケミコン	01
2893	UR848220	C.EL	220uF	25V		ケミコン	
2916	UR867100	C.EL	10uF	50V		ケミコン	
5601	AAX51440	RSNR. CRYST	13.5MHz		3141 018 80781	水晶振動子	
6601	AAX22630	DIODE. CHP	BAS316		4822 130 11397	チップダイオード	
6603	AAX22630	DIODE. CHP	BAS316		4822 130 11397	チップダイオード	
6604	AAX22630	DIODE. CHP	BAS316		4822 130 11397	チップダイオード	
6629	AAX22630	DIODE. CHP	BAS316		4822 130 11397	チップダイオード	
6630	AAX22630	DIODE. CHP	BAS316		4822 130 11397	チップダイオード	
6631	AAX22640	DIODE. CHP	UDZ15B		4822 130 11522	チップダイオード	
6632	AAX22640	DIODE. CHP	UDZ15B		4822 130 11522	チップダイオード	
6633	AAX22640	DIODE. CHP	UDZ15B		4822 130 11522	チップダイオード	
6634	AAX22640	DIODE. CHP	UDZ15B		4822 130 11522	チップダイオード	
* 7600	AAX51420	IC	ZIVA-5M		9322 195 06671	IC	
7602	AAX46690	IC	M24C64-WMN6		9322 130 41668	IC	
7603	AAX47380	TR. CHP	BC847B		3198 010 42030	チップトランジスタ	
7604	AAX47380	TR. CHP	BC847B		3198 010 42030	チップトランジスタ	
* 7605	AAX51430	IC	74LVT573DB(PHS0)L		9351 707 10112	IC	
* 7606	AAX51430	IC	74LVT573DB(PHS0)L		9351 707 10112	IC	
* 7607	AAX51430	IC	74LVT573DB(PHS0)L		9351 707 10112	IC	
* 7608	AAX51370	FET	BSN20		9965 000 04199	FET	
* 7609	AAX51370	FET	BSN20		9965 000 04199	FET	
* 7610	AAX51380	IC	M29W160DT-SD5.12		3141 017 40951	IC	
* 7611	AAX51410	IC	MT48LC4M32B2TG-7		9322 180 36671	IC	
7612	AAX47380	TR. CHP	BC847B		3198 010 42030	チップトランジスタ	
7620	AAX46780	IC	AK4382AVT		9322 177 09685	IC	
* 7622	AAX51390	IC	LD1086D2T33(ST00)		3141 018 51741	IC	
7624	AAX29510	IC	74HCT1G125		9352 456 80115	IC	
7626	AAX21660	IC	LM833D		4822 209 30095	IC	
7627	AAX21660	IC	LM833D		4822 209 30095	IC	
7628	AAX47430	TR. CHP	BC817-25		3198 010 43230	チップトランジスタ	
7629	AAX47390	TR. CHP	BC857B		3198 010 42150	チップトランジスタ	
7630	AAX47390	TR. CHP	BC857B		3198 010 42150	チップトランジスタ	
7631	AAX47380	TR. CHP	BC847B		3198 010 42030	チップトランジスタ	
7632	AAX47380	TR. CHP	BC847B		3198 010 42030	チップトランジスタ	
7633	AAX47430	TR. CHP	BC817-25		3198 010 43230	チップトランジスタ	
7640	AAX47490	TR	BC847BPN		9340 425 30115	トランジスタ	
7644	AAX47490	TR	BC847BPN		9340 425 30115	トランジスタ	
7673	AAX46760	IC	LD1117ADT18		9322 167 69668	IC	
* 7674	AAX51400	IC	MC78L05ACD		4822 209 33411	IC	

\* New Parts (新規部品)

**Note)** Those parts marked with “#” are not included in the P.C.B. ass'y. (マーク#の部品は、基板に含まれません)

## NX-SW120 P.C.B. MAIN

Ref. No.	PART NO.	Description	Remarks	Markets	部品名	Rank	
*	AAX51460	P.C.B.	MAIN	383656	J	P C B メイン	
*	AAX51470	P.C.B.	MAIN	383657	UC	P C B メイン	
*	AAX51480	P.C.B.	MAIN	383658	RTKL	P C B メイン	
*	AAX51490	P.C.B.	MAIN	383659	ABG	P C B メイン	
	CB2	AAX32010	CN	B05B-PH-K-S	081702	コネクタ	
	CB4	VP206500	HOLDER.FUS	EYF-52BCT	074277	ヒューズホルダー	
	CB5	VP206500	HOLDER.FUS	EYF-52BCT	074277	ヒューズホルダー	
	C1	FG644100	C.CE	0.01uF 50V	065452	セラコン	
	C2	UR837100	C.EL	10uF 16V	353104	ケミコン	
	C3	UA654220	C.POL	0.022uF 50V	360029	ポリエステルフィルムコン	
	C4	UR837470	C.EL	47uF 16V	338563	ケミコン	
	C5	UA655330	C.POL	0.33uF 50V	352299	ポリエステルフィルムコン	
	C6	UA655150	C.POL	0.15uF 50V	368082	ポリエステルフィルムコン	
	C7	UR867100	C.EL	10uF 50V	338565	ケミコン	
	C8	UA655180	C.POL	0.18uF 50V	368083	ポリエステルフィルムコン	
	C9	UA655180	C.POL	0.18uF 50V	368083	ポリエステルフィルムコン	
	C10	UR867100	C.EL	10uF 50V	338565	ケミコン	
	C11	UA655100	C.POL	0.1uF 50V	360033	ポリエステルフィルムコン	
	C12	UA655100	C.POL	0.1uF 50V	360033	ポリエステルフィルムコン	
	C13	UR867100	C.EL	10uF 50V	338565	ケミコン	
	C14	VG892500	C.EL	4700uF 50V	332929	ケミコン	05
	C15	VG892500	C.EL	4700uF 50V	332929	ケミコン	05
	C16	UR838100	C.EL	100uF 16V	353103	ケミコン	
	C17	UR867220	C.EL	22uF 50V	356201	ケミコン	
	C18	UR867220	C.EL	22uF 50V	356201	ケミコン	
	C19	UA655820	C.POL	0.82uF 50V	352307	ポリエステルフィルムコン	
	C20	UR867220	C.EL	22uF 50V	356201	ケミコン	
	C21	UR867220	C.EL	22uF 50V	356201	ケミコン	
	C22	UR828220	C.EL	220uF 10V	339076	ケミコン	
	C23	UR865470	C.EL	0.47uF 50V	358226	ケミコン	
	C24	UR838100	C.EL	100uF 16V	353103	ケミコン	
	C25	UR867220	C.EL	22uF 50V	356201	ケミコン	
	C26	UR837470	C.EL	47uF 16V	338563	ケミコン	
	C27	UR837470	C.EL	47uF 16V	338563	ケミコン	
	C28	UA655470	C.POL	0.47uF 50V	352302	ポリエステルフィルムコン	
	C29	AAX09530	C.CE	100pF 50V	065382	セラコン	
	C30	UA654100	C.POL	0.01uF 50V	360028	ポリエステルフィルムコン	
	C31	UA653220	C.POL	2200pF 50V	360024	ポリエステルフィルムコン	
	C32	UR868100	C.EL	100uF 50V	353102	ケミコン	01
	C33	UR868100	C.EL	100uF 50V	353102	ケミコン	01
	C34	UR867470	C.EL	47uF 50V	356202	ケミコン	
	C35	UR867100	C.EL	10uF 50V	338565	ケミコン	
	C36	UR867100	C.EL	10uF 50V	338565	ケミコン	
	C37	UA654680	C.POL	0.068uF 50V	360032	ポリエステルフィルムコン	
	C38	UA655100	C.POL	0.1uF 50V	360033	ポリエステルフィルムコン	
	C39	UA655100	C.POL	0.1uF 50V	360033	ポリエステルフィルムコン	
	C40	UR837100	C.EL	10uF 16V	353104	ケミコン	
△	C42	V6185300	C.CE.SAFETY	0.01uF 275V		規格認定コン	
	C43	FG644100	C.CE	0.01uF 50V	065452	セラコン	
	D2	VU264100	DIODE	1SR139-400	069536	ダイオード	
△	D3	VC971500	DIODE.BRG	RBV-402 4A 200V	069612	ダイオード	
*	D4	AAX51650	DIODE.ZENR	24BSBST	366911	ツェナーダイオード	
	D5	VU264100	DIODE	1SR139-400	069536	ダイオード	

\* New Parts (新規部品)

**Note)** Those parts marked with “#” are not included in the P.C.B. ass'y. (マーク#の部品は、基板に含まれません)

## NX-SW120 P.C.B. MAIN

Ref. No.	PART NO.	Description	Remarks	Markets	部品名	Rank	
* D6	AAX51640	DIODE .ZENR	12BSCST	366910		ツェナーダイオード	
* D7	AAX51640	DIODE .ZENR	12BSCST	366910		ツェナーダイオード	
D8	AAX33180	DIODE	1N4148ST(D034)	356276		ダイオード	
D9	AAX33180	DIODE	1N4148ST(D034)	356276		ダイオード	
D10	AAX33180	DIODE	1N4148ST(D034)	356276		ダイオード	
D11	AAX33180	DIODE	1N4148ST(D034)	356276		ダイオード	
D12	AAX33180	DIODE	1N4148ST(D034)	356276		ダイオード	
D13	AAX33180	DIODE	1N4148ST(D034)	356276		ダイオード	
D14	AAX33180	DIODE	1N4148ST(D034)	356276		ダイオード	
D15	AAX33180	DIODE	1N4148ST(D034)	356276		ダイオード	
D16	AAX33180	DIODE	1N4148ST(D034)	356276		ダイオード	
D17	VU264100	DIODE	1SR139-400	069536		ダイオード	
△ F1	AAX33350	FUSE	500mA 250V	357454	RTKL	ヒューズ	
△ F2	AAX33340	FUSE	2.5A 250V	357453	JUCRTKL	ヒューズ	
△ F2	AAX33350	FUSE	500mA 250V	357454	ABG	ヒューズ	
IC1	AAX41390	IC	KIA4558P	353033		I C	
IC2	AAX41390	IC	KIA4558P	353033		I C	
* IC3	AAX51450	IC	TA7317P	383666		I C	
△ IC4	AAX13490	IC	STK404-050 AF	058246		I C	
IC7	AAX41390	IC	KIA4558P	353033		I C	
* JK1	AAX51730	JACK	1P MSJ-035-12A	337670		ミニジャック	
* PJ1	AAX51700	JACK	1P MSP-241V-01	353135		ピンジャック	
* Q1	AAX51690	TR	KTC2026 Y,GR	362783		トランジスター	
* Q2	AAX51680	TR	KTA1046 Y,GR	362782		トランジスター	
Q3	AAX41650	TR	KTC3198 GR	051818		トランジスター	
Q4	AAX41660	TR	KTA1266 GR	051819		トランジスター	
Q5	AAX41650	TR	KTC3198 GR	051818		トランジスター	
* Q6	AAX51660	TR	KTA1268 GR, BL	358028		トランジスター	
* Q7	AAX51670	TR	KTC3200 GR, BL	358033		トランジスター	
Q8	AAX41660	TR	KTA1266 GR	051819		トランジスター	
Q9	AAX09180	FET	2SK304 E	051061		F E T	
R14	AAX11950	R. CAR. FP	1 1/4W	084665		不燃化カーボン抵抗	
R17	HV454820	R. CAR. FP	82 1/4W	044149		不燃化カーボン抵抗	
R18	HV454820	R. CAR. FP	82 1/4W	044149		不燃化カーボン抵抗	
R19	HL325330	R. MTL. OXD	330 2W	370598		酸化金属被膜抵抗	01
R33	HB026270	R. MTL. FLM	2.7K 1/4W	366207		金属被膜抵抗	
R35	AAX11860	R. CAR. FP	100 1/4W	044153		不燃化カーボン抵抗	
R37	AAX11880	R. CAR. FP	1K 1/4W	044454		不燃化カーボン抵抗	
R40	HB027100	R. MTL. FLM	10K 1/4W	366208		金属皮膜抵抗	
R41	HB027200	R. MTL. FLM	20K 1/4W	366209		金属被膜抵抗	
R42	HB027100	R. MTL. FLM	10K 1/4W	366208		金属皮膜抵抗	
R43	HB028100	R. MTL. FLM	100K 1/4W	366210		金属被膜抵抗	
R46	AAX11860	R. CAR. FP	100 1/4W	044153		不燃化カーボン抵抗	
R47	HB027100	R. MTL. FLM	10K 1/4W	366208		金属皮膜抵抗	
R48	Vi294900	R. MTL. OXD	0.15 2W	366140		酸化金属被膜抵抗	02
R53	AAX11870	R. CAR. FP	10 1/4W	044452		不燃化カーボン抵抗	
R58	HL922100	R. MTL. OXD	0.1 2W	366139		酸化金属被膜抵抗	01
△ RY1	VU161600	RELAY	OSA-SS-224DM3	079766		リレー	
△ RY2	AAX12490	RELAY	SDT-S-112LMR	055473		リレー	
△ SW4	AAX32040	SW	ESD26606A	336446	RTKL	スライド S W	
TE1	XX707320	PIN	IPS-5007	064821		ピン	
TE2	XX707320	PIN	IPS-5007	064821		ピン	
	BB071360	TERM	EARTH	055265		ターミナル	

\* New Parts (新規部品)

Note) Those parts marked with "#" are not included in the P.C.B. ass'y. (マーク#の部品は、基板に含まれません)

## Parts List for Chip Ceramic Capacitors

Value	Part No.	Value	Part No.	Value	Part No.
2pF 50V	US060200	120pF 50V	US062120	0.01uF 50V	US064100
3pF 50V	US060300	150pF 50V	US062150	0.015uF 50V	US064150
5pF 50V	US060500	180pF 50V	US062180	0.022uF 25V	US044220
6pF 50V	US060600	220pF 50V	US062220	0.027uF 50V	UB014270
7pF 50V	US060700	270pF 50V	US062270	0.033uF 16V	US034330
8pF 50V	US060800	330pF 50V	US062330	0.039uF 16V	US034390
10pF 50V	US061100	390pF 50V	US062390	0.047uF 16V	US034470
12pF 50V	US061120	470pF 50V	US062470	0.047uF 25V	UB214470
15pF 50V	US061150	560pF 50V	US062560	0.068uF 25V	UB214680
18pF 50V	US061180	680pF 50V	US062680	0.1uF 25V	UB215100
20pF 50V	US061200	820pF 50V	US062820	0.1uF 25V	UB245100
22pF 50V	US061220	1000pF 50V	US063100	0.15uF 25V	UB245150
24pF 50V	US061240	1200pF 50V	US063120	0.22uF 25V	UB245220
27pF 50V	US061270	1500pF 50V	US063150	0.22uF 16V	US135220
33pF 50V	US061330	1800pF 50V	US063180	0.33uF 16V	US135330
39pF 50V	US061390	2200pF 50V	US063220	0.33uF 16V	UB445330
43pF 50V	US061430	2400pF 50V	UB053240	0.47uF 16V	UB445470
47pF 50V	US061470	2700pF 50V	US063270	0.68uF 16V	UB445680
56pF 50V	US061560	3300pF 50V	US063330	0.1uF 16V	US035100
62pF 50V	US061620	3900pF 50V	US063390	0.1uF 16V	US135100
68pF 50V	US061680	4700pF 50V	US063470	0.1uF 16V	UB445100
75pF 50V	US061750	5600pF 50V	US063560	1uF 16V	UB446100
82pF 50V	UB051820	6800pF 50V	US063680		
100pF 50V	US062100	8200pF 50V	US063820		

## Parts List for Chip Carbon Resistors

Value	1/10W Type Part No.	Value	1/10W Type Part No.	Value	1/16W Type Part No.
0 Ω	RD35 0000	4.3 kΩ	RD35 6430	0 Ω	HX61 1040
1.0 Ω	RD35 3100	4.7 kΩ	RD35 6470	1.0 Ω	HX61 0750
2.2 Ω	RD35 3220	5.1 kΩ	RD35 6510	10 Ω	HX61 1160
2.4 Ω	RD35 3240	5.6 kΩ	RD35 6560	47 Ω	HX61 1150
4.7 Ω	RD35 3470	6.2 kΩ	RD35 6620	100 Ω	HX61 0900
10 Ω	RD35 4100	6.8 kΩ	RD35 6680	220 Ω	HX61 0960
22 Ω	RD35 4220	7.5 kΩ	RD35 6750	270 Ω	HX61 1120
27 Ω	RD35 4270	8.2 kΩ	RD35 6820	390 Ω	HX61 0990
33 Ω	RD35 4330	9.1 kΩ	RD35 6910	470 Ω	HX61 0890
39 Ω	RD35 4390	10 kΩ	RD35 7100	560 Ω	HX61 1010
43 Ω	RD35 4430	11 kΩ	RD35 7110	1.0 kΩ	HX61 0910
47 Ω	RD35 4470	12 kΩ	RD35 7120	1.2 kΩ	HX61 1100
51 Ω	RD35 4510	13 kΩ	RD35 7130	1.5 kΩ	HX61 1090
62 Ω	RD35 4620	15 kΩ	RD35 7150	1.8 kΩ	HX61 1050
68 Ω	RD35 4680	16 kΩ	RD35 7160	2.7 kΩ	HX61 1140
75 Ω	RD35 4750	18 kΩ	RD35 7180	3.3 kΩ	HX61 0980
82 Ω	RD35 4820	20 kΩ	RD35 7200	4.7 kΩ	HX61 1080
91 Ω	RD35 4910	22 kΩ	RD35 7220	6.8 kΩ	HX61 1030
100 Ω	RD35 5100	24 kΩ	RD35 7240	10 kΩ	HX61 0920
120 Ω	RD35 5120	27 kΩ	RD35 7270	12 kΩ	HX61 0780
130 Ω	RD35 5130	30 kΩ	RD35 7300	15 kΩ	HX61 0950
150 Ω	RD35 5150	33 kΩ	RD35 7330	18 kΩ	HX61 0770
180 Ω	RD35 5180	36 kΩ	RD35 7360	22 kΩ	HX61 1110
200 Ω	RD35 5200	39 kΩ	RD35 7390	27 kΩ	HX61 1130
220 Ω	RD35 5220	43 kΩ	RD35 7430	30 kΩ	HX61 0810
240 Ω	RD35 5240	47 kΩ	RD35 7470	47 kΩ	HX61 1060
270 Ω	RD35 5270	51 kΩ	RD35 7510	56 kΩ	HX61 1020
300 Ω	RD35 5300	56 kΩ	RD35 7560	62 kΩ	HX61 0790
330 Ω	RD35 5330	62 kΩ	RD35 7620	82 kΩ	HX61 1170
390 Ω	RD35 5390	68 kΩ	RD35 7680	100 kΩ	HX61 0930
430 Ω	RD35 5430	75 kΩ	RD35 7750	120 kΩ	HX61 0940
470 Ω	RD35 5470	82 kΩ	RD35 7820	220 kΩ	HX61 0970
510 Ω	RD35 5510	91 kΩ	RD35 7910	390 kΩ	HX61 1000
560 Ω	RD35 5560	100 kΩ	RD35 8100	560 Ω	HX61 1010
620 Ω	RD35 5620	120 kΩ	RD35 8120	1.0 MΩ	HX61 1070
680 Ω	RD35 5680	150 kΩ	RD35 8150		
820 Ω	RD35 5820	160 kΩ	RD35 8160		
910 Ω	RD35 5910	180 kΩ	RD35 8180		
1.0 kΩ	RD35 6100	200 kΩ	RD35 8200		
1.1 kΩ	RD35 6110	220 kΩ	RD35 8220		
1.2 kΩ	RD35 6120	270 kΩ	RD35 8270		
1.3 kΩ	RD35 6130	300 kΩ	RD35 8300		
1.5 kΩ	RD35 6150	330 kΩ	RD35 8330		
1.6 kΩ	RD35 6160	390 kΩ	RD35 8390		
1.8 kΩ	RD35 6180	430 kΩ	RD35 8430		
2.0 kΩ	RD35 6200	470 kΩ	RD35 8470		
2.2 kΩ	RD35 6220	510 kΩ	RD35 8510		
2.4 kΩ	RD35 6240	680 kΩ	RD35 8680		
2.7 kΩ	RD35 6270	1.0 MΩ	RD35 9100		
3.0 kΩ	RD35 6300	1.5 MΩ	RD35 9150		
3.3 kΩ	RD35 6330	2.2 MΩ	RD35 9220		
3.6 kΩ	RD35 6360	4.7 MΩ	RD35 9470		
3.9 kΩ	RD35 6390	10 MΩ	RD35 A100		

■ DVR-S120 EXPLODED VIEW

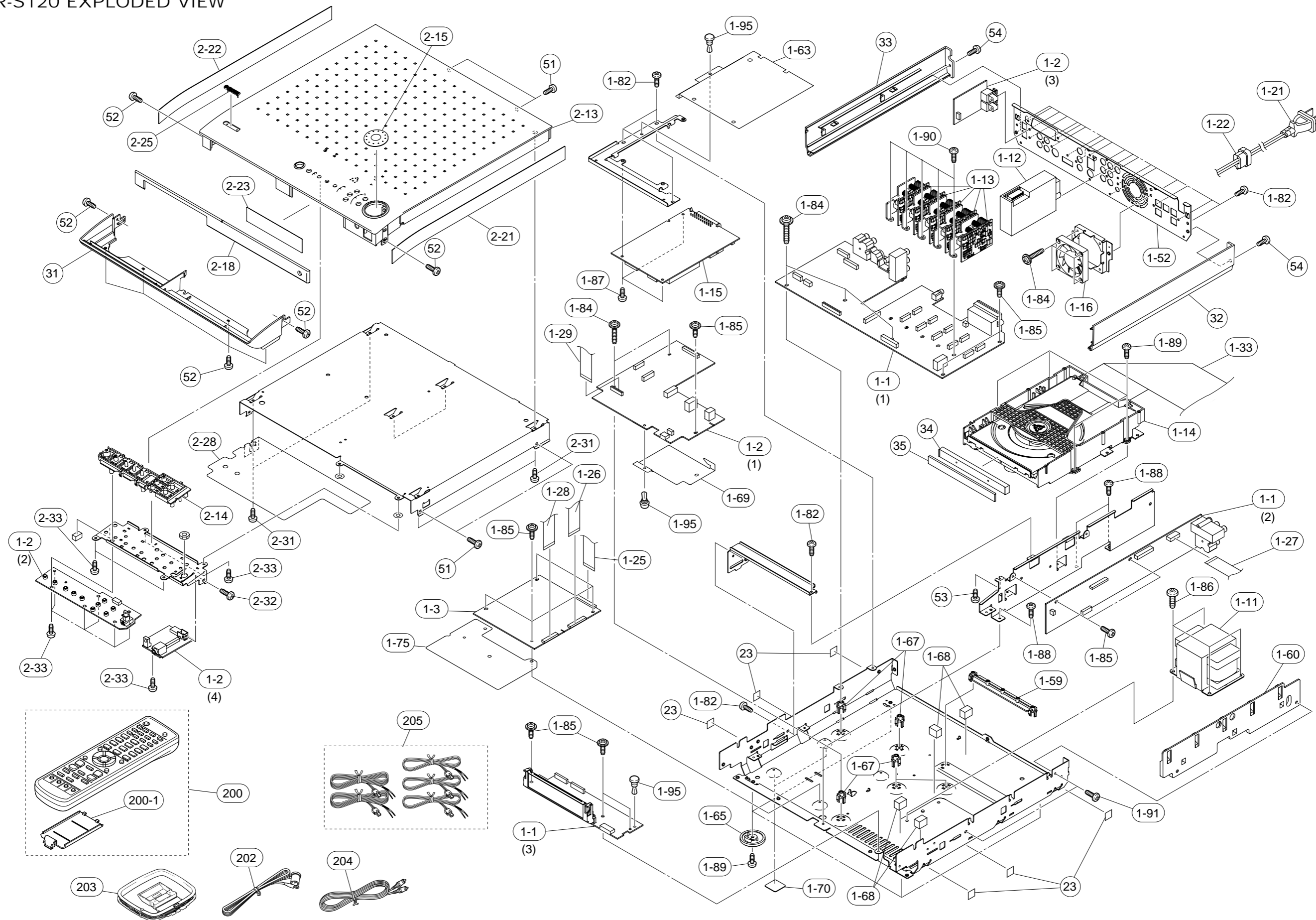

## ■ DVR-S120 MECHANICAL PARTS

Ref. No.	PART NO.	Description	Remarks	Markets	部品名	Rank
* 1-1	WB851700	P.C.B. ASS'Y	MAIN	J	P C B メイン	
* 1-1	WB851800	P.C.B. ASS'Y	MAIN	UCRTKAL	P C B メイン	
* 1-1	WB851900	P.C.B. ASS'Y	MAIN	BG	P C B メイン	
* 1-2	WB852000	P.C.B. ASS'Y	SUB	J	P C B 集成 サブ	
* 1-2	WB852100	P.C.B. ASS'Y	SUB	UC	P C B 集成 サブ	
* 1-2	WB852200	P.C.B. ASS'Y	SUB	R	P C B 集成 サブ	
* 1-2	WB852300	P.C.B. ASS'Y	SUB	T	P C B 集成 サブ	
* 1-2	WB852400	P.C.B. ASS'Y	SUB	K	P C B 集成 サブ	
* 1-2	WB852500	P.C.B. ASS'Y	SUB	A	P C B 集成 サブ	
* 1-2	WB852600	P.C.B. ASS'Y	SUB	BG	P C B 集成 サブ	
* 1-2	WB852700	P.C.B. ASS'Y	SUB	L	P C B 集成 サブ	
* 1-3	WB852800	P.C.B. ASS'Y	DIGITAL	J	P C B デジタル	
* 1-3	WB852900	P.C.B. ASS'Y	DIGITAL	UCRTKABGL	P C B デジタル	
△ 1-11	X4714A00	POWER TRANSFORMER		J	電源トランス	
△ 1-11	X4715A00	POWER TRANSFORMER		UC	電源トランス	
△ 1-11	X4716A00	POWER TRANSFORMER		R	電源トランス	
△ 1-11	X4717A00	POWER TRANSFORMER		TK	電源トランス	
△ 1-11	X4718A00	POWER TRANSFORMER		A	電源トランス	
△ 1-11	X4719A00	POWER TRANSFORMER		BG	電源トランス	
△ 1-11	X4720A00	POWER TRANSFORMER		L	電源トランス	
* 1-12	WB423900	AM/FM TUNER	ENG04705Q	J	A M / F M チューナ	
* 1-12	WB424000	AM/FM TUNER	ENG06709Q	UCRTKAL	A M / F M チューナ	
* 1-12	WB424100	AM/FM TUNER	ENG07711Q	BG	A M / F M チューナ	
* 1-13	WB876900	D-AMP MODULE	UCD 55W AMP MODULE		D アンブモジュール	
* 1-14	WB876700	DVD MECHANISM	A97H		D V D メカニズム	
* 1-15	WB876500	P.C.B. ASS'Y	DVD (SD5.12P)	JUCRTKA	P C B D V D	
* 1-15	WB876600	P.C.B. ASS'Y	DVD (SD5.12P)	BG	P C B D V D	
* 1-16	WB349500	DC FAN MOTOR	DC D05X-24TM		D C ファンモーター	
△ 1-21	V2723100	POWER CABLE	1.8m	J	電源コード	
△ 1-21	V9293500	POWER CABLE	2m	UC	電源コード	
△ 1-21	VN363200	POWER CABLE	2m	R	電源コード	
△ 1-21	VZ542500	POWER CABLE	2m	T	電源コード	
△ 1-21	V8013000	POWER CABLE	2m	K	電源コード	
△ 1-21	V2296800	POWER CABLE	2m	A	電源コード	
△ 1-21	VV437300	POWER CABLE	2m	B	電源コード	
△ 1-21	V9293600	POWER CABLE	2m	GL	電源コード	
* 1-22	V2438700	CORD STOPPER	10P1		コードストッパー	
* 1-25	MFA32100	FLEXIBLE FLAT CABLE	32P 100mm P=1.0		カード電線	
* 1-26	MFA28120	FLEXIBLE FLAT CABLE	28P 120mm P=1.0		カード電線	
* 1-27	MF113070	FLEXIBLE FLAT CABLE	13P 70mm P=1.25		カード電線 C & C	
* 1-28	MFA24160	FLEXIBLE FLAT CABLE	24P 160mm P=1.0		カード電線	
* 1-29	MFA20100	FLEXIBLE FLAT CABLE	20P 100mm P=1.0		カード電線	
* 1-33	WB488000	CONNECTOR ASS'Y	40P 160mm C&C		コネクタ A S S Y	
* 1-52	WB522500	REAR PANEL		J	リアパネル	
* 1-52	WB522700	REAR PANEL		UCRTKAL	リアパネル	
* 1-52	WB522600	REAR PANEL		BG	リアパネル	
* 1-59	WB526200	SUPPORT/UCD			サポート / U C D	
* 1-60	WB526300	SUPPORT/POWER-CABLE			サポート / コード	
* 1-63	WC805400	SHEET/BARRIER			シート / バリア	
* 1-65	WB523600	LEG ASS'Y			レッグ A S S Y	
1-67	VR264400	SPACER	H8		スペーサー	
1-68	V2879500	SPACER PCB-M			スペーサ P C B - M	
* 1-69	WC131900	SHEET			シート / バリア	

\* New Parts (新規部品)

Ref. No.	PART NO.	Description	Remarks	Markets	部品名	Rank
* 1-70	WC293700	SHEET/SCREW-MASK			シート / スクリュー	
* 1-75	WC537600	SHEET/SHIELD BOTTOM			シート / シールドボトム	
1-82	VN413300	BIND HEAD BONDING B-T. SCREW	3x8 MFZN2BL		ボンディング B タイトネジ	01
1-84	VT669400	PW HEAD B-TIGHT SCREW	3x15-8 MFC2		P W ヘッド B タイトネジ	
1-85	VH365800	PW HEAD B-TIGHT SCREW	3x6-8 MFC2		P W ヘッド B タイトネジ	01
1-86	V2728500	BIND HEAD S-TIGHT SCREW	4x7 MFZN2BL		バインド S タイトネジ	
* 1-87	WC521500	BIND HEAD BONDING B-T. SCREW	3x6 MFC2		ボンディング B タイトネジ	01
1-88	VF378100	FLAT HEAD SCREW	3x6 MFZN2Y		皿小ネジ	01
1-89	EP600250	BIND HEAD B-TIGHT SCREW	3x8 MFZN2Y		バインド B タイトネジ	01
1-90	EP600910	BIND HEAD P-TIGHT SCREW	3x10 MFC2BL		バインド P タイトネジ	01
1-91	EP630220	BIND HEAD P-TIGHT SCREW	3x8 MFZN2BL		バインド P タイトネジ	
1-95	VQ368500	PUSH RIVET	P3545-B		プッシュリベット	01
* 2-13	WB523900	TOP PANEL		Silver	トップパネル	
* 2-13	WB524100	TOP PANEL		Silver	トップパネル	
* 2-13	WB524000	TOP PANEL		Silver	トップパネル	
* 2-14	WB525500	BUTTON/OPE			ボタン / O P E	
* 2-15	WB525700	VOLUME KNOB/D35		SI	ボリュームノブ / D 3 5	
* 2-18	WB526700	WINDOW PANEL, LID			ウインドウ	
* 2-18	WB526800	WINDOW PANEL, LID			ウインドウ	
* 2-21	WB525100	SIDE/SHEET R			サイドシート R	
* 2-21	WB525200	SIDE/SHEET R			サイドシート R	
* 2-22	WB525300	SIDE/SHEET L			サイドシート L	
* 2-22	WB525400	SIDE/SHEET L			サイドシート L	
* 2-23	WB526500	HALF-MIRROR SHEET			ハーフミラーシート	
* 2-25	WC034800	EMBLEM	SI	SI	エンブレム	
* 2-28	WC537300	SHEET/SHIELD TOP			シート / シールドトップ	
2-31	EP600290	BIND HEAD P-TIGHT SCREW	3x6 MFZN2Y		バインド P タイトネジ	
2-32	VN413300	BIND HEAD BONDING B-T. SCREW	3x8 MFZN2BL		ボンディング B タイトネジ	01
2-33	EP630220	BIND HEAD P-TIGHT SCREW	3x8 MFZN2BL		バインド P タイトネジ	
* 23	VT745100	CUSHION/2	12x12		クッション / 2	
* 31	WB524500	BOTTOM COVER			ボトムカバー	
* 32	WB524700	SIDE COVER R		SI	サイドカバー R	
* 33	WB524900	SIDE COVER L		SI	サイドカバー L	
* 34	WB526000	LID, HOLDER			リッド / ホルダー	
* 35	WB526900	LID WINDOW			リッドウインドウ	
* 35	WC294700	LID WINDOW		JUCRTKA	リッドウインドウ	
51	VN413300	BIND HEAD BONDING B-T. SCREW	3x8 MFZN2BL		ボンディング B タイトネジ	01
52	EP600250	BIND HEAD B-TIGHT SCREW	3x8 MFZN2Y		バインド B タイトネジ	01
53	EP600910	BIND HEAD P-TIGHT SCREW	3x10 MFC2BL		バインド P タイトネジ	01
54	VH741100	BIND HEAD B-TIGHT SCREW	3x10 SP MFZN2BL		バインド B タイトネジ	01
* 200	WB566400	ACCESSORIES			付属品	
* 200	WB566500	REMOTE CONTROL	RRC4001-1506E	RRC4001-1506E	リモコン	
* 200	WB566600	REMOTE CONTROL	RRC4001-1503E	RRC4001-1503E	リモコン	
* 200-1	AA51940	BATTERY COVER		RRC4001-1504E	リモコン	
202	V6267000	INDOOR FM ANTENNA	1.4m 1pc		電池蓋	
202	VQ147100	INDOOR FM ANTENNA	1.4m 1pc		F M 簡易アンテナ	
* 203	WC192200	ANTENNA, AM LOOP	3083-100-0Y01		F M 簡易アンテナ	02
204	V6508900	VIDEO PIN CABLE	1P 1.5m YE-YE 1pc		A M ループアンテナ	
* 205	WC017100	SPEAKER CABLE KIT	15m 2pcs, 5m 3pcs		ビデオ用ピンケーブル	
		BATTERY	SUM-3N		スピーカコードキット	
					乾電池	

\* New Parts (新規部品)

DVR-S120/NX-P120

■ NX-P120 EXPLODED VIEW

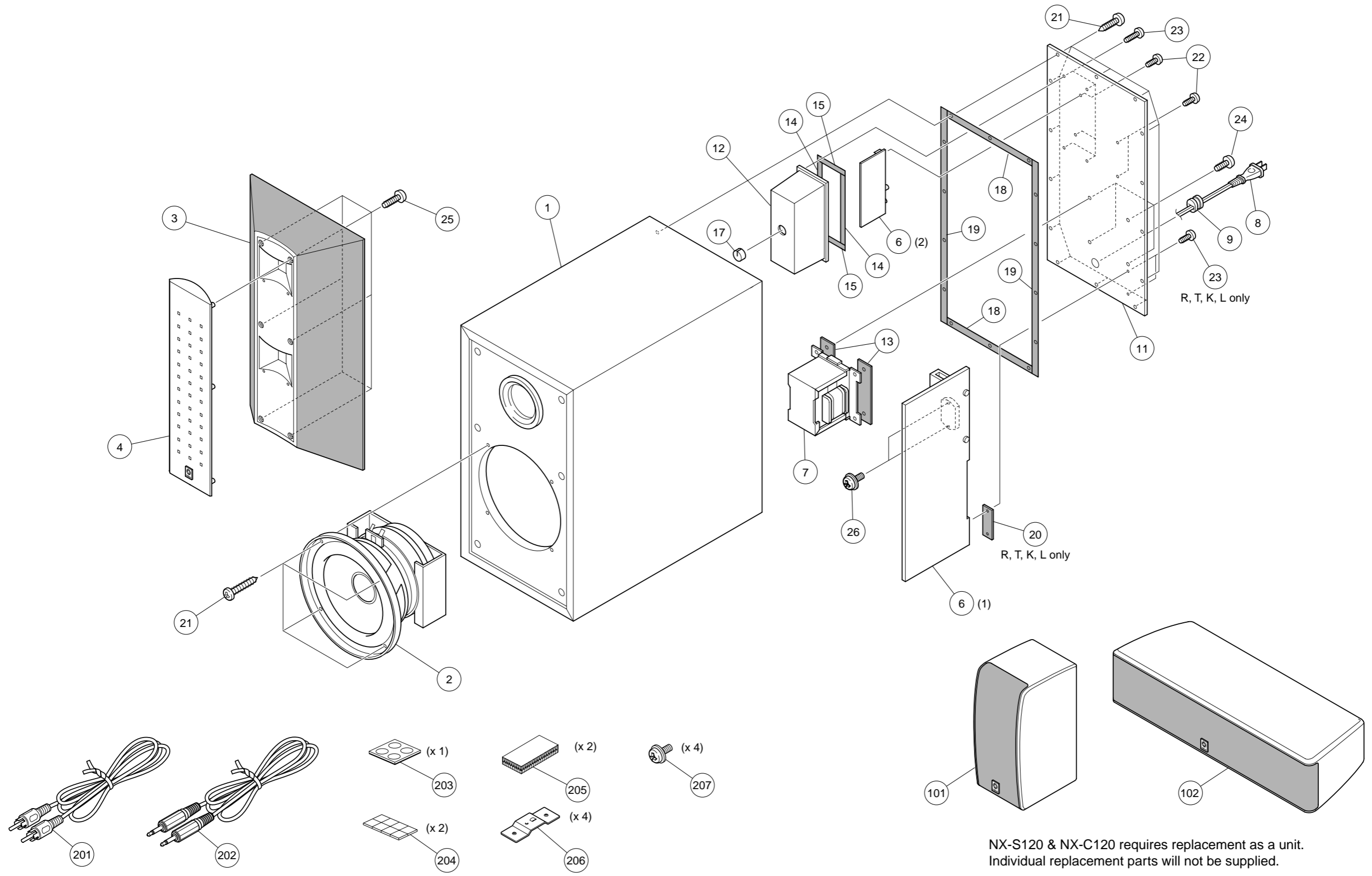

R, T, K, L only

R, T, K, L only

NX-S120 & NX-C120 requires replacement as a unit.  
Individual replacement parts will not be supplied.  
NX-S120 と NX-C120はユニット交換です。



## ■ NX-P120 MECHANICAL PARTS

Ref. No.	PART NO.	Description	Remarks	Markets	部品名	Rank
* 1	AAX51500	CABINET ASS'Y			キャビネット A S S Y	
2	X4329A00	DRIVER, WOOFER	16cm 6 25W		スピーカーユニット	
* 3	AAX51710	FRONT GRILLE ASS'Y			フロントグリル A S S Y	
* 4	AAX51720	FRONT PANEL ASS'Y			フロントパネル A S S Y	
* 6	AAX51460	P.C.B. ASS'Y	MAIN	J	P C B メイン	
* 6	AAX51470	P.C.B. ASS'Y	MAIN	UC	P C B メイン	
* 6	AAX51480	P.C.B. ASS'Y	MAIN	RTKL	P C B メイン	
* 6	AAX51490	P.C.B. ASS'Y	MAIN	ABG	P C B メイン	
△ 7	AAX32110	POWER TRANSFORMER		J	電源トランス	
△ 7	AAX32120	POWER TRANSFORMER		UC	電源トランス	
△ 7	AAX32130	POWER TRANSFORMER		RTKL	電源トランス	
△ 7	AAX32140	POWER TRANSFORMER		A	電源トランス	
△ 7	AAX32150	POWER TRANSFORMER		BG	電源トランス	
△ 8	V2723100	POWER CABLE	1.8m	J	電源コード	
△ 8	V8366300	POWER CABLE	2m	UC	電源コード	
△ 8	VZ555600	POWER CABLE	2m	RT	電源コード	
△ 8	V8012900	POWER CABLE	2m	K	電源コード	
△ 8	V8366500	POWER CABLE	2m	A	電源コード	
△ 8	V8366600	POWER CABLE	2m	B	電源コード	
△ 8	V8366400	POWER CABLE	2m	GL	電源コード	
9	CB072750	CORD STOPPER	SR-4N-4		コードストッパー	
* 11	AAX51760	REAR PANEL		J	リアパネル	
* 11	AAX51770	REAR PANEL		UC	リアパネル	
* 11	AAX51780	REAR PANEL		RTKL	リアパネル	
* 11	AAX51790	REAR PANEL		A	リアパネル	
* 11	AAX51800	REAR PANEL		BG	リアパネル	
* 12	AAX51750	MOLD COVER			モールドカバー	
* 13	AAX51530	CUSHION	18x90		クッション	
* 14	AAX51520	CUSHION	3x120		クッション	
* 15	AAX51510	CUSHION	3x50		クッション	
17	AAX31970	CUSHION, BUSH			クッション	
18	AAX31980	CUSHION	170x10x2		クッション	
19	AAX31990	CUSHION	335x10x2		クッション	
20	AAX13660	CUSHION, SWITCH		RTKL	クッション、SW	
21	AAX12120	BIND HEAD TAPPING SCREW	4x20 MFZN2BL		バインド T P ネジ	
22	EP600190	BIND HEAD B-TIGHT SCREW	3x8 MFZN2BL		バインド B タイトネジ	01
23	EP600140	BIND HEAD B-TIGHT SCREW	3x10 MFZN2BL		バインド B タイトネジ	01
24	EG340190	BIND HEAD B-TIGHT SCREW	4x8 MFZN2BL		バインド B タイトネジ	01
25	EI330126	BIND HEAD B-TIGHT SCREW	3x12 MFZN2BL	JUCABG	バインド B タイトネジ	01
* 26	AAX51590	SEMS BIND HEAD B-TIGHT SCREW	3x16 MFZN2Y		セムスナベ B タイトネジ	01
* 101	AAX51540	SATELLITE SPEAKER UNIT	SILVER	J	サテライト S P ユニット	
* 101	AAX51560	SATELLITE SPEAKER UNIT	SILVER	UCTKABG	サテライト S P ユニット	
* 101	AAX51570	SATELLITE SPEAKER UNIT	WHITE	RL	サテライト S P ユニット	
* 102	AAX51610	CENTER SPEAKER UNIT	SILVER	JUCTKABG	センター S P ユニット	
* 102	AAX51630	CENTER SPEAKER UNIT	WHITE	RL	センター S P ユニット	
		ACCESSORIES			付属品	
* 201	AAX51580	SUBWOOFER CABLE	1P 5m 1pc		サブウーファーケーブル	
* 202	AAX51740	SYSTEM CONTROL CABLE	1P 5m 1pc		システム接続ケーブル	
203	V5982400	NON SKID PAD	M25 t2 4pcs/set		滑止パッド	
204	AAX20410	NON SKID PAD	7x7x1 8pcs/set		滑止パッド	
205	AAX21240	FASTENER	51.5x39x3.5 1pair		固定テープ	
206	AAX34790	MOUNTING BRACKET	1pc		取付金具	

\* New Parts (新規部品)

Ref. No.	PART NO.	Description	Remarks	Markets	部品名	Rank
* 207	AAX51600	SEMS PAN HEAD SCREW	4x10 MFZN2BL	075194	セムスナベ子ネジ	

\* New Parts (新規部品)

# REMOTE CONTROL

▼ J model

▼ U, C, R, T, K, L, A models

▼ B, G models

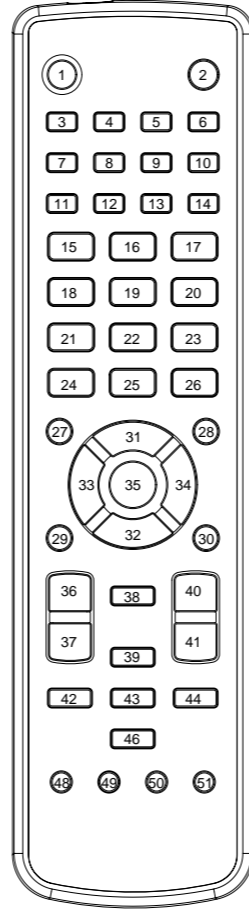
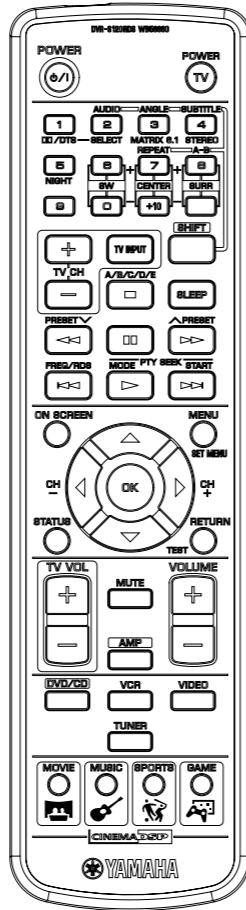
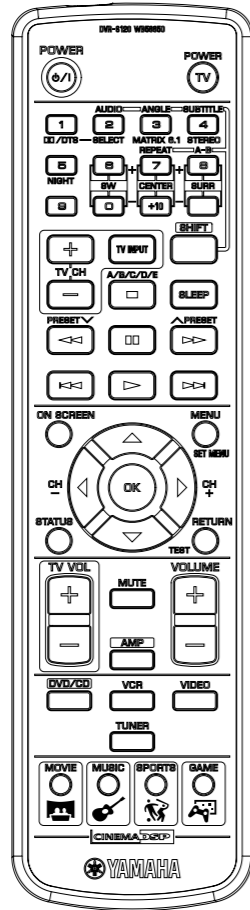
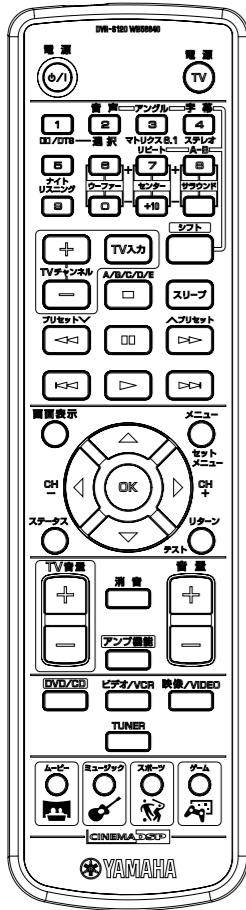

## SCHEMATIC DIAGRAM

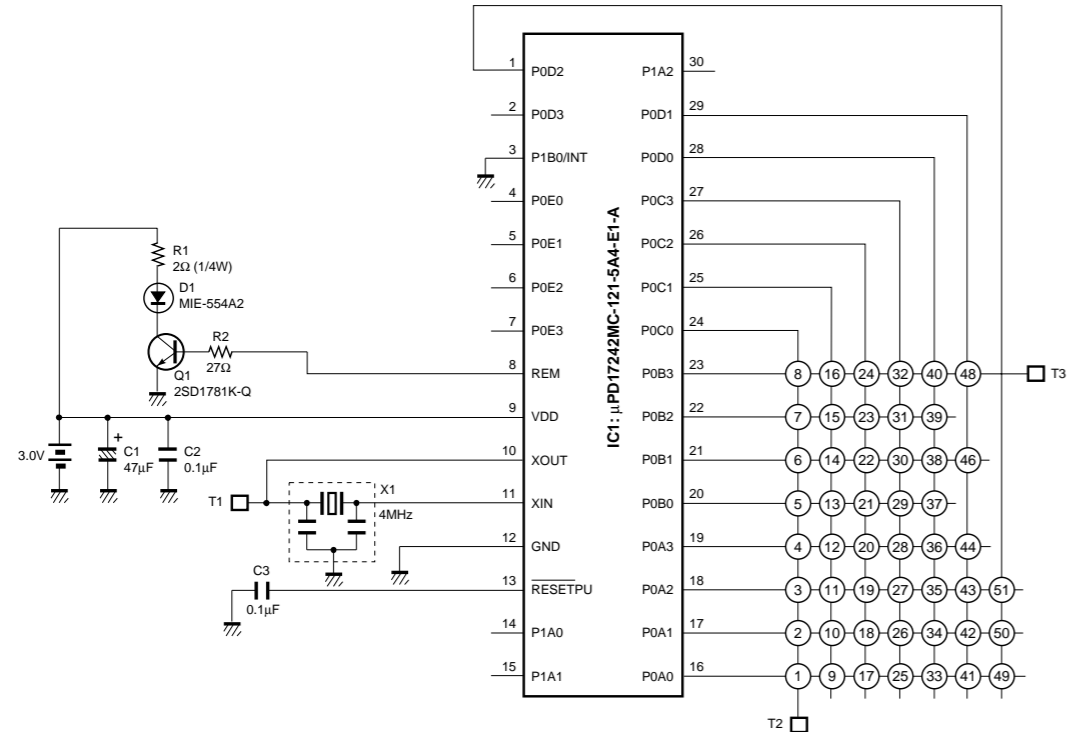

Key No.	Function	CODE					
		TUNER	DVD	SHIFT (DVD)	AMP	MD	CD-R
1	POWER	78-0F	78-0F	78-0F	78-0F	78-0F	78-0F
2	TV POWER	TV (Preset) Code Transmit					
3	1	78-11	7C-94	-	78-99	79-85	7F-91
4	2	78-12	7C-95	7C-AD	78-9A	79-86	7F-92
5	3	78-13	7C-96	7C-AE	78-90	79-87	7F-93
6	4	78-14	7C-97	7C-AA	78-50	79-88	7F-94
7	5	78-15	7C-98	7C-E2	78-8A	79-89	7F-95
8	6	78-16	7C-99	7C-A1	78-4C	79-8A	7F-96
9	7	78-17	7C-9A	7C-A3	78-86	79-8B	7F-97
10	8	78-18	7C-9B	7C-A4	78-88	79-8C	7F-98
11	9	-	7C-9C	-	-	79-8D	7F-99
12	0	-	7C-93	-	78-4D	79-8E	7F-90
13	+10	-	-	-	78-87	79-8F	7F-9A
14	SURROUND	-	-	-	78-89	-	-
15	TV CH +	TV (Preset) Code Transmit					
16	TV INPUT	TV (Preset) Code Transmit					
17	SHIFT (CODE SET)	-	-	-	-	-	-
18	TV CH -	TV (Preset) Code Transmit					
19	STOP	78-1D	7C-85	7C-85	-	79-AA	7F-84
20	SLEEP	78-4F	78-4F	78-4F	78-4F	78-4F	78-4F
21	SEARCH - (REW)	78-1C	7C-86	7C-86	-	79-AC	7F-88
22	PAUSE	-	7C-83	7C-83	-	79-A9	7F-83
23	SEARCH + (FF)	78-1B	7C-87	7C-87	-	79-AD	7F-89
24	SKIP -	78-81	7C-B9	7C-B9	-	79-AB	7F-86
25	PLAY	78-82	7C-82	7C-82	-	79-A8	7F-82
26	SKIP +	78-83	7C-BA	7C-BA	-	79-AE	7F-87
27	ON SCREEN	-	7C-A6	7C-A6	-	-	-
28	MENU	-	7C-B2	7C-B2	78-9D	-	-
29	STATUS	-	7C-A7	7C-A7	-	-	-
30	RETURN	-	7C-B7	7C-B7	78-5F	-	-
31	UP	-	7C-B4	7C-B4	78-8E	-	-
32	DOWN	-	7C-B3	7C-B3	78-8F	-	-
33	LEFT	-	7C-B5	7C-B5	78-9F	-	-
34	RIGHT	-	7C-B6	7C-B6	78-9E	-	-
35	OK	-	7C-B8	7C-B8	-	-	-
36	TV VOLUME +	TV (Preset) Code Transmit					
37	TV VOLUME -	TV (Preset) Code Transmit					
38	MUTE	78-9C	78-9C	78-9C	78-9C	78-9C	78-9C
39	AMP	-	-	-	-	-	-
40	VOLUME UP	78-1E	78-1E	78-1E	78-1E	78-1E	78-1E
41	VOLUME DOWN	78-1F	78-1F	78-1F	78-1F	78-1F	78-1F
42	DVD/CD	78-4A	78-4A	78-4A	78-4A	78-4A	78-4A
43	VCR	78-49	78-49	78-49	78-49	78-49	78-49
44	VIDEO	78-DF	78-DF	78-DF	78-DF	78-DF	78-DF
46	TUNER	78-4B	78-4B	78-4B	78-4B	78-4B	78-4B
48	MOVIE	78-D9	78-D9	78-D9	78-D9	78-D9	78-D9
49	MUSIC	78-DA	78-DA	78-DA	78-DA	78-DA	78-DA
50	SPORTS	78-DB	78-DB	78-DB	78-DB	78-DB	78-DB
51	GAME	78-DC	78-DC	78-DC	78-DC	78-DC	78-DC