

# HOME THEATER SOUND SYSTEM DVX-S150

# DVR-S150/NX-P150

## SERVICE MANUAL

The DVX-S150 is composed of the DVR-S150 and the NX-P150.

DVX-S150 は DVR-S150 と NX-P150 で構成されています。

### IMPORTANT NOTICE

This manual has been provided for the use of authorized YAMAHA Retailers and their service personnel. It has been assumed that basic service procedures inherent to the industry, and more specifically YAMAHA Products, are already known and understood by the users, and have therefore not been restated.

**WARNING:** Failure to follow appropriate service and safety procedures when servicing this product may result in personal injury, destruction of expensive components, and failure of the product to perform as specified. For these reasons, we advise all YAMAHA product owners that any service required should be performed by an authorized YAMAHA Retailer or the appointed service representative.

**IMPORTANT:** The presentation or sale of this manual to any individual or firm does not constitute authorization, certification or recognition of any applicable technical capabilities, or establish a principle-agent relationship of any form.

The data provided is believed to be accurate and applicable to the unit(s) indicated on the cover. The research, engineering, and service departments of YAMAHA are continually striving to improve YAMAHA products. Modifications are, therefore, inevitable and specifications are subject to change without notice or obligation to retrofit. Should any discrepancy appear to exist, please contact the distributor's Service Division.

**WARNING:** Static discharges can destroy expensive components. Discharge any static electricity your body may have accumulated by grounding yourself to the ground buss in the unit (heavy gauge black wires connect to this buss).

**IMPORTANT:** Turn the unit OFF during disassembly and part replacement. Recheck all work before you apply power to the unit.

## CONTENTS

TO SERVICE PERSONNEL .....	2-4
PREVENTION OF ELECTRO STATIC DISCHARGE .....	4
LOCALE MANAGEMENT INFORMATION .....	5
SYSTEM COMPOSITION / システム構成 .....	5
FRONT PANELS .....	6-7
REMOTE CONTROL PANELS .....	7
REAR PANELS .....	8-9
SPECIFICATIONS / 参考仕様 .....	10-12
INTERNAL VIEW .....	13
DVR-S150 DISASSEMBLY PROCEDURES / DVR-S150分解手順 .....	14-18
NX-SW150 DISASSEMBLY PROCEDURES / NX-SW150分解手順 .....	19-20
DVR-S150 TRAY LOCK MODE / DVR-S150トレーロックモード .....	21

DVR-S150 SELF DIAGNOSIS FUNCTION (DIAG) / DVR-S150自己診断機能(ダイアグ) .....	22-43
DVR-S150 D-AMP MODULE TROUBLESHOOTING / DVR-S150 D-アンプモジュールの故障診断 .....	44
DVR-S150 AMP ADJUSTMENT / DVR-S150アンプ部調整 .....	44
DISPLAY DATA .....	45
IC DATA .....	46-56
DVR-S150 BLOCK DIAGRAM .....	57-59
DVR-S150 PRINTED CIRCUIT BOARD .....	60-68
NX-SW150 PRINTED CIRCUIT BOARD .....	69
DVR-S150 SCHEMATIC DIAGRAM .....	70-79
NX-SW150 SCHEMATIC DIAGRAM .....	80
PARTS LIST .....	81-99
REMOTE CONTROL .....	100



このサービスマニュアルは、エコマーク認定の再生紙を使用しています。  
This Service Manual uses recycled paper.



## ■ TO SERVICE PERSONNEL

1. Critical Components Information  
Components having special characteristics are marked  $\triangle$  and must be replaced with parts having specifications equal to those originally installed.
  2. Leakage Current Measurement (For 120V Models Only)  
When service has been completed, it is imperative to verify that all exposed conductive surfaces are properly insulated from supply circuits.
- Meter impedance should be equivalent to 1500 ohm shunted by 0.15 $\mu$ F.

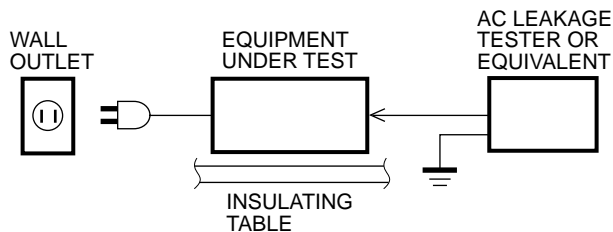

- Leakage current must not exceed 0.5mA.
- Be sure to test for leakage with the AC plug in both polarities.

## WARNING: CHEMICAL CONTENT NOTICE!

The solder used in the production of this product contains LEAD. In addition, other electrical/electronic and/or plastic (where applicable) components may also contain traces of chemicals found by the California Health and Welfare Agency (and possibly other entities) to cause cancer and/or birth defects or other reproductive harm.

DO NOT PLACE SOLDER, ELECTRICAL/ELECTRONIC OR PLASTIC COMPONENTS IN YOUR MOUTH FOR ANY REASON WHATSOEVER!

Avoid prolonged, unprotected contact between solder and your skin! When soldering, do not inhale solder fumes or expose eyes to solder/flux vapor!

If you come in contact with solder or components located inside the enclosure of this product, wash your hands before handling food.

## About lead-free solder / 無鉛ハンダについて

The P.C.B.s installed in this unit are soldered using the following solder.

本機に搭載されている基板のハンダ付けに使用されているハンダは下記の通りです。

	SIDE A / A 面	SIDE B / B 面
DIGITAL P.C.B.	Lead Free Solder / 無鉛ハンダ	Lead Free Solder / 無鉛ハンダ
MAIN P.C.B.	-	Lead Free Solder / 無鉛ハンダ
SUB P.C.B.	-	Lead Free Solder / 無鉛ハンダ

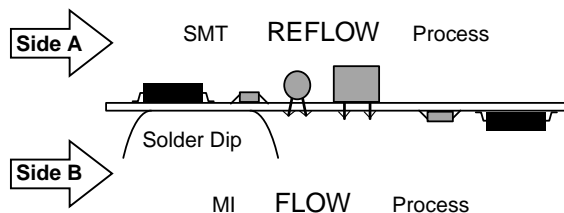

Among some types of lead-free solder currently available, it is recommended to use one of the following types for the repair work.

- Sn + Ag + Cu (tin + silver + copper)
- Sn + Cu (tin + copper)
- Sn + Zn + Bi (tin + zinc + bismuth)

### Caution:

1. As the melting point temperature of the lead-free solder is about 30°C to 40°C (50°F to 70°F) higher than that of the lead solder, be sure to use a soldering iron suitable to each solder.

無鉛ハンダにはいくつかの種類がありますが、修理時には下記のような無鉛ハンダの使用を推奨します。

- Sn+Ag+Cu (錫+銀+銅)
- Sn+Cu (錫+銅)
- Sn+Zn+Bi (錫+亜鉛+ビスマス)

### 注意:

1. 無鉛ハンダの融点温度は通常の鉛入りハンダに比べ30~40程度高くなっていますので、それぞれのハンダに合ったハンダごてをご使用ください。

DVR-S150  
NX-P150

2. If lead solder must be used, be sure to remove lead-free solder from each terminal section of the parts to be replaced and from the area around it completely before soldering, or make sure that the lead-free solder and lead solder melt together fully.

## WARNING: Laser Safety

This product contains a laser beam component. This component may emit invisible, as well as visible radiation, which may cause eye damage. To protect your eyes and skin from laser radiation, the following precautions must be used during servicing of the unit.

- 1) When testing and/or repairing any component within the product, keep your eyes and skin more than 30 cm away from the laser pick-up unit at all times. Do not stare at the laser beam at any time.
- 2) Do not attempt to readjust, disassemble or repair the laser pick-up, unless noted elsewhere in this manual.
- 3) CAUTION : Use of controls, adjustments or performance of procedures other than those specified herein may result in hazardous radiation exposure.

## Laser Emitting conditions:

- 1) When the Top Cover is removed, and the STANDBY/ON SW is turned to the "ON" position, the laser component will emit a beam for several seconds to detect if a disc is present. During this time (5-10 sec.) the laser may radiate through the lens of the laser pick-up unit. Do not attempt any servicing during this period! If no disc is detected, the laser will stop emitting the beam. When a disc is loaded, you will not be exposed to any laser emissions.
- 2) The laser power level can be adjusted with the VR on the pick-up PWB, however, this level has been set by the factory prior to shipping from the factory. Do not adjust this laser level control unless instruction is provided elsewhere in this manual. Adjustment of this control can increase the laser emission level from the device.

## Laser Diode Properties

Type:	Semiconductor laser GaAlAs
Wave length:	650 nm (DVD) 790 nm (VCD/CD)
Output Power:	1.45 mW (DVD) 1.31 mW (VCD/CD)
Beam divergence:	60 degree

2. 鉛入りハンダを使わざるを得ない場合は、あらかじめ交換する部品端子部やその周辺部の無鉛ハンダをすべて取り除くか、あるいは無鉛ハンダと鉛入りハンダが十分に溶けた状態となるようにハンダ付けしてください。

## 警告：レーザーの安全対策

本機はレーザー光線を放射する部品を搭載しています。この部品が放射するレーザー光線は目に損傷を起こします。このレーザー光線から目及び肌を保護するために、本機の修理作業中は下記の注意を厳守してください。

- 1) テスト時または修理時、目及び肌を光ピックアップから30cm以上離してください。いかなる場合もレーザー光線を見つめないでください。
- 2) 光ピックアップの再調整及び分解はしないでください。
- 3) このマニュアル上で指定されている以外の制御、調整、手順はレーザー光線を照射される結果を招く恐れがあります。

## レーザー放射条件

- 1) トップカバーを取り外しSTANDBY/ONスイッチをONにすると、ディスク検知のため5～10秒間、光ピックアップからレーザー光線が放射されます。この間、修理はしないでください。ディスクが検知されなければ、レーザー光線の放射は停止します。ディスクがセットされている場合、ディスクで遮られるのでレーザー光線は修理担当者に届きません。
- 2) レーザーパワーレベルは光ピックアップ基板上のVRにより調整可能ですが、工場出荷前に調整セット済みなので、このVRは廻さないでください。このVRを廻すと装置からのレーザー光線の放射レベルが上がる恐れがあります。

## レーザー

タイプ	半導体レーザー GaAlAs
波長	650 nm (DVD) 790 nm (VCD/CD)
出力	1.45 mW (DVD) 1.31 mW (VCD/CD)
ビーム広がり	60 度

VARO! : AVATTAESSA JA SUOJALUKITUS OHITETTAESSA OLET ALTTIINA NÄKYMÄTTÖMÄLLE LASER-SÄTEILYLLE. ÄLÄ KATSO SÄTEESEEN.

VARNING! : OSYNLIG LASERSTRÅLNING NÄR DENNA DEL ÄR ÖPPNAD OCH SPÄRREN ÄR URKOPPLAD. BETRAKTA EJ STRÅLEN.

## WARNING

The use of optical instruments with this product will increase eye hazard.  
 Repair handling should take place as much as possible with a disc loaded inside the player.

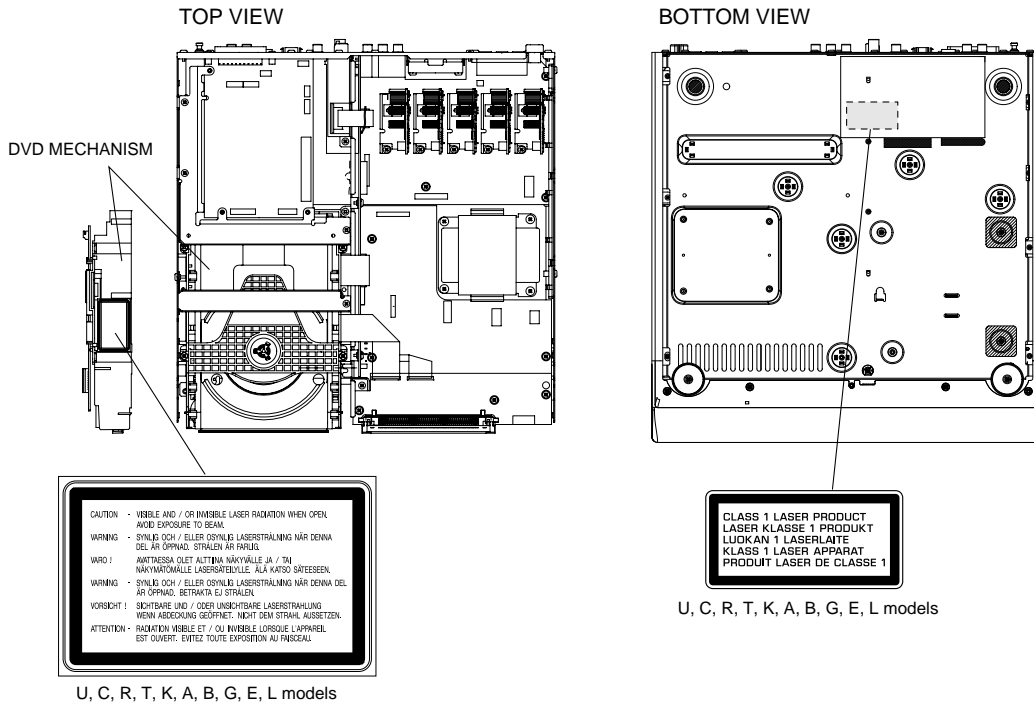

## ■ PREVENTION OF ELECTRO STATIC DISCHARGE

The laser diode in the traverse unit (optical pickup) may be damaged due to static electricity from clothes or the human body. Use caution to prevent electrostatic damage when servicing or handling the laser diode.

### 1. Grounding for electrostatic damage prevention

Some devices, such as the DVD player, use an optical pickup (laser diode) that will be damaged by static electricity in the working environment. Only attempt service after ensuring that all grounding procedures have been completed.

1. Worktable grounding  
 Put a grounded conductive material (sheet) or iron sheet on the area where the optical pickup is placed.
2. Human body grounding  
 Use an anti-static wrist strap to discharge the static electricity from your body.

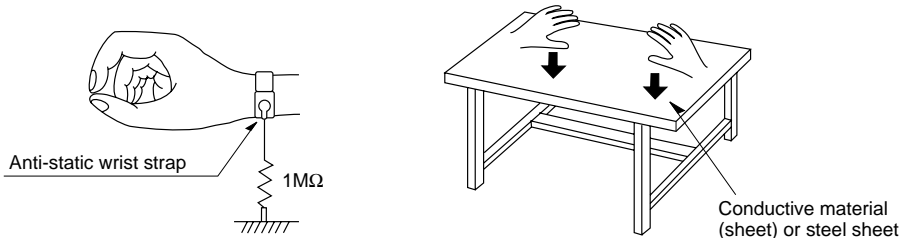

### 2. Handling of the optical pickup

1. To prevent damage to the optical pickup replacement parts during transportation and before installation, both ends of the laser diode are short-circuited. After installing the new part, remove the short circuit according to the correct procedure in this service manual.
2. Do not use a tester to check the laser diode in the optical pickup. The power supply in the tester will damage the laser diode.

### 3. Handling Precautions for the Traverse Unit (Optical Pickup)

1. Handle the traverse unit (optical pickup) gently, as it is an extremely high-precision assembly.
2. The flexible cable lines may break if an excessive force is applied to it. Use caution when handling the cable.
3. The semi-fixed resistor for laser power adjustment should not be adjusted. Do not turn the resistor.

DVR-S150  
NX-P150



## ■ LOCALE MANAGEMENT INFORMATION

Locale Management Information : This DVD player is designed and manufactured to respond to the Locale Management Information that is recorded on a DVD disc. If the Locale number described on the DVD disc does not correspond to the Locale number of this DVD player, this DVD player cannot play this disc.

This product incorporates copyright protection technology that is protected by method claims of certain U.S. patents and other intellectual property rights owned by Macrovision Corporation and other rights owners. Use of this copyright protection technology must be authorized by Macrovision Corporation, and is intended for home and other limited viewing uses only unless otherwise authorized by Macrovision Corporation. Reverse engineering or disassembly is prohibited.

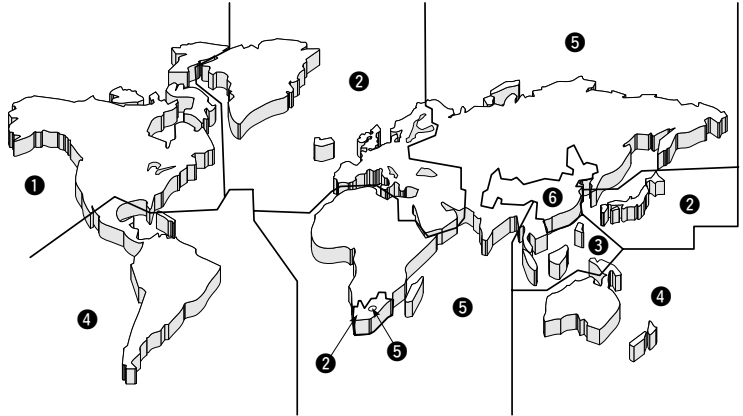

## ■ SYSTEM COMPOSITION / システム構成

The DVX-S150 is composed of the DVR-S150 and the NX-P150.

**DVR-S150**

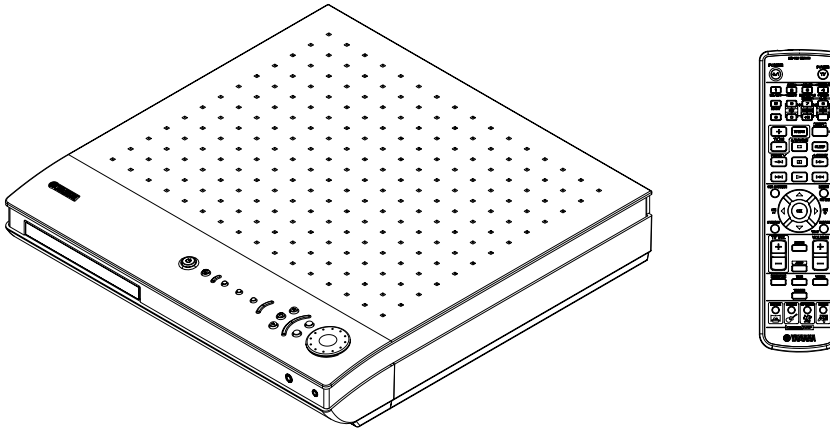

**NX-P150**

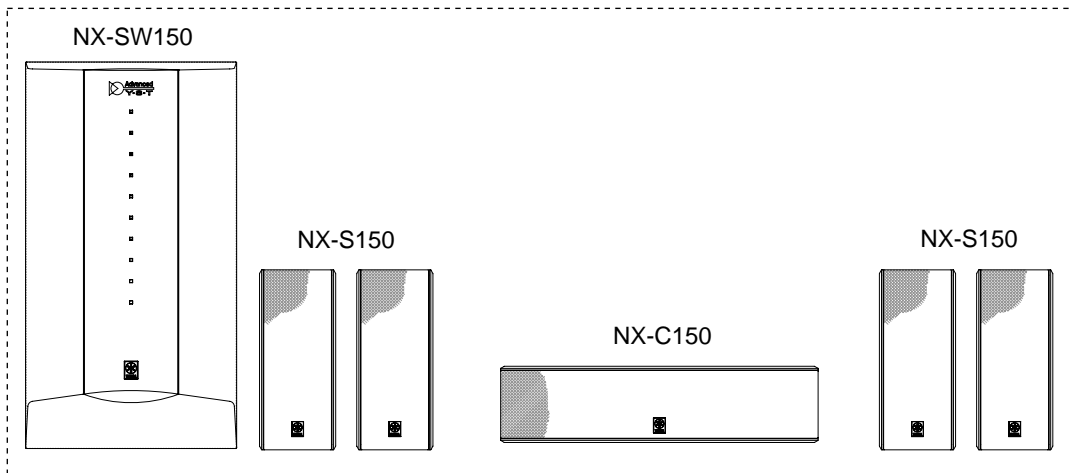

DVR-S150  
NX-P150

# FRONT PANELS

## ▼ DVR-S150

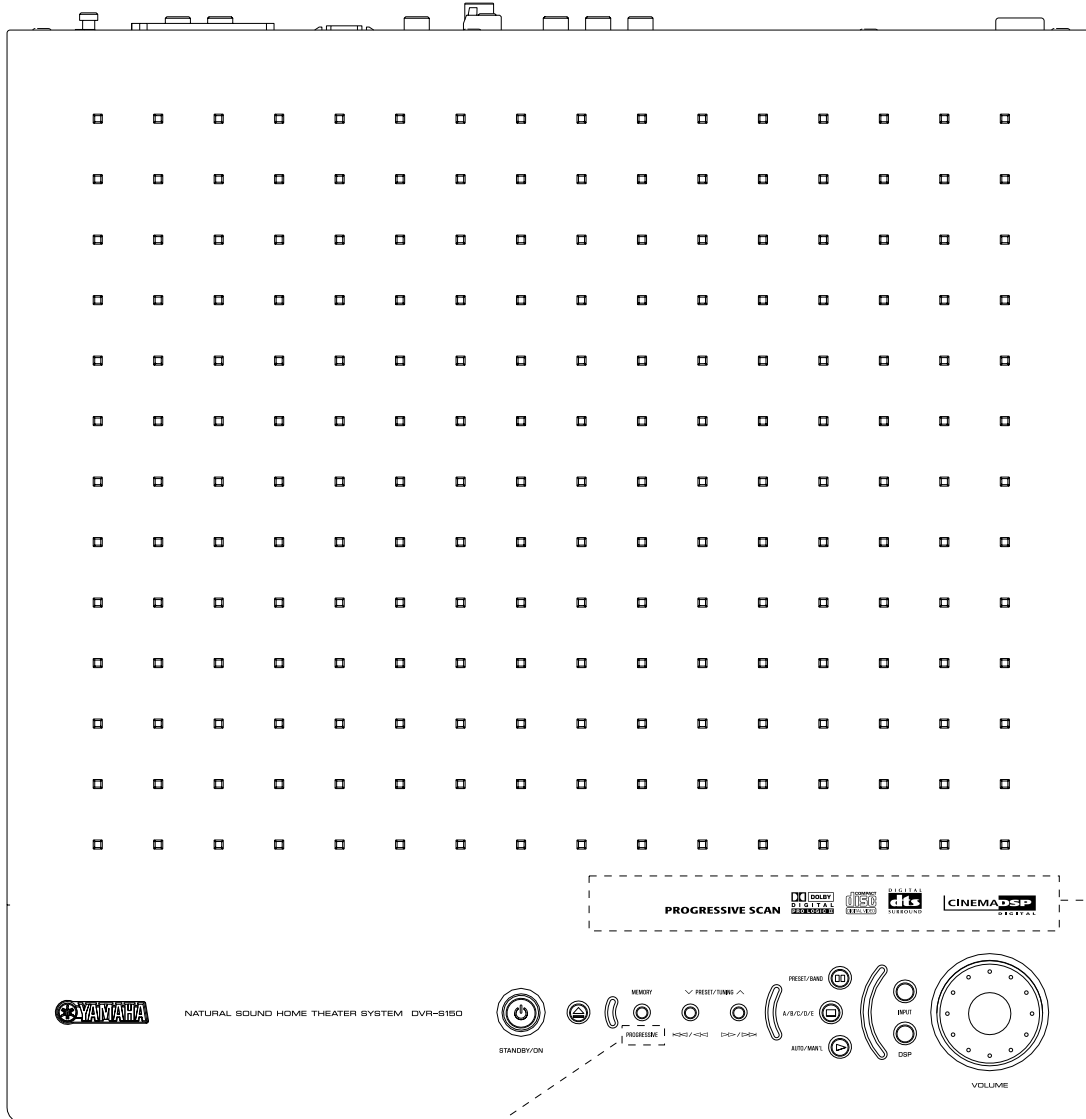
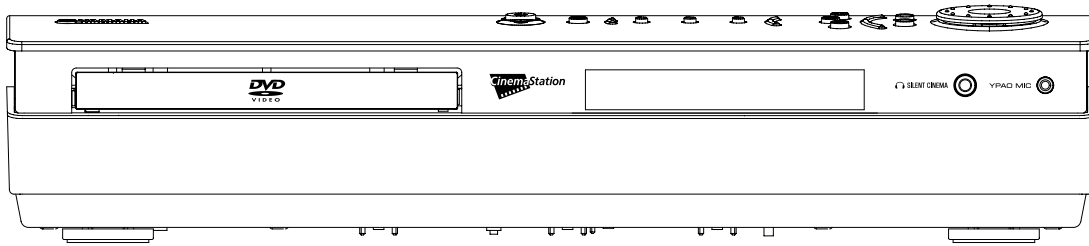

DVR-S150  
NX-P150

U, C, R, T, K, A, L, J models only

U, C, R, T, K, A, L models



B, G, E models



J model



▼ NX-SW150

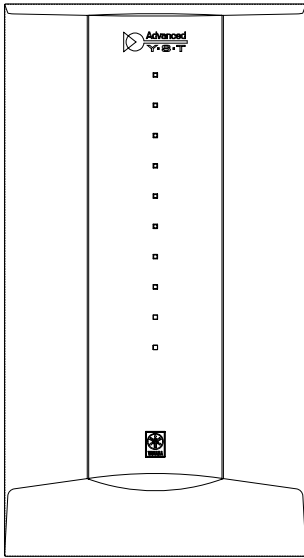

▼ NX-C150

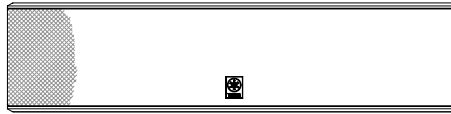

▼ NX-S150

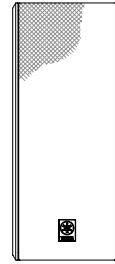

■ REMOTE CONTROL PANELS

▼ DVR-S150 BL  
(U, C, A models)

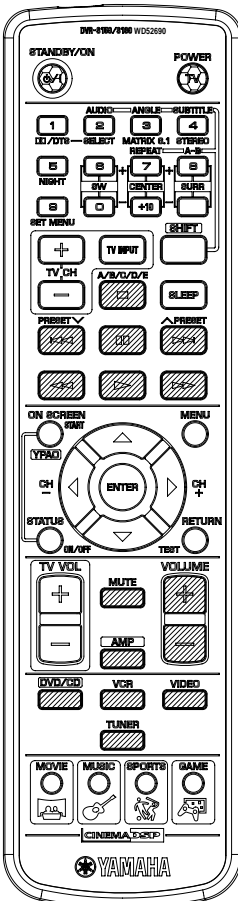

▼ DVR-S150 SI  
(U, C, R, T, K, A, L models)

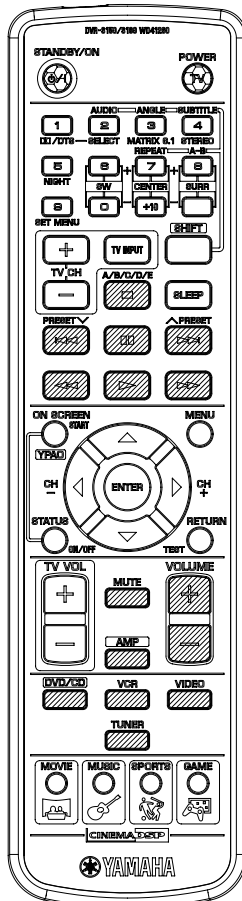

▼ DVR-S150 SI  
(B, G, E models)

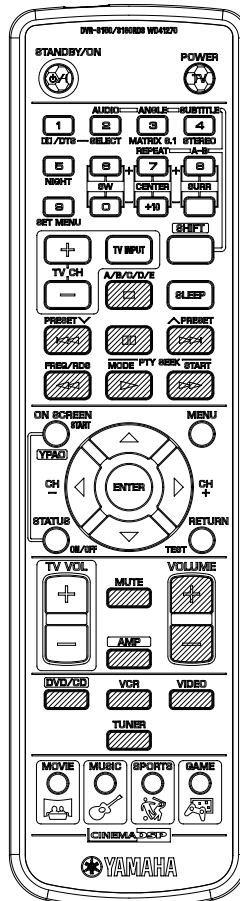

▼ DVR-S150 SI  
(J model)

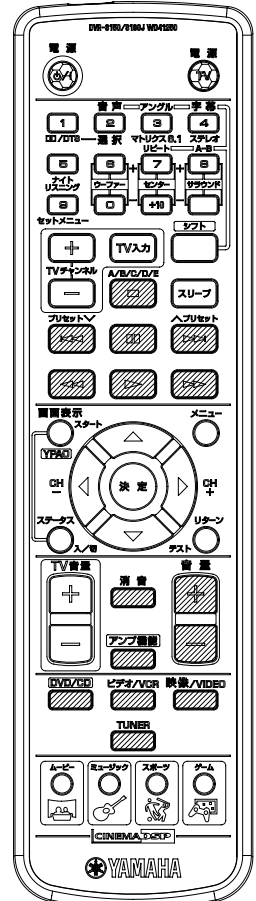

DVR-S150  
NX-P150

## REAR PANELS

### ▼ DVR-S150 (U, C, R, T, K, A, L models)

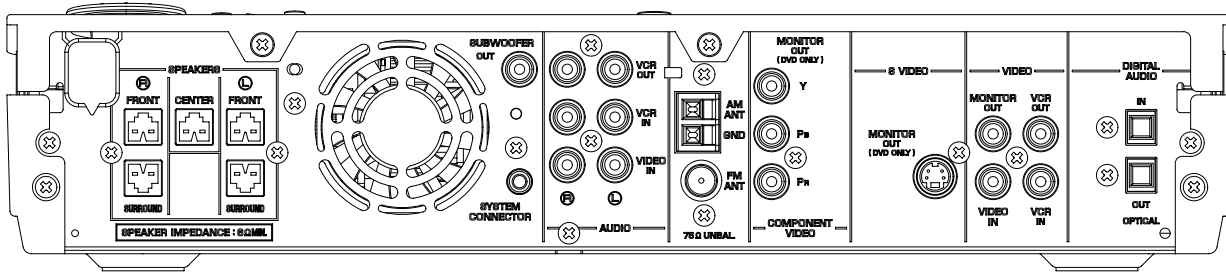

### ▼ DVR-S150 (B, G, E models)

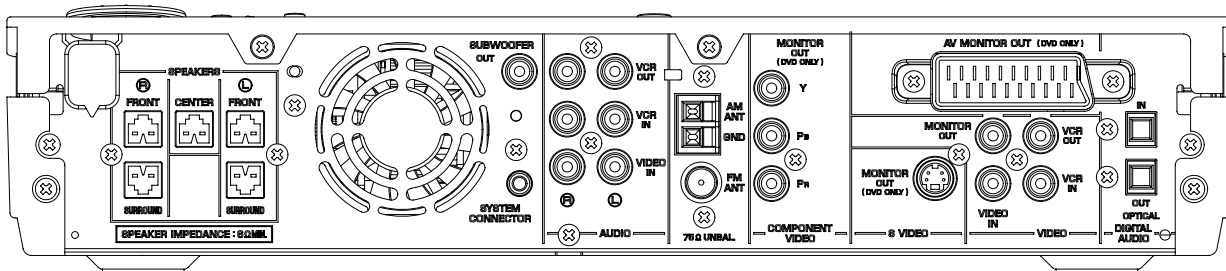

### ▼ DVR-S150 (J model)

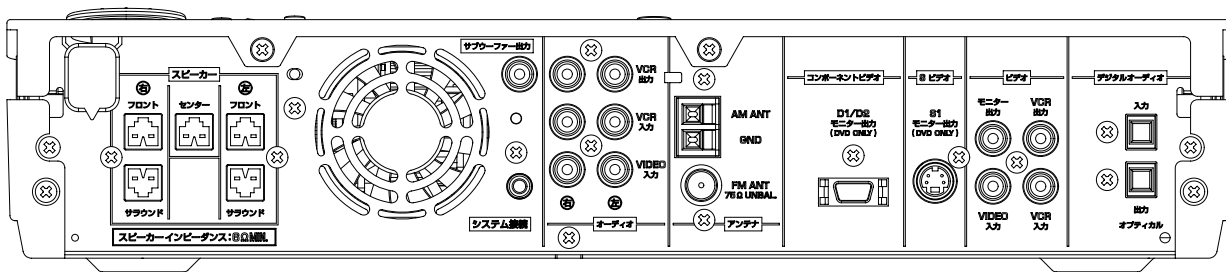

### ▼ NX-S150

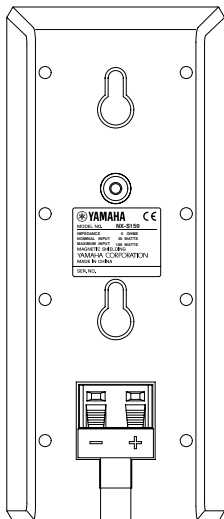

### ▼ NX-C150

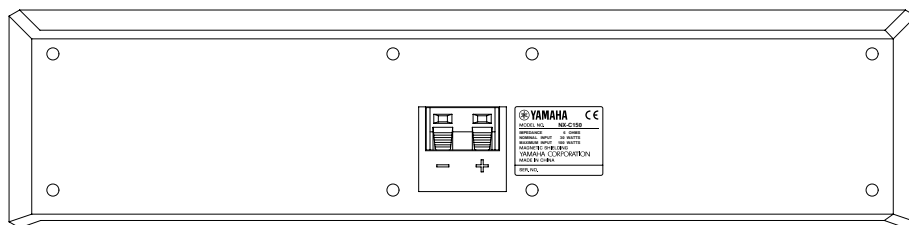

DVR-S150  
NX-P150

▼ NX-SW150 (U, C models)

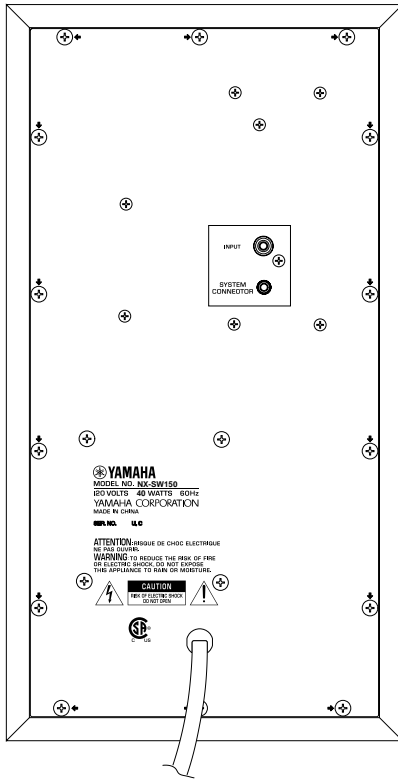

▼ NX-SW150 (R, T, K, L models)

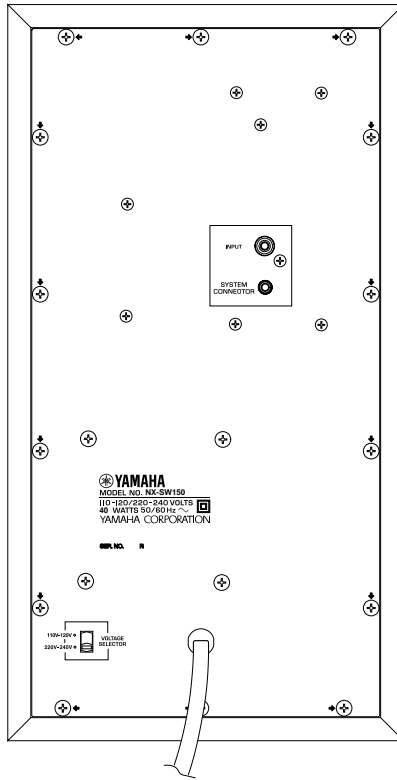

▼ NX-SW150 (B, G, E models)

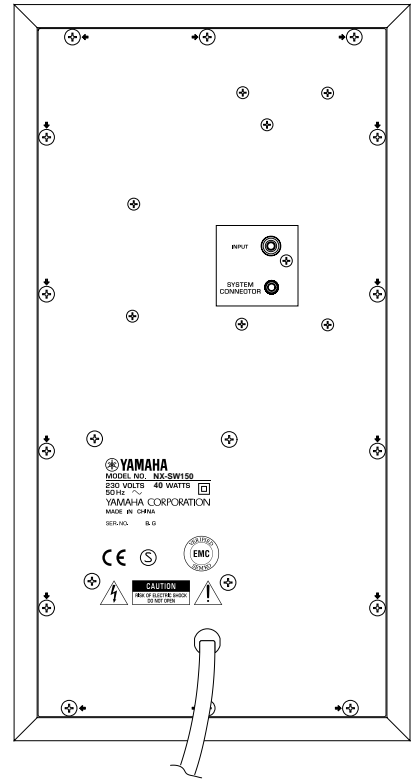

▼ NX-SW150 (A model)

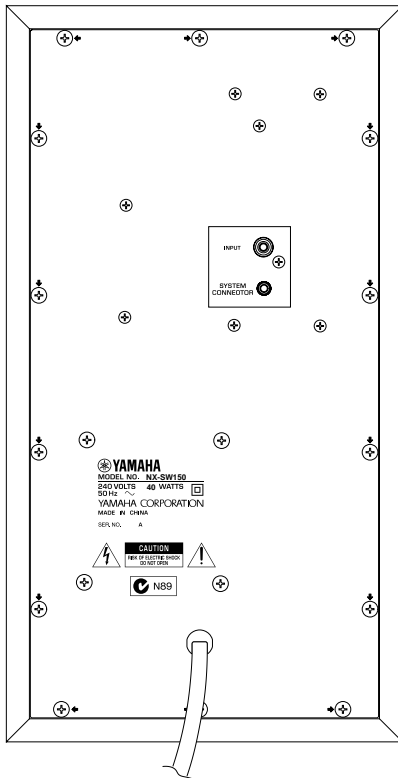

▼ NX-SW150 (J model)

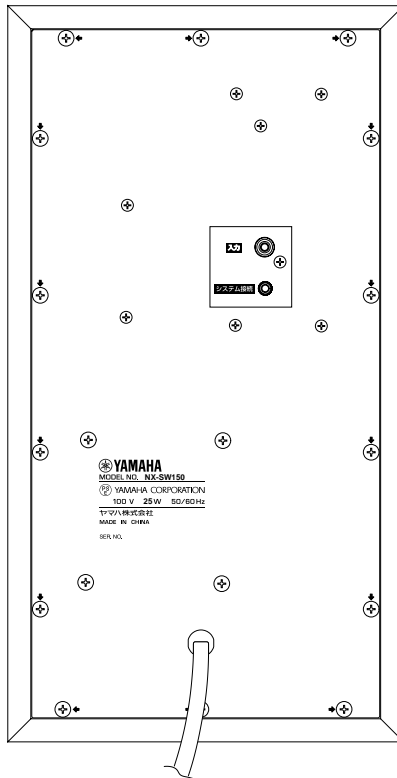

DVR-S150  
NX-P150

## SPECIFICATIONS / 参考仕様

### DVR-S150

#### AMPLIFIER SECTION / オーディオ部

Input Sensitivity/Impedance / 入力感度/インピーダンス	
VCR, VIDEO	200 mV/47 kΩ
Maximum Input Signal / 最大許容入力	
VCR, VIDEO (1kHz, 0.5 % THD)	2.2 V
Output Level/Impedance / 出力電圧/インピーダンス (when 1 kHz, 200 mV is input)	
REC OUT	200 mV/1.2 kΩ
PRE OUT (SUBWOOFER/FRONT SP Small, 50Hz)	4V
Frequency Response / 周波数特性	
REC OUT (FRONT L/R, 20 Hz to 20 kHz)	0/-1 dB
Signal to Noise Ratio (IHF-A Network) / S/N比	
VCR, VIDEO (REC OUT, Input shorted, 200mV)	90 dB
Minimum RMS Output Power / 定格出力	
R, T, K, A, B, G, E, L, J models	
FRONT L/R (6 Ω, 1 kHz, 0.9% THD)	45 W/ch
CENTER (6 Ω, 1 kHz, 0.9% THD)	45 W
SURROUND L/R (6 Ω, 1 kHz, 0.9% THD)	45 W/ch
U, C models	
FRONT L/R (6 Ω, 20 Hz to 20 kHz, 0.9% THD)	45 W/ch
CENTER (6 Ω, 20 Hz to 20 kHz, 0.9% THD)	45 W
SURROUND L/R (6 Ω, 20 Hz to 20 kHz, 0.9% THD)	45 W/ch
Maximum Power (EIAJ) / 実用最大出力	
FRONT L/R (6 Ω, 1 kHz, 10% THD)	55 W/ch
CENTER (6 Ω, 1 kHz, 10% THD)	55 W
SURROUND L/R (6 Ω, 1 kHz, 10% THD)	55 W/ch
Total Harmonic Distortion / 全高調波歪率	
FRONT L/R (1 kHz, 20 W, SP OUT)	0.05 %

#### VIDEO SECTION (VCR, VIDEO) / ビデオ部

Video Signal Type / ビデオ信号方式	NTSC/PAL
Video Signal Level / ビデオ信号	
Video	1 Vp-p/75 Ω
S-Video	
Y	1 Vp-p/75 Ω
C	0.286 Vp-p/75 Ω
Maximum Input Level / 最大許容入力	
VCR, VIDEO	1.5 Vp-p
Signal to Noise Ratio / S/N比	
Monitor Out	50 dB
Frequency Response / 周波数帯域	
Monitor Out (5 Hz to 10 MHz)	
Video	0/-3 dB
S-Video	0/-3 dB

#### TUNER SECTION / チューナー部

FM Tuning Range / FM受信周波数範囲	
U, C models	87.5 to 107.9 MHz
T, K, A, B, G, E models	87.50 to 108.00 MHz
R, L models	87.5 to 108.0 MHz
J model	87.50 to 108.00 MHz
J model	76.0 to 90.0 MHz
AM Tuning Range / AM受信周波数範囲	
U, C models	530 to 1710 kHz

T, K, A, B, G, E, J models	531 to 1611 kHz
R, L models	530 to 1710 kHz
	531 to 1611 kHz

#### DVD SECTION / DVD部

Output Level / 出力レベル	
REC OUT	
DVD/VIDEO, CD/CD-DA (1 kHz, 0 dB)	2 ± 0.3 V
Video Output / 映像信号出力	1 Vp-p/75 Ω
Y Output/S-Video Output / Y出力/S映像出力	1 Vp-p/75 Ω
C Output/S-Video Output / C出力/S映像出力	
U, C, R, J models	0.286 Vp-p/75 Ω
K, L, A, B, G, E models	0.3 Vp-p/75 Ω
Y Output/Component Video Output / Y出力/コンポーネント出力	
U, C, R, T, K, A, B, G, E, L models	1.0 Vp-p/75 Ω
Pb Output/Component Video Output / Pb出力/コンポーネント出力	
U, C, R, T, K, A, B, G, E, L models	0.7 Vp-p/75 Ω
Pr Output/Component Video Output / Pr出力/コンポーネント出力	
U, C, R, T, K, A, B, G, E, L models	0.7 Vp-p/75 Ω

#### GENERAL / 総合

Power Supply / 電源電圧	
U, C models	AC 120 V, 60 Hz
R model	AC 110-120 V, 50 Hz
T model	AC 220 V, 50 Hz
K model	AC 220 V, 60 Hz
A model	AC 240 V, 50 Hz
B, G, E models	AC 230 V, 50 Hz
L model	AC 220-240 V, 50 Hz
J model	AC 100 V, 50/60 Hz
Power Consumption / 消費電力	
J model	95 W
U, C, R, T, K, A, B, G, E, L models	85 W
Standby Power Consumption / 待機時消費電力	
U, C, T, K, A, B, G, E, J models	0.4 W
R, L models	0.5 W
Dimensions (W x H x D) / 寸法 (幅 x 高さ x 奥行き)	
	360 x 75 x 370.2 mm (14-3/16" x 2-15/16" x 14-9/16")
Weight / 質量	6.4 kg (14 lbs 1 oz)
Finish / 仕上げ	Black color (U, C, A models) Silver color (U, C, R, T, K, A, B, G, E, L, J models) White color (U, R, K, L, J models)
Accessories / 付属品	Remote Control x 1 Battery (size "UM-3", "R06") x 2 Indoor FM antenna x 1 AM loop antenna x 1 Video Pin Cable (1.5 m) x 1 Speaker Cable (Front, Center: 5 m) x 3 Speaker Cable (Surround: 15 m) x 2 Optimizer Microphone (6 m) x 1

\* Specifications subject to change without notice.

U	..... USA model	B	..... British model
C	..... Canadian model	G	..... European model
R	..... General model	E	..... South European model
T	..... Chinese model	L	..... Singapore model
K	..... Korean model	J	..... Japanese model
A	..... Australian model		

## NX-P150

### ● NX-S150

**Type / 型式** ..... Full Range Acoustic Suspension  
Magnetic Shielding Type

**Driver / スピーカーユニット**  
..... 5 cm (2") Cone Magnetic Shielding Type x 2

**Frequency Response / 再生周波数帯域**  
..... 100 Hz to 25 kHz

**Impedance / インピーダンス** ..... 6 Ω

**Nominal Input / 許容入力** ..... 45 W

**Maximum Input / 最大入力** ..... 100 W

**Sensitivity / 出力音圧レベル** ..... 86 dB/2.83 V/m

**Input Terminal / 入力端子** ..... Push Type

**Dimensions (W x H x D) / 寸法 幅 x 高さ x 奥行き )**  
..... 72 mm x 170 mm x 108 mm  
(2-13/16" x 6-11/16" x 4-1/4")

**Weight / 質量** ..... 0.9 kg (2 lbs.)

**Finish / 仕上げ** ..... Black (U, C, A models)  
Silver color (U, C, R, T, K, A, B, G, E, L, J models)

**Accessories / 付属品** ..... Nonskid Pads x 16  
Mounting Bracket x 4, Screws x 4

**Appropriate Speaker Stand / 適応スピーカースタンド** ... SPS-80

**Appropriate Speaker Bracket / 適応ブラケット** ... SPM-8S

### ● NX-C150

**Type / 型式** ..... Full Range Acoustic Suspension  
Magnetic Shielding Type

**Driver / スピーカーユニット**  
..... 5 cm (2") Cone Magnetic Shielding Type x 2

**Frequency Response / 再生周波数帯域**  
..... 100 Hz to 25 kHz

**Impedance / インピーダンス** ..... 6 Ω

**Nominal Input / 許容入力** ..... 45 W

**Maximum Input / 最大入力** ..... 100 W

**Sensitivity / 出力音圧レベル** ..... 86 dB/2.83 V/m

**Input Terminal / 入力端子** ..... Push Type

**Dimensions (W x H x D) / 寸法 幅 x 高さ x 奥行き )**  
..... 300 mm x 72 mm x 105 mm  
(11-13/16" x 2-13/16" x 4-1/8")

**Weight / 質量** ..... 1.1 kg (2 lbs. 6 oz.)

**Finish / 仕上げ** ..... Black (U, C, A models)  
Silver color (U, C, R, T, K, A, B, G, E, L, J models)

**Accessories / 付属品** ..... Fasteners x 2

### ● NX-SW150

**Type / 型式** ..... Advanced Yamaha Active Servo Technology

**Output Power / 出力** ..... 50 W (100 Hz, 5 Ω, 10 % THD)

**Dynamic Power / ダイナミックパワー** ..... 100 W, 5 Ω

**Input Impedance / 入力インピーダンス** .. INPUT (PJ): 12 kΩ

**Frequency Response / 再生周波数帯域** .... 30 Hz to 200 Hz

**Driver / スピーカーユニット** ..... 16 cm (6-1/2") cone  
Magnetic Shielding Type

**Input Section / 入力部**

INPUT ..... RCA Pin Jack

SYSTEM CONNECTOR ..... Mono Mini Jack

**Power Supply / 電源**

U, C models ..... AC 120 V, 60 Hz

R, T, K, L models .. AC 110-120/220-240 V, 50/60 Hz

A model ..... AC 240 V, 50 Hz

B, G, E models ..... AC 230 V, 50 Hz

J model ..... AC 100 V, 50/60 Hz

**Power Consumption / 消費電力**

U, C, R, T, K, A, B, G, E, L models ..... 40 W

J model ..... 25 W

**Dimensions (W x H x D) / 寸法 幅 x 高さ x 奥行き )**  
..... 200 mm x 365 mm x 390 mm  
(7-7/8" x 14-7/20" x 15-5/16")

**Weight / 質量** ..... 8.4 kg (18 lbs. 8 oz.)

**Finish / 仕上げ** ..... Black (U, C, A models)  
Silver color (U, C, R, T, K, A, B, G, E, L, J models)

**Accessories / 付属品** ..... Subwoofer Cable (5 m) x 1  
System Control Cable (5 m) x 1  
Nonskid Pad x 4

\* Specifications subject to change without notice.

<b>U</b> ..... <i>USA model</i>	<b>B</b> ..... <i>British model</i>
<b>C</b> ..... <i>Canadian model</i>	<b>G</b> ..... <i>European model</i>
<b>R</b> ..... <i>General model</i>	<b>E</b> ..... <i>South European model</i>
<b>T</b> ..... <i>Chinese model</i>	<b>L</b> ..... <i>Singapore model</i>
<b>K</b> ..... <i>Korean model</i>	<b>J</b> ..... <i>Japanese model</i>
<b>A</b> ..... <i>Australian model</i>	



Manufactured under license from Dolby Laboratories.  
 "Dolby", "Pro Logic" and the double-D symbol are trademarks of  
 Dolby Laboratories.

ドルビーラボラトリーズからの実施権により製造されています。  
 「ドルビー」、「PRO LOGIC」およびダブルD記号  は、ドル  
 ビーラボラトリーズの商標です。



"DTS" and "DTS Digital Surround" are registered trademarks of  
 Digital Theater Systems, Inc.

DTS およびDTS デジタルサラウンドはデジタルシアターシステム  
 ズの登録商標です。



AAC ロゴマーク  はドルビーラボラトリーズの登録商標です。

"SILENT CINEMA" is a trademark of YAMAHA CORPORATION.  
 「サイレントシアター / SILENT THEATER」はヤマハ株式会社の  
 登録商標です。

**DIMENSIONS / 寸法図**

● DVR-S150

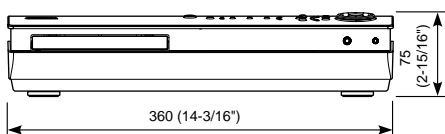
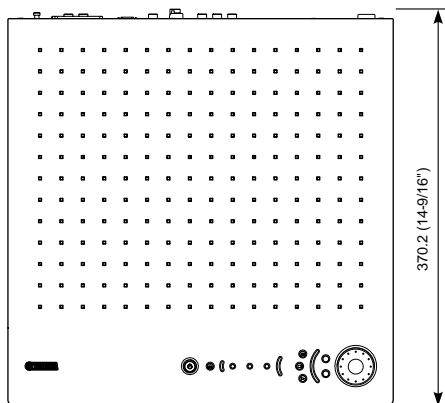

● NX-SW150

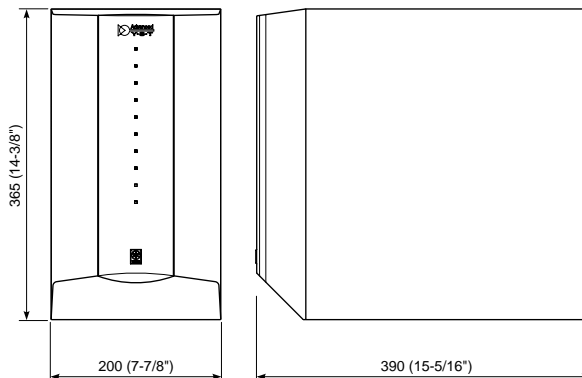

● NX-C150

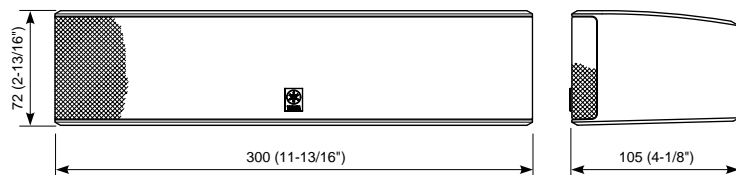

● NX-S150

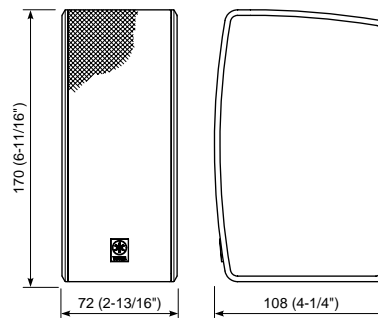

Unit : mm (inch)

DVR-S150  
NX-P150



■ INTERNAL VIEW

▼ DVR-S150

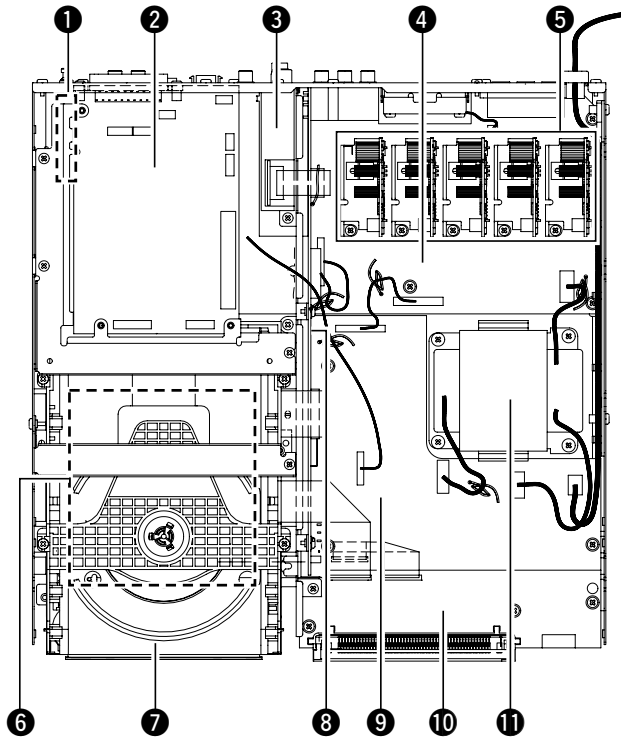

- ① SUB (3) P.C.B.
- ② DVD P.C.B.
- ③ AM/FM TUNER
- ④ MAIN (1) P.C.B.
- ⑤ D-AMP MODULE
- ⑥ DIGITAL P.C.B.
- ⑦ DVD MECHANISM
- ⑧ MAIN (2) P.C.B.
- ⑨ SUB (1) P.C.B.
- ⑩ MAIN (3) P.C.B.
- ⑪ POWER TRANSFORMER

▼ NX-SW150

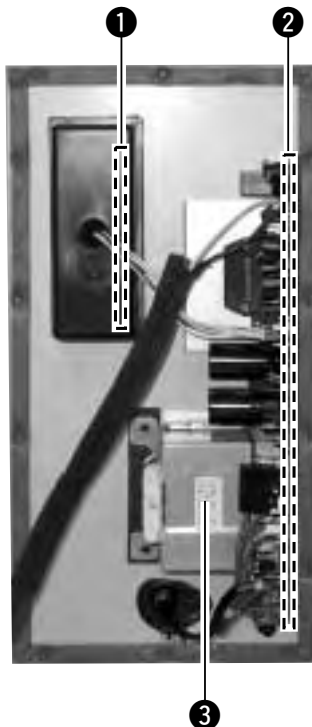

- ① MAIN (2) P.C.B.
- ② MAIN (1) P.C.B.
- ③ POWER TRANSFORMER

DVR-S150  
NX-P150

## ■ DVR-S150 DISASSEMBLY PROCEDURES / DVR-S150分解手順

(Remove parts in disassembly order as numbered.)

(番号順に部品を取り外してください。)

### 1. Removal of Side Cover L/R

- Remove 1 screw ( ① ) in Fig. 1.
- Lift the Side Cover L at the rear and move it rear-ward slantingly.
- Remove 1 screw ( ② ) in Fig. 1.
- Lift the Side Cover R at the rear and move it rear-ward slantingly.

### 1. サイドカバーL/Rの外し方

- ①のネジ1本を外します。( Fig. 1 )
- サイドカバーLを後方へスライドさせ取り外します。
- ②のネジ1本を外します。( Fig. 1 )
- サイドカバーRを後方へスライドさせ取り外します。

### 2. Removal of Bottom Cover

- Remove 2 screws ( ③ ) in Fig. 2.
- Spread soft cloth and place this unit upside down on it.
- Remove 4 screws ( ④ ) in Fig. 2.
- Release 1 hook and remove the Bottom Cover toward the Front Panel side in Fig. 2.

### 2. ボトムカバーの外し方

- ③のネジ2本を外します。( Fig. 2 )
- 柔らかい布を敷いた上に、本機を上下反転して置きます。( Fig. 2 )
- ④のネジ4本を外します。( Fig. 2 )
- フック1ヶ所を外し、ボトムカバーをフロントパネル側に外します。( Fig. 2 )

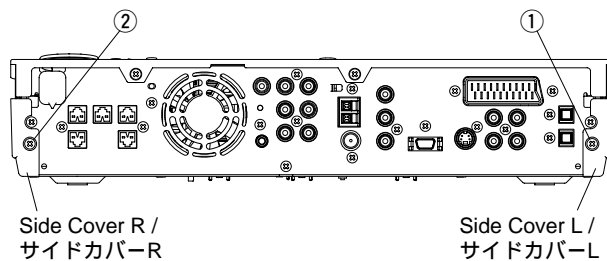
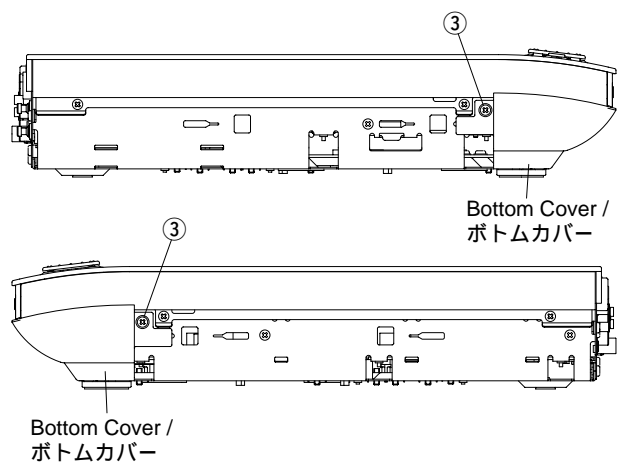

Fig. 1



### ● Bottom view

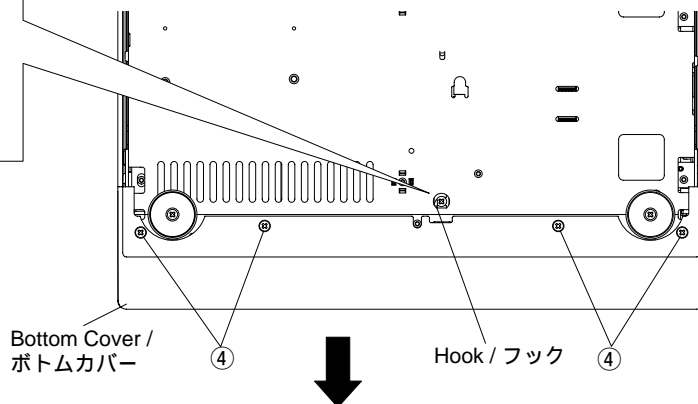

Fig. 2

### ● HOW TO MANUALLY EJECT THE TRAY

- Remove the Side Cover L/R.
- Remove the Bottom Cover.
- Move the slider in the direction indicated.
- Gently pull the tray out.

### ● 手動でトレイを開く方法

- サイドカバーL/Rを外します。
- ボトムカバーを外します。
- スライダーを矢印の方向に動かします。
- トレイをそっと引き出します。

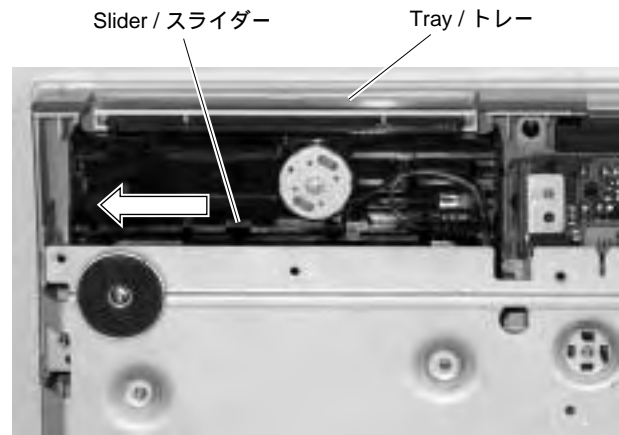

### 3. Removal of Top Unit

- Remove 1 screw ( ⑤ ) in Fig. 3.
- Remove connectors CB221, CB222 and CB278 in Fig. 3.
- Turn this unit again to set it upside up.
- Remove 6 screws ( ⑥ ) and 2 screws ( ⑦ ) in Fig. 4.
- Remove the Top Unit.

### 3. トップユニットの外し方

- ⑤のネジ1本を外します。( Fig. 3 )
- コネクターCB221、CB222、CB278を外します。( Fig. 3 )
- 再び、本機を上下反転して置きます。
- ⑥のネジ6本、⑦のネジ2本を外します。( Fig. 4 )
- トップユニットを外します。

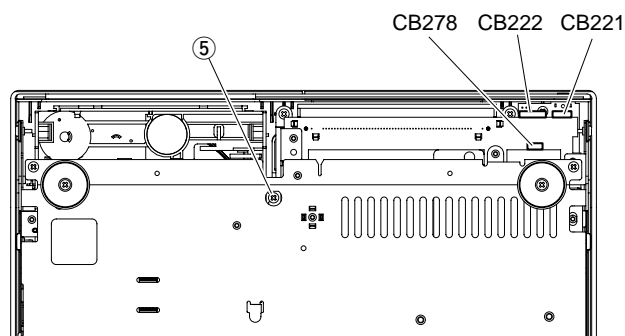

Fig. 3

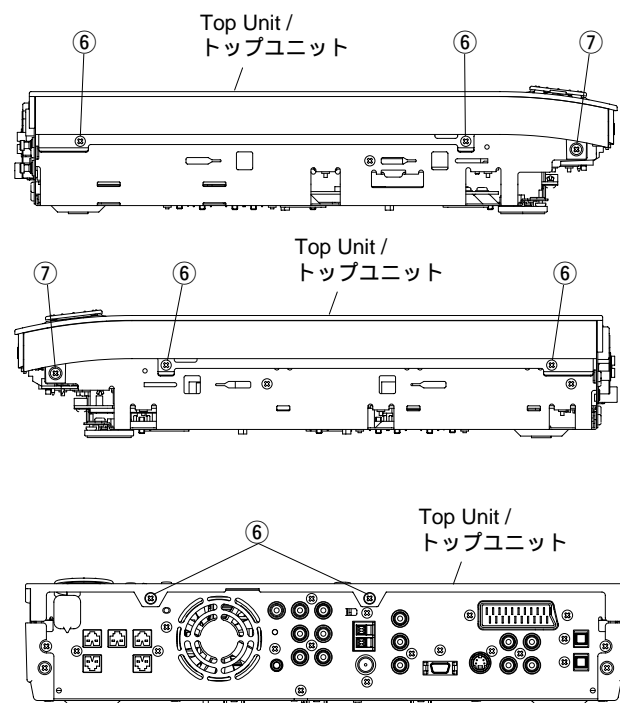

Fig. 4

**4. Removal of DVD Mechanism**

- a. Remove 2 screws ( ⑧ ) and then remove the Top Frame in Fig. 5.
- b. Remove 3 screws ( ⑨ ) in Fig. 5.
- c. Remove 2 screws ( ⑩ ) in Fig. 5. (G, B, E models only)
- d. Remove the DVD support and the DVD P.C.B. in Fig. 5.
- e. Remove connectors 1601, 1603, 1615, 1618, 1619 and 1620 in Fig. 6.
- f. Remove connector CB3 in Fig. 7.
- g. Remove 4 screws ( ⑪ ) and then remove the DVD Mechanism in Fig. 7.

**4. DVDメカニズムの外し方**

- a. ⑧のネジ2本を外し、トップフレームを外します。( Fig. 5 )
- b. ⑨のネジ3本を外します。( Fig. 5 )
- c. ⑩のネジ2本を外します。( G, B, E models only )( Fig. 5 )
- d. DVDサポート & DVD P.C.B.を外します。( Fig. 5 )
- e. コネクター1601、1603、1615、1618、1619、1620を外します。( Fig. 6 )
- f. コネクターCB3を外します。( Fig. 7 )
- g. ⑪のネジ4本を外し、DVDメカニズムを外します。( Fig. 7 )

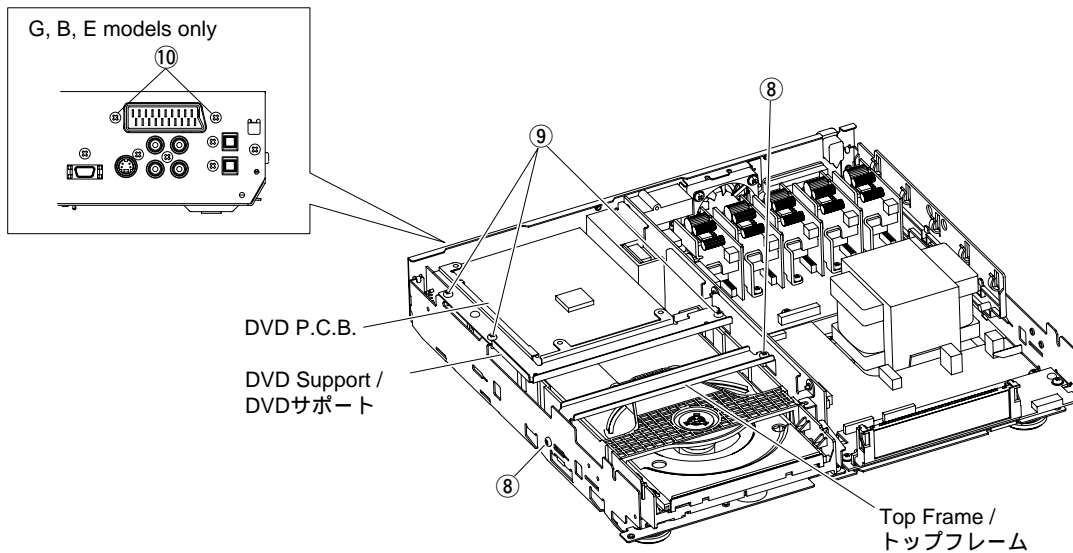

Fig. 5

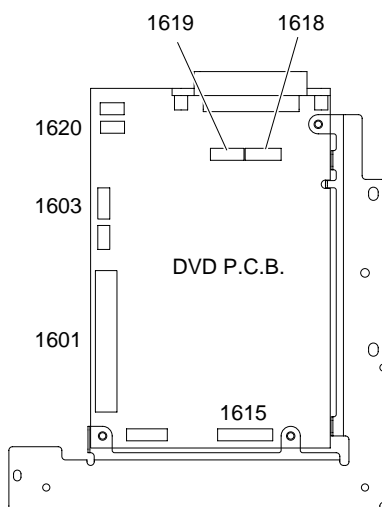

Fig. 6

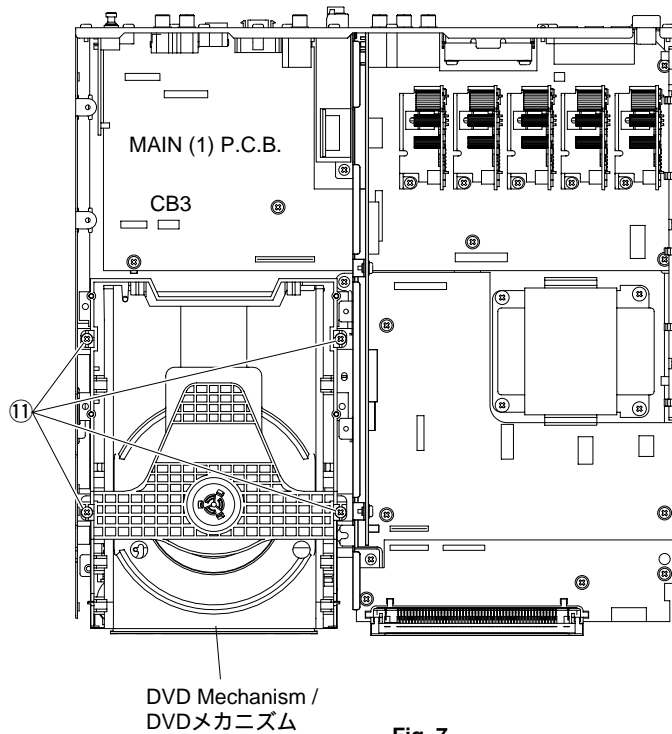

Fig. 7

DVR-S150  
NX-P150

### 5. Removal of DIGITAL P.C.B.

- Remove connectors CB1, CB3 and CB5 in Fig. 8.
- Remove 4 screws ( ⑫ ) and then remove the DIGITAL P.C.B. in Fig. 8.

### 5. DIGITAL P.C.B.の外し方

- コネクターCB1、CB3、CB5を外します。( Fig. 8 )
- ⑫のネジ4本を外し、DIGITAL P.C.B.を外します。( Fig. 8 )

### 6. Removal of D-Amp Module

Remove 5 screws ( ⑬ ) and then remove the D-Amp Modules in Fig. 8.

### 6. D-AMPモジュールの外し方

⑬のネジ5本を外し、D-アンプモジュールを外します。( Fig. 8 )

### 7. Removal of MAIN (3) P.C.B.

- Remove connector CB224 in Fig. 8.
- Remove 3 screws ( ⑭ ) and 1 push rivet ( ⑮ ) and then remove the MAIN (3) P.C.B. in Fig. 8.

### 7. MAIN (3) P.C.B.の外し方

- コネクターCB224を外します。( Fig. 8 )
- ⑭のネジ3本、⑮のプッシュリベット1本を外し、MAIN (3) P.C.B.を外します。( Fig. 8 )

### 8. Removal of AM/FM Tuner

- Remove connector CB121 in Fig. 8.
- Remove 2 screws ( ⑯ ) and then remove the AM/FM Tuner in Fig. 8.

### 8. AM/FMチューナーの外し方

- コネクターCB121を外します。( Fig. 8 )
- ⑯のネジ2本を外し、AM/FMチューナーを外します。( Fig. 8 )

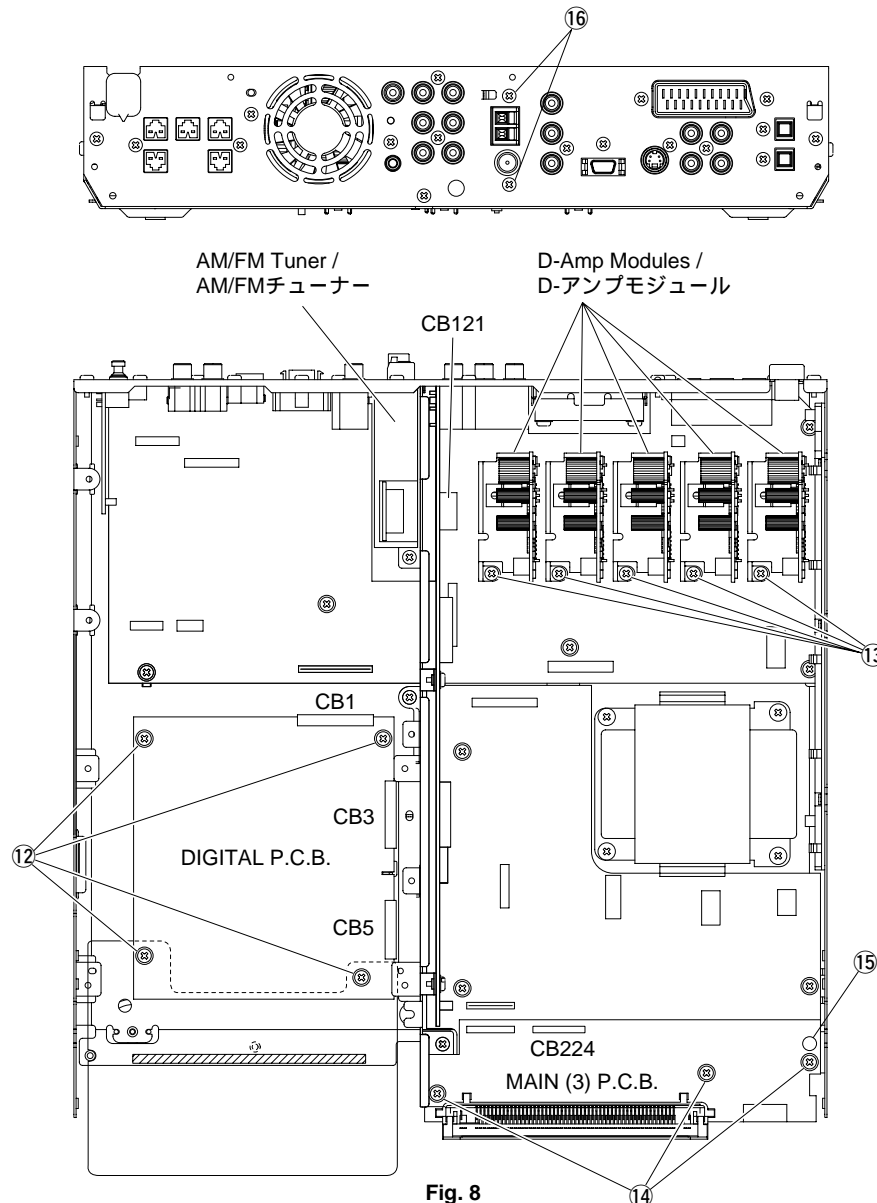

Fig. 8

**9. Removal of MAIN (2) & SUB (1) P.C.B.**

- a. Remove 2 screws ( 17 ) in Fig. 9.
- b. Remove 3 screws ( 18 ) and then remove the Shield in Fig. 9.
- c. Remove 2 screws ( 19 ) in Fig. 9.
- d. Remove 2 screws ( 20 ) and 1 screw ( 21 ) in Fig. 9.
- e. Remove connectors CB2, CB124, CB275, CB276 and CB277 in Fig. 9.
- f. Remove the MAIN (2) & SUB (1) P.C.B. in Fig. 9.

**10. Removal of MAIN (1) & SUB (3) P.C.B.**

- a. Remove 2 screws ( 22 ) and then remove the Power Cable Support in Fig. 9.
- b. Remove 3 screws ( 23 ) and 2 screws ( 24 ) in Fig. 9.
- c. Remove connector CB17 in Fig. 9.
- d. Remove 3 screws ( 25 ) in Fig. 9.
- e. Remove the MAIN (1) & SUB (3) P.C.B. with the Rear Panel attached to it in Fig. 9.

**9. MAIN (2) & SUB (1) P.C.B.の外し方**

- a. 17のネジ2本を外します。( Fig. 9 )
- b. 18のネジ3本を外し、シールドを外します。( Fig. 9 )
- c. 19のネジ2本を外します。( Fig. 9 )
- d. 20のネジ2本、21のネジ1本を外します。( Fig. 9 )
- e. コネクターCB2、CB124、CB275、CB276、CB277を外します。( Fig. 9 )
- f. MAIN (2) & SUB (1) P.C.B.を外します。( Fig. 9 )

**10. MAIN (1) & SUB (3) P.C.B.の外し方**

- a. 22のネジ2本を外し、パワーコードサポートを外します。( Fig. 9 )
- b. 23のネジ3本、24のネジ2本を外します。( Fig. 9 )
- c. コネクターCB17を外します。( Fig. 9 )
- d. 25のネジ3本を外します。( Fig. 9 )
- e. リアパネルが付いた状態でMAIN (1) & SUB (3) P.C.B.を外します。( Fig. 9 )

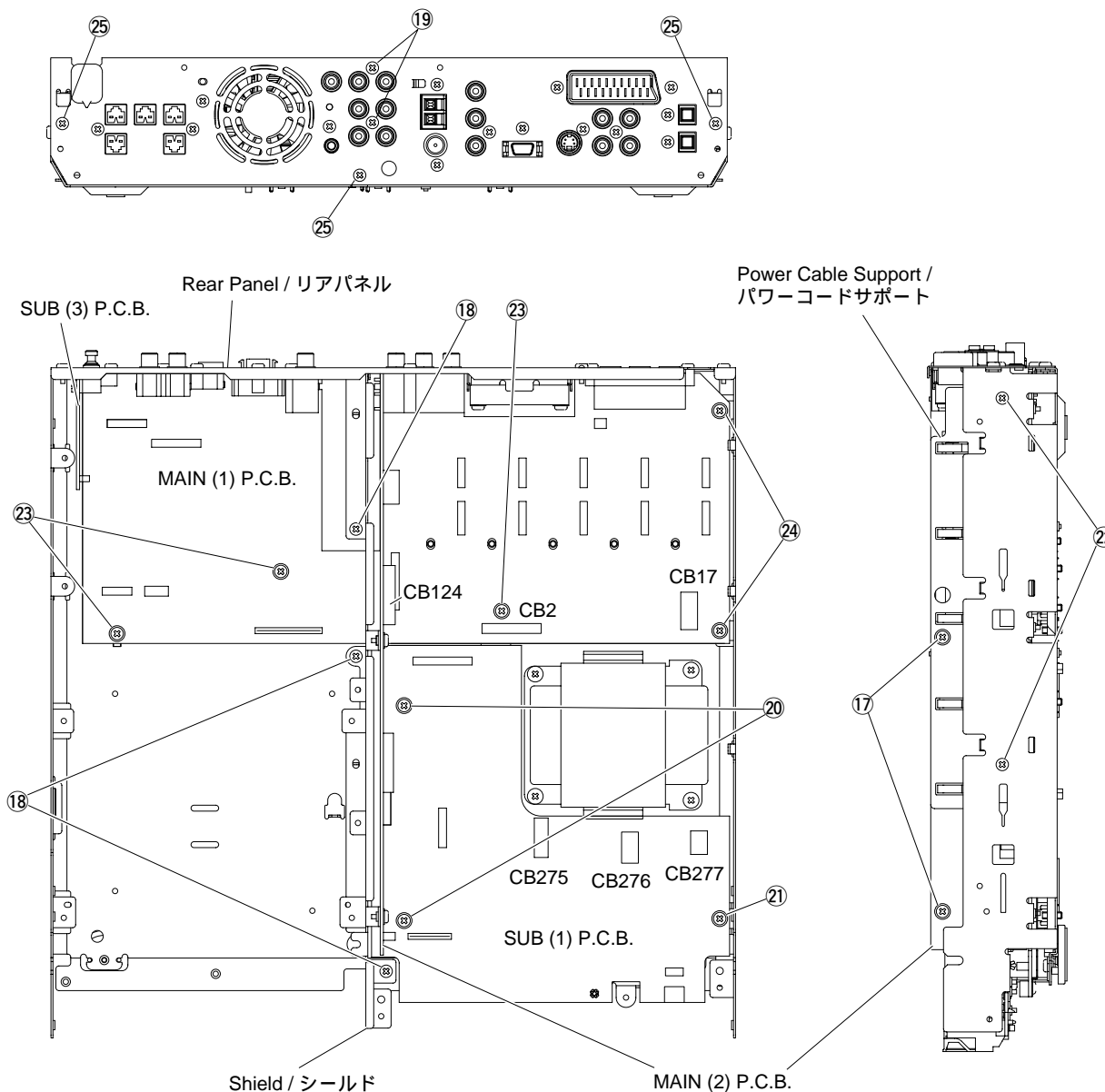
**Fig. 9**

## ■ NX-SW150 DISASSEMBLY PROCEDURES / NX-SW150分解手順

(Remove parts in disassembly order as numbered.)

(番号順に部品を取り外してください。)

### 1. Removal of Front Grille

**The Front Grille is fixed to the cabinet with dowels at 6 locations. As a screwdriver (for slotted head screw) is used for removal, use special care not to cause damage to the cabinet.**

- Using the screwdriver inserted in the gap between the Front Grille and the cabinet (bottom side first), push up the Front Grille.
- Remove the Front Grille by lifting it up.

\* **When installing the Front Grille, apply quick-drying bond to the dowels and then fit them into dowel holes for secure installation. (The Front Grille will come off easily if its dowels are fitted into dowel holes only.)**

### 2. Removal of Rear Panel

Remove 14 screws (①) in Fig. 2.

\* **Arrow marks (⇒) are printed to identify the screws to be removed.**

\* **When assembling the Rear Panel, check to ensure that the packing is not damaged so as to prevent air leakage from occurring.**

### 1. フロントグリルの外し方

フロントグリルは6箇所のダボで固定されています。取り外しの際、本体に傷が付かないよう十分注意してください。

- 底側からマイナスドライバー等を差し込み、フロントグリルを押し上げます。(Fig. 1)
- 徐々に上面へマイナスドライバー等で押し上げて、フロントグリルを外します。

\* 取り付け時には、フロントグリルのダボに速乾ボンドなどを塗って差し込み、固定してください。(フロントグリルを差し込むだけでは、簡単にはずれてしまいます。)

### 2. リアパネルの外し方

①のネジ14本を外し、リアパネルを取り出します。

(Fig. 2)

- \* 取り外すネジの箇所には矢印(マーク)が印刷されています。
- \* 組み立ての際は、パッキングの損傷など無いことを確認し、エア漏れが発生しないように組み立ててください。

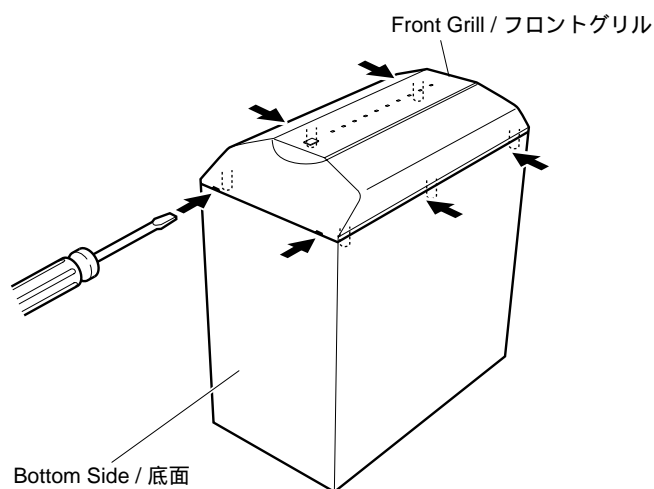

Fig. 1

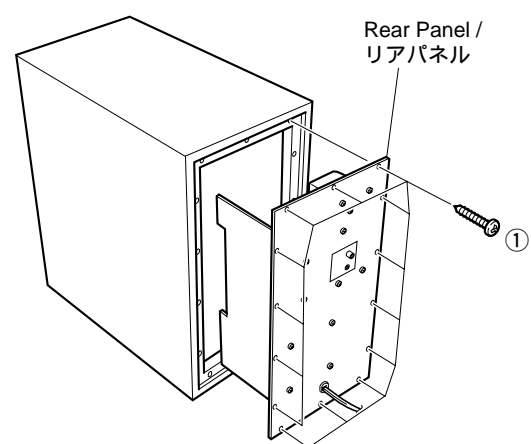

Fig. 2

When checking the P.C.B.:

Turn on the power to NX-SW150 according to the following procedure.

- Short between the terminals of RY2 (relay).
- Connect the power cable to the AC power outlet.

P.C.B.動作チェックをする場合

下記の方法により NX-SW150 に電源を投入します。

- RY $\alpha$  (リレー)の端子間をショートします。
- 電源コードを AC 電源コンセントに接続します。

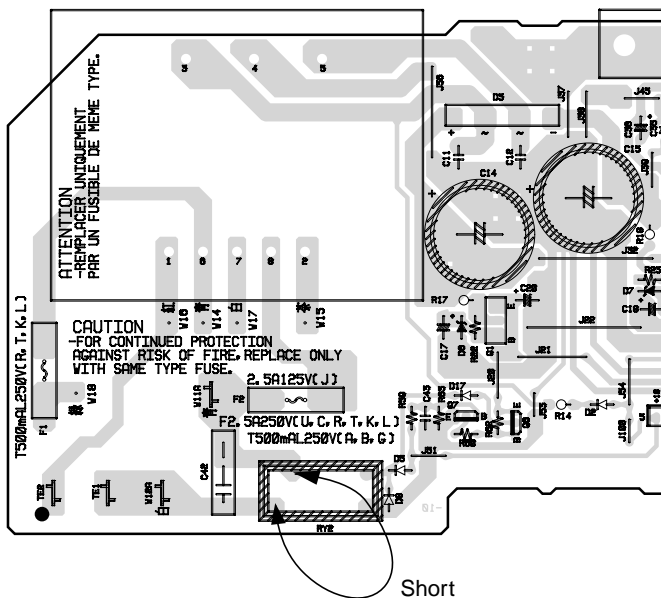

Short between these terminals for the P.C.B. check.

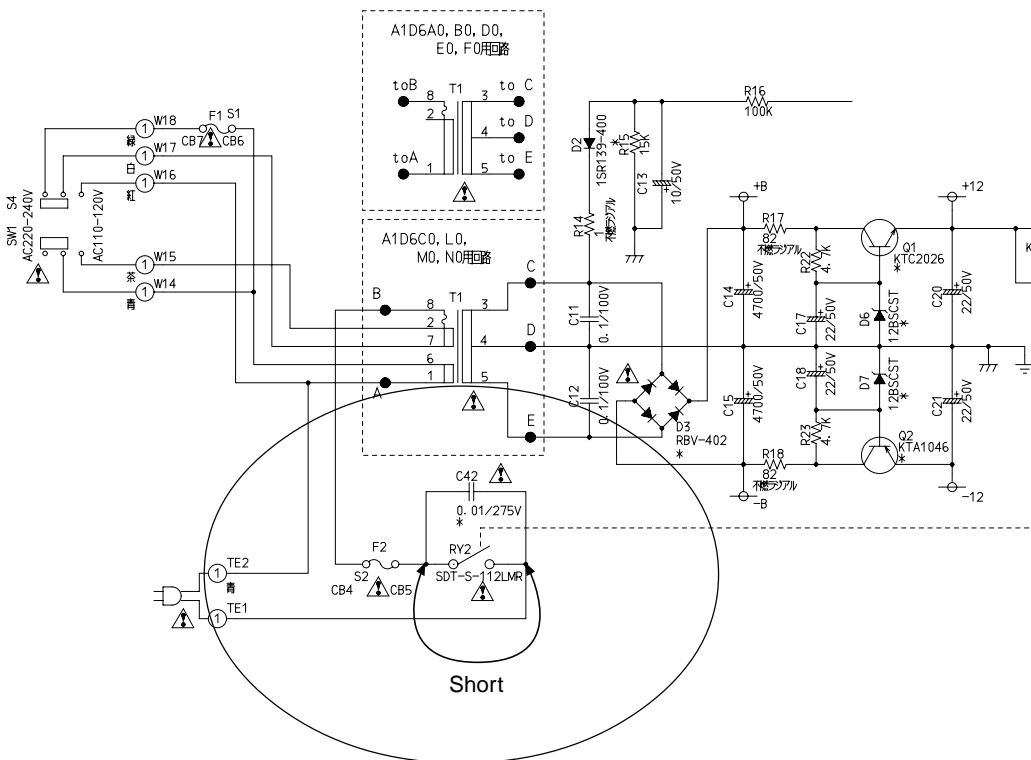

DVR-S150  
NX-P150



## ■ DVR-S150 TRAY LOCK MODE / DVR-S150 トレーロックモード

This unit has a "Tray Lock" mode. This function prevents the tray from opening even when the "▲" (open/close) key is pressed.

本機には、「▲」(オープン/クローズ)キーを押してもトレイが開かない「トレーロック」モードがあります。

### ● Setting Tray Lock mode

Start with the power of the unit turned off.

1. While pressing the "◀◀/▶▶" button, keep pressing the "STANDBY/ON" key.
2. After about 5 seconds, the Tray Lock mode is set.

### トレーロックモードの起動

本体の電源をオフの状態から行います。

1. 本体の「◀◀/▶▶」キーを押しながら「STANDBY/ON」キーを押し続けます。
2. 約5秒後、トレーロックモードが起動します。

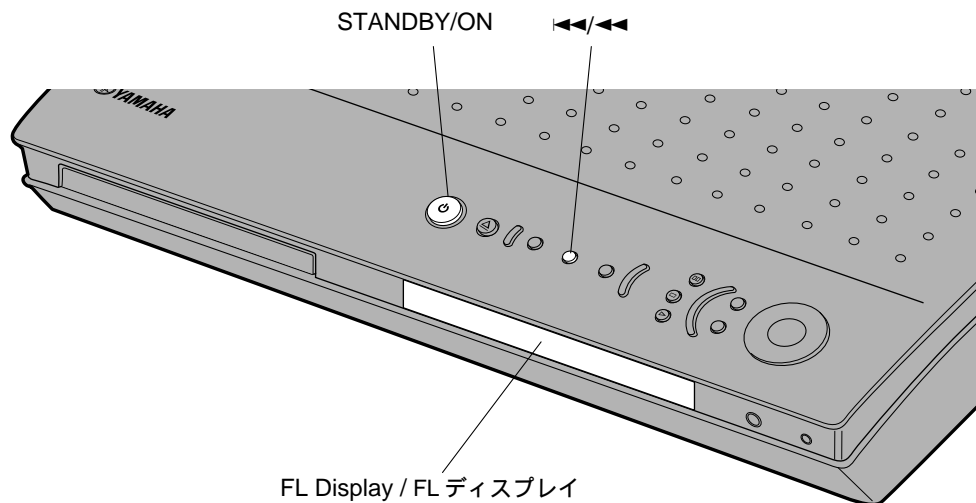

TRAY LOCK MODE display / トレーロックモード表示

Tray Locked

*\* Even after the Tray Lock mode is set, all functions remain the same as usual except the "▲" (open/close) key.*

トレーロックモード起動後、「▲」(オープン/クローズ)キー以外の操作は通常通り行うことができます。

### ● Canceling Tray Lock mode

Start with the power of the unit turned off.

1. While pressing the "◀◀/▶▶" button, keep pressing the "STANDBY/ON" key.
2. After about 5 seconds, the Tray Lock mode is cancelled.

### トレーロックモードの解除

本体の電源をオフの状態から行います。

1. 本体の「◀◀/▶▶」キーを押しながら「STANDBY/ON」キーを押し続けます。
2. 約5秒後、トレーロックモードが解除されます。

TrayUnlocked

## ■ DVR-S150 SELF DIAGNOSIS FUNCTION (DIAG) / DVR-S150自己診断機能(ダイアグ)

This product has a built-in self diagnosis function (DIAG) to facilitate inspection, measurement and determination of a faulty item, if any. There are 16 DIAG menu items, each having sub-menu items.

Listed in the table below are menu items and sub-menu items. (Start-up and operation of DIAG menu are executed by using the main unit.)

本機には、検査、測定、不良個所の発見を目的にした自己診断機能(ダイアグ)があります。

ダイアグメニューは16個あり、そのそれぞれにサブメニューがあります。

下表はメニュー一覧です。

(ダイアグのメニュー操作は本体で行います。)

No.	DIAG menu	Sub-menu
1	DSP THROUGH	1. YSS MARGIN
		2. YSS FULL BIT
2	BYPASS	1. ANALOG BYPASS
		2. DSP BYPASS
3	RAM THROUGH	1. RAM MARGIN
		2. RAM FULL BIT
4	PRO LOGIC	1. PRO LOGIC I
		2. PRO LOGIC II
5	SPEAKERS SET	1. FRONT: SML 0dB
		2. CENTER: NONE
		3. LFE/B: FRNT
		4. Pres Mix: 5ch
6	MIC CHECK	1. MIC CHK -- d
7	DISPLAY CHECK	1. VFD CHECK (Initial display / 初期表示)
		2. VFD DISP OFF (All segments OFF / 全セグメント消灯)
		3. VFD DISP ALL (All segments ON 100% / 全セグメント点灯 100%)
		4. VFD DIMMER (All segments ON 50% / 全セグメント点灯 50%)
		5. CHECKED PATTERN (ON in lattice / 格子状点灯)
8	MANUAL TEST	1. TEST ALL
		2. TEST FRNT L
		3. TEST CENTER
		4. TEST FRNT R
		5. TEST SURR R
		6. TEST SURR L
		7. TEST LFE
9	FACTORY PRESET	1. PRESET INHI (memory initialization inhibited / メモリーの初期化禁止)
		2. PRESET RSRV (memory initialized / メモリーの初期化)
10	AD DATA CHECK /FAN TEST	1. PS (protection)
		2. PANEL KEY
		3. FAN OUT/THM
		4. FAN DRIVE TEST: HIGH
		5. FAN DRIVE TEST: MID
		6. FAN DRIVE TEST: LOW
11	IF STATUS	1. INSIDE STATUS 1
		2. INSIDE STATUS 2
		3. CHANNEL STATUS 1
		4. CHANNEL STATUS 2
		5. CHANNEL STATUS 3
		6. CHANNEL STATUS 4
		7. CHANNEL STATUS 5
		8. BS 1
		9. BS 2

No.	DIAG menu	Sub-menu
		10. BS 3
		11. BS 4
		12. BS 5
		13. BS 6
		14. BS 7
		15. TI 1
		16. TI 2
		17. Mute Trigger
12	DSP RAM CHECK	1. YSS BUS
		2. SD BUS
13	PROTECTION SETTING (Not applied to these models)	1. PS L
		2. PS H
		3. DC L
		4. DC H
		5. FAN_0
		6. FAN_1
		7. FAN_2
		8. FAN_3
		9. FAN_4
		10. FAN_5
		11. TEMP
		12. PL_8_M_L:
		13. PL_8_M_H:
		14. PL_8_N_L:
		15. PL_8_N_H:
		16. PL_6_M_L:
		17. PL_6_M_H:
		18. PL_6_N_L:
		19. PL_6_N_H:
14	SOFT SWITCH	1. SW MODE: PCB/SOFT
		2. MODEL SETTING
		3. TUNER DESTINATION
		4. TUNER EXIST
		5. RDS EXIST
		6. VIDEO FORMAT
15	ROM VERSION/CHECK SUM/ PORT	1. VERSION
		2. CHECK SUM ALL
		3. PORT
		4. AAC PORT
16	ROM CORRECTION/ CHECK SUM	1. SOFT DATE
		2. ROM CORRECTION: EXIST/NOT
		3. ROM CORRECTION CHECK SUM DISP
		4. ROM CORRECTION REMOCON RECEIVE
		5. REMOCON CODE DISP
		6. Protection History
		7. UCD CLOCK LOW/HIGH
		8. ASPECT Lo/Mid/Hi

## ● Starting DIAG

While pressing the "A/B/C/D/E" key on the main unit, press the "STANDBY/ON" key until the FL display lights up. Within 4 seconds after that, press the "PRESET/BAND" key to start the DIAG function.

## ダイアグの起動

本体の "A/B/C/D/E" キーを押しながら "STANDBY/ON" キーを押し、表示点灯後4秒以内に "PRESET/BAND" キーを押すとダイアグが起動します。

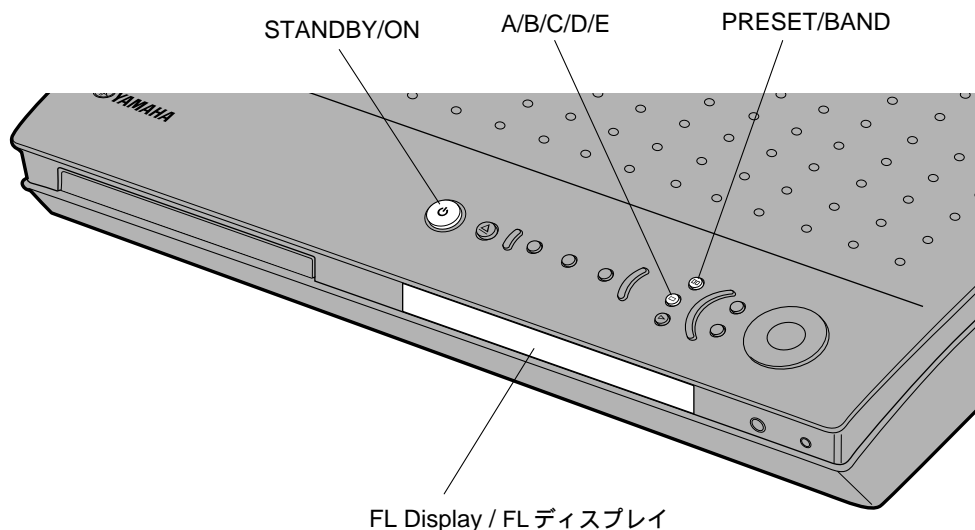

\* *In the DIAG mode, all the protection functions other than the excess current detect function are canceled, and the "SLEEP" segment of the FL display of the main unit flashes. Please note, therefore, that no protection function works even when a dangerous situation occurs while using the DIAG mode.*

ダイアグモードでは過電流検出以外のプロテクション動作が解除されます。  
このモードでは本体FLディスプレイの "SLEEP" が点滅します。  
以後、ダイアグ中、危険な状態でもプロテクション動作が働きませんので注意してください。

## ● Canceling DIAG

- 1 Before canceling DIAG, execute setting for PRESET of DIAG menu No.9 (Memory initialization inhibited or Memory initialized).
- \* *In order to keep the user memory stored, be sure to select PRESET INHIBITED (Memory initialization inhibited). Protection history will remain in memory.*
- 2 Turn off the power by pressing the "STANDBY/ON" key of the main unit.

## ダイアグの解除

- 1 ダイアグを解除する前に、ダイアグメニュー No. 9 の FACTORY PRESET (メモリーの初期化禁止/またはメモリーの初期化) の設定をします。  
ユーザーメモリーを保持したい場合は、必ず PRESET INHIBITED (メモリー初期化禁止) を選択してください。
- 2 本体の "STANDBY/ON" キーを押し、パワーオフにします。

## ● Display provided when DIAG started

On the FL display of the main unit, an opening message (the protection history) appears for a few seconds followed by the diagnostic menu display of YSS MARGIN.

## ダイアグ起動時の表示

本体FLディスプレイには、オープニング(プロテクション履歴)が表示され、数秒後にダイアグメニュー表示(YSS MARGIN)となります。

### When there is no history of protection function:

プロテクション履歴が無い場合:

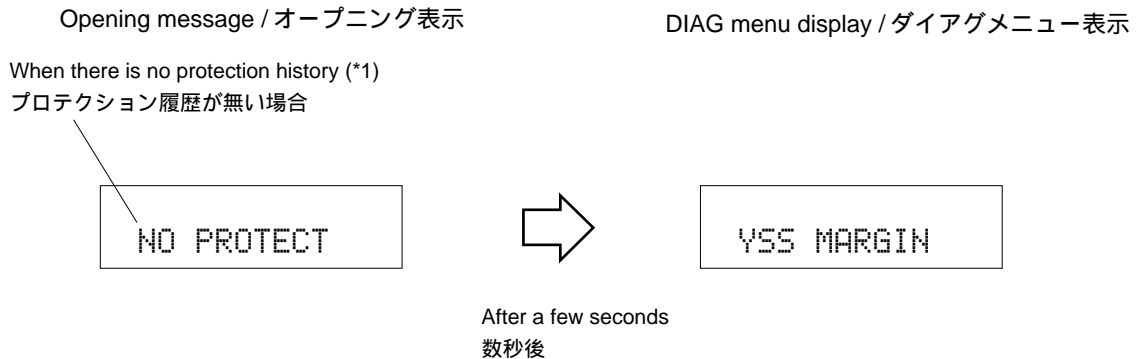

### When there is a history of protection function:

The FL display appears as shown below depending on the type of the protection function.

プロテクション履歴がある場合:

プロテクションの種類によって下記の表示が現れます。

The protection function worked due to excessive current through the amplifier. Causes could be a short at the speaker terminal or a defect in the amplifier.

I PROTECT

スピーカーをショートさせた時などが原因で、プロテクションが働いたことを示します。

The protection function worked due to a DC voltage appearing at the speaker terminal. A cause could be a defect in the amplifier.

DC PROTECT

アンプの故障でスピーカーに直流電圧が掛かるなどが原因で、プロテクションが働いたことを示します。

The protection function worked due to an AC overload. A cause could be a shorted secondary wire of the transformer.

AC PROTECT

トランスの二次巻き線がショートしたときなどが原因で、プロテクションが働いたことを示します。

The protection function worked due to the temperature limit being exceeded. Causes could be poor ventilation or a defect related to the thermal sensor.

TMP PRT:000

温度制限を越えた原因で、プロテクションが働いたことを示します。

The protection function worked due to a defect or overload in the power supply (but not related to the DVD). If the power is turned on with the abnormality unsolved, the protection function works in about 1 second to turn off the power.

PS PRT:000

電源( DVD関連以外 )による原因で、プロテクションが働いたことを示します。異常状態のままパワーオンすると、約1秒後にプロテクションが掛かり、電源が切れます。

The protection function worked due to a defect or overload in the DVD power supply. If the power is turned on with the abnormality unsolved, the protection function works in about 1 second to turn off the power.

PS2 PRT:000

電源( DVD関連 )による原因で、プロテクションが働いたことを示します。異常状態のままパワーオンすると、約1秒後にプロテクションが掛かり、電源が切れます。

The protection function worked due to a short at the sub-woofer control terminal or connection of the cable to the sub-woofer control terminal with the power turned on.

U3 PROTECT

サブウーファーコントロール端子がショートしたり、電源がオンの状態でサブウーファーコントロール端子にケーブルを接続することが原因で、プロテクションが働いたことを示します。

For detection of each protection function (except I-PROTECT), refer to DIAG menu No. 10 AD DATA CHECK described on page 36.

各プロテクションの検出に関しては、後述のダイアグメニューNo. 10 AD DATA CHECK( 36ページ )を参照してください。

#### ● History of protection function

When the protection function has worked, its history is stored in memory with a backup. Even if no abnormality is noted while servicing the unit, an abnormality which has occurred previously can be defined as long as the backup data has been stored.

The history of the protection function is cleared when DIAG is cancelled by selecting PRESET RESERVED (Memory initialized) of DIAG menu No.9 or by selecting Prt Hist < DEL (Protection history deletion reserved) of sub-menu 6 of DIAG menu No.16 and the backup data is erased.

#### プロテクションの履歴

プロテクションが働いた場合、履歴をバックアップして記憶しています。サービスのときに異常が認められなくても、バックアップが残っていれば、お客様のところで起きた異常を区別できます。

プロテクションの履歴は、ダイアグメニュー No.9 で PRESET RESERVED( メモリーの初期化 )を選んでダイアグを解除した場合や、ダイアグメニューNo.16のサブメニュー6で Prt Hist < DEL( プロテクション履歴削除の予約 )を選んでダイアグ解除した場合、バックアップが消えたときにはクリアされます。

#### ● Display during menu operation

During the DIAG operation, the function at work is indicated on the FL indicator. The contents displayed during the function operation are shown for each step.

#### メニュー動作中の表示

ダイアグ中、本体の FL ディスプレイに動作中の機能が表示されます。機能動作中の表示内容については、後述の機能詳細で記述します。

## ● Operation procedure of DIAG menu and SUB-MENU

There are 16 MENU items and some SUB-MENU items as well.

### DIAG menu selection

Main unit: PRESET TUNING ∨(forward)/∧(reverse) key

### SUB-MENU selection

Main unit: DSP (forward) key

## ダイアグメニューとサブメニューの操作

ダイアグにはNo.1～16のメニューがあり、さらにいくつかのサブメニューがあります。

### ダイアグメニューの選択

本体 : PRESET TUNING ∨(順送り)∧(逆送り)キー

### サブメニューの選択

本体 : DSP(順送り)キー

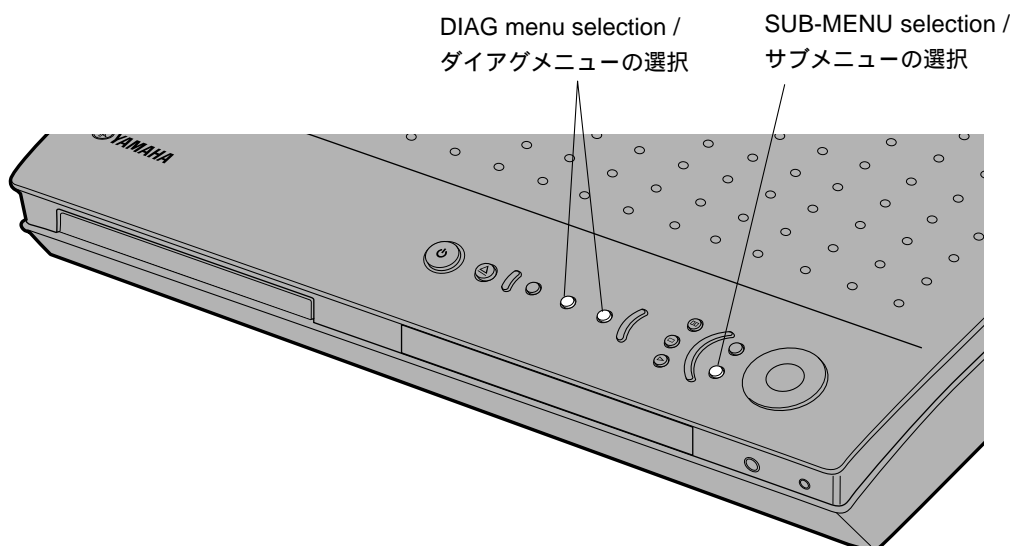

## ● Functions available during DIAG

In addition to the DIAG menu, the functions listed below are available:

- Input selection
- Center/Surround/Sub-woofer level adjustment
- Muting
- Power on/off operation
- Master volume

**\* Functions related to the tuner and the set menu are not available.**

**\* It is possible to confirm Menu No.11 "IF STATUS" while keeping the signal process (operation status) of each DIAG menu by using the INPUT MODE key of the main unit.**

### ダイアグ中の機能

ダイアグメニューの他に以下の機能が動作します。

- インプット切り換え
- センター/サラウンド/サブウーファーレベル調整
- ミューティング
- パワーオン・オフ操作
- マスターボリューム

\* チューナー関連、セットメニュー関連は機能しません。

\* 本体INPUTモードキーにより、各ダイアグメニューの信号処理(動作状態)を維持したままメニューNo. 11 "IF STATUS"の確認ができます。

## ● Initial settings used to start DIAG function

The following initial settings are used when starting the DIAG function:

(When the DIAG function is canceled, the settings before starting DIAG will be restored.)

- Input : VIDEO 1
- Master volume : 56 (-40dB)
- Effect level : 0dB
- Audio mute : OFF
- Speaker settings : LARGE /BASS OUT = BOTH
- DIAG menu : DSP THROUGH (YSS MARGIN)

### ダイアグ開始時の初期設定

ダイアグ開始時の初期設定は、下記の設定になります。また、これらの設定は、ダイアグ解除時にはダイアグ開始前の状態に戻ります。

- インプット : VIDEO 1
- マスターボリューム : 56 (-40dB)
- エフェクトレベル : 0dB
- オーディオミュート : オフ
- スピーカー設定 : LARGE / BASS OUT = BOTH
- ダイアグメニュー : DSP THROUGH (YSS MARGIN)

## Details of DIAG menu

With full-bit output specified in some modes, it is possible to execute 0dBFS output without head margin in each channel.

### 1. DSP THROUGH

Using the sub-menu, it is possible to select margin output or full-bit output.

#### MARGIN (0 dB)

- This signal is output including the head margin.

## ダイアグメニュー詳細

一部のモードでフルビット指定することで、各チャンネルのヘッドマージンを廃して0dBFS出力することが可能です。

### 1. DSP THROUGH

サブメニューにより MARGIN/Full Bit が選択可能です。

#### MARGIN (0 dB)

- ヘッドマージンを含んで出力されます。

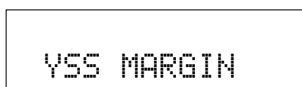

INPUT: VIDEO ANALOG

Input level	Volume	SPEAKERS OUT (1KHz)			SUBWOOFER (50 Hz)
		FRONT L/R	CENTER	SURROUND L/R	
Both ch, -20 dBm	86 (-10 dB)	+9.0 dBm	+9.0 dBm	+9.0 dBm	- 0.5 dBm

#### FULL BIT

- This signal is in digital full bit without including the head margin.

#### FULL BIT

- ヘッドマージンを含まず、デジタルフルビットで出力されます。

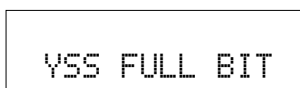

INPUT: VIDEO ANALOG

Input level	Volume	SPEAKERS OUT (1KHz)			SUBWOOFER (50 Hz)
		FRONT L/R	CENTER	SURROUND L/R	
Both ch, -20 dBm	86 (-10 dB)	+9.0 dBm	+9.0 dBm	+21.0 dBm	- 0.5 dBm

INPUT: ANALOG/PCM

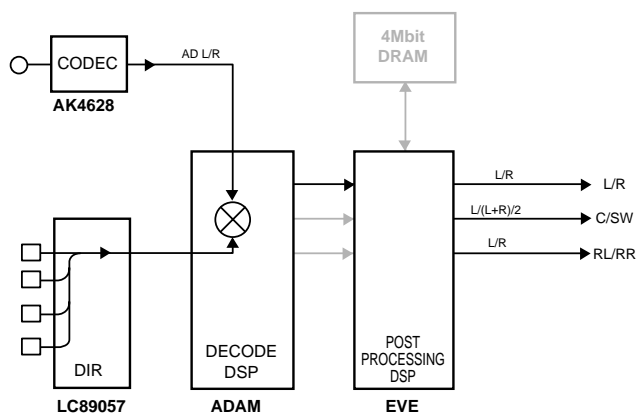

INPUT: DD/DTS/AAC

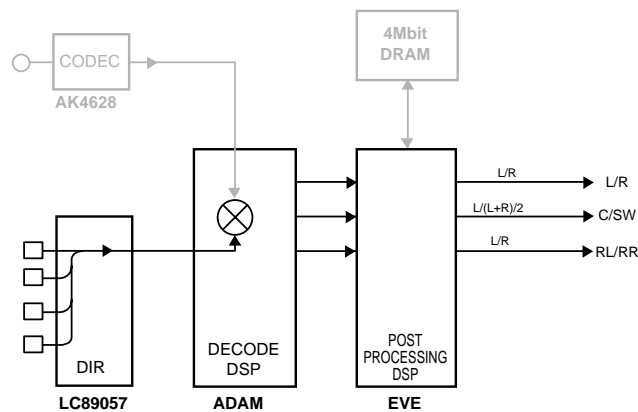

(Shaded items not used in this example)



**2. BYPASS**

Using the sub-menu, it is possible to select analog bypass output or DSP bypass output.

**ANALOG BYPASS**



INPUT: VIDEO ANALOG

Input level	Volume	SPEAKERS OUT (1KHz)			SUBWOOFER (50 Hz)
		FRONT L/R	CENTER	SURROUND L/R	
Both ch, -20 dBm	86 (-10 dB)	+9.5 dBm	- ∞	- ∞	- ∞

**2. BYPASS**

サブメニューにより ANALOG BYPASS/DSP BYPASS が選択可能です。

**ANALOG BYPASS**

**DSP BYPASS**



INPUT: VIDEO ANALOG

Input level	Volume	SPEAKERS OUT (1KHz)			SUBWOOFER (50 Hz)
		FRONT L/R	CENTER	SURROUND L/R	
Both ch, -20 dBm	86 (-10 dB)	- ∞	- ∞	- ∞	- ∞

**DSP BYPASS**

**ANALOG BYPASS**

INPUT: ANALOG

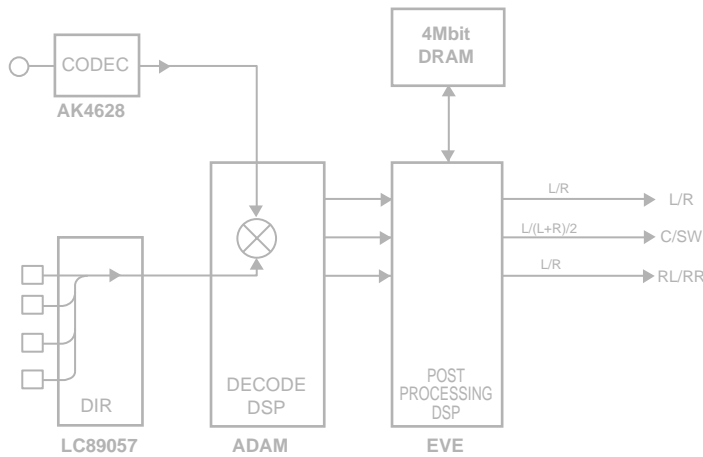

(Shaded items not used in this example)

### 3. RAM THROUGH

Using the sub-menu, it is possible to select margin output or full-bit output.

#### MARGIN (0 dB)

### 3. RAM THROUGH

サブメニューにより MARGIN/Full Bit が選択可能です。

#### MARGIN (0 dB)

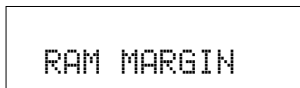

INPUT: VIDEO ANALOG

Input level	Volume	SPEAKERS OUT (1KHz)			SUBWOOFER (50 Hz)
		FRONT L/R	CENTER	SURROUND L/R	
Both ch, -20 dBm	86 (-10 dB)	+9.0 dBm	+9.0 dBm	+9.0 dBm	-0.5 dBm

#### FULL BIT

#### FULL BIT

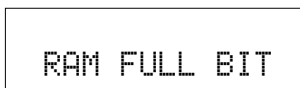

INPUT: VIDEO ANALOG

Input level	Volume	SPEAKERS OUT (1KHz)			SUBWOOFER (50 Hz)
		FRONT L/R	CENTER	SURROUND L/R	
Both ch, -20 dBm	86 (-10 dB)	+9.0 dBm	+9.0 dBm	+21.0 dBm	-0.5 dBm

#### RAM THROUGH

INPUT: ANALOG/PCM

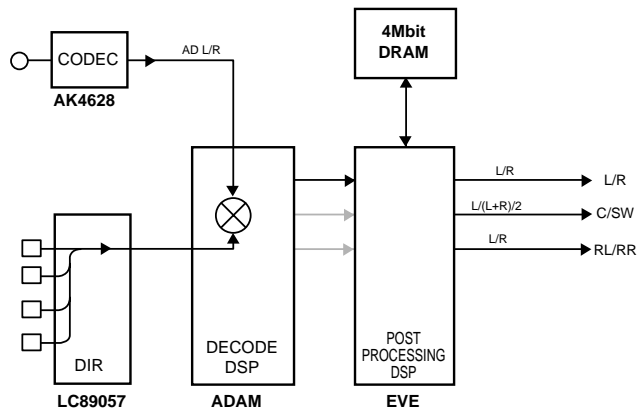

#### RAM THROUGH

INPUT: DD/DTS/AAC

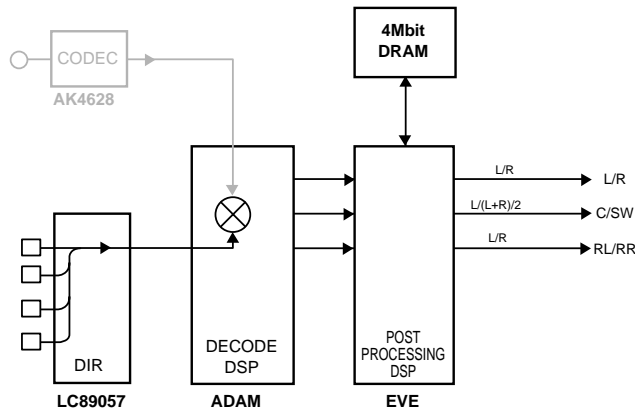

(Shaded items not used in this example)

#### 4. PRO LOGIC

The L/C/R/RL/RR signals undergo the Pro-Logic processing and C/RL/RR signals are output through Sub DSP-DRAM. Main DSP is selected for MAIN L/R output.

Using the sub-menu, it is possible to select PRO LOGIC I, II (Movie). The Auto Input Balance function is always off.

When the Dolby Digital Multi input is used, the function is the same as in the Dolby Digital Normal mode.

The LFE signal is not output when decoding in the PRO LOGIC I, II mode.

#### 4. PRO LOGIC

L/C/R/RL/RR はプロロジック処理され、C/RL/RR は Sub DSP DRAM 経由で出力されます。MAIN L/R 出力には Main DSP が選択されます。

サブメニューで PRO LOGIC I, II (Movie) を選択可能です。常時 Auto Input Balance off です。

Dolby Digital Multi 入力時は、通常の Dolby Digital Normal と同じ動作をします。

PRO LOGIC I、II デコード時は、LFE は出力されません。

#### PRO LOGIC I

#### PRO LOGIC I

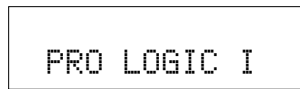

#### INPUT: VIDEO ANALOG

Input level	Volume	SPEAKERS OUT (1KHz)			SUBWOOFER (50 Hz)
		FRONT L/R	CENTER	SURROUND L/R	
Each ch, -20 dBm	86 (-10 dB)	+6.5 dBm	- ∞	- ∞	- ∞
Both ch, -20 dBm	86 (-10 dB)	- ∞	+9.0 dBm	- ∞	- ∞

#### PRO LOGIC II

#### PRO LOGIC II

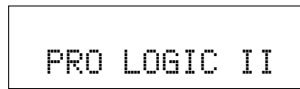

#### INPUT: VIDEO ANALOG

Input level	Volume	SPEAKERS OUT (1KHz)			SUBWOOFER (50 Hz)
		FRONT L/R	CENTER	SURROUND L/R	
Each ch, -20 dBm	86 (-10 dB)	+6.5 dBm	- ∞	- ∞	- ∞
Both ch, -20 dBm	86 (-10 dB)	- ∞	+9.0 dBm	- ∞	- ∞

#### INPUT: ANALOG

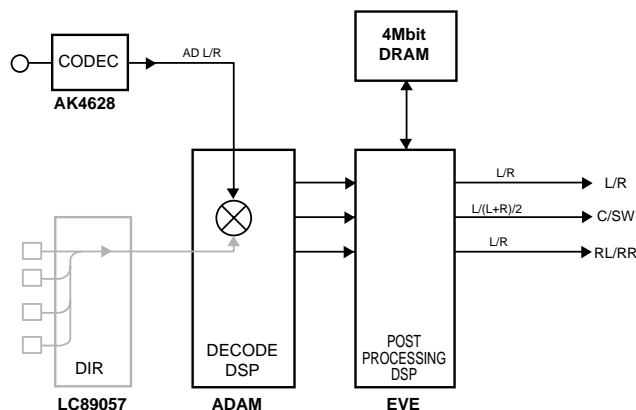

#### INPUT: PCM/DD/DTS/AAC

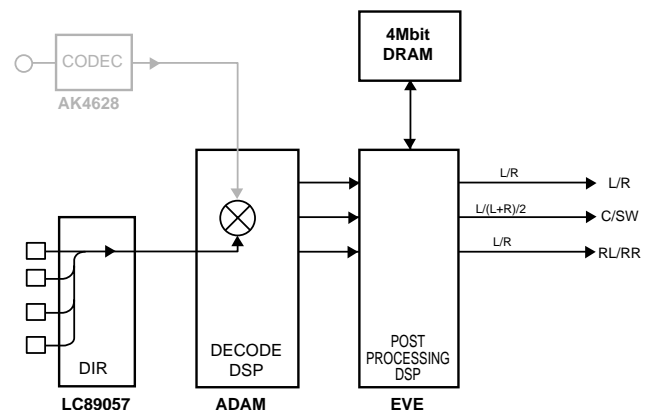

(Shaded items not used in this example)

### 5. SPEAKERS SET

The input signal is automatically identified and switched in the priority order of dts →DOLBY DIGITAL → AAC → PCM AUDIO → Analog (A/D) according to the signal detection.  
The signals output from the DSP block are the same as 1.  
DSP THROUGH: 0dB.

### 5. SPEAKERS SET

入力信号は信号検出によって、dts DOLBY DIGITAL AAC PCM AUDIO アナログ(A/D)の優先順で自動判別切り換えされます。  
DSP部からは、No. 1 DSP THROUGHの0dBと同様の信号が出力されます。

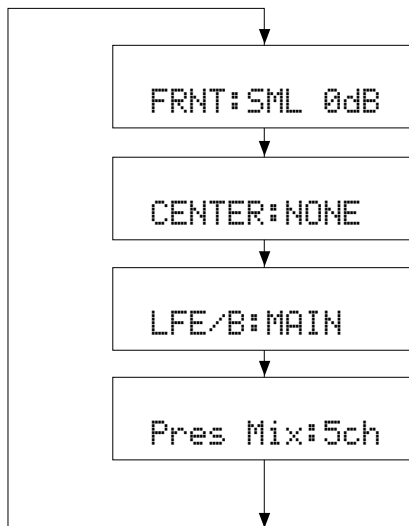

The analog switch settings for each sub-menu are as shown in the table below.

各サブメニューにおけるアナログスイッチの設定は以下の通りです。

	Sub-menu	CENTER SP	REAR SP	MAIN SP	MAIN LEVEL	LFE/BASS
1	FRNT: SML 0dB	LARGE	LARGE	SMALL	0dB	SWFR
2	CENTER: NONE	NONE	LARGE	LARGE	0dB	BOTH
3	LFE/B: FRNT	SMALL	SMALL	LARGE	0dB	MAIN
4	Pres Mix: 5cH	LARGE	LARGE	LARGE	0dB	BOTH

**LARGE:** This mode is used with a speaker with high bass reproduction performance (a large unit). Full bandwidth signals are output.  
**SMALL:** This mode is used with a speaker with low bass reproduction performance (a small unit). The signals of 90Hz or less are mixed into the channel specified by LFE/BASS.  
**NONE:** This mode is used with no center speaker. The center content is reduced by 3dB and distributed to MAIN L/R.

**LARGE :** 低音再生能力の高い(ユニットの大きい)スピーカーを使用するモードです。全帯域が出力されます。  
**SMALL :** 低音再生能力の低い(ユニットの小さい)スピーカーを使用するモードです。90Hz以下がLFE/BASSで指定したチャンネルにミックスされます。  
**NONE :** スピーカーを使用しないモードです。センター成分は 3dB されて、MAIN L/R に振り分けられます。

### INPUT: VIDEO ANALOG

Sub-menu	Input level	Volume	SPEAKERS OUT (1KHz)			SUBWOOFER (50 Hz)
			FRONT L/R	CENTER	SURROUND L/R	
1 FRNT: SML 0dB	1kHz, Both ch, -20 dBm	86 (-10 dB)	+9.0 dBm	+9.0 dBm	+21.0 dBm	-3.0 dBm
2 CENTER: NONE	1kHz, Both ch, -20 dBm	86 (-10 dB)	- ∞	+9.0 dBm	+21.0 dBm	-0.5 dBm
3 LFE/B: FRNT	1kHz, Both ch, -20 dBm	86 (-10 dB)	- ∞	+9.0 dBm	+21.0 dBm	- ∞
	50Hz, Both ch, -20 dBm	86 (-10 dB)	- ∞	- ∞	- ∞	+6.5 dBm
4 Pres Mix: 5cH	1kHz, Both ch, -20 dBm	86 (-10 dB)	+16.0 dBm	+9.0 dBm	+21.0 dBm	-3.0 dBm

DVR-S150  
NX-P150

### 6. MIC CHECK

The signals inputted through the microphone are output via A/D-D/A.

The input signal level is displayed in every few seconds.

(0 dB to -90 dB)



### 6. MIC CHECK

マイク入力された信号をA/D-D/A 経由で出力します。入力された信号のレベルを一定時間サンプリングし、表示します。(0 dB ~ -90 dB)

### 7. DISPLAY CHECK

This program is used to check the FL display section. The display condition varies as shown below according to the sub-menu operation. The signals are processed using EFFECT OFF (The L/R signal is output using ANALOG MAIN BYPASS.)

### 7. DISPLAY CHECK

FL 表示部のチェックプログラムです。サブメニュー操作により、表示状態が以下のように変わります。信号処理はEFFECT OFF(ANALOG MAIN BYPASSでL/Rを出力)です。

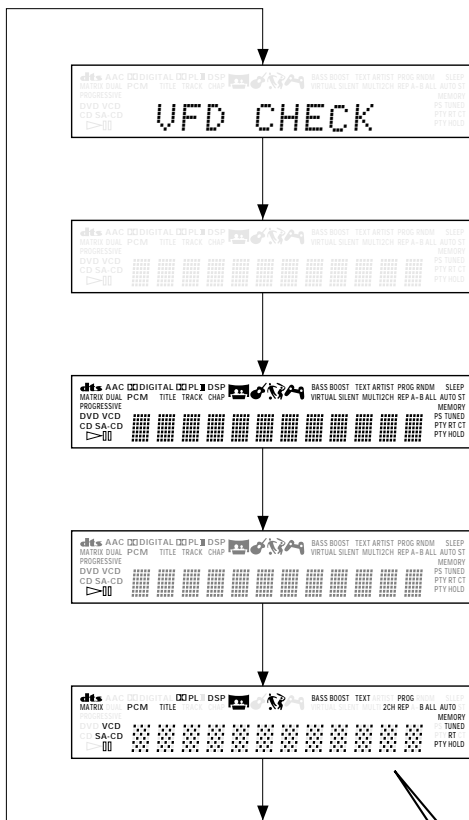

**Initial display /**  
初期表示

**All segments OFF /**  
全セグメント消灯

**All segments ON (dimmer 100%) /**  
全セグメント点灯 (ディマー 100%)

**All segments ON (dimmer 50%) /**  
全セグメント点灯 (ディマー 50%)

**Lighting of segments in lattice /**  
セグメント格子状点灯

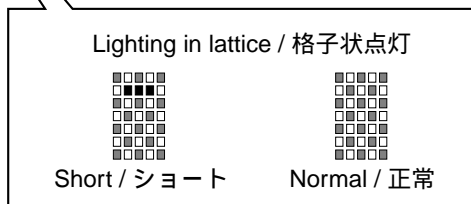

DVR-S150  
NX-P150

Segment conditions of the FL driver and the FL tube are checked by turning ON and OFF all segments. Next, the operation of the FL driver is checked by using the dimmer control. Then a short between segments next to each other is checked by turning ON and OFF all segments alternately (in lattice). (In the above example, the segments in the second row from the top are shorted.)

## 8. MANUAL TEST

The noise generator built into the DSP outputs the test noise through the channels specified by the sub-menu.

The noise frequency for LFE is 35 to 250 Hz. Other than that, the center frequency is 800Hz.

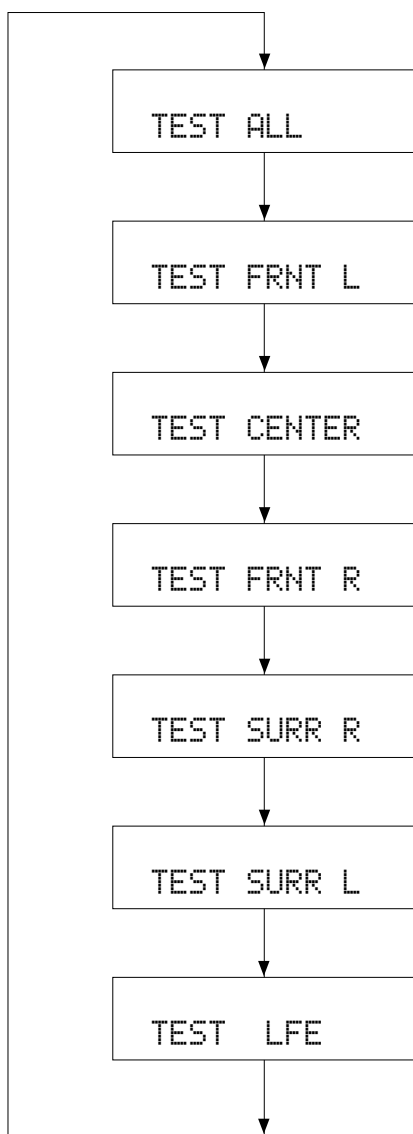

全セグメント消灯・全セグメント点灯によりFLドライバー、FL管のセグメントの不良を確認します。

次に、ディマーコントロールによってFLドライバーの動作チェックを行います。

さらに全セグメントを交互(格子状)に点灯/消灯することで、隣り合うセグメントのショートをチェックします。

## 8. MANUAL TEST

DSP 内蔵のノイズ発生回路によって、サブメニューで指定したチャンネルへテストノイズを出力します。

LFE用のノイズ周波数は35 ~ 250Hz、それ以外は中心周波数 800Hz となります。

### TEST ALL

Noise is output from all channels except SUB WOOFER.  
SUB WOOFER 以外の全チャンネルからノイズを出力

### TEST FRONT L

Noise is output from the FRONT L channel.  
FRONT L チャンネルからノイズを出力

### TEST CENTER

Noise is output from the CENTER channel.  
CENTER チャンネルからノイズを出力

### TEST FRONT R

Noise is output from the FRONT R channel.  
FRONT R チャンネルからノイズを出力

### TEST SURROUND R

Noise is output from the SURROUND R channel.  
SURROUND R チャンネルからノイズを出力

### TEST SURROUND L

Noise is output from the SURROUND L channel.  
SURROUND L チャンネルからノイズを出力

### TEST LFE

Noise is output from the SUB WOOFER channel.  
SUB WOOFER チャンネルからノイズを出力

### 9. FACTORY PRESET

This menu is used to reserve and inhibit initialization of the back-up RAM. The signals are processed using EFFECT OFF. (The L/R signal is output using ANALOG MAIN BY-PASS.)

### 9. FACTORY PRESET

バックアップ用RAM(音場プログラムのパラメーターやセットメニュー内容等)の初期化を予約/禁止します。信号処理はEFFECT OFFと同じです(ANALOG MAIN BY-PASSで、L/Rを出力)。

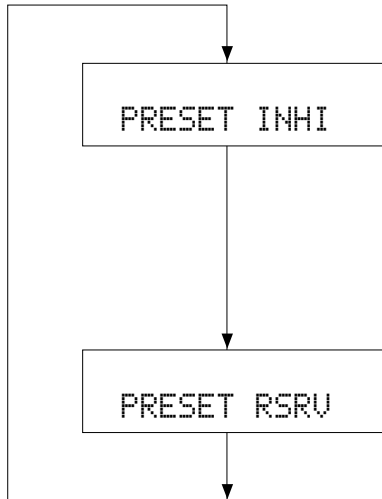

#### PRESET INHIBIT (Initialization inhibited) / PRESET INHIBIT(初期化禁止)

RAM initialization is not executed. Select this sub-menu to protect the values set by the user.

**Note: The protection history will not be erased using PRESET INHIBIT.**

RAMの初期化は行われません。ユーザーの設定値を保護するときは、こちらを選択してください。

#### PRESET RESERVED (Initialization reserved) / PRESET RESERVED(初期化予約)

Initialization of the back-up RAM is reserved. (Actually, initialization is executed the next time that the power is turned on.) Select this sub-menu to reset to the original factory settings or to reset the RAM. Use PRESET RESERVED to erase the protection history.

バックアップRAMの初期化が予約されます。(実際に初期化されるのは、次回の電源投入時です。)工場出荷時やRAMをリセットしたいときは、こちらを選択してください。

**CAUTION: Before setting to the PRESET RESERVED, write down the existing preset memory content of the Tuner in a table as shown below. (This is because setting to the PRESET RESERVED will cause the user memory content to be erased.)**

注意：PRESET RESERVEDを選んで初期化をする前に、チューナーのユーザーメモリー内容を下表に書き写してください。(初期化をすると、ユーザーメモリーの内容は消えてしまいます。)

Preset group	P1	P2	P3	P4	P5	P6	P7	P8
A								
B								
C								
D								
E								

#### ● PRESET STATIONS / プリセット局

STATION		FM FACTORY PRESET DATA (MHz)				STATION		AM FACTORY PRESET DATA (kHz)	
PAGE	NO.	U, C	R, T, K, A, B, G, E, L	J	PAGE	NO.	U, C, R, T, K	A, B, G, E, L, J	
A/C/E	1	87.5	87.50	76.0	B/D	1	630	630	
	2	90.1	90.10	83.0		2	1080	1080	
	3	95.1	95.10	84.0		3	1440	1440	
	4	98.1	98.10	86.0		4	530	531	
	5	107.9	108.00	90.0		5	1710	1611	
	6	88.1	88.10	78.0		6	900	900	
	7	106.1	106.10	88.0		7	1350	1350	
	8	107.9	108.00	82.1		8	1400	1404	

## 10. AD DATA CHECK/FAN TEST

This menu is used to display the A/D conversion value of the terminals which detect the panel keys of the main unit and protection functions in % using the sub-menu. During signal processing, the condition before execution is maintained.

When KEY menu is selected, keys become non-operable due to detection of the values of all keys.

However, it is possible to advance to the next sub-menu by turning the VOLUME of the main unit. When using this function, note that turning the VOLUME more than 2 clicks will cause the volume value to change.

*\*The figures in the diagram are given as reference only.*

### PS/PS2 (protection detection)

**PS:** Value of power supply voltage protection other than DVD (Normal value: 49 to 60)

**P2:** Value of power supply voltage protection related to DVD (Normal value: 45 to 70)

If PS or P2 is out of the normal value range, the protection function works to turn off the power after 1 second.

## 10. AD DATA CHECK/FAN TEST

本体パネルキー、プロテクションなどを検出している端子のA/D変換の値を、サブメニューで%表示します。信号処理は実行前の状態を維持します。

KEYのメニューにすると、全キーの値を検出するためキー操作はできなくなりますが、本体のVOLUMEを回すことにより、次のサブメニューに進めることができます。このとき2クリック以上回すと、ボリューム値が変化するので注意してください。

図中の数値は参考例です。

### PS/PS2 (プロテクションの検出)

**PS:** DVD以外の電源電圧プロテクションの値 (正常値49 ~ 60)

**P2:** DVD関連の電源電圧プロテクションの値 (正常値45 ~ 70)

PS、P2は正常値を外れるとプロテクションが働き、電源オフされます。

PS:057P2:055

### KEY (Panel key of main unit)

A/D of the key fails to function properly when the standard value is deviated. In this case, check the constant of partial pressure resistor, solder condition, etc. Refer to table 1.

### KEY (本体パネルキー)

キーのA/Dは基準値から外れると、正常な動きをしません。Table 1 をご覧になり、各キーの分圧抵抗の定数、ハンダ不良等の確認をしてください。

KEY:100%

[Table 1]

Display (%)	KEY
0 - 5	STOP
6 - 15	SKIP/SEARCH -
16 - 25	SKIP/SEARCH +
26 - 35	PAUSE
36 - 45	DSP
46 - 55	INPUT
56 - 65	PLAY
66 - 75	PROGRESSIVE
76 - 85	OPEN



**TH/Fa (temperature detection/fan drive level)**

**TH:** 500% display of the voltage based on the temperature detected value. Reference voltage : 5V  
(Normal value: 1 to 318)

**Fa:** Current fan drive level on the left and the past fan drive history on the right.

## TH/Fa( 温度検出/ファン駆動レベル)

**TH:** 温度検出値で電圧の500 %表示、基準電圧は5V  
( 正常値1 ~ 318 )

**Fa:** 左側は現在のファン駆動レベル、右側は過去のファン駆動履歴

```
TH:125Fa:_/_
```

**FAN DRIVE TEST  
HIGH**

FAN DRIVE TEST ( ファン駆動テスト )  
HIGH : ファン駆動強

```
FanTest:HIGH
```

**FAN DRIVE TEST  
MID**

FAN DRIVE TEST ( ファン駆動テスト )  
MID : ファン駆動中

```
FanTest:MID
```

**FAN DRIVE TEST  
LOW**

FAN DRIVE TEST ( ファン駆動テスト )  
LOW : ファン駆動弱

```
FanTest:LOW
```

## 11. IF STATUS (Input function status)

Using the sub-menu, the status data is displayed one after another in the hexadecimal notation.

During signal processing, the status before execution of this menu is maintained.

\* **Numeric values in the figure example are for reference.**

### IS1 (Internal status):

Indicates the status information of the microprocessor.

## 11. IF STATUS

サブメニュー操作により、以下のステータス情報を順次 16 進数で表示します。信号処理は、本メニュー実行前の状態を維持します。

図中の数値は参考例です。

### IS 1 (内部ステータス)

マイコンのステータス情報を表示します。

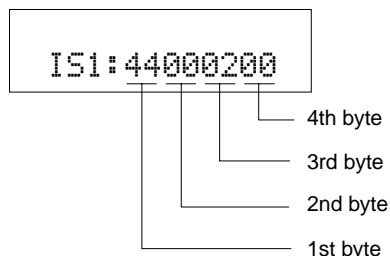

#### <1st byte>

Digital input/output setting value  
Upper 4 bits: REC OUT selected /  
lower 4 bits: INPUT selected

Value	Choice	Preset name
0	NONE	
1	NONE	
2	NONE	
3	DIGITAL	DVD/CD
4	OPT	VIDEO
6	NONE	
8	NONE	
9	NONE	

#### <第1バイト>

デジタル入出力設定値  
上位4bit REC OUT 選択 /  
下位4bit INPUT 選択

#### <2nd byte>

Fs information of reproduction signal

#### <第2バイト>

再生信号のFs情報

Display	00	01	02	03	04	05	06	0A	0B	0C	0D
<b>Fs (kHz)</b>	Analog	32	44.1	48	64	88.2	96	Unknown NRM	Unknown DBL	Unknown QUAD	Not defined

#### <3rd byte>

Audio code mode information of reproduction signal

#### <第3バイト>

再生信号のオーディオコードモード情報

Display	00	01	02	03	04	05	06	07	08	09	0A	0B	0C	0D
<b>Audio Code</b>	1+1	1/0	2/0	3/0	2/1	3/1	2/2	3/2	2/3	3/3	OVER 6.1	MULTI PCE	Unknown	Unknown

#### <4th byte>

Format information of reproduction signal

#### <第4バイト>

再生信号のフォーマット情報

Display	Signal format
00	Analog (Unlock)
01	Incorrect digital (*1)
10	PCM Audio
20	Digital Data
21	IEC1937 Data
22	None PCM
23	Unknown
50	dts

Display	Signal format
51	Red dts
54	dts-ES MATRIX
58	dts-ES DISCRETE
5C	dts-ES (Both flag)
60	AAC
C0	Dolby Digital
C1	D.D. Karaoke
C4	D.D.6.1 (D.D.EX)

(\*1): Analog processing used for digital reproduction is not possible because of a commercial bit or 4-ch audio reason.

(\*1): 業務用ビットや4ch オーディオなどの理由で、デジタル再生できずアナログ処理されます。

**IS2 (Internal status):** (Not used in this model)

IS2(内部ステータス)(使用しません)

IS2:03004572

**CS1-5:** Indicates channel status information of the input signal. (Not used in this model)

CS 1 5: 入力信号のチャンネルステータス情報を表示します。(使用しません)

CS1:FFFFFFFF

-----

CS5:DE150000

**BS1-7:** Indicates information of the bit stream. (Not used in this model)

BS1 7: ビットストリームインフォメーション情報を表示します。(使用しません)

BS1:00000000

-----

BS7:7000

**TI1-2:** Indicates information of the bit stream. (Not used in this model)

TI1 2: ビットストリームインフォメーション情報を表示します。(使用しません)

TI1:00800020

-----

TI2:01

**MTT:** Mute Trigger (Not used in this model)

MTT: Mute Trigger(使用しません)

MTT:00180018

## 12. DSP RAM CHECK

This menu is used to self-diagnose whether or not the bus connection for the YSS930 and the external RAM is made properly.

During signal processing, the status before execution of this menu is maintained.

The address bus and the data bus are checked and the connection condition is displayed.

When no error is detected, "No" appears on display.

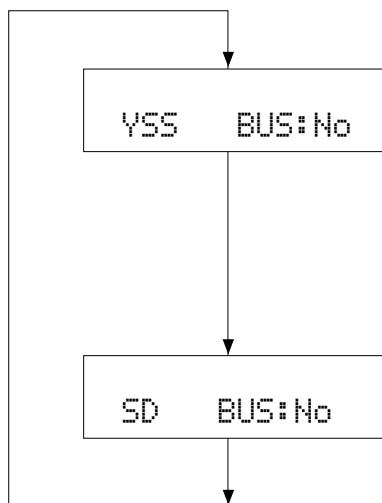

## 12. DSP RAM CHECK

YSS930と外付けRAMとのバス接続の正否を自己診断します。信号処理は、このメニューを実行する前の状態を維持します。アドレスバス、データバスのチェックを行い、接続正否を表示します。

エラーが検出されなかった場合は、“No”と表示されます。

### YSS930 BUS CHECK

Display	Description
WAIT	Bus is being checked. / バスチェック中
No	No error detected. / 不良検出なし
DATA	Data bus shorted or open. / データバスのエラー
RSCS	/RAS or /CAS shorted, or open. / /RASまたは/CASのエラー
ADDR	Address bus shorted or open. / アドレスバスのエラー

### YSS948 BUS CHECK

Display	Description
Err	Defect / 不良検出あり
No	No error detected. / 不良検出なし

## 13. PROTECTION SETTING

Not applied to these models.

## 13. PROTECTION SETTING

このモデルには適用されません。

## 14. SOFT SW

This menu is used to confirm the function settings on P.C.B..

## 14. SOFT SW

P.C.B. 上の機能設定を確認する機能です。

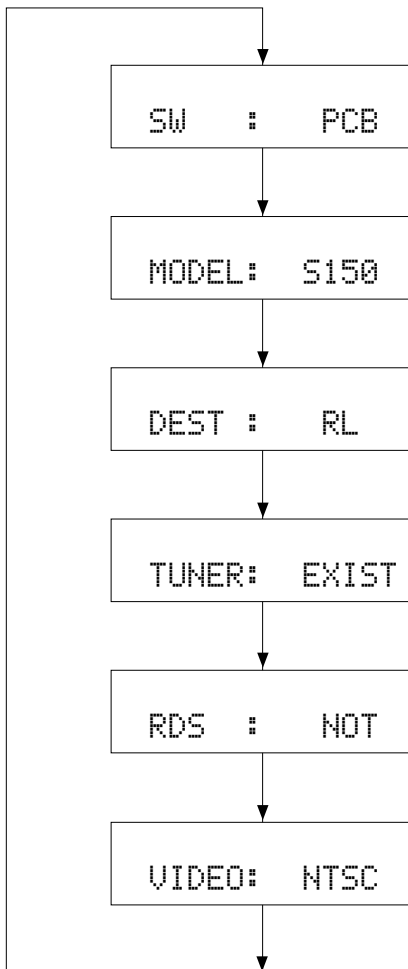

### SW MODE:

PCB or SOFT can be confirmed.  
PCBまたはSOFTを確認できます。

### MODEL SETTING:

(Not used in this model) / (使用しません)

### TUNER DESTINATION:

J, UC, ATKBG or RL can be confirmed.  
J、UC、ATKBG、RLのいずれかを確認できます。

### TUNER:

NOT or EXIST can be confirmed.  
NOTまたはEXISTを確認できます。

### RDS:

NOT or EXIST can be confirmed.  
NOTまたはEXISTを確認できます。

### VIDEO FORMAT:

NTSC or PAL can be confirmed.  
NTSCまたはPALを確認できます。

### 15. MICROPROCESSOR INFORMATION

The version, checksum and the port specified by the microprocessor are displayed. The signal is processed using EFFECT OFF. The checksum is obtained by adding the data at every 8 bits for each program area and expressing the result as a 4-figure hexadecimal data.

*\* Numeric values in the figure example are for reference.*

### 15. マイコン情報

サブメニューは4つあります。

プログラムのバージョン、チェックサム、マイコンの指定ポートを表示します。

信号はエフェクトOFFです。チェックサムは、プログラムエリア別にデータを8ビットごとに加算していき、4桁の16進データで現したものです。

図中の数値は参考例です。

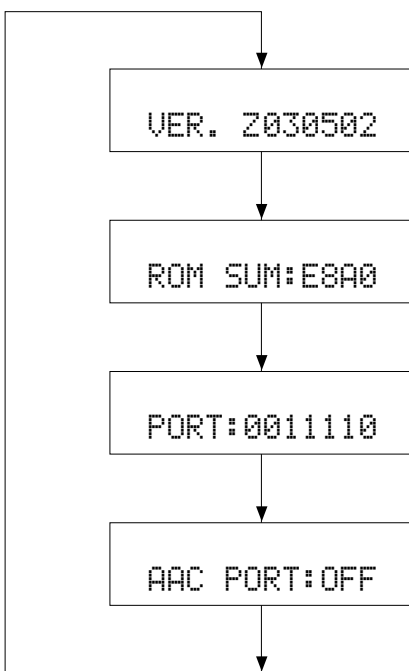

#### Version / バージョン情報

Release 1 digit / Main version 2 digit / DSP version 3 digit / DVD version

#### Checksum / チェックサム表示

A: All area

#### Check of port setting for judging microprocessor function

マイコンの機能判定用ポート設定確認

#### Display of AAC function detection port state

AAC 機能検出ポート状態表示

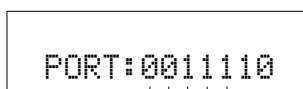

- Tuner mode 0 (\*1)
- Tuner mode 1 (\*1)
- Tuner with (1) / without (0)
- RDS with (1) / without (0)
- VIDEO format: PAL (1) / NTSC (0)

(\*1) Tuner mode

Tuner mode 1	Tuner mode 0	SET MENU	Tuner frequency	
0	0	—	FM: 76.0-90.0MHz/100kHz	AM: 531-1611kHz/9kHz
1	0	—	FM: 87.50-108.00MHz/50kHz	AM: 531-1611kHz/9kHz
0	1	—	FM: 87.5-107.9MHz/200kHz	AM: 530-1710kHz/10kHz
1	1	R10	FM: 87.5-108.0MHz/100kHz	AM: 530-1710kHz/10kHz
		R9	FM: 87.50-108.00MHz/50kHz	AM: 531-1611kHz/9kHz

## 16. Other Information

## 16. その他の情報

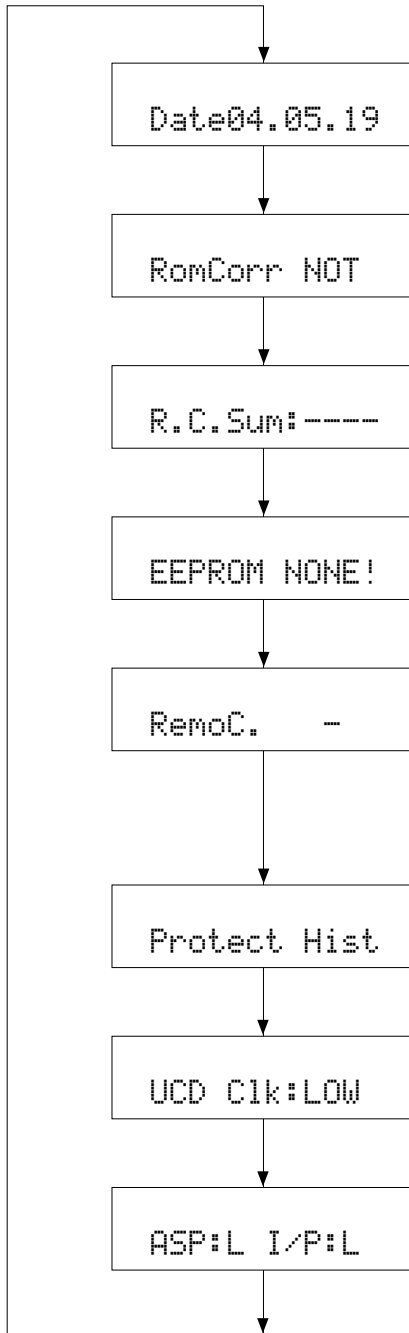
**Soft Date / ソフトの日付**

\* *Numeric values in the figure example are for reference.*

図中の数値は参考例です。

**Rom Correction Exit, Not / ROM コレクションデータの有無**

(Not used in this model) / (使用しません)

**Rom Correction Check Sum Display /**

ROM コレクションエリアのチェックサム

(Not used in this model) / (使用しません)

**Rom Correction Remote Control Receive**

ROM コレクションデータのリモコン受信

(Not used in this model) / (使用しません)

**Remote Control Code Display / リモコン受信コード表示**

Remote control received code can be checked. / リモコン受信コードが確認できます。

(For the details, refer to REMOTE CONTROL. /

詳しくは「REMOTE CONTROL」を参照してください)

**Protect History Delete**

プロテクション履歴削除の予約 / 解除

Reservation/cancellation can be selected by pressing A/B/C/D/E button.

A/B/C/D/E ボタンにより予約・解除が選択できます。

**Forced output of UCD clock / UCD クロックの強制出力**

HIGH or LOW can be selected by using the A/B/C/D/E key.

A/B/C/D/E ボタンにより HIGH/LOW の切り替えができます。

**Forced output of aspect, interlace/progressive port**

アスペクト、インターレース / プロGRESSIVEポートの強制出力

H, M or L can be selected by using the A/B/C/D/E key.

A/B/C/D/E ボタンにより H/M/L の切り替えができます。

## ■ DVR-S150 D-AMP MODULE TROUBLESHOOTING / DVR-S150 D-アンプモジュールの故障診断

When there is a possibility of the D-Amp Module being defective, use the following procedure to determine whether or not it is defective.

### Step 1

With the power turned off, remove one D-Amp Module and then turn on the power to the main unit.

If the protection function still works, turn off the power, remove another D-Amp Module and then turn on the power to the main unit. Repeat this procedure until the protection function stops working.

### Step 2

When the protection function has stopped working, install the removed D-Amp Modules one by one to the main unit and then turn on the power.

If the protection function does not work, the D-Amp Module installed then can be judged as normal.

If the protection function works, on the other hand, the D-Amp Module installed then can be judged as defective.

Repeat this procedure to check all the removed D-Amp Modules.

### Caution

**Note that there is a rare case where two or more D-Amp Modules are defective.**

D-アンプモジュールの故障が疑われる場合、下記の方法により各D-アンプモジュールの故障の有無を判定します。

### Step 1

電源OFF状態でD-アンプモジュール1個を取り外した後、本機の電源をONします。

まだプロテクションが動作する場合、電源をOFFし、更にD-アンプモジュール1個を取り外した後、本機の電源をONします。プロテクションが動作しなくなるまでこれを続けます。

### Step 2

プロテクションが動作しなくなったら、取り外したD-アンプモジュールを1個ずつ本機に取り付け電源をONします。プロテクションが動作しない場合、その取り付けたD-アンプモジュールは正常と判断できます。

プロテクションが動作する場合、その取り付けたD-アンプモジュールは故障していると判断できます。

この方法により取り外した全てのD-アンプモジュールの故障の有無を判定します。

### 注意

稀に2個以上のD-アンプモジュールが故障している場合があるので注意が必要です。

## ■ DVR-S150 AMP ADJUSTMENT / DVR-S150アンプ部調整

### ■ Condition

- Start adjustment 5 sec or more after the power is turned on.
- Headphones are not plugged in.
- No input signal.

### ■ 条件

- 電源を入れてから5秒間以上経過後に調整を始めます。
- ヘッドホンは差し込みません。
- 無入力信号

### ■ DC Offset Adjustment

Adjust the potentiometer on each D-Amp Module so that the DC voltage becomes  $0 \pm 10$  mV at each speaker output.

### ■ DC オフセット調整

各スピーカー出力端子のDC電圧が  $0 \pm 10$  mVになるように、各D-アンプモジュールの半固定VRを調整します。

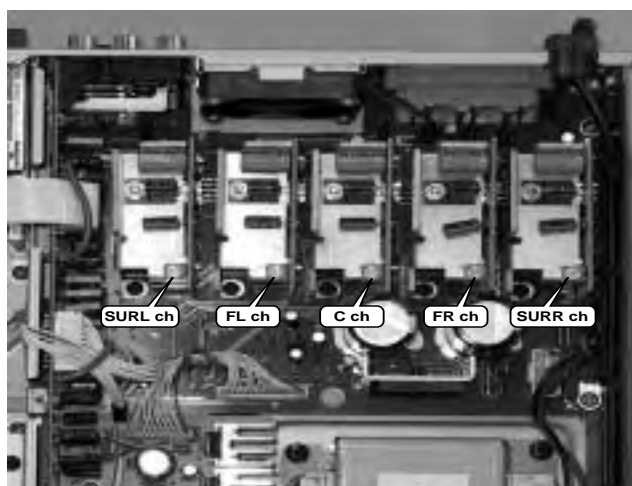



## ■ DISPLAY DATA

V221 : 14-BT-80GNKF (WB452200)

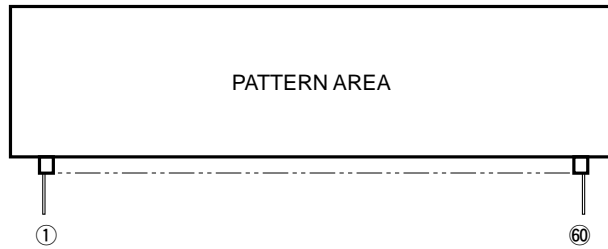

### ● PIN CONNECTION

Pin No.	1	2	3	4	5	6	7	8	9	10	11	12	13	14	15	16	17	18	19	20	21	22	23	24	25	26	27	28	29	30
Connection	F1	NX	NP	NP	1G	2G	3G	4G	5G	6G	7G	8G	9G	10G	11G	12G	13G	14G	NX	NX	NX	P35	P34	P33	P32	P31	P30	P29	P28	P27
Pin No.	31	32	33	34	35	36	37	38	39	40	41	42	43	44	45	46	47	48	49	50	51	52	53	54	55	56	57	58	59	60
Connection	P26	P25	P24	P23	P22	P21	P20	P19	P18	P17	P16	P15	P14	P13	P12	P11	P10	P9	P8	P7	P6	P5	P4	P3	P2	P1	NP	NP	NX	F2

**Note** 1) F1, F2 ..... Filament      3) NX ..... No extend pin      5) 1G~14G ..... Grid  
 2) NP ..... No Pin      4) P1~P35 ..... Datum Line

### ● GRID ASSIGNMENT

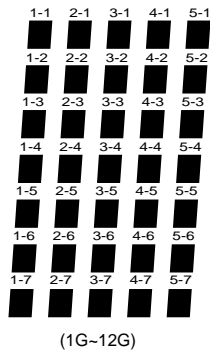
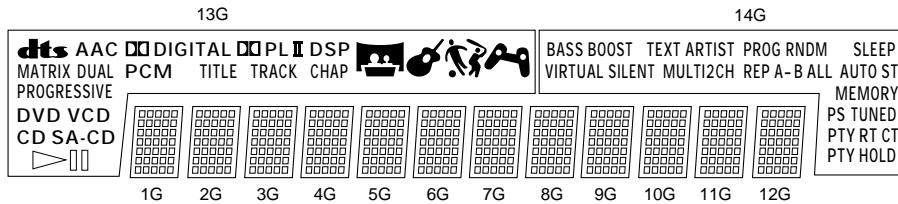

### ● ANODE CONNECTION

	1G - 12G	13G	14G
P1	1-1	S1	SLEEP
P2	2-1	S2	AUTO
P3	3-1	S3	ST
P4	4-1	S4	MEMORY
P5	5-1	CHAP	PS
P6	1-2	DSP	TUNED
P7	2-2	TRACK	PTY
P8	3-2	PL	RT
P9	4-2	II	CT
P10	5-2	TITLE	PTY HOLD
P11	1-3	DIGITAL	VIRTUAL
P12	2-3	PCM	BASS BOOST
P13	3-3	AAC	SILENT
P14	4-3	dtc	TEXT
P15	5-3	DUAL	MULTI
P16	1-4	MATRIX	2CH
P17	2-4	PROGRESSIVE	ARTIST
P18	3-4	VCD	REP
P19	4-4	DVD	A-
P20	5-4	SA-CD	B
P21	1-5	CD	ALL
P22	2-5	II	PROG
P23	3-5	▶	RNDM
P24	4-5	-	-
P25	5-5	-	-
P26	1-6	-	-
P27	2-6	-	-
P28	3-6	-	-
P29	4-6	-	-
P30	5-6	-	-
P31	1-7	-	-
P32	2-7	-	-
P33	3-7	-	-
P34	4-7	-	-
P35	5-7	-	-

DVR-S150  
NX-P150

# IC DATA

## IC6 : M30626FHPFP (DIGITAL P.C.B.) 16 bit μ-COM (CPU)

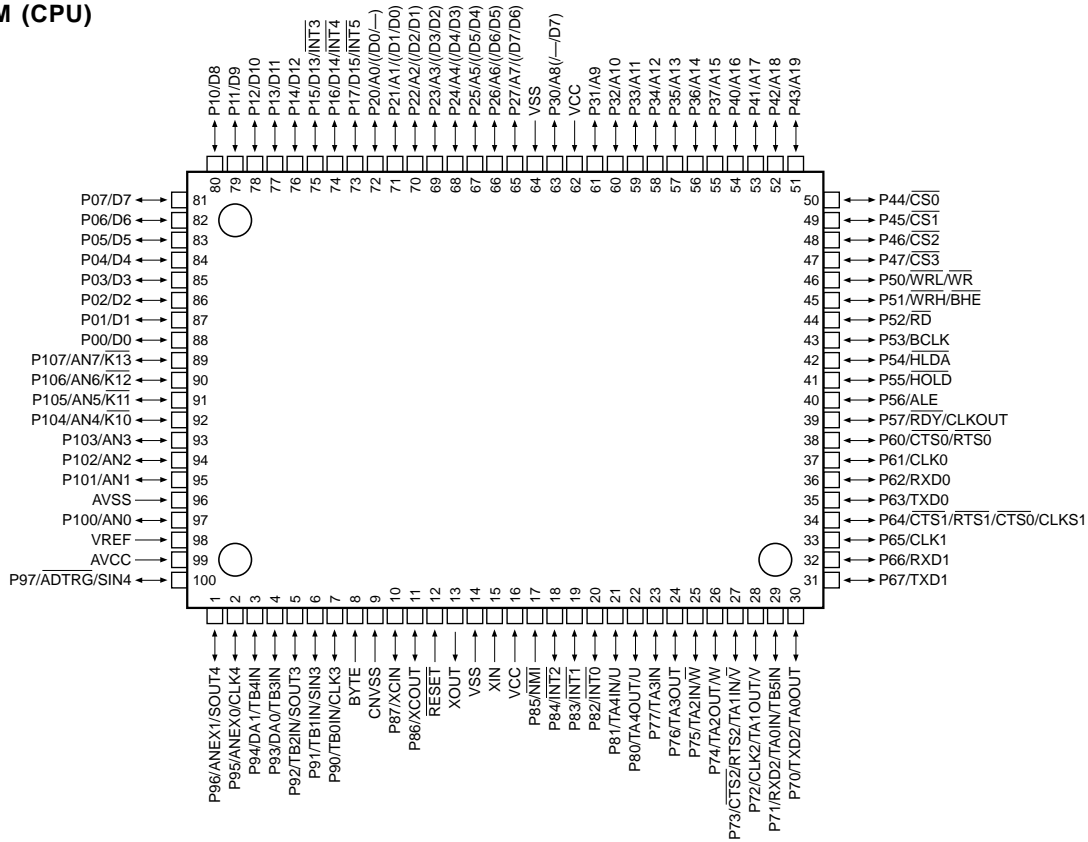

No.	Name	Port	I/O	Function
1	P96	SOUT4	OUT	FL Driver TxD (FL TXD)
2	P95	CLK4	OUT	FL Driver CLOCK OUT (FL_CLK)
3	P94	DA1	D-A OUT	FAN D-A OUT (FAN) [0 ~ VCC]
4	P93	DA0	OUT	(Pull-down resistor required)
5	P92	SOUT3	S-OUT	[SDM] YSS938 DATA OUT (Serial I/O-3)
6	P91	SIN3	S-IN	[SDD] YSS938 DATA IN (Serial I/O-3)
7	P90	CLK3	S-CLK	[SCK] YSS938 CLK OUT (Serial I/O-3)
8	BYTE	-	-	Connect to VSS (GND)
9	CNVSS	-	-	Connect to VSS (GND) via Resistor (5.1k-ohms) [For flash writing: Vcc]
10	P87	CMOS	OUT	YSS CE
11	P86	CMOS	OUT	YSS RESET
12	/RESET	-	-	RESET [L: RESET]
13	XOUT	-	-	16MHz OUT (with built-in feedback resistor)
14	VSS	-	-	GND
15	XIN	-	-	16MHz IN (with built-in feedback resistor)
16	VCC	-	-	Power supply, +5V
17	P85	/NMI	IN	Connect to Vcc via Resistor (10 k-ohms) (NMI function unused)
18	P84	/INT2	INT-IN	INTADAM
19	P83	/INT1	INT-IN	INTDIR
20	P82	/INT0	IN	Communication with DVD sub-microprocesseor / READY IN (Pull-down resistor required) [L:READY]
21	P81	TA4IN	IN	DC Protect (DC_PRT) [L: when in abnormal state]
22	P80	TA4OUT	T-OUT	Digital AMP CLOCK OUT (380KHz/421KHz) [L: Self-excited, Pulse: Separately excited]
23	P77	TA3IN	IN	Digital AMP I Protect (ERR) (Pull-up resistor required) [H: being used]
24	P76	TA3OUT	OUT	
25	P75	TA2IN	OUT	HEAD PHONE Detect (HP_DET)
26	P74	TA2OUT	OUT	DIR CS
27	P73	/CTS2	OUT	ADAM
28	P72	CLK2	S-CLK	(Serial I/O-2)
29	P71	RXD2	S-IN	Communication with DVD (IIC_SCL) [Pull-up resistor N-OD required] (Serial I/O-2)
30	P70	TXD2	S-OUT	Communication with DVD (IIC_SDA) [Pull-up resistor N-OD required] (Serial I/O-2)
31	P67	TXD1	S-OUT	DATA OUT to EEPROM/DATA OUT to Flash Writer (Serial I/O-1)
32	P66	RXD1	S-IN	DATA IN from EEPROM/DATA IN from Flash Writer (Serial I/O-1)
33	P65	CLK1	S-CLK	CLK OUT to EEPROM/CLK IN from Flash Writer (Serial I/O-1)

DVR-S150  
NX-P150

## IC6 : M30626FHPFP (DIGITAL P.C.B.)

16 bit  $\mu$ -COM (CPU)

No.	Name	Port	I/O	Function
34	P64	/CTS1	OUT	TUNER MUTE/Busy OUT to Flash Writer
35	P63	TXD0	S-OUT	(Pull-down resistor required)
36	P62	RXD0	IN	(Pull-down resistor required)
37	P61	CLK0	S-CLK	(Pull-down resistor required)
38	P60	/CTS0	OUT	DVD_ON1 [H: Request]
39	P57	CLKOUT	OUT	(Pull-down resistor required)
40	P56	ALE	IN	Digital AMP Enable OUT [L: Stop, H: Operation]
41	P55	/HOLD	IN	Connect to VSS (GND) via Resistor (10 k-ohms) (For Flash Writing: L)
42	P54	/HLDA	OUT	DAC CS
43	P53	BCLK	OUT	DIR RESET
44	P52	/RD	OUT	ADAM RESET
45	P51	/WRH	OUT	(Pull-down resistor required)
46	P50	/WRL	IN	Connect to Vcc via Resistor (10 k-ohms) [L when resetting : Sub-microprocessor 8MHz OUT at power OFF] (For Flash Writing: H)
47	P47	/CS3	OUT	DVD_ON2
48	P46	/CS2	OUT	CS OUT to EEPROM (Pull-down resistor required) [H: DATA Transfer]
49	P45	/CS1	OUT	Power Relay Output (POW-RY) [H: ON]
50	P44	/CS0	OUT	FL Driver RESET (Light OFF) OUT (FL_ON)
51	P43	CMOS	OUT	PLL/RDS IC TxD (PLL/RDS_TXD)
52	P42	-	IN	PLL IC RxD IN (TU_Dat_o)
53	P41	CMOS	OUT	PLL/RDS IC CLOCK (PLL/RDS_CLK)
54	P40	CMOS	OUT	FL Driver CE OUT (FL-CE) [L: Address, H: Data]
55	P37	CMOS	OUT	S Terminal Mute OUT
56	P36	CMOS	OUT	Component Mute OUT
57	P35	-	IN	TUNER STATION IN (STATION) (Pull-up resistor required) [L: Station provided]
58	P34	CMOS	OUT	(Pull-down resistor required)
59	P33	CMOS	OUT	PLL/RDS IC Chip Enable OUT (PLL/RDS_CE) [L: Address, H: Data]
60	P32	-	IN	RDS IC RxD (RDS_RXD) (Pull-up resistor required)
61	P31	CMOS	OUT	(Pull-down resistor required)
62	VCC	-	-	Power supply, +5V
63	P30	CMOS	OUT	(Pull-down resistor required)
64	VSS	-	-	GND
65	P27	CMOS	OUT	Aspect Select WIDE 2 (S terminal switching)
66	P26	CMOS	OUT	Aspect Select WIDE 1 (S terminal switching)
67	P25	CMOS	OUT	D Terminal Control OUT (P/I) [L: Interlace, H: Progressive]
68	P24	CMOS	OUT	VIDEO Selector D (MUTE2)
69	P23	CMOS	OUT	VIDEO Selector C (MUTE1)
70	P22	CMOS	OUT	VIDEO Selector B (V_SEL_B)
71	P21	CMOS	OUT	VIDEO Selector A (V_SEL_A)
72	P20	CMOS	OUT	(Pull-down resistor required)
73	P17	/INT5	INT-IN	Remote Control IN (REMOTE)
74	P16	/INT4	INT-IN	Standby SW IN [H: ON]
75	P15	/INT3	INT-IN	Power Down DETECT INT IN (PW_DN) [L: POWER DOWN]
76	P14	CMOS	OUT	(Pull-down resistor required)
77	P13	CMOS	OUT	Sub-woofer Mute OUT [L: MUTE]
78	P12	CMOS	OUT	Full MUTE (+ HP Muting available) OUT [L: MUTE]
79	P11	CMOS	OUT	(Pull-down resistor required)
80	P10	CMOS	OUT	(Pull-down resistor required)
81	P07	CMOS	OUT	Input Select/Electronic Volume IC CLOCK (BD3842FS/BD3815KS 2-wire serial) (CKBD)
82	P06	CMOS	OUT	Input Select/Electronic Volume IC DATA (BD3842FS/BD3815KS 2-wire serial) (DTBD)
83	P05	CMOS	OUT	HP MUTE OUT [L: MUTE]
84	P04	-	IN	Rotary Encoder B (ROT-2) (Pull-up resistor required)
85	P03	-	IN	Rotary Encoder A (ROT-1) (Pull-up resistor required)
86	P02	CMOS	OUT	(Pull-down resistor required)
87	P01	CMOS	OUT	(Pull-down resistor required)
88	P00	CMOS	OUT	
89	P107	AN7	A-D IN	Destination Select Input [0 ~ VREF]
90	P106	AN6	IN	TUNER STEREO Detect IN (Pull-up resistor required)
91	P105	AN5	A-D IN	Subwoofer Control Detect (V3_PRT) [L: when in abnormal state]
92	P104	AN4	A-D IN	Key AD Input 0 (KEY0) [0 ~ VREF]
93	P103	AN3	A-D IN	Temperature Detect (Thermistor) IN (for driving FAN) (THM-M) [0 ~ VREF]
94	P102	AN2	A-D IN	Power Voltage Detect 1 (PS Protect) IN (V1-PRT) [0 ~ VREF]
95	P101	AN1	IN	AC Power Voltage Detect (AC Protect) IN (AC-PRT) [H: when in abnormal state]
96	AVSS	-	-	Connect to VSS (GND)
97	P100	AN0	OUT	Power Voltage Detect 2 (PS2 Protect) IN (V2-PRT) [0 ~ VREF]
98	VREF	-	-	A-D, D-A Reference Voltage Input [ ~ VCC]
99	AVCC	-	-	Connect to VCC Terminal (+5V)
100	P97	SIN4	IN	(Used as Design Test Port) (Pull-down resistor required)

● KEY INPUT (A-D) PULL UP RESISTOR 10kΩ

Ω	0	+1.2k	+1.2k	+1.8k	+2.7k	+3.3k	+4.7k	+8.2k	+18k	+47k
V	0 ~ 0.25	~ 0.75	~ 1.25	~ 1.75	~ 2.25	~ 2.75	~ 3.25	~ 3.75	~ 4.25	~ 4.75
KEY 0 (92pin)	STOP A/B/C/D/E	SKIP/SEARCH- PRESET/TUNING-	SKIP/SEARCH+ PRESET/TUNING+	PAUSE PRESET/BAND	DSP	INPUT	PLAY AUTO/MAN'L	PROGRESSIVE MEMORY	OPEN/ CLOSE	-

● TUNER MARKET & DVD REGION SELECT IN (89 pin, A-D) PULL UP RESISTOR 10kΩ

Ω	4.3k	6.8k	10k	15k	24k	39k	91k	∞ (pull-up only)
V	1.25 ~ 1.75	~ 2.25	~ 2.75	~ 3.25	~ 3.75	~ 4.25	~ 4.75	4.75 ~ 5
Market	T	K	L (9K/50K) (10K/100K)	R (9K/50K) (10K/100K)	A	U, C	B, G, E	J
Region	6	3	3	3	4	1	2	2

IC3 : LC89057W-VF4D-E (DIGITAL P.C.B.)  
Digital Audio Interface Transceiver

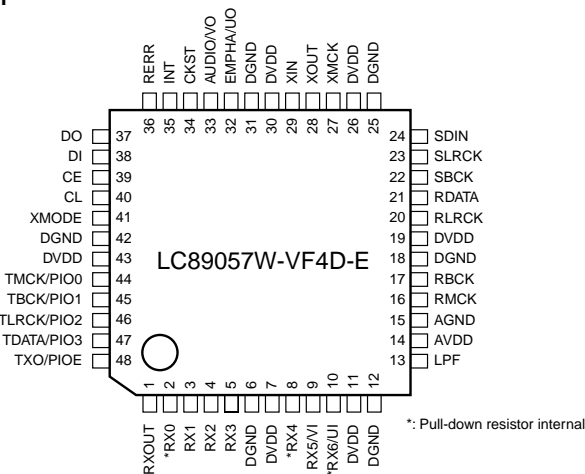

\*: Pull-down resistor internal

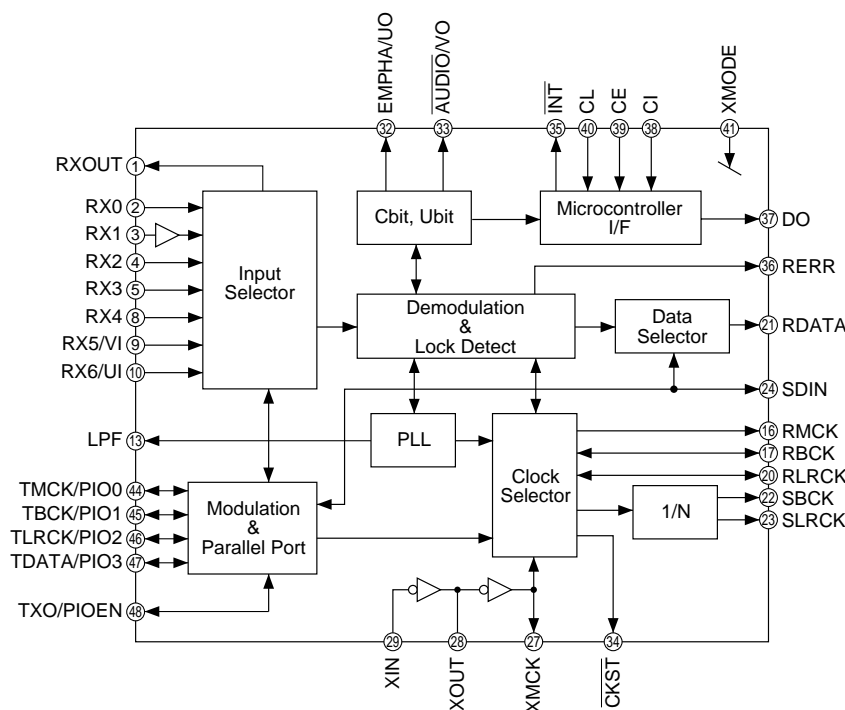

DVR-S150  
NX-P150

**IC3 : LC89057W-VF4D-E (DIGITAL P.C.B.)**  
**Digital Audio Interface Transceiver**

No.	Name	I/O	Function
1	RXOUT	O	Input bi-phase selection data output pin
2	RX0	I <sub>S</sub>	TTL-compatible digital data input pin
3	RX1	I	Coaxial-compatible digital data input pin with built-in amplifier
4	RX2	I <sub>S</sub>	TTL-compatible digital data input pin
5	RX3	I <sub>S</sub>	TTL-compatible digital data input pin
6	DGND		Digital GND
7	DVDD		Digital power supply
8	RX4	I <sub>S</sub>	TTL-compatible digital data input pin
9	RX5/VI	I <sub>S</sub>	TTL-compatible digital data / Validity flag input pin for modulation
10	RX6/UI	I <sub>S</sub>	TTL-compatible digital data / User data input pin for modulation
11	DVDD		PLL digital power supply
12	DGND		PLL digital GND
13	LPF	O	PLL loop filter connection pin
14	ACDD		PLL analog power supply
15	AGND		PLL analog GND
16	RMCK	O	R system clock output pin (256fs, 512fs, XIN, VCO)
17	RBCK	O/I	R bit clock input/output pin
18	DGND		Digital GND
19	DVDD		Digital power supply
20	RLRCK	O/I	R LR clock input/output pin (fs)
21	RDATA	O	Serial audio data input pin
22	SBCK	O	S bit clock output pin (32fs, 64fs, 128fs)
23	SLRCK	O	S LR clock output pin (fs/s, fs, 2fs)
24	SDIN	I <sub>S</sub>	Serial audio data input pin
25	DGND		Digital GND
26	DVDD		Digital power supply
27	XMCK	O	Oscillation amplifier output pin
28	XOUT	O	Crystal resonator connection output pin
29	XIN	I	Crystal resonator connection, external supply clock input pin (24.576 MHz or 12.288 MHz)
30	DVDD		Digital power supply
31	DGND		Digital GND
32	EMPHA/UO	I/O	Emphasis information / U data output / Chip address setting pin
33	AUDIO/VO	I/O	Non-PCM output / V flag output / Chip address setting pin
34	CKST	I/O	Clock switch transition period signal / Demodulation master or slave function switch pin
35	INT	I/O	Microcontroller interrupt output / Modulation or general-purpose I/O switch pin
36	RERR	O	PLL clock error, data error flag output
37	DO	O	Microcontroller I/F read data output pin (3-state)
38	DI	I <sub>S</sub>	Microcontroller I/F write data input pin
39	CE	I <sub>S</sub>	Microcontroller I/F chip enable input pin
40	CL	I <sub>S</sub>	Microcontroller I/F clock input pin
41	XMODE	I <sub>S</sub>	System reset input pin
42	DGND		Digital GND
43	DVDD		Digital power supply
44	TMCK/PIO0	I/O	Modulation 256fs system clock input / General-purpose I/O input/output pin
45	TMCK/PIO1	I/O	Modulation 64fs bit clock input / General-purpose I/O input/output pin
46	TLRCK/PIO2	I/O	Modulation fs clock input / General-purpose I/O input/output pin
47	TLRCK/PIO3	I/O	Modulation serial audio data input / General-purpose I/O input/output pin
48	TXO/PIOEN	O/I	Modulation data output / General-purpose I/O enable input pin

1) Input/output I or O = -0.3 to 3.6V, I<sub>S</sub> = -0.3 to 5.5V

2) Pins 32 and 33 are latch address setting input pins when pin 41 = "L".

3) Pin 34 is a demodulation function master or slave setting input pin when pin 41 = "L".

4) Pin 35 is a modulation function or general-purpose I/O function switch setting input pin when pin 41 = "L".

5) Perform ON/OFF for all power supplies with the same timing as a latch-up countermeasure.

IC5 : YSS948-V (DIGITAL P.C.B.)  
ADAM

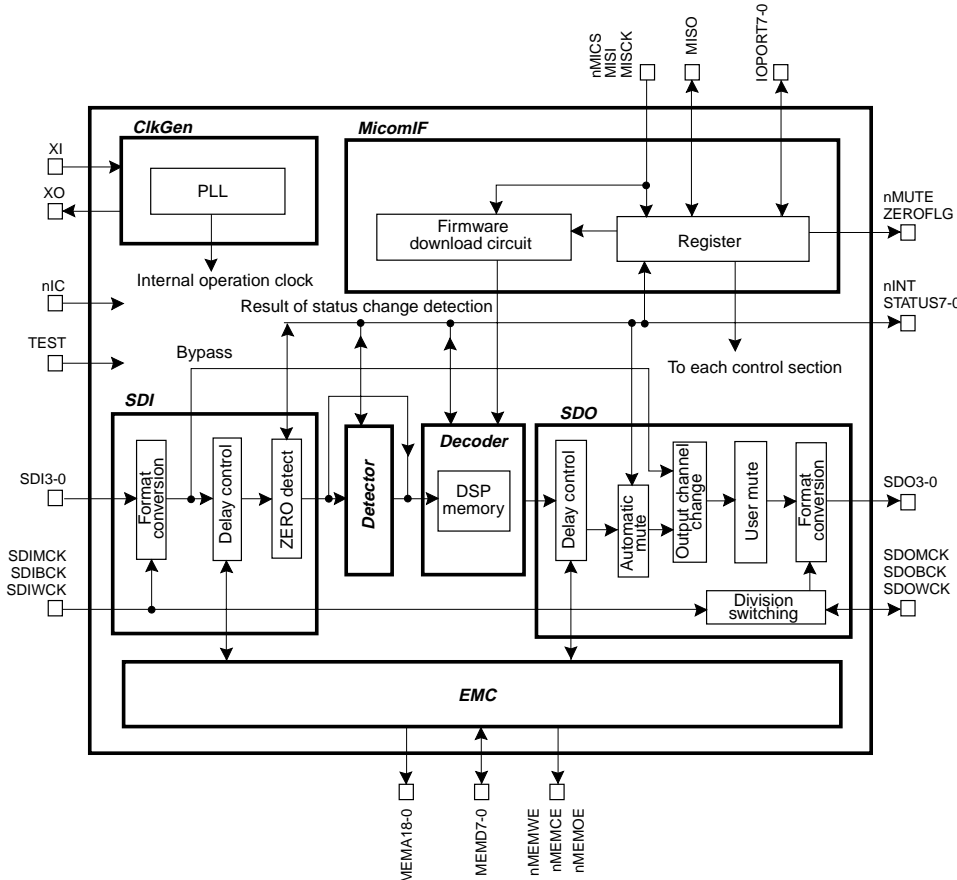
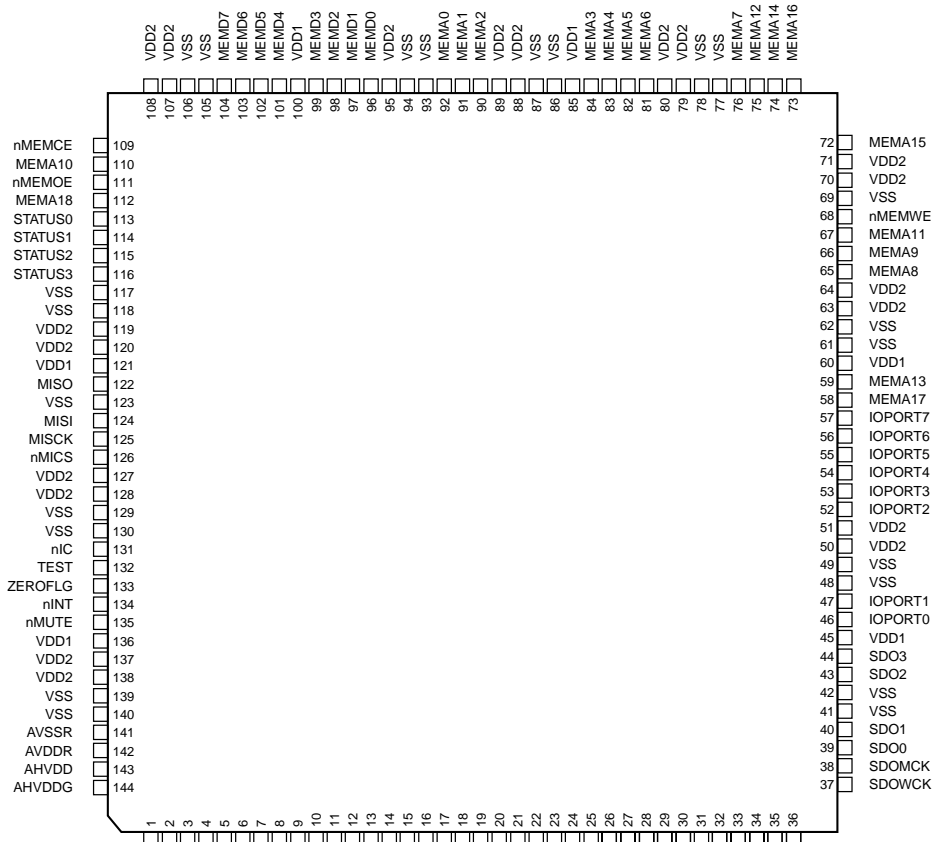

DVR-S150  
NX-P150

**IC5 : YSS948-V (DIGITAL P.C.B.)**  
**ADAM**

Category	No.	Name	I/O	Function	
Power Supply	9	VDD1	-	Power supply terminal for terminal block circuit (Typ. 3.3V)	
	33				
	45				
	60				
	85				
	100				
	121				
	136				
		5	VDD2	-	Power supply terminal for Internal Circuit (Typ. 1.2V)
	6				
	15				
	22				
	23				
	36				
	50				
	51				
	63				
	64				
	70				
	71				
	79				
	80				
	88				
	89				
	95				
	107				
	108				
	119				
	120				
	127				
	128				
	137				
	138				
		142	AVDDR	-	Power supply terminal 1 for PLL section (Typ. 3.3V)
		143	AHVDD	-	Power supply terminal 2 for PLL section (Typ. 3.3V)
		144	AHVDDG	-	Power supply terminal 3 for PLL section (Typ. 3.3V)
	4	DVDD	-	Internal power supply terminal for PLL section (Typ. 1.2V)	
	7	VSS	-	Ground terminal	
	8				
	14				
	20				
	21				
	35				
	41				
	42				
	48				
	49				
	61				
	62				
	69				
	77				
	78				
	86				
	87				
	93				

**IC5 : YSS948-V (DIGITAL P.C.B.)  
ADAM**

Category	No.	Name	I/O	Function
Power Supply	94	VSS	-	Ground terminal
	105			
	106			
	117			
	118			
	123			
	129			
	130			
	139			
	140			
		1	AHVSS	
	2	AHVSSG		Ground terminal 3 for PLL section
	3	DVSS		Ground terminal 4 for PLL section
	141	AVSSR		Ground terminal 1 for PLL section
Initial Clear	131	nIC	-	Hardware reset input terminal
Clock	18	XI	I	Clock input terminal
	19	XO	O	Clock output terminal for crystal oscillator oscillation
μ-COM Interface	126	nMICS	Is	Chip select input terminal for μ-COM interface
	125	MISCK	Is	Clock input terminal for μ-COM interface
	124	MISI	I	Address, read/write control, data input terminal for μ-COM interface
	122	MISO	Ot	Data output terminal for μ-COM interface
Audio Interface	32	SDIMCK	Is	Master clock input terminal on input side of audio interface
	31	SDIBCK	Is	Bit clock input/output terminal on input side of audio interface
	30	SDIWCK	I	Word clock terminal on input side of audio interface
	26	SDI3	I	Serial data input terminal 3 for Audio Interface
	27	SDI2	I	Serial data input terminal 2 for audio interface
	28	SDI1	I	Serial data input terminal 1 for audio interface
	29	SDI0	I	Serial data input terminal 0 for audio interface
	38	SDOMCK	Ot	Master clock output terminal on output side of audio interface
	34	SDOBCK	Is/O	Bit clock input/output terminal on output side of audio interface
	37	SDOWCK	I/O	Word clock input/output terminal on output side of audio interface
	44	SDO3	O	Serial data output terminal 3 for audio interface
	43	SDO2	O	Serial data output terminal 2 for audio interface
	40	SDO1	O	Serial data output terminal 1 for audio interface
	39	SDO0	O	Serial data output terminal 0 for audio interface
	External Memory Interface	112	MEMA18	O
58		MEMA17		
73		MEMA16		
72		MEMA15		
74		MEMA14		
59		MEMA13		
75		MEMA12		
67		MEMA11		
110		MEMA10		
66		MEMA9		
65		MEMA8		
76		MEMA7		
81		MEMA6		
82		MEMA5		
83		MEMA4		
84		MEMA3		
90		MEMA2		
91		MEMA1		
92	MEMA0			
	104	MEMD7	I/O	External memory data input/output terminals 7 to 0



**IC5 : YSS948-V (DIGITAL P.C.B.)**  
**ADAM**

Category	No.	Name	I/O	Function		
External Memory Interface	103	MEMD6	I/O	External memory data input/output terminals 7 to 0		
	102	MEMD5				
	101	MEMD4				
	99	MEMD3				
	98	MEMD2				
	97	MEMD1				
	96	MEMD0				
	109	nMEMCE			O	External memory chip select output terminal
	111	nMEMOE			O	External memory output enable output terminal
	68	nMEMWE	O	External memory write enable output terminal		
Status Port	134	nINT	O	Interrupt request output terminal		
	135	nMUTE	O	Auto mute period output terminal		
	133	ZEROF LG	O	Continuous zero data input detect terminal		
	13	STATUS7	O	Status data output Terminals 7 to 0		
	12	STATUS6				
	11	STATUS5				
	10	STATUS4				
	116	STATUS3				
	115	STATUS2				
	114	STATUS1				
	113	STATUS0				
	General Purpose I/O Port	57			IOPORT7	I(+)/O
56		IOPORT6				
55		IOPORT5				
54		IOPORT4				
53		IOPORT3				
52		IOPORT2				
47		IOPORT1				
46		IOPORT0				
Test	16	TEST	Is	Test Terminal		
	17					
	24					
	25					
	132					

**I/O symbols**
**I:** Digital Input

**Is:** Schmidt Input

**O:** Digital Output

**Ot:** 3-State Output

**I/O:** Digital Input/Output

**I(+)/O:** Pulled up for input, not pulled up for output

**IC7 : YSS930-SZ (DIGITAL P.C.B.)  
DSP**

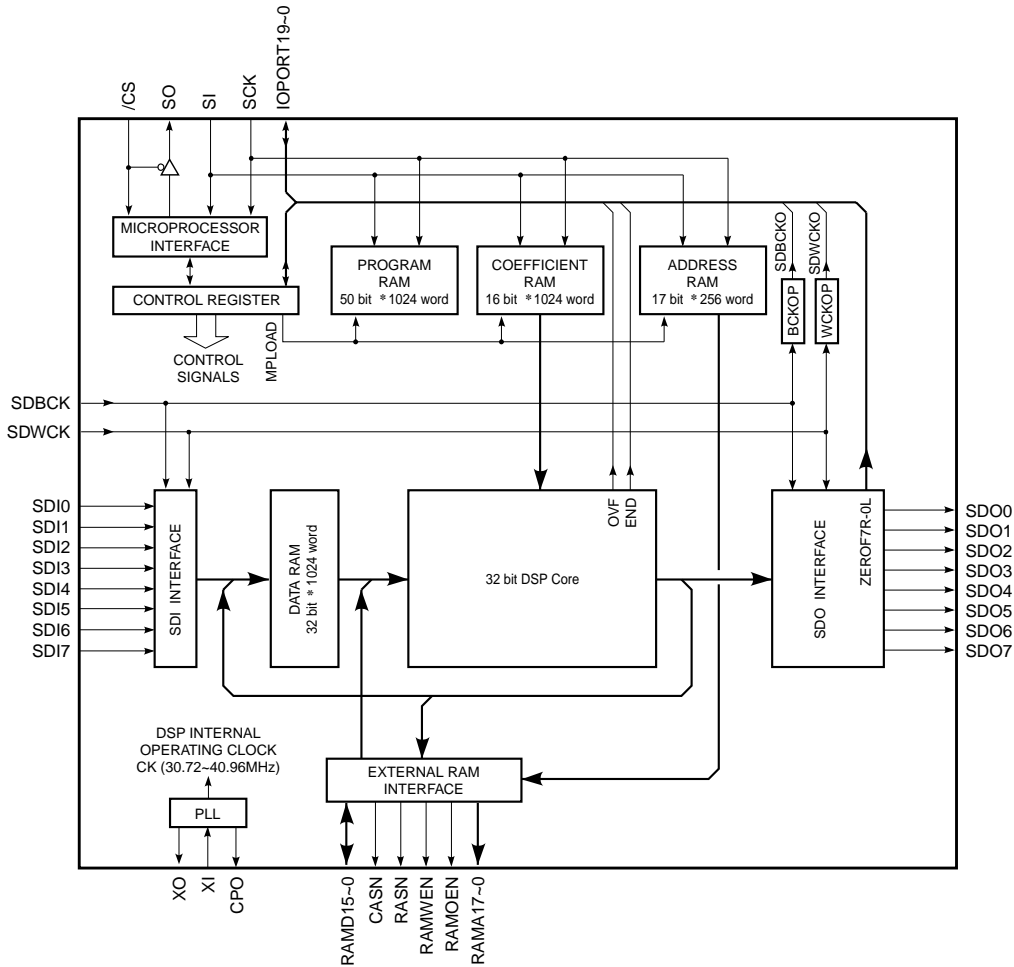
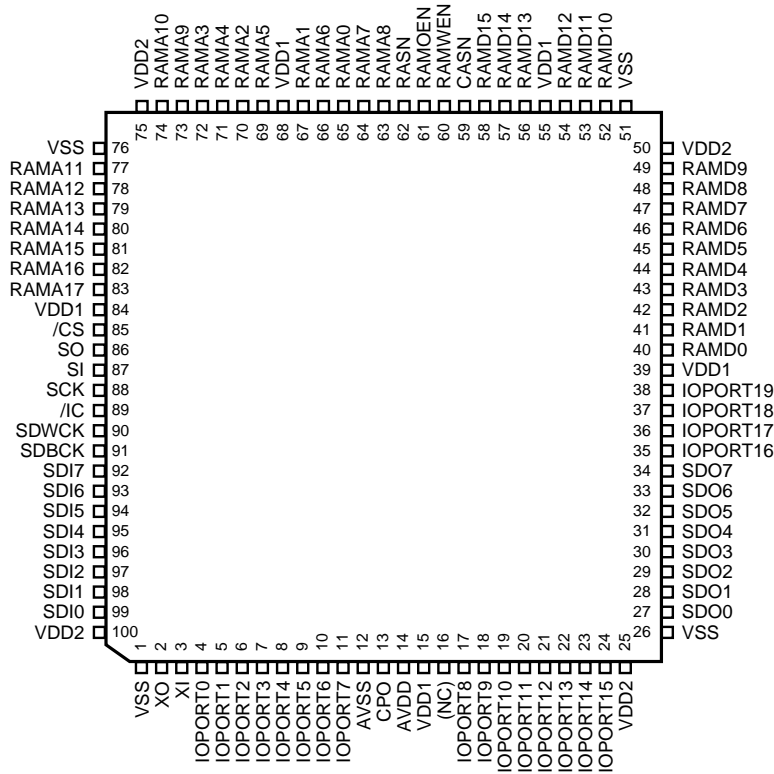

DVR-S150  
NX-P150

**IC7 : YSS930-SZ (DIGITAL P.C.B.)****DSP**

No.	Name	I/O	Function
1	VSS	-	Digital ground terminal
2	XO	O	Terminal for connecting crystal oscillator
3	XI	I	Terminal for connecting crystal oscillator (12.288 ~ 15.0MHz)
4	IOPORT0	I+/O	General purpose input/output terminal, SDO0 Lch zero-flag output terminal, input/output terminal for branching program conditions
5	IOPORT1	I+/O	General purpose input/output terminal, SDO0 Rch zero-flag output terminal, input/output terminal for branching program conditions
6	IOPORT2	I+/O	General purpose input/output terminal, SDO1 Lch zero-flag output terminal, input/output terminal for branching program conditions
7	IOPORT3	I+/O	General purpose input/output terminal, SDO1 Rch zero-flag output terminal, input/output terminal for branching program conditions
8	IOPORT4	I+/O	General purpose input/output terminal, SDO2 Lch zero-flag output terminal, input/output terminal for branching program conditions
9	IOPORT5	I+/O	General purpose input/output terminal, SDO2 Rch zero-flag output terminal, input/output terminal for branching program conditions
10	IOPORT6	I+/O	General purpose input/output terminal, SDO3 Lch zero-flag output terminal, input/output terminal for branching program conditions
11	IOPORT7	I+/O	General purpose input/output terminal, SDO3 Rch zero-flag output terminal, input/output terminal for branching program conditions
12	AVSS	-	Analog ground terminal (for PLL)
13	CPO	A	Terminal for connecting PLL filter
14	AVDD	-	+2.5V digital power supply (for PLL)
15	VDD1	-	+3.3V digital power supply (for input/output terminal)
16	(NC)	-	(Unconnected)
17	IOPORT8	I+/O	General purpose input/output terminal, SD04 Lch zero-flag output terminal
18	IOPORT9	I+/O	General purpose input/output terminal, SD04 Rch zero-flag output terminal
19	IOPORT10	I+/O	General purpose input/output terminal, SD05 Lch zero-flag output terminal
20	IOPORT11	I+/O	General purpose input/output terminal, SD05 Rch zero-flag output terminal
21	IOPORT12	I+/O	General purpose input/output terminal, SD06 Lch zero-flag output terminal, input terminal 0 for chip address setting
22	IOPORT13	I+/O	General purpose input/output terminal, SD06 Rch zero-flag output terminal, input terminal 1 for chip address setting
23	IOPORT14	I+/O	General purpose input/output terminal, SD07 Lch zero-flag output terminal, input terminal 2 for chip address setting
24	IOPORT15	I+/O	General purpose input/output terminal, SD07 Rch zero-flag output terminal, input terminal 3 for chip address setting
25	VDD2	-	+2.5V digital power supply (for internal circuit)
26	VSS	-	Digital ground terminal
27	SDO0	O	PCM output terminal
28	SDO1	O	PCM output terminal
29	SDO2	O	PCM output terminal
30	SDO3	O	PCM output terminal
31	SDO4	O	PCM output terminal
32	SDO5	O	PCM output terminal
33	SDO6	O	PCM output terminal
34	SDO7	O	PCM output terminal
35	IOPORT16	I+/O	General purpose input/output terminal, overflow detect output terminal
36	IOPORT17	I+/O	General purpose input/output terminal, program end detect output terminal
37	IOPORT18	I+/O	General purpose input/output terminal, 64fs clock output terminal
38	IOPORT19	I+/O	General purpose input/output terminal, fs clock output terminal
39	VDD1	-	+3.3V digital power supply (for input/output terminal)
40	RAMD0	I+/O	Data input/output terminal 0 for external memory
41	RAMD1	I+/O	Data input/output terminal 1 for external memory
42	RAMD2	I+/O	Data input/output terminal 2 for external memory
43	RAMD3	I+/O	Data input/output terminal 3 for external memory
44	RAMD4	I+/O	Data input/output terminal 4 for external memory
45	RAMD5	I+/O	Data input/output terminal 5 for external memory
46	RAMD6	I+/O	Data input/output terminal 6 for external memory
47	RAMD7	I+/O	Data input/output terminal 7 for external memory
48	RAMD8	I+/O	Data input/output terminal 8 for external memory
49	RAMD9	I+/O	Data input/output terminal 9 for external memory
50	VDD2	-	+2.5V digital power supply (for internal circuit)
51	VSS	-	Digital ground terminal
52	RAMD10	I+/O	Data input/output terminal 10 for external memory
53	RAMD11	I+/O	Data input/output terminal 11 for external memory
54	RMD12	I+/O	Data input/output terminal 12 for external memory
55	VDD1	-	+3.3V digital power supply (for input/output terminal)
56	RAMD13	I+/O	Data input/output terminal 13 for external memory

**IC7 : YSS930-SZ (DIGITAL P.C.B.)****DSP**

No.	Name	I/O	Function
57	RAMD14	I+/O	Data input/output terminal 14 for external memory
58	RAMD15	I+/O	Data input/output terminal 15 for external memory
59	CASN	O	Column address strobe output terminal for external DRAM
60	RAMWEN	O	Write enable output terminal for external memory
61	RAMOEN	O	Output enable output terminal for external memory
62	RASN	O	Low address strobe output terminal for external DRAM
63	RAMA8	O	Address output terminal 8 for external memory
64	RAMA7	O	Address output terminal 7 for external memory
65	RAMA0	O	Address output terminal 0 for external memory
66	RAMA6	O	Address output terminal 6 for external memory
67	RAMA1	O	Address output terminal 1 for external memory
68	VDD1	-	+3.3V digital power supply (for input/output terminal)
69	RAMA5	O	Address output terminal 5 for external memory
70	RAMA2	O	Address output terminal 2 for external memory
71	RAMA4	O	Address output terminal 4 for external memory
72	RAMA3	O	Address output terminal 3 for external memory
73	RAMA9	O	Address output terminal 9 for external memory
74	RAMA10	O	Address output terminal 10 for external memory
75	VDD2	-	+2.5V digital power supply (for internal circuit)
76	VSS	-	Digital ground terminal
77	RAMA11	O	Address output terminal 11 for external memory
78	RAMA12	O	Address output terminal 12 for external memory
79	RAMA13	O	Address output terminal 13 for external memory
80	RAMA14	O	Address output terminal 14 for external memory
81	RAMA15	O	Address output terminal 15 for external memory
82	RAMA16	O	Address output terminal 16 for external memory
83	RAMA17	O	Address output terminal 17 for external memory
84	VDD1	-	+3.3V digital power supply (for input/output terminal)
85	/CS	Is	Microprocessor interface chip select input terminal
86	SO	Ot	Microprocessor interface data output terminal
87	SI	Is	Microprocessor interface data input terminal
88	SCK	Is	Microprocessor interface clock input terminal
89	/IC	Is	Initial clear input terminal
90	SDWCK	I	Word clock (fs) input terminal for SDI/SDO interface
91	SDBCK	Is	Bit clock (64fs) input terminal for SDI/SDO interface
92	SDI7	I	PCM input terminal
93	SDI6	I	PCM input terminal
94	SDI5	I	PCM input terminal
95	SDI4	I	PCM input terminal
96	SDI3	I	PCM input terminal
97	SDI2	I	PCM input terminal
98	SDI1	I	PCM input terminal
99	SDI0	I	PCM input terminal
100	VDD2	-	+2.5V digital power supply (for internal circuit)

Is: Schmidt trigger input terminal

I+: Input terminal with pull-up resistor

O: digital output terminal

Ot: Tri-state digital output terminal

A: Analog terminal

■ DVR-S150 BLOCK DIAGRAM / ブロックダイアグラム

1

2

3

4

5

6

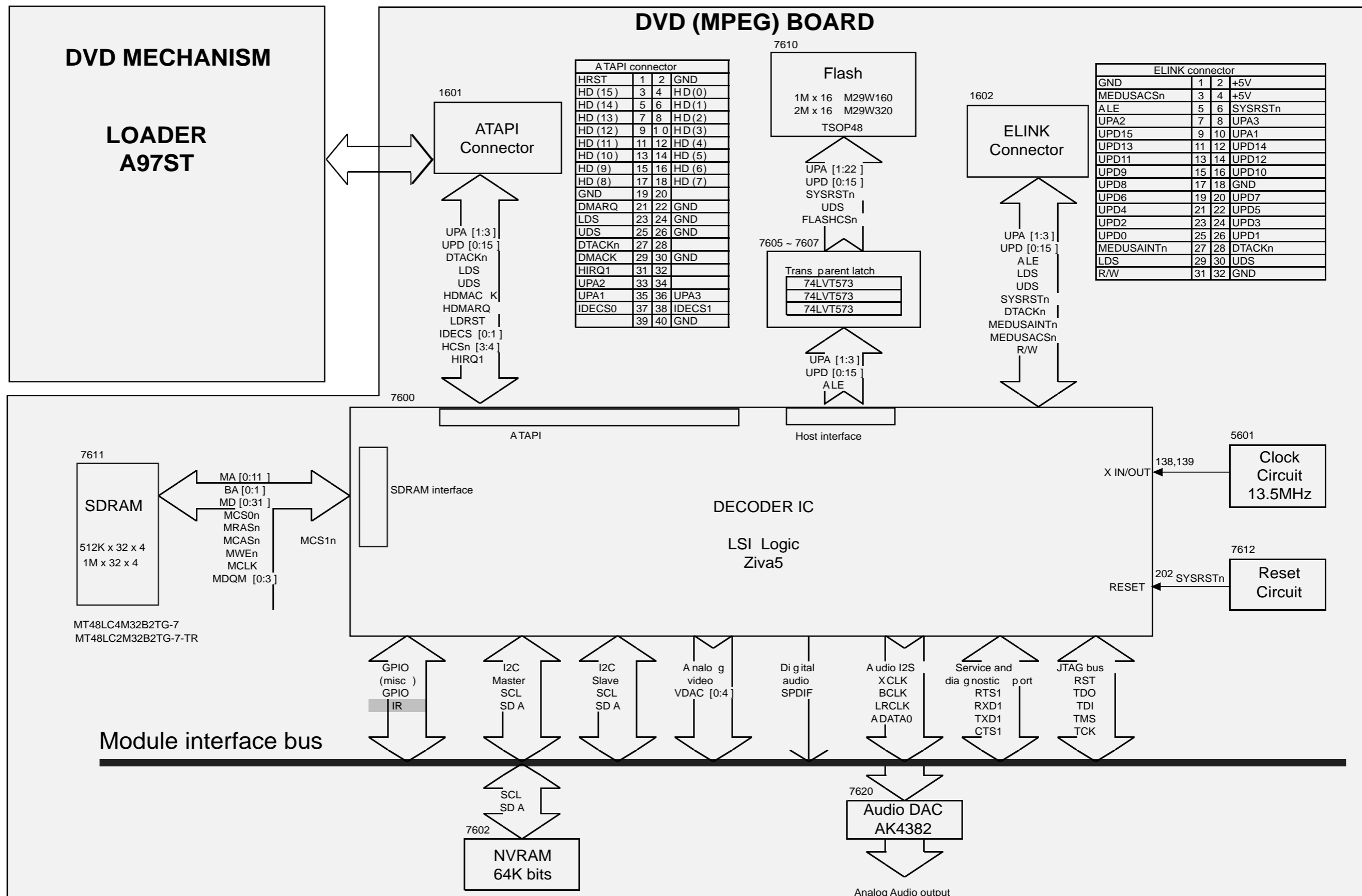

M24C64-WMN6T

# DVR-S150 BLOCK DIAGRAM / ブロックダイアグラム

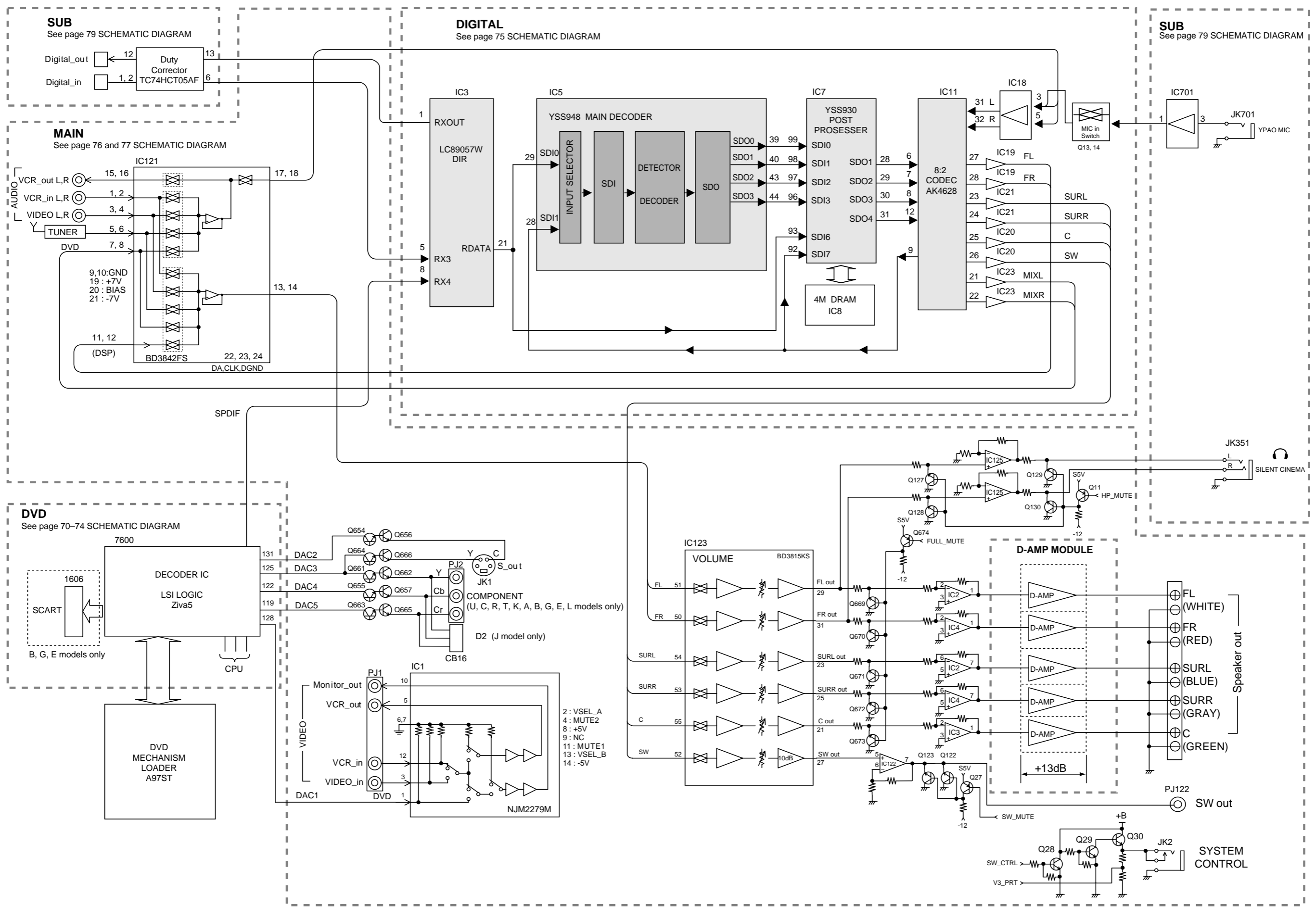

# DVR-S150 BLOCK DIAGRAM / ブロックダイアグラム

1

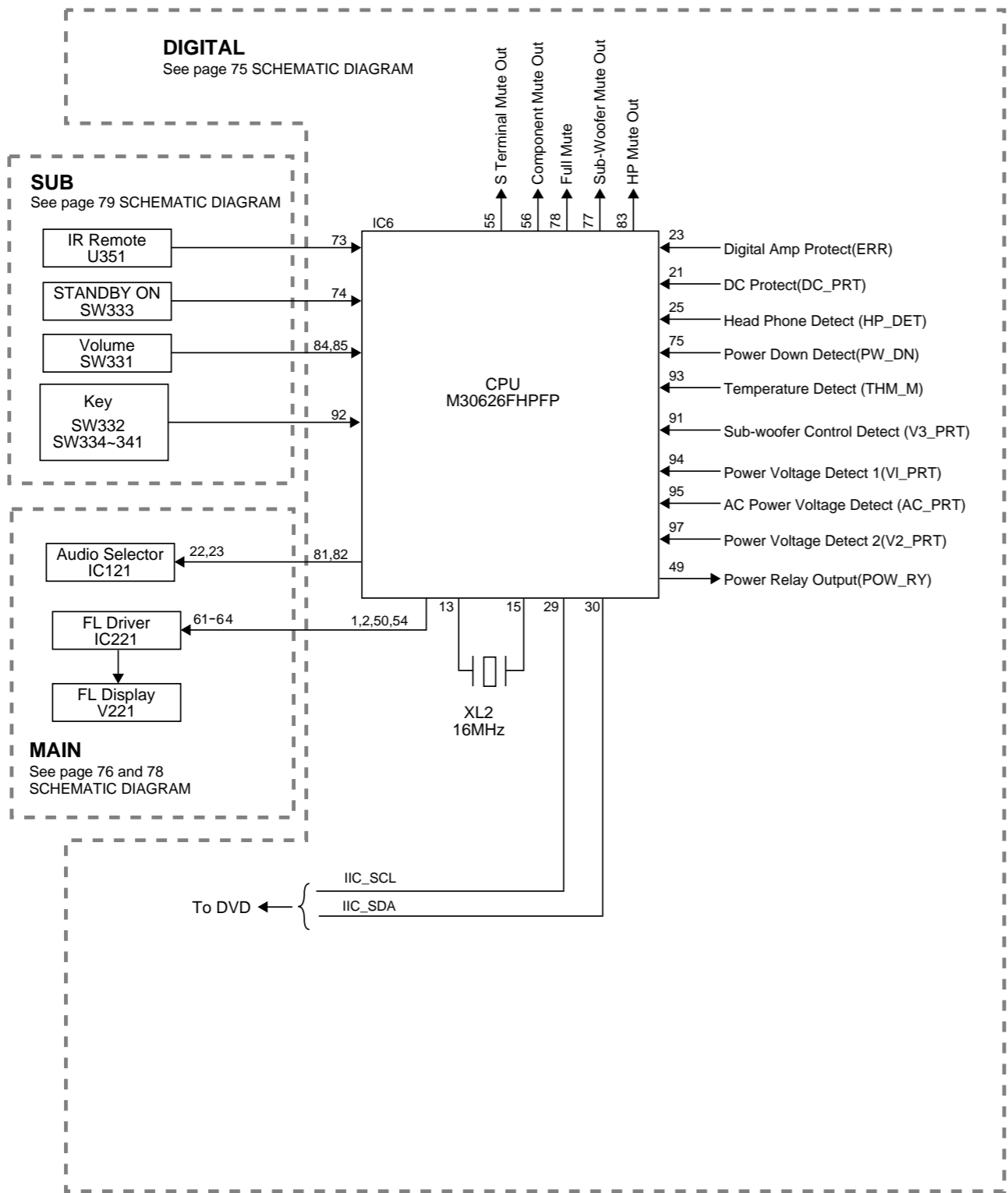

2

3

4

5

6

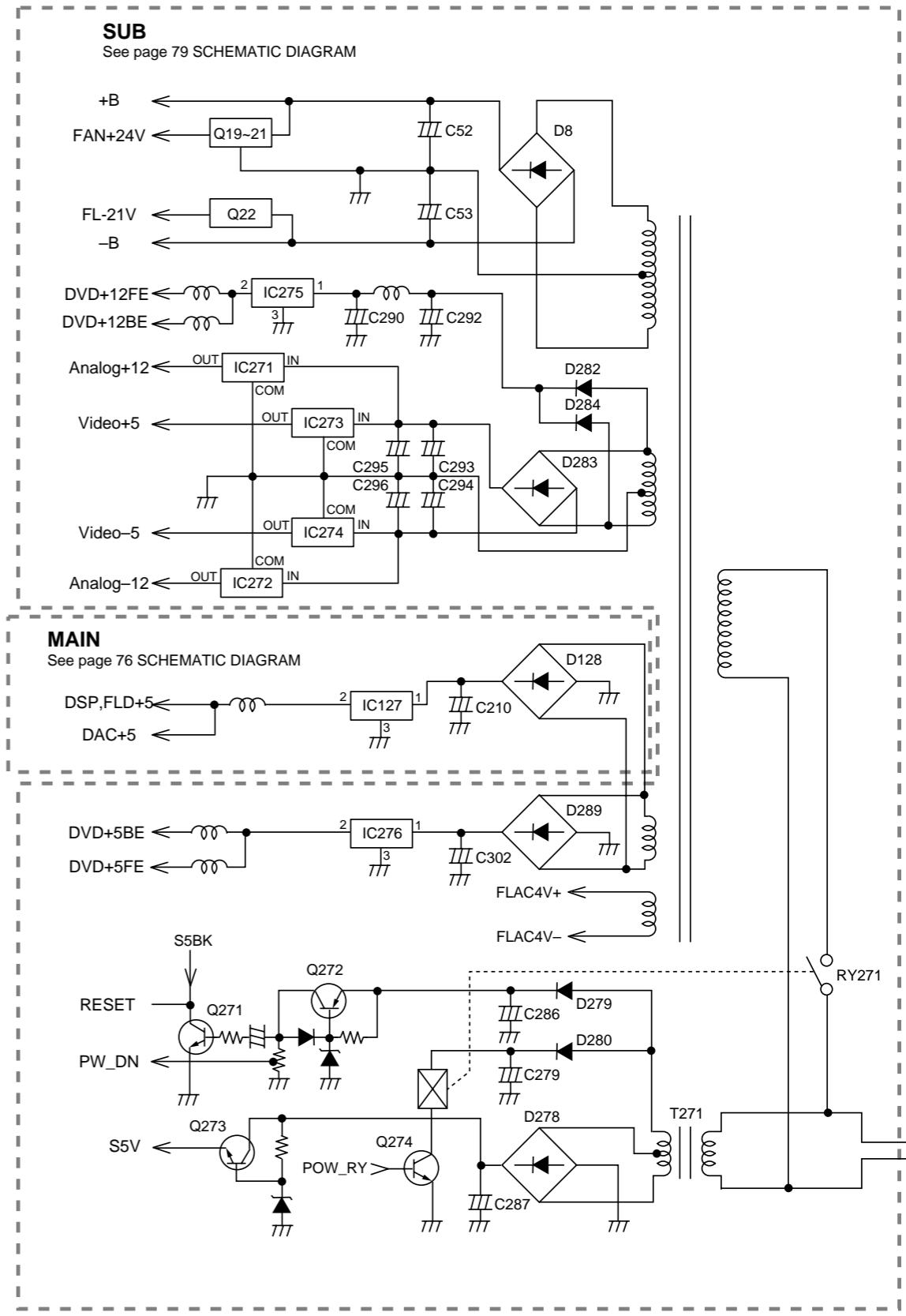

**DVR-S150**

**■ DVR-S150 PRINTED CIRCUIT BOARD**

**DVD Component Side**

The first digit of a component indicates the component type.

1xxx : Connector    3xxx : Resistor    5xxx : Coil    7xxx : IC, Transistor, FET  
 2xxx : Capacitor    4xxx : SMD jumper    6xxx : Diode    9xxx : Wire jumper

1600 B1	1619 E8	2723 C7	2771 D7	2800 F7	2817 E7	2850 G9	2869 B7	2893 F3	2908 F7	3611 C5	3635 C2	3648 C6	3665 E3	3682 D9	3716 G2	3741 D7	3760 E9	3776 C7	3799 C6	3811 F7
1601 A2	1620 B9	2752 A8	2783 D7	2801 F7	2818 E7	2852 E9	2870 B7	2895 A8	2909 F6	3612 D7	3636 C4	3653 F4	3666 E4	3685 B2	3717 G1	3747 B8	3763 C8	3777 B7	3800 C6	3812 E6
1602 B4	1621 B9	2759 D9	2785 D7	2802 F7	2819 E8	2853 G9	2871 E1	2896 B8	2910 F7	3613 C5	3637 B2	3654 A8	3667 E3	3686 C2	3718 H1	3748 B8	3764 C9	3778 B8	3801 E6	3813 F7
1603 A7	2612 B8	2760 B8	2786 D7	2803 F8	2821 A9	2854 F9	2873 G2	2900 E6	2911 F7	3614 D7	3639 B1	3655 B8	3668 F4	3698 B5	3719 H1	3750 B8	3765 B9	3779 B8	3802 E6	3814 F8
1605 C1	2663 B5	2761 C8	2787 D7	2806 G7	2822 G1	2855 F9	2881 F6	2901 E7	2912 G6	3615 D6	3640 C1	3658 F4	3673 E9	3699 A5	3720 G2	3751 B8	3766 B8	3780 B8	3803 D7	3815 F8
1606 F9	2683 B7	2762 D7	2790 F7	2808 G7	2823 G9	2856 E9	2883 F2	2902 D7	2913 G7	3616 D6	3641 C5	3659 F4	3674 E9	3700 B6	3721 H2	3752 C7	3770 C8	3781 G8	3804 E8	3816 F8
1608 B10	2690 C1	2763 C8	2792 F7	2809 G7	2824 B1	2857 F9	2884 E2	2903 E6	2914 G7	3617 D6	3642 C2	3660 C4	3675 E9	3704 G4	3722 G2	3753 D7	3771 C7	3784 C7	3805 D8	3817 F8
1610 A8	2691 D1	2765 C7	2793 F7	2810 G7	2825 F9	2859 E9	2886 F3	2904 E7	2915 B8	3618 C6	3644 B2	3661 D4	3676 E9	3712 G8	3723 E8	3754 D7	3772 C8	3785 E8	3806 D8	3818 F8
1611 A6	2692 D1	2766 B8	2794 F7	2811 G8	2838 B9	2862 H2	2888 E3	2905 E7	2916 C8	3630 C6	3645 B5	3662 D4	3677 E9	3713 F8	3724 D2	3757 C7	3773 C8	3786 E8	3807 D8	3820 F8
1615 E1	2693 D1	2769 B8	2795 F8	2814 E7	2840 D8	2866 E1	2890 F6	2906 E7	3603 C5	3633 B5	3646 A9	3663 D4	3678 C8	3714 F8	3725 D2	3758 D7	3774 C7	3787 F8	3808 D8	3821 F6
1618 F8	2694 D1	2770 C7	2798 F7	2816 E7	2848 E8	2867 E2	2892 H7	2907 F7	3604 C5	3634 B5	3647 A9	3664 E4	3680 B8	3715 E8	3734 B7	3759 C7	3775 C7	3788 F8	3810 E8	3822 E6

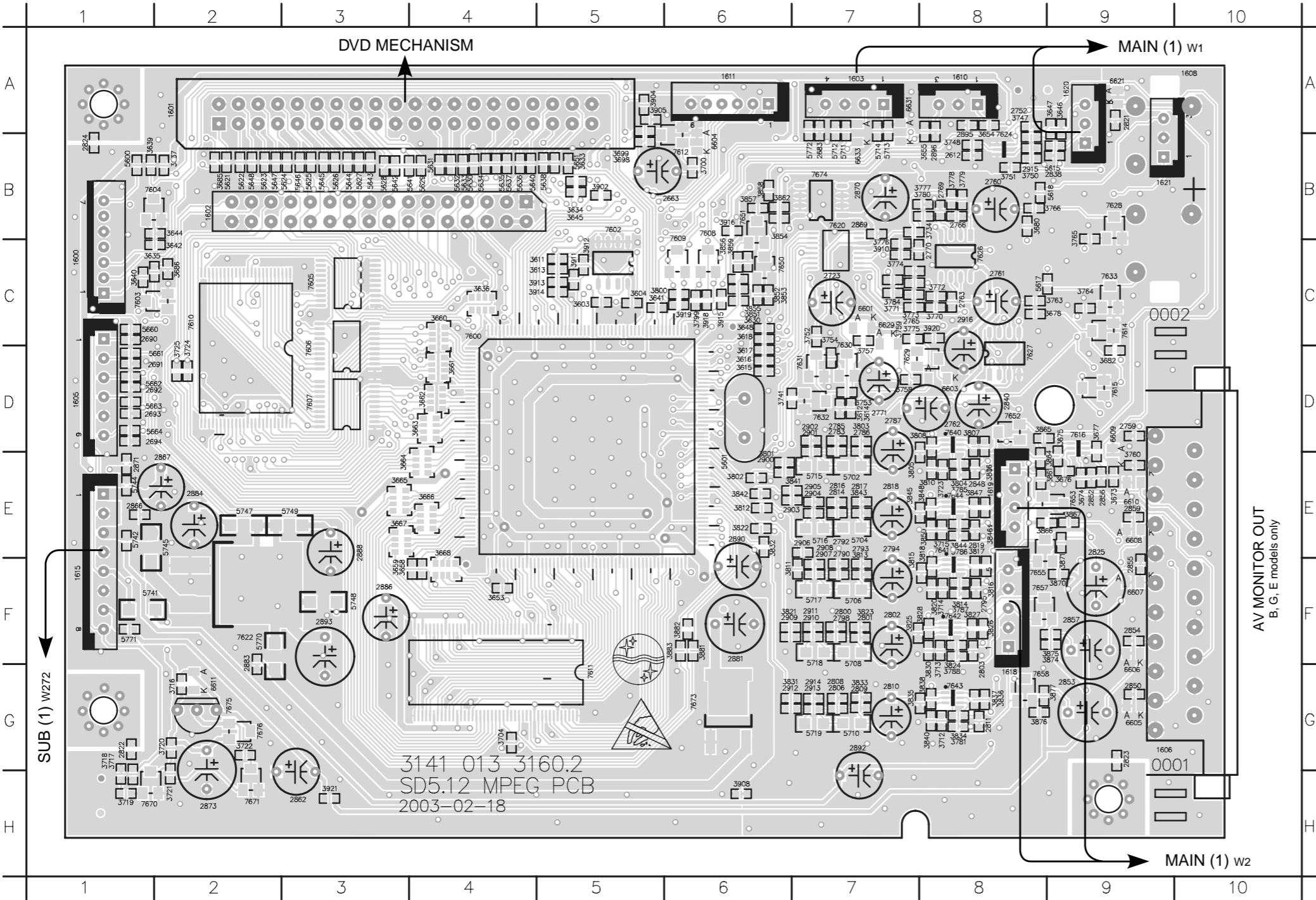

3823 F7	3881 F6	5645 B3	6631 B7
3824 F8	3882 F6	5646 B3	6633 B7
3825 F7	3883 F6	5647 B2	7600 D4
3826 F8	3902 B5	5648 B2	7602 C5
3827 F8	3904 A5	5651 B5	7603 C2
3828 F8	3905 A5	5660 C1	7604 B1
3830 F8	3908 H6	5661 D1	7605 C3
3831 G6	3910 C7	5662 D1	7606 D3
3832 E6	3911 C5	5663 D1	7607 D3
3833 G7	3912 C5	5664 D1	7608 C6
3834 G8	3913 C5	5702 E7	7609 C6
3835 G8	3914 C5	5704 E7	7610 C3
3836 G8	3915 C6	5706 F7	7611 F5
3837 G8	3916 B6	5708 F7	7612 B6
3838 G8	3918 C6	5710 G7	7614 C9
3840 G8	3919 C6	5711 B7	7615 D9
3841 E6	3920 C8	5712 B7	7616 E9
3842 E6	3921 H3	5713 B7	7620 B7
3843 E7	5600 B1	5714 B7	7622 F2
3844 E8	5601 D6	5715 E7	7624 B8
3845 E8	5615 B9	5716 E7	7626 B8
3846 E8	5617 C9	5717 F7	7627 D8
3847 E8	5618 B8	5718 F7	7628 B9
3848 E8	5621 B2	5719 G7	7629 D7
3850 E8	5622 B2	5741 F1	7630 D7
3851 C6	5623 B2	5742 E1	7631 D7
3852 C6	5624 B3	5744 E1	7632 D7
3853 C6	5625 B3	5745 E1	7633 C9
3854 B6	5626 B3	5747 E2	7640 D8
3855 C6	5627 B3	5748 F3	7641 F8
3856 C6	5628 B3	5749 E2	7642 F8
3857 B6	5629 B4	5770 F2	7643 G8
3858 B6	5630 B4	5771 F1	7644 E8
3859 C6	5631 B4	5772 B7	7650 C6
3861 E8	5632 B4	6601 C7	7651 C6
3862 B6	5633 B4	6603 D8	7652 D8
3864 E8	5634 B4	6604 B6	7653 E8
3865 D8	5635 B4	6605 G9	7655 F8
3866 E9	5636 B4	6606 F9	7657 F8
3867 E9	5637 B4	6607 F9	7658 G8
3870 F9	5638 B5	6608 E9	7670 H1
3871 E9	5640 B4	6609 D9	7671 H2
3874 F8	5641 B4	6610 E9	7673 G6
3875 F8	5642 B3	6611 G2	7674 B7
3876 G8	5643 B3	6621 A9	7675 G2
3877 G8	5644 B3	6629 C7	7676 G2



■ DVR-S150 PRINTED CIRCUIT BOARD

**DVR-S150**

The first digit of a component indicates the component type.

1xxx : Connector    3xxx : Resistor    5xxx : Coil    7xxx : IC, Transistor, FET  
 2xxx : Capacitor    4xxx : SMD jumper    6xxx : Diode    9xxx : Wire jumper

**DVD Copper Side**

2601	C1	2609	C2	2622	E6	2630	D5	2638	D5	2661	D2	2671	F4	2681	B7	2833	B7	2877	D6	3626	D6	3649	C4	3694	C2	3819	F8	3888	D6	3897	C7	3917	C6	5753	D5
2602	C3	2613	C5	2623	D5	2631	E4	2639	D4	2662	D3	2672	G5	2754	E9	2839	A10	2878	D6	3627	D6	3650	D6	3696	C2	3829	F8	3889	B6	3898	C7	5602	C8	5755	E6
2603	D3	2614	C4	2624	D6	2632	E4	2640	D4	2664	B4	2673	G4	2755	C9	2841	C8	2879	D6	3628	D6	3651	D2	3701	B6	3839	G8	3890	B7	3899	C7	5665	E6	5756	E6
2604	D3	2617	D6	2625	D4	2633	E5	2641	C4	2665	B4	2676	F5	2756	B9	2849	B10	2880	F6	3629	D6	3652	D2	3737	C7	3849	E8	3891	H6	3901	G6	5666	E6	5757	D5
2605	D6	2618	D6	2626	D4	2634	E4	2642	E5	2667	F4	2677	F4	2757	D8	2861	F1	2889	E3	3631	C6	3669	D6	3762	C9	3860	E8	3893	F6	3903	B5	5667	E6	5758	D5
2606	D6	2619	E6	2627	E4	2635	F6	2643	E4	2668	F4	2678	F4	2764	C8	2864	F2	2891	E6	3632	C6	3679	C1	3767	B9	3880	C8	3894	B8	3906	F4	5750	E6	6630	C6
2607	D6	2620	E6	2628	E5	2636	E5	2644	C5	2669	G4	2679	F4	2767	C8	2868	G7	3606	C6	3638	C2	3681	D9	3769	D9	3884	C8	3895	B8	3907	F4	5751	D5	6632	A7
2608	C6	2621	E6	2629	E5	2637	D6	2645	D6	2670	G4	2680	F5	2768	C8	2874	B7	3608	C6	3643	C1	3692	C2	3809	D8	3885	C8	3896	E6	3909	G6	5752	D5	6634	B7

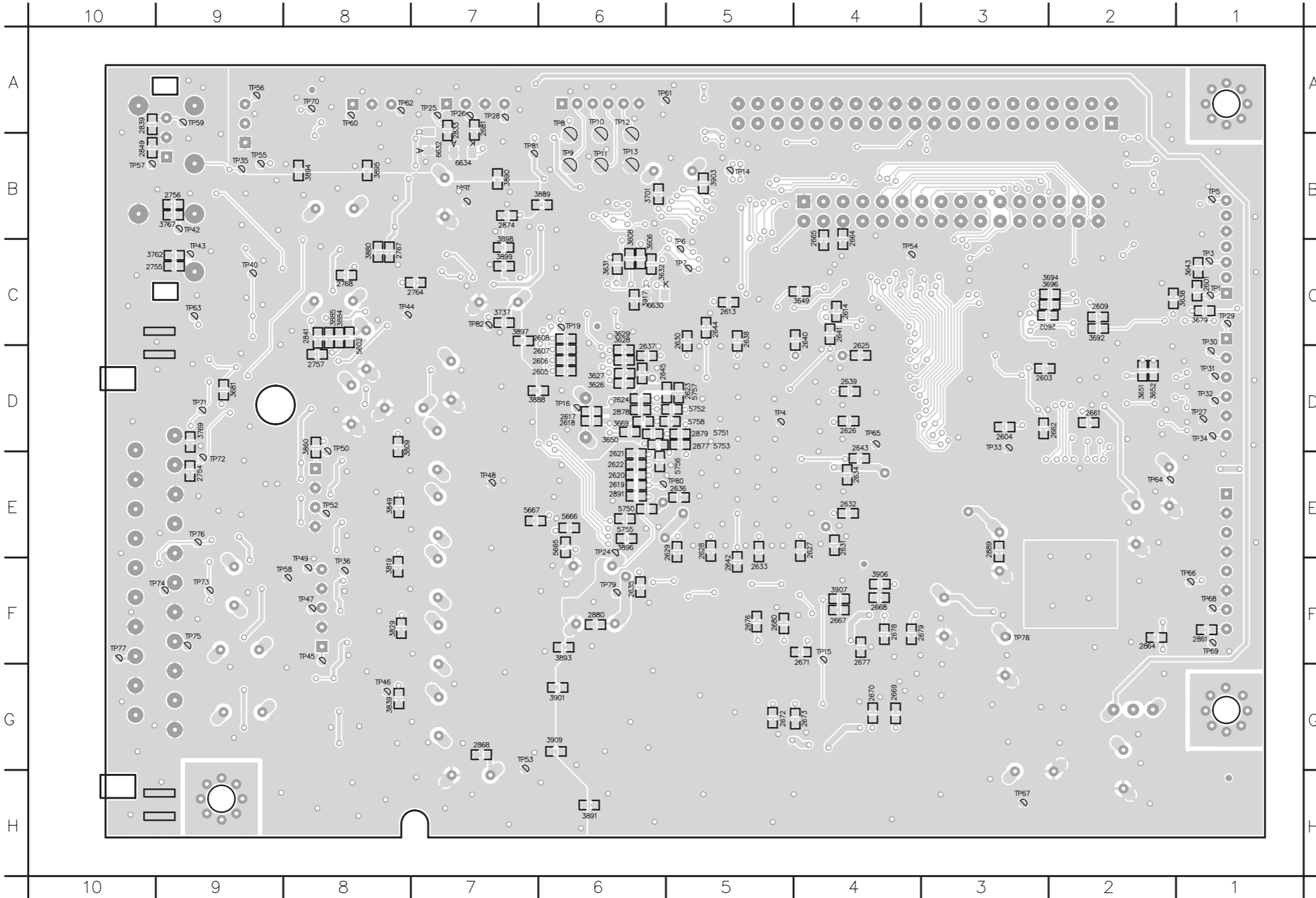

TP1	C1	TP47	F8
TP3	C1	TP48	E7
TP4	D5	TP49	F8
TP5	B1	TP50	E8
TP6	C5	TP51	B7
TP7	C5	TP52	E8
TP8	B6	TP53	G7
TP9	B6	TP54	C4
TP10	B6	TP55	B9
TP11	B6	TP56	A9
TP12	B6	TP57	B10
TP13	B6	TP58	F8
TP14	B5	TP59	A9
TP15	F4	TP60	A8
TP16	D6	TP61	A6
TP19	C6	TP62	A8
TP24	E6	TP63	C9
TP25	A7	TP64	E2
TP26	A7	TP65	D4
TP27	D1	TP66	F1
TP28	A7	TP67	H3
TP29	C1	TP68	F1
TP30	D1	TP69	F1
TP31	D1	TP70	A8
TP32	D1	TP71	D9
TP33	D3	TP72	E9
TP34	D1	TP73	F9
TP35	B9	TP74	F9
TP36	F8	TP75	F9
TP40	C9	TP76	E9
TP42	B9	TP77	F10
TP43	C9	TP78	F3
TP44	C8	TP79	F6
TP45	F8	TP80	E6
TP46	G8	TP81	B7



■ DVR-S150 PRINTED CIRCUIT BOARD (Foil side)

DVR-S150

1

2

3

4

5

6

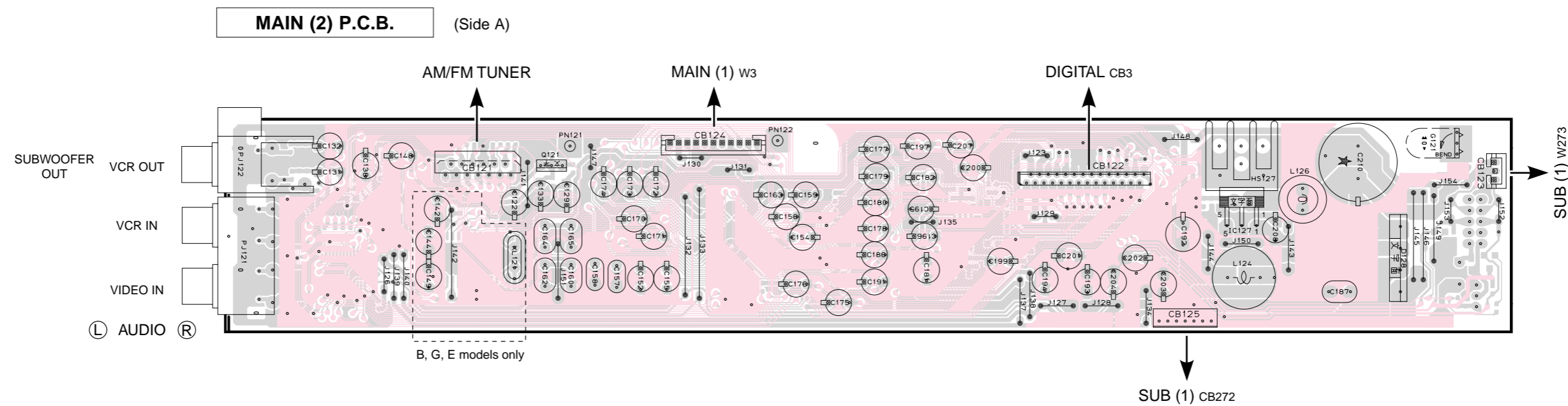

**MAIN (2) P.C.B.** (Side B) Lead Free Solder Used

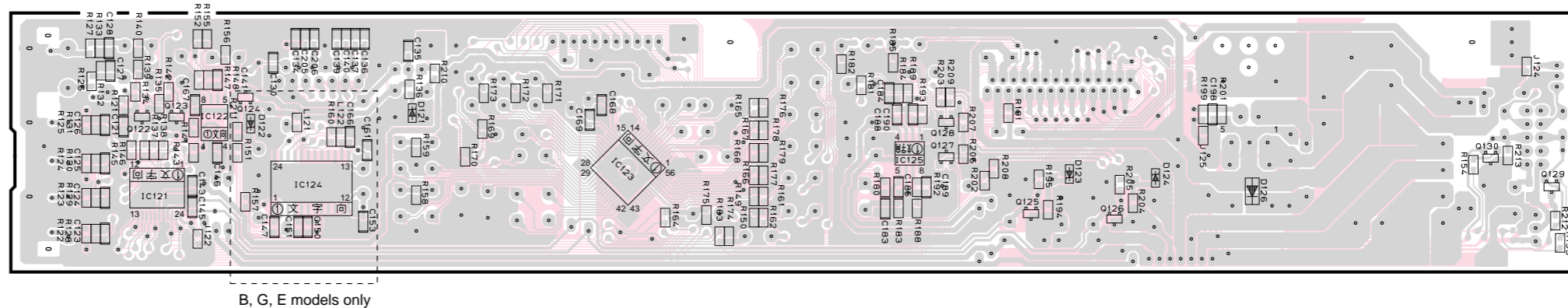







DVR-S150 PRINTED CIRCUIT BOARD (Foil side)

DVR-S150

SUB (1) P.C.B. (Side A)

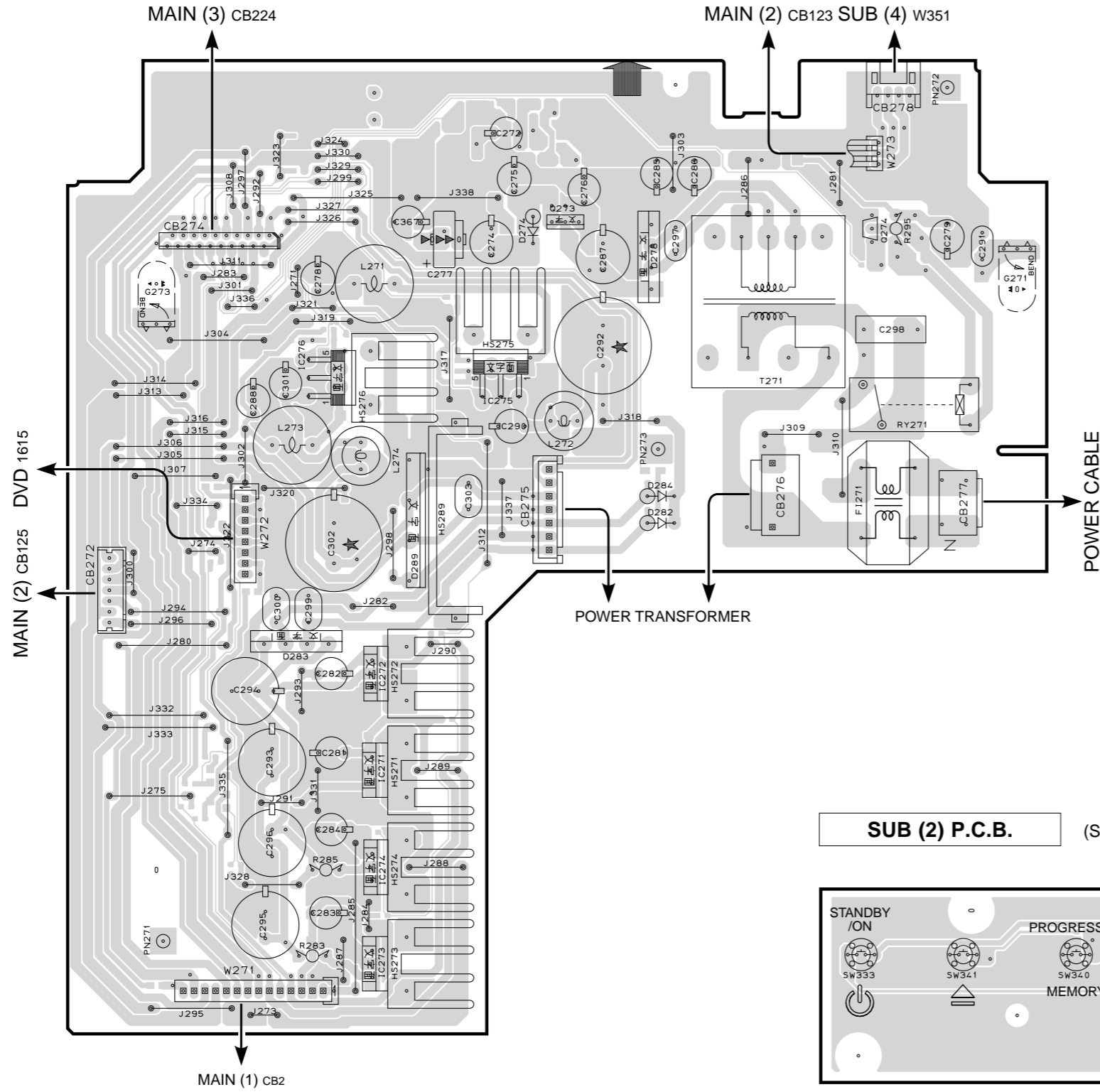

SUB (2) P.C.B. (Side A)

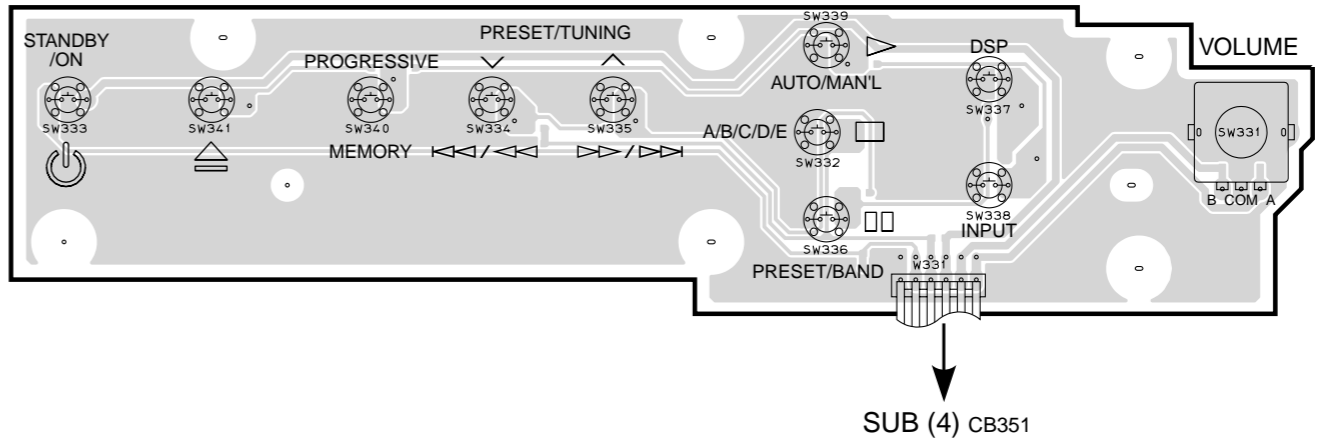

■ DVR-S150 PRINTED CIRCUIT BOARD (Foil side)

**DVR-S150**

1

**SUB (1) P.C.B.** (Side B) Lead Free Solder Used

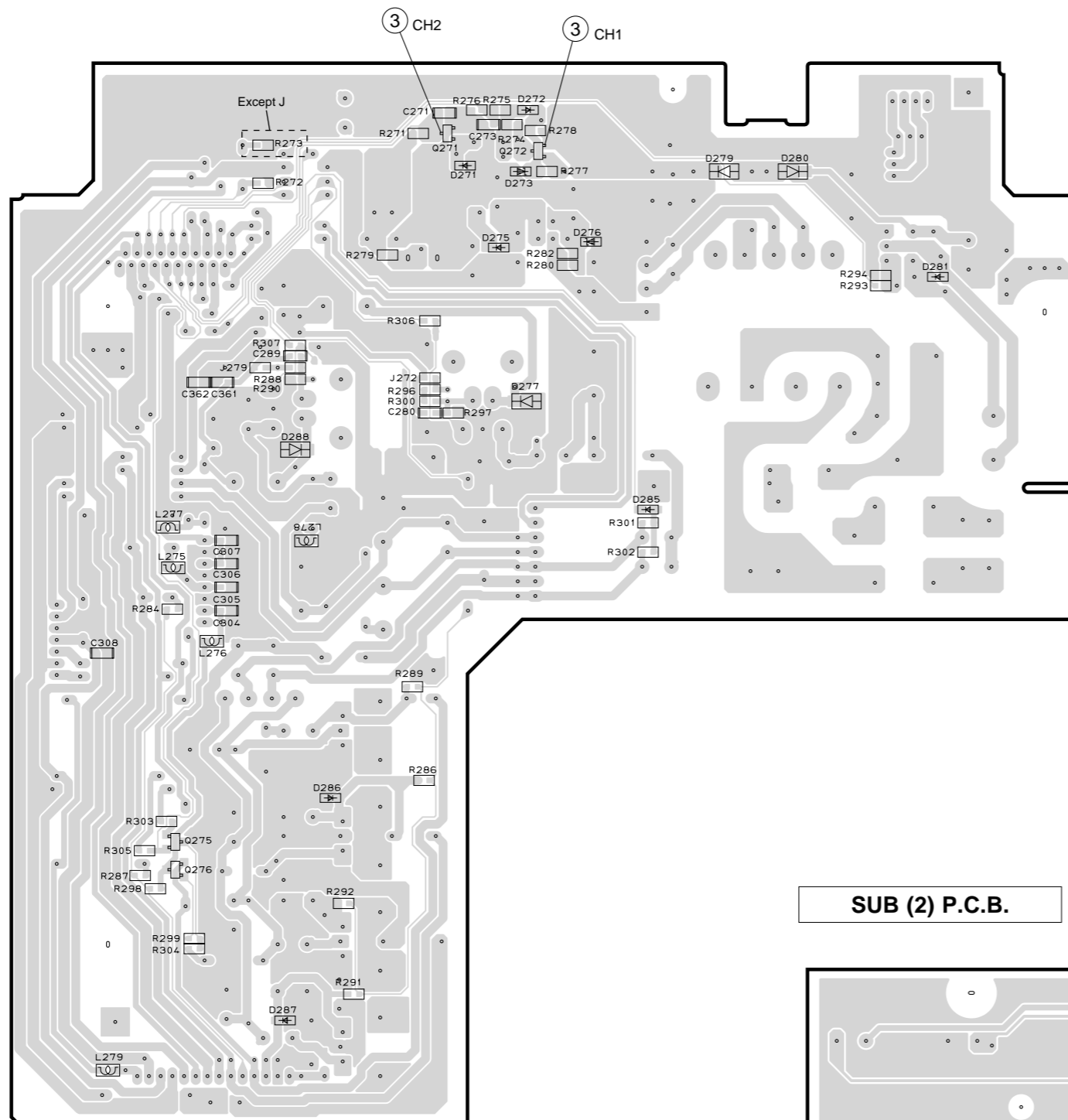

2

3

4

5

6

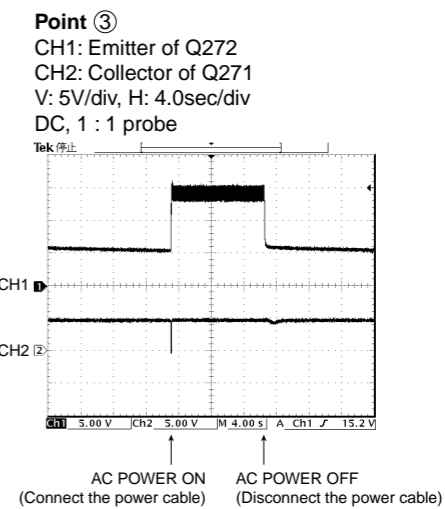

**SUB (2) P.C.B.** (Side B) Lead Free Solder Used

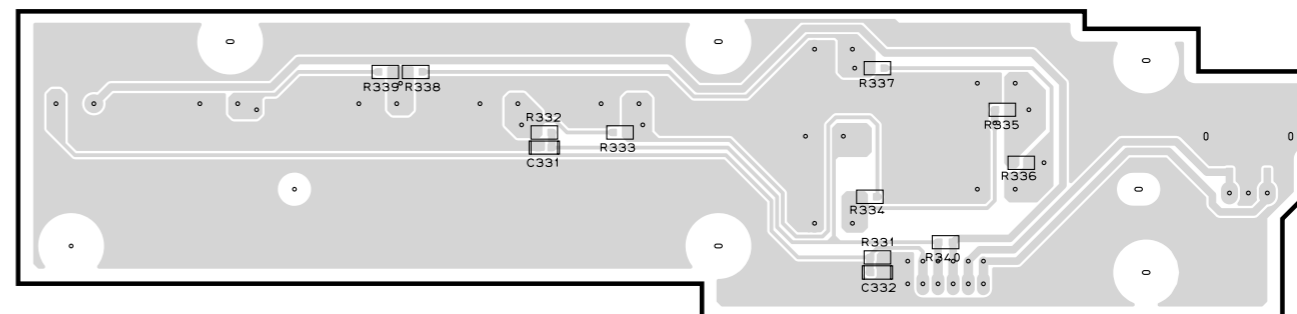





■ NX-SW150 PRINTED CIRCUIT BOARD

NX-SW150

MAIN (1) P.C.B. (Side A)

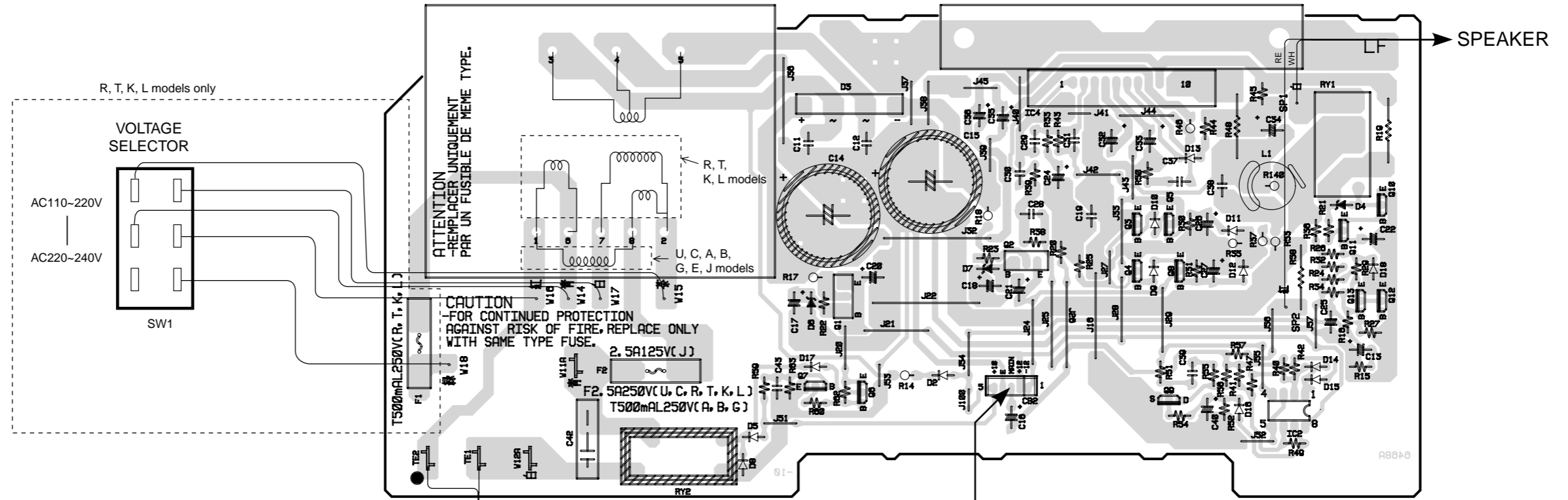

MAIN (2) P.C.B. (Side A)

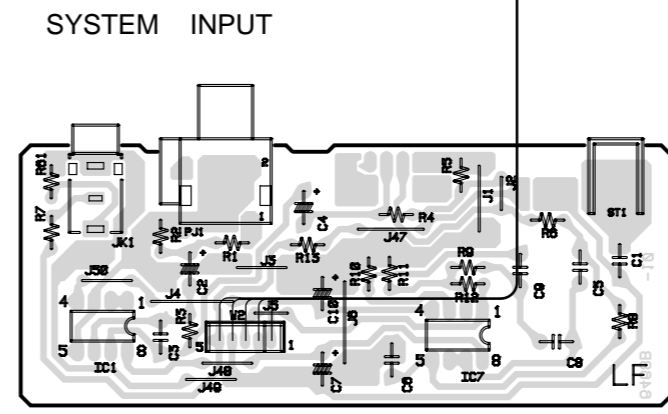

■ DVR-S150 SCHEMATIC DIAGRAM (DVD 1/5)

The first digit of a component indicates the component type.

- 1xxx : Connector    3xxx : Resistor    5xxx : Coil    7xxx : IC, Transistor, FET
- 2xxx : Capacitor    4xxx : SMD jumper    6xxx : Diode    9xxx : Wire jumper

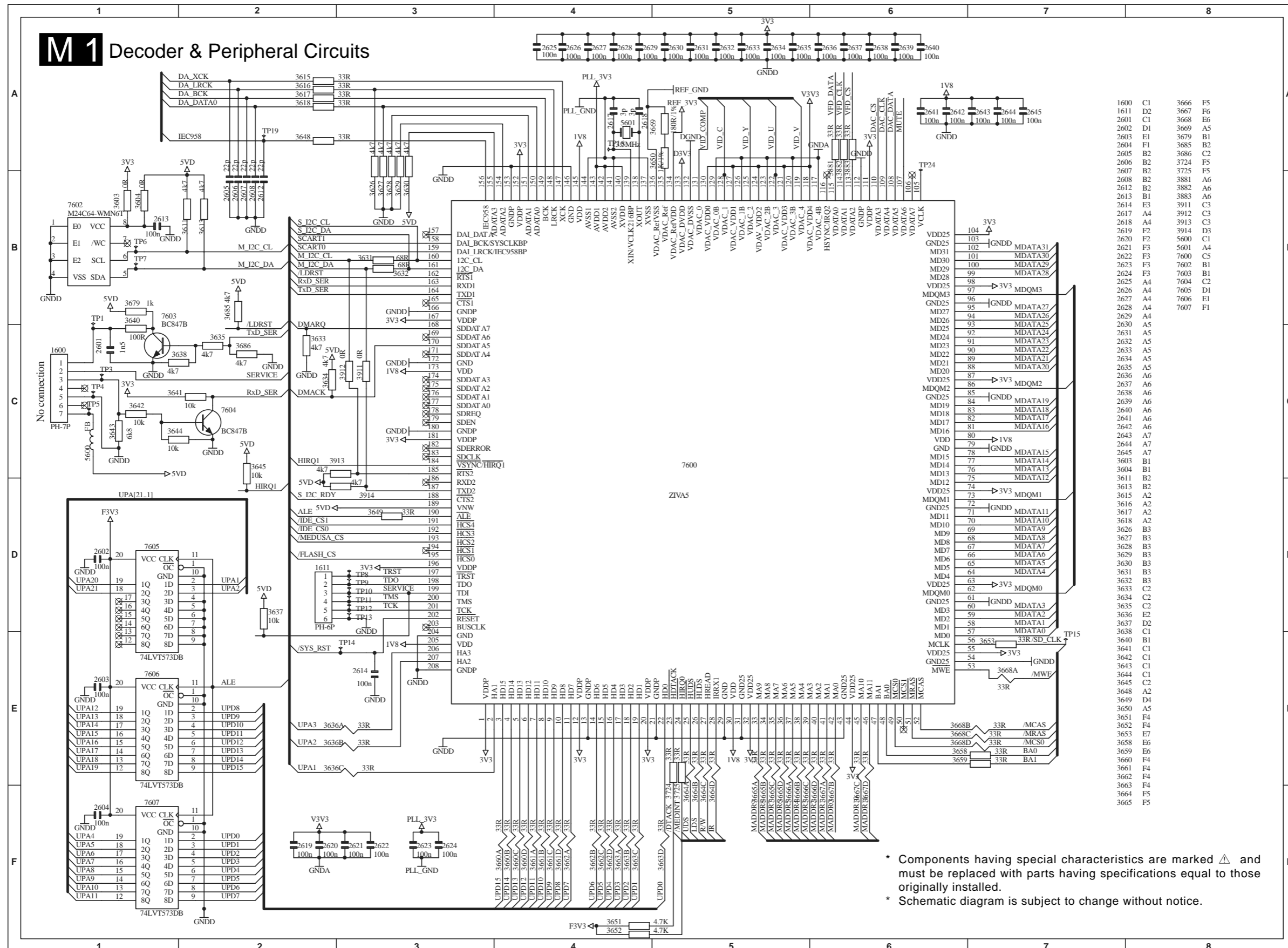

\* Components having special characteristics are marked  $\Delta$  and must be replaced with parts having specifications equal to those originally installed.  
 \* Schematic diagram is subject to change without notice.

■ DVR-S150 SCHEMATIC DIAGRAM (DVD 2/5)

The first digit of a component indicates the component type.

- 1xxx : Connector    3xxx : Resistor    5xxx : Coil    7xxx : IC, Transistor, FET
- 2xxx : Capacitor    4xxx : SMD jumper    6xxx : Diode    9xxx : Wire jumper

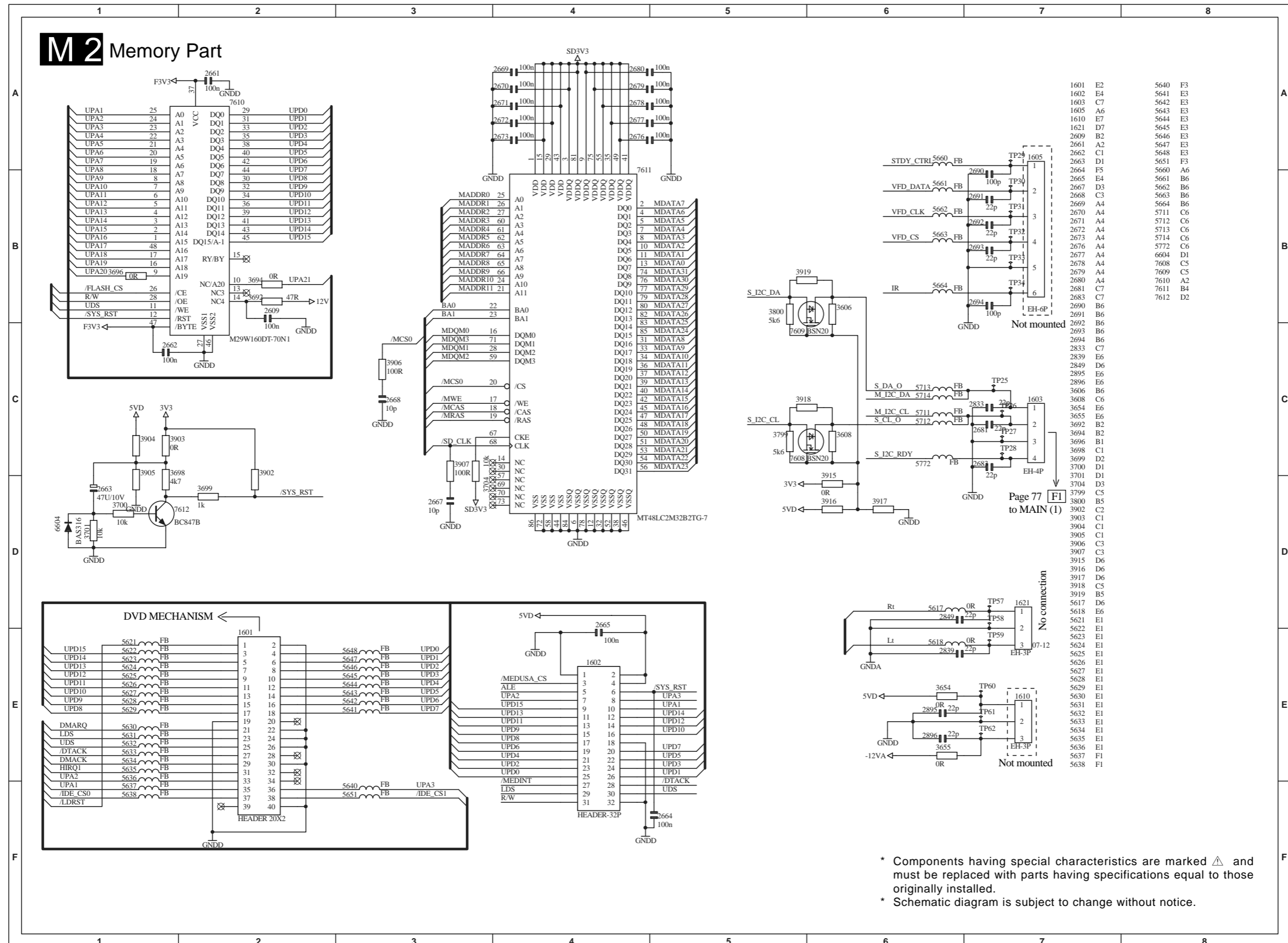

■ DVR-S150 SCHEMATIC DIAGRAM (DVD 3/5)

The first digit of a component indicates the component type.

- 1xxx : Connector    3xxx : Resistor    5xxx : Coil    7xxx : IC, Transistor, FET
- 2xxx : Capacitor    4xxx : SMD jumper    6xxx : Diode    9xxx : Wire jumper

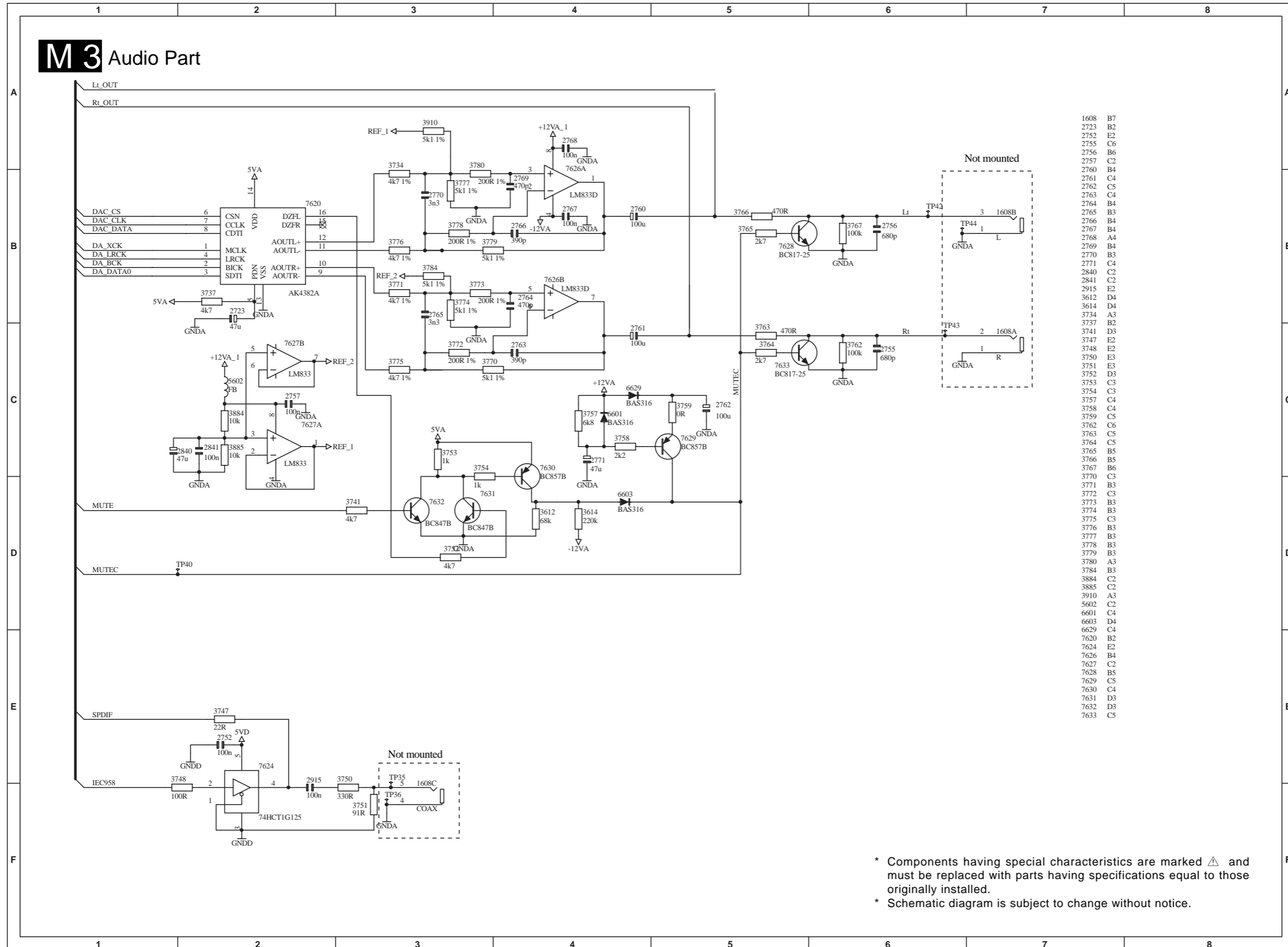

■ DVR-S150 SCHEMATIC DIAGRAM (DVD 4/5)

The first digit of a component indicates the component type.

- 1xxx : Connector    3xxx : Resistor    5xxx : Coil    7xxx : IC, Transistor, FET
- 2xxx : Capacitor    4xxx : SMD jumper    6xxx : Diode    9xxx : Wire jumper

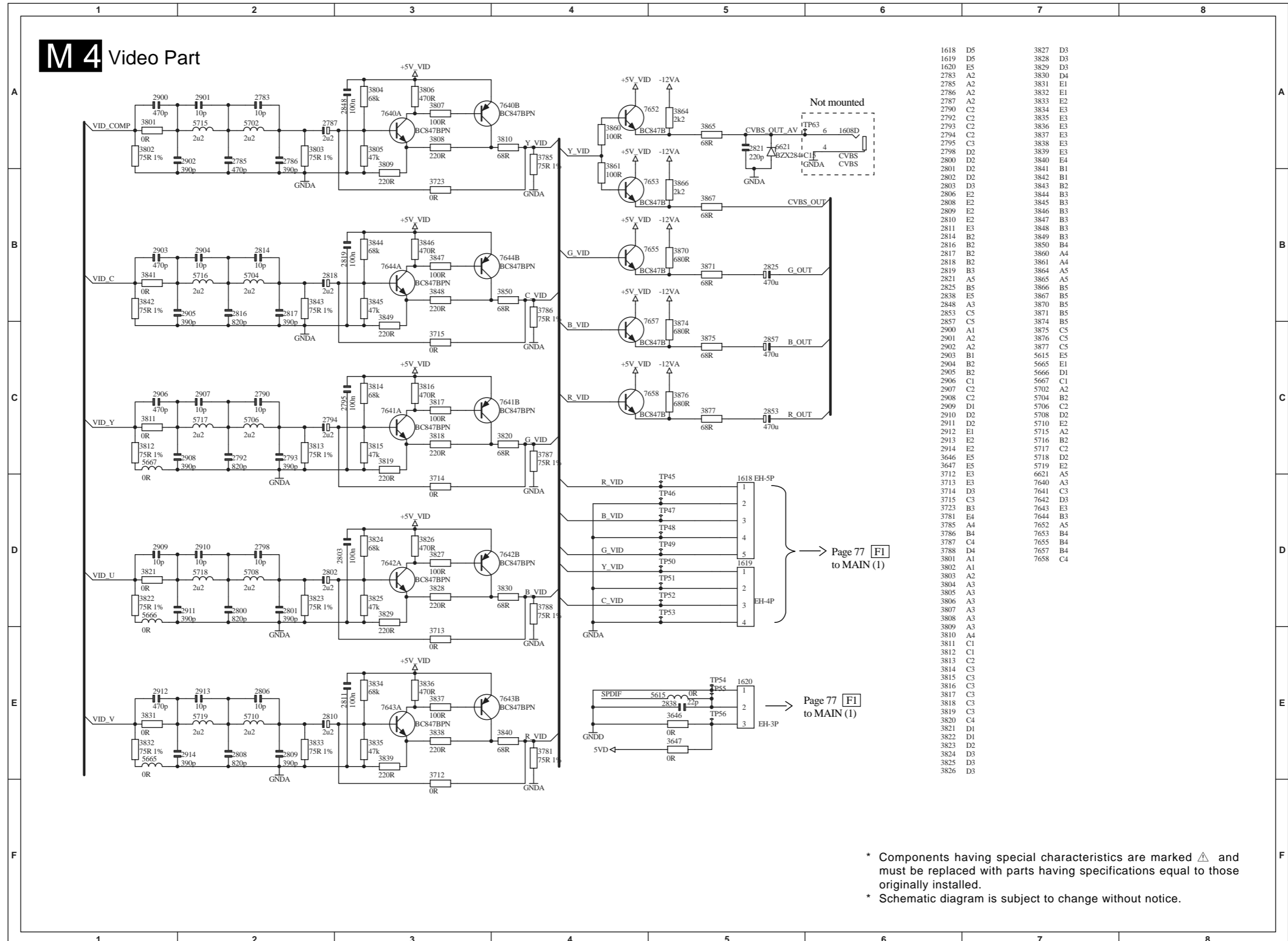

\* Components having special characteristics are marked  $\Delta$  and must be replaced with parts having specifications equal to those originally installed.  
 \* Schematic diagram is subject to change without notice.

■ DVR-S150 SCHEMATIC DIAGRAM (DVD 5/5)

The first digit of a component indicates the component type.

1xxx : Connector    3xxx : Resistor    5xxx : Coil    7xxx : IC, Transistor, FET  
 2xxx : Capacitor    4xxx : SMD jumper    6xxx : Diode    9xxx : Wire jumper

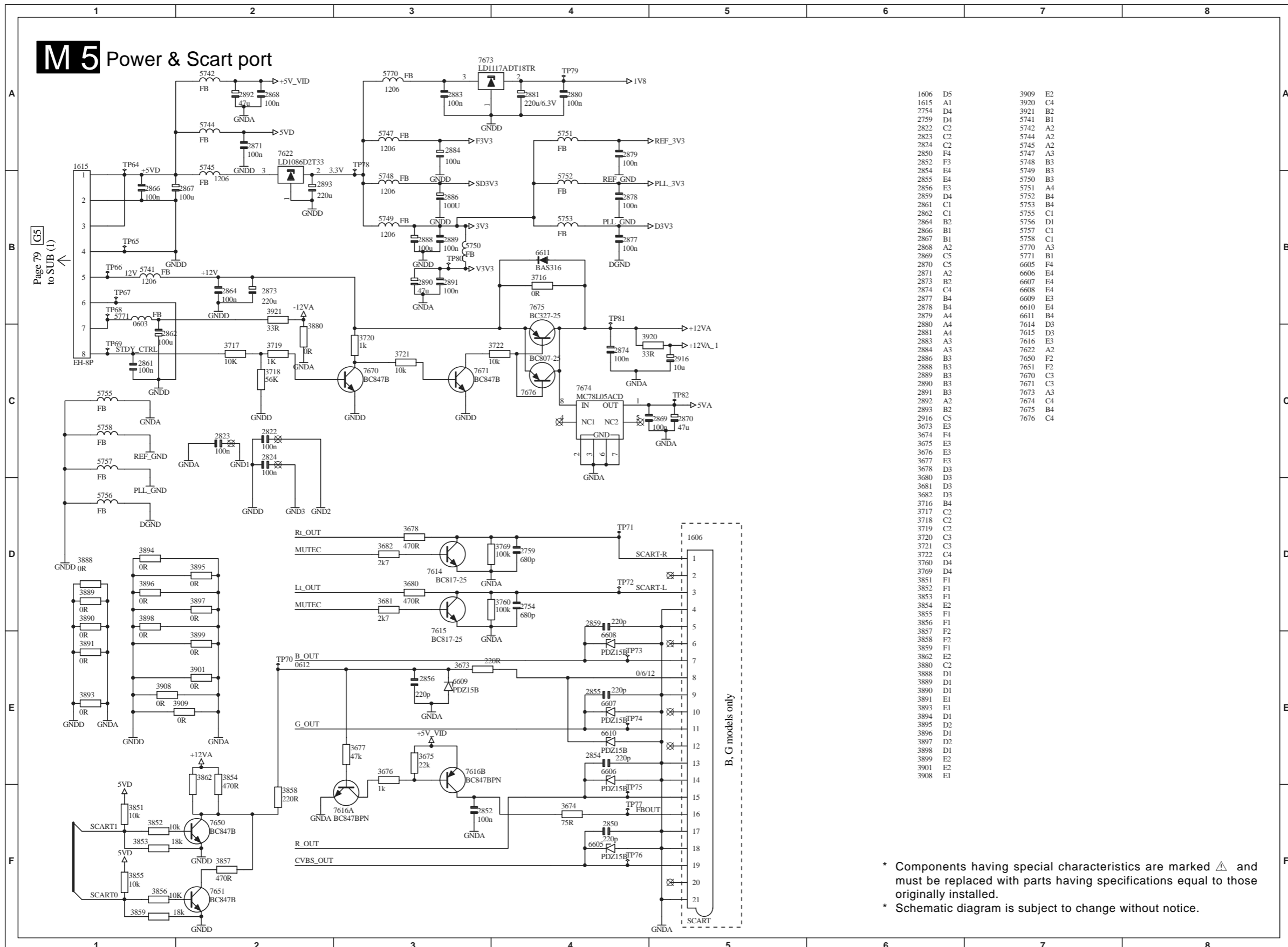



DVR-S150 SCHEMATIC DIAGRAM (DIGITAL)

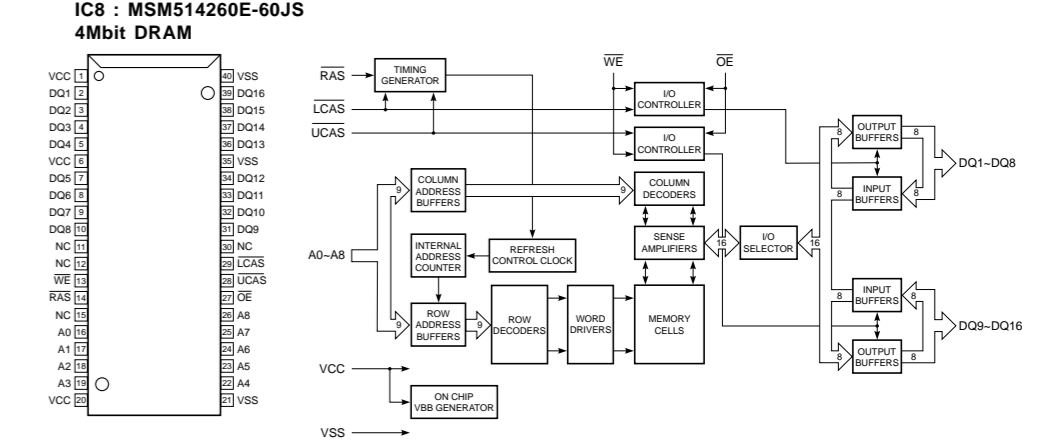
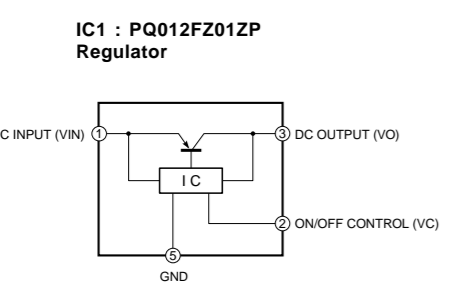
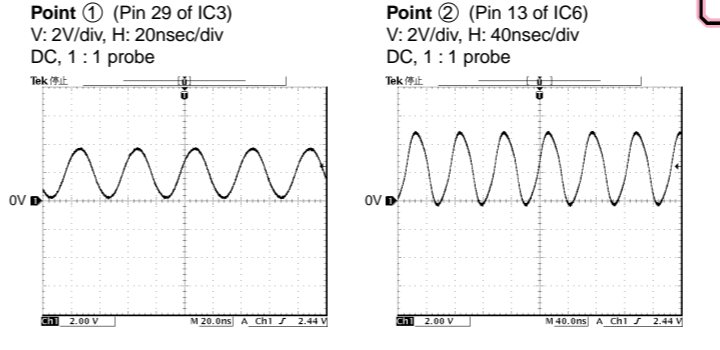
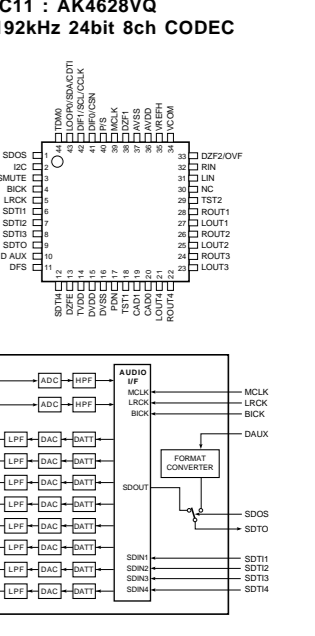
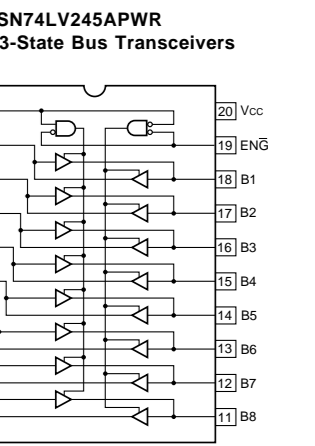
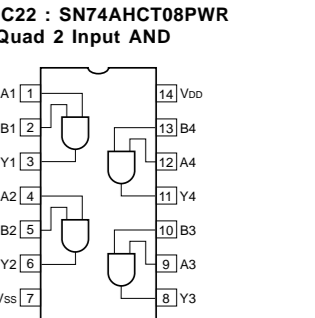
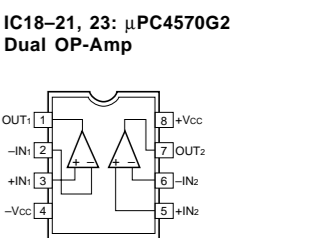
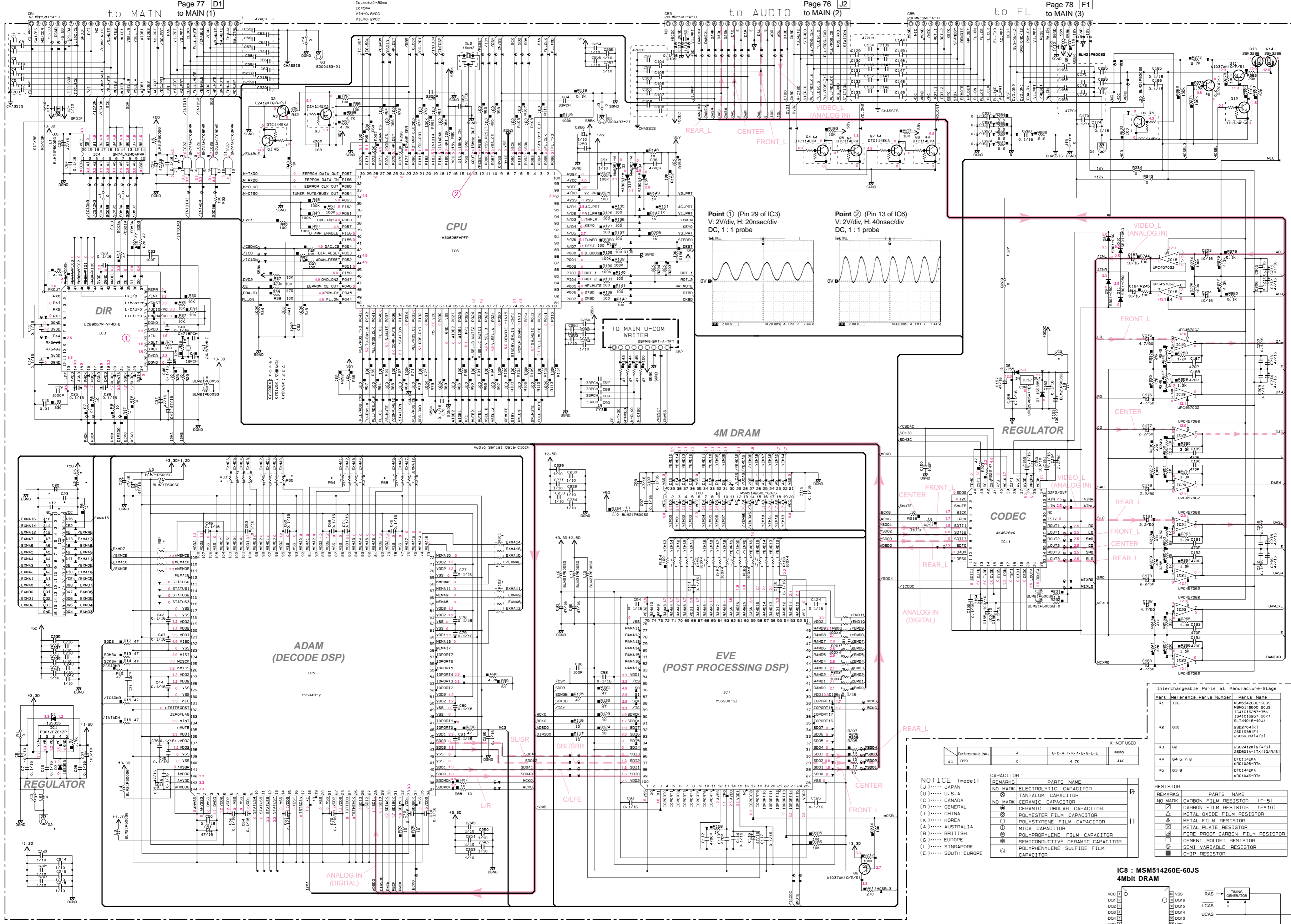

Reference No.	J	U.C.R.T.K.A.B.G.L.E	memo	AAC
s1	R99	x		

NOTICE (model)  
 (J)..... JAPAN  
 (U)..... U.S.A  
 (C)..... CANADA  
 (R)..... GENERAL  
 (T)..... CHINA  
 (K)..... KOREA  
 (A)..... AUSTRALIA  
 (B)..... BRITISH  
 (E)..... EUROPE  
 (L)..... SINGAPORE  
 (S)..... SOUTH EUROPE

MARK	Reference Parts Number	Parts Name
K1	IC8	MSM514260E-60JS MSM514260E-60JS 1E41C1807-30M 1E41C1807-30M 1E41C1807-30M
K2	Q10	PSD2701K1 PSD2701K1 PSD2701K1
K3	Q2	2SC2412K(10V/R/S) 2SD6014-1TX(1G/R/S)
K4	Q4-5, 7-8	DTC114EKA MCE1045-RTK
K5	Q4-9	DTC114EKA MCE1045-RTK

REMARKS	PARTS NAME
NO MARK	CARBON FILM RESISTOR (J=10)
NO MARK	CARBON FILM RESISTOR (P=10)
NO MARK	METAL OXIDE FILM RESISTOR
NO MARK	POLYSTYRENE FILM RESISTOR
NO MARK	METAL PLATE RESISTOR
NO MARK	FIRE PROOF CARBON FILM RESISTOR
NO MARK	CEMENT MOLDED RESISTOR
NO MARK	SEMI VARIABLE RESISTOR
NO MARK	CHIP RESISTOR

\* All voltages are measured with a 10MΩ/V DC electronic volt meter.  
 \* Components having special characteristics are marked Δ and must be replaced with parts having specifications equal to those originally installed.  
 \* Schematic diagram is subject to change without notice.

\* 電圧は、内部抵抗 10M の電圧計で測定したものです。  
 \* Δ印のある部品は、安全性確保部品を示しています。部品の交換が必要な場合、パーツリストに記載されている部品を使用してください。  
 \* 本回路図は、標準回路図です。改良のため予告なく変更することがございます。



■ DVR-S150 SCHEMATIC DIAGRAM (MAIN 1/3)

AUDIO

Reference No	UCRKTAL	B-G-E
s21	IC124	X X LC72722PM X008240
s22	XL121	X X 4.332MHz V393090
s23	Q124	X X C2412K(G/R/S) V458440
s24	D122	X X MAB056-M V99300
s25	L121,122	X X BLM18B0601SN10 V308340
s26	C142	X X 33/16 UR83733
s27	C149	X X 47/16 UR83747
s28	C144	X X 2.2/50 UR86622
s29	C147,150	X X 330P US06233
s30	C153,161	X X 27PCH US06127
s31	C151,166	X X 0.1/16 US13510
s32	R151	X X 3.3K RD35633
s33	R157	X X 100K RD39810
s34	R160	X X RD35647
s35	R211	X X 100 RD39510

Mark	Reference Parts Number	Parts Name
421	Q126	2SA1037AK1Q/R/S1 2SA1235A1E/F1
422	Q122, 123, 127-130	2SD2704(K) 2SD1938(F) 2SC5938A1A/B1

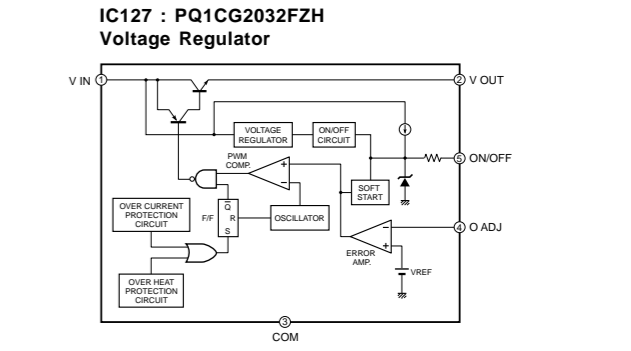
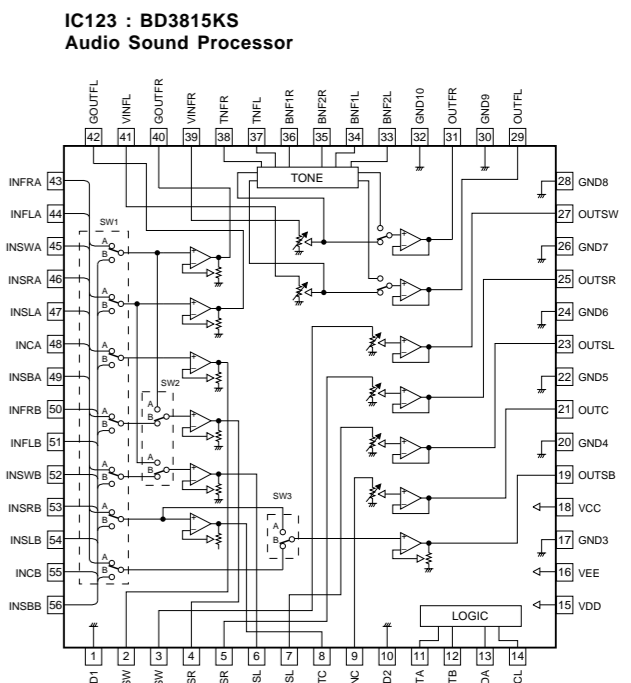
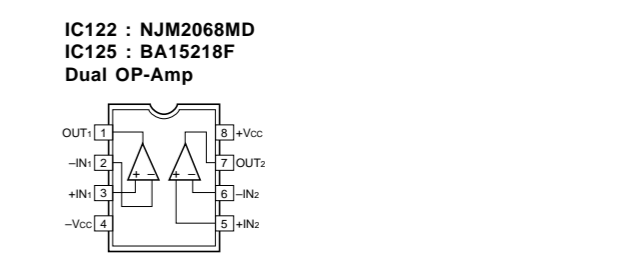
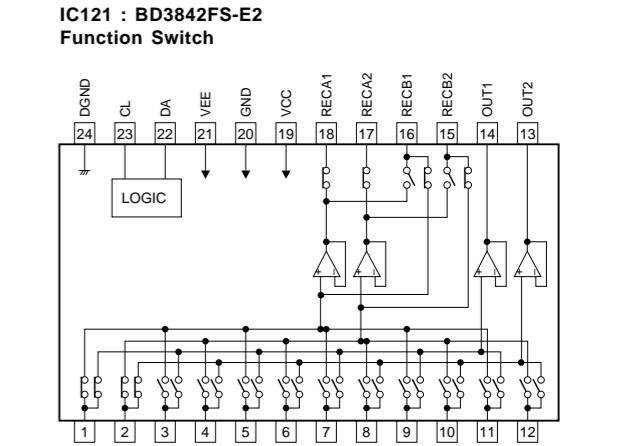
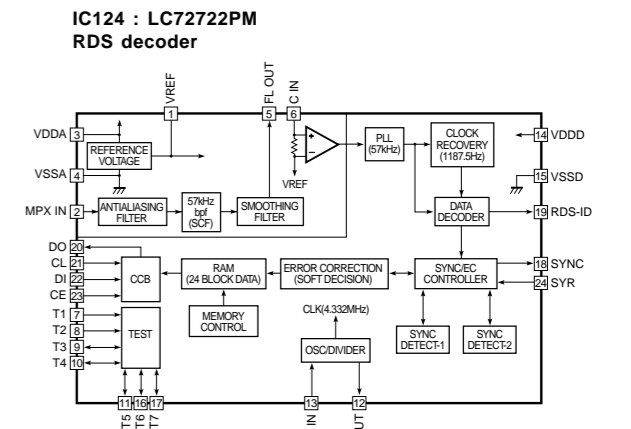
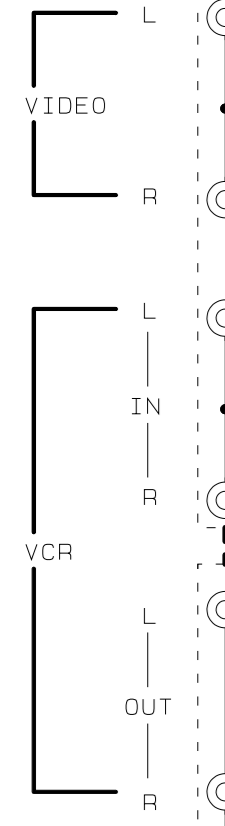
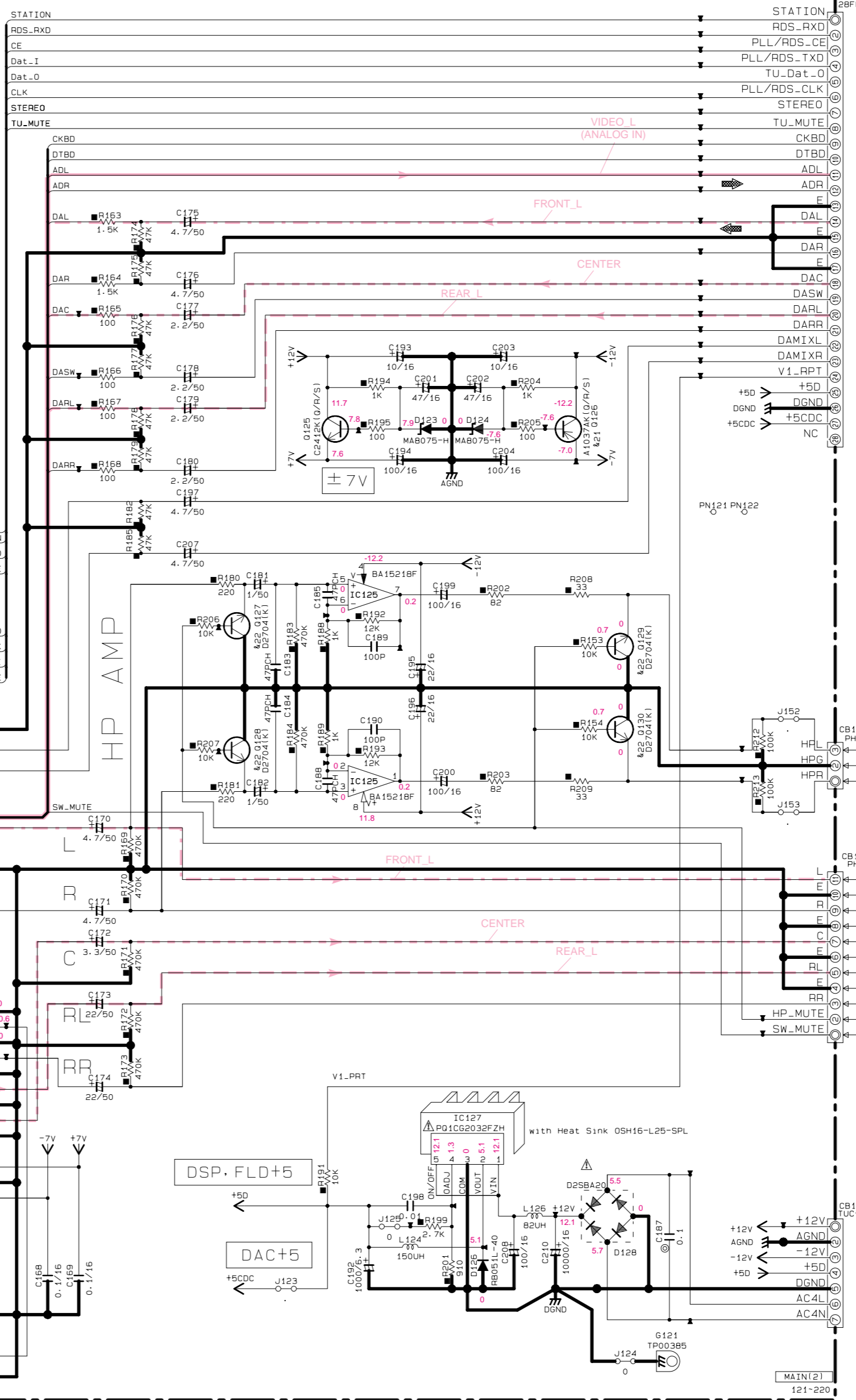
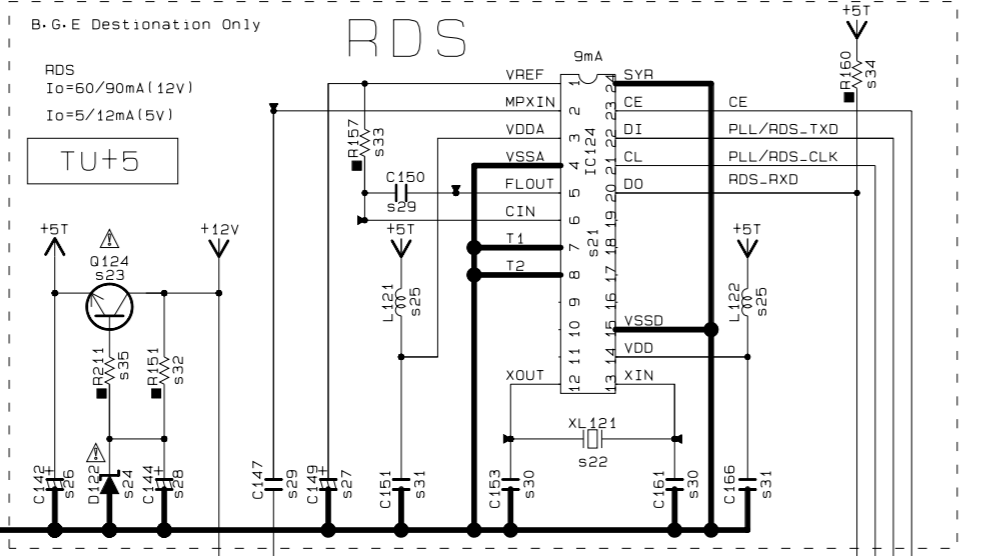

NOTICE (mode1)  
 (J)..... JAPAN  
 (U)..... U.S.A  
 (C)..... CANADA  
 (R)..... GENERAL  
 (T)..... CHINA  
 (K)..... KOREA  
 (A)..... AUSTRALIA  
 (B)..... BRITISH  
 (G)..... EUROPE  
 (L)..... SINGAPORE  
 (E)..... SOUTH EUROPE

\* All voltages are measured with a 10MΩ/V DC electronic volt meter.  
 \* Components having special characteristics are marked Δ and must be replaced with parts having specifications equal to those originally installed.  
 \* Schematic diagram is subject to change without notice.

\* 電圧は、内部抵抗10MΩの電圧計で測定したものです。  
 \* Δ印のある部品は、安全性確保部品を示しています。部品の交換が必要な場合、パーツリストに記載されている部品を使用してください。  
 \* 本回路図は、標準回路図です。改良のため予告なく変更することがございます。



DVR-S150 SCHEMATIC DIAGRAM (MAIN 2/3)

1  
2  
3  
4  
5  
6  
7  
8

MAIN

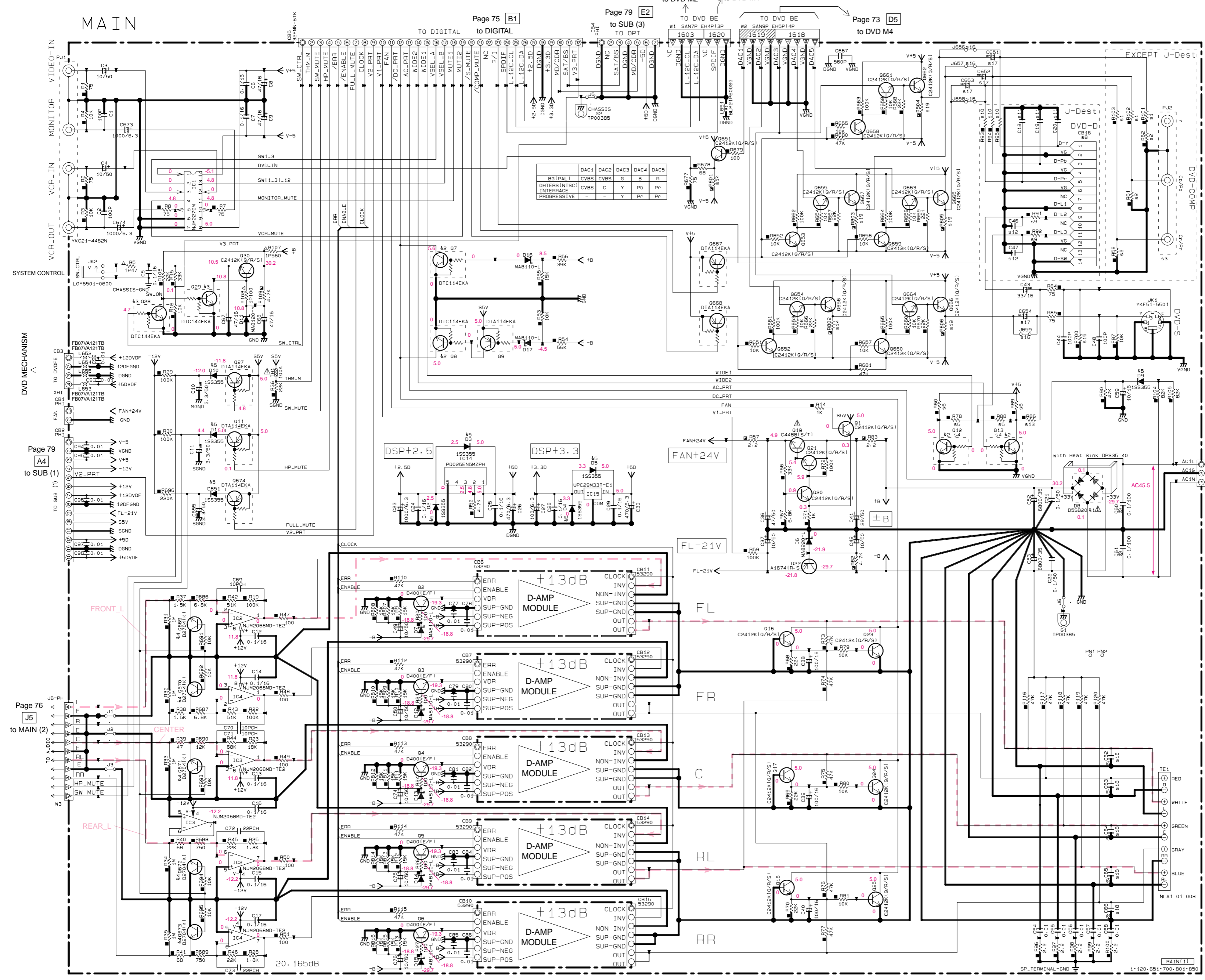

Reference No	J	UCRTKAL	BSE
s1 R101-103	X	75 (RD35475)	75 (RD35475)
s2 R58-61-62	X	100K (RD35810)	100K (RD35810)
s3 P12	X	YKC21-4195N (WB38530)	YKC21-4195N (WB38530)
s4 Q12-13	X	DTC114EKA (VV65540)	X
s5 R78-88	X	22K (RD35722)	X
s6 R60-69	X	2.2K (RD35622)	X
s7			
s8 CB16	X	YKF45-3004 (V758410)	X
s9 R91-92	X	100 (RD35510)	X
s10 R93-95	X	10K (RD35475)	X
s11 C18-20	X	BPOH (US06080)	X
s12 C46-47	X	0.01 (US06410)	X
s13 R86	X	(RD35710)	X
s14 RB01-802	X	560 (HV75855)	1K (HV75610)
s15 R700	X	220K (RD35822)	10K (RD35710)
s16 J56-659	X	(RD350001)	(RD35000)
s17 C651-654	X	470/10 (LH68247)	X
s18 C62-66	X	0.01 (UA65410)	0.047 (UA65447)
s19 RB03-806	X	(HV75547)	(HV75610)
s20			

Interchangeable Parts at Manufacture-Stage X: NOT USED

Mark	Reference Parts Number	Parts Name
k1	DB	D55B20 T56P036-C1
k2	07-B-12-13	DTC114EKA KRC1045-RTK
k3	Q28-29	DTC114EKA KRC1045-RTK
k4	0669-673	2SD27041K1 2SD19381F ESC9938A1A/B
k5	D1-5-9-10-651	1S5355 MA111 KDS160-RTK

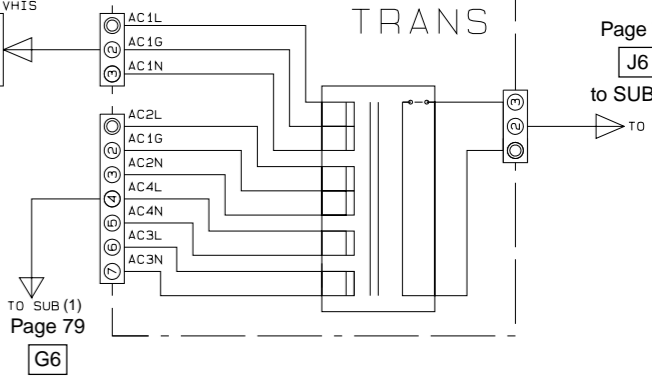
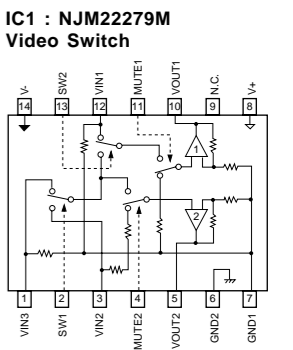

RESISTOR

REMARKS	PARTS NAME
NO MARK	CARBON FILM RESISTOR (P=5)
△	CARBON FILM RESISTOR (P=10)
□	METAL OXIDE FILM RESISTOR
⊠	METAL FILM RESISTOR
⊞	METAL PLATE RESISTOR
⊞	FIRE PROOF CARBON FILM RESISTOR
⊞	CEMENT MOLDED RESISTOR
⊞	SEMI VARIABLE RESISTOR
⊞	CHIP RESISTOR

NOTICE (mode1)  
 (J)..... JAPAN  
 (U)..... U.S.A  
 (C)..... CANADA  
 (R)..... GENERAL  
 (T)..... CHINA  
 (K)..... KOREA  
 (A)..... AUSTRALIA  
 (B)..... BRITISH  
 (G)..... EUROPE  
 (L)..... SINGAPORE  
 (E)..... SOUTH EUROPE

CAPACITOR

REMARKS	PARTS NAME
NO MARK	ELECTROLYTIC CAPACITOR
⊗	TANTALUM CAPACITOR
NO MARK	CERAMIC CAPACITOR
⊙	CERAMIC TUBULAR CAPACITOR
⊙	POLYESTER FILM CAPACITOR
⊙	POLYSTYRENE FILM CAPACITOR
⊙	MICA CAPACITOR
⊙	POLYPROPYLENE FILM CAPACITOR
⊙	SEMICONDUCTIVE CERAMIC CAPACITOR
⊙	POLYPHENYLENE SULFIDE FILM CAPACITOR

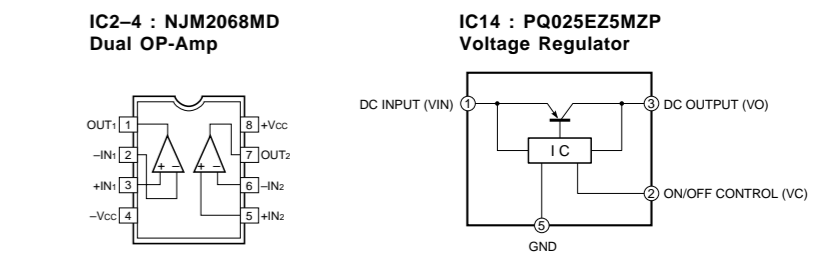

\* All voltages are measured with a 10MΩ/V DC electronic volt meter.  
 \* Components having special characteristics are marked △ and must be replaced with parts having specifications equal to those originally installed.  
 \* Schematic diagram is subject to change without notice.

\* 電圧は、内部抵抗10MΩの電圧計で測定したものです。  
 \* △印のある部品は、安全性確保部品を示しています。部品の交換が必要な場合、パーツリストに記載されている部品を使用してください。  
 \* 本回路図は、標準回路図です。改良のため予告なく変更することがございます。





■ DVR-S150 SCHEMATIC DIAGRAM (SUB)

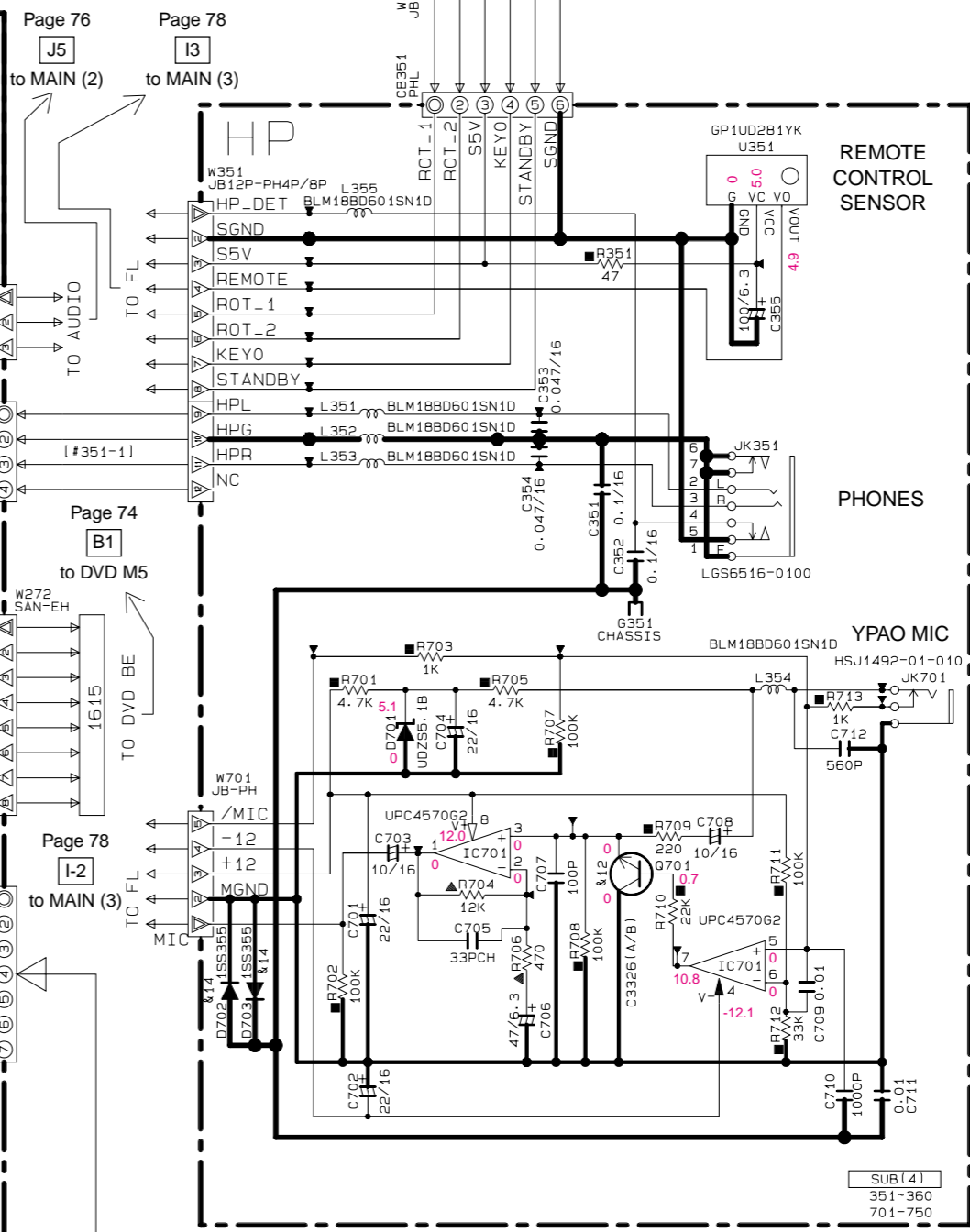
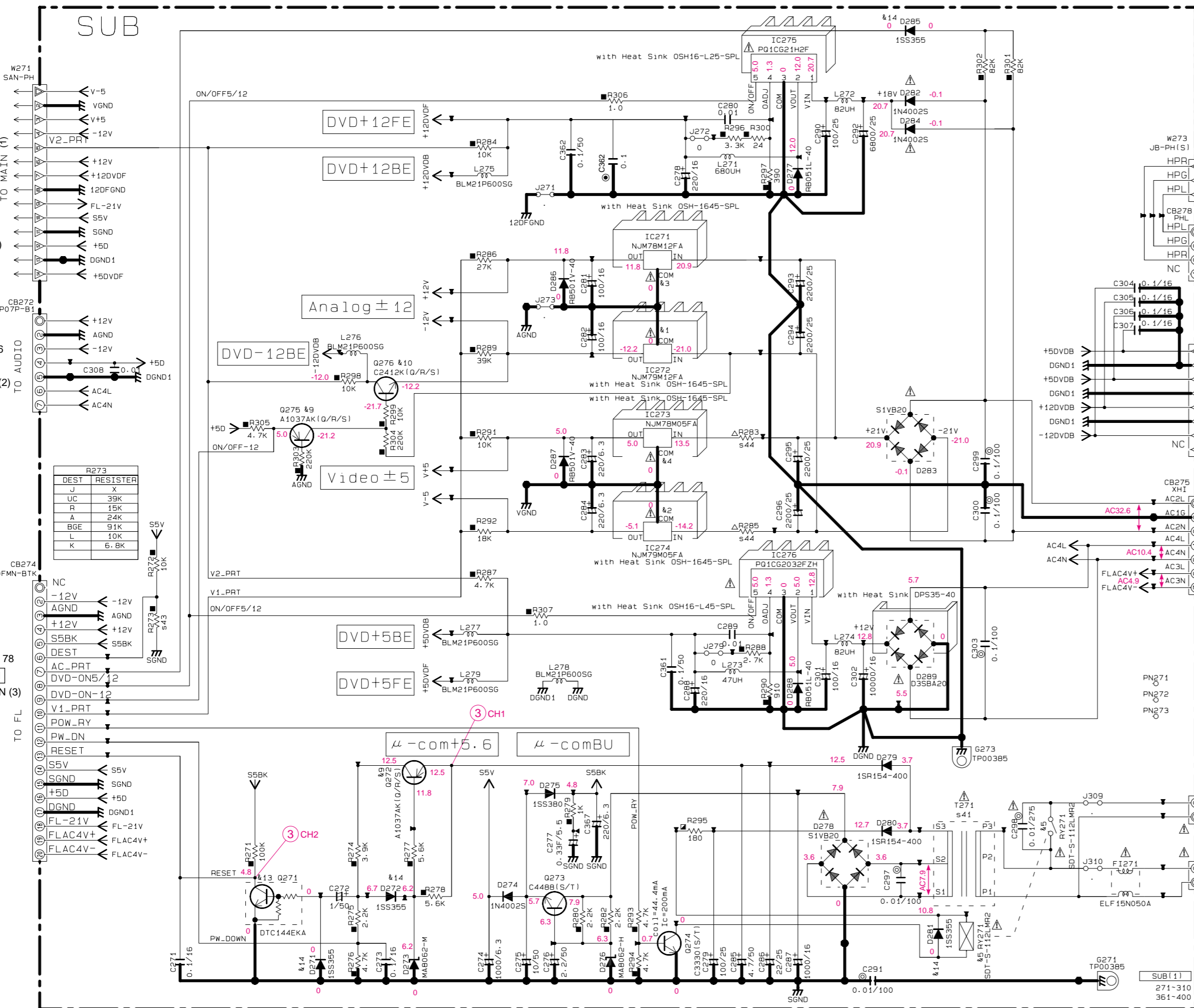
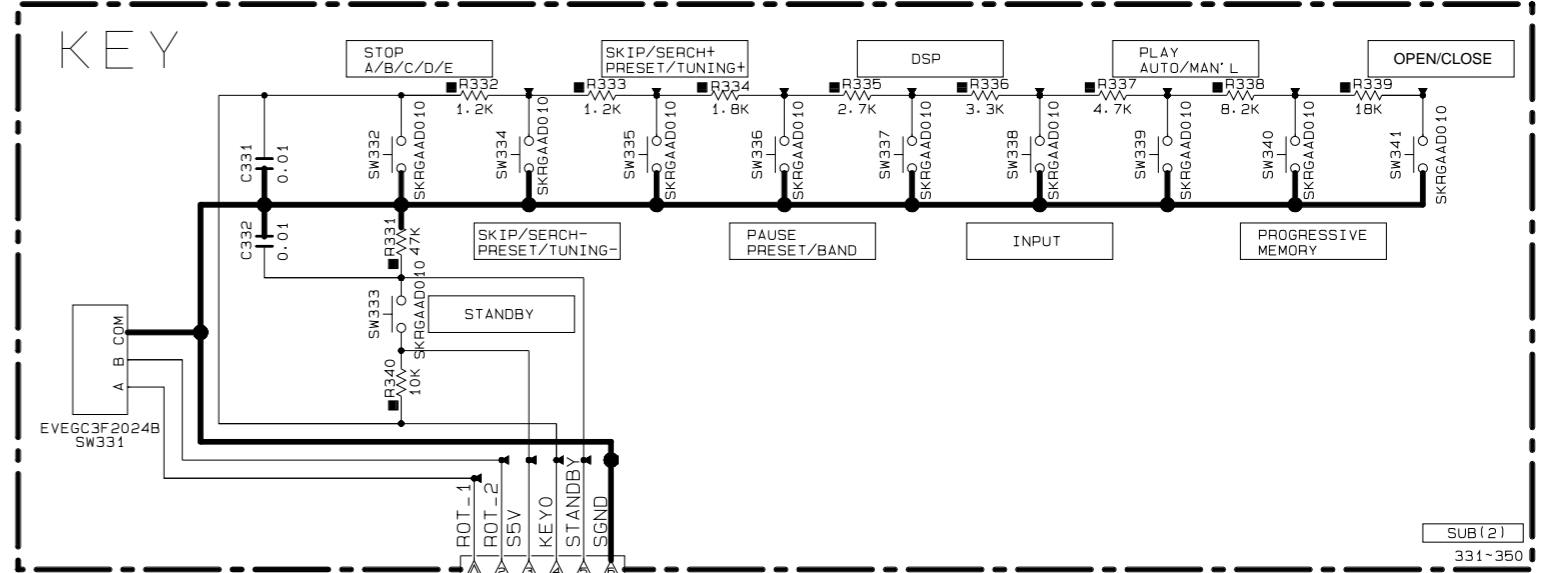
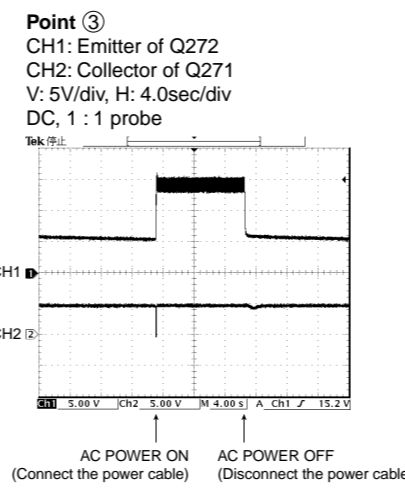
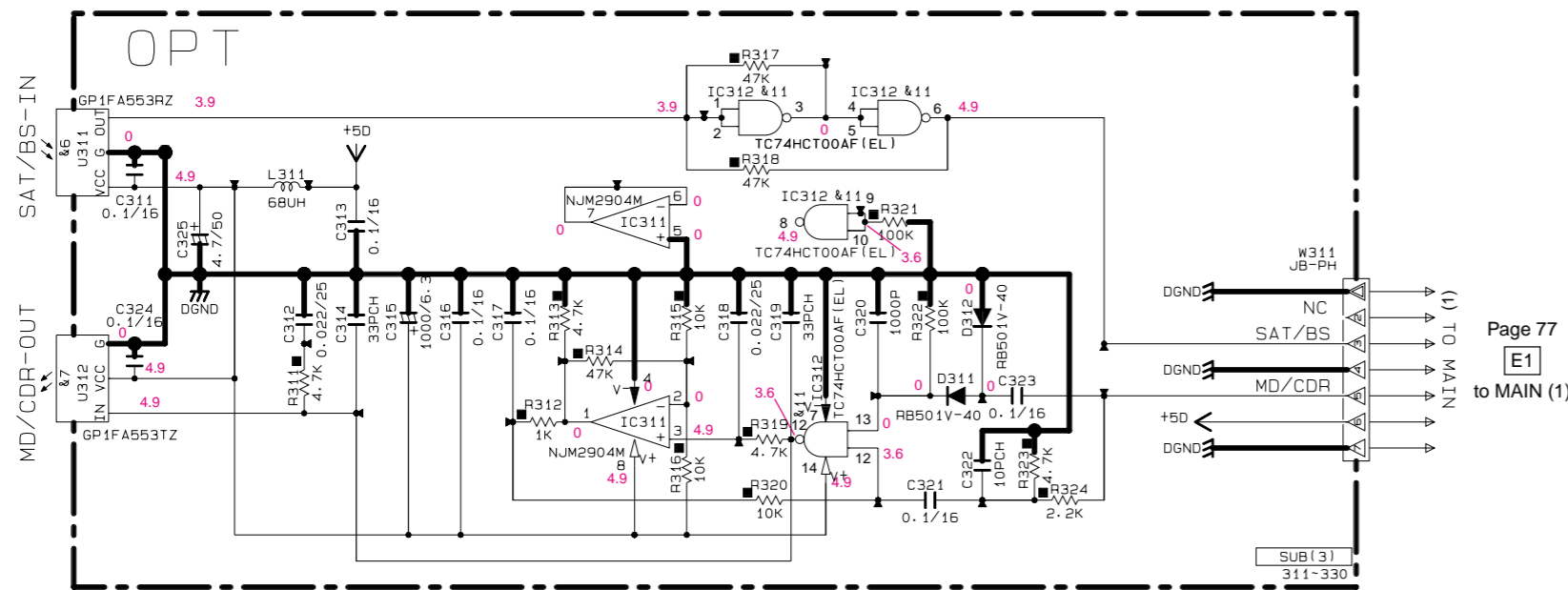

Interchangeable Parts at Manufacture-Stage

Mark	Reference Parts Number	Parts Name
&1	IC272	NJM79M12FA AN79M12F
&2	IC274	NJM79M05FA AN79M05F
&3	IC271	NJM7812FA AN78M12F
&4	IC273	NJM78M05FA AN78M05F
&5	RY271	SDT-S-112LMR2 DLS1201-D1M1
&6	U311	GP1FA553RZ TORX179
&7	U312	GP1FA553TZ TOTX179
&8		
&9	Q272-275	2SA1037AK1Q/R/S1 2SA1235A1E/F1
&10	Q275	2SC2412K1Q/R/S1 2SD2074K
&11	IC312	TC74HC00AF MM74HC00SUX
&12	0701	2SC33261A/B1 2SD2704K
&13	Q271	DTC144EKA KRC1045-RTK
&14	D271-272-281-285-702-703	1SS355 MA111 KDS160-RTK

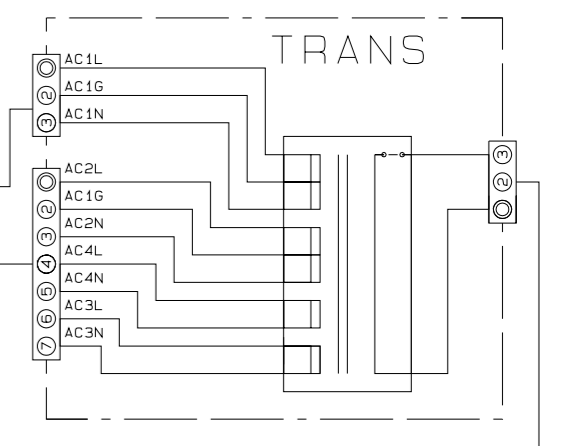

Reference No	J	U-C	R	T	K	A	B-G-E	L
s41	T271 (X2490A0)	X2491 (X2491A01)	X4434 (X4434A0)	X2948 (X2948A0)	X2948 (X2948A0)	X2493 (X2493A0)	X2948 (X2948A0)	X2948 (X2948A0)
s42								
s43	R273 X	39K (RD357391)	15K (RD35715)	4.3K (RD35643)	6.8K (RD35668)	24K (RD35724)	91K (RD35791)	10K (RD35710)
s44	R283-285 (VP94010)	IP33 (VP94020)	IP47 (VP94020)	IP47 (VP94020)	IP47 (VP94020)	IP47 (VP94020)	IP47 (VP94020)	IP47 (VP94020)

X: NOT USED

All voltages are measured with a 10MΩ/V DC electronic volt meter.  
 Components having special characteristics are marked Δ and must be replaced with parts having specifications equal to those originally installed.  
 Schematic diagram is subject to change without notice.

電圧は、内部抵抗10MΩの電圧計で測定したものです。  
 Δ印のある部品は、安全性確保部品を示しています。部品の交換が必要な場合、パーツリストに記載されている部品を使用してください。  
 本回路図は、標準回路図です。改良のため予告なく変更することがございます。

NOTICE (model)  
 (J)..... JAPAN  
 (U)..... U.S.A  
 (C)..... CANADA  
 (T)..... GENERAL  
 (R)..... CHINA  
 (K)..... KOREA  
 (A)..... AUSTRALIA  
 (B)..... BRITISH  
 (G)..... EUROPE  
 (L)..... SINGAPORE  
 (E)..... SOUTH EUROPE

■ NX-SW150 SCHEMATIC DIAGRAM (MAIN)

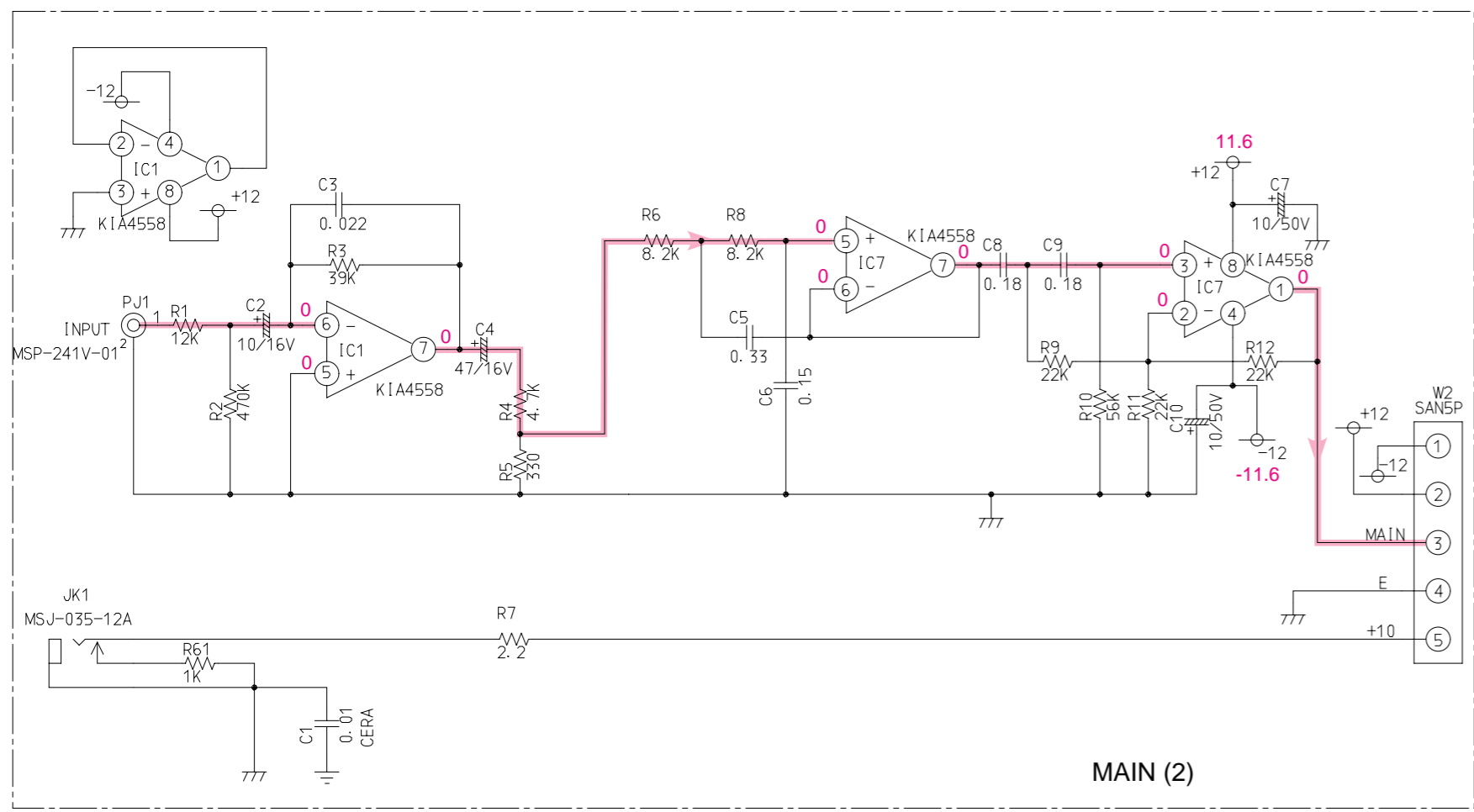

MODEL NAME	DEST.	T1	F2 (S2)	F1 (S1)	AC CORD	SW1 (S4)
A1E4A0	J	356184	2. 5A125V		405589	
A1E4B0	U/C	356186	2. 5A250V		353587	
A1E4C0	R	356187	2. 5A250V	T500mA250V	394981	084733
A1E4D0	A	356188	T500mA250V		393807	
A1E4E0	B	356189	T500mA250V		389588	
A1E4F0	G	356189	T500mA250V		355106	
A1E4L0	K	356187	2. 5A250V	T500mA250V	357511	084733
A1E4M0	T	356187	2. 5A250V	T500mA250V	356321	084733
A1E4N0	L	356187	2. 5A250V	T500mA250V	355106	084733

A1E4A0/JPN (402065)  
 A1E4B0/USA/CAN (402067)  
 A1E4C0/TPE (402068)  
 A1E4D0/OCEN (402069)  
 A1E4E0/GBR (402070)  
 A1E4F0/EURO (402071)  
 A1E4L0/KOR (402072)  
 A1E4M0/CHN (402073)  
 A1E4N0/SIN (402074)

PROTECTION

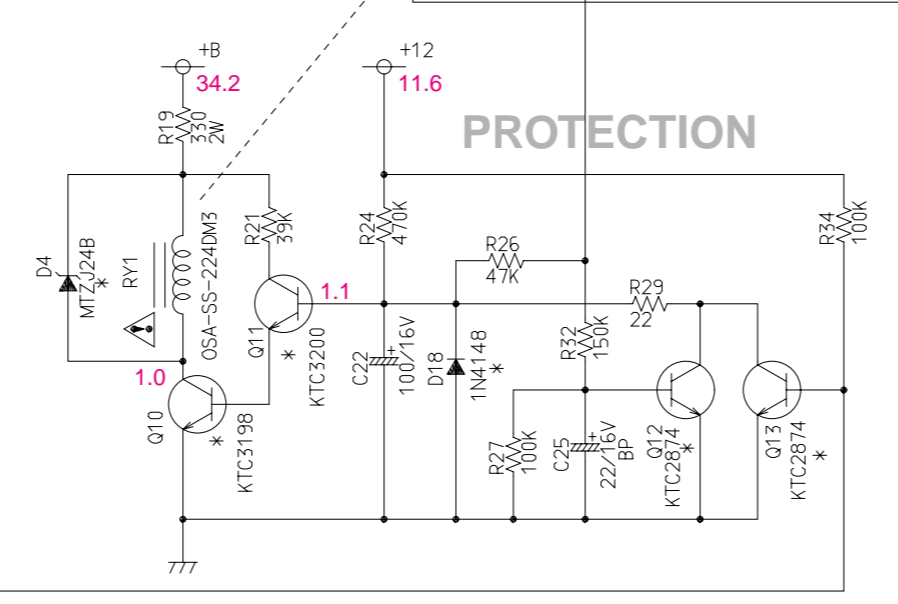

LIMITER

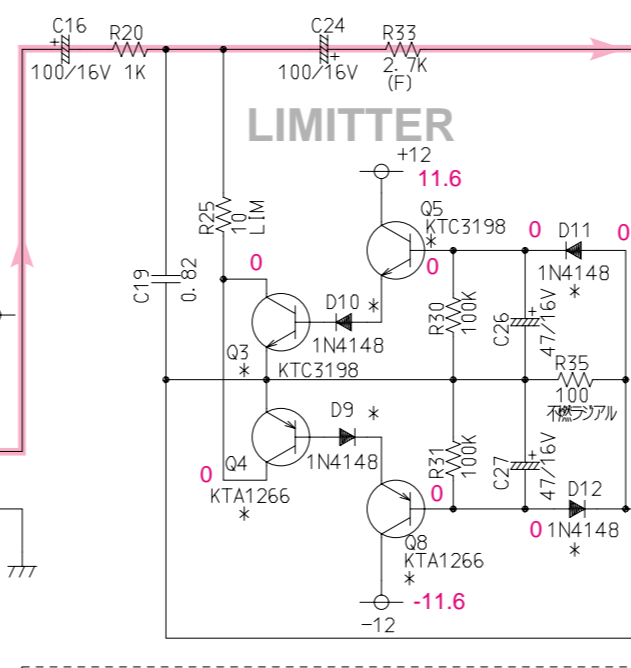

POWER AMP

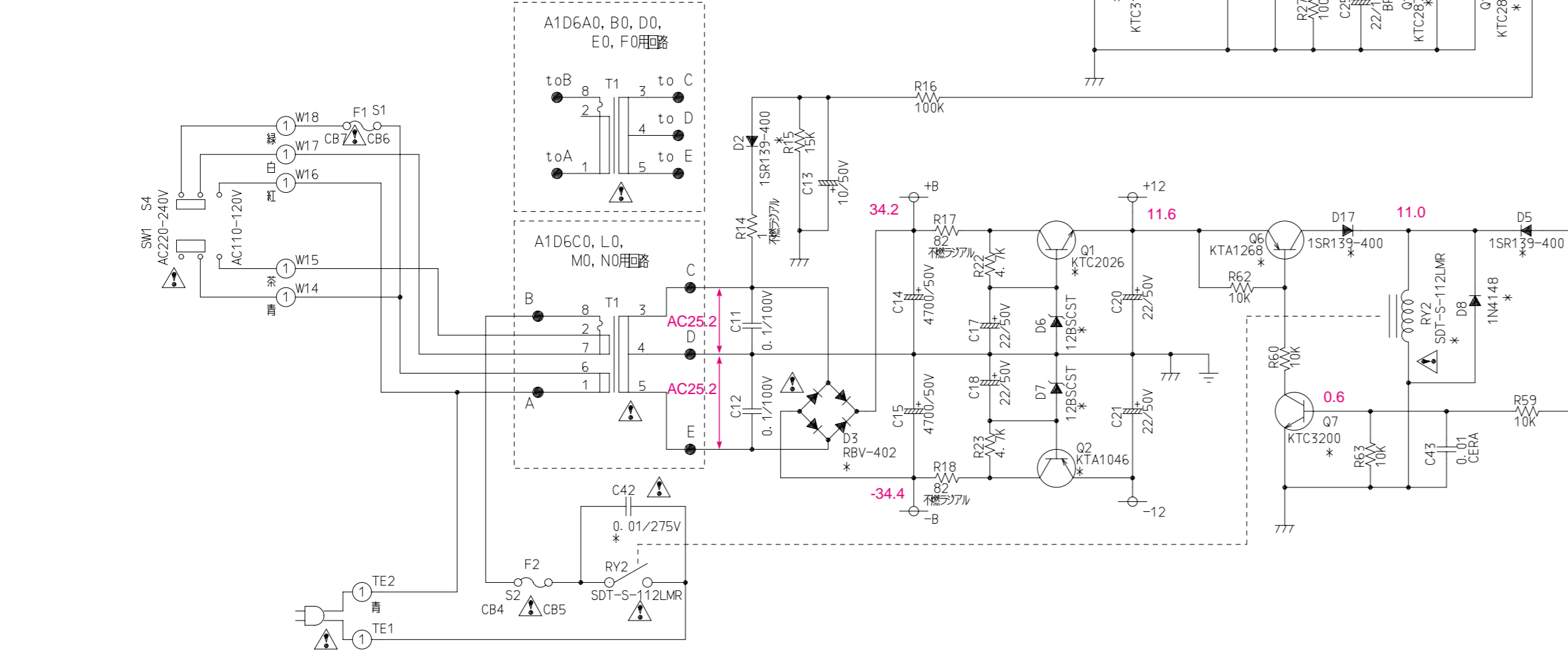
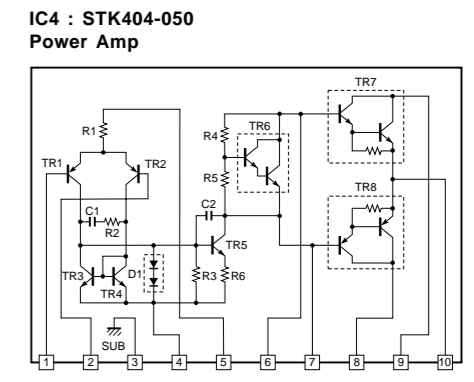
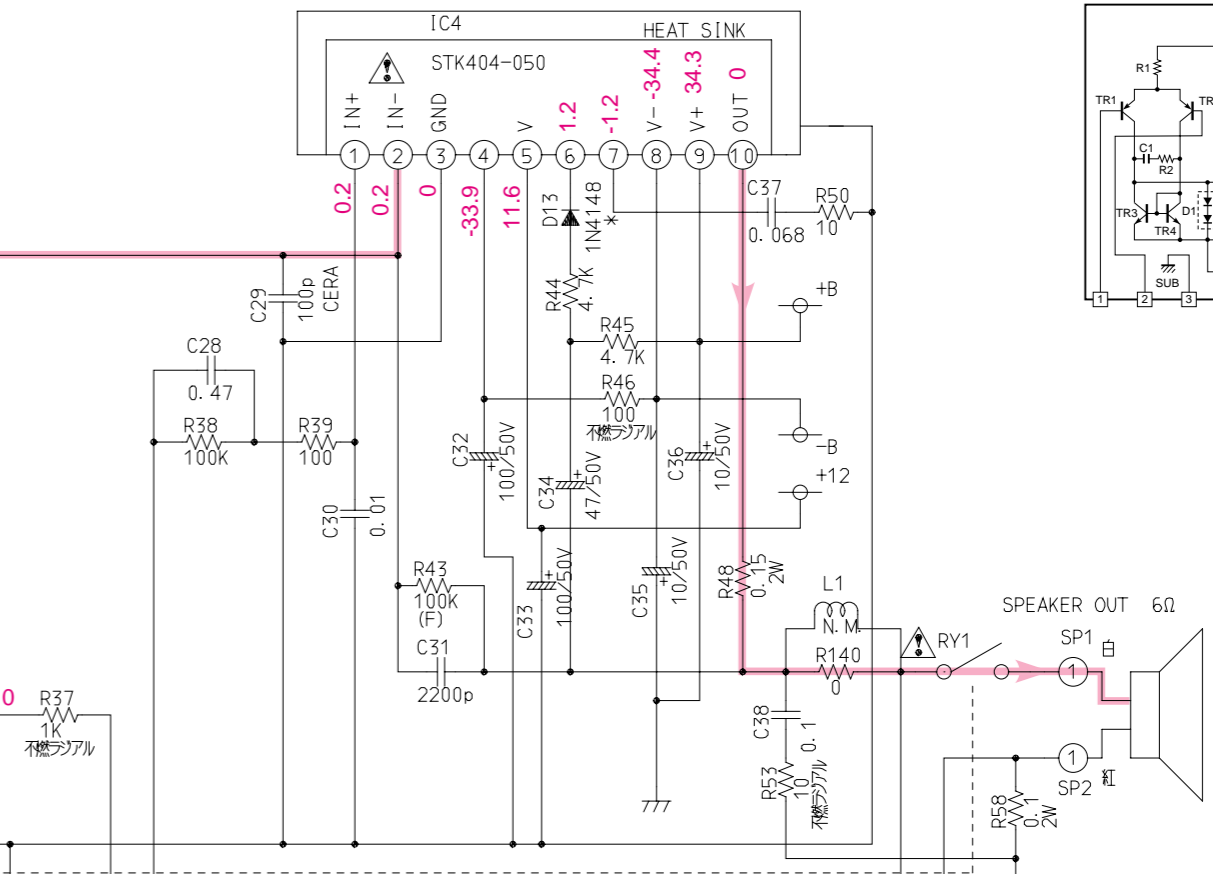

Interchangeable Parts

Ref. No.	Parts Name	Dest.
Q3, Q5, Q10	2SC1815 KTC3198 BC546	ALL
Q4, Q8	2SA1015 KTA1266 BC556	ALL
Q1	2SD2531 KTC2026	ALL
Q2	2SB1642 KTA1046	ALL
Q7, Q11	2SC2240 KTC3200	ALL
Q6	2SA970 KTA1268	ALL
Q12, Q13	2SC2878 2SC3792 KTC2874	ALL
D8, D9, D10, D11, D12, D13, D14, D15, D16	1N4148 1SS133	ALL
D3	RBV-402 D3SBA20	ALL
D6, D7	MTZJ12C 12BSCST	ALL
D4	MTZJ24B 24BSCST	ALL
RY2	SDT-S-112LMR SDT-SS112DM SDT-S-112LMR	J/U/C/B/G R/T/K/L
C49	GS-L X2 0.01UF/275V P=10 R40K121005001M R46K121000001M	ALL
AC CORD	353587 050166	U/C

NOTICE (model)

- (J)..... JAPAN
- (U)..... U. S. A
- (C)..... CANADA
- (R)..... GENERAL
- (T)..... CHINA
- (K)..... KOREA
- (A)..... AUSTRALIA
- (B)..... BRITISH
- (G)..... EUROPE
- (L)..... SINGAPORE
- (E)..... SOUTH EUROPE

IC1, 2, 7 : KIA4558P Dual OP-Amp

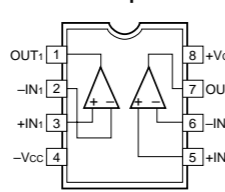

\* All voltages are measured with a 10MΩ/V DC electronic volt meter.  
 \* Components having special characteristics are marked Δ and must be replaced with parts having specifications equal to those originally installed.  
 \* Schematic diagram is subject to change without notice.

\* 電圧は、内部抵抗10MΩの電圧計で測定したものです。  
 \* Δ印のある部品は、安全性確保部品を示しています。部品の交換が必要な場合、パーツリストに記載されている部品を使用してください。  
 \* 本回路図は、標準回路図です。改良のため予告なく変更することがございます。

# PARTS LIST

## ■ ELECTRICAL PARTS

### ■ WARNING

- Components having special characteristics are marked  $\triangle$  and must be replaced with parts having specifications equal to those originally installed.

$\triangle$ 印のある部分は、安全確保部品を示しています。部品の交換が必要な場合、パーツリストに記載されている部品を使用してください。

### ABBREVIATIONS IN THIS LIST ARE AS FOLLOWS :

C.A.EL.CHP	: CHIP ALUMI. ELECTROLYTIC CAP	L.DTCT	: LIGHT DETECTING MODULE
C.CE	: CERAMIC CAP	L.EMIT	: LIGHT EMITTING MODULE
C.CE.ARRAY	: CERAMIC CAP ARRAY	LED.DSPLY	: LED DISPLAY
C.CE.CHP	: CHIP CERAMIC CAP	LED.INFRD	: LED, INFRARED
C.CE.ML	: MULTILAYER CERAMIC CAP	MODUL.RF	: MODULATOR, RF
C.CE.M.CHP	: CHIP MULTILAYER CERAMIC CAP	PHOT.CPL	: PHOTO COUPLER
C.CE.SAFTY	: RECOGNIZED CERAMIC CAP	PHOT.INTR	: PHOTO INTERRUPTER
C.CE.TUBLR	: CERAMIC TUBULAR CAP	PHOT.RFLCT	: PHOTO REFLECTOR
C.CE.SMI	: SEMI CONDUCTIVE CERAMIC CAP	PIN.TEST	: PIN, TEST POINT
C.EL	: ELECTROLYTIC CAP	PLST.RIVET	: PLASTIC RIVET
C.MICA	: MICA CAP	R.ARRAY	: RESISTOR ARRAY
C.ML.FLM	: MULTILAYER FILM CAP	R.CAR	: CARBON RESISTOR
C.MP	: METALLIZED PAPER CAP	R.CAR.CHP	: CHIP RESISTOR
C.MYLAR	: MYLAR FILM CAP	R.CAR.FP	: FLAME PROOF CARBON RESISTOR
C.MYLAR.ML	: MULTILAYER MYLAR FILM CAP	R.FUS	: FUSABLE RESISTOR
C.PAPER	: PAPER CAPACITOR	R.MTL.CHP	: CHIP METAL FILM RESISTOR
C.PLS	: POLYSTYRENE FILM CAP	R.MTL.FLM	: METAL FILM RESISTOR
C.POL	: POLYESTER FILM CAP	R.MTL.OXD	: METAL OXIDE FILM RESISTOR
C.POLY	: POLYETHYLENE FILM CAP	R.MTL.PLAT	: METAL PLATE RESISTOR
C.PP	: POLYPROPYLENE FILM CAP	RSNR.CE	: CERAMIC RESONATOR
C.TNTL	: TANTALUM CAP	RSNR.CRYS	: CRYSTAL RESONATOR
C.TNTL.CHP	: CHIP TANTALUM CAP	R.TW.CEM	: TWIN CEMENT FIXED RESISTOR
C.TRIM	: TRIMMER CAP	R.WW	: WIRE WOUND RESISTOR
CN	: CONNECTOR	SCR.BND.HD	: BIND HEAD B-TITE SCREW
CN.BS.PIN	: CONNECTOR, BASE PIN	SCR.BW.HD	: BW HEAD TAPPING SCREW
CN.CANNON	: CONNECTOR, CANNON	SCR.CUP	: CUP TITE SCREW
CN.DIN	: CONNECTOR, DIN	SCR.TERM	: SCREW TERMINAL
CN.FLAT	: CONNECTOR, FLAT CABLE	SCR.TR	: SCREW, TRANSISTOR
CN.POST	: CONNECTOR, BASE POST	SUPRT.PCB	: SUPPORT, P.C.B.
COIL.MX.AM	: COIL, AM MIX	SURG.PRTCT	: SURGE PROTECTOR
COIL.AT.FM	: COIL, FM ANTENNA	SW.TACT	: TACT SWITCH
COIL.DT.FM	: COIL, FM DETECT	SW.LEAF	: LEAF SWITCH
COIL.MX.FM	: COIL, FM MIX	SW.LEVER	: LEVER SWITCH
COIL.OUTPT	: OUTPUT COIL	SW.MICRO	: MICRO SWITCH
DIOD.ARRAY	: DIODE ARRAY	SW.PUSH	: PUSH SWITCH
DIODE.BRG	: DIODE BRIDGE	SW.RT.ENC	: ROTARY ENCODER
DIODE.CHP	: CHIP DIODE	SW.RT.MTR	: ROTARY SWITCH WITH MOTOR
DIODE.SHOT	: SCHOTTKY BARRIER DIODE	SW.RT	: ROTARY SWITCH
DIODE.VAR	: VARACTOR DIODE	SW.SLIDE	: SLIDE SWITCH
DIOD.Z.CHP	: CHIP ZENER DIODE	TERM.SP	: SPEAKER TERMINAL
DIODE.ZENR	: ZENER DIODE	TERM.WRAP	: WRAPPING TERMINAL
DSCR.CE	: CERAMIC DISCRIMINATOR	THRMST.CHP	: CHIP THERMISTOR
FER.BEAD	: FERRITE BEADS	TR.CHP	: CHIP TRANSISTOR
FER.CORE	: FERRITE CORE	TR.DGT	: DIGITAL TRANSISTOR
FET.CHP	: CHIP FET	TR.DGT.CHP	: CHIP DIGITAL TRANSISTOR
FL.DSPLY	: FLUORESCENT DISPLAY	TRANS	: TRANSFORMER
FLTR.CE	: CERAMIC FILTER	TRANS.PULS	: PULSE TRANSFORMER
FLTR.COMB	: COMB FILTER MODULE	TRANS.PWR	: POWER TRANSFORMER ASS'y
FLTR.LC.RF	: LC FILTER ,EMI	TUNER.AM	: TUNER PACK, AM
GND.MTL	: GROUND PLATE	TUNER.FM	: TUNER PACK, FM
GND.TERM	: GROUND TERMINAL	TUNER.PK	: FRONT-END TUNER PACK
HOLDER.FUS	: FUSE HOLDER	VR	: ROTARY POTENTIOMETER
IC.PRTCT	: IC PROTECTOR	VR.MTR	: POTENTIOMETER WITH MOTOR
JUMPER.CN	: JUMPER CONNECTOR	VR.SW	: POTENTIOMETER WITH ROTARY SW
JUMPER.TST	: JUMPER, TEST POINT	VR.SLIDE	: SLIDE POTENTIOMETER
		VR.TRIM	: TRIMMER POTENTIOMETER

## DVR-S150 P.C.B. DIGITAL

Ref. No.	PART NO.	Description	Remarks	Markets	部品名	Rank	
*	WD505800	P.C.B.	DIGITAL		J	P C B デジタル	
*	WD505900	P.C.B.	DIGITAL		UCRKTABGEL	P C B デジタル	
CB1	WA903200	CN	32P SE FMN			F M Nコネクター	
CB2	WC195900	CN	9P TE FMN			F M Nコネクター	
CB3	WA902800	CN	28P SE FMN			F M Nコネクター	
CB5	WA902800	CN	28P SE FMN			F M Nコネクター	
D1	VT332900	DIODE	1SS355			ダイオード	01
D2	VT332900	DIODE	1SS355			ダイオード	01
D3	VU992600	DIODE.ZENR	MA8051-M 5.1V			ツェナーダイオード	01
D4	VU992600	DIODE.ZENR	MA8051-M 5.1V			ツェナーダイオード	01
D5	VU992600	DIODE.ZENR	MA8051-M 5.1V			ツェナーダイオード	01
D6	VT332900	DIODE	1SS355			ダイオード	01
D7	VT332900	DIODE	1SS355			ダイオード	01
D8	WB081800	DIODE	SB01-05Q			ショットキダイオード	
D9	WB081800	DIODE	SB01-05Q			ショットキダイオード	
D10	WB081800	DIODE	SB01-05Q			ショットキダイオード	
D11	WB081800	DIODE	SB01-05Q			ショットキダイオード	
D12	VU992600	DIODE.ZENR	MA8051-M 5.1V			ツェナーダイオード	01
G1	WB438000	TERM.GND	M4 SD00433-21			アース端子	
G3	WB438000	TERM.GND	M4 SD00433-21			アース端子	
IC1	X4314A00	IC	PQ012FZ01ZP 1.2V1A			電源 I C Q F P	04
IC3	X5444A00	IC	LC89057W-VF4D-E			I C	
IC4	X3693A00	IC	SN74LV245APWR TRAN			ロジック I C T S S O P	
IC5	X4570A00	IC	YSS948-V			I C デジタル	09
IC6	X5709A00	IC.CPU	M30626FHFPF	MASK ROM		I C C P U	09
IC7	X3567A00	IC	YSS930-SZ			I C	08
IC8	XV077B00	IC	MSM514260E-60JS			メモリ I C 4 M	07
IC11	X3807A00	IC	AK4628VQ			I C	
IC12	X4458A00	IC	UPC29M05AT-E1			電源 I C	03
IC18	XF291A00	IC	uPC4570G2			I C	03
IC19	XF291A00	IC	uPC4570G2			I C	03
IC20	XF291A00	IC	uPC4570G2			I C	03
IC21	XF291A00	IC	uPC4570G2			I C	03
IC22	X3824A00	IC	SN74AHCT08PWR			ロジック I C	01
IC23	XF291A00	IC	uPC4570G2			I C	03
Q1	VV655700	TR.DGT	DTC144EKA			デジタルトランジスタ	01
Q2	VV556400	TR	2SC2412K Q,R,S			トランジスタ	01
Q3	VV655000	TR.DGT	DTA114EKA			デジタルトランジスタ	01
Q4	VV655400	TR.DGT	DTC114EKA			デジタルトランジスタ	01
Q5	VV655400	TR.DGT	DTC114EKA			デジタルトランジスタ	01
Q6	VV556500	TR	2SA1037K Q,R,S			トランジスタ	01
Q7	VV655400	TR.DGT	DTC114EKA			デジタルトランジスタ	01
Q8	VV655400	TR.DGT	DTC114EKA			デジタルトランジスタ	01
Q9	VV655700	TR.DGT	DTC144EKA			デジタルトランジスタ	01
Q10	WC883400	TR	2SC2704 K			トランジスタ	
Q11	VV556500	TR	2SA1037K Q,R,S			トランジスタ	01
Q12	VV655500	TR.DGT	DTC124EKA			デジタルトランジスタ	01
Q13	WC631700	FET	2SK3288			F E T	
Q14	WC631700	FET	2SK3288			F E T	
XL1	V3625700	RSNR.CRYS	24.576MHz			水晶振動子	03
XL2	WB440500	RSNR.CE	CSTCE16MOV53-R0			セラミック発振子	01

\* New Parts (新規部品)

## DVR-S150 P.C.B. MAIN

Ref. No.	PART NO.	Description	Remarks	Markets	部品名	Rank	
*	WD538700	P.C.B.	MAIN	BL	UCA	P C B メイン	
*	WD504700	P.C.B.	MAIN	SI	J	P C B メイン	
*	WD504800	P.C.B.	MAIN	SI	UCRTKAL	P C B メイン	
*	WD504900	P.C.B.	MAIN	SI	BGE	P C B メイン	
CB1	VB389800	CN.BS.PIN	2P			ベースピン	01
CB2	VE352600	CN.BS.PIN	14P			コネクタベースポスト	01
CB3	VL844800	CN.BS.PIN	4P			ベース付ポスト	01
CB4	VB390300	CN.BS.PIN	7P			ベースピン	01
CB5	V2283600	CN.BS.PIN	32P TE FMN			F F C コネクター	
CB6	VQ962700	CN.BS.PIN	6P			ウエハー	01
CB7	VQ962700	CN.BS.PIN	6P			ウエハー	01
CB8	VQ962700	CN.BS.PIN	6P			ウエハー	01
CB9	VQ962700	CN.BS.PIN	6P			ウエハー	01
CB10	VQ962700	CN.BS.PIN	6P			ウエハー	01
CB11	VQ962800	CN.BS.PIN	7P			ウエハー	02
CB12	VQ962800	CN.BS.PIN	7P			ウエハー	02
CB13	VQ962800	CN.BS.PIN	7P			ウエハー	02
CB14	VQ962800	CN.BS.PIN	7P			ウエハー	02
CB15	VQ962800	CN.BS.PIN	7P			ウエハー	02
CB16	V7684100	CN	14P SE YKF SERIES		J	D端子コネクター	
CB17	VT637800	CN.BS.PIN	3P			ベースツキポスト	01
CB121	VM923600	CN.BS.PIN	13P			F F C コネクター	01
CB122	WA894700	CN	28P TE FMN			F M N コネクター	
CB123	VB389900	CN.BS.PIN	3P			ベースピン	01
CB124	VB390700	CN.BS.PIN	11P			コネクタベースポスト	01
CB125	V7827400	SOCKET	7P TE TUC SERIES			コネクターソケット	
CB221	WA894700	CN	28P TE FMN			F M N コネクター	
CB222	VB858700	CN.BS.PIN	8P			ベースピン	01
CB224	V7667200	CN.BS.PIN	20P TE			F F C コネクター	
CB225	VB858400	CN.BS.PIN	5P			ベースピン	01
C3	UR867100	C.EL	10uF 50V			ケミコン	01
C4	UR867100	C.EL	10uF 50V			ケミコン	01
C8	UR837470	C.EL	47uF 16V			ケミコン	01
C9	UR837470	C.EL	47uF 16V			ケミコン	01
C10	UN866330	C.EL	3.3uF 50V			B P ケミコン	01
C11	UN866330	C.EL	3.3uF 50V			B P ケミコン	01
C23	UR819100	C.EL	1000uF 6.3V			ケミコン	01
C26	UR818470	C.EL	470uF 6.3V			ケミコン	01
C27	UR818100	C.EL	100uF 6.3V			ケミコン	01
C30	UR818470	C.EL	470uF 6.3V			ケミコン	01
C36	UR867470	C.EL	47uF 50V			ケミコン	01
C37	UR867100	C.EL	10uF 50V			ケミコン	01
C38	UR838100	C.EL	100uF 16V			ケミコン	01
C39	UR838100	C.EL	100uF 16V			ケミコン	01
C40	UR838100	C.EL	100uF 16V			ケミコン	01
C41	UR867220	C.EL	22uF 50V			ケミコン	01
C42	UR867100	C.EL	10uF 50V			ケミコン	01
C43	UN837330	C.EL	33uF 16V			ケミコン	
C49	UR867100	C.EL	10uF 50V			ケミコン	01
C50	UR867100	C.EL	10uF 50V			ケミコン	01
C52	WB824000	C.EL	6800uF 35V			ケミコン F W	
C53	WB824000	C.EL	6800uF 35V			ケミコン F W	
C59	UR837100	C.EL	10uF 16V			ケミコン	01

\* New Parts (新規部品)



## DVR-S150 P.C.B. MAIN

Ref. No.	PART NO.	Description	Remarks	Markets	部品名	Rank	
C60	VT898000	C.MYLAR	0.1uF	100V		マイラーコン	
C61	VT898000	C.MYLAR	0.1uF	100V		マイラーコン	
C62	UA654100	C.MYLAR	0.01uF	50V	JUCRTKAL	マイラーコン	01
C62	UA654470	C.MYLAR	0.047uF	50V	BGE	マイラーコン	01
C63	UA654100	C.MYLAR	0.01uF	50V	JUCRTKAL	マイラーコン	01
C63	UA654470	C.MYLAR	0.047uF	50V	BGE	マイラーコン	01
C64	UA654100	C.MYLAR	0.01uF	50V	JUCRTKAL	マイラーコン	01
C64	UA654470	C.MYLAR	0.047uF	50V	BGE	マイラーコン	01
C65	UA654100	C.MYLAR	0.01uF	50V	JUCRTKAL	マイラーコン	01
C65	UA654470	C.MYLAR	0.047uF	50V	BGE	マイラーコン	01
C66	UA654100	C.MYLAR	0.01uF	50V	JUCRTKAL	マイラーコン	01
C66	UA654470	C.MYLAR	0.047uF	50V	BGE	マイラーコン	01
C67	UR837470	C.EL	47uF	16V		ケミコン	01
C68	UR837470	C.EL	47uF	16V		ケミコン	01
C74	UR867100	C.EL	10uF	50V		ケミコン	01
C75	UR867100	C.EL	10uF	50V		ケミコン	01
C76	UR867100	C.EL	10uF	50V		ケミコン	01
C122	UR837330	C.EL	33uF	16V		ケミコン	01
C129	UR866220	C.EL	2.2uF	50V		ケミコン	01
C131	UR837100	C.EL	10uF	16V		ケミコン	01
C132	UR837100	C.EL	10uF	16V		ケミコン	01
C133	UR837330	C.EL	33uF	16V		ケミコン	01
C138	UR837100	C.EL	10uF	16V		ケミコン	01
C142	UR837330	C.EL	33uF	16V	BGE	ケミコン	01
C144	UR866220	C.EL	2.2uF	50V	BGE	ケミコン	01
C148	UR866220	C.EL	2.2uF	50V		ケミコン	01
C149	UR837470	C.EL	47uF	16V	BGE	ケミコン	01
C152	UR837100	C.EL	10uF	16V		ケミコン	01
C154	UR837100	C.EL	10uF	16V		ケミコン	01
C155	UR837100	C.EL	10uF	16V		ケミコン	01
C156	UR837100	C.EL	10uF	16V		ケミコン	01
C157	UA653470	C.MYLAR	4700pF	50V		マイラーコン	01
C158	UA653470	C.MYLAR	4700pF	50V		マイラーコン	01
C159	UR837100	C.EL	10uF	16V		ケミコン	01
C160	UA655100	C.MYLAR	0.1uF	50V		マイラーコン	01
C162	UA655100	C.MYLAR	0.1uF	50V		マイラーコン	01
C163	UR837100	C.EL	10uF	16V		ケミコン	01
C164	UA655100	C.MYLAR	0.1uF	50V		マイラーコン	01
C165	UA655100	C.MYLAR	0.1uF	50V		マイラーコン	01
C170	UR866470	C.EL	4.7uF	50V		ケミコン	01
C171	UR866470	C.EL	4.7uF	50V		ケミコン	01
C172	UR866330	C.EL	3.3uF	50V		ケミコン	01
C173	UR867220	C.EL	22uF	50V		ケミコン	01
C174	UR867220	C.EL	22uF	50V		ケミコン	01
C175	UR866470	C.EL	4.7uF	50V		ケミコン	01
C176	UR866470	C.EL	4.7uF	50V		ケミコン	01
C177	UR866220	C.EL	2.2uF	50V		ケミコン	01
C178	UR866220	C.EL	2.2uF	50V		ケミコン	01
C179	UR866220	C.EL	2.2uF	50V		ケミコン	01
C180	UR866220	C.EL	2.2uF	50V		ケミコン	01
C181	UR866100	C.EL	1uF	50V		ケミコン	01
C182	UR866100	C.EL	1uF	50V		ケミコン	01
C186	UR866470	C.EL	4.7uF	50V		ケミコン	01

\* New Parts (新規部品)



## DVR-S150 P.C.B. MAIN

Ref. No.	PART NO.	Description	Remarks	Markets	部品名	Rank
C187	UA655100	C.MYLAR	0.1uF 50V		マイラーコン	01
C191	UR866470	C.EL	4.7uF 50V		ケミコン	01
C192	UR819100	C.EL	1000uF 6.3V		ケミコン	01
C193	UR837100	C.EL	10uF 16V		ケミコン	01
C194	UR838100	C.EL	100uF 16V		ケミコン	01
C195	UR837220	C.EL	22uF 16V		ケミコン	01
C196	UR837220	C.EL	22uF 16V		ケミコン	01
C197	UR866470	C.EL	4.7uF 50V		ケミコン	01
C199	UR838100	C.EL	100uF 16V		ケミコン	01
C200	UR838100	C.EL	100uF 16V		ケミコン	01
C201	UR837470	C.EL	47uF 16V		ケミコン	01
C202	UR837470	C.EL	47uF 16V		ケミコン	01
C203	UR837100	C.EL	10uF 16V		ケミコン	01
C204	UR838100	C.EL	100uF 16V		ケミコン	01
C207	UR866470	C.EL	4.7uF 50V		ケミコン	01
C208	UR838100	C.EL	100uF 16V		ケミコン	01
C210	UR73A100	C.EL	10000uF 16V		ケミコン	03
C222	UR818100	C.EL	100uF 6.3V		ケミコン	01
C228	UR866470	C.EL	4.7uF 50V		ケミコン	01
C229	UR866470	C.EL	4.7uF 50V		ケミコン	01
C651	UN828470	C.EL	470 10V	J	B P ケミコン	01
C652	UN828470	C.EL	470 10V	J	B P ケミコン	01
C653	UN828470	C.EL	470 10V	J	B P ケミコン	01
C654	UN828470	C.EL	470 10V	J	B P ケミコン	01
C655	UN866330	C.EL	3.3uF 50V		B P ケミコン	01
C673	UR819100	C.EL	1000uF 6.3V		ケミコン	01
C674	UR819100	C.EL	1000uF 6.3V		ケミコン	01
D1	VT332900	DIODE	1SS355		ダイオード	01
D2	VT332900	DIODE	1SS355		ダイオード	01
D3	VT332900	DIODE	1SS355		ダイオード	01
D4	VT332900	DIODE	1SS355		ダイオード	01
D5	VT332900	DIODE	1SS355		ダイオード	01
D6	VU998600	DIODE.ZENR	MA8220-L 21.3V		ツェナーダイオード	
D7	VU995700	DIODE.ZENR	MA8110-L 10.7V		ツェナーダイオード	01
△ D8	VN011400	DIODE.BRG	D5SB20 5A 200V		ダイオード	03
D9	VT332900	DIODE	1SS355		ダイオード	01
D10	VT332900	DIODE	1SS355		ダイオード	01
D11	VU996200	DIODE.ZENR	MA8120-M 12.0V		ツェナーダイオード	01
D12	VU995700	DIODE.ZENR	MA8110-L 10.7V		ツェナーダイオード	01
D13	VU995700	DIODE.ZENR	MA8110-L 10.7V		ツェナーダイオード	01
D14	VU995700	DIODE.ZENR	MA8110-L 10.7V		ツェナーダイオード	01
D15	VU995700	DIODE.ZENR	MA8110-L 10.7V		ツェナーダイオード	01
D16	VU995700	DIODE.ZENR	MA8110-L 10.7V		ツェナーダイオード	01
D17	VU995700	DIODE.ZENR	MA8110-L 10.7V		ツェナーダイオード	01
△ D121	VU995700	DIODE.ZENR	MA8110-L 10.7V		ツェナーダイオード	01
△ D122	VU993000	DIODE.ZENR	MA8056-M 5.6V	BGE	ツェナーダイオード	01
D123	VU994300	DIODE.ZENR	MA8075-H 7.7V		ツェナーダイオード	
D124	VU994300	DIODE.ZENR	MA8075-H 7.7V		ツェナーダイオード	
D126	V6267600	DIODE	RB051L-40		ダイオード	01
△ D128	V4269600	DIODE.BRG	D2SBA20 1.5A 200V		ダイオ - ドブリッジ	
D221	VU994100	DIODE.ZENR	MA8075-L 7.3V		ツェナーダイオード	
D651	VT332900	DIODE	1SS355		ダイオード	01
IC1	X4239A00	IC	NJM2279M		I C	

\* New Parts (新規部品)

## DVR-S150 P.C.B. MAIN

Ref. No.	PART NO.	Description	Remarks	Markets	部品名	Rank
IC2	X3505A00	IC	NJM2068MD-TE2		アンプ I C S O P	02
IC3	X3505A00	IC	NJM2068MD-TE2		アンプ I C S O P	02
IC4	X3505A00	IC	NJM2068MD-TE2		アンプ I C S O P	02
IC14	X5052A00	IC	PQ025EN5MZPH		電源 I C Q F P	
IC15	XU965A00	IC	uPC29M33T-E1 3.3V		電源 I C	03
IC121	X4258A00	IC	BD3842FS-E2		I C	
IC122	X3505A00	IC	NJM2068MD-TE2		アンプ I C S O P	02
IC123	X3546A00	IC	BD3815KS		I C	
* IC124	X0082A00	IC	LC72722PM	BGE	I C S O P	
IC125	XS377A00	IC	BA15218F OP AMP		アンプ I C	01
△ IC127	XY525A00	IC	PQ1CG2032FZH		電源 I C S I L	06
IC221	XV160A00	IC	LC75712E FLD		ロジック I C フラット	07
JK1	VS867300	CN.DIN	4P YKF51-5501		D I Nコネクタ	03
JK2	VJ726800	JACK.MNI			モノラルミニジャック	01
PJ1	WB320900	JACK.PIN	4P YKC21-4482N		ピンジャック	03
* PJ2	WB385300	JACK.PIN	3P YKC21-4195N	UCRTKABGEL	ピンジャック	
PJ121	WB320800	JACK.PIN	4P YKC21-4084N		ピンジャック	03
PJ122	WB385400	JACK.PIN	3P YKC21-4534N		ピンジャック	04
Q1	VV556400	TR	2SC2412K Q,R,S		トランジスタ	01
Q2	iD040040	TR	2SD400		トランジスタ	02
Q3	iD040040	TR	2SD400		トランジスタ	02
Q4	iD040040	TR	2SD400		トランジスタ	02
Q5	iD040040	TR	2SD400		トランジスタ	02
Q6	iD040040	TR	2SD400		トランジスタ	02
Q7	VV655400	TR.DGT	DTC114EKA		デジタルトランジスタ	01
Q8	VV655400	TR.DGT	DTC114EKA		デジタルトランジスタ	01
Q9	VV655000	TR.DGT	DTA114EKA		デジタルトランジスタ	01
Q11	VV655000	TR.DGT	DTA114EKA		デジタルトランジスタ	01
Q12	VV655400	TR.DGT	DTC114EKA	J	デジタルトランジスタ	01
Q13	VV655400	TR.DGT	DTC114EKA	J	デジタルトランジスタ	01
Q16	VV556400	TR	2SC2412K Q,R,S		トランジスタ	01
Q17	VV556400	TR	2SC2412K Q,R,S		トランジスタ	01
Q18	VV556400	TR	2SC2412K Q,R,S		トランジスタ	01
△ Q19	VP872700	TR	2SC4488 S,T		トランジスタ	01
Q20	VV556400	TR	2SC2412K Q,R,S		トランジスタ	01
Q21	VV556400	TR	2SC2412K Q,R,S		トランジスタ	01
Q22	VG805300	TR	2SA1674 R,S		トランジスタ	01
Q23	VV556400	TR	2SC2412K Q,R,S		トランジスタ	01
Q24	VV556400	TR	2SC2412K Q,R,S		トランジスタ	01
Q25	VV556400	TR	2SC2412K Q,R,S		トランジスタ	01
Q27	VV655000	TR.DGT	DTA114EKA		デジタルトランジスタ	01
Q28	VV655700	TR.DGT	DTC144EKA		デジタルトランジスタ	01
Q29	VV655700	TR.DGT	DTC144EKA		デジタルトランジスタ	01
Q30	VV556400	TR	2SC2412K Q,R,S		トランジスタ	01
△ Q121	VP872700	TR	2SC4488 S,T		トランジスタ	01
Q122	WC883400	TR	2SC2704 K		トランジスタ	
Q123	WC883400	TR	2SC2704 K		トランジスタ	
△ Q124	VV556400	TR	2SC2412K Q,R,S	BGE	トランジスタ	01
Q125	VV556400	TR	2SC2412K Q,R,S		トランジスタ	01
Q126	VV556500	TR	2SA1037K Q,R,S		トランジスタ	01
Q127	WC883400	TR	2SC2704 K		トランジスタ	
Q128	WC883400	TR	2SC2704 K		トランジスタ	
Q129	WC883400	TR	2SC2704 K		トランジスタ	

\* New Parts (新規部品)

## DVR-S150 P.C.B. MAIN

Ref. No.	PART NO.	Description	Remarks	Markets	部品名	Rank
Q130	WC883400	TR	2SC2704 K		トランジスタ	
Q221	VV556400	TR	2SC2412K Q,R,S		トランジスタ	01
Q222	VV556400	TR	2SC2412K Q,R,S		トランジスタ	01
Q223	VV556400	TR	2SC2412K Q,R,S		トランジスタ	01
Q224	VV556400	TR	2SC2412K Q,R,S		トランジスタ	01
Q225	VV556400	TR	2SC2412K Q,R,S		トランジスタ	01
Q226	VV556400	TR	2SC2412K Q,R,S		トランジスタ	01
Q651	VV556400	TR	2SC2412K Q,R,S		トランジスタ	01
Q652	VV556400	TR	2SC2412K Q,R,S		トランジスタ	01
Q653	VV556400	TR	2SC2412K Q,R,S		トランジスタ	01
Q654	VV556400	TR	2SC2412K Q,R,S		トランジスタ	01
Q655	VV556400	TR	2SC2412K Q,R,S		トランジスタ	01
Q656	VV556400	TR	2SC2412K Q,R,S		トランジスタ	01
Q657	VV556400	TR	2SC2412K Q,R,S		トランジスタ	01
Q658	VV556400	TR	2SC2412K Q,R,S		トランジスタ	01
Q659	VV556400	TR	2SC2412K Q,R,S		トランジスタ	01
Q660	VV556400	TR	2SC2412K Q,R,S		トランジスタ	01
Q661	VV556400	TR	2SC2412K Q,R,S		トランジスタ	01
Q662	VV556400	TR	2SC2412K Q,R,S		トランジスタ	01
Q663	VV556400	TR	2SC2412K Q,R,S		トランジスタ	01
Q664	VV556400	TR	2SC2412K Q,R,S		トランジスタ	01
Q665	VV556400	TR	2SC2412K Q,R,S		トランジスタ	01
Q666	VV556400	TR	2SC2412K Q,R,S		トランジスタ	01
Q667	VV655000	TR.DGT	DTA114EKA		デジタルトランジスタ	01
Q668	VV655000	TR.DGT	DTA114EKA		デジタルトランジスタ	01
Q669	WC883400	TR	2SC2704 K		トランジスタ	
Q670	WC883400	TR	2SC2704 K		トランジスタ	
Q671	WC883400	TR	2SC2704 K		トランジスタ	
Q672	WC883400	TR	2SC2704 K		トランジスタ	
Q673	WC883400	TR	2SC2704 K		トランジスタ	
Q674	VV655000	TR.DGT	DTA114EKA		デジタルトランジスタ	01
R5	VP940200	R.MTL.OXD	47 1W		酸化金属被膜抵抗	01
R57	HV753220	R.CAR.FP	2.2 1/4W		不燃化カーボン抵抗	01
R82	HV756470	R.CAR.FP	4.7K 1/4W		不燃化カーボン抵抗	01
R83	HV753220	R.CAR.FP	2.2 1/4W		不燃化カーボン抵抗	01
R107	VP940900	R.MTL.OXD	560 1W		酸化金属被膜抵抗	
R108	VP940400	R.MTL.OXD	100 1W		酸化金属被膜抵抗	01
R109	HV756470	R.CAR.FP	4.7K 1/4W		不燃化カーボン抵抗	01
R264	HV755100	R.CAR.FP	100 1/4W		不燃化カーボン抵抗	01
R265	HV755100	R.CAR.FP	100 1/4W		不燃化カーボン抵抗	01
R801	HV755560	R.CAR.FP	560 1/4W	J	不燃化カーボン抵抗	01
R801	HV756100	R.CAR.FP	1K 1/4W	UCRTKABGEL	不燃化カーボン抵抗	01
R802	HV755560	R.CAR.FP	560 1/4W	J	不燃化カーボン抵抗	01
R802	HV756100	R.CAR.FP	1K 1/4W	UCRTKABGEL	不燃化カーボン抵抗	01
R803	HV755470	R.CAR.FP	470 1/4W	J	不燃化カーボン抵抗	01
R803	HV756100	R.CAR.FP	1K 1/4W	UCRTKABGEL	不燃化カーボン抵抗	01
R804	HV755470	R.CAR.FP	470 1/4W	J	不燃化カーボン抵抗	01
R804	HV756100	R.CAR.FP	1K 1/4W	UCRTKABGEL	不燃化カーボン抵抗	01
R805	HV755470	R.CAR.FP	470 1/4W	J	不燃化カーボン抵抗	01
R805	HV756100	R.CAR.FP	1K 1/4W	UCRTKABGEL	不燃化カーボン抵抗	01
R806	HV755470	R.CAR.FP	470 1/4W	J	不燃化カーボン抵抗	01
R806	HV756100	R.CAR.FP	1K 1/4W	UCRTKABGEL	不燃化カーボン抵抗	01
TE1	WB244100	TERM.SP	NLA1-01-004		スピーカー端子	05

\* New Parts (新規部品)

## DVR-S150 P.C.B. MAIN &amp; SUB

Ref. No.	PART NO.	Description	Remarks	Markets	部品名	Rank
△ TH1	V7962300	THRMST.CHP	NCP18WF104J03RB		チップサーミスタ	01
V221	WB452200	FL.DSPLY	14-BT-80GNKF		蛍光表示管	08
XL121	V3930900	RSNR.CRYS	4.332MHz	BGE	水晶振動子	05
	V6955200	SHEET	W=35	SI	保護シート	
	WC986900	SHEET		BL	シート/FL	01
	EP600140	SCR.BND.HD	3x10 MFZN2BL		バインドBタイトネジ	01
	EG330360	SCR.BND.HD	3x6 MFZN2BL		バインド小ネジ	01
* * * * *	WD505000	P.C.B.	SUB	J	P C B 集成 サブ	
	WD505100	P.C.B.	SUB	UC	P C B 集成 サブ	
	WD505200	P.C.B.	SUB	R	P C B 集成 サブ	
	WD505300	P.C.B.	SUB	T	P C B 集成 サブ	
	WD505400	P.C.B.	SUB	K	P C B 集成 サブ	
	WD505500	P.C.B.	SUB	A	P C B 集成 サブ	
	WD505600	P.C.B.	SUB	BGE	P C B 集成 サブ	
	WD505700	P.C.B.	SUB	L	P C B 集成 サブ	
	CB272	V7825700	CN	7P TE TUC SERIES	コネクタプラグ	
	CB274	V7667200	CN.BS.PIN	20P TE	FFCコネクタ	
	CB275	VL845100	CN.BS.PIN	7P	ベース付ポスト	01
△	CB276	VT807100	CN.BS.PIN	2P	ベースポスト	01
△	CB277	VG879900	CN.BS.PIN	2P	ベースピン	01
	CB278	VB858300	CN.BS.PIN	4P	コネクタベースポスト	01
	CB351	VB858500	CN.BS.PIN	6P	ベースピン	01
	C272	UM416100	C.EL	1uF 50V	ケミコン	01
	C274	UR819100	C.EL	1000uF 6.3V	ケミコン	01
	C275	UM417100	C.EL	10uF 50V	ケミコン	01
	C276	UM416220	C.EL	2.2uF 50V	ケミコン	01
	C277	WB165500	C.EL	0.33F 5.5V	ゴールドキャパシタ	
	C278	UR838220	C.EL	220uF 16V	ケミコン	01
	C279	UR848100	C.EL	100uF 25V	ケミコン	01
	C281	UR838100	C.EL	100uF 16V	ケミコン	01
	C282	UR838100	C.EL	100uF 16V	ケミコン	01
	C283	UR818220	C.EL	220uF 6.3V	ケミコン	01
	C284	UR818220	C.EL	220uF 6.3V	ケミコン	01
	C285	UM416470	C.EL	4.7uF 50V	ケミコン	01
	C286	UM407220	C.EL	22uF 25V	ケミコン	01
	C287	UR839100	C.EL	1000uF 16V	ケミコン	01
	C288	UR838220	C.EL	220uF 16V	ケミコン	01
	C290	UR848100	C.EL	100uF 25V	ケミコン	01
	C291	VR325100	C.MYLAR	0.01uF 100V	マイラーコン	01
	C292	UR749680	C.EL	6800uF 25V	ケミコン	03
	C293	UR749220	C.EL	2200uF 25V	ケミコン	03
	C294	UR749220	C.EL	2200uF 25V	ケミコン	03
	C295	UR749220	C.EL	2200uF 25V	ケミコン	03
	C296	UR749220	C.EL	2200uF 25V	ケミコン	03
	C297	VR325100	C.MYLAR	0.01uF 100V	マイラーコン	01
△	C298	V6185300	C.CE.SAFTY	0.01uF 275V	規格認定コン	
	C299	VR325400	C.MYLAR	0.1uF 100V	マイラーコン	01
	C300	VR325400	C.MYLAR	0.1uF 100V	マイラーコン	01
	C301	UR838100	C.EL	100uF 16V	ケミコン	01
	C302	UR73A100	C.EL	10000uF 16V	ケミコン	03

\* New Parts (新規部品)

## DVR-S150 P.C.B. SUB

Ref. No.	PART NO.	Description	Remarks	Markets	部品名	Rank
C303	VT898000	C.MYLAR	0.1uF 100V		マイラーコン	
C315	UR819100	C.EL	1000uF 6.3V		ケミコン	01
C325	UR866470	C.EL	4.7uF 50V		ケミコン	01
C355	UM388100	C.EL	100uF 10V		ケミコン	01
C367	UR818220	C.EL	220uF 6.3V		ケミコン	01
C701	UM397220	C.EL	22uF 25V		ケミコン	01
C702	UM397220	C.EL	22uF 25V		ケミコン	01
C703	UM397100	C.EL	10uF 16V		ケミコン	01
C704	UM397220	C.EL	22uF 25V		ケミコン	01
C706	UM387470	C.EL	47uF 16V		ケミコン	01
C708	UM397100	C.EL	10uF 16V		ケミコン	01
D271	VT332900	DIODE	1SS355		ダイオード	01
D272	VT332900	DIODE	1SS355		ダイオード	01
D273	VU993400	DIODE.ZENR	MA8062-M 6.2V		ツェナーダイオード	01
D274	VV307700	DIODE	1N4002S		ダイオード	01
D275	VV833200	DIODE	1SS380		ダイオード	01
D276	VU993500	DIODE.ZENR	MA8062-H 6.4V		ツェナーダイオード	01
D277	V6267600	DIODE	RB051L-40		ダイオード	01
△ D278	VQ379300	DIODE.BRG	S1VB20 1A 200V		ダイオード	02
D279	VT532500	DIODE	1SR154-400		ダイオード	01
D280	VT532500	DIODE	1SR154-400		ダイオード	01
D281	VT332900	DIODE	1SS355		ダイオード	01
△ D282	VV307700	DIODE	1N4002S		ダイオード	01
△ D283	VQ379300	DIODE.BRG	S1VB20 1A 200V		ダイオード	02
△ D284	VV307700	DIODE	1N4002S		ダイオード	01
D285	VT332900	DIODE	1SS355		ダイオード	01
D286	VV220700	DIODE.SHOT	RB501V-40		ショットキーダイオード	01
D287	VV220700	DIODE.SHOT	RB501V-40		ショットキーダイオード	01
D288	V6267600	DIODE	RB051L-40		ダイオード	01
△ D289	VN011300	DIODE.BRG	D3SBA20 4A 200V		ダイオード	03
D311	VV220700	DIODE.SHOT	RB501V-40		ショットキーダイオード	01
D312	VV220700	DIODE.SHOT	RB501V-40		ショットキーダイオード	01
D701	VU171900	DIODE.ZENR	UDZ5.1B 5.1V		ツェナーダイオード	01
D702	VT332900	DIODE	1SS355		ダイオード	01
D703	VT332900	DIODE	1SS355		ダイオード	01
△ Fi271	WC362100	FLTR	ELF15N050A		ラインフィルタ	
G351	V4040500	SCR.TERM	M3		スクリュー/ターミナル	01
△ IC271	XJ602A00	IC	NJM78M12FA		IC	02
△ IC272	XD343A00	IC	NJM79M12FA		IC	03
△ IC273	XJ604A00	IC	NJM78M05FA		IC	02
△ IC274	XE436A00	IC	NJM79M05FA		IC	03
△ IC275	XY455A00	IC	PQ1CG21H2F SW		電源IC SIL	04
△ IC276	XY525A00	IC	PQ1CG2032FZH		電源IC SIL	06
IC311	XV190A00	IC	NJM2904M OP AMP		アンプIC	01
IC312	XY120A00	IC	TC74HCT00AF(EL) NA		ロジックIC SOP	01
IC701	XF291A00	IC	uPC4570G2		IC	03
JK351	WB071300	JACK.MNI	LGS6516-0100		ミニジャック	03
* JK701	WD249600	JACK.MNI	HSJ1492-01-010		ミニジャック	
Q271	VV655700	TR.DGT	DTC144EKA		デジタルトランジスタ	01
Q272	VV556500	TR	2SA1037K Q,R,S		トランジスタ	01
Q273	VP872700	TR	2SC4488 S,T		トランジスタ	01
Q274	VC218900	TR	2SC3330 R,S,T		トランジスタ	01
Q275	VV556500	TR	2SA1037K Q,R,S		トランジスタ	01

\* New Parts (新規部品)

## DVR-S150 P.C.B. SUB &amp; DVD

Ref. No.	PART NO.	Description	Remarks	Markets	部品名	Rank	
Q276	VV556400	TR	2SC2412K Q, R, S		トランジスタ	01	
Q701	VD303700	TR	2SC3326 A, B		トランジスタ	01	
R283	VP940100	R. MTL. OXD	33 1W	J	酸化金属被膜抵抗	01	
R283	VP940200	R. MTL. OXD	47 1W	UCRTKABGEL	酸化金属被膜抵抗	01	
R285	VP940100	R. MTL. OXD	33 1W	J	酸化金属被膜抵抗	01	
R285	VP940200	R. MTL. OXD	47 1W	UCRTKABGEL	酸化金属被膜抵抗	01	
R295	HV755180	R. CAR. FP	180 1/4W		不燃化カーボン抵抗	01	
RY271	V6017400	RELAY	DC SDT-S-112LMR2		リレー 12V	04	
SW331	WA876500	SW. RT. ENC	EVEGC3F2024B		ロータリーエンコーダ	01	
SW332	VV020300	SW. TACT	SKQNAA		タクトSW	01	
SW333	VV020300	SW. TACT	SKQNAA		タクトSW	01	
SW334	VV020300	SW. TACT	SKQNAA		タクトSW	01	
SW335	VV020300	SW. TACT	SKQNAA		タクトSW	01	
SW336	VV020300	SW. TACT	SKQNAA		タクトSW	01	
SW337	VV020300	SW. TACT	SKQNAA		タクトSW	01	
SW338	VV020300	SW. TACT	SKQNAA		タクトSW	01	
SW339	VV020300	SW. TACT	SKQNAA		タクトSW	01	
SW340	VV020300	SW. TACT	SKQNAA		タクトSW	01	
SW341	VV020300	SW. TACT	SKQNAA		タクトSW	01	
T271	X2490A00	TRANS. PWR		J	サブトランス	05	
* T271	X2491A00	TRANS. PWR		UC	サブトランス		
* T271	X4434A00	TRANS		R	サブトランス		
* T271	X2948A00	TRANS. PWR		TKL	サブトランス		
* T271	X2493A00	TRANS. PWR		A	サブトランス		
* T271	X2494A00	TRANS. PWR		BGE	サブトランス		
U311	WB001400	CN. PHOT. SN	1P GP1FA553RZ		光ファイバ受信器	04	
U312	WB001600	CN. PHOT. SN	1P GP1FA553TZ		光ファイバリンク		
U351	WB437900	L. DTCT	GP1UD281YK		リモコン受光ユニット	04	
	EP600140	SCR. BND. HD	3x10 MFZN2BL		バインドBタイトネジ	01	
	EG330360	SCR. BND. HD	3x6 MFZN2BL		バインド小ネジ	01	
	WB876500	P. C. B.	DVD (SD5. 12P)	JUCRTKAL	DVD BOARD	28	
	WB876600	P. C. B.	DVD (SD5. 12P)	BGE	DVD BOARD		
1606	AAX29760	TERM. SCART	21P	2422 025 12352	BGE	スカート端子	
2663	UR837470	C. EL	47uF 16V		ケミコン	01	
2723	UR837470	C. EL	47uF 16V		ケミコン	01	
2760	UR837470	C. EL	47uF 16V		ケミコン	01	
2761	UR837470	C. EL	47uF 16V		ケミコン	01	
2762	UR848100	C. EL	100uF 25V		ケミコン		
2771	UR837470	C. EL	47uF 16V		ケミコン	01	
2787	UR866220	C. EL	2.2uF 50V		ケミコン		
2794	UR866220	C. EL	2.2uF 50V		ケミコン		
2802	UR866220	C. EL	2.2uF 50V		ケミコン		
2810	UR866220	C. EL	2.2uF 50V		ケミコン		
2818	UR866220	C. EL	2.2uF 50V		ケミコン		
2840	UR848100	C. EL	100uF 25V		ケミコン		
2853	UR848470	C. EL	470uF 25V		ケミコン	01	
2855	UR848470	C. EL	470uF 25V		ケミコン	01	
2857	UR848470	C. EL	470uF 25V		ケミコン	01	
2862	UR848100	C. EL	100uF 25V		ケミコン		
2867	UR848100	C. EL	100uF 25V		ケミコン		

\* New Parts (新規部品)

## DVR-S150 P.C.B. DVD

Ref. No.	PART NO.	Description	Remarks	Markets	部品名	Rank
2870	UR837470	C.EL	47uF 16V		ケミコン	01
2873	UR848220	C.EL	220uF 25V		ケミコン	
2881	UR848220	C.EL	220uF 25V		ケミコン	
2884	UR848100	C.EL	100uF 25V		ケミコン	
2886	UR848100	C.EL	100uF 25V		ケミコン	
2888	UR848100	C.EL	100uF 25V		ケミコン	
2890	UR837470	C.EL	47uF 16V		ケミコン	01
2892	UR837470	C.EL	47uF 16V		ケミコン	01
2893	UR848220	C.EL	220uF 25V		ケミコン	
2916	UR867100	C.EL	10uF 50V		ケミコン	
5601	AAX51440	RSNR.CRYS	13.5MHz	3141 018 80781	水晶振動子	
6601	AAX22630	DIODE.CHP	BAS316	4822 130 11397	チップダイオード	
6603	AAX22630	DIODE.CHP	BAS316	4822 130 11397	チップダイオード	
6604	AAX22630	DIODE.CHP	BAS316	4822 130 11397	チップダイオード	
6629	AAX22630	DIODE.CHP	BAS316	4822 130 11397	チップダイオード	
6630	AAX22630	DIODE.CHP	BAS316	4822 130 11397	チップダイオード	
6631	AAX22640	DIODE.CHP	UDZ15B	4822 130 11522	チップダイオード	
6632	AAX22640	DIODE.CHP	UDZ15B	4822 130 11522	チップダイオード	
6633	AAX22640	DIODE.CHP	UDZ15B	4822 130 11522	チップダイオード	
6634	AAX22640	DIODE.CHP	UDZ15B	4822 130 11522	チップダイオード	
7600	AAX51420	IC	Z1VA-5M	9322 195 06671	I C	
7602	AAX46690	IC	M24C64-WMN6	9322 130 41668	I C	
7603	AAX47380	TR	BC847B	3198 010 42030	トランジスタ	
7604	AAX47380	TR	BC847B	3198 010 42030	トランジスタ	
7605	AAX51430	IC	74LVT573DB(PHS0)L	9351 707 10112	I C	
7606	AAX51430	IC	74LVT573DB(PHS0)L	9351 707 10112	I C	
7607	AAX51430	IC	74LVT573DB(PHS0)L	9351 707 10112	I C	
7608	AAX51370	FET	BSN20	9965 000 04199	F E T	
7609	AAX51370	FET	BSN20	9965 000 04199	F E T	
7610	AAX51380	IC	M29W160DT-SD5.12	3141 017 40951	I C	
7611	AAX51410	IC	MT48LC4M32B2TG-7	9322 180 36671	I C	
7612	AAX47380	TR	BC847B	3198 010 42030	トランジスタ	
7620	AAX46780	IC	AK4382AVT	9322 177 09685	I C	
7622	AAX51390	IC	LD1086D2T33(ST00)	3141 018 51741	I C	
7624	AAX29510	IC	74HCT1G125	9352 456 80115	I C	
7626	AAX21660	IC	LM833D	4822 209 30095	I C	
7627	AAX21660	IC	LM833D	4822 209 30095	I C	
7628	AAX47430	TR	BC817-25	3198 010 43230	トランジスタ	
7629	AAX47390	TR	BC857B	3198 010 42150	トランジスタ	
7630	AAX47390	TR	BC857B	3198 010 42150	トランジスタ	
7631	AAX47380	TR	BC847B	3198 010 42030	トランジスタ	
7632	AAX47380	TR	BC847B	3198 010 42030	トランジスタ	
7633	AAX47430	TR	BC817-25	3198 010 43230	トランジスタ	
7640	AAX47490	TR	BC847BPN	9340 425 30115	トランジスタ	
7644	AAX47490	TR	BC847BPN	9340 425 30115	トランジスタ	
7673	AAX46760	IC	LD1117ADT18	9322 167 69668	I C	
7674	AAX51400	IC	MC78L05ACD	4822 209 33411	I C	

\* New Parts (新規部品)

## CHIP CAPACITORS &amp; CHIP RESISTORS

Ref. No.	PART NO.	Description	Remarks	Markets	部品名	Rank	
	UF028100	C.EL.CHP	100uF	10V		チップケミコン	01
	UF037100	C.EL.CHP	10uF	16V		チップケミコン	01
	UF037470	C.EL.CHP	47uF	16V		チップケミコン	01
	UF066220	C.EL.CHP	2.2uF	50V		チップケミコン	01
	UF066470	C.EL.CHP	4.7uF	50V		チップケミコン	01
	US034470	C.CE.M.CHP	0.047uF	16V		チップセラコン	01
	US044220	C.CE.M.CHP	0.022uF	25V		チップセラコン	01
	US060800	C.CE.CHP	8pF	50V		チップセラコン	01
	US061100	C.CE.M.CHP	10pF	50V		チップセラコン	01
	US061180	C.CE.CHP	18pF	50V		チップセラコン	01
	US061220	C.CE.M.CHP	22pF	50V		チップセラコン	01
	US061270	C.CE.M.CHP	27pF	50V		チップセラコン	01
	US061330	C.CE.M.CHP	33pF	50V		チップセラコン	01
	US061470	C.CE.M.CHP	47pF	50V		チップセラコン	01
	US062100	C.CE.M.CHP	100pF	50V		チップセラコン	01
	US062330	C.CE.M.CHP	330pF	50V		チップセラコン	01
	US062470	C.CE.M.CHP	470pF	50V		チップセラコン	01
	US062560	C.CE.CHP	560pF	50V		チップセラ ( S L )	01
	US063100	C.CE.M.CHP	1000pF	50V		チップセラコン	01
	US063220	C.CE.M.CHP	2200pF	50V		チップセラコン	01
	US063470	C.CE.CHP	4700pF	50V		チップセラコン	01
	US064100	C.CE.M.CHP	0.01uF	50V		チップセラコン	01
	US065100	C.CE.M.CHP	0.1uF	50V		チップセラ F	01
	US126100	C.CE.CHP	1uF	10V		チップセラ F	01
	US135100	C.CE.CHP	0.1uF	16V		チップセラコン	01
	US163100	C.CE.CHP	1000pF	50V		チップセラコン	01
	RD350000	R.CHP	0	1/16W		チップ抵抗	01
	RD353100	R.CHP	1	1/16W		チップ抵抗	01
	RD353220	R.CHP	2.2	1/16W		チップ抵抗	01
	RD353470	R.CHP	4.7	1/16W		チップ抵抗	01
	RD354100	R.CHP	10	1/16W		チップ抵抗	01
	RD354220	R.CHP	22	1/16W		チップ抵抗	01
	RD354240	R.CAR.CHP	24	1/16W		チップ抵抗	01
	RD354270	R.CHP	27	1/16W		チップ抵抗	01
	RD354330	R.CHP	33	1/16W		チップ抵抗	01
	RD354470	R.CHP	47	1/16W		チップ抵抗	01
	RD354680	R.CHP	68	1/16W		チップ抵抗	01
	RD354750	R.CHP	75	1/16W		チップ抵抗	01
	RD354820	R.CHP	82	1/16W		チップ抵抗	01
	RD355100	R.CHP	100	1/16W		チップ抵抗	01
	RD355150	R.CHP	150	1/16W		チップ抵抗	01
	RD355220	R.CHP	220	1/16W		チップ抵抗	01
	RD355270	R.CHP	270	1/16W		チップ抵抗	01
	RD355330	R.CHP	330	1/16W		チップ抵抗	01
	RD355360	R.CHP	360	1/16W		チップ抵抗	01
	RD355390	R.CHP	390	1/16W		チップ抵抗	01
	RD355470	R.CHP	470	1/16W		チップ抵抗	01
	RD355560	R.CHP	560	1/16W		チップ抵抗	01
	RD355750	R.CHP	750	1/16W		チップ抵抗	01
	RD355910	R.CHP	910	1/16W		チップ抵抗	01
	RD356100	R.CHP	1K	1/16W		チップ抵抗	01
	RD356120	R.CHP	1.2K	1/16W		チップ抵抗	01
	RD356150	R.CHP	1.5K	1/16W		チップ抵抗	01

\* New Parts (新規部品)



## CHIP RESISTORS

Ref. No.	PART NO.	Description	Remarks	Markets	部品名	Rank	
	RD356180	R. CHP	1.8K	1/16W		チップ抵抗	01
	RD356220	R. CHP	2.2K	1/16W		チップ抵抗	01
	RD356270	R. CHP	2.7K	1/16W		チップ抵抗	01
	RD356330	R. CHP	3.3K	1/16W		チップ抵抗	01
	RD356390	R. CHP	3.9K	1/16W		チップ抵抗	01
	RD356430	R. CHP	4.3K	1/16W		チップ抵抗	01
	RD356470	R. CHP	4.7K	1/16W		チップ抵抗	01
	RD356510	R. CHP	5.1K	1/16W		チップ抵抗	01
	RD356560	R. CHP	5.6K	1/16W		チップ抵抗	01
	RD356680	R. CHP	6.8K	1/16W		チップ抵抗	01
	RD356820	R. CHP	8.2K	1/16W		チップ抵抗	01
	RD356910	R. CHP	9.1K	1/16W		チップ抵抗	01
	RD357100	R. CHP	10K	1/16W		チップ抵抗	01
	RD357120	R. CHP	12K	1/16W		チップ抵抗	01
	RD357150	R. CHP	15K	1/16W		チップ抵抗	01
	RD357180	R. CHP	18K	1/16W		チップ抵抗	01
	RD357200	R. CHP	20K	1/16W		チップ抵抗	01
	RD357220	R. CHP	22K	1/16W		チップ抵抗	01
	RD357240	R. CHP	24K	1/16W		チップ抵抗	01
	RD357270	R. CHP	27K	1/16W		チップ抵抗	01
	RD357330	R. CHP	33K	1/16W		チップ抵抗	01
	RD357390	R. CHP	39K	1/16W		チップ抵抗	01
	RD357470	R. CHP	47K	1/16W		チップ抵抗	01
	RD357510	R. CHP	51K	1/16W		チップ抵抗	01
	RD357560	R. CHP	56K	1/16W		チップ抵抗	01
	RD357620	R. CHP	62K	1/16W		チップ抵抗	01
	RD357680	R. CHP	68K	1/16W		チップ抵抗	01
	RD357820	R. CHP	82K	1/16W		チップ抵抗	01
	RD357910	R. CHP	91K	1/16W		チップ抵抗	01
	RD358100	R. CHP	100K	1/16W		チップ抵抗	01
	RD358110	R. CAR. CHP	110K	1/16W		チップ抵抗	01
	RD358220	R. CHP	220K	1/16W		チップ抵抗	01
	RD358470	R. CHP	470K	1/16W		チップ抵抗	01
	RD359100	R. CHP	1M	1/16W		チップ抵抗	01
	RF355470	R. CHP	470	1/16W		チップ抵抗	01
	RF357120	R. CHP	12K	1/16W		チップ抵抗	01

\* New Parts (新規部品)

<b>NX-SW150 P.C.B. MAIN</b>
-----------------------------

Ref. No.	PART NO.	Description	Remarks	Markets	部品名	Rank	
*	AAX58610	P.C.B.	MAIN	403263	J	P C B メイン	
*	AAX58620	P.C.B.	MAIN	403264	UC	P C B メイン	
*	AAX58630	P.C.B.	MAIN	403265	RTKL	P C B メイン	
*	AAX58640	P.C.B.	MAIN	403266	ABGE	P C B メイン	
CB2	AAX32010	CN	B05B-PH-K-S	081702		コネクター	
CB4	VP206500	HOLDER.FUS	EYF-52BCT	074277		ヒューズホルダー	
CB5	VP206500	HOLDER.FUS	EYF-52BCT	074277		ヒューズホルダー	
C1	FG644100	C.CE	0.01uF 50V	065452		セラコン	
C2	UR837100	C.EL	10uF 16V	353104		ケミコン	
C3	UA654220	C.POL	0.022uF 50V	360029		ポリエステルフィルムコン	
C4	UR837470	C.EL	47uF 16V	338563		ケミコン	
C5	UA655330	C.POL	0.33uF 50V	352299		ポリエステルフィルムコン	
C6	UA655150	C.POL	0.15uF 50V	368082		ポリエステルフィルムコン	
C7	UR867100	C.EL	10uF 50V	338565		ケミコン	
C8	UA655180	C.POL	0.18uF 50V	368083		ポリエステルフィルムコン	
C9	UA655180	C.POL	0.18uF 50V	368083		ポリエステルフィルムコン	
C10	UR867100	C.EL	10uF 50V	338565		ケミコン	
C11	UA655100	C.POL	0.1uF 50V	360033		ポリエステルフィルムコン	
C12	UA655100	C.POL	0.1uF 50V	360033		ポリエステルフィルムコン	
C13	UR867100	C.EL	10uF 50V	338565		ケミコン	
C14	VG892500	C.EL	4700uF 50V	332929		ケミコン	05
C15	VG892500	C.EL	4700uF 50V	332929		ケミコン	05
C16	UR838100	C.EL	100uF 16V	353103		ケミコン	
C17	UR867220	C.EL	22uF 50V	356201		ケミコン	
C18	UR867220	C.EL	22uF 50V	356201		ケミコン	
C19	UA655820	C.POL	0.82uF 50V	352307		ポリエステルフィルムコン	
C20	UR867220	C.EL	22uF 50V	356201		ケミコン	
C21	UR867220	C.EL	22uF 50V	356201		ケミコン	
C22	UR838100	C.EL	100uF 16V	339076		ケミコン	
C24	UR838100	C.EL	100uF 16V	353103		ケミコン	
C25	VN509200	C.EL	22uF 16V			B Pケミコン	02
C26	UR837470	C.EL	47uF 16V	338563		ケミコン	
C27	UR837470	C.EL	47uF 16V	338563		ケミコン	
C28	UA655470	C.POL	0.47uF 50V	352302		ポリエステルフィルムコン	
C29	AAX09530	C.CE	100pF 50V	065382		セラコン	
C30	UA654100	C.POL	0.01uF 50V	360028		ポリエステルフィルムコン	
C31	UA653220	C.POL	2200pF 50V	360024		ポリエステルフィルムコン	
C32	UR868100	C.EL	100uF 50V	353102		ケミコン	01
C33	UR868100	C.EL	100uF 50V	353102		ケミコン	01
C34	UR867470	C.EL	47uF 50V	356202		ケミコン	
C35	UR867100	C.EL	10uF 50V	338565		ケミコン	
C36	UR867100	C.EL	10uF 50V	338565		ケミコン	
C37	UA654680	C.POL	0.068uF 50V	360032		ポリエステルフィルムコン	
C38	UA655100	C.POL	0.1uF 50V	360033		ポリエステルフィルムコン	
C39	UA655100	C.POL	0.1uF 50V	360033		ポリエステルフィルムコン	
C40	UR837100	C.EL	10uF 16V	353104		ケミコン	
△	C42	V6185300	C.CE.SAFTY	0.01uF 275V		規格認定コン	
	C43	FG644100	C.CE	0.01uF 50V	065452	セラコン	
△	D2	VU264100	DIODE	1SR139-400	069536	ダイオード	
	D3	VC971500	DIODE.BRG	RBV-402 4A 200V	069612	ダイオード	
	D4	AAX51650	DIODE.ZENR	24BSBST	366911	ツェナーダイオード	
	D5	VU264100	DIODE	1SR139-400	069536	ダイオード	
	D6	AAX51640	DIODE.ZENR	12BSCST	366910	ツェナーダイオード	

\* New Parts (新規部品)

NX-SW150 P.C.B. MAIN

NX-SW150 P.C.B. MAIN

Ref. No.	PART NO.	Description	Remarks	Markets	部品名	Rank
D7	AAX51640	DIODE.ZENR	12BSCST		ツェナーダイオード	
D8	AAX33180	DIODE	1N4148ST(D034)		ダイオード	
D9	AAX33180	DIODE	1N4148ST(D034)		ダイオード	
D10	AAX33180	DIODE	1N4148ST(D034)		ダイオード	
D11	AAX33180	DIODE	1N4148ST(D034)		ダイオード	
D12	AAX33180	DIODE	1N4148ST(D034)		ダイオード	
D13	AAX33180	DIODE	1N4148ST(D034)		ダイオード	
D14	AAX33180	DIODE	1N4148ST(D034)		ダイオード	
D15	AAX33180	DIODE	1N4148ST(D034)		ダイオード	
D16	AAX33180	DIODE	1N4148ST(D034)		ダイオード	
D17	VU264100	DIODE	1SR139-400		ダイオード	
D18	AAX33180	DIODE	1N4148ST(D034)		ダイオード	
△ F1	AAX33350	FUSE	500mA 250V	RTKL	ヒューズ	
△ F2	AAX33340	FUSE	2.5A 250V	JUCR TKL	ヒューズ	
△ F2	AAX33350	FUSE	500mA 250V	ABGE	ヒューズ	
IC1	AAX41390	IC	K1A4558P		IC	
IC2	AAX41390	IC	K1A4558P		IC	
△ IC4	AAX13490	IC	STK404-050 AF		IC	
IC7	AAX41390	IC	K1A4558P		IC	
JK1	AAX51730	JACK	1P MSJ-035-12A		ミニジャック	
* PJ1	AAX58750	JACK	1P MSP-241V-01		ピンジャック	
Q1	AAX51690	TR	KTC2026 Y,GR		トランジスター	
Q2	AAX51680	TR	KTA1046 Y,GR		トランジスター	
Q3	AAX41650	TR	KTC3198 GR		トランジスター	
Q4	AAX41660	TR	KTA1266 GR		トランジスター	
Q5	AAX41650	TR	KTC3198 GR		トランジスター	
Q6	AAX51660	TR	KTA1268 GR,BL		トランジスター	
Q7	AAX51670	TR	KTC3200 GR,BL		トランジスター	
Q8	AAX41660	TR	KTA1266 GR		トランジスター	
Q9	AAX09180	FET	2SK304 E		F E T	
Q10	AAX41650	TR	KTC3198GR AT		トランジスター	
Q11	AAX51670	TR	KTC3200 GR,BL		トランジスター	
Q12	AAX41640	TR	KTC2874 AB AT		トランジスター	
Q13	AAX41640	TR	KTC2874 AB AT		トランジスター	
R14	AAX11950	R.CAR.FP	1 1/4W		不燃化カーボン抵抗	
R17	HV454820	R.CAR.FP	82 1/4W		不燃化カーボン抵抗	
R18	HV454820	R.CAR.FP	82 1/4W		不燃化カーボン抵抗	
R19	HL325330	R.MTL.OXD	330 2W		酸化金属被膜抵抗	01
R33	HBO26270	R.MTL.FLM	2.7K 1/4W		金属被膜抵抗	
R35	AAX11860	R.CAR.FP	100 1/4W		不燃化カーボン抵抗	
R37	AAX11880	R.CAR.FP	1K 1/4W		不燃化カーボン抵抗	
R40	HBO27100	R.MTL.FLM	10K 1/4W		金属皮膜抵抗	
R41	HBO27200	R.MTL.FLM	20K 1/4W		金属被膜抵抗	
R42	HBO27100	R.MTL.FLM	10K 1/4W		金属皮膜抵抗	
R43	HBO28100	R.MTL.FLM	100K 1/4W		金属被膜抵抗	
R46	AAX11860	R.CAR.FP	100 1/4W		不燃化カーボン抵抗	
R47	HBO27100	R.MTL.FLM	10K 1/4W		金属皮膜抵抗	
R48	Vi294900	R.MTL.OXD	0.15 2W		酸化金属被膜抵抗	02
R53	AAX11870	R.CAR.FP	10 1/4W		不燃化カーボン抵抗	
R58	HL922100	R.MTL.OXD	0.1 2W		酸化金属被膜抵抗	01
△ RY1	VU161600	RELAY	OSA-SS-224DM3		リレー	
△ RY2	AAX12490	RELAY	SDT-S-112LMR		リレー	
△* SW1	AAX58710		SDKGA4	RTKL	スライドSW	

\* New Parts (新規部品)

Ref. No.	PART NO.	Description	Remarks	Markets	部品名	Rank
TE1	XX707320	PIN	IPS-5007	064821	ピン	
TE2	XX707320	PIN	IPS-5007	064821	ピン	
	BB071360	TERM	EARTH	055265	ターミナル	

\* New Parts (新規部品)

■ DVR-S150 EXPLODED VIEW

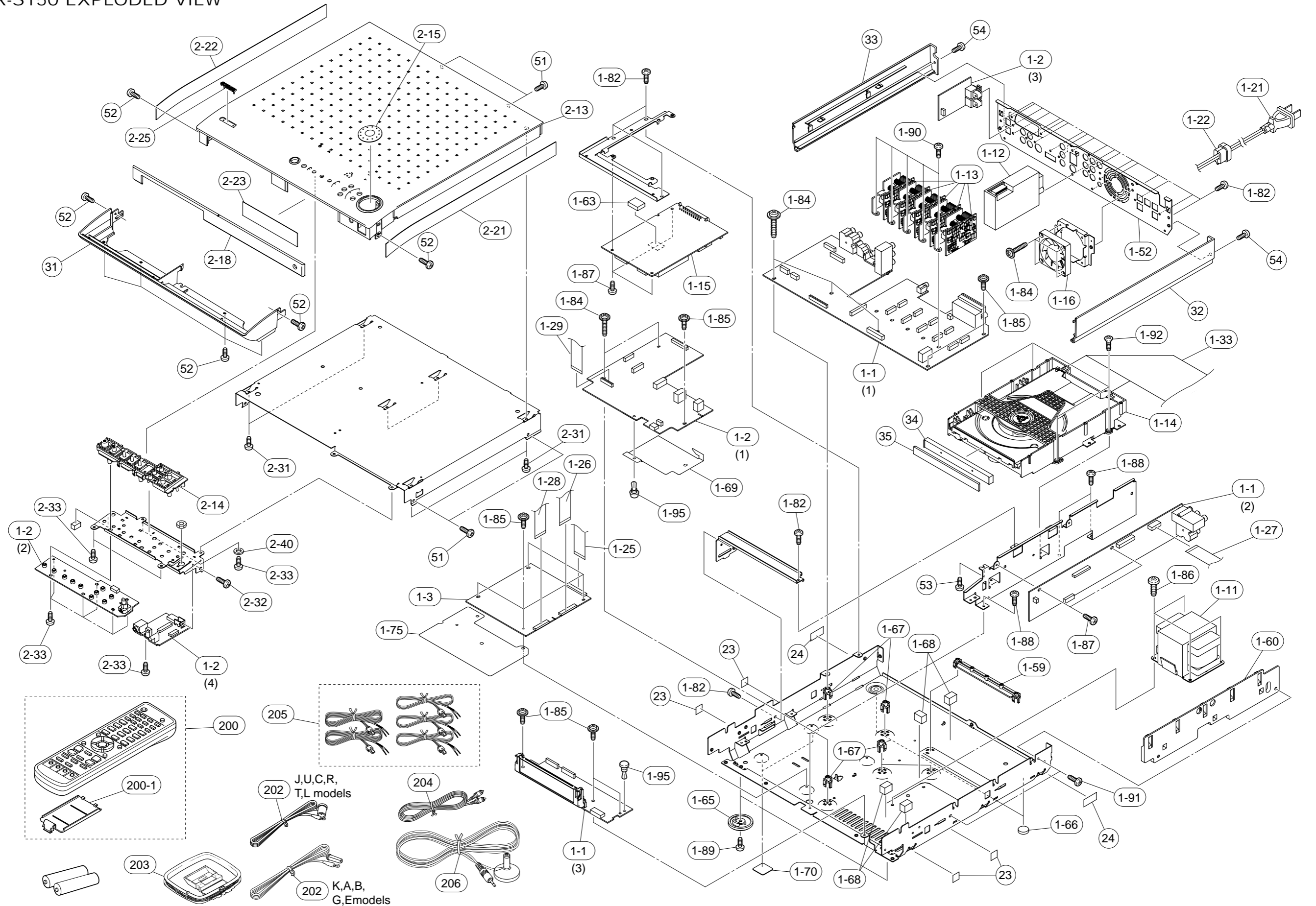

## ■ DVR-S150 MECHANICAL PARTS

Ref. No.	PART NO.	Description	Remarks	Markets	部品名	Rank
* 1-1	WD538700	P.C.B. ASS'Y	MAIN	UCA	P C B メイン	
* 1-1	WD504700	P.C.B. ASS'Y	MAIN	J	P C B メイン	
* 1-1	WD504800	P.C.B. ASS'Y	MAIN	UCRTKAL	P C B メイン	
* 1-1	WD504900	P.C.B. ASS'Y	MAIN	BGE	P C B メイン	
* 1-2	WD505000	P.C.B. ASS'Y	SUB	J	P C B 集成 サブ	
* 1-2	WD505100	P.C.B. ASS'Y	SUB	UC	P C B 集成 サブ	
* 1-2	WD505200	P.C.B. ASS'Y	SUB	R	P C B 集成 サブ	
* 1-2	WD505300	P.C.B. ASS'Y	SUB	T	P C B 集成 サブ	
* 1-2	WD505400	P.C.B. ASS'Y	SUB	K	P C B 集成 サブ	
* 1-2	WD505500	P.C.B. ASS'Y	SUB	A	P C B 集成 サブ	
* 1-2	WD505600	P.C.B. ASS'Y	SUB	BGE	P C B 集成 サブ	
* 1-2	WD505700	P.C.B. ASS'Y	SUB	L	P C B 集成 サブ	
* 1-3	WD505800	P.C.B. ASS'Y	DIGITAL	J	P C B デジタル	
* 1-3	WD505900	P.C.B. ASS'Y	DIGITAL	UCRTKABGEL	P C B デジタル	
△ 1-11	X4714A00	POWER TRANSFORMER		J	電源トランス	12
△ 1-11	X4715A00	POWER TRANSFORMER		UC	電源トランス	
△ 1-11	X4716A00	POWER TRANSFORMER		R	電源トランス	
△ 1-11	X4717A00	POWER TRANSFORMER		TK	電源トランス	
△ 1-11	X4718A00	POWER TRANSFORMER		A	電源トランス	
△ 1-11	X4719A00	POWER TRANSFORMER		BGE	電源トランス	
△ 1-11	X4720A00	POWER TRANSFORMER		L	電源トランス	
1-12	WB423900	AM/FM TUNER	ENG04705Q	J	A M / F M チューナー	12
1-12	WB424000	AM/FM TUNER	ENG06709Q	UCRTL	A M / F M チューナー	
1-12	WB424100	AM/FM TUNER	ENG07711Q	KABGE	A M / F M チューナー	
1-13	WB876900	D-AMP MODULE	UCD 55W AMP MODULE		D アンプモジュール	10
1-14	WB876700	DVD MECHANISM	A97H		D V D メカニズム	28
1-15	WB876500	P.C.B. ASS'Y	DVD (SD5.12P)	JUCRTKAL	P C B D V D	28
1-15	WB876600	P.C.B. ASS'Y	DVD (SD5.12P)	BGE	P C B D V D	
1-16	WB349500	DC FAN MOTOR	DC D05X-24TM		D C ファンモーター	08
△ 1-21	V2723100	POWER CABLE	1.8m	J	電源コード	07
△ 1-21	V9293500	POWER CABLE	2m	UC	電源コード	
△ 1-21	WC992700	POWER CABLE	2m	R	電源コード	
△ 1-21	VZ542500	POWER CABLE	2m	T	電源コード	05
△ 1-21	V8013000	POWER CABLE	2m	K	電源コード	
△ 1-21	WC743700	POWER CABLE	2m	A	電源コード	
△ 1-21	VV437300	POWER CABLE	2m	B	電源コード	08
△ 1-21	V9293600	POWER CABLE	2m	GEL	電源コード	
1-22	V2438700	CORD STOPPER	10P1		コードストッパー	02
1-25	MFA32100	FLEXIBLE FLAT CABLE	32P 100mm P=1.0		カード電線	02
1-26	MFA28120	FLEXIBLE FLAT CABLE	28P 120mm P=1.0		カード電線	02
1-27	MF113070	FLEXIBLE FLAT CABLE	13P 70mm P=1.25		カード電線 C & C	01
* 1-28	MFA28160	FLEXIBLE FLAT CABLE	28P 160mm P=1.0		カード電線	01
1-29	MFA20100	FLEXIBLE FLAT CABLE	20P 100mm P=1.0		カード電線	01
1-33	WB488000	CONNECTOR ASS'Y	40P 160mm C&C		コネクタ A S S Y	
1-52	WB522500	REAR PANEL		J	リアパネル	
* 1-52	WB522700	REAR PANEL		UCRTKAL	リアパネル	
* 1-52	WB522600	REAR PANEL		BGE	リアパネル	
1-59	WB526200	SUPPORT/UCD			サポート / U C D	
1-60	WB526300	SUPPORT/POWER-CABLE			サポート / コード	
* 1-63	V5881100	CUSHION	5x8x25		クッション	
1-65	WC984200	LEG ASS'Y			レッグ A S S Y	06
1-66	VV894300	LEG	PAD		レッグ	01
1-67	VR264400	SPACER	H8		スペーサー	01
1-68	V2879500	SPACER PCB-M			スペーサ P C B - M	01
1-69	WC131900	SHEET/BARRIER			シート / バリア	
1-70	WC293700	SHEET/SCREW-MASK			シート / スクリュー	
1-75	WC537600	SHEET/SHIELD BOTTOM			シート / シールドボトム	
1-82	VN413300	BIND HEAD BONDING B-T. SCREW	3x8 MFZN2BL		ボンディング B タイトネジ	01
1-84	VT669400	PW HEAD B-TIGHT SCREW	3x15-8 MFC2		P W ヘッド B タイトネジ	01
1-85	VH365800	PW HEAD B-TIGHT SCREW	3x6-8 MFC2		P W ヘッド B タイトネジ	01
1-86	V2728500	BIND HEAD S-TIGHT SCREW	4x7 MFZN2BL		バインド S タイトネジ	01
1-87	WC521500	BIND HEAD BONDING B-T. SCREW	3x6 MFC2		ボンディング B タイトネジ	01
1-88	VF378100	FLAT HEAD S-TIGHT SCREW	3x6 MFZN2Y		皿 S タイトネジ	01
1-89	EP600250	BIND HEAD B-TIGHT SCREW	3x8 MFZN2Y		バインド B タイトネジ	01
1-90	EP600910	BIND HEAD P-TIGHT SCREW	3x10 MFC2BL		バインド P タイトネジ	01
1-91	EP630220	BIND HEAD P-TIGHT SCREW	3x8 MFZN2BL		バインド P タイトネジ	01

\* New Parts (新規部品)

Ref. No.	PART NO.	Description	Remarks	Markets	部品名	Rank
1-92	EP600790	FLAT HEAD B-TIGHT SCREW	3x8 MFZN2BL		皿 B タイトネジ	01
1-95	VQ368500	PUSH RIVET	P3545-B		プッシュリベット	01
* 2-13	WD481700	TOP PANEL		BL	トップパネル	
* 2-13	WD372400	TOP PANEL		SI	トップパネル	
* 2-13	WD372600	TOP PANEL		SI	トップパネル	
* 2-13	WD372500	TOP PANEL		SI	トップパネル	
* 2-13	WD983000	TOP PANEL		WH	トップパネル	
* 2-13	WD983100	TOP PANEL		WH	トップパネル	
2-14	WB525500	BUTTON/OPE			ボタン / O P E	06
2-15	WC985200	VOLUME KNOB/D35		BL	ボリュームノブ / D 3 5	01
2-15	WB525700	VOLUME KNOB/D35		SI	ボリュームノブ / D 3 5	01
2-15	WD983200	VOLUME KNOB/D35		WH	ボリュームノブ / D 3 5	
* 2-18	WE073700	WINDOW PANEL, LID		BL	ウインドウ	
* 2-18	WD481800	WINDOW PANEL, LID		BL	ウインドウ	
* 2-18	WD374900	WINDOW PANEL, LID		SI	ウインドウ	
2-18	WD983300	WINDOW PANEL, LID		WH	ウインドウ	
2-21	WE073800	SIDE/SHEET R		BL	サイドシート R	
2-21	WB525200	SIDE/SHEET R		BL	サイドシート R	
* 2-21	WD372200	SIDE/SHEET R		SI	サイドシート R	
2-21	WD983400	SIDE/SHEET R		WH	サイドシート R	
2-22	WE073900	SIDE/SHEET L		BL	サイドシート L	
2-22	WB525400	SIDE/SHEET L		BL	サイドシート L	
* 2-22	WD372300	SIDE/SHEET L		SI	サイドシート L	
2-22	WD983500	SIDE/SHEET L		WH	サイドシート L	
2-23	WB526500	HALF-MIRROR SHEET		SI, WH	ハーフミラーシート	
2-25	V6034100	EMBLEM	BL		エンブレム	03
2-25	WC034800	EMBLEM	SI		エンブレム	03
2-31	EP600290	BIND HEAD P-TIGHT SCREW	3x6 MFZN2Y		バインド P タイトネジ	01
2-32	VN413300	BIND HEAD BONDING B-T. SCREW	3x8 MFZN2BL		ボンディング B タイトネジ	01
2-33	EP630220	BIND HEAD P-TIGHT SCREW	3x8 MFZN2BL		バインド P タイトネジ	01
2-40	VV637600	WASHER	3.2x14x1		ワッシャー	
23	VT745100	CUSHION/2	12x12		クッション / 2	01
24	V5881000	DAMPER	2x15x20		ダンパー	
31	WC984400	BOTTOM COVER		BL	ボトムカバー	
31	WB524500	BOTTOM COVER		SI	ボトムカバー	
31	WD373200	BOTTOM COVER		WH	ボトムカバー	
32	WC984500	SIDE COVER R		BL	サイドカバー R	
32	WB524700	SIDE COVER R		SI	サイドカバー R	04
32	WD373000	SIDE COVER R		WH	サイドカバー R	
33	WC984600	SIDE COVER L		BL	サイドカバー L	
33	WB524900	SIDE COVER L		SI	サイドカバー L	04
33	WD373100	SIDE COVER L		WH	サイドカバー L	
34	WB526000	LID, HOLDER			リッド / ホルダー	
35	WE074000	LID WINDOW		BL	リッドウインドウ	
35	WC294700	LID WINDOW		BL	リッドウインドウ	
* 35	WD375000	LID WINDOW		SI	リッドウインドウ	
35	WD982700	LID WINDOW		WH	リッドウインドウ	
51	VN413300	BIND HEAD BONDING B-T. SCREW	3x8 MFZN2BL		ボンディング B タイトネジ	01
52	EP600250	BIND HEAD B-TIGHT SCREW	3x8 MFZN2Y		バインド B タイトネジ	01
53	EP600910	BIND HEAD P-TIGHT SCREW	3x10 MFC2BL		バインド P タイトネジ	01
54	VH741100	BIND HEAD B-TIGHT SCREW	3x10 SP MFZN2BL		バインド B タイトネジ	01
* 200	WD526900	ACCESSORIES			付属品	
* 200-1	AA57560	REMOTE CONTROL	RRC4001-1520E	BL	リモコン	
* 200	WD412500	BATTERY COVER	103RRS-141-07L	BL	電池蓋	
* 200	WD412600	REMOTE CONTROL	RRC4001-1515E	SI, WH	リモコン	
* 200	WD412700	REMOTE CONTROL	RRC4001-1516E	SI, WH	リモコン	
* 200-1	AA51940	BATTERY COVER	RRC4001-1517E	SI	電池蓋	
202	V6267000	INDOOR FM ANTENNA	1.4m 1pc		F M 簡易アンテナ	03
202	VQ147100	INDOOR FM ANTENNA	1.4m 1pc		F M 簡易アンテナ	02
203	WC192200	ANTENNA, AM LOOP	3083-100-0Y01		A M ループアンテナ	05
204	V6508900	VIDEO PIN CABLE	1P 1.5m YE-YE 1pc		ビデオ用ピンケーブル	03
205	WC017100	SPEAKER CABLE KIT	15m 2pcs, 5m 3pcs		スピーカーコードキット	10
* 206	WD526800	MICROPHONES	6m 1pc		マイクロホン	
		BATTERY	SUM-3N, 2pcs		乾電池	

\* New Parts (新規部品)

DVR-S150/NX-P150

■ NX-P150 EXPLODED VIEW

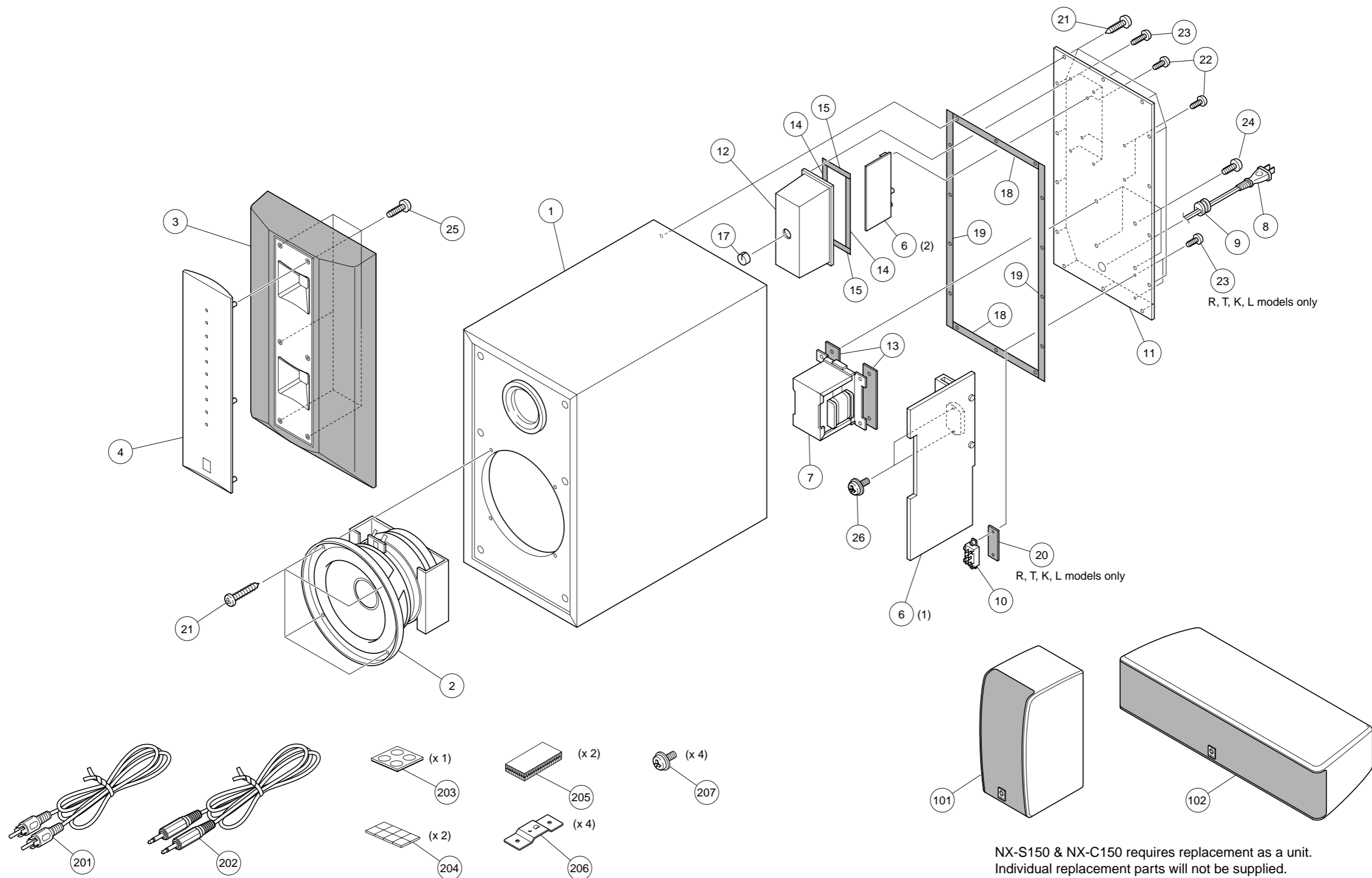

NX-S150 & NX-C150 requires replacement as a unit.  
Individual replacement parts will not be supplied.  
NX-S150 と NX-C150はユニット交換です。

## ■ NX-P150 MECHANICAL PARTS

Ref. No.	PART NO.	Description	Remarks	Markets	部品名	Rank
* 1	AAX58660	CABINET ASS'Y	BLACK	UCA	キャビネットA S S Y	
* 1	AAX58650	CABINET ASS'Y	SILVER	JUCRTKABL	キャビネットA S S Y	
1	AAX51500	CABINET ASS'Y	SILVER	GE	キャビネットA S S Y	
2	X4329A00	DRIVER, WOOFER	16cm 6 25W		スピーカーユニット	
* 3	AAX58760	FRONT GRILLE ASS'Y	BLACK		フロントグリルA S S Y	
* 3	AAX58770	FRONT GRILLE ASS'Y	SILVER		フロントグリルA S S Y	
* 4	AAX58790	FRONT PANEL ASS'Y	BLACK		フロントパネルA S S Y	
* 4	AAX58780	FRONT PANEL ASS'Y	SILVER		フロントパネルA S S Y	
* 6	AAX58610	P.C.B. ASS'Y	MAIN	J	P C B メイン	
* 6	AAX58620	P.C.B. ASS'Y	MAIN	UC	P C B メイン	
* 6	AAX58630	P.C.B. ASS'Y	MAIN	RTKL	P C B メイン	
* 6	AAX58640	P.C.B. ASS'Y	MAIN	ABGE	P C B メイン	
△ 7	AAX32110	POWER TRANSFORMER		J	電源トランス	
△ 7	AAX32120	POWER TRANSFORMER		UC	電源トランス	
△ 7	AAX32130	POWER TRANSFORMER		RTKL	電源トランス	
△ 7	AAX32140	POWER TRANSFORMER		A	電源トランス	
△ 7	AAX32150	POWER TRANSFORMER		BGE	電源トランス	
△ 8	V2723100	POWER CABLE	1.8m	J	電源コード	
△ 8	V8366300	POWER CABLE	2m	UC	電源コード	
△ 8	VZ555600	POWER CABLE	2m	RT	電源コード	
△ 8	V8012900	POWER CABLE	2m	K	電源コード	
△ 8	V8366500	POWER CABLE	2m	A	電源コード	
△ 8	V8366600	POWER CABLE	2m	B	電源コード	
△ 8	V8366400	POWER CABLE	2m	GEL	電源コード	
9	CB072750	CORD STOPPER	SR-4N-4		コードストッパー	
△ * 10	AAX58710	SLIDE SWITCH	SDKGA4	RTKL	スライド S W	
* 11	AAX58800	REAR PANEL		J	リアパネル	
* 11	AAX58810	REAR PANEL		UC	リアパネル	
* 11	AAX58820	REAR PANEL		RTKL	リアパネル	
* 11	AAX58830	REAR PANEL		A	リアパネル	
* 11	AAX58840	REAR PANEL		BGE	リアパネル	
12	AAX51750	MOLD COVER			モールドカバー	
13	AAX51530	CUSHION	18x90		クッション	
14	AAX51520	CUSHION	3x120		クッション	
15	AAX51510	CUSHION	3x50		クッション	
17	AAX31970	CUSHION, BUSH			クッション	
18	AAX31980	CUSHION	170x10x2		クッション	
19	AAX31990	CUSHION	335x10x2		クッション	
20	AAX13660	CUSHION, SWITCH		RTKL	クッション、S W	
21	AAX12120	BIND HEAD TAPPING SCREW	4x20 MFZN2BL		バインド T P ネジ	
22	EP600190	BIND HEAD B-TIGHT SCREW	3x8 MFZN2BL		バインド B タイトネジ	01
23	EP600140	BIND HEAD B-TIGHT SCREW	3x10 MFZN2BL		バインド B タイトネジ	01
24	EG340190	BIND HEAD B-TIGHT SCREW	4x8 MFZN2BL		バインド B タイトネジ	01
25	Ei330126	BIND HEAD B-TIGHT SCREW	3x12 MFZN2BL	JUCABGE	バインド B タイトネジ	01
26	AAX51590	SEMS BIND HEAD B-TIGHT SCREW	3x16 MFZN2Y		セムスナベ B タイトネジ	01
* 101	AAX58700	SATELLITE SPEAKER UNIT	NX-S150BLACK	UCA	サテライト S P ユニット	
* 101	AAX58670	SATELLITE SPEAKER UNIT	NX-S150SILVER	J	サテライト S P ユニット	
* 101	AAX58680	SATELLITE SPEAKER UNIT	NX-S150SILVER	UCTKABGE	サテライト S P ユニット	
* 101	AAX58690	SATELLITE SPEAKER UNIT	NX-S150SILVER	RL	サテライト S P ユニット	
* 102	AAX58740	CENTER SPEAKER UNIT	NX-C150BLACK	UCA	センター S P ユニット	
* 102	AAX58720	CENTER SPEAKER UNIT	NX-C150SILVER	JUCTKABGE	センター S P ユニット	
* 102	AAX58730	CENTER SPEAKER UNIT	NX-C150SILVER	RL	センター S P ユニット	

\* New Parts (新規部品)

Ref. No.	PART NO.	Description	Remarks	Markets	部品名	Rank
		ACCESSORIES			付属品	
201	AAX51580	SUBWOOFER CABLE	1P 5m 1pc		サブウーファーケーブル	
202	AAX51740	SYSTEM CONTROL CABLE	1P 5m 1pc		システム接続ケーブル	
203	V5982400	NON SKID PAD	M25 t2 4pcs/set		滑止パッド	
204	AAX20410	NON SKID PAD	7x7x1 8pcs/set		滑止パッド	
205	AAX21240	FASTENER	51.5x39x3.5 1pair		固定テープ	
206	AAX34790	MOUNTING BRACKET	1pc		取付金具	
207	AAX51600	SEMS PAN HEAD SCREW	4x10 MFZN2BL		セムスナベネジ	

\* New Parts (新規部品)

# REMOTE CONTROL

▼ DVR-S150 BL  
(U, C, A models)

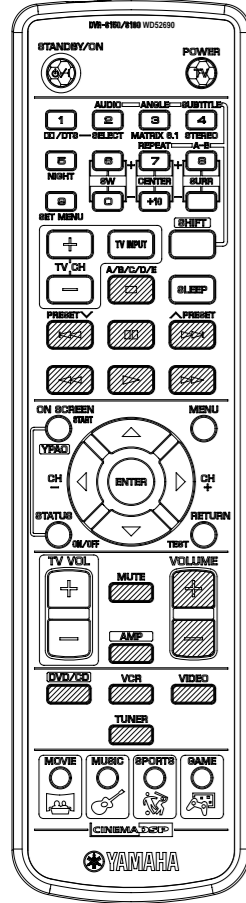

▼ DVR-S150 SI  
(U, C, R, T, K, A, L models)

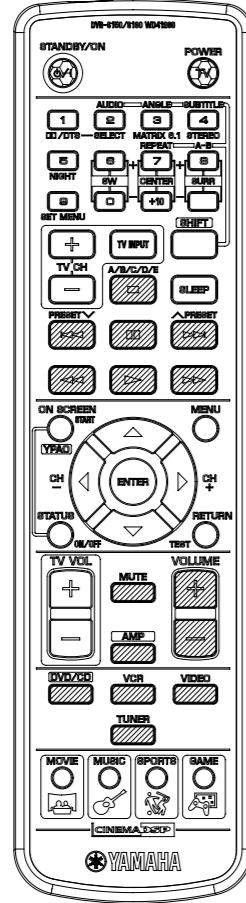

▼ DVR-S150 SI  
(B, G, E models)

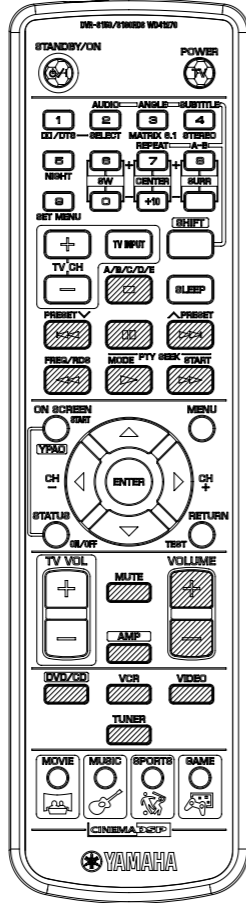

▼ DVR-S150 SI  
(J model)

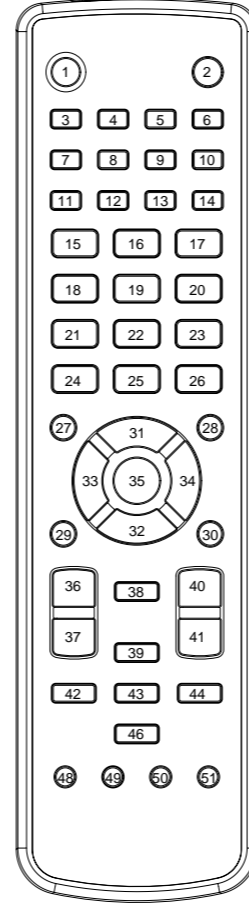
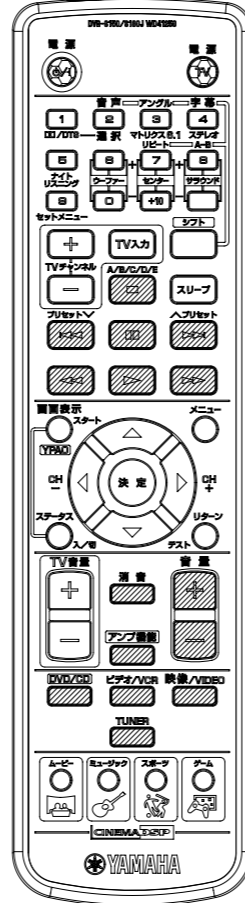

## SCHEMATIC DIAGRAM

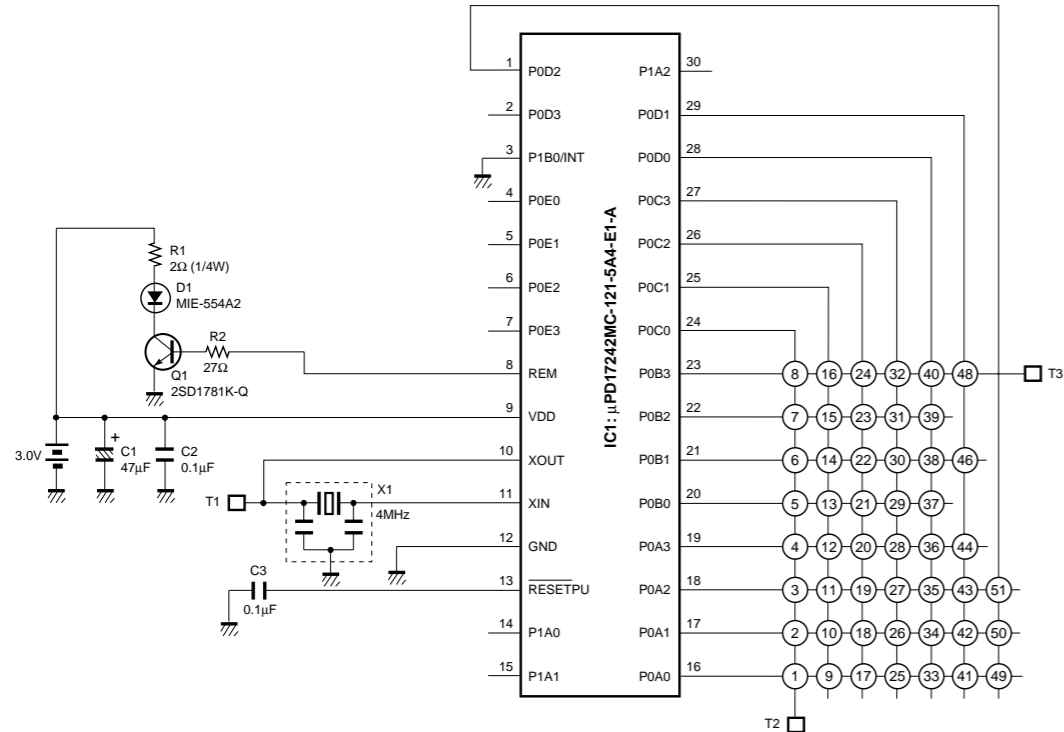

Key No.	Function	CODE					
		TUNER	DVD/CD	SHIFT (DVD)	AMP	VCR	VIDEO
1	STANDBY/ON	78-0F	78-0F	78-0F	78-0F	78-0F	78-0F
2	TV POWER	TV (Preset) Code Transmit					
3	1	78-11	7C-94	-	78-99	-	-
4	2	78-12	7C-95	7C-AD	78-9A	-	-
5	3	78-13	7C-96	7C-AE	78-90	-	-
6	4	78-14	7C-97	7C-AA	78-50	-	-
7	5	78-15	7C-98	7C-E2	78-8A	-	-
8	6	78-16	7C-99	7C-A1	78-4C	-	-
9	7	78-17	7C-9A	7C-A3	78-86	-	-
10	8	78-18	7C-9B	7C-A4	78-88	-	-
11	9	-	7C-9C	-	78-9D	-	-
12	0	-	7C-93	-	78-4D	-	-
13	+10	-	-	-	78-87	-	-
14	SURROUND	-	-	-	78-89	-	-
15	TV CH +	TV (Preset) Code Transmit					
16	TV INPUT	TV (Preset) Code Transmit					
17	SHIFT (CODE SET)	-	-	-	-	-	-
18	TV CH -	TV (Preset) Code Transmit					
19	STOP	78-1D	7C-85	7C-85	-	-	-
20	SLEEP	78-4F	78-4F	78-4F	78-4F	78-4F	78-4F
21	SKIP -	78-1C	7C-B9	7C-B9	-	-	-
22	PAUSE	-	7C-83	7C-83	-	-	-
23	SKIP +	78-1B	7C-BA	7C-BA	-	-	-
24	SEARCH - (REW)	78-81	7C-86	7C-86	-	-	-
25	PLAY	78-82	7C-82	7C-82	-	-	-
26	SEARCH + (FF)	78-83	7C-87	7C-87	-	-	-
27	ON SCREEN/YPAO	-	7C-A6	7C-A6	78-A3	-	-
28	MENU	-	7C-B2	7C-B2	-	-	-
29	STATUS ON/OFF	-	7C-A7	7C-A7	78-A4	-	-
30	RETURN/TEST	-	7C-B7	7C-B7	78-5F	-	-
31	UP	-	7C-B4	7C-B4	78-8E	-	-
32	DOWN	-	7C-B3	7C-B3	78-8F	-	-
33	LEFT	-	7C-B5	7C-B5	78-9F	-	-
34	RIGHT	-	7C-B6	7C-B6	78-9E	-	-
35	ENTER	-	7C-B8	7C-B8	-	-	-
36	TV VOLUME +	TV (Preset) Code Transmit					
37	TV VOLUME -	TV (Preset) Code Transmit					
38	MUTE	78-9C	78-9C	78-9C	78-9C	78-9C	78-9C
39	AMP	-	-	-	-	-	-
40	VOLUME UP	78-1E	78-1E	78-1E	78-1E	78-1E	78-1E
41	VOLUME DOWN	78-1F	78-1F	78-1F	78-1F	78-1F	78-1F
42	DVD/CD	78-4A	78-4A	78-4A	78-4A	78-4A	78-4A
43	VCR	78-49	78-49	78-49	78-49	78-49	78-49
44	VIDEO	78-DF	78-DF	78-DF	78-DF	78-DF	78-DF
46	TUNER	78-4B	78-4B	78-4B	78-4B	78-4B	78-4B
48	MOVIE	78-D9	78-D9	78-D9	78-D9	78-D9	78-D9
49	MUSIC	78-DA	78-DA	78-DA	78-DA	78-DA	78-DA
50	SPORTS	78-DB	78-DB	78-DB	78-DB	78-DB	78-DB
51	GAME	78-DC	78-DC	78-DC	78-DC	78-DC	78-DC