

DVD HOME THEATER SOUND SYSTEM DVX-S301/DVX-S302

DVR-S300/NX-P301/NX-P302

SERVICE MANUAL

IMPORTANT NOTICE

This manual has been provided for the use of authorized YAMAHA Retailers and their service personnel. It has been assumed that basic service procedures inherent to the industry, and more specifically YAMAHA Products, are already known and understood by the users, and have therefore not been restated.

WARNING: Failure to follow appropriate service and safety procedures when servicing this product may result in personal injury, destruction of expensive components, and failure of the product to perform as specified. For these reasons, we advise all YAMAHA product owners that any service required should be performed by an authorized YAMAHA Retailer or the appointed service representative.

IMPORTANT: The presentation or sale of this manual to any individual or firm does not constitute authorization, certification or recognition of any applicable technical capabilities, or establish a principle-agent relationship of any form.

The data provided is believed to be accurate and applicable to the unit(s) indicated on the cover. The research, engineering, and service departments of YAMAHA are continually striving to improve YAMAHA products. Modifications are, therefore, inevitable and specifications are subject to change without notice or obligation to retrofit. Should any discrepancy appear to exist, please contact the distributor's Service Division.

WARNING: Static discharges can destroy expensive components. Discharge any static electricity your body may have accumulated by grounding yourself to the ground buss in the unit (heavy gauge black wires connect to this buss).

IMPORTANT: Turn the unit OFF during disassembly and part replacement. Recheck all work before you apply power to the unit.

DVR-S300
NX-P301/NX-P302

CONTENTS

TO SERVICE PERSONNEL	2~3	DVR-S300 BLOCK DIAGRAM	25
PREVENTION OF ELECTROSTATIC DISCHARGE	4	NX-SW301 BLOCK DIAGRAM	26~27
LOCALE MANAGEMENT INFORMATION	4	DVR-S300 WIRING DIAGRAM	28
SYSTEM COMPOSITION / システム構成	5	NX-SW301 WIRING DIAGRAM	29
FRONT PANELS	6~7	DVR-S300 PRINTED CIRCUIT BOARD	30~37
REMOTE CONTROL	8	NX-SW301 PRINTED CIRCUIT BOARD	38~41
REAR PANELS	8~12	DVR-S300 SCHEMATIC DIAGRAM	42~55
SPECIFICATIONS / 参考仕様	13~15	NX-SW301 SCHEMATIC DIAGRAM	56~60
INTERNAL VIEW	16	NX-SW301 PARTS LIST	61~63
REPAIR NOTES / 修理上の留意点	17	DVR-S300 EXPLODED VIEW	64~65
DVR-S300 TRADE MODE /		NX-P301 EXPLODED VIEW	66~67
DVR-S300 トレードモード	18	NX-P302 EXPLODED VIEW	68
DVR-S300 DISASSEMBLY PROCEDURES /			
分解手順	19~21		
NX-SW301 DISASSEMBLY PROCEDURES /			
分解手順	22~23		



このサービスマニュアルは、エコマーク認定の再生紙を使用しています。
This Service Manual uses recycled paper.

■ TO SERVICE PERSONNEL

1. Critical Components Information
Components having special characteristics are marked \triangle and must be replaced with parts having specifications equal to those originally installed.
2. Leakage Current Measurement (For 120V Models Only)
When service has been completed, it is imperative to verify that all exposed conductive surfaces are properly insulated from supply circuits.
 - Meter impedance should be equivalent to 1500 ohms shunted by 0.15 μ F.

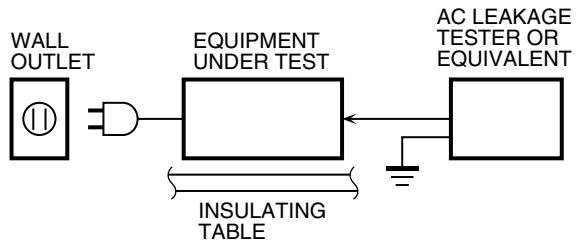

- Leakage current must not exceed 0.5mA.
- Be sure to test for leakage with the AC plug in both polarities.

THE DVD AUDIO/VIDEO PLAYER SHOULD NOT BE ADJUSTED OR REPAIRED BY ANYONE EXCEPT PROPERLY QUALIFIED SERVICE PERSONNEL.

WARNING: CHEMICAL CONTENT NOTICE!

The solder used in the production of this product contains LEAD. In addition, other electrical/electronic and/or plastic (where applicable) components may also contain traces of chemicals found by the California Health and Welfare Agency (and possibly other entities) to cause cancer and/or birth defects or other reproductive harm.

DO NOT PLACE SOLDER, ELECTRICAL/ELECTRONIC OR PLASTIC COMPONENTS IN YOUR MOUTH FOR ANY REASON WHATSOEVER!

Avoid prolonged, unprotected contact between solder and your skin! When soldering, do not inhale solder fumes or expose eyes to solder/flux vapor!

If you come in contact with solder or components located inside the enclosure of this product, wash your hands before handling food.

WARNING: Laser Safety

This product contains a laser beam component. This component may emit invisible, as well as visible radiation, which may cause eye damage. To protect your eyes and skin from laser radiation, the following precautions must be used during servicing of the unit.

- 1) When testing and/or repairing any component within the product, keep your eyes and skin more than 30 cm away from the laser pick-up unit at all times. Do not stare at the laser beam at any time.
- 2) Do not attempt to readjust, disassemble or repair the laser pick-up, unless noted elsewhere in this manual.
- 3) CAUTION : Use of controls, adjustments or performance of procedures other than those specified herein may result in hazardous radiation exposure.

Laser Emitting conditions:

- 1) When the Top Cover is removed, and the STANDBY/ON SW is turned to the "ON" position, the laser component will emit a beam for several seconds to detect if a disc is present. During this time (5-10 sec.) the laser may radiate through the lens of the laser pick-up unit. Do not attempt any servicing during this period! If no disc is detected, the laser will stop emitting the beam. When a disc is loaded, you will not be exposed to any laser emissions.
- 2) The laser power level can be adjusted with the VR on the pick-up PWB, however, this level has been set by the factory prior to shipping from the factory. Do not adjust this laser level control unless instruction is provided elsewhere in this manual. Adjustment of this control can increase the laser emission level from the device.

警告：レーザーの安全対策

本機はレーザー光線を放射する部品を搭載しています。この部品が放射するレーザー光線は目に損傷を起こします。このレーザー光線から目及び肌を保護するために、本機の修理作業中は下記の注意を厳守してください。

- 1) テスト時または修理時、目及び肌を光ピックアップから30cm以上離してください。いかなる場合もレーザー光線を見つめないでください。
- 2) 光ピックアップの再調整及び分解はしないでください。
- 3) このマニュアル上で指定されている以外の制御、調整、手順はレーザー光線を照射される結果を招く恐れがあります。

レーザー放射条件

- 1) トップカバーを取り外しSTANDBY/ONスイッチをONにすると、ディスク検知のため5~10秒間、光ピックアップからレーザー光線が放射されます。この間、修理はしないでください。ディスクが検知されなければ、レーザー光線の放射は停止します。ディスクがセットされている場合、ディスクで遮られるのでレーザー光線は修理担当者には届きません。
- 2) レーザーパワーレベルは光ピックアップ基板上のVRにより調整可能ですが、工場出荷前に調整セット済みなので、このVRは廻さないでください。このVRを廻すと装置からのレーザー光線の放射レベルが上がる恐れがあります。

Laser Diode Properties

Type: Semiconductor laser GaAlAs
 Wave length: 650 nm (DVD)
 784 nm (VCD/CD)
 Output Power: 7 mW (DVD/VCD/CD)
 Beam divergence 60 degree

VARO! : AVATTAESSA JA SUOJALUKITUS OHITETTAESSA OLET ALTTIINA NÄKYMÄTTÖMÄLLE LASER-SÄTEILYLLE. ÄLÄ KATSO SÄTEESEEN.
WARNING! : OSYNLIG LASERSTRÅLNING NÄR DENNA DEL ÄR ÖPPNAD OCH SPÄRREN ÄR URKOPPLAD. BETRAKTA EJ STRÅLEN.

WARNING

The use of optical instruments with this product will increase eye hazard.

Repair handling should take place as much as possible with a disc loaded inside the player.

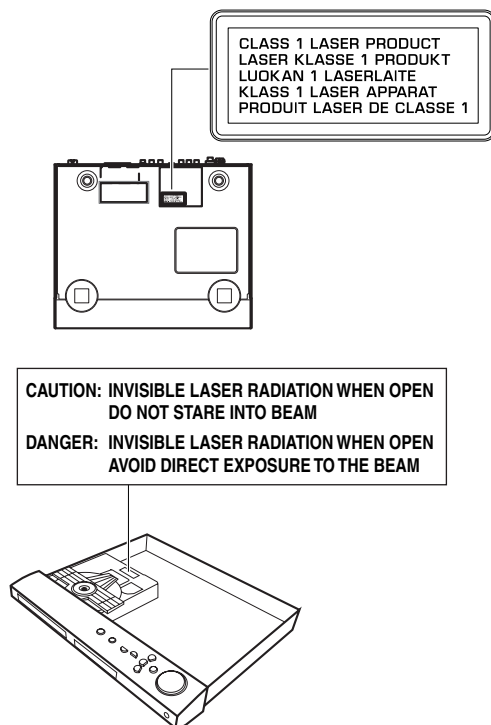

CAUTION VISIBLE AND INVISIBLE LASER RADIATION WHEN OPEN. AVOID EXPOSURE TO BEAM.
ADVARSEL SYNLIG OG USYNLIG LASERSTRÅLING VED ÅBNING. UNDGÅ UDSÆTTELSE FOR STRÅLING.
ADVARSEL SYNLIG OG USYNLIG LASERSTRÅLING NÅR DEKSEL ÅPNES. UNNGÅ EKSPONERING FOR STRÅLEN.
VARNING SYNLIG OCH OSYNLIG LASERSTRÅLNING NÄR DENNA DEL ÄR ÖPPNAD. BETRAKTA EJ STRÅLEN.
VARO! AVATTAESSA OLET ALTTIINA NÄKYVÄLLE JA NÄKYMÄTTÖMÄLLE LASER SÄ TEILYLLE. ÄLÄ KATSO SÄTEESEEN.
VORSICHT SICHTBARE UND UNSICHTBARE LASERSTRAHLUNG WENN ABDECKUNG GEÖFFNET. NICHT DEM STRAHL AUSSETZEN.
DANGER VISIBLE AND INVISIBLE LASER RADIATION WHEN OPEN. AVOID DIRECT EXPOSURE TO BEAM.
ATTENTION RAYONNEMENT LASER VISIBLE ET INVISIBLE EN CAS D'OUVERTURE. EXPOSITION DANGEREUSE AU FAISCEAU

Warning for power supply

The primary side of the power supply carries live mains voltage when the player is connected to the mains even when the player is switched off !

This primary area is not shielded so it is possible to touch copper tracks and/or components when servicing the player. Service personnel have to take precautions to prevent touching this area or components in this area.

Note:

The screws on the DVD mechanism may never be touched, removed or re-adjusted.

Handle the DVD mechanism with care when the unit has to be exchanged!

The DVD mechanism is very sensitive for dropping or giving shocks.

■ PREVENTION OF ELECTROSTATIC DISCHARGE

The laser diode in the traverse unit (optical pickup) may be damaged due to static electricity from clothes or the human body. Use caution to prevent electrostatic damage when servicing or handling the laser diode.

1. Grounding for electrostatic damage prevention

1. Worktable grounding
Put a grounded conductive material (sheet) or iron sheet on the area where the optical pickup is placed.
2. Human body grounding
Use an anti-static wrist strap to discharge the static electricity from your body.

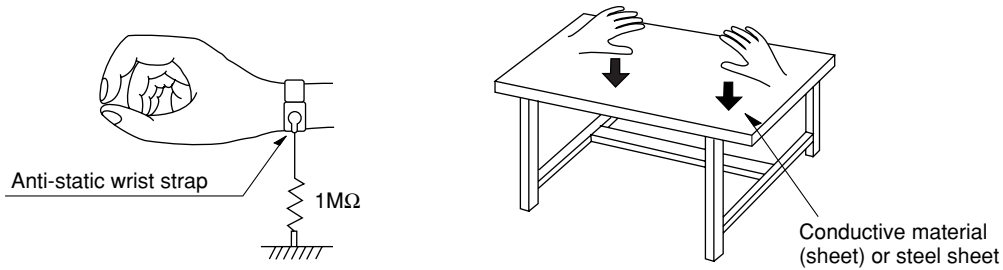

2. Handling of the optical pickup

1. To prevent damage to the optical pickup replacement parts during transportation and before installation, both ends of the laser diode are short-circuited. After installing the new part, remove the short circuit according to the correct procedure in this service manual.
2. Do not use a tester to check the laser diode in the optical pickup. The power supply in the tester will damage the laser diode.

3. Handling Precautions for the Traverse Unit (Optical Pickup)

1. Handle the traverse unit (optical pickup) gently, as it is an extremely high-precision assembly.
2. The flexible cable lines may break if an excessive force is applied to it. Use caution when handling the cable.
3. The semi-fixed resistor for laser power adjustment should not be adjusted. Do not turn the resistor.

■ LOCALE MANAGEMENT INFORMATION

Locale Management Information : This DVD player is designed and manufactured to respond to the Locale Management Information that is recorded on a DVD disc. If the Locale number described on the DVD disc does not correspond to the Locale number of this DVD player, this DVD player cannot play this disc.

This product incorporates copyright protection technology that is protected by method claims of certain U.S. patents and other intellectual property rights owned by Macrovision Corporation and other rights owners. Use of this copyright protection technology must be authorized by Macrovision Corporation, and is intended for home and other limited viewing uses only unless otherwise authorized by Macrovision Corporation. Reverse engineering or disassembly is prohibited.

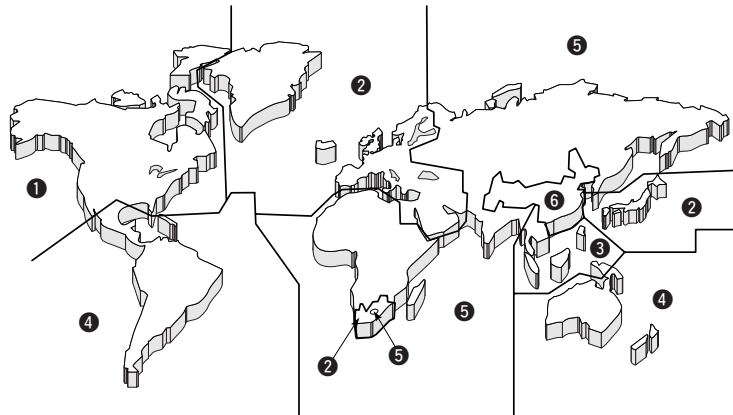

SYSTEM COMPOSITION / システム構成

The DVX-S301 consists of the DVR-S300 and the NX-P301.
 The DVX-S302 consists of the DVR-S300 and the NX-P302.

DVX-S301 (C, K, A, B, G, L, V, J models)

DVR-S300



DVX-S302 (C, K, A, B, G, L, V models)

DVR-S300



NX-P301

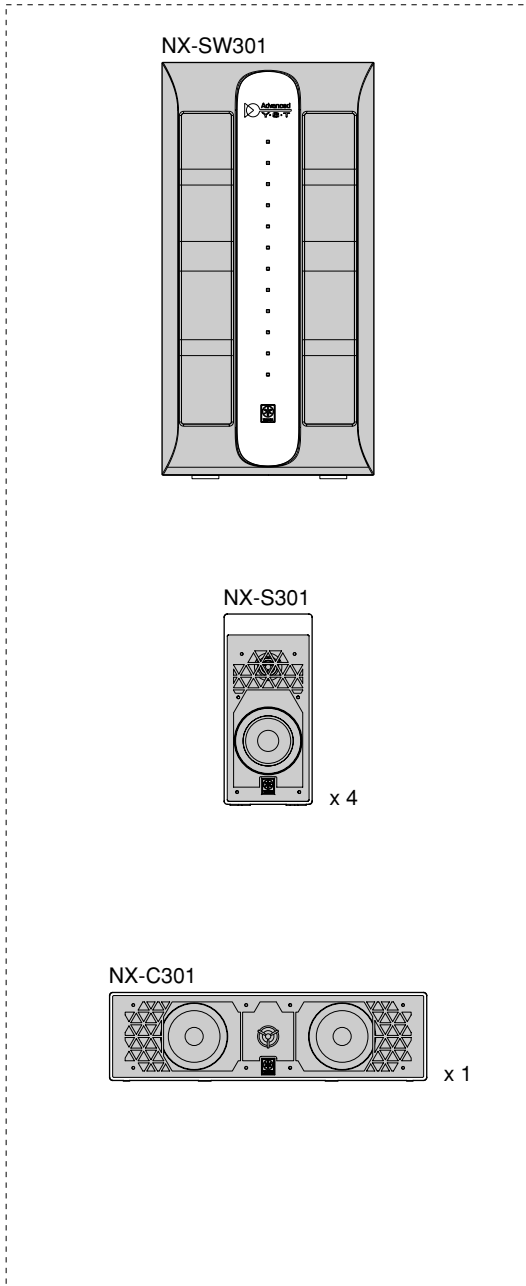

NX-P302

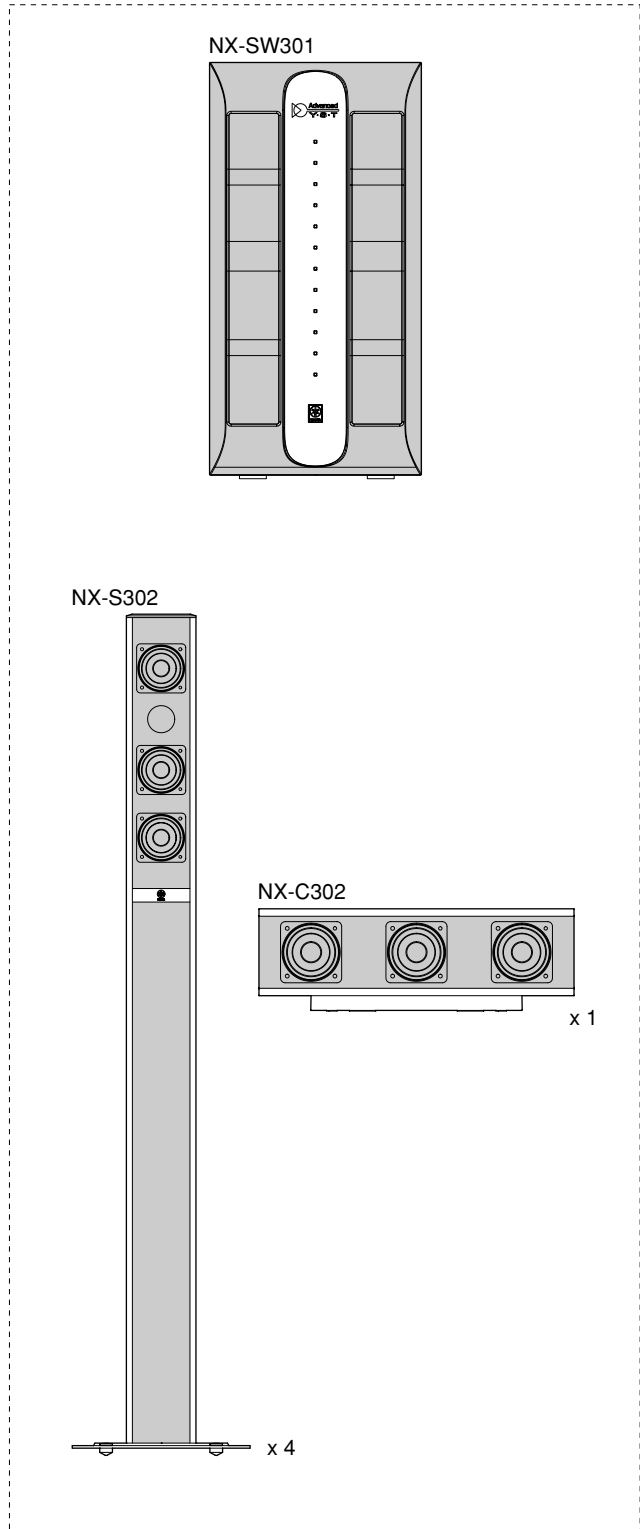

FRONT PANELS

DVR-S300

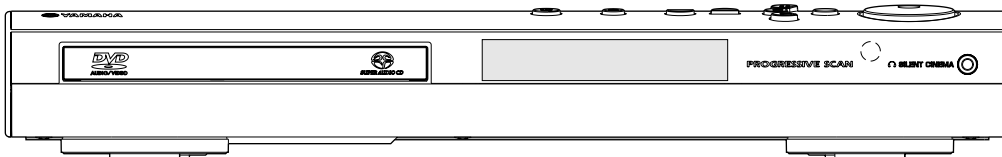
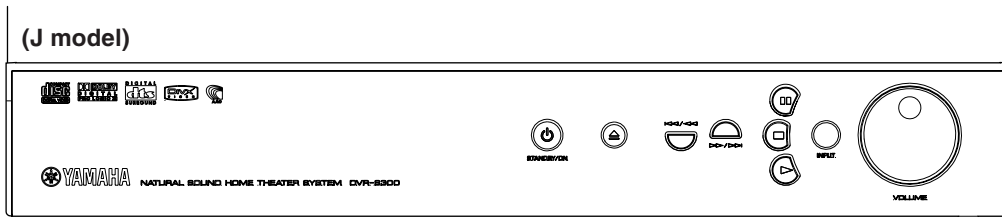
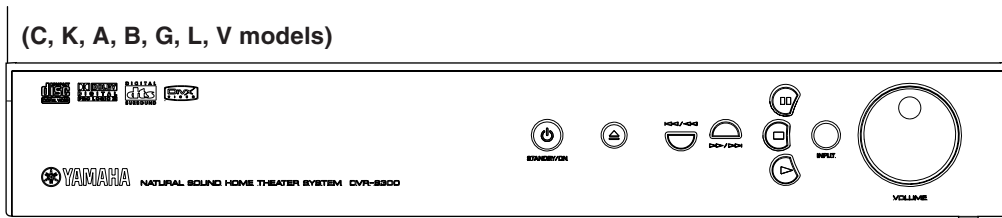

NX-SW301

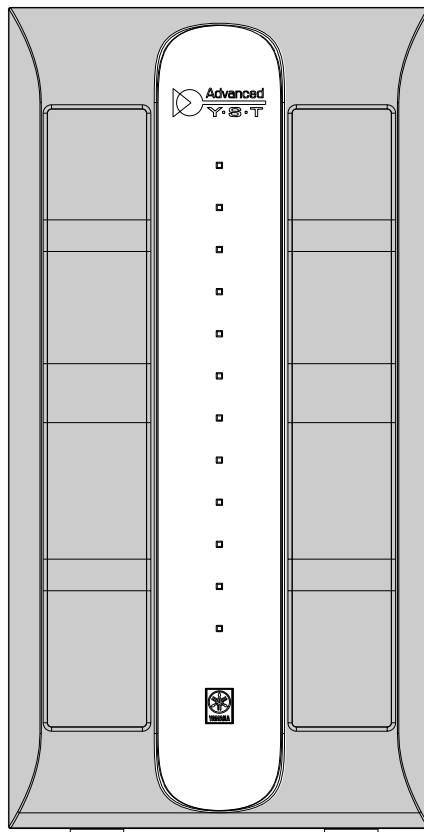

DVR-S300
NX-P301/NX-P302

NX-S301

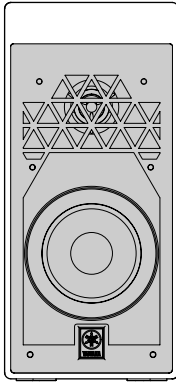

NX-C301

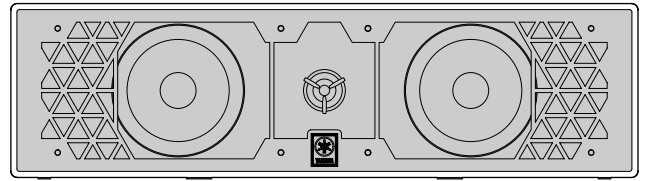

NX-S302

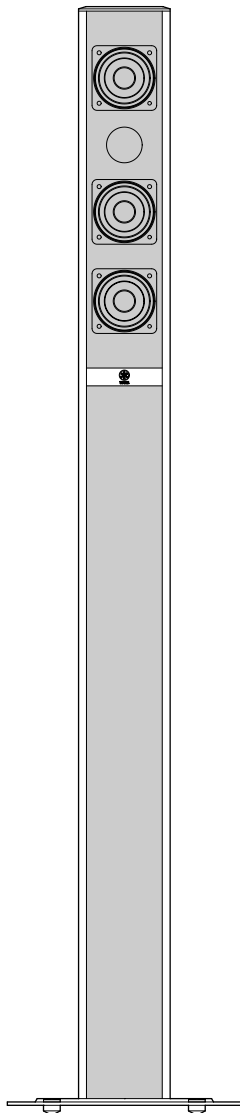

NX-C302

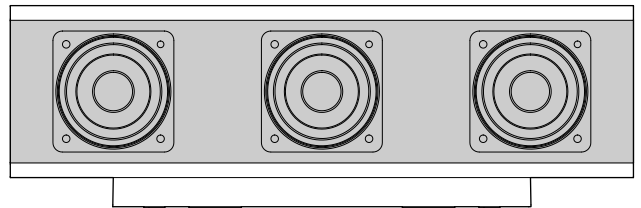

DVR-S300
NX-P301/NX-P302

REMOTE CONTROL

C, K, A, B, G, L, V models

J model

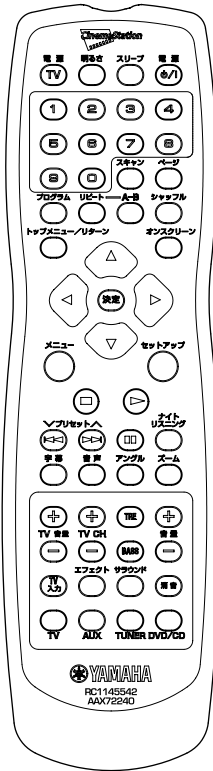
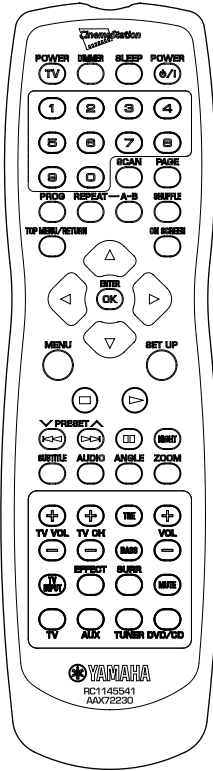

DVR-S300
NX-P301/NX-P302

REAR PANELS

DVR-S300 (C model)

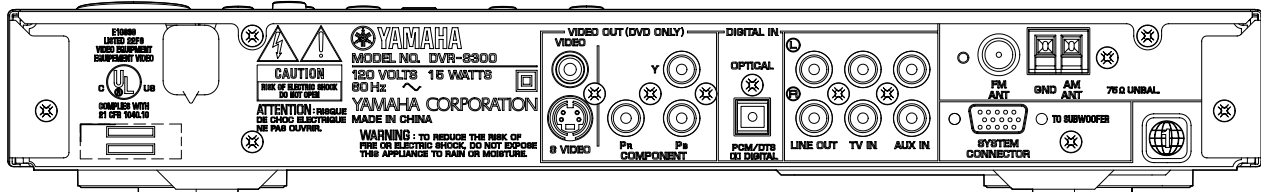

DVR-S300 (K model)

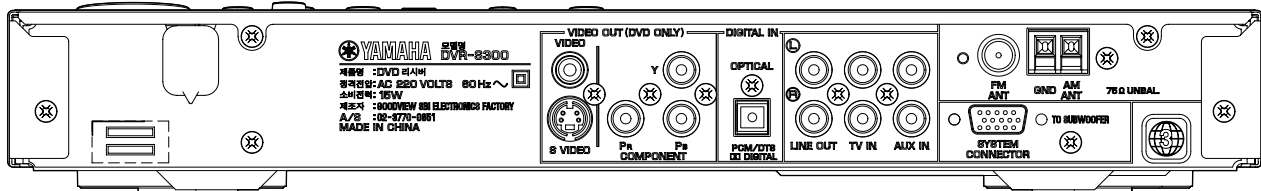

DVR-S300 (A model)

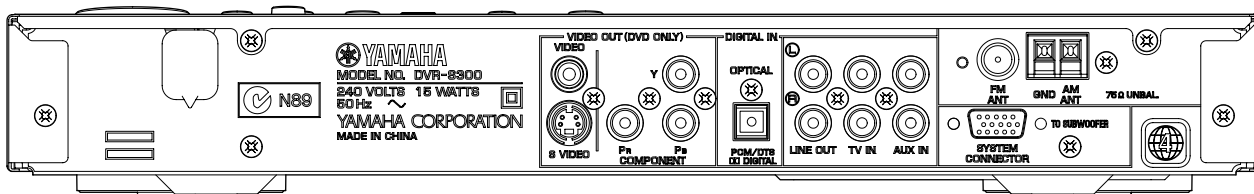

DVR-S300 (B, G models)

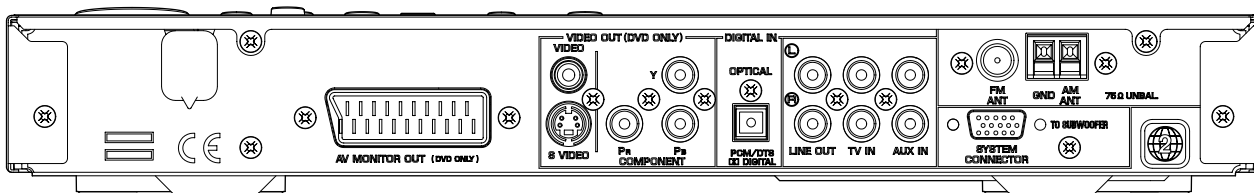

DVR-S300 (L model)

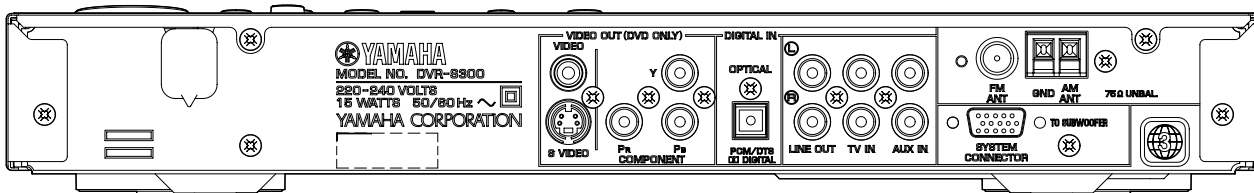

DVR-S300 (V model)

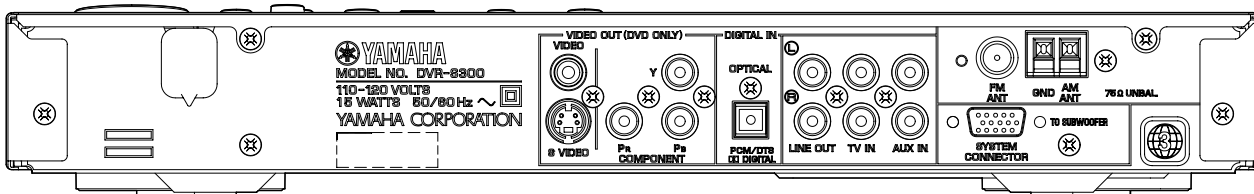

DVR-S300 (J model)

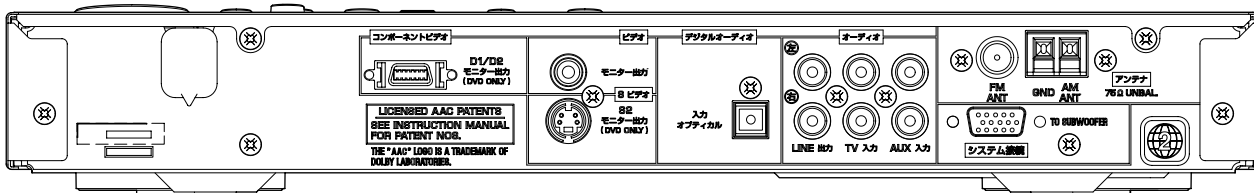

DVR-S300
NX-P301/NX-P302

NX-SW301 (C model)

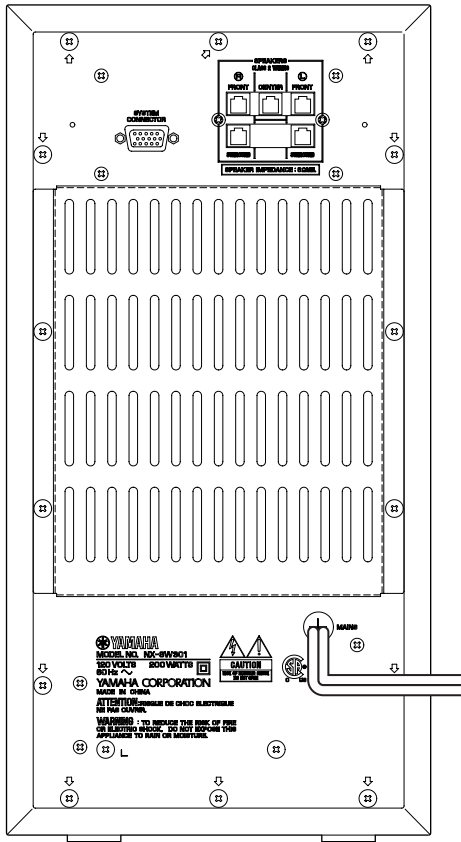

NX-SW301 (K model)

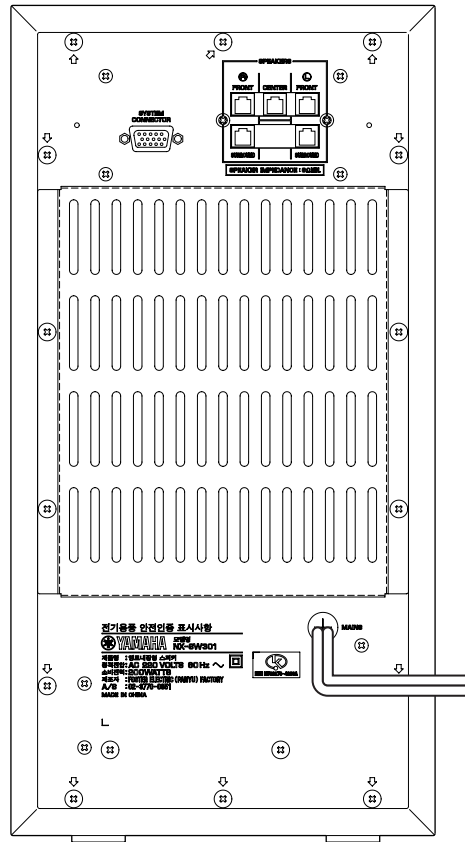

NX-SW301 (A model)

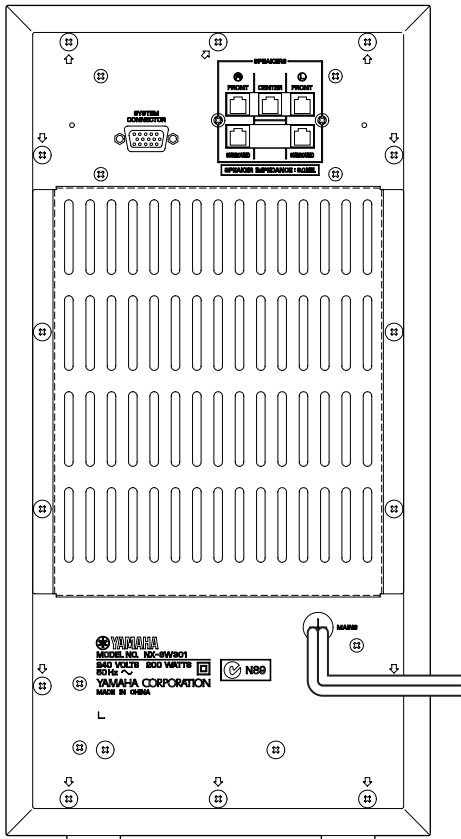

NX-SW301 (B, G models)

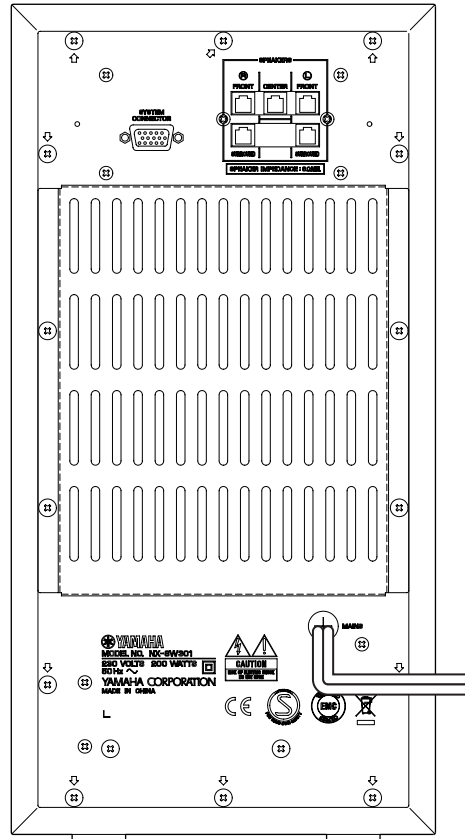

DVR-S300
NX-P301/NX-P302

NX-SW301 (L model)

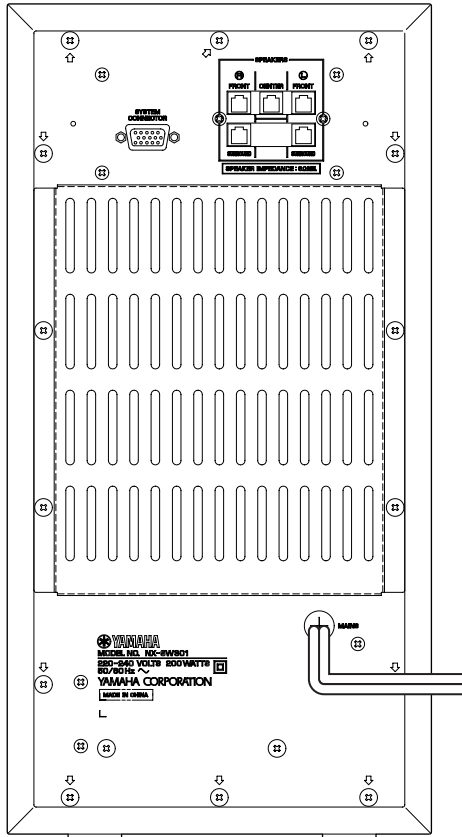

NX-SW301 (V model)

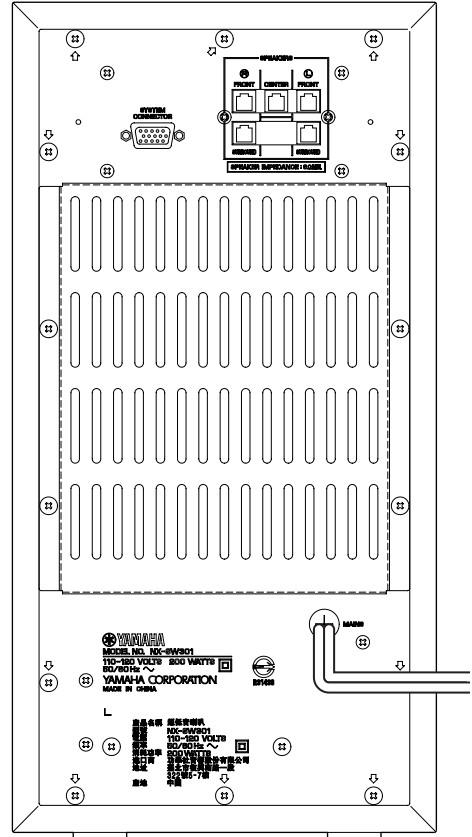

NX-SW301 (J model)

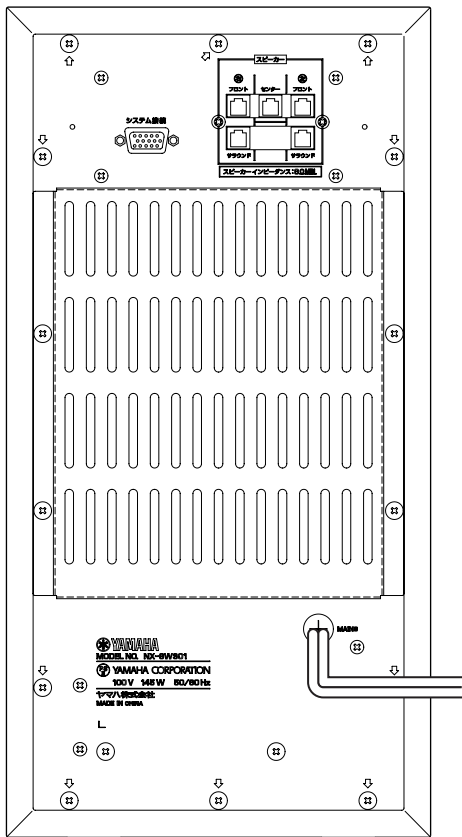

DVR-S300
NX-P301/NX-P302

NX-S301

NX-C301

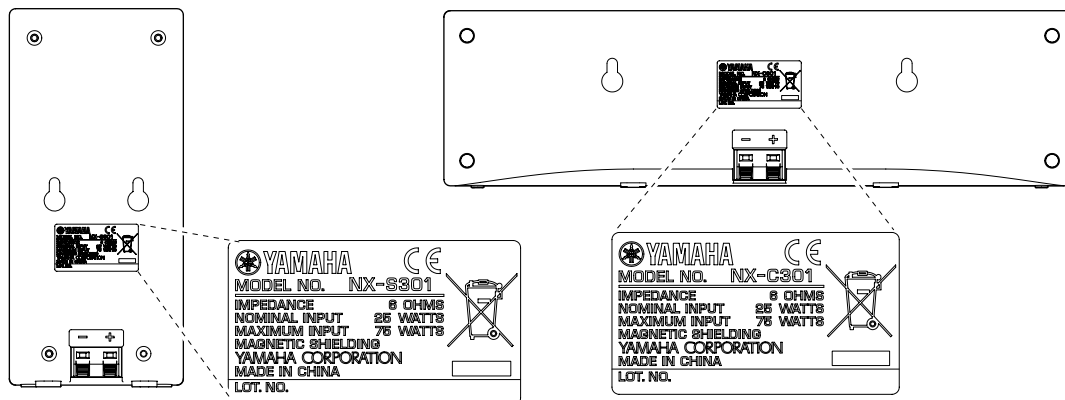

NX-S302

NX-C302

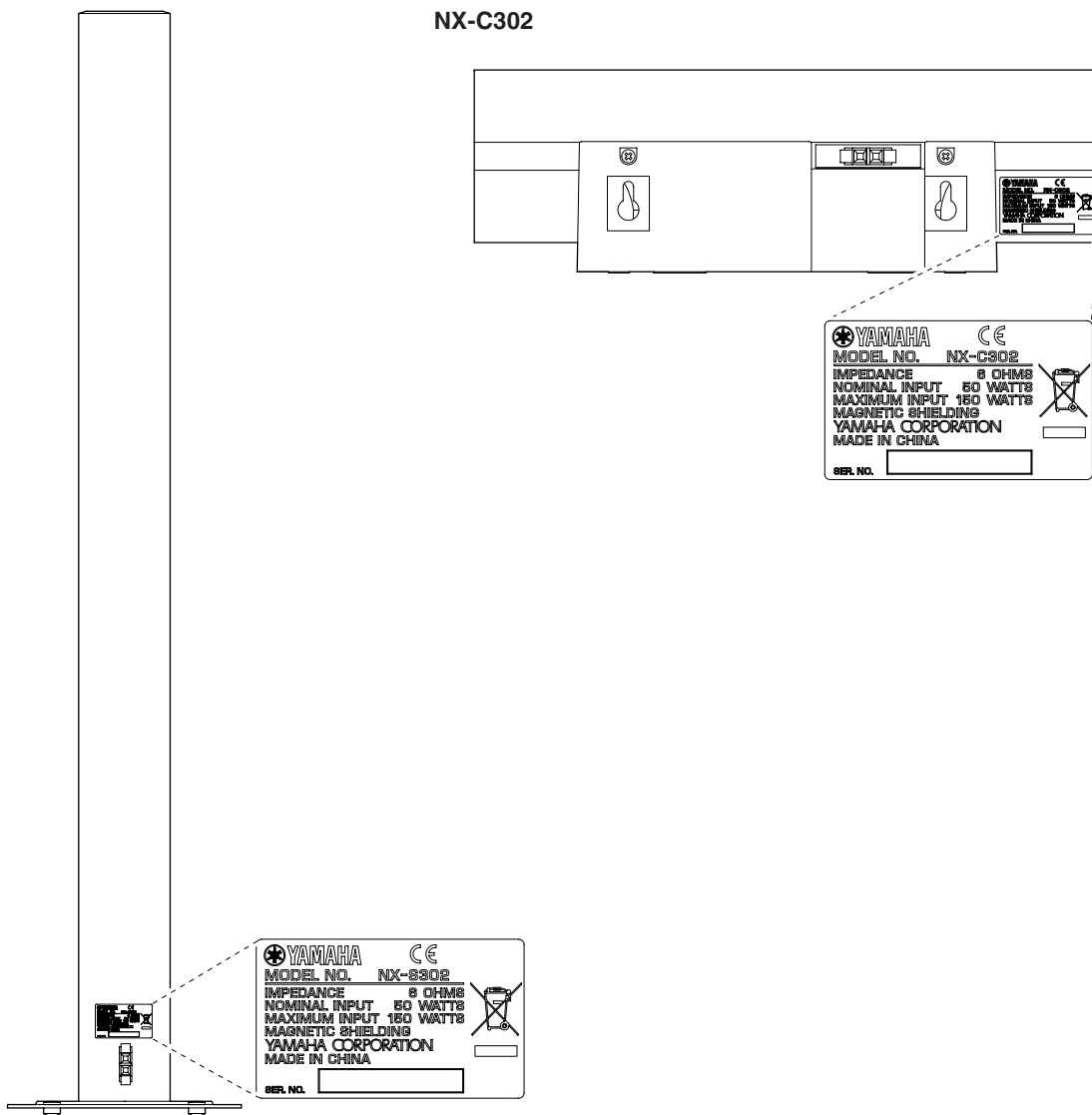

DVR-S300
NX-P301/NX-P302

■ SPECIFICATIONS / 参考仕様

TUNER SECTION

FM Tuning Range	
- C, K, A, B, G, L, V models	87.50 to 108.00 MHz
- J model	76.0 to 90.0 MHz
AM Tuning Range	
- C model	530 to 1700 kHz
- K, A, B, G models	531 to 1602 kHz
- L, V models	531 to 1602 kHz/530 to 1700 kHz
- J model	531 to 1602 kHz

DISC SECTION

Laser Type	Semiconductor
Disc Diametre	12cm / 8cm
Video Decoding	MPEG-1 / MPEG-2 / DivX 3.11, 4.x & 5.x
Video DAC	12 bits/108 MHz
Signal System	PAL / NTSC
Video Format	4:3 / 16:9
Composite Video Output	1.0 Vp-p, 75 ohms
S-video Output	Y - 1.0 Vp-p, 75 ohms C - 0.3 Vp-p, 75 ohms
RGB (SCART) output	0.7 Vp-p, 75 ohms (B, G models)
Component Video Output	Y - 1.0 Vp-p, 75 ohms PB/CB PR/CR - 0.7 Vp-p, 75 ohms
Audio DAC	24 bits / 192 kHz
Frequency Response	4 Hz to 20 kHz (44.1 kHz) 4 Hz to 22 kHz (48 kHz) 4 Hz to 44 kHz (96 kHz)
Audio S/N	105 dB
Distortion	0.0035 %
Dynamic Range	95 dB

AUDIO FORMAT

Digital	Dolby Digital/DTS/MPEG Compressed Digital
PCM	16, 20, 24 bits fs 44.1, 48, 88.2, 96, 176.4, 192 kHz
MP3 (ISO 9660)	24, 32, 56, 64, 96, 128, 256 kbps fs 16, 22.05, 24, 32, 44.1, 48 kHz
WMA	32 to 192 kbps, Mono, Stereo
Full Decoding of Dolby Digital and DTS Multi-channel Sound	
Dolby Surround Compatible Downmix from Dolby Digital Multi-channel Sound	
Dolby Pro Logic II	

MAIN UNIT (DVR-S300)

Power Supply	
- C model	120 V, 60 Hz
- K model	220 V, 60 Hz
- A model	240 V, 50 Hz
- B, G models	230 V, 50 Hz
- L model	220 - 240 V, 50/60 Hz
- V model	110 - 120 V, 50/60 Hz
- J model	100 V, 50/60 Hz
Power Consumption	15W
Frequency Response	20 Hz to 20 kHz/-3 dB
Signal-to-Noise Ratio	> 95 dB
Input Sensitivity	
- AUX In, TV In	300 mV
- SCART In	500 mV (B, G models)
Dimensions (W x H x D)	360 x 53 x 310 mm (14-3/16" x 2-1/16" x 12-3/16")
Weight	2.7 kg (5 lbs. 15 oz.)
Finish	Silver Color

SUBWOOFER (NX-SW301)

Power Supply	
- C model	120 V, 60 Hz
- K model	220 V, 60 Hz
- A model	240 V, 50 Hz
- B, G models	230 V, 50 Hz
- L model	220 - 240 V, 50/60 Hz
- V model	110 - 120 V, 50/60 Hz
- J model	100 V, 50/60 Hz
Power Consumption	
- C, K, A, B, G, L, V models	200 W
- J model	145 W
System	Bass Reflex System
Impedance	6 ohms
Driver	16 cm (6-5/16") Woofer
Frequency Response	40 Hz to 100 Hz
Dimensions (W x H x D)	200 x 390 x 382 mm (7-7/8" x 15-3/8" x 15-1/16")
Weight	11.5 kg (25 lbs. 5 oz.)
Finish	Silver Color

FRONT AND SURROUND SPEAKER

NX-S301

System	2-way System
Impedance	6 ohms
Drivers	7.0 cm (2-3/4") Woofer x 1 1.9 cm (3/4") Tweeter x 1
Frequency Response	100 Hz to 20 kHz
Dimensions (W x H x D)	83 x 181 x 78 mm (3-1/4" x 7-1/8" x 3-1/16")
Weight	0.6 kg (1 lbs. 5 oz.)
Finish	Silver Color

NX-S302

System	Full Range System
Impedance	6 ohms
Drivers	5.0 cm (2") Full Range x 3 2.5 cm (1") Piezo Tweeter x 1
Frequency Response	100 Hz to 20 kHz
Dimensions (W x H x D)	210 x 994 x 210 mm (8-1/4" x 39-1/8" x 8-1/4") with Stand
Weight	3.0 kg (6 lbs. 9 oz.)
Finish	Silver Color

CENTER SPEAKER

NX-C301

System	2-way System
Impedance	6 ohms
Drivers	7.0 cm (2-3/4") Woofer x 2 1.9 cm (3/4") Tweeter x 1
Frequency Response	100 Hz to 20 kHz
Dimensions (W x H x D)	300 x 84 x 78 mm (11-13/16" x 3-5/16" x 3-1/16")
Weight	1.0 kg (2 lbs. 3 oz.)
Finish	Silver Color

NX-C302

System	Full Range System
Impedance	6 ohms
Drivers	5.0 cm (2") Full Range x 3
Frequency Response	100 Hz to 20 kHz
Dimensions (W x H x D)	328 x 98 x 64 mm (12-15/16" x 3-7/8" x 2-1/2")
Weight	0.7 kg (1 lbs. 8 oz.)
Finish	Silver Color

ACCESSORIES

DVR-S300	Remote Control x 1 Indoor FM Antenna x 1 AM Loop Antenna x 1 System Control Cable (4m) x 1 Video Pin Cable (1.5m) x 1
NX-P301	Speaker Cable Kit (15m) x 2 Speaker Cable Kit (5m) x 3 Fastener x 2 (for NX-C301) Nonskid Pad x 4 (for NX-SW301)
NX-P302	Base x 4 (for NX-S302) Bind Head Screw x 8 (for NX-S302) Washer x 8 (for NX-S302) Fastener x 2 (for NX-C302)

** Specifications subject to change without prior notice.*

- | | |
|--|---------------------------------------|
| C <i>Canada model</i> | K <i>Korean model</i> |
| A <i>Australian model</i> | B <i>British model</i> |
| G <i>European model</i> | L <i>Singapore model</i> |
| V <i>Taiwan model</i> | J <i>Japanese model</i> |



Manufactured under license from Dolby Laboratories.
“Dolby”, “Pro Logic”, “MLP Lossless” and the double-D symbol are trademarks of Dolby Laboratories.
ドルビーラボラトリーズからの実施権により製造されています。「ドルビー」及びダブルD記号は、ドルビーラボラトリーズの商標です。



“DTS” and “DTS Digital Surround” are registered trademarks of Digital Theater Systems, Inc.
DTS およびDTS Digital Out はデジタルシアターシステムズの登録商標です。



“DivX”, “DivX Certified”, and associated logos are trademarks of DivXNetworks, Inc and are used under license.
DivX、DivX Certified およびそのロゴはDivX Networks Inc の商標であり、ライセンス承諾を得て使用されます。



AACロゴマーク  はドルビーラボラトリーズの商標です。

This product incorporates copyright protection technology that is protected by method claims of certain U.S. patents and other intellectual property rights owned by Macrovision Corporation and other rights owners. Use of this copyright protection technology must be authorized by Macrovision Corporation, and is intended for home and other limited viewing uses only unless otherwise authorized by Macrovision Corporation. Reverse engineering or disassembly is prohibited.
本製品は、著作権保護技術を採用しており、マクロビジョン社及びその他の著作権利者が保有する米国特許及びその他の知的財産権によって保護されています。この著作権保護技術の使用は、マクロビジョン社の許可が必要で、またマクロビジョン社の特別な許可がない限り家庭用及びその他の一部の視聴用の使用に制限されています。分解したり、改造することも禁じられています。



Advanced YST
Active Servo Processing Subwoofer System with built-in power amplifier.
This subwoofer system (NX-SW301) employs Advanced YAMAHA Active Servo Technology which YAMAHA has developed for reproducing higher quality super-bass sound. This super-bass sound adds a more realistic, theater-in-the-home effect to your stereo system.

DVR-S300
NX-P301/NX-P302

• DIMENSIONS / 寸法図

DVR-S300

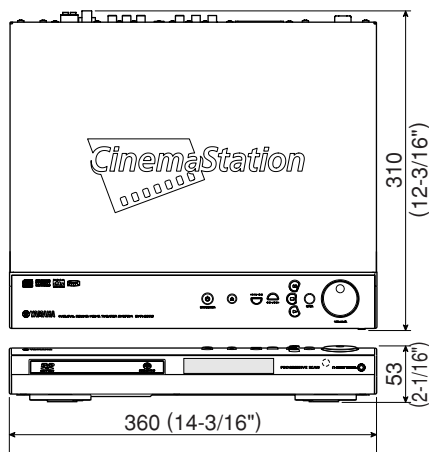

NX-S302

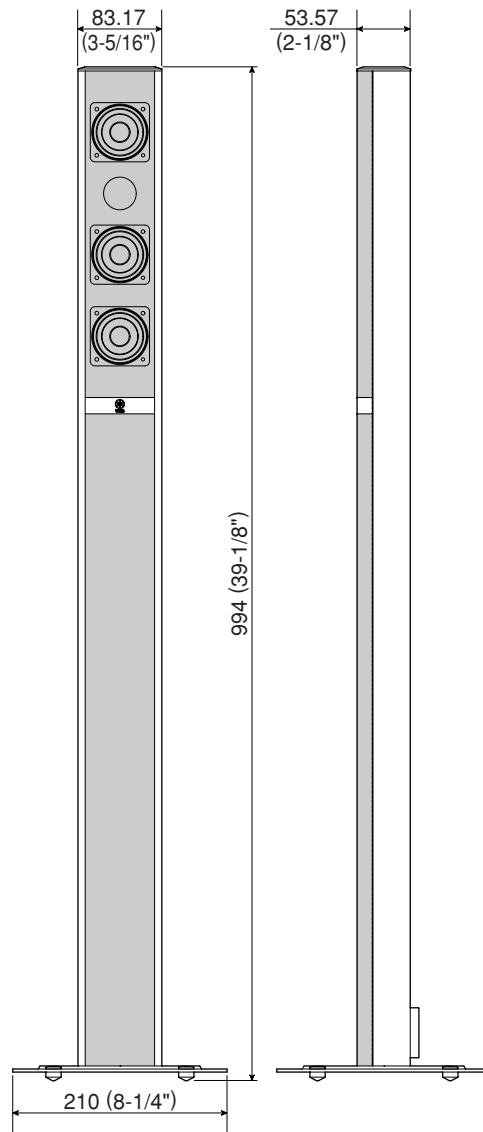

NX-SW301

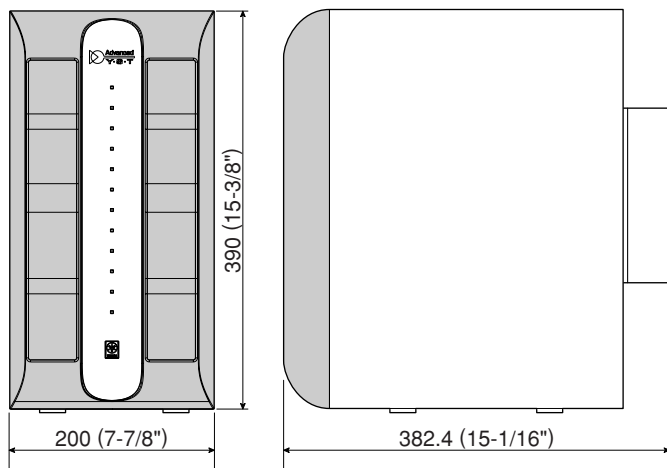

NX-S301

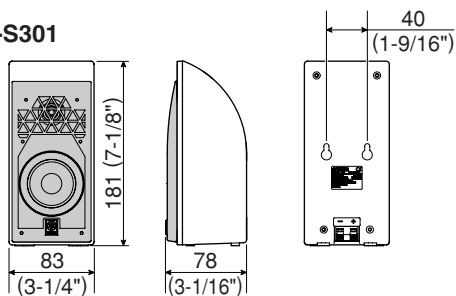

NX-C301

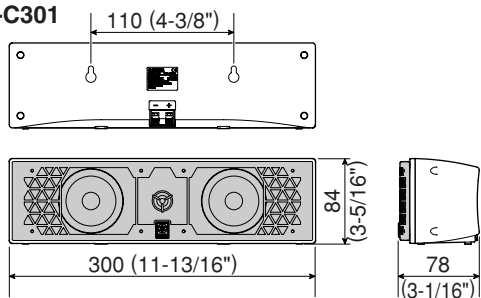

NX-C302

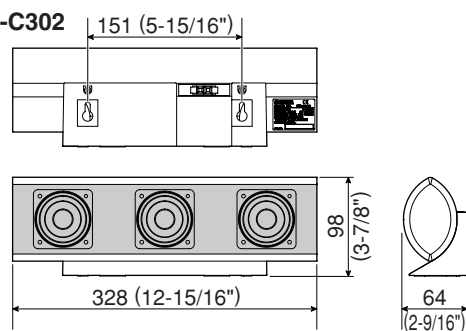

Unit : mm (inch)
単位 : mm (インチ)

DVR-S300
NX-P301/NX-P302

INTERNAL VIEW

DVR-S300

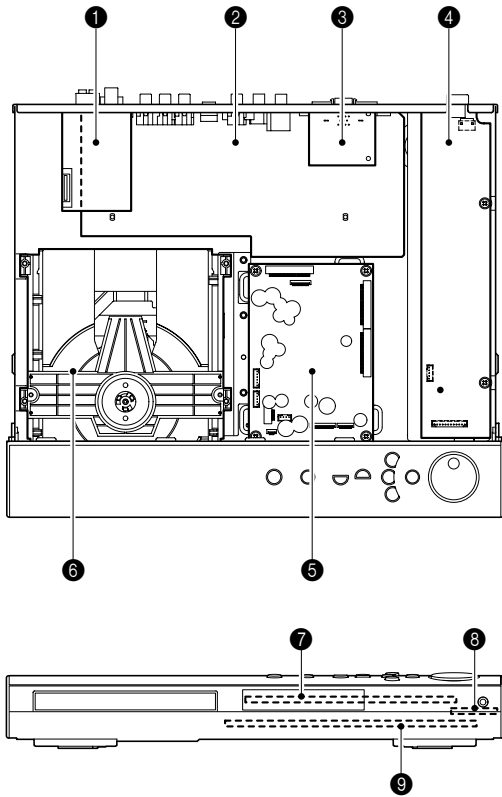

- ① TUNER
- ② AV P.C.B.
- ③ HDMI D2 P.C.B. (J model)
- ④ POWER SUPPLY UNIT
- ⑤ MONO P.C.B.
- ⑥ DVD MECHANISM
- ⑦ CONTROL P.C.B.
- ⑧ FRONT (2) HP P.C.B.
- ⑨ FRONT (1) DISPLAY P.C.B.

DVR-S300
NX-P301/NX-P302

NX-SW301

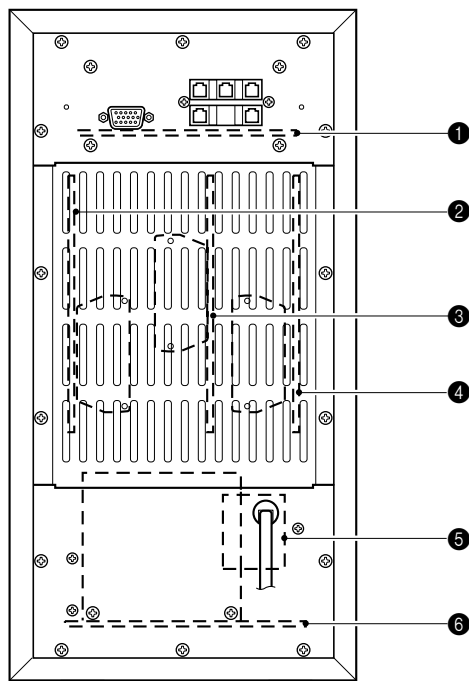

- ① POWER (3) IN/OUT P.C.B.
- ② AMP (1) FL/FR P.C.B.
- ③ AMP (2) SL/SR P.C.B.
- ④ POWER (1) C/SW P.C.B.
- ⑤ POWER (4) SUBTR P.C.B.
- ⑥ POWER (2) POWER P.C.B.

REPAIR NOTES / 修理上の留意点

● DVR-S300

None of the components of the following units can be supplied separately.

Each unit must be replaced as a whole in case of a failure.

- DVD Mechanism
- MONO P.C.B.
- FRONT P.C.B.
- CONTROL P.C.B.
- AV P.C.B.
- Power Supply Unit

● Power Supply Unit

Never touch the potentiometer (VR301) installed to the Power Supply Unit.

● DVR-S300

下記のユニットは、小部品の部品供給はできません。故障の場合は、各ユニットを交換してください。

- DVDメカ
- MONO P.C.B.
- FRONT P.C.B.
- CONTROL P.C.B.
- AV P.C.B.
- HDMI D2 P.C.B.
- 電源ユニット

● 電源ユニットについて

電源ユニットに搭載されている可変抵抗 (VR301) は、絶対に触らないでください。

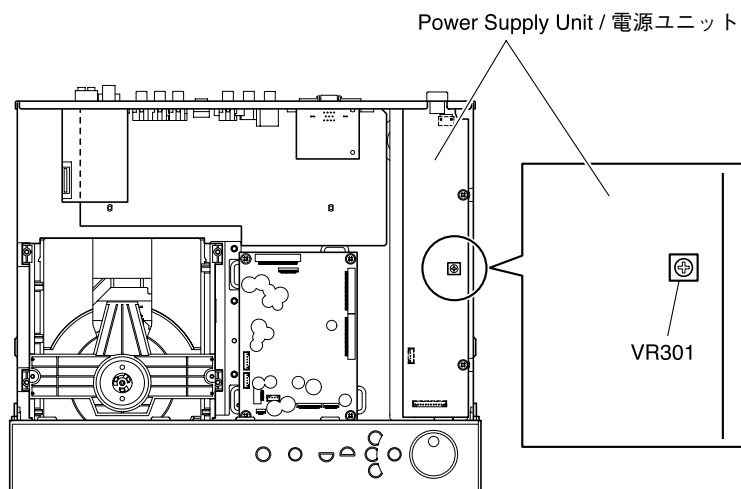

● NX-SW301

When turning on the power of NX-SW301 independently for its operation check, refer to “**When checking the P.C.B.**” of “**■ NX-SW301 DISASSEMBLY PROCEDURES**” (on page 23).

● NX-SW301

動作確認のためにNX-SW301単独で電源をONする場合、「**■ NX-SW301分解手順**」の「**P.C.B.動作チェックをする場合**」(23ページ)を参照してください。

■ DVR-S300 TRADE MODE / DVR-S300 トレードモード

This unit has "TRADE MODE" which prevents the tray from opening even when the "▲" (Open/Close) key is pressed.

● Entering TRADE MODE

The power to the main unit should be turned on before entering the TRADE MODE.

1. Press the "▲" key to open the tray. (Fig. 1)
2. Press the "DVD/CD", "⊖", "⊕" and "⊖" buttons on the remote control in that order. (Fig. 2)
3. "TRA ON" appears on the FL display of the main unit and TRADE MODE is activated. (Fig. 3)

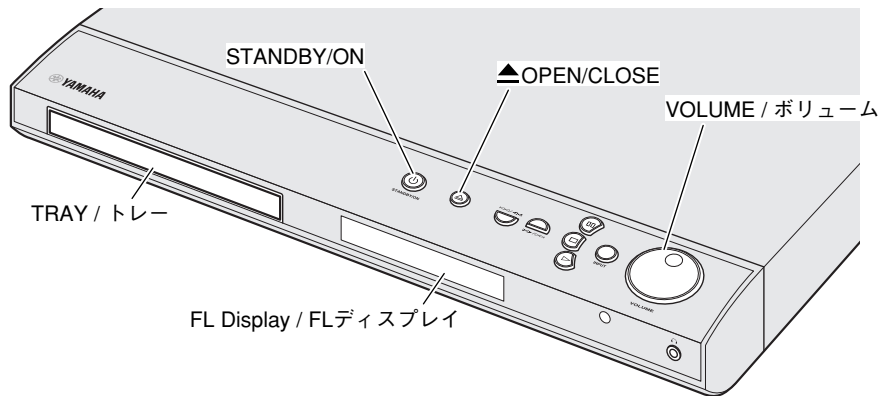

Fig. 1

TRADE MODE display / トレードモード表示

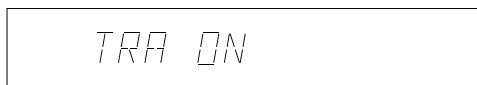

Fig. 3

Enter / 起動

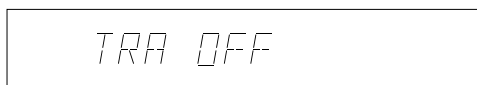

Fig. 4

Cancel / 解除

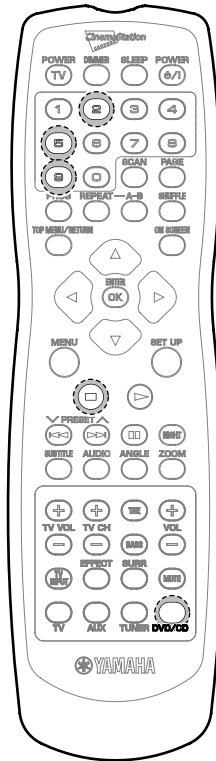

Fig. 2

DVR-S300には、“▲”(オープン/クローズ)キーを押してもトレーが開かない「トレードモード」があります。

● トレードモードの起動

本体の電源をオンの状態から行います。

1. 本体の“▲”キーを押し、トレーを開きます。(Fig. 1)
2. リモコンの“DVD/CD”ボタンを押し、次に“⊖”、“⊕”、“⊖”ボタンを順番に押します。(Fig. 2)
3. 本体FLディスプレイに“TRA ON”が表示され、トレードモードが起動します。(Fig. 3)

* After entering TRADE MODE, it is not possible to operate keys of the main unit as usual except the following keys.

STANDBY/ON (POWER ON only)
VOLUME UP/DOWN

* Operation through the remote control is available as usual.

● Canceling TRADE MODE

The power to the main unit should be turned on before canceling TRADE MODE.

1. Press the "DVD/CD" button and keep pressing the "⊖" button on the remote control. (Fig. 2)
The tray opens after about 2 second.
2. Press the "⊖", "⊕" and "⊖" buttons on the remote control in that order. (Fig. 2)
3. "TRA OFF" appears on the FL display of the main unit and TRADE MODE is cancelled. (Fig. 4)

※ トレードモード起動後、本体は下記のキー以外の操作を通常通り行うことができません。

STANDBY/ON (POWER ONのみ)
VOLUME UP/DOWN

※ リモコンからの操作は通常通り行うことができます。

● トレードモードの解除

本体の電源をオンの状態から行います。

1. リモコンの“DVD/CD”ボタンを押してから、“⊖”ボタンを押し続けます。(Fig. 2)
約2秒後、トレーが開きます。
2. リモコンの“⊖”、“⊕”、“⊖”ボタンを順番に押します。(Fig. 2)
3. 本体FLディスプレイに“TRA OFF”が表示され、トレードモードが解除されます。(Fig. 4)

■ DVR-S300 DISASSEMBLY PROCEDURES / DVR-S300分解手順

(Remove parts in the order as numbered.)

(番号順に部品を取り外してください。)

1. Removal of Top Panel

- Remove 6 screws (①). (Fig. 1)
- Remove the Top Panel by lifting it from the rear.

1. トップパネルの外し方

- ①のネジ6本を外します。(Fig. 1)
- トップカバーを後ろ側から上げて取り外します。

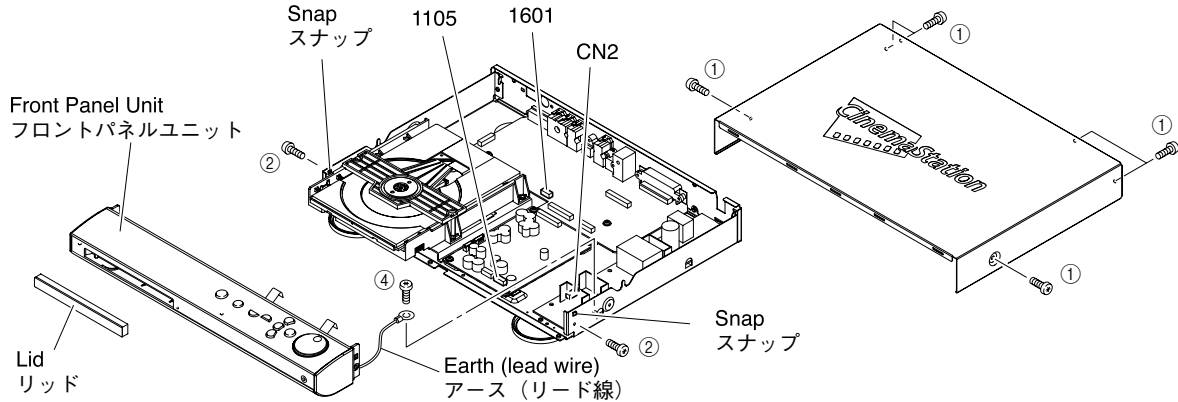

Fig. 1

2. Removal of Front Panel Unit

- Open the tray according to "HOW TO MANUALLY EJECT THE TRAY" and remove the lid.
- Close the tray.
- Remove connectors 1105, 1601 and CN2. (Fig. 1)
- Remove 2 screws (②) and 3 screws (③). (Fig. 1, 2)
- Remove 1 screw (④) and then remove the earth (lead wire). (Fig. 1)
- Release 2 snaps and remove the Front Panel.

2. フロントパネルユニットの外し方

- 「手でトレイを開く方法」でトレイを開き、リッドを外します。
- トレイを閉じます。
- コネクタ1105、1601、CN2を外します。(Fig. 1)
- ②のネジ2本、③のネジ3本を外します。(Fig. 1、2)
- ④のネジ1本を外し、アース(リード線)を外します。(Fig. 1)
- スナップ2箇所を外し、フロントパネルを取り外します。

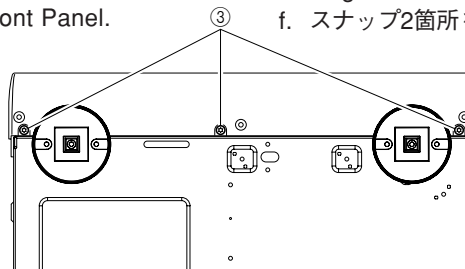

Fig. 2

HOW TO MANUALLY EJECT THE TRAY

- Turn the player bottom up.
- Move the slider in the direction indicated with a flatblade screwdriver until the tray is ejected.
- Gently pull the tray out.

手でトレイを開く方法

- 本体を上下反転します。
- トレイが出てくるまで、マイナスドライバーでスライダを図に示す矢印の方向に動かします。
- トレイをそっと引き出します。

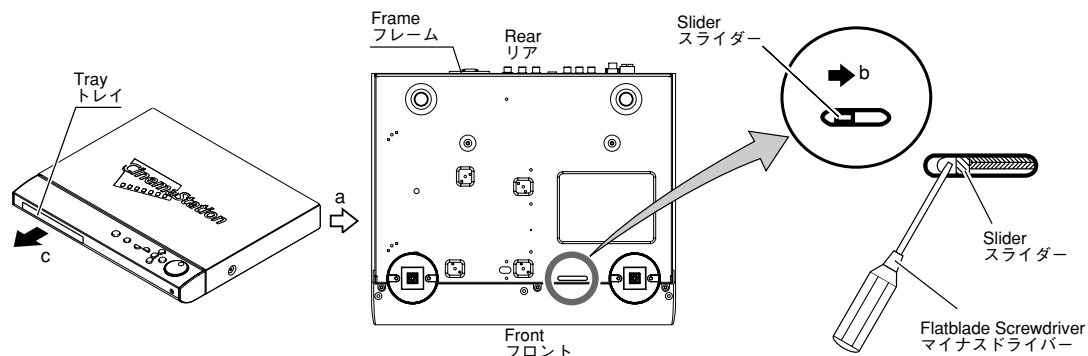

DVR-S300
NX-P301/NX-P302

3. Removal of FRONT (1), (2) and CONTROL P.C.B.s

- a. Remove 3 screws (⑤) and 1 screw (⑥). (Fig. 3)
- * Be sure to use M3 x 6 type for screws (⑥).
- b. Release 2 snaps and remove the Bottom Panel.
- c. Remove the connector 1102. (Fig. 3)
- d. Remove 1 screw (⑦). (Fig. 3)
- e. Remove FRONT (1) DISPLAY P.C.B..
- f. Remove the connector 1103. (Fig. 3)
- g. Remove 1 screw (⑧).
- h. Remove FRONT (2) HP P.C.B..
- i. Remove the Knob Volume.
- j. Remove 4 screws (⑨). (Fig. 3)
- k. Remove CONTROL P.C.B., Button Frame and Button.

3. FRONT(1)、(2)、CONTROL P.C.Bの外し方

- a. ⑤のねじ3本、⑥のネジ1本を外します。(Fig.3)
- * 組立時、⑥のネジは必ずM3×6を使用してください。
- b. スナップ2箇所を外し、ボトムパネルを取り外します。
- c. コネクター1102を外します。(Fig. 3)
- d. ⑦のネジ1本を外します。(Fig. 3)
- e. FRONT(1)DISPLAY P.C.Bを取り外します。
- f. コネクター1103を外します。(Fig. 3)
- g. ⑧のネジ1本を外します。(Fig. 3)
- h. FRONT(2)HP P.C.B.を取り外します。
- i. ノブ/ボリュームを外します。
- j. ⑨のネジ4本を外します。(Fig. 3)
- k. CONTROL P.C.B.、ボタン/フレーム、ボタンを取り外します。

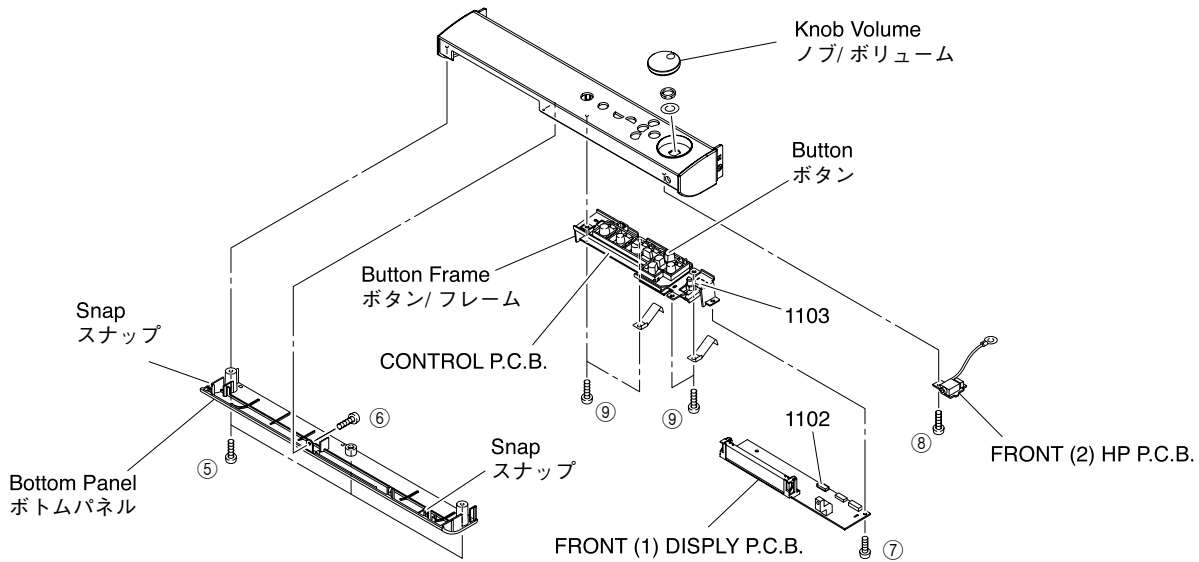

Fig. 3

4. Removal of DVD MECHANISM

- a. Remove connectors 1101, 1102 and 1103. (Fig. 4)
- b. Remove 4 screws (⑩). (Fig. 5)
- c. Remove the DVD MECHANISM.

4. DVDメカの外し方

- a. コネクター1101、1102、1103を外します。(Fig. 4)
- b. ⑩のネジ4本を外します。(Fig. 5)
- c. DVDメカを取り外します。

5. Removal of MONO P.C.B.

- a. Remove connectors 1104, 1105, 1301 and 1302. (Fig. 4)
- b. Remove 4 screws (⑪). (Fig. 5)
- c. Remove MONO P.C.B..

5. MONO P.C.B.の外し方

- a. コネクター1104、1105、1301、1302を外します。(Fig. 4)
- b. ⑪のネジ4本を外します。(Fig. 5)
- c. MONO P.C.B.を取り外します。

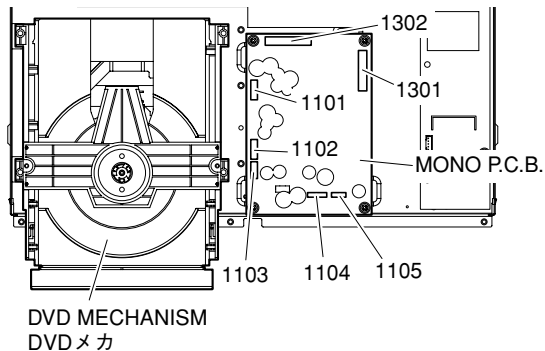

Fig. 4

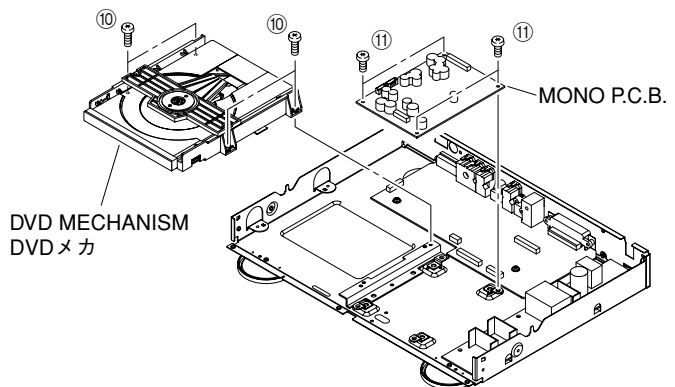

Fig. 5

6. Removal of Tuner

- Remove the connector CN1. (Fig. 6)
- Remove 2 screws (12). (Fig. 7)
- Remove the Tuner.

6. チューナーの外し方

- コネクタ-CN1を外します。(Fig. 6)
- 12のネジ2本を外します。(Fig. 7)
- チューナーを取り外します。

7. Removal of AV P.C.B.

- Remove connectors 1101, 1102, 1201, 1401 and 1601. (Fig. 6)
- Remove 6 screws (C, K, A, L, V models) / 8 screws (B, G models) (14). (Fig. 7)
- Remove 2 jack screws (15). (Fig. 7)
- Remove 2 screws (16). (Fig. 6)
- Remove AV P.C.B..

7. HDMI D2 P.C.B.の外し方 (J model)

- コネクタ-1704を外します。(Fig. 6)
- 13のネジ2本を外します。(Fig. 7)
- HDMI D2 P.C.B.を取り外します。

8. AV P.C.B.の外し方

- コネクタ-1101、1102、1201、1401、1601を外します。(Fig. 6)
- 14のネジ4本を外します。(Fig. 7)
- 15のジャックスクリュー2本を外します。(Fig. 7)
- 16のネジ2本を外します。(Fig. 6)
- AV P.C.B.を取り外します。

8. Removal of Power Supply Unit

- Remove the connector CON1. (Fig. 6)
- Remove 2 screws (17). (Fig. 6)
- Release 2 snaps. (Fig. 6)
- Remove the Power Supply Unit.

9. 電源ユニットの外し方

- コネクタ-CON1を外します。(Fig. 6)
- 17のネジ2本を外します。(Fig. 6)
- スナップ2箇所を外します。(Fig. 6)
- 電源ユニットを取り外します。

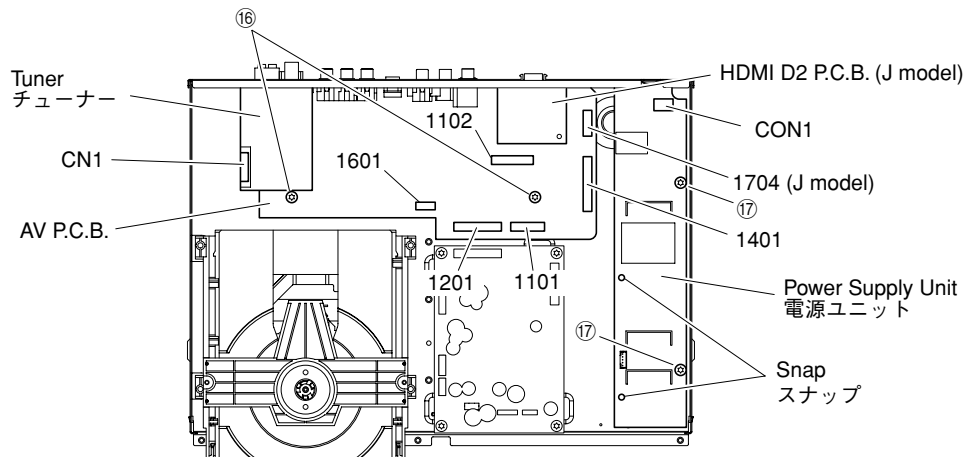

Fig. 6

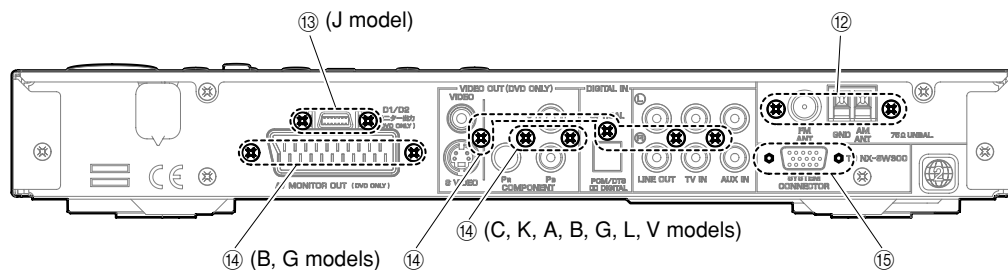

Fig. 7

■ NX-SW301 DISASSEMBLY PROCEDURES / NX-SW301分解手順

(Remove parts in disassembly order as numbered.)

(番号順に部品を取り外してください。)

1. Removal of Front Grille Ass'y

The Front Grille Ass'y is fixed to the cabinet with dowels at 6 locations. As a Flatblade Screwdriver is used for removal, use special care not to cause damage to the cabinet.

- a. Using the Flatblade Screwdriver inserted in the gap between the Front Grille Ass'y and the cabinet (bottom side first), push up the Front Grille Ass'y. (Fig. 1)
- b. Remove the Front Grille Ass'y by lifting it up.
 - * When installing the Front Grille Ass'y, apply quick-drying bond to the dowels and then fit them into dowel holes for secure installation. (The Front Grille Ass'y will come off easily if its dowels are fitted into dowel holes only.)

1. フロントグリルASSYの外し方

フロントグリルASSYは6箇所のダボで固定されています。取り外しの際、本体に傷が付かないよう十分注意してください。

- a. 底側からマイナスドライバー等を差し込み、フロントグリルASSYを押し上げます。(Fig. 1)
- b. 徐々に上面へマイナスドライバー等で押し上げて、フロントグリルASSYを外します。
 - * 取付時には、フロントグリルASSYのダボに速乾ボンドなどを塗って差し込み、固定してください。(フロントグリルASSYを差し込むだけでは、簡単にはずれてしまいます。)

2. Removal of Rear Panel Ass'y

- a. Remove 4 screws (①) and then remove the Heat Sink Cover. (Fig. 2)
- b. Remove 10 screws (②) and then take out the Rear Panel Ass'y. (Fig. 2)
 - * Arrow Marks (⇒) are printed to identify the screws to be removed.
 - * When assembling the Rear Panel, check to ensure that the packing is not damaged so as to prevent air leakage from occurring.

2. リアパネルASSYの外し方

- a. ①のネジ4本を外し、ヒートシンクカバーを外します。(Fig. 2)
- b. ②のネジ10本を外し、リアパネルASSYを取り出します。(Fig. 2)
 - * 取り外すネジの箇所には矢印(⇒)が印刷されています。
 - * 組み立ての際は、パッキングの損傷など無いことを確認し、エアリークが発生しないように組み立ててください。

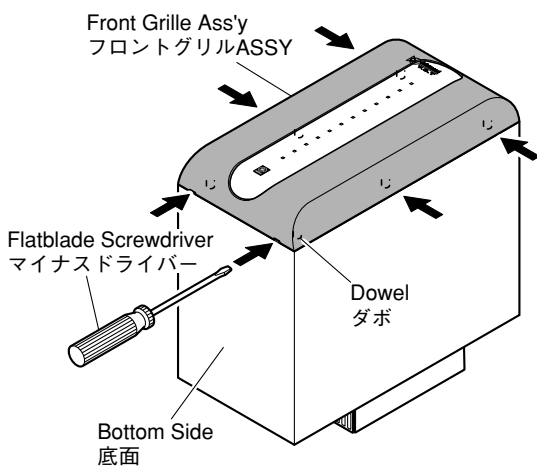

Fig. 1

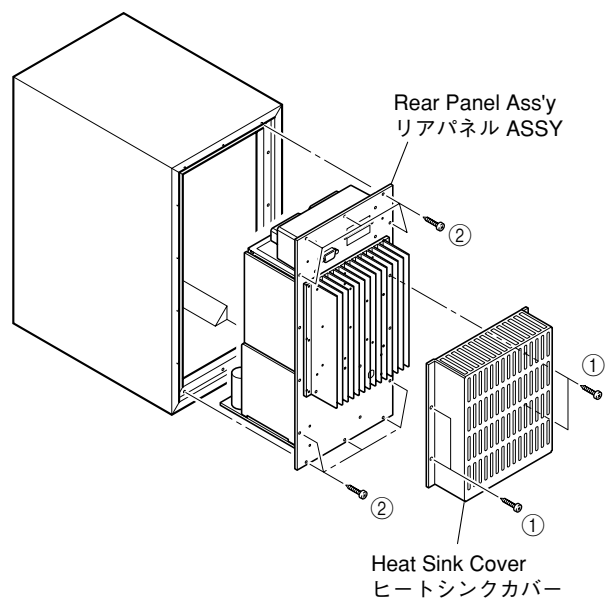

Fig. 2

When checking the P.C.B.

Turn on the power to NX-SW301 according to the following procedure.

- a. Short between the terminals No.1 and No.5 of SYSTEM CONNECTOR.
- b. Connect the power cable to the AC power outlet.

P.C.B.動作チェックをする場合

下記の方法により、NX-SW301に電源を投入します。

- a. システムコネクターの端子間(1pin <-> 5pin)をショートします。
- b. 電源コードをAC電源コンセントに接続します。

POWER (3) IN/OUT P.C.B.

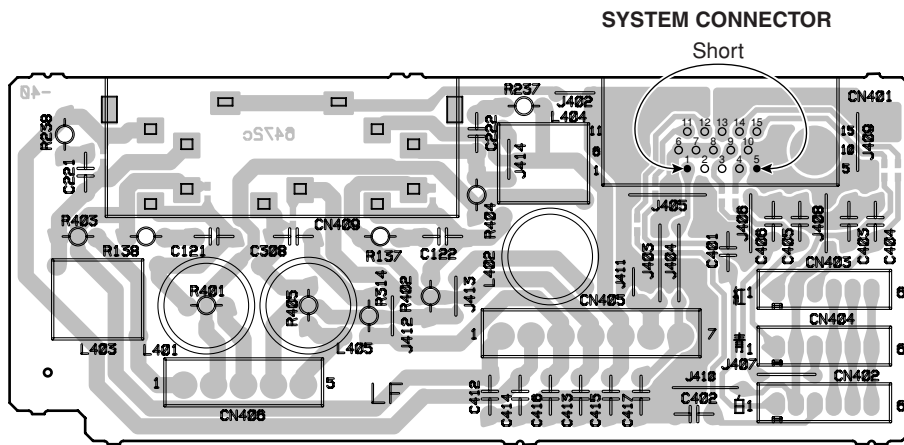

POWER (3) IN/OUT SCHEMATIC DIAGRAM

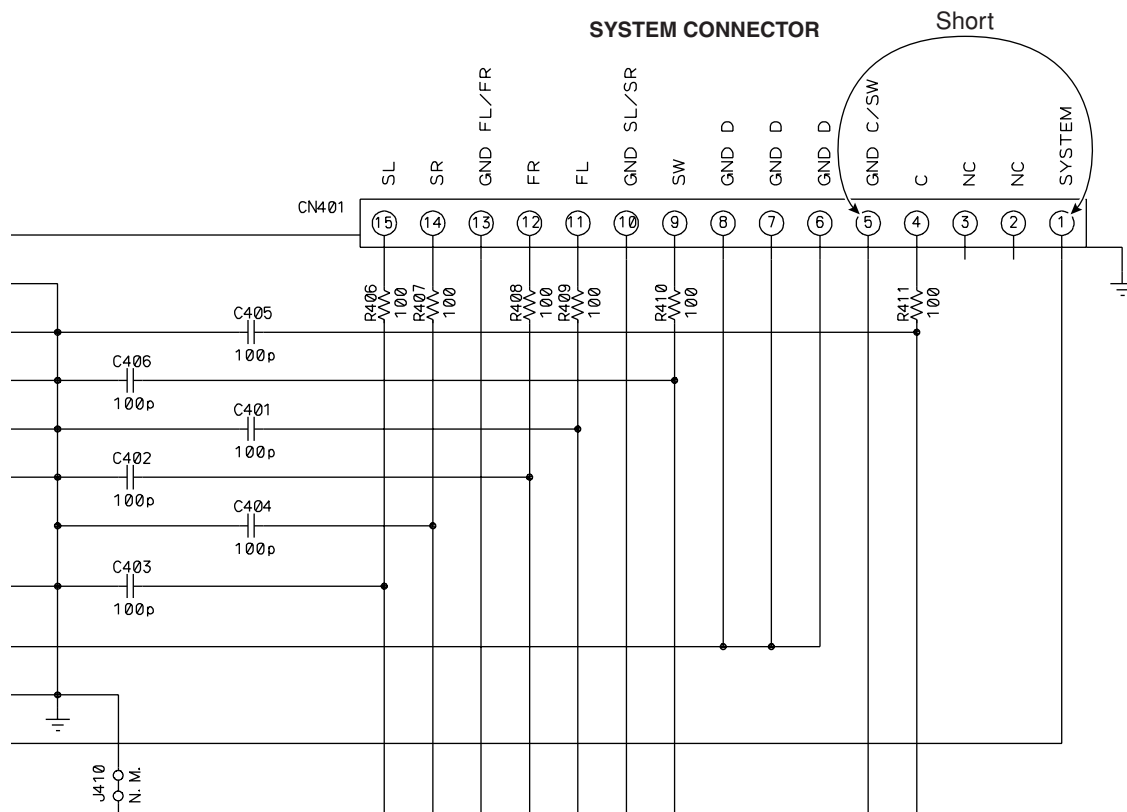

DVR-S300
NX-P301/NX-P302

MEMO

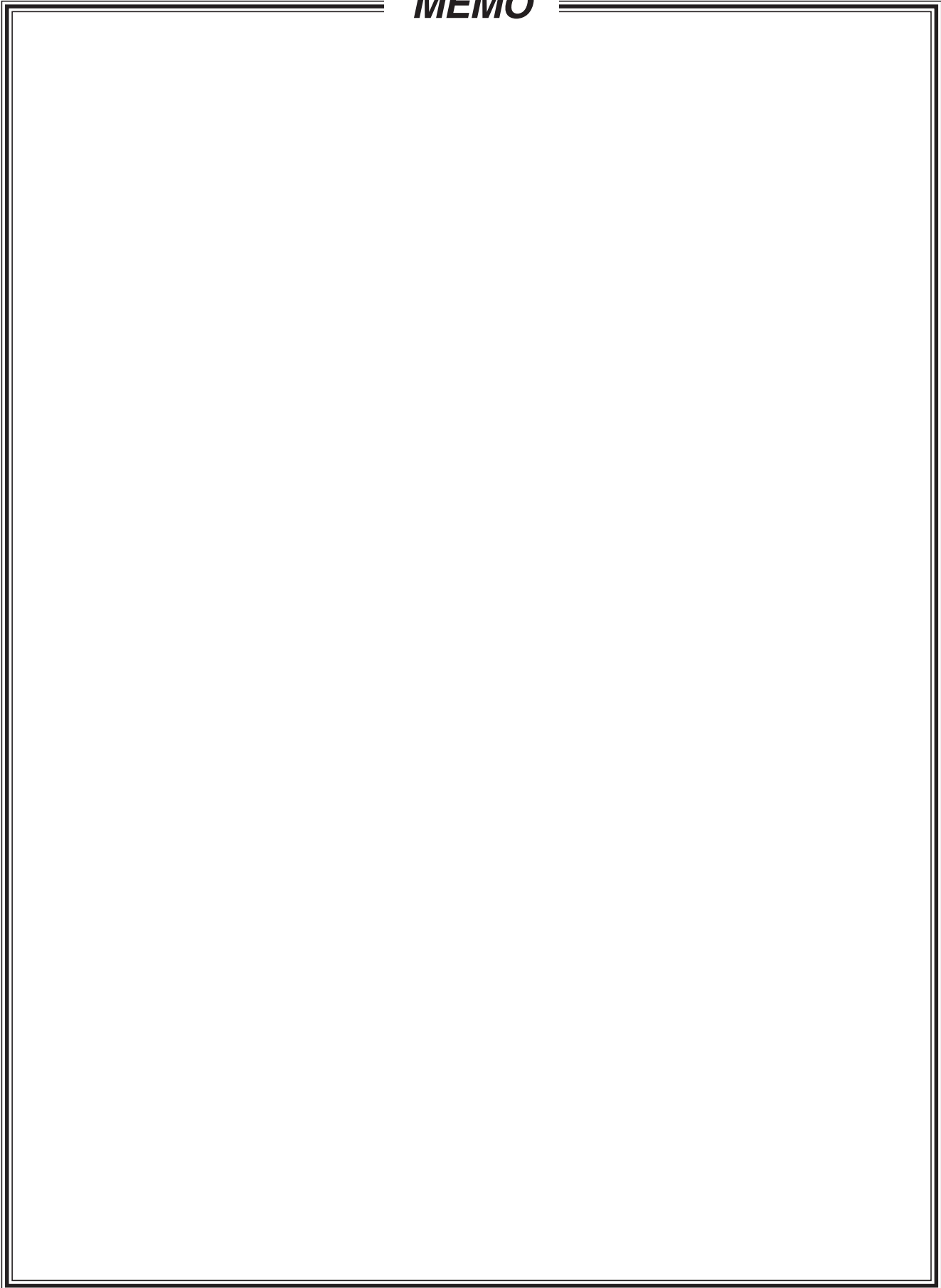

DVR-S300
NX-P301/NX-P302

■ DVR-S300 BLOCK DIAGRAM

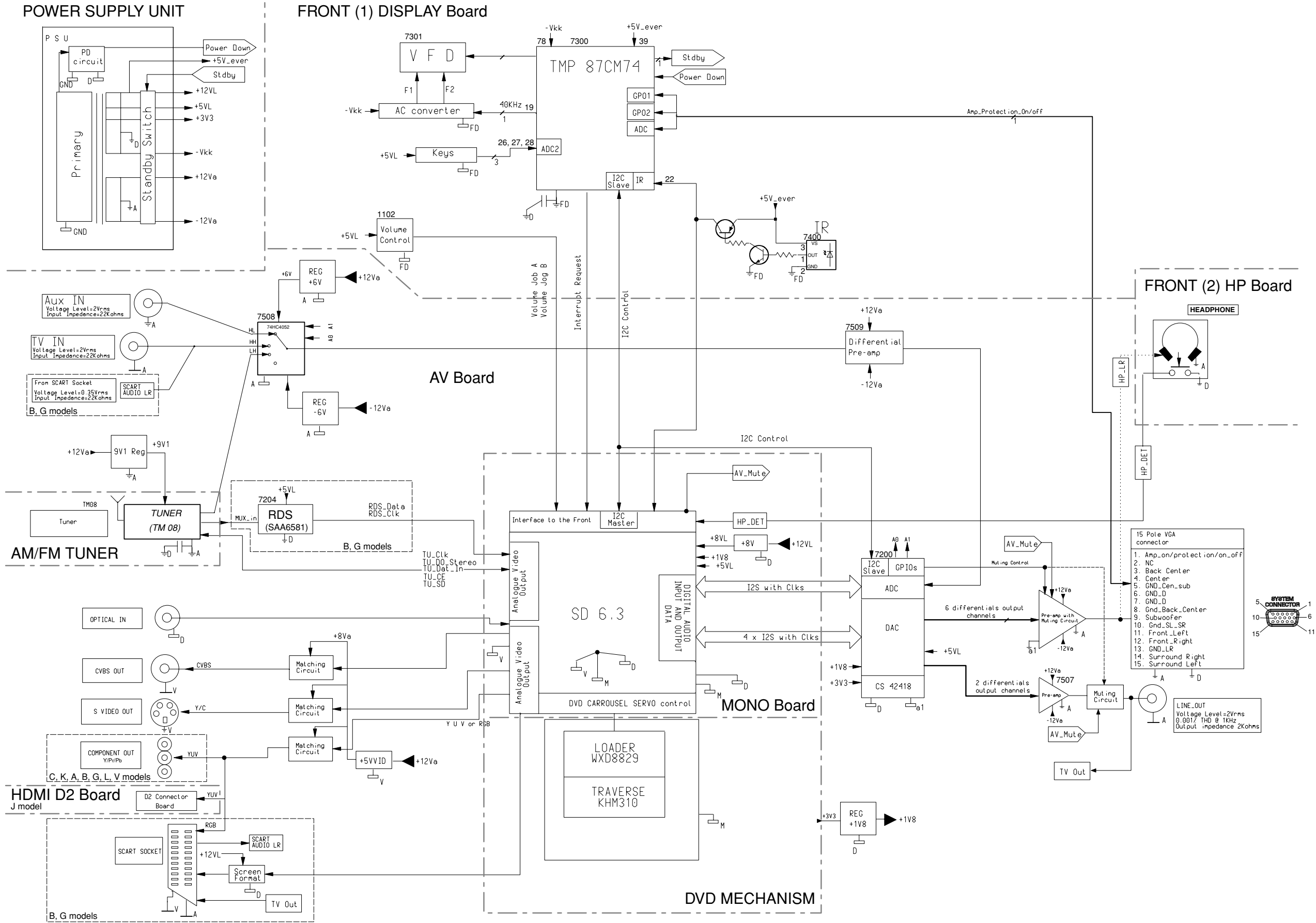

NX-SW301 BLOCK DIAGRAM (1/2)

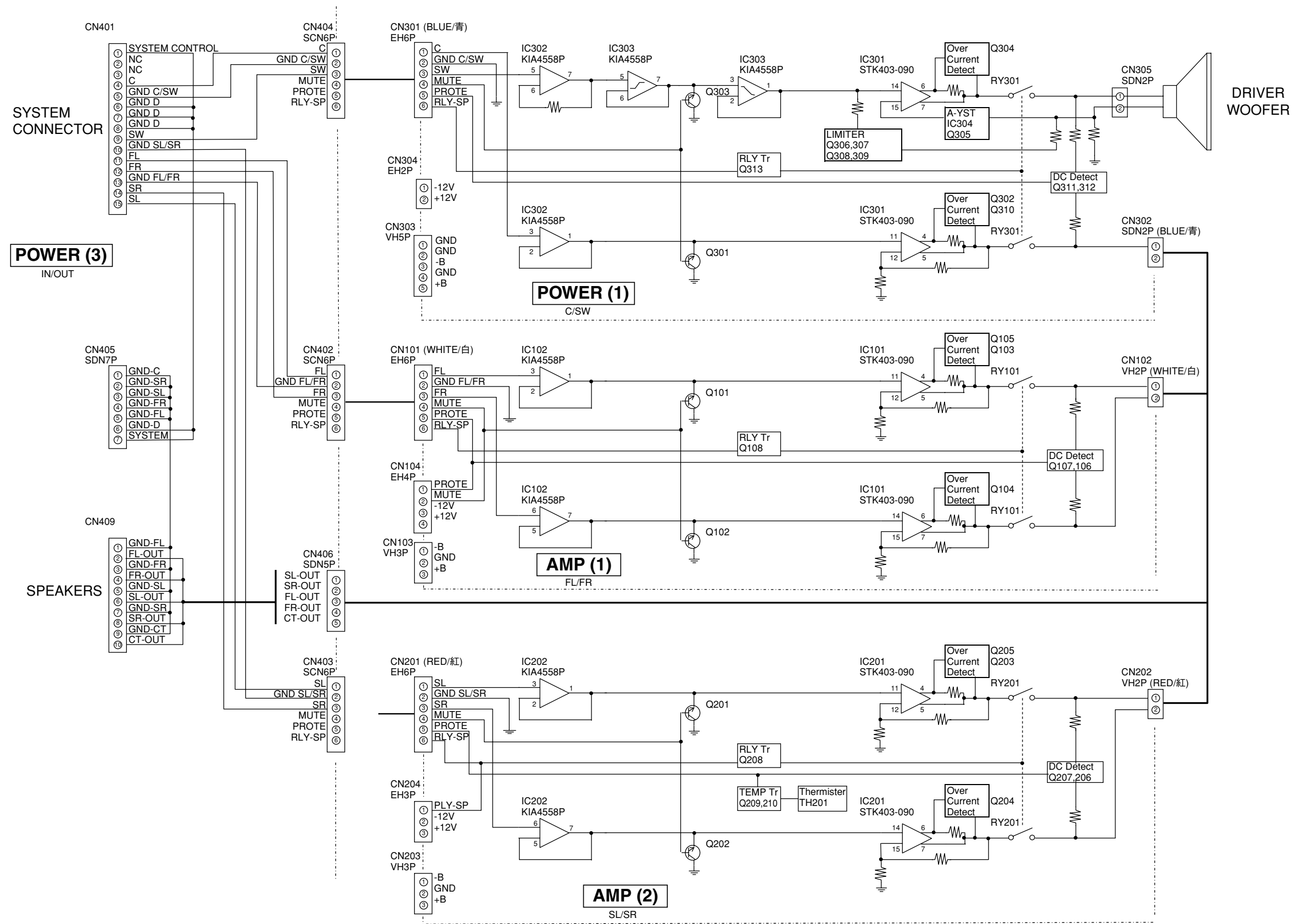

■ NX-SW301 BLOCK DIAGRAM (2/2)

POWER (2)
POWER

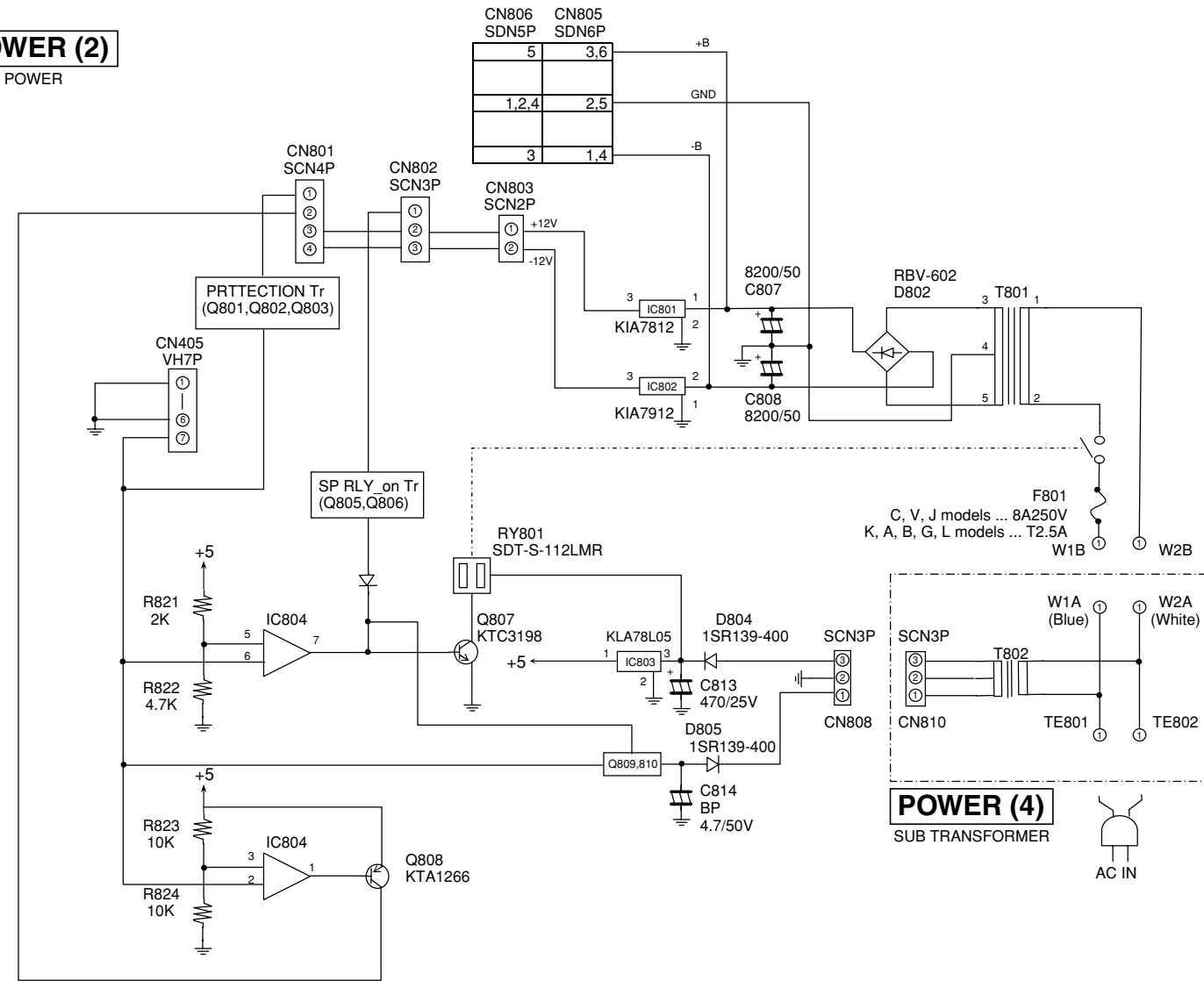

DVR-S300 WIRING DIAGRAM

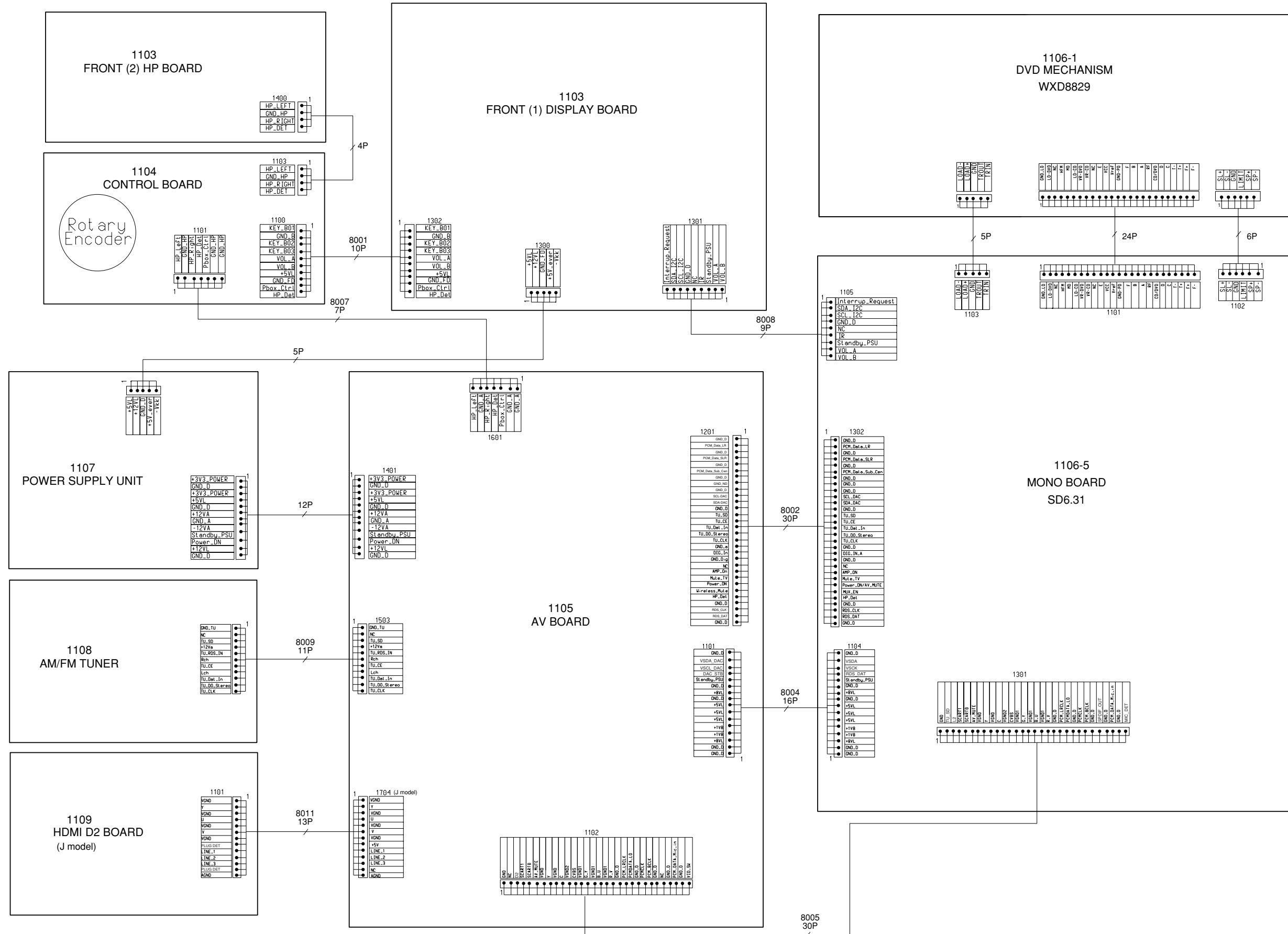

NX-SW301 WIRING DIAGRAM

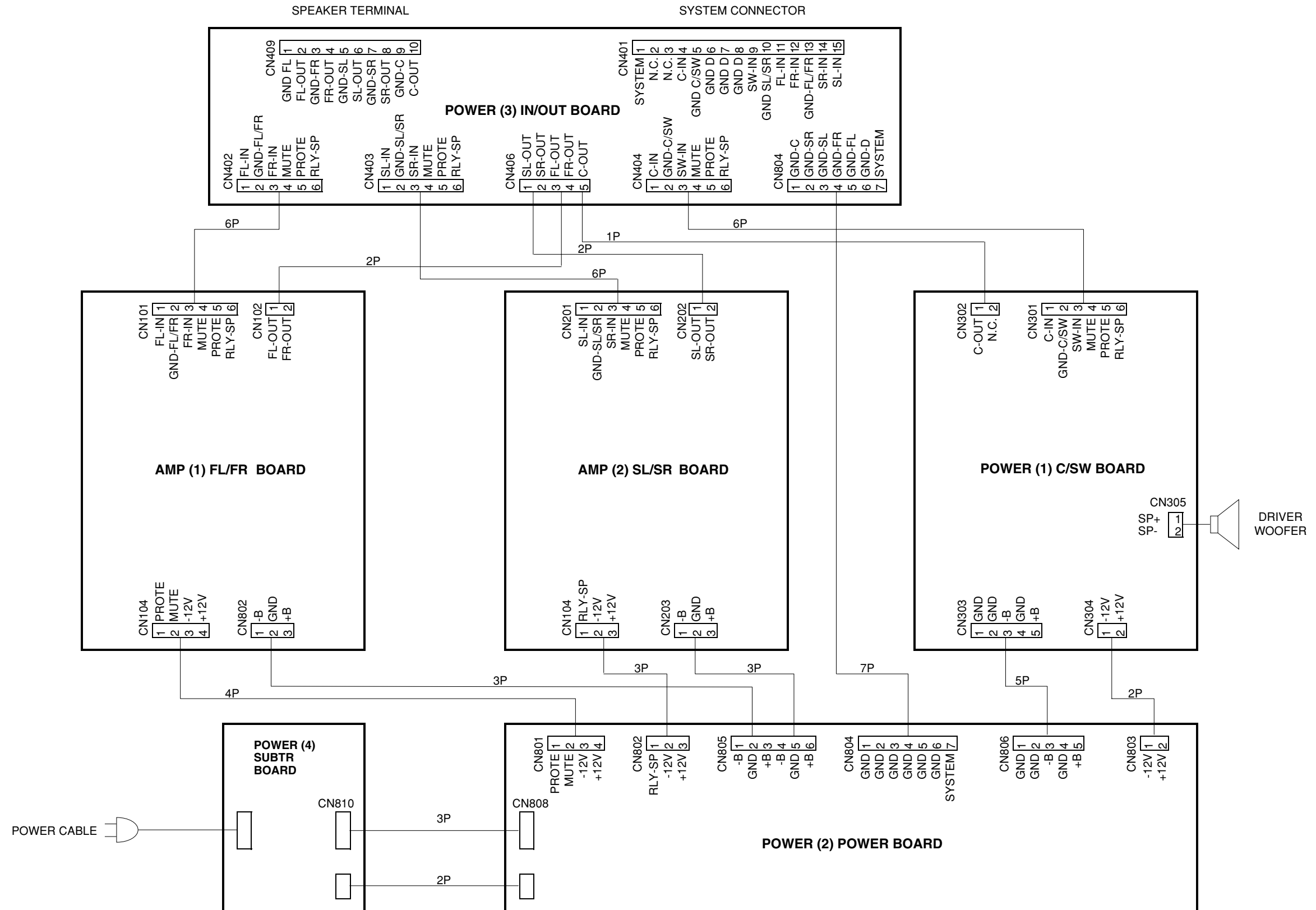

DVR-S300 PRINTED CIRCUIT BOARD

FOR INFORMATION ONLY (NO REPLACEMENT COMPONENT PARTS WILL BE AVAILABLE)

The first digit of a component indicates the component type.

1xxx : Connector 3xxx : Resistor 5xxx : Coil 7xxx : IC, Transistor, FET
 2xxx : Capacitor 4xxx : SMD jumper 6xxx : Diode 9xxx : Wire jumper

MONO Board-Top View

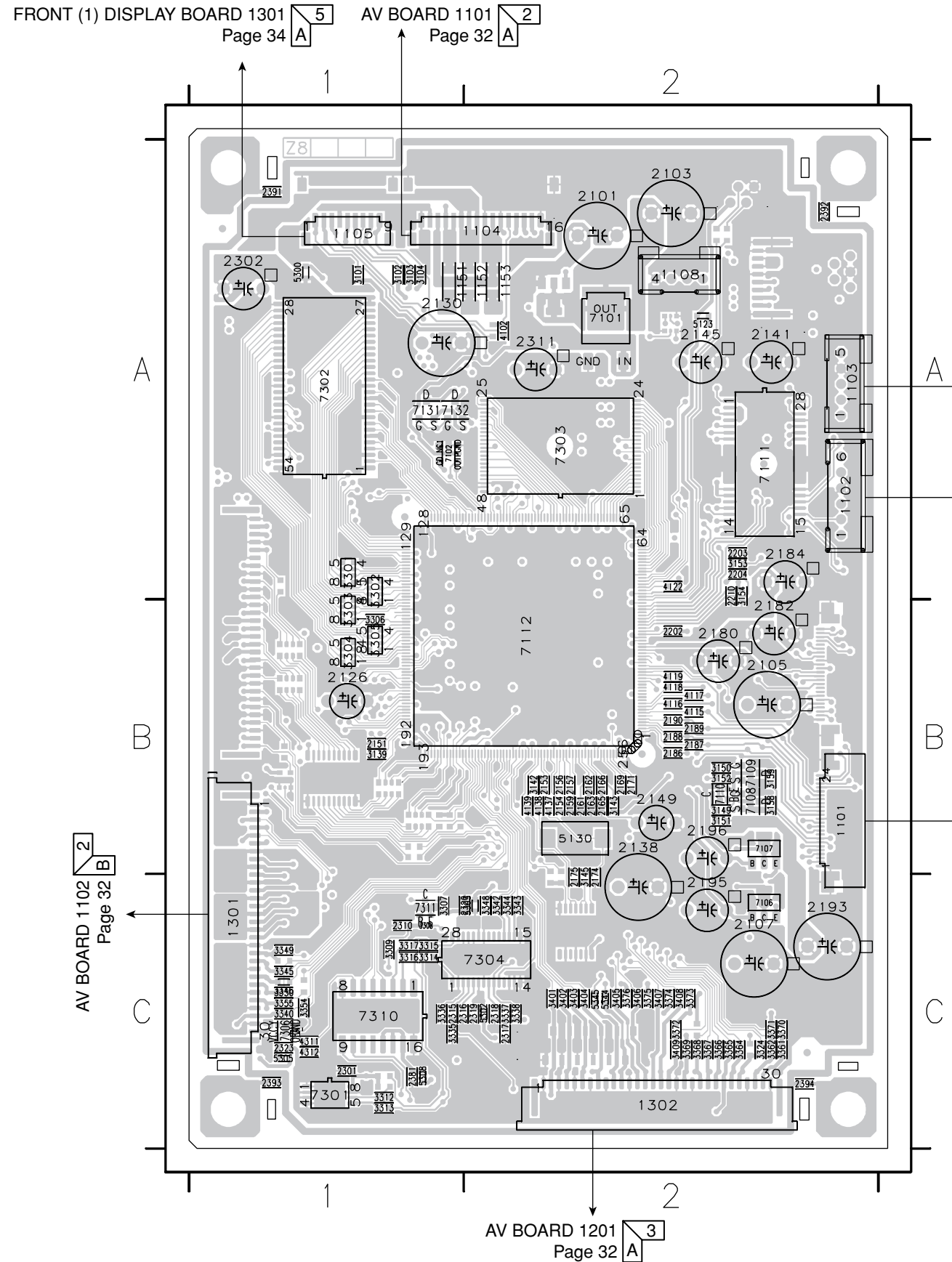

1101	B2	3102	A1	3407	C2
1102	A2	3103	A1	3408	C2
1103	A2	3104	A1	3409	C2
1104	A2	3139	B1	4102	A2
1105	A1	3140	B1	4115	B2
1108	A2	3142	B2	4116	B2
1151	A1	3143	B2	4117	B2
1152	A2	3145	C2	4118	B2
1153	A2	3149	B2	4119	B2
1301	C1	3150	B2	4122	A2
1302	C2	3151	B2	4137	B2
2101	A2	3152	B2	4138	B2
2103	A2	3153	A2	4139	B2
2105	B2	3154	A2	4311	C1
2107	C2	3158	B2	4312	C1
2126	B1	3159	B2	5123	A2
2130	A1	3301	A1	5130	B2
2138	B2	3302	A1	5300	A1
2141	A2	3303	B1	5302	C2
2145	A2	3304	B1	5303	C2
2149	B2	3305	B1	5305	C1
2151	B1	3306	B1	5308	C1
2153	B2	3307	C1	5344	C2
2154	B2	3308	C1	5345	C2
2156	B2	3309	C1	7101	A2
2157	B2	3312	C1	7102	A1
2159	B2	3313	C1	7106	C2
2161	B2	3314	C1	7107	B2
2162	B2	3315	C1	7108	B2
2163	B2	3316	C1	7109	B2
2165	B2	3317	C1	7110	B2
2166	B2	3335	C1	7111	A2
2169	B2	3336	C1	7112	B2
2171	B2	3337	C2	7131	A1
2174	C2	3338	C2	7132	A1
2175	C2	3340	C1	7301	C1
2180	B2	3342	C2	7302	A1
2182	B2	3343	C2	7303	A2
2184	A2	3344	C2	7304	C2
2186	B2	3345	C1	7306	C1
2187	B2	3346	C1	7310	C1
2188	B2	3348	C2	7311	C1
2189	B2	3349	C1		
2190	B2	3350	C1		
2193	C2	3354	C1		
2195	C2	3355	C1		
2196	B2	3361	C2		
2202	B2	3362	C2		
2203	A2	3363	C2		
2204	A2	3364	C2		
2210	A2	3365	C2		
2301	C1	3366	C2		
2302	C1	3367	C2		
2310	A1	3368	C2		
2311	A2	3369	C2		
2315	C1	3370	C2		
2316	C1	3371	C2		
2317	C2	3372	C2		
2318	C2	3373	C2		
2319	C2	3374	C2		
2320	C2	3375	C2		
2323	C1	3376	C2		
2381	C1	3401	C2		
2391	A1	3402	C2		
2392	A2	3403	C2		
2393	C1	3404	C2		
2394	C2	3405	C2		
3101	A1	3406	C2		

DVD MECHANISM

■ DVR-S300 PRINTED CIRCUIT BOARD

FOR INFORMATION ONLY (NO REPLACEMENT COMPONENT PARTS WILL BE AVAILABLE)

MONO Board-Bottom View

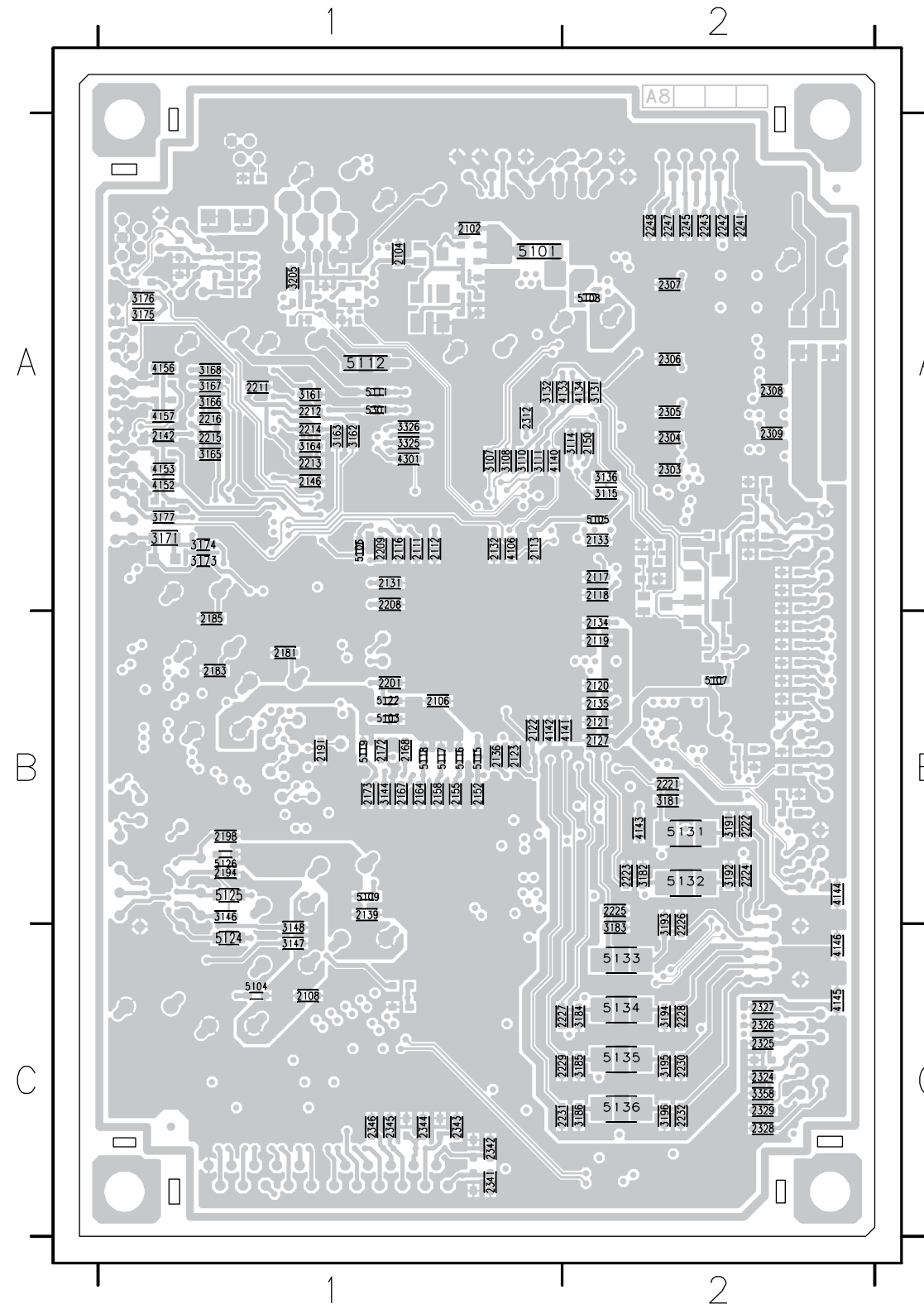

The first digit of a component indicates the component type.

- 1xxx : Connector 3xxx : Resistor 5xxx : Coil 7xxx : IC, Transistor, FET
- 2xxx : Capacitor 4xxx : SMD jumper 6xxx : Diode 9xxx : Wire jumper

2102	A1	2303	A2	3378	C1
2104	A1	2304	A2	3379	C1
2106	B1	2305	A2	3380	C1
2108	C1	2306	A2	3398	B2
2111	A1	2307	A2	4106	A1
2112	A1	2308	A2	4133	A2
2113	A1	2309	A2	4134	A2
2116	A1	2312	A1	4135	A2
2117	A2	2324	C2	4136	B2
2118	A2	2325	C2	4140	A1
2119	B2	2326	C2	4141	B2
2120	B2	2327	C2	4142	B1
2121	B2	2328	C2	4143	B2
2122	B1	2329	C2	4144	B2
2123	B1	2341	C1	4145	C2
2127	B2	2342	C1	4146	C2
2131	A1	2343	C1	4151	A1
2132	A1	2344	C1	4152	A1
2133	A2	2345	C1	4153	A1
2134	B2	2346	C1	4154	A1
2135	B2	3107	A1	4155	A1
2136	B1	3108	A1	4156	A1
2139	B1	3110	A1	4157	A1
2142	A1	3111	A1	4158	A1
2146	A1	3114	A2	4301	A1
2150	A2	3115	A2	5101	A1
2152	B1	3131	A2	5103	B1
2155	B1	3132	A1	5104	C1
2158	B1	3136	A2	5105	A2
2164	B1	3144	B1	5106	A1
2167	B1	3146	B1	5107	B2
2168	B1	3147	C1	5108	A2
2172	B1	3148	C1	5109	B1
2173	B1	3161	A1	5111	A1
2181	B1	3162	A1	5112	A1
2183	B1	3163	A1	5115	B1
2185	B1	3164	A1	5116	B1
2191	B1	3165	A1	5117	B1
2194	B1	3166	A1	5118	B1
2198	B1	3167	A1	5119	B1
2201	B1	3168	A1	5122	B1
2208	A1	3171	A1	5124	C1
2209	A1	3172	A1	5125	B1
2211	A1	3173	A1	5126	B1
2212	A1	3174	A1	5131	B2
2213	A1	3175	A1	5132	B2
2214	A1	3176	A1	5133	C2
2215	A1	3177	A1	5134	C2
2216	A1	3178	A1	5135	C2
2221	B2	3181	B2	5136	C2
2222	B2	3182	B2	5301	A1
2223	B2	3183	C2		
2224	B2	3184	C2		
2225	B2	3185	C2		
2226	C2	3186	C2		
2227	C1	3191	B2		
2228	C2	3192	B2		
2229	C1	3193	C2		
2230	C2	3194	C2		
2231	C1	3195	C2		
2232	C2	3196	C2		
2241	A2	3205	A1		
2242	A2	3325	A1		
2243	A2	3326	A1		
2245	A2	3358	C2		
2247	A2	3359	C2		
2248	A2	3377	C1		

DVR-S300 PRINTED CIRCUIT BOARD

FOR INFORMATION ONLY (NO REPLACEMENT COMPONENT PARTS WILL BE AVAILABLE)

AV Board-Top View

The first digit of a component indicates the component type.

- 1xxx : Connector 3xxx : Resistor 5xxx : Coil 7xxx : IC, Transistor, FET
- 2xxx : Capacitor 4xxx : SMD jumper 6xxx : Diode 9xxx : Wire jumper

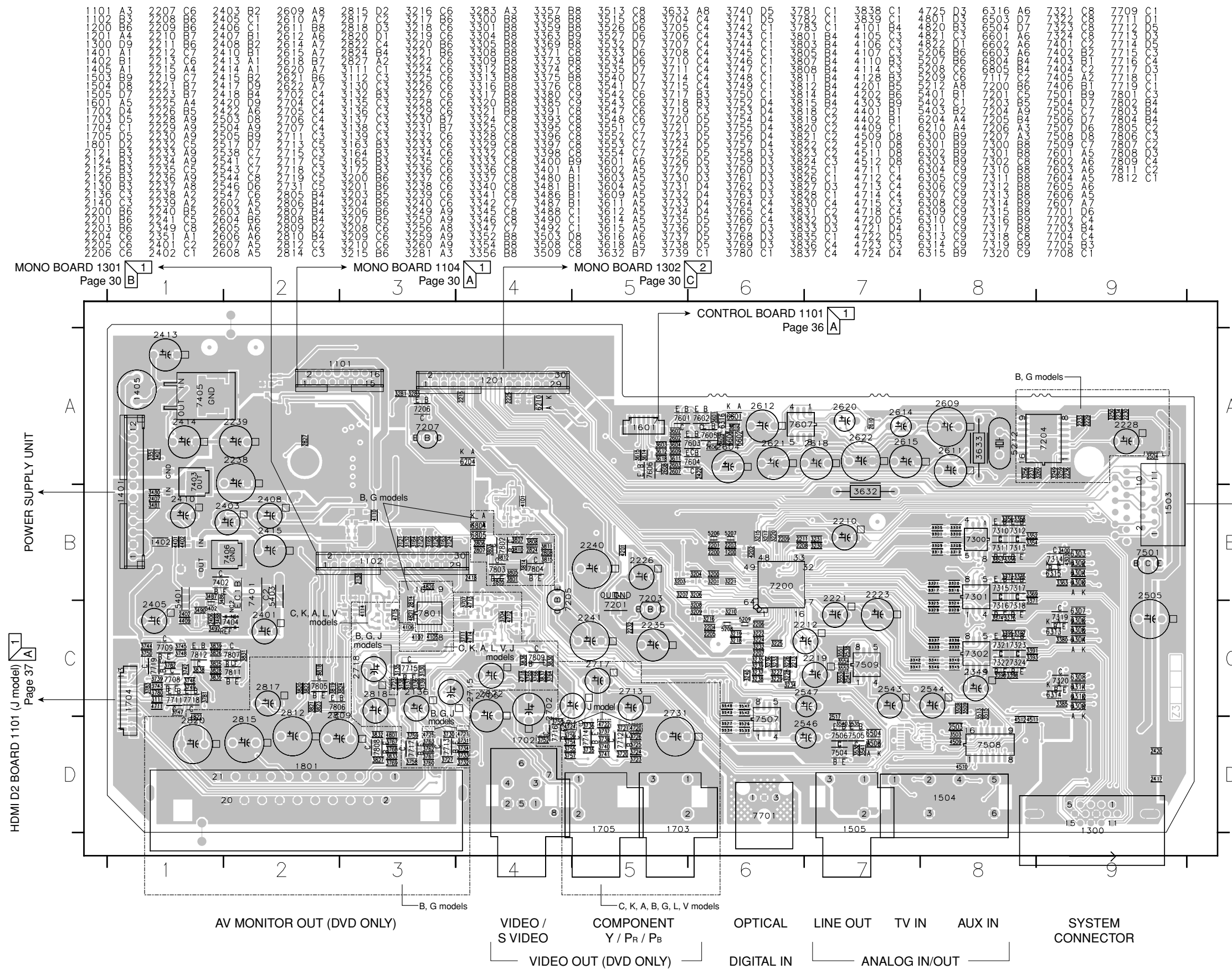

■ **DVR-S300 PRINTED CIRCUIT BOARD**

FOR INFORMATION ONLY (NO REPLACEMENT COMPONENT PARTS WILL BE AVAILABLE)

The first digit of a component indicates the component type.

1xxx : Connector 3xxx : Resistor 5xxx : Coil 7xxx : IC, Transistor, FET
 2xxx : Capacitor 4xxx : SMD jumper 6xxx : Diode 9xxx : Wire jumper

FRONT (2) HP Board-Top View

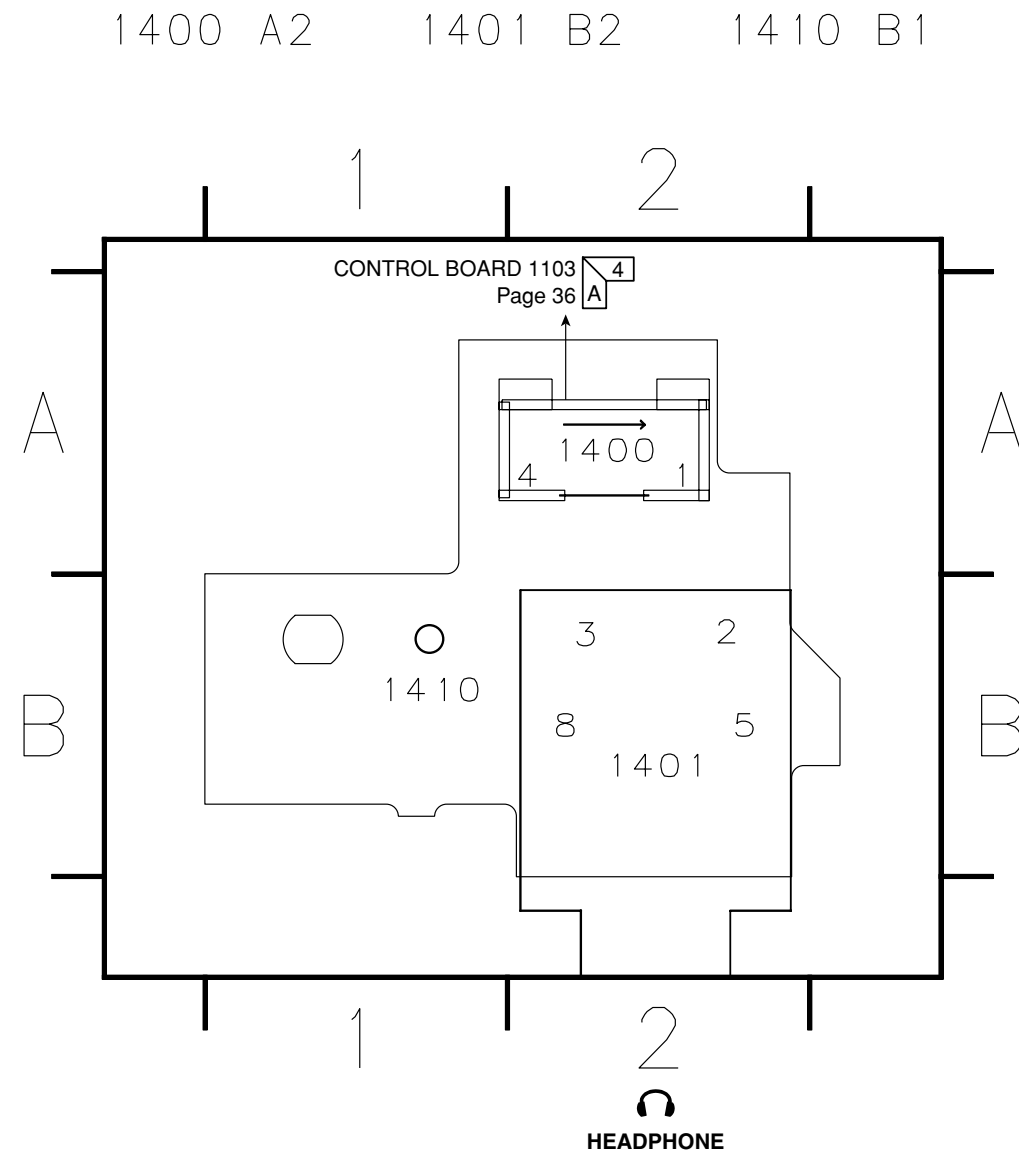

FRONT (2) HP Board-Bottom View

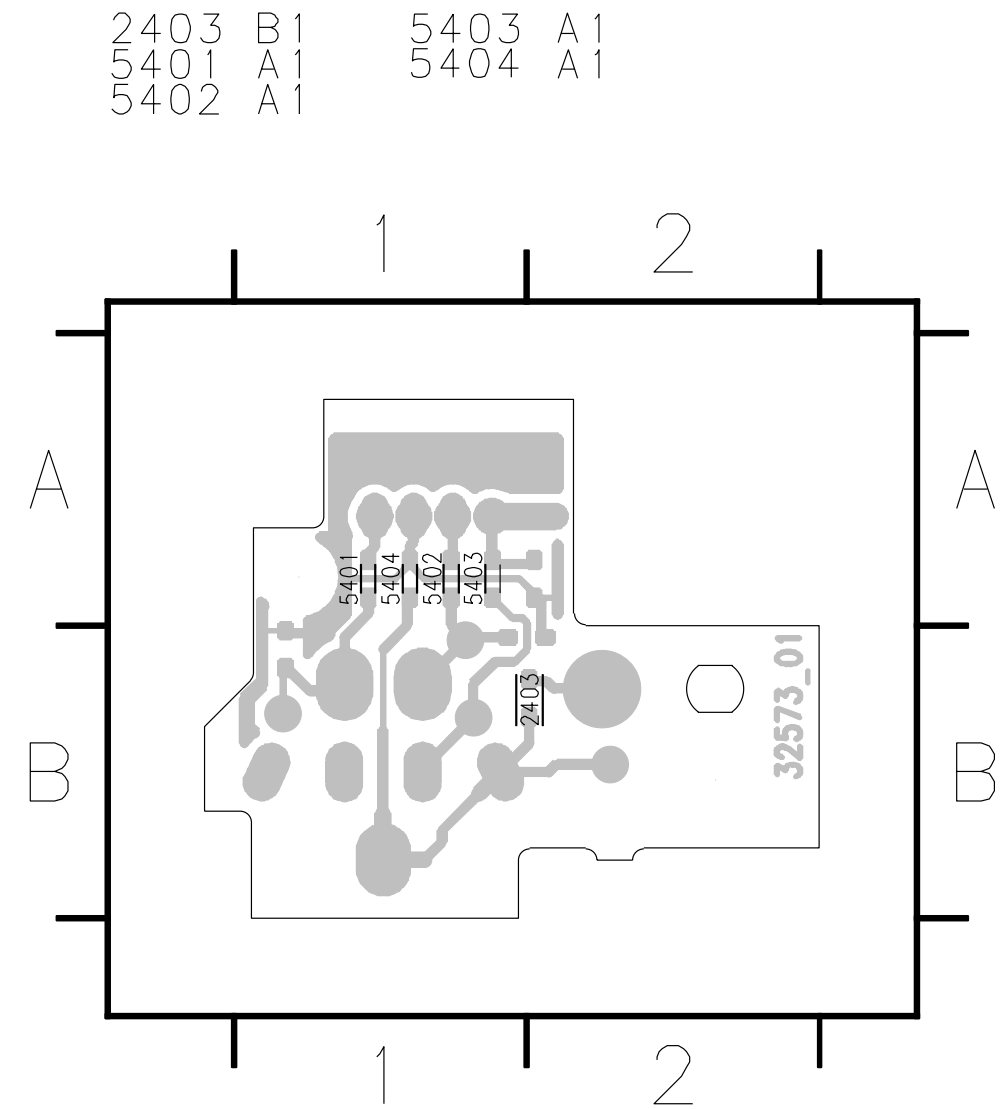

DVR-S300 PRINTED CIRCUIT BOARD

FOR INFORMATION ONLY (NO REPLACEMENT COMPONENT PARTS WILL BE AVAILABLE)

The first digit of a component indicates the component type.

- 1xxx : Connector 3xxx : Resistor 5xxx : Coil 7xxx : IC, Transistor, FET
- 2xxx : Capacitor 4xxx : SMD jumper 6xxx : Diode 9xxx : Wire jumper

CONTROL Board-Top View

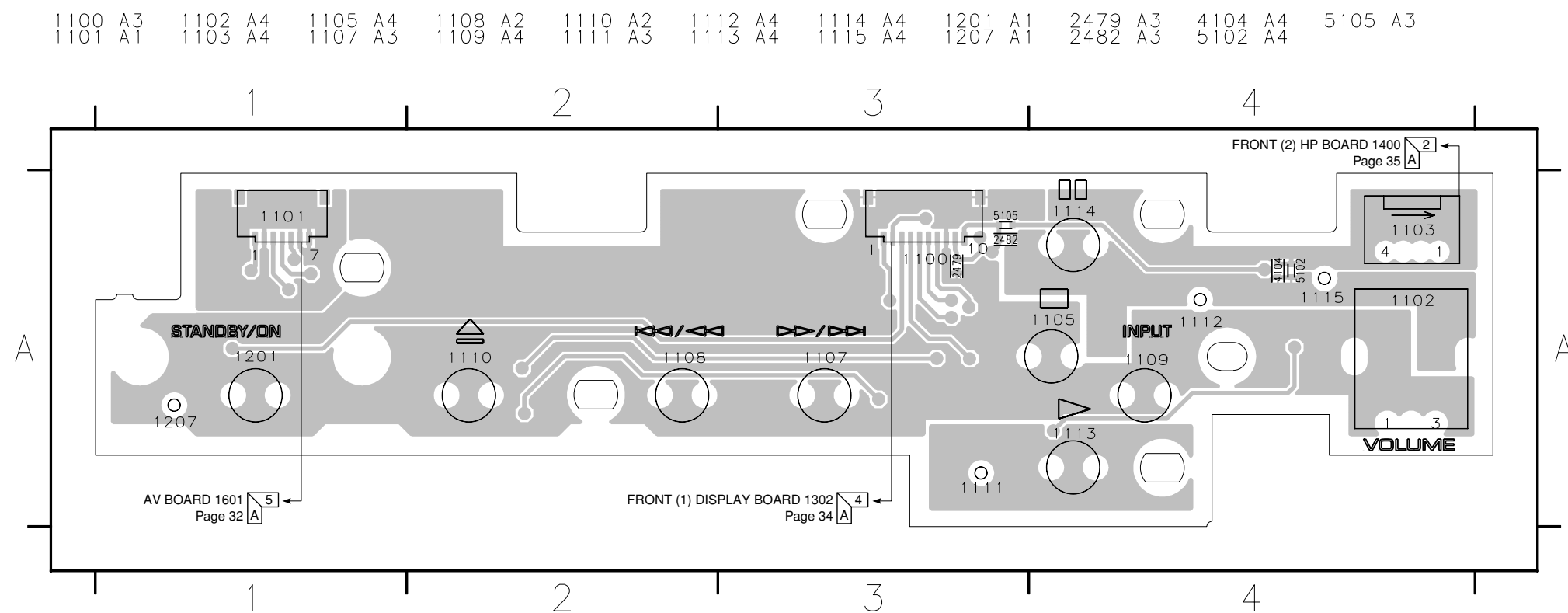

CONTROL Board-Bottom View

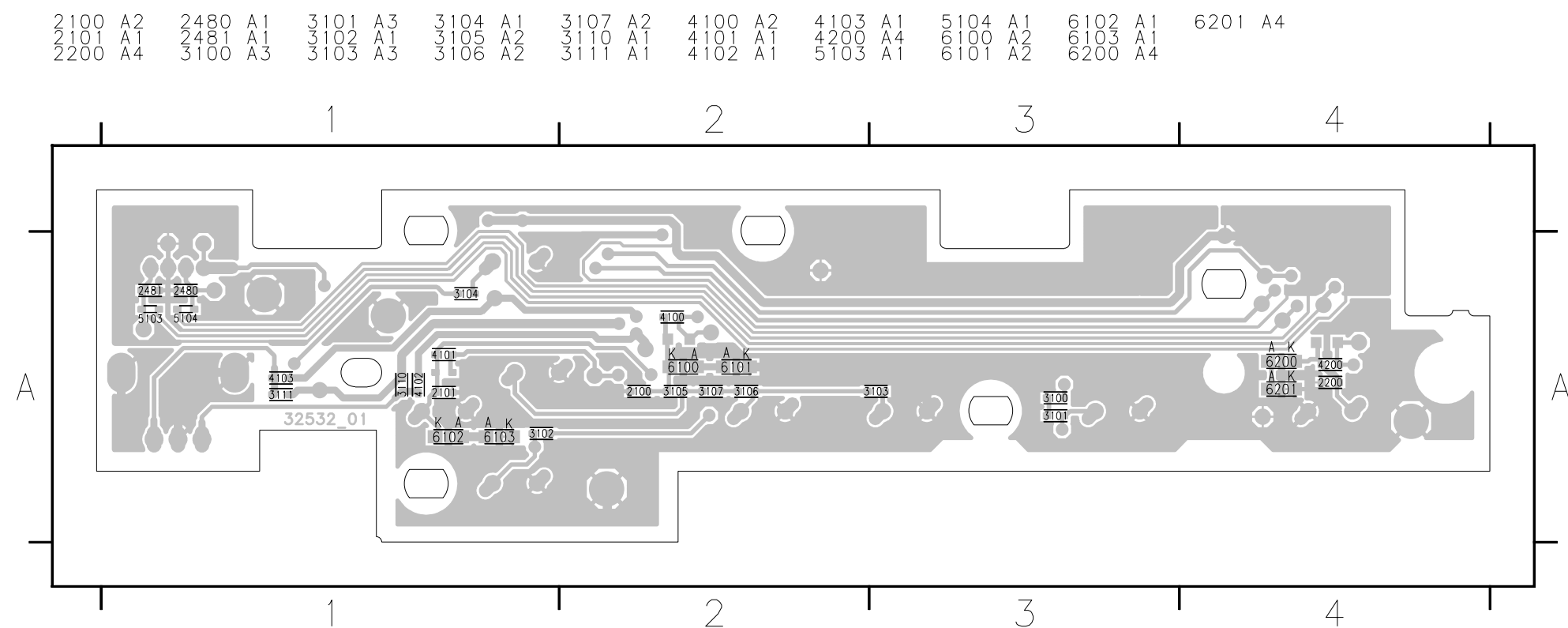

■ **DVR-S300 PRINTED CIRCUIT BOARD**

FOR INFORMATION ONLY (NO REPLACEMENT COMPONENT PARTS WILL BE AVAILABLE)

The first digit of a component indicates the component type.

1xxx : Connector 3xxx : Resistor 5xxx : Coil 7xxx : IC, Transistor, FET
 2xxx : Capacitor 4xxx : SMD jumper 6xxx : Diode 9xxx : Wire jumper

HDMI D2 Board-Top View (J model)

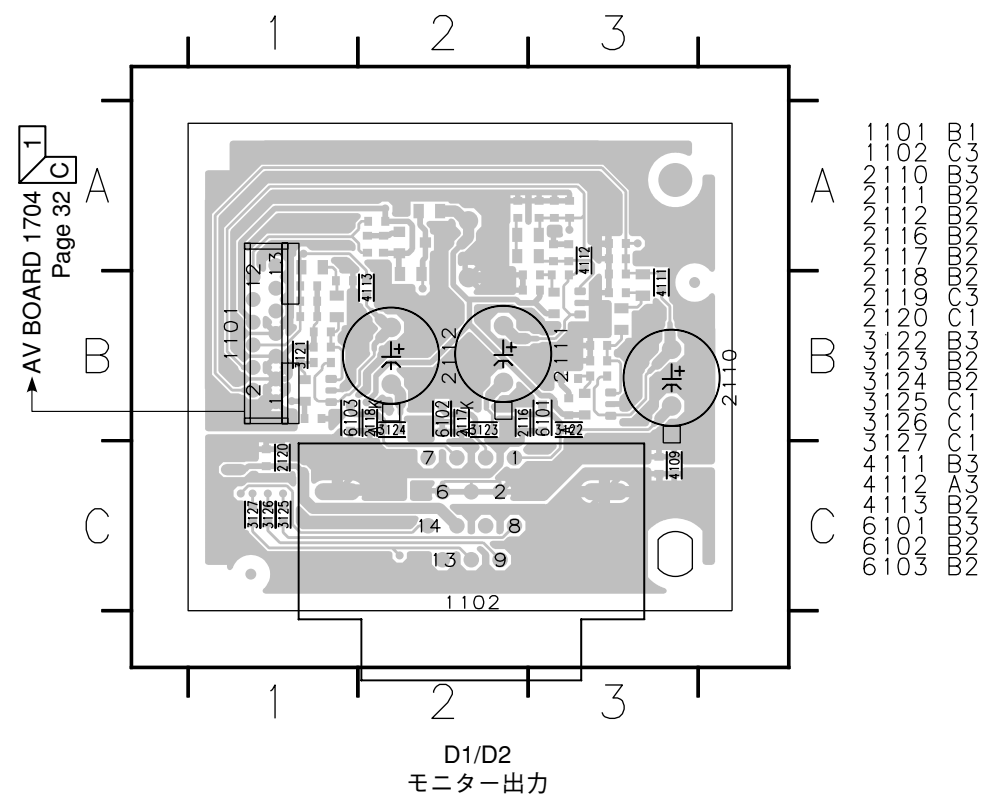

HDMI D2 Board-Bottom View (J model)

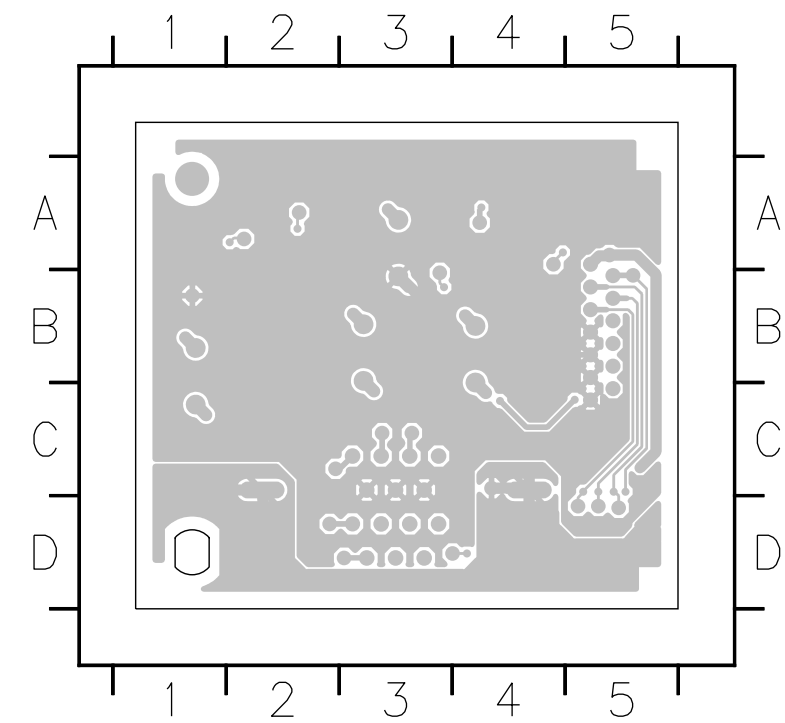

NX-SW301 PRINTED CIRCUIT BOARD

AMP (1) FL/FR Board-Top View

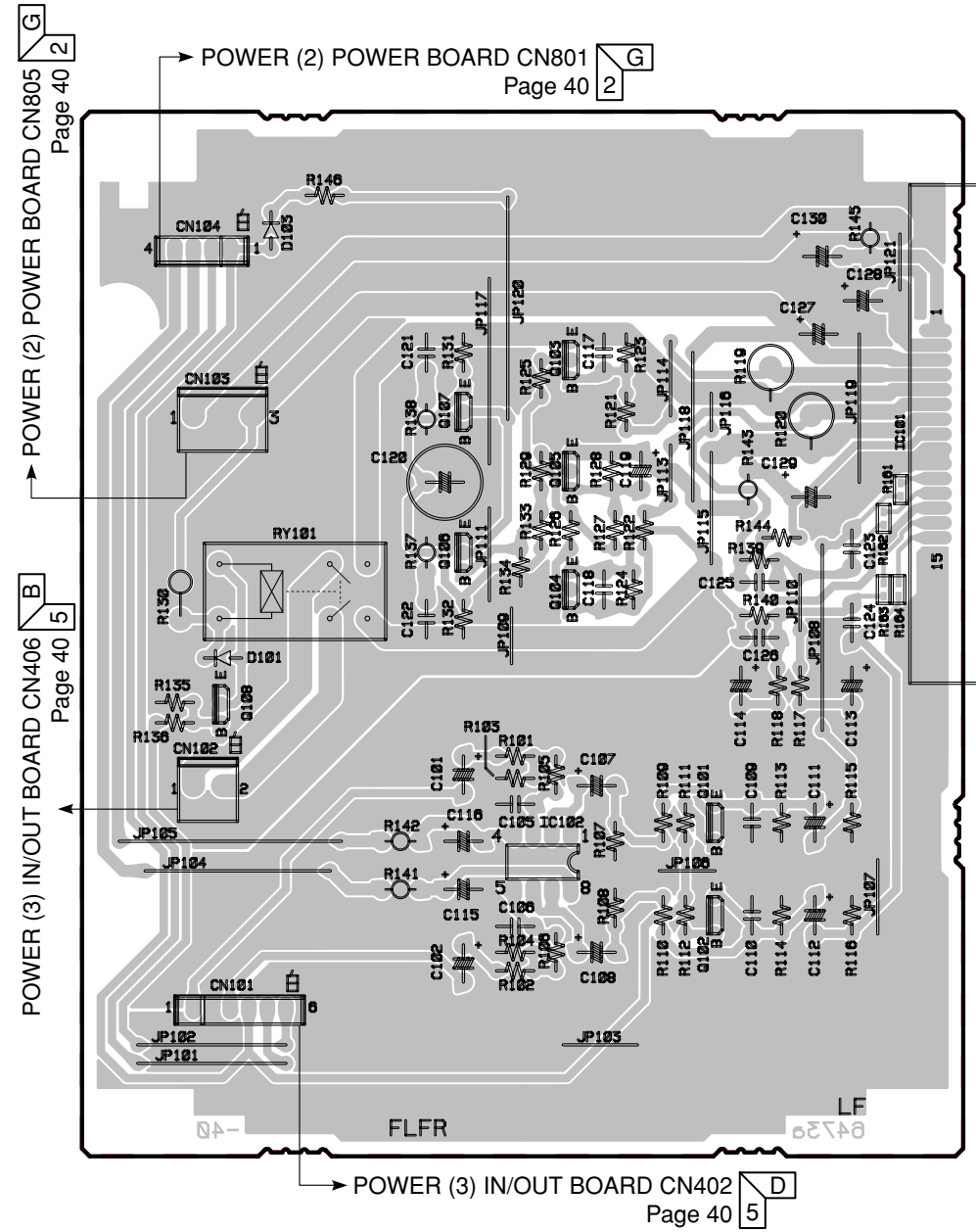

■ NX-SW301 PRINTED CIRCUIT BOARD

AMP (1) FL/FR Board-Top View

(Specifications for the beginnings of production / 生産初期の仕様)

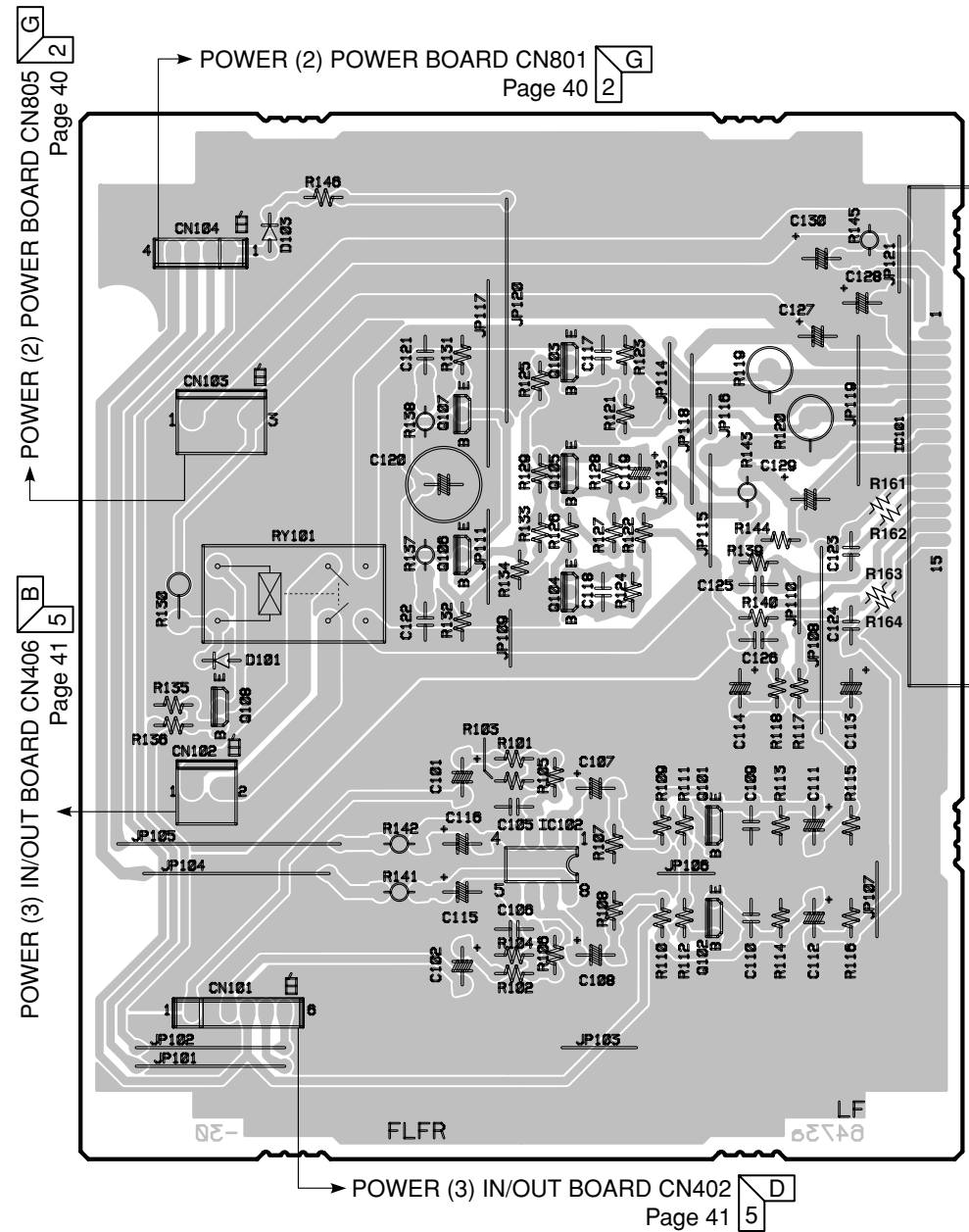

AMP (2) SL/SR Board-Top View

(Specifications for the beginnings of production / 生産初期の仕様)

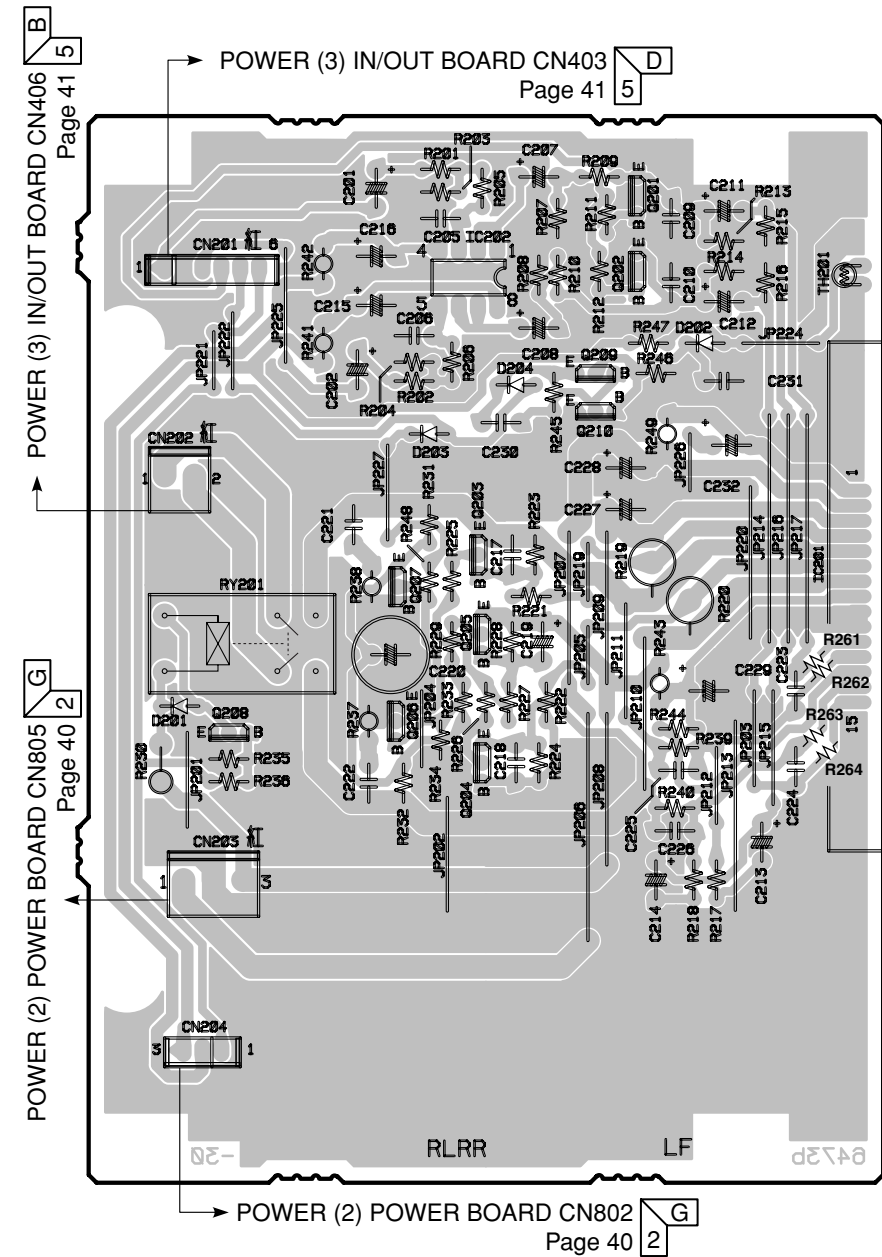

NX-SW301 PRINTED CIRCUIT BOARD

POWER (1) C/SW Board-Top View

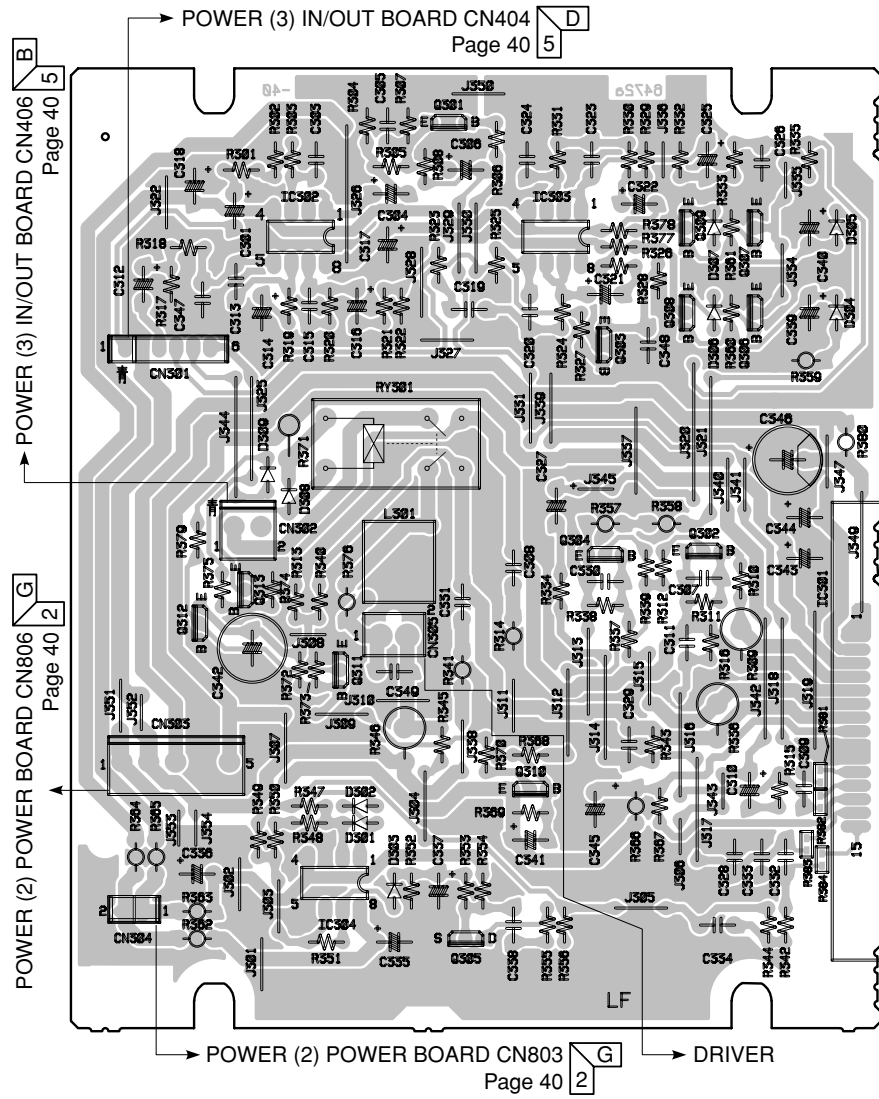

POWER (3) IN/OUT Board-Top View

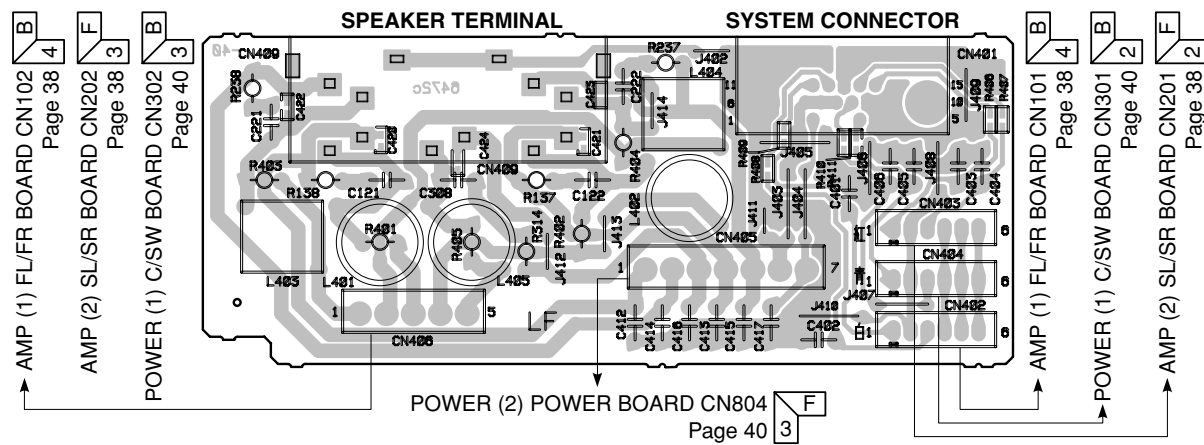

POWER (2) POWER Board-Top View

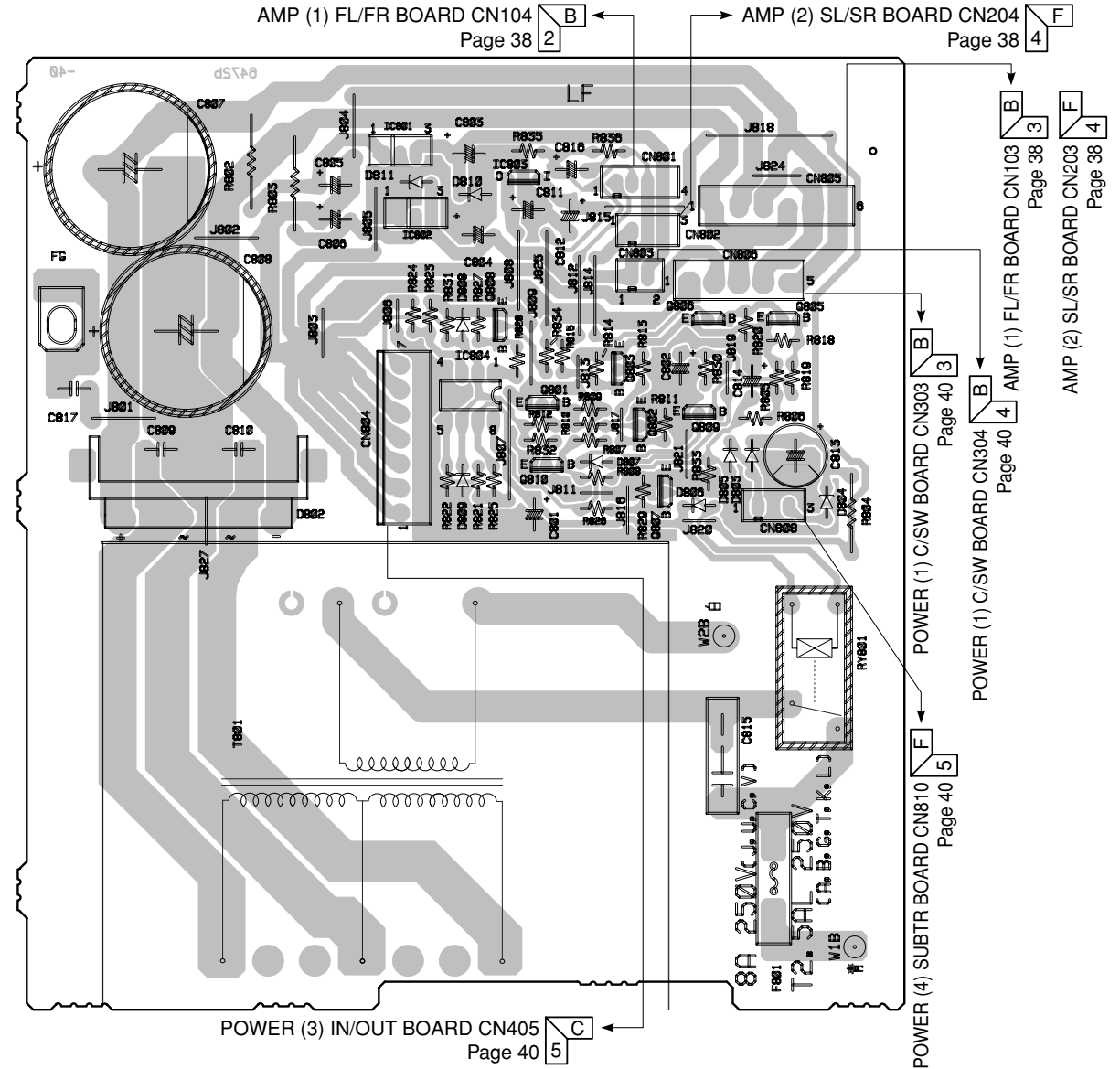

POWER (4) SUBTR Board-Top View

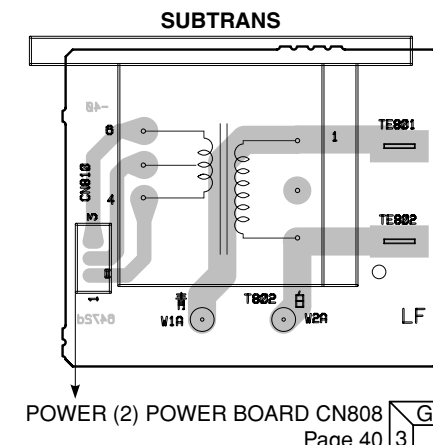

■ NX-SW301 PRINTED CIRCUIT BOARD

POWER (1) C/SW Board-Top View

(Specifications for the beginnings of production / 生産初期の仕様)

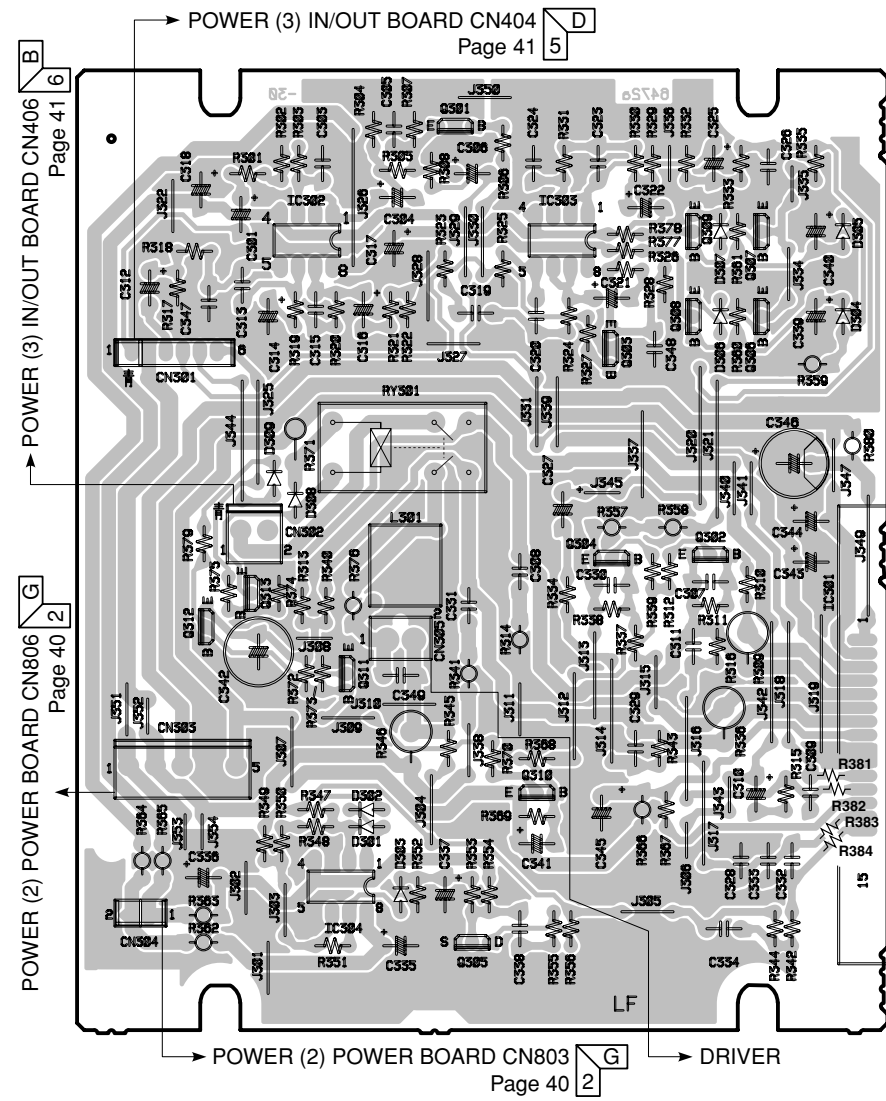

POWER (3) IN/OUT Board-Top View

(Specifications for the beginnings of production / 生産初期の仕様)

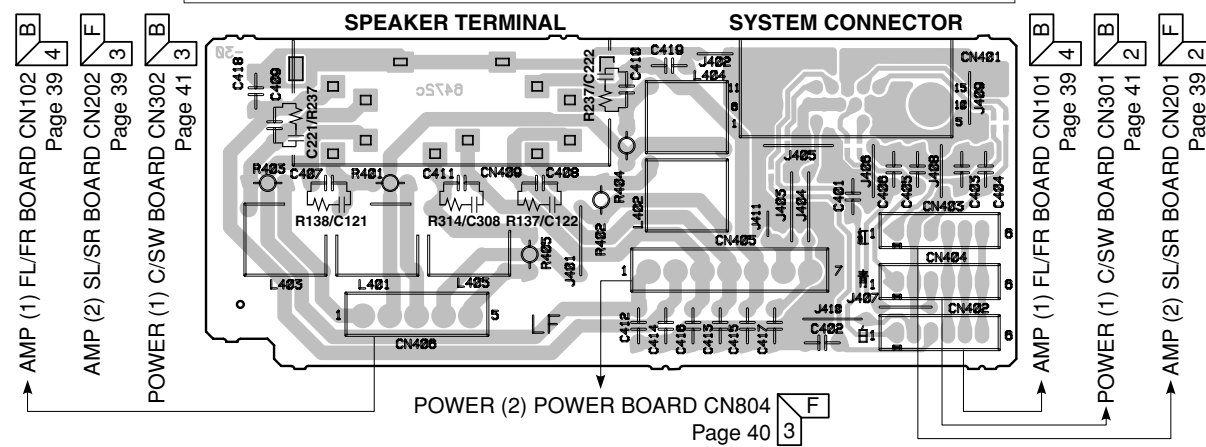

DVR-S300 SCHEMATIC DIAGRAM

FOR INFORMATION ONLY (NO REPLACEMENT COMPONENT PARTS WILL BE AVAILABLE)

The first digit of a component indicates the component type.

- 1xxx : Connector 3xxx : Resistor 5xxx : Coil 7xxx : IC, Transistor, FET
- 2xxx : Capacitor 4xxx : SMD jumper 6xxx : Diode 9xxx : Wire jumper

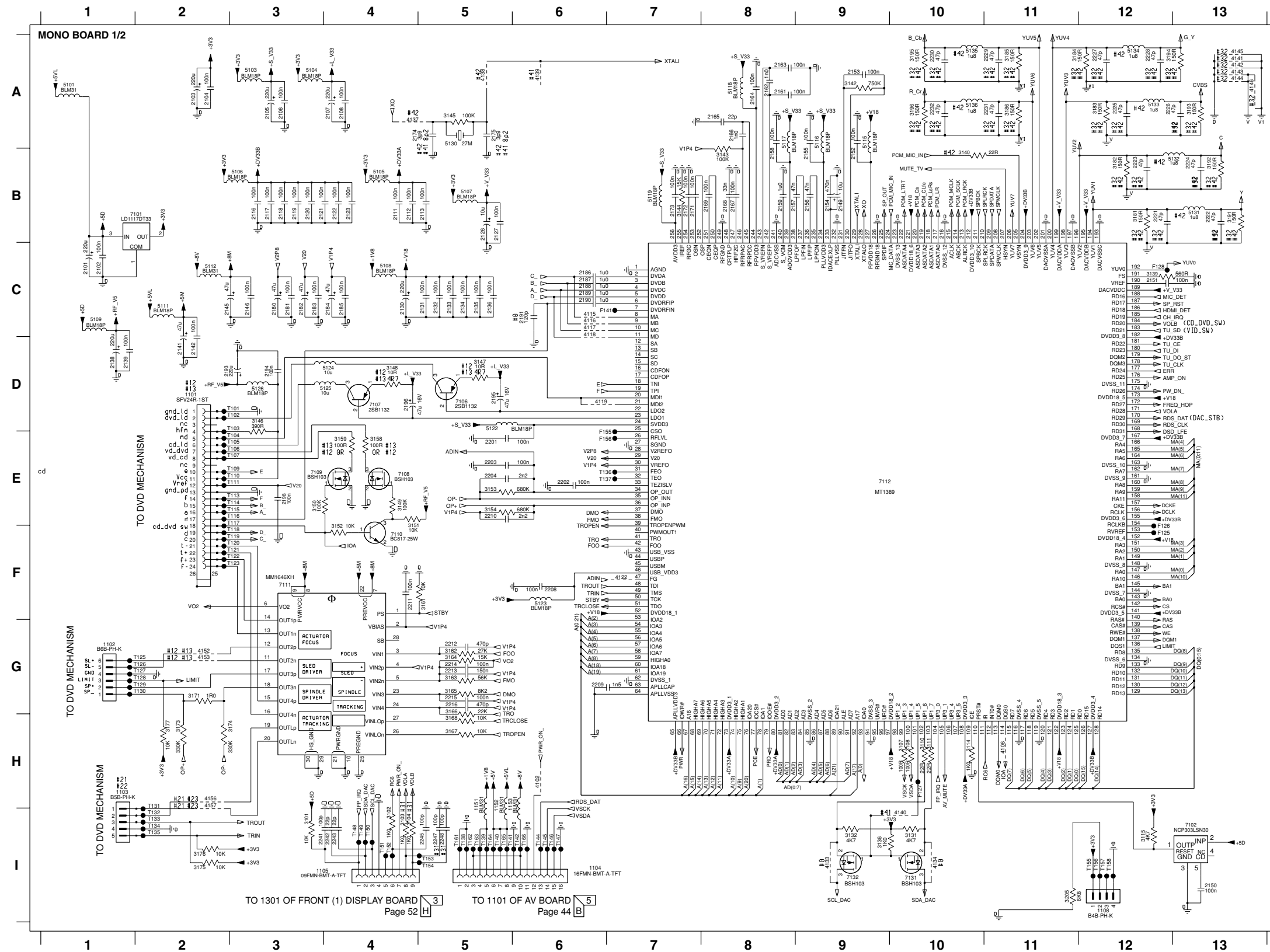

1101 D2	2247 I5	7107 D4
1102 G1	2248 I5	7108 E4
1103 H1	2232 A10	7109 E3
1104 I6	3101 I3	7110 F4
1105 I3	3102 I4	7111 F3
1108 I12	3103 I4	7112 E9
1110 I4	3104 I4	7113 E9
1111 H5	3107 H10	7132 I9
1152 H5	3108 H10	F125 F12
1153 H5	3110 H10	F126 F12
2101 C1	3111 H10	F127 H10
2102 C1	3140 E10	T102 D3
2103 A2	3115 I12	F141 C6
2104 A2	3131 I10	F155 E6
2105 A3	3132 I9	F156 E6
2106 A3	3136 I9	T101 D3
2107 A4	3139 C12	T102 D3
2108 A4	3140 E10	T103 D3
2111 B4	3142 A9	T104 E3
2112 B4	3143 B8	T105 E3
2113 B5	3144 B7	T106 E3
2116 B3	3145 A5	T107 E3
2117 B3	3146 D3	T108 E3
2118 B3	3147 D5	T113 E3
2119 B3	3148 D4	T113 E3
2120 B3	3149 E4	T113 E3
2121 B3	3150 C3	T114 E3
2122 B4	3151 F4	T115 E3
2123 B4	3152 B5	T116 E3
2124 B4	3153 E5	T117 E3
2127 B5	3154 E5	T118 F3
2130 C4	3158 E4	T119 F3
2131 C5	3159 E4	T120 F3
2132 C5	3161 F5	T121 F3
2133 C5	3162 C14	T122 F3
2134 C5	3163 G5	T123 F3
2135 C5	3164 G5	T125 G2
2136 C5	3165 G5	T126 G2
2138 D1	3166 G5	T127 G2
2139 D1	3167 H5	T128 G2
2141 D1	3168 H5	T129 G2
2142 D2	3171 G2	T130 G2
2143 D2	3172 H2	T131 H2
2144 C3	3173 H2	T132 I2
2145 C2	3174 H2	T132 I2
2146 C3	3175 I2	T132 I2
2149 B9	3176 I2	T132 I2
2150 H3	3177 H2	T135 I2
2151 B9	3181 B12	T136 E6
2152 B9	3182 B12	T137 E6
2154 B9	3183 A12	T138 I5
2155 B9	3184 A11	T139 I5
2156 B9	3185 A11	T140 I5
2157 B9	3186 A11	T141 I5
2158 B8	3191 B13	T142 I6
2159 B8	3192 B13	T144 I6
2161 A8	3193 A13	T145 I6
2162 A8	3194 A12	T146 I6
2163 A8	3195 A10	T147 I6
2164 A8	3196 A10	T148 I4
2165 A8	3205 I11	T149 I4
2166 A8	4102 H6	T150 I4
2167 B8	4106 H11	T151 I4
2168 B8	4115 C5	T152 I4
2169 B8	4116 C6	T153 I5
2171 B7	4117 C6	T154 I5
2172 B7	4118 C6	T155 I12
2173 B7	4119 D6	T156 I12
2174 A4	4122 F7	T157 I12
2175 A5	4130 C3	T158 I12
2176 A5	4131 I10	T161 I5
2177 A5	4132 A4	T162 I5
2178 A5	4133 A4	T163 I5
2179 A5	4134 A4	T164 I5
2180 C4	4135 A4	T165 I5
2181 C3	4136 A4	T166 I5
2182 C3	4137 A4	T167 I1
2183 C3	4138 A5	
2184 C4	4139 A6	
2185 C4	4140 I10	
2186 C4	4141 A13	
2187 C6	4142 A13	
2188 C6	4143 A13	
2189 C6	4144 A13	
2190 C6	4145 A13	
2191 C6	4146 A13	
2192 E7	4152 G2	
2193 D3	4153 G2	
2194 D3	4154 H2	
2195 D5	4155 H2	
2196 D4	4157 H2	
2198 E5	5101 A1	
2199 E5	5103 A3	
2200 E7	5104 A3	
2201 E5	5105 B4	
2202 E5	5106 B3	
2203 E5	5107 B5	
2204 E5	5108 C4	
2205 G6	5109 C1	
2206 G6	5110 C1	
2207 E5	5111 C2	
2208 F4	5112 C2	
2209 F4	5113 C2	
2210 F4	5114 A9	
2211 F4	5115 A9	
2212 G5	5116 A9	
2213 G5	5117 A8	
2214 G5	5118 A8	
2215 G5	5119 B7	
2216 G5	5120 B7	
2217 B12	5121 B12	
2218 B12	5122 D5	
2219 B12	5123 F6	
2220 B12	5124 D4	
2221 B12	5125 D4	
2222 A12	5126 D3	
2223 A12	5127 A5	
2224 A12	5128 A5	
2225 A12	5129 A12	
2226 A12	5130 A2	
2227 A12	5131 A1	
2228 A12	5132 B13	
2229 A11	5133 A12	
2230 A10	5134 A12	
2231 A11	5135 A10	
2232 A10	5136 A10	
2242 I4	7101 B2	
2243 I4	7102 I13	
2245 I5	7106 D5	

#0 PROVISION	#11 DV33	#21 WXD-8136	#31 RECEIVERS	#41 DIGITAL VIDEO
	#12 DV34	#22 WXD-8229	#32 PLAYERS	#42 ANALOG VIDEO
	#13 KHM310	#23 DLM-1D		
		#24 5CDC		

★ Components having special characteristics are marked Δ and must be replaced with parts having specifications equal to those originally installed.
 ★ Schematic diagram is subject to change without notice.

● 印のある部品は、安全性確保部品を示しています。部品の交換が必要な場合、パーツリストに記載されている部品を使用してください。
 ● 本回路図は標準回路図です。改良のため予告なく変更することがございます。

DVR-S300 SCHEMATIC DIAGRAM

FOR INFORMATION ONLY (NO REPLACEMENT COMPONENT PARTS WILL BE AVAILABLE)

The first digit of a component indicates the component type.

- 1xxx : Connector 3xxx : Resistor 5xxx : Coil 7xxx : IC, Transistor, FET
- 2xxx : Capacitor 4xxx : SMD jumper 6xxx : Diode 9xxx : Wire jumper

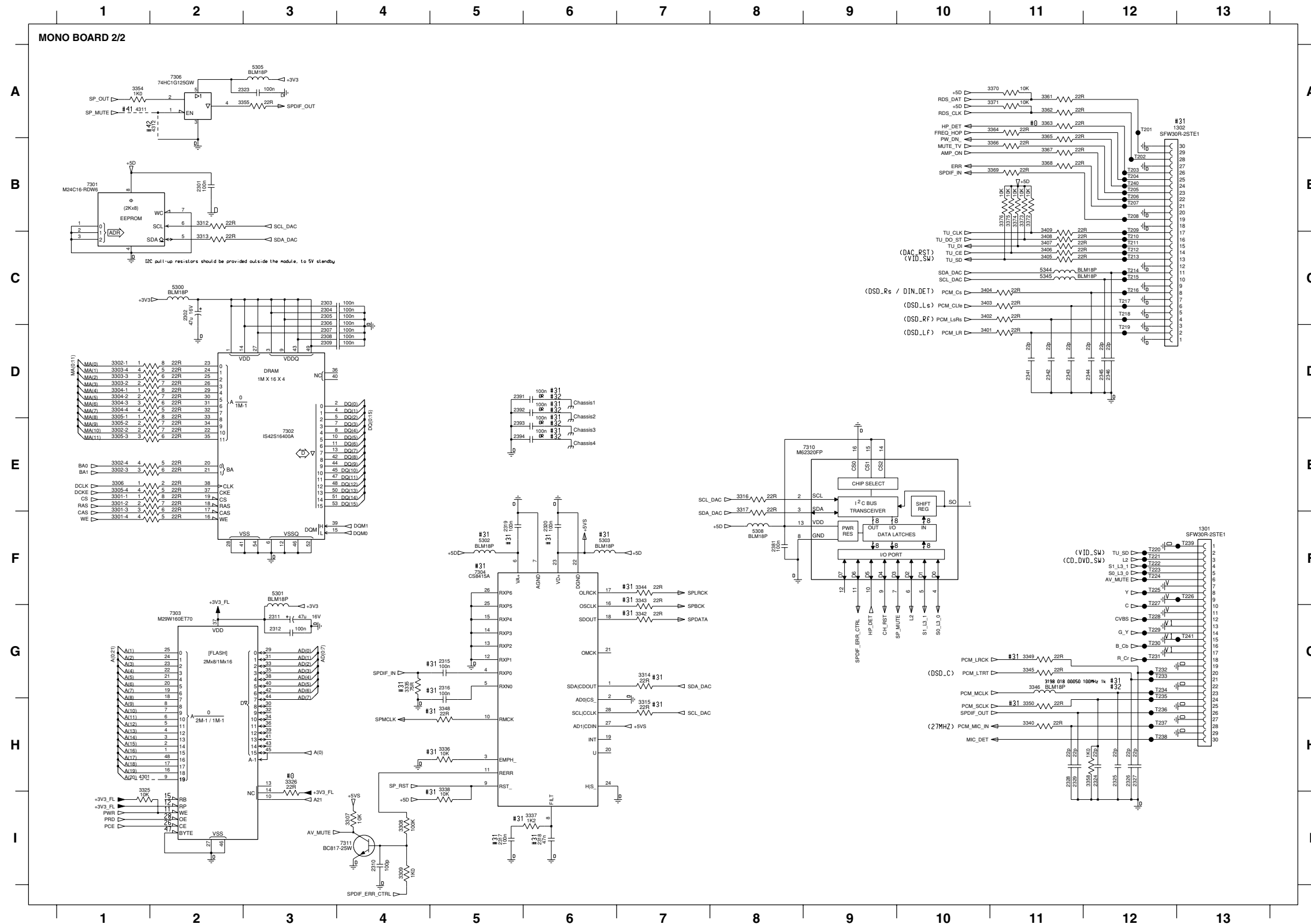

1301 F13	5300 C2
1302 A13	5301 F3
2301 B2	5302 F5
2302 C2	5303 F6
2303 C3	5305 A3
2304 C3	5308 F8
2305 C3	5344 C11
2306 D3	5345 C11
2307 D3	7301 B1
2308 D3	7302 E3
2309 D3	7303 G2
2310 I4	7304 F5
2311 G3	7306 A2
2312 G3	7310 E8
2315 G5	7311 I4
2316 G5	T200 D13
2317 I5	T201 A12
2318 I6	T202 B12
2319 F5	T203 B12
2320 F5	T204 B12
2323 A3	T205 B12
2324 H12	T206 B12
2325 H12	T207 B12
2326 H12	T208 B12
2327 H12	T209 C12
2328 H11	T210 C12
2329 H11	T211 C12
2341 D11	T212 C12
2342 D11	T213 C12
2343 D11	T214 C12
2344 D12	T215 C12
2345 D12	T216 C12
2346 D12	T217 C12
2381 F8	T218 C12
2391 D5	T219 D12
2392 D5	T220 F12
2393 E5	T221 F12
2394 E5	T222 F12
3301-1 E1	T223 F12
3301-2 E1	T224 F12
3301-3 F1	T225 F12
3301-4 F1	T226 F13
3302-1 D1	T227 G12
3302-2 E1	T228 G12
3302-3 E1	T229 G12
3302-4 E1	T230 G12
3303-2 D1	T231 G12
3303-3 D1	T232 G12
3303-4 D1	T233 G12
3304-1 D1	T234 G12
3304-2 D1	T235 H12
3304-3 D1	T236 H12
3304-4 D1	T237 H12
3305-1 E1	T238 H12
3305-2 E1	T239 H12
3305-3 E1	T240 H12
3305-4 E1	T241 G13
3306 E1	T251 C8
3307 I4	T252 C8
3308 I4	T253 C8
3309 I4	T254 C8
3312 B2	T255 C8
3313 C2	T256 C8
3314 G7	T257 C8
3315 H7	T258 B8
3316 E8	T259 B8
3317 F8	T260 B8
3325 I1	T261 B8
3326 H3	T262 B8
3335 G4	T263 A8
3336 H5	T264 A8
3337 I6	T265 B8
3338 H5	T266 B8
3340 H11	T267 A8
3342 G7	T271 H9
3343 F7	T272 H9
3344 F7	T273 H9
3345 G11	T274 H9
3346 G11	T275 I9
3348 H5	
3349 G11	
3350 H11	
3354 A1	
3355 A3	
3358 H12	
3361 A11	
3362 A11	
3363 A11	
3364 A11	
3365 B11	
3366 B11	
3367 B11	
3368 B11	
3369 B11	
3370 A11	
3371 A11	
3372 B11	
3373 B11	
3374 B11	
3375 B11	
3376 B11	
3401 D10	
3402 C10	
3403 C10	
3404 C10	
3405 C11	
3406 C11	
3407 C11	
3408 C11	
3409 C11	
4311 A1	
4312 A2	

#0 PROVISION	#11 DV33	#21 WXD-8136	#31 RECEIVERS	#41 DIGITAL VIDEO
	#12 DV34	#22 WXD-8229	#32 PLAYERS	#42 ANALOG VIDEO
	#13 KHM310	#23 DLM-1D		
		#24 5CDC		

★ Components having special characteristics are marked Δ and must be replaced with parts having specifications equal to those originally installed.
★ Schematic diagram is subject to change without notice.

● Δ 印のある部品は、安全性確保部品を示しています。部品の交換が必要な場合、パーツリストに記載されている部品を使用してください。
● 本回路図は標準回路図です。改良のため予告なく変更することがございます。

■ DVR-S300 SCHEMATIC DIAGRAM

FOR INFORMATION ONLY (NO REPLACEMENT COMPONENT PARTS WILL BE AVAILABLE)

The first digit of a component indicates the component type.

- 1xxx : Connector 3xxx : Resistor 5xxx : Coil 7xxx : IC, Transistor, FET
- 2xxx : Capacitor 4xxx : SMD jumper 6xxx : Diode 9xxx : Wire jumper

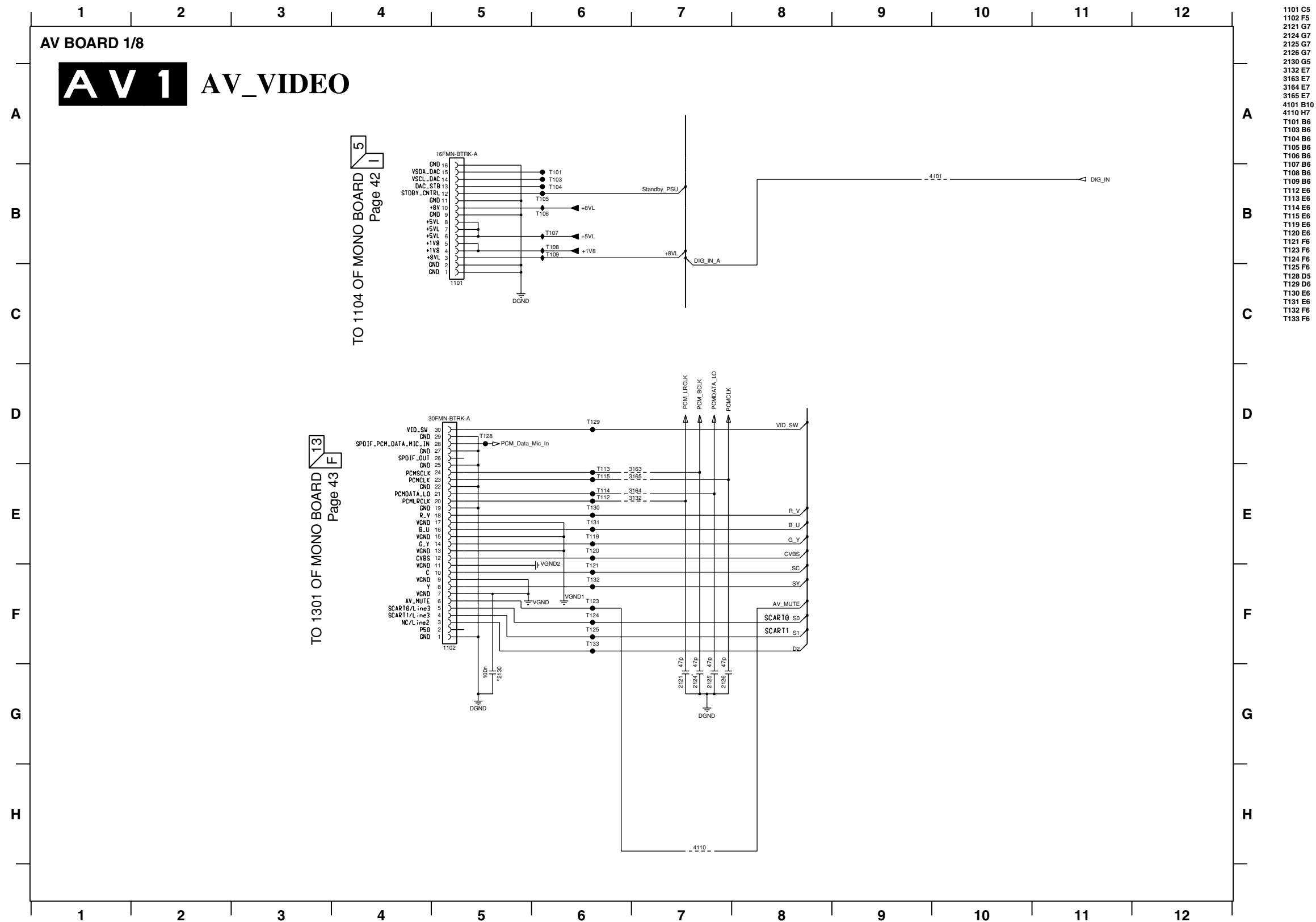

★ Components having special characteristics are marked Δ and must be replaced with parts having specifications equal to those originally installed.
 ★ Schematic diagram is subject to change without notice.

● Δ 印のある部品は、安全性確保部品を示しています。部品の交換が必要な場合、パーツリストに記載されている部品を使用してください。
 ● 本回路図は標準回路図です。改良のため予告なく変更することがございます。

DVR-S300 SCHEMATIC DIAGRAM

FOR INFORMATION ONLY (NO REPLACEMENT COMPONENT PARTS WILL BE AVAILABLE)

The first digit of a component indicates the component type.

- 1xxx : Connector 3xxx : Resistor 5xxx : Coil 7xxx : IC, Transistor, FET
- 2xxx : Capacitor 4xxx : SMD jumper 6xxx : Diode 9xxx : Wire jumper

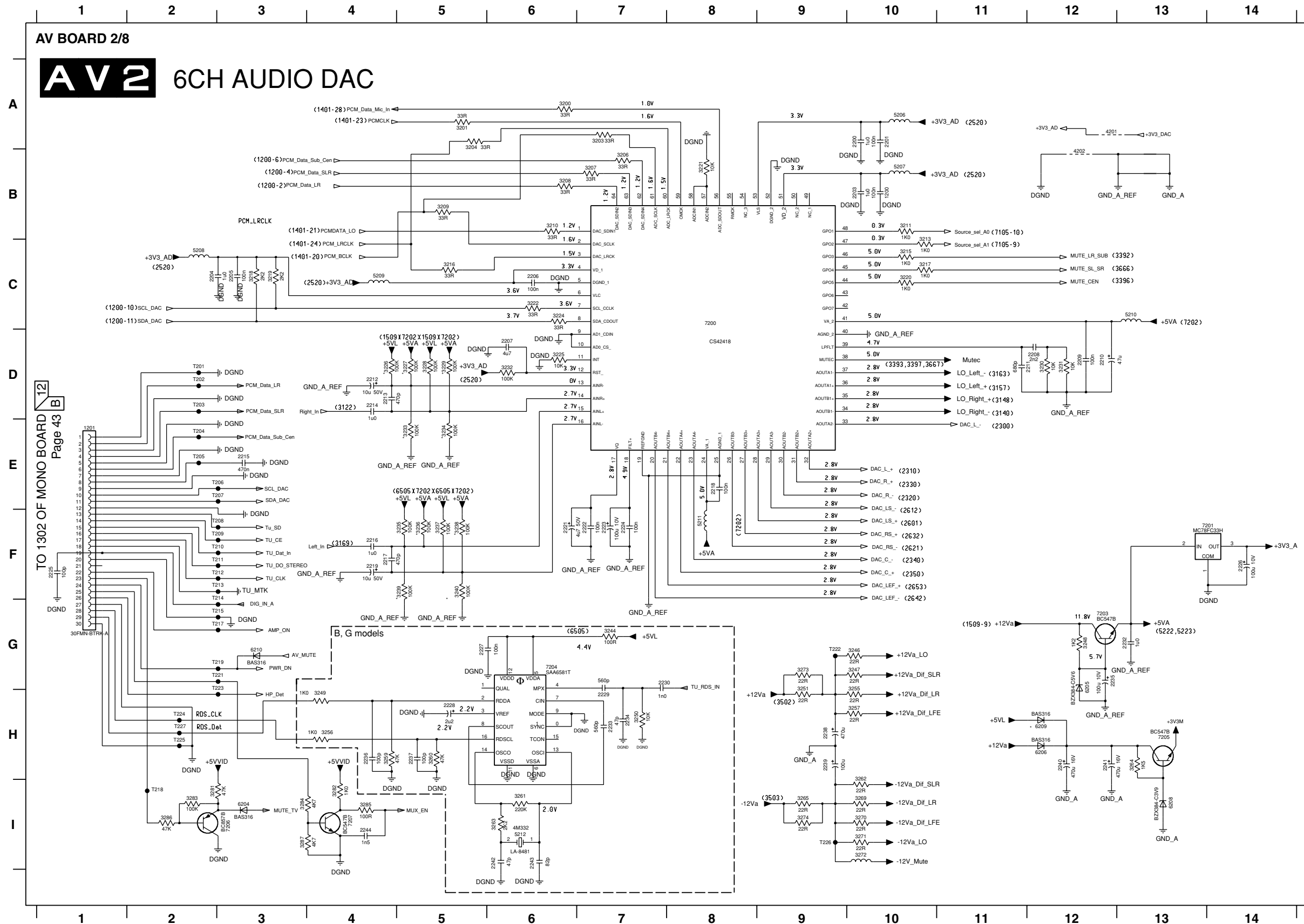

- 1200 B10
- 1201 E1
- 2200 A10
- 2201 A10
- 2203 B10
- 2204 C2
- 2205 C3
- 2206 C6
- 2207 D6
- 2208 D12
- 2209 D12
- 2210 D12
- 2211 D11
- 2212 D4
- 2213 D4
- 2214 D4
- 2215 E3
- 2216 F4
- 2217 F4
- 2218 E8
- 2219 F4
- 2221 F6
- 2222 F7
- 2223 F7
- 2224 F7
- 2225 F1
- 2226 F14
- 2227 G5
- 2228 H5
- 2229 H7
- 2230 G7
- 2232 G13
- 2233 H7
- 2234 H7
- 2235 G12
- 2236 H4
- 2237 H5
- 2238 H9
- 2239 H9
- 2240 H12
- 2241 H12
- 2242 I6
- 2243 I6
- 2244 I4
- 3200 A6
- 3201 A5
- 3203 A7
- 3204 A5
- 3206 B7
- 3207 B7
- 3208 B6
- 3209 B5
- 3210 B6
- 3211 B10
- 3213 C10
- 3215 C10
- 3216 C5
- 3217 C10
- 3218 C3
- 3219 C3
- 3220 C10
- 3221 B8
- 3222 C6
- 3224 C6
- 3225 D6
- 3226 D4
- 3227 D5
- 3228 D5
- 3229 D5
- 3230 D12
- 3231 D12
- 3232 D6
- 3233 E5
- 3234 E5
- 3235 F5
- 3236 F5
- 3237 F5
- 3238 F5
- 3239 F5
- 3240 F5
- 3244 G7
- 3246 G10
- 3247 G10
- 3248 G12
- 3249 H4
- 3250 H7
- 3251 H9
- 3255 H10
- 3256 H4
- 3257 H10
- 3259 H4
- 3260 H5
- 3261 I6
- 3262 I10
- 3263 I6
- 3264 H13
- 3265 I9
- 3269 I10
- 3270 I10
- 3271 I10
- 3272 I10
- 3273 G9
- 3274 I9
- 3281 I2
- 3282 I4
- 3283 I2
- 3284 I3
- 3285 I4
- 3286 I2
- 3287 I3
- 4201 A12
- 4202 B12
- 5206 A10
- 5207 B10
- 5208 C2
- 5209 C4
- 5210 C13
- 5211 F8
- 5212 I6
- 6204 I3
- 6205 G12
- 6206 H12
- 6208 I13
- 6209 H12
- 6210 G3
- 7200 C8
- 7201 F14
- 7203 G12
- 7204 G6
- 7205 H13
- 7206 I3
- 7207 I4
- 7201 D2
- 7202 D2
- 7203 D2
- 7204 E2
- 7205 E2
- 7206 E3
- 7207 E3
- 7208 F3
- 7209 F3
- 7210 F3
- 7211 F3
- 7212 F3
- 7213 F3
- 7214 F3
- 7215 G3
- 7216 G3
- 7217 G3
- 7218 I2
- 7219 G3
- 7221 G3
- 7222 G3
- 7223 G3
- 7224 H2
- 7225 H2
- 7226 H2

TO 1302 OF MONO BOARD Page 43 B

★ Components having special characteristics are marked Δ and must be replaced with parts having specifications equal to those originally installed.
 ★ Schematic diagram is subject to change without notice.

● Δ 印のある部品は、安全性確保部品を示しています。部品の交換が必要な場合、パーツリストに記載されている部品を使用してください。
 ● 本回路図は標準回路図です。改良のため予告なく変更することがございます。

DVR-S300 SCHEMATIC DIAGRAM

FOR INFORMATION ONLY (NO REPLACEMENT COMPONENT PARTS WILL BE AVAILABLE)

The first digit of a component indicates the component type.

- 1xxx : Connector 3xxx : Resistor 5xxx : Coil 7xxx : IC, Transistor, FET
- 2xxx : Capacitor 4xxx : SMD jumper 6xxx : Diode 9xxx : Wire jumper

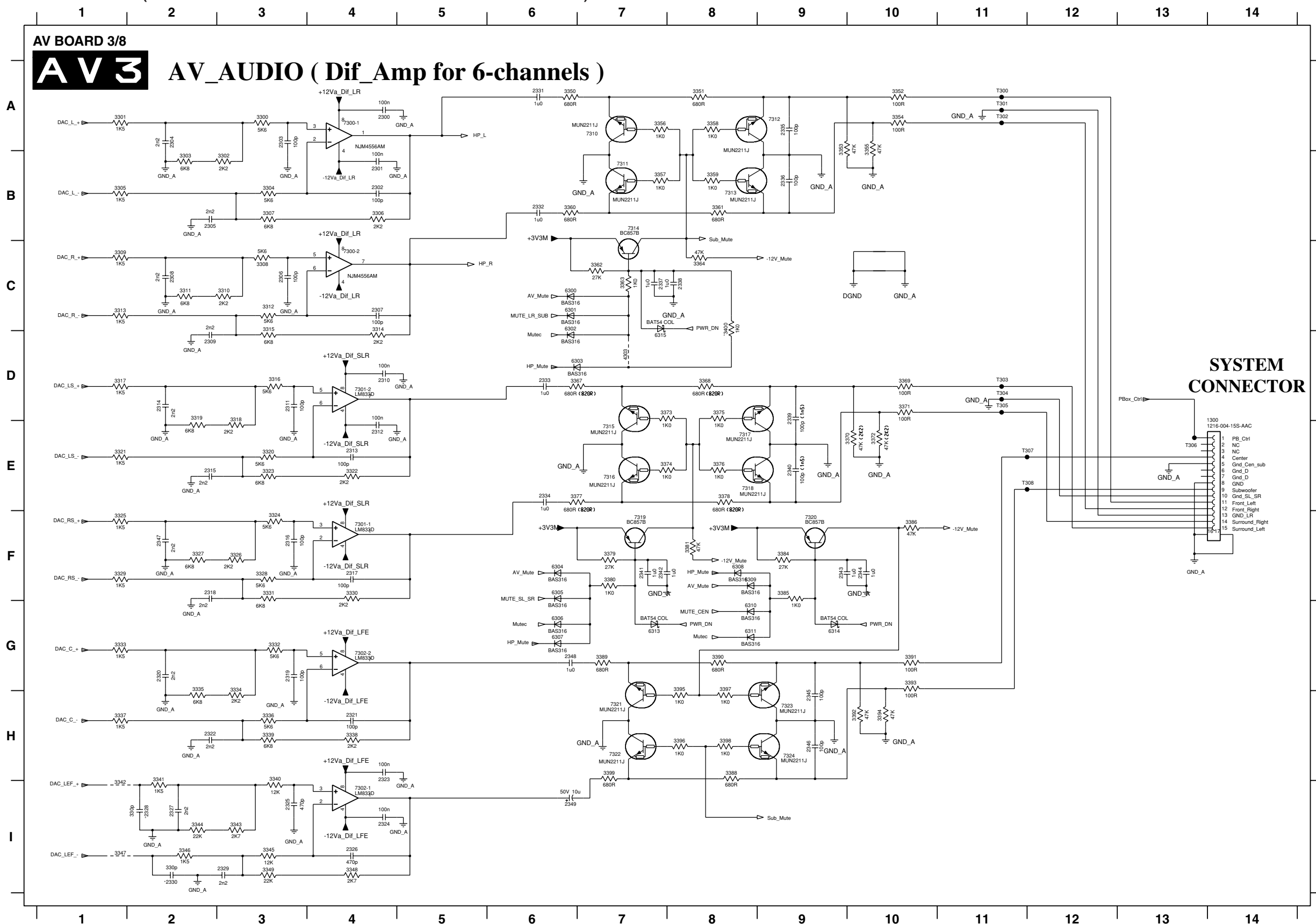

1300 E14	3367 D6
2300 A4	3368 D8
2301 B4	3369 D10
2302 B4	3370 E10
2303 A3	3371 D10
2304 A2	3372 E10
2305 B2	3373 D7
2306 C3	3374 E7
2307 C4	3375 D8
2308 C2	3376 E8
2309 D2	3377 E6
2310 D4	3378 E8
2311 D3	3379 F7
2312 E4	3380 F7
2313 E4	3381 F8
2314 D2	3382 F9
2315 E2	3385 F9
2316 F3	3386 F10
2317 F4	3388 H8
2318 F2	3389 G7
2319 G3	3390 G8
2320 G2	3391 G10
2321 H4	3392 H10
2322 H2	3393 G10
2323 H4	3394 H10
2324 I4	3395 H8
2325 I3	3396 H8
2326 I4	3397 H8
2327 I2	3398 H8
2328 I2	3399 H7
2329 I3	3400 C8
2330 I2	4300 H6
2331 A6	4303 D7
2332 B6	6300 C6
2333 D6	6301 C6
2334 E6	6302 C6
2335 A9	6303 D6
2336 B9	6304 F6
2337 C7	6305 F6
2338 C8	6306 G6
2339 D9	6307 G6
2340 E9	6308 F8
2341 F7	6309 F8
2342 F7	6310 G8
2343 F9	6311 H8
2344 F10	6313 G7
2345 H9	6314 G9
2346 H9	6315 D7
2347 F2	7300-1 A4
2348 G6	7300-2 C4
2349 I6	7301-1 F4
3300 A3	7301-2 D4
3301 A1	7302-1 I4
3302 B3	7302-2 G4
3303 B2	7310 A7
3304 B3	7311 B7
3305 B1	7312 A9
3306 B4	7313 B8
3307 B3	7314 B7
3308 C3	7315 E7
3309 C1	7316 E7
3310 C3	7317 E8
3311 C2	7318 E8
3312 C3	7319 F7
3313 C1	7320 F9
3314 D4	7321 H7
3315 D3	7322 H7
3316 D3	7323 H9
3317 D1	7324 H9
3318 E3	T300 A11
3319 D2	T301 A11
3320 E3	T302 A11
3321 E1	T303 D11
3322 E4	T304 D11
3323 E3	T305 D11
3324 F3	T306 E13
3325 F1	T307 E12
3326 F3	T308 E12
3327 F2	
3328 F3	
3329 F1	
3330 F4	
3331 F3	
3332 G3	
3333 G1	
3334 H3	
3335 H2	
3336 H3	
3337 H1	
3338 H4	
3339 H3	
3340 I3	
3341 I2	
3342 I1	
3343 I3	
3344 I2	
3345 I3	
3346 I2	
3347 I1	
3348 I4	
3349 I3	
3350 A6	
3351 A8	
3352 A10	
3353 A9	
3354 A10	
3355 A10	
3356 A7	
3357 B7	
3358 A8	
3359 B8	
3360 B6	
3361 B8	
3362 C7	
3363 C7	
3364 C8	

★ Components having special characteristics are marked Δ and must be replaced with parts having specifications equal to those originally installed.
 ★ Schematic diagram is subject to change without notice.

● Δ 印のある部品は、安全性確保部品を示しています。部品の交換が必要な場合、パーツリストに記載されている部品を使用してください。
 ● 本回路図は標準回路図です。改良のため予告なく変更することがございます。

■ DVR-S300 SCHEMATIC DIAGRAM

FOR INFORMATION ONLY (NO REPLACEMENT COMPONENT PARTS WILL BE AVAILABLE)

The first digit of a component indicates the component type.

1xxx : Connector 3xxx : Resistor 5xxx : Coil 7xxx : IC, Transistor, FET
 2xxx : Capacitor 4xxx : SMD jumper 6xxx : Diode 9xxx : Wire jumper

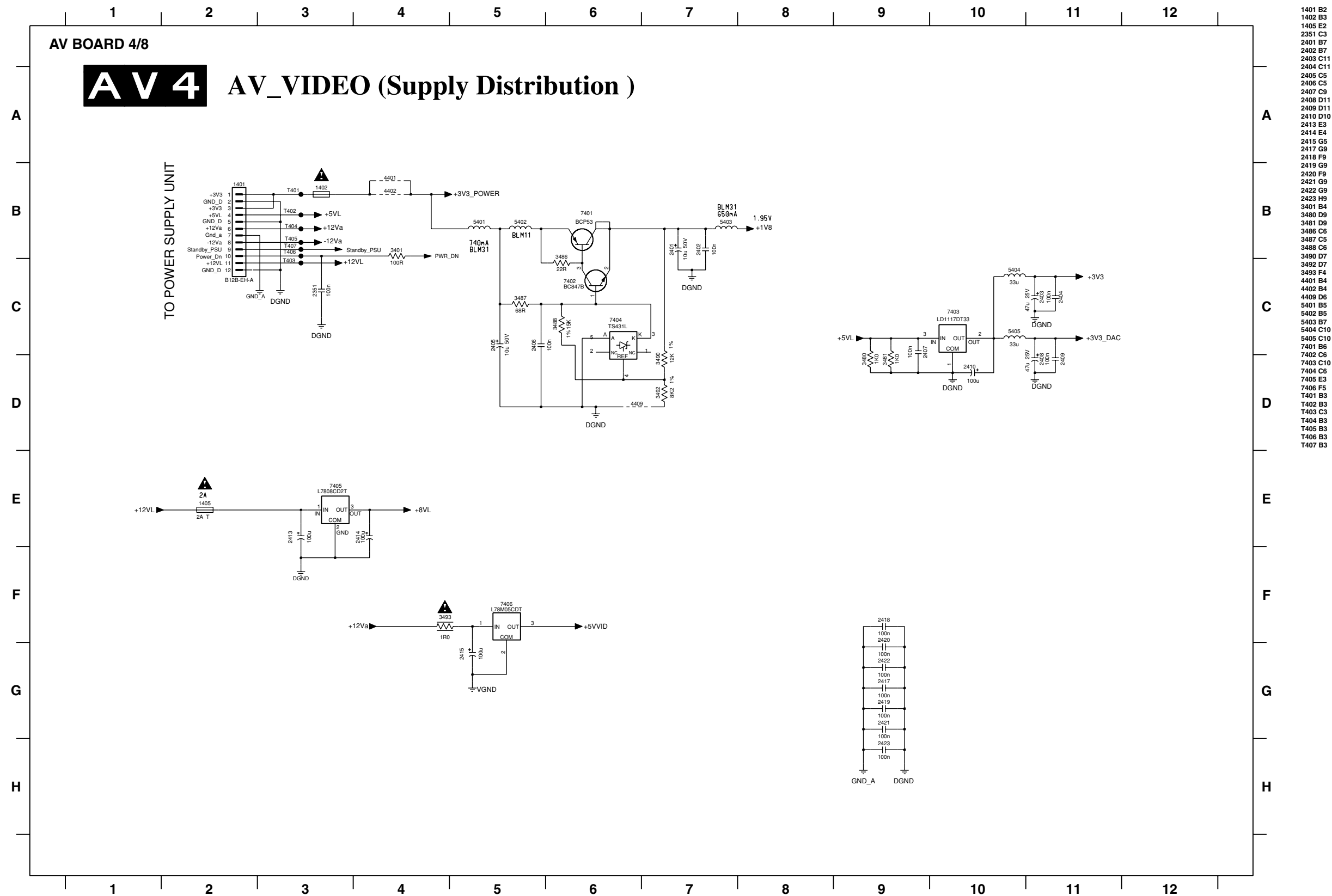

- 1401 B2
- 1402 B3
- 1405 E2
- 2351 C3
- 2401 B7
- 2402 B7
- 2403 C11
- 2404 C11
- 2405 C5
- 2406 C5
- 2407 C9
- 2408 D11
- 2409 D11
- 2410 D10
- 2413 E3
- 2414 E4
- 2415 G5
- 2417 G9
- 2418 F9
- 2419 G9
- 2420 F9
- 2421 G9
- 2422 G9
- 2423 H9
- 3401 B4
- 3480 D9
- 3481 D9
- 3485 C6
- 3487 C5
- 3488 C6
- 3490 D7
- 3492 D7
- 3493 F4
- 4401 B4
- 4402 B4
- 4409 D6
- 5401 B5
- 5402 B5
- 5403 B7
- 5404 C10
- 5405 C10
- 7401 B6
- 7402 C6
- 7403 C10
- 7404 C6
- 7405 E3
- 7406 F5
- 7401 B3
- 7402 B3
- 7403 C3
- 7404 B3
- 7405 B3
- 7406 B3
- 7407 B3

★ Components having special characteristics are marked and must be replaced with parts having specifications equal to those originally installed.
 ★ Schematic diagram is subject to change without notice.

● 印のある部品は、安全性確保部品を示しています。部品の交換が必要な場合、パーツリストに記載されている部品を使用してください。
 ● 本回路図は標準回路図です。改良のため予告なく変更することがございます。

DVR-S300 SCHEMATIC DIAGRAM

FOR INFORMATION ONLY (NO REPLACEMENT COMPONENT PARTS WILL BE AVAILABLE)

The first digit of a component indicates the component type.

- 1xxx : Connector 3xxx : Resistor 5xxx : Coil 7xxx : IC, Transistor, FET
- 2xxx : Capacitor 4xxx : SMD jumper 6xxx : Diode 9xxx : Wire jumper

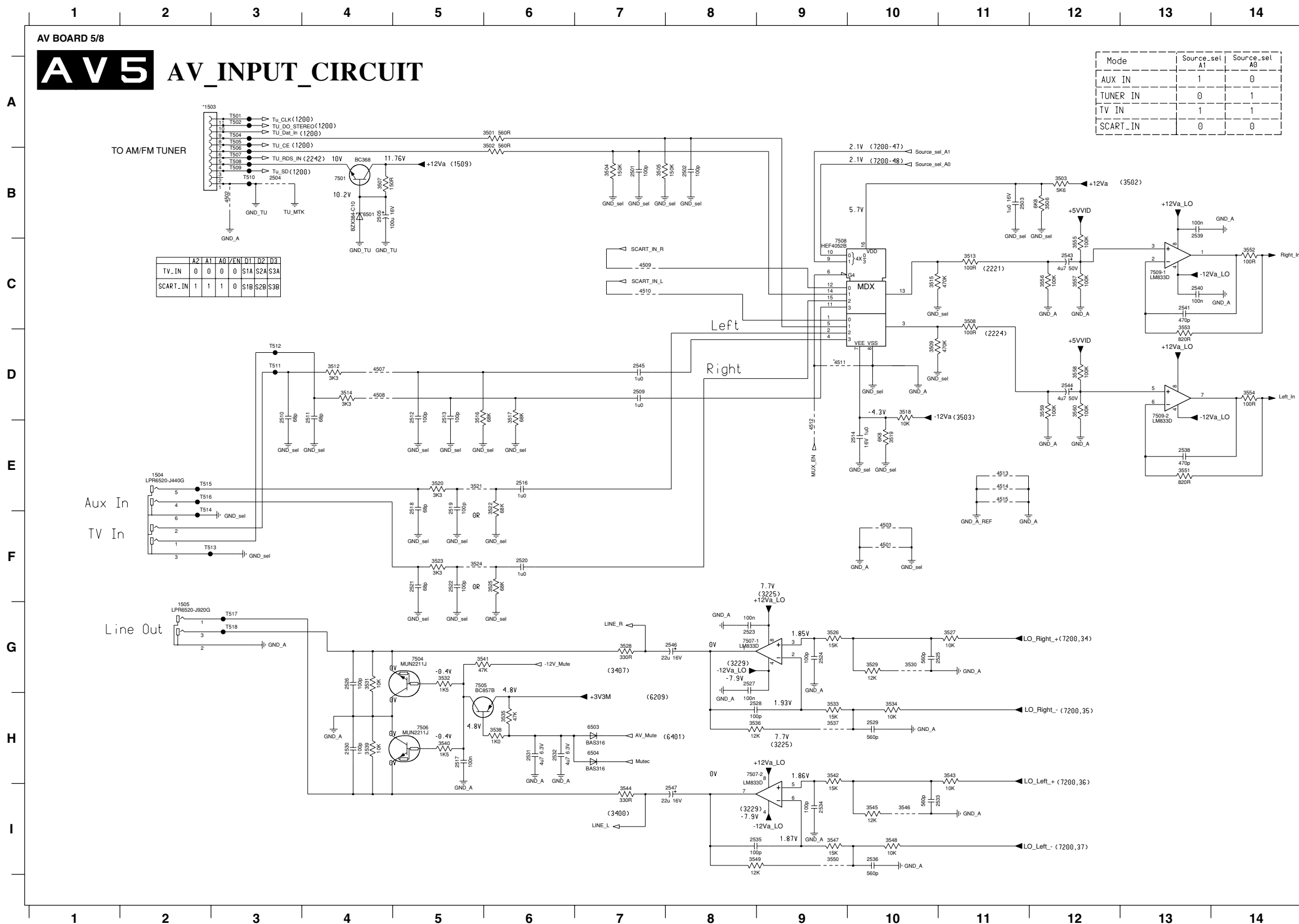

- 1503 A2
- 1504 E2
- 1505 G2
- 2501 B7
- 2502 B8
- 2503 B11
- 2504 B3
- 2505 B4
- 2509 D7
- 2510 D3
- 2511 D4
- 2512 D5
- 2513 D5
- 2514 E10
- 2516 E6
- 2517 H5
- 2518 E5
- 2519 E5
- 2520 F6
- 2521 F5
- 2522 F5
- 2523 G8
- 2524 G9
- 2525 G10
- 2526 G4
- 2527 G8
- 2528 H8
- 2529 H10
- 2530 H4
- 2531 H6
- 2532 H6
- 2533 I10
- 2534 I9
- 2535 I8
- 2536 I10
- 2538 E13
- 2539 B13
- 2540 C13
- 2541 C13
- 2543 C12
- 2544 D12
- 2545 D7
- 2546 G8
- 2547 I8
- 3501 A6
- 3502 B6
- 3503 B12
- 3504 B7
- 3505 B7
- 3506 B12
- 3507 B4
- 3508 C11
- 3509 D10
- 3512 D4
- 3513 C11
- 3514 D4
- 3515 C10
- 3516 D5
- 3517 D6
- 3518 D10
- 3519 E10
- 3520 E5
- 3521 E5
- 3522 E6
- 3523 F5
- 3524 F5
- 3525 F6
- 3526 G9
- 3527 G11
- 3528 G7
- 3529 G10
- 3530 G10
- 3531 G4
- 3532 G5
- 3533 H9
- 3534 H10
- 3535 H6
- 3536 H8
- 3537 H9
- 3538 H6
- 3539 H4
- 3540 H5
- 3541 G5
- 3542 H9
- 3543 H11
- 3544 I7
- 3545 I10
- 3546 I10
- 3547 I9
- 3548 I10
- 3549 I8
- 3550 I9
- 3551 E13
- 3552 C14
- 3553 D13
- 3554 D14
- 3555 C12
- 3556 C12
- 3557 C12
- 3558 D12
- 3559 D12
- 3560 D12
- 4501 F10
- 4502 B3
- 4503 F10
- 4507 D4
- 4508 D4
- 4509 C7
- 4510 C7
- 4511 D9
- 4512 E9
- 4513 E11
- 4514 E11
- 4515 E11
- 6501 B4
- 6503 H7
- 6504 H7
- 7501 B4
- 7504 G5
- 7505 G5
- 7506 H5
- 7507-1 G9
- 7507-2 H9
- 7508 C9
- 7509-1 C13
- 7509-2 D13
- 7501 A3
- 7502 A3
- 7504 A3
- 7505 A3
- 7506 A3
- 7507 B3
- 7508 B3
- 7509 B3
- 7510 B3
- 7511 D3
- 7512 D3
- 7513 F3
- 7514 E3
- 7515 E3
- 7516 E3
- 7517 G3
- 7518 G3

★ Components having special characteristics are marked Δ and must be replaced with parts having specifications equal to those originally installed.
 ★ Schematic diagram is subject to change without notice.

● Δ 印のある部品は、安全性確保部品を示しています。部品の交換が必要な場合、パーツリストに記載されている部品を使用してください。
 ● 本回路図は標準回路図です。改良のため予告なく変更することがございます。

■ DVR-S300 SCHEMATIC DIAGRAM

FOR INFORMATION ONLY (NO REPLACEMENT COMPONENT PARTS WILL BE AVAILABLE)

The first digit of a component indicates the component type.

1xxx : Connector 3xxx : Resistor 5xxx : Coil 7xxx : IC, Transistor, FET
 2xxx : Capacitor 4xxx : SMD jumper 6xxx : Diode 9xxx : Wire jumper

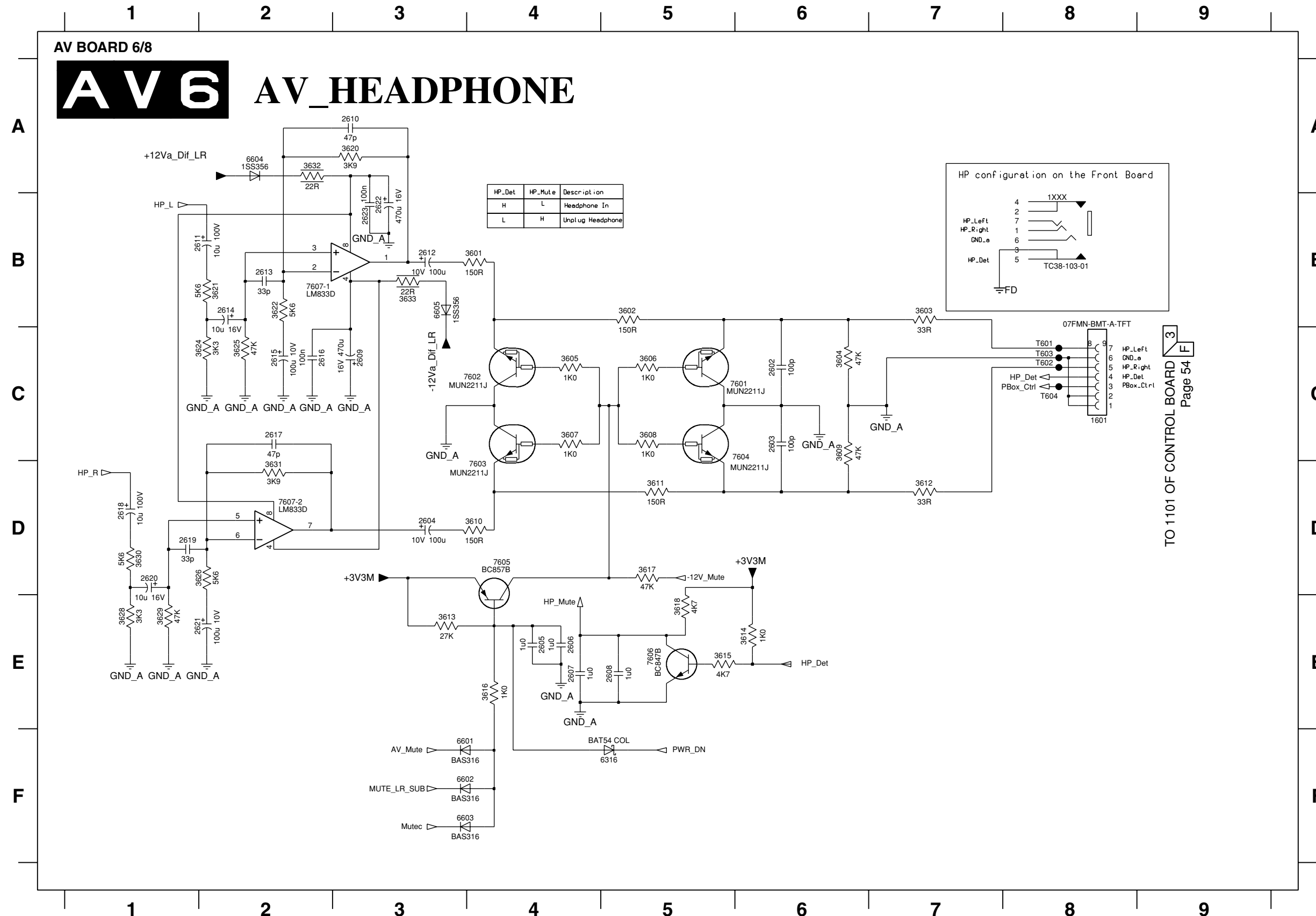

- 1601 C8
- 2602 C6
- 2603 C6
- 2604 D3
- 2605 E4
- 2606 E4
- 2607 E4
- 2608 E5
- 2609 C3
- 2610 A3
- 2611 B2
- 2612 B3
- 2613 B2
- 2614 B2
- 2615 C2
- 2616 C2
- 2617 C2
- 2618 D1
- 2619 D1
- 2620 D1
- 2621 E2
- 2622 B3
- 2623 B3
- 3601 B4
- 3602 B5
- 3603 B7
- 3604 C6
- 3605 C4
- 3606 C5
- 3607 C4
- 3608 C5
- 3609 C6
- 3610 D4
- 3611 D5
- 3612 D7
- 3613 E3
- 3614 E6
- 3615 E5
- 3616 E4
- 3617 D5
- 3618 E5
- 3620 A3
- 3621 B2
- 3622 B2
- 3624 C2
- 3625 C2
- 3626 D2
- 3628 E1
- 3629 E1
- 3630 D1
- 3631 D2
- 3632 A2
- 3633 B3
- 6316 F5
- 6601 F3
- 6602 F3
- 6603 F3
- 6604 A2
- 6605 B3
- 7601 C5
- 7602 C4
- 7603 D4
- 7604 C5
- 7605 D4
- 7606 E5
- 7607-1 B2
- 7607-2 D2
- T601 C8
- T602 C8
- T603 C8
- T604 C8

★ Components having special characteristics are marked Δ and must be replaced with parts having specifications equal to those originally installed.
 ★ Schematic diagram is subject to change without notice.

● Δ 印のある部品は、安全性確保部品を示しています。部品の交換が必要な場合、パーツリストに記載されている部品を使用してください。
 ● 本回路図は標準回路図です。改良のため予告なく変更することがございます。

DVR-S300 SCHEMATIC DIAGRAM

FOR INFORMATION ONLY (NO REPLACEMENT COMPONENT PARTS WILL BE AVAILABLE)

The first digit of a component indicates the component type.

- 1xxx : Connector 3xxx : Resistor 5xxx : Coil 7xxx : IC, Transistor, FET
- 2xxx : Capacitor 4xxx : SMD jumper 6xxx : Diode 9xxx : Wire jumper

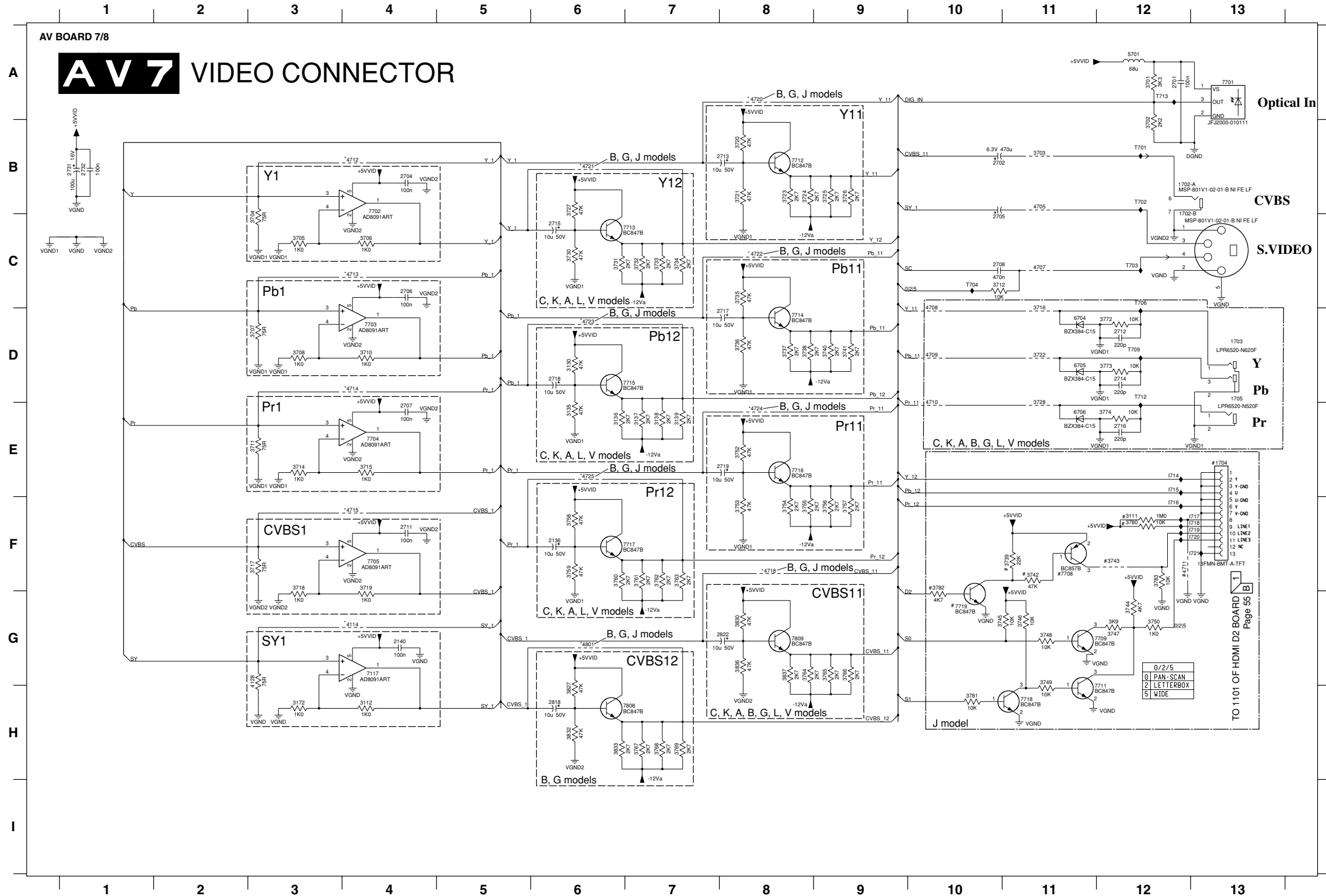

- 1702-A B12
- 1702-B B12
- 1703 D13
- 1704 E13
- 1705 D13
- 2136 F6
- 2140 G4
- 2701 A12
- 2702 B10
- 2704 B4
- 2705 C10
- 2706 C4
- 2707 E4
- 2708 C10
- 2711 F4
- 2712 D12
- 2713 B8
- 2714 D12
- 2715 C5
- 2716 E12
- 2717 D8
- 2718 D6
- 2719 E8
- 2721 B1
- 2722 B1
- 2818 H6
- 2822 G8
- 3111 F12
- 3112 H4
- 3130 D6
- 3135 E6
- 3136 E6
- 3137 E7
- 3138 E7
- 3139 E7
- 3172 H3
- 3701 A12
- 3702 B12
- 3703 B11
- 3704 C3
- 3705 C3
- 3706 C4
- 3707 D3
- 3708 D3
- 3710 D4
- 3711 E3
- 3712 C10
- 3714 E3
- 3715 E4
- 3716 D11
- 3717 F3
- 3718 F3
- 3719 F4
- 3720 B8
- 3721 B8
- 3722 D11
- 3723 B8
- 3724 B8
- 3725 B9
- 3726 B9
- 3727 B6
- 3728 E11
- 3730 C6
- 3731 C6
- 3732 C7
- 3733 C7
- 3734 C7
- 3735 C8
- 3736 D8
- 3737 D8
- 3738 D8
- 3739 F11
- 3740 D9
- 3741 D9
- 3742 F11
- 3743 F12
- 3744 G12
- 3745 G10
- 3746 G11
- 3747 G12
- 3748 G11
- 3749 G11
- 3750 G12
- 3752 E8
- 3753 F8
- 3754 F8
- 3755 F8
- 3756 F9
- 3757 F9
- 3758 F6
- 3759 F6
- 3760 F6
- 3761 F7
- 3762 F7
- 3763 F7
- 3764 G8
- 3765 G9
- 3766 G9
- 3767 H7
- 3768 H7
- 3769 H7
- 3772 D12
- 3773 D12
- 3774 E12
- 3780 F12
- 3781 H10
- 3782 F10
- 3783 F12
- 3827 H6

Region	Block												4708 4709 4710	1703	
	Y1	Pb1	Pr1	CVBS1	SY1	Y11	Y12	Pb11	Pb12	Pr11	Pr12	CVBS11			CVBS12
EU	NO(4712)	NO(4713)	NO(4714)	YES	NO(4114)	NO(4720)	-	NO(4722)	-	NO(4724)	-	YES	YES	YES	YES
JP	NO(4712)	NO(4713)	NO(4714)	NO(4715)	NO(4114)	NO(4720)	NO(4721)	NO(4722)	NO(4723)	NO(4724)	NO(4725)	NO(4718)	-	NO	NO
ROW	NO(4712)	NO(4713)	NO(4714)	NO(4715)	NO(4114)	NO(4720)	-	NO(4722)	-	NO(4724)	-	NO(4718)	-	YES	YES

★ Components having special characteristics are marked Δ and must be replaced with parts having specifications equal to those originally installed.
★ Schematic diagram is subject to change without notice.

● Δ 印のある部品は、安全性確保部品を示しています。部品の交換が必要な場合、パーツリストに記載されている部品を使用してください。
● 本回路図は標準回路図です。改良のため予告なく変更することがございます。

■ DVR-S300 SCHEMATIC DIAGRAM

FOR INFORMATION ONLY (NO REPLACEMENT COMPONENT PARTS WILL BE AVAILABLE)

The first digit of a component indicates the component type.

- 1xxx : Connector 3xxx : Resistor 5xxx : Coil 7xxx : IC, Transistor, FET
- 2xxx : Capacitor 4xxx : SMD jumper 6xxx : Diode 9xxx : Wire jumper

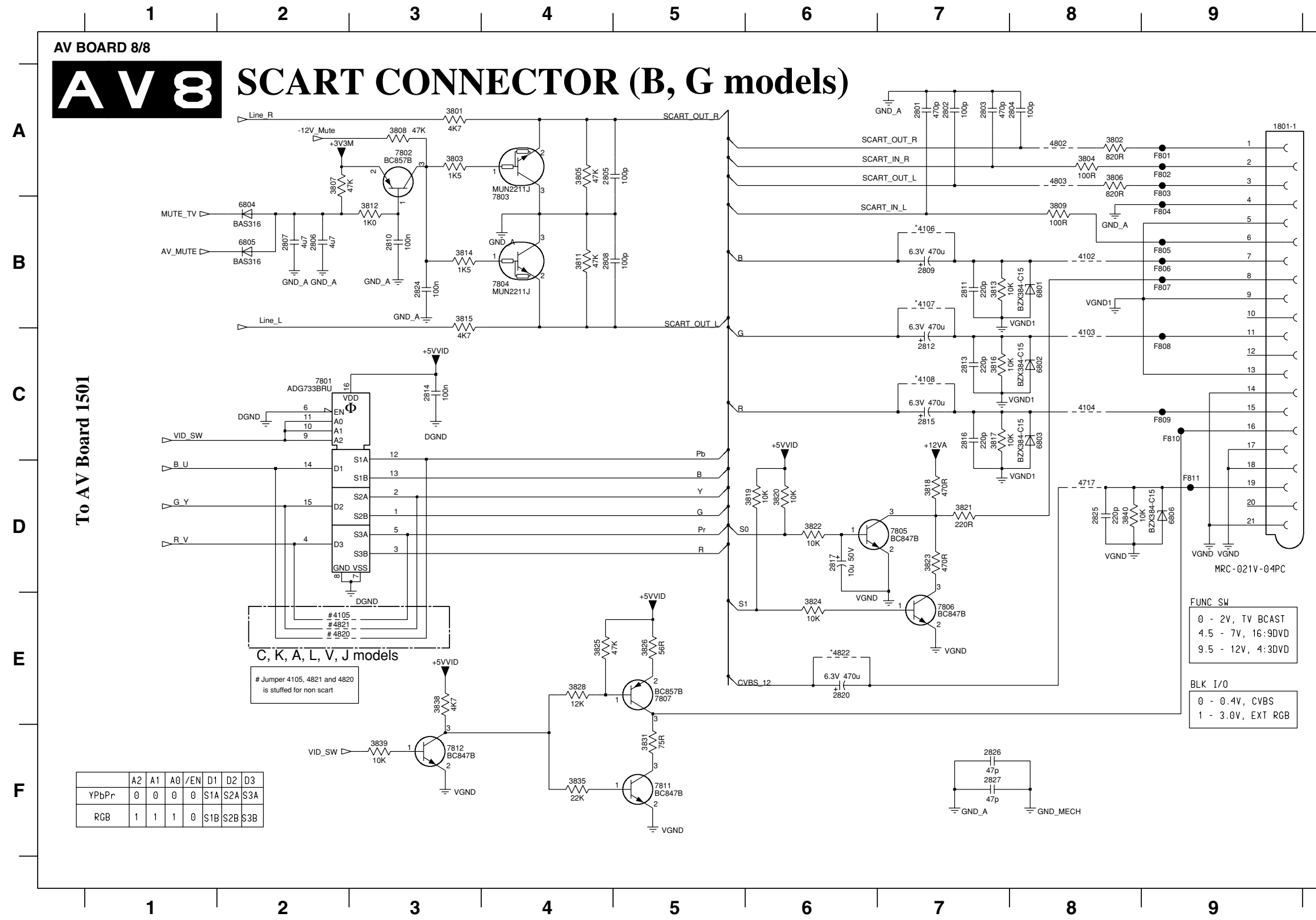

- 1801-1 A9
- 2801 A7
- 2802 A7
- 2803 A7
- 2804 A8
- 2805 A4
- 2806 B2
- 2807 B2
- 2808 B4
- 2809 B7
- 2810 B3
- 2811 B7
- 2812 C7
- 2813 C7
- 2814 C3
- 2815 C7
- 2816 C7
- 2817 D6
- 2820 E6
- 2824 B3
- 2825 D8
- 2826 F7
- 2827 F7
- 3801 A3
- 3802 A8
- 3803 A3
- 3804 A8
- 3805 A4
- 3806 A8
- 3807 A2
- 3808 A3
- 3809 B8
- 3811 B4
- 3812 B3
- 3813 B7
- 3814 B3
- 3815 B3
- 3816 C7
- 3817 C7
- 3818 D7
- 3819 D6
- 3820 D6
- 3821 D7
- 3822 D6
- 3823 D7
- 3824 E6
- 3825 E4
- 3826 E5
- 3828 E4
- 3831 F5
- 3835 F4
- 3838 E3
- 3839 F3
- 3840 D8
- 4102 B8
- 4103 C8
- 4104 C8
- 4105 E2
- 4106 B7
- 4107 B7
- 4108 C7
- 4717 D8
- 4802 A8
- 4803 A8
- 4820 E2
- 4821 E2
- 4822 E6
- 6801 B8
- 6802 C8
- 6803 C8
- 6804 B2
- 6805 B2
- 6806 D9
- 7801 C2
- 7802 A3
- 7803 A4
- 7804 B4
- 7805 D7
- 7806 E7
- 7807 E5
- 7811 F5
- 7812 F3
- F801 A9
- F802 A9
- F803 A9
- F804 B9
- F805 B9
- F806 B9
- F807 B9
- F808 C9
- F809 C9
- F810 C9
- F811 D9

★ Components having special characteristics are marked Δ and must be replaced with parts having specifications equal to those originally installed.
 ★ Schematic diagram is subject to change without notice.

● Δ 印のある部品は、安全性確保部品を示しています。部品の交換が必要な場合、パーツリストに記載されている部品を使用してください。
 ● 本回路図は標準回路図です。改良のため予告なく変更することがございます。

DVR-S300 SCHEMATIC DIAGRAM

FOR INFORMATION ONLY (NO REPLACEMENT COMPONENT PARTS WILL BE AVAILABLE)

The first digit of a component indicates the component type.

- 1xxx : Connector 3xxx : Resistor 5xxx : Coil 7xxx : IC, Transistor, FET
- 2xxx : Capacitor 4xxx : SMD jumper 6xxx : Diode 9xxx : Wire jumper

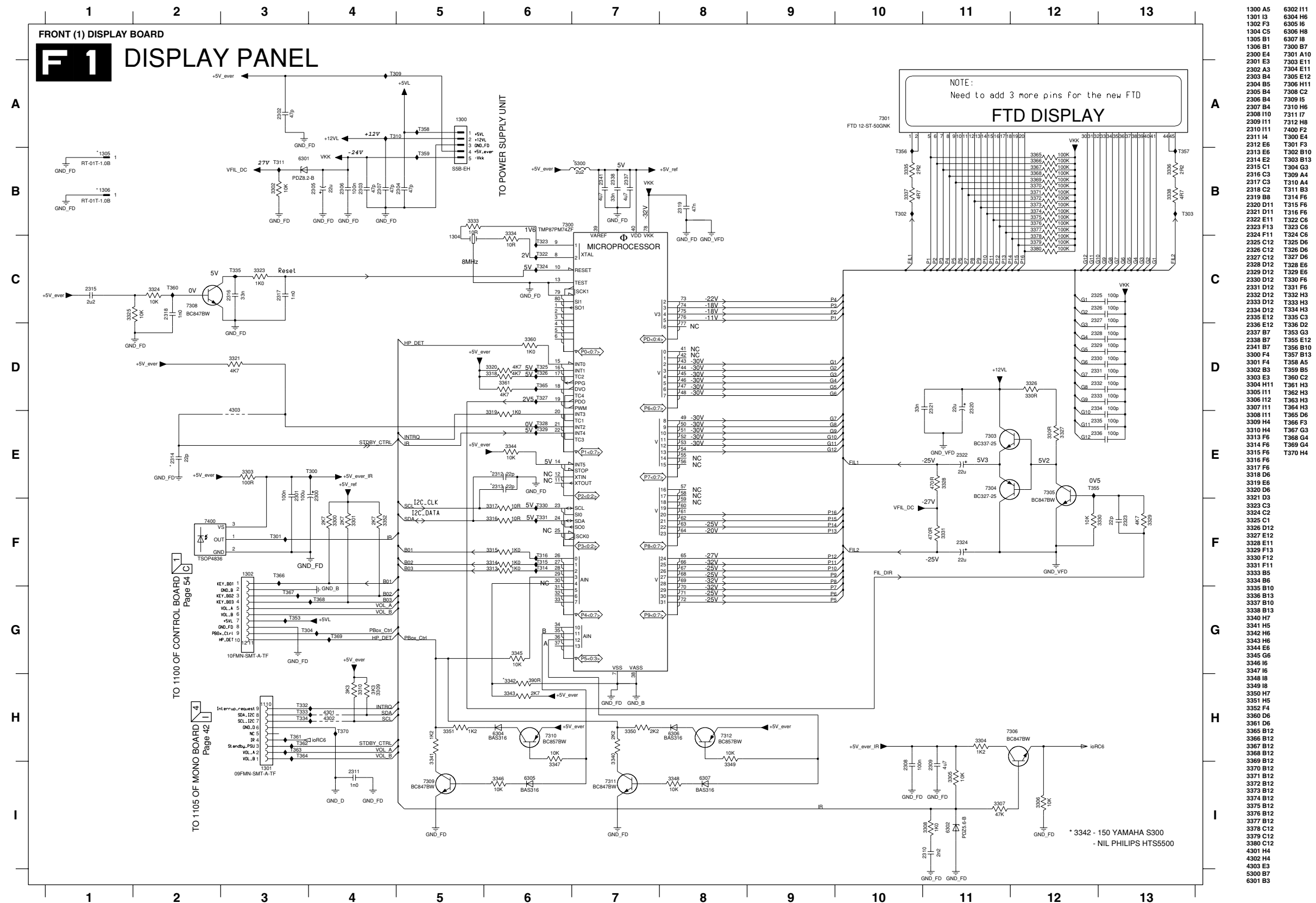

1300 A5	6302 I11
1301 I3	6304 H6
1302 F3	6305 I6
1304 C5	6306 H8
1305 B1	6307 I8
1306 B1	7300 B7
2300 E4	7301 A10
2301 E3	7303 E11
2302 A3	7304 E11
2303 B4	7305 E12
2304 B5	7306 H11
2305 B4	7308 C2
2306 B4	7309 I5
2307 B4	7310 H6
2308 I10	7311 I7
2309 I11	7312 H6
2310 I11	7400 F2
2311 I4	T300 E4
2312 E6	T301 F3
2313 E9	T302 B10
2314 E2	T303 B13
2315 C1	T304 G3
2316 C3	T309 A4
2317 C3	T310 A4
2318 C2	T311 B3
2319 B8	T314 F6
2320 D11	T315 F6
2321 D11	T316 F6
2322 E11	T322 C6
2323 F13	T323 C6
2324 F11	T324 C6
2325 C12	T325 D6
2326 C12	T326 D6
2327 C12	T327 D6
2328 D12	T328 E6
2329 D12	T329 E6
2330 D12	T330 F6
2331 D12	T331 F6
2332 D12	T332 H3
2333 D12	T333 H3
2334 D12	T334 H3
2335 E12	T335 C3
2336 E12	T336 D2
2337 E7	T335 G3
2338 B7	T355 E12
2341 B7	T356 B10
3300 F4	T357 B10
3301 F4	T358 A5
3302 B3	T359 B5
3303 E3	T360 C2
3304 H11	T361 H3
3305 I11	T362 H3
3306 I12	T363 H3
3307 I11	T364 H3
3308 I11	T365 D6
3309 H4	T366 F3
3310 H4	T367 G3
3313 F6	T368 G4
3314 F6	T369 G4
3315 F9	T370 H4
3316 F6	
3317 F6	
3318 D6	
3319 E6	
3320 D3	
3321 D3	
3322 C3	
3324 C2	
3325 C1	
3326 D12	
3327 E12	
3328 E11	
3329 F13	
3330 F12	
3331 F11	
3333 B5	
3334 B6	
3335 B10	
3336 B13	
3337 B10	
3338 B13	
3340 H7	
3341 H5	
3342 H6	
3343 H6	
3344 E6	
3345 G6	
3346 I6	
3347 I6	
3348 I8	
3349 I8	
3350 H7	
3351 H5	
3352 F4	
3350 D6	
3351 D6	
3355 B12	
3356 B12	
3357 B12	
3358 B12	
3359 B12	
3370 B12	
3371 B12	
3372 B12	
3373 B12	
3374 B12	
3375 B12	
3376 B12	
3377 B12	
3378 C12	
3379 C12	
3380 C12	
4301 H4	
4302 H4	
4303 E3	
5300 B7	
6301 B3	

★ Components having special characteristics are marked Δ and must be replaced with parts having specifications equal to those originally installed.
★ Schematic diagram is subject to change without notice.

● Δ 印のある部品は、安全性確保部品を示しています。部品の交換が必要な場合、パーツリストに記載されている部品を使用してください。
● 本回路図は標準回路図です。改良のため予告なく変更することがございます。

■ DVR-S300 SCHEMATIC DIAGRAM

FOR INFORMATION ONLY (NO REPLACEMENT COMPONENT PARTS WILL BE AVAILABLE)

The first digit of a component indicates the component type.

1xxx : Connector 3xxx : Resistor 5xxx : Coil 7xxx : IC, Transistor, FET
 2xxx : Capacitor 4xxx : SMD jumper 6xxx : Diode 9xxx : Wire jumper

FRONT (2) HP BOARD

F 2 FRONT IR_HP

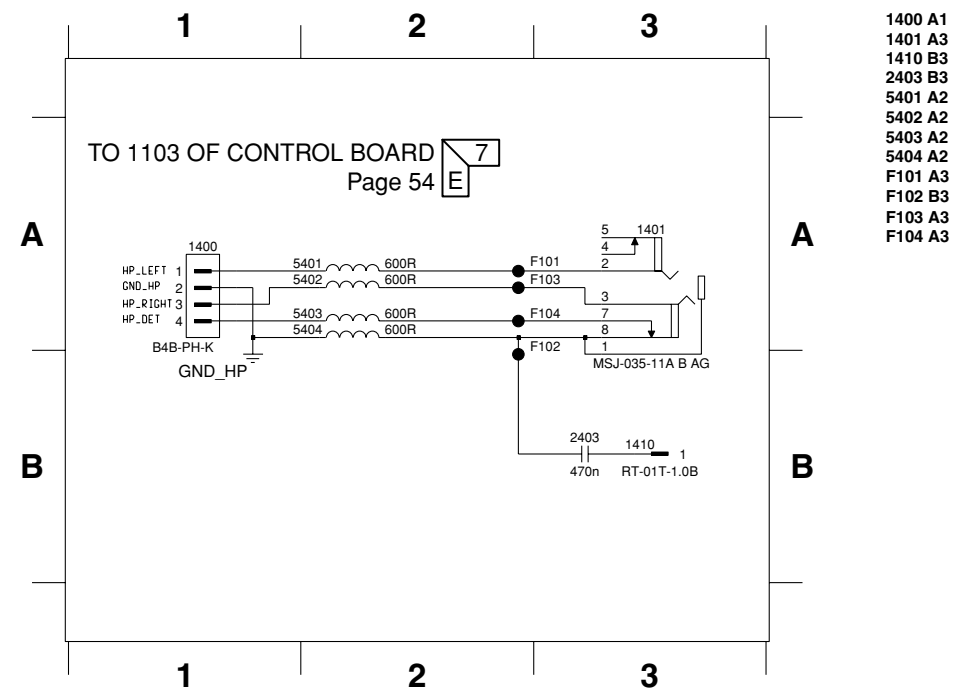

★ Components having special characteristics are marked and must be replaced with parts having specifications equal to those originally installed.
 ★ Schematic diagram is subject to change without notice.

● 印のある部品は、安全性確保部品を示しています。部品の交換が必要な場合、パーツリストに記載されている部品を使用してください。
 ● 本回路図は標準回路図です。改良のため予告なく変更することがございます。

DVR-S300 SCHEMATIC DIAGRAM

FOR INFORMATION ONLY (NO REPLACEMENT COMPONENT PARTS WILL BE AVAILABLE)

The first digit of a component indicates the component type.

- 1xxx : Connector 3xxx : Resistor 5xxx : Coil 7xxx : IC, Transistor, FET
- 2xxx : Capacitor 4xxx : SMD jumper 6xxx : Diode 9xxx : Wire jumper

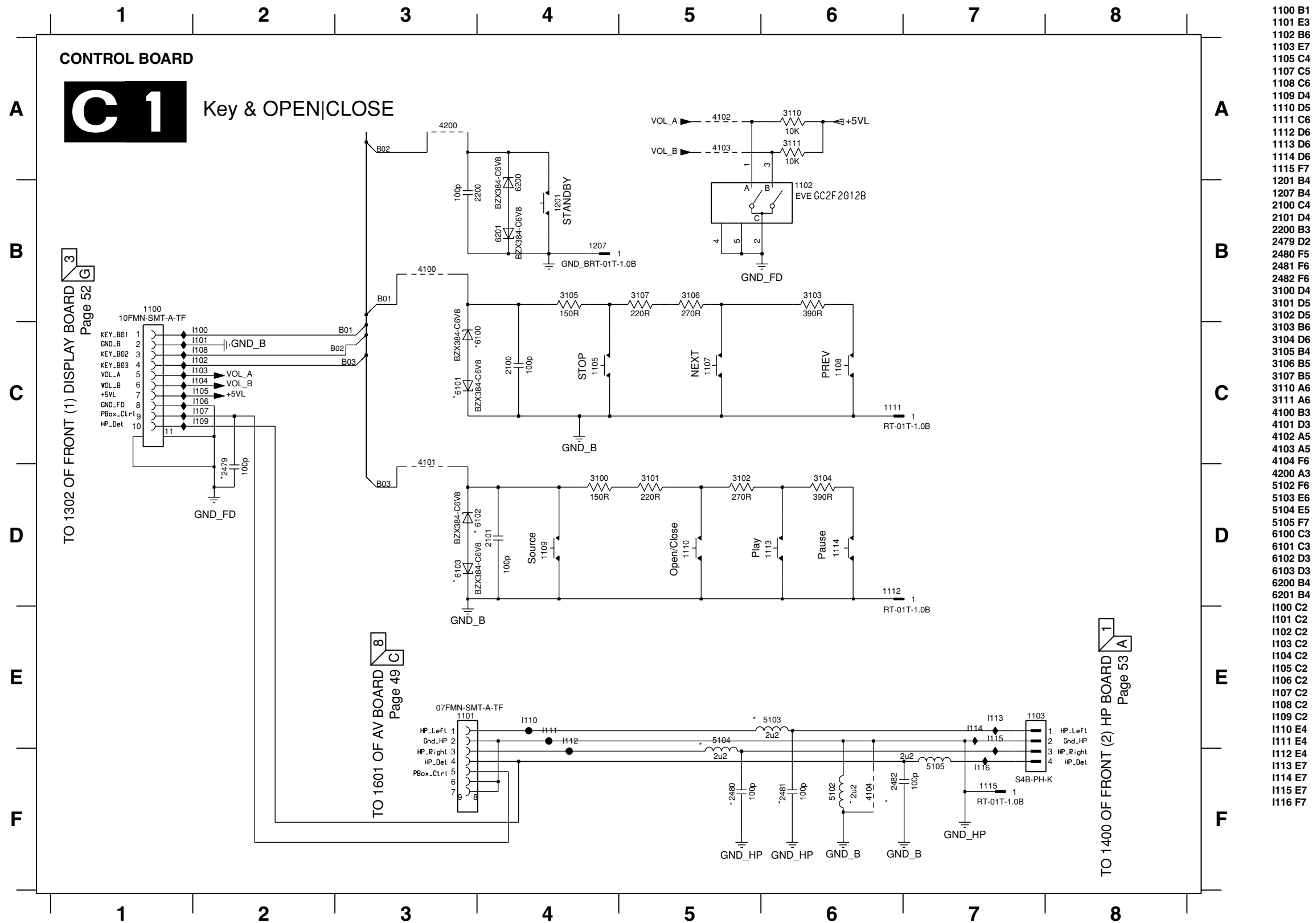

★ Components having special characteristics are marked Δ and must be replaced with parts having specifications equal to those originally installed.
 ★ Schematic diagram is subject to change without notice.

● Δ 印のある部品は、安全性確保部品を示しています。部品の交換が必要な場合、パーツリストに記載されている部品を使用してください。
 ● 本回路図は標準回路図です。改良のため予告なく変更することがございます。

DVR-S300 SCHEMATIC DIAGRAM

FOR INFORMATION ONLY (NO REPLACEMENT COMPONENT PARTS WILL BE AVAILABLE)

The first digit of a component indicates the component type.

1xxx : Connector 3xxx : Resistor 5xxx : Coil 7xxx : IC, Transistor, FET
 2xxx : Capacitor 4xxx : SMD jumper 6xxx : Diode 9xxx : Wire jumper

1101 B1	2120 A9	4112 B5	F105 C1	F114 B8
1102 B9	3122 A7	4113 C5	F106 C1	F115 C8
2110 A6	3123 C7	6101 B7	F107 C1	F116 C8
2111 C6	3124 D7	6102 C7	F108 C1	F117 C8
2112 D6	3125 E4	6103 D7	F109 D1	F118 C9
2116 B7	3126 E5	F101 B1	F110 C2	
2117 C7	3127 E5	F102 B1	F111 A7	
2118 D7	4109 A8	F103 B1	F112 C7	
2119 A8	4111 A5	F104 B1	F113 D7	

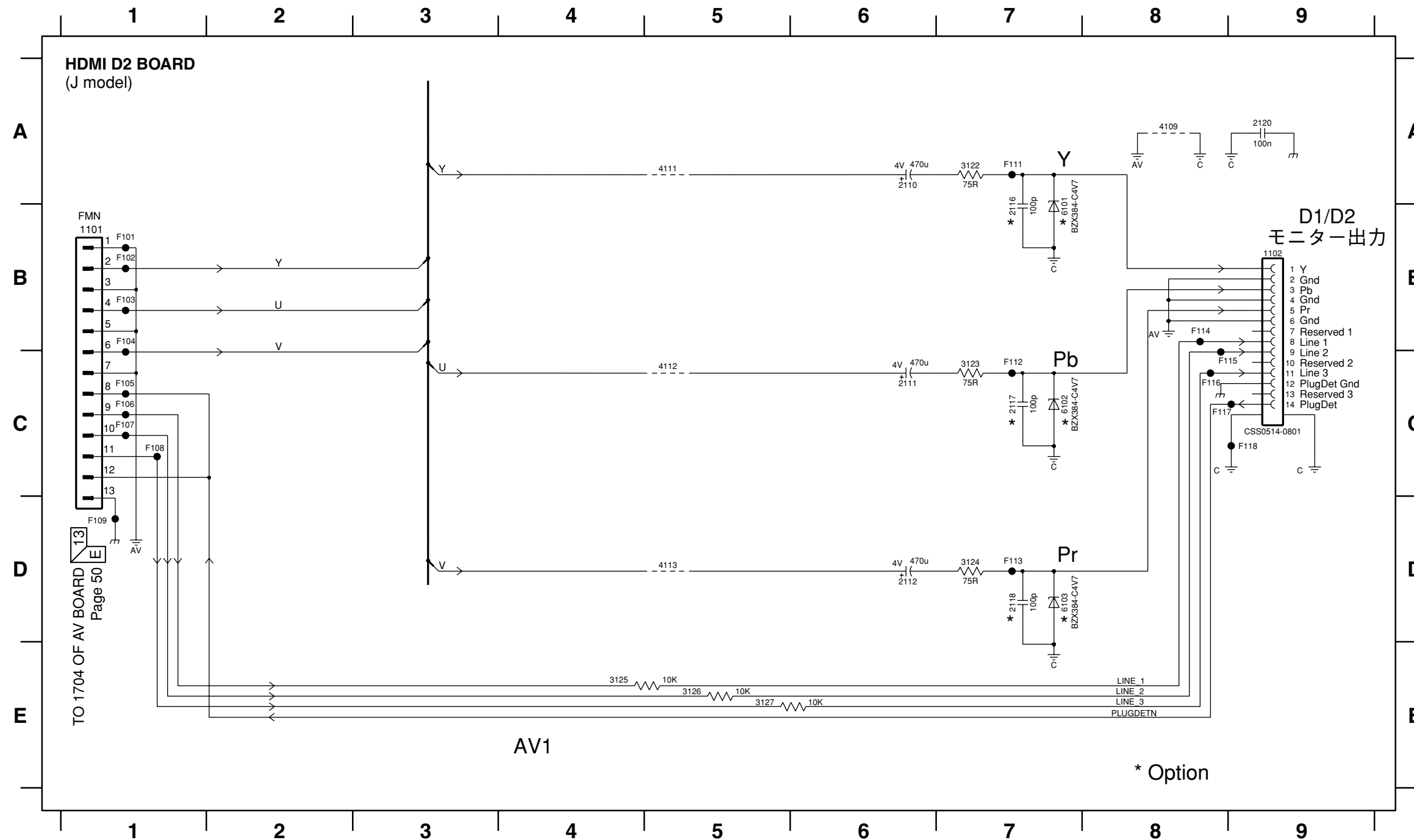

★ Components having special characteristics are marked with a star and must be replaced with parts having specifications equal to those originally installed.
 ★ Schematic diagram is subject to change without notice.

● 星印のある部品は、安全性確保部品を示しています。部品の交換が必要な場合、パーツリストに記載されている部品を使用してください。
 ● 本回路図は標準回路図です。改良のため予告なく変更することがございます。

NX-SW301 SCHEMATIC DIAGRAM

AMP (1) FL/FR BOARD

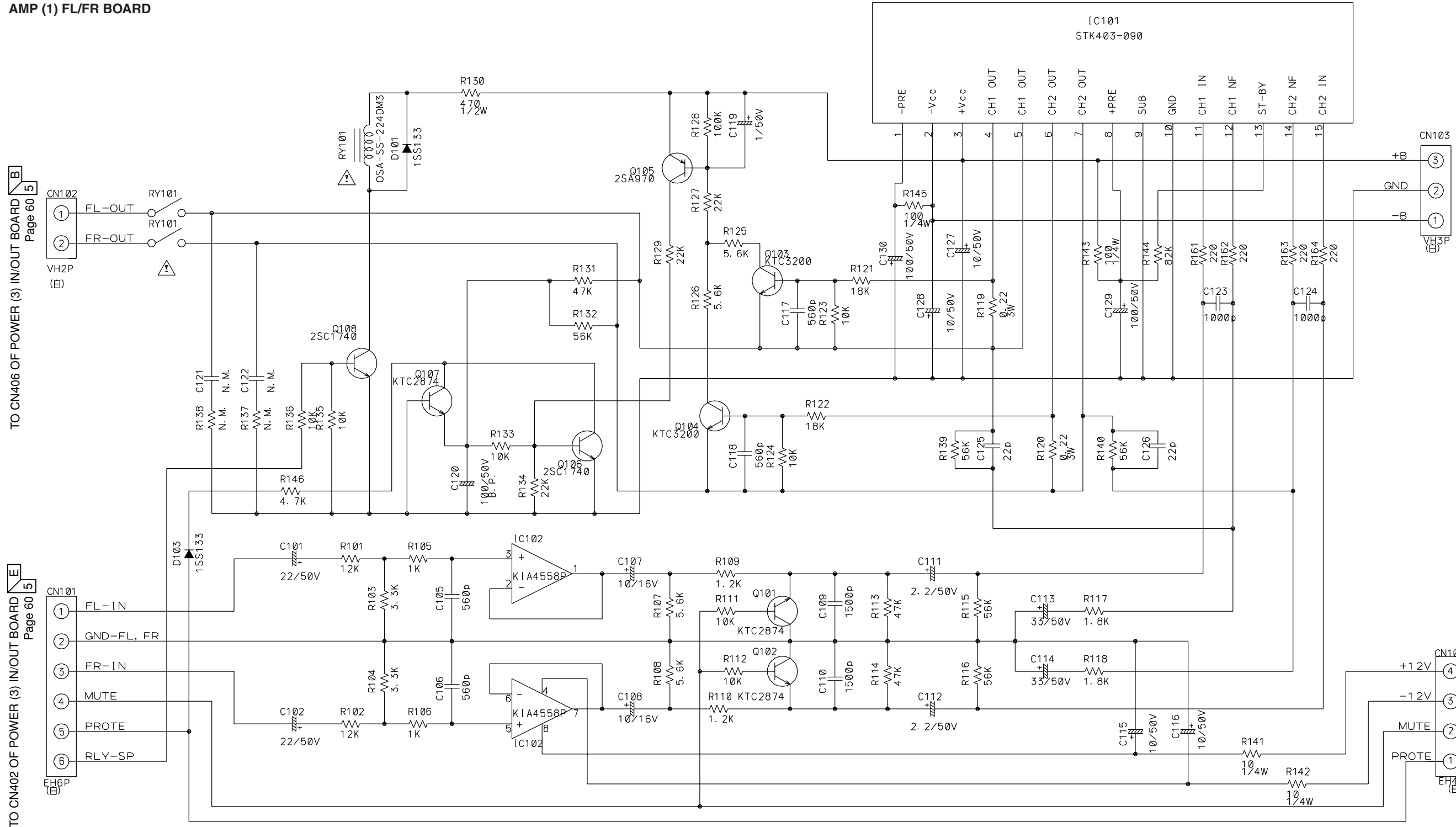

TO CN406 OF POWER (3) IN/OUT BOARD
Page 60 | 5

TO CN402 OF POWER (3) IN/OUT BOARD
Page 60 | 5

TO CN805 OF POWER (2) POWER BOARD
Page 59 | 2

TO CN801 OF POWER (2) POWER BOARD
Page 59 | 2

FL/FR

★ Components having special characteristics are marked and must be replaced with parts having specifications equal to those originally installed.
★ Schematic diagram is subject to change without notice.

● 印のある部品は、安全性確保部品を示しています。部品の交換が必要な場合、パーツリストに記載されている部品を使用してください。
● 本回路図は標準回路図です。改良のため予告なく変更することがございます。

NX-SW301 SCHEMATIC DIAGRAM

AMP (2) SL/SR BOARD

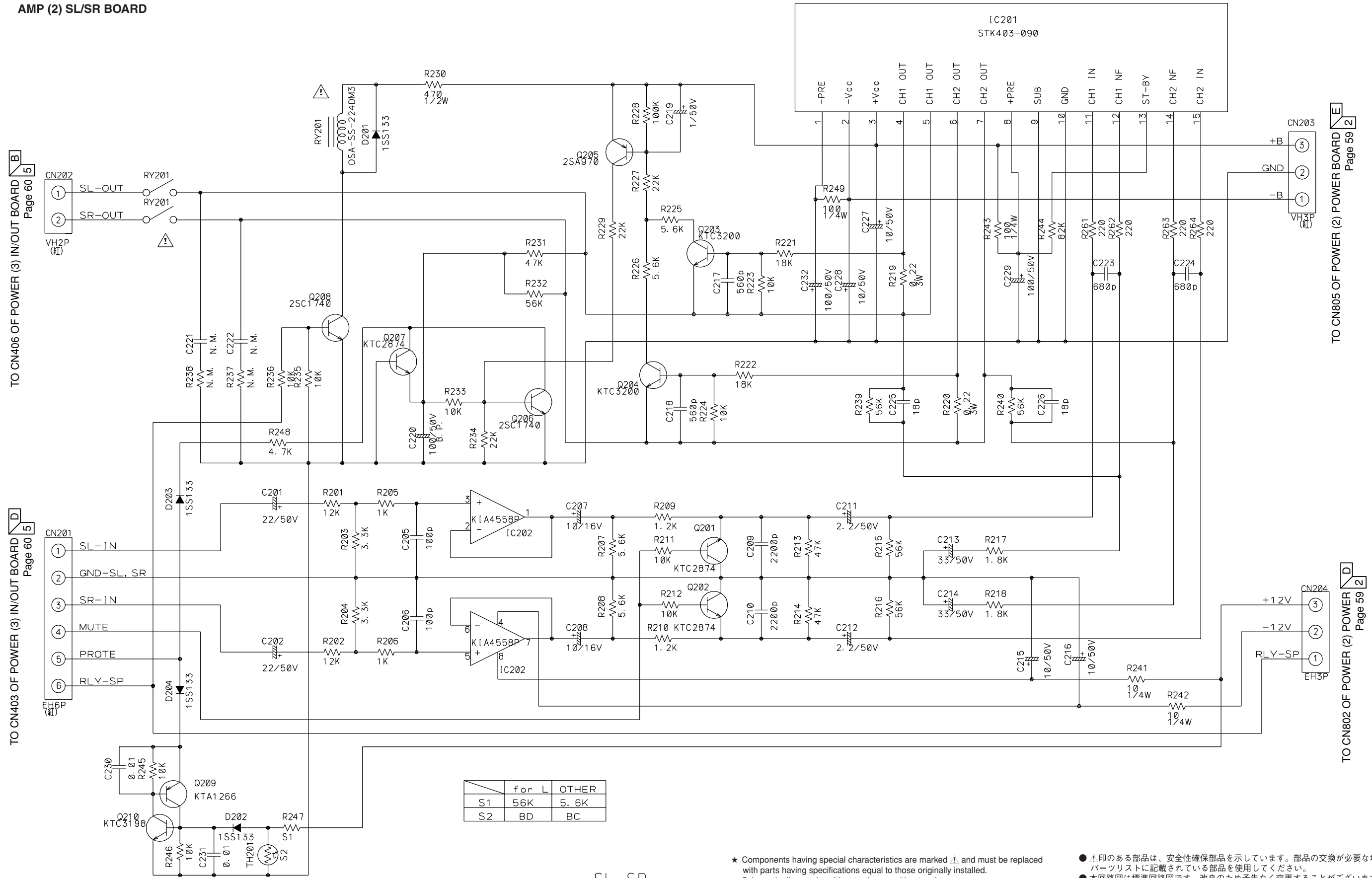

★ Components having special characteristics are marked  and must be replaced with parts having specifications equal to those originally installed.
★ Schematic diagram is subject to change without notice.

● 印のある部品は、安全性確保部品を示しています。部品の交換が必要な場合、パーツリストに記載されている部品を使用してください。
● 本回路図は標準回路図です。改良のため予告なく変更することがございます。

SL, SR

TO CN406 OF POWER (3) IN/OUT BOARD Page 60 5

TO CN403 OF POWER (3) IN/OUT BOARD Page 60 5

TO CN805 OF POWER (2) POWER BOARD Page 59 2

TO CN802 OF POWER (2) POWER BOARD Page 59 2

1
2
3
4
5
6

NX-SW301 SCHEMATIC DIAGRAM

POWER (1) C/SW BOARD

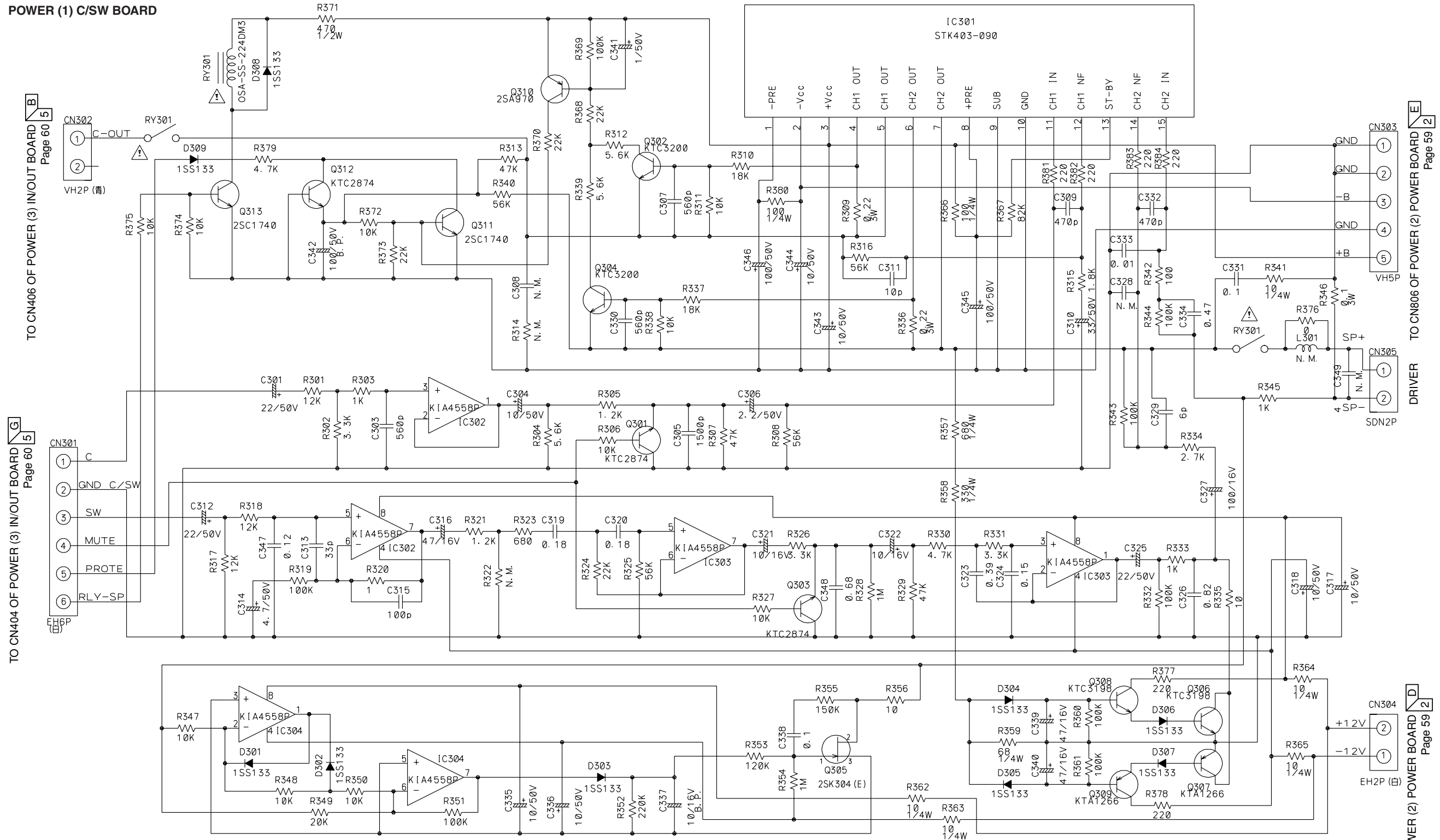

C/SW

★ Components having special characteristics are marked Δ and must be replaced with parts having specifications equal to those originally installed.
★ Schematic diagram is subject to change without notice.

● Δ 印のある部品は、安全性確保部品を示しています。部品の交換が必要な場合、パーツリストに記載されている部品を使用してください。
● 本回路図は標準回路図です。改良のため予告なく変更することがございます。

TO CN406 OF POWER (3) IN/OUT BOARD Page 60 5

TO CN404 OF POWER (3) IN/OUT BOARD Page 60 5

TO CN806 OF POWER (2) POWER BOARD Page 59 2

TO CN803 OF POWER (2) POWER BOARD Page 59 2

■ NX-SW301 SCHEMATIC DIAGRAM

POWER (2) POWER BOARD

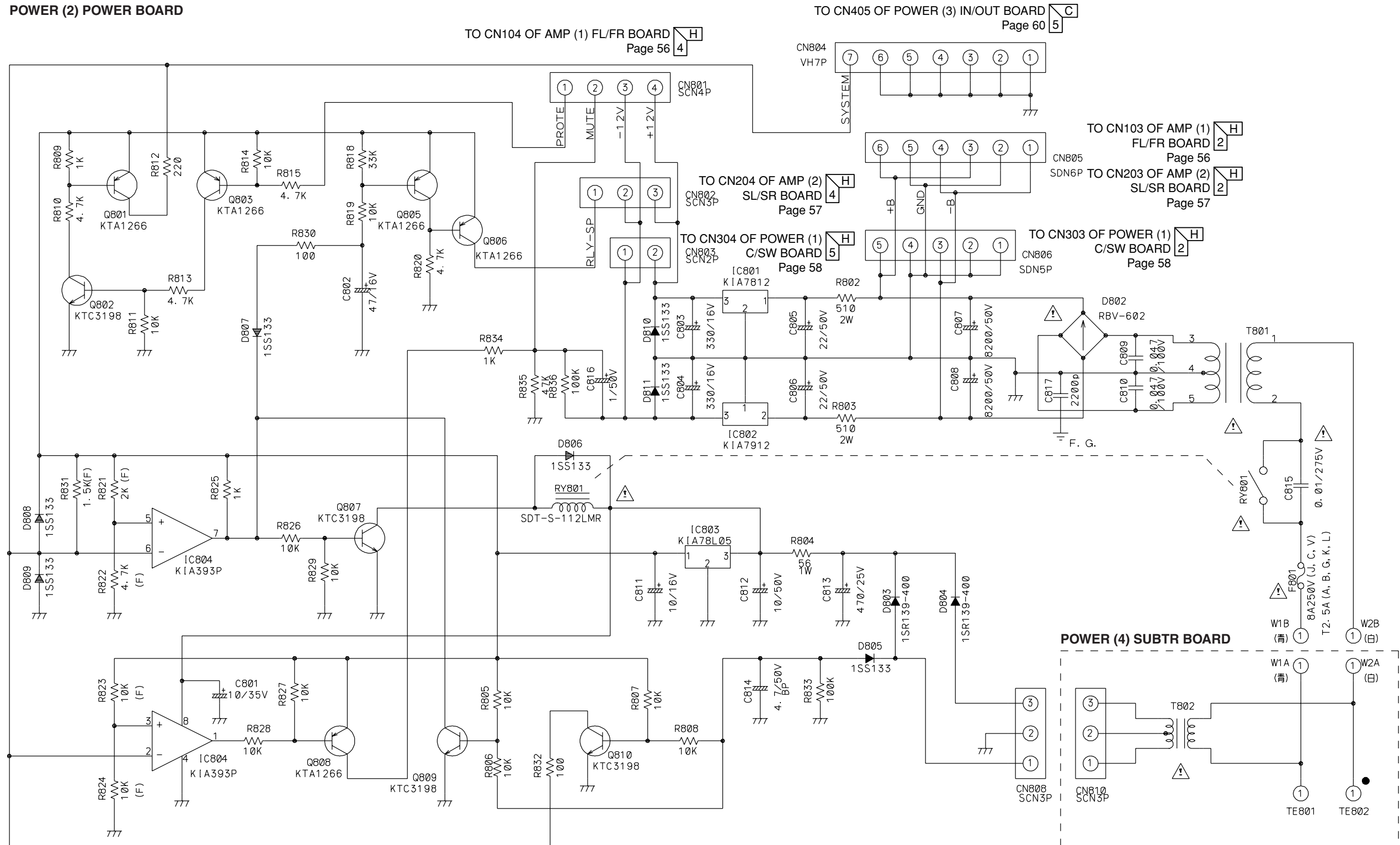

TO CN104 OF AMP (1) FL/FR BOARD
Page 56

TO CN405 OF POWER (3) IN/OUT BOARD
Page 60

TO CN103 OF AMP (1) FL/FR BOARD
Page 56

TO CN204 OF AMP (2) SL/SR BOARD
Page 57

TO CN203 OF AMP (2) SL/SR BOARD
Page 57

TO CN304 OF POWER (1) C/SW BOARD
Page 58

TO CN303 OF POWER (1) C/SW BOARD
Page 58

POWER (4) SUBTR BOARD

POWER

★ Components having special characteristics are marked and must be replaced with parts having specifications equal to those originally installed.
★ Schematic diagram is subject to change without notice.

● 印のある部品は、安全性確保部品を示しています。部品の交換が必要な場合、パーツリストに記載されている部品を使用してください。
● 本回路図は標準回路図です。改良のため予告なく変更することがございます。

NX-SW301 SCHEMATIC DIAGRAM

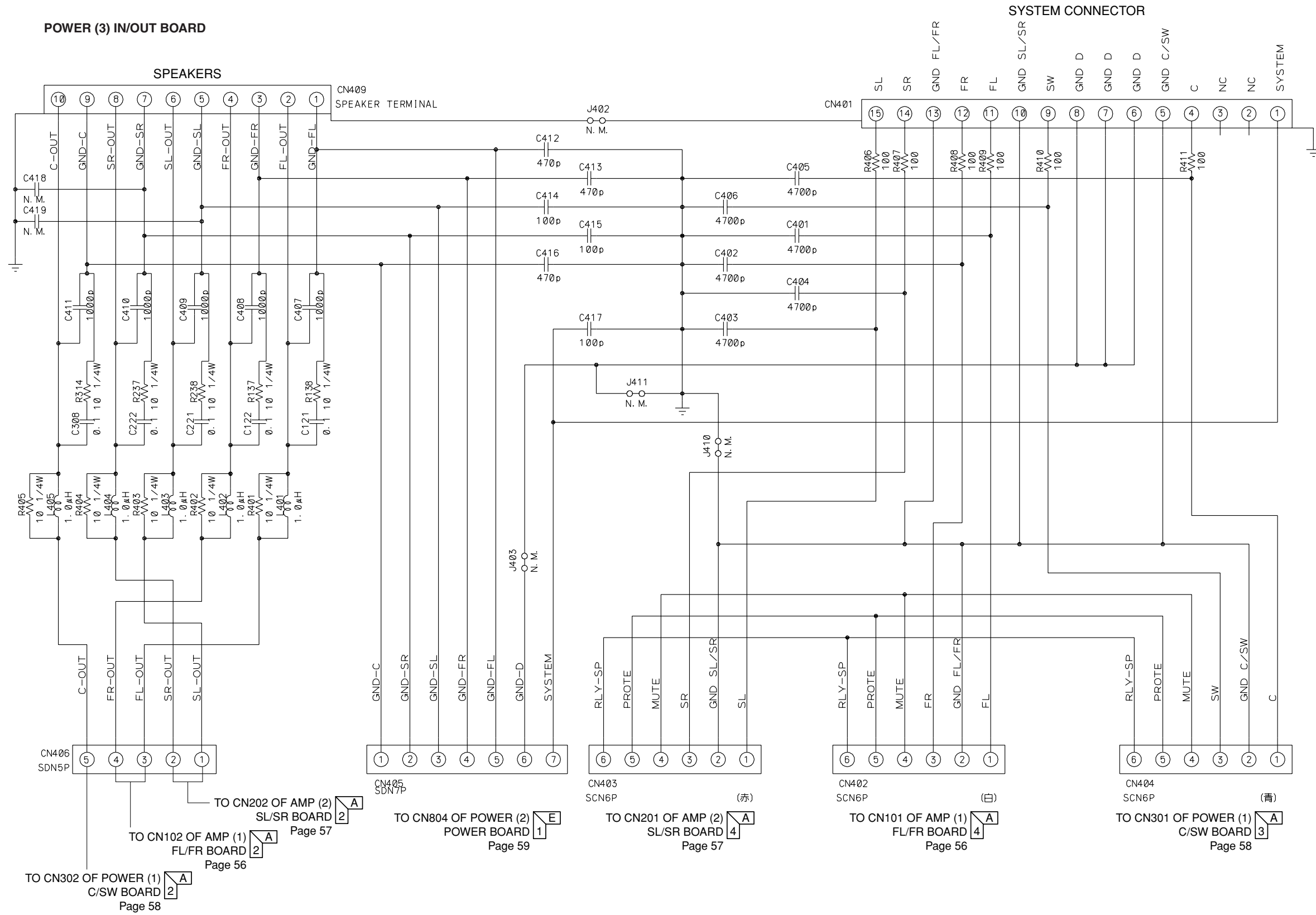

IN/OUT

★ Components having special characteristics are marked Δ and must be replaced with parts having specifications equal to those originally installed.
★ Schematic diagram is subject to change without notice.

● Δ 印のある部品は、安全性確保部品を示しています。部品の交換が必要な場合、パーツリストに記載されている部品を使用してください。
● 本回路図は標準回路図です。改良のため予告なく変更することがございます。

PARTS LIST

■ ELECTRICAL PARTS

■ WARNING

● Components having special characteristics are marked \triangle and must be replaced with parts having specifications equal to those originally installed.

● \triangle 印のある部分は、安全確保部品を示しています。部品の交換が必要な場合、パーツリストに記載されている部品を使用してください。

● 部品価格ランクは、予告なく変更することがあります。

ABBREVIATIONS IN THIS LIST ARE AS FOLLOWS:

C.A.EL.CHP	: CHIP ALUMI.ELECTROLYTIC CAP	L.EMIT	: LIGHT EMITTING MODULE
C.CE	: CERAMIC CAP	LED.DSPLY	: LED DISPLAY
C.CE.ARRAY	: CERAMIC CAP ARRAY	LED.INFRD	: LED,INFRARED
C.CE.CHP	: CHIP CERAMIC CAP	MODUL.RF	: MODULATOR,RF
C.CE.ML	: MULTILAYER CERAMIC CAP	PHOT.CPL	: PHOTO COUPLER
C.CE.M.CHP	: CHIP MULTILAYER CERAMIC CAP	PHOT.INTR	: PHOTO INTERRUPTER
C.CE.SAFTY	: RECOGNIZED CERAMIC CAP	PHOT.RFLCT	: PHOTO REFLECTOR
C.CE.TUBLR	: CERAMIC TUBULAR CAP	PIN.TEST	: PIN,TEST POINT
C.CE.SMI	: SEMI CONDUCTIVE CERAMIC CAP	PLST.RIVET	: PLASTIC RIVET
C.EL	: ELECTROLYTIC CAP	R.ARRAY	: RESISTOR ARRAY
C.MICA	: MICA CAP	R.CAR.	: CARBON RESISTOR
C.ML.FLM	: MULTILAYER FILM CAP	R.CAR.CHP	: CHIP RESISTOR
C.MP	: METALLIZED PAPER CAP	R.CAR.FP	: FLAME PROOF CARBON RESISTOR
C.MYLAR	: MYLAR FILM CAP	R.FUS	: FUSABLE RESISTOR
C.MYLAR.ML	: MULTILAYER MYLAR FILM CAP	R.MTL.CHP	: CHIP METAL FILM RESISTOR
C.PAPER	: PAPER CAPACITOR	R.MTL.FLM	: METAL FILM RESISTOR
C.PLS	: POLYSTYRENE FILM CAP	R.MTL.OXD	: METAL OXIDE FILM RESISTOR
C.POL	: POLYESTER FILM CAP	R.MTL.PLAT	: METAL PLATE RESISTOR
C.POLY	: POLYETHYLENE FILM CAP	RSNR.CE	: CERAMIC RESONATOR
C.PP	: POLYPROPYLENE FILM CAP	RSNR.CRYS	: CRYSTAL RESONATOR
C.TNTL	: TANTALUM CAP	R.TW.CEM	: TWIN CEMENT FIXED RESISTOR
C.TNTL.CHP	: CHIP TANTALUM CAP	R.CEMENT	: CEMENT RESISTOR
C.TRIM	: TRIMMER CAP	SCR.BND.HD	: BIND HEAD B-TITE SCREW
CN	: CONNECTOR	SCR.BW.HD	: BW HEAD TAPPING SCREW
CN.BS.PIN	: CONNECTOR,BASE PIN	SCR.CUP	: CUP TITE SCREW
CN.CANNON	: CONNECTOR,CANNON	SCR.TERM	: SCREW TERMINAL
CN.DIN	: CONNECTOR,DIN	SCR.TR	: SCREW,TRANSISTOR
CN.FLAT	: CONNECTOR,FLAT CABLE	SUPRT.PCB	: SUPPORT,P.C.B.
CN.POST	: CONNECTOR,BASE POST	SURG.PRTCT	: SURGE PROTECTOR
COIL.MX.AM	: COIL,AM MIX	SW.TACT	: TACT SWITCH
COIL.AT.FM	: COIL,FM ANTENNA	SW.LEAF	: LEAF SWITCH
COIL.DT.FM	: COIL,FM DETECT	SW.LEVER	: LEVER SWITCH
COIL.MX.FM	: COIL,FM MIX	SW.MICRO	: MICRO SWITCH
COIL.OUTPT	: OUTPUT COIL	SW.PUSH	: PUSH SWITCH
DIOD.ARRAY	: DIODE ARRAY	SW.RT.ENC	: ROTARY ENCODER
DIODE.BRG	: DIODE BRIDGE	SW.RT.MTR	: ROTARY SWITCH WITH MOTOR
DIODE.CHP	: CHIP DIODE	SW.RT	: ROTARY SWITCH
DIODE.VAR	: VARACTOR DIODE	SW.SLIDE	: SLIDE SWITCH
DIOD.Z.CHP	: CHIP ZENER DIODE	TERM.SP	: SPEAKER TERMINAL
DIODE.ZENR	: ZENER DIODE	TERM.WRAP	: WRAPPING TERMINAL
DSCR.CE	: CERAMIC DISCRIMINATOR	THRMST.CHP	: CHIP THERMISTOR
FER.BEAD	: FERRITE BEADS	TR.CHP	: CHIP TRANSISTOR
FER.CORE	: FERRITE CORE	TR.DGT	: DIGITAL TRANSISTOR
FET.CHP	: CHIP FET	TR.DGT.CHP	: CHIP DIGITAL TRANSISTOR
FL.DSPLY	: FLUORESCENT DISPLAY	TRANS	: TRANSFORMER
FLTR.CE	: CERAMIC FILTER	TRANS.PULS	: PULSE TRANSFORMER
FLTR.COMB	: COMB FILTER MODULE	TRANS.PWR	: POWER TRANSFORMER ASS'Y
FLTR.LC.RF	: LC FILTER,EMI	TUNER.AM	: TUNER PACK,AM
GND.MTL	: GROUND PLATE	TUNER.FM	: TUNER PACK,FM
GND.TERM	: GROUND TERMINAL	TUNER.PK	: FRONT-ENDTUNER PACK
HOLDER.FUS	: FUSE HOLDER	VR	: ROTARY POTENTIOMETER
IC.PRTCT	: IC PROTECTOR	VR.MTR	: POTENTIOMETER WITH MOTOR
JUMPER.CN	: JUMPER CONNECTOR	VR.SW	: POTENTIOMETER WITH ROTARY SW
JUMPER.TST	: JUMPER,TEST POINT	VR.SLIDE	: SLIDE POTENTIOMETER
L.DTCT	: LIGHT DETECTING MODULE	VR.TRIM	: TRIMMER POTENTIOMETER

NX-SW301 P.C.B. AMP

Ref. No.	Part No.	Description	Remarks	Markets	部 品 名	Rank	
*	AAX72270	P. C. B.	AMP	422164	P C B アンブ		
CN101	VC015000	CN	EH 6P	081522	コネクタ	01	
CN102	LB932020	CN. BS. PIN	2P	081661	ベースポスト	01	
CN103	AAX10570	CN	B 5P-VH	081672	コネクタ		
CN104	VC014800	CN	EH 4P	081493	コネクタ	01	
CN201-203	AAX72350	CN	B6B-EH-R RED	423583	コネクタ		
CN204	AAX28370	CN	B3B-EH	081465	コネクタ		
C101-102	UR867220	C. EL	22uF 50V	356201	ケミコン	01	
C105-106	AAX12400	C. POL	560pF 50V	055500	ポリエステルコン		
C107-108	UR867100	C. EL	10uF 50V	338565	ケミコン	01	
C109-110	AAX11210	C. POL	1500pF 50V	065028	ポリエステルコン		
C111-112	UR866220	C. EL	2.2uF 50V	353100	ケミコン	01	
C113-114	UR867330	C. EL	33uF 50V	368200	ケミコン	01	
C115-116	UR867100	C. EL	10uF 50V	338565	ケミコン	01	
C117-118	FG212560	C. CE	560pF 50V	065810	セラコン	01	
C119	UR866100	C. EL	1uF 50V	356367	ケミコン	01	
C120	UR868100	C. EL	100uF 50V	427664	ケミコン	01	
C123-124	FG613100	C. CE	1000pF 50V	065385	セラコン	01	
C125-126	FG651220	C. CE	22pF 50V	065741	セラコン	01	
C127-128	UR867100	C. EL	10uF 50V	338565	ケミコン	01	
C129-130	UR868100	C. EL	100uF 50V	353102	ケミコン	01	
C201-202	UR867220	C. EL	22uF 50V	356201	ケミコン	01	
C205-206	UA652100	C. MYLAR	100pF 50V J	055439	マイラーコン	01	
C207-208	UR867100	C. EL	10uF 50V	338565	ケミコン	01	
C209-210	AAX42490	C. POL	2200pF 50V	065055	ポリエステルコン	01	
C211-212	UR866220	C. EL	2.2uF 50V	353100	ケミコン	01	
C213-214	UR867330	C. EL	33uF 50V	368200	ケミコン	01	
C215-216	UR867100	C. EL	10uF 50V	338565	ケミコン	01	
C217-218	FG212560	C. CE	560pF 50V	065810	セラコン	01	
C219	UR866100	C. EL	1uF 50V	356367	ケミコン	01	
C220	UR868100	C. EL	100uF 50V	427664	ケミコン	01	
C223-224	FG612680	C. CE	680pF 50V	065824	セラコン	01	
C225-226	FG211180	C. CE	18pF 50V	065727	セラコン	01	
C227-228	UR867100	C. EL	10uF 50V	338565	ケミコン	01	
C229	UR868100	C. EL	100uF 50V	353102	ケミコン	01	
C230-231	XX698870	C. POL	0.01uF 50V	065000	ポリエステルコン	01	
C232	UR868100	C. EL	100uF 50V	353102	ケミコン	01	
D101	iF004600	DIODE	1SS133	069460	ダイオード	01	
D103	iF004600	DIODE	1SS133	069460	ダイオード	01	
D201-204	iF004600	DIODE	1SS133	069460	ダイオード	01	
#	IC101	AAX72250	IC	STK403-090-E LF	421556	IC	
#	IC102	AAX41390	IC	K1A4558P	353033	IC	03
#	IC201	AAX72250	IC	STK403-090-E LF	421556	IC	
#	IC202	AAX41390	IC	K1A4558P	353033	IC	03
Q101-102	AAX41640	TR	KTC2874 AB AT	367222	トランジスタ	01	
Q103-104	AAX51670	TR	KTC3200 GR, BL	358033	トランジスタ	01	
Q105	AAX12580	TR	2SA970 GR BL	073509	トランジスタ	03	
Q106	iC174020	TR	2SC1740S QRS	055717	トランジスタ	01	
Q107	AAX41640	TR	KTC2874 AB AT	367222	トランジスタ	01	
Q108	iC174020	TR	2SC1740S QRS	055717	トランジスタ	01	
Q201-202	AAX41640	TR	KTC2874 AB AT	367222	トランジスタ	01	
Q203-204	AAX51670	TR	KTC3200 GR, BL	358033	トランジスタ	01	
Q205	AAX12580	TR	2SA970 GR BL	073509	トランジスタ	03	
Q206	iC174020	TR	2SC1740S QRS	055717	トランジスタ	01	
Q207	AAX41640	TR	KTC2874 AB AT	367222	トランジスタ	01	
Q208	iC174020	TR	2SC1740S QRS	055717	トランジスタ	01	
Q209	AAX41660	TR	KTA1266GR AT	051819	トランジスタ	01	
Q210	AAX41650	TR	KTC3198GR AT	051818	トランジスタ	01	
R119-120	VA872100	R. MTL. OXD	0.22Ω 3W	422321	酸化金属被膜抵抗	01	
R130	HL005470	R. MTL. OXD	470Ω 1/2W	423581	酸化金属被膜抵抗		
R141-142	AAX11870	R. CAR. FP	10Ω 1/4W	044452	不燃化カーボン抵抗	01	
R143	AAX11860	R. CAR. FP	100Ω 1/4W	044153	不燃化カーボン抵抗	01	
R145	AAX11860	R. CAR. FP	100Ω 1/4W	044153	不燃化カーボン抵抗	01	
R219-220	VA872100	R. MTL. OXD	0.22Ω 3W	422321	酸化金属被膜抵抗	01	
R230	HL005470	R. MTL. OXD	470Ω 1/2W	423581	酸化金属被膜抵抗		
R241-242	AAX11870	R. CAR. FP	10Ω 1/4W	044452	不燃化カーボン抵抗	01	
R243	AAX11860	R. CAR. FP	100Ω 1/4W	044153	不燃化カーボン抵抗	01	
R249	AAX11860	R. CAR. FP	100Ω 1/4W	044153	不燃化カーボン抵抗	01	
RY101	VU161600	RELAY	OSA-SS-224DM3	079766	リレー	05	
RY201	VU161600	RELAY	OSA-SS-224DM3	079766	リレー	05	

* New Parts * 新規部品

(Note) Those parts marked with "#" are not included in the P.C.B. ass'y. (マーク#の部品は、基板に含まれません)

NX-SW301 P.C.B. AMP & POWER

NX-SW301 P.C.B. POWER

Ref. No.	Part No.	Description	Remarks	Markets	部 品 名	Rank
TH201	V9792500	POSISTOR	PTFM04BC471Q2N34B0	068554	ボジスタ	04
*	AAX72280	P. C. B.	POWER	422168	J	P C B パワー
*	AAX72290	P. C. B.	POWER	422287	CV	P C B パワー
*	AAX72320	P. C. B.	POWER	422290	K	P C B パワー
*	AAX72300	P. C. B.	POWER	422288	AL	P C B パワー
*	AAX72310	P. C. B.	POWER	422289	BG	P C B パワー
CN301-302	AAX72360	CN	B6B-EH-E BLUE	423584		コネクター
CN303	AAX10570	CN	B 5P-VH	081672		コネクター
CN304	VC014600	CN	B02B-EH	081439		コネクター
CN401	AAX72330	CN	KEY-15S-2A3F(LF) (SN)LF	422365		V G Aコネクター 1 5 P
CN409	AAX72460	CN	NAL1-01-008 LF	421559		スピーカターミナル
CN804	AAX72340	CN	B 7P-VH	081677		コネクター
C121-122	AAX11180	C. POL	0. 1uF 50V	065007		ポリエステルコン
C221-222	AAX11180	C. POL	0. 1uF 50V	065007		ポリエステルコン
C301	UR867220	C. EL	22uF 50V	356201		ケミコン
C303	AAX12400	C. POL	560pF 50V	055500		ポリエステルコン
C304	UR867100	C. EL	10uF 50V	338565		ケミコン
C305	AAX11210	C. POL	1500pF 50V	065028		ポリエステルコン
C306	UR866220	C. EL	2. 2uF 50V	353100		ケミコン
C307	FG212560	C. CE	560pF 50V	065810		セラコン
C308	AAX11180	C. POL	0. 1uF 50V	065007		ポリエステルコン
C309	FG612470	C. CE	470pF 50V	065793		セラコン
C310	UR867330	C. EL	33uF 50V	368200		ケミコン
C311	FG651100	C. CE	10pF 50V	065696		セラコン
C312	UR867220	C. EL	22uF 50V	356201		ケミコン
C313	FG651330	C. CE	33pF 50V	065767		セラコン
C314	UR866470	C. EL	4. 7uF 50V	358225		ケミコン
C315	AAX09530	C. CE	100pF 50V	065382		セラコン
C316	UR837470	C. EL	47uF 16V	338563		ケミコン
C317-318	UR867100	C. EL	10uF 50V	338565		ケミコン
C319-320	UA655180	C. MYLAR	0. 18uF 50V J	352293		マイラーコン
C321-322	UR837100	C. EL	10uF 16V	353104		ケミコン
C323	UA555390	C. MYLAR	0. 39uF 50V	352300		マイラーコン
C324	UA655150	C. MYLAR	0. 15uF 50V J	065038		マイラーコン
C325	UR867220	C. EL	22uF 50V	356201		ケミコン
C326	UA655820	C. MYLAR	0. 82uF 50V J	352307		マイラーコン
C327	UR838100	C. EL	100uF 16V	353103		ケミコン
C329	FG210600	C. CE	6pF 50V	065816		セラコン
C330	FG212560	C. CE	560pF 50V	065810		セラコン
C331	AAX11180	C. POL	0. 1uF 50V	065007		ポリエステルコン
C332	FG612470	C. CE	470pF 50V	065793		セラコン
C333	FG644100	C. CE	0. 01uF 50V	065452		セラコン
C334	UA655470	C. MYLAR	0. 47uF 50V J	352302		マイラーコン
C335-336	UR867100	C. EL	10uF 50V	338565		ケミコン
C337	V0529900	C. EL	10uF 16V	066606		B Pケミコン
C338	AAX11180	C. POL	0. 1uF 50V	065007		ポリエステルコン
C339-340	UR837470	C. EL	47uF 16V	338563		ケミコン
C341	UR866100	C. EL	1uF 50V	356367		ケミコン
C342	UR868100	C. EL	100uF 50V	427664		ケミコン
C343-344	UR867100	C. EL	10uF 50V	338565		ケミコン
C345-346	UR868100	C. EL	100uF 50V	353102		ケミコン
C347	AAX11200	C. POL	0. 12uF 50V	065024		ポリエステルコン
C348	UA555680	C. MYLAR	0. 68uF 50V	352305		マイラーコン
C349	AAX11210	C. POL	1500pF 50V	065028		ポリエステルコン
C401-406	FG613470	C. CE	4700pF 50V	065428		セラコン
C407-408	FG613100	C. CE	1000pF 50V	065385		セラコン
C409-410	FG613470	C. CE	4700pF 50V	065428		セラコン
C411	FG613100	C. CE	1000pF 50V	065385		セラコン
C412-413	FG612470	C. CE	470pF 50V	065793		セラコン
C414-415	AAX09530	C. CE	100pF 50V	065382		セラコン
C416	FG612470	C. CE	470pF 50V	065793		セラコン
C417	AAX09530	C. CE	100pF 50V	065382		セラコン
C801	UR857100	C. EL	10uF 35V	367294		ケミコン
C802	UR837470	C. EL	47uF 16V	338563		ケミコン
C803-804	UR838330	C. EL	330uF 16V	356203		ケミコン
C805-806	UR867220	C. EL	22uF 50V	356201		ケミコン
C807-808	VT202600	C. EL	8200uF 50V	422366		ケミコン

* New Parts * 新規部品

Note) Those parts marked with "#" are not included in the P.C.B. ass'y. (マーク#の部品は、基板に含まれません)

Ref. No.	Part No.	Description	Remarks	Markets	部 品 名	Rank
* C809-810	AAX43060	C. POL	0. 047uF 100V	065121		ポリエステルコン
C811	UR837100	C. EL	10uF 16V	353104		ケミコン
C812	UR867100	C. EL	10uF 50V	338565		ケミコン
C813	UR848470	C. EL	470uF 25V	338564		ケミコン
C814	VU092400	C. EL	4. 7uF 50V	066643		B Pケミコン
* C815	AAX72440	C. CE. SAFTY	0. 01uF 275V	360376		規格認定コン
C816	UR866100	C. EL	1uF 50V	356367		ケミコン
D301-309	iF004600	D1ODE	1SS133	069460		ダイオード
D802	AAAX12240	D1ODE	RBV602	069599		ダイオード
D803-804	VU264100	D1ODE	1SR139, 400	069536		ダイオード
D805-811	iF004600	D1ODE	1SS133	069460		ダイオード
F801-1	WC050700	CLIP. FUSE	EYF-52BCY	404188		ヒューズクリップ
* F801-2	AAX72430	FUSE	8A 250V	423492	JCV	ヒューズ
* F801-2	AAX72420	FUSE	2. 5A 250V	386499	KABGL	ヒューズ
* IC301	AAAX72250	IC	STK403-090-E LF	421556		IC
IC302-304	AAAX41390	IC	K1A4558P	353033		IC
IC801	X4153A00	IC	K1A7812API	354983		電源 IC
IC802	X4154A00	IC	K1A7912PI	354984		電源 IC
IC803	AAAX41450	IC	K1A78L05BP T0-92L	368508		IC
* IC804	AAAX72260	IC	K1A393P LF	422426		IC
Q301	AAAX41640	TR	KTC2874 AB AT	367222		トランジスタ
Q302	AAAX51670	TR	KTC3200 GR, BL	358033		トランジスタ
Q303	AAAX41640	TR	KTC2874 AB AT	367222		トランジスタ
Q304	AAAX51670	TR	KTC3200 GR, BL	358033		トランジスタ
Q305	AAAX09180	FET	2SK304 E	051061		F E T
Q306	AAAX41650	TR	KTC3198GR AT	051818		トランジスタ
Q307	AAAX41660	TR	KTA1266GR AT	051819		トランジスタ
Q308	AAAX41650	TR	KTC3198GR AT	051818		トランジスタ
Q309	AAAX41660	TR	KTA1266GR AT	051819		トランジスタ
Q310	AAAX12580	TR	2SA970 GR BL	073509		トランジスタ
Q311	iC174020	TR	2SC1740S QRS	055717		トランジスタ
Q312	AAAX41640	TR	KTC2874 AB AT	367222		トランジスタ
Q313	iC174020	TR	2SC1740S QRS	055717		トランジスタ
Q801	AAAX41660	TR	KTA1266GR AT	051819		トランジスタ
Q802	AAAX41650	TR	KTC3198GR AT	051818		トランジスタ
Q803	AAAX41660	TR	KTA1266GR AT	051819		トランジスタ
Q805-806	AAAX41660	TR	KTA1266GR AT	051819		トランジスタ
Q807	AAAX41650	TR	KTC3198GR AT	051818		トランジスタ
Q808	AAAX41660	TR	KTA1266GR AT	051819		トランジスタ
Q809-810	AAAX41650	TR	KTC3198GR AT	051818		トランジスタ
R137-138	AAAX11870	R. CAR. FP	10Ω 1/4W	044452		不燃化カーボン抵抗
R237-238	AAAX11870	R. CAR. FP	10Ω 1/4W	044452		不燃化カーボン抵抗
R309	VA872100	R. MTL. OXD	0. 22Ω 3W	422321		酸化金属被膜抵抗
R314	AAAX11870	R. CAR. FP	10Ω 1/4W	044452		不燃化カーボン抵抗
R336	VA872100	R. MTL. OXD	0. 22Ω 3W	422321		酸化金属被膜抵抗
R341	AAAX11870	R. CAR. FP	10Ω 1/4W	044452		不燃化カーボン抵抗
R346	VR412900	R. MTL. OXD	0. 1Ω 3W	422319		酸化金属被膜抵抗
R357	HV455680	R. CAR. FP	680Ω 1/4W	332092		不燃化カーボン抵抗
R358	HV455330	R. CAR. FP	330Ω 1/4W	332097		不燃化カーボン抵抗
R359	HV754680	R. CAR. FP	68Ω 1/4W	067490		不燃化カーボン抵抗
R362-365	AAAX11870	R. CAR. FP	10Ω 1/4W	044452		不燃化カーボン抵抗
R366	AAAX11860	R. CAR. FP	100Ω 1/4W	044153		不燃化カーボン抵抗
R371	HL005470	R. MTL. OXD	470Ω 1/2W	423581		酸化金属被膜抵抗
R380	AAAX11860	R. CAR. FP	100Ω 1/4W	044153		不燃化カーボン抵抗
R401-405	AAAX11870	R. CAR. FP	10Ω 1/4W	044452		不燃化カーボン抵抗
* R802-803	AAAX72450	R. MTL. OXD	510Ω 2W	427590		酸化金属被膜抵抗
* R804	HL314560	R. MTL. OXD	56Ω 1W	422429		酸化金属被膜抵抗
* R821	Vi510100	R. MTL. FLM	2KΩ 1/4W	423588		金属被膜抵抗
* R822	Vi511000	R. MTL. FLM	4. 7KΩ 1/4W	423589		金属被膜抵抗
* R823-824	HB027100	R. MTL. FLM	10KΩ 1/4W	366208		金属皮膜抵抗
* R831	Vi509800	R. MTL. FLM	1. 5KΩ 1/4W	423822		金属被膜抵抗
* RY301	VU161600	RELAY	OSA-SS-224DM3	079766		リレー
* RY801	AAAX12490	RELAY	SDT-S-112LMR	055473		リレー
* T802	AAAX72370	TRANS		422312	J	サブトランス
* T802	AAAX72380	TRANS		422313	CV	サブトランス
* T802	AAAX72410	TRANS		422316	K	サブトランス
* T802	AAAX72390	TRANS		422314	AL	サブトランス
* T802	AAAX72400	TRANS		422315	BG	サブトランス

* New Parts * 新規部品

Note) Those parts marked with "#" are not included in the P.C.B. ass'y. (マーク#の部品は、基板に含まれません)

■ DVR-S300 EXPLODED VIEW

When disassembling, use the special screw driver with such tip shape as shown in figure.

分解には、図のような特殊ドライバーを使用します。

T10  2.7 mm

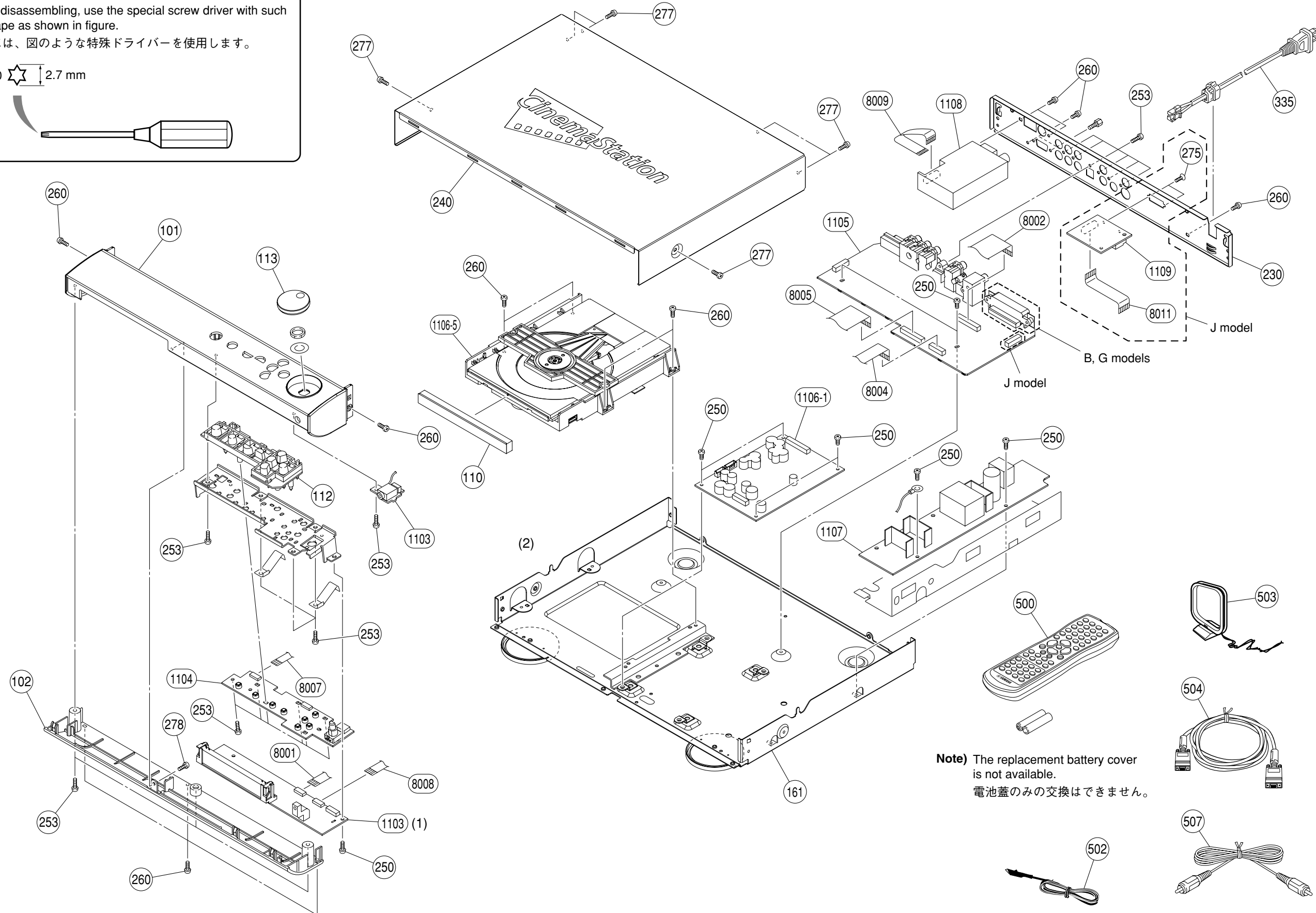
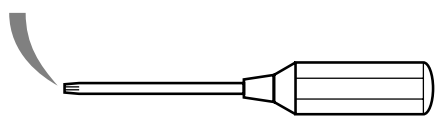

Note) The replacement battery cover is not available.
電池蓋のみの交換はできません。

■ DVR-S300 MECHANICAL PARTS

■ WARNING

- Components having special characteristics are marked △ and must be replaced with parts having specifications equal to those originally installed.
- △印のある部分は、安全確保部品を示しています。部品の交換が必要な場合、パーツリストに記載されている部品を使用してください。

Ref. No.	Part No.	Description	Remarks	Markets	部 品 名	Rank		
*	101	AAX72200	FRONT PANEL ASS'Y	3141 079 33331		フロントパネル A S S Y		
*	102	AAX73170	BOTTOM PANEL	3139 244 07771		ボトムパネル		
*	110	AAX71310	TRAY COVER ASS'Y	3141 079 33671		トレーカバー A S S Y		
*	112	AAX71350	BUTTON	3139 244 07751		ボタン		
*	113	AAX71320	KNOB VOLUME	3139 244 07741		ノブ/ボリューム		
*	161	AAX71330	FRAME ASS'Y	3141 079 33341		フレーム A S S Y		
*	230	AAX71420	REAR PANEL	3139 241 23181	J	リアパネル		
*	230	AAX71400	REAR PANEL	3139 241 23161	C	リアパネル		
*	230	AAX71380	REAR PANEL	3139 241 23141	K	リアパネル		
*	230	AAX71370	REAR PANEL	3139 241 23131	A	リアパネル		
*	230	AAX71360	REAR PANEL	3139 241 23111	BG	リアパネル		
*	230	AAX71410	REAR PANEL	3139 241 23171	L	リアパネル		
*	230	AAX71390	REAR PANEL	3139 241 23151	V	リアパネル		
*	240	AAX71300	TOP COVER	3139 241 22971		トップカバー		
	250	AAX23650	PAN HEAD TORX S-TIGHT SCREW	3x6 MFN133	2511 077 01039	ナベトルクスSタイトネジ		
	253	AAX53520	PAN HEAD TORX P-TIGHT SCREW	3x8 MFZN2BL	2511 076 50012	ナベトルクスPタイトネジ		
	260	AAX23640	PAN HEAD TORX S-TIGHT SCREW	3x6 MFZN2BL	2511 077 00039	ナベトルクスSタイトネジ		
*	275	AAX72200	FLAT HEAD B-TIGHT SCREW	3x8 MFZN2BL	2522 200 00019	皿Bタイトネジ		
*	277	AAX72220	PAN HEAD TORX S-TIGHT SCREW	3x4 MFN133	2522 201 00028	ナベトルクスSタイトネジ		
*	278	AAX72210	PAN HEAD TORX P-TIGHT SCREW	3x6 MFZN2BL	2511 076 50011	ナベトルクスPタイトネジ		
△	335	AAX53650	POWER CABLE	1.8m	2422 070 98255	J	電源コード	
△	335	AAX47750	POWER CABLE	1.8m	2422 070 98235	C	電源コード	
△	335	AAX59130	POWER CABLE	1.8m	2422 070 98222	K	電源コード	
△	335	AAX47740	POWER CABLE	1.8m	2422 070 98233	A	電源コード	
△	335	AAX53640	POWER CABLE	1.8m	2422 070 98236	B	電源コード	
△	335	AAX53630	POWER CABLE	1.8m	2422 070 98231	GL	電源コード	
* △	335	AAX71430	POWER CABLE	1.8m	2422 070 00093	V	電源コード	
*	1103	AAX71250	P.C.B. ASS'Y	FRONT	3139 248 85651	P C B フロント		
*	1104	AAX71240	P.C.B. ASS'Y	CONTROL	3139 248 85631	P C B コントロール		
*	1105	AAX71220	P.C.B. ASS'Y	AV	3139 248 85841	J	P C B AV	
*	1105	AAX71230	P.C.B. ASS'Y	AV	3139 248 85851	CKALV	P C B AV	
*	1105	AAX71210	P.C.B. ASS'Y	AV	3139 248 85361	BG	P C B AV	
*	1106-1	AAX71260	P.C.B. ASS'Y	MONO SD6.31 ST A-KEY	3141 079 33981	P C B MONO		
*	1106-5	AAX71200	DVD MECHANISM	WXD8829	3139 117 11201	D V Dメカニズム		
* △	1107	AAX71440	POWER SUPPLY UNIT	4-20 J	3139 247 11511	J	電源ユニット	
* △	1107	AAX67380	POWER SUPPLY UNIT	4-20	3139 117 11111	CKABGLV	電源ユニット	
*	1108	AAX71190	AM/FM TUNER	ENG047XX010F	2422 542 00026	J	AM/FM チューナー	
	1108	AAX67090	AM/FM TUNER	ENG067030F	2422 542 00022	CKALV	AM/FM チューナー	
*	1108	AAX71180	AM/FM TUNER	ENG077030RF	2422 542 00024	BG	AM/FM チューナー	
	1109	AAX57680	P.C.B. ASS'Y	HDMI D2 CONNECTOR	3139 248 82751	J	P C B H D M I D 2	
*	8001	AAX71730	FLEXIBLE FLAT CABLE	10P 60mm P=1mm	3139 241 01441		カード電線 C & C	
	8002	AAX59250	FLEXIBLE FLAT CABLE	30P 180mm P=1mm	3139 241 00421		カード電線 C & C	
	8004	AAX58220	FLEXIBLE FLAT CABLE	16P 220mm P=1mm	3139 111 02421		カード電線 C & C	
	8005	AAX67190	FLEXIBLE FLAT CABLE	30P 60mm P=1mm	3139 111 04271		カード電線 C & C	
*	8007	AAX71720	FLEXIBLE FLAT CABLE	7P 220mm P=1mm	3139 241 01431		カード電線 C & C	
*	8008	AAX71740	FLEXIBLE FLAT CABLE	9P 100mm P=1mm	3139 241 01461		カード電線 C & C	
	8009	AAX67170	FLEXIBLE FLAT CABLE	11P 100mm P=1mm	3103 308 93911		カード電線 C & C	

* New Parts * 新規部品

Ref. No.	Part No.	Description	Remarks	Markets	部 品 名	Rank		
*	8011	AAX71290	FLEXIBLE FLAT CABLE	13P 80mm P=1mm	3139 241 01351	J	カード電線 C & C	
			ACCESSORIES				付属品	
*	500	AAX72240	REMOTE CONTROL	RC1145542/01	3139 238 11471	J	リモコン	
*	500	AAX72230	REMOTE CONTROL	RC1145541/01	3139 238 11301	CKABGLV	リモコン	
	502	AAX67120	INDOOR FM ANTENNA	1.0m 1pc	2422 076 00546		F M簡易アンテナ	
	503	AAX67100	AM LOOP ANTENNA	1.0m 1pc	2422 549 45386		A Mループアンテナ	
	504	AAX67250	SYSTEM CONTROL CABLE	D-SUB 15P 4m 1pc	2422 076 00671		システム接続ケーブル	
	507	AAX22970	VIDEO PIN CABLE	YE 1.5m 1pc	3104 108 45432		ビデオ用ピンケーブル	
			BATTERY	SUM-3N 2pcs			乾電池	

* New Parts * 新規部品

■ NX-P301 EXPLODED VIEW

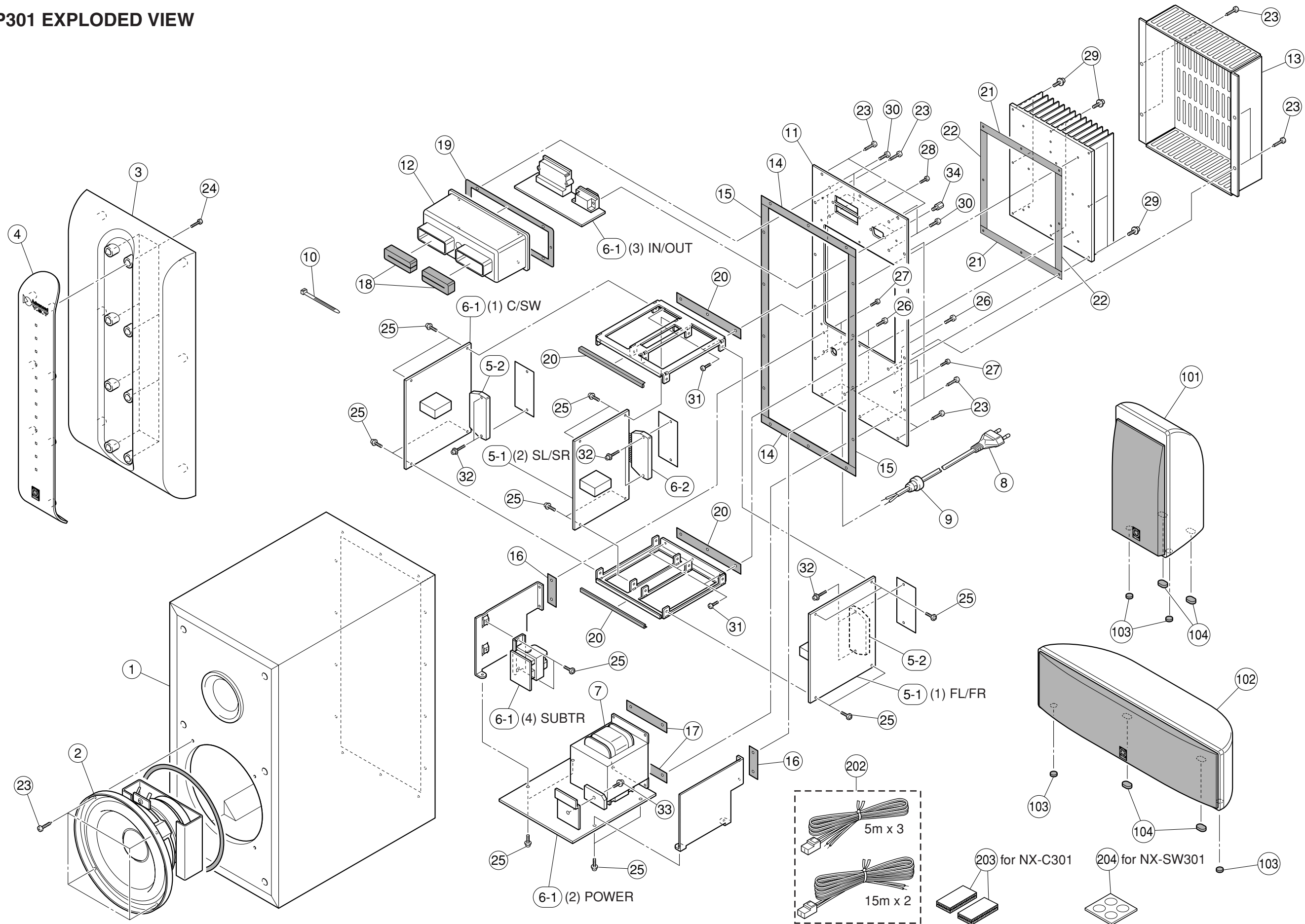

■ NX-P301 MECHANICAL PARTS

■ WARNING

- Components having special characteristics are marked △ and must be replaced with parts having specifications equal to those originally installed.
- △印のある部分は、安全確保部品を示しています。部品の交換が必要な場合、パーツリストに記載されている部品を使用してください。

Ref. No.	Part No.	Description	Remarks	Markets	部 品 名	Rank
* 1	AAX72480	CABINET ASS'Y			キャビネットASSY	
* 2	X4329800	DRIVER WOOFER	16cm 6Ω		スピーカーユニット	
* 3	AAX72750	FRONT GRILLE ASS'Y			フロントグリルASSY	
* 4	AAX72760	FRONT PANEL ASS'Y			フロントパネルASSY	
* 5-1	AAX72270	P.C.B ASS'Y	AMP		P C B アンプ	
* 5-2	AAX72250	IC (IC101, IC102)	STK403-090-E LF		I C	
* 6-1	AAX72280	P.C.B ASS'Y	POWER	J	P C B パワー	
* 6-1	AAX72290	P.C.B ASS'Y	POWER	CV	P C B パワー	
* 6-1	AAX72320	P.C.B ASS'Y	POWER	K	P C B パワー	
* 6-1	AAX72300	P.C.B ASS'Y	POWER	AL	P C B パワー	
* 6-1	AAX72310	P.C.B ASS'Y	POWER	BG	P C B パワー	
* 6-2	AAX72250	IC (IC301)	STK403-090-E LF		I C	
* △ 7	AAX72910	POWER TRANSFORMER		J	電源トランス	
* △ 7	AAX72960	POWER TRANSFORMER		C	電源トランス	
* △ 7	AAX72950	POWER TRANSFORMER		K	電源トランス	
* △ 7	AAX72930	POWER TRANSFORMER		AL	電源トランス	
* △ 7	AAX72940	POWER TRANSFORMER		BG	電源トランス	
* △ 7	AAX72920	POWER TRANSFORMER		V	電源トランス	
* △ 8	AAX72880	POWER CABLE	2m	J	電源コード	
* △ 8	V8366300	POWER CABLE	2m	C	電源コード	04
* △ 8	AAX72900	POWER CABLE	2m	K	電源コード	
* △ 8	AAX72870	POWER CABLE	2m	A	電源コード	
* △ 8	AAX72860	POWER CABLE	2m	B	電源コード	
* △ 8	V8366400	POWER CABLE	2m	GL	電源コード	04
* △ 8	AAX72890	POWER CABLE	2m	V	電源コード	
9	AAX12230	CORD STOPPER	SR-4		コードストッパー	01
10	CB069250	BINDING TIE	BK-1		束線止め	01
* 11	AAX72770	REAR PANEL		J	リアパネル	
* 11	AAX72780	REAR PANEL		C	リアパネル	
* 11	AAX72820	REAR PANEL		K	リアパネル	
* 11	AAX72800	REAR PANEL		A	リアパネル	
* 11	AAX72810	REAR PANEL		BG	リアパネル	
* 11	AAX72830	REAR PANEL		L	リアパネル	
* 11	AAX72790	REAR PANEL		V	リアパネル	
* 12	AAX72470	COVER SP TERMINAL			S P ターミナルカバー	
* 13	AAX72740	COVER HEATSINK			ヒートシンクカバー	
14	AAX12910	SEAL	13x170 t=1		シール	01
15	AAX12920	SEAL	13x370 t=1		シール	05
* 16	AAX72490	CUSHION	15x45 t=1		クッション	
* 17	AAX72510	CUSHION	18x100 t=1		クッション	
* 18	AAX72520	CUSHION BUSH	8x16x48		クッション	
* 19	AAX72530	CUSHION COVER			クッション	
* 20	AAX72540	CUSHION	15x115 t=1		クッション	
* 21	AAX72500	CUSHION	10x145 t=1		クッション	
* 22	AAX72550	CUSHION	10x160 t=1		クッション	
* 23	AAX72730	BIND HEAD TAPPING SCREW	4x20 MFZN2BL		バインド T P ネジ	
* 24	AAX72710	BIND HEAD P-TIGHT SCREW	3x16 MFZN133		バインド P タイトネジ	

* New Parts * 新規部品

Note) Those parts marked with “#” are not included in the P.C.B. ass'y. (マーク#の部品は、基板に含まれません)

Ref. No.	Part No.	Description	Remarks	Markets	部 品 名	Rank
* 25	AAX61980	BIND HEAD B-TIGHT SCREW	3x8 MFZN133		バインド B タイトネジ	
* 26	AAX72670	BIND HEAD B-TIGHT SCREW	4x8 MFZN2BL		バインド B タイトネジ	
* 27	AAX72680	BIND HEAD B-TIGHT SCREW	3x8 MFZN2BL		バインド B タイトネジ	
* 28	AAX72690	BIND HEAD B-TIGHT SCREW	3x10 MFZN2BL		バインド B タイトネジ	
* 29	AAX72620	SEMS PAN HEAD B-TIGHT SCREW	3x12 MFZN2BL		セムスナベ B タイトネジ	
* 30	AAX72720	BIND HEAD P-TIGHT SCREW	3x10 MFZN2BL		バインド P タイトネジ	
* 31	AAX72700	BIND HEAD B-TIGHT SCREW	3x8 MFZN2BL		バインド B タイトネジ	
* 32	AAX72610	SEMS PAN HEAD B-TIGHT SCREW	3x20 MFZN2BL		セムスナベ B タイトネジ	
* 33	AAX72630	SEMS PAN HEAD B-TIGHT SCREW	3x10 MFZN133		セムスナベ B タイトネジ	
* 34	AAX72590	JACK SCREW	KFS-4S-C1WM		ジャックスクリュー	
* 101	AAX72560	SATELLITE SPEAKER UNIT	NX-S301	J	サテライト S P ユニット	
* 101	AAX72570	SATELLITE SPEAKER UNIT	NX-S301	CKABG	サテライト S P ユニット	
* 101	AAX72580	SATELLITE SPEAKER UNIT	NX-S301	LV	サテライト S P ユニット	
* 102	AAX72640	CENTER SPEAKER UNIT	NX-C301	J	センター S P ユニット	
* 102	AAX72650	CENTER SPEAKER UNIT	NX-C301	CKABG	センター S P ユニット	
* 102	AAX72660	CENTER SPEAKER UNIT	NX-C301	LV	センター S P ユニット	
* 103	AAX72840	NONSKID PAD	M8 t1.5		滑止パッド	
* 104	AAX72850	NONSKID PAD	8x12 t3		滑止パッド	
		ACCESSORIES			付属品	
202	WC017100	SPEAKER CABLE KIT	15m 2pcs, 5m 3pcs		スピーカーコードキット	10
203	AAX21240	FASTENER for NX-C301	51.5x39x3.5 1pair		固定テープ	04
204	V5982400	NONSKID PAD for NX-SW301	M25 t2 4pcs/set		滑止パッド	03

* New Parts * 新規部品

Note) Those parts marked with “#” are not included in the P.C.B. ass'y. (マーク#の部品は、基板に含まれません)

■ NX-P302 EXPLODED VIEW

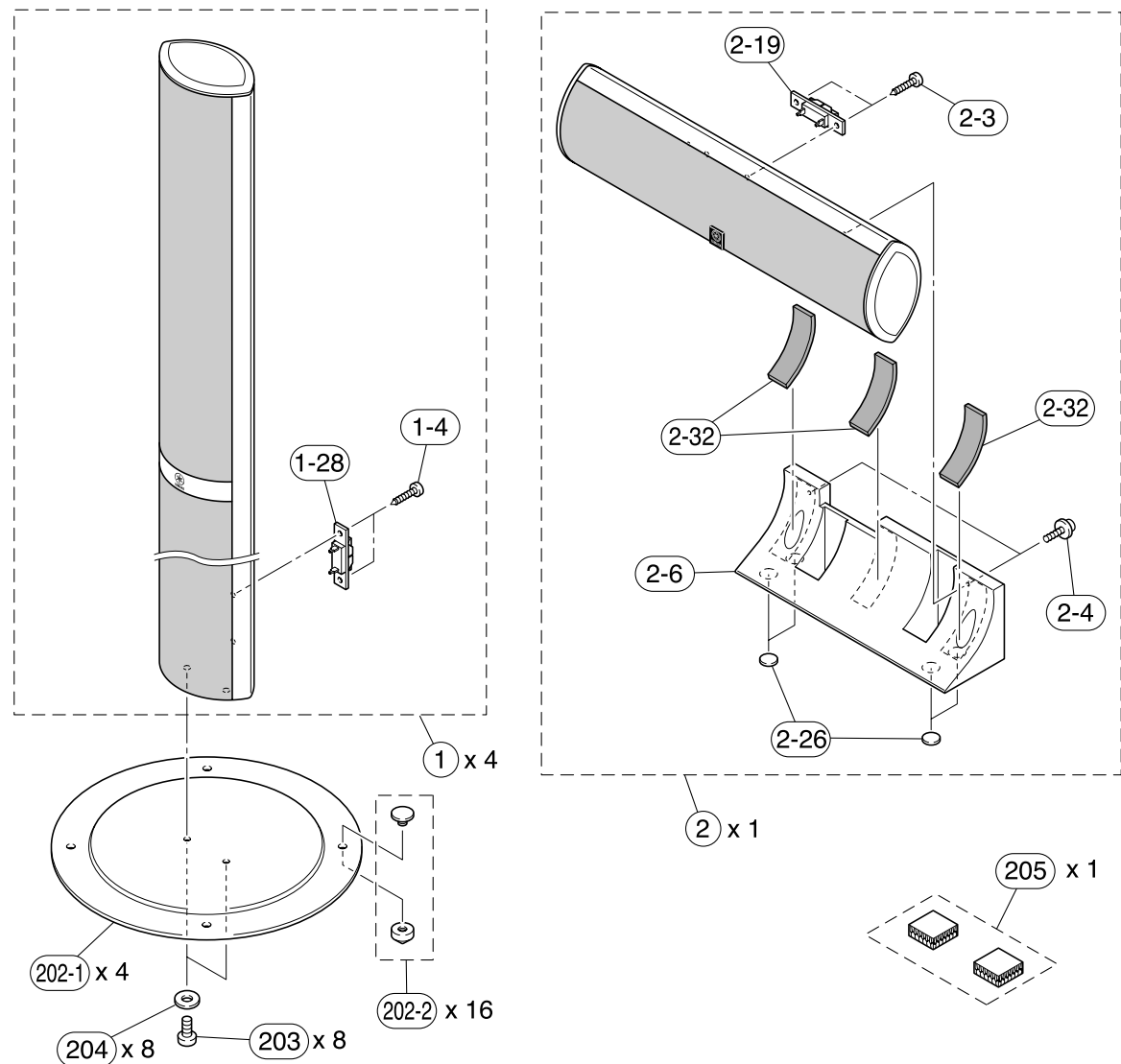

DVR-S300/NX-P301/NX-P302



Ref. No.	Part No.	Description	Remarks	Markets	部品名	Rank
* 1	AAx71470	SPEAKER FINAL ASS'Y	NX-S302		スピーカー 総組立	
1-4	EM830120	PAN HEAD TAPPING SCREW	3x10 MFZN2BL		ナベTPネジ	01
* 1-28	AAx73130	SPEAKER TERMINAL	2P PUSH	420040	スピーカーターミナル	
* 2	AAx71460	SPEAKER FINAL ASS'Y	NX-C302		スピーカー 総組立	
2-3	EM830120	PAN HEAD TAPPING SCREW	3x10 MFZN2BL		ナベTPネジ	01
2-4	VC568100	PW HEAD TAPPING SCREW	3x8-10 MFN133		PWヘッドTPネジ	01
* 2-6	AAx71530	STAND	for NX-C302	NX-SP302C000030	スタンド	
* 2-19	AAx73130	SPEAKER TERMINAL	2P PUSH	420040	スピーカーターミナル	
* 2-26	AAx71550	NONSKID PAD	M12 t2 4pcs/set	NX-SP302C000050	滑止パッド	
* 2-32	AAx73140	DAMPER	20x50 t=1 3pcs/set	NX-SP302C010020	ダンパー	
		ACCESSORIES			付属品	
* 202-1	AAx73150	BASE	for NX-S302 1pc	NX-SP302F000050	ベース	
* 202-2	AAx71540	LEG ASS'Y	M15 t=11 1pair	NX-SP302000040	レッグASSY	
203	03753460	BIND HEAD SCREW	5x10 MFN133 1pc		バインド小ネジ	
204	VZ890800	WASHER	5.5x8x0.3 1pc		ワッシャー	
* 205	AAx73160	FASTENER	25x25 2pairs	57045&57046	固定テープ	

* New Parts * 新規部品