

HOME THEATER SYSTEM VS-10/NX-SW10

SERVICE MANUAL

VS-10/NX-SW10

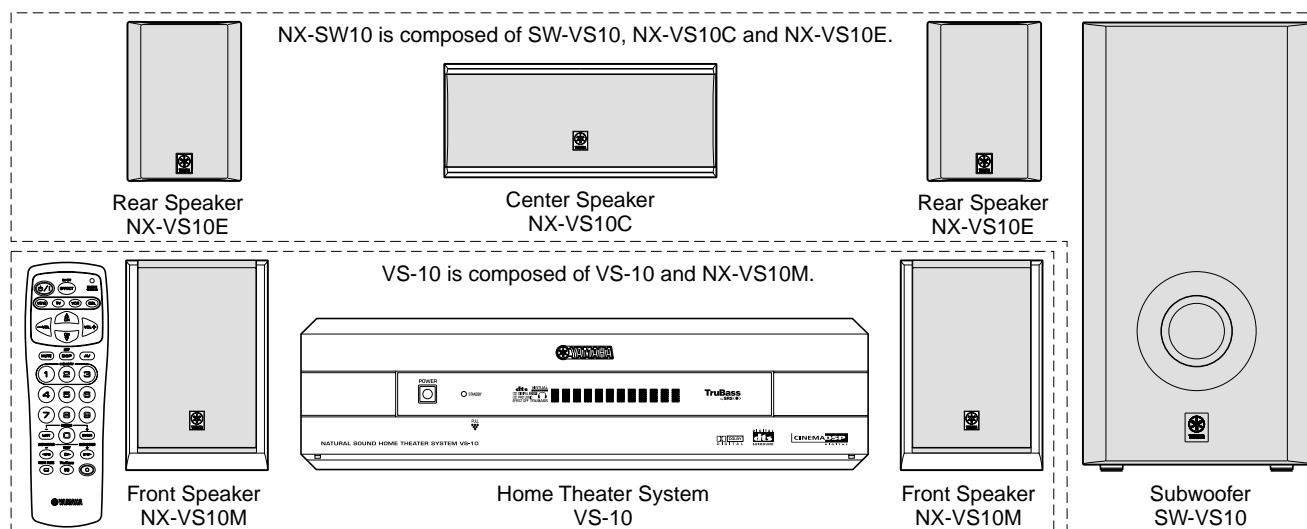

IMPORTANT NOTICE

This manual has been provided for the use of authorized YAMAHA Retailers and their service personnel. It has been assumed that basic service procedures inherent to the industry, and more specifically YAMAHA Products, are already known and understood by the users, and have therefore not been restated.

WARNING: Failure to follow appropriate service and safety procedures when servicing this product may result in personal injury, destruction of expensive components, and failure of the product to perform as specified. For these reasons, we advise all YAMAHA product owners that any service required should be performed by an authorized YAMAHA Retailer or the appointed service representative.

IMPORTANT: The presentation or sale of this manual to any individual or firm does not constitute authorization, certification or recognition of any applicable technical capabilities, or establish a principle-agent relationship of any form.

The data provided is believed to be accurate and applicable to the unit(s) indicated on the cover. The research, engineering, and service departments of YAMAHA are continually striving to improve YAMAHA products. Modifications are, therefore, inevitable and specifications are subject to change without notice or obligation to retrofit. Should any discrepancy appear to exist, please contact the distributor's Service Division.

WARNING: Static discharges can destroy expensive components. Discharge any static electricity your body may have accumulated by grounding yourself to the ground buss in the unit (heavy gauge black wires connect to this buss).

IMPORTANT: Turn the unit OFF during disassembly and part replacement. Recheck all work before you apply power to the unit.

CONTENTS

TO SERVICE PERSONNEL	1	SW-VS10 DISASSEMBLY PROCEDURES	9
REMOTE CONTROL TRANSMITTER PANELS	1	TEST PROGRAM MODE (VS-10)	10~11
FRONT/REAR PANELS	2~4	DSP DIAG MODE (Self-diagnosis)	12~18
SPECIFICATIONS	5	IC DATA	19~25
DIMENSIONS	6	BLOCK DIAGRAM	26~29
INTERNAL VIEW	7	PRINTED CIRCUIT BOARD	30~41
VS-10 DISASSEMBLY PROCEDURES	7	SCHEMATIC DIAGRAM	42~46
P. C. B. OPERATION CHECK	8	PARTS LIST	47~63
		DISPLAY DATA	64
		REMOTE CONTROL TRANSMITTER	65~66



このサービスマニュアルは、エコマーク認定の再生紙を使用しています。
This Service Manual uses recycled paper.

■ TO SERVICE PERSONNEL

1. Critical Components Information

Components having special characteristics are marked  and must be replaced with parts having specifications equal to those originally installed.

2. Leakage Current Measurement (For 120V Models Only)

When service has been completed, it is imperative to verify that all exposed conductive surfaces are properly insulated from supply circuits.

- Meter impedance should be equivalent to 1500 ohm shunted by 0.15μF.
- Leakage current must not exceed 0.5mA.
- Be sure to test for leakage with the AC plug in both polarities.

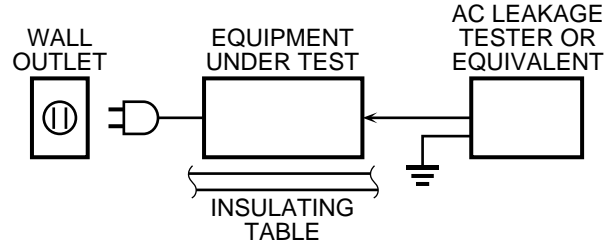

WARNING: CHEMICAL CONTENT NOTICE!

The solder used in the production of this product contains LEAD. In addition, other electrical/electronic and /or plastic (where applicable) components may also contain traces of chemicals found by the California Health and Welfare Agency (and possibly other entities) to cause cancer and/or birth defects or other reproductive harm.

DO NOT PLACE SOLDER, ELECTRICAL/ELECTRONIC OR PLASTIC COMPONENTS IN YOUR MOUTH FOR ANY REASON WHATSOEVER!

Avoid prolonged, unprotected contact between solder and your skin! When soldering, do not inhale solder fumes or expose eyes to solder/flux vapor!

If you come in contact with solder or components located inside the enclosure of this product, wash your hands before handling food.

■ REMOTE CONTROL TRANSMITTER PANELS

U, C, A models

B, G models

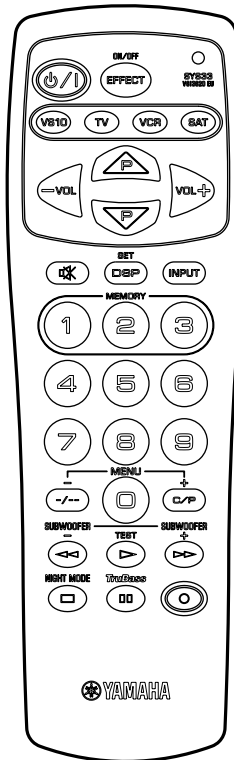
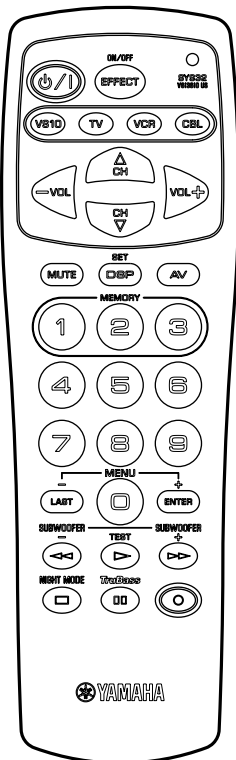

FRONT/REAR PANELS

VS-10

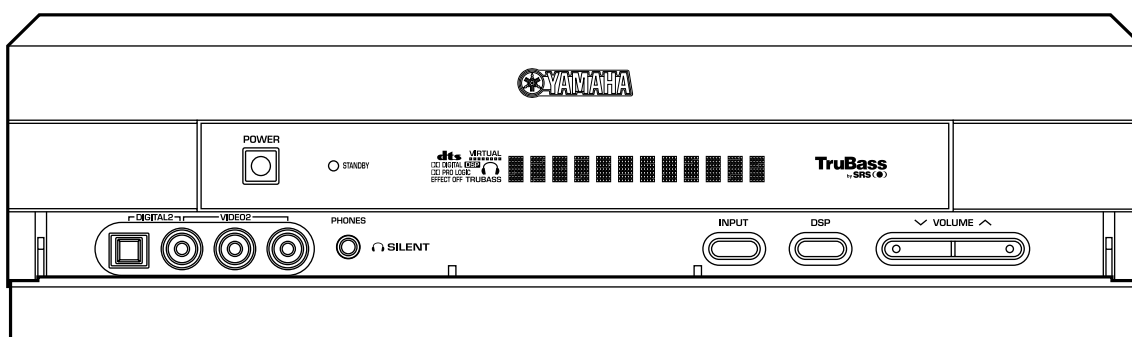
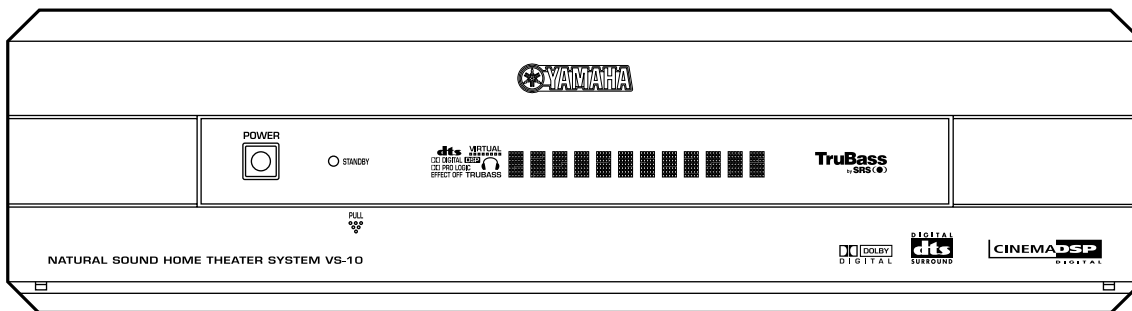

U, C models

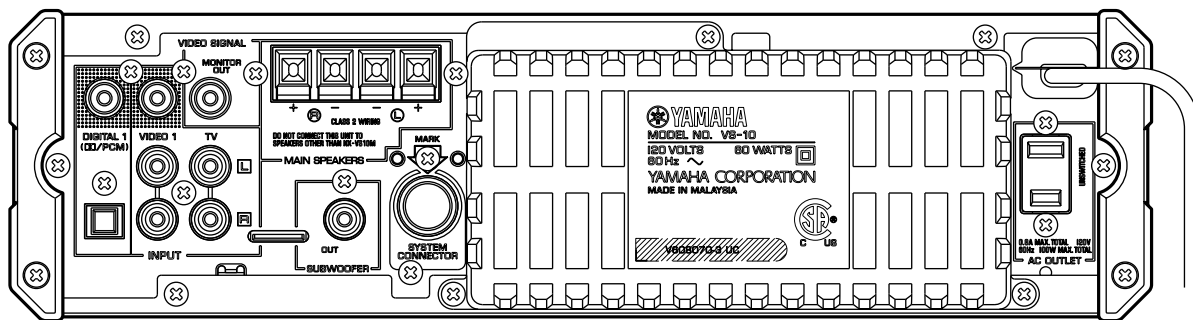

A model

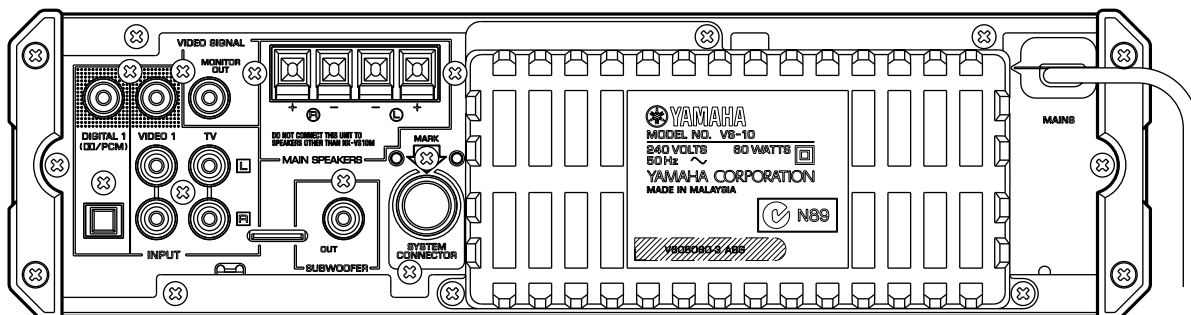

B, G model

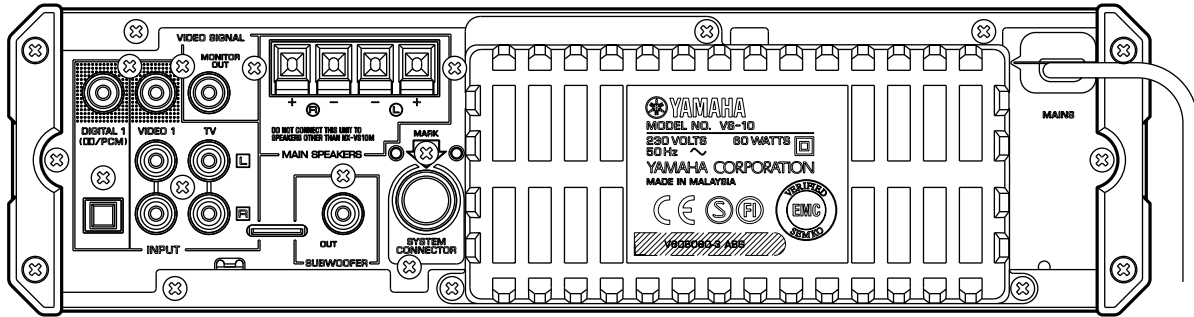

● NX-VS10M

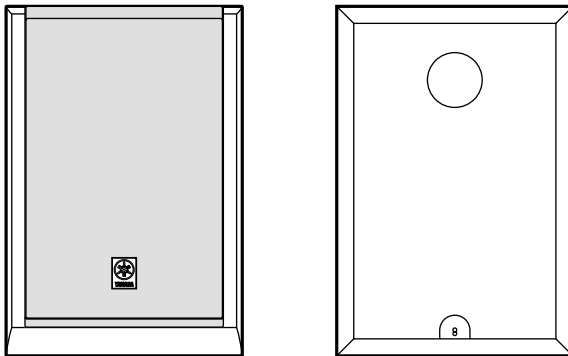

● SW-VS10 (Subwoofer)

U, C models

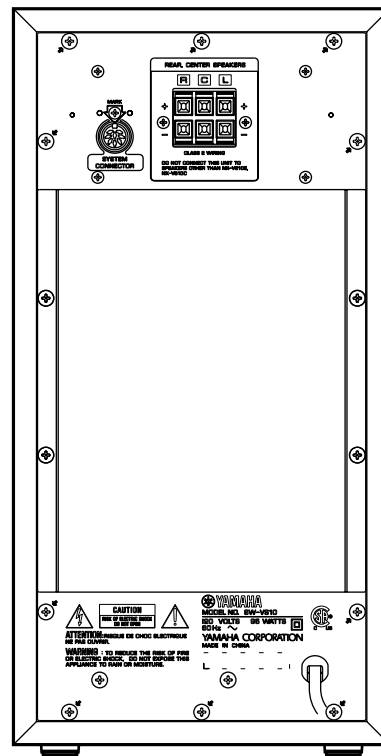
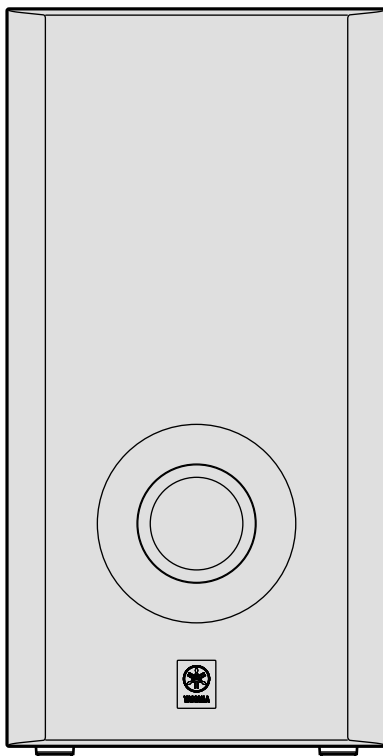

A model

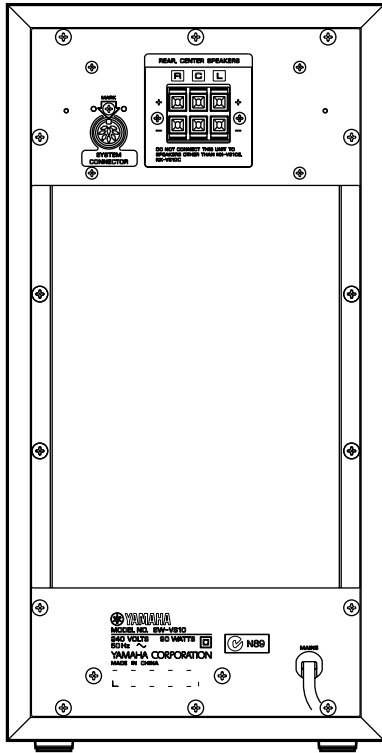

B, G model

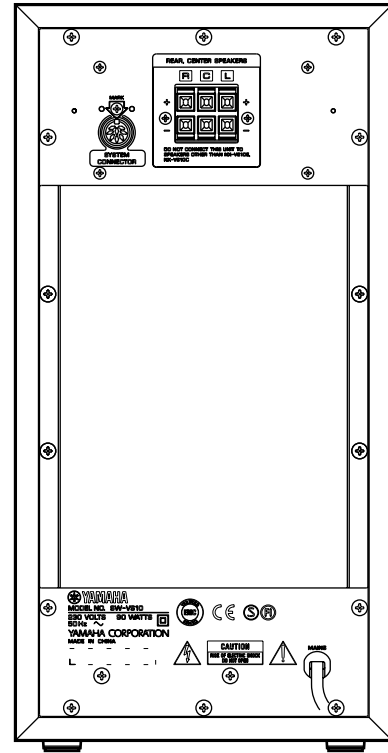

● NX-VS10C (Center Speaker)

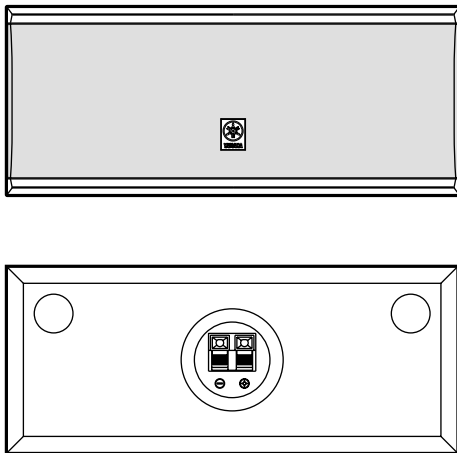

● NX-VS10E (Rear Speaker)

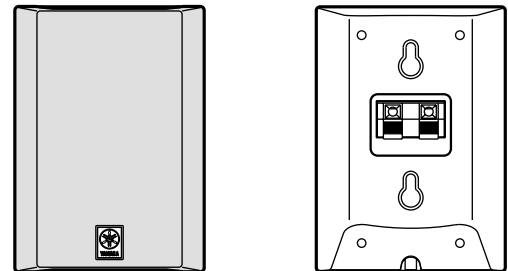

■ SPECIFICATIONS

■ VS-10 (Center Unit)

● Audio Section

Minimum RMS Output Power per Channel 1kHz, 10% THD, 6Ω	25W + 25W
Signal to Noise Ratio (IHF-A-Network) VIDEO1	90dB
Total Harmonic Distortion (1kHz, 10W/6Ω) VIDEO1	0.07%
Input Sensitivity / Impedance VIDEO1	200mV / 50kΩ

● Video Section

Signal Level	1V p-p / 75Ω
---------------------	--------------

● General

Power Supply	
U, C models	AC120V, 60Hz
B, G models	AC230V, 50Hz
A model	AC240V, 50Hz

Power Consumption	60W
--------------------------	-----

Standby Power Consumption Reference data	5.5W
--	------

Dimensions (W x H x D)	
Only VS-10	302 x 82 x 300mm (11-7/8" x 3-1/4" x 11-13/16")
Setting Vertically (Include Stand and Pads)	124 x 302.5 x 300mm (4-7/8" x 11-15/16" x 11-13/16")
Setting Horizontally (Include Pads)	302 x 88.5 x 300mm (11-7/8" x 3-1/2" x 11-13/16")

Weight Only VS-10	4.7kg (10lbs. 6oz.)
-----------------------------	---------------------

Finish	Black, Silver
---------------	---------------

Accessories	Remote Control Transmitter x1 RCA Pin Cable (Video x1, Audio x1) Stand x1 Pads (Side x1 and Bottom x1) Batteries x 4
--------------------	--

● Speaker Section (NX-VS10M)

Type	2 way Bass Reflex (Magnetic-Shielding Type)
-------------	---

Speakers	10cm Cone, 2cm Super Tweeter
-----------------	------------------------------

Maximum Power Handling Capacity	25W
--	-----

Impedance	6Ω
------------------	----

Dimensions (W x H x D)	125 x 185 x 145mm (4-15/16" x 7-5/16" x 5-11/16")
-------------------------------	--

Weight Only NX-VS10M	1.4kg (3lbs. 1oz.)
--------------------------------	--------------------

* (●) **TruBass™**

TruBass and the (●) symbol are trademarks of SRS Labs, inc. in the United States and selected foreign countries. TruBass technology is incorporated under license from SRS Labs, inc.

* Manufactured under license from Dolby Laboratories. "Dolby", "Dolby Digital", "Pro Logic", and the double-D symbol  are trademarks of Dolby Laboratories. © 1992-1997 Dolby Laboratories. All rights reserved.

* Manufactured under license from Digital Theater Systems, Inc. US Pat. No. 5,451,942 and other world-wide patents issued and pending. "DTS", "DTS Digital Surround", are trademarks of Digital Theater Systems, Inc. copyright 1996 Digital Theater Systems, inc. All rights reserved.

■ SW-VS10 (Subwoofer)

Minimum RMS Output Power per Channel	
SW-VS10: 1kHz, 10% THD, 5Ω	50W
NX-VS10C: 1kHz, 10% THD, 6Ω	40W
NX-VS10E: 1kHz, 10% THD, 6Ω	25W + 25W

Type	Advanced Active Servo Tecnology type
-------------	--------------------------------------

Speakers	16cm Cone (Magnetic-Shielding Type)
-----------------	-------------------------------------

Maximum Power Handling Capacity	50W
--	-----

Impedance	5Ω
------------------	----

Power Supply	
U, C models	AC120V, 60Hz
B, G models	AC230V, 50Hz
A model	AC240V, 50Hz

Power Consumption	
U, C models	95W
B, G, A models	90W

Standby Power Consumption Reference data	0W
--	----

Dimensions (W x H x D)	200 x 395 x 400mm (7-7/8" x 15-9/16" x 15-3/4")
-------------------------------	--

Weight	10.6kg (23lbs. 6oz.)
---------------	----------------------

Accessories	Wall Bracket x2 Bracket x2 Accessory Cord 4m x1, 15m x 2 DIN Cord x1 Pan Head Screw-sems x2 Wing Bolts x2 Fastener Tape x1set
--------------------	---

n NX-VS10C (Center Speaker)

Type	Bass Reflex (Magnetic-Shielding Type)
-------------	---------------------------------------

Speakers	8cm Cone x 2
-----------------	--------------

Maximum Power Handling Capacity	40W
--	-----

Impedance	6Ω
------------------	----

Dimensions (W x H x D)	240 x 100 x 145mm (9-7/16" x 3-15/16" x 5-11/16")
-------------------------------	--

Weight	1.7kg (3lbs. 12oz.)
---------------	---------------------

■ NX-VS10E (Rear Speaker)

Type	Acoustic Suspension (Magnetic-Shielding Type)
-------------	---

Speakers	8cm Cone
-----------------	----------

Maximum Power Handling Capacity	30W
--	-----

Impedance	6Ω
------------------	----

Dimensions (W x H x D)	100 x 140 x 112mm (3-15/16" x 5-1/2" x 4-3/8")
-------------------------------	---

Weight	0.68kg (1lbs. 8oz.)
---------------	---------------------

* Specifications subject to change without notice.

U U.S.A. model	C Canada model
G Europe model	B British model
A Australia model	

■ DIMENSIONS

● VS-10

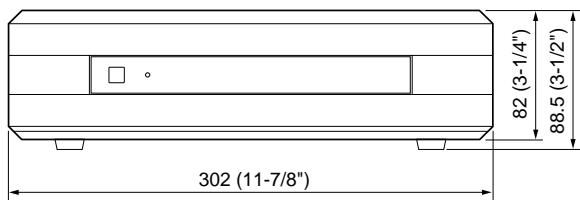
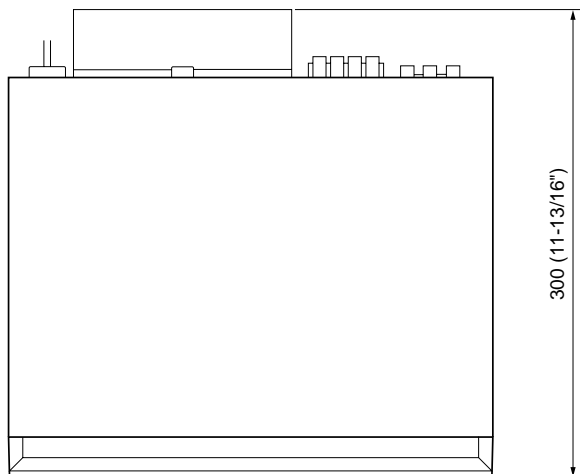

Unit : mm (inch)

● NX-VS10M

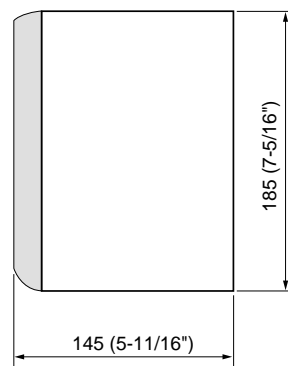
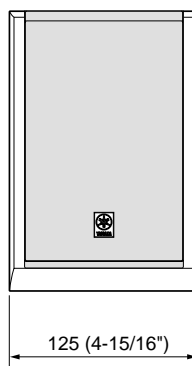

Unit : mm (inch)

● SW-VS10 (Subwoofer)

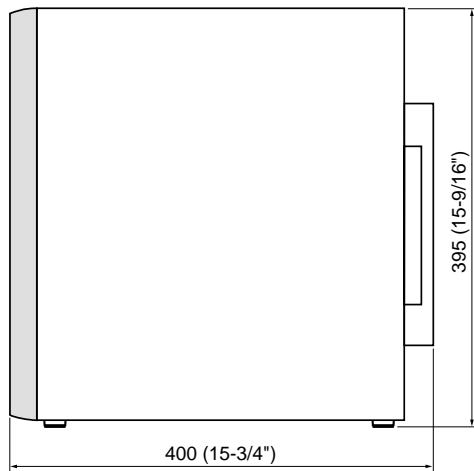
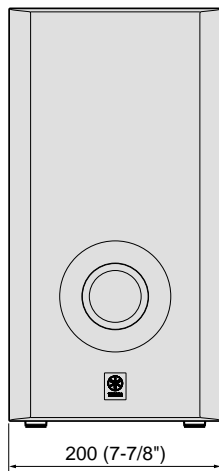

Unit : mm (inch)

● NX-VS10C (Center Speaker)

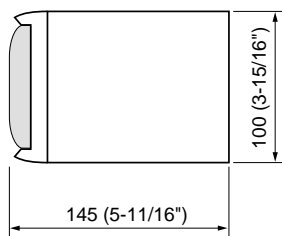
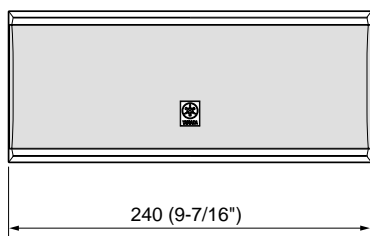

Unit : mm (inch)

● NX-VS10E (Rear Speaker)

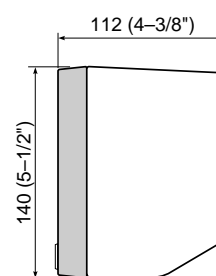
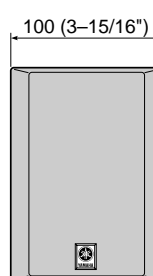

Unit : mm (inch)

INTERNAL VIEW

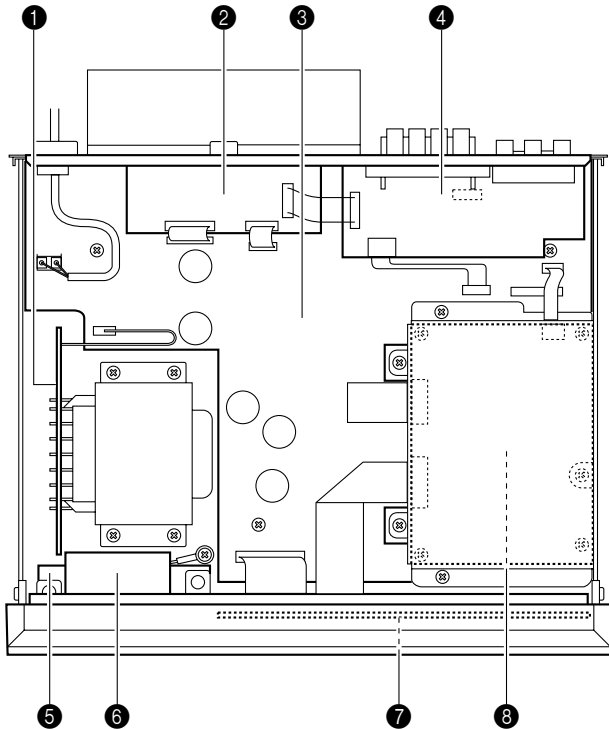

- ① MAIN P.C.B. (3)
- ② MAIN P.C.B. (4)
- ③ MAIN P.C.B. (1)
- ④ MAIN P.C.B. (2)
- ⑤ DIGITAL P.C.B. (3)
- ⑥ MAIN P.C.B. (5)
- ⑦ DIGITAL P.C.B. (2)
- ⑧ DIGITAL P.C.B. (1)

VS-10 DISASSEMBLY PROCEDURES

(Remove parts in the order as numbered below.)

1. Removal of Side Cover

- a. Remove 4 screws (①). (Fig. 1)
- b. Remove the Side Cover.

2. Removal of Bottom Cover

- a. Remove the screw (②) in Fig. 1, and 2 screws (③) in Fig. 2 to remove the heat sink cover.
- b. Remove 9 screws (④), and the Bottom Cover can be removed rearward. (Fig. 2)

3. Removal of Top Cover

- a. Remove 6 screws (⑤). (Fig. 3)
- b. Remove the Top Cover.

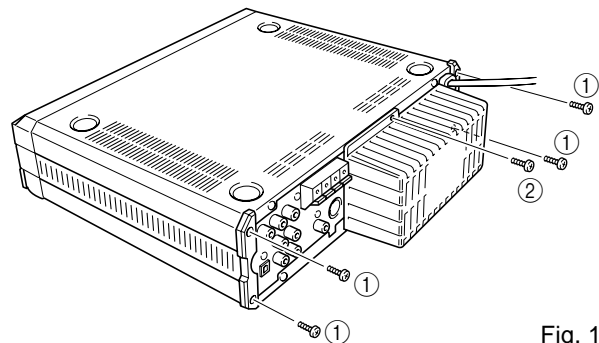

Fig. 1

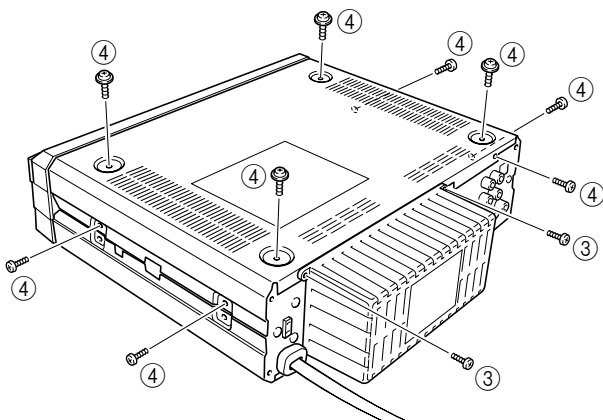

Fig. 2

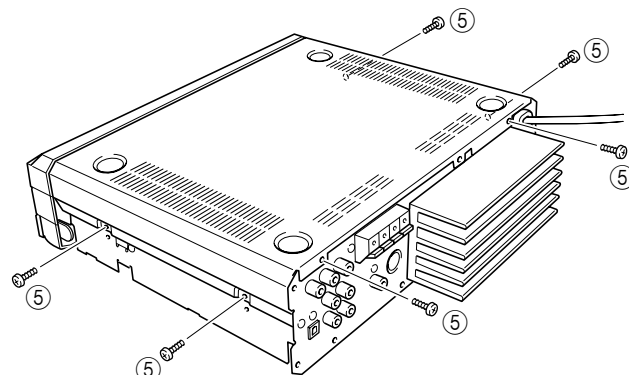

Fig. 3

■ P.C.B. OPERATION CHECK

Preparation before operation check

- a. Remove 3 screws (⑥). (Fig. 4)
- b. Remove the DSP Top Cover.
- c. Disconnect the flexible flat cable (CB1) from DIGITAL P.C.B. (1). (Fig. 4)
- d. Remove 4 screws (⑦) and then remove DIGITAL P.C.B. (1) from the DSP Bottom Cover. (Fig. 4)
- e. Remove 3 screws (⑧). (Fig. 5)
- f. Remove the DSP Bottom Cover.
- g. Remove 4 screws (⑨). (Fig. 6)
- h. Remove 3 screws (⑩). (Fig. 5)
- i. Remove MAIN P.C.B. (1) from the main chassis.
- j. Disconnect the flexible flat cable (CB305) from MAIN P.C.B. (1).
- k. Connect CB305 of MAIN P.C.B. (1) and CB1 of DIGITAL P.C.B. (1) by using an extension cable (5P:MF105250).
- l. Place MAIN P.C.B. (1) upright with a cloth spread on the main chassis. (Fig. 7)
- m. Tie one end of a string through the screw hole in the rear panel and the other end through the screw hole in the main chassis to secure them.
- n. Connect **GND** (x4 in Fig. 6, 7) to the main chassis by using a lead wire.

CAUTION: The grounding point must be connected to main chassis to keep the circuit in normal operation when MAIN P.C.B. (1) and DIGITAL P.C.B. (1) are removed from main chassis.

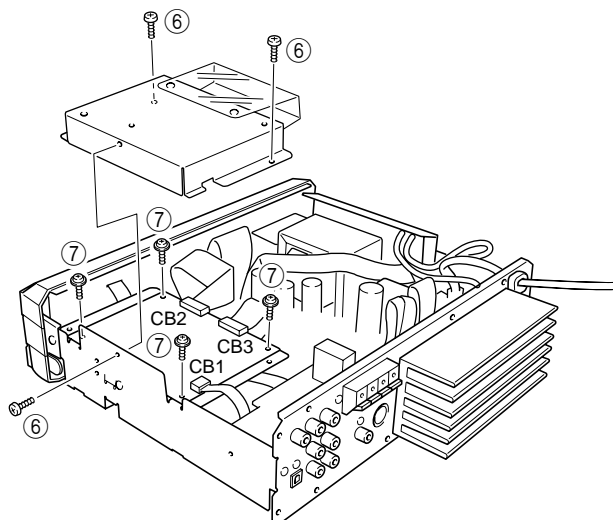

Fig. 4

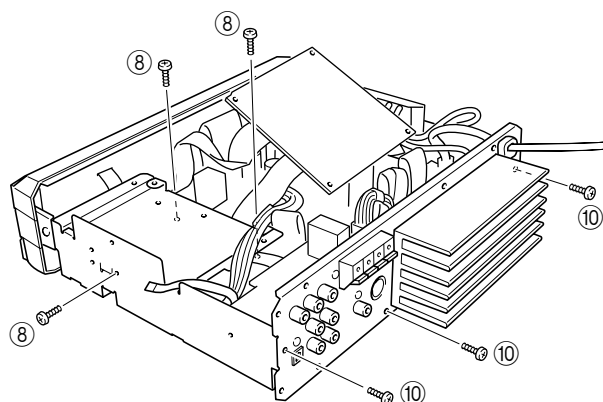

Fig. 5

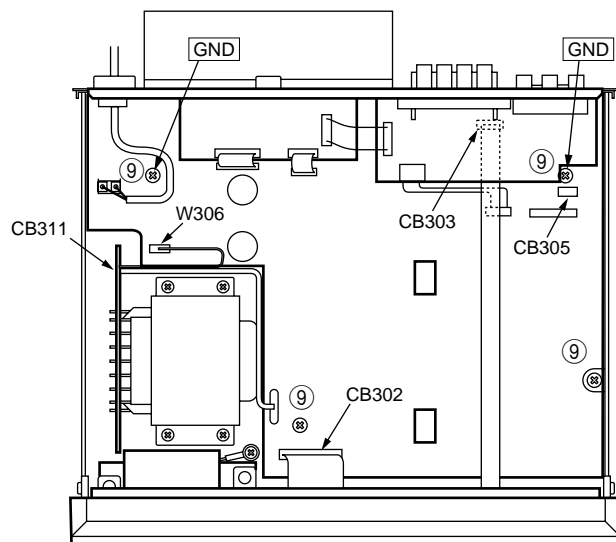

Fig. 6

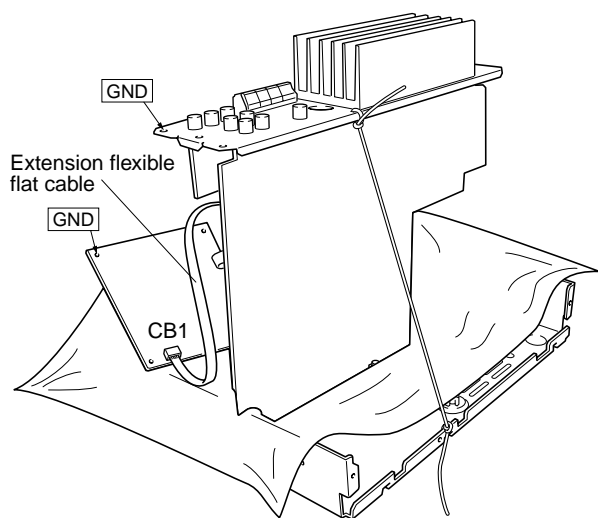

Fig. 7

■ SW-VS10 DISASSEMBLY PROCEDURES

(Remove parts in the order as numbered below.)

1. Removal of Grille Assembly.

- a. Insert the tip of flat tip (-) screwdriver to the slot on the bottom.

Push up the Grille Assembly by applying force to the screwdriver. (Fig. 8).

- b. Keep pushing up the Grille Assembly gradually until it can be removed.

* **The Grille Assembly is fixed securely at 6 dowels. When removing it, use care not to cause a scratch or any damage to the main unit. When reinstalling it, apply quick-drying type bond to the dowels of the Grille Assembly and fit it in place securely. (If it is only pushed in, it will come off easily.)**

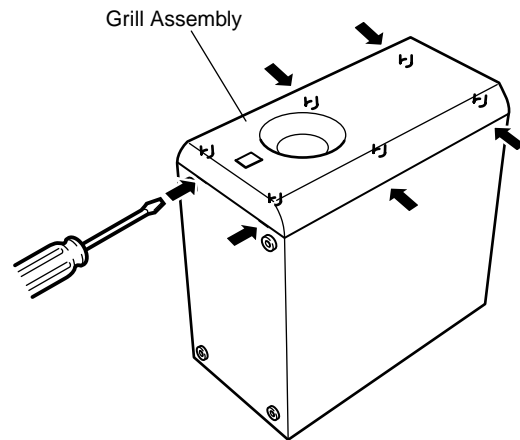

Fig. 8

2. Removal of Amplifier Unit

- a. Remove 14 screws (11) and then remove the Amplifier Unit. (Fig. 9)

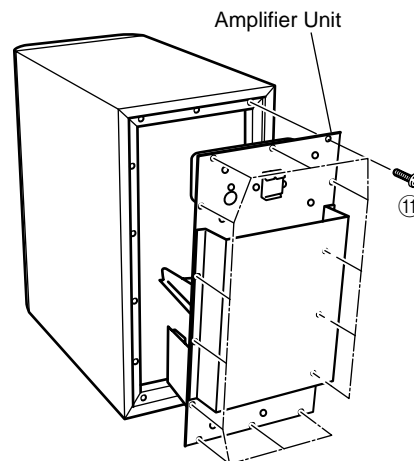

Fig. 9

■ TEST PROGRAM MODE (VS-10)

1. Procedure for starting Test Program

With the power turned off, press the POWER key while pressing the VOLUME key and the DSP key simultaneously. This initiates the Test Program function.

When the Test Program is initiated, "01 DEST-Ex" appears on the FL display.

2. Procedure for selecting and executing Test Program

Using the VOLUME + (UP) key and Volume - (DOWN) key, select the Test Program and then press the INPUT key to execute it.



3. Procedure for canceling Test Program

There are two methods for cancellation.

a. Turn off the power by pressing the POWER key of the main unit or the remote controller.

b. Select the Test Program "01 DEST-Ex" and press the INPUT key for execution. (The normal mode will be restored.)

4. Details of the Test Program function

Display	Function
01 DEST-Ex	Destination display/ test program end Destination display J:Ja J (Japanese) Ex Ex models
02 Fact. Test	Factory test mode This test mode is used for factory inspection before shipping and is not usually used. If the test program has been executed, it is not possible to shift to another test program. In such case, cancel the test program.
03 FL+CLEAR	FL display segments all light up / BACKUP RAM CLEAR 1 st time: FL display segments all light up and standby LED lights up. 2 nd time: RAM CLEAR is executed (RAM CLEAR OK on display*) * State before shipped out of the factory preset.
04 FL CHECK	FL display light-up check 1 st time: FL display segments all light up and standby LED lights up. 2 nd time: Even number segments and digits light up and standby LED lights up. 3 rd time: Odd number segments and digits light up.
1 st time	2 nd time
	
	3 rd time
	

Display	Function
05 DSP Dia9	The DSP DIAG (self-diagnosis) mode is initiated. (Refer to page 7 for the details.)
06 Ver-A1.05	Microprocessor version / date display Example of microprocessor display 06 Ver-A1.05 Example of microprocessor date display 06 '00.08.23 What is displayed varies depending on the microprocessor software.
07 SUM[cdbc]	Check sum calculation display / re-calculation
08 PrCan-OFF	All protection cancellation function ON/OFF * ¹
09 Pr!C_P_S_	Protection operation history display / clear C: VS-10 amplifier voltage (DC) P: Power supply circuit voltage S: SW-VS10 (Subwoofer) side _: Normal x: Abnormal
10 RemoCorrR	ROM collection (EEPROM) remote control data reception / data write This test mode is not usually used.

***¹ CAUTION:**

Using this product with the protection function cancelled may cause damage to itself. Use special care for this point when using this mode.

■ DSP DIAG MODE (Self-diagnosis)

Use the remote controller supplied as an accessory to select the menu.

1. Procedure for starting DSP DIAG

Referring to TEST PROGRAM MODE in the previous section, select/execute "05 DSP Diag".

When "05 DSP Diag" is executed, the current input name appears on the display followed by "Sel.1to9 Key".

2. Procedure for selecting Main menu and Sub-menu

Using [1] through [9] keys on the remote controller, select the main menu. Soon the sub-menu will appear on the display. Then, select the sub-menu. Every time the selected key (on the remote controller) is pressed, the sub-menu on the display changes.

No.	Main menu	(Display)	Sub-menu	(Display)
1	Analog through	Analog Thr.	MAIN BYPASS	A.T.M.Bypass
			DSP 0dB	A.T. DSP 0dB
2	DSP through	Dsp Through	YSS908-SRAM	DspT.908SRAM
			YS908	DspT.YSS908
			DSP FULL BIT	DspT.FullBit
3	AC-3/dts through	AC-3/dts Thr.	Status (Binary)	Analo2/0
4	Pro logic	Pro Logic	CENTER LARGE	ProL.CenterL
			EFFECT OFF	ProL.Eff.Off
5	Speakers set	Speakers Set	MAIN : SMALL 0dB	Sp.MainS 0dB
			MAIN : LARGE 0dB	Sp.MainL 0dB
			LFE/BASS : MAIN	
			CENTER : NONE	Sp.Lfe:M C:N
			LFE/BASS : MAIN	Sp.LfeBass:M
			LFE/BASS : SWFR	Sp.Lfe:Swfr
			CENTER : NONE	Sp.Cent:None
			CENTER : SMALL	
6	Effect off	Effect Off	REAR : SMALL	Sp.Ce:S Re:S
			EFFECT OFF	Effect Off
7	Manual test	Manual Test	ALL	M.Test All
			MAIN L	M.Test Left
			CENTER	M.TestCenter
			MAIN R	M.Test Right
			REAR R	M.Test RearR
			REAR L	M.Test RearL
8	No function		LFE	M.Test Lfe
9	DIAG cancel			

3. Procedure for canceling DIAG

There are two methods for cancellation of DIAG.

- a. Turn off the power by pressing the [POWER] key of the main unit or the remote controller.
- b. Press the [9] key of the remote controller. (The normal mode will be restored.)

Details of DIAG menu

1. Analog Thr.

The input is fixed to use the analog (A/D) and has 2 sub-menu items.

MAIN BYPASS

The main L/R signal is output through the analog bypass without passing the DSP section.

The main L/R signal passing through the DSP is output through C/LFE and RL/RR.

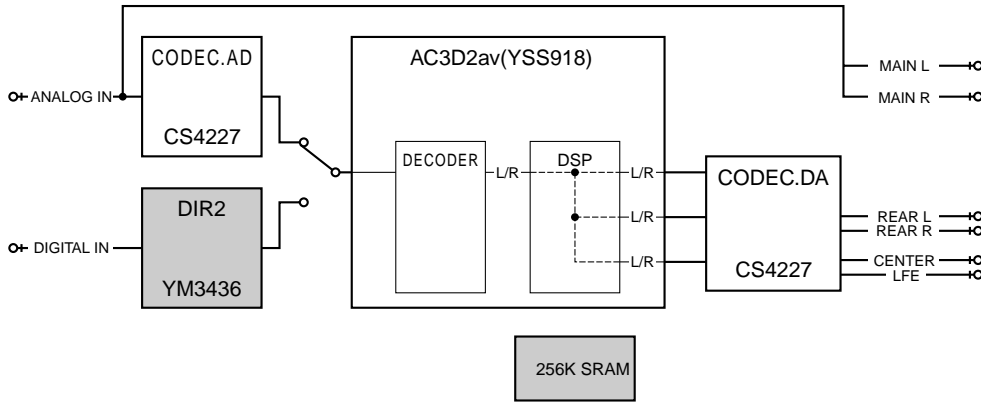

VIDEO2 IN : -20dBV, Both ch
 VOLUME : MAX

CB306 (Page E-31, F-3)
 MAIN L (1kHz) : -20dBV
 MAIN R (1kHz) : -20dBV
 LFE (30Hz) : -34dBV
 REAR L (1kHz) : -26dBV
 REAR R (1kHz) : -26dBV
 CENTER (1kHz) : -26dBV

The shaded square means that the element included in it does not operate.

DSP 0dB

The main L/R, C/LFE, RL/RR signals pass through the DSP section.

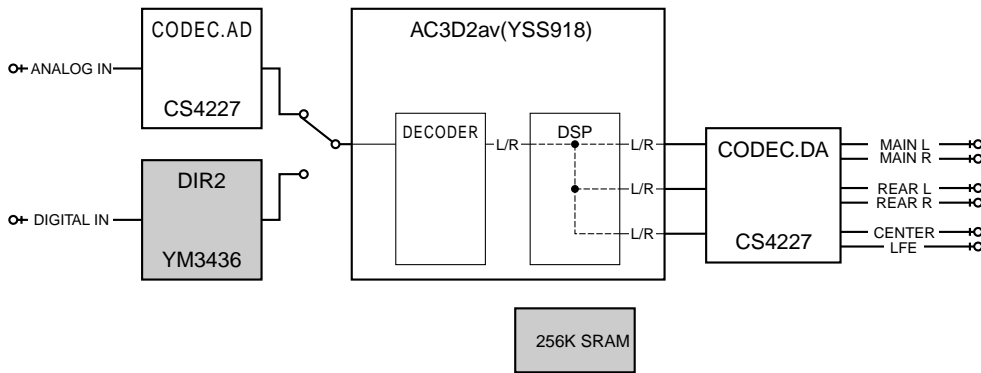

VIDEO2 IN : -20dBV, Both ch
 VOLUME : MAX

CB306 (Page E-31, F-3)
 MAIN L (1kHz) : -20dBV
 MAIN R (1kHz) : -20dBV
 LFE (30Hz) : -34dBV
 REAR L (1kHz) : -26dBV
 REAR R (1kHz) : -26dBV
 CENTER (1kHz) : -26dBV

The shaded square means that the element included in it does not operate.

2. DSP Through

In the DIGITAL input mode, AC3/PCM AUDIO signal is automatically identified. There are 3 sub-menu items.

YSS918-SRAM

The main L/R signal is sent through AC3D2av into DSP. After passing through SRAM, the main L/R signal is output through L+R and C/LFE and RL/RR signals through (L+R)/2.

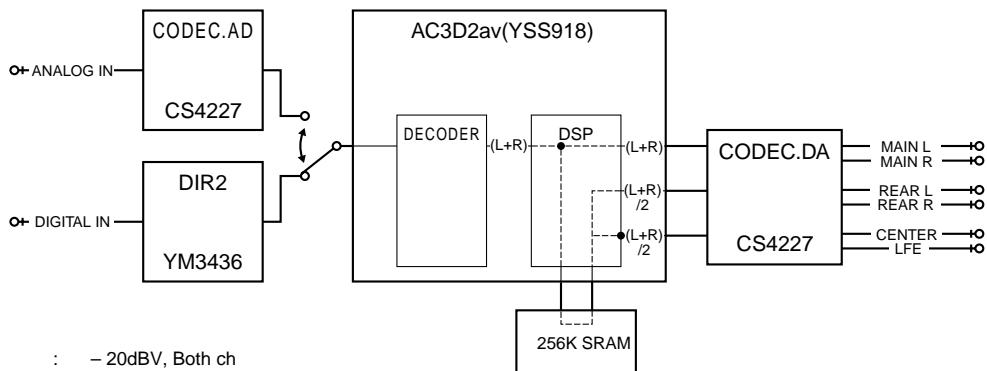

VIDEO2 IN : -20dBV, Both ch
VOLUME : MAX

CB306 (Page E-31, F-3)

MAIN L (1kHz) : -20dBV
MAIN R (1kHz) : -20dBV
LFE (30Hz) : -34dBV
REAR L (1kHz) : -26dBV
REAR R (1kHz) : -26dBV
CENTER (1kHz) : -26dBV

YSS918

The main L/R signal is sent through AC3D2av into DSP. The main L/R signal is output through L+R and C/LFE and RL/RR signals through (L+R)/2.

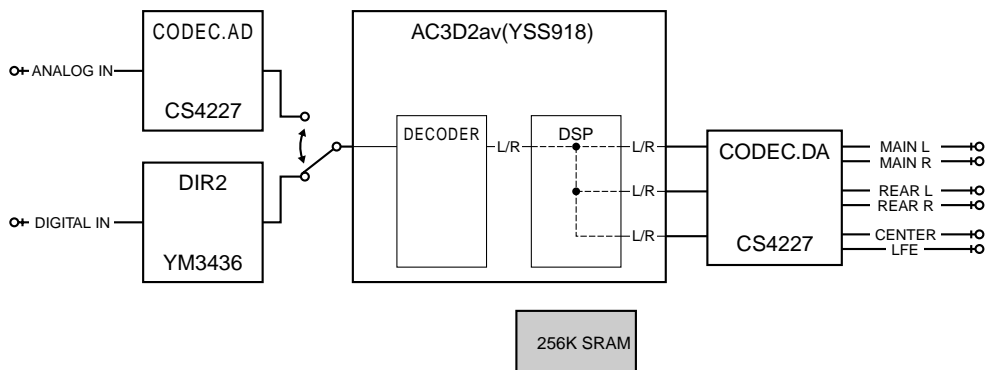

VIDEO2 IN : -20dBV, Both ch
VOLUME : MAX

CB306 (Page E-31, F-3)

MAIN L (1kHz) : -20dBV
MAIN R (1kHz) : -20dBV
LFE (30Hz) : -34dBV
REAR L (1kHz) : -26dBV
REAR R (1kHz) : -26dBV
CENTER (1kHz) : -26dBV

 The shaded square means that the element included in it does not operate.

DSP FULL BIT

The main L/R is input through AC3D2av to DSP and then output through all channels. The same applies as "YSS918" except that the digital data is output in full bit at D/A.

VIDEO2 IN : - 20dBV, Both ch
 VOLUME : MAX

CB306 (Page E-31, F-3)
 MAIN L (1kHz) : - 11dBV
 MAIN R (1kHz) : - 11dBV
 LFE (30Hz) : - 13dBV
 REAR L (1kHz) : - 17dBV
 REAR R (1kHz) : - 17dBV
 CENTER (1kHz) : - 17dBV

3. AC-3/dts Through

Only the signal of the digital system is input. The AC3 signal is decoded and reproduced according to the input source.

The AC-3 signal in each channel is AC-3 decoded and output through AC3D2av. The combined status information of the sampling frequency and the number of channels of the AC3 signal appears on the FI display.

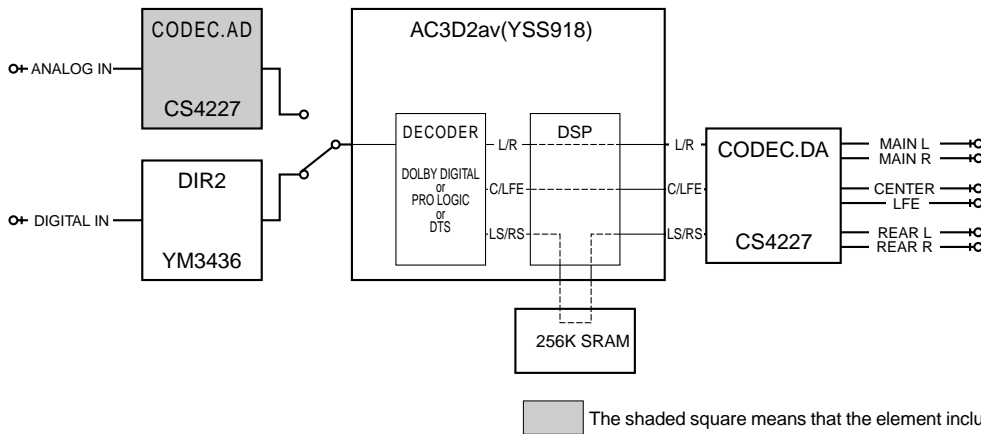

Status information

AC3 48k 3/2

Sampling frequency

Number of channels

Sampling frequency	(Display)
Analog	Analo
32kHz	32k
44.1kHz	44.1k
48kHz	48k

Number of channels (Front/Rear) (Display)	
1+1	1+1
1/0	1/0
2/0	2/0
3/0	3/0
2/1	2/1
3/1	3/1
2/2	2/2
3/2 5.1ch	3/2
7.1 (DTS)	7.1

4. Pro Logic

The sub-menu items include selection of Pro-logic (The auto input balance is off.) and EFFECT OFF.

CENTER LARGE

When the analog, PCM audio or AC-3 2/0 mode is used, L, R, C, S signals are pro-logic decoded and output. When the AC-3 mode other than 2/0 is used, the pro logic function does not work and the signals are AC-3 reproduced.

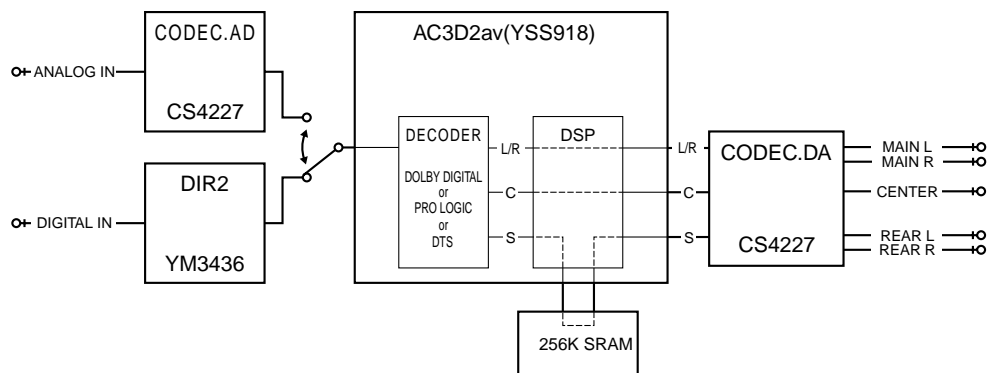

VIDEO2 IN : -20dBV, Both ch
VOLUME : MAX

CB306 (Page E-31, F-3)

MAIN L (1kHz) : -20dBV
MAIN R (1kHz) : -20dBV
LFE (30Hz) : -28dBV
REAR L (1kHz) : < -45dBV
REAR R (1kHz) : < -45dBV
CENTER (1kHz) : < -45dBV

VIDEO2 IN : -20dBV, L ch only
VOLUME : MAX

CB306 (Page E-31, F-3)

MAIN L (1kHz) : -20dBV
MAIN R (1kHz) : < -45dBV
LFE (30Hz) : -32dBV
REAR L (1kHz) : < -45dBV
REAR R (1kHz) : < -45dBV
CENTER (1kHz) : < -45dBV

EFFECT OFF

The L/R signal is output through MAIN BYPASS.

5. Speakers Set (for reference only)

This menu is for checking during the production process and not for servicing.

The input L/R signal is output through the specified channels according to the sub-menu.

There are 7 sub-menu items.

The signal output from the DSP section is normally in the EFFECT OFF state in the menus from 1 to 3. In the menus after that, the same signal as in the menu of 2. DSP THROUGH: YSS918 is output.

The analog switch settings in each sub-menu are as shown in the following table.

Sub-menu		Output										
		CENTER	REAR	MAIN	MAIN LEVEL	LFE/BASS	MAIN L	MAIN R	CENTER	REAR L	REAR R	SUBWOOFER
1	MAIN : SMALL 0dB	LARGE	LARGE	SMALL	0dB	SWFR	L	R	X	X	X	L+R
2	MAIN : LARGE 0dB	LARGE	LARGE	LARGE	0dB	SWFR	L	R	X	X	X	X
3	LFE/BASS : MAIN CENTER : NONE	NONE	LARGE	LARGE	0dB	MAIN	L	R	X	X	X	X
4	LFE/BASS : MAIN	LARGE	LARGE	LARGE	0dB	MAIN	LFE+FL	LFE+FR	X	X	X	X
5	LFE/BASS : SUBWOOFER	LARGE	LARGE	LARGE	0dB	SWFR	X	X	X	X	X	LFE
6	CENTER : NONE	NONE	LARGE	LARGE	0dB	SWFR	C+FL	C+FR	X	X	X	X
7	CENTER : SMALL REAR : SMALL	SMALL	SMALL	LARGE	0dB	SWFR	FL	FR	C	RL	RR	C+RL+RR+LFE

* In Sub-menu 1, the lower range content of the MAIN L/R is output at SWFR as well.

* In Sub-menu 7, the lower range content of LFE, CENTER and REAR is output at SWFR as well.

LARGE: Signals are output in all bandwidths.

SMALL: Only signals lower than 90Hz are mixed in the channel specified by LFE/BASS.

NONE: The center contents are distributed to the MAIN L/R channels after -3dB.

SWFR: SUBWOOFER

Output: The signal before MASTER VOLUME is indicated.

Sub-menu	Main application
MAIN : SMALL 0dB	Confirmation of high/low pass filter characteristics and gain when BASS REDIRECTION is used.
MAIN : LARGE 0dB	Reference for Sub-menu 1 and 2
LFE/BASS : MAIN CENTER : NONE	Confirmation of effect of the mix circuit to the main channel.
LFE/BASS : MAIN	Confirmation of gain of BASS MIX.
LFE/BASS : SWFR	Confirmation of the maximum output of LFE.
CENTER : NONE	Confirmation of gain of CENTER MIX.
CENTER : SMALL REAR : SMALL	Confirmation of high/low pass filter characteristics and gain when BASS REDIRECTION is used.

6. Effect Off

All effect functions are turned off.

7. Manual Test

The test noise is output by the noise generator with a built-in DSP through the channels specified by the sub-menu.

ALL	Noise is output through all channels.
MAIN L	Noise is output through the MAIN L channel.
CENTER	Noise is output through the CENTER channel.
MAIN R	Noise is output through the MAIN R channel.
REAR R	Noise is output through the REAR R channel.
REAR L	Noise is output through the REAR L channel.
LFE	Noise is output through the LFE (sub-woofer) channel.

8. No function

9. DIAG cancel

The Test Program mode is canceled.

IC DATA

IC600 : M30218FCFP (16 bit μ -COM)

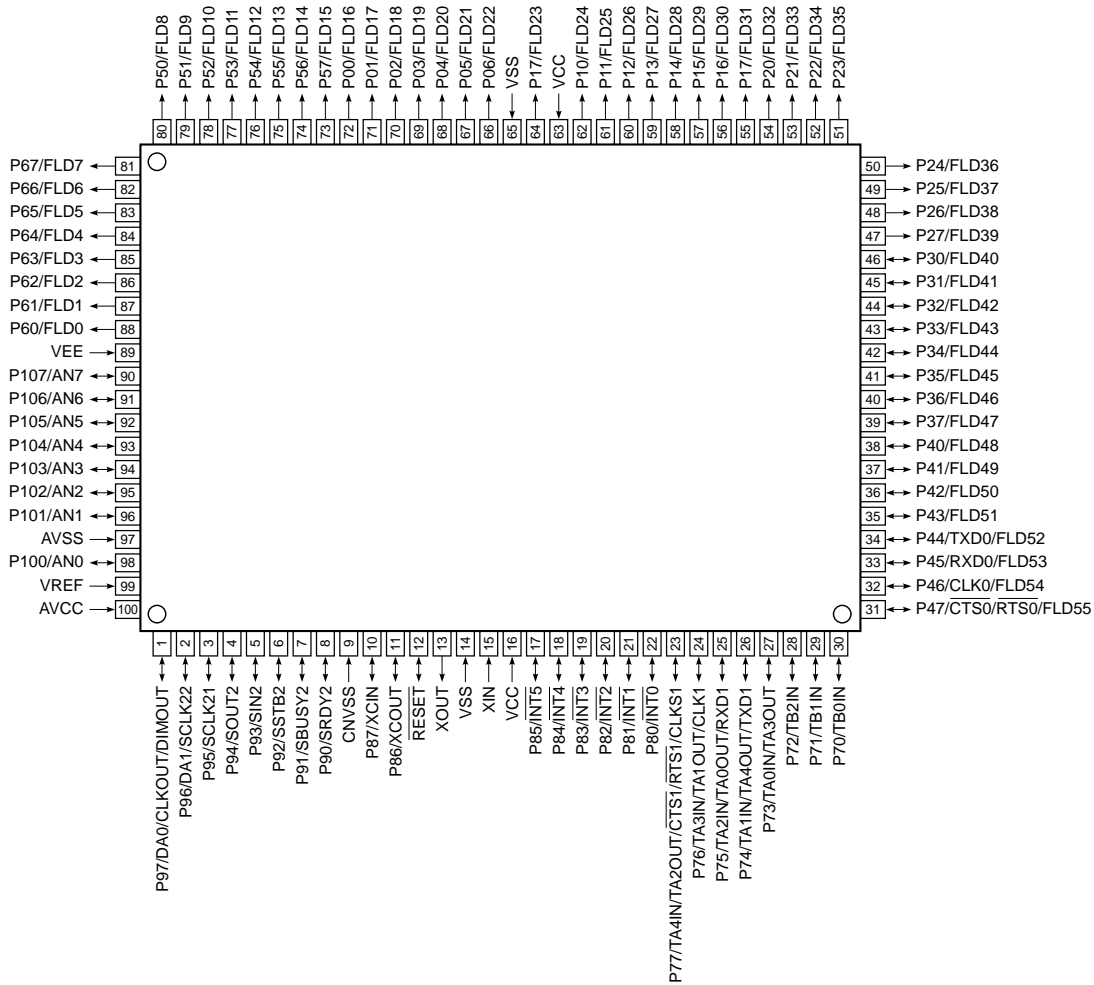

No.	PORT	Name	IN/OUT	Function
1	P97	CMOS	OUT	BASS BOOST, TruBass OUT [0:ON]
2	P96	CMOS	OUT	Center unit, RL,RR,SW MUTE OUT [0:MUTE ON]
3	P95	CMOS	OUT	LC78212 / TC9482 / (DSP) CODEC CLK OUT (SCK)
4	P94	CMOS	OUT	LC78212 / TC9482 / (DSP) CODEC DATA OUT (SDT)
5	P93	CMOS	OUT	(DSP) DIR2 CCK (CCK)
6	P92	CMOS	OUT	(DSP) DIR2 CLD (CLD) [0:DATA READ]
7	P91	CMOS	OUT	(DSP) AC3D CE1 OUT (CEAC1)
8	P90	CMOS	OUT	(DSP) AC3D CE2 OUT (CEAC2)
9	CNVSS	-	-	Connected to VSS (GND) via a resistance (5.1k Ω)
10	P87	CMOS	OUT	Switching of analog input and video selector (4052) to A OUT A B [00:TV OFF 01:DIGITAL1]
11	P86	CMOS	OUT	Switching of analog input and video selector (4052) to B OUT [10:VIDEO 11:AUX, DIGITAL2]
12	RESET	-	-	RESET [0:RESET]
13	XOUT	-	-	10 MHz IN (Feedback resistance included)
14	VSS	-	-	GND
15	XIN	-	-	10 MHz IN (Feedback resistance included)
16	VCC	-	-	+5V power supply
17	P85	INT5	INT-IN	(DSP) DIR2 ERR IN (ERRD)
18	P84	INT4	INT-IN	(DSP) AC3D MUTE IN (ERRA)
19	P83	(INT3)	IN	(DSP) DIR2 CD0 IN (CD0)
20	P82	(INT2)	IN	Center unit amplifier voltage detect IN (Protection) [0: abnormality exists]
21	P81	INT1	INT-IN	Remote controller IN
22	P80	INT0	INT-IN	Power down DC detect IN [0:POWER DOWN]

IC600 : M30218FCFP (16 bit μ -COM)

No.	PORT	Name	IN/OUT	Function
23	P77	CMOS	OUT	(DSP) /IC AC3D OUT (/ICAC)
24	P76	CLK1	S-CLK	(DSP) AC3D CLK OUT(CLKAC) (Serial I/O-1)
25	P75	RxD1	S-IN	(DSP) AC3D DATA IN(RXAC) (Serial I/O-1)
26	P74	TxD1	S-OUT	(DSP) AC3D DATA OUT(TXAC) (Serial I/O-1)
27	P73	CMOS	OUT	(DSP) CODEC CE OUT (CECOD) [0: DATA transfer]
28	P72	CMOS	OUT	Analog switch (LC78212) CE OUT [0: Address 1: Data]
29	P71	CMOS	OUT	Electronic VR (TC9482) STB OUT [1:ON]
30	P70	CMOS	OUT	CE OUT to E2PROM [1: DATA transfer]
31	P47	CTS0	OUT	DSP power supply OUT/Busy OUT to flash writer [1:ON]
32	P46	CLK0	S-CLK	CLK OUT to E2PROM/CLK IN from flash writer (Serial I/O-0)
33	P45	RxD0	S-IN	DATA IN from E2PROM/DATA IN from flash writer (Serial I/O-0)
34	P44	TxD0	S-OUT	DATA OUT to E2PROM/DATA OUT from flash writer (Serial I/O-0)
35	P43	P-OD	OUT	Headphones is connect/Unconnect IN [1:Connect]
36	P42	P-OD	OUT	6ch speaker relay control OUT [1:ON]
37	P41	-	IN	SW PRE OUT in use/unused IN [1: in use]
38	P40	P-OD	OUT	STANDBY LED OUT (Direct drive Max: 18mA) [1: light up]
39	P37	FLD47	OUT	DIGIT 13 (13G) [VEE external pull-down required]
40	P36	FLD46	OUT	DIGIT 12 (12G) [VEE external pull-down required]
41	P35	FLD45	OUT	DIGIT 11 (11G) [VEE external pull-down required]
42	P34	FLD44	OUT	DIGIT 10 (10G) [VEE external pull-down required]
43	P33	FLD43	OUT	DIGIT 9 (9G) [VEE external pull-down required]
44	P32	FLD42	OUT	DIGIT 8 (8G) [VEE external pull-down required]
45	P31	FLD41	OUT	DIGIT 7 (7G) [VEE external pull-down required]
46	P30	FLD40	OUT	DIGIT 6 (6G) [VEE external pull-down required]
47	P27	FLD39	OUT	DIGIT 5 (5G) [VEE external pull-down required]
48	P26	FLD38	OUT	DIGIT 4 (4G) [VEE external pull-down required]
49	P25	FLD37	OUT	DIGIT 3 (3G) [VEE external pull-down required]
50	P24	FLD36	OUT	DIGIT 2 (2G) [VEE external pull-down required]
51	P23	FLD35	OUT	DIGIT 1 (1G) [VEE external pull-down required]
52	P22	FLD34	OUT	SEGMENT 1 (P1) [VEE external pull-down required]
53	P21	FLD33	OUT	SEGMENT 2 (P2) [VEE external pull-down required]
54	P20	FLD32	OUT	SEGMENT 3 (P3) [VEE external pull-down required]
55	P17	FLD31	OUT	SEGMENT 4 (P4) (VEE internal pull-down)
56	P16	FLD30	OUT	SEGMENT 5 (P5) (VEE internal pull-down)
57	P15	FLD29	OUT	SEGMENT 6 (P6) (VEE internal pull-down)
58	P14	FLD28	OUT	SEGMENT 7 (P7) (VEE internal pull-down)
59	P13	FLD27	OUT	SEGMENT 8 (P8) (VEE internal pull-down)
60	P12	FLD26	OUT	SEGMENT 9 (P9) (VEE internal pull-down)
61	P11	FLD25	OUT	SEGMENT 10 (P10) (VEE internal pull-down)
62	P10	FLD24	OUT	SEGMENT 11 (P11) (VEE internal pull-down)
63	VCC	-	-	+5V power supply
64	P07	FLD23	OUT	SEGMENT 12 (P12) (VEE internal pull-down)
65	VSS	-	-	GND
66	P06	FLD22	OUT	SEGMENT 13 (P13) (VEE internal pull-down)
67	P05	FLD21	OUT	SEGMENT 14 (P14) (VEE internal pull-down)
68	P04	FLD20	OUT	SEGMENT 15 (P15) (VEE internal pull-down)
69	P03	FLD19	OUT	SEGMENT 16 (P16) (VEE internal pull-down)
70	P02	FLD18	OUT	SEGMENT 17 (P17) (VEE internal pull-down)
71	P01	FLD17	OUT	SEGMENT 18 (P18) (VEE internal pull-down)
72	P00	FLD16	OUT	SEGMENT 19 (P19) (VEE internal pull-down)
73	P57	FLD15	OUT	SEGMENT 20 (P20) (VEE internal pull-down)
74	P56	FLD14	OUT	SEGMENT 21 (P21) (VEE internal pull-down)
75	P55	FLD13	OUT	SEGMENT 22 (P22) (VEE internal pull-down)
76	P54	FLD12	OUT	SEGMENT 23 (P23) (VEE internal pull-down)
77	P53	FLD11	OUT	SEGMENT 24 (P24) (VEE internal pull-down)

IC600 : M30218FCFP (16 bit μ -COM)

No.	PORT	Name	IN/OUT	Function
78	P52	FLD10	OUT	SEGMENT 25 (P25) (VEE internal pull-down)
79	P51	FLD9	OUT	SEGMENT 26 (P26) (VEE internal pull-down)
80	P50	FLD8	OUT	SEGMENT 27 (P27) (VEE internal pull-down)
81	P67	FLD7	OUT	SEGMENT 28 (P28) (VEE internal pull-down)
82	P66	FLD6	OUT	SEGMENT 29 (P29) (VEE internal pull-down)
83	P65	FLD5	OUT	SEGMENT 30 (P30) (VEE internal pull-down)
84	P64	FLD4	OUT	SEGMENT 31 (P31) (VEE internal pull-down)
85	P63	FLD3	OUT	SEGMENT 32 (P32) (VEE internal pull-down)
86	P62	FLD2	OUT	SEGMENT 32 (P33) (VEE internal pull-down)
87	P61	FLD1	OUT	SEGMENT 34 (P34) (VEE internal pull-down)
88	P60	FLD0	OUT	SEGMENT 35 (P35) (VEE internal pull-down)
89	VEE	-	-	P0, P1, P5, P6 pull-down resistance voltage input [-29V]
90	P107	AN7	A-D IN	SW protection IN [4.0-5.0V:SW provided, 2.5V:SW not provided, 0-2.0V:SW protection ON]
91	P106	AN6	A-D IN	AUTO POWER ON/OFF identify IN (music signal) [0 — VREF]
92	P105	AN5	A-D IN	Center unit power supply voltage detect IN (protection) [0 — VREF]
93	P104	CMOS	OUT	Night mode switching OUT [1:ON]
94	P103	CMOS	OUT	Center unit power supply OUT [1:ON]
95	P102	AN2	A-D IN	Destination select input [Pull-up with 10k Ω > VREF]
96	P101	AN1	A-D IN	KEY 1 input [Pull-up with 10k Ω > VREF]
97	AVSS	-	-	Connected to VSS (GND)
98	P100	AN0	A-D IN	KEY O input [Pull-up with 10k Ω > VREF]
99	VREF	-	-	A-D, D-A reference voltage input [— VCC]
100	AVCC	-	-	Connected to VCC terminal (+5V)

● KEY input (A-C) Pull-up resistance 10k Ω

Ω	0	+2k	+1.8k	+2.4k	+3.9k	+5.6k	+10k	+24k
V	— 0.556	— 1.111	— 1.667	— 2.222	— 2.778	— 3.333	— 3.889	— 4.444
KEY 0 (98pin)	VOLUME ∨	VOLUME ∧	NO KEY	NO KEY	NO KEY	NO KEY	NO KEY	NO KEY
KEY 1 (96pin)	DSP	INPUT	NO KEY	NO KEY	NO KEY	NO KEY	NO KEY	NO KEY

● Destination select input (95 pin A-D) Pull-up resistance 10k Ω

Ω	2k	51k
V	0.556 — 1.111	3.889 — 4.444
Destination	Ex (English)	J model (Japanese)

IC3 : YM3436DK
DIR (Digital Format Interface Receiver)

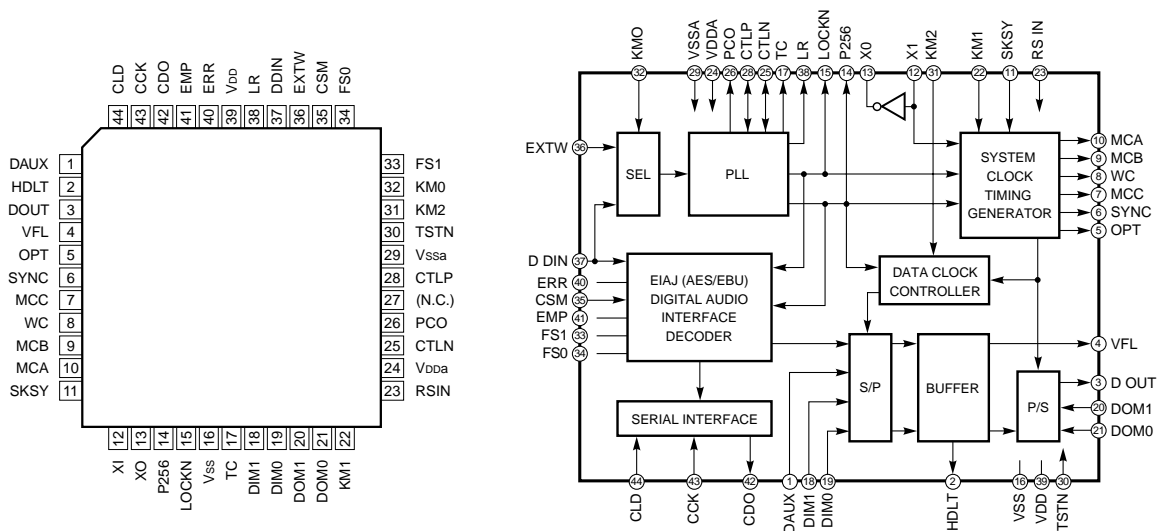

Pin No.	Pin Name	I/O	Function	Pin No.	Pin Name	I/O	Function
1	DAUX	I	Auxiliary input for audio data	26	PCO	O	PLL phase comparison output
2	HDLT	O	Asynchronous buffer operation flag	27	(NC)		
3	DOUT	O	Audio data output	28	CTLP	I	VCO control input P
4	VFL	O	Parity flag output	29	Vssa		VCO section power (GND)
5	OPT	O	Fs x 1 Synchronous output signal for DAC	30	TSTN	I	Test terminal. Open for normal use
6	SYNC	O	Fs x 1 Synchronous output signal for DSP	31	KM2	I	Clock mode switching input 2
7	MCC	O	Fs x 64Bit clock output	32	KM0	I	Clock mode switching input 0
8	WC	O	Fs x 1Word clock output	33	FS1	O	Channel status sampling frequency display output 1
9	MCB	O	Fs x 128Bit clock output	34	FS0	O	Channel status sampling frequency display output 0
10	MCA	O	Fs x 256Bit clock output	35	CSM	I	Channel status output method selection
11	SKSY	I	Clock synchronization control input	36	EXTW	I	External synchronous auxiliary input word clock
12	XI	I	Crystal oscillator connection or external clock input	37	DDIN	I	EIAJ (AES/EBU) data input
13	XO	O	Crystal oscillator connection	38	LR	O	PLL word clock output
14	P256	O	VCO oscillating clock connection	39	Vdd		Logic section power (+5V)
15	LOCK	O	PLL lock flag	40	ERR	O	Data error flag output
16	Vss		Logic section power (GND)	41	EMP	O	Channel status emphasis control code output
17	TC	O	PLL time constant switching output	42	CD0	O	3-wire type microcomputer interface data output
18	DIM1	I	Data input mode selection	43	CCK	I	3-wire type microcomputer interface clock input
19	DIM0	I	Data input mode selection	44	CLD	I	3-wire type microcomputer interface load input
20	DOM1	I	Data output mode selection				
21	DOM0	I	Data output mode selection				
22	KM1	I	Clock mode switching input 1				
23	RSTN	I	System reset input				
24	Vdda		VCO section power (+5V)				
25	CTLN	I	VCO control input N				

IC4 : YSS918D-F
AC3D2av

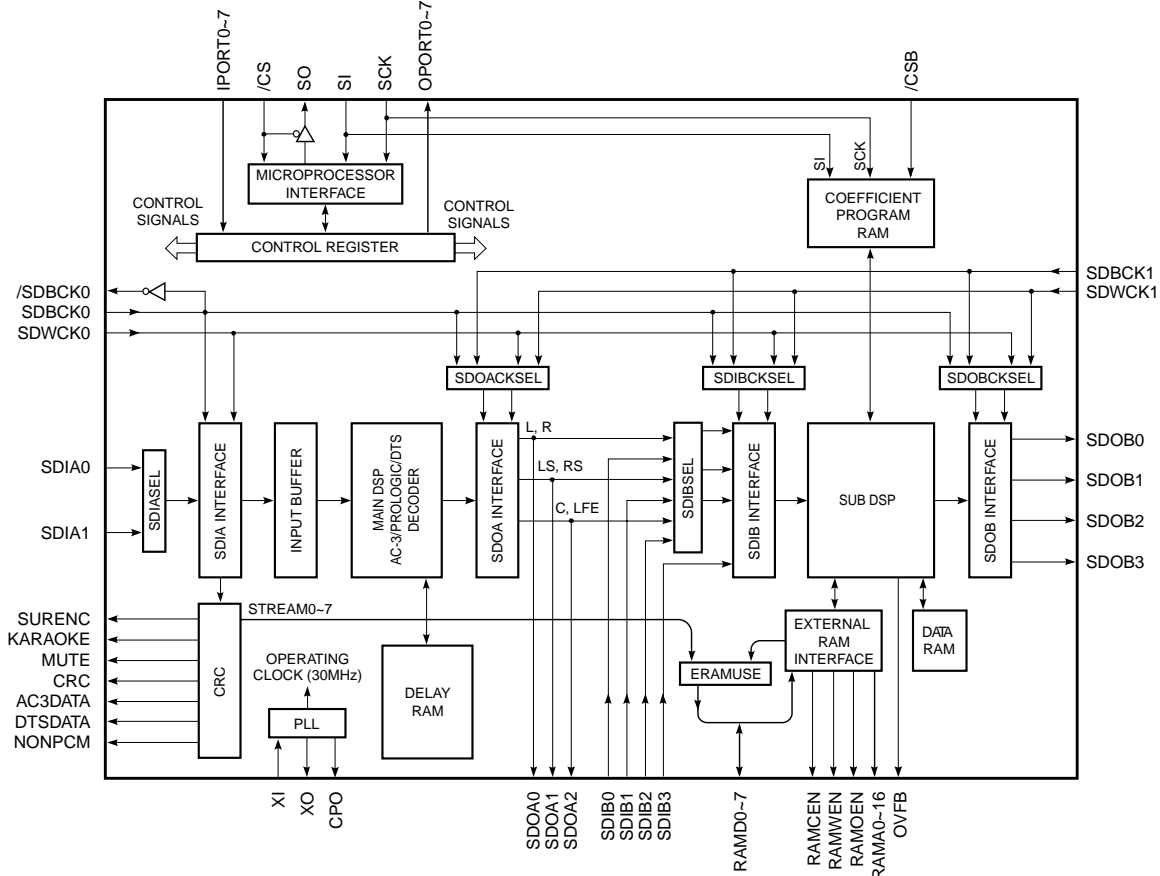
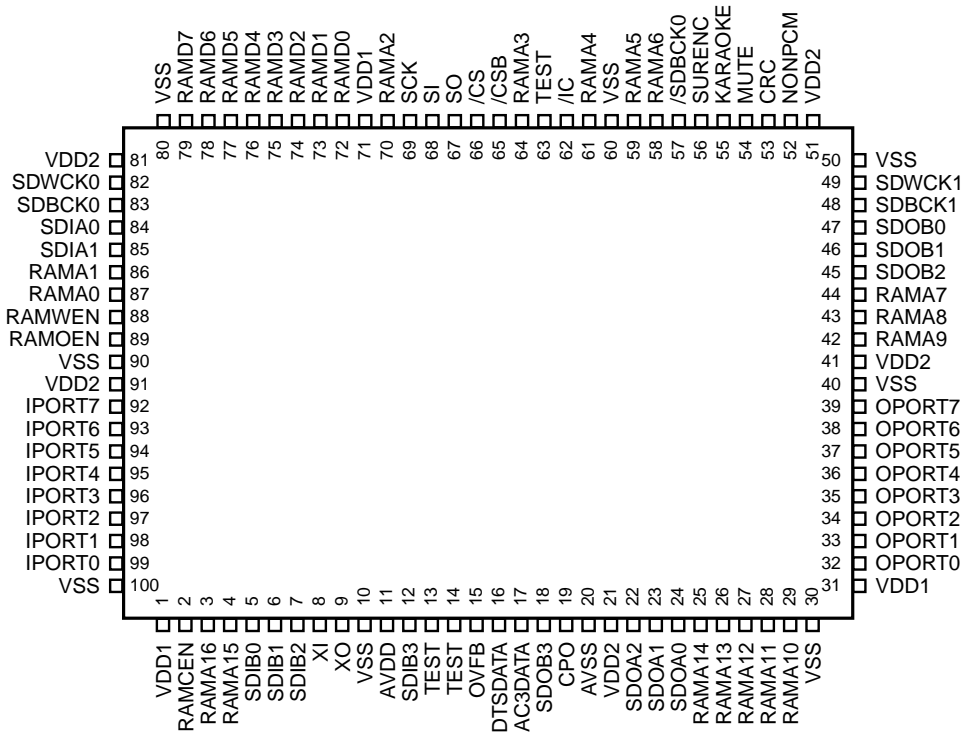

IC4 : YSS918D-F
AC3D2av

No.	Name	I/O	Function
1	VDD		+5V power supply (for terminal section)
2	RAMCEN	O	External SRAM chip enable terminal
3	RAMA16	O	External SRAM address terminal 16
4	RAMA15	O	External SRAM address terminal 15
5	SDIB0	Itp	PCM input terminal 0 to Sub DSP
6	SDIB1	Itp	PCM input terminal 1 to Sub DSP
7	SDIB2	Itp	PCM input terminal 2 to Sub DSP
8	XI	Ic	Crystal oscillator connecting terminal (12.288MHz)
9	XO	O	Crystal oscillator connecting terminal
10	VSS		Ground terminal (for terminal section)
11	AVDD		+3.3V power terminal (for PLL circuit)
12	SDIB3	Itp	PCM input terminal 3 to Sub DSP
13	TEST		Test terminal (unconnected)
14	TEST		Test terminal (unconnected)
15	OVFB	O	Sub DSP overflow detect terminal
16	DTSDATA	O	DTS data detect terminal
17	AC3DATA	O	AC-3 data detect terminal
18	SDOB3	O	PCM output terminal from Sub DSP
19	CPO	A	PLL output terminal (connected to external analog filter circuit)
20	AVSS		Ground terminal (for PLL circuit)
21	VDD2		+3.3V power terminal (for internal circuit)
22	SDOA2	O	PCM output terminal from Main DSP (C/LFE output at AC-3/DTS, C/S output at Pro Logic)
23	SDOA1	O	PCM output terminal from Main DSP (LS/RS output at AC-3/DTS, Lt/Rt output at Pro Logic)
24	SDOA0	O	PCM output terminal from Main DSP (L/R output at both AC-3/DTS and Pro Logic)
25	RAMA14	O	External SRAM address terminal 14
26	RAMA13	O	External SRAM address terminal 13
27	RAMA12	O	External SRAM address terminal 12
28	RAMA11	O	External SRAM address terminal 11
29	RAMA10	O	External SRAM address terminal 10
30	VSS		Ground terminal (for internal circuit)
31	VDD1		+5V power terminal (for terminal section)
32	OPORT0	O	General purpose output terminal (ISL0 : DIGITAL INPUT SEL)
33	OPORT1	O	General purpose output terminal (ISL1 : DIGITAL INPUT SEL)
34	OPORT2	O	General purpose output terminal (ISL2 : DIGITAL INPUT SEL)
35	OPORT3	O	General purpose output terminal (RFSL : LD RF INPUT SEL)
36	OPORT4	O	General purpose output terminal (RSL0 : DIGITAL REC OUT SEL)
37	OPORT5	O	General purpose output terminal (RSL1 : DIGITAL REC OUT SEL)
38	OPORT6	O	General purpose output terminal (RSL2 : DIGITAL REC OUT SEL)
39	OPORT7	O	General purpose output terminal (ADSL : AD INPUT SEL)
40	VSS		Ground terminal (for internal circuit)
41	VDD2		+3.3V power terminal (for internal circuit)
42	RAMA9	O	External SRAM address terminal 9
43	RAMA8	O	External SRAM address terminal 8
44	RAMA7	O	External SRAM address terminal 7
45	SDOB2	O	PCM output terminal from Sub DSP
46	SDOB1	O	PCM output terminal from Sub DSP
47	SDOB0	O	PCM output terminal from Sub DSP
48	SDBCK1	Itp	Bit clock input terminal for SDOA, SDIB, SDOB signals
49	SDWCK1	Itp	Word clock input terminal for SDOA, SDIB, SDOB signals
50	VSS		Ground terminal (for terminal section)
51	VDD2		+3.3V power terminal (for internal circuit)
52	NONPCM	O	Non-PCM data detect terminal

IC4 : YSS918D-F
AC3D2av

No.	Name	I/O	Function
53	CRC	O	AC-3 CRC error detect terminal
54	MUTE	O	Auto mute detect terminal
55	KARAOKE	O	AC-3 KARAOKE data detect terminal
56	SURENC	O	AC-3 2/0 mode Dolby surround encode input detect terminal
57	/SDBCK0	O	SDBCK0 invert clock output terminal
58	RAMA6	O	External SRAM address terminal 6
59	RAMA5	O	External SRAM address terminal 5
60	VSS		Ground terminal (for internal circuit)
61	RAMA4	O	External SRAM address terminal 4
62	/IC	Ics	Initial clear terminal
63	TEST		Test terminal (unconnected)
64	RAMA3	O	External SRAM address terminal 3
65	/CSB	Itp	Sub DSP chip select input terminal
66	/CS	Ics	Microprocessor interface chip select input terminal
67	SO	O*	Microprocessor interface data output terminal
68	SI	Ics	Microprocessor interface and Sub DSP data input terminal
69	SCK	Ics	Microprocessor interface and Sub DSP clock input terminal
70	RAMA2	O	External SRAM address terminal 2
71	VDD1		+5V power terminal (for terminal section)
72	RAMD0	Itp/O	External SRAM data terminal (STREAM 0 output when external SRAM is not used)
73	RAMD1	Itp/O	External SRAM data terminal (STREAM 1 output when external SRAM is not used)
74	RAMD2	Itp/O	External SRAM data terminal (STREAM 2 output when external SRAM is not used)
75	RAMD3	Itp/O	External SRAM data terminal (STREAM 3 output when external SRAM is not used)
76	RAMD4	Itp/O	External SRAM data terminal (STREAM 4 output when external SRAM is not used)
77	RAMD5	Itp/O	External SRAM data terminal (STREAM 5 output when external SRAM is not used)
78	RAMD6	Itp/O	External SRAM data terminal (STREAM 6 output when external SRAM is not used)
79	RAMD7	Itp/O	External SRAM data terminal (STREAM 7 output when external SRAM is not used)
80	VSS		Ground terminal (for terminal section)
81	VDD2		+3.3V power terminal (for internal circuit)
82	SDWCK0	It	Word clock input terminal for SDIA, SDOA, SDIB and SDOB signals
83	SDBCK0	It	Bit clock input terminal for SDIA, SDOA, SDIB and SDOB signals
84	SDIA0	It	AC-3/DTS bit stream (or PCM) data input terminal to Main DSP
85	SDIA1	It	AC-3/DTS bit stream (or PCM) data input terminal to Main DSP
86	RAMA1	O	External SRAM address terminal 1
87	RAMA0	O	External SRAM address terminal 0
88	RAMWEN	O	External SRAM write enable terminal
89	RAMOEN	O	External SRAM output enable terminal
90	VSS		Ground terminal
91	VDD2		+3.3V power terminal (for internal circuit)
92	IPOINT7	Itp	General purpose input terminal (Used for IC YSS908/918 identification: +3.3V)
93	IPOINT6	Itp	General purpose input terminal (GND)
94	IPOINT5	Itp	General purpose input terminal (GND)
95	IPOINT4	Itp	General purpose input terminal (GND)
96	IPOINT3	Itp	General purpose input terminal (GND)
97	IPOINT2	Itp	General purpose input terminal (GND)
98	IPOINT1	Itp	General purpose input terminal (GND)
99	IPOINT0	Itp	General purpose input terminal (GND)
100	VSS		Ground terminal

Note) Listed below are symbols in the I/O column and their meanings.

Ic: CMOS level input terminal

It: TTL level input terminal

Is: Schmidt trigger input terminal

Ip: Input terminal with pull-up resistor

O: Digital output terminal

O*: Tri-state digital output terminal

A: Analog input terminal

■ BLOCK DIAGRAM

● VS-10 (1/3)

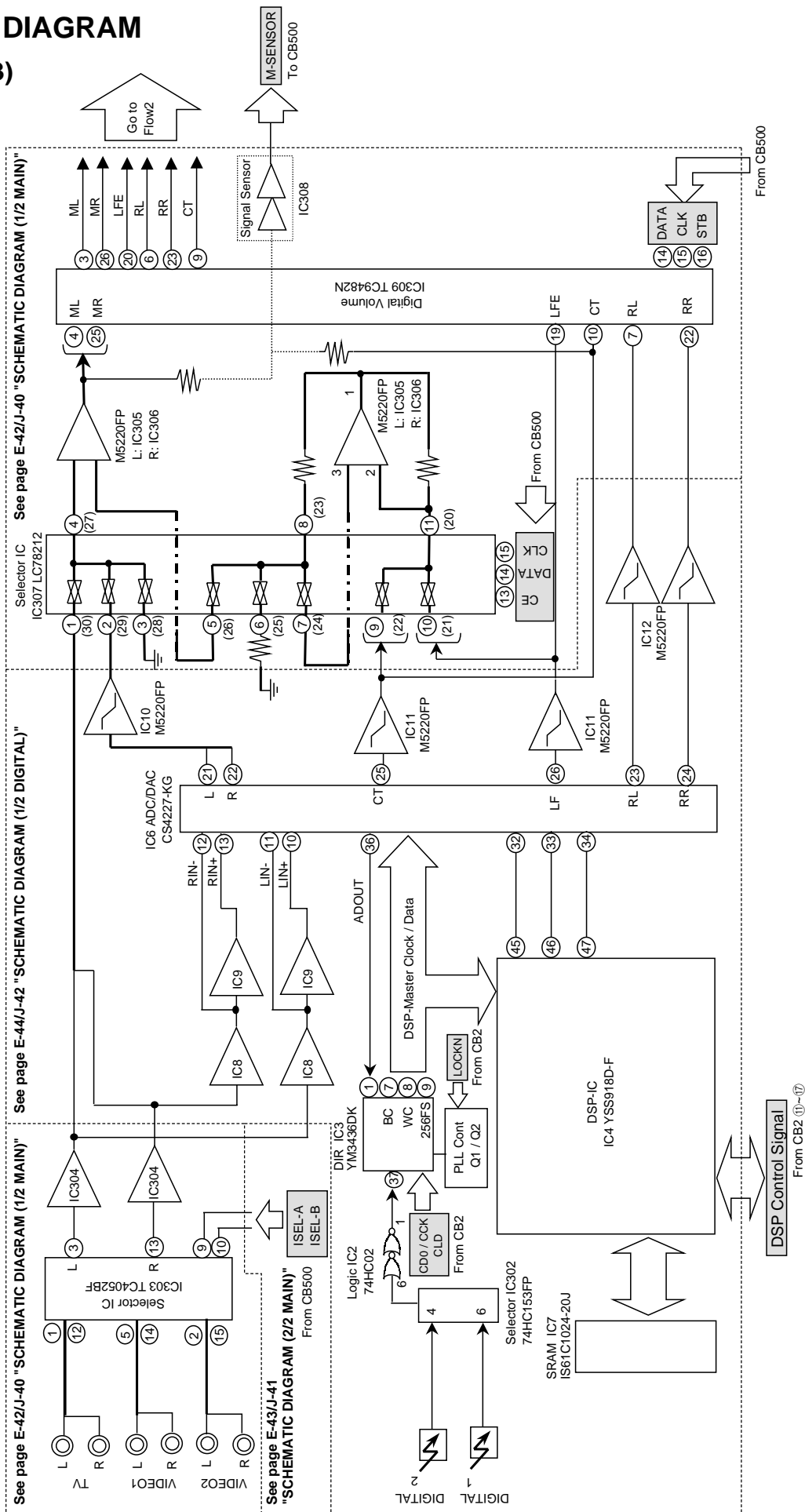

● VS-10 (2/3)

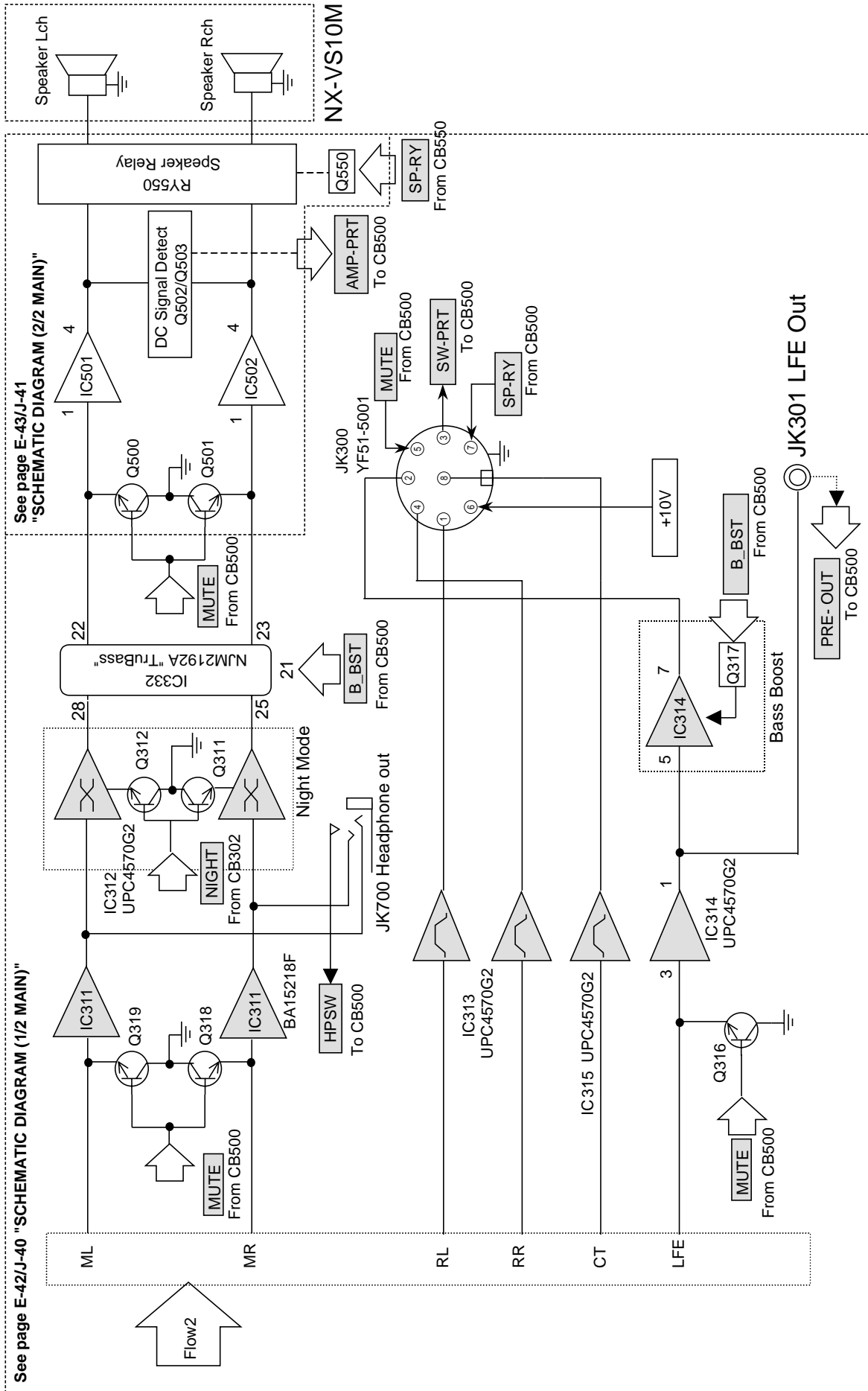

● VS-10 (3/3)

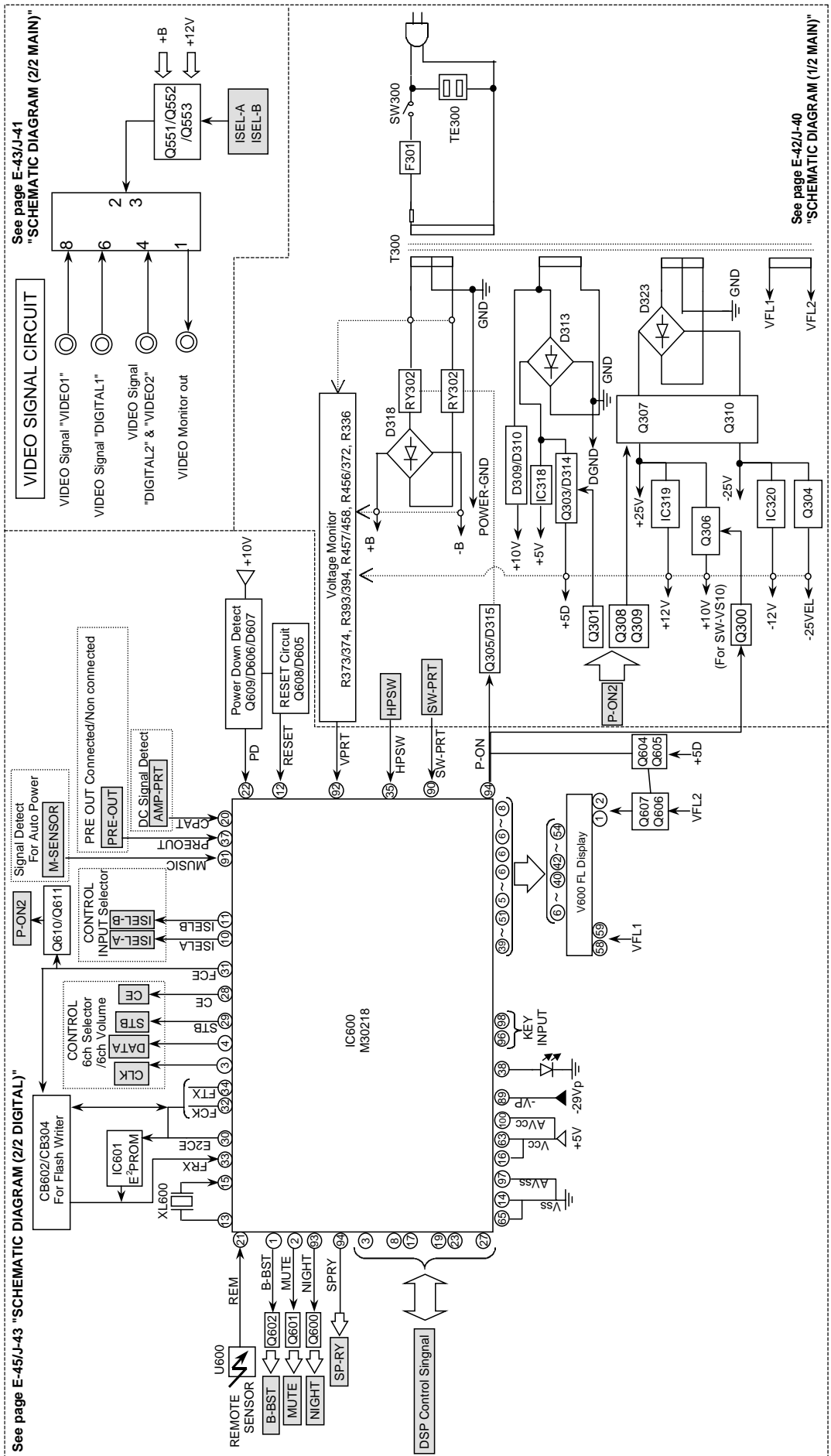

● SW-VS10

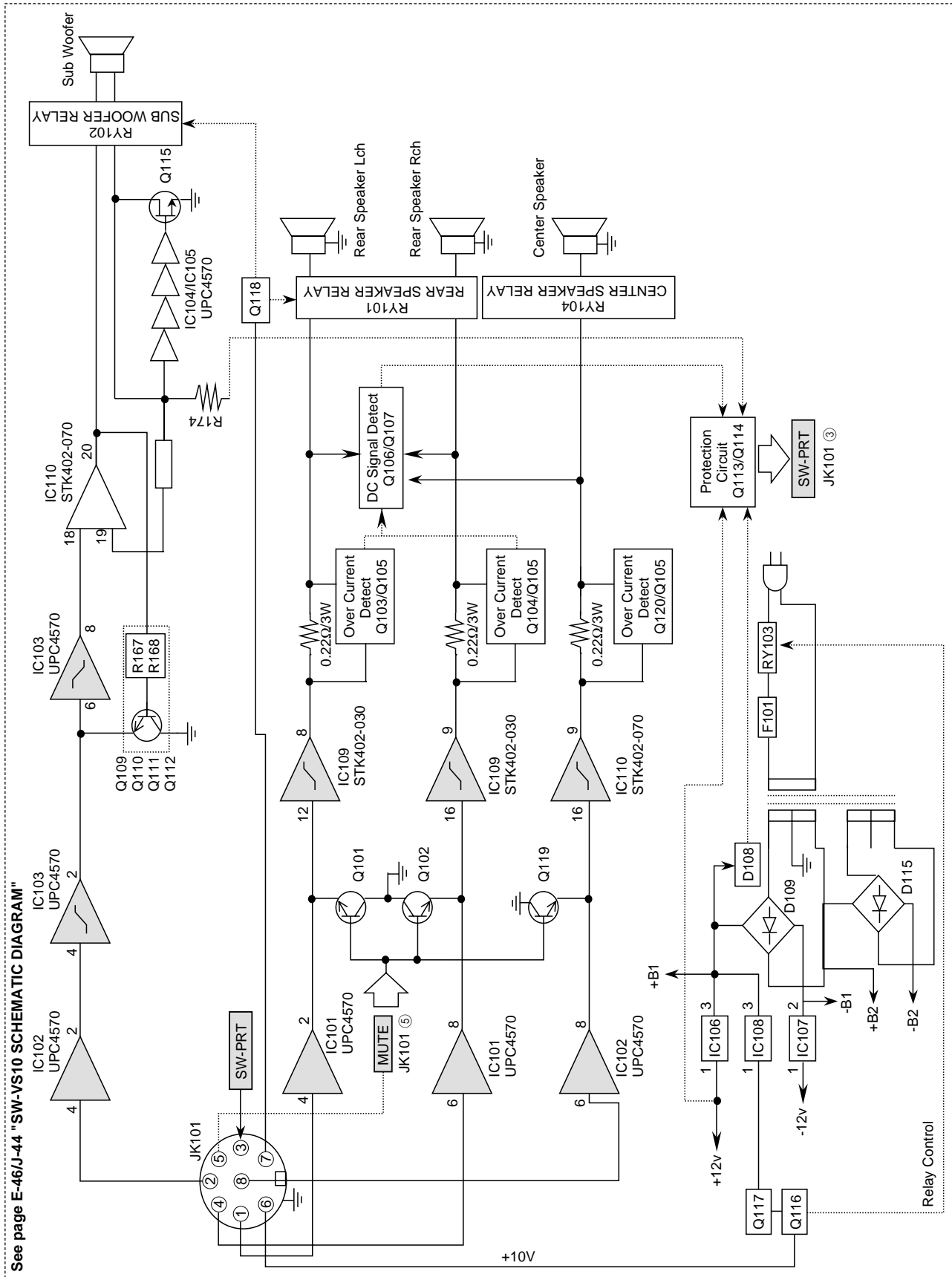

■ VS-10 PRINTED CIRCUIT BOARD (Foil side)

• Semiconductor Location

Ref. No.	Location
D309	D2
D310	D2
D313	D3
D316	B6
D317	B6
D318	B5
D323	D3
IC307	G3
IC309	G4
IC318	D3
IC319	E5
IC320	D5
Q303	E2
Q304	C5
Q305	B5
Q306	D4
Q307	E3
Q310	E4

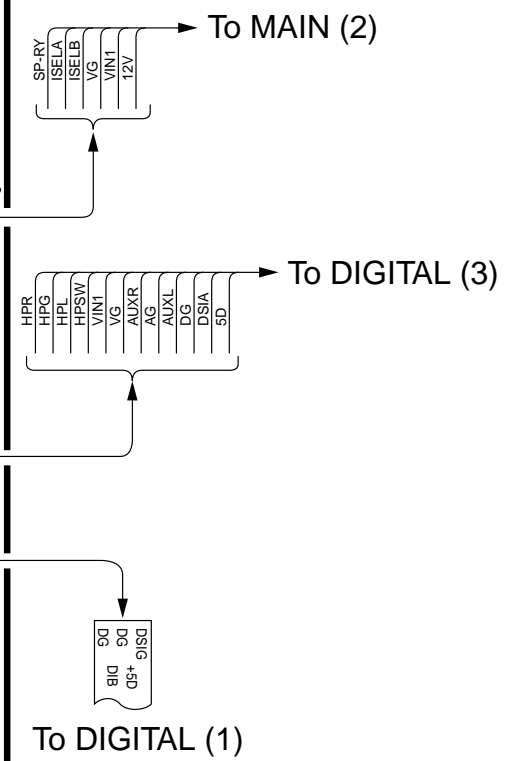
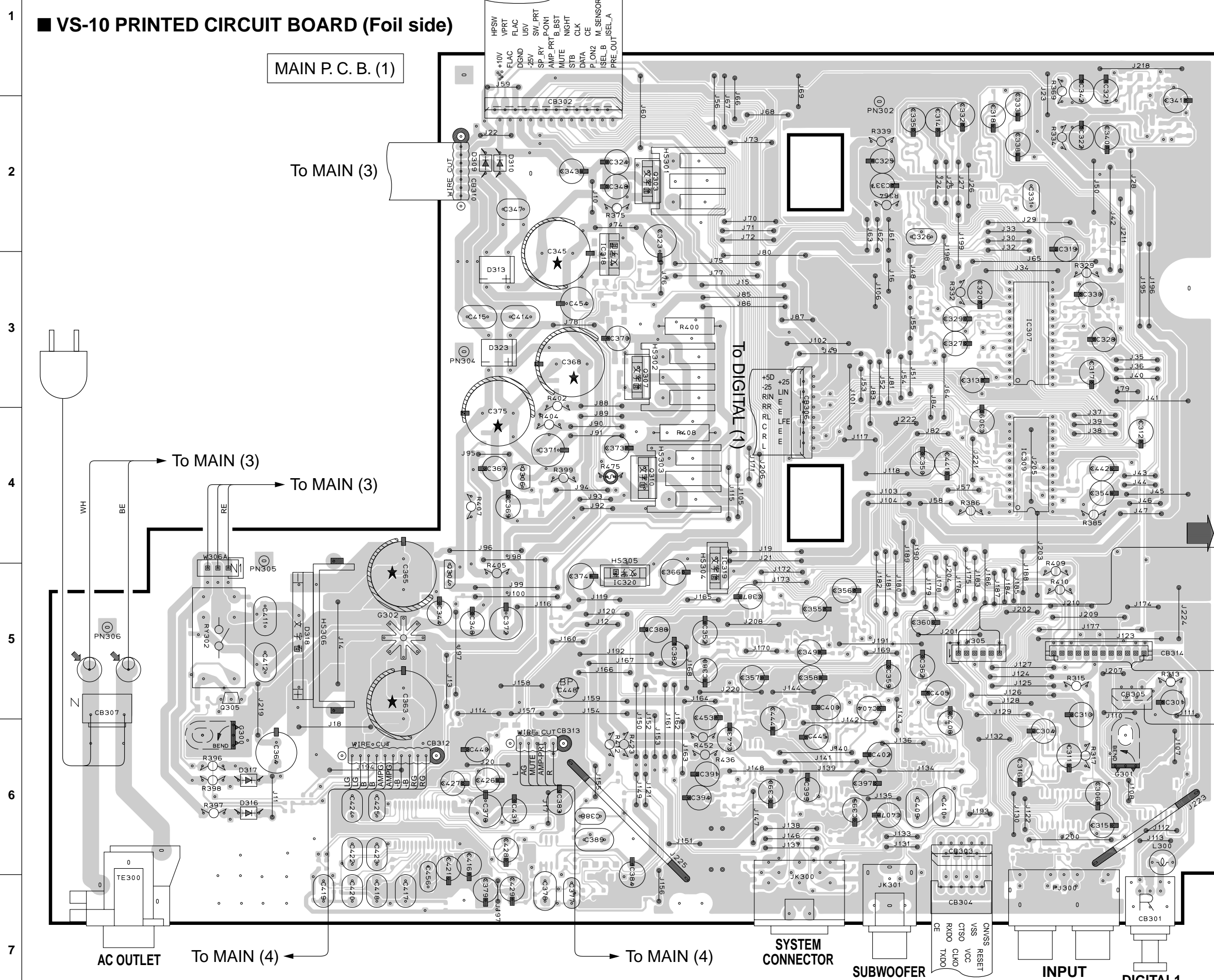

VS-10 PRINTED CIRCUIT BOARD (Foil side)

MAIN P. C. B. (1)

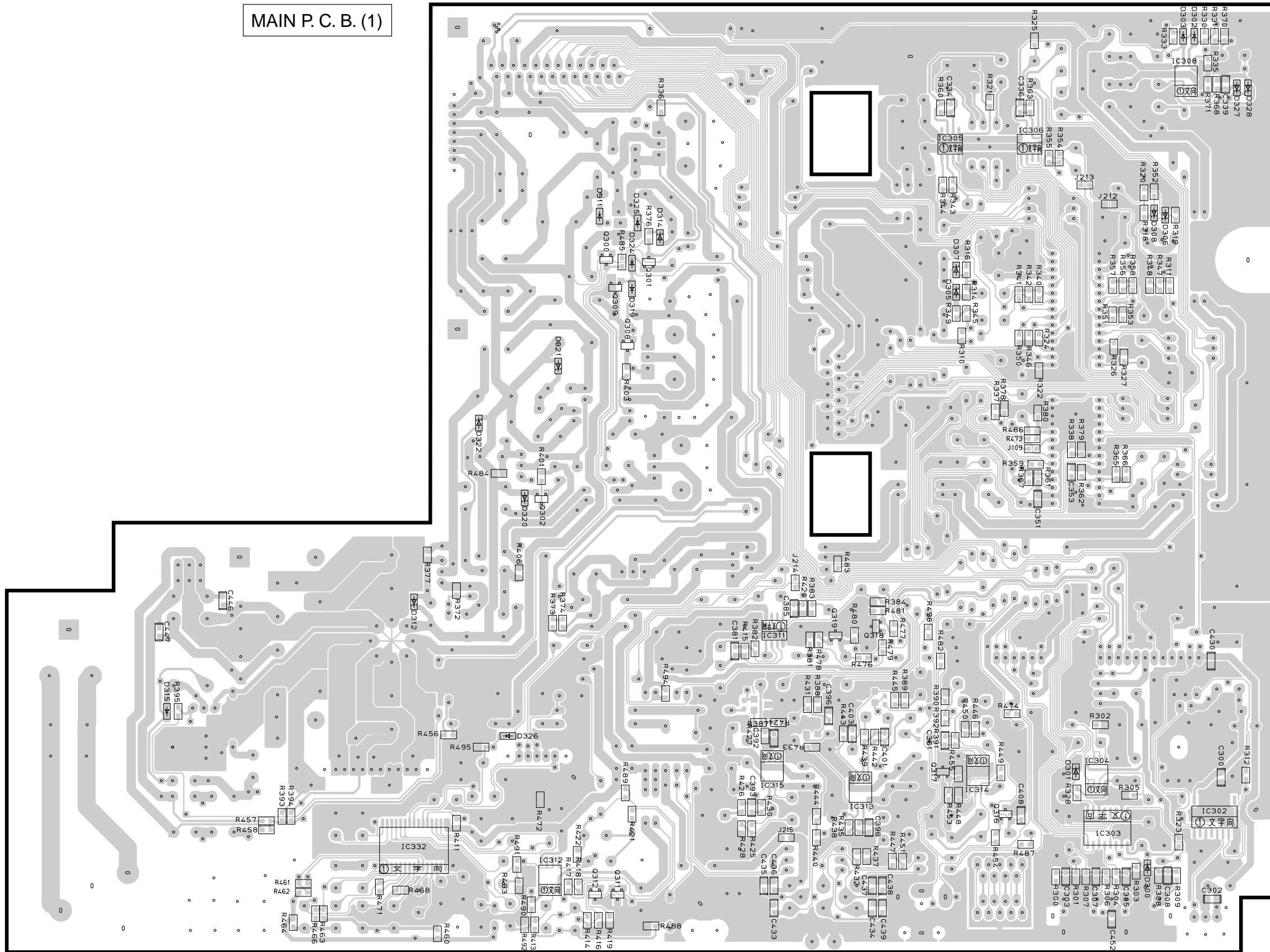

• Semiconductor Location

Ref. No.	Location
D300	H6
D301	H6
D302	H2
D303	H2
D305	G3
D306	H3
D307	G3
D308	H3
D311	E3
D312	D5
D314	E3
D315	B6
D319	E3
D320	D4
D321	E4
D322	D4
D324	E3
D325	E3
D326	D6
D327	I2
D328	I2
IC302	H6
IC303	H6
IC304	H6
IC305	G2
IC306	G2
IC308	H2
IC311	F5
IC312	D7
IC313	F6
IC314	G6
IC315	F6
IC332	D6
Q300	E3
Q301	E3
Q302	D4
Q308	E3
Q309	E3
Q311	E7
Q312	E7
Q316	G6
Q317	G6
Q318	F5
Q319	F5

VS-10 PRINTED CIRCUIT BOARD (Foil side)

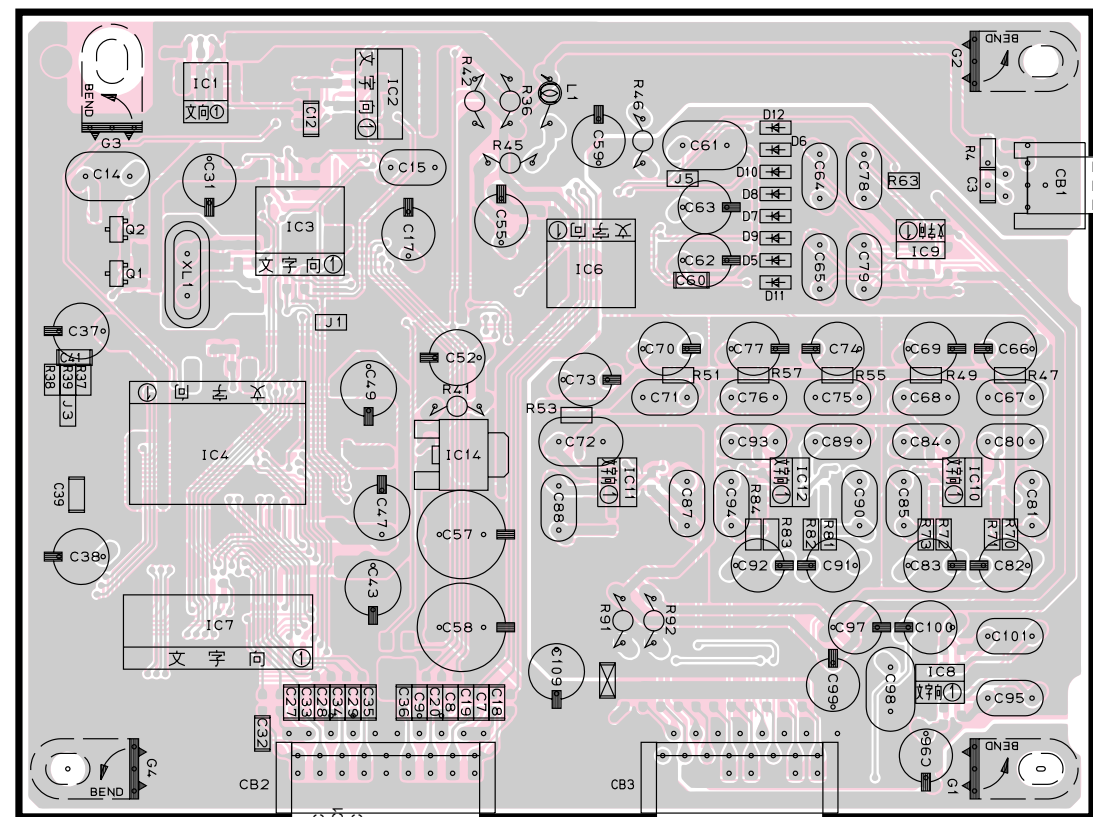

To DIGITAL (2)
 ERRR ICAC
 CEAC2 CEAC1
 RXAC TXAC
 CLKAC DG
 DG DG
 ERRD CDD
 CCK CLD
 SCK SDT
 CECOD

To MAIN (1)
 +5D
 -25 LIN
 RR E
 RL LFE
 C R E
 L

DIGITAL P. C. B. (1)

To MAIN (1)

DIGITAL P. C. B. (3)

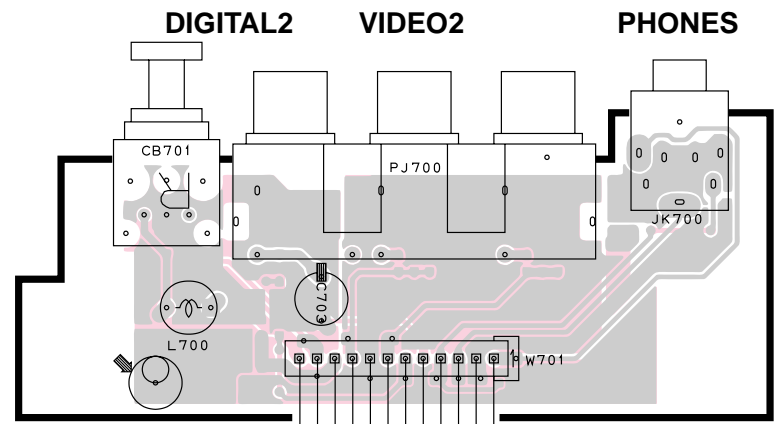

To MAIN (1)

To MAIN (1)

DIGITAL P. C. B. (2)

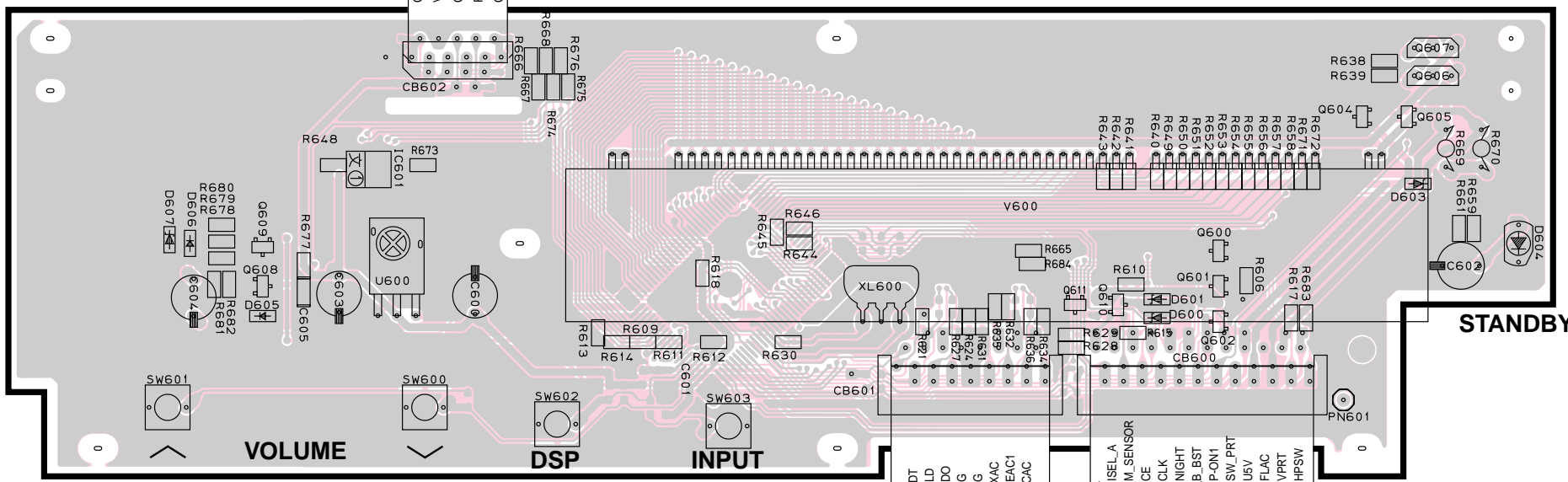

VOLUME

DSP

INPUT

STANDBY

To DIGITAL (1)

To MAIN (1)

• Semiconductor Location

Ref. No.	Location	Ref. No.	Location	Ref. No.	Location
D5	C2	IC1	A2	Q1	A2
D6	C2	IC2	B2	Q2	A2
D7	C2	IC3	B2	Q600	I6
D8	C2	IC4	A3	Q601	I6
D9	C2	IC6	C2	Q602	I6
D10	C2	IC7	A3	Q604	I5
D11	C2	IC8	D4	Q605	I5
D12	C2	IC9	D2	Q606	I5
D600	H6	IC10	D3	Q607	I5
D601	H6	IC11	C3	Q608	E6
D603	I5	IC12	C3	Q609	E6
D604	J6	IC14	B3	Q610	H6
D605	E6	IC601	E5	Q611	H6
D606	D6				
D607	D6				

1 ■ VS-10 PRINTED CIRCUIT BOARD (Foil side)

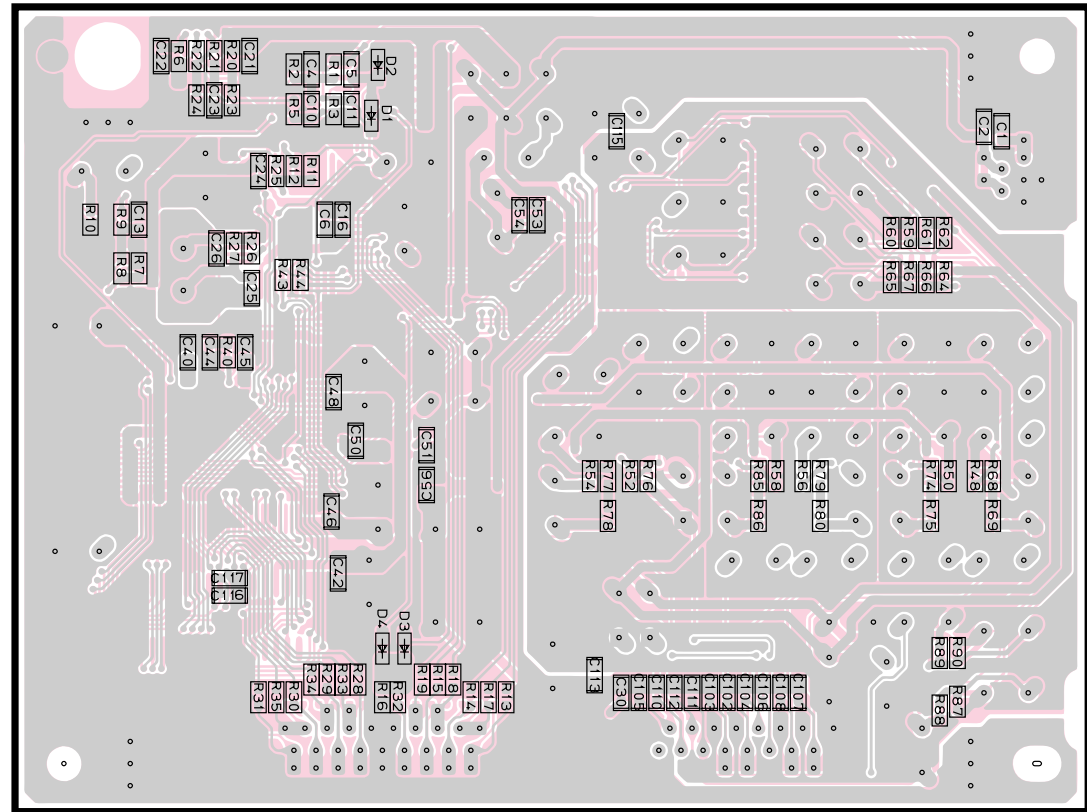

DIGITAL P. C. B. (1)

DIGITAL P. C. B. (3)

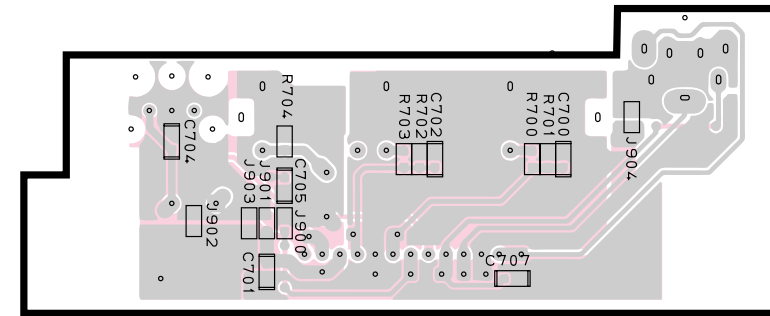

DIGITAL P. C. B. (2)

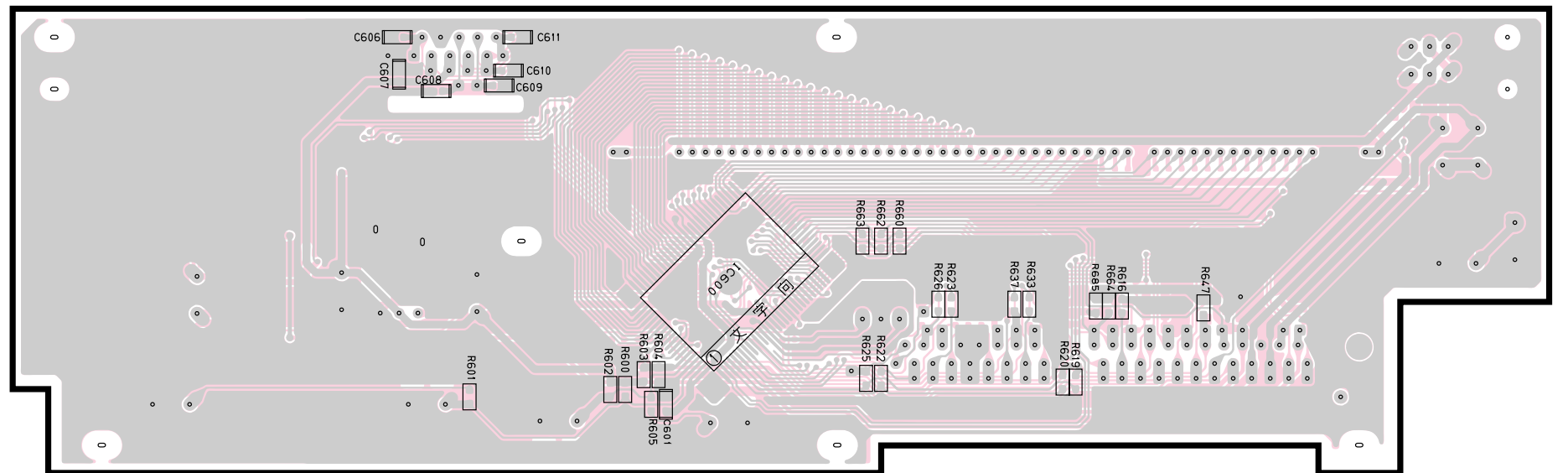

5 • Semiconductor Location

Ref. No.	Location
D1	B2
D2	B2
D3	B4
D4	B4
IC600	G6

SW-VS10 PRINTED CIRCUIT BOARD (Foil side)

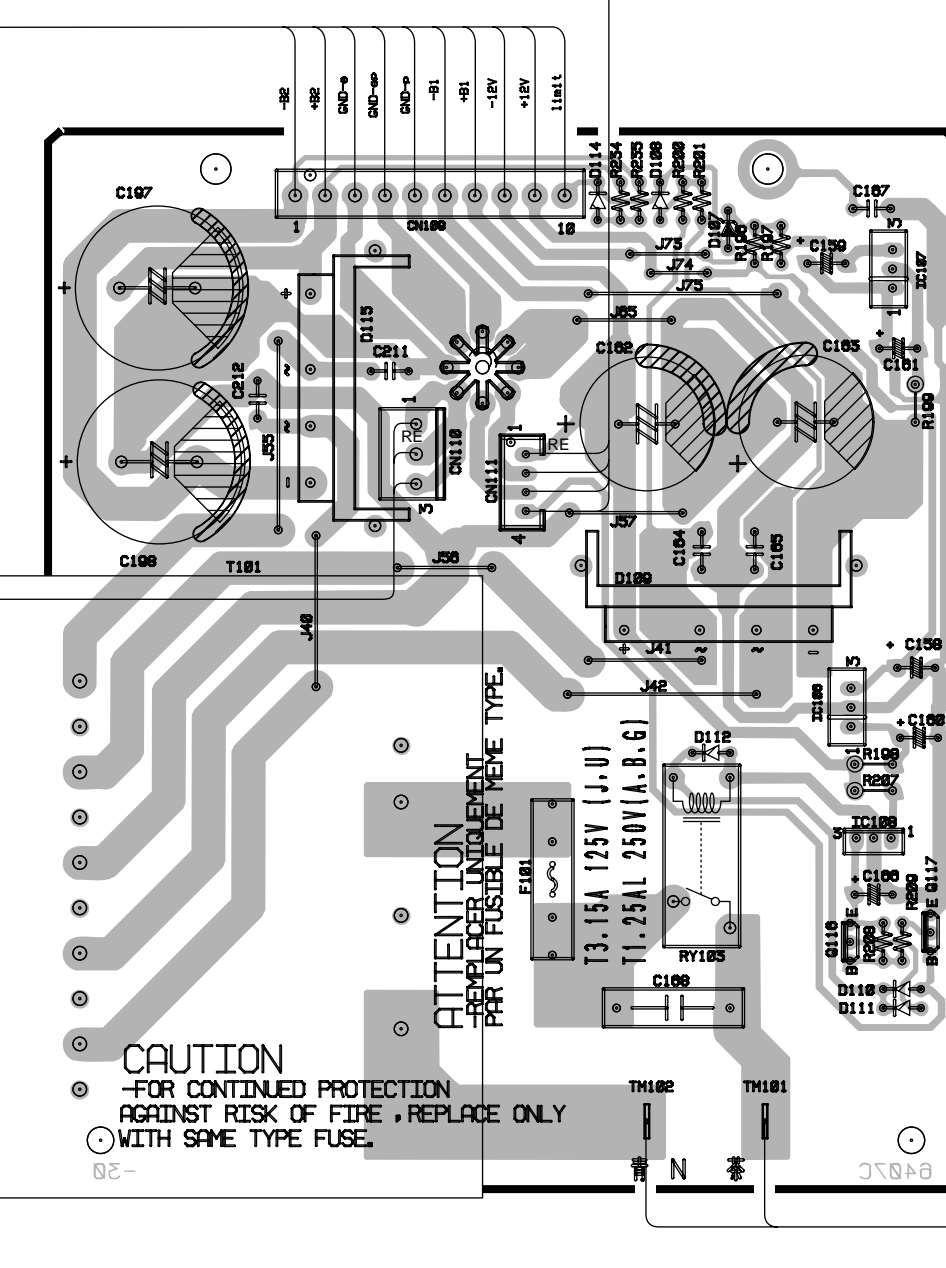
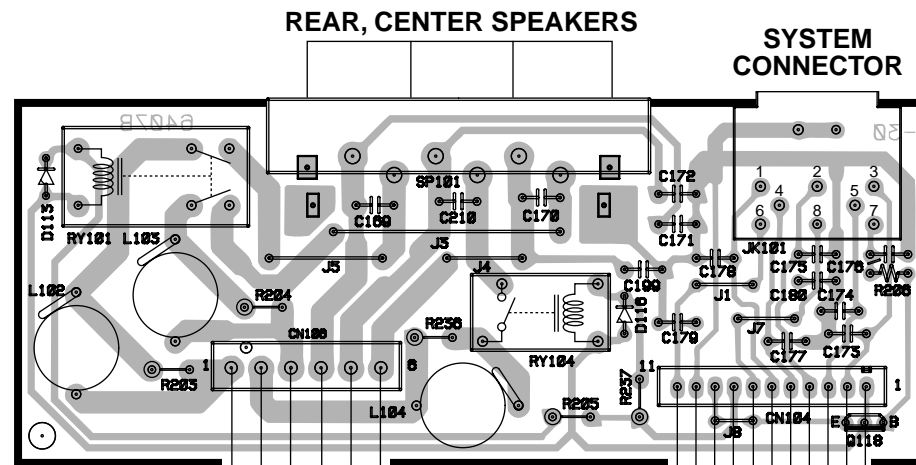
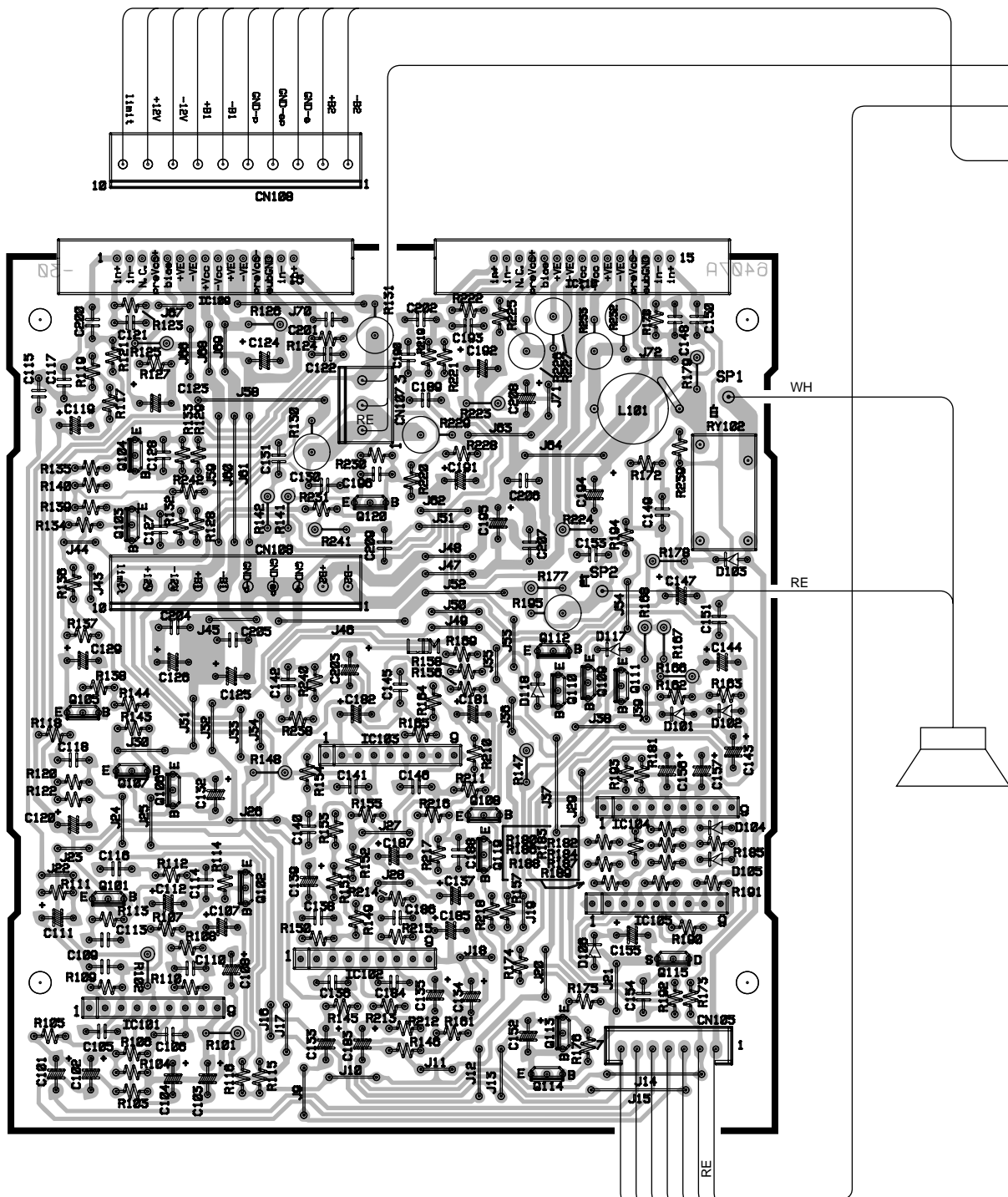

• Semiconductor Location

Ref. No.	Location
D101	D5
D102	D5
D103	D5
D104	D6
D105	D6
D106	C6
D107	H4
D108	H4
D109	H5
D110	I6
D111	I6
D112	H5
D113	F1
D114	H4
D115	G4
D116	H2
D117	D5
D118	C5
Q101	B6
Q102	B6
Q103	B4
Q104	B4
Q105	A5
Q106	B5
Q107	B5
Q108	C6
Q109	C5
Q110	C5
Q111	D5
Q112	C5
Q113	C6
Q114	C7
Q115	D6
Q116	H6
Q117	I6
Q118	I2
Q119	C6
Q120	C4
IC101	B6
IC102	C6
IC103	C5
IC104	D6
IC105	D6
IC106	H5
IC107	I4
IC108	I6
IC109	B3
IC110	C3

SCHEMATIC DIAGRAM (1/2 MAIN)

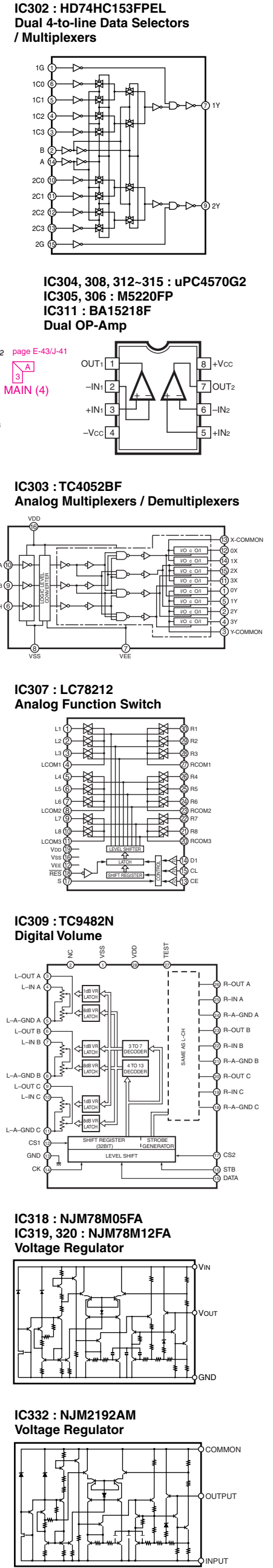
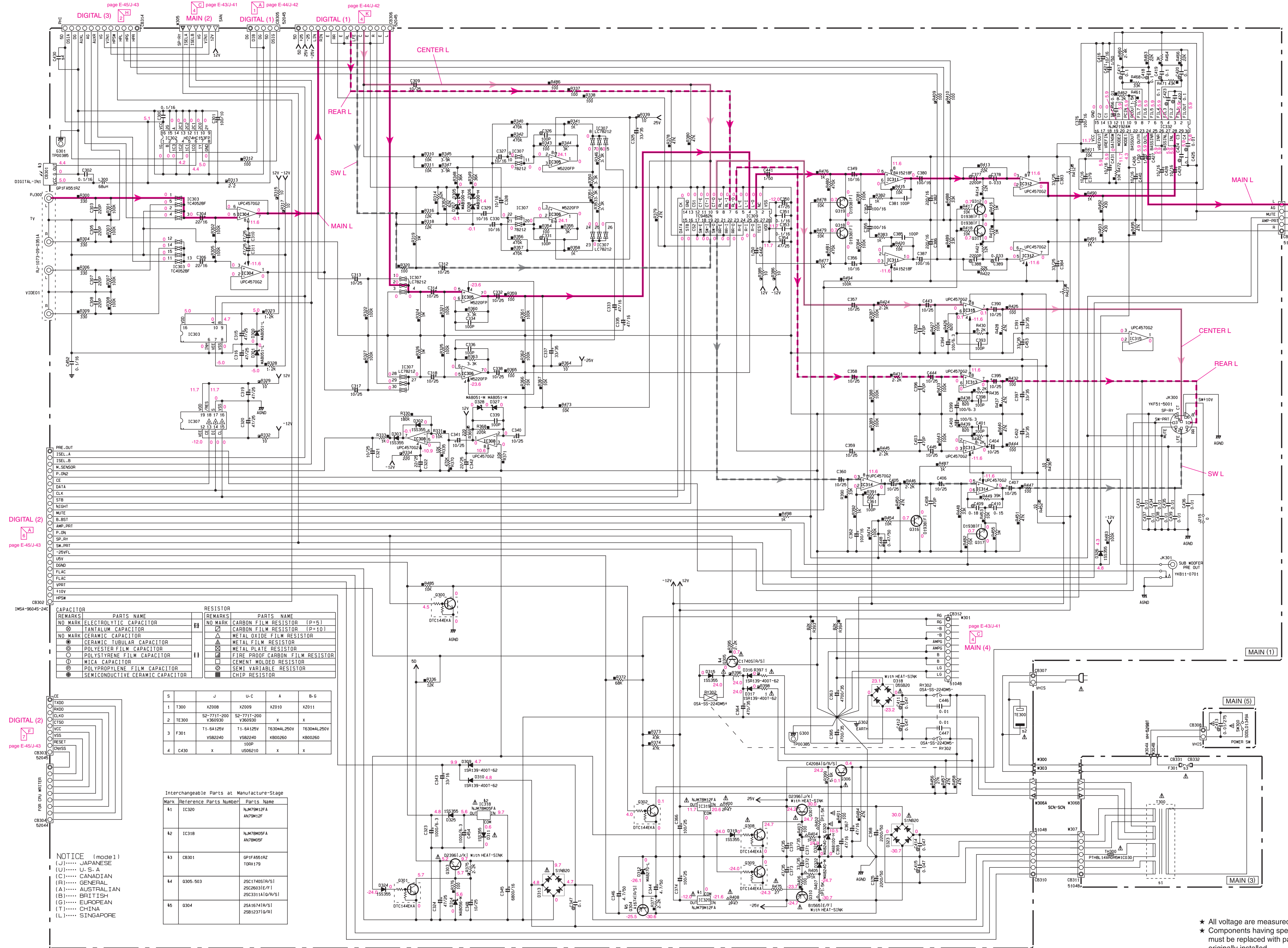

REMARKS	PARTS NAME	REMARKS	PARTS NAME
NO MARK	ELECTROLYTIC CAPACITOR	NO MARK	CARBON FILM RESISTOR (P=5)
NO MARK	TANTALUM CAPACITOR	NO MARK	CARBON FILM RESISTOR (P=10)
NO MARK	CERAMIC CAPACITOR	NO MARK	METAL OXIDE FILM RESISTOR
NO MARK	CERAMIC TUBULAR CAPACITOR	NO MARK	METAL FILM RESISTOR
NO MARK	POLYESTER FILM CAPACITOR	NO MARK	METAL PLATE RESISTOR
NO MARK	POLYSTYRENE FILM CAPACITOR	NO MARK	FIRE PROOF CARBON FILM RESISTOR
NO MARK	MICA CAPACITOR	NO MARK	CEMENT MOLDED RESISTOR
NO MARK	POLYPROPYLENE FILM CAPACITOR	NO MARK	SEMI VARIABLE RESISTOR
NO MARK	SEMICONDUCTIVE CERAMIC CAPACITOR	NO MARK	CHIP RESISTOR

NO.	MARK	REMARKS	U-C	A	B-G
1	1300	X2008	X2009	X2010	X2011
2	TE300	52-7711-200	52-7711-200		
3	F301	11-64125V	11-64125V	T630MAL250V	T630MAL250V
4	C430	X	U506210	X	X

Mark	Reference Parts Number	Parts Name
41	IC320	NJM78M12FA
42	IC318	NJM78M05FA
43	CB301	SP1F4551RZ
44	Q305-Q303	2SC1740S(R/S)
		2SC2603(E/F)
		2SC3311A(O/R/S)
45	Q304	2SA1674(R/S)
		2SB1237(O/R)

NOTICE (mode1)
 (J)..... JAPANESE
 (U)..... U.S.A
 (C)..... CANADIAN
 (R)..... GENERAL
 (A)..... AUSTRALIAN
 (B)..... BRITISH
 (G)..... EUROPEAN
 (T)..... CHINA
 (L)..... SINGAPORE

PIN CONNECTION DIAGRAM OF TRANSISTORS, DIODES AND ICs.

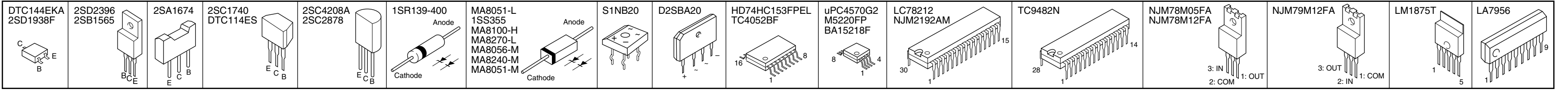

- ★ All voltage are measured with a 10MΩ/V DC electric volt meter.
- ★ Components having special characteristics are marked **!** and must be replaced with parts having specifications equal to those originally installed.
- ★ Schematic diagram is subject to change without notice.

- 電圧は、内部抵抗10MΩの電圧計で測定したものです。
- **!**印のある部品は、安全性確保部品を示しています。部品の交換が必要な場合は、パーツリストに記載されている部品を使用してください。
- 本回路図は標準回路図です。改良のため予告なく変更することがございます。

VS-10
SCHEMATIC DIAGRAM (2/2 MAIN)

REMARKS	PARTS NAME
NO MARK	CARBON FILM RESISTOR (P=5)
□	CARBON FILM RESISTOR (P=10)
△	METAL OXIDE FILM RESISTOR
▲	METAL FILM RESISTOR
▴	METAL PLATE RESISTOR
■	FIRE PROOF CARBON FILM RESISTOR
□	CEMENT MOLDED RESISTOR
⊠	SEMI VARIABLE RESISTOR
■	CHIP RESISTOR

REMARKS	PARTS NAME
NO MARK	ELECTROLYTIC CAPACITOR
⊗	TANTALUM CAPACITOR
NO MARK	CERAMIC CAPACITOR
⊙	CERAMIC TUBULAR CAPACITOR
⊕	POLYESTER FILM CAPACITOR
○	POLYSTYRENE FILM CAPACITOR
①	MICA CAPACITOR
⊖	POLYPROPYLENE FILM CAPACITOR
⊙	SEMICONDUCTIVE CERAMIC CAPACITOR
⊕	POLYPHENYLENE SULFIDE FILM CAPACITOR

NOTICE (mode1)
 (J)..... JAPANESE
 (U)..... U.S.A
 (C)..... CANADIAN
 (R)..... GENERAL
 (A)..... AUSTRALIAN
 (B)..... BRITISH
 (G)..... EUROPEAN
 (T)..... CHINA
 (L)..... SINGAPORE

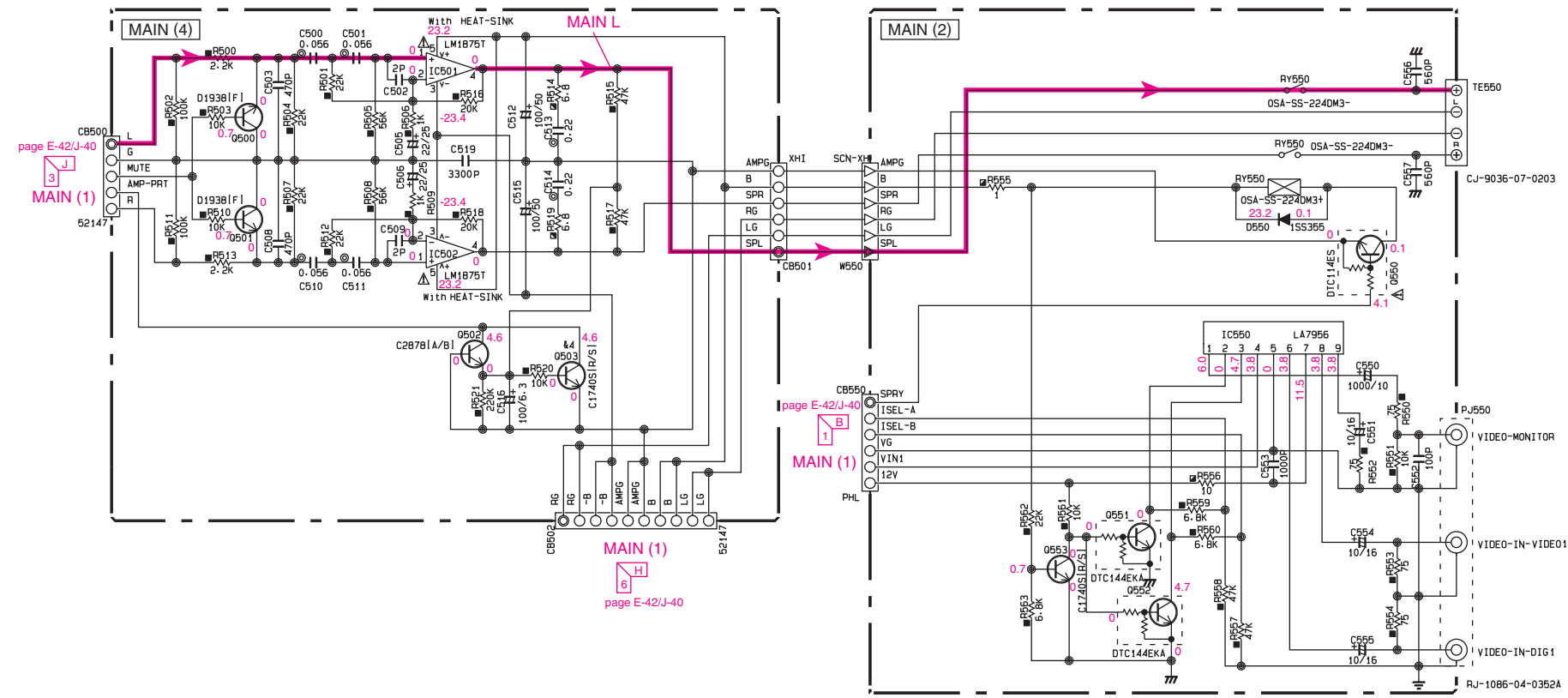

IC501, 502 : LM1875T
 Power Amp

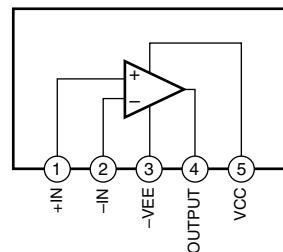

IC550 : LA7956
 Video Switch

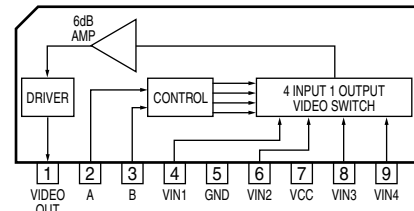

- ★ All voltage are measured with a 10MΩ/V DC electric volt meter.
- ★ Components having special characteristics are marked Δ and must be replaced with parts having specifications equal to those originally installed.
- ★ Schematic diagram is subject to change without notice.

- 電圧は、内部抵抗10MΩの電圧計で測定したものです。
- Δ 印のある部品は、安全性確保部品を示しています。部品の交換が必要な場合は、パーツリストに記載されている部品を使用してください。
- 本回路図は標準回路図です。改良のため予告なく変更することがございます。

PIN CONNECTION DIAGRAM OF TRANSISTORS, DIODES AND ICs.

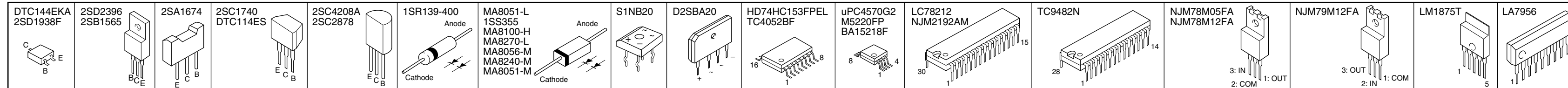

SCHEMATIC DIAGRAM (1/2 DIGITAL)

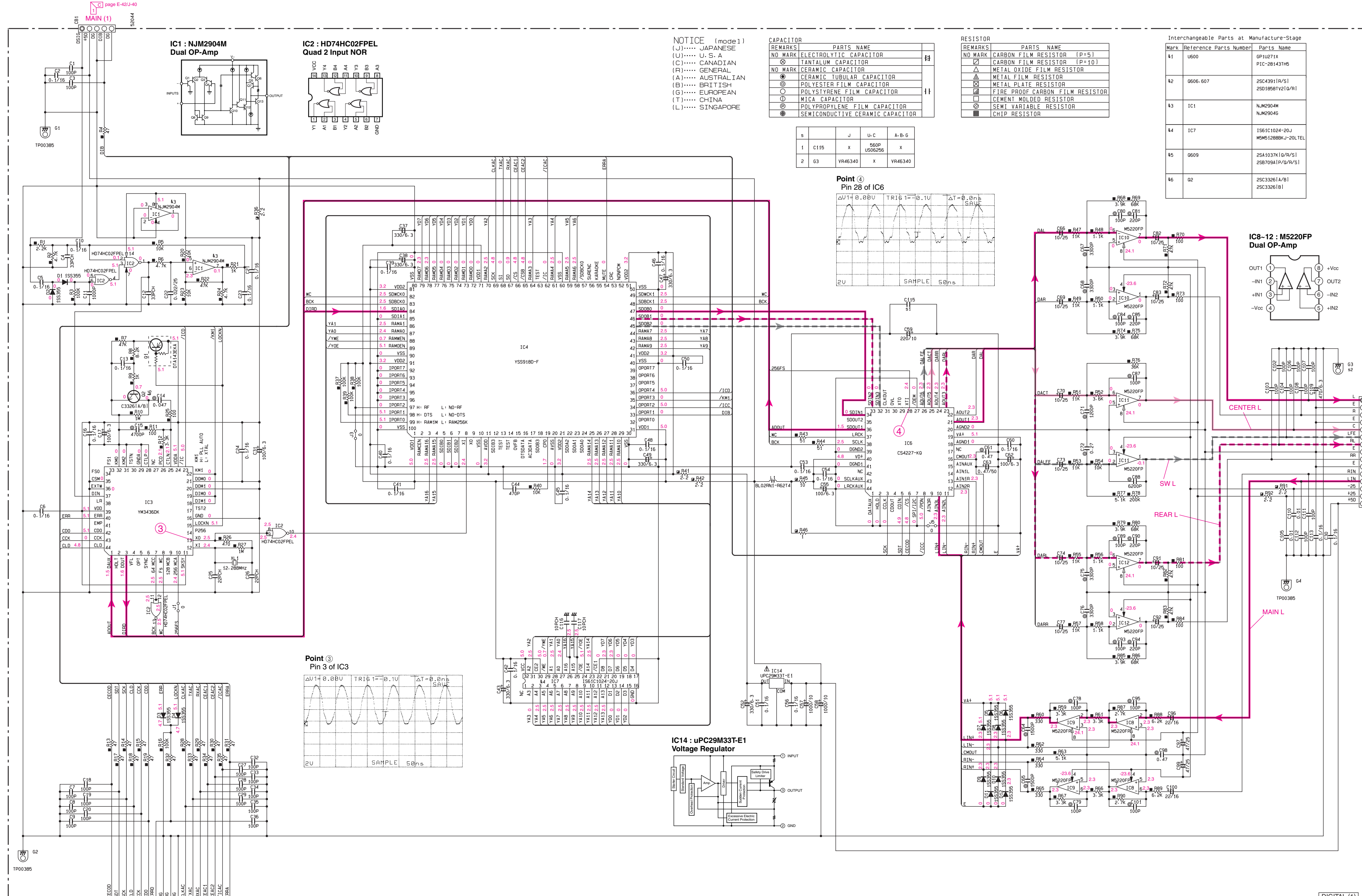

NOTICE (mode1)
 (J)..... JAPANESE
 (U)..... U.S.A
 (C)..... CANADIAN
 (R)..... GENERAL
 (A)..... AUSTRALIAN
 (B)..... BRITISH
 (G)..... EUROPEAN
 (T)..... CHINA
 (L)..... SINGAPORE

REMARKS	PARTS NAME	UNIT
NO MARK	ELECTROLYTIC CAPACITOR	μF
⊗	TANTALUM CAPACITOR	μF
⊙	CERAMIC CAPACITOR	μF
⊚	CERAMIC TUBULAR CAPACITOR	μF
⊖	POLYESTER FILM CAPACITOR	μF
⊕	POLYSTYRENE FILM CAPACITOR	μF
⊙	MICA CAPACITOR	μF
⊖	POLYPROPYLENE FILM CAPACITOR	μF
⊙	SEMICONDUCTIVE CERAMIC CAPACITOR	μF

REMARKS	PARTS NAME	UNIT
NO MARK	CARBON FILM RESISTOR (P=5)	Ω
⊖	CARBON FILM RESISTOR (P=10)	Ω
⊚	METAL FILM RESISTOR	Ω
⊖	METAL PLATE RESISTOR	Ω
⊚	FIRE PROOF CARBON FILM RESISTOR	Ω
⊖	CEMENT MOLDED RESISTOR	Ω
⊚	SEMI VARIABLE RESISTOR	Ω
⊖	CHIP RESISTOR	Ω

Mark	Reference Parts Number	Parts Name
K1	U600	6P1U271X PIC-281431H6
K2	0606-607	25C438114/S1 25D10881V210/R1
K3	IC1	NJM2904M NJM2904G
K4	IC7	IS61C1024-20J MSM1288BK-J-20J TEL
K5	0609	25A1037K10/R/S1 25B709A1P/R/S1
K6	02	25C33261A/B1 25C33261B1

S	J	U.C	A-B-G
1	C115	X	560P US06256
2	G3	X	VR46340

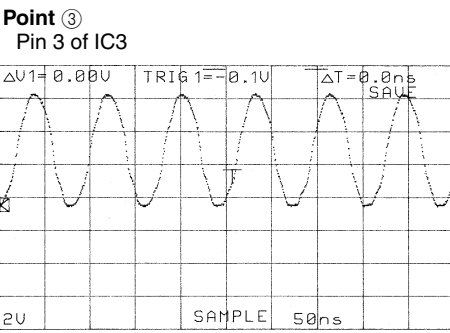
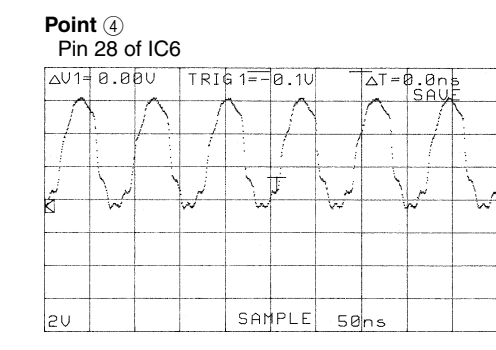

PIN CONNECTION DIAGRAM OF TRANSISTORS, DIODES AND ICs.

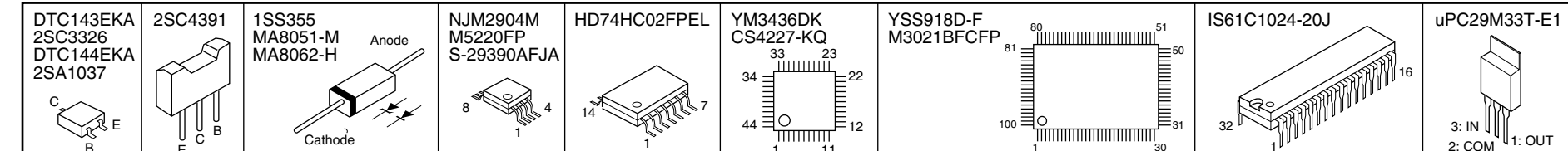

IC6 : CS4227-KQ 6ch 20bit CODEC

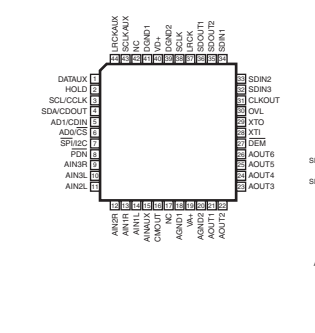

IC7 : IS61C1024-20J 128k x 8 High-speed CMOS Static RAM

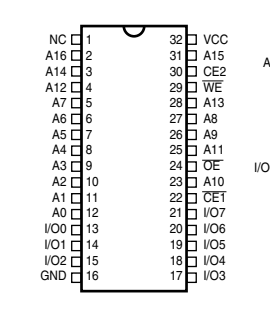

★ All voltage are measured with a 10MΩ/V DC electric volt meter.
 ★ Components having special characteristics are marked with a triangle (▲) and must be replaced with parts having specifications equal to those originally installed.
 ★ Schematic diagram is subject to change without notice.

● 電圧は、内部抵抗10MΩの電圧計で測定したものです。
 ● 印のある部品は、安全性確保部品を示しています。部品の交換が必要な場合は、パーツリストに記載されている部品を使用してください。
 ● 本回路図は標準回路図です。改良のため予告なく変更することがございます。

VS-10
SCHEMATIC DIAGRAM (2/2 DIGITAL)

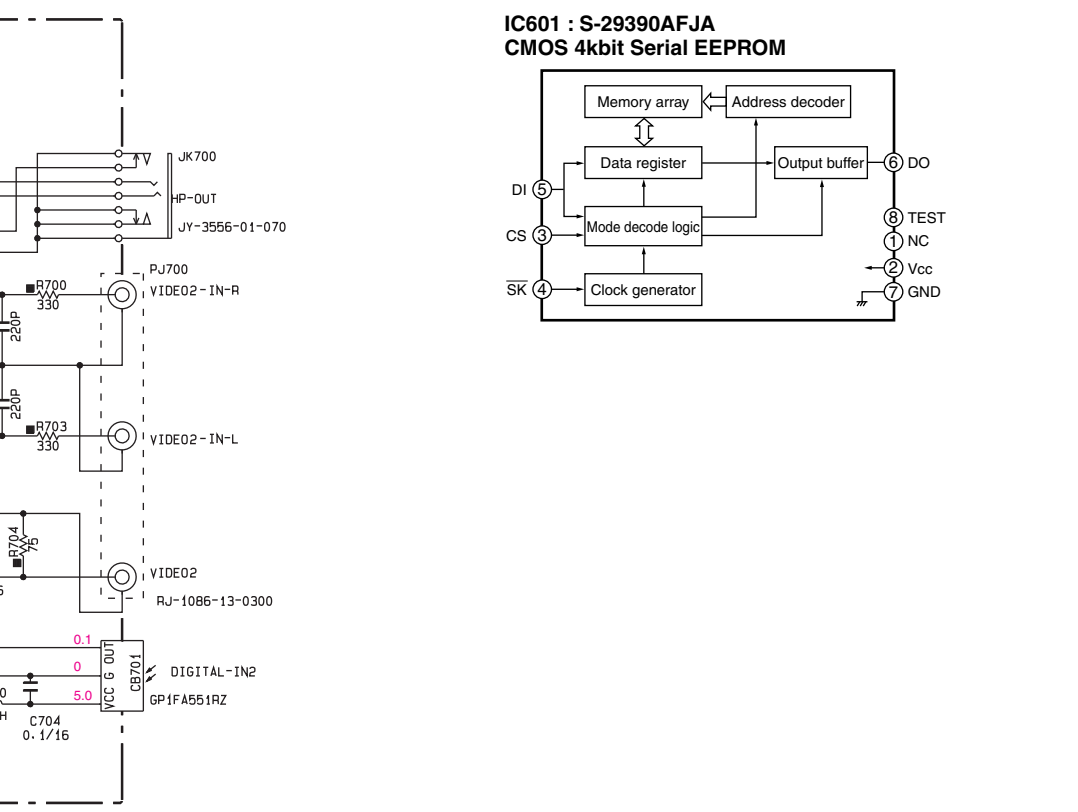
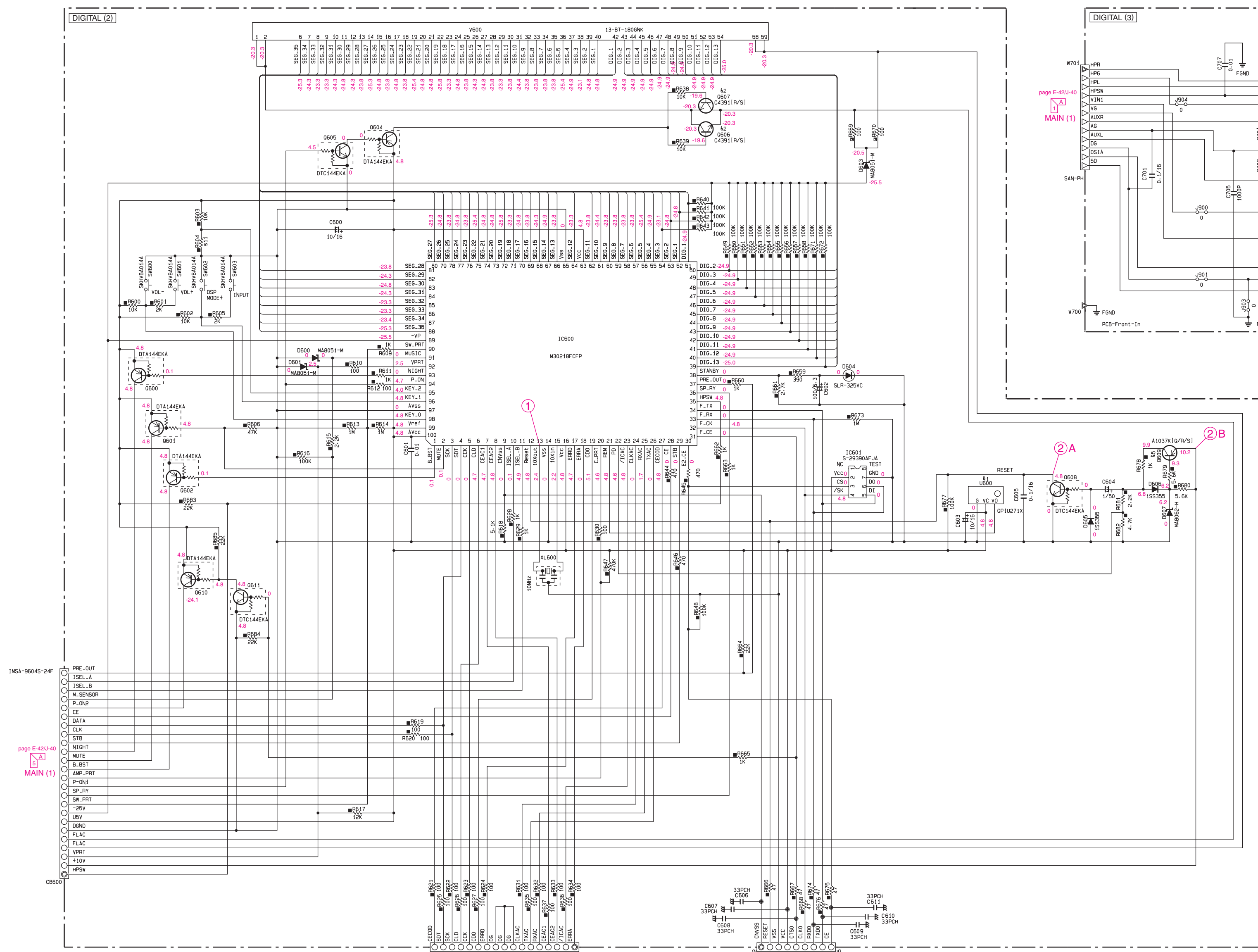

CAPACITOR

REMARKS	PARTS NAME
NO MARK	ELECTROLYTIC CAPACITOR
⊗	TANTALUM CAPACITOR
NO MARK	CERAMIC CAPACITOR
⊙	CERAMIC TUBULAR CAPACITOR
⊖	POLYESTER FILM CAPACITOR
⊕	POLYSTYRENE FILM CAPACITOR
⊖	MICA CAPACITOR
⊖	POLYPROPYLENE FILM CAPACITOR
⊖	SEMICONDUCTIVE CERAMIC CAPACITOR
⊖	POLYPHENYLENE SULFIDE FILM CAPACITOR

RESISTOR

REMARKS	PARTS NAME
NO MARK	CARBON FILM RESISTOR (P=5)
⊗	CARBON FILM RESISTOR (P=10)
△	METAL OXIDE FILM RESISTOR
△	METAL FILM RESISTOR
⊗	METAL PLATE RESISTOR
⊗	FIRE PROOF CARBON FILM RESISTOR
⊗	CEMENT MOLDED RESISTOR
⊗	SEMI VARIABLE RESISTOR
⊗	CHIP RESISTOR

NOTICE (model)
(J)..... JAPANESE
(U)..... U. S. A
(C)..... CANADIAN
(F)..... GENERAL
(A)..... AUSTRALIAN
(B)..... BRITISH
(G)..... EUROPEAN
(T)..... CHINA
(L)..... SINGAPORE

S	J	U-C	A-B-G
11	R604	5K R035751	2K R035620

page E-42(J)-40
MAIN (1)

DIGITAL (1) page E-44(J)-42
MAIN (1) page E-42(J)-40

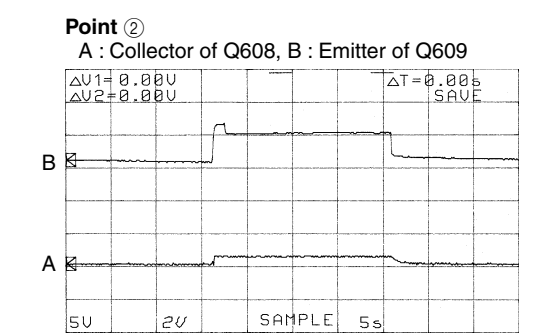
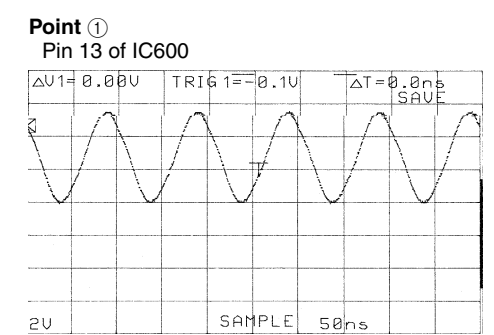

★ All voltage are measured with a 10MΩ/V DC electric volt meter.
★ Components having special characteristics are marked ⊕ and must be replaced with parts having specifications equal to those originally installed.
★ Schematic diagram is subject to change without notice.

● 電圧は、内部抵抗10MΩの電圧計で測定したものです。
● ⊕印のある部品は、安全性確保部品を示しています。部品の交換が必要な場合は、パーツリストに記載されている部品を使用してください。
● 本回路図は標準回路図です。改良のため予告なく変更することがございます。

PIN CONNECTION DIAGRAM OF TRANSISTORS, DIODES AND ICs.

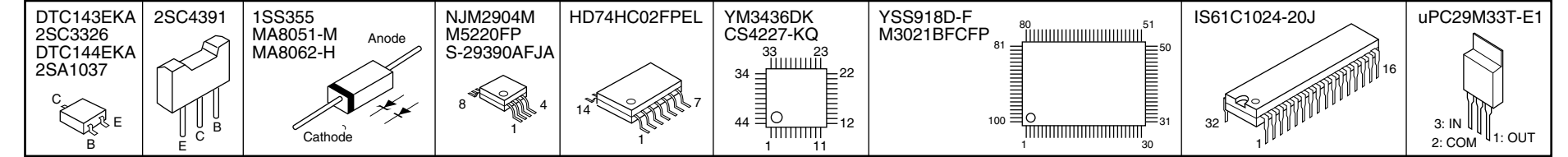

SW-VS10 SCHEMATIC DIAGRAM

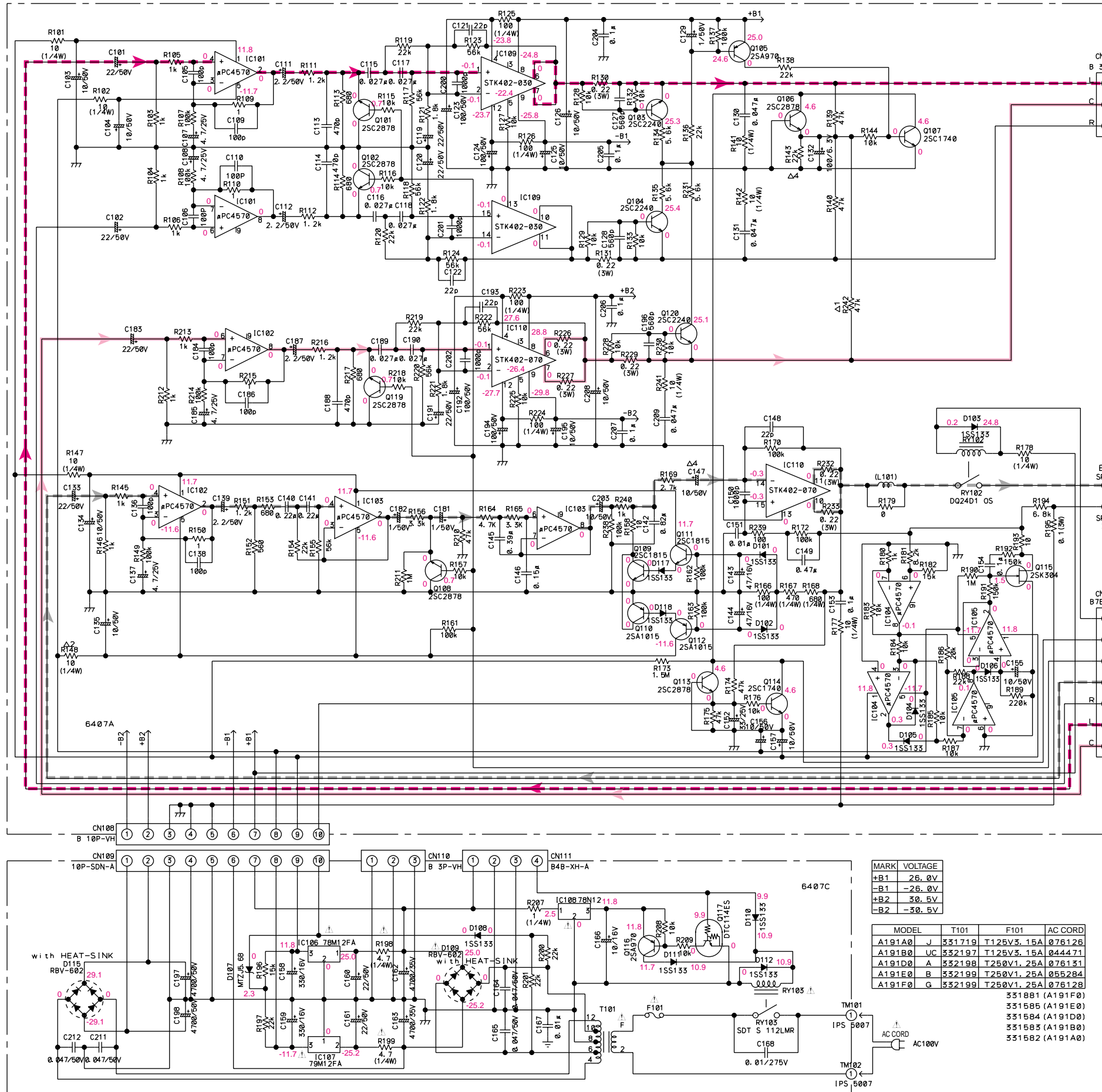

PIN CONNECTION DIAGRAM OF TRANSISTORS, DIODES AND ICs.

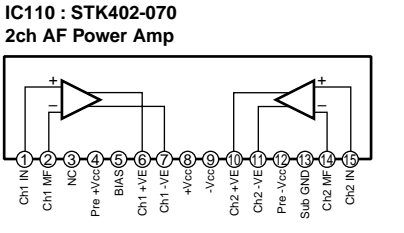
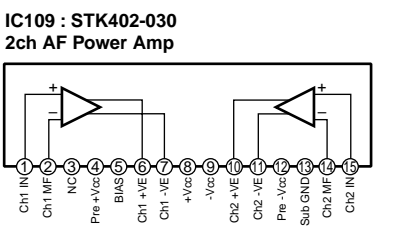
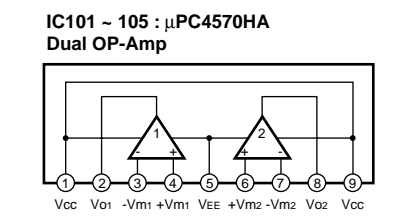
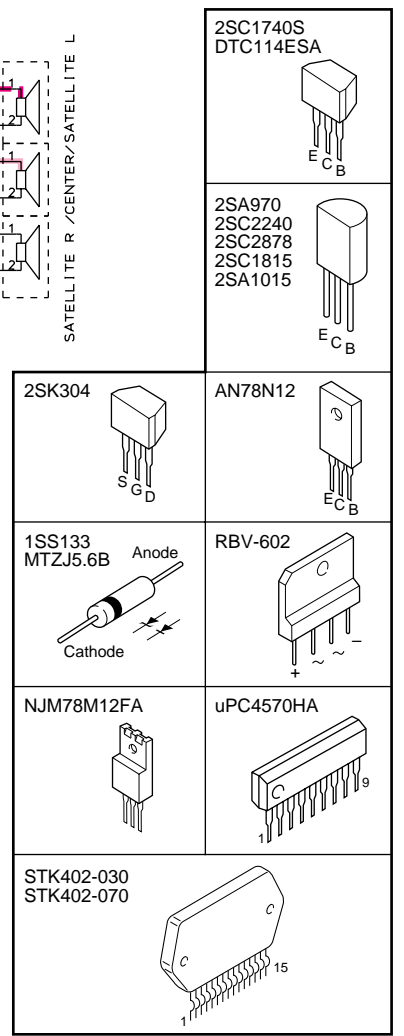

MARK VOLTAGE			
+B1			26.0V
-B1			-26.0V
+B2			30.5V
-B2			-30.5V

MODEL			
A191A0	J	531719	T125V3.15A 076126
A191B0	UC	532197	T125V3.15A 044471
A191D0	A	532198	T250V1.25A 076131
A191E0	B	532199	T250V1.25A 065284
A191F0	G	532199	T250V1.25A 076128

531881 (A191F0)
531885 (A191E0)
531884 (A191D0)
531883 (A191B0)
531882 (A191A0)

- ★ All voltage are measured with a 10MΩ/V DC electric volt meter.
- ★ Components having special characteristics are marked Δ and must be replaced with parts having specifications equal to those originally installed.
- ★ Schematic diagram is subject to change without notice.

電圧は、内部抵抗10MΩの電圧計で測定したものです。
 Δ 印のある部品は、安全性確保部品を示しています。
 部品の交換が必要な場合は、パーツリストに記載されている部品を使用してください。
 本回路図は標準回路図です。改良のため予告なく変更することがございます。

PARTS LIST

ELECTRICAL PARTS

WARNING

Components having special characteristics are marked Δ and must be replaced with parts having specifications equal to those originally installed.

- Carbon resistors (1/6W or 1/4W) are not included in the ELECTRICAL PARTS List. For the parts No. of the carbon resistors, refer to last page.

ABBREVIATIONS IN THIS LIST ARE AS FOLLOWS:

C.A.EL.CHP : CHIP ALUMI.ELECTROLYTIC CAP	L.EMIT : LIGHT EMITTING MODULE
C.CE : CERAMIC CAP	LED.DSPLY : LED DISPLAY
C.CE.ARRAY : CERAMIC CAP ARRAY	LED.INFRD : LED,INFRARED
C.CE.CHP : CHIP CERAMIC CAP	MODUL.RF : MODULATOR,RF
C.CE.ML : MULTILAYER CERAMIC CAP	PHOT.CPL : PHOTO COUPLER
C.CE.M.CHP : CHIP MULTILAYER CERAMIC CAP	PHOT.INTR : PHOTO INTERRUPTER
C.CE.SAFTY : RECOGNIZED CERAMIC CAP	PHOT.RFLCT : PHOTO REFLECTOR
C.CE.TUBLR : CERAMIC TUBULAR CAP	PIN.TEST : PIN,TEST POINT
C.CE.SMI : SEMI CONDUCTIVE CERAMIC CAP	PLST.RIVET : PLASTIC RIVET
C.EL : ELECTROLYTIC CAP	R.ARRAY : RESISTOR ARRAY
C.MICA : MICA CAP	R.CAR. : CARBON RESISTOR
C.ML.FLM : MULTILAYER FILM CAP	R.CAR.CHP : CHIPRESISTOR
C.MP : METALLIZED PAPER CAP	R.CAR.FP : FLAME PROOF CARBON RESISTOR
C.MYLAR : MYLAR FILM CAP	R.FUS : FUSABLE RESISTOR
C.MYLAR.ML : MULTILAYER MYLAR FILM CAP	R.MTL.CHP : CHIP METAL FILM RESISTOR
C.PAPER : PAPER CAPACITOR	R.MTL.FLM : METAL FILM RESISTOR
C.PLS : POLYSTYRENE FILM CAP	R.MTL.OXD : METAL OXIDE FILM RESISTOR
C.POL : POLYESTER FILM CAP	R.MTL.PLAT : METAL PLATE RESISTOR
C.POLY : POLYETHYLENE FILM CAP	RSNR.CE : CERAMIC RESONATOR
C.PP : POLYPROPYLENE FILM CAP	RSNR.CRYS : CRYSTAL RESONATOR
C.TNTL : TANTALUM CAP	R.TW.CEM : TWIN CEMENT FIXED RESISTOR
C.TNTL.CHP : CHIP TANTALUM CAP	R.WW : WIRE WOUND RESISTOR
C.TRIM : TRIMMER CAP	SCR.BND.HD : BIND HEAD B-TITE SCREW
CN : CONNECTOR	SCR.BW.HD : BW HEAD TAPPING SCREW
CN.BS.PIN : CONNECTOR,BASE PIN	SCR.CUP : CUP TITE SCREW
CN.CANNON : CONNECTOR,CANNON	SCR.TERM : SCREW TERMINAL
CN.DIN : CONNECTOR,DIN	SCR.TR : SCREW,TRANSISTOR
CN.FLAT : CONNECTOR,FLAT CABLE	SUPRT.PCB : SUPPORT,P.C.B.
CN.POST : CONNECTOR,BASE POST	SURG.PRTCT : SURGE PROTECTOR
COIL.MX.AM : COIL,AM MIX	SW.TACT : TACT SWITCH
COIL.AT.FM : COIL,FM ANTENNA	SW.LEAF : LEAF SWITCH
COIL.DT.FM : COIL,FM DETECT	SW.LEVER : LEVER SWITCH
COIL.MX.FM : COIL,FM MIX	SW.MICRO : MICRO SWITCH
COIL.OUTPT : OUTPUT COIL	SW.PUSH : PUSH SWITCH
DIOD.ARRAY : DIODE ARRAY	SW.RT.ENC : ROTARY ENCODER
DIODE.BRG : DIODE BRIDGE	SW.RT.MTR : ROTARY SWITCH WITH MOTOR
DIODE.CHP : CHIP DIODE	SW.RT : ROTARY SWITCH
DIODE.VAR : VARACTOR DIODE	SW.SLIDE : SLIDE SWITCH
DIOD.Z.CHP : CHIP ZENER DIODE	TERM.SP : SPEAKER TERMINAL
DIODE.ZENR : ZENER DIODE	TERM.WRAP : WRAPPING TERMINAL
DSCR.CE : CERAMIC DISCRIMINATOR	THRMST.CHP : CHIP THERMISTOR
FER.BEAD : FERRITE BEADS	TR.CHP : CHIP TRANSISTOR
FER.CORE : FERRITE CORE	TR.DGT : DIGITAL TRANSISTOR
FET.CHP : CHIP FET	TR.DGT.CHP : CHIP DIGITAL TRANSISTOR
FL.DSPLY : FLUORESCENT DISPLAY	TRANS : TRANSFORMER
FLTR.CE : CERAMIC FILTER	TRANS.PULS : PULSE TRANSFORMER
FLTR.COMB : COMB FILTER MODULE	TRANS.PWR : POWER TRANSFORMER ASS'Y
FLTR.LC.RF : LC FILTER,EMI	TUNER.AM : TUNER PACK,AM
GND.MTL : GROUND PLATE	TUNER.FM : TUNER PACK,FM
GND.TERM : GROUND TERMINAL	TUNER.PK : FRONT-ENDTUNER PACK
HOLDER.FUS : FUSE HOLDER	VR : ROTARY POTENTIOMETER
IC.PRTCT : IC PROTECTOR	VR.MTR : POTENTIOMETER WITH MOTOR
JUMPER.CN : JUMPER CONNECTOR	VR.SW : POTENTIOMETER WITH ROTARY SW
JUMPER.TST : JUMPER,TEST POINT	VR.SLIDE : SLIDE POTENTIOMETER
L.DTCT : LIGHT DETECTING MODULE	VR.TRIM : TRIMMER POTENTIOMETER

VS-10

P. C. B. MAIN

Schm Ref.	PART NO.	Description
*	V6423300	P. C. B.
*	V6423400	P. C. B.
*	CB301	V5478200 CN.PHOT.SN
*	CB302	VU272400 CN
*	CB303	VQ047200 CN.BS.PIN
*	CB304	VQ044400 CN.BS.PIN
*	CB305	VQ046900 CN.BS.PIN
*	CB306	VM859600 CN.BS.PIN
*	CB307	VG879900 CN.BS.PIN
*	CB308	VG879900 CN.BS.PIN
*	CB310	Vi878500 CN.BS.PIN
*	CB311	Vi878500 CN.BS.PIN
*	CB312	Vi878800 CN.BS.PIN
*	CB313	Vi878300 CN.BS.PIN
*	CB314	VB390800 CN.BS.PIN
*	CB331	VP206500 HOLDER.FUS
*	CB332	VP206500 HOLDER.FUS
*	CB500	VK024900 CN.BS.PIN
*	CB501	VL845000 CN.BS.PIN
*	CB502	VF728200 CN.BS.PIN
*	CB550	VB858500 CN.BS.PIN
*	C300	US135100 C.CE.CHP
*	C301	UR828100 C.EL
*	C302	US135100 C.CE.CHP
*	C303	US062220 C.CE.CHP
*	C304	UR837220 C.EL
*	C305	US062220 C.CE.CHP
*	C306	UR837220 C.EL
*	C307	US062220 C.CE.CHP
*	C308	US062220 C.CE.CHP
*	C309	UR847100 C.EL
*	C310	UR847470 C.EL
*	C311	UR847470 C.EL
*	C312	UR847100 C.EL
*	C313	UR847100 C.EL
*	C314	UR847100 C.EL
*	C315	UR847470 C.EL
*	C316	UR847470 C.EL
*	C317	UR847100 C.EL
*	C318	UR847100 C.EL
*	C319	UR847470 C.EL
*	C320	UR847470 C.EL
*	C321	UR847100 C.EL
*	C322	UR847220 C.EL
*	C323	UR819100 C.EL
*	C324	UR847470 C.EL
*	C325	UR857330 C.EL
*	C326	UA952100 C.MYLAR
*	C327	UR837100 C.EL
*	C328	UR837100 C.EL
*	C329	UR837100 C.EL
*	C330	UR837100 C.EL
*	C331	UA952100 C.MYLAR
*	C332	UR847100 C.EL
*	C333	UR837470 C.EL
*	C334	US062100 C.CE.M.CHP
*	C335	UR837470 C.EL
*	C336	US062100 C.CE.M.CHP
*	C337	UR857330 C.EL
*	C338	UR847100 C.EL
*	C339	US062100 C.CE.M.CHP
*	C340	UR847100 C.EL
*	C341	UR847100 C.EL

* New Parts

Schm Ref.	PART NO.	Description
*	C342	UR847220 C.EL
*	C343	UR837330 C.EL
*	C344	UR866470 C.EL
*	C345	UR739680 C.EL
*	C346	UR866470 C.EL
*	C347	VE326000 C.MYLAR.ML
*	C348	UR847100 C.EL
*	C349	UU137100 C.EL
*	C350	UR847470 C.EL
*	C351	US135100 C.CE.CHP
*	C352	UU138100 C.EL
*	C353	US135100 C.CE.CHP
*	C354	UR847470 C.EL
*	C355	UU138100 C.EL
*	C356	UU137100 C.EL
*	C357	UR847100 C.EL
*	C358	UR847100 C.EL
*	C359	UR847100 C.EL
*	C360	UR847100 C.EL
*	C361	US062100 C.CE.M.CHP
*	C362	UR838100 C.EL
*	C363	UR759470 C.EL
*	C364	UR858470 C.EL
*	C365	UR759470 C.EL
*	C366	UR848100 C.EL
*	C367	UR837470 C.EL
*	C368	UR769220 C.EL
*	C369	UR837470 C.EL
*	C370	UR857470 C.EL
*	C371	UR857330 C.EL
*	C372	UR857330 C.EL
*	C373	UR857470 C.EL
*	C374	UR848100 C.EL
*	C375	UR769220 C.EL
*	C376	UM398100 C.EL
*	C377	UA953220 C.MYLAR
*	C378	UA954330 C.MYLAR
*	C379	UM397100 C.EL
*	C380	UU138100 C.EL
*	C381	US062100 C.CE.M.CHP
*	C382	UU138220 C.EL
*	C383	UM407330 C.EL
*	C384	UM407330 C.EL
*	C385	US062100 C.CE.M.CHP
*	C386	UU138220 C.EL
*	C387	UU138100 C.EL
*	C388	UA953220 C.MYLAR
*	C389	UA954330 C.MYLAR
*	C390	UR847100 C.EL
*	C391	UR857330 C.EL
*	C392	US062470 C.CE.M.CHP
*	C393	US062100 C.CE.M.CHP
*	C394	UR818100 C.EL
*	C395	UR847100 C.EL
*	C396	US062470 C.CE.M.CHP
*	C397	UR857330 C.EL
*	C398	US062100 C.CE.M.CHP
*	C399	UR818100 C.EL
*	C400	UR818100 C.EL
*	C401	US062100 C.CE.M.CHP
*	C402	UR857330 C.EL
*	C403	US062470 C.CE.M.CHP
*	C404	UR847100 C.EL

* New Parts

Note) Those parts marked with “#” are not included in the P.C.B. ass'y.

P. C. B. MAIN

Schm Ref.	PART NO.	Description		
C405	UR847100	C.EL	10uF	25V
C406	UR847100	C.EL	10uF	25V
C407	UR847100	C.EL	10uF	25V
C408	US062470	C.CE.M.CHP	470pF	50V
C409	VE326300	C.MYLAR.ML	0.18uF	50V
C410	VE326200	C.MYLAR.ML	0.15uF	50V
C411	UA954470	C.MYLAR	0.047uF	50V
C412	UA954470	C.MYLAR	0.047uF	50V
C413	V3501400	C.CE.SAFTY	0.01uF	275V
C414	UA954470	C.MYLAR	0.047uF	50V
C415	UA954470	C.MYLAR	0.047uF	50V
C416	UM397100	C.EL	10uF	16V
C417	VE326000	C.MYLAR.ML	0.1uF	50V
C418	VE326000	C.MYLAR.ML	0.1uF	50V
C419	VE326000	C.MYLAR.ML	0.1uF	50V
C420	VE326000	C.MYLAR.ML	0.1uF	50V
C421	UM416100	C.EL	1uF	50V
C422	VE326000	C.MYLAR.ML	0.1uF	50V
C423	VE326000	C.MYLAR.ML	0.1uF	50V
C424	VE326000	C.MYLAR.ML	0.1uF	50V
C425	VE324800	C.MYLAR.ML	0.01uF	50V
C426	UM416100	C.EL	1uF	50V
C427	UM416100	C.EL	1uF	50V
C428	UM397100	C.EL	10uF	16V
C429	UM397100	C.EL	10uF	16V
C430	US062100	C.CE.M.CHP	100pF	50V(UC)
C431	UM397100	C.EL	10uF	16V
C433	US064100	C.CE.M.CHP	0.01uF	50V
C434	US064100	C.CE.M.CHP	0.01uF	50V
C435	US064100	C.CE.M.CHP	0.01uF	50V
C436	US064100	C.CE.M.CHP	0.01uF	50V
C437	US064100	C.CE.M.CHP	0.01uF	50V
C438	US064100	C.CE.M.CHP	0.01uF	50V
C439	US064100	C.CE.M.CHP	0.01uF	50V
C440	UM397100	C.EL	10uF	16V
C441	UR866100	C.EL	1uF	50V
C442	UR866100	C.EL	1uF	50V
C443	UR847100	C.EL	10uF	25V
C444	UR847100	C.EL	10uF	25V
C445	UR847100	C.EL	10uF	25V
C446	US064100	C.CE.M.CHP	0.01uF	50V
C447	US064100	C.CE.M.CHP	0.01uF	50V
C448	UN865470	C.EL	0.47uF	50V
C452	US135100	C.CE.CHP	0.1uF	16V
C453	UR857330	C.EL	33uF	35V
C454	UR819100	C.EL	1000uF	6.3V
C456	VE324800	C.MYLAR.ML	0.01uF	50V
C500	UA954560	C.MYLAR	0.056uF	50V
C501	UA954560	C.MYLAR	0.056uF	50V
C502	US060200	C.CE.CHP	2P	50V
C503	US062470	C.CE.M.CHP	470pF	50V
C505	UU147220	C.EL	22uF	25V
C506	UU147220	C.EL	22uF	25V
C508	US062470	C.CE.M.CHP	470pF	50V
C509	US060200	C.CE.CHP	2P	50V
C510	UA954560	C.MYLAR	0.056uF	50V
C511	UA954560	C.MYLAR	0.056uF	50V
C512	UR868100	C.EL	100uF	50V
C513	UA655220	C.MYLAR	0.22uF	50V
C514	UA655220	C.MYLAR	0.22uF	50V
C515	UR868100	C.EL	100uF	50V
C516	UR818100	C.EL	100uF	6.3V
C519	VG279600	C.CE.TUBLR	3300pF	16V

* New Parts

Schm Ref.	PART NO.	Description		
C550	UR829100	C.EL	1000uF	10V
C551	UR837100	C.EL	10uF	16V
C552	US062100	C.CE.M.CHP	100pF	50V
C553	US163100	C.CE.CHP	1000pF	50V
C554	UR837100	C.EL	10uF	16V
C555	UR837100	C.EL	10uF	16V
C556	US062560	C.CE.CHP	560pF	50V
C557	US062560	C.CE.CHP	560pF	50V
D300	VU992500	D.IODE.ZENR	MA8051-L	5.0V
D301	VU992500	D.IODE.ZENR	MA8051-L	5.0V
D302	VT332900	D.IODE	1SS355	
D303	VT332900	D.IODE	1SS355	
D305	VU995500	D.IODE.ZENR	MA8100-H	10.3V
D306	VU995500	D.IODE.ZENR	MA8100-H	10.3V
D307	VU995500	D.IODE.ZENR	MA8100-H	10.3V
D308	VU995500	D.IODE.ZENR	MA8100-H	10.3V
D309	VU264200	D.IODE	1SR139-400	
D310	VU264200	D.IODE	1SR139-400	
D311	VT332900	D.IODE	1SS355	
D312	VU999400	D.IODE.ZENR	MA8270-L	26V
D313	VR253700	D.IODE.BRG	S1NB20	1.0A 200V
D314	VU993000	D.IODE.ZENR	MA8056-M	5.6V
D315	VT332900	D.IODE	1SS355	
D316	VU264200	D.IODE	1SR139-400	
D317	VU264200	D.IODE	1SR139-400	
D318	VNO11400	D.IODE.BRG	D5SB20	5A 200V
D319	VT332900	D.IODE	1SS355	
D320	VU995500	D.IODE.ZENR	MA8100-H	10.3V
D321	VU999100	D.IODE.ZENR	MA8240-M	24V
D322	VU999100	D.IODE.ZENR	MA8240-M	24V
D323	VR253700	D.IODE.BRG	S1NB20	1.0A 200V
D324	VT332900	D.IODE	1SS355	
D325	VT332900	D.IODE	1SS355	
D326	VT332900	D.IODE	1SS355	
D327	VU992600	D.IODE.ZENR	MA8051-M	5.1V
D328	VU992600	D.IODE.ZENR	MA8051-M	5.1V
D550	VT332900	D.IODE	1SS355	
F301	KB002600	FUSE	T630mA	250V(ABG)
F301	VS822400	FUSE	1.6A(UC)	
G300	VR463400	TERM.GND	D3.5	TP00385
G301	VR463400	TERM.GND	D3.5	TP00385
G302	BB070700	GND.MTL		
HS301	VR110000	HEAT.SINK	UOT-16CS25	
HS302	VR110000	HEAT.SINK	UOT-16CS25	
HS303	VR110000	HEAT.SINK	UOT-16CS25	
HS304	Vi835500	HEAT.SINK	PH-0124S-B	
HS305	Vi835500	HEAT.SINK	PH-0124S-B	
HS306	VS606000	HEAT.SINK	DPS35-45	
IC302	XV494A00	IC	HD74HC153FPEL	
IC303	XG903A00	IC	TC4052BF MPX	
IC304	XF291A00	IC	uPC4570G2	
IC305	XV039A00	IC	M5220FP OP AMP	
IC306	XV039A00	IC	M5220FP OP AMP	
IC307	XP895A00	IC	LC78212	
IC308	XF291A00	IC	uPC4570G2	
IC309	XY949A00	IC	TC9482N	
IC311	XS377A00	IC	BA15218F OP AMP	
IC312	XF291A00	IC	uPC4570G2	
IC313	XF291A00	IC	uPC4570G2	
IC314	XF291A00	IC	uPC4570G2	
IC315	XF291A00	IC	uPC4570G2	
IC318	XJ604A00	IC	NJM78M05FA	
IC319	XJ602A00	IC	NJM78M12FA	

* New Parts

P. C. B. MAIN & P. C. B. DIGITAL

Schm Ref.	PART NO.	Description
* ⚠ IC320	XD343A00	IC NJM79M12FA
* IC332	XY948A00	IC NJM2192AM
⚠ IC501	XV466A00	IC LM1875T POWER
⚠ IC502	XV466A00	IC LM1875T POWER
IC550	XH436A00	IC LA7956
* JK300	VR457700	CN.DIN 8P YKF51-50
* JK301	V5879800	JACK.PIN 1P with SW
L300	GE901970	COIL 68uH
PJ300	VV306900	JACK.PIN 4P
PJ550	VV852500	JACK.PIN 3P
PN302	V3750200	PIN L=70
PN304	V3750200	PIN L=70
PN305	V3750200	PIN L=70
PN306	V3750200	PIN L=70
Q300	VV655700	TR.DGT DTC144EKA
Q301	VV655700	TR.DGT DTC144EKA
Q302	VV655700	TR.DGT DTC144EKA
⚠ Q303	VR510800	TR 2SD2396 J,K
* Q304	VG805300	TR 2SA1674 R,S
⚠ Q305	iC174020	TR 2SC1740S R,S
⚠ Q306	VK407600	TR 2SC4208A Q,R,S
⚠ Q307	VR510800	TR 2SD2396 J,K
⚠ Q308	VV655700	TR.DGT DTC144EKA
⚠ Q309	VV655700	TR.DGT DTC144EKA
⚠ Q310	VS883300	TR 2SB1565 E,F
Q311	VZ725900	TR 2SD1938F S,T
Q312	VZ725900	TR 2SD1938F S,T
Q316	VZ725900	TR 2SD1938F S,T
Q317	VZ725900	TR 2SD1938F S,T
Q318	VZ725900	TR 2SD1938F S,T
Q319	VZ725900	TR 2SD1938F S,T
Q500	VZ725900	TR 2SD1938F S,T
Q501	VZ725900	TR 2SD1938F S,T
Q502	iC287820	TR 2SC2878 A,B
Q503	iC174020	TR 2SC1740S R,S
Q550	VD678700	TR.DGT DTC114ES
Q551	VV655700	TR.DGT DTC144EKA
Q552	VV655700	TR.DGT DTC144EKA
Q553	iC174020	TR 2SC1740S R,S
R313	HV753220	R.CAR.FP 2.2 1/4W
R315	HV754100	R.CAR.FP 10 1/4W
R317	HV754100	R.CAR.FP 10 1/4W
R329	HV754100	R.CAR.FP 10 1/4W
R332	HV754100	R.CAR.FP 10 1/4W
R334	HV755220	R.CAR.FP 220 1/4W
R339	HV754100	R.CAR.FP 10 1/4W
R364	HV754100	R.CAR.FP 10 1/4W
R369	HV755220	R.CAR.FP 220 1/4W
R375	HV756220	R.CAR.FP 2.2K 1/4W
R385	HV754100	R.CAR.FP 10 1/4W
R386	HV754100	R.CAR.FP 10 1/4W
R396	HV753100	R.CAR.FP 1 1/4W
R397	HV753100	R.CAR.FP 1 1/4W
R398	HV753100	R.CAR.FP 1 1/4W
R399	HV756560	R.CAR.FP 5.6K 1/4W
* ⚠ R400	VC757900	R.MTL.OXD 47 2W
* R402	VP941200	R.MTL.OXD 1.5K 1W
R404	VP941100	R.MTL.OXD 1K 1W
R405	VP941100	R.MTL.OXD 1K 1W
* R407	VP941200	R.MTL.OXD 1.5K 1W
* ⚠ R408	VC757900	R.MTL.OXD 47 2W
R409	HV755100	R.CAR.FP 100 1/4W
R410	HV755100	R.CAR.FP 100 1/4W

* New Parts

Schm Ref.	PART NO.	Description
R412	HV753100	R.CAR.FP 1 1/4W
R423	HV753100	R.CAR.FP 1 1/4W
R436	HV754100	R.CAR.FP 10 1/4W
R452	HV754100	R.CAR.FP 10 1/4W
* ⚠ R475	VK187100	R.FUS 27 1/4W
R488	RD357330	R.MTL.CHP 33K 1/10W
R514	HV753680	R.CAR.FP 6.8 1/4W
R519	HV753680	R.CAR.FP 6.8 1/4W
R555	HV753100	R.CAR.FP 1 1/4W
R556	HV754100	R.CAR.FP 10 1/4W
RY302	VV272600	RELAY DC OSA-SS-224DM5
RY550	VU161600	RELAY DC OSA-SS-224DM3
⚠ SW300	VZ364100	SW.PUSH SDDL1-A2-F-1
⚠ TE300	V3609300	OUTLET.AC 1P(UC)
* TE550	V6916300	TERM.SP 4P
⚠ TH300	VT865700	POSISTOR PTH8L14AR0R5M1C030
	EP600140	SCR.BND.HD 3x10 MFZ2-BL
	V6423900	P.C.B. DIGITAL(UC)
	V6424000	P.C.B. DIGITAL(ABG)
CB1	VQ044100	CN.BS.PIN 5P
CB2	VF982300	CN.BS.PIN 17P
CB3	VM929900	CN.BS.PIN 15P
* CB600	VU282400	CN 24P SE
CB601	VU281700	CN 17P
CB602	VQ047200	CN.BS.PIN 9P
CB701	V5478200	CN.PHOT.SN 1P GP1FA551RZ
C1	US062100	C.CE.M.CHP 100pF 50V
C2	US135100	C.CE.CHP 0.1uF 16V
C3	US062100	C.CE.M.CHP 100pF 50V
C4	US061330	C.CE.M.CHP 33pF 50V
C5	US135100	C.CE.CHP 0.1uF 16V
C6	US135100	C.CE.CHP 0.1uF 16V
C7	US062100	C.CE.M.CHP 100pF 50V
C8	US062100	C.CE.M.CHP 100pF 50V
C9	US062100	C.CE.M.CHP 100pF 50V
C10	US135100	C.CE.CHP 0.1uF 16V
C11	US163100	C.CE.CHP 1000pF 50V
C12	US061330	C.CE.M.CHP 33pF 50V
C13	US135100	C.CE.CHP 0.1uF 16V
C14	UA954470	C.MYLAR 0.047uF 50V
C15	UA953470	C.MYLAR 4700pF 50V
C16	US135100	C.CE.CHP 0.1uF 16V
C17	UR818100	C.EL 100uF 6.3V
C18	US062100	C.CE.M.CHP 100pF 50V
C19	US062100	C.CE.M.CHP 100pF 50V
C20	US062100	C.CE.M.CHP 100pF 50V
C21	US135100	C.CE.CHP 0.1uF 16V
C22	US044220	C.CE.M.CHP 0.022uF 25V
C23	US135100	C.CE.CHP 0.1uF 16V
C24	US135100	C.CE.CHP 0.1uF 16V
C25	US061220	C.CE.M.CHP 22pF 50V
C26	US061220	C.CE.M.CHP 22pF 50V
C27	US062100	C.CE.M.CHP 100pF 50V
C28	US062100	C.CE.M.CHP 100pF 50V
C29	US062100	C.CE.M.CHP 100pF 50V
C30	US135100	C.CE.CHP 0.1uF 16V
C31	UR818100	C.EL 100uF 6.3V
C32	US062100	C.CE.M.CHP 100pF 50V
C33	US062100	C.CE.M.CHP 100pF 50V
C34	US062100	C.CE.M.CHP 100pF 50V

* New Parts

P. C. B. DIGITAL

Schm Ref.	PART NO.	Description		
C35	US062100	C.CE.M.CHP	100pF	50V
C36	US062100	C.CE.M.CHP	100pF	50V
C37	UR818330	C.EL	330uF	6.3V
C38	UR818330	C.EL	330uF	6.3V
C39	US135100	C.CE.CHP	0.1uF	16V
C40	US135100	C.CE.CHP	0.1uF	16V
C41	US135100	C.CE.CHP	0.1uF	16V
C42	US135100	C.CE.CHP	0.1uF	16V
C43	UR818330	C.EL	330uF	6.3V
C44	US062470	C.CE.M.CHP	470pF	50V
C45	US135100	C.CE.CHP	0.1uF	16V
C46	US135100	C.CE.CHP	0.1uF	16V
C47	UR818330	C.EL	330uF	6.3V
C48	US135100	C.CE.CHP	0.1uF	16V
C49	UR818330	C.EL	330uF	6.3V
C50	US135100	C.CE.CHP	0.1uF	16V
C51	US135100	C.CE.CHP	0.1uF	16V
C52	UR818330	C.EL	330uF	6.3V
C53	US135100	C.CE.CHP	0.1uF	16V
C54	US135100	C.CE.CHP	0.1uF	16V
C55	UR818100	C.EL	100uF	6.3V
C56	US135100	C.CE.CHP	0.1uF	16V
C57	UR829100	C.EL	1000uF	10V
C58	UR829100	C.EL	1000uF	10V
C59	UR828220	C.EL	220uF	10V
C60	US135100	C.CE.CHP	0.1uF	16V
C61	VE326800	C.MYLAR.ML	0.47uF	50V
C62	UR818100	C.EL	100uF	6.3V
C63	UR865470	C.EL	0.47uF	50V
C64	UA953150	C.MYLAR	1500pF	50V
C65	UA953150	C.MYLAR	1500pF	50V
C66	UR847100	C.EL	10uF	25V
C67	UA953330	C.MYLAR	3300pF	50V
C68	UA953330	C.MYLAR	3300pF	50V
C69	UR847100	C.EL	10uF	25V
C70	UR847100	C.EL	10uF	25V
C71	UA953120	C.MYLAR	1200pF	50V
C72	UA655270	C.MYLAR	0.27uF	50V
C73	UR847100	C.EL	10uF	25V
C74	UR847100	C.EL	10uF	25V
C75	UA953330	C.MYLAR	3300pF	50V
C76	UA953330	C.MYLAR	3300pF	50V
C77	UR847100	C.EL	10uF	25V
C78	UA952100	C.MYLAR	100pF	50V
C79	UA952100	C.MYLAR	100pF	50V
C80	UA952100	C.MYLAR	100pF	50V
C81	UA952220	C.MYLAR	220pF	50V
C82	UR847100	C.EL	10uF	25V
C83	UR847100	C.EL	10uF	25V
C84	UA952100	C.MYLAR	100pF	50V
C85	UA952220	C.MYLAR	220pF	50V
C87	UA952100	C.MYLAR	100pF	50V
C88	UA653620	C.MYLAR	6200pF	50V
C89	UA952100	C.MYLAR	100pF	50V
C90	UA952220	C.MYLAR	220pF	50V
C91	UR847100	C.EL	10uF	25V
C92	UR847100	C.EL	10uF	25V
C93	UA952100	C.MYLAR	100pF	50V
C94	UA952220	C.MYLAR	220pF	50V
C95	UA952100	C.MYLAR	100pF	50V
C96	UR837220	C.EL	22uF	25V
C97	UR847470	C.EL	47uF	25V
C98	VE326800	C.MYLAR.ML	0.47uF	50V

* New Parts

Schm Ref.	PART NO.	Description		
C99	UR847470	C.EL	47uF	25V
C100	UR837220	C.EL	22uF	25V
C101	UA952100	C.MYLAR	100pF	50V
C102	US062100	C.CE.M.CHP	100pF	50V
C103	US062100	C.CE.M.CHP	100pF	50V
C104	US062100	C.CE.M.CHP	100pF	50V
C105	US064100	C.CE.M.CHP	0.01uF	50V
C106	US062100	C.CE.M.CHP	100pF	50V
C107	US062100	C.CE.M.CHP	100pF	50V
C108	US062100	C.CE.M.CHP	100pF	50V
C109	UR818470	C.EL	470uF	6.3V
C110	US064100	C.CE.M.CHP	0.01uF	50V
C111	US062100	C.CE.M.CHP	100pF	50V
C112	US062100	C.CE.M.CHP	100pF	50V
C113	US135100	C.CE.CHP	0.1uF	16V
C115	US062560	C.CE.CHP	560pF	50V(UC)
C116	US061100	C.CE.CHP	10pF	50V
C117	US061100	C.CE.CHP	10pF	50V
C600	UM397100	C.EL	10uF	16V
C601	US064100	C.CE.M.CHP	0.01uF	50V
C602	UM388100	C.EL	100uF	10V
C603	UM397100	C.EL	10uF	16V
C604	UM416100	C.EL	1uF	50V
C605	US135100	C.CE.CHP	0.1uF	16V
C606	US061330	C.CE.CHP	33pF	50V
C607	US061330	C.CE.CHP	33pF	50V
C608	US061330	C.CE.CHP	33pF	50V
C609	US061330	C.CE.CHP	33pF	50V
C610	US061330	C.CE.CHP	33pF	50V
C611	US061330	C.CE.CHP	33pF	50V
C700	US062220	C.CE.CHP	220pF	50V
C701	US135100	C.CE.CHP	0.1uF	16V
C702	US062220	C.CE.CHP	220pF	50V
C703	UM397100	C.EL	10uF	16V
C704	US135100	C.CE.CHP	0.1uF	16V
C705	US063100	C.CE.M.CHP	1000pF	50V
C707	US064100	C.CE.M.CHP	0.01uF	50V
D1	VT332900	D1ODE	1SS355	
D2	VT332900	D1ODE	1SS355	
D3	VT332900	D1ODE	1SS355	
D4	VT332900	D1ODE	1SS355	
D5	VT332900	D1ODE	1SS355	
D6	VT332900	D1ODE	1SS355	
D7	VT332900	D1ODE	1SS355	
D8	VT332900	D1ODE	1SS355	
D9	VT332900	D1ODE	1SS355	
D10	VT332900	D1ODE	1SS355	
D11	VT332900	D1ODE	1SS355	
D12	VT332900	D1ODE	1SS355	
D600	VU992600	D1ODE.ZENR	MA8051-M	5.1V
D601	VU992600	D1ODE.ZENR	MA8051-M	5.1V
D603	VU992600	D1ODE.ZENR	MA8051-M	5.1V
D604	VS132300	LED(re)	SLR-325VCT31	
D605	VT332900	D1ODE	1SS355	
D606	VT332900	D1ODE	1SS355	
D607	VU993500	D1ODE.ZENR	MA8062-H	6.4V
G1	VR463400	TERM.GND	D3.5	TP00385
G2	VR463400	TERM.GND	D3.5	TP00385
G3	VR463400	TERM.GND	D3.5	TP00385
G4	VR463400	TERM.GND	D3.5	TP00385
IC1	XR038A00	IC	NJM2904M	OP AMP
IC2	XL091A00	IC	HD74HC02FPEL	NOR
IC3	XG948E00	IC	YM3436DK	

* New Parts

P. C. B. DIGITAL

■ CHIP RESISTORS

Schm Ref.	PART NO.	Description
IC4	XV304B00	IC YSS918D-F
IC6	XW233A00	IC CS4227-KQ
IC7	XV305A00	IC IS61C1024-20J SRAM *
IC8	XV039A00	IC M5220FP OP AMP
IC9	XV039A00	IC M5220FP OP AMP
IC10	XV039A00	IC M5220FP OP AMP
IC11	XV039A00	IC M5220FP OP AMP *
IC12	XV039A00	IC M5220FP OP AMP *
IC14	XU965A00	IC uPC29M33T-E1 3.3V
* IC600	XZ396A00	IC CPU
* IC601	XY887A00	IC S-29390AFJA EEPROM
JK700	V4971300	JACK.MNI 2P *
L1	GE300610	FER.BEAD BL02RN1-R62T4
L700	GE901970	COIL 68uH
* PJ700	V6753000	JACK.PIN 3P
PN601	V3750200	PIN L=70
Q1	VV655200	TR.DGT DTA143EKA *
Q2	VD303700	TR 2SC3326 A,B
Q600	VV655300	TR.DGT DTA144EKA
Q601	VV655300	TR.DGT DTA144EKA
Q602	VV655300	TR.DGT DTA144EKA *
Q604	VV655300	TR.DGT DTA144EKA
Q605	VV655700	TR.DGT DTC144EKA
* Q606	VG805500	TR 2SC4391 R,S
* Q607	VG805500	TR 2SC4391 R,S
Q608	VV655700	TR.DGT DTC144EKA *
Q609	VV556500	TR 2SA1037 Q,R,S
Q610	VV655300	TR.DGT DTA144EKA
Q611	VV655700	TR.DGT DTC144EKA
R36	HV753220	R.CAR.FP 2.2 1/4W *
R41	HV753220	R.CAR.FP 2.2 1/4W
R42	HV753220	R.CAR.FP 2.2 1/4W *
R45	HV754100	R.CAR.FP 10 1/4W
R46	HV753100	R.CAR.FP 1 1/4W
R91	HV753220	R.CAR.FP 2.2 1/4W
R92	HV753220	R.CAR.FP 2.2 1/4W
R669	HV755100	R.CAR.FP 100 1/4W *
R670	HV755100	R.CAR.FP 100 1/4W *
SW600	VG392900	SW.TACT SKHVAA
SW601	VG392900	SW.TACT SKHVAA
SW602	VG392900	SW.TACT SKHVAA
SW603	VG392900	SW.TACT SKHVAA *
U600	VU591000	L.DTCT GP1U271X
* V600	V6291400	FL.DSPLY 13-BT-180GNK
XL1	Vi552000	RSNR.CRYS 12.288MHz
* XL600	V4610100	RSNR.CE 10MHz
* V6083200		SHEET *
* V6203300		

* New Parts

Schm Ref.	PART NO.	Description
	RD350000	R.CAR.CHP 0 1/10W
	RD354470	R.CAR.CHP 47 1/16W
	RD354510	R.CAR.CHP 51 1/16W
	RD354750	R.CAR.CHP 75 1/10W
	RD355100	R.CAR.CHP 100 1/10W
	RD355330	R.CAR.CHP 330 1/10W
	RD355390	R.CAR.CHP 390 1/10W
	RD355430	R.CAR.CHP 430 1/10W
	RD355470	R.CAR.CHP 470 1/10W
	RD355820	R.CAR.CHP 820 1/10W
	RD356100	R.CAR.CHP 1K 1/10W
	RD356110	R.CAR.CHP 1.1K 1/10W
	RD356120	R.CAR.CHP 1.2K 1/10W
	RD356150	R.CAR.CHP 1.5K 1/10W
	RD356200	R.CAR.CHP 2K 1/10W
	RD356220	R.CAR.CHP 2.2K 1/10W
	RD356240	R.CAR.CHP 2.4K 1/10W
	RD356270	R.CAR.CHP 2.7K 1/10W
	RD356300	R.CAR.CHP 3K 1/10W
	RD356330	R.CAR.CHP 3.3K 1/10W
	RD356360	R.CAR.CHP 3.6 1/10W
	RD356390	R.CAR.CHP 3.9K 1/10W
	RD356470	R.CAR.CHP 4.7K 1/10W
	RD356510	R.CAR.CHP 5.1K 1/10W
	RD356560	R.CAR.CHP 5.6K 1/10W
	RD356620	R.CAR.CHP 6.2K 1/10W
	RD356680	R.CAR.CHP 6.8K 1/10W
	RD356820	R.CAR.CHP 8.2K 1/10W
	RD357100	R.CAR.CHP 10K 1/10W
	RD357110	R.CAR.CHP 11K 1/10W
	RD357120	R.CAR.CHP 12K 1/10W
	RD357200	R.CAR.CHP 20K 1/10W
	RD357220	R.CAR.CHP 22K 1/10W
	RD357270	R.CAR.CHP 27K 1/10W
	RD357330	R.CAR.CHP 33K 1/10W
	RD357360	R.CAR.CHP 36K 1/10W
	RD357390	R.CAR.CHP 39K 1/10W
	RD357430	R.CAR.CHP 43K 1/10W
	RD357470	R.CAR.CHP 47K 1/10W
	RD357510	R.CAR.CHP 51K 1/10W
	RD357560	R.CAR.CHP 56K 1/10W
	RD357620	R.CAR.CHP 62K 1/10W
	RD357680	R.CAR.CHP 68K 1/10W
	RD357820	R.CAR.CHP 82K 1/10W
	RD358100	R.CAR.CHP 100K 1/10W
	RD358180	R.CAR.CHP 180K 1/10W
	RD358200	R.CAR.CHP 200K 1/10W
	RD358220	R.CAR.CHP 220K 1/10W
	RD358470	R.CAR.CHP 470K 1/10W
	RD359100	R.CAR.CHP 1M 1/10W

* New Parts

■ SW-VS10

P. C. B. POWER AMP

Ref. No.	PART NO.	Description	Remarks	Markets
*	AAX19700	P.C.B. ASS'Y	POWER AMP(UC)	331995
*	AAX19710	P.C.B. ASS'Y	POWER AMP(ABG)	332170
C101	UR867220	ELECTROLYTIC CAP	22uF 50V	
C102	UR867220	ELECTROLYTIC CAP	22uF 50V	
C103	UR867100	ELECTROLYTIC CAP	10uF 50V	
C104	UR867100	ELECTROLYTIC CAP	10uF 50V	
C105	VF466800	CERAMIC TUBULAR CAP	100pF 50V	
C106	VF466800	CERAMIC TUBULAR CAP	100pF 50V	
C107	UR846470	ELECTROLYTIC CAP	4.7uF 25V	
C108	UR846470	ELECTROLYTIC CAP	4.7uF 25V	
C109	VF466800	CERAMIC TUBULAR CAP	100pF 50V	
C110	VF466800	CERAMIC TUBULAR CAP	100pF 50V	
C111	UR866220	ELECTROLYTIC CAP	2.2uF 50V	
C112	UR866220	ELECTROLYTIC CAP	2.2uF 50V	
C113	VF466900	CERAMIC TUBULAR CAP	470pF 50V	
C114	VF466900	CERAMIC TUBULAR CAP	470pF 50V	
C115	UA654270	MYLAR FILM CAP	0.027uF 50V	
C116	UA654270	MYLAR FILM CAP	0.027uF 50V	
C117	UA654270	MYLAR FILM CAP	0.027uF 50V	
C118	UA654270	MYLAR FILM CAP	0.027uF 50V	
C119	UR867220	ELECTROLYTIC CAP	22uF 50V	
C120	UR867220	ELECTROLYTIC CAP	22uF 50V	
C121	VG276600	CERAMIC TUBULAR CAP	22pF 50V	
C122	VG276600	CERAMIC TUBULAR CAP	22pF 50V	
C123	UR868100	ELECTROLYTIC CAP	100uF 50V	
C124	UR868100	ELECTROLYTIC CAP	100uF 50V	
C125	UR867100	ELECTROLYTIC CAP	10uF 50V	
C126	UR867100	ELECTROLYTIC CAP	10uF 50V	
C127	UA652560	MYLAR FILM CAP	560pF 50V	
C128	UA652560	MYLAR FILM CAP	560pF 50V	
C129	UR866100	ELECTROLYTIC CAP	1uF 50V	
C130	UA654470	MYLAR FILM CAP	0.047uF 50V	064987
C131	UA654470	MYLAR FILM CAP	0.047uF 50V	064987
C132	UR828100	ELECTROLYTIC CAP	100uF 10V	
C133	UR867220	ELECTROLYTIC CAP	22uF 50V	
C134	UR867100	ELECTROLYTIC CAP	10uF 50V	
C135	UR867100	ELECTROLYTIC CAP	10uF 50V	
C136	VF466800	CERAMIC TUBULAR CAP	100pF 50V	
C137	UR846470	ELECTROLYTIC CAP	4.7uF 25V	
C138	VF466800	CERAMIC TUBULAR CAP	100pF 50V	
C139	UR866220	ELECTROLYTIC CAP	2.2uF 50V	
C140	UA655220	MYLAR FILM CAP	0.22uF 50V	
C141	UA655220	MYLAR FILM CAP	0.22uF 50V	
C142	UA655820	MYLAR FILM CAP	0.82uF 50V	
C143	UR837470	ELECTROLYTIC CAP	47uF 16V	066963
C144	UR837470	ELECTROLYTIC CAP	47uF 16V	066963
C145	UA655390	MYLAR FILM CAP	0.39uF 50V	
C146	UA655150	MYLAR FILM CAP	0.15uF 50V	065292
C147	UR867100	ELECTROLYTIC CAP	10uF 50V	
C148	VG276600	CERAMIC TUBULAR CAP	22pF 50V	
C149	UA655470	MYLAR FILM CAP	0.47uF 50V	
C150	VF467000	CERAMIC TUBULAR CAP	1000pF 50V	
C151	UA654100	MYLAR FILM CAP	0.01uF 50V	

* New Parts

P. C. B. POWER AMP

Ref. No.	PART NO.	Description	Remarks	Markets
C152	UR847330	ELECTROLYTIC CAP	33uF 25V	
C153	UA655100	MYLAR FILM CAP	0.1uF 50V	065269
C154	UA655100	MYLAR FILM CAP	0.1uF 50V	065269
C155	UR867100	ELECTROLYTIC CAP	10uF 50V	
C156	UR867100	ELECTROLYTIC CAP	10uF 50V	
C157	UR867100	ELECTROLYTIC CAP	10uF 50V	
C158	UR838330	ELECTROLYTIC CAP	330uF 16V	
C159	UR838330	ELECTROLYTIC CAP	330uF 16V	
C160	UR867220	ELECTROLYTIC CAP	22uF 50V	
C161	UR867220	ELECTROLYTIC CAP	22uF 50V	
C162	UR759470	ELECTROLYTIC CAP	4700uF 35V	
C163	UR759470	ELECTROLYTIC CAP	4700uF 35V	
C164	UA654470	MYLAR FILM CAP	0.047uF 50V	064987
C165	UA654470	MYLAR FILM CAP	0.047uF 50V	064987
C166	UR867100	ELECTROLYTIC CAP	10uF 50V	
C167	FG644100	CERAMIC CAP	0.01uF 50V	065451
* C168	VS741700	RECOGNIZED CERAMIC CAP	0.01uF 275V	
C173	VF466800	CERAMIC TUBULAR CAP	100pF 50V	
C174	VF466800	CERAMIC TUBULAR CAP	100pF 50V	
C175	VF466800	CERAMIC TUBULAR CAP	100pF 50V	
C176	VF466800	CERAMIC TUBULAR CAP	100pF 50V	
C177	VF466800	CERAMIC TUBULAR CAP	100pF 50V	
C178	VF466800	CERAMIC TUBULAR CAP	100pF 50V	
C179	VF466800	CERAMIC TUBULAR CAP	100pF 50V	
C181	UR866100	ELECTROLYTIC CAP	1uF 50V	
C182	UR866100	ELECTROLYTIC CAP	1uF 50V	
C183	UR867220	ELECTROLYTIC CAP	22uF 50V	
C184	VF466800	CERAMIC TUBULAR CAP	100pF 50V	
C185	UR846470	ELECTROLYTIC CAP	4.7uF 25V	
C186	VF466800	CERAMIC TUBULAR CAP	100pF 50V	
C187	UR866220	ELECTROLYTIC CAP	2.2uF 50V	
C188	VF466900	CERAMIC TUBULAR CAP	470pF 50V	
C189	UA654270	MYLAR FILM CAP	0.027uF 50V	
C190	UA654270	MYLAR FILM CAP	0.027uF 50V	
C191	UR867220	ELECTROLYTIC CAP	22uF 50V	
C192	UR868100	ELECTROLYTIC CAP	100uF 50V	
C193	VG276600	CERAMIC TUBULAR CAP	22pF 50V	
C194	UR868100	ELECTROLYTIC CAP	100uF 50V	
C195	UR867100	ELECTROLYTIC CAP	10uF 50V	
C196	UA652560	MYLAR FILM CAP	560pF 50V	
C197	VG892500	ELECTROLYTIC CAP	4700uF 50V	
C198	VG892500	ELECTROLYTIC CAP	4700uF 50V	
C200	VF467000	CERAMIC TUBULAR CAP	1000pF 50V	
C201	VF467000	CERAMIC TUBULAR CAP	1000pF 50V	
C202	VF467000	CERAMIC TUBULAR CAP	1000pF 50V	
C203	UR867100	ELECTROLYTIC CAP	10uF 50V	
C204	UA655100	MYLAR FILM CAP	0.1uF 50V	065269
C205	UA655100	MYLAR FILM CAP	0.1uF 50V	065269
C206	UA655100	MYLAR FILM CAP	0.1uF 50V	065269
C207	UA655100	MYLAR FILM CAP	0.1uF 50V	065269
C208	UR867100	ELECTROLYTIC CAP	10uF 50V	
C209	UA654470	MYLAR FILM CAP	0.047uF 50V	064987
C211	UA654470	MYLAR FILM CAP	0.047uF 50V	064987

* New Parts

P. C. B. POWER AMP

Ref. No.	PART NO.	Description	Remarks	Markets
	C212	MYLAR FILM CAP	0.047uF 50V	064987
*	CN105	CONNECTOR	B 7B	081532
	CN107	CONNECTOR	B 3P-VH	081665
*	CN108	CONNECTOR	B 10P-VH	332119
	CN110	CONNECTOR	B 3P-VH	081665
*	CN111	CONNECTOR	B 4B	081491
	D101	DIODE	1SS133	069460
	D102	DIODE	1SS133	069460
	D103	DIODE	1SS133	069460
	D104	DIODE	1SS133	069460
	D105	DIODE	1SS133	069460
	D106	DIODE	1SS133	069460
	D107	ZENER DIODE	MTZJ5.6B	069099
	D108	DIODE	1SS133	069460
⚠	D109	DIODE	RBV602	069599
	D110	DIODE	1SS133	069460
	D111	DIODE	1SS133	069460
	D112	DIODE	1SS133	069460
	D113	DIODE	1SS133	069460
	D115	DIODE	RBV602	069599
	D116	DIODE	1SS133	069460
	D117	DIODE	1SS133	069460
	D118	DIODE	1SS133	069460
⚠	F101	FUSE	3.15A 125V(UC)	046927
⚠	F101	FUSE	1.25A 250V(ABG)	044013
	FH101	FUSE HOLDER	EYF-52BCT	074277
	IC101	IC	uPC4570HA	070111
	IC102	IC	uPC4570HA	070111
	IC103	IC	uPC4570HA	070111
	IC104	IC	uPC4570HA	070111
	IC105	IC	uPC4570HA	070111
⚠	IC106	IC	NJM78M12FA	070371
⚠	IC107	IC	NJM79M12FA	070447
⚠	IC108	IC	AN78N12	055476
*	IC109	IC ,ANALOG	STK402-030 20W 2CH	
*	IC110	IC STK402-070	STK402-070	331716
	JK101	DIN SOCKET	YKF51-5001	085092
	L102	COIL, CHOKE	1.5uH	074417
	L103	COIL, CHOKE	1.5uH	074417
	L104	COIL, CHOKE	1.5uH	074417
	Q101	TRANSISTOR	2SC2878 A,B	068813
	Q102	TRANSISTOR	2SC2878 A,B	068813
	Q103	TRANSISTOR	2SC2240 GR BL	073532
	Q104	TRANSISTOR	2SC2240 GR BL	073532
	Q105	TRANSISTOR	2SA970 GR BL	073509
	Q106	TRANSISTOR	2SC2878 A,B	068813
	Q107	TRANSISTOR	2SC1740S QRS	055717
	Q108	TRANSISTOR	2SC2878 A,B	068813
	Q109	TRANSISTOR	2SC1815 Y,GR	
	Q110	TRANSISTOR	2SA1015 O,Y	068587
	Q111	TRANSISTOR	2SC1815 Y,GR	
	Q112	TRANSISTOR	2SA1015 O,Y	068587
	Q113	TRANSISTOR	2SC2878 A,B	068813

* New Parts

P. C. B. POWER AMP

Ref. No.	PART NO.	Description	Remarks	Markets
Q114	iC174020	TRANSISTOR	2SC1740S QRS	055717
Q115	AAX09180	FET	2SK304 E	051061
Q116	AAX12580	TRANSISTOR	2SA970 GR BL	073509
Q117	VD678700	TRANSISTOR	DTC114ESA	069299
Q118	AAX12590	TRANSISTOR	2SC2240 GR BL	073532
Q119	iC287820	TRANSISTOR	2SC2878 A,B	068813
Q120	AAX12590	TRANSISTOR	2SC2240 GR BL	073532
R101	HV754100	FLAME PROOF CARBON RESISTOR	10 1/4W	
R102	HV754100	FLAME PROOF CARBON RESISTOR	10 1/4W	
R125	HV755100	FLAME PROOF CARBON RESISTOR	100 1/4W	
R126	HV755100	FLAME PROOF CARBON RESISTOR	100 1/4W	
R130	AAX12360	METAL PLATE RESISTOR	0.22 3W	055474
R131	AAX12360	METAL PLATE RESISTOR	0.22 3W	055474
R141	HV754100	FLAME PROOF CARBON RESISTOR	10 1/4W	
R147	HV754100	FLAME PROOF CARBON RESISTOR	10 1/4W	
R148	HV754100	FLAME PROOF CARBON RESISTOR	10 1/4W	
R166	HV755100	FLAME PROOF CARBON RESISTOR	100 1/4W	
R167	HV755470	FLAME PROOF CARBON RESISTOR	470 1/4W	ERDS2FJ471
R168	HV755680	FLAME PROOF CARBON RESISTOR	680 1/4W	
R177	HV754100	FLAME PROOF CARBON RESISTOR	10 1/4W	
R178	HV754100	FLAME PROOF CARBON RESISTOR	10 1/4W	
R184	VP441400	METAL FILM RESISTOR	10K 1/4W	068279
R185	VP441400	METAL FILM RESISTOR	10K 1/4W	068279
R186	AAX09780	METAL FILM RESISTOR	20K 1/4W	068187
R187	VP441400	METAL FILM RESISTOR	10K 1/4W	068279
R195	AAX12370	METAL PLATE RESISTOR	0.1 3W	055475
△ R198	HV753470	FLAME PROOF CARBON RESISTOR	4.7 1/4W	
△ R199	HV753470	FLAME PROOF CARBON RESISTOR	4.7 1/4W	
R203	HV754100	FLAME PROOF CARBON RESISTOR	10 1/4W	
R204	HV754100	FLAME PROOF CARBON RESISTOR	10 1/4W	
R205	HV754100	FLAME PROOF CARBON RESISTOR	10 1/4W	
R207	HV753100	FLAME PROOF CARBON RESISTOR	1 1/4W	
R223	HV755100	FLAME PROOF CARBON RESISTOR	100 1/4W	
R224	HV755100	FLAME PROOF CARBON RESISTOR	100 1/4W	
R226	AAX12360	METAL PLATE RESISTOR	0.22 3W	055474
R227	AAX12360	METAL PLATE RESISTOR	0.22 3W	055474
R229	AAX12360	METAL PLATE RESISTOR	0.22 3W	055474
R232	AAX12360	METAL PLATE RESISTOR	0.22 3W	055474
R233	AAX12360	METAL PLATE RESISTOR	0.22 3W	055474
R236	HV754100	FLAME PROOF CARBON RESISTOR	10 1/4W	
R237	HV754100	FLAME PROOF CARBON RESISTOR	10 1/4W	
R241	HV754100	FLAME PROOF CARBON RESISTOR	10 1/4W	
RY101	VU161600	RELAY	OSA-SS-224DM3	079766
RY102	AAX12480	RELAY	DQ24D1-OS	055472
△ RY103	AAX12490	RELAY	SDT-S-112LMR	055473
RY104	AAX12480	RELAY	DQ24D1-OS	055472
* SP101	AAX19810	SPEAKER TEARMINAL	6P CJ-9033-06	331720
TM101	XX707320	PIN, MISC	IPS-5007	064821
TM102	XX707320	PIN, MISC	IPS-5007	064821
	AAX10900	HEATSINK	DPS35-40	055524
*	AAX19520	PANHEAD TAPPING SCREW	3x12	332012

* New Parts

1 ■ EXPLODED VIEW (VS-10)

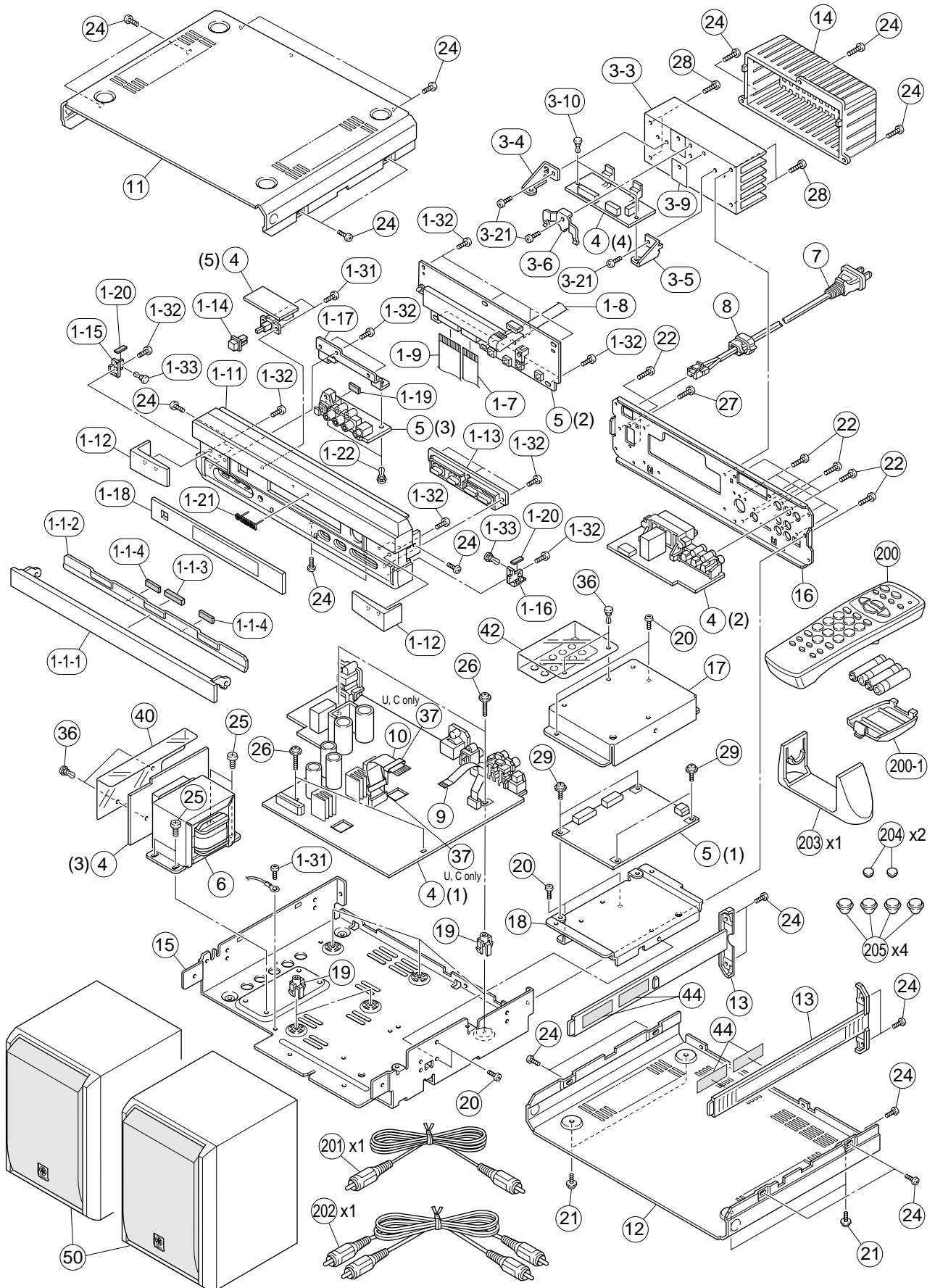

MECHANICAL PARTS (VS-10)







Ref. No.	PART NO.	Description	Remarks	Markets	
*	1-1-1	V6082300	LID/PANEL	SI	
*	1-1-1	V6240700	LID/PANEL	BL	
*	1-1-2	V6081500	LID/PLATE		
*	1-1-3	V6216700	SPACER/LID-T3		
*	1-1-4	V6216800	SPACER/LID-T1		
*	1-7	MF217160	S FLEXIBLE FLAT CABLE	17P 160mm P=1.25	
	1-8	MF109250	FLEXIBLE FLAT CABLE	9P 250mm	
*	1-9	MF124140	FLEXIBLE FLAT CABLE	24P 140mm P=1.25	
*	1-11	V6453000	FRONT PANEL	SI	
*	1-11	V6453100	FRONT PANEL	BL	
*	1-12	V6082600	ESCUTCHEON	SI	
*	1-12	V6240800	ESCUTCHEON	BL	
*	1-13	V6082800	BUTTON, 4P	SI	
*	1-13	V6242400	BUTTON, 4P	BL	
*	1-14	V6242500	BUTTON	BL	
*	1-14	V6082900	BUTTON	SI	
*	1-15	V6082400	SUPPORT/LID-L		
*	1-16	V6082500	SUPPORT/LID-R		
*	1-17	V6081200	FRAME/INPUT		
*	1-18	V6453500	WINDOW PANEL		
*	1-19	V6788000	SPACER/INPUT		
*	1-20	V6788100	SPACER/LID		
	1-21	V6034100	EMBLEM	BL	
	1-22	VQ368500	PUSH RIVET	P3545-B	
	1-31	EP600740	FLAT HEAD P-TITE SCREW	3x10 MFZN2Y	
	1-32	VF617600	PAN HEAD P-TITE SCREW	2.6x8 FCRM3-BL	
*	1-33	V6677200	PUSH RIVET	P4060(B)	
*	3-3	V6081600	HEAT SINK		
*	3-4	V6081000	FRAME/POWER-L		
*	3-5	V6081100	FRAME/POWER-R		
	3-6	V2847700	SUPPORT, IC		
	3-9	VV849300	SHEET	19x24	
	3-10	VQ368500	PUSH RIVET	P3545-B	
	3-21	EP600830	BIND HEAD B-TITE SCREW	3x8 FCRM3-BL	
*	4	V6423300	P.C.B. ASS'Y	MAIN	(UC)
*	4	V6423400	P.C.B. ASS'Y	MAIN	(ABG)
*	5	V6423900	P.C.B. ASS'Y	DIGITAL	(UC)
*	5	V6424000	P.C.B. ASS'Y	DIGITAL	(ABG)
*	△	XZ009A00	POWER TRANSFORMER		(UC)
*	△	XZ010A00	POWER TRANSFORMER		(A)
*	△	XZ011A00	POWER TRANSFORMER		(BG)
	△	V2296800	POWER CORD ASS'Y		(A)
	△	V2363800	POWER CORD ASS'Y		(UC)
	△	VN363700	POWER CORD ASS'Y		(G)
	△	VV437300	POWER CORD ASS'Y		(B)
	8	V2438700	CORD STOPPER	10P1	
*	9	MF105070	FLEXIBLE FLAT CABLE	5P 70mm P=1.25	
	10	MF115070	FLEXIBLE FLAT CABLE	15P 70mm P=1.25	
*	11	V6080400	TOP COVER	SI	
*	11	V6254700	TOP COVER	BL	
*	12	V6080500	BOTTOM COVER	SI	
*	12	V6254800	BOTTOM COVER	BL	
*	13	V6082700	SIDE PLATE	SI	

* New Parts

Ref. No.	PART NO.	Description	Remarks	Markets	
*	13	V6240900	SIDE PLATE	BL	
*	14	V6453200	HEAT SINK COVER		(UC)
*	14	V6453300	HEAT SINK COVER		(A)
*	14	V6453400	HEAT SINK COVER		(BG)
*	15	V6080900	CHASSIS		
*	16	V6080700	REAR PANEL		(UC)
*	16	V6080800	REAR PANEL		(ABG)
*	17	V6081300	COVER/DSP-TOP		
*	18	V6081400	COVER/DSP-BOTTOM		
	19	VR264400	SPACER	H8	
	20	VE190700	BIND HEAD BONDING B-T. SCREW	3x6 FCRM3-BL	
	21	V5633800	TAPPING B-TITE SCREW	3x6-8 MFN133	SI
	21	VE529700	PW HEAD B-TITE SCREW	3x6-8 FCRM3-BL	BL
	22	VN413300	BIND HEAD BONDING B-T. SCREW	3x8 MFZN2-BL	
	24	EP600830	BIND HEAD B-TITE SCREW	3x8 FCRM3-BL	
	25	V2728500	BIND HEAD S-TITE SCREW	4x7 MFZN2-BL	
	26	VT669400	PW HEAD B-TITE SCREW	3x15-8 MFC2	
	27	EP600250	BIND HEAD B-TITE SCREW	3x8 ZMC2-Y	(UC)
	28	EP600140	BIND HEAD B-TITE SCREW	3x10 MFZN2-BL	
*	29	VH365800	PW HEAD B-TITE SCREW	3x6-8 FCM3-CU	
	36	VQ368500	PUSH RIVET	P3545-B	
*	37	V6273900	FERRITE CORE	FPC-25-12	(UC)
*	40	V6670400	SHEET, TRANSFORMER		
*	42	V6781200	SHEET/BARRIER		
*	44	V6959900	DAMPER/SIDE		
*	50	AAX19230	SPEAKER SYSTEM	NX-VS10MBL 1pc	BB100018-01
*	50	AAX19240	SPEAKER SYSTEM	NX-VS10MSI 1pc	BB100018-02
			ACCESSORIES		
*	200	V6136100	REMOTE CONTROL TRANSMITTER	REMOTEC SYS32	(UCA)
*	200	V6136200	REMOTE CONTROL TRANSMITTER	REMOTEC SYS33	(BG)
	200-1	AAX15160	LID		331540
*	201	V6508900	PIN-PLUG CORD	1P 1.5m YE-YE 1pc	
*	202	V6509000	PIN-PLUG CORD	2P 1.5m RE-WH 1pc	
*	203	V6083500	STAND	1pc	SI
*	203	V6083600	STAND	1pc	BL
*	204	V6083300	LEG/SIDE	SIDE PAD 1pc	SI
*	204	V6341000	LEG/SIDE	SIDE PAD 1pc	BL
*	205	V6083400	LEG/BOTTOM	BOTTOM PAD 1pc	SI
*	205	V6242700	LEG/BOTTOM	BOTTOM PAD 1pc	BL
			BATTERY, MANGANESE	SUM-4,AAA,R03	

* New Parts

MECHANICAL PARTS (SW-VS10)

Ref. No.	PART NO.	Description	Remarks	Markets		
*	1-1	XY559A00	LOUD SPEAKER JA1678	16cm 6 25W	058529	
*	1-2	AA19530	FRONT GRILLE ASS'Y	SI	332028	
*	1-2	AA19540	FRONT GRILLE ASS'Y	BL	332029	
*	1-3	AA19550	CABINET ASS'Y	SI	332024	
*	1-3	AA19560	CABINET ASS'Y	BL	332025	
	1-4	AA12290	FOOT		055357	
	1-5	XX701830	NUT		042382	
	1-6	AA12130	BIND HEAD TAPPING SCREW	M3.5x16	021404	
	1-7	AA12120	BIND HEAD TAPPING SCREW	M4x20	021385	
	1-8	AA12930	SEAL		056813	
	2-1	AA09340	CUSHION A		053455	
	2-2	AA09720	MOLD CASE		053456	
	2-3	AA21230	COVER REAR	PAINT A191A0	335807	(UC)
	2-3	AA14940	COVER REAR		054956	(ABG)
	2-3-1	AA21220	BRACKET COVER	PAINT A191B0	335806	(UC)
* 	2-4	AA19580	TRANSFORMER POWER	A191B0-1	332197	(UC)
* 	2-4	AA19590	TRANSFORMER POWER	A191D0-1	332198	(A)
* 	2-4	AA19600	TRANSFORMER POWER	A191E0-1	332199	(BG)
*	2-5	AA19610	CUSHION TRANS		059900	
*	2-6	AA19630	REAR PANEL		332787	(UC)
*	2-6	AA19640	REAR PANEL		332788	(A)
*	2-6	AA19650	REAR PANEL		332789	(BG)
*	2-7-1	AA19660	HEATSINK	MAIN A191A0-2	333183	
*	2-7-2	AA19670	BRACKET, P.C.B	L A191A0	331986	
*	2-7-3	AA19680	BRACKET, P.C.B	R A191A0	331987	
*	2-7-4	AA19690	INSULATOR	MICA A191A0	331984	
	2-7-6	AA12380	PAN HEAD B-TITE SCREW	3x20 BL	055430	
	2-7-7	AA12090	BIND HEAD B-TITE SCREW	3x12 BL	075642	
	2-8	AA12160	BRACKET	CLIP L80 A	078004	
	2-9	EP600230	BIND HEAD B-TITE SCREW	3x6 ZMC2-BL		
	2-10	AA12090	BIND HEAD B-TITE SCREW	3x12 BL	075642	
	2-11	AA12100	BIND HEAD B-TITE SCREW	4x10 BL	075659	
	2-12	V2582500	POWER CORD		044471	(UC)
	2-12	VZ163800	POWER CORD		076131	(A)
	2-12	VZ163900	POWER CORD		055284	(B)
	2-12	VZ164000	POWER CORD		076128	(G)
	2-13	AA12230	CUSHION STOPPER	SR-4	078519	
	2-14	CB069250	BINDING TIE	BK-1	080558	
	2-15	AA12110	BIND HEAD B-TITE SCREW	3x10 BL B0	084772	
	2-16	AA09370	CUSHION BUSH		084849	
	2-17	AA12910	SEAL		055433	
	2-18	AA12920	SEAL		058018	
*	3	AA19700	P.C.B. ASS'Y	POWER AMP	331995	(UC)
*	3	AA19710	P.C.B. ASS'Y	POWER AMP	332170	(ABG)
*	4	AA19720	SATELLITE SPEAKER UNIT	NX-VS10ESI 1pc	331950	
*	4	AA19730	SATELLITE SPEAKER UNIT	NX-VS10EBL 1pc	331951	
*	5	AA19740	CENTER SPEAKER UNIT	NX-VS10CSI 1pc	331948	
*	5	AA19750	CENTER SPEAKER UNIT	NX-VS10CBL 1pc	331949	
			ACCESSORY			
202	AA12600	WALL BRACKET		1pc	012941	
203	AA12140	BRACKET		1pc	012933	

* New Parts

Ref. No.	PART NO.	Description	Remarks	Markets
* 204	AAX19950	ACCESSORY CORD	4m 1pc, 15m 2pcs	332040
205	AAX11960	DIN CORD	8P 3m 1pc	055905
206	AAX12390	PAN HEAD SCREW-SEMS	M4x8	017957
207	AAX11360	WING BOLTS	M4x0.7	057360
* 208	AAX19960	FASTENER TAPE	2pcs/set	042466

* New Parts

Parts List for Carbon Resistors

Value	1/4W Type Part No.	1/6W Type Part No.	Value	1/4W Type Part No.	1/6W Type Part No.
1.0 Ω	HJ35 3100	HF85 3100	10 kΩ	HF45 7100	HF45 7100
1.8 Ω	HJ35 3180	*	11 kΩ	HF45 7110	HF45 7110
2.2 Ω	HJ35 3220	HF85 3220	12 kΩ	HJ35 7120	HF85 7120
3.3 Ω	HJ35 3330	HF85 3330	13 kΩ	HF45 7130	HF45 7130
4.7 Ω	HJ35 3470	HF85 3470	15 kΩ	HF45 7150	HF45 7150
5.6 Ω	HJ35 3560	HF85 3560	18 kΩ	HF45 7180	HF45 7180
10 Ω	HF45 4100	HF45 4100	22 kΩ	HF45 7220	HF45 7220
15 Ω	HJ35 4150	HF85 4150	24 kΩ	HF45 7240	HF45 7240
22 Ω	HF45 4220	HF45 4220	27 kΩ	HJ35 7270	HF85 7270
27 Ω	HJ35 4270	HF85 4270	30 kΩ	HF45 7300	HF45 7300
33 Ω	HF45 4330	HF45 4330	33 kΩ	HF45 7330	HF45 7330
39 Ω	HJ35 4470	HF85 4390	36 kΩ	HF45 7360	HF45 7360
47 Ω	HF45 4470	HF45 4470	39 kΩ	HF45 7390	HF45 7390
56 Ω	HF45 4560	HF45 4560	47 kΩ	HF45 7470	HF45 7470
68 Ω	HF45 4680	HF45 4680	51 kΩ	HF45 7510	HF45 7510
75 Ω	HF45 4750	HF45 4750	56 kΩ	HF45 7560	HF45 7560
82 Ω	HF45 4820	HF45 4820	62 kΩ	HF45 7620	HF45 7620
91 Ω	HF45 4910	HF45 4910	68 kΩ	HF45 7680	HF45 7680
100 Ω	HF45 5100	HF45 5100	82 kΩ	HF45 7820	HF45 7820
110 Ω	HJ35 5110	HF85 5110	91 kΩ	HF45 7910	HF45 7910
120 Ω	HF45 5120	HF45 5120	100 kΩ	HF45 8100	HF45 8100
150 Ω	HF45 5150	HF45 5150	110 kΩ	HF45 8110	HF45 8110
160 Ω	HJ35 5160	*	120 kΩ	HF45 8120	HF45 8120
180 Ω	HF45 5180	HF45 5180	150 kΩ	HF45 8150	HF45 8150
200 Ω	HF45 5200	HF45 5200	180 kΩ	HF45 8180	HF45 8180
220 Ω	HF45 5220	HF45 5220	220 kΩ	HJ35 8220	HF85 8220
270 Ω	HF45 5270	HF45 5270	270 kΩ	HF45 8270	HF45 8270
330 Ω	HF45 5330	HF45 5330	300 kΩ	HF45 8300	HF45 8300
390 Ω	HF45 5390	HF45 5390	330 kΩ	HF45 8330	HF45 8330
430 Ω	HF45 5430	HF45 5430	390 kΩ	HJ35 8390	HF85 8390
470 Ω	HF45 5470	HF45 5470	470 kΩ	HF45 8470	HF45 8470
510 Ω	HF45 5510	HF45 5510	560 kΩ	HJ35 8560	HF85 8560
560 Ω	HF45 5560	HF45 5560	680 kΩ	HJ35 8680	HF85 8680
680 Ω	HF45 5680	HF45 5680	820 kΩ	HJ35 8820	HF85 8820
820 Ω	HF45 5820	HF45 5820	1.0 MΩ	HF45 9100	HF45 9100
910 Ω	HF45 5910	HF45 5910	1.2 MΩ	HJ35 9120	*
1.0 kΩ	HF45 6100	HF45 6100	1.5 MΩ	HJ35 9150	HF85 9150
1.2 kΩ	HF45 6120	HF45 6120	1.8 MΩ	HJ35 9180	HF85 9180
1.5 kΩ	HF45 6150	HF45 6150	2.2 MΩ	HJ35 9220	HF85 9220
1.8 kΩ	HF45 6180	HF45 6180	3.3 MΩ	HJ35 9330	HF85 9330
2.0 kΩ	HJ35 6200	HF85 6200	3.9 MΩ	HJ35 9390	*
2.2 kΩ	HF45 6220	HF45 6220	4.7 MΩ	HJ35 9470	HF85 9470
2.4 kΩ	HJ35 6240	HF85 6240			
2.7 kΩ	HF45 6270	HF45 6270			
3.0 kΩ	HF45 6300	HF45 6300			
3.3 kΩ	HF45 6330	HF45 6330			
3.6 kΩ	HJ35 6360	HF85 6360			
3.9 kΩ	HF45 6390	HF45 6390			
4.7 kΩ	HF45 6470	HF45 6470			
5.1 kΩ	HF45 6510	HF45 6510			
5.6 kΩ	HF45 6560	HF45 6560			
6.8 kΩ	HF45 6680	HF45 6680			
8.2 kΩ	HF45 6820	HF45 6820			
9.1 kΩ	HF45 6910	HF45 6910			

1/4W Type

HJ35 ○○○○
10mm

1/6W Type

HF45 ○○○○
HF85 ○○○○
5mm

* : Not available

■ DISPLAY DATA

● V600 : 13-BT-180GNK (V629140)

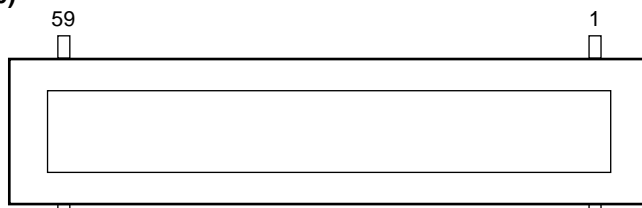

● PIN CONNECTION

Pin No.	30	29	28	27	26	25	24	23	22	21	20	19	18	17	16	15	14	13	12	11	10	9	8	7	6	5	4	3	2	1
Connection	P11	P12	P13	P14	P15	P16	P17	P18	P19	P20	P21	P22	P23	P24	P25	P26	P27	P28	P29	P30	P31	P32	P33	P34	P35	NX	NP	NP	F1	F1

Pin No.	59	58	57	56	55	54	53	52	51	50	49	48	47	46	45	44	43	42	41	40	39	38	37	36	35	34	33	32	31
Connection	F2	F2	NP	NP	NX	13G	12G	11G	10G	9G	8G	7G	6G	5G	3G	2G	1G	1G	NX	P1	P2	P3	P4	P5	P6	P7	P8	P9	P10

Note : 1) F1, F2 Filament 2) NP No pin 3) NX No extended pin 4) DL Datum Line 5) 1G ~ 13G Grid

● GRID ASSIGNMENT

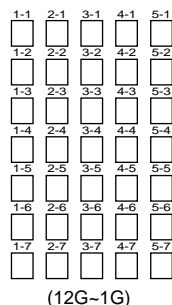
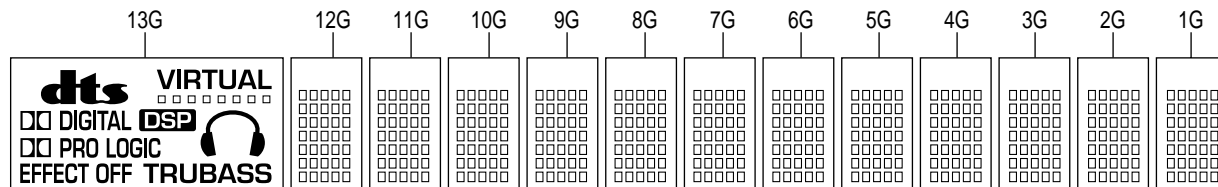

● ANODE CONNECTION

	13G	12G~1G
P1	TRUBASS	1-1
P2	—	2-1
P3	—	3-1
P4	VIRTUAL	4-1
P5	DIGITAL	5-1
P6	DIGITAL	1-2
P7	dts	2-2
P8	EFFECT OFF	3-2
P9	□□□□□□□□	4-2
P10	PRO LOGIC	5-2
P11	PRO LOGIC	1-3
P12	DSP	2-3
P13		3-3
P14	—	4-3
P15	—	5-3
P16	—	1-4
P17	—	2-4
P18	—	3-4

	13G	12G~1G
P19	—	4-4
P20	—	5-4
P21	—	1-5
P22	—	2-5
P23	—	3-5
P24	—	4-5
P25	—	5-5
P26	—	1-6
P27	—	2-6
P28	—	3-6
P29	—	4-6
P30	—	5-6
P31	—	1-7
P32	—	2-7
P33	—	3-7
P34	—	4-7
P35	—	5-7

REMOTE CONTROL TRANSMITTER

SCHEMATIC DIAGRAM

1

2

3

4

5

6

7

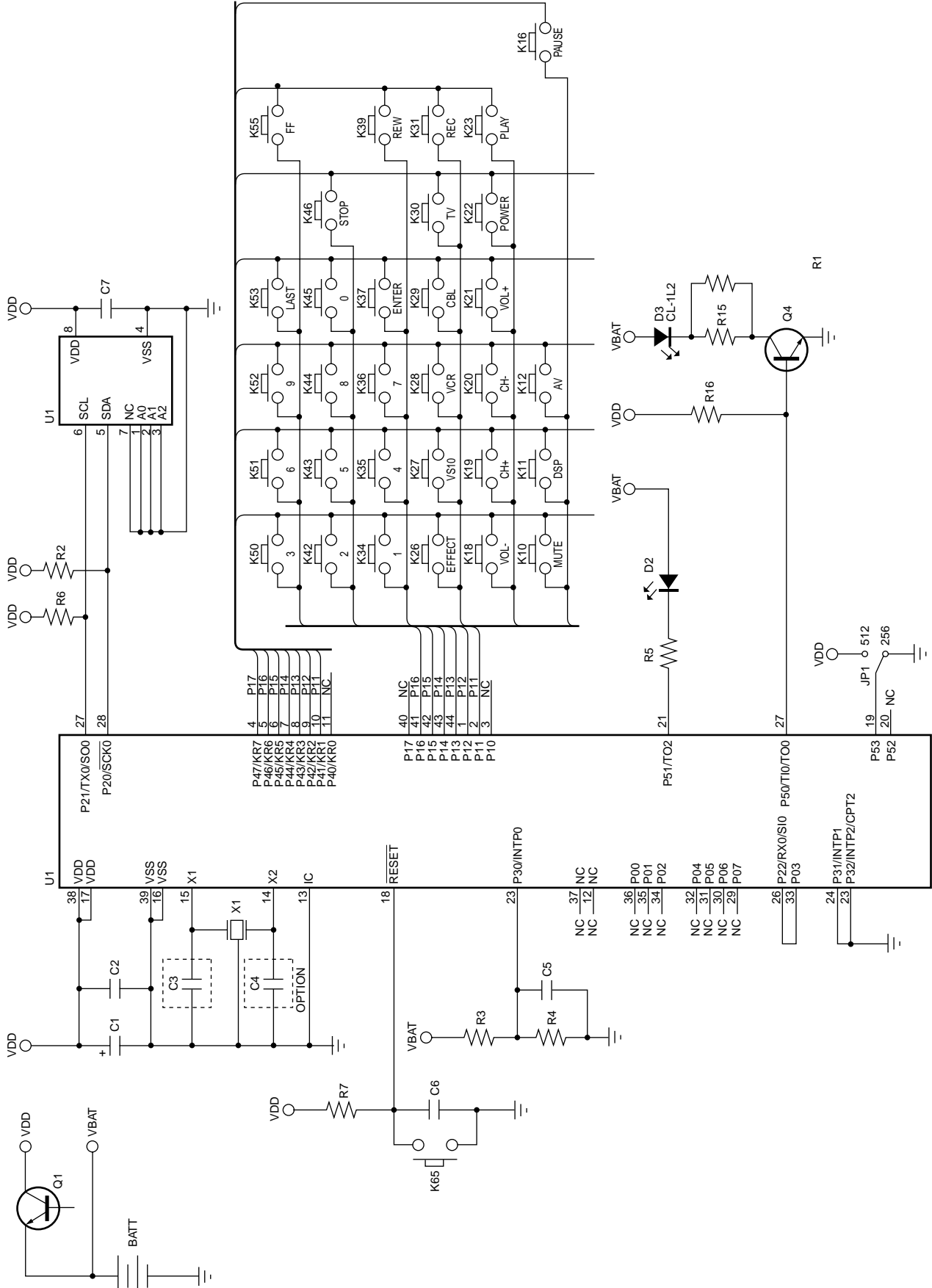

B, G models

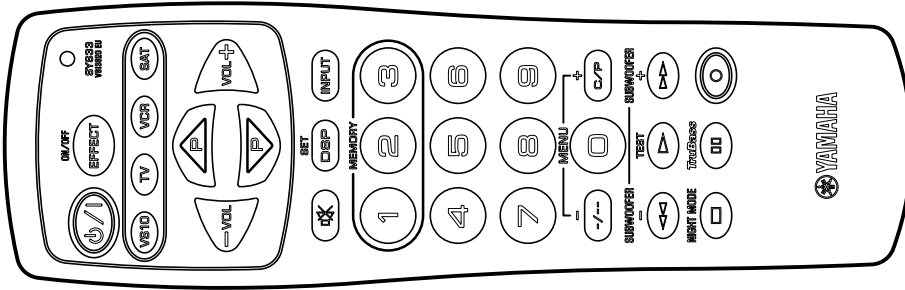

U, C, A models

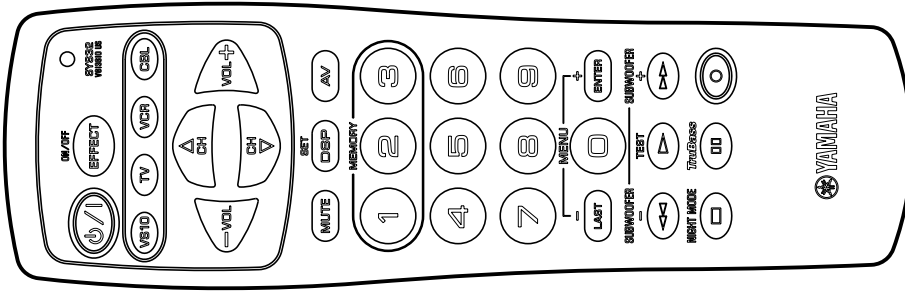

Key No.	Function	Custom Code (HEX)	Data Code (HEX)
22	⏻/⏪ POWER	78	0F
26	EFFECT	78	50
27	VS-10	-	-
30	TV	-	-
28	VCR	-	-
29	CBL (SAT)	-	-
18	VOL -	78	1F
21	VOL +	78	1E
19	CH Δ	78	51
20	CH ▽	78	52
10	MUTE	78	9C
11	DSP	-	-
12	AV (INPUT)	78	5E
34	1	78	11
42	2	78	12
50	3	78	13
35	4	78	14
43	5	78	15
51	6	78	16
36	7	78	17
44	8	78	18
52	9	78	19
53	LAST (-/-/-)	78	9F
45	0	78	9D
37	ENTER (C/P)	78	9E
39	◀◀ REW	78	4D
23	▶▶ PLAY	78	5F
55	▶▶▶ FF	78	4C
46	□ STOP	78	8A
16	▢ PAUSE	78	8B
31	○ REC	-	-

() B, G models