

# HOME THEATER SOUND SYSTEM DVX-S60

# DVR-S60/NX-SW60

## SERVICE MANUAL

The DVX-S60 is composed of the DVR-S60 and the NX-SW60.

DVX-S60 は DVR-S60 と NX-SW60 で構成されています。

### IMPORTANT NOTICE

This manual has been provided for the use of authorized YAMAHA Retailers and their service personnel. It has been assumed that basic service procedures inherent to the industry, and more specifically YAMAHA Products, are already known and understood by the users, and have therefore not been restated.

**WARNING:** Failure to follow appropriate service and safety procedures when servicing this product may result in personal injury, destruction of expensive components, and failure of the product to perform as specified. For these reasons, we advise all YAMAHA product owners that any service required should be performed by an authorized YAMAHA Retailer or the appointed service representative.

**IMPORTANT:** The presentation or sale of this manual to any individual or firm does not constitute authorization, certification or recognition of any applicable technical capabilities, or establish a principle-agent relationship of any form.

The data provided is believed to be accurate and applicable to the unit(s) indicated on the cover. The research, engineering, and service departments of YAMAHA are continually striving to improve YAMAHA products. Modifications are, therefore, inevitable and specifications are subject to change without notice or obligation to retrofit. Should any discrepancy appear to exist, please contact the distributor's Service Division.

**WARNING:** Static discharges can destroy expensive components. Discharge any static electricity your body may have accumulated by grounding yourself to the ground buss in the unit (heavy gauge black wires connect to this buss).

**IMPORTANT:** Turn the unit OFF during disassembly and part replacement. Recheck all work before you apply power to the unit.

## CONTENTS

TO SERVICE PERSONNEL .....	2-3	DVD P.C.B. OPERATION / DVD基板の動作 .....	18-34
PREVENTION OF ELECTRO STATIC DISCHARGE .....	4	DVD START-UP PROGRAM FLOW CHART .....	35
LOCALE MANAGEMENT INFORMATION .....	4	MPEG P.C.B. OPERATION / MPEG基板の動作 .....	36-40
SYSTEM COMPOSITION / システム構成 .....	5	TROUBLESHOOTING .....	42-43
FRONT PANELS .....	5-6	TUNER ADJUSTMENTS / チューナー部調整 .....	44
REMOTE CONTROL PANELS .....	6	DISPLAY DATA .....	45
REAR PANELS .....	7-8	IC DATA .....	46-65
SPECIFICATIONS / 参考仕様 .....	9-11	BLOCK DIAGRAM .....	67
INTERNAL VIEW .....	11	WIRING CONNECTION .....	68
DISASSEMBLY PROCEDURES /		PRINTED CIRCUIT BOARD .....	69-76
分解手順 .....	12-13	SCHEMATIC DIAGRAM .....	77-82
RESET PROCEDURE / リセットのしかた .....	14	VOLTAGE CHART .....	83-87
DVD MECHANISM HANDLING PRECAUTIONS /		PARTS LIST .....	88-103
DVDメカを取り扱う時の注意事項 .....	14	NX-SW60 .....	104-105
DVD MECHANISM DISASSEMBLY PROCEDURES /		REMOTE CONTROL .....	106-107
DVDメカの分解手順 .....	15	PARTS LIST FOR CARBON RESISTORS .....	108
TRAY INSTALLATION / トレーのセット方法 .....	16-17		



このサービスマニュアルは、エコマーク認定の再生紙を使用しています。  
This Service Manual uses recycled paper.



## ■ TO SERVICE PERSONNEL

1. Critical Components Information  
Components having special characteristics are marked  and must be replaced with parts having specifications equal to those originally installed.
2. Leakage Current Measurement (For 120V Models Only)  
When service has been completed, it is imperative to verify that all exposed conductive surfaces are properly insulated from supply circuits.
  - Meter impedance should be equivalent to 1500 ohm shunted by 0.15 $\mu$ F.

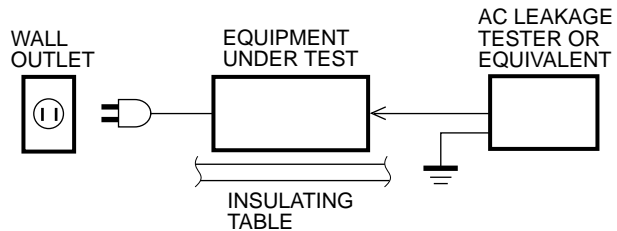

- Leakage current must not exceed 0.5mA.
- Be sure to test for leakage with the AC plug in both polarities.

### “CAUTION”

“F4101 – 4104 : FOR CONTINUED PROTECTION AGAINST RISK OF FIRE, REPLACE ONLY WITH SAME TYPE 2.0A, 250V FUSE.”

“F4131 : FOR CONTINUED PROTECTION AGAINST RISK OF FIRE, REPLACE ONLY WITH SAME TYPE 5.0A, 250V FUSE.”

“F4132 : FOR CONTINUED PROTECTION AGAINST RISK OF FIRE, REPLACE ONLY WITH SAME TYPE 0.315A, 250V FUSE.”



### CAUTION

F4101 – 4104 : REPLACE WITH SAME TYPE 2.0A, 250V FUSE.

F4131 : REPLACE WITH SAME TYPE 5.0A, 250V FUSE.

F4131 : REPLACE WITH SAME TYPE 0.315A, 250V FUSE.

### ATTENTION

F4101 – 4104 : UTILISER UN FUSIBLE DE RECHANGE DE MEME TYPE DE 2.0A, 250V.

F4131 : UTILISER UN FUSIBLE DE RECHANGE DE MEME TYPE DE 5.0A, 250V.

F4132 : UTILISER UN FUSIBLE DE RECHANGE DE MEME TYPE DE 0.315A, 250V.

## WARNING: CHEMICAL CONTENT NOTICE!

The solder used in the production of this product contains LEAD. In addition, other electrical/electronic and/or plastic (where applicable) components may also contain traces of chemicals found by the California Health and Welfare Agency (and possibly other entities) to cause cancer and/or birth defects or other reproductive harm.

DO NOT PLACE SOLDER, ELECTRICAL/ELECTRONIC OR PLASTIC COMPONENTS IN YOUR MOUTH FOR ANY REASON WHATSOEVER!

Avoid prolonged, unprotected contact between solder and your skin! When soldering, do not inhale solder fumes or expose eyes to solder/flux vapor!

If you come in contact with solder or components located inside the enclosure of this product, wash your hands before handling food.

## WARNING: Laser Safety

This product contains a laser beam component. This component may emit invisible, as well as visible radiation, which may cause eye damage. To protect your eyes and skin from laser radiation, the following precautions must be used during servicing of the unit.

- 1) When testing and/or repairing any component within the product, keep your eyes and skin more than 30 cm away from the laser pick-up unit at all times. Do not stare at the laser beam at any time.
- 2) Do not attempt to readjust, disassemble or repair the laser pick-up, unless noted elsewhere in this manual.
- 3) CAUTION : Use of controls, adjustments or performance of procedures other than those specified herein may result in hazardous radiation exposure.

## Laser Emitting conditions:

- 1) When the Top Cover is removed, and the STANDBY/ON SW is turned to the "ON" position, the laser component will emit a beam for several seconds to detect if a disc is present. During this time (5-10 sec.) the laser may radiate through the lens of the laser pick-up unit. Do not attempt any servicing during this period!  
If no disc is detected, the laser will stop emitting the beam. When a disc is set, you will not be exposed to any laser emissions.
- 2) The laser power level can be adjusted with the VR on the pick-up PWB. However, this level has been set by the factory prior to shipping from the factory. Do not adjust this laser level control unless instruction is provided elsewhere in this manual. Adjustment of this control can increase the laser emission level from the device.

## Laser Diode Properties

Type: Semiconductor laser GaAAIAs  
 Wave length: 650 nm (DVD)  
 790 nm (CD)  
 Output Power: CLASS 1  
 1mW (DVD)  
 0.5mW (CD)

**VARO!** : AVATTAESSA JA SUOJALUKITUS OHITETTAESSA OLET ALTTIINA NÄKYMÄTTÖMÄLLE LASER-SÄTEILYLLE. ÄLÄ KATSO SÄTEESEEN.

**WARNING!** : OSYNLIG LASERSTRÅLNING NÄR DENNA DEL ÄR ÖPPNAD OCH SPÄRREN ÄR URKOPPLAD. BETRAKTA EJ STRÅLEN.

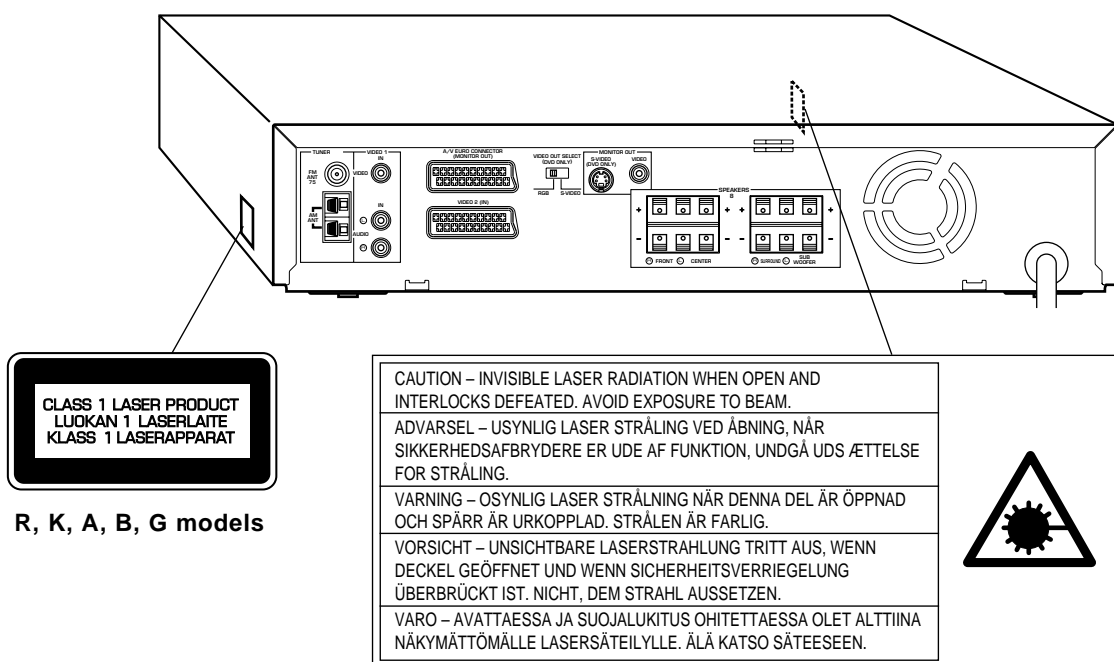

## ■ PREVENTION OF ELECTRO STATIC DISCHARGE

The laser diode in the traverse unit (optical pickup) may be damaged due to static electricity from clothes or the human body. Use caution to prevent electrostatic damage when servicing or handling the laser diode.

### 1. Grounding for electrostatic damage prevention

1. Worktable grounding  
Put a grounded conductive material (sheet) or iron sheet on the area where the optical pickup is placed.
2. Human body grounding  
Use an anti-static wrist strap to discharge the static electricity from your body.

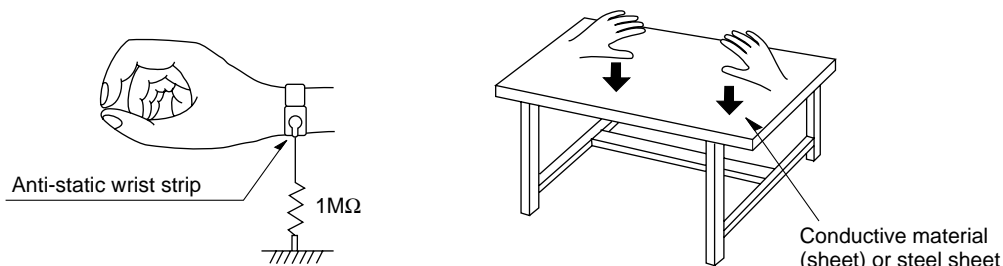

### 2. Handling of the optical pickup

1. To prevent damage to the optical pickup replacement parts during transportation and before installation, both ends of the laser diode are short-circuited. After installing the new part, remove the short circuit according to the correct procedure in this service manual.
2. Do not use a tester to check the laser diode in the optical pickup. The power supply in the tester will damage the laser diode.

### 3. Handling Precautions for the Traverse Unit (Optical Pickup)

1. Handle the traverse unit (optical pickup) gently, as it is an extremely high-precision assembly.
2. The flexible cable lines may break if an excessive force is applied to it. Use caution when handling the cable.
3. The semi-fixed resistor for laser power adjustment should not be adjusted. Do not turn the resistor.

## ■ LOCALE MANAGEMENT INFORMATION

Locale Management Information : This DVD player is designed and manufactured to respond to the Locale Management Information that is recorded on a DVD disc. If the Locale number described on the DVD disc does not correspond to the Locale number of this DVD player, this DVD player cannot play this disc.

This product incorporates copyright protection technology that is protected by method claims of certain U.S. patents and other intellectual property rights owned by Macrovision Corporation and other rights owners. Use of this copyright protection technology must be authorized by Macrovision Corporation, and is intended for home and other limited viewing uses only unless otherwise authorized by Macrovision Corporation. Reverse engineering or disassembly is prohibited.

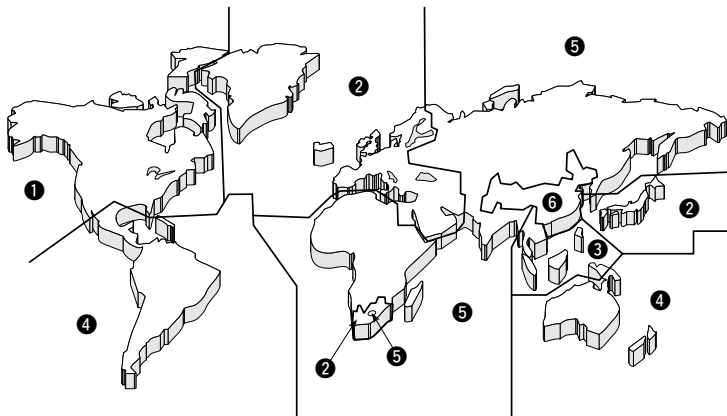

## ■ SYSTEM COMPOSITION / システム構成

The DVX-S60 is composed of the DVR-S60 and the NX-SW60.

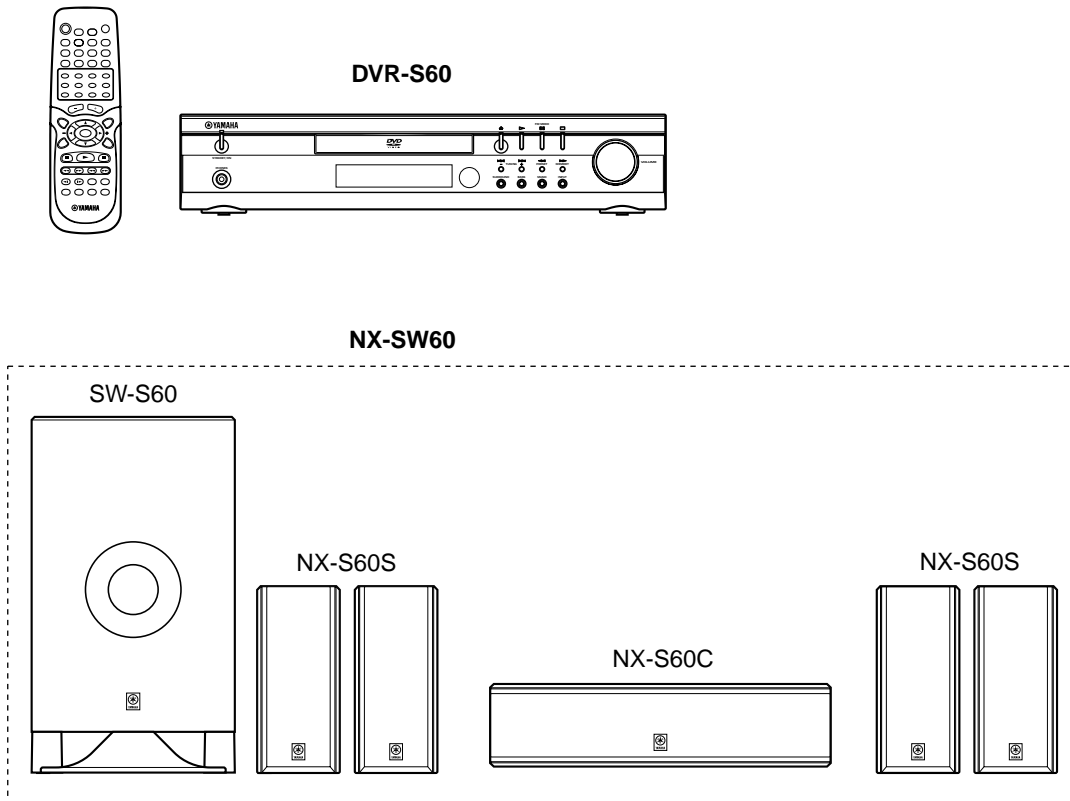

## ■ FRONT PANELS

### ▼ DVR-S60 (U, C, R, A, T, K, J models)

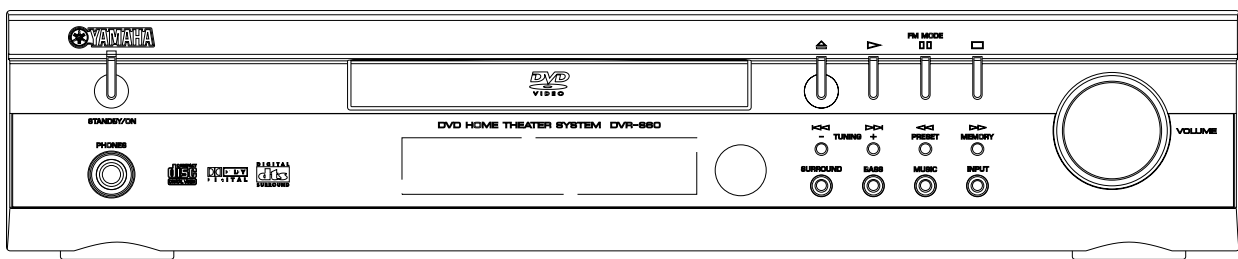

### ▼ DVR-S60 (B, G models)

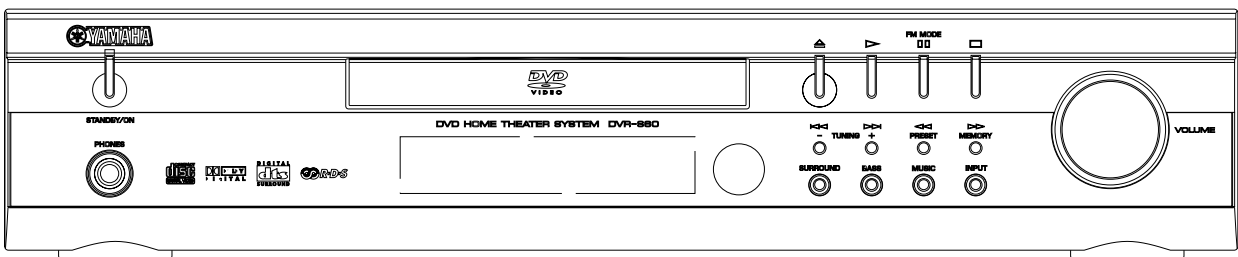

DVR-S60  
NX-SW60

▼ SW-S60

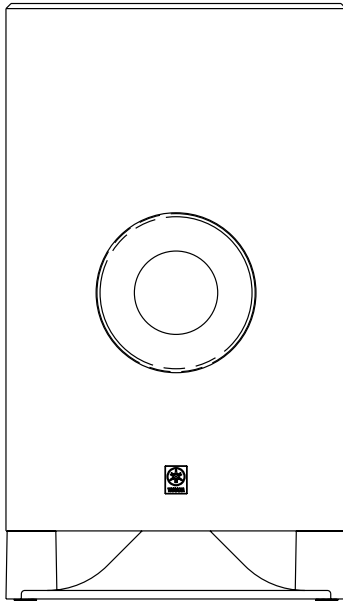

■ REMOTE CONTROL PANELS

▼ U, C, R, A, T, K models

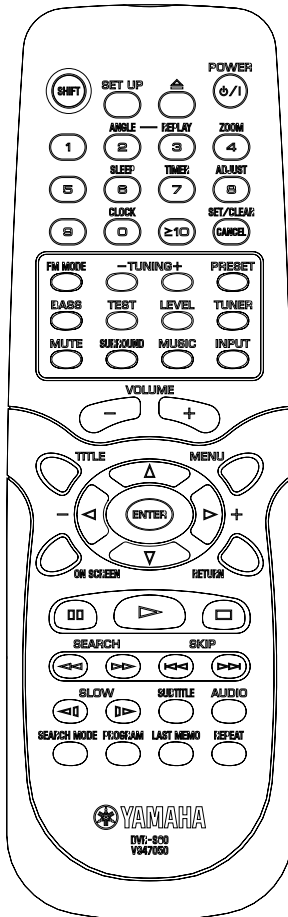

▼ B, G models

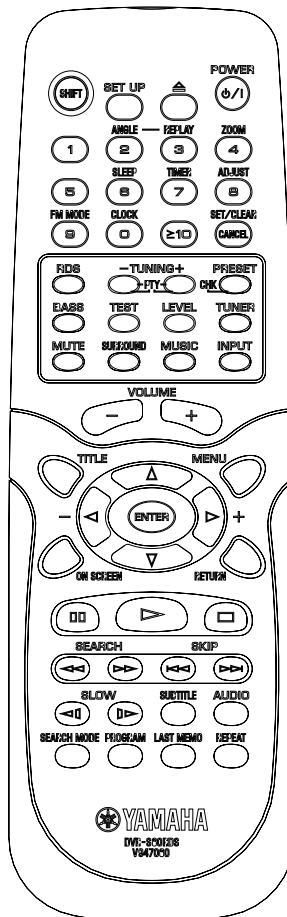

▼ J model

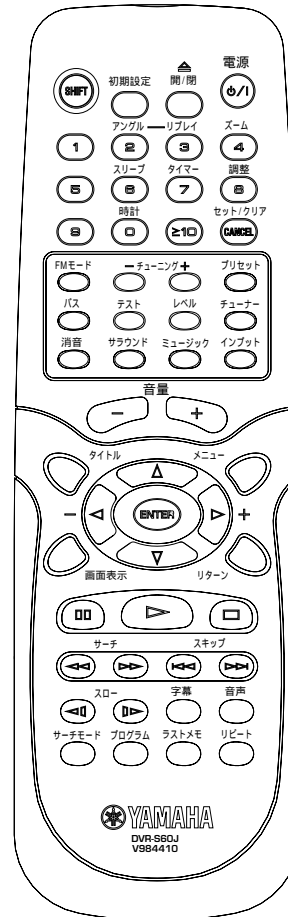

DVR-S60  
NX-SW60

# REAR PANELS

## ▼ DVR-S60 (U, C models)

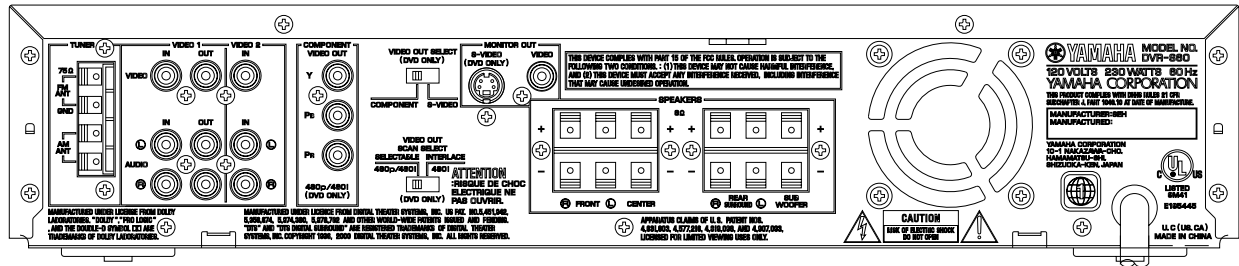

## ▼ DVR-S60 (R model)

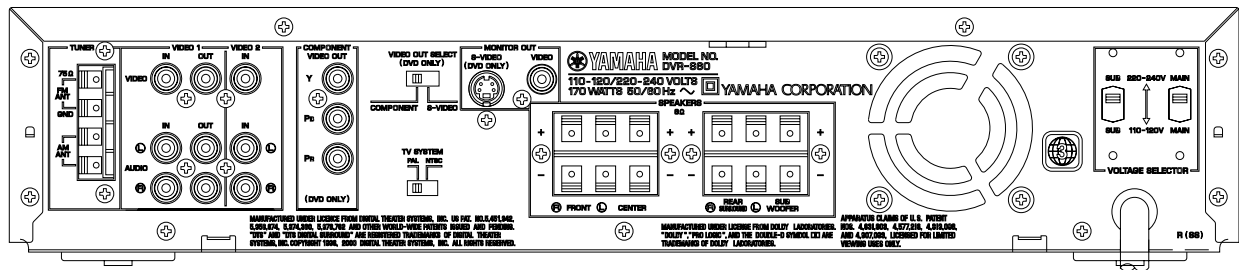

## ▼ DVR-S60 (A model)

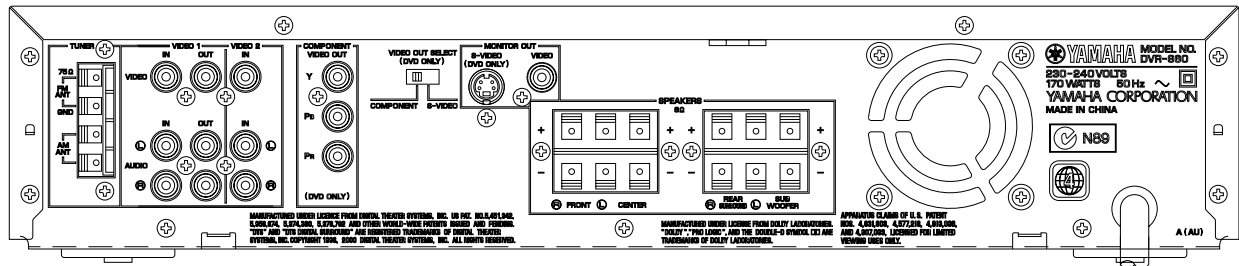

## ▼ DVR-S60 (G, B models)

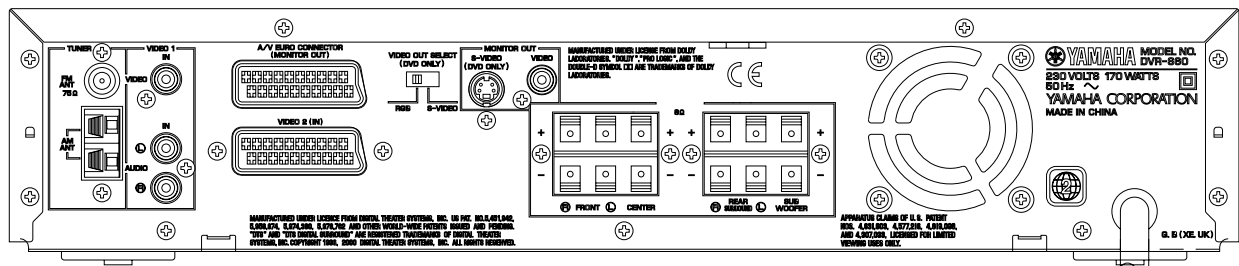

DVR-S60  
NX-SW60

▼ DVR-S60 (T model)

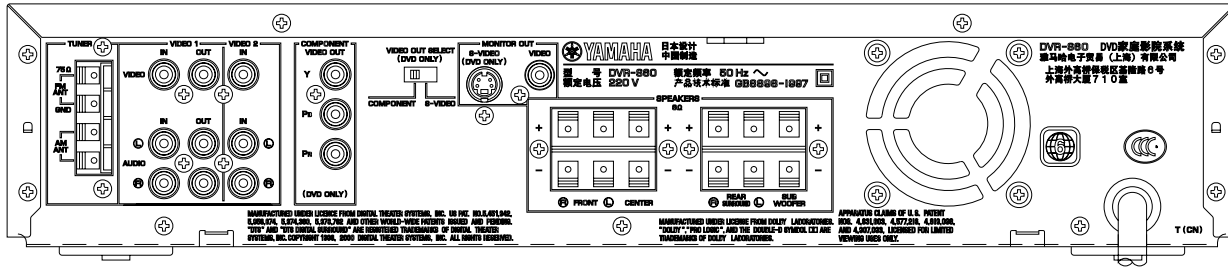

▼ DVR-S60 (K model)

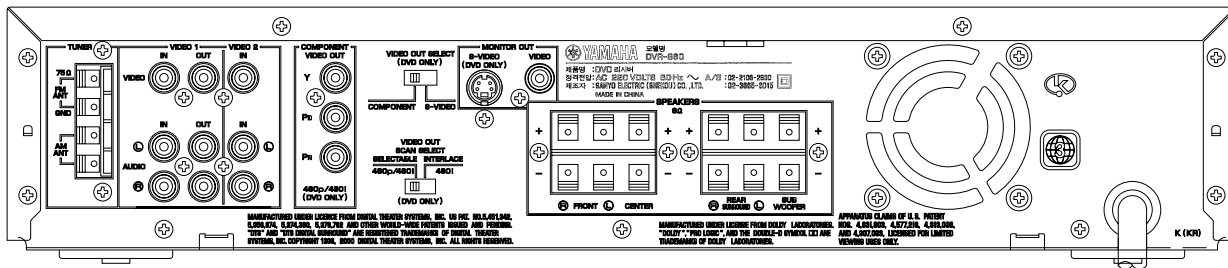

▼ DVR-S60 (J model)

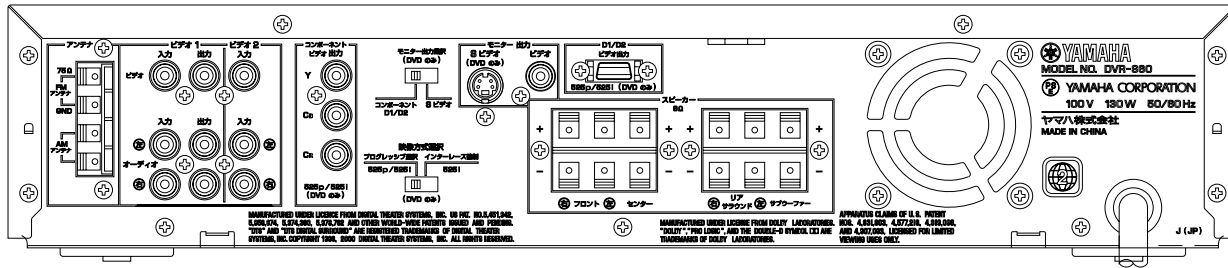

▼ SW-S60

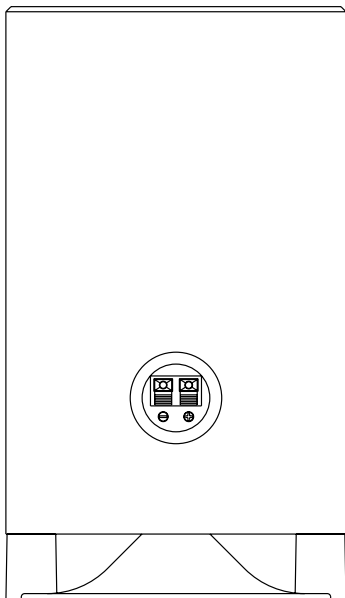

DVR-S60  
NX-SW60



## ■ SPECIFICATIONS / 参考仕様

### DVR-S60

#### AMPLIFIER SECTION / オーディオ部

• Output Power / 実用最大出力( EIAJ )	
FRONT L/R, CENTER, SURROUND L/R	
1 kHz, 10% THD, 8 Ω	35 W
SUBWOOFER	
100 Hz, 10% THD, 8 Ω	40 W
[U, C models]	
FRONT L/R, CENTER, SURROUND L/R	
1 kHz, 0.9% THD, 8 Ω	30 W
SUBWOOFER	
100 Hz, 0.9% THD, 8 Ω	35 W
• Inputs / 入力端子	
VIDEO 1 (RCA)	
AUDIO	Analog
VIDEO	Composite
VIDEO 2 (RCA)	
[U, C, A, T, K, R, J models]	
AUDIO	Analog
VIDEO	Composite
VIDEO 2 (EURO AV)	
[B, G models]	
AUDIO	Analog
VIDEO	Composite
• Outputs / 出力端子	
VIDEO 1 (RCA)	
AUDIO	Analog
VIDEO	Composite
MONITOR OUT	
VIDEO (RCA)	Composite
S-VIDEO	DVD only
COMPONENT	
[U, C, A, T, K, R, J models]	DVD only
EURO AV	
[B, G models]	
AUDIO	Analog
VIDEO	RGB (DVD only) & Composite
SPEAKERS	
FRONT L/R	8 Ω
CENTER	8 Ω
REAR L/R	8 Ω
SUBWOOFER	8 Ω

#### DVD PLAYER SECTION / DVD プレーヤー部

• Playback standard	
[U, C, K, J models]	NTSC
[R, T, A, G, B models]	PAL

• Signal to Noise Ratio / S/N比 (IHF-A Network, shorted)	More than 105 dB
• Total Harmonic Distortion / 全高調波歪率	0.003 %
• Wow and flutter / ワウ、フラッター	Below measurable level

#### TUNER SECTION / チューナー部

• FM Tuning Range / FM受信周波数範囲	
[U, C models]	87.5 to 107.9 MHz
[R, T, K, A, G, B models]	87.50 to 108.00 MHz
[J model]	76.0 to 90.0 MHz
• AM Tuning Range / AM受信周波数範囲	
[U, C models]	520 to 1710 kHz
[B, G models]	522 to 1611 kHz
[A, T, K models]	522 to 1710 kHz
[R model]	522/520 to 1710 kHz
[J model]	522 to 1629 kHz

#### GENERAL / 総合

• Power Supply / 電源電圧/周波数	
[U, C models]	AC 120 V/60 Hz
[A model]	AC 240 V/50 Hz
[B, G models]	AC 230 V/50 Hz
[T model]	AC 220 V/50 Hz
[K model]	AC 220 V/60 Hz
[R model]	AC 110–120/220–240 V, 50/60 Hz
[J model]	AC 100 V, 50/60 Hz
• Power Consumption / 消費電力	
[U, C, K models]	230 W
[B, G, A, R, T models]	170 W
[J model]	130 W
• Standby Power Consumption / 待機時消費電力	
	1.8 W
• Dimensions (W x H x D) / 寸法(幅 x 高さ x 奥行き)	
	435 x 90 x 381 mm (17-1/8" x 3-9/16" x 15")
• Weight / 質量	
	8.0kg (17 lbs 10 oz)
Accessories / 付属品	
	AM loop antenna x 1
	Indoor FM antenna x 1
	Remote Control x 1
	Battery (size "UM-3", "R06") x 2
	Audio Pin Cable x 1
	Video Pin Cable x 1

\* Specifications subject to change without notice.

U	.....	USA model	T	.....	Chinese model
C	.....	Canadian model	K	.....	Korean model
A	.....	Australian model	J	.....	Japanese model
B	.....	British model			
G	.....	European model			
R	.....	General model			

## NX-SW60

- NX-S60S
  - Type / 型式 ..... Acoustic suspension
  - Drivers / スピーカーユニット  
..... 5 cm (2 inch) full range cone x 2,  
magnetic shielding
  - Impedance / インピーダンス ..... 8 Ω
- NX-S60C
  - Type / 型式 ..... Acoustic suspension
  - Drivers / スピーカーユニット  
..... 5 cm (2 inch) full range cone x 2,  
magnetic shielding
  - Impedance / インピーダンス ..... 8 Ω
- SW-S60
  - Drivers / スピーカーユニット  
..... 16 cm (6-1/2 inch) cone woofer,  
magnetic shielding
  - Impedance / インピーダンス ..... 8 Ω
- Dimensions (W x H x D) / 寸法 幅 x 高さ x 奥行き )
  - SW-S60 ..... 200 x 351 x 206 mm  
(7-7/8" x 13-13/16" x 8-1/8")
  - NX-S60C ..... 300 x 72 x 110 mm  
(11-13/16" x 2-13/16" x 4-5/16")
  - NX-S60S ..... 72 x 164 x 111 mm  
(2-13/16" x 6-7/16" x 4-3/8")
- Weight / 質量
  - SW-S60 ..... 4.8kg (10 lbs 9 oz)
  - NX-S60C ..... 1.1kg (2 lbs 7 oz)
  - NX-S60S ..... 0.9kg (2 lbs)
- Accessories / 付属品 ..... Speaker Cable (5m) x 4  
Speaker Cable (15m) x 2  
Brackets x 4  
Screws x 4  
Fasteners x 2  
Nonskid pads (8 pcs) x 2

\* Specifications subject to change without notice.

**U** ..... *USA model*                      **T** ..... *Chinese model*  
**C** ..... *Canadian model*                **K** ..... *Korean model*  
**A** ..... *Australian model*                **J** ..... *Japanese model*  
**B** ..... *British model*  
**G** ..... *European model*  
**R** ..... *General model*



Manufactured under license from Dolby Laboratories.  
 "Dolby" and the double-D symbol are trademarks of Dolby Laboratories.  
 ドルビーラボラトリーズからの実施権により製造されています。  
 「ドルビー」、「PRO LOGIC」およびダブルD記号 は、ドルビーラボラトリーズの商標です。

"DTS" and "DTS Digital Surround" are registered trademarks of Digital Theater Systems, Inc.  
 DTS およびDTS デジタルサラウンドはデジタルシアターシステムズの登録商標です。

This product incorporates copyright protection technology that is protected by method claims of certain U.S. patents and other intellectual property rights owned by Macrovision Corporation and other rights owners. Use of this copyright protection technology must be authorized by Macrovision Corporation, and is intended for home and other limited viewing uses only unless otherwise authorized by Macrovision Corporation.

Reverse engineering or disassembly is prohibited.

本製品は、著作権保護技術を採用しており、マクロビジョン社及びその他の著作権者が保有する米国特許及びその他の知的財産権によって保護されています。

この著作権保護技術の使用は、マクロビジョン社の許可が必要で、またマクロビジョン社の特別な許可がない限り家庭用及びその他の一部の鑑賞用の使用に制限されています。分解したり、改造することも禁じられています。

**DIMENSIONS / 寸法図**

● DVR-S60

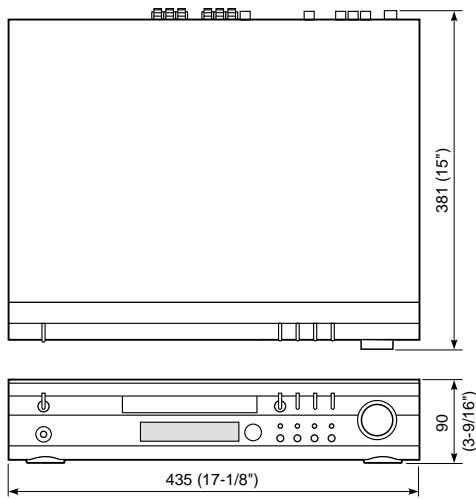

● SW-S60

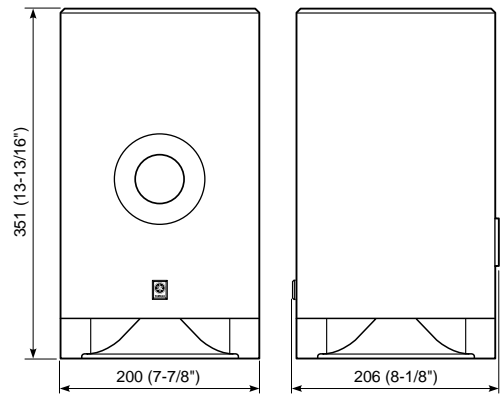

● NX-S60C

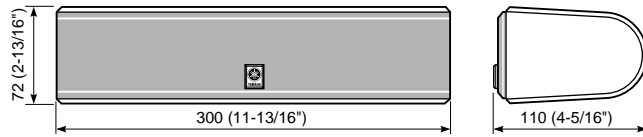

● NX-S60S

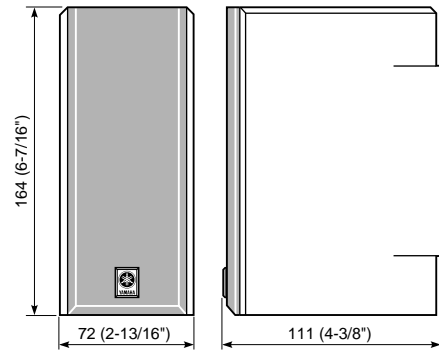

Unit : mm (inch)

**INTERNAL VIEW**

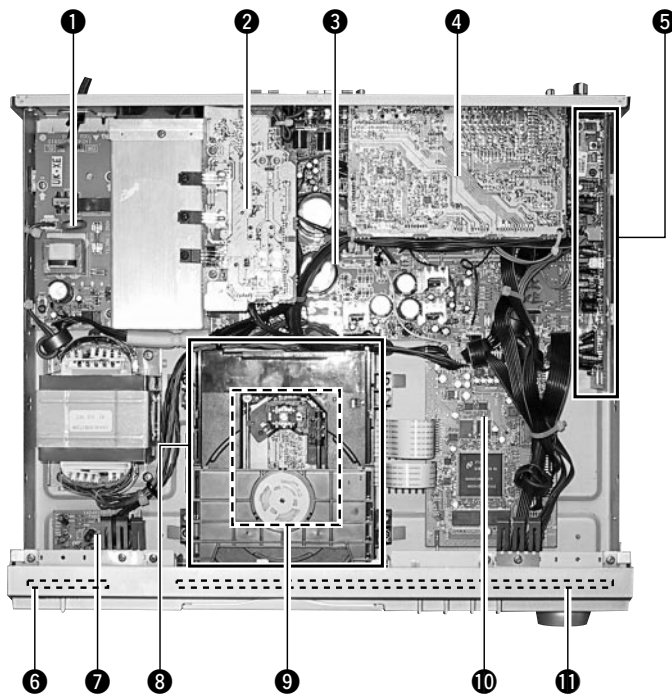

- ① STANDBY POWER P.C.B.
- ② DVD POWER P.C.B.
- ③ MAIN P.C.B.
- ④ VIDEO P.C.B.
- ⑤ TUNER P.C.B.
- ⑥ LED/SWITCH P.C.B.
- ⑦ HEADPHONE P.C.B.
- ⑧ DVD MECHANISM
- ⑨ DVD P.C.B.
- ⑩ MPEG P.C.B.
- ⑪ FRONT P.C.B.

DVR-S60  
NX-SW60

## DISASSEMBLY PROCEDURES / 分解手順

(Remove parts in disassembly order as numbered.)

(番号順に取り外しを行ってください。)

### 1. Removal of Top Cover

- Remove 10 screws ( ① ) in Fig. 1.
- Lift the Top Cover at the rear and move it rear-ward slantingly.

### 1. トップカバーの外し方

- ①のネジ10本を外します。( Fig. 1 )
- トップカバーを後方へスライドさせ取り外します。

### 2. Removal of Tray Lid

- Insert a stick or the like into the hole in the right side of the DVD mechanism and push the lever to take out the tray. (Fig. 1-1)
- Remove the Lid in Fig. 1.

### 2. トレーリッドの外し方

- DVD メカ右横の孔から棒状のものを差し込み、レバーを押して、トレーを出します。( Fig. 1-1 )
- リッドを外します。( Fig. 1-1 )

### 3. Removal of Front Panel

- Remove 8 screws ( ② ) in Fig. 1.
- Release 2 hooks and remove the Front Panel Unit by pulling it forward.

### 3. フロントパネルの外し方

- ②のネジ8本を外します。( Fig. 1 )
- フック2ヶ所を外し、フロントパネルを前方に外します。( Fig. 1 )

### 4. Removal of DVD Mechanism

Remove 4 screws ( ③ ) in Fig. 1.

### 4. DVDメカニズムの外し方

- ③のネジ4本を外します。( Fig. 1 )

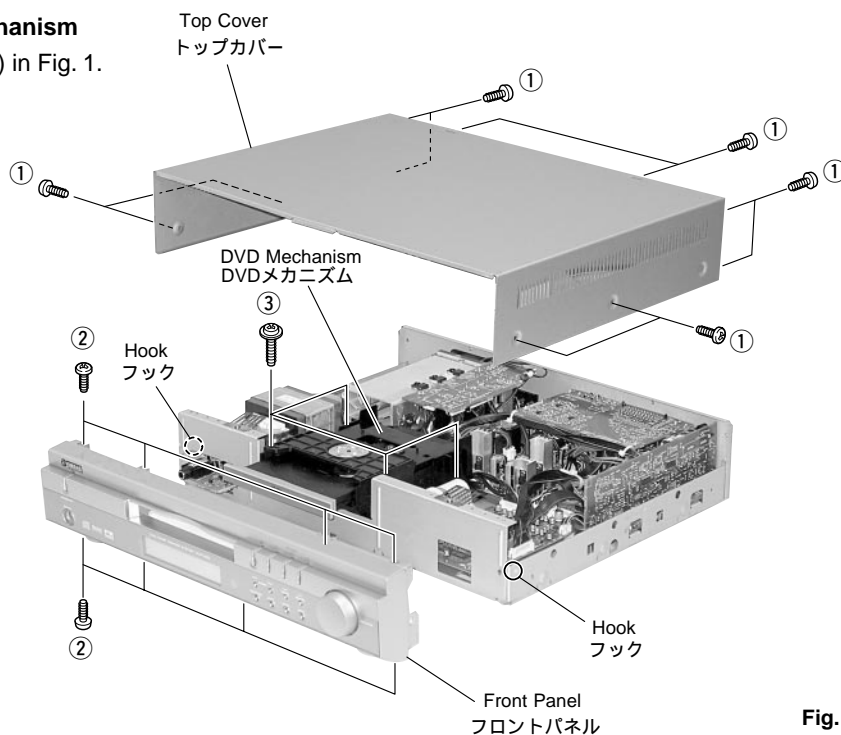

Fig. 1

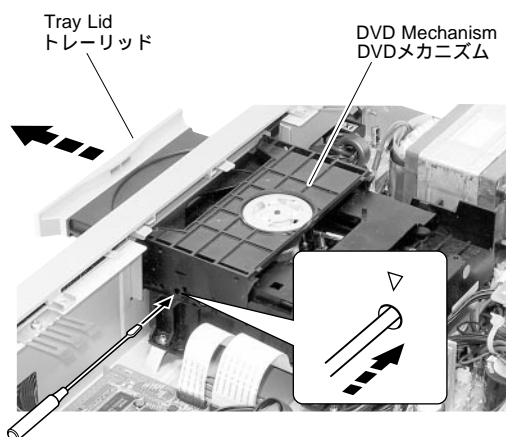

Fig. 1-1

**5. Removal of MPEG P.C.B.**

Remove 3 screws ( ④ ) in Fig. 2.

**6. Removal of Video P.C.B.**

Remove 5 screws ( ⑤ ) in Fig. 3.

**7. Removal of Tuner P.C.B.**

- a. Remove 1 screw ( ⑥ ) in Fig. 2.
- b. Remove 3 screws ( ⑦ ) in Fig. 3.
- c. Remove 7 or 8 screws ( ⑧ ) in Fig. 3.

**8. Removal of Main P.C.B.**

Remove 3 screws ( ⑨ ) and 2 screws ( ⑩ ) in Fig. 2.

**5. MPEG P.C.B.の外し方**

④のネジ3本を外します。( Fig. 2 )

**6. Video P.C.B.の外し方**

- a. ⑤のネジ5本を外します。( Fig. 3 )
- b. ⑪のネジ2本を外します。( Fig. 3-1 ( Jのみ ) )

**7. Tuner P.C.B.の外し方**

- a. ⑥のネジ1本を外します。( Fig. 2 )
- b. ⑦のネジ3本を外します。( Fig. 3 )
- c. ⑧のネジ8本を外します。( Fig. 3 )

**8. Main P.C.B.の外し方**

⑨のネジ3本と⑩のネジ2本を外します。( Fig. 2 )

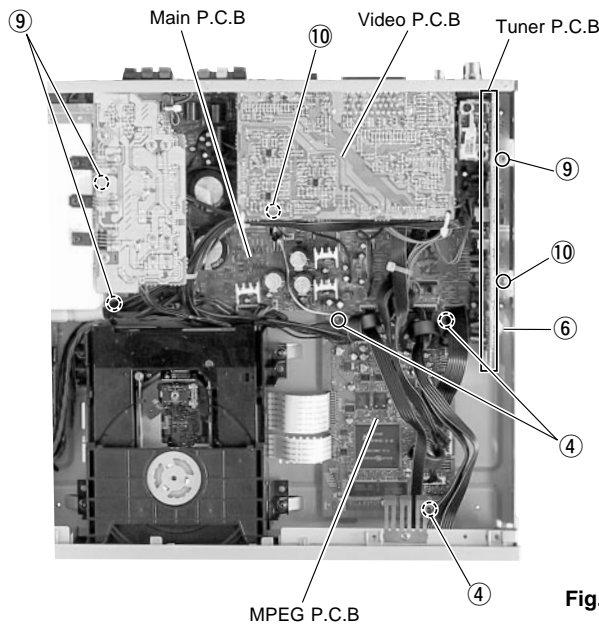

Fig. 2

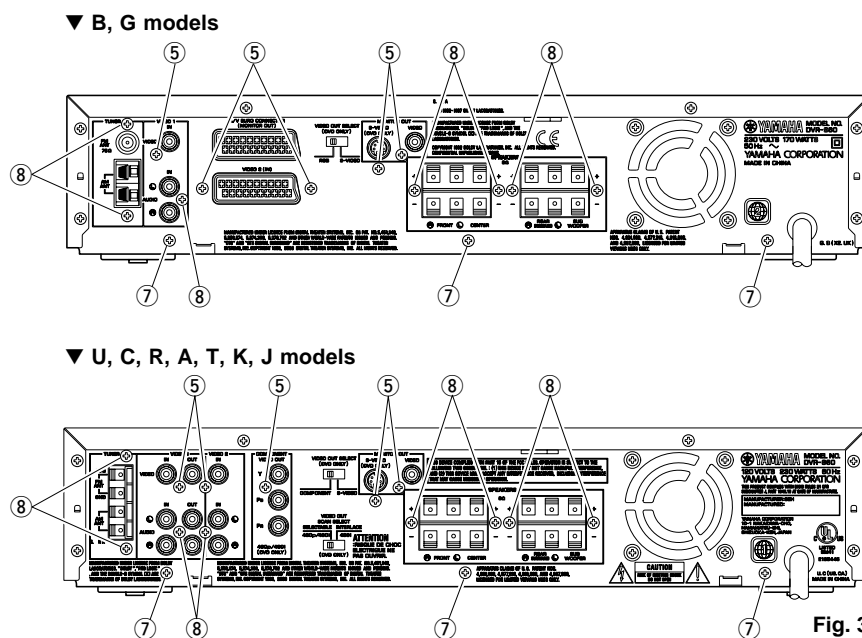

Fig. 3

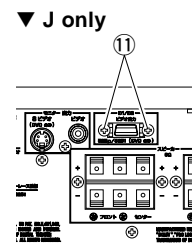

Fig. 3-1

DVR-S60  
NX-SW60

## ■ RESET PROCEDURE / リセットのしかた

If the operation of the unit or display is not normal,

1. Disconnect the power cable.
2. While pressing both BASS and MUSIC buttons on the main unit at the same time, connect the power cable. "RESET" briefly appears on the display.
3. Resume operation.

本機またはディスプレイの機能に異常が発生した場合は以下の処置を行ないます。

1. 電源コードを抜く。
2. 本機の“ BASS ”と“ MUSIC ”キーを同時に押しながら、電源コードを差し込む。“ RESET ”がディスプレイに数秒間表示されます。
3. 操作を再開する。

## ■ DVD MECHANISM HANDLING PRECAUTIONS / DVDメカを取り扱う時の注意事項

### 1. Safety instructions

Exposing your eyes or skin to the laser beam used in the pickup is harmful. Take care not to do so.

### 1. 安全のための指示

ピックアップ内で使われるレーザー光線が目や皮膚にあたると有害です。あたらないように注意してください。

### 2. Caution against static electricity and leakage voltage

The work tables, tools, fixtures, soldering irons (including those made of ceramic) and measuring instruments shall be grounded securely. The workers shall also be grounded.

### 2. 静電気やリーク電圧に対する注意

作業台、工具、取付具、ハンダごて(セラミック製のものを含む)、測定具をしっかりと接地させてください。作業者も接地させなければなりません。

### 3. Handling precautions

Do not touch the objective lens when handling a DVD mechanism, or the lens will be stained, resulting in inadequate playability.

Take care so as to protect from exposure to moisture or the entry of foreign objects.

In particular, a strong magnet adjacent to the pickup will not only prevent operation, but can damage the pickup.

### 3. 取扱い時の注意事項

DVD メカを扱っている時、対物レンズを触ってはいけません。さもないとレンズがよごれて、その結果プレー性能が悪くなります。水がかかったり、金属片がはいったり、結露したりしないように注意してください。特に、ピックアップに強い磁石を隣接させると、動作しなくなるだけでなく、ピックアップが損傷することがあります。

(Caution) (注意)



Before disconnecting FFC cable, install "SHORT" between points.

After connecting FFC cable, remove "SHORT" as shown.

FFCケーブルをはずす前に、「SHORT」にしてください。FFCケーブルを接続した後は、左に示すように「OPEN」にしてください。

# ■ DVD MECHANISM DISASSEMBLY PROCEDURES / DVDメカの分解手順

## 1. Tray and Base Mechanism Part

トレーおよびベースメカ部

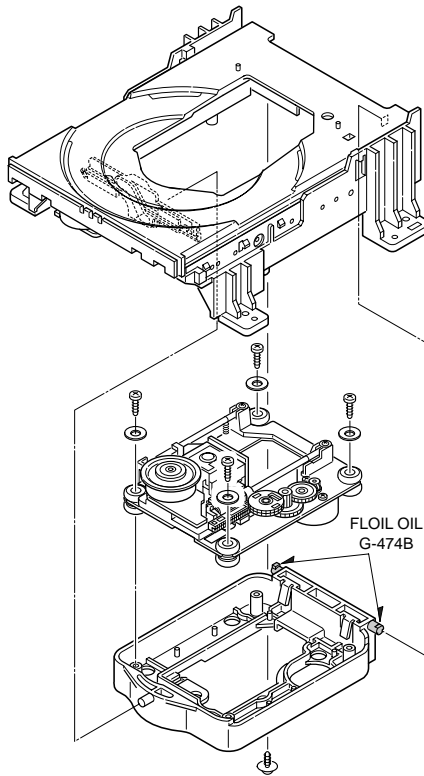

## 3. Tray Part

トレー部

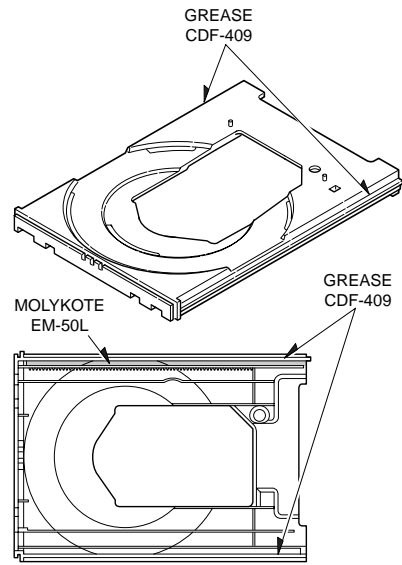

## 2. Base Mechanism Mounting Part

ベースメカ取付部

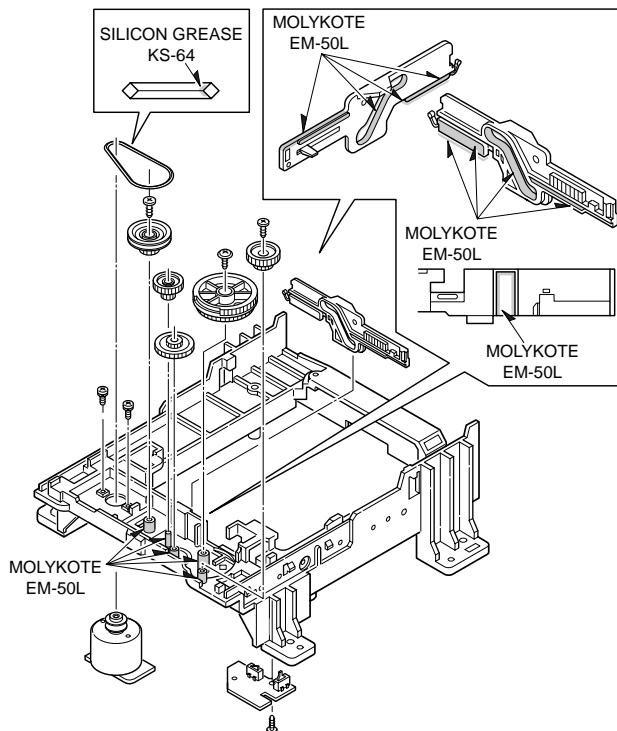

## 4. Base Mechanism Part

ベースメカ部

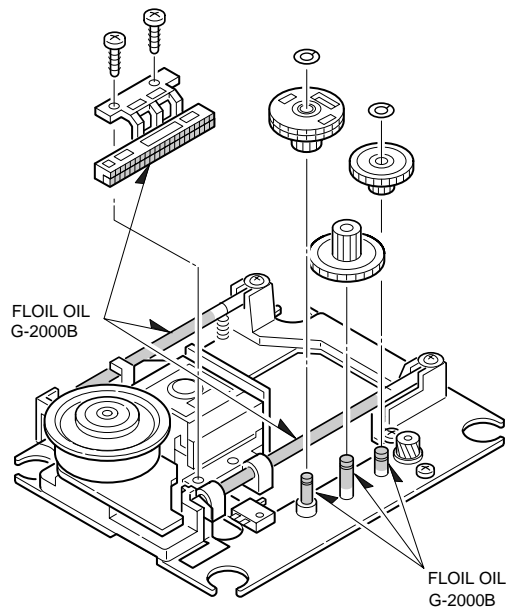

Do not remove the pick-up from base mechanism because of adjustment difficulty.

調整がむずかしくなるので、ピックアップはベースメカから取り外さないでください。

FLOIL OIL	G-474B	TX913210
FLOIL OIL	G-2000B	AAX39140
MOLYKOTE	EM-50L	AAX39170
SILICON GREASE	KS-64	AAX39040
GREASE	CDF-409	AAX39020

DVR-S60  
NX-SW60

## ■ TRAY INSTALLATION / トレーのセット方法

1. Move the SLIDE to the left side.
2. Match the GEAR HOLE with the CHASSIS HOLE and install the GEAR 1.
3. Install the gear 1 fixing screw.
1. スライドを左の方に動かします。
2. ギアの穴をシャーシの穴に合わせて、ギア1を取り付けます。
3. ギア1固定ネジを取り付けます。

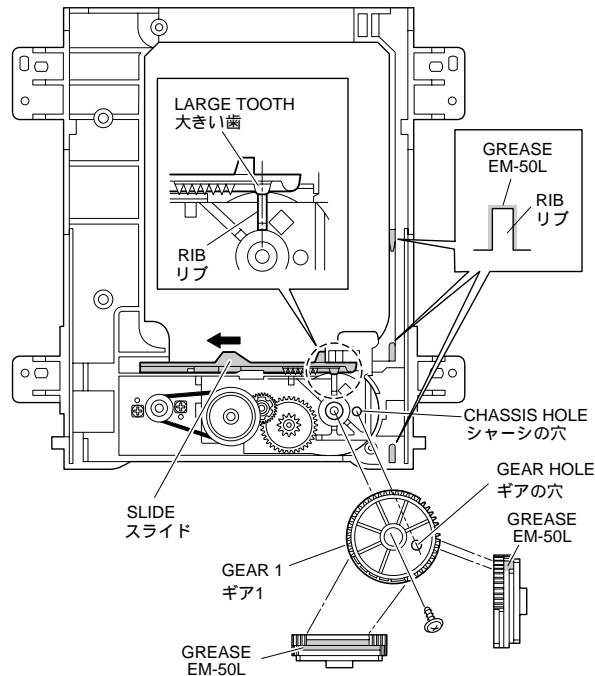

4. Match the mark "a" on the GEAR 2 with the mark on the GEAR 1 and install the GEAR 2.
5. Install the gear 2 fixing screw.
6. Turn the GEAR 3 counterclockwise and check that the SLIDE moves to the right.
4. ギア2のマークaをギア1のマークに合わせて、ギア2を取り付けます。
5. ギア2固定ネジを取り付けます。
6. ギア3を反時計方向に回して、スライドが右の方に動くことを確かめます。

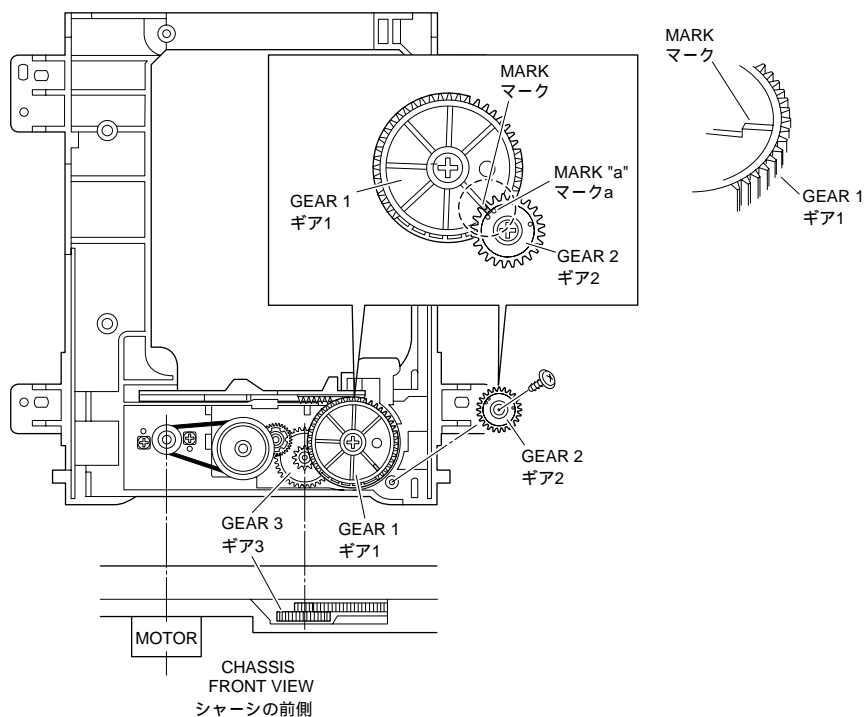



7. Turn the GEAR 3 clockwise and match the GEAR 1 HOLE with the CHASSIS HOLE (at the same position as 2).
8. Match the mark (◁) on the TRAY with the mark "b" on the GEAR 2 and place the TRAY on the loading mechanism.
9. Push the TRAY in the arrow direction while pressing on it lightly.

7. ギア3を時計方向に回転させて、ギア1の穴をシャーシの穴に合わせます。(2と同じ位置)
8. トレーのマーク(◁)とギア2のマークbを合わせて、トレーをローディングメカの上に載せます。
9. 上から軽く押さえながら、トレーを矢印の方向に押し込みます。

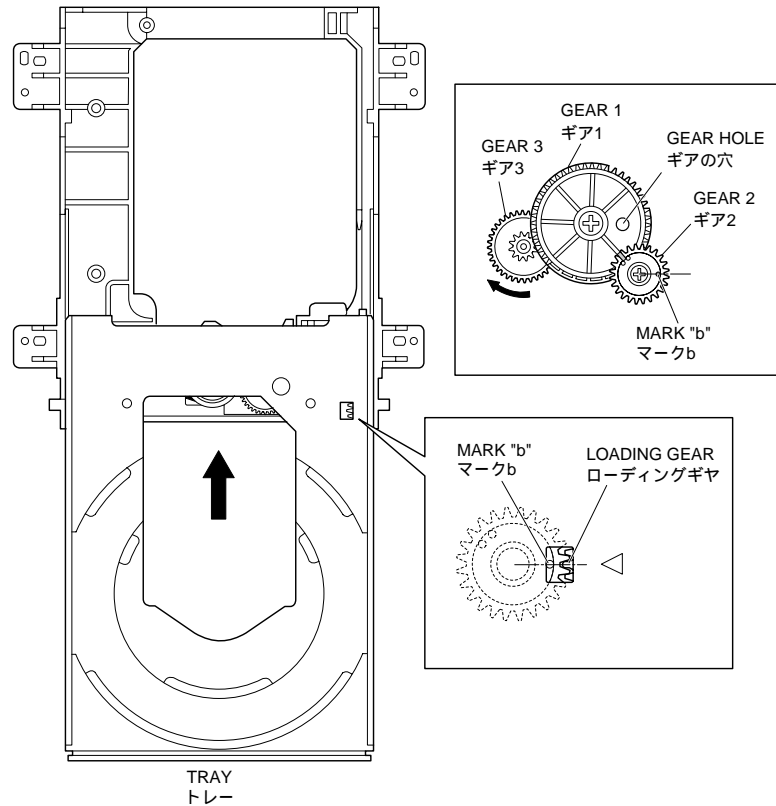

10. Install the CHUCK MOUNTING.
11. Install the chuck mounting fixing screws.

10. チャックマウンティングを取り付けます。
11. チャックマウンティング固定ネジを取り付けます。

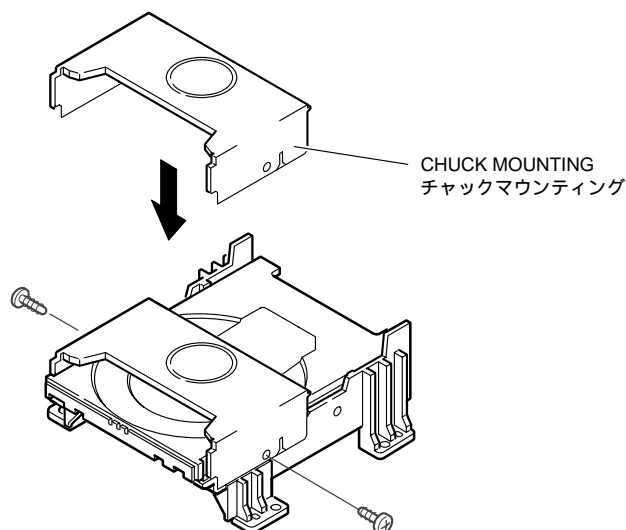

## ■ DVD P.C.B. OPERATION / DVD基板の動作

### 1. General operation diagram

The circuit mounted on the DVD part (Front-end Board) is configured as shown, which is divided into the following blocks according to the main IC's.

### 1. 一般的動作図

DVD基板(フロントエンド)に取り付けられている回路の構成は下記のとおりで、主ICにしたがって下記のブロックに分かれます。

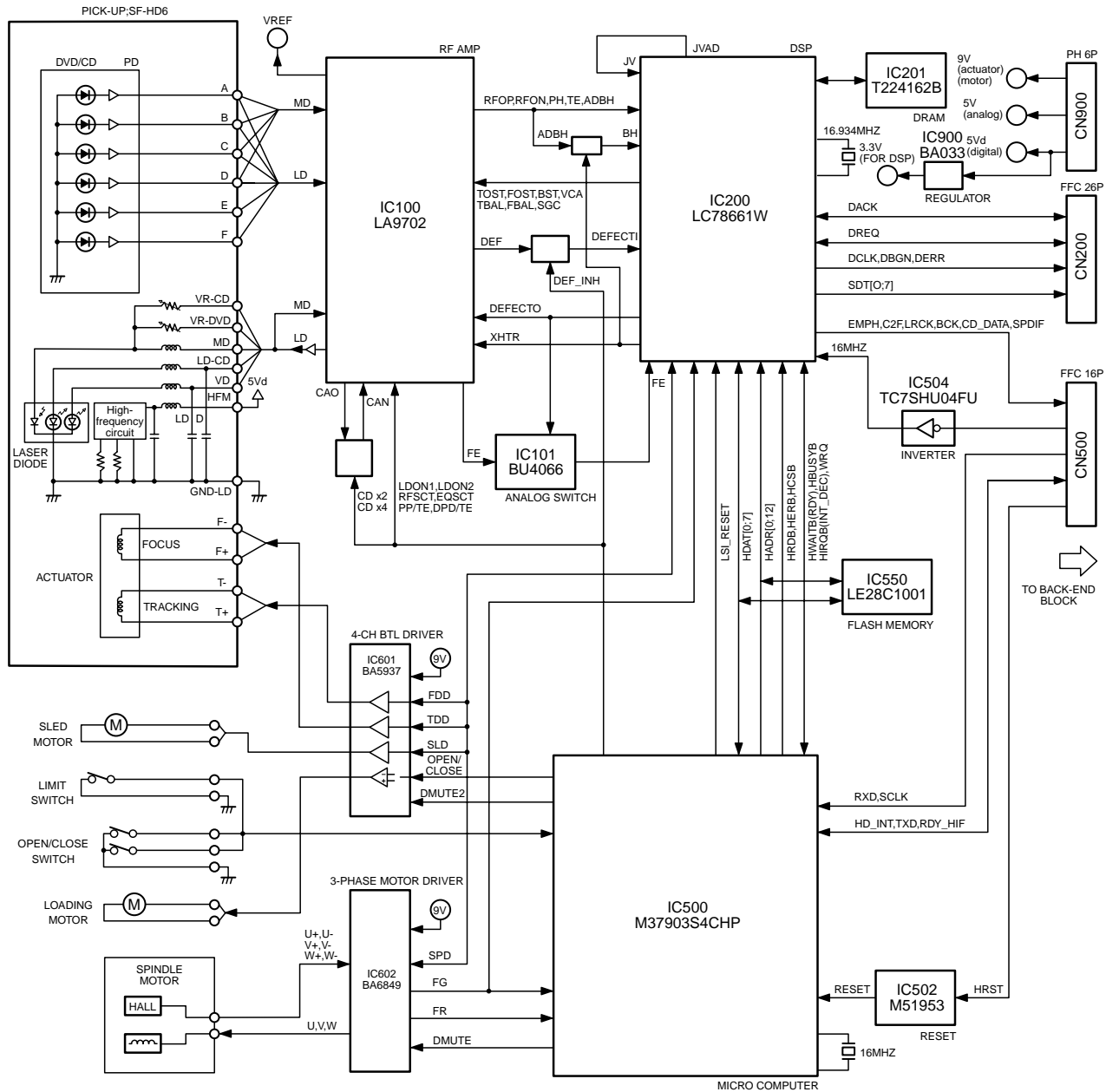

DVR-S60  
NX-SW60

2. Circuit configuration inside IC100 (LA9702W) and IC200 (LC78661W)  
(This is a basic circuit configuration diagram)

2. IC100(LA9702W)とIC200(LC78661W)の内部回路構成 (基本回路構成図)

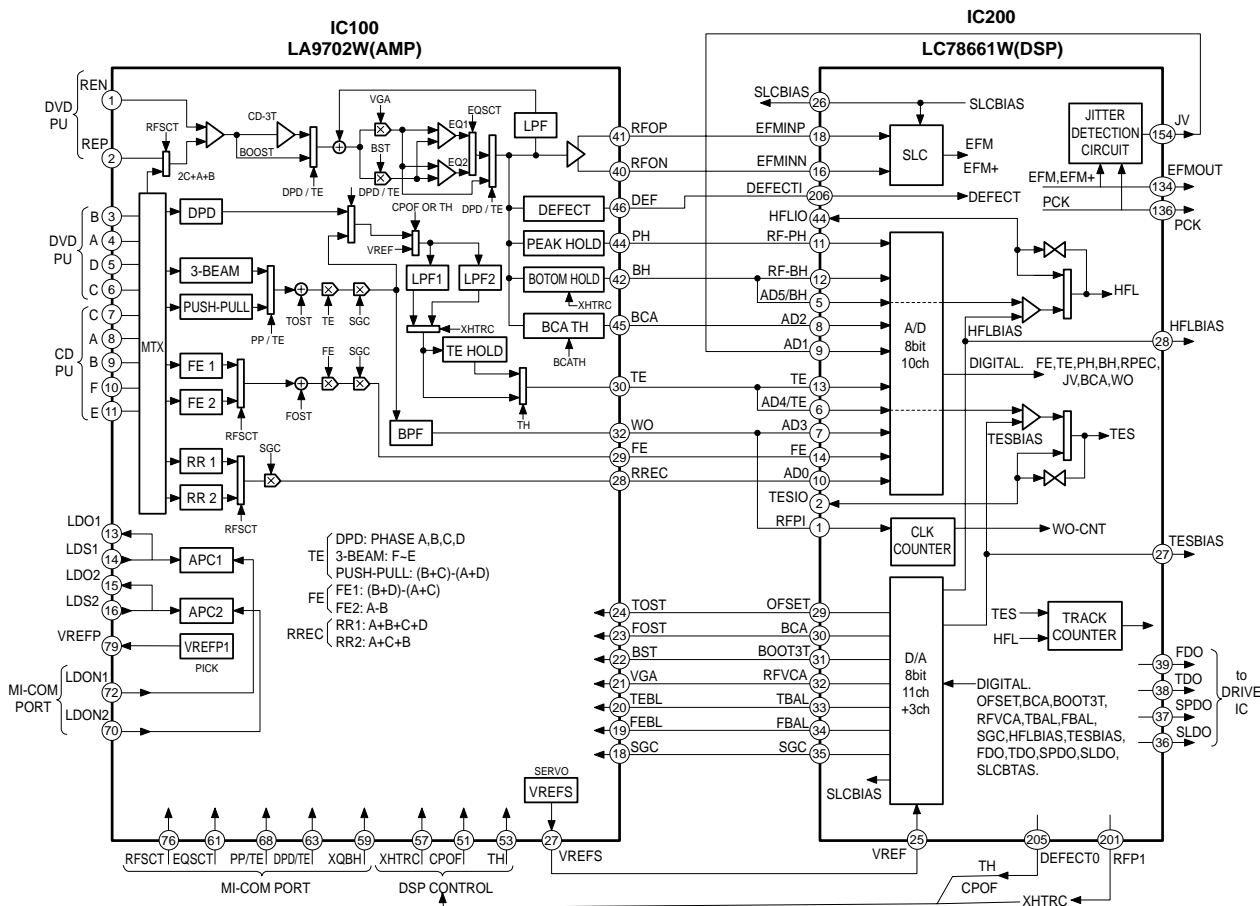

Name	TP label	IC, CN Location	Pin no.	Description	Name	TP label	IC, CN Location	Pin no.	Description
FE	TP101	IC100	25	Focus Error Signal(Analog)	TD	TP601	IC200	38	Tracking Driver out(analog)
TE	TP102	IC100	30	Tracking Error Signal(Analog)	FD	TP602	IC200	39	Focus Driver out(analog)
RFN	TP104	IC100	40	RF Signal(Analog)	SPD-FG	TP604	IC602	24	Spindle FG signal
RFP	TP105	IC100	41	RF Signal(Analog)	W	TP621	-----	-----	
BH	TP106	IC100	42	Bottom Hold Signal(Analog)	V	TP620	-----	-----	
PH	TP107	IC100	44	Peak Hold Signal(Analog)	U	TP611	-----	-----	
DEF	TP230	IC100	46	High : When passing defects	H+	TP619	-----	-----	
LD1	TP122	Q1004	E	DVD Laser Power Supply(Analog)	U+	TP618	-----	-----	
LD2	TP124	Q1005	E	CD Laser Power Supply(analog)	U-	TP617	-----	-----	
TESIO	TP201	IC200	2	TES(Track crossing signal)	V+	TP616	-----	-----	Spindle Hall Voltage
HFLBIAS	TP204	IC200	28	MIRROR Slice Bias(Analog)	V-	TP615	-----	-----	
HFLIO	TP206	IC200	44	MIRROR signal	W+	TP614	-----	-----	
FSEQ	TP211	IC200	84	High : Sync synchronized LO : Async	W-	TP613	-----	-----	
EFMOUT	TP226	IC200	134	RF Digitized signal	H-	TP612	-----	-----	
DEFECT0	TP229	IC200	201	High : When passing defects	SLD	TP607	IC200	36	Sled Driver out(analog)
TOST	TP246	IC200	29	Tracking Offset Control(analog)	SPD	TP608	IC200	37	Spindle Driver out(analog)
FOST	TP247	IC200	30	Focus Offset Control(analog)	OPEN	-----	IC601	16	TRAY control signal
BOOST3T	TP248	IC200	31	RF EQ Control(analog)	CLOSE	-----	IC601	15	TRAY control signal
RFVCA	TP249	IC200	32	RF Voltage Control(analog)	OPEN-SW	TP627	CN600	5	TRAY Limit SW
TBAL	TP250	IC200	33	Tracking Balance Control(analog)	CLOSE-SW	TP626	CN600	3	TRAY Limit SW
FBAL	TP251	IC200	34	Focus Balance Control(analog)	HRST	TP700	CN500	2	RESET from Back-end
FBAL	TP251	IC200	34	Focus Balance Control(analog)	RESET	-----	IC502	6	RESET to Micom
SGC	TP252	IC200	35	Signal Gain Control(analog)	VREF	-----	IC100	27, 79	Reference Voltage(2.5V)
HFBUSYB	TP254	IC200	50	Function Busy Low during jump, adjustment so on.	SLDO	TP603	IC601	18	Sled Motor Driver out
JVAO	TP257	IC200	154	Jitter value(analog)					

DVR-S60 NX-SW60

**MEMO**

A large, empty rectangular box with a thin black border, occupying most of the page. It is intended for writing a memo.

**DVR-S60  
NX-SW60**

# DVD P.C.B. OPERATION (SCHEMATIC DIAGRAM FOR SIGNAL CHECK)

(This is a basic signal check)

Top left section is enlarged on page 22.

Top right section is enlarged on page 23.

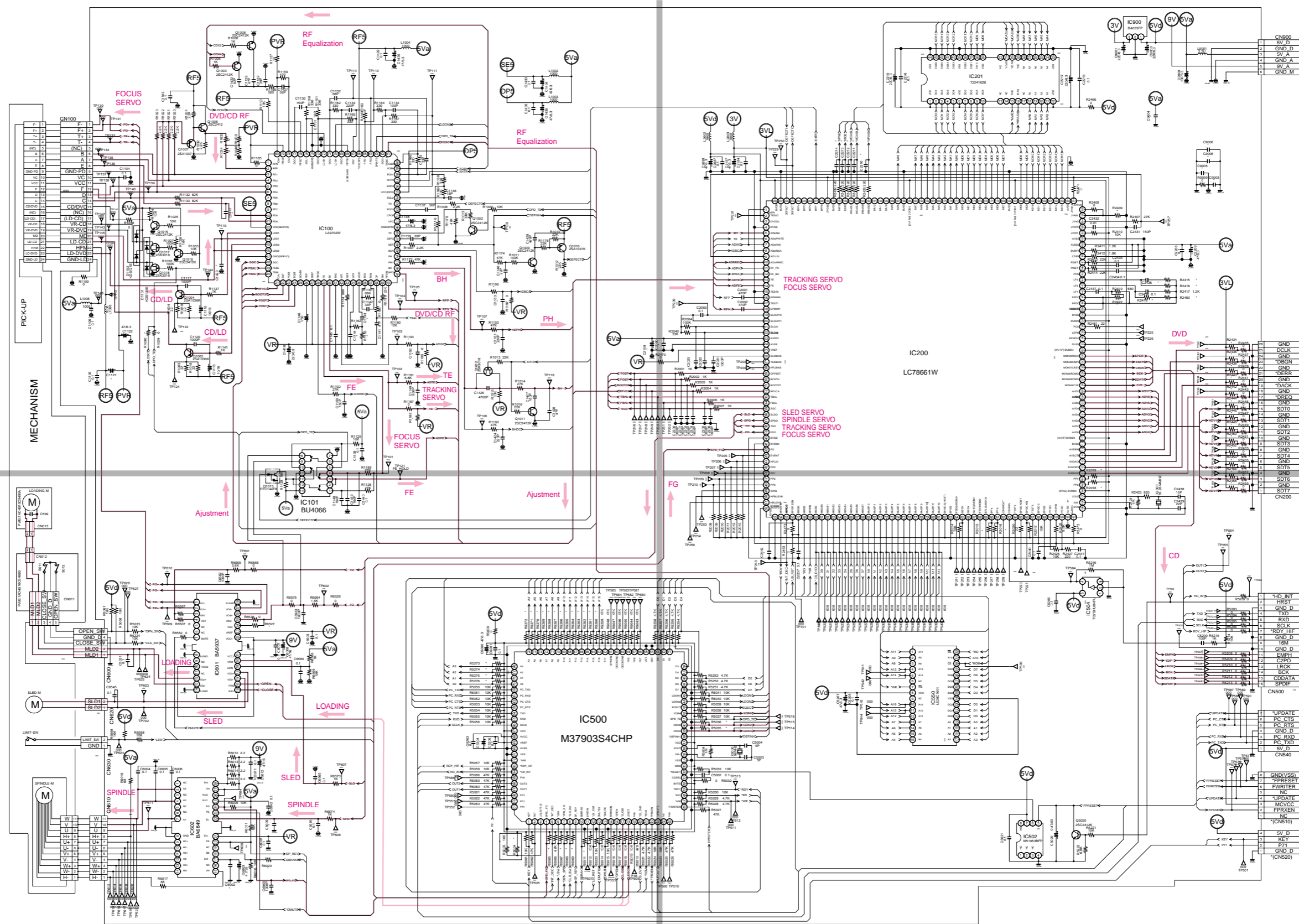

Bottom left section is enlarged on page 24.

Bottom right section is enlarged on page 25.

DVD P.C.B. OPERATION (SCHEMATIC DIAGRAM FOR SIGNAL CHECK for top left enlarged)

(This is a basic signal check)

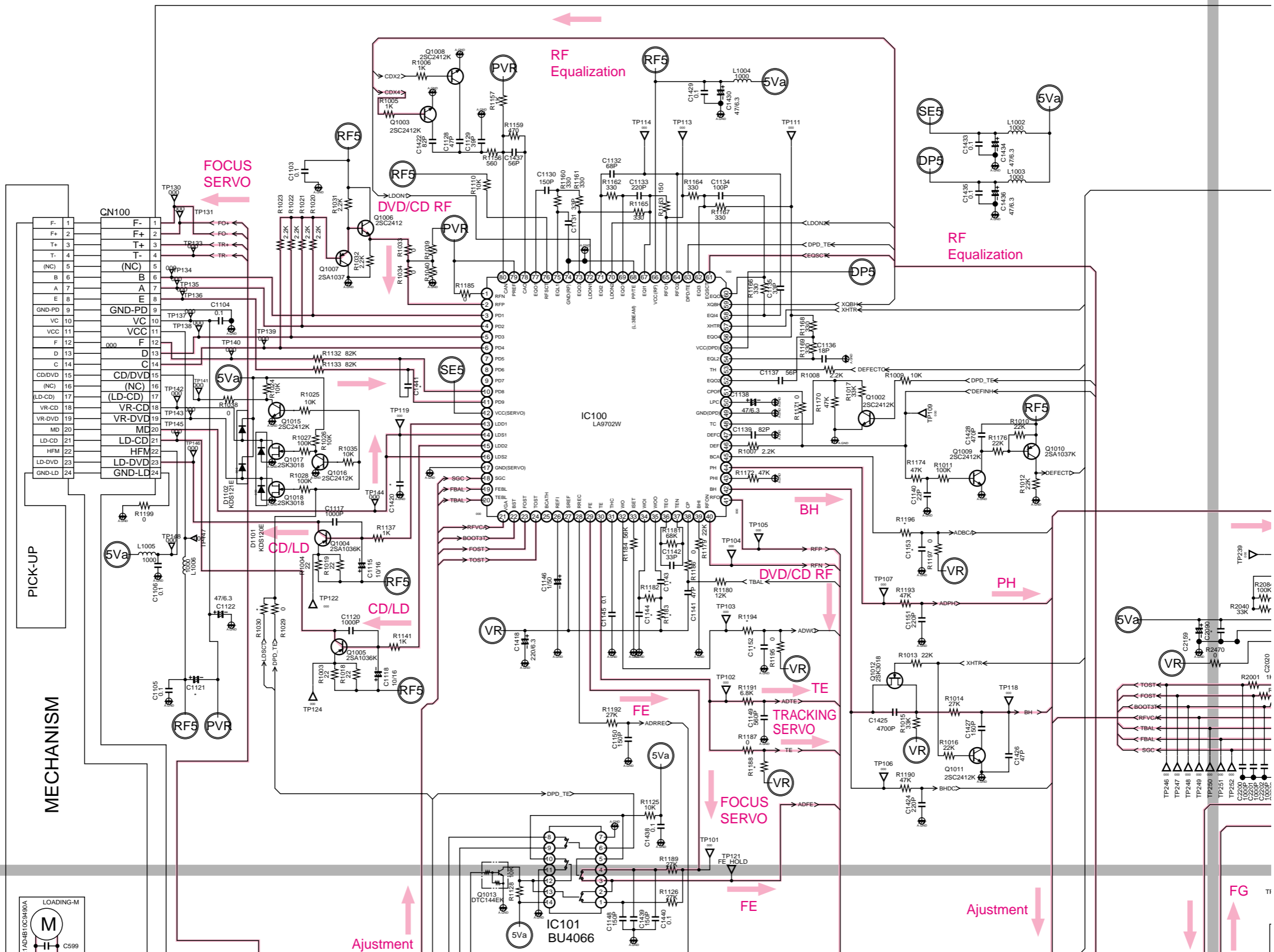

# DVD P.C.B. OPERATION (SCHEMATIC DIAGRAM FOR SIGNAL CHECK for top right enlarged)

(This is a basic signal check)

1

2

3

4

5

6

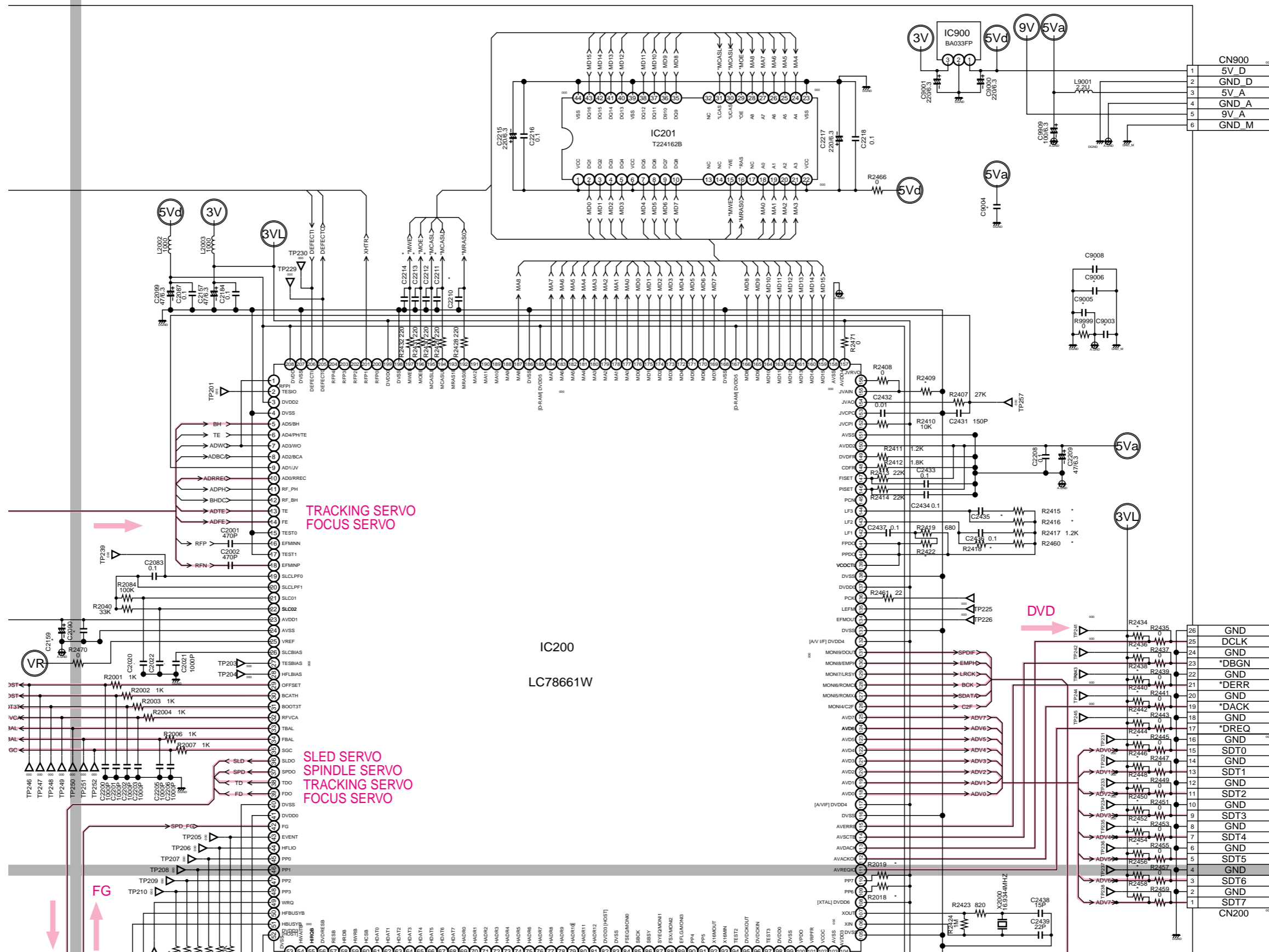

TRACKING SERVO  
FOCUS SERVO

SLD SERVO  
SPINDLE SERVO  
TRACKING SERVO  
FOCUS SERVO

FG

DVD

VR

1	5V D
2	GND D
3	5V A
4	GND A
5	9V A
6	GND M

26	GND
25	DCLK
24	GND
23	*DBGN
22	GND
21	*DERR
20	GND
19	*DACK
18	GND
17	*DREQ
16	GND
15	SDT0
14	GND
13	SDT1
12	GND
11	SDT2
10	GND
9	SDT3
8	GND
7	SDT4
6	GND
5	SDT5
4	GND
3	SDT6
2	GND
1	SDT7

DVD P.C.B. OPERATION (SCHEMATIC DIAGRAM FOR SIGNAL CHECK for bottom left enlarged)

(This is a basic signal check)

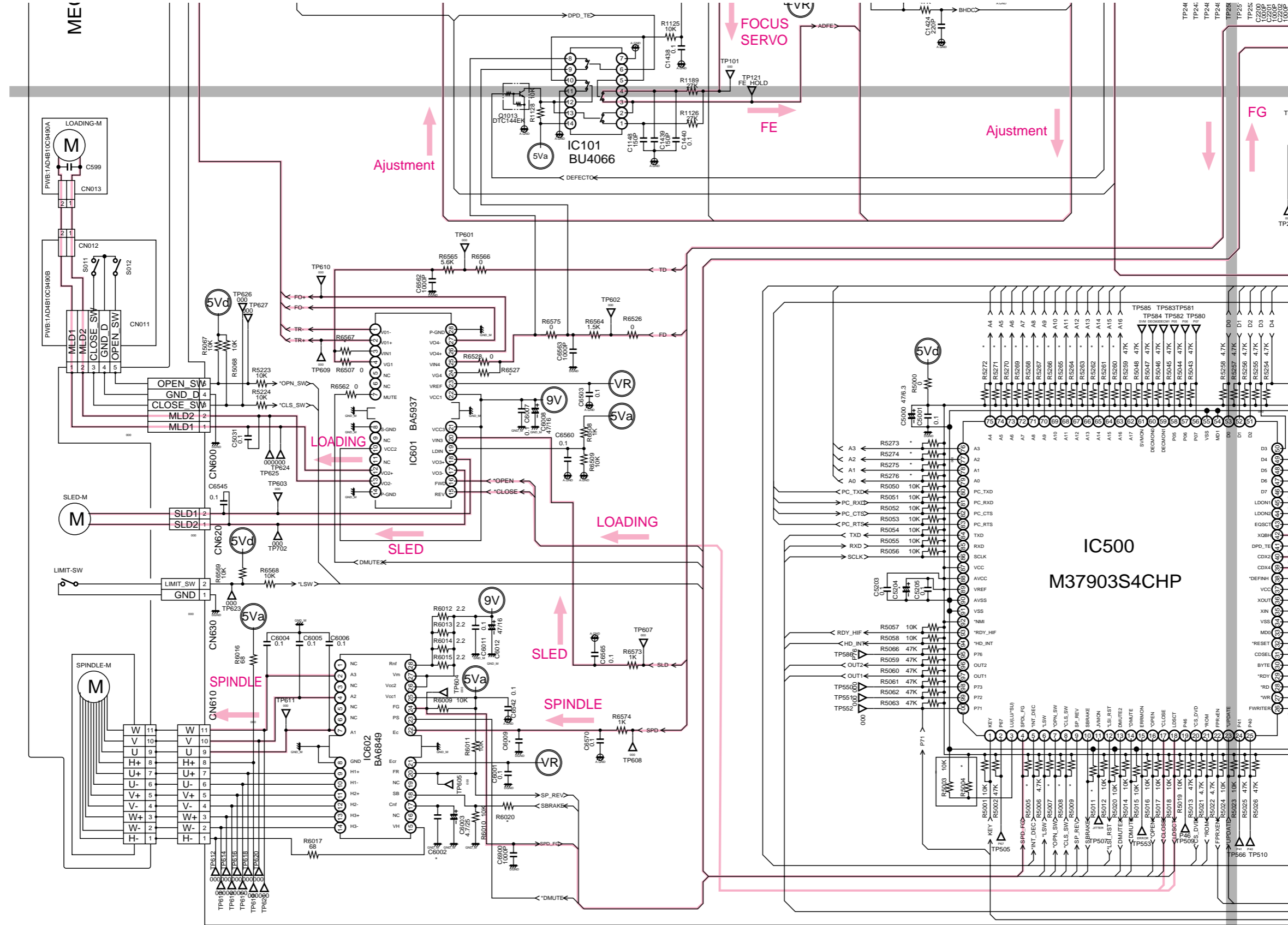



DVD P.C.B. OPERATION (SCHEMATIC DIAGRAM FOR SIGNAL CHECK for bottom right enlarged)

(This is a basic signal check)

1  
2  
3  
4  
5  
6

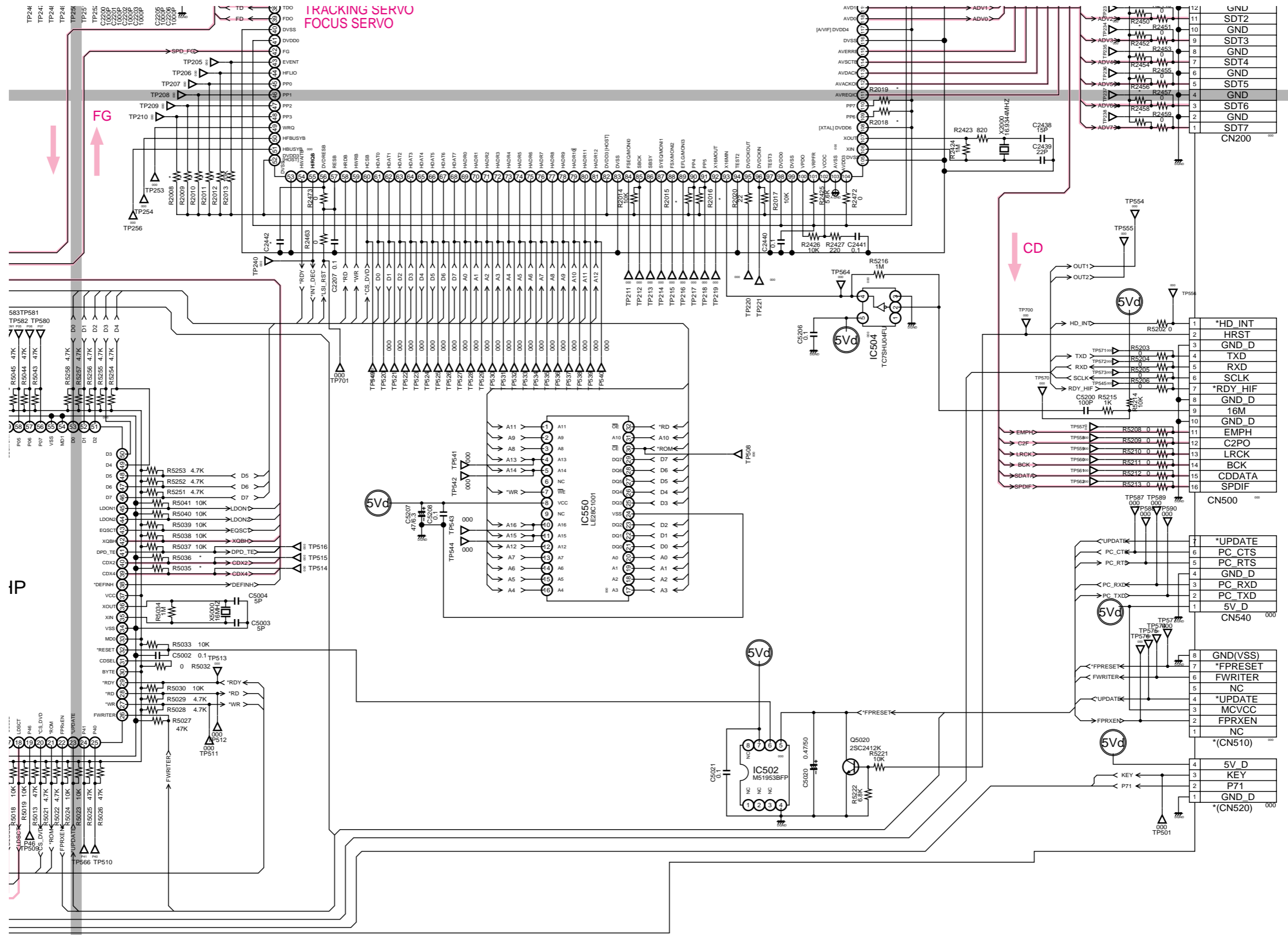

DVR-S60/NX-SW60

DVD P.C.B. OPERATION (WIRING DIAGRAM for SIGNAL CHECK)

A. A side (This is a basic signal check)

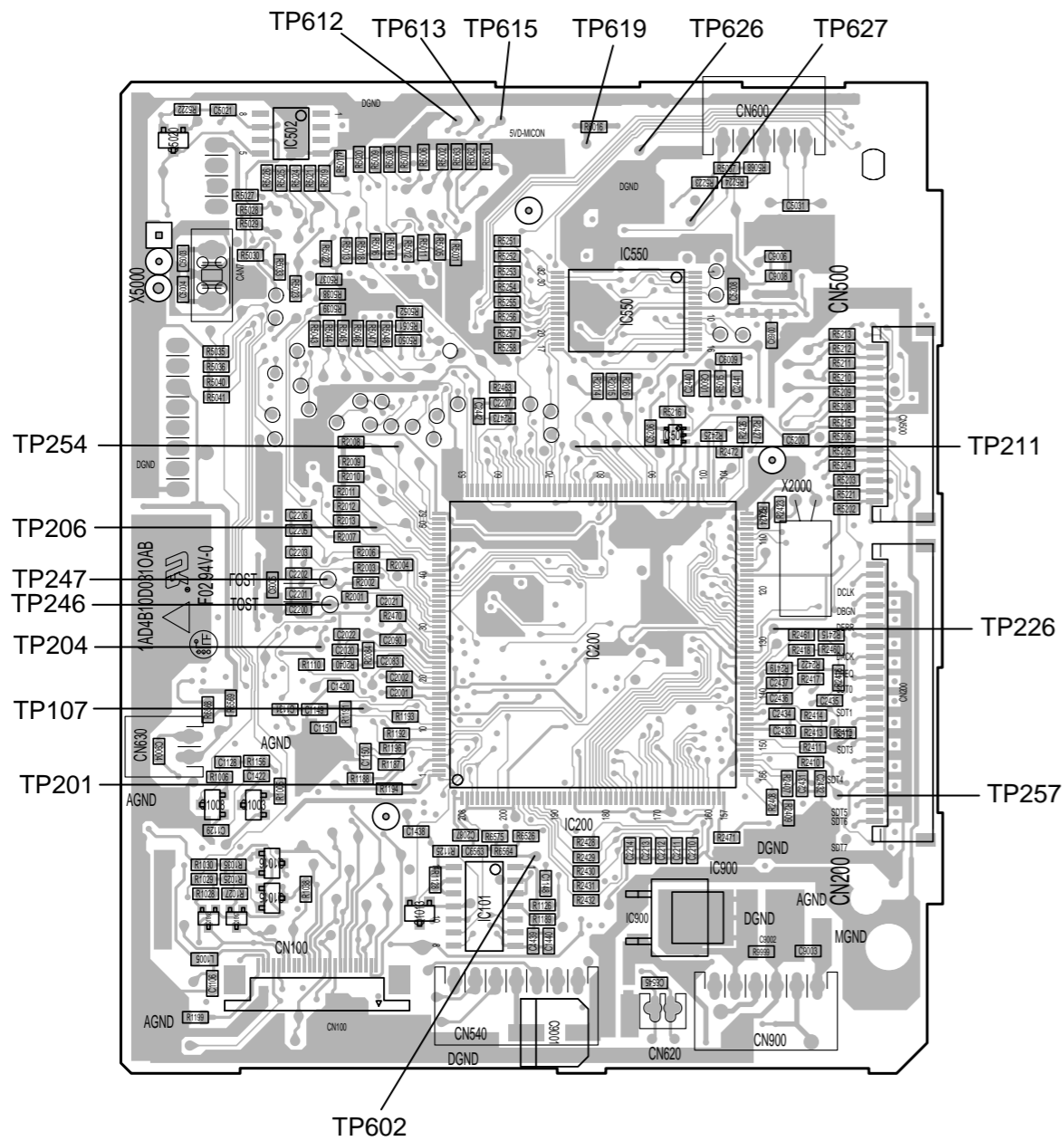

B. B side (This is a basic signal check)

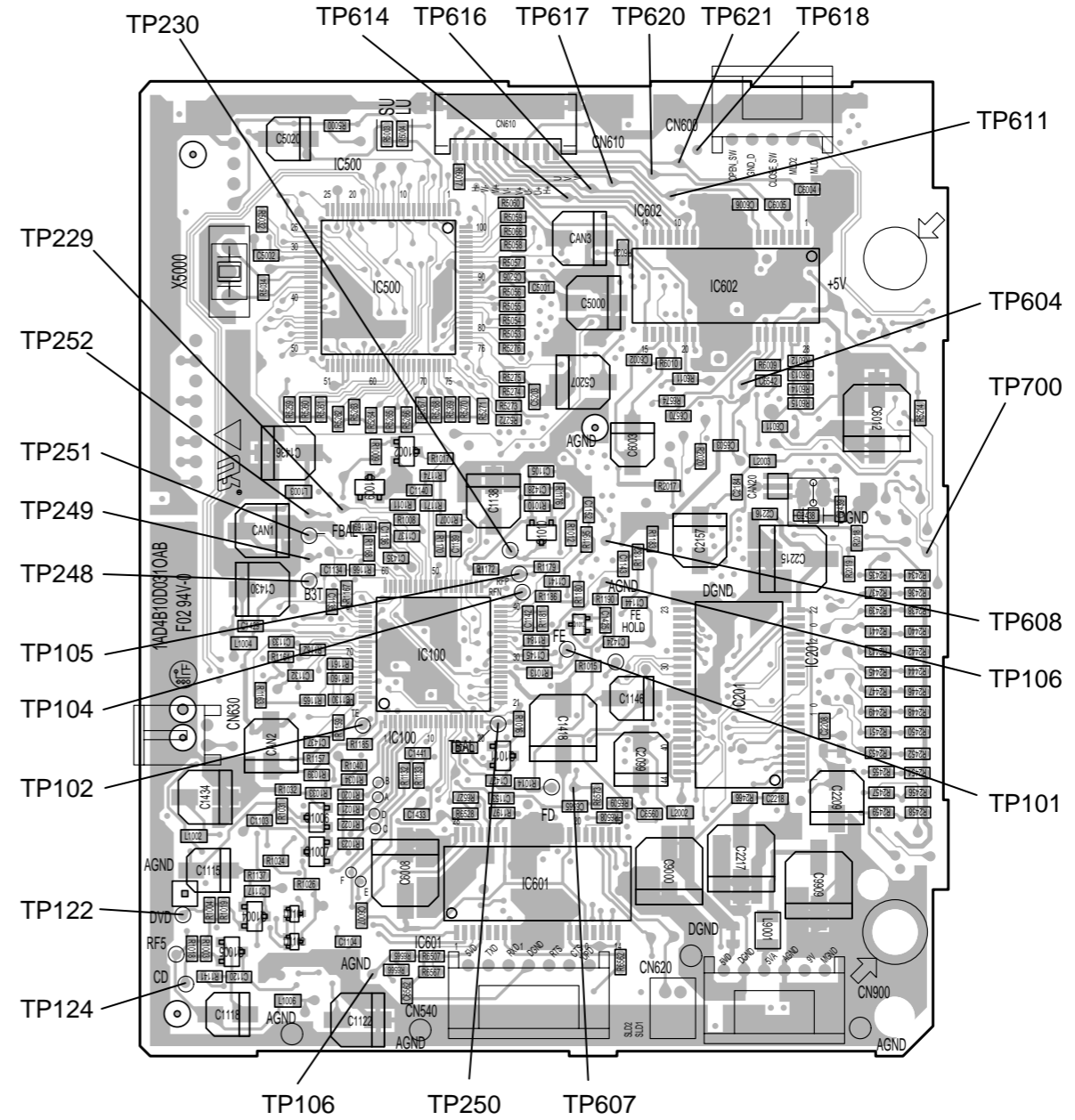

5

Name	TP label	IC, CN Location	Pin no.	Description	Name	TP label	IC, CN Location	Pin no.	Description
FE	TP101	IC100	25	Focus Error Signal(Analog)	TD	TP601	IC200	38	Tracking Driver out(analog)
TE	TP102	IC100	30	Tracking Error Signal(Analog)	FD	TP602	IC200	39	Focus Driver out(analog)
RFN	TP104	IC100	40	RF Signal(Analog)	SPD-FG	TP604	IC602	24	Spindle FG signal
RFP	TP105	IC100	41	RF Signal(Analog)	W	TP621	-----	-----	
BH	TP106	IC100	42	Bottom Hold Signal(Analog)	V	TP620	-----	-----	
PH	TP107	IC100	44	Peak Hold Signal(Analog)	U	TP611	-----	-----	
DEF	TP230	IC100	46	High : When passing defects	H+	TP619	-----	-----	
LD1	TP122	Q1004	E	DVD Laser Power Supply(Analog)	U+	TP618	-----	-----	
LD2	TP124	Q1005	E	CD Laser Power Supply(analog)	U-	TP617	-----	-----	
TESIO	TP201	IC200	2	TES(Track crossing signal)	V+	TP616	-----	-----	
HFLBIAS	TP204	IC200	28	MIRROR Slice Bias(Analog)	V-	TP615	-----	-----	Spindle Hall Voltage
HFLIO	TP206	IC200	44	MIRROR signal	W+	TP614	-----	-----	
FSEQ	TP211	IC200	84	High : Sync synchronized LO : Async	W-	TP613	-----	-----	
EFMOUT	TP226	IC200	134	RF Digitized signal	H-	TP612	-----	-----	

Name	TP label	IC, CN Location	Pin no.	Description	Name	TP label	IC, CN Location	Pin no.	Description
DEFECT0	TP229	IC200	201	High : When passing defects	SLD	TP607	IC200	36	Sled Driver out(analog)
TOST	TP246	IC200	29	Tracking Offset Control(analog)	SPD	TP608	IC200	37	Spindle Driver out(analog)
FOST	TP247	IC200	30	Focus Offset Control(analog)	OPEN	-----	IC601	16	TRAY control signal
BOOST3T	TP248	IC200	31	RF EQ Control(analog)	CLOSE	-----	IC601	15	TRAY control signal
RFVCA	TP249	IC200	32	RF Voltage Control(analog)	OPEN-SW	TP627	CN600	5	TRAY Limit SW
TBAL	TP250	IC200	33	Tracking Balance Control(analog)	CLOSE-SW	TP626	CN600	3	TRAY Limit SW
FBAL	TP251	IC200	34	Focus Balance Control(analog)	HRST	TP700	CN500	2	RESET from Back-end
SGC	TP252	IC200	35	Signal Gain Control(analog)	RESET	-----	IC502	6	RESET to Micom
HFBUSYB	TP254	IC200	50	Function Busy Low during jump, adjustment so on.	VREF	-----	IC100	27, 79	Reference Voltage(2.5V)
JVAO	TP257	IC200	154	Jitter value(analog)	SLDO	TP603	IC601	18	Sled Motor Driver out

## DVD P.C.B. OPERATION (SIGNAL) / DVD基板の動作 (信号)

### 1. RF and Defect Signal

Each signal shown refers to P.C.B, SCHEMATIC DIAGRAM and Table of monitor signals.

### 1. RFとディフェクト信号

下図の各信号は、基板、回路図、モニター信号の表に関するものです。

#### A. RF Signal during play mode.

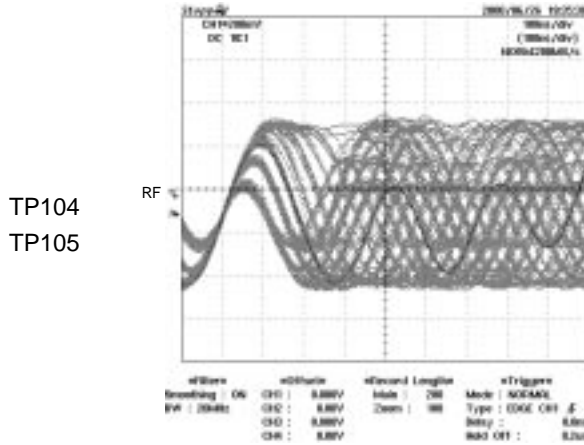

RF of DVD disc

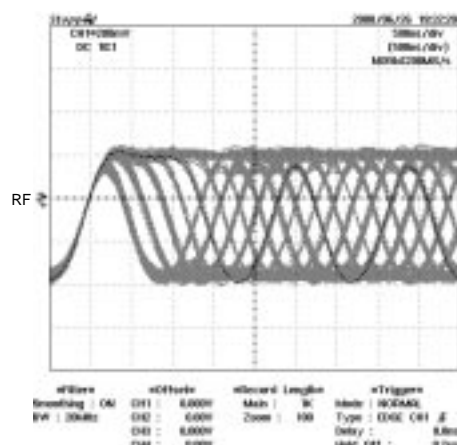

RF of CD disc

#### B. Defect Signal (Detection of low level signal)

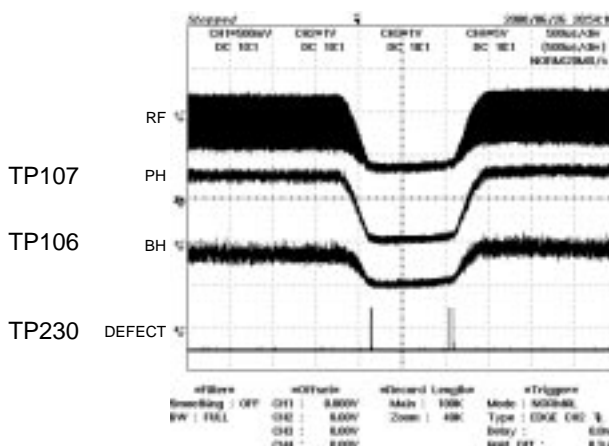

Scratched defect

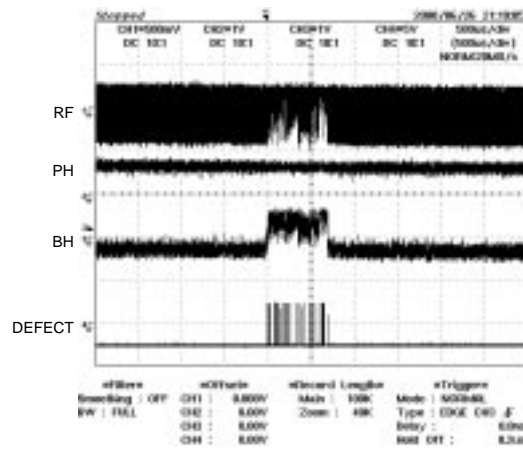

Interruption defect

### 2. Servo and Tray Control

#### A. S-Curve signal by Focus search

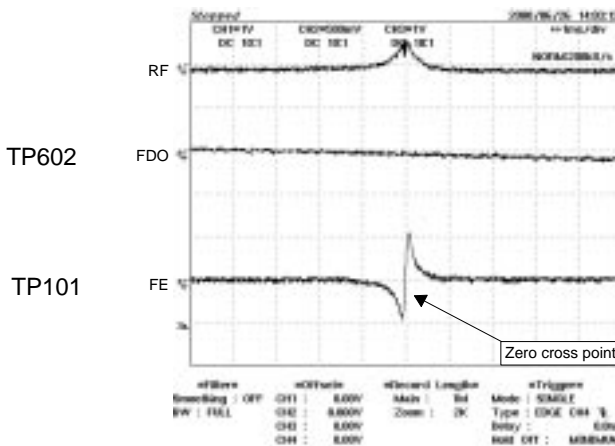

S-Curve of DVD Single Layed disc

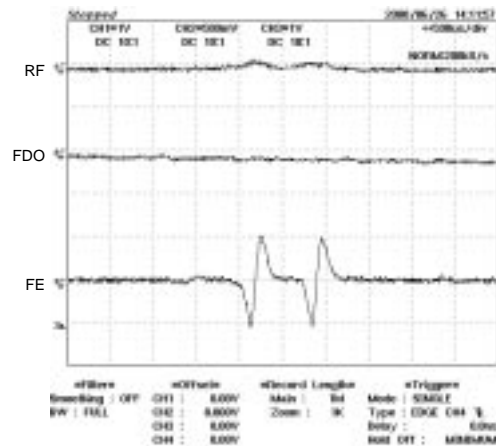

S-Curve of DVD Dual Layed disc

DVR-S60  
NX-SW60

DVD P.C.B. OPERATION (SIGNAL) / DVD基板の動作 (信号)

B. Focus In and Focus Jump

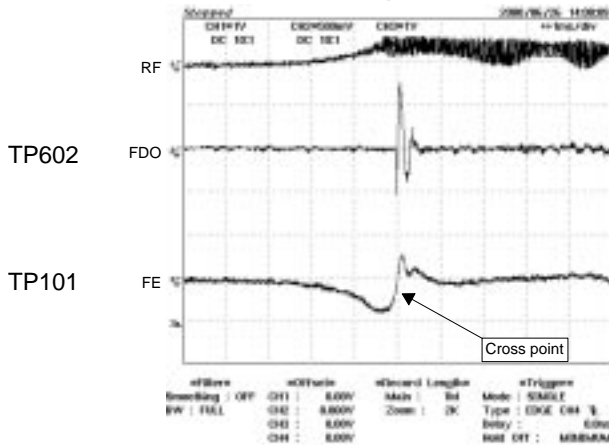

Focus In

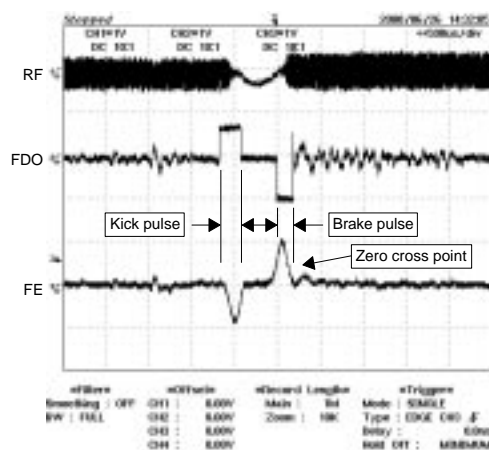

Focus Jump

C. Tracking Servo

a. TE (Tracking Error) Signal.

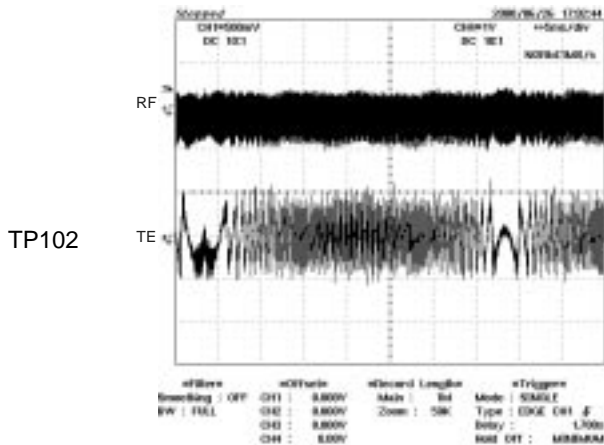

TE Curve

b. Track Jump Signal

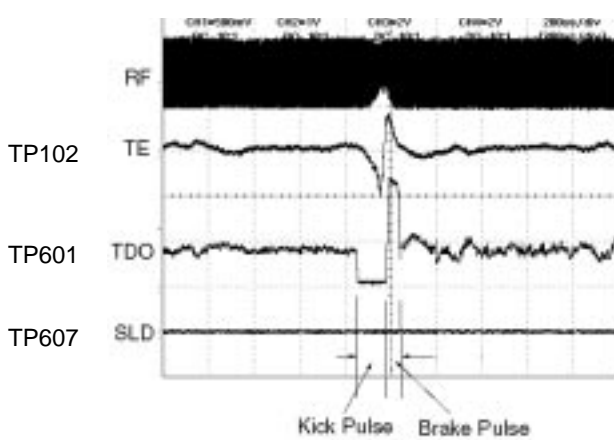

One Track Jump

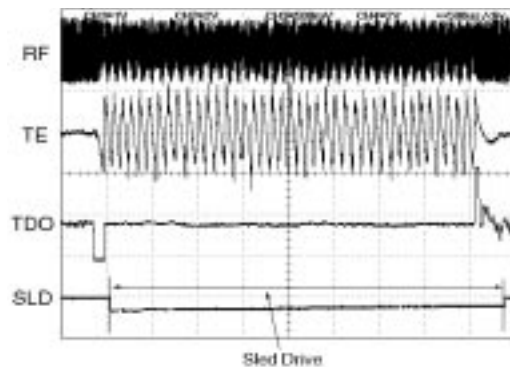

16 Track Jump

DVR-S60  
NX-SW60

DVD P.C.B. OPERATION (SIGNAL) / DVD基板の動作 (信号)

D. Sled Servo (Sled motor drive signal)

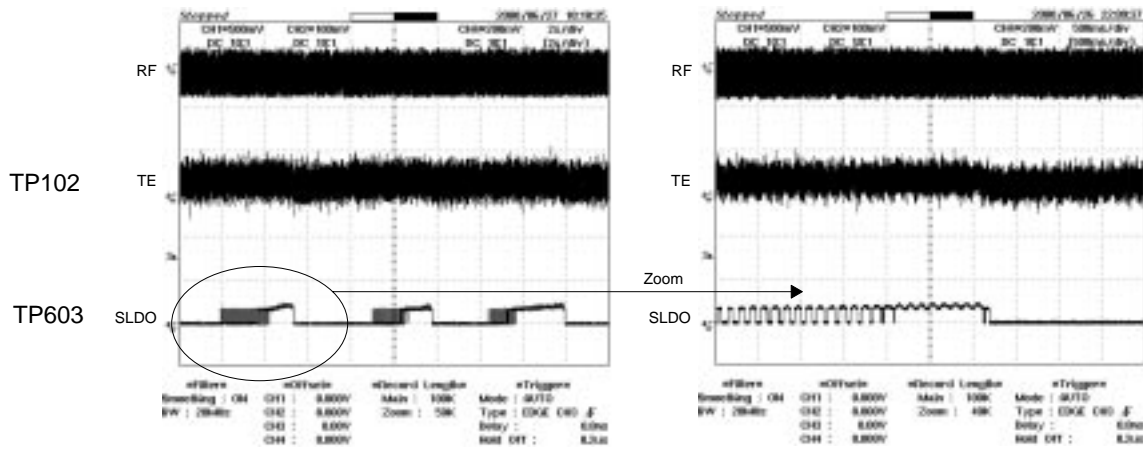

E. Spindle Servo (Spindle motor drive signal)

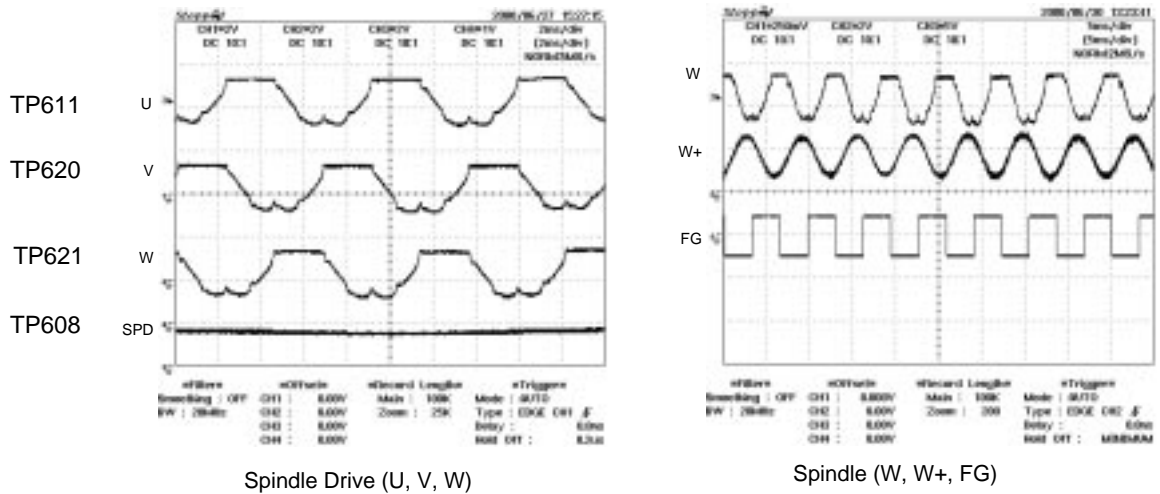

F. Tray open and close

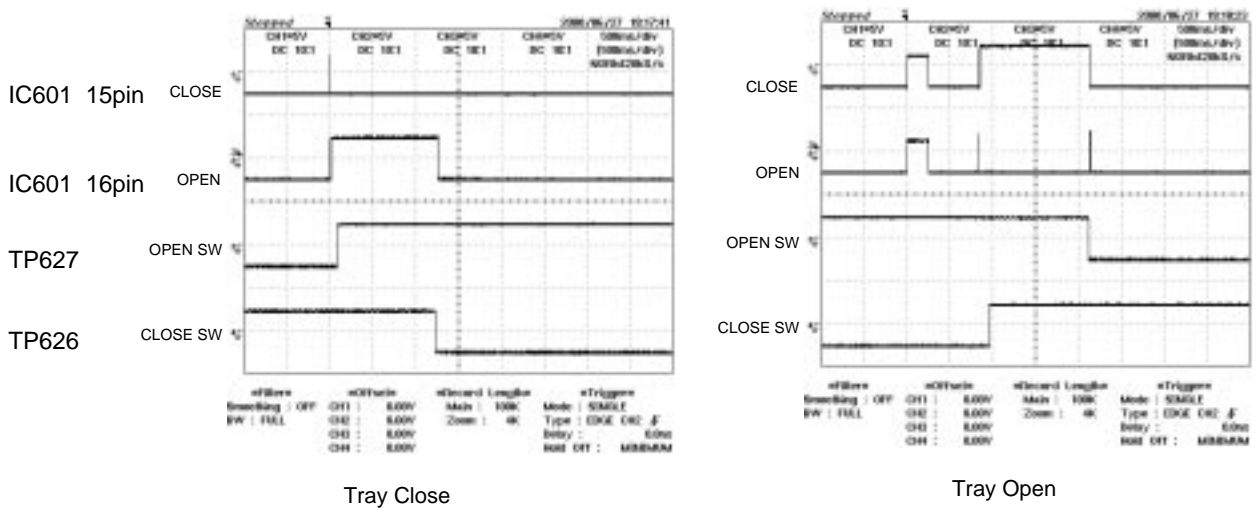

DVR-S60  
NX-SW60

DVD P.C.B. OPERATION (SIGNAL) / DVD基板の動作 (信号)

3. Decoder

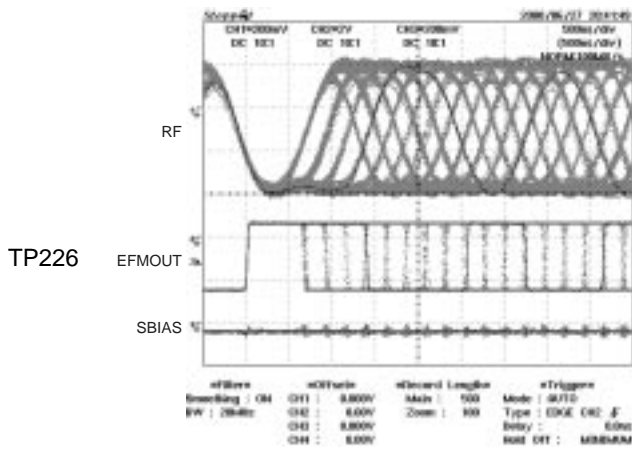

RF, EFMOUT, SBIAS

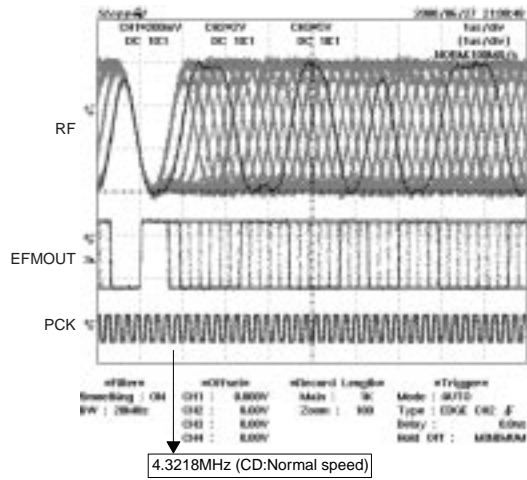

RF, EFMOUT, PCK

4. Reset Timing for Micom Cotroller

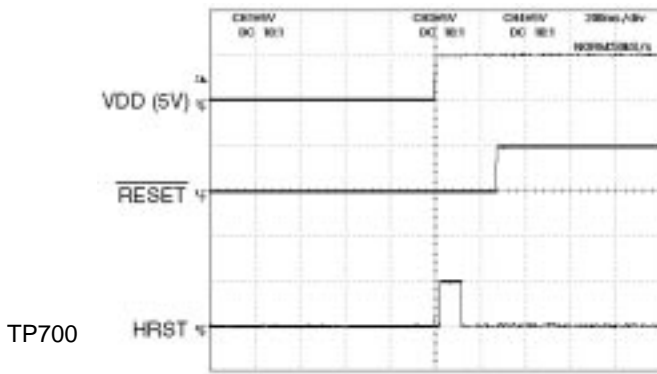

Reset Timing

5. Anti-Defect Processing

A. Disturbance by Defect

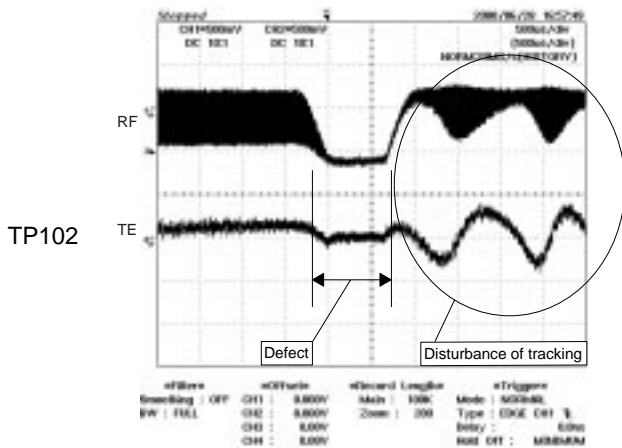

TE disturbance at Defect

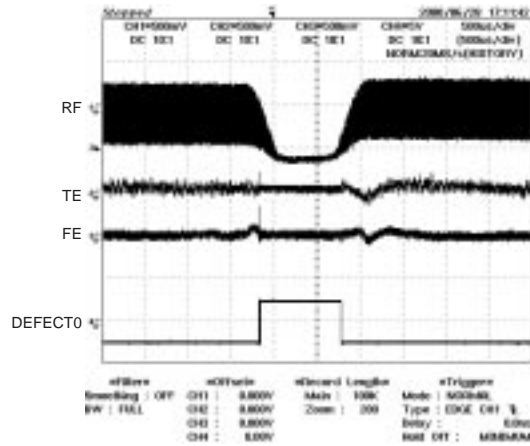

Suppressed disturbance by TE,FE hold process

DVD P.C.B. OPERATION (SIGNAL) / DVD基板の動作 (信号)

B. Circuit block of Anti-Defect

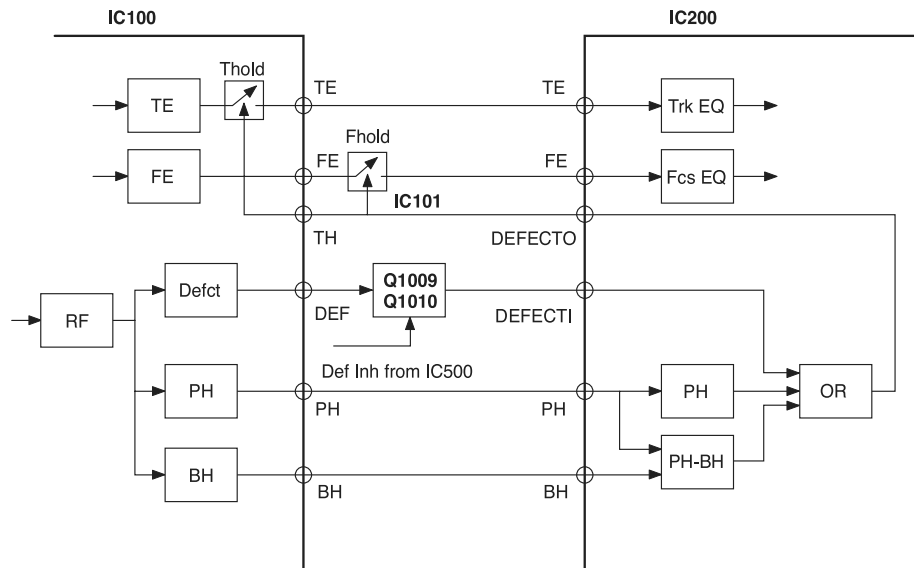

6. Start-up program

A. Disc type Identification

a. In the case of DVD Dual Disc

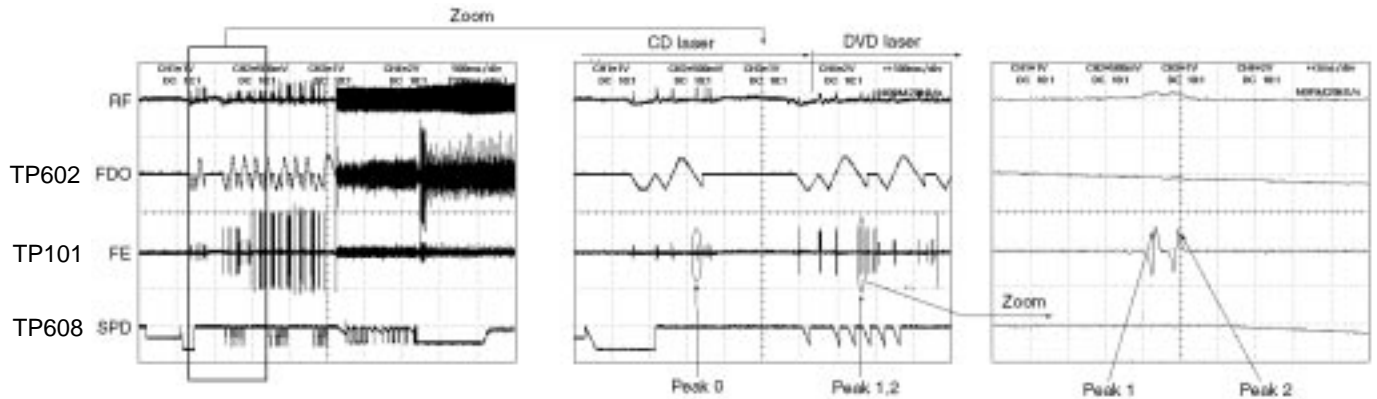

b. In the case of DVD Single Disc

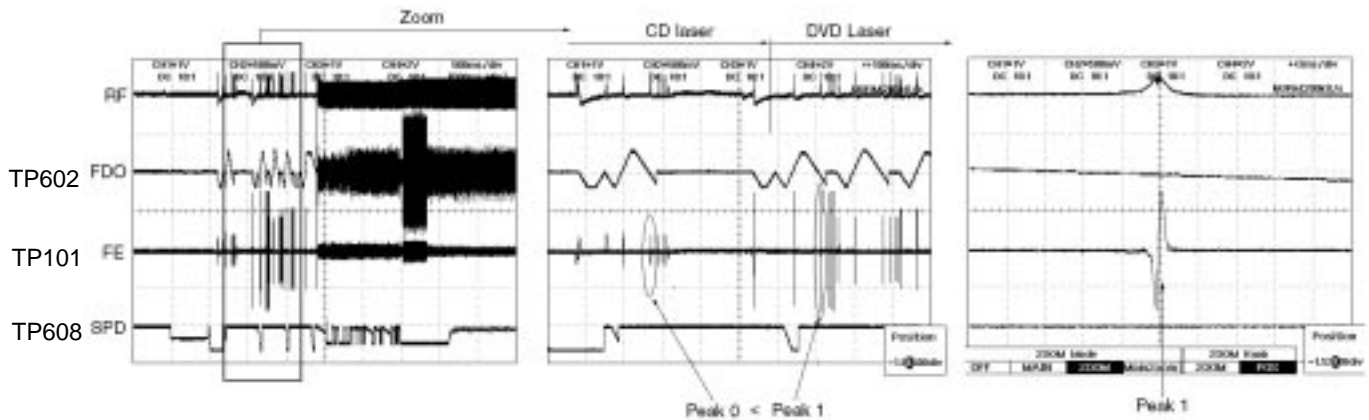

DVR-S60  
NX-SW60

DVD P.C.B. OPERATION (SIGNAL) / DVD基板の動作 (信号)

c. In the case of CD Disc

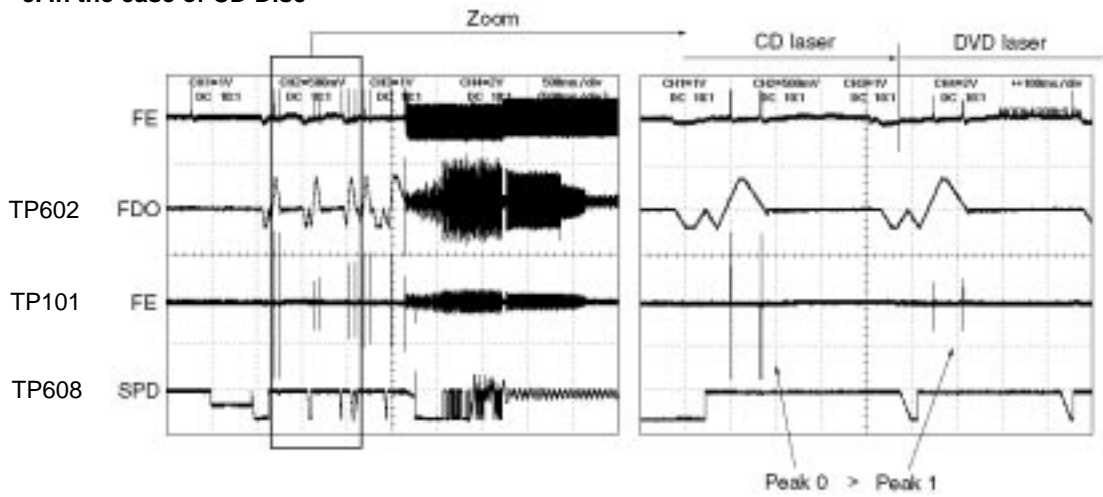

B. Disc diameter identification

a. In the case of 12cm Disc

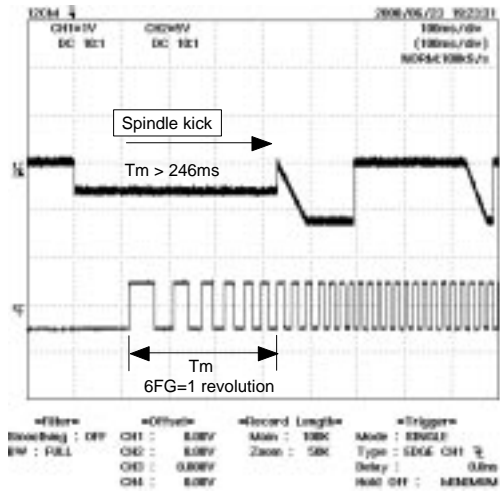

b. In the case of 8cm Disc

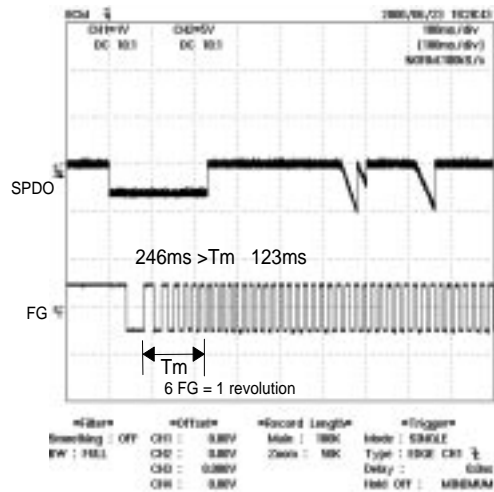

c. In the case of NO Disc

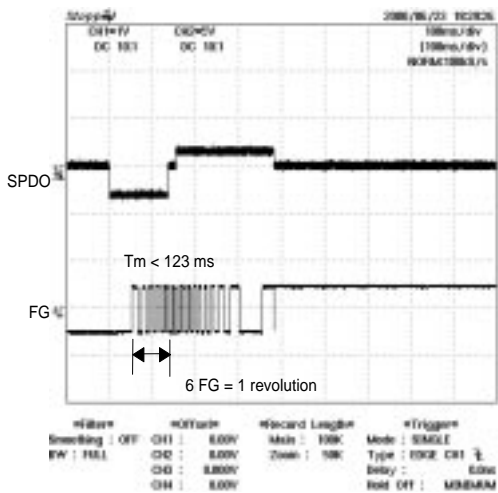

DVR-S60  
NX-SW60



DVD P.C.B. OPERATION (SIGNAL) / DVD基板の動作 (信号)

7. Adjustment (Auto Adjustment)

A. SGC(Signal Gain Control) Adjustment

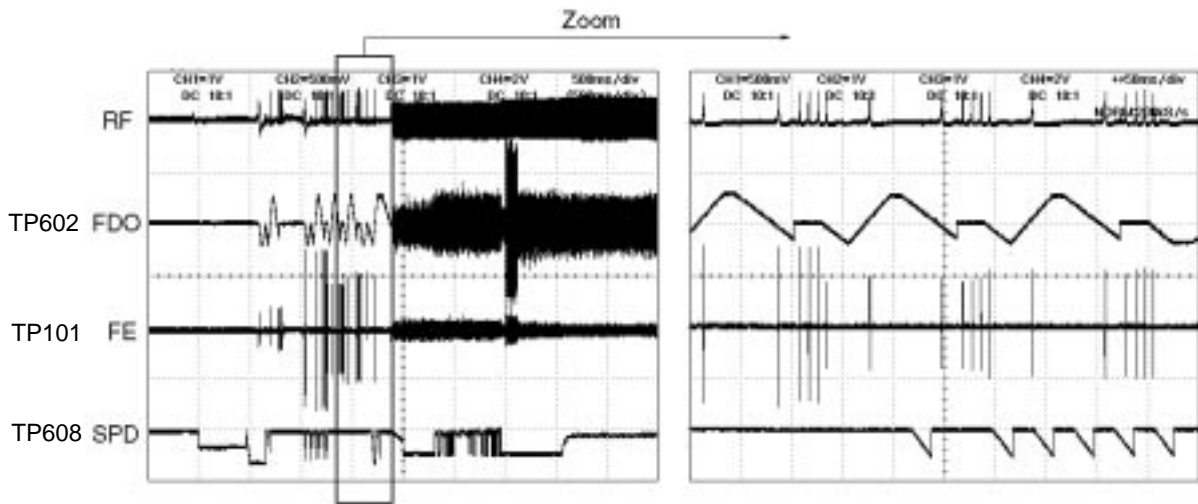

B. Tracking Balance Adjustment

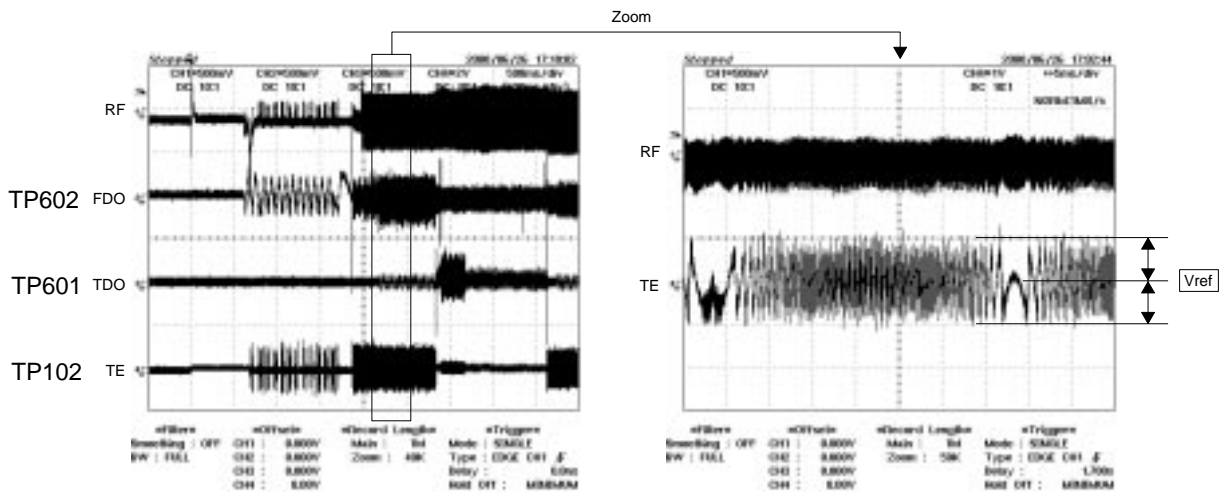

DVR-S60  
NX-SW60

DVD P.C.B. OPERATION (SIGNAL) / DVD基板の動作 (信号)

C. Focus and Tracking Gain Adjustment

a. Focus gain Adjustment

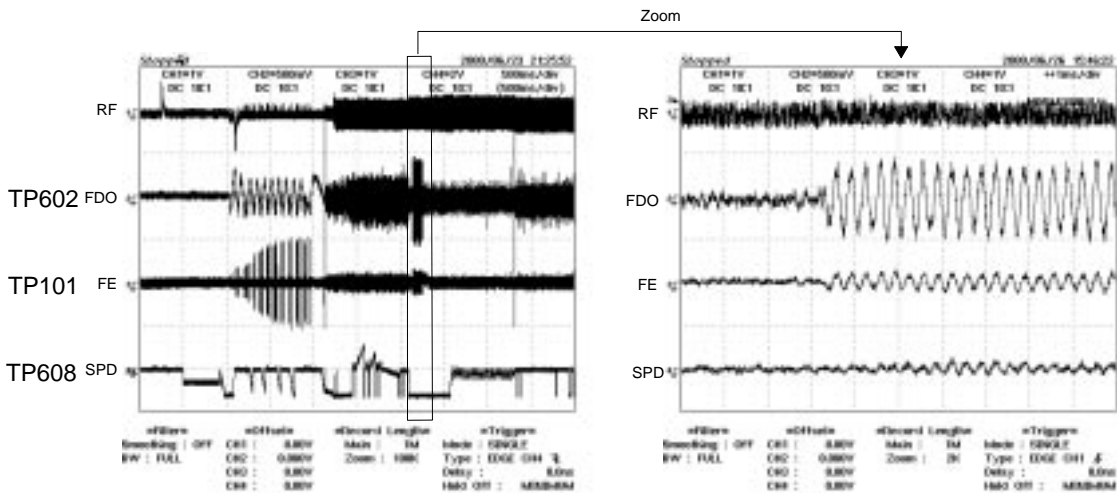

b. Tracking Gain Adjustment

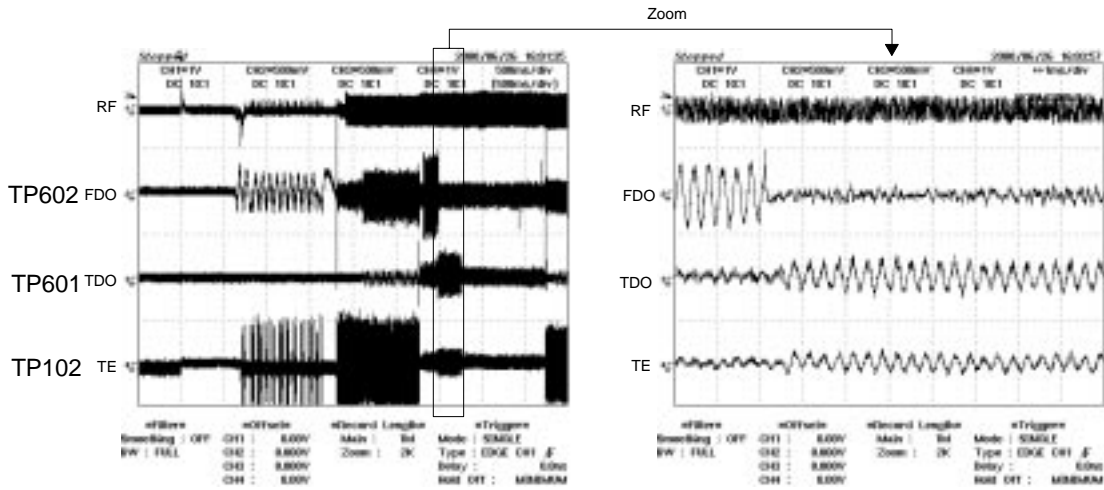

DVR-S60  
NX-SW60

# DVD START-UP PROGRAM FLOW CHART

## 1. Disc Identification

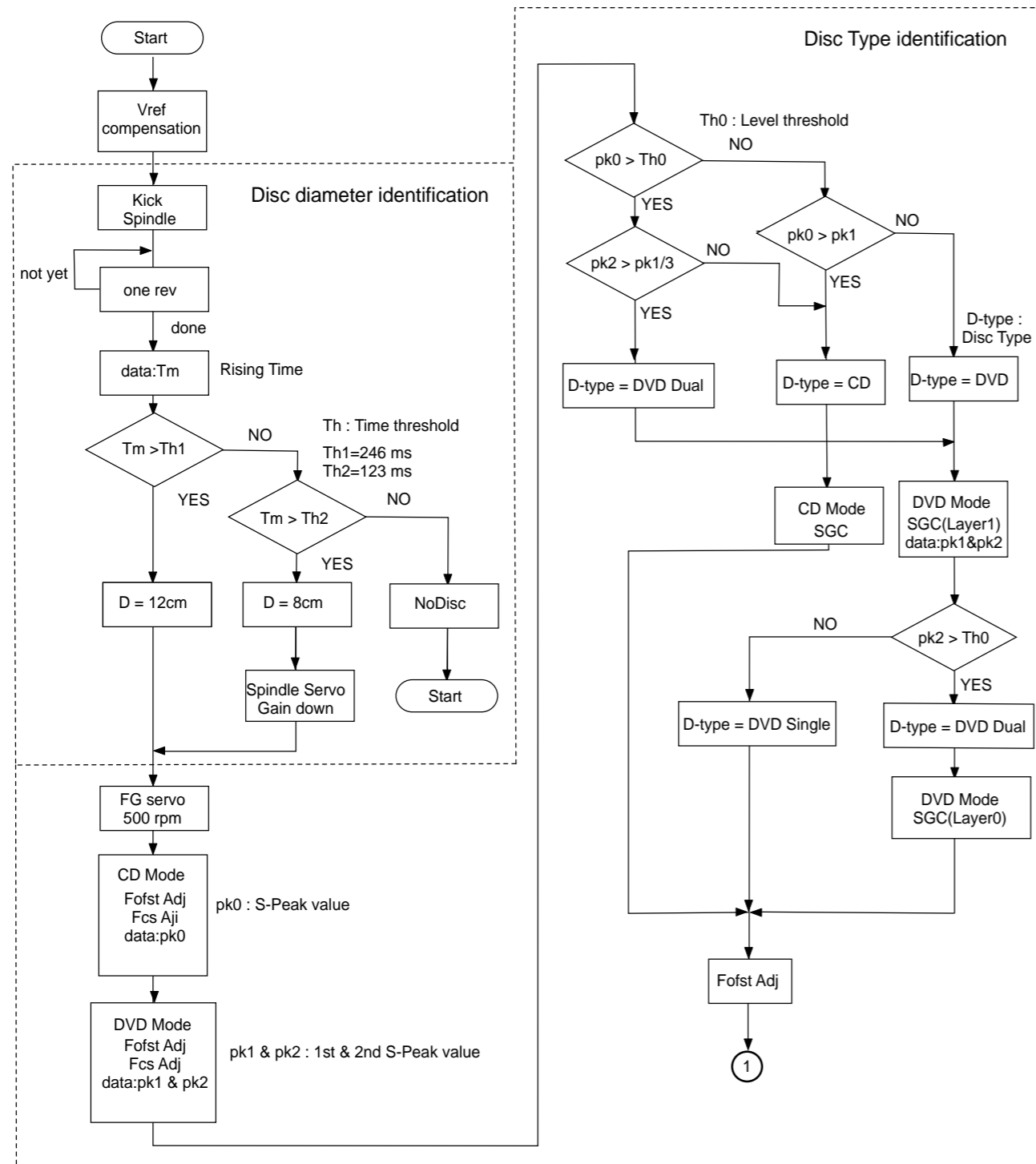

## 2. Fundamental and additional auto adjustment

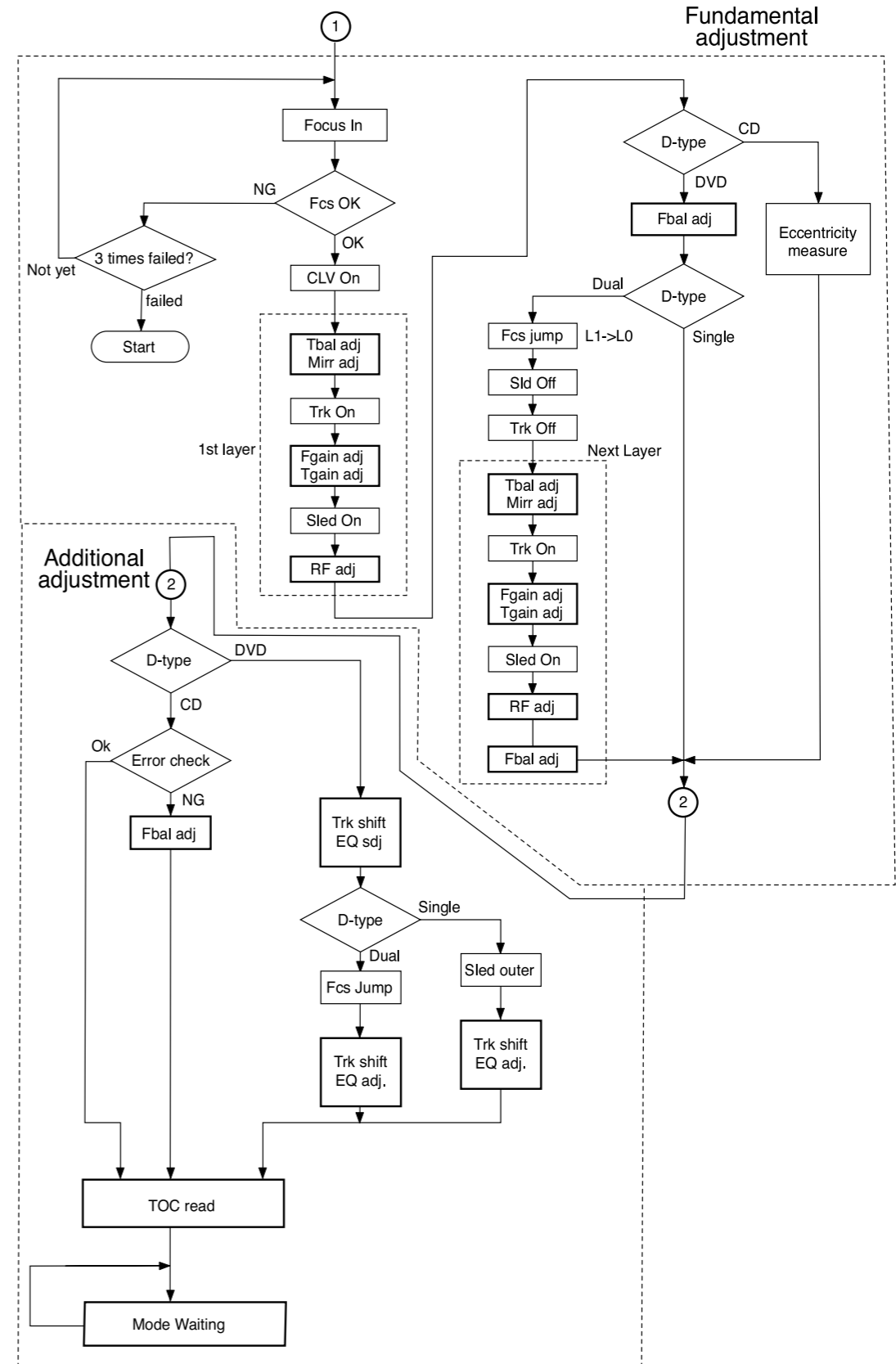

MPEG P.C.B. OPERATION (SCHEMATIC DIAGRAM FOR WAVEFORM CHECK) / MPEG基板の動作 (波形チェックポイント)

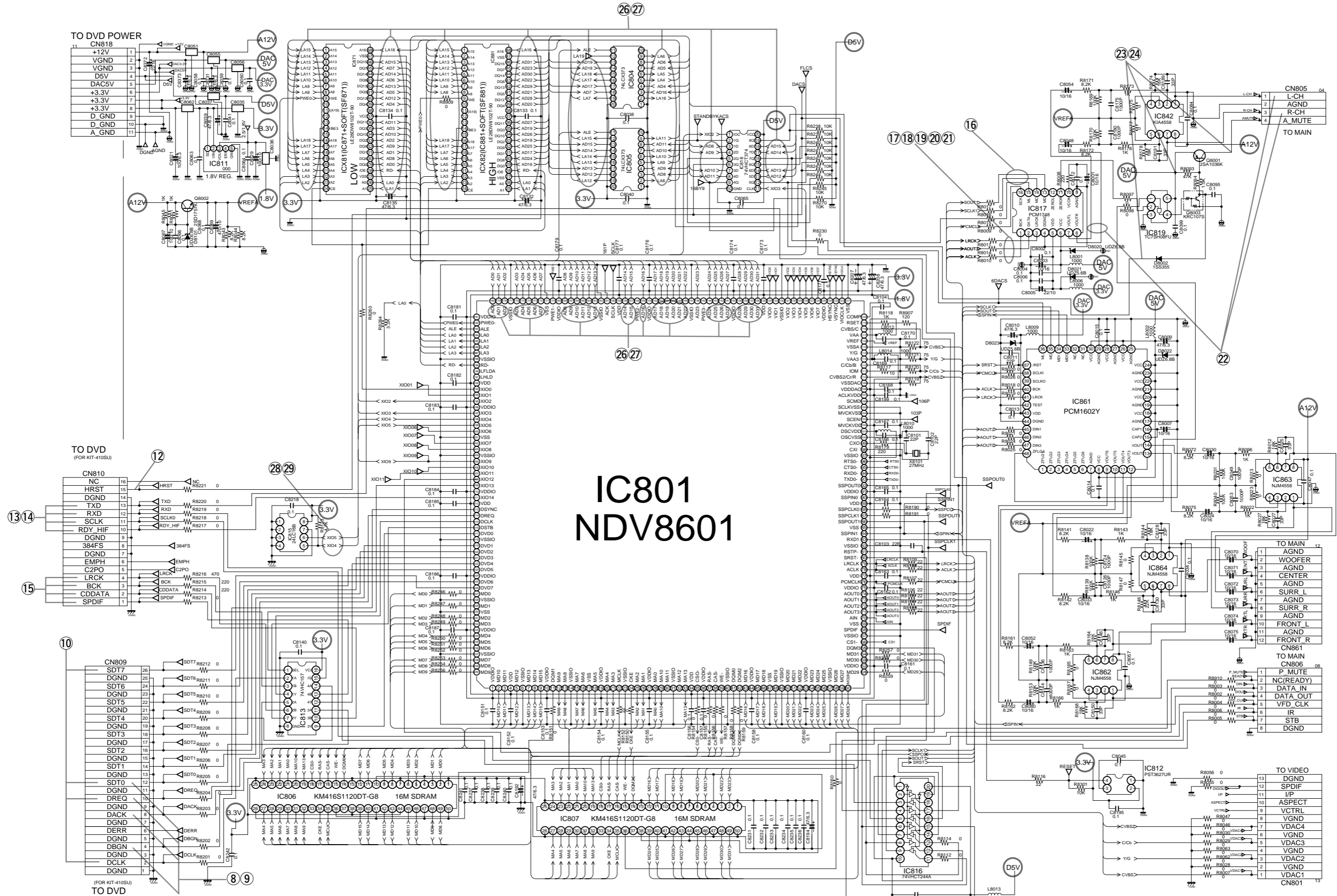

IC801  
NDV8601

**MPEG P.C.B. CHECK WAVEFORM / MPEG基板チェックの波形**

Each signal in indicate in schematic diagram of MPEG.

各信号を MPEG 基板の動作（波形チェックポイント）で示してあります。

⑧ Play DVD

⑨

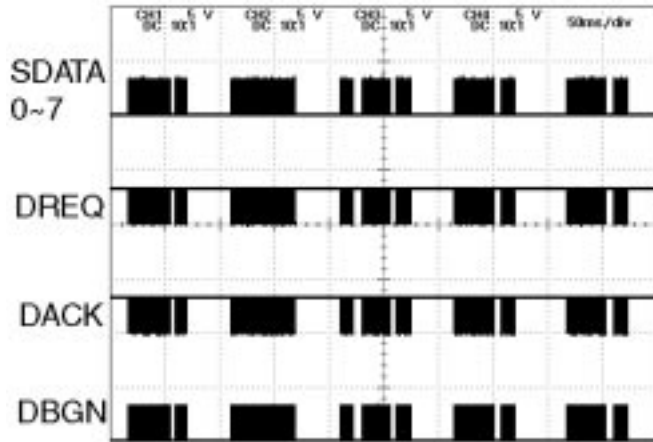

Zoom

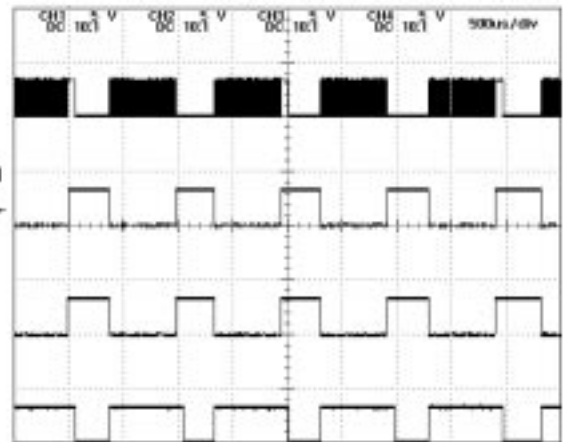

⑩ Playback DVD

⑫ At the moment when POWER KEY is pushed.

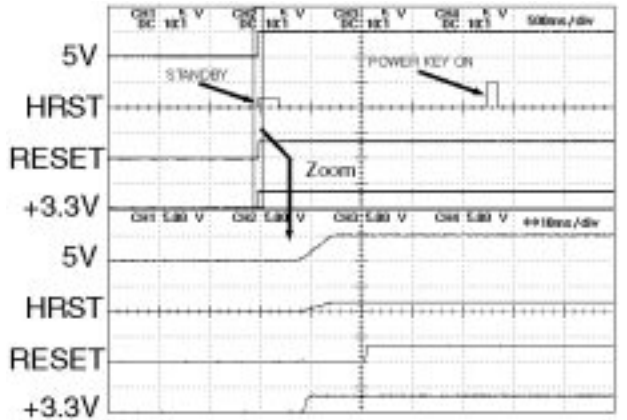
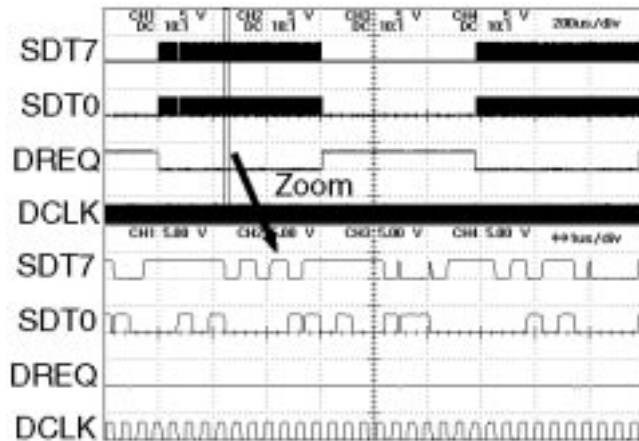

DVR-S60  
NX-SW60

MPEG P.C.B. CHECK WAVEFORM / MPEG基板チェックの波形

13 POWER KEY ON.

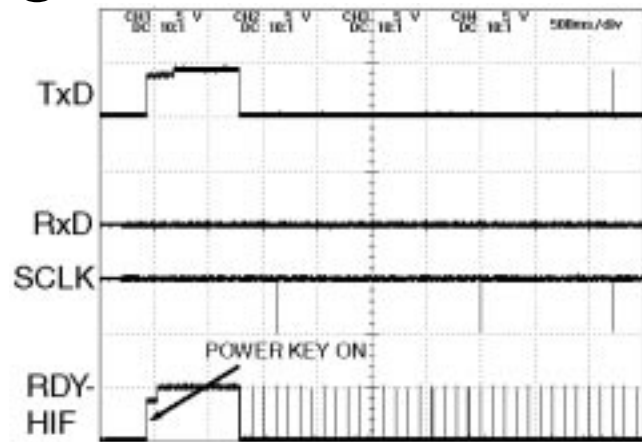

14 DVD SKIP.

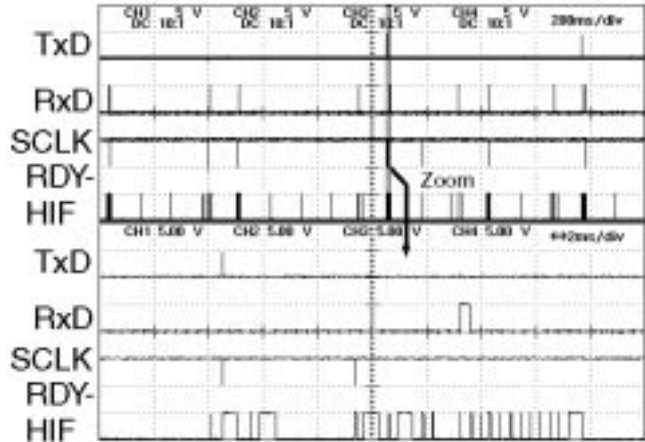

15 Play CD(When DVD play is all 0 level)

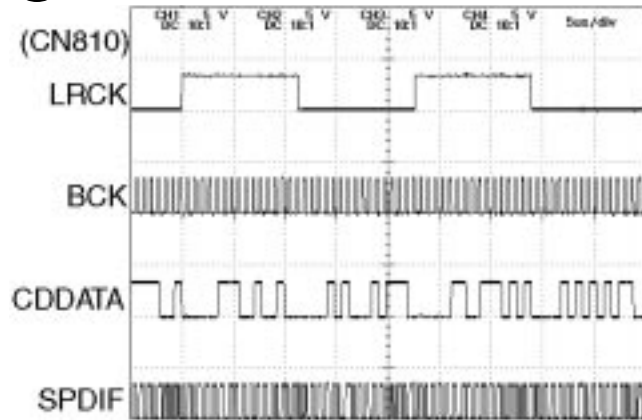

16 AC IN(STANDBY) as play.

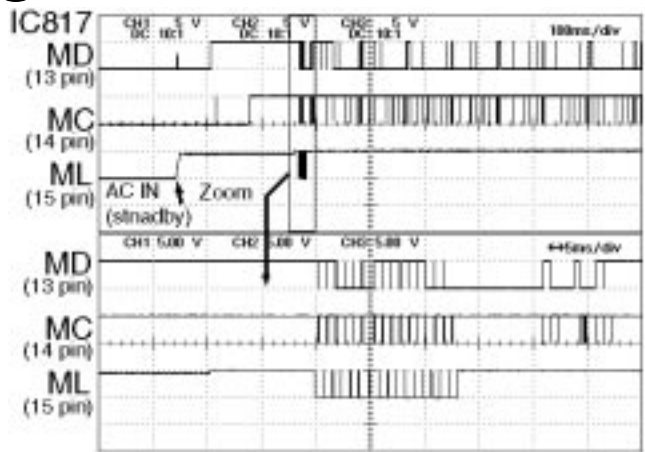

17 DVD play(48kHz sampling 16bit)

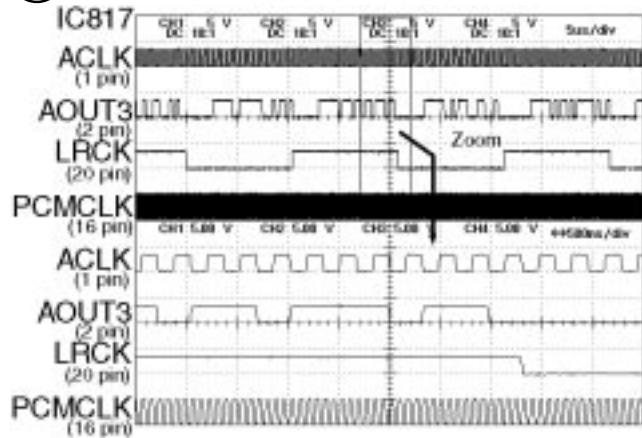

18 DVD stop

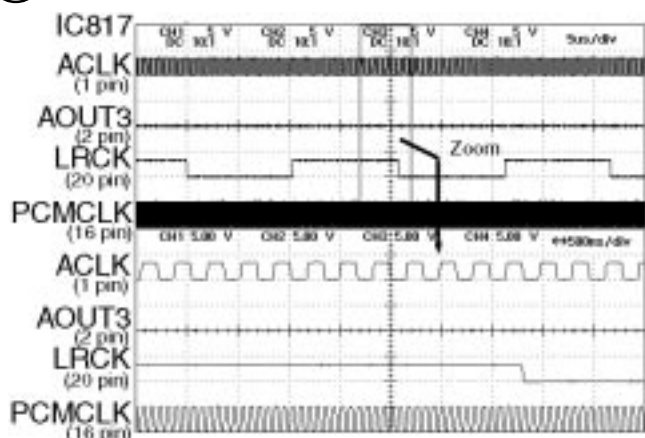

DVR-S60  
NX-SW60

MPEG P.C.B. CHECK WAVEFORM / MPEG基板チェックの波形

19 CD play(48kHz sampling)

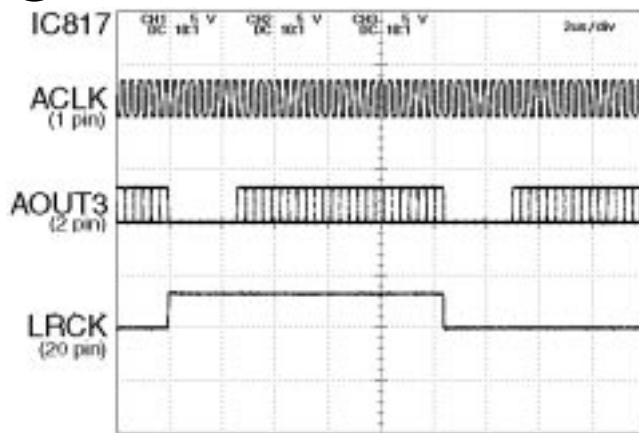

20 CD play(96kHz sampling)

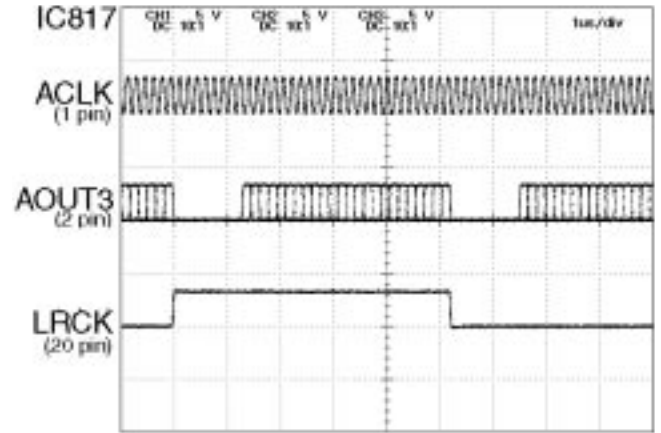

21 Play CD(44.1 kHz sampling)

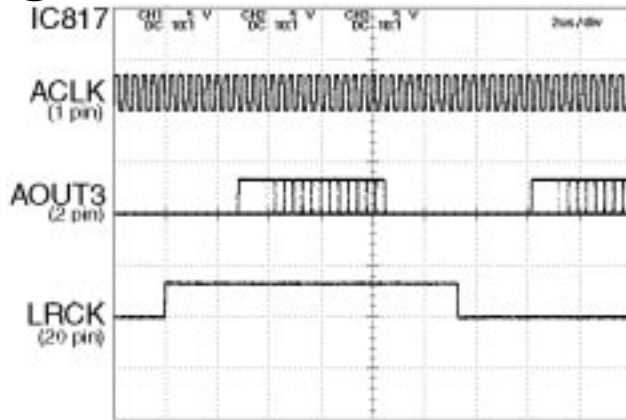

22 Playback CD(1kHz 0db)

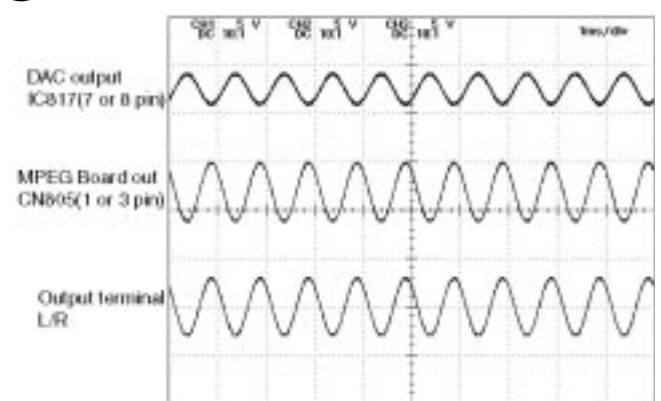

23 CD SKIP

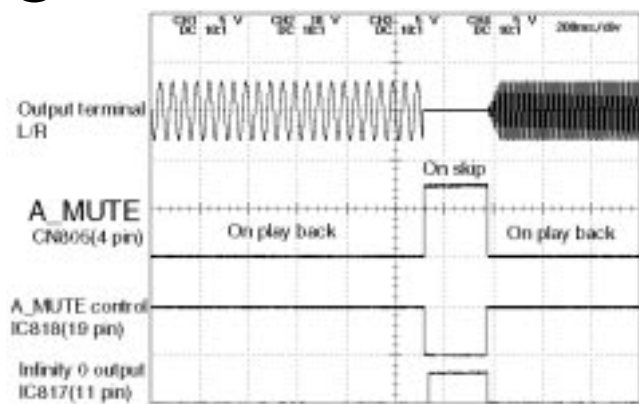

24 DVD SKIP

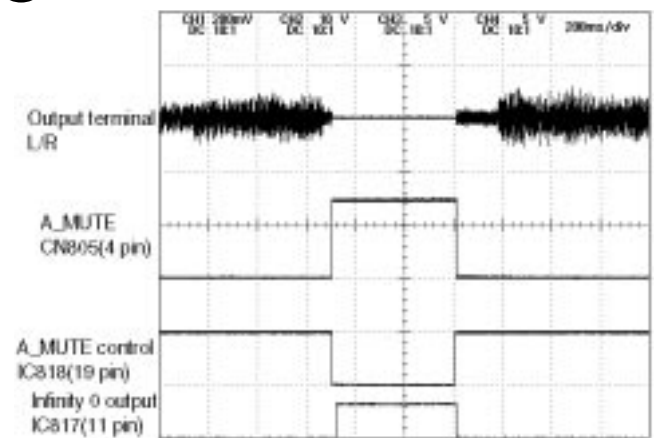

DVR-S60  
NX-SW60

MPEG P.C.B. CHECK WAVEFORM / MPEG基板チェックの波形

26 AC IN(STANDBY)

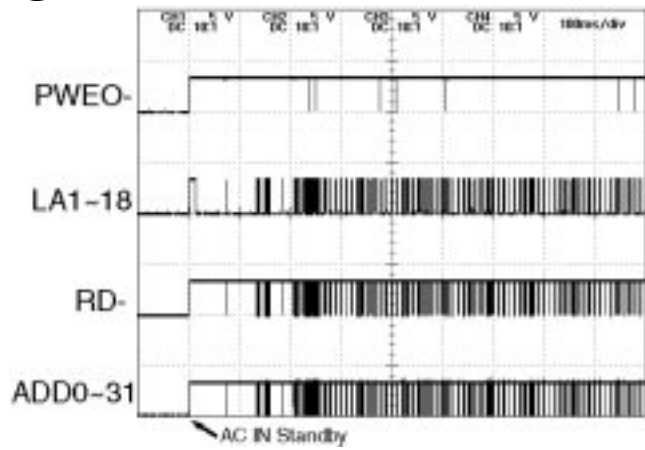

27 DVD normal play.

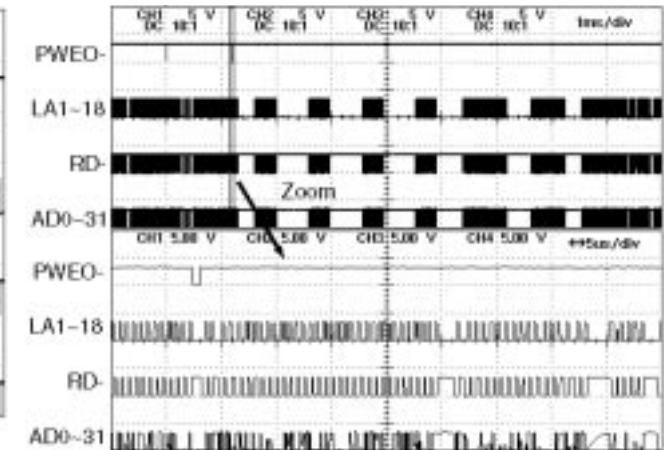

28 POWER KEY ON

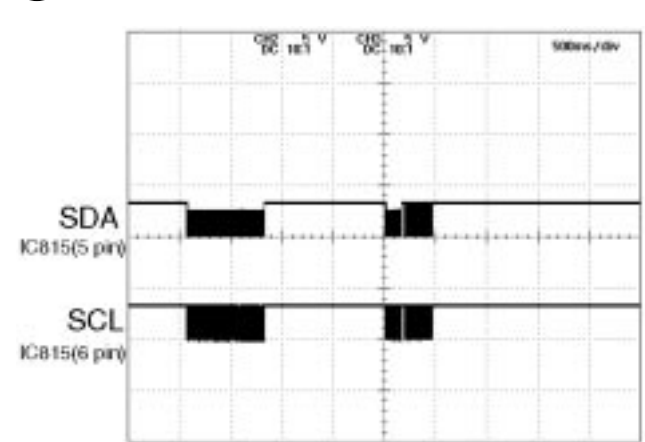

29 POWER KEY OFF

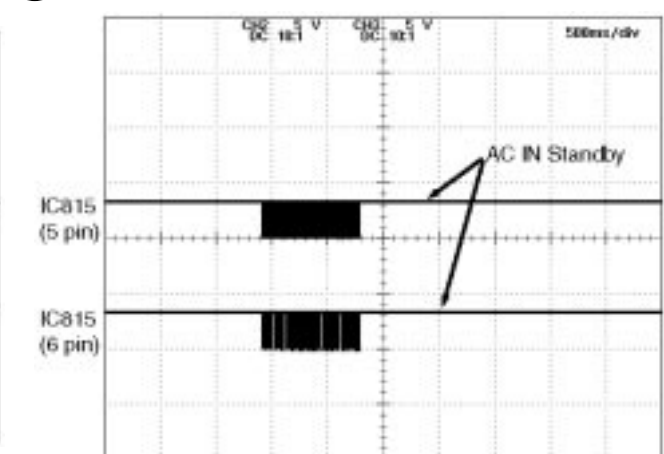

DVR-S60  
NX-SW60



# MEMO

DVR-S60  
NX-SW60

# ■ TROUBLESHOOTING

## General flow

IC411	SYSCON	D6010	I R
X4101	SYS-CLK	IC801	PANTELA
X4102	SUB-CLK	IC815	EEPROM
IC601	VFD-DRV	IC871	FLASH
IC431	VOL-IC	IC881	FLASH
IC435	SURR-IC	IC806	SDRAM
IC221	VIDEO-SW	IC807	SDRAM
IC861	6CH-DAC	IC203	TU-PLL
IC817	2CH-DAC		

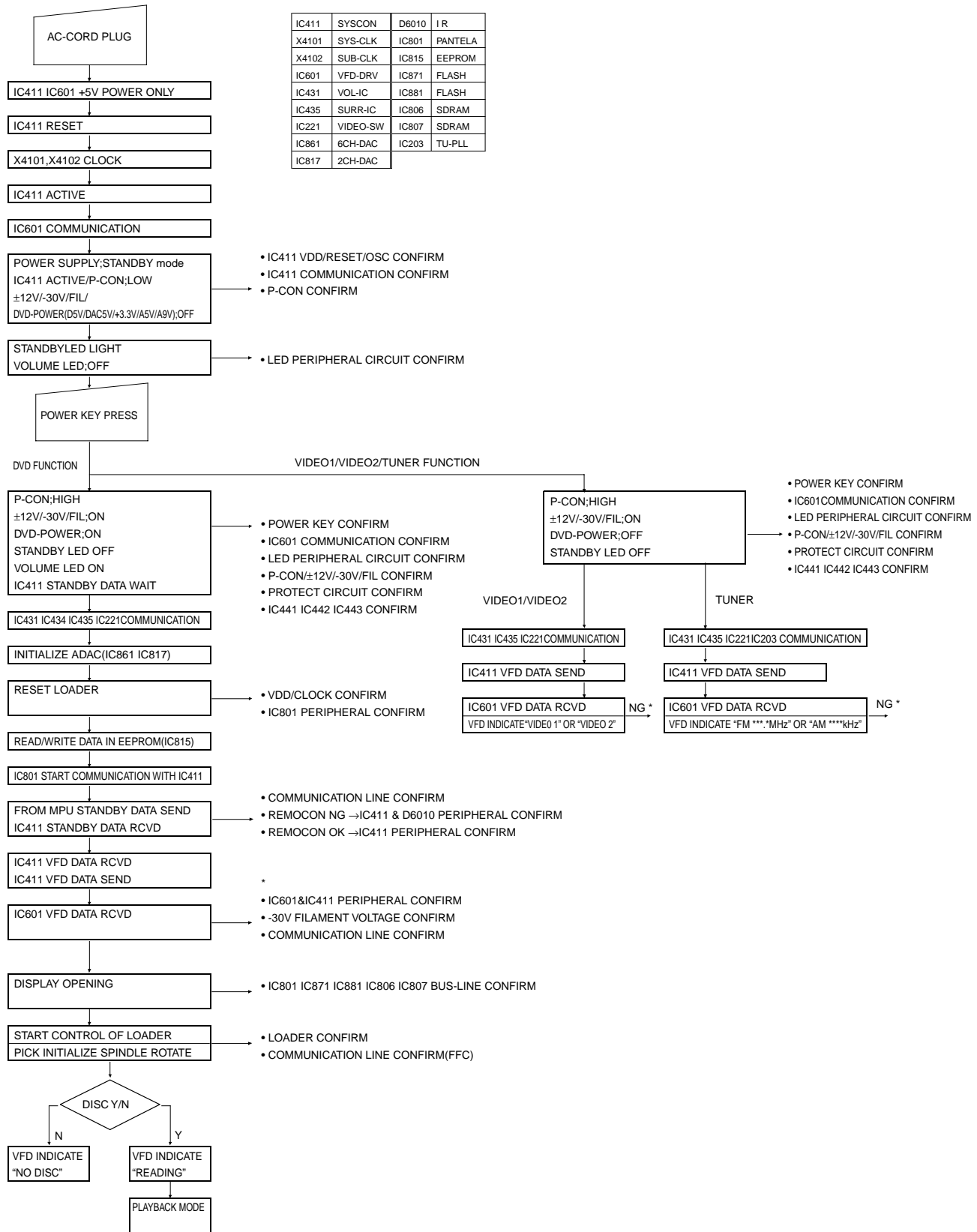

DVR-S60  
NX-SW60

# TROUBLESHOOTING

## Audio Part

IC817	2ch DAC PCM1748E	IC435	PRO LOGIC DECODER M62464BFP
IC861	6ch DAC PCM1602Y	IC431	FUNCTION & VOLUME LC75342M
IC801	MPEG NDV8501	IC434	PRESET EQ TA2078B
IC233	5V REG. KIA7805PI	IC401	+12V REG. KIA7812PI
IC819	AND GATE 7SH08FU	IC402	-12V REG KIA7912PI
IC201	FM F.E. TA8176S	IC441	POWER AMP LM4766
IC202	IF/MPX LA1844ML		
IC203	TU PLL LC72121M		

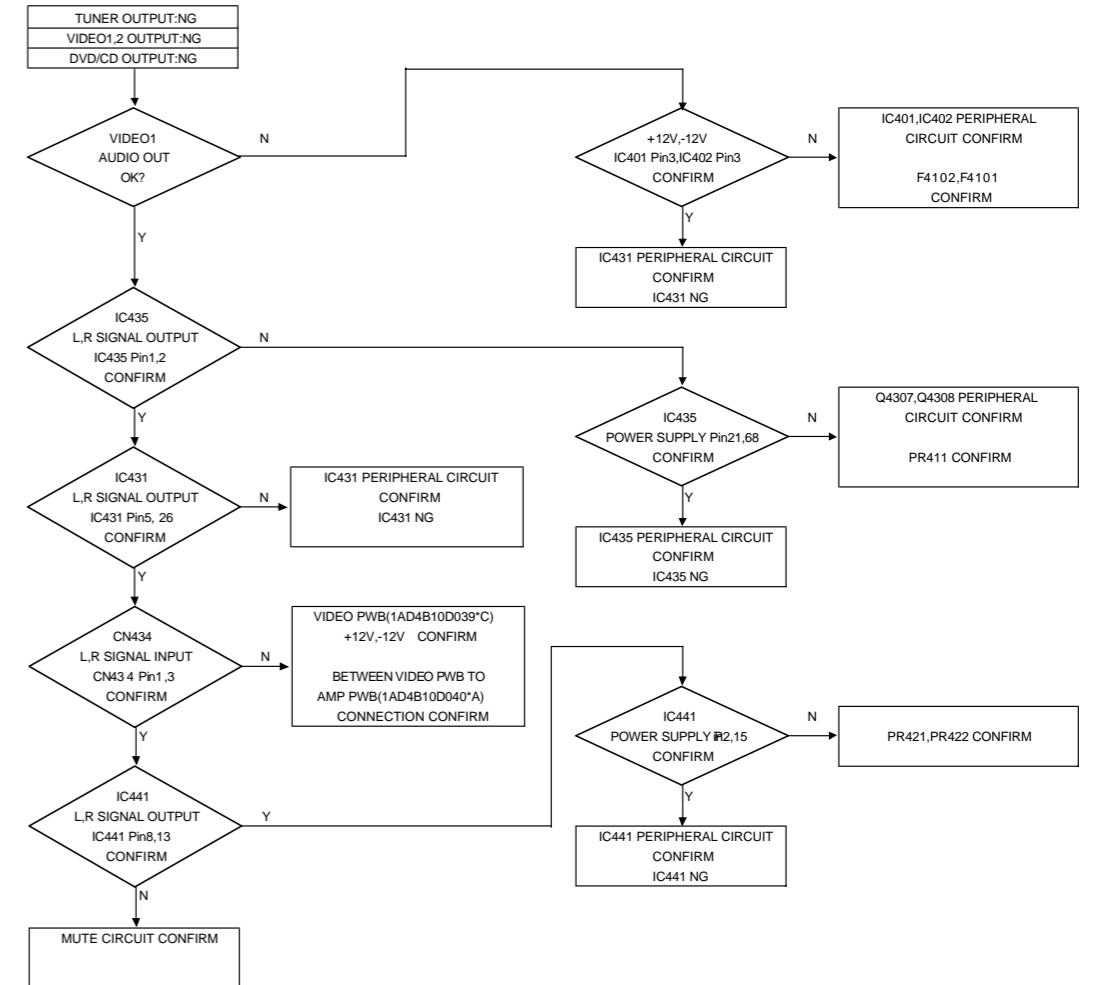
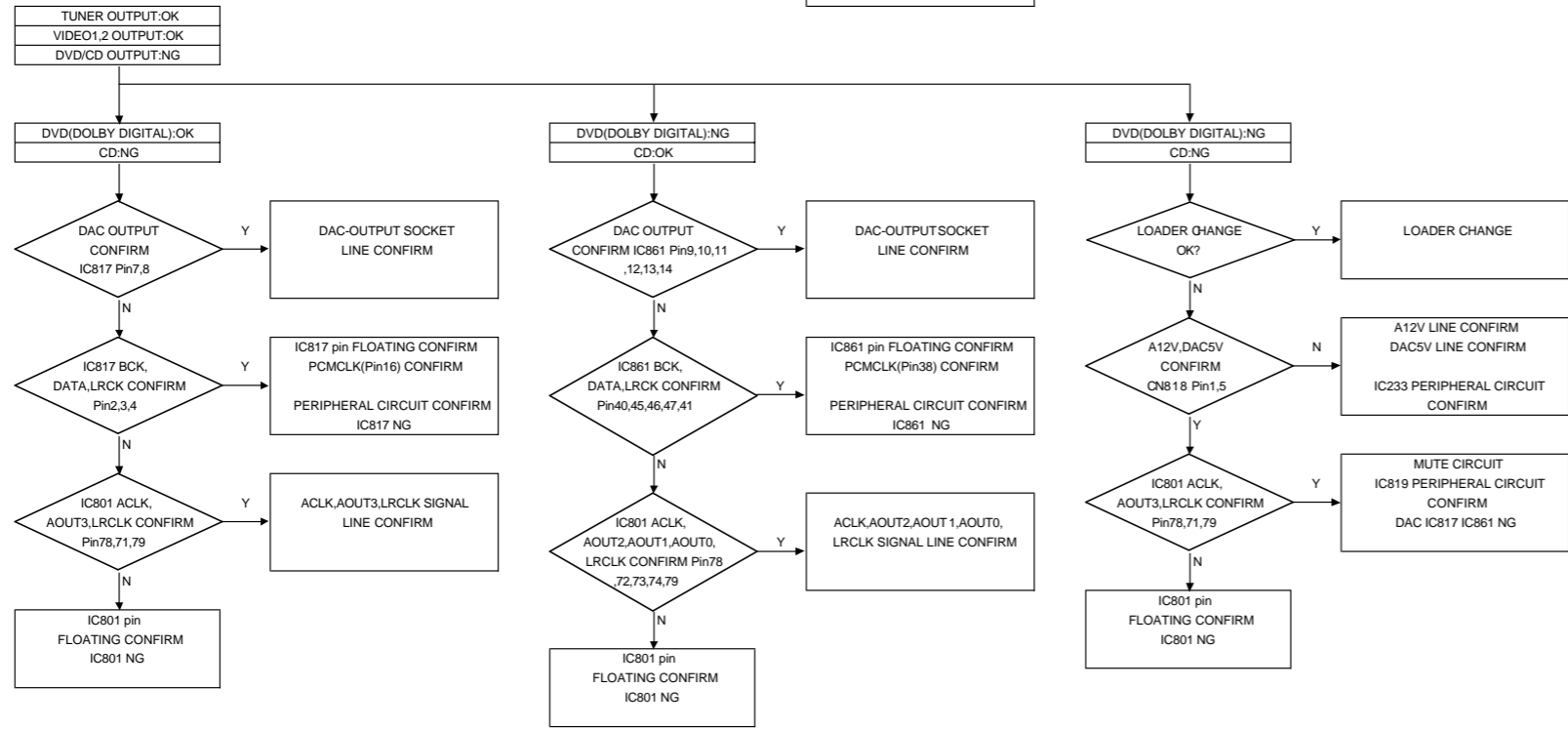

## VIDEO PART

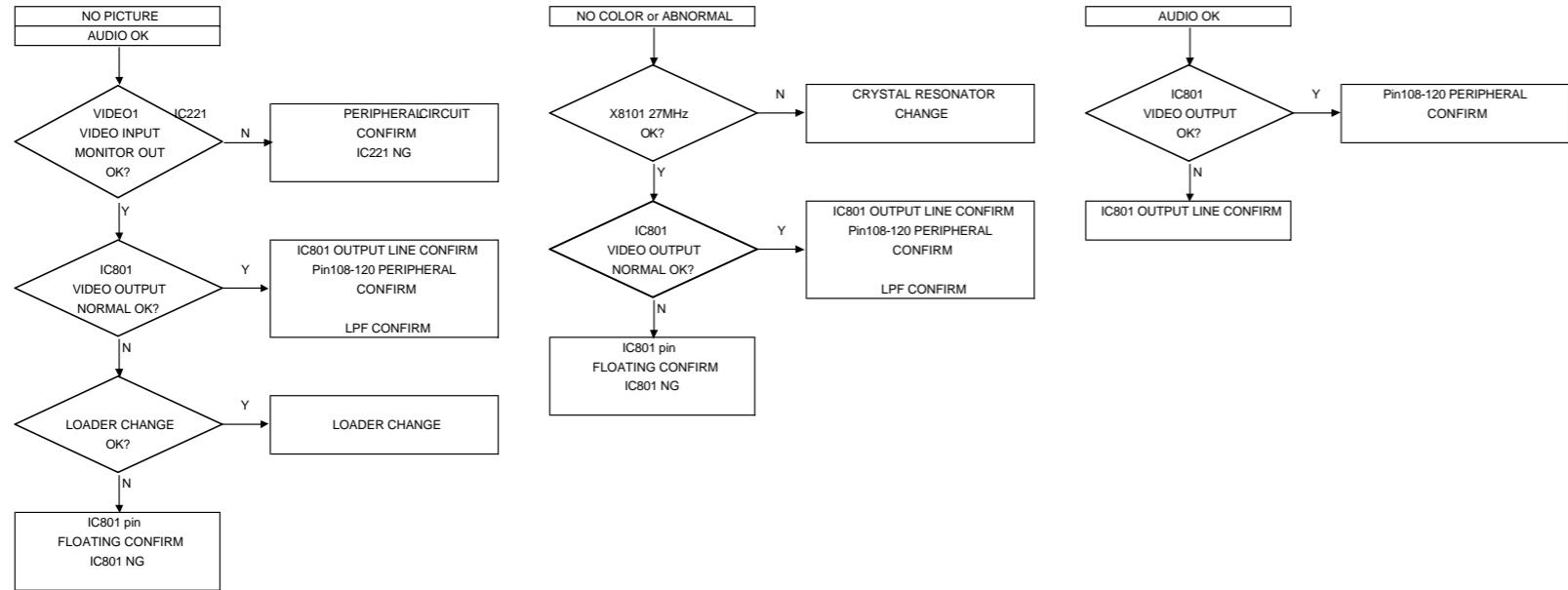

## ■ TUNER ADJUSTMENTS / チューナー部調整

- Use a plastic screw driver for adjustments.
- MODE : STEREO
- Speaker impedance : 8 ohm

SG RF Level : 75Ω open Voltage dBμV  
 Antenna : 75Ω unbalanced Direct, Modulation : 1 kHz  
 Dev. : MONO ± 22.5kHz / ± STEREO 22.5kHz (MAIN)  
 ± 6.75kHz(PILOT)  
 Output Level : about 100mV at TP25,TP26,TP27

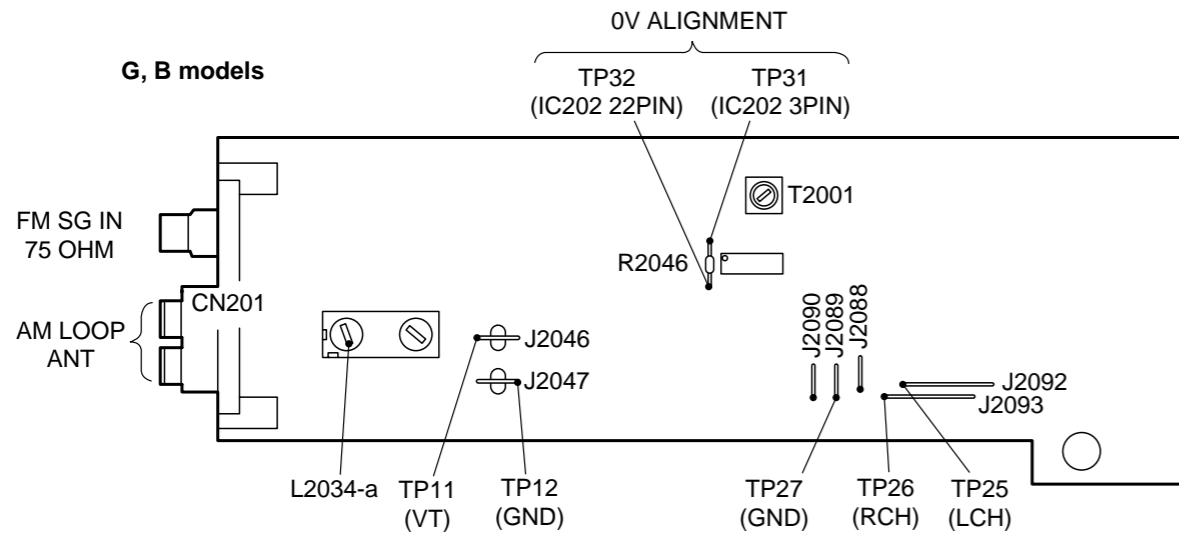
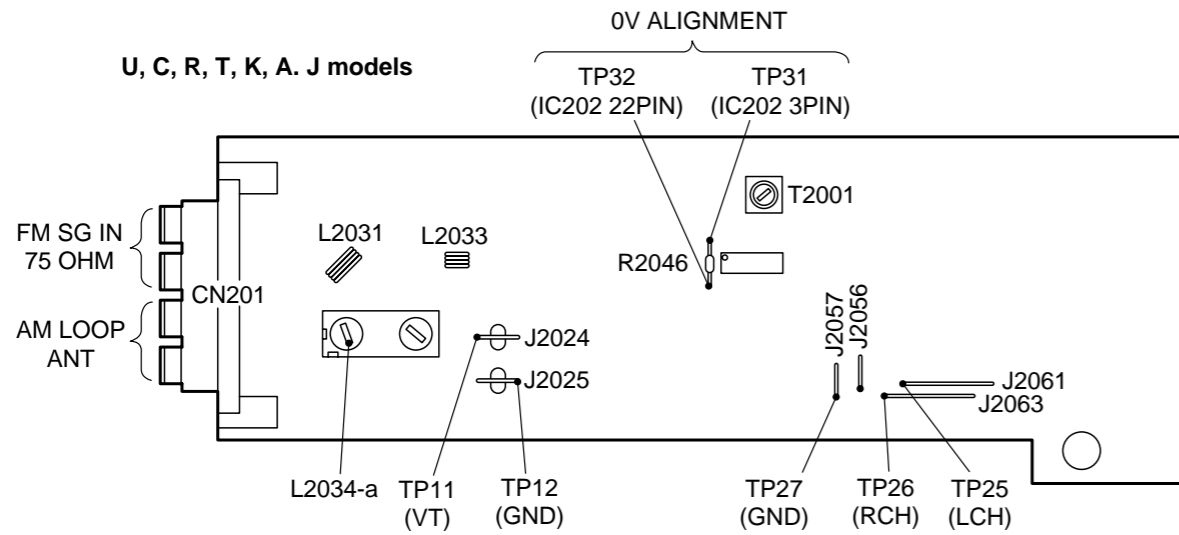

### 1. FM

Step	Adjusting Circuit	Connection		SG Frequency	Set Position	Adjustment	Remark
		Input	Output				
1	IF Alignment	FM ANT. SG=66dB μV	TP31 (IC202 3pin) TP32 (IC202 22pin)	U, C, R, T, K, A, G, B : 98.1MHz J : 83.0MHz	---	T2001	0.0 +/- 0.05V
2	Voltage range	---	Connect Digital DC voltmeter to TP11(H), TP12(E).	U, C : 87.9 MHz R, T, K, A : 87.5MHz J : 76.0MHz	Low	L2033	1.1+/- 0.1V
		---		U, C : 107.9 MHz R, T, K, A : 108.0MHz J : 90.0MHz	High	---	about 6.2V
3	Tracking	Connect FM SG to FM Antenna (SG=8dBμ V)	Connect to VTVM TP25(L) or TP26(R), TP27(E)	U, C, R, T, K, A : 90.1MHz J : 78.3MHz	Low	L2031	Max.
				U, C, R, T, K, A : 106.1MHz J : 88.2MHz	High	---	

### 2. AM

Step	Adjusting Circuit	Connection		SG Frequency	Set Position	Adjustment	Remark
		Input	Output				
1	Voltage range	---	Connect Digital DC voltmeter to TP11(H), TP12(E).	U, C, R : 520kHz T, K, A, G, B, J : 522kHz	Low	---	more than 0.8V
		---		U, C, R, T, K, A : 1710kHz G, B : 1611kHz J : 1629kHz	High	---	less than 8.0V
2	Tracking	Connect AM SG to Test loop Ant.(SG=80dB μ V)	Connect to VTVM TP25(L) or TP26(R), TP27(E).	U, C, R : 600kHz T, K, A, G, B, J : 603kHz	Low	L2034-a	Max.
				U, C, R : 1400kHz T, K, A, G, B, J : 1404kHz	High	---	

# ■ DISPLAY DATA

## FL601 Vacuum Fluorescent Display

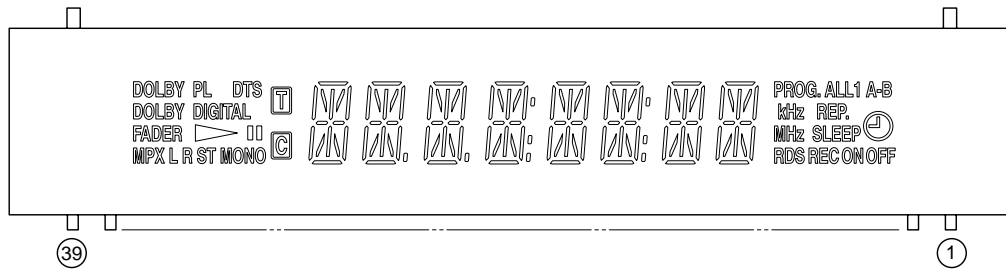

### PIN CONNECTION

PIN NO.	39	38	37	36	35	34	33	32	31	30	29	28	27	26	25	24	23	22	21	20	19	18	17	16	15	14	13	12	11	10	9	8	7	6	5	4	3	2	1
CONNECTION	F2	F2	NP	NP	1G	2G	3G	4G	5G	6G	7G	8G	9G	10G	NX	NX	NX	NX	NX	P1	P2	P3	P4	P5	P6	P7	P8	P9	P10	P11	P12	P13	P14	P15	P16	NP	NP	F1	F1

- NOTE 1) F1,F2 ----- Filament  
 2) NP ----- No pin  
 3) NX ----- No extent pin  
 4) DL ----- Datum Line  
 5) 1G-10G --- Grid

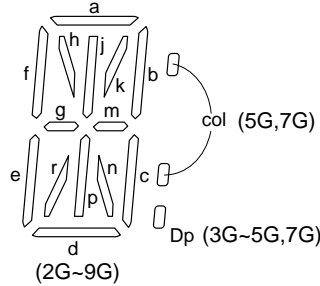
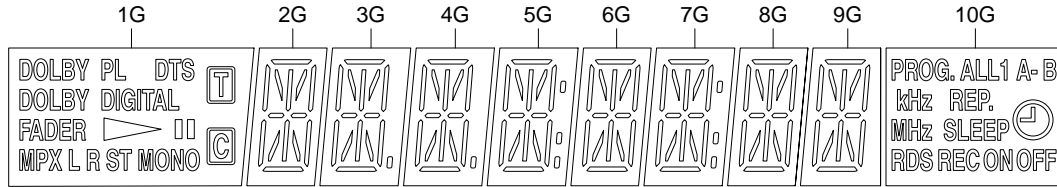

### ANODE CONNECTION

	1G	2G	3G	4G	5G	6G	7G	8G	9G	10G
P1	DOLBY PL	a	a	a	a	a	a	a	a	PROG.
P2	DTS	b	b	b	b	b	b	b	b	ALL
P3	DOLBY DIGITAL	h	h	h	h	h	h	h	h	1
P4	FADER	j	j	j	j	j	j	j	j	A-
P5	▷	k	k	k	k	k	k	k	k	B
P6		f	f	f	f	f	f	f	f	REP.
P7	MPX	g	g	g	g	g	g	g	g	kHz
P8	L	m	m	m	m	m	m	m	m	MHz
P9	R	c	c	c	c	c	c	c	c	RDS
P10	ST	r	r	r	r	r	r	r	r	REC
P11	MONO	p	p	p	p	p	p	p	p	SLEEP
P12	T	n	n	n	n	n	n	n	n	⌚
P13	C	e	e	e	e	e	e	e	e	ON
P14	-	d	d	d	d	d	d	d	d	OFF
P15	-	-	-	-	col	-	col	-	-	-
P16	-	-	Dp	Dp	Dp	-	Dp	-	-	-

DVR-S60  
NX-SW60

IC DATA

MAIN P.C.B.

IC401 KIA7812API  
IC403 KIA7809API

(3-Terminal Positive voltage Regulators)

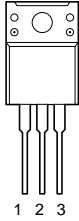

- 1. INPUT
- 2. COMMON
- 3. OUTPUT

IC402 KIA7912PI

(3-Terminal Negative Voltage Regulators)

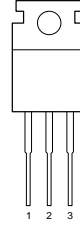

- 1. GND
- 2. INPUT
- 3. OUTPUT

IC411 uPD780055G (8-Bit Single-chip Microcontroller)

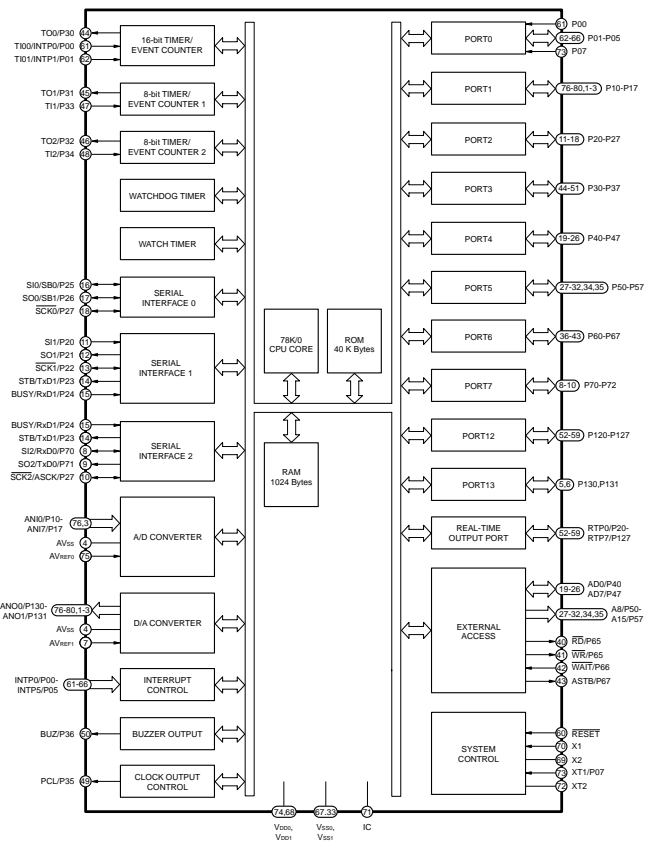
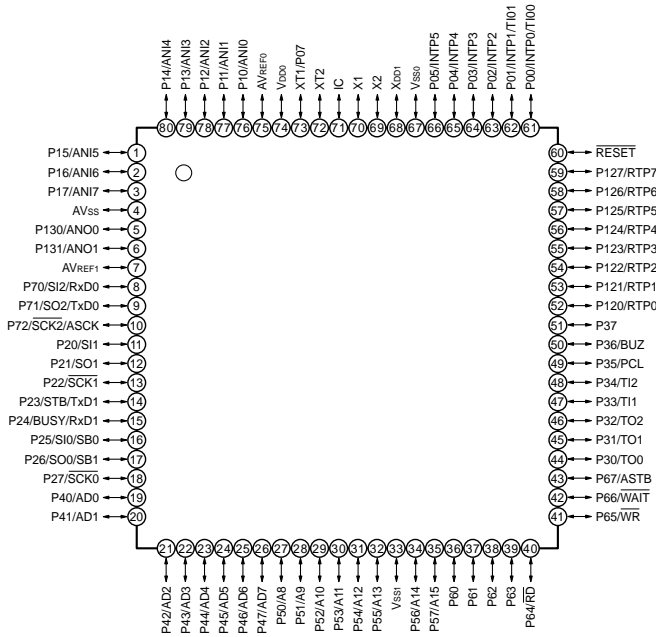

DVR-S60  
NX-SW60

## MAIN P.C.B.

## IC411 uPD780055G (8-Bit Single-chip Microcontroller)

Pin No.	Name	I/O	Function	
61	P00	I	Port 0. 7 bits I/O port.	Input only.
62-66	P01-P05	I/O		Reserved I/O of 1 bit unit. Input port:software make possible used internal pull up resistor
73	P07 <sup>Note 1</sup>	I		Input only.
76-80, 1-3	P10-P17	I/O	Port 1. 8 bits I/O port. Reserved I/O of 1 bit unit. Input port:software make possible used internal pull up resistor. <sup>Note 2</sup>	
11-18	P20-P27	I/O	Port 2. 8 bits I/O port. Input port:software make possible used internal pull up resistor.	
44-51	P30-P37	I/O	Port 3. 8 bits I/O port. Reserved I/O of 1 bit unit. Input port:software make possible used internal pull up resistor.	
19-26	P40-P47	I/O	Port 4. 8 bits I/O port. Reserved I/O of 8 bits unit. Input port:software make possible used internal pull up resistor. Set up 1 to test input flag (KRIF) by detected last edge.	
27-32, 34, 35	P50-P57	I/O	Port 5. 8 bits I/O port. Possible direct drive to LED. Reserved I/O of 1 bit unit. Input port:software make possible used internal pull up resistor.	
36-39	P60-P63	I/O	Port 6. 8 bits I/O port. Reserved I/O of 1 bit unit.	Nch open and drain I/O port. Mask option make possible internal pull up resistor. Possible direct to LED.
40-43	P64-P67		Input port:software make possible used internal pullup resistor.	
8-10	P70-P72	I/O	Port 7. 3 bits I/O port. Reserved I/O of 1 bit unit. Input port:software make possible used internal pull up resistor.	
52-59	P120-P127	I/O	Port 12. 8 bits I/O port. Reserved I/O of 1 bit unit. Input port:software make possible used internal pull up resistor.	
5, 6	P130,P131	I/O	Port 13. 2 bits I/O port. Reserved I/O of 1 bit unit. Input port:software make possible used internal pull up resistor.	
61-66	INTP0-INTP5	I	External interrupt requirements input make possible reserved effective edge.	
16, 11, 8	SI0-SI2	I	Serial data input of serial interface.	
17, 12, 9	SO0-SO2	O	Serial data output of serial interface.	
16, 17	SB0,SB1	I/O	Serial data I/O of serial interface.	
18, 13, 10	SCK0-SCK2	I/O	Serial clock I/O of serial interface.	
14	STB	O	Strobe output for serial interface auto transmission/receive.	
15	BUSY	I	Busy input for serial interface auto transmission/receive.	
8, 15	RxD0,RxD1	I	Serial data input for a synchronous serial interface.	
9, 14	TxD0,TxD1	O	Serial data output for a synchronous serial interface.	
10	ASCK	I	Serial clock input for a synchronous serial interface.	
61	TI00	I	External count clock input to 16 bits timer (TM0).	
62	TI01		Capture trigger signal input to capture register (CR00).	
47	TI1		External count clock to 8 bits timer (TM1).	
48	TI2		External count clock to 8 bits timer (TM2).	
44	TO0	O	16 bits timer (TM0) output (Use with 14 bits PWM output).	
45	TO1		8 bits timer (TM1) output.	
46	TO2		8 bits timer (TM2) output.	
49	PCL	O	Clock output (Trimming for main system clock and sub-system clock).	
50	BUZ	O	Buzzer output.	
52-59	RTP0-RTP7	O	Real-time output port,data output synchronize trigger.	
19-26	AD0-AD7	I/O	Low address/data bus for extend memory at external.	
27-32, 34, 35	A8-A15	O	Low address bus for extend memory at external.	
40	RD	O	Strobe signal output for read operation of external memory.	
41	WR		Strobe signal output for write operation of external memory.	
42	WAIT	I	Wait insert when external memory access.	
43	ASTB	O	Strobe output:latched output address data of port 4 and port 5 for access external memory.	
76-80, 1-3	ANI0-ANI7	I	Analog input of A/D converter.	
5, 6	ANO0,ANO1	O	Analog output of A/D converter.	
75	AVREF0	I	Voltage reference input A/D converter (Use with analog power source).	
7	AVREF1	I	Voltage reference input D/A converter (Use with analog power source).	
4	AVSS	-	Ground potential of A/D and D/A converter. Use common potential to VSS0.	
60	RESET	I	System reset input.	
70	X1	I	Crystal connect for main system clock oscillation.	
69	X2	-		
73	XT1	I	Crystal connect for sub system clock oscillation.	
72	XT2	-		
74	VDD0	-	+ Power source of port.	
67	VSS0	-	Ground potential of port.	
68	VDD1	-	+ Power source (Except port and analog port).	
33	VSS1	-	Ground potential (Except port and analog port).	
71	IC	-	Internal connected,connect directly to VSS0 or VSS1.	

Note 1. When use P07/X11 pin as input:Bit 6 (FRC) of processor clock control resistor (PCC) set up 1.Not use internal feedback resistor of sub-system and clock oscillation circuit.

Note 2. When use P10/ANI0-P17/ANI7 pin as analog input of A/D converter:Set up port 1 input mode and automatically not used internal pull up resistor.

**MAIN P.C.B.**

**IC412 KIA7042AP (Voltage Detector)**

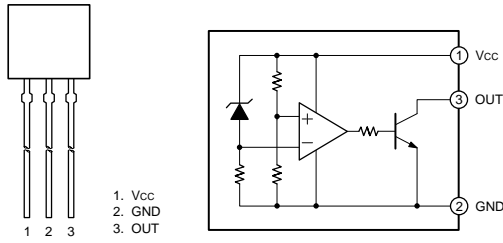

**IC432,433 NJM4558M (Operational Amplifier)**

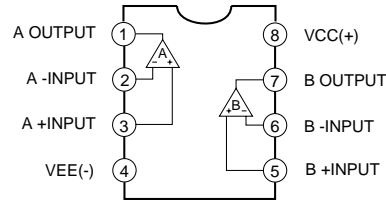

**IC431 LC75342M (2Band Equalizer)**

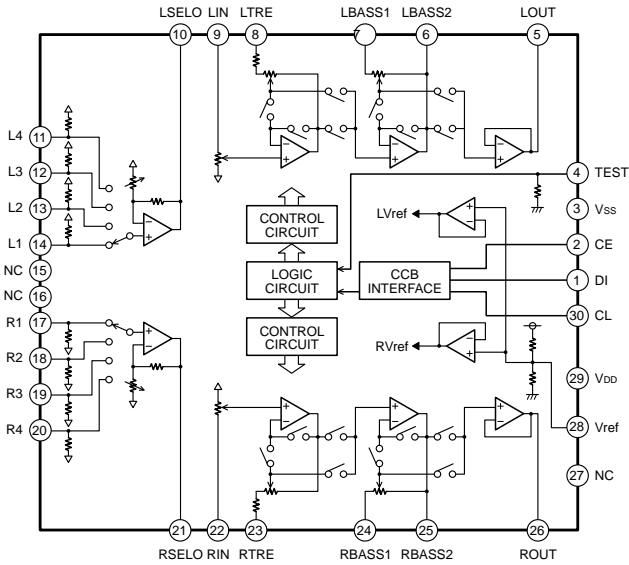

**IC435 M62464BFP (Dolby Pro Logic Surround Decoder with Discrete 5.1 ch Analog Input )**

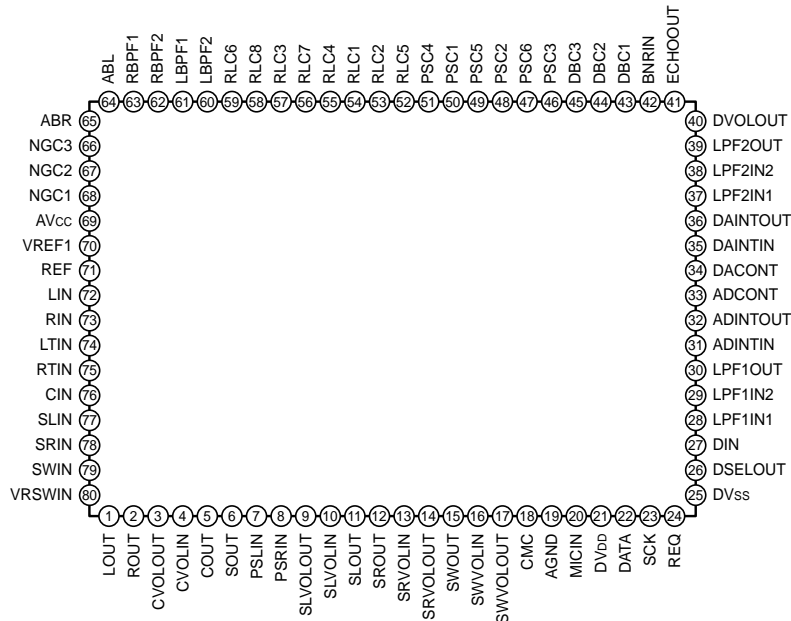

DVR-S60  
NX-SW60



MAIN P.C.B.

IC435 M62464BFP (Dolby Pro Logic Surround Decoder with Discrete 5.1 ch Analog Input )

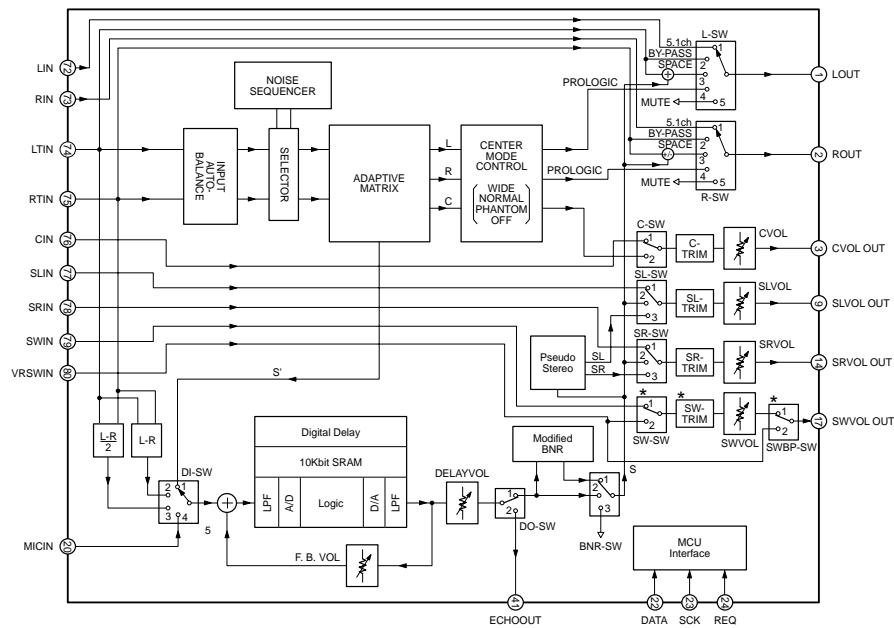
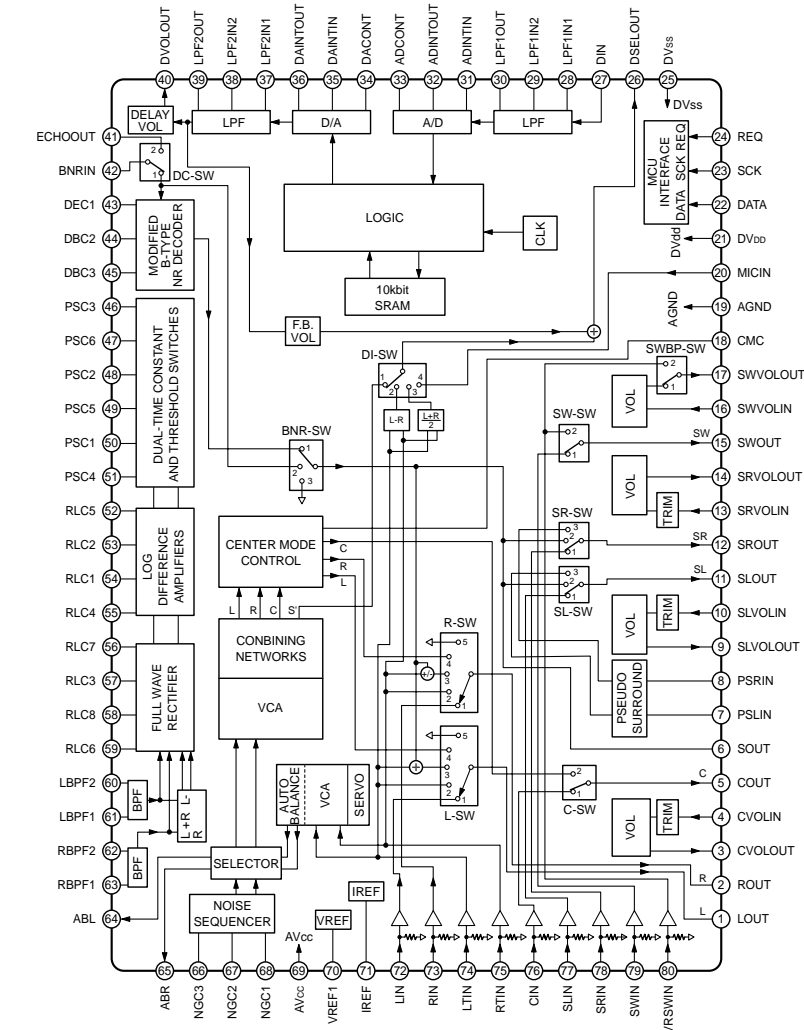

DVR-S60 NX-SW60

**MAIN P.C.B.**

**IC435 M62464BFP (Dolby Pro Logic Surround Decoder with Discrete 5.1 ch Analog Input )**

Pin No.	Symbol	Function	DC Voltage	Description
1	LOUT	Lch output	4.5V	BY-PASS:Lch and Rch output.
2	ROUT	Rch output		4ch:Dolby-prologic Lch and Rch output. 5.1ch:5.1ch output.
3	CVOLOUT	Cch volume output	4.5V	Master volume output for Cch/SLch/SRch/SWch.
9	SLVOLOUT	SLch volume output		
14	SRVOLOUT	SRch volume output		
17	SWVOLOUT	SWch volume output		
4	CVOLIN	Cch volume input	2.5V	Master volume input for Cch/SLch/SRch/SWch.
10	SLVOLIN	SLch volume input		
13	SRVOLIN	SRch volume input		
16	SWVOLIN	SWch volume input		
5	COUT	Cch output	4.5V	Cch (Dolby-prologic decode) output. Output less when center-OFF and PHANTOM.
11	SLOUT	SLch output		Surround signal (Decoded by modified BNR) output.
12	SROUT	SRch output		Monaural output (Except passing on false stereo).
15	SWOUT	SWch output		Input signal from SW/VRSW output.
6	SOUT	Sch monaural output	4.5V	Sch output for false stereo.
7	PSLIN	False stereo Lch input	4.5V	SL/SRch output for false stereo.
8	PSRIN	False stereo Rch input		
20	MICIN	Microphone input	4.5V	Mic input.
22	DATA	Serial data input	-	Control signal input terminal from microcomputer.
23	SCK	Serial data shift lock input		
24	REQ	Data request input		
26	DSEL IN	Surround signal Output before delay	4.5V	Surround signal output before delay,selected by surround mode.
27	D IN	Delay input	2.5V	Digital delay input.
28	LPF1 IN1	LPF1 Input 1		
37	LPF2 IN1	LPF2 Input 1		
29	LPF1 IN2	LPF1 Input 2		
38	LPF2 IN2	LPF2 Input 2	2.5V	Digital delay output. (Post filter output after D/A convert.)
39	LPF2 OUT	LPF2 Output		
40	DVOL OUT	Delay volume output	2.5V	Volume output after digital delay.
41	ECHO OUT	Echo output	4.5V	Karaoke output for echo.
42	DOSW IN	DOSW Input (Modified BNR input)	4.5V	Selector input ECHO OUT/S OUT.
64	LT	Auto-balance Lch output	4.5V	Auto-balance amp. output. Controlled by adaptive matrix. Get output rectified L/R balance of signsl source.
65	RT	Auto-balance Rch output		
72	LIN	Lch,RTch,Lch,Rch, Cch,SLch,SRch, SWch,VRSWch input terminal.	4.5V	LTch,RTch input (Prologic mode) Lch,Rch,Cch,SLch,SRch,SWch input (5.1ch mode) VRSWch input terminal.
73	RIN			
74	LTIN			
75	RTIN			
76	CIN			
77	SLIN			
78	SRIN			
79	SWIN			
80	/RSWIN			
70	VREF	Reference output	4.5V	Analog voltage reference output. (4.5V)

DVR-S60  
NX-SW60

**IC437 BU4066BCF (Quad Analog Switch)**

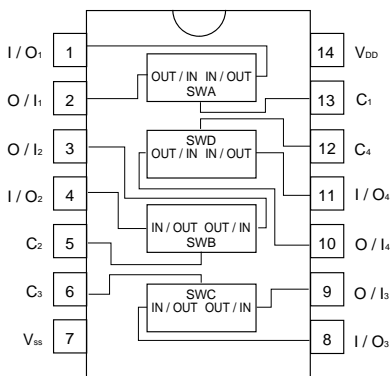

**IC441~446 LM4766 (Audio Power Amplifier with Mute)**

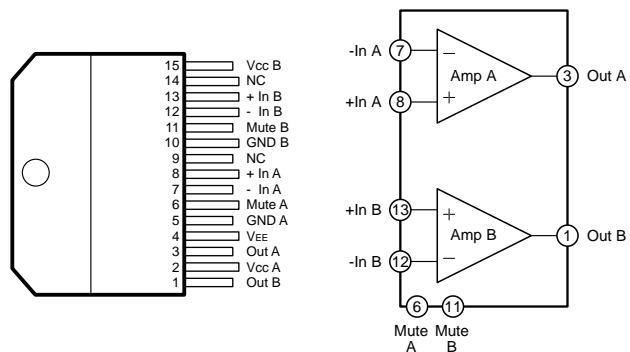

FRONT P.C.B.

**IC601 uPD16311GC-AB6 (1/8 to 1/16-Duty FIP(VFD) Controller/Driver**

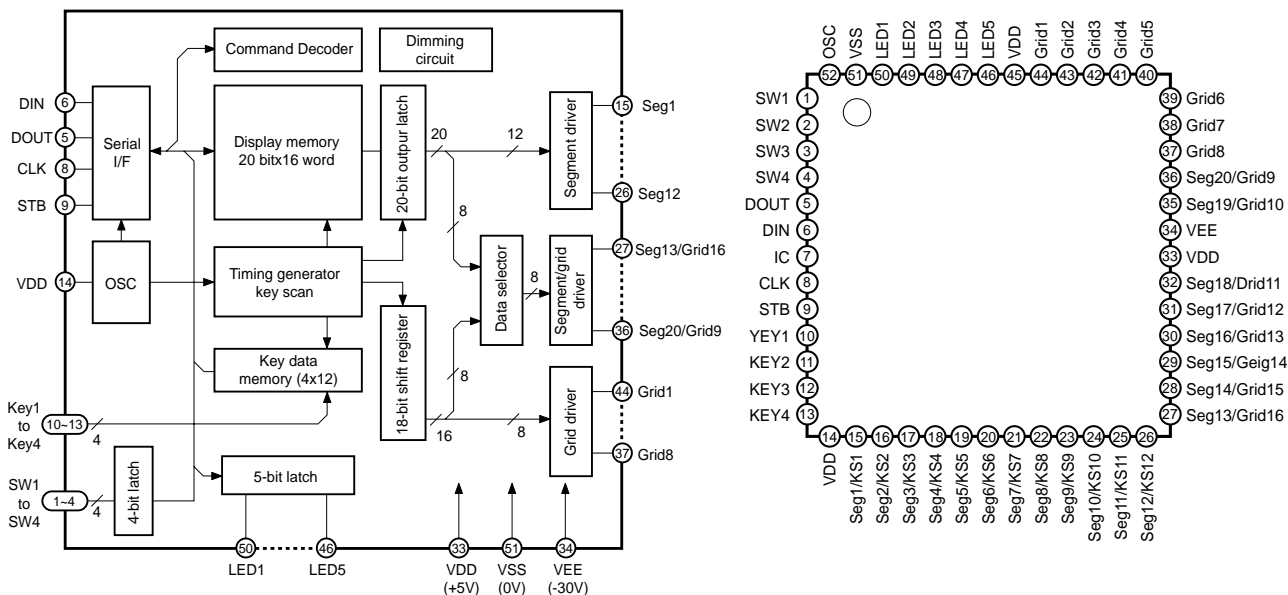

Pin No.	Symbol	Pin Name	Description
6	DIN	Data input	Inputs serial data at rising edge of shift clock, starting from lower bit.
5	DOUT	Data output	Outputs serial data at falling edge of shift clock, starting from lower bit. This is N-ch open-drain output pin.
9	STB	Strobe	Initializes serial interface at rising or falling edge to make $\mu$ PD16311 waiting for reception of command. Data input after STB has fallen is processed as command. While command data is processed, current processing is stopped, and serial interface is initialized. While STB is high, CLK is ignored.
8	CLK	Clock input	Reads serial data at rising edge, and outputs data at falling edge.
52	OSC	Oscillator pin	Connect resistor for determining oscillation frequency to this pin.
15 to 26	Seg <sub>1</sub> /KS <sub>1</sub> to Seg <sub>12</sub> /KS <sub>12</sub>	High-voltage output (segment)	Segment output pins (Dual function as key source).
44 to 37	Grid <sub>1</sub> to Grid <sub>8</sub>	High-voltage output (grid)	Grid output pins.
27 to 32 35 to 36	Seg <sub>13</sub> /Grid <sub>16</sub> to Seg <sub>20</sub> /Grid <sub>9</sub>	High-voltage output (segment/grid)	These pins are selectable for segment or grid output.
50 to 46	LED <sub>1</sub> to LED <sub>5</sub>	LED output	CMOS output, +20 mA max.
10 to 13	Key <sub>1</sub> to Key <sub>4</sub>	Key data input	Data input to these pins are latched at end of display cycle.
1 to 4	SW <sub>1</sub> to SW <sub>4</sub>	Switch input	These pins constitute 4-bit general-purpose input port.
14,33,45	V <sub>DD</sub>	Logic power	SV $\pm$ 10%
51	V <sub>SS</sub>	Logic ground	Connect this pin to GND of system.
34	V <sub>EE</sub>	Pull-down level	V <sub>DD</sub> - 35V max.
7	IC	Internally connected	Be sure to leave this pin open (this pin is at V <sub>DD</sub> level).

DVR-S60  
NX-SW60

**TUNER P.C.B.**

**IC201 TA8176SN (FM Front End)**

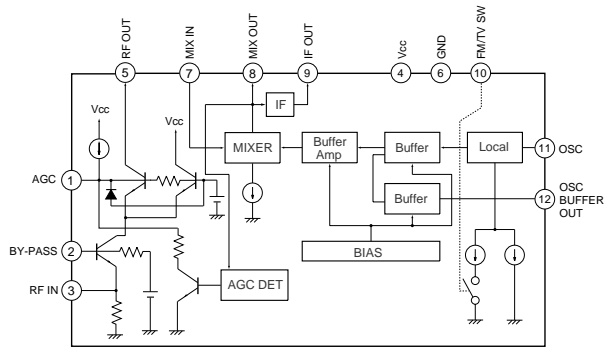

**IC202 LA1844ML (AM/FM-ZF MPX)**

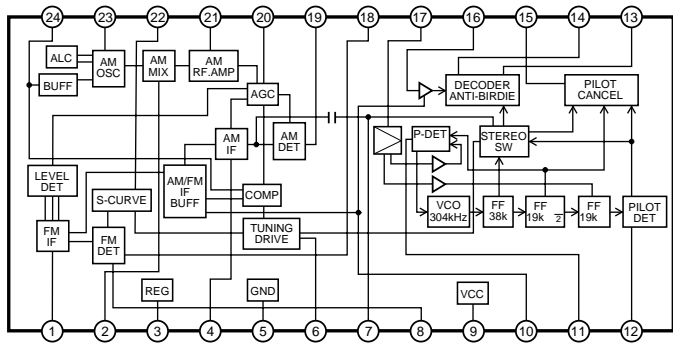

**IC203 LC72121M-D (PLL Synthesizer)**

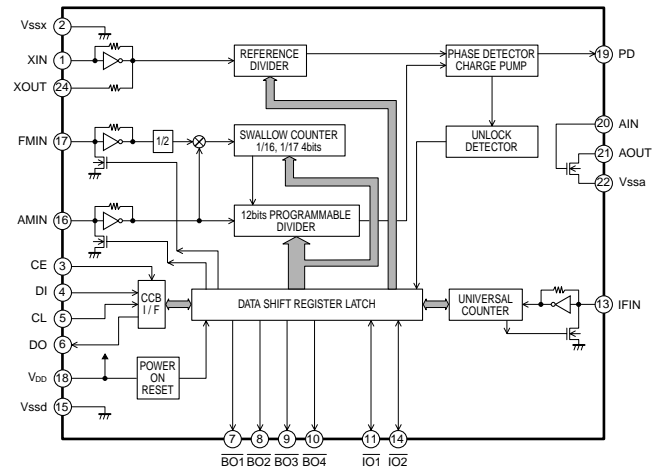

DVR-S60  
NX-SW60

**VIDEO P.C.B.**

**IC211~213 NJM4558M (Operational Amplifier)**

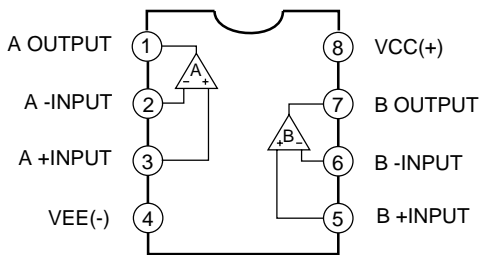

**IC221 LA7952 (Video Switch)**

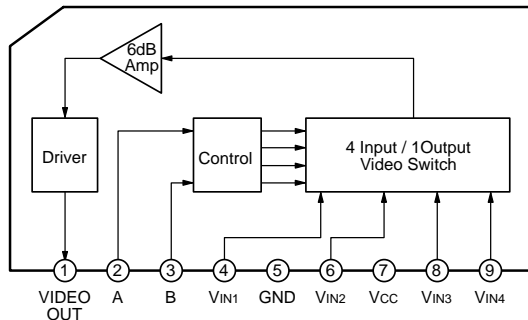

Truth Table

A	B	VIN1	VIN2	VIN3	VIN4
H	H	ON	OFF	OFF	OFF
L	H	OFF	ON	OFF	OFF
H	L	OFF	OFF	ON	OFF
L	L	OFF	OFF	OFF	ON

**STANDBY POWER P.C.B.**

**IC413 KIA7805API (3-Terminal Voltage Regulators)**

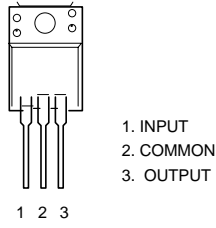

**DVD POWER P.C.B.**

**IC232 LM1086CT (1.5A Low Dropout Positive Regulators)**

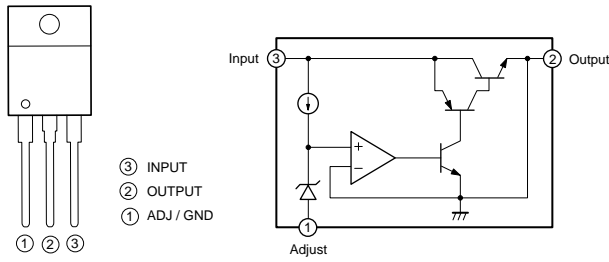

**IC231, IC233 KIA78R05PI~15PI (4-Terminal Low Drop Voltage Regulator)**

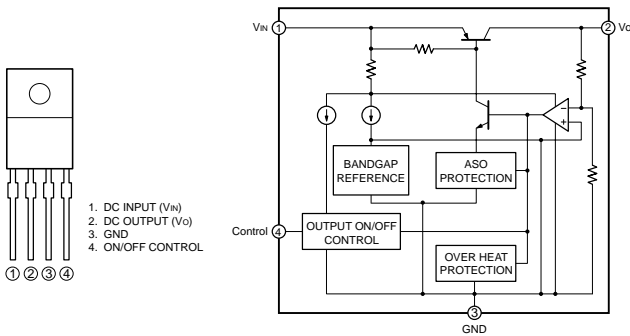

**HEADPHONE P.C.B.**

**IC241 NJM4580M (Operational Amplifier)**

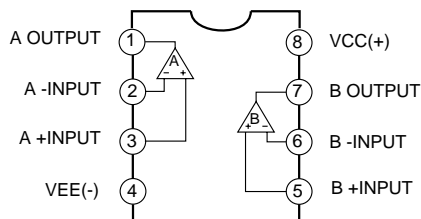

DVR-S60  
NX-SW60

MPEG P.C.B.

IC871,881 LE28DW8102T-90-MPB (Flash Memory)

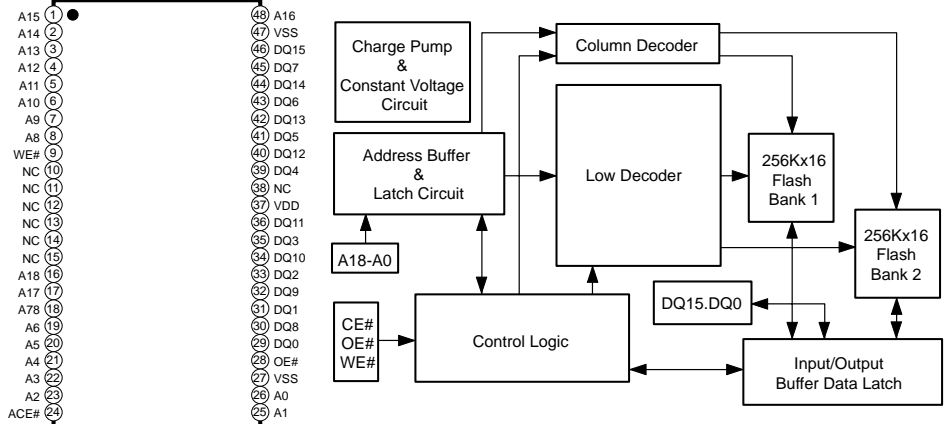

Symbol	Description	Function
A18	Bank select address	Select Bank 1 (negative) or Bank 2 (positive)
A17-A0	Flash bank address	Flash bank address during write
A17-A15	Flash bank block address	Select at flash bank for erase
A17-A10	Flash bank selector address	Select at flash bank sector for erase
DQ15-DQ0	Data input/output	Output the data during read cycle and receive the input data during write cycle
CE#	Chip enable	Enable the data flash bank when CE# is negative
OE#	Output enable	Enable the data output buffer
WE#	Write enable	Write, Erase, Program control
VDD	Power supply	Power supply (2.07V~3.6V)
GND	Ground	Ground
NC	No connect	No connect

DVR-S60  
NX-SW60

IC804,805 TC74LCX373FT (Low Voltage Octal D-type Latch with 5V Tolerant Inputs and Outputs)

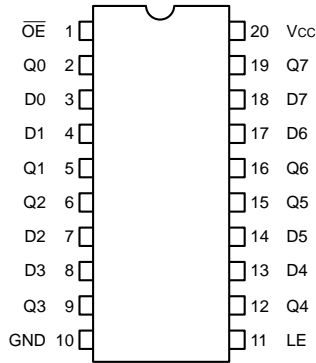

INPUTS			OUTPUTS
OE	LE	D	
H	X	X	Z
L	L	X	Qn
L	H	L	L
L	H	H	H

X : Don't Care  
Z : High impedance  
Qn : Q Output level before LE turn into "L"

Truth Table

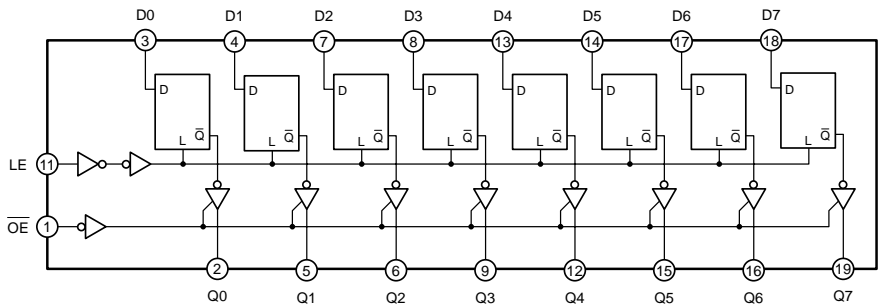

**MPEG P.C.B.**

**IC806,807 EM636165TS,KM416S1120DT,K4S161622D (1 Mega x 16 Synchronous DRAM)**

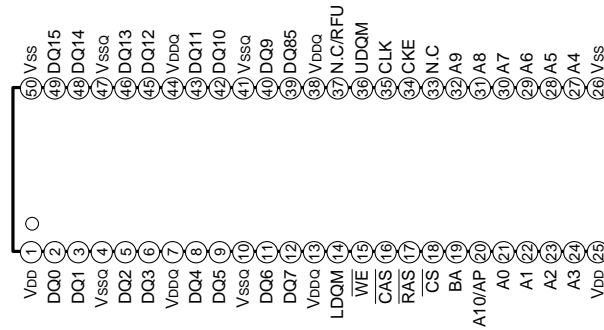

Pin	Name	Input Function
CLK	System Clock	Active on the positive going edge to sample all inputs.
CS	Chip Select	Disables or enable device operation by masking or enabling all inputs except CLK,CKE and L(U)DQM
CKE	Clock Enable	Masks system clock to freeze operation from the next clock cycle. CKE should be enabled at least one cycle prior to new command. Disable input buffers for power down in standby.
A0-A10/AP	Address	Row / column addresses are multiplexed on the same pins. Row address : RA0-RA10, column address : CA0-CA7
BA	Bank Select Address	Selects bank to be activated during row address latch time. Selects bank for read/write during column address latch time.
RAS	Row Address Strobe	Latches row addresses on the positive going edge of the CLK with RAS low. Enables row access & precharge.
CAS	Column Address Strobe	Latches column addresses on the positive going edge of the CLK with CAS low. Enables column access.
WE	Write Enable	Enables write operation and row precharge. Latches data in standing from CAS, WE active.
L(U)DQM	Data Input/Output Mask	Makes data output Hi-Z, tSHZ after the clock and masks the output. Blocks data input when L(U)DQM active.
DQ0-15	Data Input/Output	Data inputs/outputs are multiplexed on the same pins.
VDD/VSS	Power Supply/Ground	Power and ground for the input buffers and the core logic.
VDDQ/VSSQ	Data Output Power/Ground	Isolated power supply and ground for the output buffers to provide improved noise immunity.
N.C./RFU	No Connection/ Reserved for Future Use	This pin is recommended to be left No Connection on the device.

**IC811 PQ025EZ01ZPN (Low Voltage Operation Low Power-Loss VoltageRegulators)**

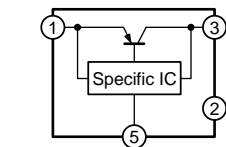
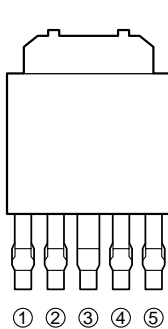

- ① DC input (VIN)
- ② ON/OFF control terminal (Vc)
- ③ DC output (Vo)
- ④ NC
- ⑤ GND

**IC812 PST3627UR (Reset IC)**

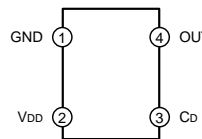
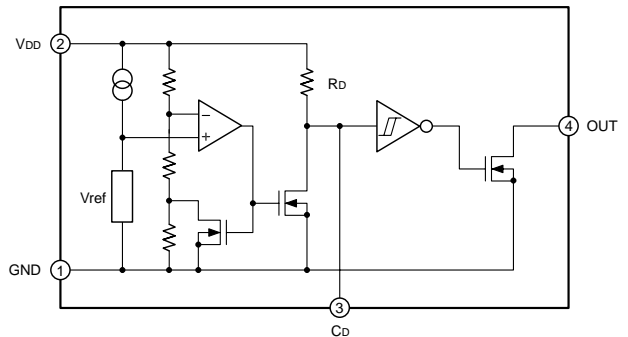

PIN No.	PIN NAME	FUNCTIONS
1	GND	GND Pin
2	VDD	VDD Pin / Voltage Detect Pin
3	Cd	Capacitor Connect Pin with Delay
4	OUT	Reset Signal Output Pin

DVR-S60  
NX-SW60

# MPEG P.C.B.

## IC813 74VHC157MTC,TC74VHC157FT (Quad 2-Channel Multiplexer)

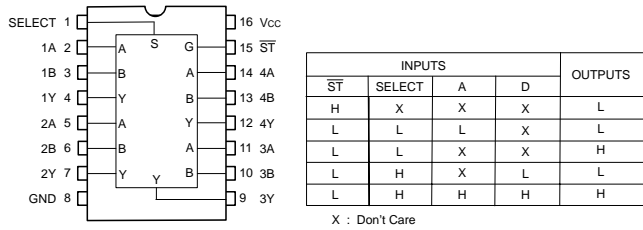

## IC817 PCM1748E (D/A Converter)

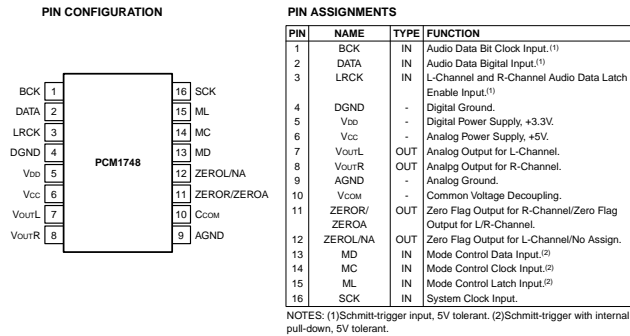

## IC815 24LC16BT, S524L50X51 (16K EEPROM)

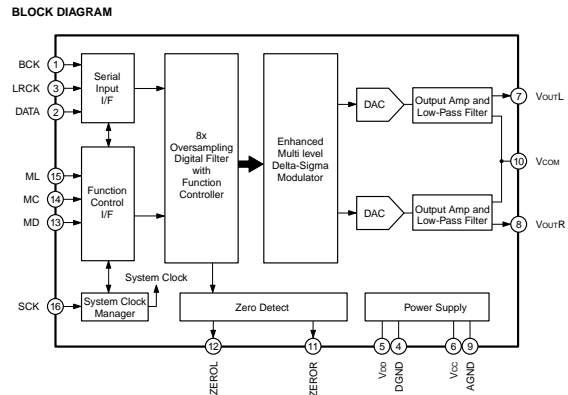
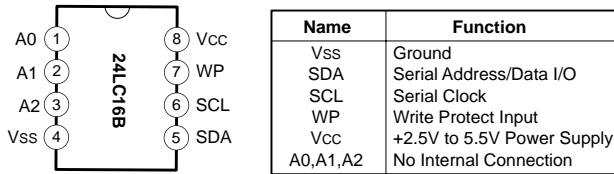

## IC842,862~864KIA4558F, NJM4558M (Operational Amplifier)

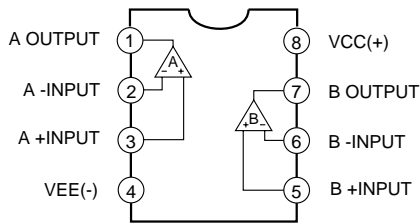

## IC818 74VHC374,TCVHC374 (Octal D-type Flip Flop)

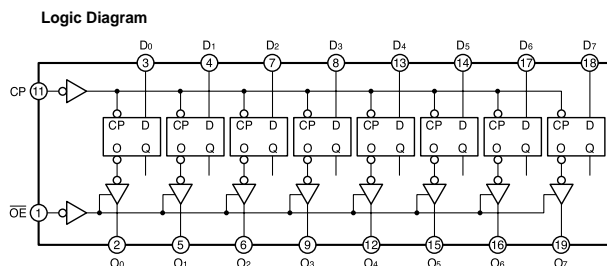

## IC816 74VHCT244,TC74VHCT244 (AFT Non-Inverted, 3-state Output)

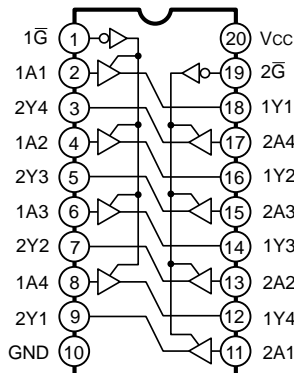

**Pin Descriptions**

Pin Names	Description
D <sub>0</sub> -D <sub>7</sub>	Data Inputs
CP	Clock Pulse Input 3-STATE
OE	Output Enable Input 3-STATE
O <sub>0</sub> -O <sub>7</sub>	Outputs

**Truth Table**

Inputs		Outputs	
D <sub>n</sub>	CP	OE	O <sub>n</sub>
H	↗	L	H
L	↗	L	L
X	X	H	Z

H = HIGH Voltage Level  
 L = LOW Voltage Level  
 X = IGNORE  
 Z = High Impedance  
 ↗ = LOW-to-HIGH Transition

## IC819 NC7SZ08P5,TC7SH08FU (2 Input AND Gate)

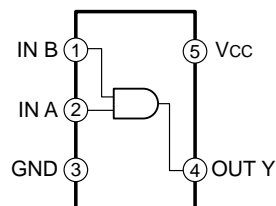



**MPEG P.C.B.**

**IC861 PCM1602Y (Digital to Analog Converter)**

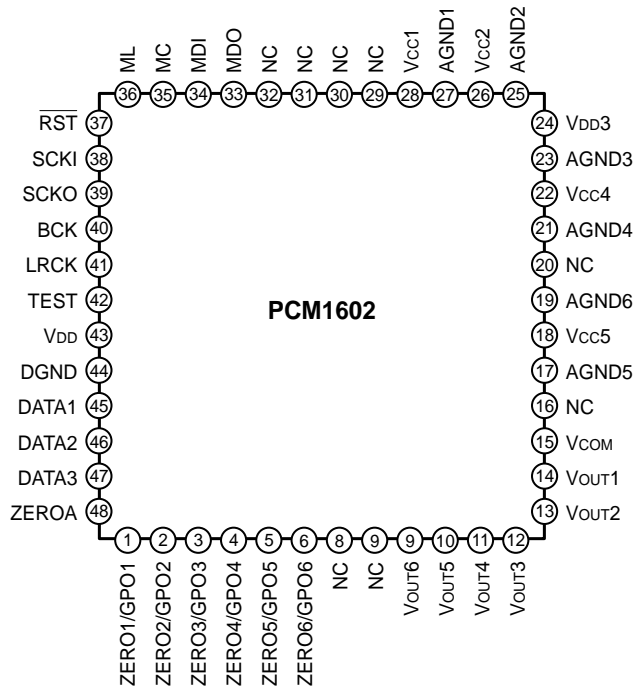
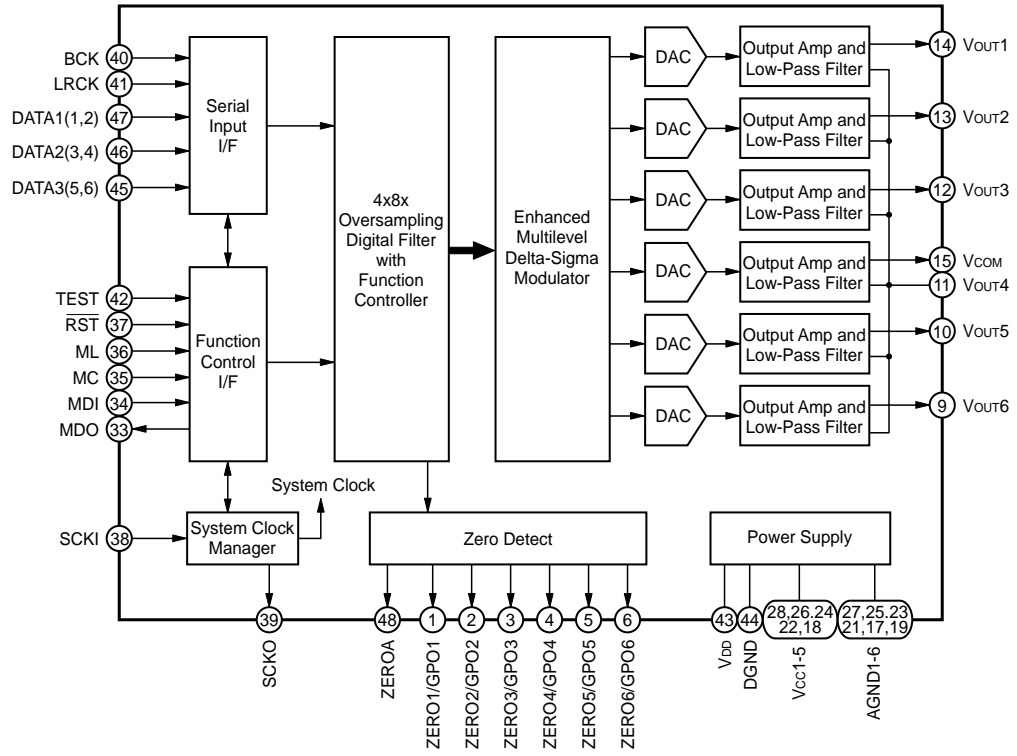

**DVR-S60  
NX-SW60**

## MPEG P.C.B.

## IC861 PCM1602Y (Digital to Analog Converter)

## PIN ASSIGNMENTS

PIN	NAME	I/O	DESCRIPTION
1	ZERO1/GPO1	O	Zero Data Flag for Vout1.
2	ZERO2/PGO2	O	Zero Data Flag for Vout2.
3	ZERO3/PGO3	O	Zero Data Flag for Vout3.
4	ZERO4/PGO4	O	Zero Data Flag for Vout4.
5	ZERO5/PGO5	O	Zero Data Flag for Vout5.
6	ZERO6/PGO6	O	Zero Data Flag for Vout6.
7	NC	-	No Connection
8	NC	-	No Connection
9	Vout6	O	Voltage Output of Audio Signal Corresponding to Rch on DATA3. Up to 96kHz.
10	Vout5	O	Voltage Output of Audio Signal Corresponding to Lch on DATA3. Up to 96kHz.
11	Vout4	O	Voltage Output of Audio Signal Corresponding to Rch on DAYA2. Up to 96kHz.
12	Vout3	O	Voltage Output of Audio Signal Corresponding to Lch on DATA2. Up to 96kHz.
13	Vout2	O	Voltage Output of Audio Signal Corresponding to Rch on DATA1. Up to 192kHz.
14	Vout1	O	Voltage Output of Audio Signal Corresponding to Lch on DATA1. Up to 192kHz.
15	Vcom	O	Common Voltage Output.
16	NC	O	No Connection
17	AGND5	-	Analog Ground
18	Vcc5	-	Analog Power Supply, +5V
19	AGND6	-	Analog Ground
20	NC	-	No Connection
21	AGND4	-	Analog Ground
22	Vcc4	-	Analog Power Supply, +5V
23	AGND3	-	Analog Ground
24	Vcc3	-	Analog Power Supply, +5V
25	AGND2	-	Analog Ground
26	Vcc2	-	Analog Power Supply, +5V
27	AGND1	-	Analog Ground
28	Vcc1	-	Analog Power Supply, +5V
29	NC	-	No Connection
30	NC	-	No Connection
31	NC	-	No Connection
32	NC	-	No Connection
33	MDO	O	Serial Data Output for Serial Control Port <sup>(3)</sup>
34	MDI	I	Serial Data Input for Serial Control Port <sup>(1)</sup>
35	MC	I	Shift Clock for Serial Control Port <sup>(1)</sup>
36	ML	I	Latch Enable for Serial Control Port <sup>(1)</sup>
37	$\overline{RST}$	I	System Reset, Active LOW <sup>(1)</sup>
38	SCKI	I	System Clock Input. Input frequency is 128,192,256,384,512, or 768fs. <sup>(2)</sup>
39	SCKO	O	Buffered Clock Output. Output frequency is 128,192,256,384,512, or 768fs, or one-half of 128,192,256,384,512, or 768fs.
40	BCK	I	Shift Clock Input for Serial Audio Data. Clock must be 32,48, or 64fs. <sup>(2)</sup>
41	LRCK	I	Left and Right Clock Input. This clock is equal to the sampling rate, fs. <sup>(2)</sup>
42	TEST	-	Test Pin. This pin should be connected to DGND. <sup>(1)</sup>
43	VDD	-	Digital Power Supply, +3.3V
44	DGND	-	Digital Ground
45	DATA1	I	Serial Audio Data Input for Vout1 and Vout2 <sup>(2)</sup>
46	DATA2	I	Serial Audio Data Input for Vout3 and Vout4 <sup>(2)</sup>
47	DATA3	I	Serial Audio Data Input for Vout5 and Vout6 <sup>(2)</sup>
48	ZEROA	O	Zero Data Flag. Logical "AND" of ZERO1 through ZERO6.

NOTES: (1) Schmitt-Trigger input with internal pull-down, 5V tolerant. (2) Schmitt-Trigger inout, 5V tolerant. (3) Tri-state output.

DVD P.C.B.

IC100 LA9702WL-MPB (Front End Processor for DVD Player)

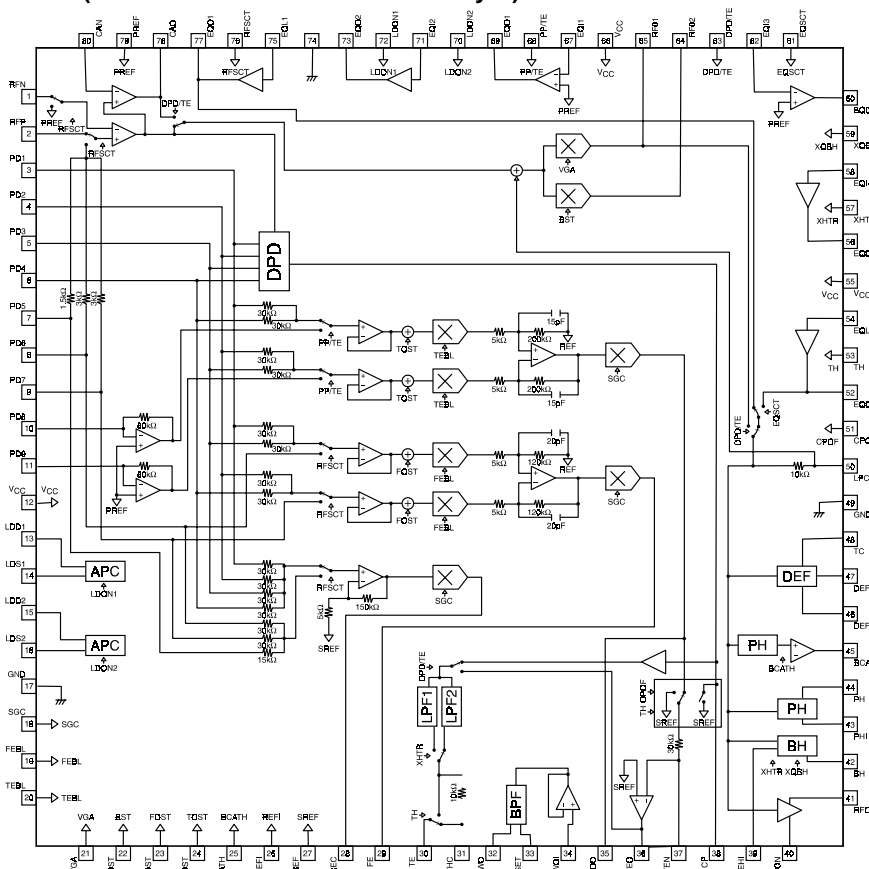

No.	Name	Description
1	RFN	RF signal -input
2	RFP	RF signal +input
3	PD1	Pickup signal input
4	PD2	Pickup signal input
5	PD3	Pickup signal input
6	PD4	Pickup signal input
7	PD5	Pickup signal input
8	PD6	Pickup signal input
9	PD7	Pickup signal input
10	PD8	Pickup signal input
11	PD9	Pickup signal input
12	VCC	Power (Servo signal)
13	DD1	APC1 output
14	LDS1	APC1 monitor voltage input
15	LDD2	APC2 output
16	LDS2	APC2 monitor voltage input
17	GND	GND.(Servo signal)
18	SGC	Servo gain control terminal (RREC,FE,TE)
19	FEBL	Focus balance adjusting terminal
20	TEBL	Tracking balance adjusting terminal
21	VGA	RF gain adjusting terminal
22	BST	Equalizer boost adjusting terminal
23	FOST	Focus offset adjusting terminal
24	TOST	Tracking offset adjusting terminal
25	BCATH	BCA threshold adjusting terminal
26	REF1	Standard voltage setting terminal
27	SREF	Standard voltage output for servo signal
28	RREC	Reflection output
29	FE	Focus error output
30	TE	Tracking error output
31	THC	TE hold time constant
32	WO	Wobble output terminal
33	ISSET	Resistance connection terminal to setting BPF center frequency
34	WOI	Push-pull signal input
35	WOO	Push-pull signal output
36	TEO	TE gain setting terminal for 3 beam
37	TEN	TE gain setting terminal for 3 beam
38	CP	Resistance to setting charge pump gain,Condenser connection terminal
39	BHI	Resistance connection terminal to setting bottom hold detect parameters
40	RFON	RF -output

No.	Name	Description
41	RFOP	RF +output
42	BH	RF bottom detection output
43	PHI	Resistance connection terminal to setting peak hold detect parameters
44	PH	RF peak detect output
45	BCA	BCA output
46	DEF	Defect output (H:Defect detect)
47	DEFEC	Condenser connect terminal for defect detect
48	TC	Resistance connection terminal to setting defect detect parameters
49	GND	GND.
50	LPC	Condenser connection terminal for RF DC servo
51	CPOF	Charge pump OFF terminal (H:OFF)
52	EQ02	RF equalizer setting terminal
53	TH	Tracking hold (H:Hold)
54	EQL2	RF equalizer setting terminal
55	VCC	Power supply
56	EQ04	RF equalizer setting terminal
57	XHTR	Tracking,Bottom detect band select (L:High band)
58	EQ14	RF equalizer setting terminal
59	XQBH	Bottom detect time constant select (L:High speed)
60	EQ03	RF equalizer setting terminal
61	QSCT	Equalizer select (H:77 pin selection,L:52 pin selection)
62	EQ13	RF equalizer setting terminal
63	DPD/TE	DPD,3 beam tracking select (H:DPD)
64	RF02	RF output
65	F01	RF output
66	VCC	Power supply (RF phase)
67	EQ11	RF equalizer setting terminal
68	PP/TE	3 beam,push-pull tracking select (L:3 beam)
69	EQ01	RF equalizer setting terminal
70	LDON2	APC2 Laser ON terminal (H:ON)
71	EQ12	RF equalizer setting terminal
72	LDON1	APC1 Laser ON terminal (H:ON)
73	EQ02	RF equalizer setting terminal
74	GND	GND.(RF phase)
75	EQL1	RF equalizer setting terminal
76	RFSC1	RF input select (H:RF differential input,PP error)
77	EQ01	RF equalizer setting terminal
78	CAO	Customer Amplifier output
79	PREF	Standard voltage output (for Pick-up)
80	CAN	Customer Amplifier input

DVR-S60  
NX-SW60

DVD P.C.B.

**IC101 BU4066BCF (Quad Analog Switch)**

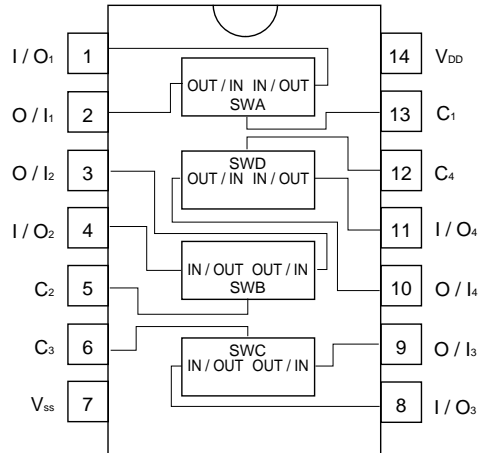

**IC201 T224162B,LC324265AT,M11B416256A (DRAM)**

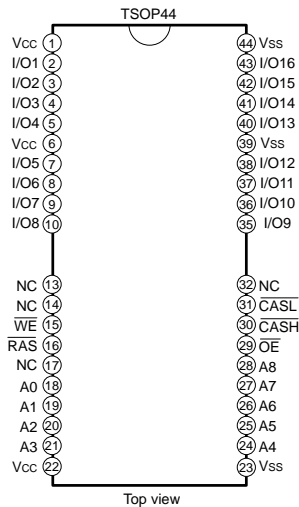
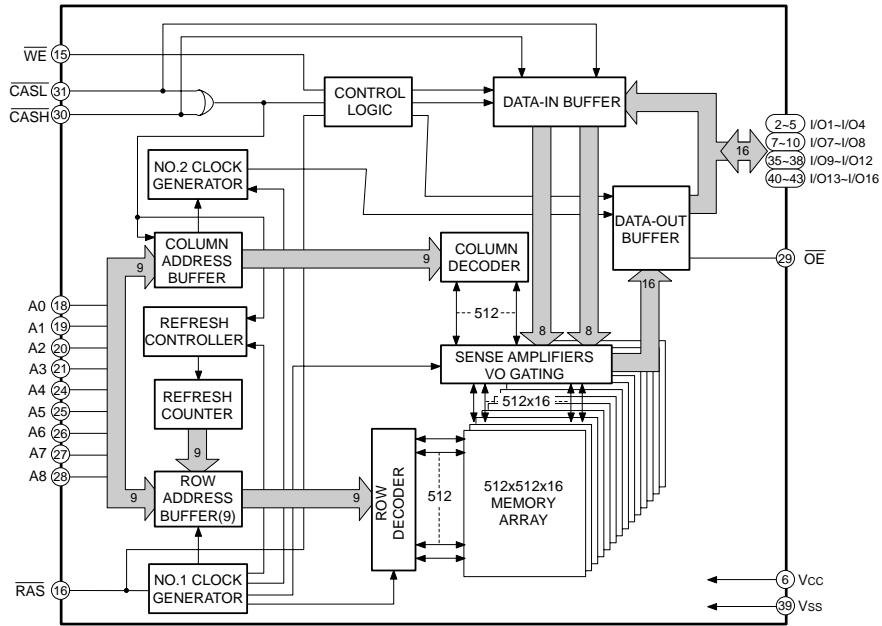

PIN NO.	SYM.	TYPE	DESCRIPTION
16-19,22-26	A0-A8	Input	Address Input
14	RAS	Input	Row Address Strobe
28	CASH	Input	Column Address Strobe /Upper Byte Control
29	CASL	Input	Column Address Strobe /Lower Byte Control
13	WE	Input	Write Enable
27	OE	Input	Output Enable
2-5,6-10,31-34,36-39	I/O1-I/O16	Input/Output	Data Input /Output
1,6,20	Vcc	Supply	Power, 5V
21,35,40	Vss	Ground	Ground
11,12,15,30	NC	-	No Connec

DVR-S60  
NX-SW60

DVD P.C.B.

IC200 LC78661W-D (DVD-CD Servo)

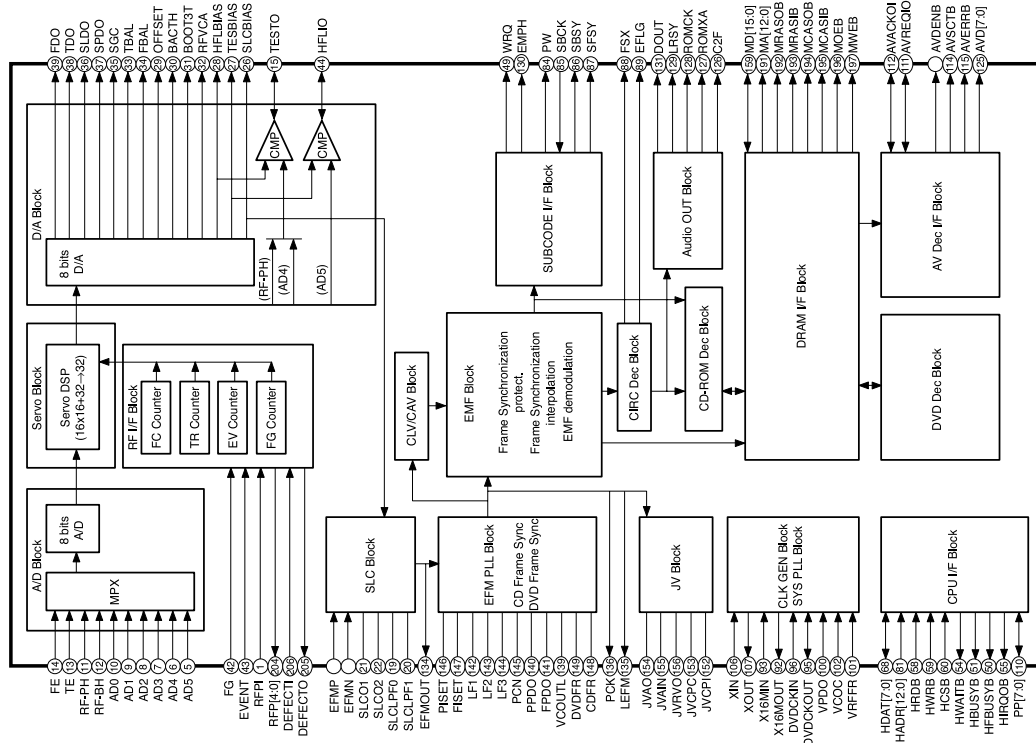

FE	TE	RF-PH	RF-BH	ADD	AD5	AD4	AD3	AD2	AD1	AD0	FG	EVENT	RFP4-0	DEFECT0	DEFECT1	DEFECT2	DEFECT3	EFMP	EFMIN	EFMINP	EFMINN	SLC1-PFO	SLC1-PFI	SLC2-PFO	SLC2-PFI	RSET	LF1	LF2	LF3	PCN	PFDO	VCOCTL	DVDFR	CDFR	PCK	LEFM	JVAO	JVAI	JVRVO	JVCPC	JVCPI	XIN	XOUT	X16MIN	X16MID	X16MAX	DVDCOUT	VDDO	VDD2	VDD4	VDD5	VDD6	VDD7	VDD8	VDD9	VDD10	VDD11	VDD12	VDD13	VDD14	VDD15	VDD16	VDD17	VDD18	VDD19	VDD20	VDD21	VDD22	VDD23	VDD24	VDD25	VDD26	VDD27	VDD28	VDD29	VDD30	VDD31	VDD32	VDD33	VDD34	VDD35	VDD36	VDD37	VDD38	VDD39	VDD40	VDD41	VDD42	VDD43	VDD44	VDD45	VDD46	VDD47	VDD48	VDD49	VDD50	VDD51	VDD52	VDD53	VDD54	VDD55	VDD56	VDD57	VDD58	VDD59	VDD60	VDD61	VDD62	VDD63	VDD64	VDD65	VDD66	VDD67	VDD68	VDD69	VDD70	VDD71	VDD72	VDD73	VDD74	VDD75	VDD76	VDD77	VDD78	VDD79	VDD80	VDD81	VDD82	VDD83	VDD84	VDD85	VDD86	VDD87	VDD88	VDD89	VDD90	VDD91	VDD92	VDD93	VDD94	VDD95	VDD96	VDD97	VDD98	VDD99	VDD100
HWAITB	HFOBE	DVRESB	RRES	HMBE	HMBE	HCBSE	HDAT0	HDAT1	HDAT2	HDAT3	HDAT4	HDAT5	HDAT6	HDAT7	HADR0	HADR1	HADR2	HADR3	HADR4	HADR5	HADR6	HADR7	HADR8	HADR9	HADR10	HADR11	HADR12	DVDD3	DVDD4	DVDD5	DVDD6	DVDD7	DVDD8	DVDD9	DVDD10	DVDD11	DVDD12	DVDD13	DVDD14	DVDD15	DVDD16	DVDD17	DVDD18	DVDD19	DVDD20	DVDD21	DVDD22	DVDD23	DVDD24	DVDD25	DVDD26	DVDD27	DVDD28	DVDD29	DVDD30	DVDD31	DVDD32	DVDD33	DVDD34	DVDD35	DVDD36	DVDD37	DVDD38	DVDD39	DVDD40	DVDD41	DVDD42	DVDD43	DVDD44	DVDD45	DVDD46	DVDD47	DVDD48	DVDD49	DVDD50	DVDD51	DVDD52	DVDD53	DVDD54	DVDD55	DVDD56	DVDD57	DVDD58	DVDD59	DVDD60	DVDD61	DVDD62	DVDD63	DVDD64	DVDD65	DVDD66	DVDD67	DVDD68	DVDD69	DVDD70	DVDD71	DVDD72	DVDD73	DVDD74	DVDD75	DVDD76	DVDD77	DVDD78	DVDD79	DVDD80	DVDD81	DVDD82	DVDD83	DVDD84	DVDD85	DVDD86	DVDD87	DVDD88	DVDD89	DVDD90	DVDD91	DVDD92	DVDD93	DVDD94	DVDD95	DVDD96	DVDD97	DVDD98	DVDD99	DVDD100																					
JVRVO	JVAI	JVAO	JVCPC	JVCPI	AVSS	AVDD2	DVDFR	CDFR	FSET	PSET	PCN	LF3	LF2	LF1	PFDO	PPDO	VCOCTL	DVDFR	CDFR	PCK	LEFM	EFMOUT	DVSS	DVDD4	DOUT	EMPH	LSRY	ROMCK	ROMXA	C2F	AVD7	AVD6	AVD5	AVD4	AVD3	AVD2	AVD1	AVD0	DVDD4	DVDD5	XOUT	XIN	DVSS																																																																																																							

DVR-S60 NX-SW60

DVD P.C.B.

IC500 M37903S4CHP (16-bit C-Mos Micro Computer)

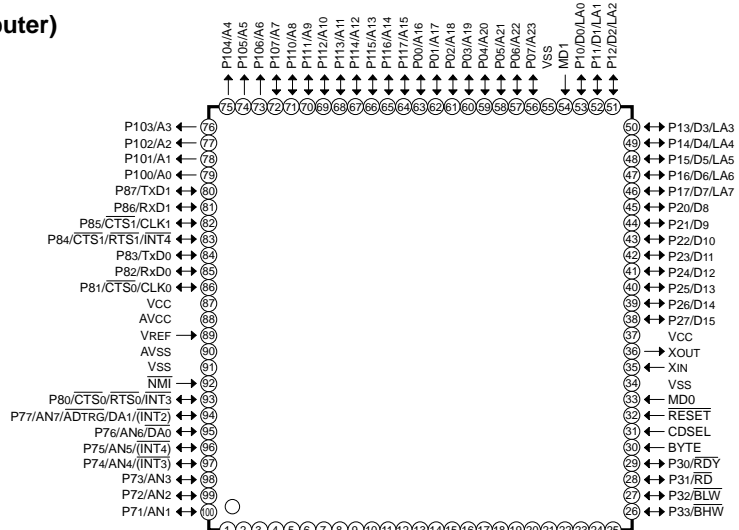

DVR-S60  
NX-SW60

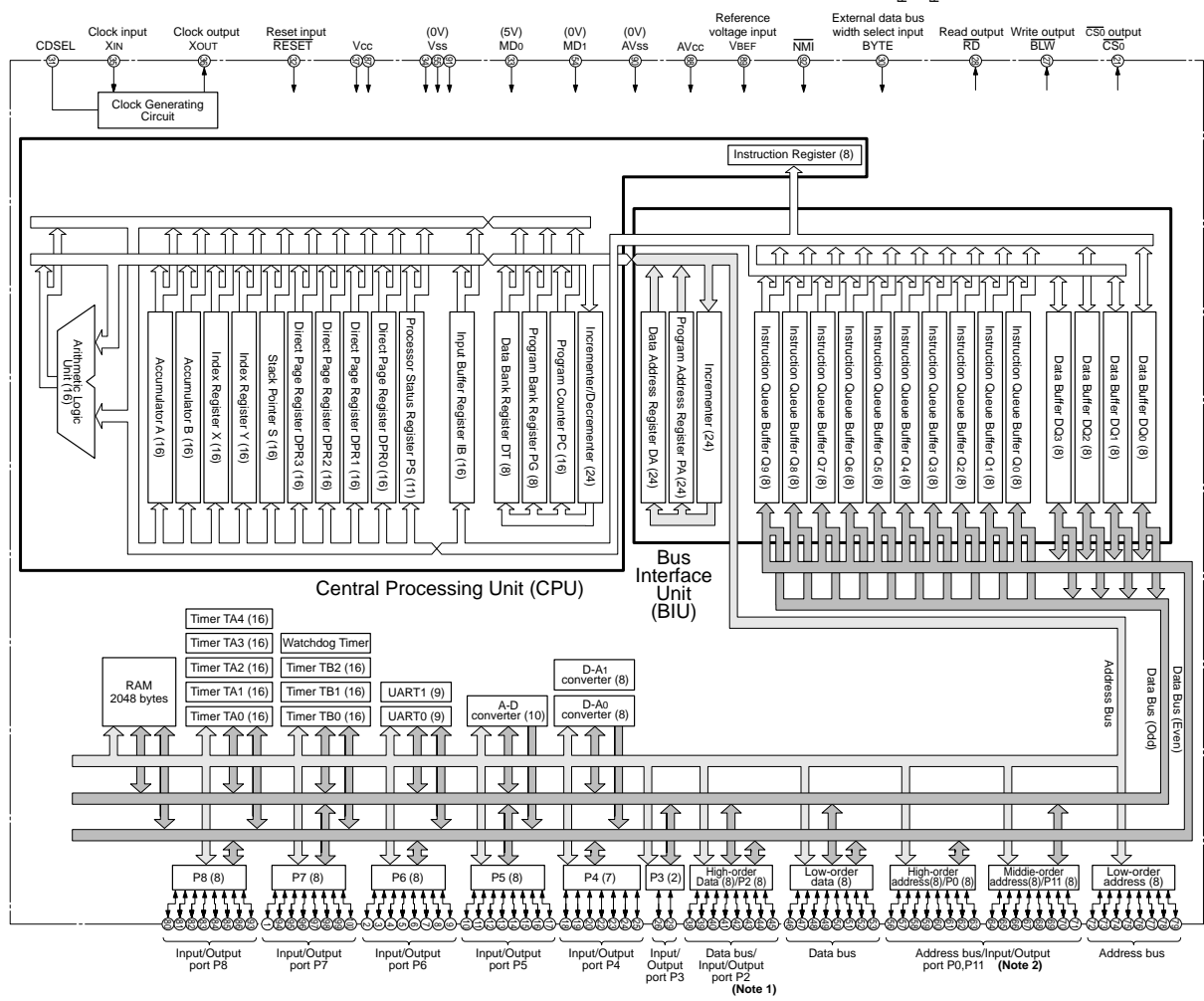

Note 1: When the external data bus width = 16 bits, this serves as the data bus; when the external data bus width = 8 bit, this serves as the I/O port.  
 Note 2: According to the register setting, this can serve as the I/O port.

## DVD P.C.B.

## IC500 M37903S4CHP (16-bit C-Mos Micro Computer)

Pin No.	Symbol	Name	Input/ Output	Description
87, 91	V <sub>CC</sub> , V <sub>SS</sub>	Power supply input	—	Apply 5V ±0.5V to V <sub>CC</sub> , and 0V to V <sub>SS</sub> .
33	MD0	MD0	Input	Connect this pin to V <sub>CC</sub> .
54	MD1	MD1	Input	Connect this pin to V <sub>SS</sub> .
32	RESET	Reset input	Input	The microcomputer is reset when V <sub>SS</sub> -level voltage is applied to this pin.
35	X <sub>IN</sub>	Clock input	Input	Input and output pins of the internal clock generating circuit.
36	X <sub>OUT</sub>	Clock output	Output	
30	BYTE	External data bus width select input	Input	This pin determines whether the external data bus has an 8-bit width or 16-bit width for the memory expansion mode or microprocessor mode. The width is 16 bits when V <sub>SS</sub> -level voltage is input, and 8 bits when V <sub>CC</sub> -level voltage is applied. When BYTE=V <sub>SS</sub> level, by the register setting, the external data bus for each of areas CS <sub>1</sub> to CS <sub>3</sub> can have a width of 8 bits.
31	CDSEL	Clock division select input	Input	This pin determines the X <sub>IN</sub> -input-clock division select bit's ( <b>note</b> ) state at reset and the input level at pin X <sub>IN</sub> .
88 90	AV <sub>CC</sub> , AV <sub>SS</sub>	Analog power supply input	—	Power supply input pins for the A-D converter and the D-A converter. Connect AV <sub>CC</sub> to V <sub>CC</sub> , and AV <sub>SS</sub> to V <sub>SS</sub> externally.
89	V <sub>REF</sub>	Reference voltage input	Input	This is the reference voltage input pin for the A-D converter and the D-A converter.
56-63	P00/A16 - P07/A23	Address (high-order) output	Output	Address (A16-A23) is output. These pins also function as I/O port pins according to the register setting.
46-53	P10/D0 - P17/D7	Data (low-order) I/O	I/O	The low-order 8 bits of data (D0-D7) are input/output. When the external data bus has an 8-bit width, address (LA0-LA7) output and data (D0-D7) input/output can be performed with the time-sharing method, according to the register setting.
38-45	P20/D8 - P27/D15	I/O port p2, Data (high-order) I/O	I/O	<ul style="list-style-type: none"> <li>■ When 8-bit external data bus is used. Port P2 is an 8-bit I/O port. This port has an I/O direction register, and each pin can be programmed for input or output. These pins enter the input mode at reset.</li> <li>■ When 16-bit external data bus is used. The high-order 8 bits of data (D8 - D15) are input or output.</li> </ul>
26-29	P30 - P33	I/O port P3	I/O	P30 functions as an input pin of $\overline{RDY}$ ; and P31, P32, P33 function as the output pins of $\overline{RD}$ , BLW, BHW, respectively. P30 also functions as an I/O port pin according to the register setting. When the external data has a width of 8 bits, be BHW pin functions
18-25	P40 - P47	I/O port P4	I/O	P40 - P44 function as output or input pins of ALE, $\phi 1$ , HLDA, $\overline{HOLD}$ , CS <sub>0</sub> , and P45 - P47 as I/O port pins, respectively. According to the register setting, P40 - P43 also function as I/O port pins, and P45 - P47 as output pins of CS <sub>1</sub> - CS <sub>3</sub> .
10-17	P50 - P57	I/O port P5	I/O	Port P5 is an 8-bit I/O port. This port has an I/O direction register, and each pin can be programmed for input or output. These pins enter the input mode at reset. These pins also function as I/O pins for timers A0 - A3, output pins for the real-time output pins for the real-time output, and input pins for the key-input interrupt.
5-9	P60 - P67	I/O port P6	I/O	Port P6 is an 8-bit I/O port. This port has an I/O direction register, and each pin can be programmed for input or output. These pins enter the input mode at reset. These pins also function as I/O pins for timers A4, input pins for external interrupt inputs $\overline{INT0}$ - $\overline{INT2}$ , and input pins for timers B0 - B2.
1, 94-100	P70 - P77	I/O port P7	I/O	Port P7 is an 8-bit I/O port. This port has an I/O direction register, and each pin can be programmed for input or output. These pins enter the input mode at reset. These pins also function as input pins for the A-D converter, output pins for the D-A converter, and input pins for $\overline{INT2}$ , $\overline{INT3}$ , and $\overline{INT4}$ .
2-4, 80, 81, 93	P80 - P87	I/O port P8	I/O	Port P8 is an 8-bit I/O port. This port has an I/O direction register, and each pin can be programmed for input or output. These pins enter the input mode at reset. These pins also function as I/O pins for UART0, UART1, and input pins for $\overline{INT3}$ and $\overline{INT4}$ .
72-79	P100/A0 - P107/A7	Address (low-order) output	Output	Address (A0-A7) is output.
64-71	P110/A8 - P117/A15	Address (middle-order) output	Output	Address (A8-A15) is output. These pins also function as I/O port pins according to the register setting.
92	$\overline{NMI}$	Non-mask able interrupt	Input	This pin is for a non-mask able interrupt.

**Note :** The X<sub>IN</sub>-input-clock division select bit is used to determine whether the input clock to pin X<sub>IN</sub> is to be divided or not.

DVD P.C.B.

**IC502 M51953BFP (Reset)**

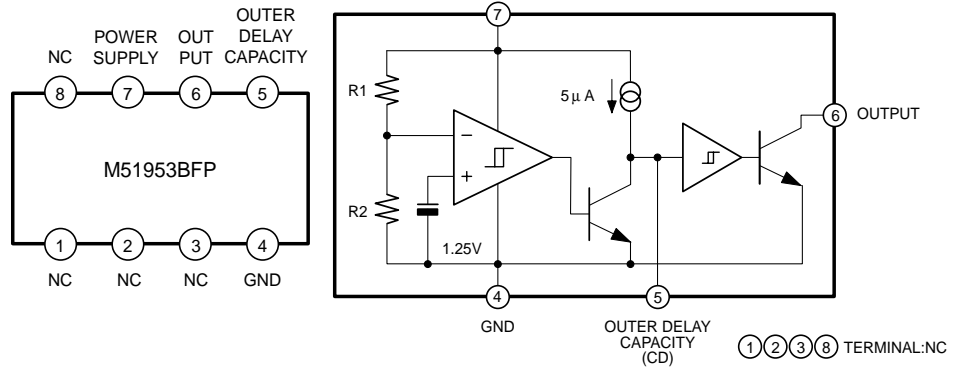

**IC504 TC7SHU04FU,NC7SZU04P5 (Inverter)**

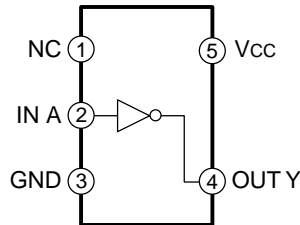

**IC550 LE28C1001DTS (Flash Memory)**

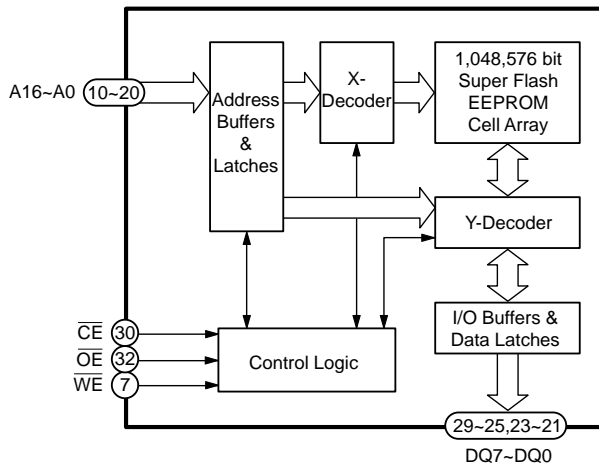

**Pin Name**

A16-A0	Address Inputs
DQ7-DQ0	Data Input/Output
$\overline{CE}$	Chip Enable
$\overline{OE}$	Output Enable
$\overline{WE}$	Write Enable
Vcc	Power Supply
Vss	Ground
NC	No Connection

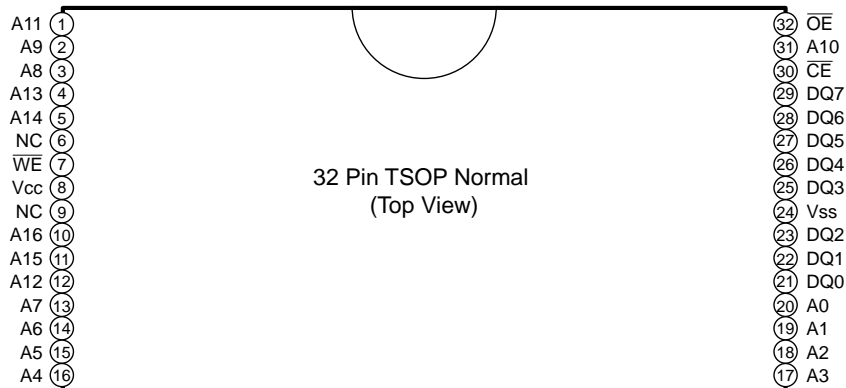



DVD P.C.B.

**IC601 BA5937AFP (Power Driver)**

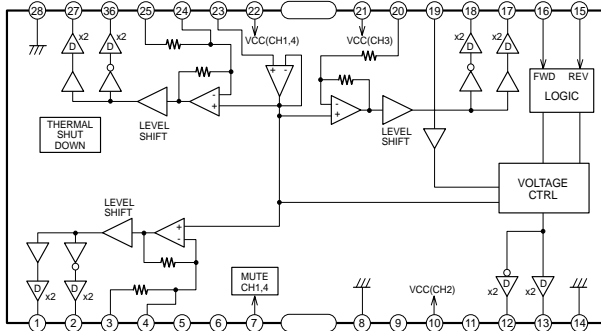

PIN NO.	NAME	DESCRIPTION	PIN NO.	NAME	DESCRIPTION
1	OUT-1	DRIVER CH1 (-)	15	REV	LOADING REV
2	OUT-2	DRIVER CH1 (+)	16	FWD	LOADING FW D
3	IN 1-1	DRIVER CH1	17	OUT3-1	DRIVER CH3 (-)
4	IN 1-2	DRIVER CH1 GAIN	18	OUT3-2	DRIVER CH3 (+)
5	NC	NOT USED	19	LD IN	LOADING
6	NC	NOT USED	20	IN 3	DRIVER CH3
7	MUTE	CH1,4 MUTE CONTROL	21	VCC3	VCC(CH3)
8	GND	GND	22	VCC1	VCC(CH1,4)
9	NC	NOT USED	23	Vref IN	BIAS
10	VCC2	VCC(CH2)	24	IN 4-2	DRIVER CH4 GAIN
11	NC	NOT USED	25	IN 4-1	DRIVE CH4
12	OUT2-2	DRIVER CH2 LOADING (+)	26	OUT4-2	DRIVER CH4 (+)
13	OUT2-1	DRIVER CH2 LOADING (-)	27	OUT4-1	DRIVER CH4 (-)
14	GND	SUB STRAIGHT GND	28	GND	SUB STRAIGHT GND

**IC602 BA6849FP (CD-ROM Motor Driver)**

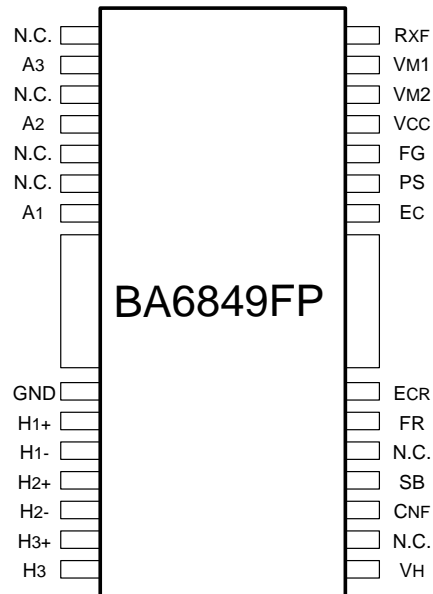
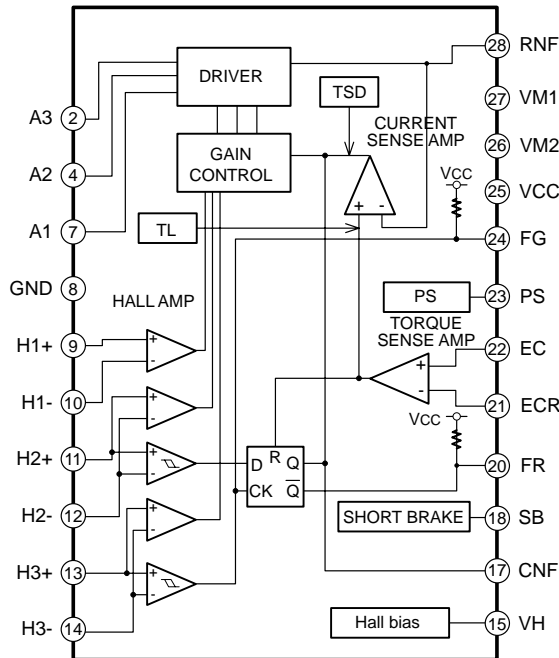

Pin No.	Name	Description	Pin No.	Name	Description
1	N.C.		15	VH	Hall bias
2	A3	Output	16	N.C.	
3	N.C.		17	CNF	Phase compensation condenser
4	A2	Output	18	SB	Short brake
5	N.C.		19	N.C.	
6	N.C.		20	FR	Rotation detection
7	A1	Output	21	ECR	Output voltage control reference
8	GND	GND	22	EC	Output voltage control
9	H1+	Hall signl input	23	PS	Power save
10	H1-	Hall signal input	24	FG	FG signal output
11	H2+	Hall signal input	25	VCC	Power source
12	H2-	Hall signal input	26	VM2	Motor power source 2
13	H3+	Hall signal input	27	VM1	Motor power source 1
14	H3-	Hall signal input	28	RNF	Resistance(output current detection) connect

**IC900 BA033FP (Regulator)**

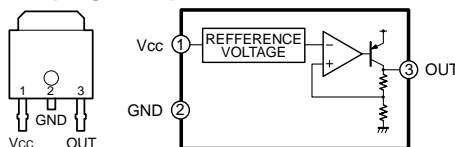

DVR-S60  
NX-SW60

**MEMO**

A large, empty rectangular box with a thin black border, occupying most of the page. It is intended for writing a memo.

DVR-S60  
NX-SW60

■ BLOCK DIAGRAM / ブロックダイアグラム

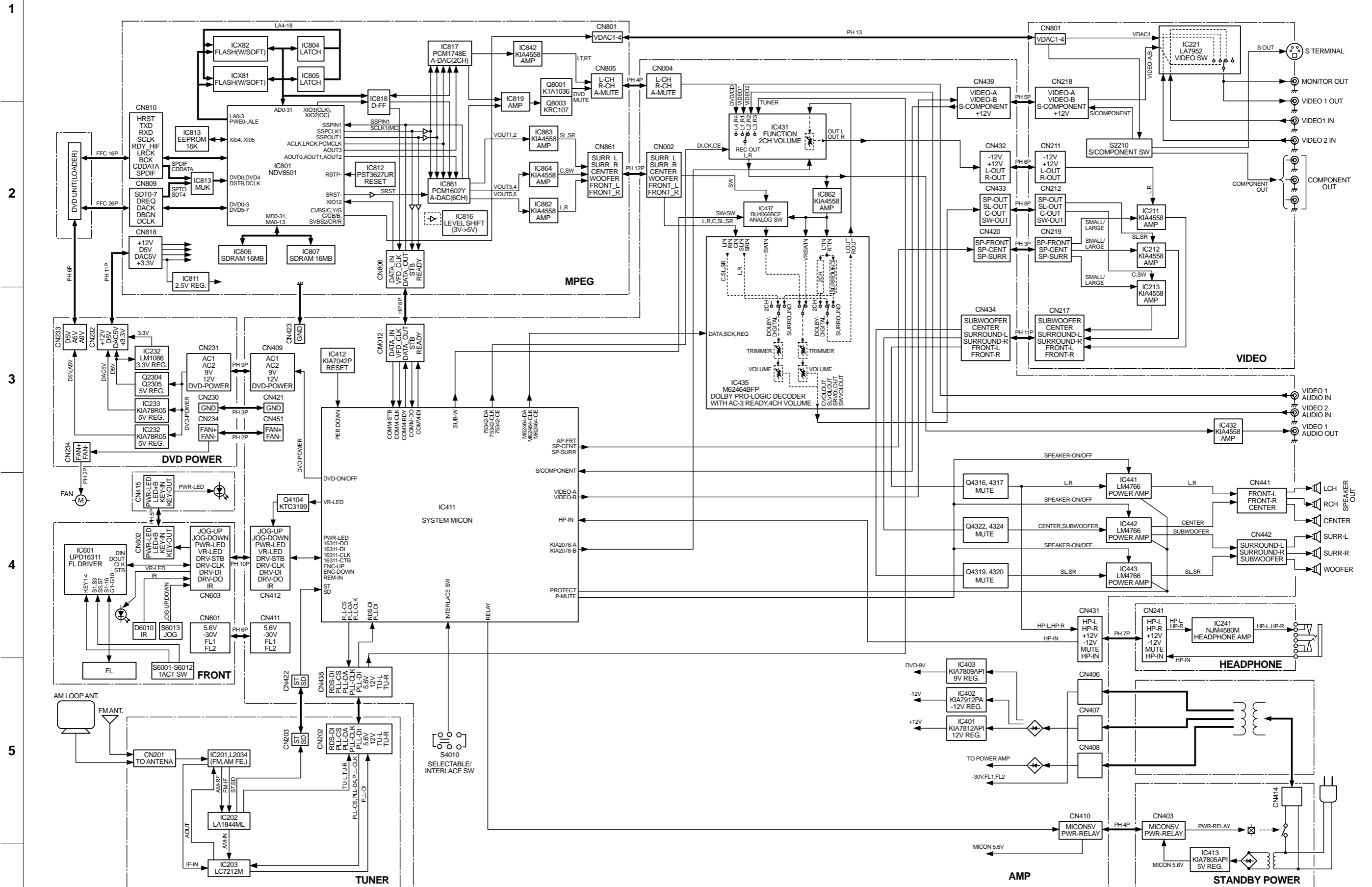

DVR-S60/NX-SW60

WIRING CONNECTION

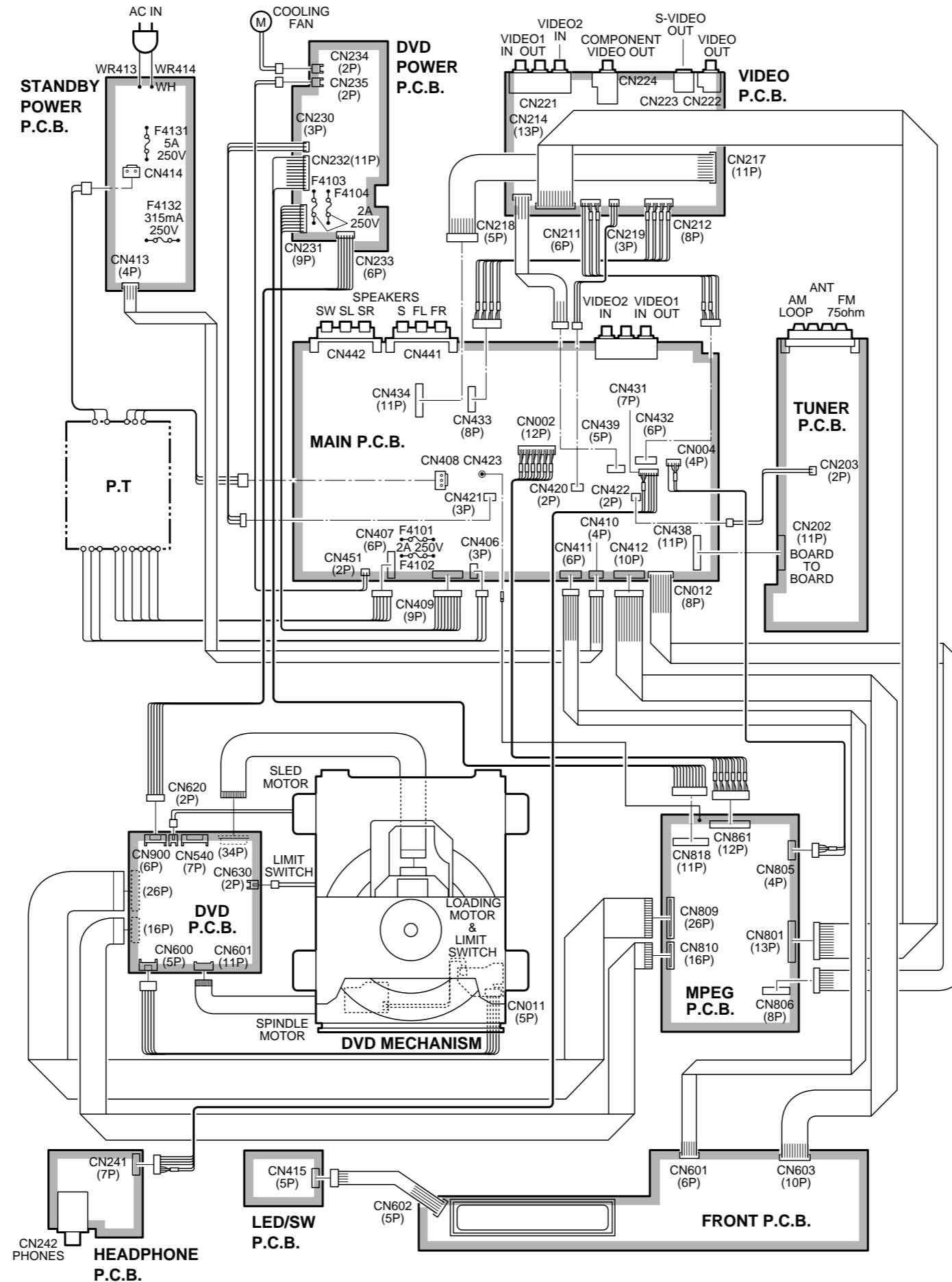

PRINTED CIRCUIT BOARD

DVD P.C.B. (A SIDE)

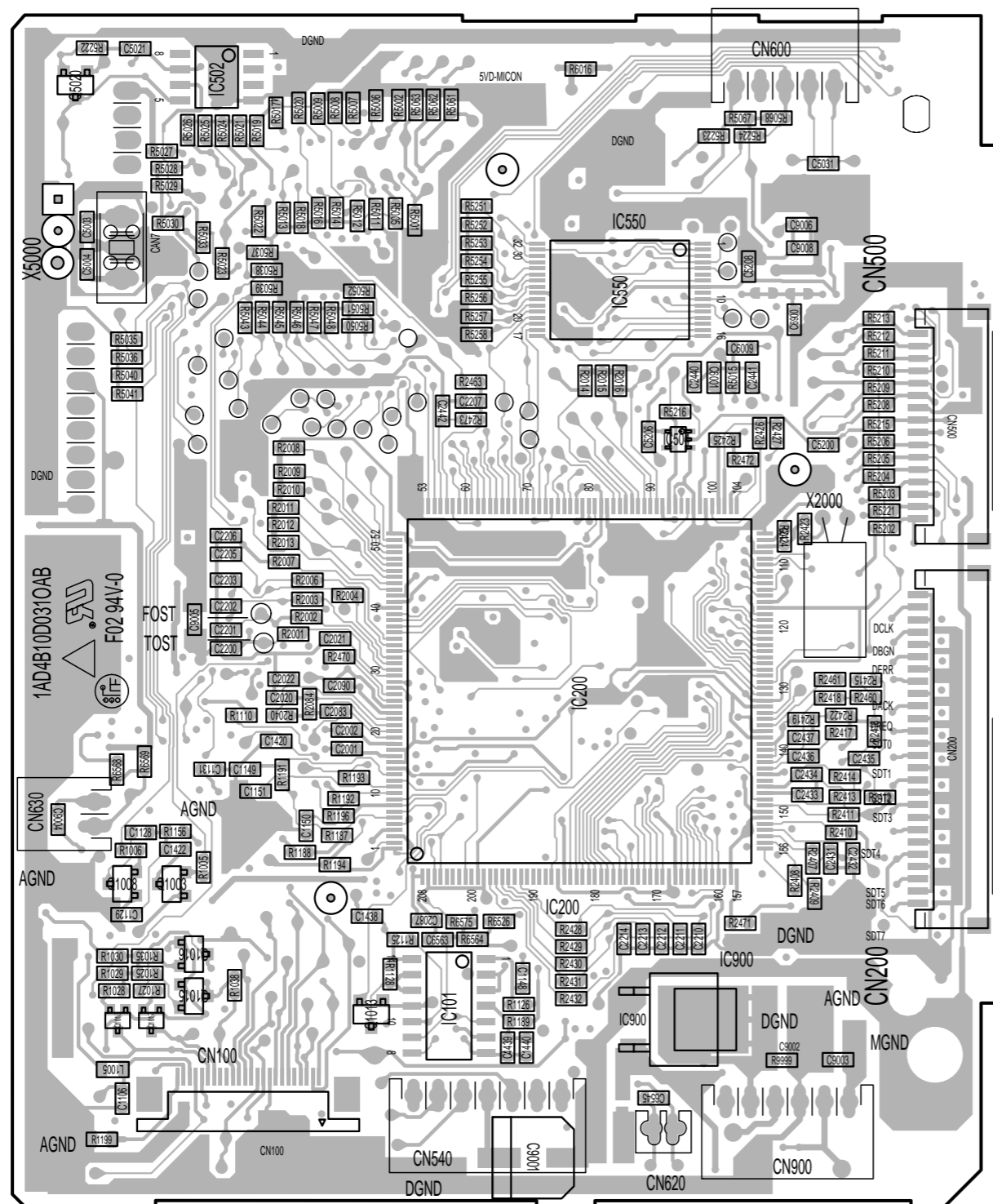

DVD P.C.B. (B SIDE)

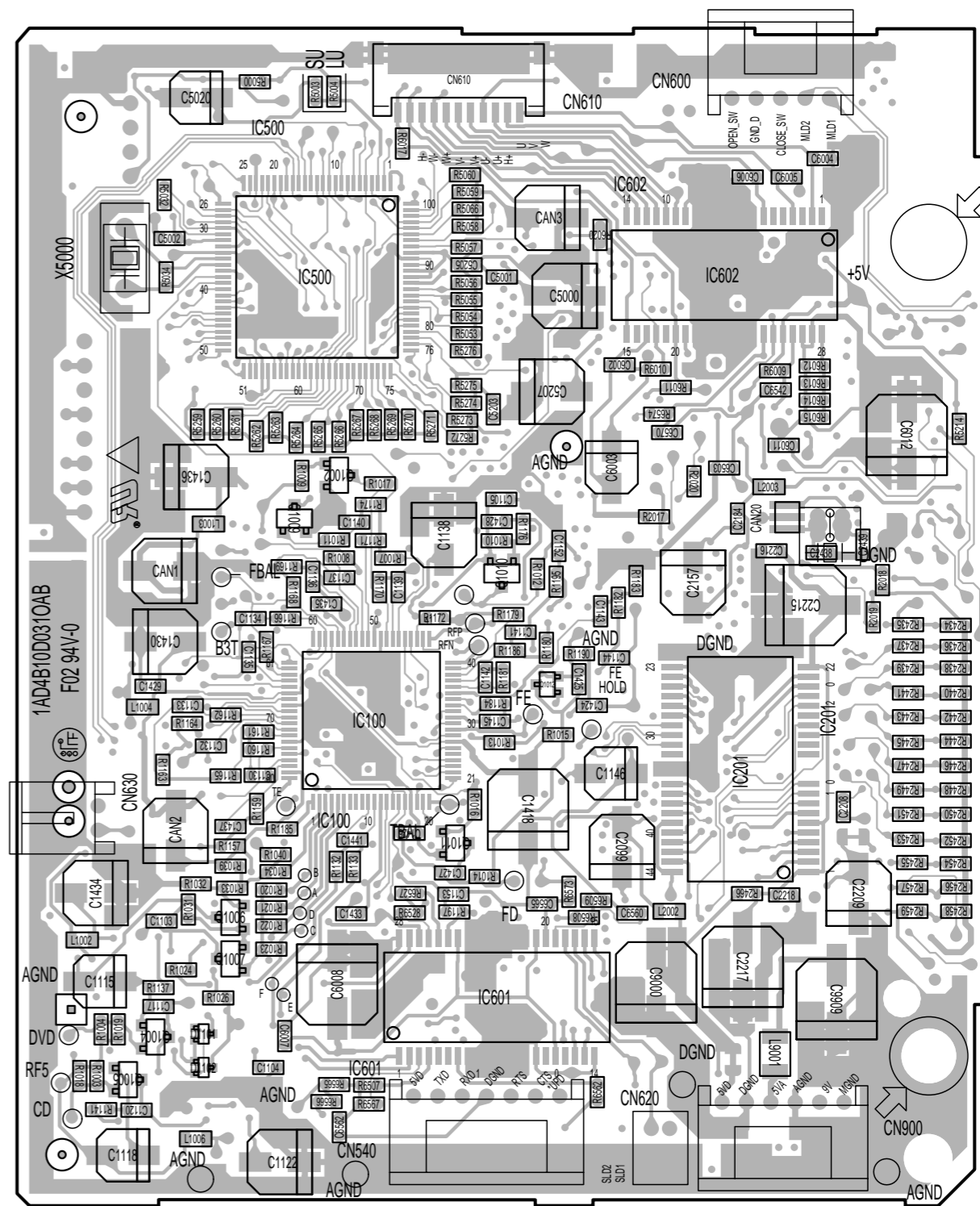

PRINTED CIRCUIT BOARD

MPEG P.C.B. (A SIDE)

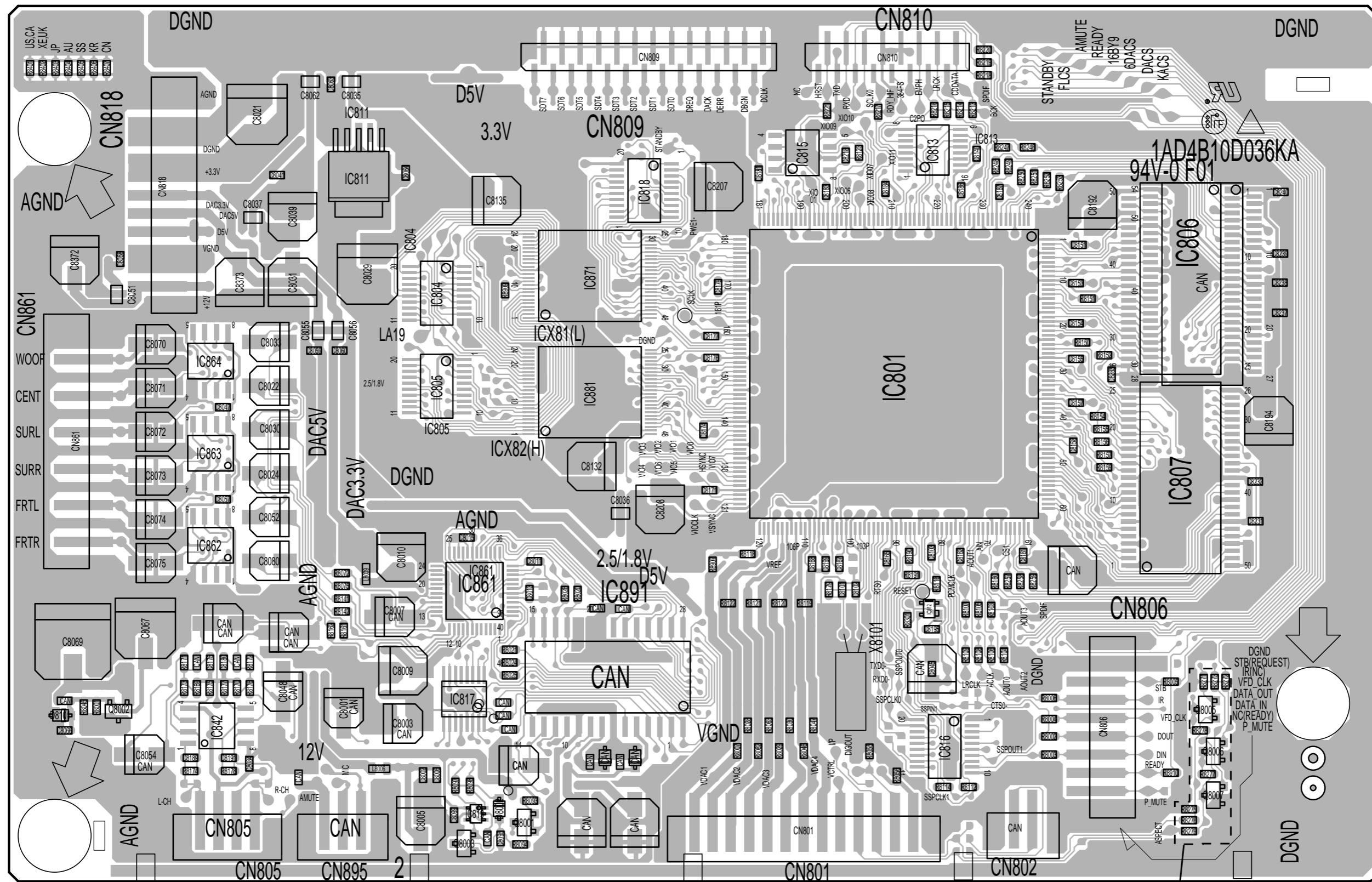

J only

■ PRINTED CIRCUIT BOARD

MPEG P.C.B. (B SIDE)

1

2

3

4

5

6

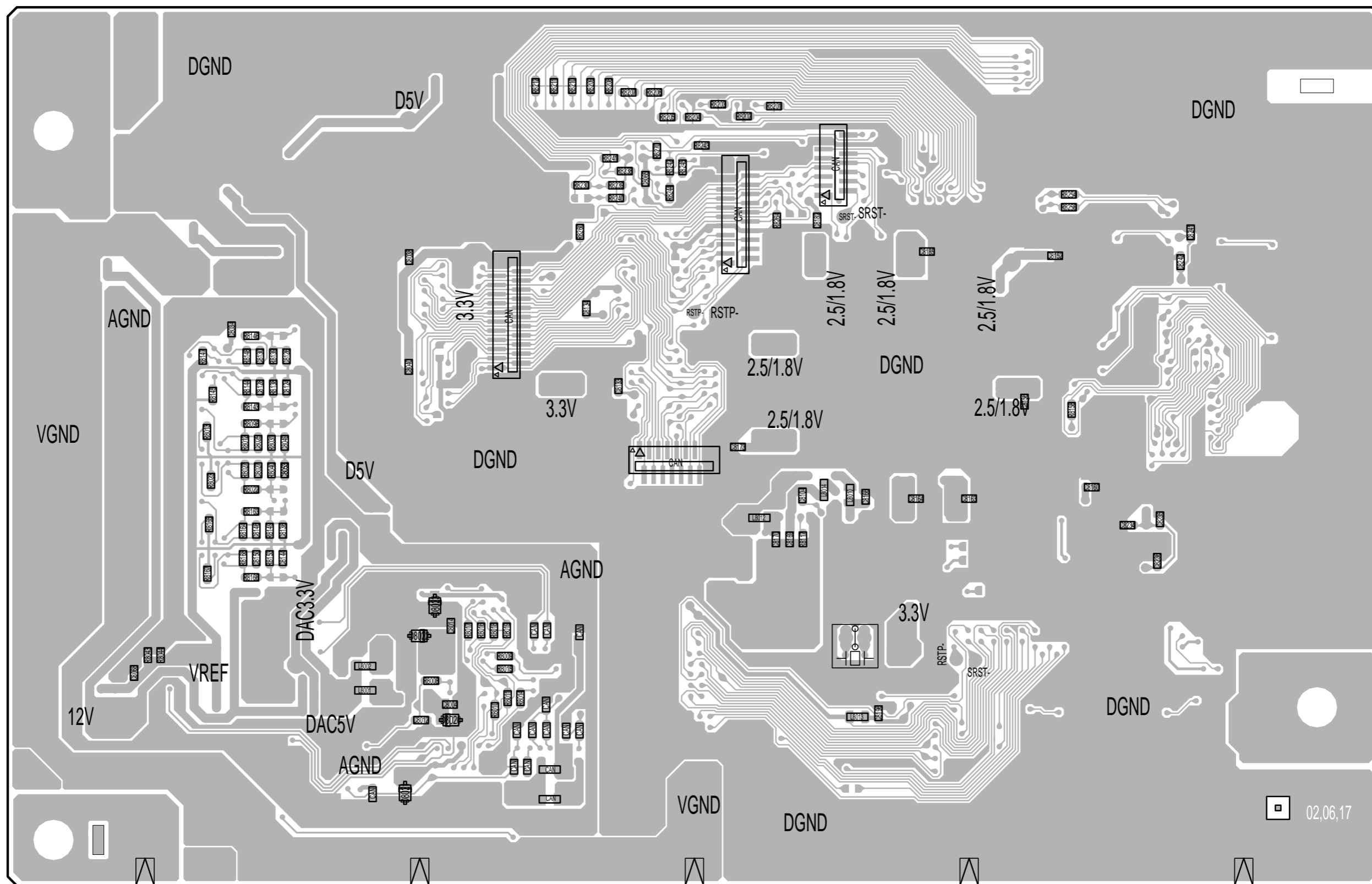

02,06,17

PRINTED CIRCUIT BOARD

TUNER P.C.B. (J, U, C, R, T, K, A models)

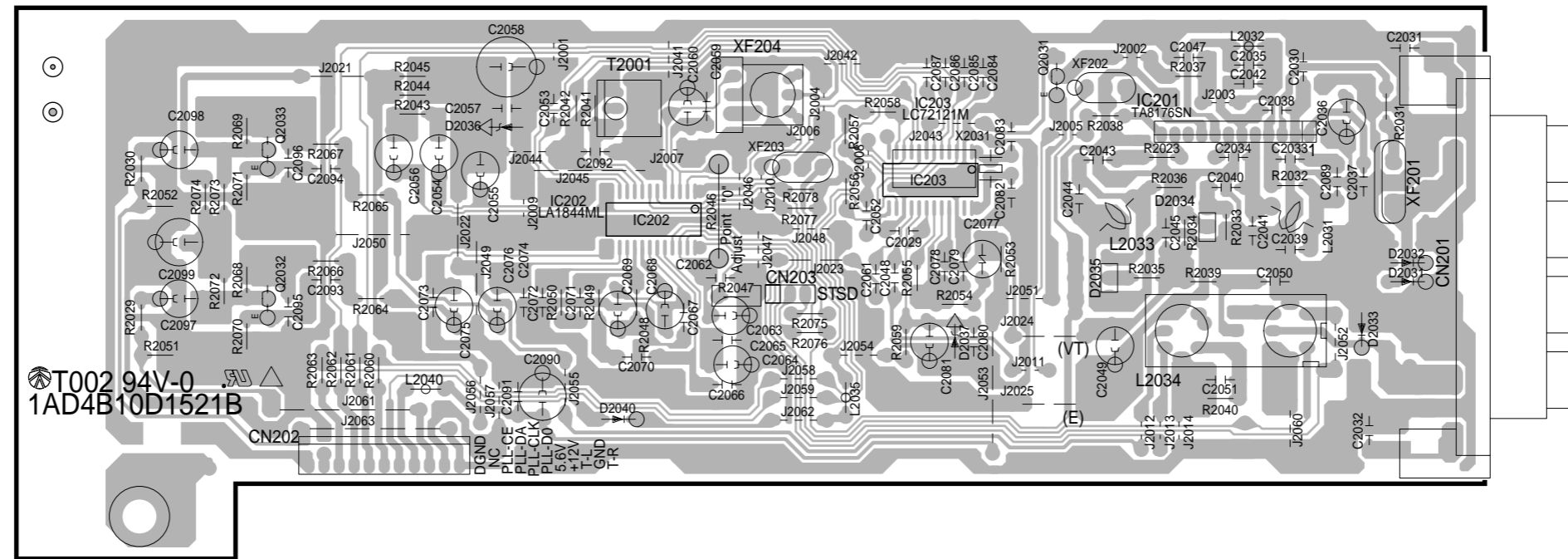

TUNER P.C.B. (G, B models)

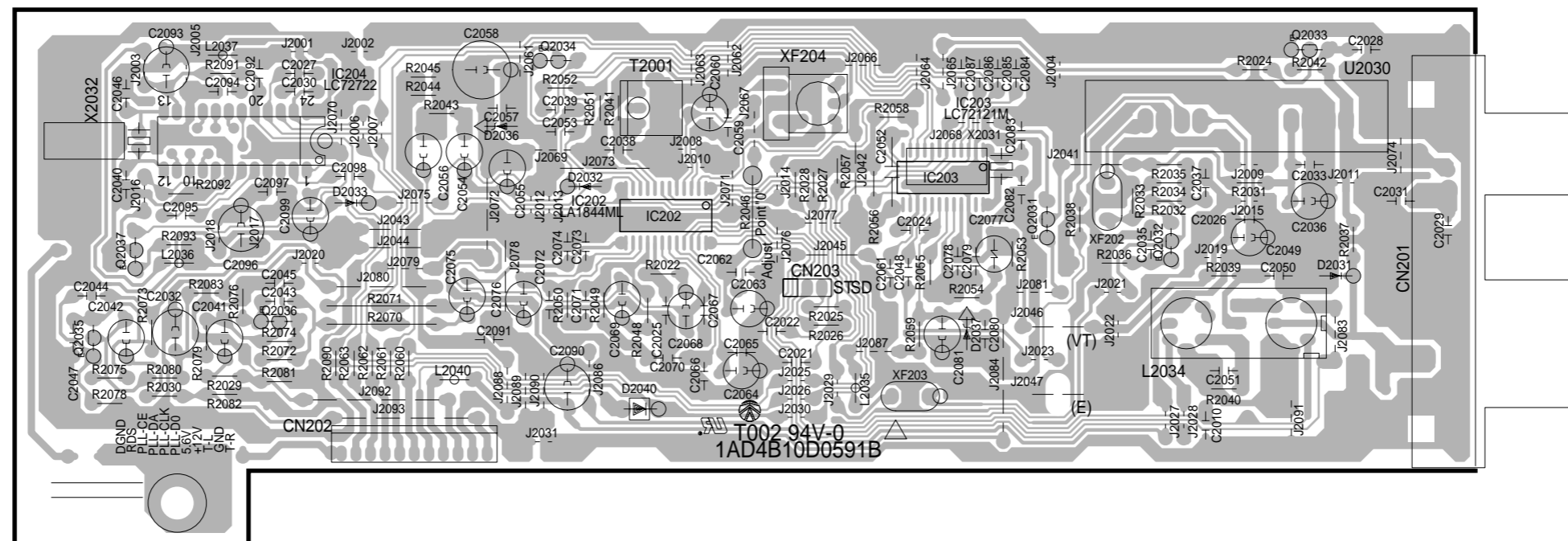



PRINTED CIRCUIT BOARD

VIDEO P.C.B. (J, U, C, R, T, K, A models)

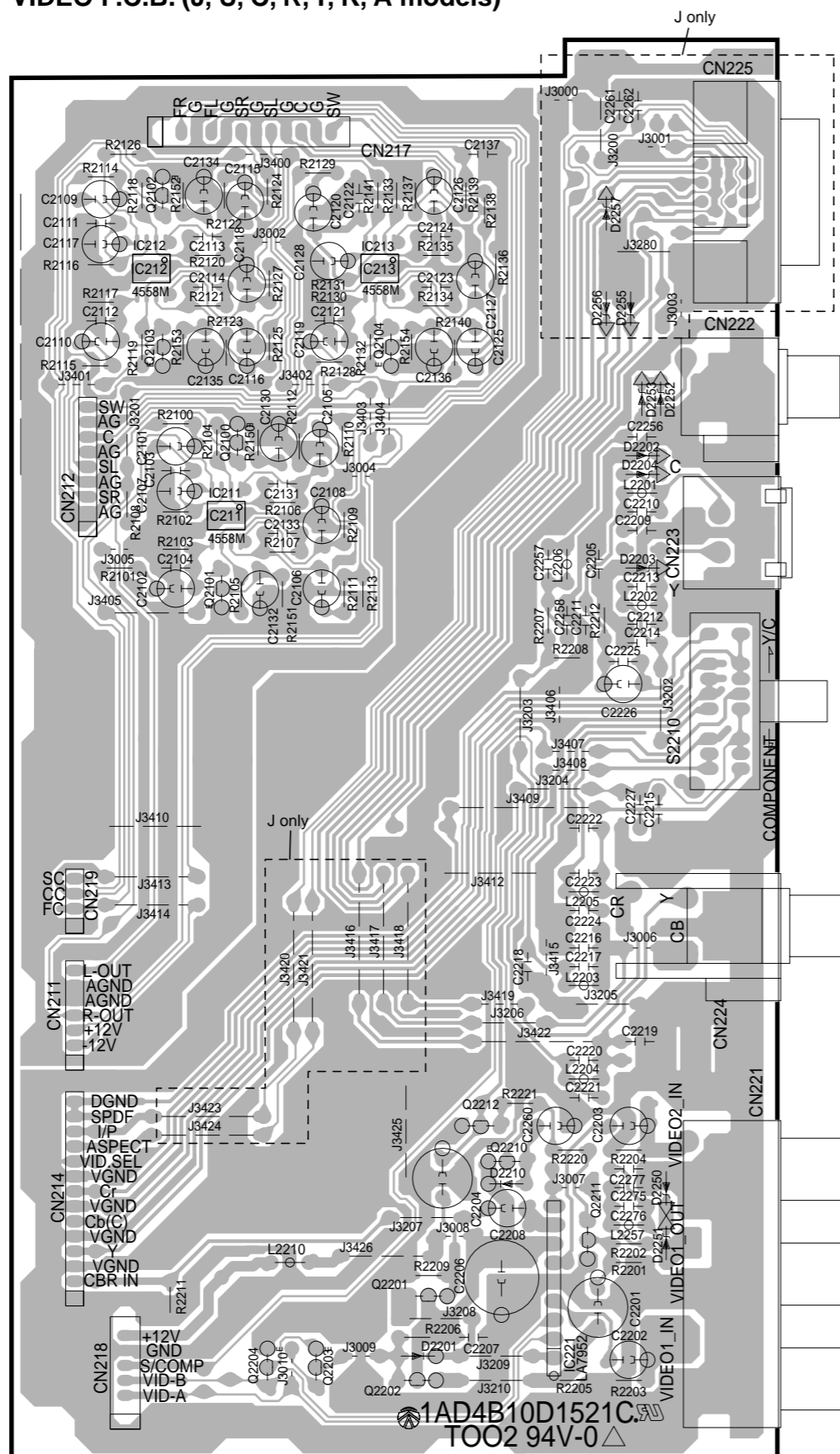

VIDEO P.C.B. (G, B models)

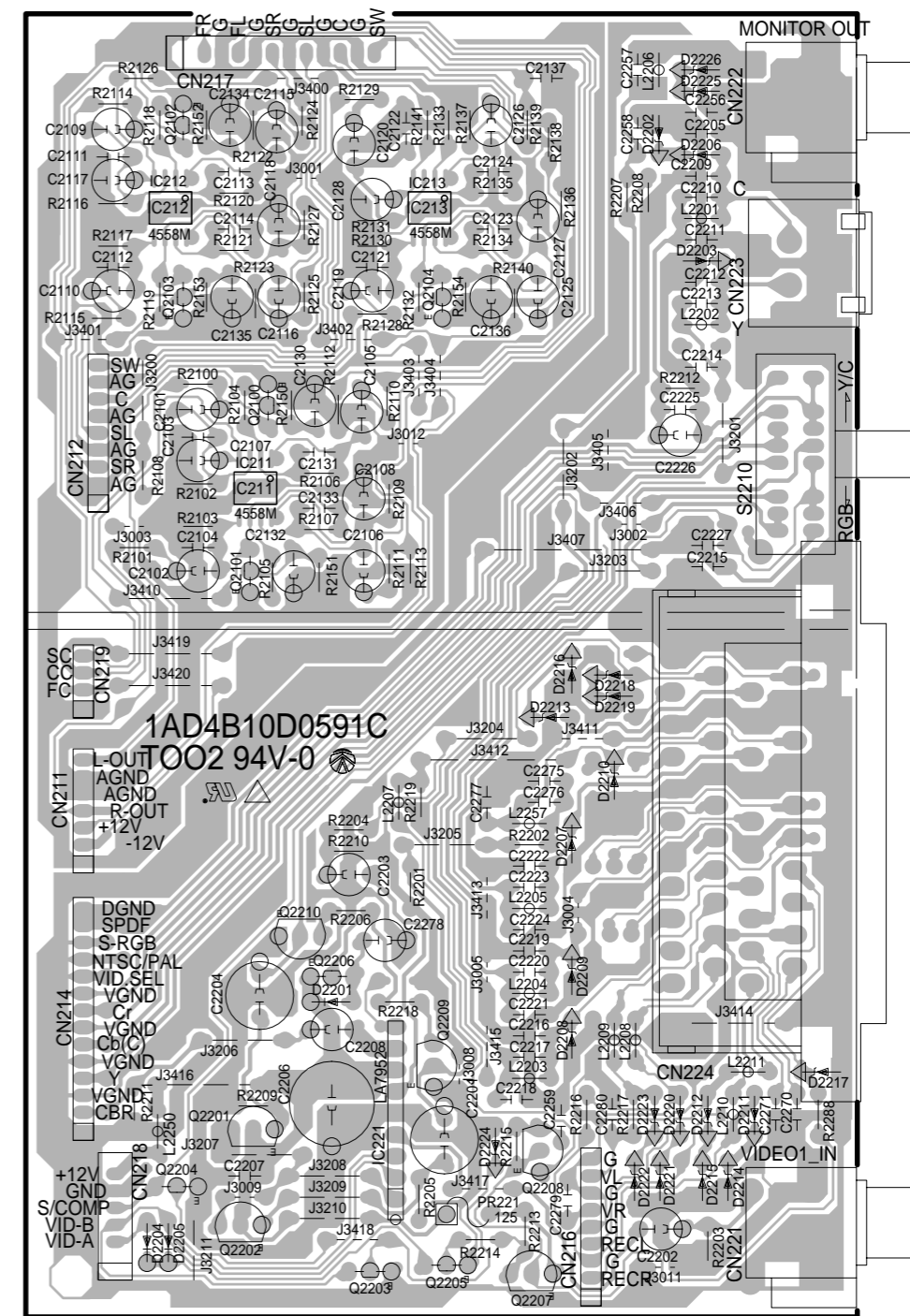

PRINTED CIRCUIT BOARD

DVD POWER P.C.B. (J, R, T, K, A, B, G models)

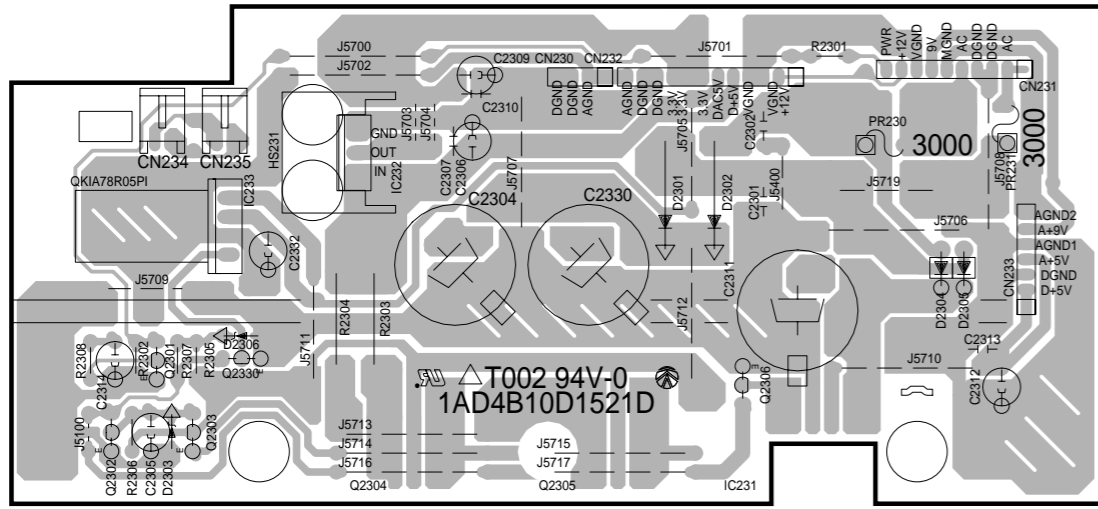

DVD POWER P.C.B. (U, C models)

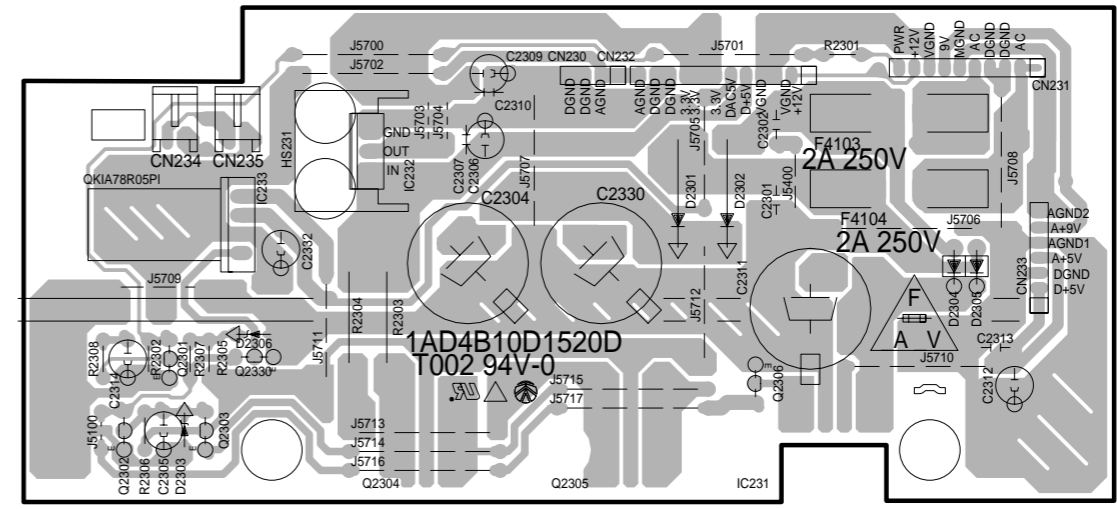

LED/SW P.C.B.

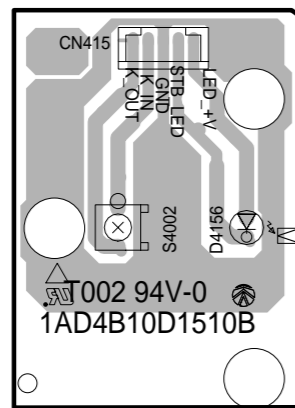

HEADPHONE P.C.B. (J, U, C, R, T, K, A models)

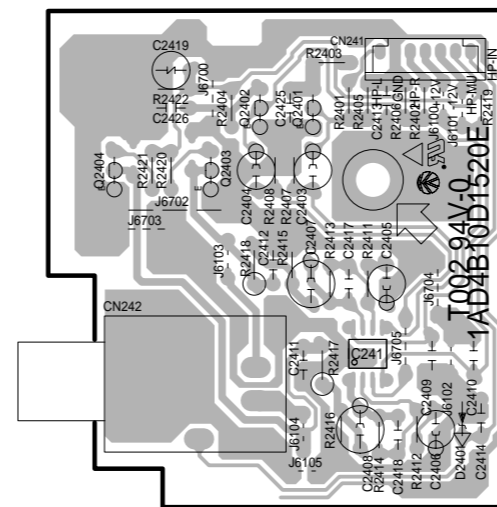

HEADPHONE P.C.B. (G, B models)

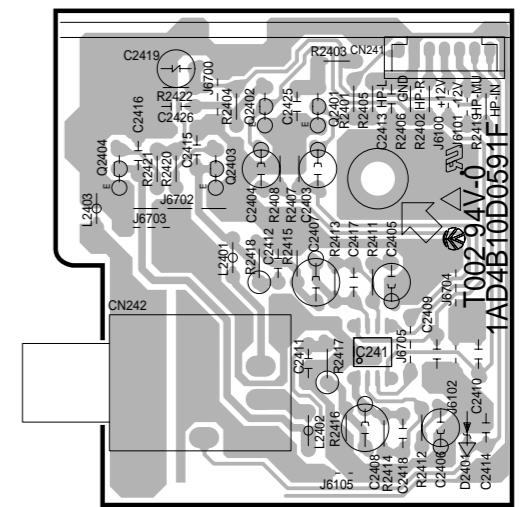

FRONT P.C.B.

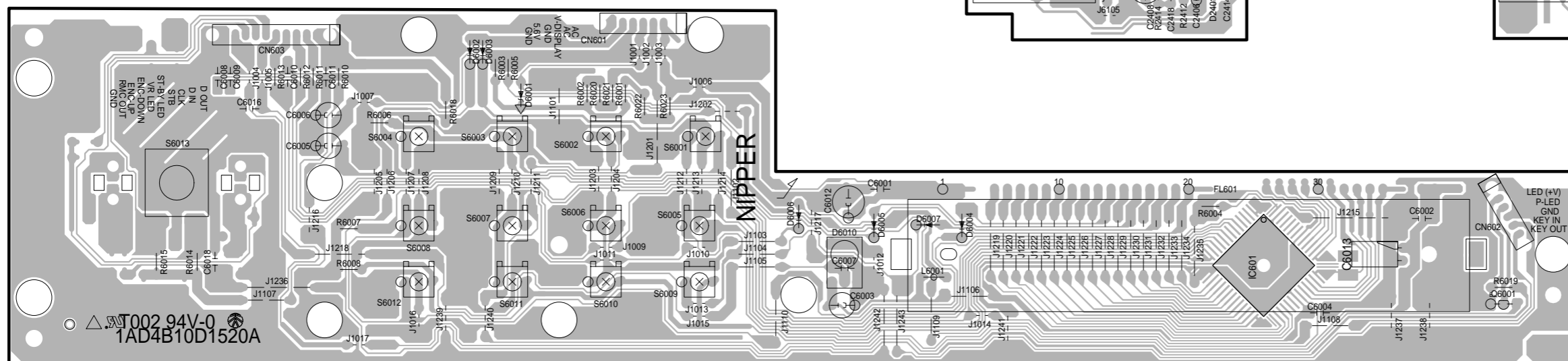

PRINTED CIRCUIT BOARD

MAIN P.C.B.

1  
2  
3  
4  
5  
6

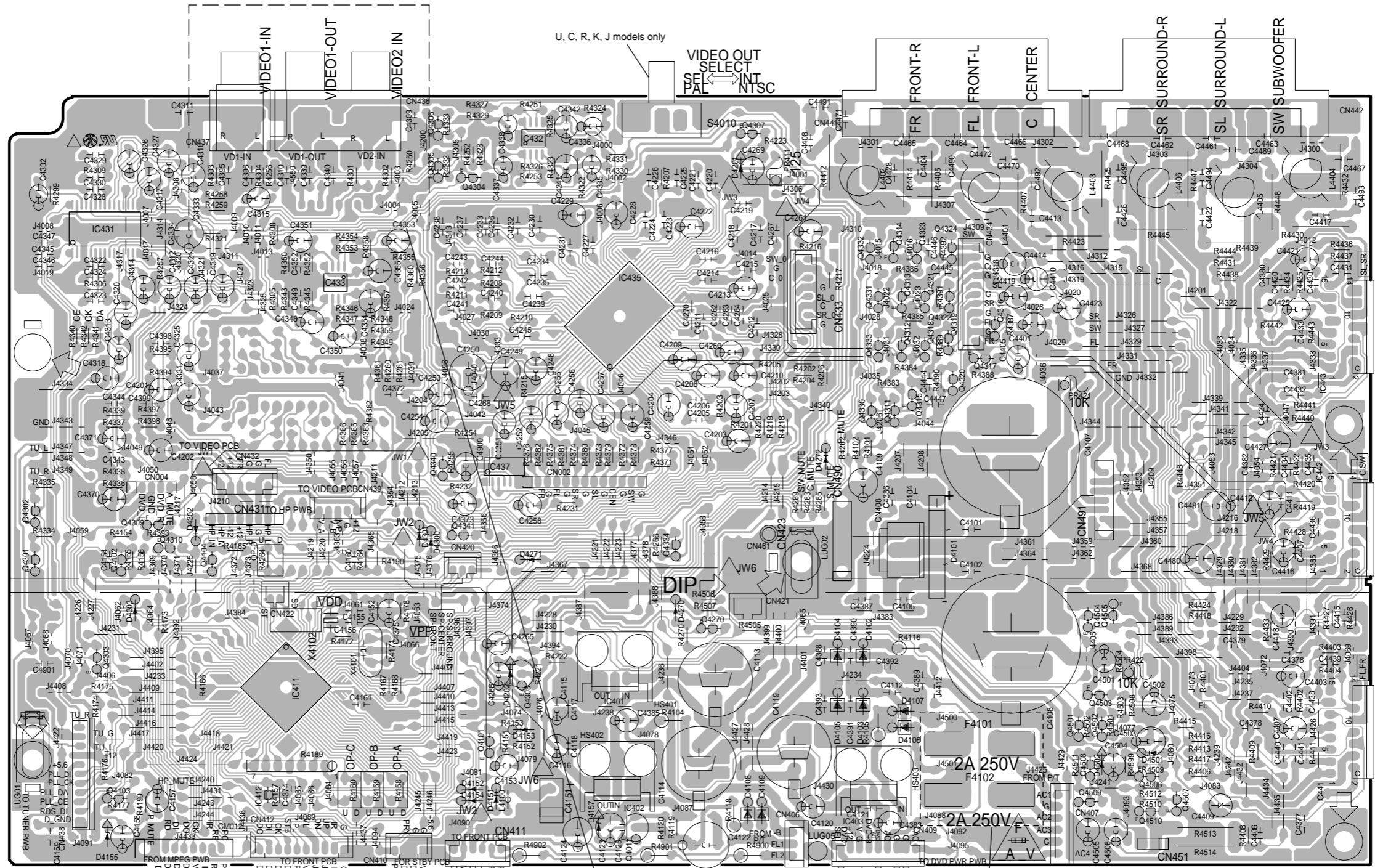

U, C, R, K, J models only

VIDEO OUT SELECT  
SEL PAL INT NTSC

FRONT-R FRONT-L CENTER  
SR SURROUND-R SL SURROUND-L SW SUBWOOFER

DIP

U, C models

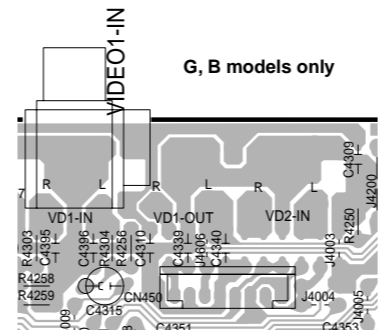

G, B models only

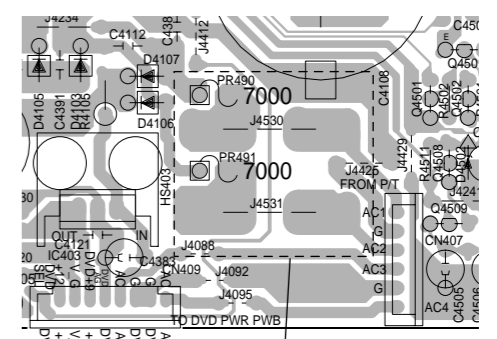

J, R, T, K, A, B, G models

PRINTED CIRCUIT BOARD

STANDBY POWER P.C.B. (U, C models)

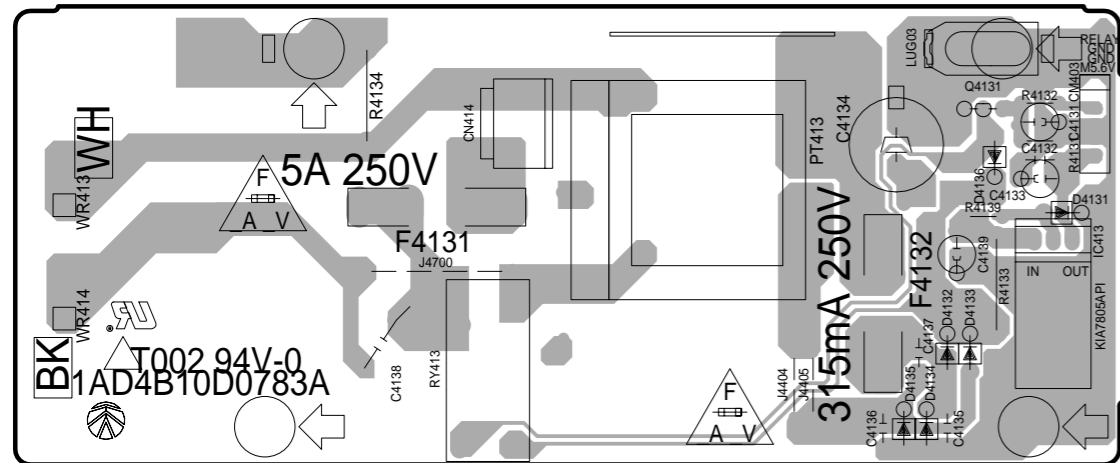

STANDBY POWER P.C.B. (R model)

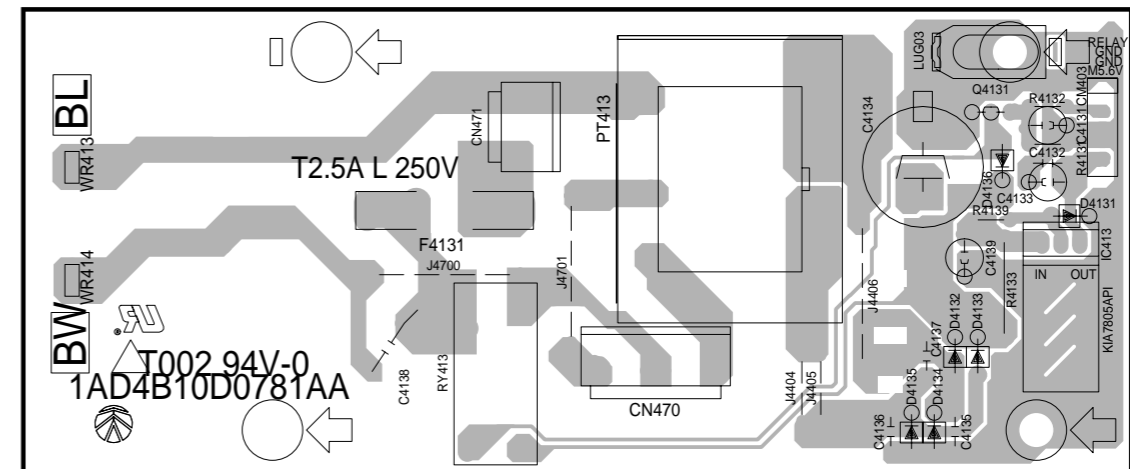

STANDBY POWER P.C.B. (J, T, K, A, B, G models)

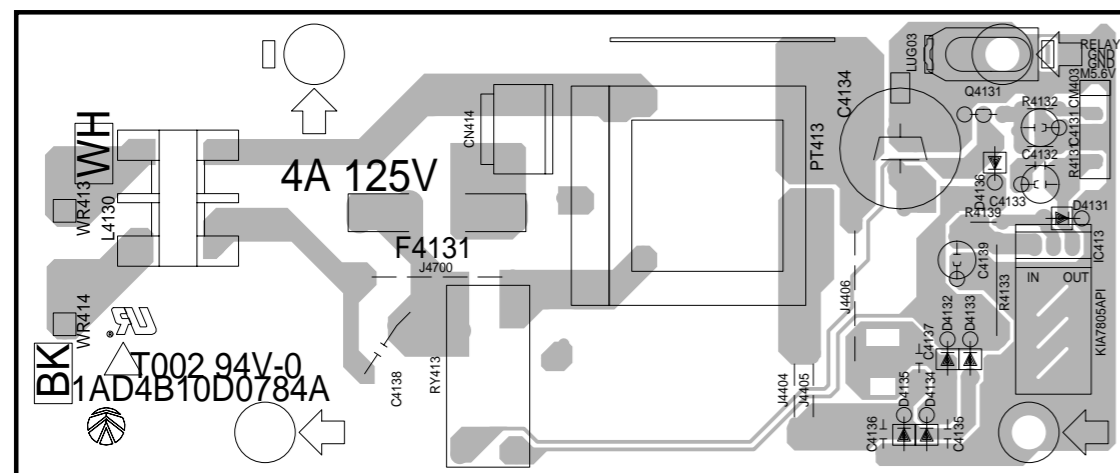

VOLTAGE SELECTOR MAIN P.C.B. (R model)

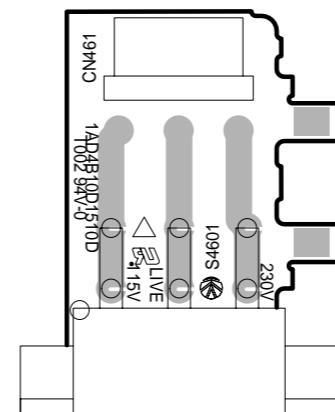

VOLTAGE SELECTOR SUB P.C.B. (R model)

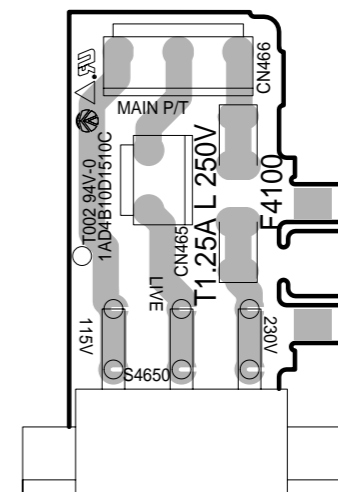

SCHEMATIC DIAGRAM (DVD)

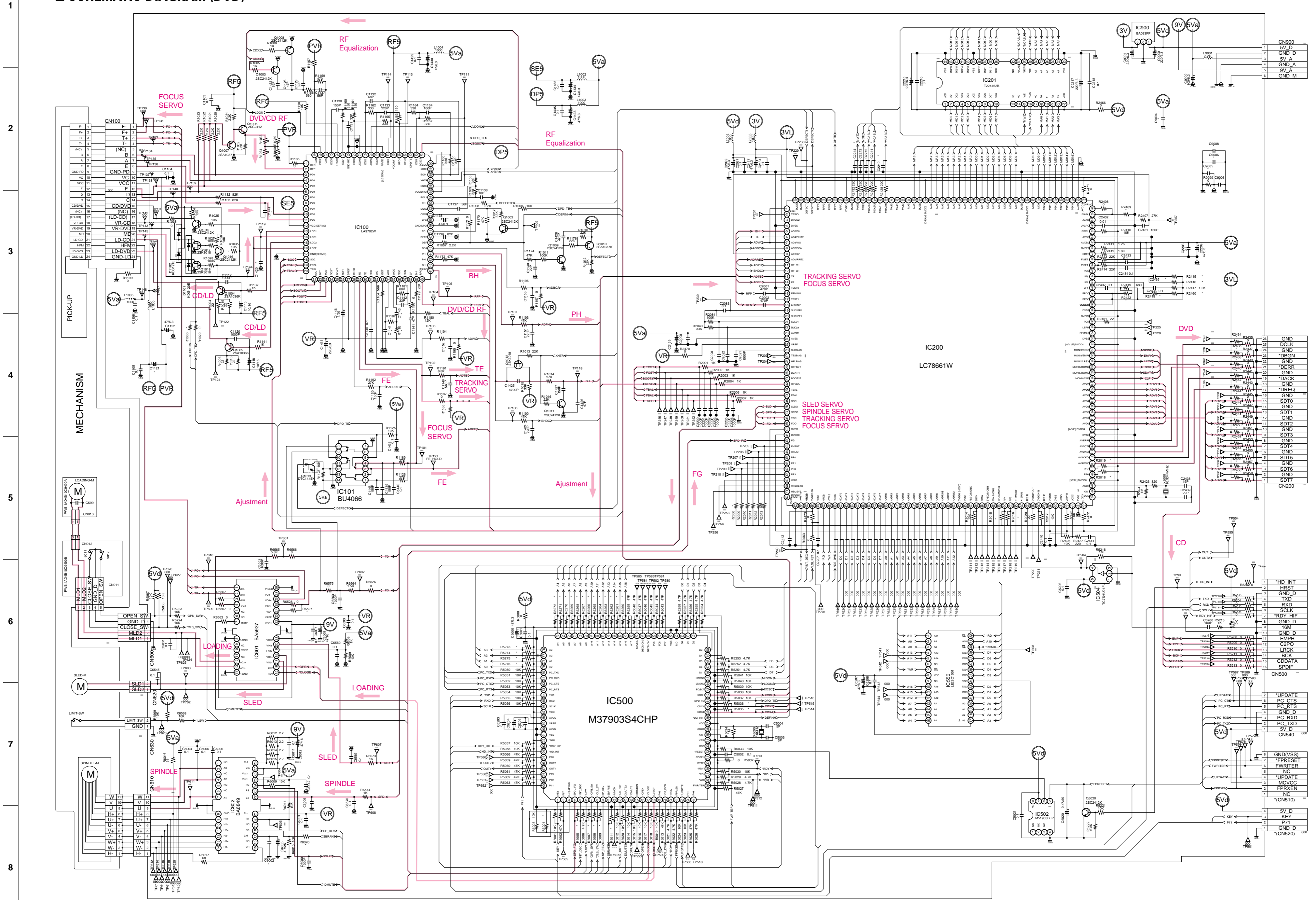

\* Components having special characteristics are marked  $\Delta$  and must be replaced with parts having specifications equal to those originally installed.  
 \* Schematic diagram is subject to change without notice.

■ SCHEMATIC DIAGRAM (MPEG)

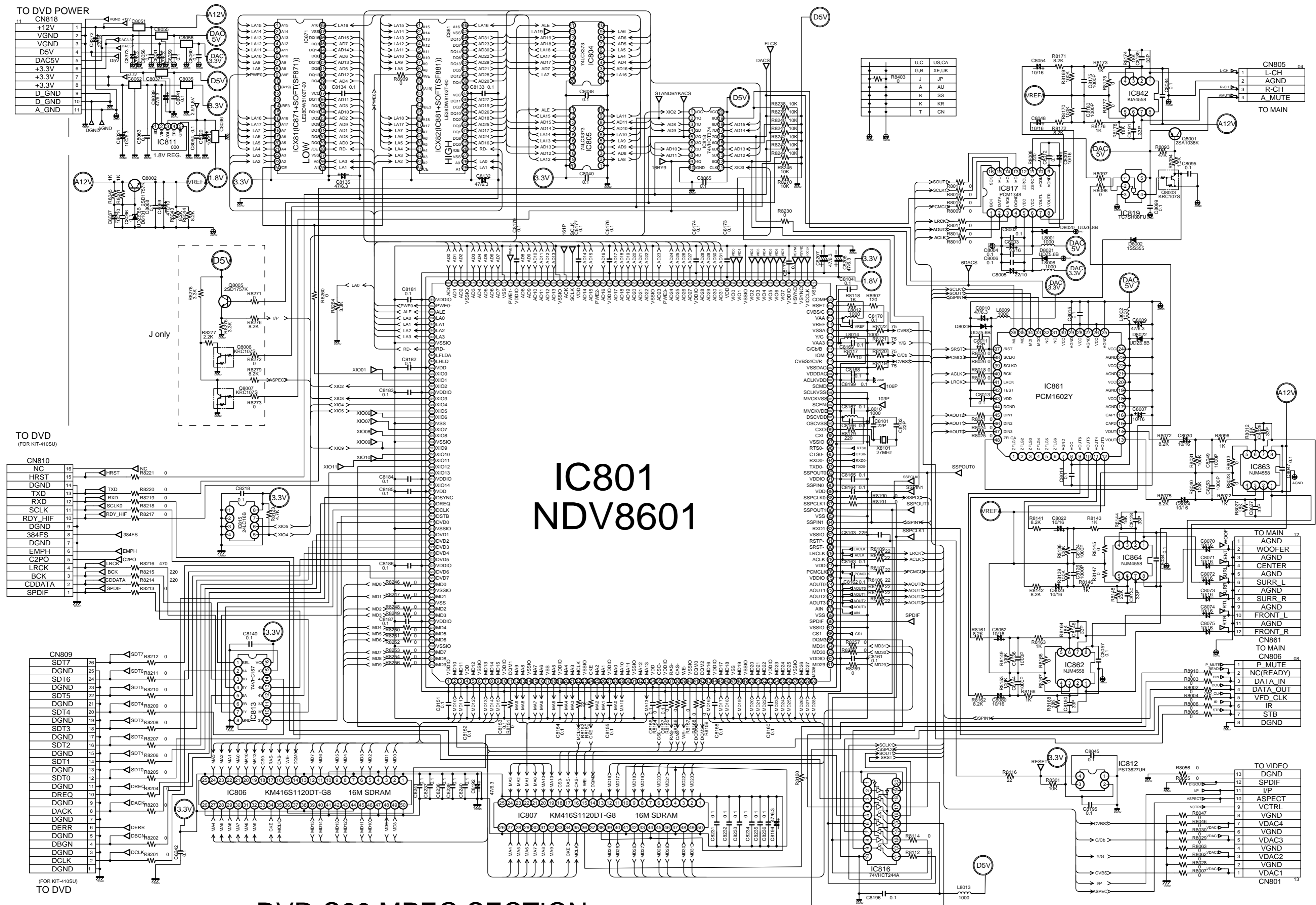

IC801  
NDV8601

DVR-S60 MPEG SECTION

\* = NO MOUNT

• Components having special characteristics are marked  $\Delta$  and must be replaced with parts having specifications equal to those originally installed.  
 • Schematic diagram is subject to change without notice.

■ SCHEMATIC DIAGRAM (TUNER)

● J, U, C, R, T, K, A models

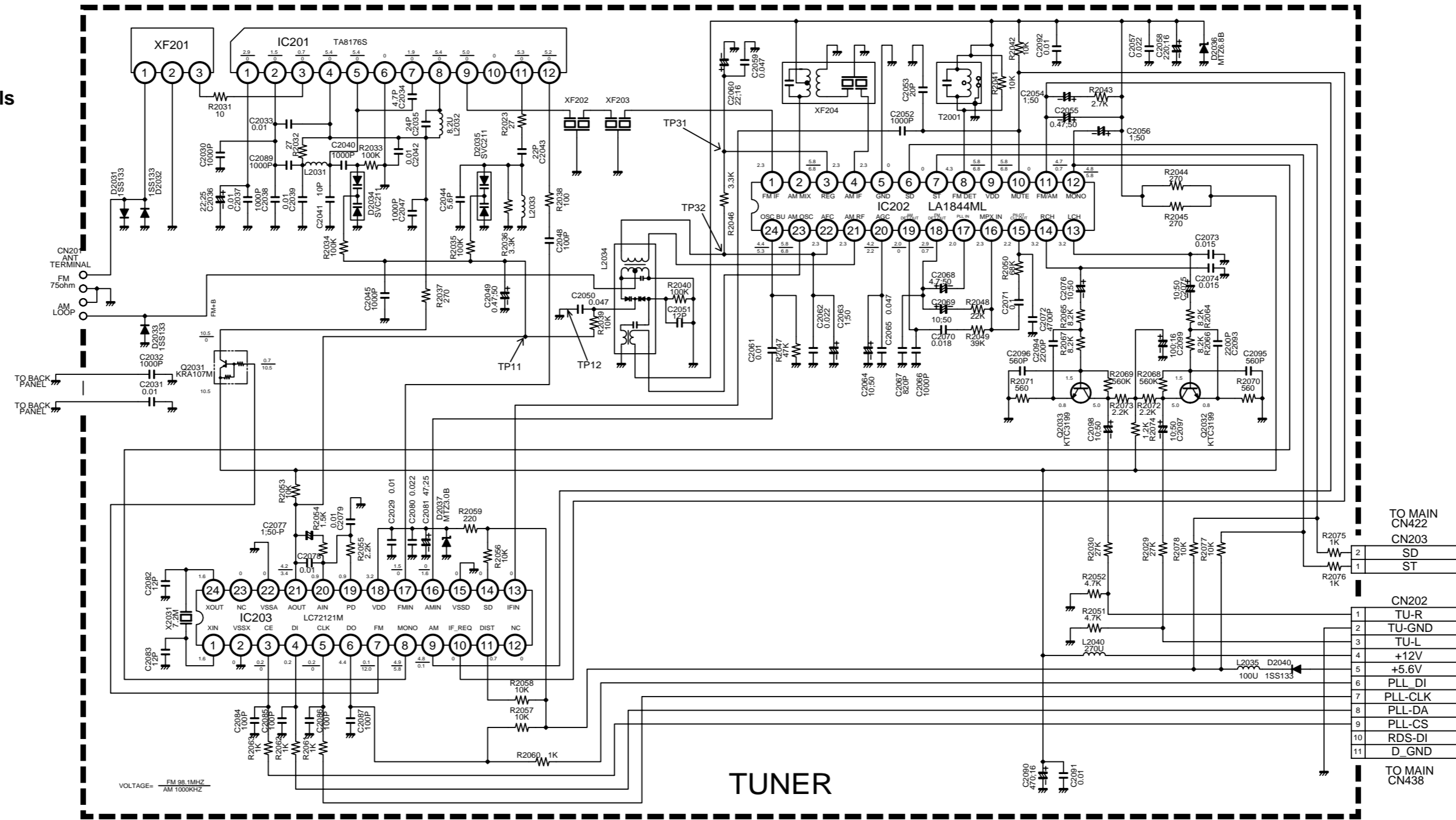

● G, B models

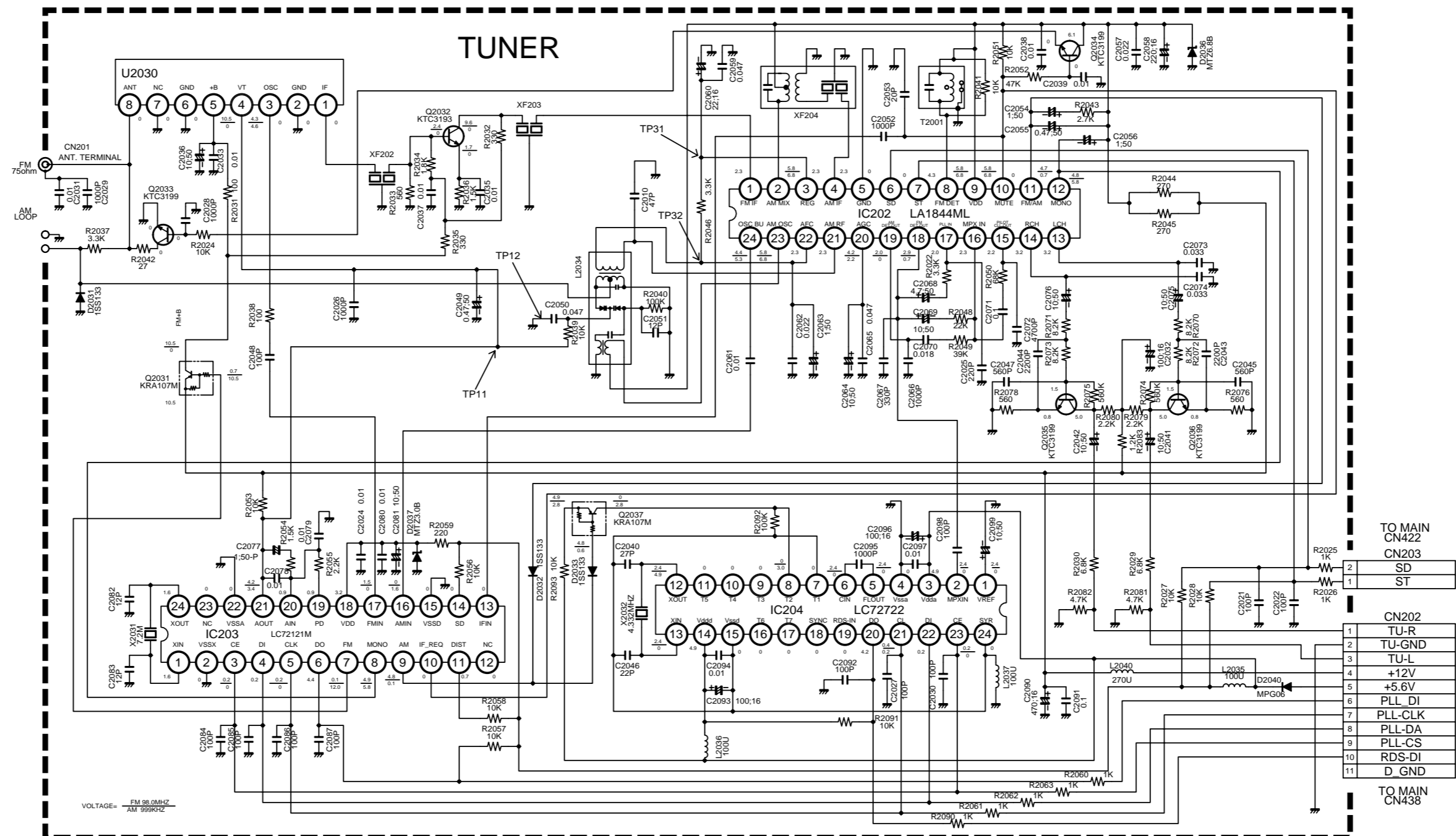

\* Components having special characteristics are marked  $\Delta$  and must be replaced with parts having specifications equal to those originally installed.  
 \* Schematic diagram is subject to change without notice.

SCHEMATIC DIAGRAM (VIDEO)

J, U, C, R, T, K, A models

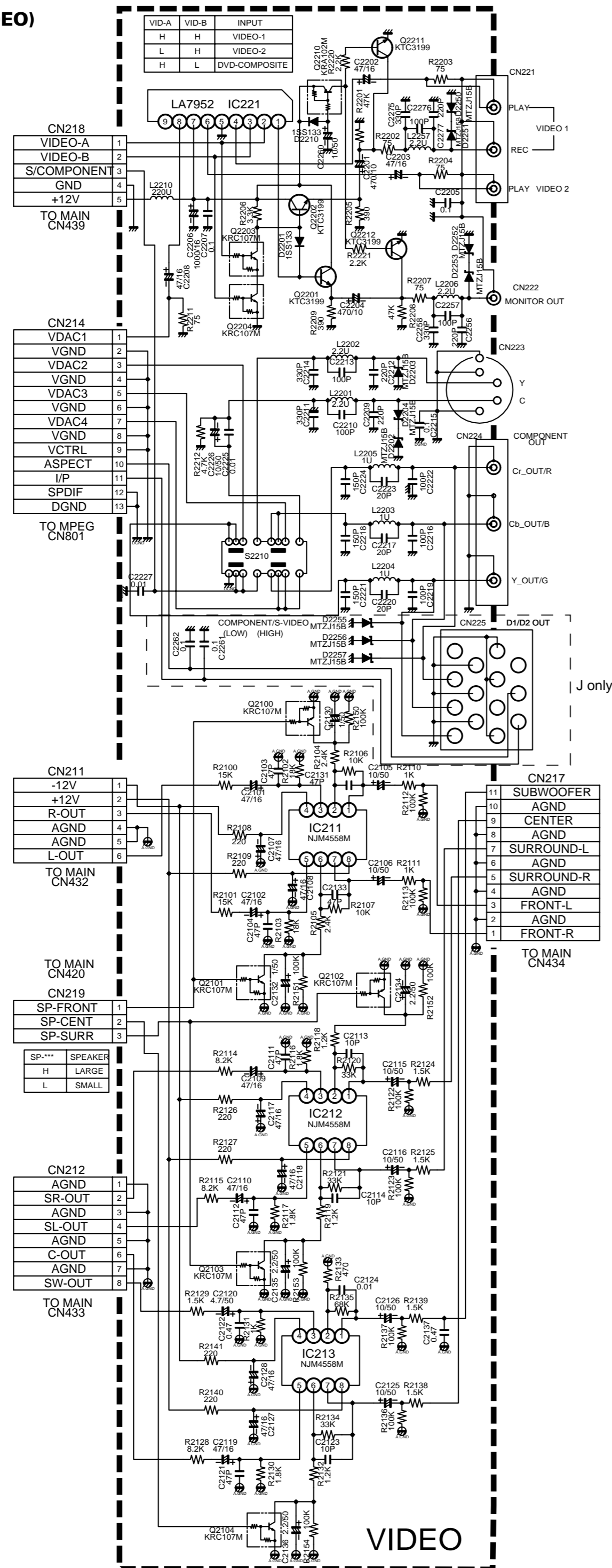

G, B models

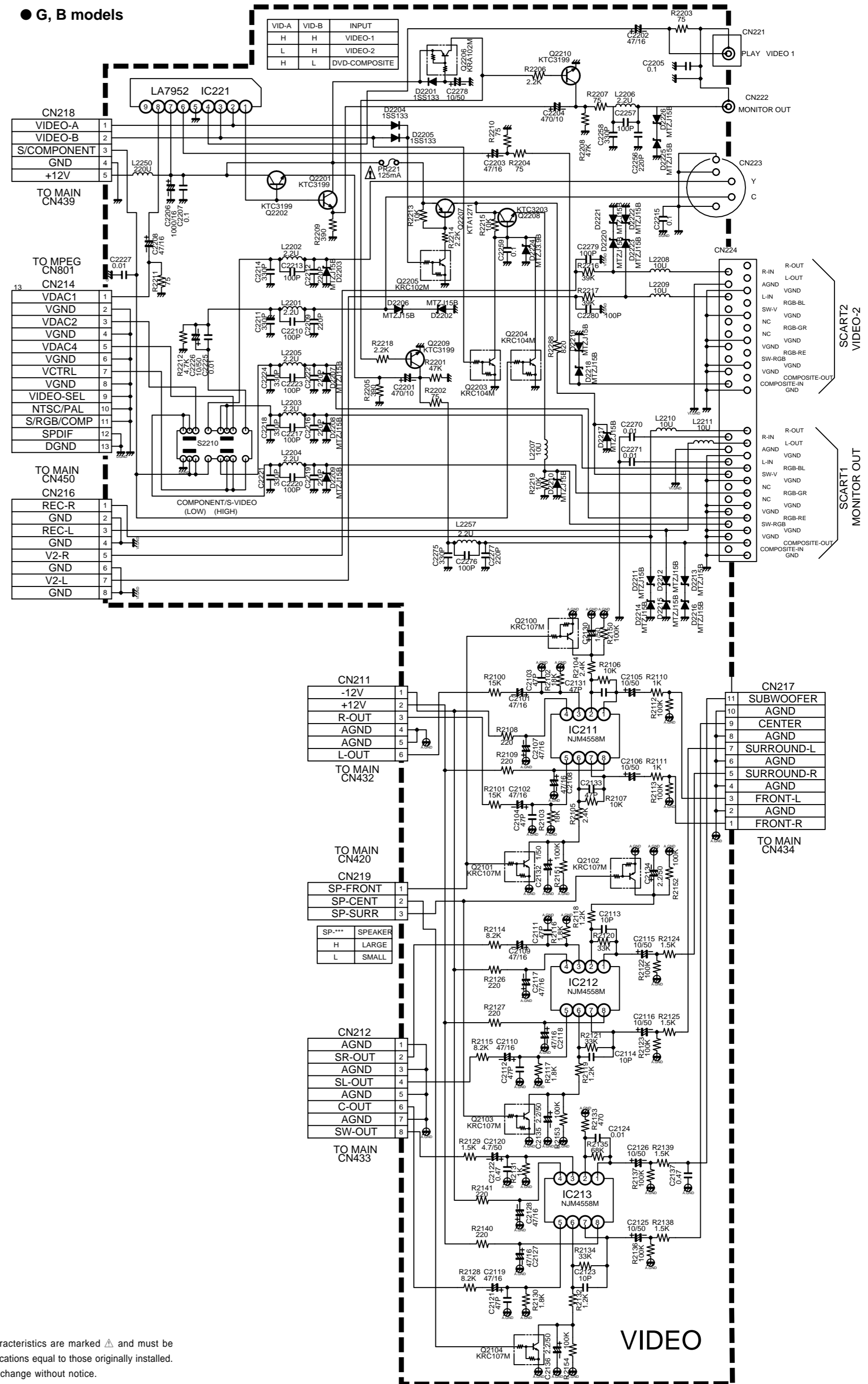

\* Components having special characteristics are marked  $\Delta$  and must be replaced with parts having specifications equal to those originally installed.  
\* Schematic diagram is subject to change without notice.



■ SCHEMATIC DIAGRAM (FRONT & LED/SW)

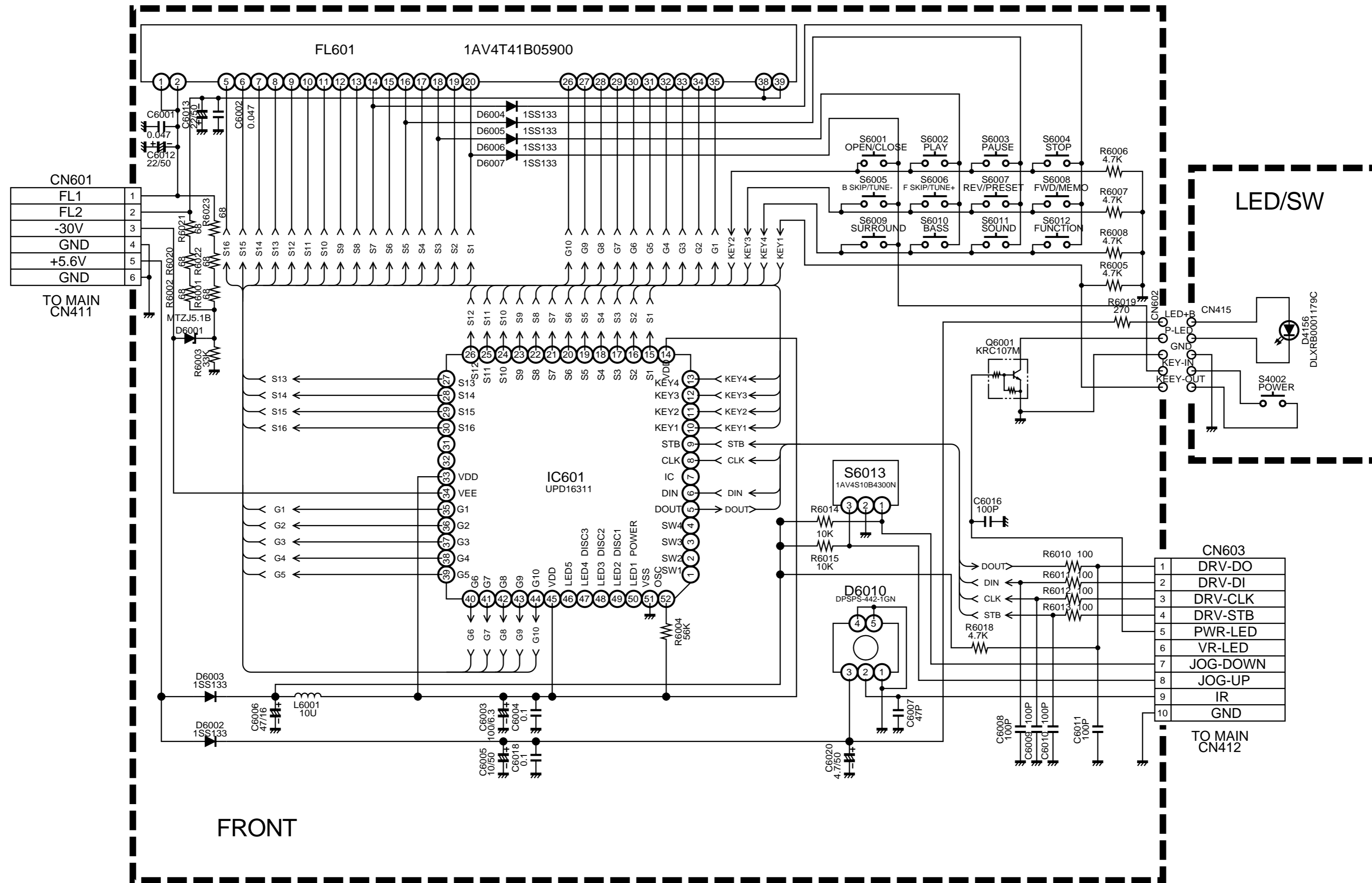

\* Components having special characteristics are marked  $\Delta$  and must be replaced with parts having specifications equal to those originally installed.  
 \* Schematic diagram is subject to change without notice.

■ SCHEMATIC DIAGRAM (MAIN, STANDBY POWER, DVD POWER, HEADPHONE & VOLTAGE SELECTOR)

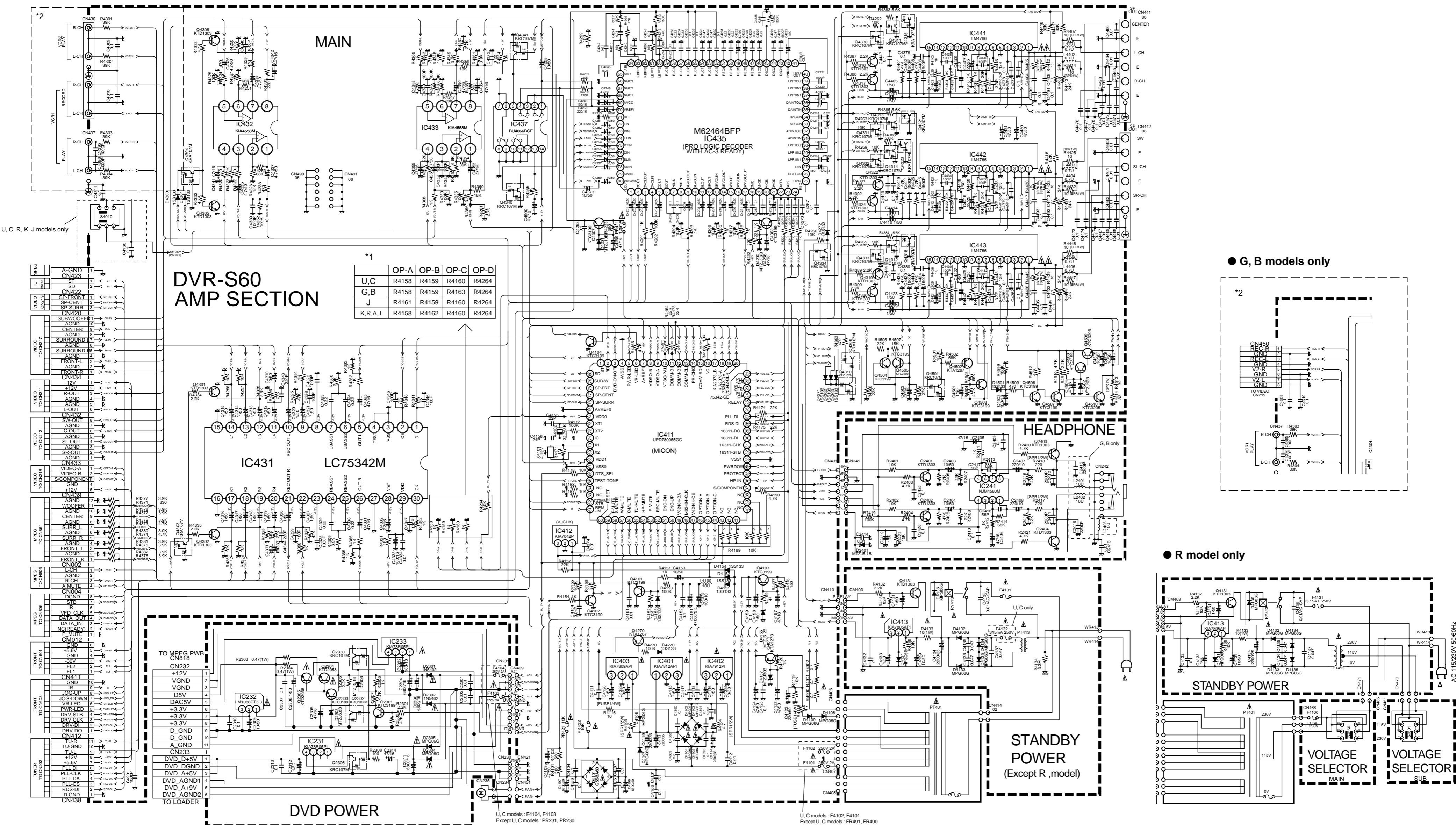

U, C, R, K, J models only

DVR-S60 AMP SECTION

	OP-A	OP-B	OP-C	OP-D
U,C	R4158	R4159	R4160	R4264
G,B	R4158	R4159	R4163	R4264
J	R4161	R4159	R4160	R4264
K,R,A,T	R4158	R4162	R4160	R4264

● G, B models only

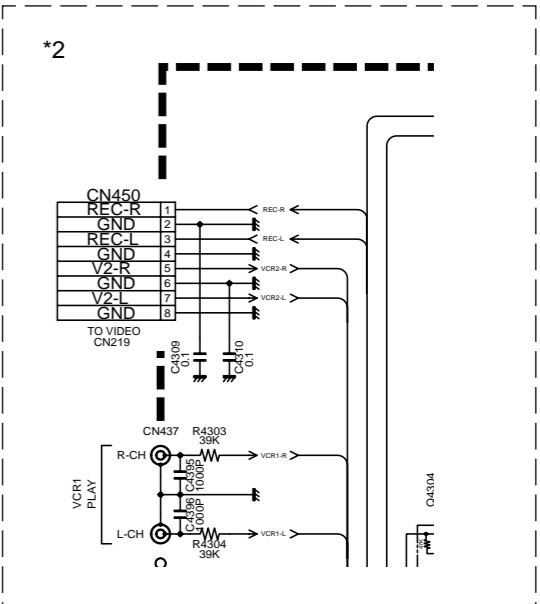

● R model only

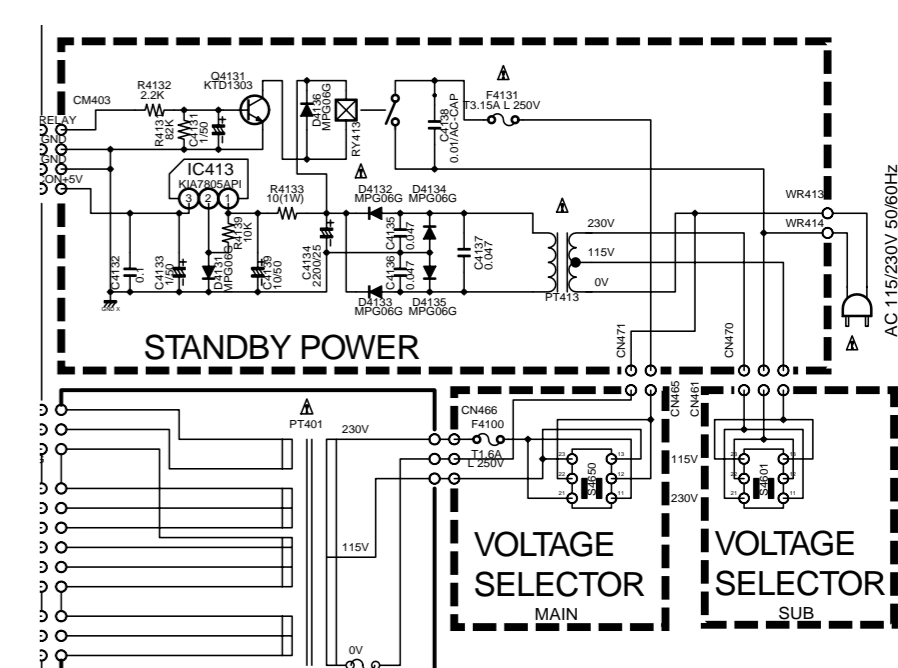

U, C models : F4104, F4103  
Except U, C models : PR231, PR230

U, C models : F4102, F4101  
Except U, C models : FR491, FR490

\*1

	OP-A	OP-B	OP-C	OP-D
U,C	R4158	R4159	R4160	R4264
G,B	R4158	R4159	R4163	R4264
J	R4161	R4159	R4160	R4264
K,R,A,T	R4158	R4162	R4160	R4264

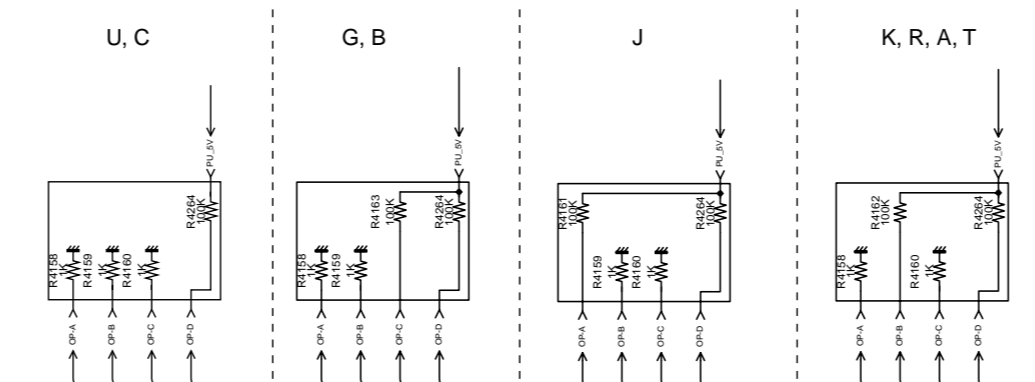

• Components having special characteristics are marked  $\Delta$  and must be replaced with parts having specifications equal to those originally installed.  
• Schematic diagram is subject to change without notice.

## VOLTAGE CHART

### MPEG P.C.B.

IC801																(V)
Pin No.	1	2	3	4	5	6	7	8	9	10	11	12	13	14	15	16
STOP	3.2V	2.0V	2.0V	2.5V	2.2V	0V	1.9V	2.0V	2.6V	3.2V	0V	0.1V	0.1V	0V	1.3V	2.1V
PLAY	3.2V	---	---	2.5V	---	0V	0V	---	0V	3.2V	0V	0.1V	0.1V	0V	1.4V	1.9V
Pin No.	17	18	19	20	21	22	23	24	25	26	27	28	29	30	31	32
STOP	0V	1.9V	3.2V	1.3V	1.4V	1.7V	0V	3.2V	2.1V	0.3V	3.2V	2.2V	0.1V	0V	0V	0V
PLAY	0V	1.7V	3.2V	---	1.4V	1.6V	0V	3.2V	---	1.3V	3.2V	3.2V	0.1V	0.1V	0V	0.1V
Pin No.	33	34	35	36	37	38	39	40	41	42	43	44	45	46	47	48
STOP	1.1V	2.5V	2.7V	3.2V	3.1V	2.8V	3.2V	0V	0V	0V	2.7V	3.2V	2.0V	2.0V	0V	1.9V
PLAY	1.3V	2.5V	---	3.2V	3.1V	2.5V	3.0V	0V	0V	0V	1.9V	3.2V	1.9V	1.9V	0V	---
Pin No.	49	50	51	52	53	54	55	56	57	58	59	60	61	62	63	64
STOP	0V	2.1V	1.9V	1.9V	3.2V	2.6V	2.7V	1.9V	0V	1.9V	1.9V	2.2V	1.9V	3.2V	1.9V	2.7V
PLAY	0V	---	---	---	3.2V	---	---	---	0V	---	---	---	---	3.2V	---	---
Pin No.	65	66	67	68	69	70	71	72	73	74	75	76	77	78	79	80
STOP	0V	---	0V	1.6V	0V	3.2V	0V	0V	0V	0V	3.2V	1.7V	2.5V	1.6V	1.6V	3.2V
PLAY	0V	---	0V	1.6V	0V	3.2V	1.2V	0V	0V	1.2V	3.2V	1.7V	2.5V	1.6V	1.6V	3.2V
Pin No.	81	82	83	84	85	86	87	88	89	90	91	92	93	94	95	96
STOP	---	0V	3.8V	3.7V	0V	0.1V	3.2V	3.2V	2.5V	0.1V	3.2V	0V	3.2V	3.2V	0V	3.2V
PLAY	---	0V	3.8V	3.6V	0V	---	3.2V	3.2V	2.5V	0.1V	3.2V	0V	3.2V	3.2V	0V	3.2V
Pin No.	97	98	99	100	101	102	103	104	105	106	107	108	109	110	111	112
STOP	0V	---	1.1V	0V	2.5V	3.2V	---	0V	0V	---	3.2V	2.5V	0V	1.3V	0.9V	1.3V
PLAY	0V	---	1.2V	0V	2.5V	3.2V	---	0V	0V	---	3.2V	2.5V	0V	1.2V	0.7V	1.4V
Pin No.	113	114	115	116	117	118	119	120	121	122	123	124	125	126	127	128
STOP	3.2V	0.7V	0V	1.2V	2.5V	0.3V	1.2V	2.0V	0V	3.2V	3.2V	3.2V	3.2V	3.2V	3.2V	3.2V
PLAY	3.2V	---	0V	1.2V	2.5V	---	1.2V	2.0V	0V	3.2V	3.2V	3.2V	3.2V	3.2V	3.2V	3.2V
Pin No.	129	130	131	132	133	134	135	136	137	138	139	140	141	142	143	144
STOP	3.2V	3.2V	3.2V	0V	3.2V	3.2V	2.5V	2.8V	2.7V	2.9V	2.8V	3.2V	2.9V	3.0V	3.0V	2.9V
PLAY	3.2V	3.2V	3.2V	0V	3.2V	3.2V	2.5V	---	---	---	---	3.2V	---	---	---	---
Pin No.	145	146	147	148	149	150	151	152	153	154	155	156	157	158	159	160
STOP	3.2V	2.9V	0V	2.9V	3.0V	2.9V	2.8V	2.8V	3.0V	3.2V	2.9V	3.2V	2.9V	2.7V	2.5V	1.5V
PLAY	3.2V	---	0V	---	---	---	---	---	---	3.2V	---	3.2V	---	---	2.5V	1.5V
Pin No.	161	162	163	164	165	166	167	168	169	170	171	172	173	174	175	176
STOP	3.2V	0V	2.8V	2.8V	2.8V	2.8V	2.8V	3.2V	3.2V	0V	2.8V	2.8V	2.9V	2.8V	2.8V	---
PLAY	3.2V	0V	---	---	---	---	---	3.2V	3.2V	0V	---	---	---	---	---	---
Pin No.	177	178	179	180	181	182	183	184	185	186	187	188	189	190	191	192
STOP	0V	2.9V	2.8V	2.8V	3.2V	3.2V	0V	0.2V	0.2V	---	---	0V	2.8V	0V	0V	2.5V
PLAY	0V	---	---	---	3.2V	3.2V	0.1V	---	---	---	---	0V	---	0V	0V	2.5V
Pin No.	193	194	195	196	197	198	199	200	201	202	203	204	205	206	207	208
STOP	2.8V	3.2V	0V	3.2V	3.2V	3.2V	3.2V	3.2V	0V	3.2V	3.2V	0V	0V	3.2V	3.2V	3.2V
PLAY	---	3.2V	0V	3.2V	3.2V	3.2V	3.2V	3.2V	0V	3.2V	3.2V	0V	0V	3.2V	3.2V	3.2V
Pin No.	209	210	211	212	213	214	215	216	217	218	219	220	221	222	223	224
STOP	0V	3.2V	0.1V	2.5V	3.3V	0V	1.6V	3.2V	0V	0V	0V	3.3V	3.3V	0V	3.3V	3.2V
PLAY	0V	3.2V	0.1V	2.5V	---	---	1.6V	---	---	0V	---	---	---	---	---	3.2V
Pin No.	225	226	227	228	229	230	231	232	233	234	235	236	237	238	239	240
STOP	3.2V	3.2V	2.7V	0V	1.9V	0V	1.9V	1.9V	3.2V	2.2V	2.0V	2.0V	0V	2.6V	2.7V	1.9V
PLAY	---	---	---	0V	---	0V	---	---	3.2V	---	---	---	0V	---	---	---

IC804																(V)
Pin No.	1	2	3	4	5	6	7	8	9	10	11	12	13	14	15	16
STOP	0V	3.1V	2.9V	2.8V	---	---	2.9V	2.8V	---	0V	0V	0V	2.8V	2.8V	0V	3.2V
PLAY	0V	2.9V	---	---	---	---	---	---	---	0V	0.1V	0V	---	---	0V	3.2V
Pin No.	17	18	19	20												
STOP	3.0V	2.8V	---	3.2V												
PLAY	---	---	---	3.2V												

**IC805**

(V)

Pin No.	1	2	3	4	5	6	7	8	9	10	11	12	13	14	15	16
STOP	0V	---	2.8V	2.8V	0.3V	3.0V	2.8V	2.8V	---	0V	0V	3.1V	2.8V	2.7V	---	---
PLAY	0V	---	---	---	---	---	---	---	---	0V	0.1V	---	---	---	0.5V	2.8V
Pin No.	17	18	19	20												
STOP	2.8V	2.8V	---	3.2V												
PLAY	---	---	---	3.2V												

**IC806**

(V)

Pin No.	1	2	3	4	5	6	7	8	9	10	11	12	13	14	15	16
STOP	3.2V	2.7V	1.9V	0V	1.9V	2.0V	3.2V	2.2V	2.0V	0V	2.0V	2.6V	3.2V	0V	3.2V	2.8V
PLAY	3.2V	---	---	0V	---	---	3.2V	---	---	0V	---	---	3.2V	0V	3.0V	---
Pin No.	17	18	19	20	21	22	23	24	25	26	27	28	29	30	31	32
STOP	3.1V	2.7V	1.1V	0.1V	2.2V	0.3V	2.1V	1.4V	3.2V	0V	1.3V	1.9V	2.1V	1.3V	0.1V	0.1V
PLAY	3.1V	---	1.3V	0.1V	---	---	---	1.4V	3.2V	0V	1.6V	1.7V	1.9V	1.4V	0.1V	0.1V
Pin No.	33	34	35	36	37	38	39	40	41	42	43	44	45	46	47	48
STOP	0V	3.2V	1.7V	0V	0V	3.2V	2.6V	1.9V	0V	1.9V	2.2V	3.2V	1.9V	2.0V	0V	1.9V
PLAY	0V	3.2V	1.7V	0V	0V	3.2V	---	---	0V	---	---	3.2V	---	---	0V	---
Pin No.	49	50														
STOP	2.7V	0V														
PLAY	---	0V														

**IC807**

(V)

Pin No.	1	2	3	4	5	6	7	8	9	10	11	12	13	14	15	16
STOP	3.2V	2.6V	2.0V	0V	1.9V	2.2V	3.2V	1.9V	2.0V	0V	2.0V	2.7V	3.2V	0V	3.2V	2.8V
PLAY	3.2V	---	---	0V	---	---	3.2V	---	---	0V	---	---	3.2V	0V	3.0V	2.5V
Pin No.	17	18	19	20	21	22	23	24	25	26	27	28	29	30	31	32
STOP	3.1V	2.7V	1.1V	0.1V	2.2V	0.3V	2.1V	1.4V	3.2V	0V	1.3V	1.9V	2.1V	1.3V	0.1V	0.1V
PLAY	3.1V	---	1.3V	0.1V	---	1.3V	---	1.4V	3.2V	0V	1.6V	1.7V	1.9V	1.4V	0.1V	0.1V
Pin No.	33	34	35	36	37	38	39	40	41	42	43	44	45	46	47	48
STOP	0V	3.2V	1.7V	0V	0V	3.2V	2.7V	1.9V	0V	1.9V	1.9V	3.2V	2.2V	1.9V	0V	1.9V
PLAY	0V	3.2V	1.7V	0V	0V	3.2V	---	---	0V	---	---	3.2V	---	---	0V	---
Pin No.	49	50														
STOP	2.7V	0V														
PLAY	---	0V														

**IC811**

(V)

Pin No.	1	2	3	4	5
STOP	3.3V	3.3V	2.5V	0V	0V
PLAY	3.2V	3.2V	2.5V	0V	0V

Q8001			
Pin No.	E	C	B
STOP	5.1V	5.0V	4.3V
PLAY	5.1V	-9.6V	5.0V

**IC812**

(V)

Pin No.	1	2	3	4
STOP	0V	3.2V	2.9V	3.3V
PLAY	0V	3.2V	2.8V	3.2V

Q8003			
Pin No.	E	C	B
STOP	0V	0V	0V
PLAY	0V	5.0V	0V

**IC813**

(V)

Pin No.	1	2	3	4	5	6	7	8	9	10	11	12	13	14	15	16
STOP	0V	1.6V	0V	1.6V	3.3V	3.3V	3.2V	0V	3.3V	0V	3.3V	0V	0V	0V	0V	3.2V
PLAY	0V	1.6V	0V	1.6V	---	0V	---	0V	---	0V	---	---	0V	---	0V	3.2V

**IC815**

(V)

Pin No.	1	2	3	4	5	6	7	8
STOP	0V	0V	0V	0V	3.2V	3.2V	0V	3.2V
PLAY	0V	0V	0V	0V	3.2V	3.2V	0V	3.2V

**IC816**

(V)

Pin No.	1	2	3	4	5	6	7	8	9	10	11	12	13	14	15	16
STOP	0V	1.7V	0V	3.2V	5.1V	---	5.0V	3.2V	---	0V	---	5.0V	3.2V	---	3.2V	5.1V
PLAY	0V	1.7V	0V	3.2V	5.1V	---	5.0V	3.2V	---	0V	---	5.0V	3.2V	---	3.2V	5.1V
Pin No.	17	18	19	20												
STOP	0V	2.6V	0V	5.1V												
PLAY	0V	2.6V	0V	5.1V												

## IC817

(V)

Pin No.	1	2	3	4	5	6	7	8	9	10	11	12	13	14	15	16
STOP	1.6V	0V	1.6V	0V	3.3V	5.1V	2.5V	2.5V	0V	2.5V	3.2V	0V	---	5.0V	5.1V	2.6V
PLAY	1.6V	1.2V	1.6V	0V	3.3V	5.1V	2.5V	2.5V	0V	2.5V	0V	0V	---	5.0V	5.1V	2.6V

## IC818

(V)

Pin No.	1	2	3	4	5	6	7	8	9	10	11	12	13	14	15	16
STOP	0V	0V	2.8V	2.8V	5.1V	0V	2.8V	2.8V	0V	0V	3.2V	---	2.8V	2.8V	0V	5.1V
PLAY	0V	0V	---	---	5.1V	0V	---	---	0V	0V	3.2V	---	---	---	0V	5.1V
Pin No.	17	18	19	20												
STOP	2.7V	2.8V	0V	5.1V												
PLAY	---	---	5.0V	5.1V												

## IC842

(V)

Pin No.	1	2	3	4	5	6	7	8
STOP	6.9V	6.9V	6.9V	0V	6.9V	6.9V	6.9V	13.8V
PLAY	6.9V	6.9V	6.9V	0V	6.9V	6.9V	6.9V	13.8V

## IC871

(V)

Pin No.	1	2	3	4	5	6	7	8	9	10	11	12	13	14	15	16
STOP	3.1V	---	---	---	---	3.0V	---	---	3.2V	0V	0V	0V	0V	3.2V	0V	0V
PLAY	---	0.5V	2.8V	---	---	2.5V	---	---	3.2V	0V	0V	0V	0V	3.2V	0V	0V
Pin No.	17	18	19	20	21	22	23	24	25	26	27	28	29	30	31	32
STOP	3.2V	---	---	---	---	---	---	2.8V	---	---	0V	2.8V	2.8V	2.8V	2.8V	2.8V
PLAY	3.2V	---	---	---	---	---	---	---	---	---	0V	---	---	---	---	---
Pin No.	33	34	35	36	37	38	39	40	41	42	43	44	45	46	47	48
STOP	2.9V	2.8V	2.8V	2.8V	3.2V	0V	2.8V	2.8V	2.9V	2.8V	2.8V	2.7V	2.8V	2.8V	0V	3.1V
PLAY	---	---	---	---	3.2V	0V	---	---	---	---	---	---	---	---	0V	2.9V

## IC881

(V)

Pin No.	1	2	3	4	5	6	7	8	9	10	11	12	13	14	15	16
STOP	3.1V	---	---	---	---	0.3V	0.3V	---	3.2V	0V	0V	0V	0V	3.2V	0V	0V
PLAY	---	0.5V	2.8V	---	---	---	---	---	3.2V	0V	0V	0V	0V	3.2V	0V	0V
Pin No.	17	18	19	20	21	22	23	24	25	26	27	28	29	30	31	32
STOP	3.2V	---	---	---	---	---	---	2.8V	0.2V	0.2V	0V	2.8V	2.9V	2.9V	2.9V	2.9V
PLAY	3.2V	---	---	---	---	---	---	---	---	---	0V	---	---	---	---	---
Pin No.	33	34	35	36	37	38	39	40	41	42	43	44	45	46	47	48
STOP	2.9V	3.0V	2.8V	2.8V	3.2V	0V	2.9V	2.8V	2.9V	2.8V	2.9V	2.7V	2.9V	2.8V	0V	3.1V
PLAY	---	---	---	---	3.2V	0V	---	---	---	---	---	---	---	---	0V	2.9V

**MAIN P.C.B.**

**IC401 (KIA7812AP1) (V)**

Pin No.	1	2	3
TUNER	21V	0V	12V

**IC402 (KIA) (V)**

Pin No.	1	2	3
TUNER	0V	-22V	-12V

**IC403 (KIA) (V)**

Pin No.	1	2	3
TUNER	22V	0V	9V

**IC411 (UPD78005) (V)**

Pin No.	1	2	3	4	5	6	7	8	9	10	11	12	13	14	15	16	17	18	19	20
TUNER	5.0V	5.0V	*1 0V	0V	0V	4.6V	4.9V	0V	0V	*4 4.9V	4.7V	0V	1.2V	0V	0V	0V	*5 0V	0V	0V	0V
POWER OFF	---	---	*2 4.6V	---	4.8V	0V	---	*3 4.8V	4.8V	---	---	---	---	---	---	---	*6 4.8V	4.8V	---	---
Pin No.	21	22	23	24	25	26	27	28	29	30	31	32	33	34	35	36	37	38	39	40
TUNER	0V	0V	4.8V	0V	4.8V	---	4.9V	4.9V	---	---	---	---	0V	5.0V	4.7V	*8 4.9V	*10 4.9V	0V	0V	0V
POWER OFF	---	---	---	---	*7 0V	---	---	---	---	---	---	---	---	---	---	*9 0V	*11 0V	---	---	---
Pin No.	41	42	43	44	45	46	47	48	49	50	51	52	53	54	55	56	57	58	59	60
TUNER	0V	0V	0V	0V	0V	0V	0V	0V	4.9V	4.9V	4.9V	0V	4.8V	4.8V	0V	*14 4.8V	*14 4.8V	*14 4.8V	---	5.0V
POWER OFF	---	---	---	---	---	---	---	---	---	---	---	*12 4.3V	0V	*13 0V	---	*15 0V	*15 0V	*15 0V	*15 0V	---
Pin No.	61	62	63	64	65	66	67	68	69	70	71	72	73	74	75	76	77	78	79	80
TUNER	4.5V	0V	0V	0V	0V	4.8V	0V	5.0V	2.9V	2.6V	0V	2.9V	2.2V	5.0V	0V	*17 4.8V	*19 4.8V	*21 4.8V	4.8V	4.9V
POWER OFF	---	---	---	---	*16 4.8V	---	---	---	---	---	---	---	---	---	---	*18 0V	*20 0V	*22 0V	*23 0V	---

- \*1=Except DVD function
- \*2=DVD function
- \*3=VIDEO 1 function
- \*4=Using NTSC system
- \*5=Power ON/TUNER/CLASSIC
- \*6=Power ON/TUNER/POP
- \*7=Power OFF
- \*8=Disconnect Headphone
- \*9=Connect Headphone
- \*10=Video Out select is "S-VIDEO"
- \*11=Video Out select is "RGB"
- \*12=DVD function/NO DISC
- \*13=DVD function/NO DISC
- \*14=Power ON/TUNER/PRO-LOGIC
- \*15=Volume 0
- \*16=Test Tone
- \*17=Large Speaker/SURROUND
- \*18=Small Speaker/SURROUND
- \*19=Large Speaker/CENTER
- \*20=Small Speaker/CENTER
- \*21=Large Speaker/FRONT
- \*22=Small Speaker/FRONT
- \*23=DVD function/DOLBY DIGITAL 5.1ch

**IC412 (KIA7042P) (V)**

Pin No.	1	2	3
TUNER	5.0V	0V	5.0V

**IC431 (LC75342M) (V)**

Pin No.	1	2	3	4	5	6	7	8	9	10	11	12	13	14	15	16	17	18	19	20
TUNER	0V	0V	0V	0V	4.0V	4.0V	4.0V	4.0V	4.0V	4.0V	4.0V	4.0V	4.0V	4.0V	4.0V	0V	0V	4.0V	4.0V	4.0V
Pin No.	21	22	23	24	25	26	27	28	29	30										
TUNER	4.0V	4.0V	4.0V	4.0V	4.0V	4.0V	0V	4.0V	8.0V	0V										

**IC432 (KIA4558M) (V)**

Pin No.	1	2	3	4	5	6	7	8
TUNER	0V	0V	0V	-11.3V	0V	0V	0V	11.1V

**IC433 (KIA4558M) (V)**

Pin No.	1	2	3	4	5	6	7	8
TUNER	0V	0V	0V	-11.3V	0V	0V	0V	11.1V

**IC434 (TA2078B) (V)**

Pin No.	1	2	3	4	5	6	7	8	9	10	11	12	13	14	15	16
TUNER CLA	5.0V	5.0V	0V	0V	5.0V	0V	11.5V	0V	0V	0V	0V	5.0V	0V	0V	5.0V	5.0V
TUNER POP	5.0V	5.0V	0V	5.0V	5.0V	5.0V	11.5V	0V	4.6V	4.6V	5.0V	5.0V	5.0V	0V	5.0V	5.0V

**IC435 (M62464FP) (V)**

Pin No.	1	2	3	4	5	6	7	8	9	10	11	12	13	14	15	16	17	18	19	20
TUNER	4.6V	4.6V	3.7V	2.5V	4.6V	4.6V	4.6V	4.6V	3.7V	2.5V	4.6V	4.6V	2.5V	3.7V	4.6V	2.5V	3.7V	4.6V	0V	0V
Pin No.	21	22	23	24	25	26	27	28	29	30	31	32	33	34	35	36	37	38	39	40
TUNER	4.9V	4.6V	0V	0V	0V	4.6V	2.5V	2.5V	2.5V	2.5V	2.5V	0.7V	0.7V	2.5V	2.5V	2.5V	2.5V	2.5V	2.5V	0V
Pin No.	41	42	43	44	45	46	47	48	49	50	51	52	53	54	55	56	57	58	59	60
TUNER	4.6V	4.6V	4.6V	4.6V	0V	4.6V	3.4V	4.6V	3.4V	4.6V	3.4V	4.6V	4.6V	4.6V	4.6V	4.6V	4.6V	4.6V	4.6V	4.6V
Pin No.	61	62	63	64	65	66	67	68	69	70	71	72	73	74	75	76	77	78	79	80
TUNER	4.6V	4.6V	4.6V	4.6V	4.6V	0V	---	2.5V	9.1V	4.6V	1.4V	4.6V	4.6V	4.6V	4.6V	4.6V	4.6V	4.6V	4.6V	4.6V

**IC437 (BU4066BCF) (V)**

Pin No.	1	2	3	4	5	6	7	8	9	10	11	12	13	14
TUNER	4.6V	4.6V	4.6V	0V	0V	0V	0V	0V	0V	0V	0V	0V	12V	12V
DVD 5.1ch	0V	4.6V	4.6V	4.6V	12V	0V	0V	0V	0V	0V	0V	0V	0V	12V

**IC441,442,443 (LM4766) (V)**

Pin No.	1	2	3	4	5	6	7	8	9	10	11	12	13	14	15
TUNER	0V	29V	0V	-29V	0V	-3.2V	0V	0V	---	0V	-3.2V	0V	0V	---	29V

**Q4011 (KTA1273) (V)**

Pin No.	E	C	B
TUNER	-27V	-27.6V	-27.6V

**Q4101 (KTC3199) (V)**

Pin No.	E	C	B
TUNER	0V	5V	0V

**Q4102 (KTC3199) (V)**

Pin No.	E	C	B
TUNER	0V	4.9V	0V
HP IN	0V	0V	0.6V

**Q4103 (KTC3199) (V)**

Pin No.	E	C	B
TUNER	5.7V	10V	6.4V

**Q4104 (KTC3199) (V)**

Pin No.	E	C	B
TUNER	0V	0V	0.7V
POWER OFF	0V	5.0V	0V

**Q4301,4302 (KTD1303) (V)**

Pin No.	E	C	B
TUNER	0V	0V	0V

**Q4303 (KRA107M) (V)**

Pin No.	E	C	B
TUNER	0V	0V	0V

**Q4304 (KRA107M) (V)**

Pin No.	E	C	B
TUNER	0V	0V	0V
DVD(NoDisc)	4.3V	4.3V	0V

**Q4305,4306 (KTD1303) (V)**

Pin No.	E	C	B
TUNER	0V	0V	0V
DVD(NoDisc)	0V	0V	0.7V

**Q4307 (KTC3199) (V)**

Pin No.	E	C	B
TUNER	9.1V	12V	9.8V

**Q4308 (KTC3199) (V)**

Pin No.	E	C	B
TUNER	4.9V	10V	5.6V

**Q4309 (KRA107M) (V)**

Pin No.	E	C	B
TUNER	5.6V	-4.5V	5.6V
DVD(NoDisc)	3.7V	3.7V	0V

**Q4310 (KRC107M) (V)**

Pin No.	E	C	B
TUNER	0V	5.6V	0V
DVD(NoDisc)	0V	0V	4.4V

**Q4311-4314 (KRC107M) (V)**

Pin No.	E	C	B
TUNER	0V	0V	2.6V
DVD(NoDisc)	0V	3.3V	0V

**Q4315,4318 (KRA107M) (V)**

Pin No.	E	C	B
TUNER	0V	0V	0V
DVD(NoDisc)	3.3V	3.3V	0V

**Q4316,4317 (KTD1303) (V)**

Pin No.	E	C	B
TUNER	0V	0V	0V
DVD(NoDisc)	0V	0V	0.7V

DVR-S60  
NX-SW60

**Q4319,4320 (KTD1303) (V)**

Pin No.	E	C	B
TUNER	0V	0V	0V
DVD(NoDisc)	0V	0V	0.7V

**Q4321,4323 (KRA107M) (V)**

Pin No.	E	C	B
TUNER	0V	0V	0V
DVD(NoDisc)	3.3V	3.3V	0V

**Q4322,4324 (KTD1303) (V)**

Pin No.	E	C	B
TUNER	0V	0V	0V
DVD(NoDisc)	0V	0V	0.7V

**Q4330~4333 (KRC107M) (V)**

Pin No.	E	C	B
TUNER	0V	0V	0V
DVD(NoDisc)	0V	0V	1.4V

**Q4334 (KRC107M) (V)**

Pin No.	E	C	B
TUNER	0V	0V	0V
TEST TONE	0V	0V	4.8V

**Q4340 (KRC107M) (V)**

Pin No.	E	C	B
TUNER	0V	12V	0V
DVD 5.1ch	0V	0V	11V

**Q4341 (KRC107M) (V)**

Pin No.	E	C	B
TUNER	0V	0V	4.8V
DVD 5.1ch	0V	11V	0V

**Q4501 (KRC107M) (V)**

Pin No.	E	C	B
TUNER	0V	0V	4.8V

**Q4502 (KTA1267) (V)**

Pin No.	E	C	B
TUNER	29V	29V	28.3V

**Q4503 (KTC3199) (V)**

Pin No.	E	C	B
TUNER	-29V	-2.9V	-28.3V

**Q4504,4505 (KTC3199) (V)**

Pin No.	E	C	B
TUNER	0V	10V	0V

**Q4508 (KTC3199) (V)**

Pin No.	E	C	B
TUNER	11.7V	20V	12.4V

**Q4509 (KTC3205) (V)**

Pin No.	E	C	B
TUNER	11V	20V	11.7V

**HEADPHONE P.C.B.**

**IC241 (NJM4580M)**

Pin No.	1	2	3	4	5	6	7	8
TUNER	0V	0V	0V	-12V	0V	0V	0V	12V

**Q2401~2404 (KTD1303) (V)**

Pin No.	E	C	B
TUNER	0V	0V	0V
DVD(NoDisc)	0V	0V	0.7V

**STANDBY POWER P.C.B.**

**IC413 (KIA7805AP1) (V)**

Pin No.	1	2	3
TUNER	10.7V	0.6V	5.6V

**Q4131 (KTD1303) (V)**

Pin No.	E	C	B
TUNER	0V	0V	0.7V
POWER OFF	0V	14V	0V

**DVD POWER P.C.B.**

**IC231 (KIA78R05PI) (V)**

Pin No.	1	2	3	4
TUNER	13.4V	0V	0V	0V
DVD(NoDisc)	10.7V	5.0V	0V	3.5V

**IC232 (LM1086CT3.3) (V)**

Pin No.	1	2	3
TUNER	0V	0V	0V
DVD(NoDisc)	5.0V	3.3V	0V

**IC233 (KIA78R05PI) (V)**

Pin No.	1	2	3	4
TUNER	13.4V	0V	0V	0V
DVD(NoDisc)	10.7V	5.0V	0V	2.6V

**Q2301 (KTC3199) (V)**

Pin No.	E	C	B
TUNER	0V	1.5V	0V
DVD(NoDisc)	0V	0V	0.7V

**Q2302 (KRC107M) (V)**

Pin No.	E	C	B
TUNER	0V	0V	1.5V
DVD(NoDisc)	0V	6.6V	0V

**Q2303 (KTC3199) (V)**

Pin No.	E	C	B
TUNER	0V	13.4V	0V
DVD(NoDisc)	6.0V	10.7V	6.6V

**Q2304 (KTC2026) (V)**

Pin No.	E	C	B
TUNER	0V	13.4V	0V
DVD(NoDisc)	5.3V	10.7V	6.0V

**Q2305 (KTC2026) (V)**

Pin No.	E	C	B
TUNER	0V	13.4V	0V
DVD(NoDisc)	5.3V	10.7V	6.0V

**Q2306 (KRC107M) (V)**

Pin No.	E	C	B
TUNER	0V	0V	1.5V
DVD(NoDisc)	0V	3.5V	0V

**Q2330 (KRC107M) (V)**

Pin No.	E	C	B
TUNER	0V	0V	1.5V
DVD(NoDisc)	0V	2.6V	0V

**FRONT P.C.B.**

**IC601 (UPD16311) (V)**

Pin No.	1	2	3	4	5	6	7	8	9	10	11	12	13	14	15	16	17	18	19	20
TUNER	1.8V	1.8V	1.8V	1.8V	4.8V	---	4.8V	4.8V	---	0V	0V	0V	0V	4.8V	---	---	---	---	---	---
Pin No.	21	22	23	24	25	26	27	28	29	30	31	32	33	34	35	36	37	38	39	40
TUNER	---	---	---	---	---	---	---	---	---	---	-24.5V	-24.5V	4.8V	-27.4V	---	---	---	---	---	---
Pin No.	41	42	43	44	45	46	47	48	49	50	51	52								
TUNER	---	---	---	---	4.8V	4.9V	4.9V	4.9V	4.9V	4.9V	0V	---								

**Q6001 (KRC107M) (V)**

Pin No.	E	C	B
TUNER	0V	5.0V	0V
POWER OFF	0V	0V	4.8V

**VIDEO P.C.B.**

**IC211~213 (NJM4558M)**

Pin No.	1	2	3	4	5	6	7	8
TUNER	0V	0V	0V	-11.3V	0V	0V	0V	11.1V

**IC221 (LA7952)**

Pin No.	1	2	3	4	5	6	7	8	9
TUNER	7.0V	0V	0V	3.1V	0V	3.1V	12V	3.1V	3.1V
VIDEO1	6.5V	4.8V	4.8V	3.1V	0V	3.1V	12V	3.1V	3.1V

**Q2100~2104 (KRC107M) (V)**

Pin No.	E	C	B
#SP Large	0V	0V	4.8V
#SP Small	0V	0V	0V

**Q2201,2202 (KTC3199) (V)**

Pin No.	E	C	B
DVD	12V	6.3V	7.0V

**Q2203 (KRC107M) (V)**

Pin No.	E	C	B
TUNER	0V	0.7V	0V
VIDEO 1	0V	0V	4.8V

**Q2204 (KRC107M) (V)**

Pin No.	E	C	B
TUNER	0V	0V	0V
VIDEO 1	0V	0V	4.8V

#Q2100,2101=FRONT Q2102,2103=SURROUND Q2104=CENTER

**Q2211,2212 (KTC3199) (V)**

Pin No.	E	C	B
TUNER	0V	0V	0V

# PARTS LIST

## ■ ELECTRICAL PARTS

### ■ WARNING

- Components having special characteristics are marked  $\triangle$  and must be replaced with parts having specifications equal to those originally installed.
- For the capacitor not found in the list, refer to the schematic diagram.
- Carbon resistors (1/6W or 1/4W) are not included in the ELECTRICAL PARTS List. For the parts No. of the carbon resistors, refer to last page.

$\triangle$ 印のある部分は、安全確保部品を示しています。部品の交換が必要な場合、パーツリストに記載されている部品を使用してください。  
リストに記載されていないコンデンサは、回路図を参照してください。  
本機に使用しているカーボン抵抗は、1/6Wです。このパーツリストには、記載しておりませんので、部品番号がHF85 タイプまたは同等品を使用してください。

### ABBREVIATIONS IN THIS LIST ARE AS FOLLOWS :

C.A.EL.CHP	: CHIP ALUMI. ELECTROLYTIC CAP	L.DTCT	: LIGHT DETECTING MODULE
C.CE	: CERAMIC CAP	L.EMIT	: LIGHT EMITTING MODULE
C.CE.ARRAY	: CERAMIC CAP ARRAY	LED.DSPLY	: LED DISPLAY
C.CE.CHP	: CHIP CERAMIC CAP	LED.INFRD	: LED, INFRARED
C.CE.ML	: MULTILAYER CERAMIC CAP	MODUL.RF	: MODULATOR, RF
C.CE.M.CHP	: CHIP MULTILAYER CERAMIC CAP	PHOT.CPL	: PHOTO COUPLER
C.CE.SAFTY	: RECOGNIZED CERAMIC CAP	PHOT.INTR	: PHOTO INTERRUPTER
C.CE.TUBLR	: CERAMIC TUBULAR CAP	PHOT.RFLCT	: PHOTO REFLECTOR
C.CE.SMI	: SEMI CONDUCTIVE CERAMIC CAP	PIN.TEST	: PIN, TEST POINT
C.EL	: ELECTROLYTIC CAP	PLST.RIVET	: PLASTIC RIVET
C.MICA	: MICA CAP	R.ARRAY	: RESISTOR ARRAY
C.ML.FLM	: MULTILAYER FILM CAP	R.CAR	: CARBON RESISTOR
C.MP	: METALLIZED PAPER CAP	R.CAR.CHP	: CHIP RESISTOR
C.MYLAR	: MYLAR FILM CAP	R.CAR.FP	: FLAME PROOF CARBON RESISTOR
C.MYLAR.ML	: MULTILAYER MYLAR FILM CAP	R.FUS	: FUSABLE RESISTOR
C.PAPER	: PAPER CAPACITOR	R.MTL.CHP	: CHIP METAL FILM RESISTOR
C.PLS	: POLYSTYRENE FILM CAP	R.MTL.FLM	: METAL FILM RESISTOR
C.POL	: POLYESTER FILM CAP	R.MTL.OXD	: METAL OXIDE FILM RESISTOR
C.POLY	: POLYETHYLENE FILM CAP	R.MTL.PLAT	: METAL PLATE RESISTOR
C.PP	: POLYPROPYLENE FILM CAP	RSNR.CE	: CERAMIC RESONATOR
C.TNTL	: TANTALUM CAP	RSNR.CRYS	: CRYSTAL RESONATOR
C.TNTL.CHP	: CHIP TANTALUM CAP	R.TW.CEM	: TWIN CEMENT FIXED RESISTOR
C.TRIM	: TRIMMER CAP	R.WW	: WIRE WOUND RESISTOR
CN	: CONNECTOR	SCR.BND.HD	: BIND HEAD B-TITE SCREW
CN.BS.PIN	: CONNECTOR, BASE PIN	SCR.BW.HD	: BW HEAD TAPPING SCREW
CN.CANNON	: CONNECTOR, CANNON	SCR.CUP	: CUP TITE SCREW
CN.DIN	: CONNECTOR, DIN	SCR.TERM	: SCREW TERMINAL
CN.FLAT	: CONNECTOR, FLAT CABLE	SCR.TR	: SCREW, TRANSISTOR
CN.POST	: CONNECTOR, BASE POST	SUPRT.PCB	: SUPPORT, P.C.B.
COIL.MX.AM	: COIL, AM MIX	SURG.PRTCT	: SURGE PROTECTOR
COIL.AT.FM	: COIL, FM ANTENNA	SW.TACT	: TACT SWITCH
COIL.DT.FM	: COIL, FM DETECT	SW.LEAF	: LEAF SWITCH
COIL.MX.FM	: COIL, FM MIX	SW.LEVER	: LEVER SWITCH
COIL.OUTPT	: OUTPUT COIL	SW.MICRO	: MICRO SWITCH
DIOD.ARRAY	: DIODE ARRAY	SW.PUSH	: PUSH SWITCH
DIODE.BRG	: DIODE BRIDGE	SW.RT.ENC	: ROTARY ENCODER
DIODE.CHP	: CHIP DIODE	SW.RT.MTR	: ROTARY SWITCH WITH MOTOR
DIODE.SHOT	: SCHOTTKY BARRIER DIODE	SW.RT	: ROTARY SWITCH
DIODE.VAR	: VARACTOR DIODE	SW.SLIDE	: SLIDE SWITCH
DIOD.Z.CHP	: CHIP ZENER DIODE	TERM.SP	: SPEAKER TERMINAL
DIODE.ZENR	: ZENER DIODE	TERM.WRAP	: WRAPPING TERMINAL
DSCR.CE	: CERAMIC DISCRIMINATOR	THRMST.CHP	: CHIP THERMISTOR
FER.BEAD	: FERRITE BEADS	TR.CHP	: CHIP TRANSISTOR
FER.CORE	: FERRITE CORE	TR.DGT	: DIGITAL TRANSISTOR
FET.CHP	: CHIP FET	TR.DGT.CHP	: CHIP DIGITAL TRANSISTOR
FL.DSPLY	: FLUORESCENT DISPLAY	TRANS	: TRANSFORMER
FLTR.CE	: CERAMIC FILTER	TRANS.PULS	: PULSE TRANSFORMER
FLTR.COMB	: COMB FILTER MODULE	TRANS.PWR	: POWER TRANSFORMER ASS'y
FLTR.LC.RF	: LC FILTER ,EMI	TUNER.AM	: TUNER PACK, AM
GND.MTL	: GROUND PLATE	TUNER.FM	: TUNER PACK, FM
GND.TERM	: GROUND TERMINAL	TUNER.PK	: FRONT-END TUNER PACK
HOLDER.FUS	: FUSE HOLDER	VR	: ROTARY POTENTIOMETER
IC.PRTCT	: IC PROTECTOR	VR.MTR	: POTENTIOMETER WITH MOTOR
JUMPER.CN	: JUMPER CONNECTOR	VR.SW	: POTENTIOMETER WITH ROTARY SW
JUMPER.TST	: JUMPER, TEST POINT	VR.SLIDE	: SLIDE POTENTIOMETER
		VR.TRIM	: TRIMMER POTENTIOMETER



Ref. No.	PART NO.	Description	Remarks	Markets	部品名	Rank	
*	AAX37650	P.C.B.	MAIN	614 324 5926	J	P C B メイン	
*	AAX37630	P.C.B.	MAIN	614 324 4257	UC	P C B メイン	
*	AAX37670	P.C.B.	MAIN	614 324 5940	RK	P C B メイン	
*	AAX37660	P.C.B.	MAIN	614 324 5933	TA	P C B メイン	
*	AAX37640	P.C.B.	MAIN	614 324 5919	GB	P C B メイン	
	C4101	UA655100	C.MYLAR	0.1uF 50V		マイラーコン	01
	C4102	UA655100	C.MYLAR	0.1uF 50V		マイラーコン	01
	C4104	UA655100	C.MYLAR	0.1uF 50V		マイラーコン	01
	C4105	UA655100	C.MYLAR	0.1uF 50V		マイラーコン	01
*	C4107	AAX37760	C.EL	6800uF 50V	404 067 7000	ケミコン	
*	C4107	AAX37760	C.EL	6800uF 50V	404 067 7000	ケミコン	
	C4112	UA654100	C.MYLAR	0.01uF 50V		マイラーコン	01
*	C4113	VG581600	C.EL	2200uF 35V		ケミコン	04
*	C4114	VG581600	C.EL	2200uF 35V		ケミコン	04
*	C4119	VG581600	C.EL	2200uF 35V		ケミコン	04
	C4151	UR819100	C.EL	1000uF 6.3V		ケミコン	01
	C4205	UA655100	C.MYLAR	0.1uF 50V		マイラーコン	01
	C4206	UA655100	C.MYLAR	0.1uF 50V		マイラーコン	01
	C4211	UA655100	C.MYLAR	0.1uF 50V		マイラーコン	01
	C4214	UA653470	C.MYLAR	4700pF 50V		マイラーコン	01
	C4215	UA653100	C.MYLAR	1000pF 50V		マイラーコン	03
	C4216	UA655100	C.MYLAR	0.1uF 50V		マイラーコン	01
	C4217	UA655220	C.MYLAR	0.22uF 50V		マイラーコン	01
	C4218	UA655220	C.MYLAR	0.22uF 50V		マイラーコン	01
	C4219	UA655100	C.MYLAR	0.1uF 50V		マイラーコン	01
	C4220	UA653470	C.MYLAR	4700pF 50V		マイラーコン	01
	C4221	UA653100	C.MYLAR	1000pF 50V		マイラーコン	03
	C4223	UA653560	C.MYLAR	5600pF 50V		マイラーコン	
	C4224	UA654470	C.MYLAR	0.047uF 50V		マイラーコン	01
	C4225	UA654680	C.MYLAR	0.068uF 50V		マイラーコン	01
	C4226	UA655220	C.MYLAR	0.22uF 50V		マイラーコン	01
	C4227	UA655220	C.MYLAR	0.22uF 50V		マイラーコン	01
	C4230	UA655220	C.MYLAR	0.22uF 50V		マイラーコン	01
	C4231	UA655220	C.MYLAR	0.22uF 50V		マイラーコン	01
	C4232	UA655100	C.MYLAR	0.1uF 50V		マイラーコン	01
	C4233	UA654470	C.MYLAR	0.047uF 50V		マイラーコン	01
	C4234	UA654470	C.MYLAR	0.047uF 50V		マイラーコン	01
	C4237	UA655220	C.MYLAR	0.22uF 50V		マイラーコン	01
	C4238	UA655220	C.MYLAR	0.22uF 50V		マイラーコン	01
	C4239	UA655100	C.MYLAR	0.1uF 50V		マイラーコン	01
	C4241	UA654100	C.MYLAR	0.01uF 50V		マイラーコン	01
	C4242	UA654100	C.MYLAR	0.01uF 50V		マイラーコン	01
	C4243	UA654100	C.MYLAR	0.01uF 50V		マイラーコン	01
	C4245	UA654100	C.MYLAR	0.01uF 50V		マイラーコン	01
	C4323	UA655220	C.MYLAR	0.22uF 50V		マイラーコン	01
	C4324	UA655220	C.MYLAR	0.22uF 50V		マイラーコン	01
	C4329	UA655220	C.MYLAR	0.22uF 50V		マイラーコン	01
	C4330	UA655220	C.MYLAR	0.22uF 50V		マイラーコン	01
	C4361	UA654680	C.MYLAR	0.068uF 50V		マイラーコン	01
	C4367	UA654680	C.MYLAR	0.068uF 50V		マイラーコン	01
	C4372	UA655220	C.MYLAR	0.22uF 50V		マイラーコン	01
	C4376-82	UA655100	C.MYLAR	0.1uF 50V		マイラーコン	01
	C4386-87	UA655100	C.MYLAR	0.1uF 50V		マイラーコン	01

\* New Parts (新規部品)

Note) Those parts marked with “#” are not included in the P.C.B. ass'y. (マーク#の部品は、基板に含まれません)

Ref. No.	PART NO.	Description	Remarks	Markets	部品名	Rank
C4404	UA655100	C.MYLAR 0.1uF 50V			マイラーコン	01
C4408	UA655100	C.MYLAR 0.1uF 50V			マイラーコン	01
C4409	VG722100	C.EL 1uF 50V			B Pケミコン	01
C4413	UA655100	C.MYLAR 0.1uF 50V			マイラーコン	01
C4417	UA655100	C.MYLAR 0.1uF 50V			マイラーコン	01
C4418	VG722100	C.EL 1uF 50V			B Pケミコン	01
C4422	UA655100	C.MYLAR 0.1uF 50V			マイラーコン	01
C4426	UA655100	C.MYLAR 0.1uF 50V			マイラーコン	01
C4427	VG722100	C.EL 1uF 50V			B Pケミコン	01
C4490-95	UA655100	C.MYLAR 0.1uF 50V			マイラーコン	01
△* D4101	AAX37890	DIODE G5SBA60L-BU04	408 043 8005		ダイオード	
△* D4102-09	AAX37860	DIODE MPG06G	407 097 8009		ダイオード	
D4151-54	iF006130	DIODE 1SS133			ダイオード	01
D4155	VG438000	DIODE.ZENR MTZJ6.2B 6.2V			ツェナーダイオード	01
D4201	VG439500	DIODE.ZENR MTZJ10B 10V			ツェナーダイオード	01
D4202	VG437700	DIODE.ZENR MTZJ5.6B 5.6V	333005631		ツェナーダイオード	
D4300-03	iF006130	DIODE 1SS133			ダイオード	01
D4502	VG440500	DIODE.ZENR MTZJ13B 13V			ツェナーダイオード	01
△* F4101,02	AAX39080	FUSE 2A 250V	423 029 3904	UC	ヒューズ	
△* IC401	AAX36880	IC KIA7812API	409 468 3309		IC	
△* IC402	AAX37060	IC KIA7912PI	409 504 4703		IC	
△* IC403	AAX37050	IC KIA 7809API	409 504 4604		IC	
* IC411	AAX37120	IC UPD780055GC	410 445 7500		IC	
* IC412	AAX36940	IC KIA7042AP	409 497 6500		IC	
IC431	XY935A00	IC LC75342M-TLM			IC SOP	
IC432	XV130A00	IC NJM4558M-D OP AMP			アンプIC	
IC433	XV130A00	IC NJM4558M-D OP AMP			アンプIC	
* IC435	AAX37070	IC M62464BFP	409 510 6005		IC	
IC437	XU834A00	IC BU4066BC			アナログSW IC	
* IC441-43	AAX36950	IC LM4766T	409 497 6708		IC	
* PR411	AAX38360	PROTECTOR 0.125A 125V	645 027 4169		プロテクター	
△* PR421-22	AAX38370	PROTECTOR 10A 125V	645 052 1072		プロテクター	
* Q4011	AAX38020	TR KTA1273-Y	405 141 3604		トランジスタ	
* Q4101-04	AAX38050	TR KTC3199-GR	405 143 8706		トランジスタ	01
* Q4301-02	AAX38070	TR KTD1303	405 151 4400		トランジスタ	03
* Q4303-04	AAX38080	TR KRA107M	405 151 5209		トランジスタ	
* Q4305-06	AAX38070	TR KTD1303	405 151 4400		トランジスタ	03
* Q4307-08	AAX38010	TR KTC3198-Y	405 141 3208		トランジスタ	
* Q4309-15	AAX38080	TR KRA107M	405 151 5209		トランジスタ	
* Q4316-17	AAX38070	TR KTD1303	405 151 4400		トランジスタ	03
* Q4318	AAX38080	TR KRA107M	405 151 5209		トランジスタ	
* Q4319-20	AAX38070	TR KTD1303	405 151 4400		トランジスタ	03
* Q4321	AAX38080	TR KRA107M	405 151 5209		トランジスタ	
* Q4322	AAX38070	TR KTD1303	405 151 4400		トランジスタ	03
* Q4323	AAX38080	TR KRA107M	405 151 5209		トランジスタ	
* Q4324	AAX38070	TR KTD1303	405 151 4400		トランジスタ	03
* Q4330-34	AAX38030	TR KRC107M	405 143 0007		トランジスタ	
* Q4340-41	AAX38030	TR KRC107M	405 143 0007		トランジスタ	
* Q4501	AAX38030	TR KRC107M	405 143 0007		トランジスタ	
* Q4502-03	AAX38040	TR KTA1267-GR	405 143 6504		トランジスタ	01
* Q4504-05	AAX38010	TR KTC3198-Y	405 141 3208		トランジスタ	
* Q4505	AAX38010	TR KTC3198-Y	405 141 3208		トランジスタ	
* Q4508	AAX38050	TR KTC3199-GR	405 143 8706		トランジスタ	01

\* New Parts (新規部品)

Ref. No.	PART NO.	Description	Remarks	Markets	部品名	Rank	
* Q4509	AAX38060	TR	KTC3205-Y	405 147 2106		トランジスタ	
△ R4104	HL313470	R.MTL.OXD	4.7 1W			酸化金属被膜抵抗	01
△ R4105	HL313470	R.MTL.OXD	4.7 1W			酸化金属被膜抵抗	01
R4116	VK186600	R.FUS	10 1/4W			ヒューズ抵抗	01
R4118	VE009700	R.FUS	4.7 1/4W			ヒューズ抵抗	01
△ R4405	HL214100	R.MTL.OXD	10 1W			酸化金属被膜抵抗	01
R4407	HL214100	R.MTL.OXD	10 1W			酸化金属被膜抵抗	01
△ R4412	HL214100	R.MTL.OXD	10 1W			酸化金属被膜抵抗	01
R4414	HL214100	R.MTL.OXD	10 1W			酸化金属被膜抵抗	01
△ R4423	HL214100	R.MTL.OXD	10 1W			酸化金属被膜抵抗	01
R4425	HL214100	R.MTL.OXD	10 1W			酸化金属被膜抵抗	01
△ R4430	HL214100	R.MTL.OXD	10 1W			酸化金属被膜抵抗	01
R4432	HL214100	R.MTL.OXD	10 1W			酸化金属被膜抵抗	01
△ R4439	HL214100	R.MTL.OXD	10 1W			酸化金属被膜抵抗	01
△ R4445	HL214100	R.MTL.OXD	10 1W			酸化金属被膜抵抗	01
R4446	HL214100	R.MTL.OXD	10 1W			酸化金属被膜抵抗	01
R4447	HL214100	R.MTL.OXD	10 1W			酸化金属被膜抵抗	01
R4513	HL214100	R.MTL.OXD	10 1W			酸化金属被膜抵抗	01
R4514	HL214100	R.MTL.OXD	10 1W			酸化金属被膜抵抗	01
* S4010	AAX37810	SW	2P-2TX2	645 040 6119		スライドスイッチ	
* X4102	AAX38650	RSNR.CRYS	32.768KHz	645 032 1627		水晶振動子	
* #	AAX37360	P.C.B.	LED/SWITCH	614 324 4264		P C B L E D / スイッチ	
* D4156	AAX37290	LED	SLP-3118B-51HAB-T1	408 032 5404		L E D	
* S4002	AAX37850	SW	1P-1T	645 006 5958		スイッチ	
* #	AAX37600	P.C.B.	FRONT	614 324 5445	JUCARKT	P C B フロント	
* #	AAX37590	P.C.B.	FRONT	614 324 4189	GB	P C B フロント	
C6005	UR867100	C.EL	10uF 50V			ケミコン	
C6006	UR847470	C.EL	47uF 25V			ケミコン	
* D6001	VQ451000	DIODE.ZENR	MTZ5.1B 5.1V			ツェナーダイオード	01
D6002-03	iF006130	DIODE	1SS133			ダイオード	01
D6005-06	iF006130	DIODE	1SS133			ダイオード	01
* D6010	AAX38330	DIODE.PHOT	SPS-442-1G	407 217 1101		フォトダイオード	
* FL601	AAX38610	FL.DSPLY		645 043 7311		蛍光表示管	
* IC601	AAX37080	IC	UPD16311GC-AB6	410 349 2700		I C	
Q6001	VV655400	TR	DTC114EKA			デジタルトランジスタ	01
* S6001-12	AAX37850	SW.TACT	1P-1T	645 006 5958		タクトスイッチ	
* S6013	AAX38550	SW.RT.ENC		645 033 3460		ロータリーエンコーダー	
* #	AAX37530	P.C.B.	TUNER	614 324 5957	J	P C B チューナー	
* #	AAX37520	P.C.B.	TUNER	614 324 5452	UC	P C B チューナー	
* #	AAX37540	P.C.B.	TUNER	614 324 5988	ARKT	P C B チューナー	
* #	AAX37510	P.C.B.	TUNER	614 324 4196	GB	P C B チューナー	
C2077	VG722100	C.EL	1uF 50V			B P ケミコン	01
C2097	UR867100	C.EL	10uF 50V			ケミコン	
C2098	UR867100	C.EL	10uF 50V			ケミコン	

\* New Parts (新規部品)

Note) Those parts marked with "#" are not included in the P.C.B. ass'y. (マーク#の部品は、基板に含まれません)

Ref. No.	PART NO.	Description	Remarks	Markets	部品名	Rank	
* CN201	AAX37710	TERM. ANT		645 005 0695	JUCARKT	アンテナ端子	
D2031-33	iF006130	DIODE	1SS133			ダイオード	01
* D2034-35	AAX38290	DIODE.VAR	SVC211-B	407 157 8109		バラクターダイオード	
D2036	VG438300	DIODE.VAR	MTZJ6.8B 6.8V			ツェナーダイオード	01
* D2037	AAX37970	DIODE.ZENR	GZS3.0	407 153 7502		ツェナーダイオード	01
D2040	iF006130	DIODE	1SS133			ダイオード	01
* IC201	AAX36790	IC	TA8176SN	409 292 5807		I C	
* IC202	AAX36890	IC	LA1844ML	409 474 3201		I C	
* IC203	AAX36860	IC	LC72121M-D	409 439 4502		I C	
* L2034	AAX37950	COIL		645 023 0127	UC	コイル	
* L2034	AAX37960	COIL		645 033 5327	GB	コイル	
* L2034	AAX37950	COIL		645 023 0127	JARKT	コイル	
* Q2031	AAX38080	TR	KRA107M	405 151 5209		トランジスタ	
* Q2032-33	AAX38050	TR	KTC3199-GR	405 143 8706		トランジスタ	01
* T2001	AAX37280	TRANS. IF	10.7MHz	645 039 9923		I Fトランス	
* X2031	AAX38640	RSNR. CRYST	7.2MHz	645 023 4965		水晶振動子	
* #	AAX37570	P.C.B.	VIDEO	614 324 5964	J	P C B ビデオ	
* #	AAX37560	P.C.B.	VIDEO	614 324 5469	UCK	P C B ビデオ	
* #	AAX37580	P.C.B.	VIDEO	614 324 5995	ART	P C B ビデオ	
* #	AAX37550	P.C.B.	VIDEO	614 324 4202	GB	P C B ビデオ	
C2101	UR866100	C.EL	1uF 50V			ケミコン	01
C2102	UR866100	C.EL	1uF 50V			ケミコン	01
C2122	UA655470	C.MYLAR	0.47uF 50V			マイラーコン	01
C2137	UA655470	C.MYLAR	0.47uF 50V			マイラーコン	01
C2206	UR839100	C.EL	1000uF 16V			ケミコン	
C2226	UR867100	C.EL	10uF 50V			ケミコン	
C2260	UR867100	C.EL	10uF 50V			ケミコン	
* CN221	AAX38320	JACK.PIN	1P	645 045 2369		ピンジャック	
* CN222	AAX38310	JACK.PIN	1P	645 038 3670		ピンジャック	
* CN223	AAX36760	CN.DIN	4P	645 044 9086		D I Nコネクター	
* CN224	AAX38300	JACK.PIN	3P	645 024 1734	JUCARKT	ピンジャック	
D2201	iF006130	DIODE	1SS133			ダイオード	01
D2202-04	VG440800	DIODE.ZENR	MTZJ15B 15V			ツェナーダイオード	
D2210	iF006130	DIODE	1SS133			ダイオード	01
D2250-53	VG440800	DIODE.ZENR	MTZJ15B 15V			ツェナーダイオード	
IC211-13	XV130A00	IC	NJM4558M-D OP AMP			アンプ I C	
* IC221	XD524A00	IC	LA7952			I C	03
* Q2100-04	AAX38030	TR	KRC107M	405 143 0007		トランジスタ	
* Q2201-02	AAX38050	TR	KTC3199-GR	405 143 8706		トランジスタ	01
* Q2203-04	AAX38030	TR	KRC107M	405 143 0007		トランジスタ	
* Q2210	AAX38000	TR	KRA102M-A	405 110 5400		トランジスタ	
* Q2211-12	AAX38050	TR	KTC3199-GR	405 143 8706		トランジスタ	01
* S2210	AAX37800	SW	2P-2Tx4	645 040 6102		スライドスイッチ	

\* New Parts (新規部品)

Ref. No.	PART NO.	Description	Remarks	Markets	部品名	Rank	
*	AAX37490	P.C.B.	STNNDY POWER	614 324 5872	J	P C B スタンバイパワー	
*	AAX37480	P.C.B.	STNNDY POWER	614 324 5865	UC	P C B スタンバイパワー	
*	AAX37450	P.C.B.	STNNDY POWER	614 319 8284	R	P C B スタンバイパワー	
*	AAX37500	P.C.B.	STNNDY POWER	614 324 5889	T	P C B スタンバイパワー	
*	AAX37440	P.C.B.	STNNDY POWER	614 319 8277	K	P C B スタンバイパワー	
*	AAX37460	P.C.B.	STNNDY POWER	614 319 8291	A	P C B スタンバイパワー	
*	AAX37470	P.C.B.	STNNDY POWER	614 324 4219	GB	P C B スタンバイパワー	
*	C4134	VG581600	C.EL	2200uF 35V		ケミコン	04
	C4135-38	UA654470	C.MYLAR	0.047uF 50V		マイラーコン	01
*	D4131-36	AAX37860	DIODE	MPG06G	407 097 8009	ダイオード	
△*	F4131	AAX39110	FUSE	4A 250V	423 030 1807	ヒューズ	
△*	F4131	AAX39100	FUSE	5A 250V	423 029 4109	ヒューズ	
△*	F4131	AAX39070	FUSE	3.15A 250V	423 028 8504	ヒューズ	
△*	F4131	AAX39060	FUSE	1.6A 250V	423 028 8405	ヒューズ	
△*	F4132	AAX39090	FUSE	0.315A 250V	423 029 4000	ヒューズ	
△*	IC413	AAX37270	IC	KIA7805API	409 463 6701	I C	
△*	PT413	AAX38750	TRANS.PWR		645 045 2383	電源トランス	
△*	PT413	AAX39220	TRANS.PWR		645 055 0881	電源トランス	
△*	PT413	AAX39190	TRANS.PWR		645 047 7812	電源トランス	
△*	PT413	AAX39210	TRANS.PWR		645 047 7850	電源トランス	
△*	PT413	AAX39200	TRANS.PWR		645 047 7836	電源トランス	
△*	PT413	AAX39230	TRANS.PWR		645 055 0898	電源トランス	
△*	PT413	AAX39220	TRANS.PWR		645 055 0881	電源トランス	
*	Q4131	AAX38070	TR	KTD1303	405 151 4400	トランジスタ	03
△*	RY413	AAX40730	RELAY		645 046 1279	リレー	
*	AAX37350	P.C.B.	DVD POWER	614 324 5971	JARKT	P C B DVDパワー	
*	AAX37340	P.C.B.	DVD POWER	614 324 5476	UC	P C B DVDパワー	
*	AAX37330	P.C.B.	DVD POWER	614 324 4226	GB	P C B DVDパワー	
	C2301-02	UA654100	C.MYLAR	0.01uF 50V		マイラーコン	01
*	C2304	VR620100	C.EL	6800uF 16V		ケミコン	03
*	C2311	VR620100	C.EL	6800uF 16V		ケミコン	03
*	C2330	VR620100	C.EL	6800uF 16V		ケミコン	03
△*	D2301-02	AAX37880	DIODE	1N5402BD82	407 196 5800	ダイオード	
	D2303	VG438300	DIODE.VAR	MTZJ6.8B 6.8V		ツェナーダイオード	01
△*	D2304	AAX37860	DIODE	MPG06G	407 097 8009	ダイオード	
△*	D2305	AAX37860	DIODE	MPG06G	407 097 8009	ダイオード	
	D2306	VG437400	DIODE.ZENR	MTZJ5.1B 5.1V		ツェナーダイオード	
△*	F4103,04	AAX39080	FUSE	2A 250V	423 029 3904	ヒューズ	
# △*	IC231	AAX36980	IC	KIA78R05PI	409 499 1503	I C	
△*	IC232	AAX37040	IC	LM1086CT-3.3	409 504 4505	I C	
# △*	IC233	AAX36980	IC	KIA78R05PI	409 499 1503	I C	
*	Q2301	AAX38050	TR	KTC3199-GR	405 143 8706	トランジスタ	01
*	Q2302	AAX38030	TR	KRC107M	405 143 0007	トランジスタ	
*	Q2303	AAX38050	TR	KTC3199-GR	405 143 8706	トランジスタ	01
# △*	Q2304	AAX38090	TR	KTC2026-Y	405 158 2102	トランジスタ	
# △*	Q2305	AAX38090	TR	KTC2026-Y	405 158 2102	トランジスタ	
*	Q2306	AAX38030	TR	KRC107M	405 143 0007	トランジスタ	
*	Q2330	AAX38030	TR	KRC107M	405 143 0007	トランジスタ	

\* New Parts (新規部品)

Note) Those parts marked with “#” are not included in the P.C.B. ass'y. (マーク#の部品は、基板に含まれません)

Ref. No.	PART NO.	Description	Remarks	Markets	部品名	Rank	
*	AAX37620	P.C.B.	HEADPHONE	614 324 5483	JUCARKT	P C B ヘッドホン	
*	AAX37610	P.C.B.	HEADPHONE	614 324 4233	GB	P C B ヘッドホン	
C2419	UR866100	C.EL	1uF 50V			ケミコン	01
* CN242	AAX38390	JACK.PHONE	D6.43	645 009 0042		ホーンジャック	
D2401	VG437400	DIODE.ZENR	MTZJ5.1B 5.1V	MTZJ5.1B		ツェナーダイオード	
IC241	XQ178A00	IC	NJM4580E-T1 OP AMP			アンプIC	
* Q2401-04	AAX38070	TR	KTD1303	405 151 4400		トランジスタ	03
*	AAX37420	P.C.B.	MPEG	614 324 6428	J	P C B M P E G	
*	AAX37370	P.C.B.	MPEG	614 324 4172	UC	P C B M P E G	
*	AAX37390	P.C.B.	MPEG	614 324 6305	R	P C B M P E G	
*	AAX37410	P.C.B.	MPEG	614 324 6329	T	P C B M P E G	
*	AAX37400	P.C.B.	MPEG	614 324 6312	K	P C B M P E G	
*	AAX37430	P.C.B.	MPEG	614 324 6435	A	P C B M P E G	
*	AAX37380	P.C.B.	MPEG	614 324 6299	GB	P C B M P E G	
D8002	iX635430	DIODE.CHP	1SS355	1SS355		チップダイオード	
* D8020	AAX37920	DIODE.ZENR	KDZ6.BV	407 221 6604		チップツェナーダイオード	
* D8021	AAX37910	DIODE.ZENR	KDZ5.6V	407 221 6505		チップツェナーダイオード	
* D8022	AAX37920	DIODE.ZENR	KDZ6.BV	407 221 6604		チップツェナーダイオード	
* D8023	AAX37910	DIODE.ZENR	KDZ5.6V	407 221 6505		チップツェナーダイオード	
* D8101	AAX37900	DIODE.ZENR	UDZS6.2B	407 209 1201		チップツェナーダイオード	
* IC804	AAX36850	IC	74LCX373MTC	409 434 3807		IC	
* IC805	AAX36850	IC	74LCX373MTC	409 434 3807		IC	
* IC806	AAX36900	IC	K4S161622D-TC80	409 482 0209		IC	
* IC807	AAX36900	IC	K4S161622D-TC80	409 482 0209		IC	
* IC813	AAX36840	IC	74VHC157MTC	409 432 8101		IC	
* IC815	AAX36800	IC	24LC16BT/SN,EEPROM	409 339 3605		IC	
* IC816	AAX37090	IC	74VHCT244AMTC-X	410 377 4707		IC	
* IC817	AAX37000	IC	PCM1748E,DAC-2CH	409 500 3304		IC	
* IC818	AAX37100	IC	74VHCT374AMTC-X	410 380 5708		IC	
* IC819	AAX36920	IC	NC7SZ08P5	409 484 7602		IC	
* IC842	AAX36830	IC	KIA4558F	409 426 1903		IC	
* IC861	AAX37030	IC	PCM1602Y,DAC-6CH	409 501 9701		IC	
* IC862	AAX36830	IC	KIA4558F	409 426 1903		IC	
* IC863	AAX36830	IC	KIA4558F	409 426 1903		IC	
* IC864	AAX36830	IC	KIA4558F	409 426 1903		IC	
* IC871	AAX37130	IC	FLASH LOW	410 446 6403	UC	IC	
* IC871	AAX37150	IC	FLASH LOW	410 450 0206	GB	IC	
* IC871	AAX37160	IC	FLASH LOW	410 450 0305	J	IC	
* IC871	AAX37170	IC	FLASH LOW	410 450 0404	A	IC	
* IC871	AAX37210	IC	FLASH LOW	410 450 0800	R	IC	
* IC871	AAX37220	IC	FLASH LOW	410 450 0909	K	IC	
* IC871	AAX37230	IC	FLASH LOW	410 450 1005	T	IC	
* IC881	AAX37140	IC	FLASH HIGH	410 446 6502	UC	IC	
* IC881	AAX37180	IC	FLASH HIGH	410 450 0503	GB	IC	
* IC881	AAX37190	IC	FLASH HIGH	410 450 0602	J	IC	
* IC881	AAX37200	IC	FLASH HIGH	410 450 0701	A	IC	
* IC881	AAX37240	IC	FLASH HIGH	410 450 1104	R	IC	
* IC881	AAX37250	IC	FLASH HIGH	410 450 1203	K	IC	
* IC881	AAX37260	IC	FLASH HIGH	410 450 1302	T	IC	
* Q8001	AAX38140	TR	KTA1504-Y	405 146 1704		トランジスター	

\* New Parts (新規部品)

Ref. No.	PART NO.	Description	Remarks	Markets	部品名	Rank
* Q8002	AAX38130	TR	2SD1757K-S	405 064 9202		トランジスター
* Q8003	AAX38190	TR	KRC107S	405 159 0503		トランジスター
* X8101	AAX38660	RSNR.CRYS	27.000MHz	645 045 8293		水晶振動子
	AAX37320	P.C.B.	DVD	614 315 7236		P C B D V D
* D1101-02	AAX37870	DIODE	DAP222	407 179 1805		ダイオード
* IC100	AAX36740	IC	LA9702WL-MPB	409 482 3903		I C
	XU834A00	IC	BU4066BC			アナログ S W I C
* IC200	AAX37020	IC	LC78661W-D	409 500 6404		I C
* IC201	AAX36870	IC	T22416B-35S	409 447 3702		I C
* IC500	AAX36970	IC	M37903S4CHP	409 498 8909		I C
* IC502	AAX36780	IC	M51953BFP	409 183 0102		I C
* IC504	AAX36910	IC	NC7SZU04P5	409 484 7503		I C
* IC601	AAX36930	IC	BA5937AFP	409 484 9101		I C
* IC602	AAX36810	IC	BA6849FP	409 405 6301		I C
* IC900	AAX36820	IC	BA033FP	409 416 6406		I C
* Q1002	AAX38150	TR	KTC3875-GR	405 146 2206		トランジスター
* Q1003	AAX38100	TR	2SC1623-L6	405 011 1006		トランジスター
* Q1004-05	AAX38180	TR	KTA1505-Y	405 158 5905		トランジスター
* Q1006	AAX38150	TR	KTC3875-GR	405 146 2206		トランジスター
* Q1007	AAX38160	TR	KTA1504-GR	405 146 9700		トランジスター
* Q1008-09	AAX38150	TR	KTC3875-GR	405 146 2206		トランジスター
* Q1010	AAX38160	TR	KTA1504-GR	405 146 9700		トランジスター
* Q1011	AAX38110	TR	2SC2412K-R	405 014 4509		トランジスター
* Q1012	AAX38170	TR	2SK3018	405 153 2008		トランジスター
* Q1013	AAX38120	TR	DTC144EK	405 029 3504		トランジスター
* Q1015-16	AAX38150	TR	KTC3875-GR	405 146 2206		トランジスター
* Q1017-18	AAX38170	TR	2SK3018	405 153 2008		トランジスター
* Q5020	AAX38150	TR	KTC3875-GR	405 146 2206		トランジスター
* X2000	AAX38630	RSNR.CRYS	16.9344MHz	645 020 9024		水晶振動子
* X5000	AAX37840	RSNR.CE	16.0MHz	645 045 6466		セラミック振動子

\* New Parts (新規部品)

Note) Those parts marked with “#” are not included in the P.C.B. ass'y. (マーク#の部品は、基板に含まれません)

Ref. No.	PART NO.	Description	Remarks	Markets	部品名	Rank
	RD353100	R. CAR. CHP 1	1/10W		チップ抵抗	01
	RD353220	R. CAR. CHP 2.2	1/10W		チップ抵抗	01
	RD353470	R. CAR. CHP 4.7	1/10W		チップ抵抗	01
	RD354100	R. CAR. CHP 10	1/10W		チップ抵抗	01
	RD354330	R. CAR. CHP 33	1/10W		チップ抵抗	01
	RD354470	R. CAR. CHP 47	1/10W		チップ抵抗	01
	RD354750	R. CAR. CHP 75	1/10W		チップ抵抗	01
	RD354820	R. CAR. CHP 82	1/10W		チップ抵抗	01
	RD355100	R. CAR. CHP 100	1/10W		チップ抵抗	01
	RD355180	R. CAR. CHP 180	1/16W		チップ抵抗	01
	RD355220	R. CAR. CHP 220	1/10W		チップ抵抗	01
	RD355270	R. CAR. CHP 270	1/10W		チップ抵抗	01
	RD355330	R. CAR. CHP 330	1/10W		チップ抵抗	01
	RD355360	R. CAR. CHP 360	1/10W		チップ抵抗	01
	RD355430	R. CAR. CHP 430	1/10W		チップ抵抗	01
	RD355470	R. CAR. CHP 470	1/10W		チップ抵抗	01
	RD355680	R. CAR. CHP 680	1/10W		チップ抵抗	01
	RD355820	R. CAR. CHP 820	1/10W		チップ抵抗	01
	RD355910	R. CAR. CHP 910	1/16W		チップ抵抗	01
	RD356100	R. CAR. CHP 1K	1/10W		チップ抵抗	01
	RD356120	R. CAR. CHP 1.2K	1/10W		チップ抵抗	01
	RD356130	R. CAR. CHP 1.3K	1/10W		チップ抵抗	01
	RD356150	R. CAR. CHP 1.5K	1/10W		チップ抵抗	01
	RD356180	R. CAR. CHP 1.8K	1/10W		チップ抵抗	01
	RD356220	R. CAR. CHP 2.2K	1/10W		チップ抵抗	01
	RD356270	R. CAR. CHP 2.7K	1/10W		チップ抵抗	01
	RD356300	R. CAR. CHP 3K	1/10W		チップ抵抗	01
	RD356330	R. CAR. CHP 3.3K	1/10W		チップ抵抗	01
	RD356390	R. CAR. CHP 3.9K	1/10W		チップ抵抗	01
	RD356430	R. CAR. CHP 4.3K	1/10W		チップ抵抗	01
	RD356470	R. CAR. CHP 4.7K	1/10W		チップ抵抗	01
	RD356510	R. CAR. CHP 5.1K	1/10W		チップ抵抗	01
	RD356560	R. CAR. CHP 5.6K	1/10W		チップ抵抗	01
	RD356680	R. CAR. CHP 6.8K	1/10W		チップ抵抗	01
	RD356820	R. CAR. CHP 8.2K	1/10W		チップ抵抗	01
	RD356910	R. CAR. CHP 9.1K	1/10W		チップ抵抗	01
	RD357100	R. CAR. CHP 10K	1/10W		チップ抵抗	01
	RD357120	R. CAR. CHP 12K	1/10W		チップ抵抗	01
	RD357150	R. CAR. CHP 15K	1/10W		チップ抵抗	01
	RD357180	R. CAR. CHP 18K	1/10W		チップ抵抗	01
	RD357200	R. CAR. CHP 20K	1/10W		チップ抵抗	01
	RD357220	R. CAR. CHP 22K	1/10W		チップ抵抗	01
	RD357240	R. CAR. CHP 24K	1/10W		チップ抵抗	01
	RD357300	R. CAR. CHP 30K	1/10W		チップ抵抗	01
	RD357330	R. CAR. CHP 33K	1/10W		チップ抵抗	01
	RD357360	R. CAR. CHP 36K	1/10W		チップ抵抗	01
	RD357390	R. CAR. CHP 39K	1/10W		チップ抵抗	01
	RD357470	R. CAR. CHP 47K	1/10W		チップ抵抗	01
	RD357560	R. CAR. CHP 56K	1/10W		チップ抵抗	01
	RD357680	R. CAR. CHP 68K	1/10W		チップ抵抗	01
	RD357910	R. CAR. CHP 91K	1/10W		チップ抵抗	01
	RD358100	R. CAR. CHP 100K	1/10W		チップ抵抗	01
	RD358220	R. CAR. CHP 220K	1/10W		チップ抵抗	01
	RD359100	R. CAR. CHP 1M	1/10W		チップ抵抗	01

\* New Parts (新規部品)



# MEMO

DVR-S60  
NX-SW60

## DVR-S60/NX-SW60

## 1 ■ DVR-S60 EXPLODED VIEW

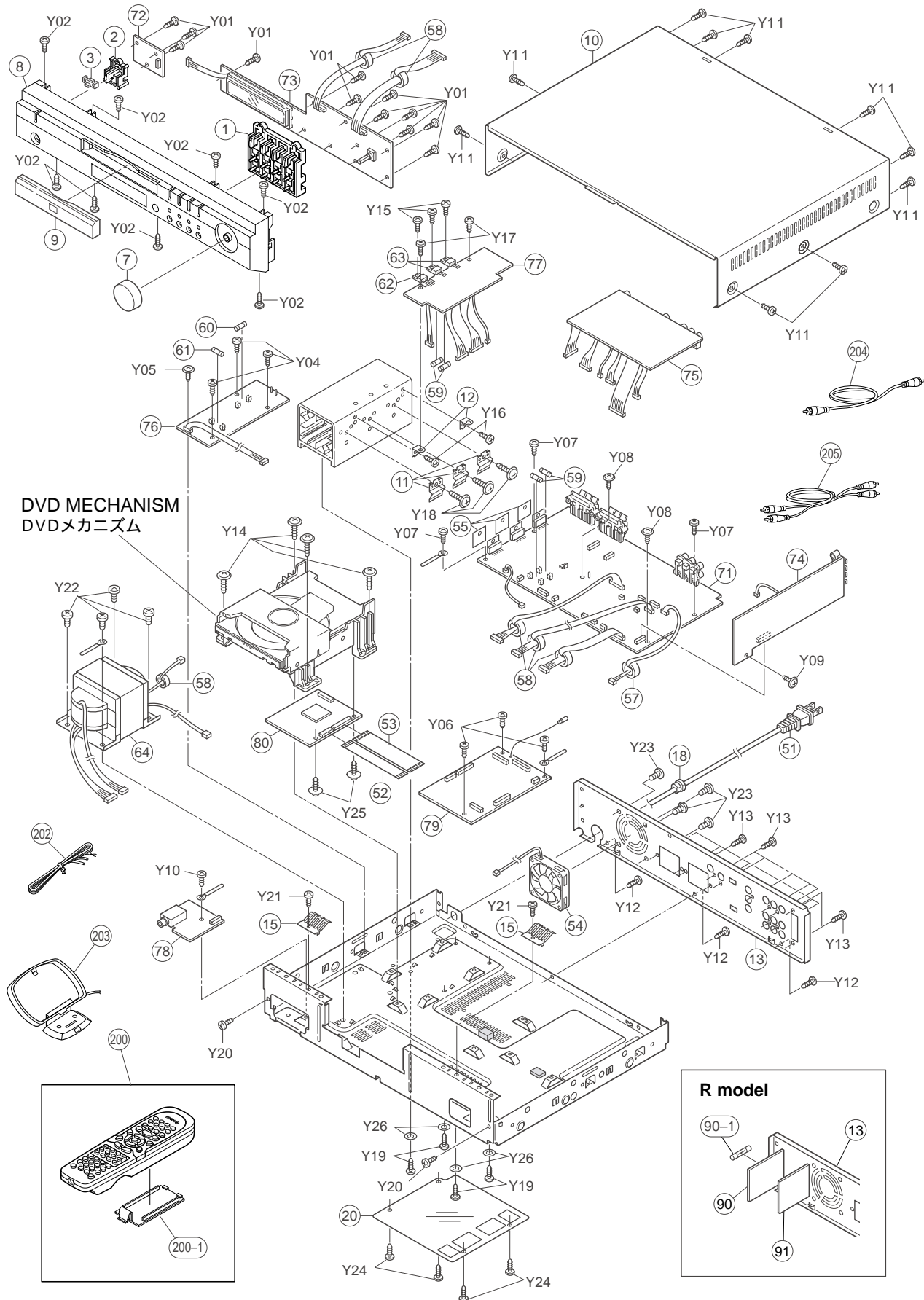

## ■ DVR-S60 MECHANICAL PARTS

Ref. No.	PART NO.	Description	Remarks	Markets	部品名	Rank
* 1	AAx39160	BUTTON FUNCTION	614 324 2970		ボタン / ファンクション	
* 2	AAx39150	BUTTON STANDBY	614 324 2987		ボタン / スタンバイ	
* 3	AAx39240	LIGHTING PIECE	614 324 3014		導光ピース	
* 7	AAx39050	KNOB VOLUME	614 324 3045		ノブ / ボリューム	
* 8	AAx38340	FRONT PANEL	614 324 7098		フロントパネル	
* 9	AAx38210	TRAY LID	614 324 3007		トレーリッド	
* 10	AAx37990	TOP COVER	614 316 1233		トップカバー	
* 11	AAx38420	MOUNTING, IC	614 316 1417		マウンティング、IC	
* 12	AAx38410	MOUNTING, DVD AC P.C.B.	614 316 1424		マウンティング、DVD	
* 13	AAx38520	REAR PANEL	614 324 4813	J	リアパネル	
* 13	AAx38490	REAR PANEL	614 324 4769	UC	リアパネル	
* 13	AAx38480	REAR PANEL	614 324 4752	R	リアパネル	
* 13	AAx38470	REAR PANEL	614 324 4745	T	リアパネル	
* 13	AAx38500	REAR PANEL	614 324 4776	K	リアパネル	
* 13	AAx38460	REAR PANEL	614 324 4738	A	リアパネル	
* 13	AAx38510	REAR PANEL	614 324 4790	GB	リアパネル	
* 15	AAx38980	EARTH PLATE	614 313 6545		アースプレート	
* 18	AAx39030	CORD STOPPER	614 129 1901		コードストッパー	
* 20	AAx39010	COVER	614 319 4804		カバー	
△ * 51	AAx38720	POWER CABLE	1.8m 645 056 7155	J	電源コード	
△ * 51	AAx38690	POWER CABLE	1.8m 645 032 7537	UC	電源コード	
△ * 51	AAx38670	POWER CABLE	1.8m 645 016 9939	RG	電源コード	
△ * 51	AAx38710	POWER CABLE	1.8m 645 038 7944	T	電源コード	
△ * 51	AAx38730	POWER CABLE	1.8m 645 047 8055	K	電源コード	
△ * 51	AAx38680	POWER CABLE	1.8m 645 032 1887	A	電源コード	
△ * 51	AAx38700	POWER CABLE	1.8m 645 036 9797	B	電源コード	
* 52	AAx39000	FLEXIBLE FLAT CABLE	16P 645 045 1546		カード電線 C & C	
* 53	AAx38990	FLEXIBLE FLAT CABLE	26P 645 045 1515		カード電線 C & C	
* 54	AAx36750	DC FAN MOTOR	645 049 8206		DCファンモーター	
* 55	AAx39180	SHEET	614 320 5531		絶縁シート	
* 57	AAx39120	FERRITE CORE	645 031 7637		フェライトコア	
* 58	AAx39130	FERRITE CORE	645 051 0656		フェライトコア	
△ * 59	AAx39080	FUSE	2A 250V F4101-04 423 029 3904	UC	ヒューズ	
△ * 60	AAx39110	FUSE	4A 250V F4131 423 030 1807	J	ヒューズ	
△ * 60	AAx39100	FUSE	5A 250V F4131 423 029 4109	UC	ヒューズ	
△ * 60	AAx39070	FUSE	3.15A 250V F4131 423 028 8504	R	ヒューズ	
△ * 60	AAx39060	FUSE	1.6A 250V F4131 423 028 8405	TKAGB	ヒューズ	
△ * 61	AAx39090	FUSE	0.315A 250V F4132 423 029 4000	UC	ヒューズ	
△ * 62	AAx36980	IC	K1A78R05P1 409 499 1503		IC	
△ * 63	AAx38090	TRANSISTOR	KTC2026-Y 405 158 2102		トランジスター	
△ * 64	AAx38770	POWER TRANSFORMER	645 047 7805	J	電源トランス	
△ * 64	AAx38740	POWER TRANSFORMER	645 045 2376	UC	電源トランス	
△ * 64	AAx38780	POWER TRANSFORMER	645 047 7829	R	電源トランス	
△ * 64	AAx38760	POWER TRANSFORMER	645 047 7782	T	電源トランス	
△ * 64	AAx38800	POWER TRANSFORMER	645 048 2229	K	電源トランス	
△ * 64	AAx38790	POWER TRANSFORMER	645 047 7843	A	電源トランス	
△ * 64	AAx38760	POWER TRANSFORMER	645 047 7782	GB	電源トランス	
* 71	AAx37650	P.C.B. ASS'Y	MAIN 614 324 5926	J	P C B メイン	
* 71	AAx37630	P.C.B. ASS'Y	MAIN 614 324 4257	UC	P C B メイン	
* 71	AAx37670	P.C.B. ASS'Y	MAIN 614 324 5940	RK	P C B メイン	
* 71	AAx37660	P.C.B. ASS'Y	MAIN 614 324 5933	TA	P C B メイン	
* 71	AAx37640	P.C.B. ASS'Y	MAIN 614 324 5919	GB	P C B メイン	
* 72	AAx37360	P.C.B. ASS'Y	LED/SWITCH 614 324 4264		P C B LED / スイッチ	

\* New Parts (新規部品)

**Note)** Those parts marked with “#” are not included in the P.C.B. ass'y. (マーク#の部品は、基板に含まれません)

Ref. No.	PART NO.	Description	Remarks	Markets	部品名	Rank	
* 73	AAX37600	P.C.B. ASS'Y	FRONT	614 324 5445	JUCARKT	P C B フロント	
* 73	AAX37590	P.C.B. ASS'Y	FRONT	614 324 4189	GB	P C B フロント	
* 74	AAX37530	P.C.B. ASS'Y	TUNER	614 324 5957	J	P C B チューナー	
* 74	AAX37520	P.C.B. ASS'Y	TUNER	614 324 5452	UC	P C B チューナー	
* 74	AAX37540	P.C.B. ASS'Y	TUNER	614 324 5988	ARKT	P C B チューナー	
* 74	AAX37510	P.C.B. ASS'Y	TUNER	614 324 4196	GB	P C B チューナー	
* 75	AAX37570	P.C.B. ASS'Y	VIDEO	614 324 5964	J	P C B ビデオ	
* 75	AAX37560	P.C.B. ASS'Y	VIDEO	614 324 5469	UCK	P C B ビデオ	
* 75	AAX37580	P.C.B. ASS'Y	VIDEO	614 324 5995	ART	P C B ビデオ	
* 75	AAX37550	P.C.B. ASS'Y	VIDEO	614 324 4202	GB	P C B ビデオ	
* 76	AAX37490	P.C.B. ASS'Y	STANDBY POWER	614 324 5872	J	P C B スタンバイパワー	
* 76	AAX37480	P.C.B. ASS'Y	STANDBY POWER	614 324 5865	UC	P C B スタンバイパワー	
* 76	AAX37450	P.C.B. ASS'Y	STANDBY POWER	614 319 8284	R	P C B スタンバイパワー	
* 76	AAX37500	P.C.B. ASS'Y	STANDBY POWER	614 324 5889	T	P C B スタンバイパワー	
* 76	AAX37440	P.C.B. ASS'Y	STANDBY POWER	614 319 8277	K	P C B スタンバイパワー	
* 76	AAX37460	P.C.B. ASS'Y	STANDBY POWER	614 319 8291	A	P C B スタンバイパワー	
* 76	AAX37470	P.C.B. ASS'Y	STANDBY POWER	614 324 4219	GB	P C B スタンバイパワー	
* 77	AAX37350	P.C.B. ASS'Y	DVD POWER	614 324 5971	JARKT	P C B DVDパワー	
* 77	AAX37340	P.C.B. ASS'Y	DVD POWER	614 324 5476	UC	P C B DVDパワー	
* 77	AAX37330	P.C.B. ASS'Y	DVD POWER	614 324 4226	GB	P C B DVDパワー	
* 78	AAX37620	P.C.B. ASS'Y	HEADPHONE	614 324 5483	JUCARKT	P C B ヘッドホン	
* 78	AAX37610	P.C.B. ASS'Y	HEADPHONE	614 324 4233	GB	P C B ヘッドホン	
* 79	AAX37420	P.C.B. ASS'Y	MPEG	614 324 6428	J	P C B MPEG	
* 79	AAX37370	P.C.B. ASS'Y	MPEG	614 324 4172	UC	P C B MPEG	
* 79	AAX37390	P.C.B. ASS'Y	MPEG	614 324 6305	R	P C B MPEG	
* 79	AAX37410	P.C.B. ASS'Y	MPEG	614 324 6329	T	P C B MPEG	
* 79	AAX37400	P.C.B. ASS'Y	MPEG	614 324 6312	K	P C B MPEG	
* 79	AAX37430	P.C.B. ASS'Y	MPEG	614 324 6435	A	P C B MPEG	
* 79	AAX37380	P.C.B. ASS'Y	MPEG	614 324 6299	GB	P C B MPEG	
* 80	AAX37320	P.C.B. ASS'Y	DVD	614 315 7236		P C B DVD	
90	AAX37700	P.C.B. ASS'Y	VOLTAGE SELECTOR M	614 324 5896	R	P C B 電圧切替メイン	
△ 90-1	AAX39060	FUSE	1.6A 250V F4100	423 028 8405	R	ヒューズ	
91	AAX37690	P.C.B. ASS'Y	VOLTAGE SELECTOR S	614 324 5902	R	P C B 電圧切替サブ	
* Y01	AAX38280	BIND HEAD S-TITE SCREW	2.3x10 MFZN2	411 165 3803		バインドSタイトネジ	***
Y02	EP600250	BIND HEAD B-TITE SCREW	3x8 MFZN2Y			バインドBタイトネジ	01
Y04	EP600250	BIND HEAD B-TITE SCREW	3x8 MFZN2Y			バインドBタイトネジ	01
Y05	VT669300	PW HEAD B-TITE SCREW	3x8-8 MFC2			PWヘッドBタイトネジ	
Y06	EP600250	BIND HEAD B-TITE SCREW	3x8 MFZN2Y			バインドBタイトネジ	01
Y07	EP600250	BIND HEAD B-TITE SCREW	3x8 MFZN2Y			バインドBタイトネジ	01
Y08	VT669300	PW HEAD B-TITE SCREW	3x8-8 MFC2			PWヘッドBタイトネジ	
Y09	VT669300	PW HEAD B-TITE SCREW	3x8-8 MFC2			PWヘッドBタイトネジ	
Y10	EP600250	BIND HEAD B-TITE SCREW	3x8 MFZN2Y			バインドBタイトネジ	01
* Y11	AAX38270	BIND HEAD B-TITE SCREW	3x8 MFCR33	411 021 6603		バインドBタイトネジ	01
Y12	EP630280	BIND HEAD B-TITE SCREW	3x10 MFC2BL			バインドBタイトネジ	01
Y13	EP630280	BIND HEAD B-TITE SCREW	3x10 MFC2BL			バインドBタイトネジ	01
* Y14	VG473200	PW HEAD B-TITE SCREW	3x10-8 MFC2BL			PWヘッドBタイトネジ	01
Y15	EP600250	BIND HEAD B-TITE SCREW	3x8 MFZN2Y			バインドBタイトネジ	01
Y16	EP600250	BIND HEAD B-TITE SCREW	3x8 MFZN2Y			バインドBタイトネジ	01
Y17	EP600250	BIND HEAD B-TITE SCREW	3x8 MFZN2Y			バインドBタイトネジ	01
* Y18	AAX38810	SPECIAL SCREW		412 005 2307		特殊ネジ	01
Y19	EP600250	BIND HEAD B-TITE SCREW	3x8 MFZN2Y			バインドBタイトネジ	01
Y20	EP600250	BIND HEAD B-TITE SCREW	3x8 MFZN2Y			バインドBタイトネジ	01
Y21	EP600250	BIND HEAD B-TITE SCREW	3x8 MFZN2Y			バインドBタイトネジ	01

\* New Parts (新規部品)

Note) Those parts marked with “#” are not included in the P.C.B. ass'y. (マーク#の部品は、基板に含まれません)

Ref. No.	PART NO.	Description	Remarks	Markets	部品名	Rank
Y22	EP640100	BIND HEAD S-TITE SCREW	4x6 MFZN2BL		バインドSタイトネジ	01
* Y23	VV945500	TAPPING SCREW#1	5x16 MFZN2BL		バインドTPネジ	
Y24	EP600130	BIND HEAD B-TITE SCREW	3x6 MFZN2Y		バインドBタイトネジ	01
Y25	VT669300	PW HEAD B-TITE SCREW	3x8-8 MFC2		PWヘッドBタイトネジ	
* Y26	AAx38600	WASHER	TW3 MFZN2Y	411 008 0402	ワッシャー	
		ACCESSORIES				
* 200	V9844100	REMOTE CONTROL			J リモコン	
* 200	V9470500	REMOTE CONTROL		UCRTKA	リモコン	
* 200	V9470600	REMOTE CONTROL		GB	リモコン	
* 200-1	AAx40740	BATTERY COVER		645 056 3170	電池蓋	
202	V6267000	INDOOR FM ANTENNA	1.4m 1pc		F M簡易アンテナ	
202	VQ147100	INDOOR FM ANTENNA	1.4m 1pc		F M簡易アンテナ	02
203	VR248500	AM LOOP ANTENNA	1.0m 1pc		A Mループアンテナ	
204	V6508900	VIDEO PIN CABLE	1P 1.5m YE-YE 1pc		ビデオ用ピンケーブル	03
205	V6509000	AUDIO PIN CABLE	2P 1.5m RE-WH 1pc		ステレオピンケーブル	
		BATTERY	UM-3,R06		乾電池	

\* New Parts (新規部品)

**Note)** Those parts marked with “#” are not included in the P.C.B. ass'y. (マーク#の部品は、基板に含まれません)

## DVR-S60/NX-SW60

# 1 ■ EXPLODED VIEW (DVD Mechanism)

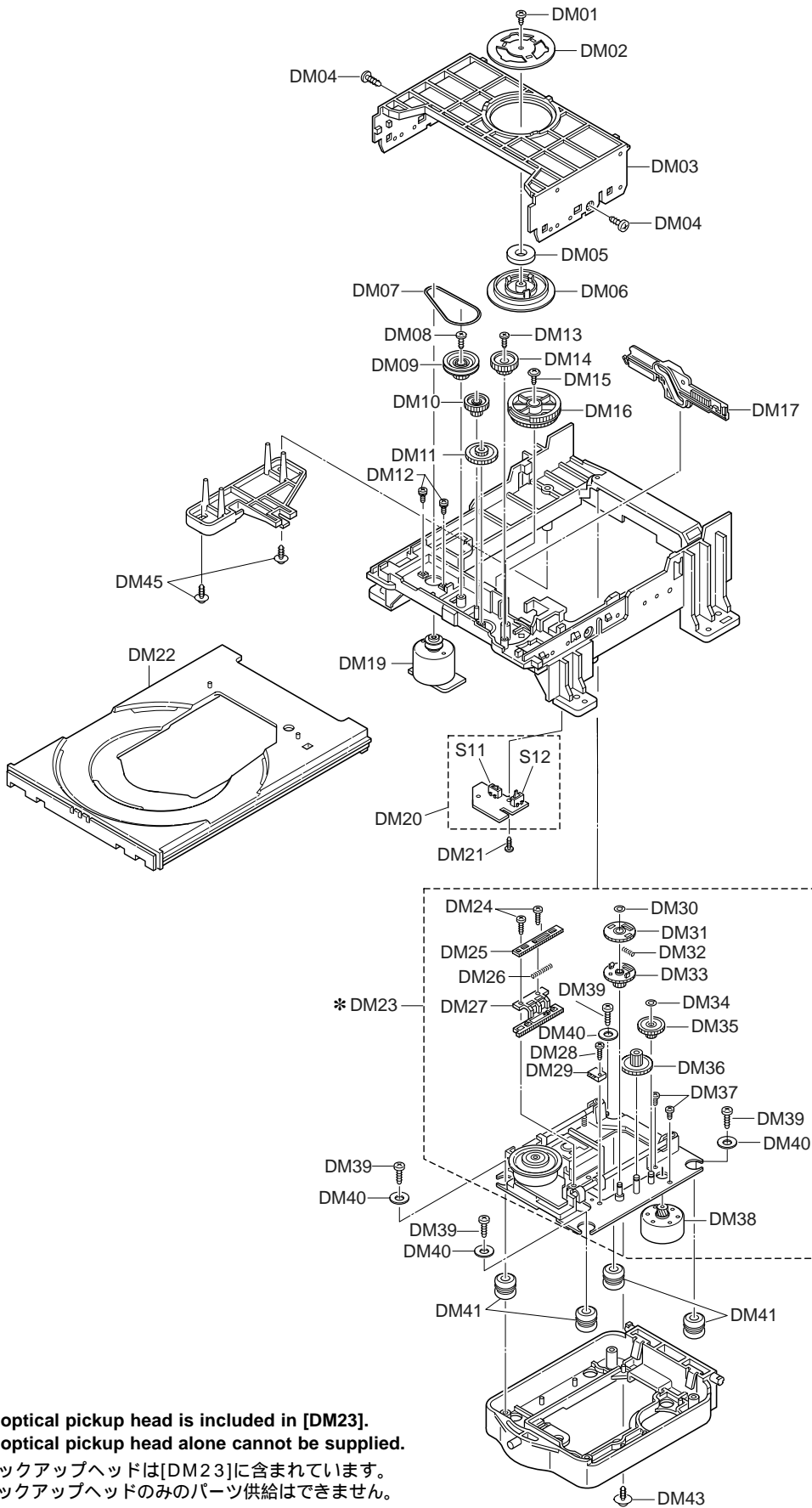

\* : The optical pickup head is included in [DM23].  
The optical pickup head alone cannot be supplied.

光ピックアップヘッドは[DM23]に含まれています。  
光ピックアップヘッドのみのパーツ供給はできません。

## MECHANICAL PARTS (DVD Mechanism)

Ref. No.	PART NO.	Description	Remarks	Markets	部品名	Rank
*	AAX36770	DVD MECHANISM ASS'Y	KIT510		D V D メカニズム A S S Y	
* DM01	AAX38220	PAN HEAD S-TITE SCREW	2x3 MFZN2BL	614 316 6115	ナベ S タイトネジ	01
* DM02	AAX37980	DISC CHUCK		614 315 7830	ディスクチャック	
* DM03	AAX37940	CHUCK MOUNTING		614 255 2605	チャックマウンティング	
* DM04	VC298900	BIND HEAD B-TITE SCREW	2.6x6 +/- MFC2BL		バインド B タイトネジ	01
* DM05	AAX38430	MAGNET CHUCK		645 043 7175	マグネットチャック	
* DM06	AAX37930	CHUCK HOLDER		614 315 7847	チャックホルダー	
* DM07	AAX38580	BELT, LOADING		614 300 8293	ローディングベルト	
* DM08	VC298900	BIND HEAD B-TITE SCREW	2.6x6 +/- MFC2BL		バインド B タイトネジ	01
* DM09	AAX38350	LOADING RELAY PULLEY		614 237 7161	プーリー / ローディング	
* DM10	AAX37310	LOADING RETARD GEAR 1		614 237 7048	L リタードギアー 1	
* DM11	AAX37300	LOADING RETARD GEAR		614 300 5124	L リタードギアー	
* DM12	AAX38260	PAN HEAD SCREW	2x5 WASHER MFZN2Y	411 044 7502	ナベ小ネジ	01
* DM13	AAX38820	SPECIAL SCREW		412 047 3904	特殊ネジ	
* DM14	AAX38570	LOADING GEAR		614 237 7079	ローディングギアー	
DM15	VT669300	PW HEAD B-TITE SCREW	3x8-8 MFC2		P W ヘッド B タイトネジ	
* DM16	AAX38560	LOADING CAM GEAR		614 300 5131	ローディングカムギアー	
* DM17	AAX37820	SLIDE BASE UP/DOWN		614 237 7208	スライドベース	
* DM19	AAX38590	LOADING MOTOR ASS'Y		645 032 4352	ローディングモーター	
* DM20	AAX37680	P.C.B. ASS'Y	MECHA-SW	614 310 6869	P C B メカスイッチ	
* DM20-S11	AAX38530	LEVER SWITCH	for CHUCK END	645 032 2044	レバースイッチ	
* DM20-S12	AAX38540	LEVER SWITCH	for TRAY OPEN	645 032 2051	レバースイッチ	
* DM21	EG320080	BIND HEAD SCREW	2x8 MFZN2Y		バインド小ネジ	01
* DM22	AAX38200	TRAY		614 310 2175	トレイ	
* DM23	AAX38380	BASE MACHANISM ASS'Y	KIT500	614 315 8646	ベースメカニズム A S S Y	
* DM24	AAX38230	PAN HEAD S-TITE SCREW	1.7x4.5 MFZN2Y	411 184 0302	ナベ S タイトネジ	01
* DM25	AAX38440	RACK GEAR, FREE		614 310 2083	ラックギアー、フリー	
* DM26	AAX37780	COMP SPRING, RACK		614 310 6159	コンプバネ、ラック	
* DM27	AAX38450	RACK GEAR, FIX		614 310 2076	ラックギアー、固定	
* DM28	AAX38240	PAN HEAD SCREW	1.7x5 MFZN2Y	411 018 4704	ナベ子ネジ	01
* DM29	AAX38400	MICRO SWITCH		645 040 9899	マイクロスイッチ	
* DM30	AAX38830	SPECIAL WASHER		412 057 8304	特殊座金	
* DM31	AAX37750	GEAR-5		614 310 2069	ギアー 5	
* DM32	AAX37770	COMP SPRING		614 310 6142	コンプバネ	
* DM33	AAX37740	GEAR-4		614 310 2052	ギアー 4	
* DM34	AAX38830	SPECIAL WASHER		412 057 8304	特殊座金	
* DM35	AAX37720	GEAR-2		614 310 2038	ギアー 2	
* DM36	AAX37730	GEAR-3		614 310 2045	ギアー 3	
* DM37	AAX38250	PAN HEAD SCREW	1.7x2.5 MFZN2Y	411 106 7709	ナベ子ネジ	01
* DM38	AAX37830	SLED MOTOR ASS'Y		645 041 0109	スレッドモーター A S S Y	
* DM39	VD791000	BIND HEAD B-TITE SCREW	2.6x10 MFZN2Y		バインド B タイトネジ	
* DM40	AAX38620	WASHER		411 092 0906	座金	
* DM41	AAX37790	SPACER, MECHA BASE		614 310 6128	スペーサー、メカベース	
DM43	VE529700	PW HEAD B-TITE SCREW	3x6-8 MFC2BL		P W ヘッド B タイトネジ	01
DM45	VT669300	PW HEAD B-TITE SCREW	3x8-8 MFC2		P W ヘッド B タイトネジ	

\* New Parts (新規部品)

**Note)** Those parts marked with “#” are not included in the P.C.B. ass'y. (マーク#の部品は、基板に含まれません)

DVR-S60/NX-SW60

■ NX-SW60 EXPLODED VIEW

1

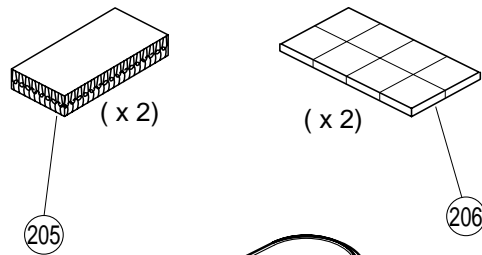
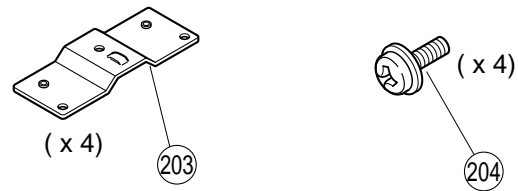
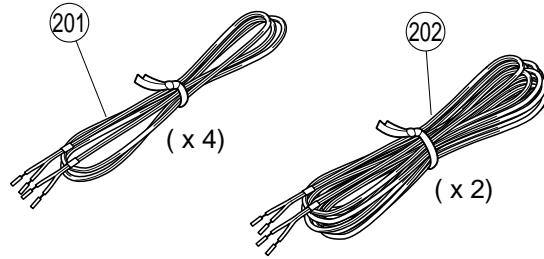
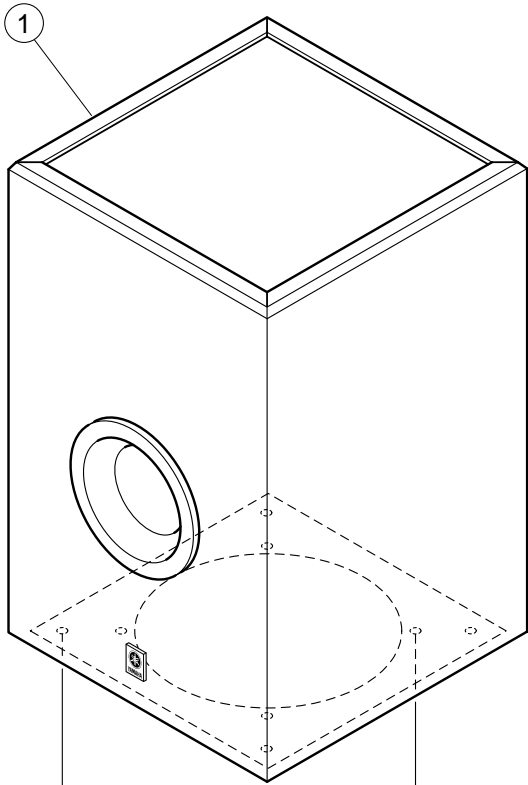

2

3

4

5

6

7

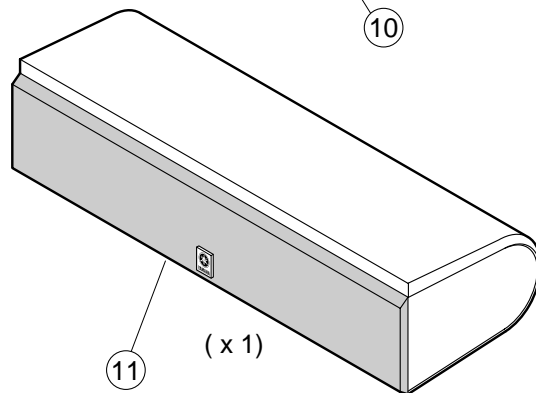
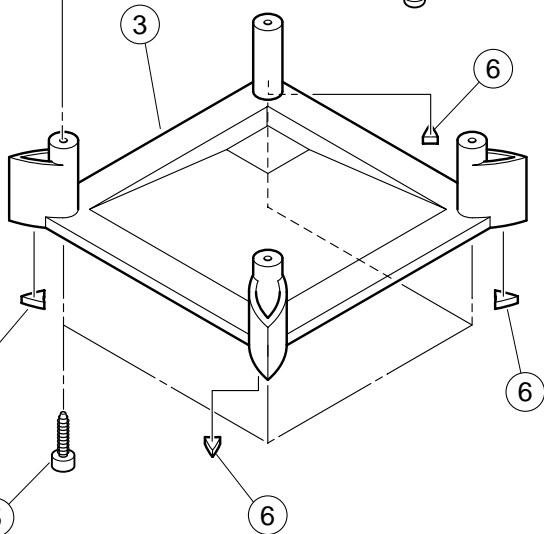
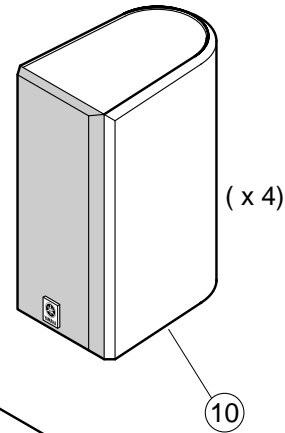
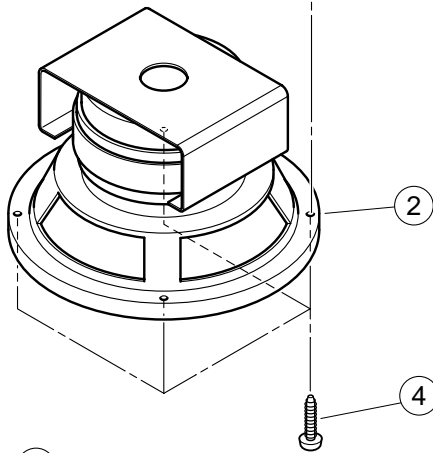



## ■ NX-SW60 MECHANICAL PARTS

Ref. No.	PART NO.	Description	Remarks	Markets	部品名	Rank
* 1	AAx38840	CABINET ASS'Y			キャビネット A S S Y	
* 2	AAx38920	DRIVER, WOOFER	16cm		スピーカーユニット	
* 3	AAx38960	REFLECTOR	A		リフレクター	
4	EP040250	BIND HEAD TAPPING SCREW	4x16 MFZN2BL		バインド T P ネジ	01
5	V5537800	HEXAGON SOCKET TAPPING SCREW	4x20 MFZN2BL		六角穴付 T P	
* 6	AAx38970	FOOT		367060	脚	
* 10	AAx38850	SATELLITE SPEAKER UNIT	NX-S60S SI 1pc	366987	サテライト S P ユニット	
* 11	AAx38930	CENTER SPEAKER UNIT	NX-S60C SI 1pc	366986	センター S P ユニット	
		ACCESSORIES			付属品	
* 201	AAx38860	SPEAKER CABLE	5m FRONT R 1pc	367401	スピーカーケーブル	
* 201	AAx38870	SPEAKER CABLE	5m FRONT L 1pc	367402	スピーカーケーブル	
* 201	AAx38900	SPEAKER CABLE	5m CENTER 1pc	367405	スピーカーケーブル	
* 201	AAx38910	SPEAKER CABLE	5m SUBWOOFER 1pc	367406	スピーカーケーブル	
* 202	AAx38880	SPEAKER CABLE	15m REAR R 1pc	367403	スピーカーケーブル	
* 202	AAx38890	SPEAKER CABLE	15m REAR L 1pc	367404	スピーカーケーブル	
203	AAx34790	BRACKET B	1pc	363894	ブラケット B	
204	AAx12390	PAN HEAD SCREW-SEMS	M4x8 P=0.7	017957	セムスナベ小ネジ	
205	AAx19960	FASTENER	30x25.5x3.5 1pc	042466	固定テープ	
206	AAx20410	NON SKID PAD	7x7x1 8pcs/set	333656	滑止パッド	

\* New Parts (新規部品)

**Note)** Those parts marked with “#” are not included in the P.C.B. ass'y. (マーク#の部品は、基板に含まれません)

# REMOTE CONTROL

## ■ SCHEMATIC DIAGRAM

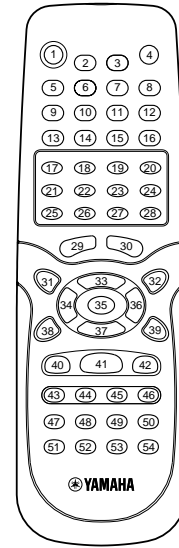
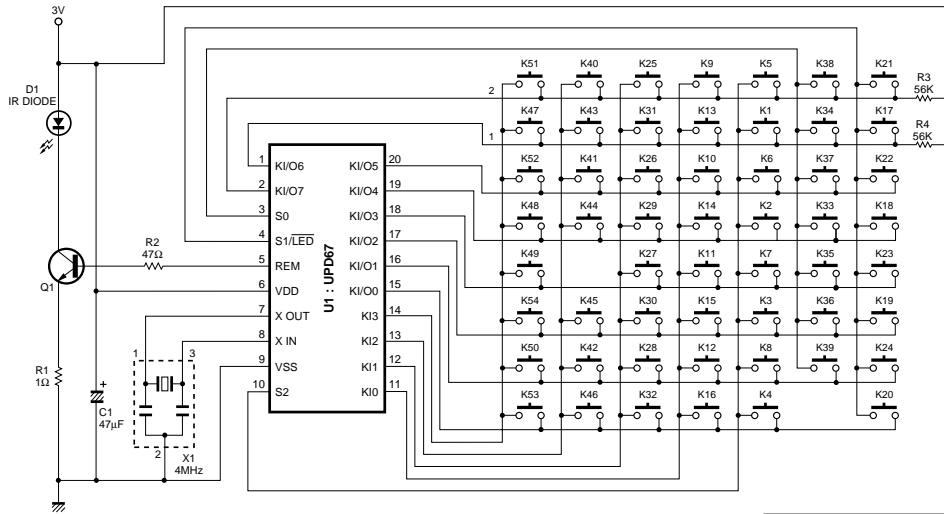

	R3	R4
U, C, R, A, T, K	○	×
G, B	×	×
J	○	×

### ▼ U, C, R, A, T, K models

### ▼ B, G models

### ▼ J model

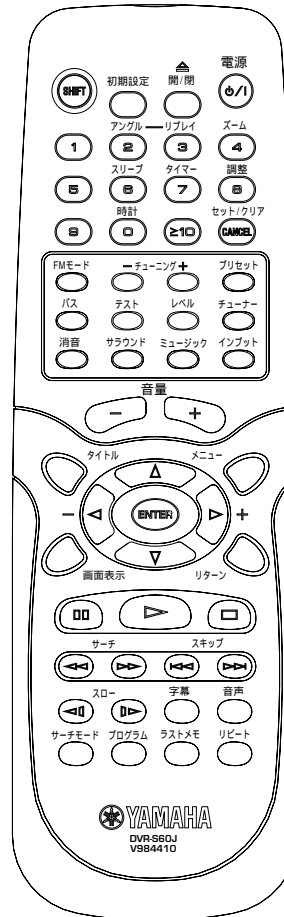
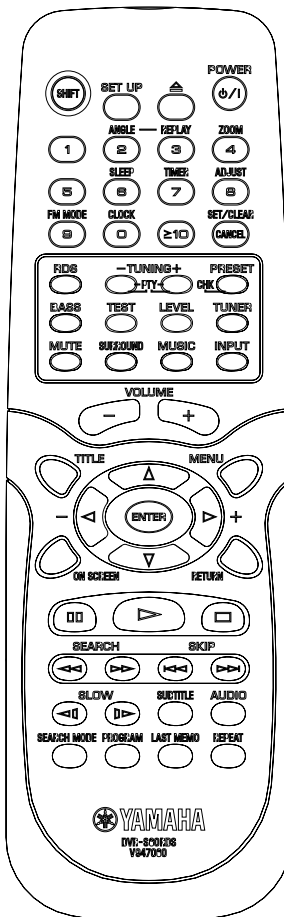
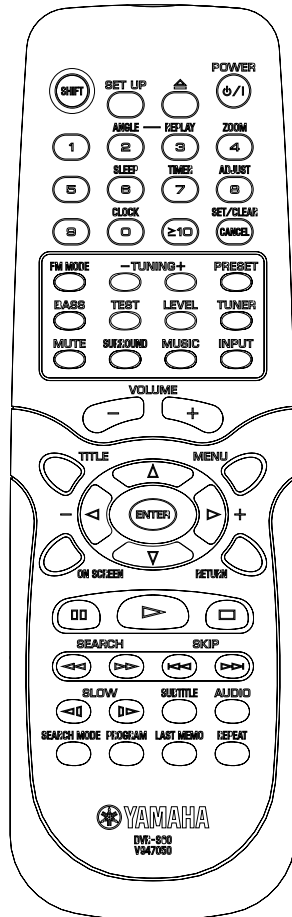

Key No.	Key Name	Format	Custom Code (Hex)	Data Code (Hex)
1	SHIFT	NEC-N	-	-
2	SET UP	NEC-N	7C	AC
3	OPEN/CLOSE	NEC-N	7C	81
4	POWER	NEC-N	78	0F
5	No.1	NEC-N	7C	94
6	No.2	NEC-N	7C	95
7	No.3	NEC-N	7C	96
8	No.4	NEC-N	7C	97
9	No.5	NEC-N	7C	98
10	No.6	NEC-N	7C	99
11	No.7	NEC-N	7C	9A
12	No.8	NEC-N	7C	9B
13	No.9	NEC-N	7C	9C
14	No.0	NEC-N	7C	93
15	+10	NEC-N	7C	9D
16	CANCEL	NEC-N	78	9F
17	FM MODE	NEC-N	78	A8
	RDS	NEC-N	78	81
18	TUNING -	NEC-N	78	A9
19	TUNING +	NEC-N	78	AA
20	PRESET	NEC-N	78	1B
21	BASS	NEC-N	78	8B
22	TEST	NEC-N	78	5F
23	LEVEL	NEC-N	78	48
24	TUNER	NEC-N	78	4B
25	MUTE	NEC-N	78	9C
26	SURROUND	NEC-N	78	51
27	MUSIC	NEC-N	78	5A
28	INPUT	NEC-N	78	5E
29	VOLUME -	NEC-N	78	1F
30	VOLUME +	NEC-N	78	1E
31	TITLE	NEC-N	7C	B1
32	MENU	NEC-N	7C	B2
33	UP	NEC-N	7C	B4
34	LEFT	NEC-N	7C	B5
35	ENTER	NEC-N	7C	B8
36	RIGHT	NEC-N	7C	B6
37	DOWN	NEC-N	7C	B3
38	ON SCREEN	NEC-N	7C	A6
39	RETURN	NEC-N	7C	B7
40	PAUSE/STOP	NEC-N	7C	83
41	PLAY	NEC-N	7C	82
42	STOP	NEC-N	7C	85
43	SEARCH -	NEC-N	7C	86
44	SEARCH +	NEC-N	7C	87
45	SKIP -	NEC-N	7C	B9
46	SKIP +	NEC-N	7C	BA
47	REV SLOW	NEC-N	7C	8E
48	FWD SLOW	NEC-N	7C	8F
49	SUB TITLE	NEC-N	7C	AA
50	AUDIO	NEC-N	7C	AD
51	SEARCH MODE	NEC-N	7C	9E
52	PROGRAM	NEC-N	7C	A0
53	LAST MEMO	NEC-N	7C	D8
54	REPEAT	NEC-N	7C	A3

Shift +	Key Name	Format	Custom Code (Hex)	Data Code (Hex)
6	ANGLE	NEC-N	7C	AE
7	A. REPLAY	NEC-N	7C	D6
8	ZOOM	NEC-N	7C	D7
10	SLEEP	NEC-N	78	4F
11	TIMER	NEC-N	78	A0
12	ADJUST	NEC-N	78	A1
13	FM MODE	NEC-N	78	A8
14	CLOCK	NEC-N	78	4E
16	SET/CLEAR	NEC-N	78	A2

B, G only

B, G only

# Parts List for Carbon Resistors

Value	1/4W Type Part No.	1/6W Type Part No.	Value	1/4W Type Part No.	1/6W Type Part No.
1.0 Ω	HJ35 3100	HF85 3100	10 kΩ	HF45 7100	HF45 7100
1.8 Ω	HJ35 3180	*	11 kΩ	HF45 7110	HF45 7110
2.2 Ω	HJ35 3220	HF85 3220	12 kΩ	HJ35 7120	HF85 7120
3.3 Ω	HJ35 3330	HF85 3330	13 kΩ	HF45 7130	HF45 7130
4.7 Ω	HJ35 3470	HF85 3470	15 kΩ	HF45 7150	HF45 7150
5.6 Ω	HJ35 3560	HF85 3560	18 kΩ	HF45 7180	HF45 7180
10 Ω	HF45 4100	HF45 4100	22 kΩ	HF45 7220	HF45 7220
15 Ω	HJ35 4150	HF85 4150	24 kΩ	HF45 7240	HF45 7240
22 Ω	HF45 4220	HF45 4220	27 kΩ	HJ35 7270	HF85 7270
27 Ω	HJ35 4270	HF85 4270	30 kΩ	HF45 7300	HF45 7300
33 Ω	HF45 4330	HF45 4330	33 kΩ	HF45 7330	HF45 7330
39 Ω	HJ35 4470	HF85 4390	36 kΩ	HF45 7360	HF45 7360
47 Ω	HF45 4470	HF45 4470	39 kΩ	HF45 7390	HF45 7390
56 Ω	HF45 4560	HF45 4560	47 kΩ	HF45 7470	HF45 7470
68 Ω	HF45 4680	HF45 4680	51 kΩ	HF45 7510	HF45 7510
75 Ω	HF45 4750	HF45 4750	56 kΩ	HF45 7560	HF45 7560
82 Ω	HF45 4820	HF45 4820	62 kΩ	HF45 7620	HF45 7620
91 Ω	HF45 4910	HF45 4910	68 kΩ	HF45 7680	HF45 7680
100 Ω	HF45 5100	HF45 5100	82 kΩ	HF45 7820	HF45 7820
110 Ω	HJ35 5110	HF85 5110	91 kΩ	HF45 7910	HF45 7910
120 Ω	HF45 5120	HF45 5120	100 kΩ	HF45 8100	HF45 8100
150 Ω	HF45 5150	HF45 5150	110 kΩ	HF45 8110	HF45 8110
160 Ω	HJ35 5160	*	120 kΩ	HF45 8120	HF45 8120
180 Ω	HF45 5180	HF45 5180	150 kΩ	HF45 8150	HF45 8150
200 Ω	HF45 5200	HF45 5200	180 kΩ	HF45 8180	HF45 8180
220 Ω	HF45 5220	HF45 5220	220 kΩ	HJ35 8220	HF85 8220
270 Ω	HF45 5270	HF45 5270	270 kΩ	HF45 8270	HF45 8270
330 Ω	HF45 5330	HF45 5330	300 kΩ	HF45 8300	HF45 8300
390 Ω	HF45 5390	HF45 5390	330 kΩ	HF45 8330	HF45 8330
430 Ω	HF45 5430	HF45 5430	390 kΩ	HJ35 8390	HF85 8390
470 Ω	HF45 5470	HF45 5470	470 kΩ	HF45 8470	HF45 8470
510 Ω	HF45 5510	HF45 5510	560 kΩ	HJ35 8560	HF85 8560
560 Ω	HF45 5560	HF45 5560	680 kΩ	HJ35 8680	HF85 8680
680 Ω	HF45 5680	HF45 5680	820 kΩ	HJ35 8820	HF85 8820
820 Ω	HF45 5820	HF45 5820	1.0 MΩ	HF45 9100	HF45 9100
910 Ω	HF45 5910	HF45 5910	1.2 MΩ	HJ35 9120	*
1.0 kΩ	HF45 6100	HF45 6100	1.5 MΩ	HJ35 9150	HF85 9150
1.2 kΩ	HF45 6120	HF45 6120	1.8 MΩ	HJ35 9180	HF85 9180
1.5 kΩ	HF45 6150	HF45 6150	2.2 MΩ	HJ35 9220	HF85 9220
1.8 kΩ	HF45 6180	HF45 6180	3.3 MΩ	HJ35 9330	HF85 9330
2.0 kΩ	HJ35 6200	HF85 6200	3.9 MΩ	HJ35 9390	*
2.2 kΩ	HF45 6220	HF45 6220	4.7 MΩ	HJ35 9470	HF85 9470
2.4 kΩ	HJ35 6240	HF85 6240			
2.7 kΩ	HF45 6270	HF45 6270			
3.0 kΩ	HF45 6300	HF45 6300			
3.3 kΩ	HF45 6330	HF45 6330			
3.6 kΩ	HJ35 6360	HF85 6360			
3.9 kΩ	HF45 6390	HF45 6390			
4.7 kΩ	HF45 6470	HF45 6470			
5.1 kΩ	HF45 6510	HF45 6510			
5.6 kΩ	HF45 6560	HF45 6560			
6.8 kΩ	HF45 6680	HF45 6680			
8.2 kΩ	HF45 6820	HF45 6820			
9.1 kΩ	HF45 6910	HF45 6910			

**1/4W Type**

HJ35 ○○○○

← 10mm →

**1/4W Type**

HF45 ○○○○

← 5mm →

**1/6W Type**

HF85 ○○○○

← 5mm →