

STEREO TURNTABLE

P-751

SERVICE MANUAL

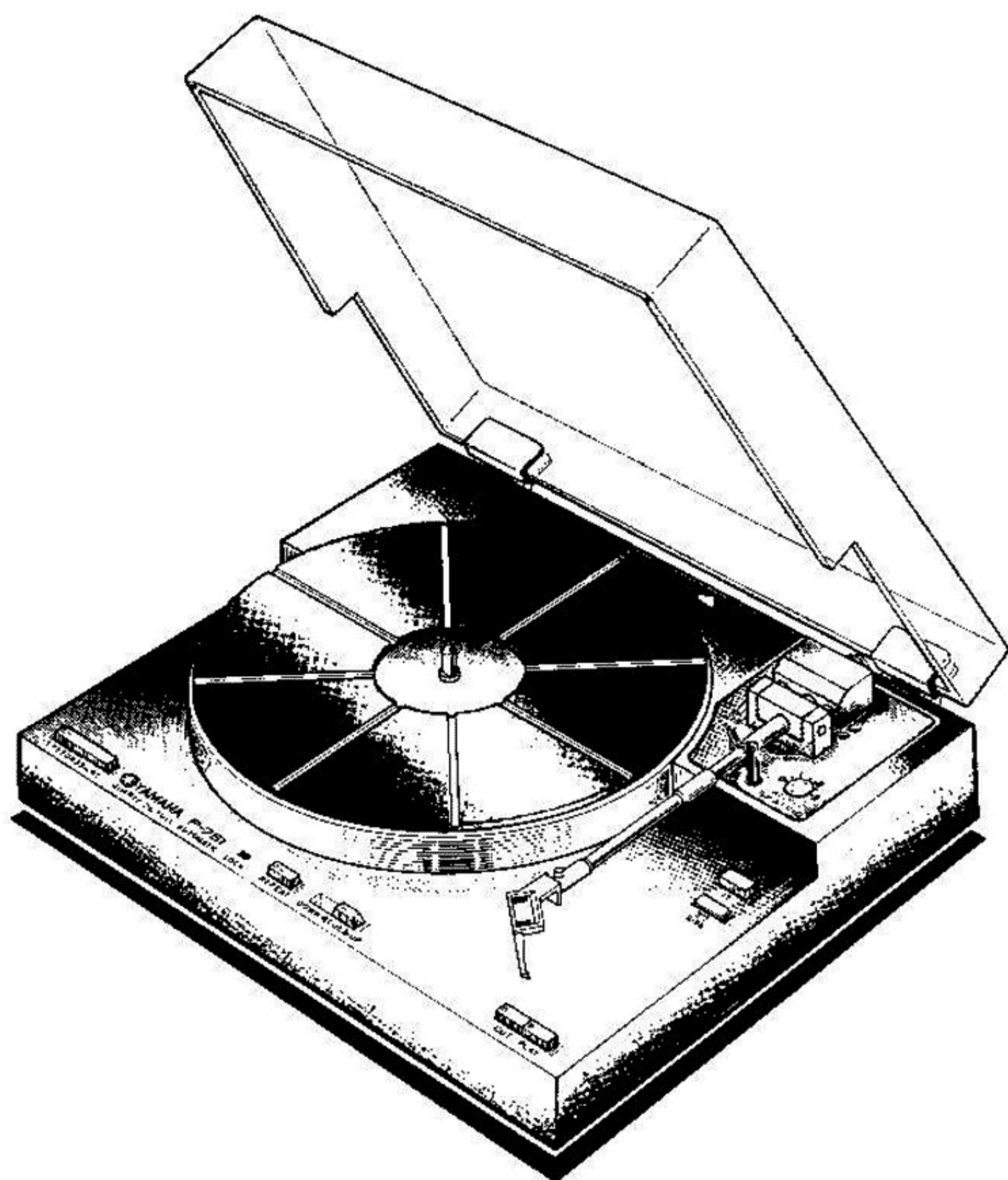

004422

SINCE 1887



YAMAHA

NIPPON GAKKI CO., LTD. HAMAMATSU, JAPAN

Printed in Japan 80. Z K.T. ϕ 2.5K

CONTENTS

PACKAGE INSTRUCTION	1
SPECIFICATIONS	2
MOTOR BLOCK DIAGRAM	2
DISASSEMBLY PROCEDURES	3
MECHANICAL DESCRIPTION	6
ADJUSTMENTS	8
WIRING	10
SCHEMATIC DIAGRAM	11

PACKAGE INSTRUCTION

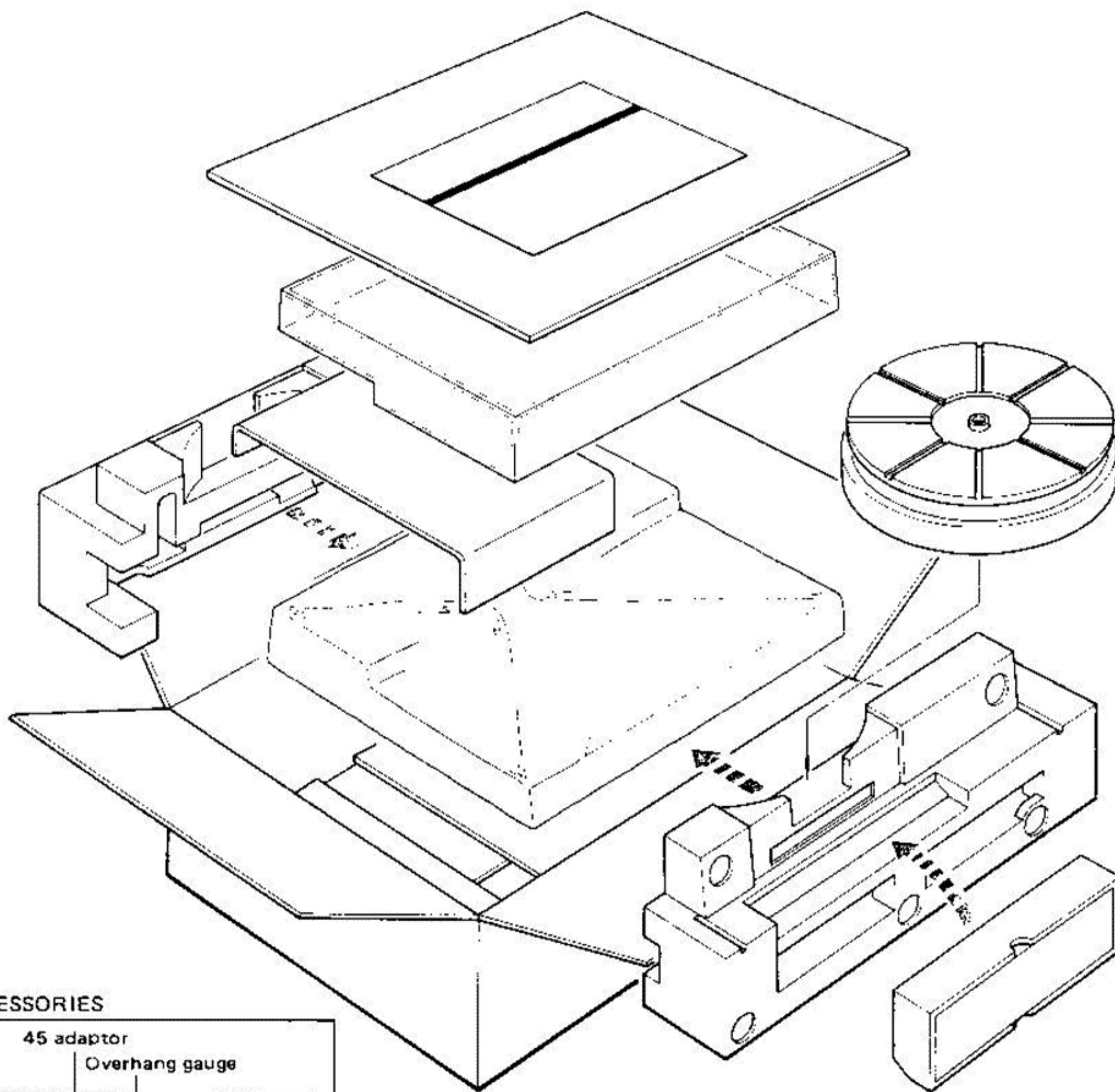

ACCESSORIES

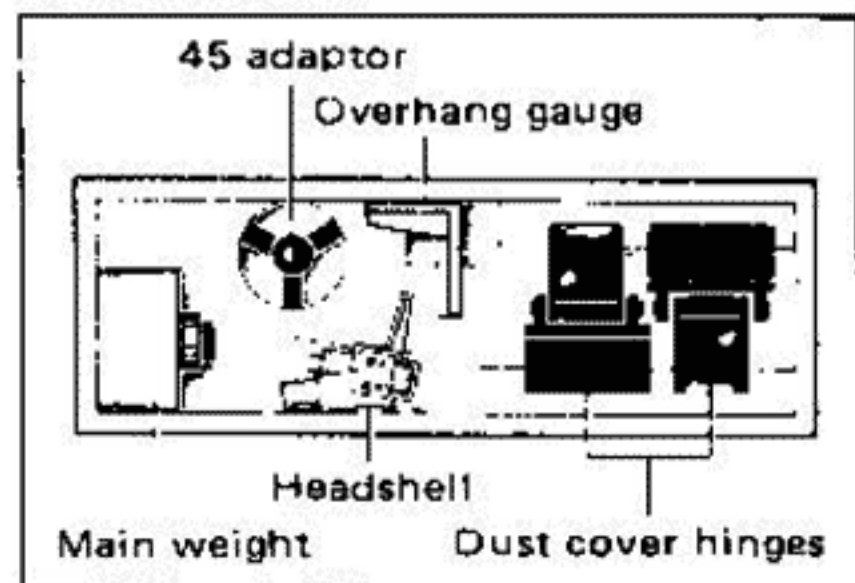

DISASSEMBLY PROCEDURES

1. Removal of bottom cover

Remove screws ① ~ ⑨ in Fig. 1 and then remove the bottom cover.

① ~ ⑨: Bind Head P-Tyte Screw 3 x 12Y

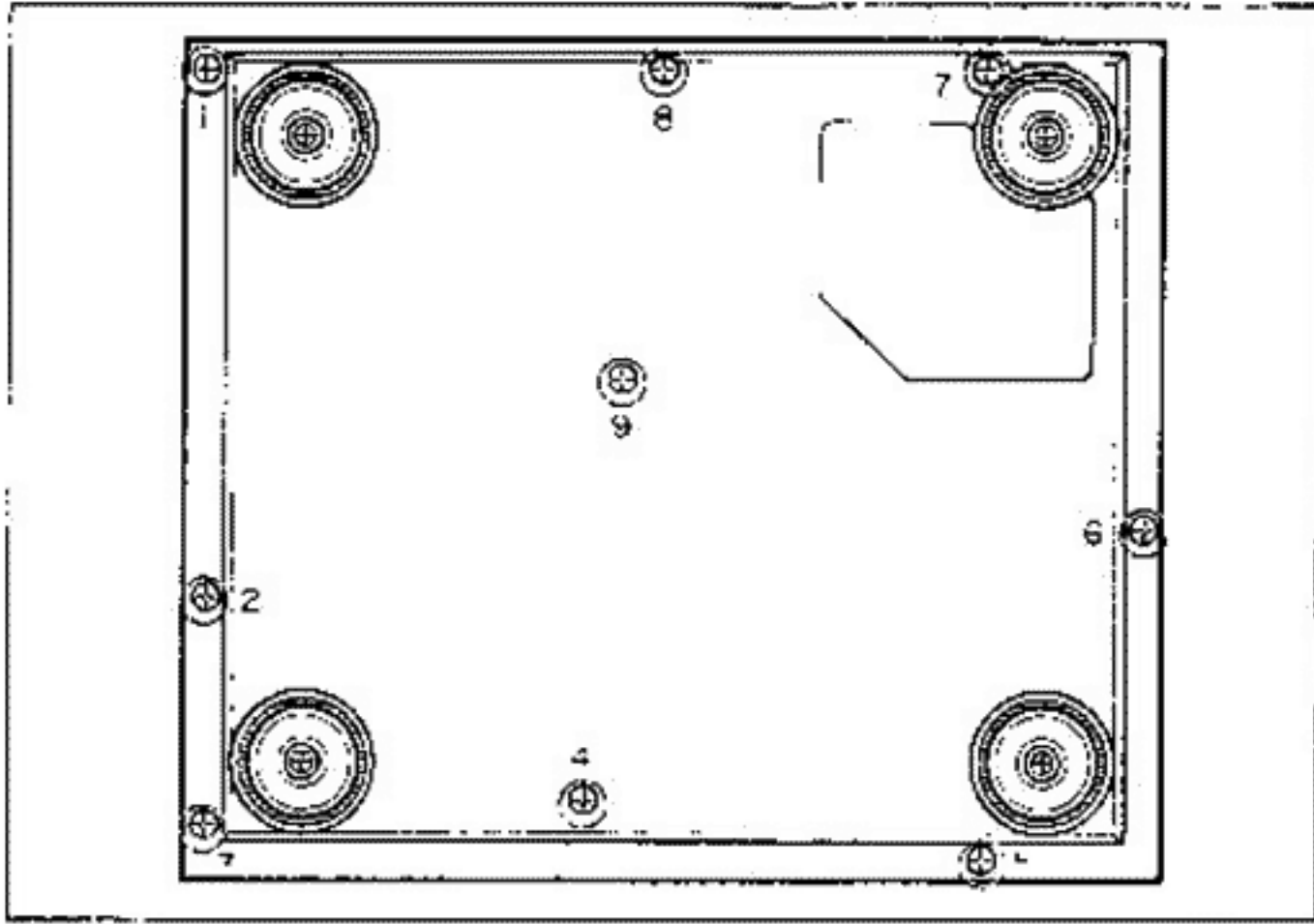

Fig. 1

2. Replacement of PU cord Ass'y

a. Remove the shield cover by unscrewing ① and ② in Fig. 2.

①: Bind Head B-Tyte Screw 3 x 8Y

②: Bind Head B-Tyte Screw with Washer 3 x 8Y

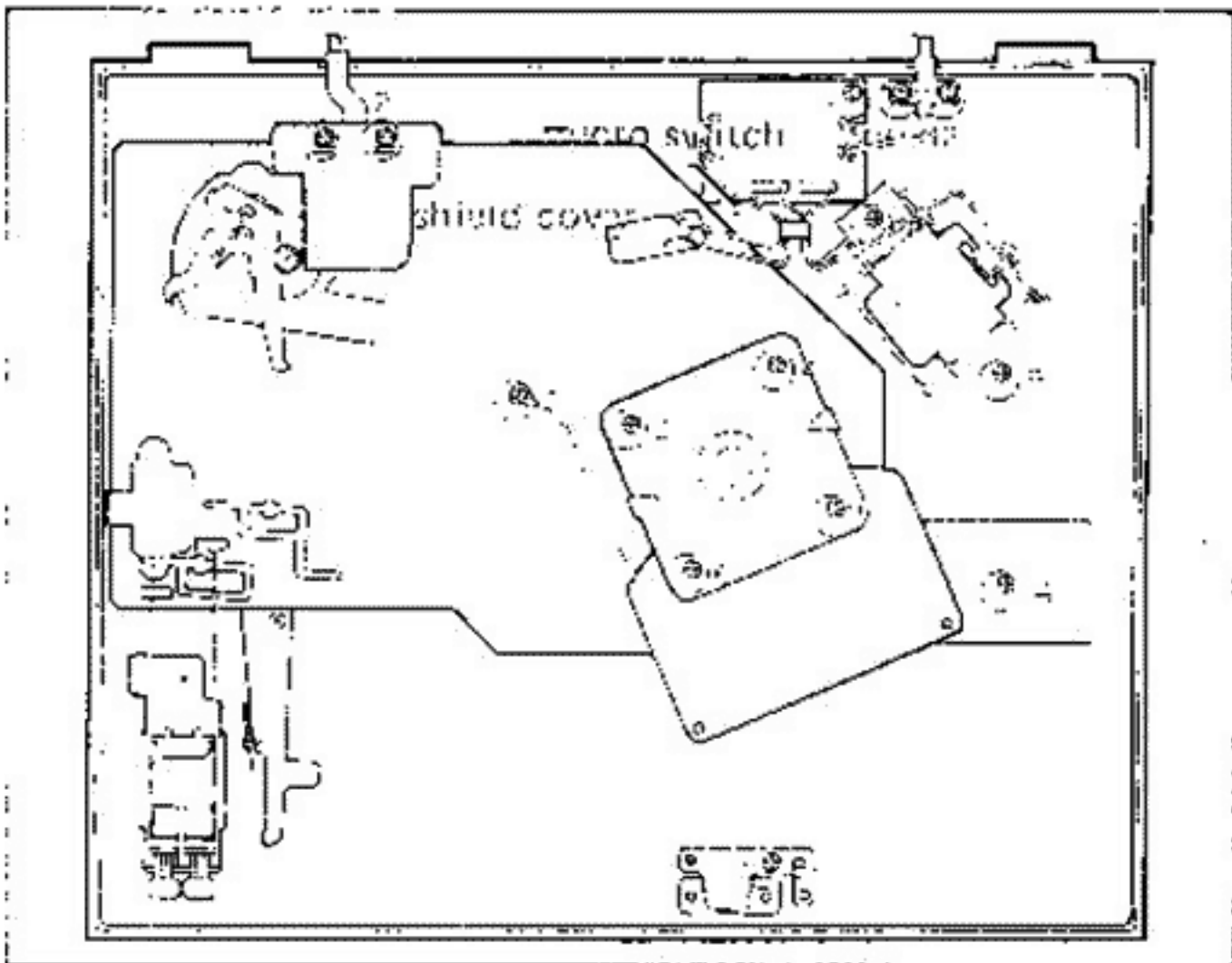

Fig. 2

b. Disconnect the tonearm lead wires in Fig. 3.

c. Remove screw ① in Fig. 3 and replace the PU cord Ass'y.

①: Bind Head B-Tyte Screw 3 x 8

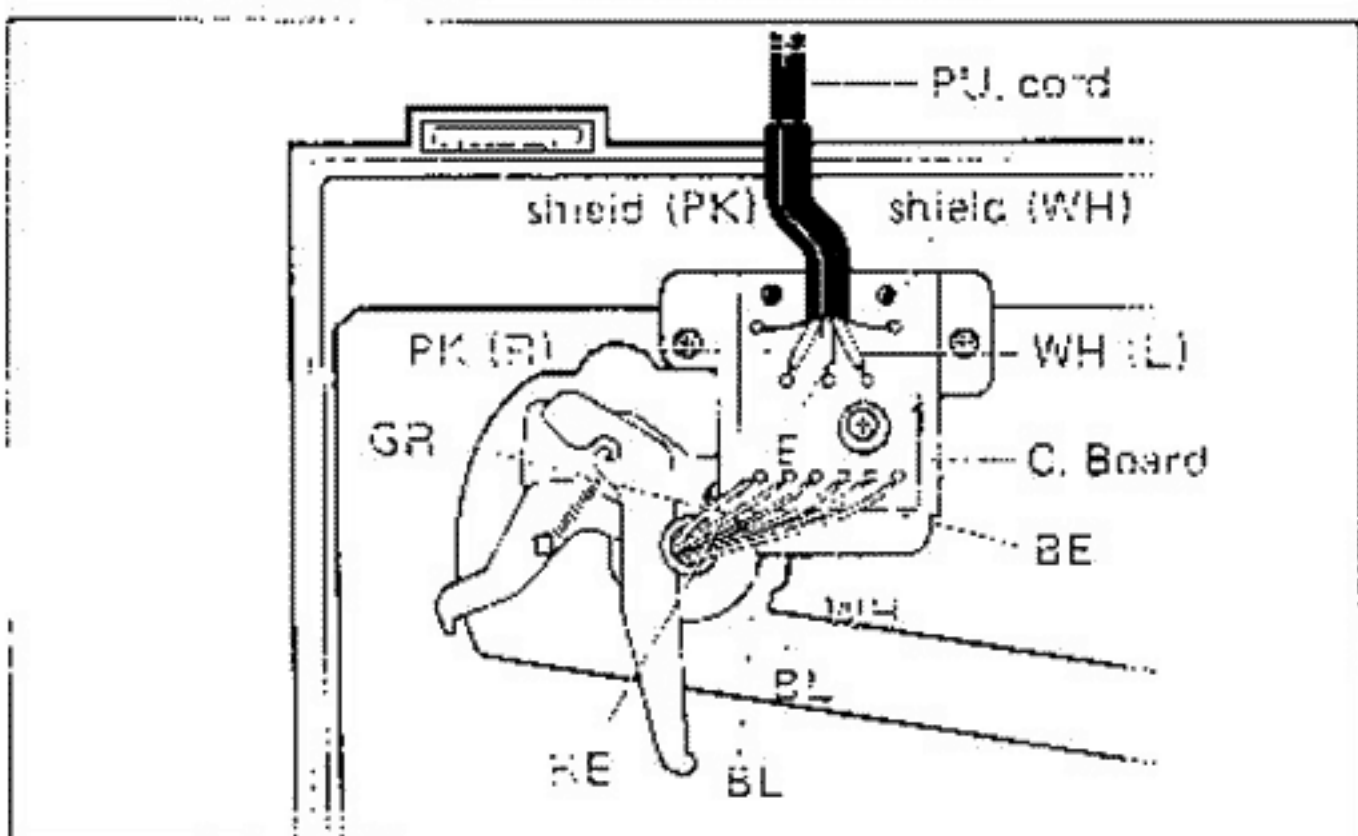

Fig. 3

3. Replacement of tonearm unit

a. Before the work, make sure that the PU cord Ass'y is removed according to the steps given under 2.

* Handle fine arm lead wires with special care.

b. Remove the screw cover by using a knife or the like as shown in Fig. 4.

* The screw cover is attached with double faced adhesive tape. Be careful not to damage it when removing it.

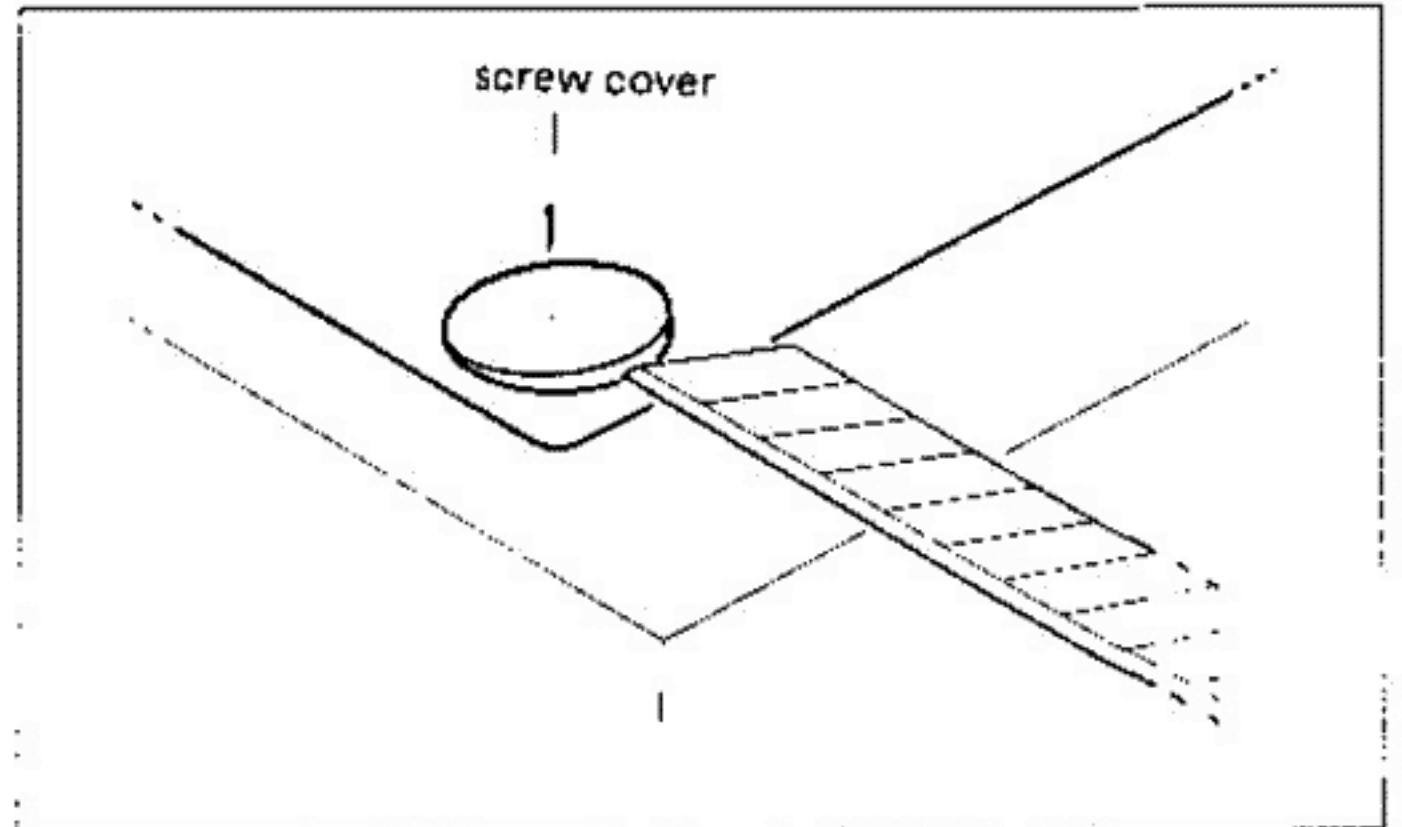

Fig. 4

c. Remove screws ① and ② in Fig. 5 and then remove the return arm Ass'y.

①, ②: Flat Head Tapping Screw 3 x 10Y

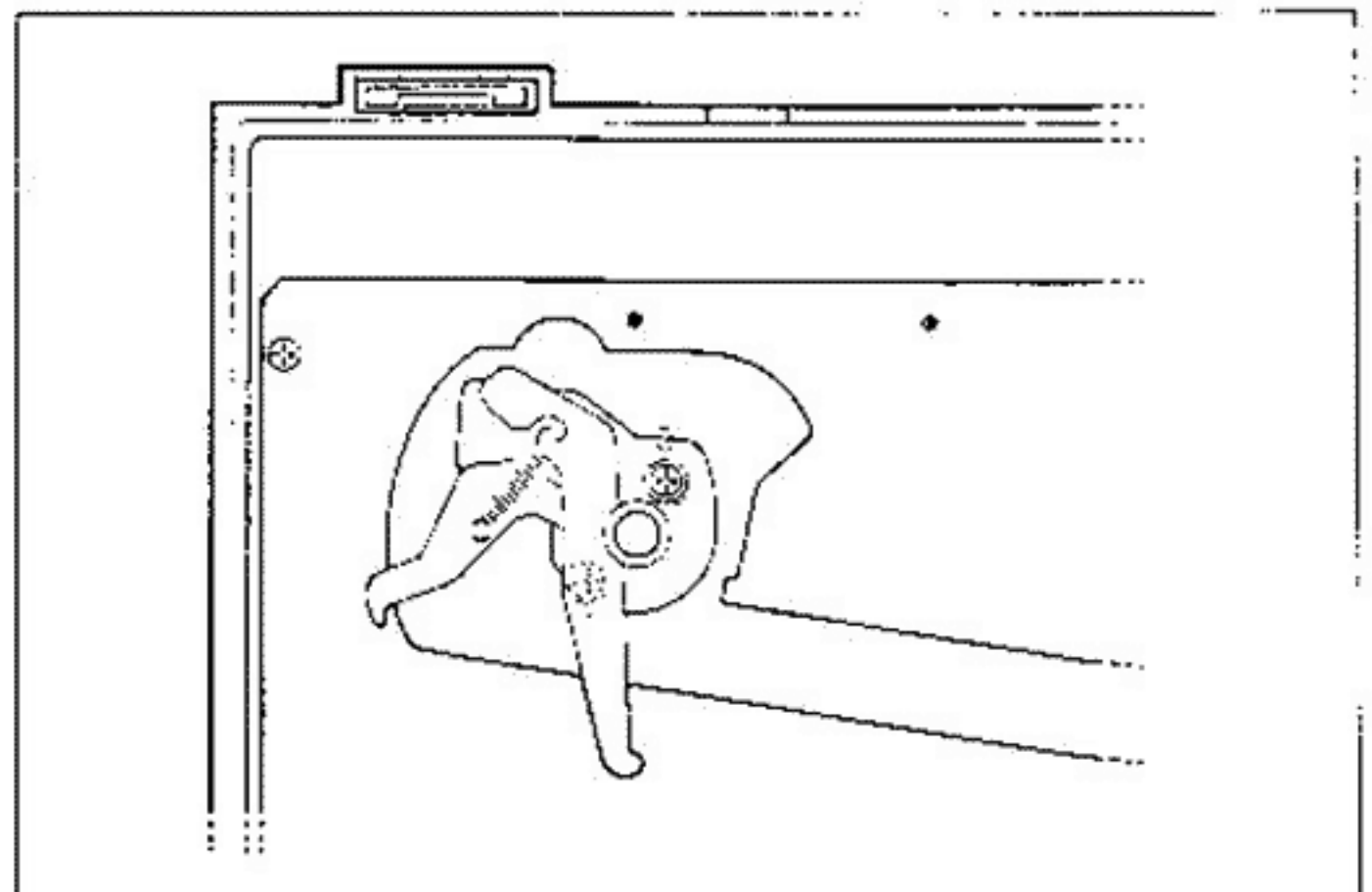

Fig. 5

d. Remove screw ① ~ ④ in Fig. 6 and then remove the tonearm unit.

① ~ ④: Bind Head P-Tyte Screw 3 x 12Y

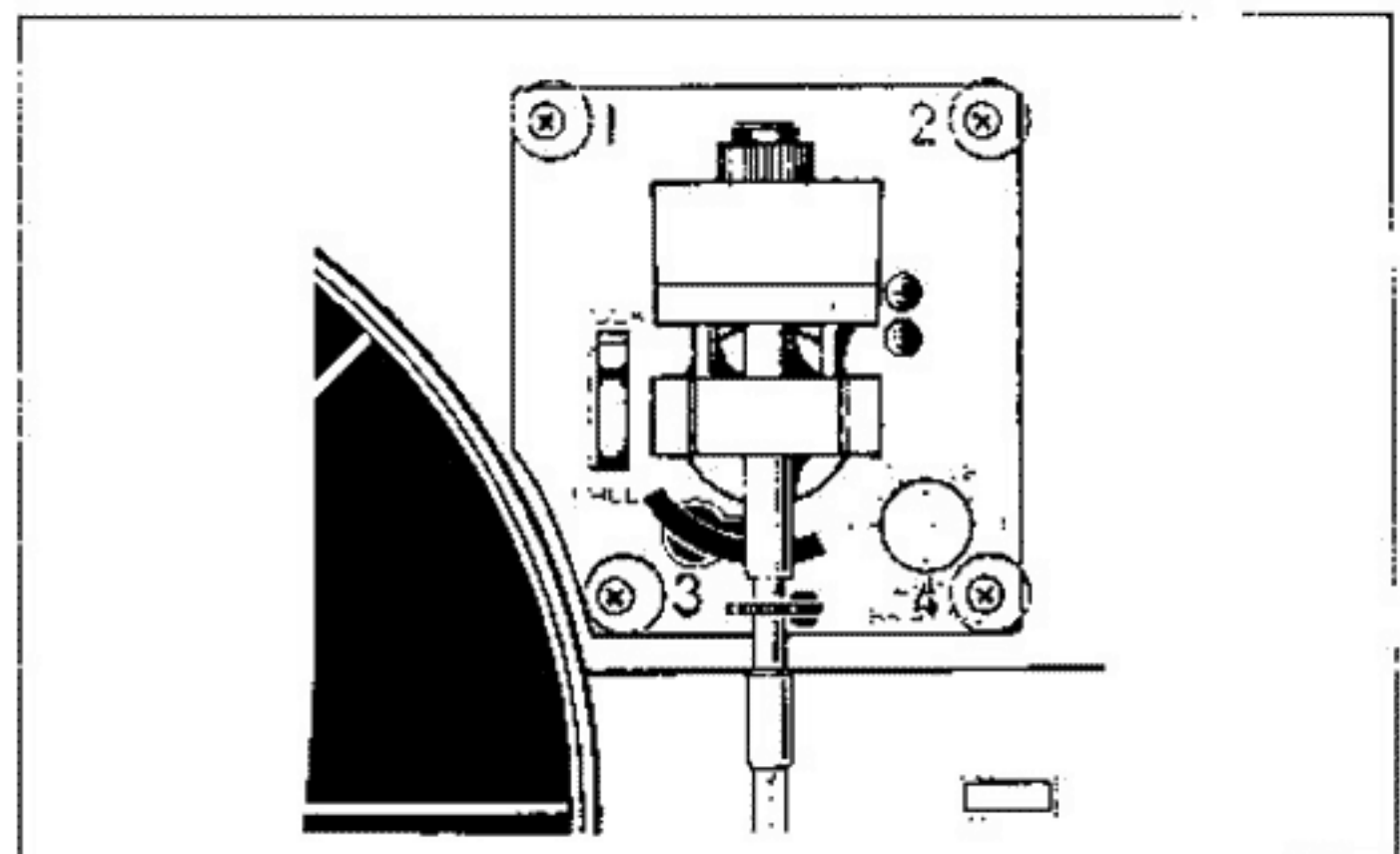

Fig. 6

e. Before installing the tonearm unit, move the cueing lever toward the center shaft as shown in Fig. 7 and turn pin A counterclockwise so as to bring the lifter up.

* Without this step, pin A and cueing lever B remain in the positions as shown in Fig. 8. This will hinder the lifter operation after the tonearm is installed.

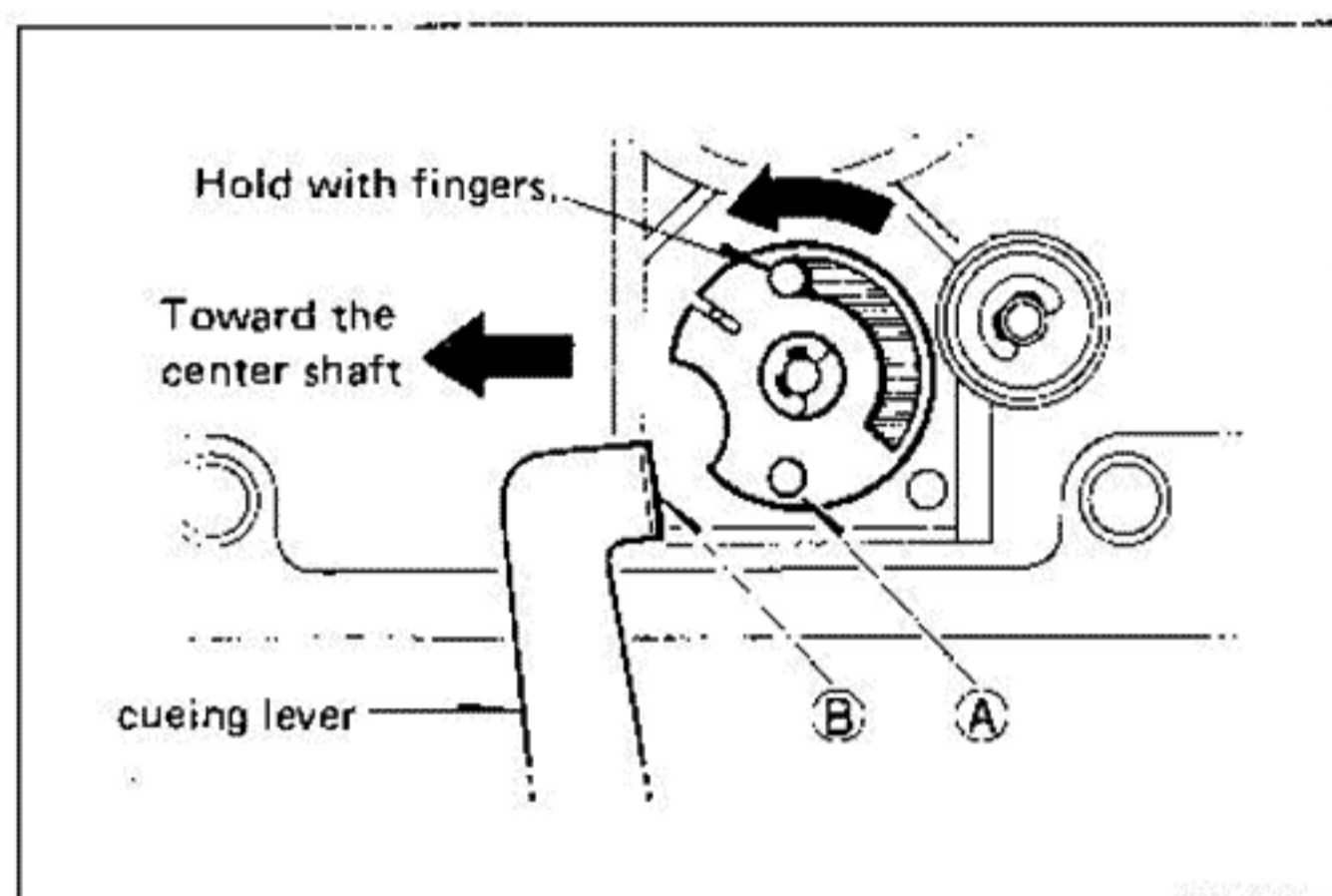

Fig. 7

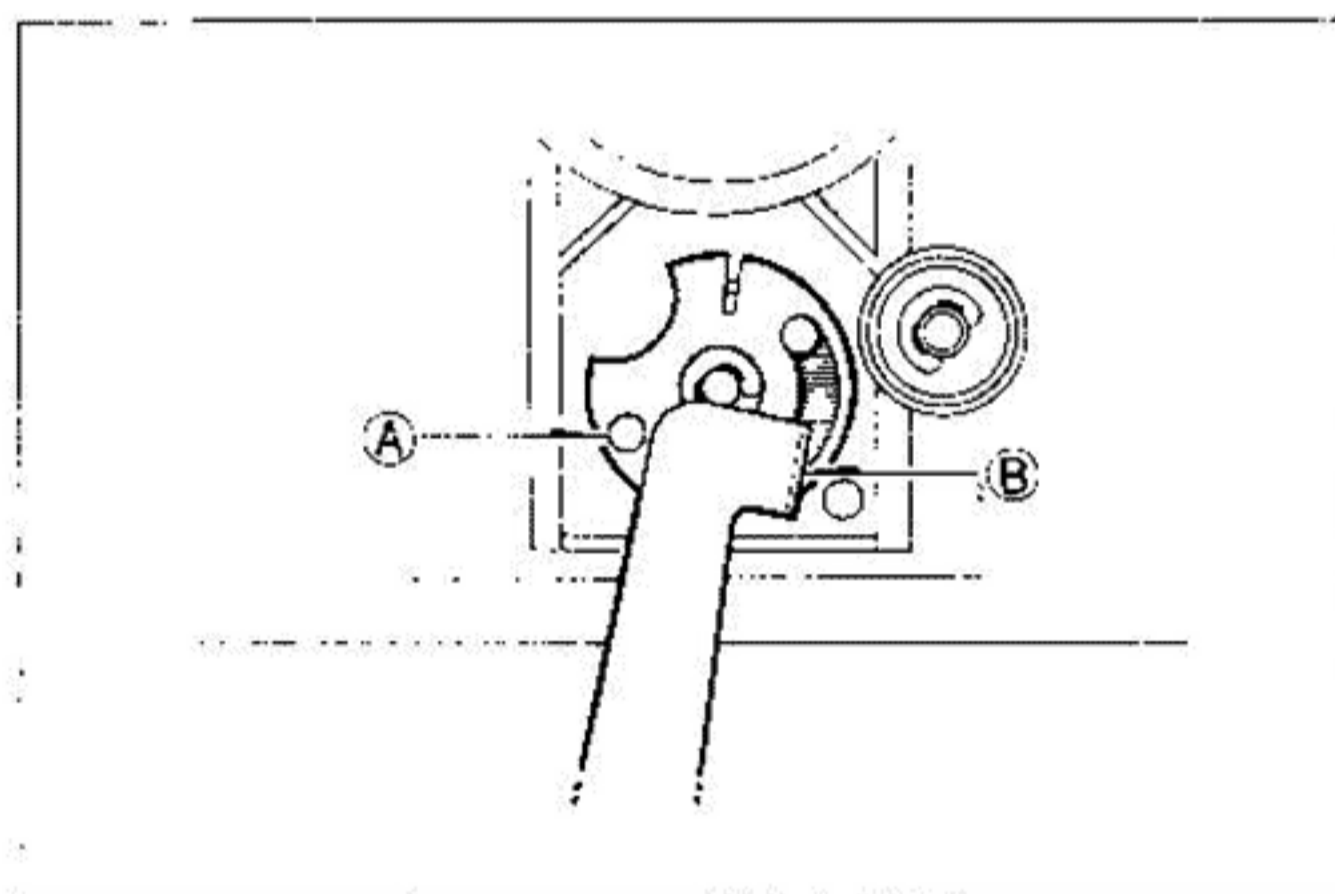

Fig. 8

4. Replacement of motor

a. Disconnect the lead wires which are connected to the motor circuit board.

* Each lead wire is wrapped. Use a wrapping tool when connecting it or solder it if a wrapping tool is not available, for an incomplete wrapping may cause a trouble.

b. Remove screws ③ ~ ⑦ in Fig. 2 and then remove the motor.

③ ~ ⑦: Bind Head P-Tyte Screw 3 x 10Y

5. Replacement of LOCK indicator LED

Remove screw ⑧ in Fig. 2 and remove the LED socket Ass'y.

* When inserting LED into the socket, make sure its anode and cathode are correctly connected.

⑧: Bind Head P-Tyte Screw 3 x 6Y

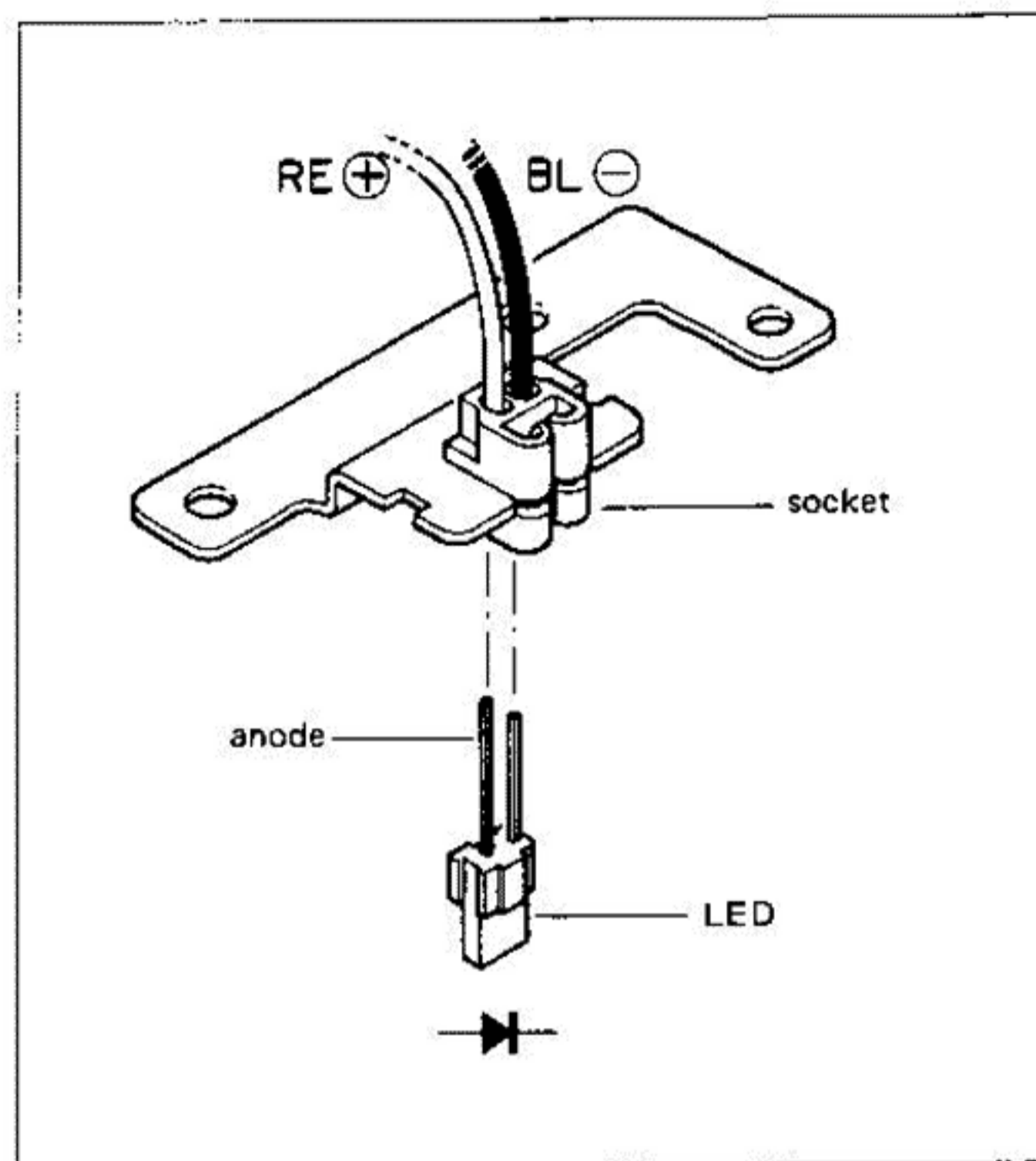

Fig. 9

6. Replacement of microswitch

a. Disconnect the wires connected to the microswitch.

b. Undo the claws A and B in Fig. 10 fixing the microswitch and replace the microswitch.

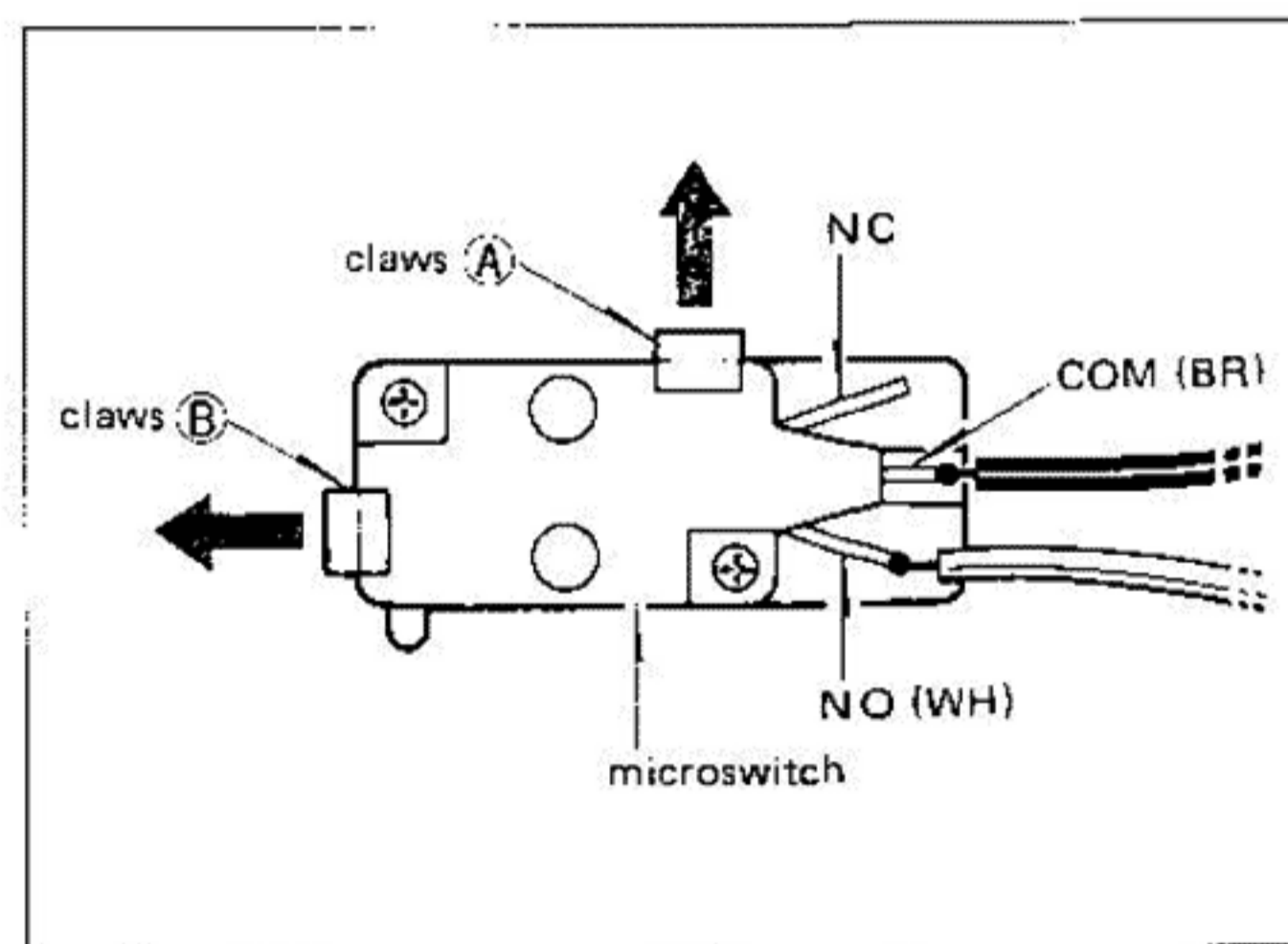

Fig. 10

7. Replacement of power transformer

a. Disconnect the lead wires connected to each circuit board.

b. Replace the power transformer by unscrewing ⑨ and ⑩ in Fig. 2.

⑨, ⑩: Bind Head P-Tyte Screw 3 x 12Y

8. Replacement of power cord

- a. Remove the cord stopper by unscrewing ⑪ and ⑫ in Fig. 2.
- b. Disconnect the wires connected to the first circuit board and replace the power cord.

⑪、⑫ : Bind Head P-Tyte Screw 3 x 12Y

9. Removal of first circuit board

- a. Disconnect the wires connected to the first circuit board.
- b. Remove the first circuit board by unscrewing ⑬ in Fig. 2.

⑬ : Bind Head P-Tyte Screw 3 x 10Y

10. Removal of second circuit board

- a. Disconnect the wires connected to the second circuit board.
- b. Remove the second circuit board by unscrewing ⑭ in Fig. 2.

⑭ : Bind Head P-Tyte Screw 3 x 10Y

11. Replacement of mechanism panel Ass'y

- a. Make sure that the tonearm unit, motor and microswitch are removed according to the steps given under 3, 4 and 6.
- b. Unscrew ① ~ ⑩ and remove the selector button Ass'y, base Ass'y and repeat Ass'y at the same time

* The base Ass'y and repeat Ass'y must be removed with the mechanism Ass'y, for the guides can't be removed from the front side of the mechanism panel Ass'y.

① ~ ⑥ : Bind Head P-Tyte 3 x 10Y

⑦ : Bind Head P-Tyte 3 x 12Y

⑧ ~ ⑩ : Bind Head P-Tyte 3 x 16Y

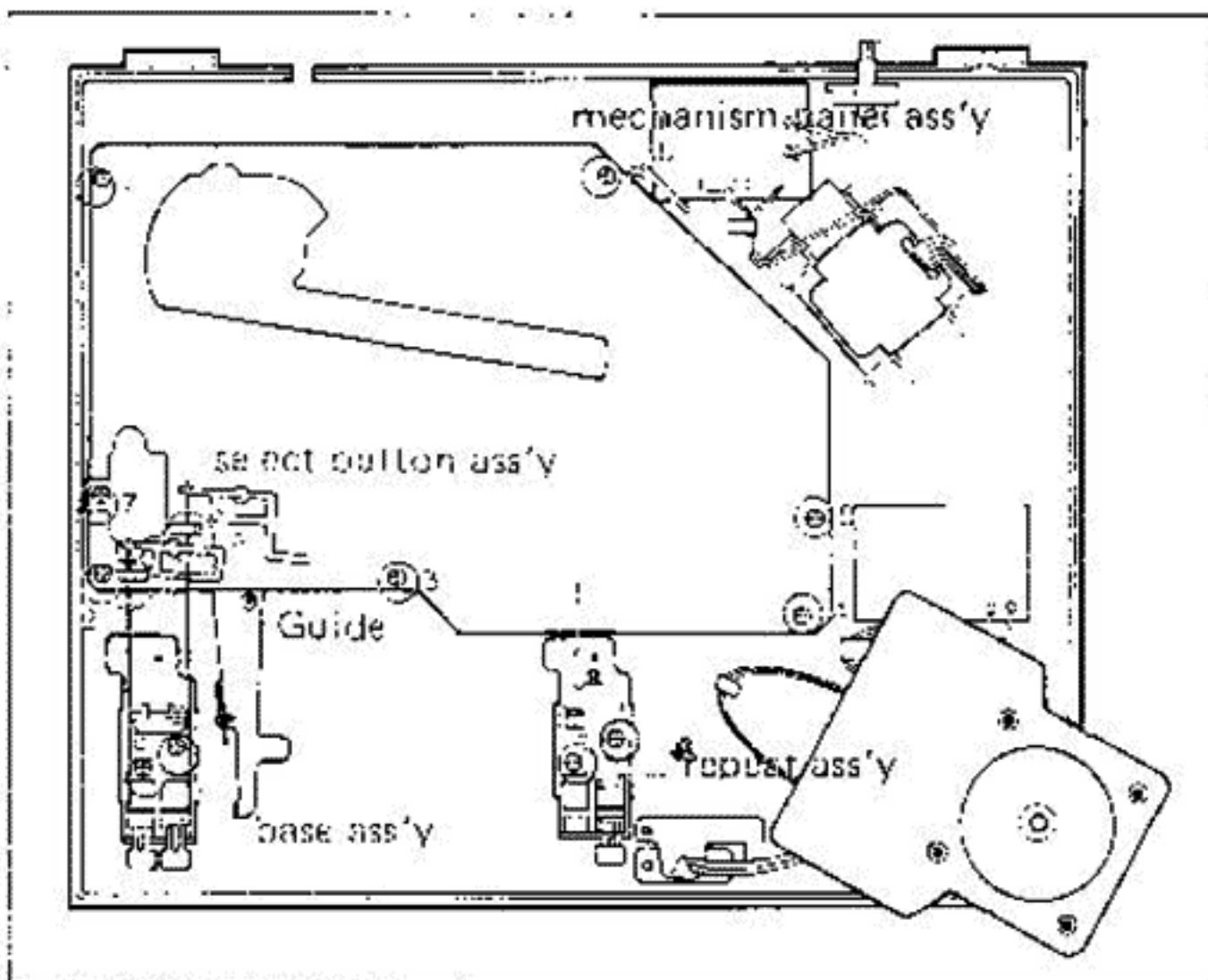

Fig. 11

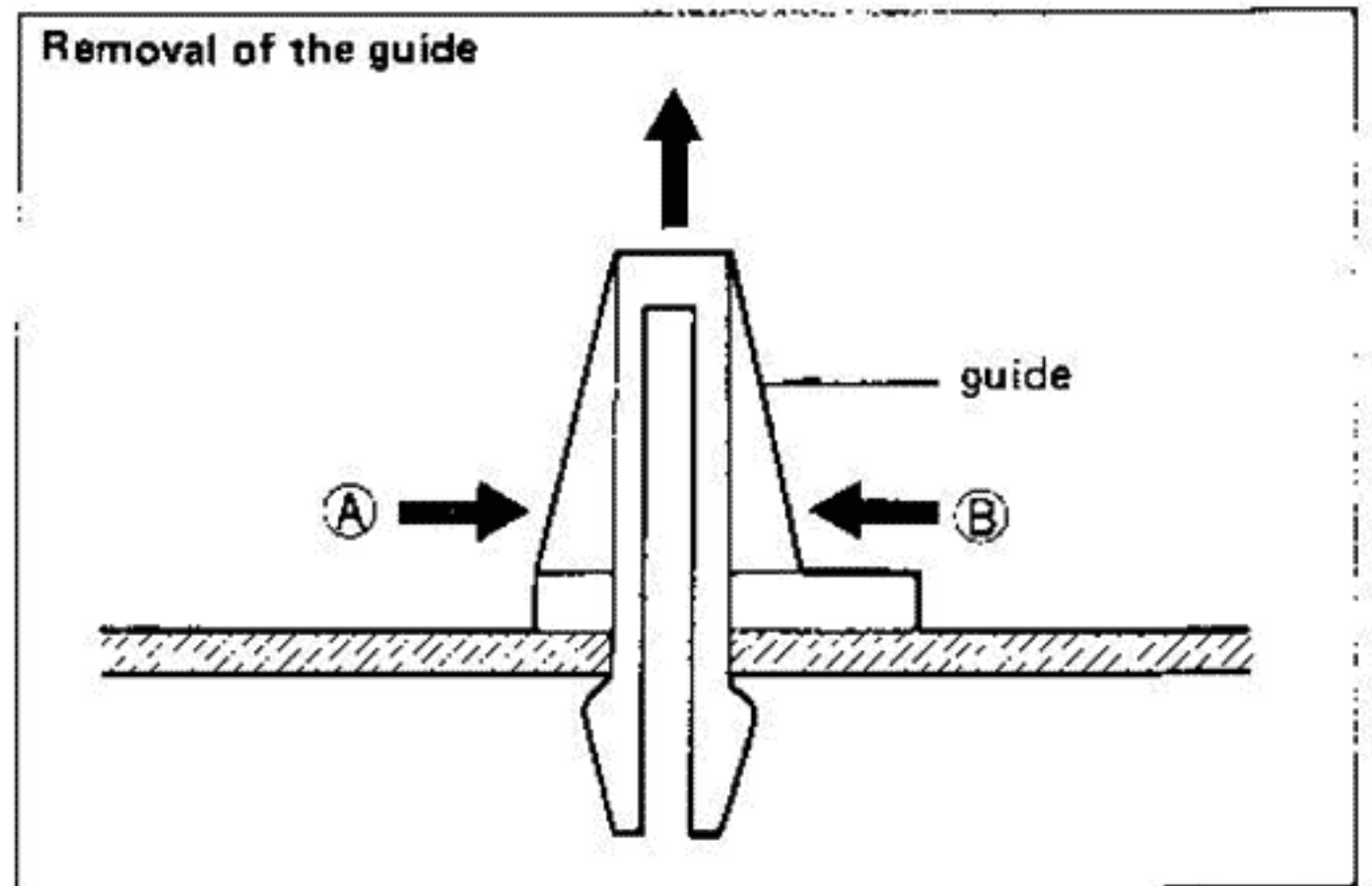

Fig. 12

- c. Hold ① and ② in Fig. 12 with a plier or the like and pull off the guide.
- d. When installing the mechanism panel Ass'y, be sure to bring the selector button Ass'y in such a position that ③ in Fig. 13 fits in the groove of its click lever.

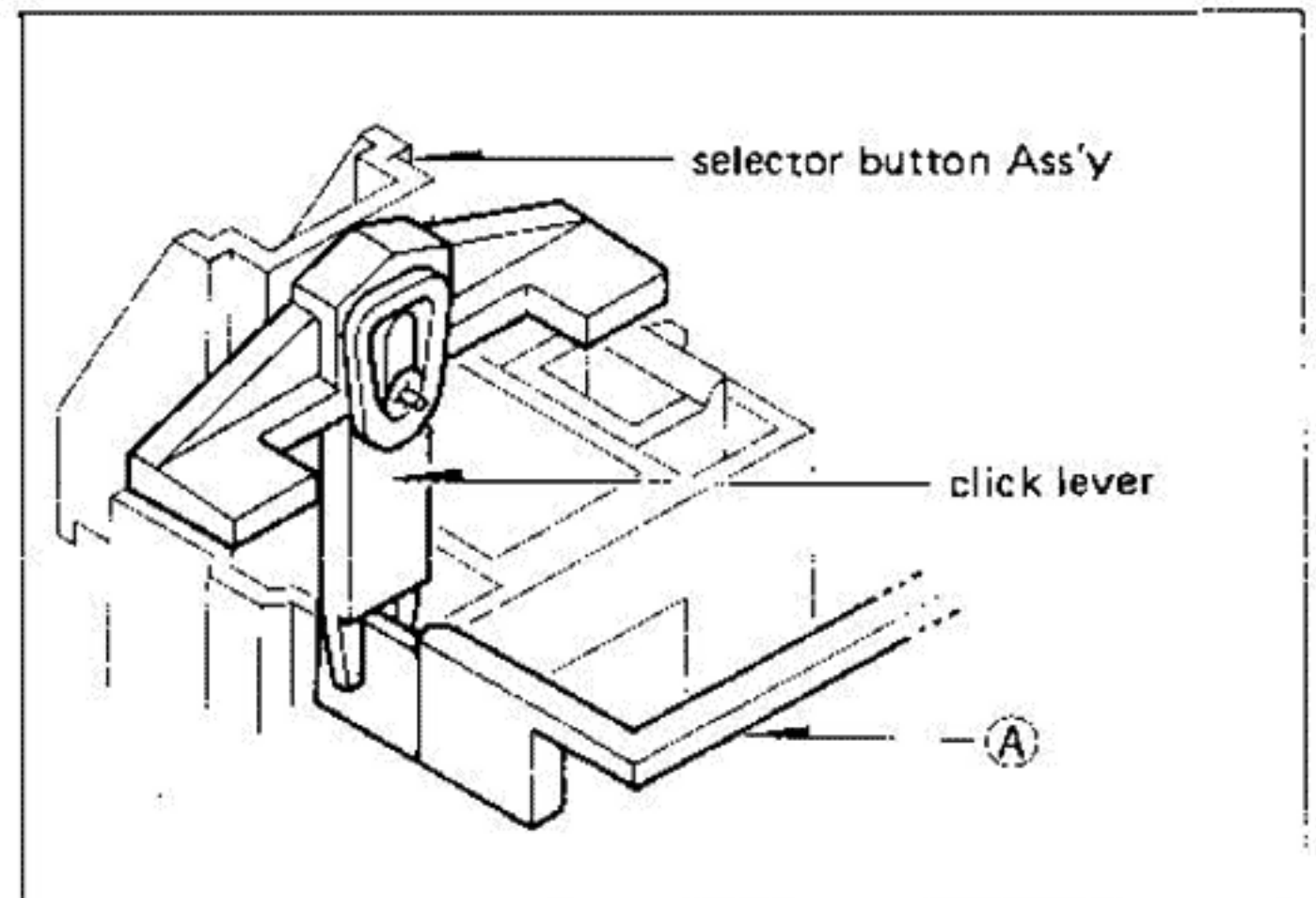
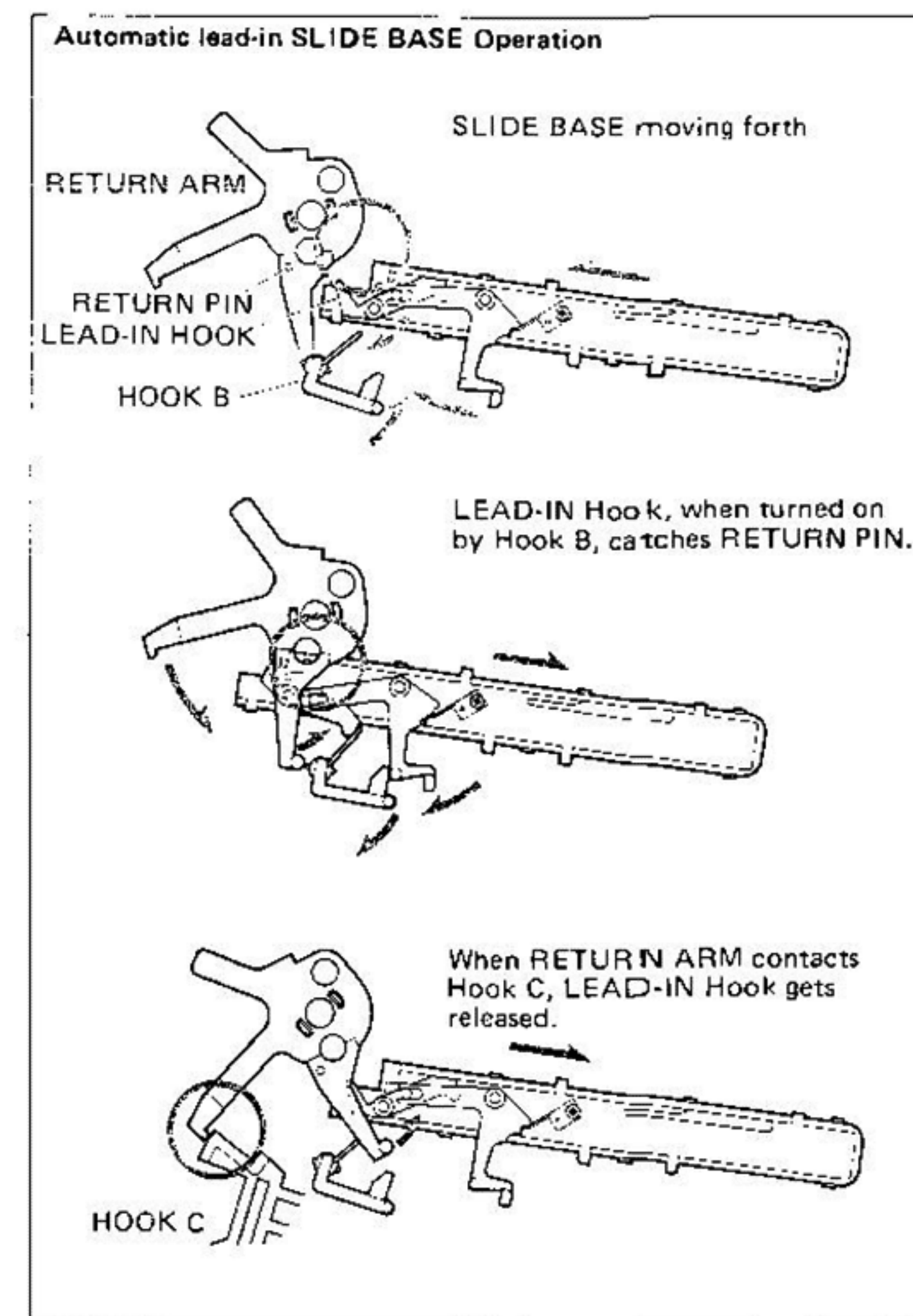
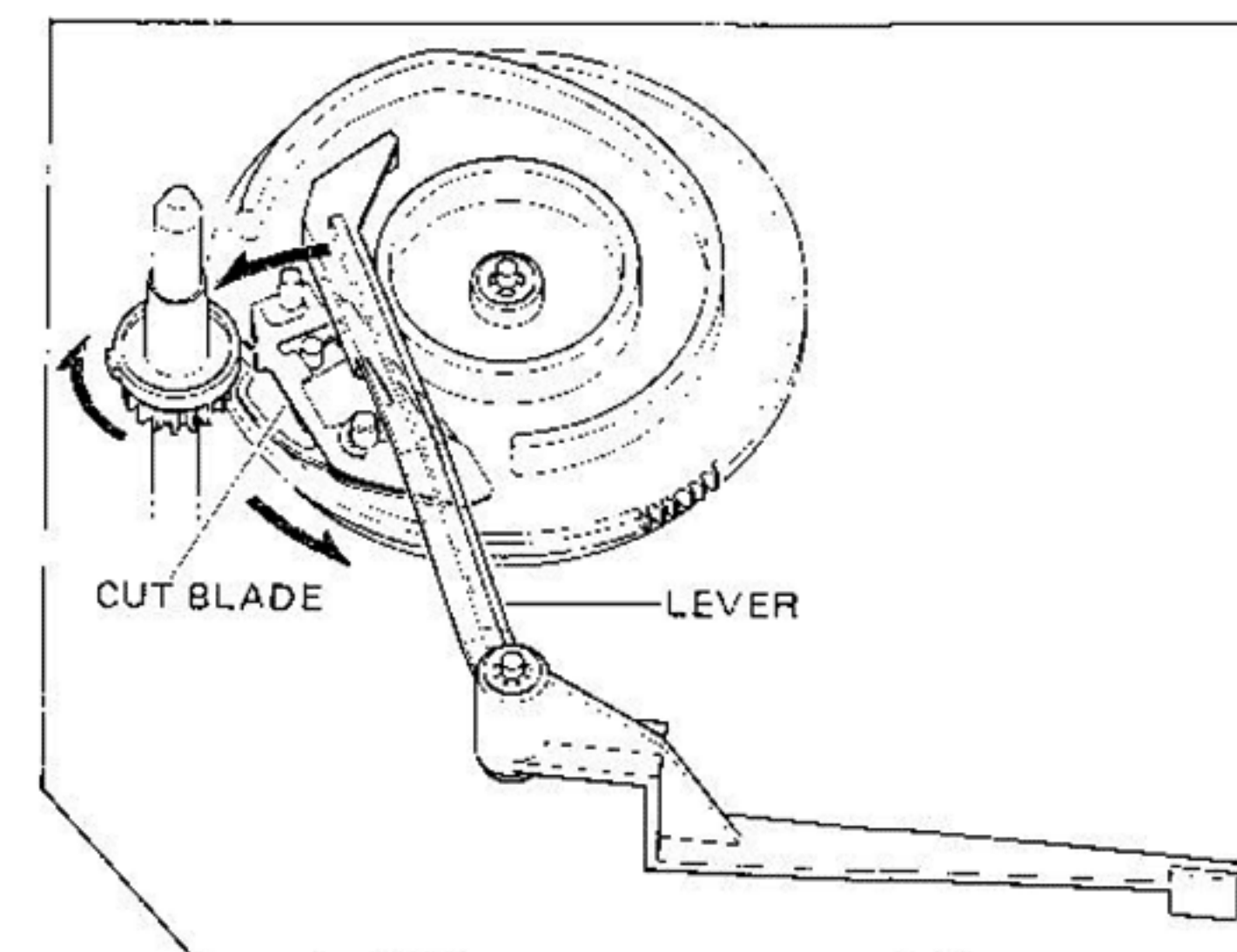
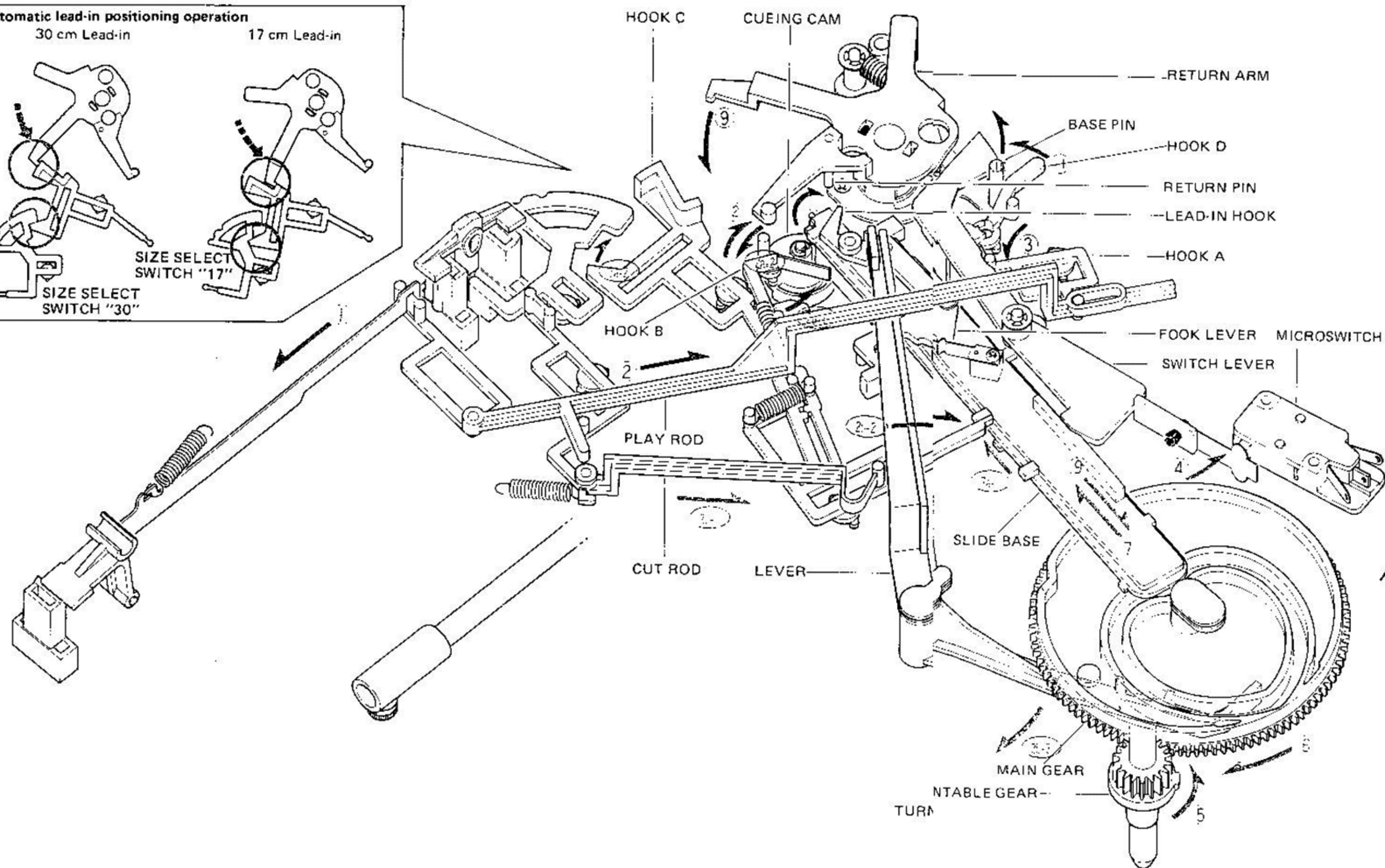
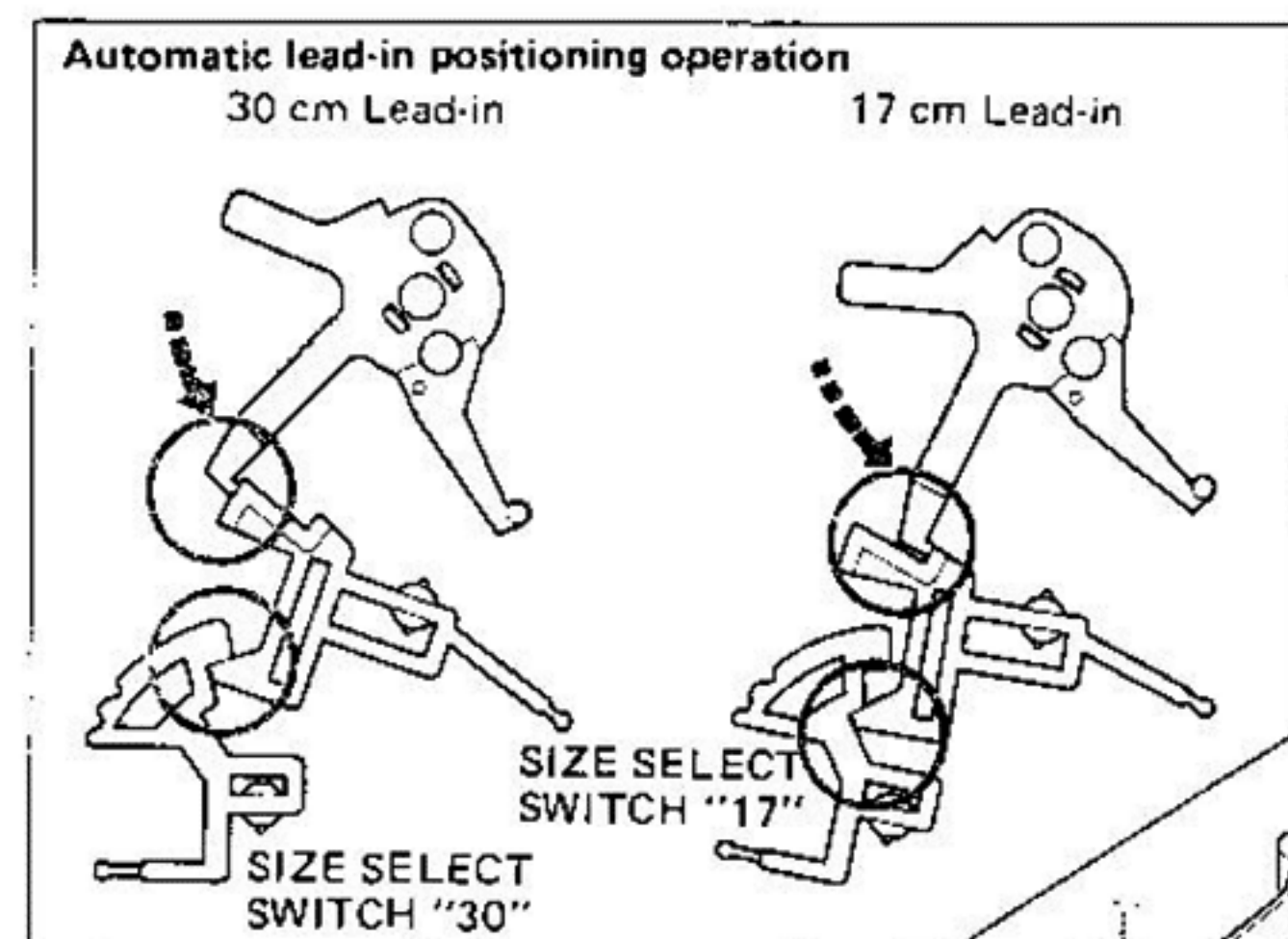

Fig. 13

* Screw color Bℓ: black
Y: yellow

MECHANICAL DESCRIPTION

AUTO LEAD-IN OPERATION



1. When PLAY button is pressed, PLAY ROD moves and pushes CUT ROD. Also as PLAY ROD moves, HOOK A and HOOK B are actuated.

HOOK A: With this hook, the SWITCH LEVER is caused to move. Then the SWITCH LEVER turns on the MICROSWITCH and the motor starts to revolve.

HOOK B: This is the hook which causes the LEAD IN FOOK to turn on. It moves only when PLAY button is pressed.

2. CUT ROD further pushes LEVER which causes the CUT BLADE to turn on. At this point, as the motor has already started revolving, TURNABLE GEAR and MAIN GEAR engage and lead-in operation will commence. (MAIN GEAR makes a turn during one lead-in operation.)

3. While the MAIN GEAR revolves a turn, SLIDE BASE reciprocates once. As SLIDE BASE moves forth, it causes CUEING to move up by pushing the CUEING CAM. Hook B turns on LEAD-IN HOOK and catches RETURN PIN. When SLIDE BASE is coming back, the tonearm is carried to the preset lead-in position and lowered. The lead-in position is determined to the position where RETURN ARM contacts HOOK C. HOOK A and HOOK B are reset as SLIDE BASE comes back.

AUTO RETURN OPERATION

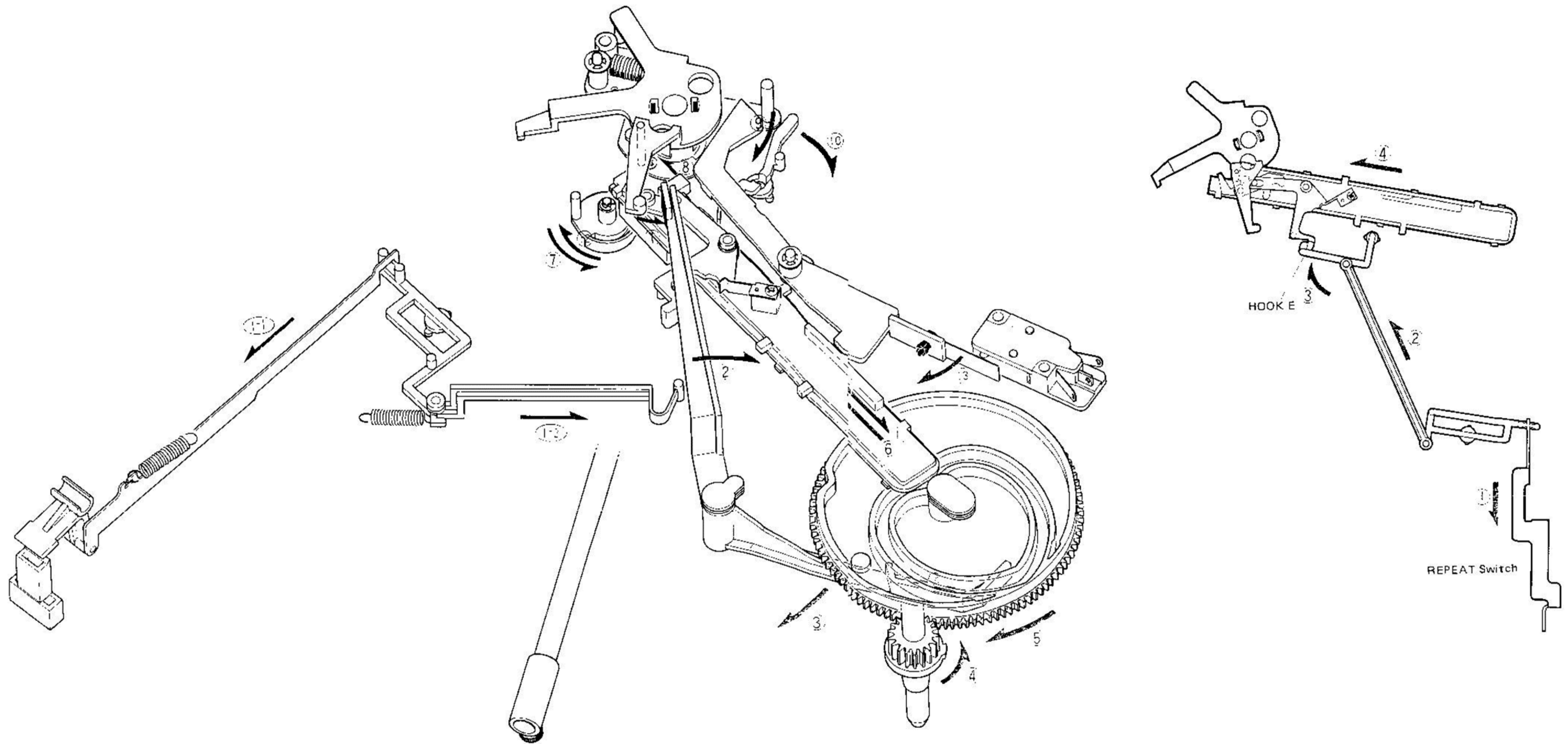

1. When the record play is over and the stylus moves into the lead in groove, RETURN ARM pushes LEVER. Or when CUT button is pressed to stop the record play, CUT ROD pushes LEVER.

2. With LEVER pushed, the CUT BLADE is turned on, causing TURNTABLE GEAR and MAIN GEAR to engage. Thus the return operation will commence.

3. When MAIN GEAR rotates a turn SLIDE BASE reciprocates once. As SLIDE BASE moves, it causes CUEING to move up by pushing the CUEING CAM and then pushes RETURN PIN to bring the arm back to its original position. When the arm returns, RETURN ARM BASE PIN pushes HOOK D which causes SWITCH LEVER to come off the MICRO-SWITCH. Thus the motor revolution stops.

1. As REPEAT button is pressed, the switch is locked and HOOK E is raised.
2. Just as the return operation follows the end of the record play, the raised HOOK E actuates HOOK LEVER on SLIDE BASE. Then LEAD IN HOOK catches RETURN ARM PIN and thus the return operation will commence.

ADJUSTMENTS

• Before adjustment

Make sure that the following conditions are obtained for adjustment.

- a. Circumferential temperature is between 5 ~ 35°C and humidity is between 45% ~ 85%.
However, these don't always apply as long as normal operation is assured and adjustment can be performed properly.

- b. The unit is located at a place free from vibration horizontally.
- c. The place for adjustment is protected against magnetic and noise disturbance from the surroundings.

• Instruments for adjustment and check

- Test record (NEC: ES-1008)
- Buffer amplifier
- Oscilloscope
- ⇒ small size driver

• Voltage check

Check DC voltage supplied to motor ass'y for the following specified value.

Voltage	DC24±2V
---------	---------

• Quartz lock synchronism check

1. Connect buffer amplifier with motor servo circuit board as shown in Fig. 14.

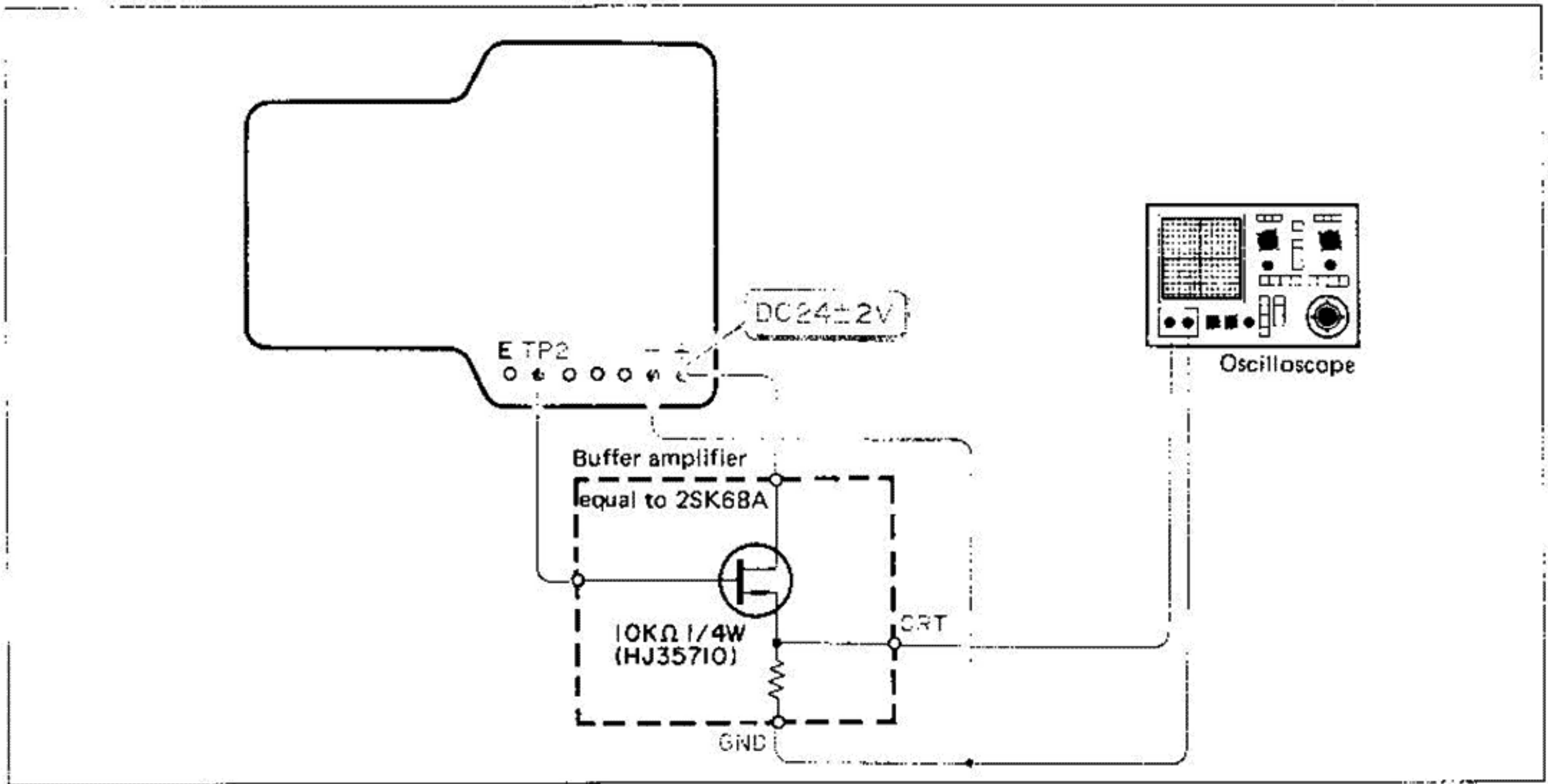

Fig. 14

2. Set SPEED switch to 33 (33 r.p.m.).
3. Start the motor by moving tonearm from arm rest.
4. Connect oscilloscope with CRT connector and GND and make sure that the wave form shown in Fig. 15 is observed.

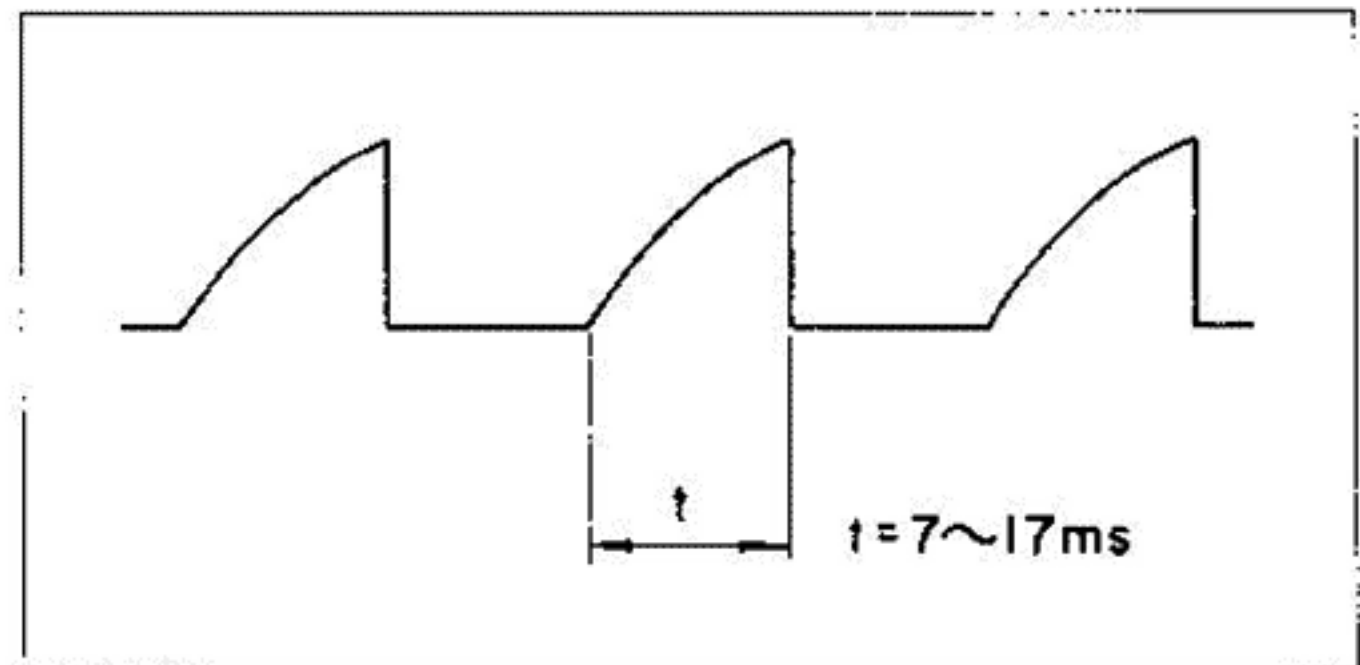

Fig. 15

MECHANICAL ADJUSTMENT

1. Lead-in position adjustment

Use test record (NEC : ES-1008) and check to ensure that tonearm leads in within the rating specified below.

Lead-in	Test record	Rating
30	Face 1 ①	19 ± 8 count
17	Face 1 ⑤	22 ± 8 count

If the lead-in position does not meet the above specification, perform lead-in position adjustment as described below with tonearm placed back on arm rest.

Insert small \ominus driver into a hole behind arm base and adjust to obtain the right lead-in position for both 30 and 17 by turning the cam in the hole.

(One cam is provided for this adjustment, so lead-in position for 30 and 17 can't be adjusted individually.)

* If a test record is not available, check for right automatic return operation with whatever record in use.

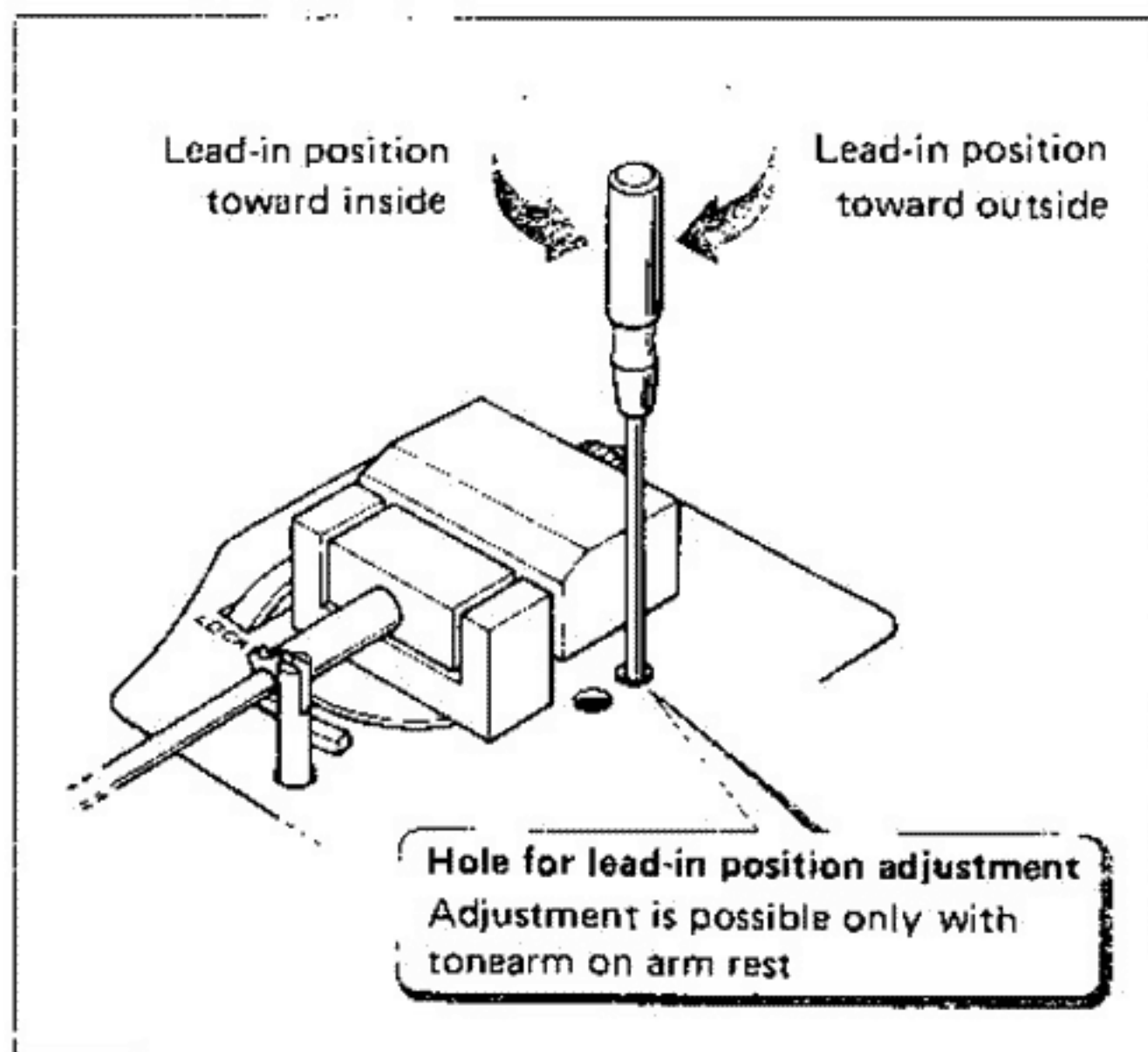

Fig. 16

2. Auto return operation check

Check to ensure that automatic return of the tone arm functions at 17±4 count in case of Face 1 ⑥ (P=3mm) and doesn't function before 26 count in case of Face 2 ④ (P=1mm) of test record (NEC: ES-1008).

3. Adjustment of the tonearm height

When adjusting the tonearm height, raise or lower the tonearm gently so that no excessive force is applied to the bearing. Also check to ensure that the tonearm is set vertically, looking from its front end.

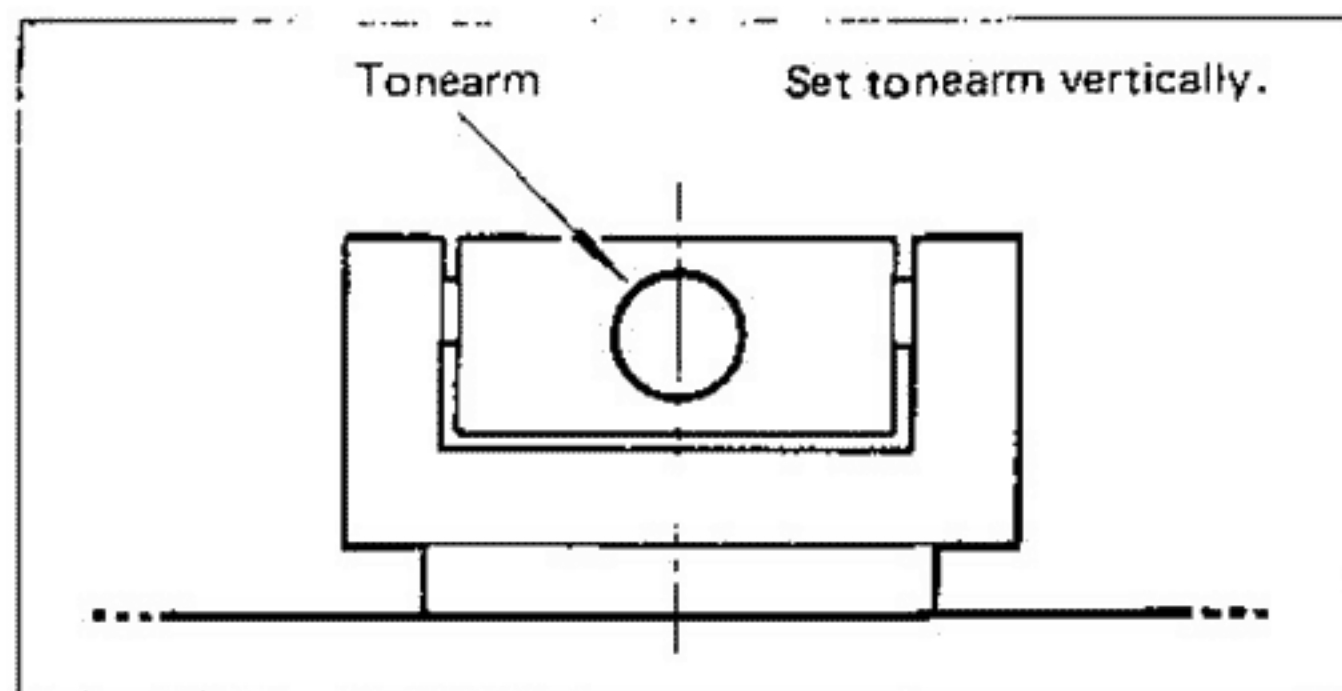

Fig. 17

4. Fitting the cartridge

When replacing the cartridge, align it perfectly with the headshell and make sure that the tip of the stylus is vertical by using an overhang gauge.

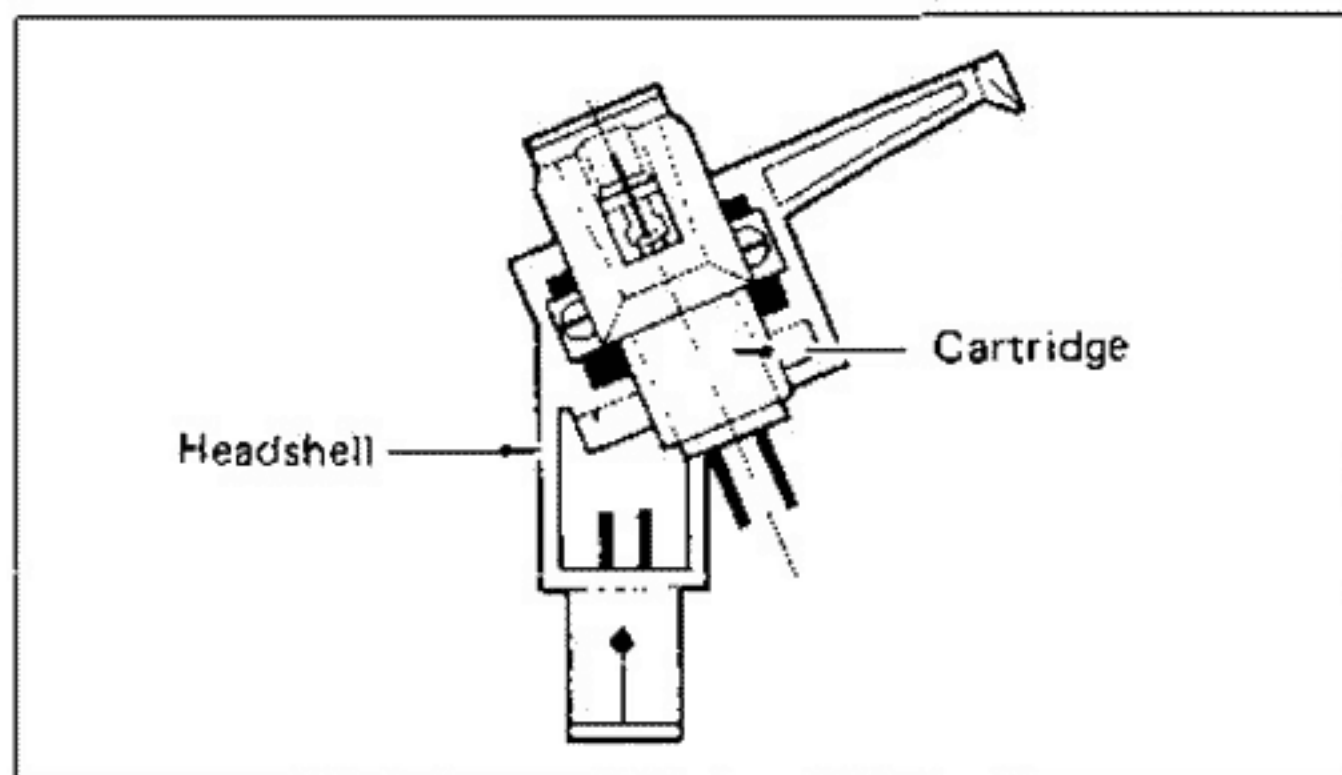

Fig. 18

5. Diagonal descent of the tonearm

If the tonearm is found descending diagonally at the time of lead-in, follow the instruction given in

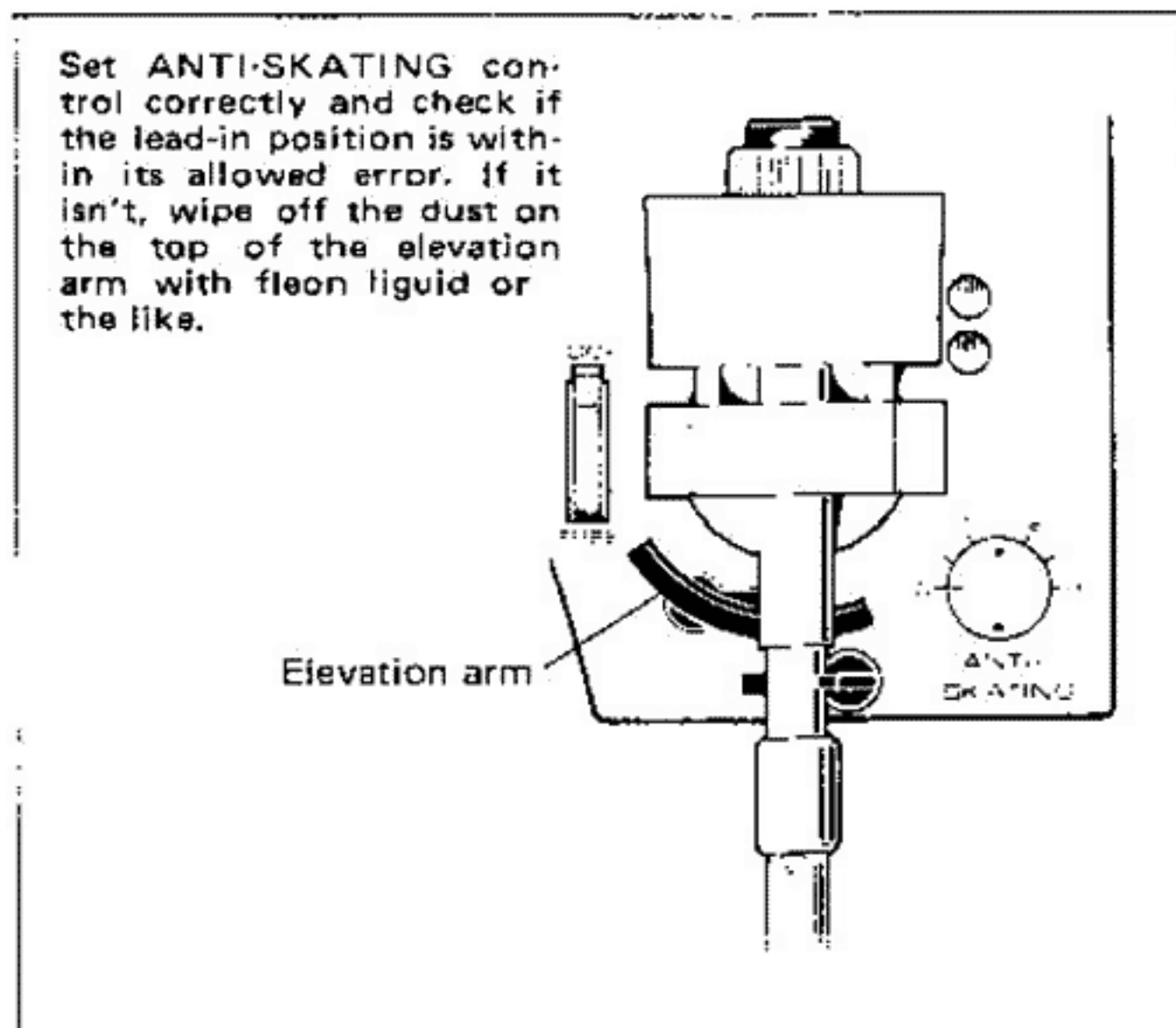

Fig. 19

