

DUAL CHANNEL POWER AMPLIFIER

PC5002M

SERVICE MANUAL

FRONT PANEL

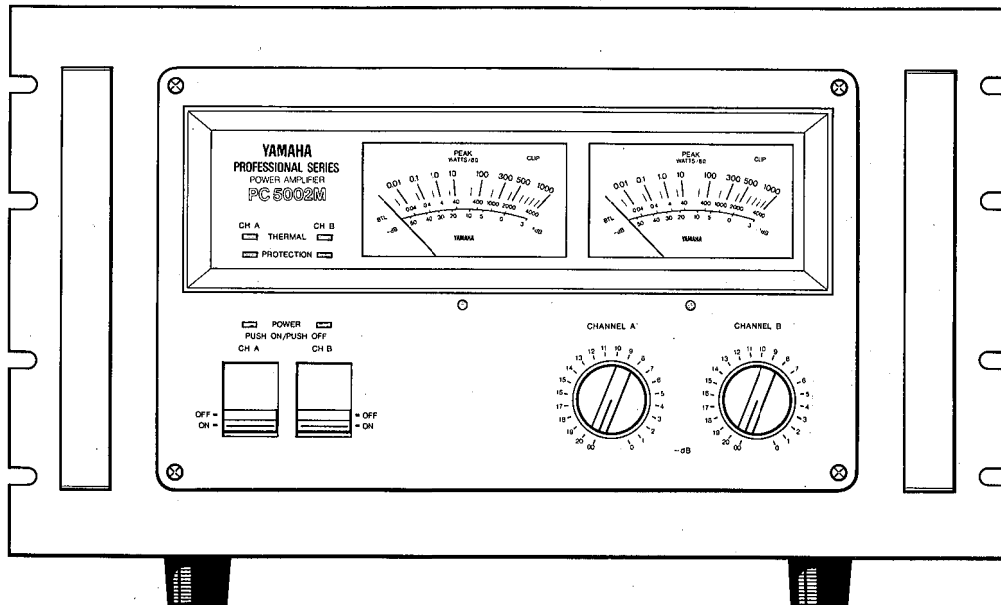

CONTENTS

REAR PANEL	1
SPECIFICATIONS	1
NAMES OF THE PARTS	2
DISASSEMBLY INSTRUCTIONS	3
GENERAL ADJUSTMENTS	4
PRINTED CIRCUIT BOARD LAYOUT	5
PARTS LIST	1~17
COMPLETE CIRCUIT DIAGRAM WIRING	

006537

SINCE 1887



YAMAHA

NIPPON GAKKI CO., LTD. HAMAMATSU, JAPAN

2.2K Printed in Japan.3.83.

PC5002M

REAR PANEL

Japan Model

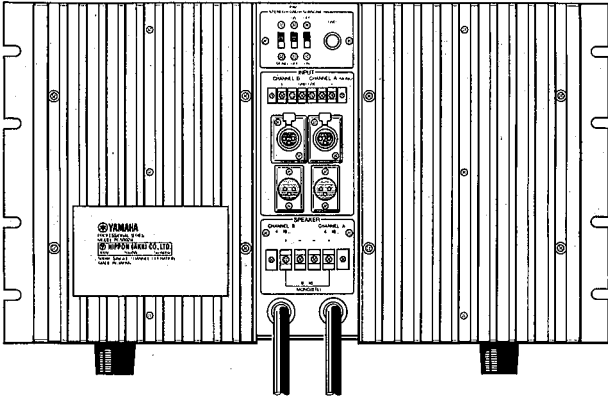

USA Model

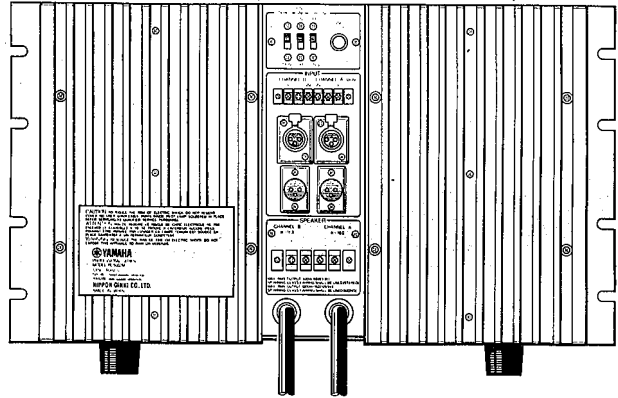

European Model

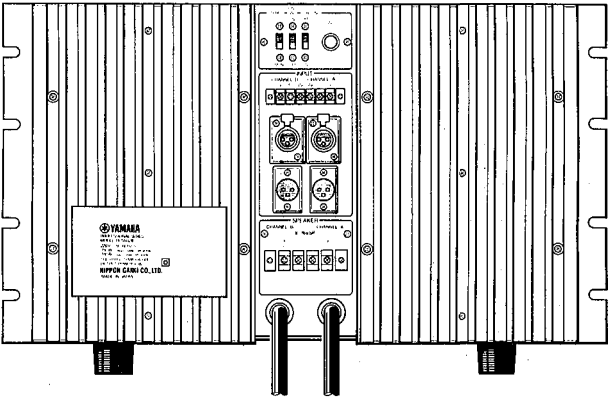

SPECIFICATIONS

Continuous RMS Output Power

STEREO 8Ω(20Hz to 20kHz, THD 0.003%) . . . 500W + 500W
 4Ω(20Hz to 20kHz, THD 0.01%) . . . 750W + 750W
 BTL(MONO) 8Ω(20Hz to 20kHz, THD 0.01%) 1500W

Power Bandwidth

250W/8Ω, THD 0.1% 10Hz to 100kHz

Input Sensitivity/Impedance

500W/8Ω 1.73V/25kΩ

Frequency Response

8Ω, 1W 10Hz to 100kHz $^{+0}_{-3}$ dB

Subsonic Filter

. fc=7Hz, -12dB/oct

Signal-to-Noise Ratio (IHF A, RL=8Ω)

. 122dB

Total Harmonic Distortion (STEREO)

20Hz to 20kHz, 250W/8Ω 0.003% less than

- Primary Fuse 15A, 250V x 2(USA model)
 T6.3A, 250V x 2(European model)
 15A, 125V x 2(Japan model)
- Power Supply AC 120V(USA model)
 AC 220/240V(European model)
 AC 100V(Japan model)
- Power Consumption (EIAJ) 1000W(Dual channel)
- Dimensions (W x H x D) 482 x 289 x 482 mm
 19 x 11-3/8 x 19 inch
- Weight 61 kg(134.2 lbs)

*Specifications subject to change without notice.

■ NAMES OF THE PARTS

トップカバーをはずす。……バッファシート, ドライブシートの交換が可能です。
 サイドカバーをはずす。……サブ電源シート, サブ電源トランスの交換が可能です。
 ヒートシンク (リア) をはずす。……パワーシートの交換が可能です。
 ターミナルユニットをはずす。……入力シート, 出力リレーシートの交換が可能です。
 ボトムカバーをはずす。……ダイオードシート, メイントランスの交換が可能です。
 フロントパネルをはずす。……メーターシート, メーターランプシート, LEDシートの交換が可能です。

Removal of top cover : buffer circuit board, drive circuit board can be replaced.
 Removal of side covers : sub power supply circuit board, sub power supply transformer can be replaced.
 Removal of heatsink (rear) : power circuit board can be replaced.
 Removal of terminal unit : input circuit board, output relay circuit board, can be removed.
 Removal of bottom cover : diode circuit board, main power transformer can be replaced.
 Removal of front panel : meter circuit board, meter lamp circuit board, LED circuit board can be replaced.

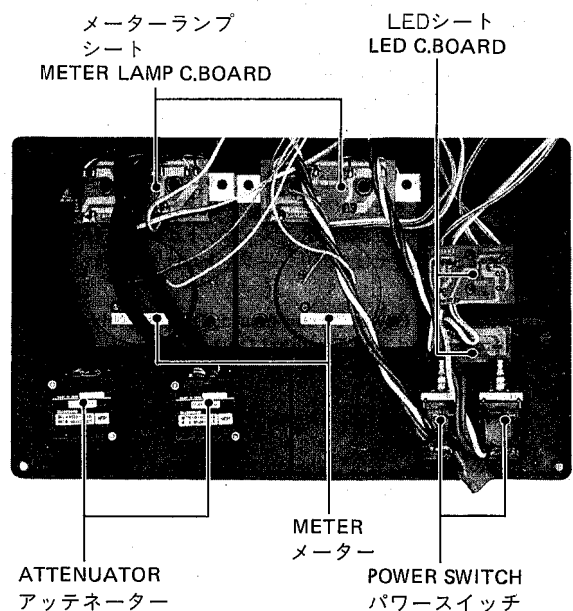
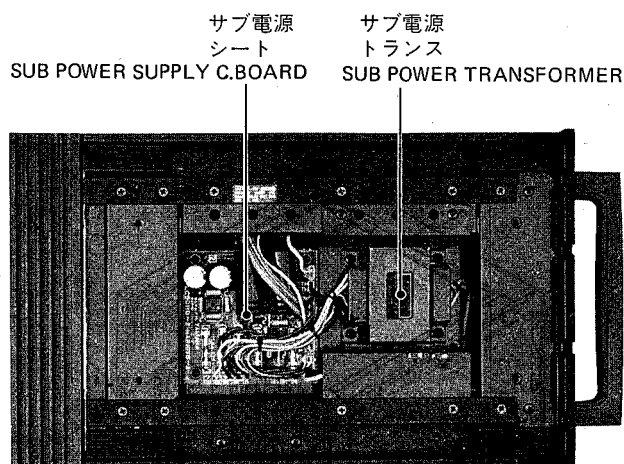
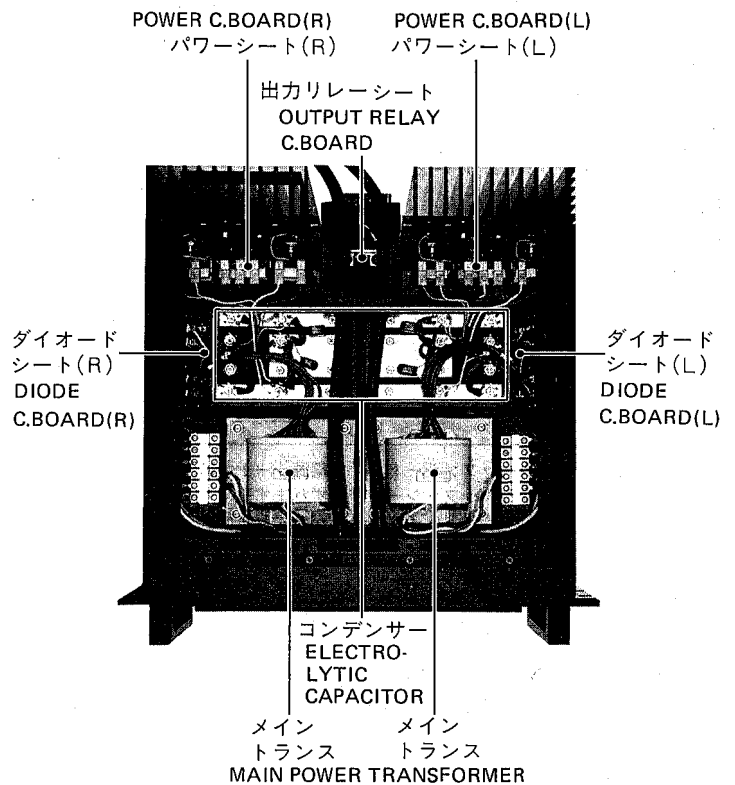
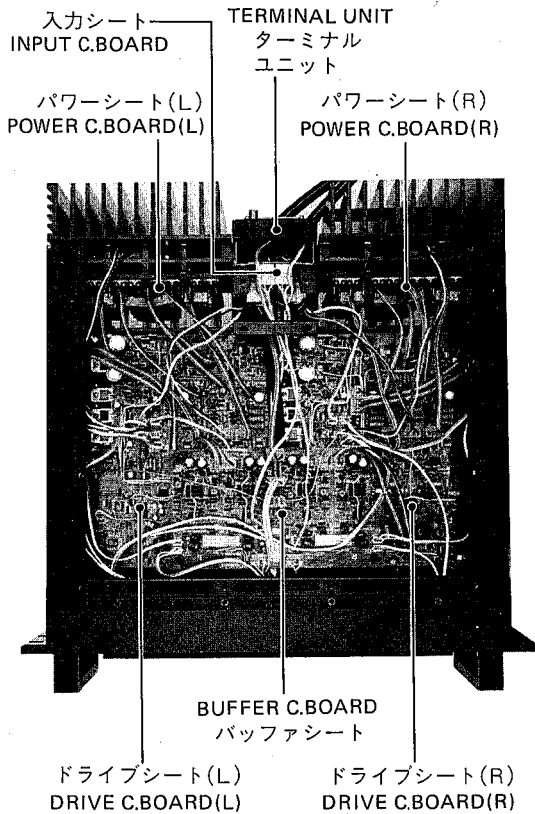

DISASSEMBLY INSTRUCTIONS

- 1、トップカバーのはずし方
①、②のネジをはずします。
- 2、サイドパネルのはずし方
③のネジをはずします。
- 3、ヒートシンク（リア）のはずし方
④、⑤のネジをはずします。
- 4、ボトムカバーのはずし方
⑥、⑦のネジをはずします。

1. Removal of Top Cover
Remove screws ① and ②.
2. Removal of Side Panels
Remove screw ③.
3. Removal of Heatsink (Rear)
Remove screws ④ and ⑤.
4. Removal of Bottom Cover
Remove screws 6 and 7.

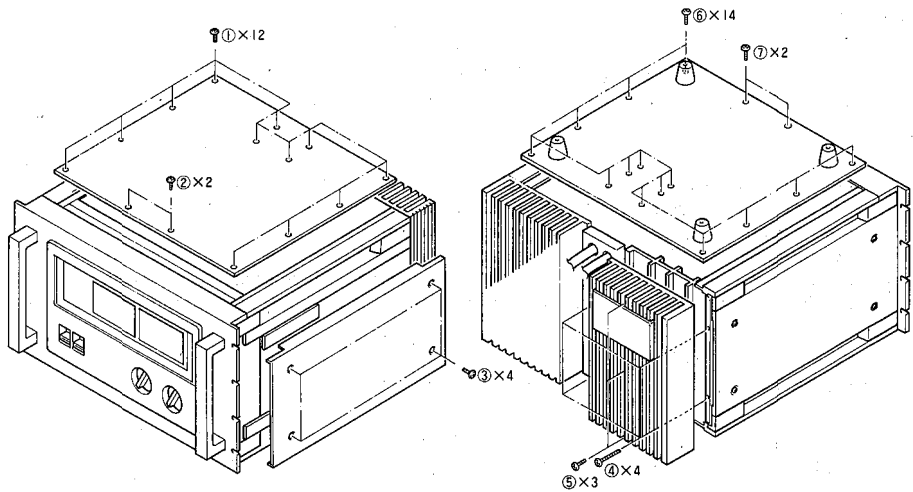

- 5、フロントパネルのはずし方
● トップカバー、ボトムカバーをはずします。
● ⑧のネジをはずします。

5. Removal of Front Panel
● Remove the top cover and bottom cover.
● Remove screw ⑧.

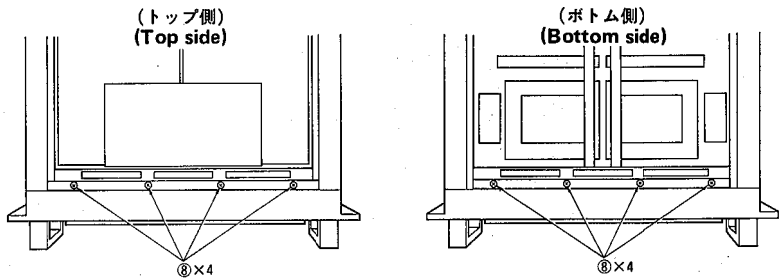

- 6、ドライブシート、バッファシート、サブ電源シートのはずし方
● ⑨のネジをはずすとバッファシートがはずれます。
● ⑩～⑬のネジをはずすとドライブシートがはずれます。
● ⑭のネジをはずすとサブ電源シートがはずれます。

- 7、サブトランスのはずし方
● ⑮、⑯のネジをはずすとサブトランスAss'yがはずれます。
● ⑰のネジをはずすとサブトランスがはずれます。

6. Removal of Drive Circuit Board, Buffer Circuit Board, Sub Power Supply Circuit Board
● Remove screw ⑨. The buffer circuit board can now be removed.
● Remove screws ⑩ ~ ⑬. The drive circuit board can now be removed.
● Remove screw ⑭. The sub power supply circuit board can now be removed.

7. Removal of Sub Power Transformer
● Remove screws ⑮ and ⑯. The sub power transformer assembly can now be removed.
● Remove screw ⑰. The sub power transformer can now be removed.

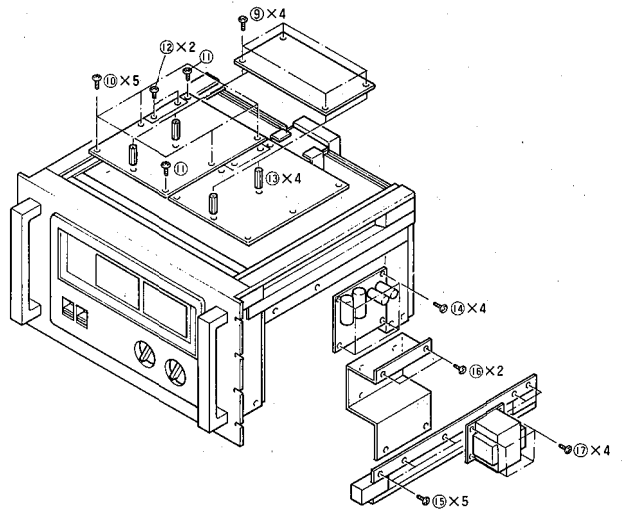

- 8、パワーシート、出力リレーシート、ターミナルユニットのはずし方
● ⑱のネジをはずせばパワーシートがはずれます。
● ⑲のネジをはずせばターミナルユニットがはずれます。
● ⑳のネジをはずせば出力リレーシートがはずれます。

8. Removal of Power Circuit Board, Output Relay Circuit Board, and Terminal Unit
● Remove screw ⑱. The power circuit board can now be removed.
● Remove screw ⑲. The terminal unit can now be removed.
● Remove screw ⑳. The output relay circuit board can now be removed.

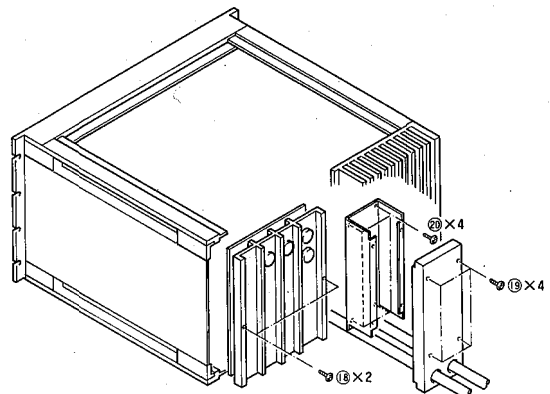

■ GENERAL ADJUSTMENTS

順序 Step	調整項目 Adjustment Item	測定器 Test Equipment	調整箇所 Adjustment Point	テストポイント Test Point	方法 Procedure	規格値 Rating	備考 Remarks
1	定電圧電源電圧調整 Voltage adjustment of regulated power supply	デジタルボルトメーター Digital Voltmeter	VR302	TPV(+) \longleftrightarrow E	テストピンTPV+とシャーシ間(グラウンド間)の電圧を規格値になるようにVRを調整する。 Adjust the VR to obtain the rated voltage reading between test pin TPV and chassis ground.	+120V \pm 1V	
			VR303	TPV(-) \longleftrightarrow E	テストピンTPV-とシャーシ間(グラウンド間)の電圧を規格値になるようにVRを調整する。 Adjust the VR to obtain the rated voltage reading between test pin TPV and chassis ground.	-120V \pm 1V	
2	アイドリング電流調整 Idling current adjustment	ミリボルトメーター Milli-voltmeter	VR301	TPE(+) \longleftrightarrow TPO TPE(-) \longleftrightarrow TPO	あらかじめVRを左いっぱいに戻しておき通電し、5分間のエージング後に規格値になるように調整する。 First turn the VR fully counter-clockwise. Then switch on the power, wait for at least 5 minutes, and adjust the VR obtain the rated reading.	5mV ~ 7mV	項目1の後に 行なう *1
3	メーター感度調整 Meter sensitivity adjustment	低周波発振器 Audio signal Generator	VR901 (L ch) VR902 (R ch)	—	1kHzの信号を入力した時の、定格出力時(500W/8 Ω , 63.3V)にメーターの指示が0dBとなるように調整する。 Adjust the VRs to obtain a meter indication of 0 dB when a 1 kHz signal is applied to the input and the output is at rated power (500 W /8 ohms, 63.3 V).	メーターの指示が0dB Meter indication 0 dB	高出力の為、 ダミーに注意 *2

*1 To be performed after step 1.

*2 Pay due attention to the dummy load, which must handle high output power.

ADJUSTING POINTS

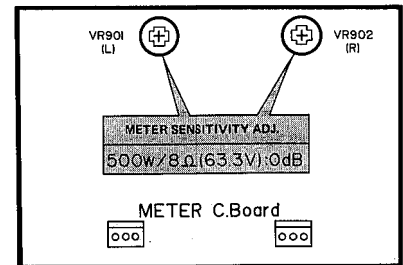
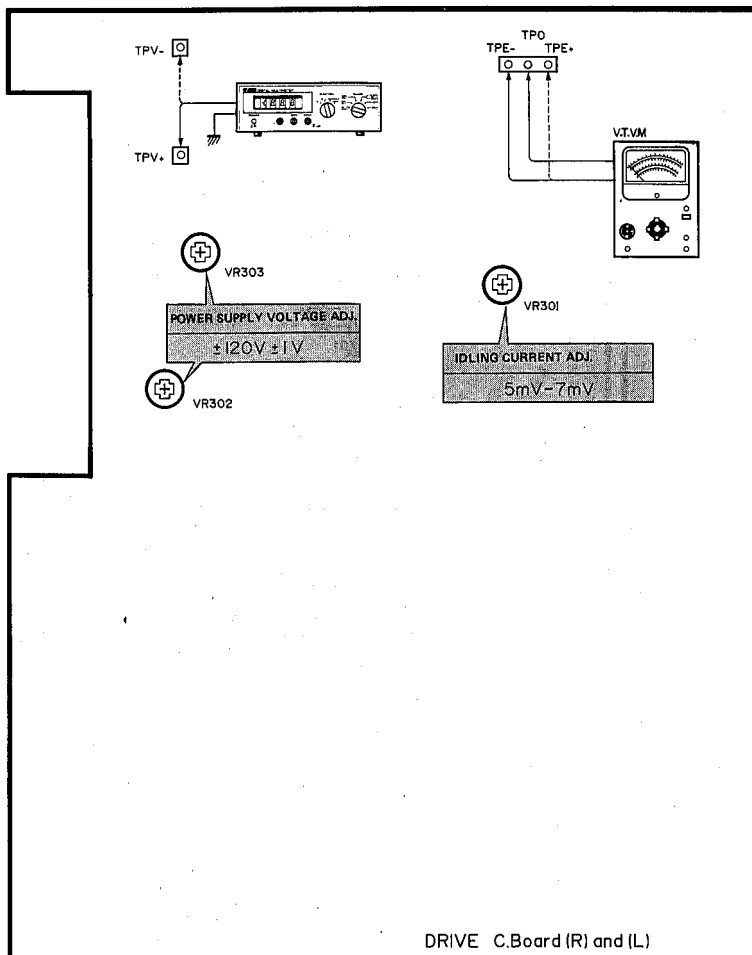

PRINTED CIRCUIT BOARD LAYOUT

Meter

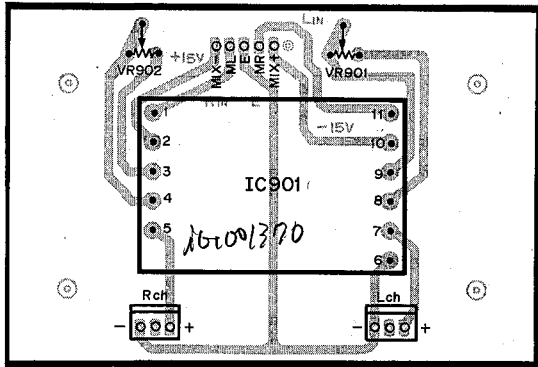

Meter Lamp.

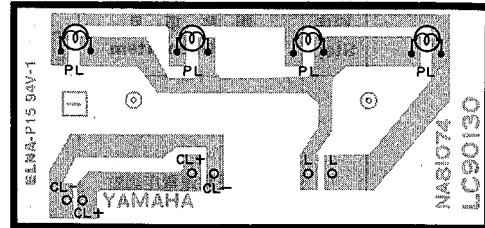

LED (1), (2)

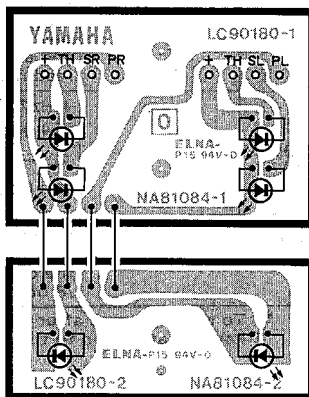

Sub Power Supply (1)

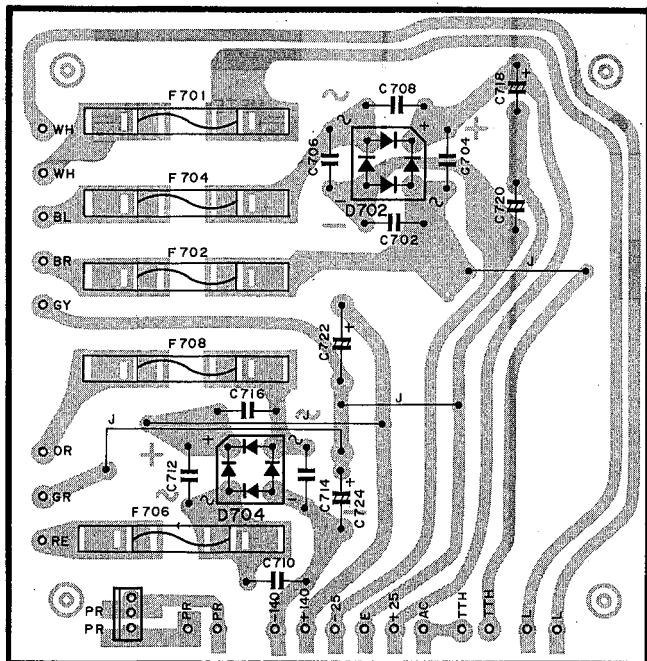

Sub Power Supply (2)

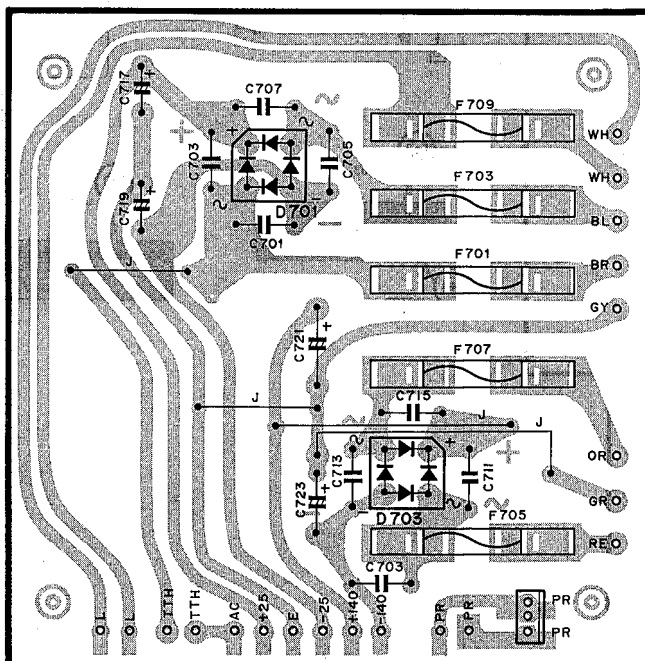

PRINTED CIRCUIT BOARD LAYOUT

Buffer

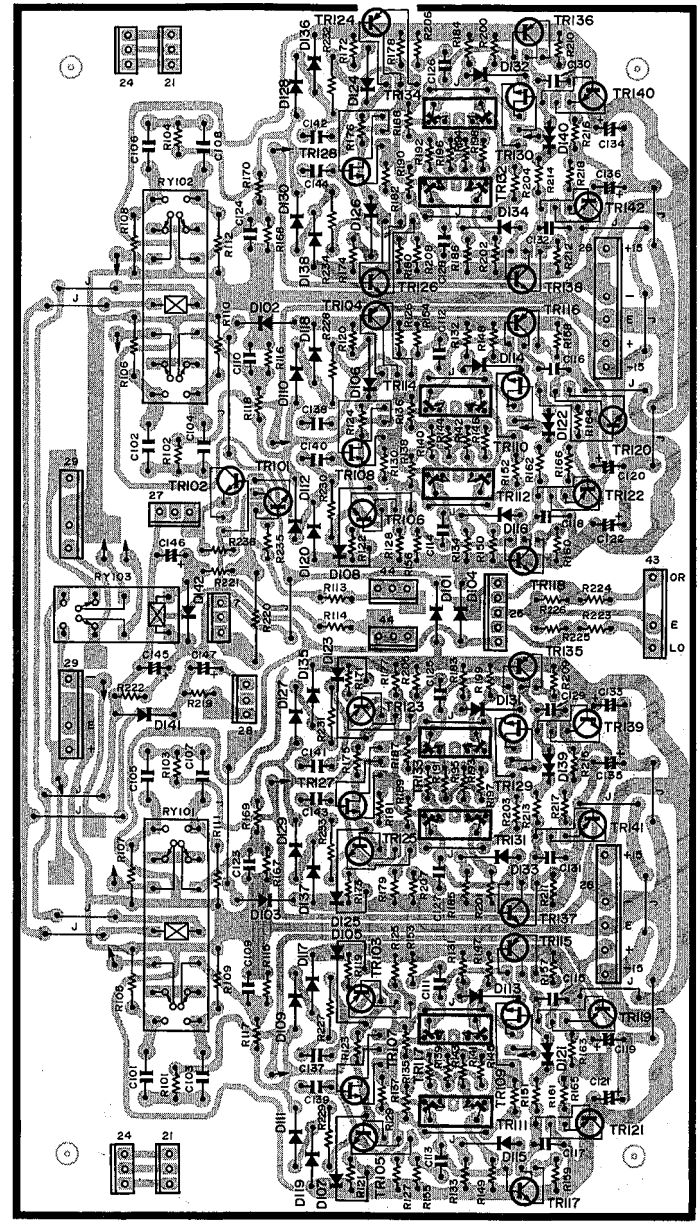

Drive

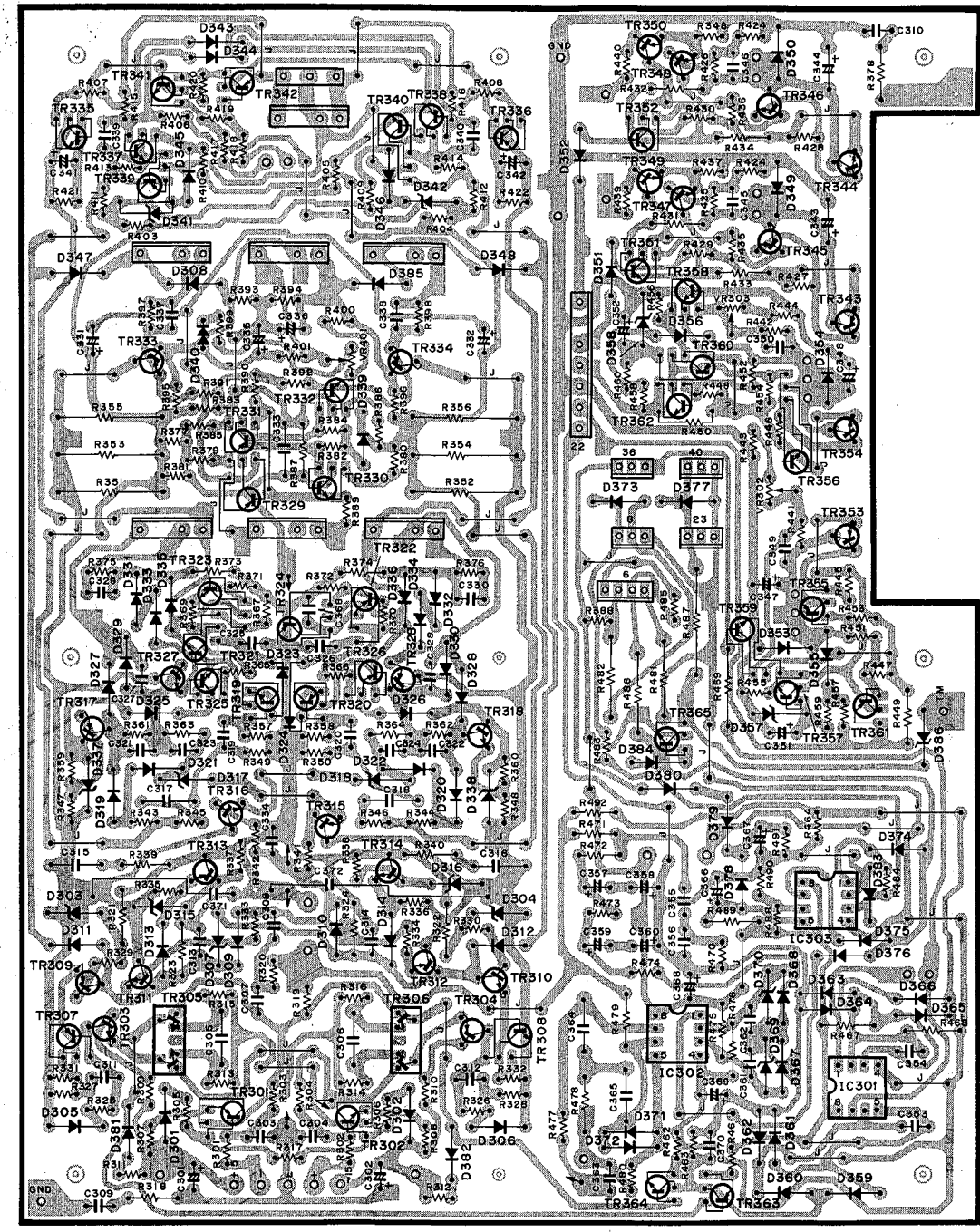

Power

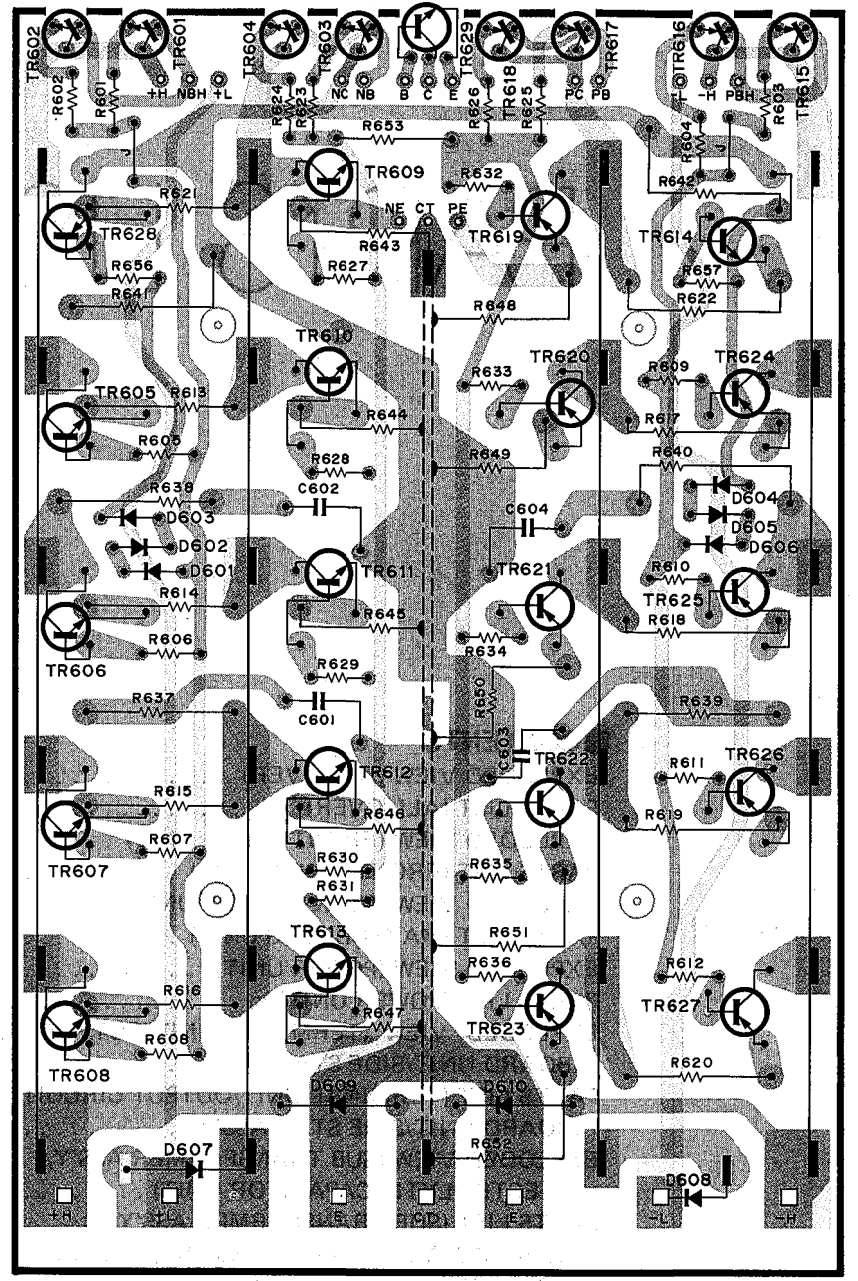

Output Relay

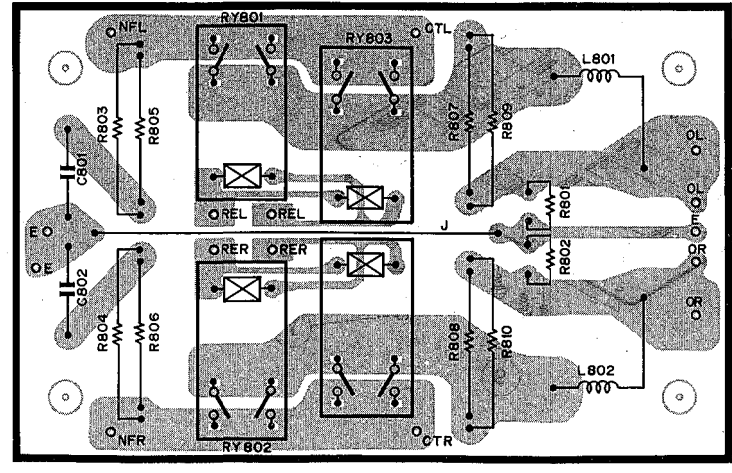

Diode

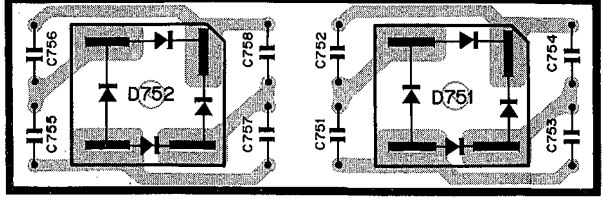

Input



PARTS LIST

■ CONTENTS

EXPLODED VIEW (ALL OVER)	1
PARTS LIST (ALL OVER)	2
EXPLODED VIEW (FRONT PANEL UNIT)	3
PARTS LIST (FRONT PANEL UNIT)	4
EXPLODED VIEW (MAIN CHASSIS UNIT)	5
PARTS LIST (MAIN CHASSIS UNIT)	6
EXPLODED VIEW (POWER UNIT)	7
PARTS LIST (POWER UNIT)	8
EXPLODED VIEW (TERMINAL UNIT/OUTPUT CIRCUIT BOARD UNIT/SIDE STAY ASS'Y)	9
PARTS LIST (TERMINAL UNIT/OUTPUT CIRCUIT BOARD UNIT/SIDE STAY ASS'Y)	10
EXPLODED VIEW (SUB TRANSFORMER ASS'Y/ ELECTROLYTIC CAPACITOR UNIT)	11
PARTS LIST (SUB TRANSFORMER ASS'Y/ ELECTROLYTIC CAPACITOR UNIT)	12
PARTS LIST (CIRCUIT BOARD)	13

006537

SINCE 1887



YAMAHA

NIPPON GAKKI CO., LTD. HAMAMATSU, JAPAN

PC5002M

EXPLODED VIEW (All over)

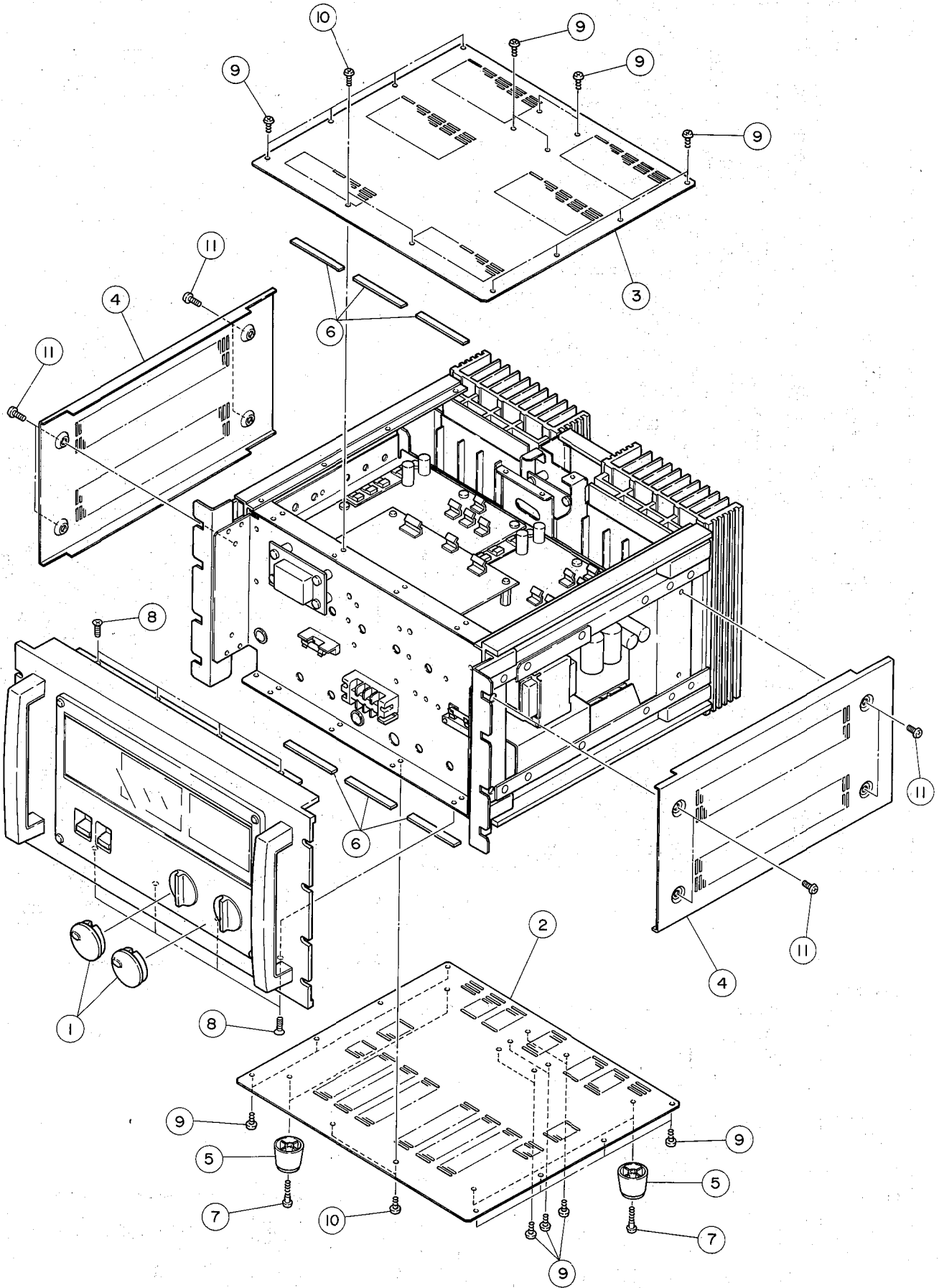

■PARTS LIST (All over)

Ref. No.	Part No.	Description	部 品 名	Remarks	Common Model	Markets	ランク
		All Over	総組立				
	CB 82 5740	Knob Lock	ノブロック		PC5002M		020
*	AA 82 4650	Bottom Cover	ボトムカバー		101M		110
*	AA 82 4660	Top Cover	トップカバー				130
*	BA 80 7350	Side Panel	サイドパネル				110
*	CB 82 6970	Leg	VC トランレグ		101M		010
*	CB 82 6980	Dumper Rubber B	ダンパーゴムB		101M		020
	Ei 03 0206	Bind Head Tapping Screw	M3×20 Bℓ バインドタッピングネジ				010
	EB 34 0126	Flat Head Screw	M4×12 Bℓ 皿小ネジ				010
	Ei 34 0086	Bind Head Tapping Screw	4×8 Bℓ バインドタッピングネジ				010
	Ei 34 0126	"	4×12 Bℓ "				010
	ED 34 0086	Bind Head Screw	M4×8 Bℓ バインド小ネジ				010

* : New Parts (新部品)

EXPLODED VIEW (Front panel unit)

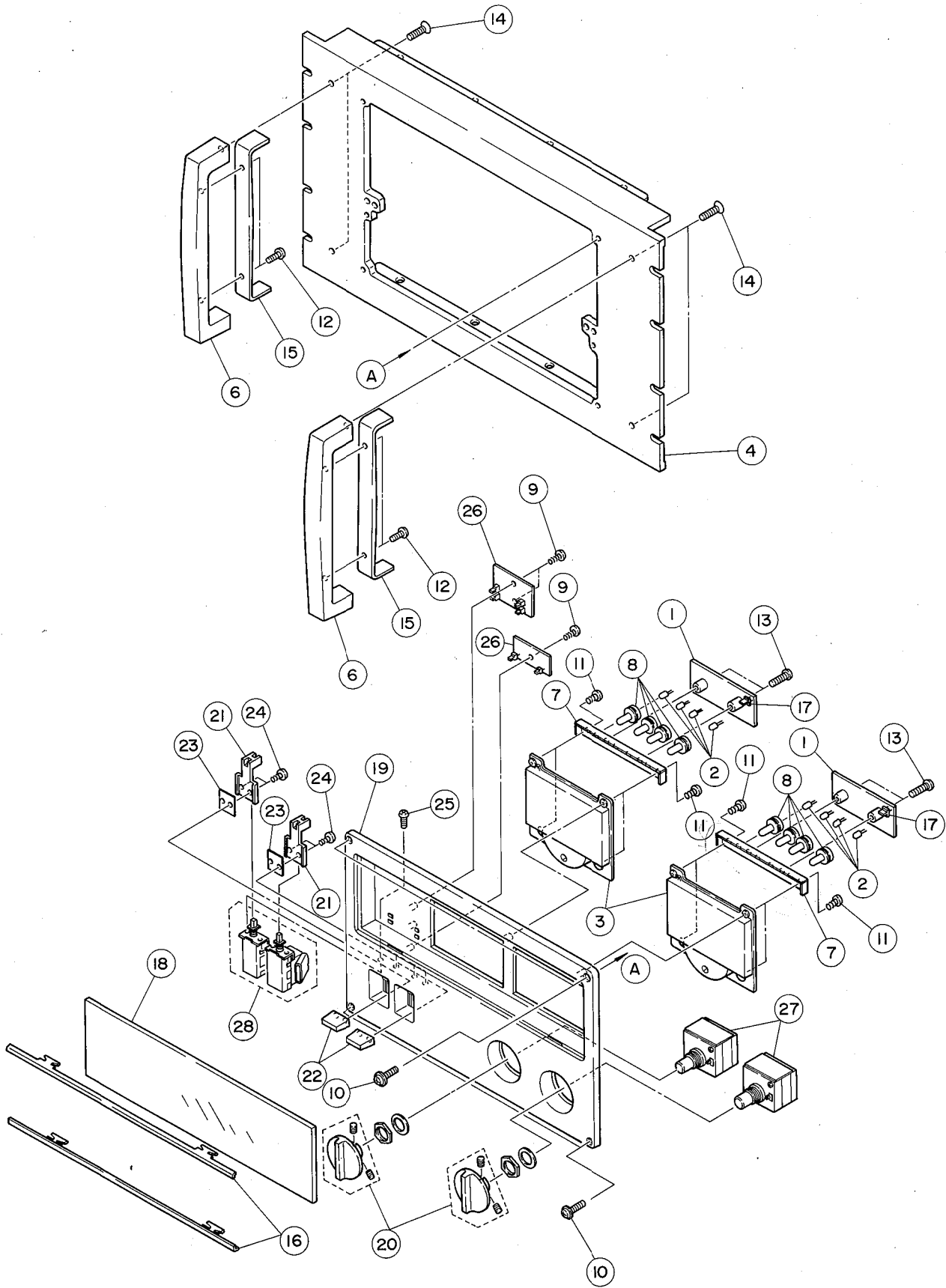

PARTS LIST (Front panel unit)

Ref. No.	Part No.	Description	部 品 名	Remarks	Common Model	Markets	ランク
		Front Panel Unit	フロントパネルユニット				
※ 1	NA:81:07:40	Meter Lamp C.Board #9013	メーターランプシート		101M		090
※ 2	JB:00:11:40	Pilot Lamp Lead Type 8V 150mA	パイロットランプリード式				020
※ 3	Ji:00:13:10	Peak Meter	ピークメーター				200
※ 4	BA:80:73:30	Front Panel	フロントパネル				270
※ 5	AA:82:58:80	Metal for Panel	パネル金具				050
※ 6	BA:80:73:40	Handle	取手				130
※ 7	BA:80:76:50	Lamp Refractor	ランプリフレクター		101M		050
※ 8	CB:60:50:70	Cap for Lamp CB619790	ランプキャップ		101M		010
	Ei:33:00:86	Bind Head Tapping Screw 3×8 Bℓ	バインドタッピングネジ				010
	ED:35:01:66	Bind Head Screw M5×16 Bℓ	バインドダブルセムス小ネジ				010
	ED:33:01:26	" M3×12 Bℓ	バインド小ネジ				010
	ED:34:00:86	" M4×8 Bℓ	"				010
	ED:33:02:06	" M3×20 Bℓ	"				010
	EF:34:01:56	Oval Head Screw M4×14 Bℓ	丸皿小ネジ				010
※ 15	CB:80:70:20	Pad for Handle	ハンドルパッド				040
※ 16	AA:82:46:70	Mount Metal	固定金具				050
	JF:00:17:20	LED (Red) LN222RP	LED (赤)				031
※ 18	CB:82:72:00	Front Window	フロント窓				080
※ 19	CB:82:58:40	Panel 3527	パネルエスカッション				100
	CB:80:81:40	Knob for Attenuator	アッテネーターノブ				050
	CB:80:66:90	Slider for Power SW	P. SWスライダー				020
	CB:80:67:00	Knob for Power SW	P. SWノブ				080
	CB:80:67:10	Tape for Indicator	インジケーターテープ				060
	Ei:33:01:26	Bind Head Tapping Screw 3×12 Bℓ	バインドタッピングネジ				010
	ED:33:00:86	Bind Head Screw M3×8 Bℓ	バインド小ネジ				010
※ 26	NA:81:08:40	LED C.Board #9018	LEDシート				110
※ 27	HY:00:17:70	Detent Rotaly Pot. 33.3K×2	デテントVR				110
※	LB:10:11:90	Terminal	ターミナル	Detent Rotaly Pot.			010
※	LB:01:10:30	Housing	ハウジング	"			010
	KA:80:32:00	Power Switch TV-10 UL	パワースイッチ			U	
※	KA:80:34:10	" 16A 125V	"			J	070
※	KA:80:34:20	" SEMKO	"			G	
※	Fi:38:41:00	Ceramic Capacitor 0.01μF VA-1	セラコン	Power Switch			010
	CB:09:52:60	Cover for Capacitor SB0833	コンデンサーカバー丸型	"			010
	CB:07:41:90	Tape W20×215	ダブルタックテープ	Handle			010

※ : New Parts (新部品)

EXPLODED VIEW (Main chassis unit)

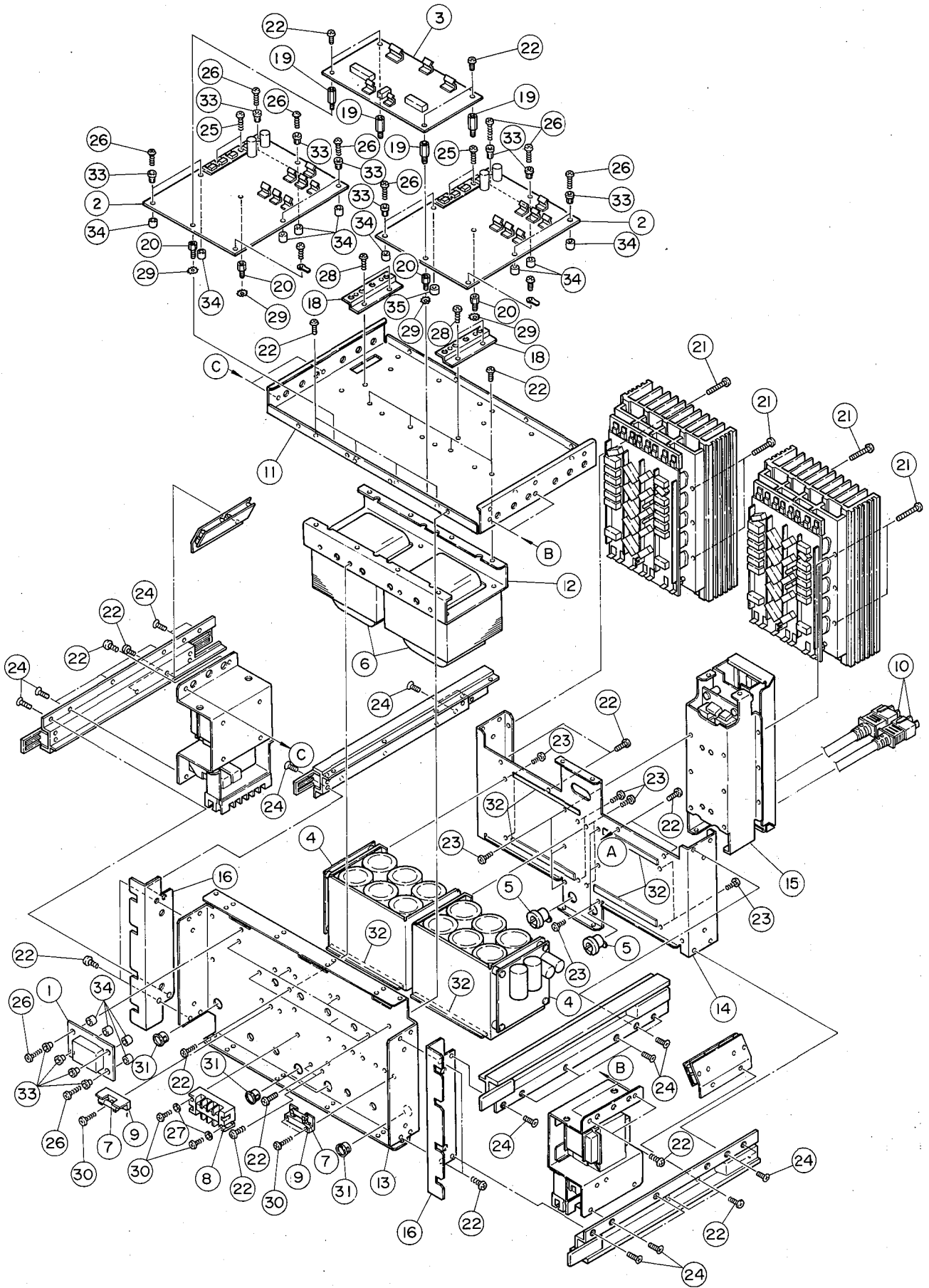

PARTS LIST (Main chassis unit)

Ref. No.	Part No.	Description	部 品 名	Remarks	Common Model	Markets	ランク
		Main Chassis Unit	メインシャーシユニット				
※	1 NA:81:09:80	Meter C. Board	#9008	メーターシート			160
※	2 NA:81:06:50	Drive C. Board	#9006	ドライブシート		101M	390
※	3 NA:81:06:60	Buffer C. Board	#9007	バッファシート		"	330
※	4 NA:81:07:00	Sub Power Supply C. Board	#9011	サブ電源シート		"	J 240
※	" NA:81:07:10	"	#9014	"		"	U
※	" NA:81:07:20	"	#9015	"		"	G
※	5 CB:82:71:10	Cord Stopper	SR-8P-2	コードストッパー		"	J 030
	" CB:81:11:70	"	SR-6P-4	"		"	U
	" CB:82:57:00	"	SR-5P-4	"		"	G
※	6 GA:65:72:00	Power Transformer		電源トランス		"	J 320
※	" GA:65:73:00	"		"		"	U
※	" GA:65:74:00	"		"		"	G
※	7 KB:00:12:70	Fuse	15A 125V	ヒューズ		"	J 010
※	" KB:00:13:80	" UL Time Lug	15A 250V	" ULタイムラグ		"	U
	" KB:00:07:70	" Ⓢ "	T6.3A 250V	" Ⓢタイムラグ		"	G
※	8 LA:00:43:60	4P Terminal	SBB101-4P	4P連絡端子台		"	060
	9 LB:20:13:40	Fuse Holder	1PFH	ヒューズホルダー		"	J,U 020
	" LB:20:14:70	"	1PFH-M	"		"	G
※	10 MG:00:14:80	Power Cord (Black)	15A 125V 2m	電源コード (黒)		"	J 150
※	" MG:00:10:10	"		"		"	U
※	" MG:00:11:30	"	10/16A 250V	"		"	G
※	11 AA:82:46:80	Main Frame		メインフレーム		101M	140
※	12 AA:82:46:90	Trans Folder		トランスホルダー		"	120
※	13 AA:82:47:00	Front Frame		フロントフレーム		"	130
※	14 AA:82:47:10	Rear Frame		リアフレーム		"	110
※	15 AA:82:47:20	Terminal Mount Metal		ターミナル取付金具		"	130
※	16 AA:82:53:30	Rack Mount Metal		ラックマウント金具		"	070
※	17 AA:82:53:70	Cord Stopper Metal		コードストッパー金具		"	G
※	" AA:82:57:90	"		"		"	U
※	18 BA:80:76:80	Heat Sink B		定電圧放熱板 B		101M	050
※	19 BB:80:69:40	Strut A		支柱 A		"	030
※	20 BB:80:69:60	" C		" C		"	030
	21 ED:94:03:00	Bind Head Screw	M4×30 Bℓ	バインド小ネジ			010
	22 ED:34:00:66	"	M4×6 Bℓ	"			010
	23 Ei:34:00:86	Bind Head Tapping Screw	4×8 Bℓ	バインドタッピングネジ			010
	24 EB:34:01:26	Flat Head Screw	M4×12 Bℓ	皿小ネジ			010
	25 ED:33:00:86	Bind Head Screw	M3×8 Bℓ	バインド小ネジ			010
	26 Ei:03:02:06	Bind Head Tapping Screw	3×20 Ye	バインドタッピングネジ			010
	27 EV:20:30:36	Plain Washer	M3 Bℓ	平座金			010
	28 Ei:33:00:86	Bind Head Tapping Screw	3×8 Bℓ	バインドタッピングネジ			010
	29 EV:41:30:46	Toothed Lock Washer	M4 Bℓ	内歯形歯付座金			010
	30 Ei:33:01:06	Bind Head Tapping Screw	3×10 Bℓ	バインドタッピングネジ			010
※	31 CB:82:71:00	Cord Bush	SB750-10	コードブッシュ		101M	020
※	32 CB:82:71:90	Dumper Rubber A		ダンパーゴム A		"	020
	33 CB:09:28:00	Bush	M3	ワンタッチブッシュ			010
	34 CB:09:28:20	Collar	H-7.5	ワンタッチカラー			010

※ : New Parts (新部品)

EXPLODED VIEW (Power unit)

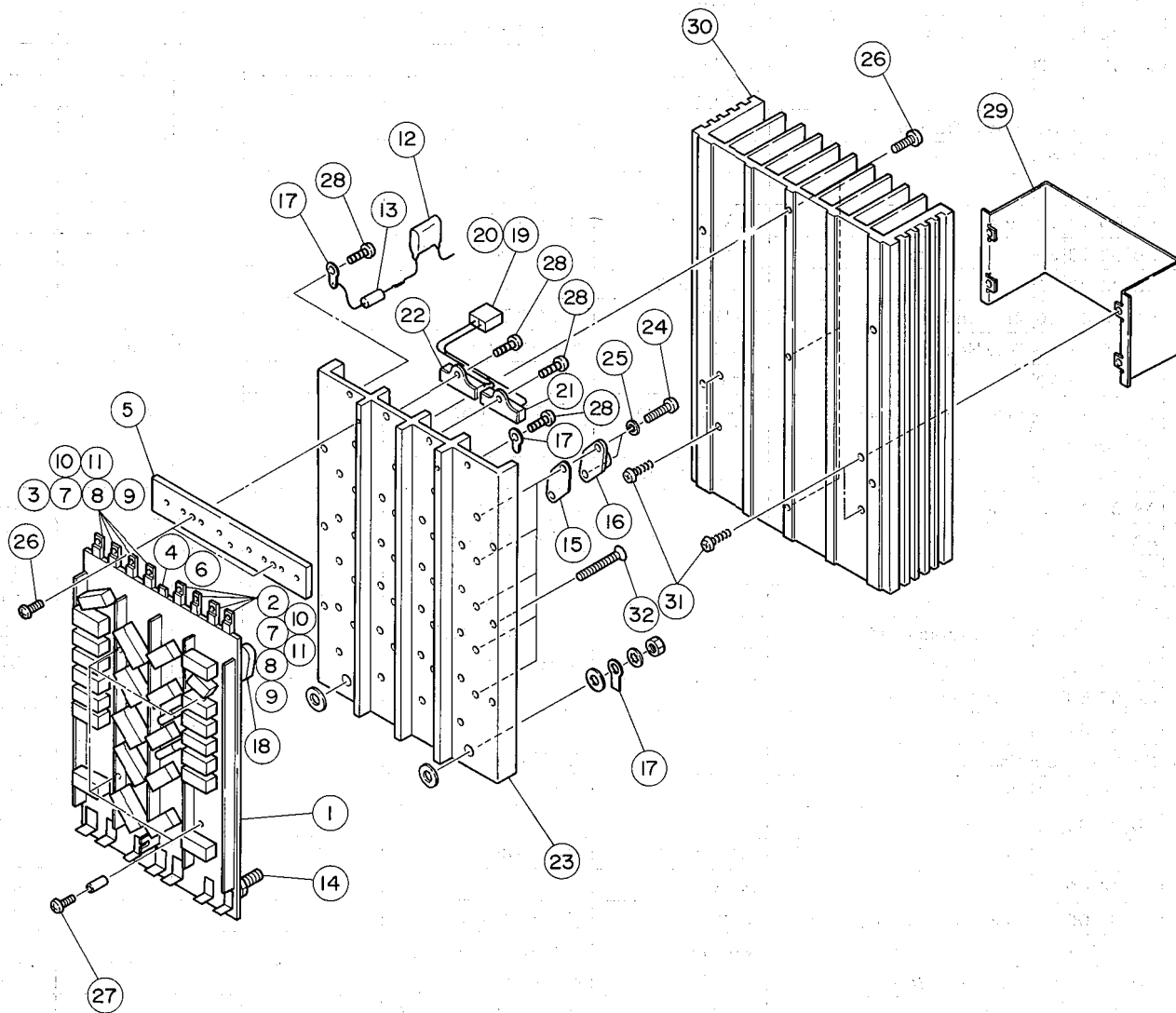

■PARTS LIST (Power unit)

35.

Ref. No.	Part No.	Description	部 品 名	Remarks	Common Model	Markets	ランク
		Power Unit	パワーユニット				
※ 1	NA:81:06:80	Power C.Board	#9009	パワーシート		101M	310
2	iC:22:38:40	Transistor	2SC2238B(O,Y)	トランジスター			041
3	iA:09:68:20	"	2SA968B(O,Y)	"			030
4	iC:19:53:50	"	2SC1953(Q,R,S,T)	"			030
5	BA:80:73:80	Heat Sink		放熱板			100
6	ED:33:00:86	Bind Head Screw	M3×8 Bℓ	バインド小ネジ			010
7	ED:02:60:66	"	M2.6×6 Yℓ	"			010
8	EV:30:02:66	Spring Washer	M2.6 Yℓ	スプリングワッシャー			010
9	EV:20:02:66	Plain Washer	M2.6 Yℓ	平座金			010
10	CB:07:28:80	Insulation Bush	M2.6	絶縁ブッシュ			010
11	iL:00:02:70	Insulation Base		絶縁ベース			010
12	FC:38:43:30	Polypropylene Capacitor	0.033μF 100V(J)	ポリプロコンQP	C605,606		020
13	HL:81:34:70	Metal Oxide Resistor	4.7Ω 2P	酸化抵抗ストレート	R654,655		010
14	iH:00:12:80	Diode High Efficiency	15CG15	高効率ダイオード	D607,608		090
15	iL:00:02:30	Mica Base	AC201	マイカベース			010
16	iX:80:02:00	Transistor	2SA1117(O,Y)	トランジスター	TR619~628		082
"	iX:80:02:10	"	2SC2608(O,Y)	"	TR605~614		080
17	LA:00:02:80	Earth Lug	3mm	アースラグ			010
18	LB:60:51:80	Socket for Transistor	M1629-D	トランジスターソケット			020
19	LB:30:07:20	Housing	H3P-SHF	ハウジング			010
20	BB:00:44:30	Contact Pin	0017-08CS	コンタクトピン			010
21	KA:00:01:70	Thermal Protector	OHD90M	サーマルプロテクター			060
22	KA:00:01:60	"	OHD70M	"		U	
23	BA:80:74:00	Transistor Mount Plate		トランジスター取付板		101M	190
24	ED:03:01:86	Bind Head Screw	M3×18 Ye	バインド小ネジ			010
25	EV:30:00:36	Spring Washer	M3 Ye	スプリングワッシャー			010
26	ED:33:01:06	Bind Head Screw	M3×10 Bℓ	バインド小ネジ			010
27	ED:33:01:66	"	M3×16 Bℓ	"			010
28	Ei:33:00:86	Bind Head Tapping Screw	3×8 Bℓ	バインドタッピング			010
29	AA:82:52:50	Rear Panel A		リアパネルA		J	090
"	AA:82:52:60	"		"		U	
"	AA:82:52:70	"		"		G	
30	BA:80:73:90	Radiator		ラジエーター		101M	220
31	Ei:33:01:06	Bind Head Tapping Screw	3×10 Bℓ	バインドタッピングネジ			010
32	EB:34:02:06	Flat Head Screw	M4×20 Bℓ	皿小ネジ			010

※ : New Parts (新部品)

■ EXPLODED VIEW (Terminal unit/Output c.board unit/Side stay Ass'y)

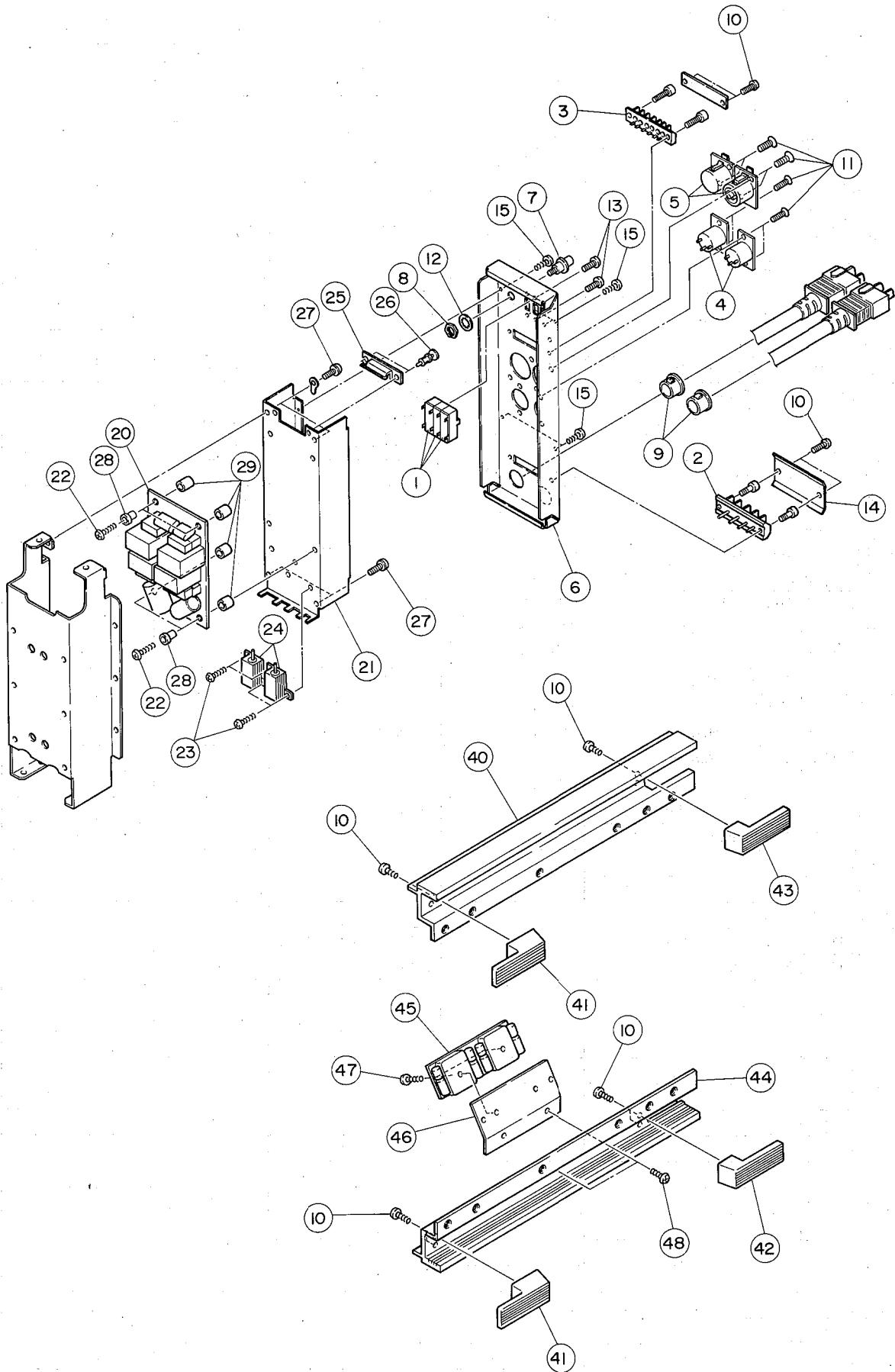

■PARTS LIST (Terminal unit/Output c.board unit/Side stay Ass'y)

Ref. No.	Part No.	Description	部 品 名	Remarks	Common Model	Markets	ランク
		Terminal Unit	ターミナルユニット				
1	KA:40:11:00	Slide Switch	4-2	スライドスイッチ			040
※ 2	LA:00:44:10	4P Terminal	FTA1	4P貫通端子台			060
※ 3	LA:00:44:70	6P "	M106A	6P "			050
4	LB:30:01:50	3P Cannon Connector		キャノン3Pオス			090
5	LB:30:01:60	3P "		" メス			070
※ 6	BA:80:74:10	Terminal Holder (J)		ターミナルホルダー (J)		J	120
※ "	BA:80:77:60	" (U)		" (U)		U	
※ "	BA:80:78:30	" (G)		" (G)		G	
7	NB:08:26:40	Earth Terminal Ass'y		アース端子Ass'y	101M		050
8	LA:00:16:80	Hexagonal Nut	M8×0.75	六角ナット	"		010
9	CB:82:71:00	Cord Bush	SB750-10	ゴードブッシュ		J	020
"	CB:07:77:60	"	SB500-6	スナップブッシング		U	
"	CB:82:70:80	"	SB500-5	コードブッシュ		G	
10	Ei:33:01:06	Bind Head Tapping Screw	3×10 Bℓ	バインドタッピングネジ			010
11	EF:23:01:06	Oval Head Screw	M3×10 Bℓ	丸皿小ネジ			010
12	EV:41:00:86	Toothed Lock Washer	8S Ye	歯付座金内歯形			010
13	ED:32:60:46	Bind Head Screw	M2.6×4 Bℓ	バインド小ネジ			010
14	CB:82:74:20	Cover, Terminal		SPターミナルカバー			030
15	Ei:33:00:86	Bind Tapping Screw		バインドタッピングネジ			010
		Output C.Board Unit	出力シートユニット				
※ 20	NA:81:07:70	Output Relay C.Board	#9017	出力リレーシート			200
21	BB:80:69:20	Output C.Board Stay		出力シートステイ			110
22	Ei:03:02:06	Bind Head Tapping Screw	3×20 Bℓ	バインドタッピングネジ			010
23	Ei:33:00:86	"	3×8 Bℓ	"			010
24	HZ:00:25:50	Metal Clad Resistor	RE70(G) 0.068Ω	メタルクラッド抵抗			080
※ 25	NA:81:06:90	Input C.Board	#9010	入力シート			100
26	CB:06:88:80	Plastic Rivet		プラスチックリベット			010
27	ED:34:00:66	Bind Head Screw	M4×6 Bℓ	バインド小ネジ			010
28	CB:09:28:00	Bush	M3	ワンタッチブッシュ			010
29	CB:09:28:20	Collar	H-7.5	ワンタッチカラー			010
		Side Stay Ass'y	サイドステー Ass'y				
40	BA:80:77:70	Side Stay (LU)		サイドステー (LU)			160
"	BA:80:77:80	" (RU)		" (RU)			160
41	CB:82:70:30	Side Leg (F)		サイドレッグ (F)	101M		030
42	CB:82:70:40	" (L)		" (L)	"		040
43	CB:82:70:50	" (U)		" (U)	"		040
44	BA:80:77:90	Side Stay (LL)		サイドステー (LL)			160
"	BA:80:78:00	" (RL)		" (RL)			160
45	NA:81:07:60	Diode C.Board	#9016	ダイオードシート	101M		180
46	BA:80:74:30	Diode Heat Sink		ダイオード放熱板	"		080
47	Ei:34:02:06	Bind Head Tapping Screw	4×20 Bℓ	バインドタッピングネジ			010
48	Ei:34:01:06	"	4×10 Bℓ	"			010

※ : New Parts (新部品)

EXPLODED VIEW (Sub transformer Ass'y/Electrolytic capacitor unit)

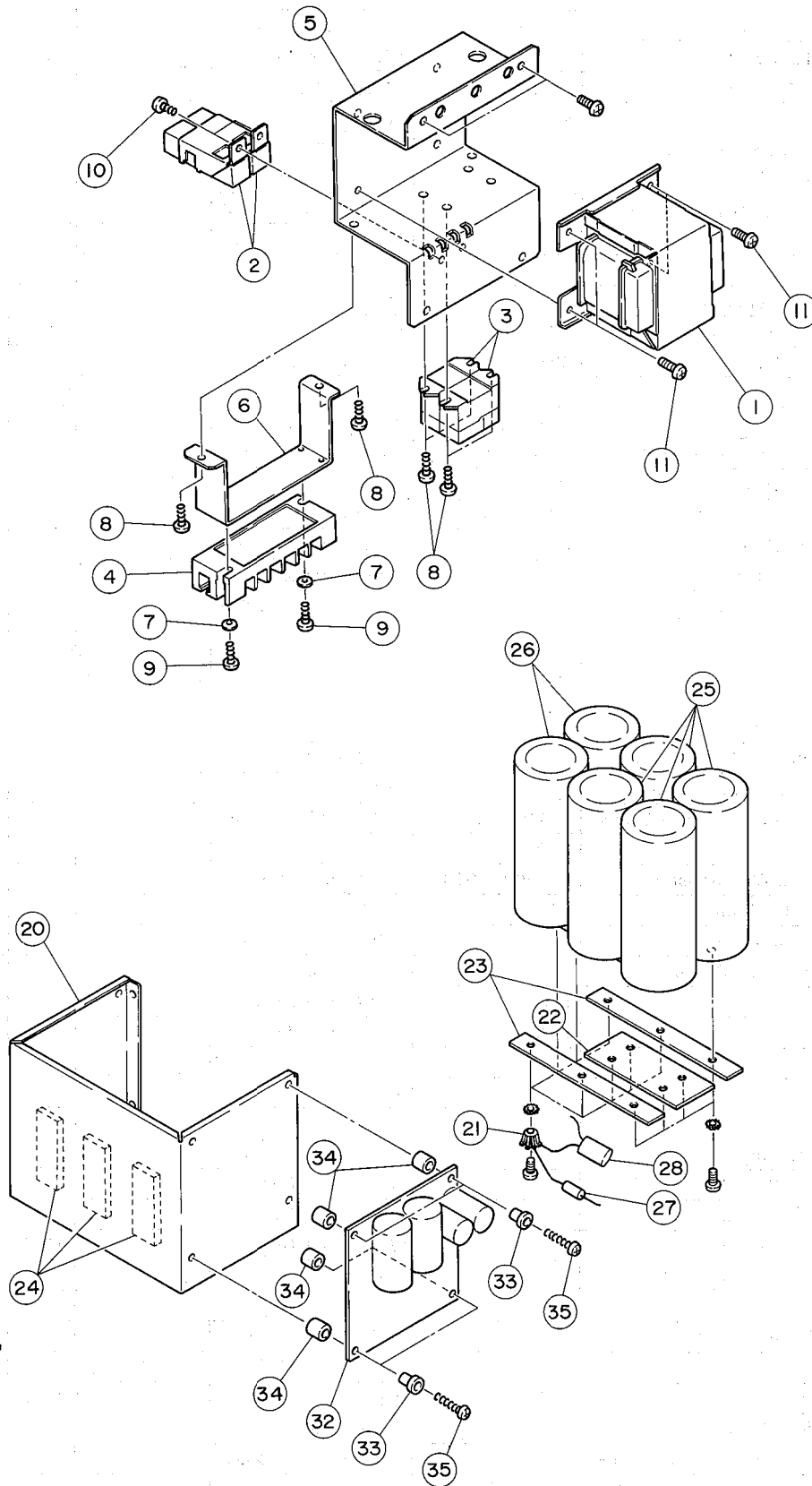

■PARTS LIST (Sub transformer Ass'y/Electrolytic capacitor unit)

Ref. No.	Part No.	Description	部 品 名	Remarks	Common Model	Markets	ランク
		Sub Trans Ass'y	サブトランスAss'y				
* 1	GA:65:76:00	Power Transformer	電源トランス			J	160
* 〃	GA:65:77:00	〃	〃			U	
* 〃	GA:65:78:00	〃	〃			G	
* 2	HZ:00:27:80	Cement Resistor	セメント抵抗	25P 4.7Ω		J,U	030
* 〃	HZ:00:27:90	〃	〃	25P 10Ω		G	
* 3	KC:00:14:20	Relay JC-1a	リレー	15A 250V			060
* 4	LA:00:43:50	6P Terminal	6P連結端子台	SBB101-6P			070
* 5	AA:82:47:60	Sub Trans. Frame (L)	サブトランスフレーム (L)				090
* 〃	AA:82:47:70	〃 (R)	〃 (R)				090
* 6	AA:82:52:40	Holder for Terminal	中継ホルダー				070
7	EV:20:30:36	Plain Washer	平座金	M3 Bl			010
8	Ei:33:00:86	Bind Head Tapping Screw	バインドタッピングネジ	3×8 Bl			010
9	Ei:33:01:06	〃	〃	3×10 Bl			010
10	Ei:33:00:66	〃	〃	3×6 Bl			010
11	ED:34:00:66	Bind Head Screw	鉄バインド小ネジ	M4×6 Bl			010
	BB:00:44:30	Contact Pin	コンタクトピン	001T-08CS			010
	LB:30:07:20	Houseing	ハウジング	H3P-SHF			010
	LA:00:44:20	Terminal	絶縁付圧着端子				010
		Electrolytic Capacitor Unit	ケミコンユニット		101M		
* 20	BA:80:74:20	Capac Holder	ケミコンホルダー		PC2002M		100
* 21	BB:06:85:40	Lug Terminal	ラグ端子板		101M		020
* 22	BB:80:19:00	Center Busber	センターバスバー		101M		050
* 23	BB:80:69:10	±B Busber	±Bバスバー				040
24	CB:08:51:40	Tape, Antivibration	防振テープ				010
* 25	FZ:00:37:60	Electrolytic Cap Block Type	ブロックケミコン	18000μF 100V			170
* 26	FZ:00:37:70	〃	〃	39000μF 63V			170
27	HL:42:71:00	Metal Oxide Resistor	酸金抵抗ストレート	2P 10KΩ			010
28	FZ:00:34:10	Mylar Capacitor VX	マイラーコン	1μF 125V			040
	LB:10:11:60	Receptacle	レセプタクル				010
	LB:10:11:80	Housing	ハウジング				010
* 32	NA:81:07:00	Sub Power Supply C.B.	サブ電源シート	#9011	101M	J	240
* 〃	NA:81:07:10	〃	〃	#9014	〃	U	
* 〃	NA:81:07:20	〃	〃	#9015	〃	G	
33	CB:09:28:00	Bush	ワンタッチブッシュ	M3			010
34	CB:09:28:20	Collar	ワンタッチカラー	H-7.5			010
35	Ei:03:02:06	Bind Head Tapping Screw	バインドタッピングネジ	M3×20 Ye			010

* : New Parts (新部品)

■PARTS LIST (Circuit board)

Ref. No.	Part No.	Description	(部 品 名)	Remarks	Common model	ランク	標準小売価
※	NA 81 06 80	Power Circuit Board	パワーシート			290	19,000
	FC 38 51 00	Polypropylene Film Capacitor	0.1μF QP100V(J)	ポリプロコン	C601~604	039	200
※	HL 71 46 80	Metal Oxide Film Resistor	68Ω 1P	酸化抵抗	R653	010	60
	HV 35 32 20	Flame Proof Carbon Resistor	2.2Ω RDF25SF	不燃化カーボン抵抗	R601~604,623~626	010	60
	HV 35 34 70	"	4.7Ω RDF25SF	"	R605~612,627~636,656,657	010	60
※	FF 09 31 20	Polystyrene Capacitor	1200PF ENQ(J)	スチコン銅リード	C607	020	100
※	HZ 00 28 10	Cement Resistor (Non-inductive)	0.33Ω(J)5P	セメント無誘導抵抗	R613~620,643~652	020	100
※	HZ 00 28 20	"	2.2Ω(K) 5P	"	R637~640	020	100
※	HZ 00 28 30	Cement Resistor	22Ω 5P	セメント抵抗	R621,622	020	100
※	HM 55 64 70	"	4.7KΩ 5P	"	R641,642	021	100
併用	iF 00 00 40	Diode	IS1555	ダイオード	D601~606	010	60
	iF 00 06 70	"	IS2473	"	"	010	60
	iF 00 13 10	"	30DL4	"	D609,610	020	100
※	LA 00 44 00			エース用ファストン90°曲げ		010	60
※	LA 00 43 40	Socket Pin	P-155	PC用ソケットピン2型		010	60
※	CB 09 28 00	One Touch Bush	M3	ワンタッチブッシュ		010	60
※	CB 09 28 20	One Touch Color	h=10	ワンタッチカラー		010	60
※	BB 80 18 80	Output Bus Bar				060	700
※	BB 80 18 90	Bus Bar				050	500
				630Vタイプではければダメ			
	NA 81 07 60	Diode Circuit Board	ダイオードシート			180	8,000
	FC 28 41 00	Polypropylene Film Capacitor	0.01μF QP250V(J)	ポリプロコン	C751~758	031	250
※	iH 00 07 80	Bridge Diode	S25VB-4	ダイオードブリッジ	D751,752	110	3,000
	NA 81 09 80	Meter Circuit Board	メーターシート			160	6,000
	HY 00 03 50	Variable Resistor	B100KΩ	メタルグレースVR	VR901,902	030	200
※	IC 09 31 00	IC(Peak Meter Drive)		ピークメータードライブIC	IC901	120	3,500
トIV	UW 86 61 00	Electrolytic Capacitor	1μF 50V	ケミコン小型自立形	C901,902	010	60
	LB 30 07 30	Base Pin	2.5Pitch TEB3P-SHF	2.5ピッチベースピン		010	60
※	CB 09 28 00	One Touch Bush	M3	ワンタッチブッシュ		010	60
	CB 09 28 20	One Touch Color	h=10	ワンタッチカラー		010	60
	NA 81 06 50	Drive Circuit Board	ドライブシート			390	29,000
	FA 15 41 00	Mylar Capacitor	0.01μF 50V MS(J)	マイラーコン	C325,326,349,350,361,362	021	100
	FA 15 45 10	"	0.1μF 50V MS(J)	"	C309,310	021	100
※	FC 38 33 90	Polypropylene Film Capacitor	3900PF QP100V(J)	ポリプロコン	C317,318	020	100
※	FC 38 43 30	"	0.033μF QP100V(J)	スチコン銅リード	C315,316	020	100
※	FF 09 22 20	Polystyrene Capacitor	220PF ENQ(J)	"	C333	020	100
※	FF 09 31 20	"	1200PF ENQ(J)	"	C319,320,329,337	020	100
※	FF 09 32 20	"	2200PF ENQ(J)	"	C311,312,330,338	020	100
※	FF 09 33 30	"	3300PF ENQ(J)	"	C303,304,339,340	020	100
	FU 35 08 00	Mica Capacitor	8PF FE500V(J)	マイカコン	C323,324	010	60
	FU 35 11 00	"	10PF FE500V(J)	"	C307,313,314,327,328,363	010	60
※	FU 35 11 30	"	13PF FE500V(J)	"	C355,356	01※	60
	FU 35 13 30	"	33PF FE500V(J)	"	C321,322,334	010	60

※ : New Parts (新部品)

Ref. No.	Part No.	Description	(部 品 名)	Remarks	Common model	ランク	標準小売価
	FU 35 15 10	Mica Capacitor	51PF FE500V(J)	マイカコン	C345,346	01※	60
	FU 35 21 00	"	100PF FE500V(J)	"	C308	020	100
※	FV 92 81 00	Electrolytic Capacitor	100 μ F 10V 105°C	ケミコン	C351,352	010	60
※	FV 94 74 70	"	47 μ F 25V 105°C	"	C301,302,335,347,348	010	60
				"	368,369		
※	FV 96 64 70	"	4.7 μ F 50V 105°C	"	C366,367	010	60
※	FV 96 71 00	"	10 μ F 50V 105°C	"	C357~360	010	60
※	FV 96 81 00	"	100 μ F 50V 105°C	"	C331,332	010	60
※	FV 99 64 70	"	4.7 μ F 100V 105°C	"	C341,342	010	60
	FZ 00 42 70	"	47 μ F 160V 85°C	"	C343,344	030	200
	FZ 00 34 10	Mylar Capacitor	1 μ F VX 125V	マイラーコン	C305,306,364,371,372	040	300
※	FZ 00 28 70	"	2.2 μ F HFV-X2B(K)	メタライズドマイラーコン	C305,306	070	1,000
	UA 55 54 70	"	0.47 μ F 50V(J)	"	C353,354	030	200
	UA 25 37 50	"	7500PF 50V(J)	"	C370	021	100
※	HL 71 62 70	Metal Oxide Film Resistor	2.7K Ω 1P	酸化抵抗 \Rightarrow HL3/6270	R469,481,482,486	010	60
	HL 72 43 30	"	33 Ω 2P	"	R487	010	60
	HL 72 71 50	"	15K Ω 1P	"	R351~356	010	60
	HY 00 01 90	Variable Resistor	B1K Ω CR19R	メタルグレースVR	VR302,303	030	200
	HY 00 01 40	"	B470 Ω	"	VR301	031	200
	HU 07 44 70	Metal Film Resistor	47 Ω RE35	金属皮膜抵抗	R327,328	021	100
	HU 07 46 80	"	68 Ω RE35	"	R375,376,397,398	021	100
	HU 07 51 20	"	120 Ω RE35	"	R331,332	021	100
	HU 07 51 50	"	150 Ω RE35	"	R313~316	021	100
	HU 07 52 20	"	220 Ω RE35	"	R461,462	021	100
	HU 07 52 70	"	270 Ω RE35	"	R311,312,325,326	021	100
	HU 07 53 30	"	330 Ω RE35	"	R309,310,329,330,341,342	021	100
				"	379,380,385,386,391,392		
				"	480		
	HU 07 55 60	"	560 Ω RE35	"	R305~308,359,360,382,384	021	100
	HU 07 56 80	"	680 Ω RE35	"	R427~403,435,436,445~448	021	100
				"	453,454		
	HU 07 57 50	"	750 Ω RE35	"	R333,334	021	100
	HU 07 58 20	"	820 Ω RE35	"	R415,416	021	100
	HU 07 59 10	"	910 Ω RE35	"	R347,348	021	100
	HU 07 61 00	"	1K Ω RE35	"	R464	021	100
	HU 07 61 20	"	1.2K Ω RE35	"	R389,420	021	100
	HU 07 61 30	"	1.3K Ω RE35	"	R400	021	100
	HU 07 61 50	"	1.5K Ω RE35	"	R443,444,455,456	021	100
	HU 07 62 20	"	2.2K Ω RE35	"	R390,459,460,463	021	100
	HU 07 62 70	"	2.7K Ω RE35	"	R485,388	021	100
	HU 07 63 30	"	3.3K Ω RE35	"	R393,394,413,441,442	021	100
	HU 07 63 90	"	3.9K Ω RE35	"	R320,339,419,437~440	021	100
	HU 07 65 60	"	5.6K Ω RE35	"	R483	021	100
	HU 07 68 20	"	8.2K Ω RE35	"	R361,362	021	100
	HU 07 69 10	"	9.1K Ω RE35	"	R317	021	100
	HU 07 71 00	"	10K Ω RE35	"	R367,368,377,395,396,491	021	100
	HU 07 71 20	"	12K Ω RE35	"	R365,366,381,383	021	100
	HU 07 71 50	"	15K Ω RE35	"	R403,404,411,412,423,424	021	100
	HU 07 71 80	"	18K Ω RE35	"	R349,350	021	100
	HU 07 72 20	"	22K Ω RE35	"	R335,336,345,357,358	021	100
				"	371,372,417,418,470,474		
				"	484		

※ : New Parts (新部品)

Ref. No.	Part No.	Description	(部 品 名)	Remarks	Common model	ランク	標準小売価
	HU:07:72:70	Metal Film Resistor	27KΩ RE35	金属皮膜抵抗	R343,344	021	100
	HU:07:73:30	"	33KΩ RE35	"	R405,406,409	021	100
	HU:07:74:70	"	47KΩ RE35	"	R473	021	100
	HU:07:75:10	"	51KΩ RE35	"	R407,408	021	100
	HU:07:76:80	"	68KΩ RE35	"	R451,452,490	021	100
	HU:07:81:00	"	100KΩ RE35	"	R337,338,369	021	100
					421,422,425,426,457,458		
	HU:27:54:30	"	430Ω SHR	"	R301~304	040	300
	HU:27:73:10	"	31KΩ SHR	"	R319,477	040	300
	HU:47:72:20	"	22KΩ RE55	"	R471,472	020	100
	HU:47:73:00	"	30KΩ RE55	"	R373,374,363	020	100
※	HU:47:75:60	"	56KΩ RE55	"	R492	020	100
※	iA:09:39:00	Transistor	2SA939(B,V)	トランジスター	TR304,309,312,313,315,317	030	200
					328,334,345,348,350		
	iA:09:68:40	"	2SA968B(O,Y)	"	TR343,353		
	iA:09:70:00	"	2SA970(GR,BL)	"	TR301,307,320,322,324,326	031	200
					329,331,336,338,339,342,351		
	iA:10:15:70	"	2SA1015(O,Y)	"	TR355,358,360,361,363	031	200
	iC:18:15:70	"	2SC1815(O,Y)	"	TR356,357,359,362,364	031	200
	iC:19:83:00	"	2SC1983	"	TR365	030	200
※	iC:20:71:00	"	2SC2071(B,V)	"	TR303,310,311,314,316,318	030	200
					327,333,346,347,349		
※	iC:22:38:40	"	2SC2238B(O,Y)	"	TR344,354		
	iC:22:40:00	"	2SC2240(GR,BL)	"	TR302,308,319,321,323,325	031	200
					330,332,335,337,340,341,352		
併用	iF:00:00:40	Diode	IS1555	ダイオード	D301,302,305,306,309,310	010	60
	iF:00:06:70	"	"	"	321~324,339,345,346,353~350,359~368,371~378	010	60
	iF:00:07:90	Varistor	MV12	バリスタ	D340	010	60
	iF:00:14:00	Diode	ISS82	ダイオード	D311~314,308,319,320,385	021	100
					325~336,343,344,347~352		
					379,380		
	iF:00:15:10	Zener Diode	HZ-6CIL	ツェナーダイオード	D303,304,307,357,358,369,370	010	60
	iF:00:15:20	"	HZ-IZBIL	"	D315~318,386,337,338,341,342	010	60
	iG:00:13:90	IC	NJM4558DV	IC	IC301,303	030	200
※	iG:07:66:00	"	TLO72CP	IC銅フレーム	IC302	040	300
	iZ:00:01:20	Dual Transistor	μPA74V	デュアルトランジスタ	TR305	030	200
	iZ:00:01:30	"	μPA75V	"	TR306	030	200
	LA:00:25:00	Wrapping Terminal type- I	1P	I型ラッピング端子板		010	60
	LA:00:21:20	"	3P P=5	"		010	60
	LB:30:07:30	Base pin	2.5Pitch TEB3P-SHF	2.5ピッチベースピン		010	60
	LB:40:05:70	"	2.5Pitch TEB4P-SHF	"		010	60
※	LB:92:20:30	Friction Lockwater Ass'y	5277-03A	フリクションロックウェファー Ass'y 金メッキ		030	200
※	LB:92:20:60	"	5277-06A	"		040	300
	LA:00:03:70	Pipe Lug	φ2×6	パイプラグ		010	60
※	CB:09:28:00	One Touch Bush	M3	ワンタッチブッシュ		010	60
※	CB:09:28:20	One Touch Color	h=10	ワンタッチカラー		010	60
※	BA:80:74:40	Heat Sink		定電圧放熱板A		060	700
※	CB:07:28:80	Bush		絶縁ブッシュ		010	60
	iL:00:05:80	Mica Base	AC249 3P	マイカベース3本足		010	60

※: New Parts (新部品)

Ref. No.	Part No.	Description	(部 品 名)	Remarks	Common model	ランク	標準小売価
	NA 81 06 60	Buffer Circuit Board	バッファシート		00	0330	23,000
※	FZ 00 39 30	Mylar Capacitor	0.68 μ F HFV(K)	マイラーコン(VXコン)	C101,102,105,106	040	300
※	FZ 00 39 20	"	0.22 μ F "	"	C103,104,107,108	030	200
※	FA 15 42 20	"	0.022 μ F 50V MS(J)	マイラーコン	C111~114,125~128	020	100
※	FU 35 12 00	Mica Capacitor	20PF FE500V(J)	マイカコン	C115~118,129~132	01※	60
※	FU 35 21 00	"	100PF "	"	C109,110,123,124,137~144	020	100
※	UW 84 82 20	Electrolytic Capacitor	220 μ F 25V	ケミコン自立形	C119~122,133~136	021	100
※	FV 96 64 70	"	4.7 μ F 50V 105°C	ケミコン	C145~147	010	60
※	HL 71 62 70	Metal Oxide Film Resistor	2.7K Ω 1P	酸化膜抵抗自立形	R220	010	60
	HU 07 42 20	Metal Film Resistor	22 Ω RE35	金属皮膜抵抗	R139~146,163~166,191~198,215~218	021	100
	HU 07 44 70	"	47 Ω "	"	R153~156,205~208	021	100
	HU 07 46 80	"	68 Ω "	"	R117,118,169,170	021	100
	HU 07 48 20	"	82 Ω "	"	R161,162,213,214	021	100
	HU 07 51 60	"	160 Ω "	"	R225,226	021	100
	HU 07 51 80	"	180 Ω "	"	R219	021	100
	HU 07 52 20	"	220 Ω "	"	R125~128,131~134,147~150,157~160,177~180,183~186,199~202,209~212	021	100
	HU 07 53 60	"	360 Ω "	"	R221	021	100
	HU 07 56 80	"	680 Ω "	"	R119~122,171~174	021	100
	HU 07 61 20	"	1.2K Ω "	"	R135~138,187~190,235,236	021	100
	HU 07 62 70	"	2.7K Ω "	"	R129,130,151,152,181,182,203,204	021	100
	HU 07 71 30	"	13K Ω "	"	R101~104	021	100
	HU 07 73 30	"	33K Ω "	"	R222	021	100
	HU 07 81 00	"	100K Ω "	"	R115,116,167,168,223,224	021	100
	iA 09 70 00	Transistor	2SA970(GR,BL)	トランジスタ	TR115,116,121,122,135,136,141,142	031	200
	iA 10 15 70	"	2SA1015(O,Y)	トランジスタ(フォーミング)	TR103,104,123,124	031	200
	iC 18 15 70	"	2SC1815(O,Y)	"	TR101,102,105,106,125,126	031	200
	iC 22 40 00	"	2SC2240(GR,BL)	トランジスタ	TR117~120,137~140	031	200
	iE 10 24 20	FET	2SK170(GR,BL)	FET	TR107~110,127~130	031	200
併用	iF 00 00 40	Diode	IS1555	ダイオード	D101~120,123~138,141,142	010	60
	iF 00 06 70	"	IS2473	"	"	010	60
	iF 00 07 90	Varistor	MV12	バリスタ	D121,122,139,140	010	60
	iZ 00 01 20	Dual Transistor	μ PA74V	デュアルトランジスタ	TR113,114,133,134	030	200
	iZ 00 01 30	"	μ PA75V	"	TR111,112,132,131	030	200
	KC 00 14 40	DS Relay	4T DS4EM DC24V	DSリレー	RY101,102	090	2,000
	KC 00 14 50	"	2T DS2EM DC24V	"	RY103	080	1,500
	LB 30 07 30	Base Pin	2.5Pitch TEB3P-SHF	2.5ピッチベースピン		010	60
	LB 50 02 50	"	2.5Pitch TEB5P-SHF	"		010	60
※	LB 92 20 30	Friction Lockwater Ass'y	5277-03A	フリクションロックウェア-Ass'y 金メッキ		030	200
※	LB 92 20 50	"	5277-05A	"		030	200
	NA 81 07 00	Sub Power Supply Circuit Board	サブ電源シート		J	240	14,000
	NA 81 07 10	"	"		U		
	NA 81 07 20	"	"		G		
	FC 28 41 00	Polypropylene Film Capacitor	0.01 μ F QP250V(J)	ポリプロコン	C701~716	030	200
	FZ 00 42 50	Electrolytic Capacitor	2200 μ F 35V 85°C	ケミコン	C717~720	050	500
	FZ 00 42 60	"	220 μ F 200V 85°C	"	C721~724	060	700
※	iH 00 13 00	Bridge Diode	S2VB40	ダイオードブリッジ	D701~704	040	300
	KB 00 02 20	Fuse	T1.5A 125V	ヒューズ(タイラッシュ)	F701~710	010	60

※ : New Parts (新部品)

WIRING

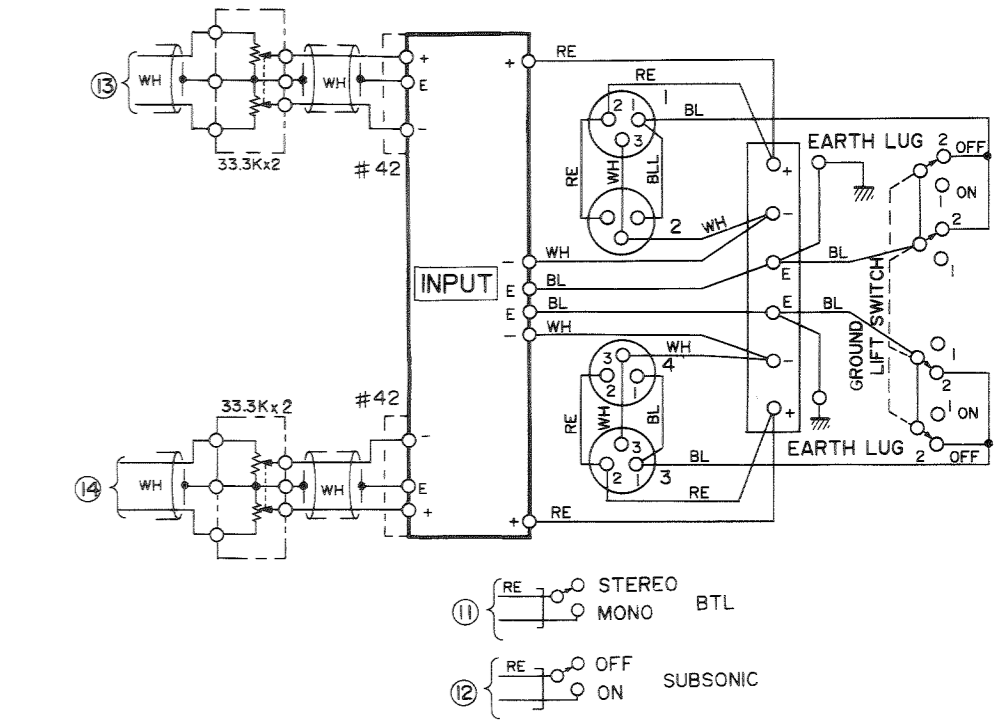
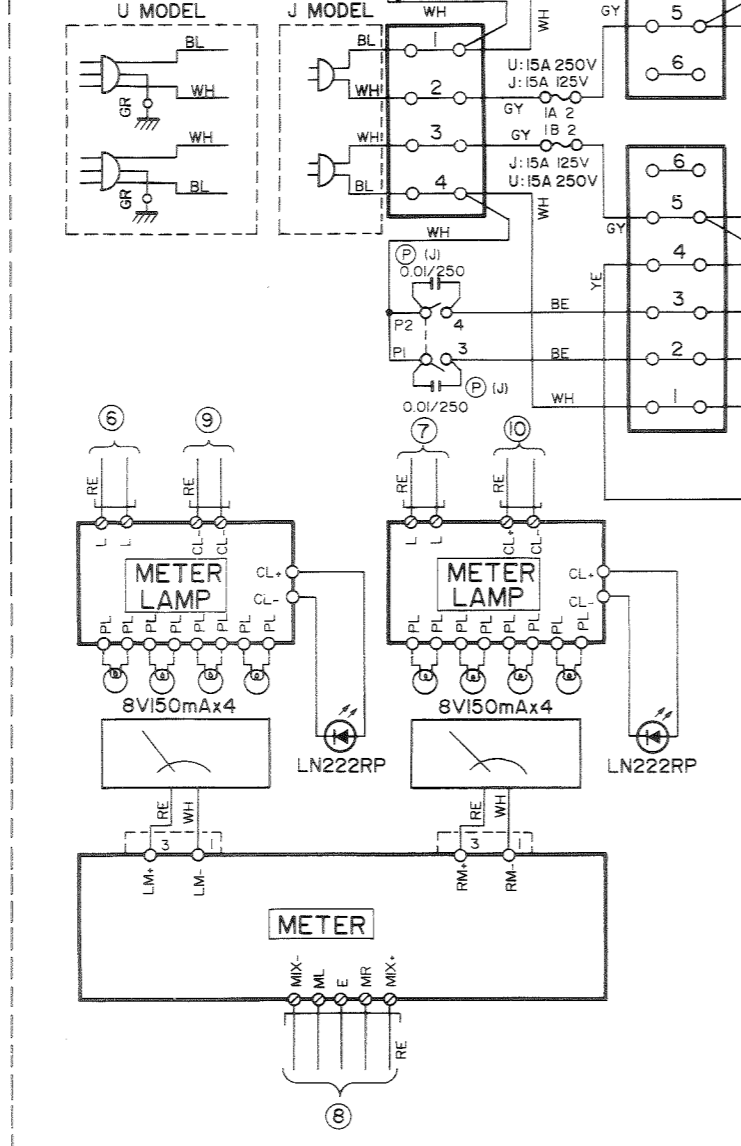
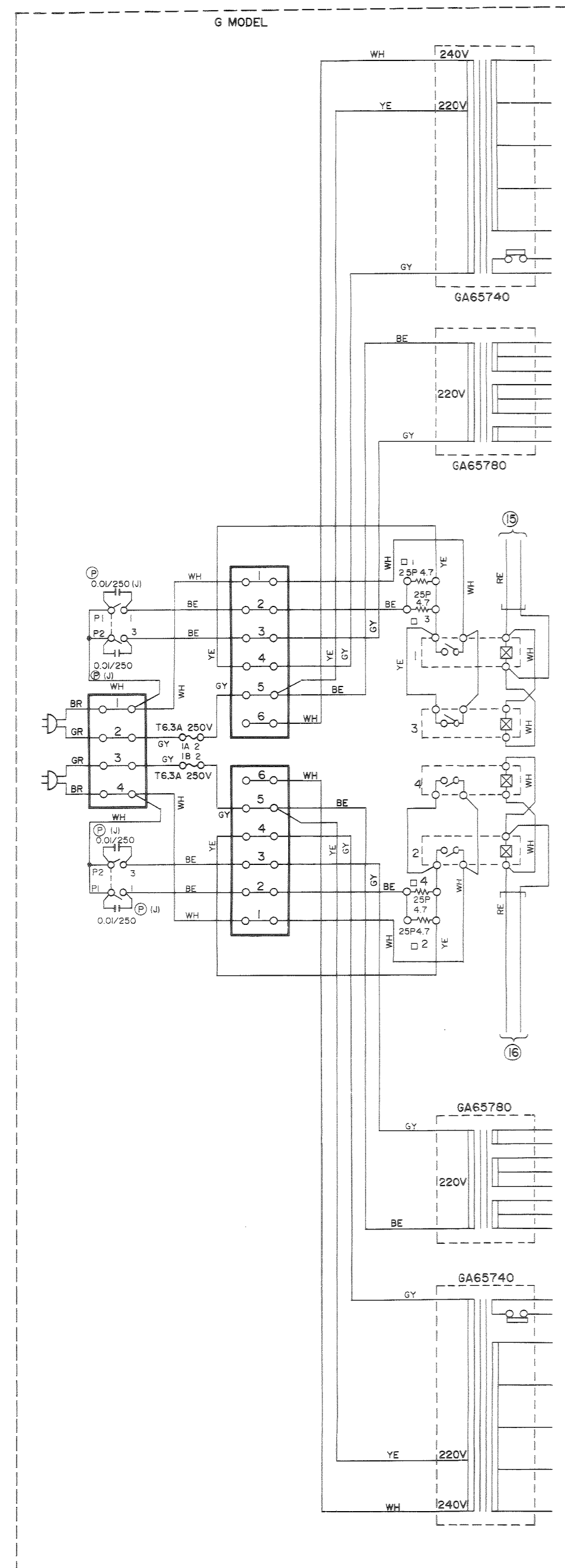
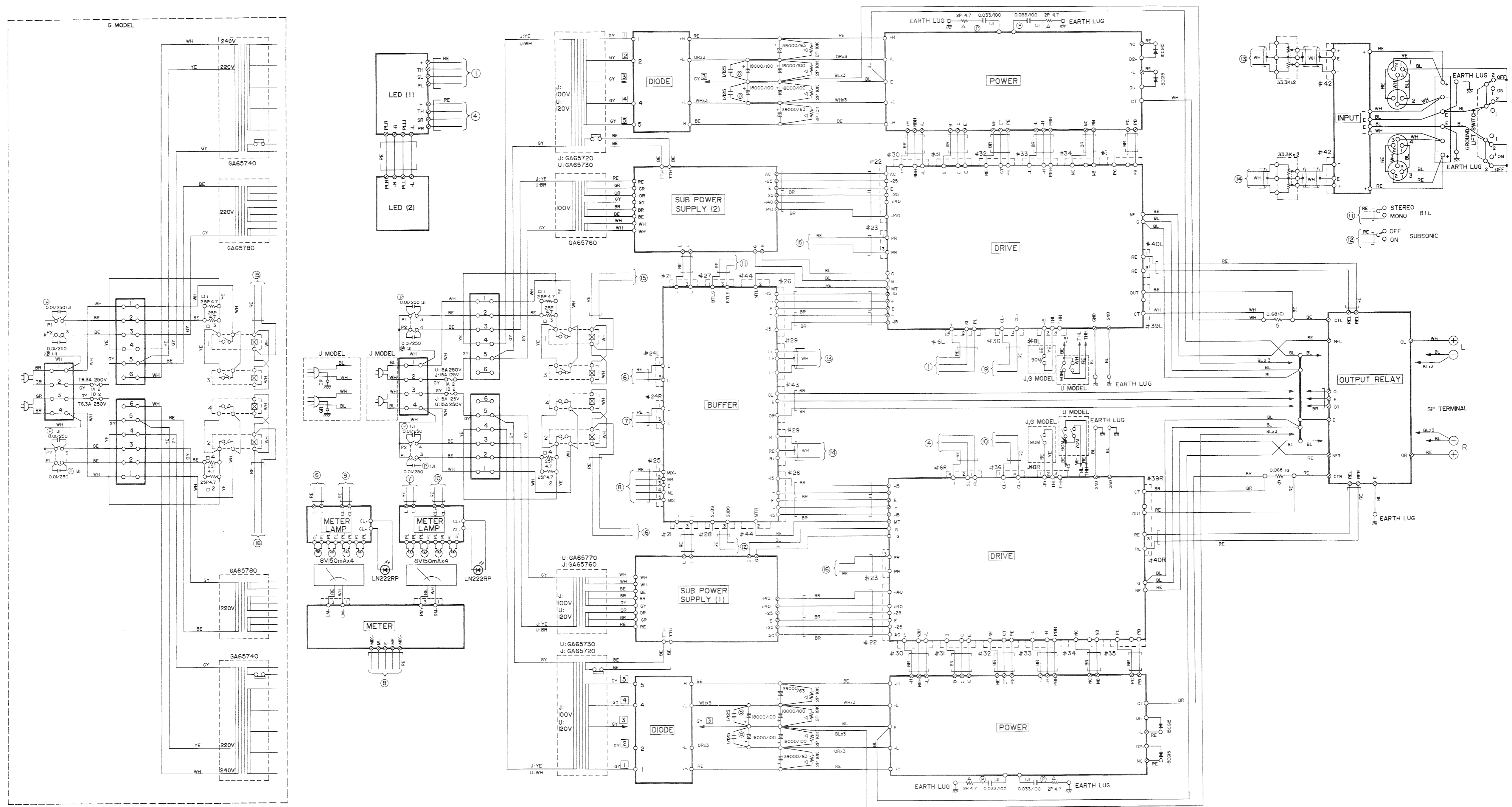

COMPLETE CIRCUIT DIAGRAM

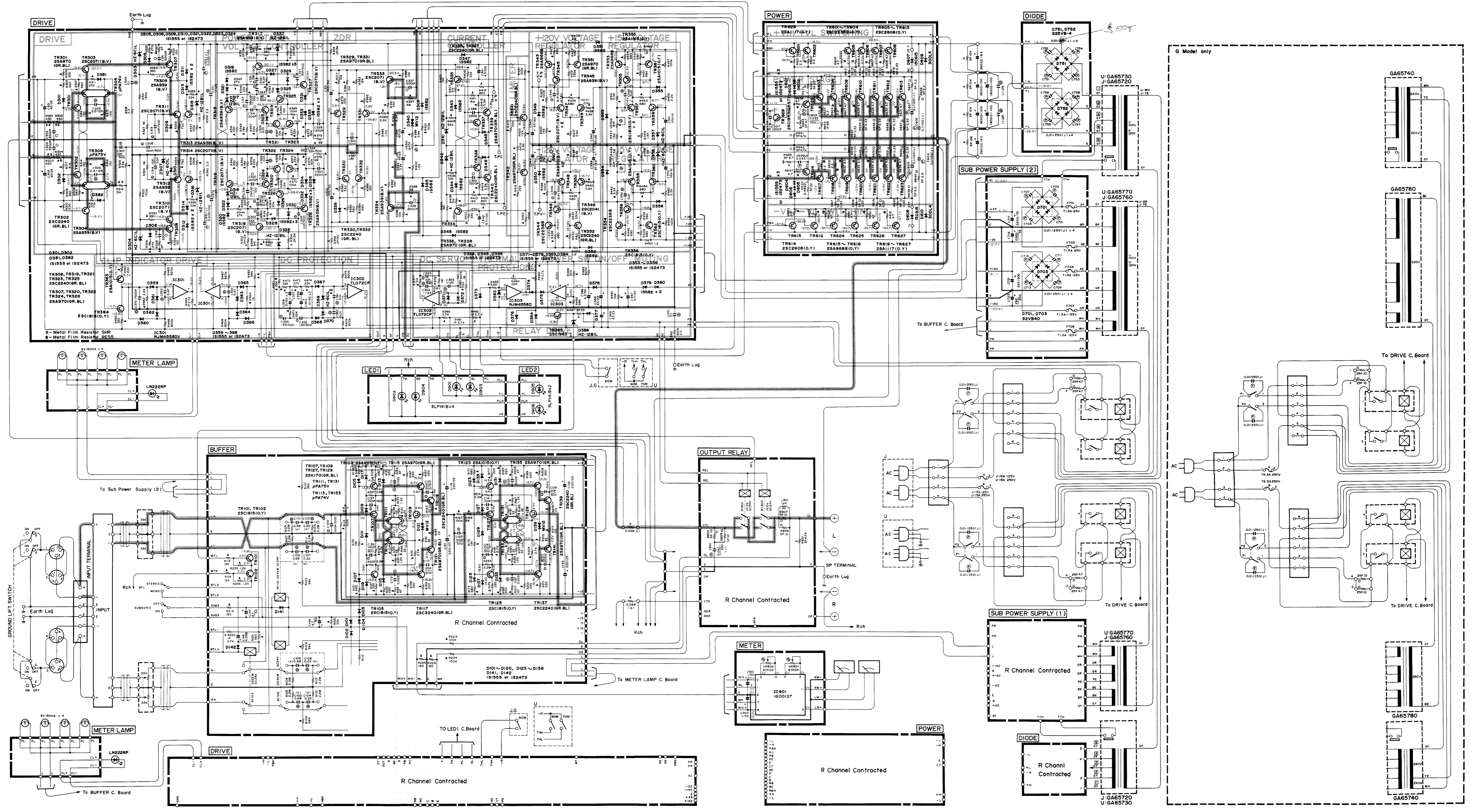

- 25A970
- 25A1015
- 25C1815
- 25C2240
- C
- E
- 25A1117
- 25C2608
- 25K170
- 25A939
- 25C2071
- 25C1983
- 25A968
- 25C1953
- 25C2238
- NJM4558
- TL072CP
- μPA74V
- μPA75V