

PA

POWER AMPLIFIER PD2500 SERVICE MANUAL

3 11 03 03 02 005 - 00 Common
 10 JA
 22 UL
 30 CSA
 40 EU
 43 D

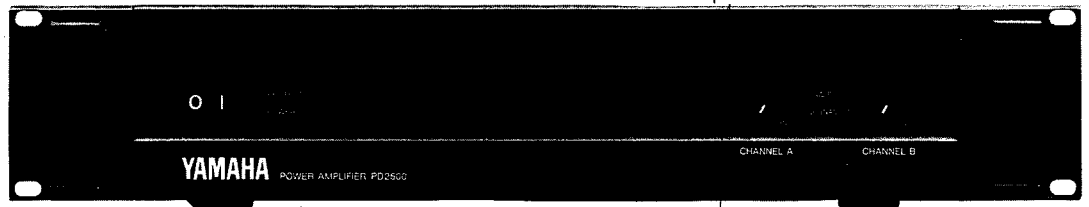

~~90 Au~~

■ CONTENTS (目次)

SPECIFICATIONS (総合仕様).....2
 PANEL LAYOUT (パネルレイアウト).....3
 DIMENSIONS (寸法図).....4
 BLOCK DIAGRAM (ブロックダイアグラム).....4
 PERFORMANCE GRAPHS (特性図).....5
 IC BLOCK DIAGRAM (ICブロック図).....7
 CIRCUIT BOARDS (シート基板図).....7
 PARTS LIST (パーツリスト)

006729

SINCE 1887  **YAMAHA**
 NIPPON GAKKI CO., LTD. HAMAMATSU, JAPAN

2.18K-272 ① Printed in Japan '86.12

IMPORTANT NOTICE

This manual has been provided for the use of authorized Yamaha Retailers and their service personnel. It has been assumed that basic service procedures inherent to the industry, and more specifically Yamaha Products, are already known and understood by the users, and have therefore not been restated.

WARNING: Failure to follow appropriate service and safety procedures when servicing this product may result in personal injury, destruction of expensive components and failure of the product to perform as specified. For these reasons, we advise all Yamaha product owners that all service required should be performed by an authorized Yamaha Retailer or the appointed service representative.

IMPORTANT: The presentation or sale of this manual to any individual or firm does not constitute authorization, certification, recognition of any applicable technical capabilities, or establish a principle-agent relationship of any form.

The data provided is believed to be accurate and applicable to the unit/s indicated on the cover. The research, engineering, and service departments of Yamaha are continually striving to improve Yamaha products. Modifications are, therefore, inevitable and changes in specification are subject to change without notice or obligation to retrofit. Should any discrepancy appear to exist, please contact the distributor's Service Division.

WARNING: Static discharges can destroy expensive components. Discharge any static electricity your body may have accumulated by grounding yourself to the ground buss in the unit (heavy gauge black wires connect to this buss).

IMPORTANT: Turn the unit OFF during disassembly and parts replacement. Recheck all work before you apply power to the unit.

■ SPECIFICATIONS (総合仕様)

POWER OUTPUT LEVEL

STEREO: 250W + 250W, RL=8 ohms, f=1 kHz, THD=0.1%
 360W + 360W, RL=4 ohms, f=1 kHz, THD=0.1%
 500W + 500W, RL=2 ohms, f=1 kHz, THD=0.2%
 BTL-MONO: 500W, RL=16 ohms, f=1 kHz, THD=0.1%
 700W, RL=8 ohms, f=1 kHz, THD=0.1%
 1000W, RL=4 ohms, f=1 kHz, THD=0.2%

FREQUENCY RESPONSE

±1.0 dB, F=10 Hz - 50kHz, RL=B8 ohms, Po=1W

POWER BANDWIDTH(<0.1% THD)

STEREO: 20 Hz - 50 kHz, Po=125W, RL=8 ohms
 20 Hz - 50 kHz, Po=180W, RL=4 ohms
 BTL-MONO: 20 Hz - 50 kHz, Po=250W, RL=16 ohms
 20 Hz - 50 kHz, Po=360W, RL=8 ohms

TOTAL HARMONIC DISTORTION

STEREO: ≤0.007%, Po=125W, f=20 Hz - 20 kHz, RL=8 ohms
 ≤0.015%, Po=180W, f=20 Hz - 20 kHz, RL=4 ohms
 ≤0.03%, Po=250W, f=20 Hz - 20 kHz, RL=2 ohms
 BTL-MONO: ≤0.007%, Po=250W, f=20 Hz - 20 kHz, RL=16 ohms
 ≤0.015%, Po=350W, f=20 Hz - 20 kHz, RL=8 ohms
 ≤0.03%, Po=500W, f=20 Hz - 20 kHz, RL=4 ohms

INTERMODULATION DISTORTION (60 Hz:7 kHz = 4:1)

STEREO: ≤0.007%, Po=125W, RL=8 ohms
 ≤0.01%, Po=175W, RL=4 ohms
 ≤0.02%, Po=250W, RL=2 ohms
 BTL-MONO: ≤0.007%, Po=250W, RL=16 ohms
 ≤0.01%, Po=350W, RL=8 ohms
 ≤0.02%, Po=500W, RL=4 ohms

CHANNEL SEPARATION (RL=8 ohms, Po=1/2 Po(max.), ATT MAX.,

Input 600 ohm shunt)
 ≥90 dB, f=1 kHz
 ≥70 dB, f=20 Hz - 20 kHz

DAMPING FACTOR

≥250, f=1 kHz, RL=8 ohms

SIGNAL-TO-NOISE RATIO

≥106 dB, INPUT 600 ohm shunt, @ fc=12.7 kHz 6 dB/oct LPF
 ≥115 dB, INPUT 600 ohm shunt, @ IHF-A Network

SLEW RATE

STEREO: ±55 V/μs, RL=8 ohms, full swing
 BTL-MONO: ±110 V/μs, RL=16 ohms, full swing

SENSITIVITY

+4 dBm (1.23 V rms), Po=500W, RL=2 ohms, ATT max., f=1 kHz

VOLTAGE GAIN

28.2 dB, ATT max., f=1 kHz

INPUT IMPEDANCE

>15k ohms, ATT max., balanced or unbalanced

RESIDUAL NOISE

<-76 dBm, ATT min., @ fc=12.7 kHz 6 dB/oct LPF
 <-90 dBm, ATT min., @ IHF-A Network

INDICATORS

Signal: Green LED, f=20 Hz - 20 kHz Vo >2V
 Clip: Red LED, THD>1%
 Protection: Red LED, lights during protection or muting circuit
 operation Pilot: Red LED, power ON

PROTECTION CIRCUITS

Muting: 6 ±2 sec. after power turned ON
 DC Sense: DC±2 V output voltage
 Ultra-Low Frequency: 20 V p-p, f=1 Hz (Po=6.2W, RL=8 ohms)
 Thermal:>85=C heat sink temperature
 PC Limiter: RL<1.0 ohms

COOLING FAN SPEED CONTROL CIRCUIT

High speed @ ≥60°C heat sink temp.
 Low-speed @ <45°C heat sink temp.

CONTROLS

Front: Seesaw-type POWER switch
 31-detent A-curve attenuators×2
 (only CH A functions during BTL-MONO operation)
 Rear: STEREO/MONITOR mode switch

POWER REQUIREMENTS

General model: 220/240 VAC, 50/60 Hz
 U.S. & Canadian models: 120 VAC, 50/60 Hz

POWER CONSUMPTION

General model: 2500 W
 U.S. & Canadian models: 1500W, 1800 VA

DIMENSIONS(W×H×D)

480×97×480mm(18.7/8"×3.7/8"×18.7/8")

WEIGHT

12 kg (26.5 lbs)

All specifications subject to change without notice

定格出力

(STEREO) 250W + 250W (RL=8 Ω, f=1kHz, THD=0.1%)
~~360W + 360W (RL=4 Ω, f=1kHz, THD=0.1%)~~
 500W + 500W (RL=2 Ω, f=1kHz, THD=0.2%)
 (BTL-MONO) 500W (RL=16 Ω, f=1kHz, THD=0.1%)
 700W (RL=8 Ω, f=1kHz, THD=0.1%)
 1000W (RL=4 Ω, f=1kHz, THD=0.2%)

周波数特性

10Hz ~ 50kHz 0dB ± 1.0dB (RL=8 Ω, Po=1W)

パワーバンド幅

(STEREO) 20Hz ~ 50kHz (Po=125W, RL=8 Ω, THD ≤ 0.1%)
 (BTL-MONO) 20Hz ~ 50kHz (Po=360W, RL=8 Ω, THD ≤ 0.1%)

全高調波歪率

(STEREO) 0.007%以下 (Po=125W, f=20Hz ~ 20kHz, RL=8 Ω)
 (BTL-MONO) 0.015%以下 (Po=350W, f=20Hz ~ 20kHz, RL=8 Ω)

混変調歪率

(STEREO) 0.007%以下 (Po=125W, 60Hz: 7kHz=4:1, RL=8 Ω)
 (BTL-MONO) 0.01%以下 (Po=350W, 60Hz: 7kHz=4:1, RL=8 Ω)

チャンネルセパレーション

90dB以上 (Po=125W, f=1kHz, RL=8 Ω)

ダンピングファクター

250以上 (RL=8 Ω, f=1kHz)

S/N比

115dB以上 (INPUT 600 Ω ショート、
 IHF-Aネットワーク使用)

スルーレート

(STEREO) ±55V/μsec (RL=8 Ω, Full Swing)
 (BTL-MONO) ±110V/μsec (RL=16 Ω, Full Swing)

入力感度

+4dBm (Po=500W, RL=2 Ω,
 入力レベルコントローラー="10", f=1kHz)

電圧利得

28.2dB (入力レベルコントローラー="10", f=1kHz)

入力インピーダンス

(バランス) 15k Ω以上 (入力レベルコントローラー="10")
 (アンバランス) 15k Ω以上 (入力レベルコントローラー="10")

残留ノイズ

-76dBm以下 (入力レベルコントローラー="0",
 12.7kHz -6dB/oct.のLPFで補正)
 -90dBm以下 (入力レベルコントローラー="0",
 IHF-Aネットワーク使用)

定格電源

AC100V, 50/60Hz

定格消費電力

800W

最大外形寸法(W×H×D)

480mm×97mm×480mm

ラックマウント

19インチ標準ラックマウント仕様(BTS準拠)

重量

12.0kg

• 0dB=0.775Vr.m.s.

• 仕様および外観は、改良のため予告なく変更することがあります。

■PANEL LAYOUT (パネルレイアウト)

●Front Panel (フロントパネル)

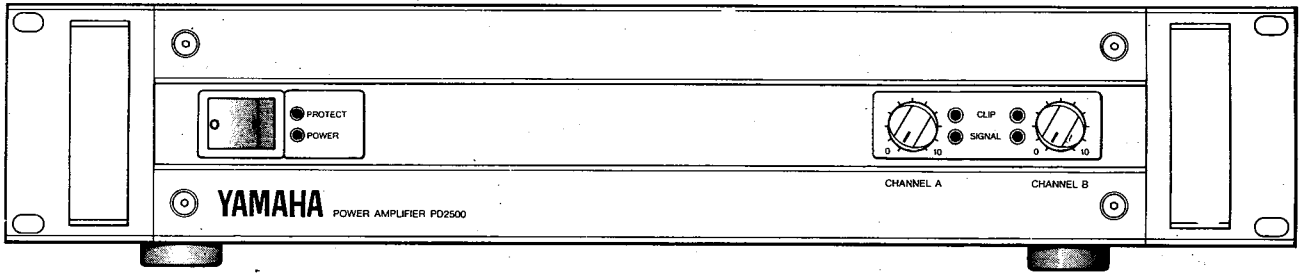

●Rear Panel (リアパネル)

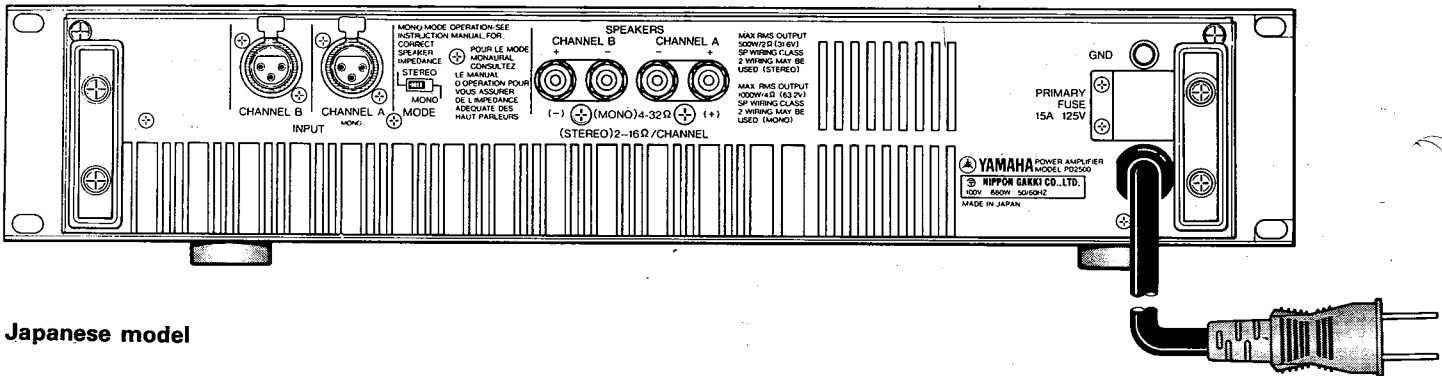

Japanese model

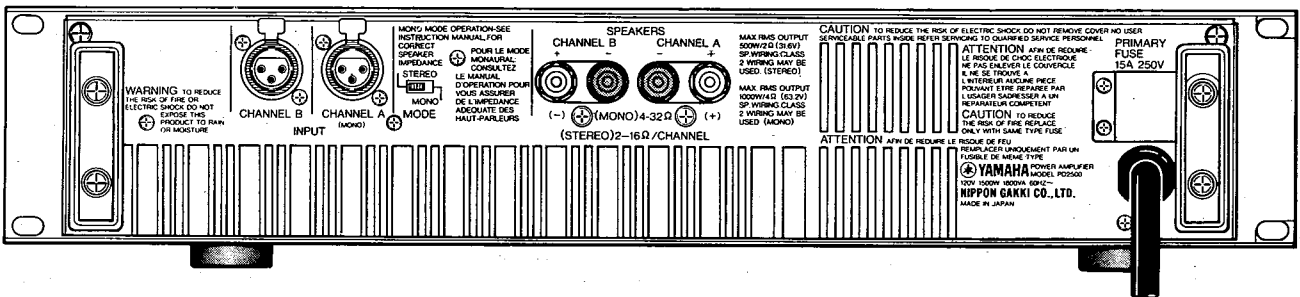

U.S. model

■ DIMENSIONS (寸法図)

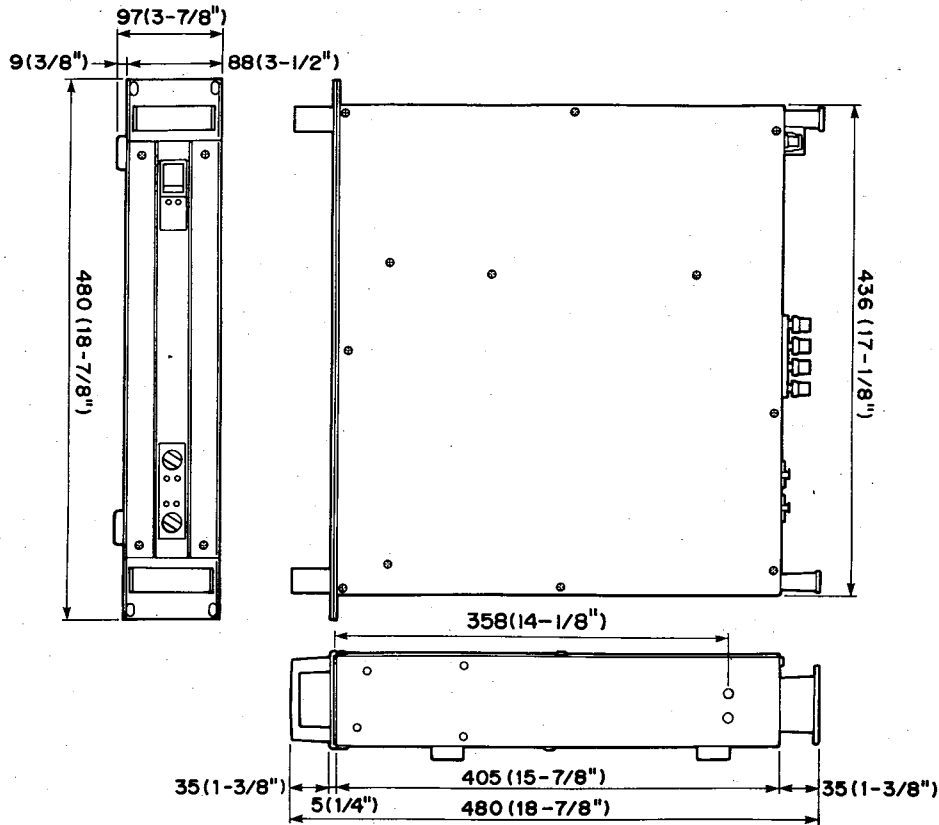

Unit: mm (Inch)

■ BLOCK DIAGRAM (ブロックダイアグラム)

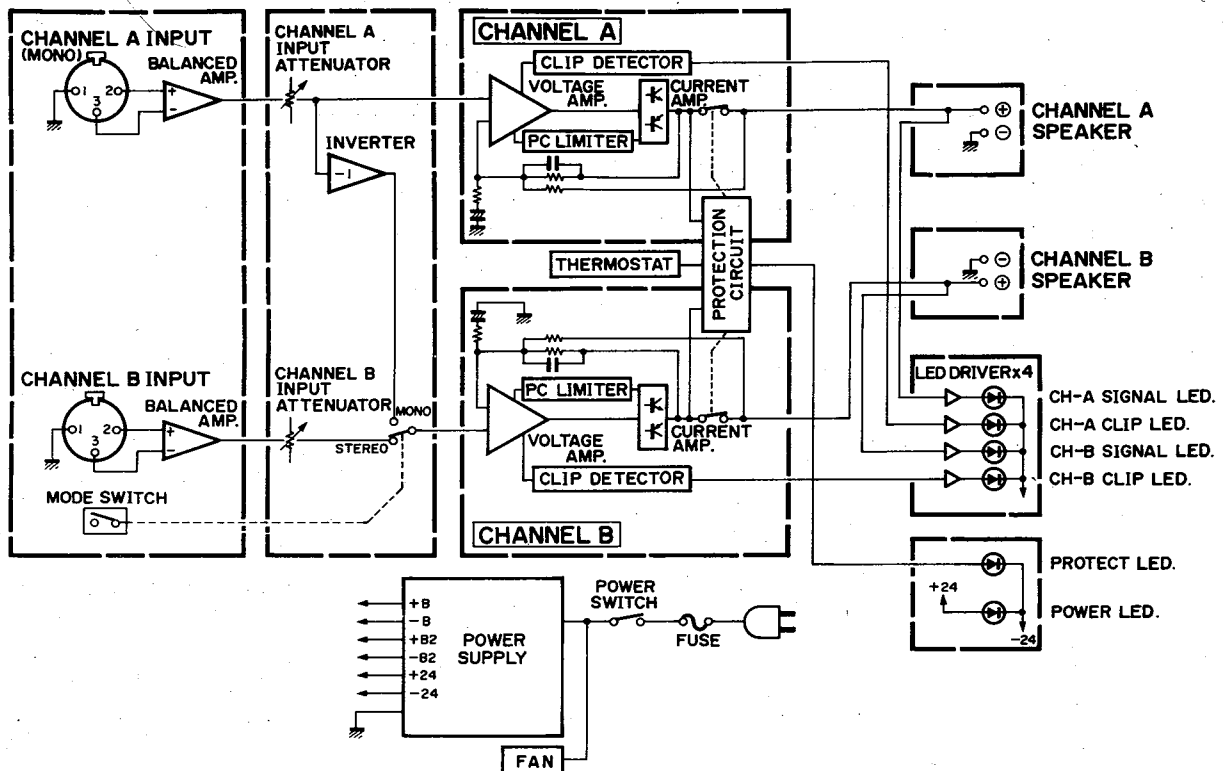

PERFORMANCE GRAPHS (特性図)

FREQUENCY RESPONSE CHARACTERISTICS

(周波数特性)

Load Impedance: 8Ω
 Input Attenuators: Max
 Mode: STEREO
 OdB = 1W/8Ω

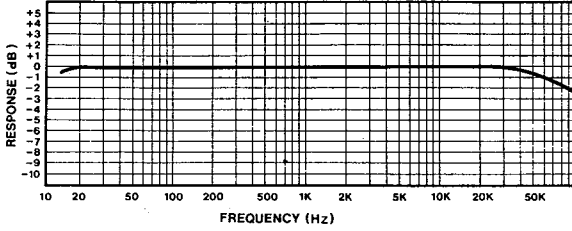

THD vs OUTPUT POWER CHARACTERISTICS

(出力対全高調波歪率)

Load Impedance: 20Ω
 Mode: STEREO
 Both Channels Driven

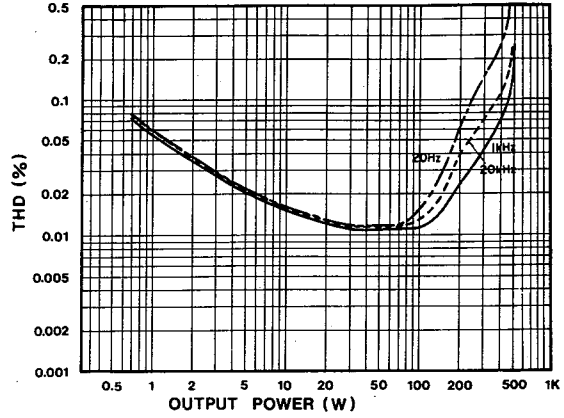

THD vs OUTPUT POWER CHARACTERISTICS

(出力対全高調波歪率)

Load Impedance: 8Ω
 Mode: STEREO
 Both Channels Driven

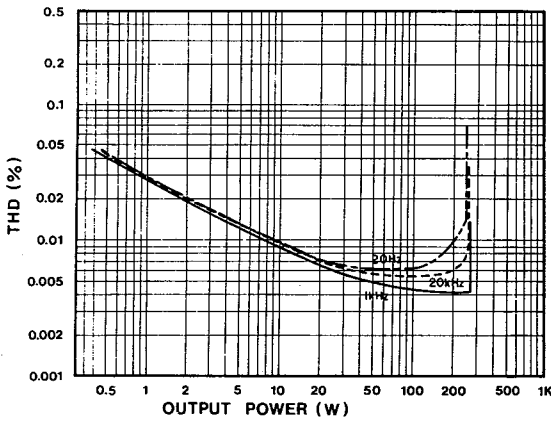

THD vs OUTPUT POWER CHARACTERISTICS

(出力対全高調波歪率)

Load Impedance: 16Ω
 Mode: MONO (BTL)

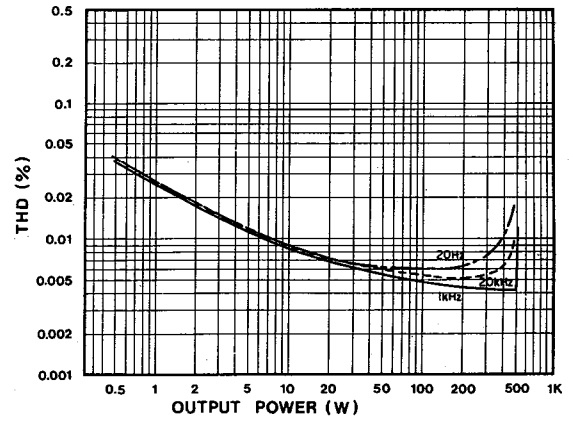

THD vs OUTPUT POWER CHARACTERISTICS

(出力対全高調波歪率)

Load Impedance: 4Ω
 Mode: STEREO
 Both Channels Driven

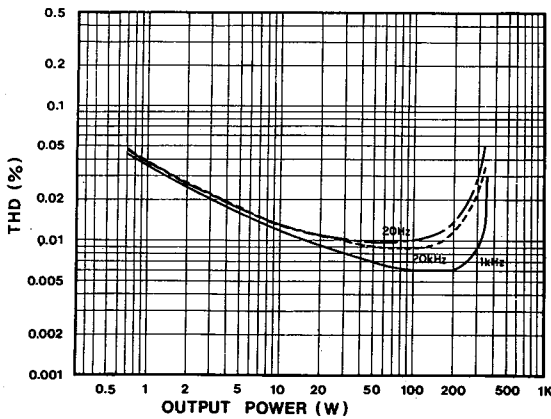

THD vs OUTPUT POWER CHARACTERISTICS

(出力対全高調波歪率)

Load Impedance: 8Ω
 Mode: MONO (BTL)

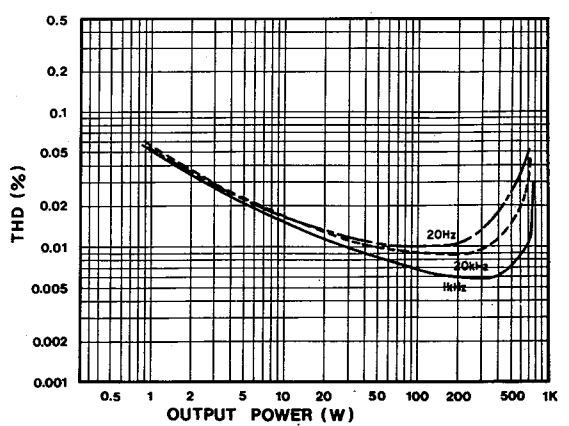

PD2500

THD vs OUTPUT POWER CHARACTERISTICS

(出力対全高調波歪率)

Load Impedance: 4Ω
Mode: MONO (BTL)

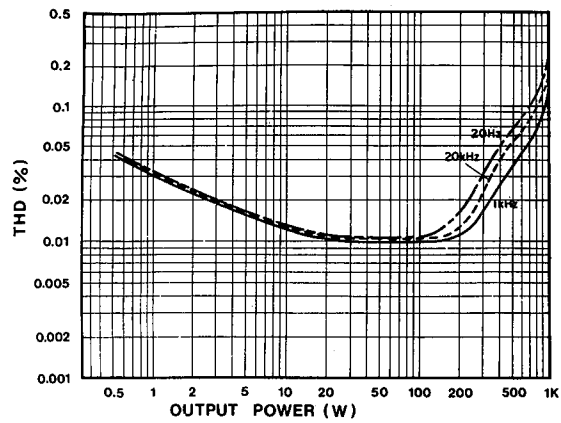

THD vs FREQUENCY CHARACTERISTICS

(周波数対全高調波歪率)

Load Impedance: 2Ω
Mode: STEREO
Both Channels Driven

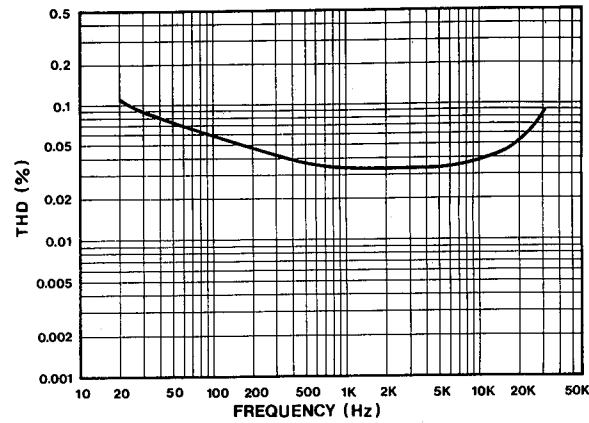

THD vs FREQUENCY CHARACTERISTICS

(周波数対全高調波歪率)

Load Impedance: 8Ω
Mode: STEREO
Both Channels Driven
Output Power: 125W constant

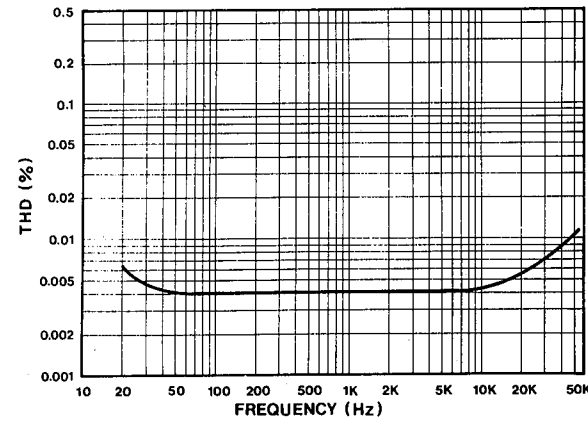

CHANNEL SEPARATION CHARACTERISTICS

(チャンネルセパレーション特性)

Load Impedance: 8Ω
0dB = 100W constant
Measuring Channel
Input 600Ω Shunt

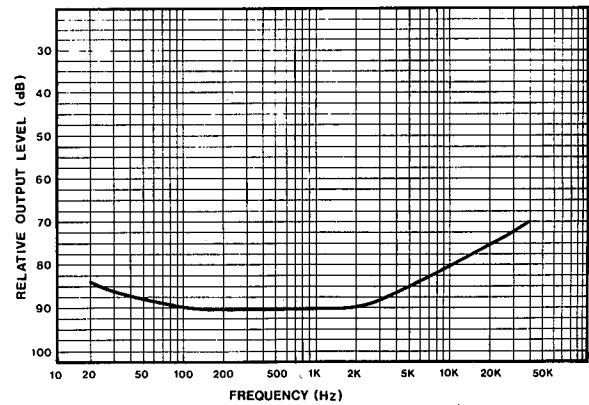

THD vs FREQUENCY CHARACTERISTICS

(周波数対全高調波歪率)

Load Impedance: 4Ω
Mode: STEREO
Both Channels Driven
Output Power: 175W constant

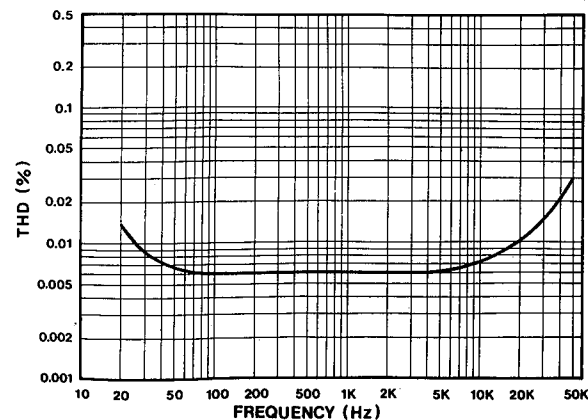

DAMPING FACTOR CHARACTERISTICS

(ダンピングファクター特性)

Load Impedance: 8Ω
ON/OFF method

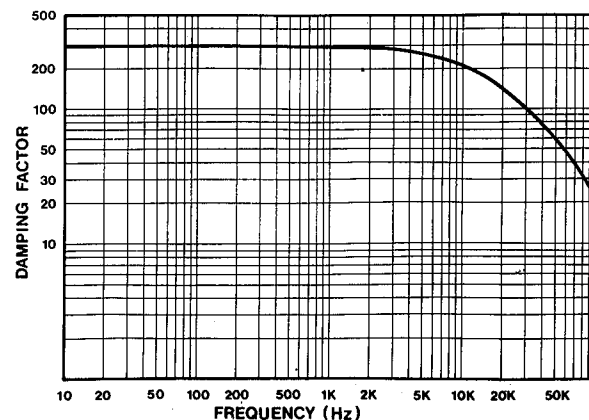

IC BLOCK DIAGRAM (ICブロックダイアグラム)

● **NJM5534D (iG149500)**
Operational Amplifier

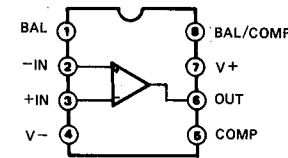

● **NE5532P (iG102500)**
Dual Operational Amplifier

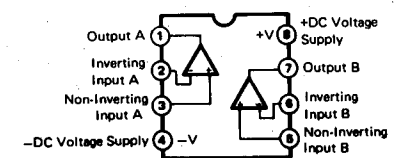

● **MN3206 (iG138900)**
128 Stage Low Voltage Operation,
Low Noise BBD for Analog Signal Delays

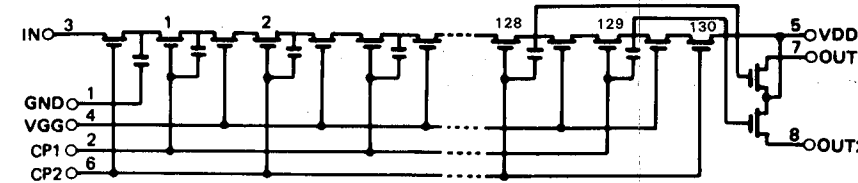

CIRCUIT BOARDS (シート基板図)

● **IN Circuit Board**

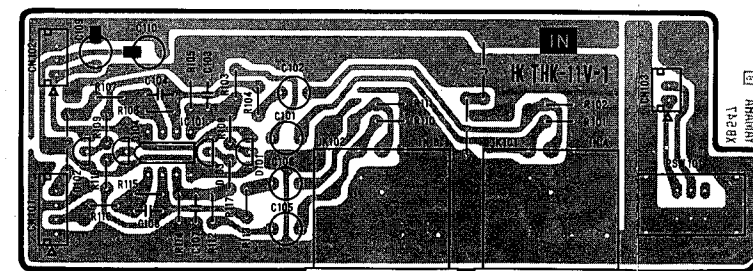

<Components side>

IN Circuit Board
(Notes)
Circuit Board: XB547B0
IC101: NE5532P (IG102500)
OP AMP.
PSW101: SSP32204 (KA401280)
Slide Switch

● **CO Circuit Board**

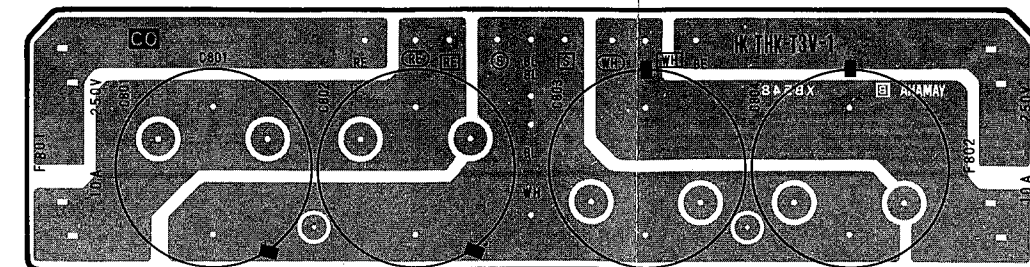

<Components side>

CO Circuit Board
(Notes)
Circuit Board: XB548B0
F801, 802: 10A 250V

3NA-VC59000 : IN Circuit Board △
3NA-VB83010 : CO Circuit Board △

POWER AMPLIFIER**PD2500****PARTS LIST****Notes DESTINATION ABBREVIATIONS**

J	: Japanese model	A	: Australian model
U	: U.S.A. model	E	: European model
C	: Canadian model	D	: West German model
X	: General model	B	: British model
M	: South African model	†	: Indonesian model
H	: North European model		

OVERALL ASSEMBLY (総組立)

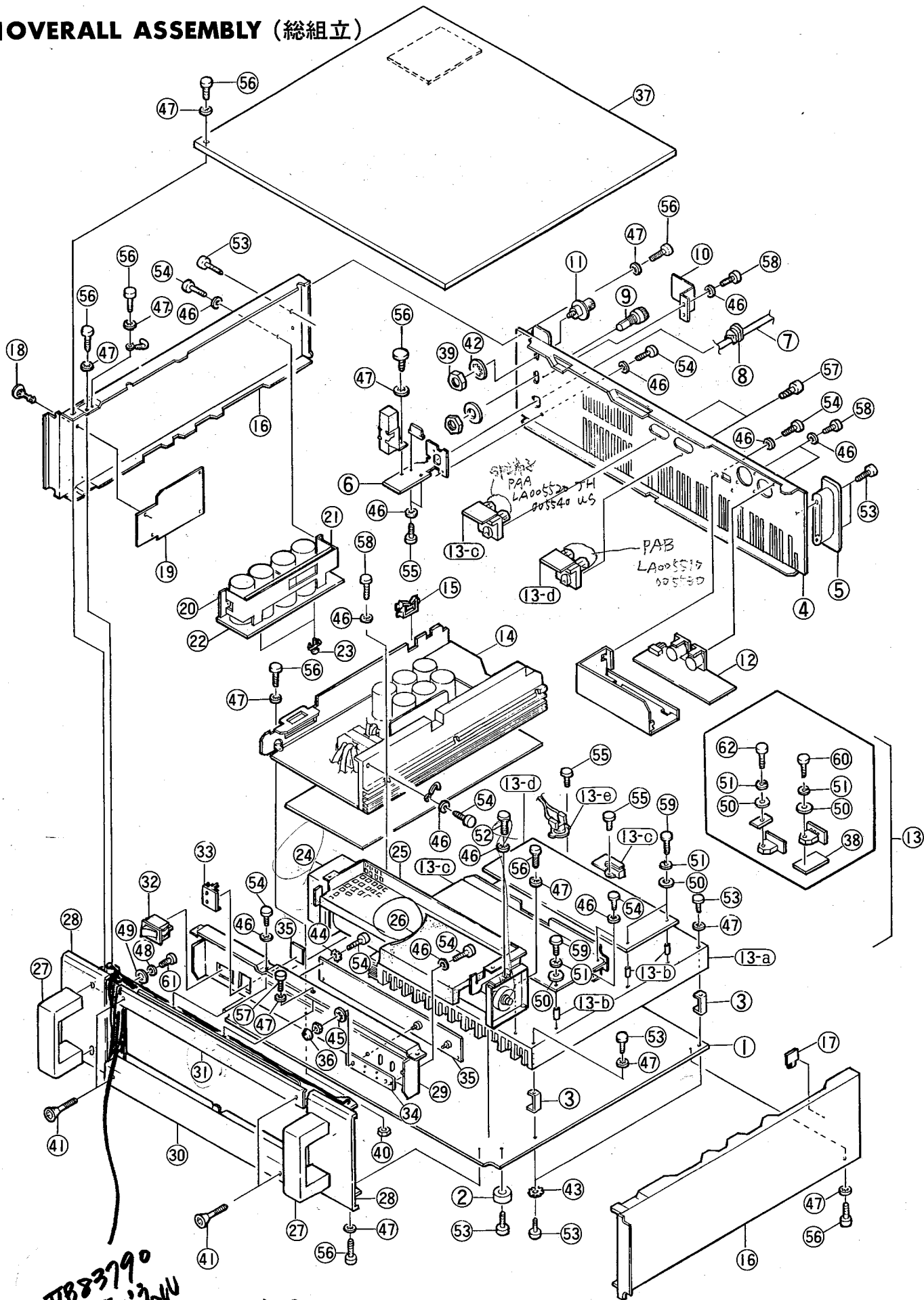

PD2500

OVERALL ASSEMBLY (総組立)

Ref No.	Part No	Description	部品名	Remarks	ランク
1	VB839100	Bottom Board	底板		14
2	CB806590	Foot	脚		01
3	VC127700	Angle	レングス		02
4	VC212800	Rear Panel	リアパネル	J	10
4	VC212900	Rear Panel	リアパネル	U	
4	VD166200	Rear Panel	リアパネル	C	
4	VC213000	Rear Panel	リアパネル	H, D	
5	CB811820	Cord Holder	コードホルダー	J	02
6	VB838900	Angle Bracket	一次アングラー		05
7	MG000610	AC Cord	電源コード	J	06
7	VC845700	AC Cord	電源コード	U, C	
7	VC845800	AC Cord	電源コード	H, D	
8	CB806850	Cord Strain Relief	コードストッパー	J	02
8	VB669000	Cord Strain Relief	コードストッパー	U, C	02
8	CB032840	Cord Strain Relief	コードストッパー	H, D	01
9	LB202940	Holder, Fuse	ヒューズホルダー	J	03
10	AA833250	Cover, Fuse	ヒューズカバー		02
11	NB082640	Terminal Assembly	アース端子	A s s 'y	05
12	VC590000	Circuit Board	JINシアン		
13	VC199200	Main Amplifier Unit	メインアンブレユニット	J, H, D	
13	VC214700	Main Amplifier Unit	メインアンブレユニット	U, C	
13-a	VB839200	Heat Sink	放熱板		20
13-b	AA077590	Support	支柱		02
13-c	VB829900	Circuit Board	PAA	J, H, D	
13-c	VC215000	Circuit Board	PAA	U, C	
13-d	VB830000	Circuit Board	PAB	J, H, D	
13-d	VC214800	Circuit Board	PAB	U, C	
13-e	KA907000	Thermostat Switch	1NT01F0459F6015	クリソニクスイッチ	05
14	XB377001	Power Supply Unit	NK534	電源ユニット	J
14	XB378001	Power Supply Unit	NK534	電源ユニット	U, C
14	XB379001	Power Supply Unit	NK534	電源ユニット	H, D
15	CB828530	Saddle	EDS-1	エッジサドル	01
16	VB838700	Side Board	K-103G	キタカワ	06
17	CB095100	Holder, Cord	K-103G	キタカワ	01
18	CB831980	Spacer	KGLS-10R	キタカワ	01
19	VB830400	Circuit Board	PS	P S シート	J
19	VC213400	Circuit Board	PS	P S シート	U, C
19	VC213500	Circuit Board	PS	P S シート	H, D
20	VB839000	Holder, Capacitor		ケミコンホルダー	03
21	VB839600	Holder, Capacitor		ケミコン押エ	01
22	VD211100	Circuit Board	CO	CO シート	J
22	VB830100	Circuit Board	CO	CO シート	U, C, H, D
23	CB086030	Spacer	215Y0255	ニフコ	01
24	VB841600	Fan	FM-04027-AS100V	クロスフローファン	J
24	VC199000	Fan	FM-04027-AS120V	クロスフローファン	U, C
24	VC199100	Fan	FM-04027-AS230V	クロスフローファン	H, D
25	VB839400	Angle Bracket, Fan		ファン金具	07
26	VB839700	Filter		フィルタ	1枚/台
27	BA803270	Handle		ハンドル	07
28	VB838000	Side Panel		サイドパネル	06
29	VB838800	Panel	Center	パネル (中)	08
30	VB838400	Panel	Lower	パネル (下)	08
31	VB838300	Panel	Upper	パネル (上)	08
32	VB841900	Switch	RUROLUX 8226	パネソフ SW	POWER
33	VB838200	Escutcheon, LED		LED エスカッション	03
34	VC128000	Escutcheon, VR		VR エスカッション	04
35	VB830200	Circuit Board	FP	F P シート	
36	VB838500	Knob		ノブ	03
37	VB839800	Top Board		天板	17
38	IL000680	Heat Sheet		放熱シート	01
39	LA001680	Hexagonal Nut	8.0 NI	六角ナット	01
40	EV103046	Hexagonal Nut	4.0 FCM3BL	六角ナット	PACK
41	VB841400	Cap Screw	4.0X8 FCM3BL	六角穴付ネジ	01
42	EV410086	Toothed Lock Washer	A8.0 ZMC2Y	歯付座金	PACK
43	EV423046	Toothed Lock Washer	B4.0 ZMC2BL	歯付座金	PACK
44	EV423036	Toothed Lock Washer	B3.0 ZMC2BL	歯付座金	PACK
45	ET800160	Toothed Lock Washer	A7.0 ZMC2BL	歯付座金	01
46	EV413036	Toothed Lock Washer	A3.0 FCM3BL	歯付座金	PACK
47	EV413046	Toothed Lock Washer	A4.0 FCM3BL	歯付座金	PACK
48	EV410056	Toothed Lock Washer	A5.0 ZMC2Y	歯付座金	PACK
49	EV200056	Flat Washer	5.0 FCM2BL	平座金	PACK
50	EV200036	Flat Washer	3.0 ZMC2Y	平座金	PACK
51	EV300036	Spring Washer	3.0 ZMC2Y	平座金	PACK
52	E1330066	Bind Tapping Screw	3.0X6 FCM3BL	バインド B タイト	PACK
53	ED340106	Bind Head Screw	4.0X10 FCM3BL	バインド小ネジ	PACK
54	E1330086	Bind Tapping Screw	3.0X8 FCM3BL	バインド B タイト	PACK
55	ED330066	Bind Head Screw	3.0X6 FCM3BL	バインド小ネジ	PACK
56	E1340086	Bind Tapping Screw	4.0X8 FCM3BL	バインド B タイト	PACK
57	E1340106	Bind Tapping Screw	4.0X10 FCM3BL	バインド P タイト	PACK

* : New Parts (新規部品)

ランク : Japan only

Ref No.	Part No	Description		部品名	Remarks	ランク
58	ED330086	Bind Head Screw	3.0X8 FCM3BL	パインド小ネジ	PACK	01
59	EA030066	Pan Head Screw	3.0X6 ZMC2Y	ナベ小ネジ	PACK	01
60	EA030126	Pan Head Screw	3.0X12 ZMC2Y	ナベ小ネジ	PACK	01
61	EA350120	Pan Head Screw	5.0X12 ZMC2BL	ナベ小ネジ	PACK	01
62	EA030166	Pan Head Screw	3.0X16 ZMC2Y	ナベ小ネジ	PACK	01
	TX900879	Allen Wrench	3mm	六角レンチ	Accessory	01

* : New Parts (新規部品)

ランク : Japan only

■ ELECTRICAL PARTS (電気部品)

Ref No.	Part No	Description	部品名	Remarks	ランク
	VC590000	Circuit Board	IN	INシート	
	VB830200	Circuit Board	FP	FPシート	
	VB830400	Circuit Board	PS	PSシート	
	VD211100	Circuit Board	CO	COシート	J
	VB830100	Circuit Board	CO	COシート	U,C,H,D
	VB829900	Circuit Board	PAA	PAAシート	J,H,D
	VC215000	Circuit Board	PAA	PAAシート	U,C
	VB830000	Circuit Board	PAB	PABシート	J,H,D
	VC214800	Circuit Board	PAB	PABシート	U,C
	VC590000	Circuit Board	IN	INシート	
	IG102500	IC	NE5532P	IC	OP AMP.
	IF005120	Diode Array	MC931 0.3A X2	ダイオードアレイ	06
	HU074470	Metal Film Resistor	47Ω 1/4 F	金属被膜抵抗	01
	HU075100	Metal Film Resistor	100Ω 1/4 F	金属被膜抵抗	02
	HU077150	Metal Film Resistor	15KΩ 1/4 F	金属被膜抵抗	02
	HU077220	Metal Film Resistor	22KΩ 1/4 F	金属被膜抵抗	02
	HU077820	Metal Film Resistor	82KΩ 1/4 F	金属被膜抵抗	02
	FU351680	Mica Cap.	68P 500V J	マイカコン	02
	KA401280	Slide Switch	SSP32204	スライドSW	03
	LB302320	XLB Connector	XLB-3-31-PCV	キャノンコネクタ	Socket
	VB830200	Circuit Board	FP	FPシート	
	IG149500	IC	NJM5534D	IC	OP AMP.
	IA097000	Transistor	2SA970 GR,BL	トランジスタ	03
	IC224000	Transistor	2SC2240 GR,BL	トランジスタ	03
	VA240700	Diode	1SS176	ダイオード	01
	IF001190	LED	TLR124 RE	LED	02
	VA767800	LED	TLG124 GR	LED	01
	HV354220	Flame Carbon Resistor	22Ω 1/4 J	不燃化カーボン抵抗	01
	HL314220	Metal Oxide Resistor	22Ω 1W J	酸化金属被膜抵抗	01
	HL316680	Metal Oxide Resistor	6.8KΩ 1W J	酸化金属被膜抵抗	01
	VC199300	Rotary Pot.	A2K RK163122	ロータリONVR	04
	FH212220	Ceramic Cap.	220P 500V K	セラコン	01
	FU351330	Mica Cap.	33P 500V J	マイカコン	01
	FU351680	Mica Cap.	68P 500V J	マイカコン	02
	VC208500	Relay → VP 56/00	DC HD1-M-DC24V	リレー	05
	VB397800	Spacer		LEDスペーサー	
	VB830400	Circuit Board	PS	PSシート	J
	VC213400	Circuit Board	PS	PSシート	U,C
	VC213500	Circuit Board	PS	PSシート	H,D
	IG063900	IC	μ PC7815H	IC	15V 1A
	IG077500	IC	μ PC7915H	IC	-15V 1A
	IH000030	Diode	10D1	ダイオード	05
	HL314330	Metal Oxide Resistor	33Ω 1W J	酸化金属被膜抵抗	01
	HV354100	Flame Carbon Resistor	10Ω 1/4 J	不燃化カーボン抵抗	01
	FJ359100	Electrolytic Cap.	1000μ 35V	ケミコン	03
	UI998330	Electrolytic Cap.	330μ 100V	ケミコン	03
	FJ298100	Electrolytic Cap.	100μ 100V	ケミコン	03
	VC495500	Coil	CLR2BD142 変	コイル	03
	KB000310	Fuse	T500mA 250V	ヒューズ	J
	KB001150	Fuse	T500mA 250V	ヒューズ	U,C
	KB000650	Fuse	T315mA 250V	ヒューズ	H,D
	LB201530	Fuse Holder	PC-FH1	ヒューズホルダ	01
	VD211100	Circuit Board	CO	COシート	J
	VB830100	Circuit Board	CO	COシート	U,C,H,D
	VC213200	Electrolytic Cap.	5600μ 100V	ケミコン	08
	KB001390	Fuse	10A 250V	ヒューズ	03
	LB201530	Fuse Holder	PC-FH1	ヒューズホルダ	01
	VC199200	Main Amplifier		メインアンプユニット	J,H,D
	VC214700	Main Amplifier Unit		メインアンプユニット	U,C
	VB829900	Circuit Board	PAA	PAAシート	J,H,D
	VC215000	Circuit Board	PAA	PAAシート	U,C
	IA097000	Transistor	2SA970 GR,BL	トランジスタ	03
	IA101530	Transistor	2SA1015 Y,GR	トランジスタ	03
	IC181530	Transistor	2SC1815 GR	トランジスタ	03
	IC224000	Transistor	2SC2240 GR,BL	トランジスタ	03
	IC229100	Transistor	2SC2291 F,G,H	トランジスタ	03
	VC211000	Transistor	2SC3421 O,Y	トランジスタ	02
	IA136000	Transistor	2SA1360	トランジスタ	02
	IC342300	Transistor	2SC3423	トランジスタ	02
	IX801630	Transistor	2SA1142 P,Q	トランジスタ	
	IX801640	Transistor	2SC2682 P,Q	トランジスタ	
	IX801650	Transistor	2SA1516 R,Q	トランジスタ	
	IX801660	Transistor	2SC3907 R,Q	トランジスタ	

* : New Parts (新規部品)

ランク : Japan only

PD2500

Ref No.	Part No	Description	部品名	Remarks	ランク
	IA096840	Transistor	2SA968B O.Y	トランジスタ	03
	IC223840	Transistor	2SC2238B O.Y	トランジスタ	03
	IE104510	FET	2SK389 BL.V	F E T	03
	IF001400	Diode	1SS82	ダイオード	02
	IH000030	Diode	10D1	ダイオード	03
	VA240700	Diode	1SS176	ダイオード	01
	VC212700	Diode	3LZ61	ダイオード	03
	IF001700	Zener Diode	RD15EB3 15V	ツェナーダイオード	01
	IF002140	Zener Diode	RD5.6EB2 5.6V	ツェナーダイオード	01
	IF001900	Zener Diode	02BZ3.3	ツェナーダイオード	02
	HM654100	Wire Wound Resistor	10Ω 5W	セメント抵抗	02
	HZ003600	Wire Wound Resistor	0.47Ω 5W K	セメント抵抗	02
	HU077390	Metal Film Resistor	39KΩ 1/4 F	金属被膜抵抗	02
	HU575330	Metal Film Resistor	330Ω 1/4 F	金属被膜抵抗	02
	HU577150	Metal Film Resistor	5KΩ 1/4 F	金属被膜抵抗	02
	HU577180	Metal Film Resistor	18KΩ 1/4 F	金属被膜抵抗	02
	HL314100	Metal Oxide Resistor	10Ω 1W J	酸化金属被膜抵抗	01
	HL314220	Metal Oxide Resistor	22Ω 1W J	酸化金属被膜抵抗	01
	HL323470	Metal Oxide Resistor	4.7Ω 2W J	酸化金属被膜抵抗	01
	HV353220	Flame Carbon Resistor	2.2Ω 1/4 J	不燃化カーボン抵抗	01
	HV353470	Flame Carbon Resistor	4.7Ω 1/4 J	不燃化カーボン抵抗	01
	HV354820	Flame Carbon Resistor	82Ω 1/4 J	不燃化カーボン抵抗	01
	HV355100	Flame Carbon Resistor	100Ω 1/4 J	不燃化カーボン抵抗	01
	HV355150	Flame Carbon Resistor	150Ω 1/4 J	不燃化カーボン抵抗	01
	HV355270	Flame Carbon Resistor	270Ω 1/4 J	不燃化カーボン抵抗	01
	HV355330	Flame Carbon Resistor	330Ω 1/4 J	不燃化カーボン抵抗	01
	HV356180	Flame Carbon Resistor	1.8KΩ 1/4 J	不燃化カーボン抵抗	01
	HT410020	Trimmer Potentiometer	B1K 3P SR1	半固定VR	02
	FZ005200	Mylar Cap.	0.1μ 100V K	マイラコン	01
	FZ005210	Mylar Cap.	0.22μ 100V K	マイラコン	02
	FZ005220	Mylar Cap.	0.47μ 100V K	マイラコン	02
	FC023470	Mylar Cap.	0.047μ 100V K	マイラコン	02
	FU351330	Mica Cap.	33P 500V J	マイカコン	01
	FU351680	Mica Cap.	68P 500V J	マイカコン	02
	FJ197470	Electrolytic Cap.	47μ 100V	ケミコン	02
	FJ298100	Electrolytic Cap.	100μ 100V	ケミコン	03
	FT552220	Polypropylene Cap.	220P 50V	ポリプロコン	03
	FT552390	Polypropylene Cap.	390P 50V	ポリプロコン	03
	FT552470	Polypropylene Cap.	470P 50V	ポリプロコン	03
	FT552680	Polypropylene Cap.	680P 50V	ポリプロコン	03
	FT463180	Polypropylene Cap.	1800P 50V	ポリプロコン	03
	GD900190	Coil	3μ	空芯コイル	03
	KA000220	Thermal Reed Switch	OHD-85B	空マールガード	06
	KC001410	Relay	DC JC2AD-DC24V	リレー	07
	VC208500	Relay → VP-56100	DC HD1-M-DC24V	リレー	05
	LA005520	Speaker Terminal	2P	スピーカ端子	06
	LA005540	Speaker Terminal	2P	スピーカ端子	U,C
	VB830000	Circuit Board	PAB	P A Bシート	J,H,D
	VC214800	Circuit Board	PAB	P A Bシート	U,C
	IA097000	Transistor	2SA970 GR,BL	トランジスタ	03
	IA101530	Transistor	2SA1015 Y,GR	トランジスタ	03
	IC181530	Transistor	2SC1815 GR	トランジスタ	03
	IC224000	Transistor	2SC2240 GR,BL	トランジスタ	03
	IC229100	Transistor	2SC2291 F,G,H	トランジスタ	03
	VC852200	Transistor	2SA1358 O.Y	トランジスタ	02
	IA136000	Transistor	2SA1360	トランジスタ	02
	IC342300	Transistor	2SC3423	トランジスタ	02
	IX801630	Transistor	2SA1142 P,Q	トランジスタ	
	IX801640	Transistor	2SC2682 P,Q	トランジスタ	
	IX801650	Transistor	2SA1516 R,O	トランジスタ	
	IX801660	Transistor	2SC3907 R,O	トランジスタ	
	IA096840	Transistor	2SA968B O.Y	トランジスタ	03
	IC223840	Transistor	2SC2238B O.Y	トランジスタ	03
	IE104510	FET	2SK389 BL.V	F E T	03
	IF001400	Diode	1SS82	ダイオード	02
	IH000030	Diode	10D1	ダイオード	03
	VA240700	Diode	1SS176	ダイオード	01
	VC212700	Diode	3LZ61	ダイオード	03
	IF001700	Zener Diode	RD15EB3 15V	ツェナーダイオード	01
	IF002140	Zener Diode	RD5.6EB2 5.6V	ツェナーダイオード	01
	IF001900	Zener Diode	02BZ3.3	ツェナーダイオード	02
	HM654100	Wire Wound Resistor	10Ω 5W	セメント抵抗	02
	HZ003600	Wire Wound Resistor	0.47Ω 5W K	セメント抵抗	02
	HU077390	Metal Film Resistor	39KΩ 1/4 F	金属被膜抵抗	02
	HU575330	Metal Film Resistor	330Ω 1/4 F	金属被膜抵抗	02
	HU577150	Metal Film Resistor	15KΩ 1/4 F	金属被膜抵抗	02
	HU577180	Metal Film Resistor	18KΩ 1/4 F	金属被膜抵抗	02
	HL314100	Metal Oxide Resistor	10Ω 1W J	酸化金属被膜抵抗	01

* : New Parts (新規部品)

ランク : Japan only

Ref No.	Part No	Description	部品名	Remarks	ランク	
	HL314220	Metal Oxide Resistor	22Ω 1W J	酸化金属被膜抵抗		01
	HL316220	Metal Oxide Resistor	2.2KΩ 1W J	酸化金属被膜抵抗		01
	HL323470	Metal Oxide Resistor	4.7Ω 2W J	酸化金属被膜抵抗		01
	HV353220	Flame Carbon Resistor	2.2Ω 1/4 J	不燃化カーボン抵抗		01
	HV353470	Flame Carbon Resistor	4.7Ω 1/4 J	不燃化カーボン抵抗		01
	HV354820	Flame Carbon Resistor	82Ω 1/4 J	不燃化カーボン抵抗		01
	HV355100	Flame Carbon Resistor	100Ω 1/4 J	不燃化カーボン抵抗		01
	HV355150	Flame Carbon Resistor	150Ω 1/4 J	不燃化カーボン抵抗		01
	HV355270	Flame Carbon Resistor	270Ω 1/4 J	不燃化カーボン抵抗		01
	HV355330	Flame Carbon Resistor	330Ω 1/4 J	不燃化カーボン抵抗		01
	HV356180	Flame Carbon Resistor	1.8KΩ 1/4 J	不燃化カーボン抵抗		01
	HT410020	Trimmer Potentiometer	B1.0K 3P SR1	半固定VR		02
	FZ005200	Mylar Cap.	0.1μ 100V K	マイラーコン		01
	FZ005210	Mylar Cap.	0.22μ 100V K	マイラーコン		02
	FZ005220	Mylar Cap.	0.47μ 100V K	マイラーコン		02
	FC023470	Mylar Cap.	0.047μ 100V K	マイラーコン		02
	FU351330	Mica Cap.	33P 500V J	マイカコン		01
	FU351680	Mica Cap.	68P 500V J	マイカコン		02
	FJ197470	Electrolytic Cap.	47μ 100V	ケミコン		02
	FJ298100	Electrolytic Cap.	100μ 100V	ケミコン		03
	FT552220	Polypropylene Cap.	220P 50V	ポリプロコン		03
	FT552390	Polypropylene Cap.	390P 50V	ポリプロコン		03
	FT552470	Polypropylene Cap.	470P 50V	ポリプロコン		03
	FT552680	Polypropylene Cap.	680P 50V	ポリプロコン		03
	FT463180	Polypropylene Cap.	1800P 50V	ポリプロコン		03
	GD900190	Coil	3μ	空芯コイル		03
	KC001410	Relay	DC JC2AD-DC24V	リレー		07
	LA005510	Speaker Terminal	2P	スピーカ端子	J, H, D	06
	LA005530	Speaker Terminal	2P	スピーカ端子	U, C	
	VC207400	Wire Wound Resistor	270Ω 25K	セメント抵抗	J, U, C	03
	VC207600	Wire Wound Resistor	560Ω 25K	セメント抵抗	H, D	03
	FI384100	Ceramic Cap.	0.01μ 400V	規格認定コン		01
	VB841900	Switch	EUROLUX 8226	スイッチ		07
	KB001270	Fuse	15A 125V	ヒューズ	J	01
	KB001380	Fuse	15A 250V	ヒューズ	U, C	03
	KB000780	Fuse	T5A 250V	ヒューズ	H, D	
	MG000610	AC Cord	2芯 15A 2.1M	電源コード	J	06
	VC845700	AC Cord	3芯 15A	電源コード	U, C	
	VC845800	AC Cord	3芯 10A	電源コード	H, D	
	XB377001	Power Supply Unit	NK534	電源ユニット	J	60
	XB378001	Power Supply Unit	NK534	電源ユニット	U, C	
	XB379001	Power Supply Unit	NK534	電源ユニット	H, D	
	VF962800	IC Protector	ICP-F50			

* : New Parts (新規部品)

ランク : Japan only

● PAA Circuit Board

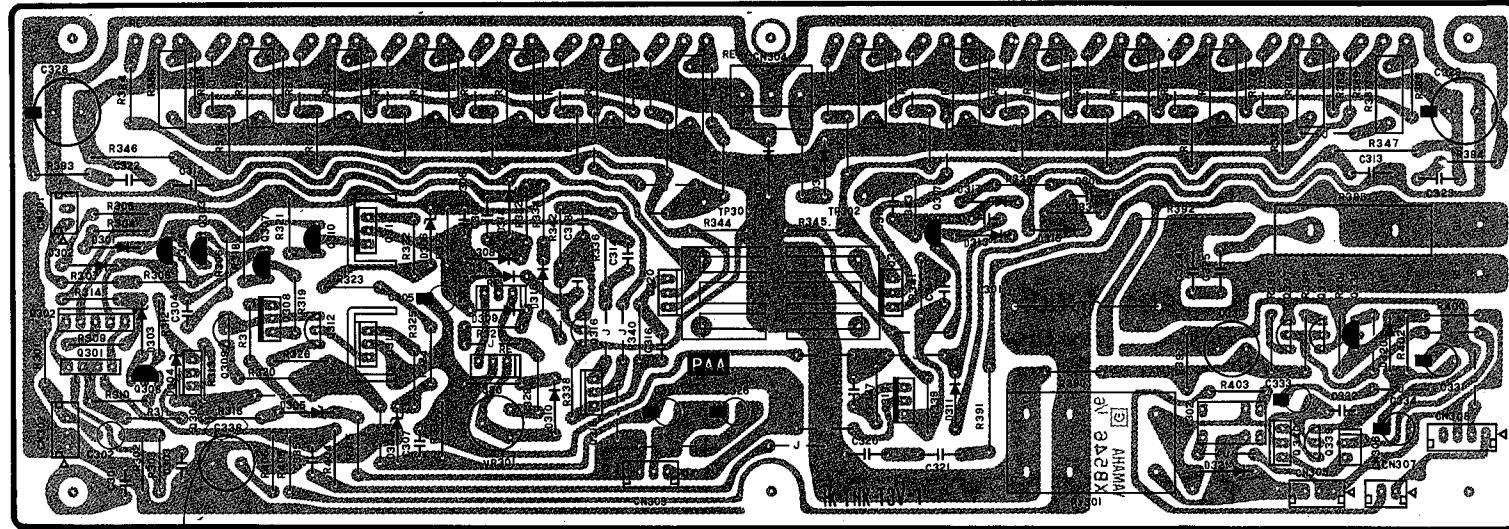

<Components side>

c336, c536
DC 59890
35V 100
8P2V

● PAB Circuit Board

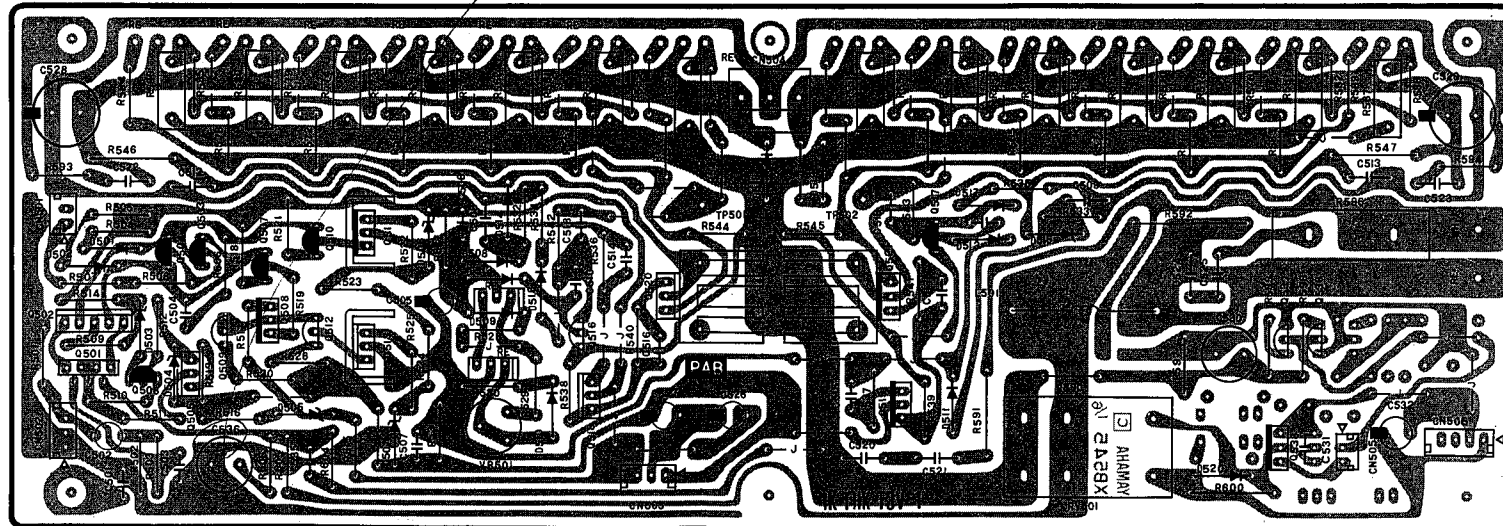

<Components side>

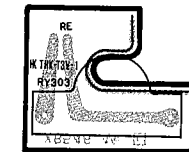
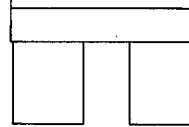
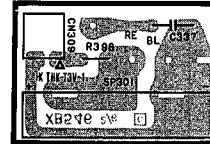

PAA Circuit Board
(Notes)
Circuit Board:

XB546B0

Q301:	2SK389(BL, V) FET	D301, 302, 309,	
302:	2SC2291 (F, G, H) Dual Transistor	310, 312, 313:	1SS176
303, 304, 306,		308, 311, 316,	
307, 317, 338:	2SA970 (GR, BL)	317:	1SS82
305, 313, 318:	2SC2682 (P, Q)	318, 319:	3NZ61
308, 311, 319:	2SA1142 (P, Q)	320, 321:	10D1
309, 316, 336,		303, 304, 306,	
337, 339:	2SC2240 (GR, BL)	307:	RD5.6E Zener Diode
310:	2SA1015 (GR)	305:	RD15E Zener Diode
312:	2SC1815 (GR)	314, 315:	02BZ3.3: Zener Diode
314:	2SC3423 (O, Y)	VR301:	H1051 1KB
315:	2SA1360 (O, Y)	L301:	3.0μH Coil
320:	2SC2238 (O, Y)	RY301:	JC2aD-DC24V Relay
321:	2SA968 (O, Y)	302:	HD1-M-DC24V Relay
322, 324, 326,		303:	OHD85B
328, 330, 332,			
334:	2SC3907 (O, R)		
323, 325, 327,			
329, 331, 333,			
335:	2SA1516 (O, R)		
340:	2SC3421 (O, Y)		

2SA1142
2SC2238
TP501 ↔ TP502 25mV ± 1mV

PAB Circuit Board
(Notes)
Circuit Board:

XB545B0

Q501:	2SK389, (BL, V) FET	D501, 502, 509,	
502:	2SC2291 (F, G, H) Dual Transistor	510, 512, 513:	1SS176
503, 504, 506,		508, 511, 516,	
507, 517:	2SA970 (GR, BL)	517:	1SS82
505, 513, 518:	2SC2682 (P, Q)	518, 519:	3NZ61
508, 511, 519:	2SA11421 (P, Q)	520:	10D1
509, 516, 536,		503, 504, 506,	
537, 539:	2SC2240 (GR, BL)	507:	RD5.6E Zener Diode
510:	2SA1015 (GR)	505:	RD15E Zener Diode
512:	2SC1815 (GR)	514, 515:	02BZ3.3: Zener Diode
514:	2SC3423 (O, Y)	VR501:	H1051 1KB
515:	2SA1360 (O, Y)	L501:	3.0μH Coil
520:	2SC2238 (O, Y)	RY501:	JC2aD-DC24V Relay
521:	2SA968 (O, Y)		
522, 524, 526,			
528, 530, 532,			
534:	2SC3907 (O, R)		
523, 525, 527,			
529, 531, 533,			
535:	2SA1516 (O, R)		

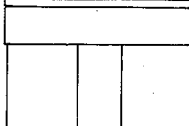
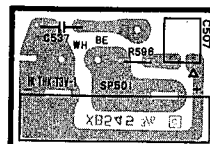

3NA-VB82990 : PAA Circuit Board △
 3NA-VB83000 : PAB Circuit Board △

● FP Circuit Board

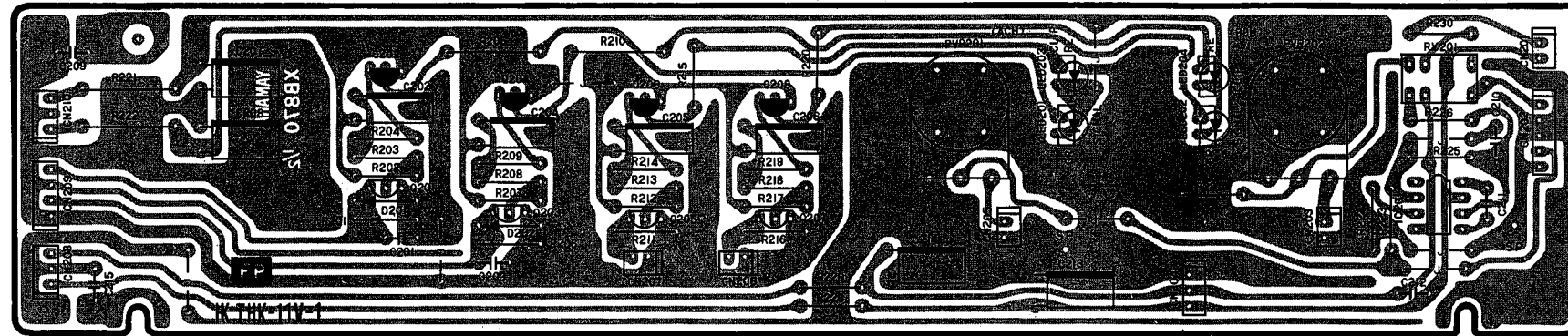

<Components side>

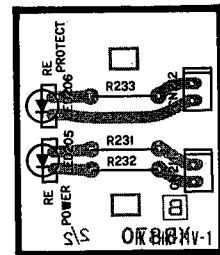

FP Circuit Board
(Notes)

- Circuit Board: XB870B0
- IC201: NJM5534D (IG149500)
OP AMP.
- Q201, 203, 205, 207 : 2SC2240 (GR, BL)
202, 204, 206, 208 : 2SA970 (GR, BL)
- D201, 202: 1SS176
- LED201, 202: TLG124 (GR)
203 ~ 206: RLR124 (RE)
- PVR201, 202: A 2K Rotary Pot.
- RY201: HD1-M-DC24V Relay

● PS Circuit Board

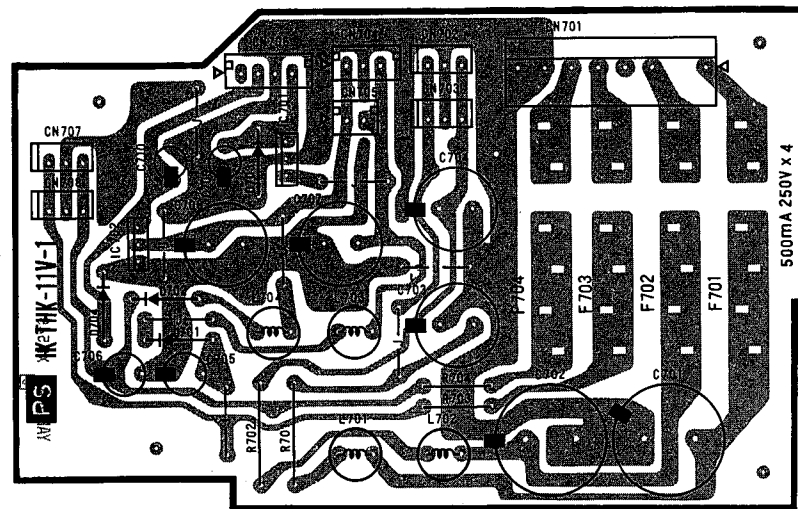

<Components side>

PS Circuit Board
(Notes)

- Circuit Board: XB549B0
- IC701: μ PC7815H (IG063900)
15V 1A
- 702: μ PC7915H (IG077500)
-15V 1A
- D701 ~ 704: 10D-1
- L701 ~ 704: 1400 μ H CLR2BD142
(VC495500)

Fuse

Market	Fuse	F701 ~ 704
Japanese		0.5A 250V
U.S.American Canadian		ST-4 0.5A 250V
North/European		T315mA 250V

● PU-A Circuit Board (POWER SUPPLY UNIT)

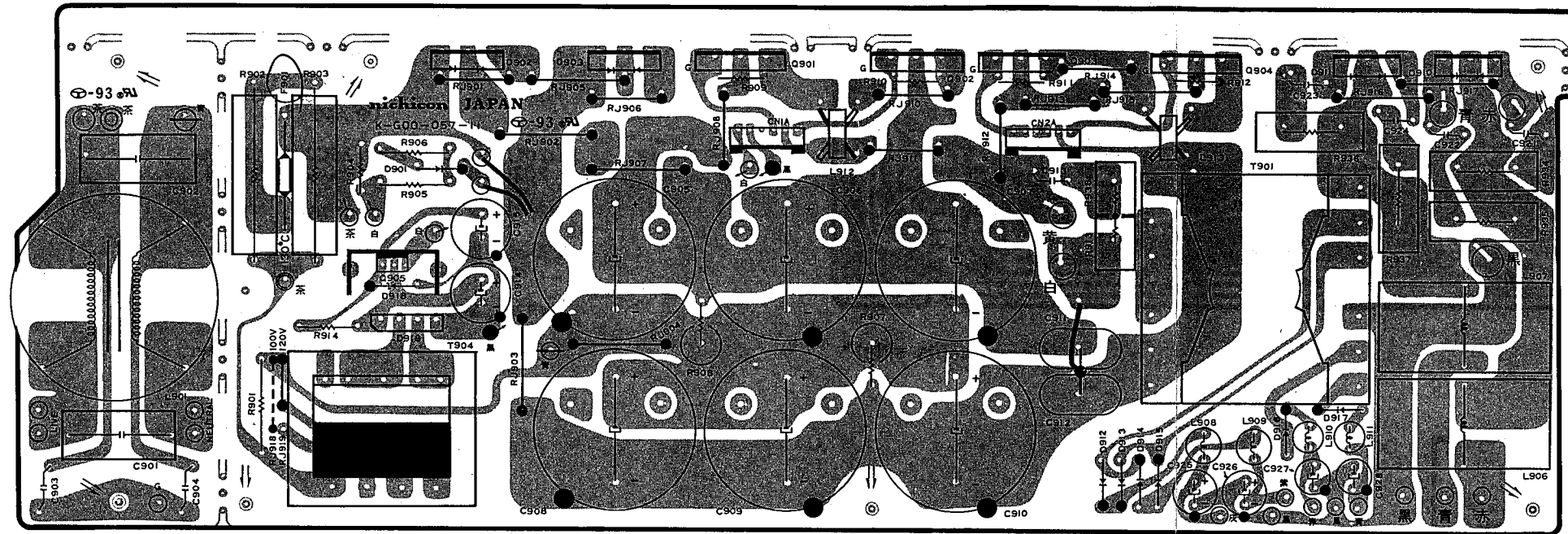

<Components side>

NX801820

● PU-B Circuit Board (POWER SUPPLY UNIT)

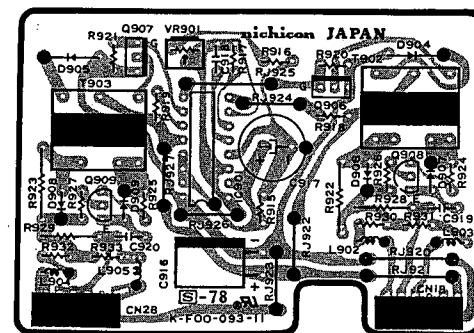

PU Circuit Board Notes)

- IC901: MB3759
- Q901~04: 2SK386 FET
- 905: 2SD880 TR
- 906, 07: 2SK462 FET
- 908, 09: 2SC1815 TR
- D901, 912~17: $\frac{1}{2}$ DF-4 1A 400V
- 902, 03: ESAD25-04C 15A 400V (J, U, C)
ESAD25-04D 15A 400V (H)
- 904, 05: 1S2095A
- 906~09: 1S1587
- 910: C25P40F 25A 400V
- 911: C25P40FR 25A 400V
- 918: RD16E-L1 16V
- 919: SIVB10 0.6A 100V
- L901: SC-15-100A 15A 1mH (J, U, C)
SC-10-100A 10A 1mH (H)
- 902~05: B-01-A
- 906, 07: HP-105Z 10A
- 908, 09: TSL0807-102KR23 1mH
- 910, 11: TSL0707-680KR73 68 μ H
- 912, 13: FB4AU (T-11)
- T901: N-T00-185-11 (J)
N-T00-161-11 (U, C, H)
- 902, 03: D-T00-048-12
- 904: N-T00-108-11 (J, C, U)
N-T00-104-11 (H)
- TA901: AC25DIF Triac
- F901: 213 (J, U, C)
X23 (H)

R909
R912 *HT457100*