

STEREO RECEIVER RX-V490/R-V701

SERVICE MANUAL

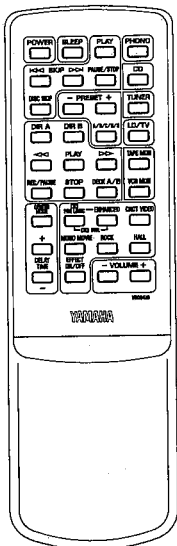
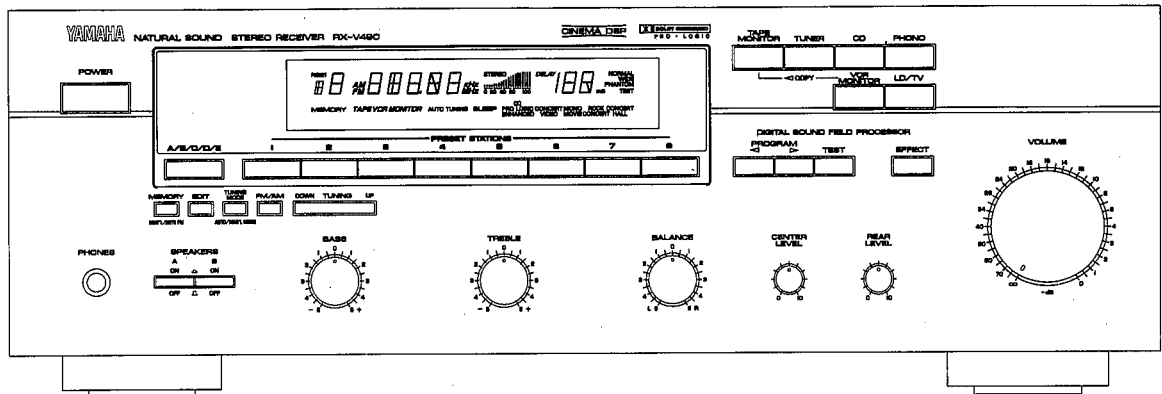

IMPORTANT NOTICE

This manual has been provided for the use of authorized YAMAHA Retailers and their service personnel. It has been assumed that basic service procedures inherent to the industry, and more specifically YAMAHA Products, are already known and understood by the users, and have therefore not been restated.

WARNING: Failure to follow appropriate service and safety procedures when servicing this product may result in personal injury, destruction of expensive components, and failure of the product to perform as specified. For these reasons, we advise all YAMAHA product owners that any service required should be performed by an authorized YAMAHA Retailer or the appointed service representative.

IMPORTANT: The presentation or sale of this manual to any individual or firm does not constitute authorization, certification or recognition of any applicable technical capabilities, or establish a principle-agent relationship of any form.

The data provided is believed to be accurate and applicable to the unit(s) indicated on the cover. The research, engineering, and service departments of YAMAHA are continually striving to improve YAMAHA products. Modifications are, therefore, inevitable and specifications are subject to change without notice or obligation to retrofit. Should any discrepancy appear to exist, please contact the distributor's Service Division.

WARNING: Static discharges can destroy expensive components. Discharge any static electricity your body may have accumulated by grounding yourself to the ground buss in the unit (heavy gauge black wires connect to this buss).

IMPORTANT: Turn the unit OFF during disassembly and part replacement. Recheck all work before you apply power to the unit.

CONTENTS

TO SERVICE PERSONNEL	1
REAR PANELS	1~2
SPECIFICATIONS	3~4
INTERNAL VIEW	5
DISASSEMBLY PROCEDURES	5
TEST SIGNAL PROGRAM	6~7
ADJUSTMENTS	8~12
IC DATA	13~16

BLOCK DIAGRAM	17~19
PRINTED CIRCUIT BOARD	20~29
DISPLAY DATA	30
TEST POINT WAVEFORMS	31
SCHEMATIC DIAGRAM	32~36
PARTS LIST	37~47
REMOTE CONTROL TRANSMITTER	48

RX-V490/R-V701

■ TO SERVICE PERSONNEL

1. Critical Components Information.
Components having special characteristics are marked and must be replaced with parts having specifications equal to those originally installed.
2. Leakage Current Measurement (For 120V Models Only).
When service has been completed, it is imperative to verify that all exposed conductive surfaces are properly insulated from supply circuits.
 - Meter impedance should be equivalent to 1500 ohm shunted by 0.15µF.
 - Leakage current must not exceed 0.5mA.
 - Be sure to test for leakage with the AC plug in both polarities.

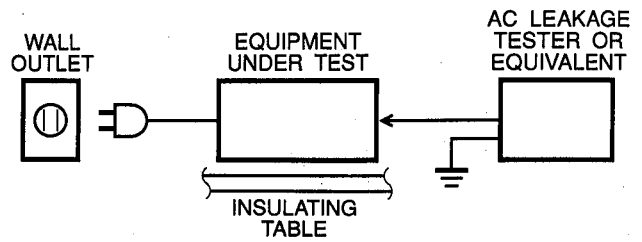

WARNING: CHEMICAL CONTENT NOTICE!

The solder used in the production of this product contains LEAD. In addition, other electrical/electronic and/or plastic (where applicable) components may also contain traces of chemicals found by the California Health and Welfare Agency (and possibly other entities) to cause cancer and/or birth defects or other reproductive harm.

DO NOT PLACE SOLDER, ELECTRICAL/ELECTRONIC OR PLASTIC COMPONENTS IN YOUR MOUTH FOR ANY REASON WHATSOEVER!

Avoid prolonged, unprotected contact between solder and your skin! When soldering, do not inhale solder fumes or expose eyes to solder/flux vapor!

If you come in contact with solder or components located inside the enclosure of this product, wash your hands before handling food.

RX-V490/R-V701

■ REAR PANELS

▼ RX-V490/R-V701 U model

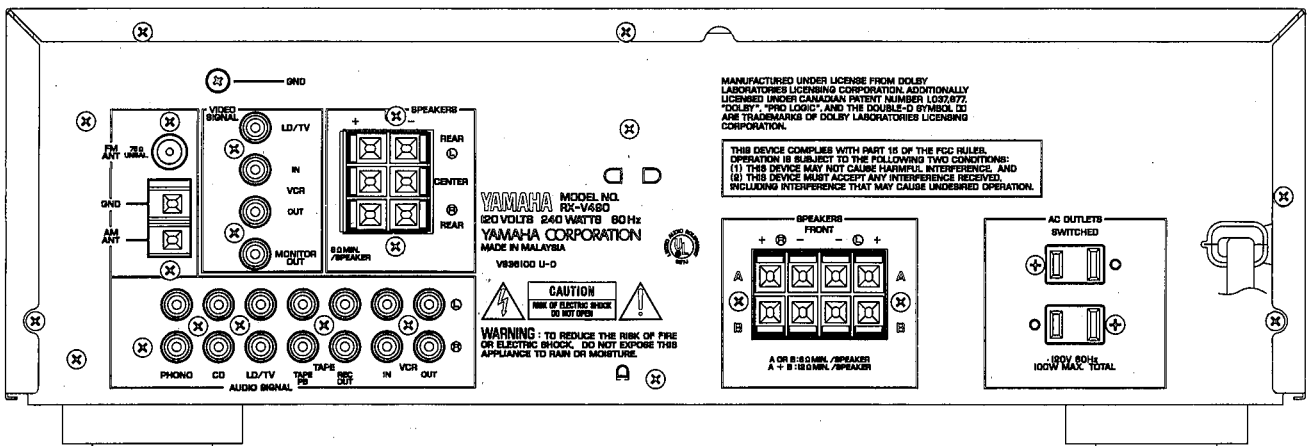

▼ RX-V490 C model

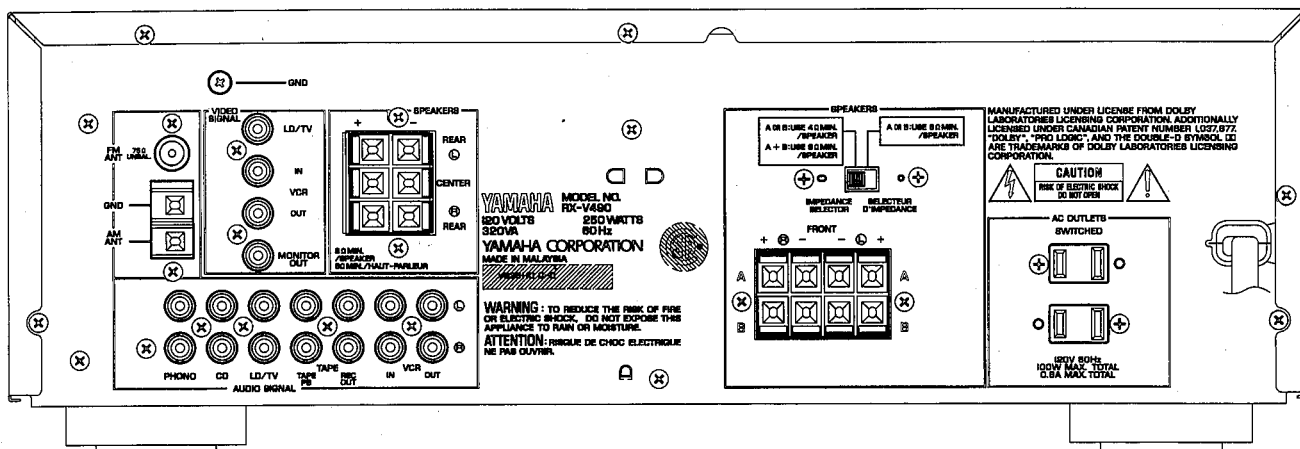

▼ RX-V490 R model

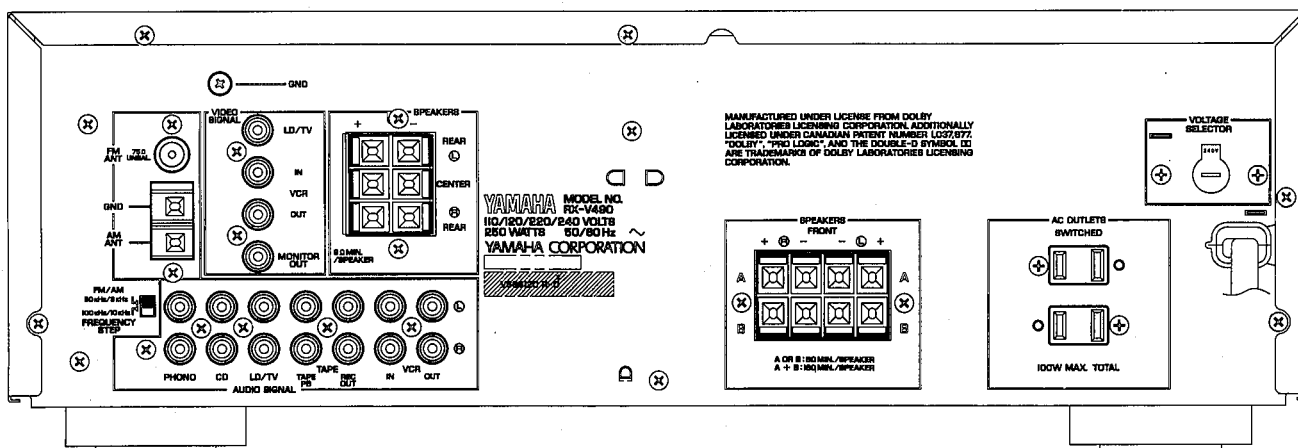

▼ RX-V490 A model

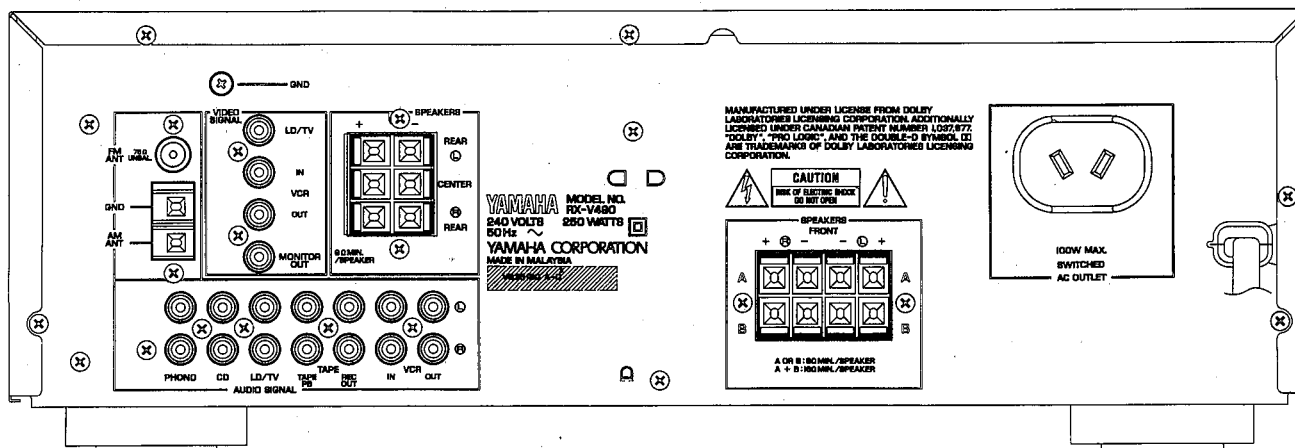

RX-V490/R-V701

■ SPECIFICATIONS

■ AUDIO SECTION

Minimum RMS Output Power per Channel

RX-V490

FRONT, 20Hz to 20kHz, 0.04% THD, 8Ω70W
 CENTER, 1kHz, 0.1% THD, 8Ω70W
 REAR, 1kHz, 0.7% THD, 8Ω15W

R-V701

FRONT, 1kHz, 0.09% THD, 8Ω80W
 CENTER, 1kHz, 0.1% THD, 8Ω80W
 REAR, 1kHz, 0.7% THD, 8Ω15W

Dynamic Power per Channel (IHF)

RX-V490

8/6/4/2Ω90/105/130/150W

R-V701

8/6/4/2Ω110/140/190/220W

Power Band Width

0.08% THD, 30W, 8Ω10Hz to 50kHz

Damping Factor

20Hz to 20kHz, 8Ω80

Maximum Power

RX-V490 R model only

1kHz, 10% THD, 8Ω100W

Input Sensitivity/Impedance

PHONO MM2.5mV/47kΩ

CD etc150mV/47kΩ

Maximum Input Signal Level (1kHz, 0.04% THD)

PHONO MM90mV

Output Level/Impedance

REC OUT150mV/600Ω

Headphone Jack Rated Output/Impedance

RX-V490

0.04% THD, RL=8Ω0.56V/330Ω

R-V701

0.04% THD, RL=8Ω0.6V/330Ω

Frequency Response (20Hz to 20kHz)

CD etc0±0.5dB

RIAA Equalization Deviation (20Hz to 20kHz)

PHONO MM0±0.5dB

Total Harmonic Distortion (20Hz to 20kHz)

PHONO MM to REC OUT (1V)0.02%

CD etc to SP OUT (30W/8Ω)0.02%

Signal-to-Noise Ratio (IHF-A-Network)

PHONO MM (5mV Input Shorted)82dB

CD etc (Shorted)93dB

Residual Noise (IHF-A-Network)

.....140μV

Channel Separation (Vol. -30dB)

PHONO MM (Input Shorted) 1kHz60dB

CD etc (Input 5.1kΩ Terminated) 1kHz60dB

Tone Control Characteristics

BASS : Boost/cut±10dB (50Hz)

Turnover Frequency350Hz

TREBLE : Boost/cut±10dB (20kHz)

Turnover Frequency3.5kHz

Gain Tracking Error (0 to -60dB)3dB

Tuner Output Level/Impedance

FM (100% mod., 1kHz)500mV/2.2kΩ

AM (30% mod., 1kHz)150mV/2.2kΩ

■ VIDEO SECTION

Video Signal

Input Level/Impedance1Vp-p/75Ω

Output Level/Impedance1Vp-p/75Ω

■ FM SECTION

Tuning Range

U, C, R models87.5 to 107.9MHz

A, R models87.5 to 108.0MHz

50dB Quieting Sensitivity (IHF, 75Ω)

Mono1.55μV (15.1dBf)

Stereo21μV (37.7dBf)

Usable Sensitivity (75Ω)

30dB S/N Quieting, 1kHz, 100% mod.0.8μV (9.3dBf)

Image Response Ratio45dB

IF Response Ratio80dB

Spurious Response Ratio70dB

AM Suppression Ratio55dB

Capture Ratio1.5dB

Alternate Channel Selectivity85dB

Signal-to-Noise Ratio (IHF)

Mono/Stereo80/75dB

Harmonic Distortion

Mono/Stereo, 1kHz0.1/0.2%

Frequency Response

30Hz to 15kHz0±1.5dB

Stereo Separation

1kHz50dB

■ AM SECTION

Tuning Range

U, C, R models530 to 1,710kHz

A, R models531 to 1,611kHz

Usable Sensitivity100μV/m

Selectivity32dB

Signal-to-Noise Ratio50dB

Image Response Ratio40dB

Spurious Response Ratio50dB

Harmonic Distortion (1kHz)0.3%

■ GENERAL

Power Supply

- U, C modelsAC 120V, 60Hz
- A modelAC 240V, 50Hz
- R modelAC 110/120/220/240V, 60/50Hz

Power Consumption

RX-V490

- U model240W
- C model320VA/250W
- A, R models250W

R-V701

- U model220W

AC Outlets

- Switched x 2
- U, C, R models100W max. (Total)
- Switched x 1
- A model100W max.

Dimensions (W x H x D)435 x 146 x 299mm
 (17-1/8" x 5-3/4" x 11-3/4")

Weight8.5kg (18lbs 11oz)

- Accessories**AM loop antenna x 1
 Indoor FM antenna x 1
 Remote Control Transmitter x 1
 Battery (size "AA", "R06") x 2

* Specifications subject to change without notice.

- UUSA model
- AAustralian model
- CCanadian model
- RGeneral model

Manufactured under license from Dolby Laboratories Licensing Corporation. Additionally licensed under Canadian patent number 1, 037, 877. "Dolby", "Pro Logic", and the double-D symbol  are trademarks of Dolby Laboratories Licensing Corporation.

● DIMENSIONS

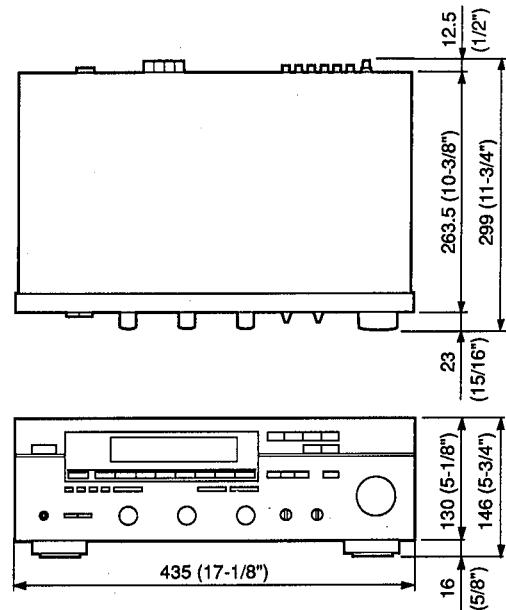

Units : mm (inch)

INTERNAL VIEW

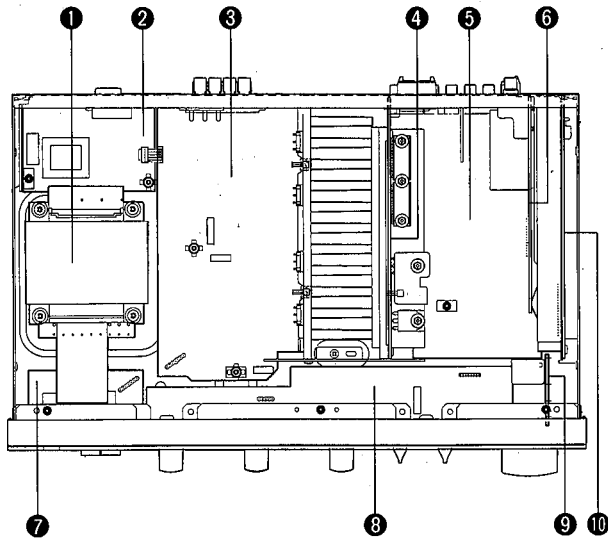

- ① POWER TRANSFORMER
- ② P. C. B. MAIN (2)
- ③ P. C. B. MAIN (1)
- ④ P. C. B. EFFECT (2)
- ⑤ P. C. B. INPUT
- ⑥ P. C. B. TUNER
- ⑦ P. C. B. MAIN (3)
- ⑧ P. C. B. OPERATION (2)
- ⑨ P. C. B. OPERATION (3)
- ⑩ P. C. B. EFFECT (1)

DISASSEMBLY PROCEDURES (Remove parts in the order as numbered.)

1. Removal of Top Cover

Remove 4 screws (①) and 3 screws (②) in Fig. 1.

2. Removal of Front Panel

- a. Remove 6 knobs.
- b. Remove 6 screws (③) in Fig. 1.

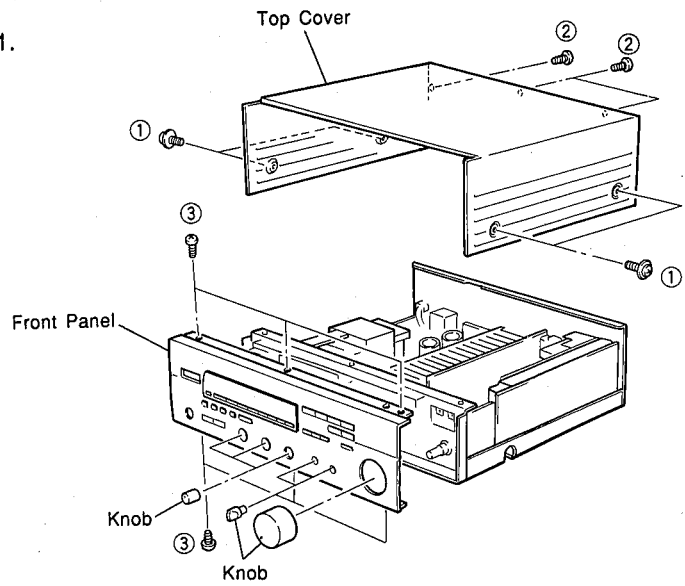

Fig. 1

3. Removal of Rear Panel

Remove 21 screws (④) in Fig. 2.

* The P. C. B. MAIN, INPUT, TUNER & EFFECT can be removed in this state.

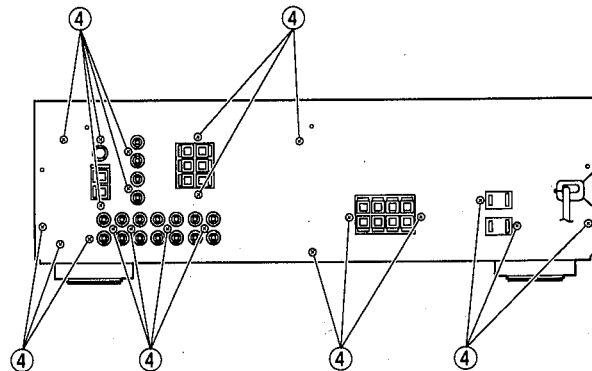

Fig. 2

■ TEST SIGNAL PROGRAM

To facilitate inspection and measurement, a test signal program is programmed in this set.

CAUTION : Using a table as shown below, write down the content of the memory preset in the tuner before setting to the test signal program mode.

(This is because setting to the test signal program mode sets the tuner memory content in the state preset by the manufacturer and erases all the memory preset by the user.)

Upon completion of the test signal program, set to the tuner mode again and enter the preset memory as written in the table.

Preset group	P1	P2	P3	P4	P5	P6	P7	P8
A								
B								
C								
D								
E								

1. Starting Operation

While pressing PHONO and CD keys simultaneously, turn ON the POWER switch, and the test signal program mode No.1 will start.

2. Functions available during the test signal program mode

In the test signal program mode, any operation other than those listed below is invalid.

- Selection key of diagnosis mode
- INPUT SELECTOR key : Switching Input source
- POWER ON/OFF key : Power ON/OFF

TEST PROGRAM 1. — LCD&INITIALIZE

When the TEST program procedure is started, all LCD's turn ON, the set is initialized and the content as preset by the manufacturer is executed.

Then, when MEMORY key is pressed once, "P1" appears in the LCD after a few seconds.

- INPUT : CD
- MONITOR OUT : LD
- SURROUND : PRO LOGIC

Note : To restore the TEST program 1 from any other TEST program, press the MEMORY key.

TEST PROGRAM 2. — LED & INHIBIT

The TEST program 2 checks the input switching function. When the EDIT key is pressed, "P2" appears in the LCD and the input selector switches automatically. When the operation stops, the LCD turns OFF.

LCD : Lighting occurs in the order of PHONO, CD, TUNER, TAPE MONITOR, VCR MONITOR, LD after the above display, the LCD turns OFF.

TEST PROGRAM 3.

The TEST program 3 is not programmed in this set.

TEST PROGRAM 4. — STEERING OFF

Press the FM/AM key

The MULTIPLYING DAC value in the DSP-LSI output step is removed from control by the internal direction emphasis circuit and now can be set through the microcomputer. The output of each channel is as listed below.

- LEFT : L signal
- RIGHT : R signal
- CENTER : L, R in-phase component
- REAR : No signal

The LCD displays "P4 CD".

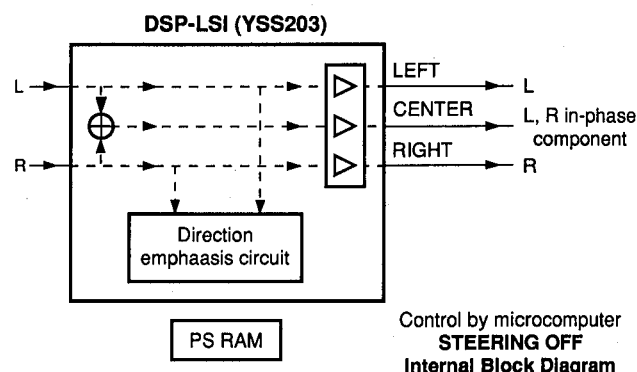

- CD INPUT : 1kHz, -25dBV
- CENTER LEVEL VR : CENTER
- REAR LEVEL VR : CENTER
- MAIN VR : MAX
- FRONT SP OUT : 19.2dBV±1dB
- CENTER SP OUT : 10.0dBV±1dB
- REAR SP OUT : -∞

TEST PROGRAM 5. — RAM THROUGH

The TEST program 5 checks the output of each channel. Press the TUNING DOWN key.

The L and R channels enter the "through state" and (L + R)/2 is output from the CENTER and REAR.

The LCD displays "P5 CD".

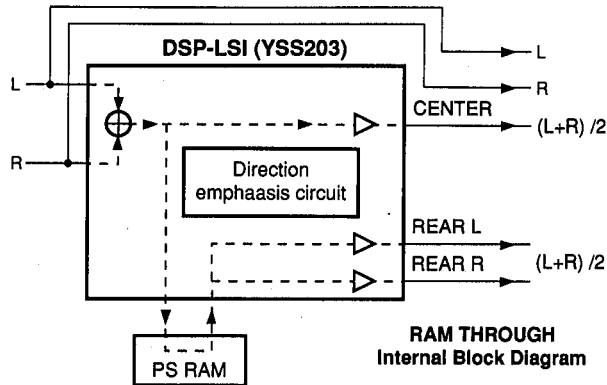

- CD INPUT : 1kHz, -25dBV
- CENTER LEVEL VR : CENTER
- REAR LEVEL VR : CENTER
- MAIN VR : MAX
- FRONT SP OUT : 19.2dBV±1dB
- CENTER SP OUT : 10.8dBV±1dB
- REAR L SP OUT : 11.8dBV±1dB
- REAR R SP OUT : 11.6dBV±1dB

TEST PROGRAM 6. — Not performed

As the TEST program 6 is not intended for servicing, do not perform it.

Note : When the TUNING UP key is pressed by mistake, "P6" appears in the LCD. This is meaningless for self-diagnosis function. If this has occurred by accident, do not proceed with other TEST programs. Turn OFF the power once and then restart the TEST program procedure.

TEST PROGRAM 7. — MANUAL TEST TONE

Press the TEST Key

The TEST tone of the DOLBY PRO LOGIC shifts in the order of L, C, R, S (Surround) at every pressing of the TEST key. Also, the LCD displays "TEST" and the TEST output position ("L", "C", "R" or "S").

Example "TEST L"

TEST PROGRAM 8. — EXIT

Press the EFFECT Key

The program exits the self diagnosis mode and reenters the normal operation mode as factory-set.

3. Cancellation

The program is reset to the normal operation mode by turning the power OFF or by pressing the EFFECT key. At the same time, the "maker preset" is also executed.

● **Maker Preset**

1) TUNER section

Preset group	P1	P2	P3	P4	P5	P6	P7	P8
A, C, E	87.5MHz	90.1MHz	95.1MHz	98.1MHz	U, C, R : 107.9MHz R, A : 108.0MHz	88.1MHz	106.1MHz	U, C, R : 107.9MHz R, A : 108.0MHz
B, D	630kHz	1080kHz	1440kHz	U, C, R : 530kHz R, A : 531kHz	U, C, R : 1710kHz R, A : 1611kHz	900kHz	1350kHz	U, C, R : 1400kHz R, A : 1404kHz

All tuning modes are AUTO TUNING and AUTO STEREO.

2) SURROUND section

- DELAY TIME : PRO LOGIC 20ms
(Factory-set surround mode)
- ENHANCED 20ms
- CONCERT VIDEO 25ms
- MONO MOVIE 25ms
- ROCK CONCERT 15ms
- CONCERT HALL 30ms
- CENTER MODE : NORMAL

3) SELECTOR section

- INPUT : CD
- MONITOR OUT : LD

ADJUSTMENTS

Measuring Instruments

- FM signal generator (FM SG)
- Stereo signal generator (SSG)
- AM signal generator (AM SG)
- Distortion meter (DIST. M)
- AC voltmeter (ACVM)
- DC voltmeter (DCVM)
- Oscilloscope
- Low pass filter (YLF-15, $f_c=15\text{kHz}$)
- Oscillator

Dummy antenna

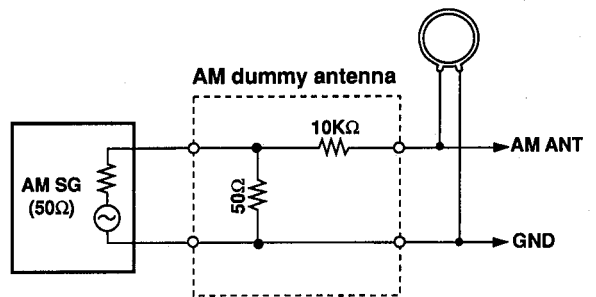
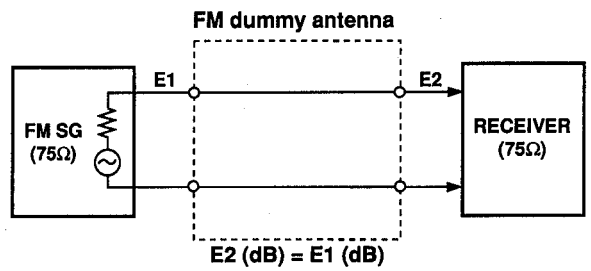
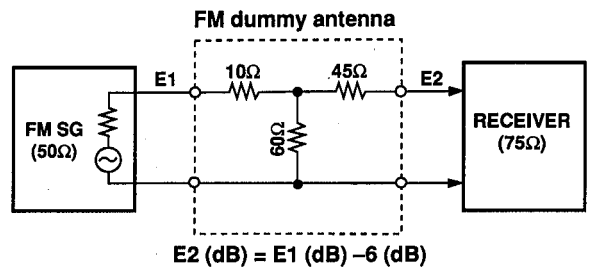

TEST POINT

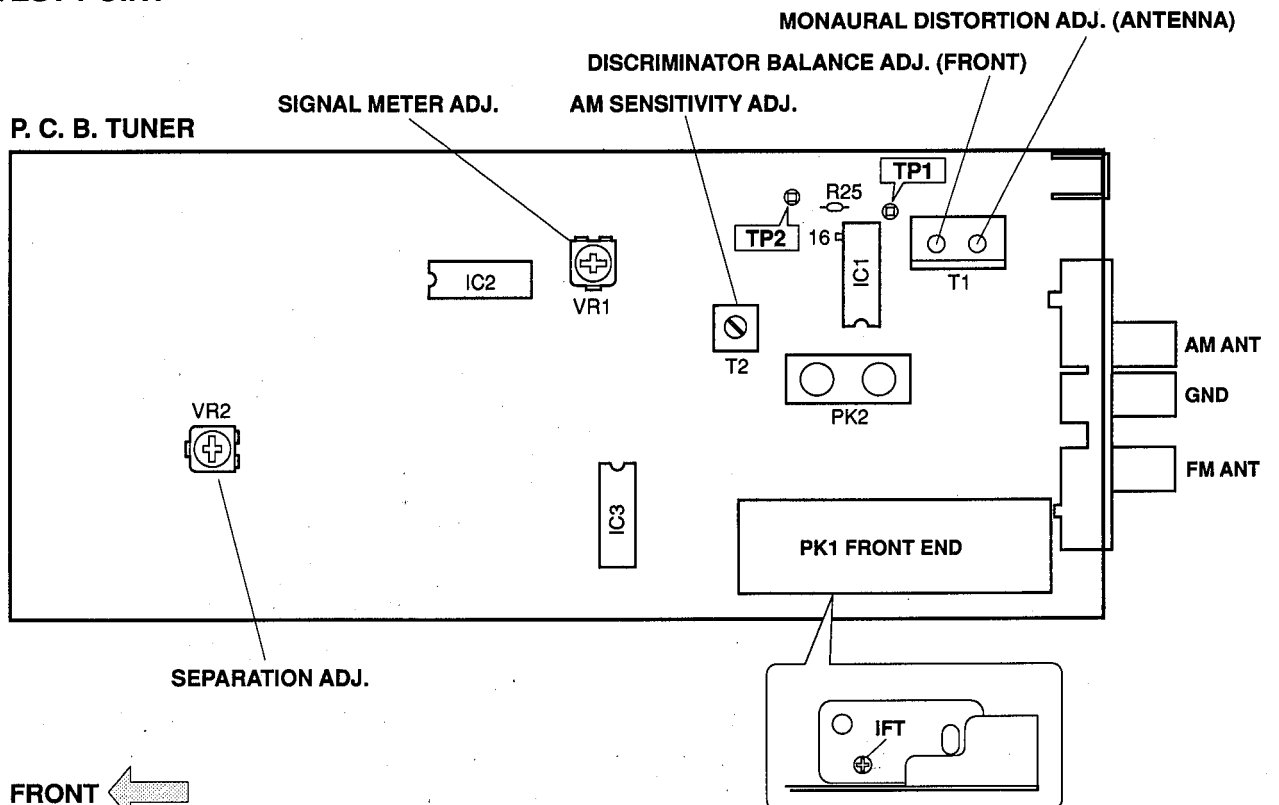

FM Adjustment

● Before Adjustment

- 1) For dB, $1\mu V = 0dB\mu$ applies.
Example : $60dB\mu = 1mV$
- 2) 100% modulation means that the frequency deviation is 75kHz.

- 3) Install the Matching Transformer and connect FM SG.
- 4) Set each switch to the following position unless otherwise specified.

INPUT SELECTOR TUNER
TUNING MODE AUTO

● Connection diagram (Measuring instruments)

1) Discriminator balance adjustment

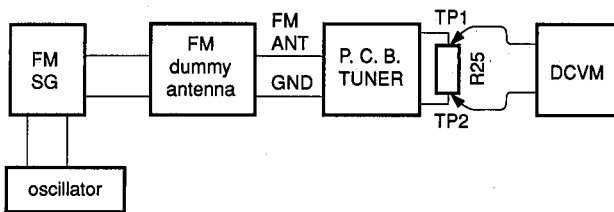

3) Stereo distortion verification/separation adjustment

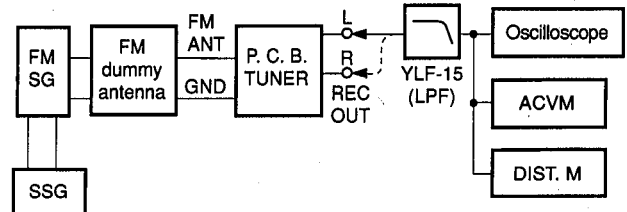

2) Monaural distortion adjustment

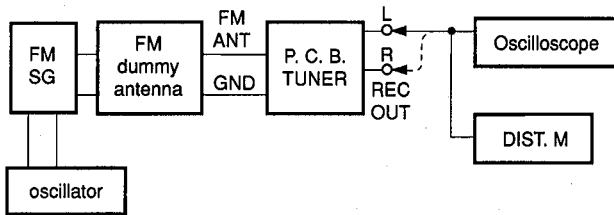

4) Sensitivity Verification

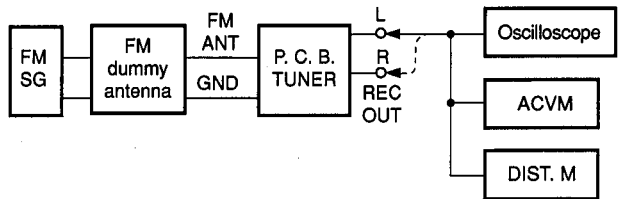

See page 8 for TP locations & adjustment points.

Step	Adjustment item	Signal (ANT IN)	Reception frequency	Adjustment point	Test point	Rating
1	Rough adjustment of discriminator balance	FM ANT (75Ω) 98.1MHz 70dBμ MONO 100Hz 100% modulation	98.1MHz * (A-4)	T1 (Front side core)	Both ends of R25 (Between TP1 and TP2)	DC 0V±100mV
2	Rough adjustment of monaural distortion	Same as Step 1.	98.1MHz * (A-4)	T1 (Antenna side core)	REC OUT L, R	Minimize the distortion.
3	Fine adjustment of discriminator balance	Same as Step 1.	98.1MHz * (A-4)	T1 (Front side core)	Both ends of R25 (Between TP1 and TP2)	DC 0V±50mV
4	Fine adjustment of monaural distortion	Same as Step 1.	98.1MHz * (A-4)	T1 (Antenna side core)	REC OUT L, R	Minimize the distortion (to 0.25% or less).
5	Verification of discriminator balance	Same as Step 1.	98.1MHz * (A-4)	T1 (Front side core)	Both ends of R25 (Between TP1 and TP2)	DC 0V±50mV

* : Execution of MAKER PRESET (Refer to TEST SIGNAL PROGRAM on pages 6 and 7.) will facilitate setting reception frequency for adjustment.

Step	Adjustment Item	Signal (ANT IN)	Reception frequency	Adjustment point	Test point	Rating
6	Adjustment of front end IFT	FM ANT (75Ω) 98.1MHz 30dBμ MONO 1kHz, 100% modulation	98.1MHz * (A-4)	Front end IFT	Pin 16 of IC1	Adjust so that the DC voltage is maximum. CAUTION: Over-adjustment of the IFT core will reduce the sensitivity. Maximum ±90°
7	Verification of monaural distortion	FM ANT (75Ω) 98.1MHz 70dBμ MONO 1kHz, 100% modulation	98.1MHz * (A-4)		REC OUT L, R	0.4% or less
8	Verification of stereo distortion	FM ANT (75Ω) 98.1MHz 70dBμ Stereo L or R 1kHz, 100% modulation	98.1MHz * (A-4) Tuning mode should be AUTO		REC OUT L, R	1% or less • STEREO indicator should light.
9	Verification of sensitivity	FM ANT (75Ω) 88.1MHz 98.1MHz 106.1MHz	88.1MHz * (A-6) 98.1MHz * (A-4) 106.1MHz * (A-7)		ANT (75Ω)	1) Set the tuning mode to MAN'L MONO. 2) S/N should be 30dB at each frequency of 88.1MHz, 98.1MHz, and 106.1MHz. 3) Check to ensure that the voltage at the ANT terminal is 3dBμ (14.25dBf) or less.
10	Adjustment of Separation	FM ANT (75Ω) 98.1MHz 70dBμ Stereo L or R 1kHz, 100% modulation	98.1MHz * (A-4)	VR2	REC OUT L, R	With SSG output at L or R, the signal leakage level at the other channel should be minimized. 36dB or more
11	Adjustment of signal meter	FM ANT (75Ω) 98.1MHz, 45dBμ MONO 1kHz 30% modulation	98.1MHz * (A-4)	VR1		Adjust so that all signal meters light.
		-10dBμ or less				Check to ensure that signal meters turn OFF.
12	Verification of auto tuning	FM ANT (75Ω) 98.1MHz 23dBμ Stereo L or R 1kHz, 30% modulation	98.1MHz			<ul style="list-style-type: none"> • Automatic reception should be available when the tuning key is moved UP and DOWN. • The stereo indicator should light. • Audio muting should be applied during tuning.

* : Execution of MAKER PRESET (Refer to TEST SIGNAL PROGRAM on pages 6 and 7.) will facilitate setting reception frequency for adjustment.

AM Adjustment (This should be done after FM adjustment.)

● **Connection Diagram (Measuring instruments)**

1) **Adjustment of sensitivity**

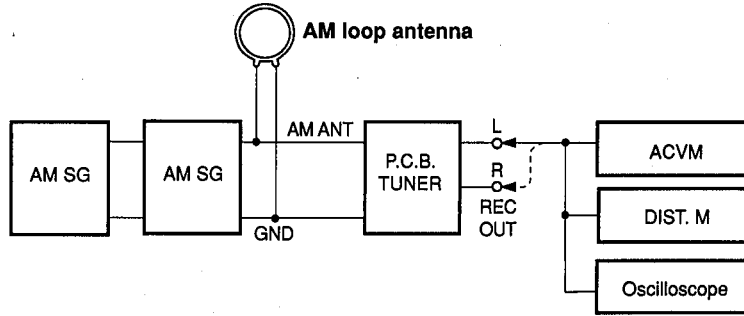

See page 8 for TP locations & adjustment points.

Step	Adjustment Item	Signal (ANT IN)	Reception frequency	Adjustment point	Test point	Rating
1	Adjustment of sensitivity (1440kHz)	AM ANT 1440KHZ 50dB μ 1kHz, 30% modulation	1440kHz *(B-3)	T2	REC OUT	Audio output should be maximized.
2	Adjustment of sensitivity (630kHz)	AM ANT 630KHZ 50dB μ 1kHz, 30% modulation	630kHz *(B-1)	T2	REC OUT	Audio output should be maximized. Repeat the Step 1 and 2.
3	Verification of sensitivity	AM ANT 630KHZ 1080kHz 1440kHz 1kHz, 30% modulation	630kHz *(B-1) 1080kHz *(B-2) 1440kHz *(B-3)		AM ANT	Distortion should be 10% or less at each frequency. Check to ensure that the voltage at the ANT terminal is 54dB μ or less.
4	Verification of auto tuning	AM ANT 60dB μ				Auto reception should be available when the tuning key is pressed UP and DOWN.

RX-V490/R-V701

Idling Current Adjustment

● Confirmation of idling current. (Main section)

After power is turned on, confirm that the voltages across R137 (L ch), R138 (R ch) are between 0.1mV~5mV.

If they exceeds 5.1mV, open (cut off) R131(L ch), R132 (R ch) and reconfirm voltage is between 0.1mV~5mV.

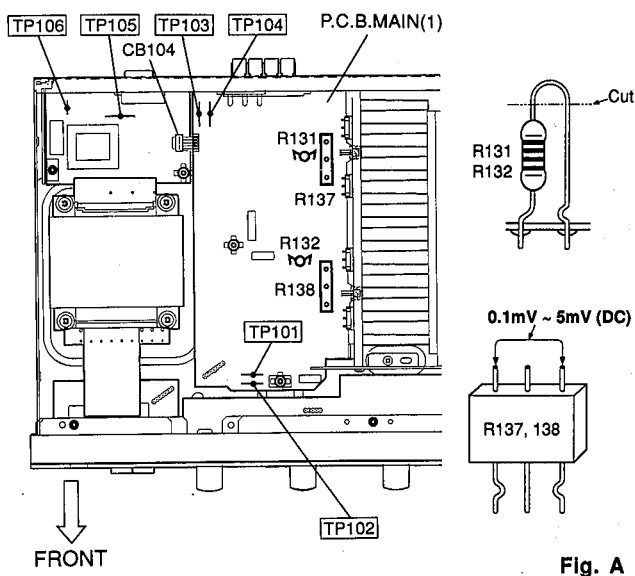

Fig. A

● Checking and Parts Replacement of P. C. B. MAIN (1).

- a. Disconnect the power cord from the AC outlet.
- b. Remove 6 screws fixing the Speaker terminals and Heat Sink.
- c. Remove 2 screws fixing the Main Unit.
- d. Detach 1 connector terminal (CB104) in Fig. A.
- e. Place the Main Unit on its side as shown in Fig. B.
- f. Operating checks can be taken by shorting between following test points in Fig. A.
- g. Connect the power cord and turn ON the POWER switch.

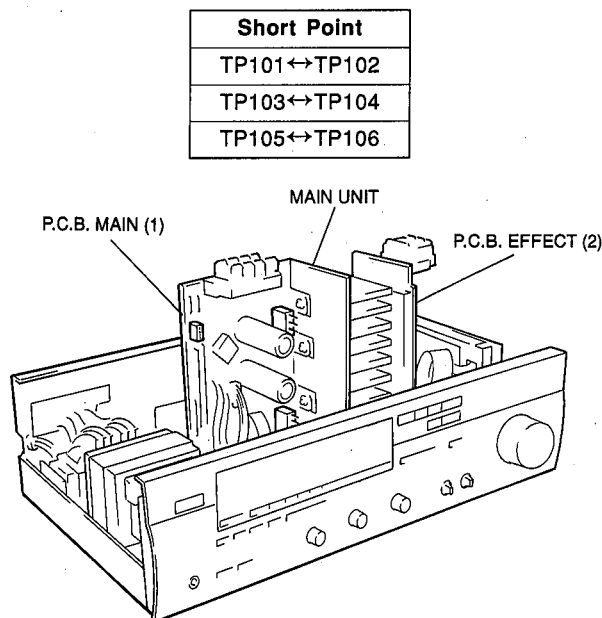

Fig. B

● Confirmation of idling current. (Effect section)

In the same way as above, confirm that the voltage across R828 is within 5mV.

If it exceeds 5mV, open (cut off) R831 and reconfirm it's within 5mV.

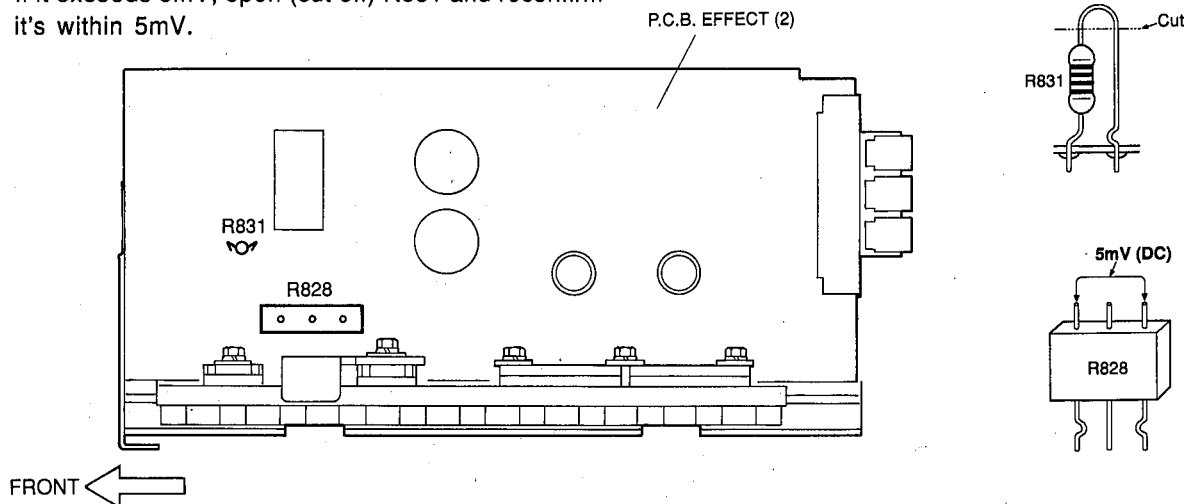
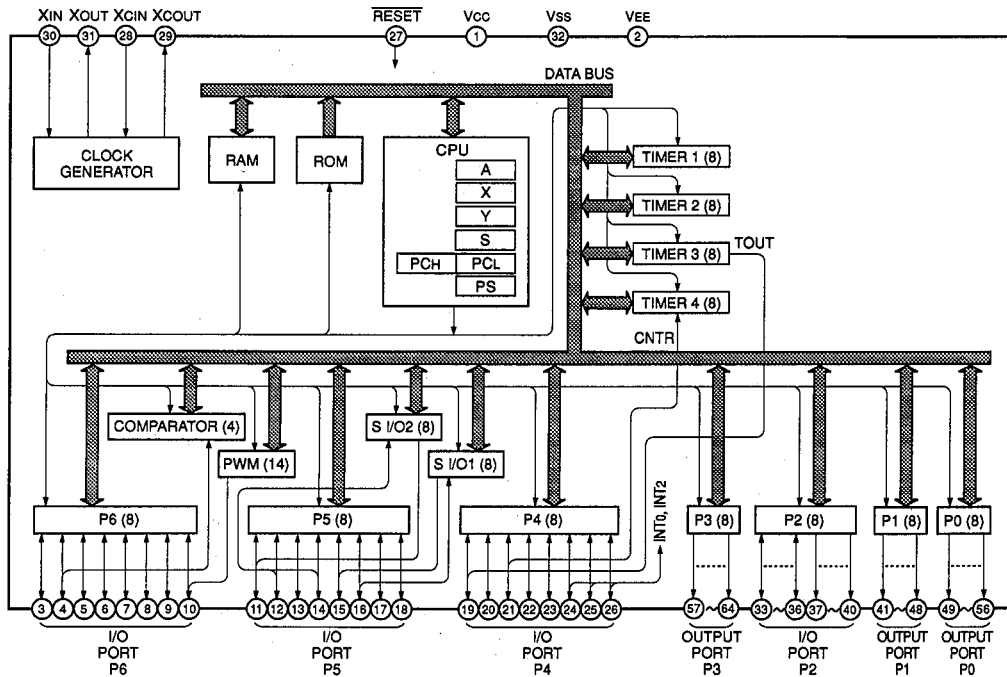
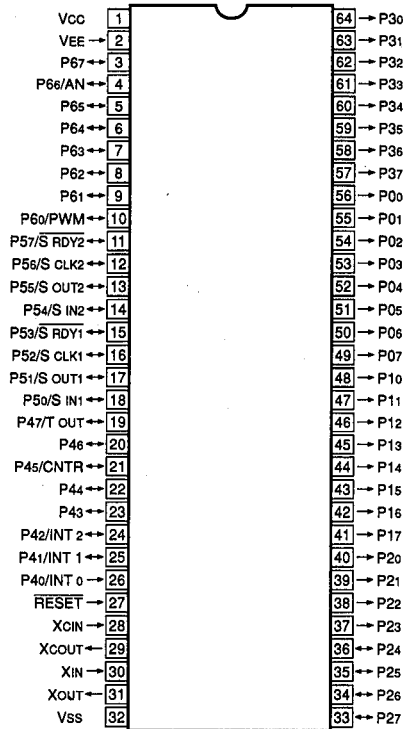

Fig. C

RX-V490/R-V701

IC DATA

IC301 : M38102M4-623SP
8 bit μ-COM



No.	Port	Name	I/O	Function
1	Vcc	VCC		+5V
2	Vee	-VEE		-25V
3	P67	PROTEC	I	Protection detect
4	P66	METER	I	Tuner meter
5	P65	V1	I	Market select
6	P64	V2	I	
7	P63	V3	I	
8	P62	PDET	I	Power down detect

MARKET SELECT TABLE

	U.C	R	A
V1	0	1	1
V2	1	1/0	0
V3	0	0	0

No.	Port	Name	I/O	Function
9	P61	STBY	O	LED for STAND BY (NC)
10	P60	PWRLY	O	Power switch drive
11	P57	FMUTE	O	Front mute
12	P56	CLKOUT2	O	Serial clock out to BU2040
13	P55	DATA2	O	Serial data out to BU2040
14	P54	SIGIN	I	Synchronous signal in
15	P53	STEREO	I	Stereo detect
16	P52	CLKOUT1	O	Serial clock out to LM7000N, NJU7313, YSS203
17	P51	DATA1	O	Serial data out to LM7000N, NJU7313, YSS203
18	P50	CETUN	O	Chip select for LM7000N
19	P47	STPOUT	I	Auto tuning stop signal
20	P46	SEL	I	DSP select
21	P45	CEDSP	O	Chip select for DSP
22	P44	CEFSR	O	Chip select for NJU7313
23	P43	EFFMT	O	Effect IC mute (IC802, 803)
24	P42	CNTMUT	O	Center mute
25	P41	REARMT	O	Rear mute
26	P40	REMIN	I	Remote control signal input
27	RESET	RESET	—	Reset
28	XCI	(NC)	—] N. C.
29	XCO	(NC)	—	
30	XIN	XIN	—] Clock (4MHz)
31	XOUT	XOUT	—	
32	VSS	VSS	—	GND
33	P27	K4	I] Key input
34	P26	K3	I	
35	P25	K2	I	
36	P24	K1	I	
37	P23	D5	O] Key scan digit
38	P22	D4	O	
39	P21	D3	O	
40	P20	D1	O	
41	P17	SG1	O] Fluorescent character display tube anode drive signal
42	P16	SG2	O	
43	P15	SG3	O	
44	P14	SG4	O	
45	P13	SG5	O	
46	P12	SG6	O	
47	P11	SG7	O	
48	P10	SG8	O	
49	P07	D2	O] Key scan digit
50	P06	D7	O	
51	P05	D6	O	
52	P04	G1	O] Fluorescent character display tube grid drive signal
53	P03	G2	O	
54	P02	G3	O	
55	P01	G4	O	
56	P00	G5	O	
57	P37	G6	O	
58	P36	G7	O	
59	P35	G8	O	
60	P34	G13	O	
61	P33	G12	O	
62	P32	G11	O	
63	P31	G10	O	
64	P30	G9	O	

	D1	D2	D3	D4	D5	D6	D7
K1	PHONO	TAPE	TUNING UP	—	A/B/C/D/E	1	5
K2	CD	VCR	TUNING DOWN	—	MEMORY	2	6
K3	TUNER	TEST	AUTOMANUAL	DSP UP	POWER	3	7
K4	LD	EFFECT ON/OFF	FM/AM	DSP DOWN	EDIT	4	8

RX-V490/R-V701

IC703 : YSS203B-F
 Digital Dolby Pro Logic Decoder with Auto Input Balance

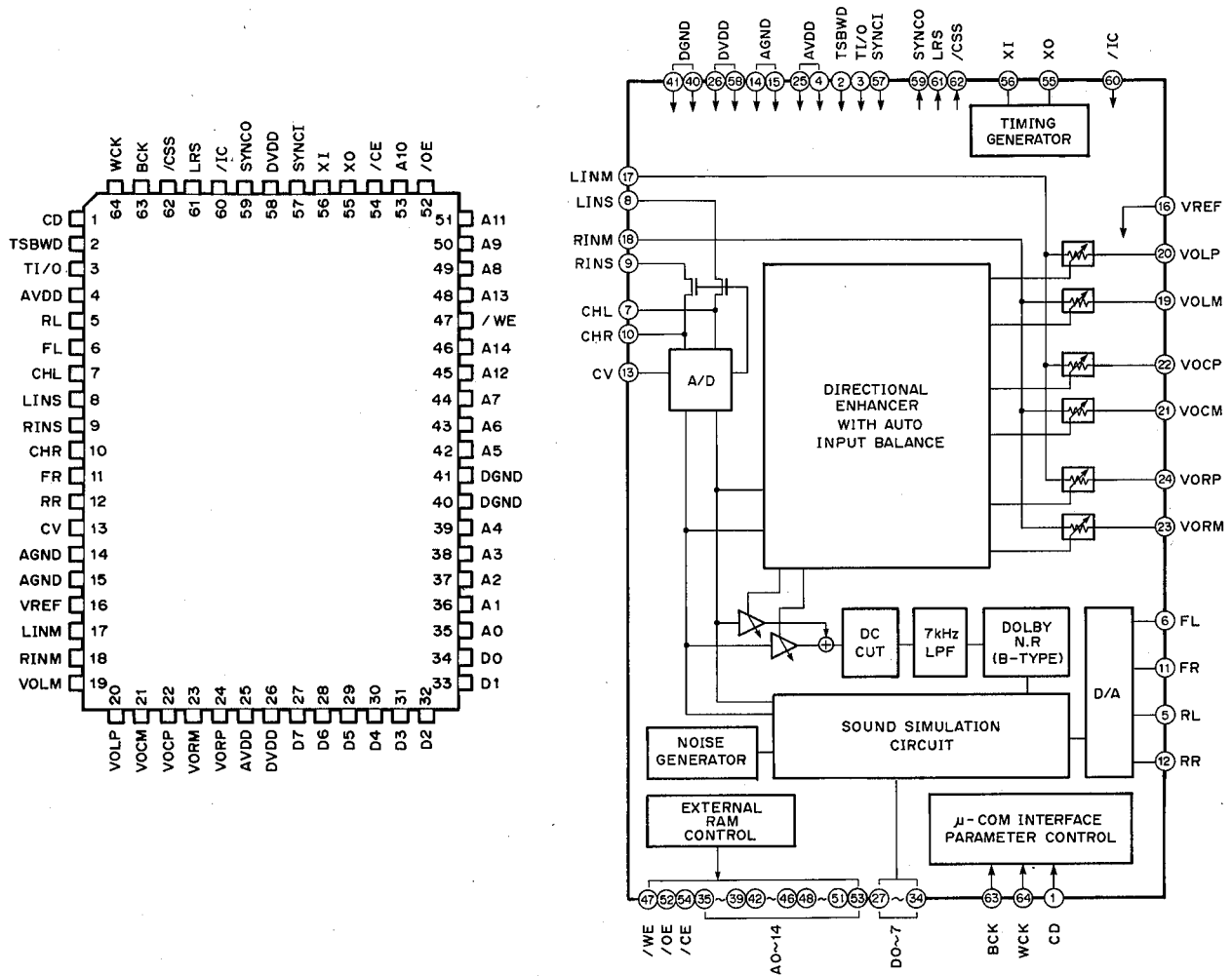

RX-V490/R-V701

No.	Name	I/O	Function
1	CD	I/O	Serial data of parameter data input
2	TSBWD	Ic	LSI test terminal Normally connected to DVDD terminal
3	TI/O	Ic	LSI test terminal Normally connected to /CSS terminal
4	AVDD	A—	+5V power supply (D/A, A/D section)
5	RL	AO	RL channel D/A output
6	FL	AO	FL channel D/A output
7	CHL	A—	LINS input Sample/hold Capacitor external terminal
8	LINS	AI	L channel A/D input
9	RINS	AI	R channel A/D input
10	CHR	A—	RINS input Sample/hold Capacitor external terminal
11	FR	AO	FR channel D/A output
12	RR	AO	RR channel D/A output
13	CV	AO	A/D, multiplying DAC center voltage
14	AGND	A—	Ground (D/A, A/D section)
15	AGND	A—	Ground (Multiplying DAC section)
16	VREF	AI	Multiplying DAC reference voltage input
17	LINM	AI	L channel Multiplying DAC input
18	RINM	AI	R channel Multiplying DAC input
19	VOLM	AO	L channel operation amplifier, connected to (-) terminal
20	VOLP	AO	L channel operation amplifier, connected to (+) terminal

No.	Name	I/O	Function
21	VOCM	AO	C channel operation amplifier, connected to (-) terminal
22	VOCP	AO	C channel operation amplifier, connected to (+) terminal
23	VORM	AO	R channel operation amplifier, connected to (-) terminal
24	VORP	AO	R channel operation amplifier, connected to (+) terminal
25	AVDD	A—	+5V power supply (multiplying DAC section)
26	DVDD	—	+5V power supply (digital section)
27	D7	I/Ot	External delay RAM data terminal
28	D6	I/Ot	External delay RAM data terminal
29	D5	I/Ot	External delay RAM data terminal
30	D4	I/Ot	External delay RAM data terminal
31	D3	I/Ot	External delay RAM data terminal
32	D2	I/Ot	External delay RAM data terminal
33	D1	I/Ot	External delay RAM data terminal
34	D0	I/Ot	External delay RAM data terminal
35	A0	O	External data RAM address terminal
36	A1	O	External data RAM address terminal
37	A2	O	External data RAM address terminal
38	A3	O	External data RAM address terminal
39	A4	O	External data RAM address terminal
40	DGND	—	Ground (digital section)
41	DGND	—	Ground (digital section)
42	A5	O	External data RAM address terminal
43	A6	O	External data RAM address terminal
44	A7	O	External data RAM address terminal
45	A12	O	External data RAM address terminal
46	A14	O	External data RAM address terminal
47	/WE	O	External delay RAM write enable terminal
48	A13	O	External delay RAM address terminal
49	A8	O	External delay RAM address terminal
50	A9	O	External delay RAM address terminal
51	A11	O	External delay RAM address terminal
52	/OE	O	External delay RAM output enable terminal
53	A10	O	External delay RAM address terminal
54	/CE	O	External delay RAM chip enable terminal
55	XO	O	Crystal oscillator connecting terminal
56	XI	I	Crystal oscillator connecting terminal
57	SYNCI	It	Test terminal for system synchronization, normally connected to DVDD
58	DVDD	—	+5V power supply (digital section)
59	SYNCO	O	Test terminal for system synchronization, normally unconnected
60	/IC	Ics	Initial clear terminal (Power ON resetting is necessary)
61	LRS	O	External automatic input balance terminal, normally left open
62	/CSS	O	External automatic input balance terminal, connected to TI/O terminal
63	BCK	I _{ts}	Bit clock for parameter data input
64	WCK	I _{ts}	Word clock for parameter data input

Note : Letters used in the above I/O column represent as follows.

I : Input terminal O : Output terminal t : TTL level
C : CMOS level S : Schmidt input A : Analog terminal

■ BLOCK DIAGRAM (TUNER)

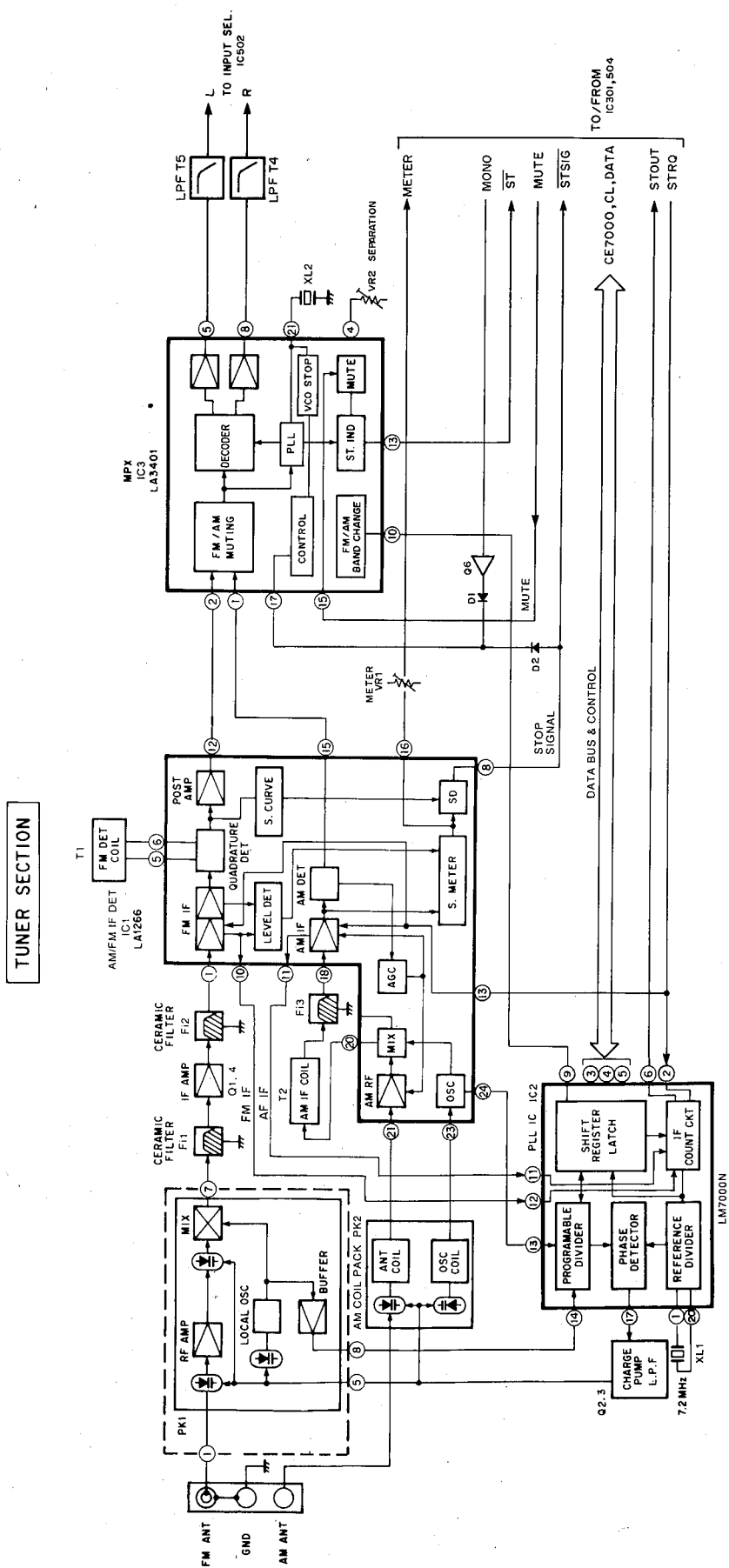

TUNER SECTION

■ BLOCK DIAGRAM (MAIN, EFFECT & OPERATION)

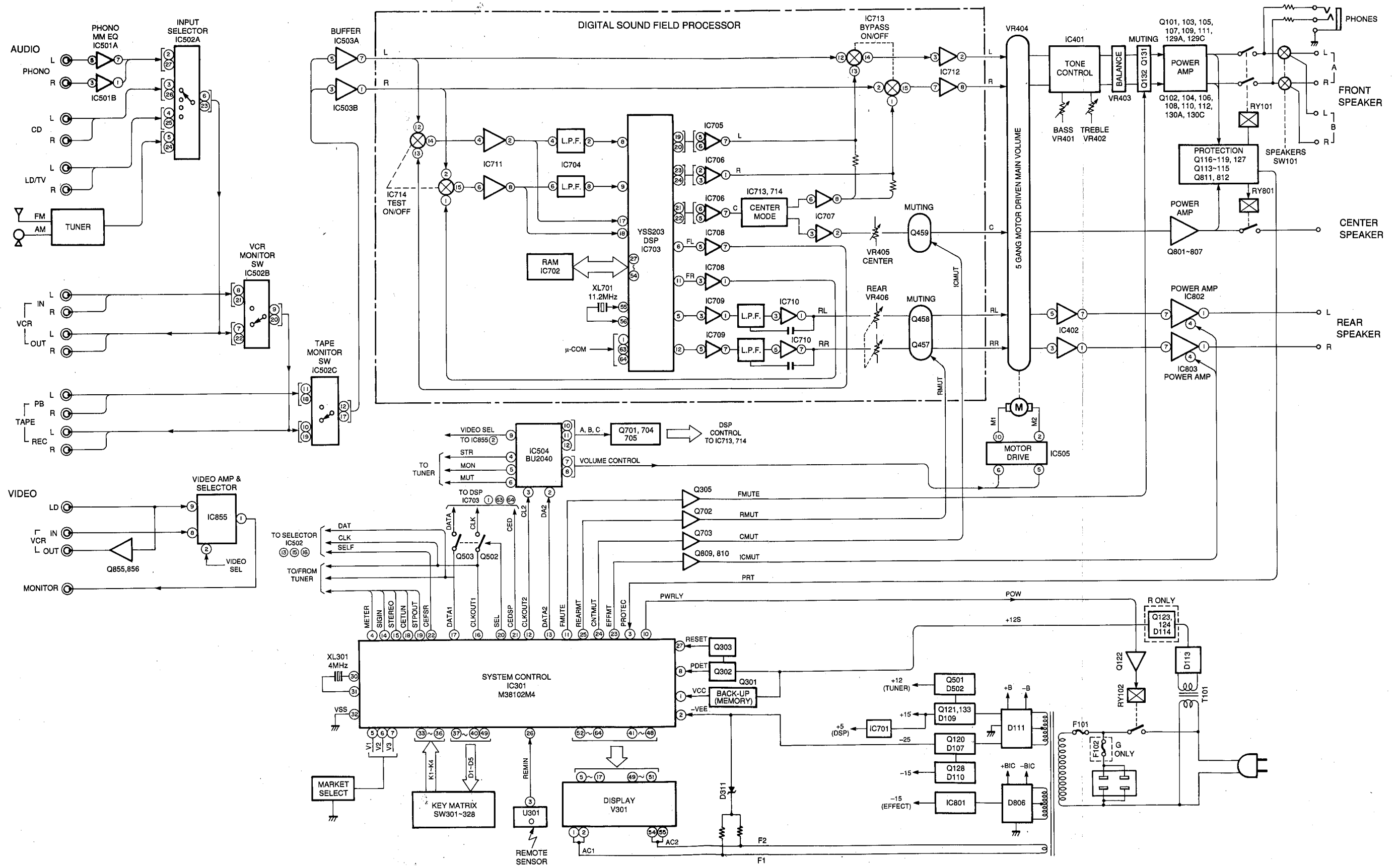

PRINTED CIRCUIT BOARD (Foil side)

P.C.B. MAIN (1)

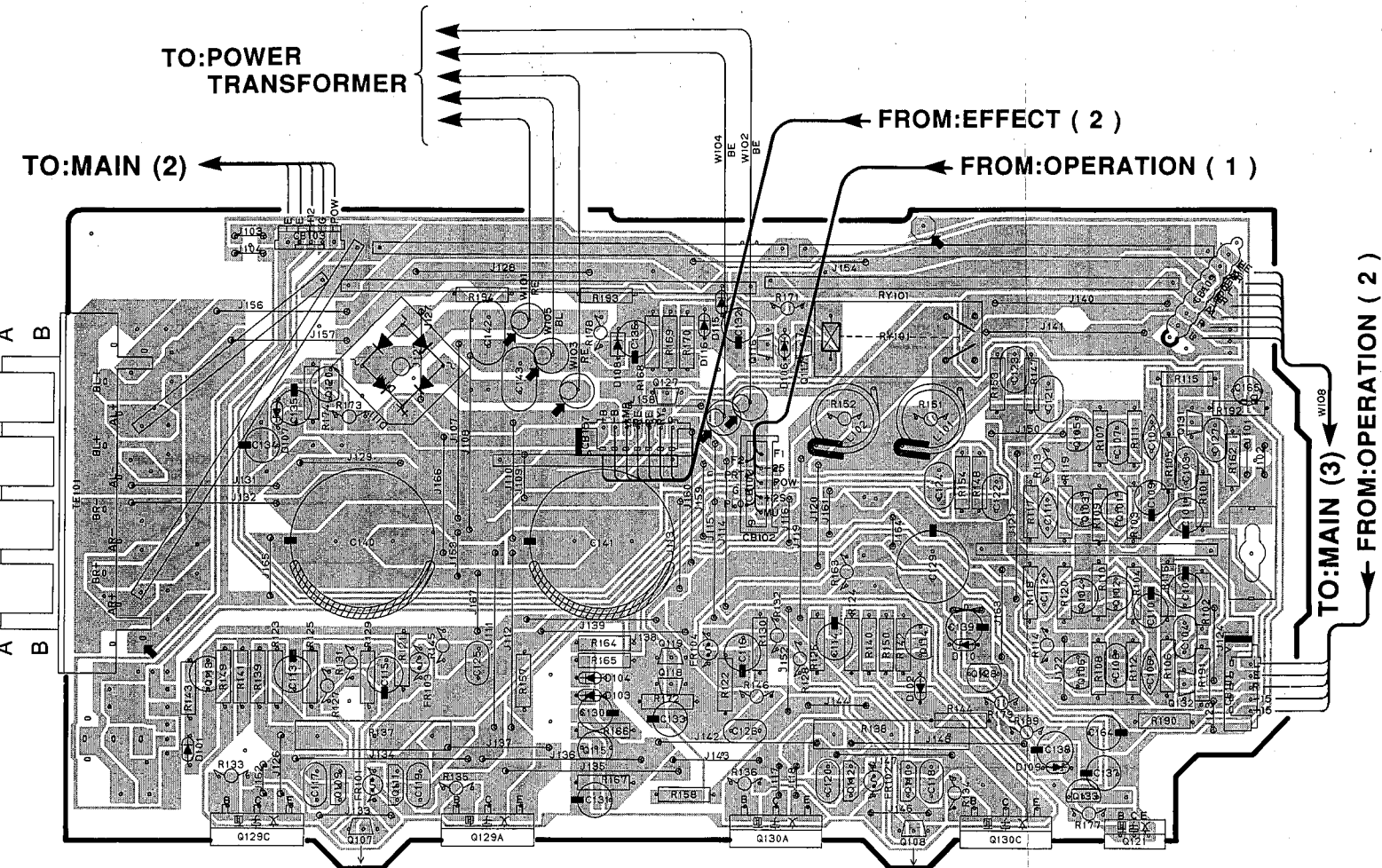

P.C.B. MAIN (3)

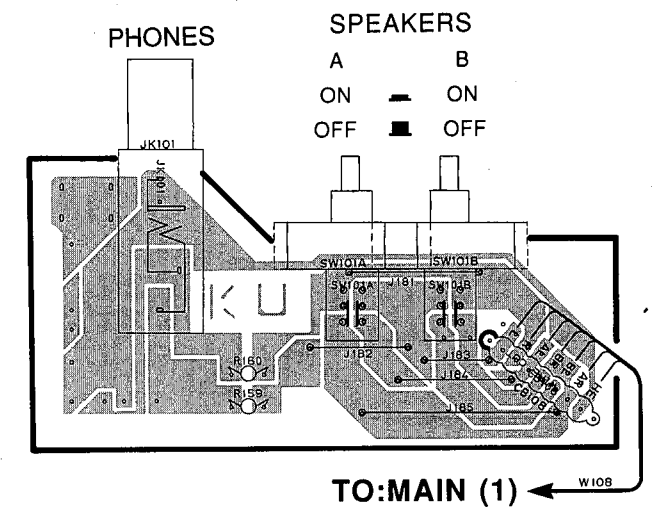

P.C.B. EFFECT (4)

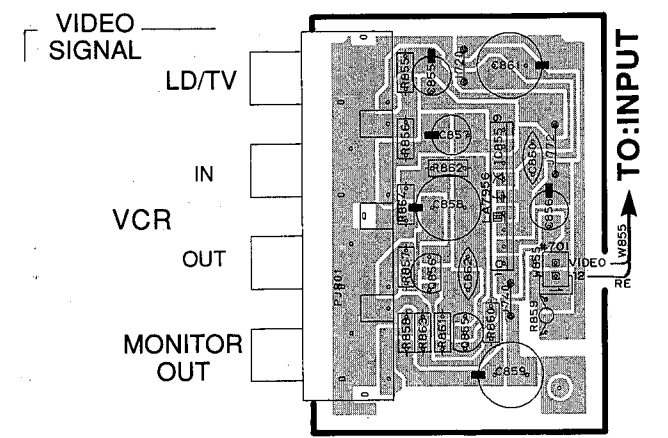

Semiconductor Location

Ref No.	Location	Ref No.	Location
Q101	E3	Q116	D2
Q102	E3	Q117	D2
Q103	E3	Q118	C3
Q104	E3	Q119	C3
Q105	E3	Q120	B2
Q106	E3	Q121	E4
Q107	B4	Q127	C2
Q108	D4	Q128	D3
Q109	B4	Q129A	C4
Q110	D4	Q129C	B4
Q111	C4	Q130A	D4
Q112	D4	Q130C	D4
Q113	B3	Q131	E3
Q114	D3	Q132	E3
Q115	C3	Q133	E4

● Q107 and Q108 are transistors for temperature correction. Apply silicone grease to the contact surface with the heat sink.

■ PRINTED CIRCUIT BOARD (Foil side)

① and ④ : TEST POINT WAVEFORMS (See page 31)

● Semiconductor Location

Ref No.	Location	Ref No.	Location
Q1	F2	IC1	E3
Q2	E2	IC2	D3
Q3	E2	IC3	E2
Q4	F2	IC701	G4
Q5	E2	IC702	F4
Q6	F2	IC703	E5
Q7	D3	IC704	E5
Q701	D5	IC705	F5
Q702	D5	IC706	F5
Q703	D5	IC707	F5
Q704	D5	IC708	E5
Q705	D5	IC709	E4
		IC710	E4
		IC711	E5
		IC712	E5
		IC713	E6
		IC714	E6

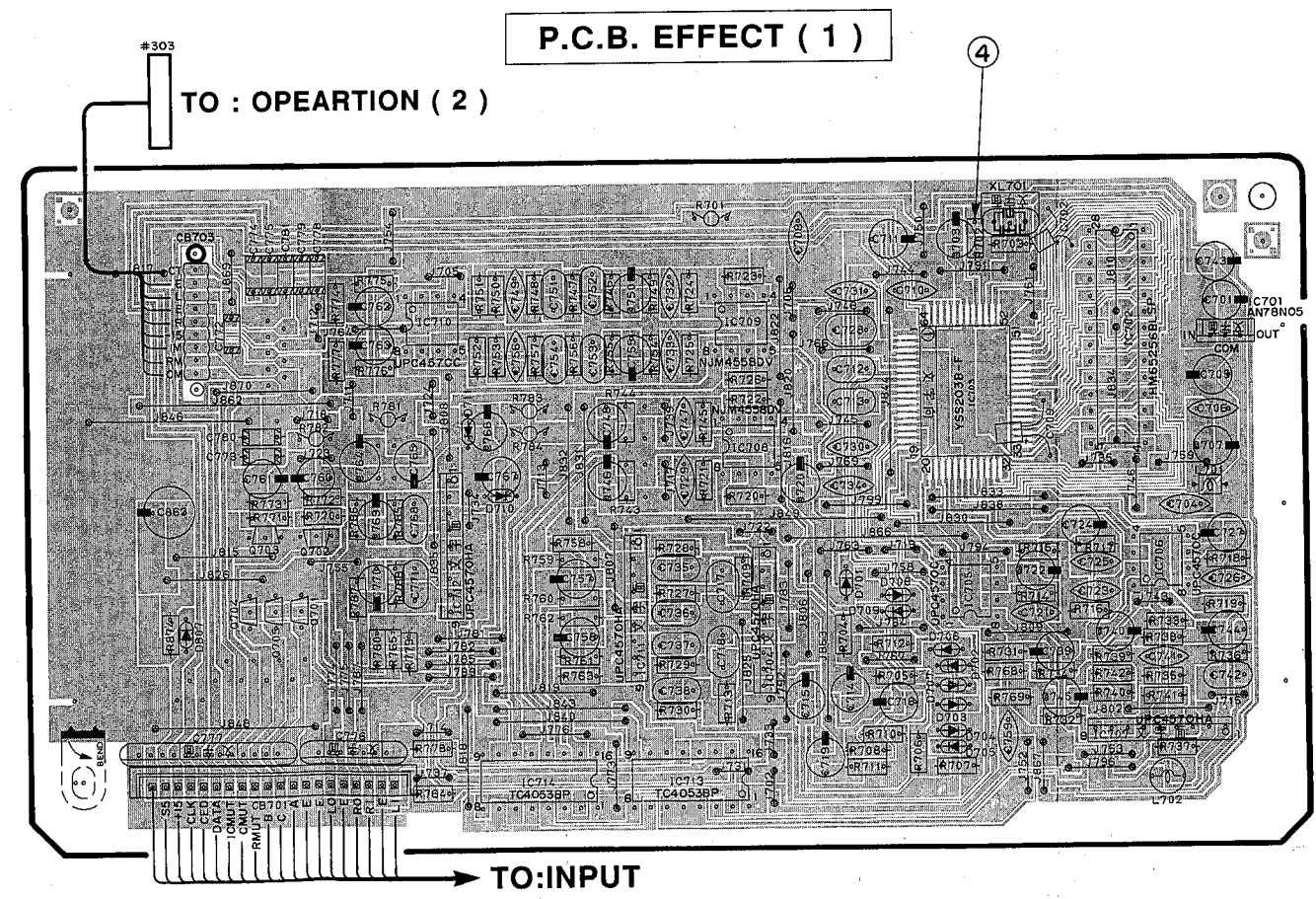
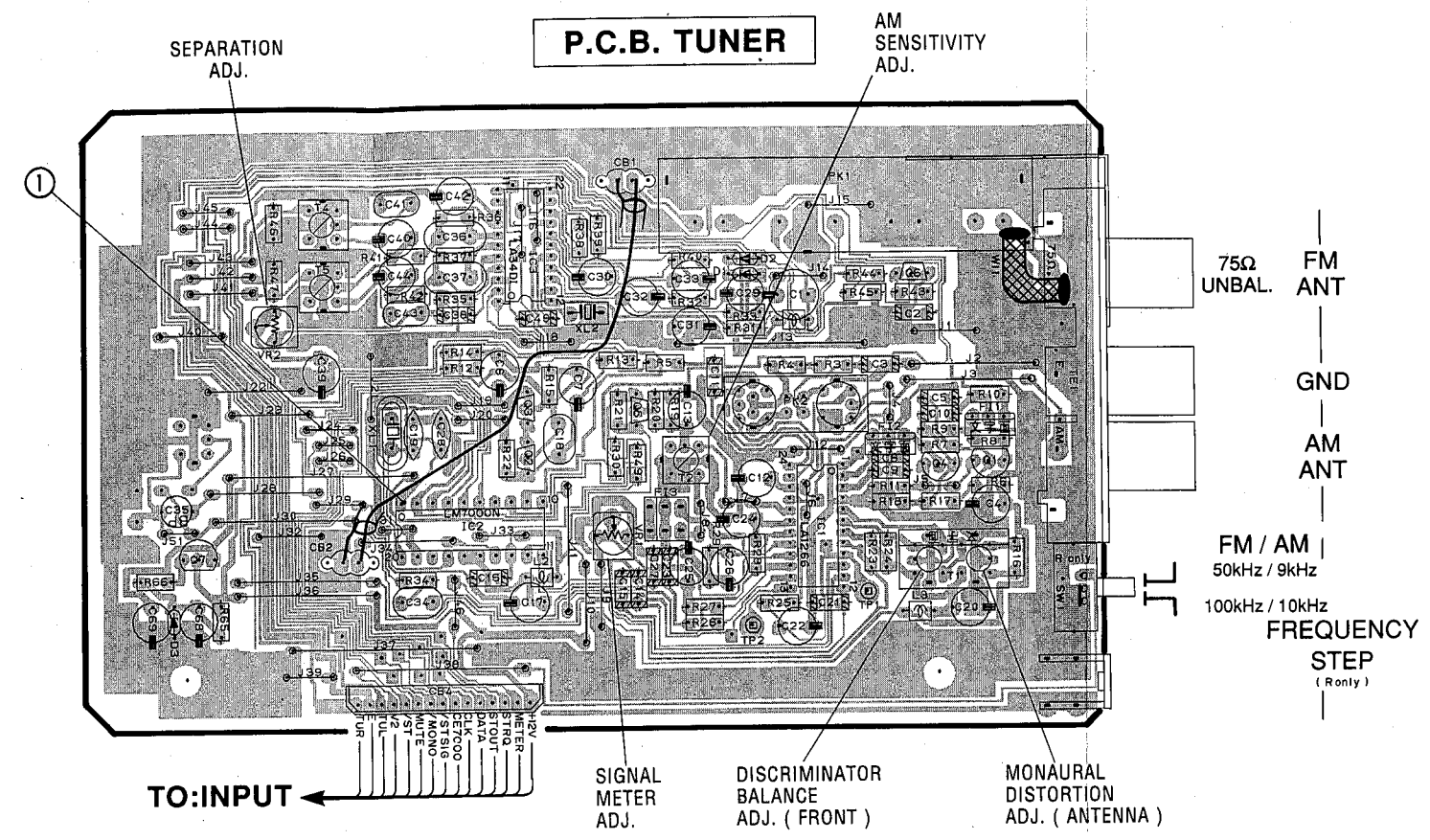

1
2
3
4
5
6

PRINTED CIRCUIT BOARD (Foil side)

Semiconductor Location

Ref No.	Location
IC501	E4
IC502	E5
IC503	D5
IC504	C5
IC505	C5
IC801	D3
IC802	D2
IC803	E2

Ref No.	Location
Q501	D4
Q502	C4
Q503	C4
Q801	C2
Q802	C2
Q803	C2
Q804	C2
Q805A	C2
Q805C	C2
Q806	C2
Q807	C3
Q809	D3
Q810	D3
Q811	C2
Q812	C2

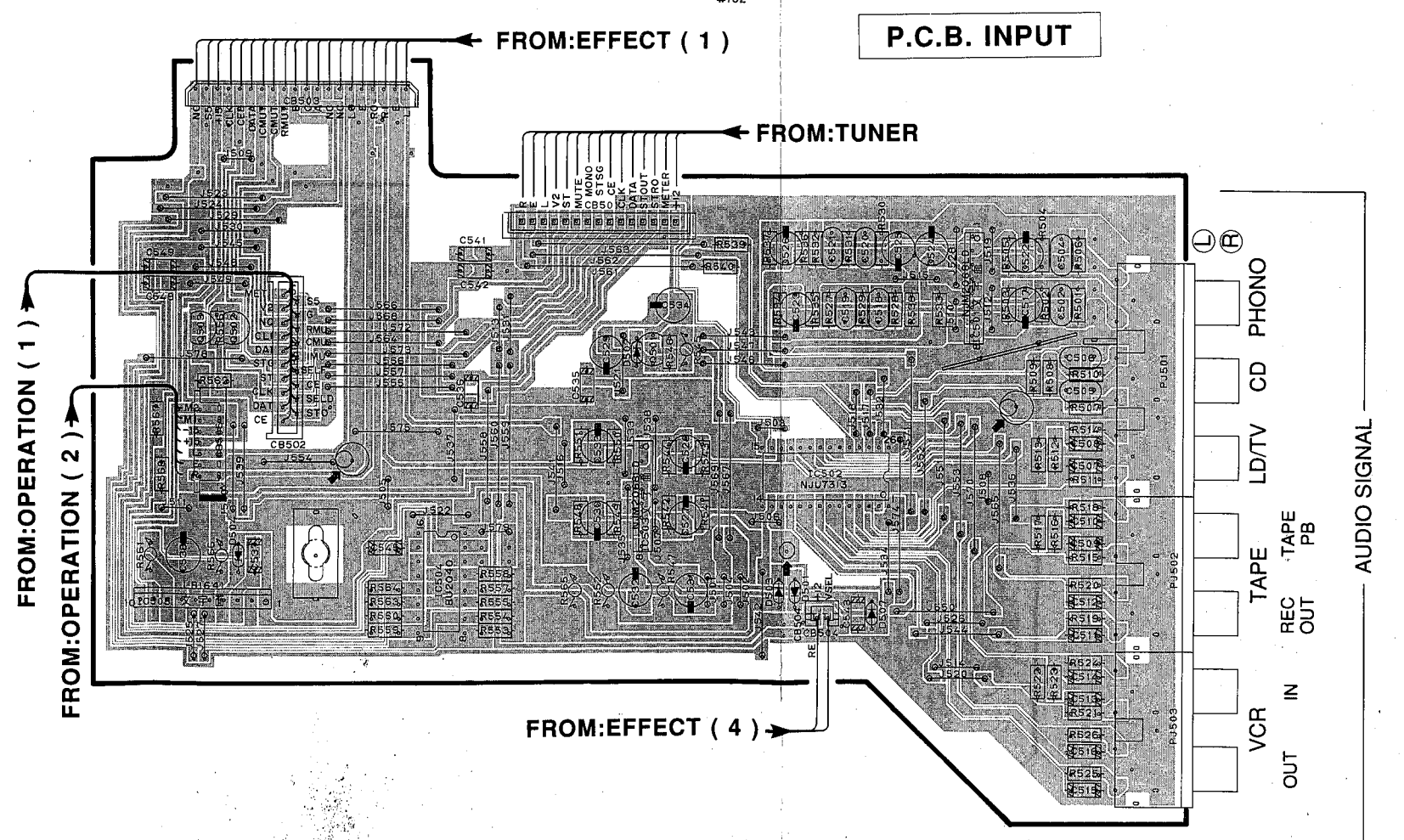
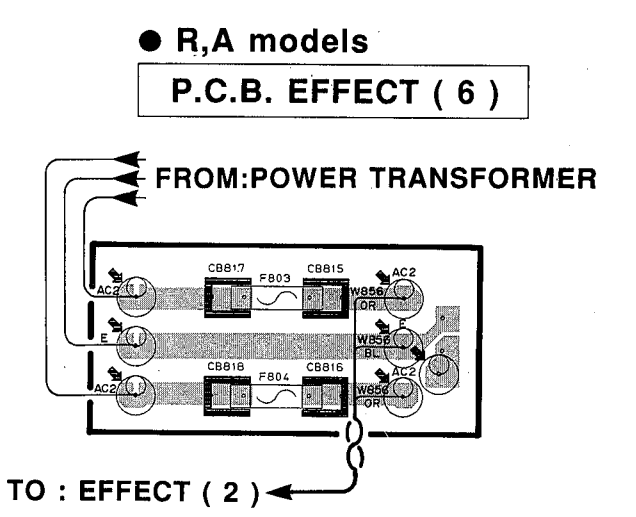
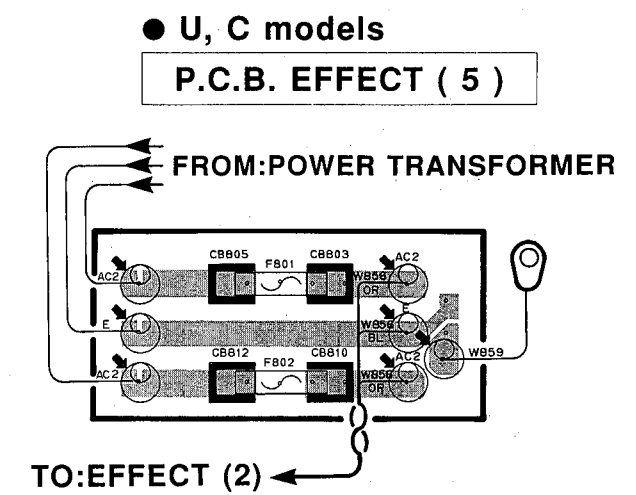
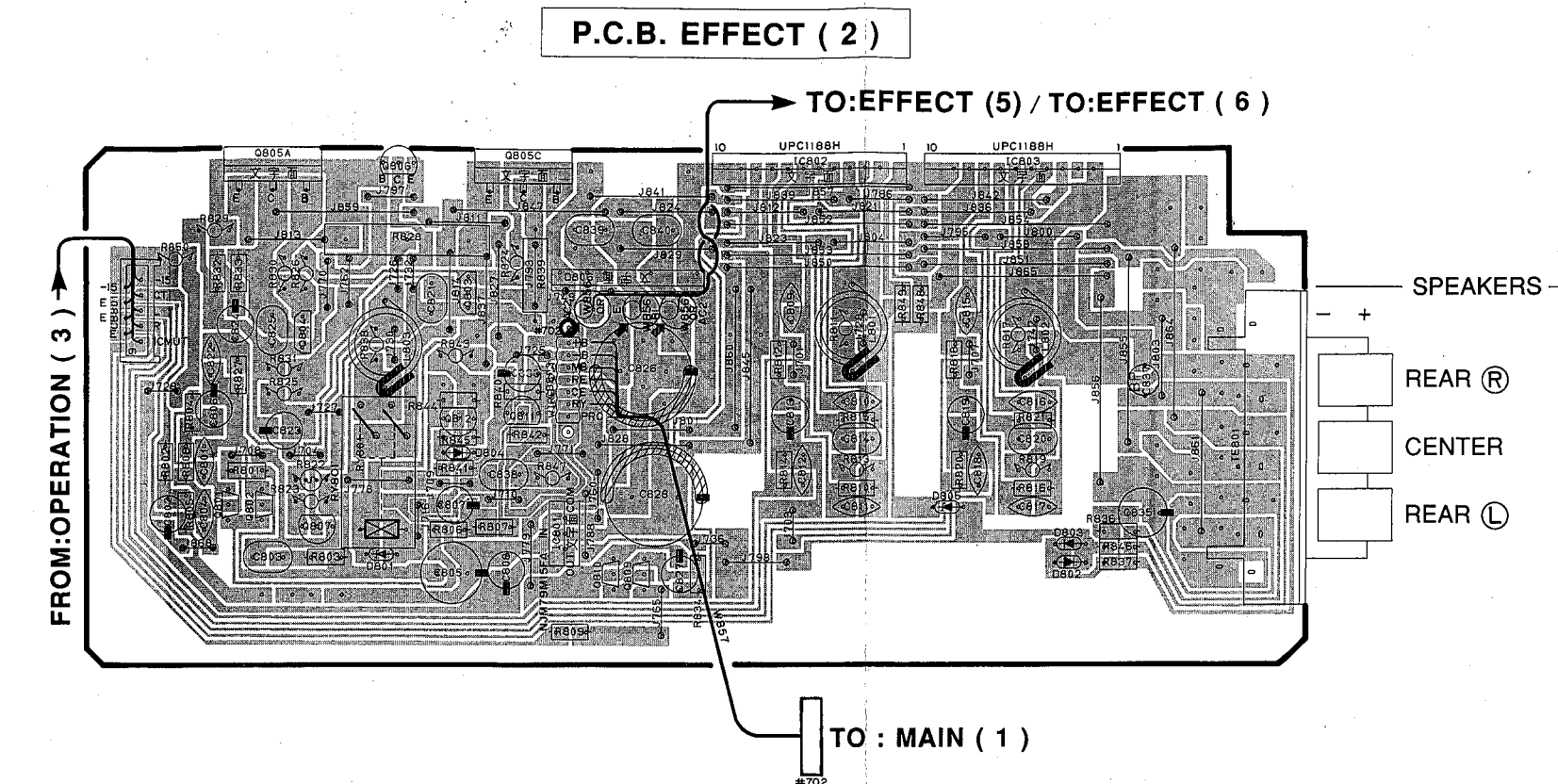

1

2

3

4

5

6

PRINTED CIRCUIT BOARD (Foil side)

② and ③ : TEST POINT WAVEFORMS (See page 31)

P.C.B. OPERATION (1)

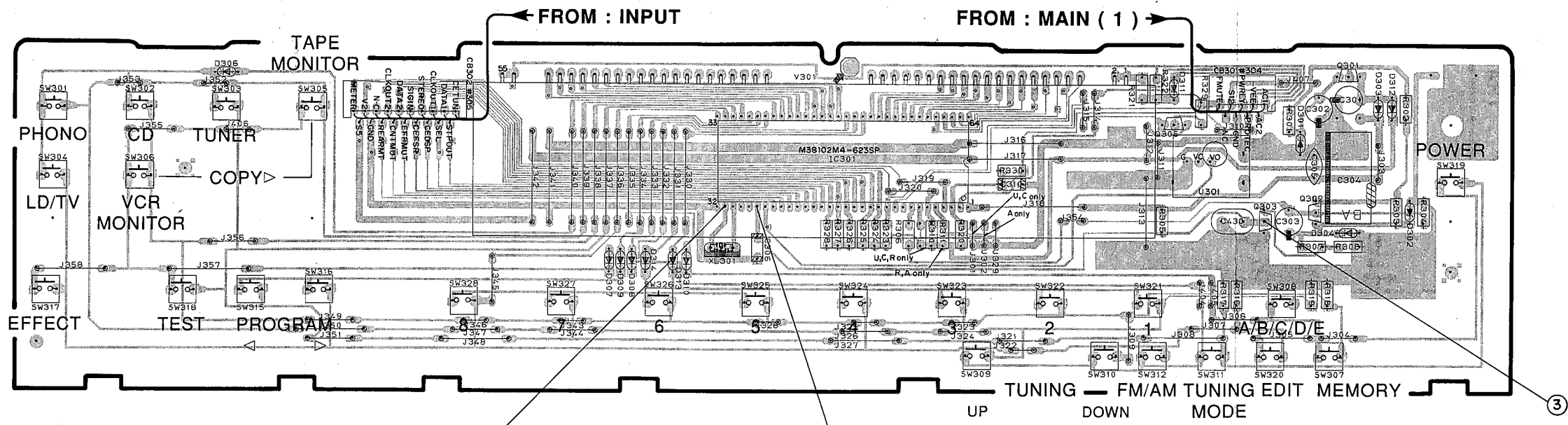

P.C.B. OPERATION (3)

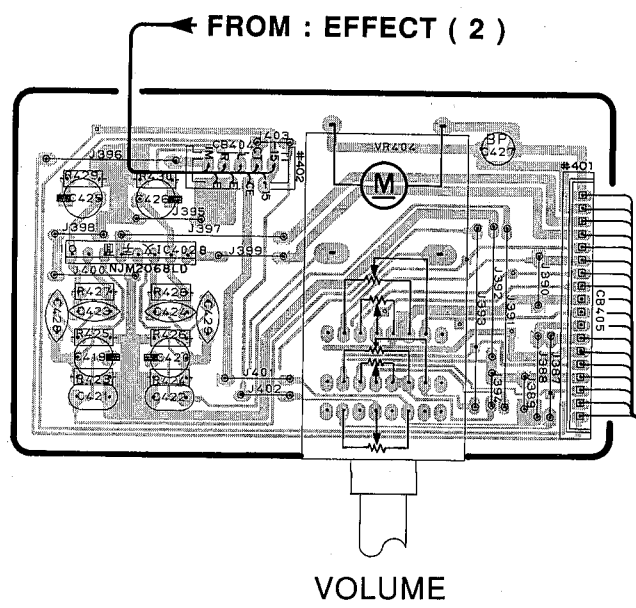

P.C.B. OPERATION (2)

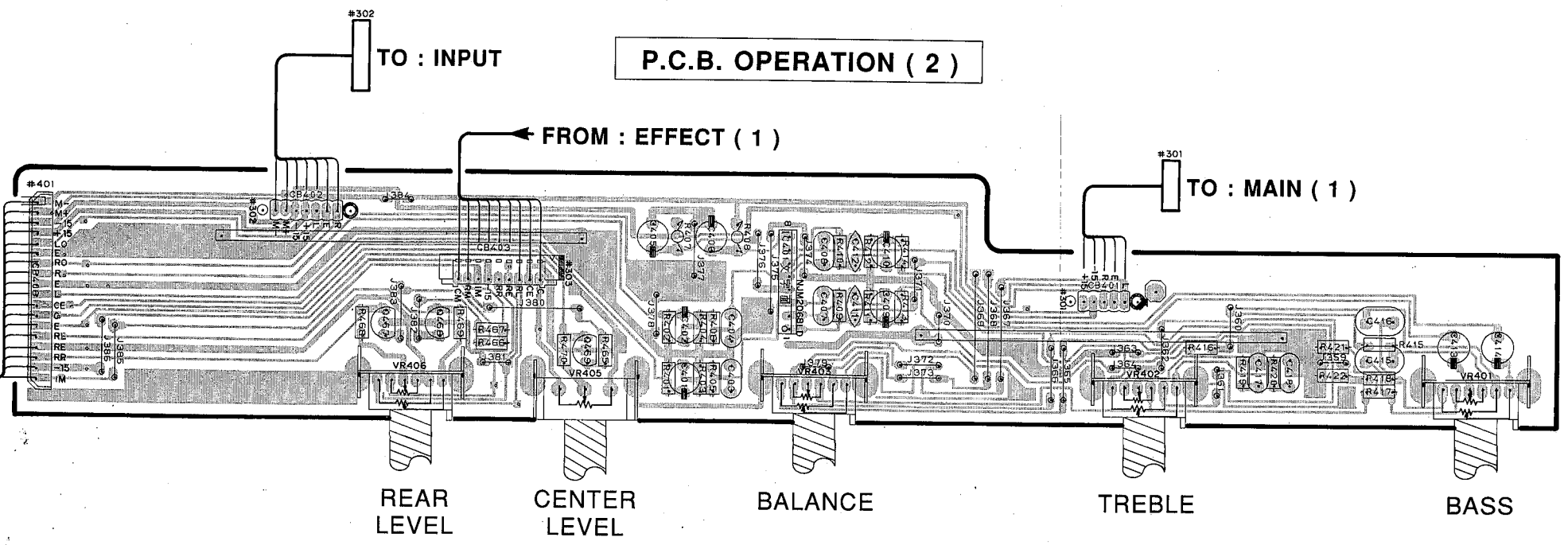

■ DISPLAY DATA (VR061700)

● V301 : 13-MT-71GK

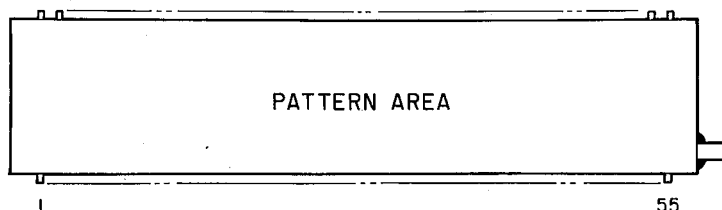

PIN CONNECTION

Pin No.	55	54	53	52	51	50	49	48	47	46	45	44	43	42	41	40	39	38	37
CONNECTION	F2	F2	NP	NP	13G	12G	11G	10G	9G	8G	7G	6G	5G	4G	3G	2G	1G	NC	NC
Pin No.	36	35	34	33	32	31	30	29	28	27	26	25	24	23	22	21	20	19	18
CONNECTION	NC	NX	NX	NX	NX	NX	NX	NX	NX	NX	NX	NX	NX	NX	NX	NX	NC	NC	NC
Pin No.	17	16	15	14	13	12	11	10	9	8	7	6	5	4	3	2	1		
CONNECTION	NC	NC	NC	NC	NC	P8	P7	P6	P5	P4	P3	P2	P1	NP	NP	F1	F1		

- Note 1) F1, F2 Filament
 2) NP No pin
 3) NC No connection
 4) P1~P8 Datum Line
 5) 1G~13G Grid
 6) NX No extend pin

GRID ASSIGNMENT

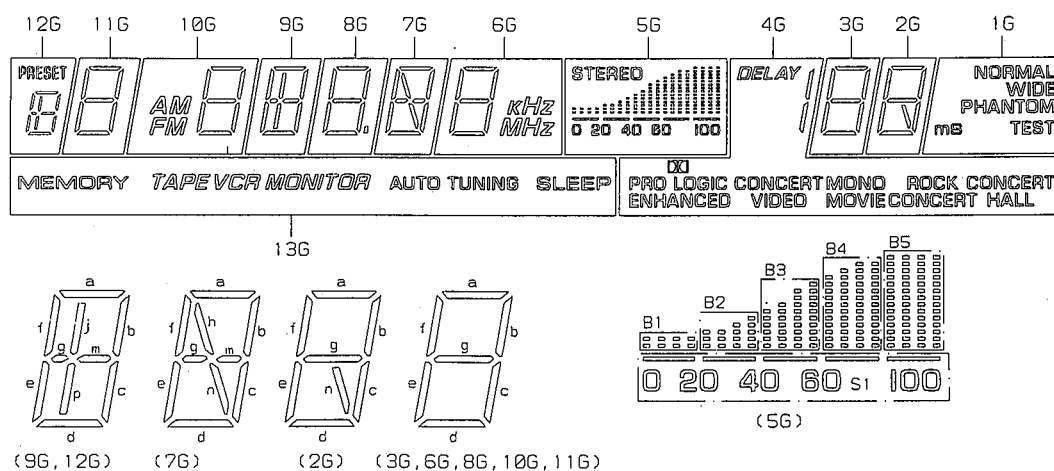

ANODE CONNECTION

	13G	12G	11G	10G	9G	8G	7G	6G	5G	4G	3G	2G	1G
P1	MEMORY	a	a	a	a	a	a	a	STEREO	DELAY	a	a	NORMAL
P2	TAPE	b, c	b	b	b	b	b	b, e	B1	/	b	b	WIDE
P3	VCR	d	c	c	c	c	c	c	B2	□	c	c	PHANTOM
P4	MONITOR	e, f	d	d	d	d	d	d	B3	ENHANCED	d	d	TEST
P5	AUTO TUNING	g	e	e, f	e	e	e	f	B4	CONCERT VIDEO	e	e	ms
P6	SLEEP	m	f	g	f	f	f	g	B5	MONO MOVIE	f	f	—
P7	—	j, p	g	AM	g, m	g	g, m	kHz	S1	ROCK CONCERT	g	g	—
P8	—	PRESET	—	FM	j, p	0	h, n	MHz	—	CONCERT HALL	—	n	—

TEST POINT WAVEFORMS

Point ① (Pin 1 of IC2)

V : 2V/div H : 50nsec/div

DC range 1 : 1 probe

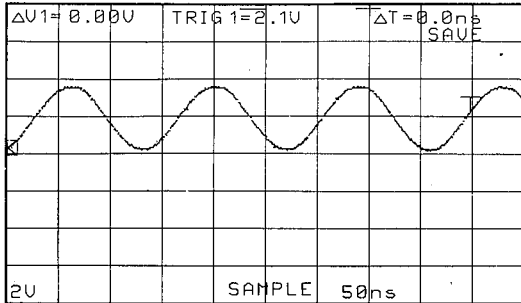

Point ② (Pin 31 of IC301)

V : 2V/div H : 0.1μsec/div

DC range 1 : 1 probe

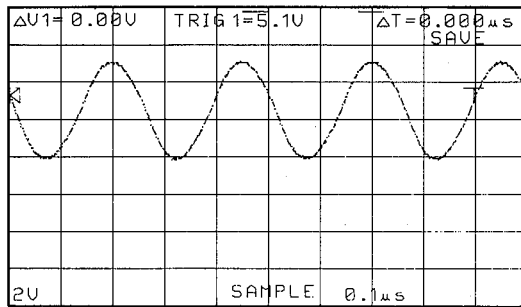

Point ③

CH 1 : Pin 27 of IC301
CH 2 : Collector of Q301

V : 2V/div (CH1) V : 5V/div (CH2)

H : 0.5sec/div

DC range 1 : 1 probe

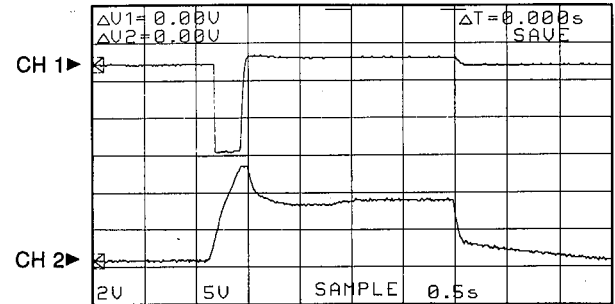

With the POWER switch turned ON, connect the power cord to the AC outlet. Disconnect the power cord from the AC outlet.

* This waveform is not available by pushing the power switch ON and OFF.

Point ④ (Pin 56 of IC703)

V : 2V/div H : 50nsec/div

DC range 1 : 1 probe

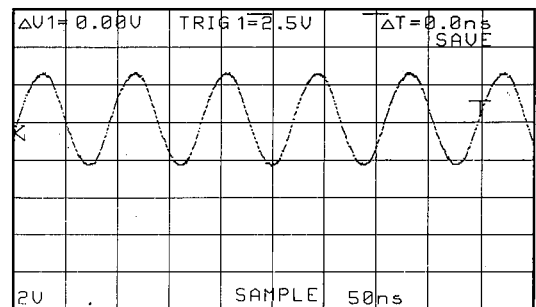

SCHEMATIC DIAGRAM (TUNER)

Each voltage given here represents that in the FM (98.1MHz, STEREO) reception mode but the one in the parentheses () is that in the AM (1080kHz, MAN'L) reception mode.
 ① : TEST POINT WAVEFORMS (See page 31)

REMARKS	PARTS NAME	UNIT
NO MARK	ELECTROLYTIC CAPACITOR	μF
⊗	TANTALUM CAPACITOR	μF
NO MARK	CERAMIC CAPACITOR	
⊙	CERAMIC TUBULAR CAPACITOR	
⊖	POLYESTER FILM CAPACITOR	
⊕	POLYSTYRENE FILM CAPACITOR	
⊖	MICA CAPACITOR	
⊖	POLYPROPYLENE FILM CAPACITOR	
⊖	SEMICONDUCTIVE CERAMIC CAPACITOR	

REMARKS	PARTS NAME	UNIT
NO MARK	CARBON FILM RESISTOR (P=5)	Ω
⊠	CARBON FILM RESISTOR (P=10)	Ω
⊡	METAL OXIDE FILM RESISTOR	Ω
⊢	METAL FILM RESISTOR	Ω
⊣	METAL PLATE RESISTOR	Ω
⊤	FIRE PROOF CARBON FILM RESISTOR	Ω
⊥	CEMENT MOLDED RESISTOR	Ω
⊦	SEMI VARIABLE RESISTOR	Ω
⊧	CHIP RESISTOR	Ω

NOTICE
 (J)..... Japanese model
 (U)..... U.S.A model
 (C)..... Canadian model
 (A)..... Australian model
 (G)..... European model
 (B)..... British model
 (R)..... General model
 (P)..... RP model

PK	U-C	R	A-B	G
PK1	VR2420	VR2420	VR2420	V998760
C21	100P	100P	100P	X
R34	10K	10K	10K	27K
J51	○	○	○	X
R48	X	X	X	4.7K
T3	X	X	X	V938570
R35	22K	22K	22K	X
C36-37	580P	580P	470P	390P
R36-37	100K	100K	100K	120K
SW1	X	VF54120	X	X
J61	X	X	X	○
C71	X	X	X	120PH

Interchangeable Parts at Manufacture-Stage

Mark	Reference Parts Number	Parts Name
R1	D1-2	HSS104
		ISS133
		ISS176

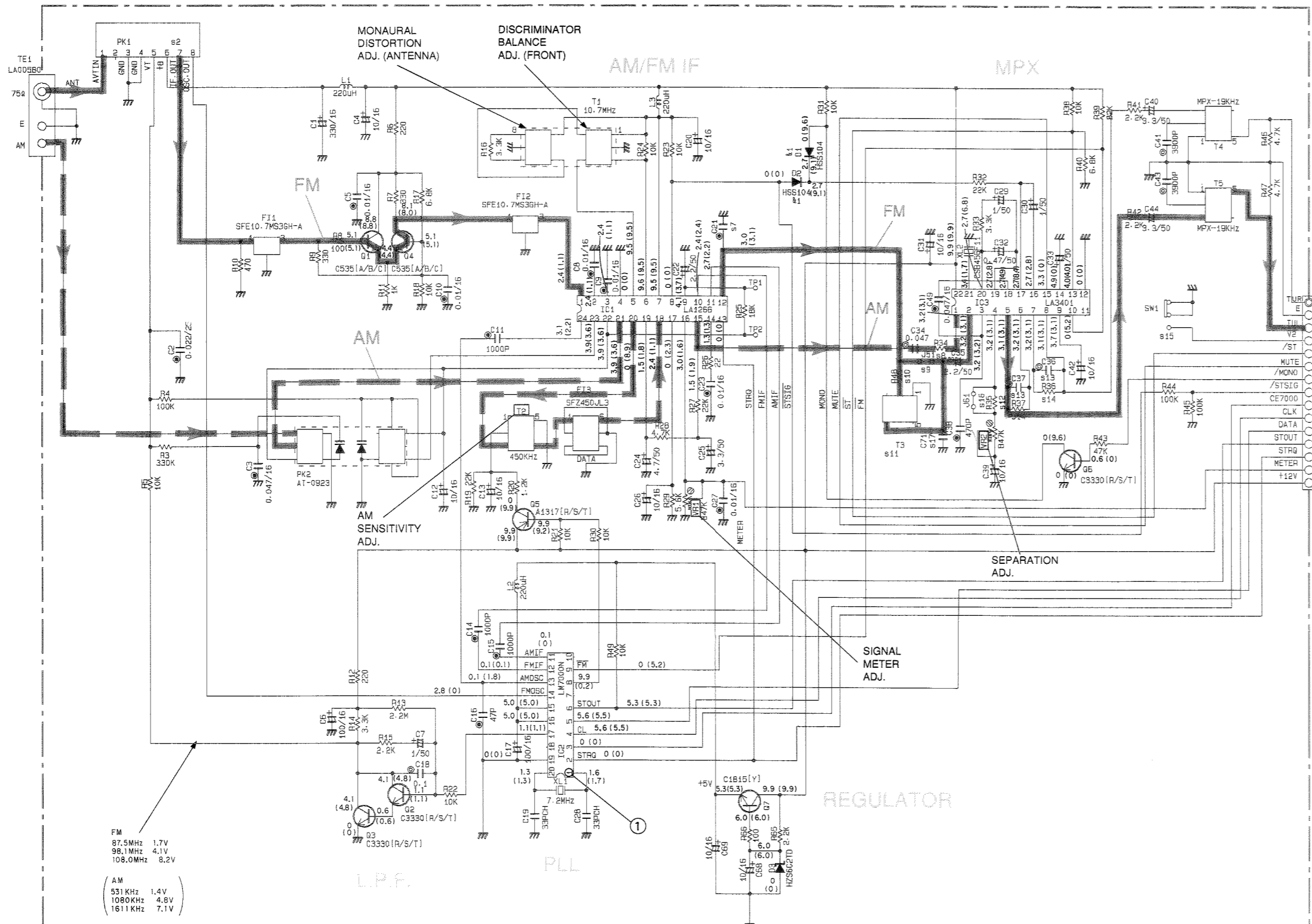

IC1 : LA1266

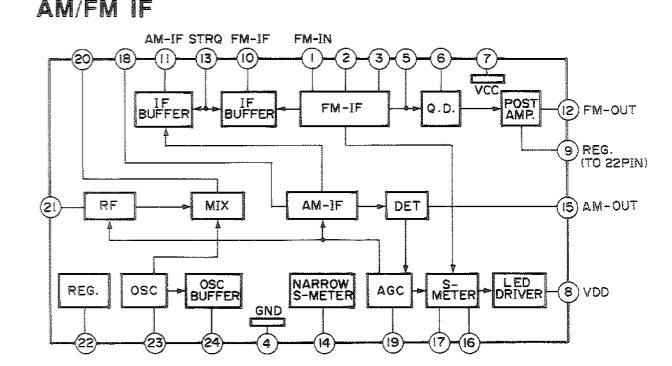

IC2 : LM7000N

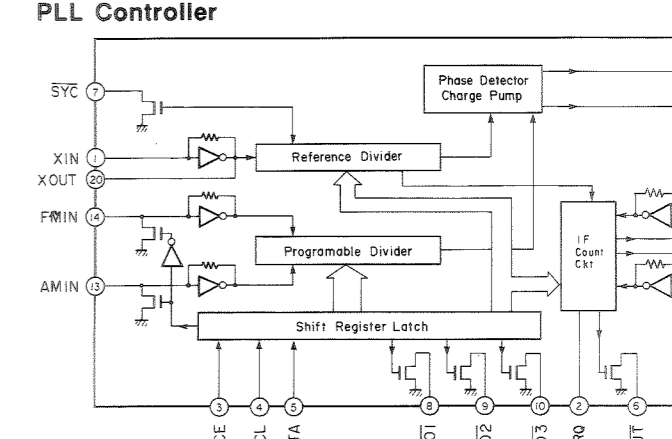

IC3 : LA3401

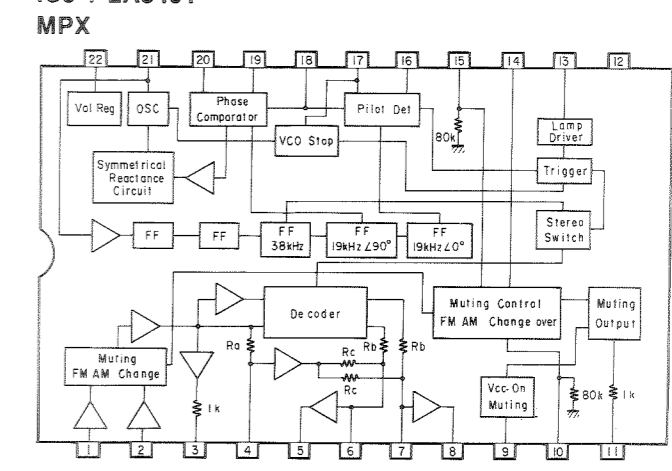

PK1 : ENV-17298GI (VR242200)

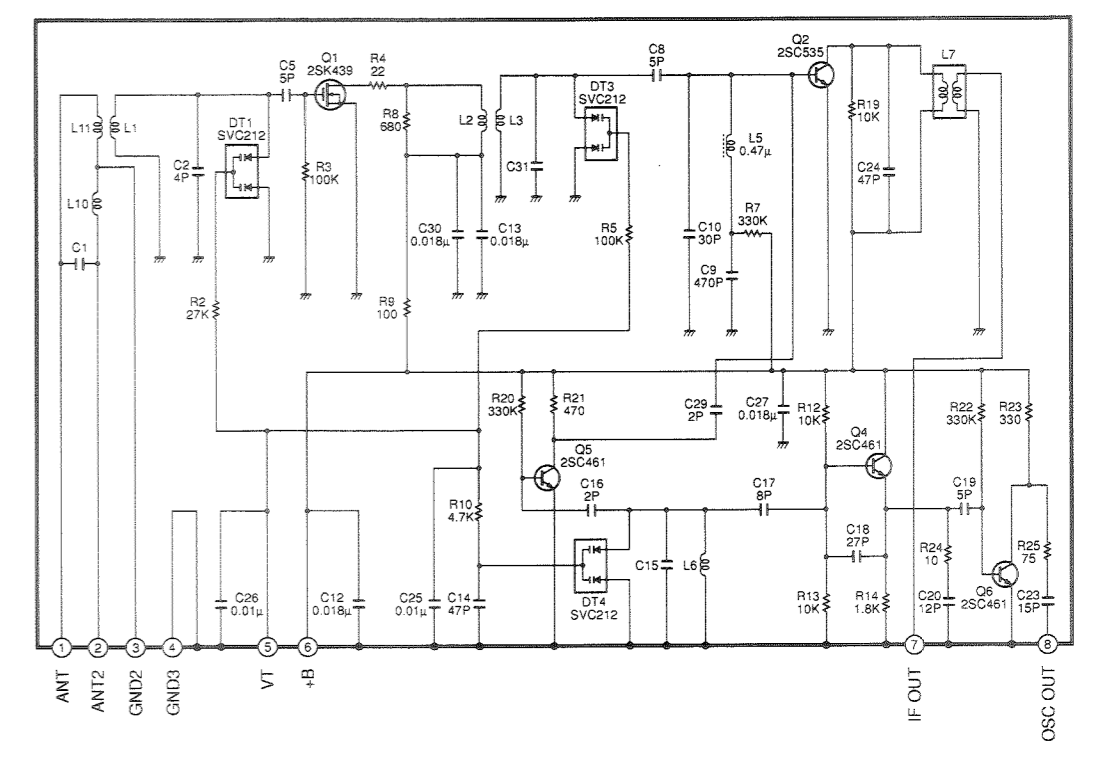

PIN CONNECTION DIAGRAM OF TRANSISTORS, DIODES AND ICs.

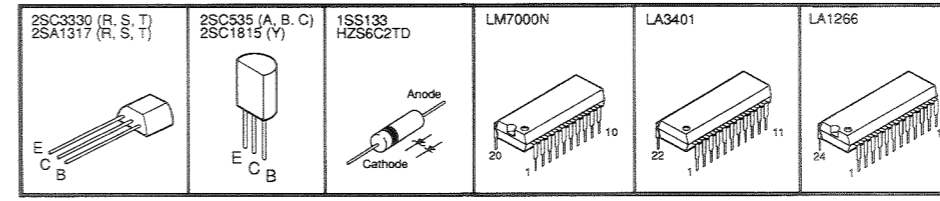

All voltage are measured with a 10MΩ/DC electric volt meter.
 Components having special characteristics are marked Δ and must be replaced with parts having specifications equal to those originally installed.
 Schematic diagram is subject to change without notice.

SCHEMATIC DIAGRAM (INPUT)

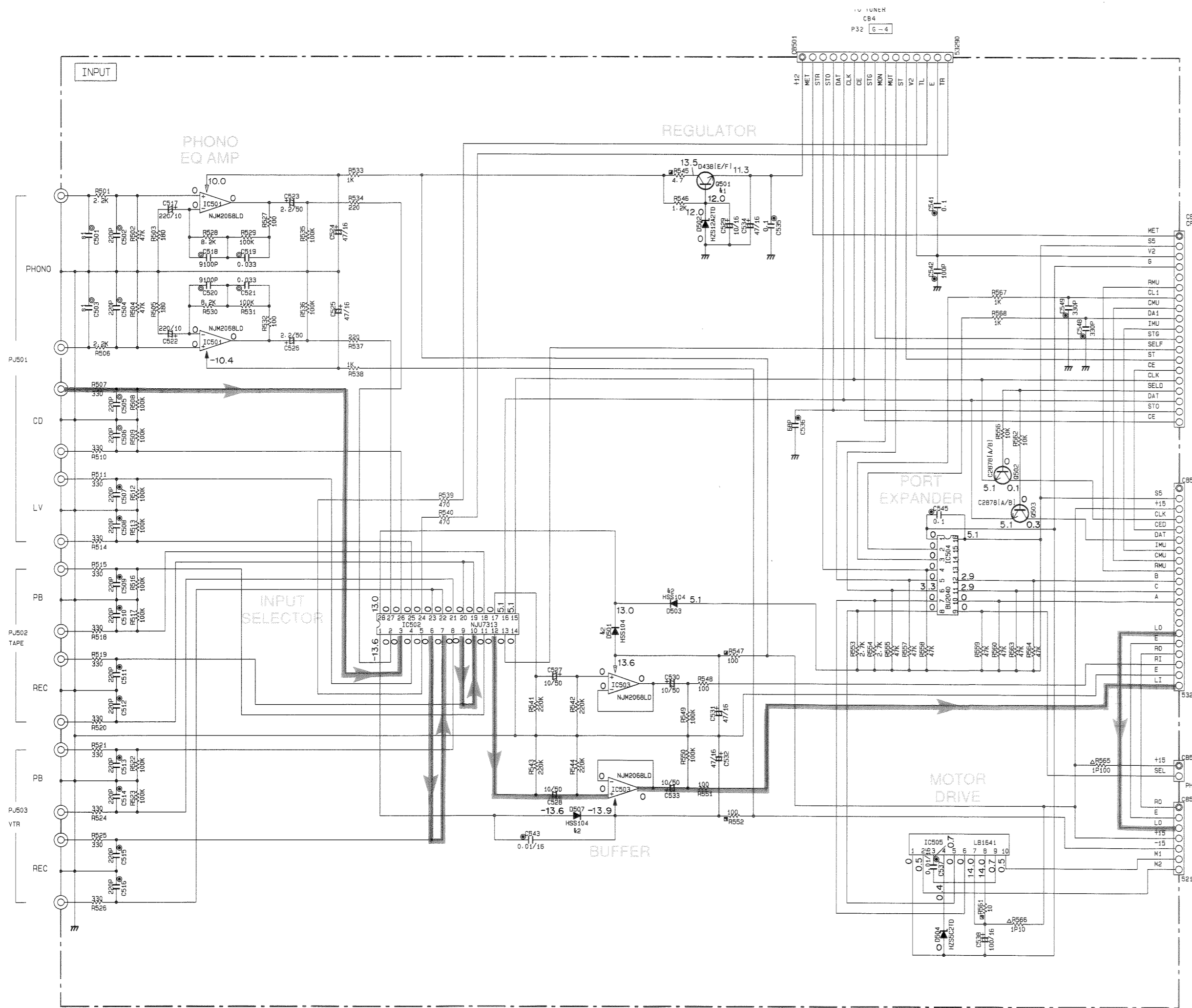

CAPACITOR

REMARKS	PARTS NAME	
NO MARK	ELECTROLYTIC CAPACITOR	
⊗	TANTALUM CAPACITOR	±5
NO MARK	CERAMIC CAPACITOR	
⊙	CERAMIC TUBULAR CAPACITOR	
⊖	POLYESTER FILM CAPACITOR	
○	POLYSTYRENE FILM CAPACITOR	
⊖	MICA CAPACITOR	
⊖	POLYPROPYLENE FILM CAPACITOR	
●	SEMICONDUCTIVE CERAMIC CAPACITOR	

RESISTOR

REMARKS	PARTS NAME	
NO MARK	CARBON FILM RESISTOR (P=5)	
□	CARBON FILM RESISTOR (P=10)	
△	METAL OXIDE FILM RESISTOR	
▲	METAL FILM RESISTOR	
⊖	METAL PLATE RESISTOR	
⊖	FIRE PROOF CARBON FILM RESISTOR	
□	CEMENT MOLDED RESISTOR	
⊖	SEMI VARIABLE RESISTOR	
■	CHIP RESISTOR	

Interchangeable Parts at Manufacture-Stage

Mark	Reference Parts Number	Parts Name
k1	0501	2SD438E/F/1 2SD5671C/D/1
k2	0501:503-507	HSS104 HSS193 HSS176

	U.C.R.A.B	G
s1	C501-503	X 220P

IC501, 503 : NJM2068L-D
Dual OP-Amp

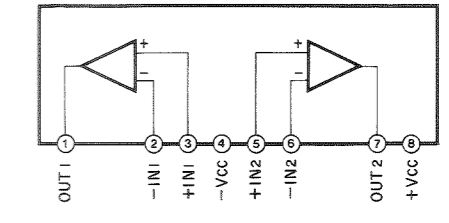

IC505 : LB1641
Motor Driver

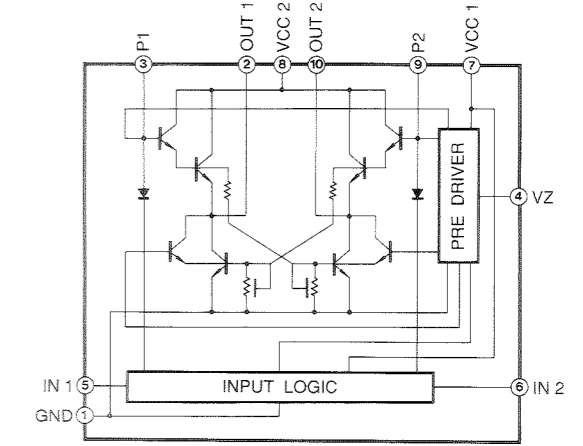

IC502 : NJU7313
Analog Function Switch

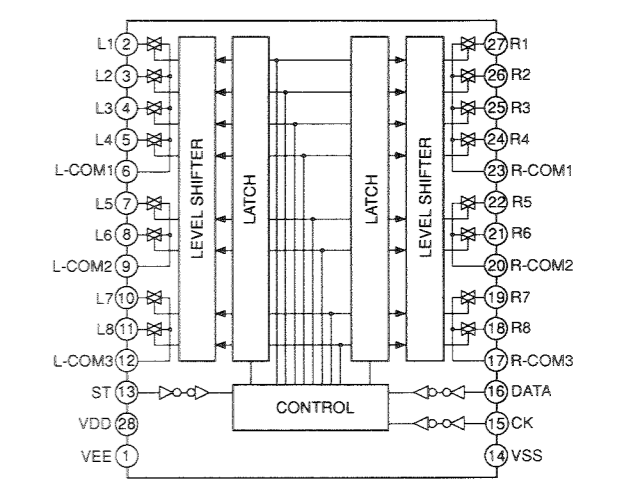

IC504 : BU2040
Port Expander

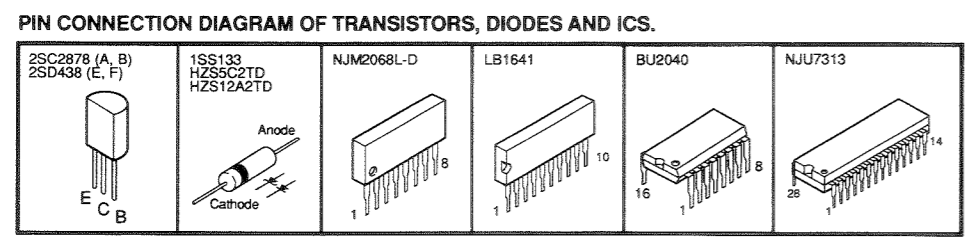
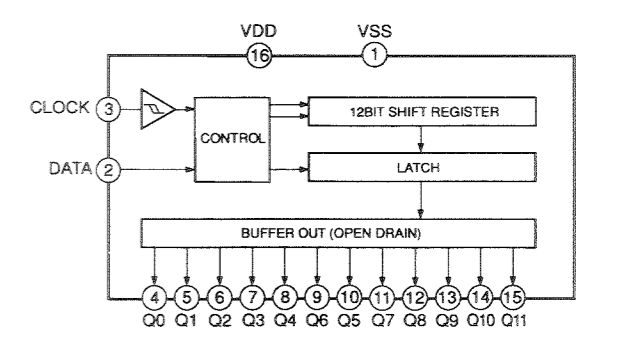

* All voltage are measured with a 10MΩ/DC electric volt meter.
* Components having special characteristics are marked △ and must be replaced with parts having specifications equal to those originally installed.
* Schematic diagram is subject to change without notice.

SCHEMATIC DIAGRAM (OPERATION)

② and ③ : TEST POINT WAVEFORMS (See page 31)

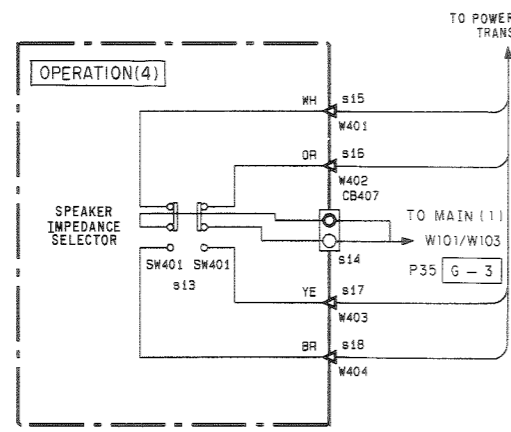
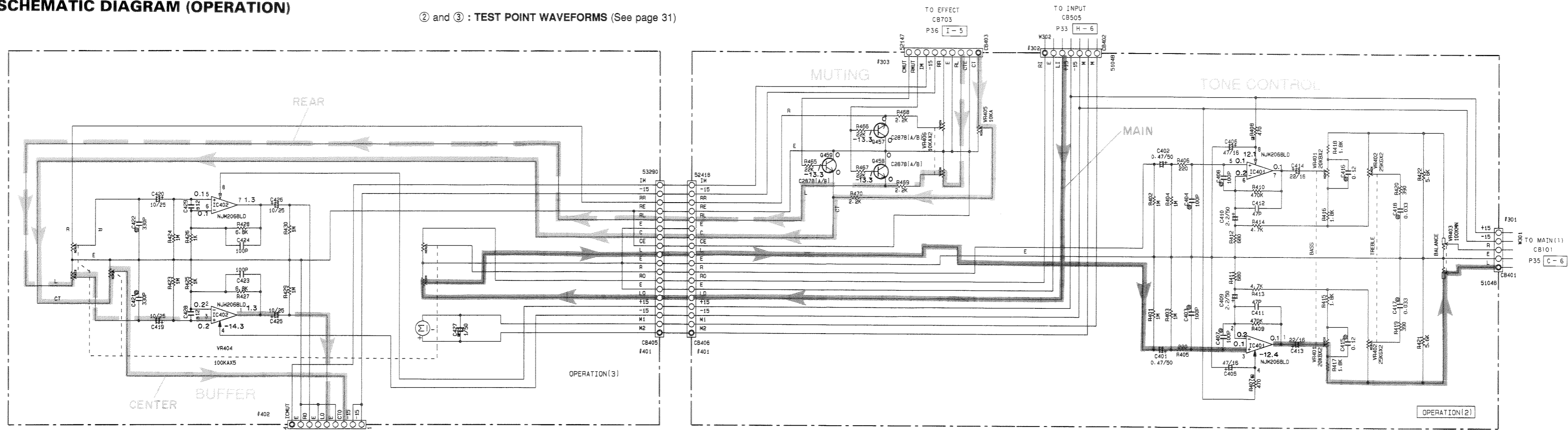

REMARKS	PARTS NAME
NO MARK	CARBON FILM RESISTOR (P=5)
⊗	CARBON FILM RESISTOR (P=10)
▲	METAL OXIDE FILM RESISTOR
△	METAL FILM RESISTOR
□	METAL PLATE RESISTOR
■	FIRE PROOF CARBON FILM RESISTOR
■	CEMENT MOLDED RESISTOR
⊕	SEMI VARIABLE RESISTOR
■	CHIP RESISTOR

REMARKS	PARTS NAME
NO MARK	ELECTROLYTIC CAPACITOR
⊗	TANTALUM CAPACITOR
NO MARK	CERAMIC CAPACITOR
⊙	CERAMIC TUBULAR CAPACITOR
⊕	POLYESTER FILM CAPACITOR
○	POLYSTYRENE FILM CAPACITOR
○	MICA CAPACITOR
⊕	POLYPROPYLENE FILM CAPACITOR
●	SEMICONDUCTIVE CERAMIC CAPACITOR

PIN CONNECTION DIAGRAM OF TRANSISTORS, DIODES AND ICs.

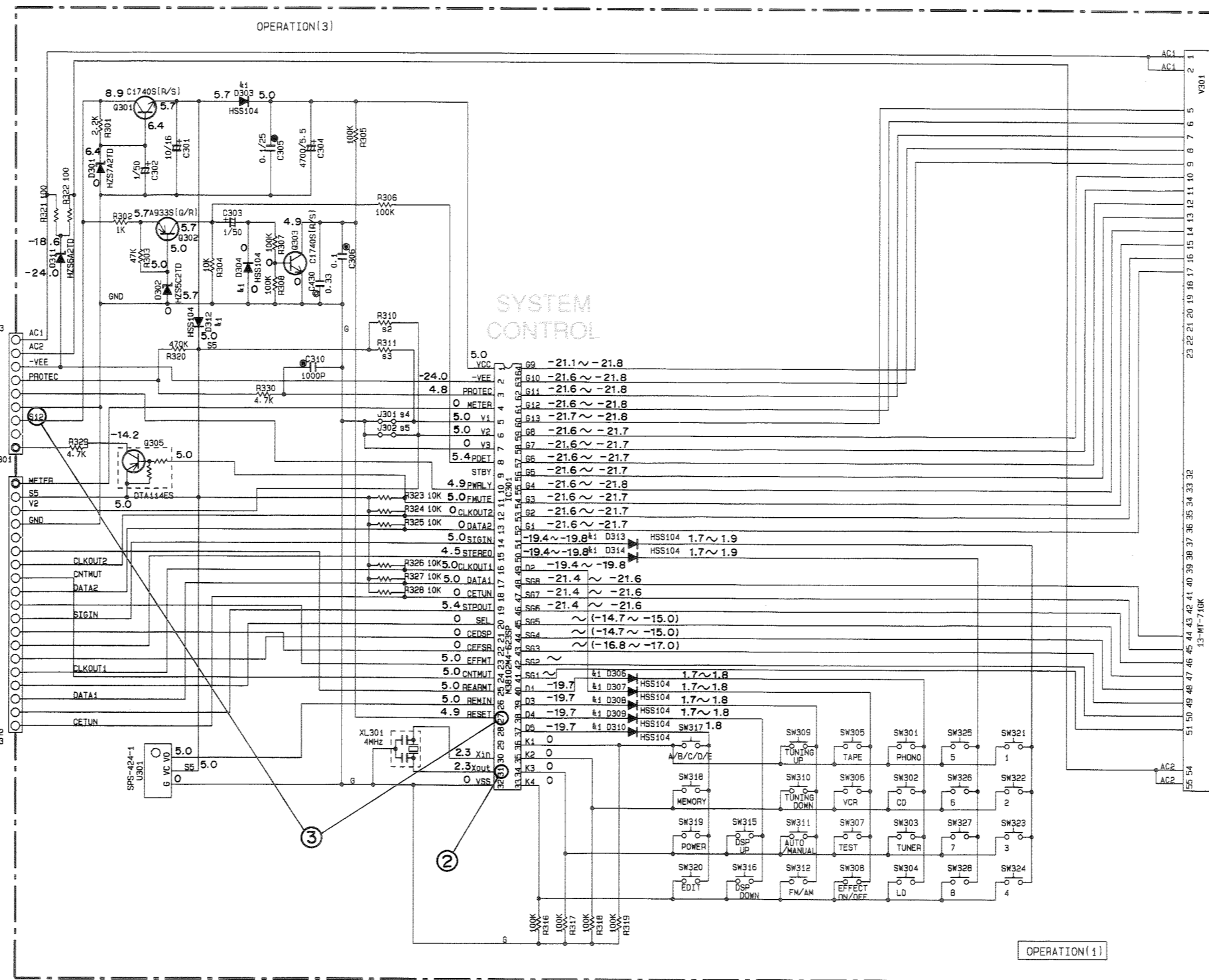
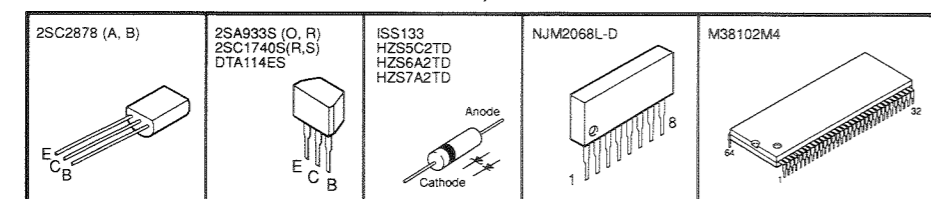

	U	C	R	A
B1				
B2	R310	100K	100K	100K
B3	R311	X	X	100K
B4	J301	○	○	X
B5	J302	X	X	X
B6				
B12				
B13	SW401	X	YE86260	X
B14	CB407	X	L400239	X
B15	W401	X	VT01360	X
B16	W402	X	VT01360	X
B17	W403	X	VT01370	X
B18	W404	X	VT01380	X

Interchangeable Parts at Manufacture Stage

Mark	Reference Parts Number	Parts Name
▲1	D303, 304, 306-310, 312-314	HSS104, 1SS133, 1SS176

IC401, 402 : NJM2068-D Dual Op-Amp

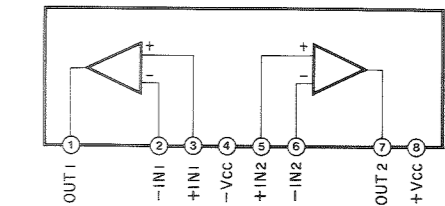

Other IC

● IC301 : M38102M4 → See page 13

* All voltage are measured with a 10MΩ/DC electric volt meter.
 * Components having special characteristics are marked ▲ and must be replaced with parts having specifications equal to those originally installed.
 * Schematic diagram is subject to change without notice.

SCHEMATIC DIAGRAM (MAIN)

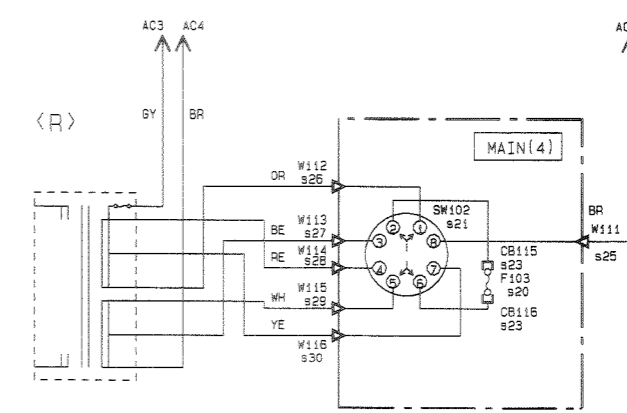
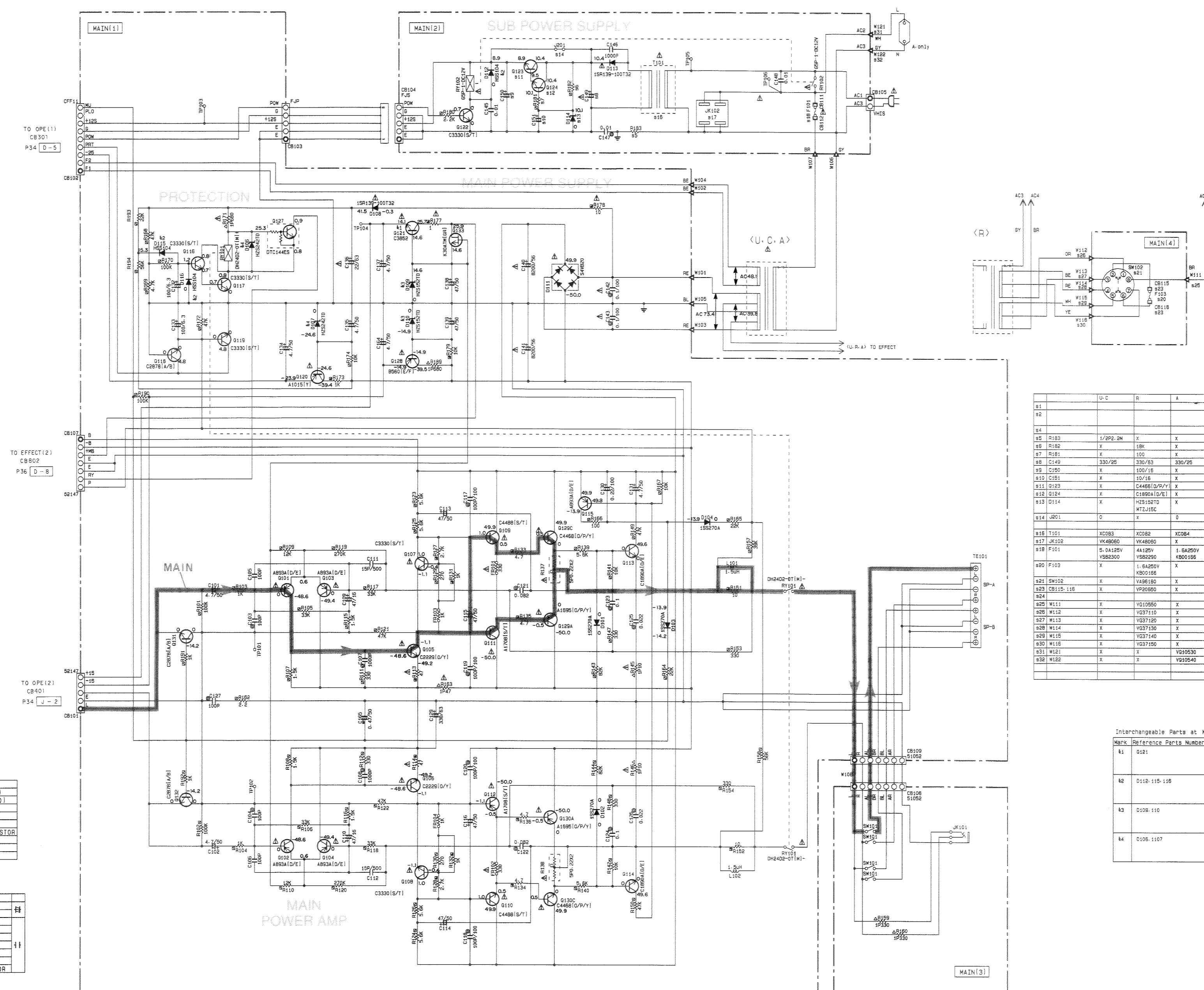

U-C	R	A
81		
82		
84		
85 R183	1/202 2M	X
86 R182	X	18K
87 R181	X	100
88 C149	330/25	330/53 330/25
89 C150	X	100/15
810 C151	X	10/15
811 D123	X	C4488(D/P/Y)
812 D124	X	C19804(D/E)
813 D114	X	H2S192TD X
814 J201	O	X
815 T101	X	X
817 JK102	X	X
818 F101	S-04125V	1.6A250V
820 F103	X	1.6A250V
821 SW102	X	VA96180 X
823 CB115-116	X	VP20800 X
824		
826 M112	X	VQ10560 X
827 M113	X	VQ37110 X
828 M114	X	VQ37130 X
829 M115	X	VQ37140 X
830 M116	X	VQ37150 X
831 M121	X	VQ10530
832 M122	X	VQ10540

REMARKS	PARTS NAME
NO MARK	CARBON FILM RESISTOR (P=5)
□	CARBON FILM RESISTOR (P=10)
△	METAL OXIDE FILM RESISTOR
▲	METAL FILM RESISTOR
■	FIRE PROOF CARBON FILM RESISTOR
⊞	CEMENT MOLDED RESISTOR
⊚	SEMI VARIABLE RESISTOR
●	CHIP RESISTOR

REMARKS	PARTS NAME
NO MARK	ELECTROLYTIC CAPACITOR
⊚	TANTALUM CAPACITOR
NO MARK	CERAMIC CAPACITOR
⊙	CERAMIC TUBULAR CAPACITOR
⊖	POLYESTER FILM CAPACITOR
⊕	POLYSTYRENE FILM CAPACITOR
○	MICA CAPACITOR
⊗	POLYPROPYLENE FILM CAPACITOR
●	SEMICONDUCTIVE CERAMIC CAPACITOR

PIN CONNECTION DIAGRAM OF TRANSISTORS, DIODES AND ICs.

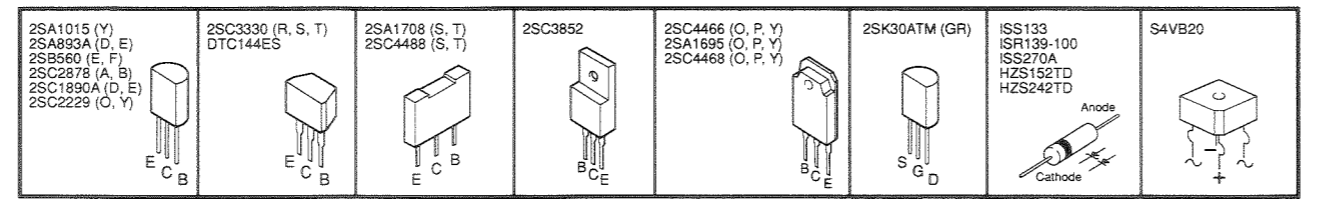

Interchangeable Parts at Manufacture-Stage

Mark	Reference Parts Number	Parts Name
81	D121	C3852 C4495
82	D112-115-116	H8S104 18S133 18S176
83	D108-110	H2S192TD MTZ150C
84	D105-1107	H2S242TD MTZ242D

* All voltage are measured with a 10MΩ/DC electric volt meter.
 * Components having special characteristics are marked Δ and must be replaced with parts having specifications equal to those originally installed.
 * Schematic diagram is subject to change without notice.

SCHEMATIC DIAGRAM (EFFECT)

④ : TEST POINT WAVEFORMS (See page 31)

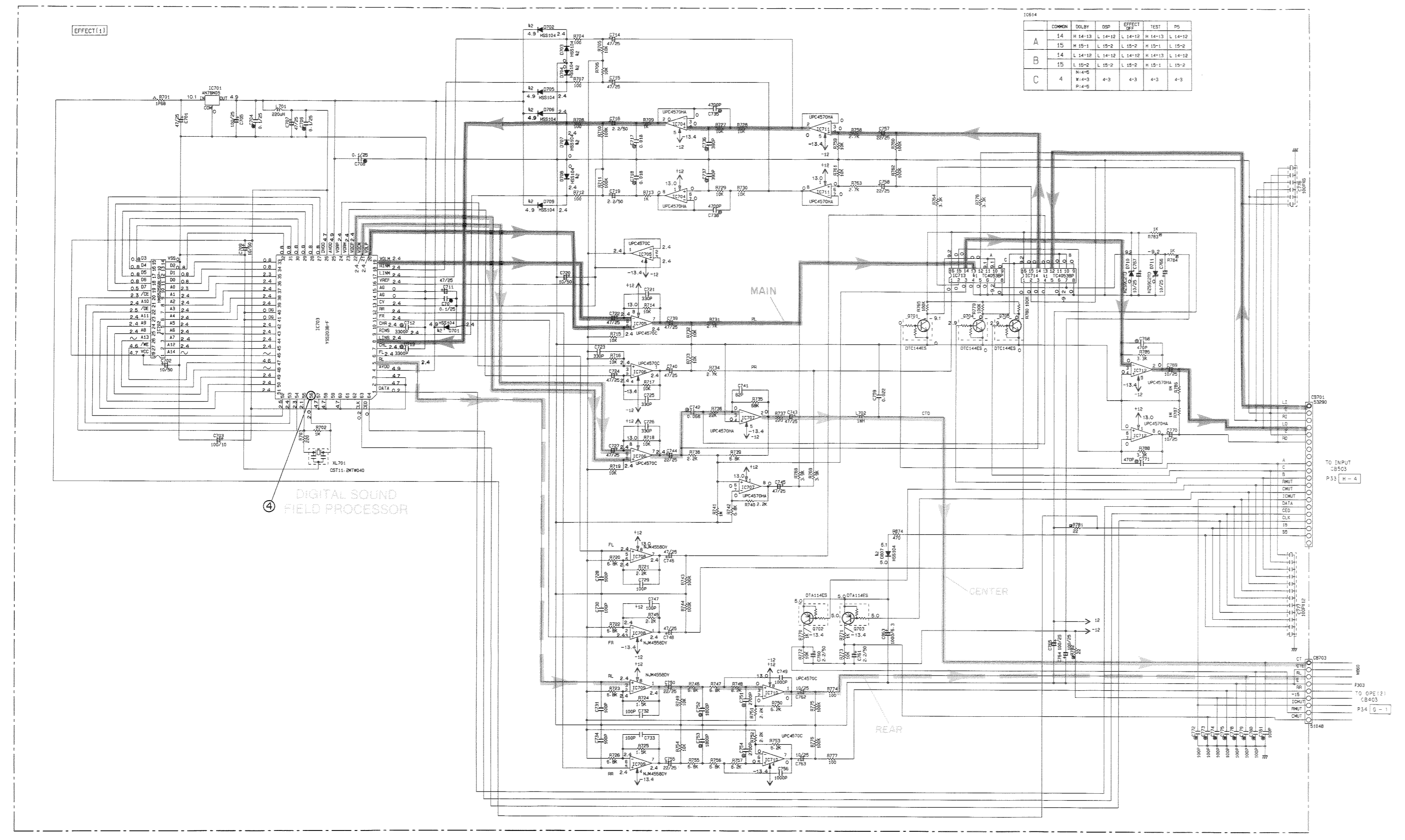

IC704, 707, 711, 712 : μPC4570HA Dual OP-Amp

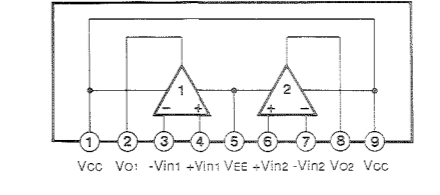

IC705, 706, 710 : μPC4570C Dual OP-Amp

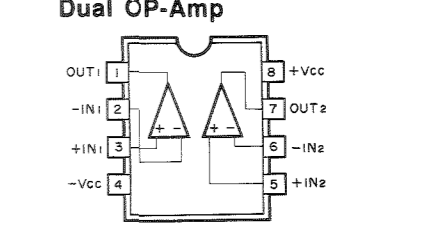

IC855 : LA7956 Video Switch

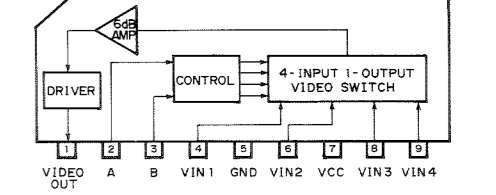

IC702 : HM65256BLS-P10 32768-word x 8-bit High Speed Pseudo Static RAM

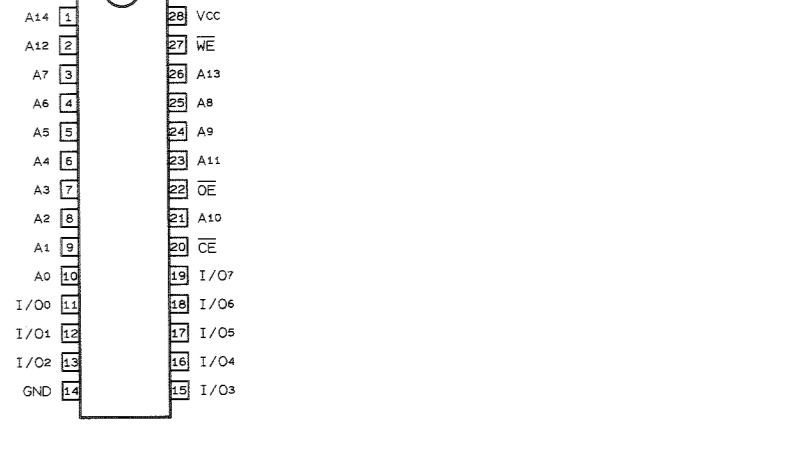
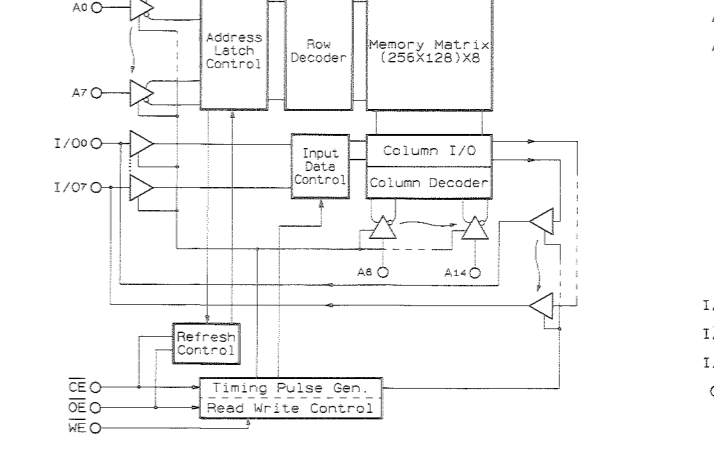

IC713, 714 : TC4053BP Triple 2 Channel Analog Multiplexers/Demultiplexers

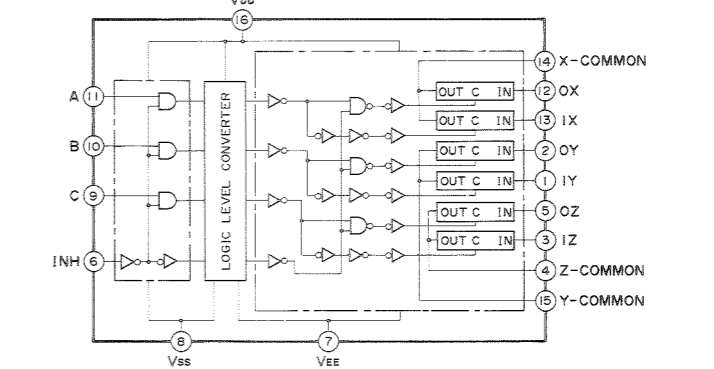
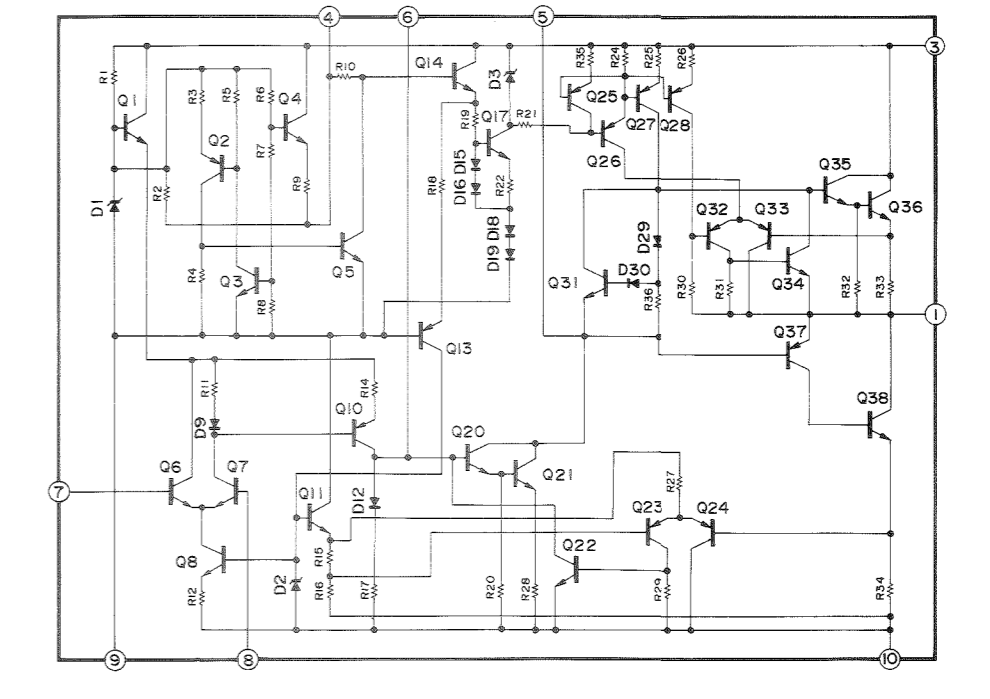
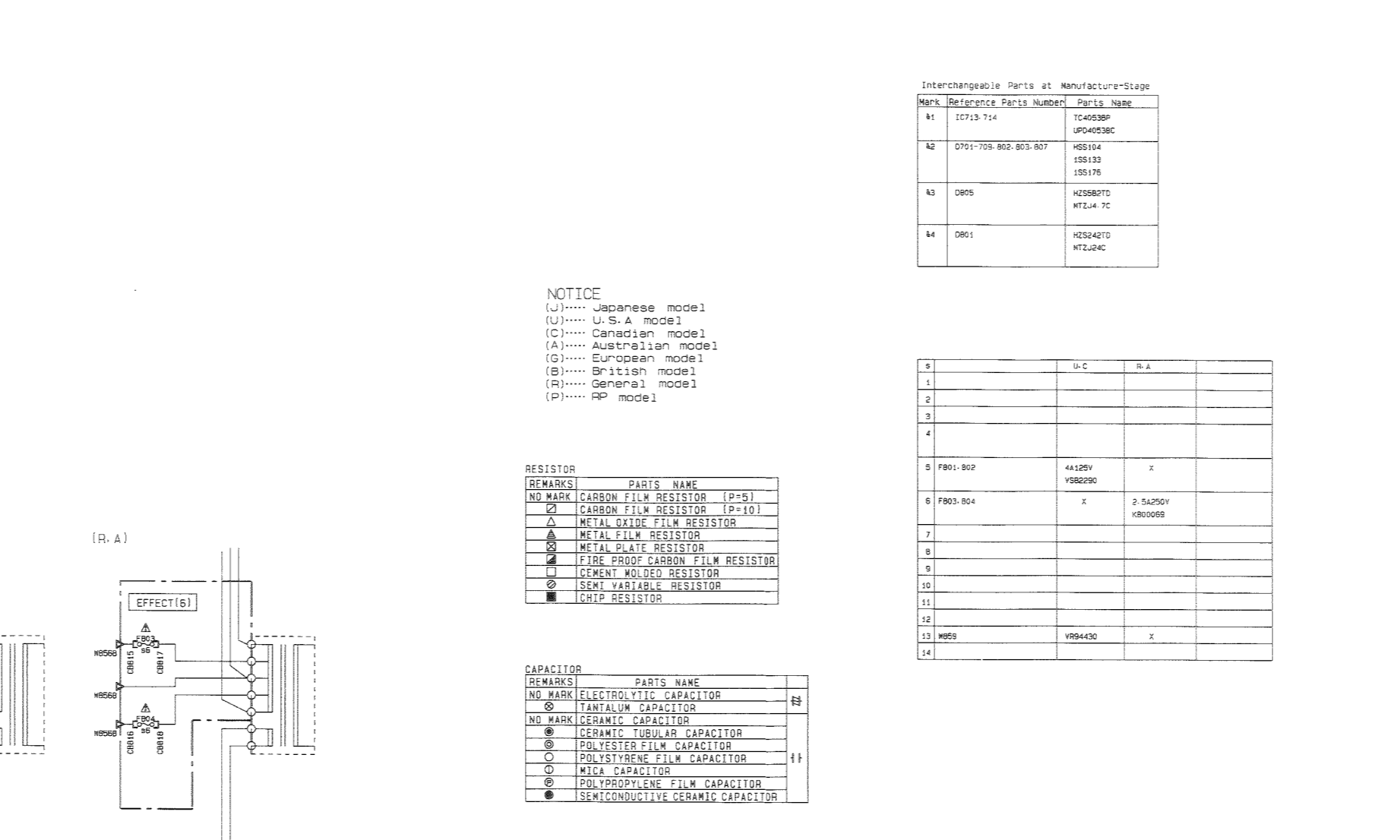
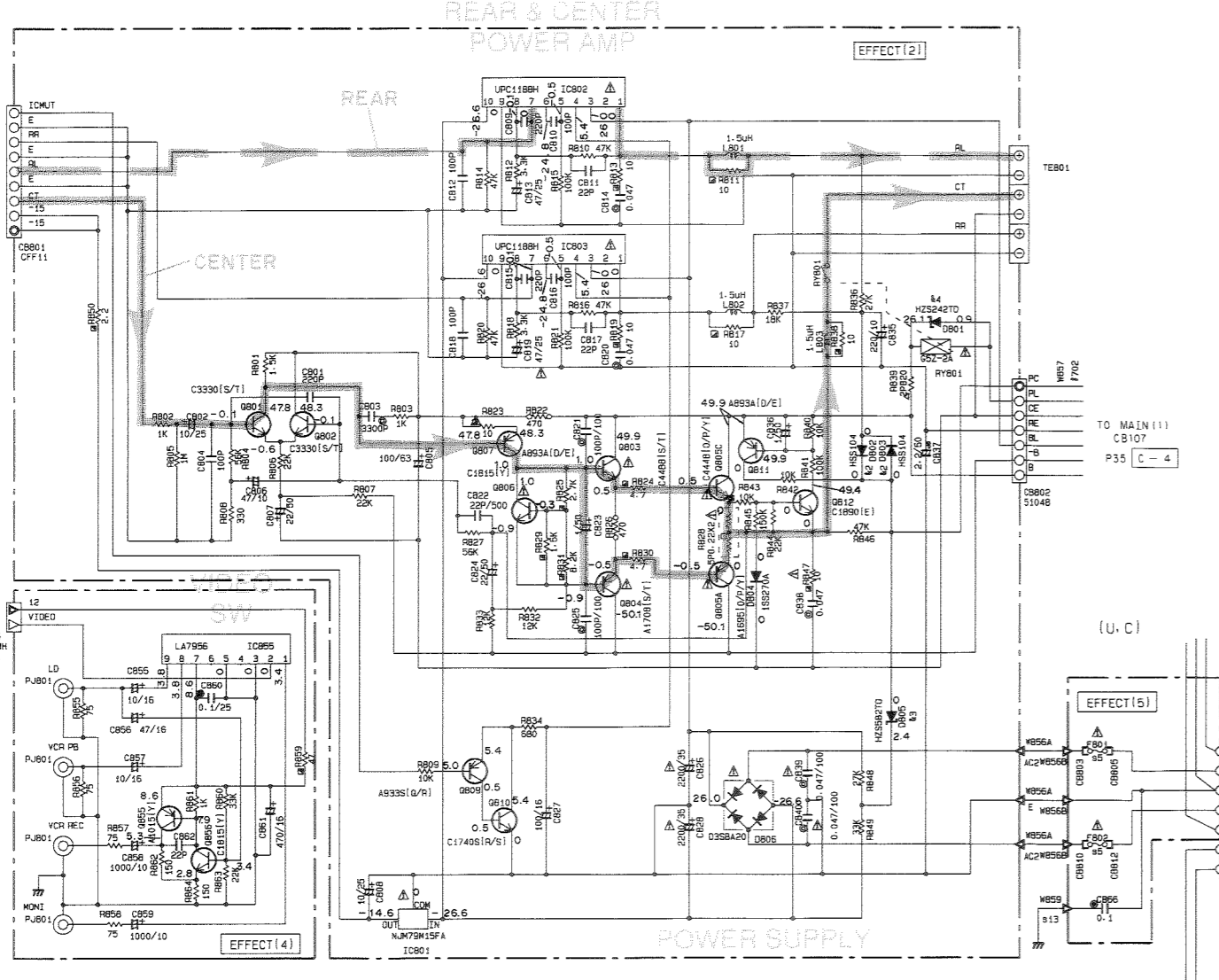

Table with columns for CONTROL INPUTS (INHIBIT, C, B, A) and ON CHANNEL (Ox, OY, OZ, OX, OY, OZ, OX, OY, OZ). It lists pin numbers and channel functions.

IC802, 803 : μPC1188H Power Amp



Other IC's ● IC703 : YSS203B - See page 15



NOTICE (U) Japanese model (U) U.S.A model (C) Canadian model (A) Australian model (E) European model (B) British model (R) General model (P) RP model

Table with columns for RESISTOR, PARTS NAME, and MARKINGS. It lists various resistor types like carbon film, metal film, and thick film.

Table with columns for CAPACITOR, PARTS NAME, and MARKINGS. It lists various capacitor types like electrolytic, ceramic, and film.

Table with columns for Mark, Reference, Data Number, and Parts Name. It lists specific components like IC713, IC702, and IC802.

Table with columns for Mark, U.C., and S.A. It lists component markings for various parts.

PIN CONNECTION DIAGRAM OF TRANSISTORS, DIODES AND IC'S.

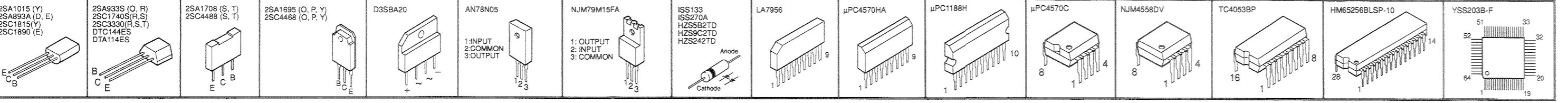

All voltage are measured with a 10MΩ/DC electric volt meter. Components having special characteristics are marked with a triangle and must be replaced with parts having specifications equal to those originally installed. Schematic diagram is subject to change without notice.

PARTS LIST

■ ELECTRICAL PARTS

■ WARNING

Components having special characteristics are marked \triangle and must be replaced with parts having specifications equal to those originally installed.

- Carbon resistors (1/6W or 1/4W) are not included in the ELECTRICAL PARTS List. For the parts No. of the carbon resistors, refer to last page.

ABBREVIATIONS IN THIS LIST ARE AS FOLLOWS :

C.A.EL.CHP	: CHIP ALUMI. ELECTROLYTIC CAP	L.EMIT	: LIGHT EMITTING MODULE
C.CE	: CERAMIC CAP	LED.DSPLY	: LED DISPLAY
C.CE.ARRAY	: CERAMIC CAP ARRAY	LED.INFRD	: LED, INFRARED
C.CE.CHP	: CHIP CERAMIC CAP	MODUL.RF	: MODULATOR, RF
C.CE.ML	: MULTILAYER CERAMIC CAP	PHOT.CPL	: PHOTO COUPLER
C.CE.M.CHP	: CHIP MULTILAYER CERAMIC CAP	PHOT.INTR	: PHOTO INTERRUPTER
C.CE.SAFTY	: RECOGNIZED CERAMIC CAP	PHOT.RFLCT	: PHOTO REFLECTOR
C.CE.TUBLR	: CERAMIC TUBULAR CAP	PIN.TEST	: PIN, TEST POINT
C.CE.SMI	: SEMI CONDUCTIVE CERAMIC CAP	PLST.RIVET	: PLASTIC RIVET
C.EL	: ELECTROLYTIC CAP	R.ARRAY	: RESISTOR ARRAY
C.MICA	: MICA CAP	R.CAR.	: CARBON RESISTOR
C.ML.FLM	: MULTILAYER FILM CAP	R.CAR.CHP	: CHIP RESISTOR
C.MP	: METALLIZED PAPER CAP	R.CAR.FP	: FLAME PROOF CARBON RESISTOR
C.MYLAR	: MYLAR FILM CAP	R.FUS	: FUSABLE RESISTOR
C.MYLAR.ML	: MULTILAYER MYLAR FILM CAP	R.MTL.CHP	: CHIP METAL FILM RESISTOR
C.PAPER	: PAPER CAPACITOR	R.MTL.FLM	: METAL FILM RESISTOR
C.PLS	: POLYSTYRENE FILM CAP	R.MTL.OXD	: METAL OXIDE FILM RESISTOR
C.POL	: POLYESTER FILM CAP	R.MTL.PLAT	: METAL PLATE RESISTOR
C.POLY	: POLYETHYLENE FILM CAP	RSNR.CE	: CERAMIC RESONATOR
C.PP	: POLYPROPYLENE FILM CAP	RSNR.CRYS	: CRYSTAL RESONATOR
C.TNTL	: TANTALUM CAP	R.TW.CEM	: TWIN CEMENT FIXED RESISTOR
C.TNTL.CHP	: CHIP TANTALUM CAP	R.WW	: WIRE WOUND RESISTOR
C.TRIM	: TRIMMER CAP	SCR.BND.HD	: BIND HEAD B-TITE SCREW
CN	: CONNECTOR	SCR.BW.HD	: BW HEAD TAPPING SCREW
CN.BS.PIN	: CONNECTOR, BASE PIN	SCR.CUP	: CUP TITE SCREW
CN.CANNON	: CONNECTOR, CANNON	SCR.TERM	: SCREW TERMINAL
CN.DIN	: CONNECTOR, DIN	SCR.TR	: SCREW, TRANSISTOR
CN.FLAT	: CONNECTOR, FLAT CABLE	SUPRT.PCB	: SUPPORT, P.C.B.
CN.POST	: CONNECTOR, BASE POST	SURG.PRTCT	: SURGE PROTECTOR
COIL.MX.AM	: COIL, AM MIX	SW.TACT	: TACT SWITCH
COIL.AT.FM	: COIL, FM ANTENNA	SW.LEAF	: LEAF SWITCH
COIL.DT.FM	: COIL, FM DETECT	SW.LEVER	: LEVER SWITCH
COIL.MX.FM	: COIL, FM MIX	SW.MICRO	: MICRO SWITCH
COIL.OUTPT	: OUTPUT COIL	SW.PUSH	: PUSH SWITCH
DIOD.ARRAY	: DIODE ARRAY	SW.RT.ENC	: ROTARY ENCODER
DIODE.BRG	: DIODE BRIDGE	SW.RT.MTR	: ROTARY SWITCH WITH MOTOR
DIODE.CHP	: CHIP DIODE	SW.RT	: ROTARY SWITCH
DIODE.VAR	: VARACTOR DIODE	SW.SLIDE	: SLIDE SWITCH
DIOD.Z.CHP	: CHIP ZENER DIODE	TERM.SP	: SPEAKER TERMINAL
DIODE.ZENR	: ZENER DIODE	TERM.WRAP	: WRAPPING TERMINAL
DSCR.CE	: CERAMIC DISCRIMINATOR	THRMST.CHP	: CHIP THERMISTOR
FER.BEAD	: FERRITE BEADS	TR.CHP	: CHIP TRANSISTOR
FER.CORE	: FERRITE CORE	TR.DGT	: DIGITAL TRANSISTOR
FET.CHP	: CHIP FET	TR.DGT.CHP	: CHIP DIGITAL TRANSISTOR
FL.DSPLY	: FLUORESCENT DISPLAY	TRANS	: TRANSFORMER
FLTR.CE	: CERAMIC FILTER	TRANS.PULS	: PULSE TRANSFORMER
FLTR.COMB	: COMB FILTER MODULE	TRANS.PWR	: POWER TRANSFORMER ASS'y
FLTR.LC.RF	: LC FILTER ,EMI	TUNER.AM	: TUNER PACK, AM
GND.MTL	: GROUND PLATE	TUNER.FM	: TUNER PACK, FM
GND.TERM	: GROUND TERMINAL	TUNER.PK	: FRONT-END TUNER PACK
HOLDER.FUS	: FUSE HOLDER	VR	: ROTARY POTENTIOMETER
IC.PRTCT	: IC PROTECTOR	VR.MTR	: POTENTIOMETER WITH MOTOR
JUMPER.CN	: JUMPER CONNECTOR	VR.SW	: POTENTIOMETER WITH ROTARY SW
JUMPER.TST	: JUMPER, TEST POINT	VR.SLIDE	: SLIDE POTENTIOMETER
L.DTCT	: LIGHT DETECTING MODULE	VR.TRIM	: TRIMMER POTENTIOMETER

Note) Those parts marked with "#" are not included in the P.C.B. ass'y.

P. C. B. TUNER & MAIN

Schm Ref.	PART NO.	Description		
	VR341800	P. C. B.	TUNER (UC)	
	VR341900	P. C. B.	TUNER (R)	
	VR342000	P. C. B.	TUNER (A)	
CB1	VR428700	CN. BS. PIN	2P	
CB2	VR428700	CN. BS. PIN	2P	
* CB4	VQ961800	CN. BS. PIN	15P	
C1	UJ638330	C. EL	330uF	16V
C2	VG280100	C. CE. TUBLR	0.022uF	25V
C3	VJ599000	C. CE. TUBLR	0.047uF	16V
C4	VJ836900	C. EL	10uF	16V
C5	VF467300	C. CE. TUBLR	0.01uF	16V
C6	VF964800	C. EL	100uF	16V
C7	VJ839100	C. EL	1uF	50V
C8	VF467300	C. CE. TUBLR	0.01uF	16V
C9	VF467300	C. CE. TUBLR	0.01uF	16V
C10	VF467300	C. CE. TUBLR	0.01uF	16V
C11	VF467000	C. CE. TUBLR	1000pF	50V
C12	VJ836900	C. EL	10uF	16V
C13	VJ836900	C. EL	10uF	16V
C14	VF467000	C. CE. TUBLR	1000pF	50V
C15	VF467000	C. CE. TUBLR	1000pF	50V
C16	VF466700	C. CE. TUBLR	47pF	50V
C17	VF964800	C. EL	100uF	16V
C18	UA655100	C. MYLAR	0.1uF	50V
C19	VA761200	C. CE	33pF	50V
C20	VJ836900	C. EL	10uF	16V
C21	VF466800	C. CE. TUBLR	100pF	50V
C22	VJ839200	C. EL	2.2uF	50V
C23	VF467300	C. CE. TUBLR	0.01uF	16V
C24	UM416470	C. EL	4.7uF	50V
C25	UM216330	C. EL	3.3uF	50V
C26	VJ836900	C. EL	10uF	16V
C27	VF467300	C. CE. TUBLR	0.01uF	16V
C28	VA761200	C. CE	33pF	50V
C29	VJ839100	C. EL	1uF	50V
C30	VJ839100	C. EL	1uF	50V
C31	VJ836900	C. EL	10uF	16V
C32	VJ839000	C. EL	0.47uF	50V
C33	VJ839100	C. EL	1uF	50V
C34	UA654470	C. MYLAR	0.047uF	50V
* C35	VD916400	C. EL	2.2uF	50V
C36	UA652470	C. MYLAR	470pF	50V (A)
C36	UA652680	C. MYLAR	680pF	50V (UCR)
C37	UA652470	C. MYLAR	470pF	50V (A)
C37	UA652680	C. MYLAR	680pF	50V (UCR)
C38	VF466900	C. CE. TUBLR	470pF	50V
C39	VJ836900	C. EL	10uF	16V
C40	UM216330	C. EL	3.3uF	50V
C41	UA653390	C. MYLAR	3900pF	50V
C42	VJ836900	C. EL	10uF	16V
C43	UA653390	C. MYLAR	3900pF	50V
C44	UM216330	C. EL	3.3uF	50V
C49	VJ599000	C. CE. TUBLR	0.047uF	16V

* New Parts

Schm Ref.	PART NO.	Description		
C68	VJ836900	C. EL	10uF	16V
C69	VJ836900	C. EL	10uF	16V
D1	VD631600	DIODE	1SS133, 176, HSS104	
D2	VD631600	DIODE	1SS133, 176, HSS104	
D3	VM974500	DIODE. ZENR	HZS6C2TD	6.0V
Fi1	GG000560	FLTR. CE	SFE10.7MS3GHY-A	
Fi2	GG000560	FLTR. CE	SFE10.7MS3GHY-A	
Fi3	VC219000	FLTR. CE	SFZ450JL3	
IC1	XB760A00	IC	LA1266	
IC2	XB818A00	IC	LM7000N	
IC3	iG158100	IC	LA3401	
L1	Vi546100	COIL	220uH	
L2	Vi546100	COIL	220uH	
L3	Vi546100	COIL	220uH	
* PK1	VR242200	TUNER. PK	EXV-17296G1	
PK2	Vi027300	COIL. AM		
Q1	iC053540	TR	2SC535	A, B, C
Q2	VC218900	TR	2SC3330	R, S, T
Q3	VC218900	TR	2SC3330	R, S, T
Q4	iC053540	TR	2SC535	A, B, C
Q5	VC218700	TR	2SA1317	R, S, T
Q6	VC218900	TR	2SC3330	R, S, T
Q7	iC1815C0	TR	2SC1815	Y
SW1	VF541200	SW. SLIDE	SSSF11 (R)	
T1	VC218600	COIL. DT. FM	10.7MHz	
T2	GE100470	COIL. IF. AM	450KHz	
* T4	VQ138200	FLTR. LC	19KHz	
* T5	VQ138200	FLTR. LC	19KHz	
TE1	LA005800	TERM. ANT	YKD31-0215	
TP1	LA004120	PIN. TEST		
TP2	LA004120	PIN. TEST		
VR1	VJ694000	VR. TRIM	B47K Ω	
VR2	VJ694000	VR. TRIM	B47K Ω	
XL1	QU003800	RSNR. CRYST	7.2MHz	
XL2	GG000750	RSNR. CE	18.95MHz	
	BB071360	SCR. TERM	8.3x13	
*	VR282500	PLATE	ANT.	
*	VS996800	P. C. B.	MAIN (UC)	
*	VS996900	P. C. B.	MAIN (R)	
*	VS997000	P. C. B.	MAIN (A)	
CB101	VK024900	CN. BS. PIN	5P	
* CB102	VR358000	CN. BS. PIN	9P	
CB103	VP768100	CN. BS. PIN	5P	
CB105	VG879900	CN. BS. PIN	2P	
CB107	VK025100	CN. BS. PIN	7P	
CB108	VQ584900	CN. BS. PIN	7P	
CB109	VQ584900	CN. BS. PIN	7P	
CB111	VP206500	HOLDER. FUS	EYF-52BC	
CB112	VP206500	HOLDER. FUS	EYF-52BC	
CB115	VP206500	HOLDER. FUS	EYF-52BC (R)	

* New Parts

RX-V490/R-V701

P. C. B. MAIN

Schm Ref.	PART NO.	Description
CB116	VP206500	HOLDER. FUS EYF-52BC (R)
C101	UM416470	C. EL 4.7uF 50V
C102	UM416470	C. EL 4.7uF 50V
C103	UA652100	C. MYLAR 100pF 50V
C104	UA652100	C. MYLAR 100pF 50V
C105	VE551900	C. CE 100pF 50V
C106	VE551900	C. CE 100pF 50V
C107	UA653100	C. MYLAR 1000pF 50V
C108	UA653100	C. MYLAR 1000pF 50V
C109	VJ837200	C. EL 47uF 16V
C110	VJ837200	C. EL 47uF 16V
* C111	VR516400	C. CE 15p 500V
* C112	VR516400	C. CE 15p 500V
C113	UJ667470	C. EL 47uF 50V
C114	UJ667470	C. EL 47uF 50V
C115	VG291200	C. EL 47uF 50V
C116	VG291200	C. EL 47uF 50V
* C117	VR325000	C. MYLAR 100pF 100V
* C118	VR325000	C. MYLAR 100pF 100V
* C119	VR325000	C. MYLAR 100pF 100V
* C120	VR325000	C. MYLAR 100pF 100V
C121	UA654820	C. MYLAR 0.082uF 50V
C122	UA654820	C. MYLAR 0.082uF 50V
C123	UA655100	C. MYLAR 0.1uF 50V
C124	UA655100	C. MYLAR 0.1uF 50V
C125	UA654220	C. MYLAR 0.022uF 50V
C126	UA654220	C. MYLAR 0.022uF 50V
C127	UA652100	C. MYLAR 100pF 50V
* C129	VK182500	C. EL 330uF 63V
C130	UJ895220	C. EL 0.22uF 100V
C131	UM416470	C. EL 4.7uF 50V
C132	VF760000	C. EL 100uF 10V
C133	VF760000	C. EL 100uF 10V
C134	UM416470	C. EL 4.7uF 50V
C135	UM416470	C. EL 4.7uF 50V
△ C136	Vi846000	C. EL 22uF 63V
C137	UM416470	C. EL 4.7uF 50V
C138	UJ667470	C. EL 47uF 50V
C139	UJ667470	C. EL 47uF 50V
△* C140	VR670100	C. EL 8200uF 56V
△* C141	VR670100	C. EL 8200uF 56V
△* C142	VR325400	C. MYLAR 0.1uF 100V
△* C143	VR325400	C. MYLAR 0.1uF 100V
C145	UG444100	C. CE 0.01uF 50V
C146	FG213100	C. CE 1000pF 50V
C147	UA654100	C. MYLAR 0.01uF 50V
C148	Fi514100	C. CE. SAFTY 0.01uF VA-1
△* C149	VK182500	C. EL 330uF 63V (R)
△ C149	VK457600	C. EL 330uF 25V (UC)
C150	VF964800	C. EL 100uF 16V (R)
C151	VJ836900	C. EL 10uF 16V (R)
C164	UM416470	C. EL 4.7uF 50V
C165	UK665470	C. EL 0.47uF 50V

* New Parts

Schm Ref.	PART NO.	Description
D101	VN008700	DIODE 1SS270A
D102	VN008700	DIODE 1SS270A
D103	VN008700	DIODE 1SS270A
D104	VN008700	DIODE 1SS270A
D106	VM976300	DIODE. ZENR HZS242TD 24V
D107	VM976300	DIODE. ZENR HZS242TD 24V
△ D108	VH770800	DIODE 1SR139-100
D109	VM975800	DIODE. ZENR HZS152TD 15V
D110	VM975800	DIODE. ZENR HZS152TD 15V
△ D111	iH001090	DIODE. BRG S4VB20 2.6A 200V
D112	VD631600	DIODE 1SS133, 176, HSS104
△ D113	VH770800	DIODE 1SR139-100
D114	VM975500	DIODE. ZENR HZS12A2TD 12V (R)
D115	VD631600	DIODE 1SS133, 176, HSS104
D116	VD631600	DIODE 1SS133, 176, HSS104
△ F101	KB001660	FUSE T1. 60A 250V (A)
△* F101	VS822900	FUSE T4. 0A 125V (R)
△* F101	VS823000	FUSE T5. 0A 125V (UC)
△ F103	KB001660	FUSE T1. 60A 250V (R)
△ FR101	VK188400	R. FUS 330 Ω 1/4W
△ FR102	VK188400	R. FUS 330 Ω 1/4W
FR103	VK189000	R. FUS 1K Ω 1/4W
FR104	VK189000	R. FUS 1K Ω 1/4W
JK101	LB301720	JACK. PHONE
△ JK102	VK480600	OUTLET. AC (UCR)
* L101	VP575600	COIL 1.5uH
* L102	VP575600	COIL 1.5uH
△* Q101	VP883000	TR 2SA893A D, E
△* Q102	VP883000	TR 2SA893A D, E
△* Q103	VP883000	TR 2SA893A D, E
△* Q104	VP883000	TR 2SA893A D, E
△* Q105	VR325600	TR 2SC2229 O, Y
△* Q106	VR325600	TR 2SC2229 O, Y
△ Q107	VC218900	TR 2SC3330 R, S, T
△ Q108	VC218900	TR 2SC3330 R, S, T
△* Q109	VP872700	TR 2SC4488 S, T
△* Q110	VP872700	TR 2SC4488 S, T
△* Q111	VP872600	TR 2SA1708 S, T
△* Q112	VP872600	TR 2SA1708 S, T
* Q113	VP883100	TR 2SC1890A D, E
* Q114	VP883100	TR 2SC1890A D, E
* Q115	VP883000	TR 2SA893A D, E
Q116	VC218900	TR 2SC3330 R, S, T
Q117	VC218900	TR 2SC3330 R, S, T
Q118	iC287820	TR 2SC2878 A, B
Q119	VC218900	TR 2SC3330 R, S, T
△ Q120	iA101521	TR 2SA1015 Y
△ Q121	VC938500	TR 2SC3852
Q122	VC218900	TR 2SC3330 R, S, T
Q123	VP768300	TR 2SC4466 O, P, Y (R)
* Q124	VP883100	TR 2SC1890A D, E (R)
Q127	VG722000	TR. DGT DTC144ES
△ Q128	iB056020	TR 2SB560 E, F

* New Parts

RX-V490/R-V701

P. C. B. MAIN & OPERATION

Schm Ref.	PART NO.	Description	
△	Q129A	iX630850	TR 2SA1695 O,P,Y
△	Q129C	iX630860	TR 2SC4468 O,P,Y
△	Q130A	iX630850	TR 2SA1695 O,P,Y
△	Q130C	iX630860	TR 2SC4468 O,P,Y
	Q131	iC287820	TR 2SC2878 A,B
	Q132	iC287820	TR 2SC2878 A,B
	Q133	iE000020	FET 2SK30ATM GR
△	R113	HV454470	R. CAR. FP 47Ω 1/4W
△	R114	HV454470	R. CAR. FP 47Ω 1/4W
	R127	HV456270	R. CAR. FP 2.7KΩ 1/4W
	R128	HV456270	R. CAR. FP 2.7KΩ 1/4W
	R131	HV456100	R. CAR. FP 1KΩ 1/4W
	R132	HV456100	R. CAR. FP 1KΩ 1/4W
	R133	HV453470	R. CAR. FP 4.7Ω 1/4W
	R134	HV453470	R. CAR. FP 4.7Ω 1/4W
	R135	HV453470	R. CAR. FP 4.7Ω 1/4W
	R136	HV453470	R. CAR. FP 4.7Ω 1/4W
△*	R137	HZ003780	R. MTL. PLAT 0.22Ω+0.22 5W
△*	R138	HZ003780	R. MTL. PLAT 0.22Ω+0.22 5W
△	R145	HL314100	R. MTL. OXD 10Ω 1W
△	R146	HL314100	R. MTL. OXD 10Ω 1W
	R151	HV454100	R. CAR. FP 10Ω 1/4W
	R152	HV454100	R. CAR. FP 10Ω 1/4W
	R159	HL315330	R. MTL. OXD 330Ω 1W
	R160	HL315330	R. MTL. OXD 330Ω 1W
△	R163	HL314470	R. MTL. OXD 47Ω 1W
△	R171	HL315680	R. MTL. OXD 680Ω 1W
△	R173	HV456100	R. CAR. FP 1KΩ 1/4W
△	R177	HV453100	R. CAR. FP 1Ω 1/4W
△	R178	HV454100	R. CAR. FP 10Ω 1/4W
△	R179	HV457100	R. CAR. FP 10KΩ 1/4W
	R189	HL315680	R. MTL. OXD 680Ω 1W
△	RY101	VK438300	RELAY DH24D2-OTM-
△	RY102	VH230800	RELAY G5P-1-DC12V
	SW101	VJ850200	SW. PUSH PSE021A2KP 2
△	SW102	VA961800	VOLT. SELCT ESE-37247-F(R)
△	T101	XC082A00	TRANS. PWR (R)
△	T101	XC083A00	TRANS. PWR (UC)
△	T101	XC084A00	TRANS. PWR (A)
*	TE101	VS722400	TERM. SP 8P
		VJ828000	PIN IMSA-6024-03E
		BB071360	SCR. TERM 8.3x13(A)
		VP753100	HEAT. SINK IC-1625-MML
		BB069510	GND. MTL No. 6951
		Ei330166	SCR. BND. HD 3x16 FCRM3-BL
*	VS955000	P. C. B.	OPERATION(U)
*	VS955100	P. C. B.	OPERATION(C)
*	VS955200	P. C. B.	OPERATION(R)
*	VS955300	P. C. B.	OPERATION(A)
*	CB301	VR361600	CN. BS. PIN 9P

* New Parts

Schm Ref.	PART NO.	Description	
*	CB302	VR362600	CN. BS. PIN 19P
	CB401	Vi878300	CN. BS. PIN 5P
	CB402	Vi878500	CN. BS. PIN 7P
	CB403	VK025300	CN. BS. PIN 9P
*	CB404	VR358000	CN. BS. PIN 9P
*	CB405	VQ963900	CN. BS. PIN 18P
*	CB406	VQ962100	CN. BS. PIN 18P
	CB407	LA002390	TERM. WRAP 2P(C)
	C301	VJ836900	C. EL 10uF 16V
	C302	VJ839100	C. EL 1uF 50V
	C303	VJ839100	C. EL 1uF 50V
	C304	VR357400	C. EL 4700uF 5.5V
	C305	VD930900	C. CE. SMI 0.1uF 25V
	C306	VH053100	C. CE. TUBLR 0.1uF 50V
	C310	VF467000	C. CE. TUBLR 1000pF 50V
	C401	VJ839000	C. EL 0.47uF 50V
	C402	VJ839000	C. EL 0.47uF 50V
	C403	UA652100	C. MYLAR 100pF 50V
	C404	UA652100	C. MYLAR 100pF 50V
	C405	VJ837200	C. EL 47uF 16V
	C406	VJ837200	C. EL 47uF 16V
	C407	UA652100	C. MYLAR 100pF 50V
	C408	UA652100	C. MYLAR 100pF 50V
	C409	VJ839200	C. EL 2.2uF 50V
	C410	VJ839200	C. EL 2.2uF 50V
	C411	VE551500	C. CE 47pF 50V
	C412	VE551500	C. CE 47pF 50V
	C413	UM407220	C. EL 22uF 25V
	C414	UM407220	C. EL 22uF 25V
	C415	UA655120	C. MYLAR 0.12uF 50V
	C416	UA655120	C. MYLAR 0.12uF 50V
	C417	UA654330	C. MYLAR 0.033uF 50V
	C418	UA654330	C. MYLAR 0.033uF 50V
	C419	UM417100	C. EL 10uF 50V
	C420	UM417100	C. EL 10uF 50V
	C421	UA652330	C. MYLAR 330pF 50V
	C422	UA652330	C. MYLAR 330pF 50V
	C423	VE551900	C. CE 100pF 50V
	C424	VE551900	C. CE 100pF 50V
	C425	UM417100	C. EL 10uF 50V
	C426	UM417100	C. EL 10uF 50V
	C427	VG722100	C. EL 1uF 50V
	C430	UA655330	C. MYLAR 0.33uF 50V
	D301	VM974600	DIODE. ZENR HZS7A2TD 7.0V
	D302	VM974200	DIODE. ZENR HZS5C2TD 5.0V
	D303	VD631600	DIODE 1SS133, 176, HSS104
	D304	VD631600	DIODE 1SS133, 176, HSS104
	D306	VD631600	DIODE 1SS133, 176, HSS104
	D307	VD631600	DIODE 1SS133, 176, HSS104
	D308	VD631600	DIODE 1SS133, 176, HSS104
	D309	VD631600	DIODE 1SS133, 176, HSS104
	D310	VD631600	DIODE 1SS133, 176, HSS104
	D311	VM974300	DIODE. ZENR HZS6A2TD 6.0V

* New Parts

RX-V490/R-V701

P. C. B. OPERATION & INPUT

Schm Ref.	PART NO.	Description	
D312	VD631600	DIODE	1SS133, 176, HSS104
D313	VD631600	DIODE	1SS133, 176, HSS104
D314	VD631600	DIODE	1SS133, 176, HSS104
IC301	XQ304A00	IC	M38102M4-623SP
IC401	XM356A00	IC	NJM2068LD
IC402	XM356A00	IC	NJM2068LD
Q301	iC174020	TR	2SC1740S R, S
Q302	iA093320	TR	2SA933S Q, R
Q303	iC174020	TR	2SC1740S R, S
Q305	VD678500	TR. DGT	DTA114ES
Q457	iC287820	TR	2SC2878 A, B
Q458	iC287820	TR	2SC2878 A, B
Q459	iC287820	TR	2SC2878 A, B
R407	HV455470	R. CAR. FP	470 Ω 1/4W
R408	HV455470	R. CAR. FP	470 Ω 1/4W
SW301	VG392900	SW. TACT	SKHVAA
SW302	VG392900	SW. TACT	SKHVAA
SW303	VG392900	SW. TACT	SKHVAA
SW304	VG392900	SW. TACT	SKHVAA
SW305	VG392900	SW. TACT	SKHVAA
SW306	VG392900	SW. TACT	SKHVAA
SW307	VG392900	SW. TACT	SKHVAA
SW308	VG392900	SW. TACT	SKHVAA
SW309	VG392900	SW. TACT	SKHVAA
SW310	VG392900	SW. TACT	SKHVAA
SW311	VG392900	SW. TACT	SKHVAA
SW312	VG392900	SW. TACT	SKHVAA
SW315	VG392900	SW. TACT	SKHVAA
SW316	VG392900	SW. TACT	SKHVAA
SW317	VG392900	SW. TACT	SKHVAA
SW318	VG392900	SW. TACT	SKHVAA
SW319	VG392900	SW. TACT	SKHVAA
SW320	VG392900	SW. TACT	SKHVAA
SW321	VG392900	SW. TACT	SKHVAA
SW322	VG392900	SW. TACT	SKHVAA
SW323	VG392900	SW. TACT	SKHVAA
SW324	VG392900	SW. TACT	SKHVAA
SW325	VG392900	SW. TACT	SKHVAA
SW326	VG392900	SW. TACT	SKHVAA
SW327	VG392900	SW. TACT	SKHVAA
SW328	VG392900	SW. TACT	SKHVAA
SW401	VE962600	SW. SLIDE	SDKGA4 (C)
* U301	VR023400	L. DETCT	SPS-424-1
* V301	VR061700	FL. DSPLY	13-MT-71GK
* VR401	VP741800	VR	B20K Ω
* VR402	VP741900	VR	G25K Ω
* VR403	VP742000	VR	MN50K Ω
VR404	VQ647000	VR. MTR	A100K Ω
VR405	VR043900	VR	A10K Ω
* VR406	VR058000	VR	A10K Ω
XL301	VE906000	RSNR. CE	4MHz
	VJ828000	PIN	IMSA-6024-03E
	VR380100	SPACER	FL-T6

* New Parts

Schm Ref.	PART NO.	Description	
*	VR011400	SHEET. FL	
*	VR342200	P. C. B.	INPUT
* CB501	VQ963600	CN. BS. PIN	15P
* CB502	VR359000	CN. BS. PIN	19P
* CB503	VQ962300	CN. BS. PIN	20P
CB504	VD004500	CN. BS. PIN	2P
CB505	VK025100	CN. BS. PIN	7P
C502	UA652220	C. MYLAR	220pF 50V
C504	UA652220	C. MYLAR	220pF 50V
C505	UA652220	C. MYLAR	220pF 50V
C506	UA652220	C. MYLAR	220pF 50V
C507	VG278400	C. CE. TUBLR	220pF 50V
C508	VG278400	C. CE. TUBLR	220pF 50V
C509	VG278400	C. CE. TUBLR	220pF 50V
C510	VG278400	C. CE. TUBLR	220pF 50V
C511	VG278400	C. CE. TUBLR	220pF 50V
C512	VG278400	C. CE. TUBLR	220pF 50V
C513	VG278400	C. CE. TUBLR	220pF 50V
C514	VG278400	C. CE. TUBLR	220pF 50V
C515	VG278400	C. CE. TUBLR	220pF 50V
C516	VG278400	C. CE. TUBLR	220pF 50V
C517	VE117600	C. EL	220uF 10V
C518	UA653910	C. MYLAR	9100pF 50V
C519	UA654330	C. MYLAR	0.033uF 50V
C520	UA653910	C. MYLAR	9100pF 50V
C521	UA654330	C. MYLAR	0.033uF 50V
C522	VE117600	C. EL	220uF 10V
C523	VJ839200	C. EL	2.2uF 50V
C524	VJ837200	C. EL	47uF 16V
C525	VJ837200	C. EL	47uF 16V
C526	VJ839200	C. EL	2.2uF 50V
C527	VG290900	C. EL	10uF 50V
C528	VG290900	C. EL	10uF 50V
C529	VJ836900	C. EL	10uF 16V
C530	VG290900	C. EL	10uF 50V
C531	VJ837200	C. EL	47uF 16V
C532	VJ837200	C. EL	47uF 16V
C533	VG290900	C. EL	10uF 50V
C534	VJ837200	C. EL	47uF 16V
C535	VH053100	C. CE. TUBLR	0.1uF 50V
C536	VG277700	C. CE. TUBLR	68pF 50V
C537	VF467300	C. CE. TUBLR	0.01uF 16V
C538	VF964800	C. EL	100uF 16V
C541	VH053100	C. CE. TUBLR	0.1uF 50V
C542	VF466800	C. CE. TUBLR	100pF 50V
C543	VF467300	C. CE. TUBLR	0.01uF 16V
C545	VH053100	C. CE. TUBLR	0.1uF 50V
C548	VG278600	C. CE. TUBLR	330pF 50V
C549	VG278600	C. CE. TUBLR	330pF 50V
D501	VD631600	DIODE	1SS133, 176, HSS104

* New Parts

P. C. B. INPUT & EFFECT

Schm Ref.	PART NO.	Description		
D502	VM975500	DIODE, ZENR	HZS12A2TD	12V
D503	VD631600	DIODE	1SS133, 176, HSS104	
D504	VM974200	DIODE, ZENR	HZS5C2TD	5.0V
D507	VD631600	DIODE	1SS133, 176, HSS104	
IC501	XM356A00	IC	NJM2068LD	
* IC502	XN588A00	IC	NJU7313	
IC503	XM356A00	IC	NJM2068LD	
* IC504	XM974A00	IC	BU2040	
IC505	XF494A00	IC	LB1641	
PJ501	VN308700	JACK, PIN	6P	
PJ502	VJ696200	JACK, PIN	4P	
PJ503	VJ696200	JACK, PIN	4P	
Q501	iD043820	TR	2SD438 E, F	
Q502	iC287820	TR	2SC2878 A, B	
Q503	iC287820	TR	2SC2878 A, B	
R545	HV453470	R. CAR. FP	4.7 Ω	1/4W
R547	HV455100	R. CAR. FP	100 Ω	1/4W
R552	HV455100	R. CAR. FP	100 Ω	1/4W
R561	HV454100	R. CAR. FP	10 Ω	1/4W
R565	HL315100	R. MTL. OXD	100 Ω	1W
R566	HL314100	R. MTL. OXD	10 Ω	1W
* VR435100		PLATE	W16	
	BB069510	GND. MTL	No. 6951	
	VB966900	CN	IMSA-6024	
* VS590300		P. C. B.	EFFECT (UC)	
* VS590400		P. C. B.	EFFECT (RA)	
* CB701	VQ964100	CN. BS. PIN	20P	
CB703	Vi878700	CN. BS. PIN	9P	
* CB801	VR358000	CN. BS. PIN	9P	
CB802	Vi878500	CN. BS. PIN	7P	
CB803	VP206500	HOLDER. FUS	EYF-52BC (UC)	
CB805	VP206500	HOLDER. FUS	EYF-52BC (UC)	
CB810	VP206500	HOLDER. FUS	EYF-52BC (UC)	
CB812	VP206500	HOLDER. FUS	EYF-52BC (UC)	
CB815	VP206500	HOLDER. FUS	EYF-52BC (RA)	
CB816	VP206500	HOLDER. FUS	EYF-52BC (RA)	
CB817	VP206500	HOLDER. FUS	EYF-52BC (RA)	
CB818	VP206500	HOLDER. FUS	EYF-52BC (RA)	
C701	UJ667470	C. EL	47uF	50V
C702	UM417100	C. EL	10uF	50V
C703	VF760000	C. EL	100uF	10V
C704	VD930900	C. CE. SMI	0.1uF	25V
C705	UJ648100	C. EL	100uF	25V
C706	VD930900	C. CE. SMI	0.1uF	25V
C707	UJ667470	C. EL	47uF	50V
C708	VD930900	C. CE. SMI	0.1uF	25V
C709	UM417100	C. EL	10uF	50V
C710	VD930900	C. CE. SMI	0.1uF	25V
C711	UJ667470	C. EL	47uF	50V
C712	UA653330	C. MYLAR	3300pF	50V

* New Parts

Schm Ref.	PART NO.	Description		
C713	UA653330	C. MYLAR	3300pF	50V
C714	UJ667470	C. EL	47uF	50V
C715	UJ667470	C. EL	47uF	50V
C716	VJ839200	C. EL	2.2uF	50V
C717	UA654180	C. MYLAR	0.018uF	50V
C718	UA654180	C. MYLAR	0.018uF	50V
C719	VJ839200	C. EL	2.2uF	50V
C720	UM417100	C. EL	10uF	50V
C721	FG212330	C. CE	330pF	50V
C722	UJ667470	C. EL	47uF	50V
C723	FG212330	C. CE	330pF	50V
C724	UJ667470	C. EL	47uF	50V
C725	FG212330	C. CE	330pF	50V
C726	FG212330	C. CE	330pF	50V
C727	UJ667470	C. EL	47uF	50V
C728	VE551900	C. CE	100pF	50V
C729	VE551900	C. CE	100pF	50V
C730	VE551900	C. CE	100pF	50V
C731	VE551900	C. CE	100pF	50V
C732	VE551900	C. CE	100pF	50V
C733	VE551900	C. CE	100pF	50V
C734	VE551900	C. CE	100pF	50V
C735	UA653470	C. MYLAR	4700pF	50V
C736	UA652390	C. MYLAR	390pF	50V
C737	UA652390	C. MYLAR	390pF	50V
C738	UA653470	C. MYLAR	4700pF	50V
C739	UJ667470	C. EL	47uF	50V
C740	UJ667470	C. EL	47uF	50V
C741	FG211820	C. CE	82pF	50V
C742	UA654680	C. MYLAR	0.068uF	50V
C743	UJ667470	C. EL	47uF	50V
C744	UM407220	C. EL	22uF	25V
C745	UJ667470	C. EL	47uF	50V
C746	UJ667470	C. EL	47uF	50V
C747	VE551900	C. CE	100pF	50V
C748	UJ667470	C. EL	47uF	50V
C749	FG213100	C. CE	1000pF	50V
C750	UM407220	C. EL	22uF	25V
C751	UA653270	C. MYLAR	2700pF	50V
C752	UA653180	C. MYLAR	1800pF	50V
C753	UA653180	C. MYLAR	1800pF	50V
C754	UA653270	C. MYLAR	2700pF	50V
C755	UM407220	C. EL	22uF	25V
C756	FG213100	C. CE	1000pF	50V
C757	UM407220	C. EL	22uF	25V
C758	UM407220	C. EL	22uF	25V
C759	UG444220	C. CE	0.022uF	50V
C760	VJ839200	C. EL	2.2uF	50V
C761	VJ839200	C. EL	2.2uF	50V
C762	UM417100	C. EL	10uF	50V
C763	UM417100	C. EL	10uF	50V
C764	UJ648100	C. EL	100uF	25V
C765	UJ648100	C. EL	100uF	25V

* New Parts

RX-V490/R-V701

P. C. B. EFFECT

Schm Ref.	PART NO.	Description
C766	UM417100	C. EL 10uF 50V
C767	UM417100	C. EL 10uF 50V
C768	UA652470	C. MYLAR 470pF 50V
C769	VG290900	C. EL 10uF 50V
C770	VG290900	C. EL 10uF 50V
C771	UA652470	C. MYLAR 470pF 50V
C772	VF466800	C. CE. TUBLR 100pF 50V
C773	VF466800	C. CE. TUBLR 100pF 50V
C774	VF466800	C. CE. TUBLR 100pF 50V
C775	VF466800	C. CE. TUBLR 100pF 50V
C776	VH483900	C. CE. ARRAY 100pF 50V
C777	VP755200	C. CE. ARRAY 100pF 50V
C778	VF466800	C. CE. TUBLR 100pF 50V
C779	VF466800	C. CE. TUBLR 100pF 50V
C780	VF466800	C. CE. TUBLR 100pF 50V
C781	VF466800	C. CE. TUBLR 100pF 50V
C801	FG212220	C. CE 220pF 50V
C802	UM417100	C. EL 10uF 50V
C803	F1553330	C. CE 3300pF 50V
C804	VE551900	C. CE 100pF 50V
C805	UH178100	C. EL 100uF 63V
C806	VJ837200	C. EL 47uF 16V
C807	U1367220	C. EL 22uF 50V
C808	UM417100	C. EL 10uF 50V
C809	FG212220	C. CE 220pF 50V
C810	VE551900	C. CE 100pF 50V
C811	FG211220	C. CE 22pF 50V
C812	VE551900	C. CE 100pF 50V
C813	UJ667470	C. EL 47uF 50V
C814	UA654470	C. MYLAR 0.047uF 50V
C815	FG212220	C. CE 220pF 50V
C816	VE551900	C. CE 100pF 50V
C817	FG211220	C. CE 22pF 50V
C818	VE551900	C. CE 100pF 50V
C819	UJ667470	C. EL 47uF 50V
C820	UA654470	C. MYLAR 0.047uF 50V
* C821	VR325000	C. MYLAR 100pF 100V
C822	FH611220	C. CE 22pF 500V
C823	VJ839100	C. EL 1uF 50V
C824	U1367220	C. EL 22uF 50V
* C825	VR325000	C. MYLAR 100pF 100V
△ C826	VG289900	C. EL 2200uF 35V
△ C827	VF964800	C. EL 100uF 16V
△ C828	VG289900	C. EL 2200uF 35V
C835	VE117600	C. EL 220uF 10V
C836	VJ839100	C. EL 1uF 50V
* C837	VD916400	C. EL 2.2uF 50V
C838	UA654470	C. MYLAR 0.047uF 50V
△* C839	VR325300	C. MYLAR 0.047uF 100V
△* C840	VR325300	C. MYLAR 0.047uF 100V
C855	VJ836900	C. EL 10uF 16V
C856	VJ837200	C. EL 47uF 16V
C857	VJ836900	C. EL 10uF 16V

* New Parts

Schm Ref.	PART NO.	Description
C858	VF637900	C. EL 1000uF 10V
C859	VF637900	C. EL 1000uF 10V
C860	VD930900	C. CE. SMI 0.1uF 25V
C861	UJ638470	C. EL 470uF 16V
C862	FG211220	C. CE 22pF 50V
C863	VF637900	C. EL 1000uF 10V
C866	VH053100	C. CE. TUBLR 0.1uF 50V
D701	VD631600	DIODE 1SS133, 176, HSS104
D702	VD631600	DIODE 1SS133, 176, HSS104
D703	VD631600	DIODE 1SS133, 176, HSS104
D704	VD631600	DIODE 1SS133, 176, HSS104
D705	VD631600	DIODE 1SS133, 176, HSS104
D706	VD631600	DIODE 1SS133, 176, HSS104
D707	VD631600	DIODE 1SS133, 176, HSS104
D708	VD631600	DIODE 1SS133, 176, HSS104
D709	VD631600	DIODE 1SS133, 176, HSS104
D710	VM975100	DIODE. ZENR HZS9C2TD 9.0V
D711	VM975100	DIODE. ZENR HZS9C2TD 9.0V
D801	VM976300	DIODE. ZENR HZS242TD 24V
D802	VD631600	DIODE 1SS133, 176, HSS104
D803	VD631600	DIODE 1SS133, 176, HSS104
D804	VN008700	DIODE 1SS270A
D805	VM974100	DIODE. ZENR HZS5B2TD 5.0V
△ D806	VN011300	DIODE. BRG D3SBA20 4A 200V
D807	VD631600	DIODE 1SS133, 176, HSS104
△* F801	VS822900	FUSE T4.0A 125V(UC)
△* F802	VS822900	FUSE T4.0A 125V(UC)
△ F803	KB000690	FUSE T2.5A 250V(RA)
△ F804	KB000690	FUSE T2.5A 250V(RA)
IC701	XA507A00	IC AN78N05
IC702	XK358A00	IC HM65256BLSP-10
IC703	Xi022B00	IC YSS203B-F
IC704	XB247301	IC uPC4570HA
IC705	XC520A01	IC uPC4570C
IC706	XC520A01	IC uPC4570C
IC707	XB247301	IC uPC4570HA
* IC708	XN324A00	IC NJM4558DV
* IC709	XN324A00	IC NJM4558DV
IC710	XC520A01	IC uPC4570C
IC711	XB247301	IC uPC4570HA
IC712	XB247301	IC uPC4570HA
IC713	iG055100	IC TC4053BP
IC714	iG055100	IC TC4053BP
△ IC801	XG505A00	IC NJM79M15FA
△ IC802	iG102700	IC uPC1188H
△ IC803	iG102700	IC uPC1188H
△ IC855	XH436A00	IC LA7956
L701	Vi546100	COIL 220uH
L702	VC362000	COIL 1mH
* L801	VP575600	COIL 1.5uH
* L802	VP575600	COIL 1.5uH
* L803	VP575600	COIL 1.5uH
PJ801	VM750500	JACK. PIN 4P

* New Parts

P. C. B. EFFECT

Schm Ref.	PART NO.	Description
Q701	VG722000	TR. DGT DTC144ES
Q702	VD678500	TR. DGT DTA114ES
Q703	VD678500	TR. DGT DTA114ES
Q704	VG722000	TR. DGT DTC144ES
Q705	VG722000	TR. DGT DTC144ES
Q801	VC218900	TR 2SC3330 R, S, T
Q802	VC218900	TR 2SC3330 R, S, T
△* Q803	VP872700	TR 2SC4488 S, T
△* Q804	VP872600	TR 2SA1708 S, T
△ Q805A	iX630850	TR 2SA1695 O, P, Y
△ Q805C	iX630860	TR 2SC4468 O, P, Y
△ Q806	iC1815C0	TR 2SC1815 Y
* Q807	VP883000	TR 2SA893A D, E
Q809	iA093320	TR 2SA933S Q, R
Q810	iC174020	TR 2SC1740S R, S
* Q811	VP883000	TR 2SA893A D, E
* Q812	VP882900	TR 2SC1890 E
Q855	iA101521	TR 2SA1015 Y
Q856	iC1815C0	TR 2SC1815 Y
R701	HL314680	R. MTL. OXD 68Ω 1W
R781	HV454220	R. CAR. FP 22Ω 1/4W
R782	HV454220	R. CAR. FP 22Ω 1/4W
R783	HV456100	R. CAR. FP 1KΩ 1/4W
R784	HV456100	R. CAR. FP 1KΩ 1/4W
R811	HV454100	R. CAR. FP 10Ω 1/4W
R813	HV454100	R. CAR. FP 10Ω 1/4W
R817	HV454100	R. CAR. FP 10Ω 1/4W
R819	HV454100	R. CAR. FP 10Ω 1/4W
△ R822	VK188600	R. FUS 470Ω 1/4W
R823	HV454100	R. CAR. FP 10Ω 1/4W
R824	HV453470	R. CAR. FP 4.7Ω 1/4W
R825	HV456270	R. CAR. FP 2.7KΩ 1/4W
R826	VK188600	R. FUS 470Ω 1/4W
△* R828	HZ003780	R. MTL. PLAT 0.22Ω+0.22 5W
R829	HV456150	R. CAR. FP 1.5KΩ 1/4W
R830	HV453470	R. CAR. FP 4.7Ω 1/4W
R831	HV456820	R. CAR. FP 8.2KΩ 1/4W
R838	HV454100	R. CAR. FP 10Ω 1/4W
R839	HL425820	R. MTL. OXD 820Ω 2W
R843	HV457100	R. CAR. FP 10KΩ 1/4W
△ R847	HV454100	R. CAR. FP 10Ω 1/4W
R850	HV453220	R. CAR. FP 2.2Ω 1/4W
R859	HV454470	R. CAR. FP 47Ω 1/4W
△ RY801	VK913100	RELAY DC G5Z-2A
TE801	VN937900	TERM. SP 6P
XL701	VK175200	RSNR. CE 11.28MHz

* New Parts

A

B

C

D

E

RX-V490/R-V701

1

EXPLODED VIEW

2

3

4

5

6

7

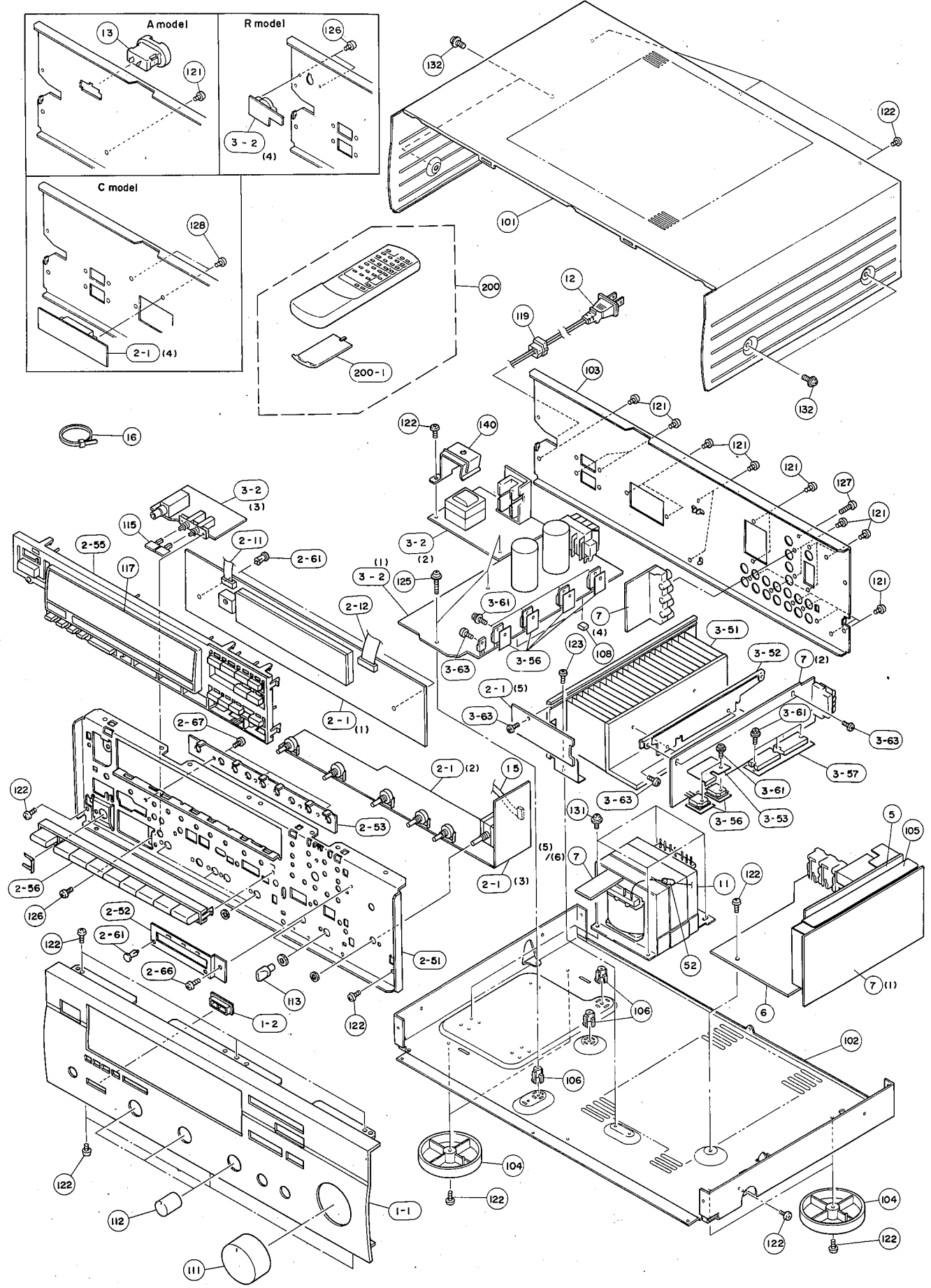

MECHANICAL PARTS

Ref. No.	PART NO.	Description	Remarks	Markets	
*	1- 1	VS789500	FRONT PANEL	RX-V490	
*	1- 1	VS789600	FRONT PANEL	R-V701	
*	1- 2	VQ793400	BUTTON GUIDE		
*	2- 1	VS955000	P. C. B. ASS'Y	OPERATION	(U)
*	2- 1	VS955100	P. C. B. ASS'Y	OPERATION	(C)
*	2- 1	VS955200	P. C. B. ASS'Y	OPERATION	(R)
*	2- 1	VS955300	P. C. B. ASS'Y	OPERATION	(A)
*	2-11	VR413500	CONNECTOR, FLAT CABLE	9P 200mm	
*	2-12	VT159800	CONNECTOR, FLAT CABLE	19P 250mm	
*	2-51	VS199600	SUB CHASSIS		
*	2-52	VS906800	HOLDER		
*	2-53	VT305900	SUPPORT, T		
*	2-55	VS864300	BUTTON, CASE		
*	2-56	VS003500	BUTTON, T		
*	2-61	VQ368600	PUSH RIVET	P3555-B	
*	2-66	Ei330086	BIND HEAD B-TITE SCREW	3x8 FCRM3-BL	
*	2-67	Ei330066	BIND HEAD B-TITE SCREW	3x6 FCRM3-BL	
*	3- 2	VS996800	P. C. B. ASS'Y	MAIN	(UC)
*	3- 2	VS996900	P. C. B. ASS'Y	MAIN	(R)
*	3- 2	VS997000	P. C. B. ASS'Y	MAIN	(A)
*	3-51	VS763300	HEAT SINK		
*	3-52	VQ796100	SUPPORT, PCB		
*	3-53	VR724200	SUPPORT, TR		
*	3-56	VK195900	SHEET	19x24	
*	3-57	VR859200	SHEET, RADIATION		
*	3-61	VK173200	SCREW, TRANSISTOR	3x15 SP FCM3	
*	3-63	Ei330086	BIND HEAD B-TITE SCREW	3x8 FCRM3-BL	
	5	VR341800	P. C. B. ASS'Y	TUNER	(UC)
	5	VR341900	P. C. B. ASS'Y	TUNER	(R)
	5	VR342000	P. C. B. ASS'Y	TUNER	(A)
	6	VR342200	P. C. B. ASS'Y	INPUT	
*	7	VS590300	P. C. B. ASS'Y	EFFECT	(UC)
*	7	VS590400	P. C. B. ASS'Y	EFFECT	(RA)
△	11	XN576A00	POWER TRANSFORMER	R-V701	(U)
△*	11	XQ099A00	POWER TRANSFORMER	RX-V490	(U)
△*	11	XQ100A00	POWER TRANSFORMER	RX-V490	(C)
△*	11	XQ101A00	POWER TRANSFORMER	RX-V490	(R)
△*	11	XQ102A00	POWER TRANSFORMER	RX-V490	(A)
△*	12	VQ508500	POWER CORD ASS'Y		(R)
△*	12	VQ508600	POWER CORD ASS'Y		(A)
△*	12	VS168300	POWER CORD ASS'Y		(UC)
△	13	VP418700	AC OUTLET	2P	(A)
	15	VT159700	CONNECTOR, FLAT CABLE	9P 150mm	
	16	CB069250	BINDING TIE	BK-1	(UC)
	52	HV453100	FLAME PROOF CARBON RESISTOR	1Ω 1/4W	(U)
*	101	VS362100	TOP COVER		
*	102	VQ794000	CHASSIS		
*	103	VS361000	REAR PANEL	RX-V490	(U)
*	103	VS361100	REAR PANEL	RX-V490	(C)
*	103	VS361200	REAR PANEL	RX-V490	(R)
*	103	VS361300	REAR PANEL	RX-V490	(A)
*	103	VS377400	REAR PANEL	R-V701	(U)
	104	VQ780300	LEG	D60xH16	

* New Parts

Ref. No.	PART NO.	Description	Remarks	Markets
	104	VQ982800 LEG	D60xH16	
*	105	VQ796200 SHIELD PLATE	DSP	
*	106	VR264400 SPACER, H8		
*	108	VQ366100 DAMPER, PCB		
*	111	VQ795100 KNOB	D42	
*	112	VS409600 KNOB	D18	
*	113	VR308400 KNOB, VR	D10	
	115	VQ779000 BUTTON	3x14	
*	117	VS003600 SHEET, F		
	119	VN158600 CORD STOPPER	No. 2104	
	121	EN301010 BIND HEAD BONDING TAP. SCREW	3x8 FCRM3-BL	
	122	Ei330086 BIND HEAD B-TITE SCREW	3x8 FCRM3-BL	
	123	Ei030046 BIND HEAD TAPPING SCREW	3x4 ZMC2-Y	
	125	EL300480 BW HEAD B-TITE SCREW	3x15-8 FCRM3-BL	
	126	ED330066 BIND HEAD SCREW	3x6 FCRM3-BL	
*	127	VS997700 BIND HEAD S-TITE SCREW	3x10 MFNI33	
	128	VF617600 PAN HEAD P-TITE SCREW	2.6x8 FCRM3-BL	(C)
	131	EK365020 BW HEAD SCREW	4x6 FCRM3-BL	
	132	EL300470 BW HEAD S-TITE SCREW	4x8-10 FCRM3-BL	
*	140	VT635000 HEAT SINK	22x44	(R)
		ACCESSORIES		
*	200	VR094100 REMOTE CONTROL TRANSMITTER		(7A)
	200-1	CX675300 LID		
*		VQ147100 ANTENNA, FM	1P 1.4m	
*		VR248500 ANTENNA, AM LOOP	1P 1.0m	
		BATTERY, MANGANESE	SUM-3, AA, R06	

* New Parts

RX-V490/R-V701

RX-V490/R-V701 REMOTE CONTROL TRANSMITTER

SCHEMATIC DIAGRAM

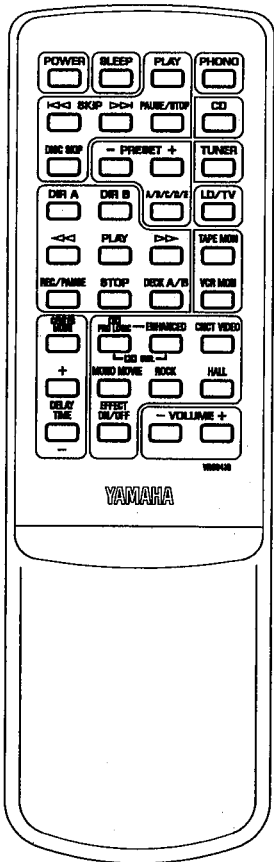
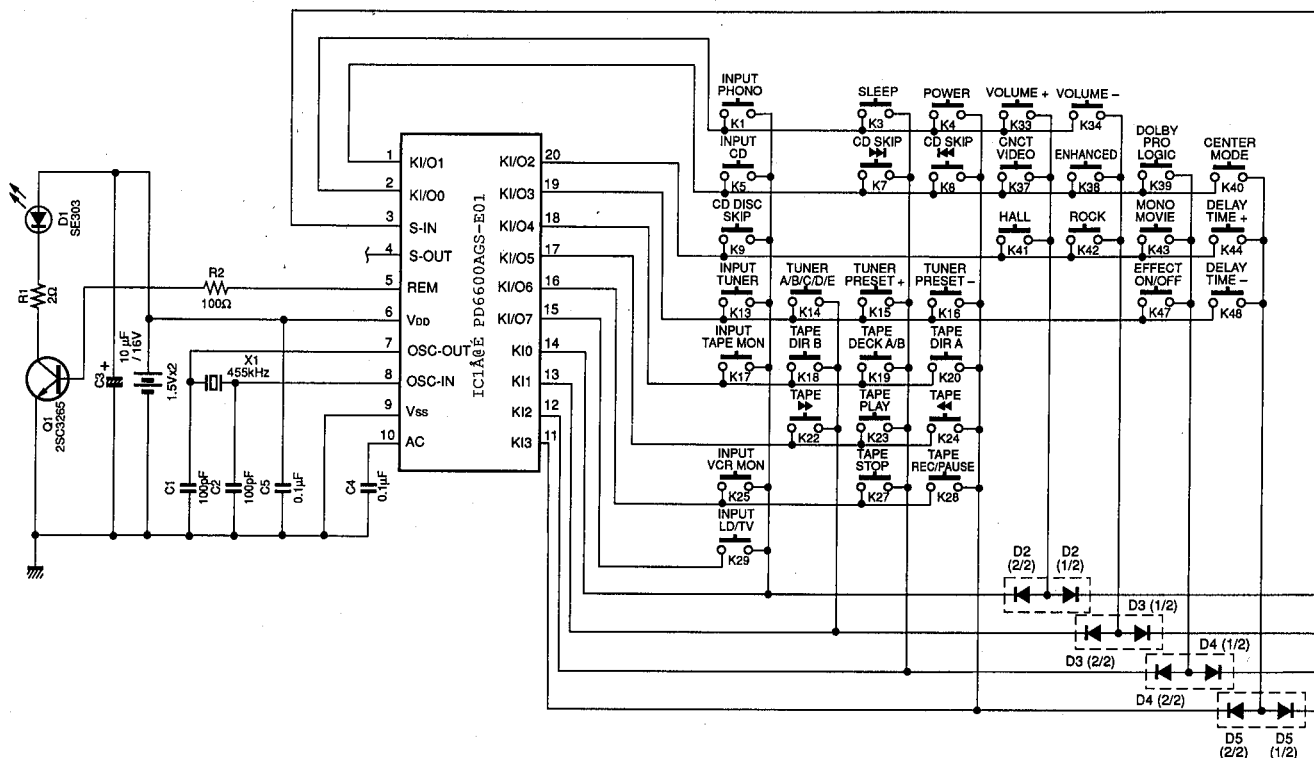

Key No.	Function	HEX		Key No.	Function	HEX	
		CUSTOM	DATA			CUSTOM	DATA
1	INPUT PHONO	7A	14	33	VOLUME +	7A	1A
3	SLEEP	7A	57	34	VOLUME -	7A	1B
4	POWER	7A	1F	37	CNCT VIDEO	7A	8A
5	INPUT CD	7A	15	38	ENHANCED	7A	89
7	CD SKIP ►►	7A	0A	39	DOLBY PRO LOGIC	7A	88
8	CD DISC SKIP ◀◀	7A	0B	40	CENTER MODE	7A	84
9	CD SKIP ►►	7A	4F	41	HALL	7A	8D
13	INPUT TUNER	7A	16	42	ROCK	7A	8C
14	TUNER A/B/C/D/E	7A	12	43	MONO MOVIE	7A	8B
15	TUNER PRESET +	7A	10	44	DELAY TIME +	7A	52
16	TUNER PRESET -	7A	11	47	EFFECT ON/OFF	7A	56
17	INPUT TAPE MON	7A	18	48	DELAY TIME -	7A	53
18	TAPE DIR B	7A	40				
19	TAPE DECK A/B	7A	06				
20	TAPE DIR A	7A	07				
22	TAPE ►►	7A	01				
23	TAPE PLAY	7A	00				
24	TAPE ◀◀	7A	01				
25	INPUT VCR MON	7A	0F				
27	TAPE STOP	7A	03				
28	TAPE REC/PAUSE	7A	04				
29	INPUT LD/TV	7A	17				

Parts List for Carbon Resistors

Value	1/4W Type Part No.	1/6W Type Part No.	Value	1/4W Type Part No.	1/6W Type Part No.
1.0 Ω	HJ35 3100	HF85 3100	10 kΩ	HF45 7100	HF45 7100
1.8 Ω	HJ35 3180	*	11 kΩ	HF45 7110	HF45 7110
2.2 Ω	HJ35 3220	HF85 3220	12 kΩ	HJ35 7120	HF85 7120
3.3 Ω	HJ35 3330	HF85 3330	13 kΩ	HF45 7130	HF45 7130
4.7 Ω	HJ35 3470	HF85 3470	15 kΩ	HF45 7150	HF45 7150
5.6 Ω	HJ35 3560	HF85 3560	18 kΩ	HF45 7180	HF45 7180
10 Ω	HF45 4100	HF45 4100	22 kΩ	HF45 7220	HF45 7220
15 Ω	HJ35 4150	HF85 4150	24 kΩ	HF45 7240	HF45 7240
22 Ω	HF45 4220	HF45 4220	27 kΩ	HJ35 7270	HF85 7270
27 Ω	HJ35 4270	HF85 4270	30 kΩ	HF45 7300	HF45 7300
33 Ω	HF45 4330	HF45 4330	33 kΩ	HF45 7330	HF45 7330
39 Ω	HJ35 4470	HF85 4390	36 kΩ	HF45 7360	HF45 7360
47 Ω	HF45 4470	HF45 4470	39 kΩ	HF45 7390	HF45 7390
56 Ω	HF45 4560	HF45 4560	47 kΩ	HF45 7470	HF45 7470
68 Ω	HF45 4680	HF45 4680	51 kΩ	HF45 7510	HF45 7510
75 Ω	HF45 4750	HF45 4750	56 kΩ	HF45 7560	HF45 7560
82 Ω	HF45 4820	HF45 4820	62 kΩ	HF45 7620	HF45 7620
91 Ω	HF45 4910	HF45 4910	68 kΩ	HF45 7680	HF45 7680
100 Ω	HF45 5100	HF45 5100	82 kΩ	HF45 7820	HF45 7820
110 Ω	HJ35 5110	HF85 5110	91 kΩ	HF45 7910	HF45 7910
120 Ω	HF45 5120	HF45 5120	100 kΩ	HF45 8100	HF45 8100
150 Ω	HF45 5150	HF45 5150	110 kΩ	HF45 8110	HF45 8110
160 Ω	HJ35 5160	*	120 kΩ	HF45 8120	HF45 8120
180 Ω	HF45 5180	HF45 5180	150 kΩ	HF45 8150	HF45 8150
200 Ω	HF45 5200	HF45 5200	180 kΩ	HF45 8180	HF45 8180
220 Ω	HF45 5220	HF45 5220	220 kΩ	HJ35 8220	HF85 8220
270 Ω	HF45 5270	HF45 5270	270 kΩ	HF45 8270	HF45 8270
330 Ω	HF45 5330	HF45 5330	300 kΩ	HF45 8300	HF45 8300
390 Ω	HF45 5390	HF45 5390	330 kΩ	HF45 8330	HF45 8330
430 Ω	HF45 5430	HF45 5430	390 kΩ	HJ35 8390	HF85 8390
470 Ω	HF45 5470	HF45 5470	470 kΩ	HF45 8470	HF45 8470
510 Ω	HF45 5510	HF45 5510	560 kΩ	HJ35 8560	HF85 8560
560 Ω	HF45 5560	HF45 5560	680 kΩ	HJ35 8680	HF85 8680
680 Ω	HF45 5680	HF45 5680	820 kΩ	HJ35 8820	HF85 8820
820 Ω	HF45 5820	HF45 5820	1.0 MΩ	HF45 9100	HF45 9100
910 Ω	HF45 5910	HF45 5910	1.2 MΩ	HJ35 9120	*
1.0 kΩ	HF45 6100	HF45 6100	1.5 MΩ	HJ35 9150	HF85 9150
1.2 kΩ	HF45 6120	HF45 6120	1.8 MΩ	HJ35 9180	HF85 9180
1.5 kΩ	HF45 6150	HF45 6150	2.2 MΩ	HJ35 9220	HF85 9220
1.8 kΩ	HF45 6180	HF45 6180	3.3 MΩ	HJ35 9330	HF85 9330
2.0 kΩ	HJ35 6200	HF85 6200	3.9 MΩ	HJ35 9390	*
2.2 kΩ	HF45 6220	HF45 6220	4.7 MΩ	HJ35 9470	HF85 9470
2.4 kΩ	HJ35 6240	HF85 6240			
2.7 kΩ	HF45 6270	HF45 6270			
3.0 kΩ	HF45 6300	HF45 6300			
3.3 kΩ	HF45 6330	HF45 6330			
3.6 kΩ	HJ35 6360	HF85 6360			
3.9 kΩ	HF45 6390	HF45 6390			
4.7 kΩ	HF45 6470	HF45 6470			
5.1 kΩ	HF45 6510	HF45 6510			
5.6 kΩ	HF45 6560	HF45 6560			
6.8 kΩ	HF45 6680	HF45 6680			
8.2 kΩ	HF45 6820	HF45 6820			
9.1 kΩ	HF45 6910	HF45 6910			

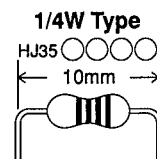

1/4W Type
HF45 ○○○○
1/6W Type
HF85 ○○○○

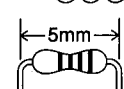

RX-V490/R-V701

RX-V490/R-V701

YAMAHA

RX-V490/R-V701
