

AV RECEIVER RX-V592/R-V902/ RX-V592RDS

SERVICE MANUAL

IMPORTANT NOTICE

This manual has been provided for the use of authorized YAMAHA Retailers and their service personnel. It has been assumed that basic service procedures inherent to the industry, and more specifically YAMAHA Products, are already known and understood by the users, and have therefore not been restated.

WARNING: Failure to follow appropriate service and safety procedures when servicing this product may result in personal injury, destruction of expensive components, and failure of the product to perform as specified. For these reasons, we advise all YAMAHA product owners that any service required should be performed by an authorized YAMAHA Retailer or the appointed service representative.

IMPORTANT: The presentation or sale of this manual to any individual of firm does not constitute authorization, certification or recognition of any applicable technical capabilities, or establish a principle-agent relationship of any form.

The data provided is believed to be accurate and applicable to the unit(s) indicated on the cover. The research, engineering, and service departments of YAMAHA are continually striving to improve YAMAHA products. Modifications are, therefore, inevitable and specifications are subject to change without notice or obligation to retrofit. Should any discrepancy appear to exist, please contact the distributor's Service Division.

WARNING: Static discharges can destroy expensive components. Discharge any static electricity your body may have accumulated by grounding yourself to the ground buss in the unit (heavy gauge black wires connect to this buss).

IMPORTANT: Turn the unit OFF during disassembly and part replacement. Recheck all work before you apply power to the unit.

■ CONTENTS

TO SERVICE PERSONNEL	1	AMP ADJUSTMENT	16
REMOTE CONTROL PANELS	1	PRINTED CIRCUIT BOARD	17~27
FRONT PANELS	2	BLOCK DIAGRAM	28~30
REAR PANELS	3~4	IC BLOCK	31~32
SPECIFICATIONS	5~6	μ-COM DATA	33~34
INTERNAL VIEW	7	DISPLAY DATA	35
DISASSEMBLY PROCEDURES	7	SCHEMATIC DIAGRAM	36~38
SELF CHECK MODE	8~10	PARTS LIST	39~54
PROTECTION OPERATION CHECK FUNCTION	11	REMOTE CONTROL TRANSMITTER	55~57
TUNER ADJUSTMENTS	12~15		

■ TO SERVICE PERSONNEL

1. Critical Components information.
Components having special characteristics are marked and must be replaced with parts having specifications equal to those originally installed.
2. Leakage Current Measurement (For 120V Model only).
When service has been completed, it is imperative that you verify that all exposed conductive surfaces are properly insulated from supply circuits.
 - Meter impedance should be equivalent to 1500 ohm shunted by 0.15 μ F.
 - Leakage current must not exceed 0.5mA.
 - Be sure to test for leakage with the AC plug in both polarities.

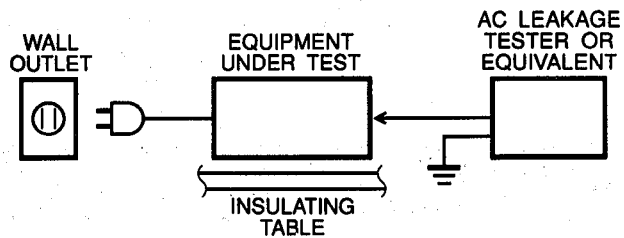

"CAUTION"



"F702: FOR CONTINUED PROTECTION AGAINST RISK OF FIRE, REPLACE ONLY WITH SAME TYPE 7.0A, 125V FUSE"

"F703: FOR CONTINUED PROTECTION AGAINST RISK OF FIRE, REPLACE ONLY WITH SAME TYPE 2.5A, 250V FUSE"

"F704: FOR CONTINUED PROTECTION AGAINST RISK OF FIRE, REPLACE ONLY WITH SAME TYPE 3.15A, 125V FUSE"

WARNING: CHEMICAL CONTENT NOTICE!

The solder used in the production of this product contains LEAD. In addition, other electrical/electronic and/or plastic (where applicable) components may also contain traces of chemicals found by the California Health and Welfare Agency (and possibly other entities) to cause cancer and/or birth defects or other reproductive harm.

DO NOT PLACE SOLDER, ELECTRICAL/ELECTRONIC OR PLASTIC COMPONENTS IN YOUR MOUTH FOR ANY REASON WHATSOEVER!

Avoid prolonged, unprotected contact between solder and your skin! When soldering, do not inhale solder fumes or expose eyes to solder/flux vapor!

If you come in contact with solder or components located inside the enclosure of this product, wash your hands before handling food.

■ REMOTE CONTROL PANELS

▼ U,C,R,A and L models

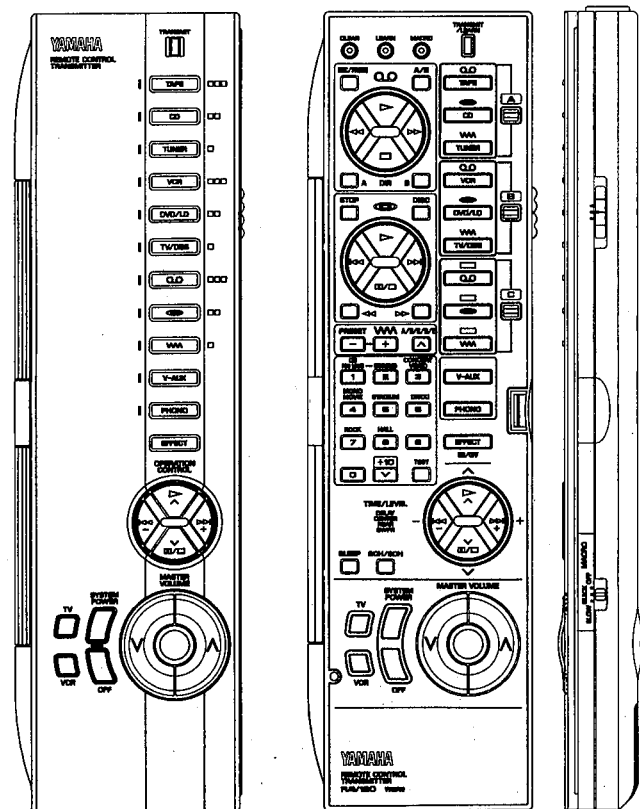

▼ B,G models

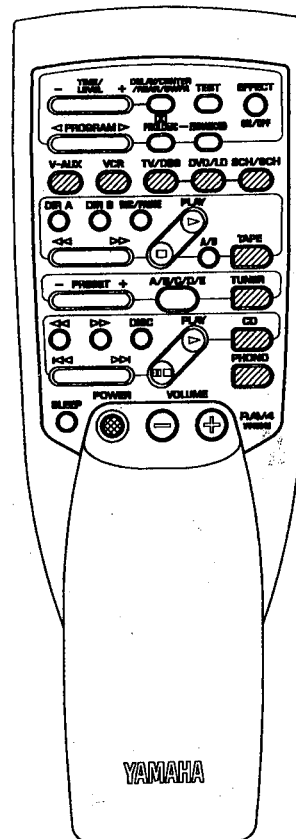

FRONT PANELS

▼ RX-V592

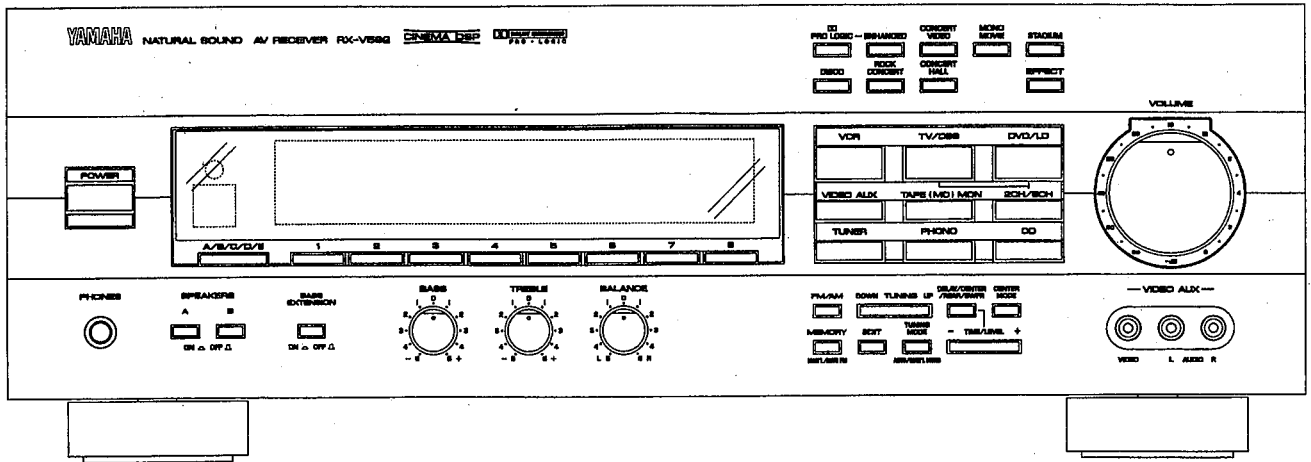

▼ R-V902 (U,C and R models Only)

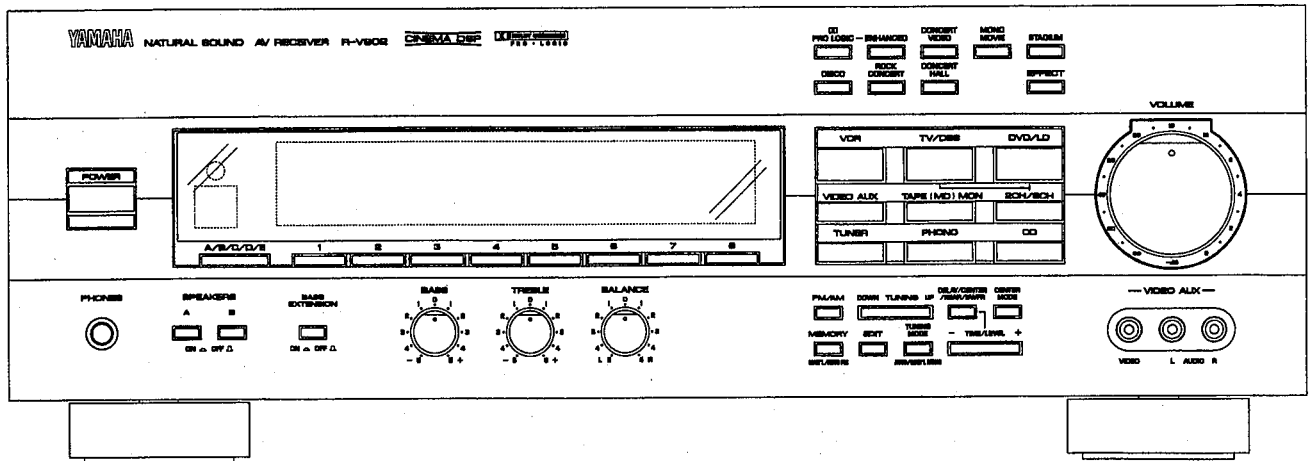

▼ RX-V592RDS (B and G models Only)

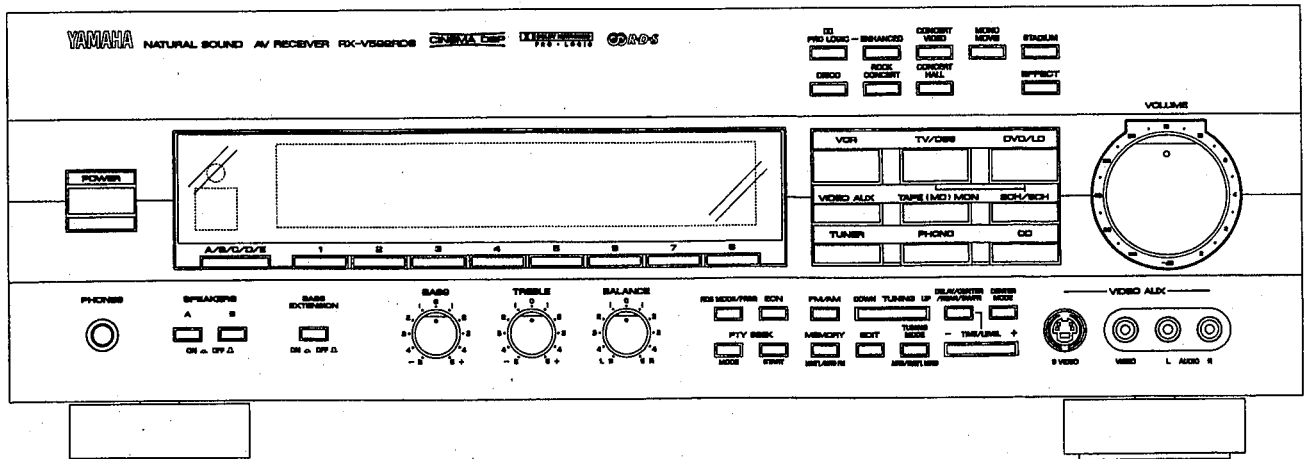

REAR PANELS

U model

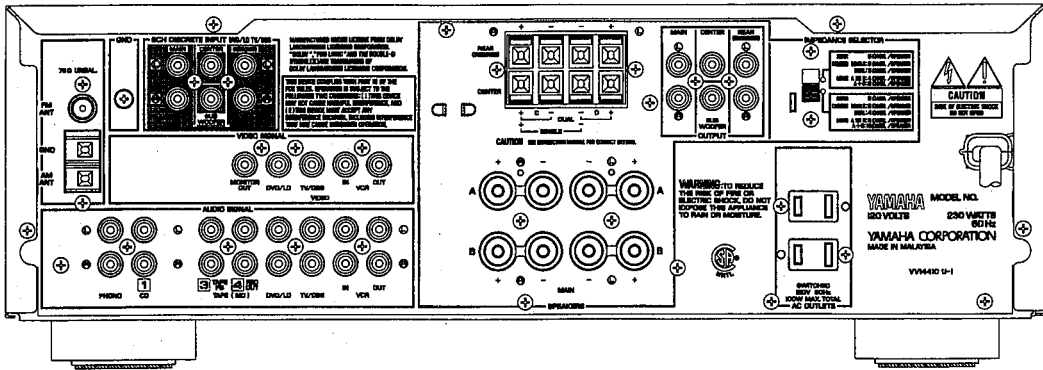

C model

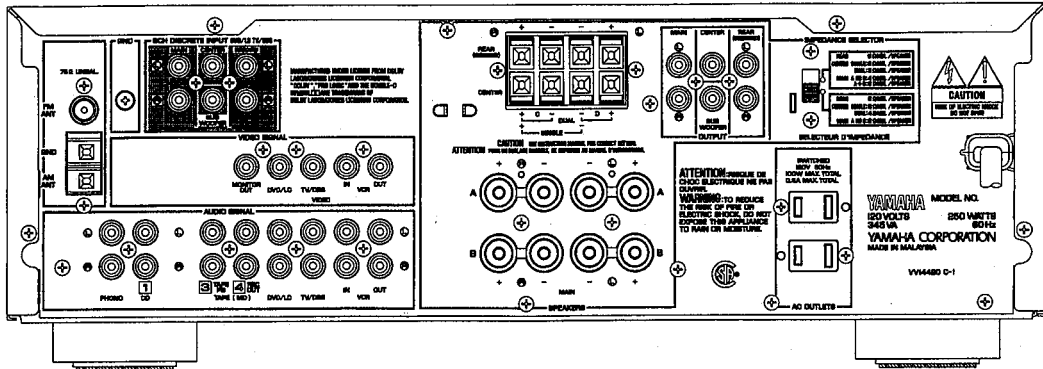

R model

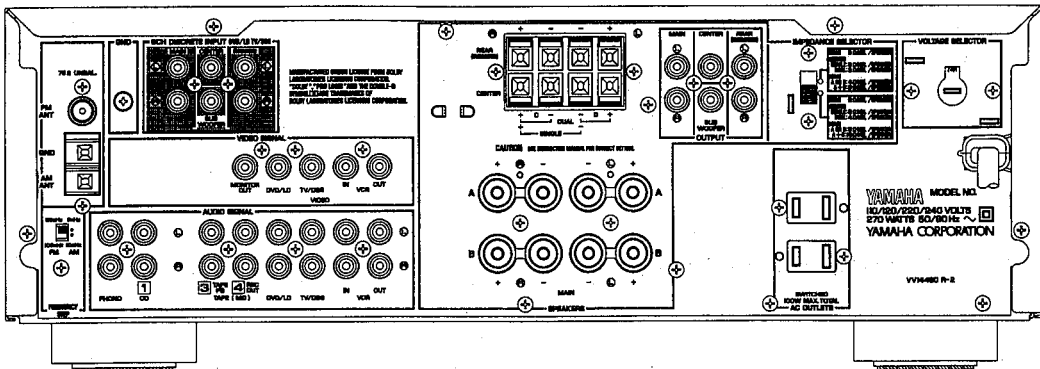

A model

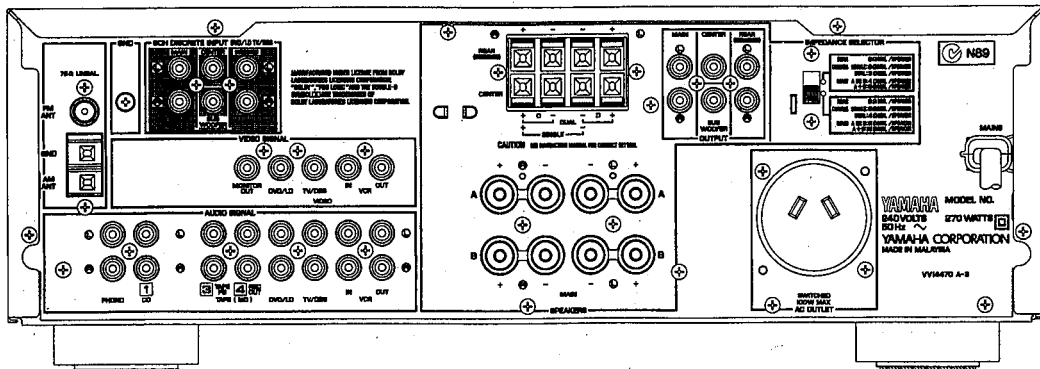

▼ B model

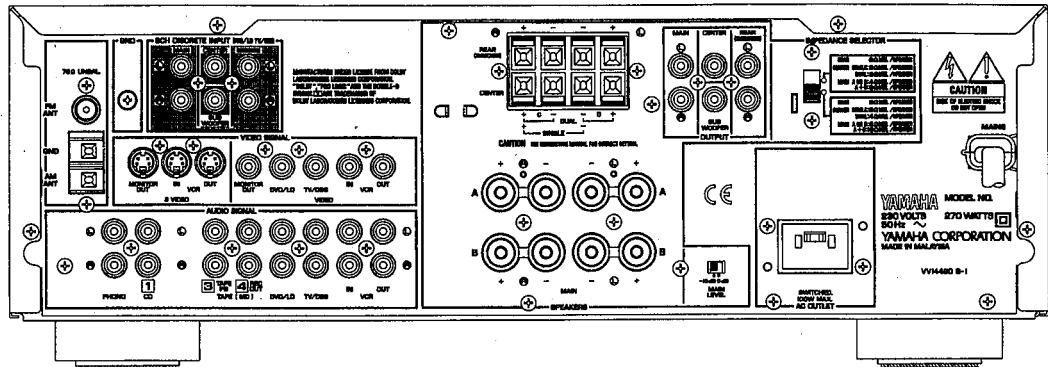

▼ G model

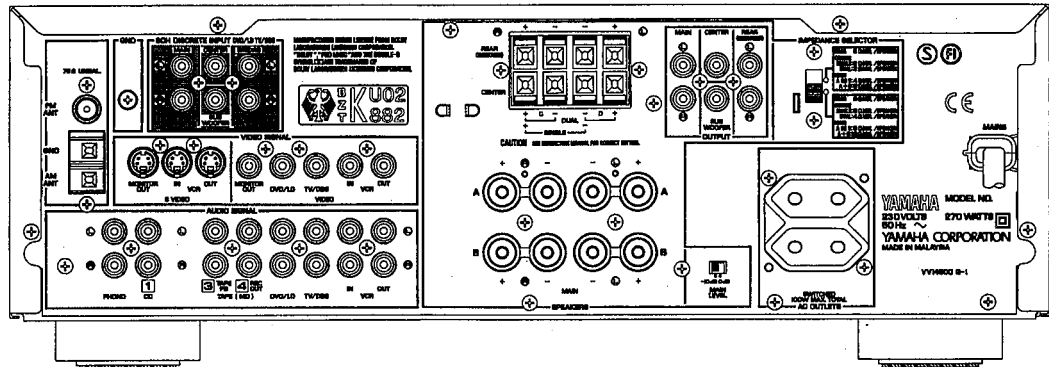

▼ L model

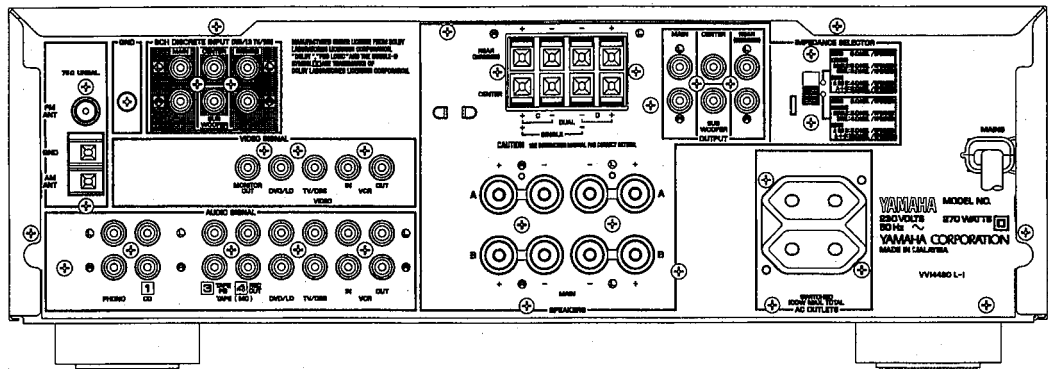

■ SPECIFICATIONS

■ AUDIO SECTION

Minimum RMS output Power per Channel	
RX-V592/RX-592RDS	
MAIN, 20Hz to 20kHz, 0.04% THD, 8Ω	
U, C models /R,A,B,G,L models	75W/70W
CENTER, 1kHz, 0.07% THD, 8Ω	
U, C models /R,A,B,G,L models	75W/70W
REAR, 1kHz, 0.3% THD, 8Ω	35W
R-V902	
MAIN, 1kHz, 0.07% THD, 8Ω	90W
CENTER, 1kHz, 0.07% THD, 8Ω	90W
REAR, 1kHz, 0.3% THD, 8Ω	35W
Dynamic Power Per Channel(IHF)	
U, C models	
8/6/4/2Ω	110/140/170/190W
R, A, B, G, L models	
8/6/4/2Ω	95/120/150/170W
DIN Standard Output Power Per Channel	
G model only	
1kHz, 0.7% THD, 4Ω	110W
Dynamic Headroom(8Ω)	
U, C models only	1.66dB
IEC Power	
G model only	
1kHz, 0.1% THD, 6Ω	85W
Power Band Width	
0.09% THD, 30W, 8Ω	10Hz to 50kHz
Dumping Factor (SP A)	
20Hz to 20kHz, 8Ω	80 or more
Maximum Power (EIAJ)	
R model only	
MAIN, 1kHz, 10% THD, 8Ω	110W
CENTER, 1kHz, 10% THD, 8Ω	50W
REAR, 1kHz, 10% THD, 8Ω	110W
Input Sensitivity/Impedance	
PHONO MM	2.5mV/47kΩ
CD etc	150mV/47kΩ
6CH DISCRETE INPUT	150mV/50kΩ
Maximum Input Signal Level (1kHz)	
PHONO MM, 0.04% THD	110mV
CD etc (EFFECT ON), 0.5% THD	2.2V
Output Level/Impedance	
REC OUT	150mV/2.5kΩ
PRE OUT, FRONT	2.2V/1.2kΩ
PRE OUT, REAR	1.6V/1.2kΩ
SUPER WOOFER (EFFECT OFF)	6.0V/1.5KΩ
Headphone Jack Rated Output/Impedance	
0.04% THD, RL=8Ω	0.5V/390Ω
Frequency Response(20Hz to 20kHz)	
CD etc	0±0.5dB
RIAA Equalization Deviation	
PHONO MM	0±0.5dB
Total Harmonic Distortion(20Hz to 20kHz)	
PHONO MM to REC OUT (1V)	0.02%
CD etc to SP OUT(30W/8Ω)	0.025%
Signal-to-Noise Ratio(IHF-A-Network)	
PHONO MM, (5mV Input Shorted), REC OUT	
U, C, R models /A, B, G, L models	85dB/82dB
CD etc(Shorted), SP OUT	85dB

Residual Noise(IHF-A-Network)	
SP OUT	140μV
Channel Separation(Vol. -30dB)	
PHONO MM(Input Shorted), 1kHz/10kHz	60dB/50dB
CD etc(Input 5.1kΩ terminated), 1kHz/10kHz	60dB/45dB
Tone Control Characteristics	
BASS : Boost/Cut	±10dB(50Hz)
: Turnover Frequency	350Hz
TREBLE : Boost/Cut	±10dB(20kHz)
: Turnover Frequency	3.5kHz
BASS Extention (50Hz)	6dB
Gain Tracking Error(0~-60dB)	3dB
Tuner Output Level/Impedance (Fixed)	
U, C, R models	
FM (100% mod, 1kHz)	500mV/2.2kΩ
AM (30% mod, 1kHz)	150mV/2.2kΩ
A, B, G, L models (FM 40kHz Dev)	
FM (100% mod, 1kHz)	400mV/2.2kΩ
AM (30% mod, 1kHz)	150mV/2.2kΩ

■ FM SECTION

Tuning Range	
U, C, R models	87.50 to 107.9MHz
A, B, G, L models	87.50 to 108.00MHz
50dB Quieting Sensitivity (IHF)	
U, C, R, A, L models	
Mono	1.55μV(15.1dBf)
Stereo	21μV(37.7dBf)
Usable Sensitivity	
A, B, G, L models	
DIN, Mono(S/N 26dB)	0.9μV
DIN, Stereo(S/N 46dB)	24μV
Image Response Ratio	
U, C, R modes	45dB
A, B, G, L models	80dB
IF Response Ratio	
U, C, R models	70dB
A, B, G, L models	80dB
Spurious Response Ratio	
70dB	
AM Suppression Ratio	
55dB	
Alternate Channel Selectivity	
U, C, R models	85dB
Selectivity(two signals, 40kHz Dev. ±300kHz)	
A, B, G, L models	70dB
Signal-to-Noise Ratio	
Mono/Stereo(IHF)	
U, C, R models	80/75dB
Mono/Stereo(DIN-weighted, 40kHz Dev.)	
A, B, G, L models	75/70dB
Harmonic Distortion	
Mono/Stereo (1kHz)	
U, C, R, A, L models	0.1/0.2%
Mono/Stereo(40kHz Dev.)	
B, G models	0.1/0.2%
Stereo Separation	
U, C, R, L models (1kHz)	50dB
B, G models(40kHz Dev.)	50dB
Frequency Response	
20Hz to 15kHz	0±0.5dB

AM SECTION

Tuning Range	
U, C models	531 to 1710kHz
R model	531 to 1611/530 to 1710kHz
A, B, G, L models	531 to 1611kHz
Usable Sensitivity	100µV/m
Selectivity	32dB
Signal-to-Noise Ratio	50dB
Image Response Ratio	40dB
Spurious Response Ratio	50dB
Harmonic Distortion (1kHz)	0.3%

VIDEO SECTION

Video Signal Type	
U, C, R models	NTSC/PAL
A, B, G, L models	PAL
Video Signal Level	1Vp-p/75Ω
S-Video Signal Level	Y:1Vp-p/75Ω C:0.286Vp-p/75Ω
Maximum Input Level	1.5Vp-p
Signal-to-Noise Ratio	50dB
Monitor Out Frequency Response(-3dB)	5Hz~10MHz

GENERAL

Power Supply	
U, C, models	AC120V, 60Hz
R model	AC110/120/220/240V, 50/60Hz
A model	AC240V, 50Hz
B, G, L models	AC230V, 50Hz
Power Consumption	
U model	230W
C model	250W
R, A, B, G, L models	270W
Maximum Power Consumption	
R model only	630W
5CH Simultaneous output, 10% THD	
AC Outlet	
U, C, R, G, L models, Switched x 2	100W max(Total)
A, B models, Switched x 1	100W max
Dimensions(W x H x D)	435 x 151 x 379.5mm (17/1/8" x 5-15/16" x 14-15/16")
Weight	11.0kg(24lbs. 4 oz)
Accessories	
	AM loop antenna x 1
	Indoor FM antenna x 1
	Remote Control Transmitter x 1
	Battery (size "AA", "R06")

* Specifications subject to change without notice.

- U U. S. A. model
- C Canadian model
- R General model
- A Australian model
- B British model
- G European model
- L Singapore model

Manufactured under license from Dolby Laboratories Licensing Corporation.
 "DOLBY", "PRO LOGIC" and the double-D symbol  are trademarks of Dolby Laboratories Licensing Corporation.

● DIMENSIONS

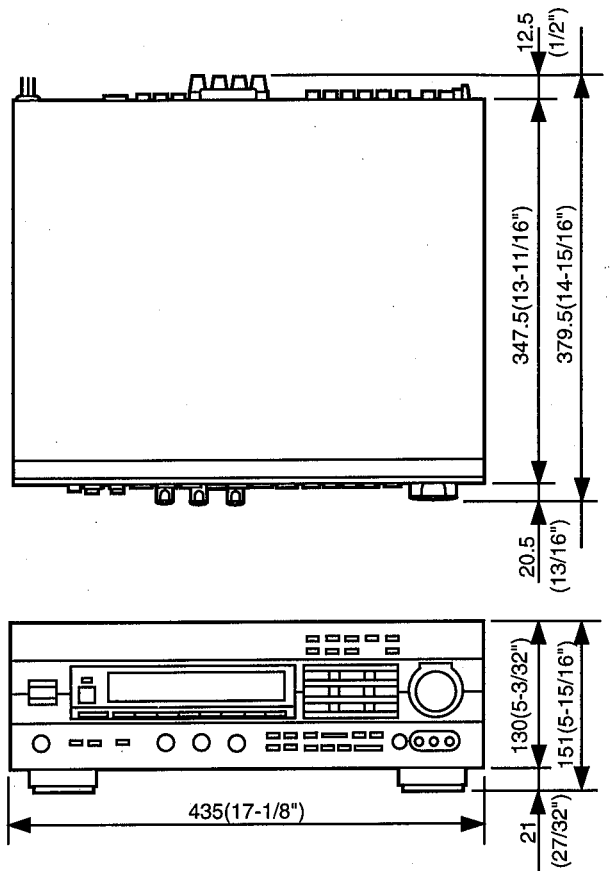

Units: mm (inch)

WARNING

Do not change the **IMPEDANCE SELECTOR** switch setting while the power to this unit is on, otherwise this unit may be damaged.

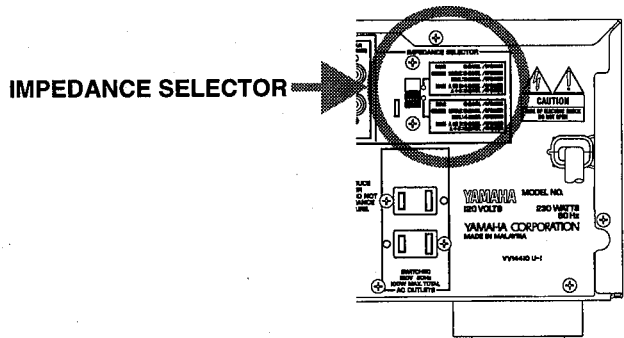

INTERNAL VIEW

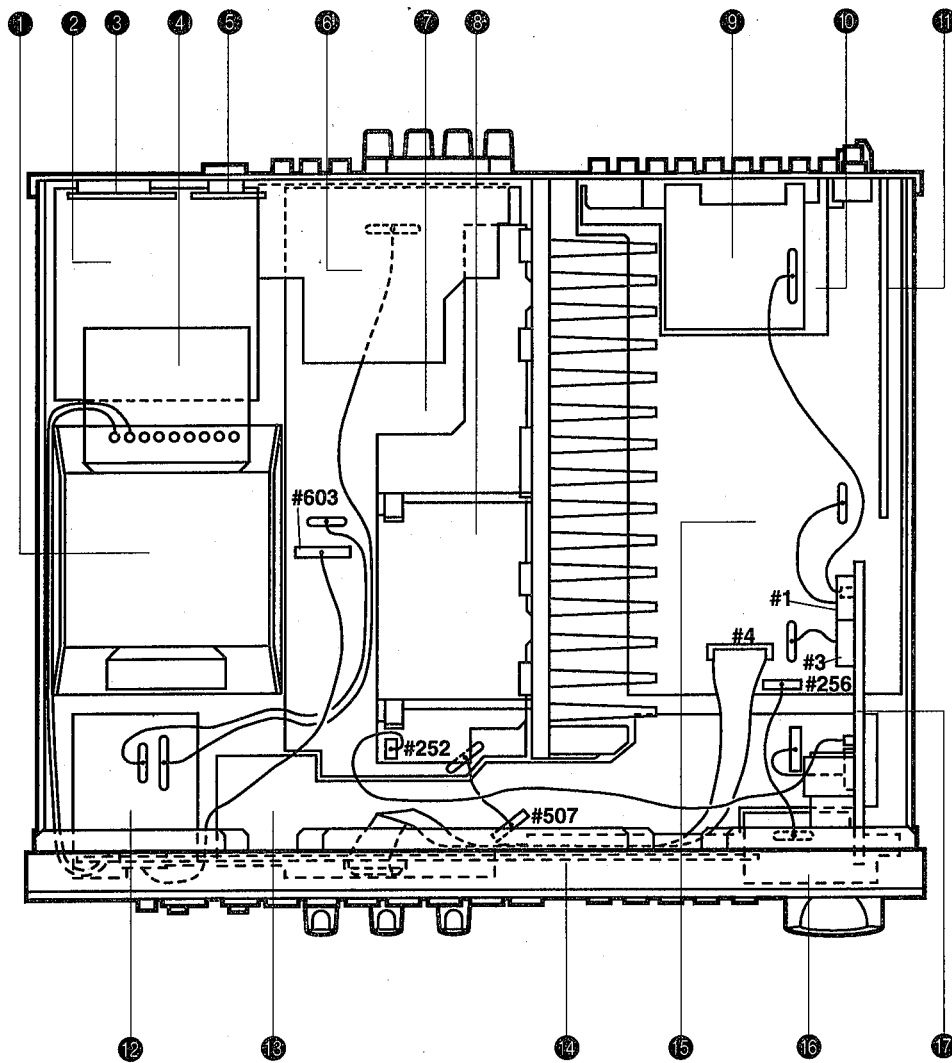

- ① POWER TRANSFORMER
- ② INPUT P.C.B. ASS'Y (4)
- ③ AMP P.C.B. ASS'Y (5)
(R model only)
- ④ INPUT P.C.B. ASS'Y (3)
- ⑤ AMP P.C.B. ASS'Y (6)
- ⑥ AMP P.C.B. ASS'Y (3)
- ⑦ AMP P.C.B. ASS'Y (2)
- ⑧ AMP P.C.B. ASS'Y (1)
- ⑨ OPERATION P.C.B. ASS'Y (4)
- ⑩ INPUT P.C.B. ASS'Y (2)
- ⑪ TUNER P.C.B. ASS'Y
- ⑫ AMP P.C.B. ASS'Y (4)
- ⑬ OPERATION P.C.B. ASS'Y (3)
- ⑭ OPERATION P.C.B. ASS'Y (1)
- ⑮ INPUT P.C.B. ASS'Y (1)
- ⑯ OPERATION P.C.B. ASS'Y (5)
- ⑰ OPERATION P.C.B. ASS'Y (2)

DISASSEMBLY PROCEDURES

(Remove parts in disassembly order as numbered.)

1. Removal of Top Cover

Remove 4 screws (①) and 3 screws (②) in Fig. 1.

2. Removal of Front Panel Unit

a. Detach 6 connectors (#1,3,4,252,256,507,603).

(See page 7, INTERNAL VIEW)

b. Remove 4 knobs.

c. Remove 6 screws (③) in Fig. 1.

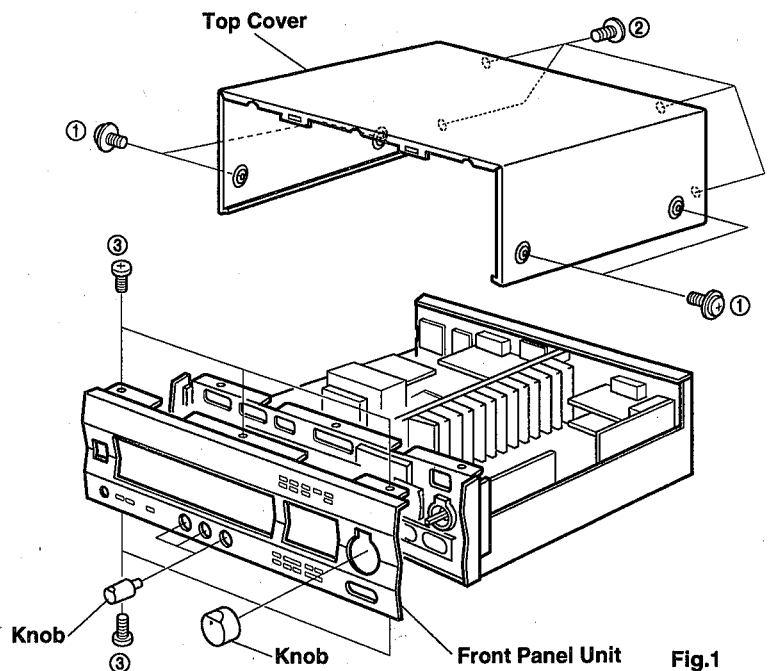

Fig.1

■ SELF CHECK MODE

This machine has the SELF CHECK MODE (SELF) for facilitating inspection and measurement.

HOW TO START & CANCEL

Turn the POWER switch ON while pressing the DVD/LD and PRESET STATION No.8 keys simultaneously, and then the unit enters the SELF CHECK MODE (SELF). FL displays "SELF 1" first. (The INPUT CD and SW levels are 0dB.)

If the sound field program key of the main unit is pressed, the mode is set to the CHECK mode of that number. It is possible to select the INPUT even during the self check (except for SELF 8).

* Switching between 2CH and 6CH is possible when SELF1 is selected.

To cancel the SELF CHECK MODE, turn the POWER switch OFF or press the PRESET STATION No. 8 key. (The unit enters the normal mode.)

HOW TO USE SELF CHECK MODE

In order to confirm characteristics (specifications) listed in the table below, use SELF NO. 1, 3 and 4. (For specifications, refer to page 5.)

No.	Items
1	<ul style="list-style-type: none"> • Output Level/Impedance • Frequency Response • Total Harmonic Distortion (Rec Out & MAIN) • S/N
3	<ul style="list-style-type: none"> • Minimum RMS Output Power Per Channel (Center & Rear) • Total Harmonic Distortion (Rear)
4	<ul style="list-style-type: none"> • Minimum RMS Output Power Per Channel (MAIN) • Input Sensitivity/Impedance • Headphone Jack Rated Output/Impedance • Channel Separation • Tone Control Characteristics

CONTENTS OF SELF CHECK MODE

No.	Menu	Select Key
1	RAM THROUGH A	PRESET STATION No. 1
2	RAM THROUGH B	PRESET STATION No. 2
3	RAM THROUGH C	PRESET STATION No. 3
4	EFFECT OFF/DISCO/FL ALL ON	PRESET STATION No. 4
5	MANUAL TEST	PRESET STATION No. 5
6	DOLBY PRO LOGIC	PRESET STATION No. 6
7	MAKER PRESET	PRESET STATION No. 7
8	EXIT	PRESET STATION No. 8

DETAILS OF SELF CONTENT

SELF 1 RAM THROUGH A

- MAIN L/R is output through the bypass.
- CENTER is output with the steering OFF and by (L+R)/2. (WIDE mode)
- RL/RR passes through the PS-RAM and is output through the DSP.
- The electronic volume is 0dB for CENTER and -2dB for REAR.
- FL displays "SELF 1"

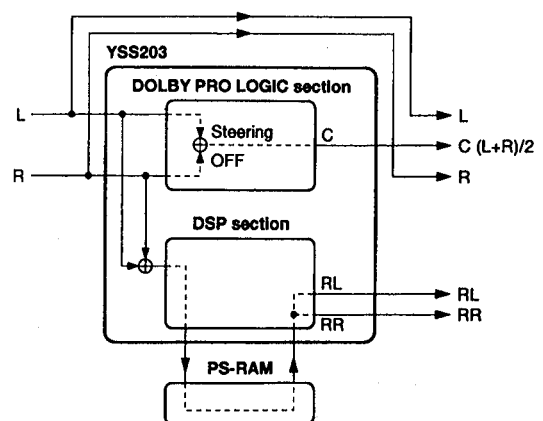

CD INPUT	: 1kHz, -20dB
VOLUME	: MAX
PRE OUT	: MAIN -7.3dB±1dB
	: CENTER -7.3dB±1dB
	: REAR -4.0dB±1dB

SELF 2 RAM THROUGH B

- L/R and RL/RR pass through the PS-RAM and are output through the DSP.
- CENTER is output with the steering OFF and by (L+R)/2. (WIDE mode)
- The electronic volume (for CENTER/REAR) is -10dB.
- FL displays "SELF 2"

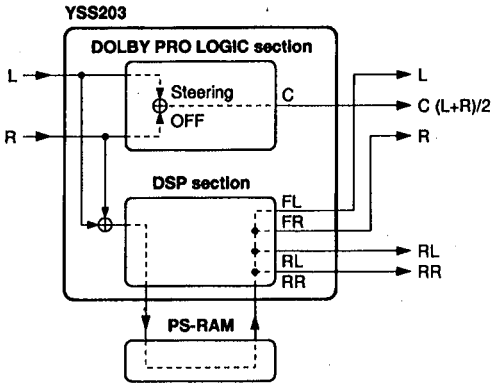

CD INPUT : 1kHz, -20dB
 VOLUME : MAX
 PRE OUT : MAIN -7.3dB±1dB
 : CENTER -2.5dB±1dB
 : REAR -4.0dB±1dB

SELF 3 RAM THROUGH C

- L/R is output with the steering OFF.
- CENTER is output with the steering OFF and by (L+R)/2. (WIDE mode)
- RL/RR passes through the PS-RAM and is output through the DSP.
- The electronic volume is +10dB for CENTER and +9dB for REAR.
- FL displays "SELF 3"

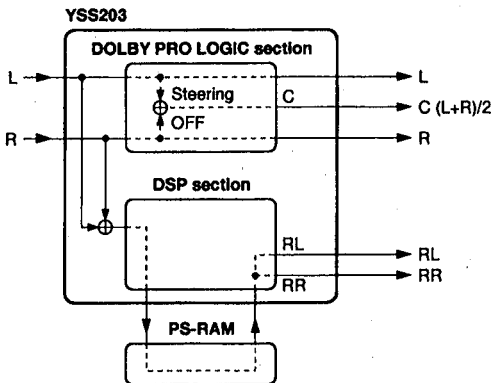

CD INPUT : 1kHz, -35dB
 VOLUME : MAX
 PRE OUT : MAIN -7.0dB±1dB
 : CENTER +2.3dB±1dB
 : REAR +1.0dB±1dB

SELF 4 EFFECT OFF/DISCO/FL ALL ON

- Every time the PRESET STATION No.4 key is pressed, the menu changes.
- 1: EFFECT OFF
- 2: DISCO (electronic volume is 0dB.)
- 3: FL displays all ON

CD INPUT : 1kHz, -35dB
 VOLUME : MAX
 PRE OUT : MAIN -7.7dB±1dB
 : CENTER -∞dB
 : REAR -∞dB

SELF 5 MANUAL TEST

- Every time PRESET STATION No.5 key is pressed, the TEST TONE shifts in the order of →L→C→R→S and is output. (The CENTER mode is WIDE)
- The electronic volume (for CENTER/REAR) is 0dB.

SELF 6 DOLBY PRO LOGIC

- The auto input balance which is ON in the normal mode is turned OFF.
- CENTER MODE is changed by pressing the PRESET STATION No. 6 key or the CENTER MODE key.
- The electronic volume (for CENTER/REAR) is 0dB.
- The FL displays "SELF 6" and the center mode.

SELF 7 MAKER PRESET

- Every time the PRESET STATION No.7 key is pressed, the mode changes between the KEEP DATA and PRESET modes. Turning OFF the power in the "PRESET" mode will restore the FACTORY PRESET mode.

CAUTION : Before setting to the FACTORY PRESET, write down the existing preset memory content of the Tuner in a table as shown below. (This is because setting to the FACTORY PRESET will cause the memory content to be as factory set, i.e., all the preset memory by the user will be erased.)

Preset group	P1	P2	P3	P4
A				
B				
C				
D				
E				

Preset group	P5	P6	P7	P8
A				
B				
C				
D				
E				

● **Factory Preset**

1) **SURROUND section**

DELAY TIME	: <input checked="" type="checkbox"/> PRO LOGIC	20ms
	: <input type="checkbox"/> ENHANCED	20ms
	: CONCERT VIDEO	28ms
	: MONO MOVIE	20ms
	: STADIUM	45ms
	: DISCO	14ms
	: ROCK CONCERT	17ms
	: CONCERT HALL	30ms
CENTER MODE	: NORMAL	
VOLUME LEVEL	: CENTER	0dB
	: REAR	0dB
	: SWFR	0dB

2) **SELECTOR section**

INPUT	: CD
VIDEO (BGV)	: DVD/LD

3) **TUNER section**

Preset group	P1	P2	P3	P4
A / C / E	87.5MHz	90.1MHz	95.1MHz	98.1MHz
B / D	630kHz	1080kHz	1440kHz	530kHz (U, C, R) 531kHz (R, A, B, G, L)

Preset group	P5	P6	P7	P8
A / C / E	107.9MHz (U, C, R) 108.0MHz (R, A, B, G, L)	88.1MHz	106.1MHz	107.9MHz (U, C, R) 108.0MHz (R, A, B, G, L)
B / D	1710kHz (U, C, R) 1611kHz (R, A, B, G, L)	900kHz	1350kHz	1400kHz (U, C, R) 1404kHz (R, A, B, G, L)

For all the above, AUTO TUNING and AUTO STEREO are selected as the TUNING mode.

SELF 8 EXIT

- "MODEL/DESTINATION" is displayed first. When the PRESET STATION No. 8 key is pressed again, the unit will exit the SELF CHECK mode and enters the catalogue photo-taking mode (while being tuned, the STEREO and TUNING meters light up). The catalogue photo-taking mode is canceled by turning OFF the power.

■ PROTECTION OPERATION CHECK FUNCTION

1. Turn the POWER switch ON while pressing the TUNER and PRESET STATION No.8 keys simultaneously, and the protection operation mode and the microprocessor AD input value are displayed for 3 seconds.

Example : PRT-PS [AD value] [PRT-PS] indicates detection of an abnormal voltage of the power supply.
 PRT-DC [AD value] [PRT-DC] indicates detection of an abnormal DC value of the amplifier.
 PRT-I [AD value] [PRT-I] indicates detection of an abnormal overcurrent of the amplifier.
 [PRT-NON] indicates no detection.

When the PRESET STATION No.8 key is pressed during the above display, the input data are retained till they are cleared.
 ("PRT-NON" appears on display when the data are cleared.)

2. Turn the POWER switch ON while pressing the TUNER and the PRESET STATION No.7 keys simultaneously, and the input value for detection of an abnormal power supply voltage and the input value for detection of an abnormal amplifier DC will be displayed.

Example : P - [AD value] D - [AD value]
 [P-] indicates detection of an abnormal power supply voltage.
 [DC-] indicates detection of an abnormal amplifier DC.

Type of protection	Normal (AD value)	Abnormal (AD value)
Detection of an abnormal power supply voltage	37 - 74	0 - 36 & 75 - 255
Detection of an abnormal amplifier DC	3 - 35	0 - 2 & 36 - 255

Press any key, and the display will be canceled.

TUNER ADJUSTMENT

1. Measuring Instruments

- FM signal generator (FM SG)
- Stereo signal generator (SSG)
- AM signal generator (AM SG)
- Distortion meter (DIST. M)
- AC Voltmeter (ACVM)
- DC Voltmeter (DCVM)
- Oscilloscope
- Low pass filter (YLF-15, $f_c=15\text{kHz}$)
- Oscillator

● Dummy antenna

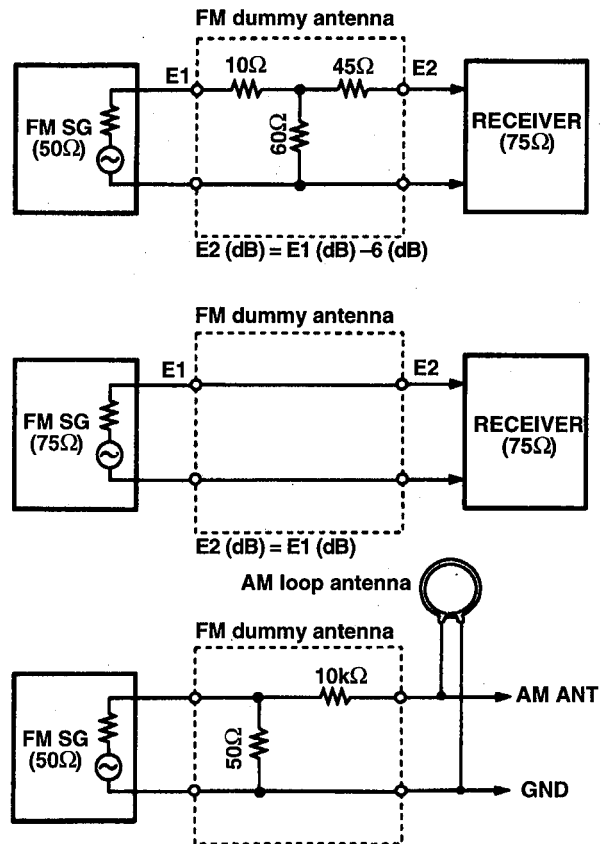

● TEST POINT

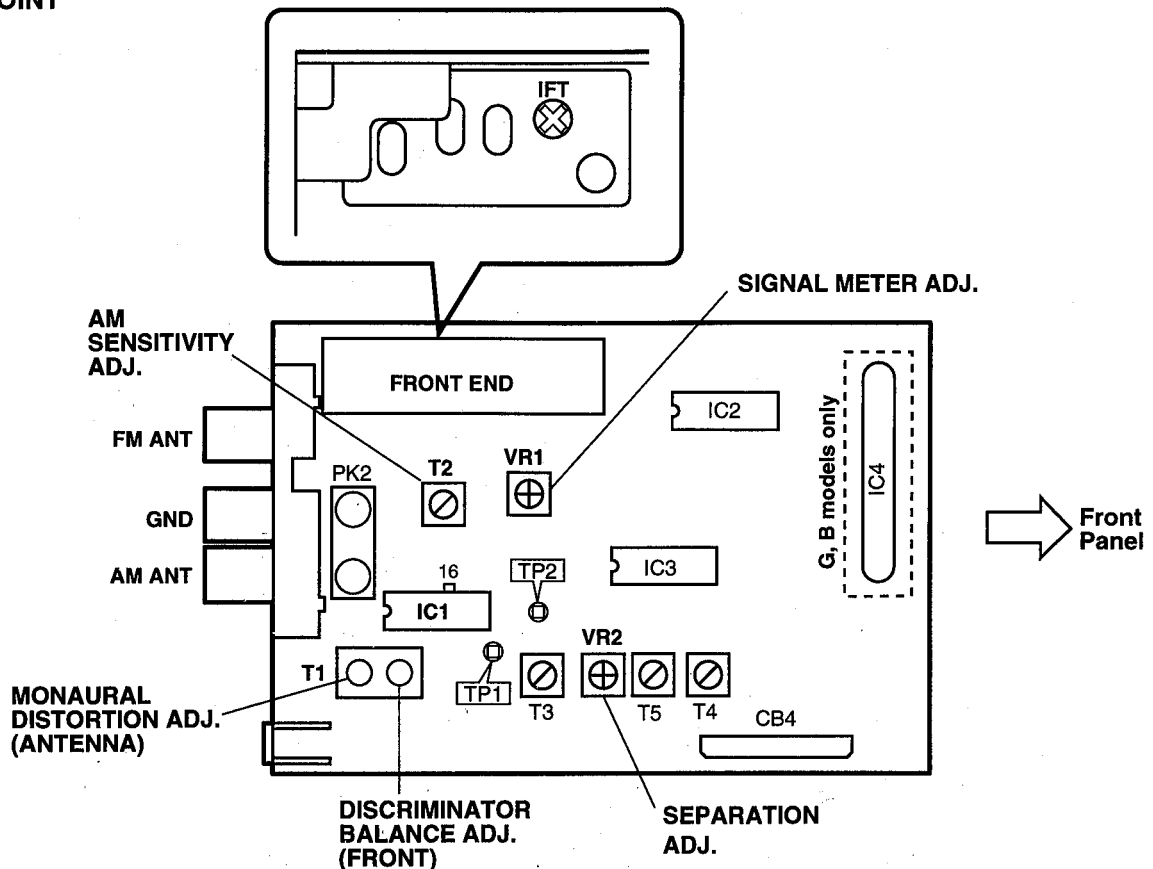

FM Adjustment

1. Before Adjustment

- For dB μ , 1 μ V=0dB μ applies.
Example : 60dB μ =1mV
- 100% modulation means that the frequency deviation is \pm 75kHz.
- Install the Matching Transformer and connect FM SG.

- Set each switch to the following position unless otherwise specified.

INPUT SELECTOR TUNER

TUNING MODE AUTO

2. Connection diagram (Measuring instruments)

- Discriminator balance adjustment.

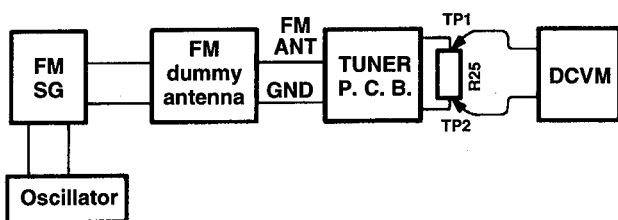

- Stereo distortion adjustment/separation adjustment.

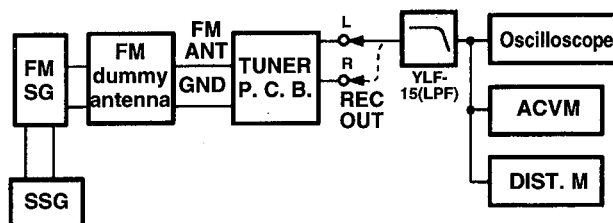

- Monaural distortion adjustment

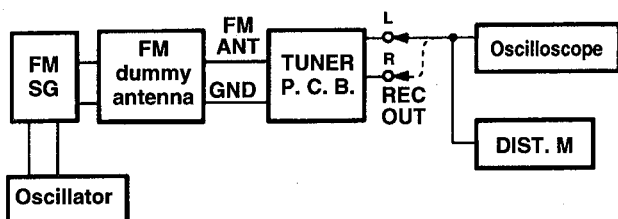

- Sensitivity Verification

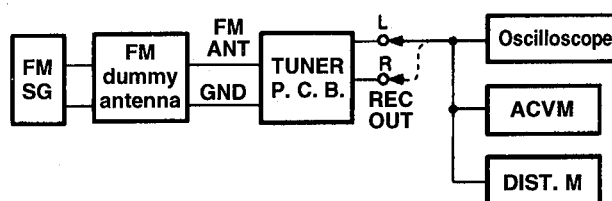

See page 12 for TP locations & adjustment points.

Step	Adjustment item	Signal (ANT IN)	Reception frequency	Adjustment point	Test point	Rating
1	Rough adjustment of discriminator balance	FM ANT (75 Ω) 98.1MHz 70dB μ MONO 1kHz 100% modulation	98.1MHz *(A-4)	T1 (Front side core)	Both ends of R25 (Between TP1 and TP2)	DC 0V \pm 100mV
2	Rough adjustment of monaural distortion	Same as Step 1.	98.1MHz *(A-4)	T1 (Antenna side core)	REC OUT L, R	Minimize the distortion.
3	Fine adjustment of discriminator balance	Same as Step 1.	98.1MHz *(A-4)	T1 (Front side core)	Both ends of R25 (Between TP1 and TP2)	DC 0V \pm 50mV
4	Fine adjustment of monaural distortion	Same as Step 1.	98.1MHz *(A-4)	T1 (Antenna side core)	REC OUT L, R	Minimize the distortion (to 0.5% or less).
5	Verification of discriminator balance	Same as Step 1.	98.1MHz *(A-4)	T1 (Front side core)	Both ends of R25 (Between TP1 and TP2)	DC 0V \pm 50mV

* Execution of FACTORY PRESET (Refer to page 10.) will facilitate setting reception frequency for adjustment.

Step	Adjustment item	Signal (ANT IN)	Reception frequency	Adjustment point	Test point	Rating
6	Adjustment of front end IFT	FM ANT (75Ω) 98.1MHz 30dBμ MONO 1kHz 100% modulation	98.1MHz *(A-4)	Front end IFT	Pin 16 of IC1	Adjust so that the meter is maximum. CAUTION: Over-adjustment of the IFT core will reduce the sensitivity. (Maximum±90°)
7	Verification of monaural distortion	FM ANT (75Ω) 98.1MHz 70dBμ MONO 1kHz 100% modulation	98.1MHz *(A-4)		REC OUT L, R	0.4% or less
8	Verification of stereo distortion	FM ANT (75Ω) 98.1MHz 70dBμ Stereo L or R 1kHz, 100% modulation	98.1MHz *(A-4) *Tuning mode should be AUTO.		REC OUT L, R	1% or less ● STEREO indicator should light.
9	Verification of sensitivity	FM ANT (75Ω) 88.1MHz 98.1MHz 106.1MHz MONO 1kHz Modulation off	88.1MHz *(A-6) 98.1MHz *(A-4) 106.1MHz *(A-7)		ANT (75Ω)	1) Set the tuning mode to MAN'L MONO. 2) S/N should be 30dB at each frequency of 88.1MHz, 98.1MHz, and 106.1MHz. 3) Check to ensure that the voltage at the ANT terminal is 3dBμ(14.25dBf) or less. (G, B only: 6dBμ or less)
10	Adjustment of separation	FM ANT (75Ω) 98.1MHz 70dBμ Stereo L or R 1kHz, 100% modulation	98.1MHz *(A-4)	VR2	REC OUT L, R	With SSG output at L or R, the signal leakage level at the other channel should be minimized. 30dB or more.
11	Adjustment of signal meter	FM ANT (75Ω) 98.1MHz 45dBμ MONO 1kHz, 30% modulation -10dBμ or less	98.1MHz *(A-4)	VR1		Adjust so that all signal meters light. Check to ensure that signal meters turn OFF.
12	Verification of auto tuning	FM ANT (75Ω) 98.1MHz 23dBμ Stereo L or R 1kHz, 30% modulation	98.1MHz			● Automatic reception should be available when the tuning key is moved UP and DOWN. ● The stereo indicator should light. ● Audio muting should be applied during tuning.

* Execution of FACTORY.PRESET (Refer to page 10.) will facilitate setting reception frequency for adjustment.

AM Adjustment (This should be done after FM adjustment.)

1. Connection diagram (Measuring instruments)

- Adjustment of sensitivity.

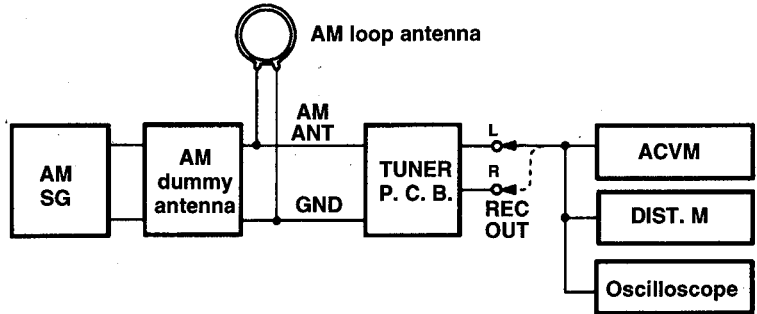

See page 12 for TP locations & adjustment points.

Step	Adjustment item	Signal (ANT IN)	Reception frequency	Adjustment point	Test point	Rating
1	Adjustment of sensitivity (630kHz)	AM ANT 630kHz 50dB μ 1kHz 30% modulation	630kHz *(B-1)	T2	REC OUT	Signal meter should be maximized.
2	Verification of sensitivity	AM ANT 630kHz 1080kHz 1440kHz 1kHz 30% modulation	630kHz *(B-1) 1080kHz *(B-2) 1440kHz *(B-3)		AM ANT	Distortion should be 10% or less at each frequency. Check to ensure that the voltage at the ANT terminal is 54dB μ or less.
3	Verification of auto tuning	AM ANT 60dB μ				Auto reception should be available when the tuning key is moved UP and DOWN.

* Execution of FACTORY PRESET (Refer to page 10.) will facilitate setting reception frequency for adjustment.

AMP ADJUSTMENT

Confirmation of Idling Current of Main Amplifier

- Right after power is turned on, confirm that the voltage across the terminals of CB529(Main Lch),CB530(Main Rch), CB531(Center ch), R745(Rear Lch); R748(Rear Rch) is between 0.1mV~3.0mV.
- If it exceeds 3.0mV, open (cut off) R557 (on CB529), R565 (on CB530), R572 (on CB531), R731 (on R745), R738 (on R748) for the non-confirming channel (S) and reconfirm the voltage again.

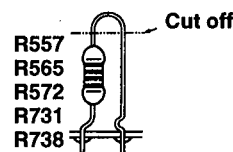
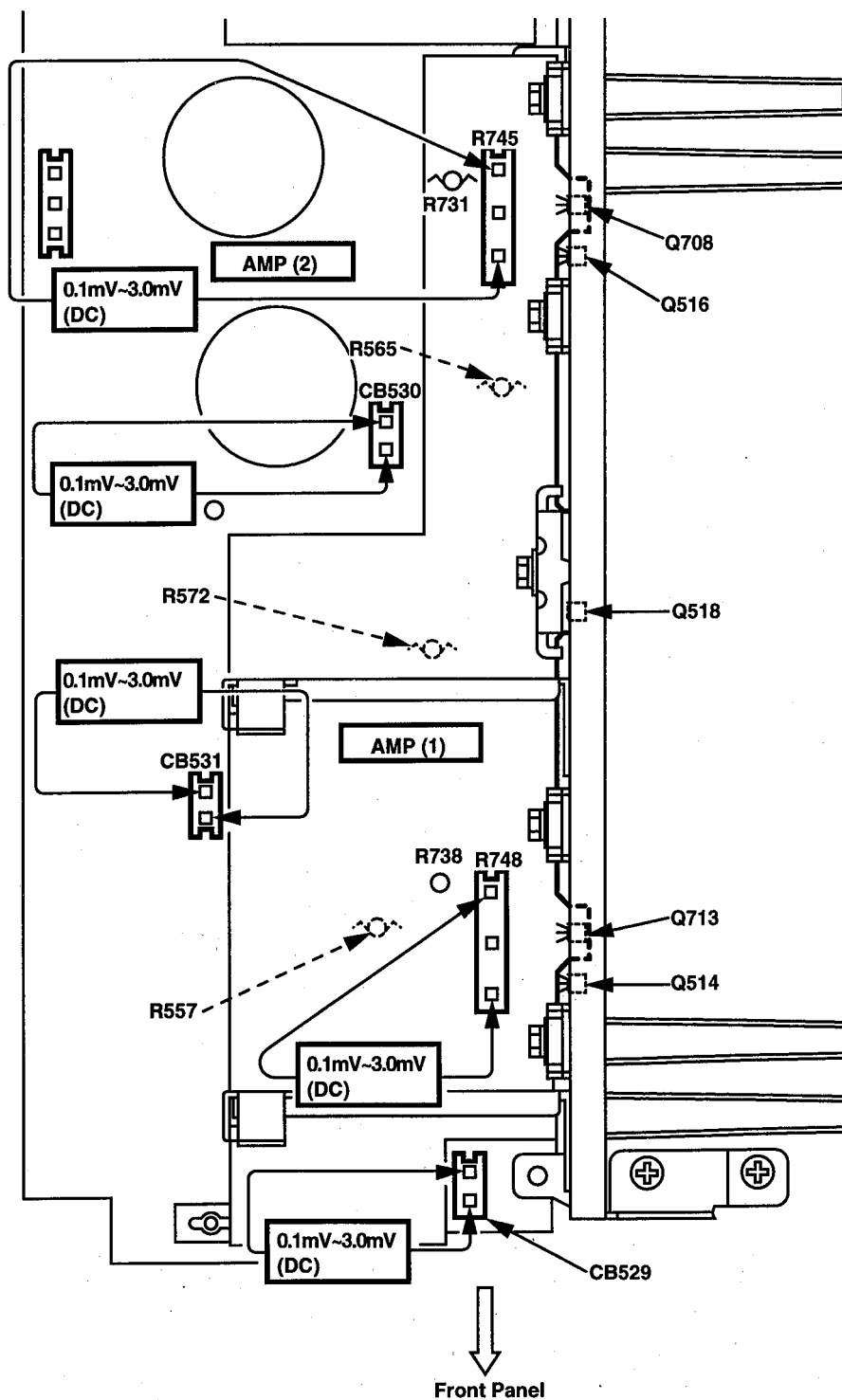

Note)

- If R557, R565, R572, R731 and R738 have already been cut off and idling current does not flow, reconnect R557, R565, R572, R731 and R738.
- Q514, Q516, Q518, Q708 and Q713 are transistors for temperature correction. Apply silicone grease to contact surface with the heat sink.

PRINTED CIRCUIT BOARD (Foil side)

①~③ : TEST POINT WAVEFORMS(See page 38)

TUNER P. C. B.

Semiconductor Location

Ref. No.	Location
D1	C5
D2	C5
D3	B5
IC1	C3
IC2	B2
IC3	B2
IC4	B2
Q1	C2
Q2	C2
Q3	C2
Q4	C3
Q5	B3
Q6	B3
Q7	C2

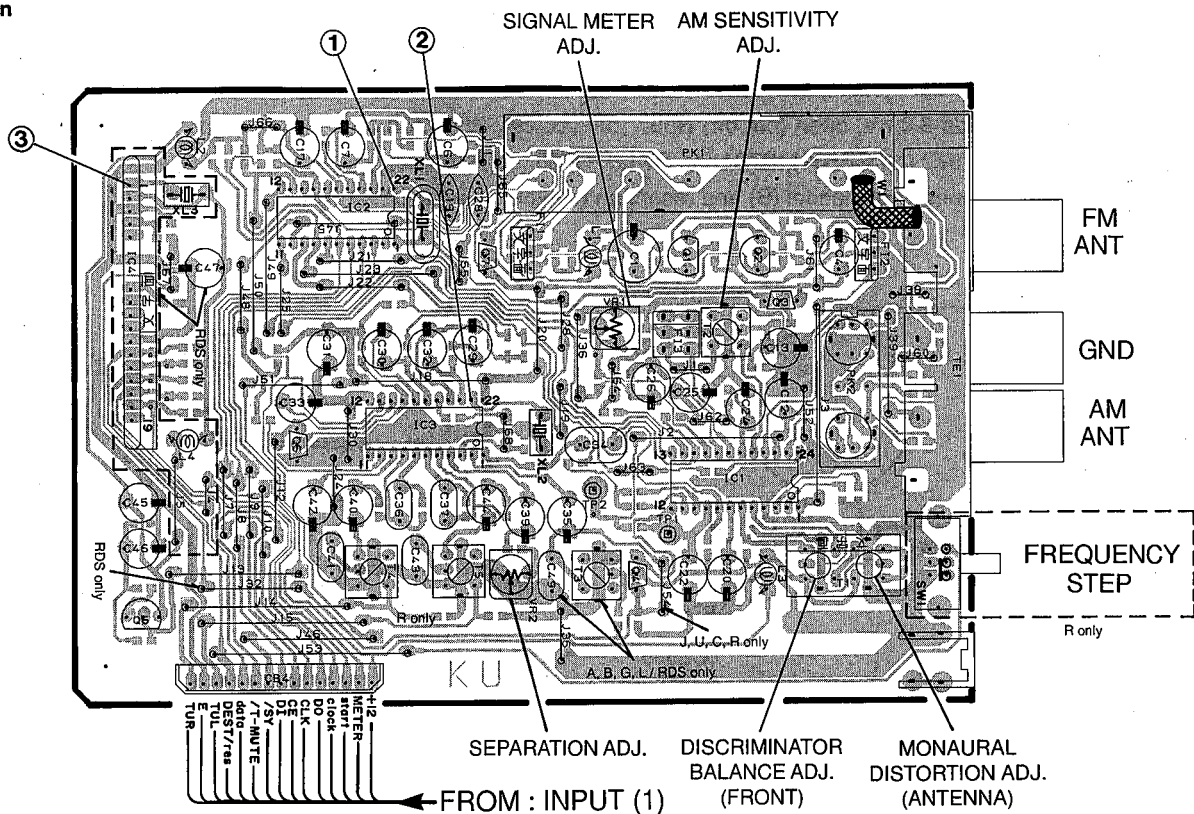

TUNER P. C. B.

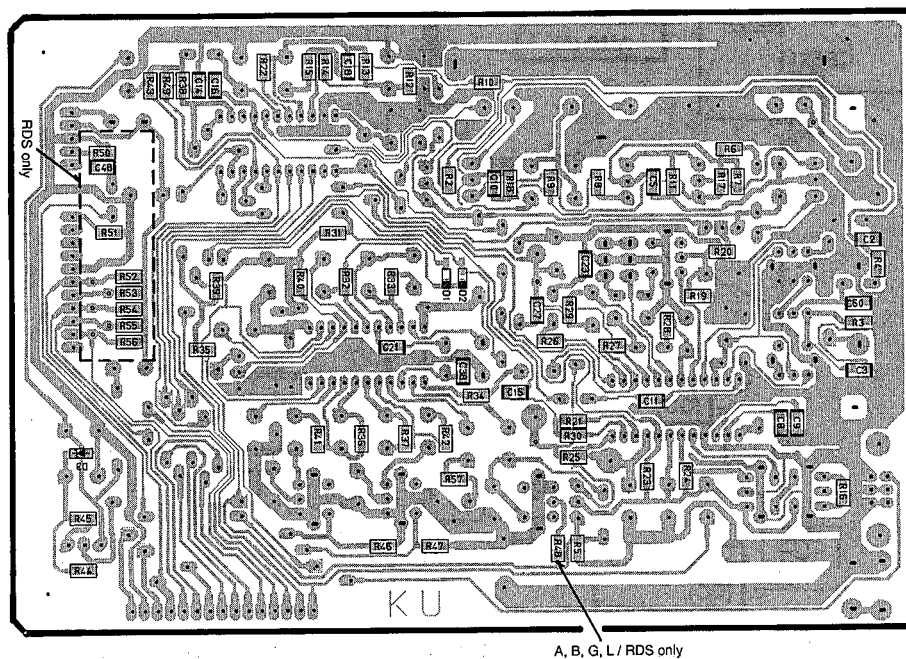

AMP P. C. B. (3)

PRINTED CIRCUIT BOARD (Foil side)

AMP P. C. B. (2)

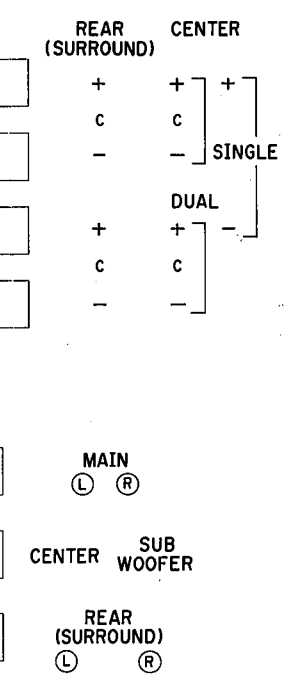
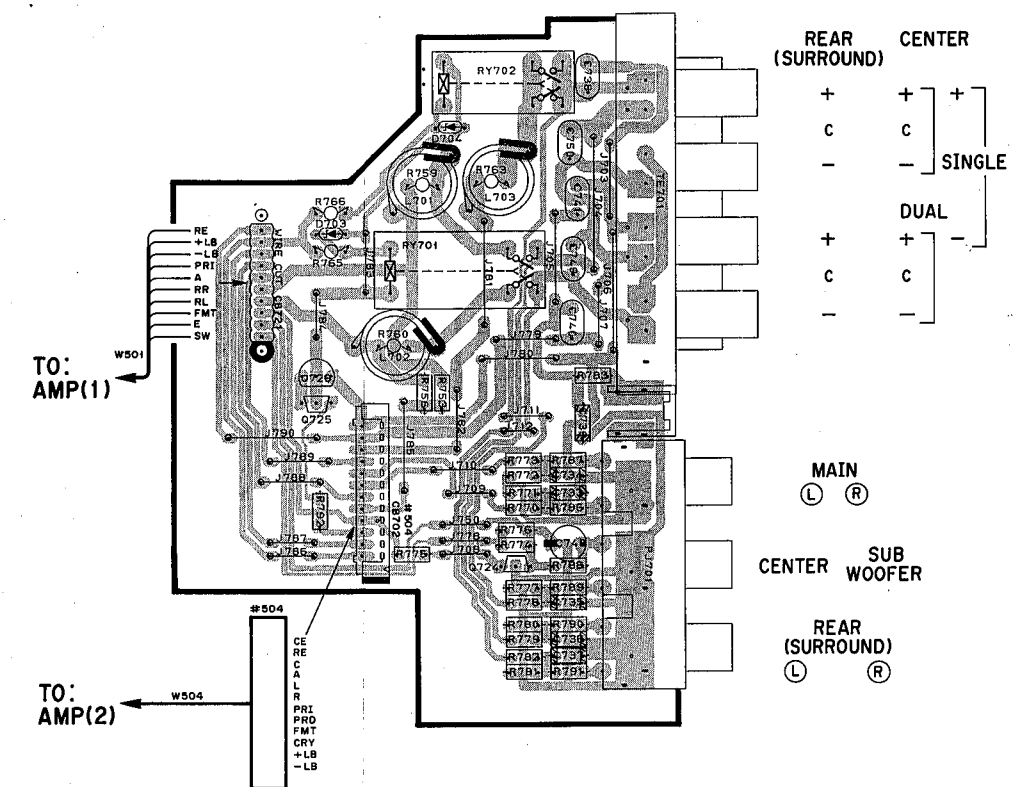
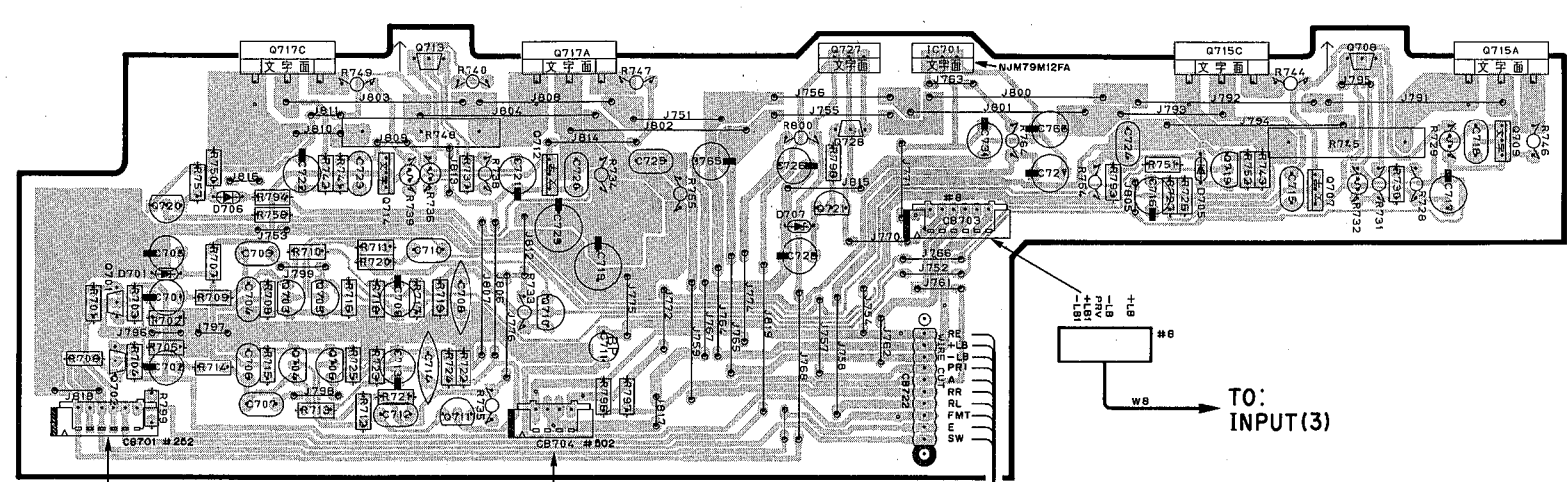

AMP P. C. B. (1)

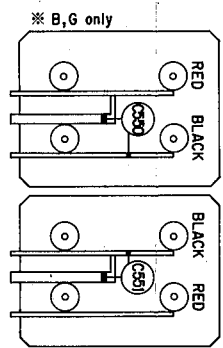
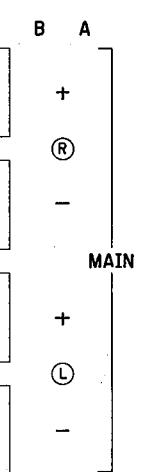
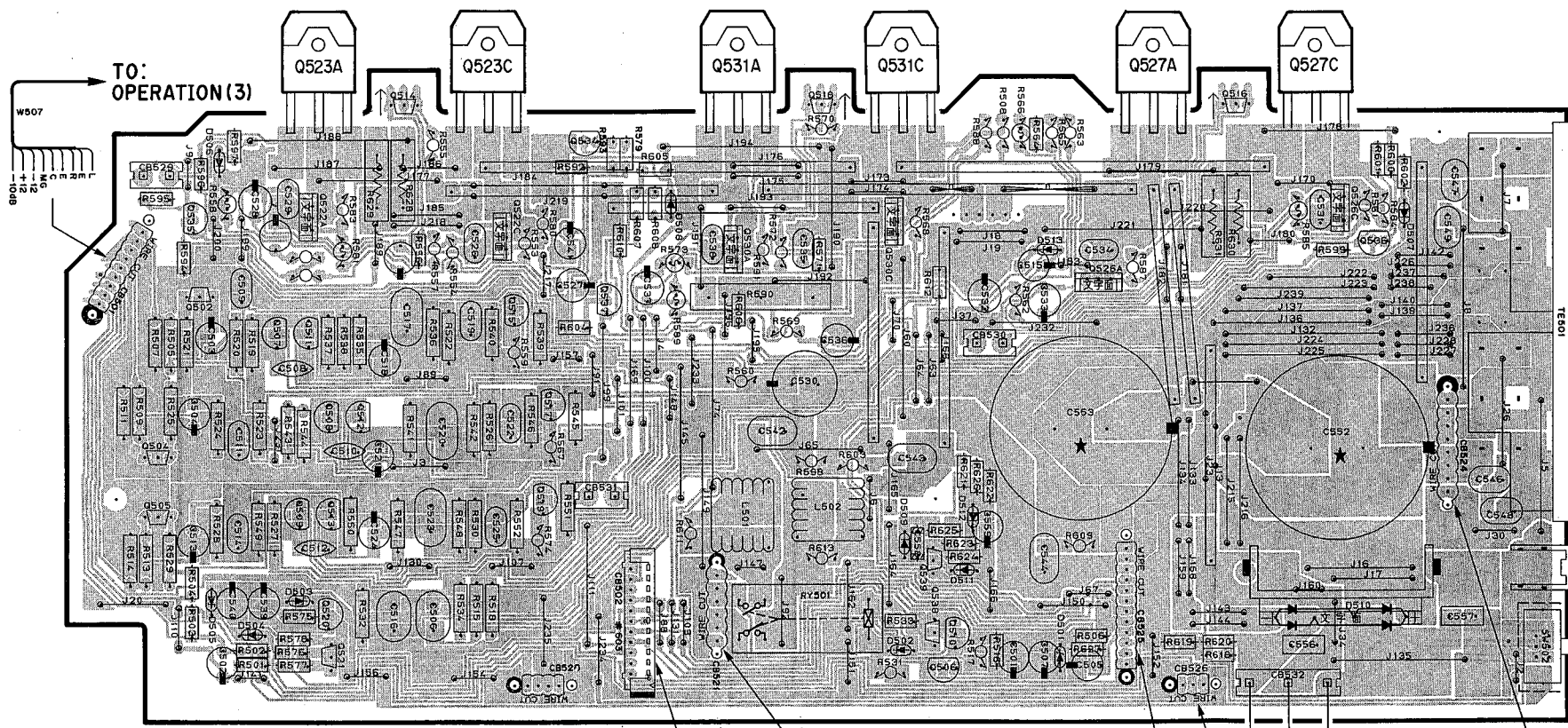

● Semiconductor Location

Ref. No.	Location	Ref. No.	Location
D501	D5	Q522A	B4
D502	C5	Q522C	B4
D503	B5	Q526A	D4
D504	A5	Q526C	E4
D505	A5	Q530A	C4
D506	A3	Q530C	C4
D507	E4	Q534	B3
D508	C4	Q535	A4
D509	C5	Q536	E4
D510	E5	Q537	C4
D511	D5	Q538	D5
D512	D5	Q539	C5
D513	D4	Q701	A2
D701	A2	Q702	A2
D703	F2	Q703	A2
D704	G1	Q704	A2
D705	D2	Q705	B2
D706	A2	Q706	B2
D707	C2	Q707	D2
IC701	C1	Q708	D1
Q502	A4	Q709	E2
Q504	A4	Q710	B2
Q505	A5	Q711	B2
Q506	D5	Q712	B2
Q507	B4	Q713	B1
Q508	B4	Q714	B2
Q509	B5	Q715A	E1
Q510	D5	Q715C	D1
Q511	B4	Q717A	B1
Q512	B4	Q717C	A1
Q513	B5	Q719	D2
Q514	B3	Q720	A2
Q515	B4	Q721	C2
Q516	D3	Q724	G2
Q517	B4	Q725	F2
Q518	C3	Q726	F2
Q519	B4	Q727	C1
Q520	B5	Q728	C2
Q521	B5		

1
2
3
4
5
6

■ PRINTED CIRCUIT BOARD (Foil side)

AMP P. C. B. (4)

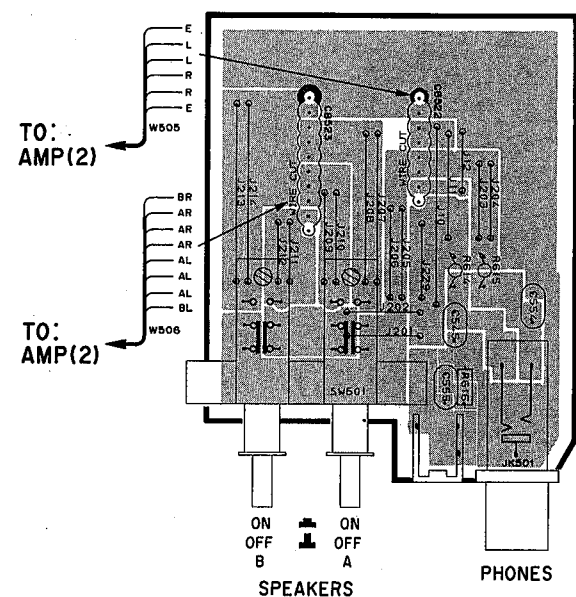

● R model only
AMP P. C. B. (5)

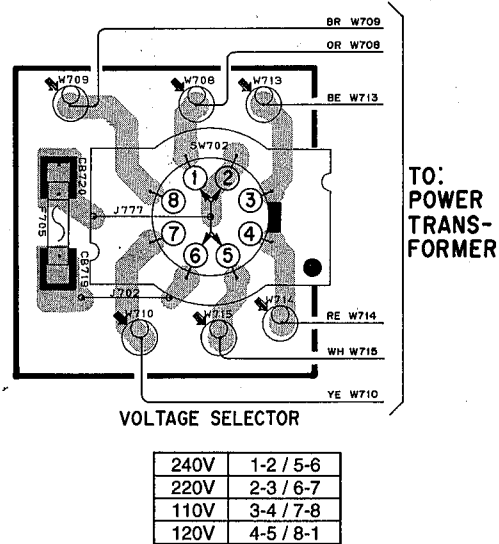

AMP P. C. B. (6)

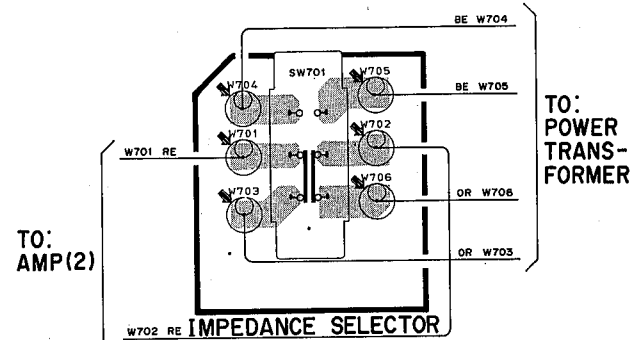

● U, C and R models
INPUT P. C. B. (4)

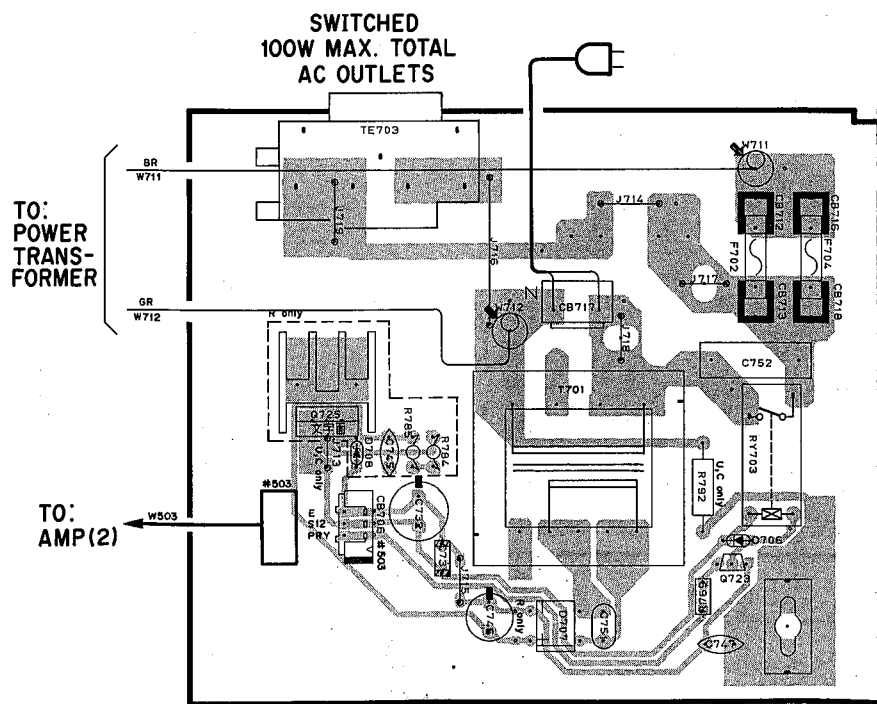

● A, B, G and L models
INPUT P. C. B. (4)

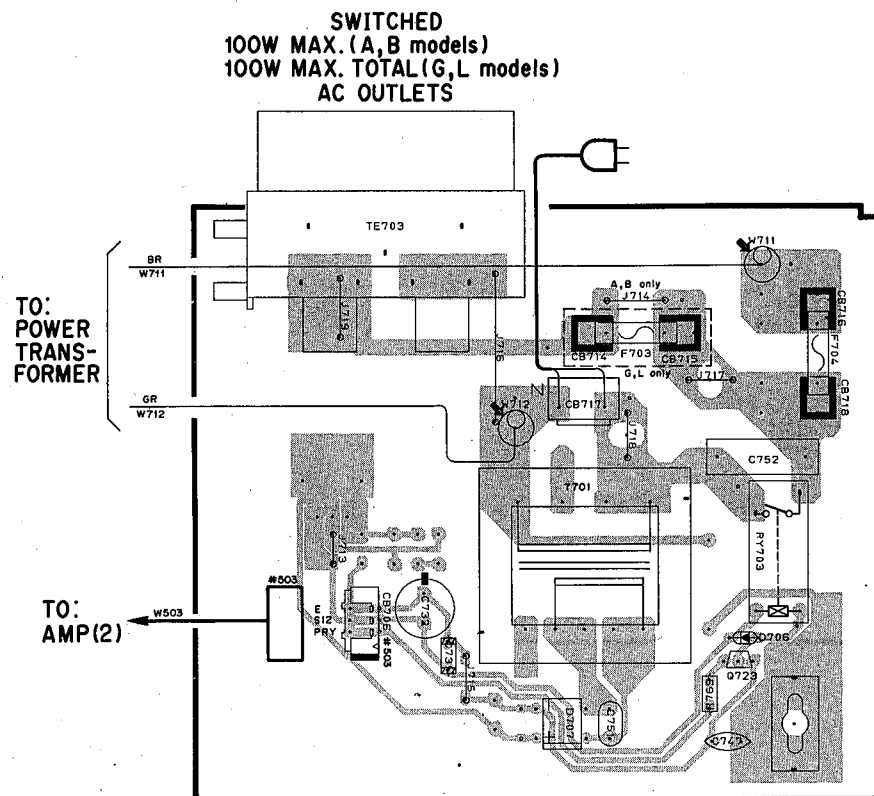

● Semiconductor Location
U, C, R models

Ref. No.	Location
D706	D5
D707	D5
D708	C5
Q723	D5
Q725	C5

● Semiconductor Location
A, B, G, L models

Ref. No.	Location
D706	G5
D707	G5
Q723	G5

PRINTED CIRCUIT BOARD (Foil side)

④ : TEST POINT WAVEFORMS(See page 36)

INPUT P. C. B. (1)

INPUT P. C. B. (2)

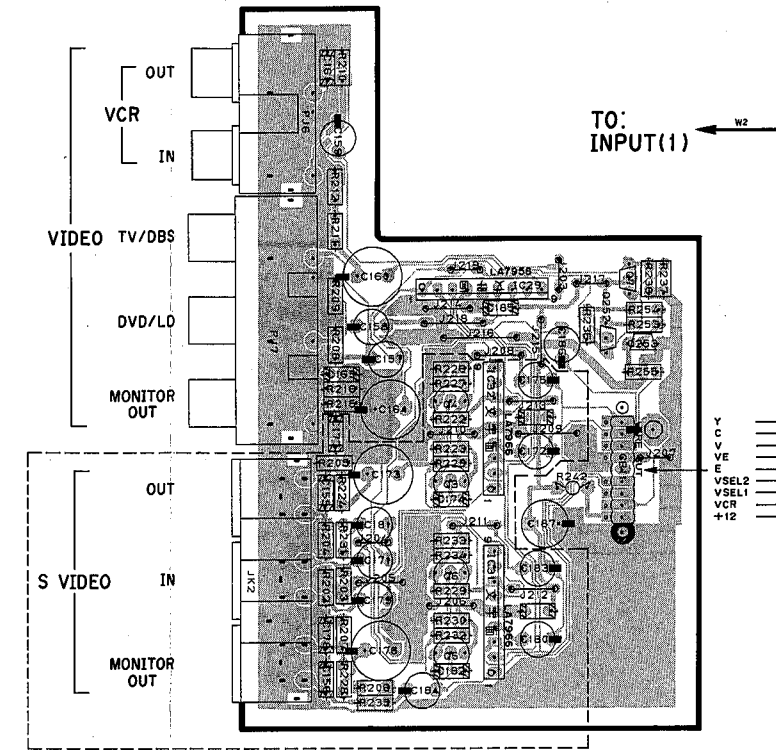
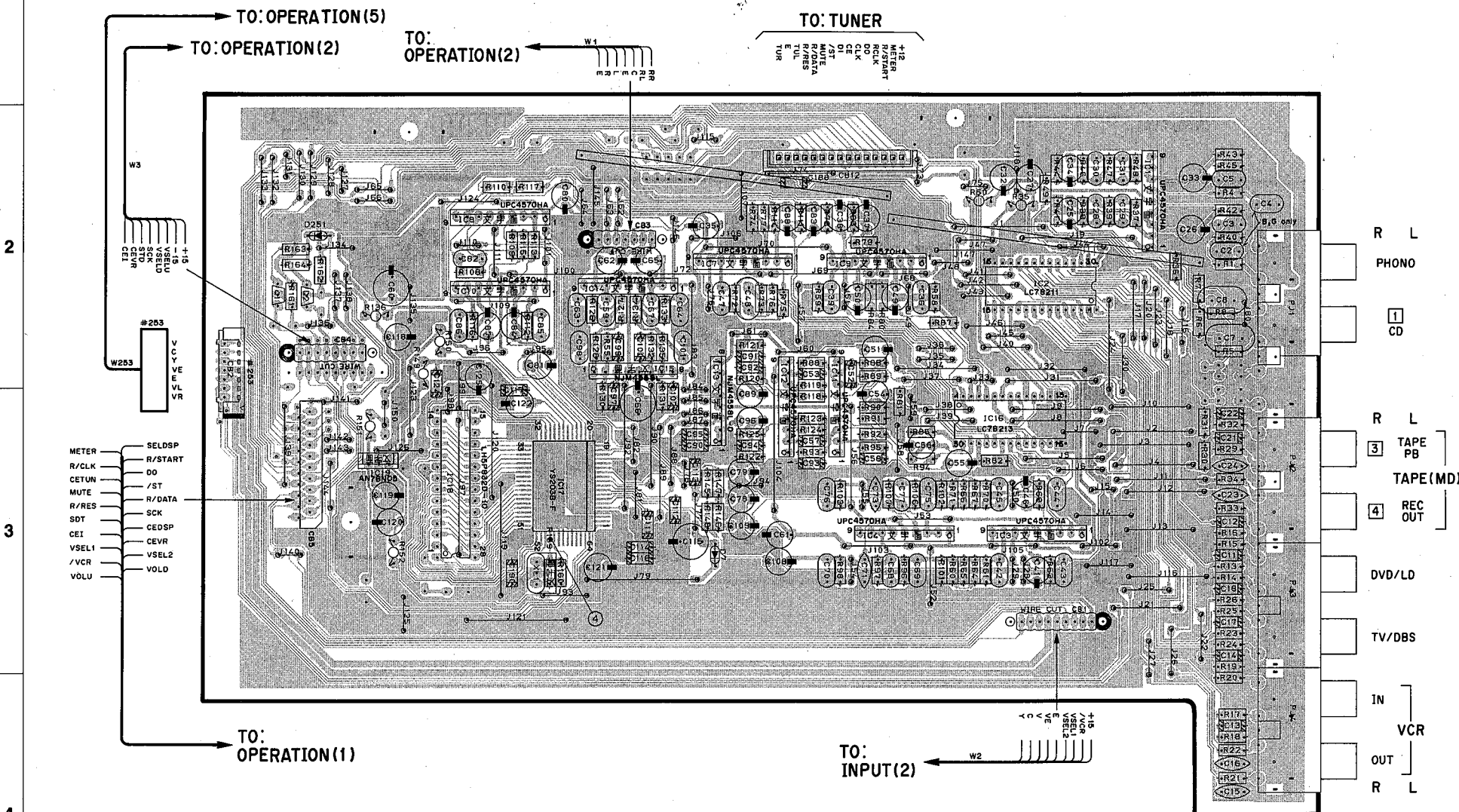

INPUT P. C. B. (3)

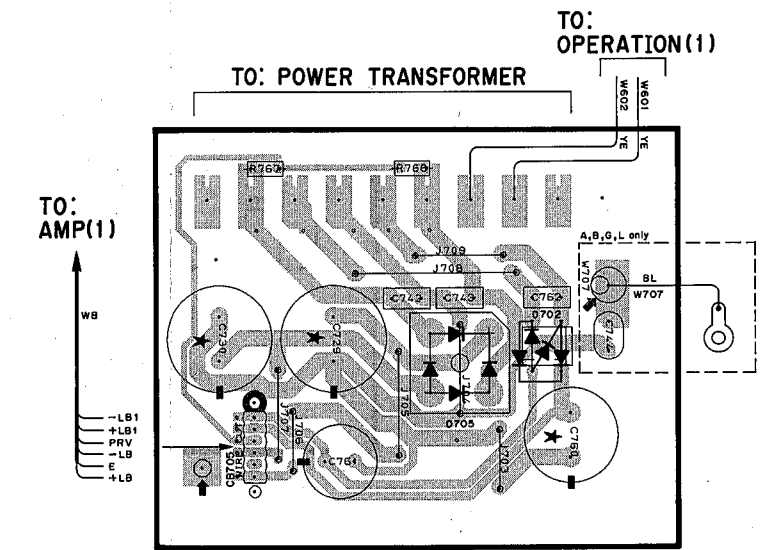

● Semiconductor Location

Ref. No.	Location	Ref. No.	Location
D7	C3	Q1	A2
D251	B2	Q2	B2
D702	G5	Q3	G2
D705	G5	Q4	G2
IC1	E2	Q5	G3
IC2	D2	Q6	G3
IC3	D3	Q7	H2
IC4	D3	Q252	G2
IC7	C2	Q253	H2
IC8	B2		
IC9	C2		
IC10	B2		
IC11	C2		
IC12	C2		
IC13	C2		
IC14	C2		
IC15	C2		
IC16	D3		
IC17	B3		
IC18	B3		
IC19	B3		
IC29	G2		
IC31	G2		
IC32	G2		

1
2
3
4
5
6

PRINTED CIRCUIT BOARD (Foil side)

⑤,⑥ : TEST POINT WAVEFORMS(See page 36)

● Semiconductor Location

Ref. No.	Location
D601	C3
D602	C3
D603	C3
D604	C3
D605	C3
D606	F2
D607	F2
D610	F2
D611	F2
D612	G2
D613	D2
D614	E2
D615	F2
IC601	E3
IC901	C5
Q601	F3
Q602	F2
Q603	F3
Q604	F3
Q901	C5
Q902	C4
Q903	D5
Q904	D5

OPERATION P. C. B. (1)

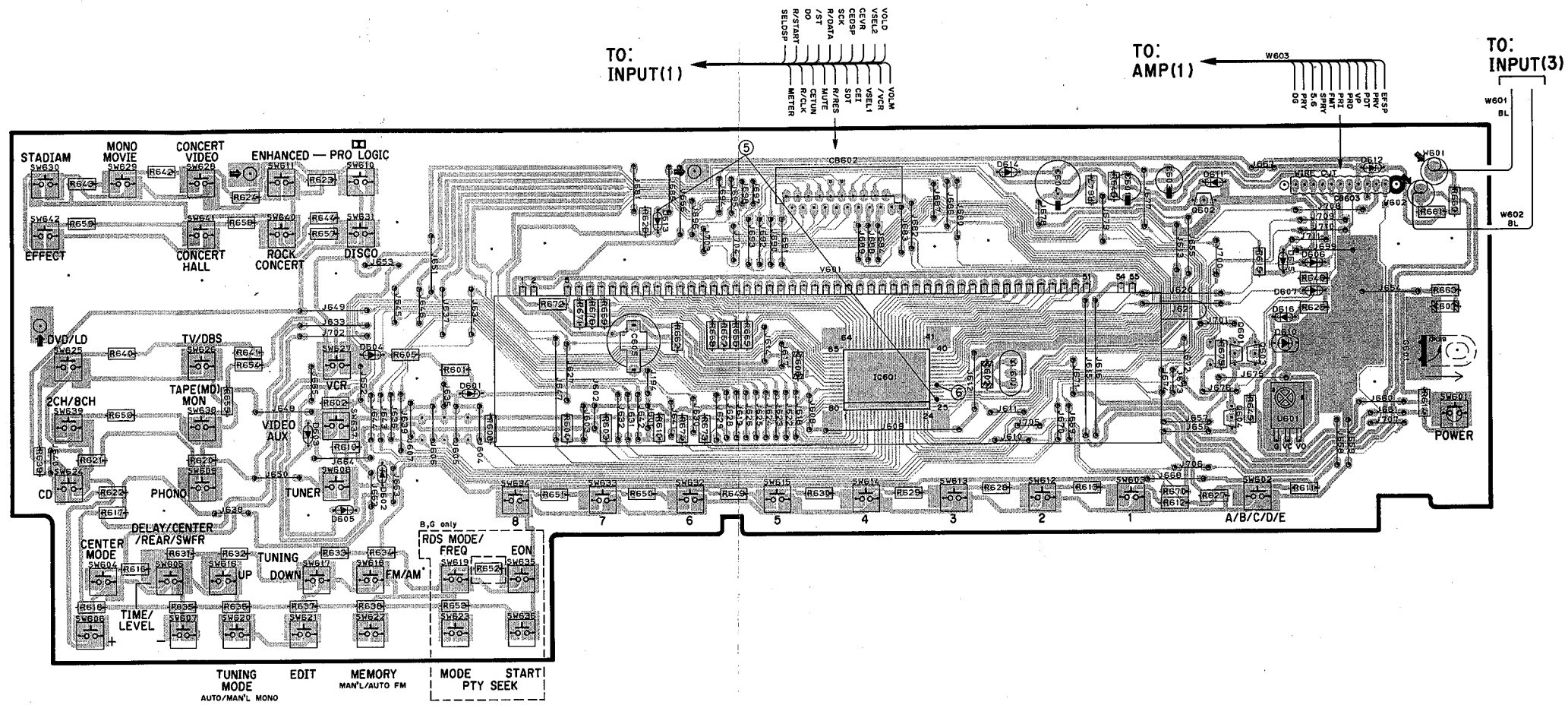

OPERATION P. C. B. (3)

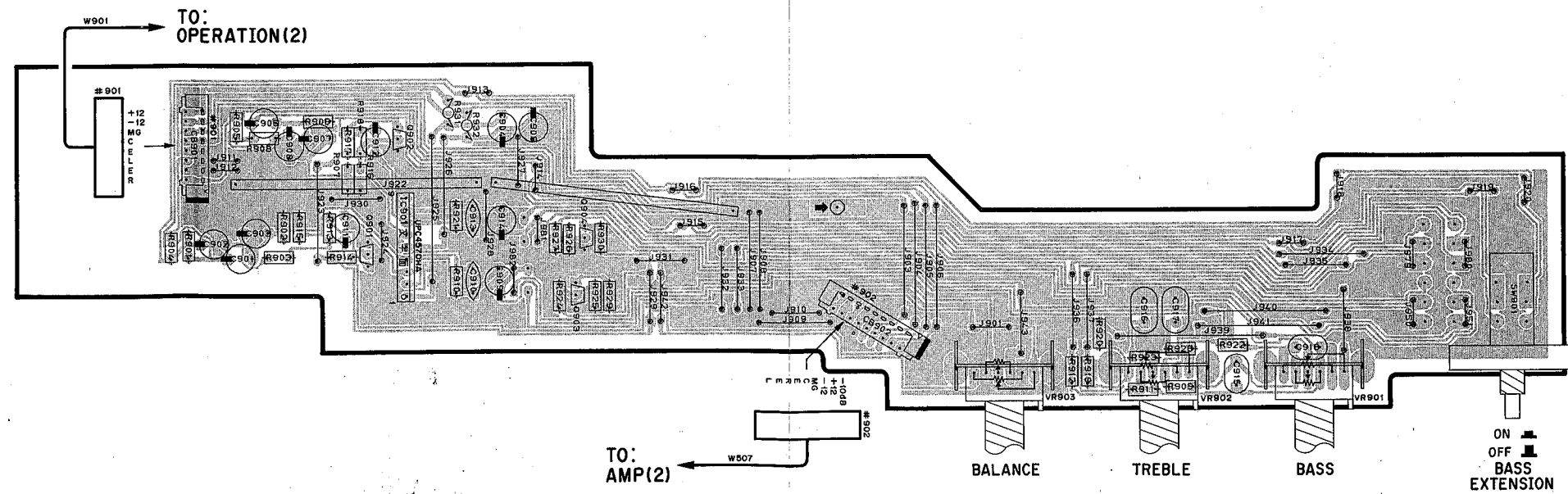

PRINTED CIRCUIT BOARD (Foil side)

OPERATION P. C. B. (2)

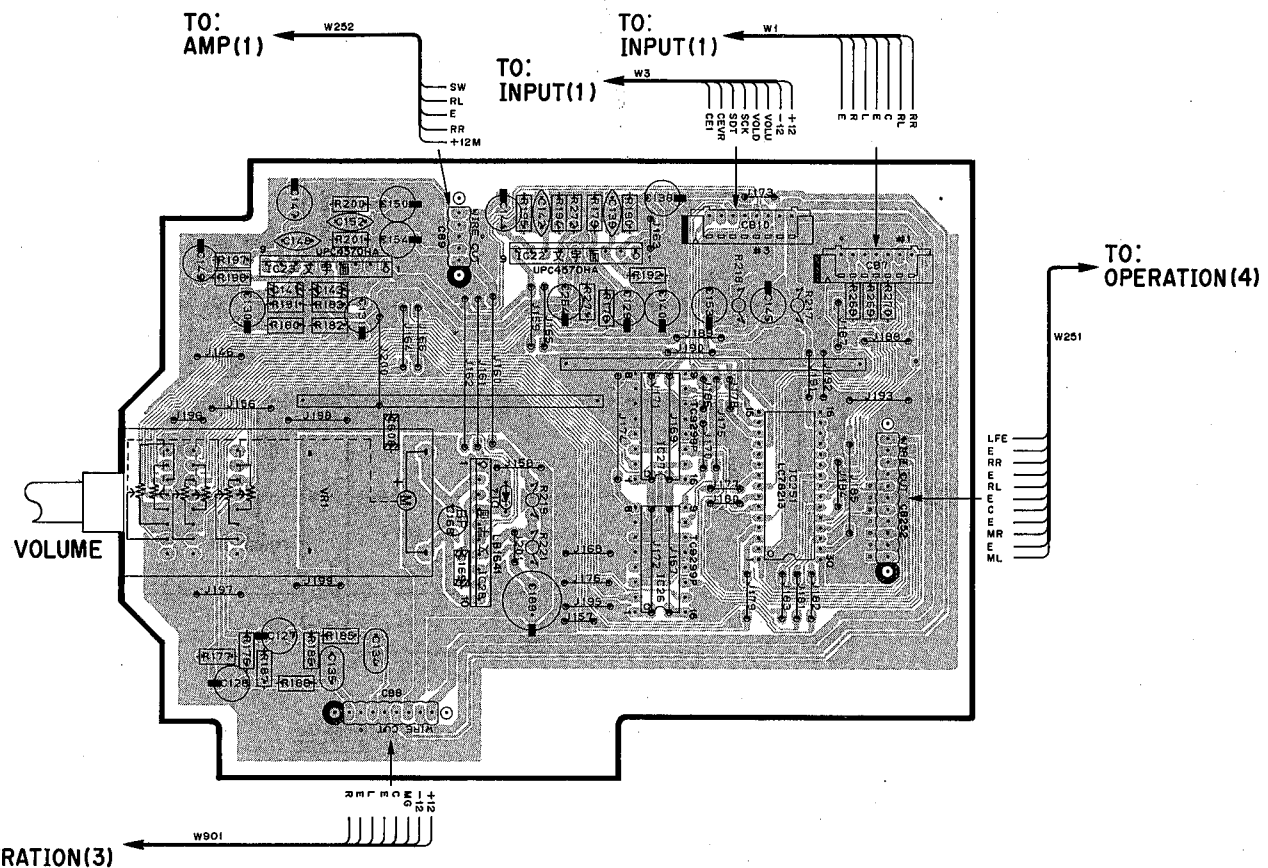

OPERATION P. C. B. (4)

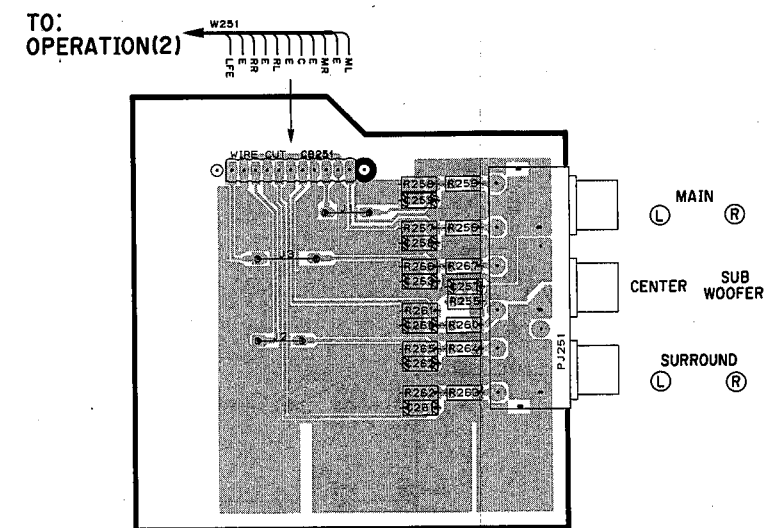

OPERATION P. C. B. (5)

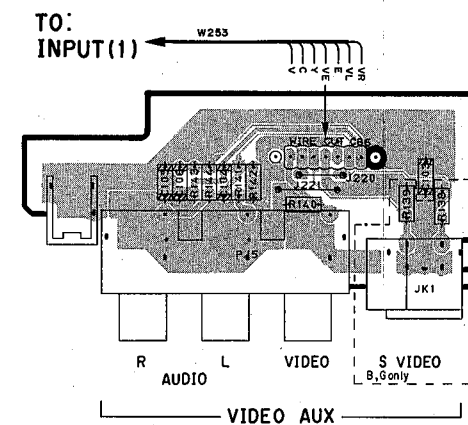

Semiconductor Location

Ref. No.	Location
D14	B3
IC22	C2
IC23	B2
IC26	C3
IC27	C3
IC28	B3
IC251	C3

BLOCK DIAGRAM

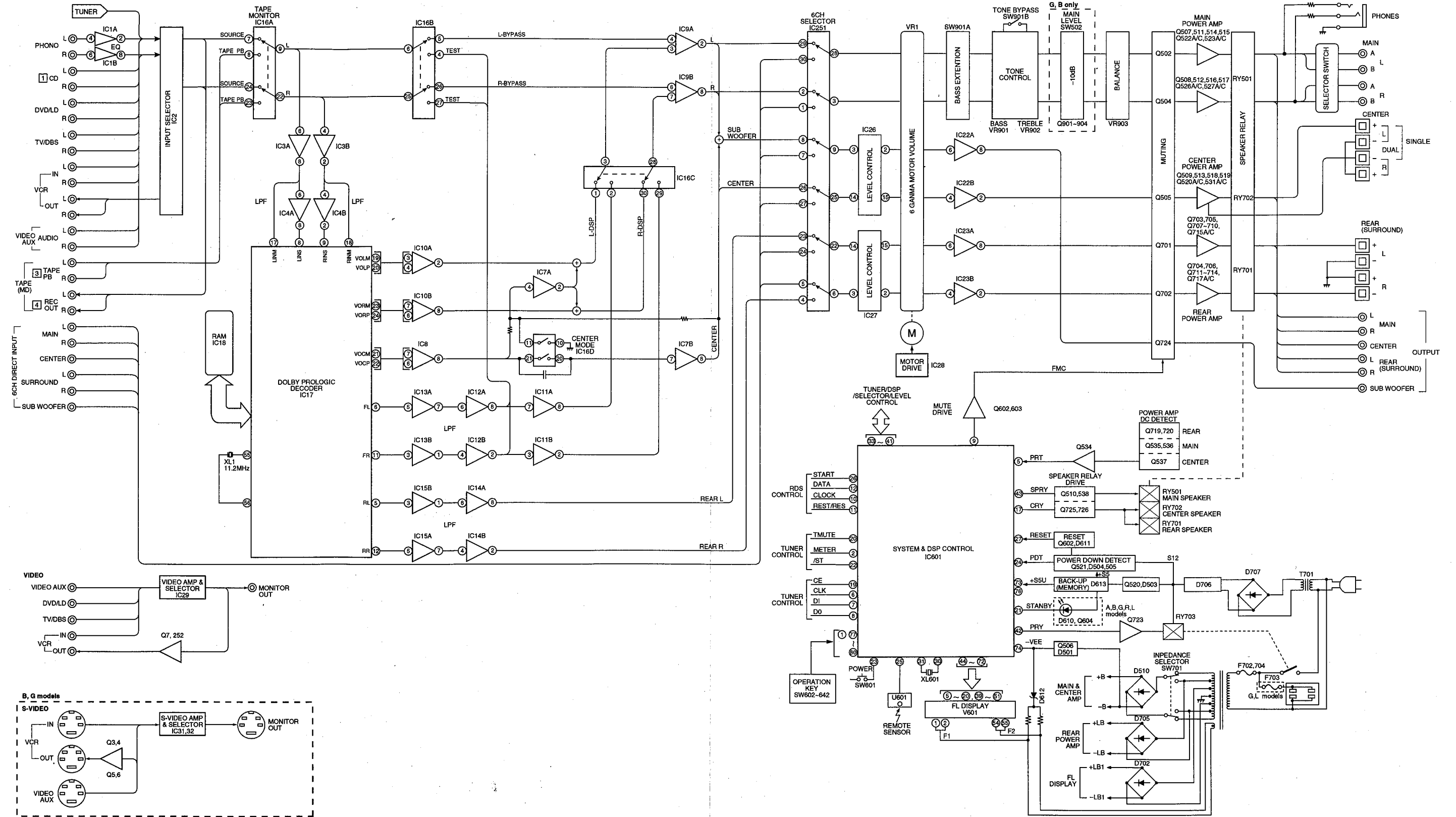

■ BLOCK DIAGRAM

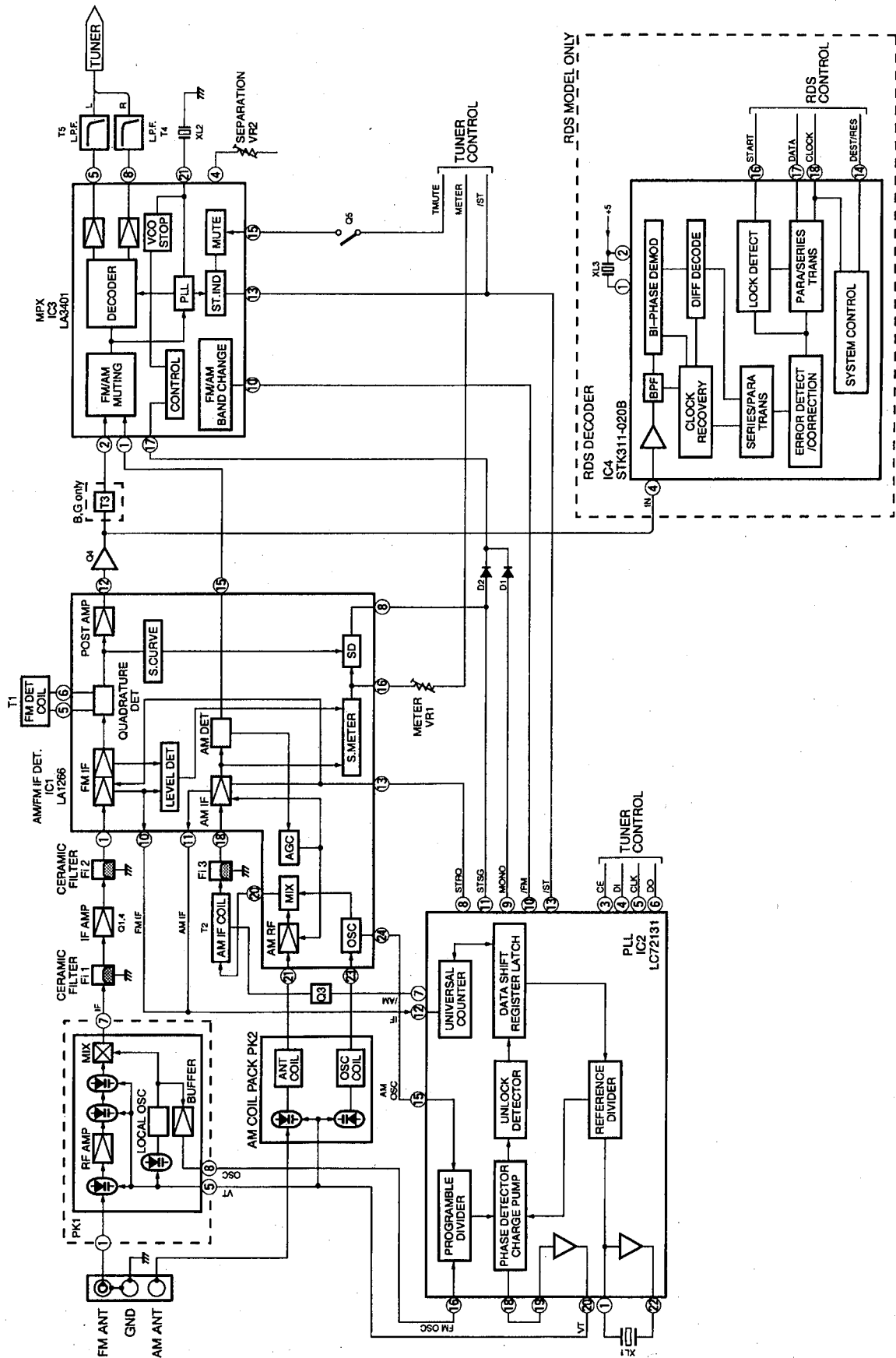

■ IC BLOCK

● INPUT P. C. B.

IC1,3,4,7~12,14 : μ PC4570HA
Dual OP-Amp

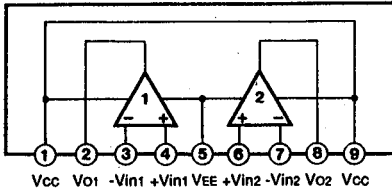

IC2 : LC78211

Analog Function Switch

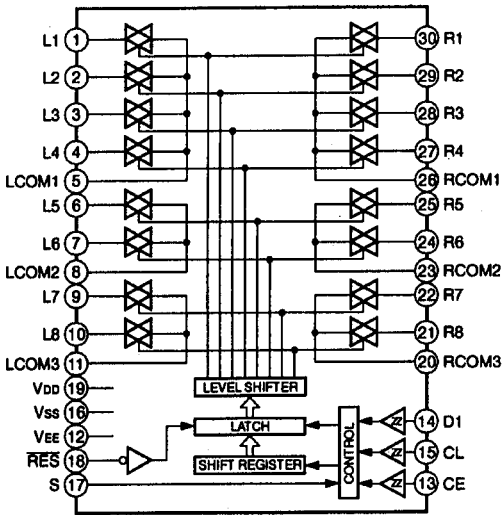

IC13 : NJM4558LD

IC15 : NJM4558L

Dual OP-Amp

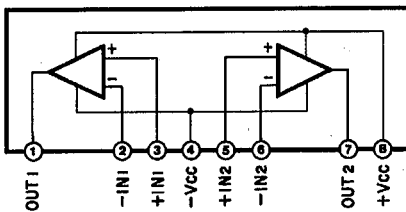

IC29,31,32 : LA7956

Video Switch

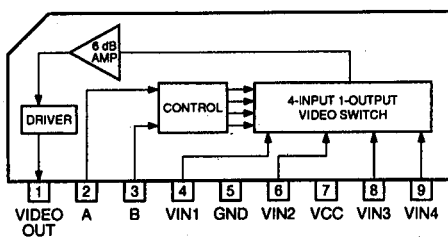

IC16 : LC78213

Analog Function Switch

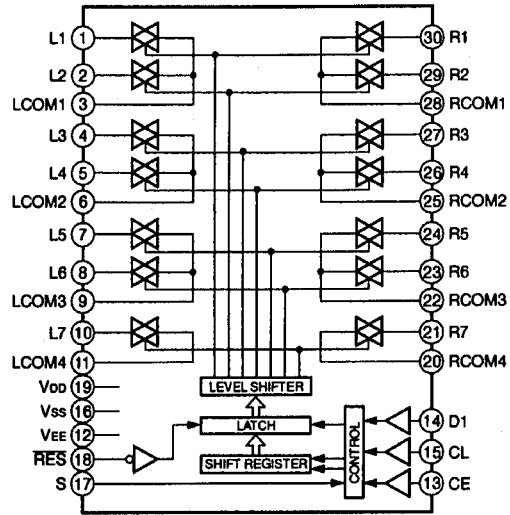

IC17 : YSS203B-F

Dolby PROLOGIC Decoder

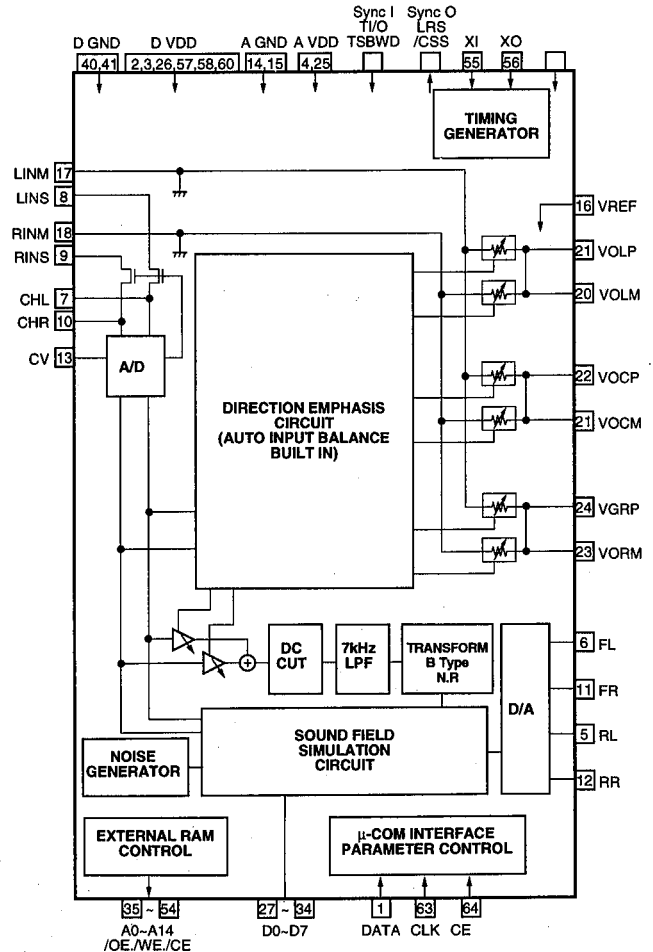

IC18 : LH5P832D-10
256K Pseudo Static RAM

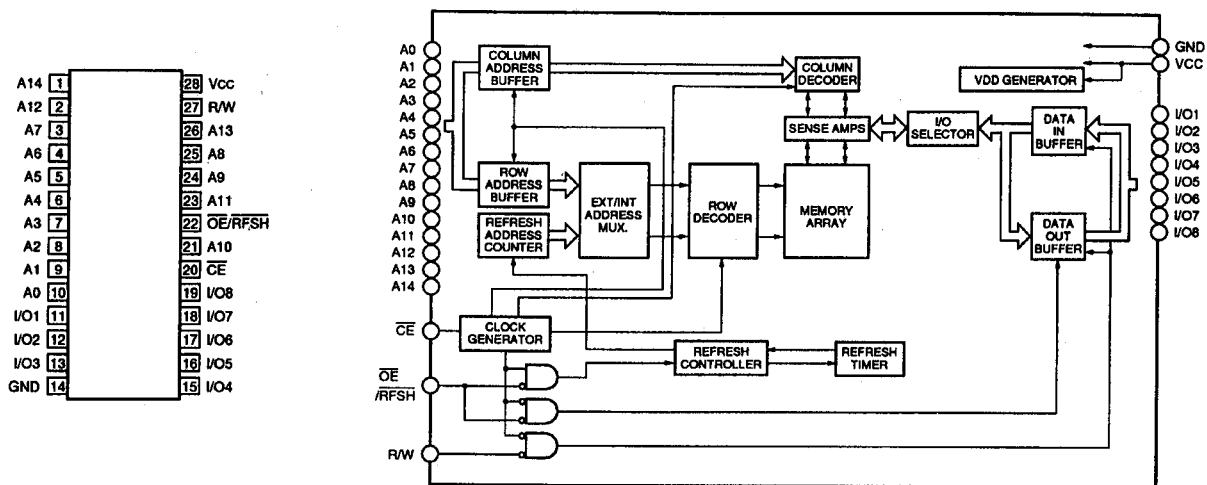

● **OPERATION P. C. B.**
IC22 23 : μPC4570HA
Dual OP-Amp

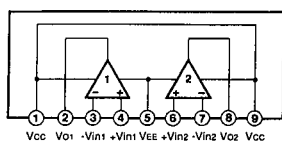

IC28 : LB1641
Motor Drive

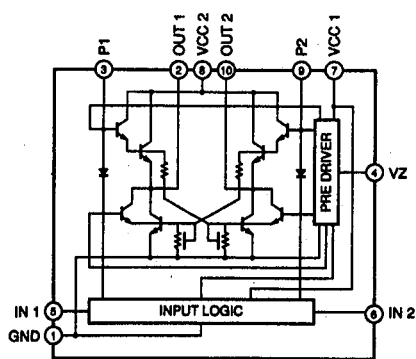

IC26, 27: TC9299P
Electric Volume

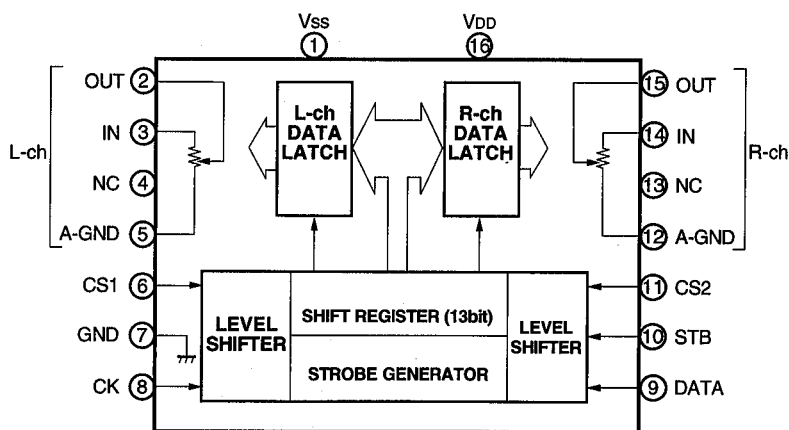

IC251 : LC78213
Analog Function Switch

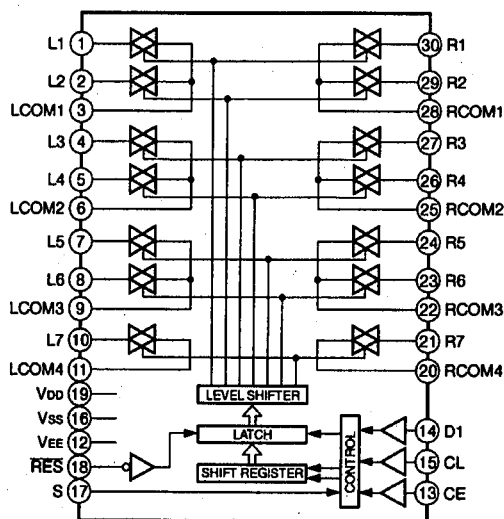

IC601: M38172M4-192FP (U, C, R, A, L models)
M38177MC-068FP (B, G models)
 → See page 33, 34

● **TUNER P. C. B.**

- IC1 : LA1266** → See page 38
- IC2 : LC72131** → See page 38
- IC3 : LA3401** → See page 38
- IC4 : STK311-020B** → See page 38

■ μ -COM DATA

IC601: M38172M4-192FP (U, C, R, A, L models)
 M38177MC-068FP (B, G models)

8 bit μ -COM

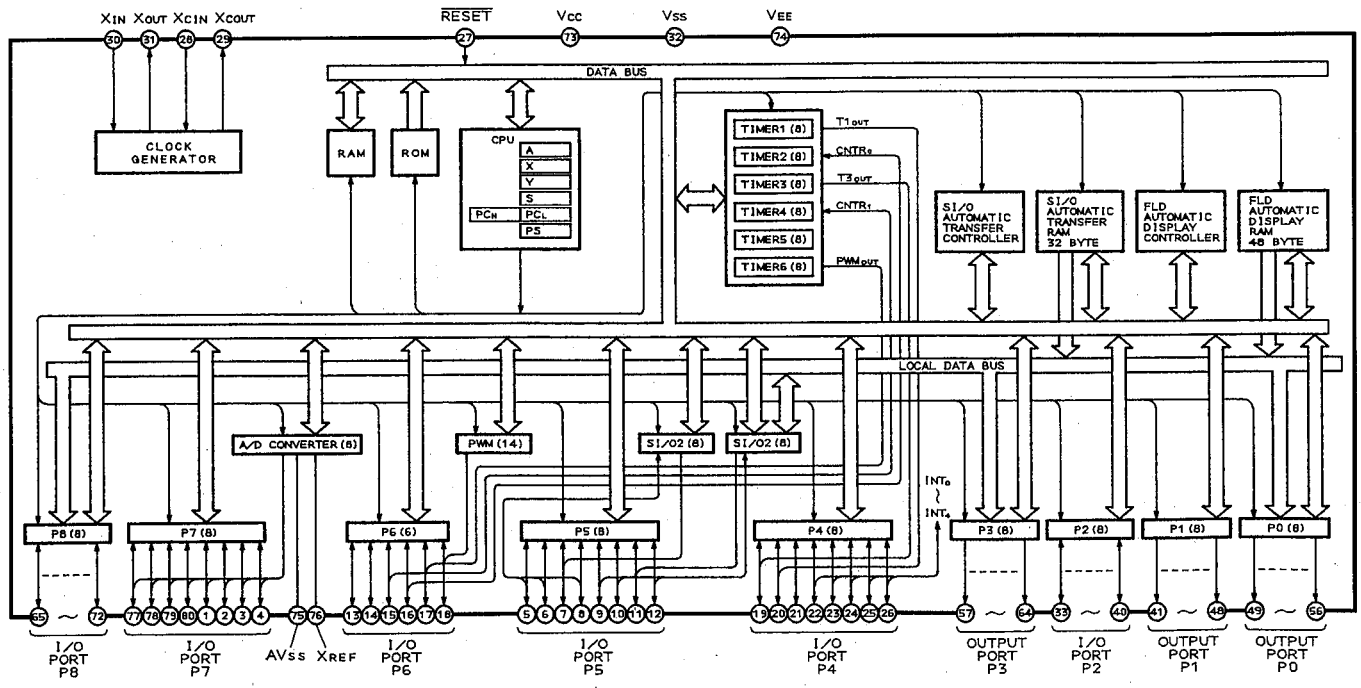
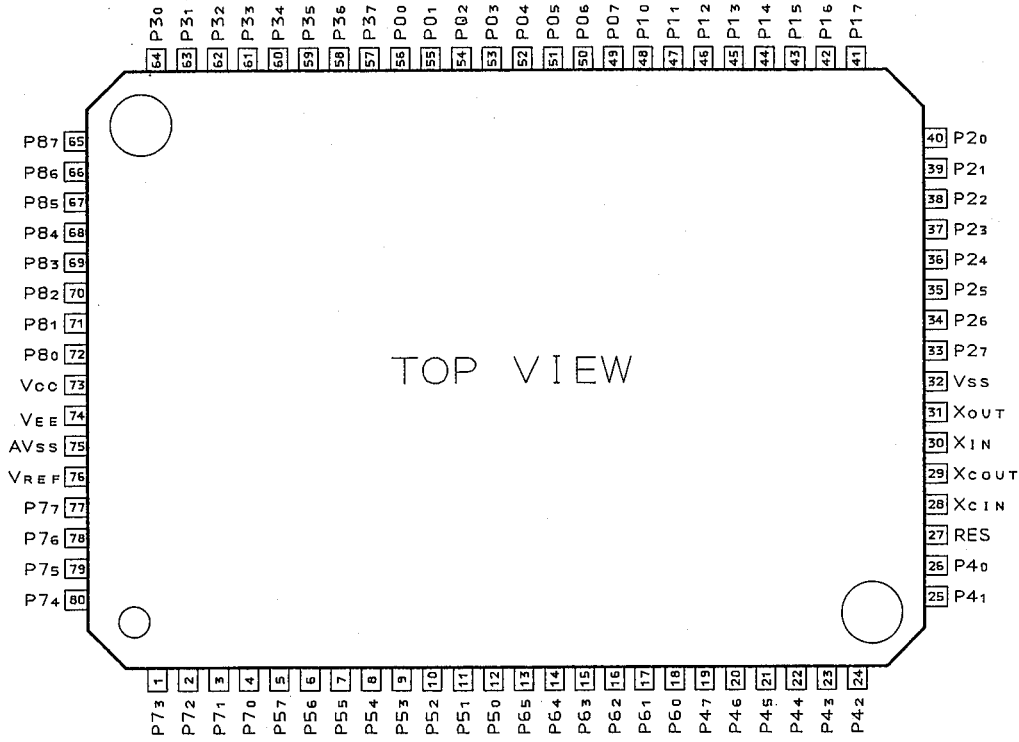

No.	Port	I/O	Function	Logic
1	P73	I	Key input 1 (A/D)	
2	P72	I	Meter input	
3	P71	I	Protection 1 detect	*
4	P70	I	Protection 2 detect	*
5	P57	I	Protection 3 detect	*
6	P56	O	Serial clock 2	
7	P55	I	Serial data 2	
8	P54	I	D0 for Tuner	
9	P53	O	Full mute	L:ON
10	P52	I	Serial clock for RDS	
11	P51	I/O	Reset for RDS (V2 market)	
12	P50	I/O	Serial data for RDS(V1 market)	
13	P65	I	Detect for RDS (B,G models)	
14	P64		GND (Detect for DSP-A)	
15	P63		GND (Detect for model)	
16	P62		GND (Detect for model)	
17	P61	O	Center and Rear Speaker relay	*
18	P60		OPEN	
19	P47	O	Chip enable for Tuner	
20	P46	O	Tuner mute	L:ON
21	P45	I/O	Standby	L:LED ON
22	P44	I	Stereo for Tuner	L:STEREO
23	P43	I	Power switch	H:ON
24	P42	I	Power down detect	L:DOWN
25	P41	I	Remote control signal	INT1
26	P40	I	RDS start trigger	INT0
27	RES		RESET	
28	X _{CIN}		GND	
29	X _{COU}		OPEN	
30	X _{IN}		6.3MHz	
31	X _{OUT}		6.3MHz	
32	V _{SS}		GND	
33	P27	O	Video selector A	VSEL1
34	P26	O	Video selector B	VSEL2
35	P25	O	Not VCR select	H:VCR
36	P24	O	Chip enable for volume	
37	P23	O	Chip enable for Input select	
38	P22	O	Chip enable for DSP	
39	P21	O	Volume up	
40	P20	O	Volume down	

No.	Port	I/O	Function	Logic
80	P74	I	Key input 2 (A/D)	
79	P75	I	Key input 3 (A/D)	
78	P76	I	Key input 4 (A/D)	
77	P77	I	Key input 5 (A/D)	
76	V _{REF}		+5V	
75	AV _{SS}		GND	
74	V _{EE}		-24V	
73	V _{CC}		+5V	
72	P80	O	FL SEGMENT 1	H:ON
71	P81	O	FL SEGMENT 2	H:ON
70	P82	O	FL SEGMENT 3	H:ON
69	P83	O	FL SEGMENT 4	H:ON
68	P84	O	FL SEGMENT 5	H:ON
67	P85	O	FL SEGMENT 6	H:ON
66	P86	O	FL SEGMENT 7	H:ON
65	P87	O	FL SEGMENT 8	H:ON
64	P30	O	FL SEGMENT 9	H:ON
63	P31	O	FL SEGMENT 10	H:ON
62	P32	O	FL SEGMENT 11	H:ON
61	P33	O	FL SEGMENT 12	H:ON
60	P34	O	FL SEGMENT 13	H:ON
59	P35	O	FL SEGMENT 14	H:ON
58	P36	O	FL SEGMENT 15	H:ON
57	P37	O	FL SEGMENT 16	H:ON
56	P00	O	FL DIGIT 13	H:ON
55	P01	O	FL DIGIT 12	H:ON
54	P02	O	FL DIGIT 11	H:ON
53	P03	O	FL DIGIT 10	H:ON
52	P04	O	FL DIGIT 9	H:ON
51	P05	O	FL DIGIT 8	H:ON
50	P06	O	FL DIGIT 7	H:ON
49	P07	O	FL DIGIT 6	H:ON
48	P10	O	FL DIGIT 5	H:ON
47	P11	O	FL DIGIT 4	H:ON
46	P12	O	FL DIGIT 3	H:ON
45	P13	O	FL DIGIT 2	H:ON
44	P14	O	FL DIGIT 1	H:ON
43	P15	O	Speaker relay	H:ON
42	P16	O	Power relay	H:ON
41	P17	O	DSP serial select	H:DSP

* OPERATION AND LOGIC

No.	Function	Operation and Logic	
3	Protection 1 detect input	Power Voltage anomalous detect.	A/D (37~74)/256 in normal. Power ON and 2 seconds after detect start. Detect at 50ms wait.
4	Protection 2 detect input	Amplifier DC anomalous detect.	A/D (3~35)/256 in normal. Power ON and 2 seconds after detect start.
5	Protection 3 detect input	Amplifier Over-current anomalous detect.	Power ON detect start.
17	Center and Rear speaker relay output	H:EFFECT ON or 6CH or Test mode.	

■ DISPLAY DATA

● V601 : 13-BT-149GK (VV485500)

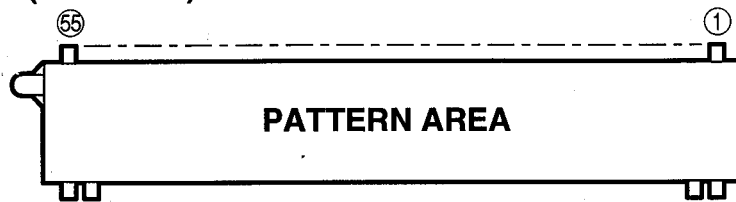

● PIN CONNECTION

Pin No.	1	2	3	4	5	6	7	8	9	10	11	12	13	14	15	16	17	18	19	20	21	22	23	24	25
CONNECTION	F1	F1	NP	NP	P1	P2	P3	P4	P5	P6	P7	P8	P9	P10	P11	P12	P13	P14	P15	P16	NC	NC	NC	NC	NC

Pin No.	26	27	28	29	30	31	32	33	34	35	36	37	38	39	40	41	42	43	44	45	46	47	48	49	50	
CONNECTION	NC	NC	NC	NC	NC	NC	NC	NC	NC	NC	NC	NC	NC	NC	13G	12G	11G	10G	9G	8G	7G	6G	5G	4G	3G	2G

Pin No.	51	52	53	54	55
CONNECTION	1G	NC	NP	F2	F2

NOTE 1) F1, F2 Filament
 2) NP No pin
 3) NC No connection
 4) DL Datum Line
 5) 1G~13G Grid

● GRID ASSIGNMENT

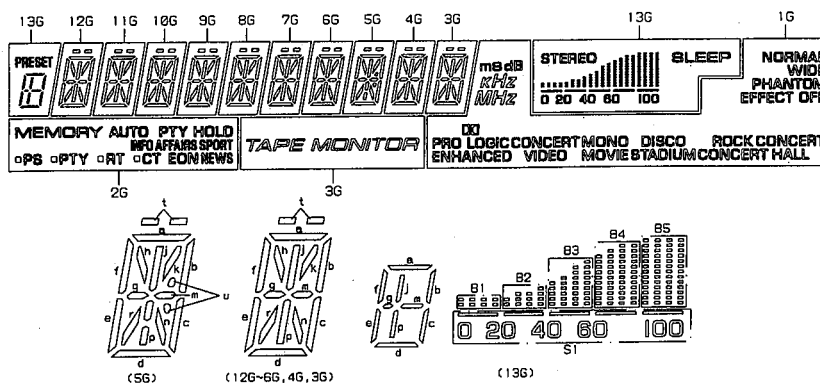

● ANODE CONNECTION

	13G	12G~6G	5G	4G	3G	2G	1G
P1	a	a	a	a	a	MEMORY	NORMAL
P2	b, c	b	b	b	b	AUTO	WIDE
P3	d	c	c	c	c	PTY HOLD	PHANTOM
P4	e, f	d	d	d	d	SPORT	EFFECT OFF
P5	g	e	e	e	e	AFFAIRS	ROCK CONCERT
P6	j, p	f	f	f	f	INFO	CONCERT HALL
P7	m	g	g	g	g	NEWS	DISCO
P8	PRESET	h	h	h	h	EON	STADIUM
P9	STEREO	j	j	j	j	CT	MONO MOVIE
P10	B1	k	k	k	k	□ (CT)	CONCERT VIDEO
P11	B2	m	m	m	m	RT	PRO LOGIC
P12	B3	n	n	n	n	□ (RT)	ENHANCED
P13	B4	p	p	p	p	PTY	dB
P14	B5	r	r	r	r	□ (PTY)	ms
P15	S1	t	t	t	t	PS	KHz
P16	SLEEP	-	u	-	TAPE MONITOR	□ (PS)	MHz

■ SCHEMATIC DIAGRAM (INPUT/OPERATION)

PIN CONNECTION DIAGRAM OF TRANSISTORS, DIODES AND ICs.

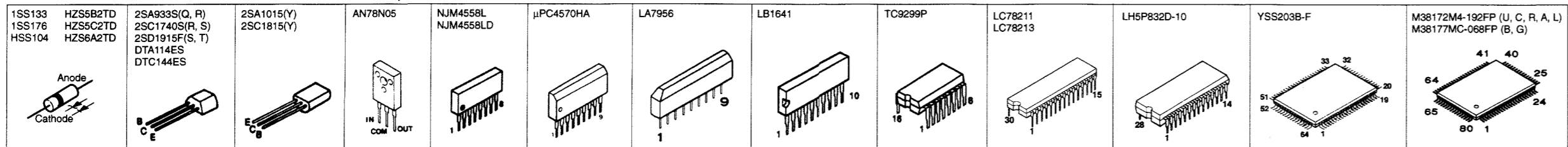

● IC BLOCK → See page 31-32

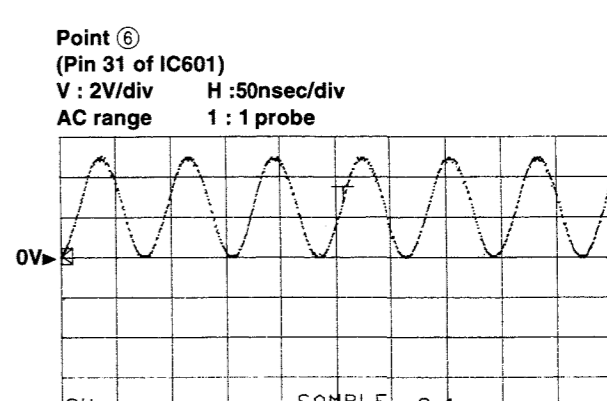
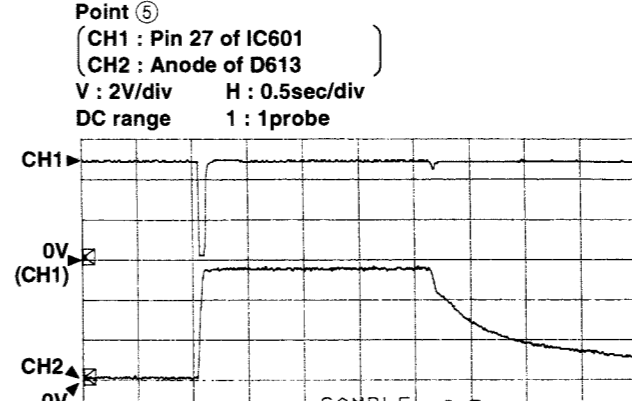
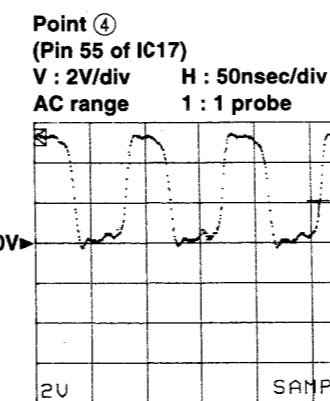

With the POWER switch turned ON, connect the power cord to the AC outlet.
Disconnect the power cord from the AC outlet.
This waveform is not available by pushing the power switch ON and OFF.

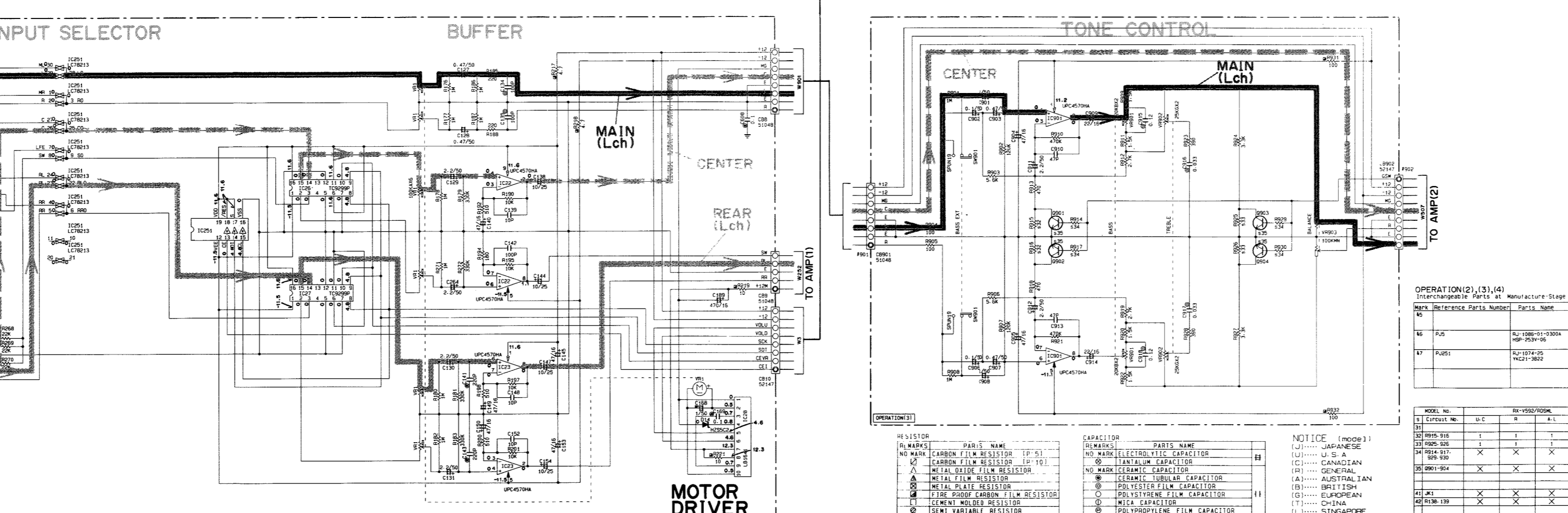
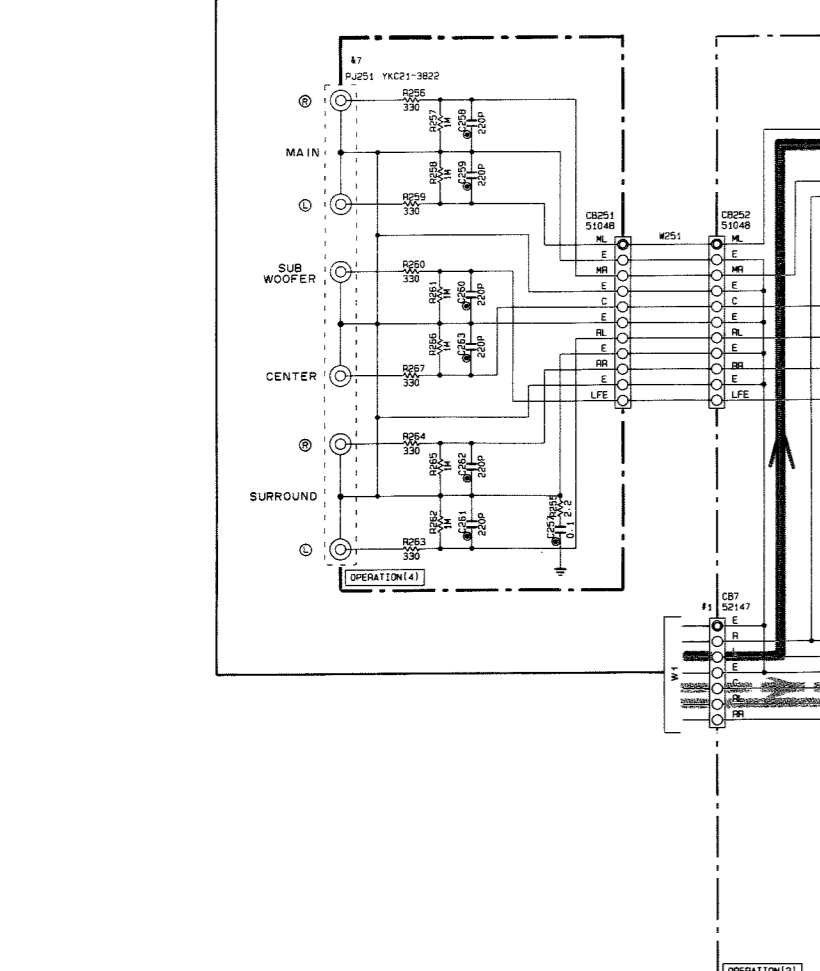
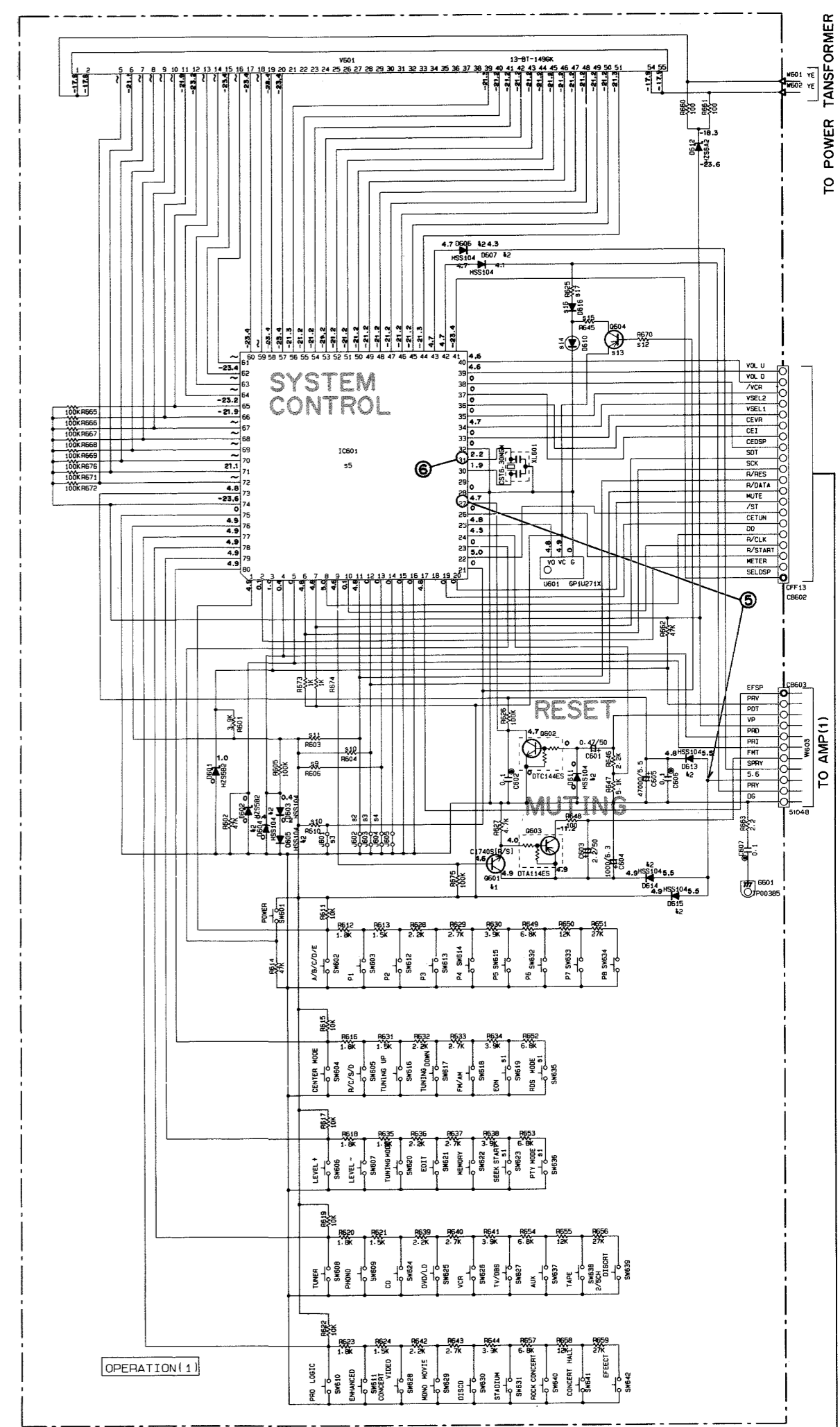
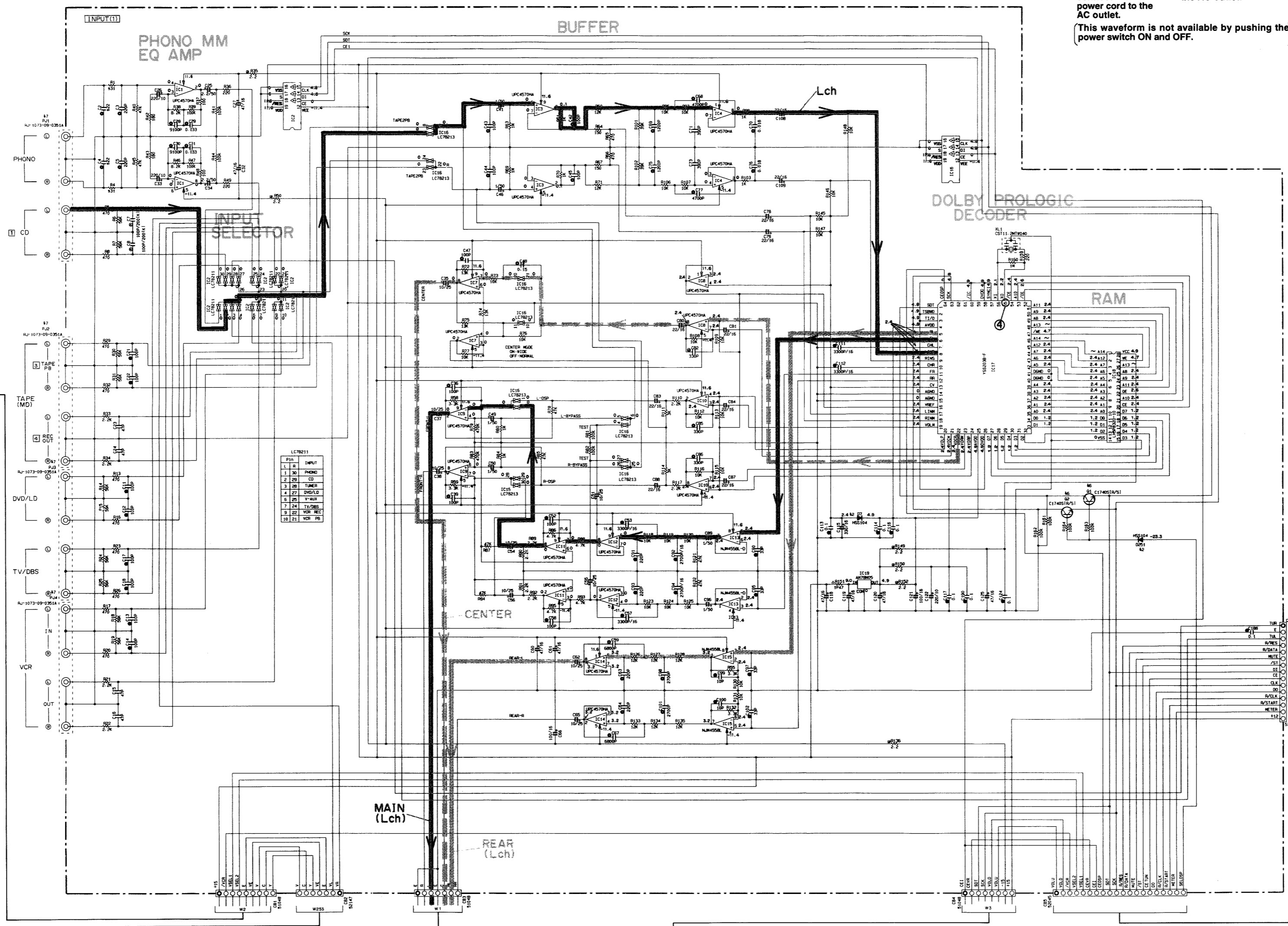
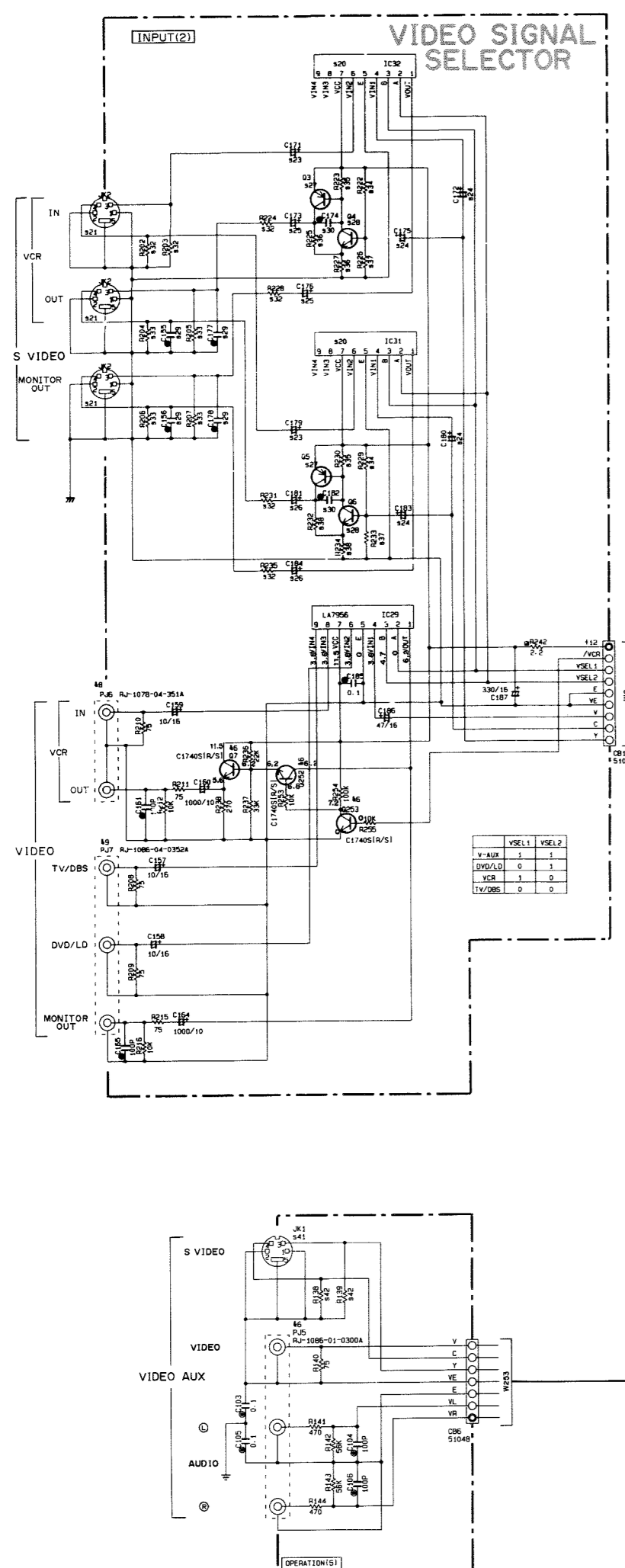

INPUT Interchangeable Parts at Manufacture Stage

Part Reference Parts Number	Parts Name
M 07 201	RES-50K
M 07 202	RES-10K
M 07 203	RES-100K
M 07 204	RES-100K
M 07 205	RES-100K
M 07 206	RES-100K
M 07 207	RES-100K
M 07 208	RES-100K
M 07 209	RES-100K
M 07 210	RES-100K
M 07 211	RES-100K
M 07 212	RES-100K
M 07 213	RES-100K
M 07 214	RES-100K
M 07 215	RES-100K
M 07 216	RES-100K
M 07 217	RES-100K
M 07 218	RES-100K
M 07 219	RES-100K
M 07 220	RES-100K
M 07 221	RES-100K
M 07 222	RES-100K
M 07 223	RES-100K
M 07 224	RES-100K
M 07 225	RES-100K
M 07 226	RES-100K
M 07 227	RES-100K
M 07 228	RES-100K
M 07 229	RES-100K
M 07 230	RES-100K
M 07 231	RES-100K
M 07 232	RES-100K
M 07 233	RES-100K
M 07 234	RES-100K

OPERATION(1) Interchangeable Parts at Manufacture Stage

Part Reference Parts Number	Parts Name
M 07 201	RES-50K
M 07 202	RES-10K
M 07 203	RES-100K
M 07 204	RES-100K
M 07 205	RES-100K
M 07 206	RES-100K
M 07 207	RES-100K
M 07 208	RES-100K
M 07 209	RES-100K
M 07 210	RES-100K
M 07 211	RES-100K
M 07 212	RES-100K
M 07 213	RES-100K
M 07 214	RES-100K
M 07 215	RES-100K
M 07 216	RES-100K
M 07 217	RES-100K
M 07 218	RES-100K
M 07 219	RES-100K
M 07 220	RES-100K
M 07 221	RES-100K
M 07 222	RES-100K
M 07 223	RES-100K
M 07 224	RES-100K
M 07 225	RES-100K
M 07 226	RES-100K
M 07 227	RES-100K
M 07 228	RES-100K
M 07 229	RES-100K
M 07 230	RES-100K
M 07 231	RES-100K
M 07 232	RES-100K
M 07 233	RES-100K
M 07 234	RES-100K

OPERATION(2), (3), (4) Interchangeable Parts at Manufacture Stage

Part Reference Parts Number	Parts Name
M 07 201	RES-50K
M 07 202	RES-10K
M 07 203	RES-100K
M 07 204	RES-100K
M 07 205	RES-100K
M 07 206	RES-100K
M 07 207	RES-100K
M 07 208	RES-100K
M 07 209	RES-100K
M 07 210	RES-100K
M 07 211	RES-100K
M 07 212	RES-100K
M 07 213	RES-100K
M 07 214	RES-100K
M 07 215	RES-100K
M 07 216	RES-100K
M 07 217	RES-100K
M 07 218	RES-100K
M 07 219	RES-100K
M 07 220	RES-100K
M 07 221	RES-100K
M 07 222	RES-100K
M 07 223	RES-100K
M 07 224	RES-100K
M 07 225	RES-100K
M 07 226	RES-100K
M 07 227	RES-100K
M 07 228	RES-100K
M 07 229	RES-100K
M 07 230	RES-100K
M 07 231	RES-100K
M 07 232	RES-100K
M 07 233	RES-100K
M 07 234	RES-100K

NOTICE (MODE1)
① JAPAN
② U.S.A.
③ CANADA
④ AUSTRALIA
⑤ EUROPEAN
⑥ CHINA
⑦ SINGAPORE

SCHEMATIC DIAGRAM (AMP/INPUT)

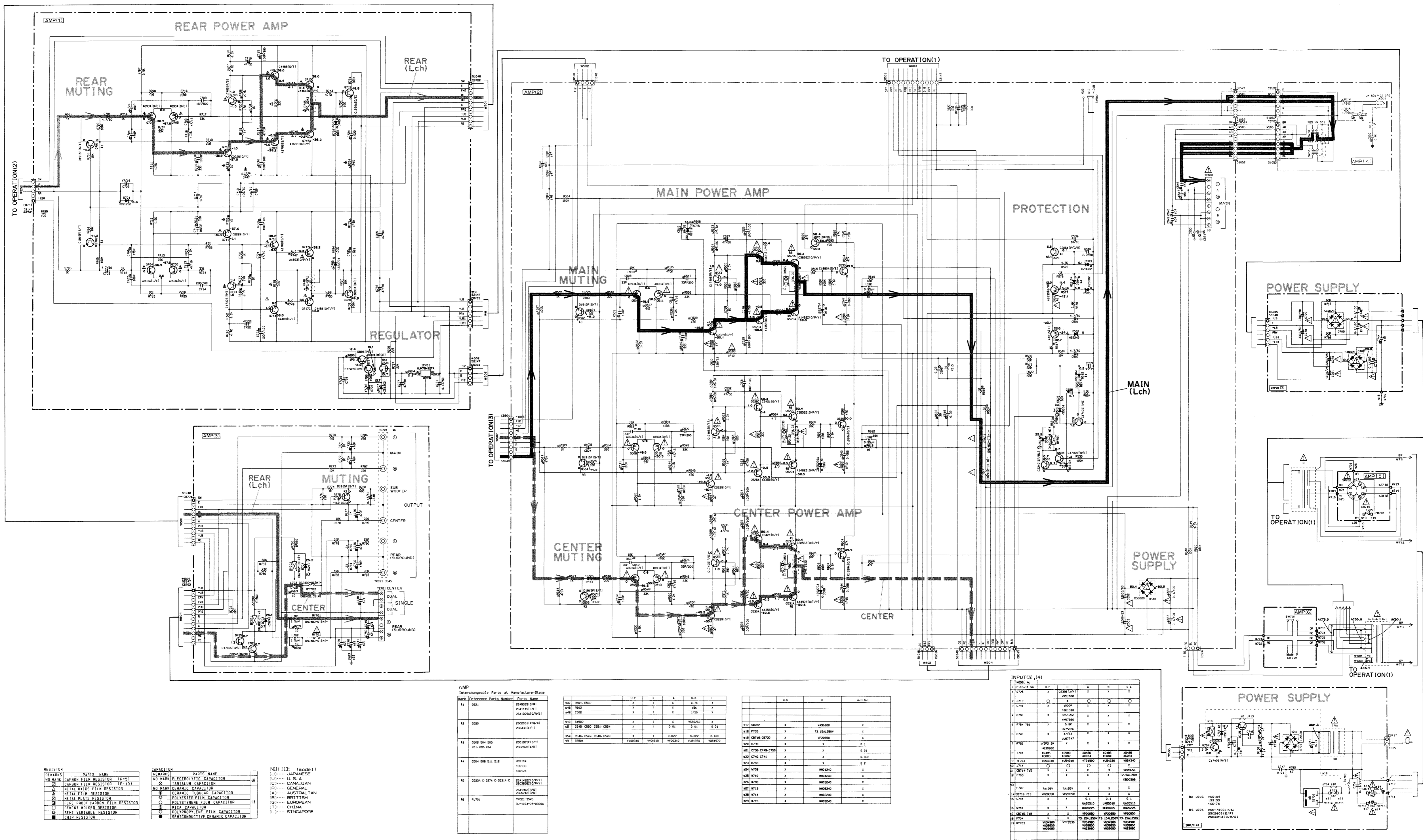

AMP
Interchangeable Parts at Manufacture-Stage

Part No.	Reference Part No.	Part Name
81	900	2SA4903A(P, R)
		2SA1389A(P, R/S)
82	900	2SC2881A(P, R/S)
		2SC2881A(P, R)
83	958 504-505	2SD1919(P, S)
		2SD2814(P, S)
84	958 505-511-512	H5514
		15S13
		15S14
85	957A-C-577A-C-578A-C	2SA4903A(P, R)
		2SC2881A(P, R/S)
86	PU71	W21-3945
		NJ-1214-39-3004

U.C.	R	A	B	S	L
147	R021-R022	X	X	X	X
148	R03	X	X	X	X
149	C02	X	X	X	X
150	SP02	X	X	X	X
151	C045-C050-C051-C054	X	X	X	X
152	C046-C047-C048-C049	X	X	X	X
153	T021	X	X	X	X

U.C.	R	A	B	S	L
117	SE702	X	X	X	X
118	ET05	X	X	X	X
119	OP105-OP109	X	X	X	X
120	CT06	X	X	X	X
121	CT06-CT07-CT08	X	X	X	X
122	CT09-CT41	X	X	X	X
123	W03	X	X	X	X
124	W09	X	X	X	X
125	W10	X	X	X	X
126	W16	X	X	X	X
127	W17	X	X	X	X
128	W18	X	X	X	X
129	W19	X	X	X	X

INPUT(3),(4)

MARK NO.	U.C.	R	A	B	S	L
1	CT101	X	X	X	X	X
2	CT13	X	X	X	X	X
3	CT45	X	X	X	X	X
4	CT08	X	X	X	X	X
5	W18-W19	X	X	X	X	X
6	CT46	X	X	X	X	X
7	CT09	X	X	X	X	X
8	CT10	X	X	X	X	X
9	CT11	X	X	X	X	X
10	CT12	X	X	X	X	X
11	CT13	X	X	X	X	X
12	CT14	X	X	X	X	X
13	CT15	X	X	X	X	X
14	CT16	X	X	X	X	X
15	CT17	X	X	X	X	X
16	CT18	X	X	X	X	X
17	CT19	X	X	X	X	X
18	CT20	X	X	X	X	X
19	CT21	X	X	X	X	X
20	CT22	X	X	X	X	X
21	CT23	X	X	X	X	X
22	CT24	X	X	X	X	X
23	CT25	X	X	X	X	X
24	CT26	X	X	X	X	X
25	CT27	X	X	X	X	X
26	CT28	X	X	X	X	X
27	CT29	X	X	X	X	X
28	CT30	X	X	X	X	X
29	CT31	X	X	X	X	X
30	CT32	X	X	X	X	X
31	CT33	X	X	X	X	X
32	CT34	X	X	X	X	X
33	CT35	X	X	X	X	X
34	CT36	X	X	X	X	X
35	CT37	X	X	X	X	X
36	CT38	X	X	X	X	X
37	CT39	X	X	X	X	X
38	CT40	X	X	X	X	X
39	CT41	X	X	X	X	X
40	CT42	X	X	X	X	X
41	CT43	X	X	X	X	X
42	CT44	X	X	X	X	X
43	CT45	X	X	X	X	X
44	CT46	X	X	X	X	X
45	CT47	X	X	X	X	X
46	CT48	X	X	X	X	X
47	CT49	X	X	X	X	X
48	CT50	X	X	X	X	X
49	CT51	X	X	X	X	X
50	CT52	X	X	X	X	X
51	CT53	X	X	X	X	X
52	CT54	X	X	X	X	X
53	CT55	X	X	X	X	X
54	CT56	X	X	X	X	X
55	CT57	X	X	X	X	X
56	CT58	X	X	X	X	X
57	CT59	X	X	X	X	X
58	CT60	X	X	X	X	X
59	CT61	X	X	X	X	X
60	CT62	X	X	X	X	X
61	CT63	X	X	X	X	X
62	CT64	X	X	X	X	X
63	CT65	X	X	X	X	X
64	CT66	X	X	X	X	X
65	CT67	X	X	X	X	X
66	CT68	X	X	X	X	X
67	CT69	X	X	X	X	X
68	CT70	X	X	X	X	X
69	CT71	X	X	X	X	X
70	CT72	X	X	X	X	X
71	CT73	X	X	X	X	X
72	CT74	X	X	X	X	X
73	CT75	X	X	X	X	X
74	CT76	X	X	X	X	X
75	CT77	X	X	X	X	X
76	CT78	X	X	X	X	X
77	CT79	X	X	X	X	X
78	CT80	X	X	X	X	X
79	CT81	X	X	X	X	X
80	CT82	X	X	X	X	X
81	CT83	X	X	X	X	X
82	CT84	X	X	X	X	X
83	CT85	X	X	X	X	X
84	CT86	X	X	X	X	X
85	CT87	X	X	X	X	X
86	CT88	X	X	X	X	X
87	CT89	X	X	X	X	X
88	CT90	X	X	X	X	X
89	CT91	X	X	X	X	X
90	CT92	X	X	X	X	X
91	CT93	X	X	X	X	X
92	CT94	X	X	X	X	X
93	CT95	X	X	X	X	X
94	CT96	X	X	X	X	X
95	CT97	X	X	X	X	X
96	CT98	X	X	X	X	X
97	CT99	X	X	X	X	X
98	CT100	X	X	X	X	X

RESISTOR

MARK	PART NAME
Ω	RESISTOR
□	METAL FILM RESISTOR (P-5)
▽	CARBON FILM RESISTOR (P-10)
△	METAL OXIDE FILM RESISTOR
◇	METAL FILM RESISTOR
◇	METAL PLATE RESISTOR
□	FILM RESISTOR
□	WIRE WOUND CARBON FILM RESISTOR
□	TEMP. VARIABLE RESISTOR
□	CHIP RESISTOR

CAPACITOR

MARK	PART NAME
⊖	ALUMINUM ELECTROLYTIC CAPACITOR
⊙	TANTALUM CAPACITOR
⊕	SEMICONDUCTIVE CERAMIC CAPACITOR
○	GENERAL CERAMIC CAPACITOR
○	POLYESTER FILM CAPACITOR
○	POLYSTYRENE FILM CAPACITOR
○	MICA CAPACITOR
○	POLYPROPYLENE FILM CAPACITOR
○	SEMICONDUCTIVE CERAMIC CAPACITOR

NOTICE (mode 1)

- (J)..... JAPANESE
- (U)..... U.S.A.
- (C)..... CANADIAN
- (G)..... GENERAL
- (A)..... AUSTRALIAN
- (B)..... BRITISH
- (O)..... EUROPEAN
- (T)..... CHINA
- (L)..... SINGAPORE

PIN CONNECTION DIAGRAM OF TRANSISTORS, DIODES AND ICs.

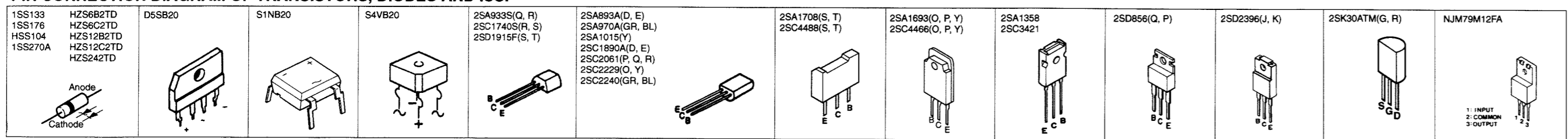

* All voltages are measured with a 10MΩ/2V DC electric volt meter.
 * Components having special characteristics are marked with a triangle (Δ) and must be replaced with parts having specifications equal to those originally installed.
 * Schematic diagram is subject to change without notice.

SCHEMATIC DIAGRAM (TUNER)

Each voltage given here represents that in the FM (98.1MHz, STEREO) reception mode but the one in the parentheses () is that in the AM (1080kHz, MAN'L) reception mode.

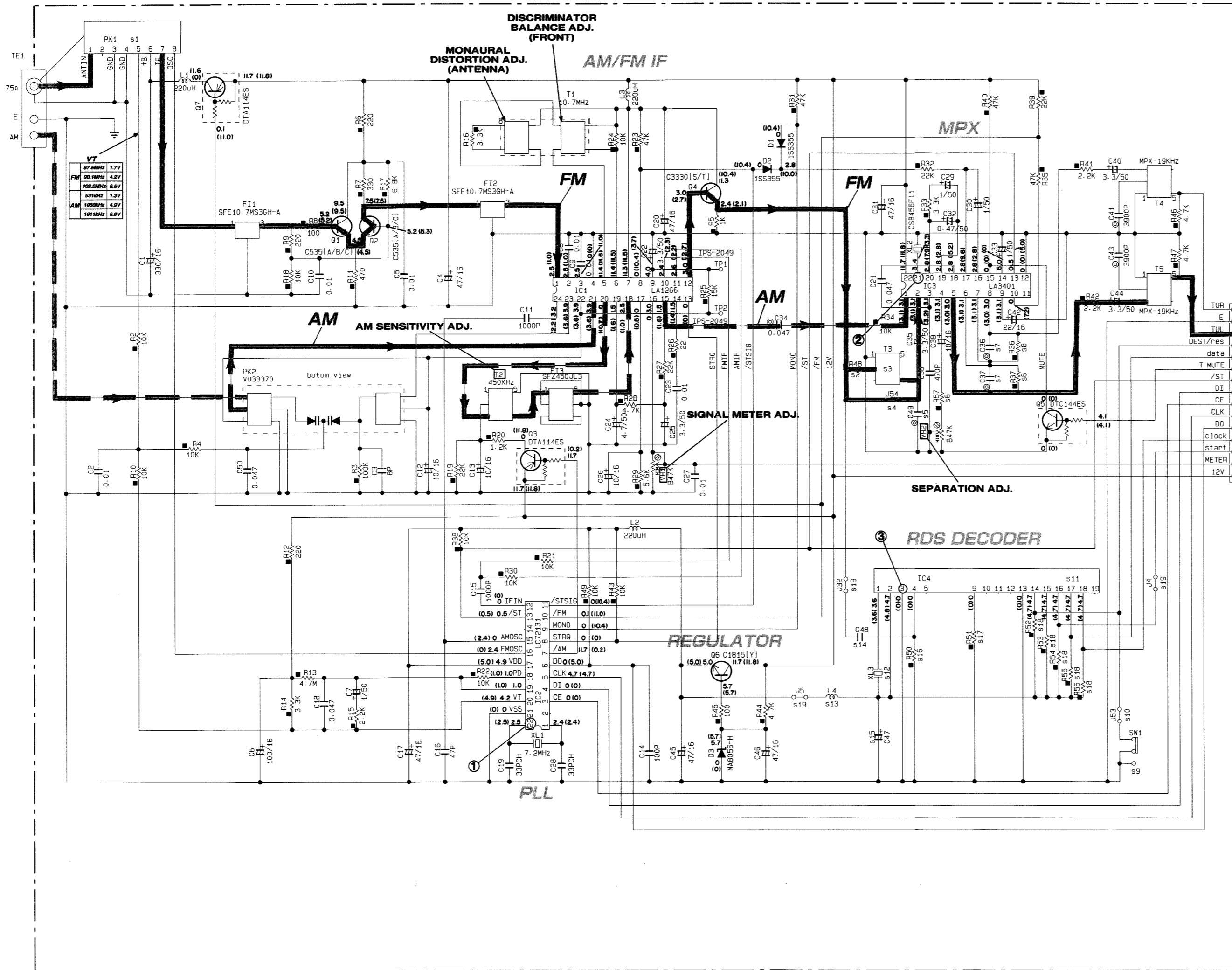

S	J	U.C	R	A. B. G. L	B. G/RDS
1	PK1	VR60440	VR24220	VR24220	V098760
2	R48				V098760
3	T3			XYA2	XYA2
4	J54				
5	C49				120P
6	H57	22K	22K	1K	1K
7	C36-37	680P	1000P	1000P	470P
8	R36-37	75K	75K	75K	100K
9	SM1				VS60260
10	J53				
11	IC4				STK311-020B
12	XL3				CSB456F33
13	L4				220UH
14	C48				100P
15	C47				47/16
16	R50				47K
17	R51				33K
18	R52-56				10K
19	J4.5.32				
20					

REMARKS	PARTS NAME
NO MARK	ELECTROLYTIC CAPACITOR
⊗	TANTALUM CAPACITOR
NO MARK	CERAMIC CAPACITOR
⊙	CERAMIC TUBULAR CAPACITOR
○	POLYESTER FILM CAPACITOR
○	POLYSTYRENE FILM CAPACITOR
○	MICA CAPACITOR
○	POLYPROPYLENE FILM CAPACITOR
⊕	SEMICONDUCTIVE CERAMIC CAPACITOR

REMARKS	PARTS NAME
NO MARK	CARBON FILM RESISTOR (P=5)
△	CARBON FILM RESISTOR (P=10)
△	METAL OXIDE FILM RESISTOR
△	METAL FILM RESISTOR
△	METAL PLATE RESISTOR
△	FIRE PROOF CARBON FILM RESISTOR
□	CEMENT MOLDED RESISTOR
⊕	SEMI VARIABLE RESISTOR
■	CHIP RESISTOR

NOTICE (model)
 (J)..... JAPANESE
 (U)..... U. S. A
 (C)..... CANADIAN
 (R)..... GENERAL
 (A)..... AUSTRALIAN
 (B)..... BRITISH
 (G)..... EUROPEAN
 (T)..... CHINA
 (L)..... SINGAPORE

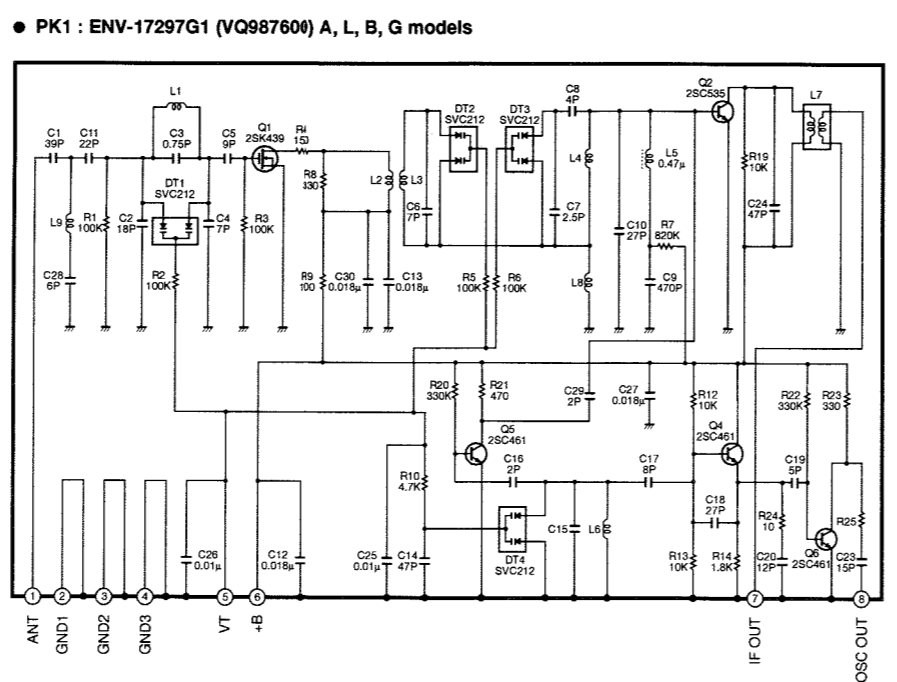
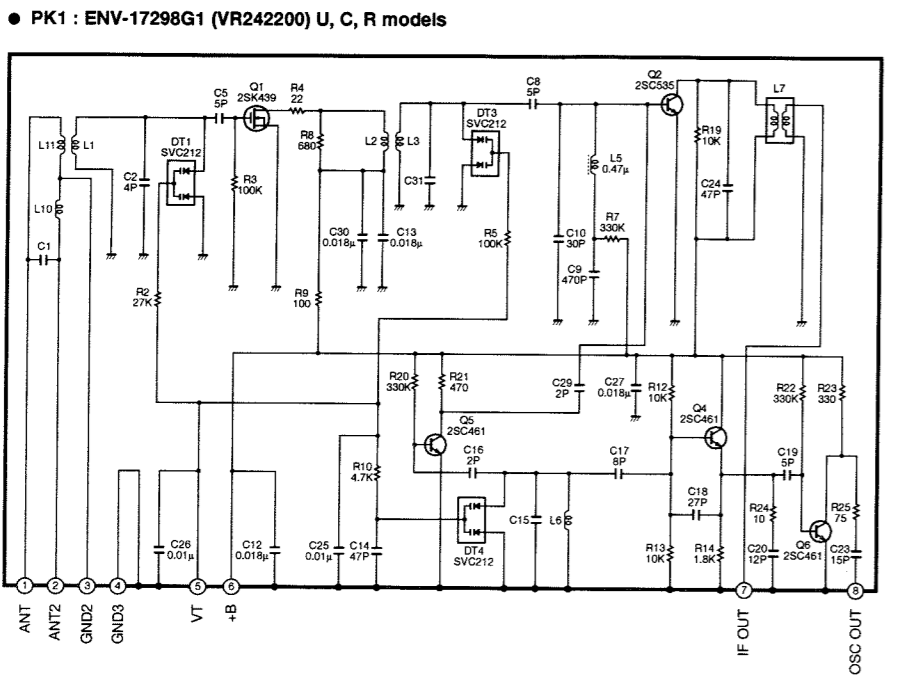
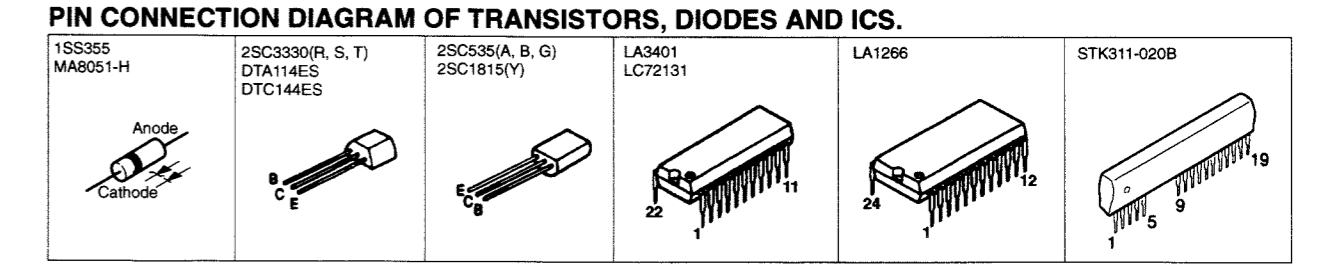
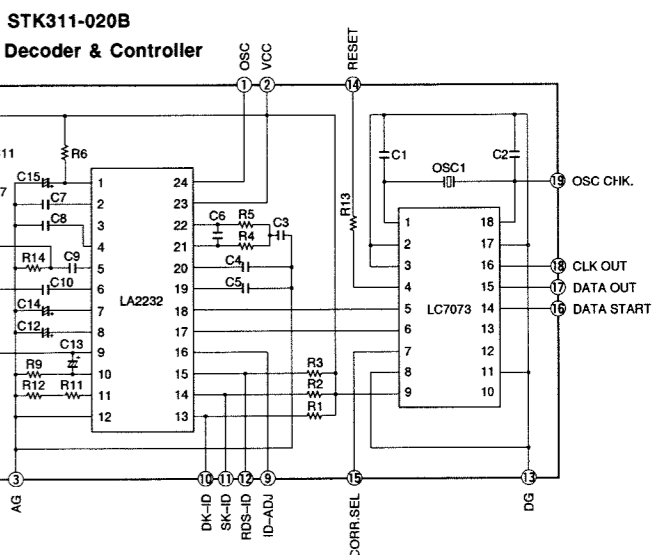
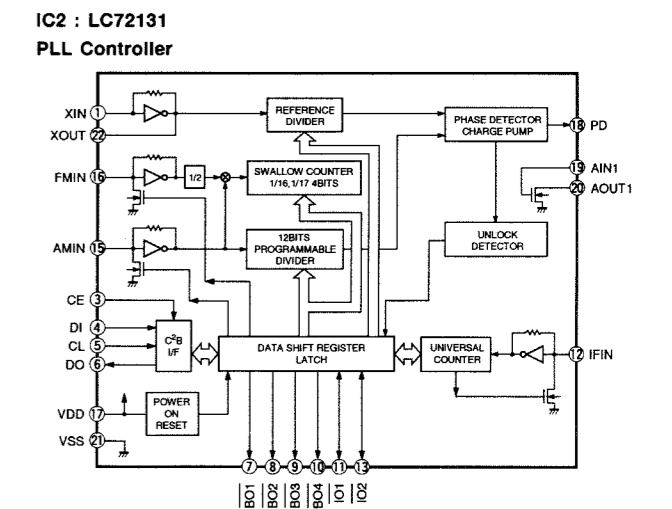
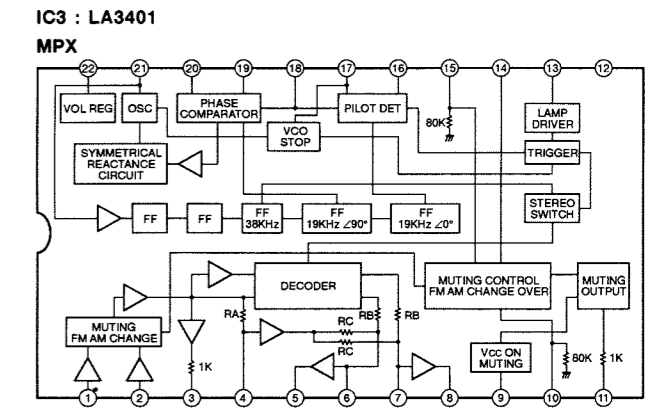
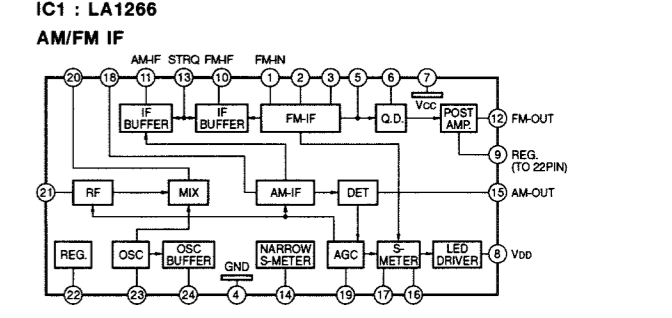

Point ① (Pin22 of IC2) FM reception
 V : 2V/div H : 50nsec/div
 DC range 1 : 1 probe

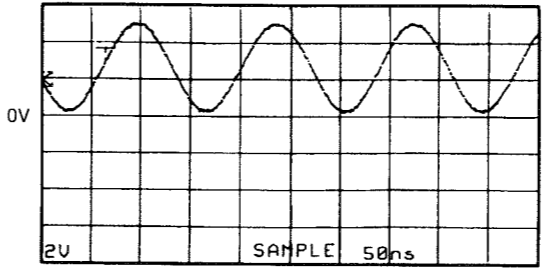

Point ② (Pin21 of IC3)
 V : 2V/div H : 1µsec/div
 DC range 1 : 1 probe

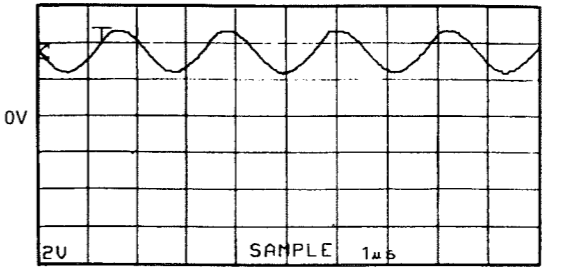

Point ③ (Pin1 of IC4)
 V : 5V/div H : 1µsec/div
 DC range 1 : 1 probe

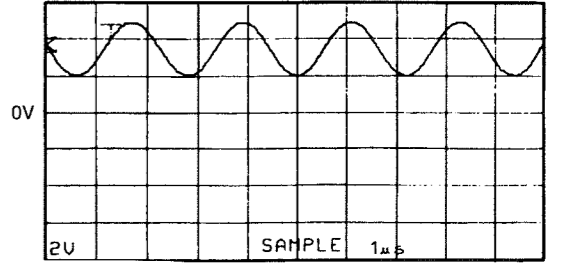

* All voltages are measured with a 10MΩ/V DC electric voltmeter.
 * Components having special characteristics are marked △ and must be replaced with parts having specifications equal to those originally installed.
 * Schematic diagram is subject to change without notice.

PARTS LIST

■ ELECTRICAL PARTS

■ WARNING

Components having special characteristics are marked Δ and must be replaced with parts having specifications equal to those originally installed.

- Carbon resistors (1/6W or 1/4W) are not included in the ELECTRICAL PARTS List. For the part Nos. of the carbon resistors, refer to the last page.

ABBREVIATIONS IN THIS LIST ARE AS FOLLOWS:

C. A. EL. CHP	: CHIP ALUMI. ELECTROLYTIC CAP	LED. DSPLY	: LED DISPLAY
C. CE	: CERAMIC CAP	LED. INFRD	: LED, INFRARED
C. CE. ARRAY	: CERAMIC CAP ARRAY	MODUL. RF	: MODULATOR, RF
C. CE. CHP	: CHIP CERAMIC CAP	PHOT. CPL	: PHOTO COUPLER
C. CE. ML	: MULTILAYER CERAMIC CAP	PHOT. INTR	: PHOTO INTERRUPTER
C. CE. M. CHP	: CHIP MULTILAYER CERAMIC CAP	PHOT. RFLCT	: PHOTO REFLECTOR
C. CE. SAFTY	: RECOGNIZED CERAMIC CAP	PIN. TEST	: PIN, TEST POINT
C. CE. TUBLR	: CERAMIC TUBULAR CAP	PLST. RIVET	: PLASTIC RIVET
C. CE. SMI	: SEMI CONDUCTIVE CERAMIC CAP	R. ARRAY	: RESISTOR ARRAY
C. EL	: ELECTROLYTIC CAP	R. CAR	: CARBON RESISTOR
C. MICA	: MICA CAP	R. CAR. CHP	: CHIP RESISTOR
C. ML. FLM	: MULTILAYER FILM CAP	R. CAR.FP	: FLAME PROOF CARBON RESISTOR
C. MP	: METALLIZED PAPER CAP	R. FUS	: FUSABLE RESISTOR
C. MYLAR	: MYLAR FILM CAP	R. MTL. CHP	: CHIP METAL FILM RESISTOR
C. MYLAR. ML	: MULTILAYER MYLAR FILM CAP	R. MTL. FILM	: METAL FILM RESISTOR
C. PAPER	: PAPER CAPACITOR	R. MTL. OXD	: METAL OXIDE FILM RESISTOR
C. PLS	: POLYSTYRENE FILM CAP	R. MTL. PLAT	: METAL PLATE RESISTOR
C. POL	: POLYESTER FILM CAP	RSNR. CE	: CERAMIC RESONATOR
C. POLY	: POLYETHYLENE FILM CAP.	RSNR. CRYST	: CRYSTAL RESONATOR
C. PP	: POLYPROPYLENE FILM CAP	R. TW. CEM	: TWIN CEMENT FIXED RESISTOR
C. TNTL	: TANTALUM CAP	R. WW	: WIRE WOUND RESISTOR
C. TNT. CHP	: CHIP TANTALUM CAP	SCR. BND. HD	: BIND HEAD B-TITE SCREW
C. TRIM	: TRIMMER CAP	SCR. BW. HD	: BW HEAD TAPPING SCREW
CN	: CONNECTOR	SCR. CUP	: CUP TITE SCREW
CN. BS. PIN	: CONNECTOR, BASE PIN	SCR. TERM	: SCREW TERMINAL
CN. CANNON	: CONNECTOR, CANNON	SCR. TR	: SCREW, TRANSISTOR
CN. DIN	: CONNECTOR, DIN	SUPRT. PCB	: SUPPORT, P. C. B.
CN. FLAT	: CONNECTOR, FLAT CABLE	SURG. PRTCT	: SURGE PROTECTOR
CN. POST	: CONNECTOR, BASE POST	SW. TACT	: TACT SWITCH
COIL. MX. AM	: COIL, AM MIX	SW. LEAF	: LEAF SWITCH
COIL. AT. FM	: COIL, FM ANTENNA	SW. LEVER	: LEVER SWITCH
COIL. DT. FM	: COIL, FM DETECT	SW. MICRO	: MICRO SWITCH
COIL. MX. FM	: COIL, FM MIX	SW. PUSH	: PUSH SWITCH
COIL. OUTPT	: OUTPUT COIL	SW. RT. ENC	: ROTARY ENCODER
DIOD. ARRAY	: DIODE ARRAY	SW. RT. MTR	: ROTARY SWITCH WITH MOTOR
DIODE. BRG	: DIODE BRIDGE	SW. RT	: ROTARY SWITCH
DIODE. CHP	: CHIP DIODE	SW. SLIDE	: SLIDE SWITCH
DIODE. VAR	: VARACTOR DIODE	TERM. SP	: SPEAKER TERMINAL
DIOD. Z. CHP	: CHIP ZENER DIODE	TERM. WRAP	: WRAPPING TERMINAL
DIODE. ZENR	: ZENER DIODE	THRMST. CHP	: CHIP THERMISTOR
DSCR. CE	: CERAMIC DISCRIMINATOR	TR. CHP	: CHIP TRANSISTOR
FER. BEAD	: FERRITE BEADS	TR. DGT	: DIGITAL TRANSISTOR
FER. CORE	: FERRITE CORE	TR. DGT. CHP	: CHIP DIGITAL TRANSISTOR
FET. CHP	: CHIP FET	TRANS	: TRANSFORMER
FL. DSPLY	: FLUORESCENT DISPLAY	TRANS. PULS	: PULSE TRANSFORMER
FLTR. CE	: CERAMIC FILTER	TRANS. PWR	: POWER TRANSFORMER ASS'y
FLTR. COMB	: COMB FILTER MODULE	TUNER. AM	: TUNER PACK, AM
FLTR. LC. RF	: LC FILTER, EMI	TUNER. FM	: TUNER PACK, FM
GND. MTL	: GROUND PLATE	TUNER. PK	: FRONT-END TUNER PACK
GND. TERM	: GROUND TERMINAL	VR	: ROTARY POTENTIOMETER
HOLDER. FUS	: FUSE HOLDER	VR. MTR	: POTENTIOMETER WITH MOTOR
IC. PRTCT	: IC PROTECTOR	VR. SW	: POTENTIOMETER WITH ROTARY SW
JUMPER. CN	: JUMPER CONNECTOR	VR. SLIDE	: SLIDE POTENTIOMETER
JUMPER. TST	: JUMPER, TEST POINT	VR. TRIM	: TRIMMER POTENTIOMETER
L. DTCT	: LIGHT DETECTING MODULE		
L. EMIT	: LIGHT EMITTING MODULE		

Note) Those parts marked with "#" are not included in the P. C. B. Ass'y.

TUNER P.C.B.

Schm Ref.	PART NO.	Description	
*	VV610200	P.C.B.	TUNER(UC)
*	VV610300	P.C.B.	TUNER(R)
*	VV610400	P.C.B.	TUNER(AL)
*	VV610500	P.C.B.	TUNER(BG)
CB4	VQ961800	CN.BS.PIN	15P
C1	VG287800	C.EL	330uF 16V
C2	UB044100	C.CE.M.CHP	0.01uF 50V
C3	UB050800	C.CE.M.CHP	8pF 50V
C4	VG291200	C.EL	47uF 50V
C5	UB044100	C.CE.M.CHP	0.01uF 50V
C6	VG288900	C.EL	100uF 25V
C7	VJ839100	C.EL	1uF 50V
C8	UB044100	C.CE.M.CHP	0.01uF 50V
C9	UB044100	C.CE.M.CHP	0.01uF 50V
C10	UB044100	C.CE.M.CHP	0.01uF 50V
C11	UB013100	C.CE.M.CHP	1000pF 50V
C12	VJ836900	C.EL	10uF 16V
C13	VJ836900	C.EL	10uF 16V
C14	UB052100	C.CE.M.CHP	100pF 50V
C15	UB013100	C.CE.M.CHP	1000pF 50V
C16	UB051470	C.CE.M.CHP	47pF 50V
C17	VG291200	C.EL	47uF 50V
C18	UB044470	C.CE.M.CHP	0.047uF 50V
C19	VA761200	C.CE	33pF 50V
C20	VG291200	C.EL	47uF 50V
C21	UB044470	C.CE.M.CHP	0.047uF 50V
C22	UM216330	C.EL	3.3uF 50V
C23	UB044100	C.CE.M.CHP	0.01uF 50V
C24	UM416470	C.EL	4.7uF 50V
C25	UM216330	C.EL	3.3uF 50V
C26	VJ836900	C.EL	10uF 16V
C27	UB044100	C.CE.M.CHP	0.01uF 50V
C28	VA761200	C.CE	33pF 50V
C29	VJ839100	C.EL	1uF 50V
C30	VJ839100	C.EL	1uF 50V
C31	VG291200	C.EL	47uF 50V
C32	VJ839000	C.EL	0.47uF 50V
C33	VJ839100	C.EL	1uF 50V
C34	UA654470	C.MYLAR	0.047uF 50V
C35	UM216330	C.EL	3.3uF 50V
C36	UA652470	C.MYLAR	470pF 50V(ALBG)
C36	UA653100	C.MYLAR	1000pF 50V(UCR)
C36	UA653100	C.MYLAR	1000pF 50V
C37	UA652470	C.MYLAR	470pF 50V(ALBG)
C37	UA653100	C.MYLAR	1000pF 50V(UCR)
C37	UA653100	C.MYLAR	1000pF 50V
C38	UB012470	C.CE.M.CHP	470pF 50V
C39	VJ836900	C.EL	10uF 16V
C40	UM216330	C.EL	3.3uF 50V
C41	UA653390	C.MYLAR	3900pF 50V
C42	UM407220	C.EL	22uF 16V
C43	UA653390	C.MYLAR	3900pF 50V
C44	UM216330	C.EL	3.3uF 50V

* New Parts

Schm Ref.	PART NO.	Description	
C45	VG291200	C.EL	47uF 50V
C46	VG291200	C.EL	47uF 50V
C47	VG291200	C.EL	47uF 50V(BG)
C48	UB052100	C.CE.M.CHP	100pF 50V(BG)
* C49	UA652120	C.MYLAR	120pF 50V(ALBG)
C50	UB044470	C.CE.M.CHP	0.047uF 50V
D1	VT332900	DIODE	1SS355
D2	VT332900	DIODE	1SS355
* D3	VU993100	DIODE.ZENR	MA8056-H 5.8V
Fi1	GG000560	FLTR.CE	SFE10.7MS3GHY-A
Fi2	GG000560	FLTR.CE	SFE10.7MS3GHY-A
Fi3	VC219000	FLTR.CE	SFZ450JL3
IC1	XB760A00	IC	LA1266
IC2	XQ944A00	IC	LC72131
IC3	iG158100	IC	LA3401
IC4	XQ359A00	IC	STK311-020B(BG)
L1	VU889500	COIL	220uH
L2	VU889500	COIL	220uH
L3	VU889500	COIL	220uH
L4	VU889500	COIL	220uH(BG)
PK1	VQ987600	TUNER.PK	EXV-17296G1(ALBG)
PK1	VR242200	TUNER.PK	EXV-17296G1(UCR)
PK2	VU333700	COIL.RF.AM	940536051A
Q1	iC053540	TR	2SC535 A,B,C
Q2	iC053540	TR	2SC535 A,B,C
Q3	VD678500	TR.DGT	DTA114ES
Q4	VC218900	TR	2SC3330 R,S,T
Q5	VG722000	TR.DGT	DTC144ES
Q6	iC1815C0	TR	2SC1815 Y
Q7	VD678500	TR.DGT	DTA114ES
R2	RD257100	R.CAR.CHP	10KΩ 1/10W
R3	RD258100	R.CAR.CHP	100KΩ 1/10W
R4	RD257100	R.CAR.CHP	10KΩ 1/10W
R5	RD256100	R.CAR.CHP	1KΩ 1/10W
R6	RD255220	R.CAR.CHP	220Ω 1/10W
R7	RD255330	R.CAR.CHP	330Ω 1/10W
R8	RD255100	R.CAR.CHP	100Ω 1/10W
R9	RD255220	R.CAR.CHP	220Ω 1/10W
R10	RD257100	R.CAR.CHP	10KΩ 1/10W
R11	RD255470	R.CAR.CHP	470Ω 1/10W
R12	RD255220	R.CAR.CHP	220Ω 1/10W
R13	RD259470	R.CAR.CHP	4.7MΩ 1/10W
R14	RD256330	R.CAR.CHP	3.3KΩ 1/10W
R15	RD256220	R.CAR.CHP	2.2KΩ 1/10W
R16	RD256330	R.CAR.CHP	3.3KΩ 1/10W
R17	RD256680	R.CAR.CHP	6.8KΩ 1/10W
R18	RD257100	R.CAR.CHP	10KΩ 1/10W
R19	RD257220	R.CAR.CHP	22KΩ 1/10W
R20	RD256120	R.CAR.CHP	1.2KΩ 1/10W
R21	RD257100	R.CAR.CHP	10KΩ 1/10W
R22	RD257100	R.CAR.CHP	10KΩ 1/10W
R23	RD257470	R.CAR.CHP	47KΩ 1/10W
R24	RD257100	R.CAR.CHP	10KΩ 1/10W

* New Parts

TUNER P.C.B. & INPUT P.C.B

Schm Ref.	PART NO.	Description
R25	RD257150	R.CAR.CHP 15K Ω 1/10W
R26	RD254220	R.CAR.CHP 22 Ω 1/10W
R27	RD257220	R.CAR.CHP 22K Ω 1/10W
R28	RD256470	R.CAR.CHP 4.7K Ω 1/10W
R29	RD256560	R.CAR.CHP 5.6K Ω 1/10W
R30	RD257100	R.CAR.CHP 10K Ω 1/10W
R31	RD257470	R.CAR.CHP 47K Ω 1/10W
R32	RD257220	R.CAR.CHP 22K Ω 1/10W
R33	RD256330	R.CAR.CHP 3.3K Ω 1/10W
R34	RD257100	R.CAR.CHP 10K Ω 1/10W
R35	RD257470	R.CAR.CHP 47K Ω 1/10W
R36	RD257750	R.CAR.CHP 75K Ω 1/10W(UCR)
R36	RD258100	R.CAR.CHP 100K Ω 1/10W(ALBG)
R37	RD257750	R.CAR.CHP 75K Ω 1/10W(UCR)
R37	RD258100	R.CAR.CHP 100K Ω 1/10W(ALBG)
R38	RD257100	R.CAR.CHP 10K Ω 1/10W
R39	RD257220	R.CAR.CHP 22K Ω 1/10W
R40	RD257470	R.CAR.CHP 47K Ω 1/10W
R41	RD256220	R.CAR.CHP 2.2K Ω 1/10W
R42	RD256220	R.CAR.CHP 2.2K Ω 1/10W
R43	RD257100	R.CAR.CHP 10K Ω 1/10W
R44	RD256470	R.CAR.CHP 4.7K Ω 1/10W
R45	RD255100	R.CAR.CHP 100 Ω 1/10W
R46	RD256470	R.CAR.CHP 4.7K Ω 1/10W
R47	RD256470	R.CAR.CHP 4.7K Ω 1/10W
R48	RD256470	R.CAR.CHP 4.7K Ω 1/10W(ALBG)
R49	RD257100	R.CAR.CHP 10K Ω 1/10W
R50	RD257470	R.CAR.CHP 47K Ω 1/10W(BG)
R51	RD257330	R.CAR.CHP 33K Ω 1/10W(BG)
R52	RD257100	R.CAR.CHP 10K Ω 1/10W(BG)
R53	RD257100	R.CAR.CHP 10K Ω 1/10W(BG)
R54	RD257100	R.CAR.CHP 10K Ω 1/10W(BG)
R55	RD257100	R.CAR.CHP 10K Ω 1/10W(BG)
R56	RD257100	R.CAR.CHP 10K Ω 1/10W(BG)
R57	RD256100	R.CAR.CHP 1K Ω 1/10W(ALBG)
R57	RD257220	R.CAR.CHP 22K Ω 1/10W
SW1	VS602600	SW.SLIDE SS070-P022 A(R)
T1	VC218600	COIL.DT.FM 10.7MHz
T2	VR895700	COIL.IF 450KHz
T3	VT486800	COIL XYA2(ALBG)
T4	VQ138200	FLTR.LC 19KHz
T5	VQ138200	FLTR.LC 19KHz
TE1	VU477800	TERM.ANT AJ-2038-040
TP1	VT969000	PIN.TEST IRS-2049
TP2	VT969000	PIN.TEST IRS-2049
VR1	VJ694000	VR.TRIM B47K Ω
VR2	VJ694000	VR.TRIM B47K Ω
XL1	QU003800	RSNR.CRYS 7.2MHz
XL2	GG000750	RSNR.CE 18.95MHz
XL3	VS860100	RSNR.CE 19KHz(BG)
	BB071360	SCR.TERM 8.3x13
	VR282500	PLATE ANT.

* New Parts

Schm Ref.	PART NO.	Description
*	VV574700	P.C.B. INPUT(UC)
*	VV574800	P.C.B. INPUT(R)
*	VV574900	P.C.B. INPUT(A)
*	VV575000	P.C.B. INPUT(B)
*	VV575100	P.C.B. INPUT(G)
*	VV575200	P.C.B. INPUT(L)
	CB1	Vi878700 CN.BS.PIN 9P
	CB2	VK025100 CN.BS.PIN 7P
	CB3	Vi878500 CN.BS.PIN 7P
	CB4	Vi878600 CN.BS.PIN 8P
	CB5	VQ047500 CN.BS.PIN 20P
	CB11	Vi878700 CN.BS.PIN 9P
	CB12	VQ963600 CN.BS.PIN 15P
	CB705	Vi878400 CN.BS.PIN 6P
	CB706	VK024700 CN.BS.PIN 3P
	CB712	VP206500 HOLDER.FUS EYF-52BC(UCR)
	CB713	VP206500 HOLDER.FUS EYF-52BC(UCR)
	CB714	VP206500 HOLDER.FUS EYF-52BC(GL)
	CB715	VP206500 HOLDER.FUS EYF-52BC(GL)
	CB716	VP206500 HOLDER.FUS EYF-52BC(ABGL)
	CB717	VG879900 CN.BS.PIN 2P
	CB718	VP206500 HOLDER.FUS EYF-52BC(ABGL)
	C2	UA652100 C.MYLAR 100pF 50V(BG)
	C3	UA652220 C.MYLAR 220pF 50V
	C4	UA652100 C.MYLAR 100pF 50V(BG)
	C5	UA652220 C.MYLAR 220pF 50V
	C7	VK533900 C.PP 100pF 200V
	C8	VK533900 C.PP 100pF 200V
	C11	VF466800 C.CE.TUBLR 100pF 50V
	C12	VF466800 C.CE.TUBLR 100pF 50V
	C13	VF466800 C.CE.TUBLR 100pF 50V
	C14	VF466800 C.CE.TUBLR 100pF 50V
	C15	FG211470 C.CE 47pF 50V
	C16	FG211470 C.CE 47pF 50V
	C17	VF466800 C.CE.TUBLR 100pF 50V
	C18	VF466800 C.CE.TUBLR 100pF 50V
	C21	VF466800 C.CE.TUBLR 100pF 50V
	C22	VF466800 C.CE.TUBLR 100pF 50V
	C23	FG211470 C.CE 47pF 50V
	C24	FG211470 C.CE 47pF 50V
	C25	VJ839200 C.EL 2.2uF 50V
	C26	VE117600 C.EL 220uF 10V
	C27	VJ837200 C.EL 47uF 16V
	C28	UA653910 C.MYLAR 9100pF 50V
	C29	UA654330 C.MYLAR 0.033uF 50V
	C30	UA653910 C.MYLAR 9100pF 50V
	C31	UA654330 C.MYLAR 0.033uF 50V
	C32	VJ837200 C.EL 47uF 16V
	C33	VE117600 C.EL 220uF 10V
	C34	VJ839200 C.EL 2.2uF 50V
	C35	UM417100 C.EL 10uF 50V
	C36	UA652100 C.MYLAR 100pF 50V
	C37	UM417100 C.EL 10uF 50V

* New Parts

INPUT P.C.B.

Schm Ref.	PART NO.	Description
C38	UM417100	C.EL 10uF 50V
C39	UA652100	C.MYLAR 100pF 50V
C41	VJ839100	C.EL 1uF 50V
C42	UA652100	C.MYLAR 100pF 50V
C43	UA652100	C.MYLAR 100pF 50V
C44	UA652100	C.MYLAR 100pF 50V
C45	UA652100	C.MYLAR 100pF 50V
C46	VJ839100	C.EL 1uF 50V
C47	UA652100	C.MYLAR 100pF 50V
C48	UA655150	C.MYLAR 0.15uF 50V
C49	VJ839100	C.EL 1uF 50V
C50	VJ839100	C.EL 1uF 50V
C51	UM417100	C.EL 10uF 50V
C52	VF466800	C.CE.TUBLR 100pF 50V
C53	VG279600	C.CE.TUBLR 3300pF 16V
C54	UM417100	C.EL 10uF 50V
C55	UM417100	C.EL 10uF 50V
C56	UM417100	C.EL 10uF 50V
C57	VG279600	C.CE.TUBLR 3300pF 16V
C58	VF466800	C.CE.TUBLR 100pF 50V
C59	UA653680	C.MYLAR 6800pF 50V
C60	VG287800	C.EL 330uF 16V
C61	VJ837200	C.EL 47uF 16V
C62	VJ839100	C.EL 1uF 50V
C63	UA652220	C.MYLAR 220pF 50V
C64	UA652220	C.MYLAR 220pF 50V
C65	VJ839100	C.EL 1uF 50V
C66	VG287800	C.EL 330uF 16V
C67	UA653680	C.MYLAR 6800pF 50V
C68	UA653470	C.MYLAR 4700pF 50V
C69	UA653120	C.MYLAR 1200pF 50V
C70	UA654180	C.MYLAR 0.018uF 50V
C71	FG612390	C.CE 390pF 50V
C73	FG612390	C.CE 390pF 50V
C75	UA653120	C.MYLAR 1200pF 50V
C76	UA654180	C.MYLAR 0.018uF 50V
C77	UA653470	C.MYLAR 4700pF 50V
C78	UM407220	C.EL 22uF 16V
C79	UM407220	C.EL 22uF 16V
C80	UM407220	C.EL 22uF 16V
C81	UM407220	C.EL 22uF 16V
C82	UA652330	C.MYLAR 330pF 50V
C83	UM407220	C.EL 22uF 16V
C84	UM407220	C.EL 22uF 16V
C85	UA652330	C.MYLAR 330pF 50V
C86	UA652330	C.MYLAR 330pF 50V
C87	UM407220	C.EL 22uF 16V
C88	UM407220	C.EL 22uF 16V
C89	VJ839100	C.EL 1uF 50V
C90	VG277000	C.CE.TUBLR 33pF 50V
C91	VG278400	C.CE.TUBLR 220pF 50V
C92	VG279500	C.CE.TUBLR 2700pF 16V
C93	VG278400	C.CE.TUBLR 220pF 50V

* New Parts

Schm Ref.	PART NO.	Description
C94	VG279500	C.CE.TUBLR 2700pF 16V
C95	VG277000	C.CE.TUBLR 33pF 50V
C96	VJ839100	C.EL 1uF 50V
C97	VG277000	C.CE.TUBLR 33pF 50V
C98	UA653270	C.MYLAR 2700pF 50V
C99	VF466600	C.CE.TUBLR 10pF 50V
C100	VF466600	C.CE.TUBLR 10pF 50V
C101	UA653270	C.MYLAR 2700pF 50V
C102	VG277000	C.CE.TUBLR 33pF 50V
C108	UM407220	C.EL 22uF 16V
C109	UM407220	C.EL 22uF 16V
C111	VG279600	C.CE.TUBLR 3300pF 16V
C112	VG279600	C.CE.TUBLR 3300pF 16V
C113	VH053100	C.CE.TUBLR 0.1uF 50V
C114	VH053100	C.CE.TUBLR 0.1uF 50V
C115	UJ638330	C.EL 330uF 16V
C116	VH053100	C.CE.TUBLR 0.1uF 50V
C117	VH053100	C.CE.TUBLR 0.1uF 50V
C118	VJ837200	C.EL 47uF 16V
C119	VJ837200	C.EL 47uF 16V
C120	VJ837200	C.EL 47uF 16V
C121	VF964800	C.EL 100uF 16V
C122	VE117600	C.EL 220uF 10V
C124	VH053100	C.CE.TUBLR 0.1uF 50V
C125	VJ837200	C.EL 47uF 16V
C155	VF466800	C.CE.TUBLR 100pF 50V(BG)
C156	VF466800	C.CE.TUBLR 100pF 50V(BG)
C157	VJ836900	C.EL 10uF 16V
C158	VJ836900	C.EL 10uF 16V
C159	VJ836900	C.EL 10uF 16V
C160	VF637900	C.EL 1000uF 10V
C161	VF466800	C.CE.TUBLR 100pF 50V
C164	VF637900	C.EL 1000uF 10V
C165	VF466800	C.CE.TUBLR 100pF 50V
C171	VJ836900	C.EL 10uF 16V(BG)
C172	VJ837200	C.EL 47uF 16V(BG)
C173	VF637900	C.EL 1000uF 10V(BG)
C174	VG276600	C.CE.TUBLR 22pF 50V(BG)
C175	VJ837200	C.EL 47uF 16V(BG)
C176	VF637900	C.EL 1000uF 10V
C176	VF637900	C.EL 1000uF 10V
C177	VF466800	C.CE.TUBLR 100pF 50V(BG)
C178	VF466800	C.CE.TUBLR 100pF 50V(BG)
C179	VJ836900	C.EL 10uF 16V(BG)
C180	VJ837200	C.EL 47uF 16V(BG)
C181	UM397330	C.EL 33uF 16V(BG)
C182	VG276600	C.CE.TUBLR 22pF 50V(BG)
C183	VJ837200	C.EL 47uF 16V(BG)
C184	UM397330	C.EL 33uF 16V(BG)
C185	VH053100	C.CE.TUBLR 0.1uF 50V
C186	VJ837200	C.EL 47uF 16V
C187	UJ638330	C.EL 330uF 16V
C190	VH053100	C.CE.TUBLR 0.1uF 50V

* New Parts

INPUT P.C.B & AMP P.C.B.

Schm Ref.	PART NO.	Description
△ C198	VH053100	C.CE.TUBLR 0.1uF 50V
△ C729	VN126700	C.EL 3300uF 50V
△ C730	VN126700	C.EL 3300uF 50V
C731	VH053100	C.CE.TUBLR 0.1uF 50V
C732	UJ648470	C.EL 470uF 25V
C733	VH053100	C.CE.TUBLR 0.1uF 50V(BG)
C734	VH053100	C.CE.TUBLR 0.1uF 50V(BG)
△ C742	VS745400	C.POL.MTL 0.1uF 100V
△ C743	VS745400	C.POL.MTL 0.1uF 100V
C744	UA655100	C.MYLAR 0.1uF 50V(ABGL)
C745	FG213100	C.CE 1000pF 50V(R)
△ C746	Ui377470	C.EL 47uF 63V(R)
C747	Vi716700	C.MYLAR 0.01uF 50V
C751	UA654100	C.MYLAR 0.01uF 50V
△ C752	VS741700	C.CE.SAFTY 0.01uF 275V
△ C760	UJ649220	C.EL 2200uF 25V
△ C761	VF606700	C.EL 1000uF 25V
△ C762	VS745400	C.POL.MTL 0.1uF 100V
D7	VD631600	DIODE 1SS133,176,HSS104
D251	VD631600	DIODE 1SS133,176,HSS104
△ D702	VR253700	DIODE.BRG S1NB20 1.0A 200V
△ D705	iH001090	DIODE.BRG S4VB20 2.6A 200V
△ D706	VD631600	DIODE 1SS133,176,HSS104
△ D707	VR253700	DIODE.BRG S1NB20 1.0A 200V
△ D708	VM975600	DIODE.ZENR HZS12B2TD 12V(R)
△ F702	VP909900	FUSE T7.0A 125V(UCR)
△ F703	KB002980	FUSE T2.5A 250V(GL)
△ F704	KB000760	FUSE T3.15A 250V(ABGL)
IC1	XB247301	IC uPC4570HA
IC2	XP894A00	IC LC78211
IC3	XB247301	IC uPC4570HA
IC4	XB247301	IC uPC4570HA
IC7	XB247301	IC uPC4570HA
IC8	XB247301	IC uPC4570HA
IC9	XB247301	IC uPC4570HA
IC10	XB247301	IC uPC4570HA
IC11	XB247301	IC uPC4570HA
IC12	XB247301	IC uPC4570HA
IC13	XQ212A00	IC NJM4558LD
IC14	XB247301	IC uPC4570HA
IC15	XM922A00	IC NJM4558L
IC16	XP896A00	IC LC78213
IC17	Xi022B00	IC YSS203B-F
* IC18	XS881A00	IC LH5P832D-10 PSRAM
IC19	XA507A00	IC AN78N05
IC29	XH436A00	IC LA7956
IC31	XH436A00	IC LA7956(BG)
IC32	XH436A00	IC LA7956(BG)
JK2	VN938100	CN.DIN 3P S(BG)
PJ1	VV306900	JACK.PIN 4P
PJ2	VV306900	JACK.PIN 4P
PJ3	VV306900	JACK.PIN 4P
PJ4	VV306900	JACK.PIN 4P

* New Parts

Schm Ref.	PART NO.	Description
* PJ6	VV325000	JACK.PIN 2P
* PJ7	VV852500	JACK.PIN 3P
Q3	iA101521	TR 2SA1015 Y(BG)
Q4	iC1815C0	TR 2SC1815 Y(BG)
Q5	iA101521	TR 2SA1015 Y(BG)
Q6	iC1815C0	TR 2SC1815 Y(BG)
Q7	iC1815C0	TR 2SC1815 Y
Q252	iC1815C0	TR 2SC1815 Y
Q253	iC174020	TR 2SC1740S R,S
Q723	iC174020	TR 2SC1740S R,S
Q725	VR510800	TR 2SD2396 J,K(R)
R35	HV453220	R.CAR.FP 2.2Ω 1/4W
R50	HV453220	R.CAR.FP 2.2Ω 1/4W
R136	HV453220	R.CAR.FP 2.2Ω 1/4W
R149	HV453220	R.CAR.FP 2.2Ω 1/4W
R150	HV453220	R.CAR.FP 2.2Ω 1/4W
R151	HL314470	R.MTL.OXD 47Ω 1W
R152	HV453220	R.CAR.FP 2.2Ω 1/4W
R242	HV453220	R.CAR.FP 2.2Ω 1/4W
R784	HV456560	R.CAR.FP 5.6KΩ 1/4W(R)
R785	HV456560	R.CAR.FP 5.6KΩ 1/4W(R)
△ RY703	VU349800	RELAY DC SDT-SS(UCABGL)
△ RY703	VY735300	RELAY DC G5P-1(R)
△ T701	XQ485B00	TRANS.PWR (UC)
△ T701	XQ486B00	TRANS.PWR (ABGL)
△ T701	XT331A00	TRANS.PWR (R)
△ * TE703	VT915000	OUTLET.AC 2P(A)
△ TE703	VU543100	OUTLET.AC 2P(UCR)
△ TE703	VU543300	OUTLET.AC 1P(B)
△ TE703	VU543400	OUTLET.AC 2P(GL)
XL1	VK175200	RSNR.CE 11.28MHz
	VJ828000	PIN IMSA-6024-03E
	VR506800	HEAT.SINK PUH16-25(R)
	VR264300	PLATE.GND
	ED330066	SCR.BND.HD 3x6 FCRM3-BL(R)
* VV577100	P.C.B.	AMP(UC)
* VV577200	P.C.B.	AMP(R)
* VV577300	P.C.B.	AMP(A)
* VV577400	P.C.B.	AMP(BG)
* VV899600	P.C.B.	AMP(L)
CB501	Vi878700	CN.BS.PIN 9P
CB502	VK025500	CN.BS.PIN 11P
CB520	Vi878200	CN.BS.PIN 4P
CB521	VQ584800	CN.BS.PIN 6P
CB522	VQ584800	CN.BS.PIN 6P
CB523	VQ585000	CN.BS.PIN 8P
CB524	VQ585000	CN.BS.PIN 8P
CB525	Vi879000	CN.BS.PIN 12P
CB526	Vi878100	CN.BS.PIN 3P
CB529	LA002110	TERM.WRAP 2P

* New Parts

AMP P.C.B.

Schm Ref.	PART NO.	Description
CB530	LA002110	TERM.WRAP 2P
CB531	LA002110	TERM.WRAP 2P
CB532	LA002320	TERM.WRAP 3P
CB701	VK024900	CN.BS.PIN 5P
CB702	VK025600	CN.BS.PIN 12P
CB703	VF728300	CN 6P
CB704	VK024800	CN.BS.PIN 4P
CB719	VP206500	HOLDER.FUS EYF-52BC(R)
CB720	VP206500	HOLDER.FUS EYF-52BC(R)
CB721	Vi878800	CN.BS.PIN 10P
CB722	Vi878800	CN.BS.PIN 10P
CB725	VP206500	HOLDER.FUS EYF-52BC
C501	UM416470	C.EL 4.7uF 50V
C502	VJ839100	C.EL 1uF 50V(BG)
C503	UM417100	C.EL 10uF 50V
C504	UM417100	C.EL 10uF 50V
C505	VF760000	C.EL 100uF 10V
C506	VK399200	C.MYLAR.ML 0.39uF 50V
C507	UM416470	C.EL 4.7uF 50V
C508	FG212220	C.CE 220pF 50V(ABGL)
C508	FG251330	C.CE 33pF 50V(UCR)
C509	UA652100	C.MYLAR 100pF 50V
C510	FG212220	C.CE 220pF 50V(ABGL)
C510	FG251330	C.CE 33pF 50V(UCR)
C512	FG212100	C.CE 100pF 50V(ABGL)
C512	FG251330	C.CE 33pF 50V(UCR)
C512	FG251330	C.CE 33pF 50V
C513	UM417100	C.EL 10uF 50V
C514	UA652100	C.MYLAR 100pF 50V
C515	UM417100	C.EL 10uF 50V
C516	VK399200	C.MYLAR.ML 0.39uF 50V
C517	VQ245400	C.PP 33pF 200V
C518	VJ837200	C.EL 47uF 16V
C519	UA653100	C.MYLAR 1000pF 50V
C520	VQ245400	C.PP 33pF 200V
C521	VJ837200	C.EL 47uF 16V
C522	UA653100	C.MYLAR 1000pF 50V
C523	VQ245400	C.PP 33pF 200V
C524	VJ837200	C.EL 47uF 16V
C525	UA653100	C.MYLAR 1000pF 50V
C526	VR325000	C.MYLAR 100pF 100V
C527	UJ667470	C.EL 47uF 50V
C528	UJ667470	C.EL 47uF 50V
C529	VR325000	C.MYLAR 100pF 100V
C530	VK347900	C.EL 470uF 63V
C531	VR325000	C.MYLAR 100pF 100V
C532	UJ667470	C.EL 47uF 50V
C533	UJ667470	C.EL 47uF 50V
C534	VR325000	C.MYLAR 100pF 100V
C535	VR325000	C.MYLAR 100pF 100V
C536	UJ667470	C.EL 47uF 50V
C537	UJ667470	C.EL 47uF 50V
C538	VR325000	C.MYLAR 100pF 100V

* New Parts

Schm Ref.	PART NO.	Description
C539	VJ836900	C.EL 10uF 16V
C540	VJ839200	C.EL 2.2uF 50V
C541	VJ839100	C.EL 1uF 50V
C542	UA654680	C.MYLAR 0.068uF 50V
C543	UA654680	C.MYLAR 0.068uF 50V
C544	UA654680	C.MYLAR 0.068uF 50V
C545	UA654100	C.MYLAR 0.01uF 50V(ABGL)
C546	UA654220	C.MYLAR 0.022uF 50V(ABGL)
C547	UA654220	C.MYLAR 0.022uF 50V(ABGL)
C548	UA654220	C.MYLAR 0.022uF 50V(ABGL)
C549	UA654220	C.MYLAR 0.022uF 50V(ABGL)
C550	Vi716700	C.MYLAR 0.022uF 50V(ABGL)
C551	Vi716700	C.MYLAR 0.01uF 50V
C551	Vi716700	C.MYLAR 0.01uF 50V(ABGL)
* C552	VV887100	C.EL 12000uF 63V
* C553	VV887100	C.EL 12000uF 63V
C554	UA654100	C.MYLAR 0.01uF 50V(ABGL)
C555	UA654100	C.MYLAR 0.01uF 50V
C556	VS745400	C.POL.MTL 0.1uF 100V
C557	VS745400	C.POL.MTL 0.1uF 100V
C558	VH053100	C.CE.TUBLR 0.1uF 50V
C559	UJ167330	C.EL 33uF 50V
C701	UM416470	C.EL 4.7uF 50V
C702	UM416470	C.EL 4.7uF 50V
C703	UA652100	C.MYLAR 100pF 50V
C704	UA652470	C.MYLAR 470pF 50V
C705	VJ837200	C.EL 47uF 16V
C706	UA652470	C.MYLAR 470pF 50V
C707	UA652100	C.MYLAR 100pF 50V
C708	VR516400	C.CE 15p 500V
C709	VJ837200	C.EL 47uF 16V
C710	UA653100	C.MYLAR 1000pF 50V
C711	VG722100	C.EL 1uF 50V
C712	UA653100	C.MYLAR 1000pF 50V
C713	VJ837200	C.EL 47uF 16V
C714	VR516400	C.CE 15p 500V
C715	VR325000	C.MYLAR 100pF 100V
C716	UJ667470	C.EL 47uF 50V
C717	UJ667470	C.EL 47uF 50V
C718	VR325000	C.MYLAR 100pF 100V
C719	UJ668100	C.EL 100uF 50V
C720	VR325000	C.MYLAR 100pF 100V
C721	UJ667470	C.EL 47uF 50V
C722	UJ667470	C.EL 47uF 50V
C723	VR325000	C.MYLAR 100pF 100V
C724	UA654220	C.MYLAR 0.022uF 50V
C725	UA654220	C.MYLAR 0.022uF 50V
C726	VJ837200	C.EL 47uF 16V
C727	UJ667470	C.EL 47uF 50V
C728	VJ837200	C.EL 47uF 16V
C729	UJ668100	C.EL 100uF 50V
C731	VJ839000	C.EL 0.47uF 50V
C733	VF466900	C.CE.TUBLR 470pF 50V

* New Parts

AMP P.C.B.

Schm Ref.	PART NO.	Description
C734	VF466900	C.CE.TUBLR 470pF 50V
C735	VF466900	C.CE.TUBLR 470pF 50V
C736	VF466900	C.CE.TUBLR 470pF 50V
C737	VF466900	C.CE.TUBLR 470pF 50V
C738	UA654220	C.MYLAR 0.022uF 50V(ABGL)
C739	VH053100	C.CE.TUBLR 0.1uF 50V(ABGL)
C740	UA654220	C.MYLAR 0.022uF 50V(ABGL)
C741	UA654220	C.MYLAR 0.022uF 50V(ABGL)
C748	VJ839000	C.EL 0.47uF 50V(UCRA)
C748	VJ839100	C.EL 1uF 50V(BGL)
C749	UA654100	C.MYLAR 0.01uF 50V(ABGL)
C750	UA654100	C.MYLAR 0.01uF 50V(ABGL)
C750	UA654100	C.MYLAR 0.01uF 50V
C765	UJ667470	C.EL 47uF 50V
C766	UJ667470	C.EL 47uF 50V
D501	VM976300	DIODE.ZENR HZS242TD 24V
D502	VM976300	DIODE.ZENR HZS242TD 24V
D503	VM974500	DIODE.ZENR HZS6C2TD 6.0V
D504	VD631600	DIODE 1SS133,176,HSS104
D505	VM974400	DIODE.ZENR HZS6B2TD 6.0V
D506	VN008700	DIODE 1SS270A
D507	VN008700	DIODE 1SS270A
D508	VN008700	DIODE 1SS270A
D509	VD631600	DIODE 1SS133,176,HSS104
D510	VN011400	DIODE.BRG D5SB20 5A 200V
D511	VD631600	DIODE 1SS133,176,HSS104
D512	VD631600	DIODE 1SS133,176,HSS104
D513	VM975700	DIODE.ZENR HZS12C2TD 12V
D701	VM975700	DIODE.ZENR HZS12C2TD 12V
D703	VM976300	DIODE.ZENR HZS242TD 24V
D704	VM976300	DIODE.ZENR HZS242TD 24V
D705	VN008700	DIODE 1SS270A
D706	VN008700	DIODE 1SS270A
D707	VM975700	DIODE.ZENR HZS12C2TD 12V
F705	KB000760	FUSE T3.15A 250V(R)
IC701	XD343A00	IC NJM79M12FA
JK501	VY687200	JACK.PHONE JY-6317-02-030 NUT
L501	VR906600	COIL 0.95uH
L502	VR906600	COIL 0.95uH
L701	VP575600	COIL 1.5uH
L702	VP575600	COIL 1.5uH
L703	VP575600	COIL 1.5uH
PJ701	VR245000	JACK.PIN 6P.
Q502	VK432900	TR 2SD1915F S,T
Q504	VK432900	TR 2SD1915F S,T
Q505	VK432900	TR 2SD1915F S,T
Q506	iA101521	TR 2SA1015 Y
Q507	VP883000	TR 2SA893A D,E
Q508	VP883000	TR 2SA893A D,E
Q509	VP883000	TR 2SA893A D,E
Q510	iC224030	TR 2SC2240 GR,BL
Q511	VP883000	TR 2SA893A D,E
Q512	VP883000	TR 2SA893A D,E

* New Parts

Schm Ref.	PART NO.	Description
Q513	VP883000	TR 2SA893A D,E
Q514	iC174020	TR 2SC1740S R,S
Q515	VR325600	TR 2SC2229 O,Y
Q516	iC174020	TR 2SC1740S R,S
Q517	VR325600	TR 2SC2229 O,Y
Q518	iC174020	TR 2SC1740S R,S
Q519	VR325600	TR 2SC2229 O,Y
Q520	iC206110	TR 2SC2061 P,Q,R
Q521	iA093320	TR 2SA933S Q,R
Q522A	iX603580	TR 2SA1358
Q522C	iX603590	TR 2SC3421
Q523A	iX606460	TR 2SA1492 O,P,Y
Q523C	iX606470	TR 2SC3856 O,P,Y
Q526A	iX603580	TR 2SA1358
Q526C	iX603590	TR 2SC3421
Q527A	iX606460	TR 2SA1492 O,P,Y
Q527C	iX606470	TR 2SC3856 O,P,Y
Q530A	iX603580	TR 2SA1358
Q530C	iX603590	TR 2SC3421
Q531A	iX606460	TR 2SA1492 O,P,Y
Q531C	iX606470	TR 2SC3856 O,P,Y
Q534	iA097000	TR 2SA970 GR,BL
Q535	VP883100	TR 2SC1890A D,E
Q536	VP883100	TR 2SC1890A D,E
Q537	VP883100	TR 2SC1890A D,E
Q538	iC174020	TR 2SC1740S R,S
Q539	iC174020	TR 2SC1740S R,S
Q701	VK432900	TR 2SD1915F S,T
Q702	VK432900	TR 2SD1915F S,T
Q703	VP883000	TR 2SA893A D,E
Q704	VP883000	TR 2SA893A D,E
Q705	VP883000	TR 2SA893A D,E
Q706	VP883000	TR 2SA893A D,E
Q707	VP872700	TR 2SC4488 S,T
Q708	iC174020	TR 2SC1740S R,S
Q709	VP872600	TR 2SA1708 S,T
Q710	VR325600	TR 2SC2229 O,Y
Q711	VR325600	TR 2SC2229 O,Y
Q712	VP872600	TR 2SA1708 S,T
Q713	iC174020	TR 2SC1740S R,S
Q714	VP872700	TR 2SC4488 S,T
Q715A	iX633320	TR 2SA1693 O,P,Y
Q715C	iX633330	TR 2SC4466 O,P,Y
Q717A	iX633320	TR 2SA1693 O,P,Y
Q717C	iX633330	TR 2SC4466 O,P,Y
Q719	VP883100	TR 2SC1890A D,E
Q720	VP883100	TR 2SC1890A D,E
Q721	iE000020	FET 2SK30ATM GR
Q724	VK432900	TR 2SD1915F S,T
Q725	iC174020	TR 2SC1740S R,S
Q726	iC224030	TR 2SC2240 GR,BL
Q727	VV855300	TR 2SD856 Q,P"
Q728	iC174020	TR 2SC1740S R,S

* New Parts

△

△

△

△

△

△

AMP P.C.B. & OPERATION P.C.B.

Schm Ref.	PART NO.	Description
R508	HV456560	R.CAR.FP 5.6KΩ 1/4W
R517	HV456100	R.CAR.FP 1KΩ 1/4W
R531	HL315560	R.MTL.OXD 560Ω 1W
R553	HL316560	R.MTL.OXD 5.6KΩ 1W
△ R554	HL316560	R.MTL.OXD 5.6KΩ 1W
△ R555	HV456270	R.CAR.FP 2.7KΩ 1/4W
R557	HV455820	R.CAR.FP 820Ω 1/4W
R558	VK189000	R.FUS 1KΩ 1/4W
△ R559	HV454470	R.CAR.FP 47Ω 1/4W
△ R560	HL314100	R.MTL.OXD 10Ω 1W
R561	HL316560	R.MTL.OXD 5.6KΩ 1W
R562	HL316560	R.MTL.OXD 5.6KΩ 1W
R563	HV456270	R.CAR.FP 2.7KΩ 1/4W
R565	HV455820	R.CAR.FP 820Ω 1/4W
R566	VK189000	R.FUS 1KΩ 1/4W
△ R567	HV454470	R.CAR.FP 47Ω 1/4W
R568	HL316560	R.MTL.OXD 5.6KΩ 1W
R569	HL316560	R.MTL.OXD 5.6KΩ 1W
R570	HV456270	R.CAR.FP 2.7KΩ 1/4W
R572	HV455820	R.CAR.FP 820Ω 1/4W
R573	VK189000	R.FUS 1KΩ 1/4W
△ R574	HV454470	R.CAR.FP 47Ω 1/4W
△ R580	HV453470	R.CAR.FP 4.7Ω 1/4W
△ R581	VK188400	R.FUS 330Ω 1/4W
R583	HV453470	R.CAR.FP 4.7Ω 1/4W
R584	HV453470	R.CAR.FP 4.7Ω 1/4W
△ R585	VK188400	R.FUS 330Ω 1/4W
R587	HV453470	R.CAR.FP 4.7Ω 1/4W
R588	HV453470	R.CAR.FP 4.7Ω 1/4W
△ R589	VK188400	R.FUS 330Ω 1/4W
△ R590	HZ003780	R.MTL.PLAT 0.22Ω +0.22 5W
R591	HV453470	R.CAR.FP 4.7Ω 1/4W
△ R598	HL314100	R.MTL.OXD 10Ω 1W
△ R603	HL314100	R.MTL.OXD 10Ω 1W
△ R609	HL314100	R.MTL.OXD 10Ω 1W
R611	HV454100	R.CAR.FP 10Ω 1/4W
R613	HV454100	R.CAR.FP 10Ω 1/4W
R614	VP944500	R.MTL.OXD 390Ω 1W
R615	VP944500	R.MTL.OXD 390Ω 1W
R628	VY689500	R.WW 0.22Ω 3W
△ R629	VY689500	R.WW 0.22Ω 3W
R630	VY689500	R.WW 0.22Ω 3W
△ R631	VY689500	R.WW 0.22Ω 3W
R728	HV456270	R.CAR.FP 2.7KΩ 1/4W
△ R729	VK188400	R.FUS 330Ω 1/4W
R731	HV456100	R.CAR.FP 1KΩ 1/4W
R732	VK189000	R.FUS 1KΩ 1/4W
△ R733	HV454470	R.CAR.FP 47Ω 1/4W
△ R734	HL314470	R.MTL.OXD 47Ω 1W
△ R735	HV454470	R.CAR.FP 47Ω 1/4W
R736	VK189000	R.FUS 1KΩ 1/4W
R738	HV456100	R.CAR.FP 1KΩ 1/4W
△ R739	VK188400	R.FUS 330Ω 1/4W

* New Parts

Schm Ref.	PART NO.	Description
R740	HV456270	R.CAR.FP 2.7KΩ 1/4W
R744	HV453470	R.CAR.FP 4.7Ω 1/4W
△ R745	VU981700	R.MTL.PLAT 0.22Ω +0.22 3W
R746	HV453470	R.CAR.FP 4.7Ω 1/4W
R747	HV453470	R.CAR.FP 4.7Ω 1/4W
△ R748	VU981700	R.MTL.PLAT 0.22Ω +0.22 3W
R749	HV453470	R.CAR.FP 4.7Ω 1/4W
R754	HL314100	R.MTL.OXD 10Ω 1W
R755	HL314100	R.MTL.OXD 10Ω 1W
R759	HV454100	R.CAR.FP 10Ω 1/4W
R760	HV454100	R.CAR.FP 10Ω 1/4W
R763	HV454100	R.CAR.FP 10Ω 1/4W
R764	HV453220	R.CAR.FP 2.2Ω 1/4W
R765	HL315560	R.MTL.OXD 560Ω 1W
R766	HL315560	R.MTL.OXD 560Ω 1W
R800	HL313220	R.MTL.FLM 2.2Ω 1W
△ RY501	VK438300	RELAY DH24D2-OT/M2
△ RY701	VK438300	RELAY DH24D2-OT/M2
RY702	VU566700	RELAY DG24D2-OS/M
* SW501	VV523900	SW.PUSH PBS-YM-001
SW502	VS602600	SW.SLIDE SS070-P022 A(BG)
* SW701	VV523800	SW.SLIDE SL13B-022-BMC1
△ SW702	VA961800	VOLT.SELCT ESE-37247-F(R)
△ TE501	VU819700	TERM.SP 8P(BGL)
△ * TE501	VV003100	TERM.SP 8P(UCRA)
△ TE701	VS578600	TERM.SP 8P
	VJ828000	PIN IMSA-6024-03E
	BB071360	SCR.TERM 8.3x13
	VS606000	HEAT.SINK DPS35-45
	EP630280	SCR.BND.HD 3x10 FCRM3-BL
* VV575600	P.C.B.	OPERATION(UC)
* VV575700	P.C.B.	OPERATION(R)
* VV575800	P.C.B.	OPERATION(AL)
* VV809100	P.C.B.	OPERATION(BG)
CB6	Vi878500	CN.BS.PIN 7P
CB7	VK025100	CN.BS.PIN 7P
CB8	Vi878600	CN.BS.PIN 8P
CB9	Vi878300	CN.BS.PIN 5P
CB10	VK025200	CN.BS.PIN 8P
CB251	Vi878900	CN.BS.PIN 11P
CB252	Vi878900	CN.BS.PIN 11P
CB602	VU282000	CN 20P
CB603	Vi878900	CN.BS.PIN 11P
CB901	VK025200	CN.BS.PIN 8P
CB902	VK025300	CN.BS.PIN 9P
C103	VH053100	C.CE.TUBLR 0.1uF 50V
C104	VF466800	C.CE.TUBLR 100pF 50V
C105	VH053100	C.CE.TUBLR 0.1uF 50V
C106	VF466800	C.CE.TUBLR 100pF 50V
C127	VJ839000	C.EL 0.47uF 50V

* New Parts

OPERATION P.C.B.

Schm Ref.	PART NO.	Description	
C128	VJ839000	C.EL	0.47uF 50V
C129	VJ839200	C.EL	2.2uF 50V
C130	VJ839200	C.EL	2.2uF 50V
C131	VJ839200	C.EL	2.2uF 50V
C134	UA652100	C.MYLAR	100pF 50V
C135	UA652100	C.MYLAR	100pF 50V
C138	UM417100	C.EL	10uF 50V
C139	FG211100	C.CE	10pF 50V
C140	VJ837200	C.EL	47uF 16V
C141	VG278400	C.CE.TUBLR	220pF 50V
C142	FG212100	C.CE	100pF 50V
C143	VG278400	C.CE.TUBLR	220pF 50V
C144	UM417100	C.EL	10uF 50V
C145	VJ837200	C.EL	47uF 16V
C147	UM417100	C.EL	10uF 50V
C148	FG211100	C.CE	10pF 50V
C149	VJ837200	C.EL	47uF 16V
C150	VJ837200	C.EL	47uF 16V
C152	FG211100	C.CE	10pF 50V
C153	VJ837200	C.EL	47uF 16V
C154	UM417100	C.EL	10uF 50V
C168	VG722100	C.EL	1uF 50V
C169	VH053100	C.CE.TUBLR	0.1uF 50V
C189	UJ638470	C.EL	470uF 16V
C257	VH053100	C.CE.TUBLR	0.1uF 50V
C258	VG278400	C.CE.TUBLR	220pF 50V
C259	VG278400	C.CE.TUBLR	220pF 50V
C260	VG278400	C.CE.TUBLR	220pF 50V
C261	VG278400	C.CE.TUBLR	220pF 50V
C262	VG278400	C.CE.TUBLR	220pF 50V
C263	VG278400	C.CE.TUBLR	220pF 50V
C264	VJ839200	C.EL	2.2uF 50V
C601	VJ839000	C.EL	0.47uF 50V
C602	VH053100	C.CE.TUBLR	0.1uF 50V
C603	VJ839200	C.EL	2.2uF 50V
C604	VF637900	C.EL	1000uF 10V
C605	VU545000	C.EL	47000uF 5.5V
C606	VH053100	C.CE.TUBLR	0.1uF 50V
C607	VH053100	C.CE.TUBLR	0.1uF 50V
C609	VF466800	C.CE.TUBLR	100pF 50V(ABGL)
C610	VF466800	C.CE.TUBLR	100pF 50V(ABGL)
C611	VF466800	C.CE.TUBLR	100pF 50V(ABGL)
C612	VF466800	C.CE.TUBLR	100pF 50V(ABGL)
C613	VF466800	C.CE.TUBLR	100pF 50V(ABGL)
C901	VJ839100	C.EL	1uF 50V
C902	UM215100	C.EL	0.1uF 50V
C903	VJ839000	C.EL	0.47uF 50V
C904	VG287800	C.EL	330uF 16V
C905	VG287800	C.EL	330uF 16V
C906	UM215100	C.EL	0.1uF 50V
C907	VJ839000	C.EL	0.47uF 50V
C908	VJ839100	C.EL	1uF 50V
C909	UM407220	C.EL	22uF 16V

* New Parts

Schm Ref.	PART NO.	Description	
C910	FG211470	C.CE	47pF 50V
C911	VJ839200	C.EL	2.2uF 50V
C912	VJ839200	C.EL	2.2uF 50V
C913	FG211470	C.CE	47pF 50V
C914	UM407220	C.EL	22uF 16V
C915	UA655120	C.MYLAR	0.12uF 50V
C916	UA654330	C.MYLAR	0.033uF 50V
C917	UA654330	C.MYLAR	0.033uF 50V
C918	UA655120	C.MYLAR	0.12uF 50V
D14	VM974200	DIODE.ZENR	HZS5C2TD 5.0V
D601	VM974100	DIODE.ZENR	HZS5B2TD 5.0V
D602	VM974100	DIODE.ZENR	HZS5B2TD 5.0V
D603	VD631600	DIODE	1SS133,176,HSS104
D604	VD631600	DIODE	1SS133,176,HSS104
D605	VD631600	DIODE	1SS133,176,HSS104
D606	VD631600	DIODE	1SS133,176,HSS104
D607	VD631600	DIODE	1SS133,176,HSS104
D610	VS132300	LED(re)	SLR325VCT31(RABGL)
D611	VD631600	DIODE	1SS133,176,HSS104
D612	VM974300	DIODE.ZENR	HZS6A2TD 6.0V
D613	VD631600	DIODE	1SS133,176,HSS104
D614	VD631600	DIODE	1SS133,176,HSS104
D615	VD631600	DIODE	1SS133,176,HSS104
G601	VR463400	TERM.GND	D3.5 TP00385
IC22	XB247301	IC	uPC4570HA
IC23	XB247301	IC	uPC4570HA
IC26	XR040A00	IC	TC9299P
IC27	XR040A00	IC	TC9299P
IC28	XF494A00	IC	LB1641
IC251	XP896A00	IC	LC78213
IC601	XS983A00	IC	M38172M4-192FP(UCARL)
IC601	XT009A00	IC	M38177MC-068FP(BG)
IC901	XB247301	IC	uPC4570HA
JK1	VU245200	CN.DIN	1P(BG)
* PJ5	VV325100	JACK.PIN	3P
* PJ251	VV577800	JACK.PIN	6P
Q601	iC174020	TR	2SC1740S R,S
Q602	VG722000	TR.DGT	DTC144ES
Q603	VD678500	TR.DGT	DTA114ES
Q604	iA093320	TR	2SA933S Q,R(RALBG)
Q604	iA093320	TR	2SA933S Q,R(R)
Q901	VK432900	TR	2SD1915F S,T(BG)
Q902	VK432900	TR	2SD1915F S,T(BG)
Q903	VK432900	TR	2SD1915F S,T(BG)
Q904	VK432900	TR	2SD1915F S,T(BG)
R217	HV453470	R.CAR.FP	4.7Ω 1/4W
R218	HV453470	R.CAR.FP	4.7Ω 1/4W
R219	HV454100	R.CAR.FP	10Ω 1/4W
R221	HV454100	R.CAR.FP	10Ω 1/4W
R931	HL315100	R.MTL.OXD	100Ω 1W
R932	HL315100	R.MTL.OXD	100Ω 1W
SW601	VG392900	SW.TACT	SKHVAA
SW602	VG392900	SW.TACT	SKHVAA

* New Parts

OPERATION P.C.B.

Schm Ref.	PART NO.	Description	
SW603	VG392900	SW.TACT	SKHVAA
SW604	VG392900	SW.TACT	SKHVAA
SW605	VG392900	SW.TACT	SKHVAA
SW606	VG392900	SW.TACT	SKHVAA
SW607	VG392900	SW.TACT	SKHVAA
SW608	VG392900	SW.TACT	SKHVAA
SW609	VG392900	SW.TACT	SKHVAA
SW610	VG392900	SW.TACT	SKHVAA
SW611	VG392900	SW.TACT	SKHVAA
SW612	VG392900	SW.TACT	SKHVAA
SW613	VG392900	SW.TACT	SKHVAA
SW614	VG392900	SW.TACT	SKHVAA
SW615	VG392900	SW.TACT	SKHVAA
SW616	VG392900	SW.TACT	SKHVAA
SW617	VG392900	SW.TACT	SKHVAA
SW618	VG392900	SW.TACT	SKHVAA
SW619	VG392900	SW.TACT	SKHVAA(BG)
SW620	VG392900	SW.TACT	SKHVAA
SW621	VG392900	SW.TACT	SKHVAA
SW622	VG392900	SW.TACT	SKHVAA
SW623	VG392900	SW.TACT	SKHVAA(BG)
SW624	VG392900	SW.TACT	SKHVAA
SW625	VG392900	SW.TACT	SKHVAA
SW626	VG392900	SW.TACT	SKHVAA
SW627	VG392900	SW.TACT	SKHVAA
SW628	VG392900	SW.TACT	SKHVAA
SW629	VG392900	SW.TACT	SKHVAA
SW630	VG392900	SW.TACT	SKHVAA
SW631	VG392900	SW.TACT	SKHVAA
SW632	VG392900	SW.TACT	SKHVAA
SW633	VG392900	SW.TACT	SKHVAA
SW634	VG392900	SW.TACT	SKHVAA
SW635	VG392900	SW.TACT	SKHVAA(BG)
SW636	VG392900	SW.TACT	SKHVAA(BG)
SW637	VG392900	SW.TACT	SKHVAA
SW638	VG392900	SW.TACT	SKHVAA
SW639	VG392900	SW.TACT	SKHVAA
SW640	VG392900	SW.TACT	SKHVAA
SW641	VG392900	SW.TACT	SKHVAA
SW642	VG392900	SW.TACT	SKHVAA
* SW901	VV887300	SW.PUSH	SPUN19
U601	VU591000	L.DTCT	GP1U271X
* V601	VV485500	FL.DSPLY	13-BT-149GK
* VR1	VV135100	VR.MTR	A100K Ω
VR901	VP741800	VR	B20K Ω
VR902	VP741900	VR	G25K Ω
VR903	VP742000	VR	MN100K Ω
XL601	VR891500	RSNR.CE	6.30MHz
	VJ828000	PIN	IMSA-6024-03E
	BB071360	SCR.TERM	8.3x13
	VR011400	SHEET.FL	
*	VV499900	SPACER	FL-T7.5

* New Parts

A

B

C

D

E

RX-V592/R-V902/RX-V592RDS

EXPLODED VIEW

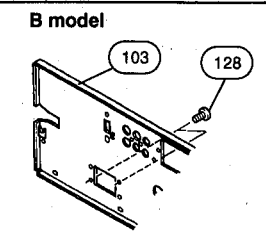
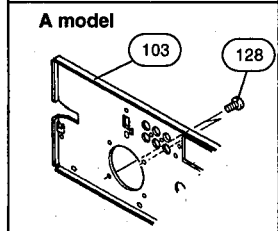
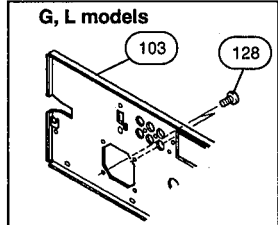
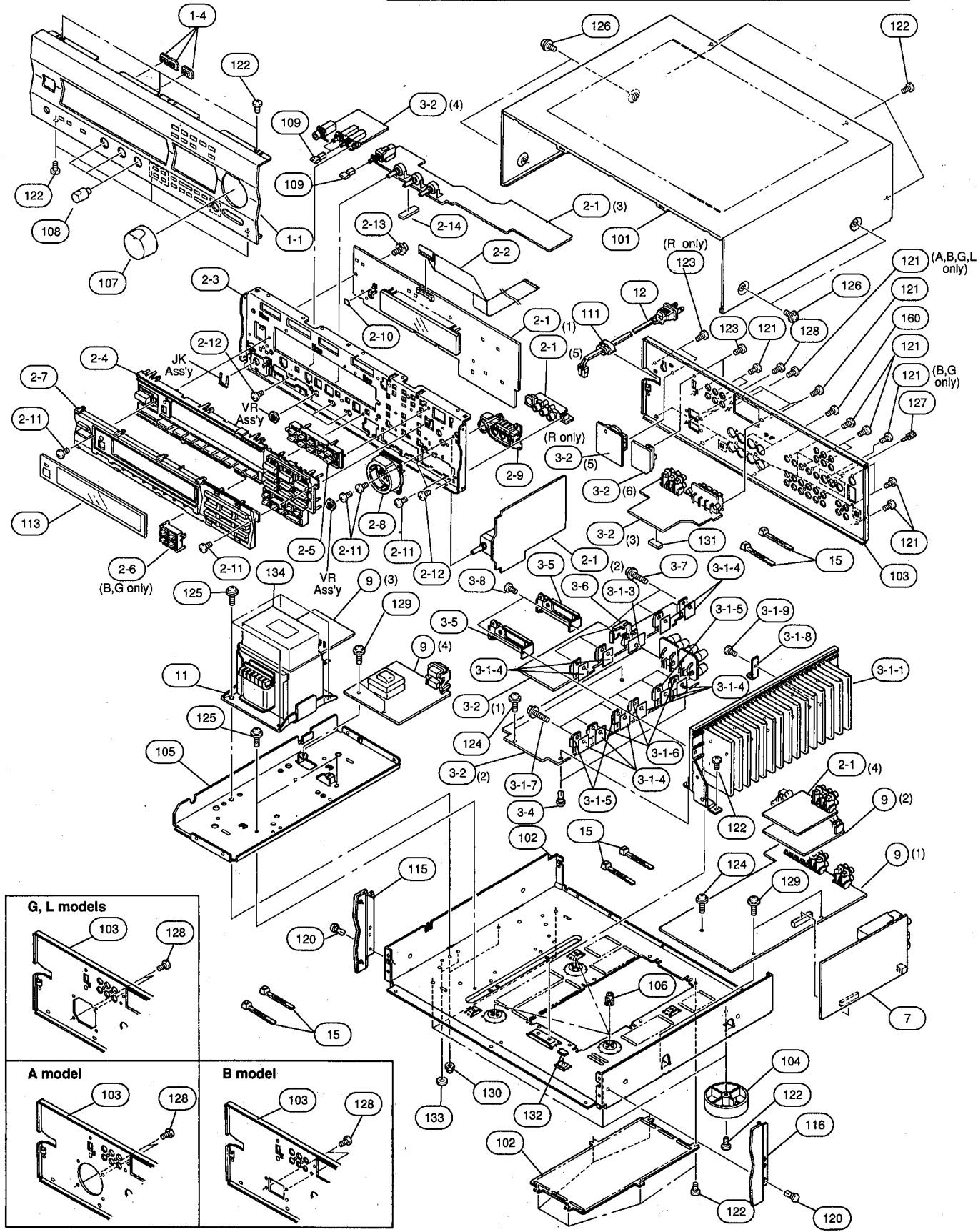
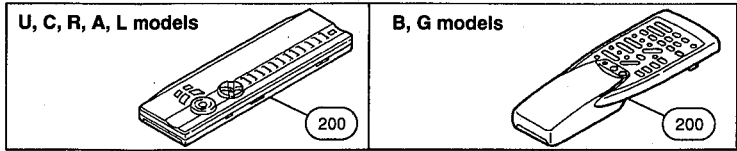

1
2
3
4
5
6
7

MECHANICAL PARTS

Ref. No.	PART NO.	Description	Remarks	Markets
*	1-1	VV141600 FRONT PANEL		(UCRAL)
*	1-1	VV141700 FRONT PANEL		(BG)
*	1-1	VV141800 FRONT PANEL		
*	1-1	VV141900 FRONT PANEL		
*	1-4	VV123700 ESCUTCHEON, 3/8	2P	
*	1-4	VV123800 ESCUTCHEON, 3/8	2P	
*	2-1	VV575600 P.C.B. ASS'Y	OPERATION	(UC)
*	2-1	VV575700 P.C.B. ASS'Y	OPERATION	(R)
*	2-1	VV575800 P.C.B. ASS'Y	OPERATION	(AL)
*	2-1	VV809100 P.C.B. ASS'Y	OPERATION	(BG)
*	2-2	MF120400 FLEXIBLE FLAT CABLE C&C	20P 400mm	
*	2-3	VV140700 SUB CHASSIS	130	
*	2-3	VV626500 SUB PANEL CASE	9	
*	2-4	VV136300 BUTTON, CASE		
*	2-4	VV136400 BUTTON, CASE		
*	2-5	VV137700 BUTTON, DSP		
*	2-5	VV137800 BUTTON, DSP		
*	2-6	VV137900 BUTTON, RDS		(BG)
*	2-6	VV138000 BUTTON, RDS		
*	2-7	VV309200 SUB PANEL CASE	9	
*	2-7	VV309300 SUB PANEL CASE	9	
*	2-7	VV626500 SUB PANEL CASE	9	
*	2-8	VV149500 ESCUTCHEON, VOL		
*	2-8	VV149600 ESCUTCHEON, VOL		
*	2-8	VV149700 ESCUTCHEON, VOL		(R)
*	2-8	VV626400 ESCUTCHEON, VOL		(UC)
*	2-9	VV149800 ESCUTCHEON, PJ		
*	2-9	VV149900 ESCUTCHEON, PJ		
	2-10	VU629200 DAMPER, LED	2x12x12	(RAB)
	2-11	Ei330086 BIND HEAD B-TITE SCREW	3x8 FCRM3-BL	
	2-12	ED330066 BIND HEAD SCREW	3x6 FCRM3-BL	
	2-13	VT669300 PW HEAD B-TITE SCREW	3x8-8 MFC2	
	2-14	VS699700 DAMPER	SIDE	
	2-15	EP630220 BIND HEAD P-TITE SCREW	3x8 ZMC2-BL	
*	3-1-1	VV143000 HEAT SINK ASS'Y		
*	3-1-3	VV901800 RADIATION SHEET		
*	3-1-4	VV849300 RADIATION SHEET	BFG-20ADH-3 19X24	
△ #	3-1-5	iX606460 TRANSISTOR	2SA1492 O,P,Y	
△ #	3-1-6	iX606470 TRANSISTOR	2SC3856 O,P,Y	
	3-1-7	VK173200 SCREW, TRANSISTOR	3x15 SP FCM3	
*	3-1-8	VV518700 SUPPORT, HEAT SINK	L	
	3-1-9	Ei330086 BIND HEAD B-TITE SCREW	3x8 FCRM3-BL	
*	3-2	VV577100 P.C.B. ASS'Y	AMP	(UC)
*	3-2	VV577200 P.C.B. ASS'Y	AMP	(R)
*	3-2	VV577300 P.C.B. ASS'Y	AMP	(A)
*	3-2	VV577400 P.C.B. ASS'Y	AMP	(BG)
*	3-2	VV899600 P.C.B. ASS'Y	AMP	(L)
	3-4	VQ368500 PUSH RIVET	P3545-B	
*	3-5	VV491300 SUPPORT, PCB		
*	3-6	VV901900 SUPPORT, TR		
	3-7	VK173200 SCREW, TRANSISTOR	3x15 SP FCM3	
	3-8	Ei330086 BIND HEAD B-TITE SCREW	3x8 FCRM3-BL	
*	7	VV610200 P.C.B. ASS'Y	TUNER	(UC)

* New Parts

Ref. No.	PART NO.	Description	Remarks	Markets
* 7	VV610300	P.C.B. ASS'Y	TUNER	(R)
* 7	VV610400	P.C.B. ASS'Y	TUNER	(AL)
* 7	VV610500	P.C.B. ASS'Y	TUNER	(BG)
* 9	VV574700	P.C.B. ASS'Y	INPUT	(UC)
* 9	VV574800	P.C.B. ASS'Y	INPUT	(R)
* 9	VV574900	P.C.B. ASS'Y	INPUT	(A)
* 9	VV575000	P.C.B. ASS'Y	INPUT	(B)
* 9	VV575100	P.C.B. ASS'Y	INPUT	(G)
* 9	VV575200	P.C.B. ASS'Y	INPUT	(L)
△ * 11	XS869A00	POWER TRANSFORMER		(U)
△ * 11	XS870A00	POWER TRANSFORMER		(C)
△ * 11	XS871A00	POWER TRANSFORMER		(R9)
△ * 11	XS872A00	POWER TRANSFORMER		(A)
△ * 11	XS873A00	POWER TRANSFORMER		(BGL)
△ 12	VL238100	POWER CORD ASS'Y		(R)
△ * 12	VN363700	POWER CORD ASS'Y		(G)
△ 12	VQ508600	POWER CORD ASS'Y		(A)
△ * 12	VV437200	POWER CORD ASS'Y		(UC)
△ * 12	VV437300	POWER CORD ASS'Y		(B)
	15	VU590000	BINDING TIE	
			CBTD001B	
* 101	VV121300	TOP COVER		
* 101	VV121500	TOP COVER		
	102	VS001400	CHASSIS	
* 103	VV144100	REAR PANEL		(U)
* 103	VV144200	REAR PANEL		(C)
* 103	VV144400	REAR PANEL		(U)
* 103	VV144500	REAR PANEL		(C)
* 103	VV144600	REAR PANEL		(R)
* 103	VV144700	REAR PANEL		(A)
* 103	VV144800	REAR PANEL		(L)
* 103	VV144900	REAR PANEL		(B)
* 103	VV145000	REAR PANEL		(G)
* 103	VV150600	REAR PANEL		(R)
	104	VS025000	LEG	
			D60xH21	
* 104	VV544300	LEG	D60xH21	(UC)
* 104	VV544600	LEG	D60xH21	(R)
* 105	VV123100	FRAME, TRANS		
	106	VR264400	SPACER	
			H8	
* 107	VV148800	KNOB	D40	(UCRAL)
* 107	VV268800	KNOB	D40	(BG)
* 107	VV268900	KNOB	D40	
* 108	VV311000	KNOB	D14	
* 108	VV311400	KNOB	D14	
* 109	VV123500	BUTTON, 3/8		
* 109	VV123600	BUTTON, 3/8		
	111	VN158600	CORD STOPPER	
			No.2104	
* 113	VV139600	SHEET, WINDOW		(UC)
* 113	VV139800	SHEET, WINDOW		(RALBG)
* 115	VV124300	PLATE SIDE L	130	
* 115	VV124400	PLATE SIDE L	130	
* 116	VV124500	PLATE SIDE R	130	
* 116	VV124600	PLATE SIDE R	130	
	120	VQ368600	PUSH RIVET	
			P3555-B	

* New Parts

Ref. No.	PART NO.	Description	Remarks	Markets
121	VN413300	BIND HEAD BONDING B-T. SCREW	3x8 MFZN2-BL	
122	Ei330086	BIND HEAD B-TITE SCREW	3x8 FCRM3-BL	
123	ED330066	BIND HEAD SCREW	3x6 FCRM3-BL	
124	VT669400	PW HEAD B-TITE SCREW	3x15-8 MFC2	
125	EK365090	PW HEAD S-TITE SCREW	4x8-10 FCRM3-BL	
126	EK365090	PW HEAD S-TITE SCREW	4x8-10 FCRM3-BL	
126	EX601150	BW HEAD S-TITE SCREW	4x8-10 FNM3-BL	
127	AA627310	GROUND TERMINAL		
128	Ei030086	BIND HEAD B-TITE SCREW	3x8 ZMC2-Y	
129	VT669300	PW HEAD B-TITE SCREW	3x8-8 MFC2	
130	VK002600	HEXAGONAL CAP NUT	4mm	
131	VS758000	DAMPER, T5		
132	VS936800	DAMPER	3x5x10	
133	VU984400	RING	D14	
134	VY731300	DAMPER	TRANS	
135	VQ366100	DAMPER, PCB		(BG)
136	VY989400	DAMPER	SIDE	
160	VY731200	BONDING HEAD TAPPING SCREW	3x10 MFNI33	(BG)
* 161	VZ047200	DAMPER	TOP	(BG)
171	VV050400	SPACER		(BG)
			ACCESSORIES	
* 200	VV486400	REMOTE CONTROL TRANSMITTER	SBGH20020A RAV4	
* 200	VV627000	REMOTE CONTROL TRANSMITTER	RAV120	
	VQ147100	ANTENNA, FM	1P 1.4m	
	VR248500	ANTENNA, AM LOOP	1P 1.0m	
	VE364900	ANTENNA ADAPTER	PAL 75-300Ω	(B)
	VT948000	ANTENNA ADAPTER		(UC)
		BATTERY, MANGANESE	SUM-3,AA,R06	

* New Parts

RX-V592/R-V902/RX-V592RDS

EXPLODED VIEW (Remote Control Transmitter)

● U, C, R, A and L models

● B and G models

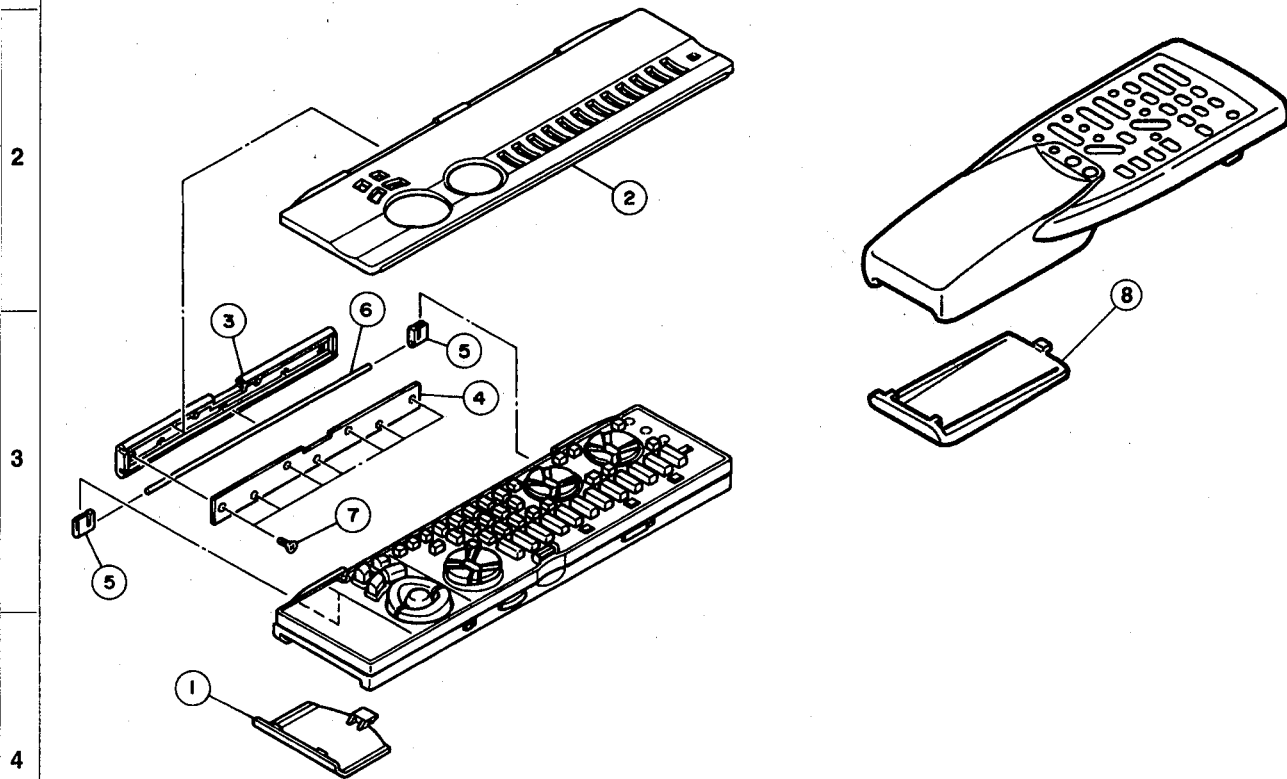

MECHANICAL PARTS (Remote Control Transmitter)

Ref. No.	PART NO.	Description	Remarks	Markets	
*	VV627000	REMOTE CONTROL TRANSMITTER	RAV120	RRC40005502R	(UCRAL)
* 1	CX680040	COVER, BATTERY		103RRC11101R	
* 2	CX680050	LID		103RRC11201R	
* 3	CX680060	BRACKET	A	503RRC00401R	
* 4	CX680070	BRACKET	B	503RRC00501R	
* 5	CX680080	GUIDE PIN		522RRC00101R	
* 6	CX680090	PIN		524RRC00101R	
* 7	EX603910	SCREW	M1.7x13.5	ABB1703321001	
* 8	VV486400	REMOTE CONTROL TRANSMITTER	SBGH20020A RAV4		(BG)
	CX679050	LID	74x34BLALPS		

* New Parts

A

B

C

D

E

■ REMOTE CONTROL TRANSMITTER

● U, C, R, A and L models

SCHEMATIC DIAGRAM

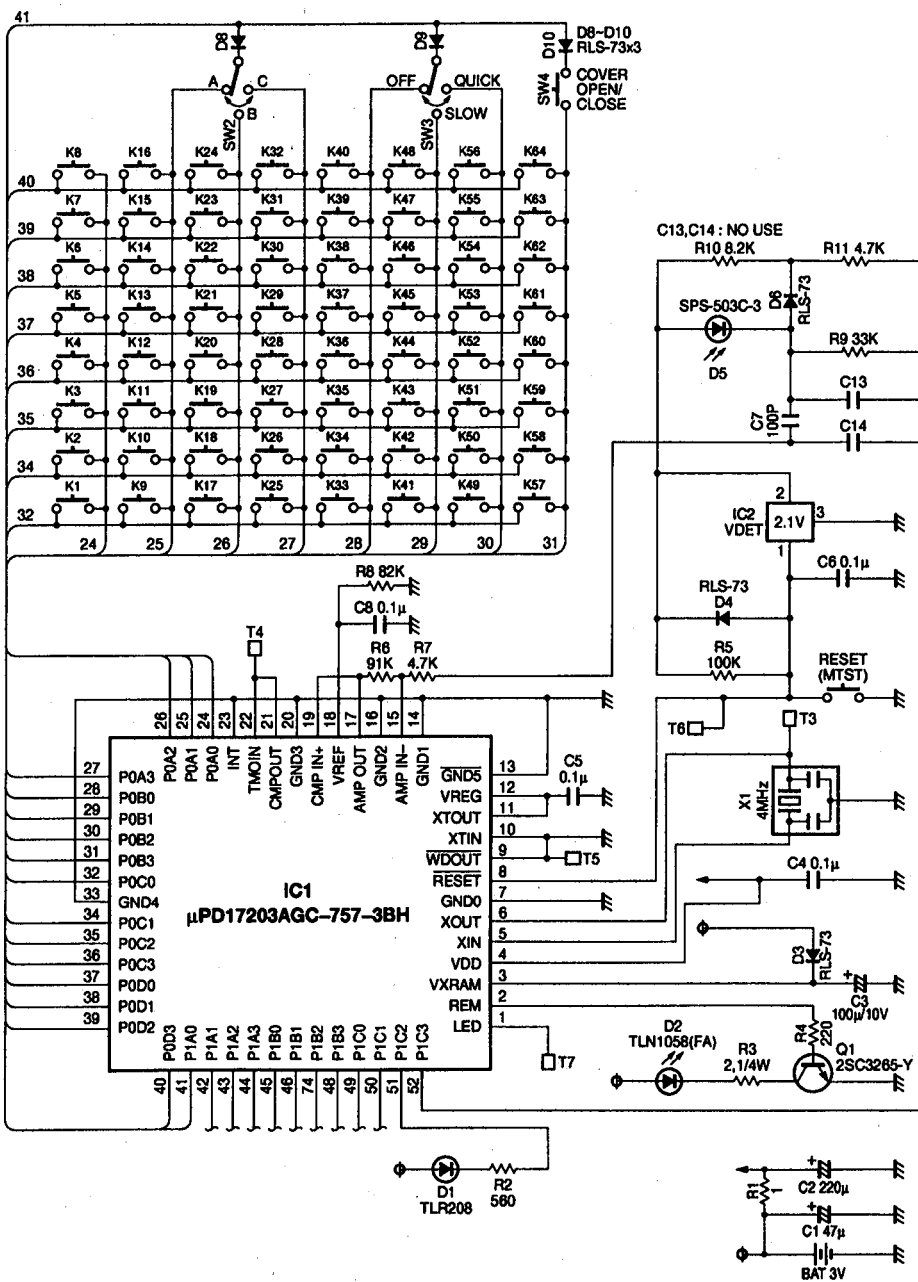

Key arrangement

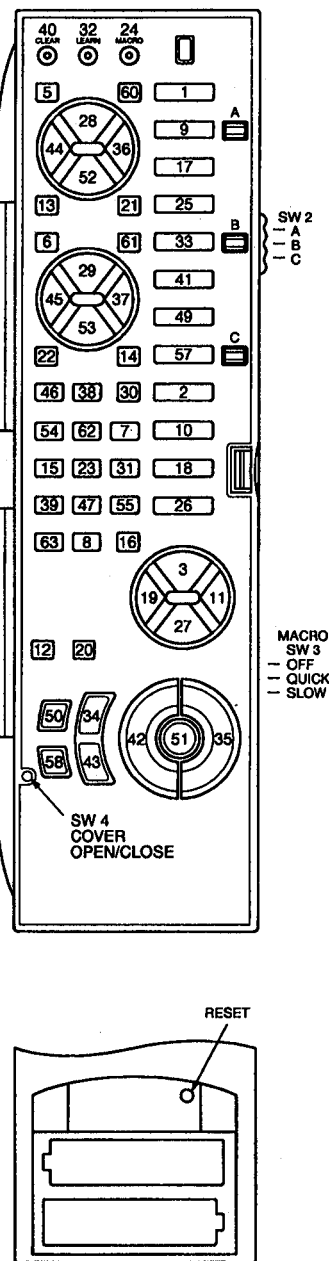

1
2
3
4
5
6
7

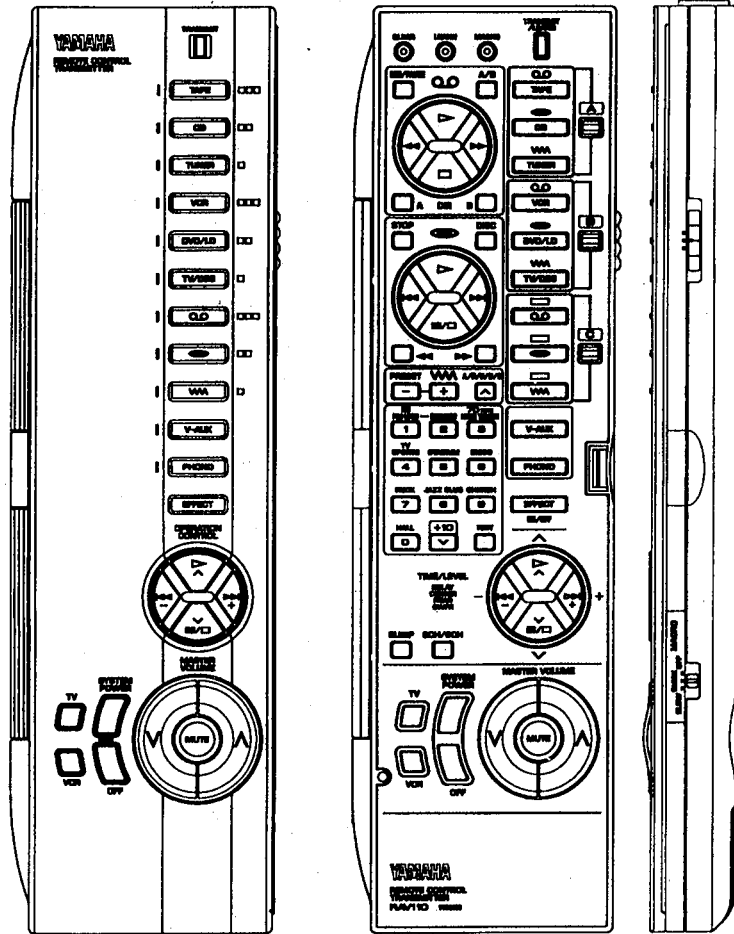

MACRO transmission

Transmission code of initial setting shows under the below. (key No.)

Each transmission code is the fixed or learning code.

Key No.	COVER		CLOSE						
	SW 2		Don't care.						
	SW 3		QUICK or SLOW						
	MACRO order		1	2	3	4	5	6	7
1	TAPE	K34	K1	K28-A	-	-	-	-	-
2	WMA	K34	K2	-	-	-	-	-	
9	CD	K34	K9	K29-A	-	-	-	-	
10	V-AUX	K34	K10	-	-	-	-	-	
17	TUNER	K34	K17	-	-	-	-	-	
18	PHONO	K34	K18	-	-	-	-	-	
25	VCR	K34	K25	K28-B	-	-	-	-	
33	DVD/LD	K34	K33	K29-B	-	-	-	-	
34	SYSTEM POWER	K34	K50	K58	-	-	-	-	
41	TV/DBS	K34	K41	-	-	-	-	-	
43	SYSTEM POWER OFF	K43	-	-	-	-	-	-	
49	Q.D	K34	K49	K28-A	-	-	-	-	
57	Ⓞ	K34	K57	K29-B	-	-	-	-	

Detail : K x x - O

Key No. The position of SW2

List of the fixed code

Key No.	FUNCTION	SW 2		
		A	B	C
1	TAPE	7A-85-18	7A-85-18	7A-85-18
2	WMA	---	---	---
3	▲▷▲	7A-85-98	7A-85-98	7A-85-98
4	NOT USED	7A-85-9B	7A-85-9B	7A-85-9B
5	REC/PAUSE	7A-85-04	---	---
6	STOP	---	---	7C-83-5B
7	3	7A-85-8A	7A-85-8A	7A-85-8A
8	+10	---	---	---
9	CD	7A-85-15	7A-85-15	7A-85-15
10	V-AUX	7A-85-55	7A-85-55	7A-85-55
11	+▷▷+	7A-85-52	7A-85-52	7A-85-52
12	SLEEP	7A-85-57	7A-85-57	7A-85-57
13	DIR A	7A-85-07	---	---
14	▷▷	7A-85-0C	---	7C-83-07
15	4	7A-85-8B	7A-85-8B	7A-85-8B
16	TEST	7A-85-85	7A-85-85	7A-85-85
17	TUNER	7A-85-16	7A-85-16	7A-85-16
18	PHONO	7A-85-14	7A-85-14	7A-85-14
19	-◀◀-	7A-85-53	7A-85-53	7A-85-53
20	2CH/6CH	7A-85-87	7A-85-87	7A-85-87
21	DIR B	7A-85-40	---	---
22	◀◀	7A-85-0D	---	7C-83-06
23	5	7A-85-8E	7A-85-8E	7A-85-8E
25	VCR	7A-85-0F	7A-85-0F	7A-85-0F
26	EFFECT	7A-85-56	7A-85-56	7A-85-56
27	▲00/□▲	7A-85-99	7A-85-99	7A-85-99
28	▷ (TAPE)	7A-85-00	---	---
29	▷ (CD)	7A-85-08	---	7C-83-05
30	A/B/C/D/E	7A-85-12	---	---
31	6	7A-85-8F	7A-85-8F	7A-85-8F

Key No.	FUNCTION	SW 2		
		A	B	C
33	DVD/LD	7A-85-17	7A-85-17	7A-85-17
34	SYSTEM POWER	7A-85-1D	7A-85-1D	7A-85-1D
35	MASTER VOL +	7A-85-1A	7A-85-1A	7A-85-1A
36	▷▷	7A-85-02	---	---
37	▷▷	7A-85-0A	---	7C-83-03
38	PRESET +	7A-85-10	---	---
39	7	7A-85-8C	7A-85-8C	7A-85-8C
41	TV/DBS	7A-85-54	7A-85-54	7A-85-54
42	MASTER VOL -	7A-85-1B	7A-85-1B	7A-85-1B
43	SYSTEM POWER OFF	7A-85-1E	7A-85-1E	7A-85-1E
44	◀◀	7A-85-01	---	---
45	◀◀	7A-85-0B	---	7C-83-02
46	PRESET -	7A-85-11	---	---
47	8	7A-85-8D	7A-85-8D	7A-85-8D
49	Q.D	---	---	---
50	SYSTEM POWER TV	---	---	---
51	MUTE	7A-85-1C	7A-85-1C	7A-85-1C
52	□	7A-85-03	---	---
53	00/□	7A-85-09	---	7C-83-04
54	1	7A-85-88	7A-85-88	7A-85-88
55	9	7A-85-90	7A-85-90	7A-85-90
57	Ⓞ	---	---	---
58	SYSTEM POWER VCR	---	---	---
59	NOT USED	7A-85-9A	7A-85-9A	7A-85-9A
60	A/B	7A-85-06	---	---
61	DISC	7A-85-4F	---	---
62	2	7A-85-89	7A-85-89	7A-85-89
63	0	7A-85-91	7A-85-91	7A-85-91

REMOTE CONTROL TRANSMITTER

● B and G models

SCHEMATIC DIAGRAM

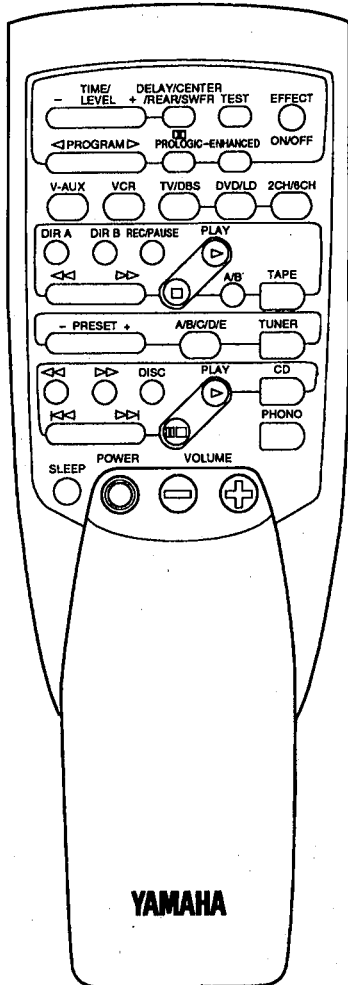
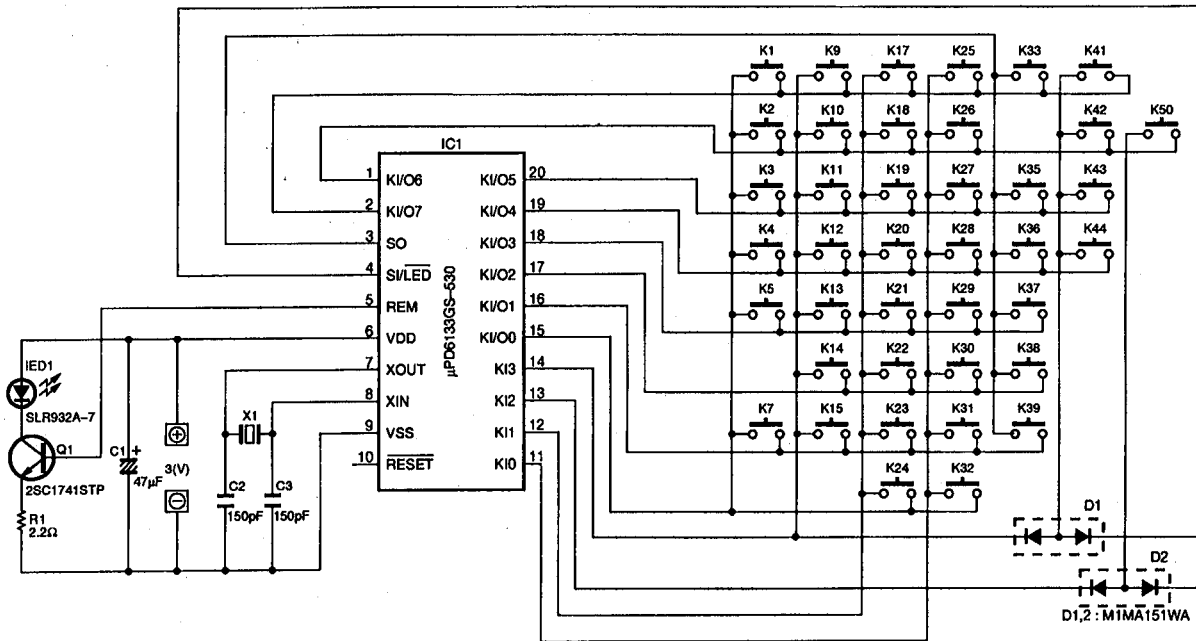

Key No.	FUNCTION	CUSTOM (BIN)	DATA (HEX)
1	EFFECT ON/OFF	7A	56
2	PROGRAM ◀	7A	59
3	PROGRAM ▶	7A	58
4	□ PROLOGIC	7A	88
5	ENHANCED	7A	89
		7A	8A
7	V-AUX	7A	55
		7A	13
9	VCR	7A	0F
10	TV/DBS	7A	54
11	DVD/LD	7A	17
12	DIR A	7A	07
13	DIR B	7A	40
14	REC/PAUSE	7A	04
15	PLAY (TAPE)	7A	00
		7A	19
17	◀◀ (TAPE)	7A	01
18	▶▶ (TAPE)	7A	02
19	□ (TAPE)	7A	03
20	DECK A/B	7A	06
21	TAPE	7A	18
22	PRESET -	7A	11
23	PRESET +	7A	10
24	A/B/C/D/E	7A	12
25	TUNER	7A	16
26	◀◀ (CD)	7A	0D
27	▶▶ (CD)	7A	0C
28	DISC	7A	4F
29	PLAY (CD)	7A	08
30	CD	7A	15
31	◀◀ (CD)	7A	0B
32	▶▶ (CD)	7A	0A
33	◻ (CD)	7A	09
		7A	0E
35	PHONO	7A	14
36	SLEEP	7A	57
37	POWER	7A	1F
38	VOLUME -	7A	1B
39	VOLUME +	7A	1A
		7A	1C
41	TIME/LEVEL -	7A	53
42	TIME/LEVEL +	7A	52
43	DELAY/CENTER/REAR/SWFR	7A	86
44	TEST	7A	85
		7A	05
		7A	5A
		7A	5B
		7A	1D
		7A	1E
50	2CH/6CH	7A	87

Parts List for Carbon Resistors

Value	1/4W Type Part No.	1/6W Type Part No.	Value	1/4W Type Part No.	1/6W Type Part No.
1.0 Ω	HJ35 3100	HF85 3100	10 kΩ	HF45 7100	HF45 7100
1.8 Ω	HJ35 3180	*	11 kΩ	HF45 7110	HF45 7110
2.2 Ω	HJ35 3220	HF85 3220	12 kΩ	HJ35 7120	HF85 7120
3.3 Ω	HJ35 3330	HF85 3330	13 kΩ	HF45 7130	HF45 7130
4.7 Ω	HJ35 3470	HF85 3470	15 kΩ	HF45 7150	HF45 7150
5.6 Ω	HJ35 3560	HF85 3560	18 kΩ	HF45 7180	HF45 7180
10 Ω	HF45 4100	HF45 4100	22 kΩ	HF45 7220	HF45 7220
15 Ω	HJ35 4150	HF85 4150	24 kΩ	HF45 7240	HF45 7240
22 Ω	HF45 4220	HF45 4220	27 kΩ	HJ35 7270	HF85 7270
27 Ω	HJ35 4270	HF85 4270	30 kΩ	HF45 7300	HF45 7300
33 Ω	HF45 4330	HF45 4330	33 kΩ	HF45 7330	HF45 7330
39 Ω	HJ35 4390	HF85 4390	36 kΩ	HF45 7360	HF45 7360
47 Ω	HF45 4470	HF45 4470	39 kΩ	HF45 7390	HF45 7390
56 Ω	HF45 4560	HF45 4560	47 kΩ	HF45 7470	HF45 7470
68 Ω	HF45 4680	HF45 4680	51 kΩ	HF45 7510	HF45 7510
75 Ω	HF45 4750	HF45 4750	56 kΩ	HF45 7560	HF45 7560
82 Ω	HF45 4820	HF45 4820	62 kΩ	HF45 7620	HF45 7620
91 Ω	HF45 4910	HF45 4910	68 kΩ	HF45 7680	HF45 7680
100 Ω	HF45 5100	HF45 5100	82 kΩ	HF45 7820	HF45 7820
110 Ω	HJ35 5110	HF85 5110	91 kΩ	HF45 7910	HF45 7910
120 Ω	HF45 5120	HF45 5120	100 kΩ	HF45 8100	HF45 8100
150 Ω	HF45 5150	HF45 5150	110 kΩ	HF45 8110	HF45 8110
160 Ω	HJ35 5160	*	120 kΩ	HF45 8120	HF45 8120
180 Ω	HF45 5180	HF45 5180	150 kΩ	HF45 8150	HF45 8150
200 Ω	HF45 5200	HF45 5200	180 kΩ	HF45 8180	HF45 8180
220 Ω	HF45 5220	HF45 5220	220 kΩ	HJ35 8220	HF85 8220
270 Ω	HF45 5270	HF45 5270	270 kΩ	HF45 8270	HF45 8270
330 Ω	HF45 5330	HF45 5330	300 kΩ	HF45 8300	HF45 8300
390 Ω	HF45 5390	HF45 5390	330 kΩ	HF45 8330	HF45 8330
430 Ω	HF45 5430	HF45 5430	390 kΩ	HJ35 8390	HF85 8390
470 Ω	HF45 5470	HF45 5470	470 kΩ	HF45 8470	HF45 8470
510 Ω	HF45 5510	HF45 5510	560 kΩ	HJ35 8560	HF85 8560
560 Ω	HF45 5560	HF45 5560	680 kΩ	HJ35 8680	HF85 8680
680 Ω	HF45 5680	HF45 5680	820 kΩ	HJ35 8820	HF85 8820
820 Ω	HF45 5820	HF45 5820	1.0 MΩ	HF45 9100	HF45 9100
910 Ω	HF45 5910	HF45 5910	1.2 MΩ	HJ35 9120	*
1.0 kΩ	HF45 6100	HF45 6100	1.5 MΩ	HJ35 9150	HF85 9150
1.2 kΩ	HF45 6120	HF45 6120	1.8 MΩ	HJ35 9180	HF85 9180
1.5 kΩ	HF45 6150	HF45 6150	2.2 MΩ	HJ35 9220	HF85 9220
1.8 kΩ	HF45 6180	HF45 6180	3.3 MΩ	HJ35 9330	HF85 9330
2.0 kΩ	HJ35 6200	HF85 6200	3.9 MΩ	HJ35 9390	*
2.2 kΩ	HF45 6220	HF45 6220	4.7 MΩ	HJ35 9470	HF85 9470
2.4 kΩ	HJ35 6240	HF85 6240			
2.7 kΩ	HF45 6270	HF45 6270			
3.0 kΩ	HF45 6300	HF45 6300			
3.3 kΩ	HF45 6330	HF45 6330			
3.6 kΩ	HJ35 6360	HF85 6360			
3.9 kΩ	HF45 6390	HF45 6390			
4.7 kΩ	HF45 6470	HF45 6470			
5.1 kΩ	HF45 6510	HF45 6510			
5.6 kΩ	HF45 6560	HF45 6560			
6.8 kΩ	HF45 6680	HF45 6680			
8.2 kΩ	HF45 6820	HF45 6820			
9.1 kΩ	HF45 6910	HF45 6910			

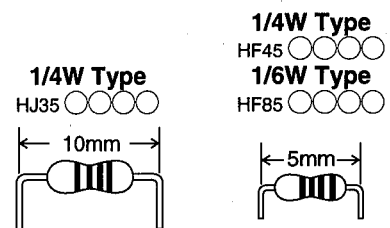

*: Not available

**RX-V592/R-V902/
RX-V592RDS**

YAMAHA
