

AV RECEIVER RX-V595/R-V905/ RX-V595RDS SERVICE MANUAL

IMPORTANT NOTICE

This manual has been provided for the use of authorized YAMAHA Retailers and their service personnel. It has been assumed that basic service procedures inherent to the industry, and more specifically YAMAHA Products, are already known and understood by the users, and have therefore not been restated.

WARNING: Failure to follow appropriate service and safety procedures when servicing this product may result in personal injury, destruction of expensive components, and failure of the product to perform as specified. For these reasons, we advise all YAMAHA product owners that any service required should be performed by an authorized YAMAHA Retailer or the appointed service representative.

IMPORTANT: The presentation or sale of this manual to any individual of firm does not constitute authorization, certification or recognition of any applicable technical capabilities, or establish a principle-agent relationship of any form.

The data provided is believed to be accurate and applicable to the unit(s) indicated on the cover. The research, engineering, and service departments of YAMAHA are continually striving to improve YAMAHA products. Modifications are, therefore, inevitable and specifications are subject to change without notice or obligation to retrofit. Should any discrepancy appear to exist, please contact the distributor's Service Division.

WARNING: Static discharges can destroy expensive components. Discharge any static electricity your body may have accumulated by grounding yourself to the ground buss in the unit (heavy gauge black wires connect to this buss).

IMPORTANT: Turn the unit OFF during disassembly and part replacement. Recheck all work before you apply power to the unit.

CONTENTS

TO SERVICE PERSONNEL	1	TUNER ADJUSTMENT	22~25
REMOTE CONTROL PANELS	1	IC DATA	26~35
FRONT PANELS	2	DISPLAY DATA	36
REAR PANELS	3~4	BLOCK DIAGRAM	37~39
SPECIFICATIONS	5~6	PRINTED CIRCUIT BOARD	40~55
INTERNAL VIEW	7	SCHEMATIC DIAGRAM	56~63
DISASSEMBLY PROCEDURES	7	PARTS LIST	64~79
SELF DIAGNOSIS FUNCTION	8~19	PRINTED CIRCUIT BOARD	80~81
FACTORY PRESET	20	REMOTE CONTROL TRANSMITTER	82
AMP ADJUSTMENT	21		



このサービスマニュアルは、エコマーク認定の再生紙を使用しています。
This Service Manual uses recycled paper.



■ TO SERVICE PERSONNEL

- Critical Components information.
Components having special characteristics are marked and must be replaced with parts having specifications equal to those originally installed.
- Leakage Current Measurement (For 120V Model only).
When service has been completed, it is imperative that you verify that all exposed conductive surfaces are properly insulated from supply circuits.
 - Meter impedance should be equivalent to 1500 ohm shunted by 0.15μF.
 - Leakage current must not exceed 0.5mA.
 - Be sure to test for leakage with the AC plug in both polarities.

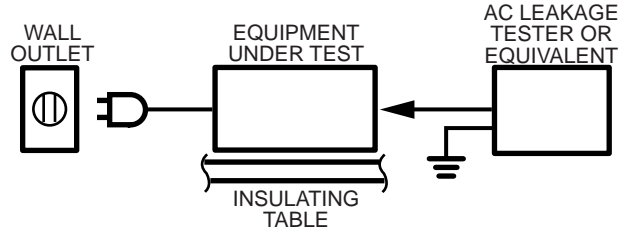

"CAUTION"



"F804: FOR CONTINUED PROTECTION AGAINST RISK OF FIRE, REPLACE ONLY WITH SAME TYPE 8.0A, 250V FUSE."

CAUTION

F804: REPLACE WITH SAME TYPE 8.0A, 250V FUSE.

ATTENTION

F804: UTILISER UN FUSIBLE DE RECHANGE DE MÊME TYPE DE 8.0A, 250V FUSE.

WARNING: CHEMICAL CONTENT NOTICE!

The solder used in the production of this product contains LEAD. In addition, other electrical/electronic and/or plastic (where applicable) components may also contain traces of chemicals found by the California Health and Welfare Agency (and possibly other entities) to cause cancer and/or birth defects or other reproductive harm.

DO NOT PLACE SOLDER, ELECTRICAL/ELECTRONIC OR PLASTIC COMPONENTS IN YOUR MOUTH FOR ANY REASON WHATSOEVER!

Avoid prolonged, unprotected contact between solder and your skin! When soldering, do not inhale solder fumes or expose eyes to solder/flux vapor!

If you come in contact with solder or components located inside the enclosure of this product, wash your hands before handling food.

■ REMOTE CONTROL PANELS

▼ U,C,R,T and L models

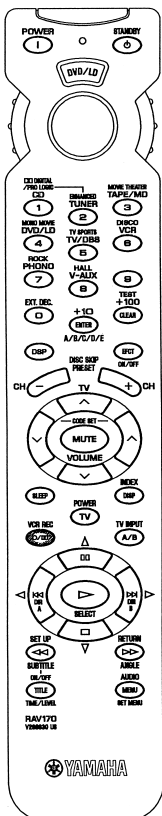

▼ A,B and G models

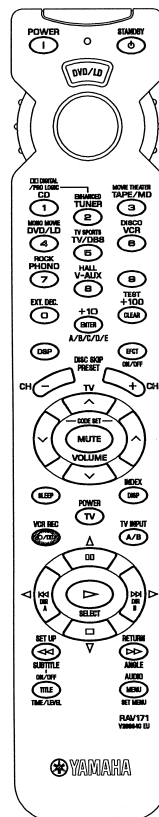

FRONT PANELS

▼ RX-V595 (U, C, R, T, A and L models)

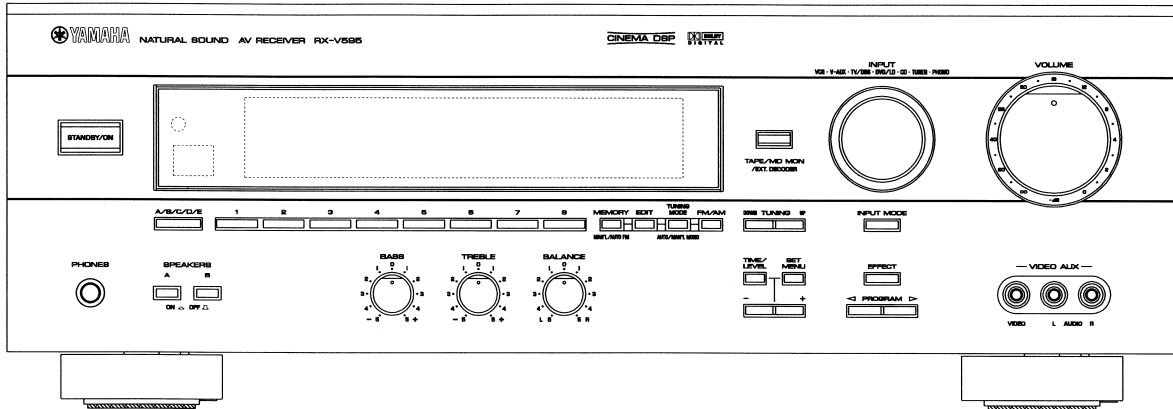

▼ R-V905 (U, C, R, T and A models)

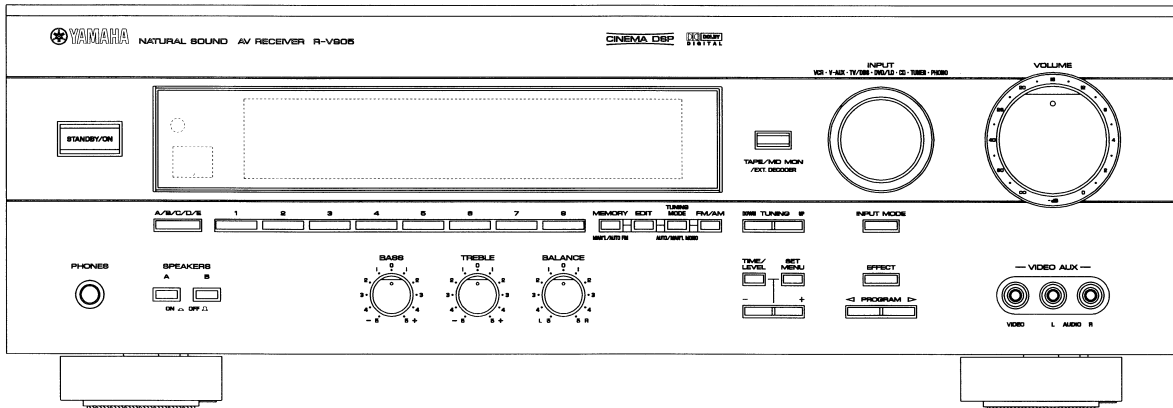

▼ RX-V595RDS (B and G models)

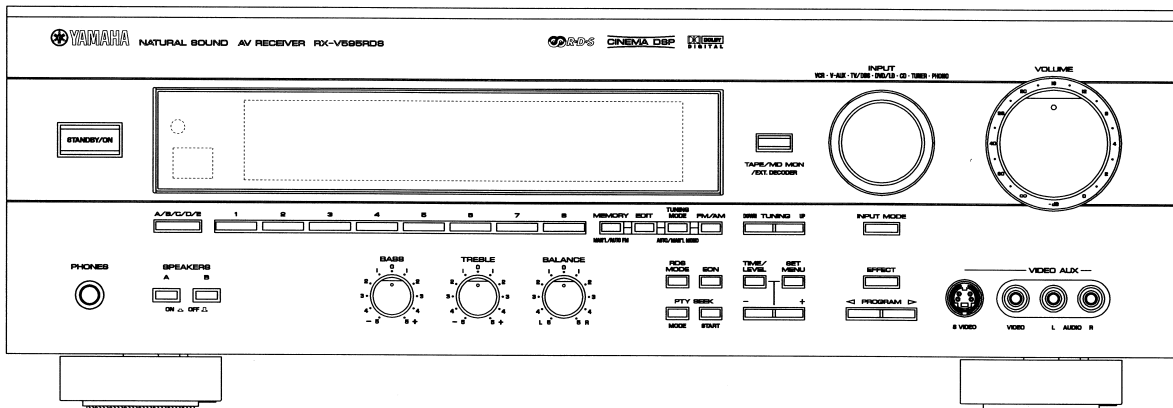

REAR PANELS

▼ RX-V595/R-V905 U model

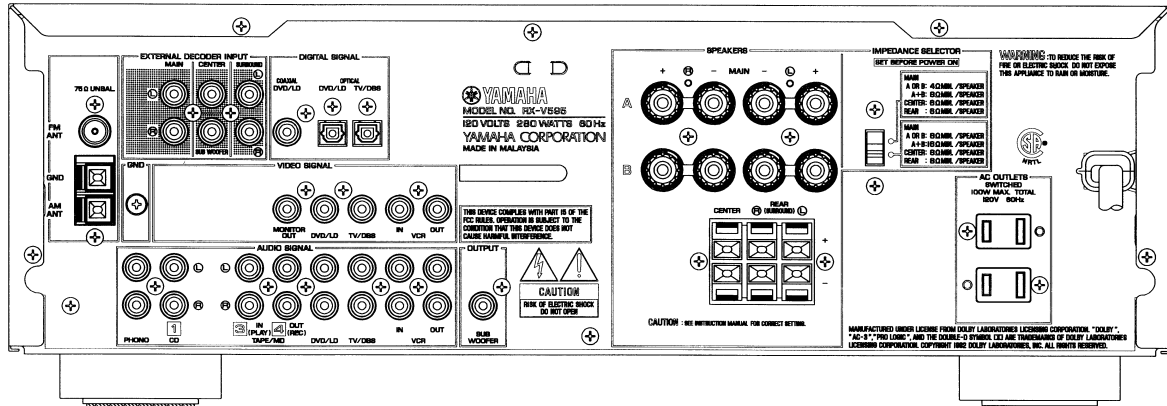

▼ RX-V595/R-V905 C model

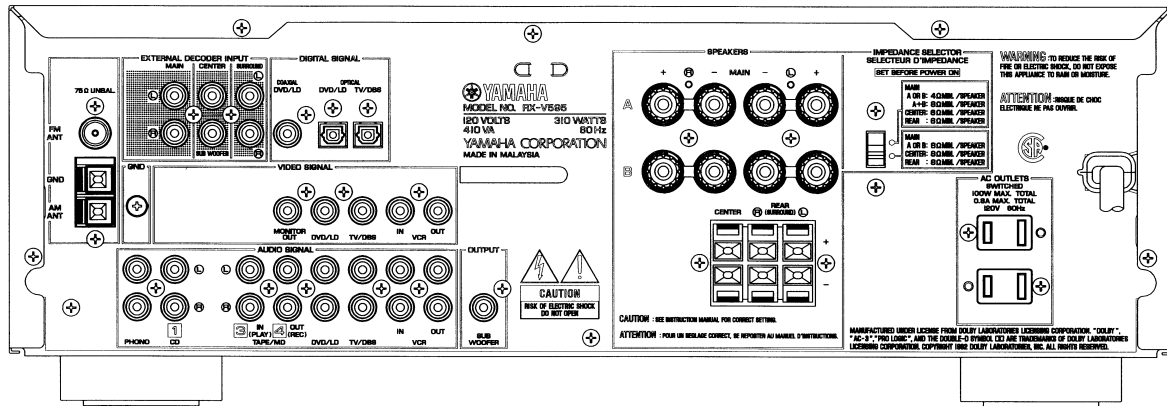

▼ RX-V595/R-V905 R model

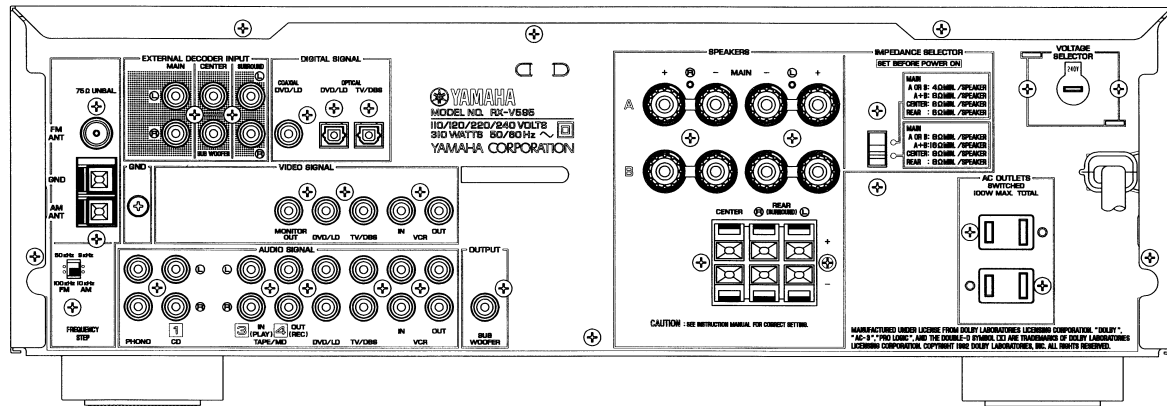

▼ RX-V595/R-V905 T model

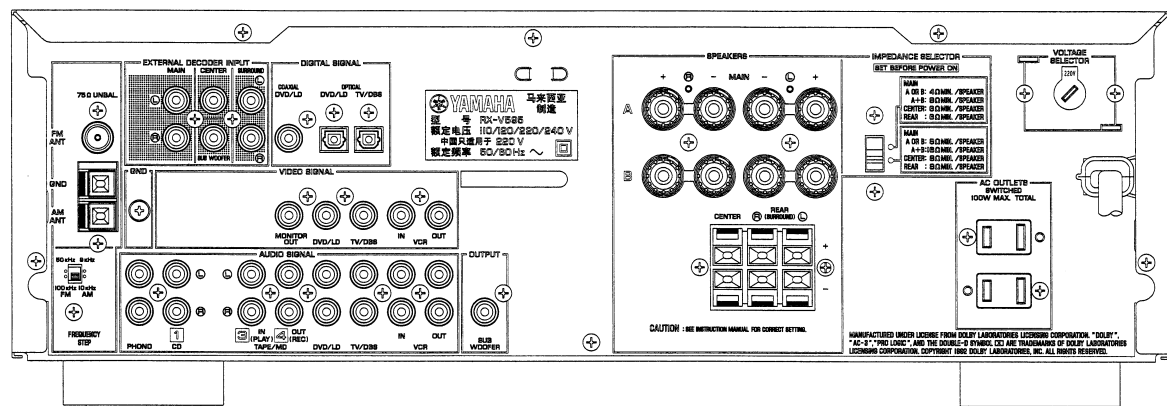

▼ RX-V595/R-V905 A model

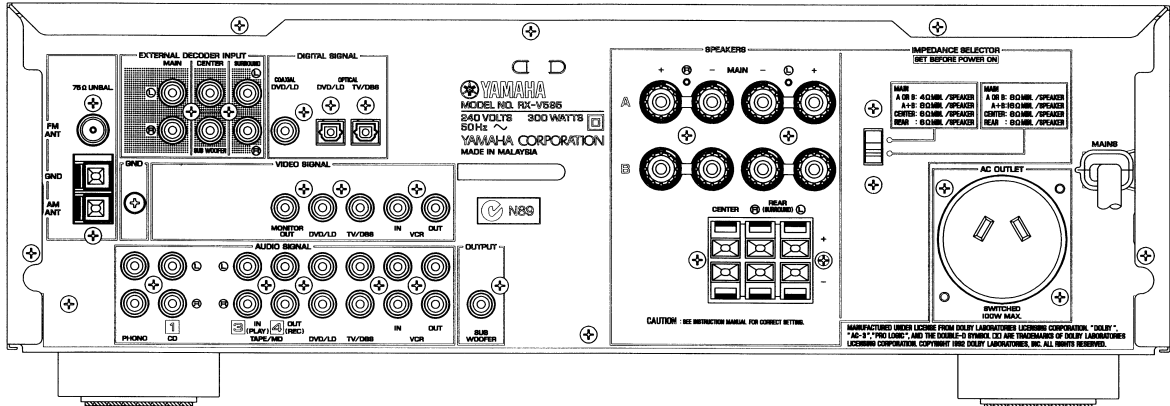

▼ RX-V595RDS B model

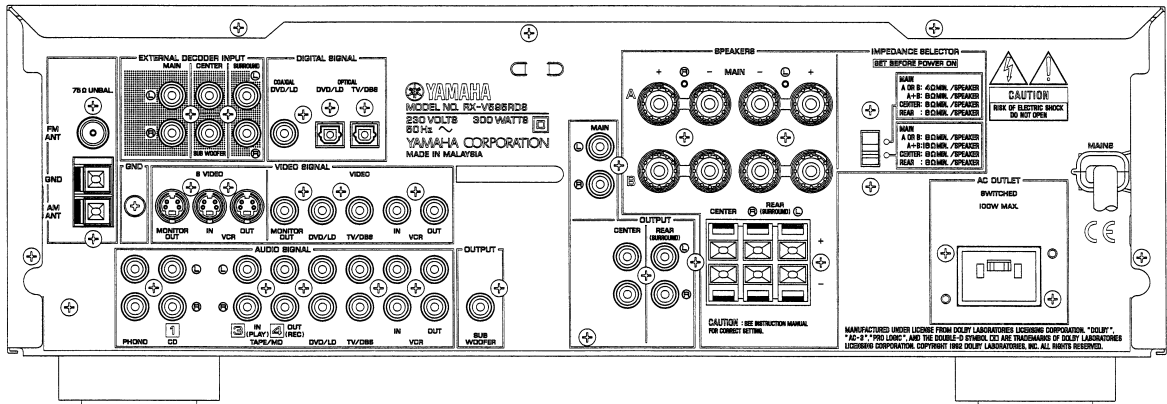

▼ RX-V595RDS G model

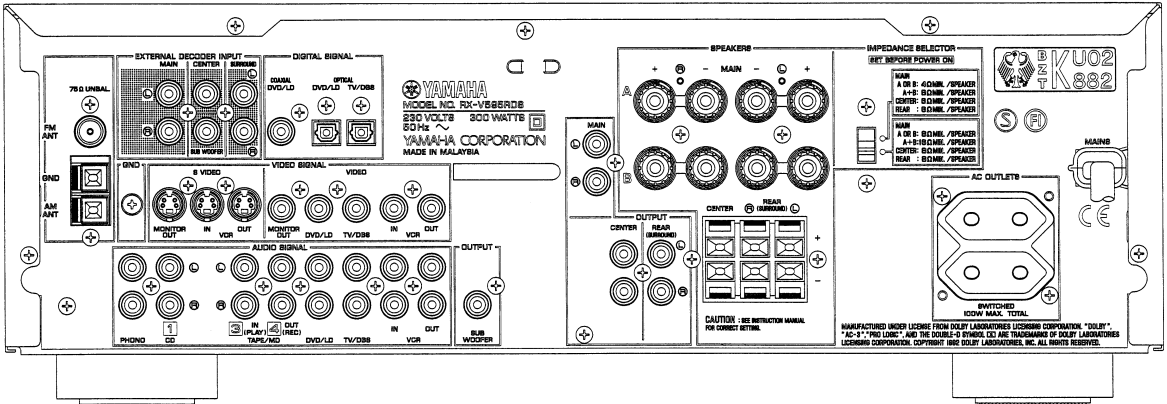

▼ RX-V595 L model

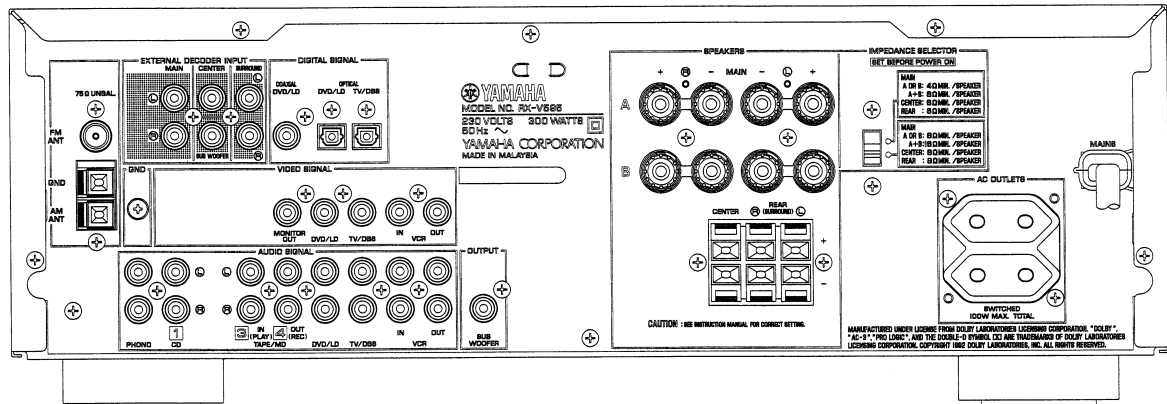

■ SPECIFICATIONS

■ AUDIO SECTION

Minimum RMS Output Power Per Channel (Power Amp. Section)

U, C models	
MAIN L/R, REAR L/R	
20Hz to 20kHz, 0.04% THD, 8Ω	70W+70W
1kHz, 0.07% THD, 8Ω	85W+85W
CENTER	
20Hz to 20kHz, 0.04% THD, 8Ω	70W
1kHz, 0.07% THD, 8Ω	85W
R,T,A,B,G,L models	
MAIN L/R, REAR L/R	
20Hz to 20kHz, 0.04% THD, 8Ω	65W+65W
1kHz, 0.07% THD, 8Ω	80W+80W
CENTER	
20Hz to 20kHz, 0.04% THD, 8Ω	65W
1kHz, 0.07% THD, 8Ω	80W

Maximum Power (EIAJ)

R, T models only	
MAIN L/R, REAR L/R	
1kHz, 10% THD, 8Ω	105W+105W
CENTER, 1kHz, 10% THD, 8Ω	105W

Dynamic Power Per Channel (IHF)

MAIN L/R	
U, C models	
8/6/4/2Ω	
100W+100W/120W+120W/145W+145W/170W+170W	
R,T,A,B,G,L models	
8/6/4/2Ω	
90W+90W/110W+110W/135W+135W/160W+160W	

DIN Standard Output Power Per Channel

G model only	
MAIN L/R, 1kHz, 0.7% THD, 4Ω	110W+110W

Dynamic Headroom(8Ω)

U, C models only	1.55dB
------------------	--------

IEC Power

G model only	
MAIN L/R, 1kHz, 0.04% THD, 8Ω	75W+75W

Power Band Width

MAIN L/R, 0.1% THD, 35W, 8Ω	10Hz to 50kHz
-----------------------------	---------------

Damping Factor (SPEAKER A)

MAIN L/R, 20Hz to 20kHz, 8Ω	60
-----------------------------	----

Input Sensitivity/Input Impedance

PHONO (MM)	2.5mV/47kΩ
CD etc.	150mV/47kΩ
MAIN L/R (EXTERNAL DECODER)	150mV/47kΩ
CENTER	150mV/40kΩ
SURROUND L/R	150mV/40kΩ
SUB WOOFER	150mV/40kΩ

Maximum Input Signal Level (1kHz)

PHONO (MM), 0.1% THD	110mV
CD etc. (EFFECT ON), 0.5% THD	2.2V

Output Level/Output Impedance

REC OUT	150mV/1.2kΩ
SUB WOOFER (MAIN SP : SMALL)	2.1V/1.2kΩ
B,G models only	
PRE OUT	4V/1.2kΩ

Headphone Jack Rated Output/Impedance

CD etc., Input=1kHz, 150mV, RL=8Ω	0.5V/390Ω
-----------------------------------	-----------

Frequency Response(20Hz to 20kHz)

CD etc., MAIN	0±0.5dB
---------------	---------

RIAA Equalization Deviation

PHONO (MM)	0±0.5dB
------------	---------

Total Harmonic Distortion(20Hz to 20kHz)

PHONO (MM) to REC OUT (1V)	0.02%
CD etc.(EFFECT OFF) to MAIN SP OUT(35W/8Ω)	0.025%

Signal-to-Noise Ratio(IHF-A-Network)

PHONO (MM), Input 5mV shorted, REC OUT	
U, C, R, T models	86dB
A, B, G, L models	81dB
CD etc.(EFFECT OFF), Input 150mV shorted, SP OUT	
	96dB

Residual Noise(IHF-A-Network)

MAIN L/R, SP OUT	150μV
------------------	-------

Channel Separation(Vol. -30dB, EFFECT OFF)

PHONO, Input shorted, 1kHz/10kHz	60dB/55dB
CD etc, Input 5.1kΩ terminated, 1kHz/10kHz	60dB/45dB

Tone Control Characteristics

BASS : Boost/Cut	±10dB(50Hz)
: Turnover Frequency	350Hz
TREBLE : Boost/Cut	±10dB(20kHz)
: Turnover Frequency	3.5kHz

Filter Characteristics

MAIN, REAR SP SMALL : H.P.F.	fc=90Hz, 12dB/oct.
SUB WOOFER : L.P.F.	fc=90Hz, 18dB/oct.

■ FM SECTION

Tuning Range

U, C models	87.50 to 107.9MHz
R, T models (Frequency Step: 100kHz)	
	87.50 to 108.0MHz
(Frequency Step: 50kHz)	
	87.50 to 108.0MHz
A, B, G, L models	87.50 to 108.0MHz

50dB Quieting Sensitivity (IHF)

U, C, R, T models only	
Mono, 1kHz, 100% mod	1.6μV(15.3dBf)
Stereo, 1kHz, 100% mod	23μV(38.5dBf)

Usable Sensitivity (DIN)

A, B, G, L models only	
DIN, Mono(S/N 26dB)	0.9μV
DIN, Stereo(S/N 46dB)	28μV

Alternate Channel Selectivity

U, C, R, T models (±400kHz)	75dB
A, B, G, L models (±300kHz)	
Selectivity(two signals, 40kHz Dev.)	55dB

Signal-to-Noise Ratio

U, C, R, T models (IHF)	
Mono/Stereo	81dB/75dB
A, B, G, L models (DIN-Weighted, 40kHz Dev.)	
Mono/Stereo	75dB/69dB

Harmonic Distortion (1kHz)

Mono/Stereo	0.1%/0.2%
-------------	-----------

Stereo Separation (1kHz)

	48dB
--	------

Frequency Response (20Hz to 15kHz)

	0±1dB
--	-------

Output Level (1kHz)

U, C, R, T models (100% mod.)	550mV
A, B, G, L models (40kHz Dev.)	550mV

Antenna Input

	75Ω unbalanced
--	----------------

AM SECTION

Tuning Range

U, C models	530 to 1710kHz
R, T models (Frequency Step : 10kHz)	530 to 1710kHz
(Frequency Step : 9kHz)	531 to 1611kHz
A, B, G, L models	531 to 1611kHz

Usable Sensitivity 300µV/m

Signal-to-Noise Ratio 52dB

Output Level (1kHz, 30% mod.) 150mV

Antenna Loop antenna

VIDEO SECTION

Video Signal Type

U, C models	NTSC
R model	NTSC/PAL
T, A, B, G, L models	PAL

Video Signal Level 1Vp-p/75Ω

S-Video Signal Level

B, G models only Y:1Vp-p/75Ω,C:0.286Vp-p/75Ω

Maximum Input Level 1.5Vp-p

Signal-to-Noise Ratio 50dB

Monitor Out Frequency Response(-3dB) 5Hz~10MHz

GENERAL

Power Supply

U, C, models	AC120V, 60Hz
R model	AC110/120/220/240V, 50/60Hz
T model	AC220V, 50Hz
A model	AC240V, 50Hz
B, G, L models	AC230V, 50Hz

Power Consumption

U model	280W
C model	310W/410W
R, T models	310W
R, A, B, G, L models	300W

Maximum Power Consumption

R model only	
5CH Simultaneous output, 10% THD	650W

AC Outlet

U, C, R, T, G, L models, Switched x 2	100W max(Total)
A, B models, Switched x 1	100W max

Dimensions(W x H x D) 435 x 151 x 391mm
(17 1/8" x 5-15/16" x 15-3/8")

Weight 12.5kg(27lbs. 9 oz)

Accessories

- AM loop antenna x 1
- Indoor FM antenna x 1
- Remote Control Transmitter x 1
- Battery (siza "AA", "R06") x 2

* Specifications subject to change without notice.

U	U. S. A. model	A	Australian model
C	Canadian model	B	British model
R	General model	G	European model
T	China model	L	Singapore model

Manufactured under license from Dolby Laboratories Licensing Corporation. "DOLBY", "AC-3", "Pro Logic", and the double-D symbol  are trademarks of Dolby Laboratories Licensing Corporation. Copyright 1992 Dolby Laboratories, inc. All rights reserved.

DIMENSIONS

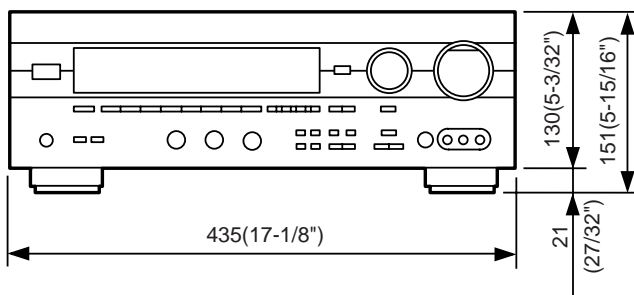
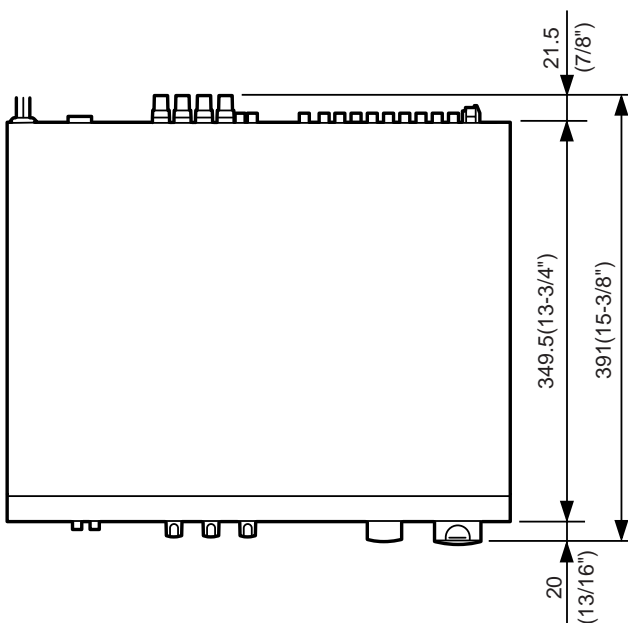

Units: mm (inch)

WARNING

Do not change the **IMPEDANCE SELECTOR** switch setting while the power to this unit is on, otherwise this unit may be damaged.

IMPEDANCE SELECTOR

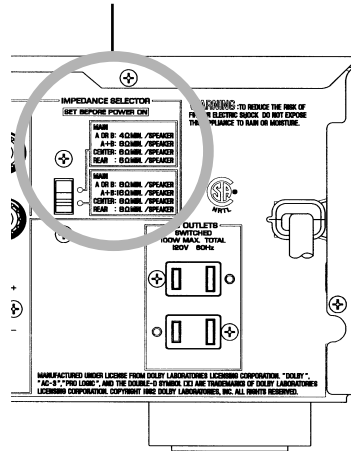

INTERNAL VIEW

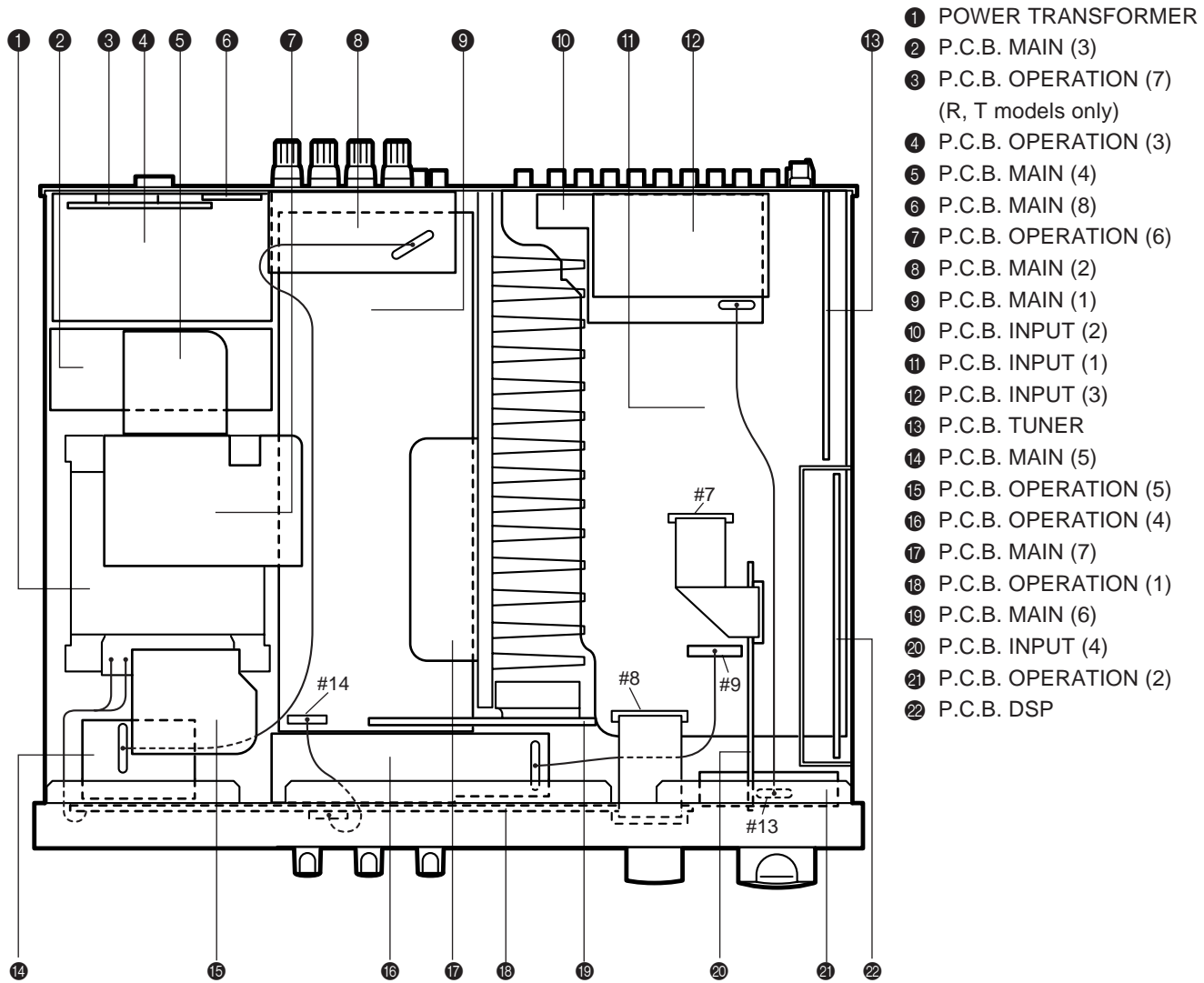

DISASSEMBLY PROCEDURES

(Remove parts in disassembly order as numbered.)

1. Removal of Top Cover

Remove 4 screws (1) and 4 screws (2) in Fig. 1.

2. Removal of Front Panel

- a. Remove 5 knobs.
- b. Remove 6 screws (3) in Fig. 1.

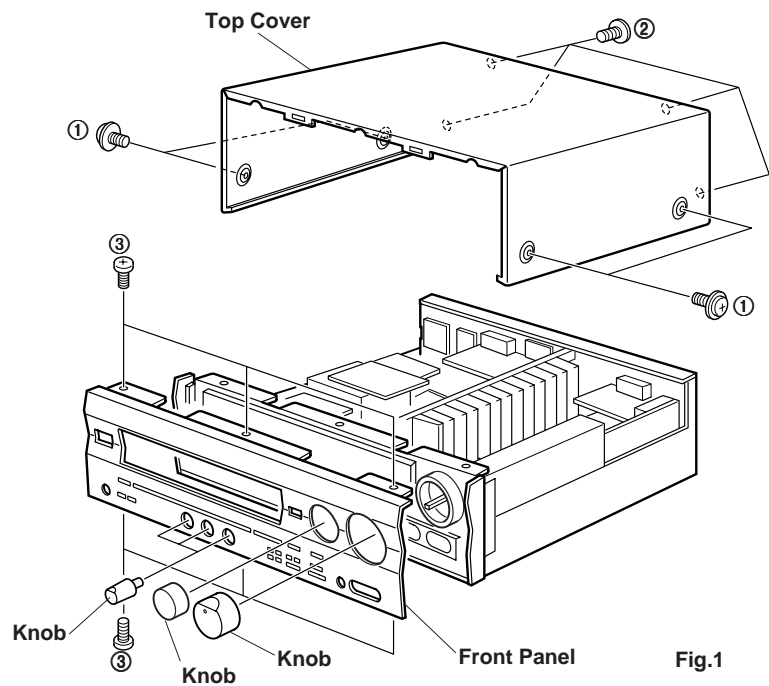

Fig.1

■ SELF DIAGNOSIS FUNCTION

1. PURPOSE AND OPERATION

The RX-V595/R-V905/RX-V595RDS has a Self Diagnosis Function to locate a faulty part, if any, by inspecting and taking measurements.

There are 11 main items in the diagnostic menu and some of them have sub-menu items as listed below.

No.	MAIN MENU	SUB MENU	REMOTE CONTROL CODE (KEY)
1	ANALOG THROUGH	1. MAIN BYPASS 2. DSP 0dB	7A-88 ("1" (DSP mode)) ----
2	DSP THROUGH	1. YSS908-SRAM 2. YSS908 3. DSP FULL BIT	7A-89 ("2" (DSP mode)) ---- ----
3	AC-3/DTS THROUGH	1. STATUS (BINARY FORM)	----
4	PRO LOGIC	1. CENTER LARGE 2. EFFECT OFF	7A-8A ("3" (DSP mode)) ----
5	SPEAKERS SET	1. MAIN : SMALL 0dB 2. MAIN : LARGE 0dB 3. MAIN : LARGE -10dB 4. LFE/BASS : MAIN CENTER : NONE 5. LFE/BASS : MAIN 6. LFE/BASS : SWFR 7. CENTER : NONE 8. CENTER : SMALL REAR : SMALL 9. FRONT MIX	7A-8B ("4" (DSP mode)) 7A-8C ("5" (DSP mode)) 7A-8D ("6" (DSP mode)) 7A-8E ("7" (DSP mode)) 7A-8F ("8" (DSP mode)) 7A-90 ("9" (DSP mode)) 7A-91 ("0" (DSP mode)) ---- 7A-12 ("ENTER" (DSP mode))
6	EFFECT OFF /DISPLAY CHECK	1. EFFECT OFF 2. VFD DISP OFF 3. VFD DISP ALL 4. CHECKED PATTERN 5. RELEASE DATE	---- ---- ---- ---- ----
7	MANUAL TEST	1. ALL 2. MAIN L 3. CENTER 4. MAIN R 5. REAR R 6. REAR L 7. LFE	---- ---- ---- ---- ---- ---- ----
8	FACTORY PRESET	1. INHIBIT(Inhibit Memory Init) 2. RESERVED (Init. Memory)	---- ----
9	AD DATA CHECK	1. ---- 2. KEY 3. TUNING SIGNAL 4. DC PROTECTION 5. PS PROTECTION	---- ---- ----
10	STATUS	1. DSP CPU STATUS 2. CHANNEL STATUS 3. VERSION INFORMATION 4. CHECK SUM 5. BSI0 (AC3/DTS) 6. BSI1 7. BSI2 8. BSI3 9. BSI4 10. BSI5	---- ---- ---- ---- ---- ---- ---- ---- ---- ----
11	VERSION CHECK /DSP CPU SUM /EXIT	1. MAIN MC CHECK SUM 2. SUB MC CHECK SUM 3. MAIN M.C. VERSION 4. SUB M.C. VERSION 5. PORT INFORMATION 6. EXIT	---- ---- ---- ---- ----

2. BEGINNING AND CANCELLATION

(1) STARTING UP THE FUNCTION AND THE DISPLAY

After starting up, menu No. 1 is selected.

A. How to start diagnostic program

Using the front panel keys of the main unit.

Hold down the "INPUT MODE" and "FM/AM" keys simultaneously, and press the "STANDBY/ON" key; submenu No. 1 of diagnosis main menu No. 1 will start.

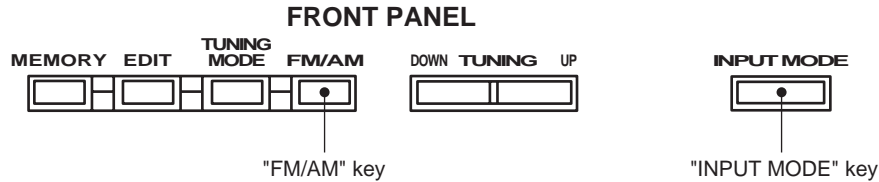

B. Settings for start-up of diagnostic program

The settings used when starting the diagnostic program are as follows.

1. EFFECT LEVEL :

CHANNEL	CENTER	R SUR	L SUR	SWFR
LEVEL (dB)	0	0	0	0

2. MUTING : OFF
 3. INPUT (VIDEO) : DVD/LD (DVD/LD)
 4. CENTER SPEAKER : LARGE
 5. REAR SPEAKER : LARGE
 6. MAIN SPEAKER : LARGE
 7. LFE/BASS OUT : SWFR

C. Start-up display

The information of the protection function appears on the front panel display of the main unit.

● FL display at start-up of diagnostic program

When the diagnostic program has started, the history (*2) of the protection function (*1) is displayed. If the protection function has been activated in the past, the type and voltage value are displayed. After a few seconds the diagnosis function menu will appear.

- (*1) If a faulty condition is detected such as excessive current, a bad power supply or excessive amplifier DC offset, the Power will be switched OFF automatically.
- (*2) The protection records will be cleared when "RESERVED" is selected in diagnosis menu No. 8 and FACTORY PRESET is engaged.

● History of protection function

Each case of the history of the protection function is displayed as shown below.

1 DVD/LD *NO PROTECT*

Appears when the protection function has not been activated.

1 DVD/LD *I PROTECT*

Appears when the current protection function has been activated. When power is turned on in an abnormal status, the power relay will come on, protection will operate immediately, and power will turn off.

1 DVD/LD *PS : 21%*

Appears when the power protection function has been activated. For the % value, the voltage at that point is shown by 5V/100%. When power is turned on in an abnormal status, power will turn off after half a second.

1 DVD/LD *DC : 19%*

Appears when the power amp DC protection function has been activated. For the % value, the voltage at that point is shown by 5V/100%. When power is turned on in an abnormal status, power will turn off after two seconds.

(2) RELEASING METHOD

The diagnosis function can be released by any of the following procedures. Take care with the setting of backup memory initialization menu (diagnosis No. 8) when releasing the diagnosis function:

1. Select diagnosis menu No. 11/submenu No. 6 "EXIT".
2. Press the "STANDBY/ON" key on the main unit or "STANDBY" key on the remote control to turn power off.

3. OPERATION AND DISPLAY WHEN STARTING DIAGNOSIS FUNCTION

(1) Selection of diagnostic menu

The diagnostic menu and the sub-menu can be selected by using the front panel keys of the main unit or the remote control unit.

● Selection by using the front panel keys

The main menu can be changed cyclically by using the "TUNING UP/DOWN" keys, and the submenu, by using the "PROGRAM</>" keys. The "UP" or ">" key will increase the main or submenu number.

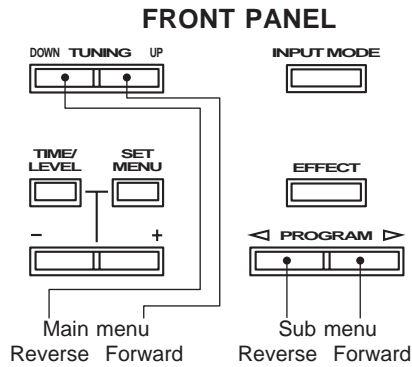

● Selection by using the remote control unit

The remote control codes in the menu list (on page 8) correspond to the DSP program, test and effect keys. See the figure on the right.

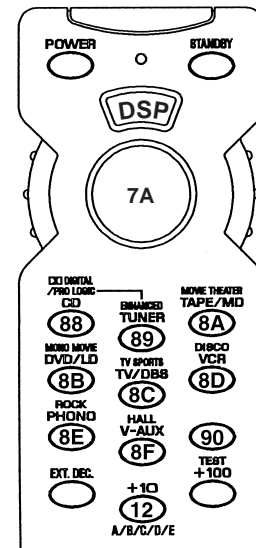

(2) Other functions available while diagnosis function is active

Listed below are the other functions available while the diagnosis function is active.

- ¥ Selecting input source (Tape monitor/Ext. decoder)
- ¥ Adjusting effect level (Center, Rear, Sub-woofer)
- ¥ Adjusting master volume
- ¥ Muting on/off
- ¥ Power on/off

(3) Diagnosis default status

When not otherwise specified, default settings and values in each menu are as follows:

- ¥ All SPEAKERS : LARGE
- ¥ ALL electronic VRs : 0dB
- ¥ DYNAMIC RANGE : MAX
- ¥ LFE LEVEL : 0dB (—10dB DOLBY DIGITAL LFE)
- ¥ CENTER DELAY : 0ms

4. CONTENTS OF DIAGNOSIS FUNCTION

This section describes the contents of the self diagnosis function in detail.

No.1 ANALOG THROUGH

The input is fixed to analog (A/D). There are two submenus.

1. MAIN BYPASS 1 DVD/LD MAIN BYPAS

The MAIN L/R signals bypass the analog circuits to be output.

For CENTER/SUBWOOFER, FRONT L/R and REAR L/R, the MAIN L/R signals via the DSP are output without being processed (through). (Remote control code 7A-88)

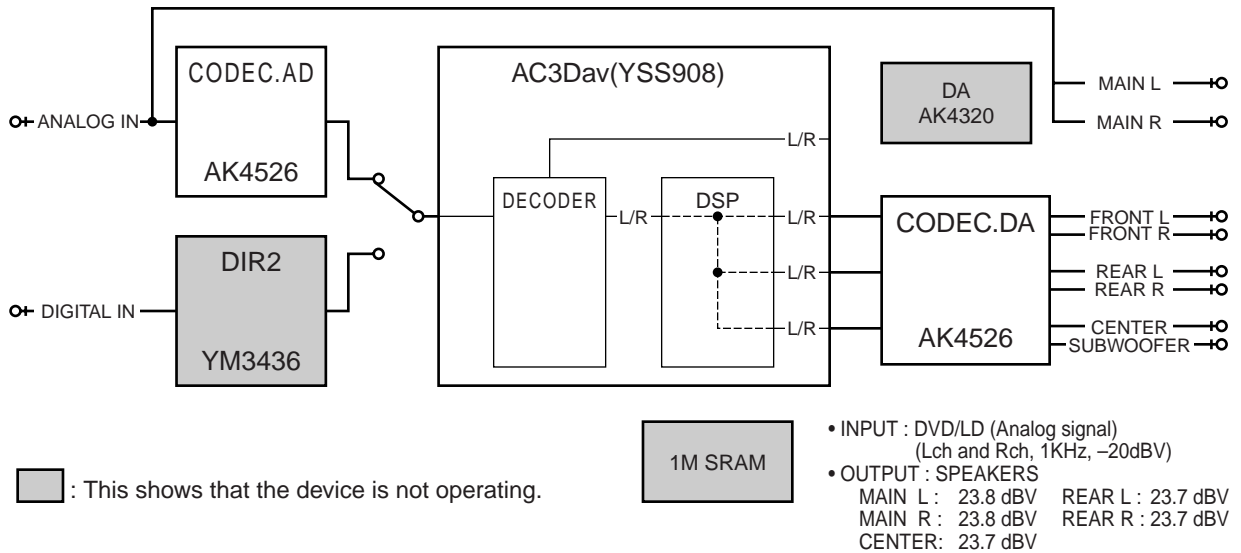

2. DSP 0dB 1 DVD/LD DSP 0DB

MAIN L/R, CENTER/SUBWOOFER/LFE, FRONT L/R and REAR L/R pass through the DSP without being processed.

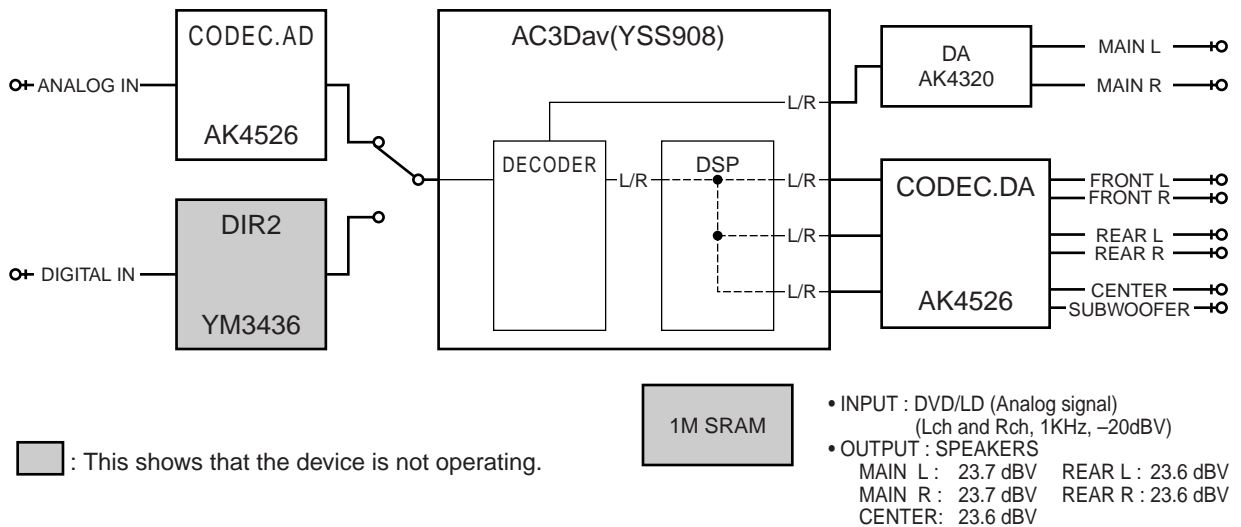

No.2 DSP THROUGH

The input is automatically discriminated by signal detection and switched with priorities AC3>PCM Audio>analog. There are the following three submenus.

1. YSS908-SRAM

2 DVD/LD YSS908SRAM

MAIN L/R are input to the DSP via AC3Dav, pass through SRAM, and are then output to all channels without being processed. (Remote control code 7A-89)

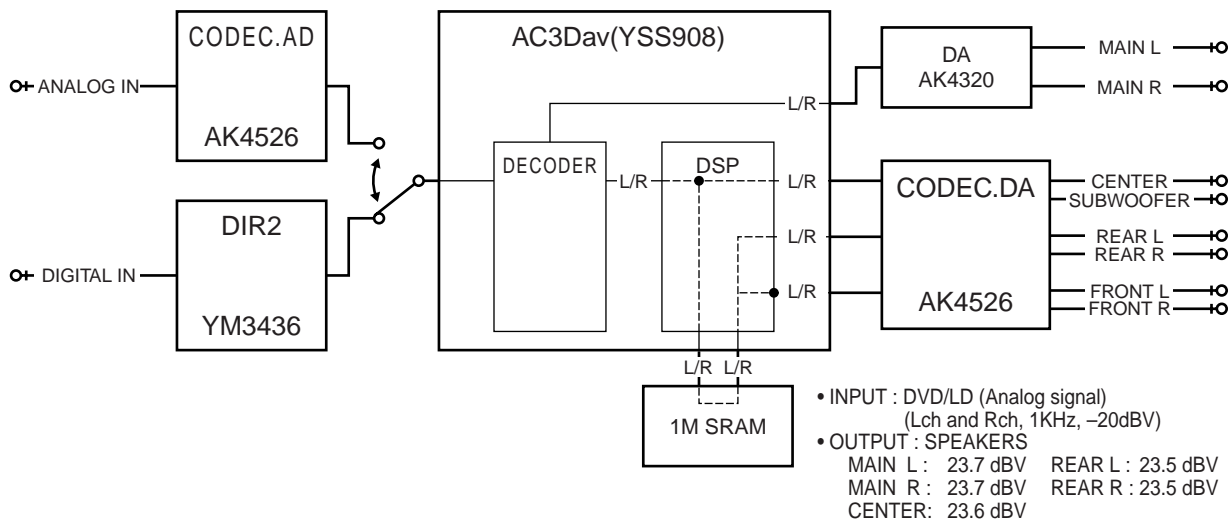

2. YSS908

2 DVD/LD YSS908

MAIN L/R are input to the DSP via AC3Dav, and then output to all channels without being processed.

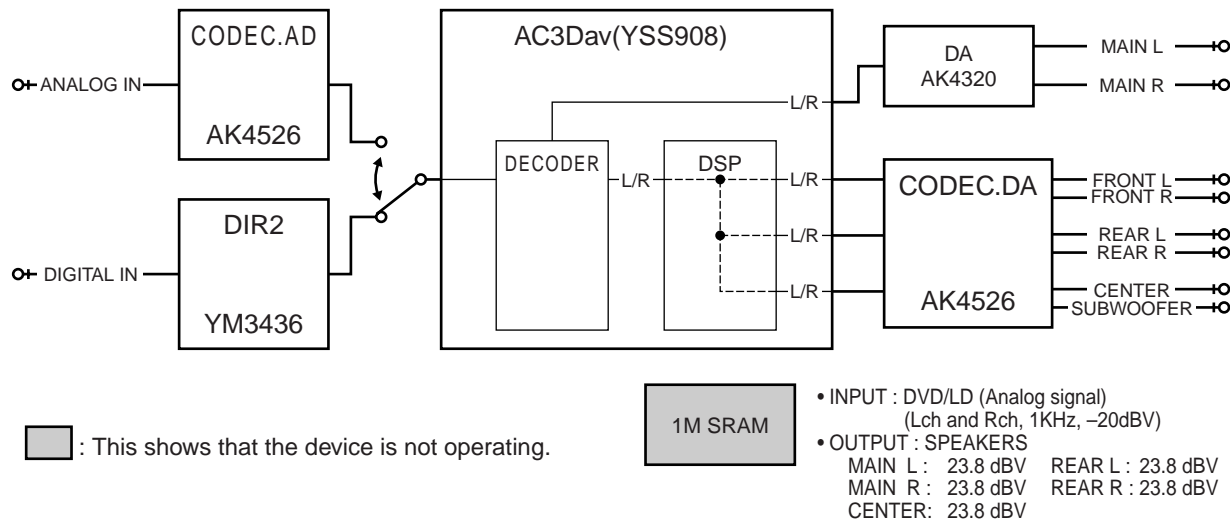

3. DSP FULL BIT

2 DVD/LD DSP FULL

MAIN L/R are input to the DSP via AC3Dav, and then output to all channels without being processed.

The head margin is abolished, and DSP outputs digital full-bit signals.

Same as the above menu, except that the digital data is output to DA with full bits.

- INPUT : DVD/LD (Analog signal)
(Lch and Rch, 1KHz, -20dBV)
- OUTPUT : SPEAKERS
MAIN L : 13.8 dBV REAR L : 22.8 dBV
MAIN R : 13.8 dBV REAR R : 22.8 dBV
CENTER : 16.8 dBV

No.3 AC3 THROUGH

The input is digital signal only. AC3 (DOLBY DIGITAL) decoding operation is executed, according to the input source.

1. STATUS(BINARY FORM) 3 DVD/LD 3T0000001

AC3 (DOLBY DIGITAL) decoded signals are output to each channel via AC3Dav.

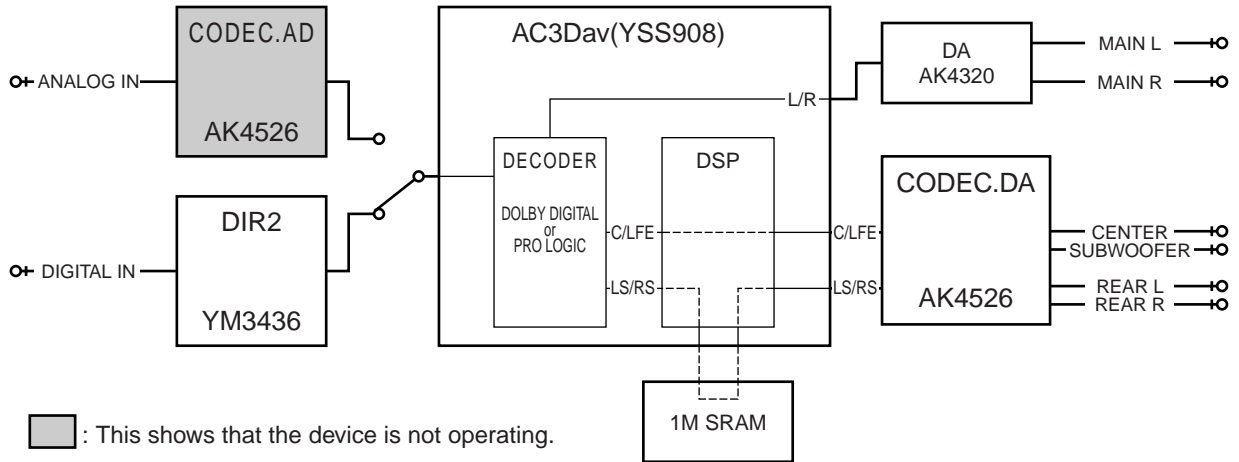

AC3 Status Info. : bit 7 6 5 4 3 2 1 0
 (Invalid in DTS) 1 0 0 0 0 0 0 0

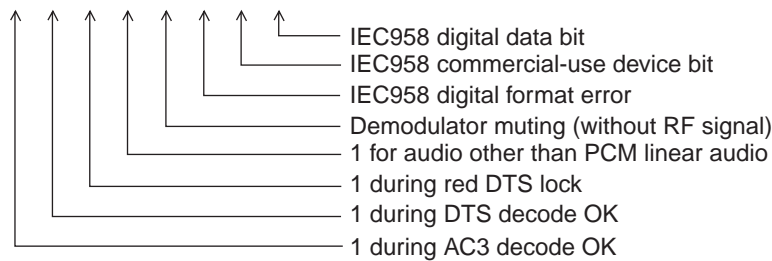

No.4 PRO LOGIC

The input is automatically discriminated by PCM>analog. AC3 (DOLBY DIGITAL) is prohibited. The submenu is switched between PRO LOGIC (AUTO BALANCE OFF) and EFFECT OFF.

1. CENTER LARGE 4 DVD/LD P.LGC C:L

The input is automatically detected whether it is PCM or analog. With analog, PCM audio or AC3 (DOLBY DIGITAL) 2/0 input, the L, R, C and S signals are PRO LOGIC decoded and output. With AC3 (DOLBY DIGITAL) other than 2/0, PRO LOGIC does not operate, and AC3 (DOLBY DIGITAL) playback is executed. (Remote control code 7A-8A)

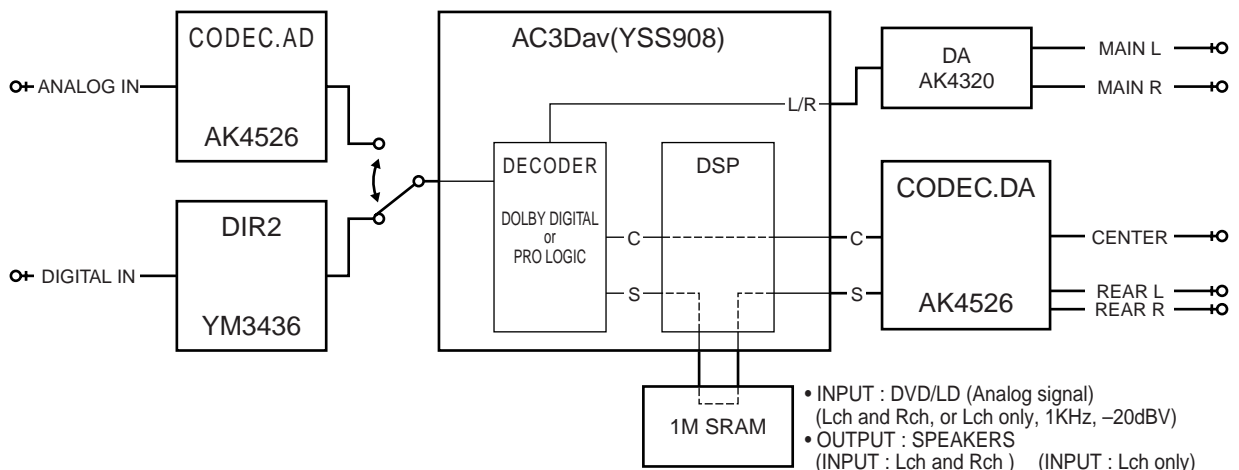

- INPUT : DVD/LD (Analog signal)
 (Lch and Rch, or Lch only, 1KHz, -20dBV)
- OUTPUT : SPEAKERS
 (INPUT : Lch and Rch) (INPUT : Lch only)
- MAIN L : -15.4 dBV REAR L : 23.8 dBV
- MAIN R : -14.2 dBV REAR R : -25.0 dBV
- CENTER: 26.6 dBV CENTER : -12.5 dBV
- REAR L : -6.0 dBV REAR L : -6.0 dBV
- REAR R : -6.5 dBV REAR R : -6.2 dBV

2. EFFECT OFF 4 DVD/LD EFFECT OFF

MAIN L/R are bypassed and output.

No.5 SPEAKERS SET

The input is automatically discriminated by AC3>PCM>analog.

There are the following 9 submenu items: The signal from the DSP block is normally in the effect off status for menu items 1-4. For other menu items, the same signal as in 2. DSP THROUGH: YSS908 menu is output.

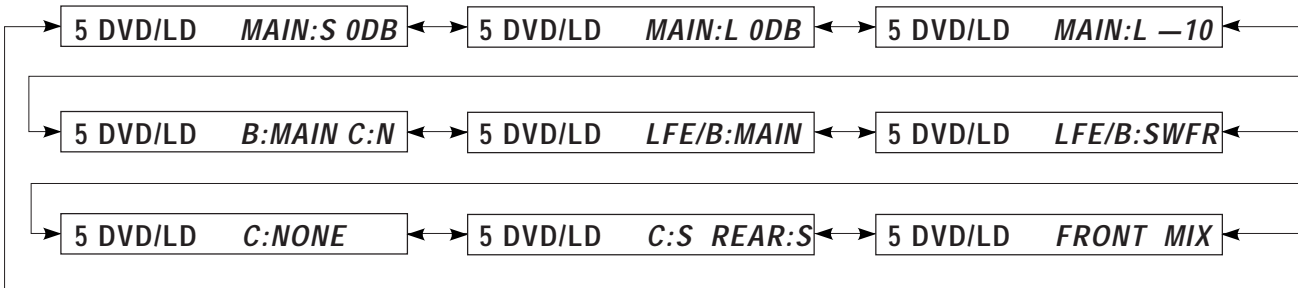

The analog switches in each submenu are set as follows:

	SUB MENU	REMOTE CODE	CENTER SP	REAR SP	MAIN SP	MAIN LEVEL	LFE/BASS	OUTPUT
1	MAIN:S 0DB	7A-8B	LARGE	LARGE	SMALL	0dB	SWFR	MAIN L/R
2	MAIN:L 0DB	7A-8C	LARGE	LARGE	LARGE	0dB	SWFR	MAIN L/R
3	MAIN:L -10	7A-8D	LARGE	LARGE	LARGE	-10dB	SWFR	MAIN L/R
4	B:MAIN C:N	7A-8E	NONE	LARGE	LARGE	0dB	MAIN	MAIN L/R
5	LFE/B:MAIN	7A-8F	LARGE	LARGE	LARGE	0dB	MAIN	LFE -> L/R
6	LFE/B:SWFR	7A-90	LARGE	LARGE	LARGE	0dB	SWFR	LFE -> SWFR
7	C:NONE	7A-91	NONE	LARGE	LARGE	0dB	SWFR	CENTER -> L/R
8	C:S REAR:S		SMALL	SMALL	LARGE	0dB	SWFR	CENTER/REAR
9	FRONT MIX	7A-12	LARGE	LARGE	LARGE	0dB	SWFR	FRONT -> L/R

LARGE : Mode in which speakers with high bass-sound playback capability (large unit) are used. Sound in all signal widths is output.

SMALL : Mode in which speakers with low bass-sound playback capability (small unit) are used. Signal of less than 90 Hz is mixed with the channel specified by LFE/BASS.

NONE : Mode in which center speaker is not used. The center components with 3 dB subtracted are branched into MAIN L/R.

LFE/B : MAIN

: Mode in which subwoofer speaker is not used. The subwoofer components with 4.5 dB subtracted are branched into MAIN L/R. But because of the phase difference, the MAIN L/R output is not simply added level.

Purpose of the submenu as follows:

	SUB MENU	PURPOSE
1	MAIN:S 0DB	Verification of the High and low pass filter response and gain in the bass redirection mode.
2	MAIN:L 0DB	Reference of the sub menu No. 1 and 2.
3	MAIN:L -10	Verification of the effect in the main level function.
4	B:MAIN C:N	Verification of the effect the mixing circuit to the main channel.
5	LFE/B:MAIN	Verification of the bass mix gain.
6	LFE/B:SWFR	Verification of the LFE maximum output.
7	C:NONE	Verification of the center mix gain.
8	C:S REAR:S	Verification of the High and low pass filter response and gain in the bass redirection mode.
9	FRONT MIX	Verification of the front mix gain.

No.6 DISPLAY CHECK

Check program for FL display. The display status will change as follows with submenu operation. The signal is processed with EFFECT OFF.

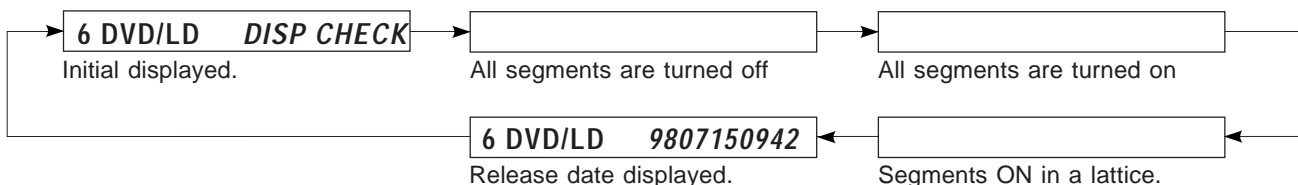

All segments are turned on and off to detect defects in the FL driver and FL display segments. Then the FL driver operation is checked by the dimmer control.

Finally, all segments are turned on and off alternately (in lattice form), to check for a short-circuit between adjacent segments.

No.7 MANUAL TEST

The noise generator built into the DSP outputs test noise from the channel specified by the submenu.

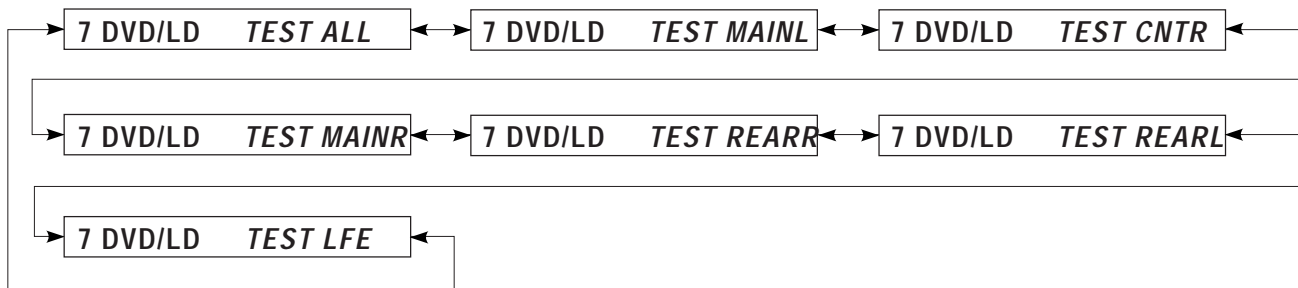

No.8 FACTORY PRESET

The menu is used to reserve whether or not to set the back-up data for the effect level, delay time and so on to the factory preset state. The Signal is processed with EFFECT OFF.

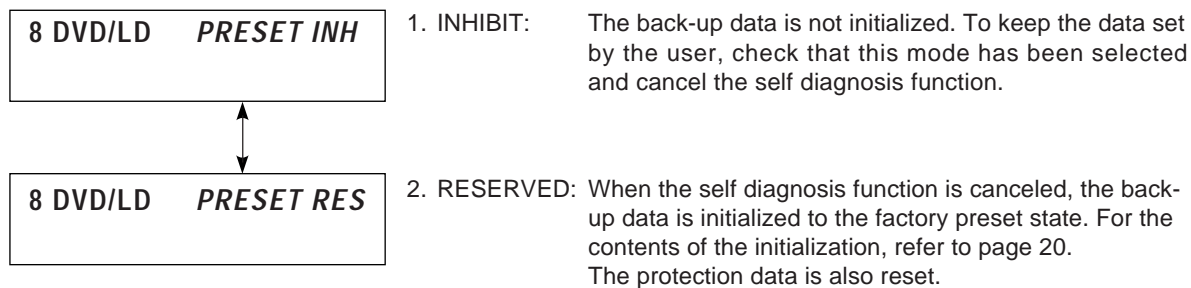

Caution : Before setting to the PRESET DATA, write down the existing preset memory contents of the Tuner in a table as shown below. (This is because setting to the PRESET DATA will cause the memory contents to be as factory set, i.e., all the preset memory by the user will be erased.)

Page	P1	P2	P3	P4	P5	P6	P7	P8
A								
B								
C								
D								
E								

No.9 AD DATA CHECK

The A/D conversion values of the main CPU which detects key scan, protection, etc. are displayed in % (100%: 5V). All signal processing before this menu is executed will be held. The keys on the main unit cannot be operated to detect the values of all keys in the K1/K2/K3/K4. Turning the rotary encoder (input selector on the main unit) will switch the submenu.

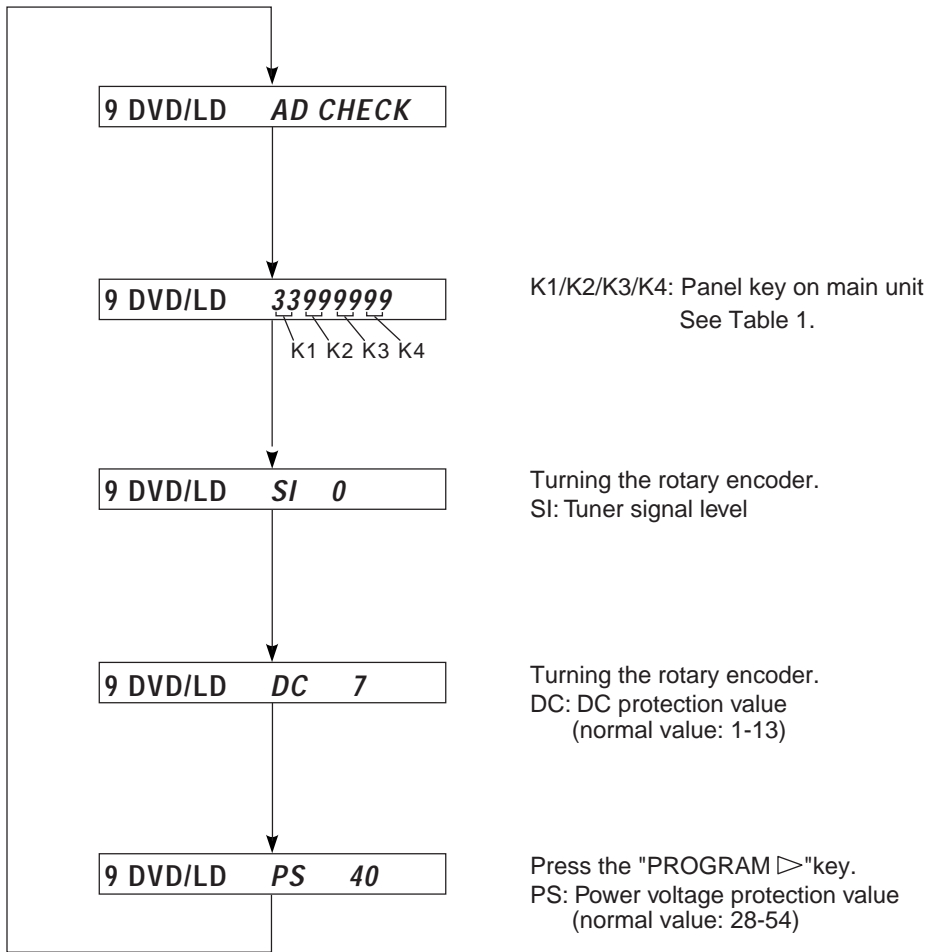

Table 1

AD Value	0	11	23	36	51	67	84
K1	TIME/ LEVEL	SET MENU	-	+	EON	PTY SEEK MODE	PTY SEEK START
K2	TAPE/MD MON /EXT. DECODER	TUNING DOWN	TUNING UP	INPUT MODE	EFFECT	PROGRAM ◁	PROGRAM ▷
K3	7	8	MEMORY	EDIT	TUNING MODE	FM/AM	RDS MODE
K4	A/B/C/D/E	1	2	3	4	5	6

Cautions:

1. If K1/K2/K3/K4 are more than -4% from the reference values, normal operation will not be executed.
2. If DC and PS are outside the normal values, the protection function will operate and power will turn off.

No.10 STATUS FROM DSP MICOM

The status data from the DSP microprocessor is sequentially displayed in a hexadecimal number.
All signal processing before this menu is executed will be held.

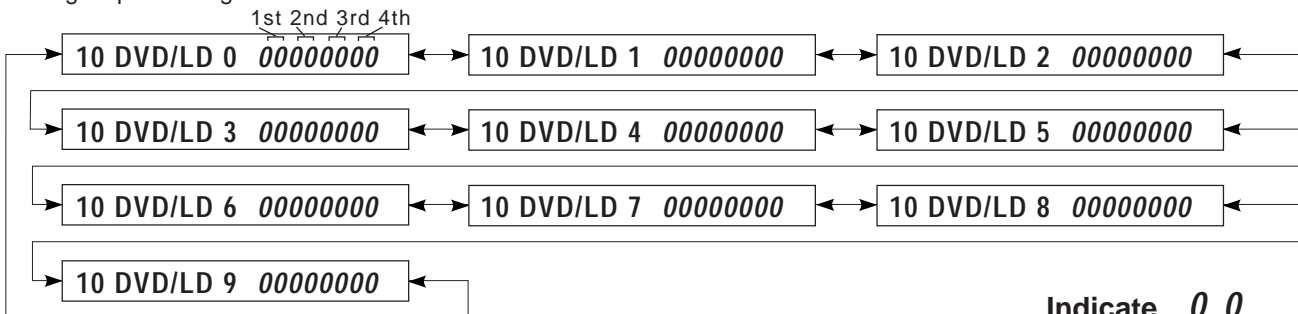

[STATUS 0]

<1st Byte>

bit7	Mute request	bit3	acmod
bit6	fs	bit2	0000B:1+1 0001B:1/0 0010B:2/0 0011B:3/0
bit5	000B:Analog 001B:32kHz 010B:44.1kHz 011B:48kHz	bit1	0100B:2/1 0101B:3/1 0110B:2/2 0111B:3/2
bit4	Others:Don't care	bit0	1000B:7.1

acmod: If it is 1000B or more with DTS 7.1 signal, the DSP block will be muted.

<2nd Byte>

bit7	1 during AC3 decode OK	bit3	Demodulator muting (without RF signal)
bit6	1 during DTS decode OK	bit2	IEC958 digital format error
bit5	1 during red DTS lock	bit1	IEC958 commercial use device bit
bit4	1 for audio other than PCM linear audio	bit0	IEC958 digital data bit

[Note]

IEC958: Standard to identify the PCM bit stream signal. Digital format error refers to a digital signal with the sampling frequency undefined (neither 44.1k, 32k nor 48k). Since the operation of each device cannot be assured at fs outside specifications, the sub-microprocessor handles this status as the forced analog mode (ignored even if decoding is OK from the detection terminal level), and selects the signal from the analog input terminal. Since the sub-microprocessor transmits 000B (analog) for STATUS#0 bits 4-6 to the main microprocessor, the main microprocessor visually operates in the same way as with digital unlocking.

<3rd Byte>

bit7	AC3 KARAOKE	bit3	On-board write mode
bit6	DIR2 LOCKN	bit2	The number of digital inputs is 2 (equivalent to 595)
bit5	DIR2 ERR	bit1	DSP is AC3D2 (DTS present)
bit4	AC3D MUTE	bit0	RF DEM present

<4th Byte> Always "00"

[STATUS 1] IEC958 channel status bits 00-31 available from DIR2

- <1st-byte> bits 00-07
- <2nd-byte> bits 08-15
- <3rd-byte> bits 16-23
- <4th-byte> bits 24-31

[STATUS 2] 4-byte ASCII code of sub CPU version data

[STATUS 3] Displays the check sum of sub microprocessor program area with ASCII 4 bytes in a hexadecimal number.

[STATUS 4] Displays the bit stream information contained in AC-3/DTS signal from the first byte.

[STATUS 5-9] Displays the bit stream information contained in AC-3 signal from the first byte.

Indicate 0 0

Indicate	bit			
	3	2	1	0
	7	6	5	4
0	0	0	0	0
1	0	0	0	1
2	0	0	1	0
3	0	0	1	1
4	0	1	0	0
5	0	1	0	1
6	0	1	1	0
7	0	1	1	1
8	1	0	0	0
9	1	0	0	1
A	1	0	1	0
B	1	0	1	1
C	1	1	0	0
D	1	1	0	1
E	1	1	1	0
F	1	1	1	1

No.11 CPU VERSION/CHECK SUM/PORT INFO/EXIT DIAG

The check sum, version and port setting of main CPU/DSP CPU are displayed.

The signal is EFFECT OFF.

Operating the submenu will finish self-diagnosis, and ordinary operation mode will be restored.

The suffix letter ("B" in the following) of version indication is for compatibility of communications between the main and DSP microprocessors.

Combining microprocessors with different suffixes will make normal operation impossible.

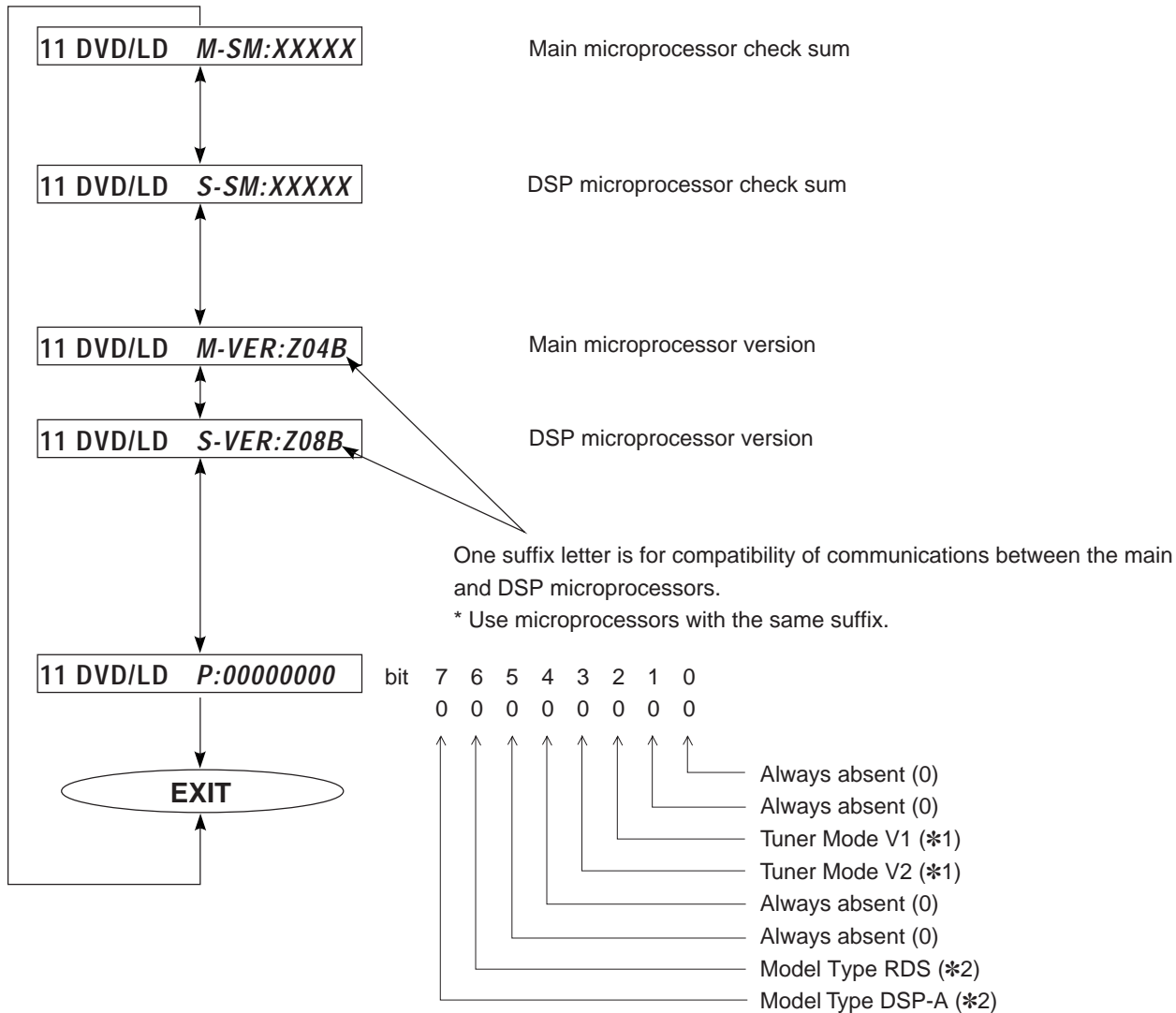

*1 Hi=1, Low=0

Tuner Mode V1 (Port 95)	0	*1	1	*2	1	*3
Tuner Mode V2 (Port 96)	1		0		1	

*1 AM:530-1710kHz/10kHz FM: 87.5-107.9MHz/200kHz (U, C models)

*2 AM:531-1611kHz/9kHz FM: 87.5-108.0MHz/50kHz (A, G, L models)

*3 AM: 530-1710kHz/10kHz FM:87.5-108.0 MHz/100kHz (R model)

*2 Hi=1, Low=0

Model Type RDS (Port 70)	0	RX-V595	0	DSP-A595	1	RX-V595RDS
Model Type DSP-A(Port 83)	0		1		0	

■ FACTORY PRESET

All the settings of the system are initialized on shipping. The settings are as follows.

- **INPUT (VIDEO)** DVD/LD (DVD/LD)

- **EFFECT LEVEL**

EFFECT CHANNEL	PRESET VALUE
CENTER	0 dB
RIGHT SURROUND	0 dB
LEFT SURROUND	0 dB
SUB WOOFER	0 dB

- **DSP PROGRAM**

INPUT	DSP PROGRAM	DELAY PRESET VALUE
CD	PRO LOGIC	20ms
TUNER	ENHANCED	20ms
TAPE/MD	MOVIE THEATER	20ms
DVD/LD	MONO MOVIE	49ms
TV/DBS	TV SPORTS	9ms
VCR	DISCO	40ms
PHONO	ROCK CONCERT	16ms
V-AUX	CONCERT HALL	44ms

- **SET MENU**

No.	SET MENU	PRESET VALUE
1.	CENTER SPEAKER	LARGE
2.	REAR SPEAKER	LARGE
3.	MAIN SPEAKER	LARGE
4.	LFE/BASS OUT	SW (SUBWOOFER)
5.	MAIN LEVEL	NRML (NORMAL)
6.	LFE LEVEL	0 dB
7.	DYNAMIC RANGE	MAX
8.	CENTER DELAY	0 ms
9.	MEMORY GUARD	OFF
10.	INPUT MODE (TV/DBS)	AUTO

- **PRESET STATIONS**

STATION		FM FACTORY PRESET DATA (MHz)		STATION		AM FACTORY PRESET DATA (kHz)	
PAGE	NO.	U, C	R, L, G, A, B	PAGE	NO.	U, C, R	R, L, G, A, B
A/C/E	1	87.5	87.5	B/D	1	630	630
	2	90.1	90.1		2	1080	1080
	3	95.1	95.1		3	1440	1440
	4	98.1	98.1		4	530	531
	5	107.9	108.0		5	1710	1611
	6	88.1	88.1		6	900	900
	7	106.1	106.1		7	1350	1350
	8	107.9	108.0		8	1400	1404

AMP ADJUSTMENT

Confirmation of Idling Current of Main Amplifier

- Right after power is turned on, confirm that the voltage across the terminals of R688(Main Lch),R690(Main Rch), R692(Center), R694(Rear Lch), R696(Rear Rch) are between 0.1mV and 5.0mV.
- If it exceeds 5.0mV, open (cut off) R571 (Main Lch), R577 (Main Rch), R589 (Center), R595 (Rear Lch), R583 (Rear Rch) and reconfirm the voltage again.
- Confirm that the voltage is 0.25mV ~ 15.0mV after 60 minutes.

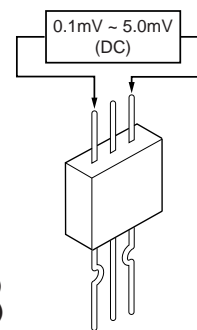
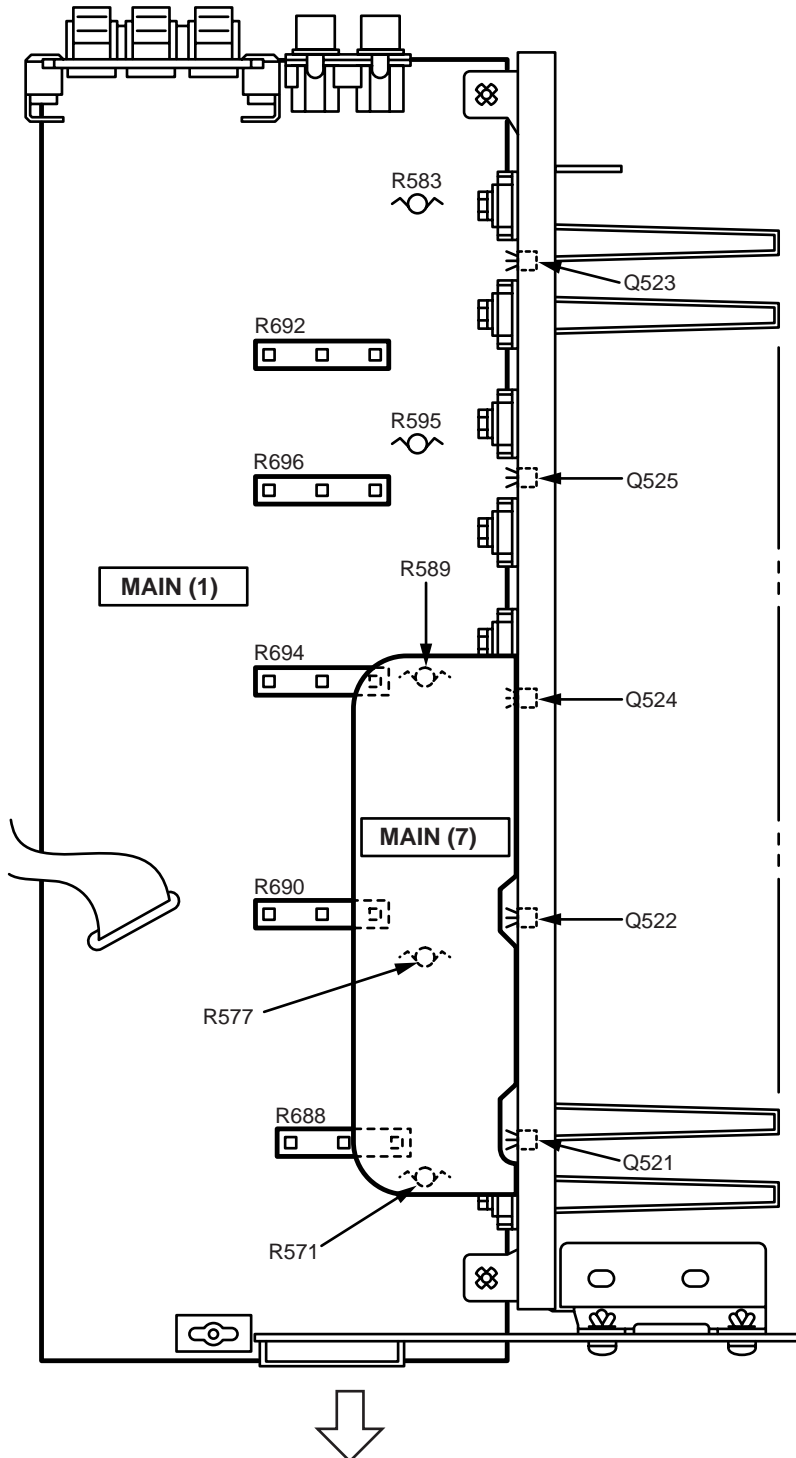

R688(Lch)
R690(Rch)
R692(Cch)
R694(RLch)
R696(RRch)

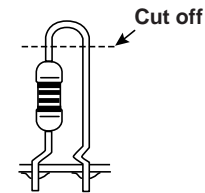

R571(Lch)
R577(Rch)
R589(Cch)
R595(RLch)
R583(RRch)

Note)

- If R571, R577, R589, R595 and R583 have already been cut off and idling current does not flow, reconnect R571, R577, R589, R595 and R583.
- Q521 ~ Q525 are transistors for temperature correction. Apply silicone grease to contact surface with the heat sink.

■ TUNER ADJUSTMENT

1. Measuring Instruments

- FM signal generator (FM SG)
- Stereo signal generator (SSG)
- AM signal generator (AM SG)
- Distortion meter (DIST. M)
- AC Voltmeter (ACVM)
- DC Voltmeter (DCVM)
- Oscilloscope
- Low pass filter (YLF-15, $f_c=15\text{kHz}$)
- Oscillator

● Dummy antenna

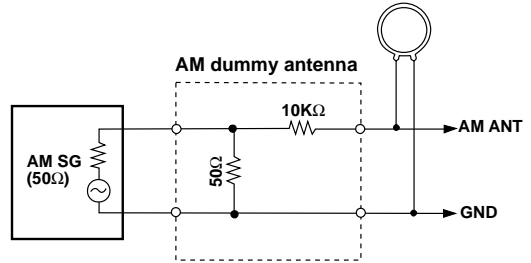
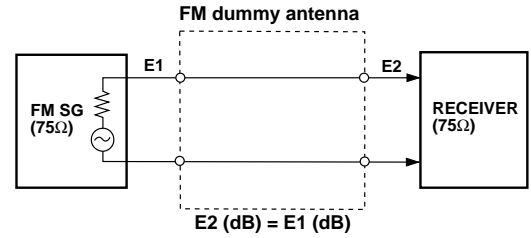
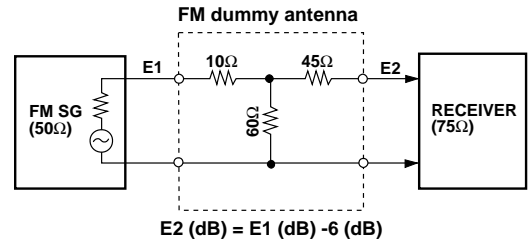

● TEST POINT

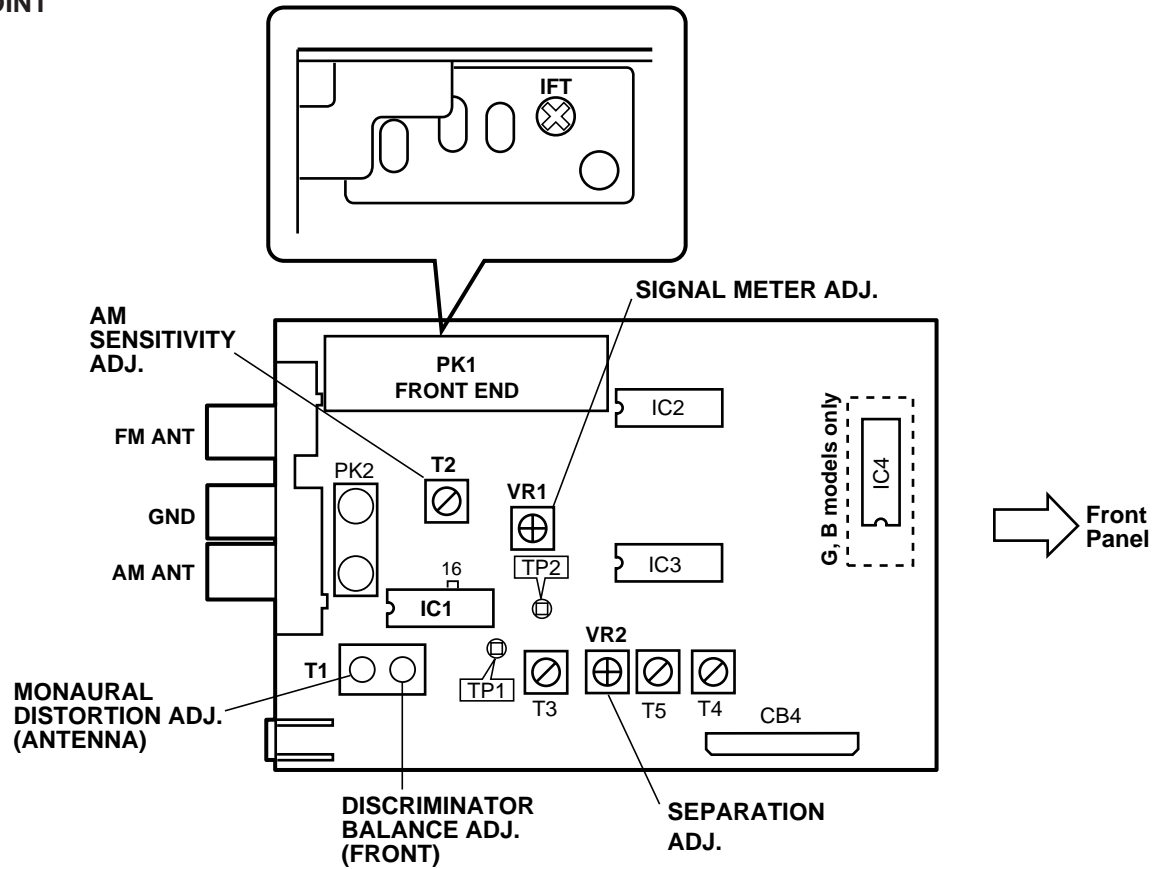

FM Adjustment

1. Before Adjustment

- For dB μ , 1 μ V=0dB μ applies.
Example : 60dB μ =1mV
- 100% modulation means that the frequency deviation is \pm 75kHz.
- Install the Matching Transformer and connect FM SG.

- Set each switch to the following position unless otherwise specified.

INPUT SELECTOR TUNER
TUNING MODE AUTO

2. Connection diagram (Measuring instruments)

- Discriminator balance adjustment.

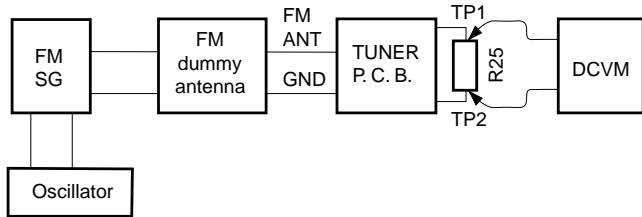

- Stereo distortion adjustment/separation adjustment.

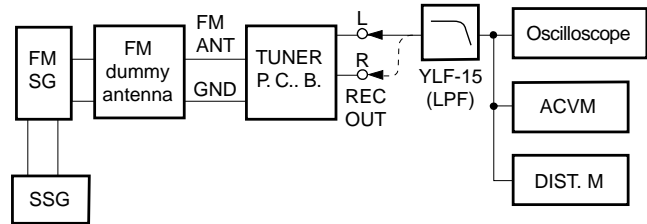

- Monaural distortion adjustment

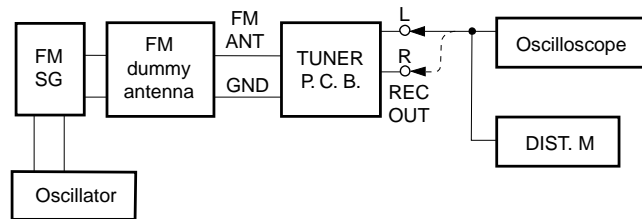

- Sensitivity Verification

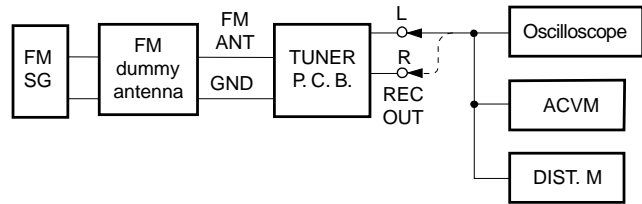

See page 22 for TP locations & adjustment points.

Step	Adjustment item	Signal (ANT IN)	Reception frequency	Adjustment point	Test point	Rating
1	Rough adjustment of discriminator balance	FM ANT (75 Ω) 98.1MHz 70dB μ MONO 100Hz 100% modulation	98.1MHz *(A-4)	T1 (Front side core)	Both ends of R25 (Between TP1 and TP2)	DC 0V \pm 100mV
2	Rough adjustment of monaural distortion	Same as Step 1.	98.1MHz *(A-4)	T1 (Antenna side core)	REC OUT L, R	Minimize the distortion.
3	Fine adjustment of discriminator balance	Same as Step 1.	98.1MHz *(A-4)	T1 (Front side core)	Both ends of R25 (Between TP1 and TP2)	DC 0V \pm 50mV
4	Fine adjustment of monaural distortion	Same as Step 1.	98.1MHz *(A-4)	T1 (Antenna side core)	REC OUT L, R	Minimize the distortion (to 0.25% or less).
5	Verification of discriminator balance	Same as Step 1.	98.1MHz *(A-4)	T1 (Front side core)	Both ends of R25 (Between TP1 and TP2)	DC 0V \pm 50mV

* Execution of FACTORY PRESET (Refer to page 20) will facilitate setting reception frequency for adjustment.

See page 22 for TP locations & adjustment points.

Step	Adjustment item	Signal (ANT IN)	Reception frequency	Adjustment point	Test point	Rating
6	Adjustment of front end IFT	FM ANT (75Ω) 98.1MHz 30dBμ MONO 1kHz 100% modulation	98.1MHz *(A-4)	Front end IFT	Pin 16 of IC1	Adjust so that the meter is maximum. CAUTION: Over-adjustment of the IFT core will reduce the sensitivity. (Maximum±90°)
7	Verification of monaural distortion	FM ANT (75Ω) 98.1MHz 70dBμ MONO 1kHz 100% modulation	98.1MHz *(A-4)		REC OUT L, R	0.4% (43dB) or less
8	Verification of stereo distortion	FM ANT (75Ω) 98.1MHz 70dBμ Stereo L or R 1kHz, 100% modulation	98.1MHz *(A-4) *Tuning mode should be AUTO.		REC OUT L, R	1% (37dB) or less ● STEREO indicator should light.
9	Verification of sensitivity	FM ANT (75Ω) 88.1MHz 98.1MHz 106.1MHz MONO 1kHz Modulation off	88.1MHz *(A-6) 98.1MHz *(A-4) 106.1MHz *(A-7)		ANT (75Ω)	1) Set the tuning mode to MAN'L MONO. 2) S/N should be 30dB at each frequency of 88.1MHz, 98.1MHz, and 106.1MHz. 3) Check to ensure that the voltage at the ANT terminal is 3dBμ(14.25dBf) or less. (U,C,R,T : 5dBμ or less A,B,G,L : 7dBμ or less)
10	Adjustment of separation	FM ANT (75Ω) 98.1MHz 70dBμ Stereo L or R 1kHz, 100% modulation	98.1MHz *(A-4)	VR2	REC OUT L, R	With SSG output at L or R, the signal leakage level at the other channel should be minimized. 35dB or more.
11	Adjustment of signal meter	FM ANT (75Ω) 98.1MHz 45dBμ MONO 1kHz, 30% modulation	98.1MHz *(A-4)	VR1		Adjust so that all signal meters light.
		-10dBμ or less				Check to ensure that signal meters turn OFF.
12	Verification of auto tuning	FM ANT (75Ω) 98.1MHz 23dBμ Stereo L or R 1kHz, 30% modulation	98.1MHz *(A-4)			● Automatic reception should be available when the tuning key is moved UP and DOWN. ● The stereo indicator should light. ● Audio muting should be applied during tuning.

* Execution of FACTORY PRESET (Refer to page 20.) will facilitate setting reception frequency for adjustment.

AM Adjustment (This should be done after FM adjustment.)

1. Connection diagram (Measuring instruments)

- Adjustment of sensitivity.

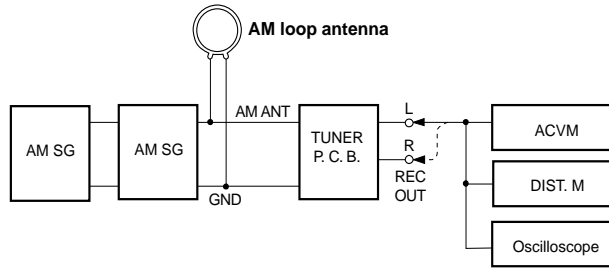

See page 22 for TP locations & adjustment points.

Step	Adjustment item	Signal (ANT IN)	Reception frequency	Adjustment point	Test point	Rating
1	Adjustment of sensitivity (630kHz)	AM ANT 630kHz 50dB μ 1kHz 30% modulation	630kHz *(B-1)	T2	REC OUT	Signal meter should be maximized.
2	Verification of sensitivity	AM ANT 630kHz 1080kHz 1440kHz 1kHz 30% modulation	630kHz *(B-1) 1080kHz *(B-2) 1440kHz *(B-3)		AM ANT	Distortion should be 10% or less at each frequency. Check to ensure that the voltage at the ANT terminal is 54dB μ or less.
3	Verification of signal meter	AM ANT 1080kHz 90dB μ -10dB or less	1080kHz *(B-2)			All signal meters should light. All signal meters should turn OFF.
4	Verification of auto tuning	AM ANT 60dB μ				Auto reception should be available when the tuning key is moved UP and DOWN.

* Execution of FACTORY PRESET (Refer to page 20.) will facilitate setting reception frequency for adjustment.

IC DATA

IC800 : LC87F65C8A (LC876564A-5K19)

8 bit μ -COM

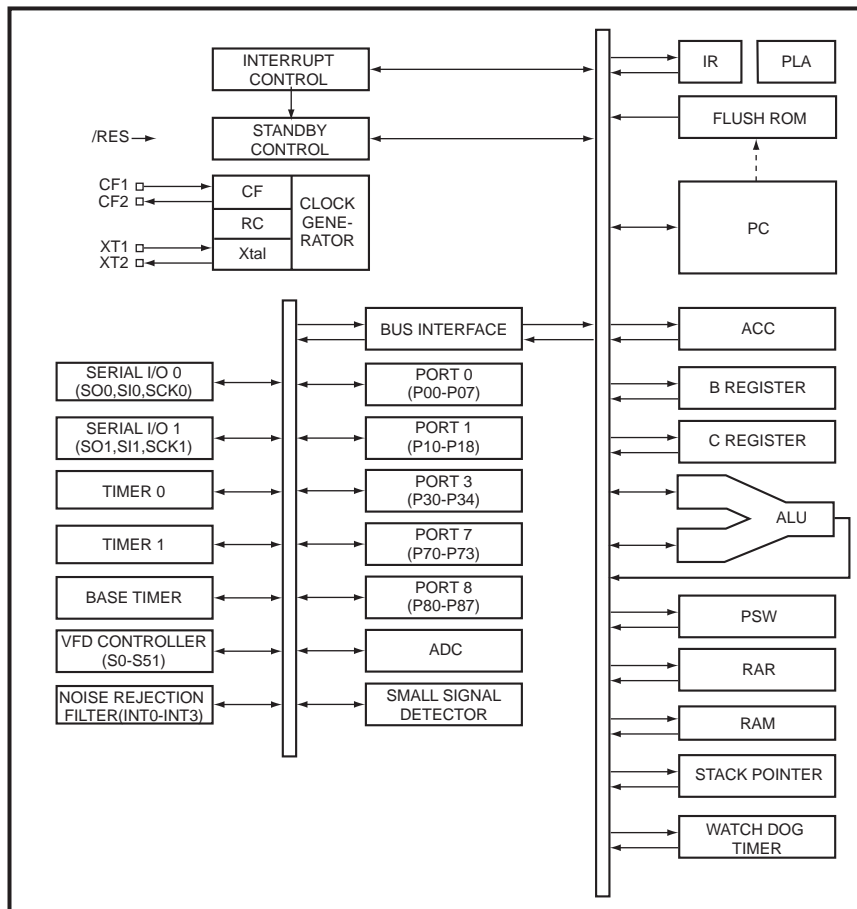
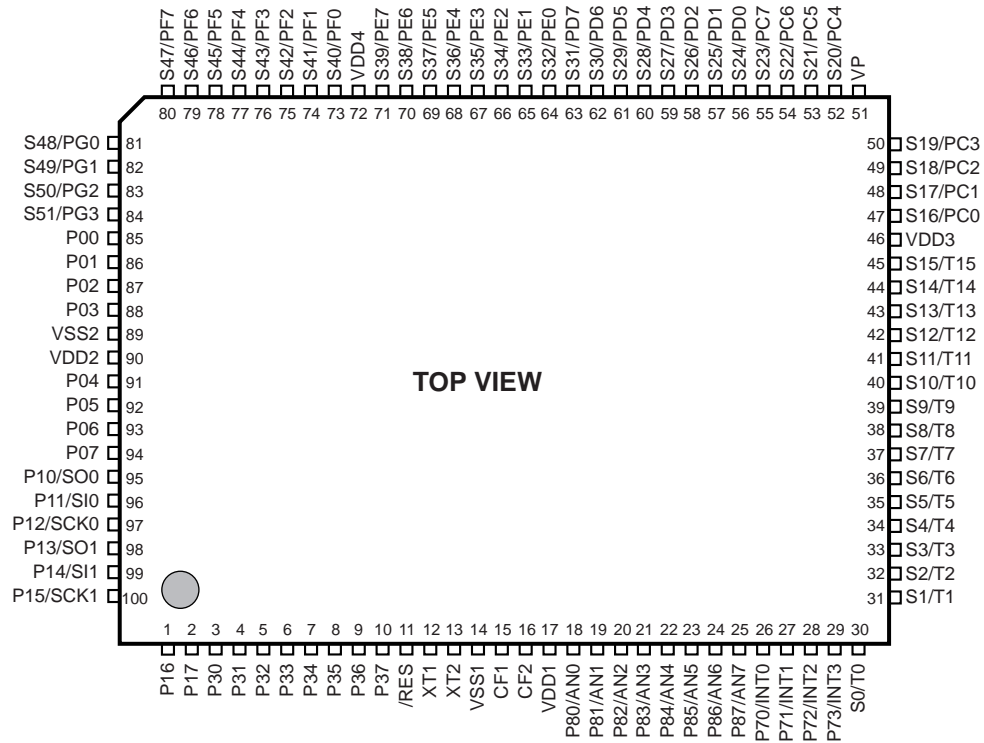

IC800 : LC87F65C8A (LC876564A-5K19)

8 bit μ -COM

Pin No.	Port	Pin Name	I/O	Function
1	P16	FLA-CLK	I/O	Flush clock
2	P17	FLA-I/O	I/O	Flush input/output
3	P30	FLA-SEL	I/O	Flush select
4	P31	T-MUTE	O	Tuner mute (L: ON)
5	P32	DSP-MTS	O	Transmit data for DSP
6	P33	DSP-STM	I	Reveive data from DSP
7	P34	DSR-SCK	O	Clock for DSP
8	P35	DSP-RTN	I	Clock from DSP
9	P36	DSP-TRQ	I	Transmit request from DSP
10	P37	DSP-RESET	O	Reset for DSP
11	/RES	/RES		System reset
12	XT1	T-/ST	I	Stereo from Tuner
13	XT2			Unconnected
14	Vss1	Vss1		Ground
15	CF1			Ceramic Oscillator Connected (10MHz)
16	CF2			Ceramic Oscillator Connected (10MHz)
17	VDD1	VDD1		Power supply
18	P80/AN0	KEY1	I	Key 1 AD input
19	P81/AN1	KEY2	I	Key 2 AD input
20	P82/AN2	KEY3	I	Key 3 AD input
21	P82/AN3	KEY4	I	Key 4 AD input
22	P84/AN4	T-METER	I	Tuner meter AD input
23	P85/AN5	PRO1	I	Protection 1 detect *1
24	P86/AN6	PRO2	I	Protection 2 detect *1
25	P85/AN5	PRO3	I	Protection 3 detect *1
Pin No.	Port	Pin Name	I/O	Function
26	P70/INT0	PDT	I	Power down detect
27	P71/INT1	FMT	O	Full mute (L : ON)
28	P72/INT2		I/O	Unconnected
29	P73/INT3	REMOTE	I	Remote Control signal
30	S0/T0	G1	O	FL Grid 1
31	S1/T1	G2	O	FL Grid 2
32	S2/T2	G3	O	FL Grid 3
33	S3/T3	G4	O	FL Grid 4
34	S4/T4	G5	O	FL Grid 5
35	S5/T5	G6	O	FL Grid 6
36	S6/T6	G7	O	FL Grid 7
37	S7/T7	G8	O	FL Grid 8
38	S8/T8	G9	O	FL Grid 9
39	S9/T9	G10	O	FL Grid 10
40	S10/T10	G11	O	FL Grid 11
41	S11/T11	G12	O	FL Grid 12
42	S12/T12	G13	O	FL Grid 13
43	S13/T13	G14	O	FL Grid 14
44	S14/T14	G15	O	FL Grid 15
45	S15/T15	G16	O	FL Grid 16
46	VDD3	VDD3		Power supply
47	S16/PC0	P1	O	FL Segment 1
48	S17/PC1	P2	O	FL Segment 2
49	S18/PC2	P3	O	FL Segment 3
50	S19/PC3	P4	O	FL Segment 4

*1 Protection 1, 2 and 3 detect

- After a few seconds the Power ON, and protection detect start.

Detection	
Protection 1	Abnormal DC of the amplifier.
Protection 2	Abnormal overcurrent of the amplifier.
Protection 3	Abnormal Voltage of the amplifier.

IC800 : LC87F65C8A (LC876564A-5K19)

8 bit μ -COM

Pin No.	Port	Pin Name	I/O	Function
51	VP	VP		
52	S20/PC4	P5	O	FL Segment 5
53	S21/PC5	P6	O	FL Segment 6
54	S22/PC6	P7	O	FL Segment 7
55	S23/PC7	P8	O	FL Segment 8
56	S24/PD0	P9	O	FL Segment 9
57	S25/PD1	P10	O	FL Segment 10
58	S26/PD2	P11	O	FL Segment 11
59	S27/PD3	P12	O	FL Segment 12
60	S28/PD4	P13	O	FL Segment 13
61	S29/PD5	P14	O	FL Segment 14
62	S30/PD6	P15	O	FL Segment 15
63	S31/PD7	P16	O	FL Segment 16
64	S32/PE0	P17	O	FL Segment 17
65	S33/PE1	P18	O	FL Segment 18
66	S34/PE2	P19	O	FL Segment 19
67	S35/PE3	P20	O	FL Segment 20
68	S36/PE4	P21	O	FL Segment 21
69	S37/PE5	P22	O	FL Segment 22
70	S38/PE6	RDS SELECT	I	Mode check RDS *2
71	S39/PE7			Unconnected
72	VDD4	VDD4		Power supply
73	S40/PF0			Unconnected
74	S41/PF1	EFFECT-RY	O	Effect relay
75	S42/PF2	SP-RY	O	Speaker relay

Pin No.	Port	Pin Name	I/O	Function
76	S43/PF3	POWER-RY	O	Power relay
77	S44/PF4	-10dB	O	-10 dB select (L : -10dB)
78	S45/PF5	/VCR	O	VCR select inhibit (H : inhibit)
79	S46/PF6			Unconnected
80	S47/PF7	STANDBY-SW	I	Standby / on (H : ON)
81	S48/PG0	ROTARY-A	I	Rotary encoder A
82	S49/PG1	ROTARY-B	I	Rotary encoder B
83	S50/PG2	DSP-A.SEL	I	Mode check DSP-A *2
84	S51/PG3			
85	P00	VOL.DN	O	Volume down
86	P01	VOL.UP	O	Volume up
87	P02	V-SEL1	O	Video selector 1 *3
88	P03	V-SEL2	O	Video selector 2 *3
89	VSS2	VSS2		Ground
90	VDD2	VDD2		Power supply
91	P04	CE-INPUT	O	Chip enable for INPUT
92	P05	CE-VR	O	Chip enable for VOLUME
93	P06	CE-TUNER	O	Chip enable for TUNER
94	P07	/CERDS	O	Chip enable for RDS
95	P10/SO0	V1/RDS-DATA	O	RDS data V1 market *4
96	P11/SI0	V2/RDS-DATA	O	RDS data V2 market *4
97	P12/SCK0	RDS-CLK	O	Clock for RDS
98	P13/SO2	SDT	O	Serial data
99	P14/SI1	TUN-SIN	I	Serial data from Tuner
100	P15/SCK1	SCK	O	Serial clock

*2 Model check

- Model check to the order of DSP, RDS, V595.

Hi = 1, Low = 0

Model Check	DSP	RDS	V595
RDS SELECT	0	1	0
DSP-A.SEL	1	0	0

*3 Video selector 1 and 2

Hi = 1, Low = 0

Video Selector	1(VSEL0)	2(VSEL1)
V-AUX	0	0
VCR	1	0
DVD/LD	0	1
TV/DBS	1	1

*4 Markets

Hi = 1, Low = 0

Market	J	U, C	A, G, L	R
V1	0	0	1	1
V2	0	1	0	1

IC14 : LC87F5164A (LC875164A-5K20)

8 bit Sub μ -COM

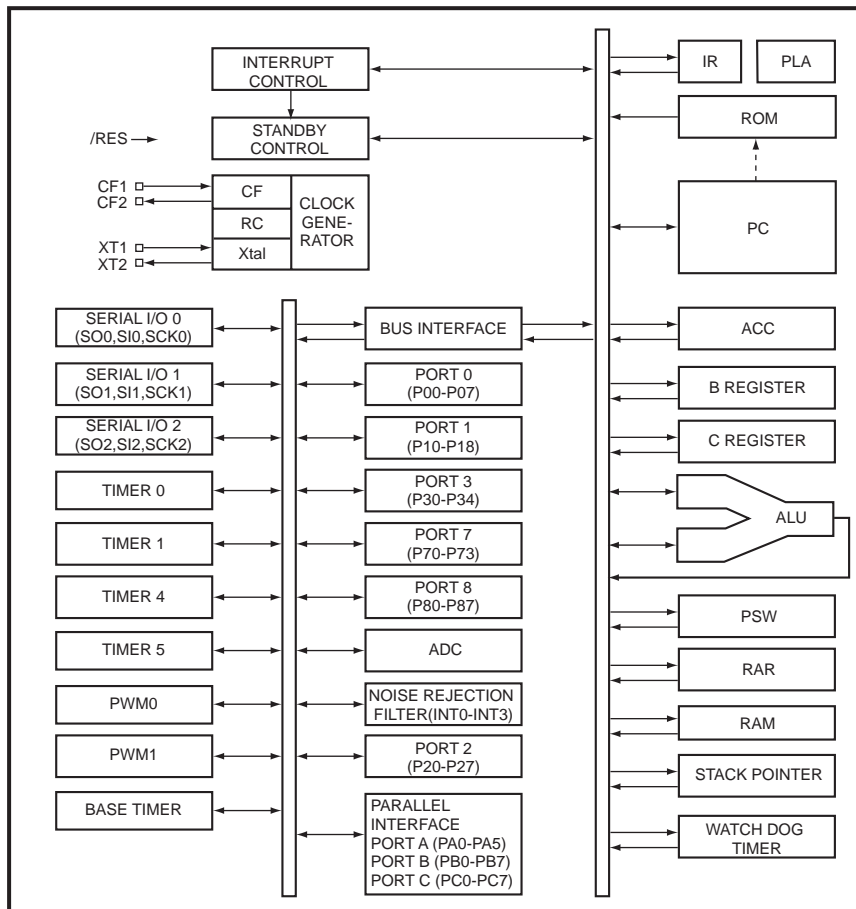
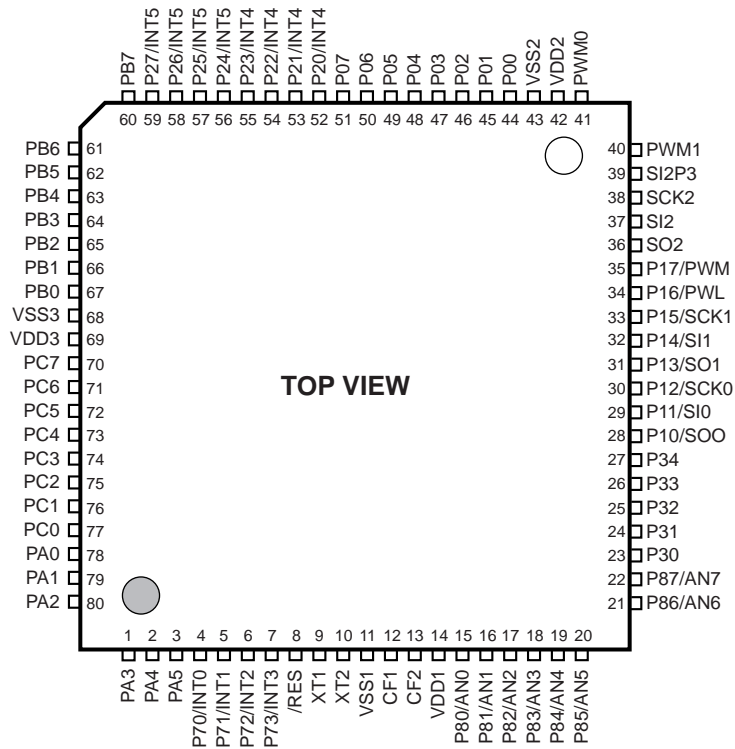

IC14 : LC87F5164A (LC875164A-5K20)

8 bit Sub μ -COM

Pin No.	Port	Pin Name	I/O	Function	Pin No.	Port	Pin Name	I/O	Function
1	PA3	CDO	I	Receive data from DIR2	41	PWM0	NC	OL	Unconnected
2	PA4	/ICDI	O	Initial clear for DIR2	42	VDD2	VDD2	+5V	+5V power supply
3	PA5	/KM1	O	Switching DIR2 forced (analog) mode	43	VSS2	VSS2	G	Ground
4	P70/INT0	LOCKN	IRQ	PLL lock flag	44	P00	NC	I/O	Unconnected
5	P71/INT1	ERRD	IRQ	DIR 2 error detect	45	P01	NC	I/O	Unconnected
6	P72/INT2	ERRA	IRQ	AC3Dav mute detect	46	P02	NC	I/O	Unconnected
7	P73/INT3	NONPCM	IRQ	AC3Dav AC-3 data detect	47	P03	NC	I/O	Unconnected
8	/RES	/RES	-	System reset	48	P04	NC	I/O	Unconnected
9	XT1	XT1	I	Connected to VDD1	49	P05	NC	I/O	Unconnected
10	XT2	XT2	I	Unconnected	50	P06	NC	I/O	Unconnected
11	VSS1	VSS1	G	Ground	51	P07	NC	I/O	Unconnected
12	CF1	CF1	\emptyset	Ceramic Oscillator Connected (10kHz)	52	P20/INT4	NC	I/O	Unconnected
13	CF2	CF2	\emptyset	Ceramic Oscillator Connected (10kHz)	53	P21/INT4	NC	I/O	Unconnected
14	VDD1	VDD1	+5V	+5V power supply	54	P22/INT4	NC	I/O	Unconnected
15	P80/AN0	NC	O	Unconnected	55	P23/INT4	NC	I/O	Unconnected
16	P81/AN1	NC	O	Unconnected	56	P24/INT5	NC	I/O	Unconnected
17	P82/AN2	NC	O	Unconnected	57	P25/INT5	NC	I/O	Unconnected
18	P83/AN3	NC	O	Unconnected	58	P26/INT5	NC	I/O	Unconnected
19	P84/AN4	NC	O	Unconnected	59	P27/INT5	NC	I/O	Unconnected
20	P85/AN5	NC	O	Unconnected	60	PB7	NC	I/O	Unconnected
21	P86/AN6	NC	O	Unconnected	61	PB6	NC	I/O	Unconnected
22	P87/AN7	NC	O	Unconnected	62	PB5	NC	I/O	Unconnected
23	P30	/ICAK	O	Initial clear for CODEC AD/DA	63	PB4	DSP	Ipu	Connected to VSS3
24	P31	CEAK	O	Chip enable for CODEC AD/DA	64	PB3	MUTO	Ipu	Unconnected (Fixed H)
25	P32	/ICAC	O	Initial clear for AC3Dav	65	PB2	LDC/O	I	LD COAX/OPT detect
26	P33	CEAC2	O	Chip enable 2 for AC3Dav	66	PB1	CDC/O	I	Fixed H
27	P34	CEAC1	O	Chip enable 1 for AC3Dav	67	PB0	RF	Ipu	Connected to VSS3 (Switched L)
28	P10/SO0	TXAC	TX	Transmit data for AC3Dav and CODEC AD/DA	68	VSS3	VSS3	G	Ground
29	P11/SI0	RXAC	RX	Receive data from AC3Dav	69	VDD3	VDD3	+5V	+5V power supply
30	P12/SCK0	CLKAC	CLK	Clock for AC3Dav and CODEC AD/DA	70	PC7	NC	I/O	Unconnected
31	P13/SO1	RSRV	Ipu	Not used (Normal)	71	PC6	NC	I/O	Unconnected
32	P14/SI1	TRXOB	I/O	Not used (Normal)	72	PC5	VER	Ipu	Connected to VSS3 (Switched L)
33	P15/SCK1	CLKOB	I	Not used (Normal)	73	PC4	DRB	O	Unconnected
34	P16/PWM	NC	I	Unconnected	74	PC3	DRA	O	Unconnected
35	P17/PWM	NC	I/O	Unconnected	75	PC2	DIC	O	Unconnected
36	SO2	STM	TX	Transmit data for CPU	76	PC1	DIB	O	Digital input selector Control B
37	SI2	MTS	RX	Receive data from CPU	77	PC0	DIA	O	Digital input selector Control A
38	SCK2	CKIF	RXCK	Clock from CPU	78	PA0	DMT	O	L/R D/A converter mute
39	SI2P3	WCIF	O	Clock for CPU	79	PA1	CLD	O	Chip select for DIR2
40	PWM1	TRQ	O	Transmit request for CPU	80	PA2	CCK	O	Serial clock for DIR2

IC3 : YM3436DK (DIR2)

Digital Format Interface Receiver

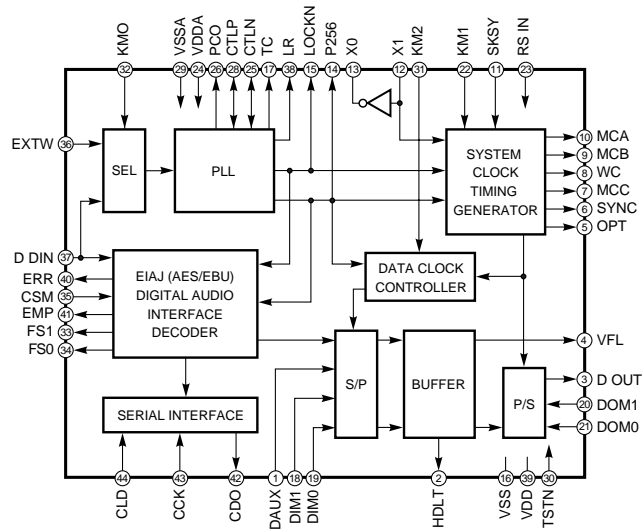
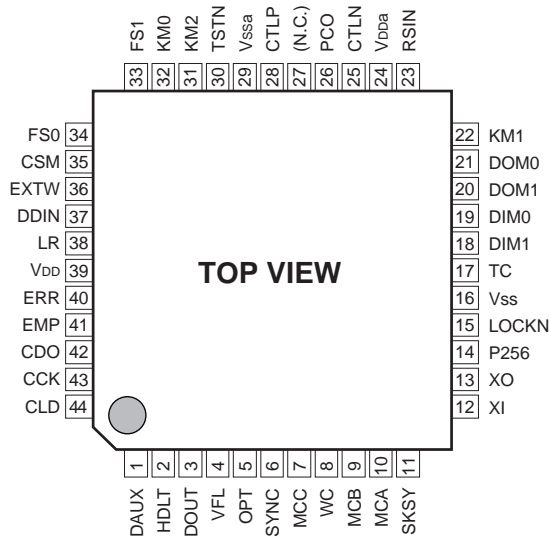

Pin No.	Pin Name	I/O	Function	Pin No.	Pin Name	I/O	Function
1	DAUX	I	Auxiliary input for audio data	26	PCO	O	PLL phase comparison output
2	HDLT	O	Asynchronous buffer operation flag	27	(NC)		
3	DOUT	O	Audio data output	28	CTLP	I	VCO control input P
4	VFL	O	Parity flag output	29	Vssa		VCO section power (GND)
5	OPT	O	Fs x 1 Synchronous output signal for DAC	30	TSTN	I	Test terminal. Open for normal use
6	SYNC	O	Fs x 1 Synchronous output signal for DSP	31	KM2	I	Clock mode switching input 2
7	MCC	O	Fs x 64Bit clock output	32	KM0	I	Clock mode switching input 0
8	WC	O	Fs x 1Word clock output	33	FS1	O	Channel status sampling frequency display output 1
9	MCB	O	Fs x 128Bit clock output	34	FS0	O	Channel status sampling frequency display output 0
10	MCA	O	Fs x 256Bit clock output	35	CSM	I	Channel status output method selection
11	SKSY	I	Clock synchronization control input	36	EXTW	I	External synchronous auxiliary input word clock
12	XI	I	Crystal oscillator connection or external clock input	37	DDIN	I	EIAJ (AES/EBU) data input
13	XO	O	Crystal oscillator connection	38	LR	O	PLL word clock output
14	P256	O	VCO oscillator clock connection	39	VDD		Logic section power (+5V)
15	LOCKN	O	PLL lock flag	40	ERR	O	Data error flag output
16	Vss		Logic section power (GND)	41	EMP	O	Channel status emphasis control code output
17	TC	O	PLL time constant switching output	42	CDO	O	3-wire type microcomputer interface data output
18	DIM1	I	Data input mode selection	43	CCK	I	3-wire type microcomputer interface clock output
19	DIM0	I	Data input mode selection	44	CLD	I	3-wire type microcomputer interface load input
20	DOM1	I	Data output mode selection				
21	DOM0	I	Data output mode selection				
22	KM1	I	Clock mode switching input 1				
23	RSTN	I	System reset input				
24	VDDa		VCO section power (+5V)				
25	CTLN	I	VCO control input N				

IC4 : YSS908-F (AC3Dav)

Digital Dolby Pro Logic Decoder +DSP

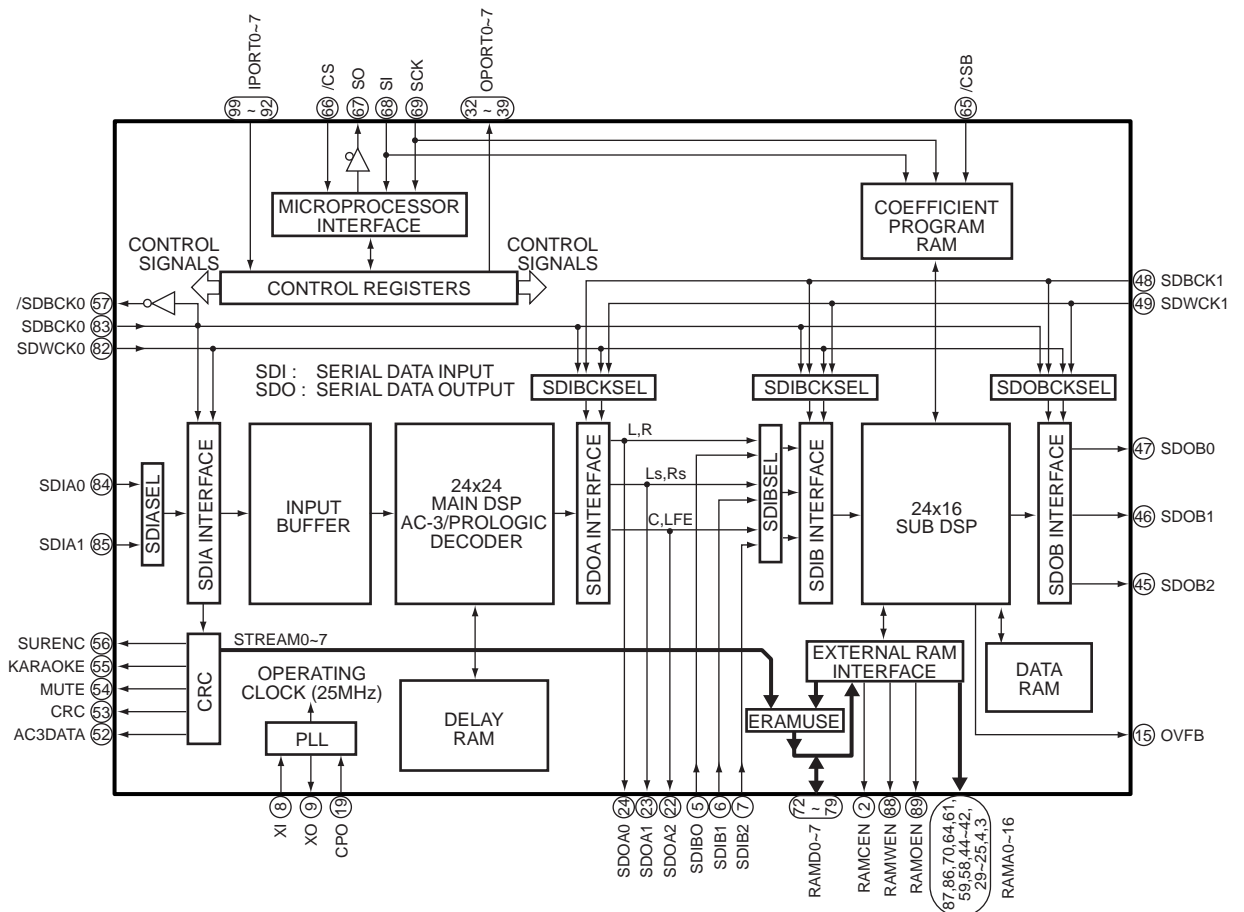
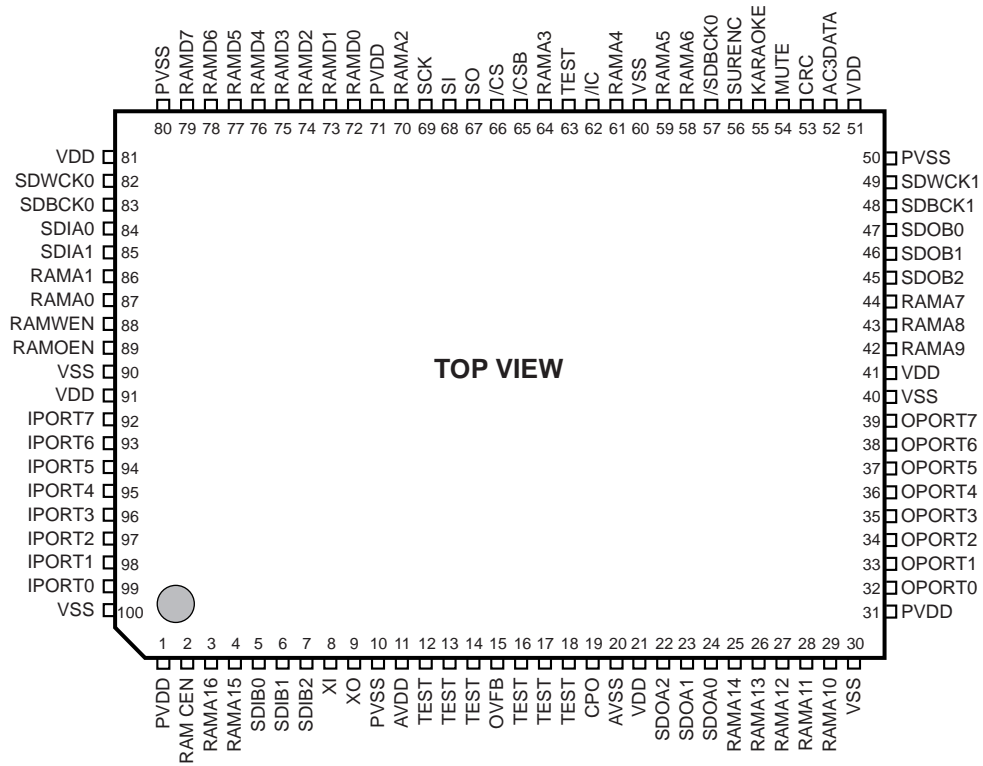

IC4 : YSS908-F (AC3Dav)

Digital Dolby Pro Logic Decoder +DSP

No.	Name	I/O	Function
1	PVDD		+5V power supply
2	RAMCEN	O	RAM chip enable output terminal, connected to external 1M SRAM chip enable
3	RAMA16	O	RAM address output terminal 16, connected to external 1M SRAM address
4	RAMA15	O	RAM address output terminal 15, connected to external 1M SRAM address
5	SDIB0	I	Serial data input B terminal 0 (normally connected to ground)
6	SDIB1	I	Serial data input B terminal 1 (normally connected to ground)
7	SDIB2	I	Serial data input B terminal 2 (normally connected to ground)
8	XI	I	Crystal oscillator connection external clock input terminal
9	XO	O	Crystal oscillator connection (normally unconnected)
10	PVSS		Ground (digital)
11	AVDD		+3V power supply (analog)
12	TEST		Test terminal (normally unconnected)
13	TEST		Test terminal (normally unconnected)
14	TEST		Test terminal (normally unconnected)
15	OVFB	O	Overflow detect terminal (normally unconnected)
16	TEST		Test terminal (normally unconnected)
17	TEST		Test terminal (normally unconnected)
18	TEST		Test terminal (normally unconnected)
19	CPO	O	PLL output terminal (connected to AVSS through external analog filter)
20	AVSS		Ground (analog)
21	VDD		+3V power supply
22	SDOA2	O	Serial data output A terminal 2 (normally unconnected)
23	SDOA1	O	Serial data output A terminal 1 (normally unconnected)
24	SDOA0	O	Serial data output A terminal 0 (normally unconnected)
25	RAMA14	O	RAM address terminal 14 output terminal, connected to external 1M SRAM address
26	RAMA13	O	RAM address terminal 13 output terminal, connected to external 1M SRAM address
27	RAMA12	O	RAM address terminal 12 output terminal, connected to external 1M SRAM address
28	RAMA11	O	RAM address terminal 11 output terminal, connected to external 1M SRAM address
29	RAMA10	O	RAM address terminal 10 output terminal, connected to external 1M SRAM address
30	VSS		Ground
31	PVDD		+5V power supply
32	OPORT0	O	Output port terminal 0, dolby pro logic signal output
33	OPORT1	O	Output port terminal 1, (normally unconnected)
34	OPORT2	O	Output port terminal 2, (normally unconnected)
35	OPORT3	O	Output port terminal 3, (normally unconnected)
36	OPORT4	O	Output port terminal 4, (normally unconnected)
37	OPORT5	O	Output port terminal 5, (normally unconnected)
38	OPORT6	O	Output port terminal 6, (normally unconnected)
39	OPORT7	O	Output port terminal 7, (normally unconnected)
40	VSS		Ground
41	VDD		+3V power supply
42	RAMA9	O	RAM address output terminal 9 , connected to external 1M SRAM address
43	RAMA8	O	RAM address output terminal 8 , connected to external 1M SRAM address
44	RAMA7	O	RAM address output terminal 7 , connected to external 1M SRAM address
45	SDOB2	O	Serial data output B terminal 2
46	SDOB1	O	Serial data output B terminal 1
47	SDOB0	O	Serial data output B terminal 0
48	SDBCK1	I	Serial data bit clock input terminal 1
49	SDWCK1	I	Serial data word clock input terminal 1
50	VSS		Ground

IC4 : YSS908-F (AC3Dav)

Digital Dolby Pro Logic Decoder +DSP

No.	Name	I/O	Function
51	VDD		+3V power supply
52	AC3DATA	O	AC-3 data output terminal, AC-3 bit stream data detect
53	CRC	O	CRC output terminal (normally unconnected)
54	MUTE	O	Mute output terminal, output data mute detect
55	KARAOKE	O	Karaoke output terminal, AC-3 karaoke data detect
56	SURENC	O	Surround encoder output terminal (normally unconnected)
57	/SDBCK0	O	Inverted signal of serial data bit clock output terminal 0
58	RAMA6	O	RAM address output terminal 6, connected to external 1M SRAM address
59	RAMA5	O	RAM address output terminal 5, connected to external 1M SRAM address
60	VSS		Ground
61	RAMA4	O	RAM address output terminal 4, connected to external 1M SRAM address
62	/IC	I	Initial clear input terminal
63	TEST		Test terminal (normally unconnected)
64	RAMA3	O	RAM address output terminal 3, connected to external 1M SRAM address
65	/CSB	I	Chip select B input terminal, coefficient and program RAM chip select signal input
66	/CS	I	Chip select input terminal, microprocessor interface chip select signal input
67	SO	O	Serial data output terminal, microprocessor interface serial data output
68	SI	I	Serial data input terminal, microprocessor interface and coefficient and program RAM serial data input
69	SCK	I	Serial clock input terminal, microprocessor interface and coefficient and program RAM serial clock input
70	RAMA2	O	RAM address output terminal 2, connected to external 1M SRAM address
71	PVDD		+5V power supply
72	RAMD0	I/O	RAM data bus terminal 0, connected to external 1M SRAM data
73	RAMD1	I/O	RAM data bus terminal 1, connected to external 1M SRAM data
74	RAMD2	I/O	RAM data bus terminal 2, connected to external 1M SRAM data
75	RAMD3	I/O	RAM data bus terminal 3, connected to external 1M SRAM data
76	RAMD4	I/O	RAM data bus terminal 4, connected to external 1M SRAM data
77	RAMD5	I/O	RAM data bus terminal 5, connected to external 1M SRAM data
78	RAMD6	I/O	RAM data bus terminal 6, connected to external 1M SRAM data
79	RAMD7	I/O	RAM data bus terminal 7, connected to external 1M SRAM data
80	PVSS		Ground
81	VDD2		+3V power supply
82	SDWCK0	I	Serial data word clock input terminal 0
83	SDBCK0	I	Serial data bit clock input terminal 0
84	SDIA0	I	Serial data input A terminal 0
85	SDIA1	I	Serial data input A terminal 1
86	RAMA1	O	RAM address output terminal 1, connected to external 1M SRAM address
87	RAMA0	O	RAM address output terminal 0, connected to external 1M SRAM address
88	RAMWEN	O	RAM write enable output terminal, connected to external 1M SRAM write enable
89	RAMOEN	O	RAM output enable output terminal, connected to external 1M SRAM output enable
90	VSS		Ground
91	VDD		+3V power supply
92	IPOINT7	I	Input port terminal 7 (normally connected to ground)
93	IPOINT6	I	Input port terminal 6 (normally connected to ground)
94	IPOINT5	I	Input port terminal 5 (normally connected to ground)
95	IPOINT4	I	Input port terminal 4 (normally connected to ground)
96	IPOINT3	I	Input port terminal 3 (normally connected to ground)
97	IPOINT2	I	Input port terminal 2 (normally connected to ground)
98	IPOINT1	I	Input port terminal 1 (normally connected to ground)
99	IPOINT0	I	Input port terminal 0 (normally connected to ground)
100	VSS		Ground

IC5 : M5M51288BKJ-20LTEL (1M SRAM)

131072-word x 8 bit High Speed Static RAM

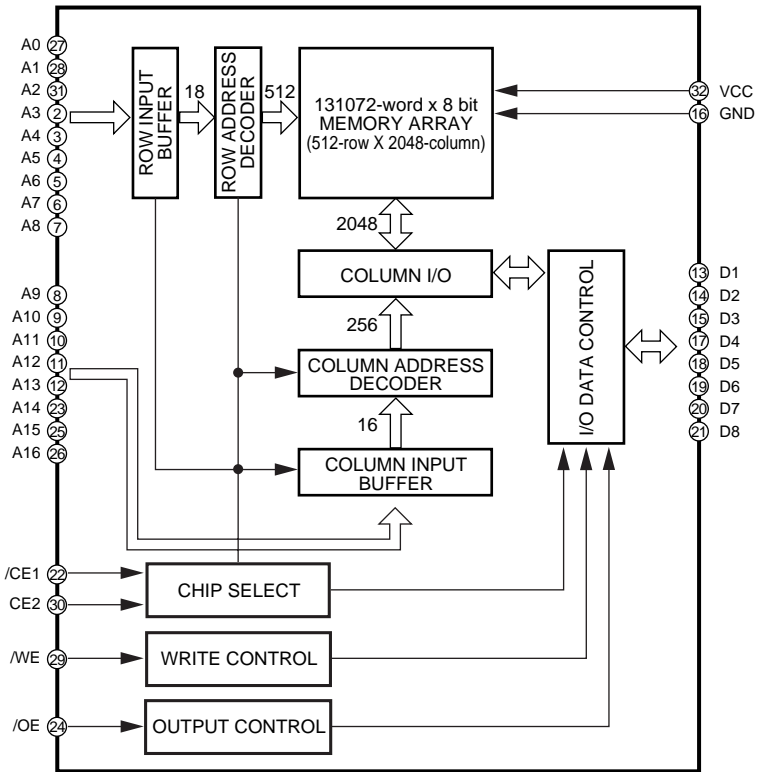
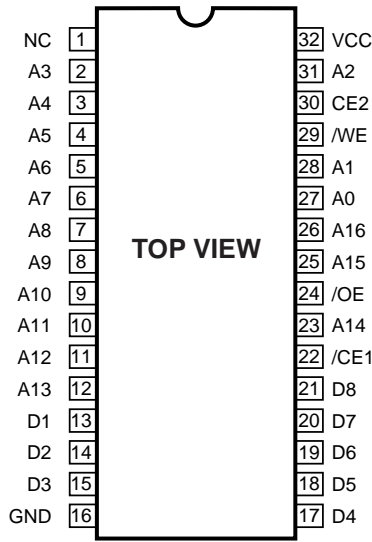

/CE1	CE2	/WE	/OW	Mode	Data I/O	Power
X	L	X	X	Non-selectable	High impedance	On
H	X	X	X	Non-selectable	High impedance	Standby
L	H	L	X	Write mode	Input	On
L	H	H	L	Read mode	Output	On
L	H	H	H		High impedance	On

NOTE) H: High Level L: Low level X: Don't care

IC6 : AK4526 (CODEC AD/DA)

20 bit 6 channel A/D, D/A Converter

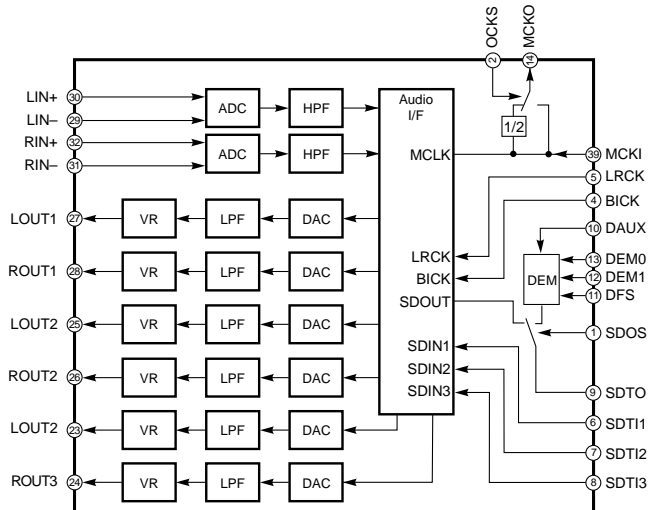
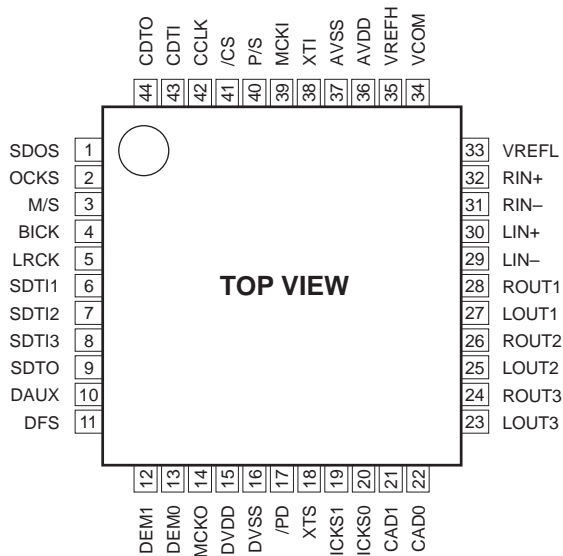

■ DISPLAY DATA

● V800 : 16-BT-59GK (V2421800)



● PIN CONNECTION

Pin No.	1	2	3	4	5	6	7	8	9	10	11	12	13	14	15	16	17	18	19	20	21	22	23	24	25
CONNECTION	F1	F1	NP	NP	NC	NC	NC	NC	NC	NC	P22	P21	P20	P19	P18	P17	P16	P15	P14	P13	P12	P11	P10	P9	
Pin No.	26	27	28	29	30	31	32	33	34	35	36	37	38	39	40	41	42	43	44	45	46	47	48	49	50
CONNECTION	P8	P7	P6	P5	P4	P3	P2	P1	IC	NP	Fd	Fd	NP	IC	16G	15G	14G	13G	12G	11G	10G	9G	8G	7G	6G
Pin No.	51	52	53	54	55	56	57	58	59	60	61	62	63	64	65										
CONNECTION	5G	4G	3G	2G	1G	NC	NC	NC	NC	NC	NC	NP	NP	F2	F2										

- NOTE**
- 1) F1, F2 Filament
 - 2) NP No pin
 - 3) NC No connection
 - 4) DL Datum Line
 - 5) 1G~16G Grid
 - 6) IC Internal connection
 - 7) Fd terminals are to be supplied through 51kΩ from Ec.

● GRID ASSIGNMENT

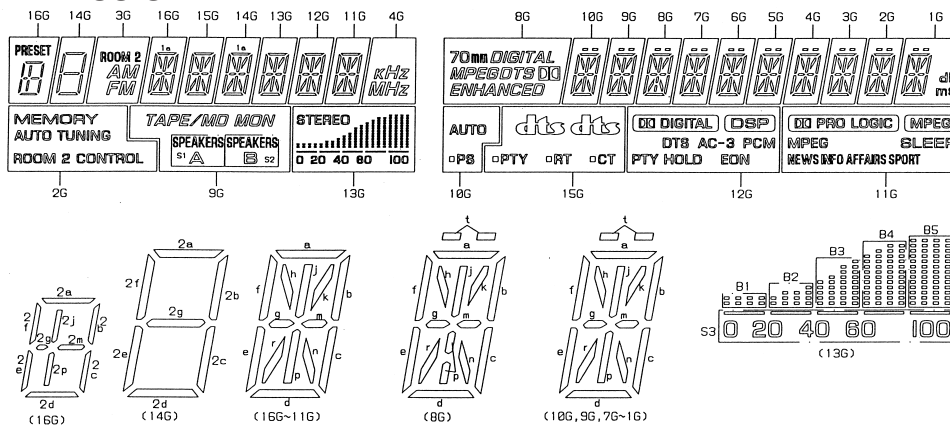

● ANODE CONNECTION

	16G	15G	14G	13G	12G	11G	10G	9G	8G	7G ~5G	4G	3G	2G	1G
P1	1a	a	1a	a	a	a	a	a	a	a	a	a	a	a
P2	1b	b	1b	b	b	b	b	b	b	b	b	b	b	b
P3	1c	c	1c	c	c	c	c	c	c	c	c	c	c	c
P4	1d	d	1d	d	d	d	d	d	d	d	d	d	d	d
P5	1e	e	1e	e	e	e	e	e	e	e	e	e	e	e
P6	1f	f	1f	f	f	f	f	f	f	f	f	f	f	f
P7	1g	g	1g	g	g	g	g	g	g	g	g	g	g	g
P8	1h	h	1h	h	h	h	h	h	h	h	h	h	h	h
P9	1j	j	1j	j	j	j	j	j	j	j	j	j	j	j
P10	1k	k	1k	k	k	k	k	k	k	k	k	k	k	k
P11	1m	m	1m	m	m	m	m	m	m	m	m	m	m	m
P12	1n	n	1n	n	n	n	n	n	n	n	n	n	n	n
P13	1p	p	1p	p	p	p	p	p	p	p	p	p	p	p
P14	1r	r	1r	r	r	r	r	r	r	r	r	r	r	r
P15	PRESET	<i>dts</i> (Left)	-	-	DX DIGITAL	DX PRO LOGIC	t	t	t	t	t	t	t	t
P16	2a	<i>dts</i> (Right)	2a	STEREO	(DSP)	(MPEG)	-	-	-	-	-	-	-	-
P17	2b,2c	<input type="checkbox"/> (PTY)	2b	B1	DTS	MPEG	-	TAPE/MO	70mm	-	kHz	ROOM 2	MEMORY	dB
P18	2d	PTY	2c	B2	AC-3	SLEEP	-	MON	DIGITAL	-	MHz	AM	AUTO TUNING	ms
P19	2e,2f	<input type="checkbox"/> (RT)	2d	B3	PCM	NEWS	-	S1	MPEG	-	-	FM	ROOM 2 CONTROL	-
P20	2g	RT	2e	B4	PTY HOLD	INFO	AUTO	S2	DTS	-	-	-	-	-
P21	2j,2p	<input type="checkbox"/> (CT)	2f	B5	EON	AFFAIRS	<input type="checkbox"/> (PS)	-	DD	-	-	-	-	-
P22	2m	CT	2g	S3	-	SPORT	PS	-	ENHANCED	-	-	-	-	-

■ BLOCK DIAGRAM (1/2)

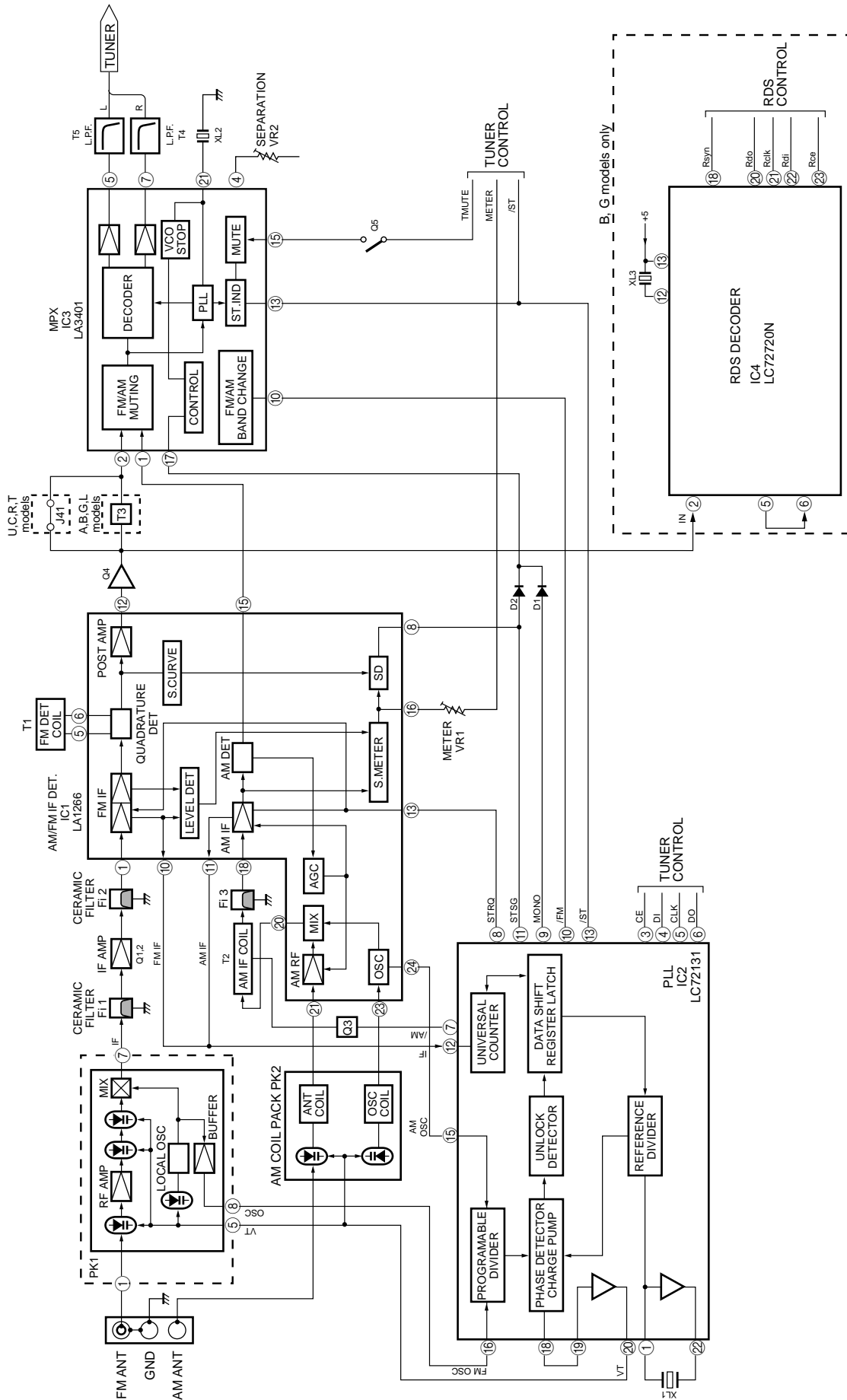

■ BLOCK DIAGRAM (2/2)

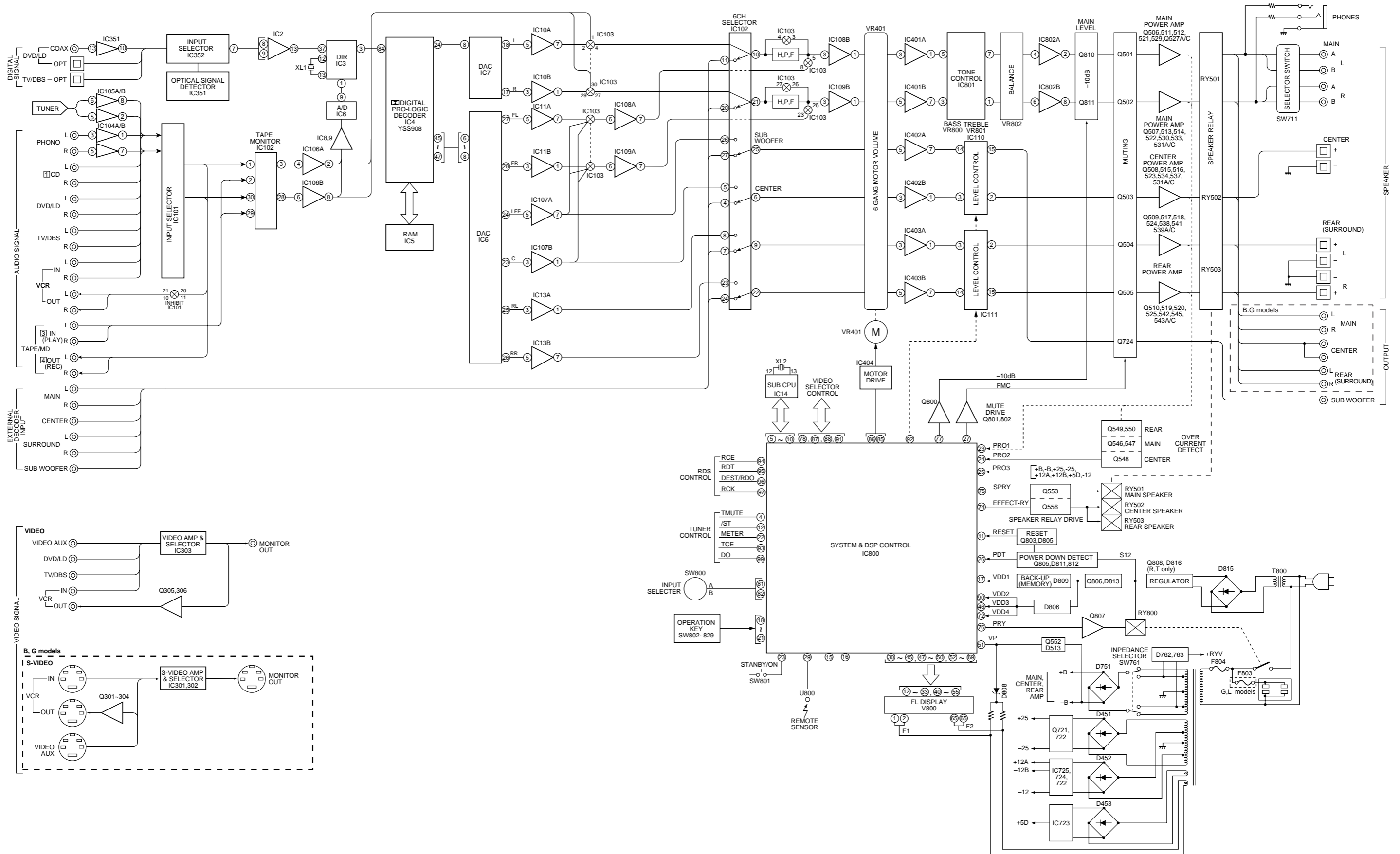

PRINTED CIRCUIT BOARD (Foil side)

There are two types of P. C. B. Assembly Tuner for this models in items of construction of components. One uses the Lead Type Device only and the other uses the Lead Type device and Surface Mount Device (SMD). These P. C. B. assemblies are interchangeable.

P. C. B. ASS'Y TUNER LIST

Model	Markets	Lead Type	Lead & SMD
RX-V595	U, C	V2518600	V2519300
RX-V595	R, T	V2518700	V2519400
RX-V595	A, L	V2518800	V2519500
RX-V595RDS	B, G	V2518900	V2519600

Lead & SMD : See page 80~81, PRINTED CIRCUIT BOARD
P. C. B. TUNER (Lead Type & SMD)

U, C, R, T, A and L models

P. C. B. TUNER (Lead Type)

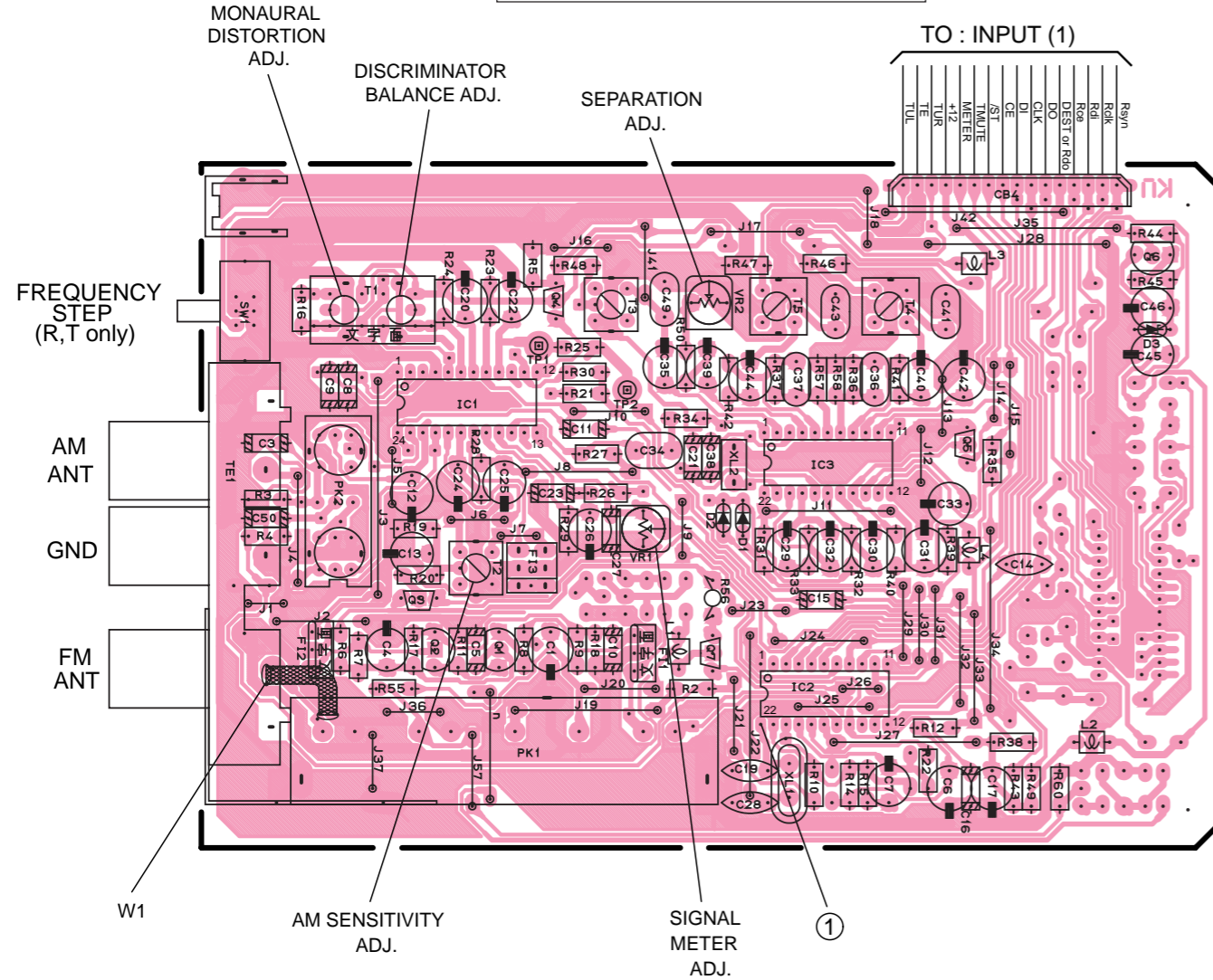

B and G models

P. C. B. TUNER (Lead Type)

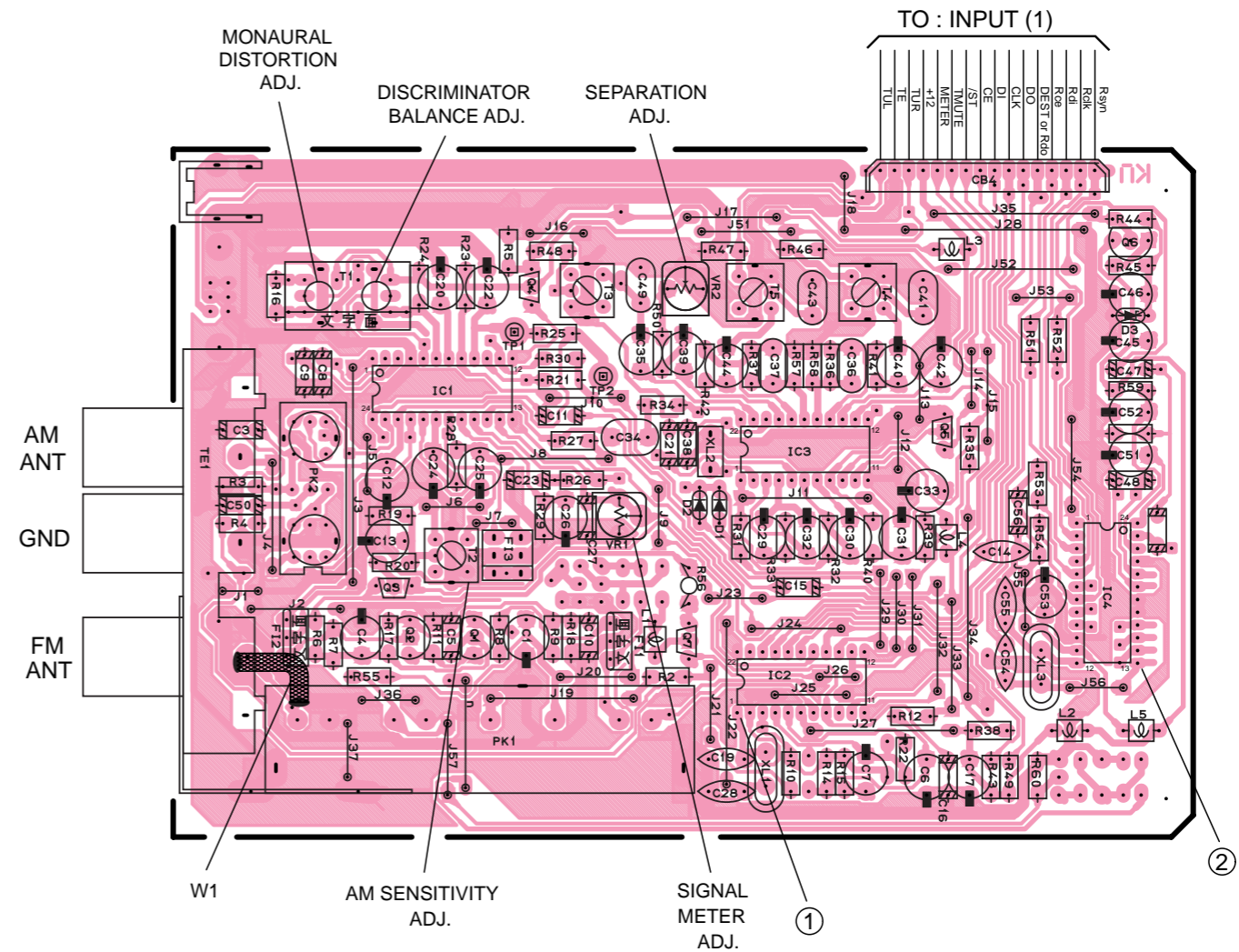

U, C, R, T, A and L models

● Semiconductor Location

Ref. No.	Location
D1	C3
D2	C3
D3	D3
IC1	B3
IC2	C4
IC3	C3
Q1	B4
Q2	B4
Q3	B3
Q4	B2
Q5	D3
Q6	D2
Q7	C4

CIRCUIT CHANGES BY MARKET.

	U,C	R,T	A,L
R48	×	×	○
T3	×	×	○
J41	○	○	×
J42	×	○	×
R55	×	×	○
R57	×	×	○
R58	×	×	○
R60	×	×	○

○ : USED
× : NOT USED

Point ① (Pin22 of IC2)

V : 2V/div H : 0.1μsec/div DC range 1 : 1 probe

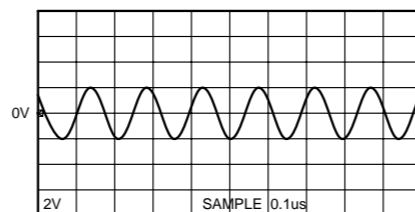

B and G models

● Semiconductor Location

Ref. No.	Location
D1	G3
D2	F3
D3	H3
IC1	F3
IC2	G4
IC3	G3
IC4	H3
Q1	F4
Q2	F4
Q3	F3
Q4	F2
Q5	G3
Q6	H2
Q7	F4

Point ① (Pin22 of IC2)

V : 2V/div H : 50nsec/div DC range 1 : 1 probe

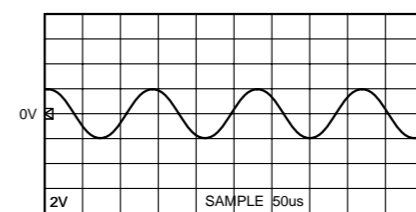

Point ② (Pin12 of IC4)

V : 2V/div H : 0.1μsec/div DC range 1 : 1 probe

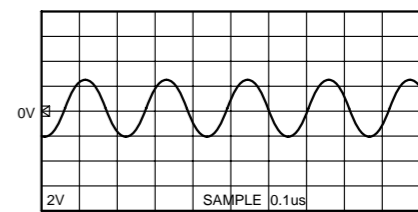

■ PRINTED CIRCUIT BOARD (Foil side)

P. C. B. DSP

P. C. B. DSP

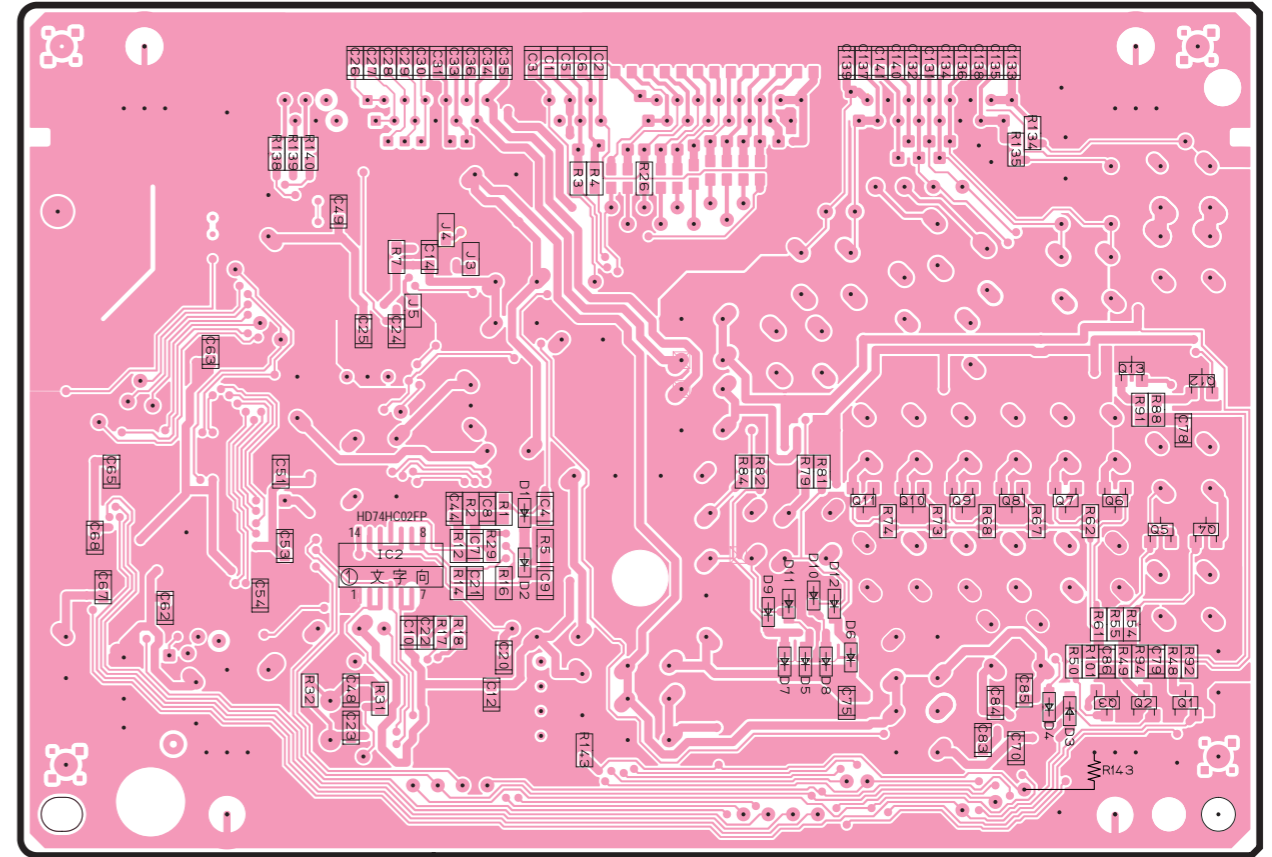
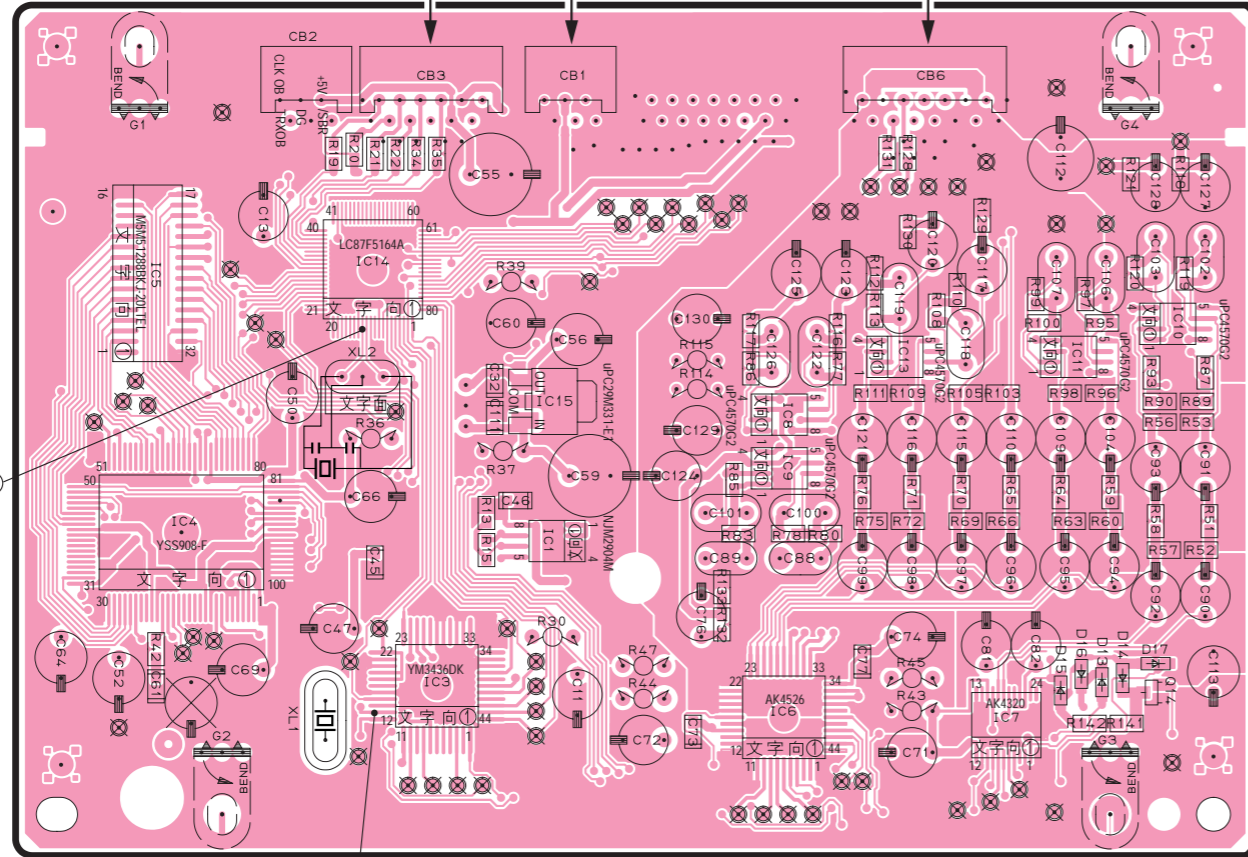
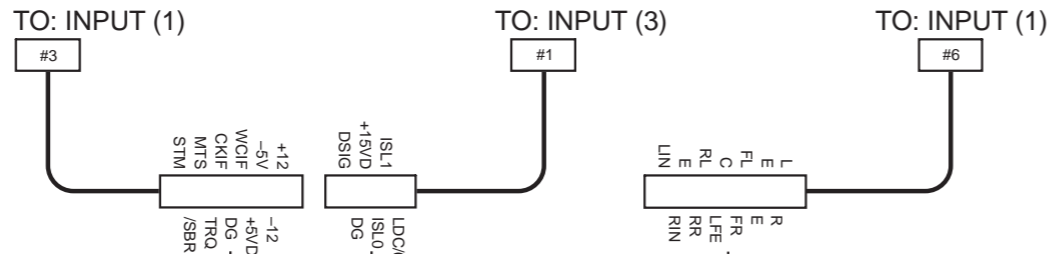

● Semiconductor Location

Ref. No.	Location	Ref. No.	Location	Ref. No.	Location
D1	F3	IC1	B3	Q1	H4
D2	F3	IC2	E3	Q2	G4
D3	G4	IC3	B4	Q3	G4
D4	G4	IC4	A3	Q4	H3
D5	G4	IC5	A3	Q5	G3
D6	G4	IC6	C4	Q6	G3
D7	G4	IC7	D4	Q7	G3
D8	G4	IC8	C3	Q8	G3
D9	F4	IC9	C3	Q9	G3
D10	G4	IC10	D3	Q10	G3
D11	G4	IC11	D3	Q11	G3
D12	G4	IC13	C3	Q12	H3
D13	D4	IC14	B3	Q13	G3
D14	D4				
D15	D4				
D16	D4				
D17	D4				

Point ⑤
Pin 13 of IC3
V : 2V/div H : 50nsec/div
AC range 1 : 1probe

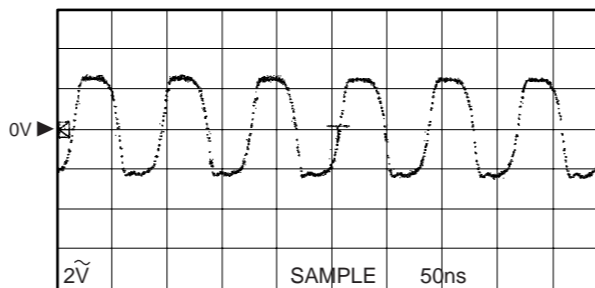

Point ⑥
Pin 13 of IC4
V : 2V/div H : 50nsec/div
AC range 1 : 1probe

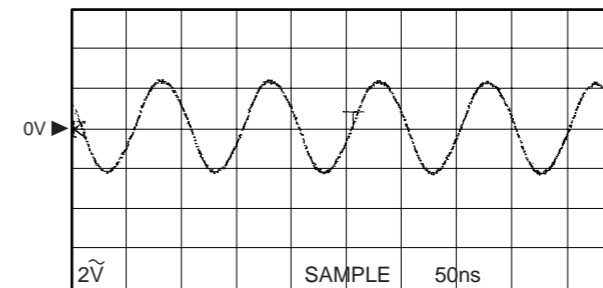

PRINTED CIRCUIT BOARD (Foil side)

● Semiconductor Location

Ref. No.	Location
D800	C2
D801	C2
D802	C2
D803	C2
D805	C2
D806	C3
D807	C2
D808	E3
D809	C3
D811	C3
D812	C3
D813	C3
IC800	E2
IC801	D5
IC802	E5
Q800	F3
Q801	E3
Q802	E3
Q803	C2
Q805	C3
Q806	C3
Q810	E5
Q811	E5

P. C. B. OPERATION (1)

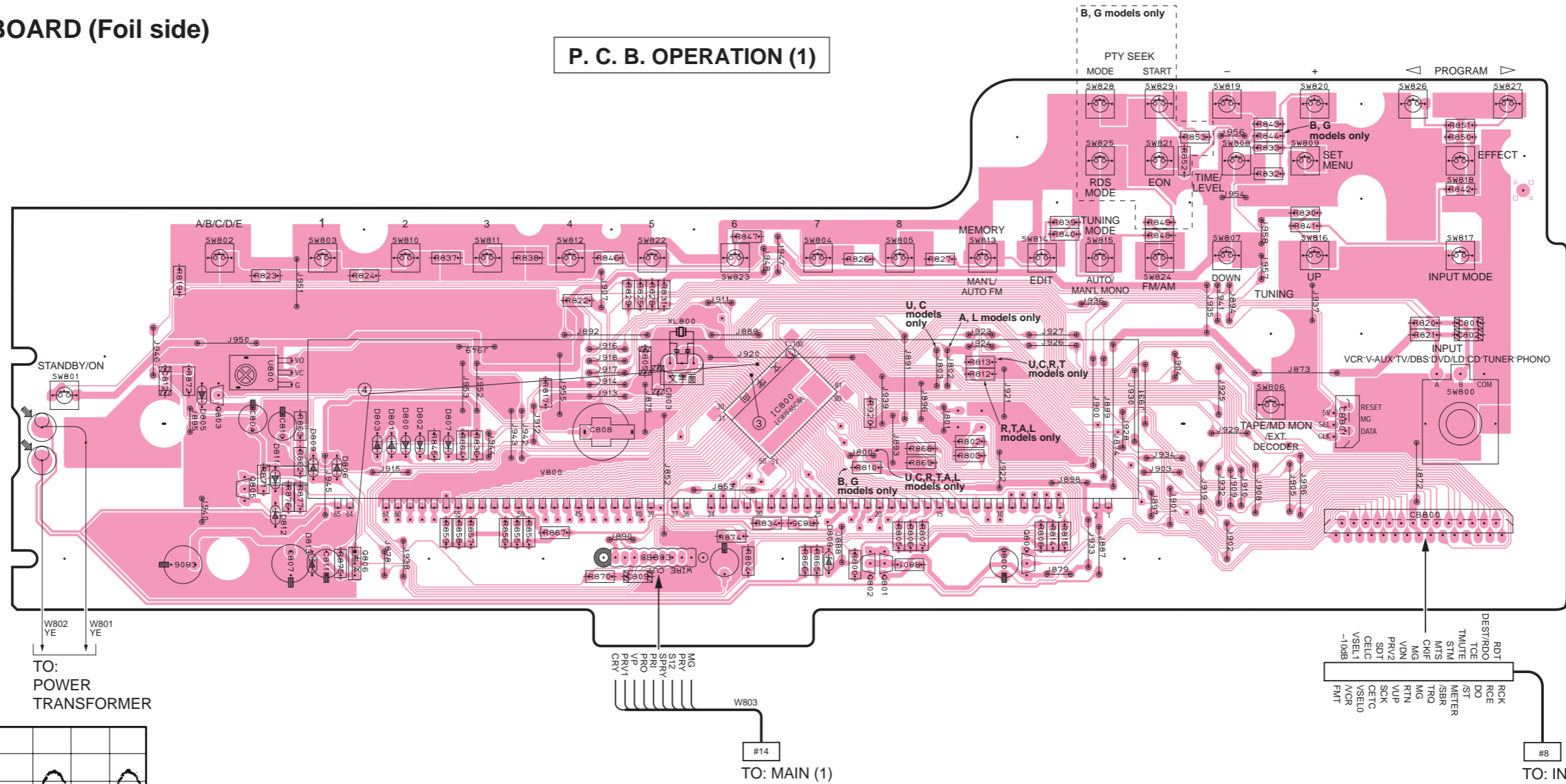

P. C. B. OPERATION (4)

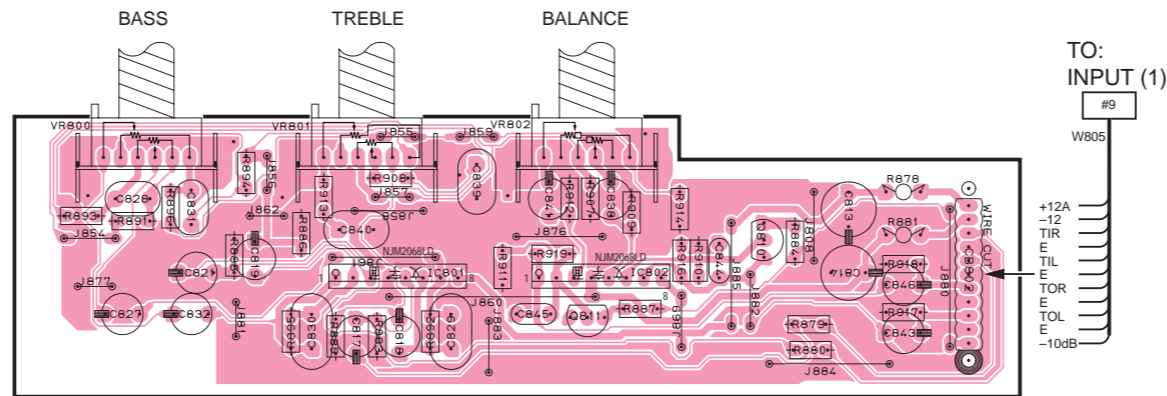

P. C. B. OPERATION (2)

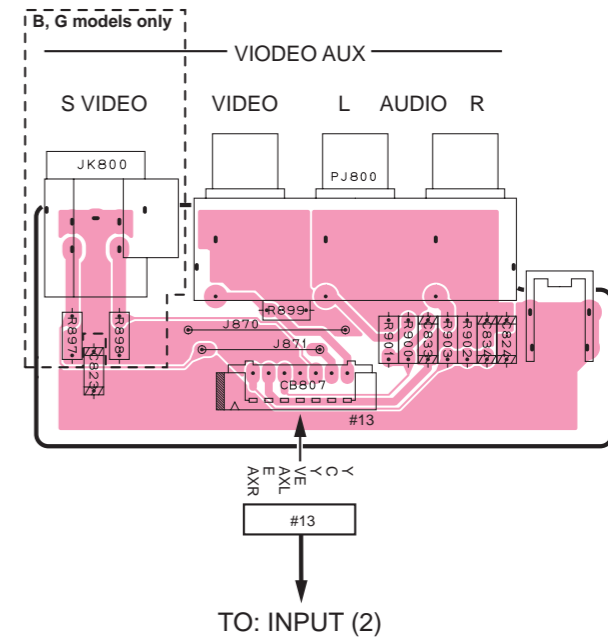

Point ③
(Pin 16 of IC800)
V : 2V/div H : 50nsec/div
AC range 1 : 1 probe

TO:
POWER
TRANSFORMER

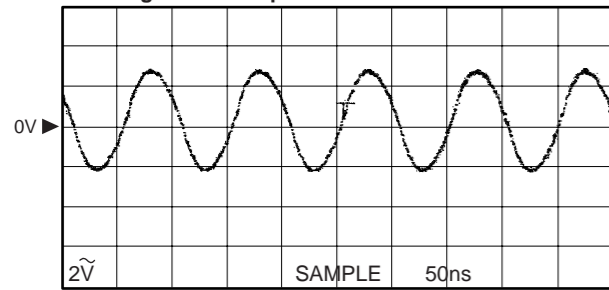

Point ④
(CH1 : Pin 11 of IC800
CH2 : Emitter of Q806)
V : 2V/div H : 0.5sec/div
DC range 1 : 1probe

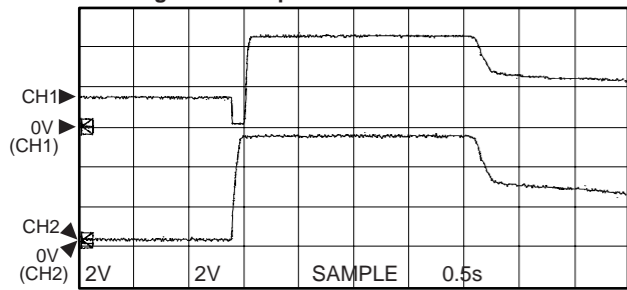

With the POWER switch turned ON, connect the power cord to the AC outlet.

Disconnect the power cord from the AC outlet.

(This waveform is not available by pushing the power switch ON and OFF.)

PRINTED CIRCUIT BOARD (Foil side)

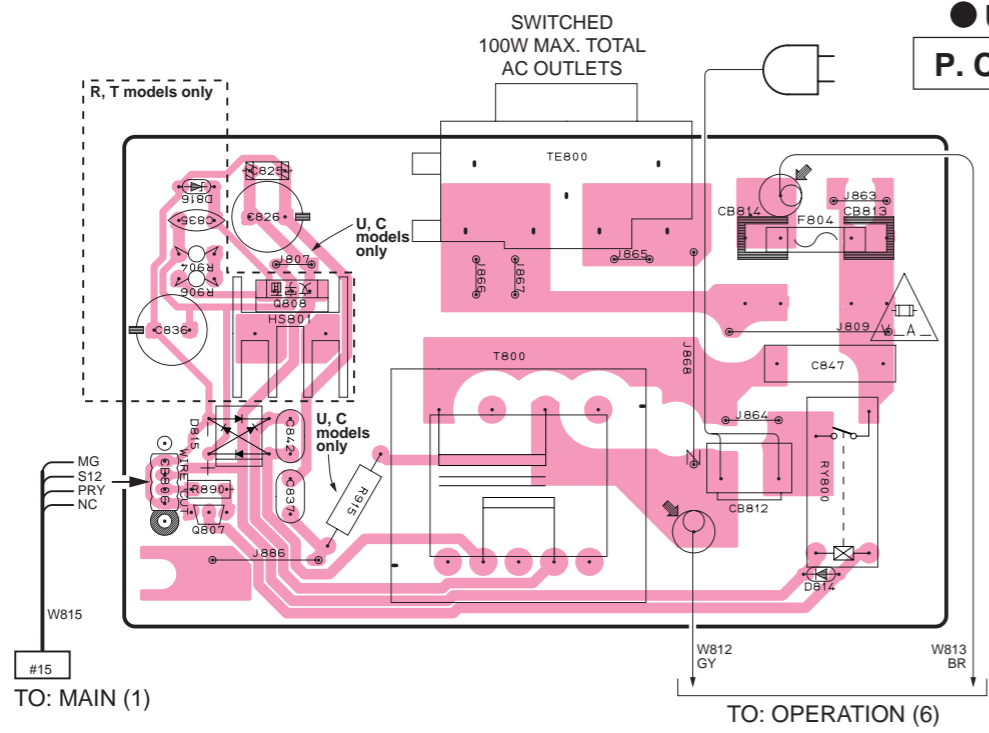

● U, C, R and T models
P. C. B. OPERATION (3)

U, C, R and T Models
● Semiconductor Location

Ref. No.	Location
D814	C3
D815	A2
D816	A2
Q807	A2
Q808	A2

P. C. B. OPERATION (6)

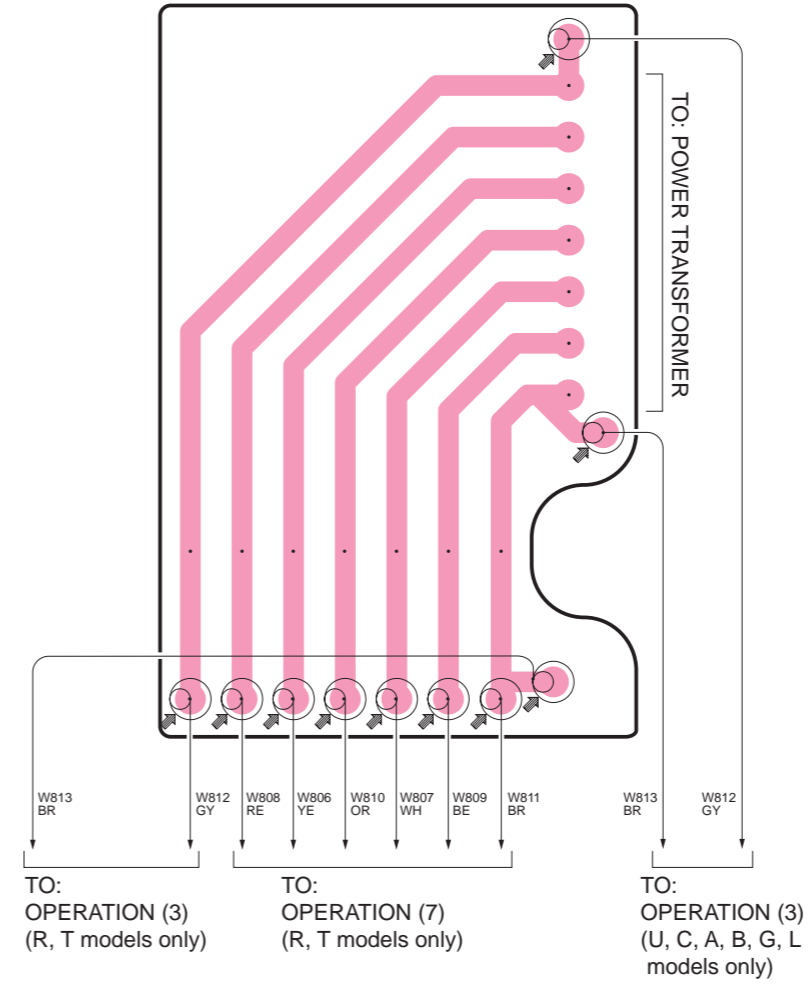

P. C. B. OPERATION (5)

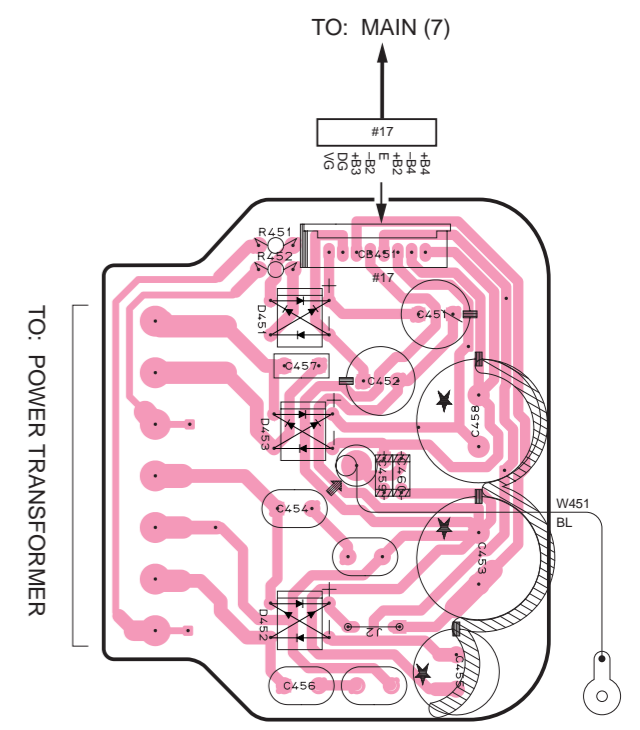

● Semiconductor Location

Ref. No.	Location
D451	G2
D452	G3
D453	G2

● A, B, G and L models
P. C. B. OPERATION (3)

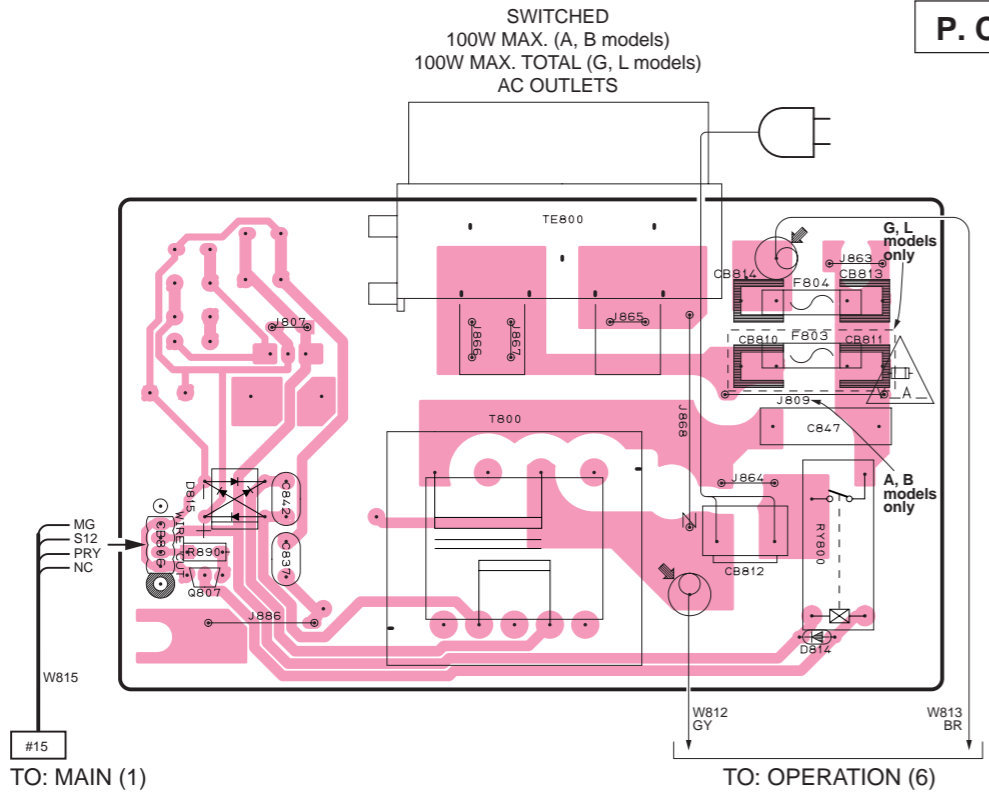

A, B, G and L Models
● Semiconductor Location

Ref. No.	Location
D814	C5
D815	A5
Q807	A5

● R and T models only
P. C. B. OPERATION (7)

240V	1-2 / 5-6
220V	2-3 / 6-7
110V	3-4 / 7-8
120V	4-5 / 8-1

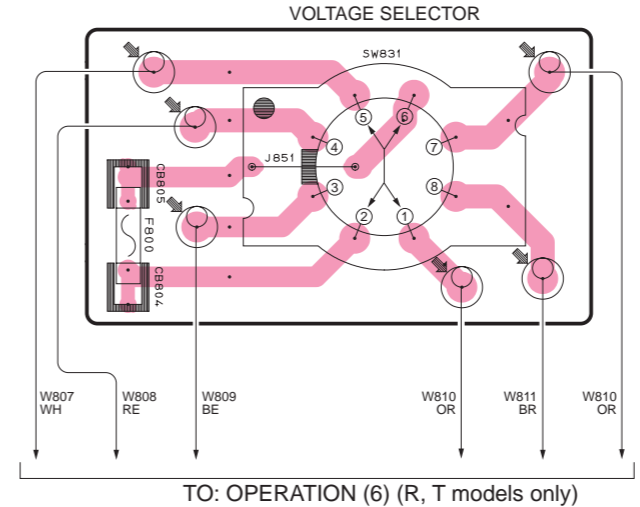

PRINTED CIRCUIT BOARD (Foil side)

P. C. B. MAIN (1)

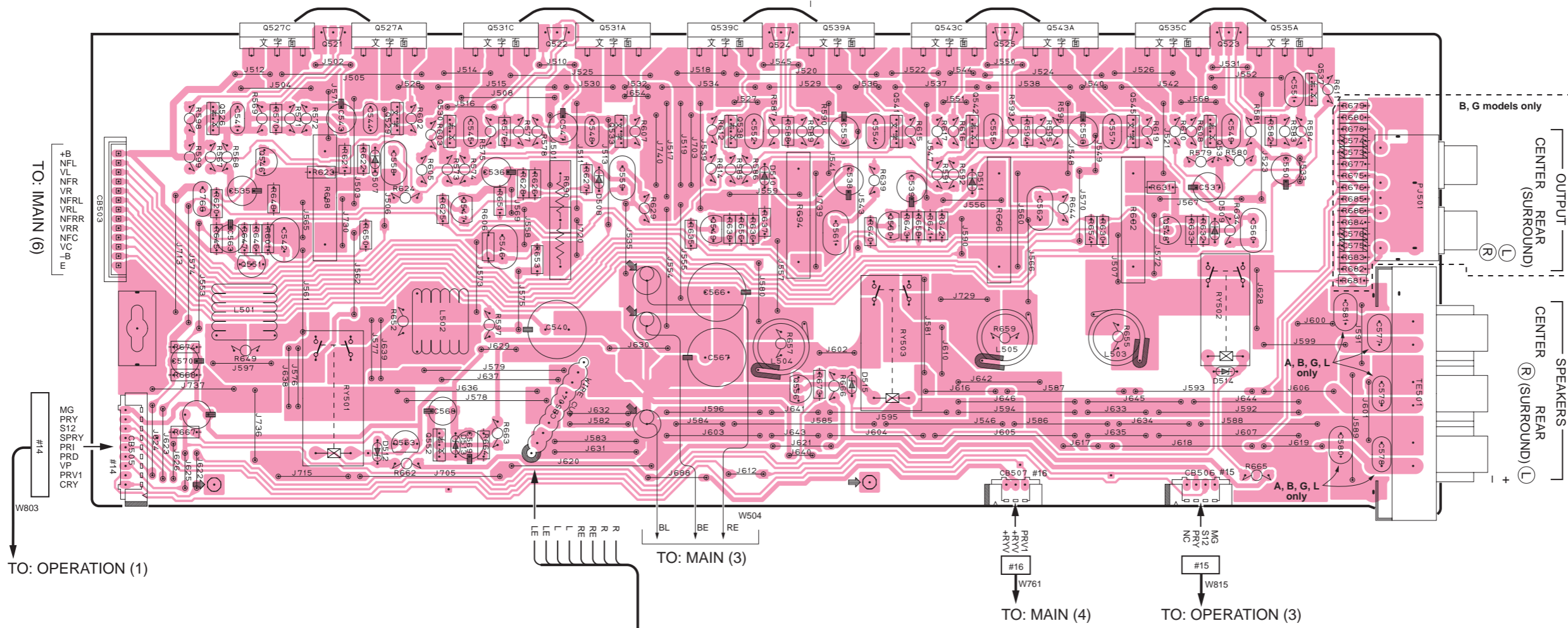

P. C. B. MAIN (5)

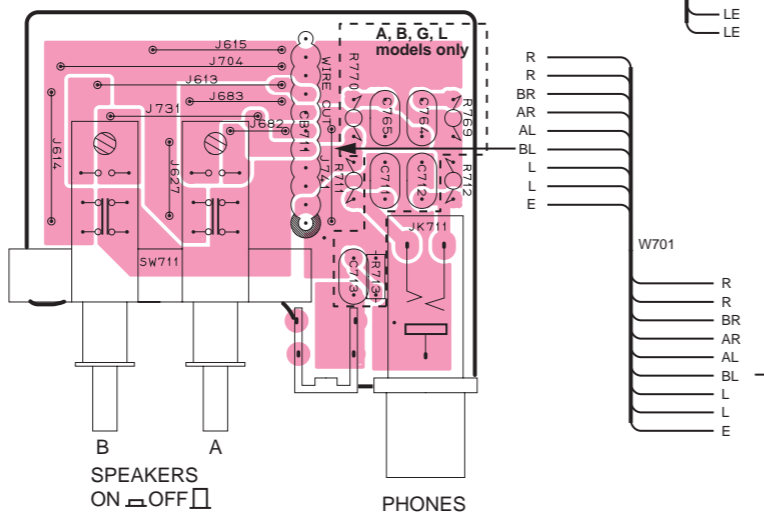

P. C. B. MAIN (2)

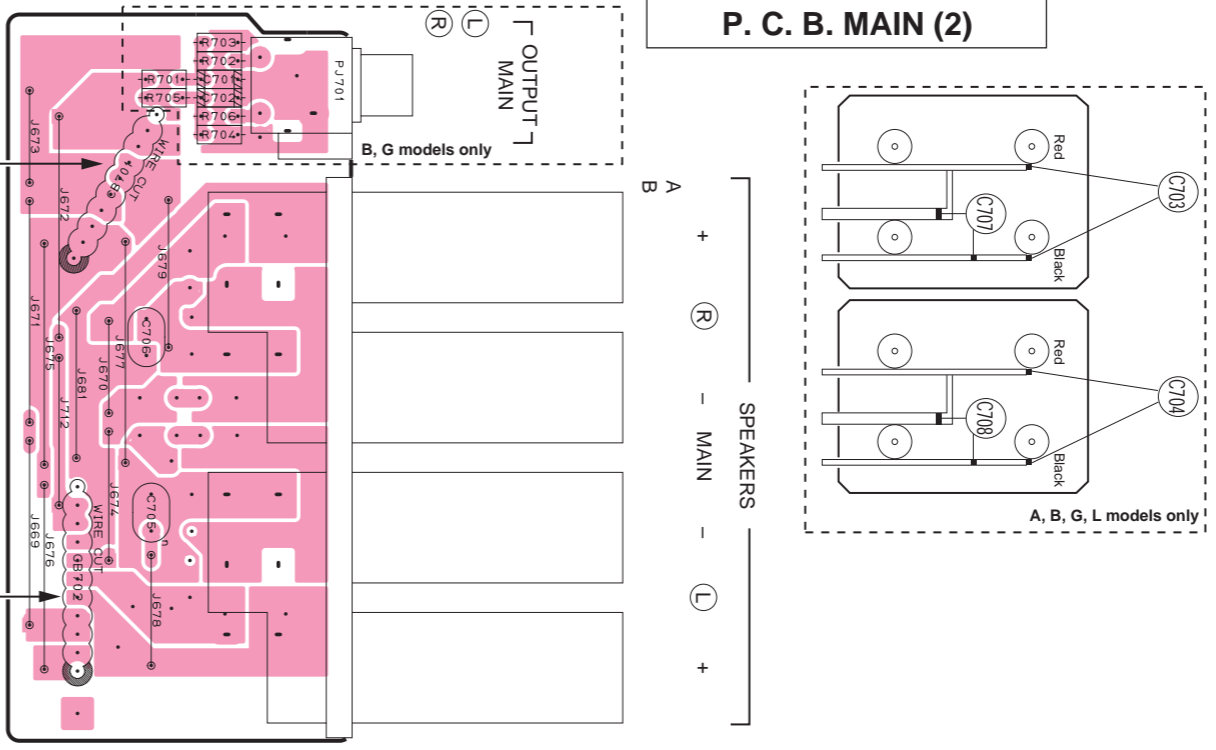

Semiconductor Location

Ref. No.	Location	Ref. No.	Location
D507	C2	Q542	E2
D508	C2	Q543A	E1
D509	F2	Q543C	E1
D510	D2	Q545	F2
D511	E2	Q547	C2
D512	C3	Q548	F2
D513	C3	Q549	D2
D514	F3	Q550	E2
D515	E3	Q551	B2
Q521	B1	Q552	C3
Q522	C1	Q553	C3
Q523	F1	Q556	D3
Q524	D1		
Q525	E1		
Q526	B2		
Q527A	C1		
Q527C	B1		
Q529	C2		
Q530	C2		
Q531A	D1		
Q531C	C1		
Q533	D2		
Q534	F2		
Q535A	F1		
Q535C	F1		
Q537	F1		
Q538	D2		
Q539A	D1		
Q539C	D1		
Q541	E2		

PRINTED CIRCUIT BOARD (Foil side)

P. C. B. MAIN (3)

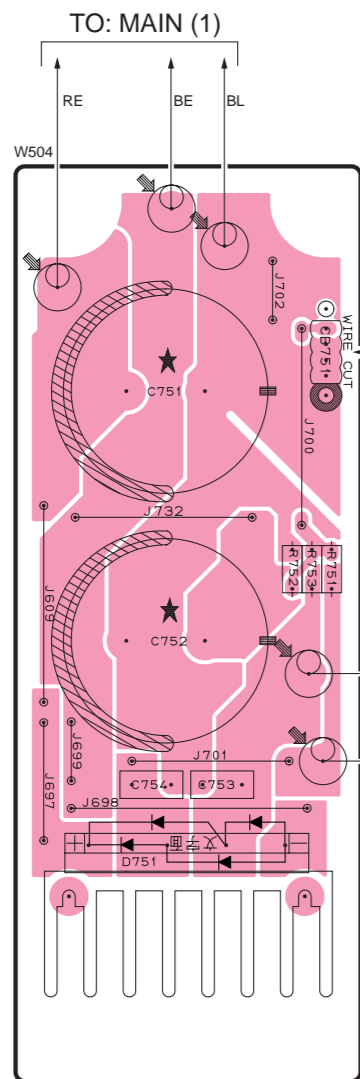

P. C. B. MAIN (4)

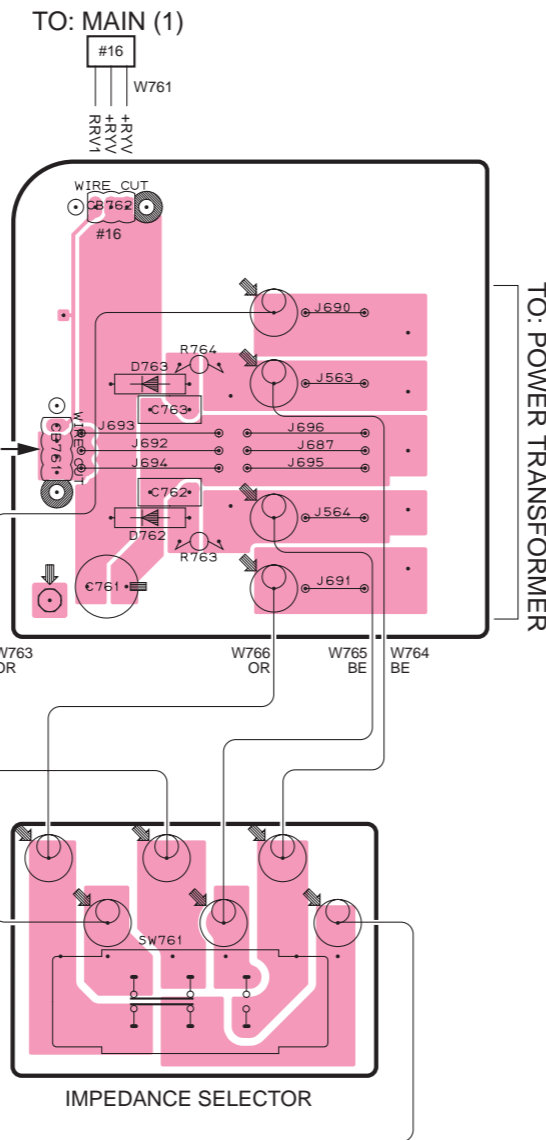

P. C. B. MAIN (6)

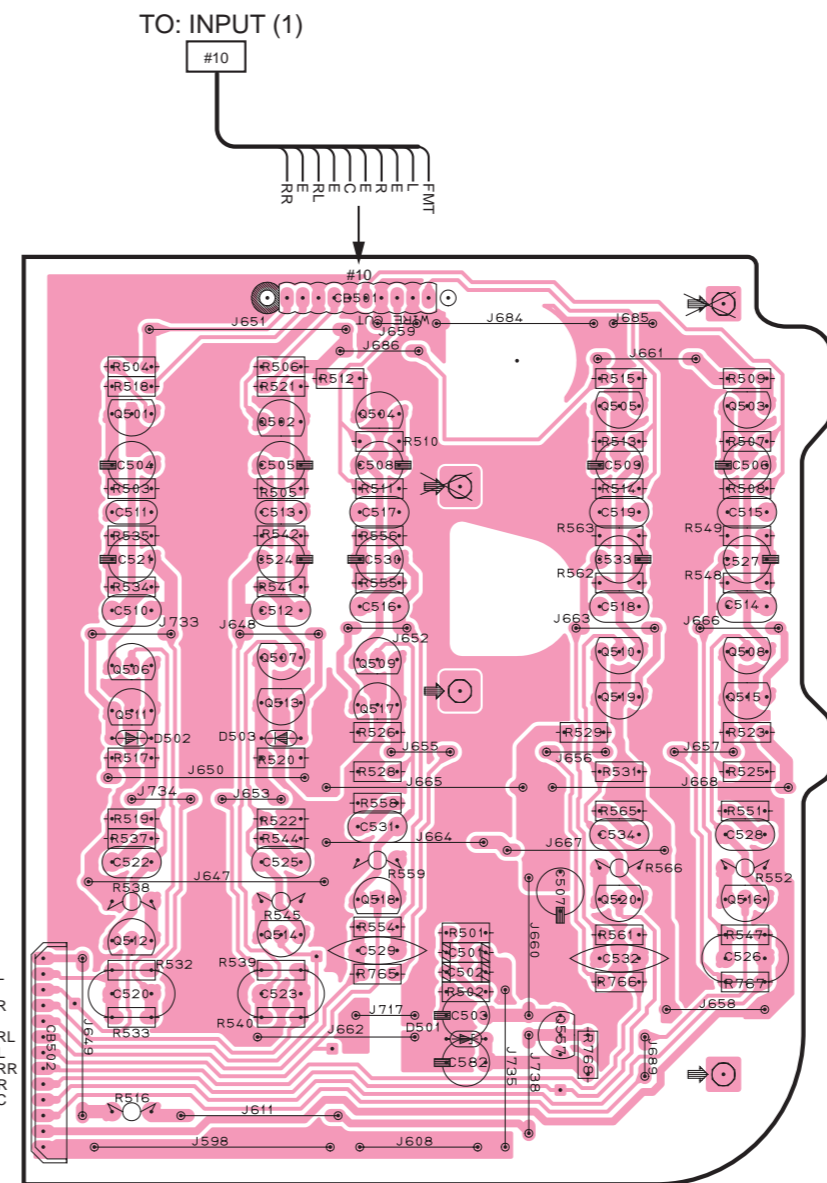

P. C. B. MAIN (7)

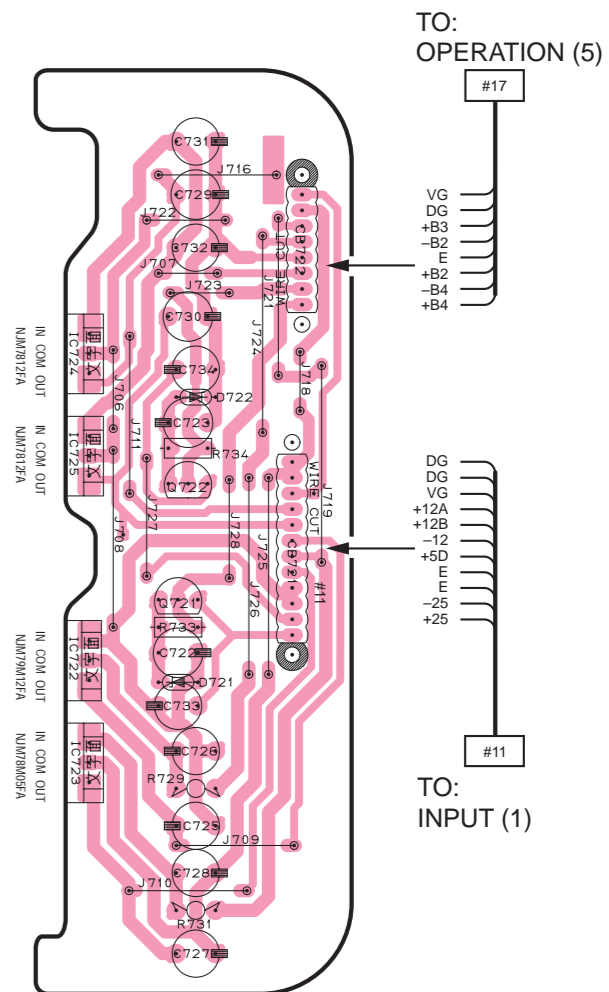

P. C. B. MAIN (8)

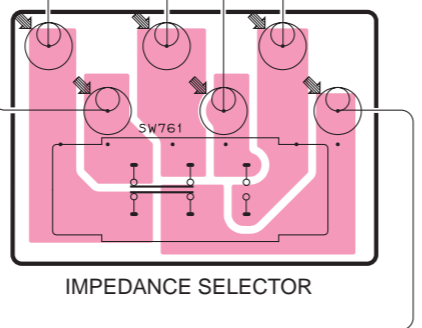

● Semiconductor Location

Ref. No.	Location	Ref. No.	Location	Ref. No.	Location
D501	E4	Q501	D2	Q513	E3
D502	D3	Q502	E2	Q514	E4
D503	E3	Q503	F2	Q515	F3
D721	G3	Q504	E2	Q516	F4
D722	G3	Q505	F2	Q517	E3
D751	A4	Q506	D3	Q518	E4
D762	C3	Q507	E3	Q519	F3
D763	C2	Q508	F3	Q520	F4
IC722	G3	Q509	E3	Q557	F4
IC723	G4	Q510	F3	Q721	G3
IC724	G3	Q511	D3	Q722	G3
IC725	G3	Q512	D4		

TO: IMAIN (1)

TO: OPERATION (5)

TO: INPUT (1)

PRINTED CIRCUIT BOARD (Foil side)

P. C. B. INPUT (1)

Semiconductor Location

Ref. No.	Location
D101	E2
D102	E3
D103	E2
D104	E3
IC101	F4
IC102	F4
IC103	E4
IC104	G2
IC105	F2
IC106	E2
IC107	D3
IC108	E4
IC109	E4
IC110	C3
IC111	D3
IC112	C4
IC113	D4
Q101	F4

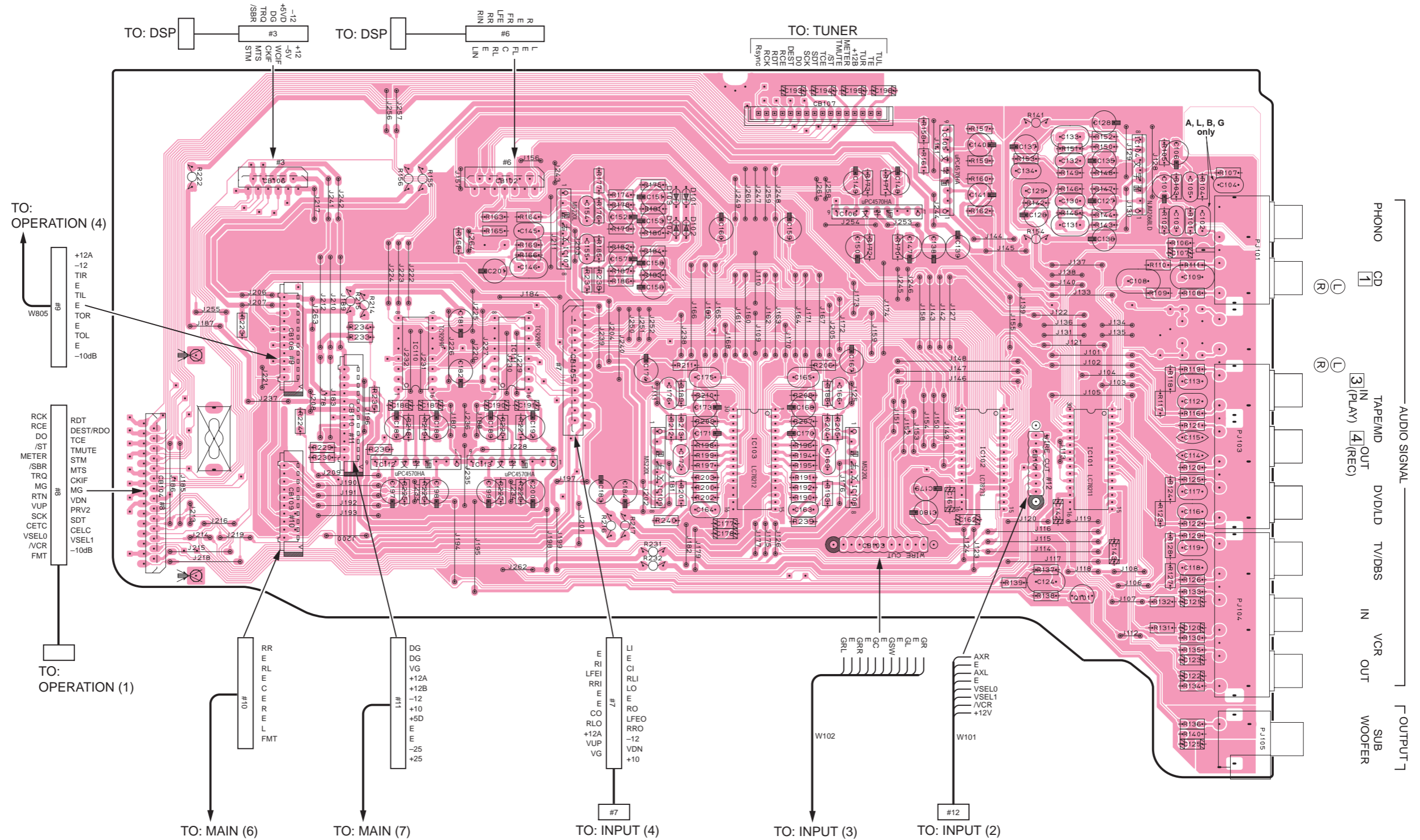

■ PRINTED CIRCUIT BOARD (Foil side)

1
2
3
4
5
6

P. C. B. INPUT (2)

P. C. B. INPUT (3)

P. C. B. INPUT (4)

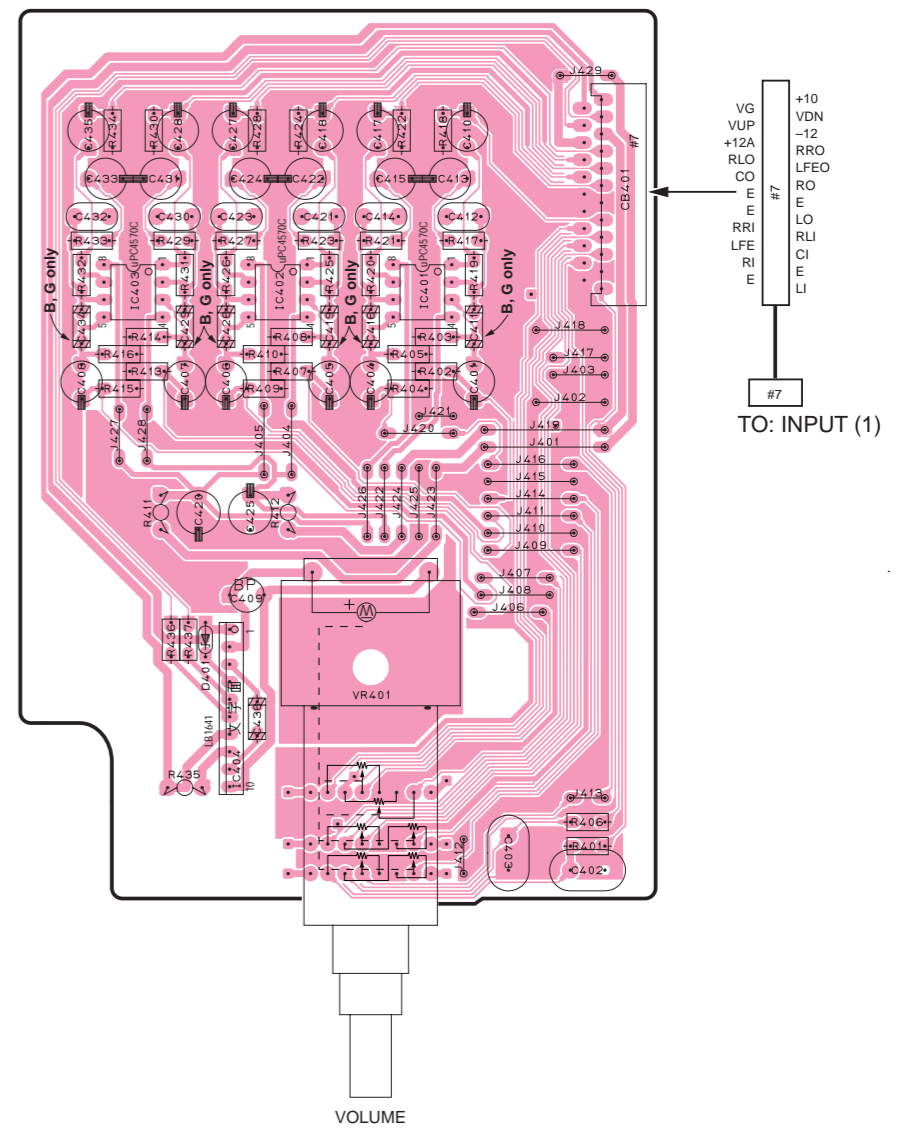
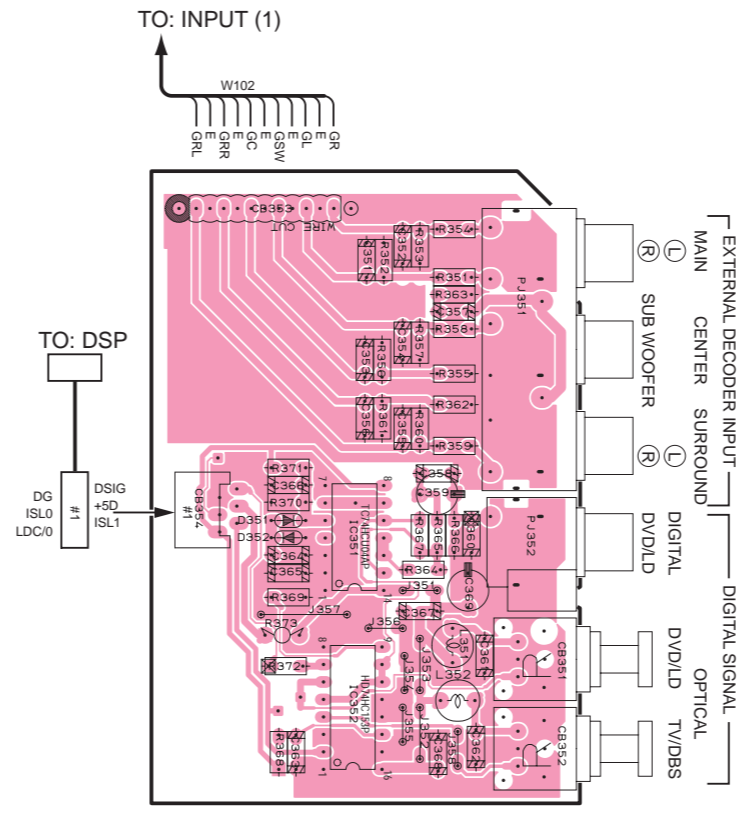
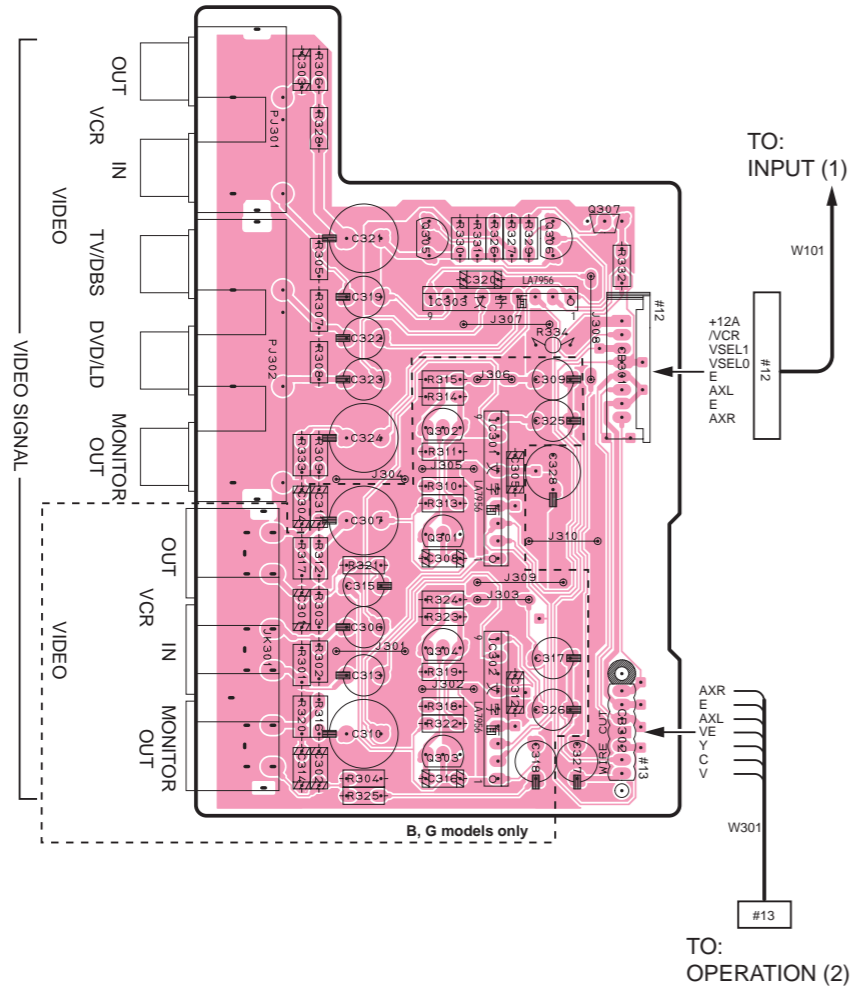

● Semiconductor Location

Ref. No.	Location	Ref. No.	Location
D351	D3	Q301	B3
D352	D3	Q302	B3
D401	F4	Q303	B4
IC301	B3	Q304	B4
IC302	B4	Q305	B3
IC303	B3	Q306	B3
IC351	D3	Q307	B3
IC352	D4		
IC401	G3		
IC402	F3		
IC403	F3		
IC404	F4		

■ SCHEMATIC DIAGRAM (INPUT)

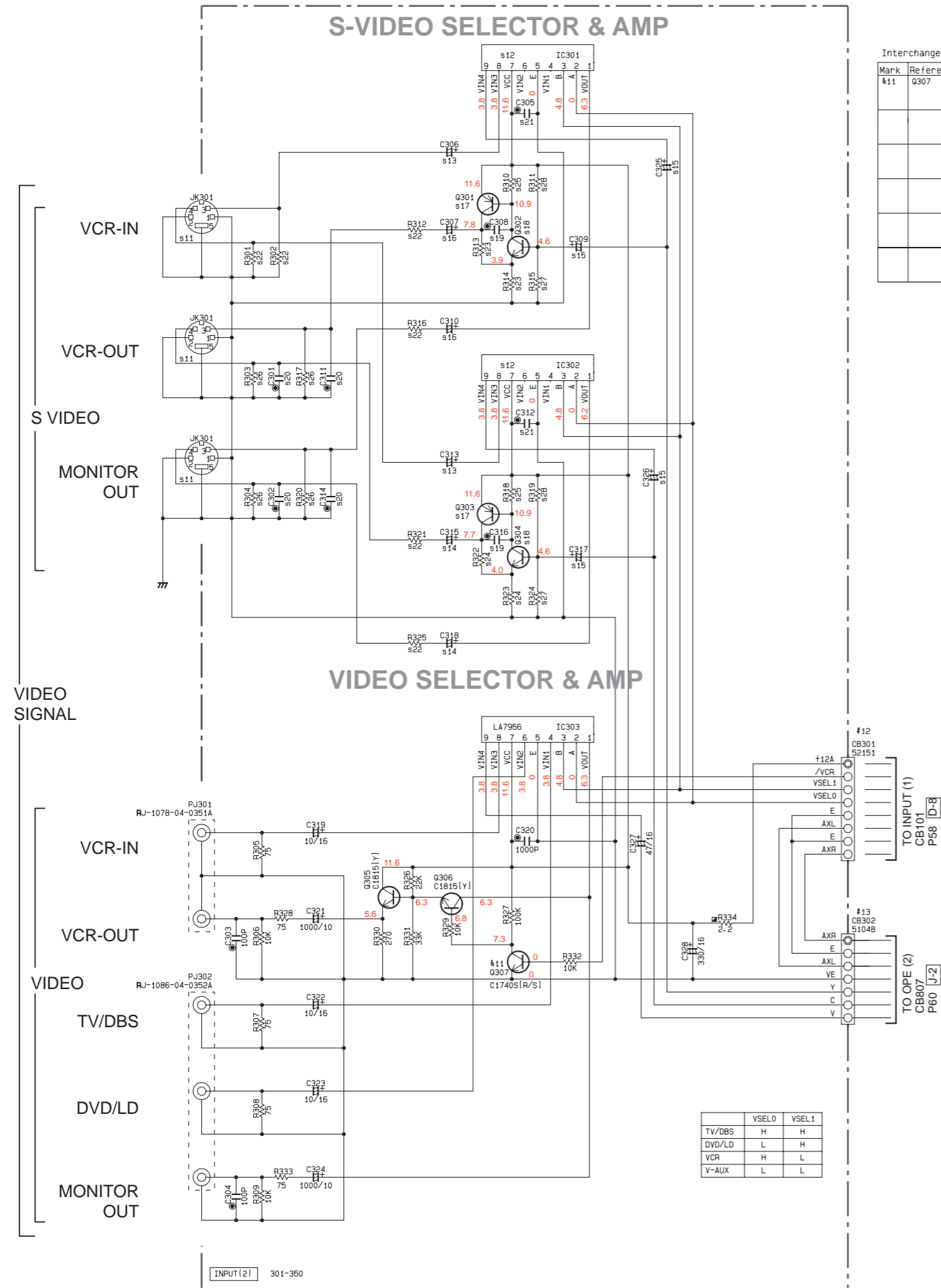

Interchangeable Parts at Manufacture-Stage

Mark	Reference Parts Number	Parts Name
#11	Q307	2SC1740S(R/S) 2SC26031E(F1) 2SC3311A(Q/R/S)

S	U-C-R-T	A-L	B-G
11	JK301	X	X
12	IC301-302	X	X
13	C306-313	X	X
14	C315-318	X	X
15	C309-317-325-326	X	X
16	C307-310	X	X
17	Q301-303	X	X
18	Q302-304	X	X
19	C308-316	X	X
20	C301-302-311-314	X	X
21	C305-312	X	X
22	R301-302-312-316-321-325	X	X
23	R313-314	X	X
24	R322-323	X	X
25	R310-318	X	X
26	R303-304-317-320	X	X
27	R315-324	X	X
28	R311-319	X	X

X: NOT USED

NOTICE (model)

- (J)..... JAPANESE
- (U)..... U. S. A
- (C)..... CANADIAN
- (R)..... GENERAL
- (A)..... AUSTRALIAN
- (B)..... BRITISH
- (G)..... EUROPEAN
- (T)..... CHINA
- (L)..... SINGAPORE

RESISTOR

REMARKS	PARTS NAME
NO MARK	CARBON FILM RESISTOR (P=5)
□	CARBON FILM RESISTOR (P=10)
△	METAL OXIDE FILM RESISTOR
▲	METAL FILM RESISTOR
⊠	METAL PLATE RESISTOR
⊞	FIRE PROOF CARBON FILM RESISTOR
⊞	CEMENT MOLDED RESISTOR
⊞	SEMI VARIABLE RESISTOR
■	CHIP RESISTOR

CAPACITOR

REMARKS	PARTS NAME
NO MARK	ELECTROLYTIC CAPACITOR
⊗	TANTALUM CAPACITOR
NO MARK	CERAMIC CAPACITOR
●	CERAMIC TUBULAR CAPACITOR
⊙	POLYESTER FILM CAPACITOR
○	POLYSTYRENE FILM CAPACITOR
⊖	MICA CAPACITOR
⊕	POLYPROPYLENE FILM CAPACITOR
⊕	SEMICONDUCTIVE CERAMIC CAPACITOR
⊕	POLYPHENYLENE SULFIDE FILM CAPACITOR

IC301~303 : LA7956
Video Switch

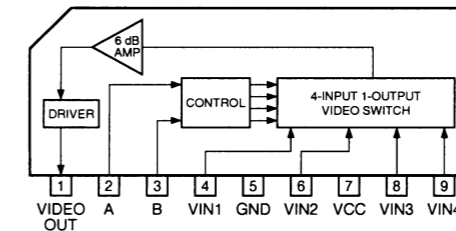

PIN CONNECTION DIAGRAM OF TRANSISTORS AND IC's.

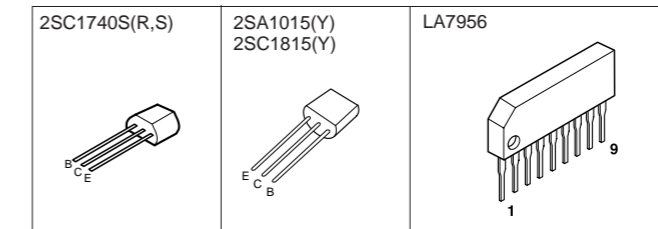

Conditions (RX-V595RDS)

- INPUT → CD
- VOLUME → minimum(-∞)
- IMPEDANCE
- SELECTOR → Upper
- PRO LOGIC → On

- ★ All voltages are measured with a 10MΩ/V DC electric volt meter.
- ★ Components having special characteristics are marked △ and must be replaced with parts having specifications equal to those originally installed.
- ★ Schematic diagram is subject to change without notice.

SCHEMATIC DIAGRAM (INPUT)

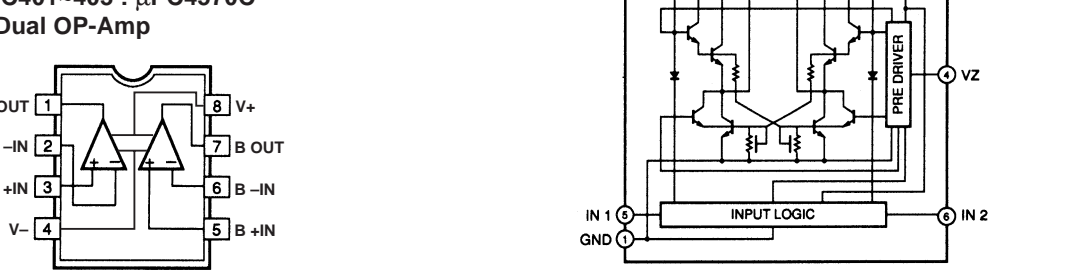
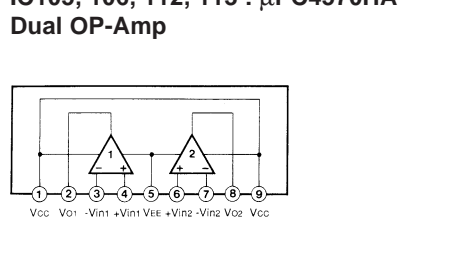
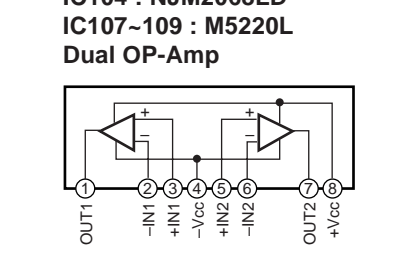
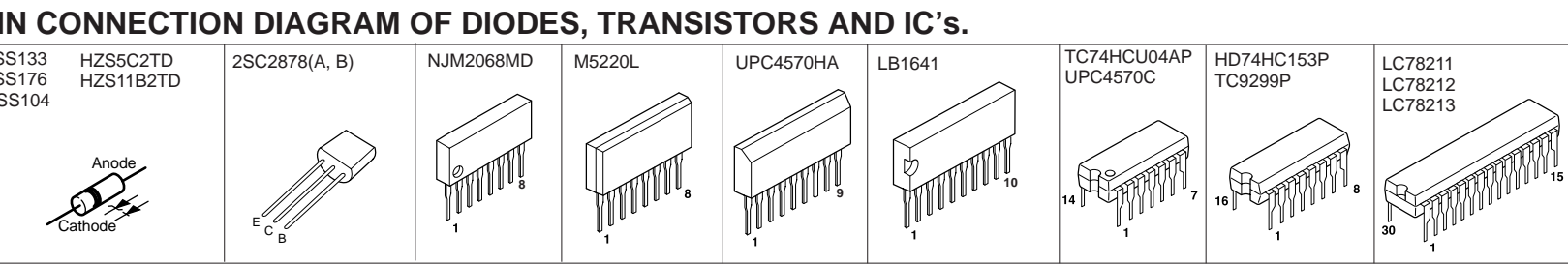
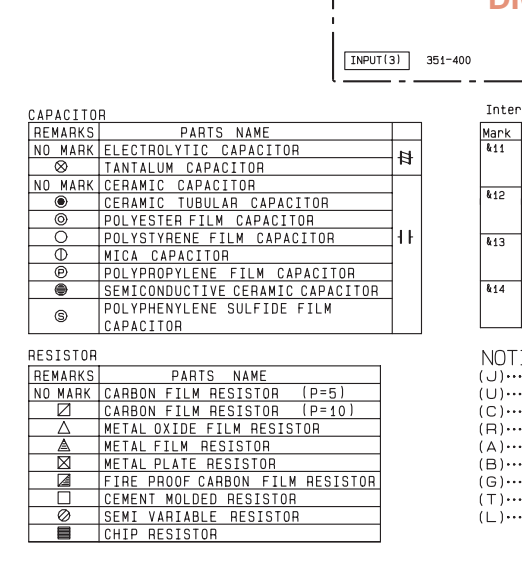
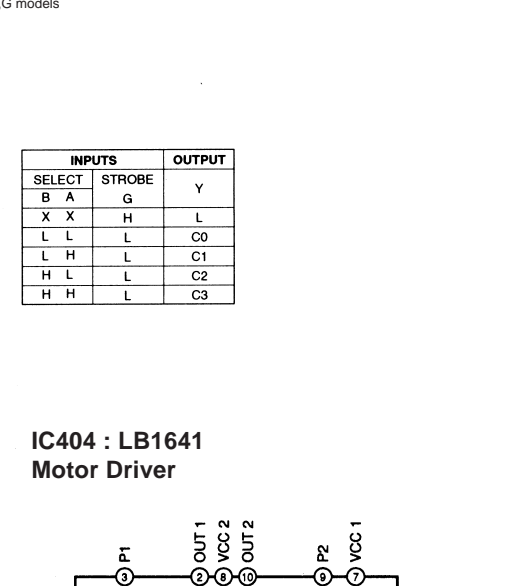
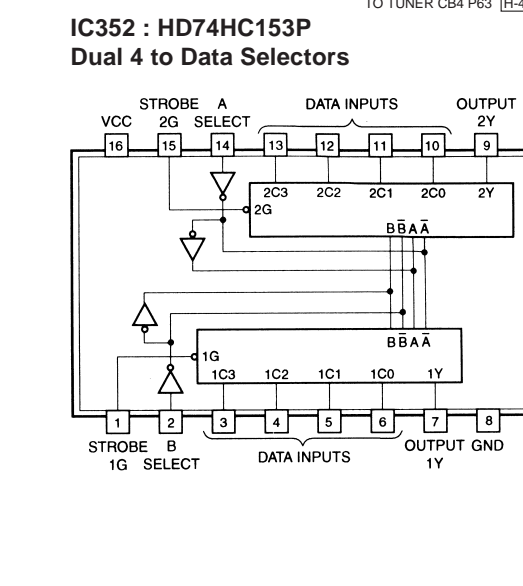
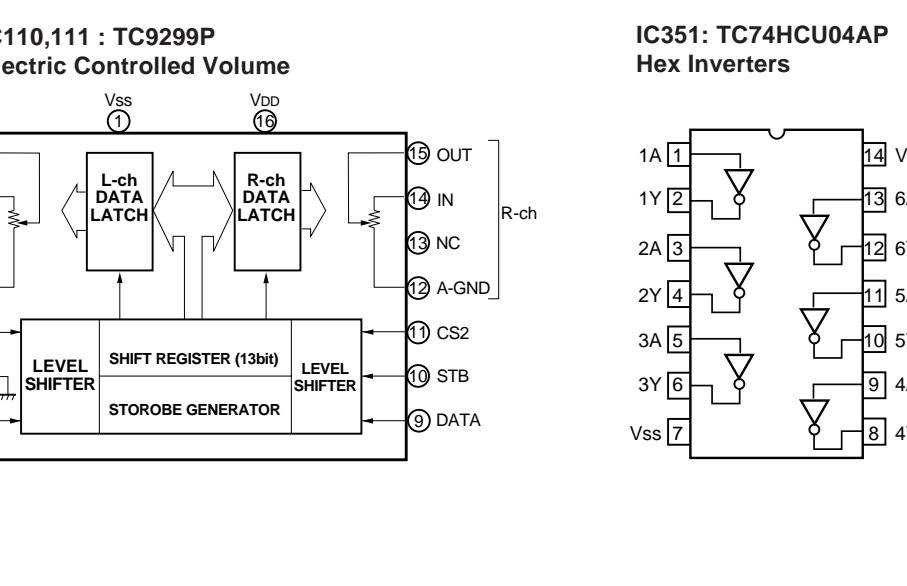
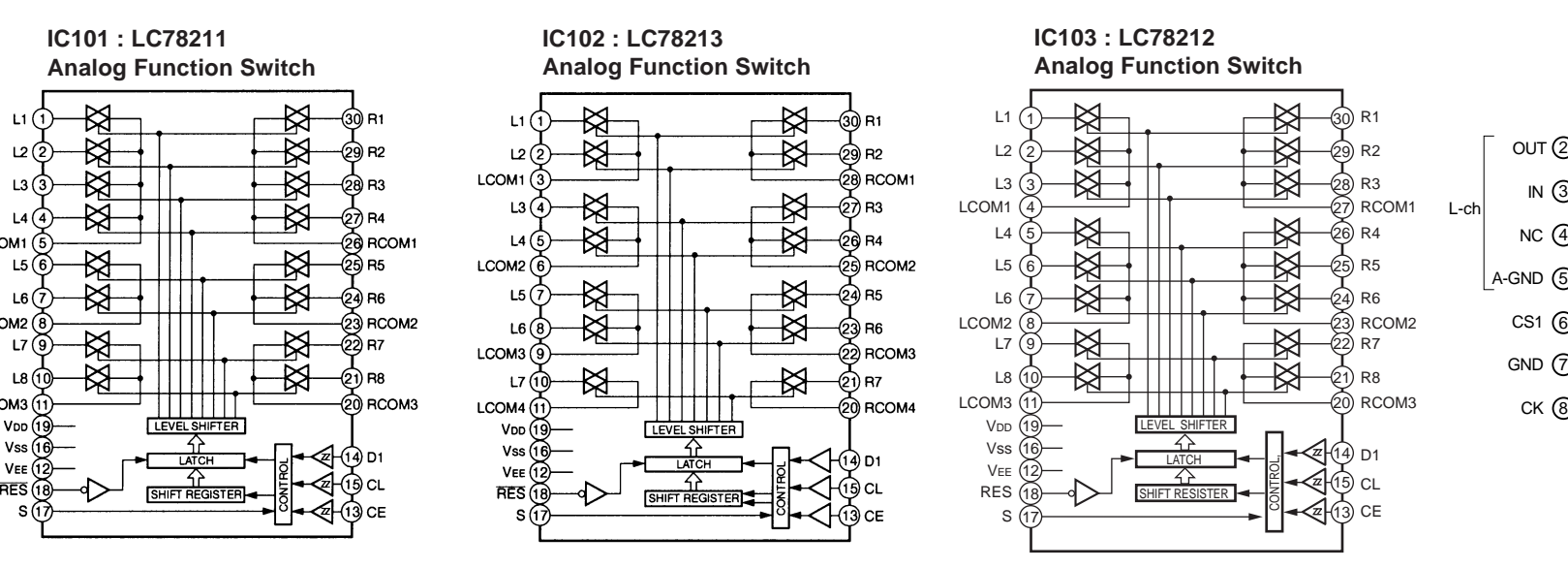
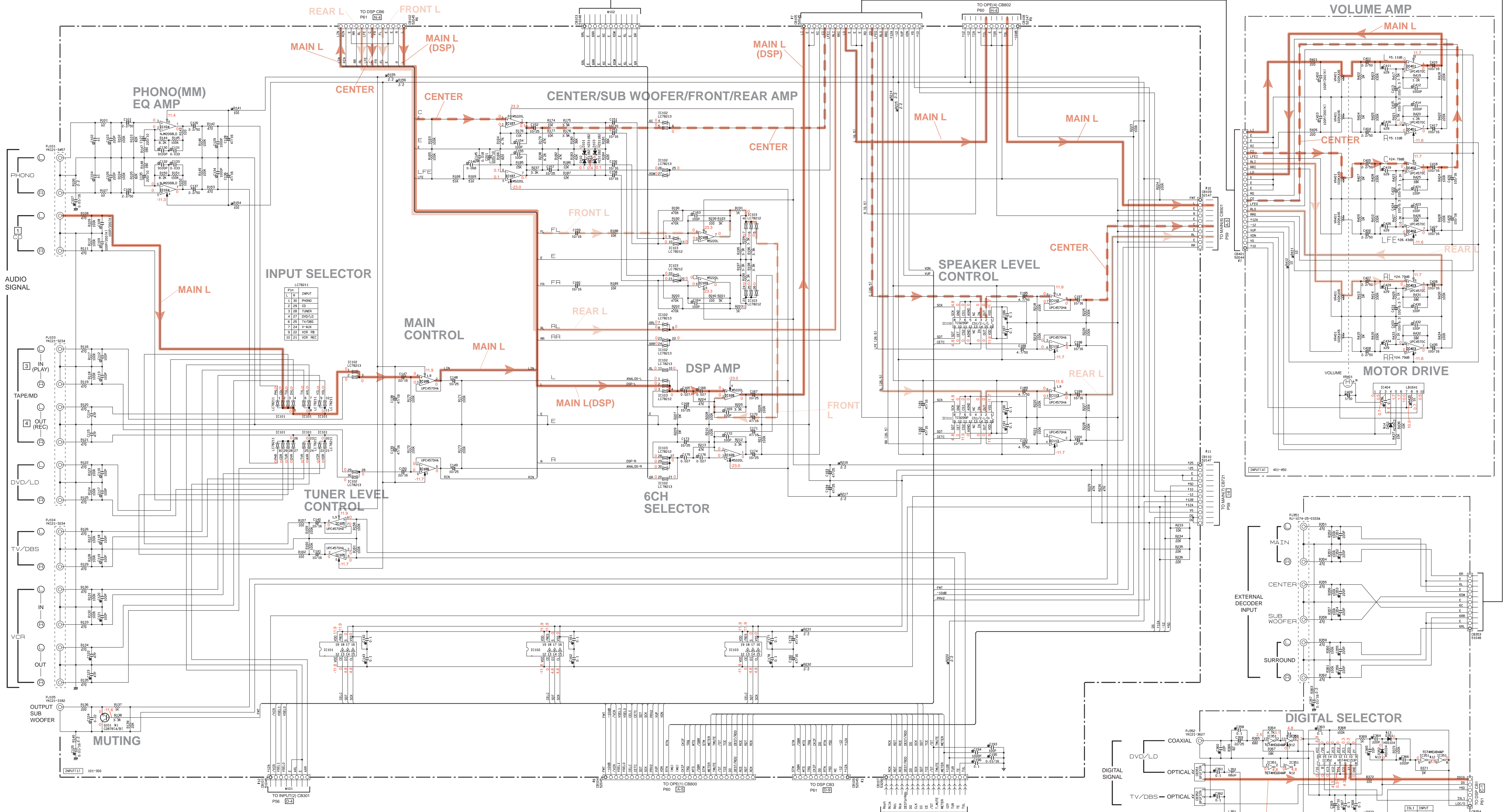

CAPACITOR		PARTS NAME	
NO MARK	ELECTROLYTIC CAPACITOR	NO MARK	CARBON FILM RESISTOR (P±5)
NO MARK	TANTALUM CAPACITOR	⊖	CARBON FILM RESISTOR (P±10)
NO MARK	CERAMIC CAPACITOR	⊙	METAL OXIDE FILM RESISTOR
⊙	POLYESTER FILM CAPACITOR	⊖	METAL FILM RESISTOR
⊙	POLYSTYRENE FILM CAPACITOR	⊖	FIBRE PROOF CARBON FILM RESISTOR
⊙	MYLA CAPACITOR	⊖	CEMENT WOUND RESISTOR
⊙	POLYPROPYLENE FILM CAPACITOR	⊖	SEMI-VARIABLE RESISTOR
⊙	SEMICONDUCTIVE CERAMIC CAPACITOR	⊖	CHIP RESISTOR
⊙	POLYPHENYLENE SULFONE FILM CAPACITOR		

RESISTOR		PARTS NAME	
NO MARK	CARBON FILM RESISTOR (P±5)	U	U.S.A.
⊖	CARBON FILM RESISTOR (P±10)	C	CANADIAN
⊖	METAL OXIDE FILM RESISTOR	⊖	GENERAL
⊖	METAL FILM RESISTOR	A	AUSTRALIAN
⊖	FIBRE PROOF CARBON FILM RESISTOR	B	BRITISH
⊖	CEMENT WOUND RESISTOR	G	EUROPEAN
⊖	SEMI-VARIABLE RESISTOR	T	CHINA
⊖	CHIP RESISTOR	J	JAPANESE
		L	TAIWANESE

Interchangeable Parts at Manufacture Stage			
Part No.	Part Name	Part No.	Part Name
M1	3307	X	100P
M2	33K1	X	100P
M3	33K1	X	100P
M4	33K1	X	100P

NOTICE (model)

- U..... U.S.A.
- C..... CANADIAN
- ⊖..... GENERAL
- A..... AUSTRALIAN
- B..... BRITISH
- G..... EUROPEAN
- T..... CHINA
- J..... JAPANESE
- L..... TAIWANESE

Conditions (RX-V595RDS)

- INPUT → CD
- VOLUME → minimum(∞)
- IMPEDANCE SELECTOR → Upper
- PRO LOGIC → On

All voltages are measured with a 10MΩ/V DC electric volt meter.
 Components having special characteristics are marked with a triangle and must be replaced with parts having specifications equal to those originally installed.
 Schematic diagram is subject to change without notice.

SCHEMATIC DIAGRAM (MAIN)

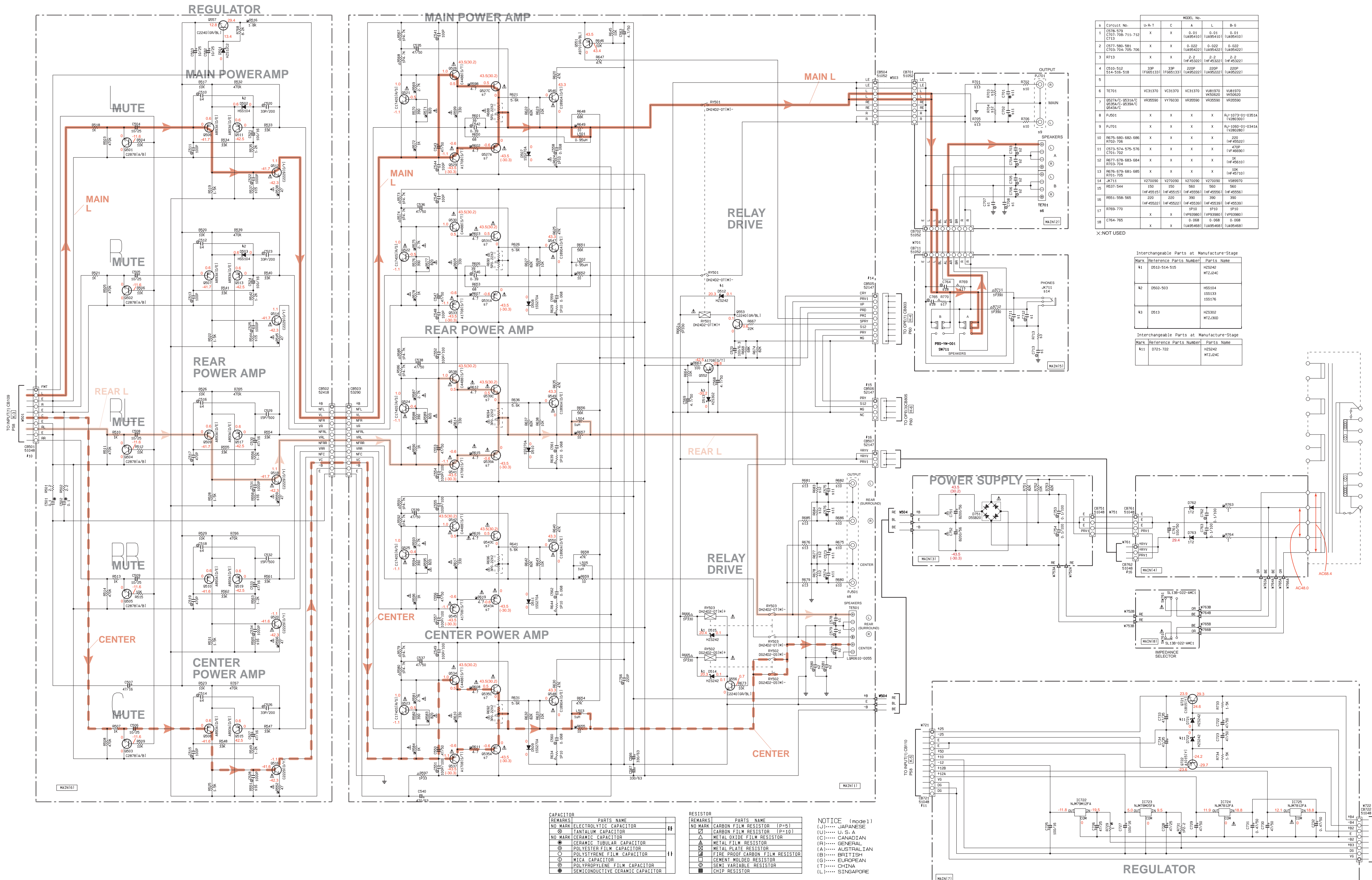

IC/Part No.	U-R-T	C	A	L	B-S
1 C576 576	X	X	0.01	0.01	0.01
2 C711 709-711-712	X	X	10K941	10K941	10K941
3 C712 709-711-712	X	X	0.02	0.02	0.02
4 C713 709-711-712	X	X	10K942	10K942	10K942
5 D510-511 514-516-518	X	X	3P	2P	2P
6 T501	X	X	10K943	10K943	10K943
7 W501A/C W501B/C W501C/C W501D/C	X	X	W501A	W501B	W501C
8 P501	X	X	X	X	X
9 P501	X	X	X	X	X
10 R501 680-680-680 R502 700	X	X	X	X	X
11 C573 574-575-576 R503 700	X	X	X	X	X
12 R577 678-681-684 R578 700	X	X	X	X	X
13 R579 678-681-685 R580 700	X	X	X	X	X
14 R581 680-680-680 R582 700	X	X	X	X	X
15 R583 544 R584 500 R585 500 R586 500	X	X	X	X	X
16 R587 500 R588 500 R589 500 R590 500	X	X	X	X	X
17 R591 770 R592 770 R593 770 R594 770	X	X	X	X	X
18 C764 765	X	X	0.068	0.068	0.068

X: NOT USED

Interchangeable Parts at Manufacture Stage		
Mark	Reference Parts Number	Parts Name
41	D510-514-515	HES42
		WZJ24C
42	D503-503	HES54
		LS533
		LS576
43	D513	HES302
		WZJ300

Interchangeable Parts at Manufacture Stage		
Mark	Reference Parts Number	Parts Name
41	D721-722	HES42
		WZJ24C

CAPACITOR	
(E)	NO MARK ELECTROLYTIC CAPACITOR
(T)	TANTALUM CAPACITOR
(C)	NO MARK CERAMIC CAPACITOR
(K)	CERAMIC TUBULAR CAPACITOR
(P)	POLYESTER FILM CAPACITOR
(S)	POLYSTYRENE FILM CAPACITOR
(M)	MICA CAPACITOR
(F)	POLYPROPYLENE FILM CAPACITOR
(G)	SEMICONDUCTIVE CERAMIC CAPACITOR

RESISTOR	
(J)	NO MARK CARBON FILM RESISTOR (P/R)
(K)	CARBON FILM RESISTOR (P/R)
(A)	METAL OXIDE FILM RESISTOR
(R)	METAL FILM RESISTOR
(M)	METAL PLATE RESISTOR
(F)	FILM PROOF CARBON FILM RESISTOR
(C)	CEMENT MOLDED RESISTOR
(V)	SEM VARIABLE RESISTOR
(S)	CHIP RESISTOR

NOTICE (mode1)
 (J)..... JAPANESE
 (U)..... U. S. A.
 (C)..... CANADIAN
 (R)..... GENERAL
 (A)..... AUSTRALIAN
 (B)..... BRITISH
 (G)..... EUROPEAN
 (T)..... CHINA
 (L)..... SINGAPORE

PIN CONNECTION DIAGRAM OF DIODES, TRANSISTORS AND IC'S.

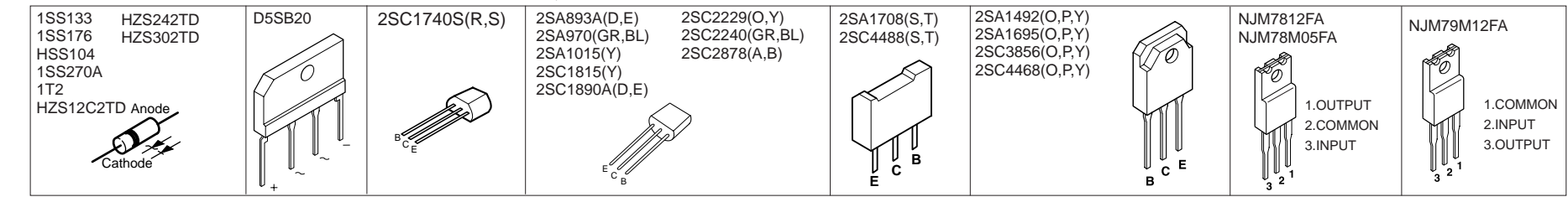

Conditions (RX-V595RDS)
 • INPUT → CD
 • VOLUME → minimum(←)
 • IMPEDANCE SELECTOR → Upper
 • PRO LOGIC → On

• All voltages are measured with a 10MΩ/V DC electric volt meter.
 • Components having special characteristics are marked with a triangle and must be replaced with parts having specifications equal to those originally installed.
 • Schematic diagram is subject to change without notice.

SCHEMATIC DIAGRAM (OPERATION)

IC801, 802 : NJM2068LD Dual OP-Amp • IC800 → See page 26-28, IC DATA

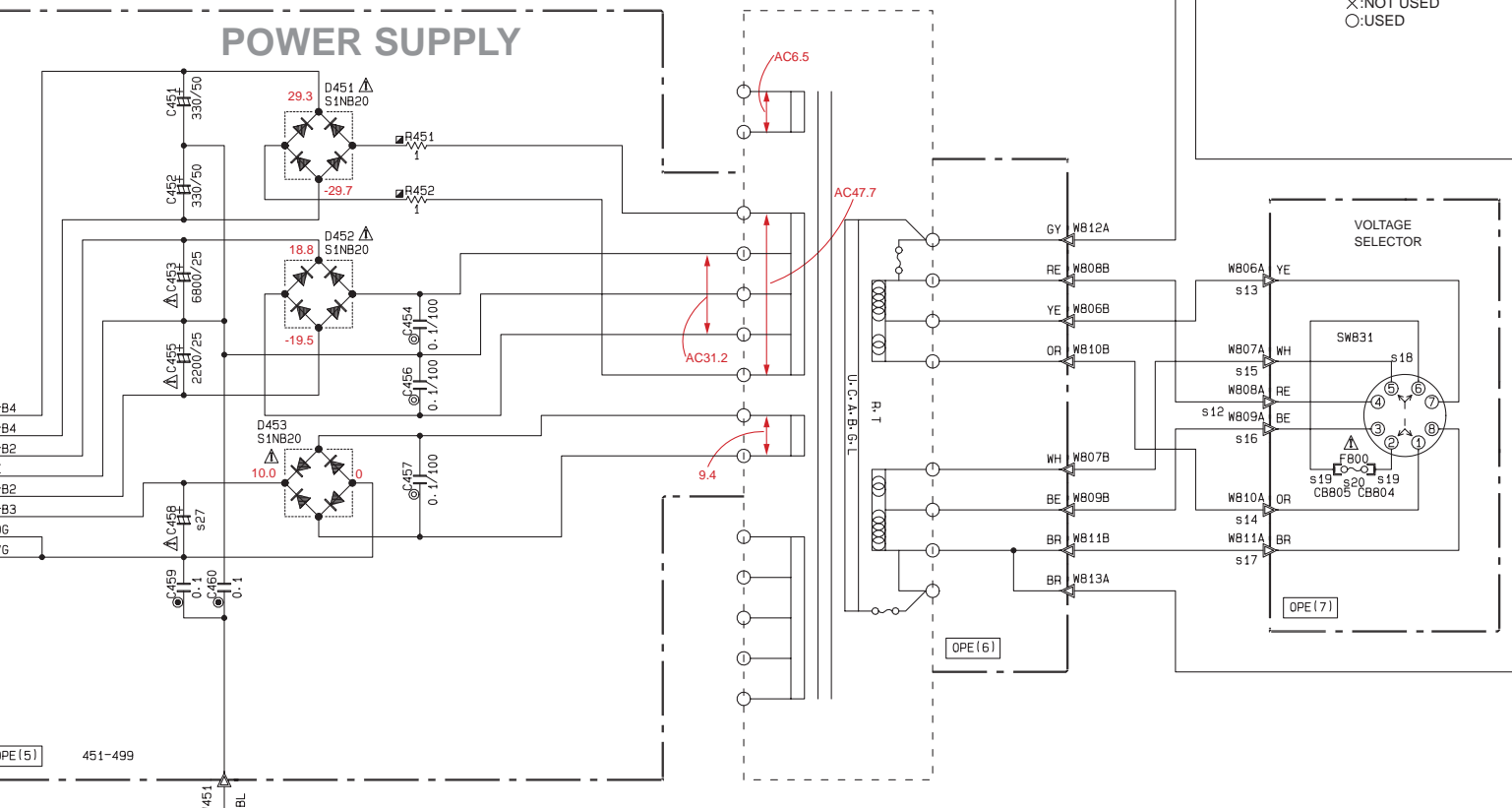
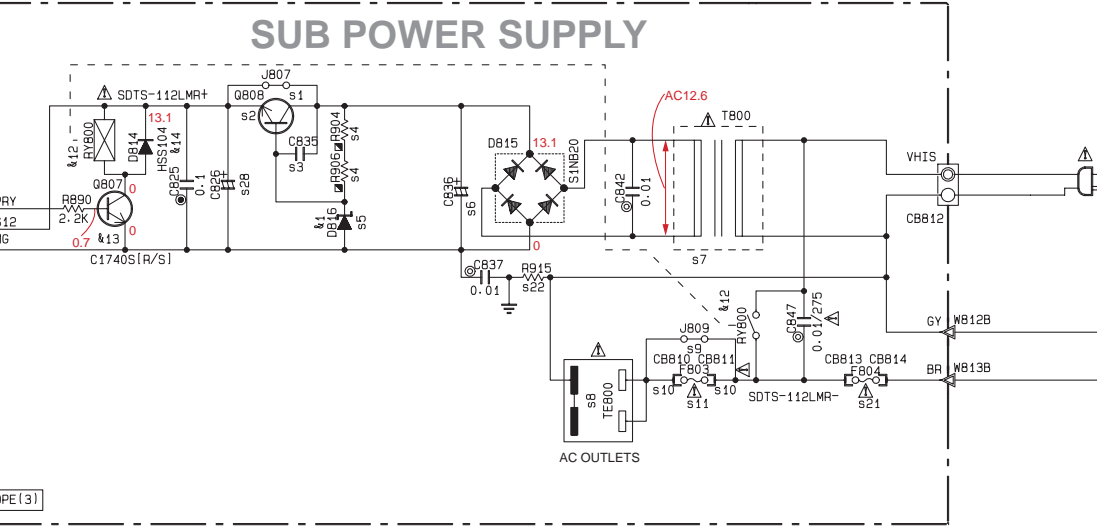
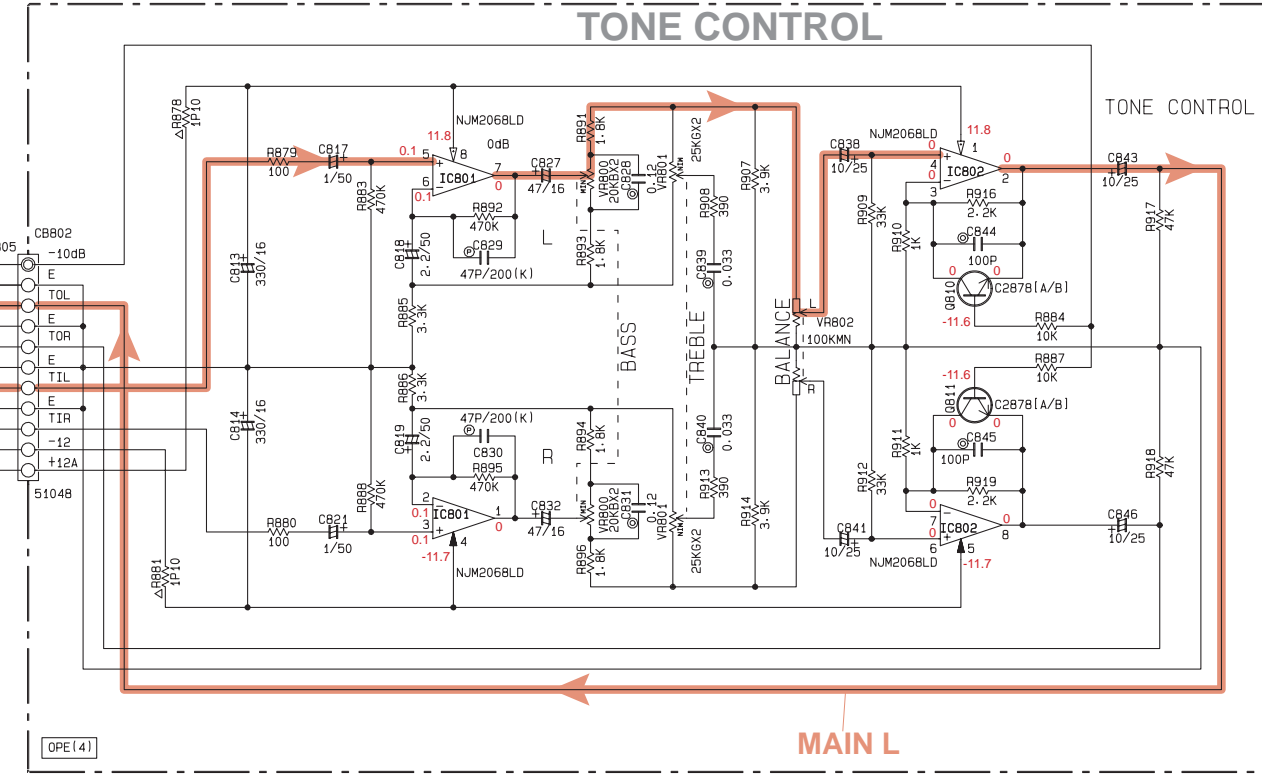
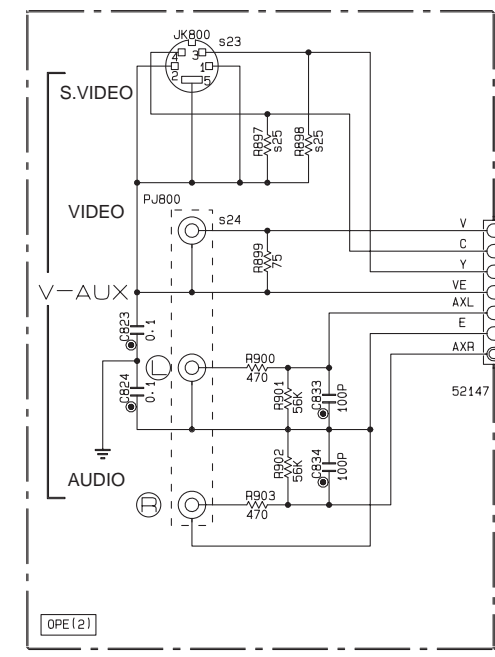
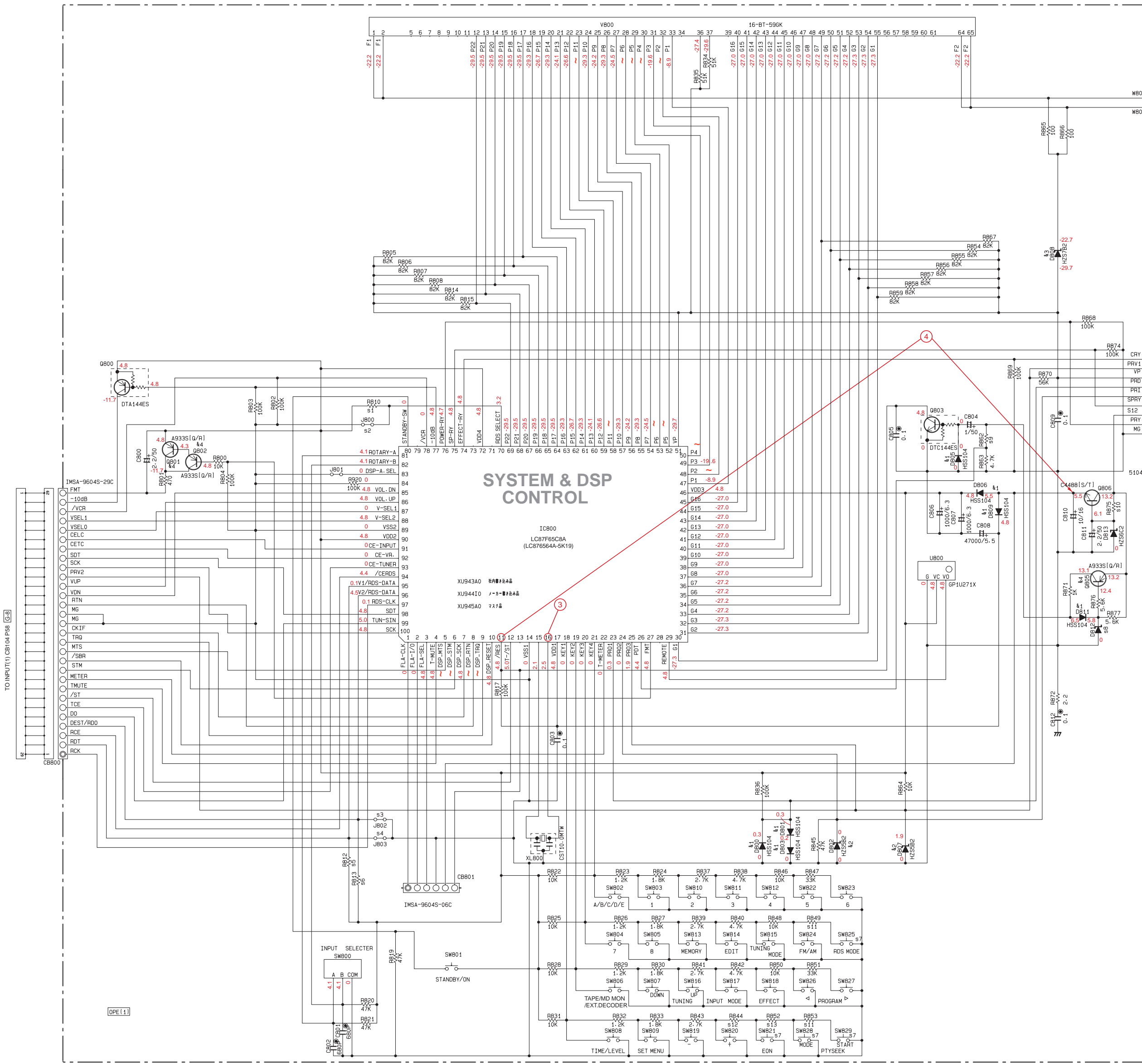
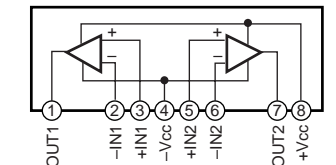

OPED123(4)

Mark	Reference Parts Number	Parts Name
811		
812	RY800	S075-115JNR D0101-01M11 ALX531
813	8807	ES17401(R/S) 25C8031E/F1 25C8031A(G/R/S)
814	8814	H5514 15S13 15S176

	U-C	A-T	A	B	G	L
81	J807	0	X	0	0	0
82	8808	X	D0391(J/W)	X	X	X
83	CB35	X	100P F651310	X	X	X
84	R004-806	X	5.6K W7606	X	X	X
85	DB16	X	H2518270 V97530	X	X	X
86	CB36	X	4.7/100 U69647	X	X	X
87	T800	XC083	XT331	XC084	XC084	XC084
88	TE800	VU54310	VU54310	VU54330	VU54340	VU54340
89	J809	0	0	0	0	X
90	CB810-811	X	X	X	X	VF20050 VF20050
91	F803	X	X	X	X	V194290 V194290
92	W808	X	MH02030	X	X	X
93	W806	X	MH04030	X	X	X
94	W810	X	MH03030	X	X	X
95	W807	X	MH09030	X	X	X
96	W809	X	MH06030	X	X	X
97	W811	X	MH10030	X	X	X
98	W831	X	VAN180	X	X	X
99	CB804-805	X	VP20050	X	X	X
900	F800	X	T4.0A/250V K800079	X	X	X
921	F804	BA129V V82330	BA129V V82330	T4.0A/250V K800079	T4.0A/250V K800079	T4.0A/250V K800079
922	R815	1/2PD-2M H630922	X	X	X	X
923	J800	X	X	X	V258290	V258290
924	FL800	VV8270	VV8270	VV8270	VV82510	VV82510
925	R807-808	X	X	X	75 HF45475	75 HF45475
926	W815	MF00407	MF00416	MF00407	MF00407	MF00407
927	C458	4700/25 U73447	10000/16 U73410	10000/16 U73410	10000/16 U73410	10000/16 U73410
928	CB26	330/25 UR4833	220/25 UR4833	330/25 UR4833	330/25 UR4833	330/25 UR4833

RESISTOR

REMARKS	PARTS NAME
NO MARK	CARBON FILM RESISTOR (P=5)
□	CARBON FILM RESISTOR (P=10)
△	METAL OXIDE FILM RESISTOR
▲	METAL FILM RESISTOR
■	METAL PLATE RESISTOR
⊗	FIRE PROOF CARBON FILM RESISTOR
⊙	CEMENT MOLDED RESISTOR
⊕	SEM. VARIABLE RESISTOR
⊖	CHIP RESISTOR

CAPACITOR

REMARKS	PARTS NAME
NO MARK	ELECTROLYTIC CAPACITOR
NO MARK	TANTALUM CAPACITOR
□	CERAMIC CAPACITOR
○	POLYESTER FILM CAPACITOR
○	POLYSTYRENE FILM CAPACITOR
○	MYLAR CAPACITOR
○	POLYPROPYLENE FILM CAPACITOR
○	SEMICONDUCTIVE CERAMIC CAPACITOR
○	POLYPHENYLENE SULFIDE FILM CAPACITOR

NOTICE (mode1)
 (J)..... JAPANESE
 (U)..... U.S.A.
 (C)..... CANADIAN
 (Q)..... GENERAL
 (R)..... AUSTRALIAN
 (B)..... BRITISH
 (G)..... EUROPEAN
 (T)..... CHINA
 (L)..... SINGAPORE

Point ③
 (Pin 16 of IC800)
 V : 2V/div H : 50nsec/div
 AC range 1 : 1 probe

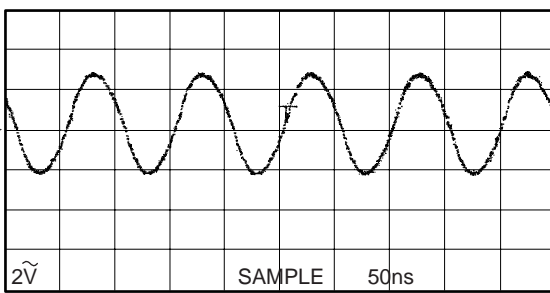

Point ④
 (CH1 : Pin 11 of IC800
 CH2 : Emitter of Q806)
 V : 2V/div H : 0.5sec/div
 DC range 1 : 1 probe

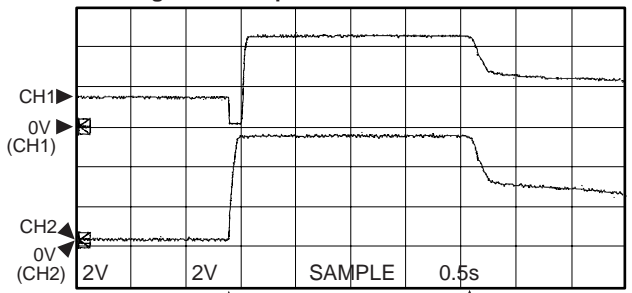

With the POWER switch turned ON, connect the power cord from the AC outlet.
 Disconnect the power cord from the AC outlet.
 (This waveform is not available by pushing the power switch ON and OFF.)

OPED10

Mark	Reference Parts Number	Parts Name
81	8800-801,803,805,806,809,811	H55104 15S133 15S176
82	8800-807	H25989 M124-7C
83	8808	H23783 M121-5A
84	8801-802,805	S249331(G/R) S241151(F) S241361(G/R/S)

	U-C	R-T	A-L	B-G
81	R810	X	X	X
82	J800	0	0	X
83	J802	X	X	X
84	J803	0	X	X
85	R812	X	100K HF45810	X
86	R813	100K HF45810	100K HF45810	X
87	SW801-805,808,809	X	X	X
88	DB12	H2574270 V97460	H2568070 V97440	H2574270 V97460
89	R802	2.2K HF45622	1.5K HF45615	2.2K HF45622
90	R875	2.2K HF45622	1.5K HF45615	2.2K HF45622
91	R849-R853	X	X	X
92	R844	X	X	X
93	R852	X	X	X

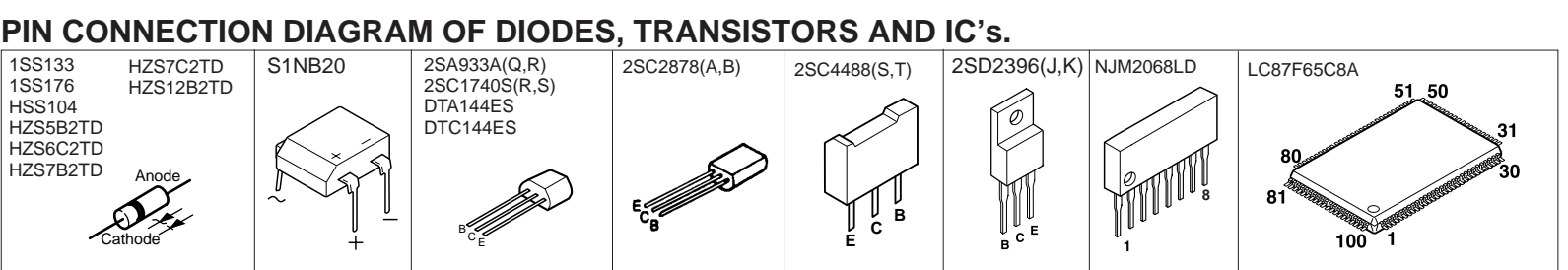

* All voltages are measured with a 10MΩ/V DC electric volt meter.
 * Components having special characteristics are marked with a triangle and must be replaced with parts having specifications equal to those originally installed.
 * Schematic diagram is subject to change without notice.

SCHEMATIC DIAGRAM (DSP)

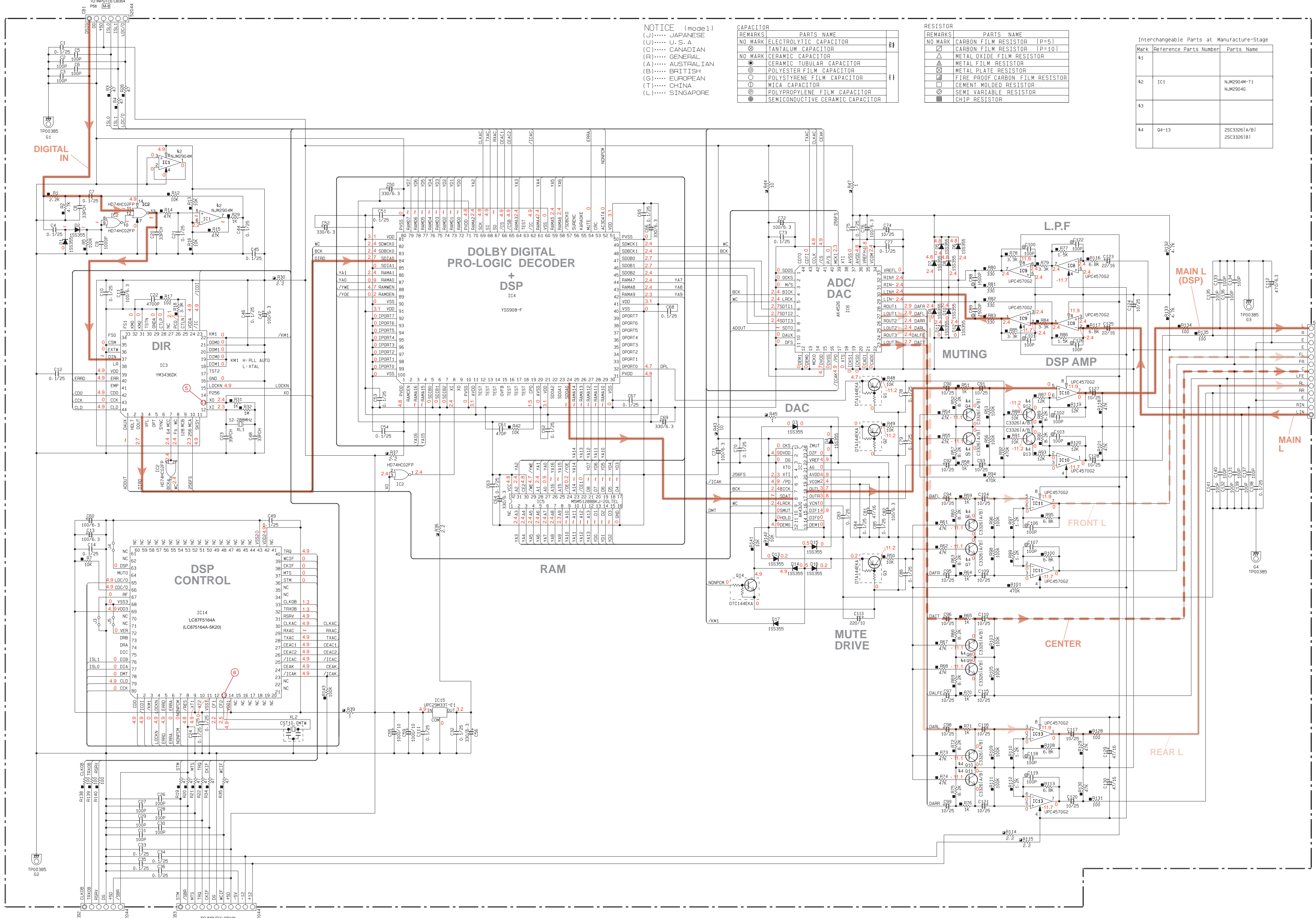

NOTICE (model)
 (J)..... JAPANESE
 (U)..... U. S. A.
 (C)..... CANADIAN
 (R)..... GENERAL
 (A)..... AUSTRALIAN
 (B)..... BRITISH
 (G)..... EUROPEAN
 (T)..... CHINA
 (L)..... SINGAPORE

REMARKS	PARTS NAME
NO MARK	ELECTROLYTIC CAPACITOR
⊗	TANTALUM CAPACITOR
⊙	CERAMIC CAPACITOR
⊚	CERAMIC TUBULAR CAPACITOR
⊖	POLYESTER FILM CAPACITOR
⊕	POLYSTYRENE FILM CAPACITOR
⊘	MICA CAPACITOR
⊙	POLYPROPYLENE FILM CAPACITOR
⊚	SEMICONDUCTIVE CERAMIC CAPACITOR

REMARKS	PARTS NAME
NO MARK	CARBON FILM RESISTOR [P=5]
⊖	CARBON FILM RESISTOR [P=10]
⊚	METAL OXIDE FILM RESISTOR
⊖	METAL FILM RESISTOR
⊕	METAL PLATE RESISTOR
⊖	FIRE PROOF CARBON FILM RESISTOR
⊚	CEMENT MOLDED RESISTOR
⊖	SEMI VARIABLE RESISTOR
⊚	CHIP RESISTOR

Interchangeable Parts at Manufacture-Stage

Mark	Reference Parts Number	Parts Name
K1		
K2	IC1	NJM2904M-T1 NJM2904G
K3		
K4	04-13	25C33261A/01 25C33261B1

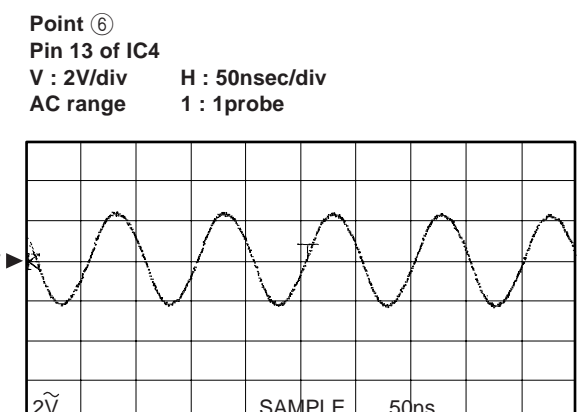
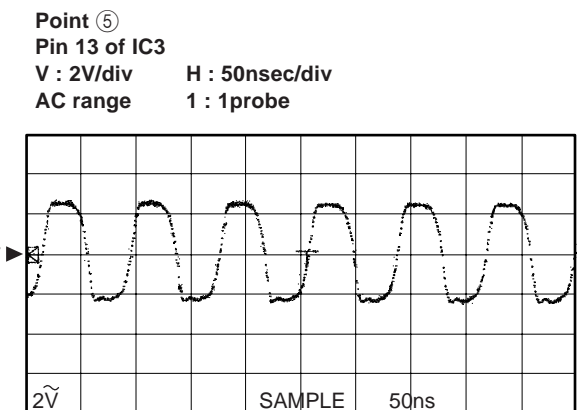

IC1 : NJM2904M
 IC8-13 : uPC4570G2
 Dual OP AMP

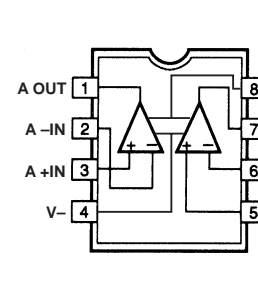

IC2 : HD74HC02FP
 Quad 2 Input NOR

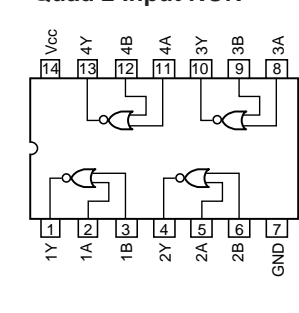

IC7 : AK4320
 1 bit D/A Converter

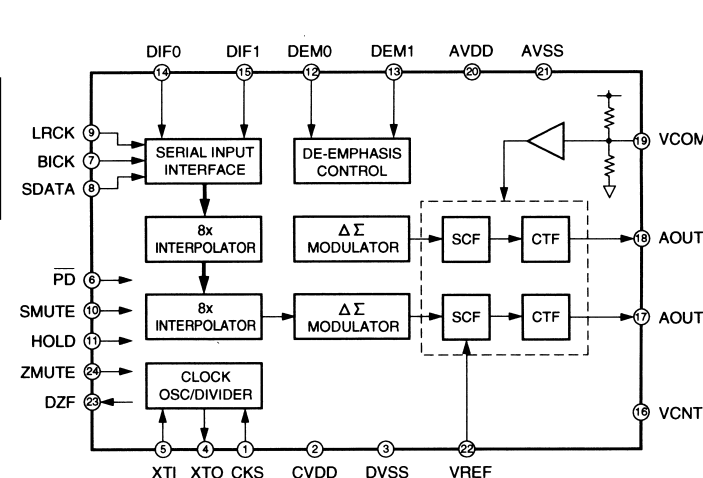

* IC3-6, 14 → See page 29-35, IC DATA

PIN CONNECTION DIAGRAM OF DIODES, TRANSISTORS AND IC's.

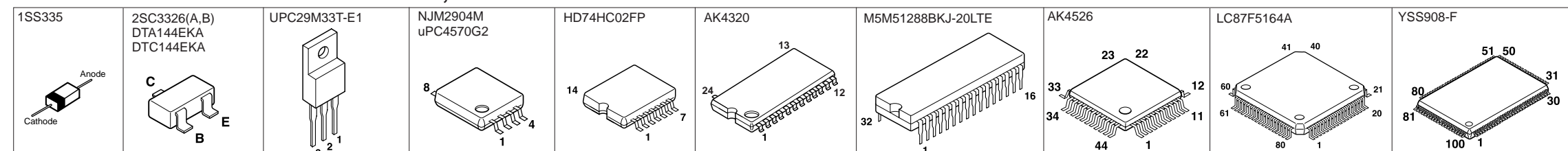

Conditions (RX-V595RDS)

- INPUT → CD
- VOLUME → minimum(←)
- IMPEDANCE →
- SELECTOR → Upper
- PRO LOGIC → On

* All voltages are measured with a 10MΩ/V DC electric volt meter.
 * Components having special characteristics are marked Δ and must be replaced with parts having specifications equal to those originally installed.
 * Schematic diagram is subject to change without notice.

■ SCHEMATIC DIAGRAM (TUNER) U, C, R, T, A and L models

Each voltage given here represents that in the FM (98.1MHz STEREO) reception mode but the one in the parentheses () is that in the AM (1080kHz, MAN'L) reception mode.

REMARKS	PARTS NAME	SYMBOL
NO MARK	ELECTROLYTIC CAPACITOR	\square
NO MARK	TANTALUM CAPACITOR	\square
NO MARK	CERAMIC CAPACITOR	\square
○	CERAMIC TUBULAR CAPACITOR	\square
○	POLYESTER FILM CAPACITOR	\square
○	POLYSTYRENE FILM CAPACITOR	\square
○	MICA CAPACITOR	\square
○	POLYPROPYLENE FILM CAPACITOR	\square
○	SEMICONDUCTIVE CERAMIC CAPACITOR	\square

REMARKS	PARTS NAME	SYMBOL
NO MARK	CARBON FILM RESISTOR (P=5)	\square
□	CARBON FILM RESISTOR (P=10)	\square
△	METAL OXIDE FILM RESISTOR	\square
△	METAL FILM RESISTOR	\square
△	METAL PLATE RESISTOR	\square
△	FIRE PROOF CARBON FILM RESISTOR	\square
□	CEMENT MOLDED RESISTOR	\square
□	SEMI VARIABLE RESISTOR	\square
□	CHIP RESISTOR	\square

NOTICE (model)
 (J)..... JAPANESE
 (U)..... U. S. A
 (C)..... CANADIAN
 (R)..... GENERAL
 (A)..... AUSTRALIAN
 (B)..... BRITISH
 (G)..... EUROPEAN
 (T)..... CHINA
 (L)..... SINGAPORE

Mark	Reference Parts Number	Parts Name
41	D1-2	HSS104 1SS133 1SS176

S	U-C	R-T	A-L
1	PK1	V290910	V290910
2	R4B		4.7K
3	T3		XYA2 V148680
4	J41		
5	C49	2200P UA95322	2200P UA95322
6	R50	22K	22K
7	C36-37	1000P UA95310	1000P UA95310
8	R36-37	75K	75K
9	SW1		V560260
10	J42		
11	R56	100	100
12	R55-57, 58, 60		270K

○:USED
 □:NOT USED

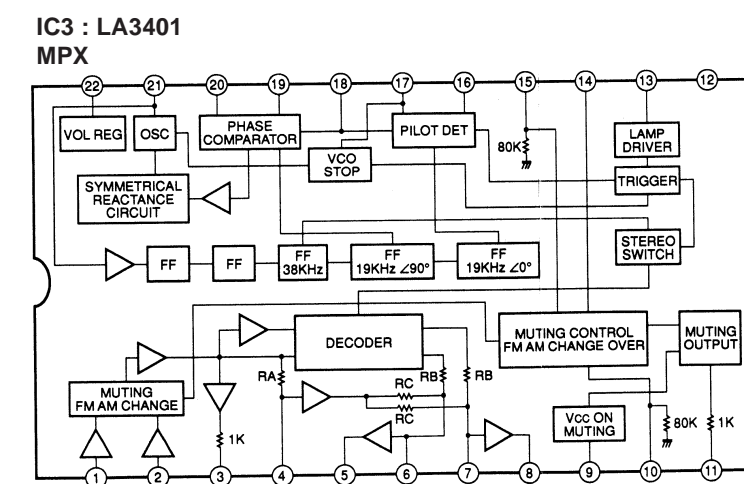
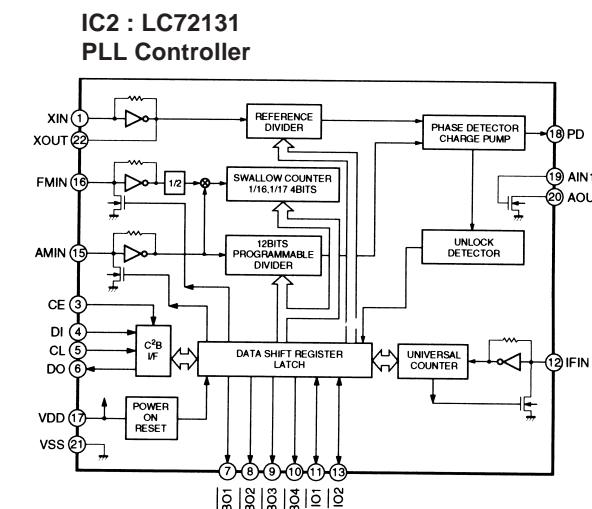
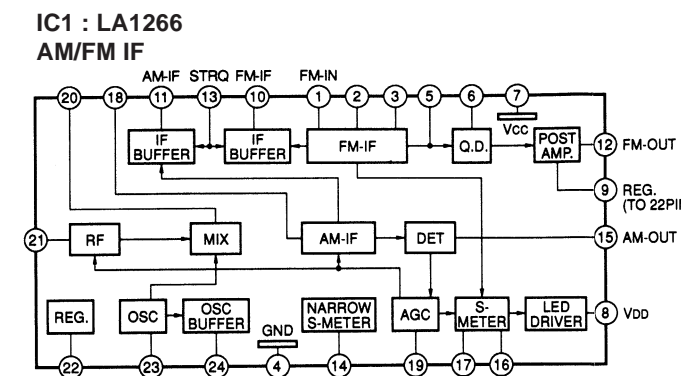
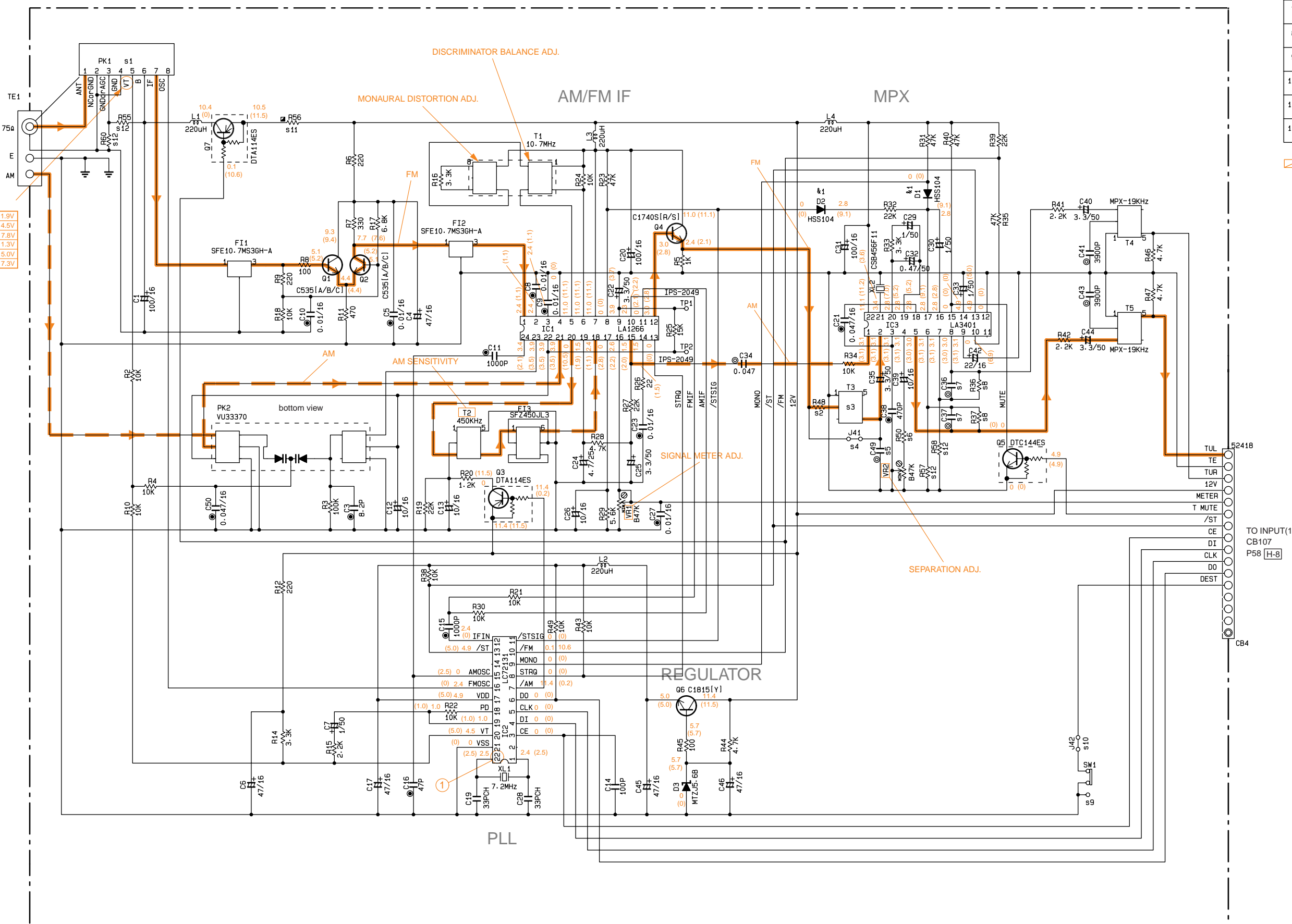

• PK1 : ENV-172C8G1R (V2909100) U, C, R, T models

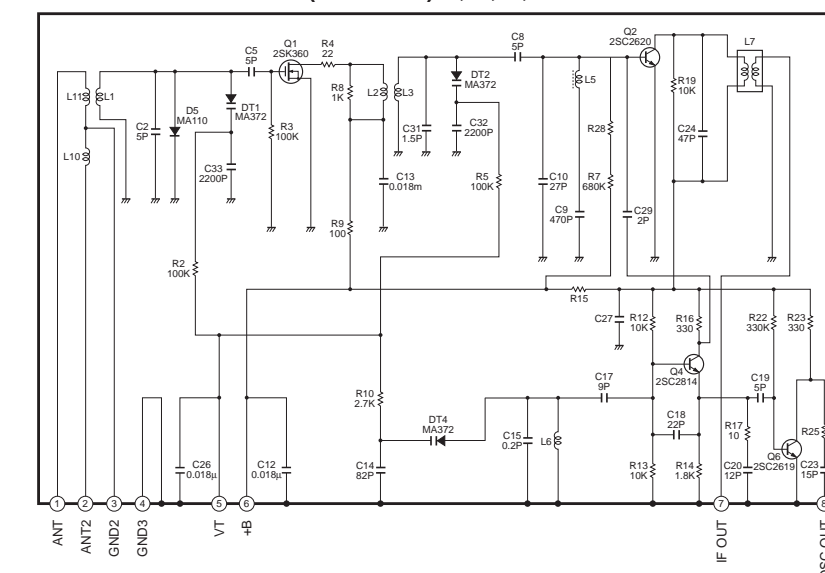

• PK1 : ENV-172A4G1 (V2716700) A, L models

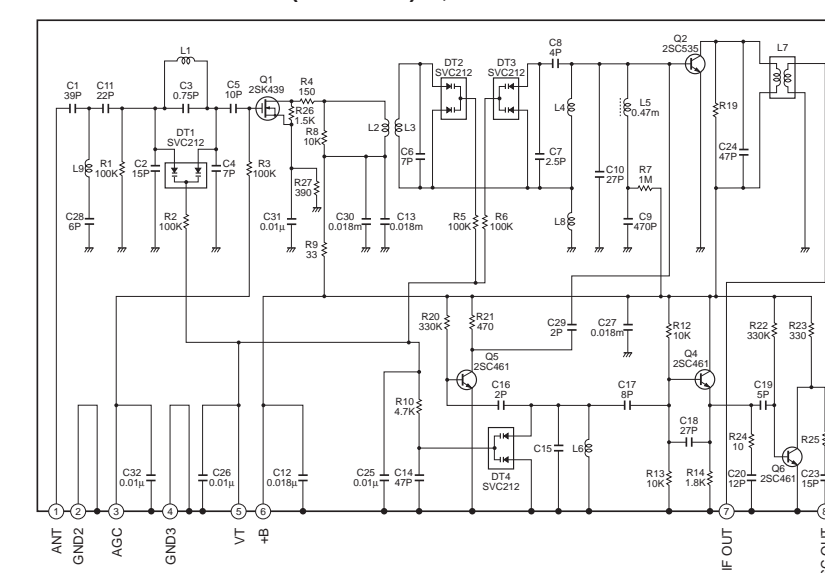

* All voltages are measured with a 10MΩ/V DC electric volt meter.
 * Components having special characteristics are marked with a triangle symbol and must be replaced with parts having specifications equal to those originally installed.
 * Schematic diagram is subject to change without notice.

PIN CONNECTION DIAGRAM OF DIODES, TRANSISTORS AND IC'S.

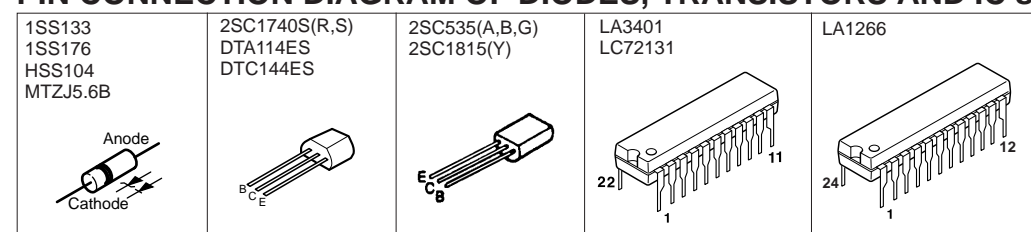

Point ① (Pin22 of IC2)

V : 2V/div H : 0.1µsec/div DC range 1 : 1 probe

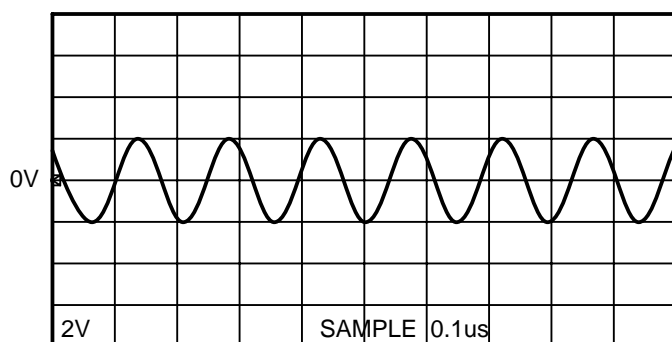

■ SCHEMATIC DIAGRAM (TUNER) B, G models

Each voltage given here represents that in the FM (98.1MHz STEREO) reception mode but the one in the parentheses () is that in the AM (1080kHz, MAN'L) reception mode.

REMARKS	PARTS NAME	MARK
NO MARK	ELECTROLYTIC CAPACITOR	⊘
NO MARK	TANTALUM CAPACITOR	⊗
NO MARK	CERAMIC CAPACITOR	□
⊙	CERAMIC TUBULAR CAPACITOR	⊙
○	POLYESTER FILM CAPACITOR	○
○	POLYSTYRENE FILM CAPACITOR	○
○	MICA CAPACITOR	○
○	POLYPROPYLENE FILM CAPACITOR	○
●	SEMICONDUCTIVE CERAMIC CAPACITOR	●

REMARKS	PARTS NAME	MARK
NO MARK	CARBON FILM RESISTOR (P=5)	□
NO MARK	CARBON FILM RESISTOR (P=10)	□
△	METAL OXIDE FILM RESISTOR	△
△	METAL FILM RESISTOR	△
⊠	METAL PLATE RESISTOR	⊠
⊠	FIRE PROOF CARBON FILM RESISTOR	⊠
⊠	CEMENT MOLDED RESISTOR	⊠
⊠	SEMI-VARIABLE RESISTOR	⊠
■	CHIP RESISTOR	■

NOTICE (model)
 (J)..... JAPANESE
 (U)..... U.S.A
 (C)..... CANADIAN
 (R)..... GENERAL
 (A)..... AUSTRALIAN
 (B)..... BRITISH
 (G)..... EUROPEAN
 (T)..... CHINA
 (L)..... SINGAPORE

Interchangeable Parts at Manufacture-Stage

Mark	Reference Parts Number	Parts Name
#1	D1.2	HSS104
		1SS133
		1SS176

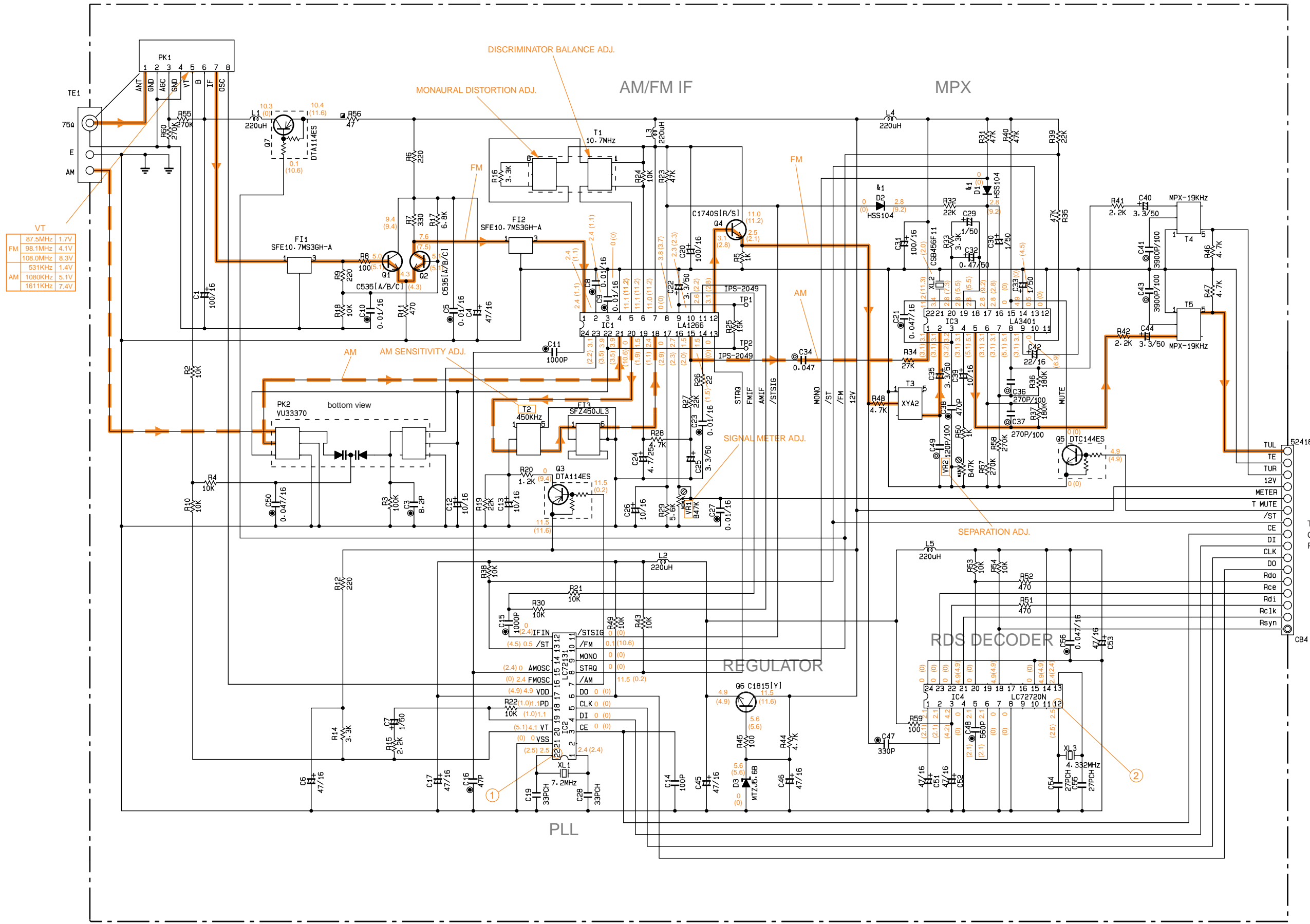

VT

FM	87.5MHz	1.7V
FM	98.1MHz	4.1V
FM	108.0MHz	5.3V
FM	131.0MHz	1.4V
AM	1080kHz	5.1V
AM	1611kHz	7.4V

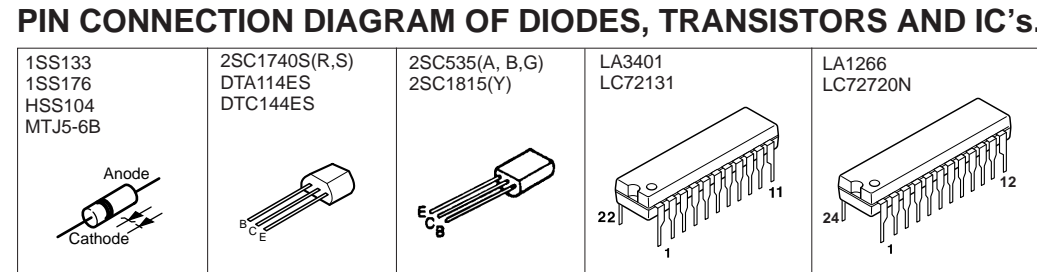
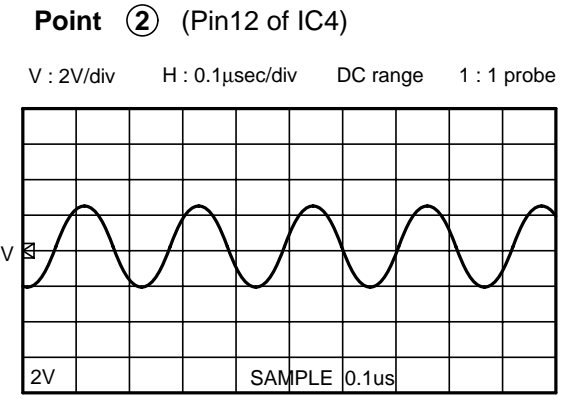
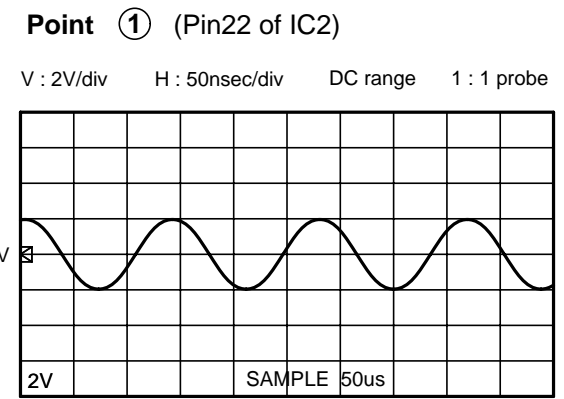
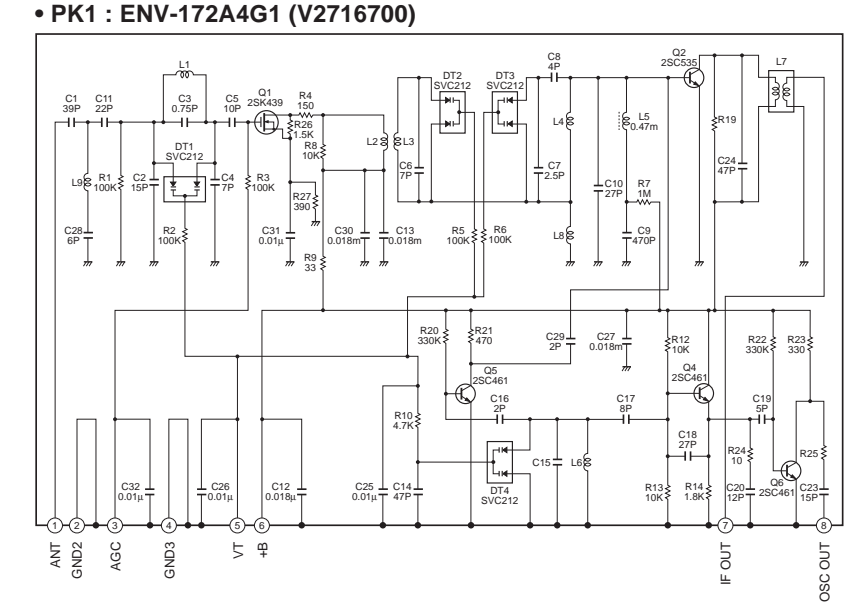
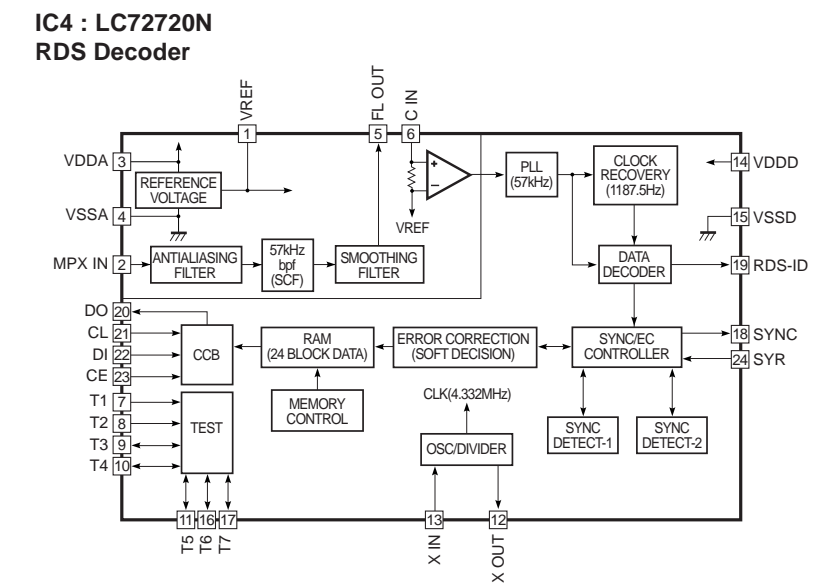
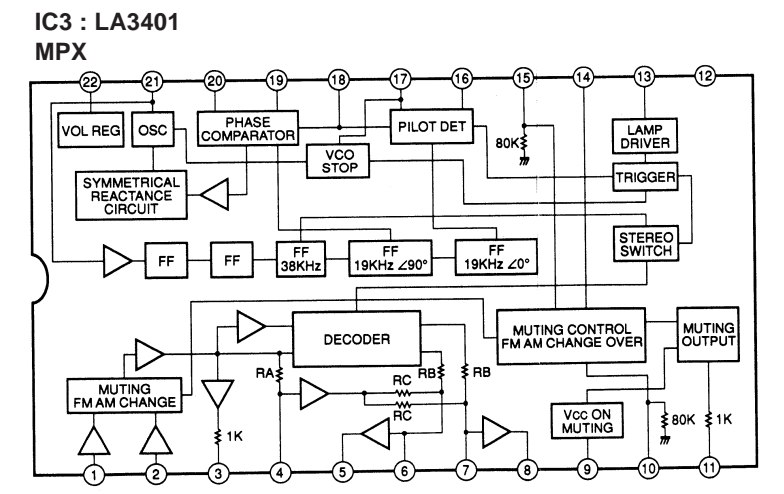
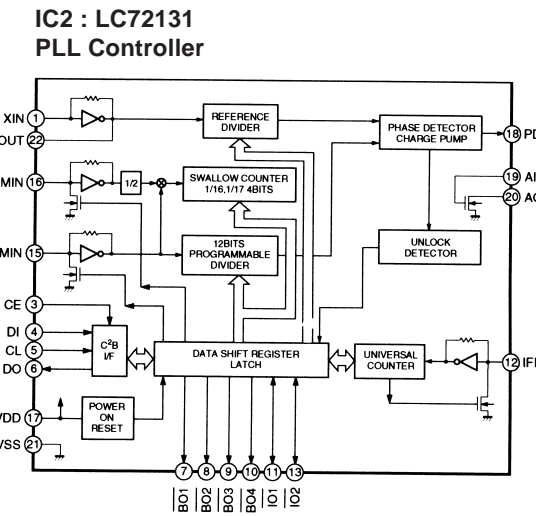
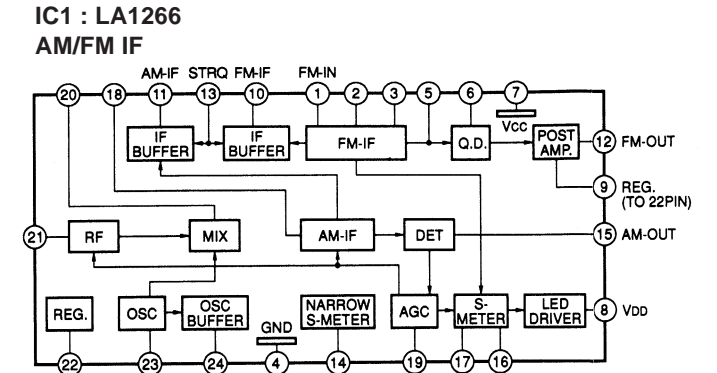

* All voltages are measured with a 10MΩ/V DC electric volt meter.
 * Components having special characteristics are marked ⊠ and must be replaced with parts having specifications equal to those originally installed.
 * Schematic diagram is subject to change without notice.

PARTS LIST

■ ELECTRICAL PARTS

■ WARNING

Components having special characteristics are marked \triangle and must be replaced with parts having specifications equal to those originally installed.

- Carbon resistors (1/6W or 1/4W) are not included in the ELECTRICAL PARTS List. For the part Nos. of the carbon resistores, refer to the last page.

ABBREVIATIONS IN THIS LIST ARE AS FOLLOWS:

C. A. EL. CHP	: CHIP ALUMI. ELECTROLYTIC CAP	LED. DSPLY	: LED DISPLAY
C. CE	: CERAMIC CAP	LED. INFRD	: LED, INFRARED
C. CE. ARRAY	: CERAMIC CAP ARRAY	MODUL. RF	: MODULATOR, RF
C. CE. CHP	: CHIP CERAMIC CAP	PHOT. CPL	: PHOTO COUPLER
C. CE. ML	: MULTILAYER CERAMIC CAP	PHOT. INTR	: PHOTO INTERRUPTER
C. CE. M. CHP	: CHIP MULTILAYER CERAMIC CAP	PHOT. RFLCT	: PHOTO REFLECTOR
C. CE. SAFTY	: RECOGNIZED CERAMIC CAP	PIN. TEST	: PIN, TEST POINT
C. CE. TUBLR	: CERAMIC TUBULAR CAP	PLST. RIVET	: PLASTIC RIVET
C. CE. SMI	: SEMI CONDUCTIVE CERAMIC CAP	R. ARRAY	: RESISTOR ARRAY
C. EL	: ELECTROLYTIC CAP	R. CAR	: CARBON RESISTOR
C. MICA	: MICA CAP	R. CAR. CHP	: CHIP RESISTOR
C. ML. FLM	: MULTILAYER FILM CAP	R. CAR.FP	: FLAME PROOF CARBON RESISTOR
C. MP	: METALLIZED PAPER CAP	R. FUS	: FUSABLE RESISTOR
C. MYLAR	: MYLAR FILM CAP	R. MTL. CHP	: CHIP METAL FILM RESISTOR
C. MYLAR. ML	: MULTILAYER MYLAR FILM CAP	R. MTL. FILM	: METAL FILM RESISTOR
C. PAPER	: PAPER CAPACITOR	R. MTL. OXD	: METAL OXIDE FILM RESISTOR
C. PLS	: POLYSTYRENE FILM CAP	R. MTL. PLAT	: METAL PLATE RESISTOR
C. POL	: POLYESTER FILM CAP	RSNR. CE	: CERAMIC RESONATOR
C. POLY	: POLYETHYLENE FILM CAP	RSNR. CRYST	: CRYSTAL RESONATOR
C. PP	: POLYPROPYLENE FILM CAP	R. TW. CEM	: TWIN CEMENT FIXED RESISTOR
C. TNTL	: TANTALUM CAP	R. WW	: WIRE WOUND RESISTOR
C. TNT. CHP	: CHIP TANTALUM CAP	SCR. BND. HD	: BIND HEAD B-TITE SCREW
C. TRIM	: TRIMMER CAP	SCR. BW. HD	: BW HEAD TAPPING SCREW
CN	: CONNECTOR	SCR. CUP	: CUP TITE SCREW
CN. BS. PIN	: CONNECTOR, BASE PIN	SCR. TERM	: SCREW TERMINAL
CN. CANNON	: CONNECTOR, CANNON	SCR. TR	: SCREW, TRANSISTOR
CN. DIN	: CONNECTOR, DIN	SUPRT. PCB	: SUPPORT, P. C. B.
CN. FLAT	: CONNECTOR, FLAT CABLE	SURG. PRTCT	: SURGE PROTECTOR
CN. POST	: CONNECTOR, BASE POST	SW. TACT	: TACT SWITCH
COIL. MX. AM	: COIL, AM MIX	SW. LEAF	: LEAF SWITCH
COIL. AT. FM	: COIL, FM ANTENNA	SW. LEVER	: LEVER SWITCH
COIL. DT. FM	: COIL, FM DETECT	SW. MICRO	: MICRO SWITCH
COIL. MX. FM	: COIL, FM MIX	SW. PUSH	: PUSH SWITCH
COIL. OUTPT	: OUTPUT COIL	SW. RT. ENC	: ROTARY ENCODER
DIOD. ARRAY	: DIODE ARRAY	SW. RT. MTR	: ROTARY SWITCH WITH MOTOR
DIODE. BRG	: DIODE BRIDGE	SW. RT	: ROTARY SWITCH
DIODE. CHP	: CHIP DIODE	SW. SLIDE	: SLIDE SWITCH
DIODE. VAR	: VARACTOR DIODE	TERM. SP	: SPEAKER TERMINAL
DIOD. Z. CHP	: CHIP ZENER DIODE	TERM. WRAP	: WRAPPING TERMINAL
DIODE. ZENR	: ZENER DIODE	THRMST. CHP	: CHIP THERMISTOR
DSCR. CE	: CERAMIC DISCRIMINATOR	TR. CHP	: CHIP TRANSISTOR
FER. BEAD	: FERRITE BEADS	TR. DGT	: DIGITAL TRANSISTOR
FER. CORE	: FERRITE CORE	TR. DGT. CHP	: CHIP DIGITAL TRANSISTOR
FET. CHP	: CHIP FET	TRANS	: TRANSFORMER
FL. DSPLY	: FLUORESCENT DISPLAY	TRANS. PULS	: PULSE TRANSFORMER
FLTR. CE	: CERAMIC FILTER	TRANS. PWR	: POWER TRANSFORMER ASS'y
FLTR. COMB	: COMB FILTER MODULE	TUNER. AM	: TUNER PACK, AM
FLTR. LC. RF	: LC FILTER, EMI	TUNER. FM	: TUNER PACK, FM
GND. MTL	: GROUND PLATE	TUNER. PK	: FRONT-END TUNER PACK
GND. TERM	: GROUND TERMINAL	VR	: ROTARY POTENTIOMETER
HOLDER. FUS	: FUSE HOLDER	VR. MTR	: POTENTIOMETER WITH MOTOR
IC. PRTCT	: IC PROTECTOR	VR. SW	: POTENTIOMETER WITH ROTARY SW
JUMPER. CN	: JUMPER CONNECTOR	VR. SLIDE	: SLIDE POTENTIOMETER
JUMPER. TST	: JUMPER, TEST POINT	VR. TRIM	: TRIMMER POTENTIOMETER
L. DTCT	: LIGHT DETECTING MODULE		
L. EMIT	: LIGHT EMITTING MODULE		

Note) Those parts marked with "#" are not included in the P. C. B. Ass'y.

P. C. B. DSP

Schm Ref	PART NO.	Description			
*	V3005700	P.C.B.	DSP		
*CB1	VQ044200	CN.BS.PIN	6P		
*CB3	VQ044500	CN.BS.PIN	11P		
CB6	VQ044600	CN.BS.PIN	13P		
C1	UB245100	C.CE.M.CHP	0.1uF	25V	
C2	UB052100	C.CE.M.CHP	100pF	50V	
C3	UB052100	C.CE.M.CHP	100pF	50V	
C4	UB245100	C.CE.M.CHP	0.1uF	25V	
C5	UB052100	C.CE.M.CHP	100pF	50V	
C6	UB052100	C.CE.M.CHP	100pF	50V	
C7	UB245100	C.CE.M.CHP	0.1uF	25V	
C8	VJ900700	C.CE.M.CHP	33pF	50V	
C9	UB013100	C.CE.M.CHP	1000pF	50V	
C10	UB245100	C.CE.M.CHP	0.1uF	25V	
C11	UR818100	C.EL	100uF	6.3V	
C12	UB245100	C.CE.M.CHP	0.1uF	25V	
C13	UR818100	C.EL	100uF	6.3V	
C14	UB245100	C.CE.M.CHP	0.1uF	25V	
C20	VJ900700	C.CE.M.CHP	33pF	50V	
C21	UB245100	C.CE.M.CHP	0.1uF	25V	
C22	UB013470	C.CE.M.CHP	4700pF	50V	
C23	VJ900900	C.CE.M.CHP	39pF	50V	
C24	UB245100	C.CE.M.CHP	0.1uF	25V	
C25	UB245100	C.CE.M.CHP	0.1uF	25V	
C26	UB052100	C.CE.M.CHP	100pF	50V	
C27	UB052100	C.CE.M.CHP	100pF	50V	
C28	UB052100	C.CE.M.CHP	100pF	50V	
C29	UB052100	C.CE.M.CHP	100pF	50V	
C30	UB052100	C.CE.M.CHP	100pF	50V	
C31	UB052100	C.CE.M.CHP	100pF	50V	
C32	UB245100	C.CE.M.CHP	0.1uF	25V	
C33	UB245100	C.CE.M.CHP	0.1uF	25V	
C34	UB245100	C.CE.M.CHP	0.1uF	25V	
C35	UB245100	C.CE.M.CHP	0.1uF	25V	
C36	UB245100	C.CE.M.CHP	0.1uF	25V	
C44	UB245100	C.CE.M.CHP	0.1uF	25V	
C45	UB245100	C.CE.M.CHP	0.1uF	25V	
C46	UB245100	C.CE.M.CHP	0.1uF	25V	
C47	UR818100	C.EL	100uF	6.3V	
C48	VJ900700	C.CE.M.CHP	33pF	50V	
C49	UB245100	C.CE.M.CHP	0.1uF	25V	
C50	UR818330	C.EL	330uF	6.3V	
C51	UB245100	C.CE.M.CHP	0.1uF	25V	
C52	UR818330	C.EL	330uF	6.3V	
C53	UB245100	C.CE.M.CHP	0.1uF	25V	
C54	UB245100	C.CE.M.CHP	0.1uF	25V	
C55	UR829100	C.EL	1000uF	10V	
C56	UR818330	C.EL	330uF	6.3V	
C59	UR829100	C.EL	1000uF	10V	
C60	UR818100	C.EL	100uF	6.3V	
C61	UB012470	C.CE.M.CHP	470pF	50V	
C62	UB245100	C.CE.M.CHP	0.1uF	25V	
C63	UB245100	C.CE.M.CHP	0.1uF	25V	
C64	UR818330	C.EL	330uF	6.3V	

* New Parts

Schm Ref	PART NO.	Description			
C65	UB245100	C.CE.M.CHP	0.1uF	25V	
C66	UR818330	C.EL	330uF	6.3V	
C67	UB245100	C.CE.M.CHP	0.1uF	25V	
C68	UB245100	C.CE.M.CHP	0.1uF	25V	
C69	UR818330	C.EL	330uF	6.3V	
C70	UB245100	C.CE.M.CHP	0.1uF	25V	
C71	UR818100	C.EL	100uF	6.3V	
C72	UR818100	C.EL	100uF	6.3V	
C73	UB245100	C.CE.M.CHP	0.1uF	25V	
C74	UR847100	C.EL	10uF	25V	
C75	UB245100	C.CE.M.CHP	0.1uF	25V	
C76	UR818100	C.EL	100uF	6.3V	
C77	UB245100	C.CE.M.CHP	0.1uF	25V	
C78	UB245100	C.CE.M.CHP	0.1uF	25V	
C79	UB245100	C.CE.M.CHP	0.1uF	25V	
C81	UR837470	C.EL	47uF	16V	
C82	UR818100	C.EL	100uF	6.3V	
C83	UB245100	C.CE.M.CHP	0.1uF	25V	
C84	UB245100	C.CE.M.CHP	0.1uF	25V	
C85	UB245100	C.CE.M.CHP	0.1uF	25V	
C86	UB245100	C.CE.M.CHP	0.1uF	25V	
C88	UA953150	C.MYLAR	1500pF	50V	
C89	UA953150	C.MYLAR	1500pF	50V	
C90	UR847100	C.EL	10uF	25V	
C91	UR847100	C.EL	10uF	25V	
C92	UR847100	C.EL	10uF	25V	
C93	UR847100	C.EL	10uF	25V	
C94	UR847100	C.EL	10uF	25V	
C95	UR847100	C.EL	10uF	25V	
C96	UR847100	C.EL	10uF	25V	
C97	UR847100	C.EL	10uF	25V	
C98	UR847100	C.EL	10uF	25V	
C99	UR847100	C.EL	10uF	25V	
C100	UA952100	C.MYLAR	100pF	50V	
C101	UA952100	C.MYLAR	100pF	50V	
C102	UA952100	C.MYLAR	100pF	50V	
C103	UA952100	C.MYLAR	100pF	50V	
C104	UR847100	C.EL	10uF	25V	
C106	UA952100	C.MYLAR	100pF	50V	
C107	UA952100	C.MYLAR	100pF	50V	
C109	UR847100	C.EL	10uF	25V	
C110	UR847100	C.EL	10uF	25V	
C111	UB245100	C.CE.M.CHP	0.1uF	25V	
C112	UR818470	C.EL	470uF	6.3V	
C113	UR828220	C.EL	220uF	10V	
C115	UR847100	C.EL	10uF	25V	
C116	UR847100	C.EL	10uF	25V	
C117	UR847100	C.EL	10uF	25V	
C118	UA952100	C.MYLAR	100pF	50V	
C119	UA952100	C.MYLAR	100pF	50V	
C120	UR847100	C.EL	10uF	25V	
C121	UR847100	C.EL	10uF	25V	
C122	UA952100	C.MYLAR	100pF	50V	
C123	UR837220	C.EL	22uF	25V	

* New Parts

P. C. B. DSP & P. C. B. INPUT
--

Schm Ref	PART NO.	Description		
C124	UR847100	C.EL	10uF	25V
C125	UR837220	C.EL	22uF	25V
C126	UA952100	C.MYLAR	100pF	50V
C127	UR847100	C.EL	10uF	25V
C128	UR847100	C.EL	10uF	25V
C129	UR837470	C.EL	47uF	16V
C130	UR837470	C.EL	47uF	16V
C131	UB052100	C.CE.M.CHP	100pF	50V
C132	UB052100	C.CE.M.CHP	100pF	50V
C133	UB052100	C.CE.M.CHP	100pF	50V
C134	UB052100	C.CE.M.CHP	100pF	50V
C135	UB052100	C.CE.M.CHP	100pF	50V
C136	UB052100	C.CE.M.CHP	100pF	50V
C137	UB052100	C.CE.M.CHP	100pF	50V
C138	UB245100	C.CE.M.CHP	0.1uF	25V
C139	UB052100	C.CE.M.CHP	100pF	50V
C140	UB052100	C.CE.M.CHP	100pF	50V
C141	UB052100	C.CE.M.CHP	100pF	50V
D1	VT332900	DIODE	1SS355	
D2	VT332900	DIODE	1SS355	
D3	VT332900	DIODE	1SS355	
D4	VT332900	DIODE	1SS355	
D5	VT332900	DIODE	1SS355	
D6	VT332900	DIODE	1SS355	
D7	VT332900	DIODE	1SS355	
D8	VT332900	DIODE	1SS355	
D9	VT332900	DIODE	1SS355	
D10	VT332900	DIODE	1SS355	
D11	VT332900	DIODE	1SS355	
D12	VT332900	DIODE	1SS355	
D13	VT332900	DIODE	1SS355	
D14	VT332900	DIODE	1SS355	
D15	VT332900	DIODE	1SS355	
D16	VT332900	DIODE	1SS355	
D17	VT332900	DIODE	1SS355	
G1	VR463400	TERM.GND	D3.5	TP00385
G2	VR463400	TERM.GND	D3.5	TP00385
G3	VR463400	TERM.GND	D3.5	TP00385
G4	VR463400	TERM.GND	D3.5	TP00385
IC1	XR038A00	IC	NJM2904M	OP
IC2	XL091A00	IC	HD74HC02FPEL	NOR
IC3	XG948E00	IC	YM3436DK	
*IC4	XU728A00	IC	YSS908-F	
*IC5	XV457A00	IC	M5M51288BKJ-20LTEL	
*IC6	XU722A00	IC	AK4526	
IC7	XR361A00	IC	AK4320-VM-E1	
IC8	XF291A00	IC	uPC4570G2	
IC9	XF291A00	IC	uPC4570G2	
IC10	XF291A00	IC	uPC4570G2	
IC11	XF291A00	IC	uPC4570G2	
IC13	XF291A00	IC	uPC4570G2	
IC14	XV260E00	IC	LC875164A-5K20	CPU
*IC15	XU965A00	IC	uPC29M33T-E1	3.3V
Q1	VV655300	TR.DGT	DTA144EKA	

* New Parts

Schm Ref	PART NO.	Description		
Q2	VV655300	TR.DGT	DTA144EKA	
Q3	VV655300	TR.DGT	DTA144EKA	
Q4	VD303700	TR	2SC3326 A,B	
Q5	VD303700	TR	2SC3326 A,B	
Q6	VD303700	TR	2SC3326 A,B	
Q7	VD303700	TR	2SC3326 A,B	
Q8	VD303700	TR	2SC3326 A,B	
Q9	VD303700	TR	2SC3326 A,B	
Q10	VD303700	TR	2SC3326 A,B	
Q11	VD303700	TR	2SC3326 A,B	
Q12	VD303700	TR	2SC3326 A,B	
Q13	VD303700	TR	2SC3326 A,B	
Q14	VV655700	TR.DGT	DTC144EKA	
R30	HV753220	R.CAR.FP	2.2Ω	1/4W
R36	HV753220	R.CAR.FP	2.2Ω	1/4W
R37	HV753220	R.CAR.FP	2.2Ω	1/4W
R39	HV753100	R.CAR.FP	1Ω	1/4W
R43	HV754100	R.CAR.FP	10Ω	1/4W
R44	HV754100	R.CAR.FP	10Ω	1/4W
R45	HV753100	R.CAR.FP	1Ω	1/4W
R47	HV753100	R.CAR.FP	1Ω	1/4W
R114	HV753220	R.CAR.FP	2.2Ω	1/4W
R115	HV753220	R.CAR.FP	2.2Ω	1/4W
XL1	Vi552000	RSNR.CRYS	12.288MHz	
XL2	VQ791000	RSNR.CE	10MHz	
*	V3003900	P.C.B.	INPUT(UCRT)	
*	V3004000	P.C.B.	INPUT(AL)	
*	V3004100	P.C.B.	INPUT(BG)	
CB101	Vi878600	CN.BS.PIN	8P	
CB102	VM923600	CN.BS.PIN	13P	
CB103	Vi878900	CN.BS.PIN	11P	
*CB104	VQ047900	CN	29P	
CB105	VM689000	CN.BS.PIN	23P	
CB106	VM859500	CN.BS.PIN	11P	
CB107	VQ963700	CN.BS.PIN	16P	
CB108	VK025500	CN.BS.PIN	11P	
CB109	VF728200	CN.BS.PIN	10P	
CB110	VK025600	CN.BS.PIN	12P	
CB301	VK026700	CN.BS.PIN	8P	
CB302	Vi878500	CN.BS.PIN	7P	
*CB351	V2508700	CN.PHOT.SN	1P	GP1F37R
*CB352	V2508700	CN.PHOT.SN	1P	GP1F37R
CB353	Vi878900	CN.BS.PIN	11P	
*CB354	VQ044200	CN.BS.PIN	6P	
CB401	VQ045300	CN.BS.PIN	23P	
C101	UR866220	C.EL	2.2uF	50V
C102	UA952100	C.MYLAR	100pF	50V(ALBG)
C104	UA952100	C.MYLAR	100pF	50V(ALBG)
C105	UA952220	C.MYLAR	220pF	50V
C106	UR866220	C.EL	2.2uF	50V
C107	VF467300	C.CE.TUBLR	0.01uF	16V
C108	VK533900	C.PP	100pF	200V

* New Parts

P. C. B. INPUT

Schm Ref	PART NO.	Description		
C109	VK533900	C.PP	100pF	200V
C112	UA952100	C.MYLAR	100pF	50V
C113	UA952100	C.MYLAR	100pF	50V
C114	FG651470	C.CE	47pF	50V
C115	FG651470	C.CE	47pF	50V
C116	UA952100	C.MYLAR	100pF	50V
C117	UA952100	C.MYLAR	100pF	50V
C118	UA952100	C.MYLAR	100pF	50V
C119	UA952100	C.MYLAR	100pF	50V
C120	VF466800	C.CE.TUBLR	100pF	50V
C121	VF466800	C.CE.TUBLR	100pF	50V
C122	VF466700	C.CE.TUBLR	47pF	50V
C123	VF466700	C.CE.TUBLR	47pF	50V
C124	UA655220	C.MYLAR	0.22uF	50V
C125	VF467300	C.CE.TUBLR	0.01uF	16V
C126	UR866220	C.EL	2.2uF	50V
C127	UR828220	C.EL	220uF	10V
C128	UR837470	C.EL	47uF	16V
C129	UA953100	C.MYLAR	1000pF	50V
C130	UA653910	C.MYLAR	9100pF	50V
C131	UA954330	C.MYLAR	0.033uF	50V
C132	UA653910	C.MYLAR	9100pF	50V
C133	UA954330	C.MYLAR	0.033uF	50V
C134	UA953100	C.MYLAR	1000pF	50V
C135	UR828220	C.EL	220uF	10V
C136	UR837470	C.EL	47uF	16V
C137	UR866220	C.EL	2.2uF	50V
C138	UR837470	C.EL	47uF	16V
C139	UR837470	C.EL	47uF	16V
C140	UR837100	C.EL	10uF	16V
C141	UR837100	C.EL	10uF	16V
C142	VJ599100	C.CE.TUBLR	0.1uF	50V
C143	VJ599100	C.CE.TUBLR	0.1uF	50V
C145	UA954180	C.MYLAR	0.018uF	50V
C146	UA954680	C.MYLAR	0.068uF	50V
C147	UR837220	C.EL	22uF	25V
C148	UR847100	C.EL	10uF	25V
C149	UR847100	C.EL	10uF	25V
C150	UR837220	C.EL	22uF	25V
C151	UR837100	C.EL	10uF	16V
C152	UR847100	C.EL	10uF	25V
C153	UR837100	C.EL	10uF	16V
C154	UA952100	C.MYLAR	100pF	50V
C155	UA952100	C.MYLAR	100pF	50V
C156	UR837100	C.EL	10uF	16V
C157	UR847100	C.EL	10uF	25V
C158	UR837100	C.EL	10uF	16V
C159	UR837100	C.EL	10uF	16V
C160	UR837100	C.EL	10uF	16V
C161	VJ599100	C.CE.TUBLR	0.1uF	50V
C162	VJ599100	C.CE.TUBLR	0.1uF	50V
C163	UA952100	C.MYLAR	100pF	50V
C164	UA952100	C.MYLAR	100pF	50V
C165	UA954270	C.MYLAR	0.027uF	50V

* New Parts

Schm Ref	PART NO.	Description		
C166	UA954270	C.MYLAR	0.027uF	50V
C167	UR847100	C.EL	10uF	25V
C168	UR847100	C.EL	10uF	25V
C169	UA952100	C.MYLAR	100pF	50V
C170	UR837470	C.EL	47uF	16V
C171	UR837470	C.EL	47uF	16V
C172	UA952100	C.MYLAR	100pF	50V
C173	UR847100	C.EL	10uF	25V
C174	UR847100	C.EL	10uF	25V
C175	UA954270	C.MYLAR	0.027uF	50V
C176	UA954270	C.MYLAR	0.027uF	50V
C177	VJ599100	C.CE.TUBLR	0.1uF	50V
C178	VJ599100	C.CE.TUBLR	0.1uF	50V
C179	UR837470	C.EL	47uF	16V
C180	UR837470	C.EL	47uF	16V
C181	UR837470	C.EL	47uF	16V
C182	UR837470	C.EL	47uF	16V
C183	UR847470	C.EL	47uF	25V
C184	UR847470	C.EL	47uF	25V
C185	UR866470	C.EL	4.7uF	50V
C186	VJ599100	C.CE.TUBLR	0.1uF	50V
C187	VJ599100	C.CE.TUBLR	0.1uF	50V
C188	UR866470	C.EL	4.7uF	50V
C189	UR866470	C.EL	4.7uF	50V
C190	VJ599100	C.CE.TUBLR	0.1uF	50V
C191	VJ599100	C.CE.TUBLR	0.1uF	50V
C192	UR866470	C.EL	4.7uF	50V
C193	VF466800	C.CE.TUBLR	100pF	50V
C194	VF467000	C.CE.TUBLR	1000pF	50V
C195	VF467300	C.CE.TUBLR	0.01uF	16V
C196	VJ599100	C.CE.TUBLR	0.1uF	50V
C197	UR837100	C.EL	10uF	16V
C198	UR837100	C.EL	10uF	16V
C199	UR837100	C.EL	10uF	16V
C200	UR837100	C.EL	10uF	16V
C201	UR828220	C.EL	220uF	10V
C202	VF467000	C.CE.TUBLR	1000pF	50V
C301	VF466800	C.CE.TUBLR	100pF	50V(BG)
C302	VF466800	C.CE.TUBLR	100pF	50V(BG)
C303	VF466800	C.CE.TUBLR	100pF	50V
C304	VF466800	C.CE.TUBLR	100pF	50V
C305	VF467000	C.CE.TUBLR	1000pF	50V(BG)
C306	UR837100	C.EL	10uF	16V(BG)
C307	UR829100	C.EL	1000uF	10V(BG)
C308	VG276600	C.CE.TUBLR	22pF	50V(BG)
C309	UR837470	C.EL	47uF	16V(BG)
C310	UR829100	C.EL	1000uF	10V(BG)
C311	VF466800	C.CE.TUBLR	100pF	50V(BG)
C312	VF467000	C.CE.TUBLR	1000pF	50V(BG)
C313	UR837100	C.EL	10uF	16V(BG)
C314	VF466800	C.CE.TUBLR	100pF	50V(BG)
C315	UR837330	C.EL	33uF	16V(BG)
C316	VG276600	C.CE.TUBLR	22pF	50V(BG)
C317	UR837470	C.EL	47uF	16V(BG)

* New Parts

P. C. B. INPUT

Schm Ref	PART NO.	Description		
C318	UR837330	C.EL	33uF	16V(BG)
C319	UR837100	C.EL	10uF	16V
C320	VF467000	C.CE.TUBLR	1000pF	50V
C321	UR829100	C.EL	1000uF	10V
C322	UR837100	C.EL	10uF	16V
C323	UR837100	C.EL	10uF	16V
C324	UR829100	C.EL	1000uF	10V
C325	UR837470	C.EL	47uF	16V(BG)
C326	UR837470	C.EL	47uF	16V(BG)
C327	UR837470	C.EL	47uF	16V
C328	UR838330	C.EL	330uF	16V
C351	VG278400	C.CE.TUBLR	220pF	50V
C352	VG278400	C.CE.TUBLR	220pF	50V
C353	VG278400	C.CE.TUBLR	220pF	50V
C354	VG278400	C.CE.TUBLR	220pF	50V
C355	VG278400	C.CE.TUBLR	220pF	50V
C356	VG278400	C.CE.TUBLR	220pF	50V
C357	VF467300	C.CE.TUBLR	0.01uF	16V
C358	VJ599100	C.CE.TUBLR	0.1uF	50V
C359	UR847220	C.EL	22uF	25V
C360	VG276600	C.CE.TUBLR	22pF	50V
C361	VJ599100	C.CE.TUBLR	0.1uF	50V
C362	VJ599100	C.CE.TUBLR	0.1uF	50V
C363	VJ599100	C.CE.TUBLR	0.1uF	50V
C364	VG278400	C.CE.TUBLR	220pF	50V
C365	VF466600	C.CE.TUBLR	10pF	50V
C366	VF467000	C.CE.TUBLR	1000pF	50V
C367	VJ599100	C.CE.TUBLR	0.1uF	50V
C368	VJ599100	C.CE.TUBLR	0.1uF	50V
C369	UR828100	C.EL	100uF	10V
C401	UR866220	C.EL	2.2uF	50V
C402	VK533900	C.PP	100pF	200V
C403	VK533900	C.PP	100pF	200V
C404	UR866220	C.EL	2.2uF	50V
C405	UR866220	C.EL	2.2uF	50V
C406	UR866220	C.EL	2.2uF	50V
C407	UR866220	C.EL	2.2uF	50V
C408	UR866220	C.EL	2.2uF	50V
C409	UN866100	C.EL	1uF	50V
C410	UR838100	C.EL	100uF	16V
C411	VG277000	C.CE.TUBLR	33pF	50V(BG)
C412	UA953100	C.MYLAR	1000pF	50V
C413	UR818100	C.EL	100uF	6.3V
C414	UA953100	C.MYLAR	1000pF	50V
C415	UR818100	C.EL	100uF	6.3V
C416	VG277000	C.CE.TUBLR	33pF	50V(BG)
C417	UR838100	C.EL	100uF	16V
C418	UR838100	C.EL	100uF	16V
C419	VG277000	C.CE.TUBLR	33pF	50V(BG)
C420	VG287600	C.EL	100uF	25V
C421	UA952100	C.MYLAR	100pF	50V
C422	UR818100	C.EL	100uF	6.3V
C423	UA952100	C.MYLAR	100pF	50V
C424	UR818100	C.EL	100uF	6.3V

* New Parts

Schm Ref	PART NO.	Description		
C425	VG287600	C.EL	100uF	25V
C426	VG277000	C.CE.TUBLR	33pF	50V(BG)
C427	UR838100	C.EL	100uF	16V
C428	UR838100	C.EL	100uF	16V
C429	VG277000	C.CE.TUBLR	33pF	50V(BG)
C430	UA952100	C.MYLAR	100pF	50V
C431	UR818100	C.EL	100uF	6.3V
C432	UA952100	C.MYLAR	100pF	50V
C433	UR818100	C.EL	100uF	6.3V
C434	VG277000	C.CE.TUBLR	33pF	50V(BG)
C435	UR838100	C.EL	100uF	16V
C436	VJ599100	C.CE.TUBLR	0.1uF	50V
D101	VM975300	DIODE.ZENR	HZS11B2TD	11V
D102	VM975300	DIODE.ZENR	HZS11B2TD	11V
D103	VM975300	DIODE.ZENR	HZS11B2TD	11V
D104	VM975300	DIODE.ZENR	HZS11B2TD	11V
D351	VD631600	DIODE	1SS133,176,HSS104	
D352	VD631600	DIODE	1SS133,176,HSS104	
D401	VM974200	DIODE.ZENR	HZS5C2TD	5.0V
IC101	XP894A00	IC	LC78211	
IC102	XP896A00	IC	LC78213	
IC103	XP895A00	IC	LC78212	
IC104	XM356A00	IC	NJM2068LD	
IC105	XB247A00	IC	uPC4570HA	
IC106	XB247A00	IC	uPC4570HA	
IC107	iG092000	IC	M5220L	
IC108	iG092000	IC	M5220L	
IC109	iG092000	IC	M5220L	
IC110	XR040A00	IC	TC9299P	
IC111	XR040A00	IC	TC9299P	
IC112	XB247A00	IC	uPC4570HA	
IC113	XB247A00	IC	uPC4570HA	
IC301	XH436A00	IC	LA7956(BG)	
IC302	XH436A00	IC	LA7956(BG)	
IC303	XH436A00	IC	LA7956	
IC351	iG142200	IC	TC74HCU04AP	
IC352	XT208A00	IC	HD74HC153P MPX	
IC401	XC520A00	IC	uPC4570C	
IC402	XC520A00	IC	uPC4570C	
IC403	XC520A00	IC	uPC4570C	
IC404	XF494A00	IC	LB1641	
JK301	VN938100	CN.DIN	3P	S(BG)
L351	GE901970	COIL	68uH	
L352	GE901970	COIL	68uH	
PJ101	VQ260900	JACK.PIN	4P	
PJ103	VU857800	JACK.PIN	6P	
PJ104	VU857800	JACK.PIN	6P	
PJ105	VK437600	JACK.PIN	1P	
PJ301	VV325000	JACK.PIN	2P	
PJ302	VV852500	JACK.PIN	3P	
* PJ351	V2874800	JACK.PIN	6P	
PJ352	VY667700	JACK.PIN	1P	
Q101	iC287820	TR	2SC2878 A,B	
Q301	iA101510	TR	2SA1015 Y(BG)	

* New Parts

P. C. B. INPUT & P. C. B. MAIN

Schm Ref	PART NO.	Description	
Q302	iC1815I0	TR	2SC1815 Y(BG)
Q303	iA1015I0	TR	2SA1015 Y(BG)
Q304	iC1815I0	TR	2SC1815 Y(BG)
Q305	iC1815I0	TR	2SC1815 Y
Q306	iC1815I0	TR	2SC1815 Y
Q307	iC174020	TR	2SC1740S R,S
R141	HV755100	R.CAR.FP	100Ω 1/4W
R154	HV755100	R.CAR.FP	100Ω 1/4W
R155	HV753220	R.CAR.FP	2.2Ω 1/4W
R156	HV753220	R.CAR.FP	2.2Ω 1/4W
R214	HV753220	R.CAR.FP	2.2Ω 1/4W
R215	HV753220	R.CAR.FP	2.2Ω 1/4W
R216	HV753220	R.CAR.FP	2.2Ω 1/4W
R217	HV753220	R.CAR.FP	2.2Ω 1/4W
R222	HV753220	R.CAR.FP	2.2Ω 1/4W
R231	HV753220	R.CAR.FP	2.2Ω 1/4W
R232	HV753220	R.CAR.FP	2.2Ω 1/4W
R334	HV753220	R.CAR.FP	2.2Ω 1/4W
R373	HV753220	R.CAR.FP	2.2Ω 1/4W
R411	HV754100	R.CAR.FP	10Ω 1/4W
R412	HV754100	R.CAR.FP	10Ω 1/4W
R435	HV754100	R.CAR.FP	10Ω 1/4W
VR401	VV613500	VR	A100KΩ
*	V3003000	P.C.B.	MAIN(URT)
*	V3003100	P.C.B.	MAIN(C)
*	V3003200	P.C.B.	MAIN(A)
*	V3003300	P.C.B.	MAIN(BG)
*	V3003400	P.C.B.	MAIN(L)
CB501	Vi878800	CN.BS.PIN	10P
CB502	VQ961600	CN	13P
CB503	VQ963400	CN.BS.PIN	13P
CB504	VQ585000	CN.BS.PIN	8P
CB505	VK025300	CN.BS.PIN	9P
CB506	VK024800	CN.BS.PIN	4P
CB507	VK024700	CN.BS.PIN	3P
CB701	VQ585000	CN.BS.PIN	8P
*CB702	VQ585100	CN.BS.PIN	9P
*CB711	VQ585100	CN.BS.PIN	9P
CB721	Vi879000	CN.BS.PIN	12P
CB722	Vi878600	CN.BS.PIN	8P
CB751	Vi878200	CN.BS.PIN	4P
CB761	Vi878200	CN.BS.PIN	4P
CB762	Vi878100	CN.BS.PIN	3P
C501	VJ599100	C.CE.TUBLR	0.1uF 50V
C502	VJ599100	C.CE.TUBLR	0.1uF 50V
C503	UR847100	C.EL	10uF 25V
C504	UR847100	C.EL	10uF 25V
C505	UR847100	C.EL	10uF 25V
C506	UR847100	C.EL	10uF 25V
C507	UR837470	C.EL	47uF 16V
C508	UR847100	C.EL	10uF 25V
C509	UR847100	C.EL	10uF 25V

* New Parts

Schm Ref	PART NO.	Description		
C510	FG651330	C.CE	33pF	50V(URTC)
C510	UA952220	C.MYLAR	220pF	50V(ABGL)
C510	UA952220	C.MYLAR	220pF	50V
C511	VQ645600	C.MYLAR	100pF	50V
C512	FG651330	C.CE	33pF	50V(URTC)
C512	UA952220	C.MYLAR	220pF	50V(ABGL)
C513	VQ645600	C.MYLAR	100pF	50V
C514	FG651330	C.CE	33pF	50V(URTC)
C514	UA952220	C.MYLAR	220pF	50V(ABGL)
C515	UA952100	C.MYLAR	100pF	50V
C516	FG651330	C.CE	33pF	50V(URTC)
C516	UA952220	C.MYLAR	220pF	50V(ABGL)
C517	UA952470	C.MYLAR	470pF	50V
C518	FG651330	C.CE	33pF	50V(URTC)
C518	UA952220	C.MYLAR	220pF	50V(ABGL)
C519	UA952470	C.MYLAR	470pF	50V
C520	VQ245400	C.PP	33pF	200V
C521	UR838100	C.EL	100uF	16V
C522	UA953100	C.MYLAR	1000pF	50V
C523	VQ245400	C.PP	33pF	200V
C524	UR838100	C.EL	100uF	16V
C525	UA953100	C.MYLAR	1000pF	50V
C526	VQ245400	C.PP	33pF	200V
C527	UR837470	C.EL	47uF	16V
C528	UA953100	C.MYLAR	1000pF	50V
C529	VR516400	C.CE	15pF	500V
C530	UR837470	C.EL	47uF	16V
C531	UA953100	C.MYLAR	1000pF	50V
C532	VR516400	C.CE	15pF	500V
C533	UR837470	C.EL	47uF	16V
C534	UA953100	C.MYLAR	1000pF	50V
C535	UR867470	C.EL	47uF	50V
C536	UR867470	C.EL	47uF	50V
C537	UR867470	C.EL	47uF	50V
C538	UR867470	C.EL	47uF	50V
C539	UR867470	C.EL	47uF	50V
C540	VK347900	C.EL	470uF	63V
C541	VQ645600	C.MYLAR	100pF	50V
C542	VK399200	C.MYLAR.ML	0.39uF	50V
C543	UR867470	C.EL	47uF	50V
C544	VQ645600	C.MYLAR	100pF	50V
C545	VQ645600	C.MYLAR	100pF	50V
C546	VK399200	C.MYLAR.ML	0.39uF	50V
C547	UR867470	C.EL	47uF	50V
C548	VQ645600	C.MYLAR	100pF	50V
C549	VR325000	C.MYLAR	100pF	100V
C550	UR867470	C.EL	47uF	50V
C551	VR325000	C.MYLAR	100pF	100V
C552	VR325000	C.MYLAR	100pF	100V
C553	UR867470	C.EL	47uF	50V
C554	VR325000	C.MYLAR	100pF	100V
C555	VR325000	C.MYLAR	100pF	100V
C556	UR867470	C.EL	47uF	50V
C557	VR325000	C.MYLAR	100pF	100V

* New Parts

P. C. B. MAIN

Schm Ref	PART NO.	Description		
C558	UA954680	C.MYLAR	0.068uF	50V
C559	UA954680	C.MYLAR	0.068uF	50V
C560	UA954680	C.MYLAR	0.068uF	50V
C561	UA954680	C.MYLAR	0.068uF	50V
C562	UA954680	C.MYLAR	0.068uF	50V
C563	UR866470	C.EL	4.7uF	50V
C566	UJ778330	C.EL	330uF	63V
C567	UJ778330	C.EL	330uF	63V
C568	UR866470	C.EL	4.7uF	50V
C569	UR866470	C.EL	4.7uF	50V
C570	UR818100	C.EL	100uF	6.3V
C573	VF466900	C.CE.TUBLR	470pF	50V(BG)
C574	VF466900	C.CE.TUBLR	470pF	50V(BG)
C575	VF466900	C.CE.TUBLR	470pF	50V(BG)
C576	VF466900	C.CE.TUBLR	470pF	50V(BG)
C577	UA954220	C.MYLAR	0.022uF	50V(ABGL)
C578	UA954100	C.MYLAR	0.01uF	50V(ABGL)
C579	UA954100	C.MYLAR	0.01uF	50V(ABGL)
C580	UA954220	C.MYLAR	0.022uF	50V(ABGL)
C581	UA954220	C.MYLAR	0.022uF	50V(ABGL)
C582	UR847100	C.EL	10uF	25V
C701	VF466900	C.CE.TUBLR	470pF	50V(BG)
C702	VF466900	C.CE.TUBLR	470pF	50V(BG)
C703	UA954220	C.MYLAR	0.022uF	50V(ABGL)
C704	UA954220	C.MYLAR	0.022uF	50V(ABGL)
C705	UA954220	C.MYLAR	0.022uF	50V(ABGL)
C706	UA954220	C.MYLAR	0.022uF	50V(ABGL)
C707	UA954100	C.MYLAR	0.01uF	50V(ABGL)
C708	UA954100	C.MYLAR	0.01uF	50V(ABGL)
C711	UA954100	C.MYLAR	0.01uF	50V(ABGL)
C712	UA954100	C.MYLAR	0.01uF	50V(ABGL)
C713	UA954100	C.MYLAR	0.01uF	50V(ABGL)
C722	UR867470	C.EL	47uF	50V
C723	UR867470	C.EL	47uF	50V
C725	UR838100	C.EL	100uF	16V
C726	UR847470	C.EL	47uF	25V
C727	UR838100	C.EL	100uF	16V
C728	UR847470	C.EL	47uF	25V
C729	UR867470	C.EL	47uF	50V
C730	UR867470	C.EL	47uF	50V
C731	UR865470	C.EL	0.47uF	50V
C732	UR865470	C.EL	0.47uF	50V
C733	UR857470	C.EL	47uF	35V
C734	UR857470	C.EL	47uF	35V
C751	VV951800	C.EL	6800uF	56V
C752	VV951800	C.EL	6800uF	56V
C753	VS745400	C.POL.MTL	0.1uF	100V
C754	VS745400	C.POL.MTL	0.1uF	100V
C761	UR868100	C.EL	100uF	50V
C762	VS745400	C.POL.MTL	0.1uF	100V
C763	VS745400	C.POL.MTL	0.1uF	100V
C764	UA954680	C.MYLAR	0.068uF	50V(ABGL)
C765	UA954680	C.MYLAR	0.068uF	50V(ABGL)
C766	UA952220	C.MYLAR	220pF	50V

* New Parts

Schm Ref	PART NO.	Description	
D501	VM975700	DIODE.ZENR	HZS12C2TD 12V
D502	VD631600	DIODE	1SS133,176,HSS104
D503	VD631600	DIODE	1SS133,176,HSS104
D507	VN008700	DIODE	1SS270A
D508	VN008700	DIODE	1SS270A
D509	VN008700	DIODE	1SS270A
D510	VN008700	DIODE	1SS270A
D511	VN008700	DIODE	1SS270A
D512	VM976300	DIODE.ZENR	HZS242TD 24V
D513	VM976500	DIODE.ZENR	HZS302TD 30V
D514	VM976300	DIODE.ZENR	HZS242TD 24V
D515	VM976300	DIODE.ZENR	HZS242TD 24V
D721	VM976300	DIODE.ZENR	HZS242TD 24V
D722	VM976300	DIODE.ZENR	HZS242TD 24V
D751	VN011400	DIODE.BRG	D5SB20 5A
D762	VS997800	DIODE	1T2
D763	VS997800	DIODE	1T2
* HS501	V2692300	HEAT.SINK	BPUE36-30
IC722	XD343A00	IC	NJM79M12FA
IC723	XJ604A00	IC	NJM78M05FA
IC724	XJ608A00	IC	NJM7812FA
IC725	XJ608A00	IC	NJM7812FA
* JK711	V2700900	JACK.PHONE	(URTCAL)
JK711	VS899700	JACK.PHONE	JY-6317-02-030(BG)
L501	VU038200	COIL	0.95uH
L502	VU038200	COIL	0.95uH
* L503	V2604200	COIL	1uH
* L504	V2604200	COIL	1uH
* L505	V2604200	COIL	1uH
* PJ501	V2803000	JACK.PIN	4P(BG)
* PJ701	V2802800	2P(BG)	
Q501	iC287820	TR	2SC2878 A,B
Q502	iC287820	TR	2SC2878 A,B
Q503	iC287820	TR	2SC2878 A,B
Q504	iC287820	TR	2SC2878 A,B
Q505	iC287820	TR	2SC2878 A,B
Q506	VP883000	TR	2SA893A D,E
Q507	VP883000	TR	2SA893A D,E
Q508	VP883000	TR	2SA893A D,E
Q509	VP883000	TR	2SA893A D,E
Q510	VP883000	TR	2SA893A D,E
Q511	VP883000	TR	2SA893A D,E
△ Q512	VR325600	TR	2SC2229 O,Y
△ Q513	VP883000	TR	2SA893A D,E
△ Q514	VR325600	TR	2SC2229 O,Y
Q515	VP883000	TR	2SA893A D,E
△ Q516	VR325600	TR	2SC2229 O,Y
Q517	VP883000	TR	2SA893A D,E
△ Q518	VR325600	TR	2SC2229 O,Y
Q519	VP883000	TR	2SA893A D,E
△ Q520	VR325600	TR	2SC2229 O,Y
△ Q521	iC174020	TR	2SC1740S R,S
△ Q522	iC174020	TR	2SC1740S R,S
△ Q523	iC174020	TR	2SC1740S R,S

* New Parts

P. C. B. MAIN

Schm Ref	PART NO.	Description	
△ Q524	iC174020	TR	2SC1740S R,S
△ Q525	iC174020	TR	2SC1740S R,S
△ Q526	VP872700	TR	2SC4488 S,T
△ Q527	VR355900	TR.PAIR	A1695/C4468URTABGL
△ Q527	VY760300	TR.PAIR	2SA1492/C3856 (C)
△ Q529	VP872600	TR	2SA1708 S,T
△ Q530	VP872700	TR	2SC4488 S,T
△ Q531	VR355900	TR.PAIR	A1695/C4468URTABGL
△ Q531	VY760300	TR.PAIR	2SA1492/C3856 (C)
△ Q533	VP872600	TR	2SA1708 S,T
△ Q534	VP872700	TR	2SC4488 S,T
△ Q535	VR355900	TR.PAIR	A1695/C4468URTABGL
△ Q535	VY760300	TR.PAIR	2SA1492/C3856 (C)
△ Q537	VP872600	TR	2SA1708 S,T
△ Q538	VP872700	TR	2SC4488 S,T
△ Q539	VR355900	TR.PAIR	A1695/C4468URTABGL
△ Q539	VY760300	TR.PAIR	2SA1492/C3856 (C)
△ Q541	VP872600	TR	2SA1708 S,T
△ Q542	VP872700	TR	2SC4488 S,T
△ Q543	VR355900	TR.PAIR	A1695/C4468URTABGL
△ Q543	VY760300	TR.PAIR	2SA1492/C3856 (C)
△ Q545	VP872600	TR	2SA1708 S,T
△ Q546	VP883100	TR	2SC1890A D,E
△ Q547	VP883100	TR	2SC1890A D,E
△ Q548	VP883100	TR	2SC1890A D,E
△ Q549	VP883100	TR	2SC1890A D,E
△ Q550	VP883100	TR	2SC1890A D,E
Q551	iA097030	TR	2SA970 GR,BL
Q552	VP872600	TR	2SA1708 S,T
Q553	iC224030	TR	2SC2240 GR,BL
Q556	iC224030	TR	2SC2240 GR,BL
Q557	iC224030	TR	2SC2240 GR,BL
Q721	iC181510	TR	2SC1815 Y
Q722	iA101510	TR	2SA1015 Y
R516	HV756180	R.CAR.FP	1.8KΩ 1/4W
△ R538	HV754470	R.CAR.FP	47Ω 1/4W
△ R545	HV754470	R.CAR.FP	47Ω 1/4W
△ R552	HV754470	R.CAR.FP	47Ω 1/4W
△ R559	HV754470	R.CAR.FP	47Ω 1/4W
△ R566	HV754470	R.CAR.FP	47Ω 1/4W
R567	VP941500	R.MTL.OXD	4.7KΩ 1W
R568	VP941500	R.MTL.OXD	4.7KΩ 1W
R569	HV756270	R.CAR.FP	2.7KΩ 1/4W
△ R571	HV755820	R.CAR.FP	820Ω 1/4W
R572	HV756100	R.CAR.FP	1KΩ 1/4W
R573	VP941500	R.MTL.OXD	4.7KΩ 1W
R574	VP941500	R.MTL.OXD	4.7KΩ 1W
△ R575	HV756270	R.CAR.FP	2.7KΩ 1/4W
△ R577	HV755820	R.CAR.FP	820Ω 1/4W
△ R578	HV756100	R.CAR.FP	1KΩ 1/4W
R579	VP941500	R.MTL.OXD	4.7KΩ 1W
R580	VP941500	R.MTL.OXD	4.7KΩ 1W
△ R581	HV756270	R.CAR.FP	2.7KΩ 1/4W
△ R583	HV755820	R.CAR.FP	820Ω 1/4W

* New Parts

Schm Ref	PART NO.	Description	
△ R584	HV756100	R.CAR.FP	1KΩ 1/4W
R585	VP941500	R.MTL.OXD	4.7KΩ 1W
R586	VP941500	R.MTL.OXD	4.7KΩ 1W
△ R587	HV756270	R.CAR.FP	2.7KΩ 1/4W
△ R589	HV755820	R.CAR.FP	820Ω 1/4W
△ R590	HV756100	R.CAR.FP	1KΩ 1/4W
R591	VP941500	R.MTL.OXD	4.7KΩ 1W
R592	VP941500	R.MTL.OXD	4.7KΩ 1W
△ R593	HV756270	R.CAR.FP	2.7KΩ 1/4W
△ R595	HV755820	R.CAR.FP	820Ω 1/4W
△ R596	HV756100	R.CAR.FP	1KΩ 1/4W
R597	VP940100	R.MTL.OXD	33Ω 1W
R598	HV753470	R.CAR.FP	4.7Ω 1/4W
△ R599	HV755330	R.CAR.FP	330Ω 1/4W
R602	HV753470	R.CAR.FP	4.7Ω 1/4W
R603	HV753470	R.CAR.FP	4.7Ω 1/4W
△ R605	HV755330	R.CAR.FP	330Ω 1/4W
R607	HV753470	R.CAR.FP	4.7Ω 1/4W
△ R608	HV753470	R.CAR.FP	4.7Ω 1/4W
△ R610	HV755330	R.CAR.FP	330Ω 1/4W
R611	HV753470	R.CAR.FP	4.7Ω 1/4W
△ R612	HV753470	R.CAR.FP	4.7Ω 1/4W
△ R614	HV755330	R.CAR.FP	330Ω 1/4W
△ R615	HV753470	R.CAR.FP	4.7Ω 1/4W
△ R616	HV753470	R.CAR.FP	4.7Ω 1/4W
△ R617	HV755330	R.CAR.FP	330Ω 1/4W
△ R619	HV753470	R.CAR.FP	4.7Ω 1/4W
△ R624	VP939800	R.MTL.OXD	10Ω 1W
R629	VP939800	R.MTL.OXD	10Ω 1W
R634	VP939800	R.MTL.OXD	10Ω 1W
R639	VP939800	R.MTL.OXD	10Ω 1W
R644	VP939800	R.MTL.OXD	10Ω 1W
R649	HV754100	R.CAR.FP	10Ω 1/4W
R652	HV754100	R.CAR.FP	10Ω 1/4W
R655	HV754100	R.CAR.FP	10Ω 1/4W
R657	HV754100	R.CAR.FP	10Ω 1/4W
R659	HV754100	R.CAR.FP	10Ω 1/4W
R662	VP940700	R.MTL.OXD	330Ω 1W
R663	HV755100	R.CAR.FP	100Ω 1/4W
R665	VP940700	R.MTL.OXD	330Ω 1W
R666	VP940700	R.MTL.OXD	330Ω 1W
△ R688	HZ003780	R.MTL.PLAT	0.22Ω+0.22 5W
△ R690	HZ003780	R.MTL.PLAT	0.22Ω+0.22 5W
△ R692	VU981700	R.MTL.PLAT	0.22Ω+0.22 3W
△ R694	VU981700	R.MTL.PLAT	0.22Ω+0.22 3W
△ R696	VU981700	R.MTL.PLAT	0.22Ω+0.22 3W
R711	VP944500	R.MTL.OXD	390Ω 1W
R712	VP944500	R.MTL.OXD	390Ω 1W
R729	HV753100	R.CAR.FP	1Ω 1/4W
R731	VP939600	R.MTL.FLM	2.2Ω 1W
R763	HV753100	R.CAR.FP	1Ω 1/4W
R764	HV753100	R.CAR.FP	1Ω 1/4W
R769	VP939800	R.MTL.OXD	10Ω 1W(ABGL)
R770	VP939800	R.MTL.OXD	10Ω 1W(ABGL)

* New Parts

P. C. B. MAIN & P. C. B. OPERATION

Schm Ref	PART NO.	Description	
△ RY501	VK438300	RELAY	DH24D2-OT/M2
△ RY502	VU566700	RELAY	DG24D2-OS/M
△ RY503	VK438300	RELAY	DH24D2-OT/M2
SW711	VV523900	SW.PUSH	PBS-YM-001
SW761	VZ361100	SW.SLIDE	SL13B-022-AMC1
TE501	V2984800	TERM.SP	6P
TE701	VC313700	TERM.SP	8P(URTCA)
TE701	VU819700	TERM.SP	8P(BGL)
	VJ828000	PIN	IMSA-6024-03E
	BB071360	SCR.TERM	8.3x13
	VR264300	PLATE.GND	
	EP600140	SCR.BND.HD	3x10 MFZN2-BL
	V3004500	P.C.B.	OPERATION(U)
	V3004600	P.C.B.	OPERATION(RT)
	V3004700	P.C.B.	OPERATION(A)
	V3004800	P.C.B.	OPERATION(B)
	V3004900	P.C.B.	OPERATION(G)
	V3005000	P.C.B.	OPERATION(L)
	V3252200	P.C.B.	OPERATION(C)
* CB451	VK026700	CN.BS.PIN	8P
CB800	VU272900	CN	29P
CB802	Vi878900	CN.BS.PIN	11P
CB803	Vi878700	CN.BS.PIN	9P
CB804	VP206500	HOLDER.FUS	EYF-52BC(RT)
CB805	VP206500	HOLDER.FUS	EYF-52BC(RT)
CB806	Vi878200	CN.BS.PIN	4P
CB807	VK025100	CN.BS.PIN	7P
CB810	VP206500	HOLDER.FUS	EYF-52BC(GL)
CB811	VP206500	HOLDER.FUS	EYF-52BC(GL)
CB812	VG879900	CN.BS.PIN	2P
CB813	VP206500	HOLDER.FUS	EYF-52BC
CB814	VP206500	HOLDER.FUS	EYF-52BC
C451	UR868330	C.EL	330uF 50V
C452	UR868330	C.EL	330uF 50V
C453	UR749680	C.EL	6800uF 25V
C454	VE326400	C.MYLAR.ML	0.22uF 50V
C455	UR749220	C.EL	2200uF 25V
C456	VE326400	C.MYLAR.ML	0.22uF 50V
C457	VS745400	C.POL.MTL	0.1uF 100V
C458	UR73A100	C.EL	10000uF 16V(RTABGL)
C458	UR749470	C.EL	4700uF 25V(UC)
C459	VJ599100	C.CE.TUBLR	0.1uF 50V
C460	VJ599100	C.CE.TUBLR	0.1uF 50V
C461	VE326400	C.MYLAR.ML	0.22uF 50V
C462	VE326400	C.MYLAR.ML	0.22uF 50V
C800	UR866220	C.EL	2.2uF 50V
C801	VG278900	C.CE.TUBLR	680pF 50V
C802	VG278900	C.CE.TUBLR	680pF 50V
C803	VJ599100	C.CE.TUBLR	0.1uF 50V
C804	UR866100	C.EL	1uF 50V
C805	VJ599100	C.CE.TUBLR	0.1uF 50V
C806	UR819100	C.EL	1000uF 6.3V

* New Parts

Schm Ref	PART NO.	Description	
C807	UR819100	C.EL	1000uF 6.3V
C808	VU545000	C.EL	47000uF 5.5V
C809	VJ599100	C.CE.TUBLR	0.1uF 50V
C810	UR837100	C.EL	10uF 16V
C811	UR866220	C.EL	2.2uF 50V
C812	VJ599100	C.CE.TUBLR	0.1uF 50V
C813	UR838330	C.EL	330uF 16V
C814	UR838330	C.EL	330uF 16V
C817	UR866100	C.EL	1uF 50V
C818	UR866220	C.EL	2.2uF 50V
C819	UR866220	C.EL	2.2uF 50V
C821	UR866100	C.EL	1uF 50V
C823	VJ599100	C.CE.TUBLR	0.1uF 50V
C824	VJ599100	C.CE.TUBLR	0.1uF 50V
C825	VJ599100	C.CE.TUBLR	0.1uF 50V
C826	UR848220	C.EL	220uF 25V(RT)
C826	UR848330	C.EL	330uF 25V(UABGLC)
C826	UR848330	C.EL	330uF 25V
C827	UR837470	C.EL	47uF 16V
C828	UA655120	C.MYLAR	0.12uF 50V
C829	VK533800	C.PP	47pF 200V
C830	VK533800	C.PP	47pF 200V
C831	UA655120	C.MYLAR	0.12uF 50V
C832	UR837470	C.EL	47uF 16V
C833	VF466800	C.CE.TUBLR	100pF 50V
C834	VF466800	C.CE.TUBLR	100pF 50V
C835	FG613100	C.CE	1000pF 50V(RT)
C836	UR896470	C.EL	4.7uF 100V(RT)
C837	Vi716700	C.MYLAR	0.01uF 50V
C838	UR847100	C.EL	10uF 25V
C839	UA954330	C.MYLAR	0.033uF 50V
C840	UA954330	C.MYLAR	0.033uF 50V
C841	UR847100	C.EL	10uF 25V
C842	UA954100	C.MYLAR	0.01uF 50V
C843	UR847100	C.EL	10uF 25V
C844	VQ645600	C.MYLAR	100pF 50V
C845	VQ645600	C.MYLAR	100pF 50V
C846	UR847100	C.EL	10uF 25V
△ C847	VS741700	C.CE.SAFTY	0.01uF 275V
△ D451	VR253700	DIODE.BRG	S1NB20 1.0A
△ D452	VR253700	DIODE.BRG	S1NB20 1.0A
△ D453	VR253700	DIODE.BRG	S1NB20 1.0A
D800	VD631600	DIODE	1SS133,176,HSS104
D801	VD631600	DIODE	1SS133,176,HSS104
D802	VM974100	DIODE.ZENR	HZS5B2TD 5.0V
D803	VD631600	DIODE	1SS133,176,HSS104
D805	VD631600	DIODE	1SS133,176,HSS104
D806	VD631600	DIODE	1SS133,176,HSS104
D807	VM974100	DIODE.ZENR	HZS5B2TD 5.0V
D808	VM974700	DIODE.ZENR	HZS7B2TD 7.0V
D809	VD631600	DIODE	1SS133,176,HSS104
D811	VD631600	DIODE	1SS133,176,HSS104
D812	VM974400	DIODE.ZENR	HZS6B2TD 6.0V(RT)
D812	VM974600	DIODE.ZENR	HZS7A2TD (UABGLC)

* New Parts

P. C. B. OPERATION

Schm Ref	PART NO.	Description
D813	VM974500	DIODE.ZENR HZS6C2TD 6.0V
D814	VD631600	DIODE 1SS133,176,HSS104
D815	VR253700	DIODE.BRG S1NB20 1.0A
D816	VM975300	DIODE.ZENR HZS11B2TD 11V(RT)
△ F800	KB000790	FUZE T4.0A 250V(RT)
△ F803	VT942900	FUZE TH2.5A 250V(GL)
△ F804	KB000790	FUZE T4.0A 250V(ABGL)
△ F804	VS823300	FUZE T8.0A 125V(URTC)
HS801	VR506800	HEAT.SINK PUH16-25(RT)
IC800	XU945J00	IC LC876564A-5K19 CPU
IC801	XM356A00	IC NJM2068LD
IC802	XM356A00	IC NJM2068LD
JK800	V2982900	CN 1P YKF51-5567(BG)
PJ800	VV325100	JACK.PIN 3P(BG)
PJ800	VV852700	JACK.PIN 3P(URTALC)
Q800	VG721700	TR.DGT DTA144ES
Q801	iA093320	TR 2SA933S Q,R
Q802	iA093320	TR 2SA933S Q,R
Q803	VG722000	TR.DGT DTC144ES
Q805	iA093320	TR 2SA933S Q,R
Q806	VP872700	TR 2SC4488 S,T
Q807	iC174020	TR 2SC1740S R,S
Q808	VR510800	TR 2SD2396 J,K(RT)
Q810	iC287820	TR 2SC2878 A,B
Q811	iC287820	TR 2SC2878 A,B
R451	HV753100	R.CAR.FP 1Ω 1/4W
R452	HV753100	R.CAR.FP 1Ω 1/4W
R878	VP939800	R.MTL.OXD 10Ω 1W
R881	VP939800	R.MTL.OXD 10Ω 1W
R904	HV756560	R.CAR.FP 5.6KΩ 1/4W(RT)
R906	HV756560	R.CAR.FP 5.6KΩ 1/4W(RT)
△*RY800	V2712300	RELAY DC SDT-S-112LMR
SW800	VT140300	SW.RT.ENC EC16B12204
SW801	VG392900	SW.TACT SKHVAA
SW802	VG392900	SW.TACT SKHVAA
SW803	VG392900	SW.TACT SKHVAA
SW804	VG392900	SW.TACT SKHVAA
SW805	VG392900	SW.TACT SKHVAA
SW806	VG392900	SW.TACT SKHVAA
SW807	VG392900	SW.TACT SKHVAA
SW808	VG392900	SW.TACT SKHVAA
*SW809	VG392900	SW.TACT SKHVAA
SW810	VG392900	SW.TACT SKHVAA
SW811	VG392900	SW.TACT SKHVAA
SW812	VG392900	SW.TACT SKHVAA
SW813	VG392900	SW.TACT SKHVAA
SW814	VG392900	SW.TACT SKHVAA
SW815	VG392900	SW.TACT SKHVAA
SW816	VG392900	SW.TACT SKHVAA
SW817	VG392900	SW.TACT SKHVAA
SW818	VG392900	SW.TACT SKHVAA
SW819	VG392900	SW.TACT SKHVAA
SW820	VG392900	SW.TACT SKHVAA
SW821	VG392900	SW.TACT SKHVAA(BG)

* New Parts

Schm Ref	PART NO.	Description
SW822	VG392900	SW.TACT SKHVAA
SW823	VG392900	SW.TACT SKHVAA
SW824	VG392900	SW.TACT SKHVAA
SW825	VG392900	SW.TACT SKHVAA(BG)
SW826	VG392900	SW.TACT SKHVAA
SW827	VG392900	SW.TACT SKHVAA
SW828	VG392900	SW.TACT SKHVAA(BG)
SW829	VG392900	SW.TACT SKHVAA(BG)
SW831	VA961800	VOLT.SELCT ESE-37247-F(RT)
△ T800	XC083A00	TRANS.PWR (UC)
△ T800	XC084A00	TRANS.PWR (ABGL)
△ T800	XT331A00	TRANS.PWR (RT)
△ TE800	VT915000	OUTLET.AC 2P(A)
△ TE800	VU543100	OUTLET.AC 2P(URTC)
△ TE800	VU543300	OUTLET.AC 1P(B)
△ TE800	VU543400	OUTLET.AC 2P(GL)
U800	VU591000	L.DTCT GP1U271X
*V800	V2421800	FL.DSPLY 16-BT-59GK
VR800	VP741800	VR B20KΩ
VR801	VP741900	VR G25KΩ
VR802	VP742000	VR MN100KΩ
XL800	VQ791000	RSNR.CE 10MHz
	BB071360	SCR.TERM 8.3x13
	VS588900	SHEET
	V3422300	SPACER FL-WIDE
	EP600140	SCR.BND.HD 3x10 MFZN2-BL(RT)

* New Parts

■ Chip Resistors

Schm Ref	PART NO.	Description
	RD250000	R.CAR.CHP 0Ω 1/10W
	RD254470	R.CAR.CHP 47Ω 1/10W
	RD255100	R.CAR.CHP 100Ω 1/10W
	RD255330	R.CAR.CHP 330Ω 1/10W
	RD256100	R.CAR.CHP 1KΩ 1/10W
	RD256120	R.CAR.CHP 1.2KΩ 1/10W
	RD256150	R.CAR.CHP 1.5KΩ 1/10W
	RD256220	R.CAR.CHP 2.2KΩ 1/10W
	RD256330	R.CAR.CHP 3.3KΩ 1/10W
	RD256470	R.CAR.CHP 4.7KΩ 1/10W
	RD256680	R.CAR.CHP 6.8KΩ 1/10W
	RD256820	R.CAR.CHP 8.2KΩ 1/10W
	RD257100	R.CAR.CHP 10KΩ 1/10W
	RD257120	R.CAR.CHP 12KΩ 1/10W
	RD257470	R.CAR.CHP 47KΩ 1/10W
	RD258100	R.CAR.CHP 100KΩ 1/10W
	RD258470	R.CAR.CHP 470KΩ 1/10W
	RD259100	R.CAR.CHP 1MΩ 1/10W

* New Parts

P. C. B. TUNER (Lead Type)

Schm Ref	PART NO.	Description		
* * *	V2518600 V2518700 V2518800 V2518900	P.C.B. P.C.B. P.C.B. P.C.B.	TUNER/TU-01(UC) TUNER/TU-01(RT) TUNER/TU-01(ABGL) TUNER/TU-01RDS(BG)	
CB4	VQ961900	CN	16P	
C1	VG287600	C.EL	100uF	25V
C3	VG275800	C.CE.TUBLR	8.2pF	50V
C4	UR837470	C.EL	47uF	16V
C5	VF467300	C.CE.TUBLR	0.01uF	16V
C6	UR837470	C.EL	47uF	16V
C7	UM416100	C.EL	1uF	50V
C8	VF467300	C.CE.TUBLR	0.01uF	16V
C9	VF467300	C.CE.TUBLR	0.01uF	16V
C10	VF467300	C.CE.TUBLR	0.01uF	16V
C11	VF467000	C.CE.TUBLR	1000pF	50V
C12	UM397100	C.EL	10uF	16V
C13	UM397100	C.EL	10uF	16V
C14	FG652100	C.CE	100pF	50V
C15	VF467000	C.CE.TUBLR	1000pF	50V
C16	VF466700	C.CE.TUBLR	47pF	50V
C17	UR837470	C.EL	47uF	16V
C19	V3625800	C.CE	33pF	50V
C20	VG287600	C.EL	100uF	25V
C21	VJ599000	C.CE.TUBLR	0.047uF	16V
C22	VG290700	C.EL	3.3uF	50V
C23	VF467300	C.CE.TUBLR	0.01uF	16V
C24	UM406470	C.EL	4.7uF	50V
C25	UM416330	C.EL	3.3uF	50V
C26	UM397100	C.EL	10uF	16V
C27	VF467300	C.CE.TUBLR	0.01uF	16V
C28	VA761200	C.CE	33pF	50V
C29	UM416100	C.EL	1uF	50V
C30	UM416100	C.EL	1uF	50V
C31	VG287600	C.EL	100uF	25V
C32	UM415470	C.EL	0.47uF	50V
C33	UM416100	C.EL	1uF	50V
C34	UA954470	C.MYLAR	0.047uF	50V
C35	VG290700	C.EL	3.3uF	50V
C36	UA953100	C.MYLAR	1000pF	50V(UCRT)
C36	V3451700	C.PP	270pF	100V(ABGL)
C37	UA953100	C.MYLAR	1000pF	50V(UCRT)
C37	V3451700	C.PP	270pF	100V(ABGL)
C38	VF466900	C.CE.TUBLR	470pF	50V
C39	VG287200	C.EL	10uF	50V
C40	VE020000	C.EL	3.3uF	50V
C41	VL884100	C.PP	3900pF	100V
C42	UM397220	C.EL	22uF	25V
C43	UA953390	C.MYLAR	3900pF	50V
C43	VL884100	C.PP	3900pF	100V
C44	VE020000	C.EL	3.3uF	50V
C45	UR837470	C.EL	47uF	16V
C46	UR837470	C.EL	47uF	16V
C47	VG278600	C.CE.TUBLR	330pF	50V
C48	VG278800	C.CE.TUBLR	560pF	50V

* New Parts

P. C. B. TUNER (Lead Type & SMD)

Schm Ref	PART NO.	Description			
C49	UA953220	C.MYLAR	2200pF	50V(UCRT)	
C49	V3451600	C.PP	120pF	100V(ABGL)	
C50	VJ599000	C.CE.TUBLR	0.047uF	16V	
C51	UR837470	C.EL	47uF	16V	
C52	UR837470	C.EL	47uF	16V	
C53	UR837470	C.EL	47uF	16V	
C54	VA761100	C.CE	27pF	50V	
C55	VA761100	C.CE	27pF	50V	
C56	VJ599000	C.CE.TUBLR	0.047uF	16V	
C57	VG278600	C.CE.TUBLR	330pF	50V	
D1	VD631600	DIODE	1SS133,176,HSS104		
D2	VD631600	DIODE	1SS133,176,HSS104		
D3	VG437700	DIODE.ZENR	MTZJ5.6B	5.6V	
Fi1	GG000560	FLTR.CE	SFE10.7MS3GHY-A		
Fi2	GG000560	FLTR.CE	SFE10.7MS3GHY-A		
Fi3	VC219000	FLTR.CE	SFZ450JL3		
IC1	XB760A00	IC	LA1266		
IC2	XQ944A00	IC	LC72131		
IC3	iG158100	IC	LA3401		
IC4	XU664A00	IC	LC72720N		
L1	Vi546100	COIL	220uH		
L2	Vi546100	COIL	220uH		
L3	Vi546100	COIL	220uH		
L4	Vi546100	COIL	220uH		
L5	Vi546100	COIL	220uH		
* PK1	V2716700	TUNER.PK	ENV-172A4G1(ABGL)		
* PK1	V2909100	TUNER.PK	ENV-172C8G1R(UCRT)		
PK2	VU333700	COIL.RF.AM	940536051A		
Q1	iC053540	TR	2SC535 A,B,C		
Q2	iC053540	TR	2SC535 A,B,C		
Q3	VD678500	TR.DGT	DTA114ES		
Q4	iC174020	TR	2SC1740S R,S		
Q5	VG722000	TR.DGT	DTC144ES		
Q6	iC181510	TR	2SC1815 Y		
Q7	VD678500	TR.DGT	DTA114ES		
R56	HV754470	R.CAR.FP	47Ω	1/4W	
SW1	VS602600	SW.SLIDE	SS070-P022 A(RT)		
T1	VC218600	COIL.DT.FM	10.7MHz		
T2	VR895700	COIL.IF	450KHz		
T3	VT486800	COIL	XYA2(ABGL)		
T4	VQ138200	FLTR.LC	19KHz		
T5	VQ138200	FLTR.LC	19KHz		
TE1	VU477800	TERM.ANT	AJ-2038-040		
TP1	VT969000	PIN.TEST	IRS-2049		
TP2	VT969000	PIN.TEST	IRS-2049		
VR1	VJ694000	VR.TRIM	B47KΩ		
VR2	VJ694000	VR.TRIM	B47KΩ		
XL1	QU003800	RSNR.CRYS	7.2MHz		
XL2	GG000750	RSNR.CE	18.95KHz		
XL3	VY704900	RSNR.CRYS	4.332MHz		
	BB071360	SCR.TERM	8.3x13		
	VR282500	PLATE	ANT.		

* New Parts

P. C. B. TUNER (Lead Type & SMD)

Schm Ref	PART NO.	Description		
* * *	V2519300 V2519400 V2519500 V2519600	P.C.B. CHP P.C.B. CHP P.C.B. CHP P.C.B. CHP	TUNER/TU-01(UC) TUNER/TU-01(RT) TUNER/TU-01(ABGL) TUNER/TU-01RDS(BG)	
CB4	VQ961900	CN	16P	
C1	VG287600	C.EL	100uF	25V
C3	UB050800	C.CE.M.CHP	8pF	50V
C4	UR837470	C.EL	47uF	16V
C5	UB044100	C.CE.M.CHP	0.01uF	50V
C6	UR837470	C.EL	47uF	16V
C7	UM416100	C.EL	1uF	50V
C8	UB044100	C.CE.M.CHP	0.01uF	50V
C9	UB044100	C.CE.M.CHP	0.01uF	50V
C10	UB044100	C.CE.M.CHP	0.01uF	50V
C11	UB013100	C.CE.M.CHP	1000pF	50V
C12	UM397100	C.EL	10uF	16V
C13	UM397100	C.EL	10uF	16V
C14	FG652100	C.CE	100pF	50V
C15	UB013100	C.CE.M.CHP	1000pF	50V
C16	UB051470	C.CE.M.CHP	47pF	50V
C17	UR837470	C.EL	47uF	16V
C19	V3625800	C.CE	33pF	50V
C20	VG287600	C.EL	100uF	25V
C21	UB044470	C.CE.M.CHP	0.047uF	50V
C22	VG290700	C.EL	3.3uF	50V
C23	UB044100	C.CE.M.CHP	0.01uF	50V
C24	UM406470	C.EL	4.7uF	50V
C25	UM416330	C.EL	3.3uF	50V
C26	UM397100	C.EL	10uF	16V
C27	UB044100	C.CE.M.CHP	0.01uF	50V
C28	VA761200	C.CE	33pF	50V
C29	UM416100	C.EL	1uF	50V
C30	UM416100	C.EL	1uF	50V
C31	VG287600	C.EL	100uF	25V
C32	UM415470	C.EL	0.47uF	50V
C33	UM416100	C.EL	1uF	50V
C34	UA954470	C.MYLAR	0.047uF	50V
C35	VG290700	C.EL	3.3uF	50V
C36	UA953100	C.MYLAR	1000pF	50V(UCRT)
C36	V3451700	C.PP	270pF	100V(ABGL)
C37	UA953100	C.MYLAR	1000pF	50V(UCRT)
C37	V3451700	C.PP	270pF	100V(ABGL)
C38	UB012470	C.CE.M.CHP	470pF	50V
C39	VG287200	C.EL	10uF	50V
C40	VG290700	C.EL	3.3uF	50V
C41	VL884100	C.PP	3900pF	100V
C42	UM397220	C.EL	22uF	25V
C43	UA953390	C.MYLAR	3900pF	50V
C43	VL884100	C.PP	3900pF	100V
C44	VG290700	C.EL	3.3uF	50V
C45	UR837470	C.EL	47uF	16V
C46	UR837470	C.EL	47uF	16V
C47	UB012330	C.CE.M.CHP	330pF	50V
C48	UB012560	C.CE.M.CHP	560pF	50V

* New Parts

Schm Ref	PART NO.	Description			
C49	UA953220	C.MYLAR	2200pF	50V(UCRT)	
C49	V3451600	C.PP	120pF	100V(ABGL)	
C50	UB044470	C.CE.M.CHP	0.047uF	50V	
C51	UR837470	C.EL	47uF	16V	
C52	UR837470	C.EL	47uF	16V	
C53	UR837470	C.EL	47uF	16V	
C54	VA761100	C.CE	27pF	50V	
C55	VA761100	C.CE	27pF	50V	
C56	UB044470	C.CE.M.CHP	0.047uF	50V	
C57	UB012330	C.CE.M.CHP	330pF	50V	
D1	VT332900	DIODE	1SS355		
D2	VT332900	DIODE	1SS355		
D3	VU172000	DIODE.ZENR	UDZS5.6BTE-17	5.6V	
Fi1	GG000560	FLTR.CE	SFE10.7MS3GHY-A		
Fi2	GG000560	FLTR.CE	SFE10.7MS3GHY-A		
Fi3	VC219000	FLTR.CE	SFZ450JL3		
IC1	XB760A00	IC	LA1266		
IC2	XQ944A00	IC	LC72131		
IC3	iG158100	IC	LA3401		
IC4	XU664A00	IC	LC72720N		
L1	VU889500	COIL	220uH		
L2	VU889500	COIL	220uH		
L3	VU889500	COIL	220uH		
L4	VU889500	COIL	220uH		
L5	VU889500	COIL	220uH		
* PK1	V2716700	TUNER.PK	ENV-172A4G1(ABGL)		
* PK1	V2909100	TUNER.PK	ENV-172C8G1R(UCRT)		
PK2	VU333700	COIL.RF.AM	940536051A		
Q1	iC053540	TR	2SC535 A,B,C		
Q2	iC053540	TR	2SC535 A,B,C		
Q3	VD678500	TR.DGT	DTA114ES		
Q4	iC174020	TR	2SC1740S R,S		
Q5	VG722000	TR.DGT	DTC144ES		
Q6	iC181510	TR	2SC1815 Y		
Q7	VD678500	TR.DGT	DTA114ES		
R56	HV754470	R.CAR.FP	47Ω	1/4W	
SW1	VS602600	SW.SLIDE	SS070-P022 A(RT)		
T1	VC218600	COIL.DT.FM	10.7MHz		
T2	VR895700	COIL.IF	450KHz		
T3	VT486800	COIL	XYA2		
T4	VQ138200	FLTR.LC	19KHz		
T5	VQ138200	FLTR.LC	19KHz		
TE1	VU477800	TERM.ANT	AJ-2038-040		
TP1	VT969000				

EXPLODED VIEW

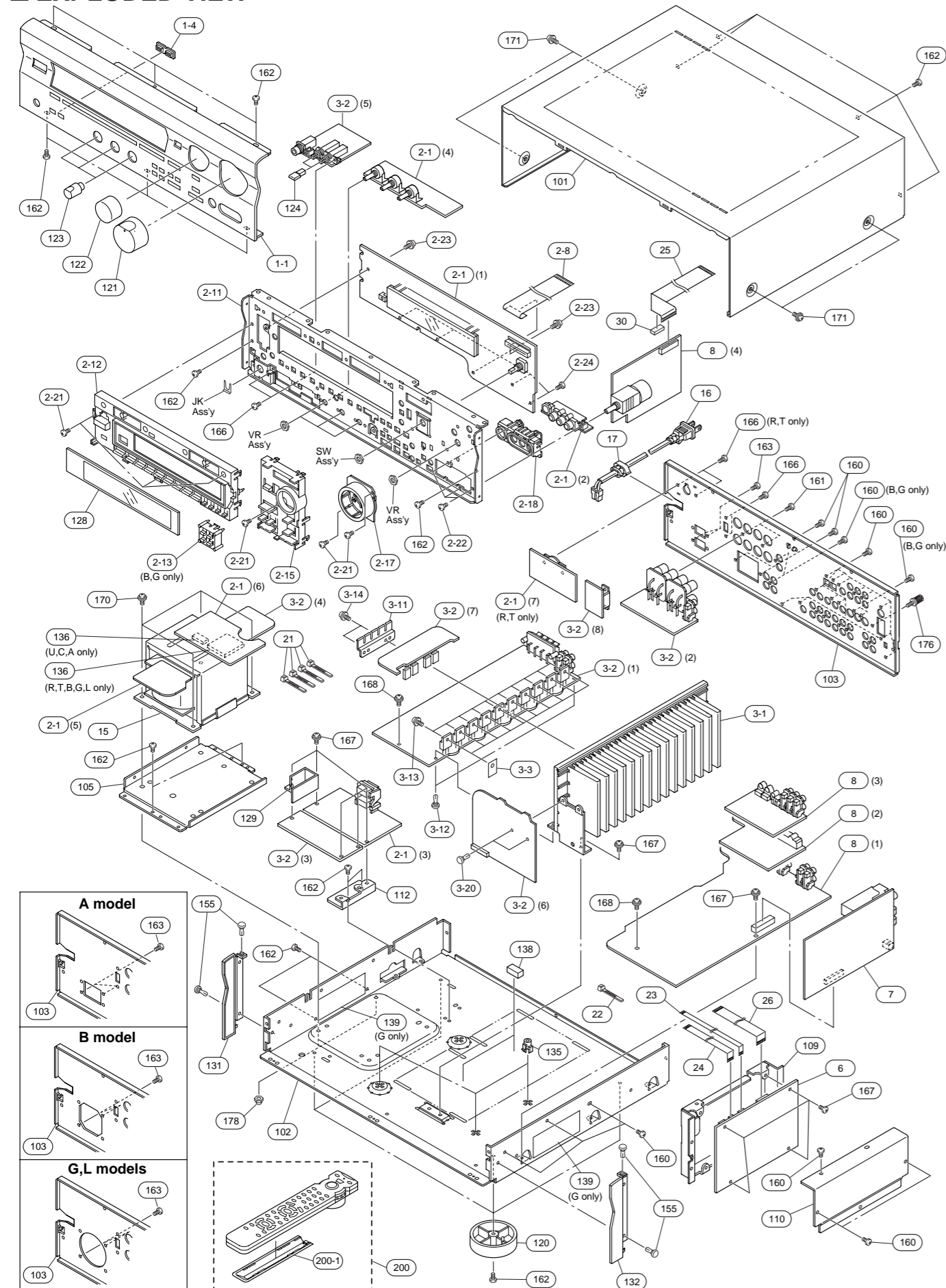

MECHANICAL PARTS

Ref. No.	PART NO.	Description	Remarks	Markets
* 1-1	V2463700	FRONT PANEL		(T)
* 1-1	V2463800	FRONT PANEL		(BG)
* 1-1	V2463900	FRONT PANEL		(G)
1-1	V2464100	FRONT PANEL		
1-1	V3542100	FRONT PANEL		
* 1-4	V2468600	ESCUTCHOEN	3/8	(UCRALT)
* 2-1	V3004500	P.C.B. ASS'Y	OPERATION	(U)
* 2-1	V3004600	P.C.B. ASS'Y	OPERATION	(RT)
* 2-1	V3004700	P.C.B. ASS'Y	OPERATION	(A)
* 2-1	V3004800	P.C.B. ASS'Y	OPERATION	(B)
* 2-1	V3004900	P.C.B. ASS'Y	OPERATION	(G)
* 2-1	V3005000	P.C.B. ASS'Y	OPERATION	(L)
2-1	V3252200	P.C.B. ASS'Y	OPERATION	(C)
* 2-8	MF229160	S FLEXIBLE FLAT CABLE C&C	29P 160mm	
* 2-11	V2460700	SUB CHASSIS		
* 2-12	V2465500	BUTTON CASE		RX-V595 BL
* 2-12	V2465600	BUTTON CASE		RX-V595RDS TI
* 2-12	V2465700	BUTTON CASE		RX-V595 GD
2-12	V2633800	BUTTON CASE		R-V905
* 2-13	V2467000	BUTTON, RDS		BL
* 2-13	V2467100	BUTTON, RDS		TI
* 2-15	V2465800	BUTTON INPUT		BL
* 2-15	V2465900	BUTTON INPUT		TI
* 2-15	V2466000	BUTTON INPUT		GD
* 2-17	V2467900	ESCUTCHEON, VOL		BL
* 2-17	V2468000	ESCUTCHEON, VOL		TI
* 2-17	V2468100	ESCUTCHEON, VOL		GD
2-17	V2468200	ESCUTCHEON, VOL		GP
* 2-18	V2468300	ESCUTCHEON, PJ		BL
* 2-18	V2468400	ESCUTCHEON, PJ		TI
* 2-18	V2468500	ESCUTCHEON, PJ		GD
2-21	EP600830	BIND HEAD B-TITE SCREW	3x8 FCRM3-BL	
2-22	VN413300	BIND HEAD BONDING B-T. SCREW	3x8 MFZN2-BL	
2-23	VT669300	PW HEAD B-TITE SCREW	3x8-8 MFC2	
2-24	EP630220	BIND HEAD P-TITE SCREW	3x8 ZMC2-BL	
* 3-1	V2463200	HEAT SINK		
* 3-2	V3003000	P.C.B. ASS'Y	MAIN	(URT)
* 3-2	V3003100	P.C.B. ASS'Y	MAIN	(C)
* 3-2	V3003200	P.C.B. ASS'Y	MAIN	(A)
* 3-2	V3003300	P.C.B. ASS'Y	MAIN	(BG)
* 3-2	V3003400	P.C.B. ASS'Y	MAIN	(L)
3-3	VV849300	SHEET	19x24	
* 3-11	V2461000	SUPPORT, TR		
3-12	VQ368500	PUSH RIVET	P3545-B	
3-13	VK173200	SCREW, TRANSISTOR	3x15 SP FCM3	
3-14	VT669300	PW HEAD B-TITE SCREW	3x8-8 MFC2	
3-20	VQ368600	PUSH RIVET	P3555-B	
* 6	V3005700	P.C.B. ASS'Y	DSP	
* 7	V2518600	P.C.B. ASS'Y	TUNER/TU-01	(UC)
* 7	V2518700	P.C.B. ASS'Y	TUNER/TU-01	(RT)
* 7	V2518800	P.C.B. ASS'Y	TUNER/TU-01	(AL)
7	V2518900	P.C.B. ASS'Y	TUNER/TU-01RDS	(BG)
* 8	V3004000	P.C.B. ASS'Y	INPUT	(AL)

* New Parts

Ref. No.	PART NO.	Description	Remarks	Markets
* 8	V3004100	P.C.B. ASS'Y		(BG)
△ 15	XV315A00	POWER TRANSFORMER		(U)
△ 15	XV316A00	POWER TRANSFORMER		(C)
△ 15	XV317A00	POWER TRANSFORMER		(RT)
△ 15	XV318A00	POWER TRANSFORMER		(A)
△ 15	XV319B00	POWER TRANSFORMER		(BGL)
△ 16	V2296800	POWER CORD ASS'Y		(A)
△* 16	V2363800	POWER CORD ASS'Y		(UC)
△ 16	VN363700	POWER CORD ASS'Y		(GL)
△ 16	VV437300	POWER CORD ASS'Y		(B)
△ 16	VZ542500	POWER CORD ASS'Y		(RT)
* 17	V2438700	CORD STOPPER	#10P1	
21	VU590000	BINDING TIE	CBTD001B	
22	VZ625600	BINDING TIE	SE140 L=140	
* 23	MF106250	FLEXIBLE FLAT CABLE	6P 250mm	
24	MF211140	S FLEXIBLE FLAT CABLE	11P 140mm	
25	MF123180	FLEXIBLE FLAT CABLE	23P 180mm	
26	MF113140	FLEXIBLE FLAT CABLE	13P 140mm	
30	V2126000	DAMPER	T2x10x20	
101	VV121300	TOP COVER		BL
101	VV121500	TOP COVER		TI
101	VZ884500	TOP COVER		GD
* 102	V2460600	CHASSIS		
* 103	V2461200	REAR PANEL		RX-V595 (U)
* 103	V2461300	REAR PANEL		RX-V595 (C)
* 103	V2461400	REAR PANEL		RX-V595 (RT)
* 103	V2461500	REAR PANEL		RX-V595 (A)
* 103	V2461600	REAR PANEL		RX-V595 (L)
* 103	V2461800	REAR PANEL		RX-V595RDS (B)
* 103	V2461900	REAR PANEL		RX-V595RDS (G)
103	V2462000	REAR PANEL		R-V905 (U)
103	V2462100	REAR PANEL		R-V905 (C)
103	V2462200	REAR PANEL		R-V905 (T)
103	V2462300	REAR PANEL		R-V905 (A)
* 105	V2460800	FRAME, TRANSFORMER		
* 109	V2461100	SHIELD CASE		
110	VZ332800	SHIELD CASE COVER		
* 112	V2460900	FRAME		
120	V0042500	LEG	D60xH21	R-V905 (T)
120	VS025000	LEG	D60xH21	RX-V595 BL/TI
120	VV544300	LEG	D60xH21	RXV595GD R-V905 (UCA)
121	V3346400	KNOB	D40 BL	
121	V3346500	KNOB	D40 TI	
121	V3346600	KNOB	D40 GD	
* 122	V2467600	KNOB, ENC	D30 BL	
* 122	V2467700	KNOB, ENC	D30 TI	
* 122	V2467800	KNOB, ENC	D30 GD	
123	V0016700	KNOB	D14 GD	
123	VV311000	KNOB	D14 BL	
123	VV311400	KNOB	D14 TI	
* 124	V2467300	BUTTON	3/8 BL	
* 124	V2467400	BUTTON	3/8 TI	
* 124	V2467500	BUTTON	3/8 GD	

* New Parts

Ref. No.	PART NO.	Description	Remarks	Markets
* 128	V2469400	SHEET, WINDOW		
129	V3153900	SHHET		(RABGLT)
* 131	V2468800	PLATE SIDE L	130 BL	
* 131	V2468900	PLATE SIDE L	130 TI	
* 131	V2469000	PLATE SIDE L	130 GD	
* 132	V2469100	PLATE SIDE R	130 BL	
* 132	V2469200	PLATE SIDE R	130 TI	
* 132	V2469300	PLATE SIDE R	130 GD	
135	VR264400	SPACER	H8	
136	VQ948200	SPACER	FL	
* 138	V2879500	SPACER PCB-M		
139	V3198100	DAMPER	GUARD	(G)
155	VQ368600	PUSH RIVET	P3555-B	
160	VN413300	BIND HEAD BONDING B-T. SCREW	3x8 MFZN2-BL	
161	VY731200	BONDING HEAD TAPPING SCREW	3x10 MFNI33	
162	EP600830	BIND HEAD B-TITE SCREW	3x8 FCRM3-BL	
163	EP600250	BIND HEAD B-TITE SCREW	3x8 ZMC2-Y	
166	EG330030	BIND HEAD SCREW	3x6 FCRM3-BL	
167	VT669300	PW HEAD B-TITE SCREW	3x8-8 MFC2	
168	VT669400	PW HEAD B-TITE SCREW	3x15-8 MFC2	
170	21991500	PW HEAD S-TITE SCREW	4x8-10 FCRM3-BL	
171	21991500	PW HEAD S-TITE SCREW	4x8-10 FCRM3-BL	BL
171	VD069600	PW HEAD S-TITE SCREW	4x8-10 MFNI-33	GD
171	VH313200	BW HEAD S-TITE SCREW	4x8-10 FNM3-BL	TI
176	AA627310	GROUND TERMINAL		
178	03700480	HEXAGONAL CAP NUT	4.0 MFNI33	
		ACCESSORIES		
* 200	V2686300	REMOTE CONTROL TRANSMITTER	RRC4000-7001R	(UCRLT)
* 200	V2686400	REMOTE CONTROL TRANSMITTER	RRC4000-7002R	(ABG)
200-1	XX702560	LID		
	VQ147100	ANTENNA, FM	1P 1.4m	
	VR248500	ANTENNA, AM LOOP	1P 1.0m	
	VE364900	ANTENNA ADAPTER	PAL 75-300Ω	(B)
	VT948000	ANTENNA ADAPTER		(UC)
		BATTERY, MANGANESE	SUM-3,AA,R06	

* New Parts

PRINTED CIRCUIT BOARD (Foil side)

There are two types of P. C. B. Assembly Tuner for this models in items of construction of components. One uses the Lead Type Device only and the other uses the Lead Type device and Surface Mount Device (SMD). These P. C. B. assemblies are interchangeable.

● U, C, R, T, A and L models

P. C. B. TUNER (Lead Type & SMD)

P. C. B. ASS'Y TUNER LIST

Model	Markets	Lead & SMD	Lead Type
RX-V595	U, C	V2519300	V2518600
RX-V595	R, T	V2519400	V2518700
RX-V595	A, L	V2519500	V2518800
RX-V595RDS	B, G	V2519600	V2518900

Lead Type : See page 40~41, PRINTED CIRCUIT BOARD
P. C. B. TUNER (Lead Type)

● B and G models

P. C. B. TUNER (Lead Type & SMD)

(Lead Type Device)

(Surface Mount Device)

(Lead Type Device)

(Surface Mount Device)

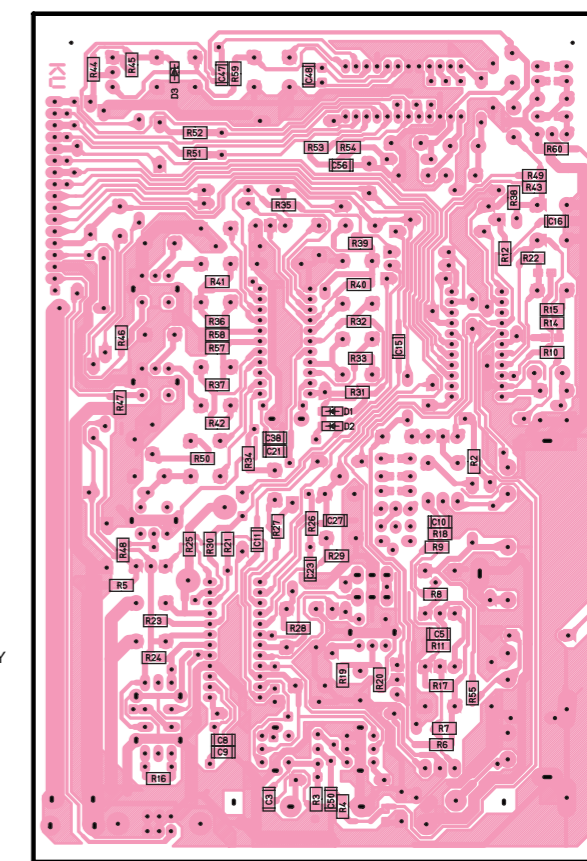
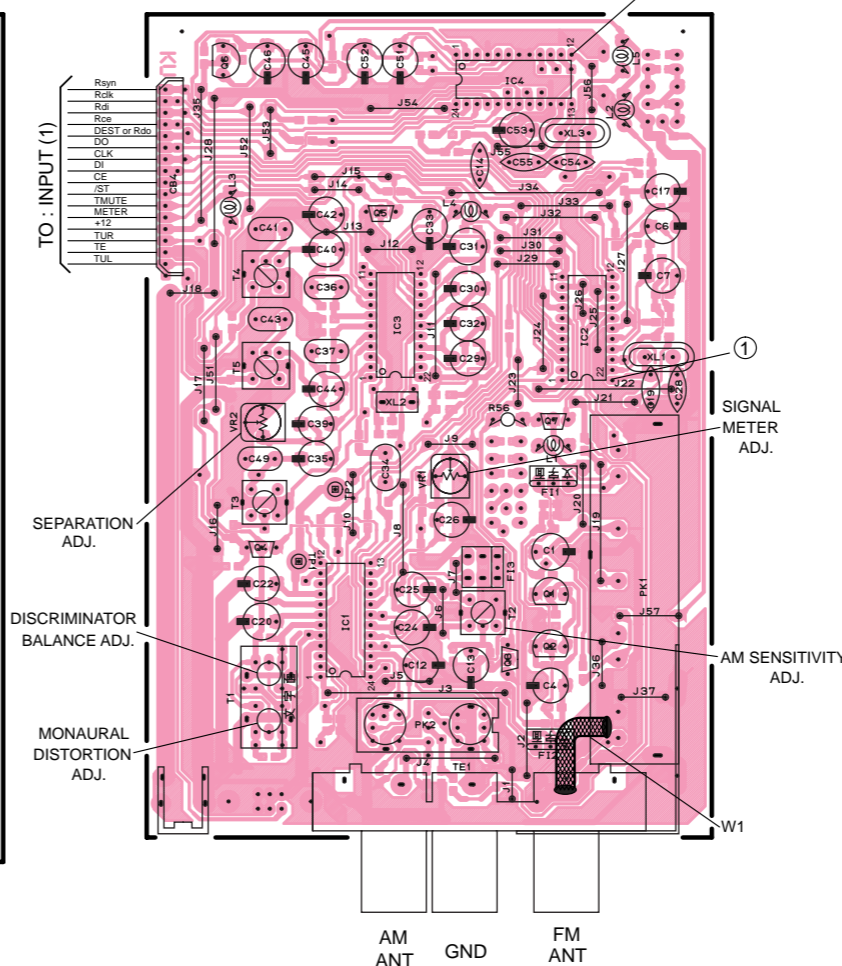
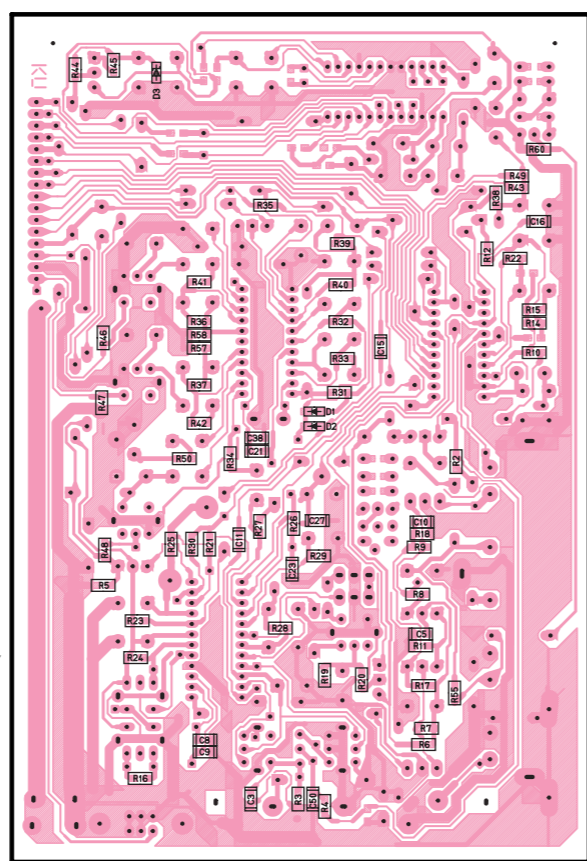
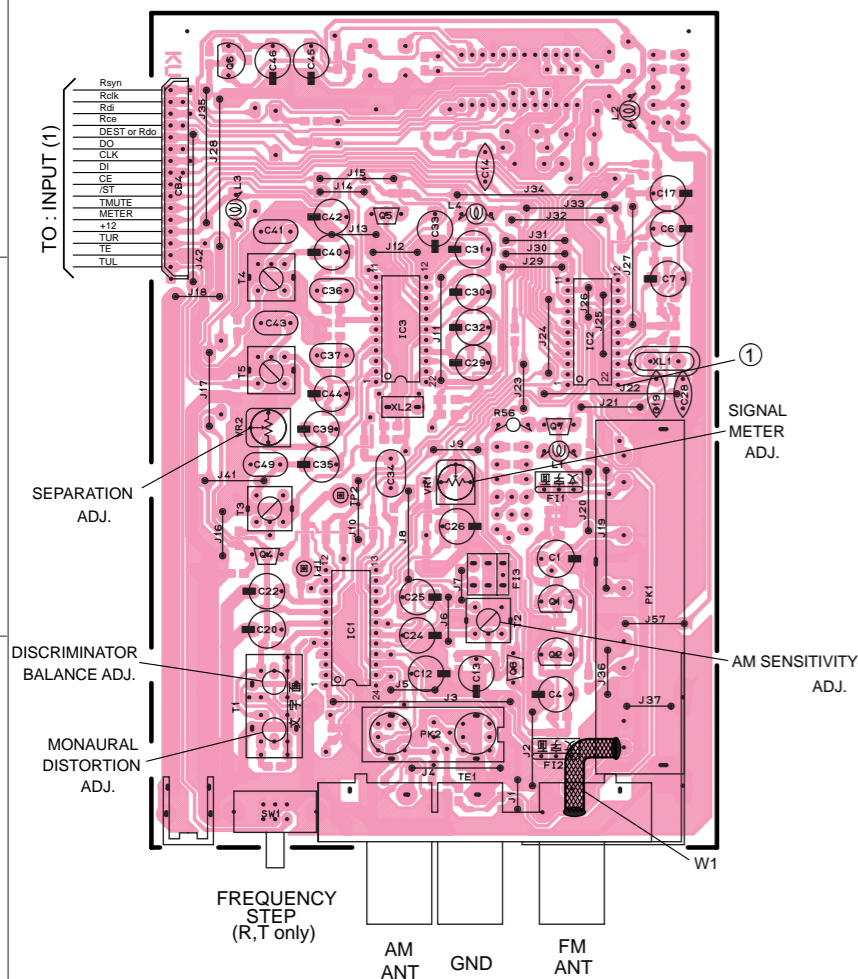

U, C, R, T, A and L models

● Semiconductor Location

Ref. No.	Location
D1	D3
D2	D3
D3	C2
IC1	A4
IC2	B3
IC3	B3
Q1	B3
Q2	B4
Q3	B4
Q4	A3
Q5	B2
Q6	A2
Q7	B3

CIRCUIT CHANGES BY MARKET.

	U,C	R,T	A,L
R48	×	×	○
T3	×	×	○
J41	○	○	×
J42	×	○	×
R55	×	×	○
R57	×	×	○
R58	×	×	○
R60	×	×	○

○ : USED
× : NOT USED

Point ① (Pin22 of IC2)

V : 2V/div H : 0.1μsec/div DC range 1 : 1 probe

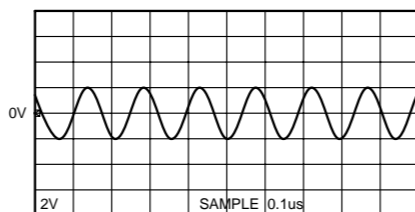

B and G models

● Semiconductor Location

Ref. No.	Location
D1	H3
D2	H3
D3	G2
IC1	E4
IC2	F3
IC3	E3
IC4	F2
Q1	F3
Q2	F4
Q3	F4
Q4	E3
Q5	E2
Q6	E2
Q7	F3

Point ① (Pin22 of IC2)

V : 2V/div H : 50nsec/div DC range 1 : 1 probe

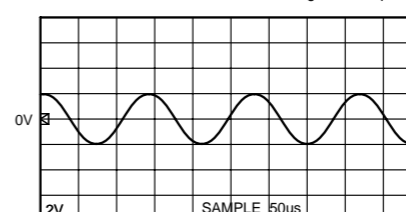

Point ② (Pin12 of IC4)

V : 2V/div H : 0.1μsec/div DC range 1 : 1 probe

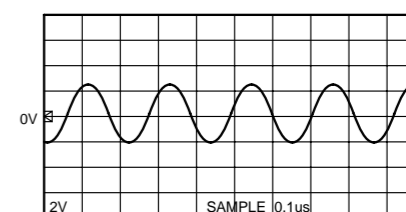

REMOTE CONTROL TRANSMITTER

SCHEMATIC DIAGRAM

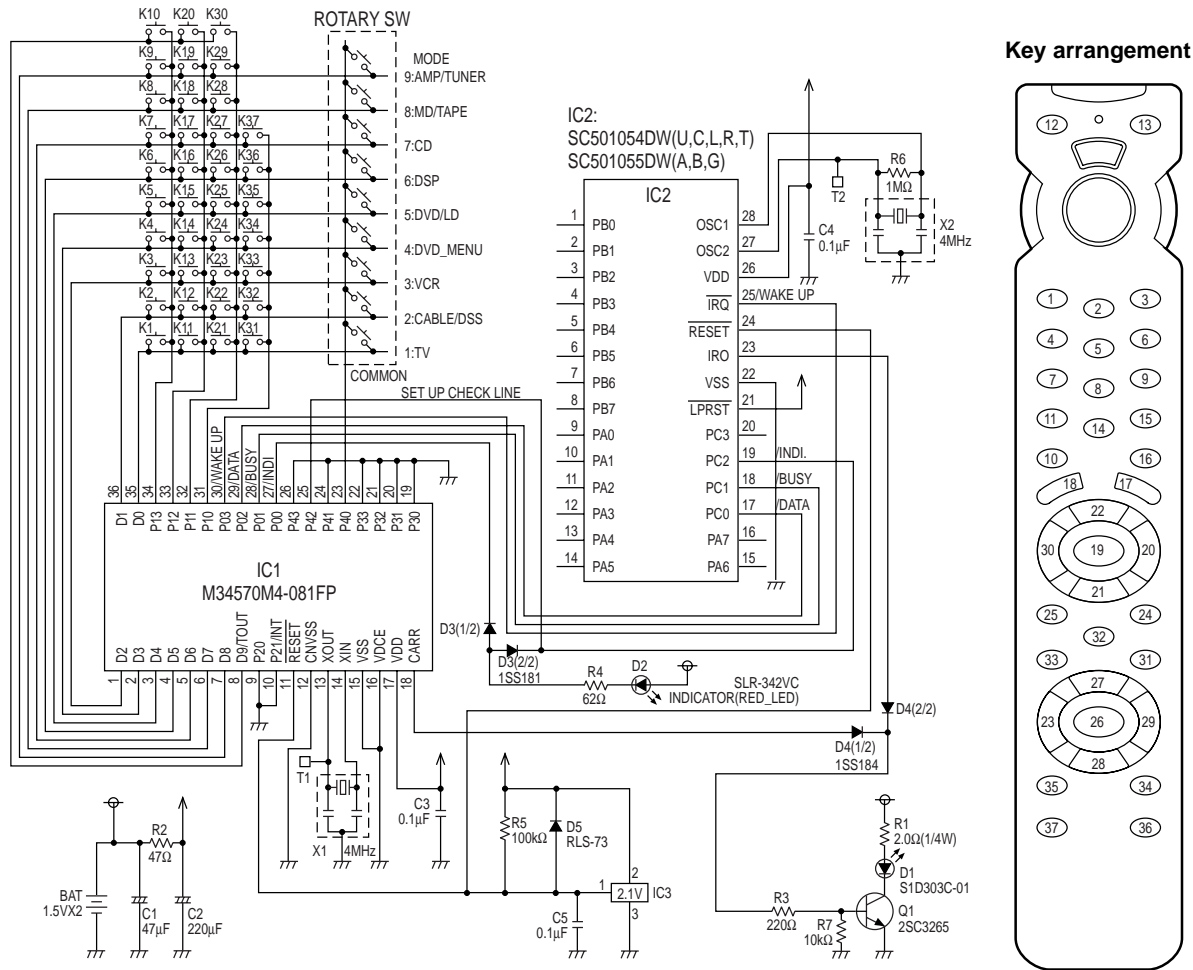

List of the fixed code

Key No.	Key NAME	MODE ID #	TV	Cable/DSS	VCR	DVD Menu	DVD/LD	DSP	CD	Tape/MD	AMP/Tuner	
1	1		CH1	CH1	CH1	7C-94	7A-15	7A-88		7A-15		
2	2		CH2	CH2	CH2	7C-95	7A-16	7A-89		7A-16		
3	3		CH3	CH3	CH3	7C-96	7A-18	7A-8A		7A-18		
4	4		CH4	CH4	CH4	7C-97	7A-17	7A-8B		7A-17		
5	5		CH5	CH5	CH5	7C-98	7A-54	7A-8C		7A-54		
6	6		CH6	CH6	CH6	7C-99	7A-0F	7A-8D		7A-0F		
7	7		CH7	CH7	CH7	7C-9A	7A-14	7A-8E		7A-14		
8	8		CH8	CH8	CH8	7C-9B	7A-55	7A-8F		7A-55		
9	9		CH9	CH9	CH9	7C-9C	7A-13	7A-90		7A-13		
10	DSP		Shift of only Ten key in DSP Mode							Shift of only Ten key in DSP Mode		
11	0		CH0	CH0	CH0	7C-93	7A-87	7A-91		7A-87		
12	POWER		7A-1D	Power	Power	7A-1D			7A-1D			
13	STANDBY					7A-1E			7A-1E			
14	ENTER		CH Select	CH Select	CH Select	7C-9D		7A-12			7A-12	
15	CLEAR			+100		7C-9F		7A-85			7A-85	
16	EFFECT		Surround			7A-56			7A-56			
17	CH+		CH+	CH+	CH+	7C-8B		7A-10	7A-4F		7A-10	
18	CH-		CH-	CH-	CH-	7C-8A		7A-11	7A-50		7A-11	
19	MUTE		Mute			7A-1C			7A-1C			
20	VOL+					7A-1A			7A-1A			
21	TV VOL-					TV VOL-			TV VOL-			
22	TV VOL+					TV VOL+			TV VOL+			
23	SKIP-			Left		7C-B5	7C-B9	7A-53	7A-0B	7A-07	7A-53	
24	DISPLAY		Display	Display	Display	7C-9E	7C-A6	7A-C2	79-0B		7A-C2	
25	SLEEP		Sleep			7A-57			7A-57			
26	PLAY		VCR Play	Menu Select	Play	7C-B8	7C-82		7A-08	7A-00		
27	PAUSE		VCR Pause	Up	Pause	7C-B4	7C-83	7A-98	7A-09		7A-98	
28	STOP		VCR Stop	Down	Stop	7C-B3	7C-85	7A-99	7A-09	7A-03	7A-99	
29	SKIP+			Right		7C-B6	7C-BA	7A-52	7A-0A	7A-40	7A-52	
30	VOL-					7A-1B			7A-1B			
31	TV INPUT					TV Input			TV input	7A-06		
32	TV POWER					TV Power			TV Power			
33	REC		VCR REC		REC					7A-04		
34	FF		VCR FF	Recall	FF	7C-B7	7C-AE	7A-58	7A-0C	7A-02	7A-58	
35	REW		VCR REW		REW	7C-AC	7C-AB	7A-59	7A-0D	7A-01	7A-59	
36	MENU			Menu		7C-B2	7C-AD	7A-9C			7A-9C	
37	TITLE					7C-B1	7C-AA	7A-86			7A-86	

----- : No Code

Parts List for Carbon Resistors

Value	1/4W Type Part No.	1/6W Type Part No.	Value	1/4W Type Part No.	1/6W Type Part No.
1.0 Ω	HJ35 3100	HF85 3100	10 kΩ	HF45 7100	HF45 7100
1.8 Ω	HJ35 3180	*	11 kΩ	HF45 7110	HF45 7110
2.2 Ω	HJ35 3220	HF85 3220	12 kΩ	HJ35 7120	HF85 7120
3.3 Ω	HJ35 3330	HF85 3330	13 kΩ	HF45 7130	HF45 7130
4.7 Ω	HJ35 3470	HF85 3470	15 kΩ	HF45 7150	HF45 7150
5.6 Ω	HJ35 3560	HF85 3560	18 kΩ	HF45 7180	HF45 7180
10 Ω	HF45 4100	HF45 4100	22 kΩ	HF45 7220	HF45 7220
15 Ω	HJ35 4150	HF85 4150	24 kΩ	HF45 7240	HF45 7240
22 Ω	HF45 4220	HF45 4220	27 kΩ	HJ35 7270	HF85 7270
27 Ω	HJ35 4270	HF85 4270	30 kΩ	HF45 7300	HF45 7300
33 Ω	HF45 4330	HF45 4330	33 kΩ	HF45 7330	HF45 7330
39 Ω	HJ35 4390	HF85 4390	36 kΩ	HF45 7360	HF45 7360
47 Ω	HF45 4470	HF45 4470	39 kΩ	HF45 7390	HF45 7390
56 Ω	HF45 4560	HF45 4560	47 kΩ	HF45 7470	HF45 7470
68 Ω	HF45 4680	HF45 4680	51 kΩ	HF45 7510	HF45 7510
75 Ω	HF45 4750	HF45 4750	56 kΩ	HF45 7560	HF45 7560
82 Ω	HF45 4820	HF45 4820	62 kΩ	HF45 7620	HF45 7620
91 Ω	HF45 4910	HF45 4910	68 kΩ	HF45 7680	HF45 7680
100 Ω	HF45 5100	HF45 5100	82 kΩ	HF45 7820	HF45 7820
110 Ω	HJ35 5110	HF85 5110	91 kΩ	HF45 7910	HF45 7910
120 Ω	HF45 5120	HF45 5120	100 kΩ	HF45 8100	HF45 8100
150 Ω	HF45 5150	HF45 5150	110 kΩ	HF45 8110	HF45 8110
160 Ω	HJ35 5160	*	120 kΩ	HF45 8120	HF45 8120
180 Ω	HF45 5180	HF45 5180	150 kΩ	HF45 8150	HF45 8150
200 Ω	HF45 5200	HF45 5200	180 kΩ	HF45 8180	HF45 8180
220 Ω	HF45 5220	HF45 5220	220 kΩ	HJ35 8220	HF85 8220
270 Ω	HF45 5270	HF45 5270	270 kΩ	HF45 8270	HF45 8270
330 Ω	HF45 5330	HF45 5330	300 kΩ	HF45 8300	HF45 8300
390 Ω	HF45 5390	HF45 5390	330 kΩ	HF45 8330	HF45 8330
430 Ω	HF45 5430	HF45 5430	390 kΩ	HJ35 8390	HF85 8390
470 Ω	HF45 5470	HF45 5470	470 kΩ	HF45 8470	HF45 8470
510 Ω	HF45 5510	HF45 5510	560 kΩ	HJ35 8560	HF85 8560
560 Ω	HF45 5560	HF45 5560	680 kΩ	HJ35 8680	HF85 8680
680 Ω	HF45 5680	HF45 5680	820 kΩ	HJ35 8820	HF85 8820
820 Ω	HF45 5820	HF45 5820	1.0 MΩ	HF45 9100	HF45 9100
910 Ω	HF45 5910	HF45 5910	1.2 MΩ	HJ35 9120	*
1.0 kΩ	HF45 6100	HF45 6100	1.5 MΩ	HJ35 9150	HF85 9150
1.2 kΩ	HF45 6120	HF45 6120	1.8 MΩ	HJ35 9180	HF85 9180
1.5 kΩ	HF45 6150	HF45 6150	2.2 MΩ	HJ35 9220	HF85 9220
1.8 kΩ	HF45 6180	HF45 6180	3.3 MΩ	HJ35 9330	HF85 9330
2.0 kΩ	HJ35 6200	HF85 6200	3.9 MΩ	HJ35 9390	*
2.2 kΩ	HF45 6220	HF45 6220	4.7 MΩ	HJ35 9470	HF85 9470
2.4 kΩ	HJ35 6240	HF85 6240			
2.7 kΩ	HF45 6270	HF45 6270			
3.0 kΩ	HF45 6300	HF45 6300			
3.3 kΩ	HF45 6330	HF45 6330			
3.6 kΩ	HJ35 6360	HF85 6360			
3.9 kΩ	HF45 6390	HF45 6390			
4.7 kΩ	HF45 6470	HF45 6470			
5.1 kΩ	HF45 6510	HF45 6510			
5.6 kΩ	HF45 6560	HF45 6560			
6.8 kΩ	HF45 6680	HF45 6680			
8.2 kΩ	HF45 6820	HF45 6820			
9.1 kΩ	HF45 6910	HF45 6910			

1/4W Type
HJ35 ○○○○

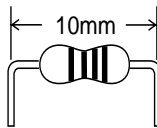

← 10mm →

1/6W Type
HF45 ○○○○
HF85 ○○○○

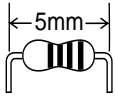

← 5mm →

*: Not available