

STEREO RECEIVER

RX-450

SERVICE MANUAL

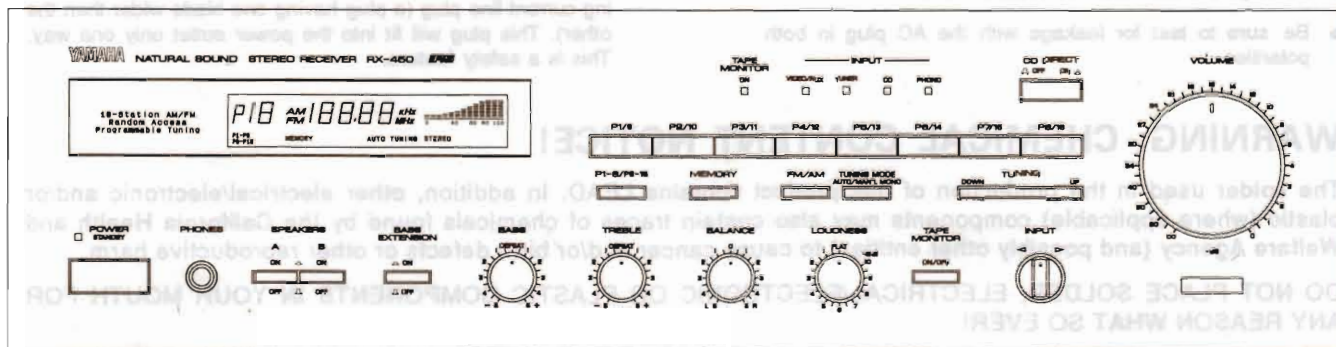

RX-450



IMPORTANT NOTICE

This manual has been provided for the use of authorized YAMAHA Retailers and their service personnel. It has been assumed that basic service procedures inherent to the industry, and more specifically YAMAHA Products, are already known and understood by the users, and have therefore not been restated.

WARNING: Failure to follow appropriate service and safety procedures when servicing this product may result in personal injury, destruction of expensive components, and failure of the product to perform as specified. For these reasons, we advise all YAMAHA product owners that any service required should be performed by an authorized YAMAHA Retailer or the appointed service representative.

IMPORTANT: The presentation or sale of this manual to any individual or firm does not constitute authorization, certification or recognition of any applicable technical capabilities, or establish a principle-agent relationship of any form.

The data provided is believed to be accurate and applicable to the unit(s) indicated on the cover. The research, engineering, and service departments of YAMAHA are continually striving to improve YAMAHA products. Modifications are, therefore, inevitable and specifications are subject to change without notice or obligation to retrofit. Should any discrepancy appear to exist, please contact the distributor's Service Division.

WARNING: Static discharges can destroy expensive components. Discharge any static electricity your body may have accumulated by grounding yourself to the ground buss in the unit (heavy gauge black wires connect to this buss).

IMPORTANT: Turn the unit OFF during disassembly and part replacement. Recheck all work before you apply power to the unit.

CONTENTS

TO SERVICE PERSONNEL	1	BLOCK DIAGRAM	12-13
REAR PANELS	1~2	PRINTED CIRCUIT BOARD	14-19
INTERNAL VIEW	2	INTERCONNECT WIRING DIAGRAM	20
SPECIFICATIONS	3~4	WAVEFORM OF TEST POINT	21
DISASSEMBLY PROCEDURES	4	SCHEMATIC DIAGRAM	22
ADJUSTMENTS	5~8	FRONT END PACK	23
U-COM DATA	9~10	PARTS LIST	24-31
DISPLAY DATA	11	REMOTE CONTROL TRANSMITTER	32

TO SERVICE PERSONNEL

- Critical Components Information.**
Components having special characteristics are marked and must be replaced with parts having specifications equal to those originally installed.
 - Leakage Current Measurement (For 120V Models Only).**
When service has been completed, it is imperative to verify that all exposed conductive surfaces are properly insulated from supply circuits.
- Meter impedance should be equivalent to 1500 ohm shunted by 0.15 μ F.
 - Leakage current must not exceed 0.5mA.
 - Be sure to test for leakage with the AC plug in both polarities.

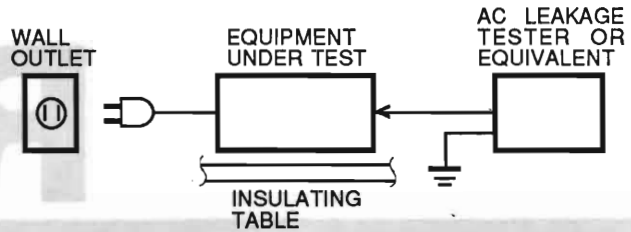

- POLARIZATION (U model only)**
This amplifier product is equipped with a polarized alternating-current line plug (a plug having one blade wider than the other). This plug will fit into the power outlet only one way. This is a safety feature.

WARNING: CHEMICAL CONTENT NOTICE!

The solder used in the production of this product contains LEAD. In addition, other electrical/electronic and/or plastic (where applicable) components may also contain traces of chemicals found by the California Health and Welfare Agency (and possibly other entities) to cause cancer and/or birth defects or other reproductive harm.

DO NOT PLACE SOLDER, ELECTRICAL/ELECTRONIC OR PLASTIC COMPONENTS IN YOUR MOUTH FOR ANY REASON WHAT SO EVER!

Avoid prolonged, unprotected contact between solder and your skin! When soldering, do not inhale solder fumes or expose eyes to solder/flux vapor!

If you come in contact with solder or components located inside the enclosure of this product, wash your hands before handling food.

REAR PANELS

USA & Canadian models

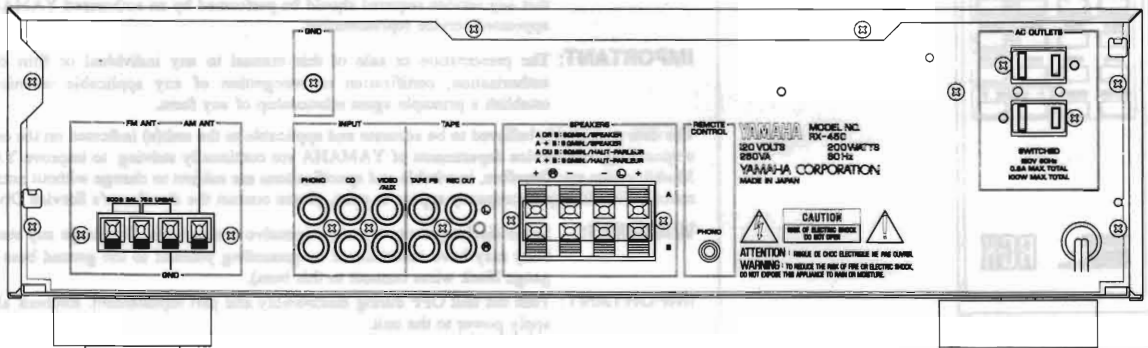

General model

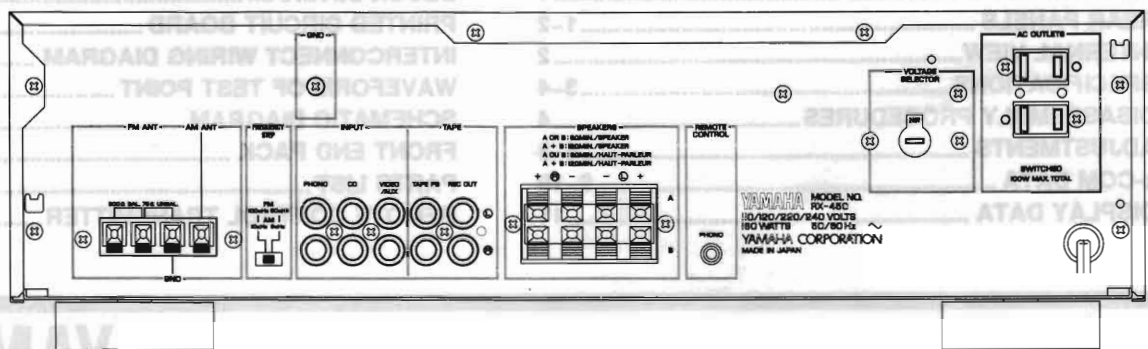

▼ European model

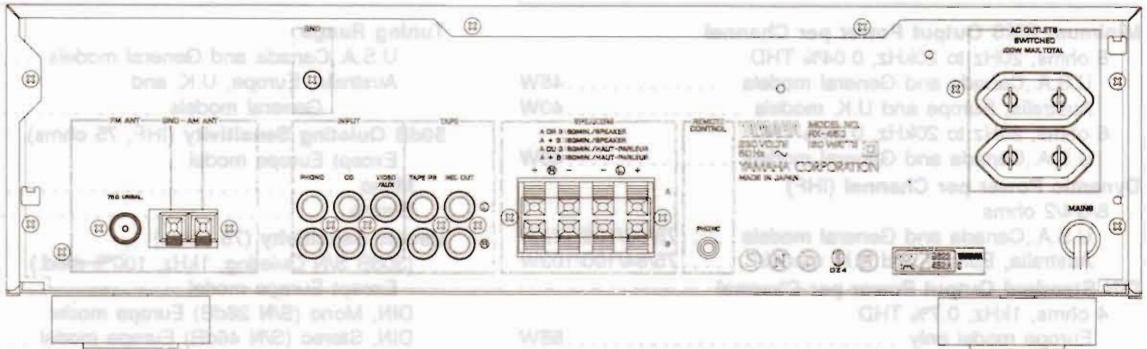

▼ Australian & British models

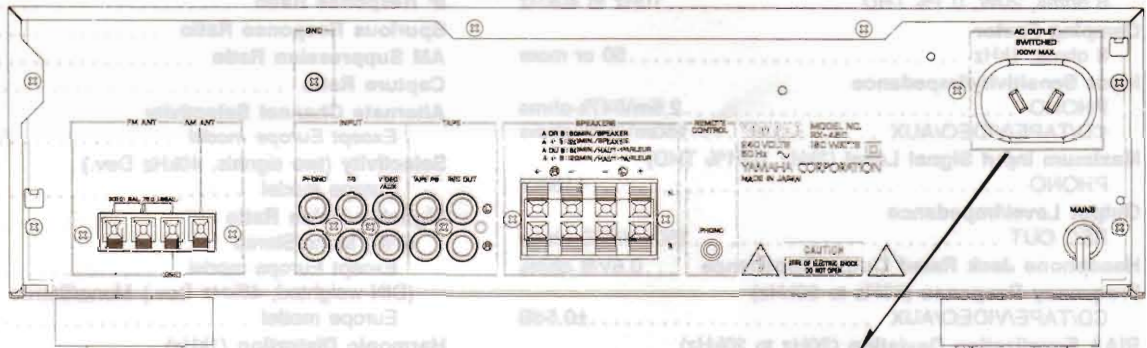

British model only

RX-450

■ INTERNAL VIEW

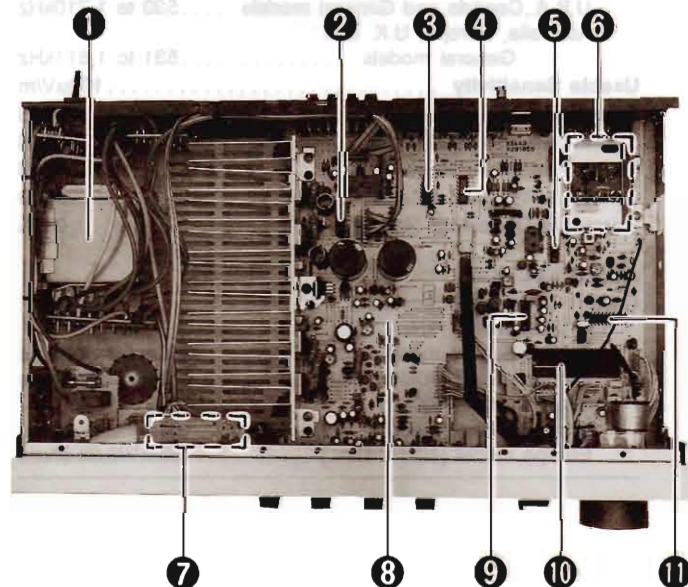

- ① POWER TRANSFORMER
- ② D112 : RBV-402
- ③ IC103 : TC4053BP (TAPE MONITOR)
- ④ IC102 : TC4052BP (INPUT SELECTOR)
- ⑤ IC1 : LA1266 (AM/FM IF)
- ⑥ FRONT END PACK
- ⑦ LCD DISPLAY CIRCUIT BOARD
- ⑧ MAIN CIRCUIT BOARD (1)
- ⑨ IC2 : LA3401 (MPX)
- ⑩ IC4 : LC6554 (4 bit μ-COM)
- ⑪ IC3 : LM7000N (PLL)

■ SPECIFICATIONS

■ AUDIO SECTION

Minimum RMS Output Power per Channel

8 ohms, 20Hz to 20kHz, 0.04% THD	
U.S.A., Canada and General models	45W
Australia, Europe and U.K. models	40W
6 ohms, 20Hz to 20kHz, 0.06% THD	
U.S.A., Canada and General models	48W

Dynamic Power per Channel (IHF)

8/6/4/2 ohms	
U.S.A., Canada and General models	78/90/108/112W
Australia, Europe and U.K. models	75/84/100/103W

DIN Standard Output Power per Channel

4 ohms, 1kHz, 0.7% THD	
Europe model only	55W

IEC Power (1kHz, 0.04% THD, 8 ohms)

Europe model only	50W
-------------------	-----

Power Bandwidth

8 ohms, 20W, 0.1% THD	10Hz to 40kHz
-----------------------	---------------

Damping Factor

8 ohms, 1kHz	50 or more
--------------	------------

Input Sensitivity/Impedance

PHONO	2.5mV/47k-ohms
CD/TAPE/VIDEO/AUX	150mV/50k-ohms

Maximum Input Signal Level (1kHz, 0.01% THD)

PHONO	110mV
-------	-------

Output Level/Impedance

REC OUT	150mV/550 ohms
---------	----------------

Headphone Jack Rated Output/Impedance

	0.6V/8 ohms
--	-------------

Frequency Response (20Hz to 20kHz)

CD/TAPE/VIDEO/AUX	±0.5dB
-------------------	--------

RIAA Equalization Deviation (20Hz to 20kHz)

PHONO	±0.5dB
-------	--------

Total Harmonic Distortion (20Hz to 20kHz)

PHONO to REC OUT (3V)	0.01%
CD/TAPE/VIDEO/AUX to SP OUT (20W/8 ohms)	0.02%

Intermodulation Distortion

CD/TAPE/VIDEO/AUX (Rated Output/8 ohms)	0.04%
---	-------

Signal-to-Noise Ratio (IHF-A Network)

PHONO (5mV Input Shorted)	
U.S.A., Canada and General models	87dB
Australia Europe and U.K. models	82dB
CD/TAPE/VIDEO/AUX (Shorted)	103dB

Residual Noise (IHF-A Network)

	140µV
--	-------

Channel Separation (1kHz, Vol. -30dB)

PHONO (Input Shorted)	55dB
CD/TAPE/VIDEO/AUX	
(input 5.1k-ohms Terminated)	52dB

Tone Control Characteristics

BASS : Boost/cut	±10dB (50Hz)
Turnover Frequency	350Hz
TREBLE : Boost/cut	±10dB (20kHz)
Turnover Frequency	3.5kHz

Filter Characteristics

Bass Extension	60Hz, +8dB
----------------	------------

Continuous Loudness Control

	-40dB (1kHz)
--	--------------

(Level related equalization)

■ FM SECTION

Tuning Range

U.S.A., Canada and General models	87.5 to 107.9MHz
Australia, Europe, U.K. and	
General models	87.5 to 108.0MHz

50dB Quieting Sensitivity (IHF, 75 ohms)

Except Europe model	
Mono	1.55µV (15.1dBf)
Stereo	21µV (37.7dBf)

Usable Sensitivity (75 ohms)

(30dB S/N Quieting, 1kHz, 100% mod.)	
Except Europe model	0.8µV (9.3dBf)
DIN, Mono (S/N 26dB) Europe model	0.9µV
DIN, Stereo (S/N 46dB) Europe model	24µV

Image Response Ratio

Except Europe model	45dB
Europe model	80dB

IF Response Ratio

	80dB
--	------

Spurious Response Ratio

	70dB
--	------

AM Suppression Ratio

	55dB
--	------

Capture Ratio

	1.5dB
--	-------

Alternate Channel Selectivity

Except Europe model	85dB
---------------------	------

Selectivity (two signals, 40kHz Dev.)

Europe model	50dB
--------------	------

Signal-to-Noise Ratio

(IHF) Mono/Stereo	
Except Europe model	81/76dB
(DIN-weighted, 40kHz Dev.) Mono/Stereo	
Europe model	75/70dB

Harmonic Distortion (1kHz)

Mono/Stereo	
Except Europe model	0.1/0.2%
Stereo (40kHz Dev.)	
Europe model	0.2%

Frequency Response

30Hz to 13kHz	0 ± 0.5dB
20Hz to 15kHz	0 ± 1.5dB

Stereo Separation (1kHz)

Except Europe model	50dB
Europe model (40kHz Dev.)	50dB

■ AM SECTION

Tuning Range

U.S.A., Canada and General models	530 to 1,710kHz
Australia, Europe, U.K. and	
General models	531 to 1,611kHz

Usable Sensitivity

	100µV/m
--	---------

Selectivity

	32dB
--	------

Signal-to-Noise Ratio

	50dB
--	------

Image Response Ratio

	40dB
--	------

Spurious Response Ratio

	50dB
--	------

Harmonic Distortion (400Hz)

	0.3%
--	------

AUDIO SECTION

Output Level/Impedance

FM (30% mod., 1kHz)	
Except Europe model	500mV/2.2k-ohms
Europe model (40kHz Dev.)	400mV/6.8k-ohms

AM (30% mod., 400Hz)

Except Europe model	150mV/2.2k-ohms
Europe model (40kHz Dev.)	150mV/6.8k-ohms

GENERAL

Power Supply

- U.S.A. and Canada modelsAC 120V, 60Hz
- Australia and U.K. modelsAC 240V, 50Hz
- Europe modelAC 230V, 50Hz
- General modelAC 110-120/220-240V, 60/50Hz

Power Consumption

- U.S.A. model180W
- Canadian model200W
- General model160W
- Australia, Europe and U.K. models160W

AC Outlets

- Switched100W max.

Dimensions (W x H x D)

435 x 131 x 291.7mm
(17-1/8" x 5-3/16" x 11-1/2")

Weight

5.7 kg (12 lbs. 9 oz.)

Accessories

- AM loop antenna x 1
- Indoor FM antenna x 1

* Specifications subject to change without notice.

- UUSA model
- CCanadian model
- AAustralian model
- BBritish model
- GEuropean model
- RGeneral model

DIMENSIONS

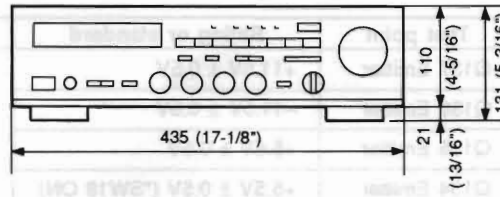
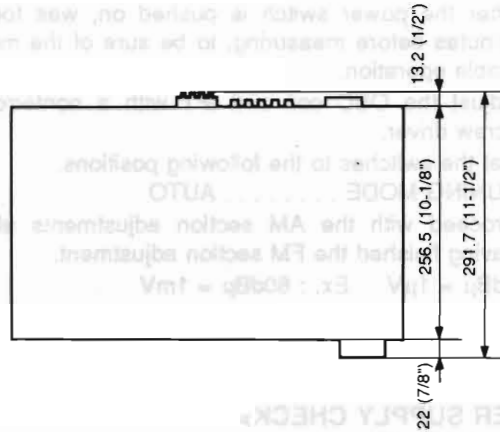

Units : mm (inch)

RX-450

DISASSEMBLY PROCEDURES

(Remove parts in the order as numbered.)

1. Removal of Top Cover

Remove 7 screws (①) in Fig. 1 and slide the Top Cover back and up.

2. Removal of Front Panel

Remove 3 screws (②) and 4 hooks in Fig. 1, and pull the Front Panel forward.

3. Check of Main Circuit Board (1) and replacement of parts.

- a. Remove 12 screws (③) in Fig. 1.
- b. Remove the P.C. Support.
- c. Remove the Main Chassis as shown in Fig. 2. In this condition it is possible for you check the Main Circuit Board (1), and replace the parts.

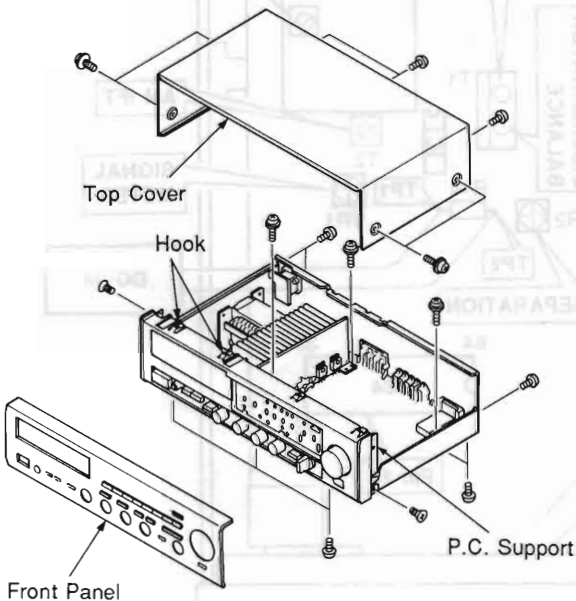

Fig. 1

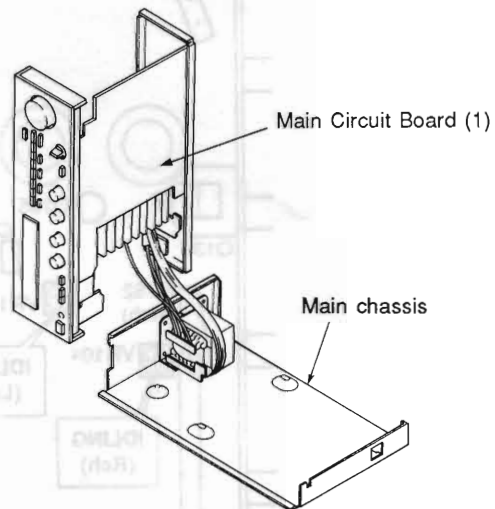

Fig. 2

ADJUSTMENTS

1. Before adjustment

- 1) After the power switch is pushed on, wait for 5 minutes before measuring, to be sure of the most stable operation.
- 2) Adjust the OSC coil and IFT with a nonferrous screw driver.
- 3) Set the switches to the following positions.
TUNING MODE AUTO
- 4) Proceed with the AM section adjustments after having finished the FM section adjustment.
- 5) 0dB μ = 1 μ V Ex. : 60dB μ = 1mV

2. Measuring Instruments abbreviation

- FM SG** : FM signal generator
- SSG** : Stereo signal generator
- AM SG** : AM signal generator
- DIST.M** : Distortion meter
- FC** : Frequency counter
- A.C.V.M.** : AC voltmeter
- D.C.V.M.** : DC voltmeter

<POWER SUPPLY CHECK>

Check that the following voltages are obtained respectively across each test point and ground on main circuit.

Test point	Rating or standard	Remark								
Q137 Emitter	+11.5V \pm 0.5V	Make sure that AC line voltage comes within <table border="1"> <thead> <tr> <th>Models</th> <th>AC line voltage</th> </tr> </thead> <tbody> <tr> <td>U, C</td> <td>120V \pm 10%</td> </tr> <tr> <td>G</td> <td>220V \pm 10%</td> </tr> <tr> <td>A, B</td> <td>240V \pm 10%</td> </tr> </tbody> </table>	Models	AC line voltage	U, C	120V \pm 10%	G	220V \pm 10%	A, B	240V \pm 10%
Models	AC line voltage									
U, C	120V \pm 10%									
G	220V \pm 10%									
A, B	240V \pm 10%									
Q138 Emitter	-11.5V \pm 0.5V									
Q135 Emitter	+5.6V \pm 0.5V									
Q134 Emitter	+5.5V \pm 0.5V (*SW18 ON)									
Q133 Collector	+10.8V \pm 0.5V (*SW18 ON)									

* SW18: POWER SWITCH

TEST POINT

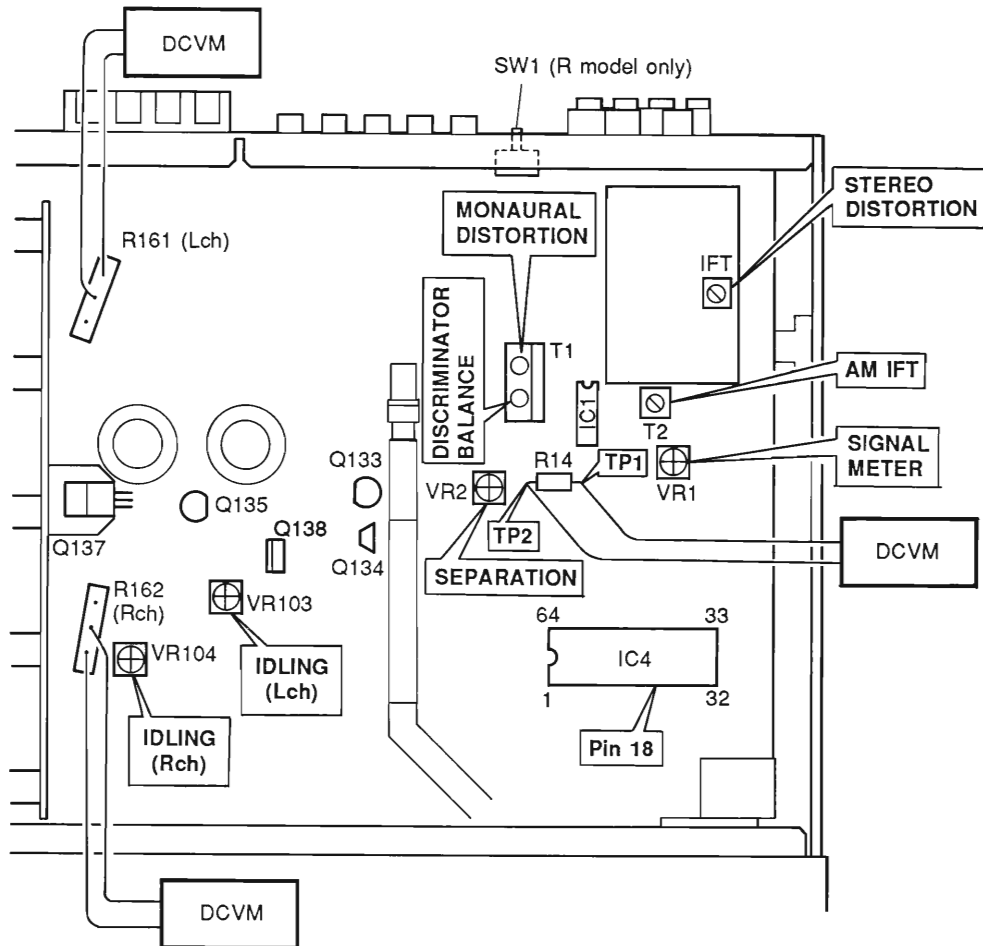

<AUDIO SECTION>

● IDLING CURRENT ADJUSTMENT

When replacing the power and drive transistors, adjust idling current. After the power has been turned on, age about 5 minutes in non loaded condition. Adjust VR103 (Lch) and VR104 (Rch) so that the voltage across the terminals of R161 and R162 come to 6 m — 15 mV DC.

Test points		Adjustment point	Rating
Lch	Across the terminals of R161	VR103	6 mV — 15 mV DC
Rch	Across the terminals of R162	VR104	6 mV — 15 mV DC

<FM TUNER SECTION>

- Use 19kHz L.P.F. to measure the output.
- 100% modulation means that the Frequency Deviation is 75kHz. (R, U, C, A, B)
- For the G model, Frequency Deviation is 40kHz.
- For the G, B models, install the Matching Transformer and connect FM SG.

- Shorting Pin 18 of IC4 and GND while set at FM will result in automatic memory of each preset from P1/P9 to P8/P16 as given in the under table. This is convenient when making an adjustment.

Note : The memory content preset by the user will be erased entirely.

	SW101 * (R model only)		P1/P9	P2/P10	P3/P11	P4/P12	P5/P13	P6/P14	P7/P15	P8/P16
U, C	AM 10kHz	FM 200kHz	AM 630kHz	AM 1080kHz	AM 1440kHz	FM 87.5MHz	FM 95.1MHz	FM 98.1MHz	FM 101.5MHz	FM 107.9MHz
A, B, G	AM 9kHz	FM 50kHz	AM 630kHz	AM 1080kHz	AM 1440kHz	FM 87.5MHz	FM 95.1MHz	FM 98.1MHz	FM 101.5MHz	FM 108.0MHz

Note : * Marked.

U, C models change by step of AM 10kHz, FM 200kHz.

A, G, B models change by step of AM 9kHz, FM 50kHz.

Every time you push SW1, the SW1 will change to Step of U, C or to Step of A, B, G.

● Connection diagram (Instrumentation required)

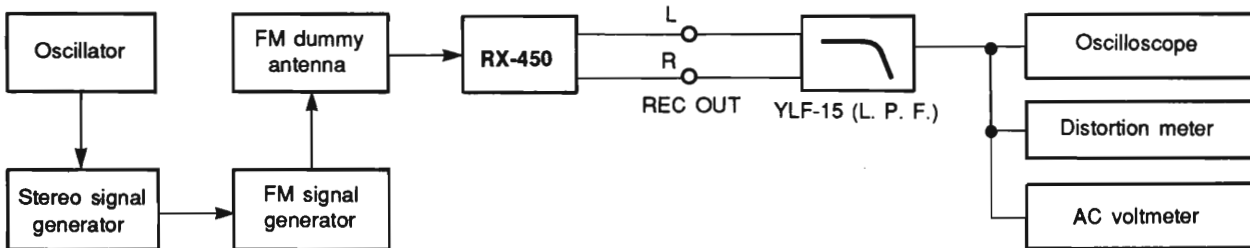

Step	Item to be adjusted	Connection terminal	Instrument required	Adjustment locations	Adjustment method	Rating or standard	Remarks
1	Discriminator balance	FM ANT Except G model 300Ω G model only 75Ω	FM SG 98.1MHz 70dBμ MONO 100Hz 100% MOD	T1 (CENTER)	Receive 98.1MHz and confirm that the voltage at both ends of R14 (TP1 and TP2) is DC 0V ± 50mV.	0V ± 50mV DCVM	Tuned point
		Both ends of R14 (TP1 and TP2)	DCVM				
2	Monaural distortion	FM ANT Except G model 300Ω G model only 75Ω	FM SG 98.1MHz 70dBμ MONO 100Hz 100% MOD	T1 (MONO)	Make distortion rate minimum		
		REC OUT	LPF, DIST-M				
3	Stereo distortion	FM ANT Except G model 300Ω G model only 75Ω	FM SG, SSG 98.1MHz 70dBμ STEREO (L or R) 1kHz 100% MOD	Front end IFT	Make distortion minimum	-46dB or less (G model only) -40dB or less)	Check that STEREO indicator lights.
		REC OUT	LPF, DIST-M				

Step	Item to be adjusted	Connection terminal	Instrument required	Adjustment locations	Adjustment method	Rating or standard	Remarks
4	Confirmation of Monaural distortion	FM ANT Except G model 300Ω G model only 75Ω	FM SG 98.1MHz 70dBμ MONO 1kHz 100% MOD		Confirm that the monaural distortion is satisfied the specifications.	-56dB or less (G model only) -46dB or less	
		REC OUT	LPF, DIST-M				
5	Sensitivity	FM ANT Except G model 300Ω G model only 75Ω	FM SG 98.1MHz MONO 1kHz 100% MOD		Read antenna terminal voltage with an S/N ratio of 30dB using an FM SG.	10dBμ or less (Except G model) 6dBμ or less (G model only)	FM ANT 300Ω 9dBμ or less (Except G model)
		REC OUT	ACVM				
6	Separation adjustment	FM ANT Except G model 300Ω G model only 75Ω	FM SG, SSG 98.1MHz 70dBμ STEREO (L or R) 1kHz 100% MOD	VR2 (SEPARATION)	Set SSG output to L or R and make signal leakage for opposite channel minimum	36dB or less	
		REC OUT	LPF ACVM				
7	Confirmation of Discriminator balance	FM ANT Except G model 300Ω G model only 75Ω	FM SG 98.1MHz 70dBμ MONO 1kHz 100% MOD		Confirm that the voltage at both ends of R14 (TP1 and TP2) is DC 0V ± 50mV.		If not, return to step one and readjust.
		Both ends of R14 (TP1 and TP2)	DCVM				
8	Signal meter	FM ANT Except G model 300Ω G model only 75Ω	FM SG 98.1MHz 45dBμ/75Ω MONO 1kHz 30% MOD	VR1	Adjust VR1, so that all indicators light up		Confirm that all signal quality indicators goes out at detuned point.
9	Confirmation of auto search reception	FM ANT Except G model 300Ω G model only 75Ω	FM SG 98.1MHz 26dBμ/75Ω MONO 1kHz 30% MOD		Confirm that auto search reception is possible with the tuning key.		Confirm that muting is performed at auto reception.

<AM TUNER SECTION>

- Connect the AM loop antenna to the AM ANT terminal.
- Connect the AM dummy antenna for adjustment to AM SG.
- Check that the AM SG precision is within ±0.1kHz.

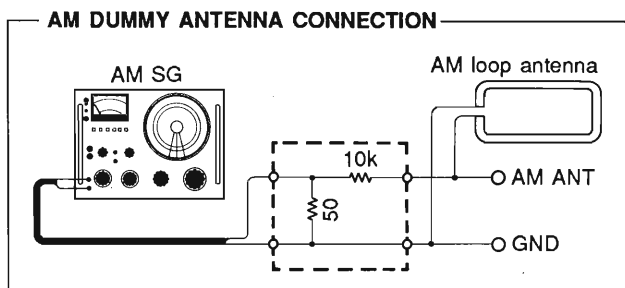

● Connection diagram (Instrumentation required)

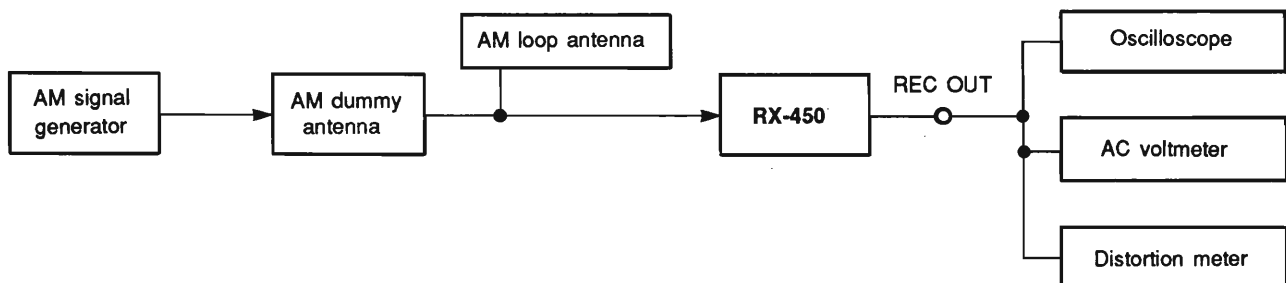

Step	Item to be adjusted	Connection terminal	Instrument required	Adjustment locations	Adjustment method	Remarks or standard
1	IFT Adjustment	AM ANT	AM dummy antenna AM SG 1080kHz 400Hz, 30% MOD	T2	Adjust so that the detector output is at maximum.	Non AGC
		REC OUT	ACVM			
2	Confirmation of sensitivity	AM ANT	AM dummy antenna AM SG 1080kHz 400Hz, 30% MOD		Obtain AM SG output level where distortion become 10%.	60dB μ or less
		REC OUT	ACVM, DIST-M			
3	Signal meter full-scale	AM ANT	AM dummy antenna AM SG 1080kHz 100dB μ 400Hz, 30% MOD		All signal quality indicators light.	Confirm that all signal quality indicators goes out at returned point.
4	Confirmation auto-search	AM ANT	AM dummy antenna AM SG 1080kHz 65dB μ 400Hz, 30% MOD		Confirm that auto search reception is possible with the tuning key.	Confirm that muting is performed at auto reception.

<DIGITAL CONTROL SECTION>

Step	Confirmation item	Connection terminal	Instrument required	Operation key	Confirmation method
1	Press memory	FM ANT Except G model 300 Ω G model only 75 Ω	FM SG, SSG 98.1MHz 70dB μ STEREO (L or R) 1kHz, 100% MOD	FM, AM TUNING MODE (UP or DOWN) MEMORY PRESET STATION P1-P8/P9-P16	<ol style="list-style-type: none"> 1. Receive FM 98.1MHz by means of auto search. 2. Press MEMORY key → MEMORY indicator flashes about 5 seconds. 3. Press P1 → MEMORY indicator goes OFF P1 indicator lights. 4. Receive AM 1080kHz 5. Press TUNING MODE key → AUTO indicator goes OFF. 6. Press P1-P8/P9-P16 key → P9-P16 indicator flashes. 7. Press MEMORY key → MEMORY indicator flashes about 5 seconds. 8. Press P15 → MEMORY indicator goes OFF, P15 indicator light. 9. Press P1 and P15 and check that Content is read out properly. → P1 and P15 light.
		AM ANT	AM dummy antenna AM SG 1080kHz 80dB μ 400Hz, 30% MOD		
2	Tuning modes	Same as step 1	Same as step 1	FM, AM TUNING MODE (UP or DOWN)	<ol style="list-style-type: none"> 1. Tune to FM 98.1MHz and AM 1080kHz. 2. Press TUNING MODE key → AUTO. STEREO (for FM) indicators goes OFF.
3	Last station memory			PRESET STATION P1 POWER	<ol style="list-style-type: none"> 1. Press P1. → FM 98.1MHz is read out. 2. Disconnect the power cord from AC outlet. 3. Reconnect the power cord to AC outlet 5 seconds later. 4. Check that P1 content is read out. → P1 indicator lights. FM 98.1MHz is displayed.

μ-COM DATA

IC4 : LC6554
(4-bit μ-COM)

Adjustment method	Adjustment locations	Instrument required	Connection terminal
PN ₀ 1	64	V _{DD}	RAM : Data memory
PN ₁ 2	63	PM ₃	F : Flag
PN ₂ 3	62	PM ₂	WR : Working register
PN ₃ 4	61	PM ₁	AC : Accumulator
PO ₀ 5	60	PM ₀	ALU : Arithmetic and logic unit
PO ₁ 6	59	PL ₃	DP : Data pointer
PO ₂ 7	58	PL ₂	E : E register
PO ₃ 8	57	PL ₁	CTL : Control register
PP ₀ 9	56	PL ₀	OSC : Oscillator
PA ₀ 10	55	PK ₁	TM : Timer
PA ₁ 11	54	PK ₂	STS : Status register
PA ₂ 12	53	PK ₁	ROM : Program memory
PA ₃ 13	52	PK ₀	PC : Program counter
PB ₀ 14	51	V _P	INT : Interrupt control
PB ₁ 15	50	PJ ₁	IR : Instruction register
PB ₂ 16	49	PJ ₂	I. DEC : Instruction decoder
PB ₃ 17	48	PJ ₁	CF, CSF : Carry flag, carry save flag
PC ₀ 18	47	PJ ₀	ZF, ZSF : Zero flag, zero save flag
PC ₁ 19	46	PI ₁	EXTF : External interrupt request
PC ₂ 20	45	PI ₂	TMF : Internal interrupt request
PC ₃ 21	44	PI ₁	
PD ₀ 22	43	PI ₀	
PD ₁ 23	42	PG ₁	
PD ₂ 24	41	PG ₂	
PD ₃ 25	40	PG ₁	
PE ₀ 26	39	PG ₀	
PE ₁ 27	38	PF ₁ INT	
PE ₂ 28	37	PF ₂ SCK	
PE ₃ 29	36	PF ₁ SO	
TEST 30	35	PF ₀ SI	
V _{SS} 31	34	RES	
OSC1 32	33	OSC2	

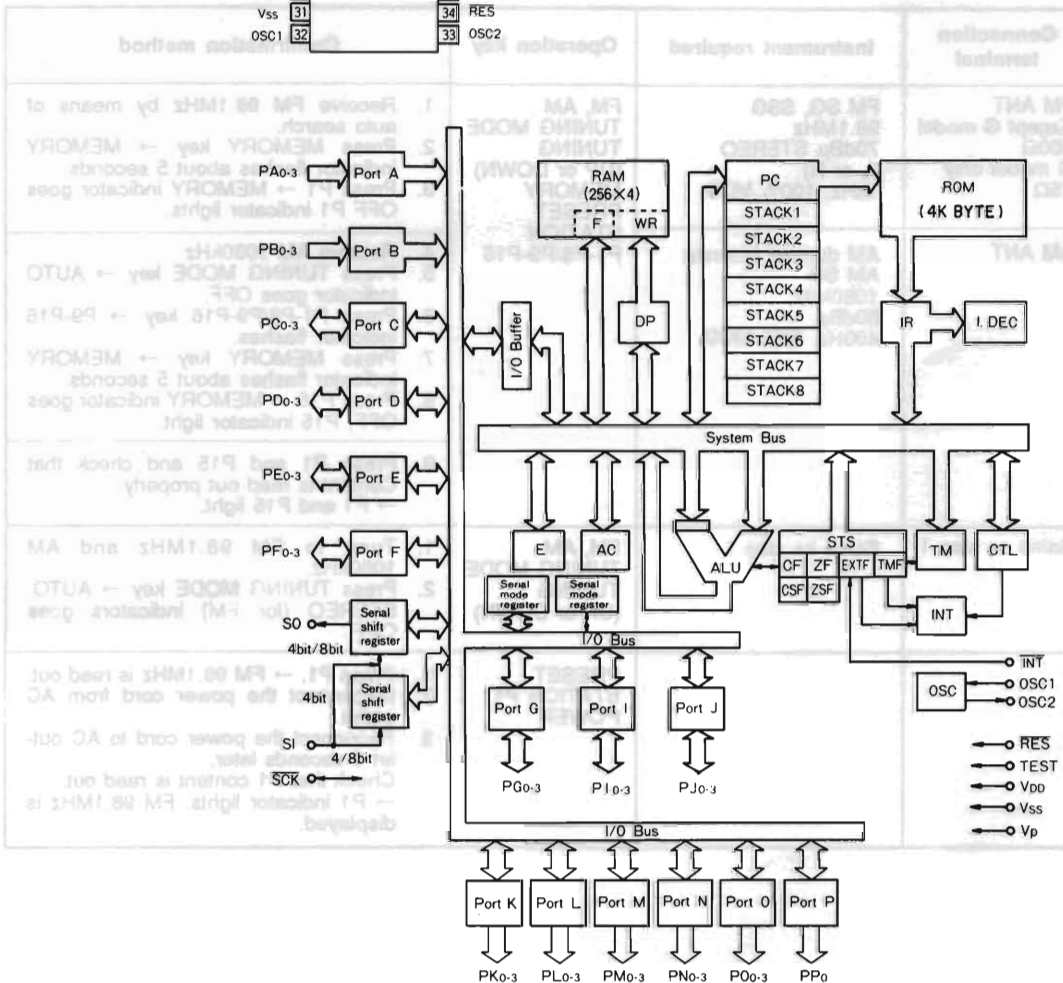

RX-450

Pin No.	Pin Name	I/O	Description	Function	Pin No.	Pin Name	I/O	Description	Function
1	PN0	O		NC	64	VDD	—	VDD	+5V
2	PN1	O		NC	63	PM3	O	PLRS	Player Control Signal
3	PN2	O		NC	62	PM2	O		NC
4	PN3	O		NC	61	PM1	O		NC
5	PO0	O	D1	KEY DIGIT	60	PM0	O		NC
6	PO1	O	D2		59	PL3	O	V DN	Volume Down
7	PO2	O	D3		58	PL2	O	V UP	Volume Up
8	PO3	O	D4		57	PL1	O		NC
9	PP0	O	D5		56	PL0	O	P ON	Main Drive
10	PA0	I	K1	KEY IN	55	PK3	O		NC
11	PA1	I	K2		54	PK2	O		NC
12	PA2	I	K3		53	PK1	O		NC
13	PA3	I	K4		52	PK0	O		NC
14	PB0	I		NC	51	VP	—		to GND
15	PB1	I		NC	50	PJ3	O	LED5	TAPE MONI
16	PB2	I	PODN	POWER DOWN DET	49	PJ2	O	STBY	LED for Stand By
17	PB3	I	HOLD	GND	48	PJ1	O	B	MUTING
18	PC0	I		NC	47	PJ0	O	A, C	TAPE MONITOR
19	PC1	I	A1	TUNER MARKET SELECT	46	PI3	O	T MUTE	Tuner Mute
20	PC2	I	A2	TUNER MARKET SELECT	45	PI2	O	MONO	Monoral
21	PC3	I	PSW	POWER SW	44	PI1	O	INH	LC75821, INH
22	PD0	O	A	INPUT SELECTOR	43	PI0	O	CE2	LC75821, CE
23	PD1	O	B		42	PG3	O	STRQ	LM7000, STRQ
24	PD2	O	INH		41	PG2	O	CEI	LM7000, CE
25	PD3	O		NC	40	PG1	O	CL	Serial Clock
26	PE0	O	LED1	LED	39	PG0	O	DATA	Serial Data
27	PE1	O	LED2		38	PF3/INT	I	REMO	Remote Control Input
28	PE2	O	LED3		37	PF2/SCK	I	STO	ST OUT
29	PE3	O	LED4		36	PF1/SO	I	STSG	STOP SIGNAL
30	TEST	—		GND	35	PF0/SI	I	ST	STEREO
31	VSS	—		GND	34	RES	I		Reset
32	OSCI	—			33	OSC2	—		

PIN 47 : TAPE MONITOR

	ON	OFF
PJ0	0	1

PIN 19, 20 : TUNER MARKET SELECT

	E	U	R
A2	0	1	0,1
A1	1	0	1

PIN : 22, 23, 24, INPUT SELECT

	PHONO	CD	TUNER	AUX
PD0	0	1	0	1
PD1	0	0	1	1
PD2	0	0	0	0

KEY MATRIX

	K1	K2	K3	K4
D1	—	—	MEMO	A/B
D2	TUNER ▷	TUNER ◁	FM/AM	AUTO/MAN'L
D3	P1/P9	P2/P10	P3/P11	P4/P12
D4	P5/P13	P6/P14	P7/P15	P8/P16
D5	TAPE MONI	—	INPUT ◁ DN	INPUT ▷ UP

■ DISPLAY DATA

LCD8046MJP

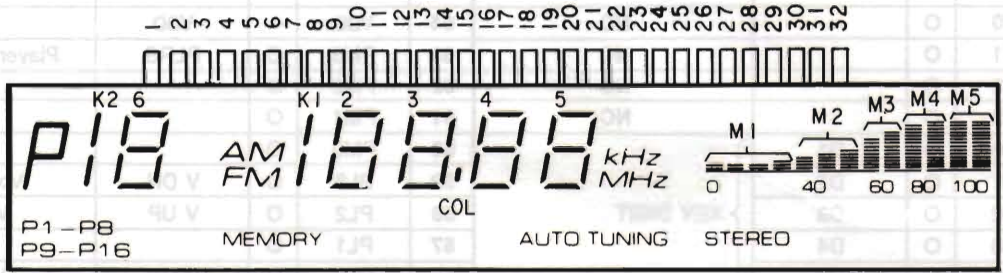

SEGMENTS

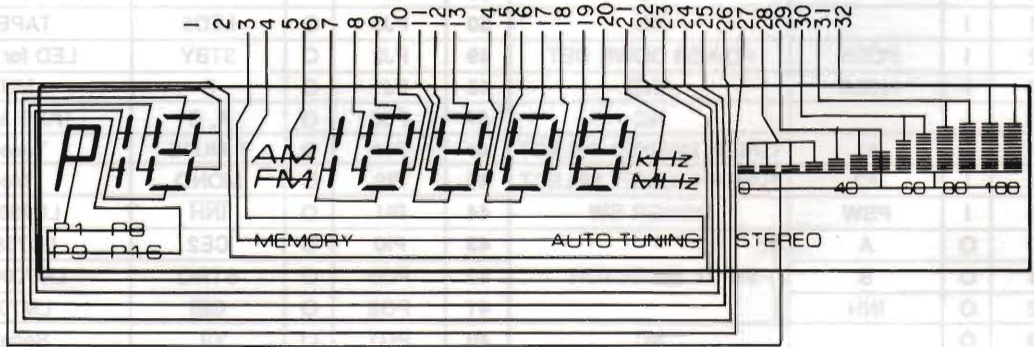

COMMON

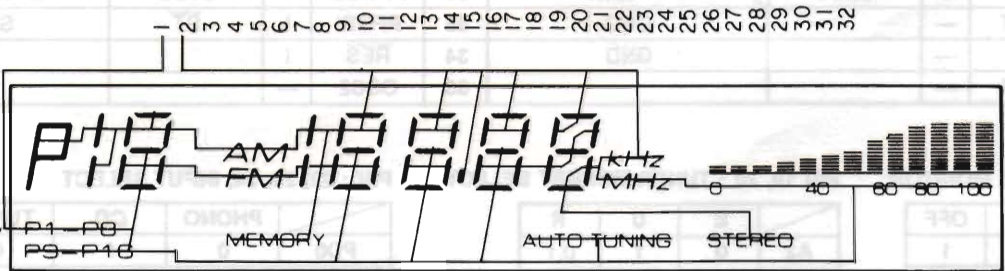

IC PinNo	63	64	2	3	1	4	5	6	7	8	9	10	11	12	13	14
NO	1	2	3	4	5	6	7	8	9	10	11	12	13	14	15	16
COM1	-	COM	MEMORY	STEREO	-	AM	K1	2f	2a	2b	-	3f	3a	3b	COL	4f
COM2	COM	-	AUTO TUNING	0-100	-	FM	2d	2e	2g	2c	3d	3e	3g	3c	4d	4e
IC PinNo	15	16	17	18	20	21	22	23	25	26	27	50	51	52	53	54
NO	17	18	19	20	21	22	23	24	25	26	27	28	29	30	31	32
COM1	4a	4b	5cd	5af	kHz	P	-	K2	6f	6a	6b	-	-	-	-	-
COM2	4g	4c	5be	5g	MHz	P1-P8	P9-P16	6d	6e	6g	6c	M1	M2	M3	M4	M5

I BLOCK DIAGRAM

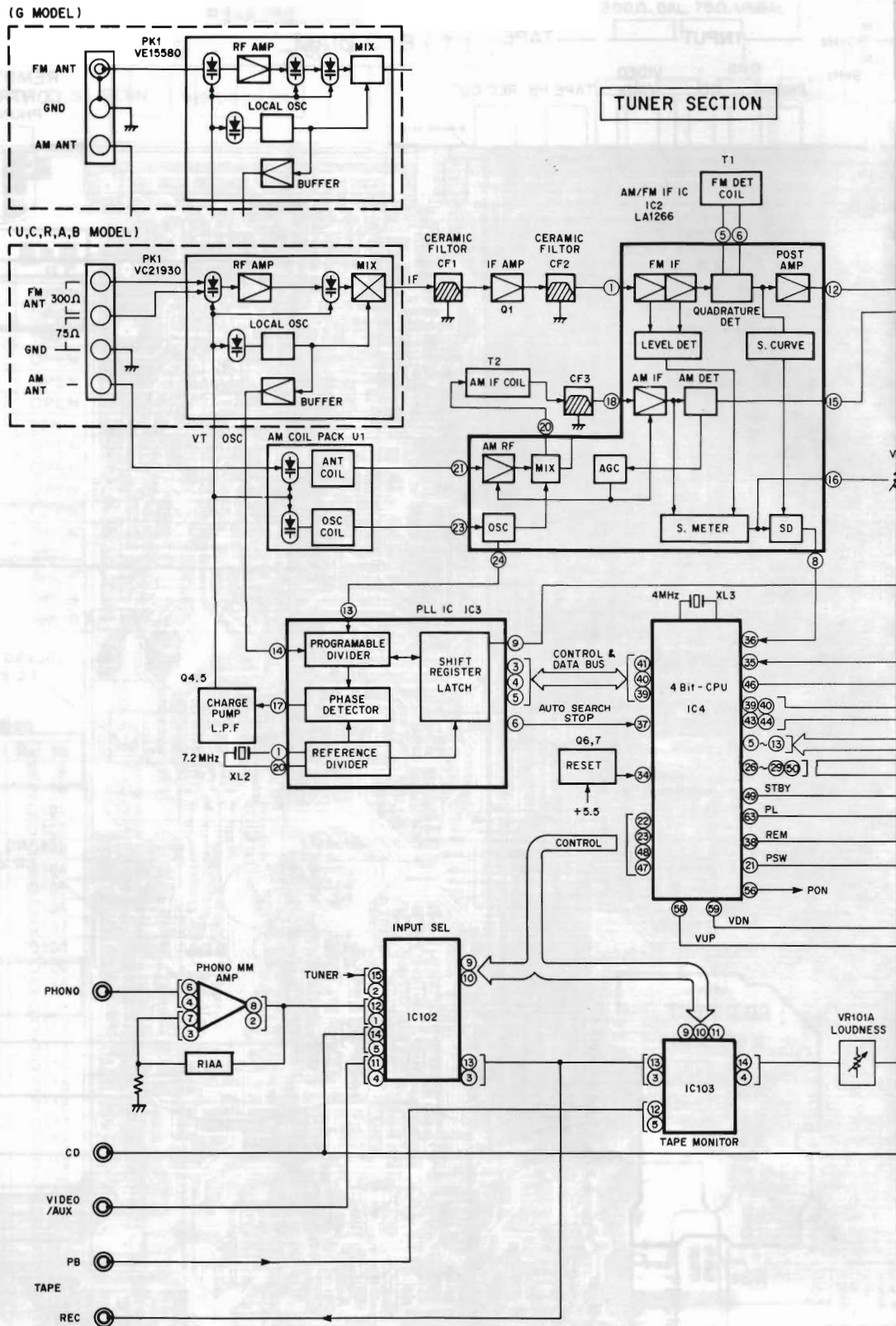

PRINTED CIRCUIT BOARD (Foil side)

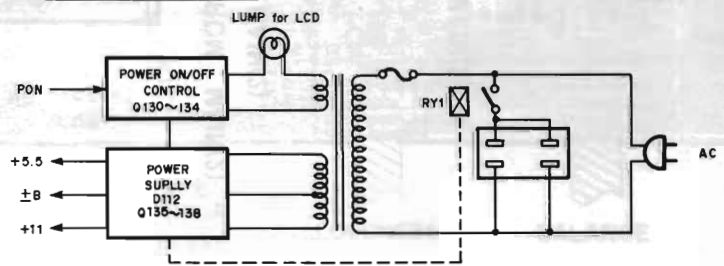
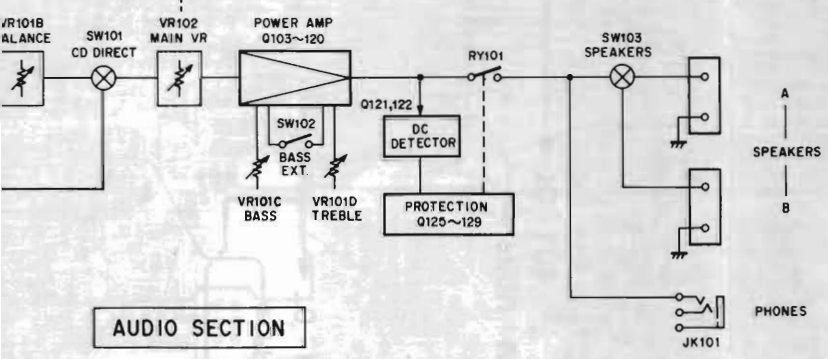
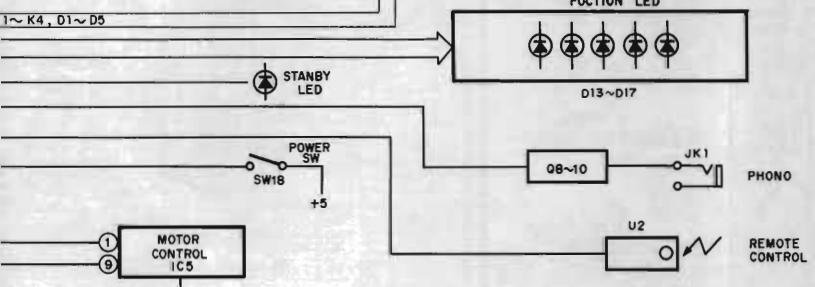
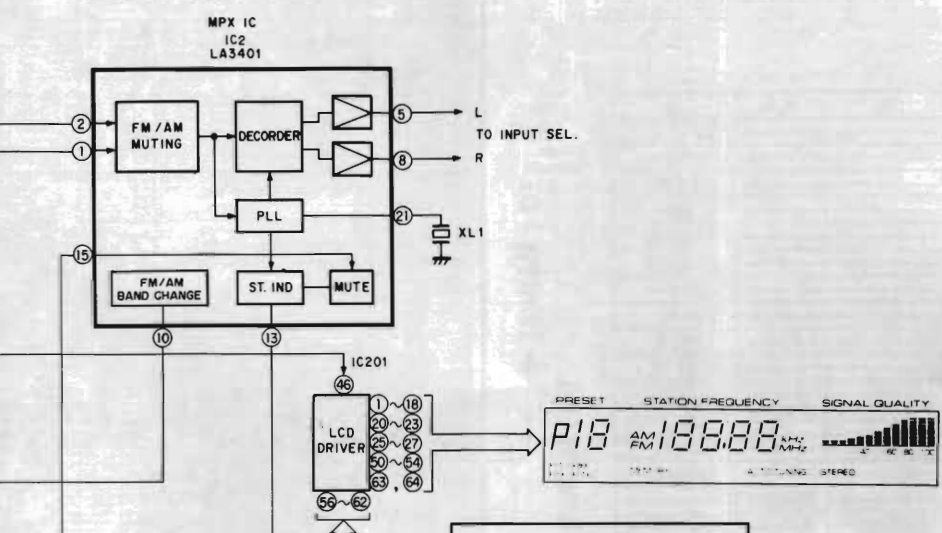

PRINTED CIRCUIT BOARD (Foil side)

Note) 文字面 : Component side

MAIN C. B (1)

(A) to (C) : WAVEFORM OF TEST POINT (See page 21)

X:Marked

		U.C	R	A.B	G
*1	R1	OPEN		→	220K
*2	R2	OPEN		→	100K
*3	C11	100P		→	OPEN
*4	R35	OPEN		→	4.7K
*5	T3	OPEN		→	114KHz
*6	J302. 303	OPEN		→	SHORT
*7	R48	22K		→	J305
*8	C157. 158. 173~180	OPEN		→	220P
*9	C151~154.	OPEN		→	2200P
*10	C147~150	OPEN		→	0.01
*11	C155. 156	OPEN		→	0.022
*12	R179. 180	OPEN		→	2.2
*13	C45	J262		→	0.047
*14	J261. 263	SHORT		→	OPEN
*15	J301	OPEN		→	SHORT
*16	J306	SHORT	OPEN	→	→

● Semiconductor Location

Ref. No.	Location	Ref. No.	Location
D 1	D3	Q 9	D5
D 2	D3	Q 10	D5
D 3	D4	Q101	F5
D 4	C5	Q102	F5
D 6	D5	Q103	F4
D 8	D4	Q104	F5
D 9	D4	Q105	F4
D 10	D4	Q106	F5
D 11	D4	Q107	F4
D 12	D4	Q108	F5
D 20	C4	Q109	F4
D101	E3	Q110	F4
D102	E3	Q111	G3
D103	F4	Q112	G4
D104	F4	Q113	G3
D105	F2	Q114	G4
D106	F2	Q115	G3
D107	F2	Q116	G4
D108	F2	Q117	G3
D109	F3	Q118	G4
D110	F3	Q119	G3
D111	F3	Q120	G4
D112	F3	Q121	G2
D113	F3	Q122	G5
IC 1	D3	Q123	F4
IC 2	D4	Q124	G5
IC 3	C4	Q125	F2
IC 4	D4	Q126	F2
IC 5	D5	Q127	F3
IC101	D3	Q128	F3
IC102	E2	Q129	F2
IC103	E2	Q130	F2
Q 1	D2	Q133	E3
Q 3	D3	Q134	E4
Q 4	C3	Q135	F3
Q 5	C3	Q136	F3
Q 6	C5	Q137	G3
Q 7	D5	Q138	F4
Q 8	D5		

AM IF ADJ.

TO : MAIN(8)

TO : MAIN(3)

MONAURAL DISTORTION ADJ.

SIGNAL METER ADJ.

DISCRIMINATOR BALANCE ADJ.

(B)

TO : LCD

FROM : MAIN(2)

TO : MAIN(2)

SEPARATION ADJ.

FROM : MAIN(2)

FM ANT AM ANT
300Ω. BAL. 75Ω. UNBAL.
GND

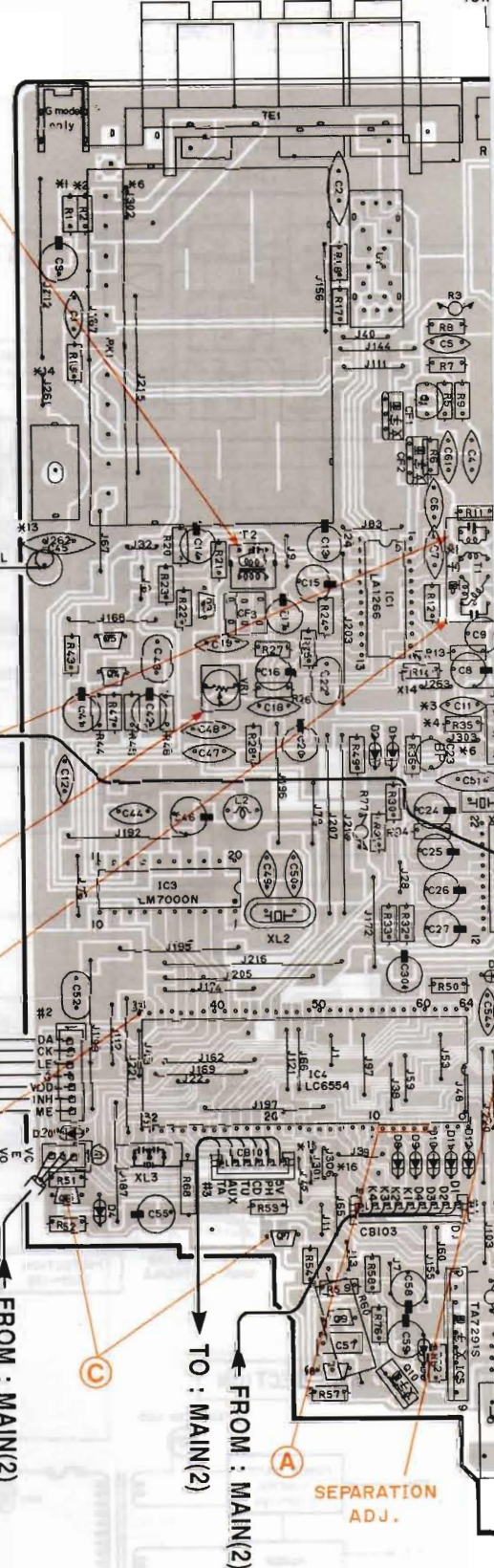

FREQUENCY
STEP

FM
45-50kHz
AM
9kHz

INPUT TAPE

PHONO CD VIDEO /AUX TAPE PB REC OUT

SPEAKER

+ (R) - - (L) +

REMOTE CONTROL
PHONO

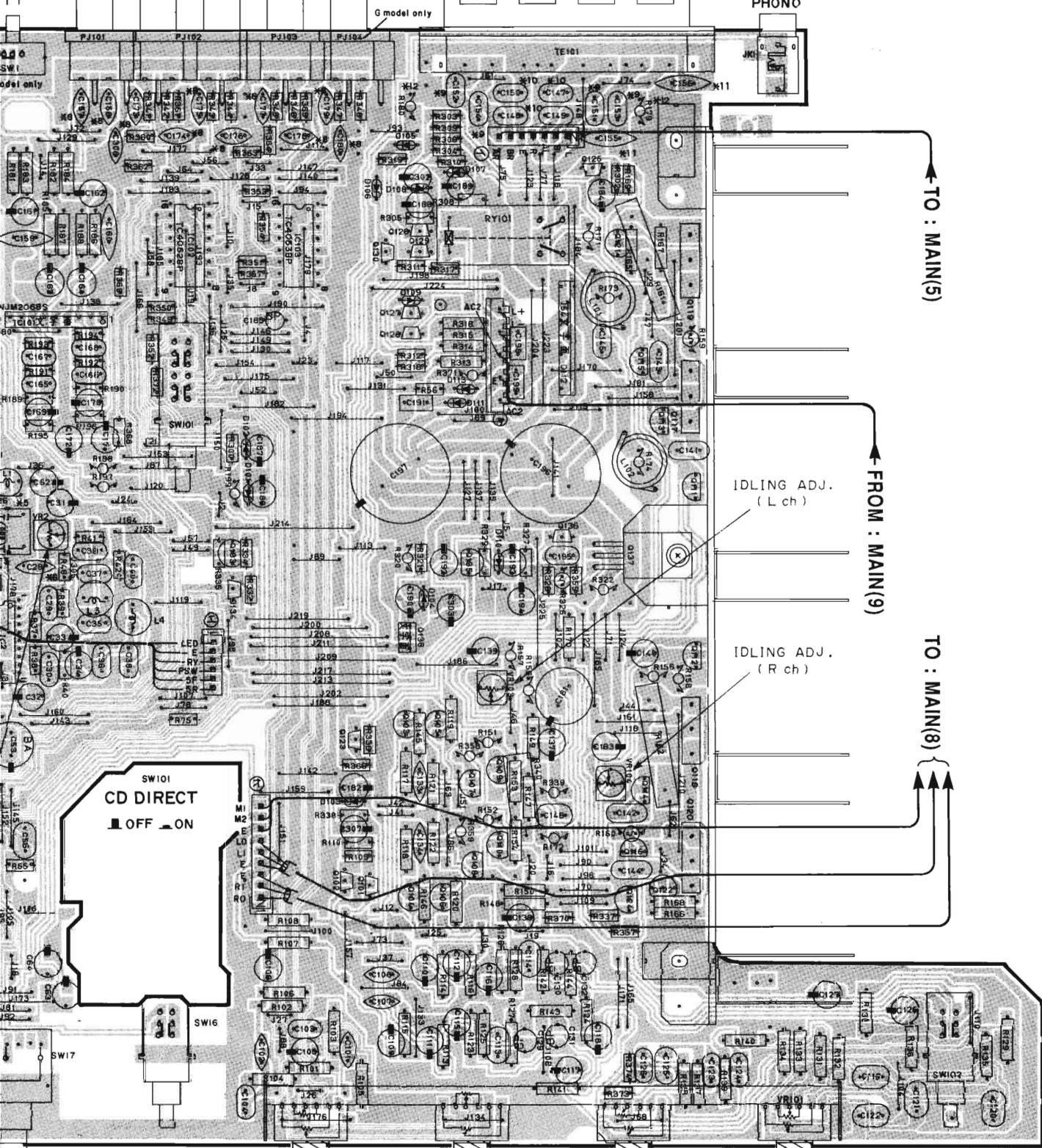

TO : MAIN(5)

FROM : MAIN(9)

TO : MAIN(8)

IDLING ADJ.
(L ch)

IDLING ADJ.
(R ch)

CD DIRECT
OFF ON

TAPE MONITOR
ON/OFF

LOUDNESS

BALANCE

TREBLE

BASS

BASS EXTENSION

ON
OFF

PRINTED CIRCUIT BOARD (Foil side)

Note) 文字面 : Component side

MAIN C. B (2)

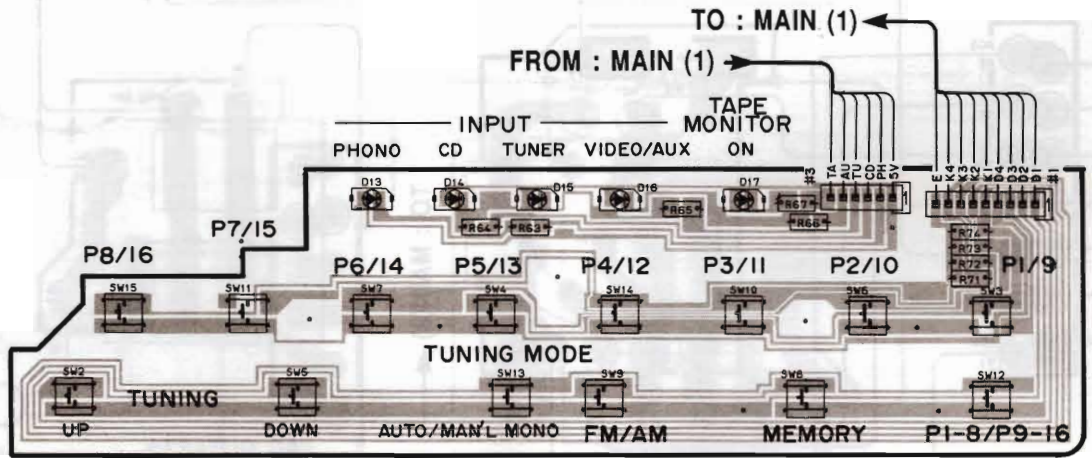

LCD C. B

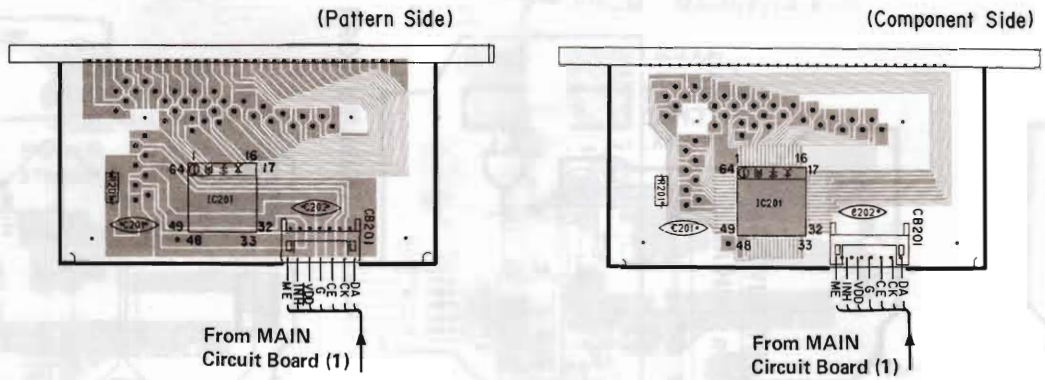

MAIN C. B (5)

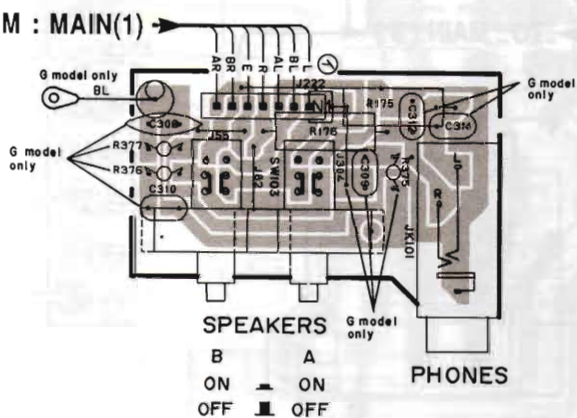

MAIN C. B (8)

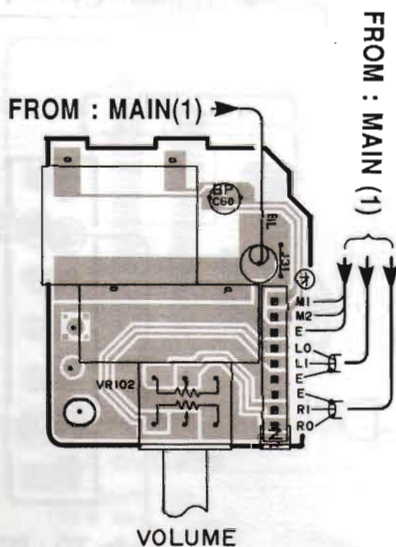

MAIN C. B (12)

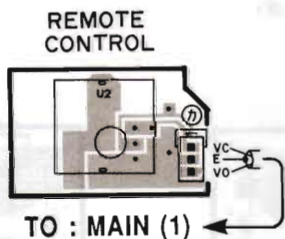

MAIN C. B (9)

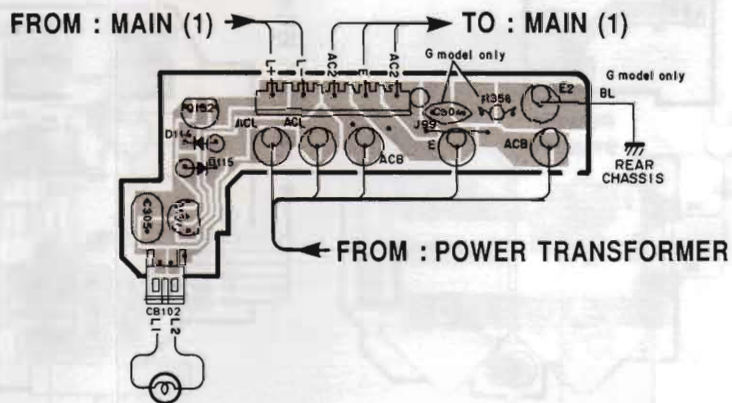

PRINTED CIRCUIT BOARD (Foil side)

● U, C models

MAIN C. B (10)

MAIN C. B (7)

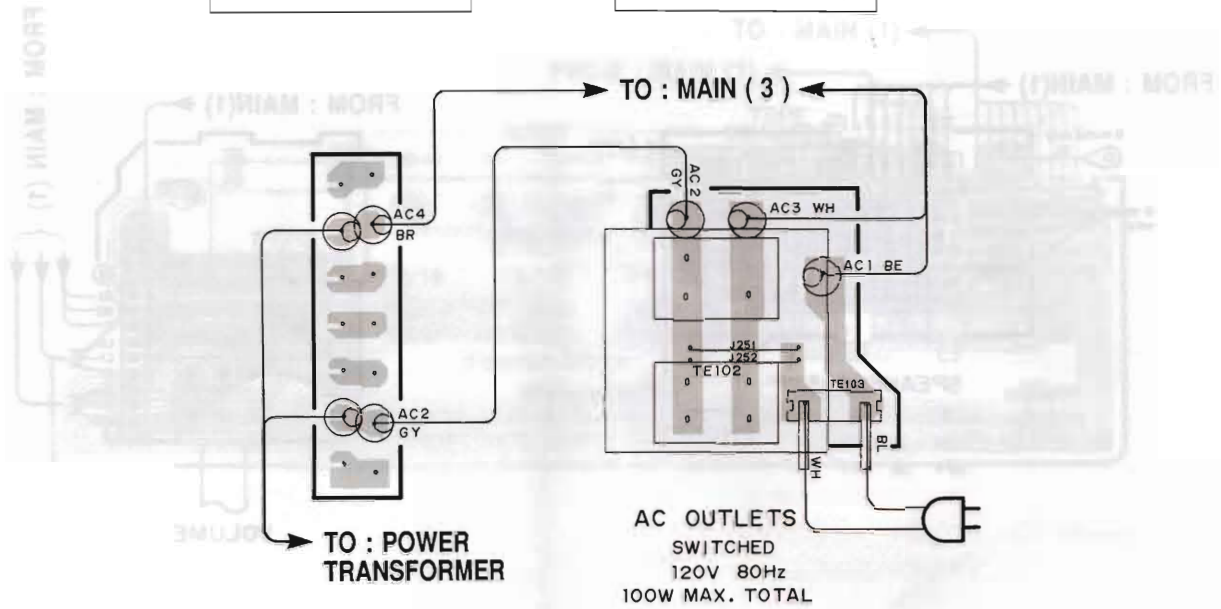

MAIN C. B (11)

MAIN C. B (3)

● A model

MAIN C. B ()

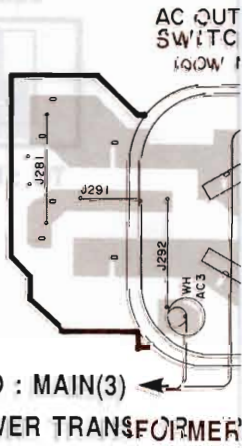
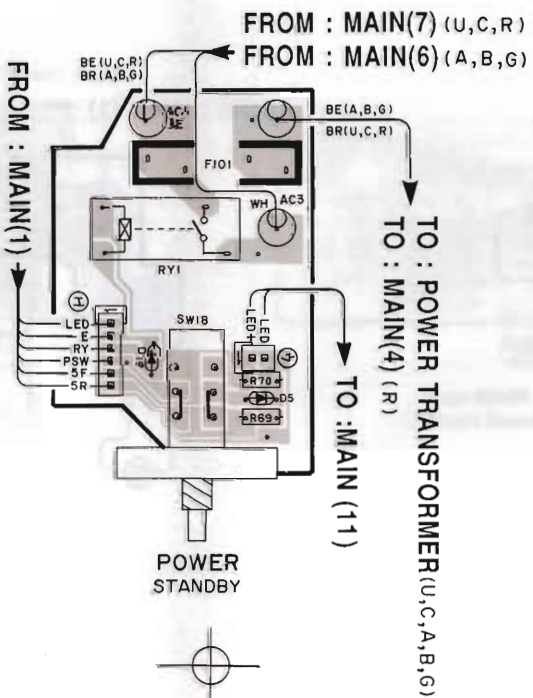
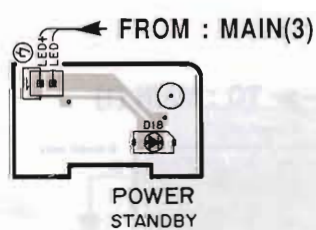

● R model

MAIN C. B (10)

MAIN C. B (4)

MAIN C. B (7)

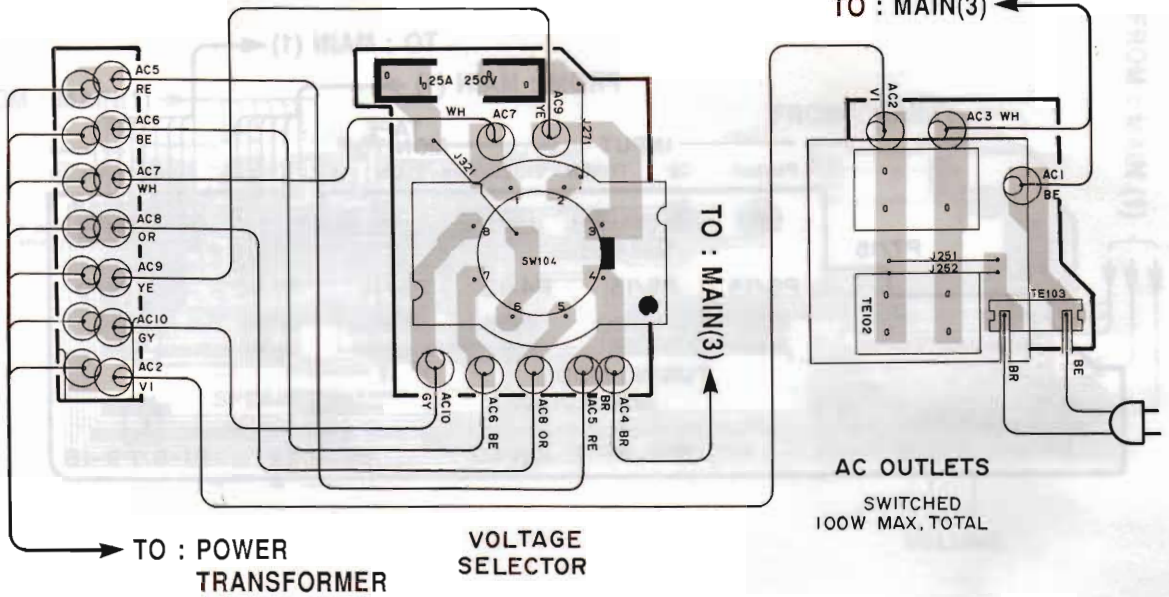

● B model

MAIN C. B (6)

● G model

MAIN C. B (6)

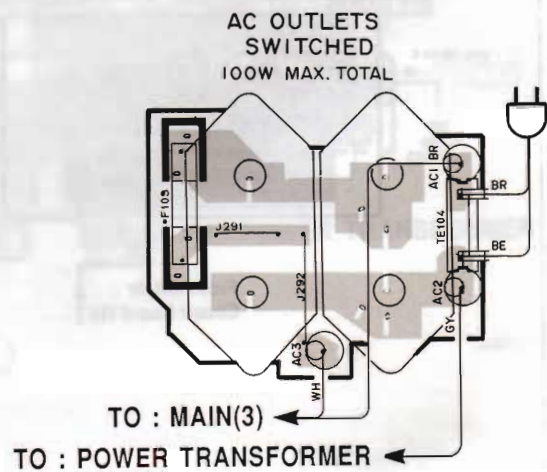
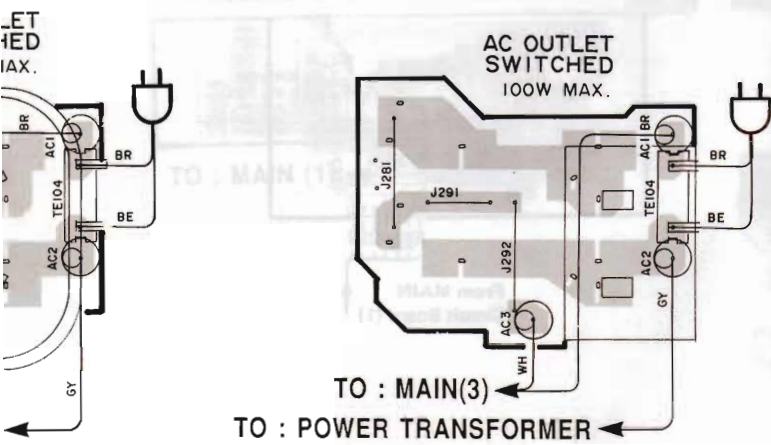

WAVEFORM OF TEST POINT

Point (A)
(Pin 5 to 9 of IC14)

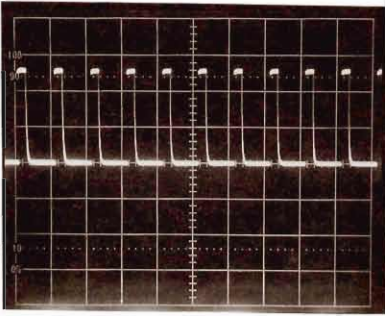

Point (B)
(Pin 33 of IC14)

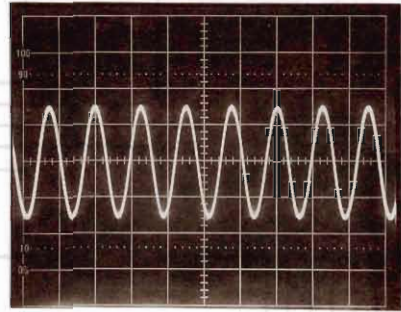

V : 2V/div
H : 5m sec/div
DC range
1 : 1 probe

V : 0.5V/div
H : 0.2μ sec/div
AC range
1 : 1 probe

Point (C)
(CH 1 : Q6 collector, CH 2 : Q7 emitter)

V : 0.5V/div
H : 0.2μ sec/div
DC range
1 : 1 probe

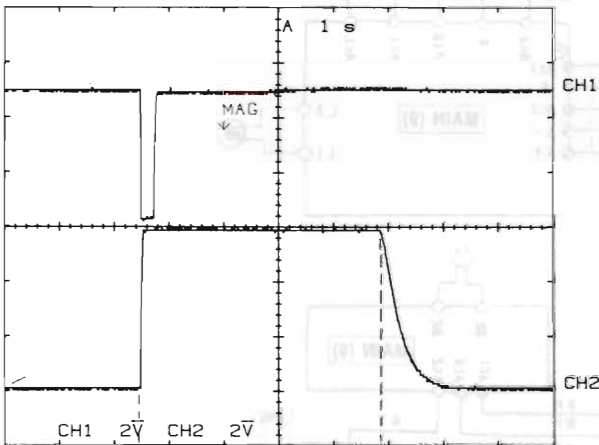

When the power cord is connected to AC outlet.

When the power cord is disconnected from AC outlet.

Note : When the power switch ON/OFF will not produce the above waveform.

SCHEMATIC DIAGRAM

(A) to (C) : WAVEFORM OF TEST POINT (See page 21)

* The voltages are measured at FM (98.1MHz, STEREO) reception mode.

Only the voltages () are at AM (1080kHz) reception mode.

● Set the controls to the following position

INPUT TUNER
 BASS DEFEAT
 TREBLE DEFEAT
 BALANCE " 0 "
 LOUDNESS FLAT

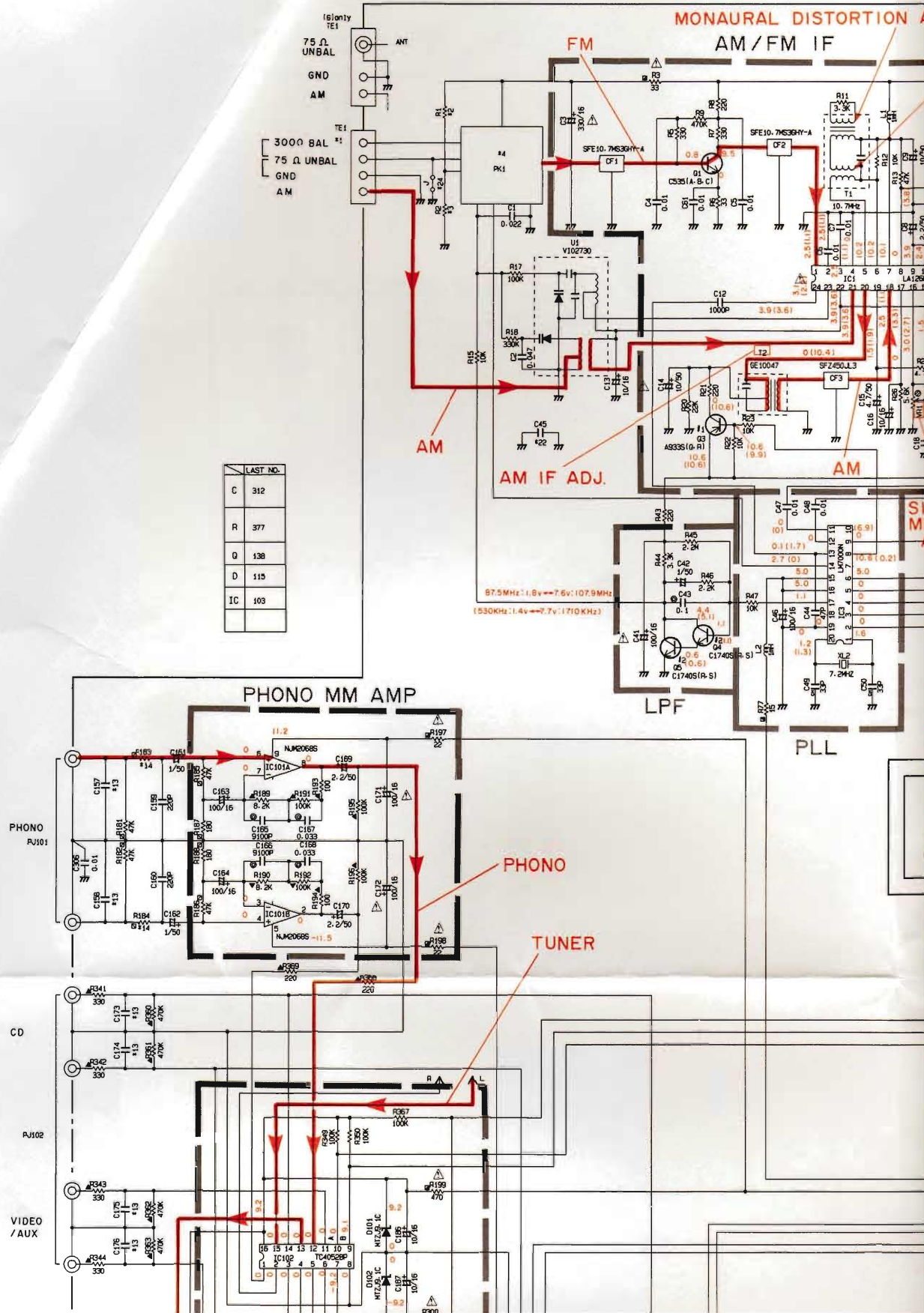

LAST NO.	
C	312
R	377
Q	138
D	115
IC	103

1
2
3
4
5
6

positions

- CD DIRECT OFF
- SPEAKERS (A, B) OFF
- BASS EXTENSION OFF
- TAPE MONITOR OFF

N ADJ. DISCRIMINATOR BALANCE ADJ.

FM

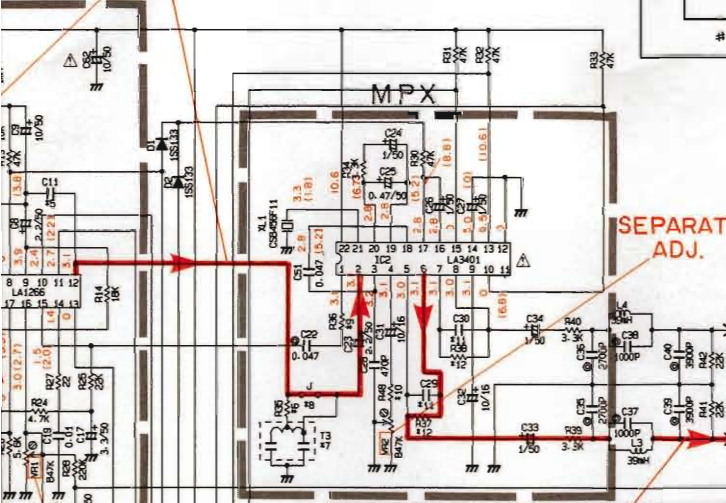
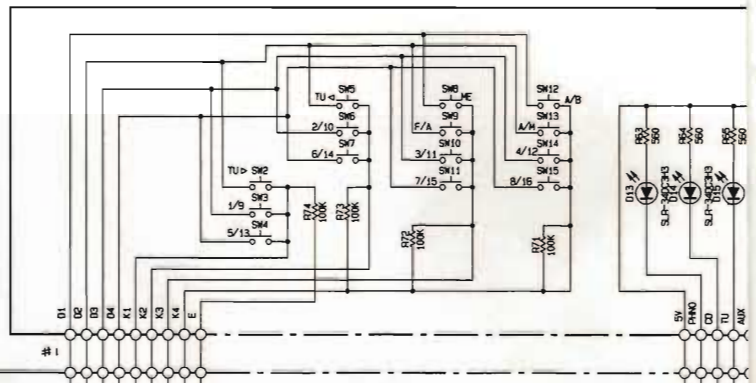

SEPARATION ADJ.

TUNER

SIGNAL METER ADJ.

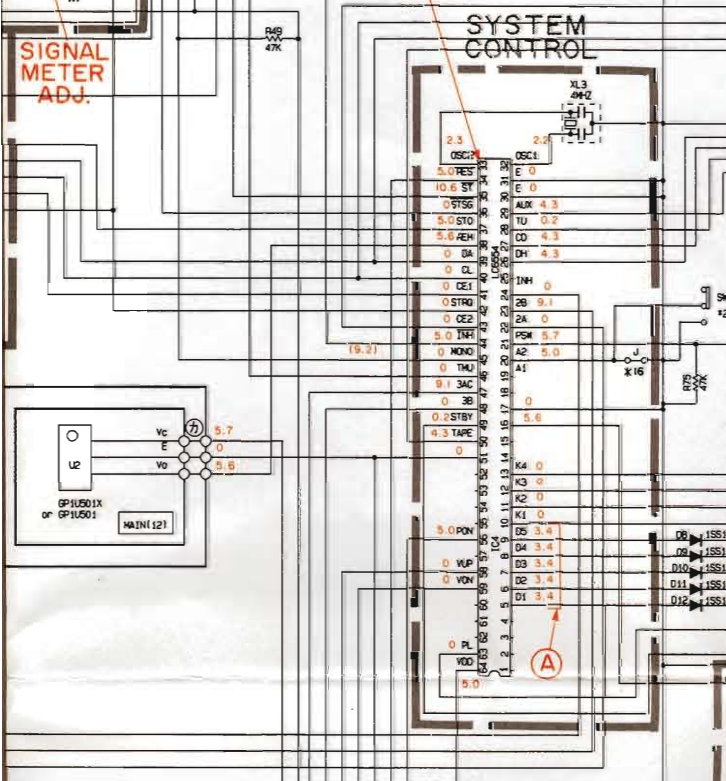

PHONO REMOTE CONTROL

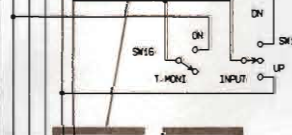

RESET

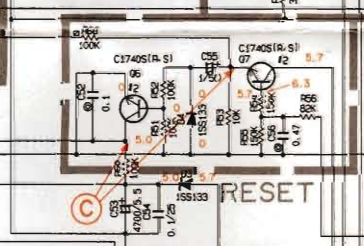

MOTOR CONTROL

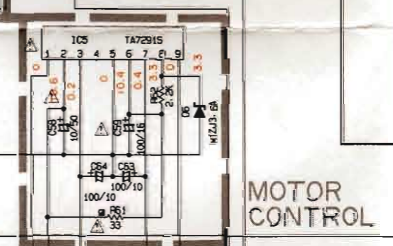

IDLING CURRENT ADJ. (Lch)



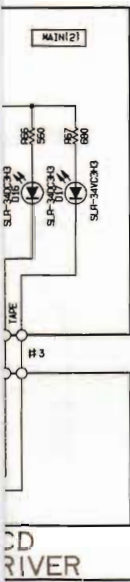

Interchangeable Parts at Manufacture-Stage

Mark	Reference Parts Number	Parts Name
#1	03-126-129	2SA933S(Q-R) 2SA1115(E-F) 2SA1309A(Q-R-S)
#2	04-7-130-136	2SC1740S(R-S) 2SC2603(E-F) 2SC3311A(Q-R-S)
#3	0132	2SC2060 2SD400
#4	0131	2SA934(P-Q-R) 2SB544(D-E-F-G)

	U-C	R	A-B	S
1	TE1	V84590		LA00580
2	R1	OPEN		220K
3	R2	OPEN		100K
4	RK1	TFF61U117A		TFF63E132A
5	C11	100P		OPEN
6	R35	OPEN		4.7K
7	T3	OPEN		114KQZ
8	J	SHORT		OPEN
9	R36	10K		22K
10	R48	22K		SHORT
11	C29-30	100P	880P/100	390P/100
12	R37-38	56K		120K
13	C157-158 173-176	OPEN		220P
14	R83-184	150		1.2K
15	C151-154 309-310	OPEN		2200P
16	J306	SHORT	OPEN	
17				
18	C147-150	OPEN		0.01
19	C155-156 307-308	OPEN		0.022
20	R179-180-356 373-377	OPEN		2-2
21	F103	OPEN	SHORT	T2-5A250V
22	C45	SHORT		0.047
23	J	OPEN	SHORT	
24	J	OPEN		SHORT
25	F101	4A125V	T3-15A250V	T1-25A250V
26	SW1	OPEN	V05-4120	OPEN
27				
28	09-125	C3312(R-S-T)	C2240(GR-BL)	C3312(R-S-T)
29	09-123	A1310(R-S-T)	A970(GR-BL)	A1310(R-S-T)
30	C311-312	OPEN		1500P

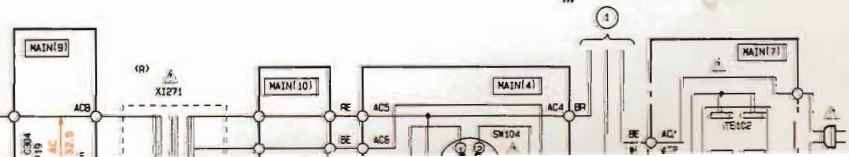
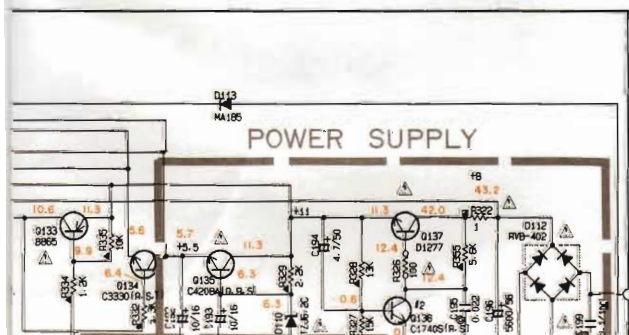
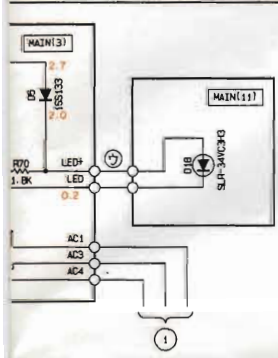
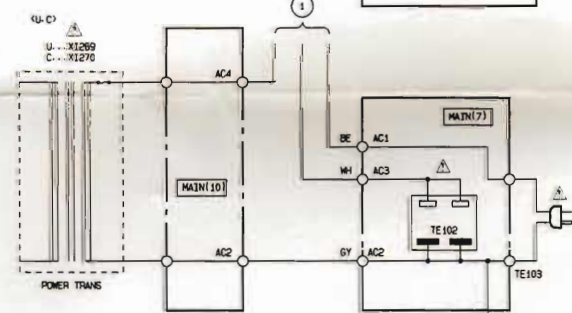
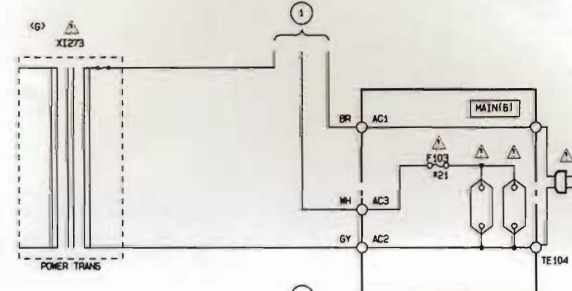
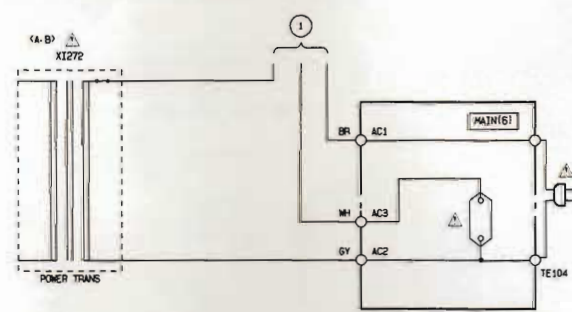
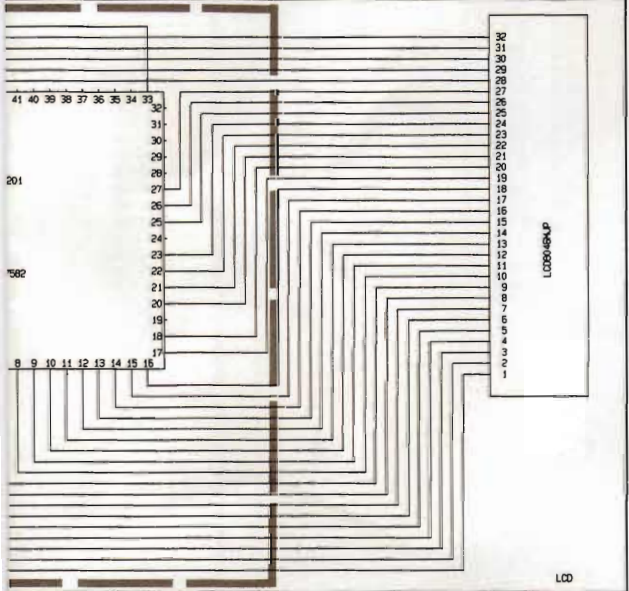

IC1 : LA1266
(AM/FM IF)

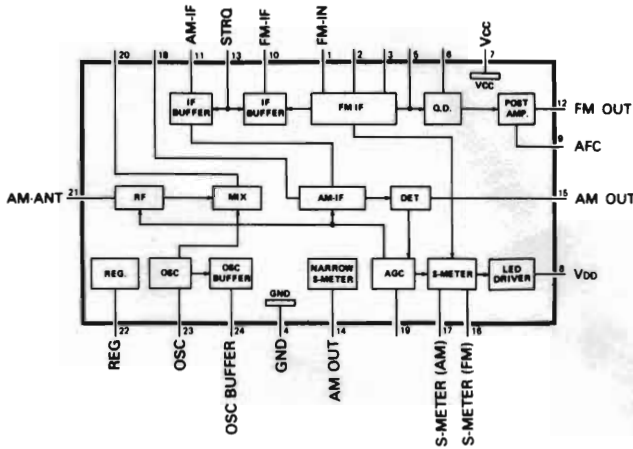

IC2 : LA3401
(MPX)

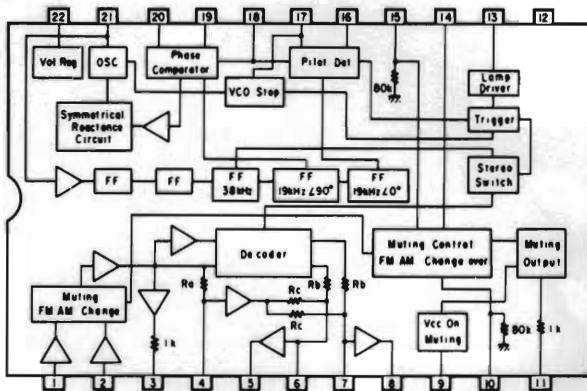

Pin No.	Function
1	Input (AM)
2	Input (FM)
3	Composite Amp Output
4	Separation Adi
5	Post Amp Output
6	Post Amp Input
7	Post Amp Input
8	Post Amp Output
9	Muting ON (Vcc)
10	AM/FM Select
11	Muting Output
12	GND
13	Stereo Indicator
14	Mute Select
15	Muting
16	Pilot Detector Filter
17	Pilot Detector Filter, VCO Stop
18	PLL Input
19	Loop Filter
20	Loop Filter
21	OSC
22	Vcc

IC3 : LM7000N
(PLL)

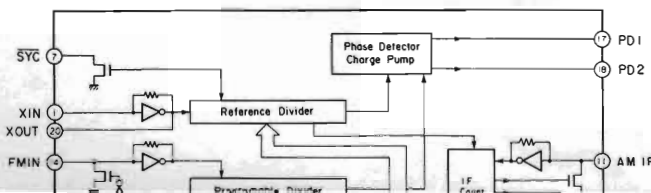

6

7

8

9

10

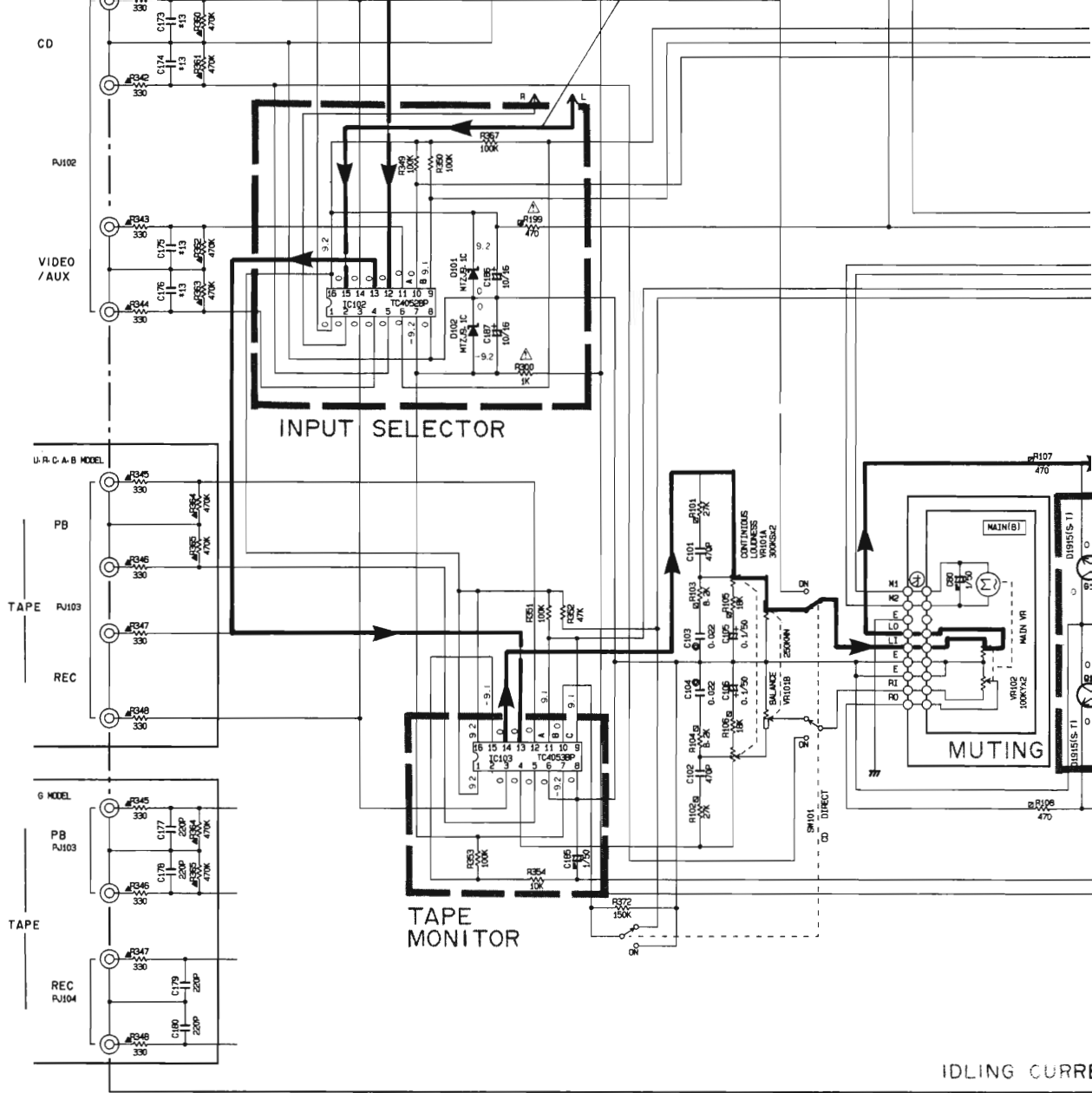

IDLING CURR

PIN CONNECTION DIAGRAM OF TRANSISTORS, DIODES AND ICs.

2SA933S(Q,R)	2SC2603(E,F)	2SC3330(R,S,T)	2SB1332	2SA1490	1SS133	MTZJ12C	RBV-402
2SA1115(E,F)	2SC3311A(Q,R,S)	2SD1915(S,T)	2SB1274(Q,R,S)	2SC3854	MA185	MTZJ24B	
2SA1309A(Q,R,S)	2SC535(A,B,C)	2SB560(E,F)	2SD1277		1SR35-100AT-93X		
2SA934(P,Q,R)	2SC4208A(Q,R,S)	2SD438(E,F)			MTZJ3.0A		
2SB544(D,E,F,G)	2SC2060				MTZJ3.6A		
2SA970(G,R,BL)	2SD400				MTZJ6.2C		
2SA1310(R,S,T)	2SC2240(G,R,BL)				MTZJ9.1C		
2SB865	2SC3312(R,S,T)				MTZJ12B		
2SC1740S(R,S)	2SD438(E,F)						

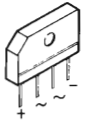
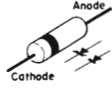
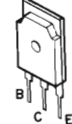
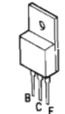

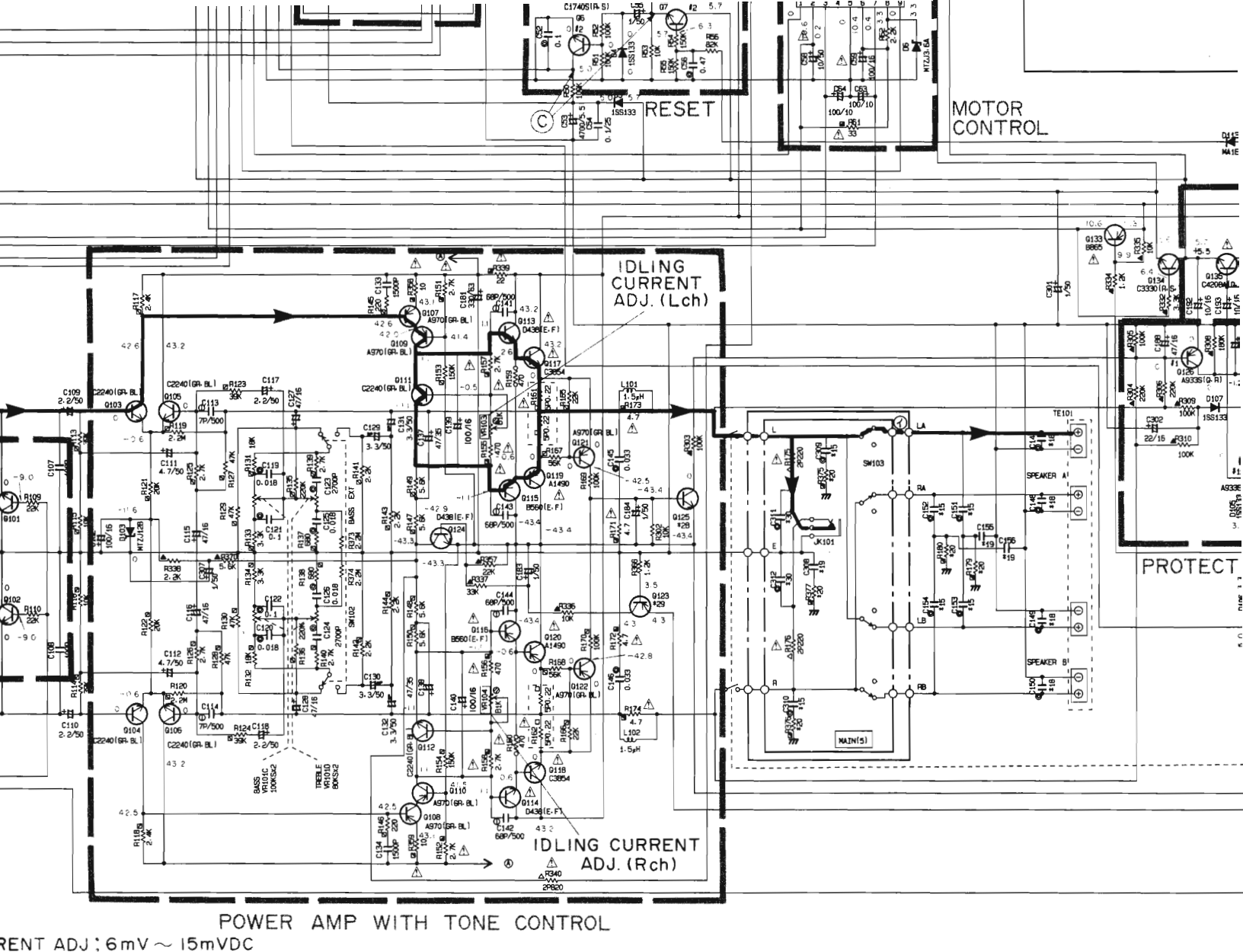

POWER AMP WITH TONE CONTROL

CURRENT ADJ: 6mV ~ 15mVDC

IC101 : NJM2068S
(Dual Low-Noise Ope-Amp)

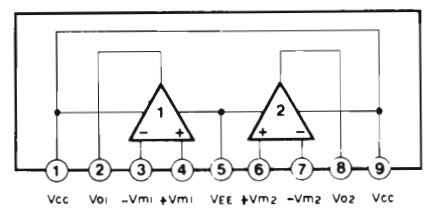

IC5
(Mo

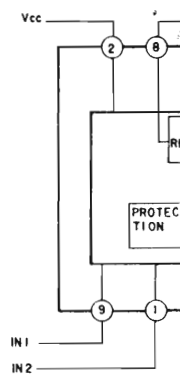

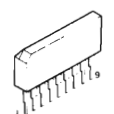
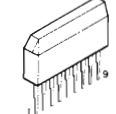
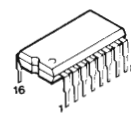
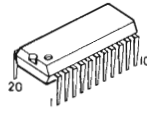
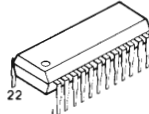
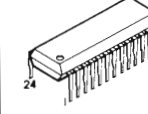
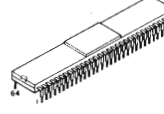
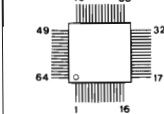
<p>NJM2068S</p> 	<p>TA7291S</p> 	<p>TC4053BP TC4052BP</p> 	<p>LM7000N</p> 	<p>LA3401</p> 	<p>LA1266</p> 	<p>LC6554</p> 	<p>LC7582</p> 
--	--	--	--	---	---	---	---

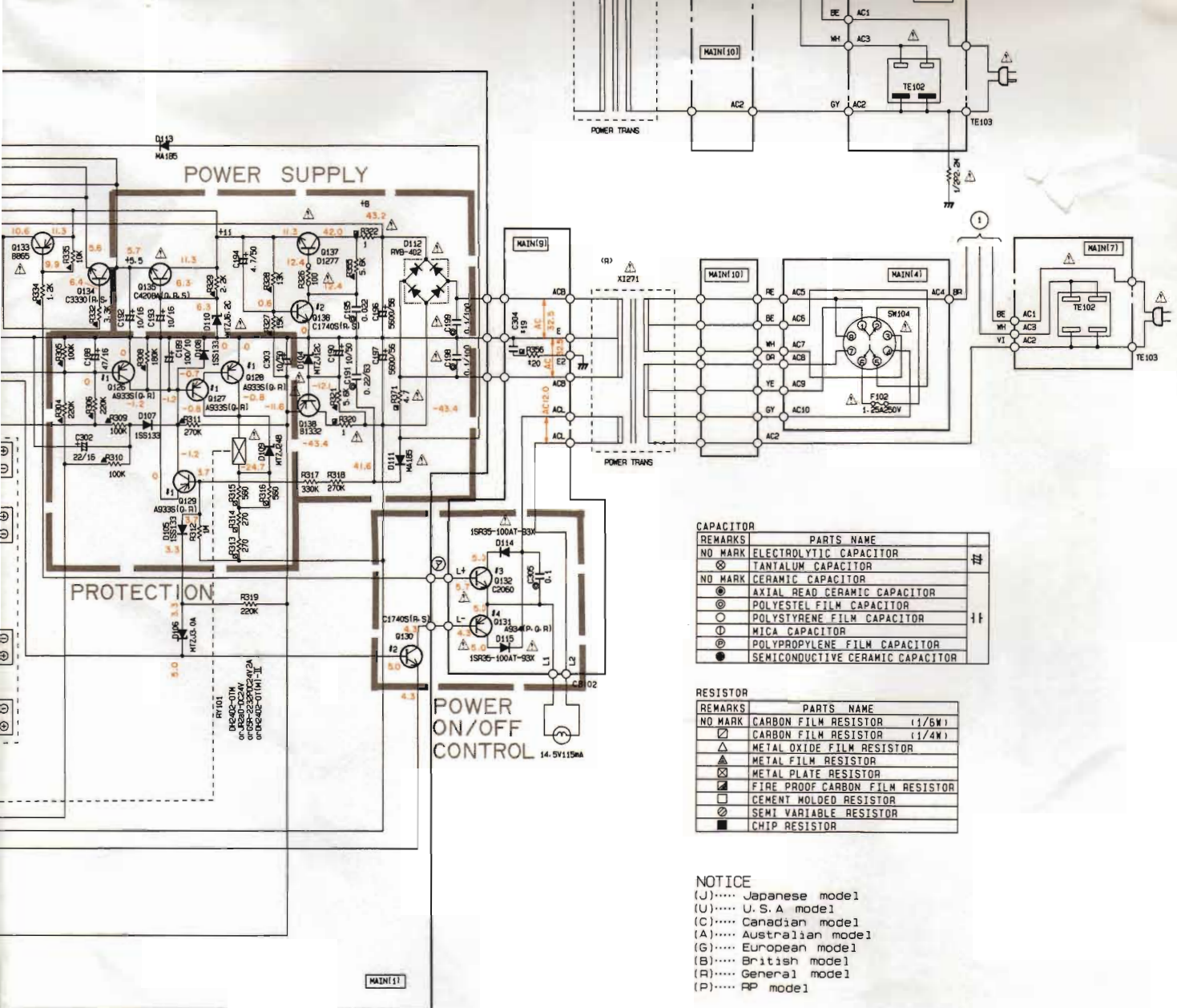

REMARKS	PARTS NAME	
NO MARK	ELECTROLYTIC CAPACITOR	10
⊗	TANTALUM CAPACITOR	10
NO MARK	CERAMIC CAPACITOR	
⊙	AXIAL LEAD CERAMIC CAPACITOR	
⊖	POLYESTER FILM CAPACITOR	
○	POLYSTYRENE FILM CAPACITOR	
⊕	MICA CAPACITOR	
⊗	POLYPROPYLENE FILM CAPACITOR	
●	SEMICONDUCTIVE CERAMIC CAPACITOR	

REMARKS	PARTS NAME	
NO MARK	CARBON FILM RESISTOR (1/8W)	
⊠	CARBON FILM RESISTOR (1/4W)	
△	METAL OXIDE FILM RESISTOR	
▲	METAL FILM RESISTOR	
⊠	METAL PLATE RESISTOR	
⊠	FIRE PROOF CARBON FILM RESISTOR	
□	CEMENT MOLDED RESISTOR	
⊗	SEMI VARIABLE RESISTOR	
■	CHIP RESISTOR	

NOTICE
 (J)..... Japanese model
 (U)..... U. S. A model
 (C)..... Canadian model
 (A)..... Australian model
 (G)..... European model
 (B)..... British model
 (R)..... General model
 (P)..... RP model

**IC5 : TA7291S
(Motor Driver)**

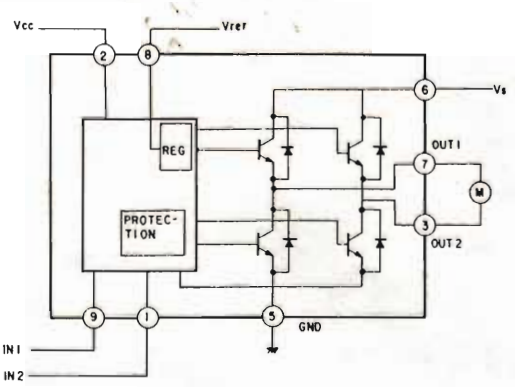

**IC102 : TC4052BP
(Differential 4-Channel Multiplexer/Demultiplexer)**

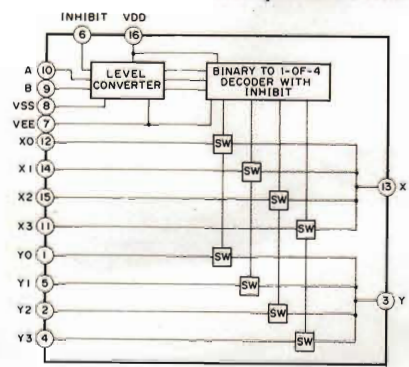

**IC103 : TC4053BP
(Triple 2-Channel Multiplexer/Demultiplexer)**

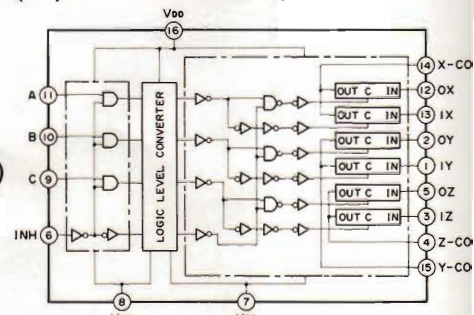

CONTROL INPUTS				"ON" CHANNEL	
INHIBIT (Pin 6)	C (Pin 9)	B (Pin 10)	A (Pin 11)	0X (Pin 12), 0Y (Pin 2), 0Z (Pin 13)	1X (Pin 13), 1Y (Pin 1), 1Z (Pin 14)
L	L	L	L	0X, 0Y, 0Z	
L	L	L	H	1X, 0Y, 0Z	
L	L	H	L	0X, 1Y, 0Z	
L	L	H	H	1X, 1Y, 0Z	
L	H	L	L	0X, 0Y, 1Z	
L	H	L	H	1X, 0Y, 1Z	
L	H	H	L	0X, 1Y, 1Z	
L	H	H	H	1X, 1Y, 1Z	
H	*	*	*	NOTE	

* Don't Care

20	Loop Filter
21	OSC
22	Vcc

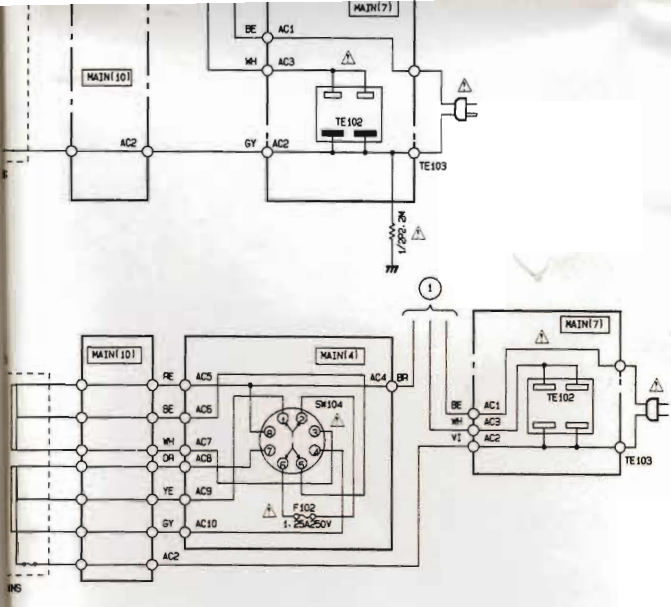

CAPACITOR	
REMARKS	PARTS NAME
NO MARK	ELECTROLYTIC CAPACITOR
⊗	TANTALUM CAPACITOR
NO MARK	CERAMIC CAPACITOR
⊙	AXIAL LEAD CERAMIC CAPACITOR
⊖	POLYESTER FILM CAPACITOR
○	POLYSTYRENE FILM CAPACITOR
⊕	MICA CAPACITOR
⊖	POLYPROPYLENE FILM CAPACITOR
●	SEMICONDUCTIVE CERAMIC CAPACITOR

RESISTOR	
REMARKS	PARTS NAME
NO MARK	CARBON FILM RESISTOR (1/6W)
□	CARBON FILM RESISTOR (1/4W)
△	METAL OXIDE FILM RESISTOR
▲	METAL FILM RESISTOR
⊠	METAL PLATE RESISTOR
▣	FIRE PROOF CARBON FILM RESISTOR
□	CEMENT MOLDED RESISTOR
⊠	SEMI VARIABLE RESISTOR
■	CHIP RESISTOR

NOTICE
 (J)..... Japanese model
 (U)..... U.S. A model
 (C)..... Canadian model
 (A)..... Australian model
 (G)..... European model
 (B)..... British model
 (R)..... General model
 (P)..... RP model

IC3 : LM7000N (PLL)

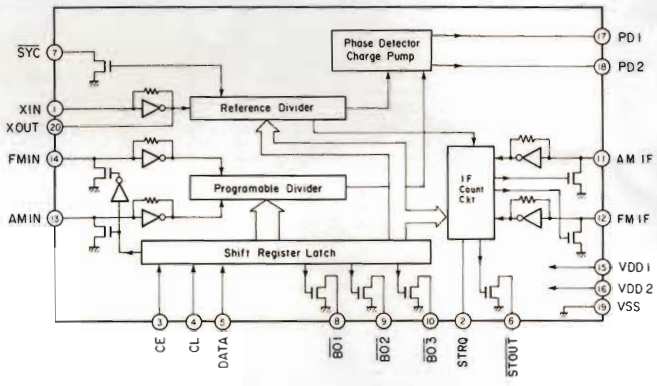

IC201 : LC7582 (LCD Driver)

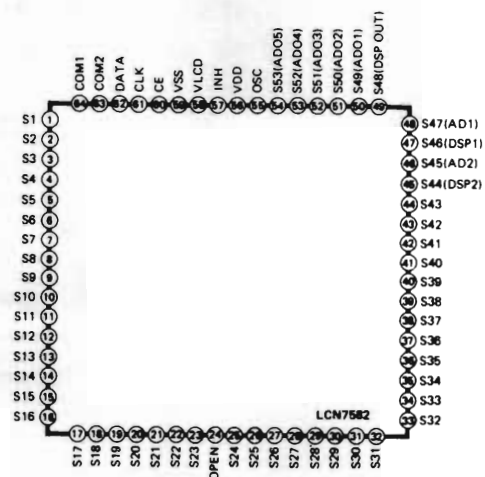

IC103 : TC4053BP (Triple 2-Channel Multiplexer/Demultiplexer)

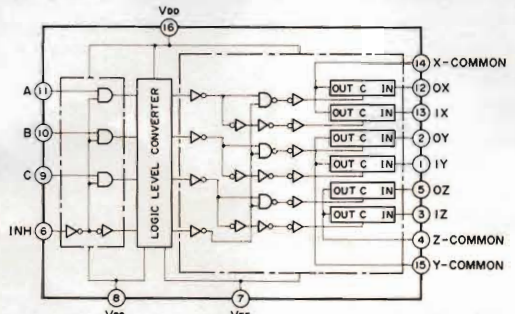

CONTROL INPUTS			"ON" CHANNEL		
INHIBIT (Pin 8)	C (Pin 9)	B (Pin 10)	A (Pin 11)	0X (Pin 12)	0Y (Pin 2), 0Z (Pin 5)
L	L	L	L	1X (Pin 13)	1Y (Pin 1), 1Z (Pin 3)
L	L	L	H		0X, 0Y, 0Z
L	L	H	L		1X, 0Y, 0Z
L	L	H	H		0X, 1Y, 0Z
L	H	L	L		1X, 1Y, 0Z
L	H	L	H		0X, 0Y, 1Z
L	H	H	L		1X, 0Y, 1Z
L	H	H	H		0X, 1Y, 1Z
H	*	*	*		1X, 1Y, 1Z
NOTE					

Binary to 1-of-4 Decoder with Inhibit

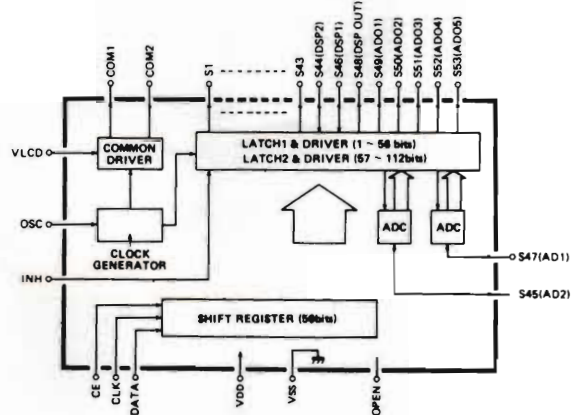
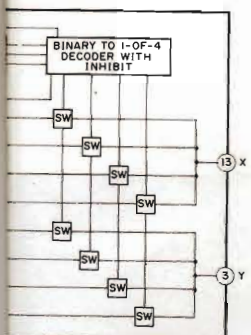

* All voltage are measured with a 10MΩ/DC electric volt meter.
 * Components having special characteristics are marked △ and must be replaced with parts having specifications equal to those originally installed.
 * Schematic diagram is subject to change without notice.

PARTS LIST
ELECTRICAL PARTS

FRONT END PACK

FM FRONT END PACK (PK101)

U, C, R, A, B Models : TFFG1U117A

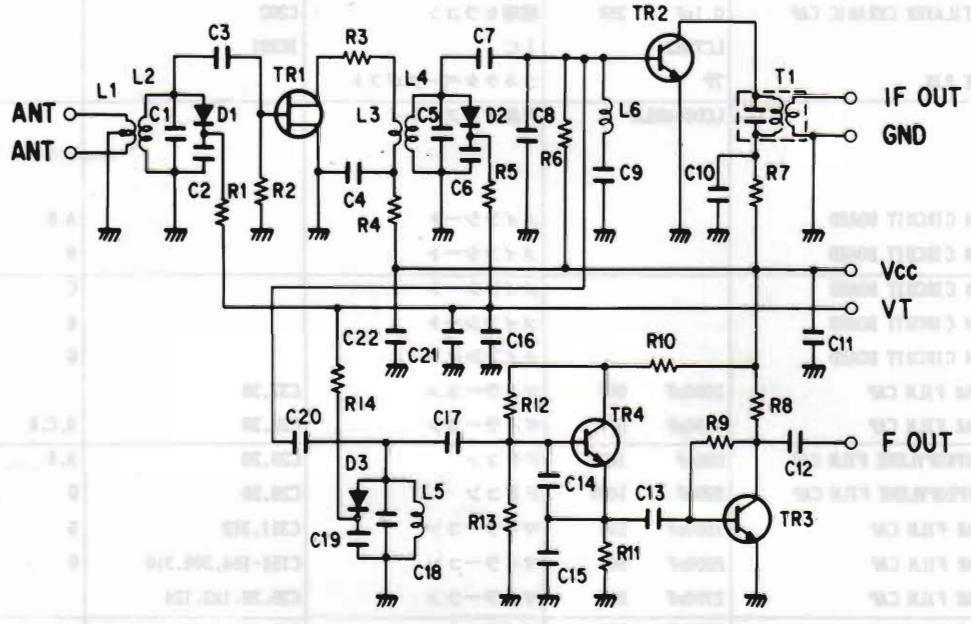

G Model only : TFFG3E132A

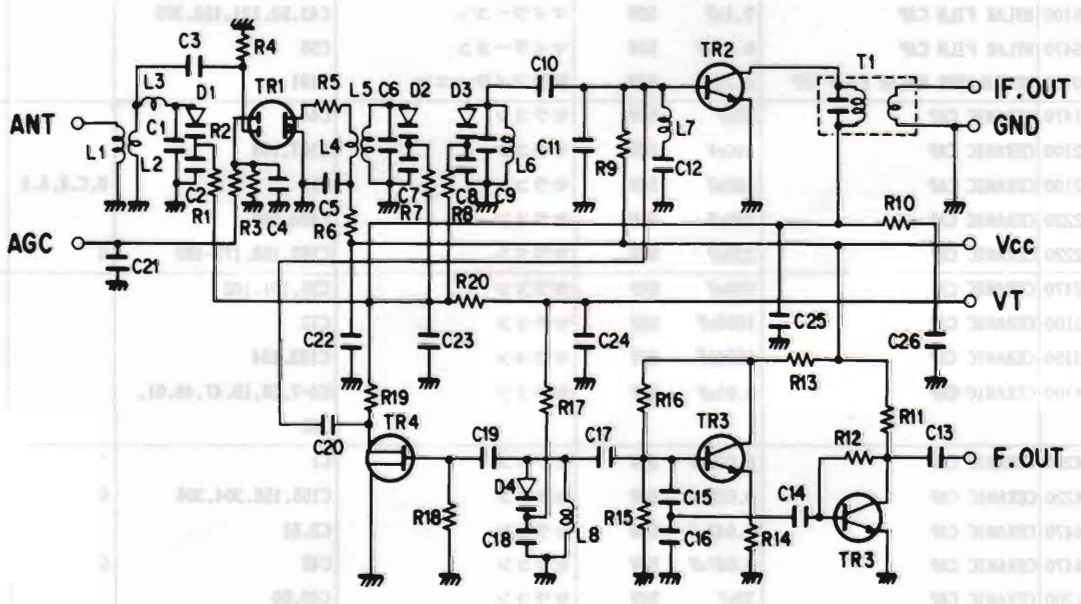

RX-450

PARTS LIST

■ ELECTRICAL PARTS

■ WARNING

Components having special characteristics are marked \triangle and must be replaced with parts having specifications equal to those originally installed.

- Carbon resistors (1/6W or 1/4W) are not included in the ELECTRICAL PARTS List. For the parts No. of the carbon resistors, refer to P. 33.

Ref. NO.	PART NO.	Description			部 品 名	Remarks	Markets	ランク
	VG479100	LCD DISPLAY CIRCUIT BOARD			LCDシート			
	FG212680	CERAMIC CAP	680pF	50V	セラコン	C201		
	FZ005880	MULTILAYER CERAMIC CAP	0.1uF	25V	積層セラコン	C202		
	XB417001	IC	LC7582		IC	IC201		
	VB858600	BASE PIN	7P		コネクタベースポスト			
	VF948400	LCD	LCD8046BJP		液晶ディスプレイ			
*	VJ918600	MAIN CIRCUIT BOARD			メインシート		A, B	
*	VJ918300	MAIN CIRCUIT BOARD			メインシート		U	
*	VJ918400	MAIN CIRCUIT BOARD			メインシート		C	
*	VJ918500	MAIN CIRCUIT BOARD			メインシート		R	
*	VJ918700	MAIN CIRCUIT BOARD			メインシート		G	
	FA153100	MYLAR FILM CAP	1000pF	50V	マイラーコン	C37, 38		
	FA153110	MYLAR FILM CAP	1100pF	50V	マイラーコン	C29, 30	U, C, R	
	UT452680	POLYPROPYLENE FILM CAP	680pF	100V	PPコン	C29, 30	A, B	
	UT452390	POLYPROPYLENE FILM CAP	390pF	100V	PPコン	C29, 30	G	
	FA153150	MYLAR FILM CAP	1500pF	50V	マイラーコン	C311, 312	G	
	FA153220	MYLAR FILM CAP	2200pF	50V	マイラーコン	C151-154, 309, 310	G	
	FA153270	MYLAR FILM CAP	2700pF	50V	マイラーコン	C35, 36, 123, 124		
	FA153390	MYLAR FILM CAP	3900pF	50V	マイラーコン	C39, 40		
	FA153910	MYLAR FILM CAP	9100pF	50V	マイラーコン	C165, 166		
	FA154100	MYLAR FILM CAP	0.01uF	50V	マイラーコン	C147-150	G	
	FA154180	MYLAR FILM CAP	0.018uF	50V	マイラーコン	C119, 120, 125, 126		
	FA154220	MYLAR FILM CAP	0.022uF	50V	マイラーコン	C103, 104, 195		
	FA154330	MYLAR FILM CAP	0.033uF	50V	マイラーコン	C145, 146, 167, 168		
	FA154470	MYLAR FILM CAP	0.047uF	50V	マイラーコン	C22		
	FA155100	MYLAR FILM CAP	0.1uF	50V	マイラーコン	C43, 52, 121, 122, 305		
	FA155470	MYLAR FILM CAP	0.47uF	50V	マイラーコン	C56		
*	VK500700	MULTILAYER MYLAR FILM CAP	0.22uF	63V	積層マイラーコン	C191		
	FG211470	CERAMIC CAP	47pF	50V	セラコン	C44		
	FG212100	CERAMIC CAP	100pF	50V	セラコン	C107, 108		
	FG212100	CERAMIC CAP	100pF	50V	セラコン	C11	U, C, R, A, B	
	FG212220	CERAMIC CAP	220pF	50V	セラコン	C159, 160		
	FG212220	CERAMIC CAP	220pF	50V	セラコン	C157, 158, 173-180	G	
	FG212470	CERAMIC CAP	470pF	50V	セラコン	C28, 101, 102		
	FG213100	CERAMIC CAP	1000pF	50V	セラコン	C12		
	FG213150	CERAMIC CAP	1500pF	50V	セラコン	C133, 134		
	FG244100	CERAMIC CAP	0.01uF	50V	セラコン	C4-7, 18, 19, 47, 48, 61, 306		
	FG244220	CERAMIC CAP	0.022uF	50V	セラコン	C1		
	FG244220	CERAMIC CAP	0.022uF	50V	セラコン	C155, 156, 304, 308	G	
	FG244470	CERAMIC CAP	0.047uF	50V	セラコン	C2, 51		
	FG244470	CERAMIC CAP	0.047uF	50V	セラコン	C45	G	
	VA761200	CERAMIC CAP	33pF	50V	セラコン	C49, 50		
	FZ005880	MULTILAYER CERAMIC CAP	0.1uF	25V	積層セラコン	C54		
	UJ828100	ELECTROLYTIC CAP	100uF	10V	ケミコン	C63, 64, 189		
	UJ837100	ELECTROLYTIC CAP	10uF	16V	ケミコン	C13, 16, 31, 32, 186, 187, 192, 193		
	UJ837220	ELECTROLYTIC CAP	22uF	16V	ケミコン	C302		

*New Parts (新規部品)

ランク : Japan only

Ref. NO.	PART NO.	Description			部 品 名	Remarks	Markets	ランク
*	UJ837470	ELECTROLYTIC CAP	47uF	16V	ケミコン	C115, 116, 127, 128, 188		
	UJ838100	ELECTROLYTIC CAP	100uF	16V	ケミコン	C41, 46, 59, 163, 164, 171, 172, 182, 139, 140		△
	UJ838330	ELECTROLYTIC CAP	330uF	16V	ケミコン	C3		△
	UJ857470	ELECTROLYTIC CAP	47uF	35V	ケミコン	C137, 138		
*	UJ865100	ELECTROLYTIC CAP	0.1uF	50V	ケミコン	C105, 106		
	UJ865470	ELECTROLYTIC CAP	0.47uF	50V	ケミコン	C20, 25		
	UJ866100	ELECTROLYTIC CAP	1uF	50V	ケミコン	C24, 26, 27, 33, 34, 42, 55, 161, 162, 183, 184, 301, 307		
*	UJ866220	ELECTROLYTIC CAP	2.2uF	50V	ケミコン	C8, 109, 110, 117, 118, 169, 170		
	UJ866330	ELECTROLYTIC CAP	3.3uF	50V	ケミコン	C17		
	UJ866470	ELECTROLYTIC CAP	4.7uF	50V	ケミコン	C15, 111, 112, 194		
	UJ867100	ELECTROLYTIC CAP	10uF	50V	ケミコン	C9, 14, 58, 62, 190, 303		△
*	VK182500	ELECTROLYTIC CAP	330uF	63V	ケミコン	C181		
	VK043200	ELECTROLYTIC CAP	5600uF	56V	ケミコン	C196, 197		
	FM116100	ELECTROLYTIC CAP	1uF	50V	B P ケミコン	C60, 185		
	FM176220	ELECTROLYTIC CAP	2.2uF	50V	B P ケミコン	C23		
	FM176330	ELECTROLYTIC CAP	3.3uF	50V	B P ケミコン	C129-132		
	VB170100	ELECTROLYTIC CAP	4.7mF	5.5V	バックアップケミコン	C53		
	Vi861500	METALIZED POLYESTER FILM CAP	3900pF	100V	メタライズドポリコン	C57		
	Vi862200	METALIZED POLYESTER FILM CAP	0.1uF	100V	メタライズドポリコン	C198, 199		
	FU350700	MICA CAP	7pF	500V	マイカコン	C113, 114		
	FU451680	MICA CAP	68pF	500V	マイカコン	C141-144		
	VC793700	COIL			空芯コイル	L101, 102		
	VC362000	COIL	1mH		コイル	L1, 2		
	GE901850	COIL	39mH		固定インダクター	L3, 4		
	GE100470	AM COIL	450K P-7GB		I F T	T2		
	VC218800	COIL	10.7MHz	RZ-002	検波コイル	T1		
	GE200530	FILTER	KW-10DB		LCフィルター	T3	G	
	HV453100	FLAME PROOF CARBON RESISTOR	1Ω	1/4W	不燃化カーボン抵抗	R322, 320	G	△
	HV453220	FLAME PROOF CARBON RESISTOR	2.2Ω	1/4W	不燃化カーボン抵抗	R179, 180, 356, 357-377	G	△
	HV453470	FLAME PROOF CARBON RESISTOR	4.7Ω	1/4W	不燃化カーボン抵抗	R171-174, 371		△
	HV454100	FLAME PROOF CARBON RESISTOR	10Ω	1/4W	不燃化カーボン抵抗	R358, 359		△
	HV454150	FLAME PROOF CARBON RESISTOR	15Ω	1/4W	不燃化カーボン抵抗	R77		
	HV454220	FLAME PROOF CARBON RESISTOR	22Ω	1/4W	不燃化カーボン抵抗	R339, 197, 198		△
	HV454330	FLAME PROOF CARBON RESISTOR	33Ω	1/4W	不燃化カーボン抵抗	R3, 61		△
	HV455470	FLAME PROOF CARBON RESISTOR	470Ω	1/4W	不燃化カーボン抵抗	R155, 156, 199		△
	HV456270	FLAME PROOF CARBON RESISTOR	2.7KΩ	1/4W	不燃化カーボン抵抗	R151, 152, 157, 158		△
	HU595100	METAL FILM RESISTOR	100Ω	1/4W	金属被膜抵抗	R193, 194		
	HU575220	METAL FILM RESISTOR	220Ω	1/4W	金属被膜抵抗	R368, 369		
	HU575330	METAL FILM RESISTOR	330Ω	1/4W	金属被膜抵抗	R341-348		
	HU576120	METAL FILM RESISTOR	1.2KΩ	1/4W	金属被膜抵抗	R334		
	HU576220	METAL FILM RESISTOR	2.2KΩ	1/4W	金属被膜抵抗	R329, 338		
	HU576330	METAL FILM RESISTOR	3.3KΩ	1/4W	金属被膜抵抗	R332		
	HU576560	METAL FILM RESISTOR	5.6KΩ	1/4W	金属被膜抵抗	R321, 355, 370		
	HU576820	METAL FILM RESISTOR	8.2KΩ	1/4W	金属被膜抵抗	R189, 190		
	HU597100	METAL FILM RESISTOR	10KΩ	1/4W	金属被膜抵抗	R335, 336		
	HU597130	METAL FILM RESISTOR	13KΩ	1/4W	金属被膜抵抗	R328		

*New Parts (新規部品)

ランク : Japan only

Ref. NO.	PART NO.	Description	部 品 名		Remarks	Markets	ラック
	HU577150	METAL FILM RESISTOR	15KΩ	1/4W	金属被膜抵抗	R327	
	HU577220	METAL FILM RESISTOR	22KΩ	1/4W	金属被膜抵抗	R357	
	HU577330	METAL FILM RESISTOR	33KΩ	1/4W	金属被膜抵抗	R337	
	HU598100	METAL FILM RESISTOR	100KΩ	1/4W	金属被膜抵抗	R191, 192, 195, 196, 303, 305, 309, 310	
	HU578180	METAL FILM RESISTOR	180KΩ	1/4W	金属被膜抵抗	R308	
	HU598220	METAL FILM RESISTOR	220KΩ	1/4W	金属被膜抵抗	R304, 306	
	HU578270	METAL FILM RESISTOR	270KΩ	1/4W	金属被膜抵抗	R311	
	HU578470	METAL FILM RESISTOR	470KΩ	1/4W	金属被膜抵抗	R360-365	
	HL324680	METAL OXIDE RESISTOR	68Ω	2W	酸化金属被膜抵抗	R60	
	HL325220	METAL OXIDE RESISTOR	220Ω	2W	酸化金属被膜抵抗	R175, 176	
	HL425820	METAL OXIDE RESISTOR	820Ω	2W	酸化金属被膜抵抗	R340	
	VJ787600	METAL PLATE RESISTOR	MPC725	0.22+0.22	金属板抵抗	R161, 162	
	VK187800	FUSABLE RESISTOR	100Ω	1/4W	ヒューズ抵抗	R326	
	VK188600	FUSABLE RESISTOR	470Ω	1/4W	ヒューズ抵抗	R159, 160	
	IG158100	IC	LA3401		IC	IC2	
	XA956A00	IC	NJM2068S		IC	IC101	
	XB760A00	IC	LA1266		IC	IC1	
	XF557A00	IC	TA7291S		IC	IC5	
	IG055100	IC	TC4053BP		IC	IC103	
	XA053A00	IC	TC4052BP		IC	IC102	
	XI267B00	IC	LC6554		IC	IC4	
	XB818A00	IC	LM7000N		IC	IC3	
	VF926500	LIGHT DETECTING MODULE	GP1U501X		リモコン受光ユニット	U2	
	VI027300	AM COIL PACK			AM コイルパック	U1	
	VA961800	VOLTAGE SELECTOR	ESE-37247-F		電圧切替器	SW104	R
	VF541200	SLIDE SWITCH	SSSF11		スライドSW	SW1	R
	VJ774800	ROTARY SWITCH	SRBU		ロータリーSW	SW17	
	KA906380	PUSH SWITCH	EVQ-QRB04M		プッシュSW	SW2-15	
	VG604400	PUSH SWITCH	PSE0P-A4KX		プッシュSW	SW101	
	VJ850400	PUSH SWITCH	PSE0YP-CF2LX		プッシュSW	SW102	
	VJ888600	PUSH SWITCH	PSE 2-2		プッシュSW	SW16	
	VJ850200	PUSH SWITCH	PSE021A2KP 2		プッシュSW	SW103	
	VE681500	PUSH SWITCH	SPUN12		プッシュSW	SW18	
	KB002980	FUSE	2.5A	250V	ヒューズ	F103	G
	VC278600	RELAY	G5R-2232P		リレー	RY101	
	VJ888700	RELAY	DG24D1-0		リレー	RY1	
	LA002410	LAPPING TERMINAL	2P	L-102B	ラッピング端子	TE103	U, C, R
	LA002410	LAPPING TERMINAL	2P	L-102B	ラッピング端子	TE104	A, B, G
	LB301720	PHONES JACK	M1669-A		ホーンジャック	JK101	
	VJ726800	MINI JACK	SWツキ	JC-6	モノラル ミニジャック	JK1	
	VB845900	SPEAKER TERMINAL	PT-C08P04		スピーカ端子	TE101	
	VA845900	ANTENNA TERMINAL	YKD21-0028A		アンテナ端子	TE1	U, C, R, A, B
	LA005800	ANTENNA TERMINAL	YKD31-0215		アンテナ端子	TE1	G
	LB401460	AC OUTLET	2P	M7031-C	電源コネクタ	TE102	U, C, R
	LB202290	PIN JACK	T5856-A		ピンジャック	PJ101	
	LB202290	PIN JACK	T5856-A		ピンジャック	PJ104	G
	LB401030	PIN JACK	T5857-A		ピンジャック	PJ102	
	LB401030	PIN JACK	T5857-A		ピンジャック	PJ103	U, C, R, A, B
	LB202270	PIN JACK	T5854-A		ピンジャック	PJ103	G

*New Parts (新規部品)

ラック : Japan only

Ref. NO.	PART NO.	Description	部 品 名	Remarks	Markets	ランク
	VD004900	BASE PIN	PH 6P TE	ベースピン	CB101	
	VD005200	BASE PIN	PH 9P TE	ベースピン	CB103	
	VD005400	BASE PIN	PH 2P SE	ベースピン	CB102	
	VC219300	FRONT END PACK	TFFG1U117A	バック	PK1	U, C, R, A, B
	VE155800	FRONT-END PACK		フロントエンドバック	PK1	G
	QU003800	QUARTS CRYSTAL	7.2Mz HC-49/U	水晶振動子	XL2	
	GG000750	CERAMIC RESONATOR	18.95Mz CSB456F11	セラミック振動子	XL1	
	VD827600	CERAMIC RESONATOR	4MHz	セラミック振動子	XL3	
	VC219000	CERAMIC FILTER	450Kz SFZ450JL3	セラミックフィルター	CF3	
	GG000560	CERAMIC FILTER	10.7Mz SFE10.7MS3G	セラミックフィルター	CF1,2	
*	VJ693000	PRE-SET POTENTIOMETER	B1KΩ	半固定VR	VR103,104	
	VJ694000	PRE-SET POTENTIOMETER	B47KΩ	半固定VR	VR1.2	
	VG194100	POTENTIOMETER	RK16Z	VR 4連	VR101	
*	VJ774900	POTENTIOMETER WITH MOTOR	Y100KΩ	モーターツキVR	VR102	
	iA093370	TRANSISTOR	2SA933S Q,R	トランジスタ	Q3,126-129	
	iA093410	TRANSISTOR	2SA934 P,Q,R	トランジスタ	Q131	
	iA097030	TRANSISTOR	2SA970 GR,BL	トランジスタ	Q107-110,121,122	
	iA097030	TRANSISTOR	2SA970 GR,BL	トランジスタ	Q9,123	R
*	iA131000	TRANSISTOR	2SA1310 R,S,T	トランジスタ	Q9,123	U, C, A, B, G
	VK334300	TRANSISTOR	2SB1332	トランジスタ	Q138	
*	VC614000	TRANSISTOR	2SB1274 Q,R,S	トランジスタ	Q10	
	VJ888800	TRANSISTOR	2SB865	トランジスタ	Q133	
	iC174070	TRANSISTOR	2SC1740S R,S	トランジスタ	Q4-7,130,136	
	iC053540	TRANSISTOR	2SC535 A,B,C	トランジスタ	Q1	
*	VK407600	TRANSISTOR	2SC4208A Q,R,S	トランジスタ	Q135	
	iC206010	TRANSISTOR	2SC2060 P,Q,R	トランジスタ	Q132	
	iC224000	TRANSISTOR	2SC2240 GR,BL	トランジスタ	Q103-106	
	iC224030	TRANSISTOR	2SC2240 GR,BL	トランジスタ	Q111,112	
	iC224030	TRANSISTOR	2SC2240 GR,BL	トランジスタ	Q8,125	R
	iC331200	TRANSISTOR	2SC3312 R,S,T	トランジスタ	Q8,125	U, C, A, B, G
*	iD043820	TRANSISTOR	2SD438	トランジスタ	Q124	
	VC218900	TRANSISTOR	2SC3330 R,S,T	トランジスタ	Q134	
*	VJ913300	TRANSISTOR	2SD1277 R,Q,P	トランジスタ	Q137	
*	VK432900	TRANSISTOR	2SD1915 (F)	トランジスタ	Q101,102	
*	iB056010	TRANSISTOR	2SB560 E,F	トランジスタ	Q115,116	
	iD043810	TRANSISTOR	2SD438 E,F	トランジスタ	Q113,114	
	iF004600	DIODE	1SS133 T-77	ダイオード	D1-5,8-12,20,105,107,108	
	VC398400	DIODE	MA185	ダイオード	D111,113	
	iF008480	DIODE	1SR35-100AT	ダイオード	D114,115	
*	VG435800	ZENER DIODE	WTZJ3A 3V	ツェナーダイオード	D106	
	VG436200	ZENER DIODE	WTZJ3.6A 3.6V	ツェナーダイオード	D6	
	VG438100	ZENER DIODE	WTZJ6.2C 6.2V	ツェナーダイオード	D110	
	VG439300	ZENER DIODE	WTZJ9.1C 9.1V	ツェナーダイオード	D101,102	
	VG440200	ZENER DIODE	WTZJ12B 12V	ツェナーダイオード	D103	
	VG440300	ZENER DIODE	WTZJ12C 12V	ツェナーダイオード	D104	
	VG442500	ZENER DIODE	WTZJ24B 24V	ツェナーダイオード	D19,109	
	VC971500	DIODE BRIDGE	RBV-402 4A 200V	ダイオードブリッジ	D112	
	Vi013600	LED	SLR-34VC3H3	LED	D17,18	
	VF402500	LED	SLR-34DC3H3	LED	D13-16	

*New Parts (新規部品)

ランク : Japan only

Ref. NO.	PART NO.	Description	部 品 名		Remarks	Markets	ランク	
	LB201880	FUSE HOLDER PIN	PC-FH1	ヒューズホルダピン		C		
	VB966900	PIN	IWSA-6024	スタイルピン				
	BB069510	GROUND PLATE	#6951	ランド金具				
	BB070910	TR PUSHER		TRプッシャー				
	CB005620	PLASTIC RIVET	NO.1057	ブラリベット				
	EX600250	CUP B-TYTE SCREW	3x10 FCRM3-BL	カップBタイトネジ		G		
	VG646600	FRAME,SHIELD		フレーム・シールド				
	BB071360	TERMINAL,SCREW	8.3X13	ネジ 端子				
	iX615600	TRANSISTOR	2SA1490 O,P,Y	トランジスタ	Q119,120			△
	iX615610	TRANSISTOR	2SC3854 O,P,Y	トランジスタ	Q117,118			△
	VG432700	RADIATOR		ラジエータ				
	VG428900	SHEET		シート				
	VH083500	SHEET		シート Wタック				
	EZ001350	CUP B-TYTE SCREW	3x14 FCRM3-BL	カップBタイトネジ				

※New Parts (新規部品)

ランク : Japan only

EXPLODED VIEW

1

2

3

4

5

6

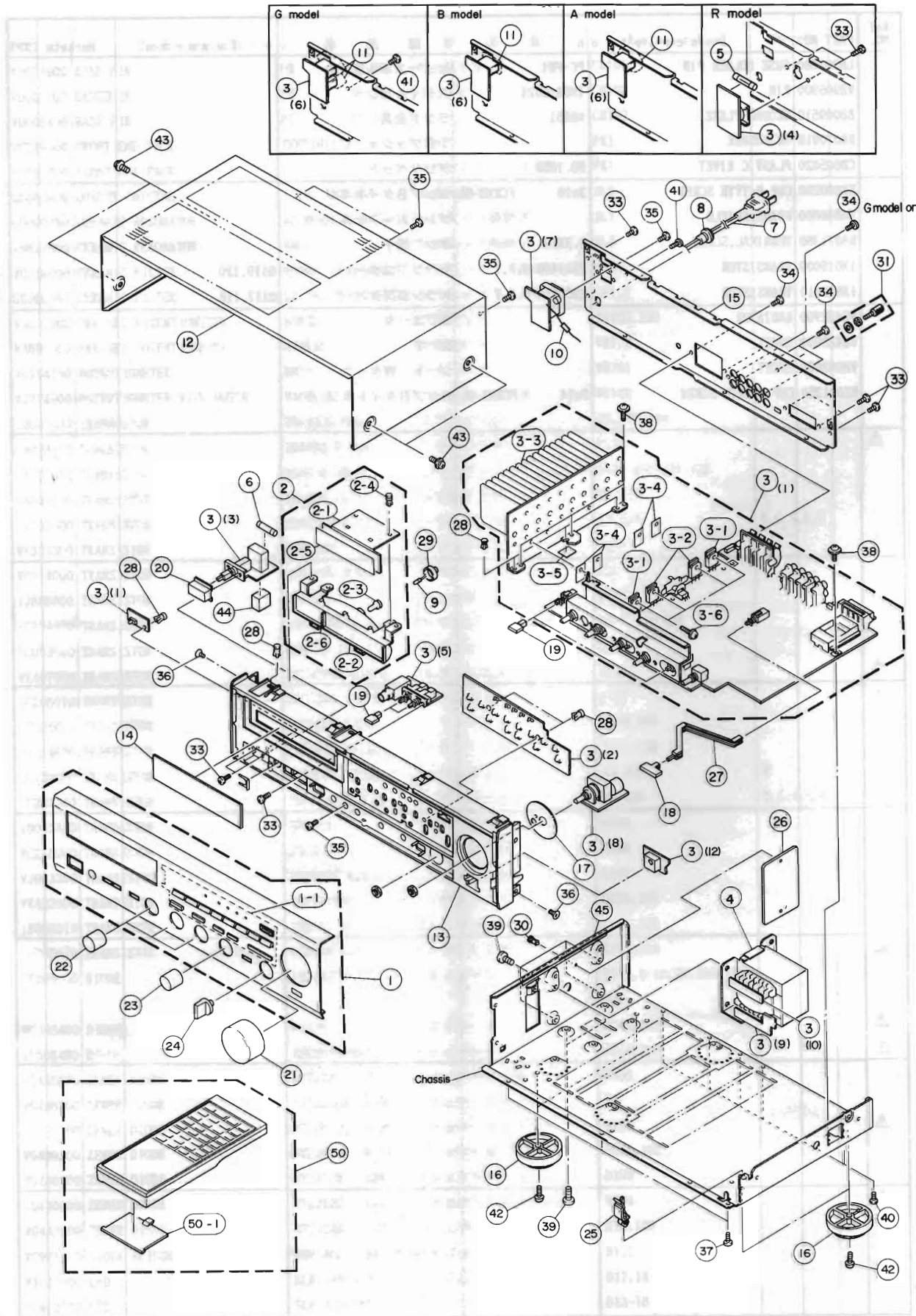

MECHANICAL PARTS Note) ∅ : Diameter

Ref. NO.	PART NO.	Description	部 品 名	Remarks	Markets	ランク
* 01	VJ918100	PANEL UNIT	パネルユニット	BL		
* 01	VJ918200	PANEL UNIT	パネルユニット	T		
02	VG478900	LCD UNIT	LCDユニット			
02-1	VG479100	LCD DISPLAY CIRCUIT BOARD	LCDシート			
02-2	VG433100	REFLECTOR, LCD	リフレクター			
02-3	VF444500	LAMP CAP	AG-4015 ランプキャップ			
02-4	CB605620	PLASTIC RIVET	NO.1057 ブラリベット			
02-5	VG433200	SHEET, LCD	LCD シート			
02-6	VH083600	DUMPER	ダンパー シャコウ			
* 03	VJ918300	MAIN CIRCUIT BOARD	メインシート		U	
* 03	VJ918400	MAIN CIRCUIT BOARD	メインシート		C	
* 03	VJ918500	MAIN CIRCUIT BOARD	メインシート		R	
* 03	VJ918600	MAIN CIRCUIT BOARD	メインシート		A, B	
* 03	VJ918700	MAIN CIRCUIT BOARD	メインシート		G	
03-1	iX615600	TRANSISTOR	2SA1490 トランジスタ	Q119, 120		△
03-2	iX615610	TRANSISTOR	2SC3854 トランジスタ	Q117, 118		△
03-3	VG432700	RADIATOR	ラジエター			
03-4	VG428900	SHEET	シート			
03-5	VH083500	SHEET	シート			
03-6	EZ001350	CUP TIGHT SCREW	3x14 FCRM3-BL カップタイトネジ			
* 04	Xi269A00	POWER TRANSFORMER	電源トランス		U	△
* 04	Xi270A00	POWER TRANSFORMER	電源トランス		C	△
* 04	Xi271A00	POWER TRANSFORMER	電源トランス		R	△
* 04	Xi272A00	POWER TRANSFORMER	電源トランス		A, B	△
* 04	Xi273A00	POWER TRANSFORMER	電源トランス		G	△
05	KB000680	FUSE	1.25A 250V ヒューズ		R	△
06	KB003180	FUSE	4A 250V ヒューズ		U, C	△
06	KB000680	FUSE	1.25A 250V ヒューズ		A, B, G	△
06	KB000760	FUSE	3.15A 250V ヒューズ		R	△
07	MG002220	POWER CORD	10A 125V 電源コード		U	△
07	VE371000	POWER CORD	6A 250V 電源コード		R	△
07	MG002310	POWER CORD	7.5A 250V 電源コード		A	△
07	MG002330	POWER CORD	6A 300V 電源コード		B	△
07	MG002320	POWER CORD	2.5A 250V 電源コード		G	△
08	CB620200	CORD STOPPER	CM-22C コードストッパー		U, C	△
08	CB620190	CORD STOPPER	CM-22B コードストッパー		R, A, B, G	△
* 09	VJ835300	LAMP	14.5V 115mA ランプ			△
10	HG309220	CARBON RESISTOR	2.2MΩ 1/2W カーボン抵抗		U, C	△
* 11	VJ775000	AC OUTLET	2P ACアウトレット		B	△
* 11	VJ775100	AC OUTLET	2P ACアウトレット		G	△
11	VC626100	AC OUTLET	電源コネクタ		A	△
12	AA625520	TOP COVER	トップカバー	BL		
12	VH249400	TOP COVER	トップカバー	T		
13	VJ423200	SUB CHASSIS	サブシャーシ	BL		
13	VJ423300	SUB CHASSIS	サブシャーシ	T		
14	VK248300	PLATE LCD	LCD プレート			
* 15	VJ829200	REAR PANEL	リヤパネル		U	
* 15	VJ829300	REAR PANEL	リヤパネル		C	
* 15	VJ829400	REAR PANEL	リヤパネル		R	
* 15	VJ829500	REAR PANEL	リヤパネル		A, B	

*New Parts (新規部品)

ランク : Japan only

Ref. NO.	PART NO.	Description	部 品 名	Remarks	Markets	ランク
* 15	VJ829600	REAR PANEL	リヤパネル		G	
16	CB660950	LEG	レッグ	BL		
16	Vi175700	LEG	レッグ	T		
17	VH087800	SHIELD PLATE	シールドプレート			
18	VH877000	BUTTON	ボタン	BL		
18	VH877100	BUTTON	ボタン	T		
19	VH816000	BUTTON	ボタン	BL		
19	VH816100	BUTTON	ボタン	T		
20	VH841900	BUTTON	ボタン	BL		
20	VH842000	BUTTON	ボタン	T		
* 21	VK054300	KNOB	ノブ	BL		
* 21	VK054400	KNOB	ノブ	T		
22	Vi211300	KNOB	ノブ	BL		
22	Vi211200	KNOB	ノブ	T		
23	VJ424200	KNOB	ノブ	BL		
23	VJ424300	KNOB	ノブ	T		
24	VI251000	KNOB	ノブ	BL		
24	VI251100	KNOB	ノブ	T		
25	VA772900	P.C.B SUPPORT	基板サポート			
26	VJ646800	FRAME, RADIATOR	フレーム・ハウネツ			
27	VJ423900	ROD	ロッド			
28	CB605620	PLASTIC RIVET	ブラリベット			
29	VG650400	RING	リング			
30	CB603240	PLASTIC RIVET	ブラリベット			
31	AA627310	GROUND TERMINAL	GNDターミナル			
33	ED330066	BIND HEAD SCREW	3x6 FCM3-BL	バインド小ネジ		
34	EZ000460	BONDING TAPPING SCREW	3x8 FCM3-BL	ボンディングネジ		
35	Ei330086	BIND TAPPING SCREW	3x8 FCM3-BL	バインドタッピングネジ		
36	E0330066	FLAT HEAD TAPPING SCREW	3x6 ZMC2-BL	皿タッピングネジ		
37	EX601360	BIND TAPPING SCREW	3x10 MFC3-BL	バインドタッピングネジ		
38	EX600240	BW HEAD TAPPING SCREW	3x8 FCM3-BL	BWヘッドタッピングネジ		
39	Ei340086	BIND TAPPING SCREW	4x8 FCRM3-BL	バインドタッピングネジ		
40	Ei030066	BIND TAPPING SCREW	3x6 ZMC2-BL	バインドタッピングネジ		
41	Ei130120	BIND TAPPING SCREW	3x12 FNM3-3G	バインドタッピングネジ	U.C.G	
42	EK336010	BW HEAD TAPPING SCREW	3x8 FCM3-BL	BWヘッドタッピングネジ		
43	EK365040	BW HEAD SCREW	4x8 FCM3-BL	BWヘッド小ネジ	BL	
43	EX601150	BW HEAD S-TYTE SCREW	4x8 FNM3-BL	BWヘッド小ネジ	T	
44	VH088000	SPACER	スペーサー			
45	CB652050	DAMPER	ダンパー			
46	CB069250	BIND TIE	BK-1	束線止め		
* 50	VJ931500	ACCESSOR IS REMOTE CONTROL TRANSMITTER	付属品 トランスミッター			
* 50-1	CX615920	LID	UM-4 (NG)	電池蓋		
	VE366200	LOOP ANTENNA		マンガン電池		
	VG850600	ANTENNA, FM	1.42M	ループアンテナ		U.C.R.A.B
	VG850700	ANTENNA, FM	1.43M	FMアンテナコード		G

*New Parts (新規部品)

ランク : Japan only

REMOTE CONTROL TRANSMITTER

SCHEMATIC DIAGRAM

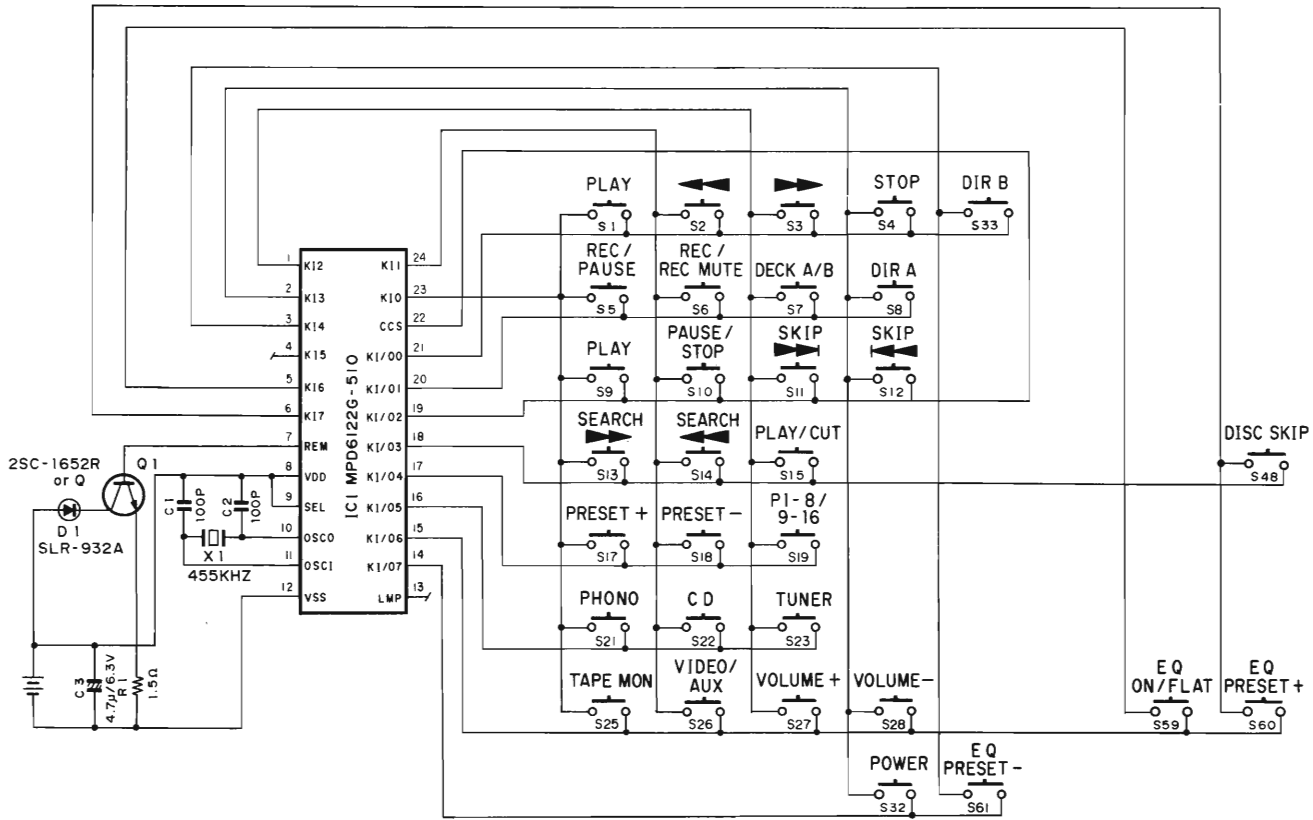

CUSTOM CODE

C0 C1 C2 C3 C4 C5 C6 C7
 0 1 0 1 1 1 1 0

KEY No.	DATA CODE								FUNCTION
	D0	D1	D2	D3	D4	D5	D6	D7	
1	0	0	0	0	0	0	0	0	TAPE PLAY
2	1	0	0	0	0	0	0	0	TAPE ◀◀
3	0	1	0	0	0	0	0	0	TAPE ▶▶
4	1	1	0	0	0	0	0	0	TAPE STOP
5	0	0	1	0	0	0	0	0	TAPE REC/PAUSE
6	1	0	1	0	0	0	0	0	TAPE REC MUTE
7	0	1	1	0	0	0	0	0	TAPE DECK A/B
8	1	1	1	0	0	0	0	0	TAPE DIR A
9	0	0	0	1	0	0	0	0	CD PLAY
10	1	0	0	1	0	0	0	0	CD PAUSE/STOP
11	0	1	0	1	0	0	0	0	CD ▶▶
12	1	1	0	1	0	0	0	0	CD ◀◀
13	0	0	1	1	0	0	0	0	CD ◀◀
14	1	0	1	1	0	0	0	0	CD ◀◀
15	0	1	1	1	0	0	0	0	PHONO PLAY/CUT
17	0	0	0	0	1	0	0	0	TUNER PRESET +
18	1	0	0	0	1	0	0	0	TUNER PRESET -
19	0	1	0	0	1	0	0	0	TUNER P1-8/P9-16
21	0	0	1	0	1	0	0	0	PHONO
22	1	0	1	0	1	0	0	0	CD
23	0	1	1	0	1	0	0	0	TUNER
25	0	0	0	1	1	0	0	0	TAPE MON
26	1	0	0	1	1	0	0	0	VIDEO/AUX
27	0	1	0	1	1	0	0	0	VOLUME +
28	1	1	0	1	1	0	0	0	VOLUME -
32	1	1	1	1	1	0	0	0	POWER
33	0	0	0	0	0	0	1	0	TAPE DIR B
48	1	1	1	1	0	0	1	0	CD DISC SKIP
59	0	1	0	1	1	0	1	0	EQ ON/FLAT
60	1	1	0	1	1	0	1	0	EQ PRESET +
61	0	0	1	1	1	0	1	0	EQ PRESET -

Parts List for Carbon Resistors

Value	1/4W Type Part No.	1/6W Type Part No.	Value	1/4W Type Part No.	1/6W Type Part No.
1.0 Ω	HJ35 3100	HF85 3100	12 KΩ	HJ35 7120	HF85 7120
1.8 Ω	HJ35 3180	*	15 KΩ	HJ35 7150	HF85 7150
2.2 Ω	HJ35 3220	HF85 3220	18 KΩ	HJ35 7180	HF85 7180
3.3 Ω	HJ35 3330	HF85 3330	22 KΩ	HJ35 7220	HF85 7220
4.7 Ω	HJ35 3470	HF85 3470	27 KΩ	HJ35 7270	HF85 7270
5.6 Ω	HJ35 3560	HF85 3560	33 KΩ	HJ35 7330	HF85 7330
10 Ω	HJ35 4100	HF85 4100	39 KΩ	HJ35 7390	HF85 7390
15 Ω	HJ35 4150	HF85 4150	47 KΩ	HJ35 7470	HF85 7470
22 Ω	HJ35 4220	HF85 4220	56 KΩ	HJ35 7560	HF85 7560
27 Ω	HJ35 4270	HF85 4270	68 KΩ	HJ35 7680	HF85 7680
33 Ω	HJ35 4330	HF85 4330	82 KΩ	HJ35 7820	HF85 7820
39 Ω	HJ35 4390	HF85 4390	91 KΩ	HJ35 7910	HF85 7910
47 Ω	HJ35 4470	HF85 4470	100 KΩ	HJ35 8100	HF85 8100
56 Ω	HJ35 4560	HF85 4560	120 KΩ	HJ35 8120	HF85 8120
68 Ω	HJ35 4680	HF85 4680	150 KΩ	HJ35 8150	HF85 8150
82 Ω	HJ35 4820	HF85 4820	180 KΩ	HJ35 8180	HF85 8180
100 Ω	HJ35 5100	HF85 5100	220 KΩ	HJ35 8220	HF85 8220
110 Ω	HJ35 5110	HF85 5110	270 KΩ	HJ35 8270	HF85 8270
120 Ω	HJ35 5120	HF85 5120	330 KΩ	HJ35 8330	HF85 8330
150 Ω	HJ35 5150	HF85 5150	390 KΩ	HJ35 8390	HF85 8390
160 Ω	HJ35 5160	*	470 KΩ	HJ35 8470	HF85 8470
180 Ω	HJ35 5180	HF85 5180	560 KΩ	HJ35 8560	HF85 8560
220 Ω	HJ35 5220	HF85 5220	680 KΩ	HJ35 8680	HF85 8680
270 Ω	HJ35 5270	HF85 5270	820 KΩ	HJ35 8820	HF85 8820
330 Ω	HJ35 5330	HF85 5330	1.0 MΩ	HJ35 9100	HF85 9100
390 Ω	HJ35 5390	HF85 5390	1.2 MΩ	HJ35 9120	*
470 Ω	HJ35 5470	HF85 5470	1.5 MΩ	HJ35 9150	HF85 9150
510 Ω	*	HF85 5510	1.8 MΩ	HJ35 9180	HF85 9180
560 Ω	HJ35 5560	HF85 5560	2.2 MΩ	HJ35 9220	HF85 9220
680 Ω	HJ35 5680	HF85 5680	3.3 MΩ	HJ35 9330	HF85 9330
820 Ω	HJ35 5820	HF85 5820	3.9 MΩ	HJ35 9390	*
910 Ω	HJ35 5910	HF85 5910	4.7 MΩ	HJ35 9470	HF85 9470
1.0 KΩ	HJ35 6100	HF85 6100			
1.2 KΩ	HJ35 6120	HF85 6120			
1.5 KΩ	HJ35 6150	HF85 6150			
1.8 KΩ	HJ35 6180	HF85 6180			
2.0 KΩ	HJ35 6200	HF85 6200			
2.2 KΩ	HJ35 6220	HF85 6220			
2.4 KΩ	HJ35 6240	HF85 6240			
2.7 KΩ	HJ35 6270	HF85 6270			
3.0 KΩ	HJ35 6300	HF85 6300			
3.3 KΩ	HJ35 6330	HF85 6330			
3.6 KΩ	HJ35 6360	HF85 6360			
3.9 KΩ	HJ35 6390	HF85 6390			
4.7 KΩ	HJ35 6470	HF85 6470			
5.1 KΩ	HJ35 6510	HF85 6510			
5.6 KΩ	HJ35 6560	HF85 6560			
6.8 KΩ	HJ35 6680	HF85 6680			
8.2 KΩ	HJ35 6820	HF85 6820			
9.1 KΩ	HJ35 6910	HF85 6910			
10 KΩ	HJ35 7100	HF85 7100			

1/4W Type

HJ35 ○○○○

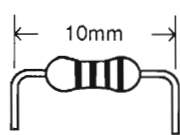

← 10mm →

1/6W Type

HF85 ○○○○

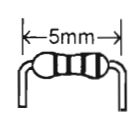

← 5mm →