

CENTER

STEREO RECEIVER RX-495/ RX-495RDS

SERVICE MANUAL

RX-495/
RX-495RDS

IMPORTANT NOTICE

This manual has been provided for the use of authorized YAMAHA Retailers and their service personnel. It has been assumed that basic service procedures inherent to the industry, and more specifically YAMAHA Products, are already known and understood by the users, and have therefore not been restated.

WARNING: Failure to follow appropriate service and safety procedures when servicing this product may result in personal injury, destruction of expensive components, and failure of the product to perform as specified. For these reasons, we advise all YAMAHA product owners that any service required should be performed by an authorized YAMAHA Retailer or the appointed service representative.

IMPORTANT: The presentation or sale of this manual to any individual or firm does not constitute authorization, certification or recognition of any applicable technical capabilities, or establish a principle-agent relationship of any form.

The data provided is believed to be accurate and applicable to the unit(s) indicated on the cover. The research, engineering, and service departments of YAMAHA are continually striving to improve YAMAHA products. Modifications are, therefore, inevitable and specifications are subject to change without notice or obligation to retrofit. Should any discrepancy appear to exist, please contact the distributor's Service Division.

WARNING: Static discharges can destroy expensive components. Discharge any static electricity your body may have accumulated by grounding yourself to the ground buss in the unit (heavy gauge black wires connect to this buss).

IMPORTANT: Turn the unit OFF during disassembly and part replacement. Recheck all work before you apply power to the unit.

■ CONTENTS

TO SERVICE PERSONNEL	1	RX-495RDS μ -COM DATA	14~15
FRONT PANELS	1~2	RX-495 BLOCK DIAGRAM	16~17
REAR PANELS	2~3	RX-495RDS BLOCK DIAGRAM	18~19
SPECIFICATIONS	4~5	RX-495 PRINTED CIRCUIT BOARD	20~25
INTERNAL VIEW	5	RX-495RDS PRINTED CIRCUIT BOARD	26~30
DISASSEMBLY PROCEDURES	6	PIN CONNECTION DIAGRAM	31
AMP ADJUSTMENTS	6	RX-495 SCHEMATIC DIAGRAM	32~35
TEST MODE	7	RX-495RDS SCHEMATIC DIAGRAM	36~39
TUNER ADJUSTMENTS	8~11	REMOTE CONTROL TRANSMITTER	40
RX-495 μ -COM DATA	12~13	PARTS LIST	41~50

100543

YAMAHA

YAMAHA CORPORATION
P.O. Box 1, Hamamatsu, Japan

2.65K-826  Printed in Japan '96.4

■ TO SERVICE PERSONNEL

1. Critical Components Information.
Components having special characteristics are marked and must be replaced with parts having specifications equal to those originally installed.
2. Leakage Current Measurement (For 120V Models Only).
When service has been completed, it is imperative to verify that all exposed conductive surfaces are properly insulated from supply circuits.
 - Meter impedance should be equivalent to 1500 ohm shunted by 0.15 μ F.
 - Leakage current must not exceed 0.5mA.
 - Be sure to test for leakage with the AC plug in both polarities.

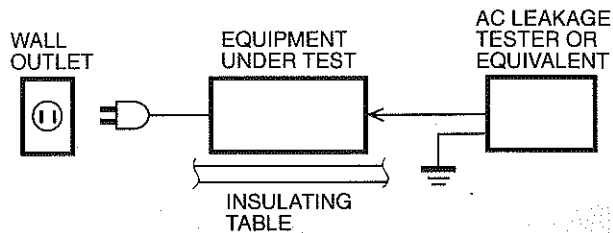

WARNING: CHEMICAL CONTENT NOTICE!

The solder used in the production of this product contains LEAD. In addition, other electrical/electronic and/or plastic (where applicable) components may also contain traces of chemicals found by the California Health and Welfare Agency (and possibly other entities) to cause cancer and/or birth defects or other reproductive harm.

DO NOT PLACE SOLDER, ELECTRICAL/ELECTRONIC OR PLASTIC COMPONENTS IN YOUR MOUTH FOR ANY REASON WHAT SO EVER!

Avoid prolonged, unprotected contact between solder and your skin! When soldering, do not inhale solder fumes or expose eyes to solder/flux vapor!

If you come in contact with solder or components located inside the enclosure of this product, wash your hands before handling food.

■ FRONT PANELS

▼ RX-495

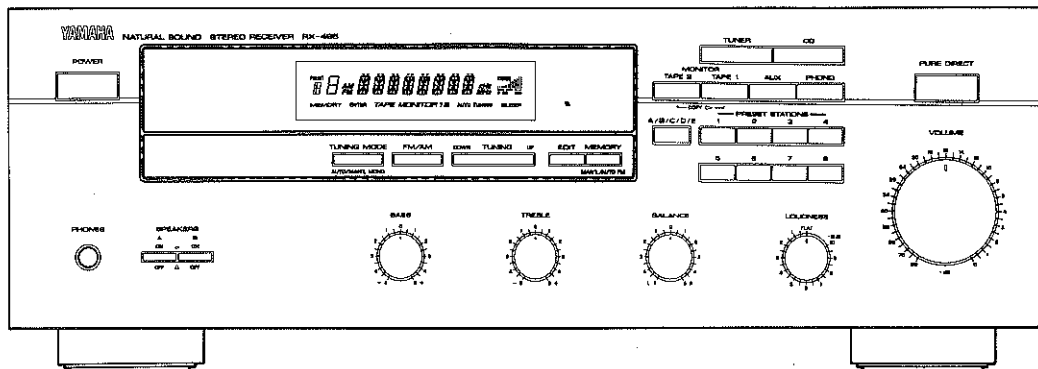

▼ RX-495RDS

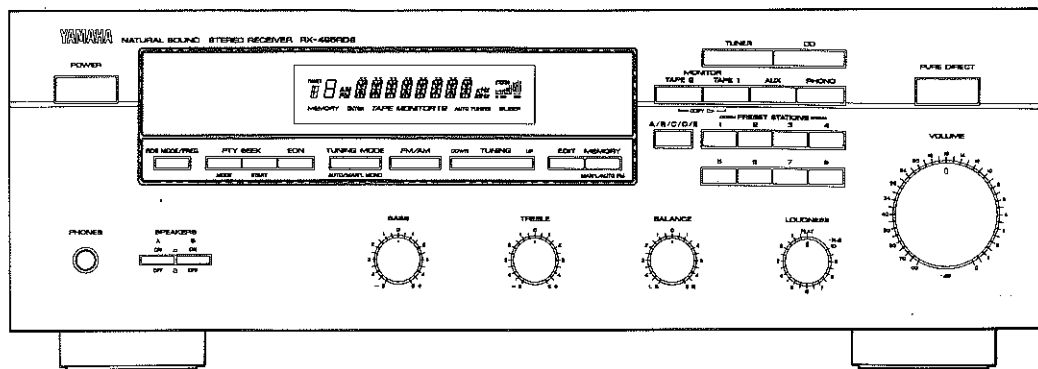

▼ RX-495/RX-495RDS

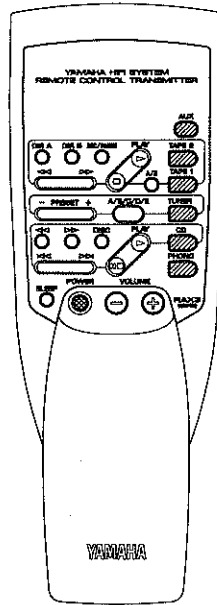

■ REAR PANELS

▼ RX-495 U model

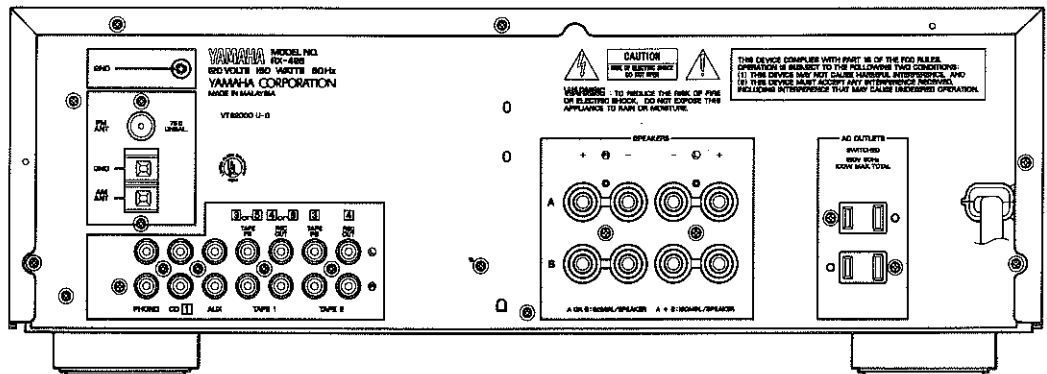

▼ RX-495 C model

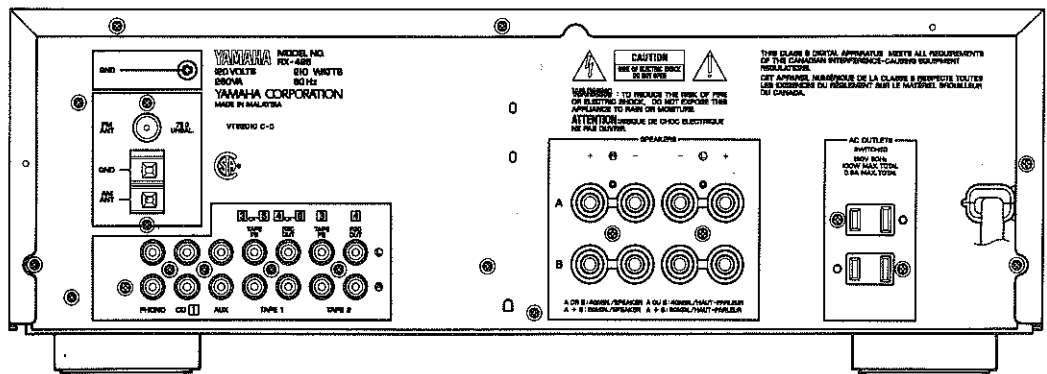

▼ RX-495 R model

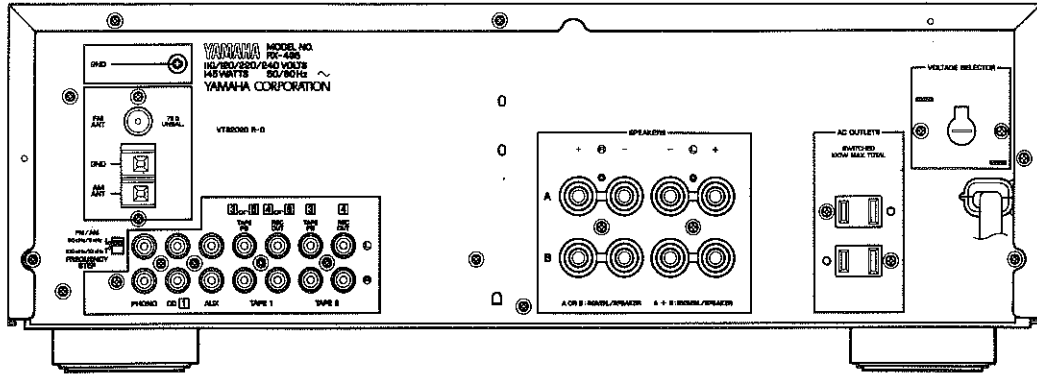

▼ RX-495 A model

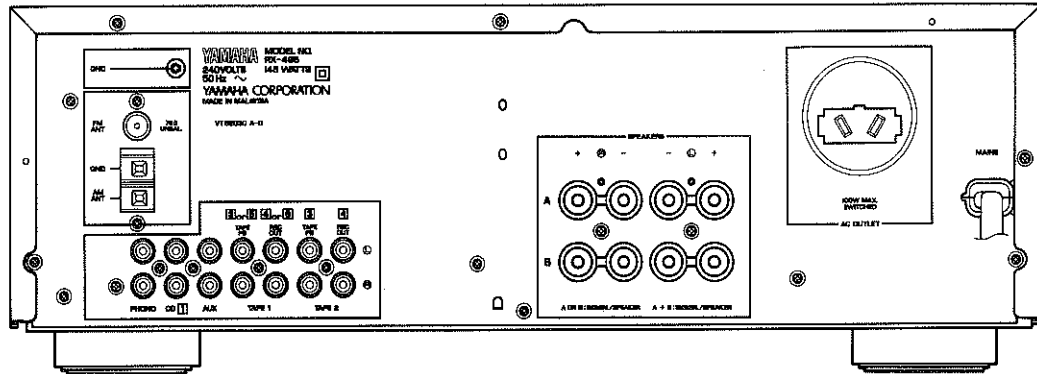

▼ RX-495 L model

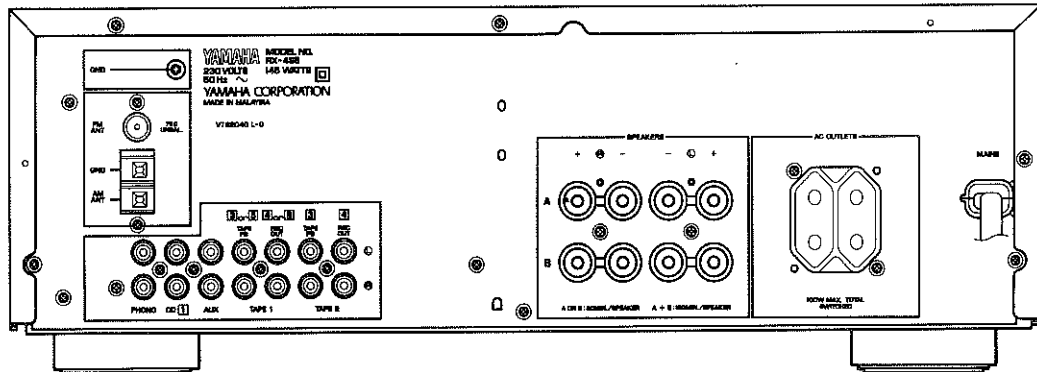

▼ RX-495RDS G model

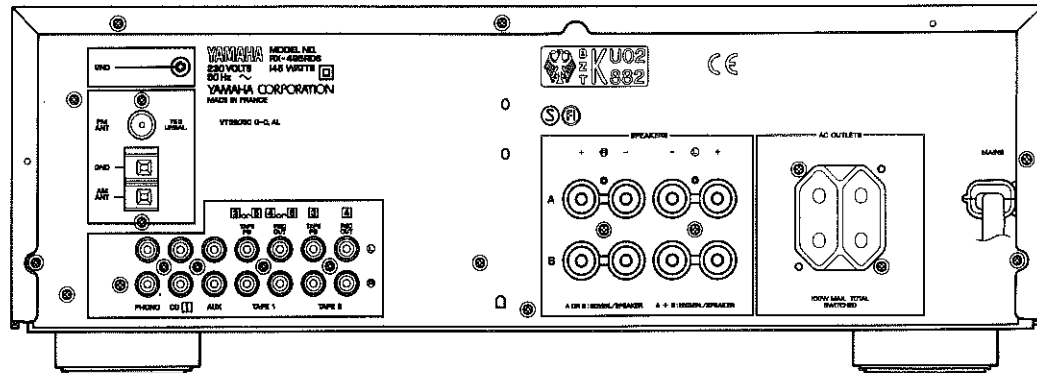

■ SPECIFICATIONS

■ AUDIO SECTION

Minimum RMS Output Power per Channel	
8 ohms, 20Hz to 20kHz, 0.04% THD	70W
6 ohms, 20Hz to 20kHz, 0.06% THD (U, C models only)	80W
Dynamic Power per Channel (IHF)	
8/6/4/2 ohms	100/120/145/170W
DIN Standard Output Power per Channel (G, L models only)	
4 ohms, 1kHz, 0.7% THD	100W
IEC Power (G, L models only)	
1kHz, 0.04% THD, 8 ohms	80W
Power Band Width	
8 ohms, 35W, 0.08% THD	10Hz to 50kHz
Damping Factor	
8 ohms, 20Hz to 20kHz	100 or more
Maximum Power (EIAJ) (R model only)	
8 ohms, 1kHz, 10%THD	100W
Input Sensitivity/Impedance	
PHONO MM	2.5mV/47k-ohms
CD etc	150mV/47k-ohms
Maximum Input Signal Level (1kHz, 0.04% THD)	
PHONO MM	90mV
Output Level	
REC OUT	150mV
Headphone Jack Rated Output/Impedance	
0.04% THD, RL=8 ohms	0.48V/390 ohms
Frequency Response (20Hz to 20kHz)	
CD etc	0±0.5dB
RIAA Equalization Deviation (20Hz to 20kHz)	
PHONO MM	0±0.5dB
Total Harmonic Distortion (20Hz to 20kHz)	
PHONO MM to REC OUT (3V)	0.02%
CD etc to SP OUT (35W/8 ohms)	0.02%
Signal-to-Noise Ratio (IHF-A Network)	
PHONO MM (5mV Input Shorted)	82dB
CD etc (Shorted)	108dB
Residual Noise (IHF-A Network)	
	100µV
Channel Separation (1kHz, Vol. -30dB)	
CD etc (input 5.1k-ohms Terminated)	60dB
Tone Control Characteristics	
BASS : Boost/cut	±10dB (50Hz)
Turnover Frequency	350Hz
TREBLE: Boost/cut	±10dB (20kHz)
Turnover Frequency	3.5kHz
Continuous Loudness Control	
	-30dB (1kHz)
	(Level related equalization)

■ FM SECTION Tuning Range

Tuning Range	
U, C models	87.5 to 107.9MHz
A model	87.5 to 108.0MHz
G, L models	87.50 to 108.00MHz
R model	87.5 to 107.9/87.5 to 108.0MHz
50dB Quieting Sensitivity (IHF, 75 ohms)	
Except G, L models	
Mono	1.55µV (15.1dBf)
Stereo	21µV (37.7dBf)
Usable Sensitivity (75 ohms)	
(30dB S/N Quieting, 1kHz, 100% mod.)	
Except G, L models	0.8µV (9.3dBf)
DIN, Mono (S/N 26dB) G, L models	0.9µV
DIN, Stereo (S/N 46dB) G, L models	24µV
Image Response Ratio	
Except G, L models	45dB
G, L models	80dB
IF Response Ratio	
	80dB
Spurious Response Ratio	
	70dB
AM Suppression Ratio	
	55dB
Capture Ratio	
	1.5dB
Alternate Channel Selectivity	
Except G, L models	85dB
Selectivity (two signals, 40kHz Dev.)	
G, L models	70dB
Signal-to-Noise Ratio	
(IHF) Mono/Stereo	
Except G, L models	80/75dB
(DIN-weighted, 40kHz Dev.) Mono/Stereo	
G, L models	75/70dB
Harmonic Distortion (1kHz)	
Mono/Stereo	
Except G, L models	0.1/0.2%
Mono/Stereo (40kHz Dev.)	
G, L models	0.1/0.2%
Frequency Response	
20Hz to 15kHz	0±1.5dB
Stereo Separation (1kHz)	
Except G, L models	50dB

■ AM SECTION

Tuning Range	
U, C models	530 to 1,710kHz
A, G, L models	531 to 1,611kHz
R model	530 to 1,710/531 to 1,611kHz
Usable Sensitivity	
	100µV/m
Selectivity	
	32dB
Signal-to-Noise Ratio	
	50dB
Image Response Ratio	
	40dB
Spurious Response Ratio	
	50dB
Harmonic Distortion (400Hz)	
	0.3%

AUDIO SECTION

Output Level/Impedance	
FM (100% mod., 1kHz)	
Except G, L models	500mV/2.2k-ohms
G, L models (40kHz Dev.)	500mV/2.2k-ohms
AM (30% mod., 400Hz)	
Except G, L models	150mV/2.2k-ohms
G, L models	150mV/2.2k-ohms

RX-495/RX-495RDS

■ GENERAL

Power Supply

U, C models AC 120V, 60Hz
 A model AC 240V, 50Hz
 G, L models AC 230V, 50Hz
 R model AC 110/120/220/240V, 60/50Hz

Power Consumption

R, A, G, L models 145W
 C model 260VA, 210W
 U model 160W

AC Outlets

Switched x 2
 U, C, R, G, L models 100W max
 Switched x 1
 A model 100W max

Dimensions (W x H x D) 435 x 146 x 308.5mm
 (17-1/8" x 5-3/4" x 12-1/8")

Weight 7.8 kg (17 lbs 3 oz.)

Accessories AM loop antenna x 1
 Indoor FM antenna x 1
 Remote Control Transmitter x 1
 Battery (size "AA", "R06") x 2

* Specifications subject to change without notice.

U USA model G European model
 C Canadian model L Singapore model
 A Australian model R General model

● DIMENSIONS

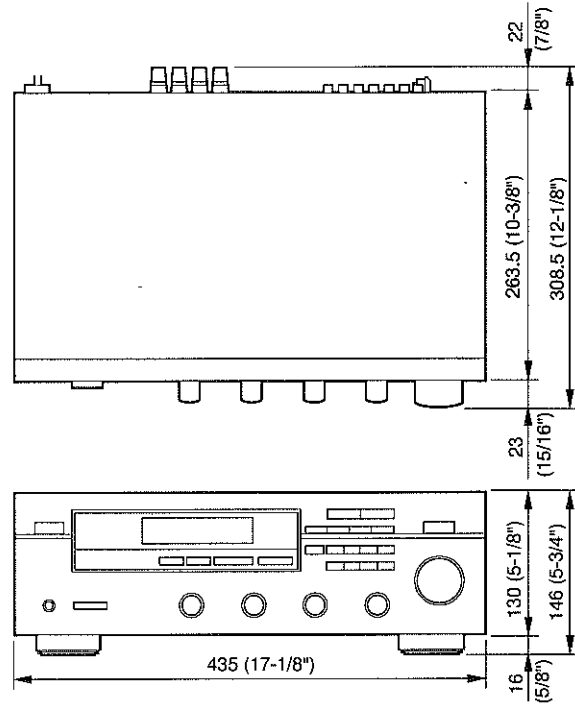

Units : mm (inch)

■ INTERNAL VIEW

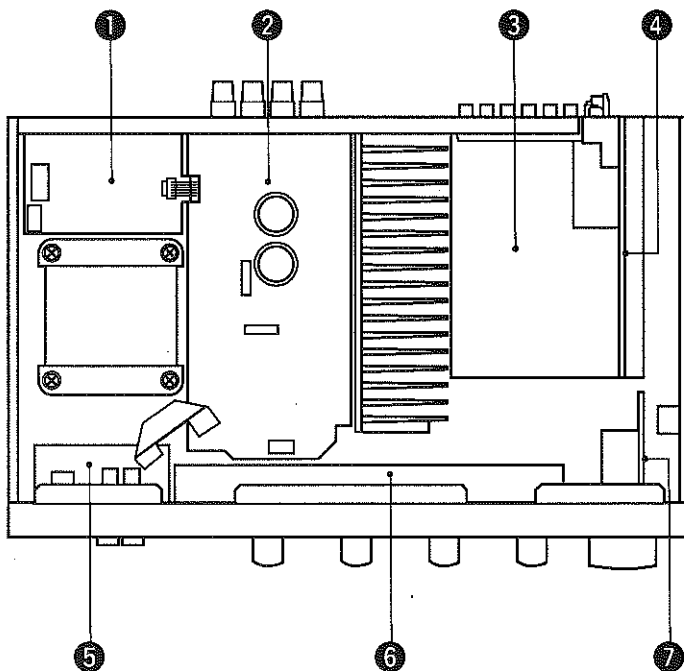

- ① P. C. B. MAIN (2)
- ② P. C. B. MAIN (1)
- ③ P. C. B. FUNCTION (1)
- ④ P. C. B. TUNER
- ⑤ P. C. B. MAIN (3)
- ⑥ P. C. B. FUNCTION (3)
- ⑦ P. C. B. FUNCTION (2)

DISASSEMBLY PROCEDURES

(Remove parts in the order as numbered.)

1. Removal of Top Cover

Remove 4 screws (①) and 3 screws (②) in Fig. 1.

2. Removal of Front Panel

a. Remove 5 knobs.

b. Remove 6 screws (③) in Fig. 1.

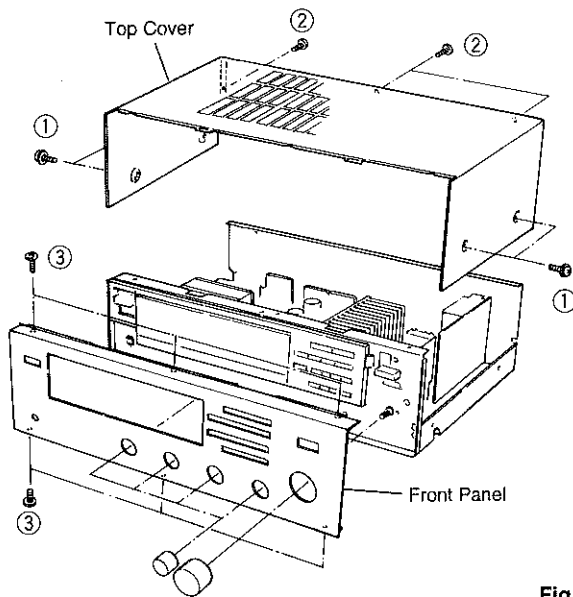

Fig. 1

3. Checking and Parts Replacement of P.C.B. MAIN (1)

a. Disconnect the power cord from the AC outlet.

b. Remove 3 screws (④) fixing the Speaker terminal and Heat Sink in Fig. 2.

c. Remove 3 screws (⑤) fixing the Main Unit in Fig. 3.

d. Detach 1 connector terminal (CB104) in Fig. 3.

e. Operating checks can be taken by shorting between following test points in Fig. 3.

Short Point	
TP101	and TP102
TP103	and TP104
TP105	and TP106

f. Place the Main Unit on its side as shown in Fig. 4.

g. Connect the power cord and turn ON the POWER switch.

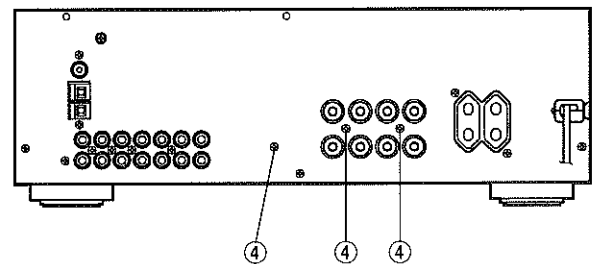

Fig. 2

AMP ADJUSTMENTS

● Confirmation of idling current. (Fig. 3)

After Power is turned on.

Confirm that the voltages across R137 (L ch), R138 (R ch) are between 0.1~3mV.

If they exceed 3.1mV, open (cut off) R131 (L ch) and R132 (R ch), and reconfirm voltage is between 0.1~3mV.

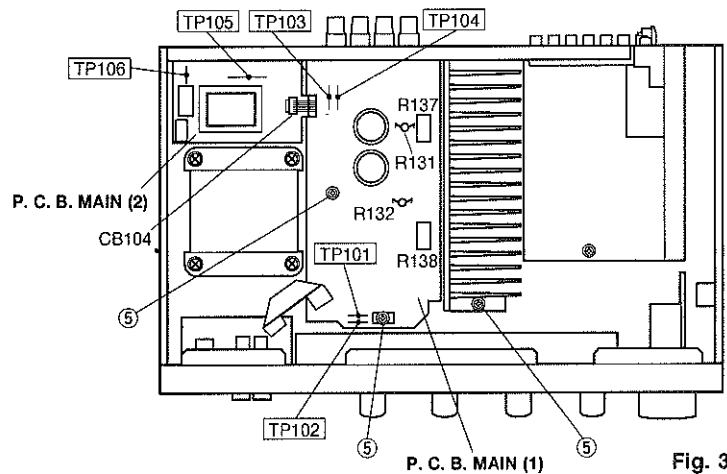
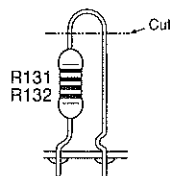
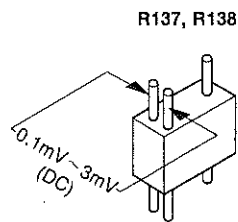

Fig. 3

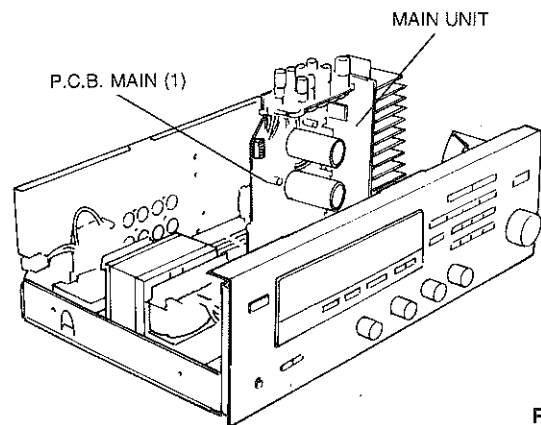

Fig. 4

RX-495/RX-495RDS

■ TEST MODE

CAUTION : Before setting to the TEST mode, write down the existing preset memory content of the Tuner in a table as shown below. (This is because setting to the TEST mode will cause the memory content to be as factory set, i.e., all the preset memory by the user will be erased.)

Preset group	P1	P2	P3	P4	P5	P6	P7	P8
A								
B								
C								
D								
E								

RX-495

How to start

Turn the POWER switch ON while pressing the P1 and TUNING UP keys simultaneously. The unit enters the TEST mode for the display check (All display segments light immediately).

After that, the DISPLAY mode switches by means of the PRESET STATION keys.

Content of the TEST mode key

- P1 key : ALL LIGHTS ON mode
- P2 key : LIGHTS OFF mode
- P3 to 8 keys : The mode is switched to NORMAL and the TEST mode is cancelled.

How to cancel

Normal operation is restored when the POWER switch is turned OFF or the P3 to 8 keys pressed. At the same time, the factory preset, memory is also restored.

● Factory preset memory content

Preset group	P1	P2	P3	P4
A/C/E	87.5MHz	90.1MHz	95.1MHz	98.1MHz
B/D	630kHz	1080kHz	1440kHz	530kHz (U, C, R) 531kHz (R, A, L)

Preset group	P5	P6	P7	P8
A/C/E	107.9MHz (U, C, R) 108MHz (R, A, L)	88.1MHz	106.1MHz	107.9MHz (U, C, R) 108MHz (R, A, L)
B/D	1710kHz (U, C, R) 1611kHz (R, A, L)	900kHz	1350kHz	1400kHz (U, C, R) 1404kHz (R, A, L)

For all the above, AUTO TUNING and AUTO STEREO are selected as the TUNING mode.

RX-495RDS

How to start

Turn the POWER switch ON while pressing the P1 and FM/AM keys simultaneously. The unit enters the TEST mode for the display check.

After this, steps 1) through 4) are cycled.

- 1) The DISPLAY lights all segments.
- 2) The DISPLAY scrolls 'RX-x95RDS' to the left.
- 3) The DISPLAY scrolls Markets to the left.
- 4) The DISPLAY scrolls μ -COM Version to the left.

Push the P1 key to start from 1).

Push the other keys to switch to the NORMAL mode.

How to cancel

Normal operation is restored when the POWER switch is turned OFF or another key is pressed. At the same time, the factory preset memory is also restored.

● Factory preset memory content

Preset group	P1	P2	P3	P4
A/C/E	87.50MHz	90.10MHz	95.10MHz	98.10MHz
B/D	630kHz	1080kHz	1440kHz	531kHz

Preset group	P5	P6	P7	P8
A/C/E	108.00MHz	88.10MHz	106.10MHz	108.00MHz
B/D	1611kHz	900kHz	1350kHz	1404kHz

For all the above, AUTO TUNING and AUTO STEREO are selected as the TUNING mode.

TUNER ADJUSTMENTS

Measuring instruments

- FM signal generator (FM SG)
- Stereo signal generator (SSG)
- AM signal generator (AM SG)
- Distortion meter (DIST. M)
- AC voltmeter (ACVM)
- DC voltmeter (DCVM)
- Oscilloscope
- Low pass filter (YLF-15, $f_c=15\text{kHz}$)
- Oscillator

Dummy antenna

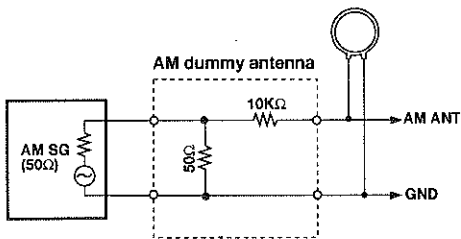
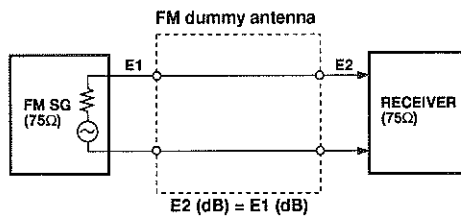
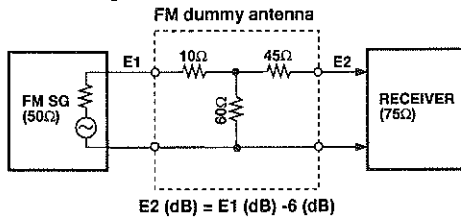

Test point

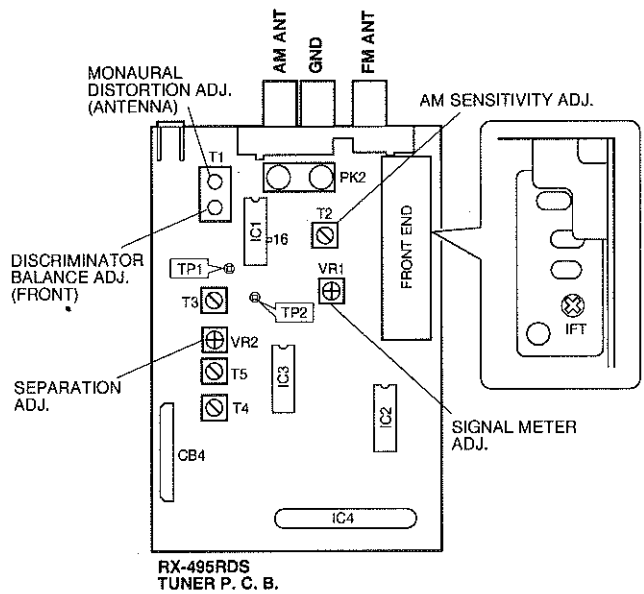
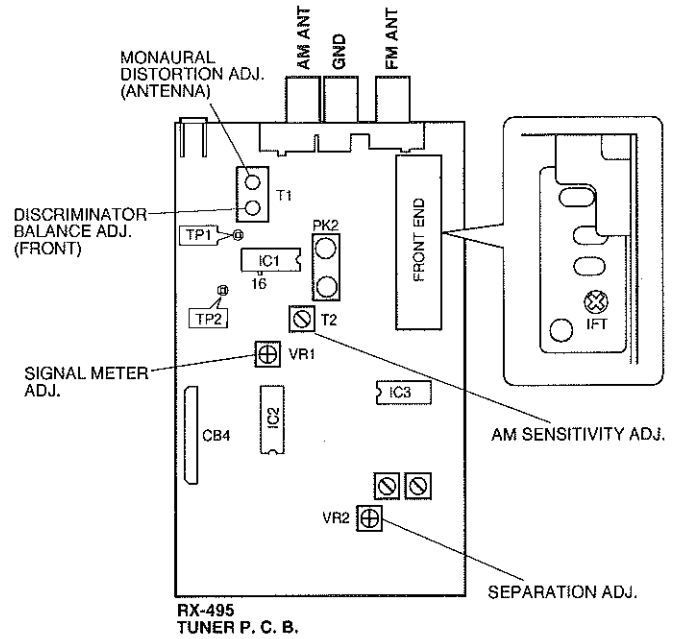

RX-495/
RX-495RDS

FM Adjustment

● **Before Adjustment**

- 1) For dB, $1\mu V=0dB\mu$ applies.
Example : $60dB\mu=1mV$
- 2) 100% modulation means that the frequency deviation is 75kHz.

- 3) Install the Matching Transformer and connect FM SG.
- 4) Set each switch at the following position unless otherwise specified.

INPUT SELECTOR TUNER
 TUNING MODE AUTO

● **Connection diagram (Measuring instruments)**

1) **Discriminator balance adjustment**

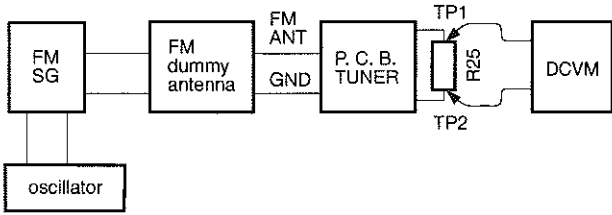

3) **Stereo distortion adjustment/separation adjustment**

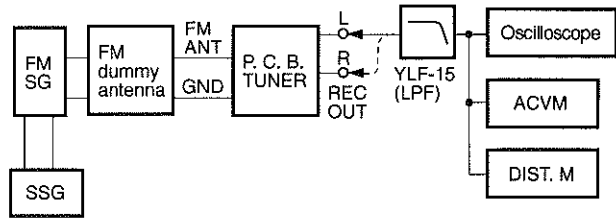

2) **Monaural distortion adjustment**

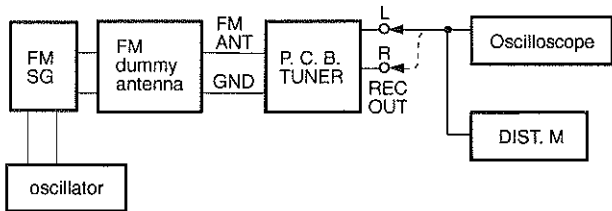

4) **Sensitivity Verification**

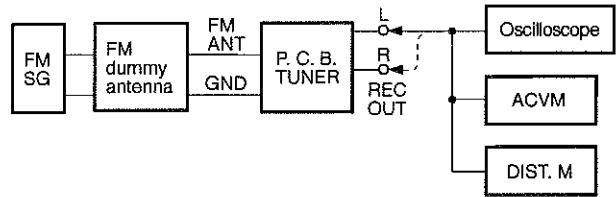

See page 8 for TP locations & adjustment points.

Step	Adjustment item	Signal (ANT IN)	Reception frequency	Adjustment point	Test point	Rating
1	Rough adjustment of discriminator balance	FM ANT (75Ω) 98.1MHz 70dBμ MONO 100Hz 100% modulation	98.1MHz * (A-4)	T1 (Front side core)	Both ends of R25 (Between TP1 and TP2)	DC 0V±100mV
2	Rough adjustment of monaural distortion	Same as Step 1.	98.1MHz * (A-4)	T1 (Antenna side core)	REC OUT L, R	Minimize the distortion.
3	Fine adjustment of discriminator balance	Same as Step 1.	98.1MHz * (A-4)	T1 (Front side core)	Both ends of R25 (Between TP1 and TP2)	DC 0V±50mV
4	Fine adjustment of monaural distortion	Same as Step 1.	98.1MHz * (A-4)	T1 (Antenna side core)	REC OUT L, R	Minimize the distortion (to 0.25% or less).
5	Verification of discriminator balance	Same as Step 1.	98.1MHz * (A-4)	T1 (Front side core)	Both ends of R25 (Between TP1 and TP2)	DC 0V±50mV

* : Execution of MAKER PRESET (Refer to TEST MODE on pages 7.) will facilitate setting reception frequency for adjustment.

Step	Adjustment item	Signal (ANT IN)	Reception frequency	Adjustment point	Test point	Rating
6	Adjustment of frontend IFT	FM ANT (75Ω) 98.1MHz 30dBμ MONO 1kHz, 100% modulation	98.1MHz * (A-4)	Front end IFT	Pin 16 of IC1	Adjust so that the DC voltage is maximum. CAUTION : Over-adjustment of the IFT core will reduce the sensitivity. Maximum ±90°
7	Verification of monaural distortion	FM ANT (75Ω) 98.1MHz 70dBμ MONO 1kHz, 100% modulation	98.1MHz * (A-4)		REC OUT L, R	0.4% or less
8	Verification of stereo distortion	FM ANT (75Ω) 98.1MHz 70dBμ Stereo L or R 1kHz, 100% modulation	98.1MHz * (A-4) * Tuning mode should be AUTO.		REC OUT L, R	1% or less • STEREO indicator should light.
9	Verification of sensitivity	FM ANT (75Ω) 88.1MHz 98.1MHz 106.1MHz MONO 1kHz Modulation off	88.1MHz * (A-6) 98.1MHz * (A-4) 106.1MHz * (A-7)		ANT (75Ω)	Set the tuning mode to MAN'L MONO. (Muting OFF) S/N should be 30dB at each frequency of 88.1MHz, 98.1MHz, and 106.1MHz. Check to ensure that the voltage at the ANT terminal is 3dBμ (14.25dBf) or less. (G, L only : 6dBμ or less)
10	Adjustment of Separation	FM ANT (75Ω) 98.1MHz 70dBμ Stereo L or R 1kHz, 100% modulation	98.1MHz * (A-4)	VR2	REC OUT L, R	With SSG output at L or R, the signal leakage level at the other channel should be minimized. 36dB or more
11	Adjustment of Signal meter	FM ANT (75Ω) 98.1MHz 45dBμ MONO 1kHz 30% modulation	98.1MHz * (A-4)	VR1		Adjust so that all signal meters light.
		-10dBμ or less				Check to ensure that signal meters turn OFF.
12	Verification of auto tuning	FM ANT (75Ω) 98.1MHz 23dBμ Stereo L or R 1kHz, 30% modulation	98.1MHz			<ul style="list-style-type: none"> • Automatic reception should be available when the tuning key is moved UP and DOWN. • The stereo indicator should light. • Audio muting should be applied during tuning.

* : Execution of MAKER PRESET (Refer to TEST MODE on pages 7.) will facilitate setting reception frequency for adjustment.

AM Adjustment (This should be done after FM adjustment.)

● **Connection Diagram (Measuring instruments)**

1) Adjustment of sensitivity

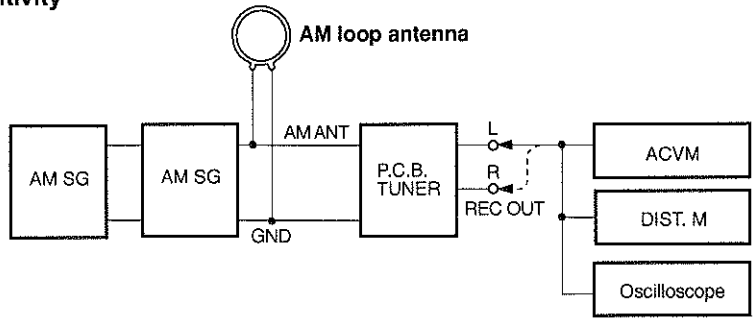

See page 8 for TP locations & adjustment points.

Step	Adjustment item	Signal (ANT IN)	Reception frequency	Adjustment point	Test point	Rating
1	Adjustment of sensitivity (1440Hz)	AM ANT 1440kHz 50dB μ 1kHz, 30% modulation	1440kHz * (B-3)	T2	REC OUT	Audio output should be maximized.
2	Verification of sensitivity (630kHz)	AM ANT 630kHz 50dB μ 1kHz 30% modulation	630kHz * (B-1)	T2	REC OUT	Audio output should be maximized. Repeat the Step 1 and 2.
3	Verification of sensitivity	AM ANT 630kHz 1080kHz 1440kHz 30% modulation	630kHz * (B-1) 1080kHz * (B-2) 1440kHz * (B-3)		AM ANT	Distortion should be 10% or less at each frequency. Check to ensure that the voltage at the ANT terminal is 54dB μ or less.
4	Verification of auto tuning	AM ANT 60dB μ				Auto reception should be available when the tuning key is moved UP and DOWN.

* : Execution of MAKER PRESET (Refer to TEST MODE on pages 7.) will facilitate setting reception frequency for adjustment.

■ RX-495 μ -COM DATA

IC301 : LC866008C-5A41
8 bit μ -COM

P10/SO0	1	64	P07
P11/S10/SB0	2	63	P06
P12/SCK0	3	62	P05
P13/SO1	4	61	P04
P14/S11/SB1	5	60	P03
P15/SCK1	6	59	P02
P16/BUZ	7	58	P01
P17/PWM	8	57	P00
TEST1	9	56	S29
RES	10	55	S28
XT1	11	54	S27
XT2	12	53	S26
VSS	13	52	S25
CF1	14	51	S24
CF2	15	50	S23
VDD	16	49	S22
P80/AN0	17	48	S21
P81/AN1	18	47	S20
P82/AN2	19	46	S19
P83/AN3	20	45	S18
P70/INT0	21	44	S17
P71/INT1	22	43	S16
P72/INT2/T0IN	23	42	VP
P73/INT3/T0IN	24	41	VDDVPP
S0/T0	25	40	S15/T15
S1/T1	26	39	S14/T14
S2/T2	27	38	S13/T13
S3/T3	28	37	S12/T12
S4/T4	29	36	S11/T11
S5/T5	30	35	S10/T10
S6/T6	31	34	S9/T9
S7/T7	32	33	S8/T8

No.	Port	Name	I/O	Function
1	P10	CEPLL	O	CE for LM7000
2	P11	DTPLL	O	DATA for LM7000
3	P12	CLPLL	O	CLOCK for LM7000
4	P13	TMUTE	O	Tuner mute out
5	P14	MONO	O	Forced mono out
6	P15	STPREQ	O	Stop request out
7	P16	V1	I	Tuner Market 1
8	P17	V2	I	Tuner Market 2
9	TEST	—	—	N. C.
10	RES	RESET	I	Reset
11	XT1	+5BU	—	+5V
12	XT2	—	—	N. C.
13	VSS	G	—	GND
14	CF1	CF1	—] Clock (4MHz)
15	CF2	CF2	—	
16	VDD	+5BU	—	+5V
17	P80	KEYIN 1	I	Key in 1 (A/D)
18	P81	KEYIN 2	I	Key in 2 (A/D)
19	P82	KEYIN 3	I	Key in 3 (A/D)
20	P83	METER	I	Tuner meter input (A/D)

• Market Input

Name	Market		
	A, L	U, C	R
V1	1	1	0
V2	1	0	1

IC301 : LC866008C-5A41

8 bit μ -COM

No.	Port	Name	I/O	Function
21	P70	PWDWN	I	Power down detect
22	P71	PWRSW	I	POWER SW
23	P72	395/495	I	Model detect (H)
24	P73	REMCON	I	Remote control
25	S0	VOLUP	O	VOLUME UP
26	S1	VOLDN	O	VOLUME DOWN
27	S2	T1	O	TAPE MONITOR 1
28	S3	T2	O	TAPE MONITOR 2
29	S4	SEL1	O	INPUT SELECTOR 1
30	S5	SEL2	O	INPUT SELECTOR 2
31	S6	—		N. C.
32	S7	—		N. C.
33	S8	G8	O	FL grid 8
34	S9	G7	O	FL grid 7
35	S10	G6	O	FL grid 6
36	S11	G5	O	FL grid 5
37	S12	G4	O	FL grid 4
38	S13	G3	O	FL grid 3
39	S14	G2	O	FL grid 2
40	S15	G1	O	FL grid 1
41	VDD VPP	+5BU	I	+5V
42	VP	-VEE	I	-VEE (-24V)
43	S16	S1	O	FL segment 1
44	S17	S2	O	FL segment 2
45	S18	S3	O	FL segment 3
46	S19	S4	O	FL segment 4
47	S20	S5	O	FL segment 5
48	S21	S6	O	FL segment 6
49	S22	S7	O	FL segment 7
50	S23	S8	O	FL segment 8
51	S24	S9	O	FL segment 9
52	S25	S10	O	FL segment 10
53	S26	S11	O	FL segment 11
54	S27	S12	O	FL segment 12
55	S28	STNDBY	O	STBY LED OUT
56	S29	MUTE	O	Mute
57	P00	POW	O	Power on relay out
58	P01	—		N. C.
59	P02	—		N. C.
60	P03	—		N. C.
61	P04	PROTCT	I	Protection
62	P05	STEREO	I	STEREO (TUNER)
63	P06	STO	I	IF Count (TUNER)
64	P07	STSG	I	Signal in (TUNER)

• Selector output

Name	FUNCTION			
	PHONO	CD	TUNER	AUX
SEL 1	1	1	0	0
SEL 2	1	0	1	0

• A/D KEY INPUT

No.	Name	KEY							
		1	2	3	4	5	6	7	8
17	KEYIN 1	P1	P2	P2	P4	P5	P6	P7	P8
18	KEYIN 2	POWER	PHONO	CD	TUNER	AUX	TAPE 1	TAPE 2	—
19	KEYIN 3	TUNING MODE	FM/AM	TUNING DOWN	TUNING UP	EDIT	MEMORY	A/B/C/D/E	—

■ RX-495RDS μ-COM DATA

IC301 : LC866420A-5A64

8 bit μ-COM

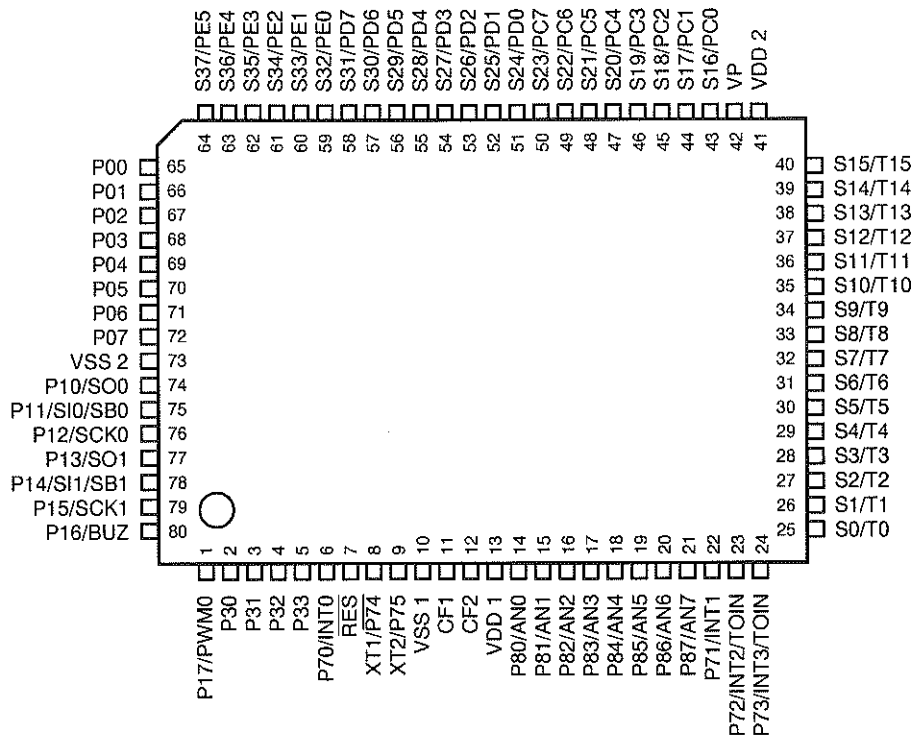

No.	Port	I/O	Name	Function	No.	Port	I/O	Name	Function
1	P17/PWMO	O	/TMUTE	Tuner mute	41	VDD2		VDD	+5V
2	P30	I	POWIN	Power state	42	VP		VDDVPP	-24V
3	P31	I	/PRTIN	Protection	43	S16/PC0	O	P1	FL segment 1
4	P32	I	MODEL 1	Model detect 1 (H)	44	S17/PC1	O	P2	FL segment 2
5	P33	I	MODEL 2	Model detect 2 (H)	45	S18/PC2	O	P3	FL segment 3
6	P70/INT0	I	/ST	STEREO (TUNER)	46	S19/PC3	O	P4	FL segment 4
7	/RES	I	/RESET	RESET	47	S20/PC4	O	P5	FL segment 5
8	/P74/XT1			N. C.	48	S21/PC5	O	P6	FL segment 6
9	P75/XT2			N. C.	49	S22/PC6	O	P7	FL segment 7
10	VSS1		VSS	GND	50	S23/PC7	O	P8	FL segment 8
11	CF1		CF1	6MHz	51	S24/PD0	O	P9	FL segment 9
12	CF2		CF2	6MHz	52	S25/PD1	O	P10	FL segment 10
13	VDD1		VDD	+5V	53	S26/PD2	O	P11	FL segment 11
14	P80/AN0	I	TUKIN1	Tuner key in 1 (A/D)	54	S27/PD3	O	P12	FL segment 12
15	P81/AN1	I	TUKIN2	Tuner key in 2 (A/D)	55	S28/PD4	O	P13	FL segment 13
16	P82/AN2	I	TUKIN3	Tuner key in 3 (A/D)	56	S29/PD5	O	P14	FL segment 14
17	P83/AN3	I	METER	Signal level in (A/D)	57	S30/PD6	O	P15	FL segment 15
18	P84/AN4	I	AMPKIN	Amp key in (A/D)	58	P31/PD7	O	P16	FL segment 16

• A/D KEY INPUT

No.	Name	KEY						
		1	2	3	4	5	6	7
14	KEYIN 1	P3	P4	P5	P6	P7	P8	—
15	KEYIN 2	TUNING MODE	EDIT	MEMORY	A/B/C/D/E	P1	P2	—
16	KEYIN 3	RDS MODE	PTY	START	EON	FM/AM	TUNING DOWN	TUNING UP
18	AMPIN	PHONO	CD	TUNER	AUX	TAPE 1	TAPE 2	—

IC301 : LC866420A-5A64

8 bit μ -COM

No.	Port	I/O	Name	Function	No.	Port	I/O	Name	Function
19	P85/AN5		G	GND	59	S32/PE0			N. C.
20	P86/AN6		G	GND	60	S33/PE1			N. C.
21	P87/AN7		G	GND	61	S34/PE2			N. C.
22	P71/INT1	I	/RDSSTART	RDS START (STK311-020B)	62	S35/PE3			N. C.
23	P72/INT2	I	/POWERDOWN	Power down detect	63	S36/PE4			N. C.
24	P73/INT3	I	REMCON	Remote control	64	S37/PE5	O	STANBY	STAND BY LED
25	SO/TO	O	1G	FL grid 1	65	P00	O	SEL1	Input Selector out 1
26	S1/T1	O	2G	FL grid 2	66	P01	O	SEL2	Input Selector out 2
27	S2/T2	O	3G	FL grid 3	67	P02	O	MONI1	Tape monitor 1 out
28	S3/T3	O	4G	FL grid 4	68	P03	O	MONI2	Tape monitor 2 out
29	S4/T4	O	5G	FL grid 5	69	P04	O	/MUTE	Main mute
30	S5/T5	O	6G	FL grid 6	70	P05	O	VOLUP	Volume up
31	S6/T6	O	7G	FL grid 7	71	P06	O	VOLDN	Volume down
32	S7/T7	O	8G	FL grid 8	72	P07	O	POWERON	POWER LED
33	S8/T8	O	9G	FL grid 9	73	VSS2		GND	GND
34	S9/T9	O	10G	FL grid 10	74	P10/S00	O	RDSRESET	RDS RESET (STK311-020B)
35	S10/T10	O	11G	FL grid 11	75	P11/SI0	I	RDSDATA	RDS DATA (STK311-020B)
36	S11/T11	O	12G	FL grid 12	76	P12/SCKO	I	RDSCLK	RDS CLOCK (STK311-020B)
37	S12/T12	O	13G	FL grid 13	77	P13/S01	I	DATA7000	PLL DATA (LC72131)
38	S13/T13			N. C.	78	P14/SI1	O	PLLIN	DATA for PLL (LC72131)
39	S14/T14			N. C.	79	P15/SCK1	O	CLK7000	CLOCK for PLL (LC72131)
40	S15/T15			N. C.	80	P16/BUZ	O	CE7000	CE for PLL (LC72131)

• SELECTOR OUTPUT

No.	Name	FUNCTION			
		PHONO	CD	TUNER	AUX
65	SELL 1	1	1	0	0
66	SELL 2	1	0	1	0

RX-495 BLOCK DIAGRAM

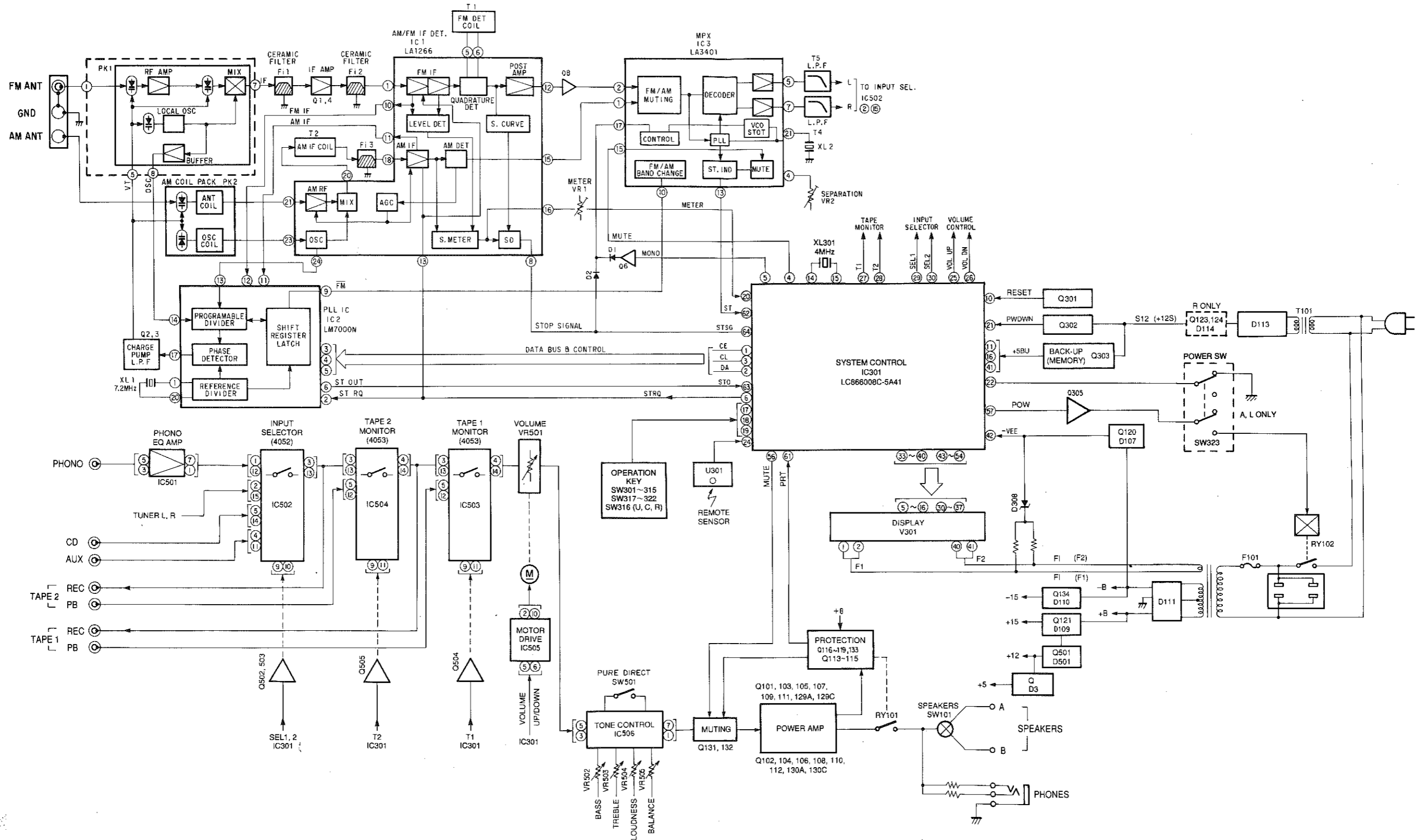

RX-495RDS BLOCK DIAGRAM

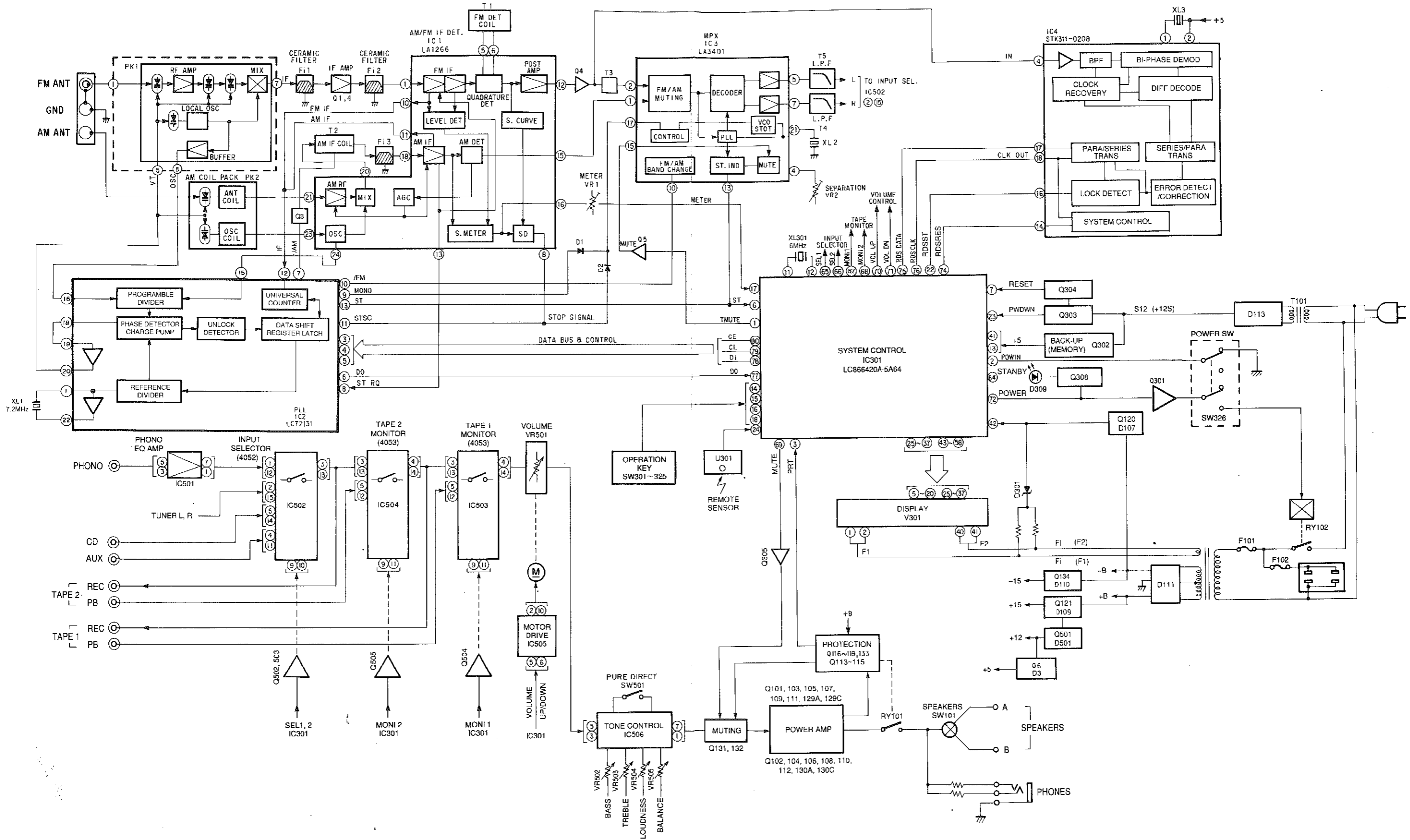

RX-495 PRINTED CIRCUIT BOARD (Foil side) ① : TEST POINT WAVEFORMS (See page 32)

1
2
3
4
5
6

P.C.B. FUNCTION (1)

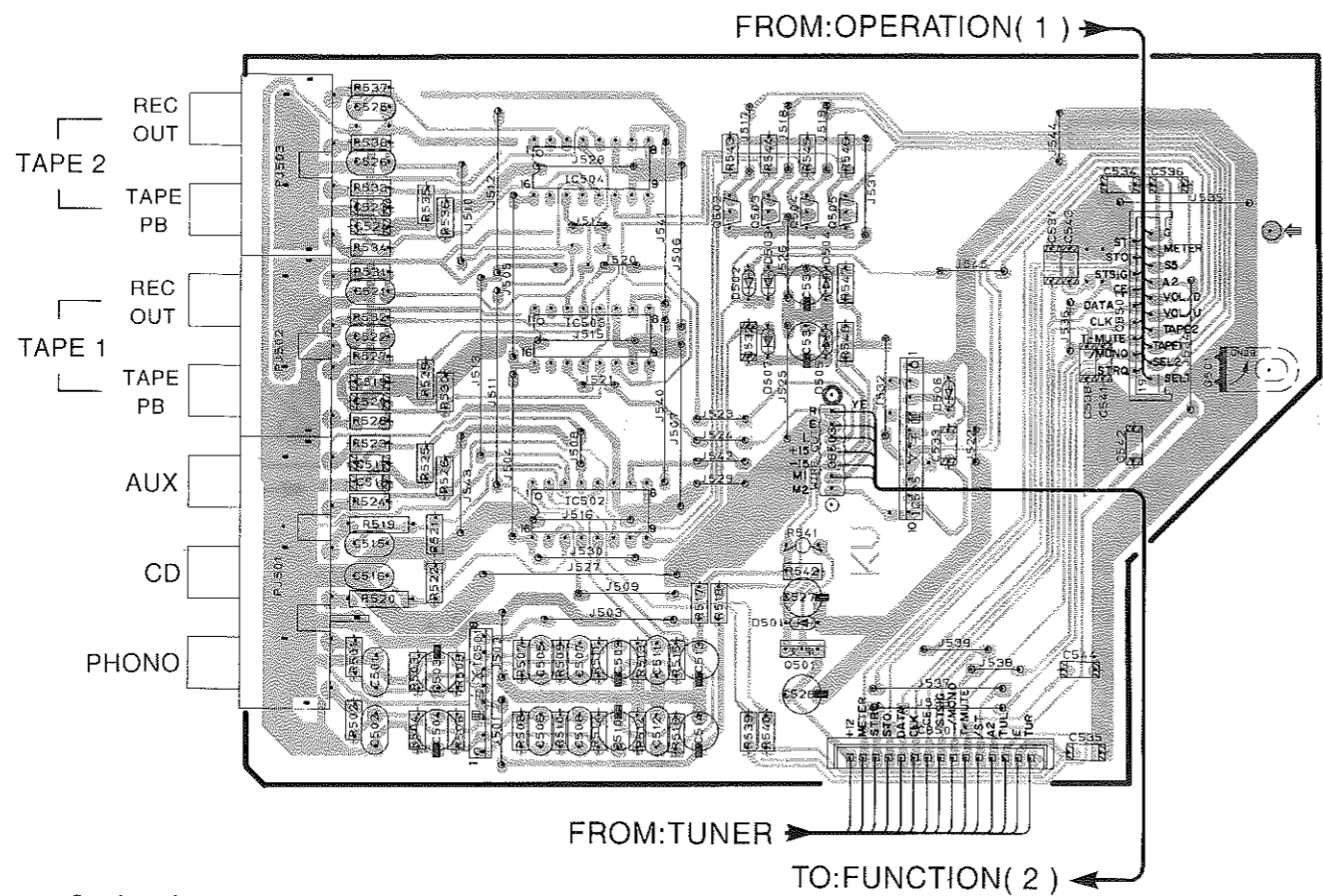

● Semiconductor Locations

Ref. No.	Location	Ref. No.	Location
IC 501	B3	Q 501	C3
IC 502	B3	Q 502	C2
IC 503	B2	Q 503	C2
IC 504	B2	Q 504	C2
IC 505	C2	Q 505	C2
IC 506	F5		

P.C.B. TUNER

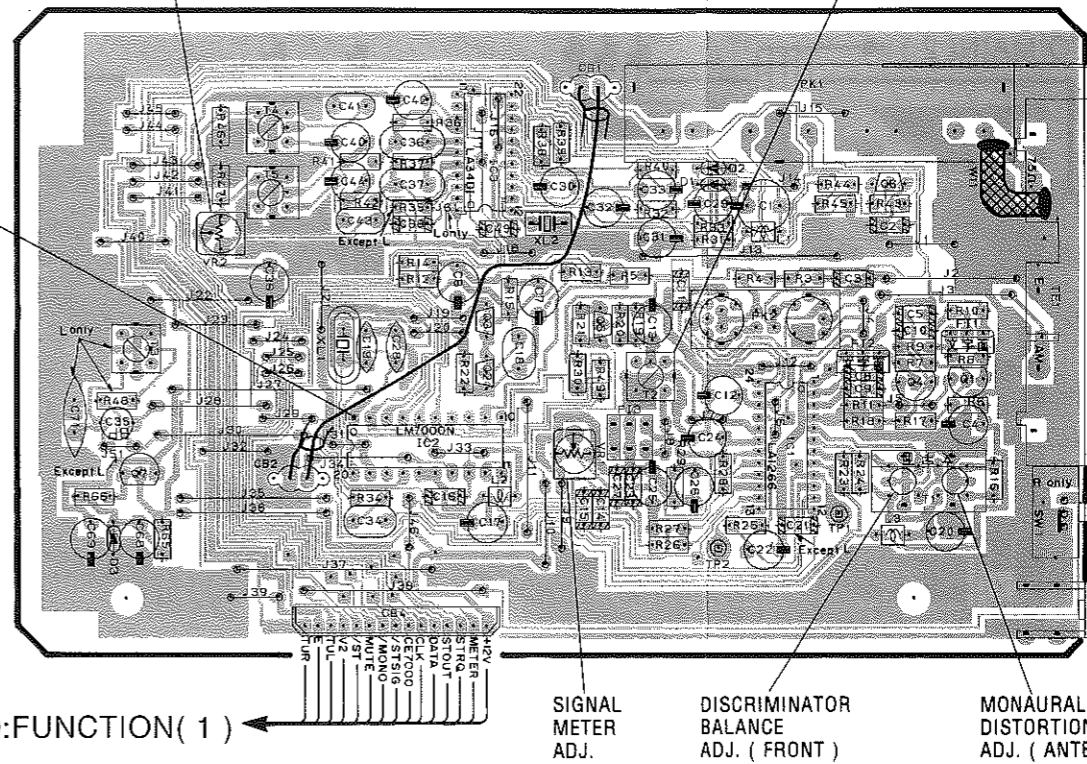

● Semiconductor Locations

Ref. No.	Location
IC 1	F3
IC 2	E3
IC 3	F2
Q 1	G2
Q 2	F2
Q 3	F2
Q 4	G2
Q 5	F2
Q 6	G2
Q 7	E3

P.C.B. FUNCTION (3)

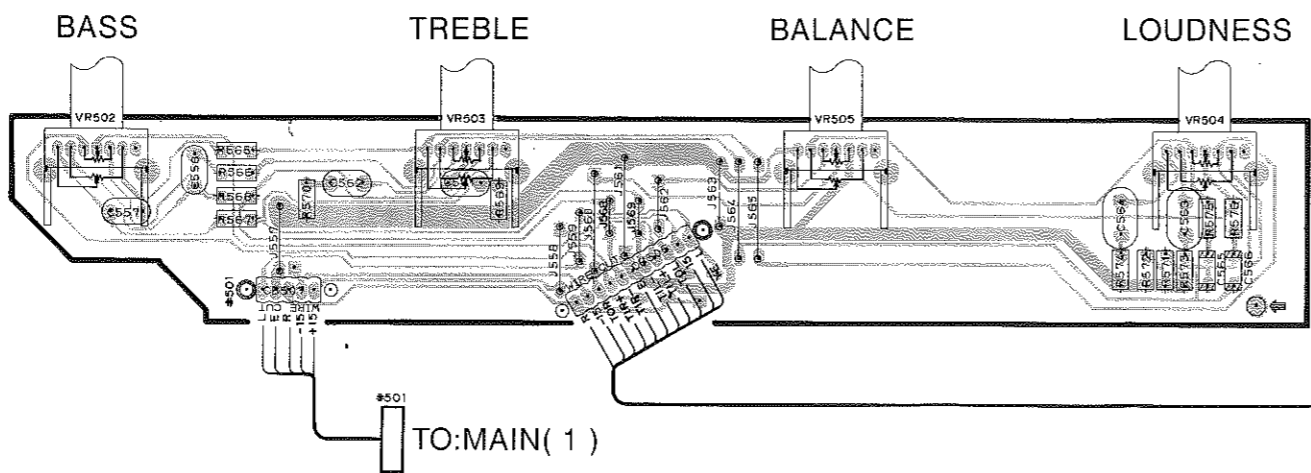

P.C.B. FUNCTION (2)

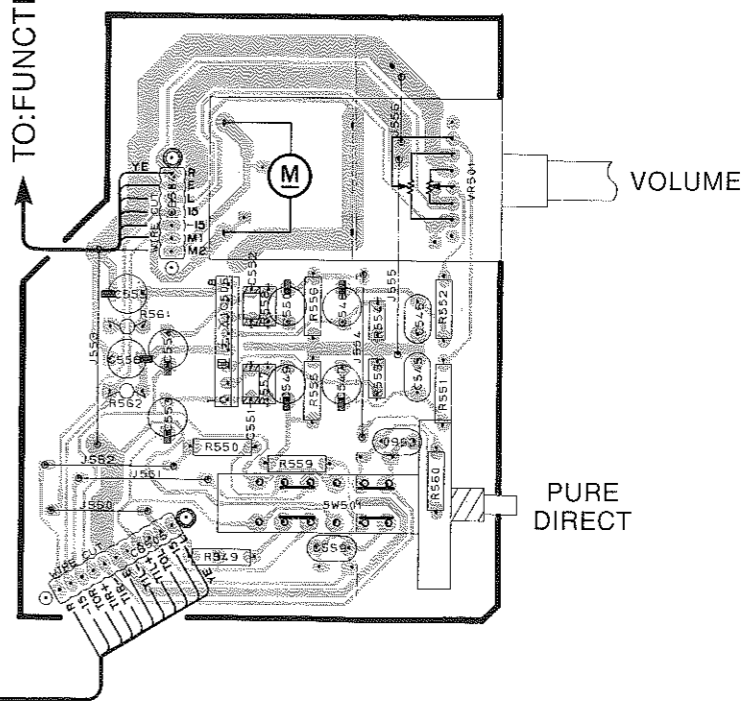

RX-495 PRINTED CIRCUIT BOARD (Foil side)

② and ③ : TEST POINT WAVEFORMS (See page 34)

1
2
3
4
5
6

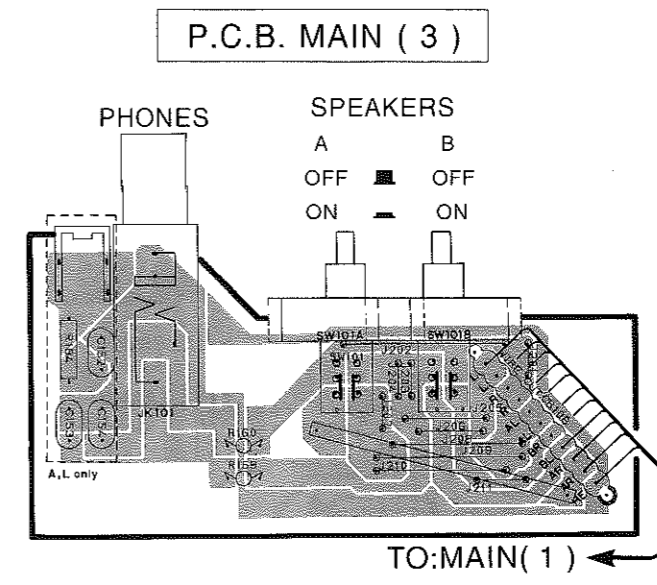
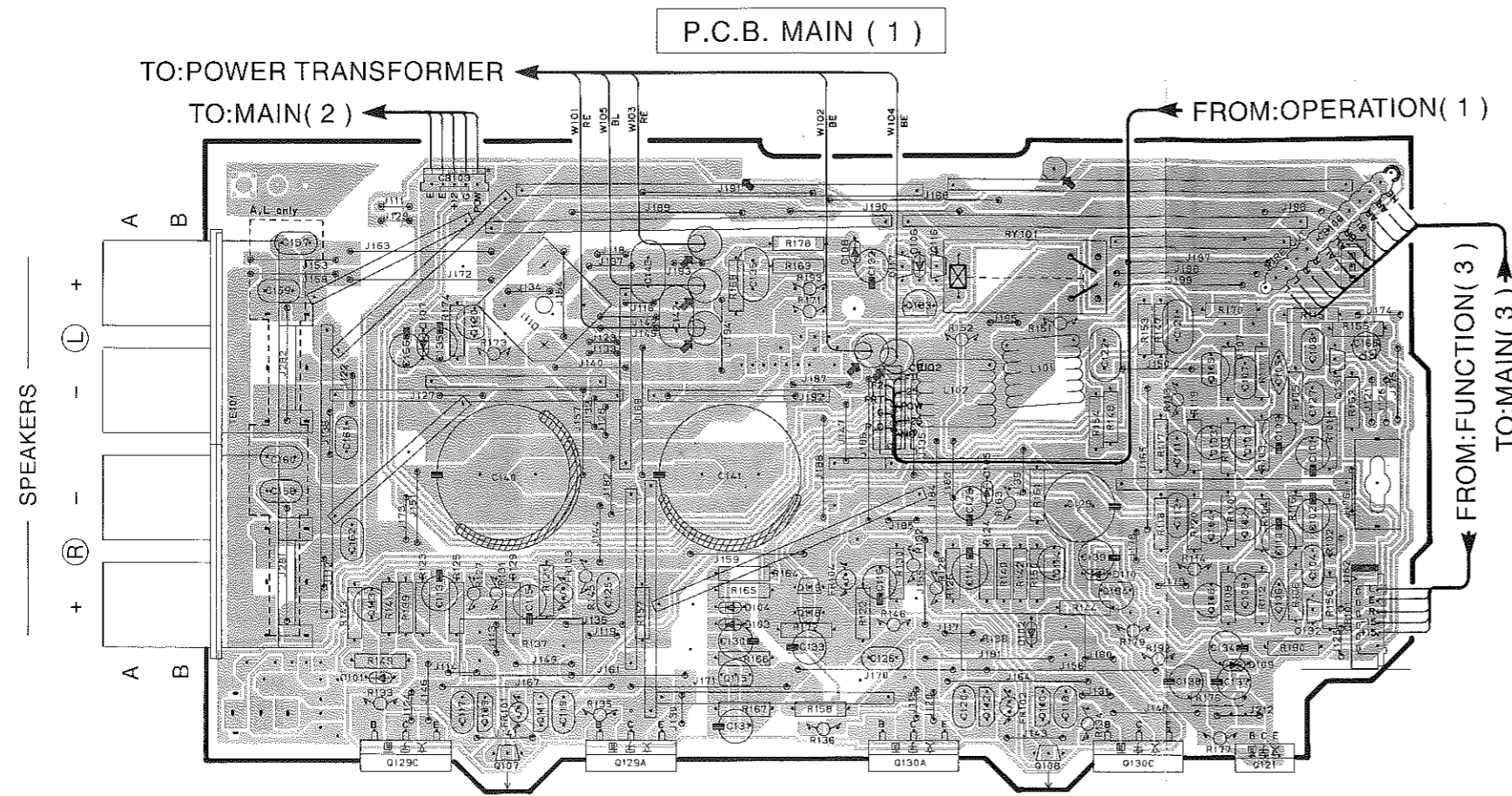

● Semiconductor Locations

Ref. No.	Location
Q 101	E2
Q 102	E3
Q 103	E2
Q 104	E3
Q 105	E2
Q 106	E3
Q 107	B3
Q 108	D3
Q 109	B3
Q 110	D3
Q 111	C3
Q 112	D3
Q 113	B3
Q 114	D3
Q 115	C3
Q 116	D2
Q 117	D2
Q 118	C3
Q 119	C3
Q 120	B2
Q 121	E3
Q129A	C3
Q129C	B3
Q130A	D3
Q130C	D3
Q 131	E2
Q 132	E3
Q 133	D2
Q 134	D3

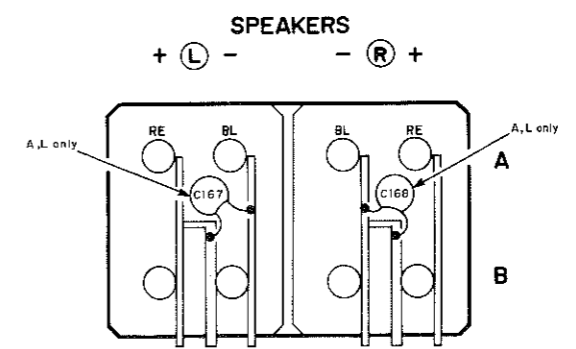

P.C.B. OPERATION (1)

P.C.B. OPERATION (2)

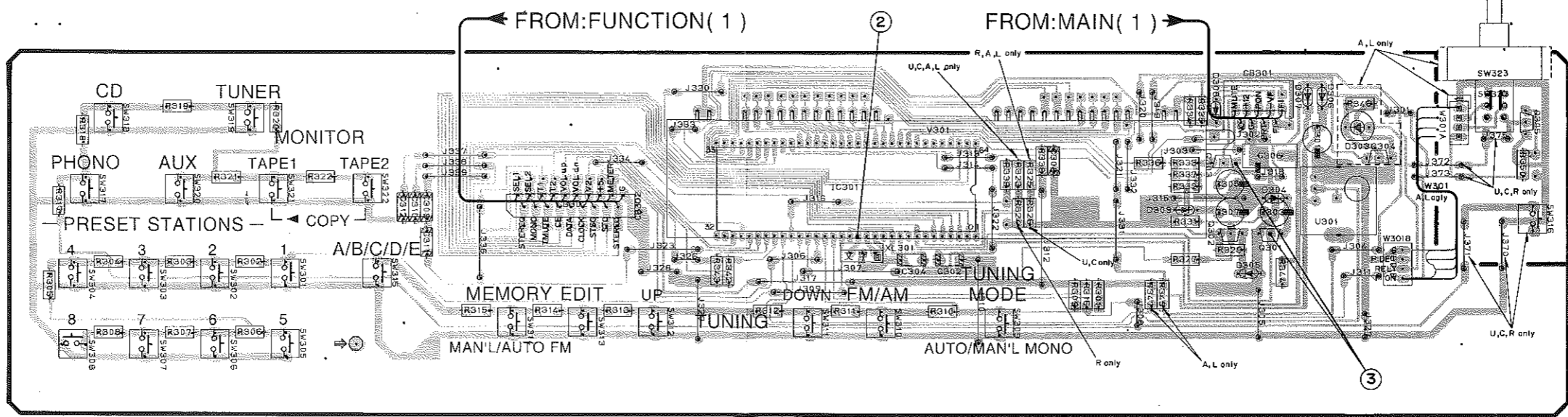

● Semiconductor Locations

Ref. No.	Location
IC301	E5
Q 301	F5
Q 302	F5
Q 303	F5
Q 304	G5
Q 305	G5

RX-495 PRINTED CIRCUIT BOARD (Foil side)

1
2
3
4
5
6

● U,C models
P.C.B. MAIN (2)

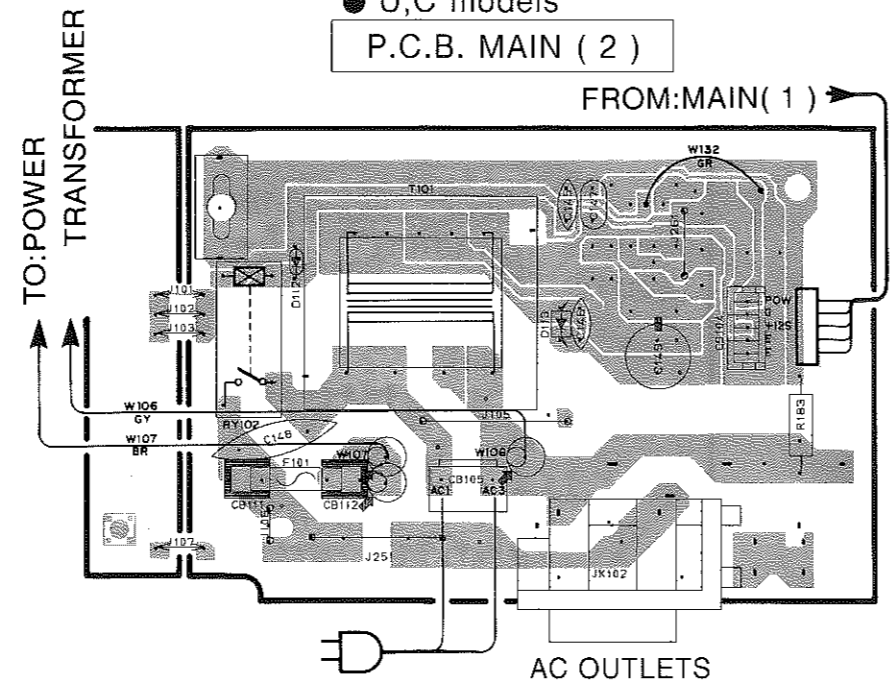

● R model
P.C.B. MAIN (2)

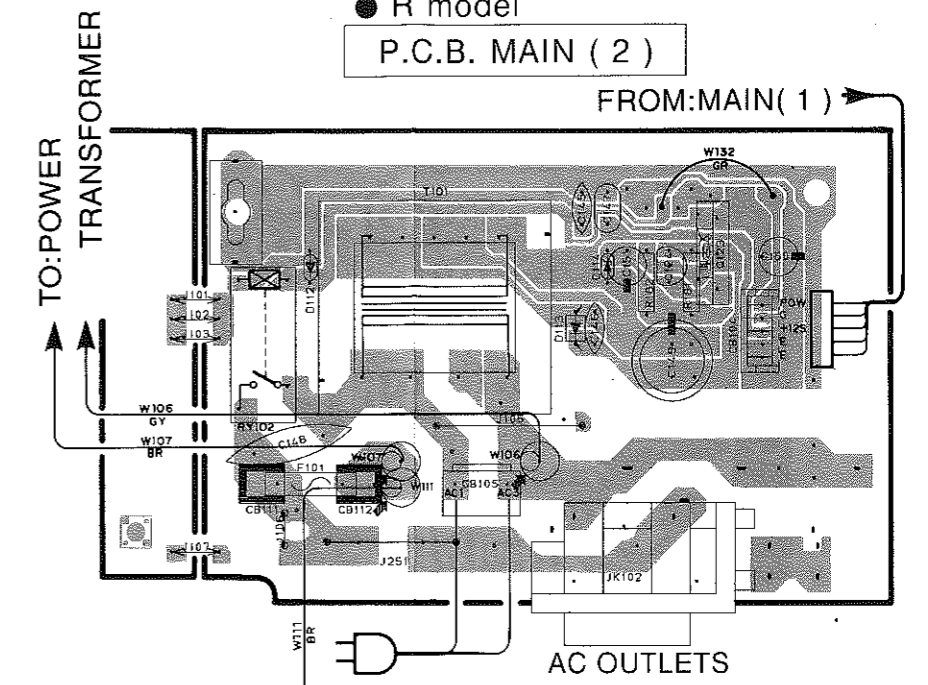

● L model
P.C.B. MAIN (2)

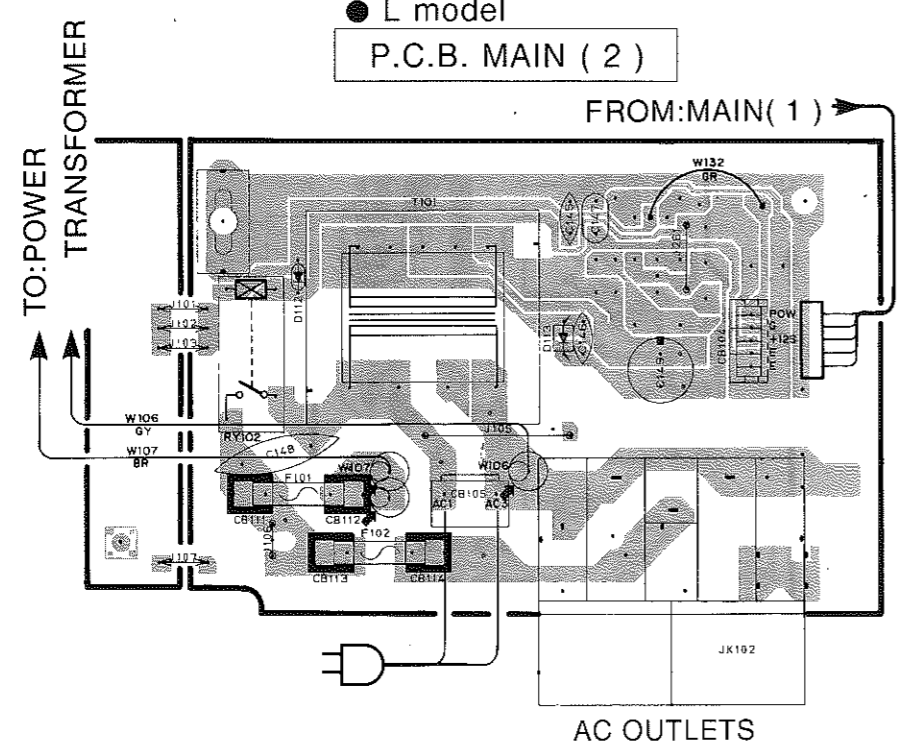

● A model
P.C.B. MAIN (2)

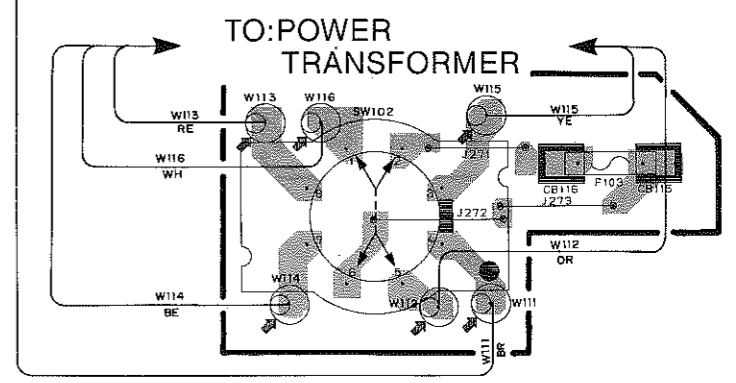
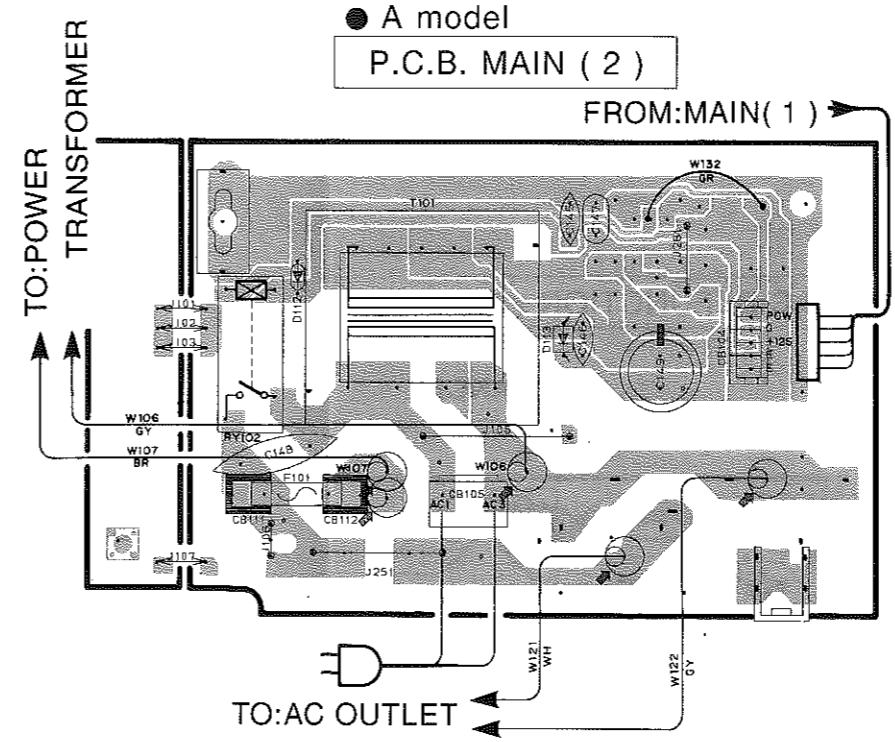

● R model
P.C.B. MAIN (4)

240V	1-2/5-6
220V	2-3/6-7
110V	3-4/7-8
120V	4-5/8-1

RX-495RDS PRINTED CIRCUIT BOARD (Foil side)

④ to ⑥ : TEST POINT WAVEFORMS (See page 36)

P.C.B. FUNCTION (1)

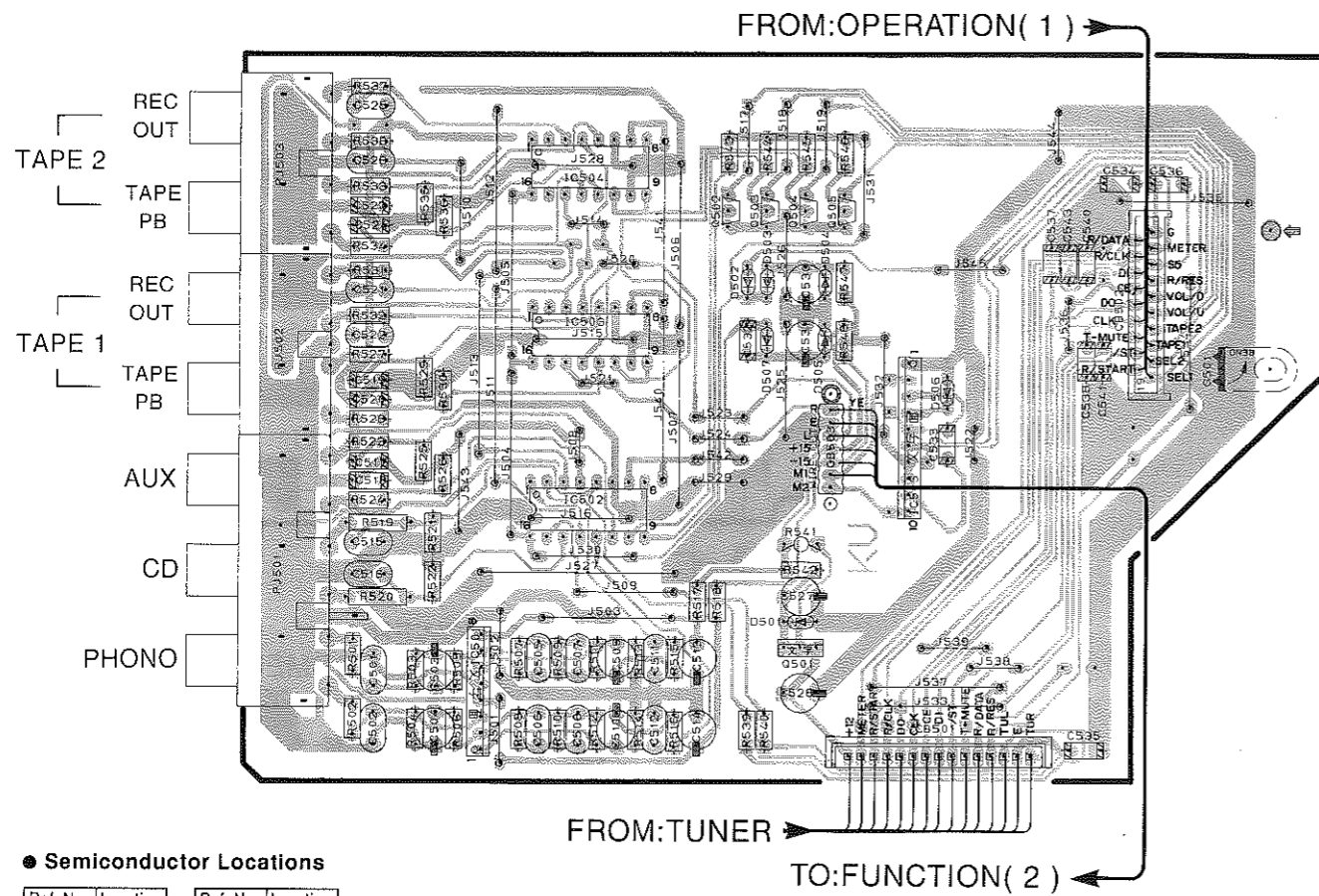

● Semiconductor Locations

Ref. No.	Location	Ref. No.	Location
IC501	B3	Q 501	C3
IC502	B3	Q 502	C2
IC503	B2	Q 503	C2
IC504	B2	Q 504	C2
IC505	C3	Q 505	C2
IC506	F5		

P.C.B. TUNER

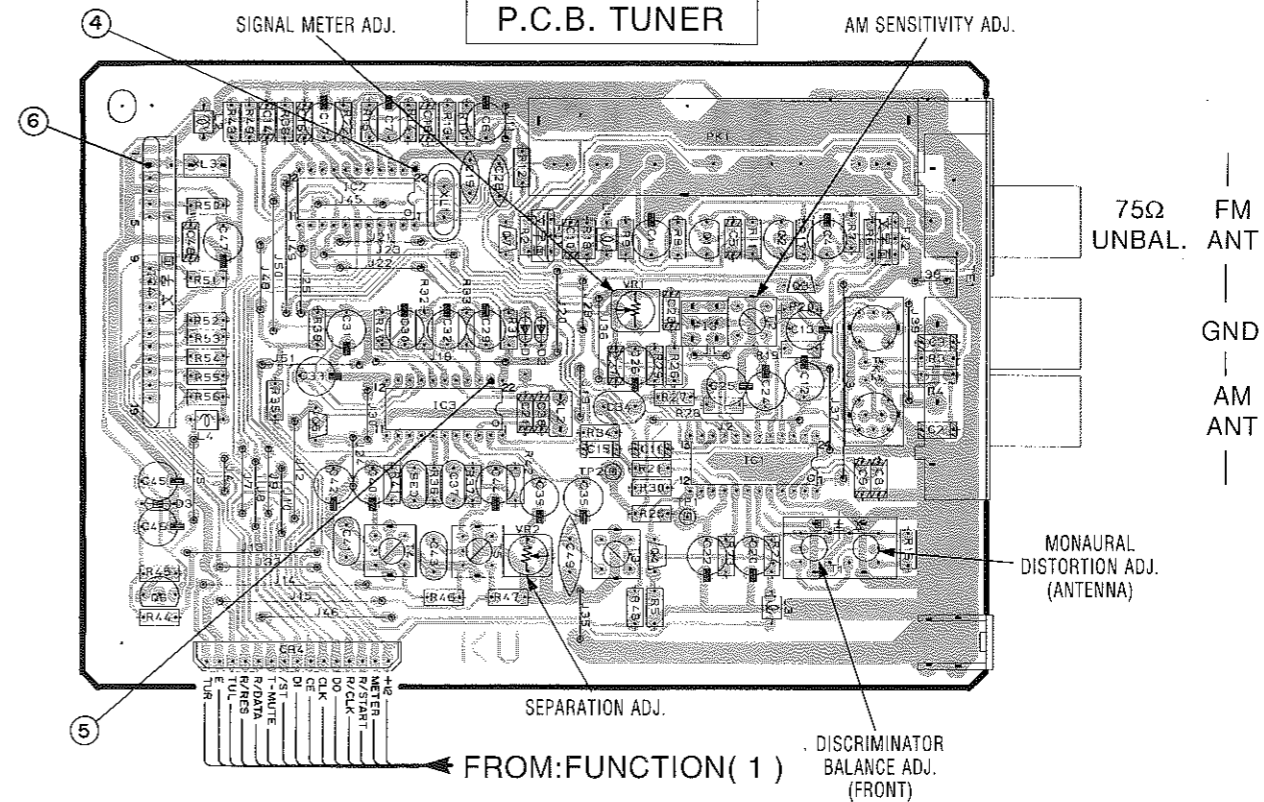

● Semiconductor Locations

Ref. No.	Location
IC 1	G3
IC 2	F2
IC 3	F2
IC 4	E2
Q 1	F2
Q 2	G2
Q 3	G2
Q 4	F3
Q 5	E2
Q 6	E3
Q 7	F2

P.C.B. FUNCTION (3)

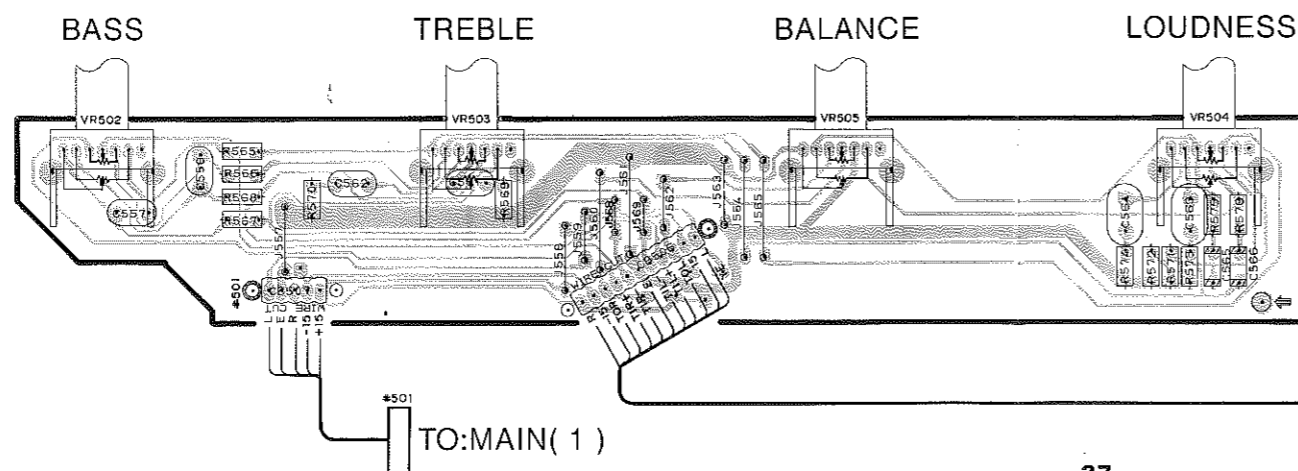

P.C.B. FUNCTION (2)

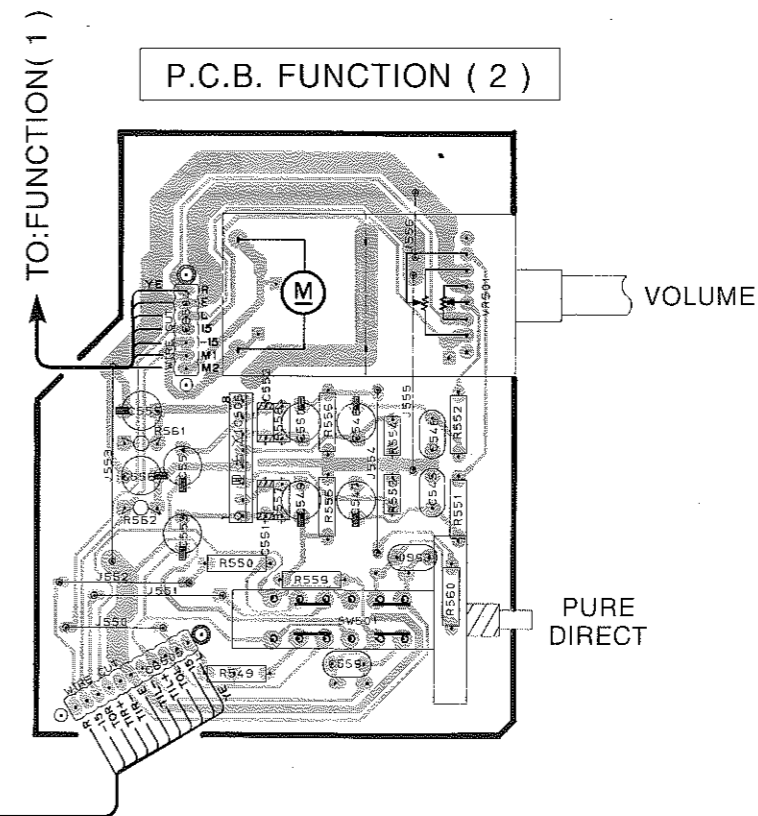

RX-495RDS PRINTED CIRCUIT BOARD (Foil side)

⑦ and ⑧ : TEST POINT WAVEFORMS (See page 38)

Semiconductor Locations

Ref. No.	Location
Q 101	F3
Q 102	F3
Q 103	F3
Q 104	F3
Q 105	F2
Q 106	F3
Q 107	D3
Q 108	F3
Q 109	D3
Q 110	F3
Q 111	D3
Q 112	F3
Q 113	D3
Q 114	F3
Q 115	E3
Q 116	E2
Q 117	E2
Q 118	E3
Q 119	E3
Q 120	D2
Q 121	G3
Q129A	E3
Q129C	D3
Q130A	E3
Q130C	F3
Q 131	G2
Q 132	G3
Q 133	E2
Q 134	F3

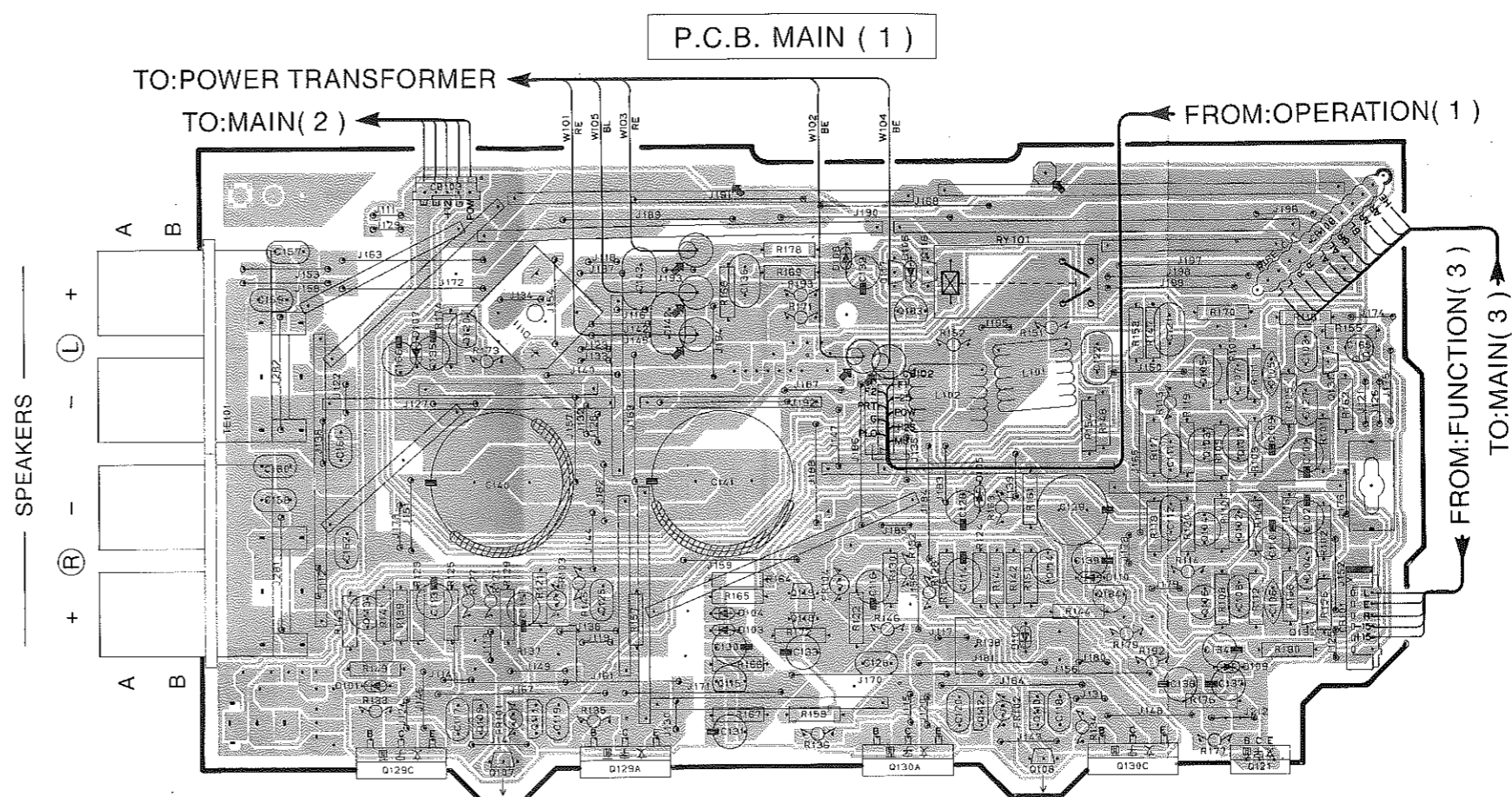
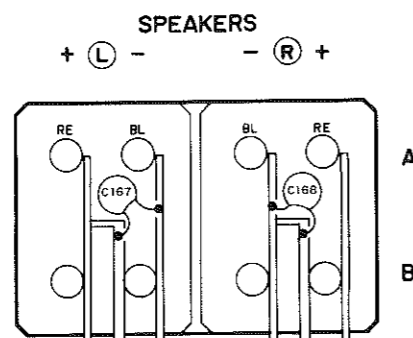

P.C.B. OPERATION (1)

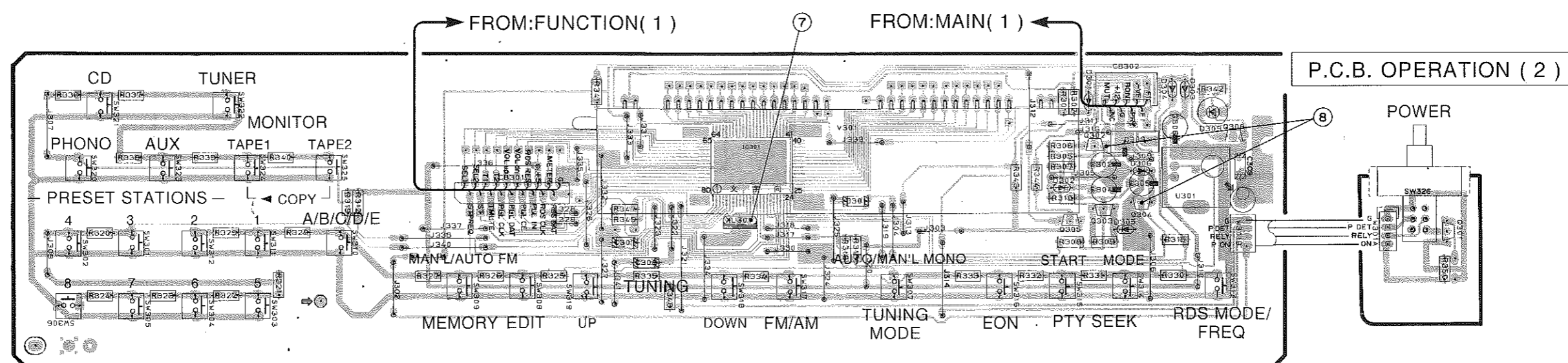

Semiconductor Locations

Ref. No.	Location
IC301	D5
Q 301	G5
Q 302	E5
Q 303	F5
Q 304	F5
Q 305	E5
Q 306	F5

RX-495RDS PRINTED CIRCUIT BOARD (Foil side)

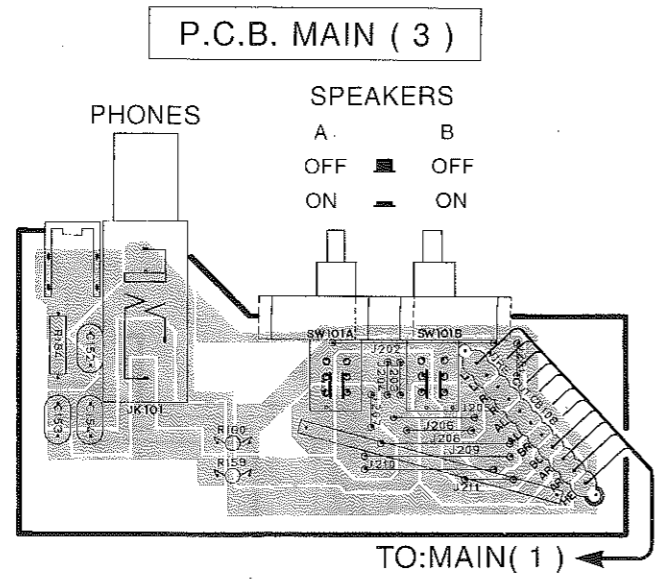
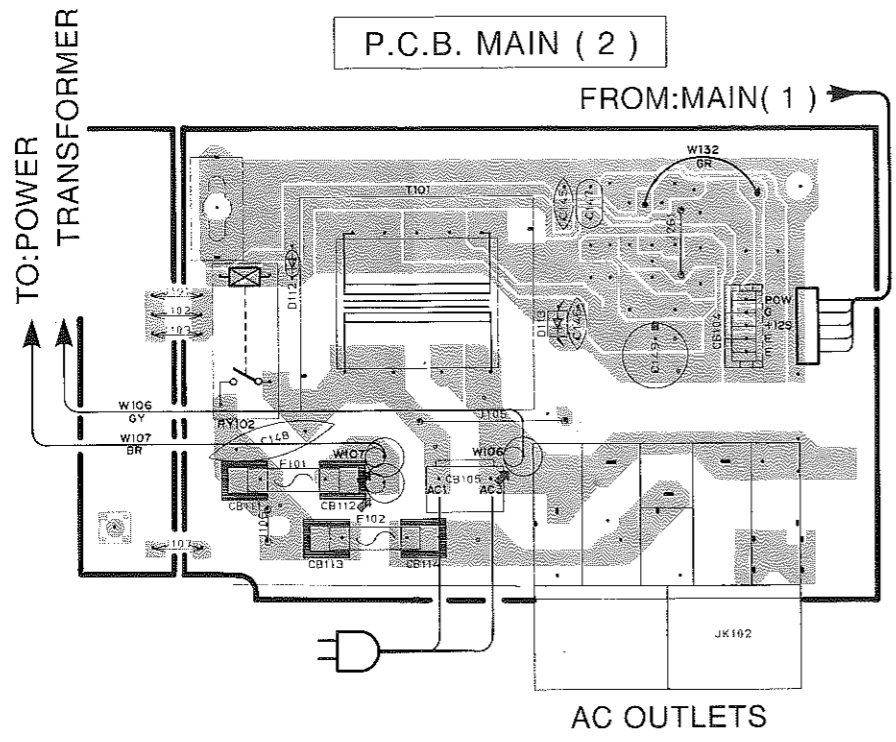

PIN CONNECTION DIAGRAM

● ICs

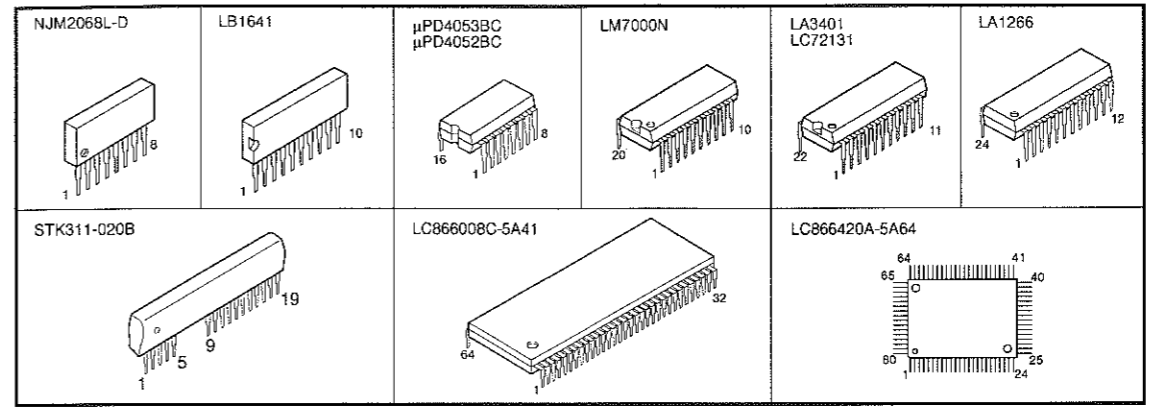

● Diodes

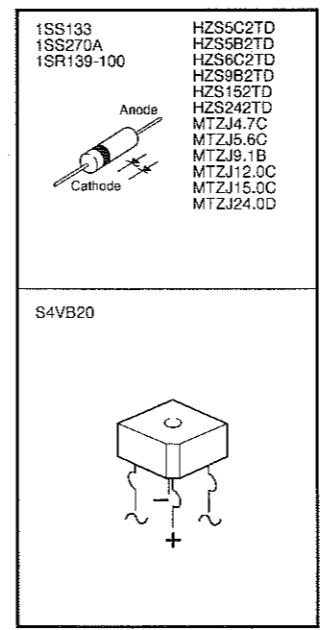

● Transistors

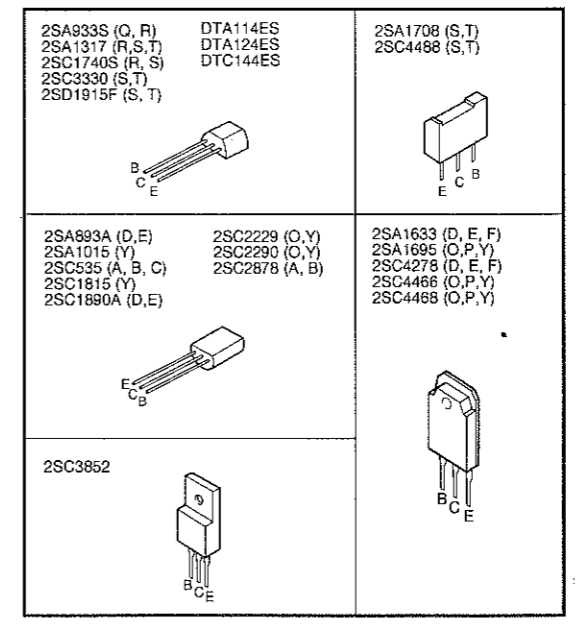

RX-495 SCHEMATIC DIAGRAM (TUNER)

Each voltage given here represents that in the FM (98.1MHz, STEREO) reception mode but the one in the parentheses () is that in the AM (1080kHz, MAN'L) reception mode.

CAPACITOR		
REMARKS	PARTS NAME	
NO MARK	ELECTROLYTIC CAPACITOR	#
⊗	TANTALUM CAPACITOR	#
NO MARK	CERAMIC CAPACITOR	
⊙	CERAMIC TUBULAR CAPACITOR	
⊖	POLYESTER FILM CAPACITOR	
⊕	POLYSTYRENE FILM CAPACITOR	#
○	MICA CAPACITOR	
⊖	POLYPROPYLENE FILM CAPACITOR	
⊕	SEMICONDUCTIVE CERAMIC CAPACITOR	

RESISTOR		
REMARKS	PARTS NAME	
NO MARK	CARBON FILM RESISTOR (P=5)	
⊠	CARBON FILM RESISTOR (P=10)	
△	METAL OXIDE FILM RESISTOR	
▲	METAL FILM RESISTOR	
⊠	METAL PLATE RESISTOR	
⊠	FIRE PROOF CARBON FILM RESISTOR	
□	CEMENT MOLDED RESISTOR	
⊖	SEMI VARIABLE RESISTOR	
■	CHIP RESISTOR	

NOTICE
 (J)..... Japanese model
 (U)..... U.S.A model
 (C)..... Canadian model
 (A)..... Australian model
 (G)..... European model
 (B)..... British model
 (P)..... General model
 (P)..... RP model

S		U-C	R	A-B	S(L)
1					
2	PK1	VR24220	VR24220	VR24220	V99B760
3					
4					
5					
6					
7	C21	100P	100P	100P	X
8	R34	10K	10K	10K	27K
9	J51	○	○	○	X
10	R4B	X	X	X	4.7K
11	T3	X	X	X	V936570
12	R35	22K	22K	22K	X
13	C36-37	560P	590P	470P	390P
14	R36-37	100K	100K	100K	120K
15	SW1	X	VF54120	X	X
16	J61	X	X	X	○
17	C71	X	X	X	120PCH

Interchangeable Parts at Manufacture-Stage

Mark	Reference Parts Number	Parts Name
#1	D1-2	HSS104 ISS133 ISS176

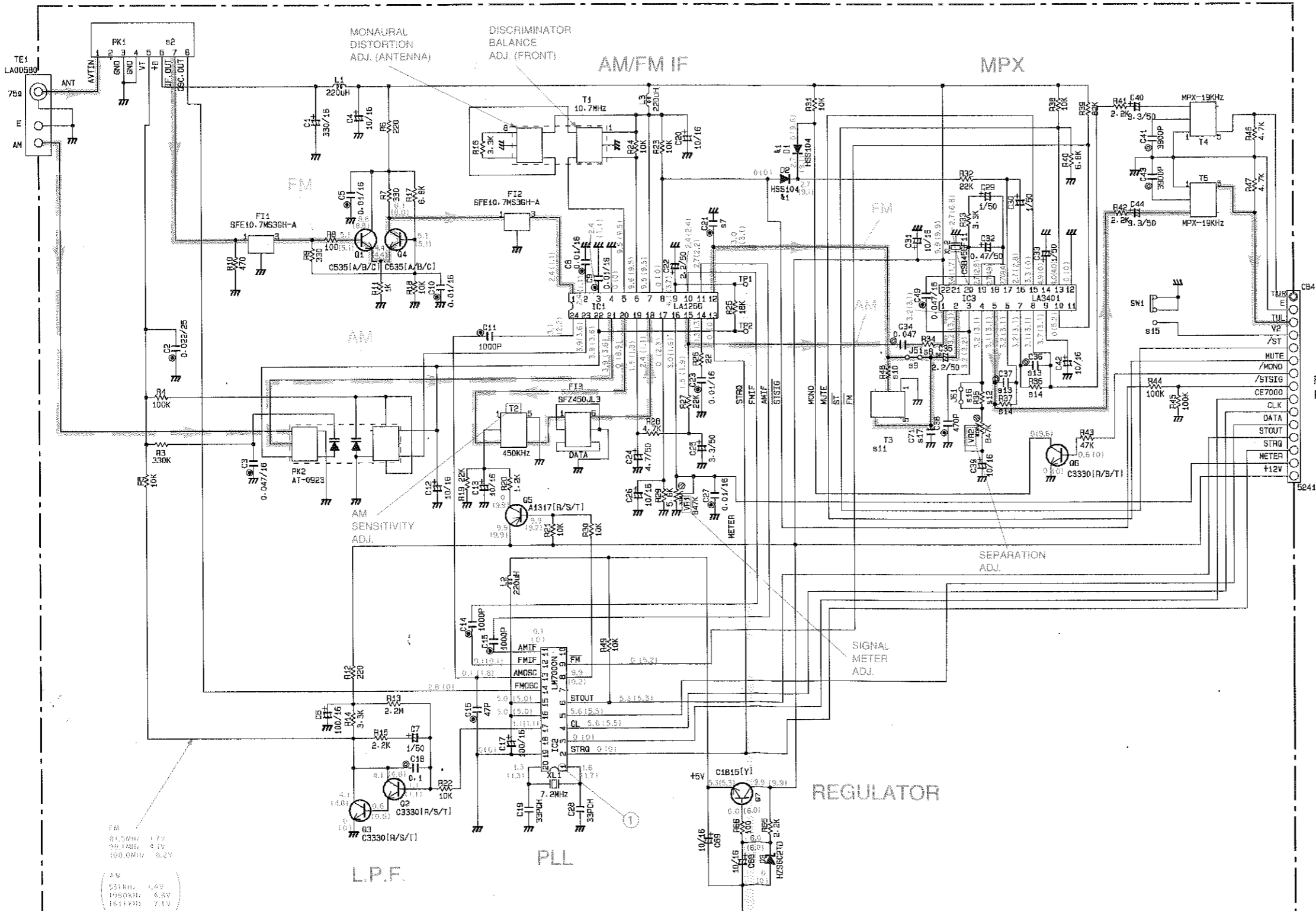

FUNCTION (1)
P33 [F-1]

Point ①
 (Pin 1 of IC2)
 V: 2V/div H: 50nsec/div
 DC range 1:1 probe

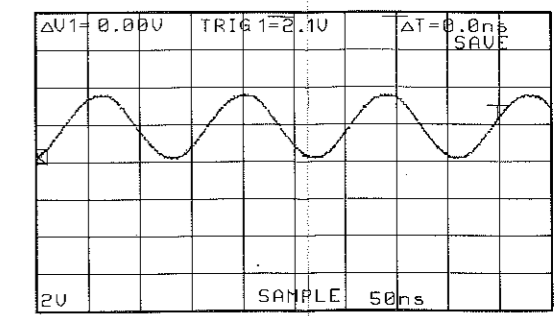

FM

97.5MHz	1.7V
98.1MHz	4.1V
108.0kHz	8.2V

AM

531kHz	1.4V
1080kHz	4.8V
1611kHz	7.1V

1
2
3
4
5
6

Each voltage given here represents that in the FM (98.1MHz, STEREO) reception mode but the one in the parentheses () is that in the AM (1080kHz, MAN'L) reception mode.

RESISTOR	[P=5]
RESISTOR	[P=10]
RESISTOR	[P=10]
RESISTOR	[P=10]
RESISTOR	[P=10]
RESISTOR	[P=10]
RESISTOR	[P=10]
RESISTOR	[P=10]
RESISTOR	[P=10]
RESISTOR	[P=10]
RESISTOR	[P=10]
RESISTOR	[P=10]
RESISTOR	[P=10]
RESISTOR	[P=10]
RESISTOR	[P=10]
RESISTOR	[P=10]
RESISTOR	[P=10]
RESISTOR	[P=10]
RESISTOR	[P=10]
RESISTOR	[P=10]
RESISTOR	[P=10]
RESISTOR	[P=10]
RESISTOR	[P=10]
RESISTOR	[P=10]
RESISTOR	[P=10]
RESISTOR	[P=10]
RESISTOR	[P=10]

NOTICE

- (J)..... Japanese model
- (U)..... U.S.A model
- (C)..... Canadian model
- (A)..... Australian model
- (G)..... European model
- (B)..... British model
- (P)..... General model
- (P)..... AP model

Mark	U-C	R	A-B	G(L)
1				
2	PK1	VR24220	VR24220	VR24220
3				
4				
5				
6				
7	C21	100P	100P	100P
8	R34	10K	10K	10K
9	J51	○	○	○
10	R48	×	×	4.7K
11	T3	×	×	VQ36570
12	R35	22K	22K	22K
13	C36, 37	680P	680P	470P
14	R36, 37	100K	100K	100K
15	SW1	×	VF54120	×
16	J61	×	×	○
17	C71	×	×	120PCH

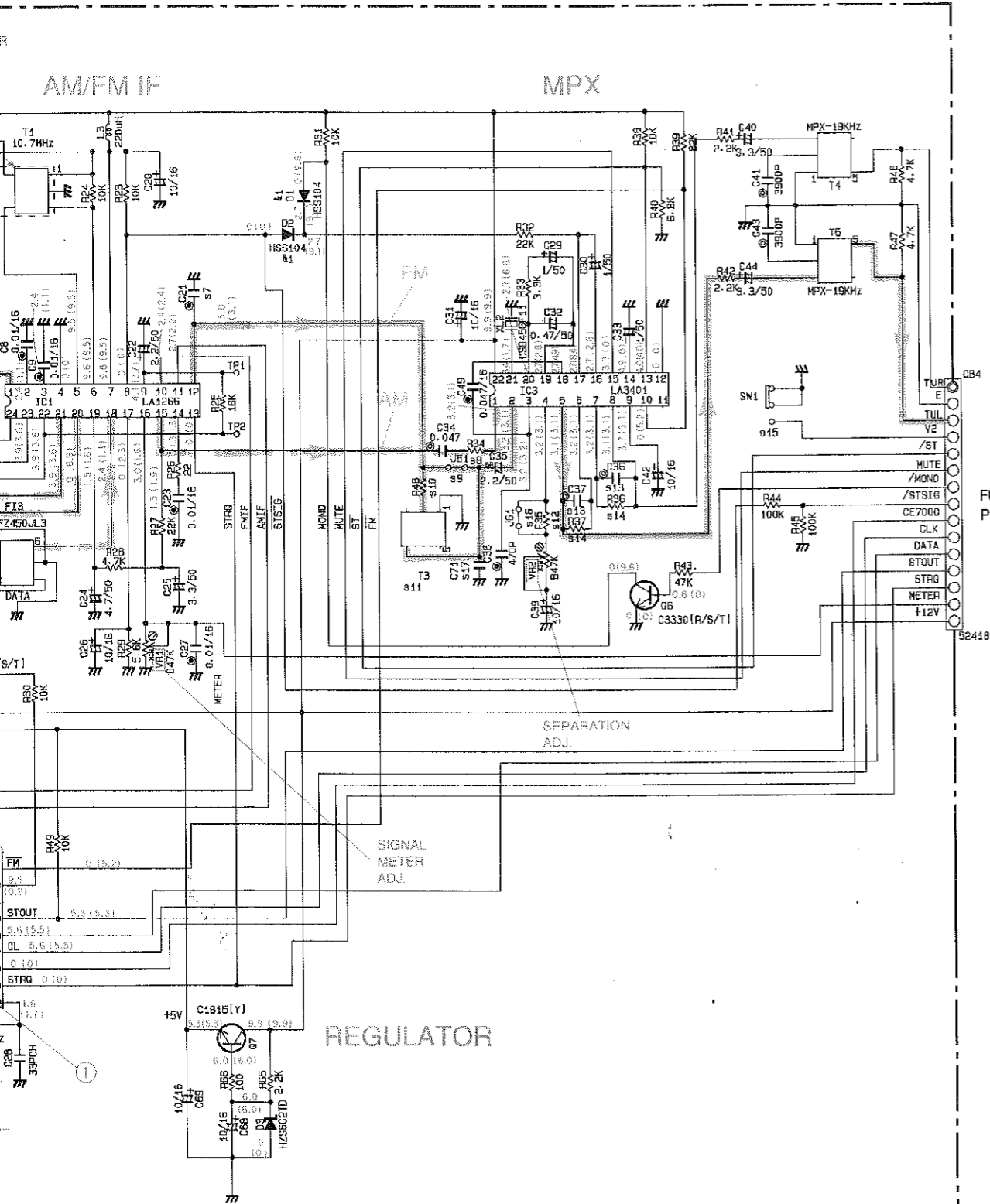

Interchangeable Parts at Manufacture-Stage

Mark	Reference Parts Number	Parts Name
R1	D1-2	HS104
		1S8139
		1S8176

Except L model
PK1 : ENV-17298GI (VR24220)

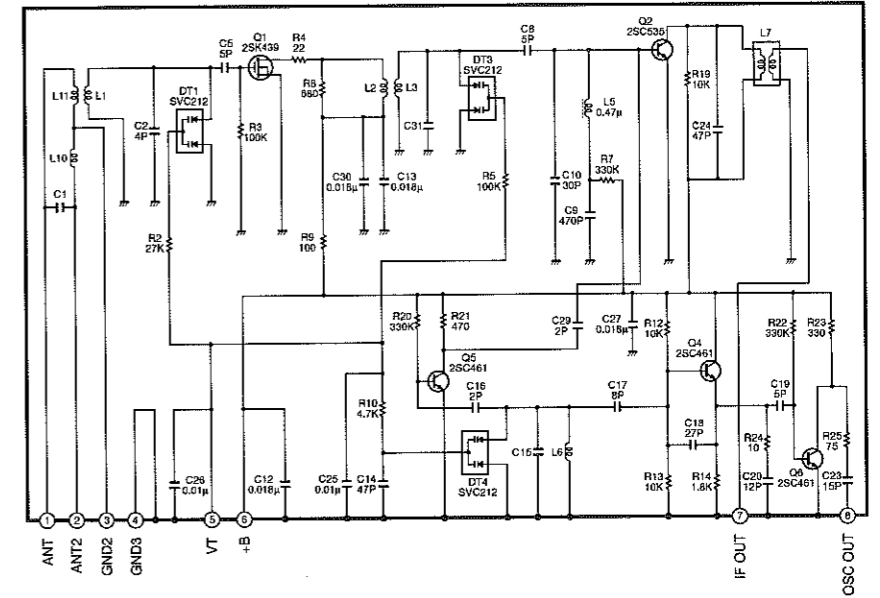

L model only
PK1 : ENV-17297GI (VQ987600)

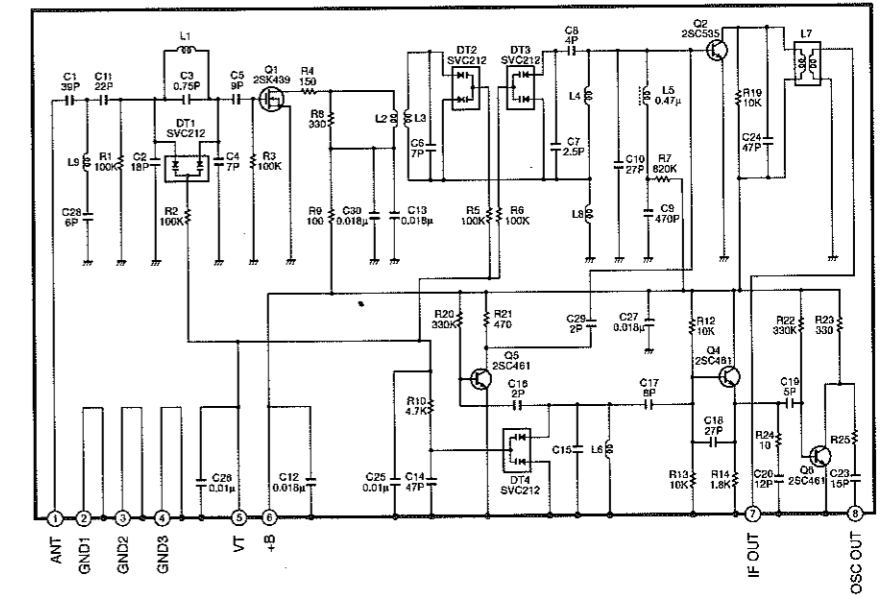

Point ①
(Pin 1 of IC2)
V: 2V/div H: 50nsec/div
DC range 1:1 probe

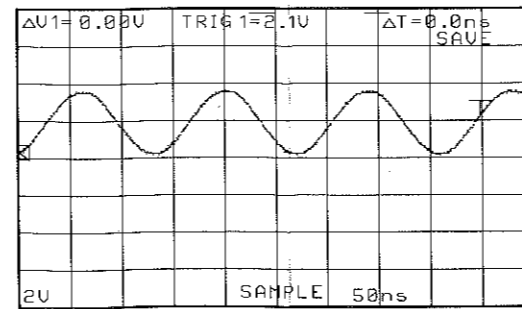

Interchangeable Parts at Manufacture-Stage

Mark	Reference Parts Number	Parts Name
K1	D1-2	HSS104 ISS133 ISS176

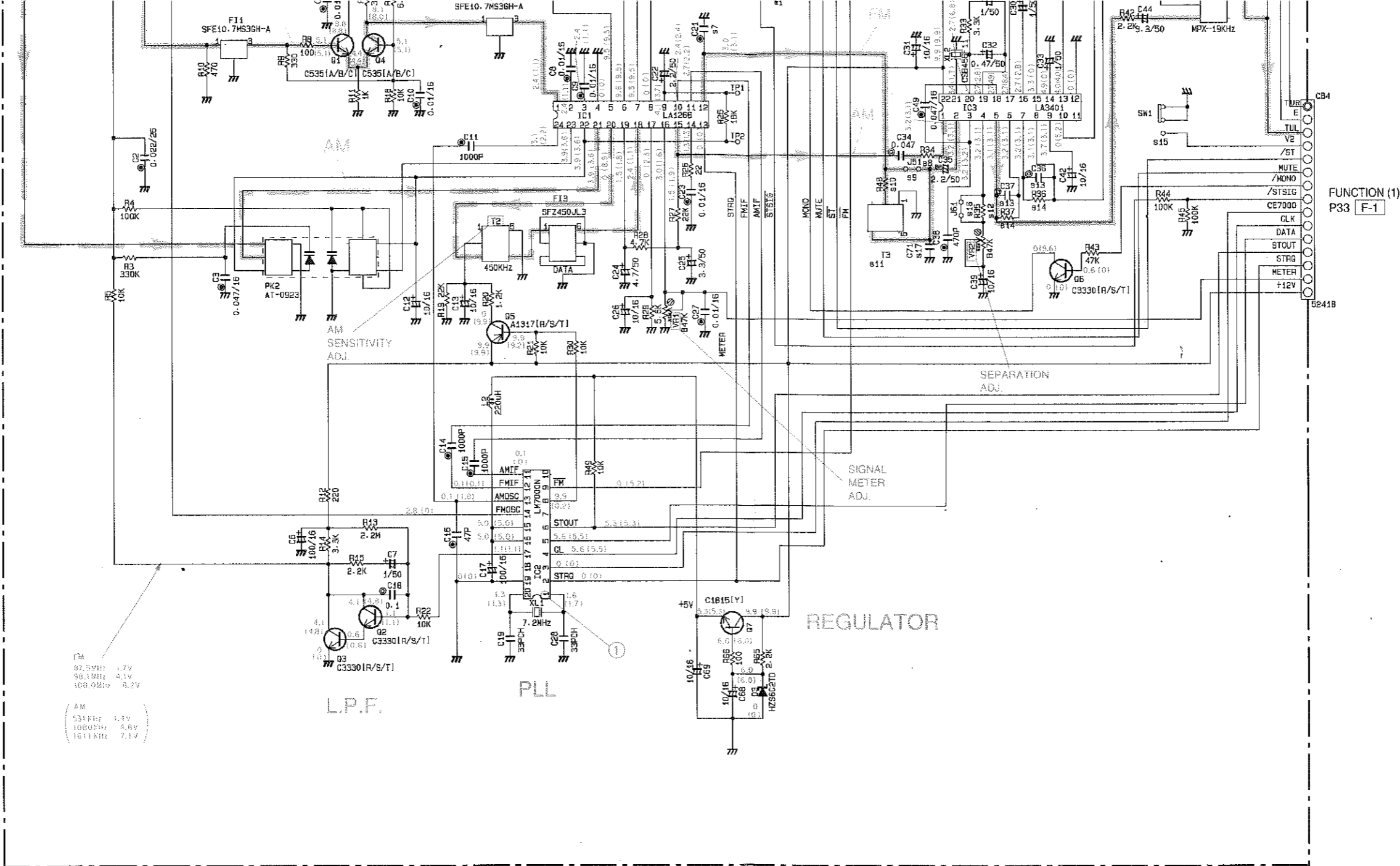

Point ①
(Pin 1 of IC2)
V: 2V/div H: 50nsec/div
DC range 1:1 probe

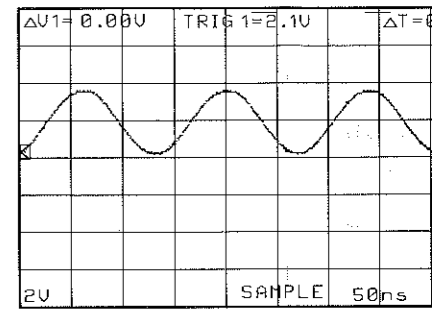

FM

87.5MHz	1.7V
98.1MHz	4.1V
108.9MHz	6.2V

AM

531KHz	1.4V
1080KHz	4.6V
1611KHz	7.1V

IC1 : LA1266
AM/FM IF

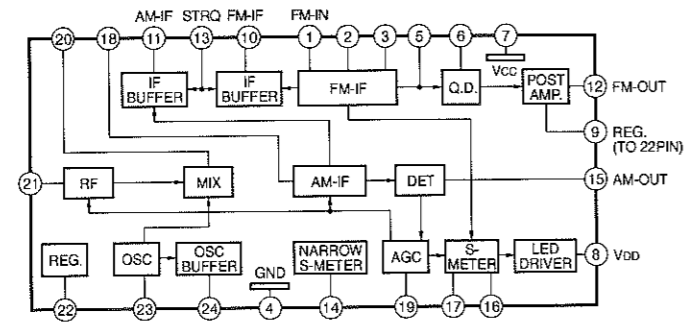

IC2 : LM7000N
PLL Controller

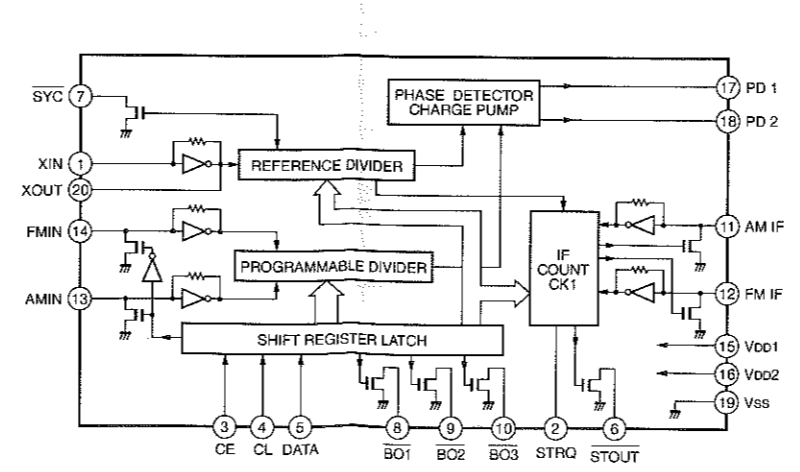

IC3 : LA3401
MPX

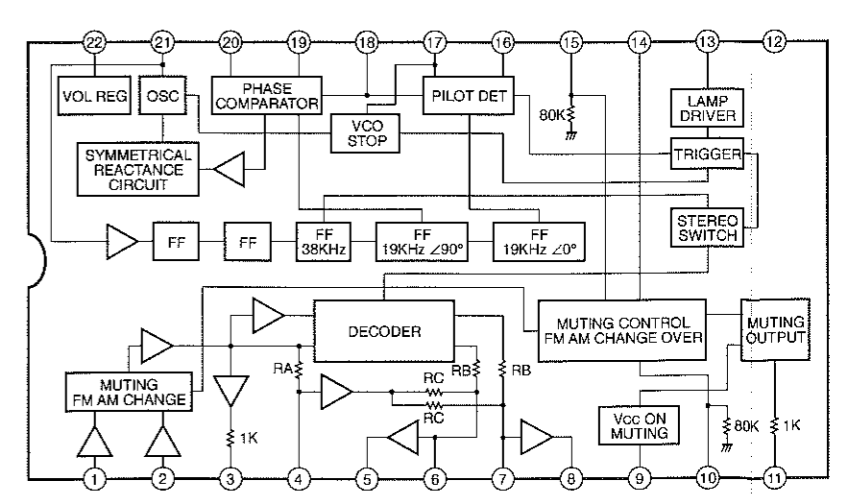

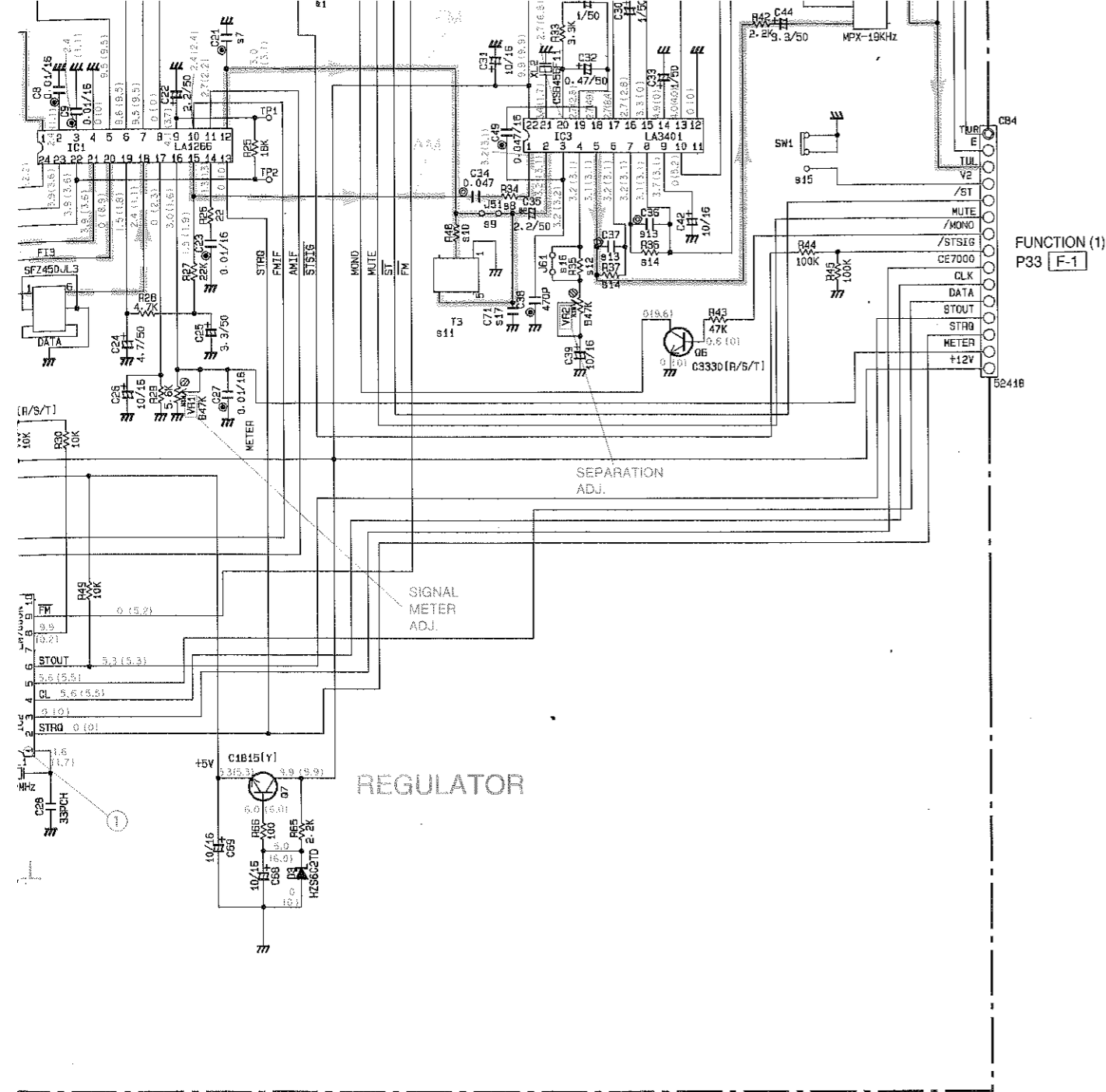

Interchangeable Parts at Manufacture-Stage

Mark	Reference Parts Number	Parts Name
k1	D1.2	HSS104 ISS133 ISS176

● L model only
PK1 : ENV-17297Gi (VQ987600)

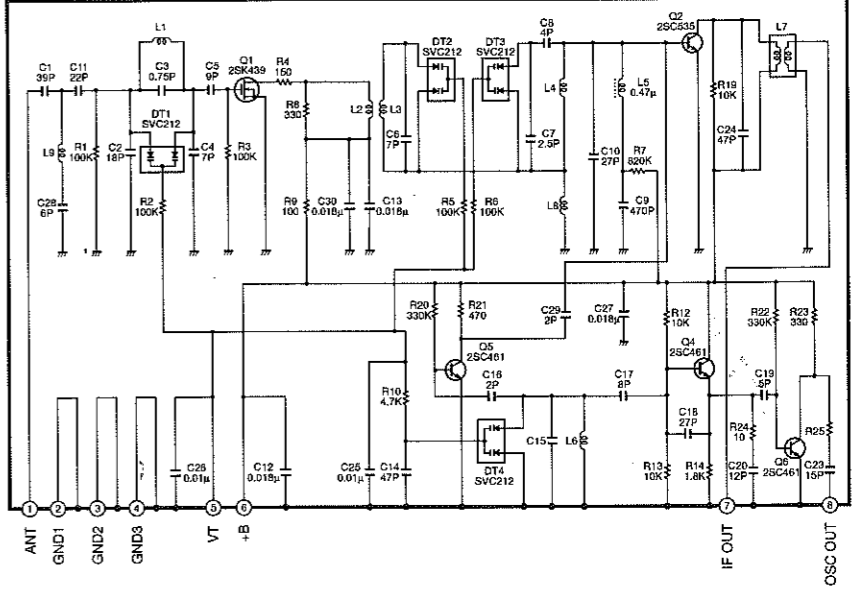

Point ①
(Pin 1 of IC2)
V : 2V/div H : 50nsec/div
DC range 1 : 1 probe

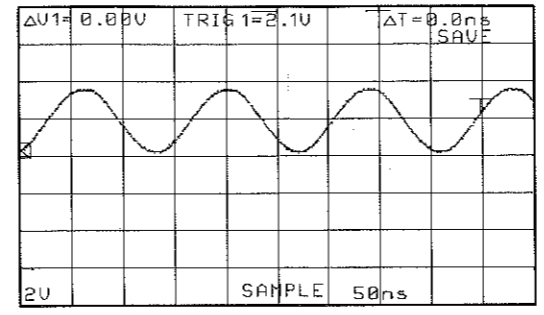

IC2 : LM7000N
PLL Controller

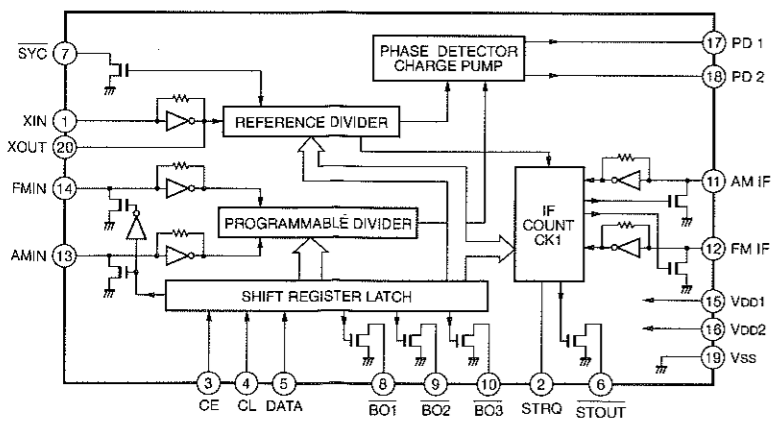

IC3 : LA3401
MPX

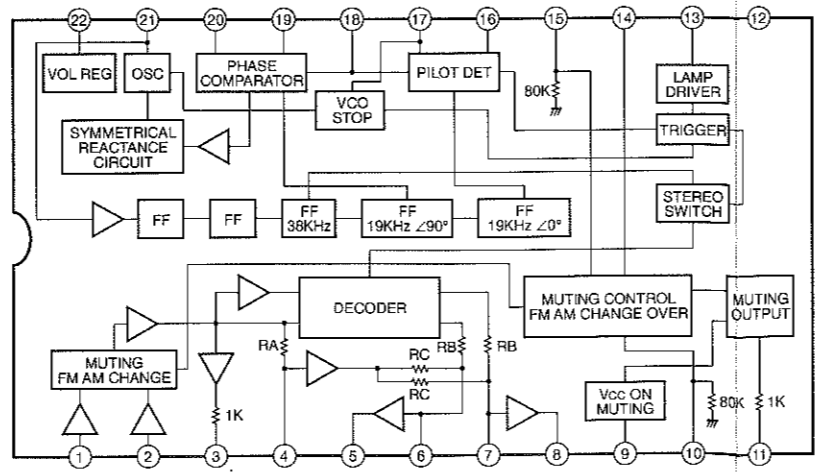

* All voltage are measured with a 10MΩ/DC electric volt meter.
* Components having special characteristics are marked Δ and must be replaced with parts having specifications equal to those originally installed.
* Schematic diagram is subject to change without notice.

■ RX-495 SCHEMATIC DIAGRAM (FUNCTION)

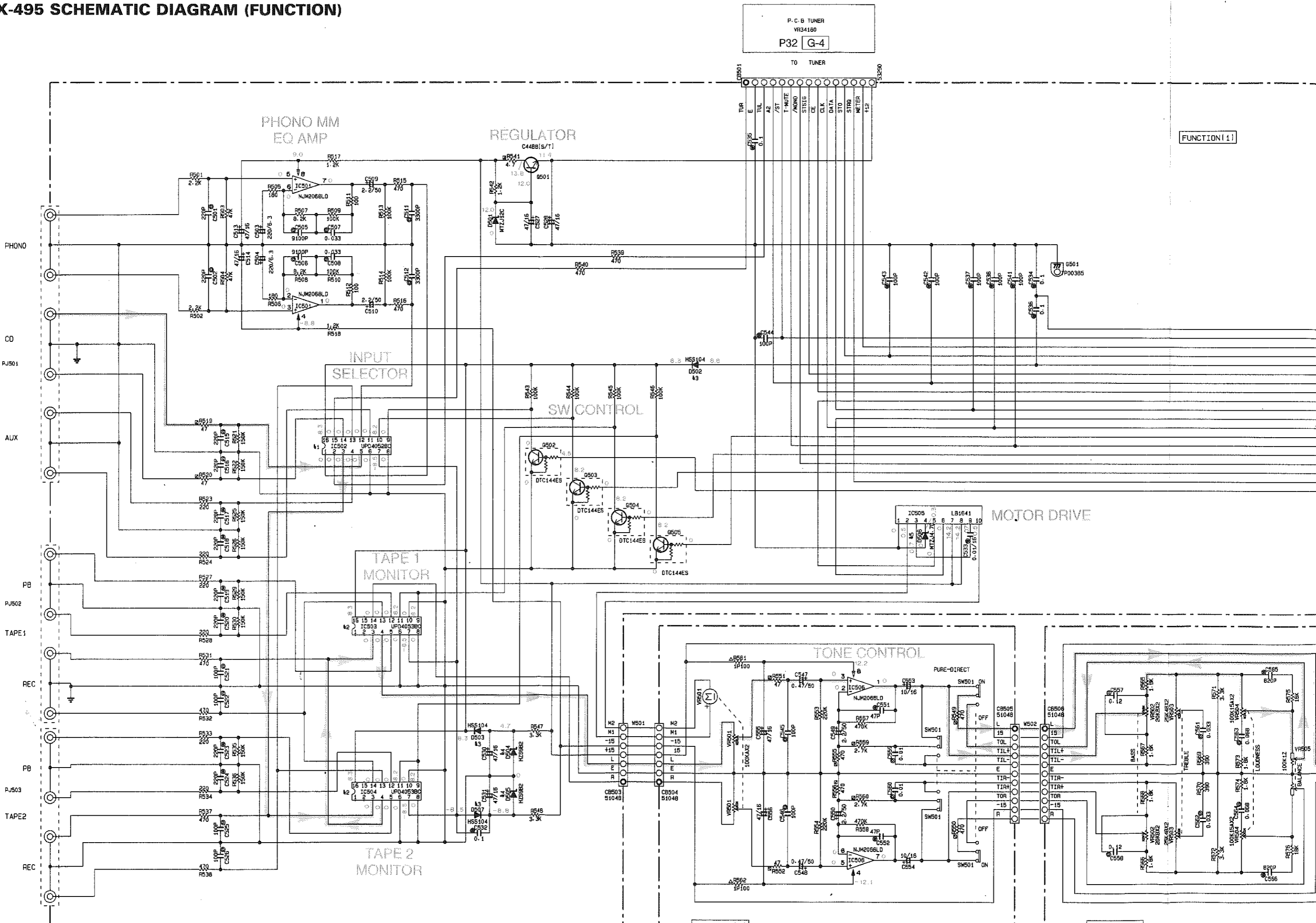

P.C.B TUNER
VR34180
P32 G-4

TO TUNER

REGULATOR

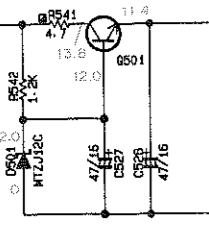

FUNCTION(1)

REMARKS	PARTS NAME
NO MARK	CARBON FILM RESISTOR (P=5)
☑	CARBON FILM RESISTOR (P=10)
△	METAL OXIDE FILM RESISTOR
▲	METAL FILM RESISTOR
☒	METAL PLATE RESISTOR
☑	FIRE PROOF CARBON FILM RESISTOR
□	CEMENT MOLDED RESISTOR
⊗	SEMI VARIABLE RESISTOR
■	CHIP RESISTOR

REMARKS	PARTS NAME
NO MARK	ELECTROLYTIC CAPACITOR
⊗	TANTALUM CAPACITOR
NO MARK	CERAMIC CAPACITOR
⊙	CERAMIC TUBULAR CAPACITOR
⊙	POLYESTER FILM CAPACITOR
○	POLYSTYRENE FILM CAPACITOR
⊙	MICA CAPACITOR
⊙	POLYPROPYLENE FILM CAPACITOR
●	SEMICONDUCTIVE CERAMIC CAPACITOR

Interchangeable Parts at Manufacture-Stage

Mark	Reference Parts Number	Parts Name
#1	IC502	UPD4052BC TC4052BP
#2	IC503.504	UPD4053BC TC4053BP
#3	0502-503.507	HSS104 ISS133 ISS176
#4	0504.505	HZS982 MTZJ4.1B
#5	0506	MTZJ4.7C HZS982

SW CONTROL

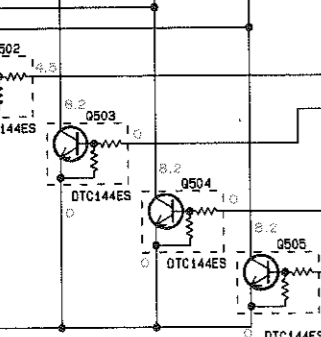

MOTOR DRIVE

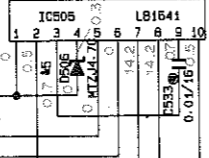

TONE CONTROL

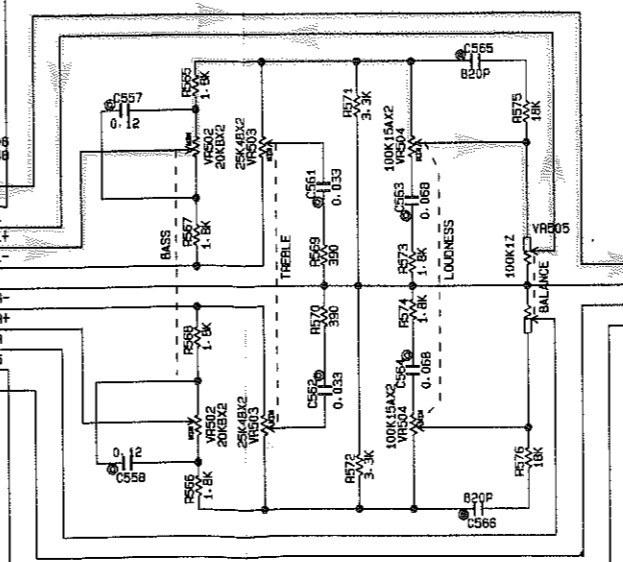
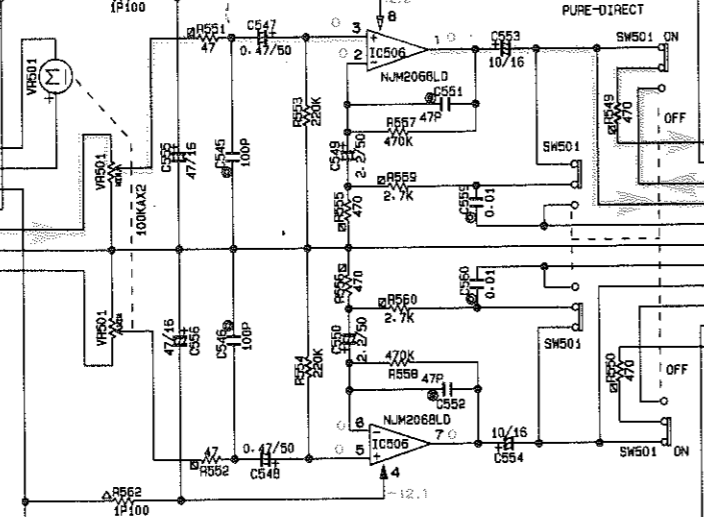

TO OPERATION(1)

P34 H-4

TO MAIN(1)

P35 B-6

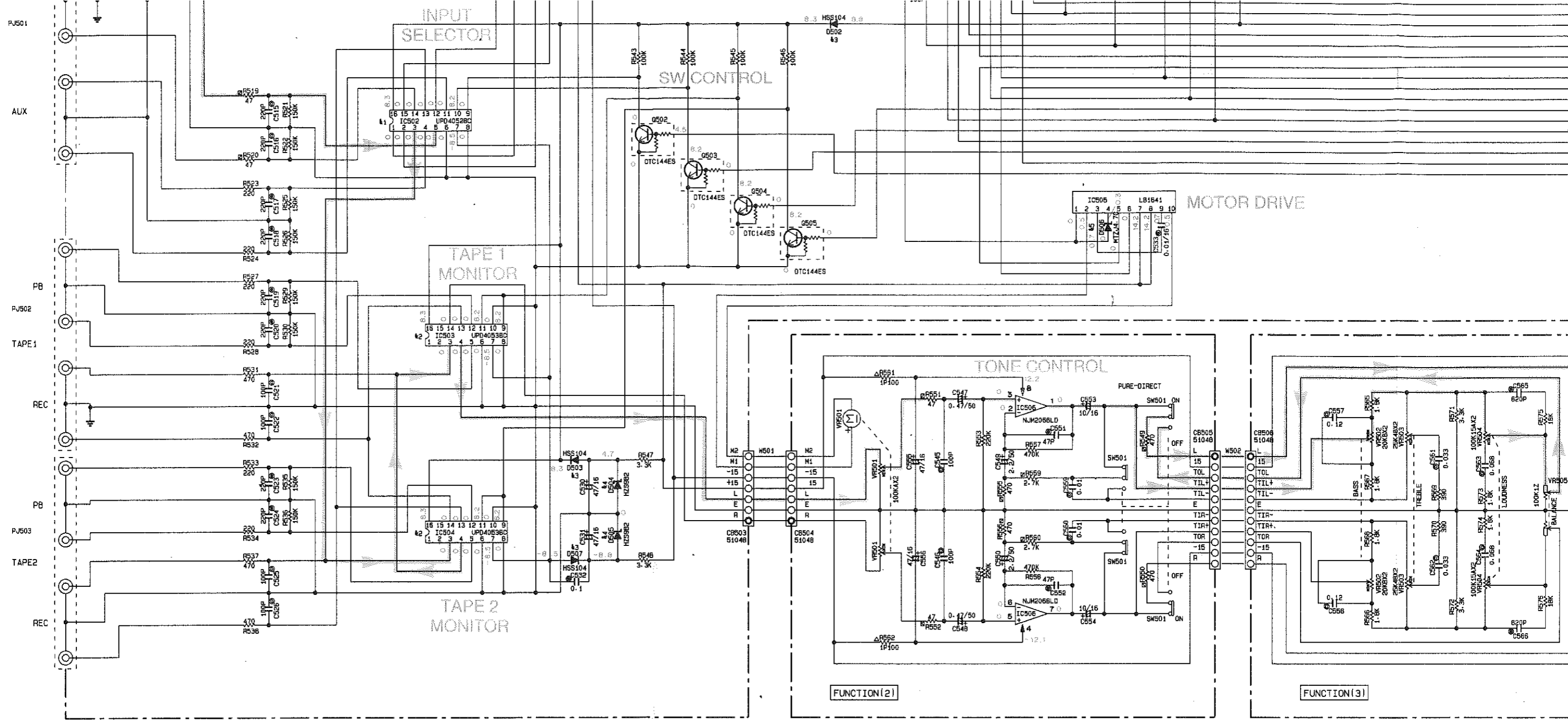

IC501, 506 : NJM2068L-D
Dual OP-Amp

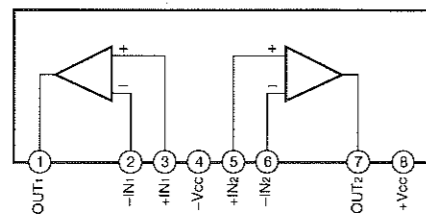

IC502 : μ PD4052BC
Dual 4 Channel Analog Multiplexers/Demultiplexers

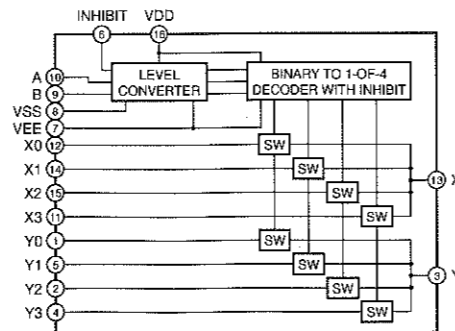

INHIBIT	B	A	
0	0	0	0x, 0y
0	0	1	1x, 1y
0	1	0	2x, 2y
0	1	1	3x, 3y
1	X	X	NONE

IC503, 504 : μ PD4053BC
Triple 2-Channel Multiplexer/Demultiplexer

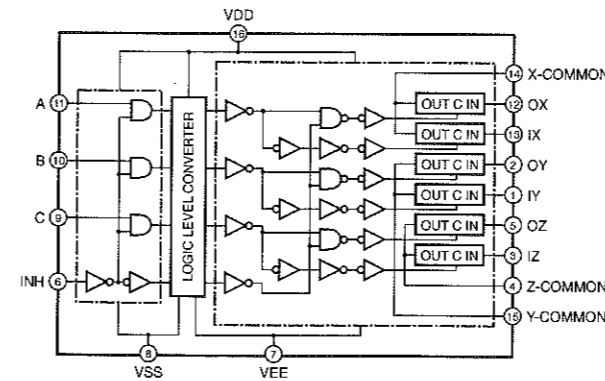

CONTROL INPUTS				"ON" CHANNEL
INHIBIT (Pin 6)	C (Pin 9)	B (Pin 10)	A (Pin 11)	0X (Pin 12), 0Y (Pin 2), 0Z (Pin 5) 1X (Pin 13), 1Y (Pin 1), 1Z (Pin 3)
L	L	L	L	0X, 0Y, 0Z
L	L	L	H	1X, 0Y, 0Z
L	L	H	L	0X, 1Y, 0Z
L	L	H	H	1X, 1Y, 0Z
L	H	L	L	0X, 0Y, 1Z
L	H	L	H	1X, 0Y, 1Z
L	H	H	L	0X, 1Y, 1Z
L	H	H	H	1X, 1Y, 1Z
H	.	.	.	NOTE

* Don't Care

IC505 : LB1641
Motor Driver

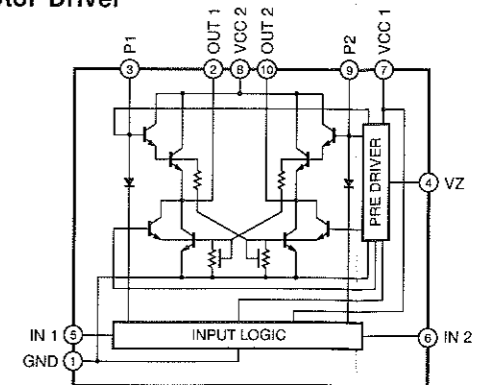

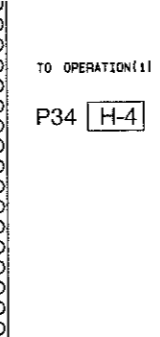
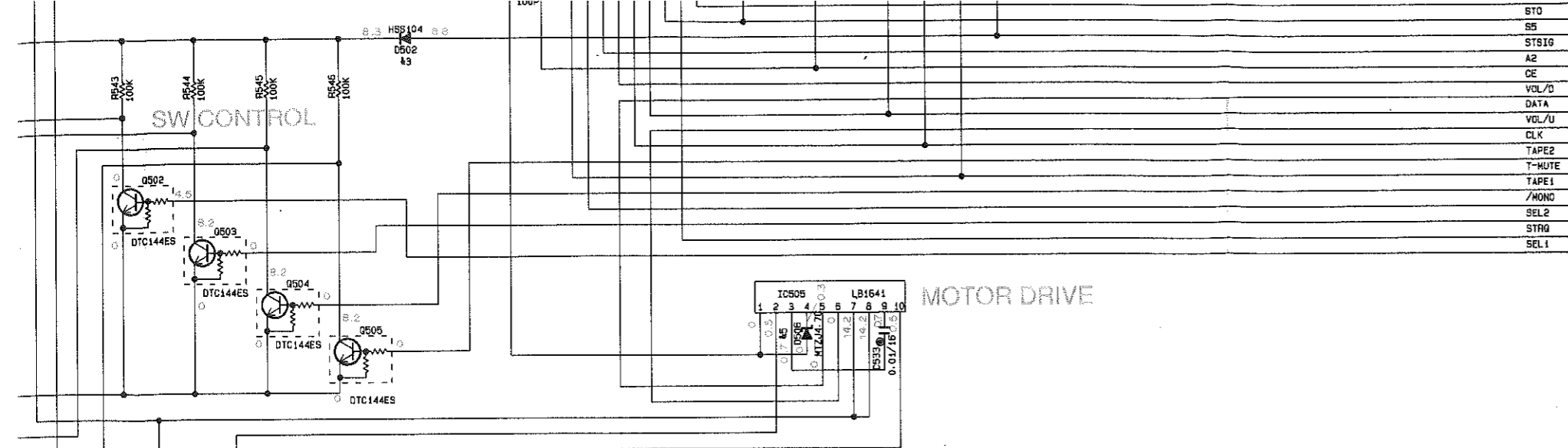

P34 H-4

Interchangeable Parts at Manufacture-Stage

Mark	Reference Parts Number	Parts Name
41	IC502	UPD4052BC TC4052BP
42	IC503-504	UPD4053BC TC4053BP
43	D502-503-507	HSS104 ISS133 ISS176
44	D504-505	HZ5902 MTZJ9-1B
45	D506	MTZJ4-7C HZ9562

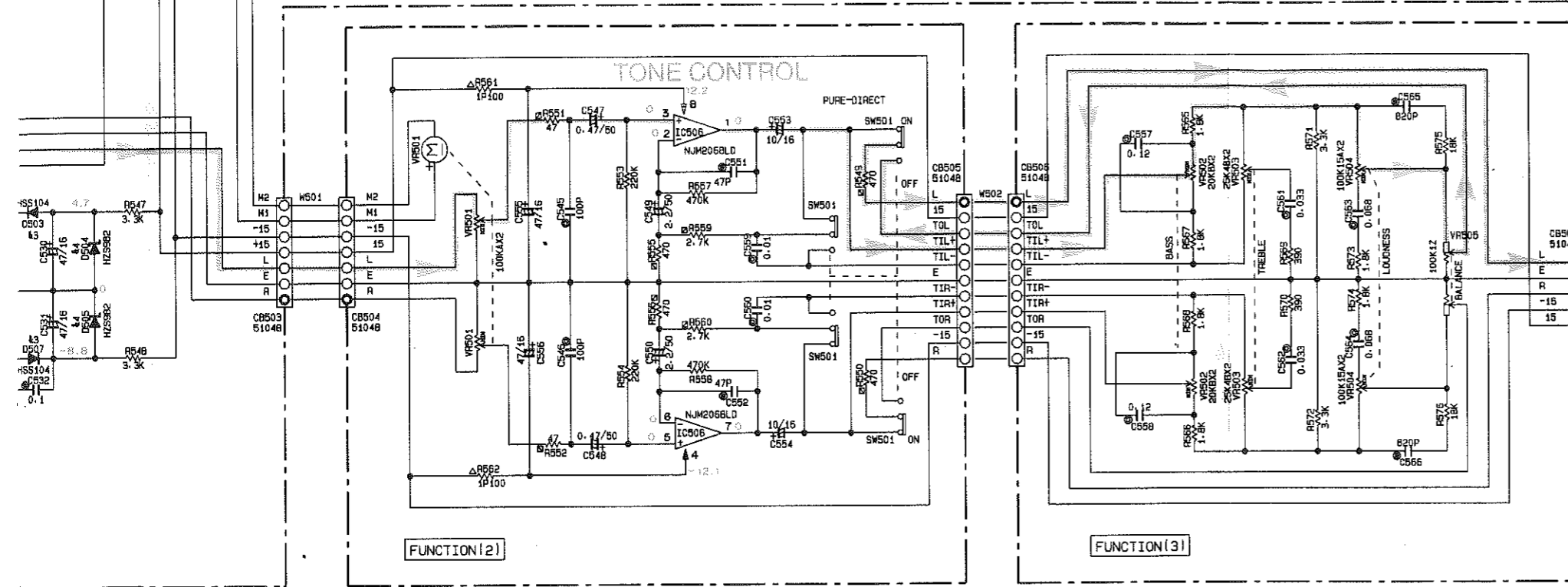

P35 B-6

TO MAIN(1)

Multiplexers/Demultiplexers

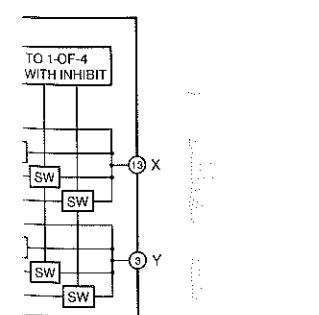

IC503, 504 : μ PD4053BC
Triple 2-Channel Multiplexer/Demultiplexer

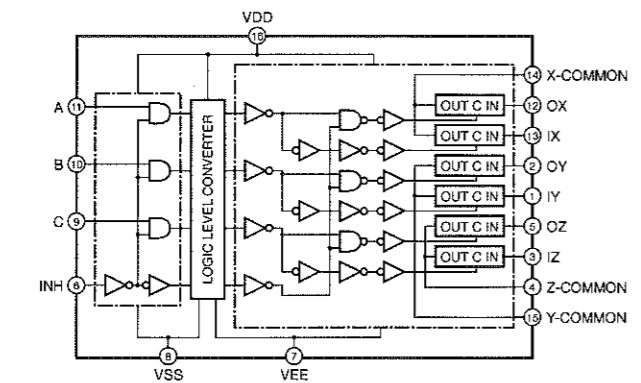

CONTROL INPUTS				"ON" CHANNEL		
INHIBIT (Pin 6)	C (Pin 9)	B (Pin 10)	A (Pin 11)	OX (Pin 12), OY (Pin 2), OZ (Pin 5)	1X (Pin 13), 1Y (Pin 1), 1Z (Pin 3)	
L	L	L	L	OX, OY, OZ		
L	L	L	H	1X, OY, OZ		
L	L	H	L	OX, 1Y, OZ		
L	L	H	H	1X, 1Y, OZ		
L	H	L	L	OX, OY, 1Z		
L	H	L	H	1X, OY, 1Z		
L	H	H	L	OX, 1Y, 1Z		
L	H	H	H	1X, 1Y, 1Z		
H				NOTE		

* Don't Care

IC505 : LB1641
Motor Driver

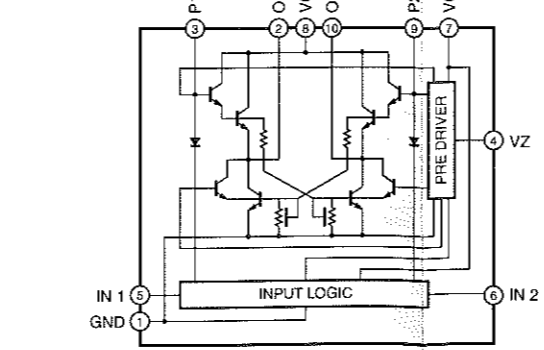

* All voltage are measured with a 10M Ω /DC electric volt meter.
 * Components having special characteristics are marked Δ and must be replaced with parts having specifications equal to those originally installed.
 * Schematic diagram is subject to change without notice.

RX-495 SCHEMATIC DIAGRAM (OPERATION)

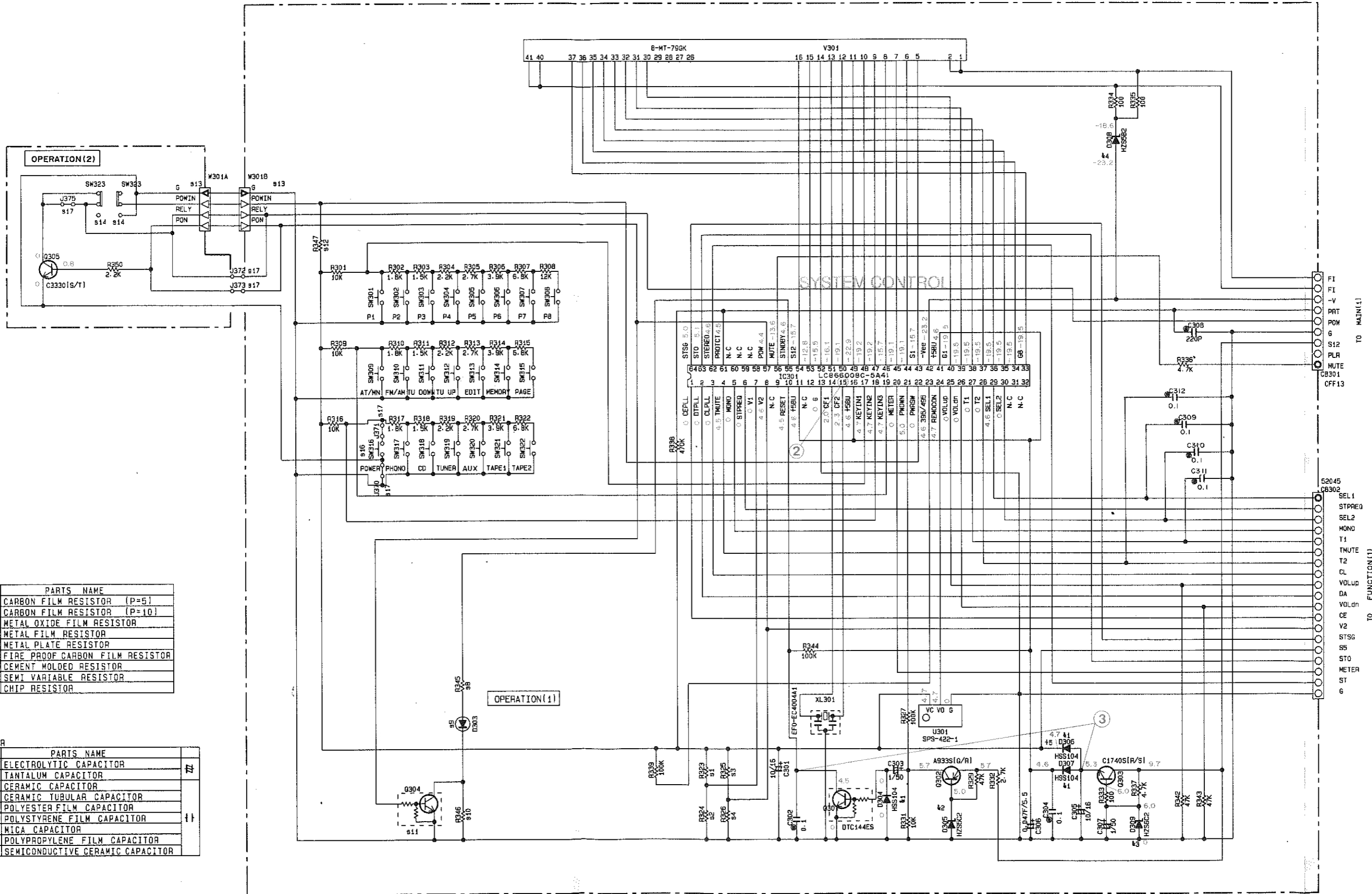

RESISTOR	
REMARKS	PARTS NAME
NO MARK	CARBON FILM RESISTOR (P=5)
☑	CARBON FILM RESISTOR (P=10)
△	METAL OXIDE FILM RESISTOR
▲	METAL FILM RESISTOR
⊗	METAL PLATE RESISTOR
⊠	FIRE PROOF CARBON FILM RESISTOR
□	CEMENT MOLDED RESISTOR
⊙	SEMI VARIABLE RESISTOR
■	CHIP RESISTOR

CAPACITOR	
REMARKS	PARTS NAME
NO MARK	ELECTROLYTIC CAPACITOR
⊗	TANTALUM CAPACITOR
NO MARK	CERAMIC CAPACITOR
⊙	CERAMIC TUBULAR CAPACITOR
⊚	POLYESTER FILM CAPACITOR
○	POLYSTYRENE FILM CAPACITOR
⊖	MICA CAPACITOR
⊕	POLYPROPYLENE FILM CAPACITOR
●	SEMICONDUCTIVE CERAMIC CAPACITOR

P35 B-2

P33 I-3

- FI
- VI
- PRT
- POM
- G
- S12
- PLR
- MUTE
- CB301
- CFF13
- SEL1
- STPREQ
- SEL2
- MONO
- T1
- TMUTE
- T2
- CL
- VOLUP
- DA
- VOLdn
- CE
- V2
- STSG
- S5
- STO
- METER
- ST
- G

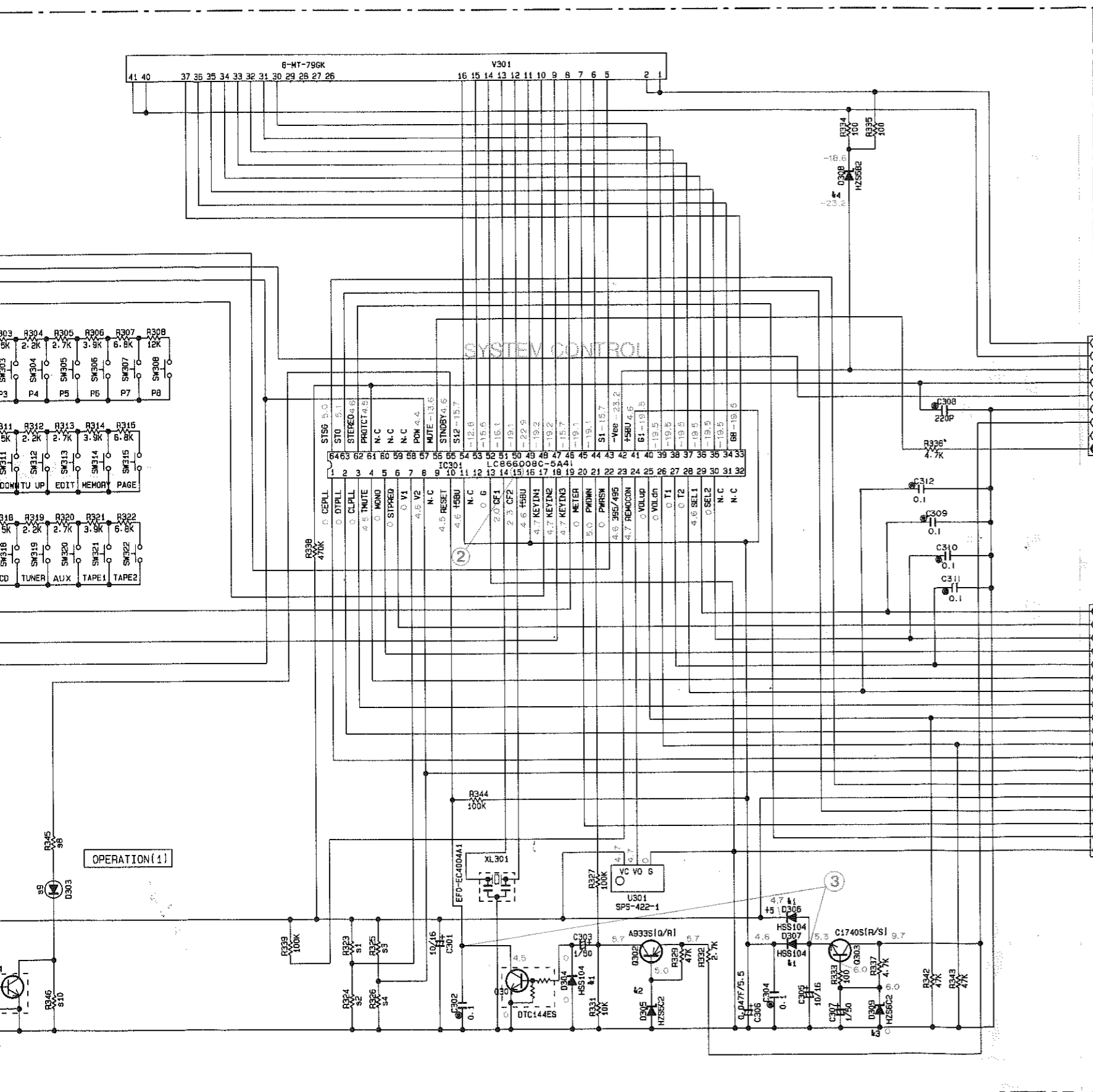

Interchangeable Parts at Manufacture-Stage

Mark	Reference Parts Number	Parts Name
1	D304.306.307	HSS104 ISS133 ISS176
2	D305	HZ56C2 MTZJ6.1B
3	D309	HZ56C2 MTZJ6.2B
4	D308	HZ55B2 MTZJ4.7C

	U.C	R	A.L	
1	R323	100K	X	100K
2	R324	X	100K	X
3	R325	X	100K	100K
4	R326	100K	X	X
5				
6				
7				
8	R345	X	X	470
9	D303	X	X	SLR-305VCA47 SLR-325VCT31
10	R346	X	X	560
11	Q304	X	X	DTC144ES
12	R347	X	X	100K
13	W301	X	X	VUJ39190
14	SW323	X	X	VT98540
15				
16	SW316	V639290	V639290	X
17	J370-373 375			X

Point ②
 (Pin 15 of IC301)
 V: 2V/div H: 0.1μsec/div
 DC range 1:1 probe

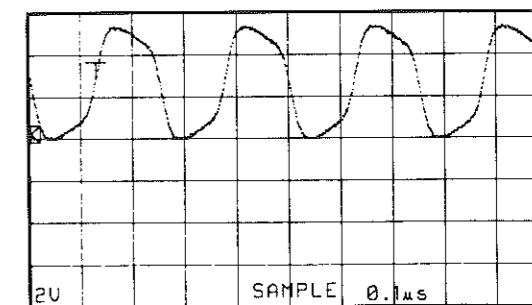

Point ③
 (CH 1: Pin 10 of IC301)
 (CH 2: Emitter of Q303)
 V: 2V/div CH1
 V: 2V/div CH2
 H: 0.5sec/div
 DC range 1:1 probe
 (This waveform is not available by pushing the power switch ON and OFF.)

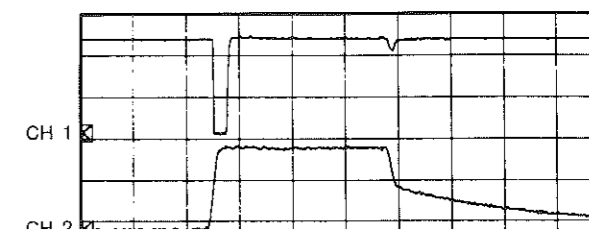

• GRID ASSIGNMENT

• ANODE CONNECTION

3

4

5

6

7

8

RESISTOR

REMARKS	PARTS NAME
NO MARK	CARBON FILM RESISTOR (P=5)
□	CARBON FILM RESISTOR (P=10)
△	METAL OXIDE FILM RESISTOR
▲	METAL FILM RESISTOR
⊠	METAL PLATE RESISTOR
⊞	FIRE PROOF CARBON FILM RESISTOR
□	CEMENT MOLDED RESISTOR
⊕	SEMI VARIABLE RESISTOR
■	CHIP RESISTOR

CAPACITOR

REMARKS	PARTS NAME
NO MARK	ELECTROLYTIC CAPACITOR
⊗	TANTALUM CAPACITOR
NO MARK	CERAMIC CAPACITOR
⊙	CERAMIC TUBULAR CAPACITOR
⊚	POLYESTER FILM CAPACITOR
○	POLYSTYRENE FILM CAPACITOR
⊖	MICA CAPACITOR
⊕	POLYPROPYLENE FILM CAPACITOR
●	SEMICONDUCTIVE CERAMIC CAPACITOR

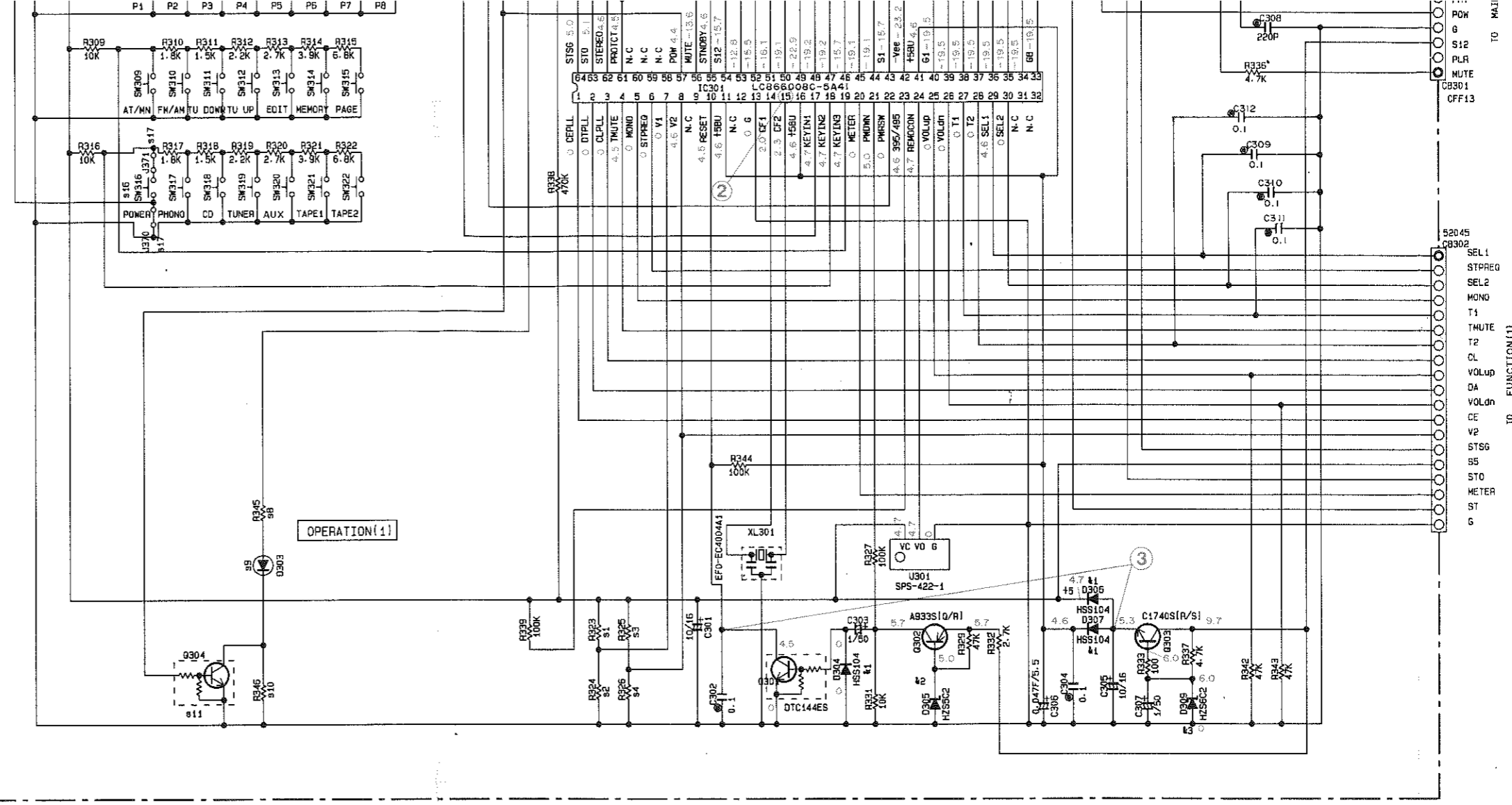

● V301 : 8-MT-79GK (VQ915100)

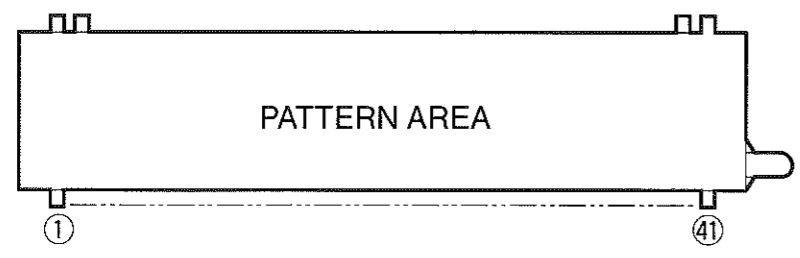

• PIN CONNECTION

PIN NO.	1	2	3	4	5	6	7	8	9	10	11	12	13	14	15	16	17	18	19	20	21
CONNECTION	F1	F1	NP	NP	P1	P2	P3	P4	P5	P6	P7	P8	P9	P10	P11	P12	NX	NX	NX	NX	NX

PIN NO.	22	23	24	25	26	27	28	29	30	31	32	33	34	35	36	37	38	39	40	41
CONNECTION	NX	NX	NX	NX	NC	NC	NC	NC	1G	2G	3G	4G	5G	6G	7G	8G	NP	NP	F2	F2

NOTE 1) F1, F2 Filament
 2) NP No pin
 3) NC No connection
 4) NX No extend pin
 5) DL Datum Line
 6) 1G~11G .. Grid

• GRID ASSIGNMENT

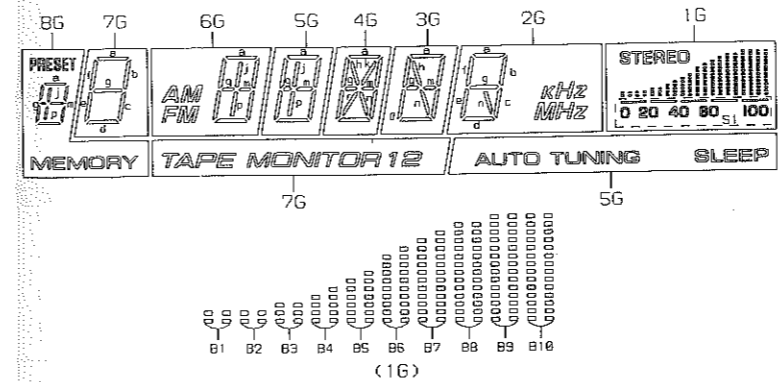

• ANODE CONNECTION

	8G	7G	6G	5G	4G	3G
P1	a	a	a	a	a	a
P2	b	b	b	b	b	b
P3	c	c	c	c	c	c
P4	d	d	d	d	d	d
P5	e	e	e	e	e	e
P6	f	f	f	f	f	f
P7	g	g	g	g	g	g
P8	j	—	j	j	h	h
P9	PRESET	TAPE MONITOR	AM	AUTO TUNING	k	o
P10	m	?	M	m	m	m
P11	p	2	P	p	n	n
P12	MEMORY	—	FM	SLEEP	r	—

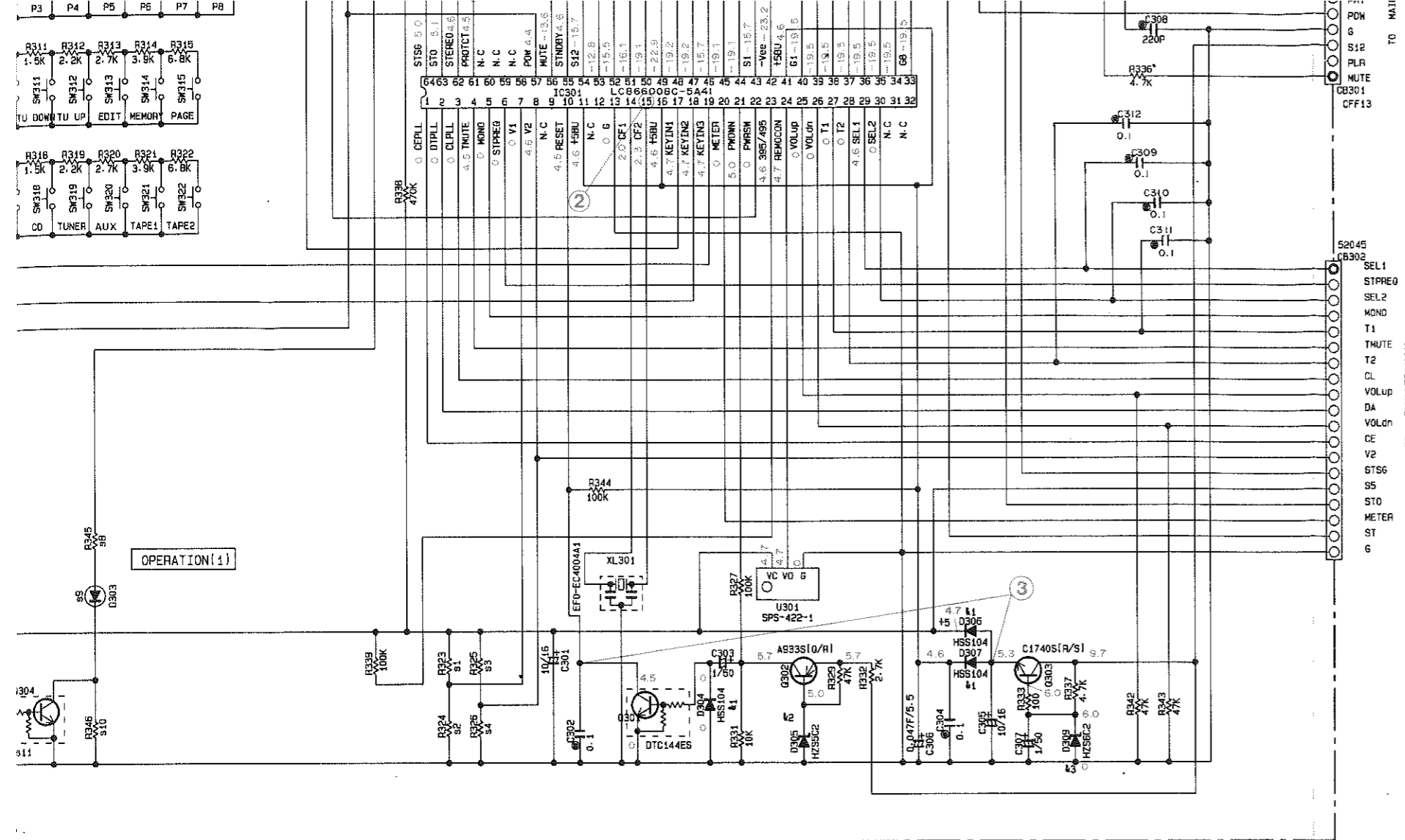

10	R346	X	X	560
11	Q304	X	X	DTC144ES
12	R347	X	X	100K
13	W301	X	X	VU39190
14	SW323	X	X	VT98540
15				
16	SW316	V639290	V639290	X
17	J370-373 375	○	○	X

Point ②
(Pin 15 of IC301)
V: 2V/div H: 0.1μsec/div
DC range 1:1 probe

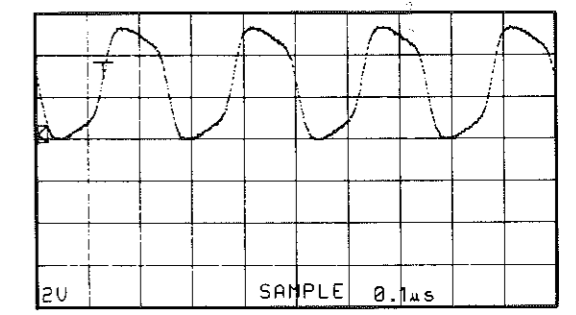

Point ③
(CH 1 : Pin 10 of IC301)
(CH 2 : Emitter of Q303)
V: 2V/divCH1
V: 2V/divCH2
H: 0.5sec/div
DC range 1:1 probe
(This waveform is not available by pushing the power switch ON and OFF.)

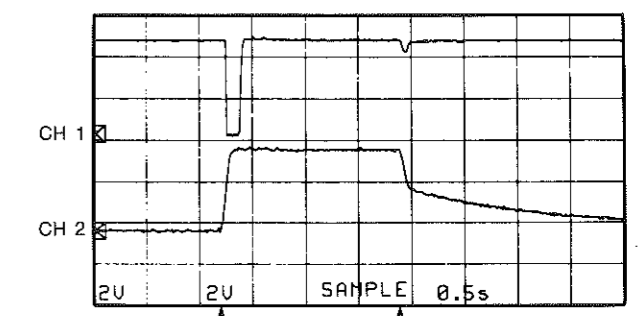

With the POWER switch turned ON, connect the power cord to the AC outlet.
Disconnect the power cord from the AC outlet.

• GRID ASSIGNMENT

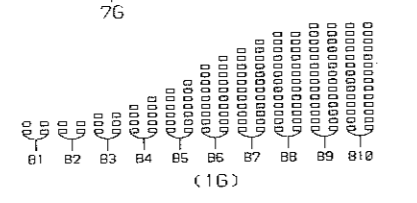
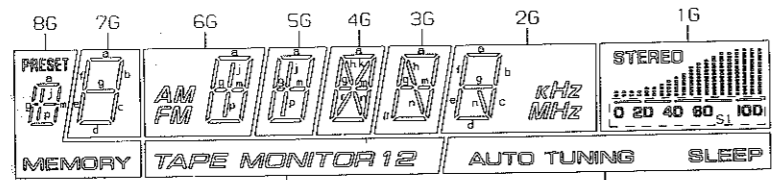

• ANODE CONNECTION

	8G	7G	6G	5G	4G	3G	2G	1G
P1	a	a	a	a	a	a	a	STEREO
P2	b	b	b	b	b	b	b	S1
P3	c	c	c	c	c	c	c	B1
P4	d	d	d	d	d	d	d	B2
P5	e	e	e	e	e	e	e	B3
P6	f	f	f	f	f	f	f	B4
P7	g	g	g	g	g	g	g	B5
P8	j	—	j	j	h	h	—	B6
P9	PRESET	TAPE MONITOR	AM	AUTO TUNING	k	o	kHz	B7
P10	m	1	M	m	m	m	—	B8
P11	p	2	P	p	n	n	n	B9
P12	MEMORY	—	FM	SLEEP	r	—	MHz	B10

17	18	19	20	21
NX	NX	NX	NX	NX
38	39	40	41	
NP	NP	F2	F2	

X No extend pin
L Datum Line
G~11G .. Grid

* All voltage are measured with a 10MΩ/DC electric volt meter.
* Components having special characteristics are marked Δ and must be replaced with parts having specifications equal to those originally installed.
* Schematic diagram is subject to change without notice.

■ RX-495 SCHEMATIC DIAGRAM (MAIN)

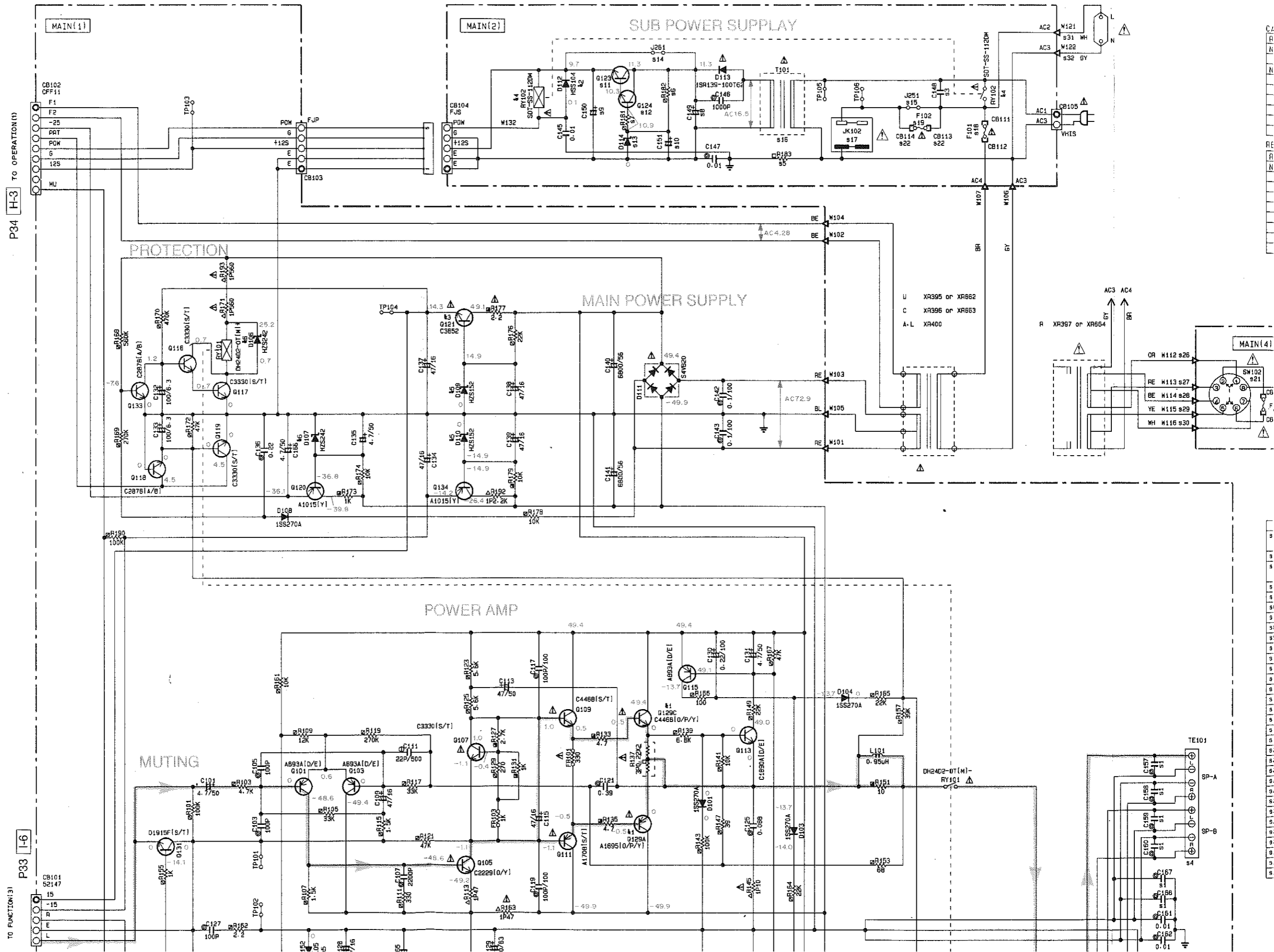

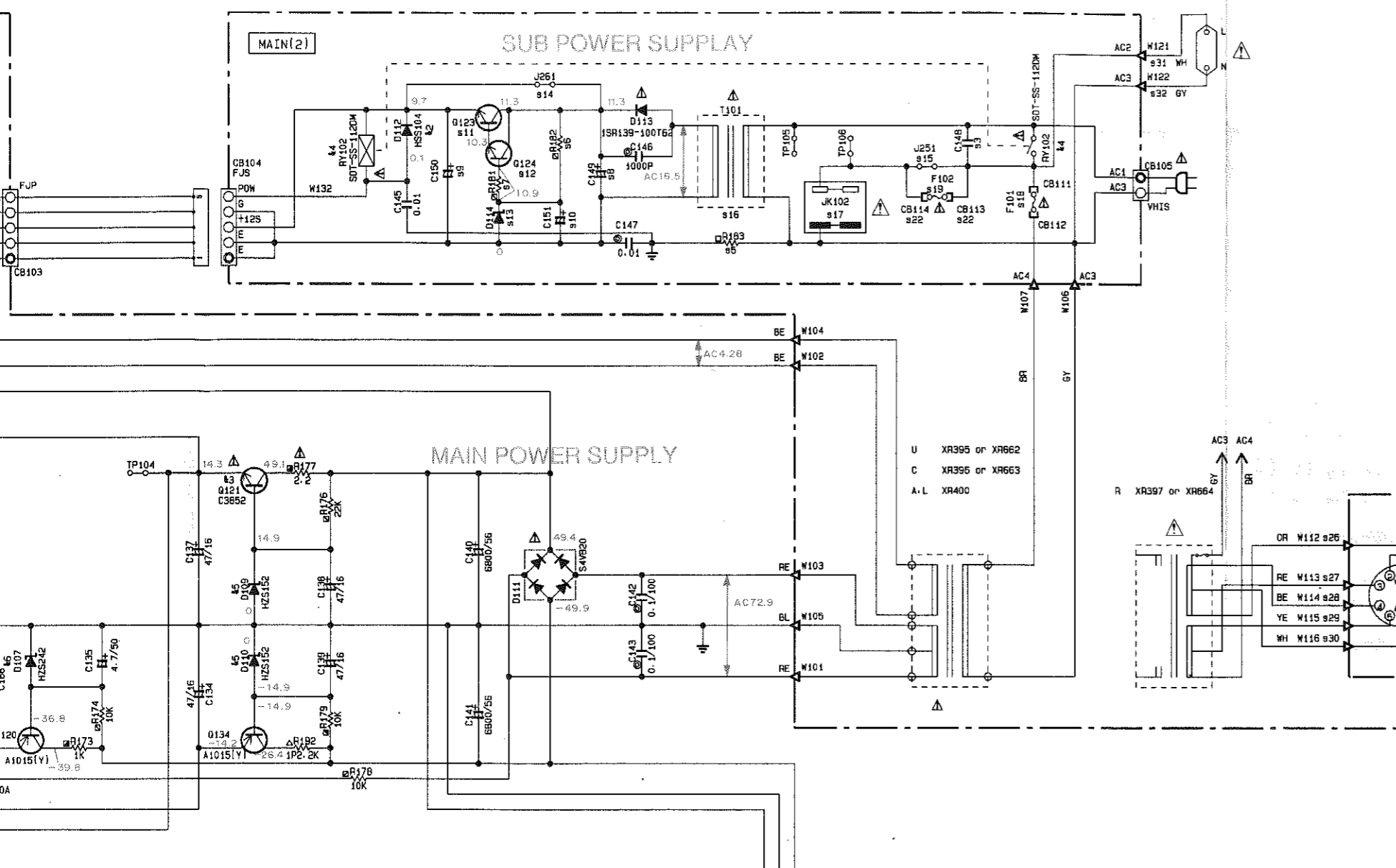

CAPACITOR

REMARKS	PARTS NAME	
NO MARK	ELECTROLYTIC CAPACITOR	77
⊗	TANTALUM CAPACITOR	
NO MARK	CERAMIC CAPACITOR	11
⊙	CERAMIC TUBULAR CAPACITOR	
⊖	POLYESTER FILM CAPACITOR	
○	POLYSTYRENE FILM CAPACITOR	
①	MICA CAPACITOR	
⊕	POLYPROPYLENE FILM CAPACITOR	
●	SEMICONDUCTIVE CERAMIC CAPACITOR	

RESISTOR

REMARKS	PARTS NAME
NO MARK	CARBON FILM RESISTOR (P=5)
⊠	CARBON FILM RESISTOR (P=10)
△	METAL OXIDE FILM RESISTOR
▲	METAL FILM RESISTOR
⊞	METAL PLATE RESISTOR
⊞	FIRE PROOF CARBON FILM RESISTOR
□	CEMENT MOLDED RESISTOR
⊗	SEMI VARIABLE RESISTOR
■	CHIP RESISTOR

		U.C	R	A	L
s1	C152-154, 157-160 C157, 168	X	X	0.01	0.01
s2	R184	X	X	2.2	2.2
s3	C148	0.01	0.01	0.01	0.01
		[F741410]	[F741410]	[VJ46630]	[VJ46630]
s4	TE101	VC31370	VC31370	VK50620	VK50620
s5	R183	1/2P2.2M	X	X	X
s6	R182	X	18K	X	X
s7	R181	X	100	X	X
s8	C149	330/25	330/53	330/25	330/25
s9	C150	X	100/15	X	X
s10	C151	X	10/16	X	X
s11	G123	X	C446610/P/Y	X	X
s12	G124	X	C1890A[D/E]	X	X
s13	D114	X	MTZJ12C	X	X
s14	J251	0	X	0	0
s15	J251	0	0	0	X
s16	T101	XC0B3	XC0B2	XC0B4	XC0B4
s17	JK102	VK48060	VK48060	X	VK48070
s18	F101	5A125V	5A125V	T1.6AL250V	T1.6AL250V
s19	F102	X	X	X	T2.5AL250V
s20	F103	X	T1.6AL250V	X	X
s21	SW102	X	VA96180	X	X
s22	CB113, 114	X	X	X	VP20650
s23	CB115, 116	X	VP20650	X	X
s24					
s25	W111	X	MH0101B	X	X
s26	W112	X	MH03220	X	X
s27	W113	X	MH02220	X	X
s28	W114	X	MH06220	X	X
s29	W115	X	MH04220	X	X
s30	W116	X	MH09220	X	X
s31	W121	X	X	MH09118	X
s32	W122	X	X	MH08118	X

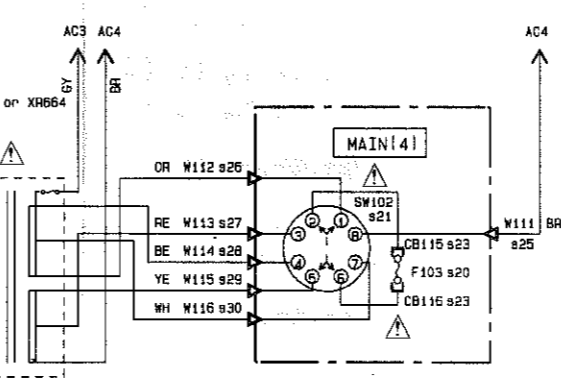
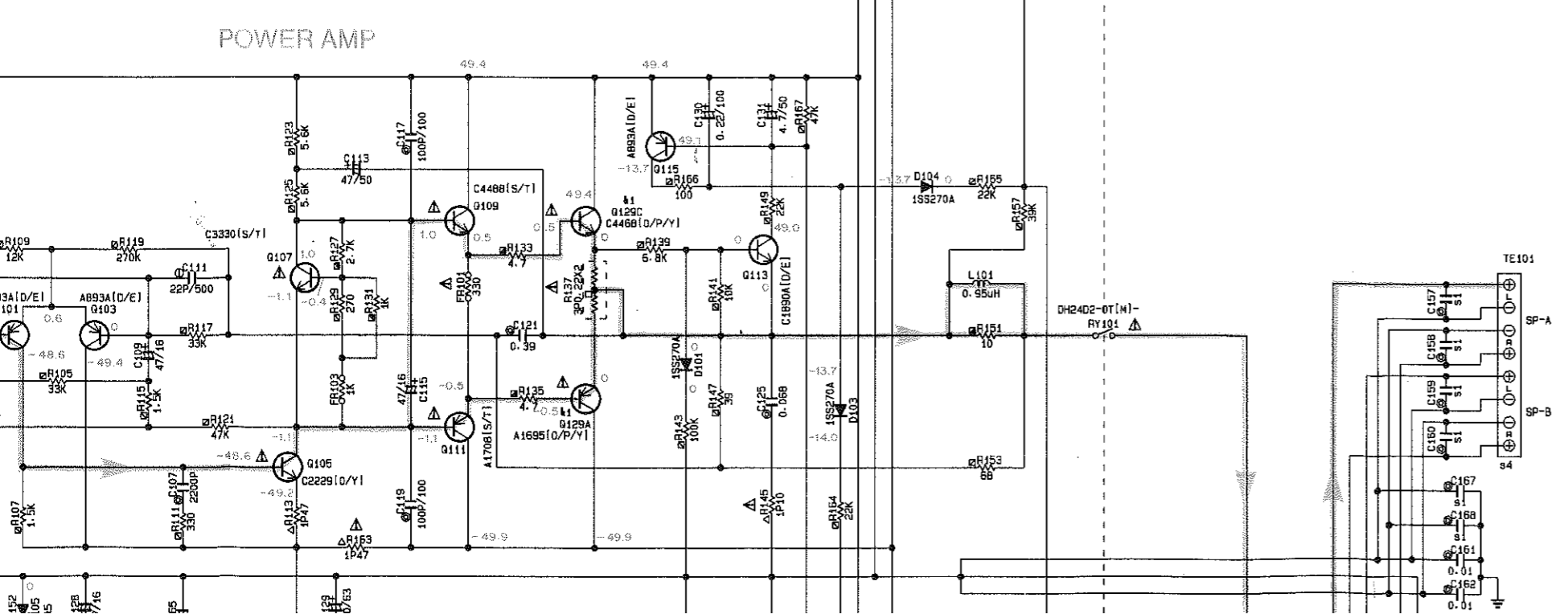

U XR395 or XR662
 C XR395 or XR663
 A.L. XR400
 R XR397 or XR664

3

4

5

6

7

8

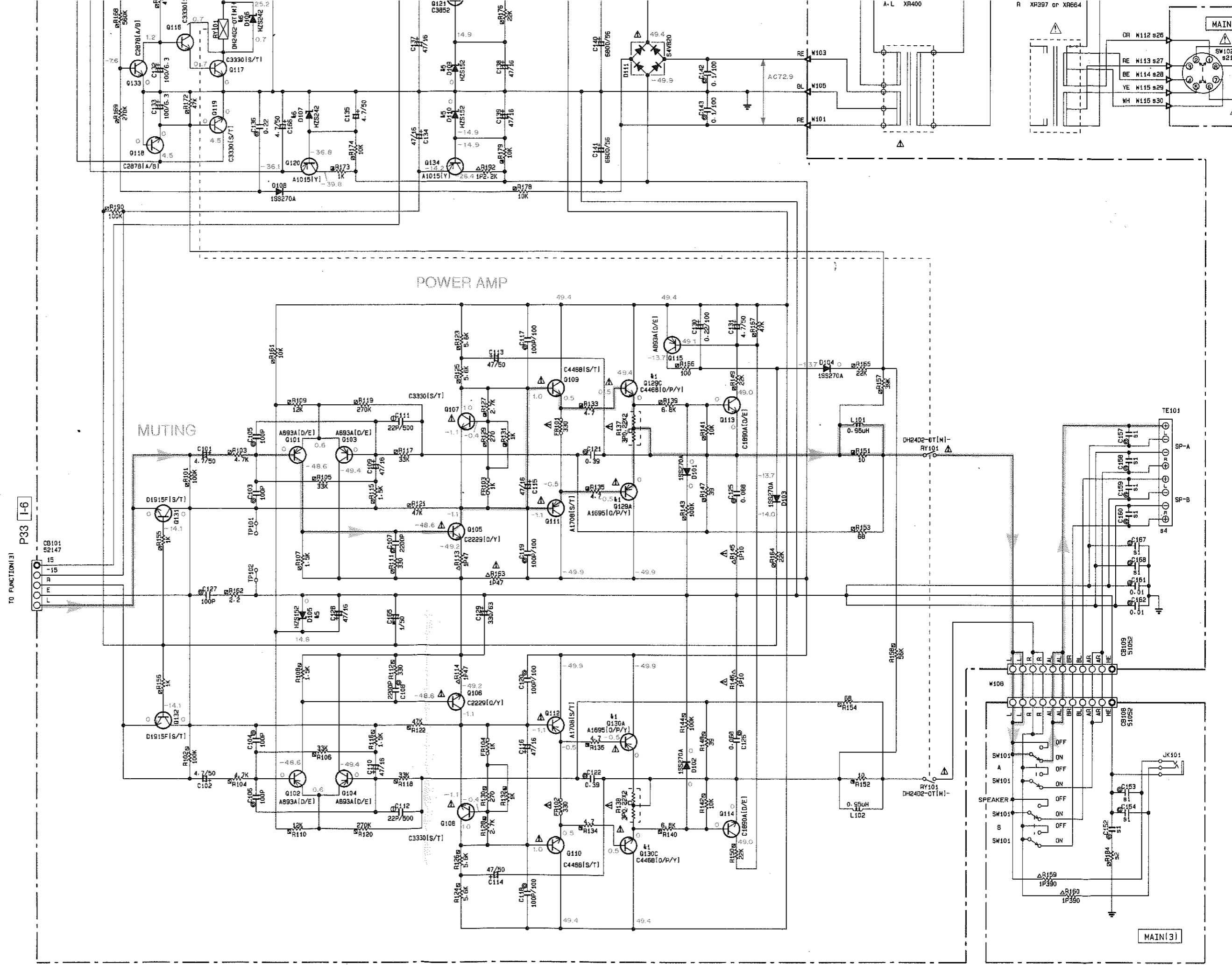

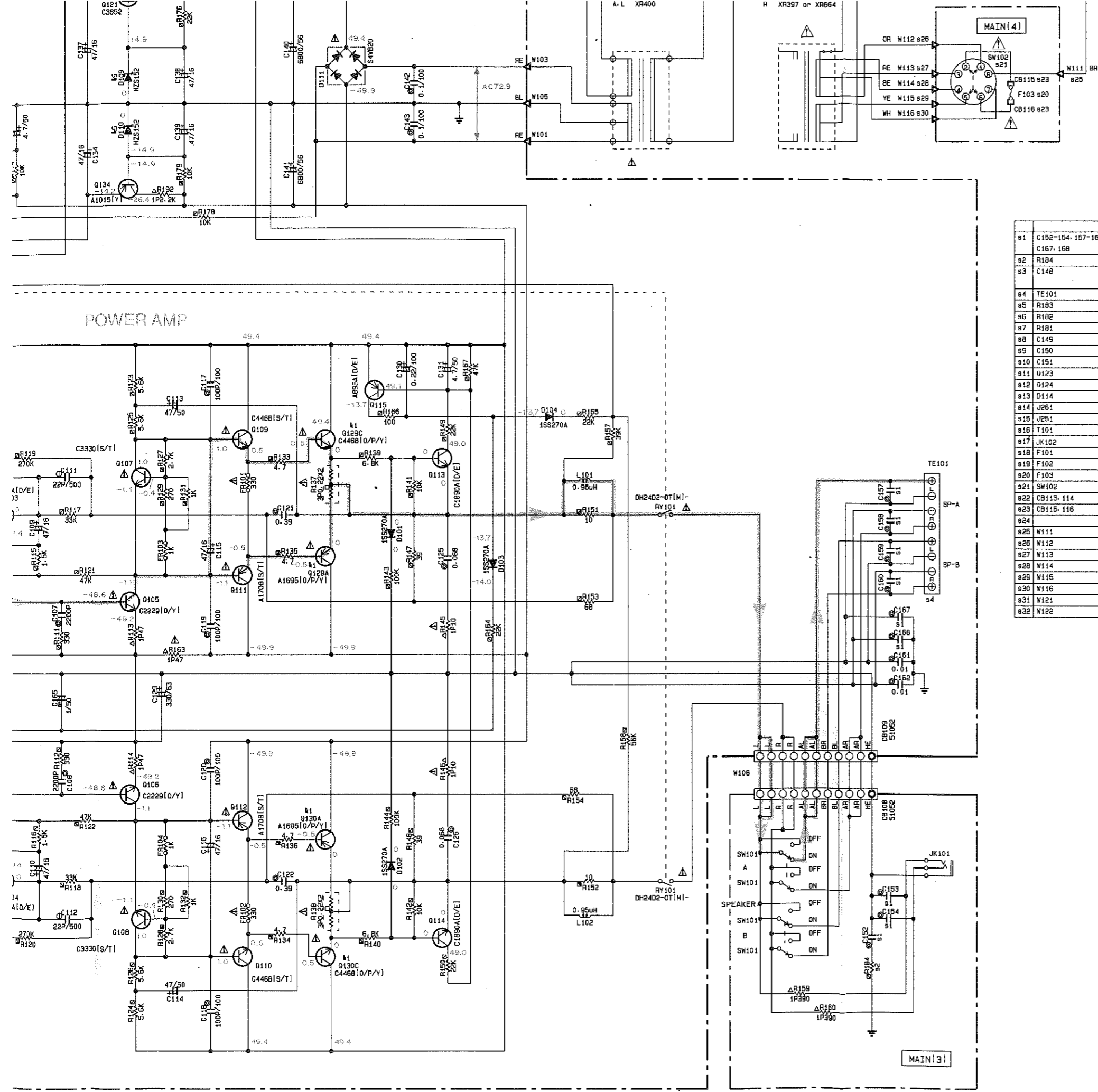

	U.C	R	A	L
81	C152-154, 157-160 C167, 168	X	X	0.01 0.01
82	R104	X	X	2.2 2.2
83	C148	0.01	0.01	0.01 0.01
84	TE101	VC31370	VC31370	VK50620 VK50620
85	R103	1/2P2.2W	X	X
86	R102	X	18K	X
87	R101	X	100	X
88	C149	330/25	330/25	330/25
89	C150	X	100/15	X
90	C151	X	10/18	X
91	O123	X	C446510/P/Y	X
92	O124	X	C1890A1D/E	X
93	D114	X	MTZJ12C	X
94	J261	0	X	0
95	J251	0	0	X
96	T101	XC083	XC082	XC084 XC084
97	JK102	VK48050	VK48050	X VK48070
98	F101	5A125V	5A125V	T1.6AL250V T1.6AL250V
99	F102	X	X	X T2.5AL250V
100	F103	X	T1.6AL250V	X
101	SW102	X	VA95180	X
102	CB113, 114	X	X	X VP20550
103	CB115, 116	X	VP20550	X
104				
105	W111	X	MH01018	X
106	W112	X	MH03220	X
107	W113	X	MH02220	X
108	W114	X	MH06220	X
109	W115	X	MH04220	X
110	W116	X	MH09220	X
111	W121	X	X	MH09118 X
112	W122	X	X	MH08118 X

Interchangeable Parts at Manufacture-Stage

Mark	Reference Parts Number	Parts Name
11	Q129A/C, Q130A/C	A1695/C446810/P/Y [VR36990]
		A1633/C42781D/E/F [VT94050]
12	O112	HSS104 1SS133 1SS176
13	O121	2SC3852 2SC4495
14	RY102	SDT-SS-1120M G5P-1-DC12V
15	O105, 109, 110	HZS152 MTZJ15C
16	O106, 107	HZS242 MTZJ24D

* All voltage are measured with a 10MΩ/DC electric volt meter.
 * Components having special characteristics are marked Δ and must be replaced with parts having specifications equal to those originally installed.
 * Schematic diagram is subject to change without notice.

RX-495RDS SCHEMATIC DIAGRAM (TUNER)

Each voltage given here represents that in the FM (98.1MHz, STEREO) reception mode but the one in the parentheses () is that in the AM (1080kHz, MAN'L) reception mode.

PK1 : ENV-1729

CAPACITOR		
REMARKS	PARTS NAME	SYMBOL
NO MARK	ELECTROLYTIC CAPACITOR	Π
⊗	TANTALUM CAPACITOR	Π
NO MARK	CERAMIC CAPACITOR	Π
⊙	CERAMIC TUBULAR CAPACITOR	Π
⊕	POLYESTER FILM CAPACITOR	Π
○	POLYSTYRENE FILM CAPACITOR	Π
⊖	MICA CAPACITOR	Π
⊙	POLYPROPYLENE FILM CAPACITOR	Π
⊙	SEMICONDUCTIVE CERAMIC CAPACITOR	Π

RESISTOR		
REMARKS	PARTS NAME	SYMBOL
NO MARK	CARBON FILM RESISTOR (P=5)	\square
⊠	CARBON FILM RESISTOR (P=10)	\square
⊡	METAL OXIDE FILM RESISTOR	\square
⊠	METAL FILM RESISTOR	\square
⊠	METAL PLATE RESISTOR	\square
⊠	FIRE PROOF CARBON FILM RESISTOR	\square
⊠	CEMENT MOLDED RESISTOR	\square
⊠	SEMI VARIABLE RESISTOR	\square
⊠	CHIP RESISTOR	\square

NOTICE
 (J)..... Japanese model
 (U)..... U.S.A model
 (C)..... Canadian model
 (A)..... Australian model
 (G)..... European model
 (B)..... British model
 (R)..... General model
 (P)..... RP model

Mode	Freq	Volt
FM	87.5MHz	1.7V
FM	98.1MHz	4.1V
FM	108.0kHz	8.3V
FM	99.1MHz	1.8V
AM	1080kHz	4.9V
AM	1611kHz	7.4V

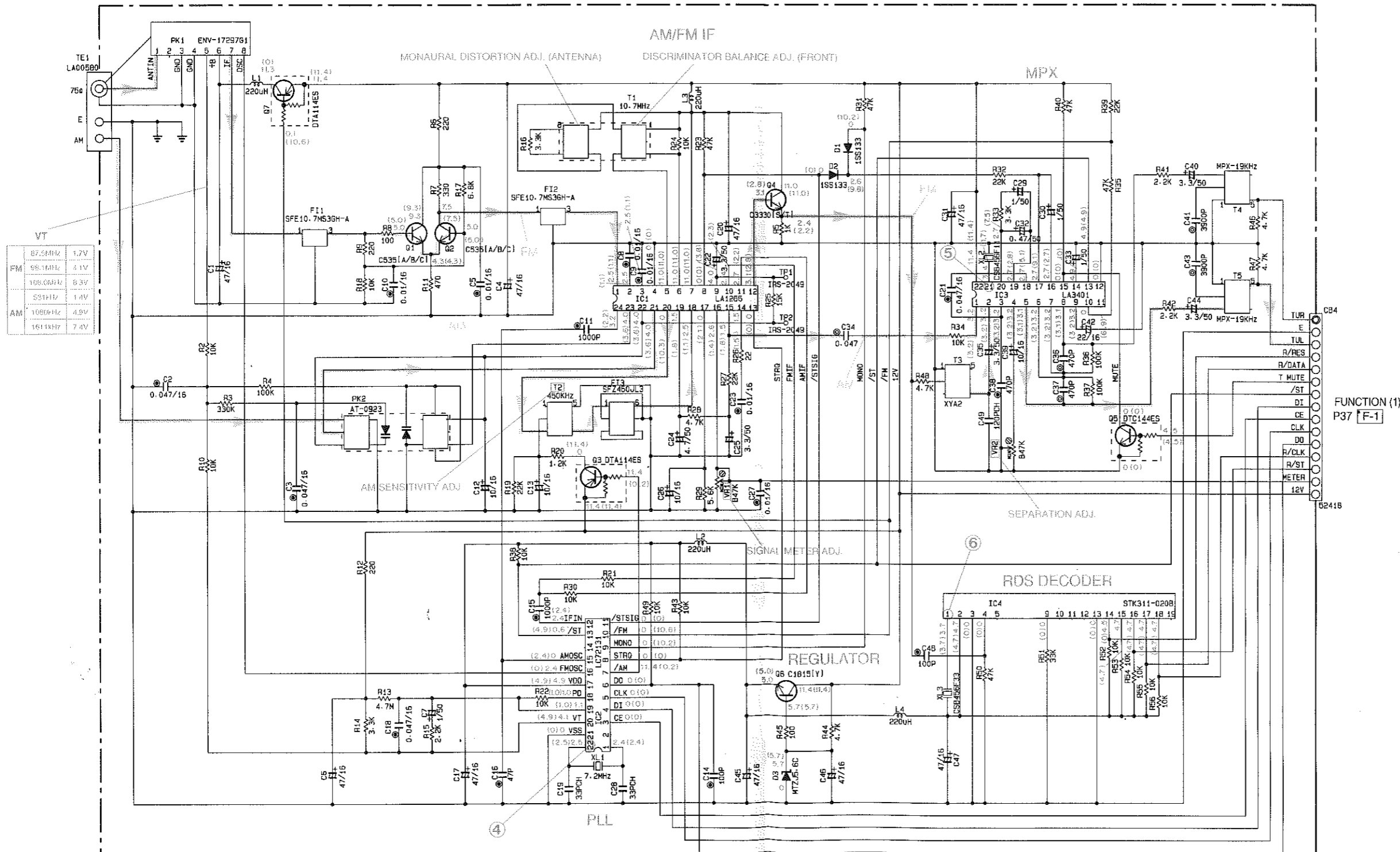
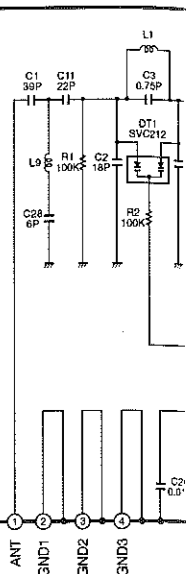

IC4 : STK311-020B
RDS Decoder & Controller

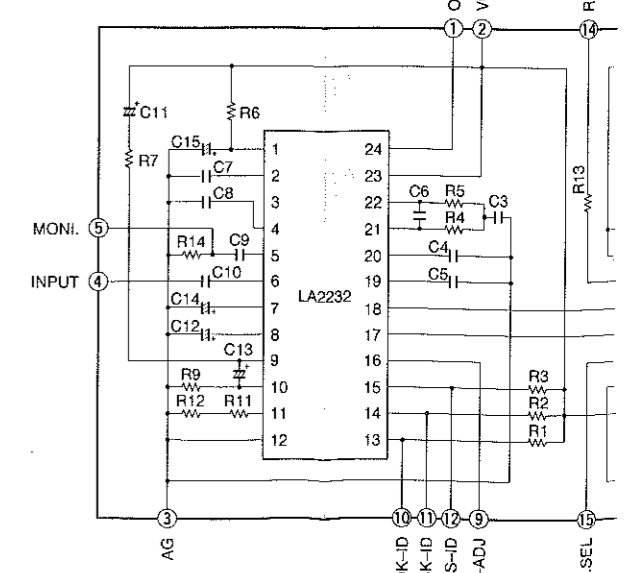

Each voltage given here represents that in the FM (98.1MHz, STEREO) reception mode but the one in the parentheses () is that in the AM (1080kHz, MAN'L) reception mode.

NAME	
RESISTOR (P=5)	
RESISTOR (P=10)	
ILM RESISTOR	
RESISTOR	
RESISTOR	
RESISTOR	
RESISTOR	
RESISTOR	
RESISTOR	
RESISTOR	
RESISTOR	

NOTICE
 (J)..... Japanese model
 (U)..... U.S.A model
 (C)..... Canadian model
 (A)..... Australian model
 (G)..... European model
 (B)..... British model
 (R)..... General model
 (P)..... AP model

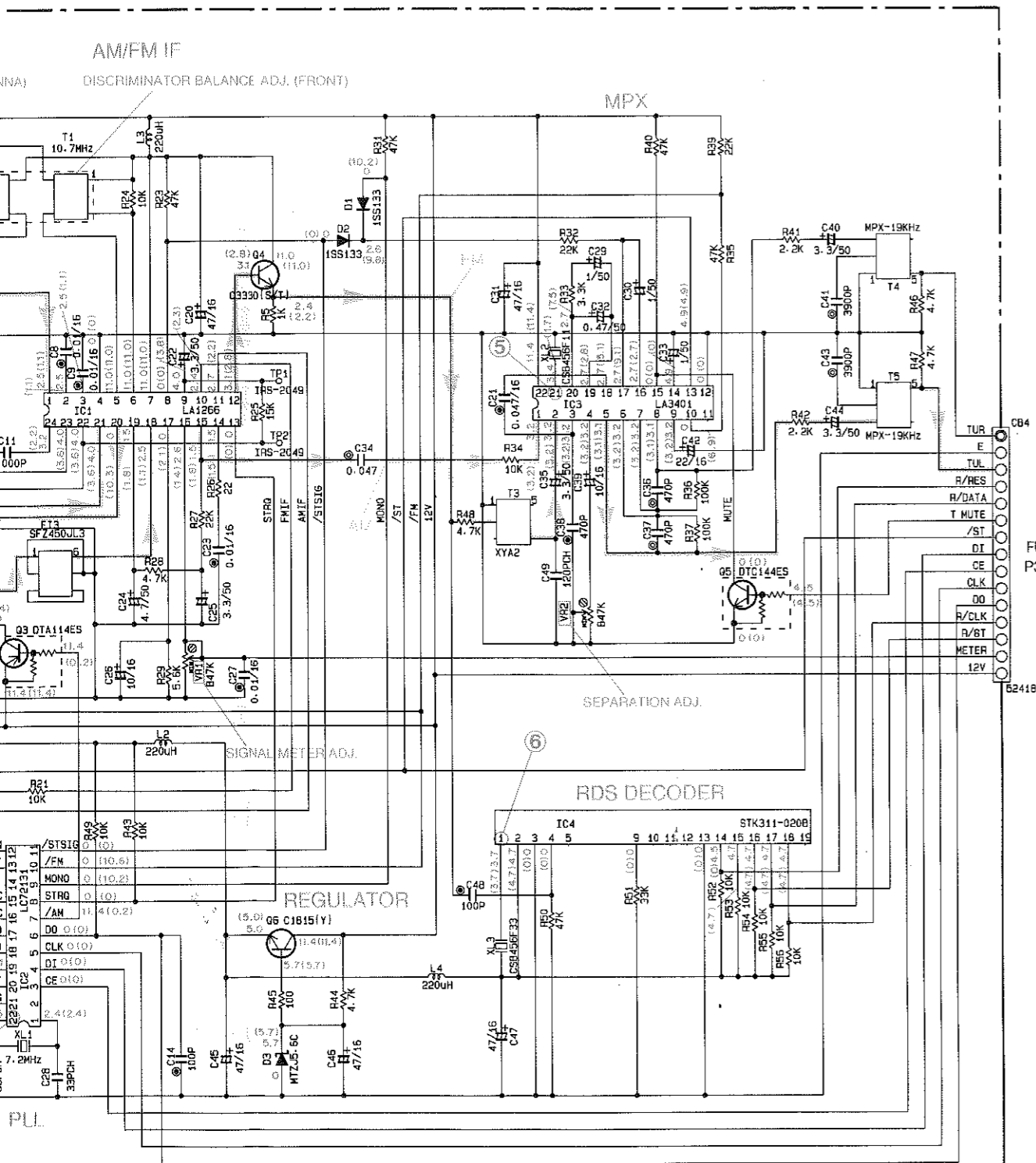

PK1 : ENV-17297GI (VQ987600)

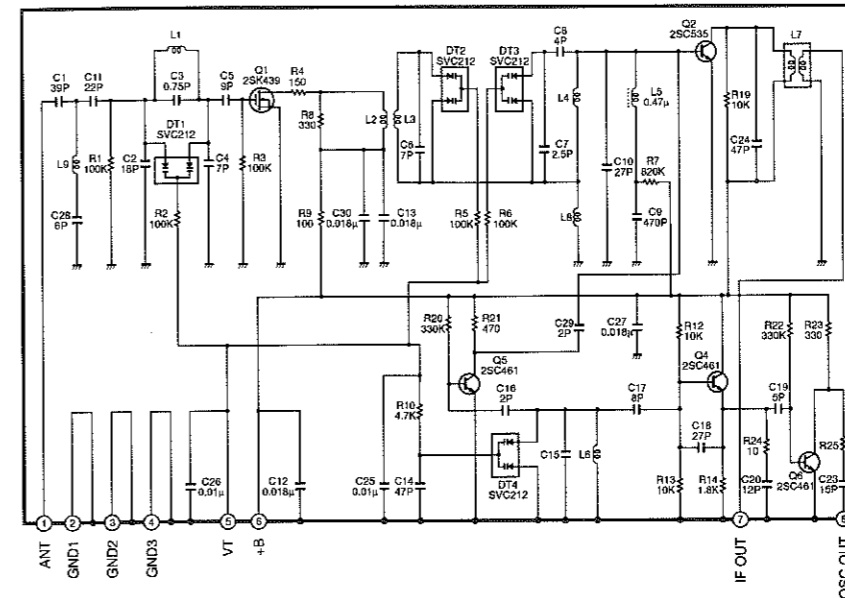

Point ④
 (Pin 22 of IC2)
 V: 2V/div H: 50nsec/div
 DC range 1:1 probe

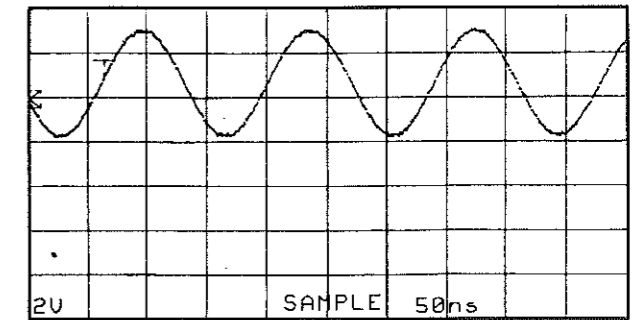

Point ⑤
 (Pin 21 of IC3)
 V: 2V/div H: 1μsec/div
 DC range 1:1 probe

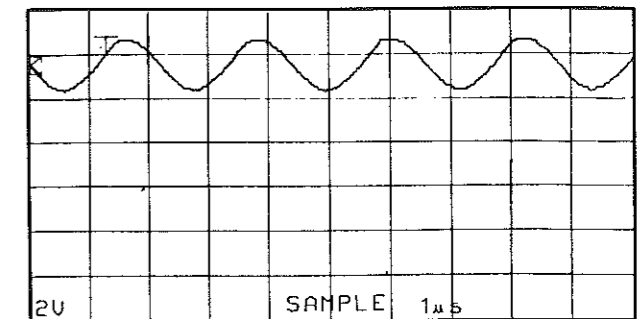

IC4 : STK311-020B
 RDS Decoder & Controller

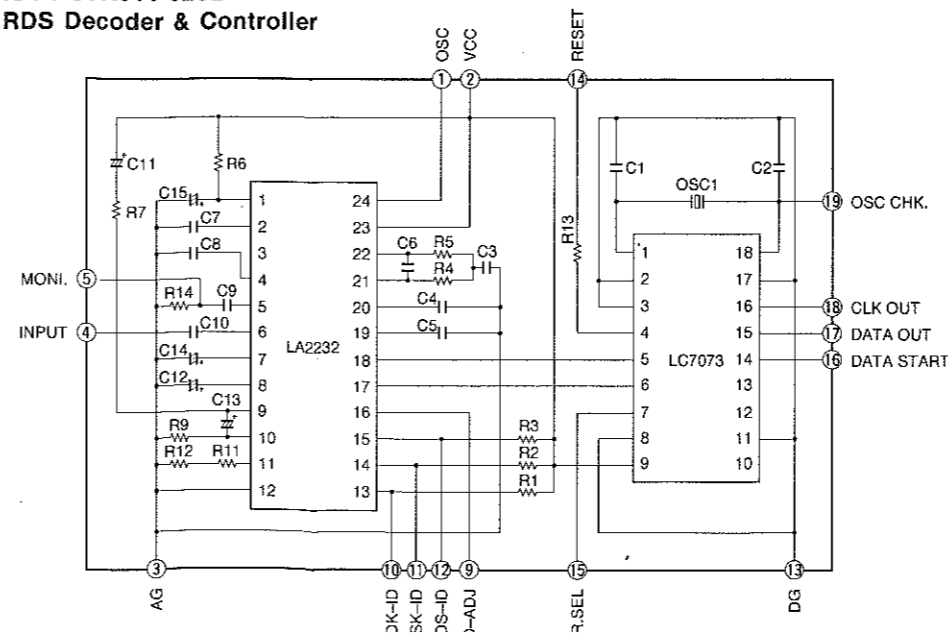

Point ⑥
 (Pin 1 of IC4)
 V: 2V/div H: 1μsec/div
 DC range 1:1 probe

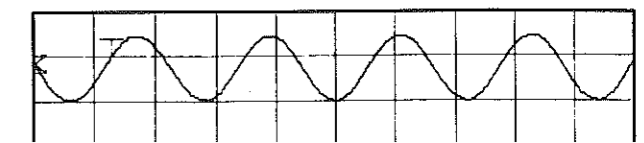

3

4

5

6

7

8

VT		
FM	87.5MHz	1.7V
FM	95.1MHz	4.1V
FM	108.3MHz	8.3V
FM	53.1MHz	1.4V
AM	108.6MHz	4.9V
AM	161.1MHz	7.4V

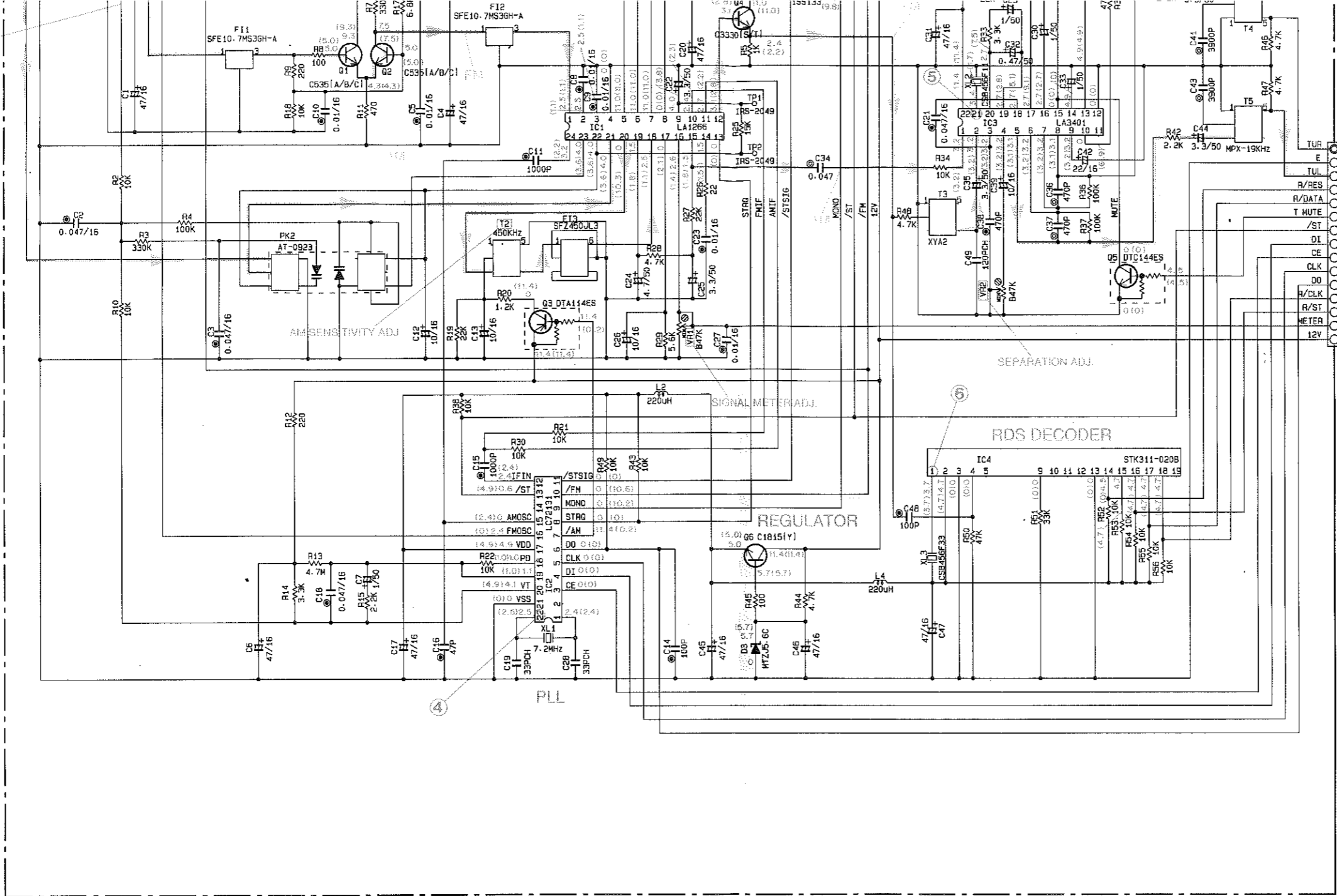

FUNCTION (1)
P37 F-1

IC4 : STK311-020B
RDS Decoder & Controller

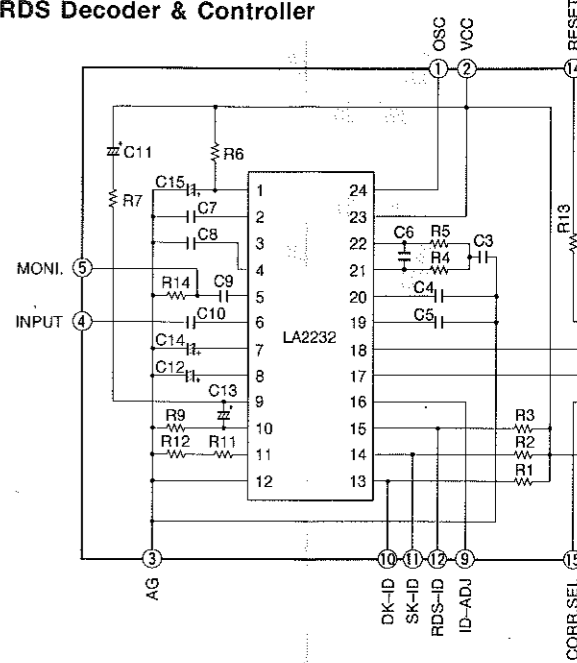

IC1 : LA1266
AM/FM IF

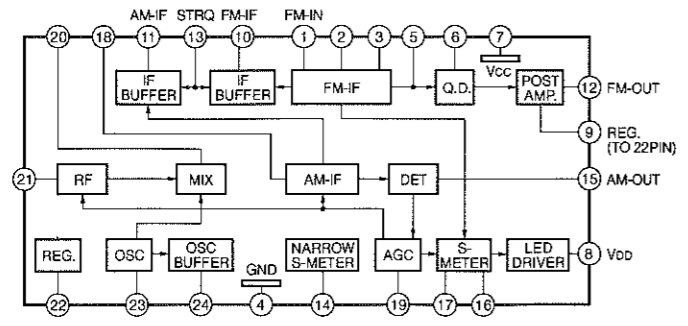

IC2 : LC72131
PLL Controller

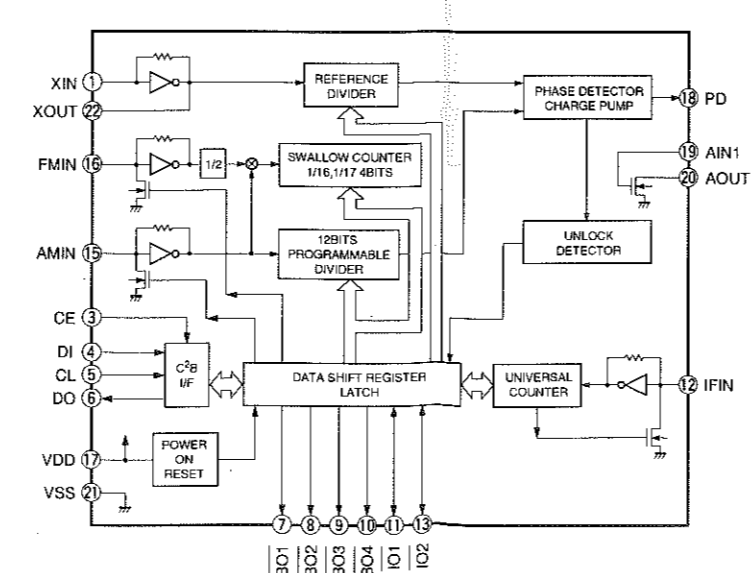

IC3 : LA3401
MPX

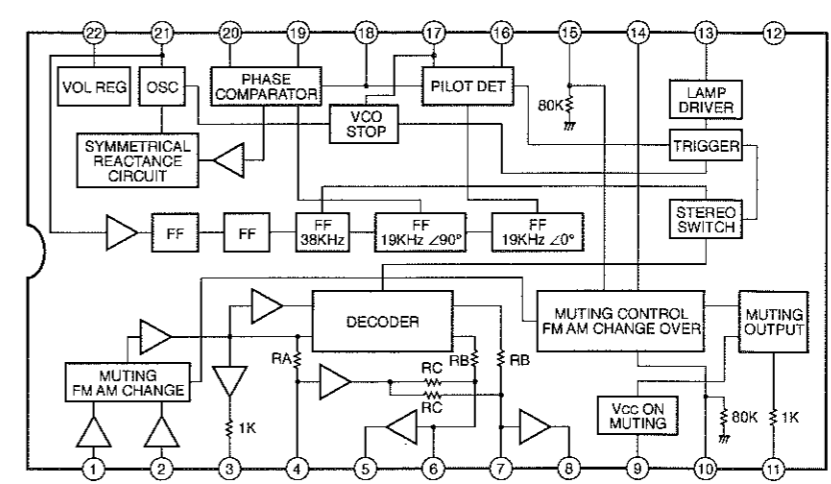

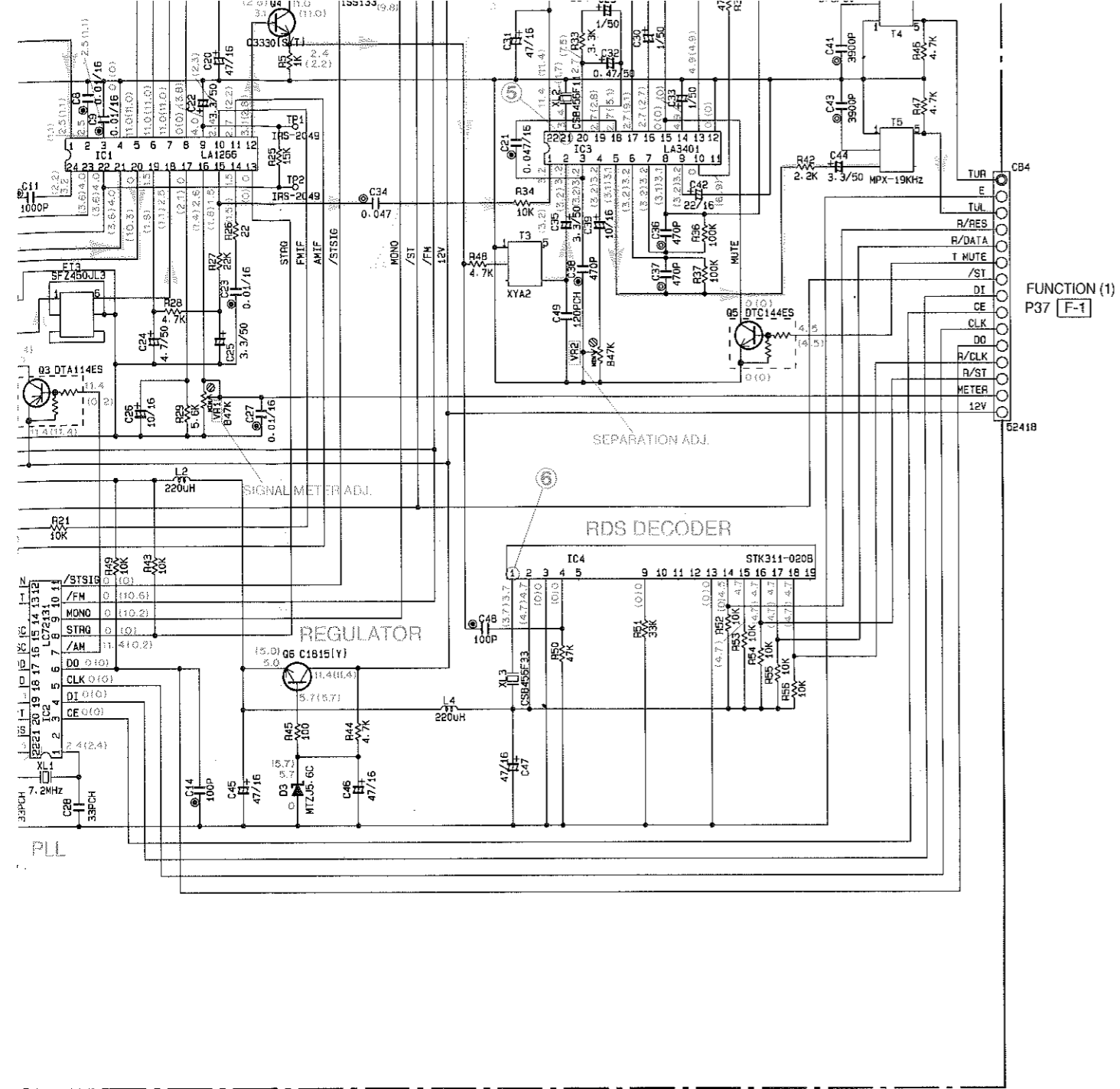

IC4 : STK311-020B
RDS Decoder & Controller

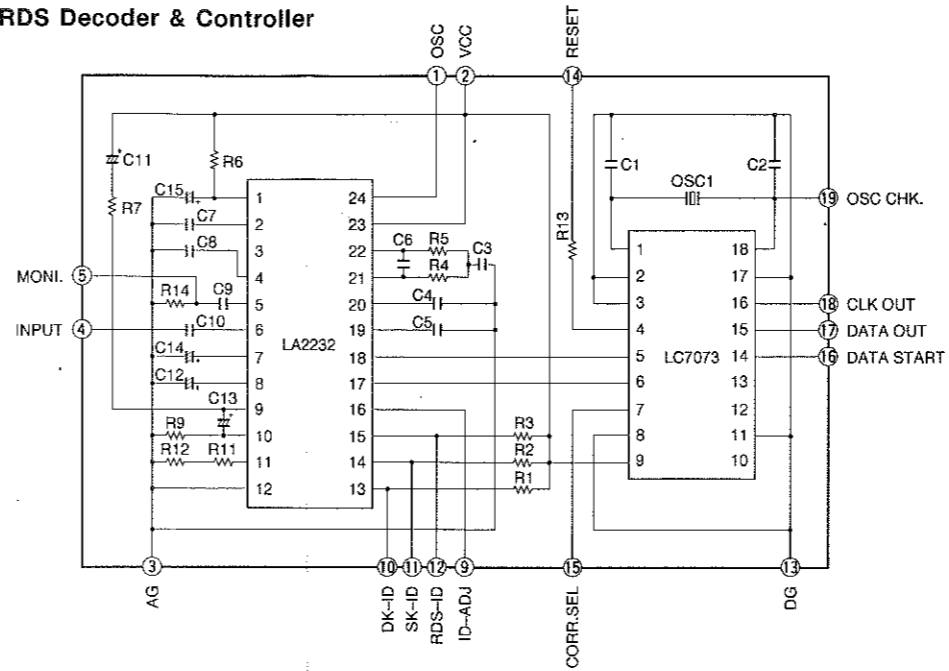

Point ④
(Pin 22 of IC2)
V: 2V/div H: 50nsec/div
DC range 1:1 probe

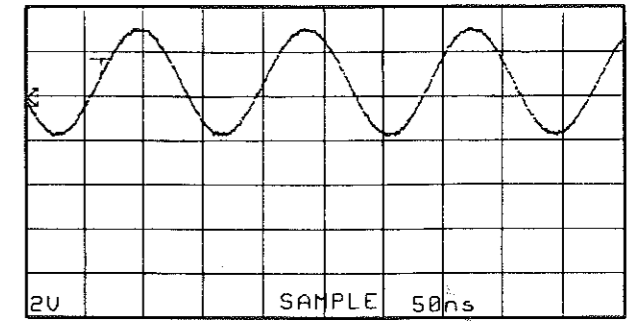

Point ⑤
(Pin 21 of IC3)
V: 2V/div H: 1μsec/div
DC range 1:1 probe

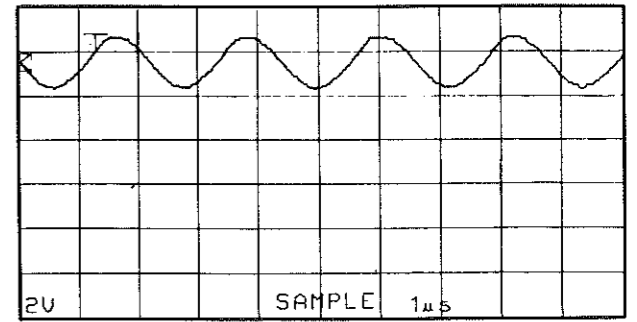

Point ⑥
(Pin 1 of IC4)
V: 2V/div H: 1μsec/div
DC range 1:1 probe

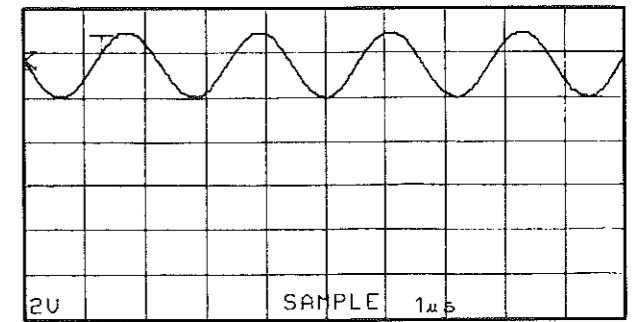

C72131
ontroller

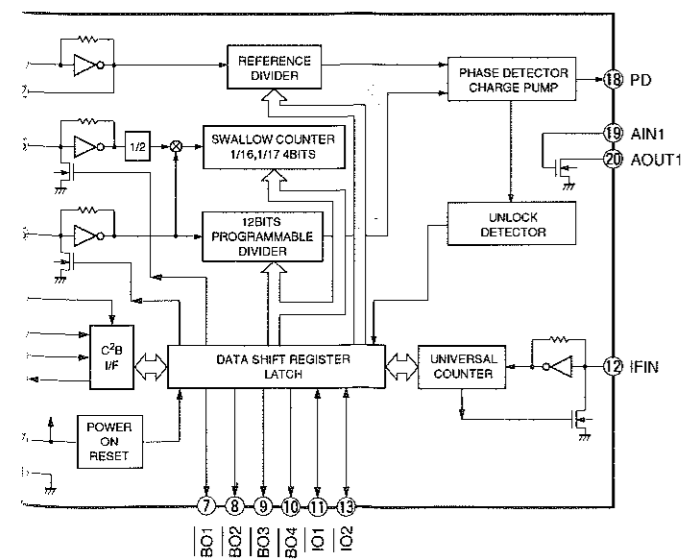

IC3 : LA3401
MPX

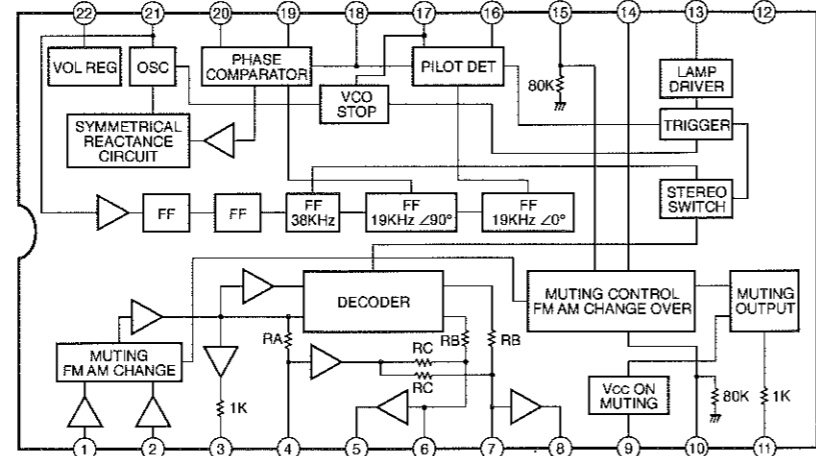

* All voltage are measured with a 10MΩ/DC electric volt meter.
* Components having special characteristics are marked Δ and must be replaced with parts having specifications equal to those originally installed.
* Schematic diagram is subject to change without notice.

RX-495RDS SCHEMATIC DIAGRAM (FUNCTION)

P36 G-4

TO TUNER

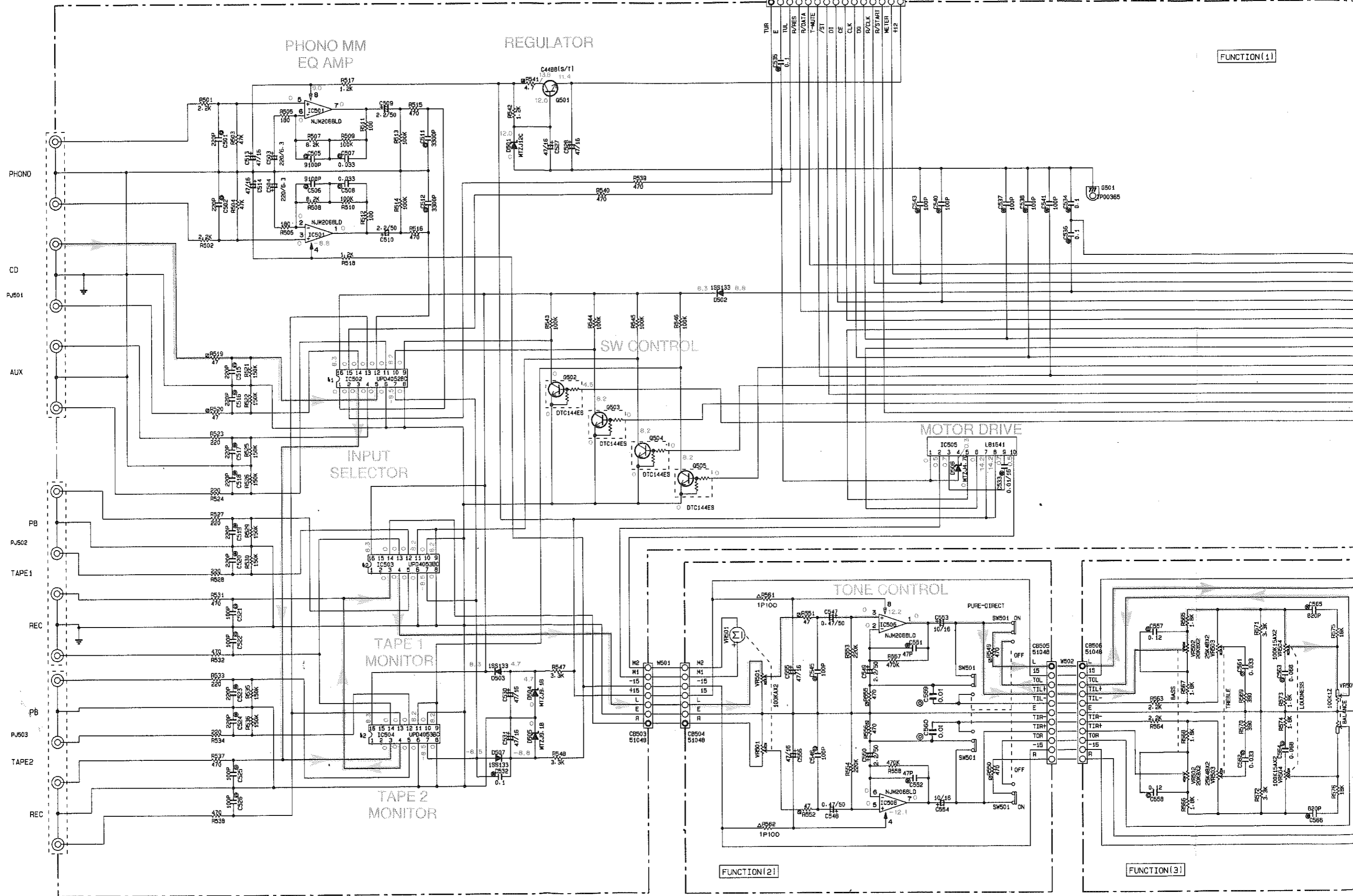

FUNCTION(1)

FUNCTION(2)

FUNCTION(3)

REGULATOR

FUNCTION (1)

RESISTOR

REMARKS	PARTS NAME
NO MARK	CARBON FILM RESISTOR (P=5)
⊗	CARBON FILM RESISTOR (P=10)
△	METAL OXIDE FILM RESISTOR
▲	METAL FILM RESISTOR
⊠	METAL PLATE RESISTOR
⊞	FIRE PROOF CARBON FILM RESISTOR
□	CEMENT MOLDED RESISTOR
⊕	SEMI VARIABLE RESISTOR
■	CHIP RESISTOR

CAPACITOR

REMARKS	PARTS NAME
NO MARK	ELECTROLYTIC CAPACITOR
⊗	TANTALUM CAPACITOR
NO MARK	CERAMIC CAPACITOR
⊙	CERAMIC TUBULAR CAPACITOR
⊖	POLYESTER FILM CAPACITOR
○	POLYSTYRENE FILM CAPACITOR
⊕	MICA CAPACITOR
⊖	POLYPROPYLENE FILM CAPACITOR
●	SEMICONDUCTIVE CERAMIC CAPACITOR

Interchangeable Parts at Manufacture-Stage

Mark	Reference Parts Number	Parts Name
#1	IC502	UPD4052BC TC4052BP
#2	IC503.504	UPD4053BC TC4053BP

P36 G-4

TO TUNER

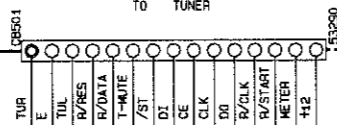

TO OPERATION(1)

P38 B-5

MAIN(1)
P39 B-6

SW CONTROL

MOTOR DRIVE

TONE CONTROL

FUNCTION (2)

FUNCTION (3)

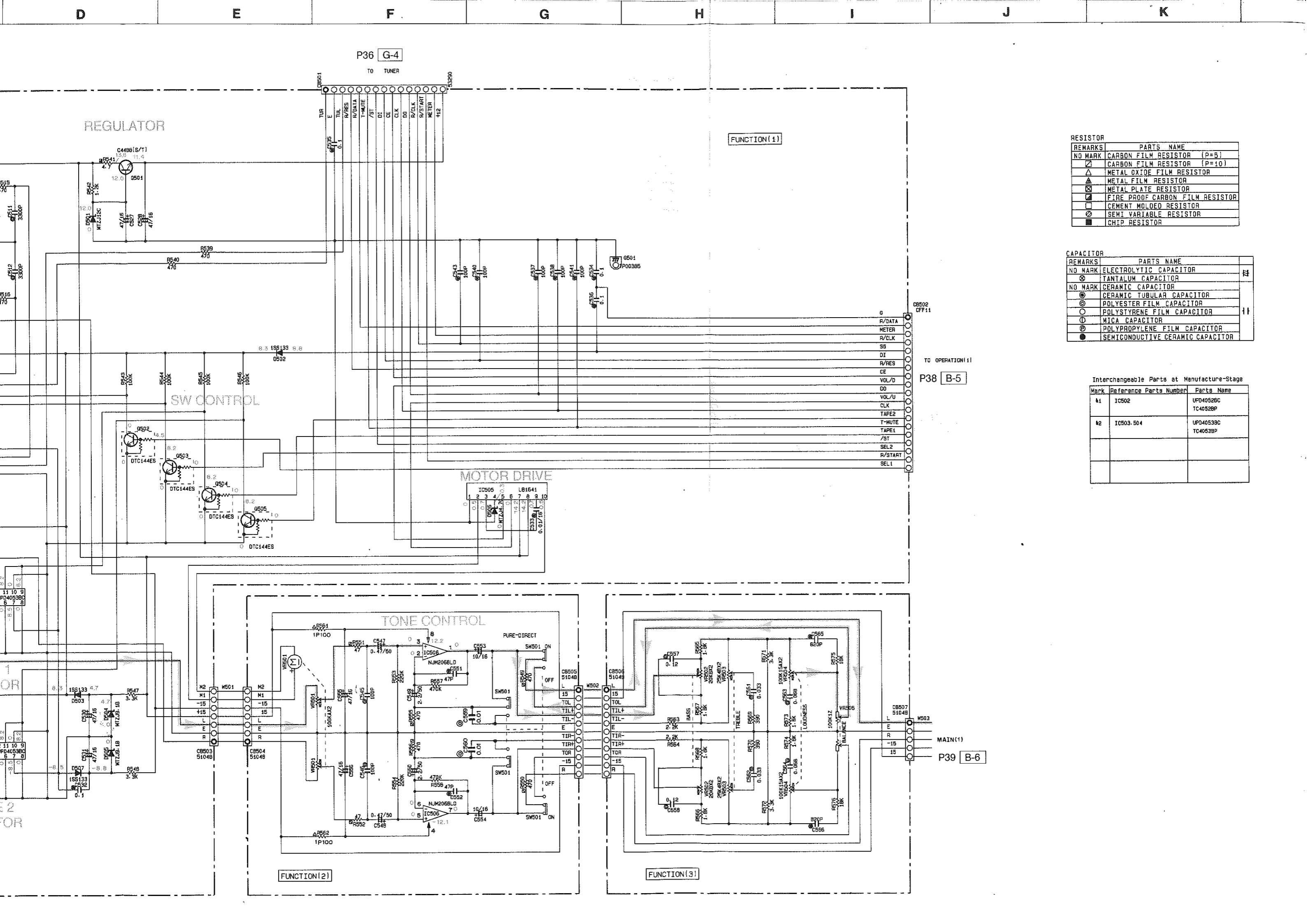

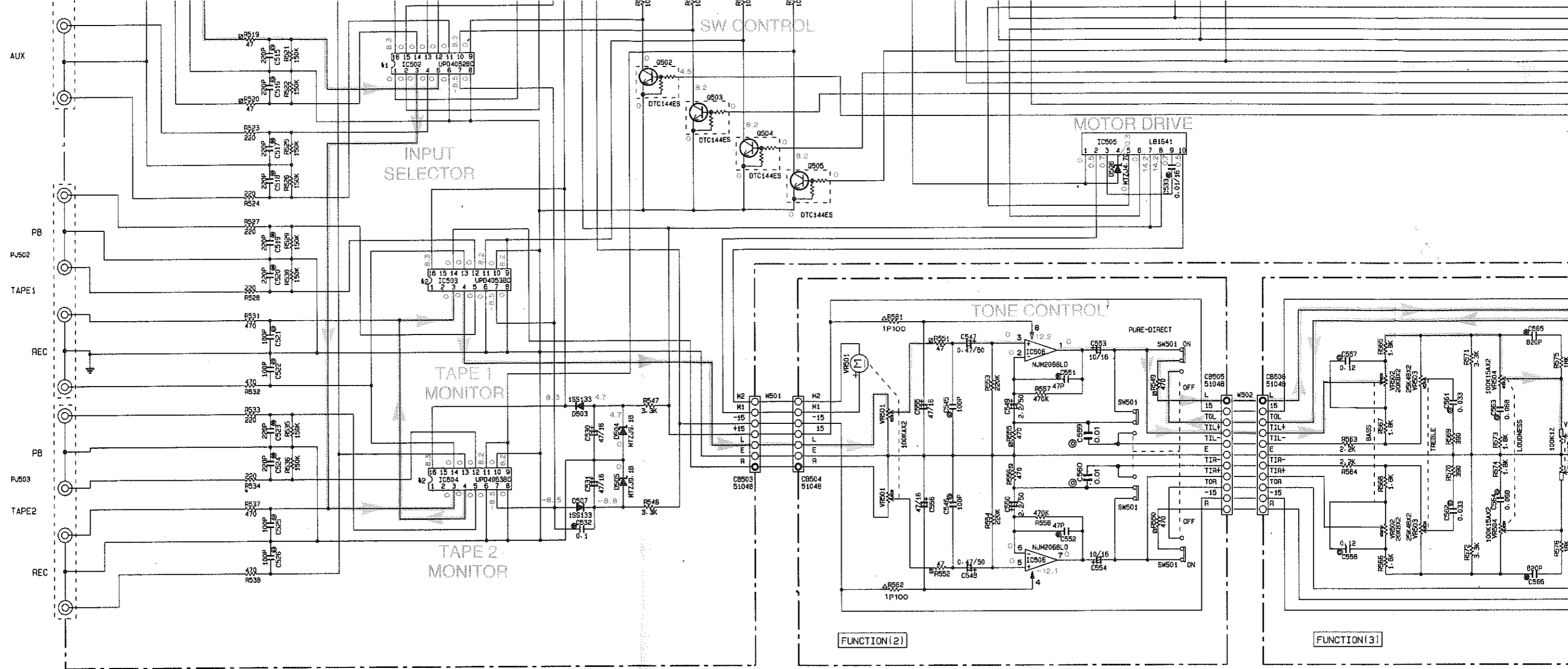

IC501, 506 : NJM2068L-D
Dual OP-Amp

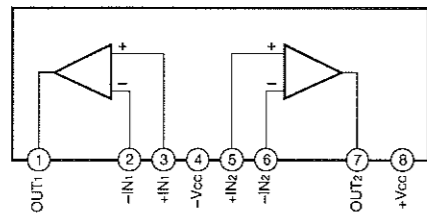

IC502 : μ PD4052BC
Dual 4 Channel Analog Multiplexers/Demultiplexers

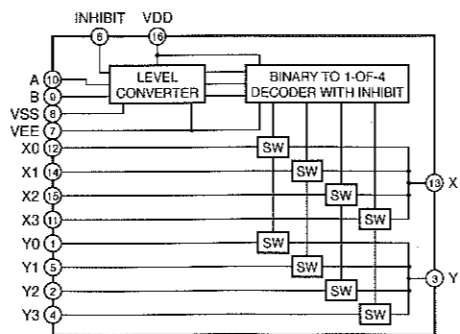

INHIBIT	B	A	
0	0	0	0x, 0y
0	0	1	1x, 1y
0	1	0	2x, 2y
0	1	1	3x, 3y
1	X	X	NONE

IC503, 504 : μ PD4053BC
Triple 2-Channel Multiplexer/Demultiplexer

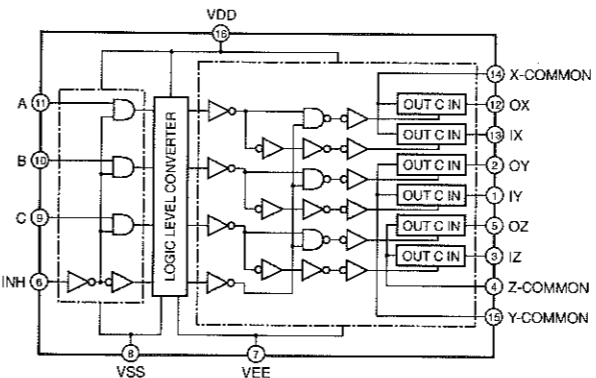

CONTROL INPUTS				'ON' CHANNEL		
INHIBIT (Pin 6)	C (Pin 9)	B (Pin 10)	A (Pin 11)	0X (Pin 12), 0Y (Pin 2), 0Z (Pin 5)	1X (Pin 13), 1Y (Pin 1), 1Z (Pin 3)	
L	L	L	L	0X, 0Y, 0Z		
L	L	L	H	1X, 0Y, 0Z		
L	L	H	L	0X, 1Y, 0Z		
L	L	H	H	1X, 1Y, 0Z		
L	H	L	L	0X, 0Y, 1Z		
L	H	L	H	1X, 0Y, 1Z		
L	H	H	L	0X, 1Y, 1Z		
L	H	H	H	1X, 1Y, 1Z		
H	.	.	.	NOTE		

* Don't Care

IC505 : LB1641
Motor Driver

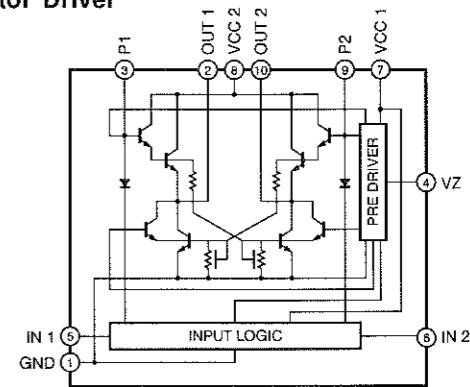

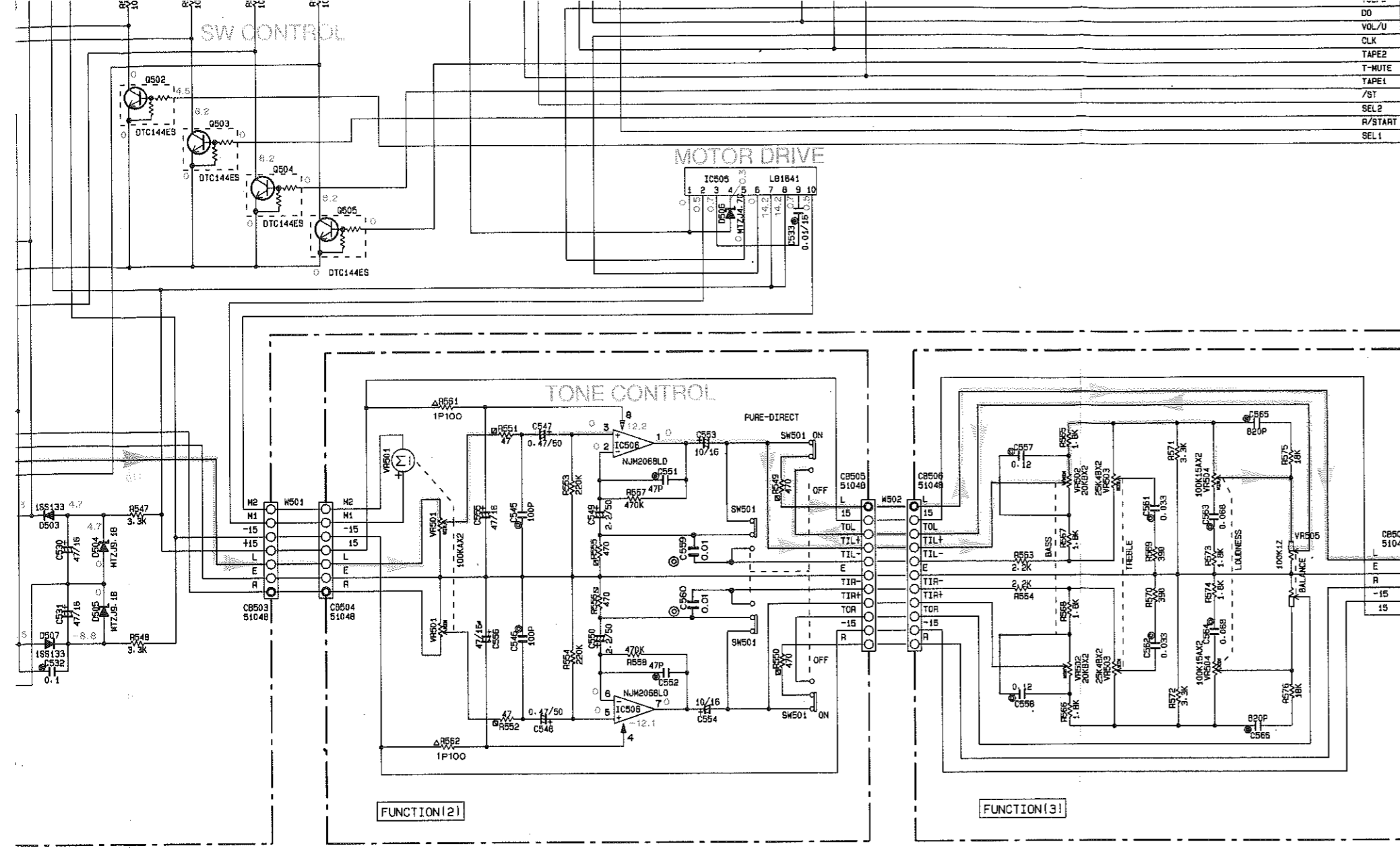

Mark	Reference Parts Number	Parts Name
*1	IC502	UPD4052BC TC4052BP
*2	IC503, 504	UPD4053BC TC4053BP

IC503, 504 : μ PD4053BC
Triple 2-Channel Multiplexer/Demultiplexer

IC505 : LB1641
Motor Driver

Multiplexers/Demultiplexers

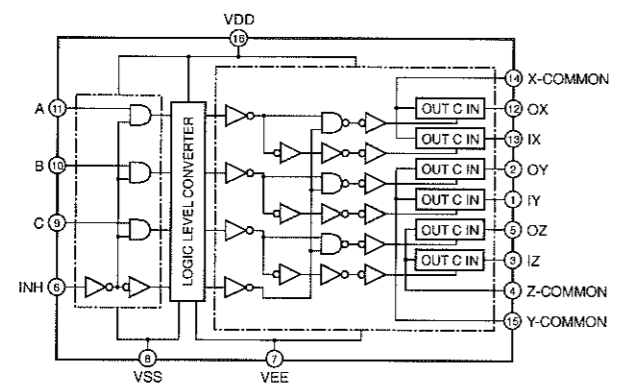
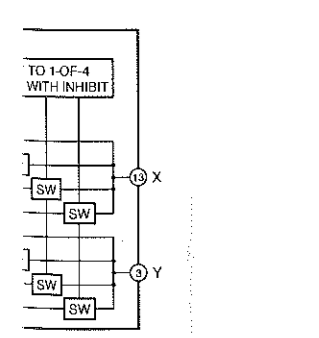

CONTROL INPUTS				"ON" CHANNEL
INHIBIT (Pin 6)	C (Pin 9)	B (Pin 10)	A (Pin 11)	0X (Pin 12), 0Y (Pin 2), 0Z (Pin 5) 1X (Pin 13), 1Y (Pin 1), 1Z (Pin 3)
L	L	L	L	0X, 0Y, 0Z
L	L	L	H	1X, 0Y, 0Z
L	L	H	L	0X, 1Y, 0Z
L	L	H	H	1X, 1Y, 0Z
L	H	L	L	0X, 0Y, 1Z
L	H	L	H	1X, 0Y, 1Z
L	H	H	L	0X, 1Y, 1Z
L	H	H	H	1X, 1Y, 1Z
H	.	.	.	NOTE

* Don't Care

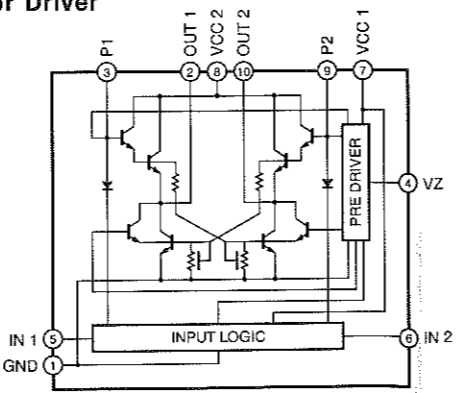

* All voltage are measured with a 10M Ω /DC electric volt meter.
 * Components having special characteristics are marked Δ and must be replaced with parts having specifications equal to those originally installed.
 * Schematic diagram is subject to change without notice.

RX-495RDS SCHEMATIC DIAGRAM (OPERATION)

● V301 : 13-BT-140GK (VT668)

REMARKS	PARTS NAME
NO MARK	CARBON FILM RESISTOR (P=5)
□	CARBON FILM RESISTOR (P=10)
△	METAL OXIDE FILM RESISTOR
▲	METAL FILM RESISTOR
▢	METAL PLATE RESISTOR
▣	FIRE PROOF CARBON FILM RESISTOR
◻	CEMENT MOLDED RESISTOR
⊗	SEMI VARIABLE RESISTOR
■	CHIP RESISTOR

REMARKS	PARTS NAME
NO MARK	ELECTROLYTIC CAPACITOR
⊗	TANTALUM CAPACITOR
NO MARK	CERAMIC CAPACITOR
⊙	CERAMIC TUBULAR CAPACITOR
○	POLYESTER FILM CAPACITOR
○	POLYSTYRENE FILM CAPACITOR
⊖	NICA CAPACITOR
⊕	POLYPROPYLENE FILM CAPACITOR
●	SEMICONDUCTIVE CERAMIC CAPACITOR

Interchangeable Parts at Manufacture-Stage

Mark	Reference Parts Number	Parts Name
k1		
k2	D301	HZS982 WTZJ4-7C
k3	D305	HZS9C2 WTZJ5-1B
k4	D302	HZS9C2 WTZJ6-2B
k5	D309	SLR-305VCA47 SLR-325VCT31

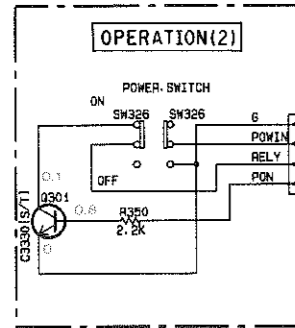

TO FUNCTION(1)
P37 I-3

TO MAIN(1)
P39 B-2

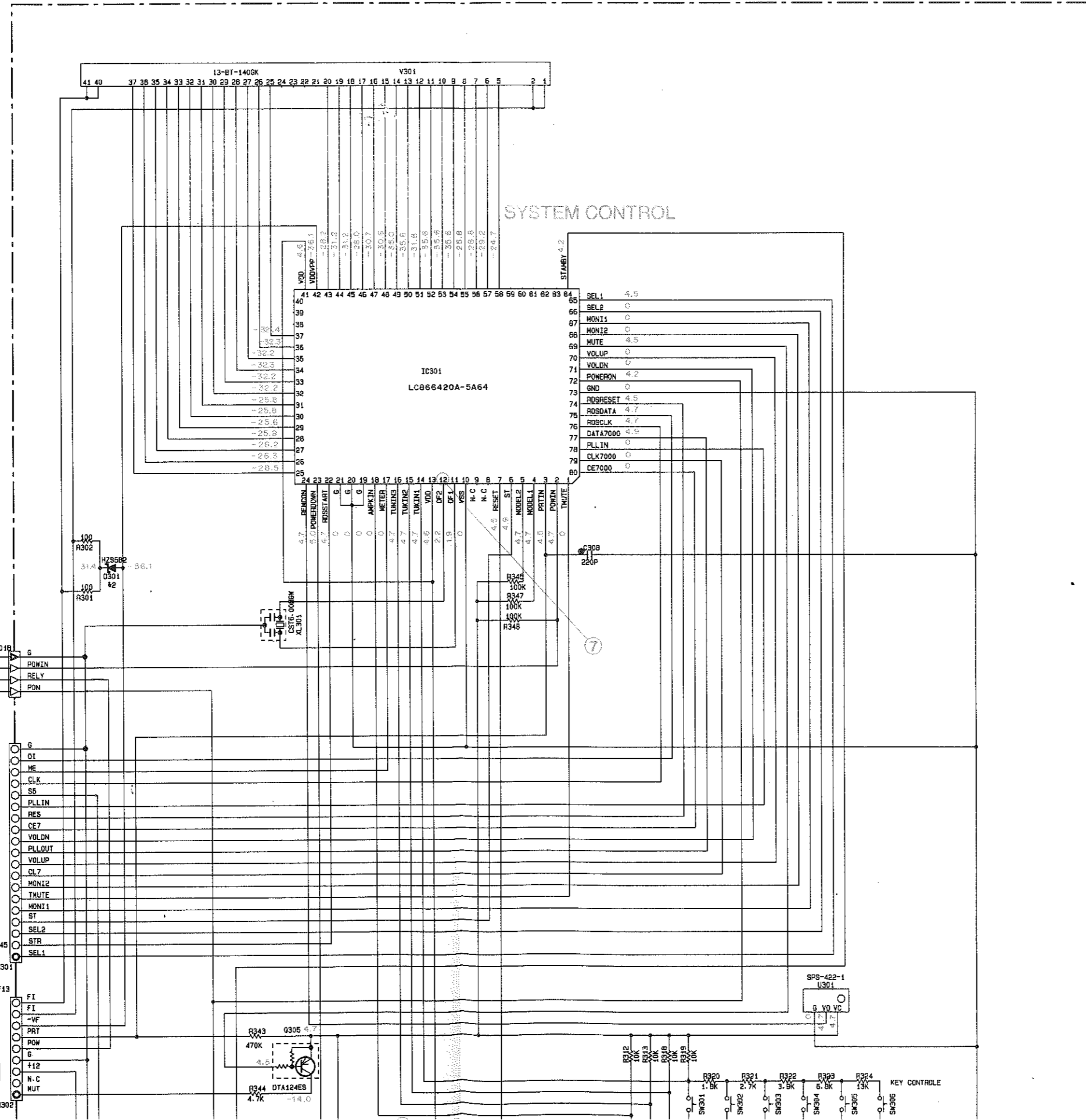

PIN CONNECTION

PIN NO.	1	2	3
CONNECTION	F1	F1	N1

PIN NO.	22	23	24
CONNECTION	NX	NX	N1

NOTE 1)
2)
3)

GRID ASSIGNMENT



ANODE CONNECTION

	13G	12G	11G
P1	SPORT	a	a
P2	AFFAIRS	b	b
P3	INFO	c	c
P4	NEWS	d	d
P5	EON	e	e
P6	PTY HOLD	f	f
P7	CT	g	g
P8	□ (CT)	h	h
P9	RT	j	j
P10	□ (RT)	k	k
P11	PTY	m	m
P12	□ (PTY)	n	n
P13	PS	p	p
P14	□ (PS)	r	r
P15	MEMO	t, u	t, u
P16	—	—	—

Point ⑦
(Pin 12 of IC301)
V: 2V/div H: 50nsec/div

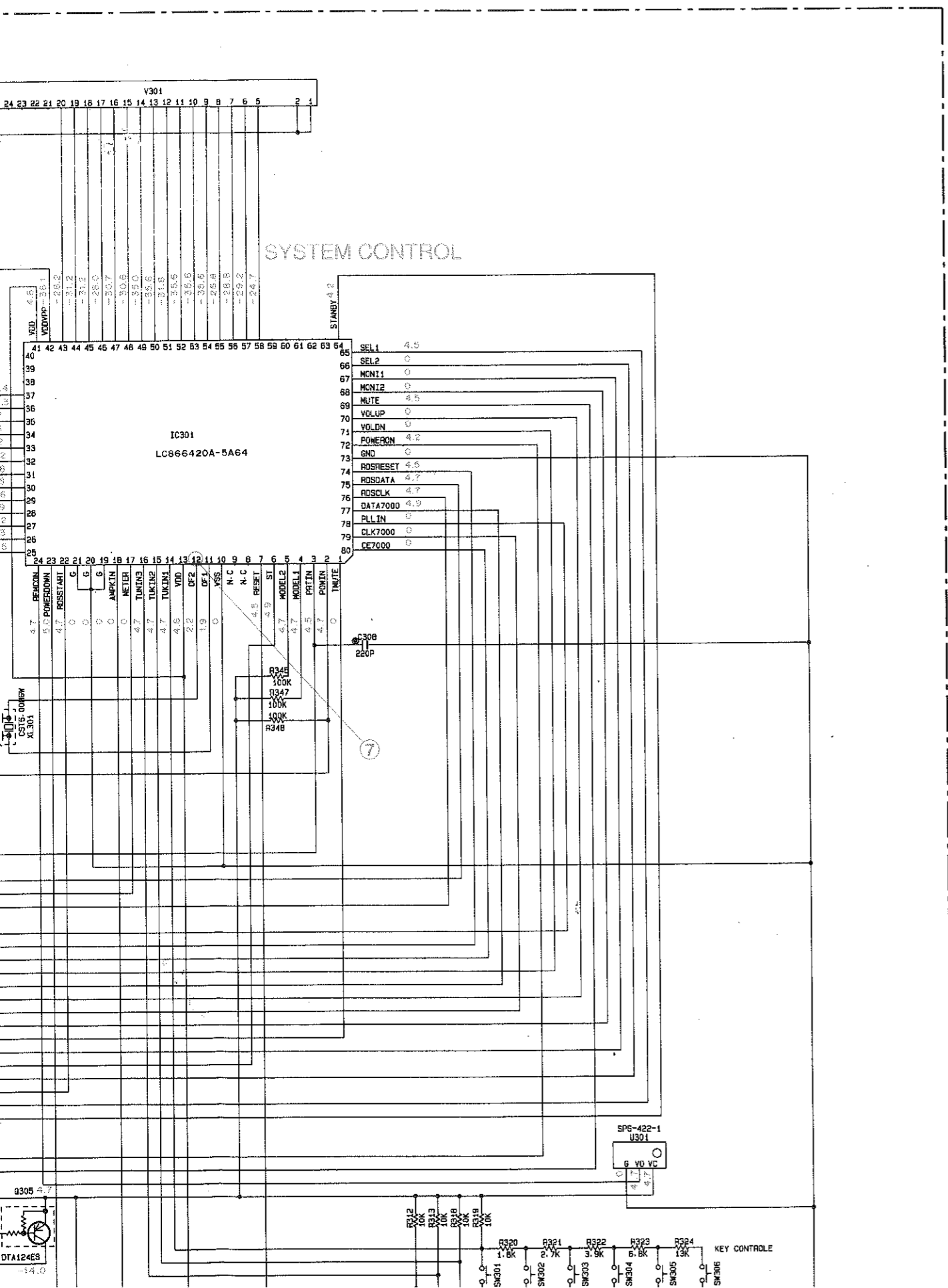

● V301 : 13-BT-140GK (VT668600)

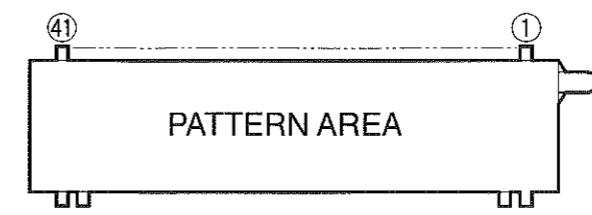

• PIN CONNECTION

PIN NO.	1	2	3	4	5	6	7	8	9	10	11	12	13	14	15	16	17	18	19	20	21
CONNECTION	F1	F1	NP	NP	P16	P15	P14	P13	P12	P11	P10	P9	P8	P7	P6	P5	P4	P3	P2	P1	NX
PIN NO.	22	23	24	25	26	27	28	29	30	31	32	33	34	35	36	37	38	39	40	41	
CONNECTION	NX	NX	NX	1G	2G	3G	4G	5G	6G	7G	8G	9G	10G	11G	12G	13G	NP	NP	F2	F2	

NOTE 1) F1, F2 Filament
 2) NP No pin
 3) NC No connection
 4) NX No extend pin
 5) DL Datum Line
 6) 1G~11G .. Grid

• GRID ASSIGNMENT

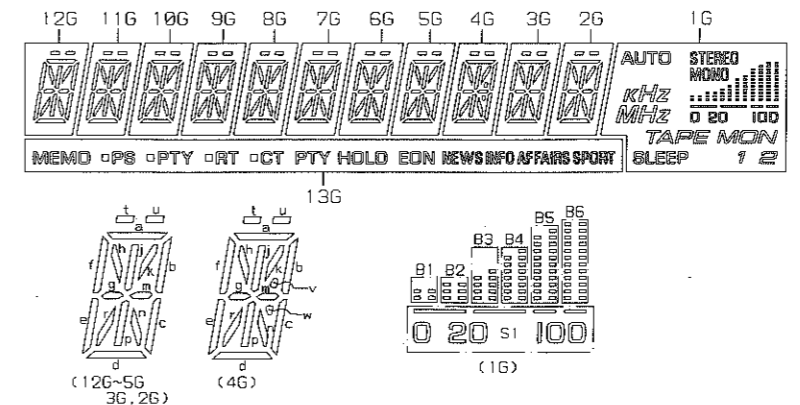

• ANODE CONNECTION

	13G	12G	11G	10G	9G	8G	7G	6G	5G	4G	3G	2G	1G
P1	SPORT	a	a	a	a	a	a	a	a	a	a	a	AUTO
P2	AFFAIRS	b	b	b	b	b	b	b	b	b	b	b	kHz
P3	INFO	c	c	c	c	c	c	c	c	c	c	c	MHz
P4	NEWS	d	d	d	d	d	d	d	d	d	d	d	STEREO
P5	EON	e	e	e	e	e	e	e	e	e	e	e	MONO
P6	PTY HOLD	f	f	f	f	f	f	f	f	f	f	f	B1
P7	CT	g	g	g	g	g	g	g	g	g	g	g	B2
P8	□ (CT)	h	h	h	h	h	h	h	h	h	h	h	B3
P9	RT	j	j	j	j	j	j	j	j	j	j	j	B4
P10	□ (RT)	k	k	k	k	k	k	k	k	k	k	k	B5
P11	PTY	m	m	m	m	m	m	m	m	m	m	m	B6
P12	□ (PTY)	n	n	n	n	n	n	n	n	n	n	n	S1
P13	PS	p	p	p	p	p	p	p	p	p	p	p	TAPE MON
P14	□ (PS)	r	r	r	r	r	r	r	r	r	r	r	1
P15	MEMO	t, u	t, u	t, u	t, u	t, u	t, u	t, u	t, u	t, u	t, u	t, u	2
P16	—	—	—	—	—	—	—	—	—	v, w	—	—	SLEEP

Point ⑦
 (Pin 12 of IC301)
 V: 2V/div H: 50nsec/div

Point ⑧
 (CH 1 : Pin 7 of IC301
 CH 2 : Emitter of Q302)

3
4
5
6
7
8

Interchangeable Parts at Manufacture-Stage

Mark	Reference Parts Number	Parts Name
k1		
k2	D301	HZS6B2 MTZJ4.7C
k3	D305	HZS6C2 MTZJ5.1B
k4	D302	HZS6C2 MTZJ5.2B
k5	D309	SLR-305VCA47 SLR-325VCT31

IC301
LC866420A-5A64

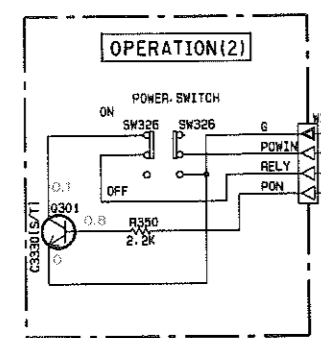

TO FUNCTION(1)
P37 I-3

TO MAIN(1)
P39 B-2

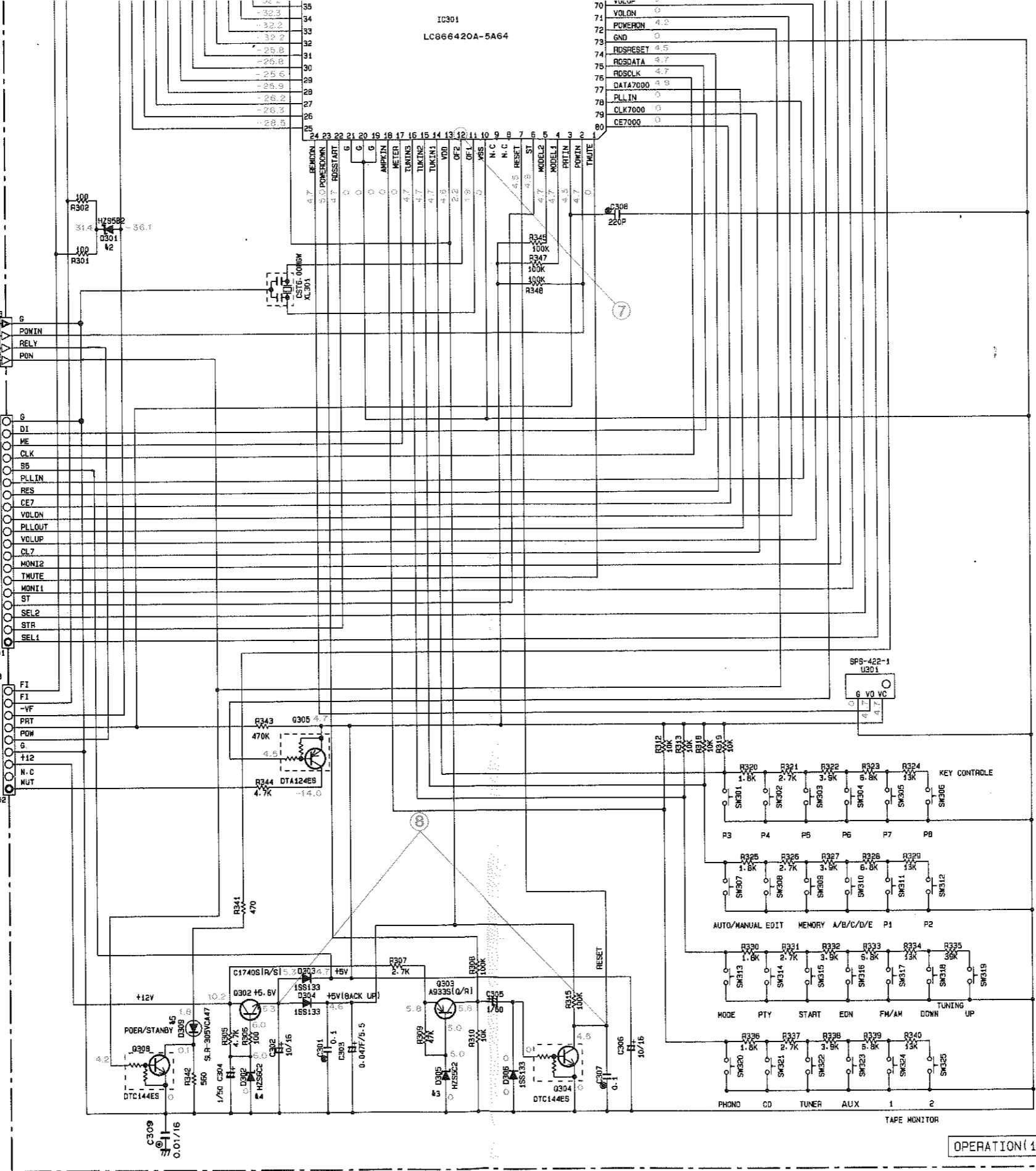

• ANODE CONNECTION

	13G	12G
P1	SPORT	a
P2	AFFAIRS	b
P3	INFO	c
P4	NEWS	d
P5	EON	e
P6	PTY HOLD	f
P7	CT	g
P8	□ (CT)	h
P9	RT	j
P10	□ (RT)	k
P11	PTY	m
P12	□ (PTY)	n
P13	PS	p
P14	□ (PS)	r
P15	MEMO	t, u
P16	—	—

Point ⑦
(Pin 12 of IC301)
V: 2V/div H: 50nsec/div
DC range 1:1 probe

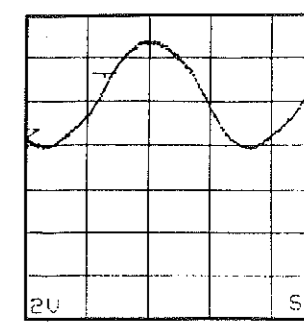

OPERATION(1)

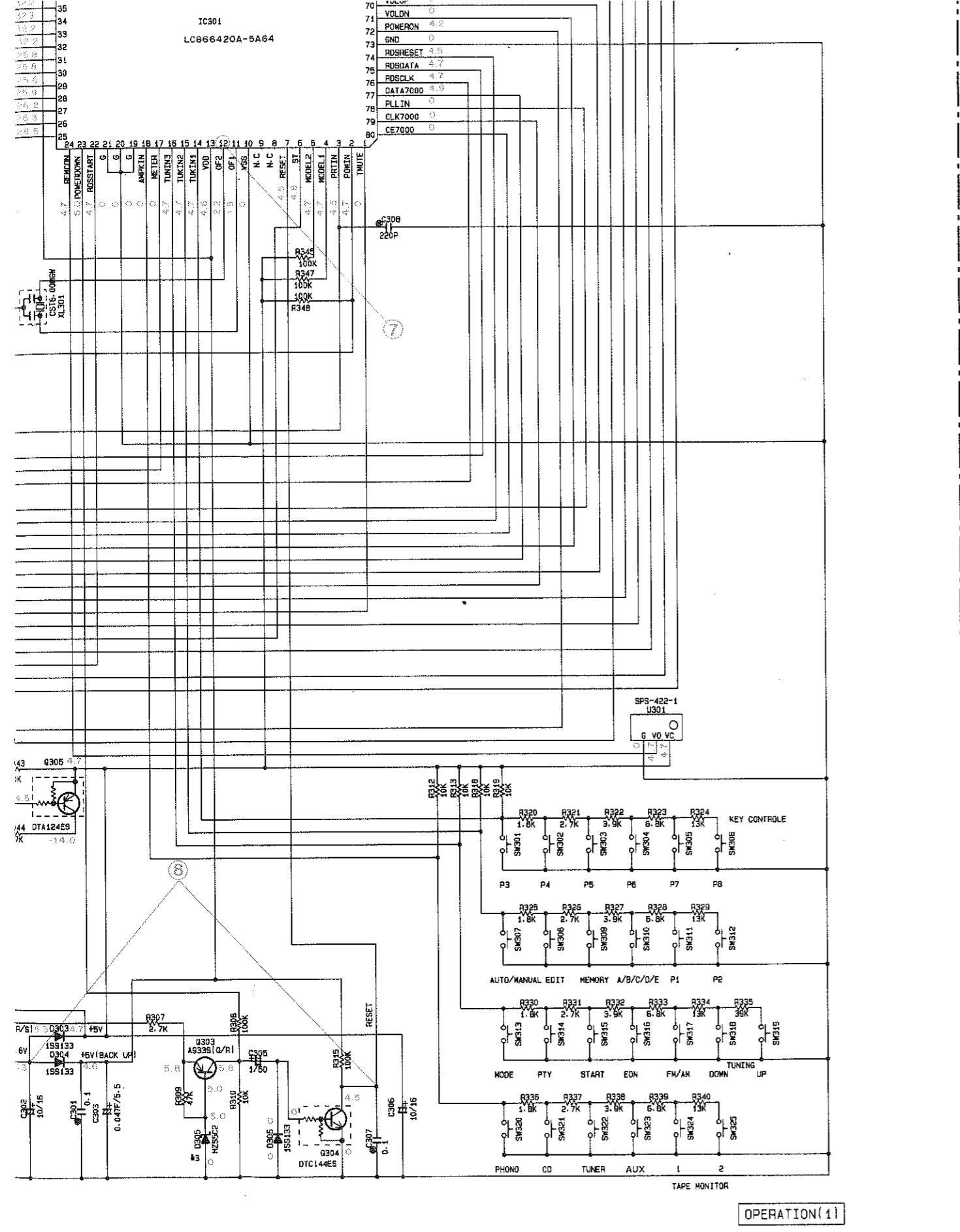

OPERATION(11)

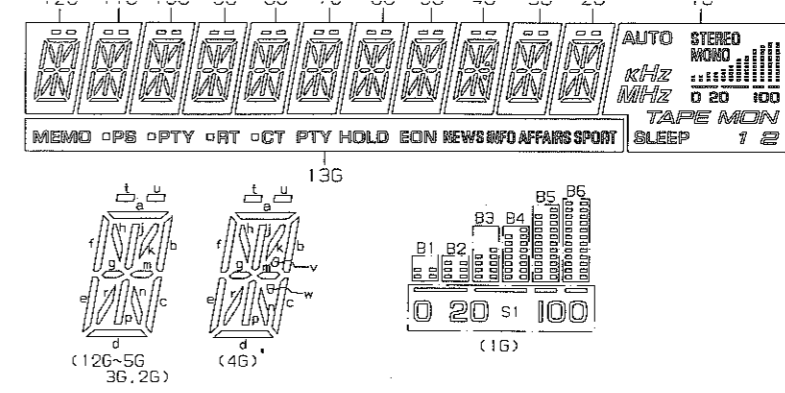

• ANODE CONNECTION

	13G	12G	11G	10G	9G	8G	7G	6G	5G	4G	3G	2G	1G
P1	SPORT	a	a	a	a	a	a	a	a	a	a	a	AUTO
P2	AFFAIRS	b	b	b	b	b	b	b	b	b	b	b	KHz
P3	INFO	c	c	c	c	c	c	c	c	c	c	c	MHz
P4	NEWS	d	d	d	d	d	d	d	d	d	d	d	STEREO
P5	EON	e	e	e	e	e	e	e	e	e	e	e	MONO
P6	PTY HOLD	f	f	f	f	f	f	f	f	f	f	f	B1
P7	CT	g	g	g	g	g	g	g	g	g	g	g	B2
P8	<input type="checkbox"/> (CT)	h	h	h	h	h	h	h	h	h	h	h	B3
P9	RT	j	j	j	j	j	j	j	j	j	j	j	B4
P10	<input type="checkbox"/> (RT)	k	k	k	k	k	k	k	k	k	k	k	B5
P11	PTY	m	m	m	m	m	m	m	m	m	m	m	B6
P12	<input type="checkbox"/> (PTY)	n	n	n	n	n	n	n	n	n	n	n	S1
P13	PS	p	p	p	p	p	p	p	p	p	p	p	TAPE MON
P14	<input type="checkbox"/> (PS)	r	r	r	r	r	r	r	r	r	r	r	1
P15	MEMO	t, u	t, u	t, u	t, u	t, u	t, u	t, u	t, u	t, u	t, u	t, u	2
P16	—	—	—	—	—	—	—	—	—	v, w	—	—	SLEEP

Point ⑦
 (Pin 12 of IC301)
 V: 2V/div H: 50nsec/div
 DC range 1 : 1 probe

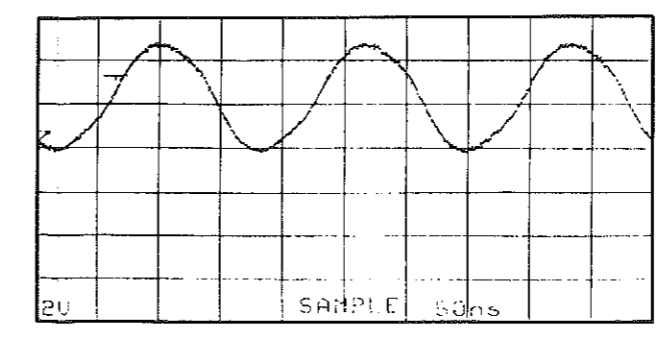

Point ⑧
 (CH 1 : Pin 7 of IC301
 CH 2 : Emitter of Q302)
 V: 2V/divCH1
 V: 2V/divCH2
 H: 0.5sec/div
 DC range 1 : 1 probe
 (This waveform is not available by pushing the power switch ON and OFF.)

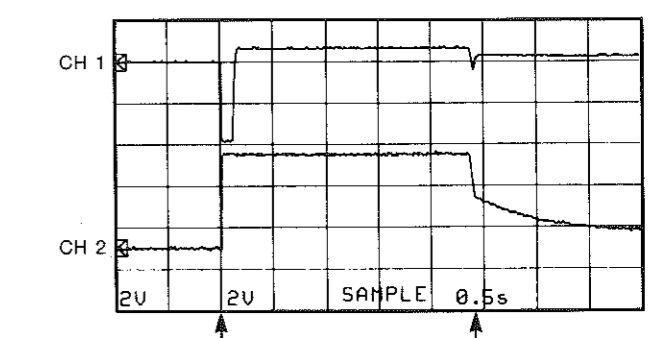

With the POWER switch turned ON, connect the power cord to the AC outlet.
 Disconnect the power cord from the AC outlet.

* All voltage are measured with a 10MΩ/DC electric volt meter.
 * Components having special characteristics are marked Δ and must be replaced with parts having specifications equal to those originally installed.
 * Schematic diagram is subject to change without notice.

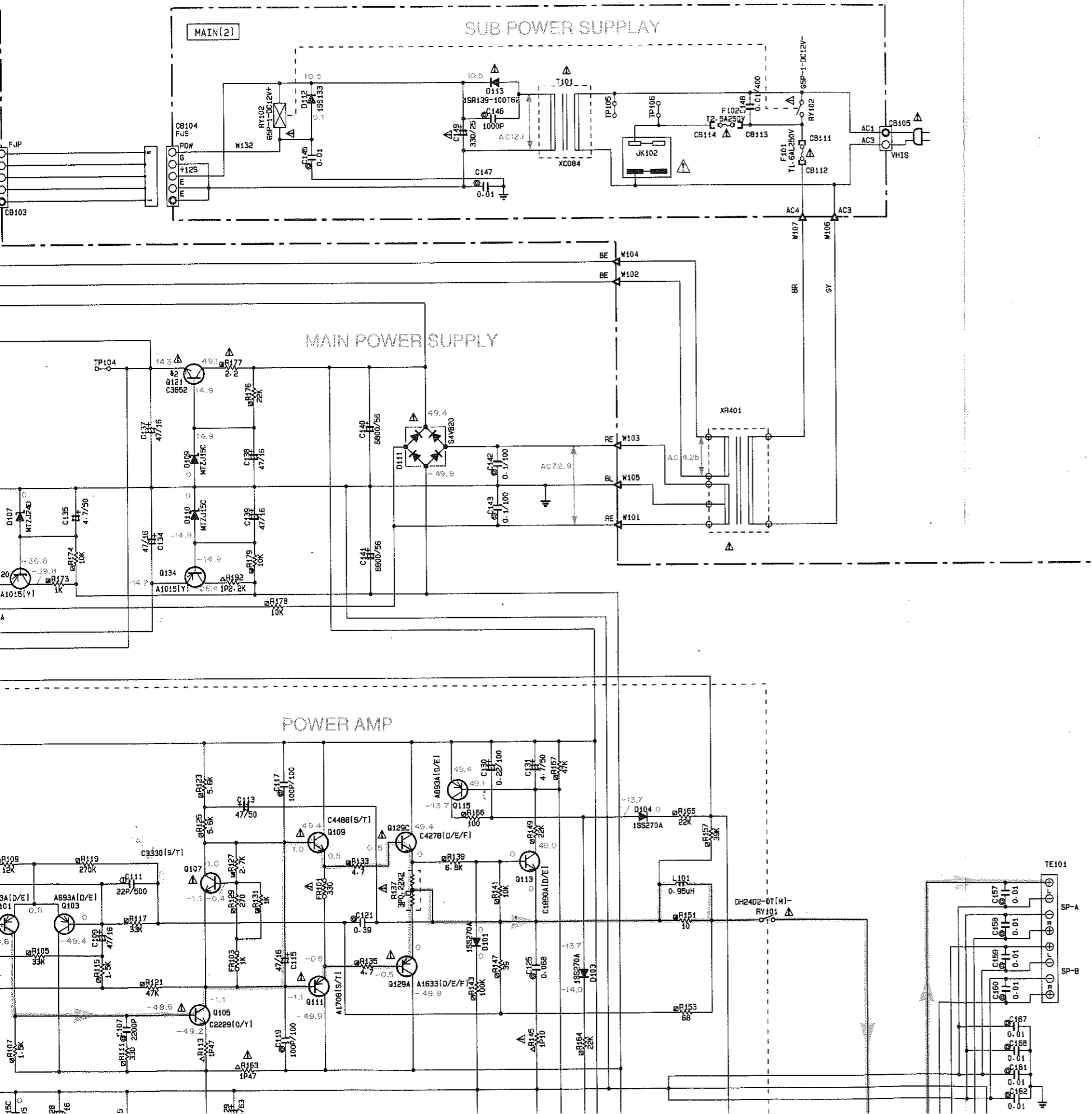

CAPACITOR	
REMARKS	PARTS NAME
NO MARK	ELECTROLYTIC CAPACITOR
⊗	TANTALUM CAPACITOR
NO MARK	CERAMIC CAPACITOR
⊙	CERAMIC TUBULAR CAPACITOR
⊖	POLYESTER FILM CAPACITOR
○	POLYSTYRENE FILM CAPACITOR
⊕	MICA CAPACITOR
⊗	POLYPROPYLENE FILM CAPACITOR
●	SEMICONDUCTIVE CERAMIC CAPACITOR

RESISTOR	
REMARKS	PARTS NAME
NO MARK	CARBON FILM RESISTOR (P=5)
⊠	CARBON FILM RESISTOR (P=10)
△	METAL OXIDE FILM RESISTOR
▲	METAL FILM RESISTOR
⊠	METAL PLATE RESISTOR
⊠	FIRE PROOF CARBON FILM RESISTOR
⊠	CEMENT MOLDED RESISTOR
⊗	SEMI VARIABLE RESISTOR
■	CHIP RESISTOR

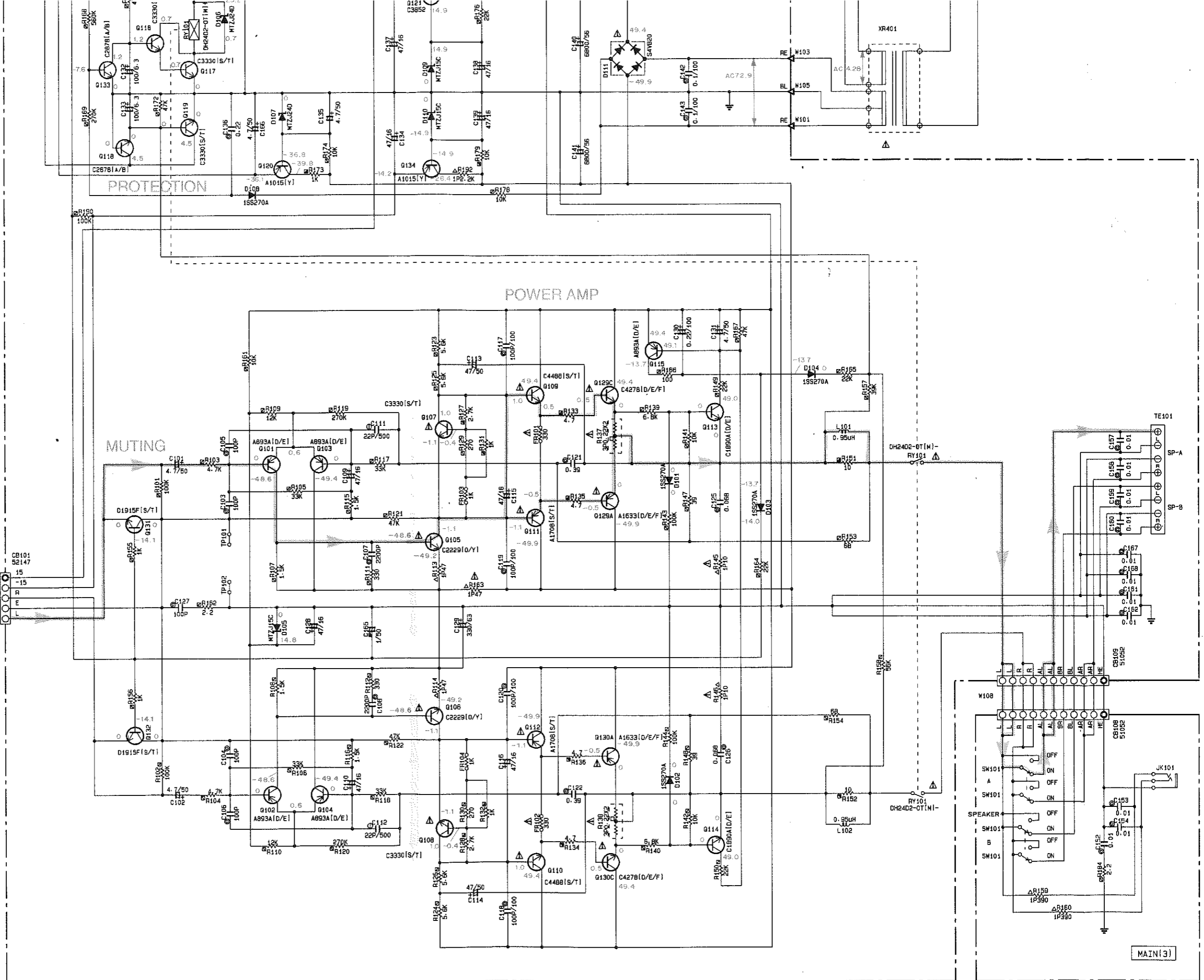

TO FUNCTION(3) P37 I-5

MAIN(3)

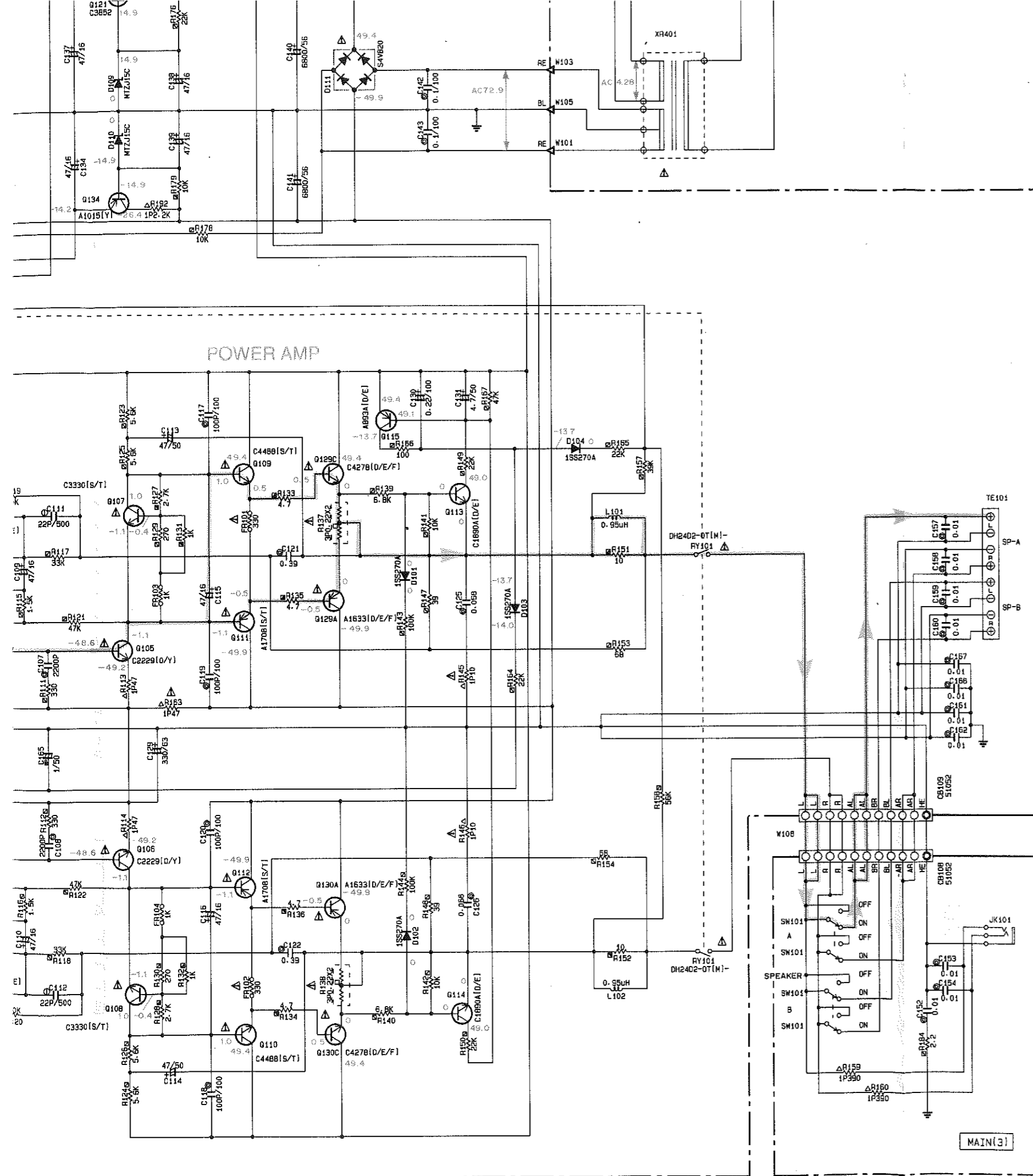

Interchangeable Parts at Manufacture-Stage

Mark	Reference Parts Number	Parts Name
41		
42	Q121	2SC3652 2SC4495

* All voltage are measured with a 10MΩ/DC electric volt meter.
 * Components having special characteristics are marked Δ and must be replaced with parts having specifications equal to those originally installed.
 * Schematic diagram is subject to change without notice.

REMOTE CONTROL TRANSMITTER

■ SCHEMATIC DIAGRAM

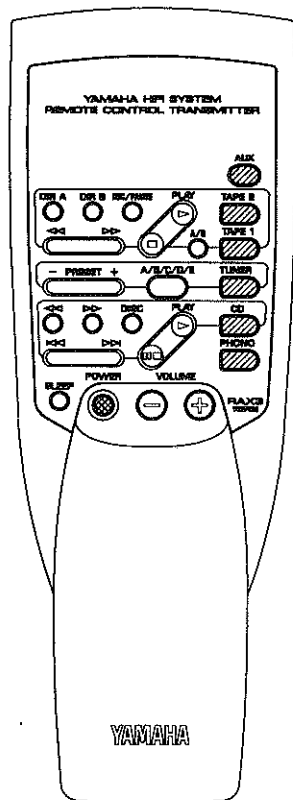
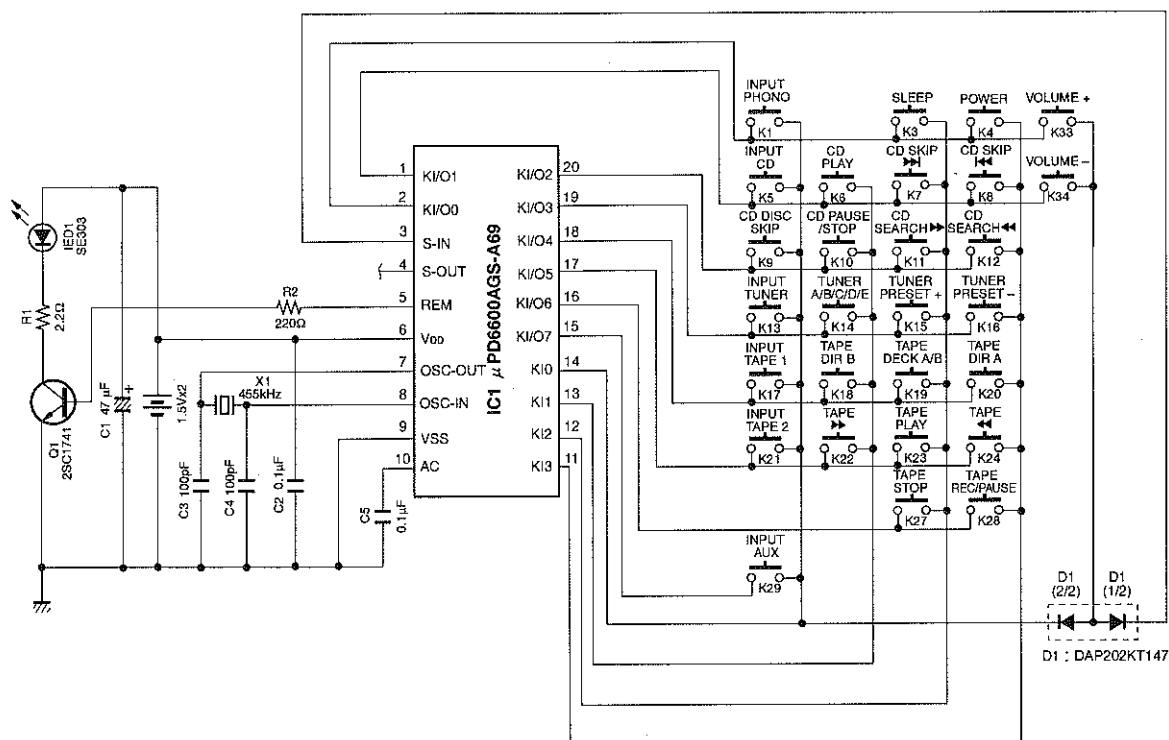

Key No.	Function	HEX	
		CUSTOM	DATA
1	INPUT PHONO	7A	14
3	SLEEP	7A	57
4	POWER	7A	1F
5	INPUT CD	7A	15
6	CD PLAY	7A	08
7	CD SKIP >>>	7A	0A
8	CD SKIP <<<	7A	0B
9	CD DISC SKIP	7A	4F
10	CD PAUSE/STOP	7A	09
11	CD SEARCH >>	7A	0C
12	CD SEARCH <<	7A	0D
13	INPUT TUNER	7A	16
14	TUNER A/B/C/D/E	7A	12
15	TUNER PRESET +	7A	10
16	TUNER PRESET -	7A	11
17	INPUT TAPE 1	7A	18
18	TAPE DIR B	7A	40
19	TAPE DECK A/B	7A	06
20	TAPE DIR A	7A	07
21	INPUT TAPE 2	7A	19
22	TAPE >>	7A	02
23	TAPE PLAY	7A	00
24	TAPE <<	7A	01
27	TAPE STOP	7A	03
28	TAPE REC/PAUSE	7A	04
29	INPUT AUX	7A	17
33	VOLUME +	7A	1A
34	VOLUME -	7A	1B

PARTS LIST

■ ELECTRICAL PARTS

■ WARNING

Components having special characteristics are marked Δ and must be replaced with parts having specifications equal to those originally installed.

- Carbon resistors (1/6W or 1/4W) are not included in the ELECTRICAL PARTS List. For the parts No. of the carbon resistors, refer to last page.

ABBREVIATIONS IN THIS LIST ARE AS FOLLOWS :

C.A.EL.CHP	: CHIP ALUMI. ELECTROLYTIC CAP	L.EMIT	: LIGHT EMITTING MODULE
C.CE	: CERAMIC CAP	LED.DSPLY	: LED DISPLAY
C.CE.ARRAY	: CERAMIC CAP ARRAY	LED.INFRD	: LED, INFRARED
C.CE.CHP	: CHIP CERAMIC CAP	MODUL.RF	: MODULATOR, RF
C.CE.ML	: MULTILAYER CERAMIC CAP	PHOT.CPL	: PHOTO COUPLER
C.CE.M.CHP	: CHIP MULTILAYER CERAMIC CAP	PHOT.INTR	: PHOTO INTERRUPTER
C.CE.SAFY	: RECOGNIZED CERAMIC CAP	PHOT.RFLCT	: PHOTO REFLECTOR
C.CE.TUBLR	: CERAMIC TUBULAR CAP	PIN.TEST	: PIN, TEST POINT
C.CE.SMI	: SEMI CONDUCTIVE CERAMIC CAP	PLST.RIVET	: PLASTIC RIVET
C.EL	: ELECTROLYTIC CAP	R.ARRAY	: RESISTOR ARRAY
C.MICA	: MICA CAP	R.CAR	: CARBON RESISTOR
C.ML.FLM	: MULTILAYER FILM CAP	R.CAR.CHP	: CHIP RESISTOR
C.MP	: METALLIZED PAPER CAP	R.CAR.FP	: FLAME PROOF CARBON RESISTOR
C.MYLAR	: MYLAR FILM CAP	R.FUS	: FUSABLE RESISTOR
C.MYLAR.ML	: MULTILAYER MYLAR FILM CAP	R.MTL.CHP	: CHIP METAL FILM RESISTOR
C.PAPER	: PAPER CAPACITOR	R.MTL.FLM	: METAL FILM RESISTOR
C.PLS	: POLYSTYRENE FILM CAP	R.MTL.OXD	: METAL OXIDE FILM RESISTOR
C.POL	: POLYESTER FILM CAP	R.MTL.PLAT	: METAL PLATE RESISTOR
C.POLY	: POLYETHYLENE FILM CAP	RSNR.CE	: CERAMIC RESONATOR
C.PP	: POLYPROPYLENE FILM CAP	RSNR.CRYS	: CRYSTAL RESONATOR
C.TNTL	: TANTALUM CAP	R.TW.CEM	: TWIN CEMENT FIXED RESISTOR
C.TNTL.CHP	: CHIP TANTALUM CAP	R.WW	: WIRE WOUND RESISTOR
C.TRIM	: TRIMMER CAP	SCR.BND.HD	: BIND HEAD B-TITE SCREW
CN	: CONNECTOR	SCR.BW.HD	: BW HEAD TAPPING SCREW
CN.BS.PIN	: CONNECTOR, BASE PIN	SCR.CUP	: CUP TITE SCREW
CN.CANNON	: CONNECTOR, CANNON	SCR.TERM	: SCREW TERMINAL
CN.DIN	: CONNECTOR, DIN	SCR.TR	: SCREW, TRANSISTOR
CN.FLAT	: CONNECTOR, FLAT CABLE	SUPRT.PCB	: SUPPORT, P.C.B.
CN.POST	: CONNECTOR, BASE POST	SURG.PRTCT	: SURGE PROTECTOR
COIL.MX.AM	: COIL, AM MIX	SW.TACT	: TACT SWITCH
COIL.AT.FM	: COIL, FM ANTENNA	SW.LEAF	: LEAF SWITCH
COIL.DT.FM	: COIL, FM DETECT	SW.LEVER	: LEVER SWITCH
COIL.MX.FM	: COIL, FM MIX	SW.MICRO	: MICRO SWITCH
COIL.OUTPT	: OUTPUT COIL	SW.PUSH	: PUSH SWITCH
DIOD.ARRAY	: DIODE ARRAY	SW.RT.ENC	: ROTARY ENCODER
DIODE.BRG	: DIODE BRIDGE	SW.RT.MTR	: ROTARY SWITCH WITH MOTOR
DIODE.CHP	: CHIP DIODE	SW.RT	: ROTARY SWITCH
DIODE.VAR	: VARACTOR DIODE	SW.SLIDE	: SLIDE SWITCH
DIOD.Z.CHP	: CHIP ZENER DIODE	TERM.SP	: SPEAKER TERMINAL
DIODE.ZENR	: ZENER DIODE	TERM.WRAP	: WRAPPING TERMINAL
DSCR.CE	: CERAMIC DISCRIMINATOR	THRMST.CHP	: CHIP THERMISTOR
FER.BEAD	: FERRITE BEADS	TR.CHP	: CHIP TRANSISTOR
FER.CORE	: FERRITE CORE	TR.DGT	: DIGITAL TRANSISTOR
FET.CHP	: CHIP FET	TR.DGT.CHP	: CHIP DIGITAL TRANSISTOR
FL.DSPLY	: FLUORESCENT DISPLAY	TRANS	: TRANSFORMER
FLTR.CE	: CERAMIC FILTER	TRANS.PULS	: PULSE TRANSFORMER
FLTR.COMB	: COMB FILTER MODULE	TRANS.PWR	: POWER TRANSFORMER ASS'y
FLTR.LC.RF	: LC FILTER, EMI	TUNER.AM	: TUNER PACK, AM
GND.MTL	: GROUND PLATE	TUNER.FM	: TUNER PACK, FM
GND.TERM	: GROUND TERMINAL	TUNER.PK	: FRONT-END TUNER PACK
HOLDER.FUS	: FUSE HOLDER	VR	: ROTARY POTENTIOMETER
IC.PRTCT	: IC PROTECTOR	VR.MTR	: POTENTIOMETER WITH MOTOR
JUMPER.CN	: JUMPER CONNECTOR	VR.SW	: POTENTIOMETER WITH ROTARY SW
JUMPER.TST	: JUMPER, TEST POINT	VR.SLIDE	: SLIDE POTENTIOMETER
L.DTCT	: LIGHT DETECTING MODULE	VR.TRIM	: TRIMMER POTENTIOMETER

Note) Those parts marked with "#" are not included in the P.C.B. ass'y.

P.C.B. TUNER

Schm Ref.	PART NO.	Description
	VR341800	P. C. B. TUNER (UC)
	VR341900	P. C. B. TUNER (R)
	VR342000	P. C. B. TUNER (A)
	VR342100	P. C. B. TUNER (L)
	VU293900	P. C. B. TUNER (G)
CB1	VR428700	CN. BS. PIN 2P (UCRAL)
CB2	VR428700	CN. BS. PIN 2P (UCRAL)
CB4	VQ961800	CN. BS. PIN 15P
C1	UJ638330	C. EL 330uF 16V (UCRAL)
C1	VG291200	C. EL 47uF 50V (G)
C2	VG280100	C. CE. TUBLR 0.022uF 25V (UCRAL)
C2	VJ599000	C. CE. TUBLR 0.047uF 16V (G)
C3	VJ599000	C. CE. TUBLR 0.047uF 16V
C4	VG291200	C. EL 47uF 50V (UCRAL)
C4	VJ836900	C. EL 10uF 16V (G)
C5	VF467300	C. CE. TUBLR 0.01uF 16V
C6	VF964800	C. EL 100uF 16V (UCRAL)
C6	VG291200	C. EL 47uF 50V (G)
C7	VJ839100	C. EL 1uF 50V
C8	VF467300	C. CE. TUBLR 0.01uF 16V
C9	VF467300	C. CE. TUBLR 0.01uF 16V
C10	VF467300	C. CE. TUBLR 0.01uF 16V
C11	VF467000	C. CE. TUBLR 1000pF 50V
C12	VJ836900	C. EL 10uF 16V
C13	VJ836900	C. EL 10uF 16V
C14	VF466800	C. CE. TUBLR 100pF 50V (G)
C14	VF467000	C. CE. TUBLR 1000pF 50V (UCRAL)
C15	VF467000	C. CE. TUBLR 1000pF 50V
C16	VF466700	C. CE. TUBLR 47pF 50V
C17	VF964800	C. EL 100uF 16V (UCRAL)
C17	VG291200	C. EL 47uF 50V (G)
C18	UA655100	C. MYLAR 0.1uF 50V (UCRAL)
C18	VJ599000	C. CE. TUBLR 0.047uF 16V (G)
C19	VA761200	C. CE 33pF 50V
C20	VG291200	C. EL 47uF 50V (G)
C20	VJ836900	C. EL 10uF 16V (UCRAL)
C21	VF466800	C. CE. TUBLR 100pF 50V (UCRA)
C21	VJ599000	C. CE. TUBLR 0.047uF 16V (G)
C22	UM216330	C. EL 3.3uF 50V (G)
C22	VJ839200	C. EL 2.2uF 50V (UCRAL)
C23	VF467300	C. CE. TUBLR 0.01uF 16V
C24	UM416470	C. EL 4.7uF 50V
C25	UM216330	C. EL 3.3uF 50V
C26	VJ836900	C. EL 10uF 16V
C27	VF467300	C. CE. TUBLR 0.01uF 16V
C28	VA761200	C. CE 33pF 50V
C29	VJ839100	C. EL 1uF 50V
C30	VJ839100	C. EL 1uF 50V
C31	VG291200	C. EL 47uF 50V (G)
C31	VJ836900	C. EL 10uF 16V (UCRAL)
C32	VJ839000	C. EL 0.47uF 50V
C33	VJ839100	C. EL 1uF 50V
C34	UA654470	C. MYLAR 0.047uF 50V

* New Parts

Schm Ref.	PART NO.	Description
C35	UM216330	C. EL 3.3uF 50V (G)
C35	VD916400	C. EL 2.2uF 50V (UCRAL)
C36	UA652390	C. MYLAR 390pF 50V (L)
C36	UA652470	C. MYLAR 470pF 50V (AG)
C36	UA652680	C. MYLAR 680pF 50V (UCR)
C37	UA652390	C. MYLAR 390pF 50V (L)
C37	UA652470	C. MYLAR 470pF 50V (AG)
C37	UA652680	C. MYLAR 680pF 50V (UCR)
C38	VF466900	C. CE. TUBLR 470pF 50V
C39	VJ836900	C. EL 10uF 16V
C40	UM216330	C. EL 3.3uF 50V
C41	UA653390	C. MYLAR 3900pF 50V
C42	UM407220	C. EL 22uF 16V (G)
C42	VJ836900	C. EL 10uF 16V (UCRAL)
C43	UA653390	C. MYLAR 3900pF 50V
C44	UM216330	C. EL 3.3uF 50V
C45	VG291200	C. EL 47uF 50V
C46	VG291200	C. EL 47uF 50V
C47	VG291200	C. EL 47uF 50V
C48	VF466800	C. CE. TUBLR 100pF 50V
C49	VA777400	C. CE 120pF 50V (G)
C49	VJ599000	C. CE. TUBLR 0.047uF 16V (UCRAL)
C68	VJ836900	C. EL 10uF 16V (UCRAL)
C69	VJ836900	C. EL 10uF 16V (UCRAL)
C71	VA777400	C. CE 120pF 50V (L)
D1	iF004600	DIODE 1SS133
D2	iF004600	DIODE 1SS133
D3	VG437800	DIODE. ZENR MIZJ5.6C 5.6V (G)
D3	VM974500	DIODE. ZENR HZS6C2TD 6V (UCRAL)
Fi1	GG000560	FLTR. CE SFE10.7MS3GHY-A
Fi2	GG000560	FLTR. CE SFE10.7MS3GHY-A
Fi3	VC219000	FLTR. CE SFZ450JL3
IC1	XB760A00	IC LA1266
IC2	XB818A00	IC LM7000N (UCRAL)
IC2	XQ944A00	IC LC72131 (G)
IC3	iG158100	IC LA3401
IC4	XQ359A00	IC STK311-020B (G)
L1	Vi546100	COIL 220uH
L2	Vi546100	COIL 220uH
L3	Vi546100	COIL 220uH
L4	Vi546100	COIL 220uH (G)
PK1	VQ987600	TUNER. PK EXV-17296G1 (LG)
PK1	VR242200	TUNER. PK EXV-17296G1 (UCRA)
PK2	Vi027300	COIL. AM
Q1	iC053540	TR 2SC535 A, B, C
Q2	iC053540	TR 2SC535 A, B, C (G)
Q2	VC218900	TR 2SC3330 R, S (UCRAL)
Q3	VC218900	TR 2SC3330 R, S (UCRAL)
Q3	VD678500	TR. DGT DTA114ES (G)
Q4	iC053540	TR 2SC535 A, B, (UCRAL)
Q4	VC218900	TR 2SC3330 R, S, T (G)
Q5	VC218700	TR 2SA1317 R, S (UCRAL)
Q5	VG722000	TR. DGT DTC144ES (G)

* New Parts

P.C.B. TUNER & MAIN

Schm Ref.	PART NO.	Description
Q6	iC1815C0	TR 2SC1815 Y(G)
Q6	VC218900	TR 2SC3330 R, S(UCRAL)
Q7	iC1815C0	TR 2SC1815 Y(UCRAL)
Q7	VD678500	TR. DGT DTA114ES(G)
SW1	VF541200	SW. SLIDE SSSF11(R)
T1	VC218600	COIL. DT. FM 10.7MHz
T2	GE100470	COIL. IF. AM 450KHz
T3	VQ365700	FLTR. LP FB-7SG(L)
T3	VT486800	COIL XYA2(G)
T4	VQ138200	FLTR. LC 19KHz
T5	VQ138200	FLTR. LC 19KHz
TE1	LA005800	TERM. ANT YKD31-0215
TP1	VT969000	PIN. TEST IRS-2049
TP2	VT969000	PIN. TEST IRS-2049
VR1	VJ694000	VR. TRIM B47KΩ
VR2	VJ694000	VR. TRIM B47KΩ
XL1	QU003800	RSNR. CRY5 7.2MHz
XL2	GG000750	RSNR. CE 18.95MHz
XL3	VS860100	RSNR. CE 19KHz(G)
	BB071360	SCR. TERM 8.3x13
	VR282500	PLATE ANT.
*	VU286700	P. C. B. MAIN(UC)
*	VU286800	P. C. B. MAIN(R)
*	VU286900	P. C. B. MAIN(A)
*	VU287000	P. C. B. MAIN(L)
*	VU293700	P. C. B. MAIN(G)
CB101	VK024900	CN. BS. PIN 5P
CB102	VR358000	CN. BS. PIN 9P
CB103	VP768100	CN. BS. PIN 5P
CB104	VP768200	CN 5P
CB105	VG879900	CN. BS. PIN 2P
CB108	VQ585300	CN. BS. PIN 11P
CB109	VQ585300	CN. BS. PIN 11P
CB111	VP206500	HOLDER. FUS EYF-52BC
CB112	VP206500	HOLDER. FUS EYF-52BC
CB113	VP206500	HOLDER. FUS EYF-52BC(LG)
CB114	VP206500	HOLDER. FUS EYF-52BC(LG)
CB115	VP206500	HOLDER. FUS EYF-52BC(R)
CB116	VP206500	HOLDER. FUS EYF-52BC(R)
C101	UM416470	C. EL 4.7uF 50V
C102	UM416470	C. EL 4.7uF 50V
C103	UA652100	C. MYLAR 100pF 50V
C104	UA652100	C. MYLAR 100pF 50V
C105	UA652100	C. MYLAR 100pF 50V
C106	UA652100	C. MYLAR 100pF 50V
C107	Vi715900	C. MYLAR 2200pF 50V
C108	Vi715900	C. MYLAR 2200pF 50V
C109	VG291200	C. EL 47uF 50V
C110	VG291200	C. EL 47uF 50V

Schm Ref.	PART NO.	Description
C111	FU351220	C. MICA 22pF 500V
C112	FU351220	C. MICA 22pF 500V
C113	UJ667470	C. EL 47uF 50V
C114	UJ667470	C. EL 47uF 50V
C115	VJ837200	C. EL 47uF 16V
C116	VJ837200	C. EL 47uF 16V
C117	VR325000	C. MYLAR 100pF 100V
C118	VR325000	C. MYLAR 100pF 100V
C119	VR325000	C. MYLAR 100pF 100V
C120	VR325000	C. MYLAR 100pF 100V
C121	VK399200	C. MYLAR. ML 0.39uF 50V
C122	VK399200	C. MYLAR. ML 0.39uF 50V
C125	UA654680	C. MYLAR 0.068uF 50V
C126	UA654680	C. MYLAR 0.068uF 50V
C127	UA652100	C. MYLAR 100pF 50V
C128	VG291200	C. EL 47uF 50V
C129	VK699400	C. EL 330uF 63V
C130	UJ895220	C. EL 0.22uF 100V
C131	UM416470	C. EL 4.7uF 50V
C132	VF760000	C. EL 100uF 10V
C133	VF760000	C. EL 100uF 10V
C134	VG291200	C. EL 47uF 50V
C135	UM416470	C. EL 4.7uF 50V
C136	UA655220	C. MYLAR 0.22uF 50V
C137	VG291200	C. EL 47uF 50V
C138	VG291200	C. EL 47uF 50V
C139	VG291200	C. EL 47uF 50V
C140	VR024000	C. EL 6800uF 56V
C141	VR024000	C. EL 6800uF 56V
C142	VR325400	C. MYLAR 0.1uF 100V
C143	VR325400	C. MYLAR 0.1uF 100V
C145	FG214100	C. CE 0.01uF 50V(UCRAL)
C145	UA654100	C. MYLAR 0.01uF 50V(G)
C146	UA653100	C. MYLAR 1000pF 50V
C147	UA654100	C. MYLAR 0.01uF 50V
C148	Fi414100	C. CE. SAFTY 0.01uF VA-1(UCR)
C148	VU466300	C. CE. SAFTY 0.01uF 400V(ALG)
C149	VK182500	C. EL 330uF 63V(R)
C149	VK457600	C. EL 330uF 25V(UCALG)
C150	VF964800	C. EL 100uF 16V(R)
C151	VJ836900	C. EL 10uF 16V(R)
C152	UA654100	C. MYLAR 0.01uF 50V(ALG)
C153	UA654100	C. MYLAR 0.01uF 50V(ALG)
C154	UA654100	C. MYLAR 0.01uF 50V(ALG)
C157	UA654100	C. MYLAR 0.01uF 50V(ALG)
C158	UA654100	C. MYLAR 0.01uF 50V(ALG)
C159	UA654100	C. MYLAR 0.01uF 50V(ALG)
C160	UA654100	C. MYLAR 0.01uF 50V(ALG)
C161	UA654100	C. MYLAR 0.01uF 50V
C162	UA654100	C. MYLAR 0.01uF 50V
C165	VG722100	C. EL 1uF 50V
C166	UM416470	C. EL 4.7uF 50V
C167	UA654100	C. MYLAR 0.01uF 50V(ALG)

△
△

* New Parts

* New Parts

P.C.B. MAIN

Schm Ref.	PART NO.	Description
C168	UA654100	C. MYLAR 0.01uF 50V(ALG)
D101	VN008700	DIODE 1SS270A
D102	VN008700	DIODE 1SS270A
D103	VN008700	DIODE 1SS270A
D104	VN008700	DIODE 1SS270A
D105	VG440900	DIODE. ZENR MIZJ15C 15V
D106	VG442700	DIODE. ZENR MIZJ24D 24V
D107	VG442700	DIODE. ZENR MIZJ24D 24V
D108	VN008700	DIODE 1SS270A
D109	VG440900	DIODE. ZENR MIZJ15C 15V
D110	VG440900	DIODE. ZENR MIZJ15C 15V
△ D111	iH001090	DIODE. BRG S4VB20 2.6A 200V
D112	iF004600	DIODE 1SS133
△ D113	VH770800	DIODE 1SR139-100
D114	VG440300	DIODE. ZENR MIZJ12C 12V(R)
△ F101	KB003060	FUSE TL1.6A 250V(AL)
△ F101	KB003630	FUSE 5.0A 125V(UCR)
△ F102	KB000690	FUSE T2.5A 250V(LG)
△ F102	KB000690	FUSE T2.5A 250V(L)
△ F103	KB003060	FUSE TL1.6A 250V(R)
△ FR101	VK188400	R. FUS 330Ω 1/4W
△ FR102	VK188400	R. FUS 330Ω 1/4W
FR103	VK189000	R. FUS 1KΩ 1/4W
FR104	VK189000	R. FUS 1KΩ 1/4W
JK101	LB301720	JACK. PHONE
△ JK102	VK480600	OUTLET. AC (UCR)
△ JK102	VK480700	OUTLET. AC (LG)
L101	VR906600	COIL 0.95uH
L102	VR906600	COIL 0.95uH
Q101	VP883000	TR 2SA893A D, E
Q102	VP883000	TR 2SA893A D, E
Q103	VP883000	TR 2SA893A D, E
Q104	VP883000	TR 2SA893A D, E
△ Q105	VR325600	TR 2SC2229 O, Y
△ Q106	VR325600	TR 2SC2229 O, Y
△ Q107	VC218900	TR 2SC3330 R, S, T
△ Q108	VC218900	TR 2SC3330 R, S, T
△ Q109	VP872700	TR 2SC4488 S, T
△ Q110	VP872700	TR 2SC4488 S, T
△ Q111	VP872600	TR 2SA1708 S, T
△ Q112	VP872600	TR 2SA1708 S, T
Q113	VP883100	TR 2SC1890A D, E
Q114	VP883100	TR 2SC1890A D, E
Q115	VP883000	TR 2SA893A D, E
Q116	VC218900	TR 2SC3330 R, S, T
Q117	VC218900	TR 2SC3330 R, S, T
Q118	iC287820	TR 2SC2878 A, B
Q119	VC218900	TR 2SC3330 R, S, T
Q120	iA101521	TR 2SA1015 Y
△ Q121	VC938500	TR 2SC3852
Q123	VP768300	TR 2SC4466 O, P, Y(R)
Q124	VP883100	TR 2SC1890A D, E(R)
△ Q129A	iX630850	TR 2SA1695 O, P(UCRAL)

* New Parts

Schm Ref.	PART NO.	Description
△ Q129C	iX630860	TR 2SC4468 O, P(UCRAL)
△ Q129A	iX632650	TR 2SA1633 D, E, F(G)
△ Q129C	iX632660	TR 2SC4278 D, E, F(G)
△ Q130A	iX630850	TR 2SA1695 O, P(UCRAL)
△ Q130C	iX630860	TR 2SC4468 O, P(UCRAL)
△ Q130A	iX632650	TR 2SA1633 D, E, F(G)
△ Q130C	iX632660	TR 2SC4278 D, E, F(G)
Q131	VK432900	TR 2SD1915F S, T
Q132	VK432900	TR 2SD1915F S, T
Q133	iC287820	TR 2SC2878 A, B
Q134	iA101521	TR 2SA1015 Y
R113	HL314470	R. MIL. OXD 47Ω 1W
R114	HL314470	R. MIL. OXD 47Ω 1W
R127	HV456270	R. CAR. FP 2.7KΩ 1/4W
R128	HV456270	R. CAR. FP 2.7KΩ 1/4W
R131	HV456100	R. CAR. FP 1KΩ 1/4W
R132	HV456100	R. CAR. FP 1KΩ 1/4W
R133	HV453470	R. CAR. FP 4.7Ω 1/4W
R134	HV453470	R. CAR. FP 4.7Ω 1/4W
R135	HV453470	R. CAR. FP 4.7Ω 1/4W
R136	HV453470	R. CAR. FP 4.7Ω 1/4W
△ R137	VJ695400	R. WW 0.22Ωx2 3W
△ R138	VJ695400	R. WW 0.22Ωx2 3W
△ R145	HL314100	R. MIL. OXD 10Ω 1W
△ R146	HL314100	R. MIL. OXD 10Ω 1W
R151	HV454100	R. CAR. FP 10Ω 1/4W
R152	HV454100	R. CAR. FP 10Ω 1/4W
R159	VP944500	R. MIL. OXD 390Ω 1W
R160	VP944500	R. MIL. OXD 390Ω 1W
△ R163	HL314470	R. MIL. OXD 47Ω 1W
△ R171	HL315560	R. MIL. OXD 560Ω 1W
R173	HV456100	R. CAR. FP 1KΩ 1/4W
△ R177	HV453220	R. CAR. FP 2.2Ω 1/4W
R179	HV457100	R. CAR. FP 10KΩ 1/4W
R192	HL416220	R. MIL. OXD 2.2KΩ 1W
△ R193	HL315560	R. MIL. OXD 560Ω 1W
△ RY101	VK438300	RELAY DH24D2-OTM-
△ RY102	VH230800	RELAY G5P-1-DC12V
SW101	VJ850200	SW. PUSH PSE021A2KP 2
△ SW102	VA961800	VOLT. SELECT ESE-37247-F(R)
△ T101	XC082A00	TRANS. PWR (R)
△ T101	XC083A00	TRANS. PWR (UC)
△ T101	XC084A00	TRANS. PWR (ALG)
TE101	VC313700	TERM. SP 8P(UCR)
TE101	VK506200	TERM. SP 8P(ALG)
	VJ828000	PIN IMSA-6024-03E
	BB071360	SCR. TERM 8.3x13(ALG)
	BB069510	GND. MIL No. 6951
	VR264300	PLATE. GND

* New Parts

RX-495/RX-495RDS

P.C.B. OPERATION & FUNCTION

Schm Ref.	PART NO.	Description
*	VU286400	P. C. B. OPERATION (UC)
*	VU286500	P. C. B. OPERATION (R)
*	VU286600	P. C. B. OPERATION (AL)
*	VU293600	P. C. B. OPERATION (G)
CB301	VQ047400	CN. BS. PIN 19P (G)
CB301	VR361600	CN. BS. PIN 9P (UCRAL)
CB302	VQ047400	CN. BS. PIN 19P (UCRAL)
CB302	VR361600	CN. BS. PIN 9P (G)
C301	VH053100	C. CE. TUBLR 0.1uF 50V (G)
C301	VJ836900	C. EL 10uF 16V (UCRAL)
C302	VH053100	C. CE. TUBLR 0.1uF 50V (UCRAL)
C302	VJ836900	C. EL 10uF 16V (G)
C303	VJ839100	C. EL 1uF 50V (UCRAL)
C303	VT740700	C. EL 4700uF 5.5V (G)
C304	VH053100	C. CE. TUBLR 1uF 50V (UCRAL)
C304	VJ839100	C. EL 1uF 50V (G)
C305	VJ836900	C. EL 10uF 16V (UCRAL)
C305	VJ839100	C. EL 1uF 50V (G)
C306	VJ836900	C. EL 10uF 16V (G)
C306	VT740700	C. EL 4700uF 5.5V (UCRAL)
C307	VH053100	C. CE. TUBLR 0.1uF 50V (G)
C307	VJ839100	C. EL 1uF 50V (UCRAL)
C308	VG278400	C. CE. TUBLR 220pF 50V
C309	VF467300	C. CE. TUBLR 0.01uF 16V (G)
C309	VH053100	C. CE. TUBLR 0.1uF 50V (UCRAL)
C310	VH053100	C. CE. TUBLR 0.1uF 50V (UCRAL)
C311	VH053100	C. CE. TUBLR 0.1uF 50V (UCRAL)
C312	VH053100	C. CE. TUBLR 0.1uF 50V (UCRAL)
D301	VM974100	DIODE, ZENR HZS5B2TD 5.0V (G)
D302	VM974500	DIODE, ZENR HZS6C2TD 6.0V (G)
D303	iF004600	DIODE 1SS133 (G)
D303	VS132300	LED (re) SLR-325VCT31 (AL)
D304	iF004600	DIODE 1SS133 (G)
D304	VD631600	DIODE 1SS133, 176 (UCRAL)
D305	VM974200	DIODE, ZENR HZS5C2TD 5.0V (G)
D306	iF004600	DIODE 1SS133 (G)
D306	VD631600	DIODE 1SS133, 176 (UCRAL)
D307	VD631600	DIODE 1SS133, 176 (UCRAL)
D308	VM974100	DIODE, ZENR HZS5B2TD 5.0V
D309	VM974500	DIODE, ZENR HZS6C2TD 6.0V
D309	VP594000	LED (re) SLR-305VCA47 (G)
IC301	XQ942A00	IC LC866420A-XXXX (G)
IC301	XR714A00	IC LC866008C (UCRAL)
Q301	VC218900	TR 2SC3330 R, S, T (G)
Q301	VG722000	TR, DGT DTC144ES (UCRAL)
Q302	iA093320	TR 2SA933S Q, R (UCRAL)
Q302	iC174020	TR 2SC1740S R, S (G)
Q303	iA093320	TR 2SA933S Q, R (G)
Q303	iC174020	TR 2SC1740S R, (UCRAL)
Q304	VG722000	TR, DGT DTC144ES (ALG)
Q305	VC218900	TR 2SC3330 R, S (UCRAL)
Q305	VH257100	TR, DGT DTA124ES (G)
Q308	VG722000	TR, DGT DTC144ES (G)

* New Parts

Schm Ref.	PART NO.	Description
SW301	VG392900	SW. TACT SKHVAA
SW302	VG392900	SW. TACT SKHVAA
SW303	VG392900	SW. TACT SKHVAA
SW304	VG392900	SW. TACT SKHVAA
SW305	VG392900	SW. TACT SKHVAA
SW306	VG392900	SW. TACT SKHVAA
SW307	VG392900	SW. TACT SKHVAA
SW308	VG392900	SW. TACT SKHVAA
SW309	VG392900	SW. TACT SKHVAA
SW310	VG392900	SW. TACT SKHVAA
SW311	VG392900	SW. TACT SKHVAA
SW312	VG392900	SW. TACT SKHVAA
SW313	VG392900	SW. TACT SKHVAA
SW314	VG392900	SW. TACT SKHVAA
SW315	VG392900	SW. TACT SKHVAA
SW316	VG392900	SW. TACT SKHVAA (UCRG)
SW317	VG392900	SW. TACT SKHVAA
SW318	VG392900	SW. TACT SKHVAA
SW319	VG392900	SW. TACT SKHVAA
SW320	VG392900	SW. TACT SKHVAA
SW321	VG392900	SW. TACT SKHVAA
SW322	VG392900	SW. TACT SKHVAA
SW323	VG392900	SW. TACT SKHVAA (G)
SW323	VT985400	SW. PUSH PSE01-A2K (AL)
SW324	VG392900	SW. TACT SKHVAA (G)
SW325	VG392900	SW. TACT SKHVAA (G)
SW326	VT985400	SW. PUSH PSE01-A2K (G)
U301	VR860700	L. DTCT SPS-422-1
V301	VQ915100	FL. DSPLY 8-MT-79GK (UCRAL)
V301	VT668600	FL. DSPLY 13-BT-140GK (G)
XL301	VD827600	RSNR. CE 4MHz (UCRAL)
XL301	VH611900	RSNR. CE CST6.00MGW-TF01 (G)
	VJ828000	PIN IMSA-6024-03E
	VR519500	SHEET
	VR380100	SPACER FL-T6
*	VU287100	P. C. B. FUNCTION (UCRAL)
*	VU293800	P. C. B. FUNCTION (G)
CB501	VQ963600	CN. BS. PIN 15P
CB502	VR359000	CN. BS. PIN 19P
CB503	Vi878500	CN. BS. PIN 7P
CB504	Vi878500	CN. BS. PIN 7P
CB505	Vi878900	CN. BS. PIN 11P
CB506	Vi878900	CN. BS. PIN 11P
CB507	Vi878300	CN. BS. PIN 5P
C501	UA652220	C. MYLAR 220pF 50V
C502	UA652220	C. MYLAR 220pF 50V
C503	VC815000	C. EL 220uF 6.3V
C504	VC815000	C. EL 220uF 6.3V
C505	UA653910	C. MYLAR 9100pF 50V
C506	UA653910	C. MYLAR 9100pF 50V

* New Parts

P.C.B. FUNCTION

Schm Ref.	PART NO.	Description
C507	UA654330	C. MYLAR 0.033uF 50V
C508	UA654330	C. MYLAR 0.033uF 50V
C509	VJ839200	C. EL 2.2uF 50V
C510	VJ839200	C. EL 2.2uF 50V
C511	UA653330	C. MYLAR 3300pF 50V
C512	UA653330	C. MYLAR 3300pF 50V
C513	VG291200	C. EL 47uF 50V
C514	VG291200	C. EL 47uF 50V
C515	UA652220	C. MYLAR 220pF 50V
C516	UA652220	C. MYLAR 220pF 50V
C517	VG278400	C. CE. TUBLR 220pF 50V
C518	VG278400	C. CE. TUBLR 220pF 50V
C519	VG278400	C. CE. TUBLR 220pF 50V
C520	VG278400	C. CE. TUBLR 220pF 50V
C521	UA652100	C. MYLAR 100pF 50V
C522	UA652100	C. MYLAR 100pF 50V
C523	VG278400	C. CE. TUBLR 220pF 50V
C524	VG278400	C. CE. TUBLR 220pF 50V
C525	UA652100	C. MYLAR 100pF 50V
C526	UA652100	C. MYLAR 100pF 50V
C527	VG291200	C. EL 47uF 50V
C528	VG291200	C. EL 47uF 50V
C530	VG291200	C. EL 47uF 50V
C531	VG291200	C. EL 47uF 50V
C532	VH053100	C. CE. TUBLR 0.1uF 50V
C533	VF467300	C. CE. TUBLR 0.01uF 16V
C534	VH053100	C. CE. TUBLR 0.1uF 50V
C535	VH053100	C. CE. TUBLR 0.1uF 50V
C536	VH053100	C. CE. TUBLR 0.1uF 50V
C537	VF466800	C. CE. TUBLR 100pF 50V
C538	VF466800	C. CE. TUBLR 100pF 50V
C540	VF466800	C. CE. TUBLR 100pF 50V
C541	VF466800	C. CE. TUBLR 100pF 50V
C542	VF466800	C. CE. TUBLR 100pF 50V
C543	VF466800	C. CE. TUBLR 100pF 50V
C544	VF466800	C. CE. TUBLR 100pF 50V
C545	UA652100	C. MYLAR 100pF 50V
C546	UA652100	C. MYLAR 100pF 50V
C547	VG290300	C. EL 0.47uF 50V
C548	VG290300	C. EL 0.47uF 50V
C549	VJ839200	C. EL 2.2uF 50V
C550	VJ839200	C. EL 2.2uF 50V
C551	VF466700	C. CE. TUBLR 47pF 50V
C552	VF466700	C. CE. TUBLR 47pF 50V
C553	VJ836900	C. EL 10uF 16V
C554	VJ836900	C. EL 10uF 16V
C555	VG291200	C. EL 47uF 50V
C556	VG291200	C. EL 47uF 50V
C557	UA655120	C. MYLAR 0.12uF 50V(UCRAL)
C557	VR168400	C. MYLAR, ML ECQ-V1H124JL3(G)
C558	UA655120	C. MYLAR 0.12uF 50V(UCRAL)
C558	VR168400	C. MYLAR, ML ECQ-V1H124JL3(G)
C559	UA654100	C. MYLAR 0.01uF 50V

* New Parts

Schm Ref.	PART NO.	Description
C560	UA654100	C. MYLAR 0.01uF 50V
C561	UA654330	C. MYLAR 0.033uF 50V
C562	UA654330	C. MYLAR 0.033uF 50V
C563	UA654680	C. MYLAR 0.068uF 50V
C564	UA654680	C. MYLAR 0.068uF 50V
C565	VG279000	C. CE. TUBLR 820pF 50V
C566	VG279000	C. CE. TUBLR 820pF 50V
D501	VG440300	DIODE, ZENR MTZJ12C 12V
D502	iF004600	DIODE 1SS133
D503	iF004600	DIODE 1SS133
D504	VG439200	DIODE, ZENR MTZJ9.1B 9.1V
D505	VG439200	DIODE, ZENR MTZJ9.1B 9.1V
D506	VG437200	DIODE, ZENR MTZJ4.7C 4.7V
D507	iF004600	DIODE 1SS133
G501	VR463400	TERM. GND D3.5 TP00385
IC501	XM356A00	IC NJM2068LD
IC502	XA070A00	IC uPD4052BC
IC503	iG105900	IC uPD4053BC
IC504	iG105900	IC uPD4053BC
IC505	XF494A00	IC LB1641
IC506	XM356A00	IC NJM2068LD
PJ501	VN308700	JACK, PIN 6P
PJ502	VJ696300	JACK, PIN 4P
PJ503	VJ696200	JACK, PIN 4P
Q501	VP872700	TR 2SC4488 S, T
Q502	VG722000	TR, DGT DTC144ES
Q503	VG722000	TR, DGT DTC144ES
Q504	VG722000	TR, DGT DTC144ES
Q505	VG722000	TR, DGT DTC144ES
R541	HV453470	R, CAR, FP 4.7 Ω 1/4W
R561	HL315100	R, MIL, OXD 100 Ω 1W
R562	HL315100	R, MIL, OXD 100 Ω 1W
SW501	VP870900	SW, PUSH SPUL12
VR501	VR262000	VR, MTR A100K Ω
VR502	VT743800	VR B20K Ω
VR503	VT743900	VR B25K Ω
VR504	VT744000	VR A100K Ω
VR505	VT744100	VR Z100K Ω
	VJ828000	PIN IMSA-6024-03E

* New Parts

■ EXPLODED VIEW

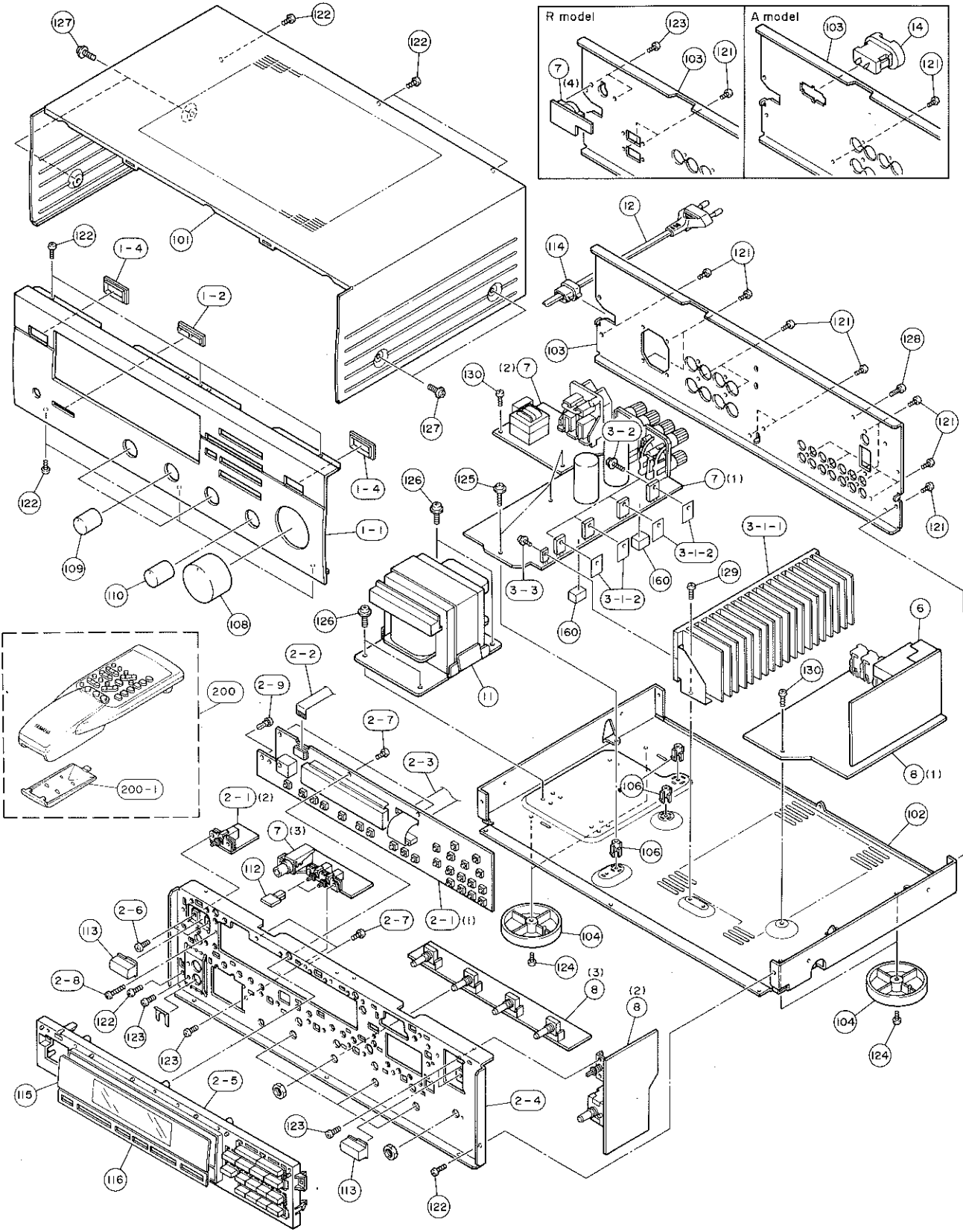

MECHANICAL PARTS

Ref. No.	PART NO.	Description	Remarks	Markets
* 1- 1	VT818400	FRONT PANEL	RX-495	
* 1- 1	VT818500	FRONT PANEL	RX-495RDS BL	
* 1- 1	VT818600	FRONT PANEL	RX-495RDS TI	
1- 2	VQ793400	BUTTON GUIDE	2P	BL
1- 2	VQ793500	BUTTON GUIDE	2P	TI
1- 4	VT754100	BUTTON GUIDE	10x25	BL
1- 4	VT754200	BUTTON GUIDE	10x25	TI
* 2- 1	VU286400	P. C. B. ASS'Y	OPERATION	(UC)
* 2- 1	VU286500	P. C. B. ASS'Y	OPERATION	(R)
* 2- 1	VU286600	P. C. B. ASS'Y	OPERATION	(AL)
* 2- 1	VU293600	P. C. B. ASS'Y	OPERATION	(G)
2- 2	MF109250	FLEXIBLE FLAT CABLE C&C	9P 250mm	
2- 3	MF119300	FLEXIBLE FLAT CABLE C&C	19P 300mm	
2- 4	VT817800	SUB CHASSIS		
* 2- 5	VT821200	BUTTON, CASE		BL
* 2- 5	VT821300	BUTTON, CASE		TI
2- 6	ED330066	BIND HEAD SCREW	3x6 FCRM3-BL	
2- 7	EX600310	BIND HEAD P-TITE SCREW	3x8 FCRM3-BL	
2- 8	VB770500	BIND HEAD B-TITE SCREW	3x12 FNM3-3G	
2- 9	CB068880	PLASTIC RIVET	No. 1027	
3-1-1	VQ967500	HEAT SINK ASS'Y		(C)
3-1-1	VR282200	HEAT SINK ASS'Y		(URALG)
3-1-2	VK195900	SHEET	19x24	
3-2	VK173200	SCREW, TRANSISTOR	3x15 SP FCM3	
3-3	EK930010	PW HEAD B-TITE SCREW	3x8-8 FCRM3-BL	
6	VR341800	P. C. B. ASS'Y	TUNER	(UC)
6	VR341900	P. C. B. ASS'Y	TUNER	(R)
6	VR342000	P. C. B. ASS'Y	TUNER	(A)
6	VR342100	P. C. B. ASS'Y	TUNER	(L)
6	VU293900	P. C. B. ASS'Y	TUNER	(G)
* 7	VU286700	P. C. B. ASS'Y	MAIN	(UC)
* 7	VU286800	P. C. B. ASS'Y	MAIN	(R)
* 7	VU286900	P. C. B. ASS'Y	MAIN	(A)
* 7	VU287000	P. C. B. ASS'Y	MAIN	(L)
* 7	VU293700	P. C. B. ASS'Y	MAIN	(G)
* 8	VU287100	P. C. B. ASS'Y	FUNCTION	(UCRAL)
* 8	VU293800	P. C. B. ASS'Y	FUNCTION	(G)
△ * 11	XR395A00	POWER TRANSFORMER		(U)
△ * 11	XR396A00	POWER TRANSFORMER		(C)
△ * 11	XR397A00	POWER TRANSFORMER		(R)
△ * 11	XR400A00	POWER TRANSFORMER		(AL)
△ * 11	XR401A00	POWER TRANSFORMER		(G)
△ 12	VL238900	POWER CORD ASS'Y		(LG)
△ 12	VQ508500	POWER CORD ASS'Y		(R)
△ 12	VQ508600	POWER CORD ASS'Y		(A)
△ 12	VS168300	POWER CORD ASS'Y		(UC)
△ 14	VT915100	AC OUTLET	2P	(A)
101	VS362100	TOP COVER		BL
101	VS362200	TOP COVER		TI
102	VQ794000	CHASSIS		
* 103	VT820000	REAR PANEL		(U)
* 103	VT820100	REAR PANEL		(C)
* 103	VT820200	REAR PANEL		(R)

*New Parts

Ref. No.	PART NO.	Description	Remarks	Markets
* 103	VT820300	REAR PANEL		(A)
* 103	VT820400	REAR PANEL		(L)
* 103	VT820500	REAR PANEL		(G)
104	VQ780300	LEG	D60xH16	
106	VR264400	SPACER	H8	
108	VQ795100	KNOB	D42	BL
108	VU068800	KNOB	D42	TI
109	VS409600	KNOB	D18	BL
109	VU068600	KNOB	D18	TI
110	VS587400	KNOB	D18L	BL
110	VU068700	KNOB	D18L	TI
112	VQ779000	BUTTON	3x14	BL
112	VU103000	BUTTON	3x14	TI
113	VQ780000	BUTTON	10x25	BL
113	VT990000	BUTTON	10x25	TI
114	VN158600	CORD STOPPER	No. 2104	
115	VT821600	SHEET		(UCR)
115	VT821700	SHEET		(ALG)
116	VT821800	SHEET, BUTTON		RX-495 BL
116	VT841100	SHEET, BUTTON		RX-495RDS BL
116	VT841200	SHEET, BUTTON		RX-495RDS TI
121	EN301010	BIND HEAD BONDING TAP. SCREW	3x8 FCRM3-BL	
122	Ei330086	BIND HEAD B-TITE SCREW	3x8 FCRM3-BL	
123	ED330066	BIND HEAD SCREW	3x6 FCRM3-BL	
124	EK930010	PW HEAD B-TITE SCREW	3x8-8 FCRM3-BL	
125	VT669400	PW HEAD B-TITE SCREW	3x15-8 MFC2	
126	EK365020	PW HEAD SCREW	4x6 FCRM3-BL	
127	EK365090	PW HEAD S-TITE SCREW	4x8-10 FCRM3-BL	BL
127	EX601150	BW HEAD S-TITE SCREW	4x8-10 FNM3-BL	TI
128	VS997700	BIND HEAD S-TITE SCREW	3x10 MFNI33	
129	Ei030046	BIND HEAD TAPPING SCREW	3x4 ZMC2-Y	
130	VT669300	SCREW+PWH BT	3x8-8 MFC2	
160	VQ366100	DAMPER, PCB		
		ACCESSORIES		
* 200	VU074300	REMOTE CONTROL TRANSMITTER		
200-1	CX679050	LID		
	VQ147100	ANTENNA, FM	IP 1.4m	
	VR248500	ANTENNA, AM LOOP	IP 1.0m	
	VT948000	ANTENNA ADAPTER		
		BATTERY, MANGANESE	SUM-3, AA, R06	

*New Parts

Parts List for Carbon Resistors

Value	1/4W Type Part No.	1/6W Type Part No.	Value	1/4W Type Part No.	1/6W Type Part No.
1.0 Ω	HJ35 3100	HF85 3100	10 kΩ	HF45 7100	HF45 7100
1.8 Ω	HJ35 3180	*	11 kΩ	HF45 7110	HF45 7110
2.2 Ω	HJ35 3220	HF85 3220	12 kΩ	HJ35 7120	HF85 7120
3.3 Ω	HJ35 3330	HF85 3330	13 kΩ	HF45 7130	HF45 7130
4.7 Ω	HJ35 3470	HF85 3470	15 kΩ	HF45 7150	HF45 7150
5.6 Ω	HJ35 3560	HF85 3560	18 kΩ	HF45 7180	HF45 7180
10 Ω	HF45 4100	HF45 4100	22 kΩ	HF45 7220	HF45 7220
15 Ω	HJ35 4150	HF85 4150	24 kΩ	HF45 7240	HF45 7240
22 Ω	HF45 4220	HF45 4220	27 kΩ	HJ35 7270	HF85 7270
27 Ω	HJ35 4270	HF85 4270	30 kΩ	HF45 7300	HF45 7300
33 Ω	HF45 4330	HF45 4330	33 kΩ	HF45 7330	HF45 7330
39 Ω	HJ35 4470	HF85 4390	36 kΩ	HF45 7360	HF45 7360
47 Ω	HF45 4470	HF45 4470	39 kΩ	HF45 7390	HF45 7390
56 Ω	HF45 4560	HF45 4560	47 kΩ	HF45 7470	HF45 7470
68 Ω	HF45 4680	HF45 4680	51 kΩ	HF45 7510	HF45 7510
75 Ω	HF45 4750	HF45 4750	56 kΩ	HF45 7560	HF45 7560
82 Ω	HF45 4820	HF45 4820	62 kΩ	HF45 7620	HF45 7620
91 Ω	HF45 4910	HF45 4910	68 kΩ	HF45 7680	HF45 7680
100 Ω	HF45 5100	HF45 5100	82 kΩ	HF45 7820	HF45 7820
110 Ω	HJ35 5110	HF85 5110	91 kΩ	HF45 7910	HF45 7910
120 Ω	HF45 5120	HF45 5120	100 kΩ	HF45 8100	HF45 8100
150 Ω	HF45 5150	HF45 5150	110 kΩ	HF45 8110	HF45 8110
160 Ω	HJ35 5160	*	120 kΩ	HF45 8120	HF45 8120
180 Ω	HF45 5180	HF45 5180	150 kΩ	HF45 8150	HF45 8150
200 Ω	HF45 5200	HF45 5200	180 kΩ	HF45 8180	HF45 8180
220 Ω	HF45 5220	HF45 5220	220 kΩ	HJ35 8220	HF85 8220
270 Ω	HF45 5270	HF45 5270	270 kΩ	HF45 8270	HF45 8270
330 Ω	HF45 5330	HF45 5330	300 kΩ	HF45 8300	HF45 8300
390 Ω	HF45 5390	HF45 5390	330 kΩ	HF45 8330	HF45 8330
430 Ω	HF45 5430	HF45 5430	390 kΩ	HJ35 8390	HF85 8390
470 Ω	HF45 5470	HF45 5470	470 kΩ	HF45 8470	HF45 8470
510 Ω	HF45 5510	HF45 5510	560 kΩ	HJ35 8560	HF85 8560
560 Ω	HF45 5560	HF45 5560	680 kΩ	HJ35 8680	HF85 8680
680 Ω	HF45 5680	HF45 5680	820 kΩ	HJ35 8820	HF85 8820
820 Ω	HF45 5820	HF45 5820	1.0 MΩ	HF45 9100	HF45 9100
910 Ω	HF45 5910	HF45 5910	1.2 MΩ	HJ35 9120	*
1.0 kΩ	HF45 6100	HF45 6100	1.5 MΩ	HJ35 9150	HF85 9150
1.2 kΩ	HF45 6120	HF45 6120	1.8 MΩ	HJ35 9180	HF85 9180
1.5 kΩ	HF45 6150	HF45 6150	2.2 MΩ	HJ35 9220	HF85 9220
1.8 kΩ	HF45 6180	HF45 6180	3.3 MΩ	HJ35 9330	HF85 9330
2.0 kΩ	HJ35 6200	HF85 6200	3.9 MΩ	HJ35 9390	*
2.2 kΩ	HF45 6220	HF45 6220	4.7 MΩ	HJ35 9470	HF85 9470
2.4 kΩ	HJ35 6240	HF85 6240			
2.7 kΩ	HF45 6270	HF45 6270			
3.0 kΩ	HF45 6300	HF45 6300			
3.3 kΩ	HF45 6330	HF45 6330			
3.6 kΩ	HJ35 6360	HF85 6360			
3.9 kΩ	HF45 6390	HF45 6390			
4.7 kΩ	HF45 6470	HF45 6470			
5.1 kΩ	HF45 6510	HF45 6510			
5.6 kΩ	HF45 6560	HF45 6560			
6.8 kΩ	HF45 6680	HF45 6680			
8.2 kΩ	HF45 6820	HF45 6820			
9.1 kΩ	HF45 6910	HF45 6910			

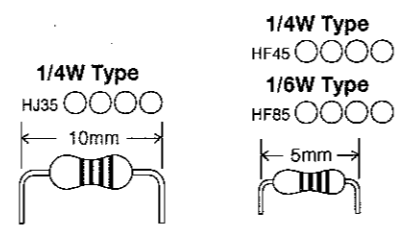

RX-495/RX-495RDS

YAMAHA