

# STEREO RECEIVER RX-396RDS RX-496RDS SERVICE MANUAL

## IMPORTANT NOTICE

This manual has been provided for the use of authorized YAMAHA Retailers and their service personnel. It has been assumed that basic service procedures inherent to the industry, and more specifically YAMAHA Products, are already known and understood by the users, and have therefore not been restated.

**WARNING:** Failure to follow appropriate service and safety procedures when servicing this product may result in personal injury, destruction of expensive components, and failure of the product to perform as specified. For these reasons, we advise all YAMAHA product owners that any service required should be performed by an authorized YAMAHA Retailer or the appointed service representative.

**IMPORTANT:** The presentation or sale of this manual to any individual or firm does not constitute authorization, certification or recognition of any applicable technical capabilities, or establish a principle-agent relationship of any form.

The data provided is believed to be accurate and applicable to the unit(s) indicated on the cover. The research, engineering, and service departments of YAMAHA are continually striving to improve YAMAHA products. Modifications are, therefore, inevitable and specifications are subject to change without notice or obligation to retrofit. Should any discrepancy appear to exist, please contact the distributor's Service Division.

**WARNING:** Static discharges can destroy expensive components. Discharge any static electricity your body may have accumulated by grounding yourself to the ground buss in the unit (heavy gauge black wires connect to this buss).

**IMPORTANT:** Turn the unit OFF during disassembly and part replacement. Recheck all work before you apply power to the unit.

## ■ CONTENTS

TO SERVICE PERSONNEL .....	1	IC DATA .....	13~14
FRONT PANELS .....	1	DISPLAY DATA .....	15
REAR PANELS .....	2	BLOCK DIAGRAM .....	16~17
SPECIFICATIONS .....	3~4	PRINTED CIRCUIT BOARD .....	18~28
INTERNAL VIEW .....	4	PIN CONNECTION DIAGRAM .....	29
DISASSEMBLY PROCEDURES .....	5~6	RX-396RDS SCHEMATIC DIAGRAM .....	30~33
TEST MODE .....	7	RX-496RDS SCHEMATIC DIAGRAM .....	34~37
PROTECTION OPERATION CHECK FUNCTION ...	7	PARTS LIST .....	38~52
AMP ADJUSTMENTS .....	8	REMOTE CONTROL TRANSMITTER .....	53
TUNER ADJUSTMENTS .....	9~12		



このサービスマニュアルは、エコマーク認定の再生紙を使用しています。  
This Service Manual uses recycled paper.

100637



**YAMAHA**  
YAMAHA CORPORATION  
P.O. Box 1, Hamamatsu, Japan

1.2K-528 Printed in Japan '98.6

## ■ TO SERVICE PERSONNEL

Critical Components Information.  
 Components having special characteristics are marked  $\Delta$  and must be replaced with parts having specifications equal to those originally installed.

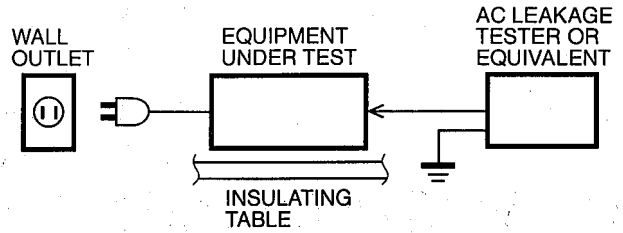

## ■ FRONT PANELS

### ▼ RX-396RDS

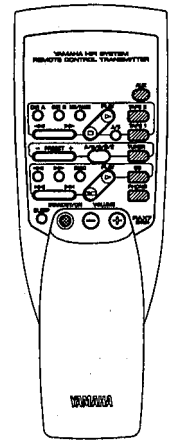
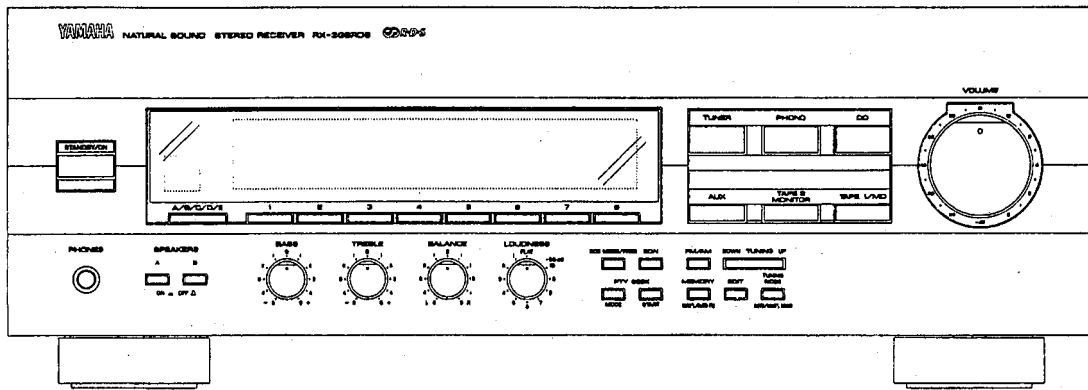

### ▼ RX-496RDS

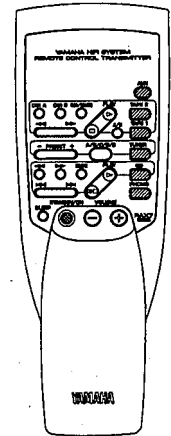
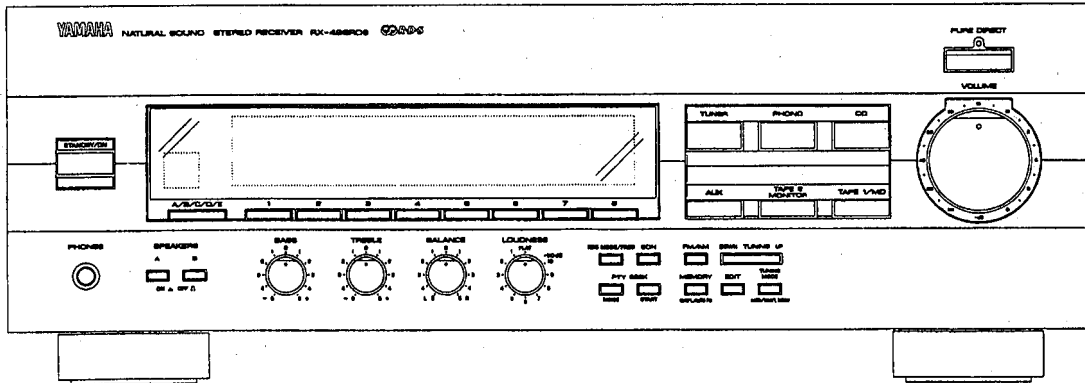

### WARNING

Do not change the IMPEDANCE SELECTOR switch setting while the power to this unit is on, otherwise this unit may be damaged.

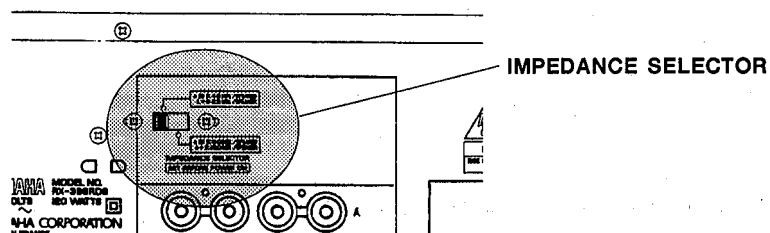

RX-396RDS  
 RX-496RDS

# REAR PANELS

## ▼ RX-396RDS B model

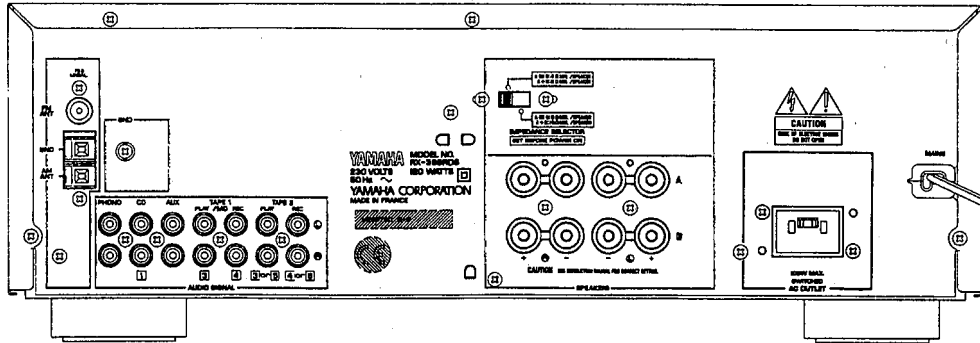

## ▼ RX-396RDS G model

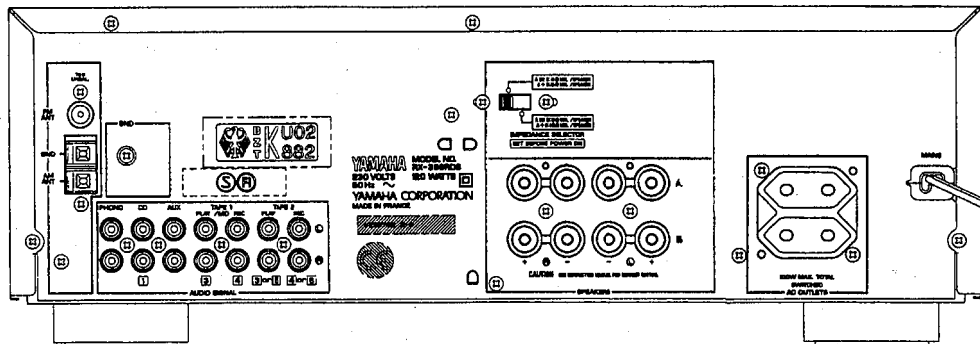

## ▼ RX-496RDS B model

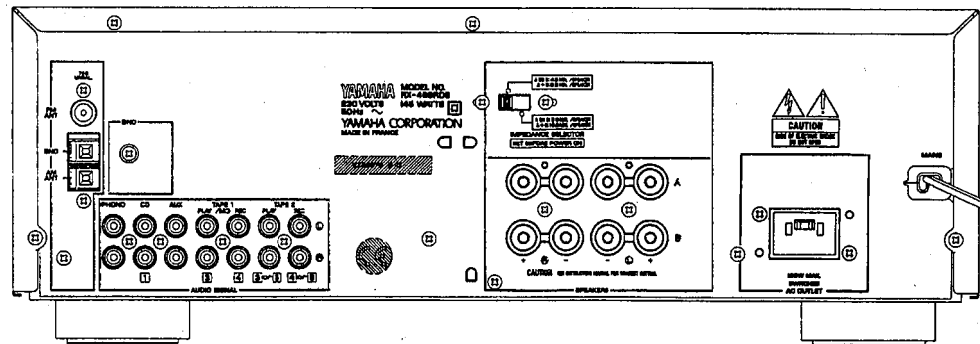

## ▼ RX-496RDS G model

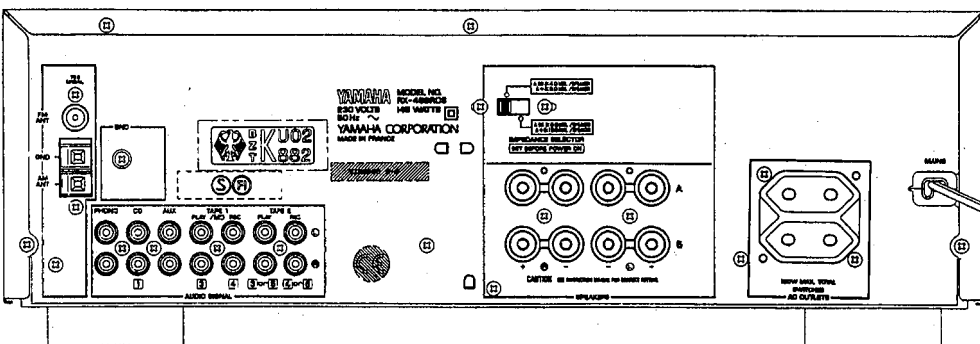

RX-396RDS  
RX-496RDS

## ■ SPECIFICATIONS

### ■ AUDIO SECTION

<b>Minimum RMS Output Power per Channel</b>	
<b>RX-396RDS</b>	
20Hz to 20kHz, 0.04% THD, 8Ω	50W + 50W
<b>RX-496RDS</b>	
20Hz to 20kHz, 0.04% THD, 8Ω	75W + 75W
<b>Dynamic Power per Channel (IHF)</b>	
<b>RX-396RDS</b>	
8/6/4/2Ω	70/77/89/100W
<b>RX-496RDS</b>	
8/6/4/2Ω	105/125/150/178W
<b>DIN Standard Output Power per Channel</b>	
<b>RX-396RDS (G model only)</b>	
1kHz, 0.7% THD, 4Ω	55W
<b>RX-496RDS (G model only)</b>	
1kHz, 0.7% THD, 4Ω	105W
<b>IEC Power</b>	
<b>RX-396RDS (G model only)</b>	
1kHz, 0.04% THD, 8Ω	52W
<b>RX-496RDS (G model only)</b>	
1kHz, 0.04% THD, 8Ω	84W
<b>Power Band Width</b>	
<b>RX-396RDS</b>	
0.08% THD, 22.5W, 8Ω	10Hz to 50kHz
<b>RX-496RDS</b>	
0.08% THD, 35W, 8Ω	10Hz to 50kHz
<b>Damping Factor</b>	
20Hz to 20kHz, 8Ω	100 or more
<b>Input Sensitivity/Impedance</b>	
PHONO MM	2.5mV/47kΩ
CD, etc	150mV/47kΩ
<b>Maximum Input Signal Level (1kHz, 0.04% THD)</b>	
PHONO MM	90mV
<b>Output Level</b>	
REC OUT	150mV
<b>Headphone Jack Rated Output/Impedance</b>	
<b>RX-396RDS</b>	
0.04% THD, 8Ω	0.47V/330Ω
<b>RX-496RDS</b>	
0.04% THD, 8Ω	0.49V/390Ω
<b>Frequency Response (20Hz to 20kHz)</b>	
CD, etc	0±0.5dB
<b>RIAA Equalization Deviation (20Hz to 20kHz)</b>	
PHONO MM	0±0.5dB
<b>Total Harmonic Distortion (20Hz to 20kHz)</b>	
PHONO MM to REC OUT (1V)	0.02%
CD, etc to SP OUT (35W/8Ω)	0.02%
<b>Signal-to-Noise Ratio (IHF-A-Network)</b>	
PHONO MM, Input Shorted (5mV)	82dB
CD, etc, Input Shorted	108dB
<b>Residual Noise (IHF-A-Network)</b>	
	100μV
<b>Channel Separation (Vol. -30dBf)</b>	
CD, etc, Input 5.1kΩ Shorted, 1kHz	60dB
<b>Tone Control Characteristics</b>	
BASS : Boost/cut	±10dB (50Hz)
Turnover Frequency	350Hz
TREBLE : Boost/cut	±10dB (20kHz)
Turnover Frequency	3.5kHz
<b>Continuous Loudness Control</b>	
	- 30dB (1kHz)
	(Level related equalization)

### ■ FM SECTION

<b>Tuning Range</b>	87.50 to 108.00MHz
<b>Usable Sensitivity (75 Ω)</b>	
DIN, Mono (S/N 26dB)	0.9μV
DIN, Stereo (S/N 46dB)	24μV
<b>Image Response Ratio</b>	80dB
<b>IF Response Ratio</b>	80dB
<b>Spurious Response Ratio</b>	70dB
<b>AM Suppression Ratio</b>	55dB
<b>Capture Ratio</b>	1.5dB
<b>Alternate Channel Sensitivity</b>	
Selectivity (two Signals, 40kHz Dev.)	70dB
<b>Signal-to-Noise Ratio</b>	
Mono/Stereo (DIN-weighted, 40kHz Dev.)	75/70dB
<b>Harmonic Distortion (1kHz)</b>	
Mono/Stereo (40kHz Dev.)	0.1/0.2%
<b>Stereo Separation (40kHz Dev. 1kHz)</b>	
	50dB
<b>Frequency Response</b>	
20Hz to 15kHz	0 ± 1.5dB
<b>Output Level/Impedance</b>	
FM 100% mod. 1kHz (40kHz Dev.)	500mV/2.2kΩ

### ■ AM SECTION

<b>Tuning Range</b>	531 to 1611kHz
<b>Usable Sensitivity</b>	
	100μV/m
<b>Selectivity</b>	32dB
<b>Signal-to-Noise Ratio</b>	50dB
<b>Image Response Ratio</b>	40dB
<b>Spurious Response Ratio</b>	50dB
<b>Harmonic Distortion (1kHz)</b>	0.3%
<b>Output Level/Impedance</b>	
AM 30% mod. 1kHz	150mV/2.2kΩ

### ■ GENERAL

<b>Power Supply</b>	AC 230V, 50Hz
<b>Power Consumption</b>	
<b>RX-396RDS</b>	120W
<b>RX-496RDS</b>	145W
<b>AC Outlets</b>	
G model, Switched x 2	100W max (Total)
B model, Switched x 1	100W max
<b>Dimensions (W x H x D)</b>	435 x 151 x 309.3mm
	(17-1/8" x 5-15/16" x 12-3/16")
<b>Weight</b>	
<b>RX-396RDS</b>	6.4 kg (14 lbs. 1 oz)
<b>RX-496RDS</b>	8.2 kg (18 lbs. 1 oz)
<b>Accessories</b>	
	AM loop antenna x 1
	Indoor FM antenna x 1
	Remote Control Transmitter x 1
	Battery (size "AA", "R06") x 2

\* Specifications subject to change without notice.

**B** ..... British model  
**G** ..... European model

● DIMENSIONS

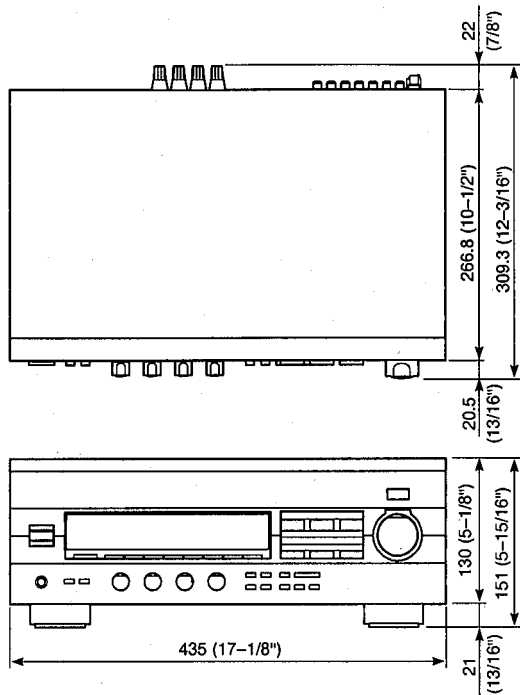

Units : mm (inch)

■ INTERNAL VIEW

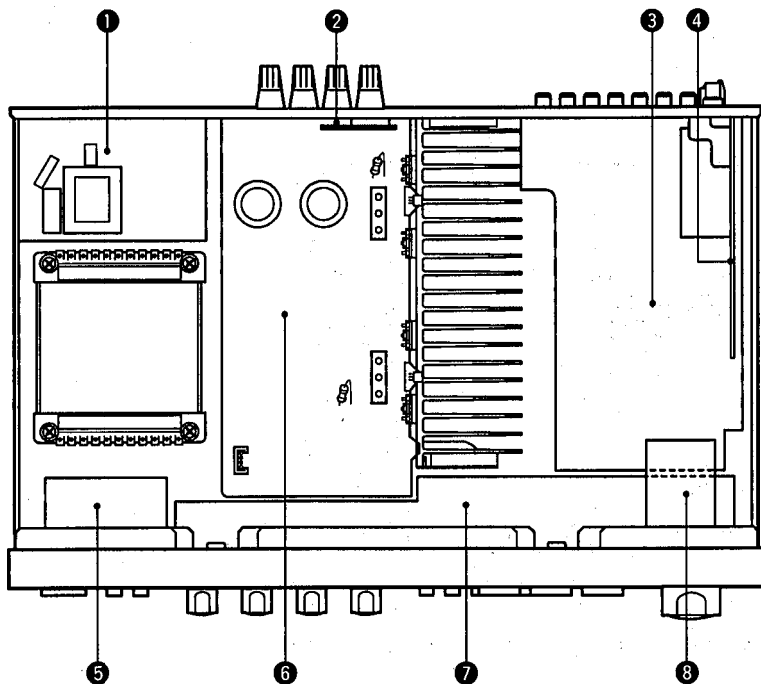

- ① P. C. B. MAIN (2)
- ② P. C. B. MAIN (5)
- ③ P. C. B. INPUT (1)
- ④ P. C. B. TUNER
- ⑤ P. C. B. MAIN (3)
- ⑥ P. C. B. MAIN (1)
- ⑦ P. C. B. INPUT (2)
- ⑧ P. C. B. INPUT (4) .....RX-496RDS only

RX-396RDS  
RX-496RDS

**DISASSEMBLY PROCEDURES** (Remove parts in disassembly order as numbered.)

**1. Removal of Top Cover**

a. Remove 4 screws ( ① ) and 4 screws ( ② ) in Fig. 1.

**2. Removal of Front Panel**

a. Remove the knobs.

b. Remove 6 screws ( ③ ) in Fig. 1.

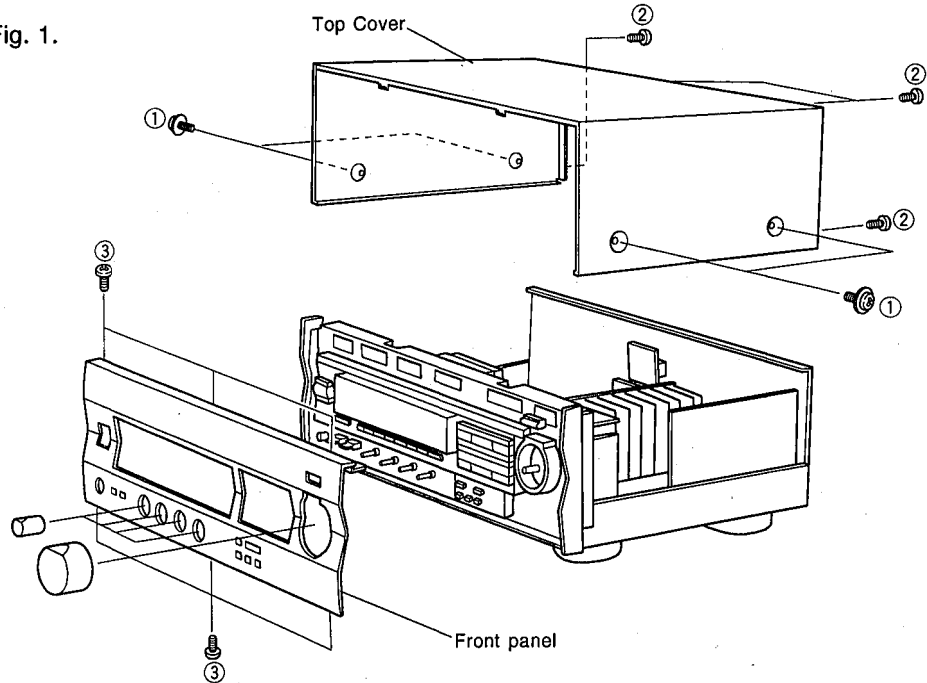

Fig. 1

**3. Checking and Parts Replacement of Main Unit**

a. Disconnect the power cord from the AC outlet.

b. Remove 2 screws ( ④ ) and 1 screw ( ⑤ ) in Fig. 2.

c. Detach 1 connector terminal (CB103) in Fig. 2.

d. Operating checks can be taken by shorting between following test points in Fig. 2.

Short Point
TP101 and TP102
TP103 and TP104
TP105 and TP106

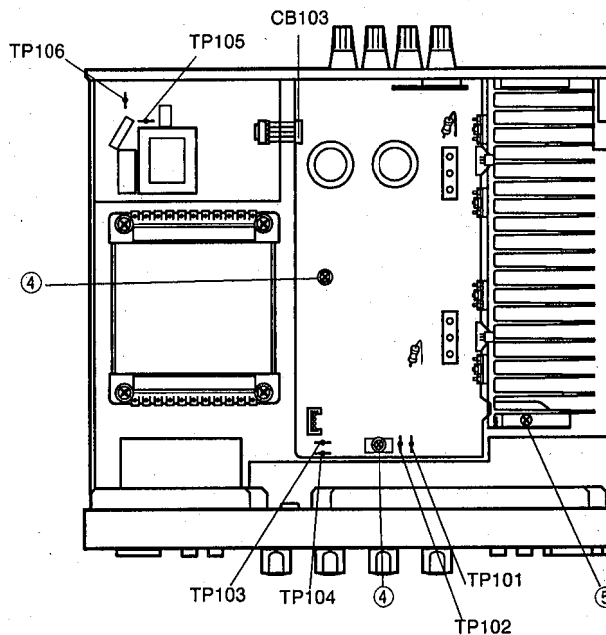

Fig. 2

RX-396RDS  
RX-496RDS

- e. Remove 5 screws (ⓐ) in Fig. 3.
- f. Place the Main Unit on its side as shown in Fig. 4.
- g. Connect the power cord and turn ON the POWER switch.

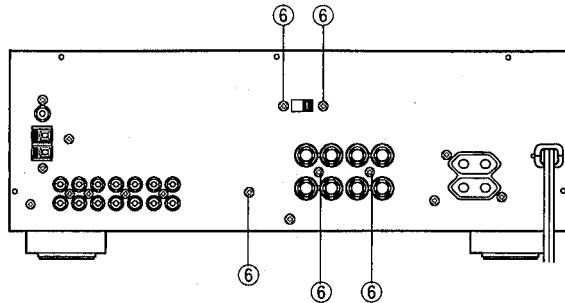

Fig. 3

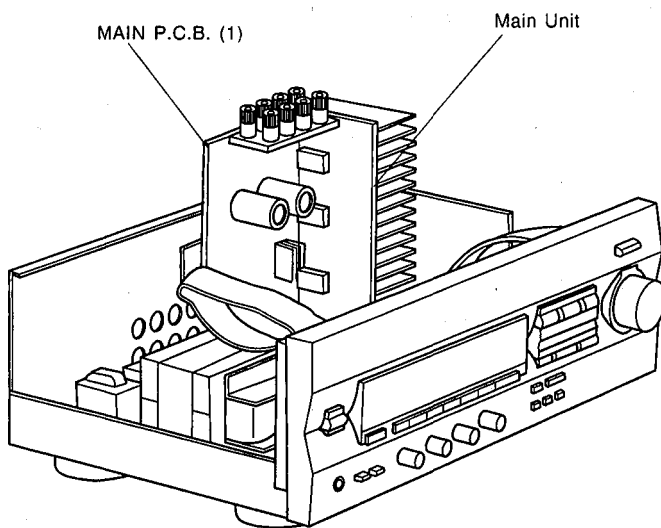

Fig. 4

## ■ TEST MODE

**CAUTION :** Before setting to the TEST mode, write down the existing preset memory content of the Tuner in a table as shown below. (This is because setting to the TEST mode will cause the memory content to be as factory set, i.e., all the preset memory by the user will be erased.)

Preset group	P1	P2	P3	P4	P5	P6	P7	P8
A								
B								
C								
D								
E								

### How to start

Turn the POWER switch ON while pressing the CD and PRESET STATION No. 8 keys simultaneously. The unit enters the TEST mode for the display check (All display segments light immediately).

### How to cancel

Normal operation is restored when the POWER switch is turned OFF. At the same time, the factory preset, memory is also restored.

### ● Factory preset memory content

Preset group	P1	P2	P3	P4
A / C / E	87.50MHz	90.10MHz	95.10MHz	98.10MHz
B / D	630kHz	1080kHz	1440kHz	531kHz

Preset group	P5	P6	P7	P8
A / C / E	108.00MHz	88.10MHz	106.10MHz	108.00MHz
B / D	1611kHz	900kHz	1350kHz	1404kHz

For all the above, AUTO TUNING and AUTO STEREO are selected as the TUNING mode.

## ■ PROTECTION OPERATION CHECK FUNCTION

1. Turn the POWER switch ON while pressing the AUX and PRESET STATION No. 8 keys simultaneously, and the protection operation mode and the microprocessor AD input value are displayed for 3 seconds.

**Example :** PRT-PS [AD value] [PRT-PS] indicates detection of an abnormal DC value from the amplifier.  
 PRT-DC [PRT-DC] indicates detection of an abnormal overcurrent from the amplifier.  
 [PRT-NON] indicates no detection.

When the PRESET STATION No. 8 key is pressed during the above display, the input data are retained till they are cleared.  
 ("PRT-NON" appears on display when the data are cleared.)

2. Turn the POWER switch ON while pressing the AUX and the PRESET STATION No. 7 keys simultaneously, and the input value for detection of an abnormal amplifier DC will be displayed.

**Example :** DC - [AD value]  
 [DC- ] indicates detection of an abnormal amplifier DC.

Type of protection	Normal (AD value)	Abnormal (AD value)
Detection of an abnormal amplifier DC	128 - 255	0 - 127

Press any key, and the display will be canceled.

RX-396RDS  
RX-496RDS



## AMP ADJUSTMENTS

### Confirmation of Idling Current

- 1) No signal applied.
- 2) Non-loaded condition.
- 3) Aging is not necessary.

Item	Test Point	Rating (DC)	Note
MAIN L	TP107 (CB120)	0.05mV~2.5mV	If the measured voltage exceeds 2.6mV, cut the lead wire of R131(L ch) or R132(R ch) and then check again if each measured value satisfies the rating.
MAIN R			

**Note)**

- If R131(L ch) or R132(R ch) have already been cut off and idling current does not flow, reconnect R131(1kΩ) or R132(1kΩ).
- Q107 and Q108 are transistors for temperature correction. Apply silicone grease to the contact surface with the heat sink.

R131 (L ch)  
R132 (R ch)

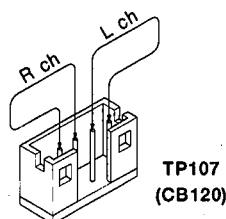
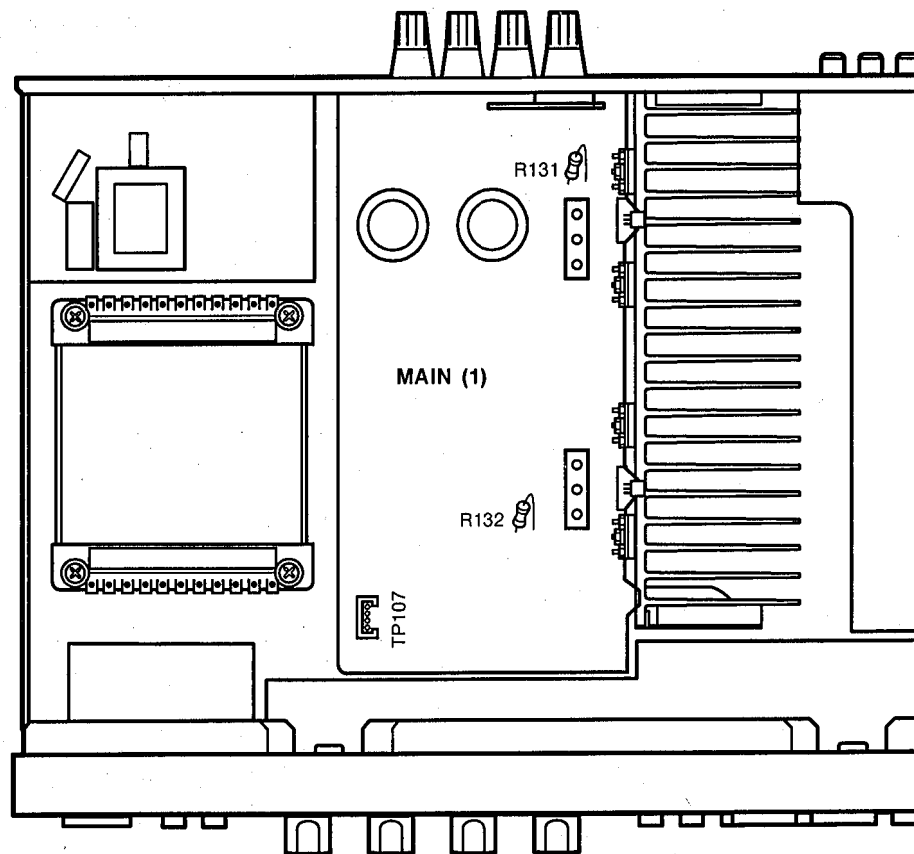
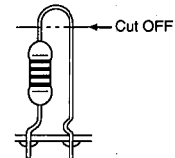

RX-396RDS  
RX-496RDS

## TUNER ADJUSTMENTS

### Measuring Instruments

- FM signal generator (FM SG)
- Stereo signal generator (SSG)
- AM signal generator (AM SG)
- Distortion meter (DIST. M)
- AC voltmeter (ACVM)
- DC voltmeter (DCVM)
- Oscilloscope
- Low pass filter (YLF-15,  $f_c=15\text{kHz}$ )
- Oscillator

### Dummy antenna

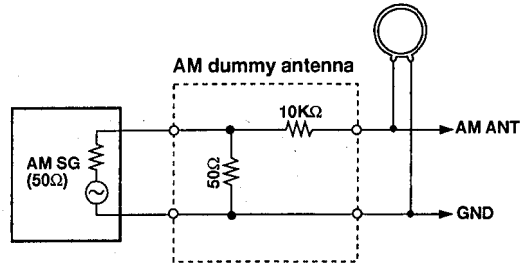
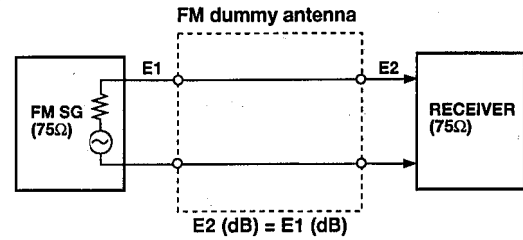
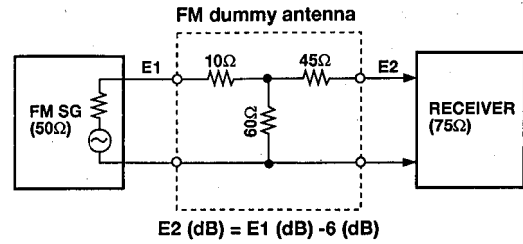

### Test point

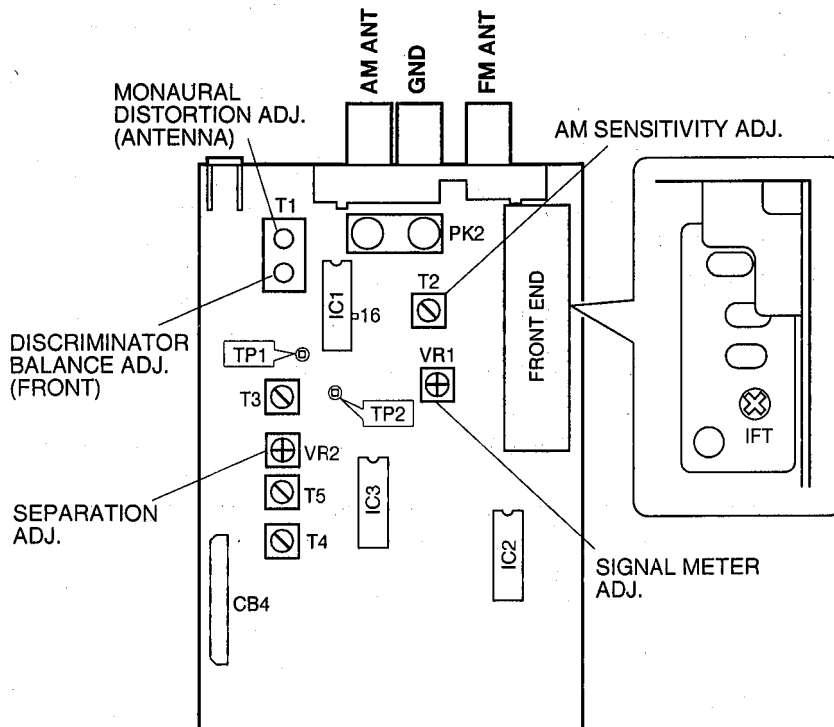

**FM Adjustment**

● **Before Adjustment**

- 1) For dB,  $1\mu V = 0dB\mu$   
**Example** :  $60dB\mu = 1mV$
- 2) 100% modulation means that the frequency deviation is  $\pm 75kHz$ .

- 3) Install the Matching Transformer and connect FM SG.
- 4) Set each switch to the following position unless otherwise specified.

INPUT SELECTOR..... TUNER  
 TUNING MODE ..... AUTO

● **Connection diagram (Measuring instruments)**

1) **Discriminator balance adjustment**

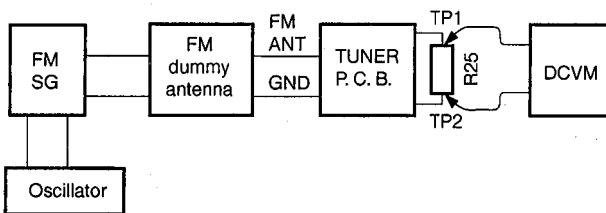

3) **Stereo distortion adjustment/separation adjustment**

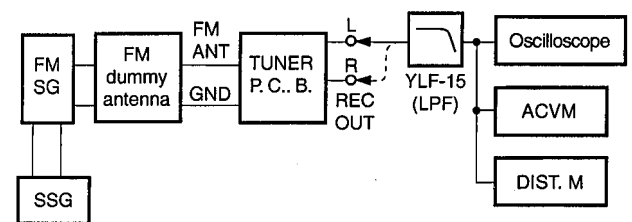

2) **Monaural distortion adjustment**

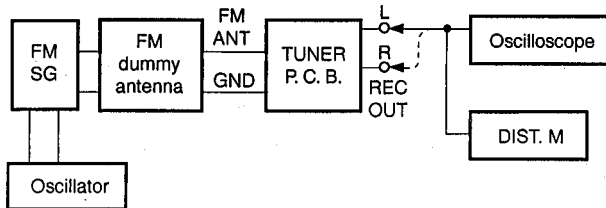

4) **Sensitivity Verification**

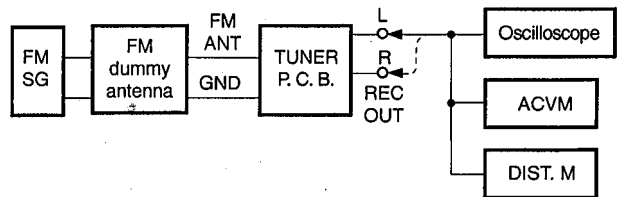

See page 9 for TP locations & adjustment points.

Step	Adjustment item	Signal (ANT IN)	Reception frequency	Adjustment point	Test point	Rating
1	Rough adjustment of discriminator balance	FM ANT (75Ω) 98.1MHz ** 70dBμ MONO 1kHz 100% modulation	98.1MHz * (A-4)	T1 (Front side core)	Both ends of R25 (Between TP1 and TP2)	DC 0V±100mV
2	Rough adjustment of monaural distortion	Same as Step 1.	98.1MHz * (A-4)	T1 (Antenna side core)	REC OUT L, R	Minimize the distortion.
3	Fine adjustment of discriminator balance	Same as Step 1.	98.1MHz * (A-4)	T1 (Front side core)	Both ends of R25 (Between TP1 and TP2)	DC 0V±50mV
4	Fine adjustment of monaural distortion	Same as Step 1.	98.1MHz * (A-4)	T1 (Antenna side core)	REC OUT L, R	Minimize the distortion (to 0.25% or less).
5	Verification of discriminator balance	Same as Step 1.	98.1MHz * (A-4)	T1 (Front side core)	Both ends of R25 (Between TP1 and TP2)	DC 0V±50mV

\* : Execution of FACTORY PRESET (Refer to page 7.) will facilitate setting reception frequency for adjustment.

\*\* Must be 98.1MHz ± 5kHz

RX-396RDS  
RX-496RDS

Step	Adjustment item	Signal (ANT IN)	Reception frequency	Adjusted point	Test point	Rating
6	Adjustment of front end IFT	FM ANT (75Ω) 98.1MHz 30dBμ MONO 1kHz, 100% modulation	98.1MHz * (A-4)	Front end IFT	Pin 16 of IC1	Adjust so that the DC voltage is maximum. <b>CAUTION</b> : Over-adjustment of the IFT core will reduce the sensitivity. Maximum ±90°
7	Verification of monaural distortion	FM ANT (75Ω) 98.1MHz 70dBμ MONO 1kHz, 100% modulation	98.1MHz * (A-4)		REC OUT L, R	0.4% or less
8	Verification of stereo distortion	FM ANT (75Ω) 98.1MHz 70dBμ Stereo L or R 1kHz, 100% modulation	98.1MHz * (A-4) * Tuning mode should be AUTO.		REC OUT L, R	1% or less • STEREO indicator should light.
9	Verification of sensitivity	FM ANT (75Ω) 88.1MHz 98.1MHz 106.1MHz MONO 1kHz Modulation off	88.1MHz * (A-6) 98.1MHz * (A-4) 106.1MHz * (A-7)		ANT (75Ω)	1) Set the tuning mode to MAN'L MONO. (Muting OFF) 2) S/N should be 30dB at each frequency of 88.1MHz, 98.1MHz, and 106.1MHz. 3) Check to ensure that the voltage at the ANT terminal is 6dBμ or less.
10	Adjustment of Separation	FM ANT (75Ω) 98.1MHz 70dBμ Stereo L or R 1kHz, 100% modulation	98.1MHz * (A-4)	VR2	REC OUT L, R	With SSG output at L or R, the signal leakage level at the other channel should be minimized. 36dB or more
11	Adjustment of Signal meter	FM ANT (75Ω) 98.1MHz 45dBμ MONO 1kHz 30% modulation	98.1MHz * (A-4)	VR1		Adjust so that all segments light.
		-10dBμ or less				Check to ensure that signal meters turn OFF.
12	Verification of auto tuning	FM ANT (75Ω) 98.1MHz 23dBμ Stereo L or R 1kHz, 30% modulation	98.1MHz			• Automatic reception should be available when the tuning key is moved UP and DOWN. • The stereo indicator should light. • Audio muting should be applied during tuning.

\* : Execution of FACTORY PRESET (Refer to page 7.) will facilitate setting reception frequency for adjustment.

**AM Adjustment (This should be done after FM adjustment.)**

● **Connection Diagram (Measuring instruments)**

1) Adjustment of sensitivity

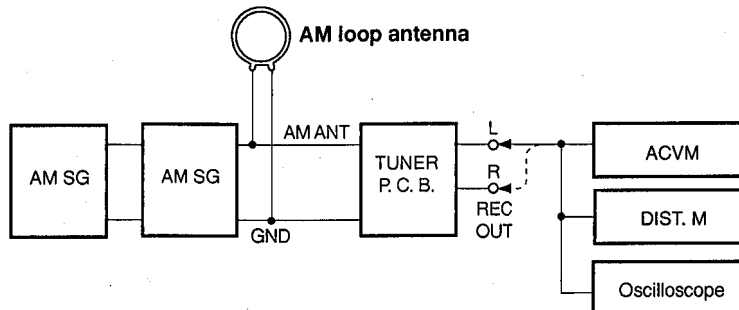

See page 9 for TP locations & adjustment points.

Step	Adjustment item	Signal (ANT IN)	Reception frequency	Adjustment point	Test point	Rating
1	Adjustment of sensitivity (1440Hz)	AM ANT 1440kHz 50dB $\mu$ 1kHz 30% modulation	1440kHz * (B-3)	T2	REC OUT	Audio output should be maximized.
2	Verification of sensitivity (630kHz)	AM ANT 630kHz 50dB $\mu$ 1kHz 30% modulation	630kHz * (B-1)	T2	REC OUT	Audio output should be maximized. Repeat the Step 1 and 2.
3	Verification of sensitivity	AM ANT 630kHz 1080kHz 1440kHz 30% modulation	630kHz * (B-1) 1080kHz * (B-2) 1440kHz * (B-3)		AM ANT	Distortion should be 10% or less at each frequency. Check to ensure that the voltage at the ANT terminal is 54dB $\mu$ or less.
4	Verification of auto tuning	AM ANT 60dB $\mu$				Auto reception should be available when the tuning key is moved UP and DOWN.

\* : Execution of FACTORY PRESET (Refer to page 7.) will facilitate setting reception frequency for adjustment.

RX-396RDS  
RX-496RDS

IC DATA

IC4 : M38B59EFP  
8 bit μ-COM

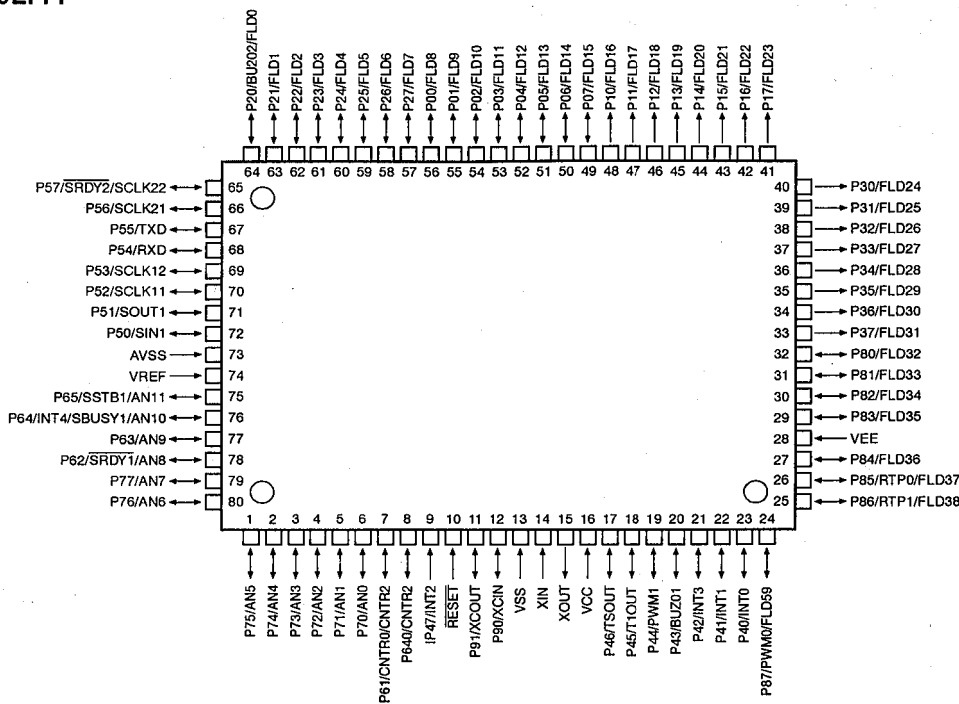

Pin No.	Port	I/O	Function
1	P75	I	KEY AD IN 4 (A-D)
2	P74	I	KEY AD IN 3 (A-D)
3	P73	I	KEY AD IN 2 (A-D)
4	P72	I	KEY AD IN 1 (A-D)
5	P71	I	PROTECTION 1 DETECT (A-D)
6	P70	I	PROTECTION 2 DETECT (A-D)
7	P61	O	Full mute [L : ON]
8	P60	O	OPEN
9	P47	I	REMOTE CONTROL IN
10	/RES	I	RESET
11	P91	I	V2 market
12	P90	I	V1 market
13	VSS	I	GND
14	XIN	I	4MHZ
15	XOUT	O	4MHZ
16	VCC	I	+ 5V
17	P46	O	OPEN
18	P45	O	OPEN
19	P44	O	OPEN
20	P43	O	OPEN
21	P42	O	OPEN
22	P41	I	Power down detect [L : DOWN]
23	P40	I	START IN RDS (INT0)
24	P87	O	OPEN [L : ON]
25	P86	O	OPEN [L : ON]
26	P85	O	Volume up out
27	P84	O	Volume down out

**Protection 1 (5 pin)**  
Detection of an abnormal amplifier DC. Normal when AD value 128 - 255.  
Detection starts 2 seconds after the power is turned ON.

**Protection 2 (6 pin)**  
Detection of an abnormal amplifier overcurrent. Abnormality detected at H.  
Detection starts after the power is turned ON.

**IC4 : M38B59EFFF**  
**8 bit  $\mu$ -COM**

Pin No.	Port	I/O	Function
28	VEE	I	- 25V
29	P83	I	POWER switch in [H : ON]
30	P82	O	OPEN
31	P81	O	SPEAKER RELAY OUT (MAIN) [H : ON]
32	P80	O	POWER RELAY OUT [H : ON]
33	P37	O	OPEN [H : ON]
34	P36	O	OPEN [H : ON]
35	P35	O	OPEN [H : ON]
36	P34	O	FL SEGMENT 4 [H : ON]
37	P33	O	FL SEGMENT 5 [H : ON]
38	P32	O	FL SEGMENT 6 [H : ON]
39	P31	O	FL SEGMENT 7 [H : ON]
40	P30	O	FL SEGMENT 8 [H : ON]
41	P17	O	FL SEGMENT 9 [H : ON]
42	P16	O	FL SEGMENT 10 [H : ON]
43	P15	O	FL SEGMENT 11 [H : ON]
44	P14	O	FL SEGMENT 12 [H : ON]
45	P13	O	FL SEGMENT 13 [H : ON]
46	P12	O	FL SEGMENT 14 [H : ON]
47	P11	O	FL SEGMENT 15 [H : ON]
48	P10	O	FL SEGMENT 16 [H : ON]
49	P07	O	FL DIGIT 12 [H : ON]
50	P06	O	FL DIGIT 11 [H : ON]
51	P05	O	FL DIGIT 10 [H : ON]
52	P04	O	FL DIGIT 9 [H : ON]
53	P03	O	FL DIGIT 8 [H : ON]
54	P02	O	FL DIGIT 7 [H : ON]
55	P01	O	FL DIGIT 6 [H : ON]
56	P00	O	FL DIGIT 5 [H : ON]
57	P27	O	FL DIGIT 4 [H : ON]
58	P26	O	FL DIGIT 3 [H : ON]
59	P25	O	FL DIGIT 2 [H : ON]
60	P24	O	FL DIGIT 1 [H : ON]
61	P23	O	Not used (GND)
62	P22	O	Not used (GND)
63	P21	O	Not used (GND)
64	P20	O	Not used (GND)
65	P57	O	CE INPUT out
66	P56	O	Serial clock out
67	P55	O	Serial data out
68	P54	I	DO IN for tuner
69	P53	O	OPEN
70	P52	I/O	RDS serial clock in
71	P51	I	OPEN
72	P50	I/O	RDS serial data in
73	AVSS		GND [H : ON]
74	VREF		+ 5V
75	P65	I	OPEN [H : RDS]
76	P64	O	TMUTE for tuner [L : ON]
77	P63	I	/ST for tuner [L : stereo]
78	P62	O	CE TUN for tuner
79	P77	I	METER IN
80	P76	O	OPEN

## ■ DISPLAY DATA

● V1 : 13-BT-140GK (VT668600)

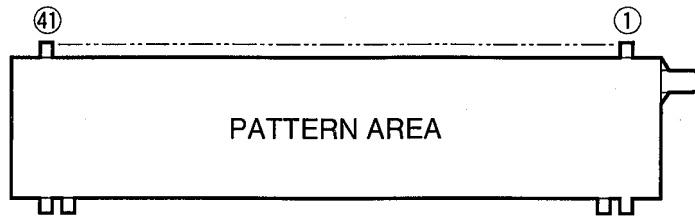

### • PIN CONNECTION

PIN NO.	1	2	3	4	5	6	7	8	9	10	11	12	13	14	15	16	17	18	19	20	21
CONNECTION	F1	F1	NP	NP	P16	P15	P14	P13	P12	P11	P10	P9	P8	P7	P6	P5	P4	P3	P2	P1	NX
PIN NO.	22	23	24	25	26	27	28	29	30	31	32	33	34	35	36	37	38	39	40	41	
CONNECTION	NX	NX	NX	1G	2G	3G	4G	5G	6G	7G	8G	9G	10G	11G	12G	13G	NP	NP	F2	F2	

NOTE 1) F1, F2 ..... Filament  
 2) NP ..... No pin  
 3) NC ..... No connection  
 4) NX ..... No extend pin  
 5) P1~P16 ..... Datum Line  
 6) 1G~13G .... Grid

### • GRID ASSIGNMENT

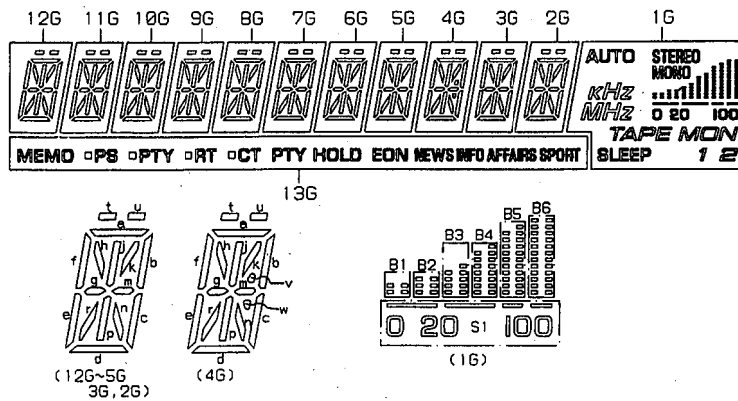

### • ANODE CONNECTION

	13G	12G	11G	10G	9G	8G	7G	6G	5G	4G	3G	2G	1G
P1	SPORT	a	a	a	a	a	a	a	a	a	a	a	AUTO
P2	AFFAIRS	b	b	b	b	b	b	b	b	b	b	b	kHz
P3	INFO	c	c	c	c	c	c	c	c	c	c	c	MHz
P4	NEWS	d	d	d	d	d	d	d	d	d	d	d	STEREO
P5	EON	e	e	e	e	e	e	e	e	e	e	e	MONO
P6	PTY HOLD	f	f	f	f	f	f	f	f	f	f	f	B1
P7	CT	g	g	g	g	g	g	g	g	g	g	g	B2
P8	□(CT)	h	h	h	h	h	h	h	h	h	h	h	B3
P9	RT	j	j	j	j	j	j	j	j	j	j	j	B4
P10	□(RT)	k	k	k	k	k	k	k	k	k	k	k	B5
P11	RTY	m	m	m	m	m	m	m	m	m	m	m	B6
P12	□(RTY)	n	n	n	n	n	n	n	n	n	n	n	S1
P13	PS	p	p	p	p	p	p	p	p	p	p	p	TAPE MON
P14	□(RS)	r	r	r	r	r	r	r	r	r	r	r	1
P15	MEMO	t, u	t, u	t, u	t, u	t, u	t, u	t, u	t, u	t, u	t, u	t, u	2
P16	—	—	—	—	—	—	—	—	—	v, w	—	—	SLEEP



■ BLOCK DIAGRAM

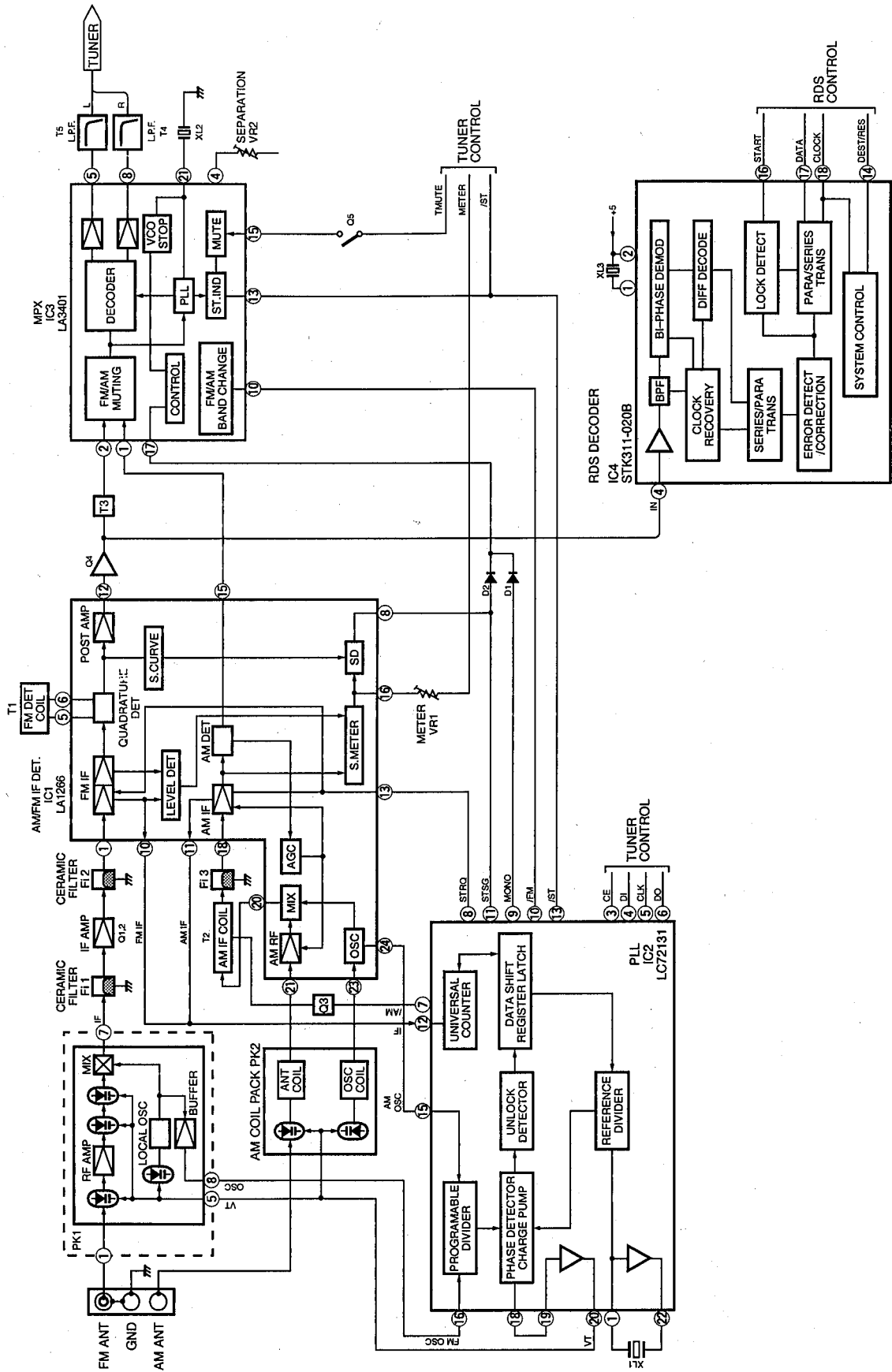

RX-396RDS  
RX-496RDS

■ BLOCK DIAGRAM

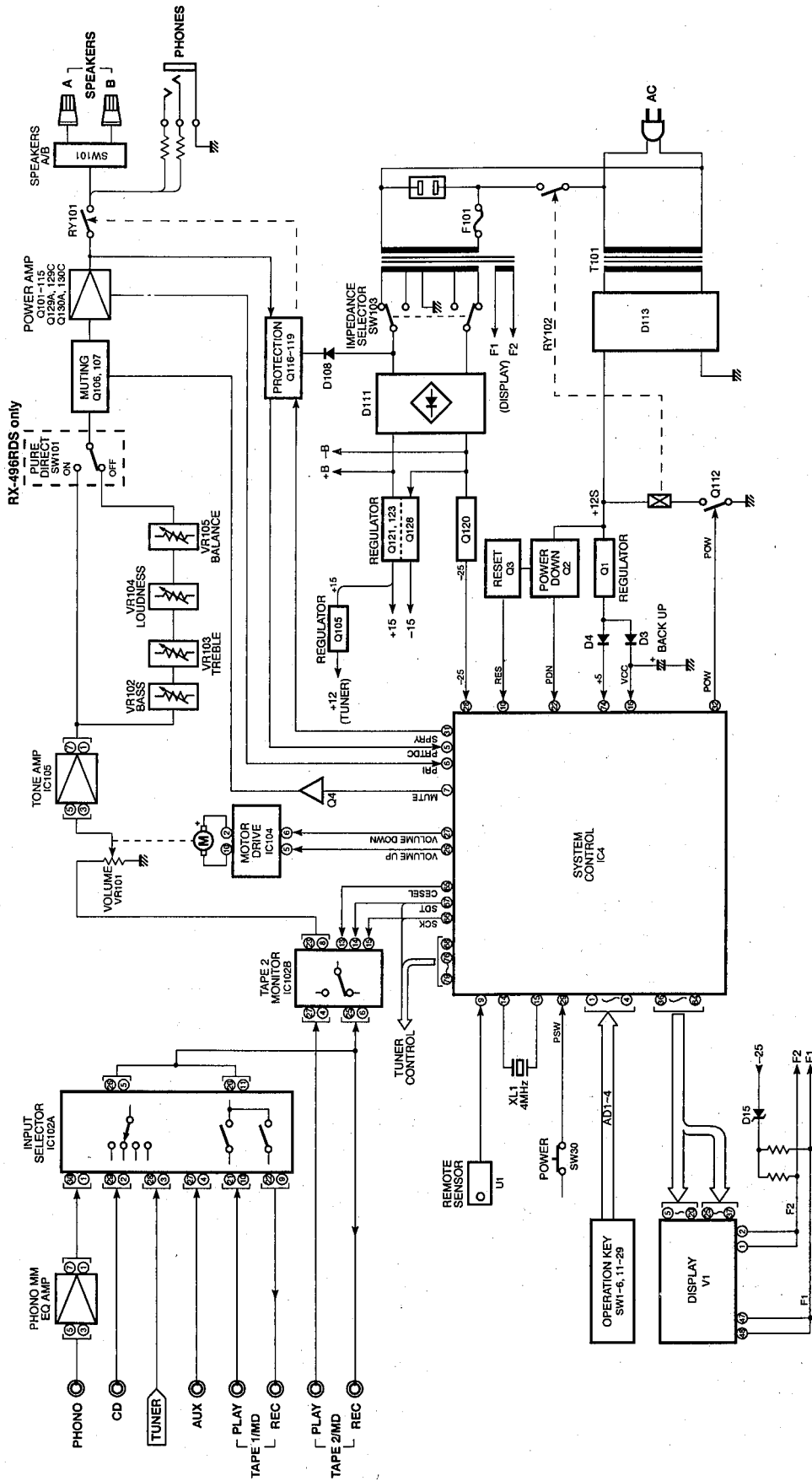

RX-396RDS  
RX-496RDS

PRINTED CIRCUIT BOARD (Foil side)

● RX-396RDS

P.C.B. INPUT (1)

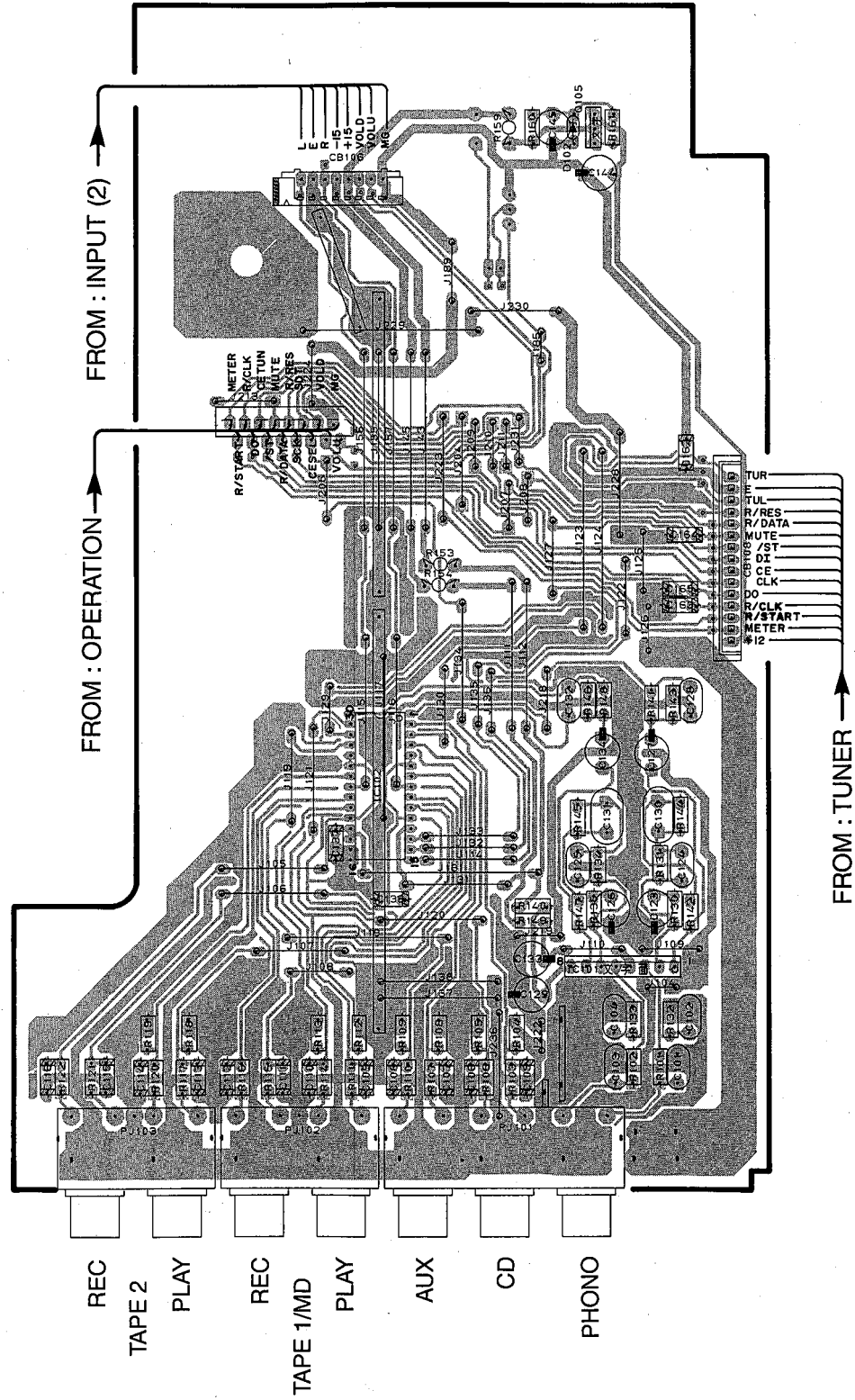

● RX-496RDS

P.C.B. INPUT (1)

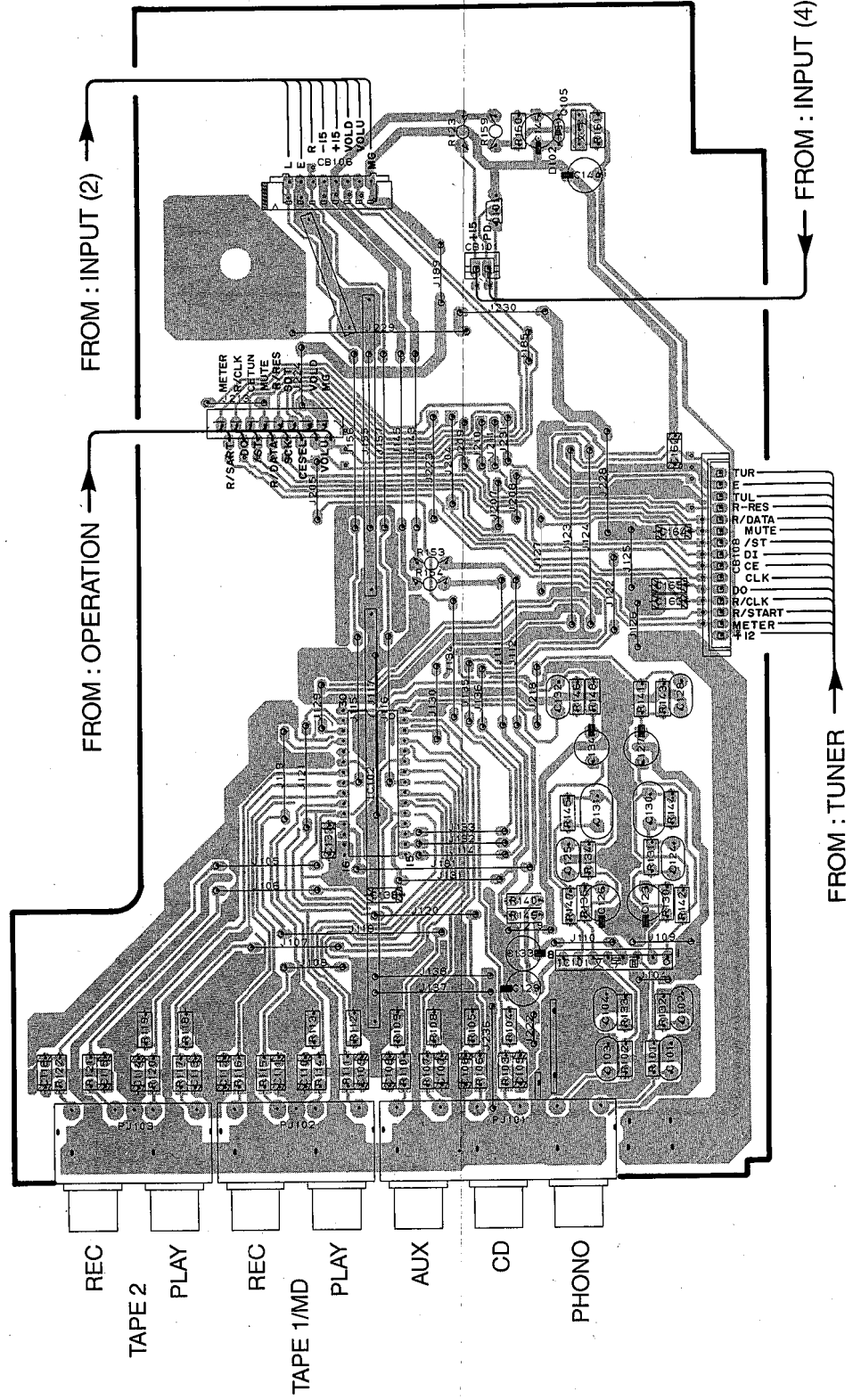

A

B

C

D

E

F

G

H

RX-396RDS/RX-496RDS

PRINTED CIRCUIT BOARD (Foil side)

RX-396RDS

P.C.B. INPUT (2)

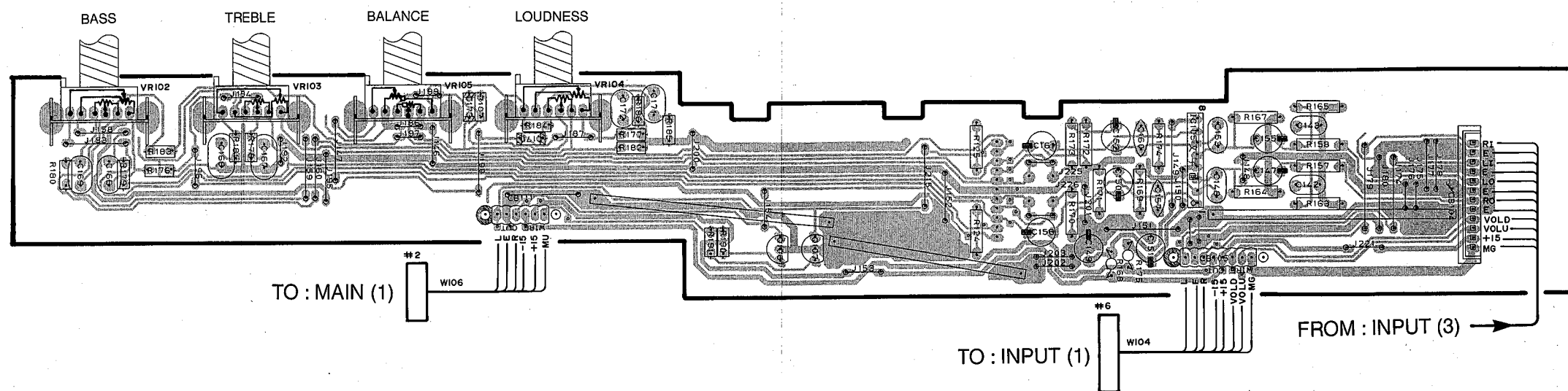

RX-496RDS

P.C.B. INPUT (2)

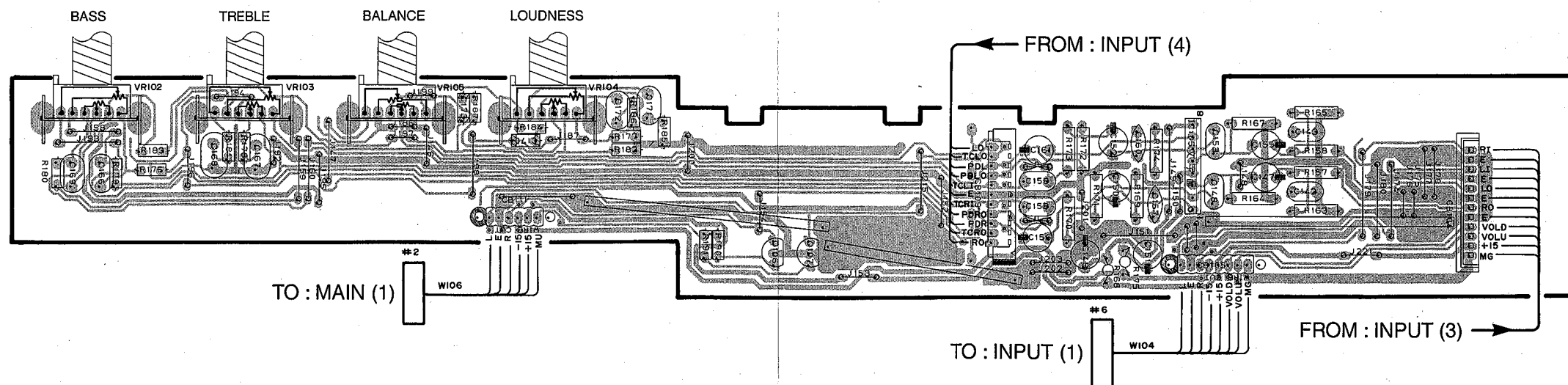

1

2

3

4

5

6

PRINTED CIRCUIT BOARD (Foil side)

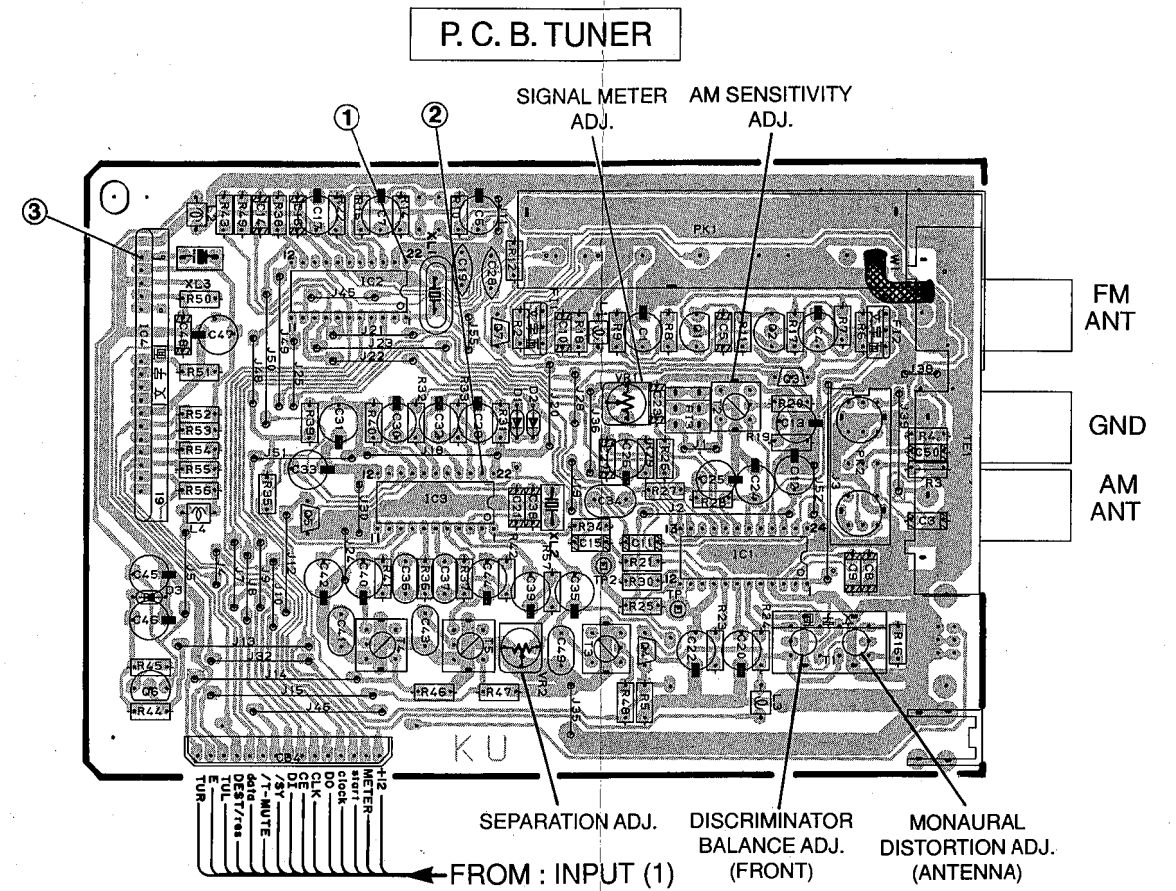
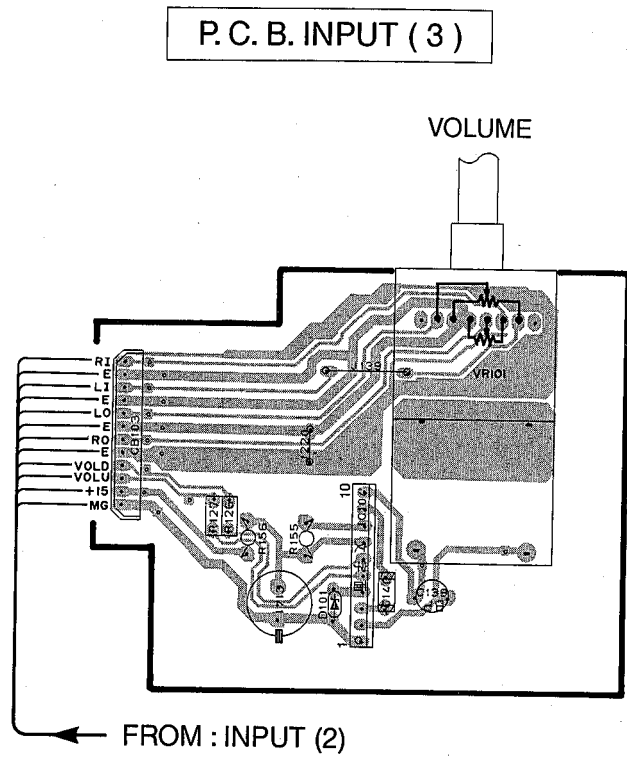

● RX-496RDS only

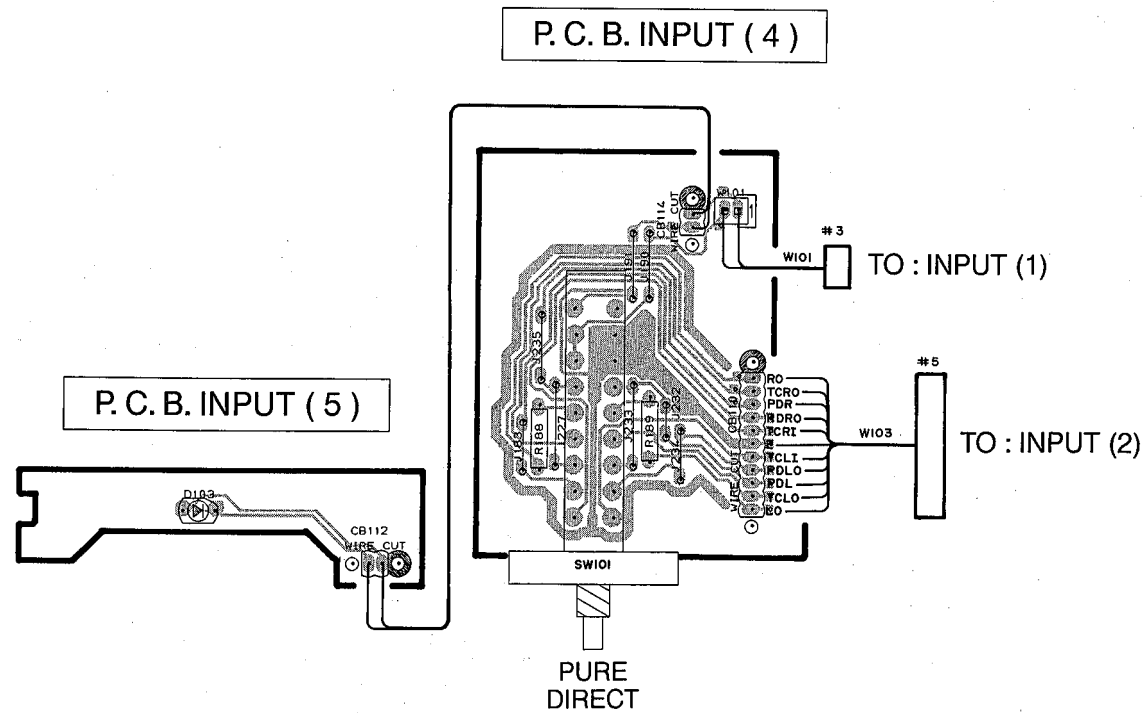

Point ① (Pin22 of IC2) FM reception  
 V : 2V/div H : 50 nsec/div  
 DC range 1 : 1 probe

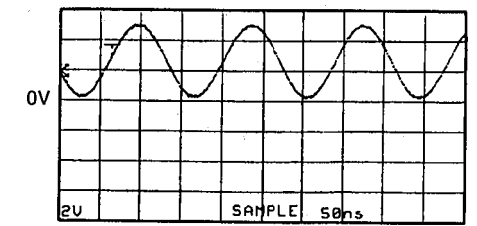

Point ② (Pin21 of IC3)  
 V : 2V/div H : 1 μsec/div  
 DC range 1 : 1 probe

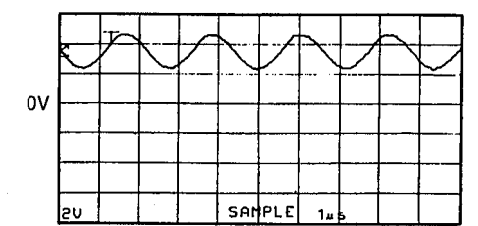

Point ③ (Pin1 of IC4)  
 V : 2V/div H : 1 μsec/div  
 DC range 1 : 1 probe

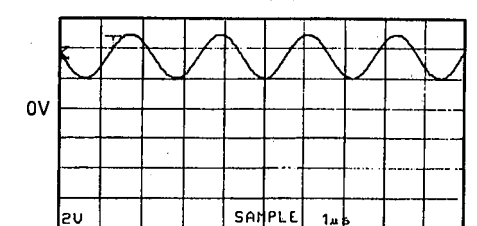

■ PRINTED CIRCUIT BOARD (Foil side)

P. C. B. OPERATION

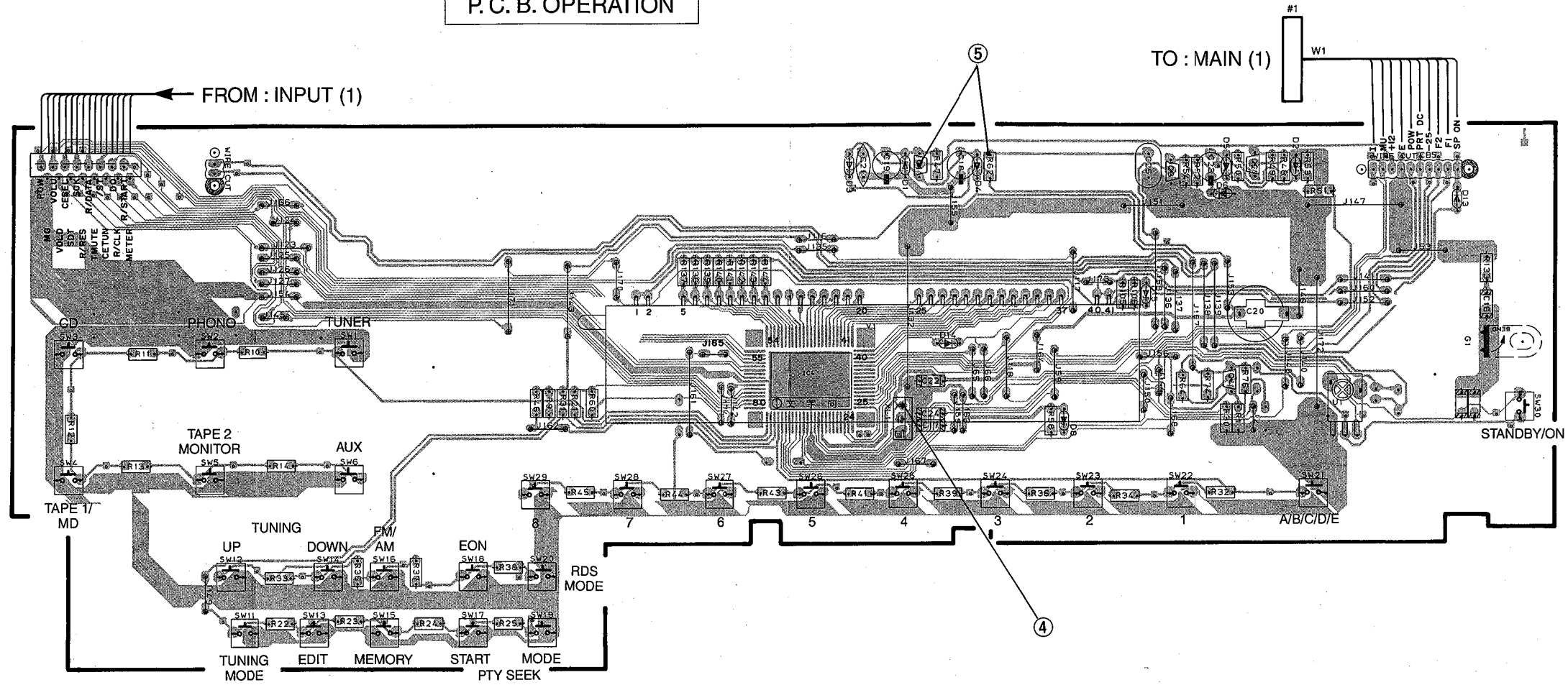

Point ④ (Pin15 of IC4)  
 V : 2V/div H : 0.2 μsec/div  
 DC range 1 : 1 probe

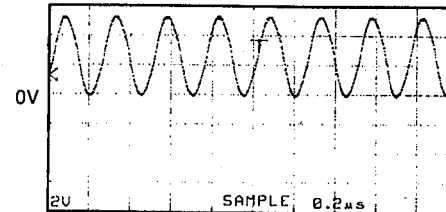

Point ⑤  
 CH1 : Collector of Q3 V : 2V/div (CH1)  
 CH2 : Collector of Q1 V : 5V/div (CH2)

H : 0.5 sec/div DC range 1 : 1 probe  
 (This waveform is not available by pushing the power switch ON and OFF.)

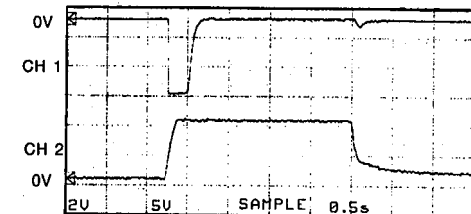

With the POWER ON, disconnect the A/C power cord. Reconnect the A/C power cord and the above waveforms will start.

Disconnect the power cord from the AC outlet.

■ PRINTED CIRCUIT BOARD (Foil side)

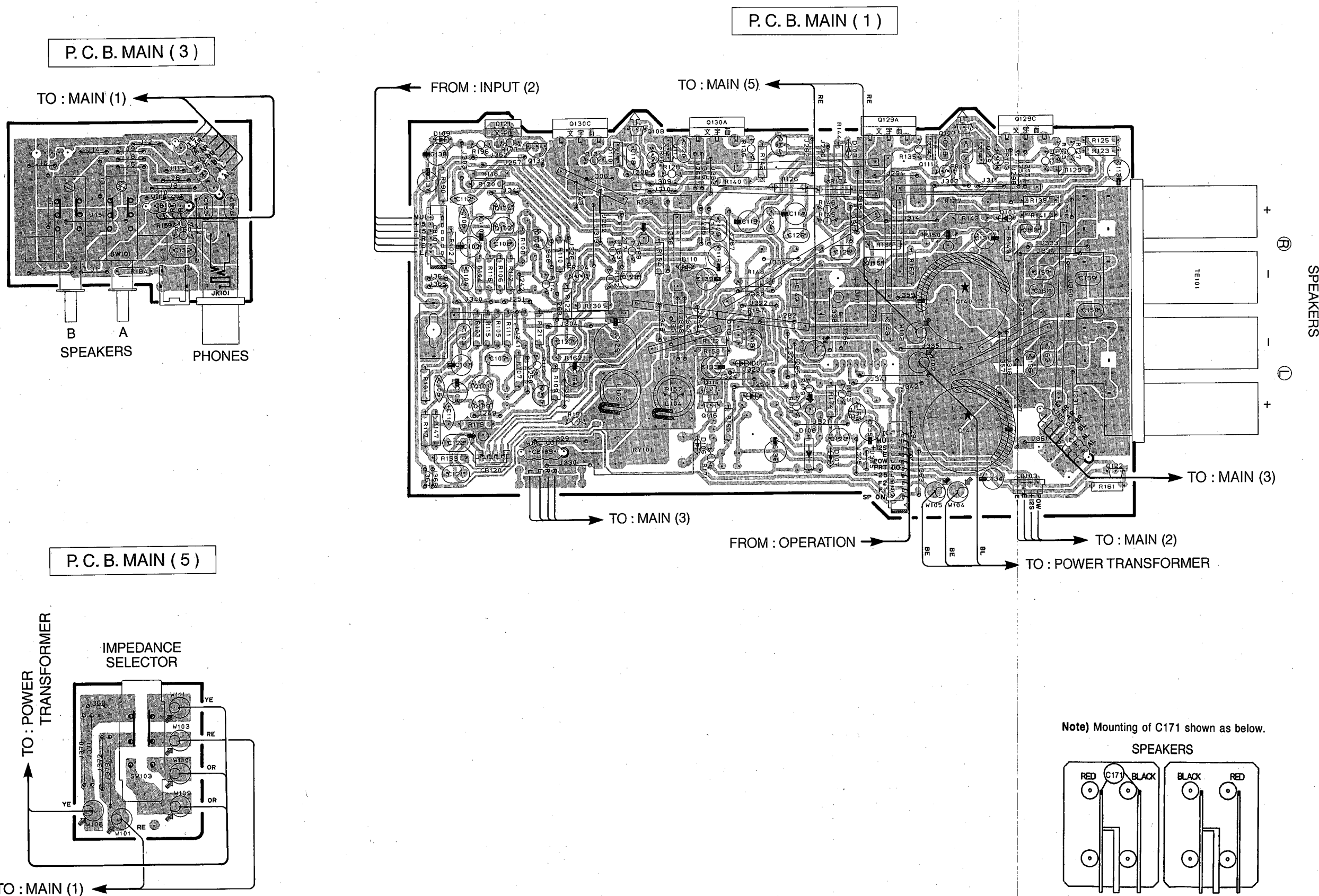

P. C. B. MAIN (3)

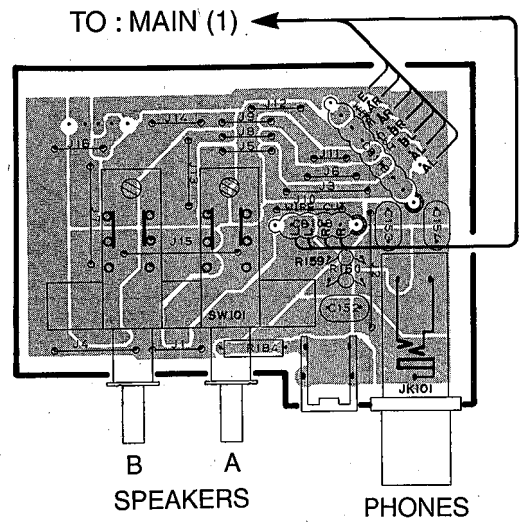

P. C. B. MAIN (5)

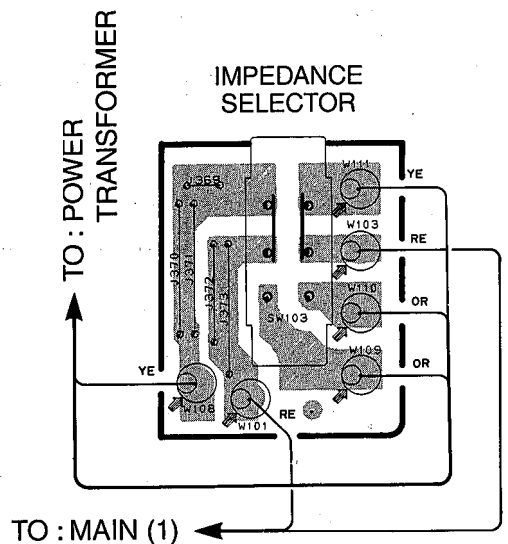

Note) Mounting of C171 shown as below.

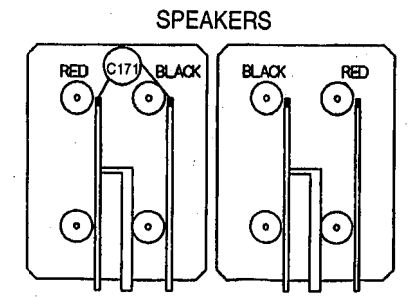

1  
2  
3  
4  
5  
6

PRINTED CIRCUIT BOARD (Foil side)

B model

P. C. B. MAIN (2)

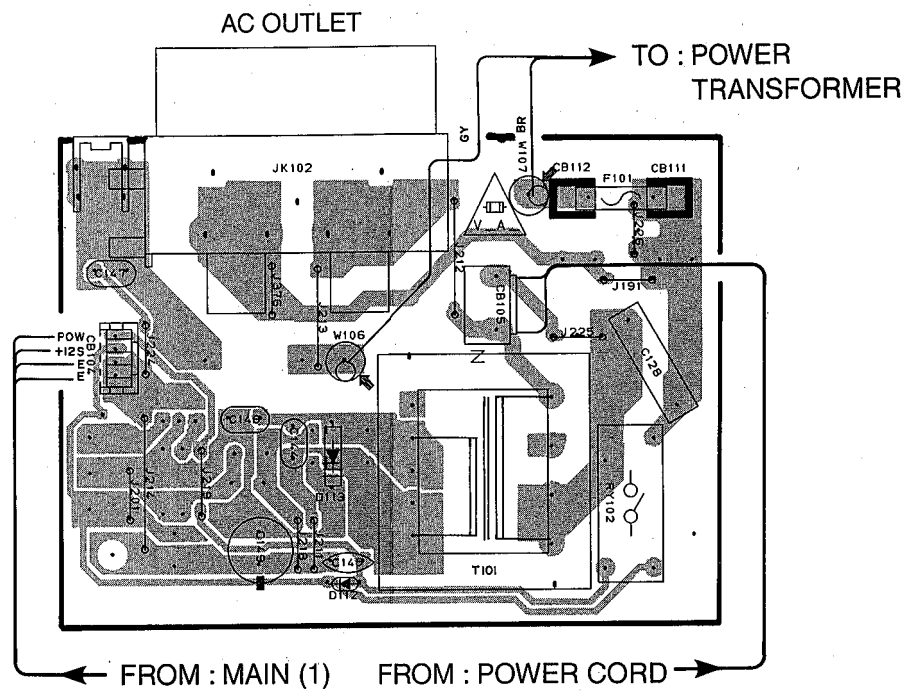

G model

P. C. B. MAIN (2)

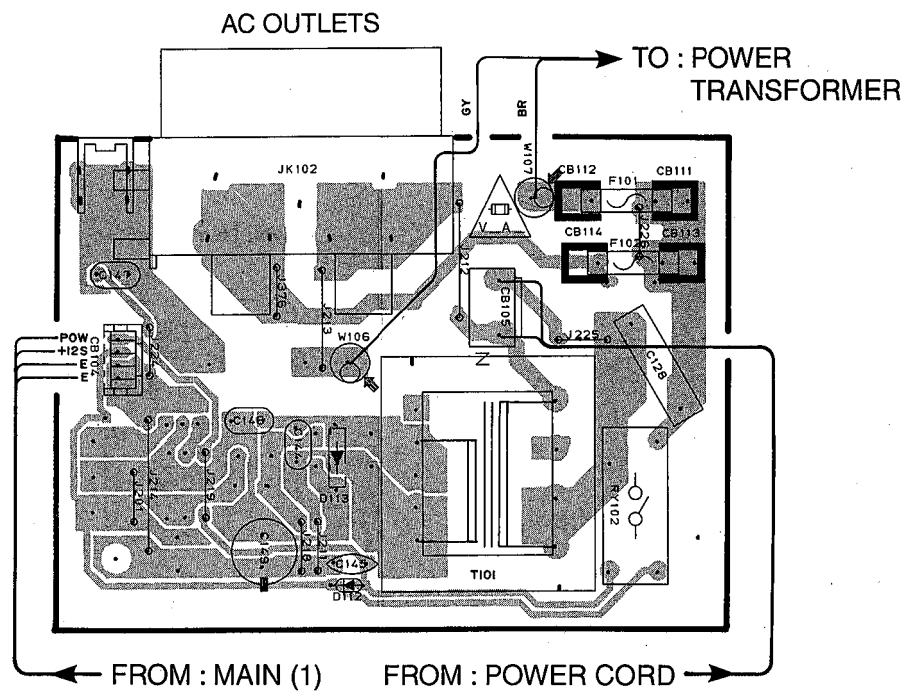

PIN CONNECTION DIAGRAM

Diodes

1SS133  
1SS270A  
1T2

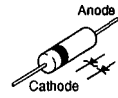

HZS5C2TD  
HZS5B2TD  
HZS6A2TD  
HZS7A2TD  
HZS12A2TD  
HZS152TD  
HZS162TD  
HZS242TD  
MTZJ5.6C

S4VB20

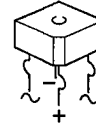

Transistors

2SA933S (G, R)  
2SA1740S (R, S)  
2SC3330 (S, T)  
DTA114ES  
DTC144ES

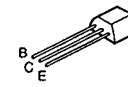

2SA1708 (S, T)  
2SC4488 (S, T)

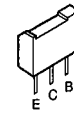

2SA693A (D, E)  
2SA1015 (Y)  
2SB647 (C, D)

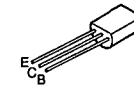

2SC1809 (N, P)  
2SC1815 (Y)  
2SC1890A (D, E)  
2SC2229 (O, Y)  
2SC2878 (A, B)



2SK30ATM (GR)



2SA1694 (O, P, Y)  
2SC4467 (O, P, Y, S)  
2SA1695 (O, P, Y, S)  
2SC4468 (O, P, Y)



2SC4495

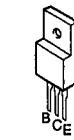

ICs

NJM2068L-D

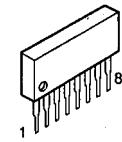

LB1641

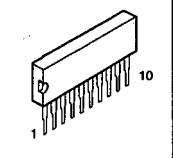

STK311-020B

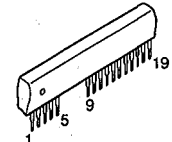

LA3401  
LC72131

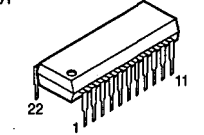

LA1266

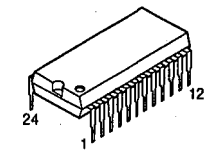

LC78211

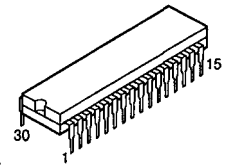

M38B57M6-103FP

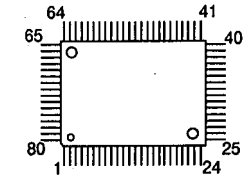



**RX-396RDS SCHEMATIC DIAGRAM (TUNER)**

Each voltage given here represents that in the FM (98.1MHz, STEREO) reception mode but the one in the parentheses ( ) is measured in the AM (1080kHz, MAN'L) reception mode.

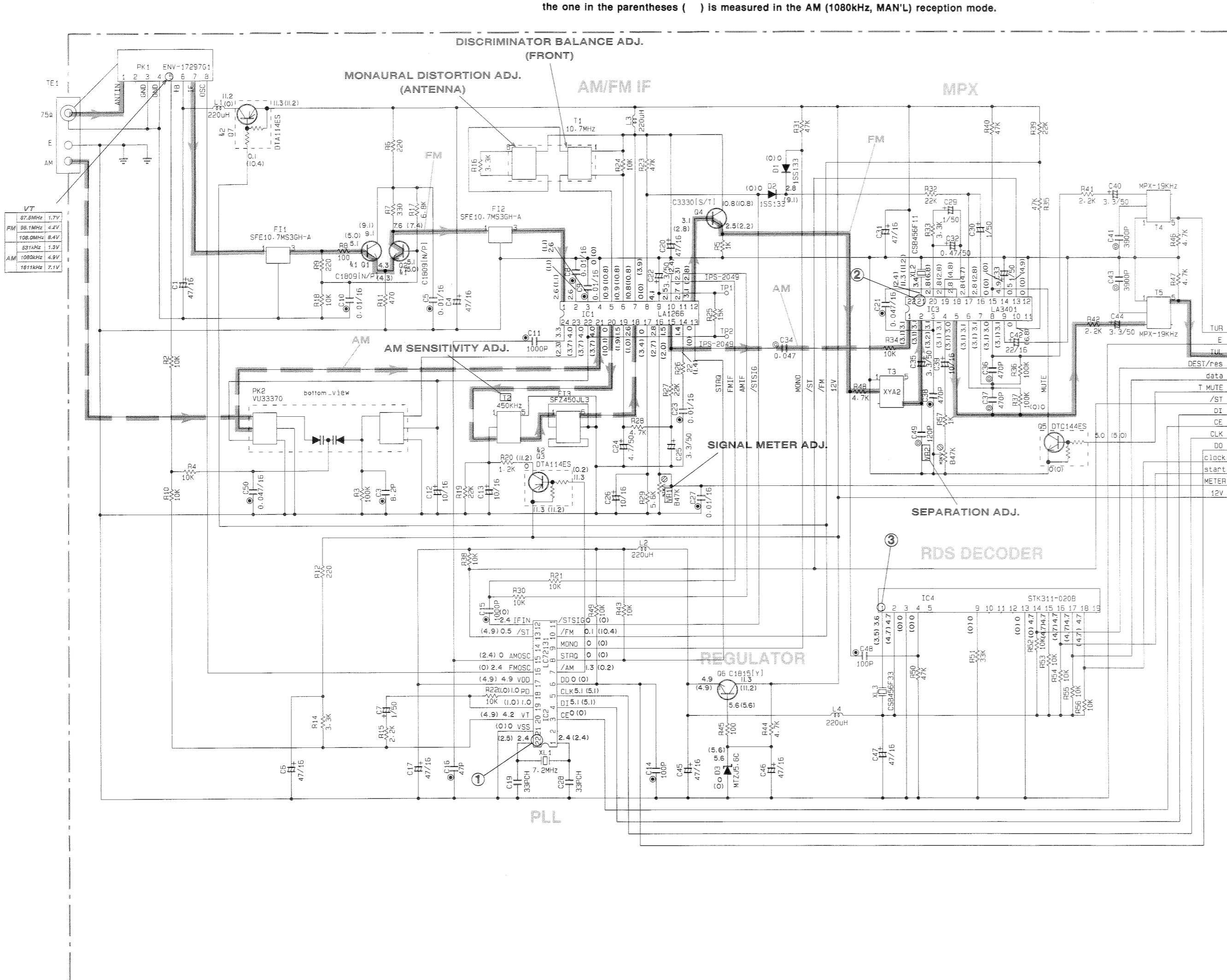

**CAPACITOR**

REMARKS	PARTS NAME
NO MARK	ELECTROLYTIC CAPACITOR
⊗	TANTALUM CAPACITOR
NO MARK	CERAMIC CAPACITOR
⊙	CERAMIC TUBULAR CAPACITOR
⊚	POLYESTER FILM CAPACITOR
○	POLYSTYRENE FILM CAPACITOR
⊖	MICA CAPACITOR
⊕	POLYPROPYLENE FILM CAPACITOR
⊗	SEMICONDUCTIVE CERAMIC CAPACITOR

**RESISTOR**

REMARKS	PARTS NAME
NO MARK	CARBON FILM RESISTOR (P=5)
⊚	CARBON FILM RESISTOR (P=10)
△	METAL OXIDE FILM RESISTOR
⊖	METAL FILM RESISTOR
⊕	METAL PLATE RESISTOR
⊗	FIRE PROOF CARBON FILM RESISTOR
⊖	CEMENT MOLDED RESISTOR
⊕	SEMI VARIABLE RESISTOR
⊗	CHIP RESISTOR

**NOTICE (model)**  
 (J)..... JAPANESE  
 (U)..... U.S. A  
 (C)..... CANADIAN  
 (R)..... GENERAL  
 (A)..... AUSTRALIAN  
 (B)..... BRITISH  
 (G)..... EUROPEAN  
 (T)..... CHINA  
 (L)..... SINGAPORE

**Interchangeable Parts at Manufacture-Stage**

Mark	Reference Parts Number	Parts Name
⊕1	Q1.2	25C180S(N/P) 25C180S(N/P)
⊕2	Q3.7	DTA114ES UN4111

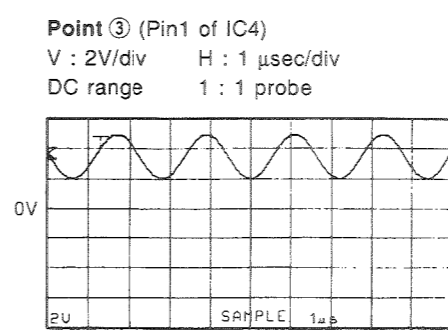
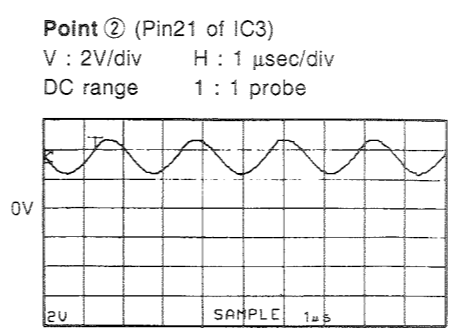
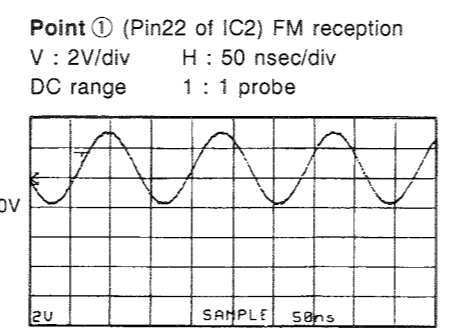
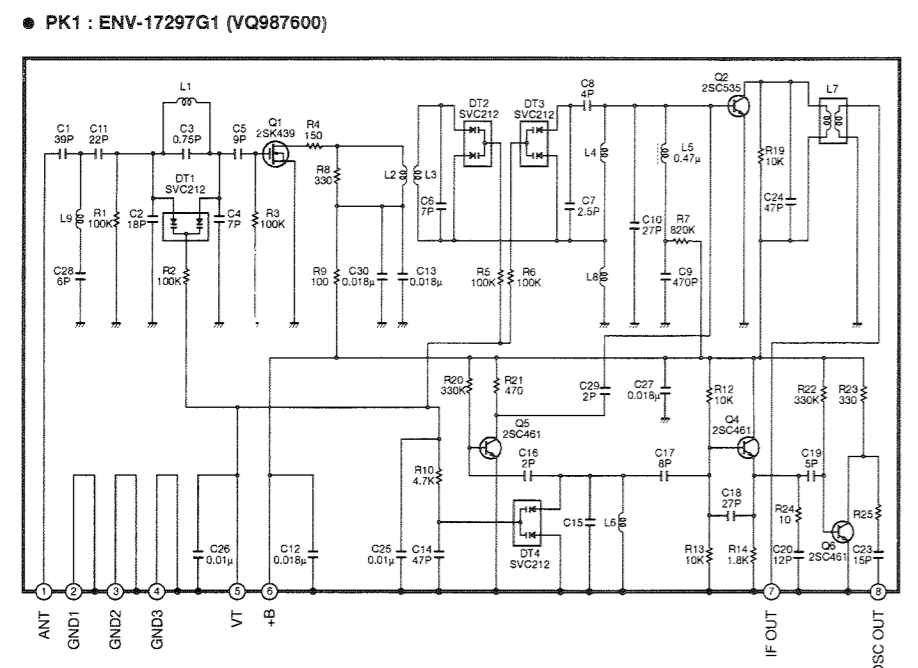
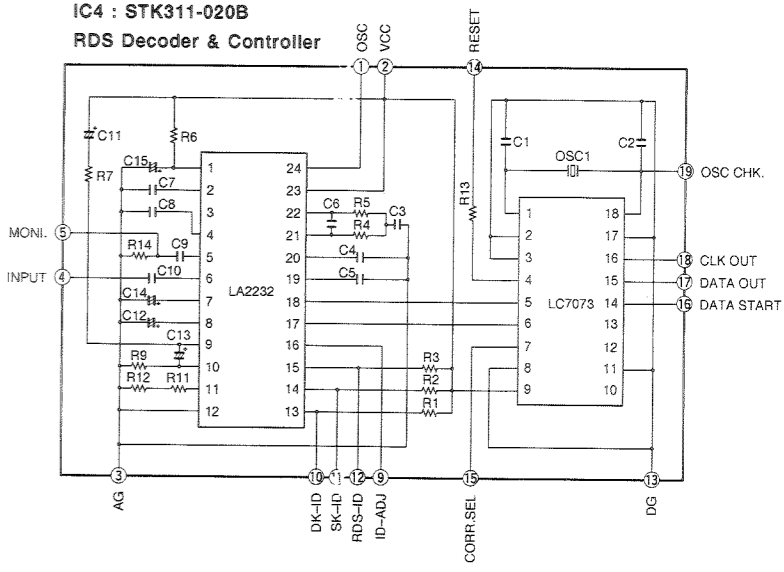
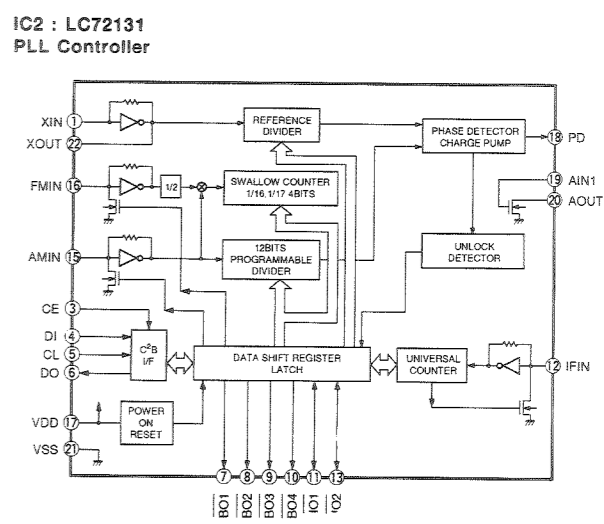
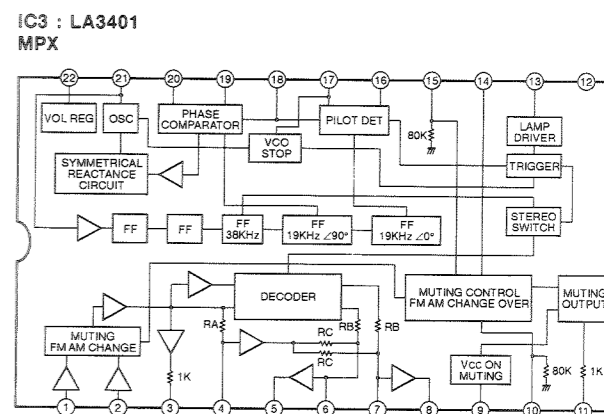
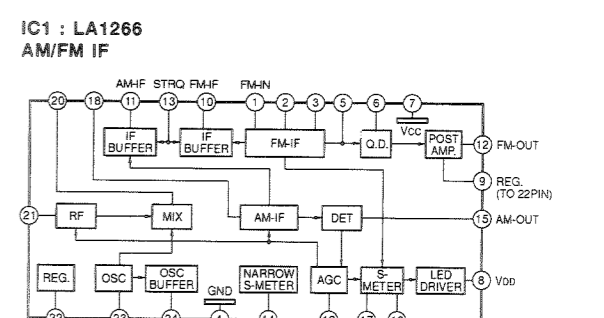

\* All voltages are measured with a 10MΩ/DC electric volt meter.  
 \* Components having special characteristics are marked △ and must be replaced with parts having specifications equal to those originally installed.  
 \* Schematic diagram is subject to change without notice.

**RX-396RDS SCHEMATIC DIAGRAM (INPUT)**

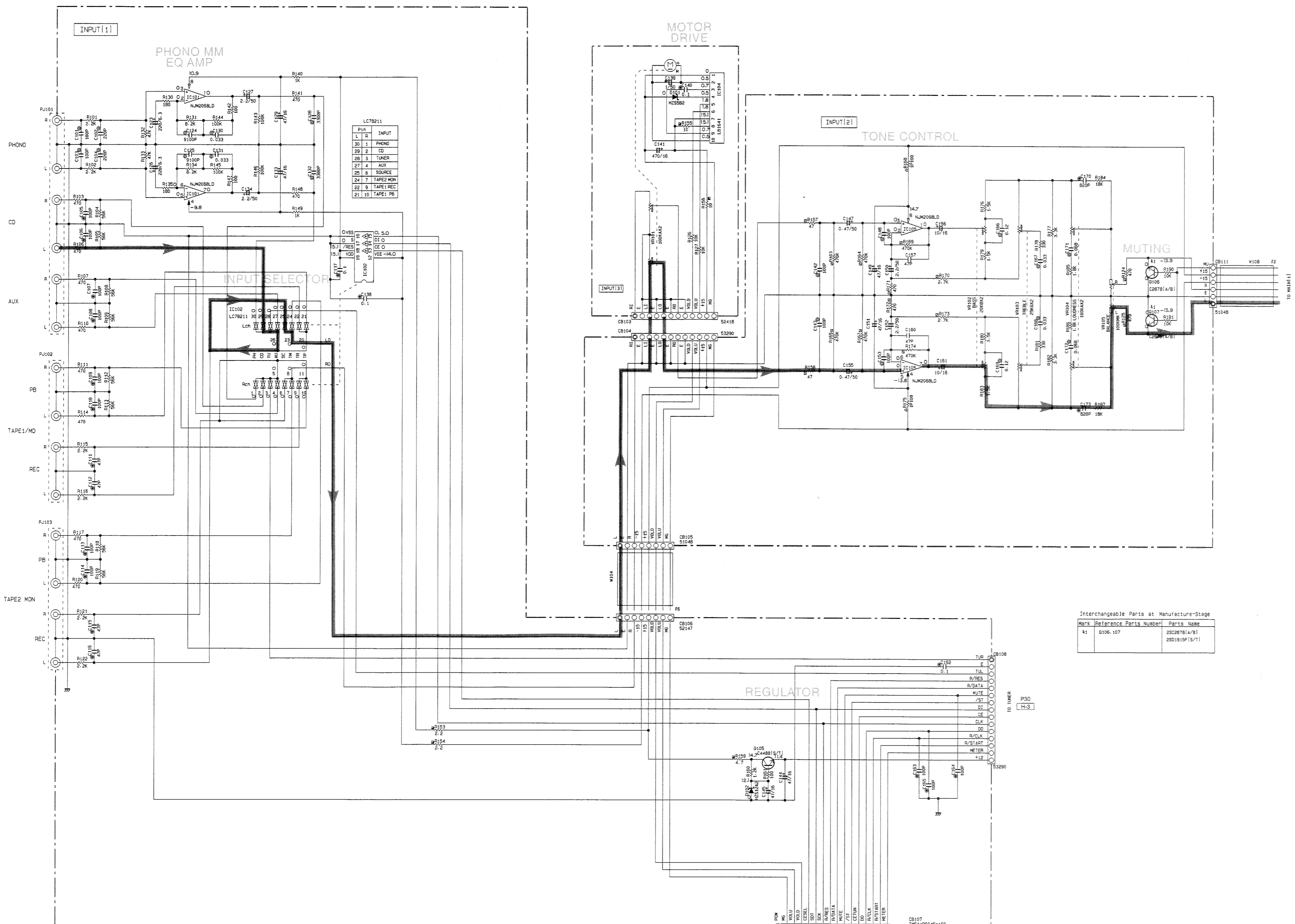

Interchangeable Parts at Manufacture-Stage

Mark	Reference Parts Number	Parts Name
4	0106-107	2520781A/91 2501515/15/71

REMARKS	PARTS NAME	REMARKS	PARTS NAME
NO MARK	CARBON FILM RESISTOR (P=5)	NO MARK	ELECTROLYTIC CAPACITOR
□	CARBON FILM RESISTOR (P=10)	⊗	TANTALUM CAPACITOR
△	METAL OXIDE FILM RESISTOR	NO MARK	CERAMIC CAPACITOR
⊠	METAL FILM RESISTOR	●	CERAMIC "BUBBLER" CAPACITOR
⊡	METAL PLATE RESISTOR	○	POLYESTER FILM CAPACITOR
⊞	FIRE PROOF CARBON FILM RESISTOR	○	POLYSTYRENE FILM CAPACITOR
⊚	CEMENT MOLDED RESISTOR	○	MICA CAPACITOR
⊛	SEMI VARIABLE RESISTOR	⊙	POLYPROPYLENE FILM CAPACITOR
■	CHIP RESISTOR	●	SEMICONDUCTIVE CERAMIC CAPACITOR

IC101, 105 : NJM2068L-D  
Dual OP-Amp

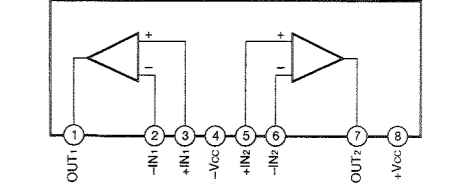

IC102 : LC78211  
Analog Function Switch

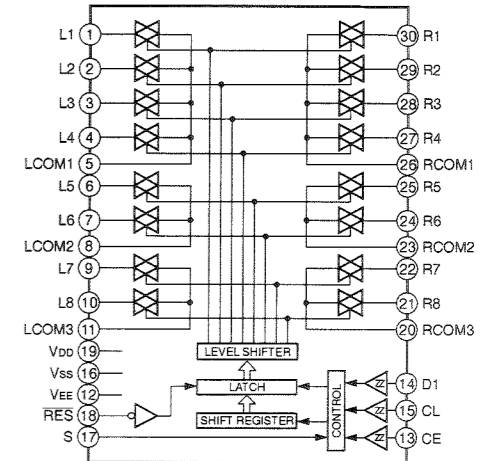

IC104 : LB1641  
Motor Driver

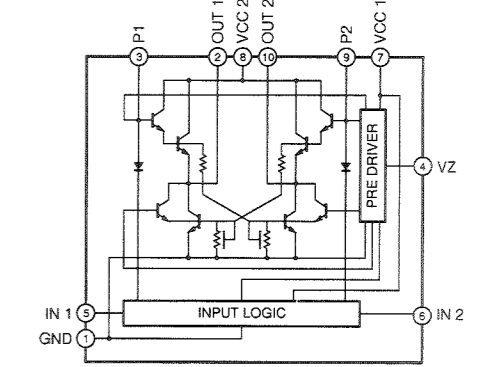

\* All voltages are measured with a 10MΩ/DC electric volt meter.  
 \* Components having special characteristics are marked △ and must be replaced with parts having specifications equal to those originally installed.  
 \* Schematic diagram is subject to change without notice.

■ RX-396RDS SCHEMATIC DIAGRAM (OPERATION)

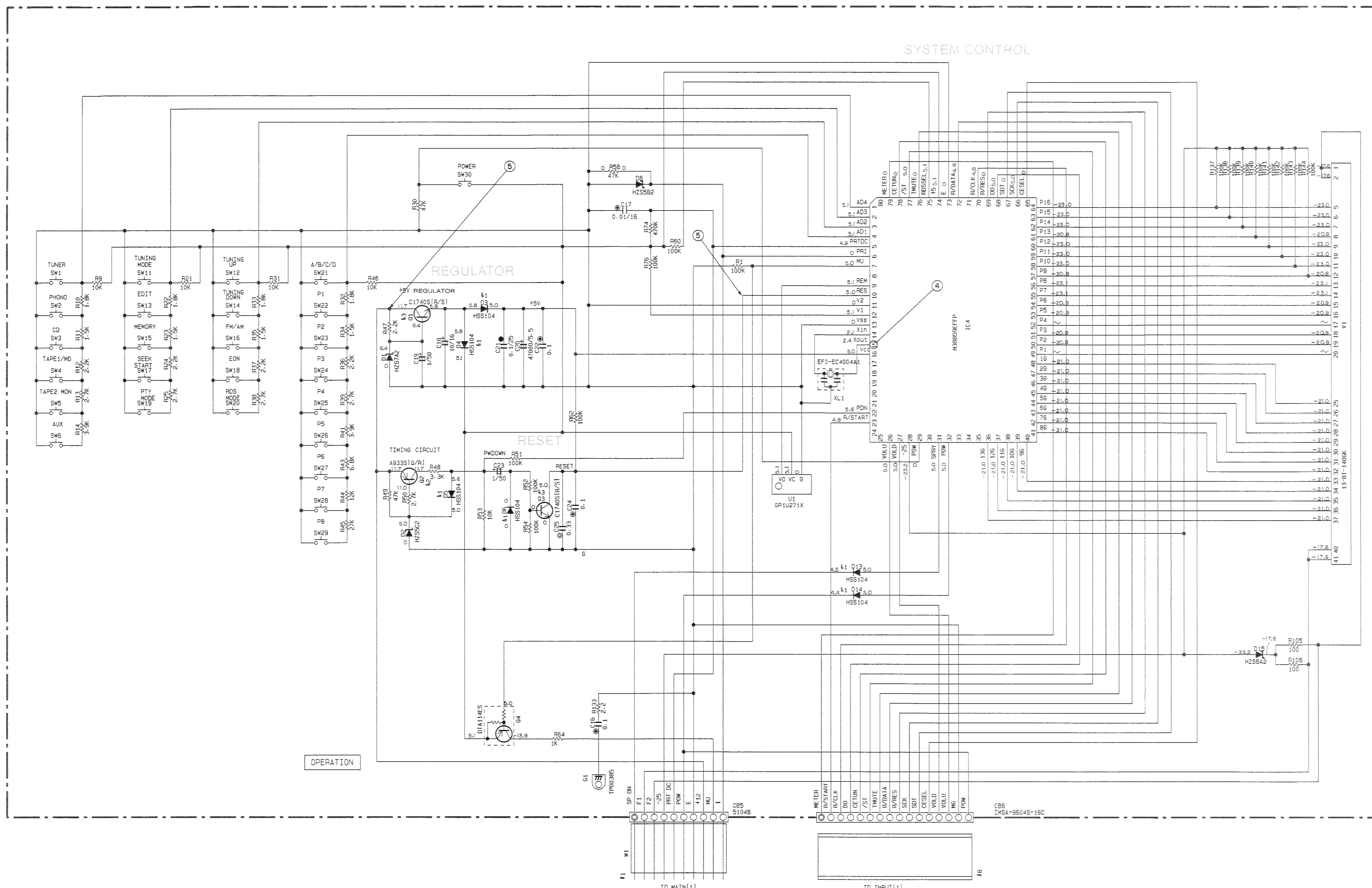

Interchangeable Parts at Manufacture-Stage

Mark	Reference	Parts Number	Parts Name
41	D3-6-13-14	HSS104 1SS133 1SS176	
42	02	2SA933S(O/R) 2SA1115E(F) 2SA1309A(O/R/S)	
43	01-3	2SC1740S(R/S) 2SC2603E(F) 2SC3311A(O/R/S)	

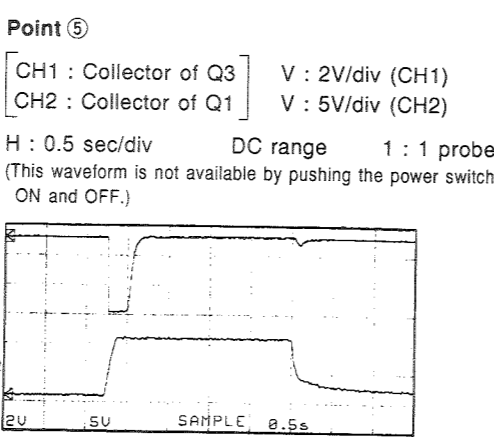
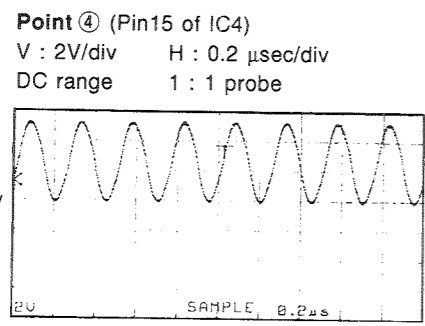

With the POWER ON, disconnect the A/C power cord. Reconnect the A/C power cord and the above waveforms will start.

Disconnect the power cord from the AC outlet. Reconnect the power cord and the AC outlet. The above waveforms will start.

RESISTOR

REMARKS	PARTS NAME
NO MARK	CARBON FILM RESISTOR (P=5)
△	CARBON FILM RESISTOR (P=10)
□	METAL OXIDE FILM RESISTOR
△	METAL FILM RESISTOR
△	METAL PLATE RESISTOR
⊠	FIRE PROOF CARBON FILM RESISTOR
□	CEMENT MOLDED RESISTOR
⊗	SEMI VARIABLE RESISTOR
■	CHIP RESISTOR

CAPACITOR

REMARKS	PARTS NAME
NO MARK	ELECTROLYTIC CAPACITOR
⊗	TANTALUM CAPACITOR
NO MARK	CERAMIC CAPACITOR
●	CERAMIC TUBULAR CAPACITOR
⊙	POLYESTER FILM CAPACITOR
○	POLYSTYRENE FILM CAPACITOR
⊖	MICA CAPACITOR
⊕	POLYPROPYLENE FILM CAPACITOR
⊙	SEMICONDUCTIVE CERAMIC CAPACITOR

\* All voltages are measured with a 10MΩ/DC electric volt meter.  
 \* Components having special characteristics are marked △ and must be replaced with parts having specifications equal to those originally installed.  
 \* Schematic diagram is subject to change without notice.

RX-396RDS SCHEMATIC DIAGRAM (MAIN)

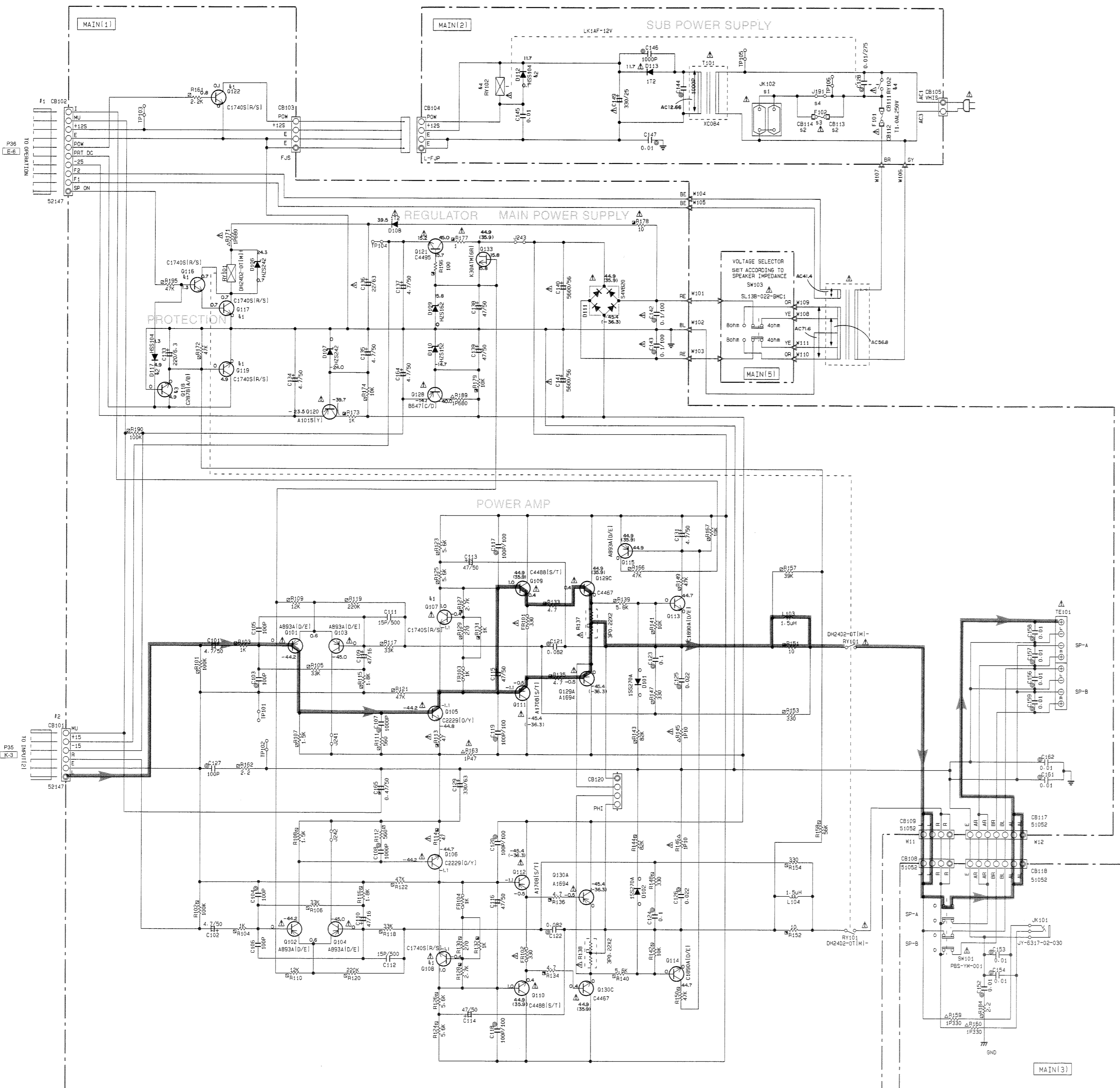

CIRCUIT CHANGES BY MARKET.

s1	B	6
JK102	VU54330	VU54340
CB113- CB114	X	VP20690
F102	X	T2-5AL250V KB00069
J191	O	X

X: NOT USED  
O: USED

Interchangeable Parts at Manufacture-Stage

Mark	Reference Parts Number	Parts Name
k1	0107-108-116-117	2SC1740S/R/S1
	119-122	2SC2603E/F1
		2SC3311A/G/R/S1
k2	D112-117	HSS104
		1SS133
		1SS176
k3	Q118	2SC2878A/B1
		2SD1915F1S/T1
k4	RY102	VU39950 VU34900 VH23080
k5		

RESISTOR

REMARKS	PARTS NAME
NO MARK	CARBON FILM RESISTOR (P=5)
□	CARBON FILM RESISTOR (P=10)
△	METAL OXIDE FILM RESISTOR
▽	METAL FILM RESISTOR
▣	METAL PLATE RESISTOR
▤	FIRE PROOF CARBON FILM RESISTOR
▥	CEMENT MOLDED RESISTOR
▦	SEMI VARIABLE RESISTOR
▧	CHIP RESISTOR

CAPACITOR

REMARKS	PARTS NAME
NO MARK	ELECTROLYTIC CAPACITOR
⊗	TANTALUM CAPACITOR
NO MARK	CERAMIC CAPACITOR
⊙	CERAMIC TUBULAR CAPACITOR
⊚	POLYESTER FILM CAPACITOR
○	POLYSTYRENE FILM CAPACITOR
⊖	MICA CAPACITOR
⊕	POLYPROPYLENE FILM CAPACITOR
⊗	SEMICONDUCTIVE CERAMIC CAPACITOR

NOTICE (model)  
(J)..... JAPANESE  
(U)..... U. S. A  
(C)..... CANADIAN  
(R)..... GENERAL  
(A)..... AUSTRALIAN  
(B)..... BRITISH  
(G)..... EUROPEAN  
(T)..... CHINA  
(L)..... SINGAPORE

\* All voltages are measured with a 10MQ/DC electric volt meter.  
\* Components having special characteristics are marked Δ and must be replaced with parts having specifications equal to those originally installed.  
\* Schematic diagram is subject to change without notice.

**RX-496RDS SCHEMATIC DIAGRAM (TUNER)**

Each voltage given here represents that in the FM (98.1MHz, STEREO) reception mode but the one in the parentheses ( ) is measured in the AM (1080kHz, MAN'L) reception mode.

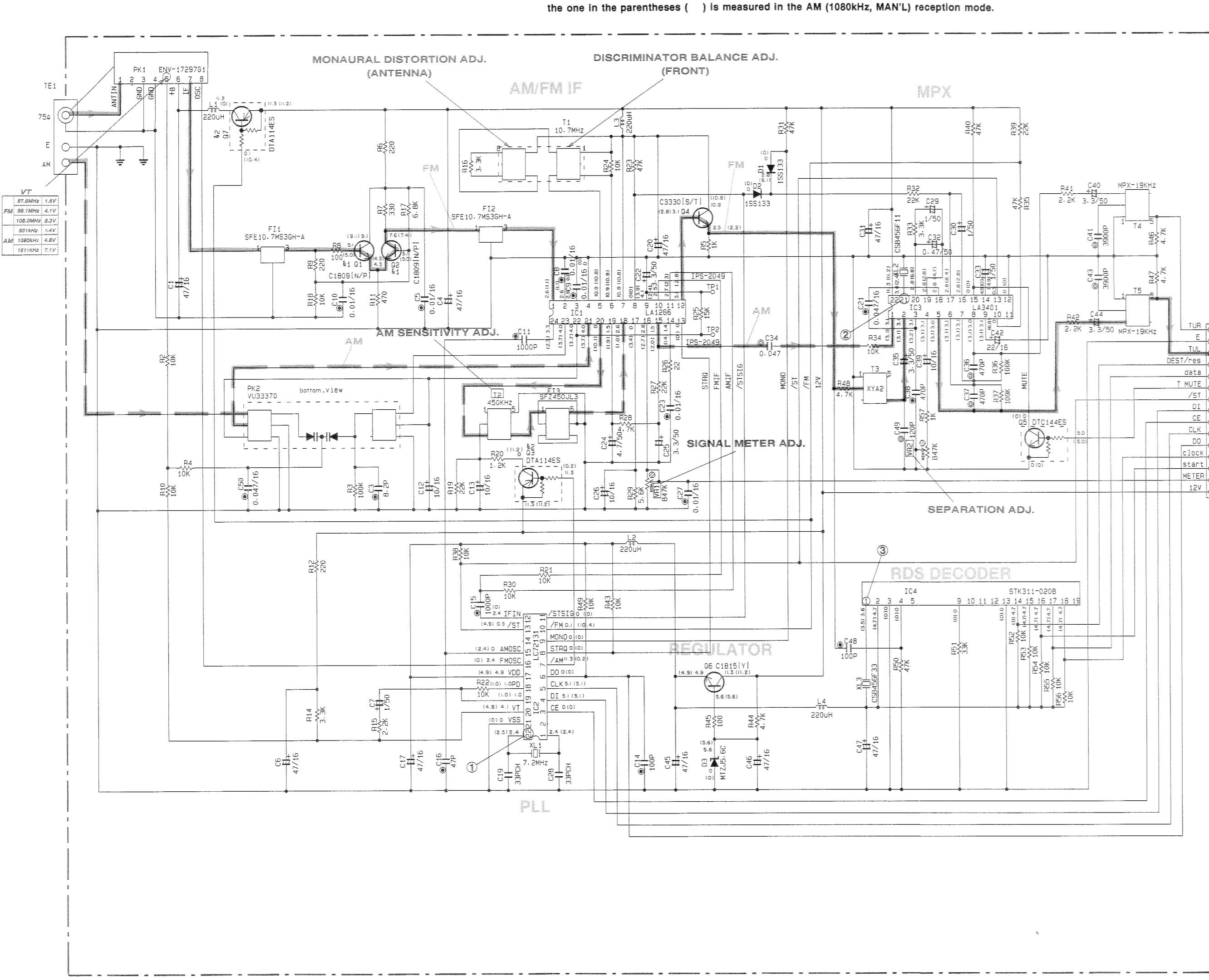

**CAPACITOR**

REMARKS	PARTS NAME	
NO MARK	ELECTROLYTIC CAPACITOR	77
⊗	TANTALUM CAPACITOR	
NO MARK	CERAMIC CAPACITOR	
⊙	CERAMIC TUBULAR CAPACITOR	
○	POLYESTER FILM CAPACITOR	
○	POLYSTYRENE FILM CAPACITOR	
○	MICA CAPACITOR	
○	POLYPROPYLENE FILM CAPACITOR	
●	SEMICONDUCTIVE CERAMIC CAPACITOR	

**RESISTOR**

REMARKS	PARTS NAME	
NO MARK	CARBON FILM RESISTOR (P=5)	
□	CARBON FILM RESISTOR (P=10)	
△	METAL OXIDE FILM RESISTOR	
△	METAL FILM RESISTOR	
△	METAL PLATE RESISTOR	
△	FIRE PROOF CARBON FILM RESISTOR	
□	CEMENT MOLDED RESISTOR	
□	SEMI VARIABLE RESISTOR	
■	CHIP RESISTOR	

**NOTICE (model)**  
 (J)..... JAPANESE  
 (U)..... U.S.A  
 (C)..... CANADIAN  
 (R)..... GENERAL  
 (A)..... AUSTRALIAN  
 (B)..... BRITISH  
 (G)..... EUROPEAN  
 (T)..... CHINA  
 (L)..... SINGAPORE

**Interchangeable Parts at Manufacture-Stage**

Mark	Reference Parts Number	Parts Name
⊕1	01.2	2SC1809N/P1 2SC1809S/N/P1
⊕2	03.7	DTA114ES UN4111

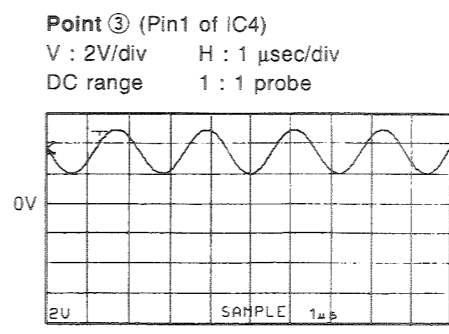
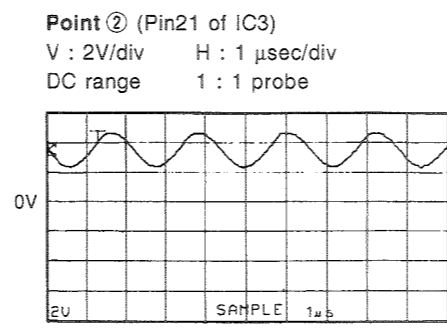
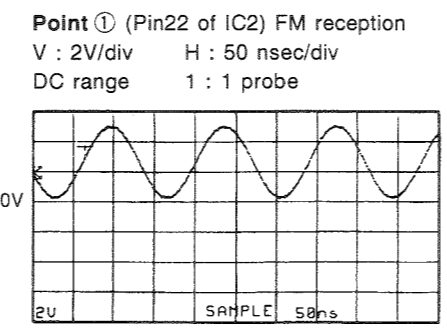
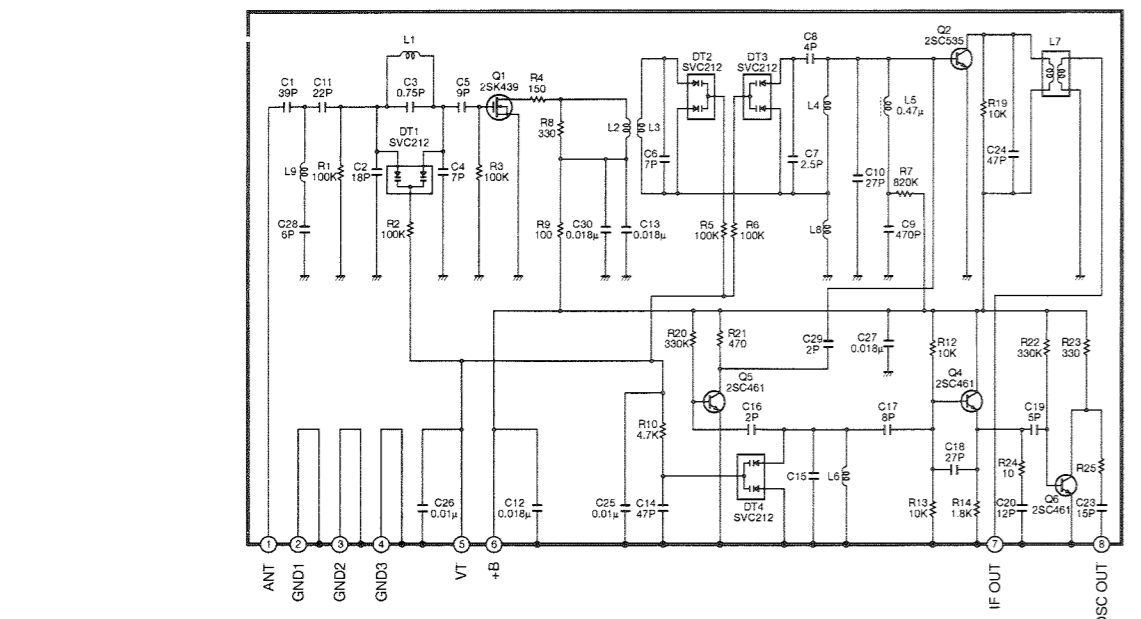
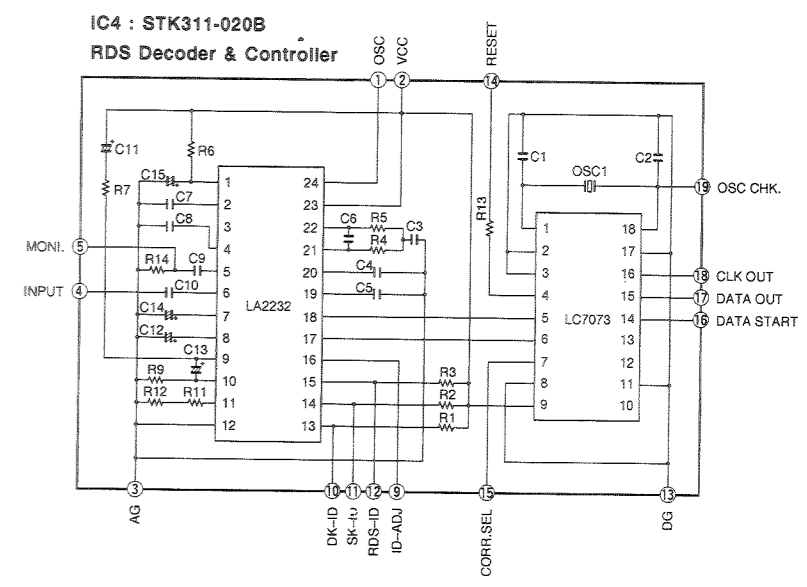
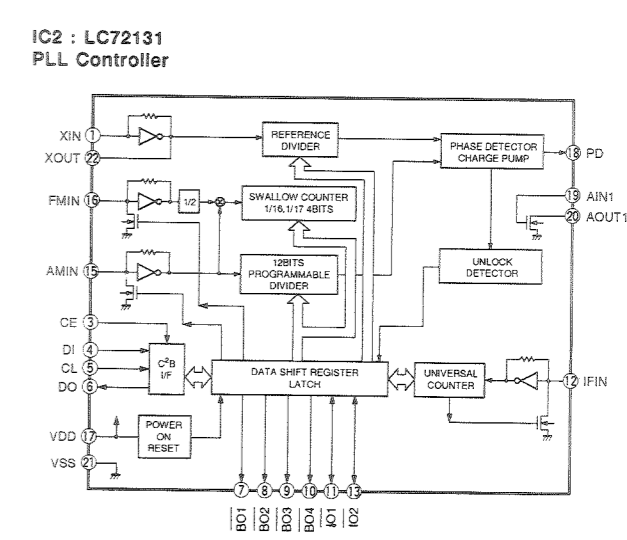
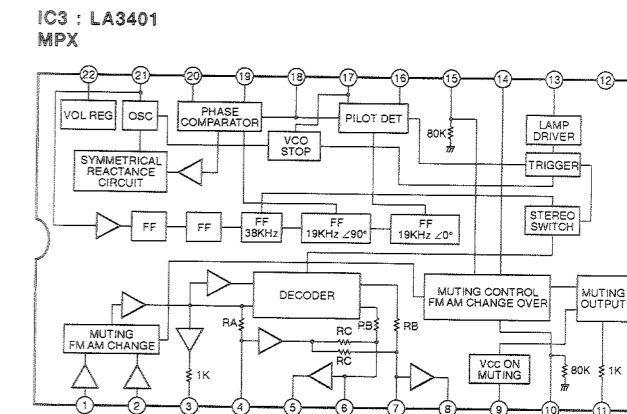
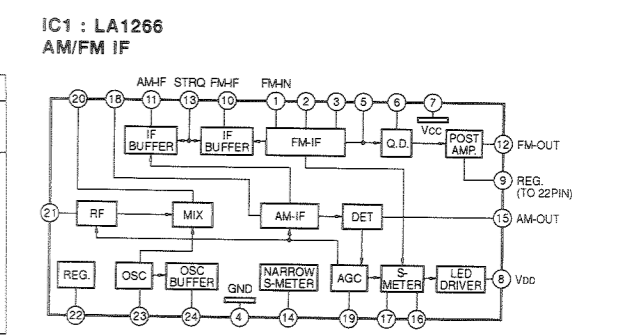

\* All voltages are measured with a 10MΩ/DC electric volt meter.  
 \* Components having special characteristics are marked △ and must be replaced with parts having specifications equal to those originally installed.  
 \* Schematic diagram is subject to change without notice.

RX-496RDS SCHEMATIC DIAGRAM (INPUT)

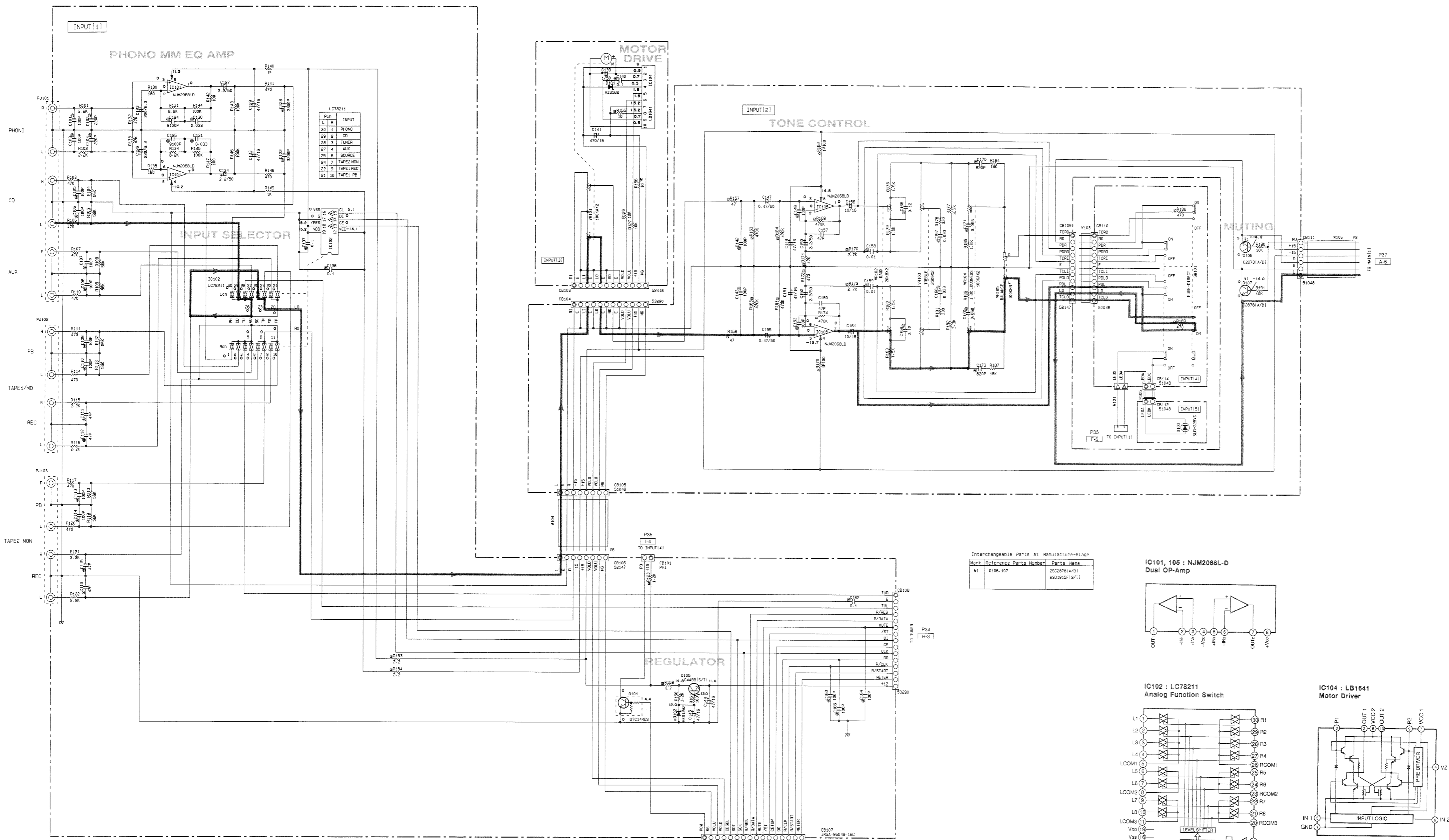

Interchangeable Parts at Manufacture-Stage

Mark	Reference Parts Number	Parts Name
K1	0196-107	25C2876(A/B) 25C1915F(13/71)

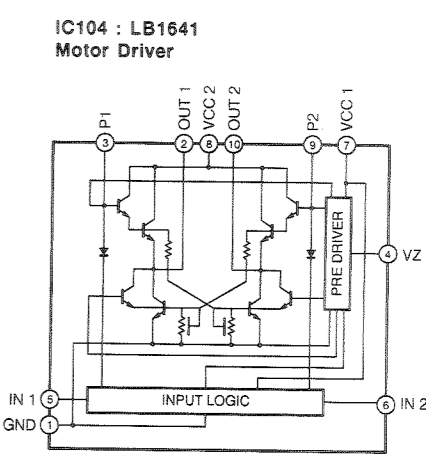
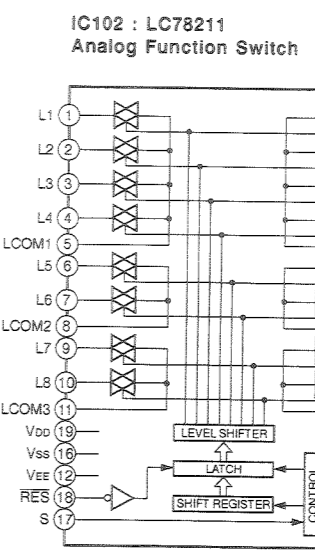
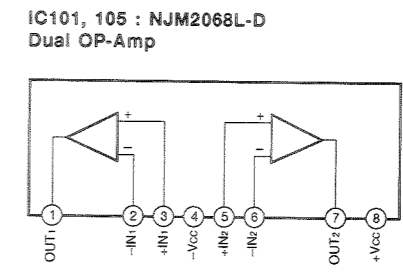

REMARKS	PARTS NAME	REMARKS	PARTS NAME
NO MARK	CARBON FILM RESISTOR (P=5)	NO MARK	ELECTROLYTIC CAPACITOR
□	CARBON FILM RESISTOR (P=10)	⊗	TANTALUM CAPACITOR
△	METAL OXIDE FILM RESISTOR	NO MARK	CERAMIC CAPACITOR
▲	METAL FILM RESISTOR	⊙	CERAMIC TUBULAR CAPACITOR
□	METAL PLATE RESISTOR	⊖	POLYESTER FILM CAPACITOR
■	FIRE PROOF CARBON FILM RESISTOR	○	POLYSTYRENE FILM CAPACITOR
□	CEMENT MOLDED RESISTOR	○	MICA CAPACITOR
□	SEMI VARIABLE RESISTOR	⊙	POLYPROPYLENE FILM CAPACITOR
■	CHIP RESISTOR	●	SEMICONDUCTIVE CERAMIC CAPACITOR

\* All voltages are measured with a 10MΩ/DC electric volt meter.  
 \* Components having special characteristics are marked △ and must be replaced with parts having specifications equal to those originally installed.  
 \* Schematic diagram is subject to change without notice.

**RX-496RDS SCHEMATIC DIAGRAM (OPERATION)**

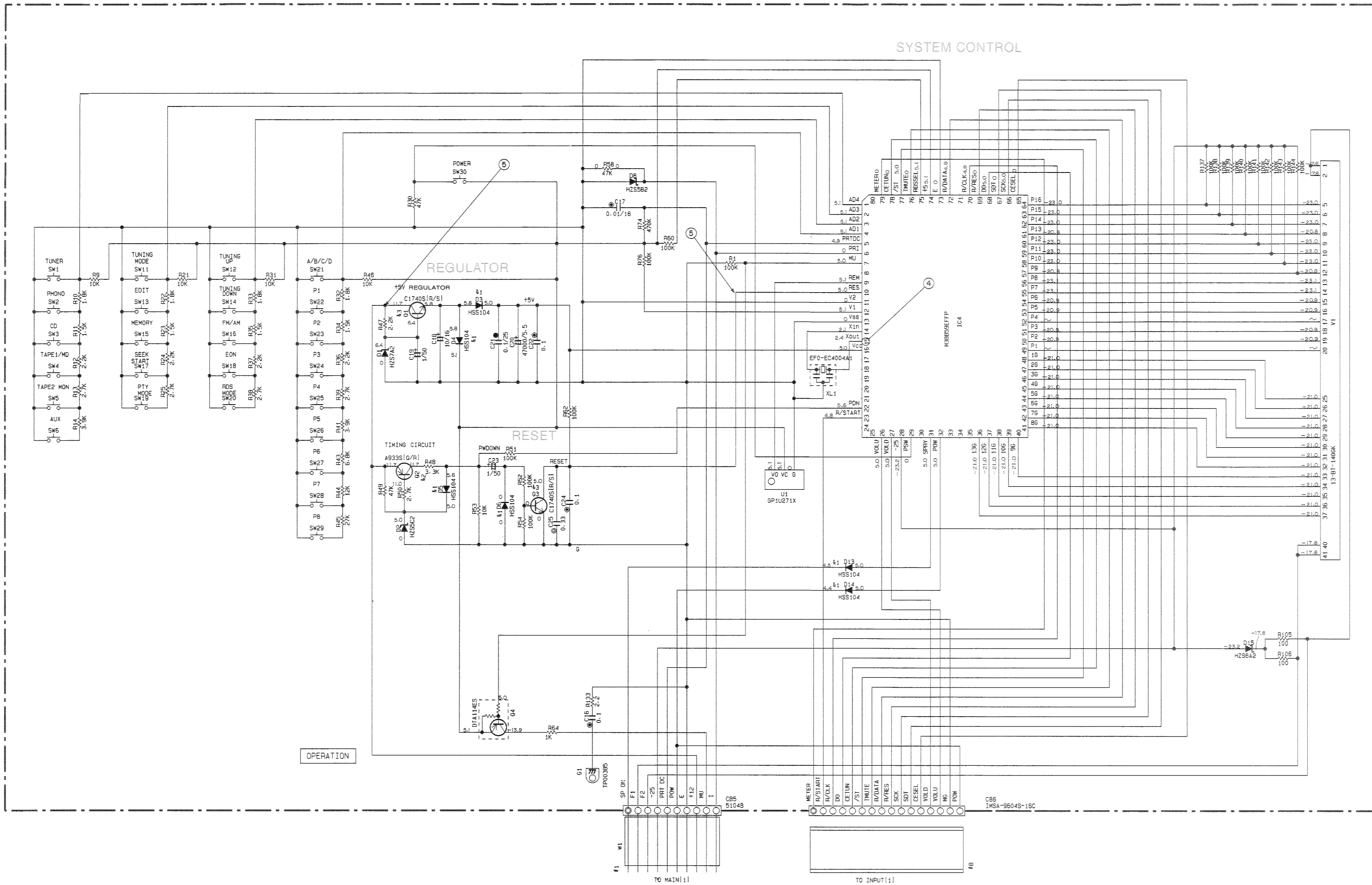

Interchangeable Parts at Manufacture-Stage

Mark	Reference Parts Number	Parts Name
k1	D3-6-13-14	HSS104 ISS133 ISS176
k2	02	2SA933S[G/R] 2SA1115[E/F] 2SA1309A[G/R/S]
k3	01-3	2SC1740S[R/S] 2SC2603[E/F] 2SC3311A[G/R/S]

**Point ④ (Pin15 of IC4)**  
 V : 2V/div H : 0.2 μsec/div  
 DC range 1 : 1 probe

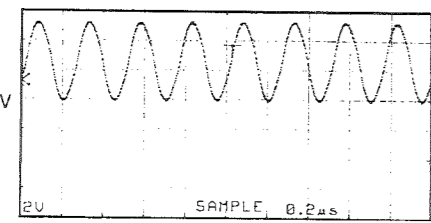

**Point ⑤**  
 CH1 : Collector of Q3 V : 2V/div (CH1)  
 CH2 : Collector of Q1 V : 5V/div (CH2)  
 H : 0.5 sec/div DC range 1 : 1 probe  
 (This waveform is not available by pushing the power switch ON and OFF.)

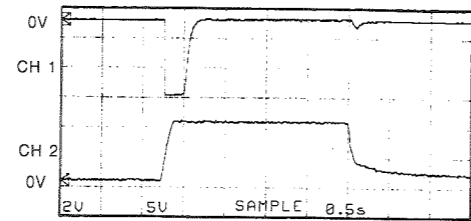

With the POWER ON, disconnect the A/C power cord. Reconnect the A/C power cord and the above waveforms will start.

Disconnect the power cord from the AC outlet.

REMARKS	PARTS NAME
NO MARK	CARBON FILM RESISTOR (P=5)
□	CARBON FILM RESISTOR (P=10)
△	METAL OXIDE FILM RESISTOR
▲	METAL FILM RESISTOR
⊠	METAL PLATE RESISTOR
■	FIRE PROOF CARBON FILM RESISTOR
□	CEMENT MOLDED RESISTOR
⊙	SEMI VARIABLE RESISTOR
■	CHIP RESISTOR

REMARKS	PARTS NAME
NO MARK	ELECTROLYTIC CAPACITOR
⊗	TANTALUM CAPACITOR
NO MARK	CERAMIC CAPACITOR
⊙	CERAMIC TUBULAR CAPACITOR
⊙	POLYESTER FILM CAPACITOR
⊙	POLYSTYRENE FILM CAPACITOR
○	MICA CAPACITOR
⊙	POLYPROPYLENE FILM CAPACITOR
⊙	SEMICONDUCTIVE CERAMIC CAPACITOR

\* All voltages are measured with a 10MΩ/DC electric volt meter.  
 \* Components having special characteristics are marked Δ and should be replaced with parts having specifications equal to those originally installed.  
 \* Schematic diagram is subject to change without notice.

RX-496RDS SCHEMATIC DIAGRAM (MAIN)

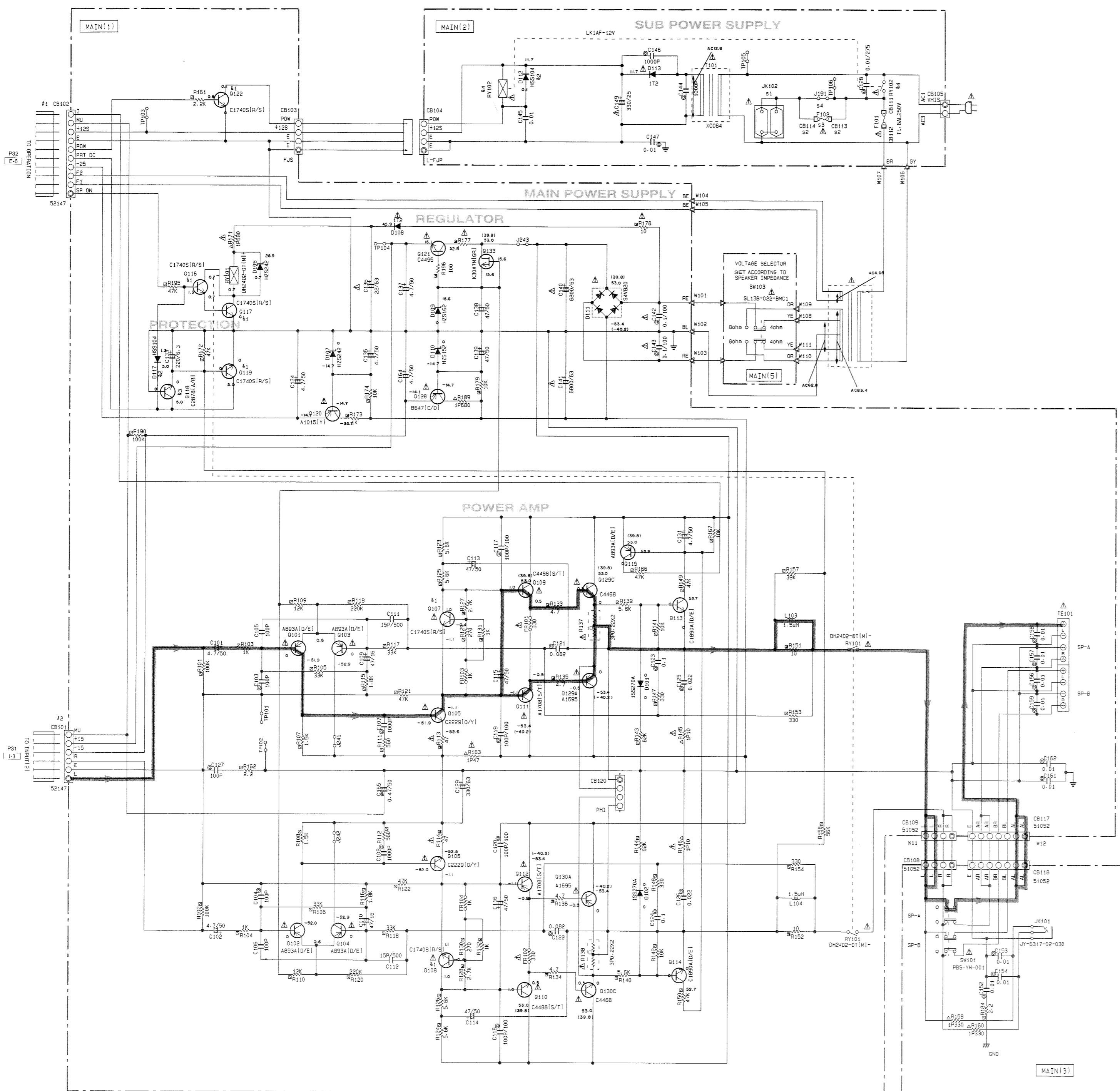

CIRCUIT CHANGES BY MARKET.

S1	JK102	B V208040	G V208050
S2	CB113- CB114	V054330	V054340
S3	F102	X	T2 5AL250V
S4	J191	○	KB00069

X: NOT USED  
O: USED

Interchangeable Parts at Manufacture-Stage

Mark	Reference Parts Number	Parts Name
41	0107, 108, 116, 117, 119, 122	2SC1740S(R/S) 2SC26031E(F) 2SC3311A(G/R/S)
42	D102-117	HSS104 1SS133 1SS176
43	0118	2SC28781A/B1 2SD1919F1(S/T)
44	RY102	VU39850 VU34980 VH23080
45		

RESISTOR

REMARKS	PARTS NAME
NO MARK	CARBON FILM RESISTOR (P=5)
□	CARBON FILM RESISTOR (P=10)
△	METAL OXIDE FILM RESISTOR
⊠	METAL FILM RESISTOR
⊡	METAL PLATE RESISTOR
⊞	FIRE PROOF CARBON FILM RESISTOR
⊞	CEMENT WOLDED RESISTOR
⊞	SEMI VARIABLE RESISTOR
⊞	CHIP RESISTOR

NOTICE (mode1)

(J)..... JAPANESE  
(U)..... U.S.A  
(C)..... CANADIAN  
(R)..... GENERAL  
(A)..... AUSTRALIAN  
(B)..... BRITISH  
(G)..... EUROPEAN  
(T)..... CHINA  
(L)..... SINGAPORE

CAPACITOR

REMARKS	PARTS NAME
NO MARK	ELECTROLYTIC CAPACITOR
⊗	TANTALUM CAPACITOR
NO MARK	CERAMIC CAPACITOR
⊙	CERAMIC TUBULAR CAPACITOR
⊙	POLYESTER FILM CAPACITOR
⊙	POLYSTYRENE FILM CAPACITOR
⊙	MICA CAPACITOR
⊙	POLYPROPYLENE FILM CAPACITOR
⊙	SEMICONDUCTIVE CERAMIC CAPACITOR

\* All voltages are measured with a 10MΩ/DC electric volt meter.  
 \* Components having special characteristics are marked Δ and must be replaced with parts having specifications equal to those originally installed.  
 \* Schematic diagram is subject to change without notice.



# PARTS LIST

## ■ ELECTRICAL PARTS

### ■ WARNING

Components having special characteristics are marked  $\Delta$  and must be replaced with parts having specifications equal to those originally installed.

- Carbon resistors (1/6W or 1/4W) are not included in the ELECTRICAL PARTS List. For the part Nos. of the carbon resistors, refer to the last page.

### ABBREVIATIONS IN THIS LIST ARE AS FOLLOWS :

C.A.EL.CHP	: CHIP ALUMI. ELECTROLYTIC CAP	L.EMIT	: LIGHT EMITTING MODULE
C.CE	: CERAMIC CAP	LED.DSPLY	: LED DISPLAY
C.CE.ARRAY	: CERAMIC CAP ARRAY	LED.INFRD	: LED, INFRARED
C.CE.CHP	: CHIP CERAMIC CAP	MODUL.RF	: MODULATOR, RF
C.CE.ML	: MULTILAYER CERAMIC CAP	PHOT.CPL	: PHOTO COUPLER
C.CE.M.CHP	: CHIP MULTILAYER CERAMIC CAP	PHOT.INTR	: PHOTO INTERRUPTER
C.CE.SAFTY	: RECOGNIZED CERAMIC CAP	PHOT.RFLCT	: PHOTO REFLECTOR
C.CE.TUBLR	: CERAMIC TUBULAR CAP	PIN.TEST	: PIN, TEST POINT
C.CE.SMI	: SEMI CONDUCTIVE CERAMIC CAP	PLST.RIVET	: PLASTIC RIVET
C.EL	: ELECTROLYTIC CAP	R.ARRAY	: RESISTOR ARRAY
C.MICA	: MICA CAP	R.CAR	: CARBON RESISTOR
C.ML.FLM	: MULTILAYER FILM CAP	R.CAR.CHP	: CHIP RESISTOR
C.MP	: METALLIZED PAPER CAP	R.CAR.FP	: FLAME PROOF CARBON RESISTOR
C.MYLAR	: MYLAR FILM CAP	R.FUS	: FUSABLE RESISTOR
C.MYLAR.ML	: MULTILAYER MYLAR FILM CAP	R.MTL.CHP	: CHIP METAL FILM RESISTOR
C.PAPER	: PAPER CAPACITOR	R.MTL.FLM	: METAL FILM RESISTOR
C.PLS	: POLYSTYRENE FILM CAP	R.MTL.OXD	: METAL OXIDE FILM RESISTOR
C.POL	: POLYESTER FILM CAP	R.MTL.PLAT	: METAL PLATE RESISTOR
C.POLY	: POLYETHYLENE FILM CAP	RSNR.CE	: CERAMIC RESONATOR
C.PP	: POLYPROPYLENE FILM CAP	RSNR.CRYS	: CRYSTAL RESONATOR
C.TNTL	: TANTALUM CAP	R.TW.CEM	: TWIN CEMENT FIXED RESISTOR
C.TNTL.CHP	: CHIP TANTALUM CAP	R.WW	: WIRE WOUND RESISTOR
C.TRIM	: TRIMMER CAP	SCR.BND.HD	: BIND HEAD B-TITE SCREW
CN	: CONNECTOR	SCR.BW.HD	: BW HEAD TAPPING SCREW
CN.BS.PIN	: CONNECTOR, BASE PIN	SCR.CUP	: CUP TITE SCREW
CN.CANNON	: CONNECTOR, CANNON	SCR.TERM	: SCREW TERMINAL
CN.DIN	: CONNECTOR, DIN	SCR.TR	: SCREW, TRANSISTOR
CN.FLAT	: CONNECTOR, FLAT CABLE	SUPRT.PCB	: SUPPORT, P.C.B.
CN.POST	: CONNECTOR, BASE POST	SURG.PRTCT	: SURGE PROTECTOR
COIL.MX.AM	: COIL, AM MIX	SW.TACT	: TACT SWITCH
COIL.AT.FM	: COIL, FM ANTENNA	SW.LEAF	: LEAF SWITCH
COIL.DT.FM	: COIL, FM DETECT	SW.LEVER	: LEVER SWITCH
COIL.MX.FM	: COIL, FM MIX	SW.MICRO	: MICRO SWITCH
COIL.OUTPT	: OUTPUT COIL	SW.PUSH	: PUSH SWITCH
DIOD.ARRAY	: DIODE ARRAY	SW.RT.ENC	: ROTARY ENCODER
DIODE.BRG	: DIODE BRIDGE	SW.RT.MTR	: ROTARY SWITCH WITH MOTOR
DIODE.CHP	: CHIP DIODE	SW.RT	: ROTARY SWITCH
DIODE.VAR	: VARACTOR DIODE	SW.SLIDE	: SLIDE SWITCH
DIOD.Z.CHP	: CHIP ZENER DIODE	TERM.SP	: SPEAKER TERMINAL
DIODE.ZENR	: ZENER DIODE	TERM.WRAP	: WRAPPING TERMINAL
DSCR.CE	: CERAMIC DISCRIMINATOR	THRMST.CHP	: CHIP THERMISTOR
FER.BEAD	: FERRITE BEADS	TR.CHP	: CHIP TRANSISTOR
FER.CORE	: FERRITE CORE	TR.DGT	: DIGITAL TRANSISTOR
FET.CHP	: CHIP FET	TR.DGT.CHP	: CHIP DIGITAL TRANSISTOR
FL.DSPLY	: FLUORESCENT DISPLAY	TRANS	: TRANSFORMER
FLTR.CE	: CERAMIC FILTER	TRANS.PULS	: PULSE TRANSFORMER
FLTR.COMB	: COMB FILTER MODULE	TRANS.PWR	: POWER TRANSFORMER ASS'Y
FLTR.LC.RF	: LC FILTER ,EMI	TUNER.AM	: TUNER PACK, AM
GND.MTL	: GROUND PLATE	TUNER.FM	: TUNER PACK, FM
GND.TERM	: GROUND TERMINAL	TUNER.PK	: FRONT-END TUNER PACK
HOLDER.FUS	: FUSE HOLDER	VR	: ROTARY POTENTIOMETER
IC.PRTCT	: IC PROTECTOR	VR.MTR	: POTENTIOMETER WITH MOTOR
JUMPER.CN	: JUMPER CONNECTOR	VR.SW	: POTENTIOMETER WITH ROTARY SW
JUMPER.TST	: JUMPER, TEST POINT	VR.SLIDE	: SLIDE POTENTIOMETER
L.DTCT	: LIGHT DETECTING MODULE	VR.TRIM	: TRIMMER POTENTIOMETER

**Note)** Those parts marked with “#” are not included in the P.C.B. ass'y.

RX-396RDS P.C.B. OPERATION & MAIN

Schm Ref.	PART NO.	Description
*	V2054700	P. C. B.
	OPERATION	
CB5	Vi878800	CN. BS. PIN 10P
CB6	VU271600	CN 16P
C16	VH053100	C. CE. TUBLR 0. 1uF 50V
C17	VF467300	C. CE. TUBLR 0. 01uF 16V
C18	VJ836900	C. EL 10uF 16V
C19	VJ839100	C. EL 1uF 50V
C20	VU545000	C. EL 47000uF 5. 5V
C21	VD930900	C. CE. SMI 0. 1uF 25V
C22	VH053100	C. CE. TUBLR 0. 1uF 50V
C23	VJ839100	C. EL 1uF 50V
C24	VH053100	C. CE. TUBLR 0. 1uF 50V
C25	UA655330	C. MYLAR 0. 33uF 50V
C25	VH053100	C. CE. TUBLR 0. 1uF 50V
D1	VM974600	DIODE. ZENR HZS7A2TD 7. 0V
D2	VM974200	DIODE. ZENR HZS5C2TD 5. 0V
D3	VD631600	DIODE 1SS133, 176, HSS104
D4	VD631600	DIODE 1SS133, 176, HSS104
D5	VD631600	DIODE 1SS133, 176, HSS104
D6	VD631600	DIODE 1SS133, 176, HSS104
D8	VM974100	DIODE. ZENR HZS5B2TD 5. 0V
D13	VD631600	DIODE 1SS133, 176, HSS104
D14	VD631600	DIODE 1SS133, 176, HSS104
D15	VM974300	DIODE. ZENR HZS6A2TD 6. 0V
G1	VR463400	TERM. GND D3. 5 TP00385
IC4	XU108A00	IC M38B57M6-103FP CPU
Q1	iC174020	TR 2SC1740S R, S
Q2	iA093320	TR 2SA933S Q, R
Q3	iC174020	TR 2SC1740S R, S
Q4	VD678500	TR. DGT DTA114ES
SW1	VG392900	SW. TACT SKHVAA
SW2	VG392900	SW. TACT SKHVAA
SW3	VG392900	SW. TACT SKHVAA
SW4	VG392900	SW. TACT SKHVAA
SW5	VG392900	SW. TACT SKHVAA
SW6	VG392900	SW. TACT SKHVAA
SW11	VG392900	SW. TACT SKHVAA
SW12	VG392900	SW. TACT SKHVAA
SW13	VG392900	SW. TACT SKHVAA
SW14	VG392900	SW. TACT SKHVAA
SW15	VG392900	SW. TACT SKHVAA
SW16	VG392900	SW. TACT SKHVAA
SW17	VG392900	SW. TACT SKHVAA
SW18	VG392900	SW. TACT SKHVAA
SW19	VG392900	SW. TACT SKHVAA
SW20	VG392900	SW. TACT SKHVAA
SW21	VG392900	SW. TACT SKHVAA
SW22	VG392900	SW. TACT SKHVAA
SW23	VG392900	SW. TACT SKHVAA
SW24	VG392900	SW. TACT SKHVAA
SW25	VG392900	SW. TACT SKHVAA
SW26	VG392900	SW. TACT SKHVAA
SW27	VG392900	SW. TACT SKHVAA

\* New Parts

Schm Ref.	PART NO.	Description
SW28	VG392900	SW. TACT SKHVAA
SW29	VG392900	SW. TACT SKHVAA
SW30	VG392900	SW. TACT SKHVAA
U1	VU591000	L. DTCT GPIU271X
V1	VT668600	FL. DSPLY 13-BT-140GK
XL1	VD827600	RSNR. CE 4MHz
	VR380100	SPACER FL-T6
	VR519500	SHEET
*	V2055500	P. C. B.
*	V2055600	P. C. B.
CB101	VF728300	CN 6P
CB102	VF728200	CN. BS. PIN 10P
CB103	VS839400	CN. BS. PIN 4P
CB104	VS839500	CN 4P
CB105	VG879900	CN. BS. PIN 2P
CB108	VR428900	CN. BS. PIN 4P
CB109	VR428900	CN. BS. PIN 4P
CB111	VP206500	HOLDER. FUS EYF-52BC
CB112	VP206500	HOLDER. FUS EYF-52BC
CB113	VP206500	HOLDER. FUS EYF-52BC(G)
CB114	VP206500	HOLDER. FUS EYF-52BC(G)
CB117	VQ584900	CN. BS. PIN 7P
CB118	VQ584900	CN. BS. PIN 7P
CB120	VD004700	CN. BS. PIN 4P
C101	UM416470	C. EL 4. 7uF 50V
C102	UM416470	C. EL 4. 7uF 50V
C103	UA652100	C. MYLAR 100pF 50V
C104	UA652100	C. MYLAR 100pF 50V
C105	FG212100	C. CE 100pF 50V
C106	FG212100	C. CE 100pF 50V
C107	UA653100	C. MYLAR 1000pF 50V
C108	UA653100	C. MYLAR 1000pF 50V
C109	VJ837200	C. EL 47uF 16V
C110	VJ837200	C. EL 47uF 16V
C111	VR516400	C. CE 15pF 500V
C112	VR516400	C. CE 15pF 500V
C113	UJ667470	C. EL 47uF 50V
C114	UJ667470	C. EL 47uF 50V
C115	VG291200	C. EL 47uF 50V
C116	VG291200	C. EL 47uF 50V
C117	VR325000	C. MYLAR 100pF 100V
C118	VR325000	C. MYLAR 100pF 100V
C119	VR325000	C. MYLAR 100pF 100V
C120	VR325000	C. MYLAR 100pF 100V
C121	UA654820	C. MYLAR 0. 082uF 50V
C122	UA654820	C. MYLAR 0. 082uF 50V
C123	UA655100	C. MYLAR 0. 1uF 50V
C124	UA655100	C. MYLAR 0. 1uF 50V
C125	UA654220	C. MYLAR 0. 022uF 50V
C126	UA654220	C. MYLAR 0. 022uF 50V

\* New Parts

RX-396RDS  
RX-496RDS

RX-396RDS P.C.B. MAIN

Schm Ref.	PART NO.	Description
C127	UA652100	C. MYLAR 100pF 50V
C128	VS741700	C. CE. SAFTY 0.01uF 275V
C129	VK182500	C. EL 330uF 63V
C131	UM416470	C. EL 4.7uF 50V
C133	VC815000	C. EL 220uF 6.3V
C134	UM416470	C. EL 4.7uF 50V
C135	UM416470	C. EL 4.7uF 50V
△ C136	Vi846000	C. EL 22uF 63V
C137	UM416470	C. EL 4.7uF 50V
C138	UJ667470	C. EL 47uF 50V
C139	UJ667470	C. EL 47uF 50V
△ C140	VR023900	C. EL 5600uF 56V
△ C141	VR023900	C. EL 5600uF 56V
△ C142	VR325400	C. MYLAR 0.1uF 100V
△ C143	VR325400	C. MYLAR 0.1uF 100V
C144	UA653100	C. MYLAR 1000pF 50V
C145	FG214100	C. CE 0.01uF 50V
C146	UA653100	C. MYLAR 1000pF 50V
C147	UA654100	C. MYLAR 0.01uF 50V
△ C149	VK457600	C. EL 330uF 25V
C152	UA654100	C. MYLAR 0.01uF 50V
C153	UA654100	C. MYLAR 0.01uF 50V
C154	UA654100	C. MYLAR 0.01uF 50V
C156	UA654100	C. MYLAR 0.01uF 50V
C157	UA654100	C. MYLAR 0.01uF 50V
C158	UA654100	C. MYLAR 0.01uF 50V
C159	UA654100	C. MYLAR 0.01uF 50V
C161	UA654100	C. MYLAR 0.01uF 50V
C162	UA654100	C. MYLAR 0.01uF 50V
C164	UM416470	C. EL 4.7uF 50V
C165	UK665470	C. EL 0.47uF 50V
C171	UA654100	C. MYLAR 0.01uF 50V
C191	VH053100	C. CE. TUBLR 0.1uF 50V
D101	VN008700	DIODE 1SS270A
D102	VN008700	DIODE 1SS270A
D106	VM976300	DIODE. ZENR HZS242TD 24V
D107	VM976300	DIODE. ZENR HZS242TD 24V
△ D108	VS997800	DIODE 1T2
D109	VM975900	DIODE. ZENR HZS162TD 16V
D110	VM975800	DIODE. ZENR HZS152TD 15V
△ D111	iH001090	DIODE. BRG S4VB20 2.6A 200V
D112	VD631600	DIODE 1SS133, 176, HSS104
△ D113	VS997800	DIODE 1T2
D117	VD631600	DIODE 1SS133, 176, HSS104
△ F101	KB003040	FUSE TL1.0A S
△ F102	KB000690	FUSE T2.5A 250V(G)
△ FR101	VK188400	R. FUS 330Ω 1/4W
△ FR102	VK188400	R. FUS 330Ω 1/4W
FR103	VK189000	R. FUS 1KΩ 1/4W
FR104	VK189000	R. FUS 1KΩ 1/4W
G105	VR463400	TERM. GND D3.5 TP00385
JK101	VY687200	JACK. PHONE JY-6317-02-030 NUT
△ JK102	VU543300	OUTLET. AC 1P(B)

\* New Parts

Schm Ref.	PART NO.	Description
△ JK102	VU543400	OUTLET. AC 2P(G)
L103	VP575600	COIL 1.5uH
L104	VP575600	COIL 1.5uH
△ Q101	VP883000	TR 2SA893A D, E
△ Q102	VP883000	TR 2SA893A D, E
△ Q103	VP883000	TR 2SA893A D, E
△ Q104	VP883000	TR 2SA893A D, E
△ Q105	VR325600	TR 2SC2229 O, Y
△ Q106	VR325600	TR 2SC2229 O, Y
△ Q107	iC174020	TR 2SC1740S R, S
△ Q108	iC174020	TR 2SC1740S R, S
△ Q109	VP872700	TR 2SC4488 S, T
△ Q110	VP872700	TR 2SC4488 S, T
△ Q111	VP872600	TR 2SA1708 S, T
△ Q112	VP872600	TR 2SA1708 S, T
Q113	VP883100	TR 2SC1890A D, E
Q114	VP883100	TR 2SC1890A D, E
Q115	VP883000	TR 2SA893A D, E
Q116	iC174020	TR 2SC1740S R, S
Q117	iC174020	TR 2SC1740S R, S
Q118	iC287820	TR 2SC2878 A, B
Q119	iC174020	TR 2SC1740S R, S
△ Q120	iA101521	TR 2SA1015 Y
△ Q121	VN996900	TR 2SC4495
Q122	iC174020	TR 2SC1740S R, S
△ Q128	VR402300	TR 2SB647 C, D
△ Q129A	iX615750	TR 2SA1694 O, P, Y
△ Q129C	iX615760	TR 2SC4467 O, P, Y
△ Q130A	iX615750	TR 2SA1694 O, P, Y
△ Q130C	iX615760	TR 2SC4467 O, P, Y
Q133	iE000020	FET 2SK30ATM GR
△ R113	HV454470	R. CAR. FP 47Ω 1/4W
△ R114	HV454470	R. CAR. FP 47Ω 1/4W
R127	HV456270	R. CAR. FP 2.7KΩ 1/4W
R128	HV456270	R. CAR. FP 2.7KΩ 1/4W
R131	HV456100	R. CAR. FP 1KΩ 1/4W
R132	HV456100	R. CAR. FP 1KΩ 1/4W
R133	HV453470	R. CAR. FP 4.7Ω 1/4W
R134	HV453470	R. CAR. FP 4.7Ω 1/4W
R135	HV453470	R. CAR. FP 4.7Ω 1/4W
R136	HV453470	R. CAR. FP 4.7Ω 1/4W
△ R137	VU981700	R. MIL. PLAT 0.22Ω+0.22 3W
△ R138	VU981700	R. MIL. PLAT 0.22Ω+0.22 3W
△ R145	HL314100	R. MIL. OXD 10Ω 1W
△ R146	HL314100	R. MIL. OXD 10Ω 1W
△ R151	HV454100	R. CAR. FP 10Ω 1/4W
R152	HV454100	R. CAR. FP 10Ω 1/4W
R159	HL315330	R. MIL. OXD 330Ω 1W
R160	HL315330	R. MIL. OXD 330Ω 1W
△ R163	HL314470	R. MIL. OXD 47Ω 1W
△ R171	HL315680	R. MIL. OXD 680Ω 1W
△ R173	HV456100	R. CAR. FP 1KΩ 1/4W
△ R177	HV453100	R. CAR. FP 1Ω 1/4W

\* New Parts

RX-396RDS  
RX-496RDS

**RX-396RDS P.C.B. MAIN & INPUT**

Schm Ref.	PART NO.	Description		
△ R178	HV454100	R. CAR. FP	10 Ω	1/4W
R179	HV457100	R. CAR. FP	10K Ω	1/4W
R189	HL315680	R. MTL. OXD	680 Ω	1W
R196	HV455100	R. CAR. FP	100 Ω	1/4W
△ RY101	VK438300	RELAY	DH24D2-OT/M2	
△ RY102	VU398500	RELAY	DC LK1AF-12V	
△ SW101	VV523900	SW. PUSH	PBS-YM-001	
△ SW103	VZ361100	SW. SLIDE	SL13B-022-AMC1	
△ T101	XC084A00	TRANS. PWR		
△ TE101	VU819700	TERM. SP	8P	
	VJ828000	PIN	IMSA-6024-03E	
	BB071360	SCR. TERM	8. 3x13	
*	V2569900	PLATE. GND		
	VP753100	HEAT. SINK	IC-1625-MML	
	Ei330166	SCR. BND. HD	3x16	FCRM3-BL
	VY834500	SUPRT		
*	V2055000	P. C. B.	INPUT	
CB103	VQ961500	CN. BS. PIN	12P	
CB104	VQ963300	CN. BS. PIN	12P	
CB105	Vi878600	CN. BS. PIN	8P	
CB106	VK025200	CN. BS. PIN	8P	
CB107	VU271600	CN	16P	
CB108	VQ963600	CN. BS. PIN	15P	
CB111	Vi878400	CN. BS. PIN	6P	
C101	UA652100	C. MYLAR	100pF	50V
C102	UA652220	C. MYLAR	220pF	50V
C103	UA652100	C. MYLAR	100pF	50V
C104	UA652220	C. MYLAR	220pF	50V
C105	VF466800	C. CE. TUBLR	100pF	50V
C106	VF466800	C. CE. TUBLR	100pF	50V
C107	VF466800	C. CE. TUBLR	100pF	50V
C108	VF466800	C. CE. TUBLR	100pF	50V
C109	VF466800	C. CE. TUBLR	100pF	50V
C110	VF466800	C. CE. TUBLR	100pF	50V
C111	VF466700	C. CE. TUBLR	47pF	50V
C112	VF466700	C. CE. TUBLR	47pF	50V
C113	VF466800	C. CE. TUBLR	100pF	50V
C114	VF466800	C. CE. TUBLR	100pF	50V
C115	VF466700	C. CE. TUBLR	47pF	50V
C116	VF466700	C. CE. TUBLR	47pF	50V
C123	VC815000	C. EL	220uF	6. 3V
C124	UA653910	C. MYLAR	9100pF	50V
C125	UA653910	C. MYLAR	9100pF	50V
C126	VC815000	C. EL	220uF	6. 3V
C127	VJ839200	C. EL	2. 2uF	50V
C128	UA653330	C. MYLAR	3300pF	50V
C129	VJ837200	C. EL	47uF	16V
C130	UA654330	C. MYLAR	0. 033uF	50V
C131	UA654330	C. MYLAR	0. 033uF	50V
C132	UA653330	C. MYLAR	3300pF	50V

\* New Parts

Schm Ref.	PART NO.	Description		
C133	VJ837200	C. EL	47uF	16V
C134	VJ839200	C. EL	2. 2uF	50V
C137	VH053100	C. CE. TUBLR	0. 1uF	50V
C138	VH053100	C. CE. TUBLR	0. 1uF	50V
C139	VG722100	C. EL	1uF	50V
C140	VH053100	C. CE. TUBLR	0. 1uF	50V
C141	UJ638470	C. EL	470uF	16V
C142	UA652100	C. MYLAR	100pF	50V
C143	UA652100	C. MYLAR	100pF	50V
C144	VJ837200	C. EL	47uF	16V
C145	VJ837200	C. EL	47uF	16V
C147	VJ839000	C. EL	0. 47uF	50V
C148	UA652100	C. MYLAR	100pF	50V
C149	VG291200	C. EL	47uF	50V
C150	VJ839200	C. EL	2. 2uF	50V
C151	VG291200	C. EL	47uF	50V
C152	VJ839200	C. EL	2. 2uF	50V
C153	UA652100	C. MYLAR	100pF	50V
C155	VJ839000	C. EL	0. 47uF	50V
C156	VG290900	C. EL	10uF	50V
C157	FG211470	C. CE	47pF	50V
C160	FG211470	C. CE	47pF	50V
C161	VG290900	C. EL	10uF	50V
C162	VH053100	C. CE. TUBLR	0. 1uF	50V
C164	VF466800	C. CE. TUBLR	100pF	50V
C165	VF466800	C. CE. TUBLR	100pF	50V
C166	UA655120	C. MYLAR	0. 12uF	50V
C167	UA654330	C. MYLAR	0. 033uF	50V
C168	UA654330	C. MYLAR	0. 033uF	50V
C169	UA655120	C. MYLAR	0. 12uF	50V
C170	VG279000	C. CE. TUBLR	820pF	50V
C171	UA654680	C. MYLAR	0. 068uF	50V
C172	UA654680	C. MYLAR	0. 068uF	50V
C173	VG279000	C. CE. TUBLR	820pF	50V
D101	VM974100	DIODE. ZENR	HZS5B2TD	5. 0V
D102	VM975500	DIODE. ZENR	HZS12A2TD	12V
IC101	XM356A00	IC	NJM2068LD	
IC102	XP894A00	IC	LC78211	
IC104	XF494A00	IC	LB1641	
IC105	XM356A00	IC	NJM2068LD	
PJ101	VN308700	JACK. PIN	6P	
PJ102	VV306900	JACK. PIN	4P	
PJ103	VV306900	JACK. PIN	4P	
Q105	VP872700	TR	2SC4488	S, T
Q106	iC287820	TR	2SC2878	A, B
Q107	iC287820	TR	2SC2878	A, B
R153	HV453220	R. CAR. FP	2. 2 Ω	1/4W
R154	HV453220	R. CAR. FP	2. 2 Ω	1/4W
R155	HV454100	R. CAR. FP	10 Ω	1/4W
R156	HV454100	R. CAR. FP	10 Ω	1/4W
R159	HV453470	R. CAR. FP	4. 7 Ω	1/4W
R168	HL315100	R. MTL. OXD	100 Ω	1W
R175	HL315100	R. MTL. OXD	100 Ω	1W

\* New Parts

RX-396RDS  
RX-496RDS

RX-396RDS P.C.B. INPUT & TUNER

Schm Ref.	PART NO.	Description			
VR101	VR710500	VR. MTR	A100K $\Omega$		
VR102	VP741800	VR	B20K $\Omega$		
VR103	VP741900	VR	G25K $\Omega$		
VR104	VP700700	VR	A100K $\Omega$		
VR105	VP742000	VR	MN100K $\Omega$		
	VR435100	PLATE	W16		
	VV173600	P. C. B.	TUNER		
CB4	VQ961800	CN. BS. PIN	15P		
C1	VG291200	C. EL	47uF	50V	
C2	VF467300	C. CE. TUBLR	0.01uF	16V	
C3	VG275800	C. CE. TUBLR	8.2pF	50V	
C4	VG291200	C. EL	47uF	50V	
C5	VF467300	C. CE. TUBLR	0.01uF	16V	
C6	VG291200	C. EL	47uF	50V	
C7	VJ839100	C. EL	1uF	50V	
C8	VF467300	C. CE. TUBLR	0.01uF	16V	
C9	VF467300	C. CE. TUBLR	0.01uF	16V	
C10	VF467300	C. CE. TUBLR	0.01uF	16V	
C11	VF467000	C. CE. TUBLR	1000pF	50V	
C12	VJ836900	C. EL	10uF	16V	
C13	VJ836900	C. FL	10uF	16V	
C14	VF466800	C. CE. TUBLR	100pF	50V	
C15	VF467000	C. CE. TUBLR	1000pF	50V	
C16	VF466700	C. CE. TUBLR	47pF	50V	
C17	VG291200	C. EL	47uF	50V	
C18	VJ599000	C. CE. TUBLR	0.047uF	16V	
C19	VA761200	C. CE	33pF	50V	
C20	VG291200	C. EL	47uF	50V	
C21	VJ599000	C. CE. TUBLR	0.047uF	16V	
C22	UM216330	C. EL	3.3uF	50V	
C23	VF467300	C. CE. TUBLR	0.01uF	16V	
C24	UM416470	C. EL	4.7uF	50V	
C25	UM216330	C. EL	3.3uF	50V	
C26	VJ836900	C. EL	10uF	16V	
C27	VF467300	C. CE. TUBLR	0.01uF	16V	
C28	VA761200	C. CE	33pF	50V	
C29	VJ839100	C. EL	1uF	50V	
C30	VJ839100	C. EL	1uF	50V	
C31	VG291200	C. EL	47uF	50V	
C32	VJ839000	C. EL	0.47uF	50V	
C33	VJ839100	C. EL	1uF	50V	
C34	UA654470	C. MYLAR	0.047uF	50V	
C35	UM216330	C. EL	3.3uF	50V	
C36	UA652470	C. MYLAR	470pF	50V	
C37	UA652470	C. MYLAR	470pF	50V	
C38	VF466900	C. CE. TUBLR	470pF	50V	
C39	VJ836900	C. EL	10uF	16V	
C40	UM216330	C. EL	3.3uF	50V	
C41	UA653390	C. MYLAR	3900pF	50V	
C42	UM407220	C. EL	22uF	25V	

\* New Parts

Schm Ref.	PART NO.	Description			
C43	UA653390	C. MYLAR	3900pF	50V	
C44	UM216330	C. EL	3.3uF	50V	
C45	VG291200	C. EL	47uF	50V	
C46	VG291200	C. EL	47uF	50V	
C47	VG291200	C. EL	47uF	50V	
C48	VF466800	C. CE. TUBLR	100pF	50V	
C49	UA652120	C. MYLAR	120pF	50V	
C50	VJ599000	C. CE. TUBLR	0.047uF	16V	
D1	iF004600	DIODE	1SS133		
D2	iF004600	DIODE	1SS133		
D3	VG437800	DIODE. ZENR	MTZJ5.6C	5.6V	
Fi1	GG000560	FLTR. CE	SFE10.7MS3GHY-A		
Fi2	GG000560	FLTR. CE	SFE10.7MS3GHY-A		
Fi3	VC219000	FLTR. CE	SFZ450JL3		
IC1	XB760A00	IC	LA1266		
IC2	XQ944A00	IC	LC72131		
IC3	iG158100	IC	LA3401		
IC4	XQ359A00	IC	STK311-020B		
L1	Vi546100	COIL	220uH		
L2	Vi546100	COIL	220uH		
L3	Vi546100	COIL	220uH		
L4	Vi546100	COIL	220uH		
PK1	VQ987600	TUNER. PK	ENV-17297G1		
PK2	VU333700	COIL. RF. AM	940536051A		
Q1	VB433300	TR	2SC1809 M, N, P		
Q2	VB433300	TR	2SC1809 M, N, P		
Q3	VD678500	TR. DGT	DTA114ES		
Q4	VC218900	TR	2SC3330 R, S, T		
Q5	VG722000	TR. DGT	DTC144ES		
Q6	iC1815C0	TR	2SC1815 Y		
Q7	VD678500	TR. DGT	DTA114ES		
T1	VC218600	COIL. DT. FM	10.7MHz		
T2	GE100470	COIL. IF. AM	450KHz		
T3	VI486800	COIL	XYA2		
T4	VQ138200	FLTR. LC	19KHz		
T5	VQ138200	FLTR. LC	19KHz		
TE1	VU477800	TERM. ANT	AJ-2038-040		
TP1	VI969000	PIN. TEST	IRS-2049		
TP2	VI969000	PIN. TEST	IRS-2049		
VR1	VJ694000	VR. TRIM	B47K $\Omega$		
VR2	VJ694000	VR. TRIM	B47K $\Omega$		
XL1	VC219100	RSNR. CRYST	7.2MHz		
XL2	GG000750	RSNR. CE	18.95KHz		
XL3	VS860100	RSNR. CE	19KHz		
	BB071360	SCR. TERM	8.3x13		
	VR282500	PLATE	ANT.		

\* New Parts

RX-396RDS  
RX-496RDS

**RX-496RDS P.C.B. OPERATION & MAIN**

Schm Ref.	PART NO.	Description
*	V2054700	P. C. B. OPERATION
CB5	Vi878800	CN. BS. PIN 10P
CB6	VU271600	CN 16P
C16	VH053100	C. CE. TUBLR 0.1uF 50V
C17	VF467300	C. CE. TUBLR 0.01uF 16V
C18	VJ836900	C. EL 10uF 16V
C19	VJ839100	C. EL 1uF 50V
C20	VU545000	C. EL 47000uF 5.5V
C21	VD930900	C. CE. SMI 0.1uF 25V
C22	VH053100	C. CE. TUBLR 0.1uF 50V
C23	VJ839100	C. EL 1uF 50V
C24	VH053100	C. CE. TUBLR 0.1uF 50V
C25	UA655330	C. MYLAR 0.33uF 50V
C25	VH053100	C. CE. TUBLR 0.1uF 50V
D1	VM974600	DIODE. ZENR HZS7A2TD 7.0V
D2	VM974200	DIODE. ZENR HZS5C2TD 5.0V
D3	VD631600	DIODE 1SS133, 176, HSS104
D4	VD631600	DIODE 1SS133, 176, HSS104
D5	VD631600	DIODE 1SS133, 176, HSS104
D6	VD631600	DIODE 1SS133, 176, HSS104
D8	VM974100	DIODE. ZENR HZS5B2TD 5.0V
D13	VD631600	DIODE 1SS133, 176, HSS104
D14	VD631600	DIODE 1SS133, 176, HSS104
D15	VM974300	DIODE. ZENR HZS6A2TD 6.0V
G1	VR463400	TERM. GND D3.5 TP00385
IC4	XU108A00	IC M38B57M6-103FP CPU
Q1	iC174020	TR 2SC1740S R, S
Q2	iA093320	TR 2SA933S Q, R
Q3	iC174020	TR 2SC1740S R, S
Q4	VD678500	TR. DGT DTA114ES
SW1	VG392900	SW. TACT SKHVAA
SW2	VG392900	SW. TACT SKHVAA
SW3	VG392900	SW. TACT SKHVAA
SW4	VG392900	SW. TACT SKHVAA
SW5	VG392900	SW. TACT SKHVAA
SW6	VG392900	SW. TACT SKHVAA
SW11	VG392900	SW. TACT SKHVAA
SW12	VG392900	SW. TACT SKHVAA
SW13	VG392900	SW. TACT SKHVAA
SW14	VG392900	SW. TACT SKHVAA
SW15	VG392900	SW. TACT SKHVAA
SW16	VG392900	SW. TACT SKHVAA
SW17	VG392900	SW. TACT SKHVAA
SW18	VG392900	SW. TACT SKHVAA
SW19	VG392900	SW. TACT SKHVAA
SW20	VG392900	SW. TACT SKHVAA
SW21	VG392900	SW. TACT SKHVAA
SW22	VG392900	SW. TACT SKHVAA
SW23	VG392900	SW. TACT SKHVAA
SW24	VG392900	SW. TACT SKHVAA
SW25	VG392900	SW. TACT SKHVAA
SW26	VG392900	SW. TACT SKHVAA
SW27	VG392900	SW. TACT SKHVAA

\* New Parts

Schm Ref.	PART NO.	Description
SW28	VG392900	SW. TACT SKHVAA
SW29	VG392900	SW. TACT SKHVAA
SW30	VG392900	SW. TACT SKHVAA
U1	VU591000	L. DTCT GP1U271X
V1	VT668600	FL. DSPLY 13-BT-140GK
XL1	VD827600	RSNR. CE 4MHZ
	VR380100	SPACER FL-T6
	VR519500	SHEET
*	V2060400	P. C. B. MAIN(B)
*	V2060500	P. C. B. MAIN(G)
CB101	VF728300	CN 6P
CB102	VF728200	CN. BS. PIN 10P
CB103	VS839400	CN. BS. PIN 4P
CB104	VS839500	CN 4P
CB105	VG879900	CN. BS. PIN 2P
CB108	VR428900	CN. BS. PIN 4P
CB109	VR428900	CN. BS. PIN 4P
CB111	VP206500	HOLDER. FUS EYF-52BC
CB112	VP206500	HOLDER. FUS EYF-52BC
CB113	VP206500	HOLDER. FUS EYF-52BC(G)
CB114	VP206500	HOLDER. FUS EYF-52BC(G)
CB117	VQ584900	CN. BS. PIN 7P
CB118	VQ584900	CN. BS. PIN 7P
CB120	VD004700	CN. BS. PIN 4P
C101	UM416470	C. EL 4.7uF 50V
C102	UM416470	C. EL 4.7uF 50V
C103	UA652100	C. MYLAR 100pF 50V
C104	UA652100	C. MYLAR 100pF 50V
C105	FG212100	C. CE 100pF 50V
C106	FG212100	C. CE 100pF 50V
C107	UA653100	C. MYLAR 1000pF 50V
C108	UA653100	C. MYLAR 1000pF 50V
C109	VJ837200	C. EL 47uF 16V
C110	VJ837200	C. EL 47uF 16V
C111	VR516400	C. CE 15pF 500V
C112	VR516400	C. CE 15pF 500V
C113	UJ667470	C. EL 47uF 50V
C114	UJ667470	C. EL 47uF 50V
C115	VG291200	C. EL 47uF 50V
C116	VG291200	C. EL 47uF 50V
C117	VR325000	C. MYLAR 100pF 100V
C118	VR325000	C. MYLAR 100pF 100V
C119	VR325000	C. MYLAR 100pF 100V
C120	VR325000	C. MYLAR 100pF 100V
C121	UA654820	C. MYLAR 0.082uF 50V
C122	UA654820	C. MYLAR 0.082uF 50V
C123	UA655100	C. MYLAR 0.1uF 50V
C124	UA655100	C. MYLAR 0.1uF 50V
C125	UA654220	C. MYLAR 0.022uF 50V
C126	UA654220	C. MYLAR 0.022uF 50V
C127	UA652100	C. MYLAR 100pF 50V

\* New Parts

RX-396RDS  
RX-496RDS

## RX-496RDS P.C.B. MAIN

Schm Ref.	PART NO.	Description		
C128	VS741700	C. CE. SAFTY	0.01uF	275V
C129	VK182500	C. EL	330uF	63V
C131	UM416470	C. EL	4.7uF	50V
C133	VC815000	C. EL	220uF	6.3V
C134	UM416470	C. EL	4.7uF	50V
C135	UM416470	C. EL	4.7uF	50V
△ C136	Vi846000	C. EL	22uF	63V
C137	UM416470	C. EL	4.7uF	50V
C138	UJ667470	C. EL	47uF	50V
C139	UJ667470	C. EL	47uF	50V
△ C140	V2376100	C. EL	6800uF	63V
△ C141	V2376100	C. EL	6800uF	63V
△ C142	VR325400	C. MYLAR	0.1uF	100V
△ C143	VR325400	C. MYLAR	0.1uF	100V
C144	UA653100	C. MYLAR	1000pF	50V
C145	FG214100	C. CE	0.01uF	50V
C146	UA653100	C. MYLAR	1000pF	50V
C147	UA654100	C. MYLAR	0.01uF	50V
△ C149	VK457600	C. EL	330uF	25V
C152	UA654100	C. MYLAR	0.01uF	50V
C153	UA654100	C. MYLAR	0.01uF	50V
C154	UA654100	C. MYLAR	0.01uF	50V
C156	UA654100	C. MYLAR	0.01uF	50V
C157	UA654100	C. MYLAR	0.01uF	50V
C158	UA654100	C. MYLAR	0.01uF	50V
C159	UA654100	C. MYLAR	0.01uF	50V
C161	UA654100	C. MYLAR	0.01uF	50V
C162	UA654100	C. MYLAR	0.01uF	50V
C164	UM416470	C. EL	4.7uF	50V
C165	UK665470	C. EL	0.47uF	50V
C171	UA654100	C. MYLAR	0.01uF	50V
C191	VH053100	C. CE. TUBLR	0.1uF	50V
D101	VN008700	DIODE	1SS270A	
D102	VN008700	DIODE	1SS270A	
D106	VM976300	DIODE. ZENR	HZS242TD	24V
D107	VM976300	DIODE. ZENR	HZS242TD	24V
△ D108	VS997800	DIODE	1T2	
D109	VM975900	DIODE. ZENR	HZS162TD	16V
D110	VM975800	DIODE. ZENR	HZS152TD	15V
△ D111	iH001090	DIODE. BRG	S4VB20	2.6A 200V
D112	VD631600	DIODE	1SS133, 176, HSS104	
△ D113	VS997800	DIODE	1T2	
D117	VD631600	DIODE	1SS133, 176, HSS104	
△ F101	KB001660	FUSE	T1.6A	250V
△ F102	KB000690	FUSE	T2.5A	250V(G)
△ FR101	VK188400	R. FUS	330Ω	1/4W
△ FR102	VK188400	R. FUS	330Ω	1/4W
△ FR103	VK189000	R. FUS	1KΩ	1/4W
△ FR104	VK189000	R. FUS	1KΩ	1/4W
G105	VR463400	TERM. GND	D3.5	TP00385
△ JK101	VY687200	JACK. PHONE	JY-6317-02-030	NUT
△ JK102	VU543300	OUTLET. AC	1P(B)	
△ JK102	VU543400	OUTLET. AC	2P(G)	

\* New Parts

Schm Ref.	PART NO.	Description		
L103	VP575600	COIL	1.5uH	
L104	VP575600	COIL	1.5uH	
△ Q101	VP883000	TR	2SA893A	D, E
△ Q102	VP883000	TR	2SA893A	D, E
△ Q103	VP883000	TR	2SA893A	D, E
△ Q104	VP883000	TR	2SA893A	D, E
△ Q105	VR325600	TR	2SC2229	O, Y
△ Q106	VR325600	TR	2SC2229	O, Y
△ Q107	iC174020	TR	2SC1740S	R, S
△ Q108	iC174020	TR	2SC1740S	R, S
△ Q109	VP872700	TR	2SC4488	S, T
△ Q110	VP872700	TR	2SC4488	S, T
△ Q111	VP872600	TR	2SA1708	S, T
△ Q112	VP872600	TR	2SA1708	S, T
△ Q113	VP883100	TR	2SC1890A	D, E
△ Q114	VP883100	TR	2SC1890A	D, E
△ Q115	VP883000	TR	2SA893A	D, E
△ Q116	iC174020	TR	2SC1740S	R, S
△ Q117	iC174020	TR	2SC1740S	R, S
△ Q118	iC287820	TR	2SC2878	A, B
△ Q119	iC174020	TR	2SC1740S	R, S
△ Q120	iA101521	TR	2SA1015	Y
△ Q121	VN996900	TR	2SC4495	
△ Q122	iC174020	TR	2SC1740S	R, S
△ Q128	VR402300	TR	2SB647	C, D
△ Q129A	iX630850	TR	2SA1695	O, P, Y
△ Q129C	iX630850	TR	2SA1695	O, P, Y
△ Q130A	iX630850	TR	2SA1695	O, P, Y
△ Q130C	iX630850	TR	2SA1695	O, P, Y
△ Q133	iE000020	FET	2SK30ATM	GR
△ R113	HV454470	R. CAR. FP	47Ω	1/4W
△ R114	HV454470	R. CAR. FP	47Ω	1/4W
△ R127	HV456270	R. CAR. FP	2.7KΩ	1/4W
△ R128	HV456270	R. CAR. FP	2.7KΩ	1/4W
△ R131	HV456100	R. CAR. FP	1KΩ	1/4W
△ R132	HV456100	R. CAR. FP	1KΩ	1/4W
△ R133	HV453470	R. CAR. FP	4.7Ω	1/4W
△ R134	HV453470	R. CAR. FP	4.7Ω	1/4W
△ R135	HV453470	R. CAR. FP	4.7Ω	1/4W
△ R136	HV453470	R. CAR. FP	4.7Ω	1/4W
△ R137	VU981700	R. MIL. PLAT	0.22Ω+0.22	3W
△ R138	VU981700	R. MIL. PLAT	0.22Ω+0.22	3W
△ R145	HL314100	R. MIL. OXD	10Ω	1W
△ R146	HL314100	R. MIL. OXD	10Ω	1W
△ R151	HV454100	R. CAR. FP	10Ω	1/4W
△ R152	HV454100	R. CAR. FP	10Ω	1/4W
△ R159	VP944500	R. MIL. OXD	390Ω	1W
△ R160	VP944500	R. MIL. OXD	390Ω	1W
△ R163	HL314470	R. MIL. OXD	47Ω	1W
△ R171	HL315680	R. MIL. OXD	680Ω	1W
△ R173	HV456100	R. CAR. FP	1KΩ	1/4W
△ R177	HV453100	R. CAR. FP	1Ω	1/4W
△ R178	HV454100	R. CAR. FP	10Ω	1/4W

\* New Parts

**RX-496RDS P.C.B. MAIN & INPUT**

Schm Ref.	PART NO.	Description		
R179	HV457100	R. CAR. FP	10KΩ	1/4W
R189	HL315680	R. MTL. OXD	680Ω	1W
R196	HV455100	R. CAR. FP	100Ω	1/4W
△ RY101	VK438300	RELAY	DH24D2-OT/M2	
△ RY102	VU398500	RELAY	DC LK1AF-12V	
△ SW101	VV523900	SW. PUSH	PBS-YM-001	
△ SW103	VZ361100	SW. SLIDE	SL13B-022-AMC1	
△ T101	XC084A00	TRANS. PWR		
△ TE101	VU819700	TERM. SP	8P	
	VJ828000	PIN	IMSA-6024-03E	
	BB071360	SCR. TERM	8.3x13	
*	V2569900	PLATE. GND		
	VP753100	HEAT. SINK	IC-1625-MML	
	Ei330166	SCR. BND. HD	3x16	FCRM3-BL
	VY834500	SUPRT		
*	V2060000	P. C. B.	INPUT	
CB101	VD004500	CN. BS. PIN	2P	
CB103	VQ961500	CN. BS. PIN	12P	
CB104	VQ963300	CN. BS. PIN	12P	
CB105	Vi878600	CN. BS. PIN	8P	
CB106	VK025200	CN. BS. PIN	8P	
CB107	VU271600	CN	16P	
CB108	VQ963600	CN. BS. PIN	15P	
CB109	VK025500	CN. BS. PIN	11P	
CB110	Vi878900	CN. BS. PIN	11P	
CB111	Vi878400	CN. BS. PIN	6P	
CB112	Vi878000	CN. BS. PIN	2P	
CB114	Vi878000	CN. BS. PIN	2P	
C101	UA652100	C. MYLAR	100pF	50V
C102	UA652220	C. MYLAR	220pF	50V
C103	UA652100	C. MYLAR	100pF	50V
C104	UA652220	C. MYLAR	220pF	50V
C105	VF466800	C. CE. TUBLR	100pF	50V
C106	VF466800	C. CE. TUBLR	100pF	50V
C107	VF466800	C. CE. TUBLR	100pF	50V
C108	VF466800	C. CE. TUBLR	100pF	50V
C109	VF466800	C. CE. TUBLR	100pF	50V
C110	VF466800	C. CE. TUBLR	100pF	50V
C111	VF466700	C. CE. TUBLR	47pF	50V
C112	VF466700	C. CE. TUBLR	47pF	50V
C113	VF466800	C. CE. TUBLR	100pF	50V
C114	VF466800	C. CE. TUBLR	100pF	50V
C115	VF466700	C. CE. TUBLR	47pF	50V
C116	VF466700	C. CE. TUBLR	47pF	50V
C123	VC815000	C. EL	220uF	6.3V
C124	UA653910	C. MYLAR	9100pF	50V
C125	UA653910	C. MYLAR	9100pF	50V
C126	VC815000	C. EL	220uF	6.3V
C127	VJ839200	C. EL	2.2uF	50V
C128	UA653330	C. MYLAR	3300pF	50V
C129	VJ837200	C. EL	47uF	16V

\* New Parts

Schm Ref.	PART NO.	Description		
C130	UA654330	C. MYLAR	0.033uF	50V
C131	UA654330	C. MYLAR	0.033uF	50V
C132	UA653330	C. MYLAR	3300pF	50V
C133	VJ837200	C. EL	47uF	16V
C134	VJ839200	C. EL	2.2uF	50V
C137	VH053100	C. CE. TUBLR	0.1uF	50V
C138	VH053100	C. CE. TUBLR	0.1uF	50V
C139	VG722100	C. EL	1uF	50V
C140	VH053100	C. CE. TUBLR	0.1uF	50V
C141	UJ638470	C. EL	470uF	16V
C142	UA652100	C. MYLAR	100pF	50V
C143	UA652100	C. MYLAR	100pF	50V
C144	VJ837200	C. EL	47uF	16V
C145	VJ837200	C. EL	47uF	16V
C147	VJ839000	C. EL	0.47uF	50V
C148	UA652100	C. MYLAR	100pF	50V
C149	VG291200	C. EL	47uF	50V
C150	VJ839200	C. EL	2.2uF	50V
C151	VG291200	C. EL	47uF	50V
C152	VJ839200	C. EL	2.2uF	50V
C153	UA652100	C. MYLAR	100pF	50V
C155	VJ839000	C. EL	0.47uF	50V
C156	VG290900	C. EL	10uF	50V
C157	FG211470	C. CE	47pF	50V
C158	UA654100	C. MYLAR	0.01uF	50V
C159	UA654100	C. MYLAR	0.01uF	50V
C160	FG211470	C. CE	47pF	50V
C161	VG290900	C. EL	10uF	50V
C162	VH053100	C. CE. TUBLR	0.1uF	50V
C164	VF466800	C. CE. TUBLR	100pF	50V
C165	VF466800	C. CE. TUBLR	100pF	50V
C166	UA655120	C. MYLAR	0.12uF	50V
C167	UA654330	C. MYLAR	0.033uF	50V
C168	UA654330	C. MYLAR	0.033uF	50V
C169	UA655120	C. MYLAR	0.12uF	50V
C170	VG279000	C. CE. TUBLR	820pF	50V
C171	UA654680	C. MYLAR	0.068uF	50V
C172	UA654680	C. MYLAR	0.068uF	50V
C173	VG279000	C. CE. TUBLR	820pF	50V
D101	VM974100	DIODE. ZENR	HZS5B2TD	5.0V
D102	VM975500	DIODE. ZENR	HZS12A2TD	12V
D103	VS132300	LED(re)	SLR-325VCT31	
IC101	XM356A00	IC	NJM2068LD	
IC102	XP894A00	IC	LC78211	
IC104	XF494A00	IC	LB1641	
IC105	XM356A00	IC	NJM2068LD	
PJ101	VN308700	JACK. PIN	6P	
PJ102	VV306900	JACK. PIN	4P	
PJ103	VV306900	JACK. PIN	4P	
Q101	VG722000	TR. DGT	DTC144ES	
Q105	VP872700	TR	2SC4488 S, T	
Q106	iC287820	TR	2SC2878 A, B	
Q107	iC287820	TR	2SC2878 A, B	

\* New Parts

RX-396RDS  
RX-496RDS



## RX-496RDS P.C.B. INPUT &amp; TUNER

Schm Ref.	PART NO.	Description		
R123	HV456680	R. CAR. FP	6.8K $\Omega$	1/4W
R153	HV453220	R. CAR. FP	2.2 $\Omega$	1/4W
R154	HV453220	R. CAR. FP	2.2 $\Omega$	1/4W
R155	HV454100	R. CAR. FP	10 $\Omega$	1/4W
R156	HV454100	R. CAR. FP	10 $\Omega$	1/4W
R159	HV453470	R. CAR. FP	4.7 $\Omega$	1/4W
R168	HL315100	R. MTL. OXD	100 $\Omega$	1W
R175	HL315100	R. MTL. OXD	100 $\Omega$	1W
SW101	VV399800	SW. PUSH	SPUN12	
VR101	VR710500	VR. MTR	A100K $\Omega$	
VR102	VP741800	VR	B20K $\Omega$	
VR103	VP741900	VR	G25K $\Omega$	
VR104	VP700700	VR	A100K $\Omega$	
VR105	VP742000	VR	MN100K $\Omega$	
	VR435100	PLATE	W16	
	VV173600	P.C.B.	TUNER	
CB4	VQ961800	CN. BS. PIN	15P	
C1	VG291200	C. EL	47uF	50V
C2	VF467300	C. CE. TUBLR	0.01uF	16V
C3	VG275800	C. CE. TUBLR	8.2pF	50V
C4	VG291200	C. EL	47uF	50V
C5	VF467300	C. CE. TUBLR	0.01uF	16V
C6	VG291200	C. EL	47uF	50V
C7	VJ839100	C. EL	1uF	50V
C8	VF467300	C. CE. TUBLR	0.01uF	16V
C9	VF467300	C. CE. TUBLR	0.01uF	16V
C10	VF467300	C. CE. TUBLR	0.01uF	16V
C11	VF467000	C. CE. TUBLR	1000pF	50V
C12	VJ836900	C. FL	10uF	16V
C13	VJ836900	C. EL	10uF	16V
C14	VF466800	C. CE. TUBLR	100pF	50V
C15	VF467000	C. CE. TUBLR	1000pF	50V
C16	VF466700	C. CE. TUBLR	47pF	50V
C17	VG291200	C. EL	47uF	50V
C18	VJ599000	C. CE. TUBLR	0.047uF	16V
C19	VA761200	C. CE	33pF	50V
C20	VG291200	C. EL	47uF	50V
C21	VJ599000	C. CE. TUBLR	0.047uF	16V
C22	UM216330	C. EL	3.3uF	50V
C23	VF467300	C. CE. TUBLR	0.01uF	16V
C24	UM416470	C. EL	4.7uF	50V
C25	UM216330	C. EL	3.3uF	50V
C26	VJ836900	C. EL	10uF	16V
C27	VF467300	C. CE. TUBLR	0.01uF	16V
C28	VA761200	C. CE	33pF	50V
C29	VJ839100	C. EL	1uF	50V
C30	VJ839100	C. EL	1uF	50V
C31	VG291200	C. EL	47uF	50V
C32	VJ839000	C. EL	0.47uF	50V
C33	VJ839100	C. EL	1uF	50V
C34	UA654470	C. MYLAR	0.047uF	50V
C35	UM216330	C. EL	3.3uF	50V

\* New Parts

Schm Ref.	PART NO.	Description		
C36	UA652470	C. MYLAR	470pF	50V
C37	UA652470	C. MYLAR	470pF	50V
C38	VF466900	C. CE. TUBLR	470pF	50V
C39	VJ836900	C. EL	10uF	16V
C40	UM216330	C. EL	3.3uF	50V
C41	UA653390	C. MYLAR	3900pF	50V
C42	UM407220	C. EL	22uF	25V
C43	UA653390	C. MYLAR	3900pF	50V
C44	UM216330	C. EL	3.3uF	50V
C45	VG291200	C. EL	47uF	50V
C46	VG291200	C. EL	47uF	50V
C47	VG291200	C. EL	47uF	50V
C48	VF466800	C. CE. TUBLR	100pF	50V
C49	UA652120	C. MYLAR	120pF	50V
C50	VJ599000	C. CE. TUBLR	0.047uF	16V
D1	iF004600	DIODE	1SS133	
D2	iF004600	DIODE	1SS133	
D3	VG437800	DIODE. ZENR	MTZJ5.6C	5.6V
Fi1	GG000560	FLTR. CE	SFE10.7MS3GHY-A	
Fi2	GG000560	FLTR. CE	SFE10.7MS3GHY-A	
Fi3	VC219000	FLTR. CE	SFZ450JL3	
IC1	XB760A00	IC	LA1266	
IC2	XQ944A00	IC	LC72131	
IC3	iG158100	IC	LA3401	
IC4	XQ359A00	IC	STK311-020B	
L1	Vi546100	COIL	220uH	
L2	Vi546100	COIL	220uH	
L3	Vi546100	COIL	220uH	
L4	Vi546100	COIL	220uH	
PK1	VQ987600	TUNER. PK	ENV-17297G1	
PK2	VU333700	COIL. RF. AM	940536051A	
Q1	VB433300	TR	2SC1809 M, N, P	
Q2	VB433300	TR	2SC1809 M, N, P	
Q3	VD678500	TR. DGT	DTA114ES	
Q4	VC218900	TR	2SC3330 R, S, T	
Q5	VG722000	TR. DGT	DTC144ES	
Q6	iC1815C0	TR	2SC1815 Y	
Q7	VD678500	TR. DGT	DTA114ES	
T1	VC218600	COIL. DT. FM	10.7MHz	
T2	GE100470	COIL. IF. AM	450KHz	
T3	VT486800	COIL	XYA2	
T4	VQ138200	FLTR. LC	19KHz	
T5	VQ138200	FLTR. LC	19KHz	
TE1	VU477800	TERM. ANT	AJ-2038-040	
TP1	VT969000	PIN. TEST	IRS-2049	
TP2	VT969000	PIN. TEST	IRS-2049	
VR1	VJ694000	VR. TRIM	B47K $\Omega$	
VR2	VJ694000	VR. TRIM	B47K $\Omega$	
XL1	VC219100	RSNR. CRYST	7.2MHz	
XL2	GG000750	RSNR. CE	18.95KHz	
XL3	VS860100	RSNR. CE	19KHz	
	BB071360	SCR. TERM	8.3x13	
	VR282500	PLATE	ANT.	

\* New Parts

A

B

C

D

E

RX-396RDS/RX-496RDS

## 1 ■ RX-396RDS EXPLODED VIEW

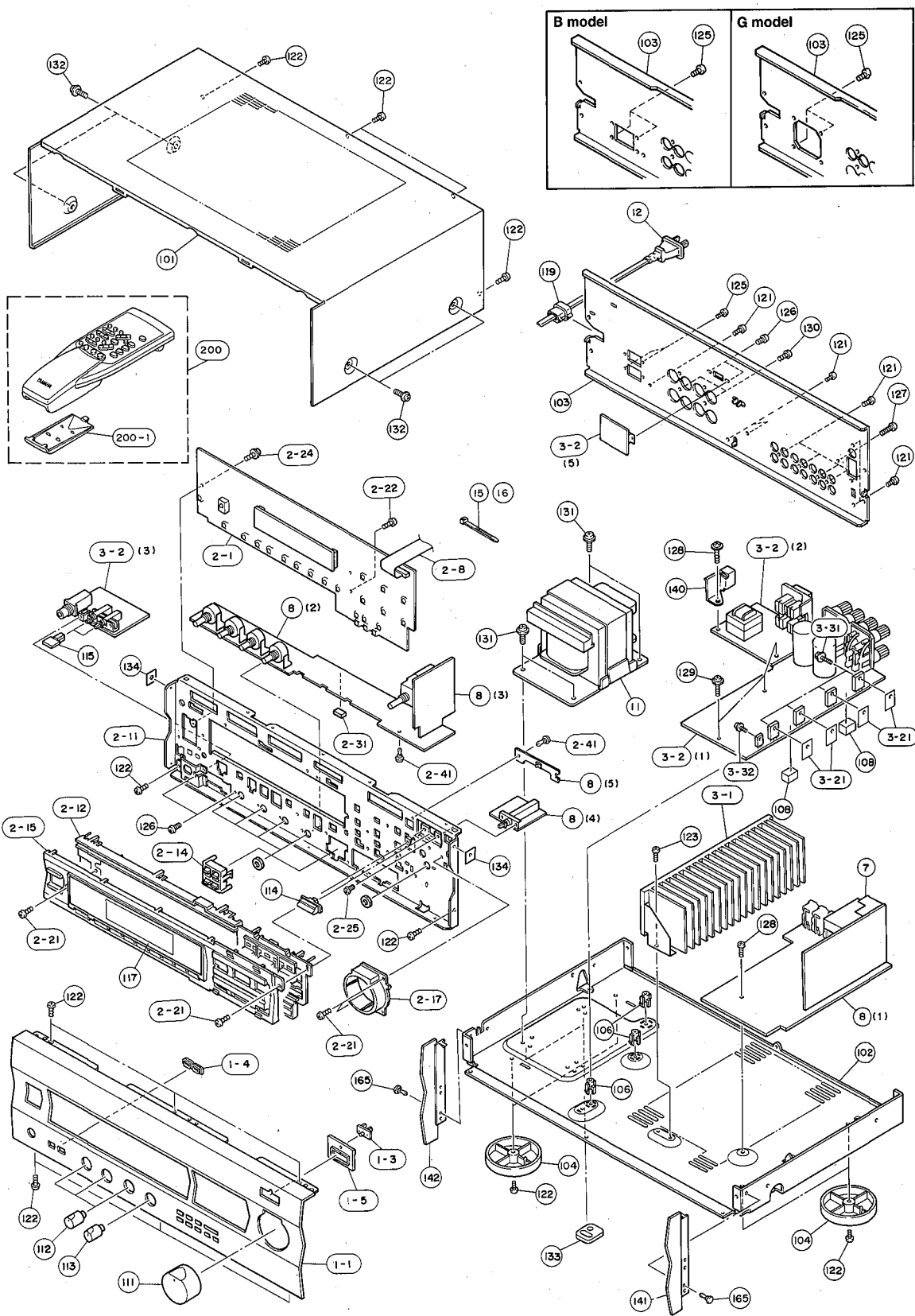

7

■ RX-396RDS MECHANICAL PARTS

Ref. No.	PART NO.	Description	Remarks	Markets
* 1- 1	VZ702200	FRONT PANEL		BL
* 1- 1	VZ702300	FRONT PANEL		TI
1- 4	VV123700	ESCUTCHEON, 3/8	2P	BL
1- 4	VV123800	ESCUTCHEON, 3/8	2P	TI
* 2- 1	V2054700	P. C. B. ASS'Y	OPERATION	
2- 8	MF116200	FLEXIBLE FLAT CABLE	16P 200mm	
* 2-11	VZ701700	SUB CHASSIS		
* 2-12	VZ702700	BUTTON CASE 6		BL
* 2-12	VZ702800	BUTTON CASE 6		TI
2-14	VV137900	BUTTON, RDS		BL
2-14	VV138000	BUTTON, RDS		TI
* 2-15	VZ702900	SUB PANEL CASE 6		BL
* 2-15	VZ703000	SUB PANEL CASE 6		TI
2-17	VV149500	ESCUTCHEON, VOL		BL
2-17	VV149600	ESCUTCHEON, VOL		TI
2-21	Ei330086	BIND HEAD B-TITE SCREW	3x8 FCRM3-BL	
2-22	EP630220	BIND HEAD P-TITE SCREW	3x8 ZMC2-BL	
2-24	VT669300	PW HEAD B-TITE SCREW	3x8-8 MFC2	
2-31	VZ092400	DAMPER	6x5x10	
2-41	VQ368500	PUSH RIVET	P3545-B	
* 3- 1	VZ702500	HEAT SINK ASS'Y		
* 3- 2	V2055500	P. C. B. ASS'Y	MAIN	(B)
* 3- 2	V2055600	P. C. B. ASS'Y	MAIN	(G)
3-21	VK195900	SHEET	19x24	
3-31	VK173200	SCREW, TRANSISTOR	3x15 SP FCM3	
3-32	Ei330086	BIND HEAD B-TITE SCREW	3x8 FCRM3-BL	
7	VV173600	P. C. B. ASS'Y	TUNER	
* 8	V2055000	P. C. B. ASS'Y	INPUT	
△ * 11	XU565A00	POWER TRANSFORMER		
△ 12	VN363700	POWER CORD ASS'Y		(G)
△ 12	VS680700	POWER CORD ASS'Y		(B)
15	VU590000	BINDING TIE	CBTD001B	
16	VZ625600	BINDING TIE	SE140 L=140	
101	VV140400	TOP COVER		BL
101	VV140500	TOP COVER		TI
102	VQ794000	CHASSIS		
* 103	VZ557300	REAR PANEL		(B)
* 103	VZ557400	REAR PANEL		(G)
104	VS025000	LEG	D60xH21	
106	VR264400	SPACER	H8	
108	VQ366100	DAMPER, PCB		
111	VV148800	KNOB	D40	BL
111	VV148900	KNOB	D40	TI
112	VV311000	KNOB	D14	BL
112	VV311400	KNOB	D14	TI
113	VZ529900	KNOB	D14L	BL
* 113	VZ530000	KNOB	D14L	TI
115	VV123500	BUTTON, 3/8		BL
115	VV123600	BUTTON, 3/8		TI
* 117	VZ702600	SHEET, WINDOW		
119	VN158600	CORD STOPPER	No. 2104	
121	VN413300	BIND HEAD BONDING B-T. SCREW	3x8 MFZN2-BL	
122	Ei330086	BIND HEAD B-TITE SCREW	3x8 FCRM3-BL	

\* New Parts

Ref. No.	PART NO.	Description	Remarks	Markets
123	Ei030046	BIND HEAD TAPPING SCREW	3x4 ZMC2-Y	
125	Ei030086	BIND HEAD B-TITE SCREW	3x8 ZMC2-Y	
126	ED330066	BIND HEAD SCREW	3x6 FCRM3-BL	
127	VS997700	BIND HEAD S-TITE SCREW	3x10 MFNI33	
128	VT669300	PW HEAD B-TITE SCREW	3x8-8 MFC2	
129	VT669400	PW HEAD B-TITE SCREW	3x15-8 MFC2	
130	VY731200	BONDING HEAD TAPPING SCREW	3x10 MFNI33	
131	EK365090	PW HEAD S-TITE SCREW	4x8-10 FCRM3-BL	
132	EK365090	PW HEAD S-TITE SCREW	4x8-10 FCRM3-BL	BL
132	EX601150	BW HEAD S-TITE SCREW	4x8-10 FNM3-BL	TI
133	VY731400	DAMPER	HOLE	
134	VY989400	DAMPER	SIDE	
140	VZ319700	STOPPER	SCREW	
141	VV124500	PLATE SIDE R	130	BL
141	VV124600	PLATE SIDE R	130	TI
142	VV124300	PLATE SIDE L	130	BL
142	VV124400	PLATE SIDE L	130	TI
165	VQ368600	PUSH RIVET	P3555-B	
		ACCESSORIES		
* 200	VZ453500	REMOTE CONTROL TRANSMITTER	SBGH20035A RAX7	
200-1	CX679050	LID		
	VQ147100	ANTENNA, FM	1P 1.4m	
	VR248500	ANTENNA, AM LOOP	1P 1.0m	
	VE364900	ANTENNA ADAPTER	PAL 75-300 Ω	
		BATTERY, MANGANESE	SUM-3, AA, R06	

\* New Parts

**1 RX-496RDS EXPLODED VIEW**

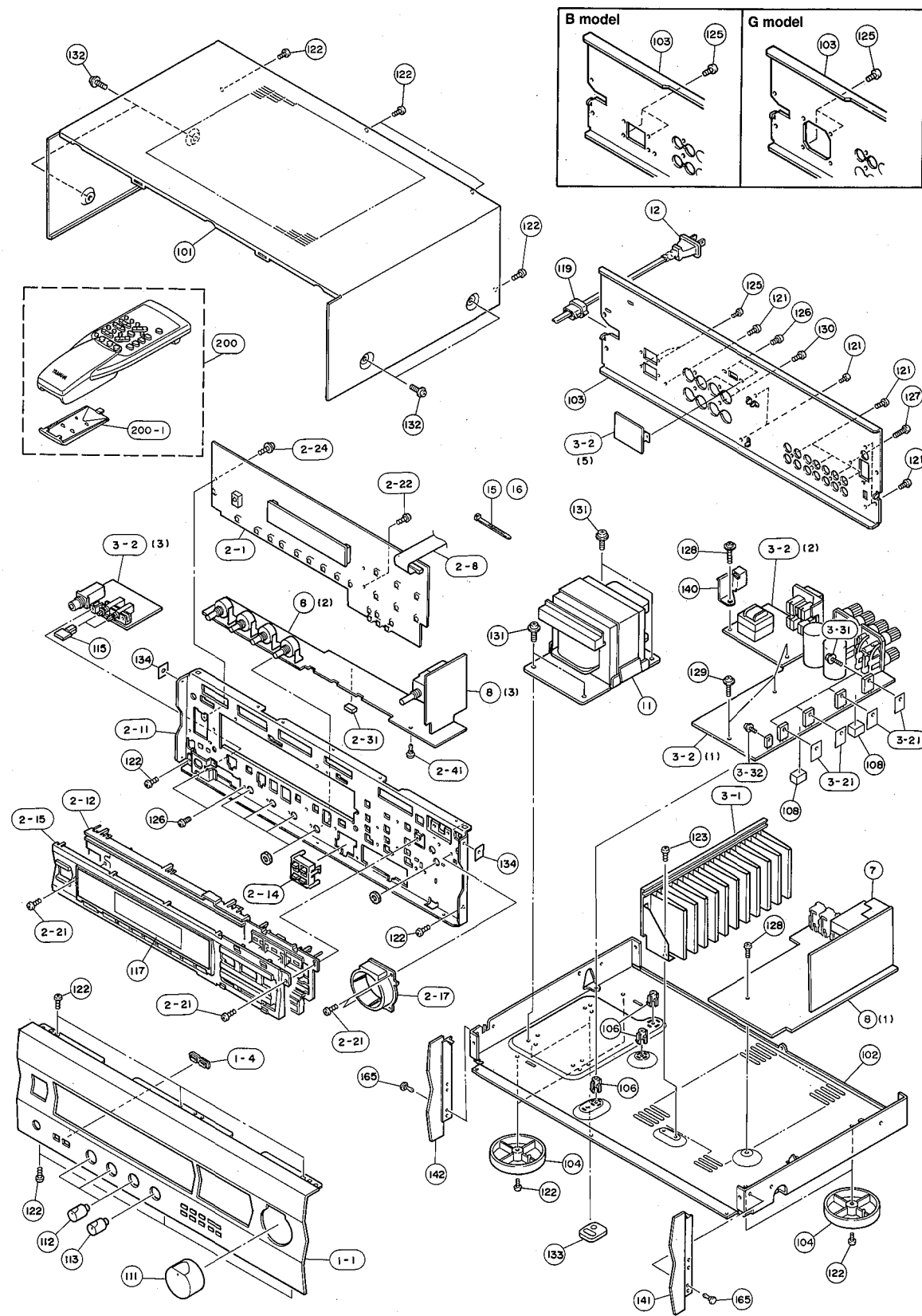

**■ RX-496RDS MECHANICAL PARTS**

Ref. No.	PART NO.	Description	Remarks	Markets
* 1- 1	VZ701900	FRONT PANEL	BL	
* 1- 1	VZ702000	FRONT PANEL	TI	
1- 3	VV185600	LENS, LED	D2	
1- 4	VV123700	ESCUTCHEON, 3/8	2P	BL
1- 4	VV123800	ESCUTCHEON, 3/8	2P	TI
1- 5	VV185400	ESCUTCHEON	8x26	BL
1- 5	VV185500	ESCUTCHEON	8x26	TI
* 2- 1	V2054700	P. C. B. ASS'Y	OPERATION	
2- 8	MF116200	FLEXIBLE FLAT CABLE	16P 200mm	
* 2-11	VZ701700	SUB CHASSIS		BL
* 2-12	VZ702700	BUTTON CASE 6		TI
* 2-12	VZ702800	BUTTON CASE 6		BL
2-14	VV137900	BUTTON, RDS		TI
2-14	VV138000	BUTTON, RDS		BL
* 2-15	VZ702900	SUB PANEL CASE 6		TI
* 2-15	VZ703000	SUB PANEL CASE 6		BL
2-17	VV149500	ESCUTCHEON, VOL		TI
2-17	VV149600	ESCUTCHEON, VOL		BL
2-21	Ei330086	BIND HEAD B-TITE SCREW	3x8	FCRM3-BL
2-22	EP630220	BIND HEAD P-TITE SCREW	3x8	ZMC2-BL
2-24	VT669300	PW HEAD B-TITE SCREW	3x8-8	MFC2
2-25	ED330066	BIND HEAD SCREW	3x6	FCRM3-BL
2-31	VZ092400	DAMPER	6x5x10	
2-41	VQ368500	PUSH RIVET	P3545-B	
3- 1	VQ967700	HEAT SINK ASS'Y		
* 3- 2	V2060400	P. C. B. ASS'Y	MAIN	(B)
* 3- 2	V2060500	P. C. B. ASS'Y	MAIN	(G)
3-21	VK195900	SHEET	19x24	
3-31	VK173200	SCREW, TRANSISTOR	3x15 SP	FCM3
3-32	Ei330086	BIND HEAD B-TITE SCREW	3x8	FCRM3-BL
7	VV173600	P. C. B. ASS'Y	TUNER	
* 8	V2060000	P. C. B. ASS'Y	INPUT	
△ * 11	XU575A00	POWER TRANSFORMER		(B)
△ 12	VN363700	POWER CORD ASS'Y		(G)
△ 12	VS680700	POWER CORD ASS'Y		(B)
15	VU590000	BINDING TIE	CBTD001B	
16	VZ625600	BINDING TIE	SE140 L=140	
101	VV140400	TOP COVER		BL
101	VV140500	TOP COVER		TI
102	VQ794000	CHASSIS		
* 103	VZ556700	REAR PANEL		(B)
* 103	VZ556800	REAR PANEL		(G)
104	VS025000	LEG	D60xH21	
106	VR264400	SPACER	H8	
108	VQ366100	DAMPER, PCB		
111	VV148800	KNOB	D40	BL
111	VV148900	KNOB	D40	TI
112	VV311000	KNOB	D14	BL
112	VV311400	KNOB	D14	TI
113	VZ529900	KNOB	D14L	BL
* 113	VZ530000	KNOB	D14L	TI
114	VV185200	BUTTON	8x26	BL
114	VV185300	BUTTON	8x26	TI

\* New Parts

Ref. No.	PART NO.	Description	Remarks	Markets
115	VV123500	BUTTON, 3/8	BL	
115	VV123600	BUTTON, 3/8	TI	
* 117	VZ702600	SHEET, WINDOW		
119	VN158600	CORD STOPPER	No. 2104	
121	VN413300	BIND HEAD BONDING B-T. SCREW	3x8 MFZN2-BL	
122	Ei330086	BIND HEAD B-TITE SCREW	3x8 FCRM3-BL	
123	Ei030046	BIND HEAD TAPPING SCREW	3x4 ZMC2-Y	
125	Ei030086	BIND HEAD B-TITE SCREW	3x8 ZMC2-Y	
126	ED330066	BIND HEAD SCREW	3x6 FCRM3-BL	
127	VS997700	BIND HEAD S-TITE SCREW	3x10 MFNI33	
128	VT669300	PW HEAD B-TITE SCREW	3x8-8 MFC2	
129	VT669400	PW HEAD B-TITE SCREW	3x15-8 MFC2	
130	VY731200	BONDING HEAD TAPPING SCREW	3x10 MFNI33	
131	EK365090	PW HEAD S-TITE SCREW	4x8-10 FCRM3-BL	
132	EK365090	PW HEAD S-TITE SCREW	4x8-10 FCRM3-BL	BL
132	EX601150	BW HEAD S-TITE SCREW	4x8-10 FNM3-BL	TI
133	VY731400	DAMPER	HOLE	
134	VY989400	DAMPER	SIDE	
140	VZ319700	STOPPER	SCREW	
141	VV124500	PLATE SIDE R	130	BL
141	VV124600	PLATE SIDE R	130	TI
142	VV124300	PLATE SIDE L	130	BL
142	VV124400	PLATE SIDE L	130	TI
165	VQ368600	PUSH RIVET	P3555-B	
		ACCESSORIES		
* 200	VZ453500	REMOTE CONTROL TRANSMITTER	SBGH20035A RAX7	
200-1	CX679050	LID	74x34BLALPS	
	VQ147100	ANTENNA, FM	1P 1.4m	
	VR248500	ANTENNA, AM LOOP	1P 1.0m	
	VE364900	ANTENNA ADAPTER	PAL 75-300Ω	
		BATTERY, MANGANESE	SUM-3, AA, R06	

\*New Parts

RX-396RDS  
RX-496RDS

RX-396RDS/RX-496RDS

# REMOTE CONTROL TRANSMITTER

## SCHEMATIC DIAGRAM

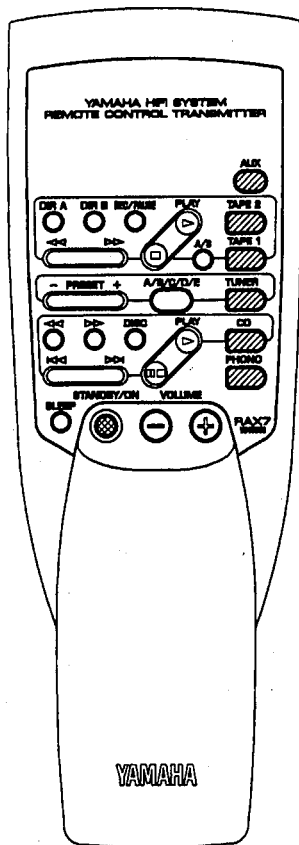
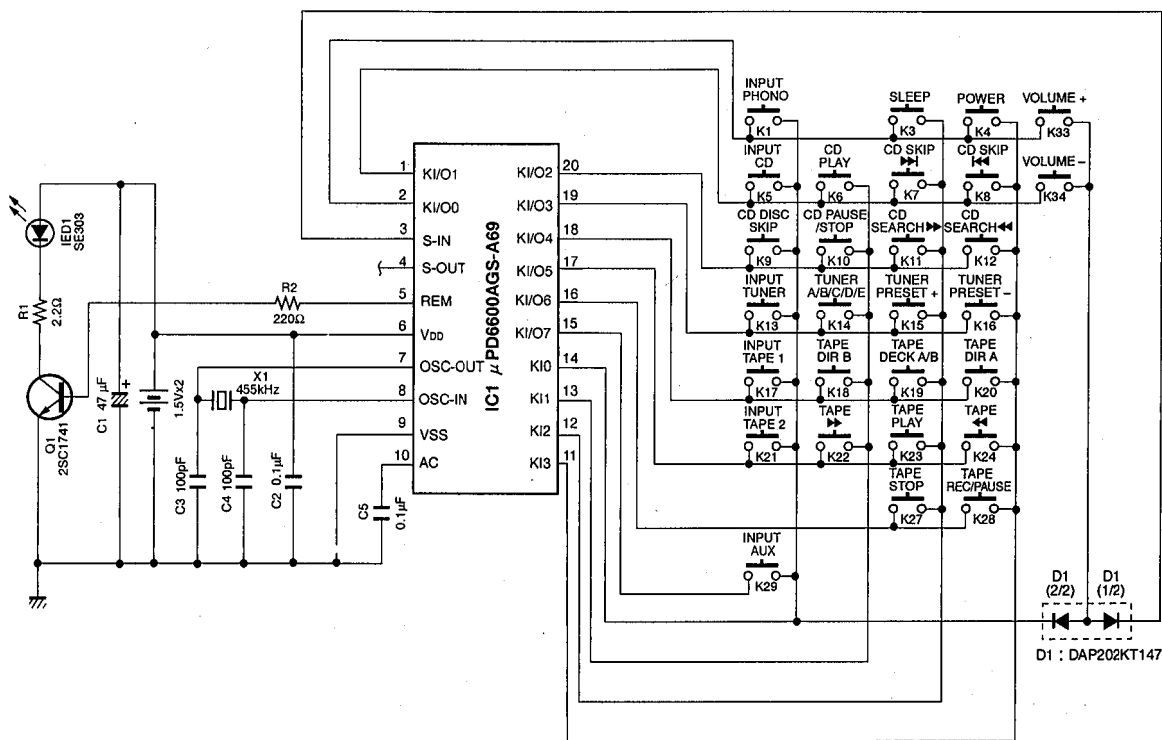

Key No.	Function	HEX	
		CUSTOM	DATA
1	INPUT PHONO	7A	14
3	SLEEP	7A	57
4	POWER	7A	1F
5	INPUT CD	7A	15
6	CD PLAY	7A	08
7	CD SKIP >>>	7A	0A
8	CD SKIP <<<	7A	0B
9	CD DISC SKIP	7A	4F
10	CD PAUSE/STOP	7A	09
11	CD SEARCH >>	7A	0C
12	CD SEARCH <<	7A	0D
13	INPUT TUNER	7A	16
14	TUNER A/B/C/D/E	7A	12
15	TUNER PRESET +	7A	10
16	TUNER PRESET -	7A	11
17	INPUT TAPE 1	7A	18
18	TAPE DIR B	7A	40
19	TAPE DECK A/B	7A	06
20	TAPE DIR A	7A	07
21	INPUT TAPE 2	7A	19
22	TAPE >>	7A	02
23	TAPE PLAY	7A	00
24	TAPE <<	7A	01
27	TAPE STOP	7A	03
28	TAPE REC/PAUSE	7A	04
29	INPUT AUX	7A	17
33	VOLUME +	7A	1A
34	VOLUME -	7A	1B

# Parts List for Carbon Resistors

Value	1/4W Type Part No.	1/6W Type Part No.	Value	1/4W Type Part No.	1/6W Type Part No.
1.0 Ω	HJ35 3100	HF85 3100	10 kΩ	HF45 7100	HF45 7100
1.8 Ω	HJ35 3180	*	11 kΩ	HF45 7110	HF45 7110
2.2 Ω	HJ35 3220	HF85 3220	12 kΩ	HJ35 7120	HF85 7120
3.3 Ω	HJ35 3330	HF85 3330	13 kΩ	HF45 7130	HF45 7130
4.7 Ω	HJ35 3470	HF85 3470	15 kΩ	HF45 7150	HF45 7150
5.6 Ω	HJ35 3560	HF85 3560	18 kΩ	HF45 7180	HF45 7180
10 Ω	HF45 4100	HF45 4100	22 kΩ	HF45 7220	HF45 7220
15 Ω	HJ35 4150	HF85 4150	24 kΩ	HF45 7240	HF45 7240
22 Ω	HF45 4220	HF45 4220	27 kΩ	HJ35 7270	HF85 7270
27 Ω	HJ35 4270	HF85 4270	30 kΩ	HF45 7300	HF45 7300
33 Ω	HF45 4330	HF45 4330	33 kΩ	HF45 7330	HF45 7330
39 Ω	HJ35 4470	HF85 4390	36 kΩ	HF45 7360	HF45 7360
47 Ω	HF45 4470	HF45 4470	39 kΩ	HF45 7390	HF45 7390
56 Ω	HF45 4560	HF45 4560	47 kΩ	HF45 7470	HF45 7470
68 Ω	HF45 4680	HF45 4680	51 kΩ	HF45 7510	HF45 7510
75 Ω	HF45 4750	HF45 4750	56 kΩ	HF45 7560	HF45 7560
82 Ω	HF45 4820	HF45 4820	62 kΩ	HF45 7620	HF45 7620
91 Ω	HF45 4910	HF45 4910	68 kΩ	HF45 7680	HF45 7680
100 Ω	HF45 5100	HF45 5100	82 kΩ	HF45 7820	HF45 7820
110 Ω	HJ35 5110	HF85 5110	91 kΩ	HF45 7910	HF45 7910
120 Ω	HF45 5120	HF45 5120	100 kΩ	HF45 8100	HF45 8100
150 Ω	HF45 5150	HF45 5150	110 kΩ	HF45 8110	HF45 8110
160 Ω	HJ35 5160	*	120 kΩ	HF45 8120	HF45 8120
180 Ω	HF45 5180	HF45 5180	150 kΩ	HF45 8150	HF45 8150
200 Ω	HF45 5200	HF45 5200	180 kΩ	HF45 8180	HF45 8180
220 Ω	HF45 5220	HF45 5220	220 kΩ	HJ35 8220	HF85 8220
270 Ω	HF45 5270	HF45 5270	270 kΩ	HF45 8270	HF45 8270
330 Ω	HF45 5330	HF45 5330	300 kΩ	HF45 8300	HF45 8300
390 Ω	HF45 5390	HF45 5390	330 kΩ	HF45 8330	HF45 8330
430 Ω	HF45 5430	HF45 5430	390 kΩ	HJ35 8390	HF85 8390
470 Ω	HF45 5470	HF45 5470	470 kΩ	HF45 8470	HF45 8470
510 Ω	HF45 5510	HF45 5510	560 kΩ	HJ35 8560	HF85 8560
560 Ω	HF45 5560	HF45 5560	680 kΩ	HJ35 8680	HF85 8680
680 Ω	HF45 5680	HF45 5680	820 kΩ	HJ35 8820	HF85 8820
820 Ω	HF45 5820	HF45 5820	1.0 MΩ	HF45 9100	HF45 9100
910 Ω	HF45 5910	HF45 5910	1.2 MΩ	HJ35 9120	*
1.0 kΩ	HF45 6100	HF45 6100	1.5 MΩ	HJ35 9150	HF85 9150
1.2 kΩ	HF45 6120	HF45 6120	1.8 MΩ	HJ35 9180	HF85 9180
1.5 kΩ	HF45 6150	HF45 6150	2.2 MΩ	HJ35 9220	HF85 9220
1.8 kΩ	HF45 6180	HF45 6180	3.3 MΩ	HJ35 9330	HF85 9330
2.0 kΩ	HJ35 6200	HF85 6200	3.9 MΩ	HJ35 9390	*
2.2 kΩ	HF45 6220	HF45 6220	4.7 MΩ	HJ35 9470	HF85 9470
2.4 kΩ	HJ35 6240	HF85 6240			
2.7 kΩ	HF45 6270	HF45 6270			
3.0 kΩ	HF45 6300	HF45 6300			
3.3 kΩ	HF45 6330	HF45 6330			
3.6 kΩ	HJ35 6360	HF85 6360			
3.9 kΩ	HF45 6390	HF45 6390			
4.7 kΩ	HF45 6470	HF45 6470			
5.1 kΩ	HF45 6510	HF45 6510			
5.6 kΩ	HF45 6560	HF45 6560			
6.8 kΩ	HF45 6680	HF45 6680			
8.2 kΩ	HF45 6820	HF45 6820			
9.1 kΩ	HF45 6910	HF45 6910			

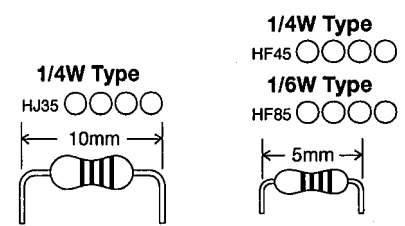

RX-396RDS  
RX-496RDS

**RX-396RDS/RX-496RDS**

---

**YAMAHA**

**RX-396RDS  
RX-496RDS**

---