

# STEREO RECEIVER RX-497

## SERVICE MANUAL

### IMPORTANT NOTICE

This manual has been provided for the use of authorized YAMAHA Retailers and their service personnel. It has been assumed that basic service procedures inherent to the industry, and more specifically YAMAHA Products, are already known and understood by the users, and have therefore not been restated.

**WARNING:** Failure to follow appropriate service and safety procedures when servicing this product may result in personal injury, destruction of expensive components, and failure of the product to perform as specified. For these reasons, we advise all YAMAHA product owners that any service required should be performed by an authorized YAMAHA Retailer or the appointed service representative.

**IMPORTANT:** The presentation or sale of this manual to any individual or firm does not constitute authorization, certification or recognition of any applicable technical capabilities, or establish a principle-agent relationship of any form.

The data provided is believed to be accurate and applicable to the unit(s) indicated on the cover. The research, engineering, and service departments of YAMAHA are continually striving to improve YAMAHA products. Modifications are, therefore, inevitable and specifications are subject to change without notice or obligation to retrofit. Should any discrepancy appear to exist, please contact the distributor's Service Division.

**WARNING:** Static discharges can destroy expensive components. Discharge any static electricity your body may have accumulated by grounding yourself to the ground buss in the unit (heavy gauge black wires connect to this buss).

**IMPORTANT:** Turn the unit OFF during disassembly and part replacement. Recheck all work before you apply power to the unit.

## ■ CONTENTS

TO SERVICE PERSONNEL .....	2	AMP ADJUSTMENT .....	16
IMPEDANCE SELECTOR .....	3	IC DATA .....	17-18
FRONT PANELS .....	3	DISPLAY DATA .....	19
REAR PANELS .....	4-5	PIN CONNECTION DIAGRAM .....	20
REMOTE CONTROL PANELS .....	5	PRINTED CIRCUIT BOARD .....	21-27
SPECIFICATIONS .....	6-7	BLOCK DIAGRAM .....	28
INTERNAL VIEW .....	7	SCHEMATIC DIAGRAM .....	29-32
DISASSEMBLY PROCEDURES .....	8	PARTS LIST .....	33-43
SELF DIAGNOSIS FUNCTION .....	9-15	REMOTE CONTROL RAX100/RAX101 .....	44-45



このサービスマニュアルは、エコマーク認定の再生紙を使用しています。  
This Service Manual uses recycled paper.

100977

© 2005 YAMAHA CORPORATION. All rights reserved.  
This manual is copyrighted by YAMAHA and may not be copied or redistributed either in print or electronically without permission.



# YAMAHA

YAMAHA CORPORATION  
P.O.Box 1, Hamamatsu, Japan

ED01 '05.11

## ■ TO SERVICE PERSONNEL

- Critical Components Information**  
Components having special characteristics are marked  and must be replaced with parts having specifications equal to those originally installed.
- Leakage Current Measurement (For 120V Models Only)**  
When service has been completed, it is imperative to verify that all exposed conductive surfaces are properly insulated from supply circuits.
  - Meter impedance should be equivalent to 1500 ohms shunted by 0.15µF.

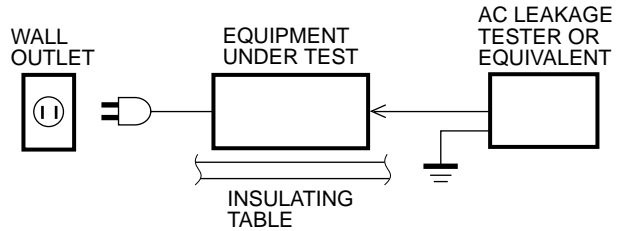

- Leakage current must not exceed 0.5mA.
- Be sure to test for leakage with the AC plug in both polarities.



**“CAUTION”**

“F251, F252 : FOR CONTINUED PROTECTION AGAINST RISK OF FIRE, REPLACE ONLY WITH SAME TYPE 8A, 125V FUSE.”

**CAUTION**

F251, F252 : REPLACE WITH SAME TYPE 8A, 125V FUSE.

**ATTENTION**

F251, F252 : UTILISER UN FUSIBLE DE RECHANGE DE MEME TYPE DE 8A, 125V.

## WARNING: CHEMICAL CONTENT NOTICE!

The solder used in the production of this product contains LEAD. In addition, other electrical/electronic and/or plastic (where applicable) components may also contain traces of chemicals found by the California Health and Welfare Agency (and possibly other entities) to cause cancer and/or birth defects or other reproductive harm.

DO NOT PLACE SOLDER, ELECTRICAL/ELECTRONIC OR PLASTIC COMPONENTS IN YOUR MOUTH FOR ANY REASON WHATSOEVER!

Avoid prolonged, unprotected contact between solder and your skin! When soldering, do not inhale solder fumes or expose eyes to solder/flux vapor!

If you come in contact with solder or components located inside the enclosure of this product, wash your hands before handling food.

## About Lead Free Solder

The P.C.B.s installed in this unit are soldered using the following solder.

	SIDE A	SIDE B
FUNCTION P.C.B.	-	Lead Free Solder
OPERATION P.C.B.	-	Lead Free Solder
MAIN P.C.B.	-	Lead Free Solder
XM P.C.B.	Lead Free Solder	Lead Free Solder

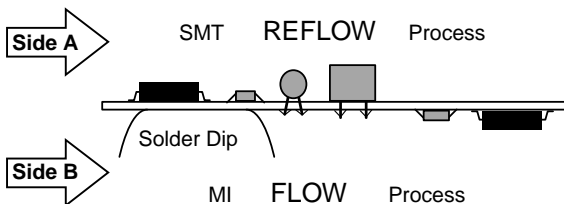

Among some types of lead free solder currently available, it is recommended to use one of the following types for the repair work.

- Sn + Ag + Cu (tin + silver + copper)
- Sn + Cu (tin + copper)
- Sn + Zn + Bi (tin + zinc + bismuth)

**Caution:**

- As the melting point temperature of the lead free solder is about 30°C to 40°C (50°F to 70°F) higher than that of the lead solder, be sure to use a soldering iron suitable to each solder.
- If lead solder must be used, be sure to remove lead free solder from each terminal section of the parts to be replaced and from the area around it completely before soldering, or make sure that the lead free solder and lead solder melt together fully.

RX-497

## ■ IMPEDANCE SELECTOR

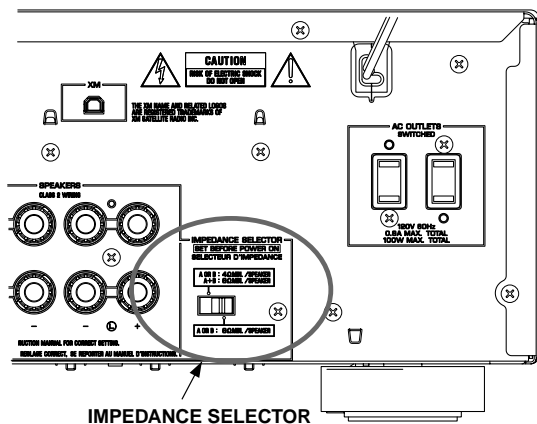

### WARNING:

Do not change the setting of the IMPEDANCE SELECTOR switch when the unit power is switched on, as doing so may damage the unit.

## ■ FRONT PANELS

### ▼ U, C models

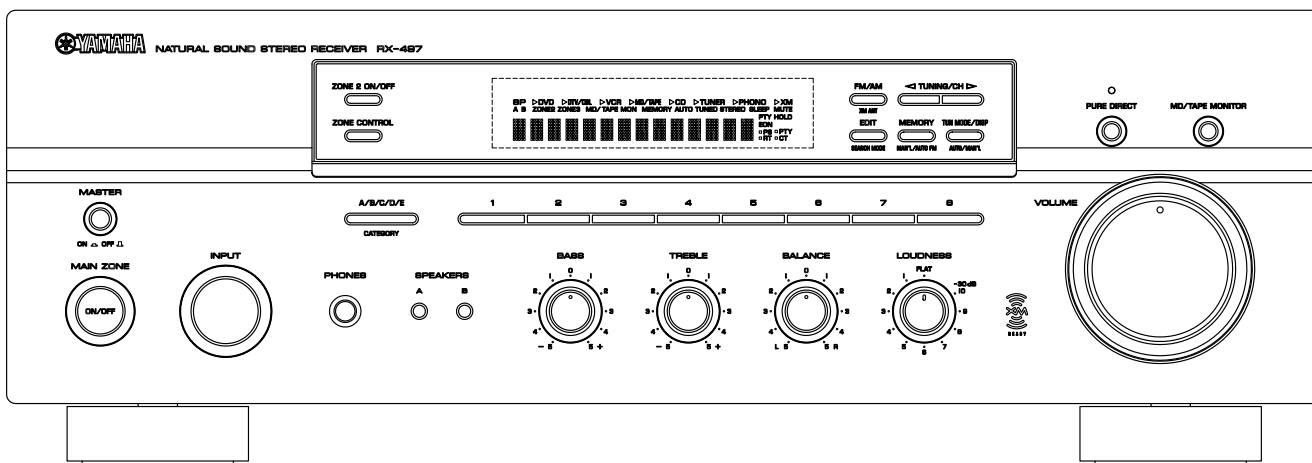

### ▼ R, A, G, E, L models

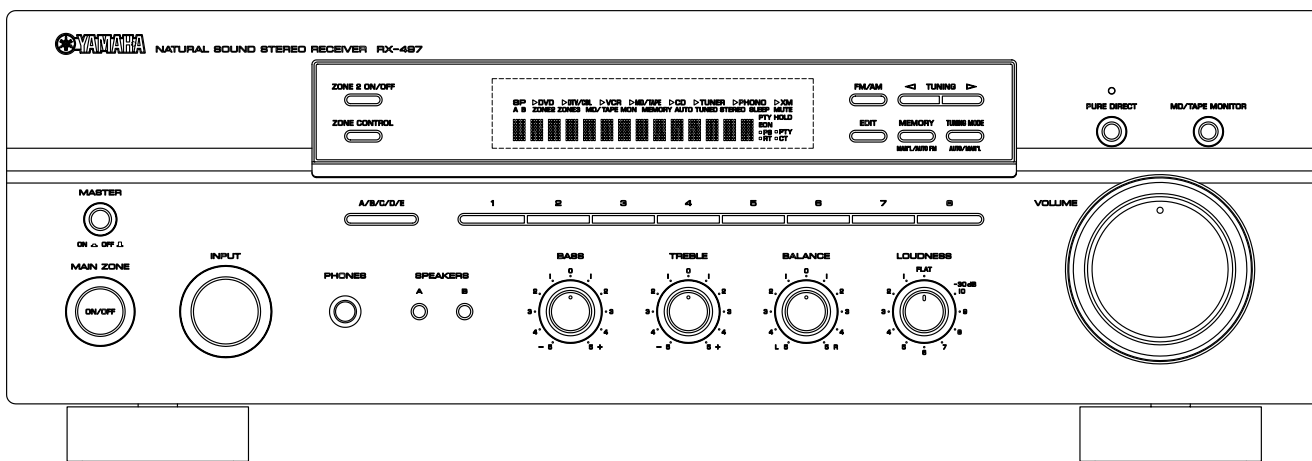

RX-497

# REAR PANELS

## U, C models

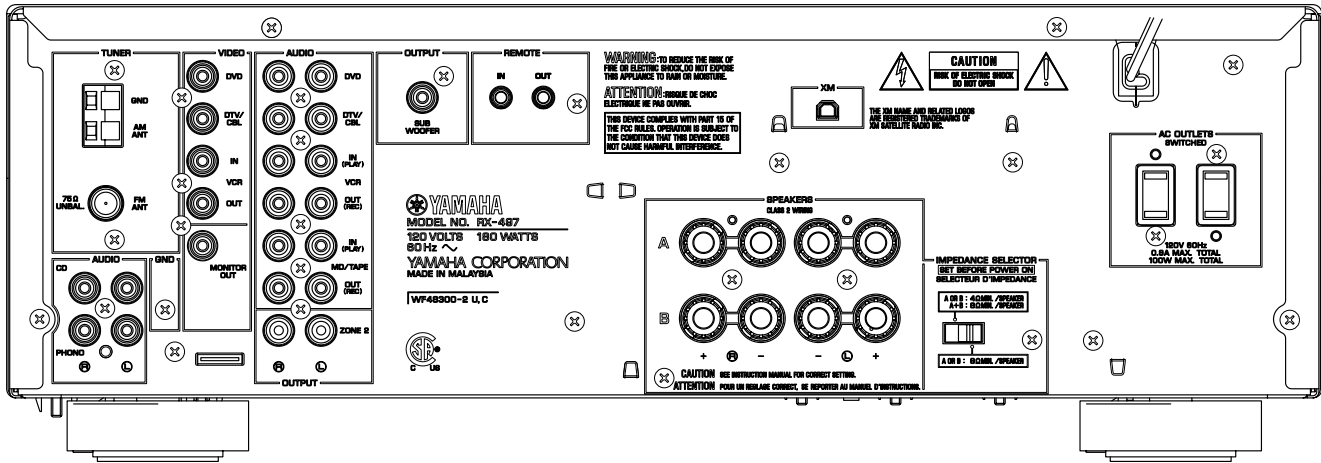

## R model

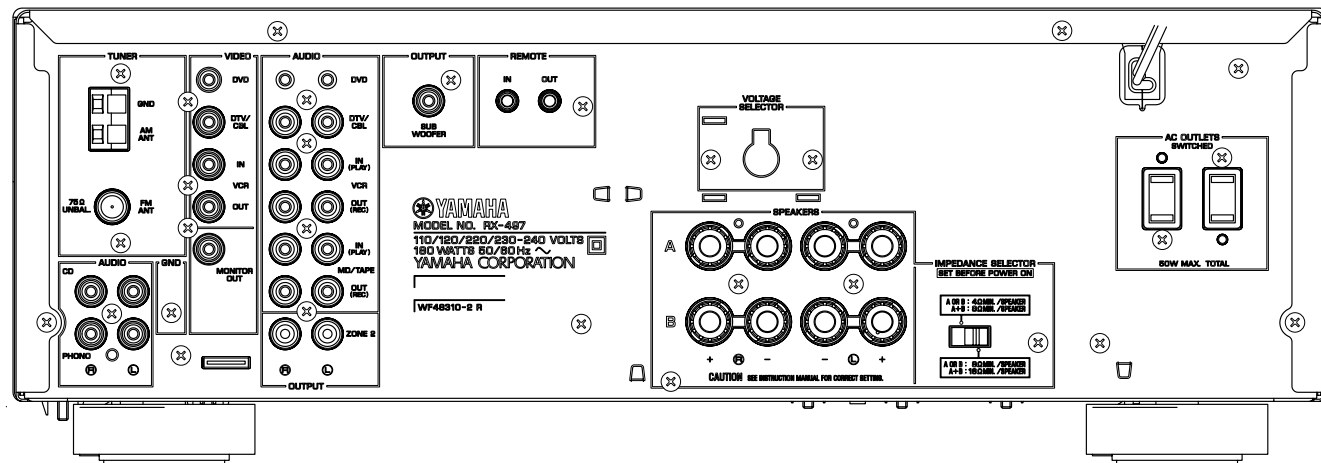

## A model

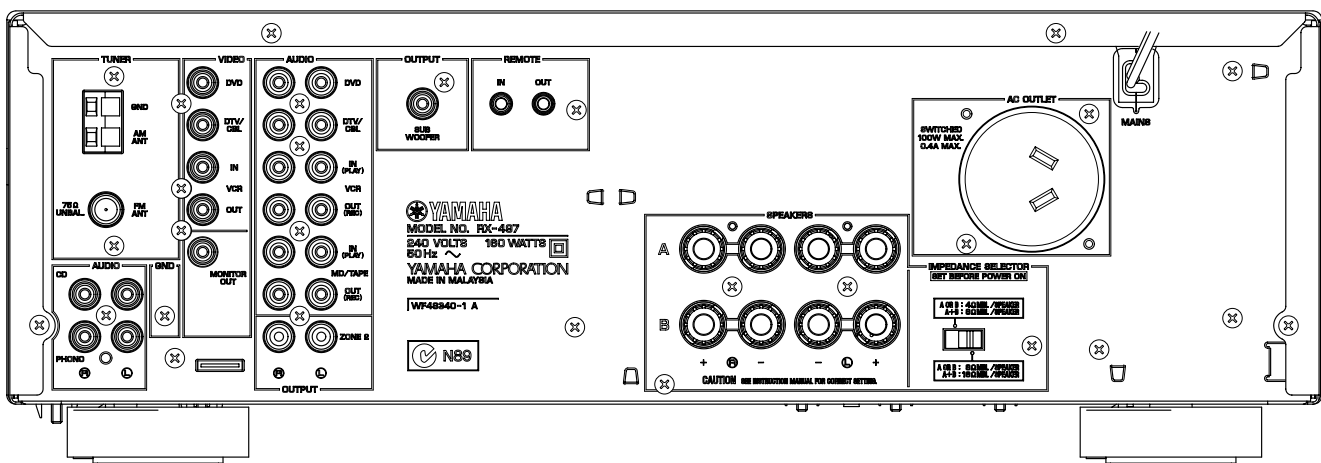

RX-497

▼ G, E models

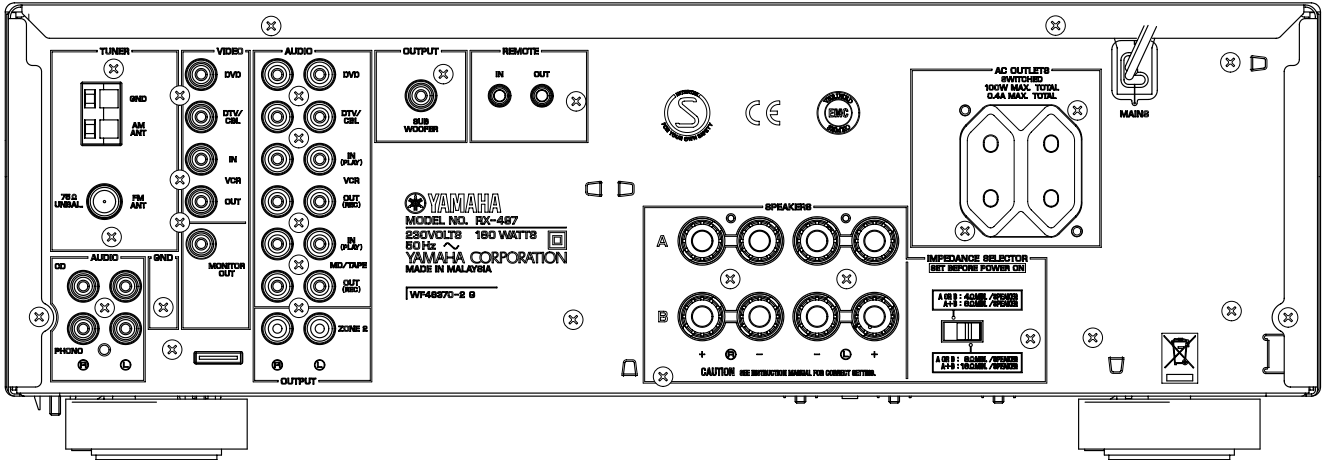

▼ L model

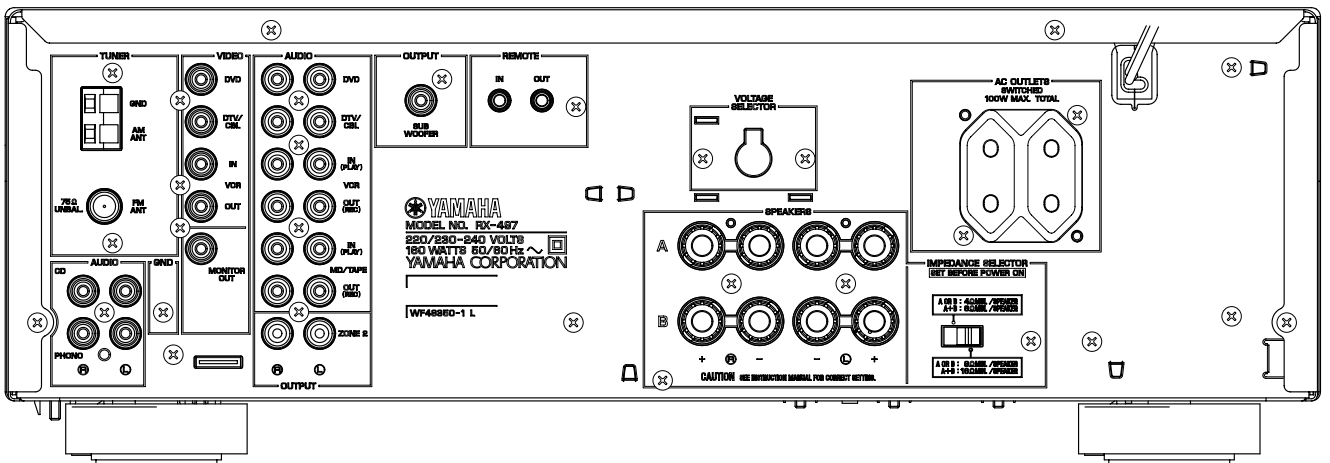

■ REMOTE CONTROL PANELS

▼ RAX100 (U, C models)

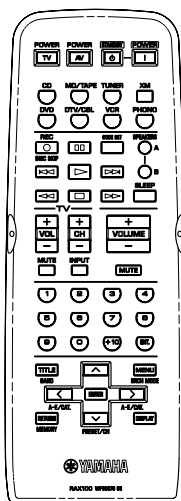

▼ RAX101 (R, A, G, E, L models)

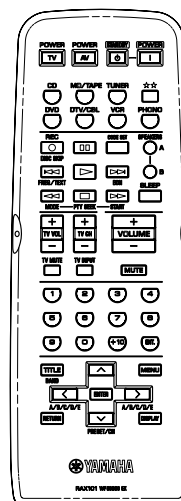

## ■ SPECIFICATIONS

### AUDIO SECTION

#### Minimum RMS Output Power (Power Amp. Section)

L/R, 20 Hz to 20 kHz, 0.04% THD, 8 ohms ..... 75 W + 75 W

#### Dynamic Power Per Channel (IHF)

8/6/4/2 ohms ..... 105/125/150/178 W

#### Maximum Power Per Channel (G, E models)

1 kHz, 0.7 % THD, 4 ohms ..... 105 W

#### IEC Power (G, E models)

1 kHz, 0.04% THD, 8 ohms ..... 84 W

#### Maximum Power (EIAJ) (R, L models)

1 kHz, 10% THD, 8 ohms ..... 115 W

#### Power Band Width

L/R, 0.08% THD, 35 W, 8 ohms ..... 10 Hz to 50 kHz

#### Damping Factor

20 Hz to 20 kHz, SPEAKER-A, 8 ohms ..... 150 or more

#### Input Sensitivity/Input Impedance

PHONO MM ..... 3.0 mV/47 k-ohms

CD, etc. .... 185 mV/47 k-ohms

#### Maximum Input Signal

PHONO MM, 1kHz, 0.04 % THD ..... 70 mV

CD, etc., 1kHz, 0.04 % THD ..... 2.2 V

#### Output Level/Output Impedance

SUBWOOFER ..... 4 V/1.2 k-ohms

ZONE2 OUT ..... 185 mV/1.2 k-ohms

REC OUT ..... 185 mV/1.2 k-ohms

#### Headphone Jack Rated Output/Output Impedance

CD, etc. 1 kHz, 185 mV, 8 ohms, 0.04% THD ..... 0.47 V/390 ohms

#### Frequency Response

CD, etc. 20 Hz to 20 kHz ..... 0 ± 0.5 dB

CD, etc. PURE DIRECT ON, 10 Hz to 100 kHz ..... 0 ± 1.0 dB

#### RIAA Equalization Deviation

PHONO MM ..... 0 ± 0.5 dB

#### Total Harmonic Distortion (20 Hz to 20 kHz)

PHONO MM to REC OUT (3 V) ..... 0.02 % or less

CD, etc. to SP OUT (35 W/8 ohms) ..... 0.02 % or less

#### Signal to Noise Ratio (IHF-A Network)

PHONO MM (Input shorted, 5 mV) ..... 82 dB or more

CD, etc. (Input shorted, 185mV) ..... 108 dB or more

#### Residual Noise (IHF-A Network)

PURE DIRECT ON ..... 100 µV

#### Channel Separation

CD, etc. (Input 5.1 k-ohms shorted)

1 kHz ..... 65 dB or more

10 kHz ..... 50 dB or more

#### Tone Control Characteristics

BASS Boost/Cut (50 Hz) ..... +10 dB/-10 dB

Turnover Frequency ..... 350 Hz

TREBLE Boost/Cut (20 kHz) ..... +10 dB/-10 dB

Turnover Frequency ..... 3.5 kHz

#### Continuous Loudness Control

Attenuation (1 kHz) ..... -30 dB

#### Gain Tracking Error

0 to -60 dB ..... 2 dB or less

### VIDEO SECTION

#### Video Signal Type

U, C, R models ..... NTSC

A, G, E, L models ..... PAL

#### Video Signal Level

..... 1 Vp-p/75 ohms

#### Video Maximum Input Level

..... 1.5 Vp-p or more

#### Video Signal to Noise Ratio

..... 50 dB or more

#### Monitor Out Frequency Response

..... 5 Hz to 10 MHz, -3 dB

### FM SECTION

#### Tuning Range

U, C models ..... 87.5 to 107.9 MHz

R, L models ..... 87.5 to 108.0/87.50 to 108.00 MHz

A, G, E models ..... 87.50 to 108.00 MHz

#### 50 dB Quieting Sensitivity (IHF)

1 kHz 100% MOD.

Mono ..... 2.0 µV (17.3 dBf)

Stereo ..... 25 µV (39.2 dBf)

#### Usable Sensitivity (IHF)

Mono ..... 1.0 µV (11.2 dBf)

#### Selectivity

at 400 kHz ..... 70 dB

#### Signal to Noise Ratio (IHF)

Mono ..... 76 dB

Stereo ..... 70 dB

#### Harmonic Distortion (1 kHz)

Mono ..... 0.2 %

Stereo ..... 0.3 %

#### Stereo Separation (1 kHz)

..... 45 dB

#### Frequency Response

20 Hz to 15 kHz ..... +0.5/-2.0 dB

#### Antenna Input

..... 75 ohms unbalanced

### AM SECTION

#### Tuning Range

U, C models ..... 530 to 1710 kHz

R, L models ..... 530 to 1710/531 to 1611 kHz

A, G, E models ..... 531 to 1611 kHz

#### Usable Sensitivity

..... 300 µV/m

#### Antenna

..... Loop antenna

### GENERAL

#### Power Supply

U, C models ..... AC 120 V, 60 Hz

R model ..... AC 110/120/220/230-240 V, 50/60 Hz

A model ..... AC 240 V, 50 Hz

G, E models ..... AC 230 V, 50 Hz

L model ..... AC 220/230-240 V, 50/60 Hz

#### Power Consumption

..... 180 W

#### Standby Power Consumption (reference)

..... 0.1 W

#### Maximum Power Consumption (R model)

1 kHz, 8 ohms, 10% THD ..... 400 W

#### AC Outlet

2 Switched Outlet

R model ..... 50 W Max. total

U, C, G, E, L models ..... 100 W Max. total

1 Switched Outlet

A models ..... 100 W Max.

#### Dimensions (W x H x D)

..... 435 x 151 x 308 mm

(17-1/8" x 5-15/16" x 12-1/8")

#### Weight

..... 8.7 kg (19 lbs 3 oz)

#### Finish

..... Black Color (U, C, R, A, G, E, L models)

..... Titanium Color (R, G, E, L models)

..... Gold Color (L model)

#### Accessories

..... Remote Control x 1

..... Battery (AA, R6, UM-3) x 2

..... Indoor FM Antenna x 1

..... AM Loop Antenna x 1

\* Specifications subject to change without notice.



© 2005 XM Satellite Radio Inc. All rights reserved. All other trademarks are the property of their respective owners.

U ..... USA model  
 C ..... Canadian model  
 R ..... General model  
 A ..... Australian model

G ..... European model  
 E ..... South European model  
 L ..... Singapore model

**DIMENSIONS**

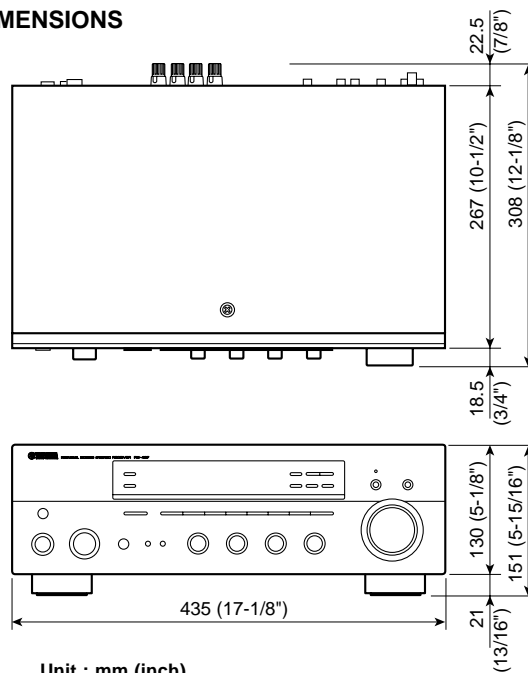

Unit : mm (inch)

**INTERNAL VIEW**

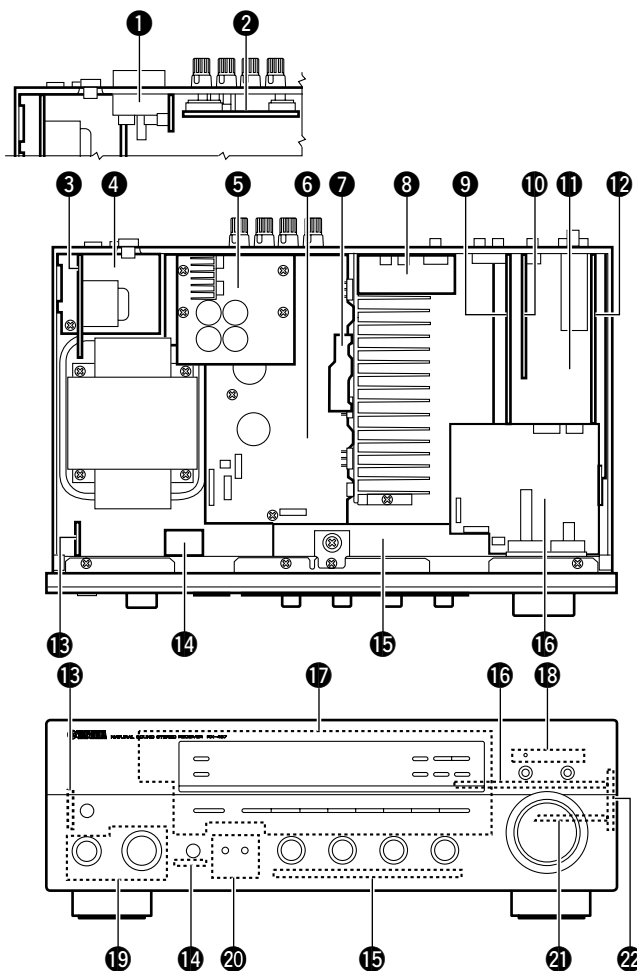

- 1 OPERATION (12) P.C.B. (A, G, E, L models)
- 2 MAIN (4) P.C.B. (R, L models)
- 3 MAIN (2) P.C.B.
- 4 MAIN (3) P.C.B.
- 5 XM P.C.B. (U, C models)
- 6 MAIN (1) P.C.B.
- 7 MAIN (5) P.C.B.
- 8 FUNCTION (4) P.C.B.
- 9 FUNCTION (1) P.C.B.
- 10 FUNCTION (3) P.C.B.
- 11 FUNCTION (2) P.C.B.
- 12 OPERATION (13) P.C.B.
- 13 OPERATION (6) P.C.B.
- 14 OPERATION (10) P.C.B.
- 15 OPERATION (3) P.C.B.
- 16 OPERATION (2) P.C.B.
- 17 OPERATION (1) P.C.B.
- 18 OPERATION (8) P.C.B.
- 19 OPERATION (5) P.C.B.
- 20 OPERATION (7) P.C.B.
- 21 OPERATION (4) P.C.B.
- 22 OPERATION (9) P.C.B.

RX-497

## ■ DISASSEMBLY PROCEDURES

- Remove parts in disassembly order as numbered.
- Disconnect the power cable from the AC outlet.

### 1. Removal of Top Cover

- Remove 4 screws ( ① ), 1 screw ( ② ) and 4 screws ( ③ ). (Fig. 1)
- Slide the Top Cover rearward to remove it. (Fig. 1)

### 2. Removal of Front Panel Unit

- Remove 5 knobs (INPUT, BASS, TREBLE, BALANCE and LOUDNESS).
- Remove 1 screw ( ④ ) and then remove the Support Top. (Fig. 1)
- Remove 7 screws ( ⑤ ) and then remove the Front Panel Unit. (Fig. 1)

### 3. Removal of Plate Side

Remove 2 push rivets ( ⑥ ) and then remove the Plate Side L/R. (Fig. 1)

### 4. Removal of Sub Chassis Unit

- Remove 2 screws ( ⑦ ) and then slide the Sub Chassis Unit forward. (Fig. 1)
- Loosen the harness fixture fixing the cable.
- Remove connectors CB103, CB401, CB404, CB506, CB606 and CB611 and then remove the Sub Chassis Unit. (Fig. 1)

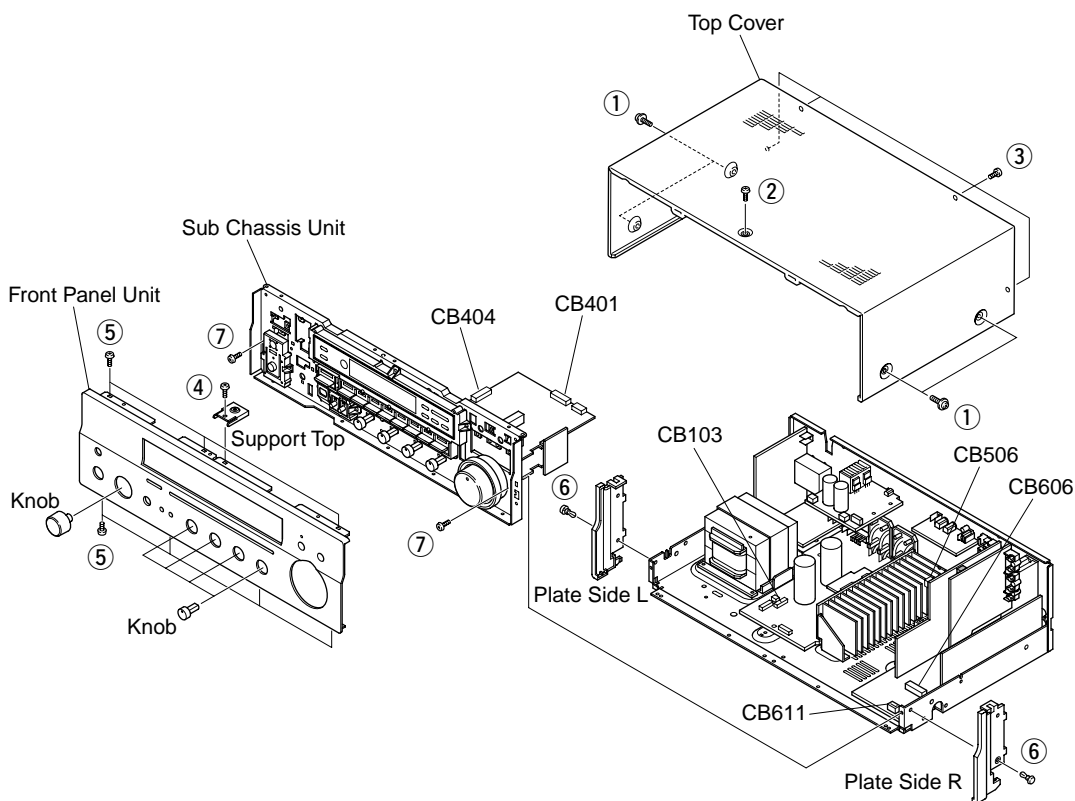

Fig. 1



## ■ SELF DIAGNOSIS FUNCTION

This product has a built-in self diagnosis function (DIAG) to facilitate inspection, measurement and determination of a faulty item, if any. There are 8 DIAG menu items, each having sub-menu items.

No.	DIAG menu	Sub-menu
1	DISPLAY CHECK	1. VFD CHECK (Initial display)
		2. VFD DISP OFF (All segments OFF)
		3. VFD DISP ALL (All segments ON 100%)
		4. VFD DIMMER (All segments ON 50%)
		5. CHECKED PATTERN (ON in lattice)
2	FACTORY PRESET	1. PRESET INHI (memory initialization inhibited)
		2. PRESET RSRV (memory initialized)
3	AD DATA CHECK	1. DC/PS (protection)
		2. THM L, R
		3. REC-OUT (No applied to this model)
		4. K0 / K1 (panel key)
4	XM STATUS	1. XMS1
		2. XMS2
5	PROTECTION SETTING	1. PS_Lo :
		2. PS_Hi :
		3. DC_Lo :
		4. DC_Hi :
		5. TEMP :
6	PROTECTION HISTORY	1. history 1
		2. history 2
		3. history 3
		4. history 4
7	SOFT SWITCH	1. SW MODE : PCB (/MODEL/FNC)
		2. MODEL SETTING : RX497 (/RX797/RX397)
		3. DESTINATION : UC (/RL/A/BG)
		4. TUNER DESTINATION : (/RL/ABG)
		5. TUNER TYPE : NRM (/RDS/XM)
		6. ZONE2 : EXIST (/NOT)
8	MICROPROCESSOR INFORMATION	1. VERSION
		2. CHECK SUM
		3. OPE / XM
		4. PORT
		5. EE SUM

## ● Starting DIAG

Press the "MASTER" key of the main unit while simultaneously pressing the "FM/AM" key and the "8" key to activate the DIAG function.

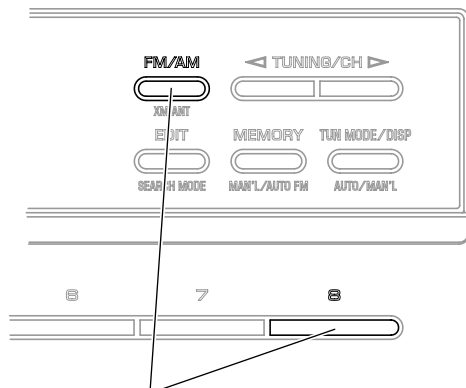

Turn on the power while pressing these keys.

## ● Starting DIAG in the protection cancel mode

If the protection function works and causing hindrance to trouble diagnosis, cancel the protection function as described below and it will be possible to enter the DIAG mode. (The protection functions other than the excess current detect function will be disabled.)

Press the "MASTER" key while simultaneously pressing those two keys indicated in the figure above. At this time, keep pressing those two keys for 3 seconds or longer.

In this mode, the "SLEEP" segment of the FL display of the main unit flashes to indicate that the mode is DIAG mode with the protection functions disabled.

### CAUTION!

**Using this product with the protection function disabled may cause damage to itself. Use special care for this point when using this mode.**

## ● Canceling DIAG

- 1 Before canceling DIAG, execute setting for PRESET of DIAG menu No.2 (Memory initialization inhibited or Memory initialized).
- \* **In order to keep the user memory stored, be sure to select PRESET INHIBITED (Memory initialization inhibited). Protection history will remain in memory.**
- 2 Turn off the power by pressing the "MASTER" key of the main unit.

## ● Display provided when DIAG started

On the FL display of the main unit, an opening message (including the version and the protection history) appears for a few seconds followed by the diagnostic menu display (1. VFD CHECK).

### When there is no history of protection function:

#### Opening message

When there is no protection history.

NO PROTECT Z

Version (1 alphabet)



After a few seconds.

#### DIAG menu display

1. VFD CHECK

### When there is a history of protection function:

The FL display appears as shown below depending on the type of the protection function.

The protection function worked due to excessive current through the amplifier. The protection function activates immediately to turn off the power, with no history display at turn-on, if the amplifier is defective.

I PROTECT Z

The protection function worked due to a defect or overload in the power supply. The abnormal voltage is displayed in % based on 5V as 100%. If the power is turned on with the abnormality unsolved, the protection function works in about 1 second to turn off the power.

PS PRT :000 Z

The protection function worked due to a DC voltage appearing at the speaker terminal.

A cause could be a defect in the amplifier. If the power is turned on with the abnormality unsolved, the protection function works in about 3 seconds to turn off the power.



DC PRT :000 Z

The protection function worked due to the temperature limit being exceeded. Causes could be poor ventilation or a defect related to the thermal sensor. The abnormal voltage is displayed in % based on 5V as 500%. If the power is turned on with the abnormality unsolved, the protection function works in about 1 second to turn off the power.



TMR PRT:000 Z

For detection of each protection function (except I-PROTECT) , refer to DIAG MENU No.3 AD DATA CHECK (p.13).

#### ● History of protection function

When the protection function has worked, its history is stored in memory with a backup. Even if no abnormality is noted while servicing the unit, an abnormality which has occurred previously can be defined as long as the backup data has been stored.

The history of the protection function is cleared when DIAG is cancelled by selecting PRESET RESERVED (Memory initialized) of DIAG menu No.2 or when the backup data is erased.

#### ● Display during menu operation

During the DIAG operation, the function at work is indicated on the FL indicator. The contents displayed during the function operation are described later in the “Details of DIAG menu” section.

#### ● Operation procedure of DIAG MENU and SUB-MENU

There are 8 MENU items, each of which has some SUB-MENU items.

##### DIAG menu selection

Select the menu using PRESET NO keys.

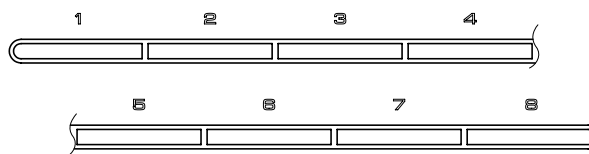

##### SUB-MENU selection

Select the sub-menu using ▷ (Forward) and ◁ (Reverse) keys of TUNING.

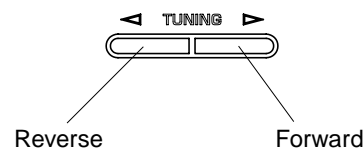

#### ● Functions in DIAG mode

In addition to the DIAG menu items, functions as listed below are available.

- Input selection
- Muting
- Power on/off
- Master volume

\* Functions related to the tuner is not available.

#### ● Initial settings used to start DIAG

The following initial settings are used when starting DIAG. When DIAG is canceled, these settings are restored to those before starting DIAG.

- Input: DVD
- Audio mute: OFF
- DIAG menu: DISPLAY CHECK (1. VFD CHECK)

### 1. DISPLAY CHECK

This program is used to check the FL display section. The display condition varies as shown below according to the sub-menu operation.

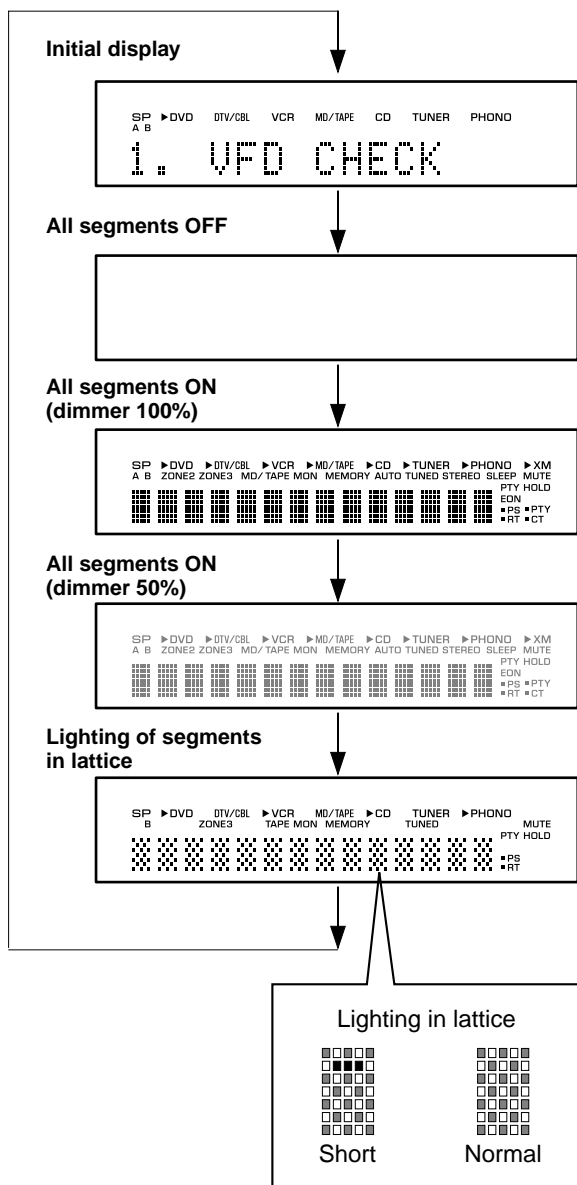

Segment conditions of the FL driver and the FL tube are checked by turning ON and OFF all segments. Next, the operation of the FL driver is checked by using the dimmer control. Then a short between segments next to each other is checked by turning ON and OFF all segments alternately (in lattice). (In the above example, the segments in the second row from the top are shorted.)

### 2. FACTORY PRESET

This menu is used to reserve/inhibit initialization of the back-up RAM.

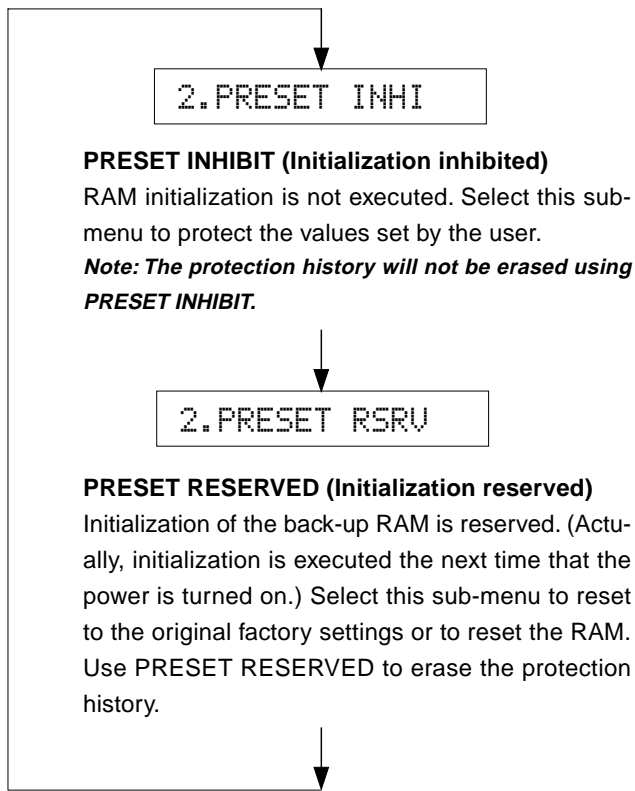

**CAUTION:** Before setting to the PRESET RESERVED, write down the existing preset memory content of the Tuner in a table as shown below. (This is because setting to the PRESET RESERVED will cause ALL user memory contents to be erased.)

Preset group	P1	P2	P3	P4
A				
B				
C				
D				
E				

Preset group	P5	P6	P7	P8
A				
B				
C				
D				
E				

RX-497

● PRESET STATIONS

STATION		FM FACTORY PRESET DATA (MHz)	
PAGE	NO.	U, C	R, A, G, E, L
A/C/E	1	87.5	87.50
	2	90.1	90.10
	3	95.1	95.10
	4	98.1	98.10
	5	107.9	108.00
	6	88.1	88.10
	7	106.1	106.10
	8	107.9	108.00

STATION		AM FACTORY PRESET DATA (kHz)	
PAGE	NO.	U, C, R	A, G, E, L
B/D	1	630	630
	2	1080	1080
	3	1440	1440
	4	530	531
	5	1710	1611
	6	900	900
	7	1350	1350
	8	1400	1404

3. AD DATA CHECK

With this sub-menu used, the key scanning, A/D value of the voltage at the abnormality detect (protection) port, etc. are displayed. The A/D conversion value is displayed in %. The state before audio signal processing is kept.

When K0/K1 menu is selected, keys become nonoperable due to detection of the values of all keys.

However, it is possible to advance to the next sub-menu by turning the INPUT of the main unit. When using this function, note that turning the INPUT more than 2 clicks will cause the volume value to change.

*\* The numeric value in the diagram is for reference.*

DC/PS (protection detection)

DC: DC detect protection value

Normal value: 19 to 51 (Reference: 5V = 100%)

PS: Power supply voltageprotection value

Normal value: 54 to 84 (Reference: 5V = 100%)

When the value is outside of the normal range, the protection function works to turn off the power.

```
DC:035 PS:067
```

THM (temperature detection)

When the value is outside of the normal range, the protection function works to turn off the power.

500% display of the voltage based on the temperature detected value. Reference voltage: 5V

*\* For RX-497, only R ch is effective.*

```
THM:L000 R098
```

REC-OUT

Not applied to this model.

```
REC-OUT:225
```

K0/K1

This is the A/D value of the panel key input ports KEY0 and KEY1 (microprocessor). The table below shows the A/D value obtained when each key is pressed. When the value is not within the standard value range, no correct operation is provided. Referring to the table below, check the value of each voltage dividing resistor of each key, solder condition, etc.

```
K0:100 K1:099
```

	%	Key0	Key1
1	0 – 4	FM/AM	P8
2	4 – 12	TUNING DOWN	P7
3	12 – 21	TUNING UP	P6
4	21 – 30	TUNING MODE	P5
5	31 – 41	MEMORY	P4
6	42 – 52	EDIT	P3
7	52 – 61	ZONE CTRL	P2
8	61 – 68	SPEAKER B	P1
9	68 – 74	SPEAKER A	A/B/C/D/E
10	75 – 81		
11	81 – 89		

4. XM STATUS

XM Radio data is displayed.

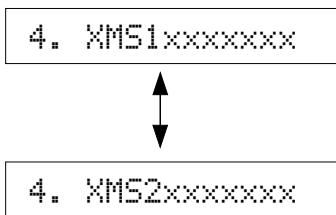

## 5. PROTECTION SETTING

This menu is used to change the protection setting value. The change is effective in this menu only. A set value can be specified between 0 – 255 (0V – 5V).

### Operation:

Change the digit with the “EDIT” key.

UP / DOWN with the TUNING MODE / MEMORY key.

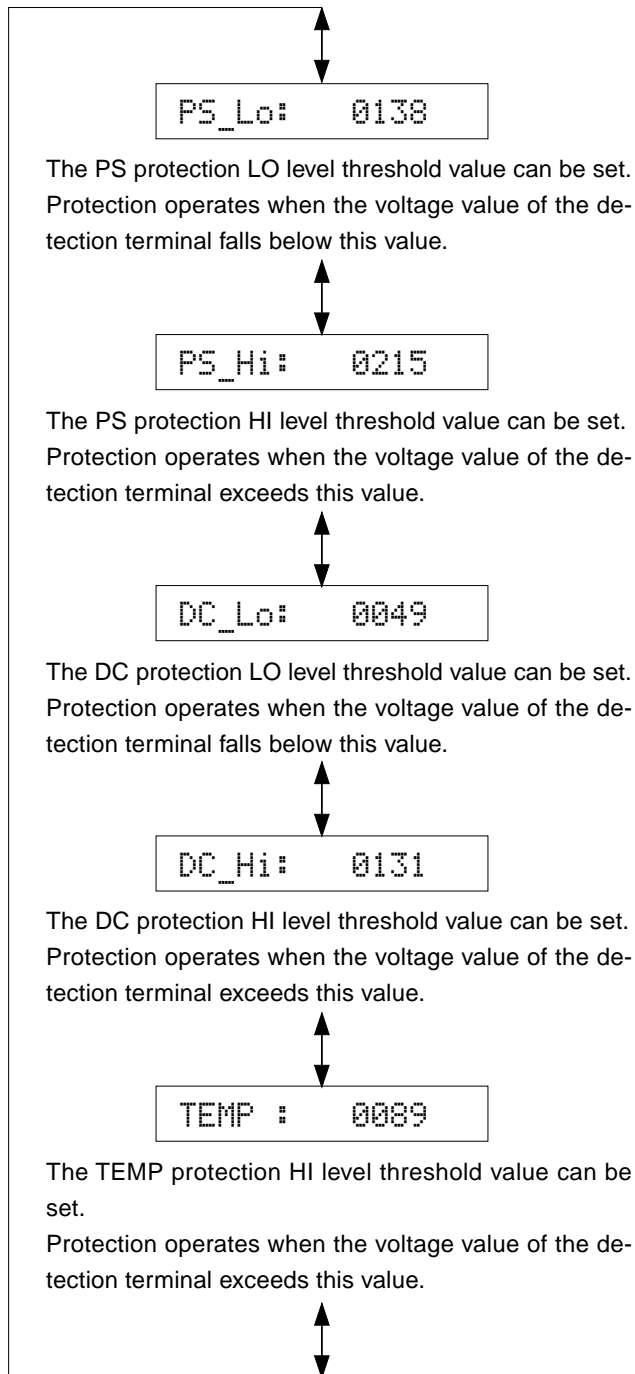

## 6. PROTECTION HISTORY

Four protection histories are display.

The history is cleared by the initialization reservation of DIAG menu No. 2.

### When there is no history of protection function:

There is no history of protection function.

```
6-1 NoPRT
```

### When there is a history of protection function:

There is a history of protection function due to excess current.

```
6-1 I PRT
```

There is a history of protection function due to abnormal voltage in the power supply section.

The abnormal voltage is displayed in % based on 5V as 100%.

```
6-2 PsPRT 069
```

There is a history of protection function due to abnormal DC output.

The abnormal voltage is displayed in % based on 5V as 100%.

```
6-3 DcPRT 059
```

There is a history of protection function excessive heatsink temperature. (R ch)

The abnormal voltage is displayed in % based on 5V as 500%.

```
6-4 TmRPRT 245
```

There is a history of protection function excessive heatsink temperature. (L ch)

Not applied to this model.

```
6-4 TmLPRT 245
```

*\*The numeric value in the diagram is for reference.*

## 7. SOFT SWITCH

**Note) Changing the function setting may hinder the proper operation.**

This menu is used to switch the function settings on P.C.B. through the software so as to activate the product.

The operation mode can be changed by selecting the sub-menu and then using the EDIT key.

The protection function follows the P.C.B. settings.

When connected to AC, the unit is initialized to the P.C.B. setting. Display of each function after initialization varies depending on settings on P.C.B.

**SW MODE:** PCB, MODEL or FNC can be selected.

7.SW :PCB

**MODEL SETTING:** RX797, RX497 or RX397 can be selected. (SW MODE: Selectable when MODEL has been selected.)

7.MODEL :RX497

**DESTINATION:** UC / RL / A or BGE can be selected. (SW MODE: Selectable when MODEL has been selected.)

7.DEST :UC

**TUNER DEST INATION:** UC, RL or ABGE can be selected. (SW MODE: Selectable when FNC has been selected.)

7.TuDest :UC

**TUNER TYPE:** NRM, RDS or XM can be selected. (SW MODE: Selectable when FNC has been selected.)

7.TuTyp :XM

**ZONE2:** NOT or EXIST can be selected. (SW MODE: Selectable when FNC has been selected.)

7.ZONE2 :EXIST

## 8. MICROPROCESSOR INFORMATION

The version, checksum and the port specified by the microprocessor are displayed. The checksum is obtained by adding the data at every 16 bits for each program area and expressing the result as a 4-figure hexadecimal data.

*\*The numeric value in the diagram is for reference.*

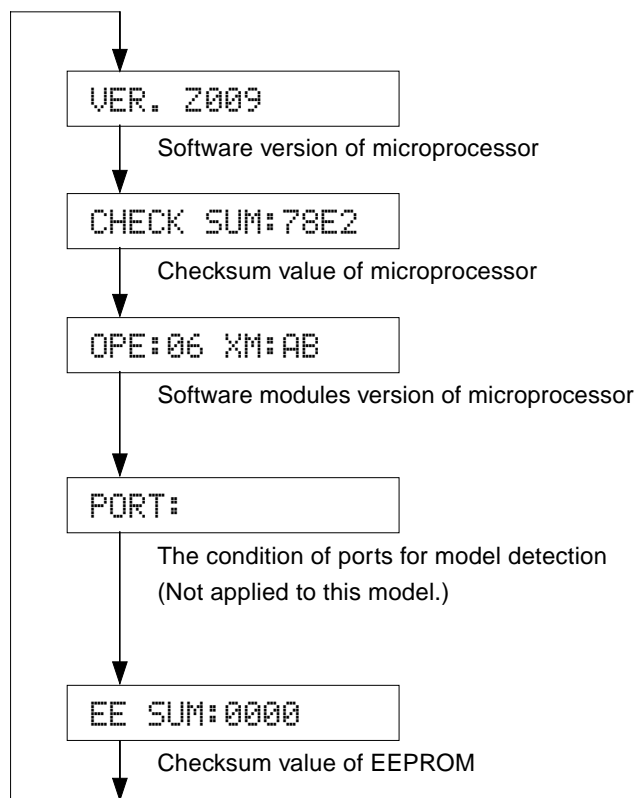

Tuner Dest	Frequency Range		Comment
	FM	AM	
UC	87.5-107.9MHz/200kHz	530-1710kHz/10kHz	
RL	87.5-108.0MHz/50kHz	531-1611kHz/9kHz	The frequency range is selected with Advanced Set Up
	87.5-108.0MHz/100kHz	530-1710kHz/10kHz	
ABG	87.5-108.0MHz/50kHz	531-1611kHz/9kHz	

## ■ AMP ADJUSTMENT

### ● CONFIRMATION OF IDLING CURRENT

1. Right after the power is turned on, confirm that the voltage across the terminals of R137 (L ch) and R138 (R ch) are between 0.1mV to 10.0mV.
2. If the measured voltage exceeds 10.0mV, open (cut off) R131 (L ch), R132 (R ch) and reconfirm the voltage.
3. Confirm that the voltage is between 0.20mV and 15.0mV after 60 minutes.

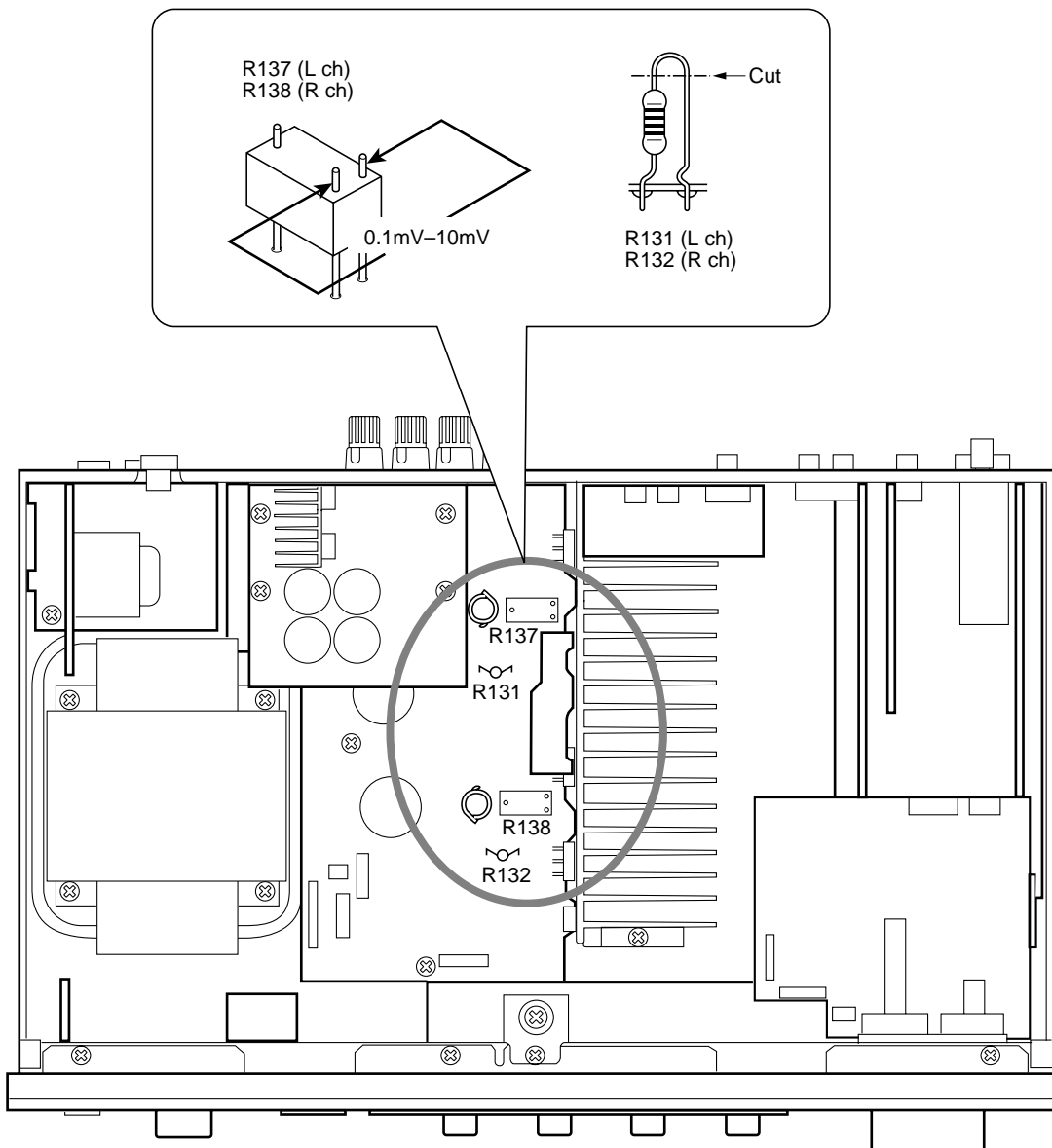



■ IC DATA

**IC602 : M30626FHPFP (FUNCTION (2) P.C.B.)**  
**16-bit Microprocessor**

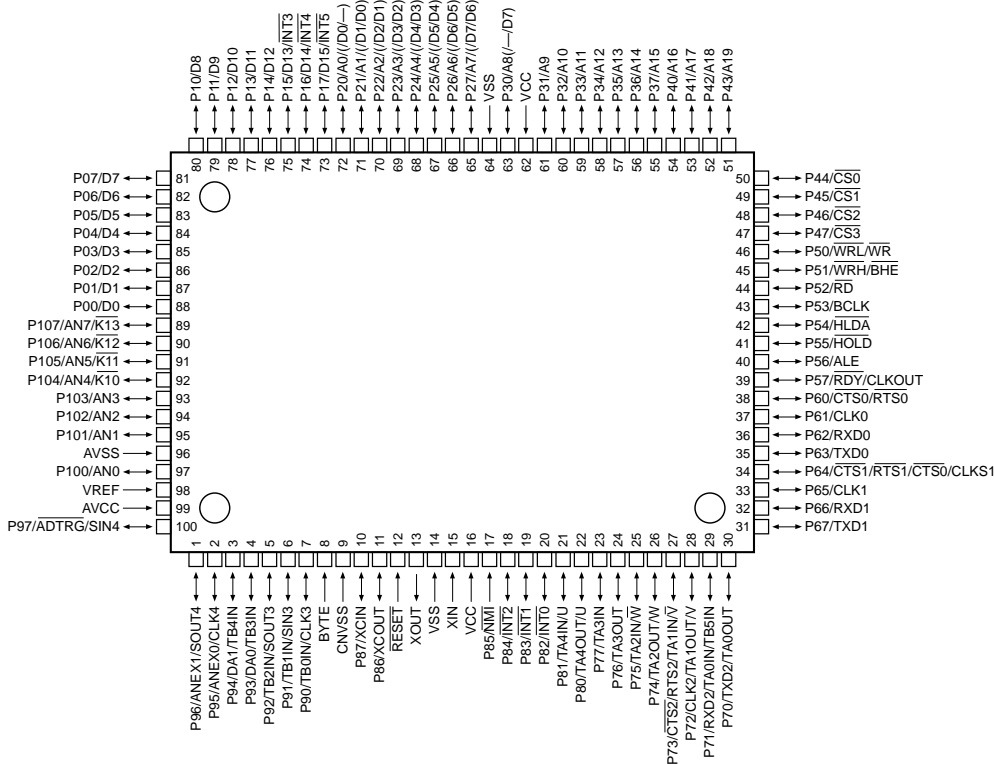

No.	Port	Name	I/O	Function
1	P96/ANEX1	DTFD	O	FL Driver Tx DATA
2	P95/ANEX0	CKFD	O	FL Driver CLOCK
3	P94		O	
4	P93	DEST1	I	Model Distinction 1
5	P92/TB2in	DEST0	I	Model Distinction 0
6	P91/TB1in	MOD1	I	Destination Distinction 1 (Reserve)
7	P90/TB0in	MOD0	I	Destination Distinction 0 (Reserve)
8	BYTE	BYTE	MCU	Vss: when single chip mode is used (Gnd)
9	CNVss	CNVss	MCU	Vss: when single chip mode is used, Vcc: when flash writing is used (PullDown)
10	P87/Xcin	/CEEEP	O	EEPROM CE
11	P86/Xcout	N.C.	O	
12	/RESET	/RESET	MCU	Reset
13	Xout	Xout	MCU	Oscillator Out
14	Vss	Vss	MCU	Ground (Gnd)
15	Xin	Xin	MCU	Oscillator In
16	Vcc1	Vcc	MCU	Power Supply, +5V (Vcc)
17	P85/NMI	NMI	I	Connect to Vcc because it is unused (PullUp)
18	P84/INT2	MPSW	IRQ	MAIN Power SW INT
19	P83/INT1	ZPSW	IRQ	Zone2 Power SW INT
20	P82/INT0	PDET	IRQ	Power Down Detect INT
21	P81	N.C.	O	(LevelConv)
22	P80	N.C.	O	(LevelConv)
23	P77	TRIG	O	Triger OUT (Unconnected)
24	P76	/POMT	O	Pre Out Mute (Unconnected)
25	P75/TA2in	/Z2MT	O	Zone2 Mute
26	P74/TA2out	N.C.	O	
27	P73/CTS2/RTS2/TA1in	XMPWR	O	XM/DT BUS POWER CONTROL
28	P72/CLK2/TA1out	/ICXM	O	DABIC IC Reset
29	P71/RXD2/SCL2/TA0in	DRXM	SI	DABIC IC RxD (LevelConv)
30	P70/TXD2/SDA2/TA0out	DTXM	SO	DABIC IC TxD (LevelConv)
31	P67/TXD1/SDA1	DTEV	SO	Zone2Volume Tx DATA(YAC526) (Unconnected)
		TXDF	SO	Data Transmit Terminal for AF220
32	P66/RXD1/SCL1	CEEV	O	Zone2Volume CE(YAC526) (Unconnected)
		RXDF	SO	Flash ROM RxD
33	P65/CLK1	CKEV	SO	Zone2Volume CLOCK(YAC526) (Unconnected)
		CLKF	SO	Clock Transmit Terminal for AF220

RX-497

**IC602 : M30626FHPFP (FUNCTION (2) P.C.B.)**  
**16-bit Microprocessor**

No.	Port	Name	I/O	Function
34	P64/CTS1/RTS1/CTS0/CLKS1	BSY	O	AF220 BUSY Signal Output
35	P63/TXD0/SDA0	DTIS	SO	Input Selector Tx DATA
36	P62/RXD0/SCL0	CEIS	O	Input Selector CE
37	P61/CLK0	CKIS	SO	Input Selector CLOCK
38	P60/CTS0/RTS0	DTRZ	O	Rec/Zone2 selector DATA
39	P57/RDY/CLKout	CKRZ	O	Rec/Zone2 selector CLOCK
40	P56	N.C.	O	
41	P55	/EMP	I	For Flash Writing (LO) (PullDown)
42	P54	CER	O	RDS CE
43	P53	SCKR	O	RDS CLOCK
44	P52	SDRR	I	RDS Rx DATA
45	P51	SDTR	O	RDS Tx DATA
46	P50	/CE	I	For Flash Writing (HI) (PullUp)
47	P47	CEP	O	TUNER CE
48	P46	SCKP	O	TUNER CLOCK
49	P45	SDTP	O	TUNER Tx DATA
50	P44	/TMU	O	TUNER MUTE
51	P43	SDRP	I+	TUNER Rx DATA
52	P42	TUNED	I+	TUNER TUNED
53	P41	/ST	I+	TUNER /ST
54	P40	N.C.	O	
55	P37	VIA	O	Video Input SelectorA (PullDown)
56	P36	VIB	O	Video Input SelectorB (PullDown)
57	P35	/VR	O	Video Rec Mute (PullDown)
58	P34	VRB	O	Video Rec SelectorB (Unconnected)
59	P33	VZA	O	VIDEO Zone2 SelectorA (Unconnected)
60	P32	VZB	O	VIDEO Zone2 SelectorB (Unconnected)
61	P31	/SWMT	O	Sub Woofer Mute
62	Vcc2	Vcc	MCU	Power Supply, +5V (Vcc)
63	P30	/CDMT	O	CD Direct Mute (Unconnected)
64	Vss	Vss	MCU	Ground (Gnd)
65	P27	/MIMT	O	Main IN Mute
66	P26	PDon	I+	Pure Direct ON Detect
67	P25	CDon	I+	Tape Monitor Key
68	P24	PLED	O	Pure Direct LED
69	P23	CLED	O	CD Direct/TapeMonitor LED
70	P22	PRY	O	Power Relay
71	P21	N.C.	O	
72	P20	HPRY	O	Head Phone Pelay
73	P17	PDET	IRQ	Power Down Detect INT
74	P16	SPSW	IRQ	SYSTEM Power SW INT(MasterPower)
75	P15	REM	IRQ	Remote Controler INT
76	P14	FBRY	O	Front B Speaker Relay
77	P13	FARY	O	Front A Speaker Relay
78	P12	VRup	O	Volume Up
79	P11	VRdn	O	Volume Down
80	P10	PRI	I	I Protection
81	P07	/PSV	O	Power save mode
82	P06	N.C.	O	
83	P05	/BLK	O	FL Driver /BLK
84	P04	ISA	I	Input Selector A (PullUp)
85	P03	ISB	I	Input Selector B (PullUp)
86	P02	LSBY	O	StandBy LED (Unconnected)
87	P01	N.C.	O	
88	P00	N.C.	O	
89	P107/AN7/K13	REC	AD	Rec/Zone2 selector (Unconnected)
90	P106/AN6/K12	PRV	AD	PS Protection (PullUp)
91	P105/AN5/K11	PRD	AD	DC Protection (PullUp)
92	P104/AN4/K10	THML	AD	THM L Protection (Unconnected)
93	P103/AN3	THMR	AD	THM R Protection (PullUp)
94	P102/AN2	KEY0	AD	AD Key 0
95	P101/AN1	KEY1	AD	AD Key 1
96	Avss	Avss	MCU	AD Ground (Gnd)
97	P100/AN0	DEST	AD	Destination Detect
98	Vref	Vref	MCU	AD Reference (Vcc)
99	Avcc	Avcc	MCU	AD Power Supply (Vcc)
100	P97/Adtrg	CEFD	O	FL Driver CE

■ DISPLAY DATA

V801 : 15-BT-105GNK (WF519900)

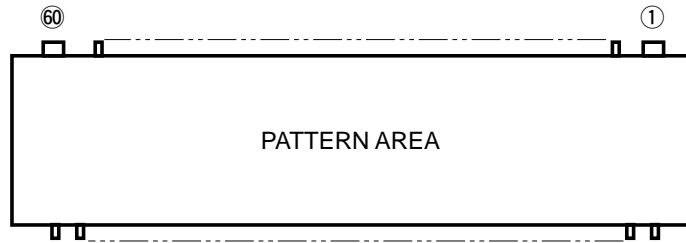

● PIN CONNECTION

PIN NO.	54444444433333333222222222211111111111111111
CONNECTION	P N N 5 4 3 2 1 0 9 8 7 6 5 4 3 2 1 0 9 8 7 6 5 4 3 2 1

PIN NO.	6555555
CONNECTION	F N N N N P P P P P

- Note 1) F1, F2 ..... Filament
- 2) NP ..... No Pin
- 3) NX ..... No Extend Pin
- 4) P1~P35 ..... Datum Line
- 5) 1G~15G ..... Grid

● GRID ASSIGNMENT

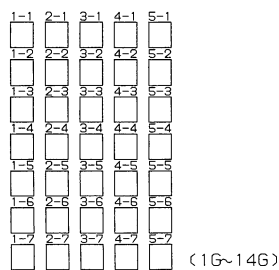
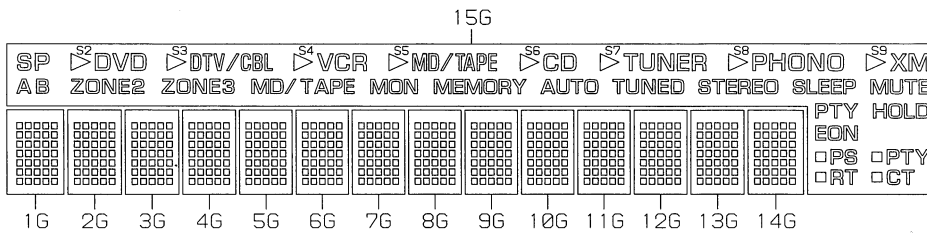

(15G)

- S10 □ □ S11
- S12 □ □ S13

(15G)

● ANODE CONNECTION

	1G~14G	15G
P1	1-1	SP
P2	2-1	A
P3	3-1	B
P4	4-1	ZONE2
P5	5-1	ZONE3
P6	1-2	MD/
P7	2-2	TAPE MON
P8	3-2	AUTO
P9	4-2	TUNED
P10	5-2	STEREO
P11	1-3	MEMORY
P12	2-3	SLEEP
P13	3-3	PTY HOLD
P14	4-3	EON
P15	5-3	S10
P16	1-4	S11
P17	2-4	S12
P18	3-4	S13
P19	4-4	PS
P20	5-4	PTY
P21	1-5	RT
P22	2-5	CT
P23	3-5	S2
P24	4-5	S3
P25	5-5	S4
P26	1-6	S5
P27	2-6	S6
P28	3-6	S7
P29	4-6	S8
P30	5-6	S9
P31	1-7	S1
P32	2-7	XM
P33	3-7	MUTE
P34	4-7	-
P35	5-7	-

# PIN CONNECTION DIAGRAM

## ICs

LM61CIZ

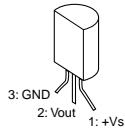

NJU7201L55

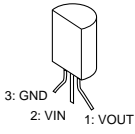

NJM7805FA

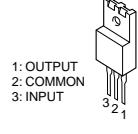

PQ05RD11

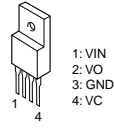

μPC29M33T-E1

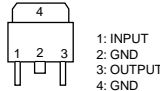

TLP421

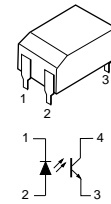

TC4013BP

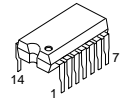

SN74AHC1G32DCK

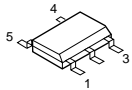

NE5532DR

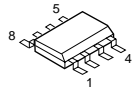

NJM2068MD

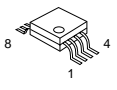

AK4384ET

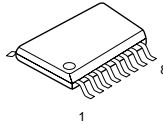

SN74LV245APWR

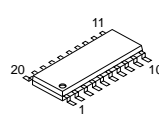

LC72722PM

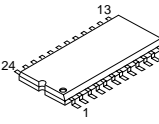

NJU7313AM

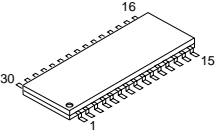

BD3841FS

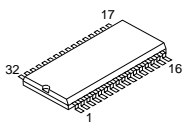

LA7956

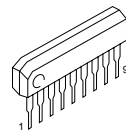

LB1641

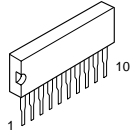

F2602E-01

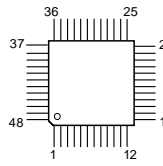

M66003-0131FP

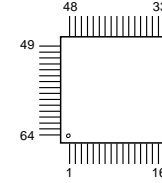

M30626FHPFP

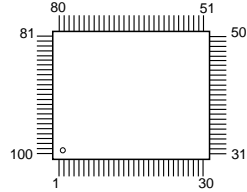

## Diodes

- 1SS355
- 1SS380
- MA8056-M
- MA8075-H
- MA8051-M
- MA8120-H
- UDZ5.1B
- UDZS3.0BTE-17
- AVRL161A1R1NTB
- RB500V-40
- UDZS22BTE-17

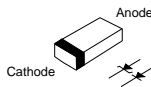

- 1SS133
- 1SS270A
- 1SR139
- 1T2
- MTZJ16A
- MTZJ6.8B
- MTZJ10B
- MTZJ9.1B
- MTZJ6.2B
- MTZJ3.0A
- MTZJ27B

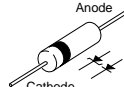

KBP103G

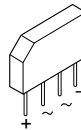

S1NB20  
S1NB60

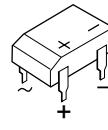

S4VB20

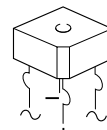

## Transistors

- 2SC2412K (Q, R, S)
- 2SD1938F (S, T)
- DTC144EKA
- 2SA1037K (Q, R, S)



- 2SA1708 (S, T)
- 2SC4488 (S, T)

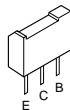

- 2SC1740S (Q, R, S)
- DTC144ESA-TP

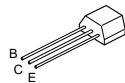

- 2SA1015 (Y)
- 2SC1815 (Y)
- 2N5401C-AT
- 2N5551C-AT
- 2SC2229 (O, Y)
- 2SA970 (GR, BL)
- 2SB647 (C, D)

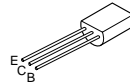

2SD2375 (Q, P)

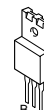

2SC4495

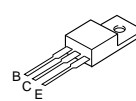

## Transistors

- 2SA1695 (O, P, Y)
- 2SC4468 (O, P, Y)
- 2SA2151 (O, P, Y)
- 2SC6011 (O, P, Y)

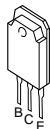

## FETs

- 2SK30ATM
- 2SK3850

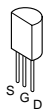

**PRINTED CIRCUIT BOARD**

1

**FUNCTION (1) P.C.B.** (Side A)

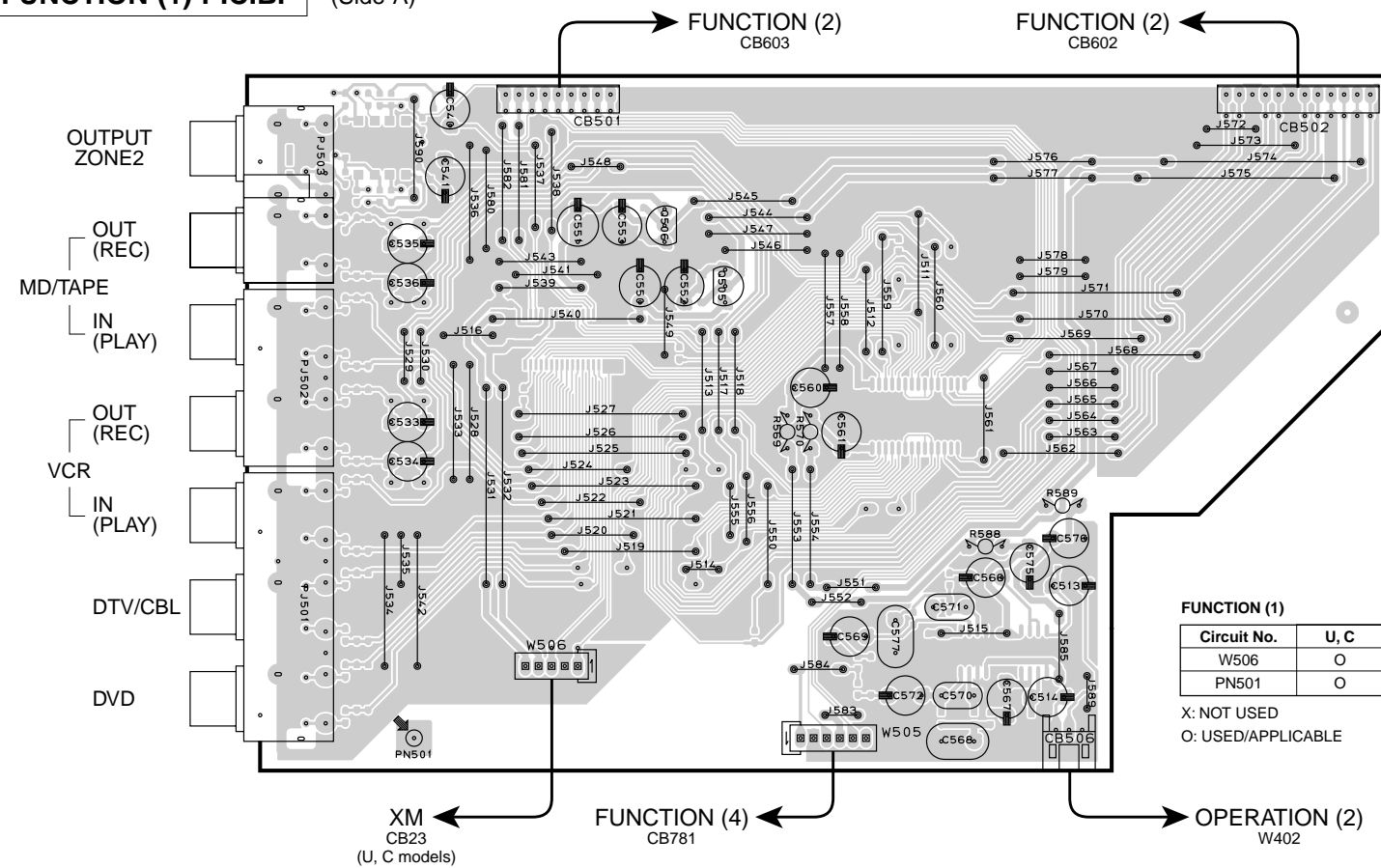

**FUNCTION (1)**

Circuit No.	U, C	R, L	A	G, E
W506	O	X	X	X
PN501	O	X	X	X

X: NOT USED  
O: USED/APPLICABLE

**FUNCTION (3) P.C.B.**

(Side A)

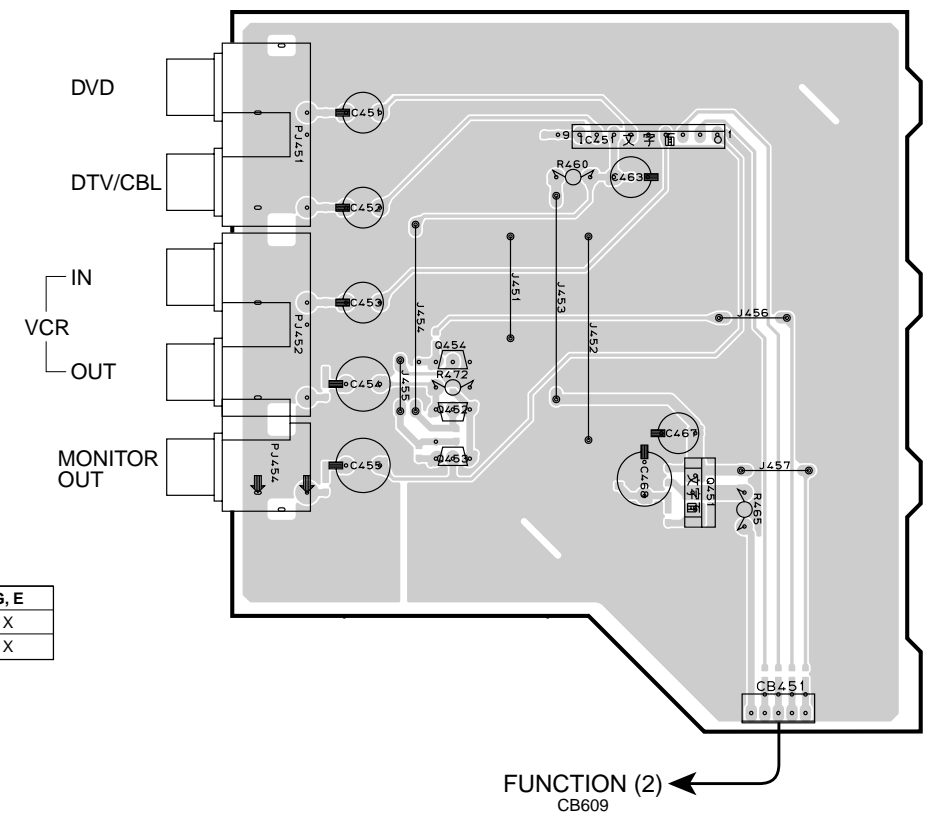

2

3

**FUNCTION (1) P.C.B.** (Side B) Lead Free Solder Used

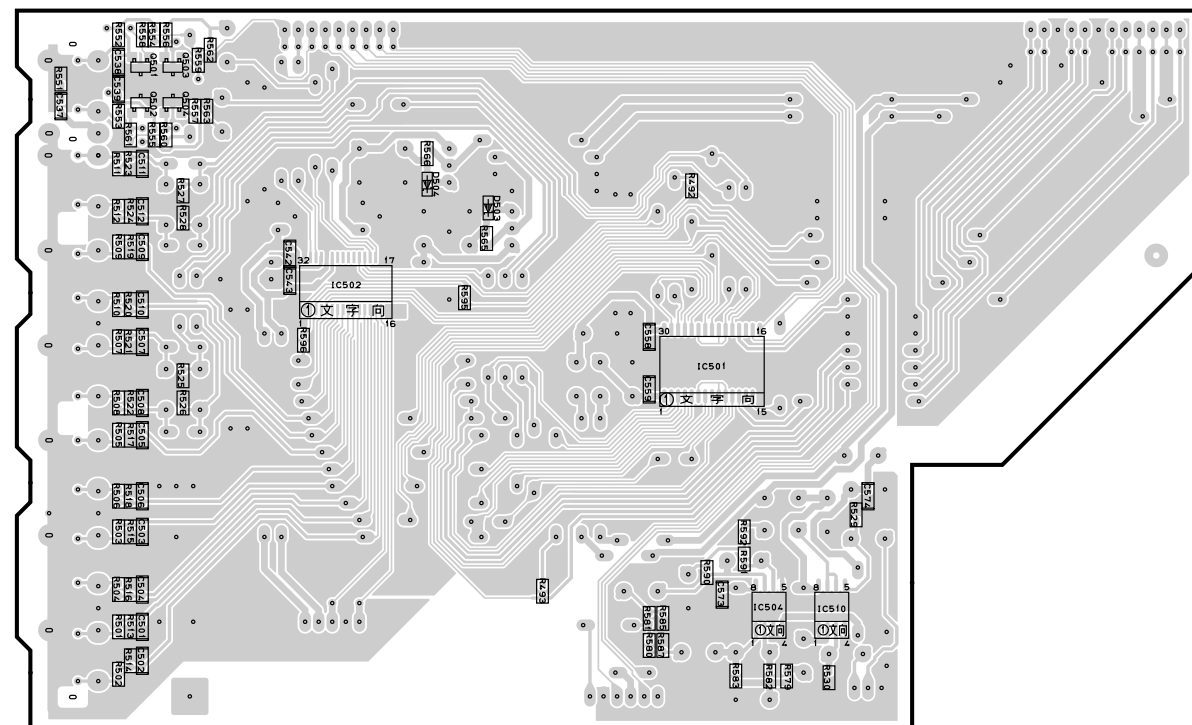

**FUNCTION (3) P.C.B.**

(Side B) Lead Free Solder Used

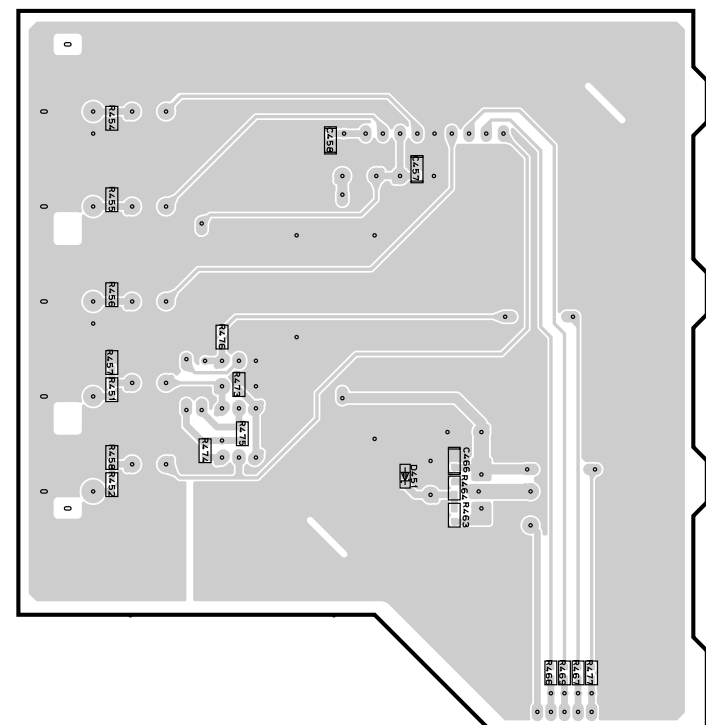

5

6

PRINTED CIRCUIT BOARD

FUNCTION (2) P.C.B. (Side A)

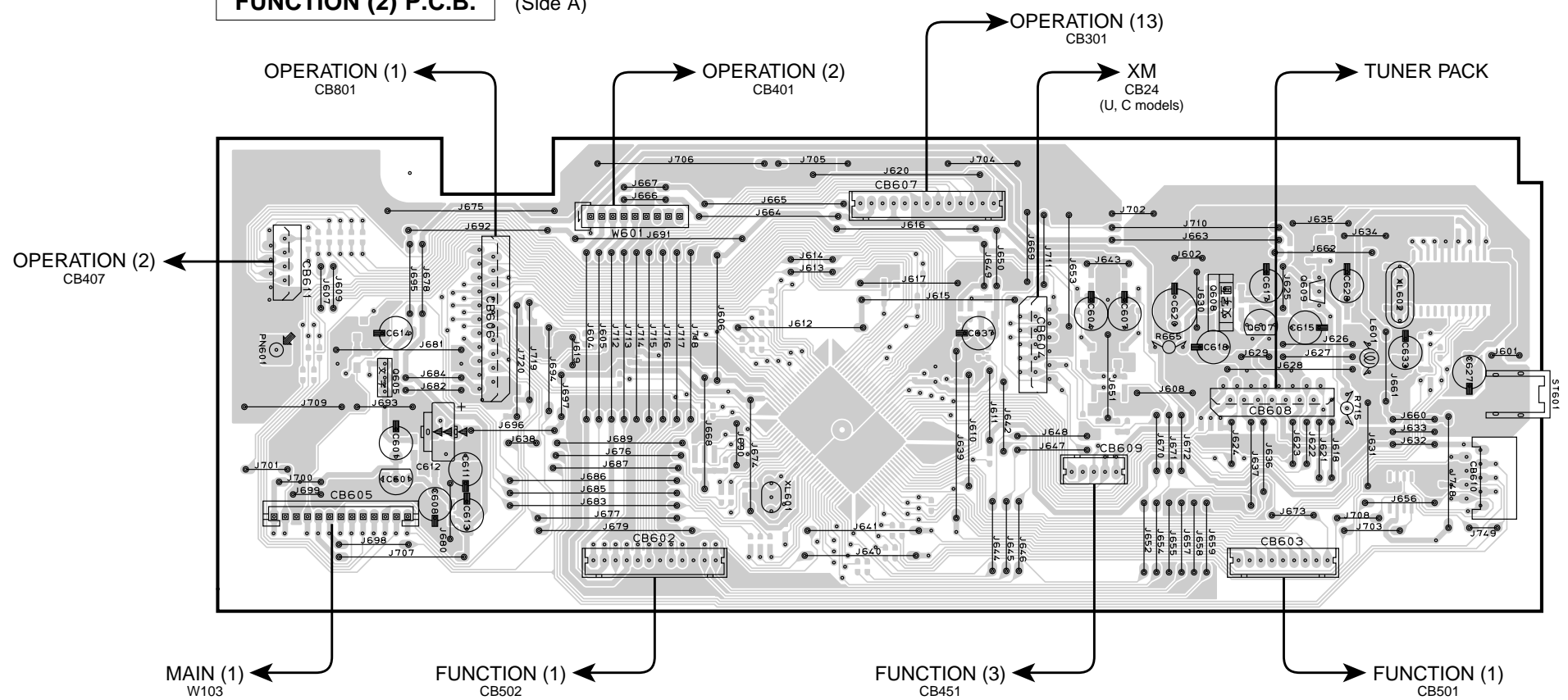

FUNCTION (2)

Circuit No.	U, C	R, L	A	G, E
CB604	O	X	X	X
R679, 681, 683, 686	O	X	X	X
R687, 688	O	X	X	X
R601	X	O	O	O
IC603	X	X	X	O
XL602	X	X	X	O
C630, 632	X	X	X	O
C622, 623	X	X	X	O
C629	X	X	X	O
C621, 631	X	X	X	O
C627, 628, 633	X	X	X	O
R698	X	X	X	O
R710, 711	X	X	X	O
R684	X	X	X	O
R714, 717	X	X	X	O
R688	X	X	X	O
R678	X	X	X	O
R677	X	X	X	O
L601	X	X	X	O
Q609	X	X	X	O

X: NOT USED  
O: USED/APPLICABLE

FUNCTION (2) P.C.B. (Side B) Lead Free Solder Used

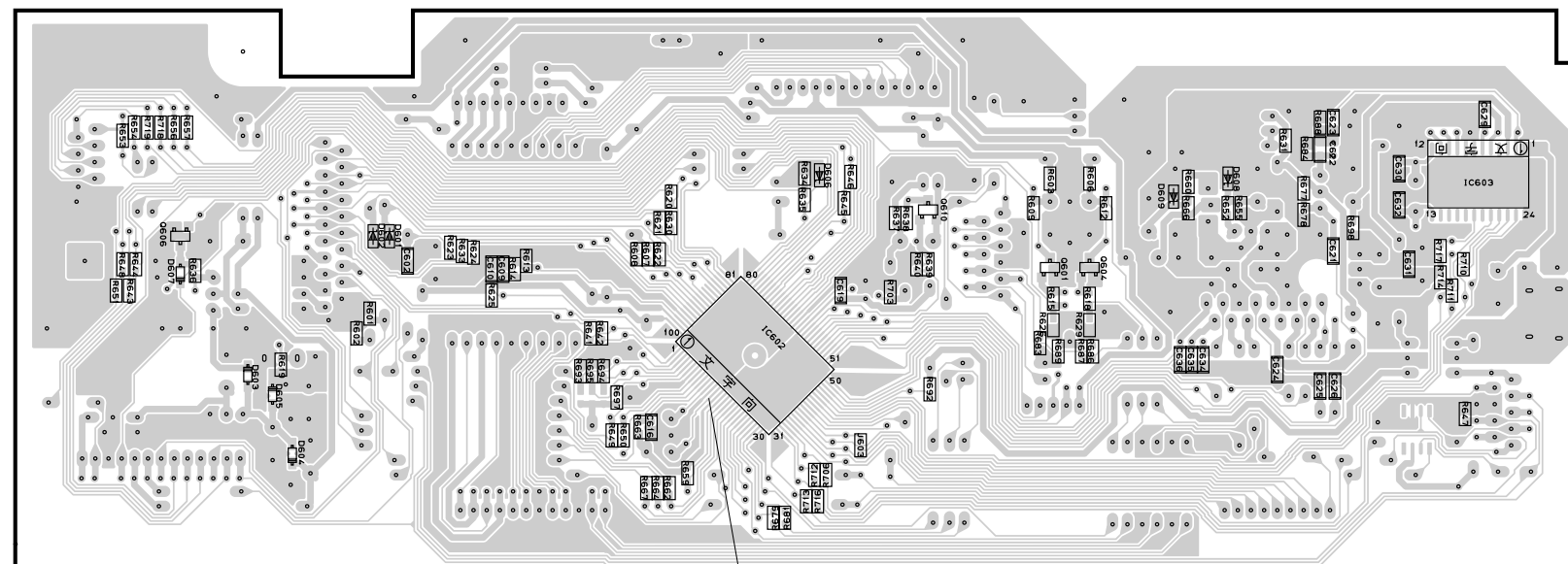

Point ① (Pin 13 of IC602)

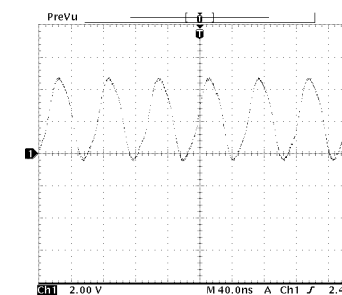

■ PRINTED CIRCUIT BOARD

**FUNCTION (4) P.C.B.**

(Side A)

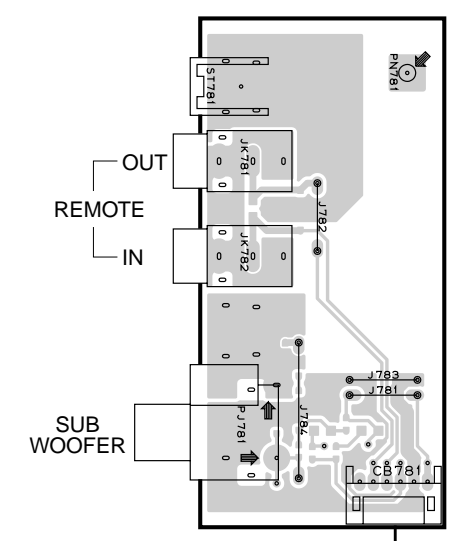

FUNCTION (1)  
W505

FUNCTION (4)

Circuit No.	U, C	R, L	A	G, E
PN781	O	X	X	X

X: NOT USED  
O: USED/APPLICABLE

**FUNCTION (4) P.C.B.**

(Side B) Lead Free Solder Used

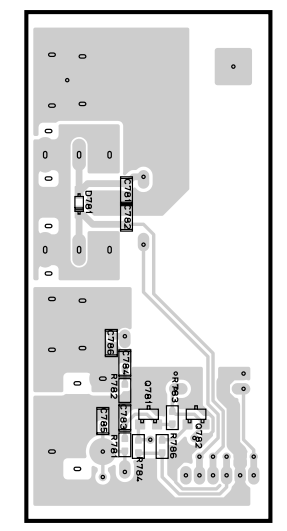

**OPERATION (1) P.C.B.**

(Side A)

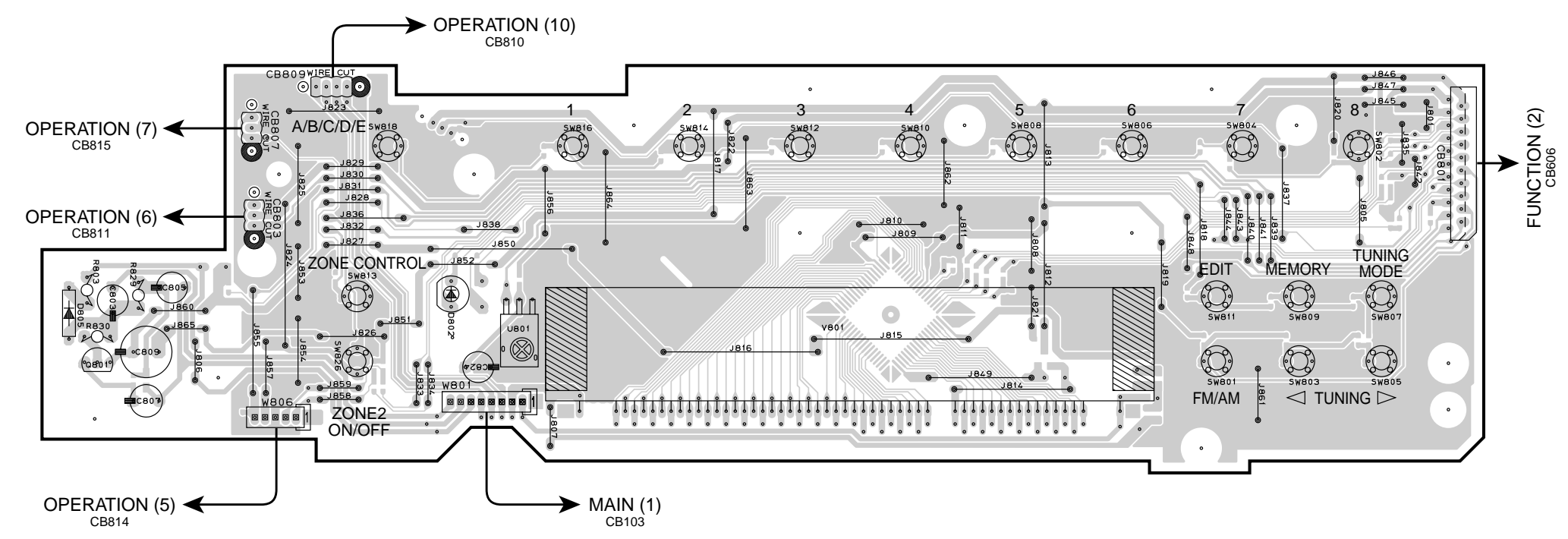

**OPERATION (1) P.C.B.**

(Side B) Lead Free Solder Used

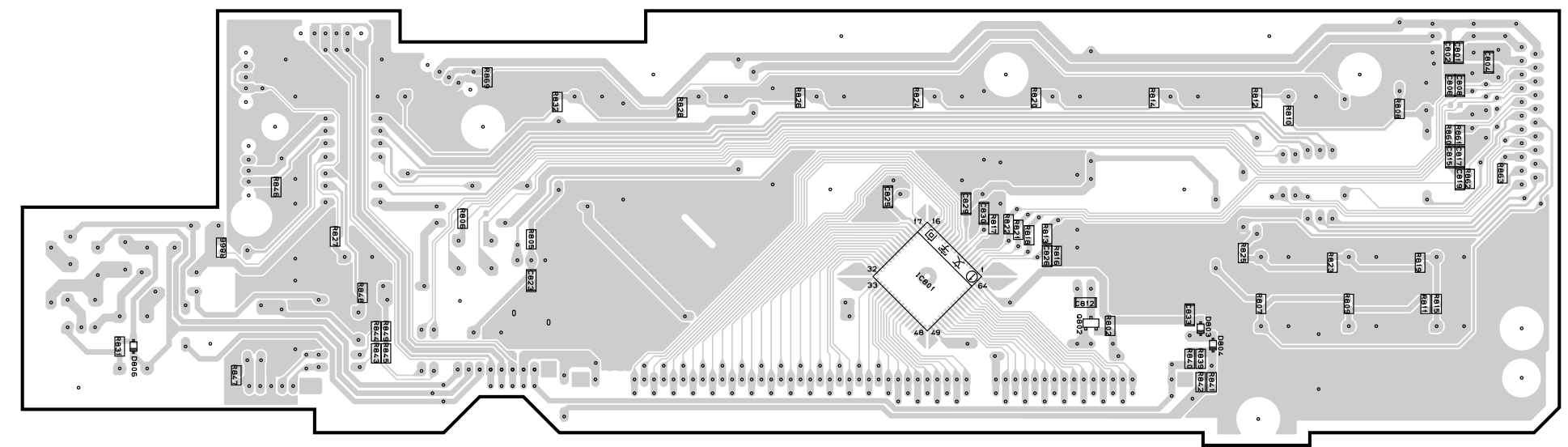

1  
2  
3  
4  
5  
6

PRINTED CIRCUIT BOARD

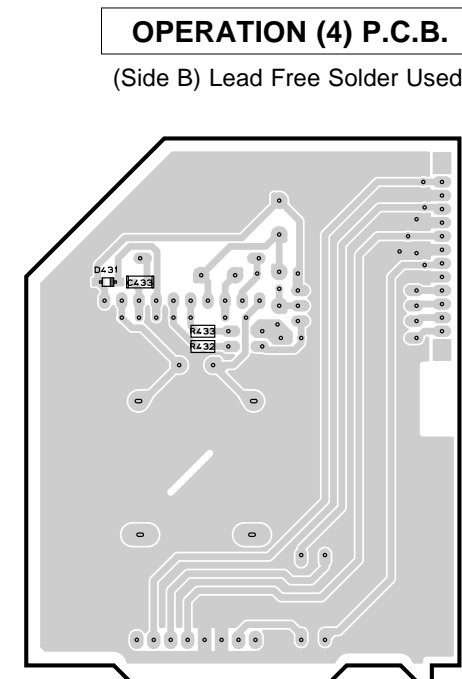
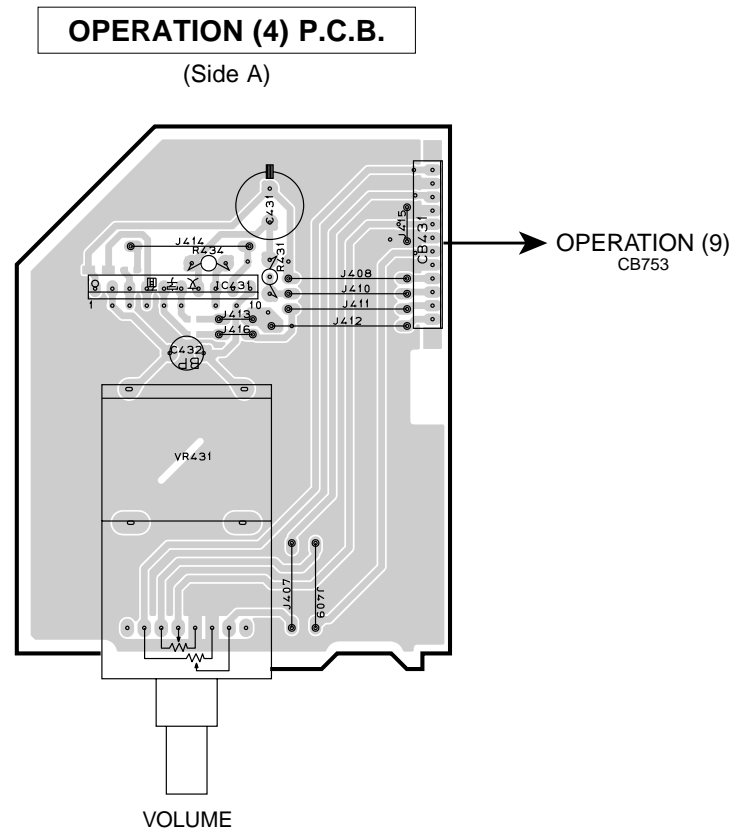
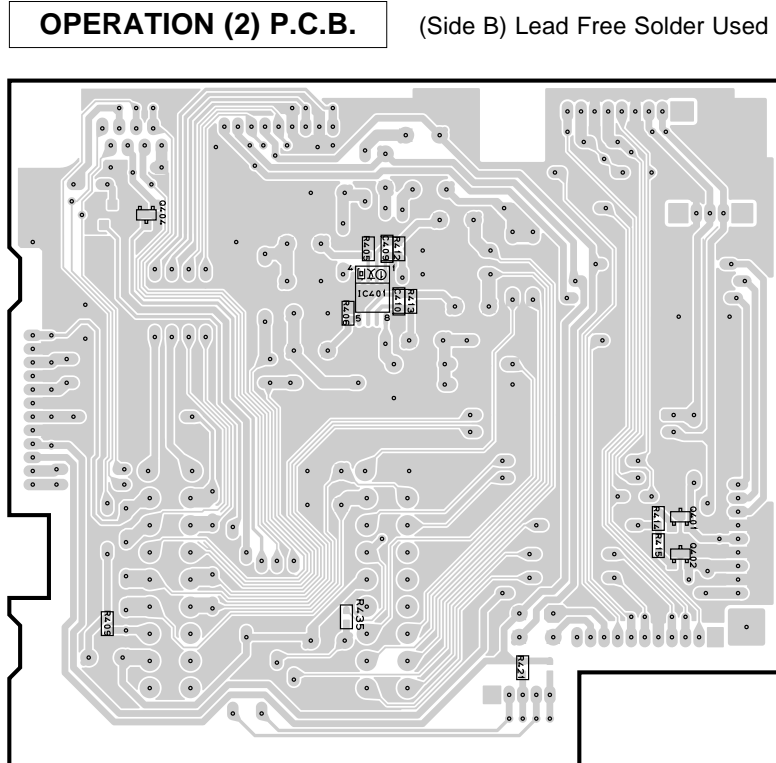
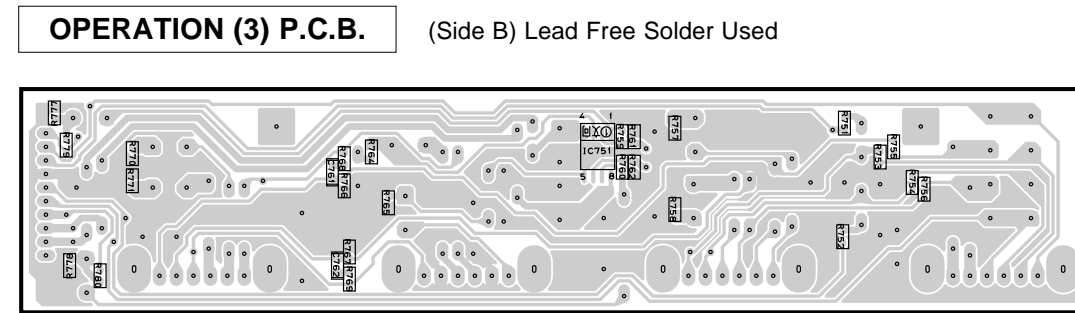
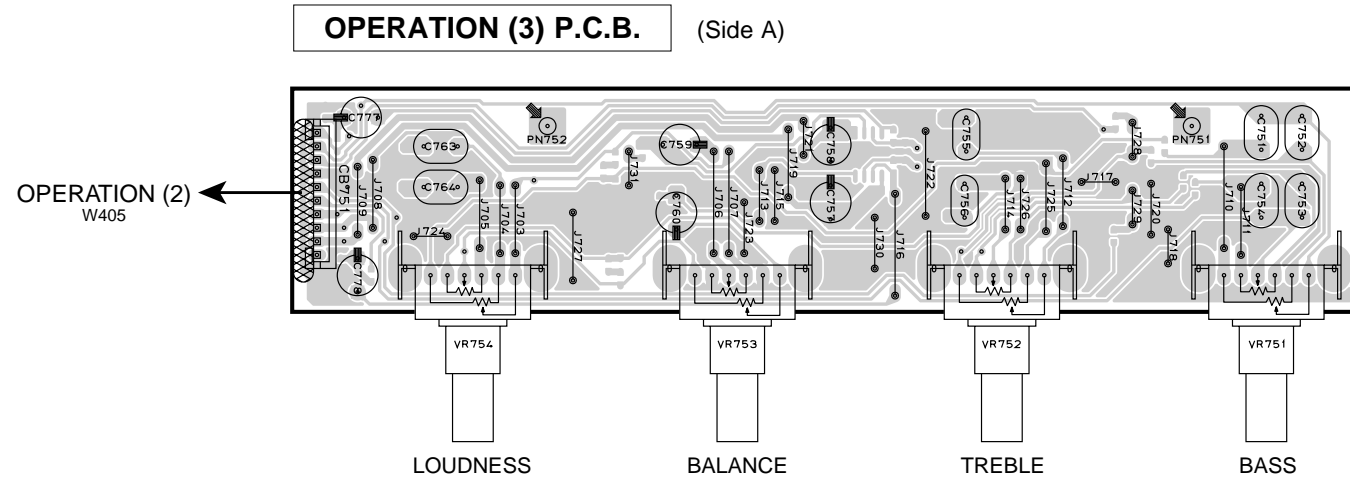
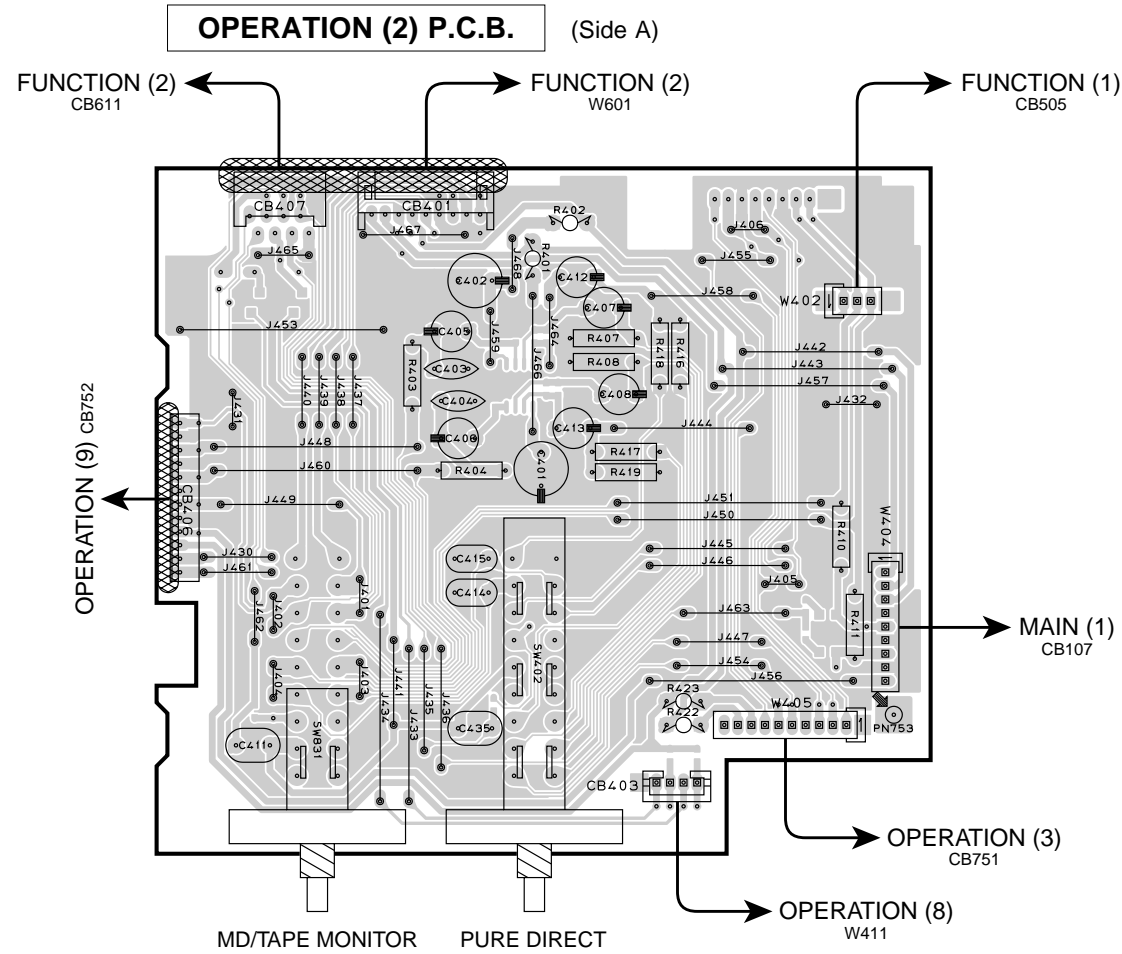

1  
2  
3  
4  
5  
6



PRINTED CIRCUIT BOARD

OPERATION (5) P.C.B.

(Side A)

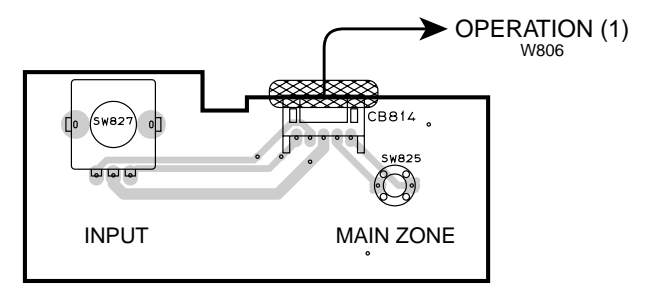

OPERATION (7) P.C.B.

(Side A)

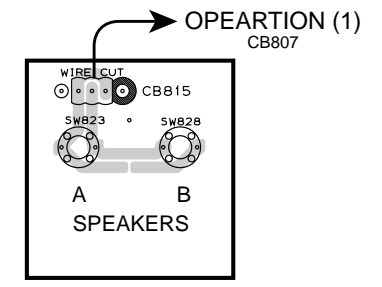

OPERATION (8) P.C.B.

(Side A)

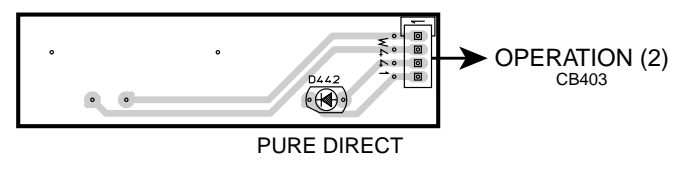

OPERATION (9) P.C.B.

(Side A)

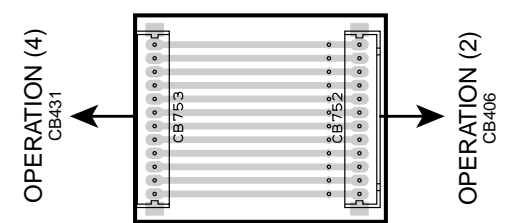

OPERATION (6) P.C.B.

(Side A)

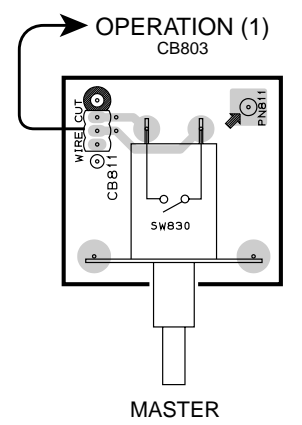

OPERATION (7) P.C.B.

(Side B) Lead Free Solder Used

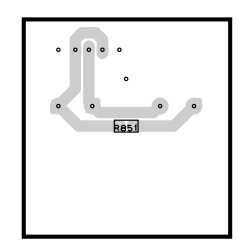

OPERATION (13) P.C.B.

(Side A)

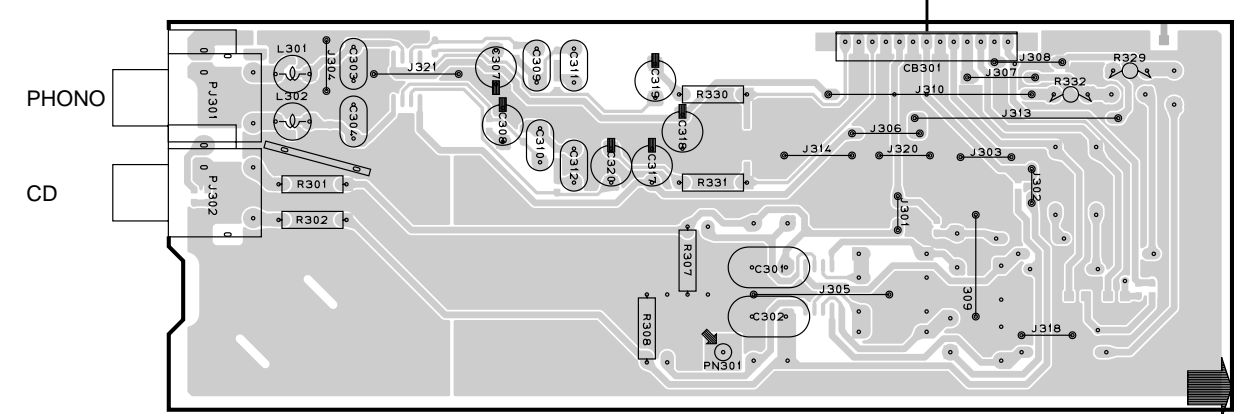

OPERATION (10) P.C.B.

(Side A)

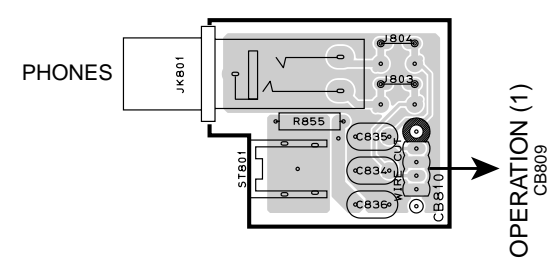

OPERATION (12) P.C.B.

(Side A)

A, G, E, L models

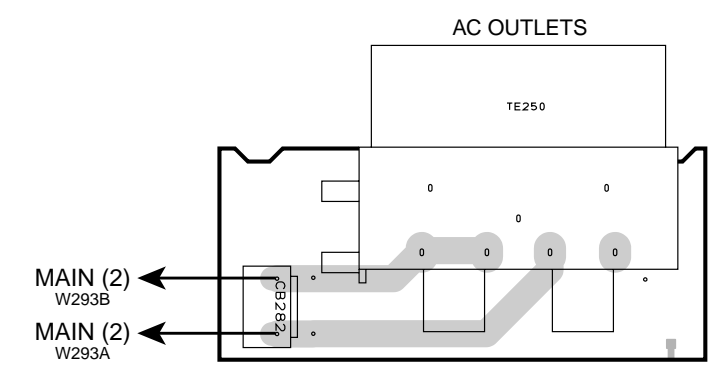

OPERATION (13) P.C.B.

(Side B) Lead Free Solder Used

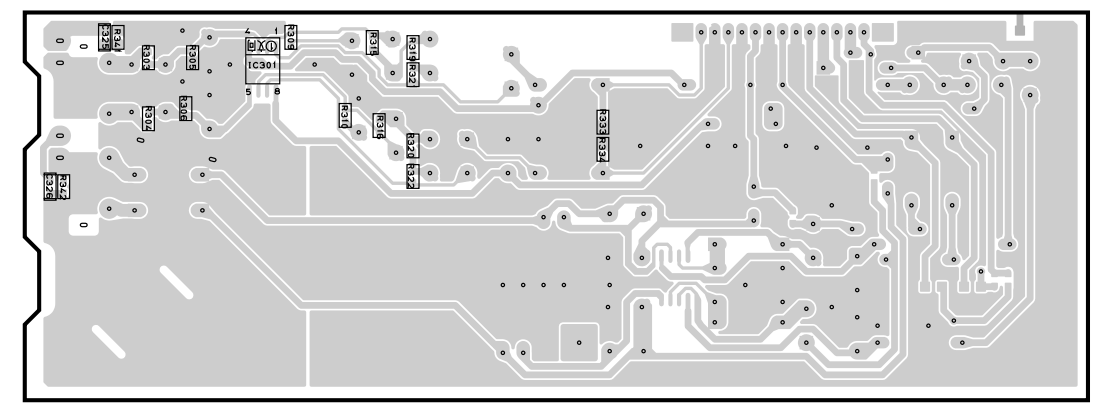

1

2

3

4

5

6

PRINTED CIRCUIT BOARD Lead Free Solder Used

**MAIN (1) P.C.B.**  
(Side A)

**MAIN (5) P.C.B.**  
(Side A)

**MAIN (3) P.C.B.**  
(Side A)

MAIN (1)

Circuit No.	A, G, E, L	U, C, R
C156-159, 161, 162	O	X

X: NOT USED  
O: USED/APPLICABLE

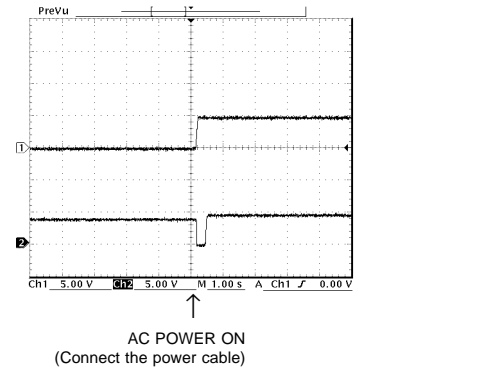
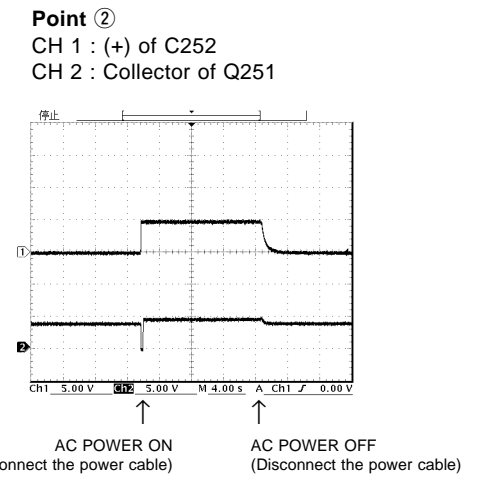
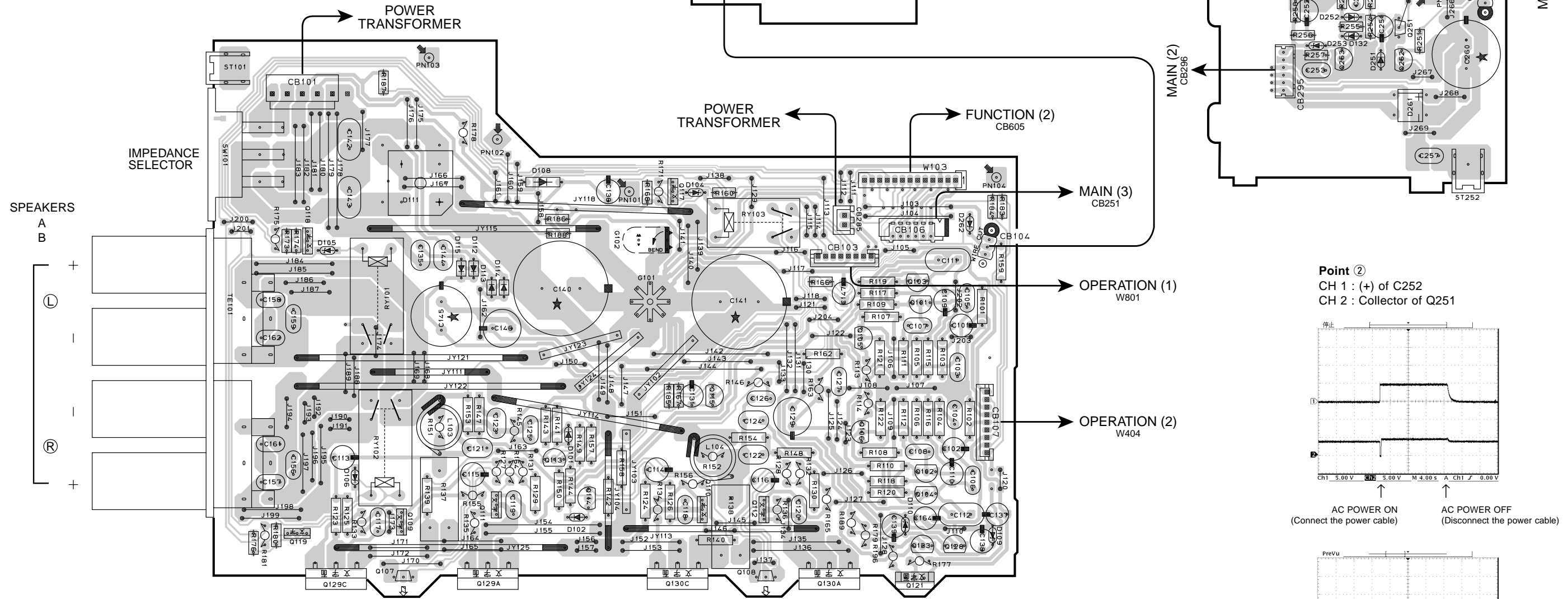

PRINTED CIRCUIT BOARD Lead Free Solder Used

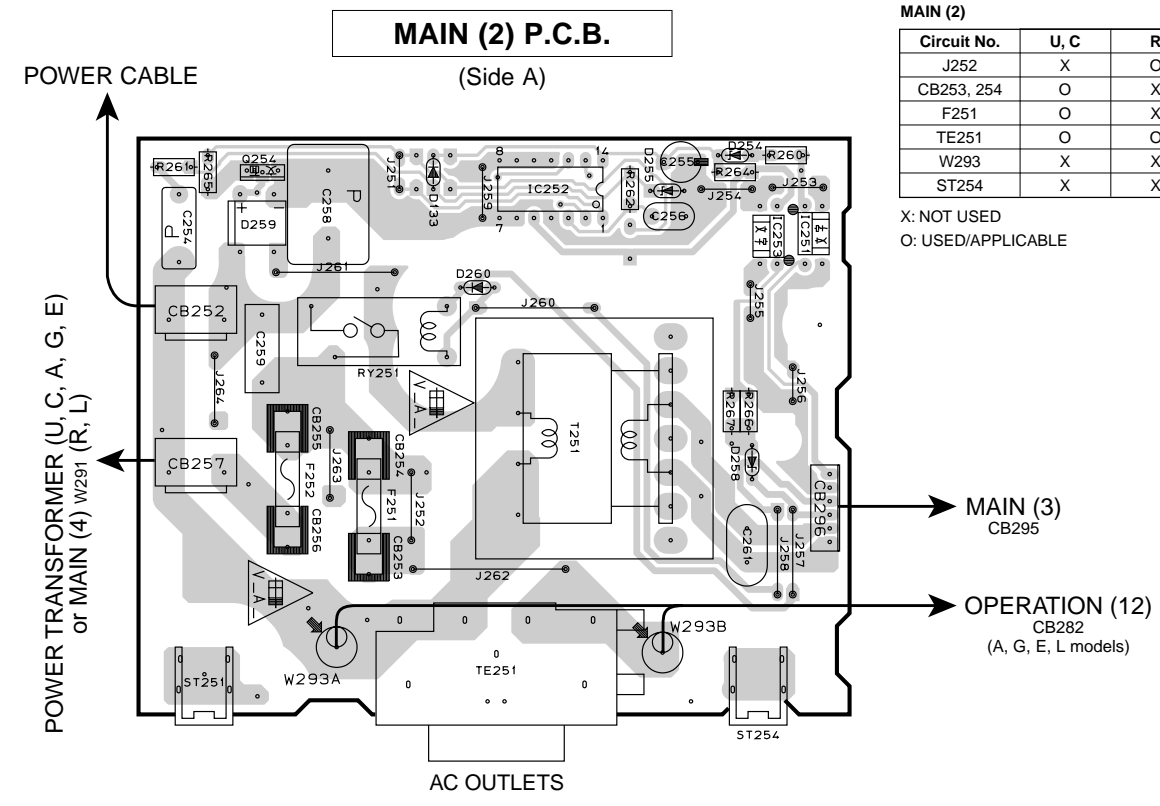

**MAIN (2)**

Circuit No.	U, C	R	A	G, E	L
J252	X	O	O	X	O
CB253, 254	O	X	X	O	X
F251	O	X	X	O	X
TE251	O	O	X	X	X
W293	X	X	O	O	O
ST254	X	X	O	O	O

X: NOT USED  
O: USED/APPLICABLE

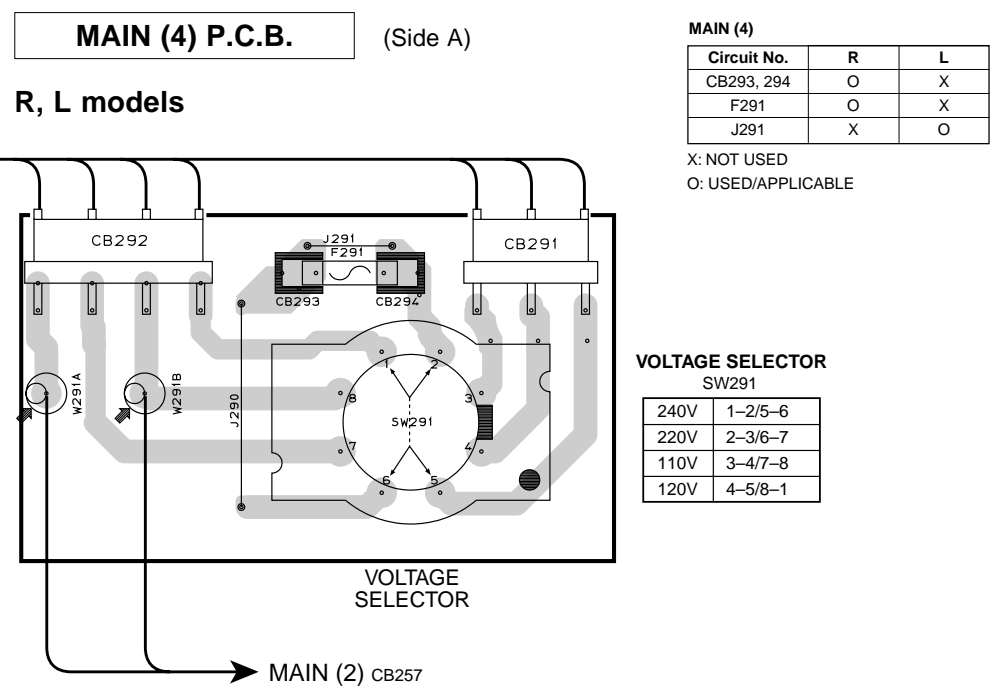
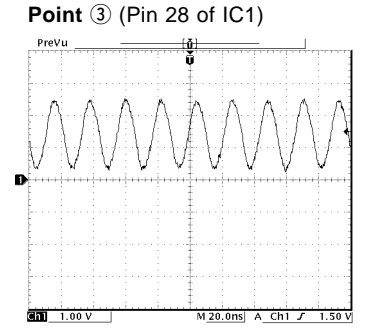
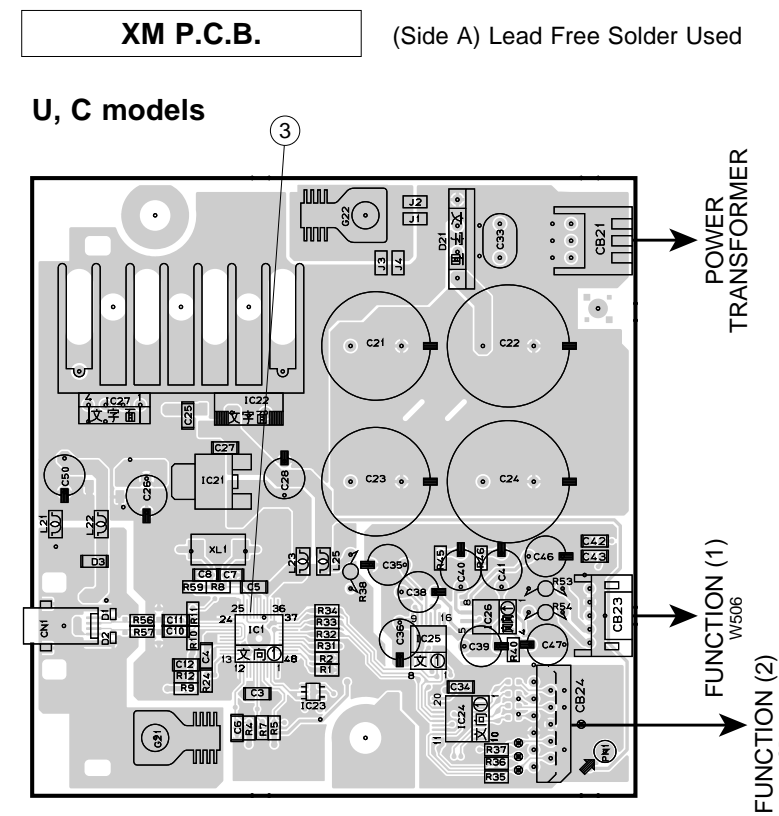

**MAIN (4)**

Circuit No.	R	L
CB293, 294	O	X
F291	O	X
J291	X	O

X: NOT USED  
O: USED/APPLICABLE

**VOLTAGE SELECTOR**  
SW291

240V	1-2/5-6
220V	2-3/6-7
110V	3-4/7-8
120V	4-5/8-1

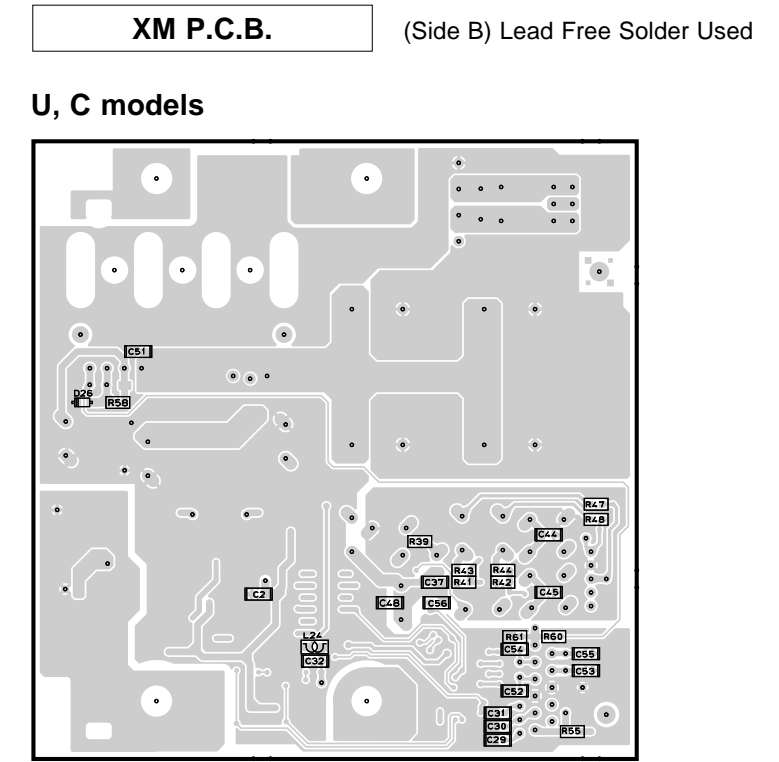

1  
2  
3  
4  
5  
6

■ BLOCK DIAGRAM

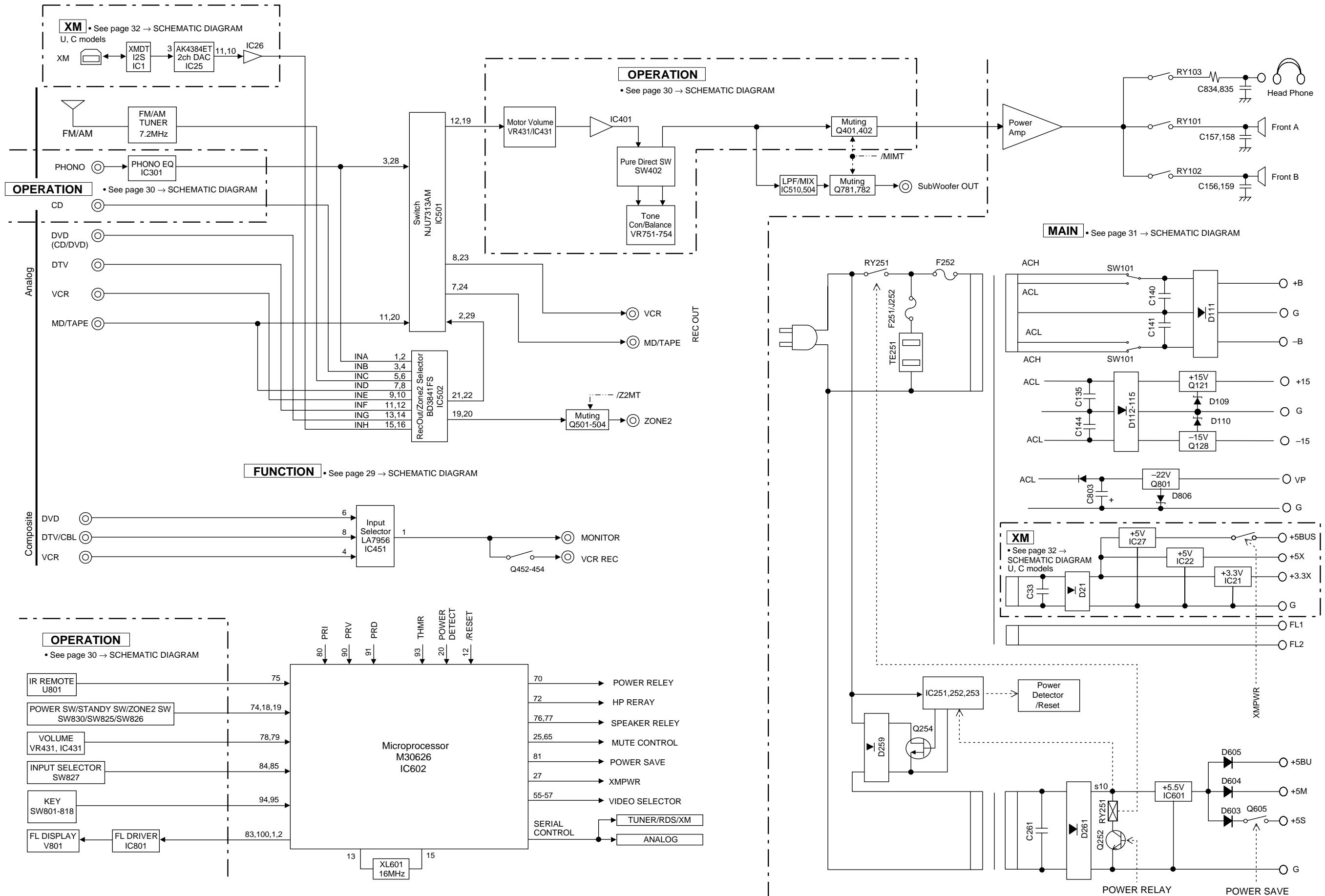

SCHEMATIC DIAGRAM (FUNCTION)

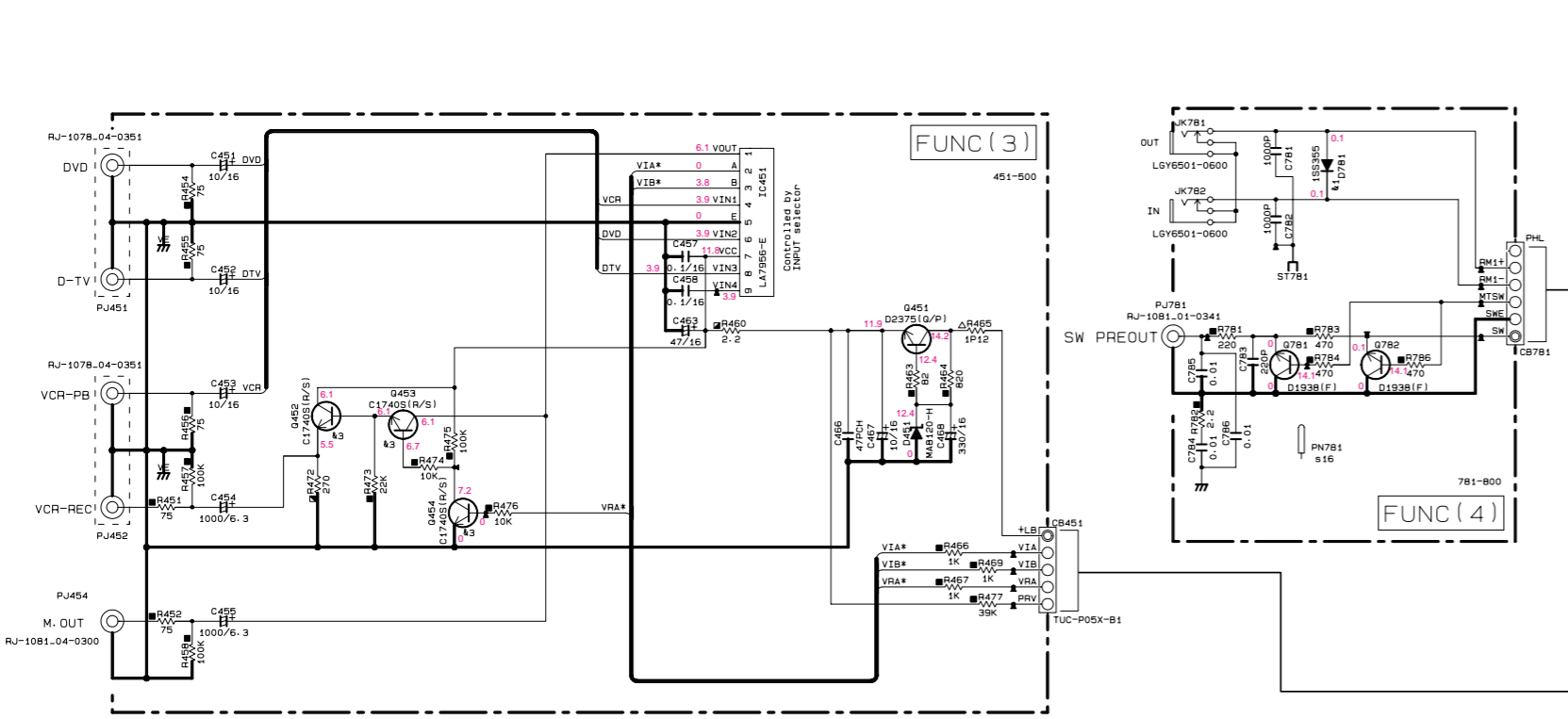

Destination Part List

SX	LOC	LC	RL	A	OE
81	R613	RD3547	RD3562	RD3572	RD3572
811	R606	WF4026	X	X	X
812	CB504	VH8920	X	X	X
813	R686	RD3510	X	X	X
814	R689	RD3515	X	X	X
815	R601	RD35715	RD35715	RD35715	RD35715
816	RN781	VH83750	X	X	X
821	IC603	X	X	X	LC72722PM-TLM-E
822	KL602	X	X	X	VH83750
823	CB30	CB32	X	X	U906177
824	CB23	CB22	X	X	U906233
825	CB29	CB29	X	X	U906256
826	CB21	CB21	X	X	U906250
827	CB28	CB27	X	X	U906177
828	R698	X	X	X	RD35510
829	R710	R711	X	X	RD35715
830	R684	X	X	X	RD3533
831	R717	X	X	X	RD35715
832	R688	X	X	X	RD35715
833	R678	X	X	X	RD3573
834	R677	X	X	X	RD35810
835	L501	X	X	X	VH8920
836	G509	X	X	X	C174518(R/S)

NOTICE (mode 1)  
 (J)..... JAPAN  
 (U)..... U.S.A  
 (C)..... CANADA  
 (R)..... GENERAL  
 (T)..... CHINA  
 (K)..... KOREA  
 (A)..... AUSTRALIA  
 (B)..... BRITISH  
 (G)..... EUROPE  
 (L)..... SINGAPORE  
 (E)..... SOUTH EUROPE  
 (V)..... TAIWAN

Interchangeable Parts at Manufacture-Stage

Mark	Reference Parts Number	Part Name
81	0604-604-007	M111
8781		K0360-RTK/P
82	0601-604-610	2S41037AK(G/R/S)
83	0452-454-609	2S01740B(R/S)
84	0506	2S41016(V)
85	0505-607	2S01815(V)
86	0506	DT144KA
87		KR1045-RTK/P
88		
89		
90		
91		
92		
93		
94		

RESISTOR

REMARKS	PARTS NAME
NO MARK	CARBON FILM RESISTOR (P=5)
□	CARBON FILM RESISTOR (P=10)
△	METAL OXIDE FILM RESISTOR
○	METAL FILM RESISTOR
◇	METAL PLATE RESISTOR
■	FIRE PROOF CARBON FILM RESISTOR
⊖	CEMENT MOLDED RESISTOR
⊕	SEMI-VARIABLE RESISTOR
⊗	CHIP RESISTOR

CAPACITOR

REMARKS	PARTS NAME
NO MARK	ELECTROLYTIC CAPACITOR
○	TANTALUM CAPACITOR
□	CERAMIC CAPACITOR
○	CERAMIC TUBULAR CAPACITOR
○	POLYESTER FILM CAPACITOR
○	POLYSTYRENE FILM CAPACITOR
○	MICA CAPACITOR
○	POLYPROPYLENE FILM CAPACITOR
○	SEMICONDUCTIVE CERAMIC CAPACITOR

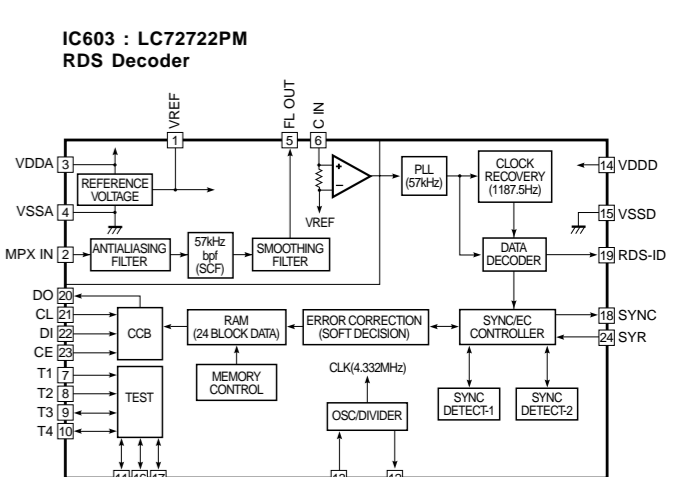
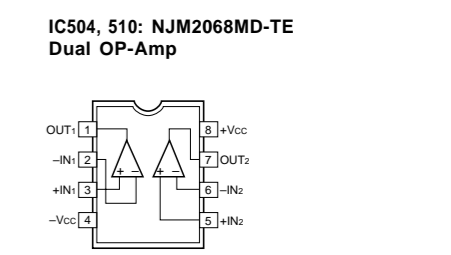
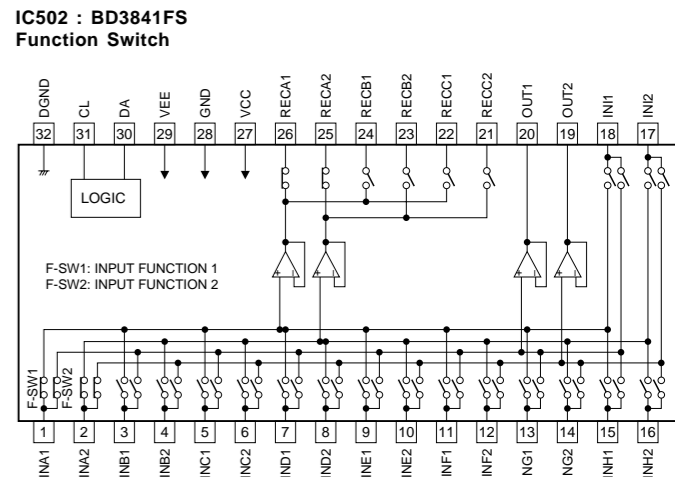
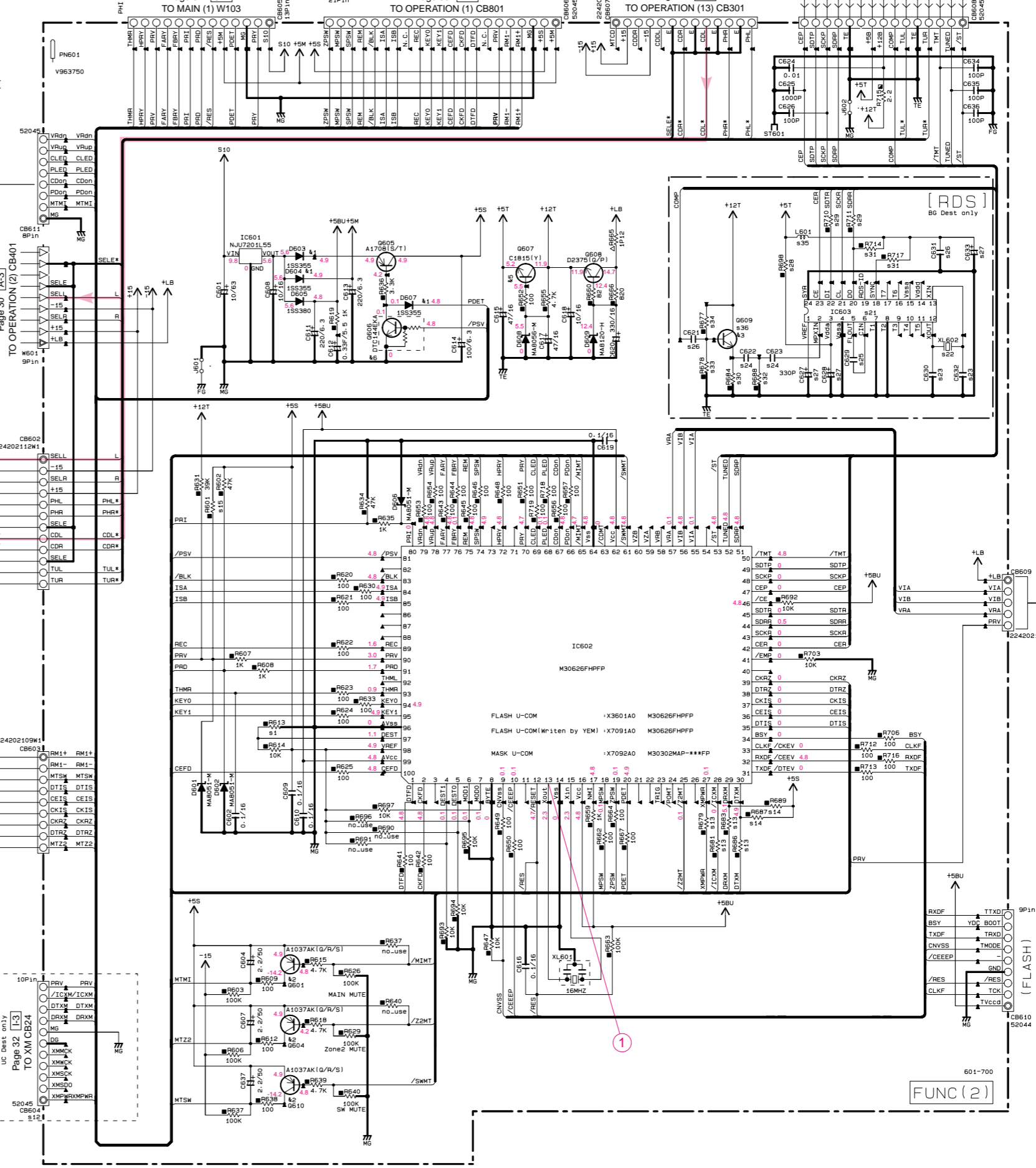
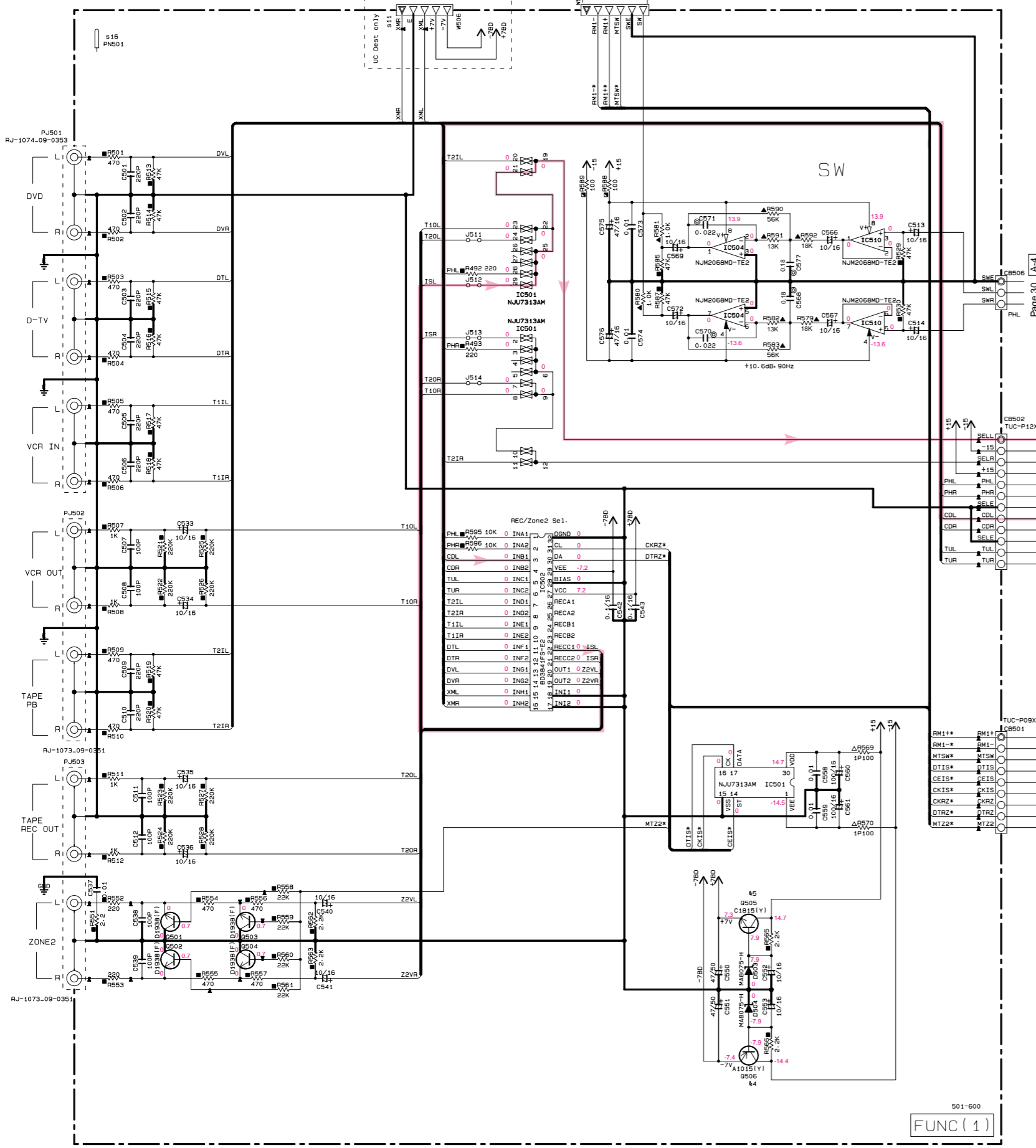
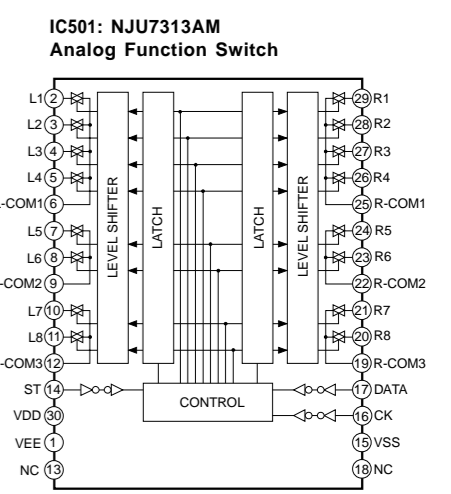
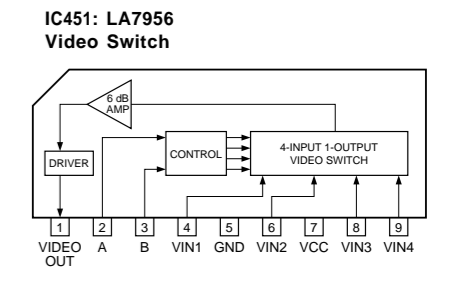

Point ① (Pin 13 of IC602)

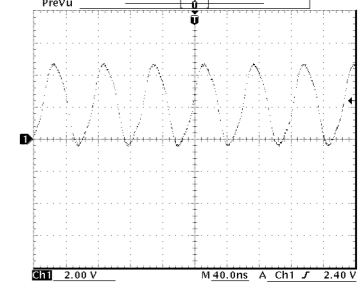

\* All voltages are measured with a 10MΩ/V DC electronic volt meter.  
 \* Components having special characteristics are marked △, and must be replaced with parts having specifications equal to those originally installed.  
 \* Schematic diagram is subject to change without notice.

SCHEMATIC DIAGRAM (OPERATION)

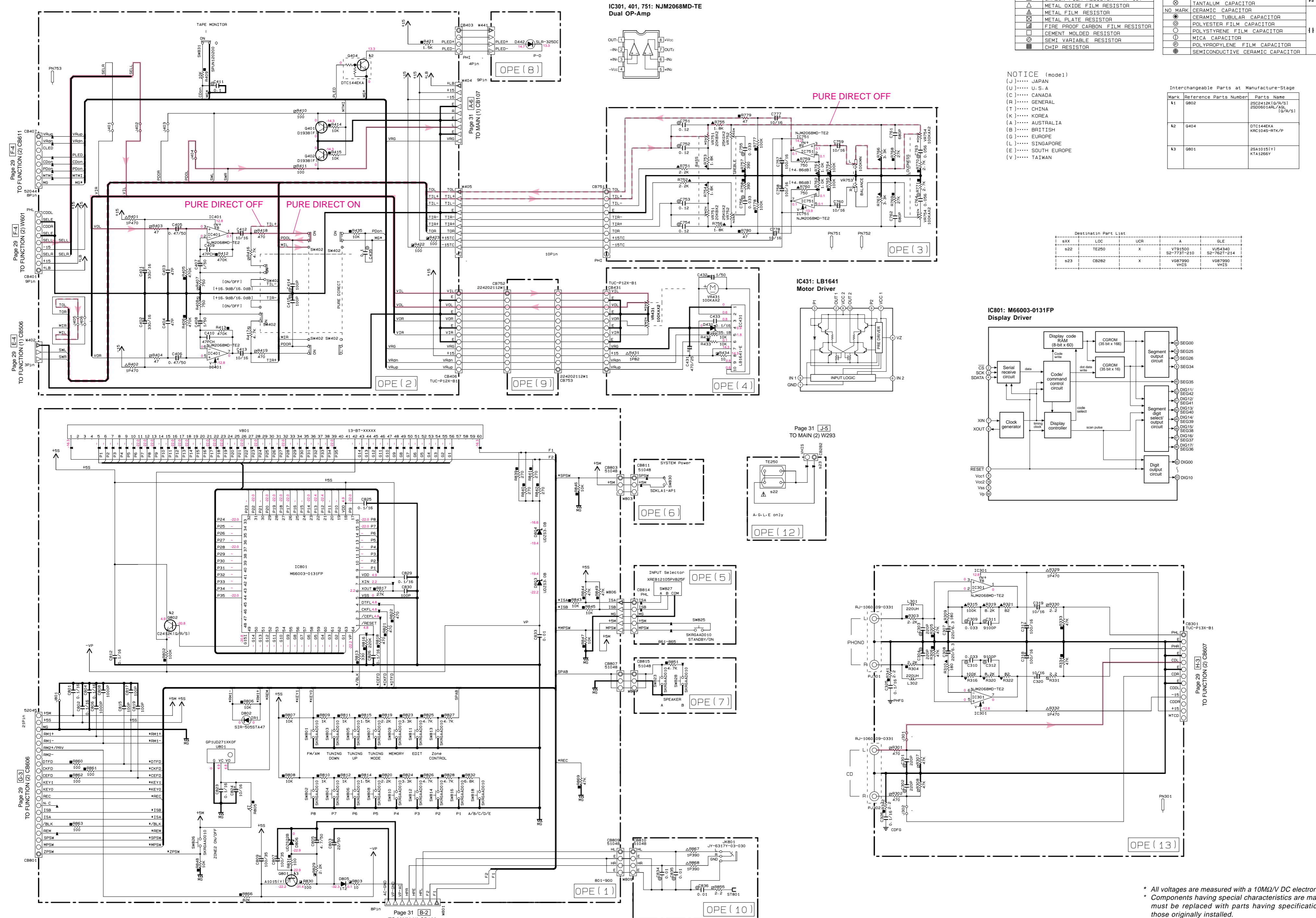

RESISTOR		CAPACITOR	
REMARKS	PARTS NAME	REMARKS	PARTS NAME
NO MARK	CARBON FILM RESISTOR (P=5)	NO MARK	ELECTROLYTIC CAPACITOR
△	CARBON FILM RESISTOR (P=10)	⊗	TANTALUM CAPACITOR
□	METAL OXIDE FILM RESISTOR	NO MARK	CERAMIC CAPACITOR
△	METAL FILM RESISTOR	⊙	CERAMIC TUBULAR CAPACITOR
□	METAL PLATE RESISTOR	⊖	POLYESTER FILM CAPACITOR
△	FIRE-PROOF CARBON FILM RESISTOR	⊕	POLYSTYRENE FILM CAPACITOR
□	CEMENT MOLDED RESISTOR	⊖	MICA CAPACITOR
⊖	SEMI-VARIABLE RESISTOR	⊕	POLYPROPYLENE FILM CAPACITOR
■	CHIP RESISTOR	⊙	SEMICONDUCTIVE CERAMIC CAPACITOR

**NOTICE (model)**  
 (J)..... JAPAN  
 (U)..... U.S.A  
 (C)..... CANADA  
 (R)..... GENERAL  
 (T)..... CHINA  
 (K)..... KOREA  
 (A)..... AUSTRALIA  
 (B)..... BRITISH  
 (G)..... EUROPE  
 (L)..... SINGAPORE  
 (E)..... SOUTH EUROPE  
 (V)..... TAIWAN

**Interchangeable Parts at Manufacture-Stage**

Mark	Reference Parts Number	Parts Name
△1	0802	25C2412K (1/4W/5% 2500601AR/L/AD 1/4W/5%)
△2	0404	DTC144EKA KRC1045-RTK/P
△3	0801	28A10151V1 KTA1266Y

Destination Part List				
sxx	LOC	UCR	A	GLE
△22	TE250	X	VT91500	VU54340
△23	CB282	X	SP-737-210	SP-7627-214
△23	CB282	X	V687990	V687990
△23	CB282	X	VHS	VHS

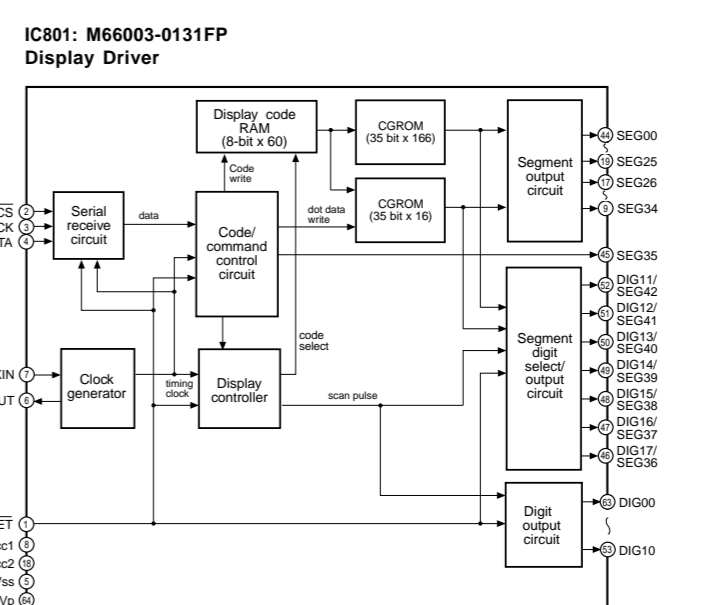

\* All voltages are measured with a 10MΩ/V DC electronic volt meter.  
 \* Components having special characteristics are marked △ and must be replaced with parts having specifications equal to those originally installed.  
 \* Schematic diagram is subject to change without notice.

SCHEMATIC DIAGRAM (MAIN)

IC102 : LM61C1Z Temperature Sensor

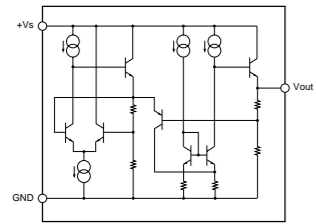

NOTICE (model)
(J)..... JAPAN
(U)..... U.S.A
(C)..... CANADA
(R)..... GENERAL
(T)..... CHINA
(K)..... KOREA
(A)..... AUSTRALIA
(B)..... BRITISH
(G)..... EUROPE
(L)..... SINGAPORE
(E)..... SOUTH EUROPE
(V)..... TAIWAN

Table with 2 columns: REMARKS and PARTS NAME. Lists various resistor types such as CARBON FILM RESISTOR, METAL OXIDE FILM RESISTOR, etc.

Table with 2 columns: REMARKS and PARTS NAME. Lists various capacitor types such as ELECTROLYTIC CAPACITOR, TANTALUM CAPACITOR, CERAMIC CAPACITOR, etc.

Large table with columns: Reference No, U-C, R, A, B, G-E, L. Contains a list of component reference numbers and their corresponding specifications.

Table titled 'Interchangeable Parts at Manufacture-Stage'. Columns: Mark, Reference Parts Number, Parts Name. Lists specific components like RV103, D132, Q254, etc.

Point 2
CH 1 : (+) of C252
CH 2 : Collector of Q251

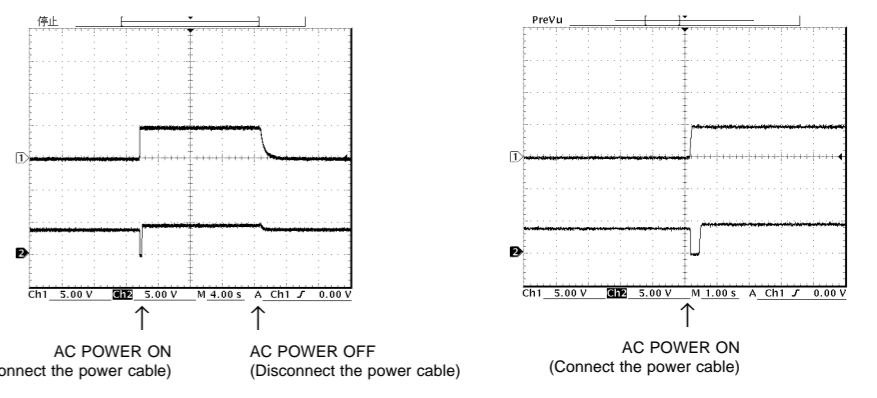

IC252 : TC4013BP Dual D Flip Flop

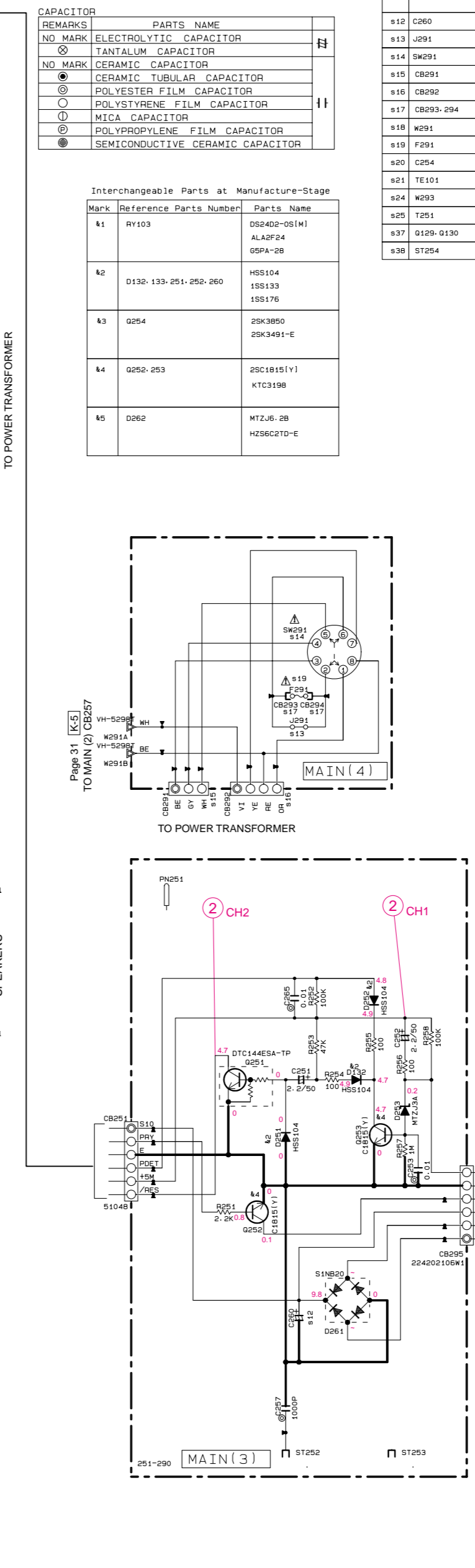
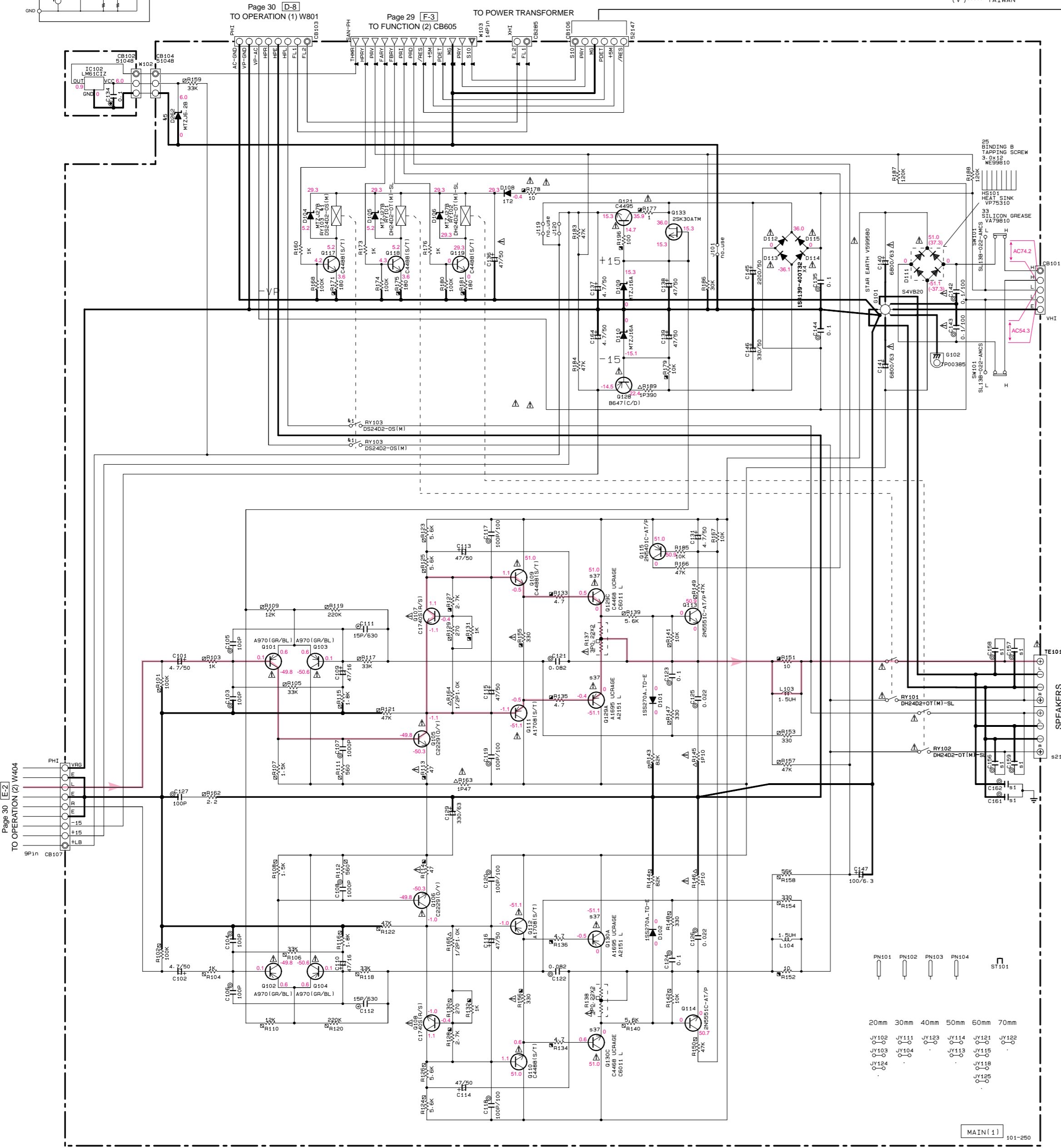
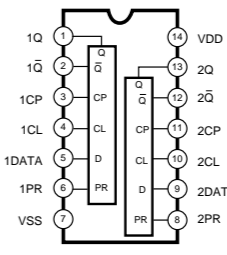

\* All voltages are measured with a 10MΩ/V DC electronic volt meter.
\* Components having special characteristics are marked Δ, and must be replaced with parts having specifications equal to those originally installed.
\* Schematic diagram is subject to change without notice.

■ SCHEMATIC DIAGRAM (XM)

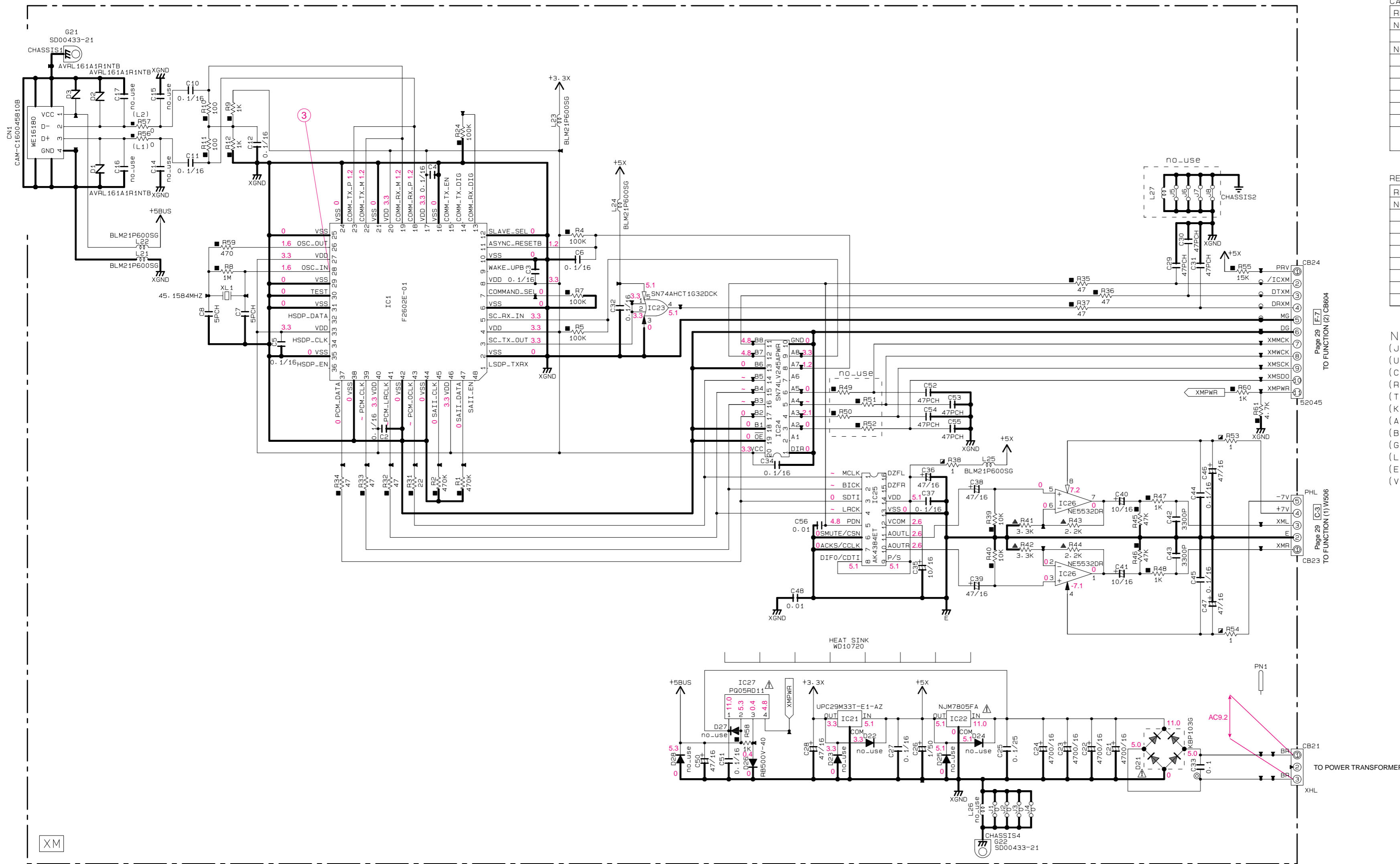

REMARKS	PARTS NAME	
NO MARK	ELECTROLYTIC CAPACITOR	#
⊗	TANTALUM CAPACITOR	
NO MARK	CERAMIC CAPACITOR	#
●	CERAMIC TUBULAR CAPACITOR	
⊙	POLYESTER FILM CAPACITOR	
○	POLYSTYRENE FILM CAPACITOR	
⊖	MICA CAPACITOR	
⊕	POLYPROPYLENE FILM CAPACITOR	
⊗	SEMICONDUCTIVE CERAMIC CAPACITOR	
⊙	POLYPHENYLENE SULFIDE FILM CAPACITOR	

REMARKS	PARTS NAME	
NO MARK	CARBON FILM RESISTOR (P=5)	
⊠	CARBON FILM RESISTOR (P=10)	
△	METAL OXIDE FILM RESISTOR	
⊠	METAL FILM RESISTOR	
⊠	METAL PLATE RESISTOR	
⊠	FIRE PROOF CARBON FILM RESISTOR	
⊠	CEMENT MOLDED RESISTOR	
⊠	SEMI VARIABLE RESISTOR	
⊠	CHIP RESISTOR	

NOTICE (model)

(J)..... JAPAN  
 (U)..... U.S.A  
 (C)..... CANADA  
 (R)..... GENERAL  
 (T)..... CHINA  
 (K)..... KOREA  
 (A)..... AUSTRALIA  
 (B)..... BRITISH  
 (G)..... EUROPE  
 (L)..... SINGAPORE  
 (E)..... SOUTH EUROPE  
 (V)..... TAIWAN

XM

IC23 : SN74AHC1G32DCKR  
Single 2 Input OR

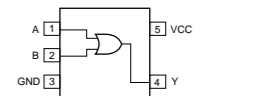

IC24 : SN74LV245APWR  
Octal 3-State Bus Transceivers

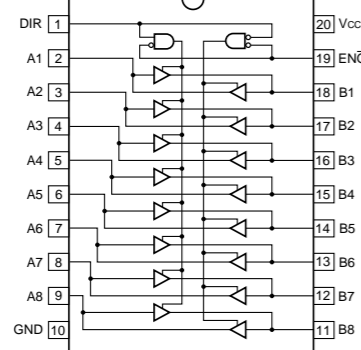

IC26 : NE5532DR  
Dual OP-Amp

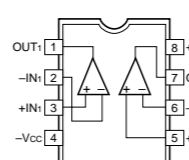

IC27 : PQ05RD11  
Regulator

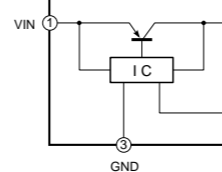

IC25 : AK4384ET  
D/A Converter

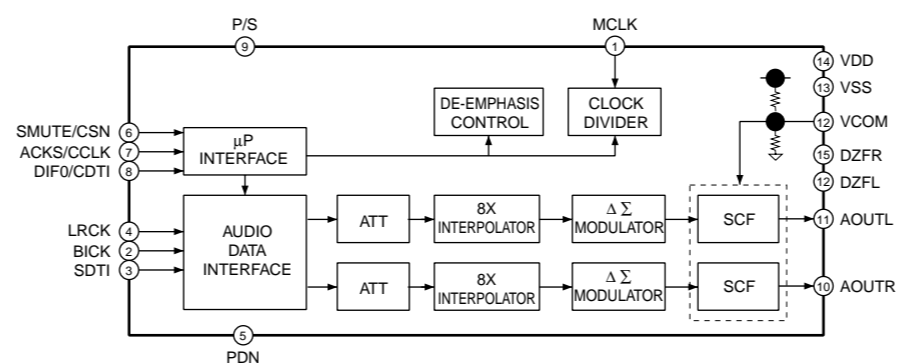

Point ③ (Pin 28 of IC1)

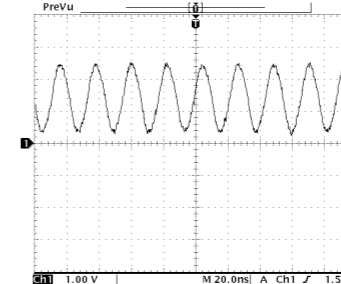

\* All voltages are measured with a 10MΩ/V DC electronic volt meter.  
 \* Components having special characteristics are marked △ and must be replaced with parts having specifications equal to those originally installed.  
 \* Schematic diagram is subject to change without notice.



# PARTS LIST

## ■ ELECTRICAL PARTS

### ■ WARNING

Components having special characteristics are marked  $\triangle$  and must be replaced with parts having specifications equal to those originally installed.

### ABBREVIATIONS IN THIS LIST ARE AS FOLLOWS :

C.A.EL.CHP	: CHIP ALUMI. ELECTROLYTIC CAP	L.EMIT	: LIGHT EMITTING MODULE
C.CE	: CERAMIC CAP	LED.DSPLY	: LED DISPLAY
C.CE.ARRAY	: CERAMIC CAP ARRAY	LED.INFRD	: LED, INFRARED
C.CE.CHP	: CHIP CERAMIC CAP	MODUL.RF	: MODULATOR, RF
C.CE.ML	: MULTILAYER CERAMIC CAP	PHOT.CPL	: PHOTO COUPLER
C.CE.M.CHP	: CHIP MULTILAYER CERAMIC CAP	PHOT.INTR	: PHOTO INTERRUPTER
C.CE.SAFTY	: RECOGNIZED CERAMIC CAP	PHOT.RFLCT	: PHOTO REFLECTOR
C.CE.TUBLR	: CERAMIC TUBULAR CAP	PIN.TEST	: PIN, TEST POINT
C.CE.SMI	: SEMI CONDUCTIVE CERAMIC CAP	PLST.RIVET	: PLASTIC RIVET
C.EL	: ELECTROLYTIC CAP	R.ARRAY	: RESISTOR ARRAY
C.MICA	: MICA CAP	R.CAR	: CARBON RESISTOR
C.ML.FLM	: MULTILAYER FILM CAP	R.CAR.CHP	: CHIP RESISTOR
C.MP	: METALLIZED PAPER CAP	R.CAR.FP	: FLAME PROOF CARBON RESISTOR
C.MYLAR	: MYLAR FILM CAP	R.CEMENT	: CEMENT RESISTOR
C.MYLAR.ML	: MULTILAYER MYLAR FILM CAP	R.FUS	: FUSABLE RESISTOR
C.PAPER	: PAPER CAPACITOR	R.MTL.CHP	: CHIP METAL FILM RESISTOR
C.PLS	: POLYSTYRENE FILM CAP	R.MTL.FLM	: METAL FILM RESISTOR
C.POL	: POLYESTER FILM CAP	R.MTL.OXD	: METAL OXIDE FILM RESISTOR
C.POLY	: POLYETHYLENE FILM CAP	R.MTL.PLAT	: METAL PLATE RESISTOR
C.PP	: POLYPROPYLENE FILM CAP	RSNR.CE	: CERAMIC RESONATOR
C.TNTL	: TANTALUM CAP	RSNR.CRYS	: CRYSTAL RESONATOR
C.TNTL.CHP	: CHIP TANTALUM CAP	R.TW.CEM	: TWIN CEMENT FIXED RESISTOR
C.TRIM	: TRIMMER CAP	SCR.BND.HD	: BIND HEAD B-TITE SCREW
CN	: CONNECTOR	SCR.BW.HD	: BW HEAD TAPPING SCREW
CN.BS.PIN	: CONNECTOR, BASE PIN	SCR.CUP	: CUP TITE SCREW
CN.CANNON	: CONNECTOR, CANNON	SCR.TERM	: SCREW TERMINAL
CN.DIN	: CONNECTOR, DIN	SCR.TR	: SCREW, TRANSISTOR
CN.FLAT	: CONNECTOR, FLAT CABLE	SUPRT.PCB	: SUPPORT, P.C.B.
CN.POST	: CONNECTOR, BASE POST	SURG.PRTCT	: SURGE PROTECTOR
COIL.MX.AM	: COIL, AM MIX	SW.TACT	: TACT SWITCH
COIL.AT.FM	: COIL, FM ANTENNA	SW.LEAF	: LEAF SWITCH
COIL.DT.FM	: COIL, FM DETECT	SW.LEVER	: LEVER SWITCH
COIL.MX.FM	: COIL, FM MIX	SW.MICRO	: MICRO SWITCH
COIL.OUTPT	: OUTPUT COIL	SW.PUSH	: PUSH SWITCH
DIOD.ARRAY	: DIODE ARRAY	SW.RT.ENC	: ROTARY ENCODER
DIODE.BRG	: DIODE BRIDGE	SW.RT.MTR	: ROTARY SWITCH WITH MOTOR
DIODE.CHP	: CHIP DIODE	SW.RT	: ROTARY SWITCH
DIODE.SHOT	: SCHOTTKY BARRIER DIODE	SW.SLIDE	: SLIDE SWITCH
DIODE.VAR	: VARACTOR DIODE	TERM.SP	: SPEAKER TERMINAL
DIOD.Z.CHP	: CHIP ZENER DIODE	TERM.WRAP	: WRAPPING TERMINAL
DIODE.ZENR	: ZENER DIODE	THRMST.CHP	: CHIP THERMISTOR
DSCR.CE	: CERAMIC DISCRIMINATOR	TR.CHP	: CHIP TRANSISTOR
FER.BEAD	: FERRITE BEADS	TR.DGT	: DIGITAL TRANSISTOR
FER.CORE	: FERRITE CORE	TR.DGT.CHP	: CHIP DIGITAL TRANSISTOR
FET.CHP	: CHIP FET	TRANS	: TRANSFORMER
FL.DSPLY	: FLUORESCENT DISPLAY	TRANS.PULS	: PULSE TRANSFORMER
FLTR.CE	: CERAMIC FILTER	TRANS.PWR	: POWER TRANSFORMER ASS'y
FLTR.COMB	: COMB FILTER MODULE	TUNER.AM	: TUNER PACK, AM
FLTR.LC.RF	: LC FILTER, EMI	TUNER.FM	: TUNER PACK, FM
GND.MTL	: GROUND PLATE	TUNER.PK	: FRONT-END TUNER PACK
GND.TERM	: GROUND TERMINAL	VR	: ROTARY POTENTIOMETER
HOLDER.FUS	: FUSE HOLDER	VR.MTR	: POTENTIOMETER WITH MOTOR
IC.PRTCT	: IC PROTECTOR	VR.SW	: POTENTIOMETER WITH ROTARY SW
JUMPER.CN	: JUMPER CONNECTOR	VR.SLIDE	: SLIDE POTENTIOMETER
JUMPER.TST	: JUMPER, TEST POINT	VR.TRIM	: TRIMMER POTENTIOMETER
L.DTCT	: LIGHT DETECTING MODULE		

**Note)** Those parts marked with “#” are not included in the P.C.B. ass'y.

<b>P.C.B. FUNCTION</b>
------------------------

Ref No.	Part No.	Description	Market
*	WG053700	P.C.B.	FUNNCTION UC
*	WG053800	P.C.B.	FUNNCTION RL
*	WG053900	P.C.B.	FUNNCTION A
*	WG054000	P.C.B.	FUNNCTION GE
CB451	V7827200	SOCKET	5P TE TUC SERIES
CB501	V7827600	SOCKET	9P SE TUC SERIES
CB502	V7827900	SOCKET	12P TE TUC SERIES
CB506	VB858200	CN.BS.PIN	3P
CB602	V7826200	CN	12P TE TUC SERIES
CB603	V7825900	CN	9P TE TUC SERIES
CB604	VM859500	CN.BS.PIN	11P UC
CB605	VF283100	CN.BS.PIN	13P
CB606	VQ047600	CN.BS.PIN	21P
CB607	V7826300	CN	13P TE TUC SERIES
CB608	VM859600	CN.BS.PIN	15P
CB609	V7825500	CN	5P TE TUC SERIES
CB610	VQ044400	CN.BS.PIN	9P
CB611	VP682200	CN.BS.PIN	8P
CB781	VB858500	CN.BS.PIN	6P
C451-453	UR837100	C.EL	10uF 16V
C454-455	UR819100	C.EL	1000uF 6.3V
C457-458	US135100	C.CE.CHP	0.1uF 16V
C463	UR837470	C.EL	47uF 16V
C466	US061470	C.CE.CHP	47pF 50V B
C467	UR837100	C.EL	10uF 16V
C468	UR838330	C.EL	330uF 16V
C501-506	US062220	C.CE.CHP	220pF 50V B
C507-508	US062100	C.CE.CHP	100pF 50V B
C509-510	US062220	C.CE.CHP	220pF 50V B
C511-512	US062100	C.CE.CHP	100pF 50V B
C513-514	UR837100	C.EL	10uF 16V
C533-536	UR837100	C.EL	10uF 16V
C537	US064100	C.CE.CHP	0.01uF 50V B
C538-539	US062100	C.CE.CHP	100pF 50V B
C540-541	UR837100	C.EL	10uF 16V
C542-543	US135100	C.CE.CHP	0.1uF 16V
C550-551	UR867470	C.EL	47uF 50V
C552-553	UR837100	C.EL	10uF 16V
C558-559	US064100	C.CE.CHP	0.01uF 50V B
C560-561	UR838100	C.EL	100uF 16V
C566-567	UR837100	C.EL	10uF 16V
C568	UA655180	C.MYLAR	0.18uF 50V J
C569	UR837100	C.EL	10uF 16V
C570-571	UA654220	C.MYLAR	0.022uF 50V J
C572	UR837100	C.EL	10uF 16V
C573-574	US064100	C.CE.CHP	0.01uF 50V B
C575-576	UR837470	C.EL	47uF 16V
C577	UA655180	C.MYLAR	0.18uF 50V J
C601	UR877100	C.EL	10uF 63V
C602	US135100	C.CE.CHP	0.1uF 16V
C604	UR866220	C.EL	2.2uF 50V
C607	UR866220	C.EL	2.2uF 50V
C608	UR837100	C.EL	10uF 16V

\* New Parts

Ref No.	Part No.	Description	Market
C609-610	US135100	C.CE.CHP	0.1uF 16V
C611	UR818220	C.EL	220uF 6.3V
C612	WB165500	C.EL	0.33F 5.5V
C613	UR818220	C.EL	220uF 6.3V
C614	UR818100	C.EL	100uF 6.3V
C615	UR837470	C.EL	47uF 16V
C616	US135100	C.CE.CHP	0.1uF 16V
C617	UR837470	C.EL	47uF 16V
C618	UR837100	C.EL	10uF 16V
C619	US135100	C.CE.CHP	0.1uF 16V
C620	UR838330	C.EL	330uF 16V
C621	US135100	C.CE.CHP	0.1uF 16V
C622-623	US062330	C.CE.CHP	330pF 50V B
C624	US064100	C.CE.CHP	0.01uF 50V B
C625	US063100	C.CE.CHP	1000pF 50V B
C626	US062100	C.CE.CHP	100pF 50V B
C627-628	UR837470	C.EL	47uF 16V
C629	US062560	C.CE.CHP	560pF 50V B
C630	US061270	C.CE.CHP	27pF 50V B
C631	US135100	C.CE.CHP	0.1uF 16V
C632	US061270	C.CE.CHP	27pF 50V B
C633	UR837470	C.EL	47uF 16V
C634-636	US062100	C.CE.CHP	100pF 50V B
C637	UR866220	C.EL	2.2uF 50V
C781-782	US063100	C.CE.CHP	1000pF 50V B
C783	US062220	C.CE.CHP	220pF 50V B
C784-786	US064100	C.CE.CHP	0.01uF 50V B
D451	VU996300	DIODE.ZENR	MA8120-H 12.3V
D503-504	VU994300	DIODE.ZENR	MA8075-H 7.7V
D601-602	VU992600	DIODE.ZENR	MA8051-M 5.1V
D603-604	VT332900	DIODE	1SS355
D605	VV833200	DIODE	1SS380
D606	VU992600	DIODE.ZENR	MA8051-M 5.1V
D607	VT332900	DIODE	1SS355
D608	VU993000	DIODE.ZENR	MA8056-M 5.6V
D609	VU996300	DIODE.ZENR	MA8120-H 12.3V
D781	VT332900	DIODE	1SS355
IC451	XH436A00	IC	LA7956
IC501	X5043A00	IC	NJU7313AM
IC502	X3547A00	IC	BD3841FS
IC504	X3505A00	IC	NJM2068MD-TE2
IC510	X3505A00	IC	NJM2068MD-TE2
IC601	X5041A00	IC	NJU7201L55 5.5V
* IC602	X7092A00	IC.CPU	CPU MASK ROM
IC603	X0082A00	IC	LC72722PM
JK781-782	VJ726800	JACK.MNI	LGY6501-0600C
PJ451-452	WD195500	JACK.PIN	RJ-1078_04-0351A
* PJ454	WD195700	JACK.PIN	1P
* PJ501	WD195400	JACK.PIN	6P
PJ502-503	WD195200	JACK.PIN	4P
* PJ781	WD195600	JACK.PIN	1P
PN501	V9637500	PIN	L=70 #18
PN601	V9637500	PIN	L=70 #18

\* New Parts

<b>P.C.B. FUNCTION &amp; OPERATION</b>
--

Ref No.	Part No.	Description	Market
PN781	V9637500	PIN	L=70 #18 UC
Q451	VS826900	TR	2SD2375 Q,P
Q452-454	iC174020	TR	2SC1740S QRS
Q501-504	VZ725900	TR	2SD1938F S,T
Q505	iC181510	TR	2SC1815 Y
Q506	iA101510	TR	2SA1015 Y
Q601	VV556500	TR	2SA1037K Q,R,S
Q604	VV556500	TR	2SA1037K Q,R,S
Q605	VP872600	TR	2SA1708 S,T
Q606	VV655700	TR.DGT	DTC144EKA
Q607	iC181510	TR	2SC1815 Y
Q608	VS826900	TR	2SD2375 Q,P
Q609	iC174020	TR	2SC1740S QRS
Q610	VV556500	TR	2SA1037K Q,R,S
Q781-782	VZ725900	TR	2SD1938F S,T
R460	HV753220	R.CAR.FP	2.2 1/4W
R465	VY893200	R.MTL.OXD	12 1W
R472	HV755270	R.CAR.FP	270 1/4W
R569-570	VP940400	R.MTL.OXD	100 1W
R588-589	HV755100	R.CAR.FP	100 1/4W
R601		R.CHP	15K 1/16W J RLAG
R613		R.CHP	4.7K 1/16W J UC
R613		R.CHP	8.2K 1/16W J RL
R613		R.CHP	12K 1/16W J A
R613		R.CHP	22K 1/16W J GE
R665	VY893200	R.MTL.OXD	12 1W
R677		R.CHP	100K 1/16W J GE
R678		R.CHP	33K 1/16W J GE
R679		R.CHP	100 1/16W J UC
R681		R.CHP	100 1/16W J UC
R683		R.CHP	100 1/16W J UC
R684		R.CHP	3.3K 1/16W J GE
R686		R.CHP	100 1/16W J UC
R687		R.CHP	1.5K 1/16W J UC
R688		R.CHP	22K 1/16W J GE
R689		R.CHP	1.5K 1/16W J UC
R698		R.CHP	100 1/16W J GE
R710-711		R.CHP	470 1/16W J GE
R714		R.CHP	10K 1/16W J GE
R715	HV753220	R.CAR.FP	2.2 1/4W
R717		R.CHP	10K 1/16W J GE
ST601	V4040500	SCR.TERM	M3
ST781	V4040500	SCR.TERM	M3
XL601	WA674700	RSNR.CE	16MHz CSTLS16MOX51
XL602	V3930900	RSNR.CRYS	4.332MHz GE
*	WG054600	P.C.B.	OPERATION UCR
*	WG054700	P.C.B.	OPERATION A
*	WG054800	P.C.B.	OPERATION GEL
CB282	VG879900	CN.BS.PIN	2P AGEL
CB282	VG879900	CN.BS.PIN	2P

\* New Parts

Ref No.	Part No.	Description	Market
CB301	V7828000	SOCKET	13P SE TUC SERIES
CB401	VB858800	CN.BS.PIN	9P
CB403	VB390000	CN.BS.PIN	4P
CB406	V7827900	SOCKET	12P TE TUC SERIES
CB407	VP682300	CN.BS.PIN	8P
CB431	V7827900	SOCKET	12P TE TUC SERIES
CB751	VB390600	CN.BS.PIN	10P
CB752-753	V7826200	CN	12P TE TUC SERIES
CB801	VQ047600	CN.BS.PIN	21P
CB814	VB858400	CN.BS.PIN	5P
C301-304	UA652220	C.MYLAR	220pF 50V J
C307-308	UU318220	C.EL	220uF 6.3V
C309-310	UA654330	C.MYLAR	0.033uF 50V J
C311-312	UA653910	C.MYLAR	9100pF 50V J
C317-318	UU338100	C.EL	100uF 16V
C319-320	UU337100	C.EL	10uF 16V
C325-326	US135100	C.CE.CHP	0.1uF 16V
C401-402	UU338330	C.EL	330uF 16V
C403-404	FG651470	C.CE	47pF 50V
C405-406	UU365470	C.EL	0.47uF 50V
* C407-408	UU366100	C.EL	1uF 50V
C409-410	US061470	C.CE.CHP	47pF 50V B
C411	UA655100	C.MYLAR	0.1uF 50V J
C412-413	UU337100	C.EL	10uF 16V
C414-415	UA652100	C.MYLAR	100pF 50V J
C431	UR848470	C.EL	470uF 25V
C432	UN866100	C.EL	1uF 50V
C433	US135100	C.CE.CHP	0.1uF 16V
C435	UA655100	C.MYLAR	0.1uF 50V J
C751-754	UA655120	C.MYLAR	0.12uF 50V J
C755-756	UA654330	C.MYLAR	0.033uF 50V J
C757-758	UU338100	C.EL	100uF 16V
C759-760	UU337100	C.EL	10uF 16V
C761-762	US062680	C.CE.CHP	680pF 50V B
C763-764	UA654560	C.MYLAR	0.056uF 50V J
C777-778	UU337100	C.EL	10uF 16V
C801-802	US135100	C.CE.CHP	0.1uF 16V
C803	UR867220	C.EL	22uF 50V
C804	US135100	C.CE.CHP	0.1uF 16V
C805	UR066470	C.EL	4.7uF 50V
C806	US063100	C.CE.CHP	1000pF 50V B
C807	UR058100	C.EL	100uF 35V
C808	US063100	C.CE.CHP	1000pF 50V B
C809	UR858100	C.EL	100uF 35V
C812	US135100	C.CE.CHP	0.1uF 16V
C815	US062100	C.CE.CHP	100pF 50V B
C817	US062100	C.CE.CHP	100pF 50V B
C819	US062100	C.CE.CHP	100pF 50V B
C823	US135100	C.CE.CHP	0.1uF 16V
C824	UM397100	C.EL	10uF 16V
C825-826	US135100	C.CE.CHP	0.1uF 16V
C829	US135100	C.CE.CHP	0.1uF 16V
C830	US062100	C.CE.CHP	100pF 50V B

\* New Parts

**P.C.B. OPERATION & MAIN**

Ref No.	Part No.	Description	Market
C833	US064100	C.CE.CHP	0.01uF 50V B
C834-836	UA654100	C.MYLAR	0.01uF 50V J
D431	VU171900	DIODE.ZENR	UDZ5.1B 5.1V
D442	VR711500	LED(or)	SLR-325DC
D802	V2598200	LED	SIR-505ST
* D803-804	VU171300	DIODE.ZENR	UDZS3.0BTE-17 3.0V
D805	VS997800	DIODE	1T2
* D806	VU173400	DIODE.ZENR	UDZS22B TE-17 22V
IC301	X3505A00	IC	NJM2068MD-TE2
IC401	X3505A00	IC	NJM2068MD-TE2
IC431	XF494A00	IC	LB1641
IC751	X3505A00	IC	NJM2068MD-TE2
IC801	X6386A00	IC	M66003-0131FP
JK801	V4478300	JACK.PHONE	JY-6317Y-03-030
* PJ301-302	WD195100	JACK.PIN	2P
PN301	V9637500	PIN	L=70 #18
PN751-753	V9637500	PIN	L=70 #18
Q401-402	VZ725900	TR	2SD1938F S,T
Q404	VV655700	TR.DGT	DTC144EKA
Q801	iA101510	TR	2SA1015 Y
Q802	VV556400	TR	2SC2412K Q,R,S
R329	VP940800	R.MTL.OXD	470 1W
* R330-331	HC653220	R.CAR	2.2 1/4 J AX TP
R332	VP940800	R.MTL.OXD	470 1W
R401-402	VP940800	R.MTL.OXD	470 1W
R422-423	HV755100	R.CAR.FP	100 1/4W
R431	VS267200	R.MTL.OXD	82 1W
R434	HV754100	R.CAR.FP	10 1/4W
R803	HV754100	R.CAR.FP	10 1/4W
R829	HV756220	R.CAR.FP	2.2K 1/4W
R830	HV755100	R.CAR.FP	100 1/4W
R867-868	VP944500	R.MTL.OXD	390 1W
ST801	V4040500	SCR.TERM	M3
SW402	VV399800	SW.PUSH	SPUN12
SW801-814	WD483100	SW.TACT	SKRGAAD010
SW816	WD483100	SW.TACT	SKRGAAD010
SW818	WD483100	SW.TACT	SKRGAAD010
SW823	WD483100	SW.TACT	SKRGAAD010
SW825-826	WD483100	SW.TACT	SKRGAAD010
SW827	V9266400	SW.RT.ENC	XREB12105PVB25F
SW828	WD483100	SW.TACT	SKRGAAD010
SW830	V4466400	SW.PUSH	SDKLA1-AP1 TV-5
SW831	V3573100	SW.PUSH	SPUN120200
△ TE250	VT915000	OUTLET.AC	1P
△ TE250	VU543400	OUTLET.AC	2P
U801	V8210200	L.DTCT	GP1UD271XK
* V801	WF519900	FL.DSPLY	
VR431	VR710500	VR.MTR	A100K
VR751	VP741800	VR	B20K
VR752	VP741900	VR	G25K
VR753	VP742000	VR	MN100K
VR754	WF774500	VR	A100K
*	WG083700	SHEET	

\* New Parts

Ref No.	Part No.	Description	Market
	VR380100	SPACER	FL-T6
*	WG052200	P.C.B.	MAIN
*	WG052300	P.C.B.	MAIN
*	WG052400	P.C.B.	MAIN
*	WG052500	P.C.B.	MAIN
*	WG052600	P.C.B.	MAIN
CB101	LB932050	CN.BS.PIN	5P
CB103	VB390400	CN.BS.PIN	8P
CB106	VF728300	CN	6P
CB107	VB390500	CN.BS.PIN	9P
△ CB252	VG879900	CN.BS.PIN	2P
CB253-254	WC050700	CLIP.FUSE	EYF-52BCY
CB255-256	WC050700	CLIP.FUSE	EYF-52BCY
△ CB257	VG879900	CN.BS.PIN	2P
CB285	LB918020	CN.BS.PIN	2P
* CB291	V9377800	CN.BS.PIN	3P SE VH SERIES
* CB292	V9377900	CN.BS.PIN	4P SE VH SERIES
CB293-294	WC050700	CLIP.FUSE	EYF-52BCY
CB295	V7825600	CN	6P TE TUC SERIES
CB296	V7827300	SOCKET	6P TE TUC SERIES
C101-102	UR866470	C.EL	4.7uF 50V
C103-106	UA652100	C.MYLAR	100pF 50V J
C107-108	UA653100	C.MYLAR	1000pF 50V J
C109-110	UR837470	C.EL	47uF 16V
C111-112	WE100100	C.PP	15pF 630V
C113-114	UR867470	C.EL	47uF 50V
C115-116	UU367470	C.EL	47uF 50V
C117-120	VR325000	C.MYLAR	100pF 100V
C121-122	UA654820	C.MYLAR	0.082uF 50V J
C123-124	UA655100	C.MYLAR	0.1uF 50V J
C125-126	UA654220	C.MYLAR	0.022uF 50V J
C127	UA652100	C.MYLAR	100pF 50V J
C129	UR778330	C.EL	330uF 63V
C131	UR866470	C.EL	4.7uF 50V
C134	VJ599100	C.CE.TUBLR	0.1uF 50V
C135	UA655100	C.MYLAR	0.1uF 50V J
△ C136	UR867470	C.EL	47uF 50V
C137	UR866470	C.EL	4.7uF 50V
C138-139	UR867470	C.EL	47uF 50V
△ * C140-141	WG399600	C.EL	6800uF 63V
△ C142-143	VR324900	C.MYLAR	0.1uF 100V
C144	UA655100	C.MYLAR	0.1uF 50V J
C145	UR769220	C.EL	2200uF 50V
C146	UR868330	C.EL	330uF 50V
C147	UR818100	C.EL	100uF 6.3V
C156-159	UA654100	C.MYLAR	0.01uF 50V J
C161-162	UA654100	C.MYLAR	0.01uF 50V J
C164	UR866470	C.EL	4.7uF 50V
C251-252	UR866220	C.EL	2.2uF 50V
C253	UA654100	C.MYLAR	0.01uF 50V J

\* New Parts

RX-497

## P.C.B. MAIN

Ref No.	Part No.	Description	Market	Ref No.	Part No.	Description	Market		
* C254	WD054200	C. POL. MTL	0.047uF 630V	UC	△ Q129C	WD281100	TR	2SC6011 0,P,Y	L
C254	WC041600	C. PP	0.022uF 630V	RAGEL	△ Q130A	iX630850	TR	2SA1695 0,P,Y	UCRAGE
C255	UM416100	C. EL	1uF 50V		△ Q130C	iX630860	TR	2SC4468 0,P,Y	UCRAGE
C256	UA653470	C. MYLAR	4700pF 50V J		△ Q130A	WD281000	TR	2SA2151 0,P,Y	L
C257	UA653100	C. MYLAR	1000pF 50V J		△ Q130C	WD281100	TR	2SC6011 0,P,Y	L
C258	WB696300	C. POL. MTL	0.1uF 400V	UC	* Q133	WF730900	FET	2SK30ATM GR TP	
C258	WF081500	C. PP	0.047uF 630V J	RAGEL	Q251	VV912300	TR. DGT	DTC144ESA-TP	
C258	WF081500	C. PP	0.047uF 630V J		Q252-253	iC181510	TR	2SC1815 Y	
△ C259	V6185300	C. CE. SAFTY	0.01uF 275V		△ Q254	WC741200	FET	2SK3850	
C260	UR039330	C. EL	3300uF 16V	UCRAGEL	△ R113-114	HV754470	R. CAR. FP	47 1/4W	
C261	WE102900	C. PP	0.01uF 100V		△ R127-128	HV756270	R. CAR. FP	2.7K 1/4W	
C265	UA654100	C. MYLAR	0.01uF 50V J		R131-132	HV756100	R. CAR. FP	1K 1/4W	
D101-102	VN008700	DIODE	1SS270A		R133-136	HV753470	R. CAR. FP	4.7 1/4W	
D104-106	VG442900	DIODE. ZENR	MTZJ27B 27V		△ R137-138	V3873200	R. CEMENT	0.22 3W	
D108	VS997800	DIODE	1T2		△ R145-146	VP939800	R. MTL. OXD	10 1W	
D109-110	VG441000	DIODE. ZENR	MTZJ16A 16V		R151-152	HV754100	R. CAR. FP	10 1/4W	
△ D111	iH001090	DIODE. BRG	S4VB20 2.6A 200V		△ R155-156	HV755330	R. CAR. FP	330 1/4W	
△ D112-115	VU264100	DIODE	1SR139,400		△ R163	VP940200	R. MTL. OXD	47 1W	
D132-133	VD631600	DIODE	1SS133,176		R164-165	HLO06100	R. MTL. OXD	1K 1/2W	
D251-252	VD631600	DIODE	1SS133,176		R171	HV755180	R. CAR. FP	180 1/4W	
D253	VG435800	DIODE. ZENR	MTZJ3.0A 3.0V		R175	HV755180	R. CAR. FP	180 1/4W	
D254	VG438300	DIODE. ZENR	MTZJ6.8B 6.8V		△ R177	HV753100	R. CAR. FP	1 1/4W	
D255	VG439500	DIODE. ZENR	MTZJ10B 10V		△ R178	HV754100	R. CAR. FP	10 1/4W	
D258	VG439200	DIODE. ZENR	MTZJ9.1B 9.1V		R179	HV757100	R. CAR. FP	10K 1/4W	
△ D259	V4756800	DIODE	S1NB60 1.0A 600V		R181	HV755180	R. CAR. FP	180 1/4W	
D260	VD631600	DIODE	1SS133,176		R189	VP944500	R. MTL. OXD	390 1W	
D261	VR253700	DIODE. BRG	S1NB20 1A 200V		R196	HV755100	R. CAR. FP	100 1/4W	
D262	VG438000	DIODE. ZENR	MTZJ6.2B 6.2V		△ RY101-102	V6322600	RELAY	DC DH24D2-OT(M) -SL	
△ F251	WG410700	FUSE	8A 125V	UC	RY103	V5966300	RELAY	DS24D2-OS(M)	
△ F251	VT942900	FUSE	T2.5A 250V	GE	△ RY251	WE513800	RELAY	DC HRM3H-DC12V	
△ F252	WG410700	FUSE	8A 125V	UCR	ST101	V4040500	SCR. TERM	M3	
△ F252	KB000790	FUSE	T4A 250V	AGEL	ST251-253	V4040500	SCR. TERM	M3	
△ F291	KB000790	FUSE	T4A 250V	RL	ST254	V4040500	SCR. TERM	M3	AGEL
G101	V5995800	PLATE. GND			SW101	V4104200	SW. SLIDE	SL13B-022-AMCS	
IC102	X0515A00	IC	LM61C1Z THERMAL		△ * SW291	WB493700	VOLT. SELECT	R8140246	R
△ IC251	V8100500	PHOT. CPL	TLP421 GR		△ SW291	WD073700	VOLT. SELECT	R8140254	L
△ IC252	iG001180	IC	TC4013BP FF		△ * T251	XW606A00	TRANS. PWR		UC
△ IC253	V8100500	PHOT. CPL	TLP421 GR		△ T251	X6351A00	TRANS. PWR		R
PN101-104	V9637500	PIN	L=70 #18		△ * T251	XW608A00	TRANS. PWR		AGEL
PN251	V9637500	PIN	L=70 #18		△ TE101	VC313700	TERM. SP	8P	UCRA
△ Q101-104	iA097030	TR	2SA970 GR, BL		△ TE101	V4811400	TERM. SP	8P	GEL
△ Q105-106	VR325600	TR	2SC2229 0, Y		△ TE251	VU543100	OUTLET. AC	2P	UC
△ Q107-108	iC174020	TR	2SC1740S QRS		△ TE251	V5867400	OUTLET. AC	2P AC-182-GB-11V	R
△ Q109-110	VP872700	TR	2SC4488 S, T		* WE998100	SCR. BND. HD	3x12 MFZN2B3		
△ Q111-112	VP872600	TR	2SA1708 S, T						
Q113-114	WC398400	TR	2SC2N5551C-AT						
Q115	WC397700	TR	2SA2N5401C-AT						
Q117-119	VP872700	TR	2SC4488 S, T						
△ Q121	VN996900	TR	2SC4495						
△ Q128	VR402300	TR	2SB647 C, D						
△ Q129A	iX630850	TR	2SA1695 0, P, Y	UCRAGE					
△ Q129C	iX630860	TR	2SC4468 0, P, Y	UCRAGE					
△ Q129A	WD281000	TR	2SA2151 0, P, Y	L					

\* New Parts

\* New Parts

**P.C.B. XM & CHIP RESISTORS**

Ref No.	Part No.	Description	Market
*	WG055200	P.C.B.	UC
CB21	LB919030	CN.BS.PIN	3P
CB23	VB858400	CN.BS.PIN	5P
CB24	VM859500	CN.BS.PIN	11P
C2-6	US035100	C.CE.CHP	0.1uF 16V B
C7-8	US060500	C.CE.CHP	5pF 50V B
C10-12	US035100	C.CE.CHP	0.1uF 16V B
C21-24	UR739470	C.EL	4700uF 16V
C25	US145100	C.CE.CHP	0.1uF 25V
C26	UR866100	C.EL	1uF 50V
C27	US035100	C.CE.CHP	0.1uF 16V B
C28	UR837470	C.EL	47uF 16V
C29-31	US061470	C.CE.CHP	47pF 50V B
C32	US035100	C.CE.CHP	0.1uF 16V B
C33	VE326000	C.MYLAR	0.1uF 50V
C34	US035100	C.CE.CHP	0.1uF 16V B
C35	UR837100	C.EL	10uF 16V
C36	UR837470	C.EL	47uF 16V
C37	US135100	C.CE.CHP	0.1uF 16V
C38-39	UR837470	C.EL	47uF 16V
C40-41	UR837100	C.EL	10uF 16V
C42-43	US063330	C.CE.CHP	3300pF 50V B
C44-45	US135100	C.CE.CHP	0.1uF 16V
C46-47	UR837470	C.EL	47uF 16V
C48	US064100	C.CE.CHP	0.01uF 50V B
C50	UR837470	C.EL	47uF 16V
C51	US035100	C.CE.CHP	0.1uF 16V B
C52-55	US061470	C.CE.CHP	47pF 50V B
C56	US064100	C.CE.CHP	0.01uF 50V B
* CN1	WE161800	CN	CAM-C16 4P SE
D1-3	WE674800	DIODE	AVRL161A1R1NTB
△ D21	WA653100	DIODE.BRG	KBP103G 1.0A 200V
D26	V2376600	DIODE.SHOT	RB500V-40
G21-22	WB438000	TERM.GND	M4 SD00433-21
* IC1	X6227B00	IC	F2602E-01
IC21	X6051A00	IC	UPC29M33T-E1-AZ
△ IC22	XJ607A00	IC	NJM7805FA 5V
IC23	X2080A00	IC	SN74AHCT1G32DCKR
IC24	X3693A00	IC	SN74LV245APWR TRAN
* IC25	X6231A00	IC	AK4384ET
IC26	X5482A00	IC	NE5532DR OP AMP
△ IC27	XU814A00	IC	PQ05RD11 +5V 1.0A
PN1	V9637500	PIN	L=70 #18
R38	HV753100	R.CAR.FP	1 1/4W
R53-54	HV753100	R.CAR.FP	1 1/4W
* XL1	WE436500	RSNR.CRYS	45.1584M DSX840GA
	WE774200	SCR.BND.HD	3x10 MFZN2W3

\* New Parts

Ref No.	Part No.	Description	Market
		R.CHP	0 1/16W J
		R.CHP	2.2 1/16W J
		R.CHP	22 1/16W J
		R.CHP	47 1/16W J
		R.CHP	75 1/16W J
		R.CHP	82 1/16W J
		R.CHP	100 1/16W J
		R.CHP	220 1/16W J
		R.CHP	270 1/16W J
		R.CHP	330 1/16W J
		R.CHP	390 1/16W J
		R.CHP	470 1/16W J
		R.CHP	820 1/16W J
		R.CHP	1K 1/16W J
		R.CHP	1.5K 1/16W J
		R.CHP	2.2K 1/16W J
		R.CHP	2.7K 1/16W J
		R.CHP	3.3K 1/16W J
		R.CHP	4.7K 1/16W J
		R.CHP	6.8K 1/16W J
		R.CHP	8.2K 1/16W J
		R.CHP	10K 1/16W J
		R.CHP	12K 1/16W J
		R.CHP	15K 1/16W J
		R.CHP	22K 1/16W J
		R.CHP	27K 1/16W J
		R.CHP	33K 1/16W J
		R.CHP	39K 1/16W J
		R.CHP	47K 1/16W J
		R.CHP	82K 1/16W J
		R.CHP	100K 1/16W J
		R.CHP	220K 1/16W J
		R.CHP	470K 1/16W J
		R.CHP	1M 1/16W J
		R.MTL.CHP	82 1/16W D
		R.MTL.CHP	180 1/16W D
		R.MTL.CHP	750 1/16W D
		R.MTL.CHP	1.0K 1/16W D
		R.MTL.CHP	1.8K 1/16W D
		R.MTL.CHP	2.2K 1/16W D
		R.MTL.CHP	3.3K 1/16W D
		R.MTL.CHP	8.2K 1/16W D
		R.MTL.CHP	15K 1/16W D
		R.MTL.CHP	56K 1/16W D
		R.MTL.CHP	100K 1/16W D

**NOTE**

- The chip resistor is not supplied as a replacement part.
- When a chip resistor is necessary, use the following part.  
AAX60720: CHIP RESISTOR SAMPLE BOOK

\* New Parts

RX-497

# Parts List for Carbon Resistors

Value	1/4W Type Part No.	1/6W Type Part No.	Value	1/4W Type Part No.	1/6W Type Part No.
1.0 Ω	HJ35 3100	HF85 3100	10 kΩ	HF45 7100	HF45 7100
1.8 Ω	HJ35 3180	*	11 kΩ	HF45 7110	HF45 7110
2.2 Ω	HJ35 3220	HF85 3220	12 kΩ	HJ35 7120	HF85 7120
3.3 Ω	HJ35 3330	HF85 3330	13 kΩ	HF45 7130	HF45 7130
4.7 Ω	HJ35 3470	HF85 3470	15 kΩ	HF45 7150	HF45 7150
5.6 Ω	HJ35 3560	HF85 3560	18 kΩ	HF45 7180	HF45 7180
10 Ω	HF45 4100	HF45 4100	22 kΩ	HF45 7220	HF45 7220
15 Ω	HJ35 4150	HF85 4150	24 kΩ	HF45 7240	HF45 7240
22 Ω	HF45 4220	HF45 4220	27 kΩ	HJ35 7270	HF85 7270
27 Ω	HJ35 4270	HF85 4270	30 kΩ	HF45 7300	HF45 7300
33 Ω	HF45 4330	HF45 4330	33 kΩ	HF45 7330	HF45 7330
39 Ω	HJ35 4470	HF85 4390	36 kΩ	HF45 7360	HF45 7360
47 Ω	HF45 4470	HF45 4470	39 kΩ	HF45 7390	HF45 7390
56 Ω	HF45 4560	HF45 4560	47 kΩ	HF45 7470	HF45 7470
68 Ω	HF45 4680	HF45 4680	51 kΩ	HF45 7510	HF45 7510
75 Ω	HF45 4750	HF45 4750	56 kΩ	HF45 7560	HF45 7560
82 Ω	HF45 4820	HF45 4820	62 kΩ	HF45 7620	HF45 7620
91 Ω	HF45 4910	HF45 4910	68 kΩ	HF45 7680	HF45 7680
100 Ω	HF45 5100	HF45 5100	82 kΩ	HF45 7820	HF45 7820
110 Ω	HJ35 5110	HF85 5110	91 kΩ	HF45 7910	HF45 7910
120 Ω	HF45 5120	HF45 5120	100 kΩ	HF45 8100	HF45 8100
150 Ω	HF45 5150	HF45 5150	110 kΩ	HF45 8110	HF45 8110
160 Ω	HJ35 5160	*	120 kΩ	HF45 8120	HF45 8120
180 Ω	HF45 5180	HF45 5180	150 kΩ	HF45 8150	HF45 8150
200 Ω	HF45 5200	HF45 5200	180 kΩ	HF45 8180	HF45 8180
220 Ω	HF45 5220	HF45 5220	220 kΩ	HJ35 8220	HF85 8220
270 Ω	HF45 5270	HF45 5270	270 kΩ	HF45 8270	HF45 8270
330 Ω	HF45 5330	HF45 5330	300 kΩ	HF45 8300	HF45 8300
390 Ω	HF45 5390	HF45 5390	330 kΩ	HF45 8330	HF45 8330
430 Ω	HF45 5430	HF45 5430	390 kΩ	HJ35 8390	HF85 8390
470 Ω	HF45 5470	HF45 5470	470 kΩ	HF45 8470	HF45 8470
510 Ω	HF45 5510	HF45 5510	560 kΩ	HJ35 8560	HF85 8560
560 Ω	HF45 5560	HF45 5560	680 kΩ	HJ35 8680	HF85 8680
680 Ω	HF45 5680	HF45 5680	820 kΩ	HJ35 8820	HF85 8820
820 Ω	HF45 5820	HF45 5820	1.0 MΩ	HF45 9100	HF45 9100
910 Ω	HF45 5910	HF45 5910	1.2 MΩ	HJ35 9120	*
1.0 kΩ	HF45 6100	HF45 6100	1.5 MΩ	HJ35 9150	HF85 9150
1.2 kΩ	HF45 6120	HF45 6120	1.8 MΩ	HJ35 9180	HF85 9180
1.5 kΩ	HF45 6150	HF45 6150	2.2 MΩ	HJ35 9220	HF85 9220
1.8 kΩ	HF45 6180	HF45 6180	3.3 MΩ	HJ35 9330	HF85 9330
2.0 kΩ	HJ35 6200	HF85 6200	3.9 MΩ	HJ35 9390	*
2.2 kΩ	HF45 6220	HF45 6220	4.7 MΩ	HJ35 9470	HF85 9470
2.4 kΩ	HJ35 6240	HF85 6240			
2.7 kΩ	HF45 6270	HF45 6270			
3.0 kΩ	HF45 6300	HF45 6300			
3.3 kΩ	HF45 6330	HF45 6330			
3.6 kΩ	HJ35 6360	HF85 6360			
3.9 kΩ	HF45 6390	HF45 6390			
4.7 kΩ	HF45 6470	HF45 6470			
5.1 kΩ	HF45 6510	HF45 6510			
5.6 kΩ	HF45 6560	HF45 6560			
6.8 kΩ	HF45 6680	HF45 6680			
8.2 kΩ	HF45 6820	HF45 6820			
9.1 kΩ	HF45 6910	HF45 6910			

**1/4W Type**

HJ35 ○○○○

10mm

**1/6W Type**

HF85 ○○○○

5mm

RX-497

# EXPLODED VIEW

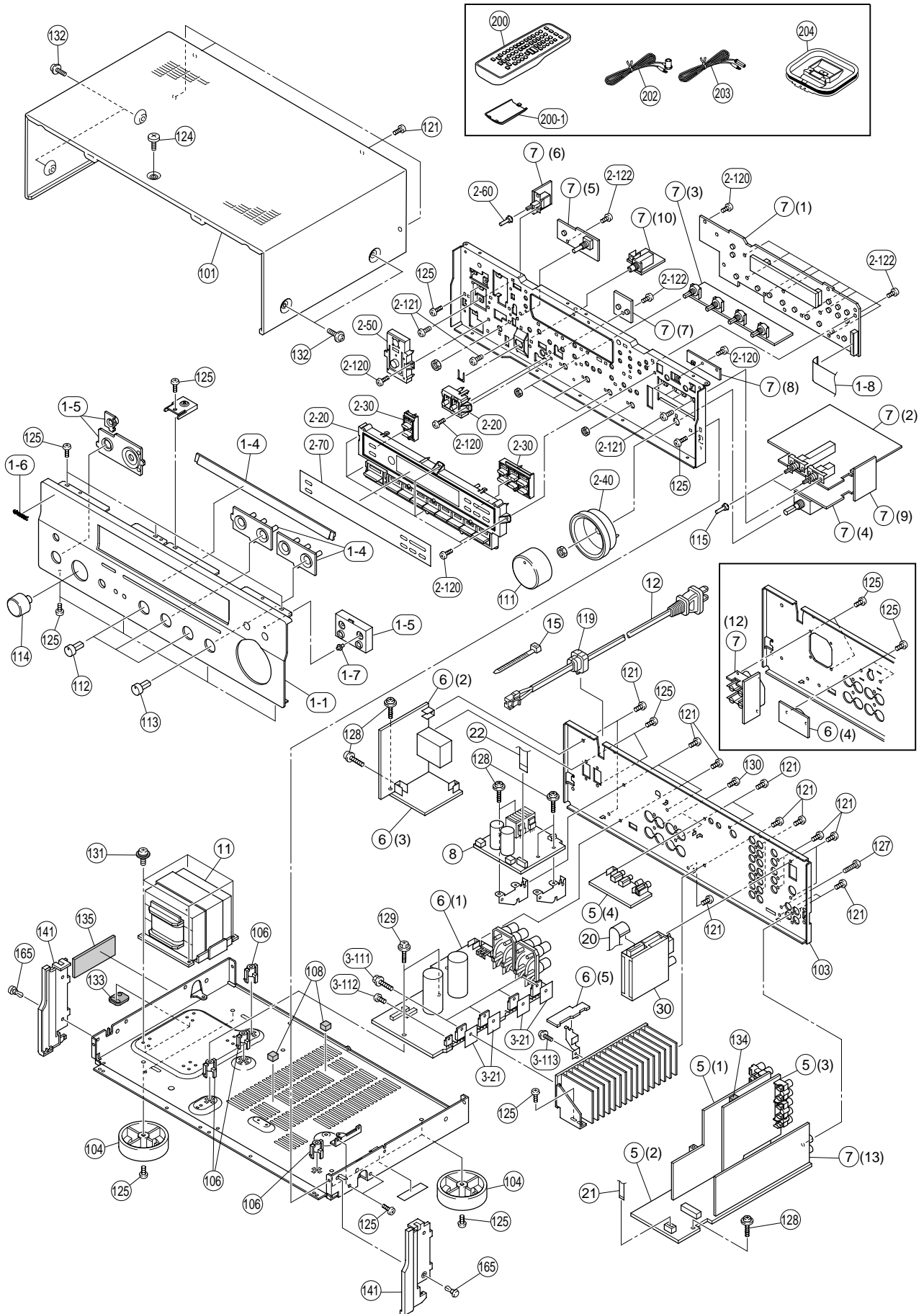



## MECHANICAL PARTS

Ref. No.	Part No.	Description	Remarks	Markets
* 1-1	WF478800	FRONT PANEL	GD	
* 1-1	WF784200	FRONT PANEL	BL	UC
* 1-1	WF478700	FRONT PANEL	BL	RAGEL
* 1-1	WF478900	FRONT PANEL	TI	
* 1-4	WF486900	ESCUTCHEON R	GD	
* 1-4	WF486800	ESCUTCHEON R	BL	
* 1-4	WF487000	ESCUTCHEON R	TI	
1-5	WF629000	ESCUTCHEON	GD	
1-5	WF628900	ESCUTCHEON	BL	
1-5	WF629100	ESCUTCHEON	TI	
1-6	V6034200	EMBLEM	GD	
1-6	V6034100	EMBLEM	BL, TI	
1-7	V4598900	LENS, 1P		
* 1-8	MF121250	FLEXIBLE FLAT CABLE	21P 250mm P=1.25	
* 2-20	WF484200	BUTTON CASE	GD	
* 2-20	WF484100	BUTTON CASE	BL	
* 2-20	WF484300	BUTTON CASE	TI	
* 2-30	WF485000	BUTTON TUNER		
2-40	WF486600	ESCUTCHEON VOL	GD	
2-40	WF486500	ESCUTCHEON VOL	BL	
2-40	WF486700	ESCUTCHEON VOL	TI	
* 2-50	WF588200	BUTTON MAIN	GD	
* 2-50	WF588000	BUTTON MAIN	BL	
* 2-50	WF588300	BUTTON MAIN	TI	
2-60	V6876200	BUTTON/D5	GD	
2-60	V6876100	BUTTON/D5	BL	
2-60	V8540300	BUTTON/D5	TI	
* 2-70	WF488100	SHEET WINDOW R		UC
* 2-70	WF488000	SHEET WINDOW R		RAGEL
2-120	WE774300	BIND HEAD B-TIGHT SCREW	3x8 MFZN2W3	
2-121	WE774000	BIND HEAD SCREW	3x6 MFZN2W3	
2-122	WE774800	BIND HEAD P-TIGHT SCREW	3x8 MFZN2W3	
3-21	VV849300	RADIATION SHEET	19x24	
3-111	VK173200	SCREW, TRANSISTOR	3x15 SP MFC2	
3-112	WE774300	BIND HEAD B-TIGHT SCREW	3x8 MFZN2W3	
3-113	VT669300	PW HEAD B-TIGHT SCREW	3x8-8 MFC2	
* 5	WG053700	P.C.B. ASS'Y	FUNNCTION	UC
* 5	WG053800	P.C.B. ASS'Y	FUNNCTION	RL
* 5	WG053900	P.C.B. ASS'Y	FUNNCTION	A
* 5	WG054000	P.C.B. ASS'Y	FUNNCTION	GE
* 6	WG052200	P.C.B. ASS'Y	MAIN	UC
* 6	WG052300	P.C.B. ASS'Y	MAIN	R
* 6	WG052400	P.C.B. ASS'Y	MAIN	A
* 6	WG052500	P.C.B. ASS'Y	MAIN	GE
* 6	WG052600	P.C.B. ASS'Y	MAIN	L
* 7	WG054600	P.C.B. ASS'Y	OPERATION	UCR
* 7	WG054700	P.C.B. ASS'Y	OPERATION	A
* 7	WG054800	P.C.B. ASS'Y	OPERATION	GEL
* 8	WG055200	P.C.B. ASS'Y	XM	UC
△* 11	X7065A00	POWER TRANSFORMER		UC
△* 11	X7066A00	POWER TRANSFORMER		RL
△* 11	X7067A00	POWER TRANSFORMER		A
△* 11	X7068A00	POWER TRANSFORMER		GE

\* New Parts

Ref. No.	Part No.	Description	Remarks	Markets	
△ *	12	V2727500	POWER CABLE 2m		UC
△ *	12	VN363600	POWER CABLE 2m		GEL
△ *	12	WC743700	POWER CABLE 2m		A
△ *	12	WC992700	POWER CABLE 2m		R
	15	VU590000	BINDING TIE CBTD001B		
	20	MF115140	FLEXIBLE FLAT CABLE 15P 140mm P=1.25		
*	21	MF108160	FLEXIBLE FLAT CABLE 8P 160mm P=1.25		
	22	MF111400	FLEXIBLE FLAT CABLE 11P 400mm P=1.25		UC
	30	V6782300	AM/FM TUNER TFCE1U115A		UCRL
*	30	V6782400	AM/FM TUNER TFCE1E317A		AGE
*	101	WF480600	TOP COVER	GD	
*	101	WF480500	TOP COVER	BL	
*	101	WF480700	TOP COVER	TI	
*	103	WF483000	REAR PANEL		UC
*	103	WF483100	REAR PANEL		R
*	103	WF483400	REAR PANEL		A
*	103	WF483500	REAR PANEL		L
*	103	WF483700	REAR PANEL		GE
	104	V0042500	LEG D60xH21	GD	
	104	VS025000	LEG D60xH21	BL, TI	
	106	VR264400	SPACER H8		
	108	VQ366100	DAMPER, PCB		
	111	WF817500	KNOB D48	GD	
	111	WF817400	KNOB D48	BL	
	111	WF817600	KNOB D48	TI	
*	112	WF485700	KNOB	GD	
*	112	WF485600	KNOB	BL	
*	112	WF485800	KNOB	TI	
*	113	WF486000	KNOB D14L	GD	
*	113	WF485900	KNOB D14L	BL	
*	113	WF486100	KNOB D14L	TI	
	114	WC560600	KNOB D23	GD	
	114	WC560500	KNOB D23	BL	
	114	WC560700	KNOB D23	TI	
	115	V6876200	BUTTON/D5	GD	
	115	V6876100	BUTTON/D5	BL	
	115	V8540300	BUTTON/D5	TI	
	119	V2438700	CORD STOPPER 10P1		
	121	WE774100	BIND HEAD BONDING B-T. SCREW 3x8 MFZN2B3		
	124	WE200400	DISH HEAD B-TIGHT SCREW 3x6 MFN133	GD, TI	
	124	WE200500	DISH HEAD B-TIGHT SCREW 3x6 MFN13BL	BL	
	125	WE774300	BIND HEAD B-TIGHT SCREW 3x8 MFZN2W3		
	127	VS997700	BIND HEAD S-TIGHT SCREW 3x10 MFN133		
	128	VT669300	PW HEAD B-TIGHT SCREW 3x8-8 MFC2		
	129	WE774600	SCREW IC 3x18 MFZN2W3		
	130	VY731200	BONDING HEAD TAPPING SCREW 3x10 MFN133		
	131	WE774700	BIND HEAD S-TIGHT SCREW 4x10 MFZN2W3		
	132	VD069600	PW HEAD S-TIGHT SCREW 4x8-10 MFN133	GD, TI	
	132	VH313200	PW HEAD S-TIGHT SCREW 4x8-10 MFN13BL	BL	
	133	VY731400	DAMPER HOLE		
	134	VZ679700	DAMPER T8/PCB		
	135	V4780900	DAMPER 4x30x50		RAGEL
	141	WF487700	PLATE SIDE	GD	

\* New Parts

Ref. No.	Part No.	Description	Remarks	Markets
141	WF487600	PLATE SIDE		
141	WF487800	PLATE SIDE	BL	
165	VQ368600	PUSH RIVET	TI	
		ACCESSORIES		
* 200	WF688700	REMOTE CONTROL	P3555-B	
* 200	WF688800	REMOTE CONTROL	RAX100	UC
			RAX101	RAGEL
200-1	AAX46580	BATTERY COVER		103RRC-244-01G
202	V6267000	INDOOR FM ANTENNA	1.4m 1pc	UCRL
203	VQ147100	INDOOR FM ANTENNA	1.4m 1pc	AGE
204	VQ307400	AM LOOP ANTENNA	81-653-645-110	
		BATTERY, MANGANESE DRY	SUM-3M 2pcs	

\* New Parts

RX-497

# REMOTE CONTROL TRANSMITTER (RAX100/RAX101)

## SCHEMATIC DIAGRAM

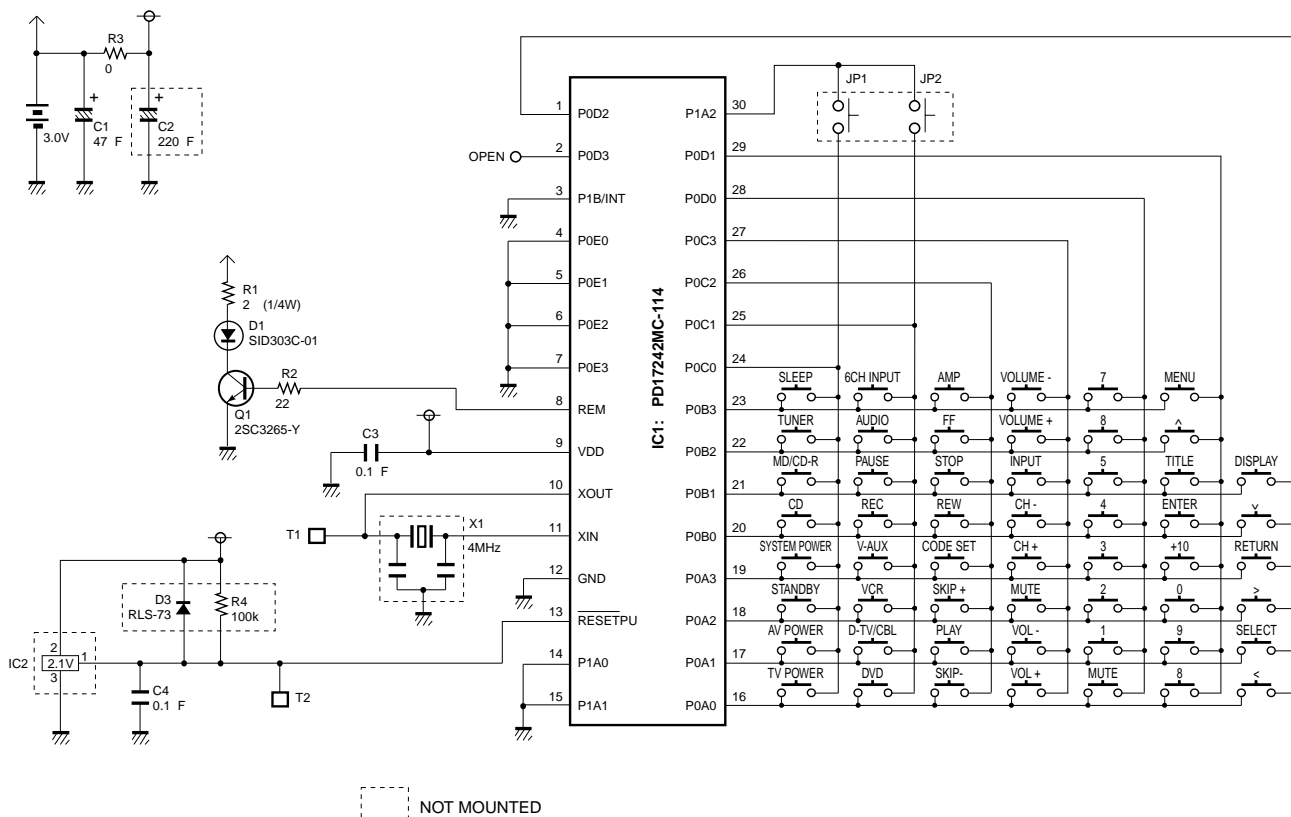

▼ RAX100 (U, C models)

▼ RAX101 (R, A, G, E, L models)

KEY NO. LAYOUT

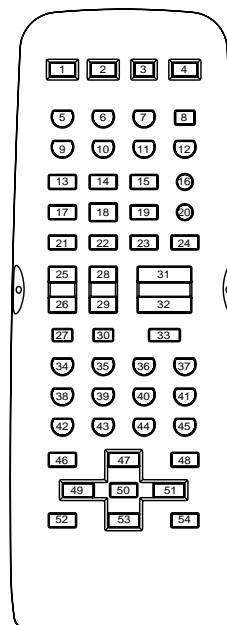
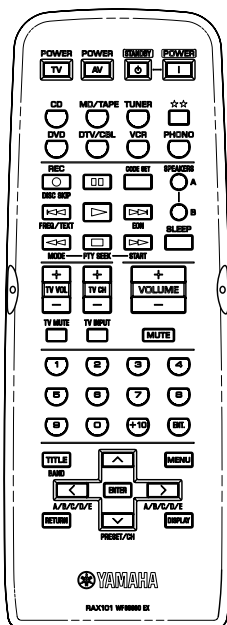
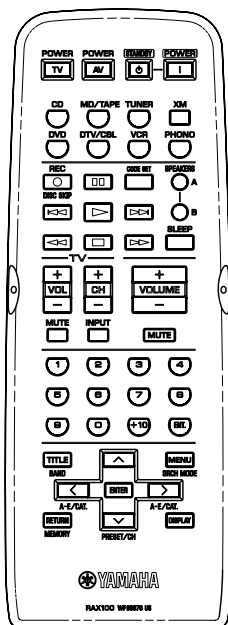

## DATA CODE LIST

Key No.	Function	CODE							
		COMMON	CD	TAPE	MD	CD-R	DVD	TUNER	XM
1	TV POWER	-	-	-	-	-	-	-	-
2	AV POWER	-	-	-	-	7F-80	7C-80	-	-
3	STANDBY	7E-7F	-	-	-	-	-	-	-
4	SYSTEM POWER	7E-7E	-	-	-	-	-	-	-
5	CD	7A-15	-	-	-	-	-	-	-
6	MD/TAPE	7A-18	-	-	-	-	-	-	-
7	TUNER	7A-16	-	-	-	-	-	-	-
8	XM ☆☆	7A-B4	-	-	-	-	-	-	-
9	DVD	7A-C1	-	-	-	-	-	-	-
10	DTV/CBL	7A-54	-	-	-	-	-	-	-
11	VCR	7A-0F	-	-	-	-	-	-	-
12	PHONO	7A-14	-	-	-	-	-	-	-
13	REC/DISC SKIP	-	7A-4F	7A-04	79-AF	-	7C-8B	-	-
14	PAUSE	-	7A-09	7A-06	79-A9	7F-83	7C-83	-	-
15	CODE SET	-	-	-	-	-	-	-	-
16	SPEAKERS A	7A-9A	-	-	-	-	-	-	-
17	SKIP -	-	7A-0B	7A-07	A9-AB	7F-86	7C-B9	7A-A4	-
18	PLAY	-	7A-08	7A-00	79-A8	7F-82	7C-82	-	-
19	SKIP +	-	7A-0A	7A-40	79-AE	7F-87	7C-BA	7A-A5	-
20	SPEAKERS B	7A-9B	-	-	-	-	-	-	-
21	REW	-	7A-OD	7A-01	79-AC	7F-88	7C-86	7A-A6	-
22	STOP	-	7A-09	7A-03	79-AA	7F-84	7C-85	-	-
23	FF	-	7A-0C	7A-02	79-AD	7F-89	7C-87	7A-A7	-
24	SLEEP	7A-57	-	-	-	-	-	-	-
25	TV VOL +	-	-	-	-	-	-	-	-
26	TV VOL -	-	-	-	-	-	-	-	-
27	TV MUTE	-	-	-	-	-	-	-	-
28	TV VH +	-	-	-	-	-	-	-	-
29	TV CH -	-	-	-	-	-	-	-	-
30	TV INPUT	-	-	-	-	-	-	-	-
31	VOL up	7A-1A	-	-	-	-	-	-	-
32	VOL down	7A-1B	-	-	-	-	-	-	-
33	MUTE	7A-1C	-	-	-	-	-	-	-
34	1	-	79-11	-	79-85	7F-91	7C-94	7A-E5	7A-61
35	2	-	79-12	-	79-86	7F-92	7C-95	7A-E6	7A-62
36	3	-	79-13	-	79-87	7F-93	7C-96	7A-E7	7A-63
37	4	-	79-14	-	79-88	7F-94	7C-97	7A-E8	7A-64
38	5	-	79-15	-	79-89	7F-95	7C-98	7A-E9	7A-65
39	6	-	79-16	-	79-8A	7F-96	7C-99	7A-EA	7A-66
40	7	-	79-17	-	79-8B	7F-97	7C-9A	7A-EB	7A-67
41	8	-	79-18	-	79-8C	7F-98	7C-9B	7A-EC	7A-68
42	9	-	79-19	-	79-8D	7F-99	7C-9C	7A-B1	7A-69
43	0	-	79-10	-	79-8E	7F-90	7C-93	7A-B2	7A-60
44	+10	-	9-1A	-	79-8F	7F-9A	7C-9D	-	-
45	ENT	-	79-0B	-	-	7F-8A	7C-9E	7A-B3	7A-8F
46	TITLE	-	-	-	-	-	7C-B1	7A-AE	7A-70
47	UP	-	-	-	-	-	7C-B4	7A-10	7A-6A
48	MENU	-	-	-	-	-	7C-B2	7A-AB	7A-6D
49	LEFT	-	-	-	-	-	7C-B5	7A-AC	7A-6E
50	SELECT	-	-	-	-	-	7C-B8	7A-AD	7A-6F
51	RIGHT	-	-	-	-	-	7C-B6	7A-12	7A-6C
52	RETURN	-	-	-	-	-	7C-B7	7A-AF	7A-71
53	DOWN	-	-	-	-	-	7C-B3	7A-11	7A-6B
54	DISPLAY	-	79-0A	-	79-A5	7F-9E	7C-A6	7A-B0	7A-72

# RX-497

---

