

1 ■ BLOCK DIAGRAMS

AUDIO Section Block Diagram

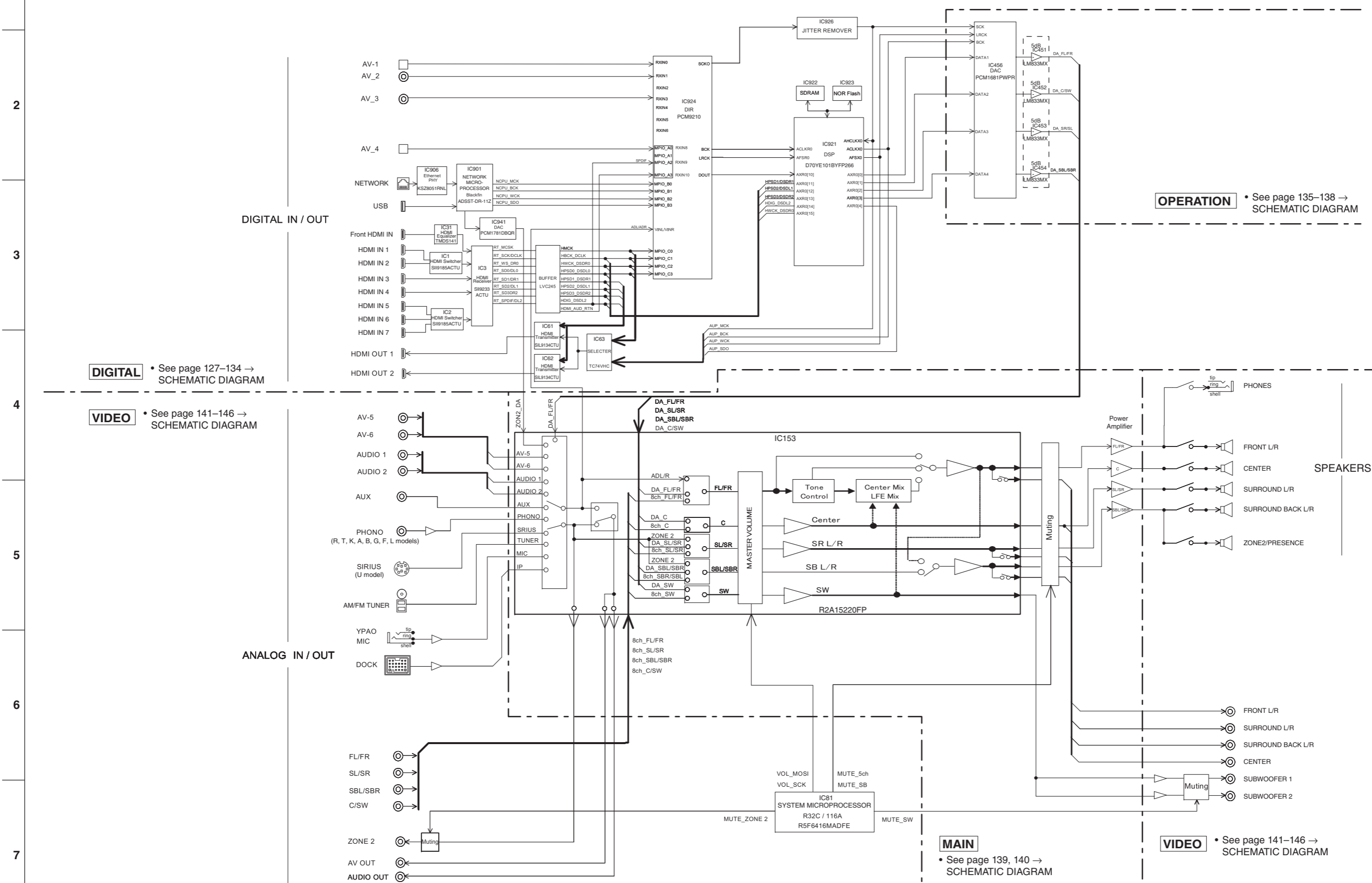

OPERATION • See page 135–138 → SCHEMATIC DIAGRAM

DIGITAL • See page 127–134 → SCHEMATIC DIAGRAM

VIDEO • See page 141–146 → SCHEMATIC DIAGRAM

MAIN • See page 139, 140 → SCHEMATIC DIAGRAM

VIDEO • See page 141–146 → SCHEMATIC DIAGRAM

DIGITAL P.C.B. Section Block Diagram

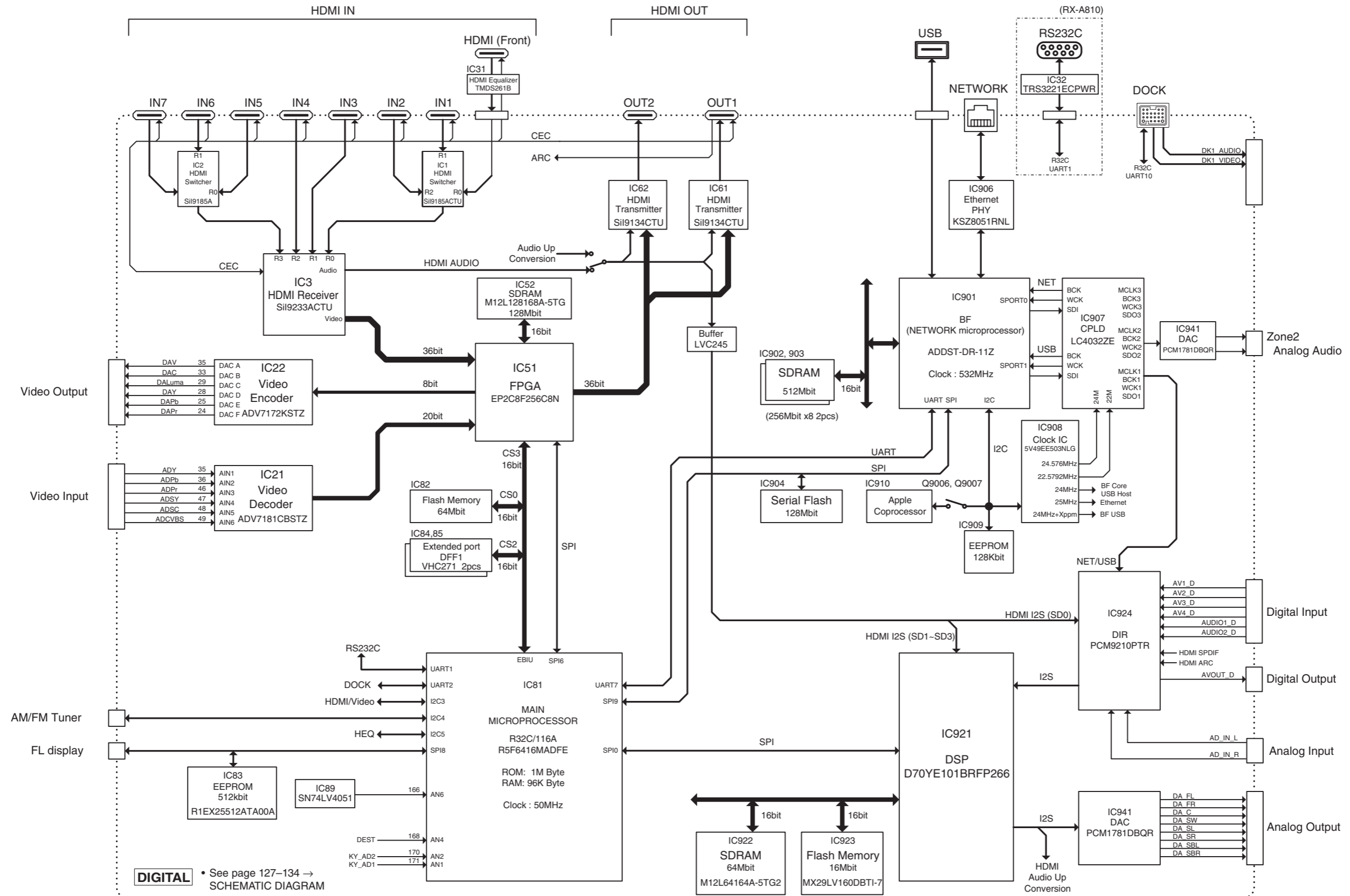

NET/USB Section Block Diagram

DIGITAL • See page 127-134 → SCHEMATIC DIAGRAM

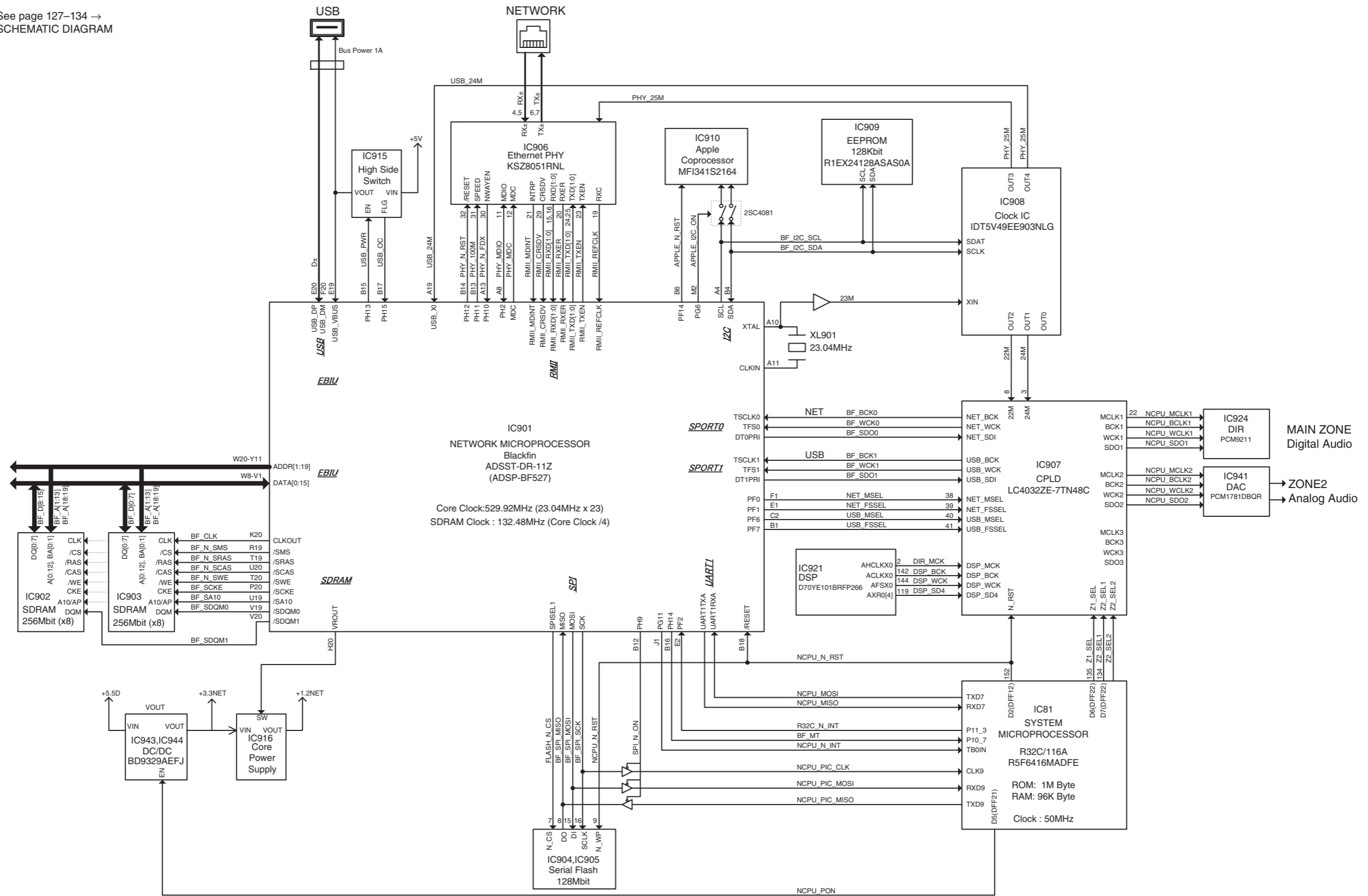

VIDEO Section Block Diagram

VIDEO • See page 141–146 → SCHEMATIC DIAGRAM

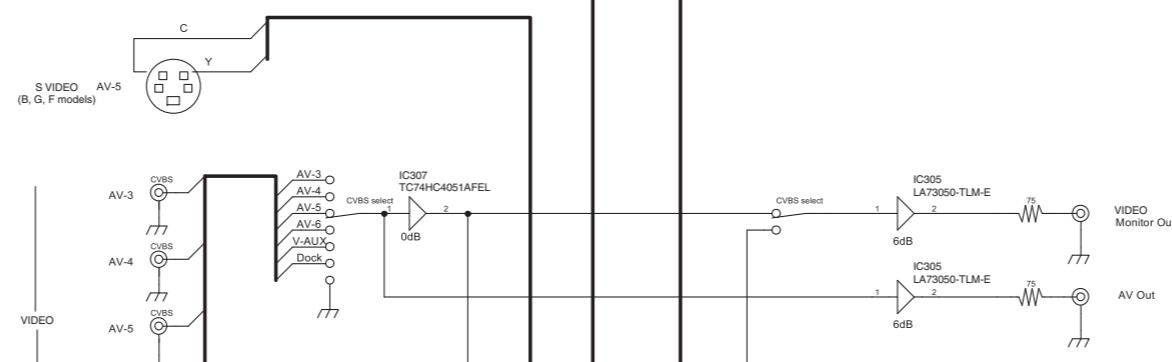
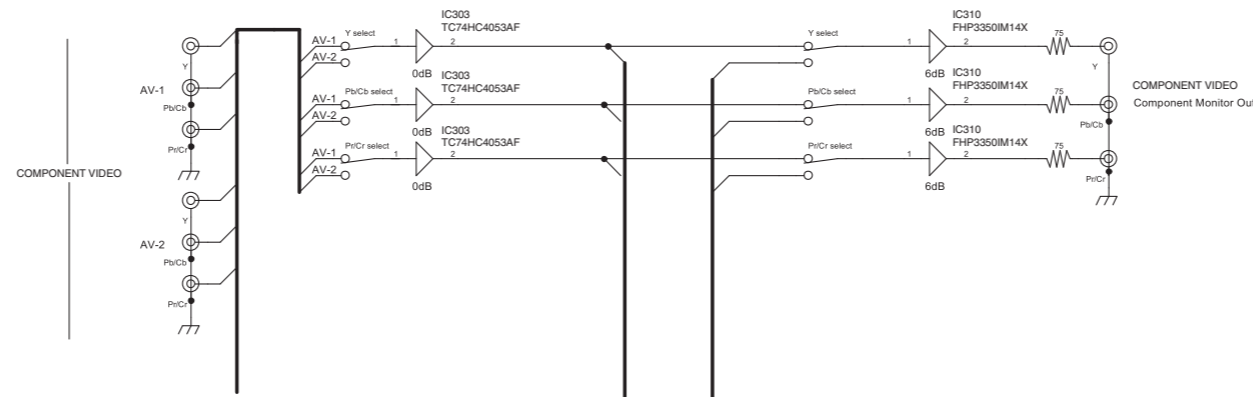

DIGITAL • See page 127–134 → SCHEMATIC DIAGRAM

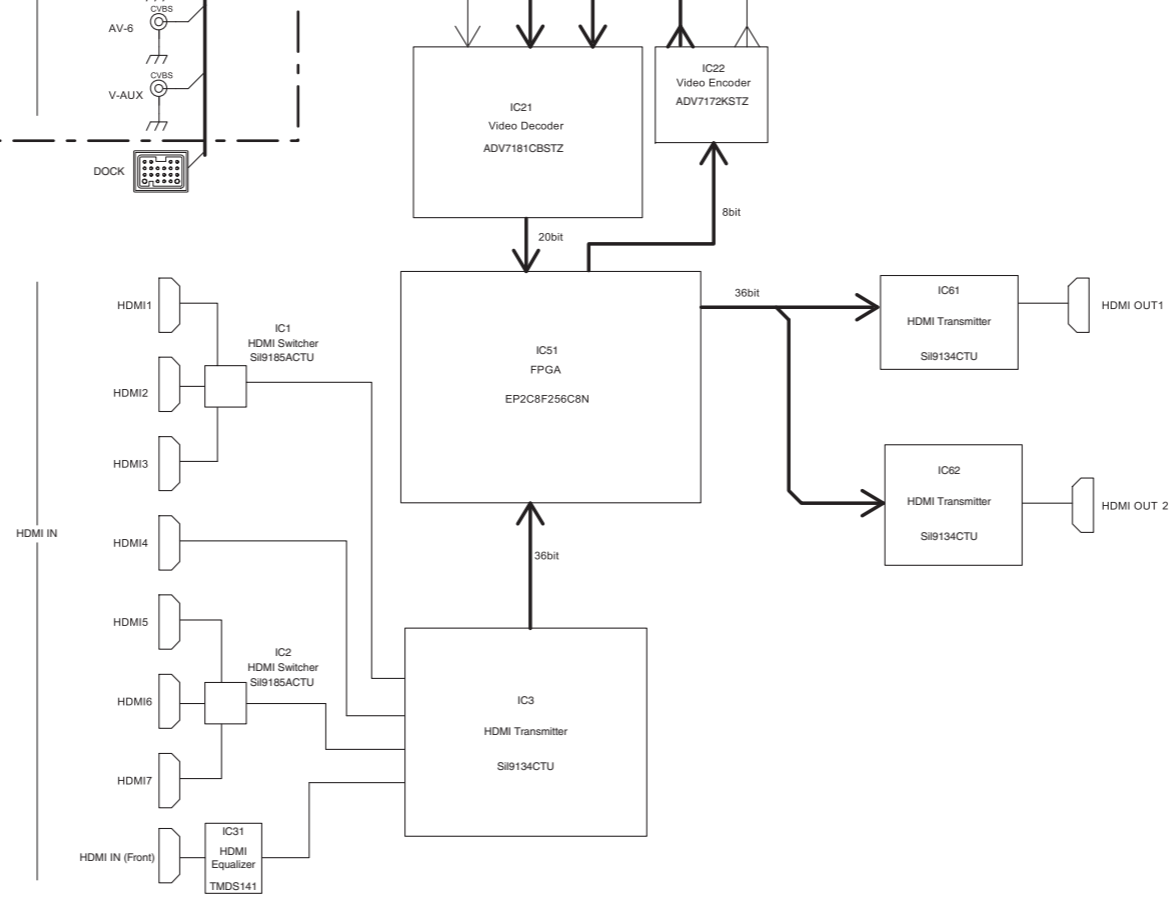

Power Supply Section Block Diagram

1
2
3
4
5
6
7

MAIN

• See page 139, 140 → SCHEMATIC DIAGRAM

VIDEO

• See page 141-146 → SCHEMATIC DIAGRAM

DIGITAL

• See page 127-134 → SCHEMATIC DIAGRAM

OPERATION

• See page 135-138 → SCHEMATIC DIAGRAM

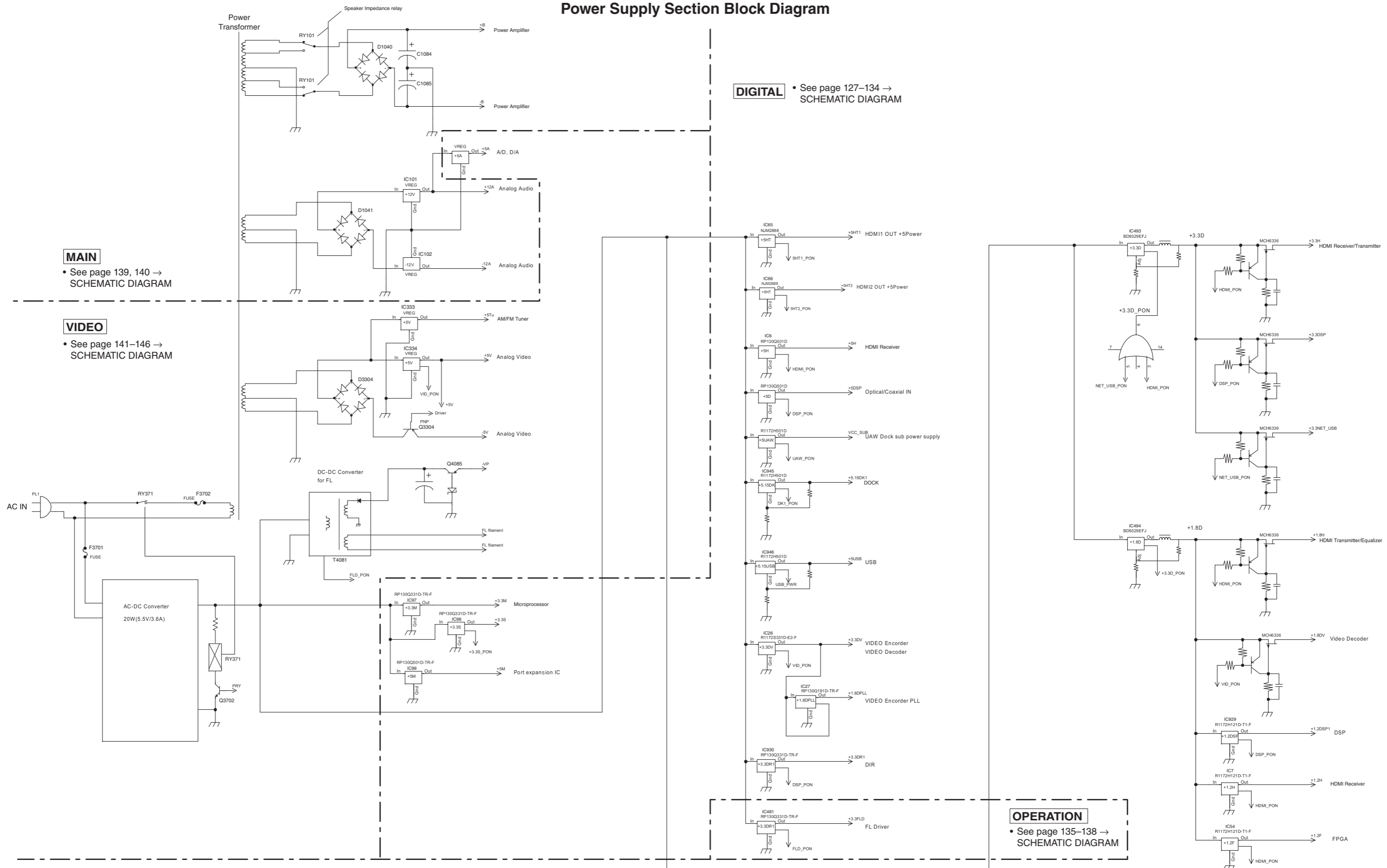

PRINTED CIRCUIT BOARDS

DIGITAL (1) (Side A)

Ref no.	Location	Ref no.	Location
IC54	G3	IC85	G5
IC61	E3	IC89	E5
IC62	E3	IC97	G5
IC63	E4	IC98	G5
IC64	E4	IC99	I4
IC66	D3	IC901	C3
IC68	D3	IC902	C3
IC81	F5	IC903	C3
IC82	F4	IC904	C3
IC84	G5	IC906	D2

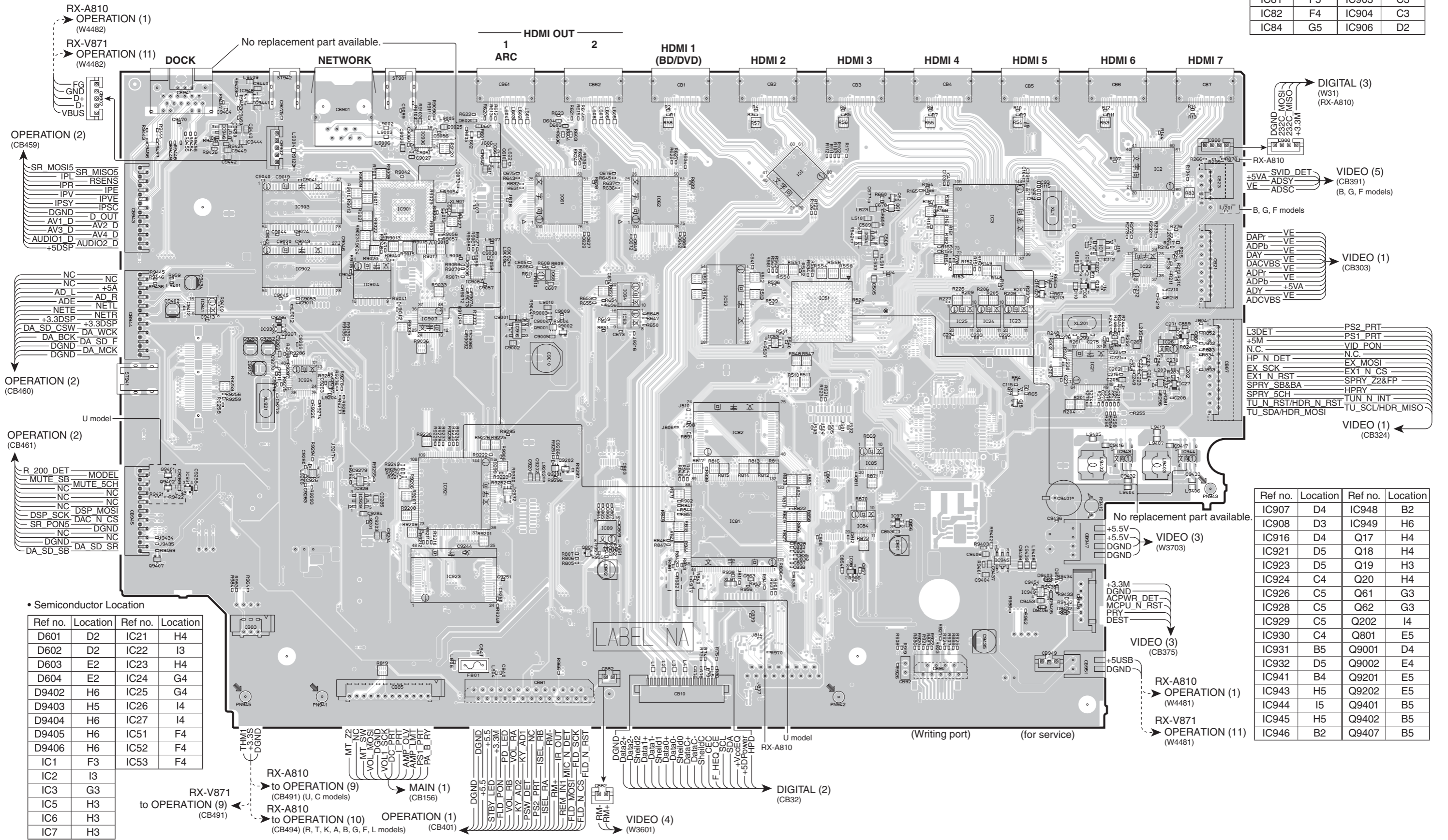

• Semiconductor Location

Ref no.	Location	Ref no.	Location
D601	D2	IC21	H4
D602	D2	IC22	I3
D603	E2	IC23	H4
D604	E2	IC24	G4
D9402	H6	IC25	G4
D9403	H5	IC26	I4
D9404	H6	IC27	I4
D9405	H6	IC51	F4
D9406	H6	IC52	F4
IC1	F3	IC53	F4
IC2	I3		
IC3	G3		
IC5	H3		
IC6	H3		
IC7	H3		

Ref no.	Location	Ref no.	Location
IC907	D4	IC948	B2
IC908	D3	IC949	H6
IC916	D4	Q17	H4
IC921	D5	Q18	H4
IC923	D5	Q19	H3
IC924	C4	Q20	H4
IC926	C5	Q61	G3
IC928	C5	Q62	G3
IC929	C5	Q202	I4
IC930	C4	Q801	E5
IC931	B5	Q9001	D4
IC932	D5	Q9002	E4
IC941	B4	Q9201	E5
IC943	H5	Q9202	E5
IC944	I5	Q9401	B5
IC945	H5	Q9402	B5
IC946	B2	Q9407	B5