

AV RECEIVER

RX-V10MK II

SERVICE MANUAL

IMPORTANT NOTICE

This manual has been provided for the use of authorized YAMAHA Retailers and their service personnel. It has been assumed that basic service procedures inherent to the industry, and more specifically YAMAHA Products, are already known and understood by the users, and have therefore not been restated.

WARNING: Failure to follow appropriate service and safety procedures when servicing this product may result in personal injury, destruction of expensive components, and failure of the product to perform as specified. For these reasons, we advise all YAMAHA product owners that any service required should be performed by an authorized YAMAHA Retailer or the appointed service representative.

IMPORTANT: The presentation or sale of this manual to any individual of firm does not constitute authorization, certification or recognition of any applicable technical capabilities, or establish a principle-agent relationship of any form.

The data provided is believed to be accurate and applicable to the unit(s) indicated on the cover. The research, engineering, and service departments of YAMAHA are continually striving to improve YAMAHA products. Modifications are, therefore, inevitable and specifications are subject to change without notice or obligation to retrofit. Should any discrepancy appear to exist, please contact the distributor's Service Division.

WARNING: Static discharges can destroy expensive components. Discharge any static electricity your body may have accumulated by grounding yourself to the ground buss in the unit (heavy gauge black wires connect to this buss).

IMPORTANT: Turn the unit OFF during disassembly and part replacement. Recheck all work before you apply power to the unit.

■ CONTENTS

TO SERVICE PERSONNEL	1	TUNER ADJUSTMENTS	11~14
REMOTE CONTROL PANEL	1	IC DATA	15~20
FRONT PANELS	2	DISPLAY DATA	21
REAR PANELS	3	BLOCK DIAGRAM	22~25
SPECIFICATIONS	4~5	PRINTED CIRCUIT BOARD	26~39
INTERNAL VIEW	6	SCHEMATIC DIAGRAM	40~43
DISASSEMBLY PROCEDURES	6	PARTS LIST	44~55
SELF CHECK MODE	7~9	REMOTE CONTROL TRANSMITTER	56
AMP ADJUSTMENT	10		



このサービスマニュアルは、エコマーク認定の再生紙を使用しています。
This Service Manual uses recycled paper.



■ TO SERVICE PERSONNEL

1. Critical Components information.

Components having special characteristics are marked and must be replaced with parts having specifications equal to those originally installed.

2. Leakage Current Measurement (For 120V Model only).

When service has been completed, it is imperative that you verify that all exposed conductive surfaces are properly insulated from supply circuits.

- Meter impedance should be equivalent to 1500 ohm shunted by 0.15μF.
- Leakage current must not exceed 0.5mA.
- Be sure to test for leakage with the AC plug in both polarities.

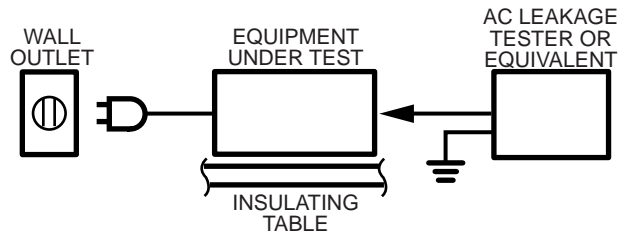

WARNING: CHEMICAL CONTENT NOTICE!

The solder used in the production of this product contains LEAD. In addition, other electrical/electronic and/or plastic (where applicable) components may also contain traces of chemicals found by the California Health and Welfare Agency (and possibly other entities) to cause cancer and/or birth defects or other reproductive harm.

DO NOT PLACE SOLDER, ELECTRICAL/ELECTRONIC OR PLASTIC COMPONENTS IN YOUR MOUTH FOR ANY REASON WHATSOEVER!

Avoid prolonged, unprotected contact between solder and your skin! When soldering, do not inhale solder fumes or expose eyes to solder/flux vapor!

If you come in contact with solder or components located inside the enclosure of this product, wash your hands before handling food.

■ REMOTE CONTROL PANEL

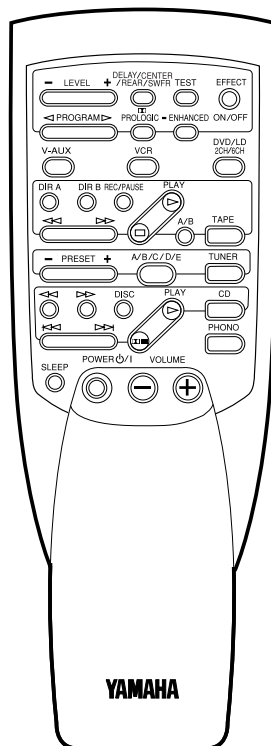

FRONT PANELS

▼ R model

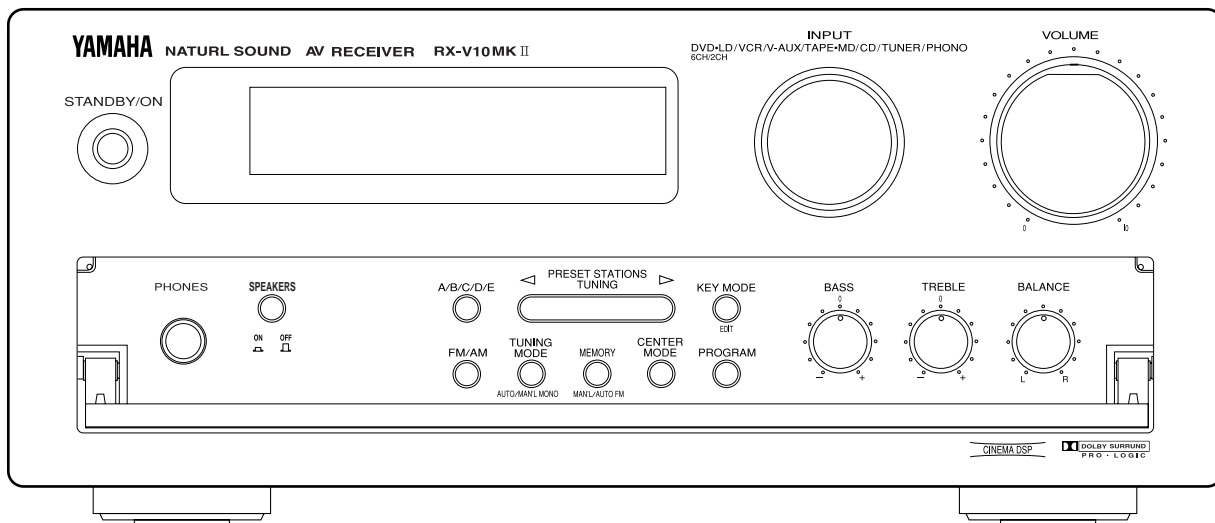

▼ B ,G models

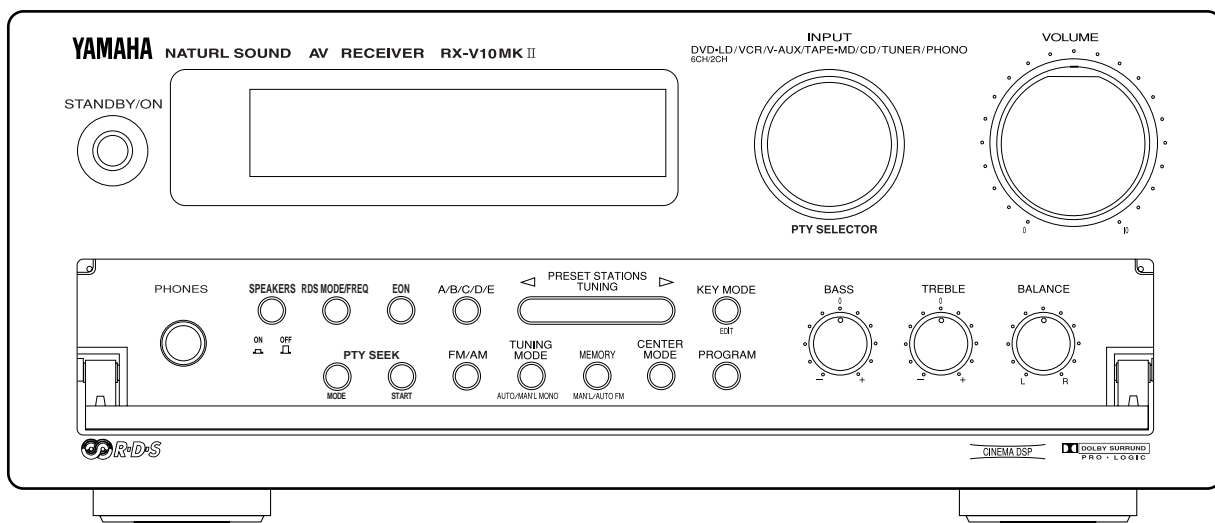

REAR PANELS

▼ R model

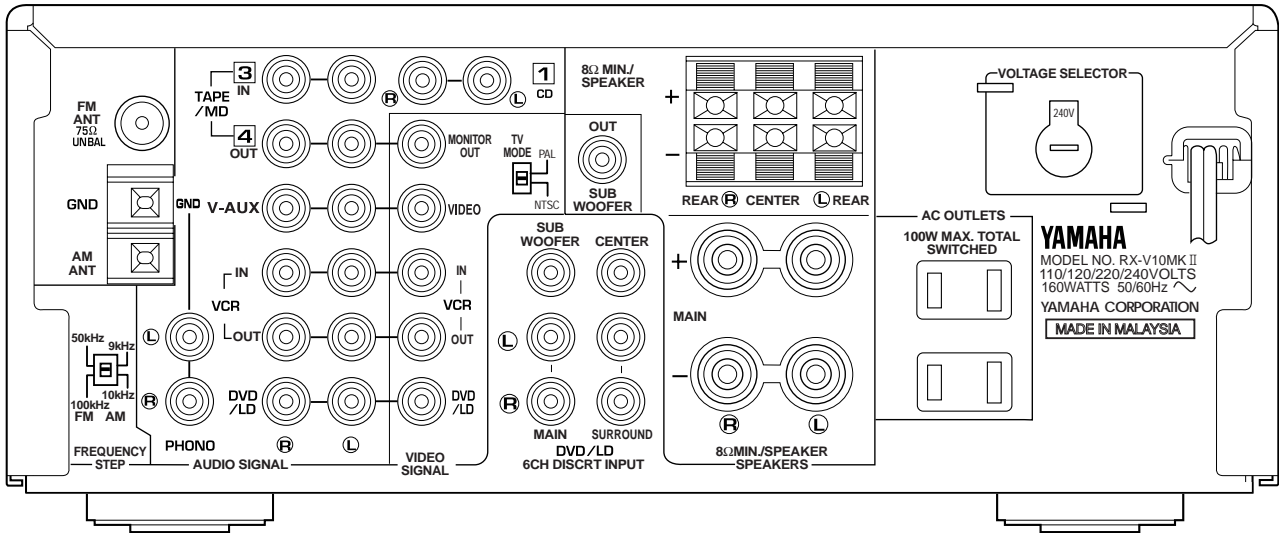

▼ B model

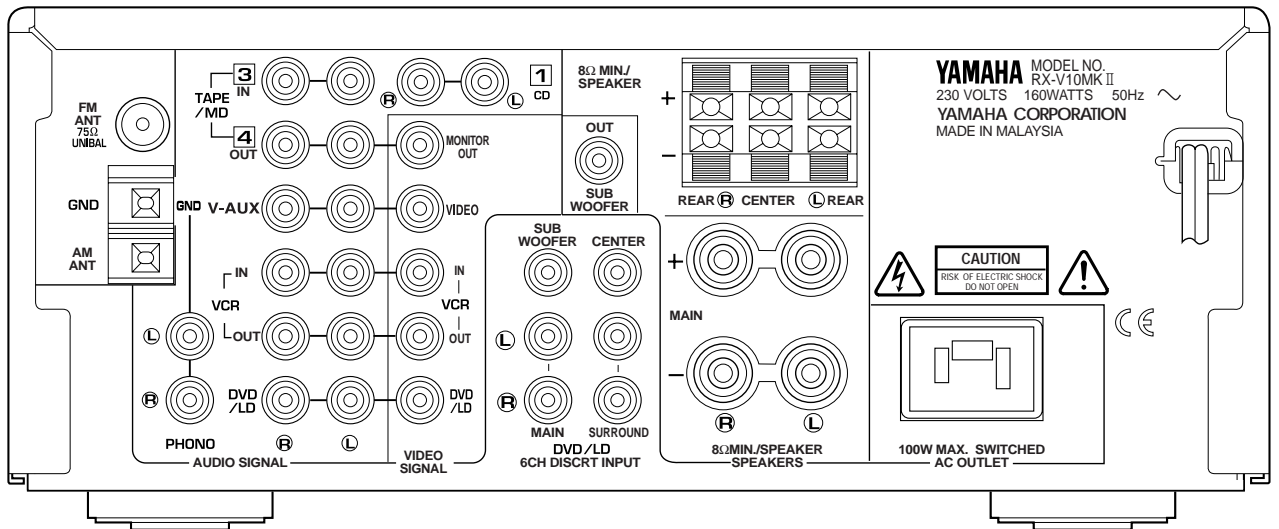

▼ G model

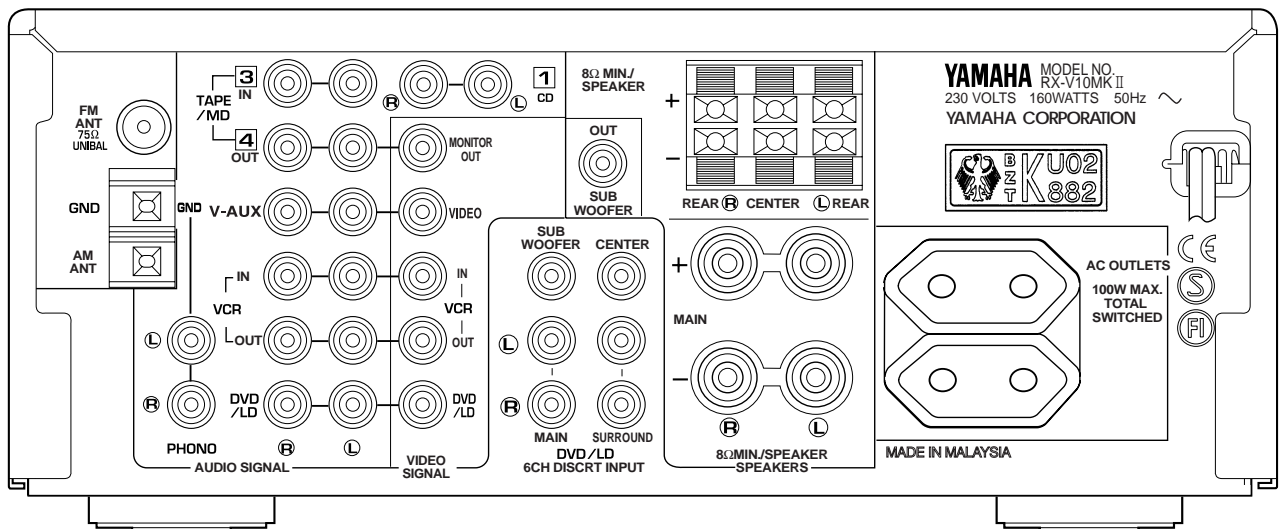

■ SPECIFICATIONS

■ AUDIO SECTION

Minimum RMS output Power per Channel (Power Amp. Section)

MAIN	20Hz to 20kHz, 0.04% THD, 8Ω	45W+45W
CENTER	1kHz, 0.04% THD, 8Ω	45W
REAR	1kHz, 0.3% THD, 8Ω	15W+15W

Maximum Power Per Channel (EIAJ)

R model only	1kHz, 10% THD, 8Ω	65W+65W
--------------	-------------------	---------

Dynamic Power Per Channel(IHF)

MAIN, L/R Stereo	8/6Ω	65W+65W/75W+75W
	4/2Ω	95W+95W/105W+105W

DIN Standard Output Power Per Channel

G model only	MAIN, 1kHz, 0.7% THD, L/R Stereo 4Ω	60W+60W
--------------	-------------------------------------	---------

IEC Power Per Channel

G model only	MAIN, 1kHz, 0.1% THD, L/R Stereo 8Ω	50W+50W
--------------	-------------------------------------	---------

Power Band Width

MAIN, 0.1% THD, 22.5W, 8Ω	10Hz to 50kHz
---------------------------	---------------

Input Sensitivity/Impedance

PHONO (MM)	2.5mV/47kΩ
CD etc	150mV/47kΩ
6ch MAIN L/R	150mV/70kΩ
CENTER	150mV/40kΩ
REAR L/R	90mV/40kΩ
SUBWOOFER	150mV/40kΩ

Maximum input Signal Level

PHONO (MM), 1kHz, 0.5% THD	100mV
CD etc (EFFECT ON), 1kHz, 0.5% THD	2.5V

Output Level/Impedance

REC OUT (CD etc, Input = 150mV)	150mV/0.9kΩ
SUBWOOFER (EFFECT OFF, CD etc, Input = 150mV)	3.5V/1.6kΩ

Headphone Jack Rated Output/Impedance

CD etc, INPUT=1kHz, 150mV, 8Ω	0.45V/330Ω
-------------------------------	------------

Frequency Response(20Hz to 20kHz)

CD etc, MAIN	0±0.5dB
--------------	---------

RIAA Equalization Deviation

PHONO (MM)	0±0.5dB
------------	---------

Total Harmonic Distortion(20Hz to 20kHz)

PHONO (MM) to REC OUT (1V)	0.02%
CD etc (EFFECT OFF) to MAIN SP OUT (22.5W/8Ω)	0.02%

Signal-to-Noise Ratio(IHF-A-Network)

PHONO (MM), Input 5mV Shorted, REC OUT	82dB
CD etc(EFFECT OFF), Input 150mV Shorted, SP OUT	95dB

Residual Noise(IHF-A-Network)

MAIN L/R, SP OUT	140μV
------------------	-------

Channel Separation(Vol. MAX, EFFECT OFF)

PHONO (MM), Input Shorted, 1kHz	60dB
CD etc, Input 5.1kΩ terminated, 1kHz	60dB

Tone Control Characteristics

BASS	: Boost/Cut	±10dB(50Hz)
	: Turnover Frequency	350Hz
TREBLE	: Boost/Cut	±10dB(20kHz)
	: Turnover Frequency	3.5kHz

Gain Tracking Error(0~-60dB)

MAIN L/R	3dB
----------	-----

■ FM SECTION

Tuning Range

R model	87.50 to 108.00MHz
B, G, models	87.50 to 108.00MHz

50dB Quieting Sensitivity(IHF)

R model only	
Mono	1.6μV(15.3dBf)
Stereo	23μV(38.5dBf)

Usable Sensitivity

B, G models	
DIN, Mono(S/N 26dB)	0.9μV
DIN, Stereo(S/N 46dB)	28μV

Alternate Channel Selectivity

R model (±400kHz)	75dB
G, B models	
Selectivity(two signals, 40kHz Dev. ±300kHz)	55dB

Signal-to-Noise Ratio

R model	
Mono/Stereo(IHF)	80/75dB
G, B models	
Mono/Stereo(DIN-weighted, 40kHz Dev.)	74/69dB

Harmonic Distortion(1kHz)

R model	
Mono/Stereo	0.1/0.2%
G, B models	
Mono/Stereo(40kHz Dev.)	0.1/0.2%

Stereo Separation(1kHz)

R model	48dB
G, B models(40kHz Dev.)	48dB

Frequency Response

30Hz to 15kHz	0±1dB
---------------	-------

Output Level(1kHz)

R model	
100% mod	500mV
B, G models (40kHz Dev.)	400mV

Antenna Input

75Ω unbalanced

■AM SECTION

Tuning Range	
R model	531 to 1611/530 to 1710kHz
B, G, models	531 to 1611kHz
Usable Sensitivity	300μV/m
Output Level(1kHz)	
30% mod.	150mV
Signal to Noise Ratio	50dB
Antenna	Loop antenna

■VIDEO SECTION

Video Signal Type	
R model	NTSC/PAL
B, G models	PAL
Signal Level	1Vp-p/75Ω
Maximum Input Level	1.5Vp-p
Signal-to-Noise Ratio	50dB
Monitor Out Frequency Response(-3dB)	5Hz~10MHz

■GENERAL

Power Supply	
R model	AC110/120/220/240V, 50/60Hz
B, G models	AC230V, 50Hz
Power Consumption	160W
Maximum Power Consumption	
R model only	
1kHz, 10% THD, 8Ω	360W
AC Outlet	
R, G models, Switched x 2	100W max(Total)
B model, Switched x 1	100W max
Dimensions(W x H x D)	280 x 118.5 x 388.5mm (11" x 4-11/16" x 15-9/16")
Weight	7.3kg(16lbs 3 oz)
Accessories	AM loop antenna x 1 Indoor FM antenna x 1 Remote Control Transmitter x 1 Battery (size "AA", "R06")

* Specifications subject to change without notice.

- R General model
- B British model
- G European model

● DIMENSIONS

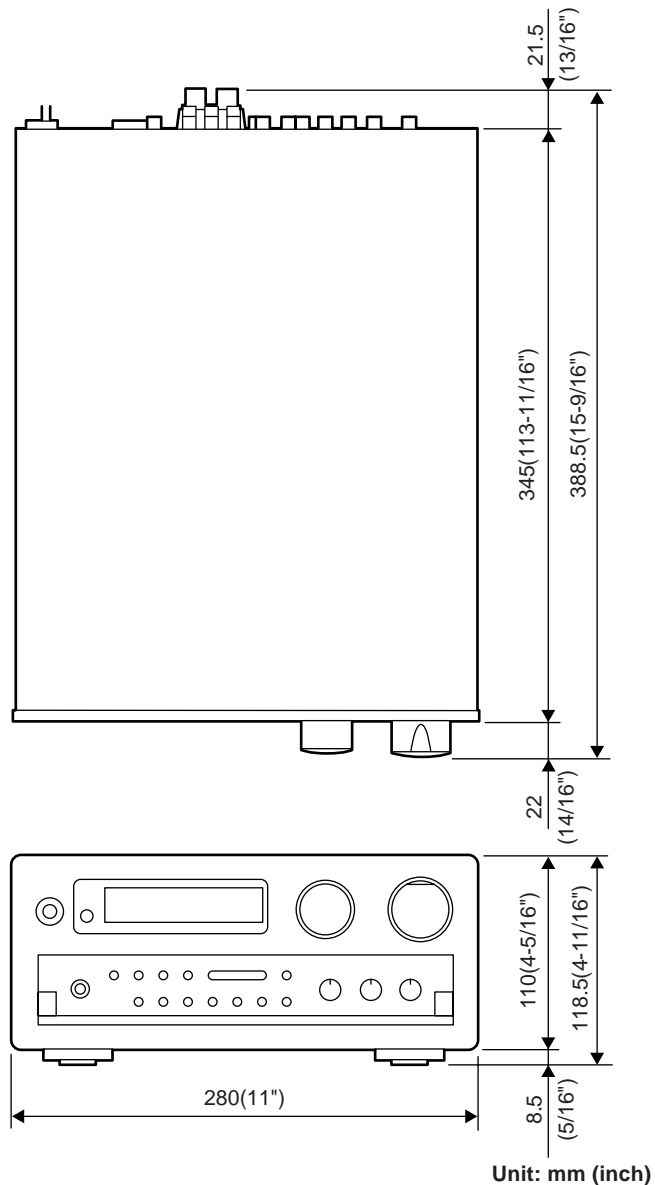

Unit: mm (inch)

INTERNAL VIEW

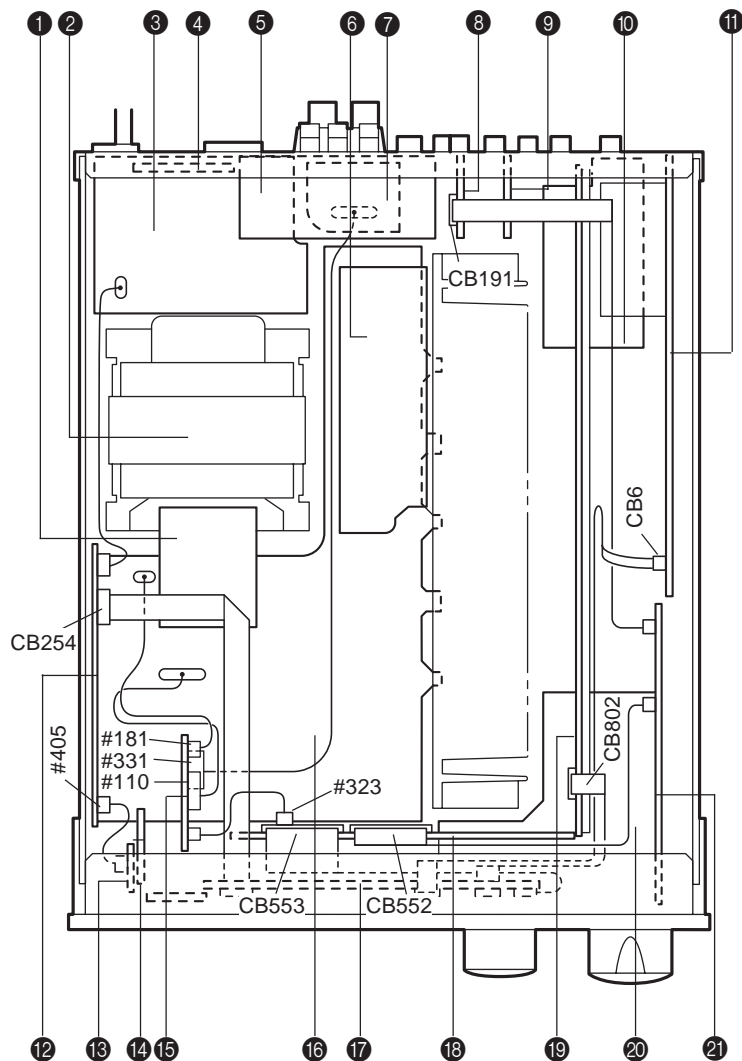

- ① MAIN P.C.B. ASS'Y (10)
- ② POWER TRANSFORMER
- ③ MAIN P.C.B. ASS'Y (3)
- ④ MAIN P.C.B. ASS'Y (8)
(R model only)
- ⑤ MAIN P.C.B. ASS'Y (6)
- ⑥ MAIN P.C.B. ASS'Y (4)
- ⑦ MAIN P.C.B. ASS'Y (9)
- ⑧ MAIN P.C.B. ASS'Y (7)
- ⑨ MAIN P.C.B. ASS'Y (5)
- ⑩ VOLUME P.C.B. ASS'Y (3)
- ⑪ TUNER P.C.B. ASS'Y
- ⑫ MAIN P.C.B. ASS'Y (2)
- ⑬ VOLUME P.C.B. ASS'Y (4)
- ⑭ FUNCTION P.C.B. ASS'Y (5)
- ⑮ FUNCTION P.C.B. ASS'Y (4)
- ⑯ MAIN P.C.B. ASS'Y (1)
- ⑰ FUNCTION P.C.B. ASS'Y (2)
- ⑱ VOLUME P.C.B. ASS'Y (1)
- ⑲ FUNCTION P.C.B. ASS'Y (1)
- ⑳ FUNCTION P.C.B. ASS'Y (3)
- ㉑ VOLUME P.C.B. ASS'Y (2)

DISASSEMBLY PROCEDURES

(Remove parts in disassembly order as numbered.)

1. Removal of Top Cover

Remove 2 screws (①) and 3 screws (②) in Fig. 1.

2. Removal of Front Panel Unit

- a. Detach 11 connectors (CB191, 254, 552, 553, 802, 6, #110, 181, 323, 331, 405). (See page 6, INTERNAL VIEW) (CB6 : B, G models only)
- b. Remove 4 screws (③) and 2 plastic rivets (④) and then remove the Front Panel Unit in Fig. 1.

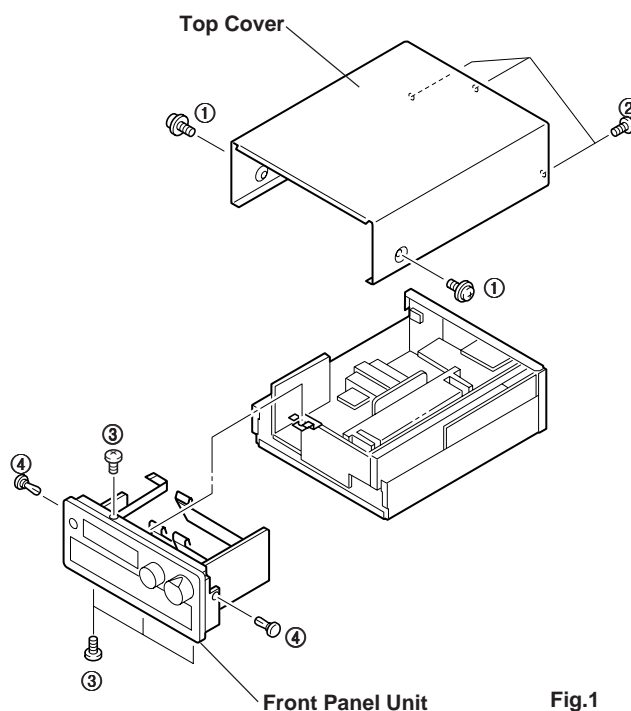

Fig.1

■ SELF CHECK MODE

This machine has the SELF CHECK MODE (SELF) for facilitating inspectional measurement.

HOW TO START (2 options)

● SELF CHECK MODE with MAKER PRESET

Turn the POWER switch ON while pressing the CENTER MODE key and PROGRAM key simultaneously, and then the unit enters the SELF CHECK MODE.

WARNING : MAKER PRESET is initialized.
All user memory erased.

● SELF CHECK MODE without MAKER PRESET

Turn the POWER switch ON while pressing the A/B/C/D/E key and TUNING MODE key simultaneously, and then the unit enters the SELF CHECK MODE.

WARNING : MAKER PRESET is disabled.

● MAKER PRESET

1. TUNER section

Preset Group	P1	P2	P3	P4	P5	P6	P7	P8
A, C, E (FM)	87.5MHz	90.1MHz	95.1MHz	98.1MHz	108.0MHz	88.1MHz	106.1MHz	108.0MHz
B, D (AM)	630kHz	1080kHz	1440kHz	R : 530kHz R, B, G : 531kHz	R : 1710kHz R, B, G : 1611kHz	900kHz	1350kHz	R : 1400kHz R, B, G : 1404kHz

All tuning modes are AUTO.

2. SURROUND section

SURROUND MODE : ROCK CONCERT
CENTER MODE : NORMAL

3. SELECTOR section

INPUT : CD

CAUTION : Before setting to MAKER PRESET, write down the existing preset memory content of the Tuner in a table as shown below. (This is because setting to the MAKER PRESET will cause the user memory content to be erased.)

Preset group	P1	P2	P3	P4	P5	P6	P7	P8
A								
B								
C								
D								
E								

CONTENTS OF SELF CHECK MODE

SELF NO.	Menu	Select key	Remote Control Transmitter	Supplement
1	RAM THROUGH A	FM/AM	TEST	<ul style="list-style-type: none"> At first, SELF No. is 1, INPUT is CD, SWFR LEVEL is set on 0 dB. INPUT is changeable at SELF No. 1 to 5. CENTER LEVEL, REAR LEVEL and SWFR LEVEL are changeable at SELF No. 1 to 6. The information of the SELF CHECK MODE is displayed on the MONITOR OUT at SELF No. 1 to 9.
2	RAM THROUGH B	TUNING MODE	EFFECT	
3	RAM THROUGH C	MEMORY	PROGRAM DOWN	
4	PRO LOGIC	CENTER MODE	PROGRAM UP	
5	DSP OFF		CD STOP PAUSE	
6	MANUAL TEST	PROGRAM	SLEEP	
7	DISPLAY CHECK	A/B/C/D/E	A/B/C/D/E	
8	PHOTO MODE	TUNING DOWN	PRESET DOWN	
9	BRIDGE CHECK	TUNING UP	PRESET UP	
10	EXIT	KEY MODE	ENHANCED	
11	OSD OFF		CD REW	

DETAILS OF SELF CONTENTS

SELF 1 RAM THROUGH A

- L/R is output through the bypass.
- CENTER is output with the steering OFF and by (L+R)/2 (WIDE mode).
- RL/RR passes through the PS-RAM and is output through the DSP.
- The electronic volume is 0dB for CENTER and -5dB for REAR.
- FL displays "C 1".

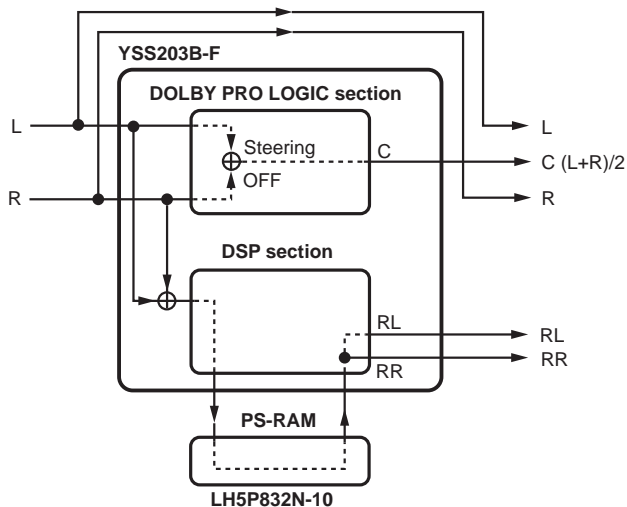

CD INPUT : 1kHz, -20.0dB
 SP OUT (L and Rch inputs)
 : MAIN +21.0dB
 : CENTER +4.0dB
 : REAR +17.0dB

SELF 2 RAM THROUGH B

- FL/FR and RL/RR pass through the PS-RAM and are output through the DSP.
- CENTER is output with the steering OFF and by (L+R)/2 (WIDE mode).
- The electronic volume (for CENTER/REAR) is 0dB.
- FL displays "C 2".

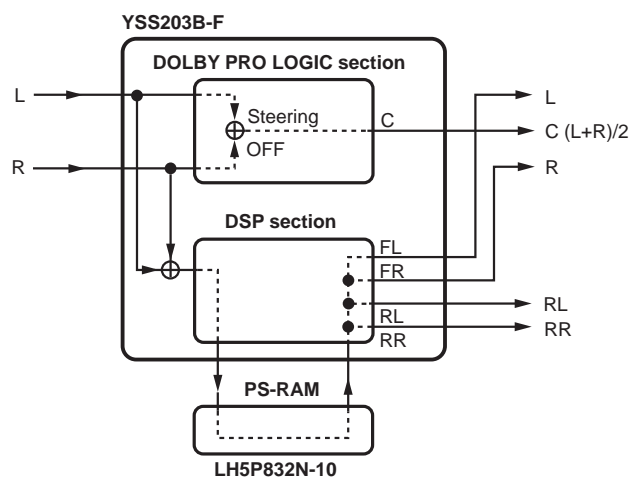

CD INPUT : 1kHz, -20.0dB
 SP OUT (L and Rch inputs)
 : MAIN +21.2dB
 : CENTER +13.2dB
 : REAR +22.0dB

SELF 3 RAM THROUGH C

- L/R is output through the DSP.
- CENTER is output with the steering OFF and by $(L+R)/2$ (WIDE mode).
- RL/RR passes through the PS-RAM and is output through the DSP.
- The electronic volume (for CENTER /REAR) is 0dB.
- FL displays "C 3".

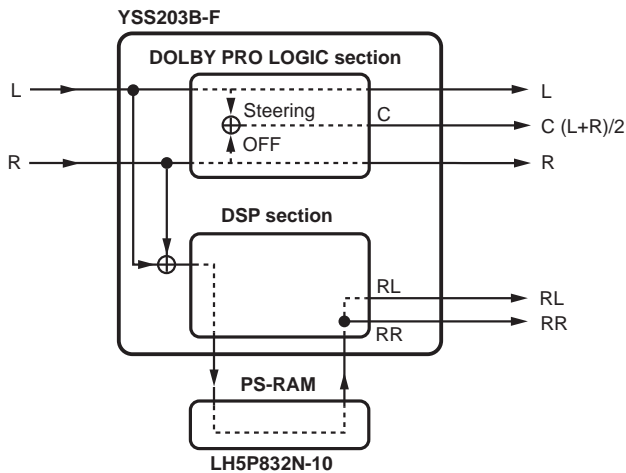

CD INPUT : 1kHz, -20.0dB
 SP OUT (L and Rch inputs)
 : MAIN +22.5dB
 : CENTER +13.0dB
 : REAR +22.0dB

SELF 4 PRO LOGIC

- The auto input balance which is ON in the normal mode is turned OFF.
- CENTER MODE is changed by pressing the PRO LOGIC key on the Remote Control Transmitter.
- The electronic volume (for CENTER /REAR) is 0dB.
- FL displays "C 4".

CD INPUT : 1kHz, -20.0dB
 SP OUT (L and Rch inputs)
 : MAIN +1.2dB
 : CENTER +23.5dB
 : REAR -34.0dB

SP OUT (L or Rch input)
 : MAIN +22.0dB
 : CENTER -23.5dB
 : REAR -33.0dB

SELF 5 DSP OFF

- L/R output through the bypass.
- The FL displays "C 5".

SELF 6 MANUAL TEST

- Every time PROGRAM key or SLEEP key on the Remote Control Transmitter is pressed, the TEST TONE shifts in the order of $L \rightarrow C \rightarrow R \rightarrow S$ and is output. (The CENTER mode is WIDE)
- The electronic volume (for CENTER /REAR) is 0dB.
- FL displays "C 6".

SELF 7 DISPLAY CHECK

- All the segments of FL display will turn on for about 3 seconds.

SELF 8 PHOTO MODE

- The FL displays "NDR 3" and the catalogue photographing mode.

SELF 9 MANUAL TEST

- The FL displays "c1c1c1", "PRESET", "RT", "FM", "ENHANCED" and "ms".

SELF 10 EXIT

- The state of the system (RX-V10MKII) will escape from SELF CHECK MODE.

SELF 11 OSD OFF

- OSD FUNCTION (BLUE BACK and SUPERIMPOSE) is turned OFF.
- THE FL displays "C 11".

■ AMP ADJUSTMENT

Confirmation and Adjustment of Idling Current of Main Amplifier

- Right after power is turned on, confirm that the voltage across the terminals of CB111, CB112 and CB113 is between 0.1mV~3.0mV.
- If it exceeds 3.0mV, open (cut off) R120 (on CB111), R127 (on CB112) or R134 (on CB113) and reconfirm the voltage again.

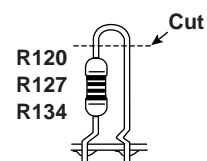
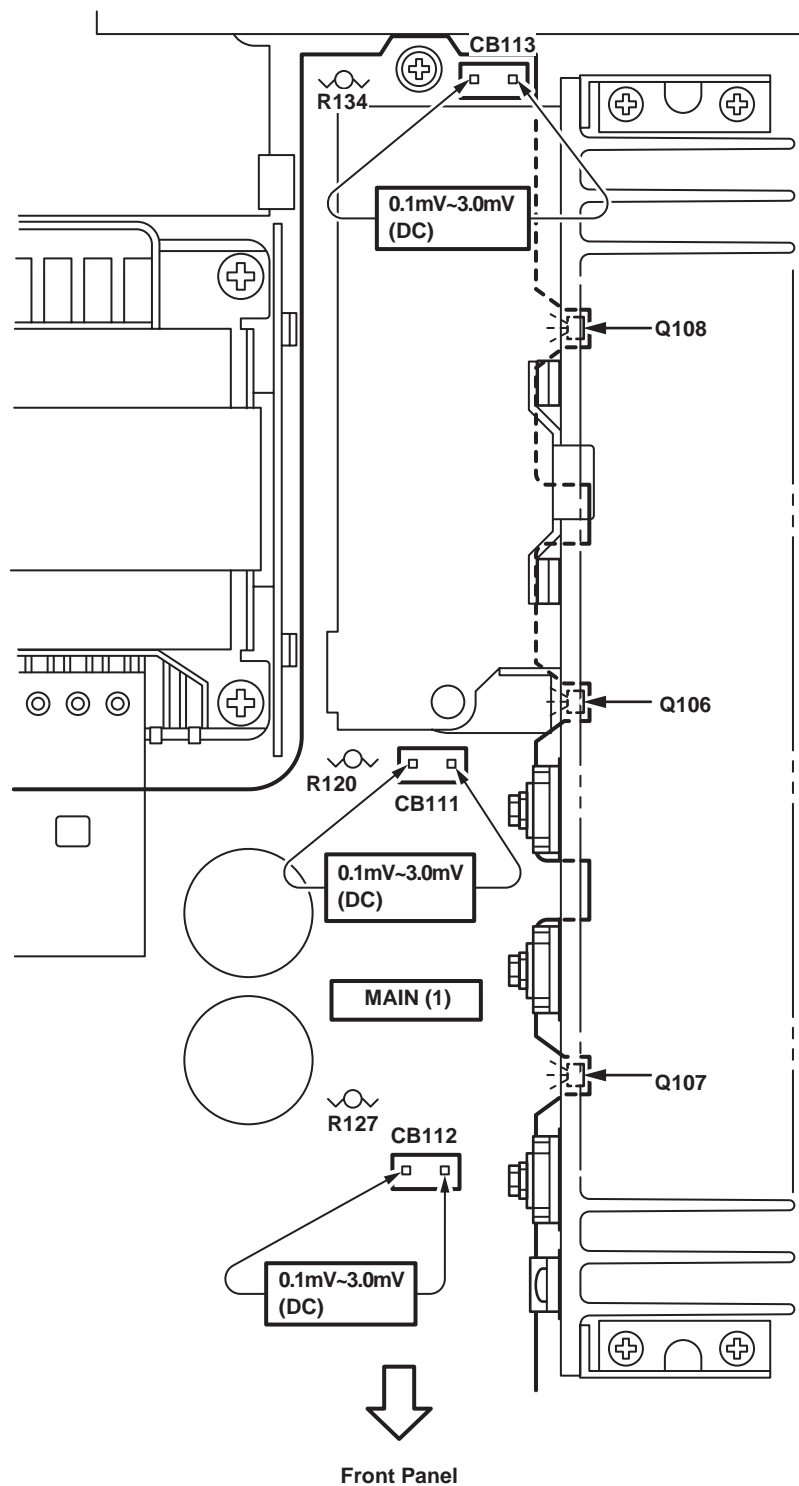

Note)

- If R120 and R127 or R134 have already been cut off and idling current does not flow, reconnect R120 and R127 or R134.
- Q106, Q107 and Q108 are transistors for temperature correction.
Apply silicone grease to contact surface with the heat sink.

TUNER ADJUSTMENT

1. Measuring Instruments

- FM signal generator (FM SG)
- Stereo signal generator (SSG)
- AM signal generator (AM SG)
- Distortion meter (DIS. M)
- AC Voltmeter (ACVM)
- DC Voltmeter (DCVM)
- Oscilloscope
- Low pass filter (YLF-15, $f_c=15\text{kHz}$)
- Oscillator

● Dummy antenna

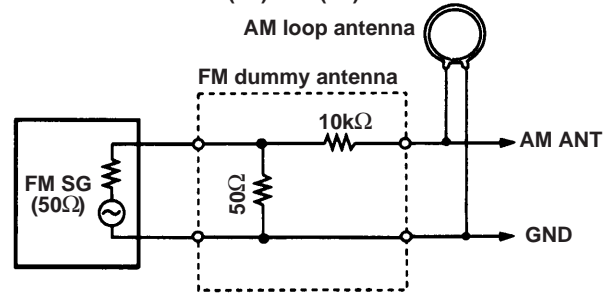
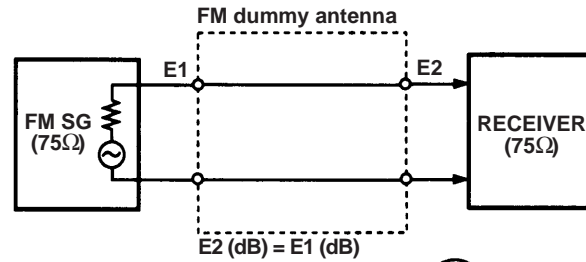
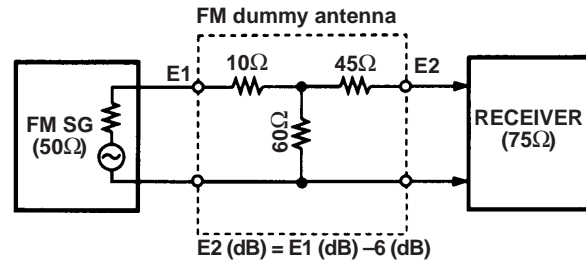

● TEST POINT

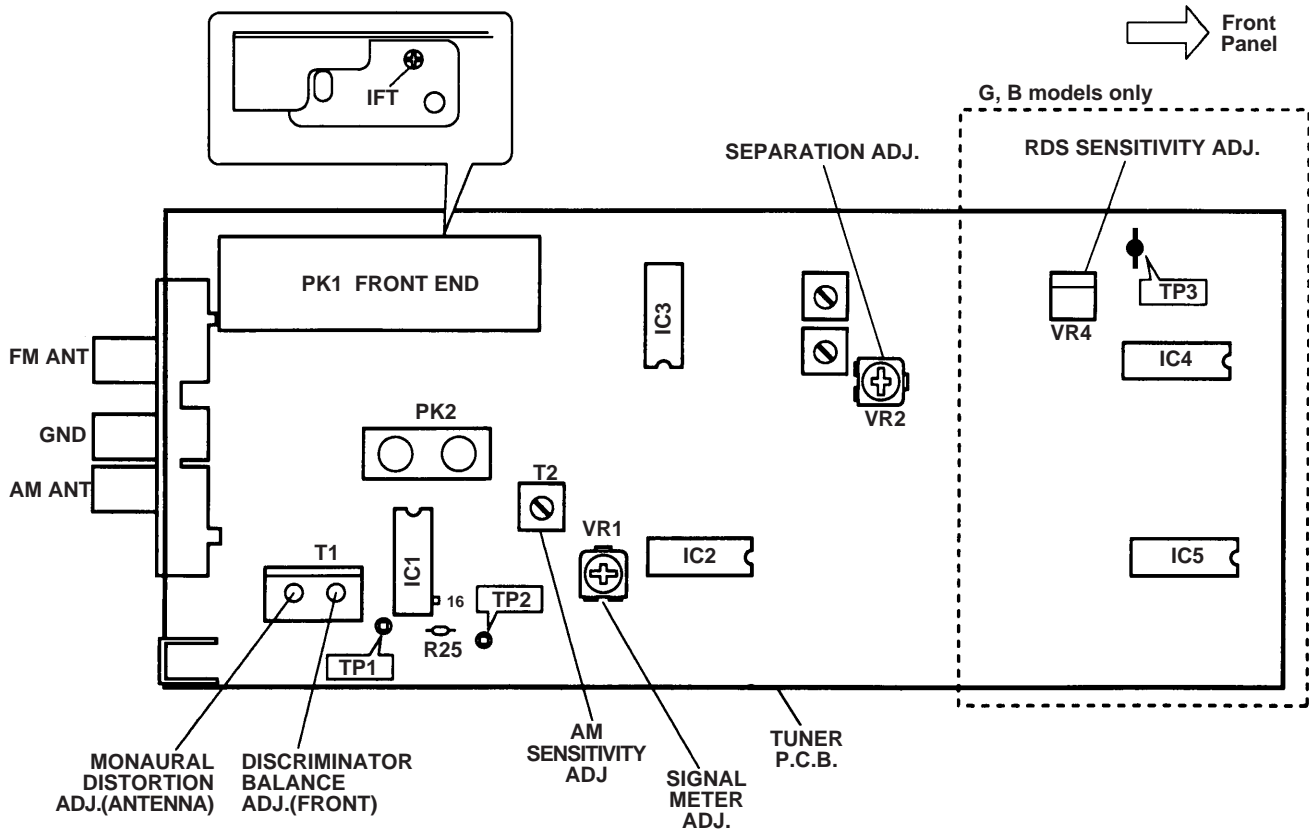

FM Adjustment

1. Befor Adjustment

- For dB μ , 1 μ V=0dB μ applies.
Example : 60dB μ =1mV
- 100% modulation means that the frequency deviation is \pm 75kHz.
- Install the Matching Transformer and connect FM SG.

- Set each switch to the following position unless otherwise specified.

INPUT SELECTOR TUNER
TUNING MODE AUTO

2. Connection diagram (Measuring instruments)

- Discriminator balance adjustment.

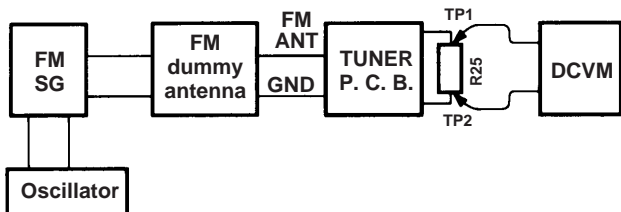

- Stereo distortion adjustment/separation adjustment.

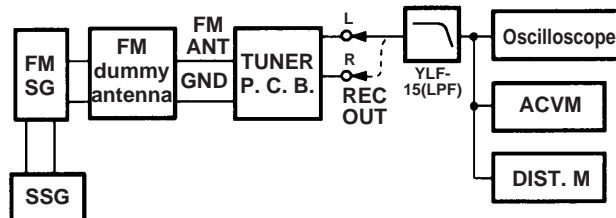

- Monaural distortion adjustment

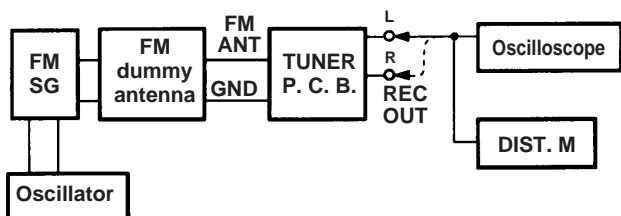

- Sensitivity Verification

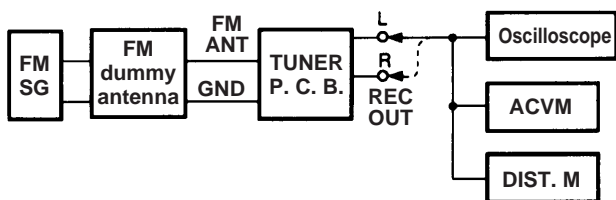

See page 11 for TP locations & adjustment points.

Step	Adjustment item	Signal (ANT IN)	Reception frequency	Adjustment point	Test point	Rating
1	Rough adjustment of discriminator balance	FM ANT (75 Ω) 98.1MHz 70dB μ MONO 100Hz 100% modulation	98.1MHz *(A-4)	T1 (Front side core)	Both ends of R25 (Between TP1 and TP2)	DC 0V \pm 100mV
2	Rough adjustment of monaural distortion	Same as Step 1.	98.1MHz *(A-4)	T1 (Antenna side core)	REC OUT L, R	Minimize the distortion.
3	Fine adjustment of discriminator balance	Same as Step 1.	98.1MHz *(A-4)	T1 (Front side core)	Both ends of R25 (Between TP1 and TP2)	DC 0V \pm 50mV
4	Fine adjustment of monaural distortion	Same as Step 1.	98.1MHz *(A-4)	T1 (Antenna side core)	REC OUT L, R	Minimize the distortion (to -44dB or less).
5	Verification of discriminator balance	Same as Step 1.	98.1MHz *(A-4)	T1 (Front side core)	Both ends of R25 (Between TP1 and TP2)	DC 0V \pm 50mV

* Execution of MAKER PRESET (Refer to page 7.) will facilitate setting reception frequency for adjustment.

Step	Adjustment item	Signal (ANT IN)	Reception frequency	Adjustment point	Test point	Rating
6	Adjustment of front end IFT	FM ANT (75Ω) 98.1MHz 30dBμ MONO 1kHz 100% modulation	98.1MHz *(A-4)	Front end IFT		Adjust so that the meter is maximum. CAUTION: Over-adjustment of the IFT core will reduce the sensitivity. (Maximum±90°)
7	Verification of monaural distortion	FM ANT (75Ω) 98.1MHz 70dBμ MONO 1kHz 100% modulation	98.1MHz *(A-4)		REC OUT L, R	-43dB or less
8	Verification of stereo distortion	FM ANT (75Ω) 98.1MHz 70dBμ Stereo L or R 1kHz, 100% modulation	98.1MHz *(A-4) *Tuning mode should be AUTO.		REC OUT L, R	-33dB or less ● STEREO indicator should light.
9	Verification of sensitivity	FM ANT (75Ω) 88.1MHz 98.1MHz 106.1MHz	88.1MHz *(A-6) 98.1MHz *(A-4) 106.1MHz *(A-7)		ANT (75Ω)	1) Set the tuning mode to MAN'L MONO. 2) S/N should be 30dB at each frequency of 88.1MHz, 98.1MHz, and 106.1MHz. 3) Check to ensure that the voltage at the ANT terminal is 4dBμ or less. (B, G only : 8 dBμ or less)
10	Adjustment of separation	FM ANT (75Ω) 98.1MHz 70dBμ Stereo L or R 1kHz, 100% modulation	98.1MHz *(A-4)	VR2	REC OUT L, R	With SSG output at L or R, the signal leakage level at the other channel should be minimized. 30dB or more.
11	Adjustment of signal meter	FM ANT (75Ω) 98.1MHz 45dBμ MONO 1kHz, 30% modulation -10dBμ or less	98.1MHz *(A-4)	VR1		Adjust so that all signal meters light. Check to ensure that signal meters turn OFF.
12	Verification of auto tuning	FM ANT (75Ω) 98.1MHz 23dBμ Stereo L or R 1kHz, 30% modulation	98.1MHz			● Automatic reception should be available when the tuning key is moved UP and DOWN. ● The stereo indicator should light. ● Audio muting should be applied during tuning.

* Execution of MAKER PRESET (Refer to page 7.) will facilitate setting reception frequency for adjustment.

AM Adjustment (This should be done after FM adjustment.)

1. Connection DIAGRAM (Measuring instruments)

- Adjustment of sensitivity.

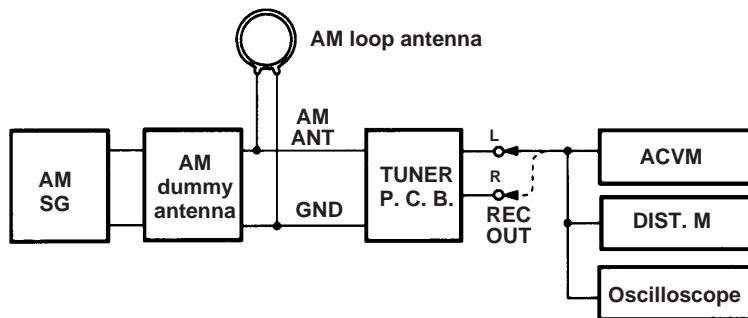

See page 11 for TP locations & adjustment points.

Step	Adjustment item	Signal (ANT IN)	Reception frequency	Adjustment point	Test point	Rating
1	Adjustment of sensitivity (630kHz)	AM ANT 630kHz 50dBμ 1kHz 30% modulation	630kHz *(B-1)	T2	REC OUT	Signal meter should be maximized.
2	Verification of sensitivity	AM ANT 630kHz 1080kHz 1440kHz 1kHz 30% modulation	630kHz *(B-1) 1080kHz *(B-2) 1440kHz *(B-3)		AM ANT	Distortion should be 10% or less at each frequency. Check to ensure that the voltage at the ANT terminal is 54dBμ or less.
3	Verification of auto tuning	AM ANT 60dBμ				Auto reception should be available when the tuning key is moved UP and DOWN.

* Execution of MAKER PRESET (Refer to page 7.) will facilitate setting reception frequency for adjustment.

RDS Adjustment (B, G models ONLY) (This should be done after FM and AM adjustment.)

See page 11 for TP locations & adjustment points.

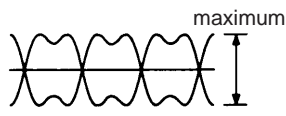
Step	Adjustment item	Signal (ANT IN)	Reception frequency	Adjustment point	Test point	Rating
1	Adjustment of RDS sensitivity		Receive RDS station	VR4	Between TP3 and GND	Adjust so that the AC voltage is maximum. 
2	Verification of auto PS (Program service name)					Confirm that the display automatically tunes to the PS when tuned again.

IC DATA

IC401 : M38B59MFH-A100FP

8 bit μ -COM

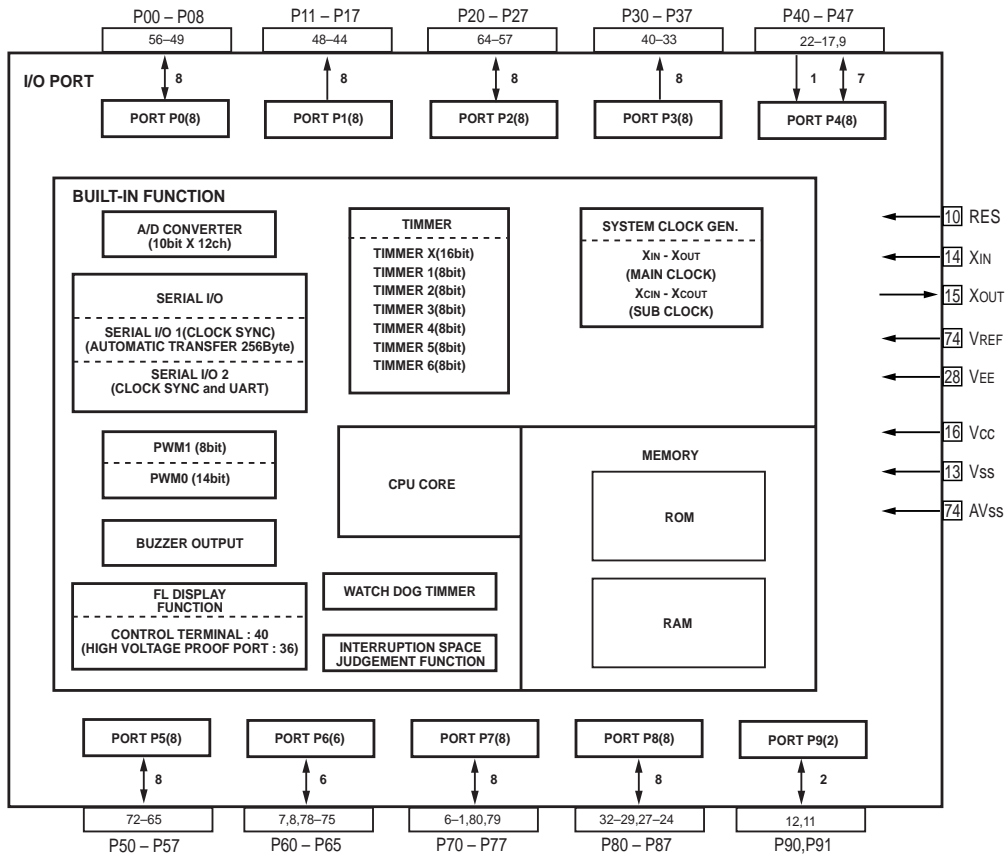
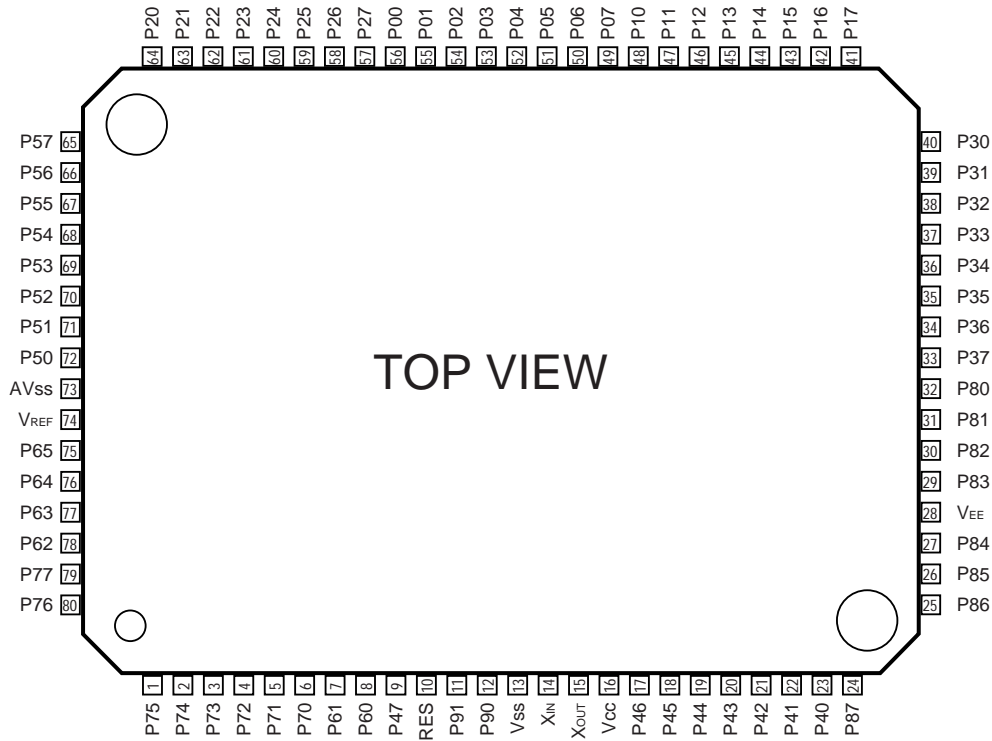

No.	Port	I/O	Function	Remarks	No.	Port	I/O	Function	Remarks
1	P75	I	Meter input	AN5	80	P76	O	Volume up	
2	P74	I	Stereo input		79	P77	O	Volume down	
3	P73	I	SIGIN (station detect)		78	P62	O	Self check	
4	P72	I	ST0 (IF OK signal)		77	P63	O	DSP C	
5	P71	O	STRQ (IF count request)		76	P64	O	DSP B	
6	P70	O	MONO (forced MONO)	L: MONO	75	P65	O	DSP A	
7	P61	O	Tuner mute		74	VREF		+5V	
8	P60	O	Chip enable for LM7000		73	AVSS		GND	
9	P47	I	Power down detect		72	P50	I	RDS data (V2) (* 2)	SIN1
10	RES		Reset		71	P51	I	RDS check	G, B models
11	P91	O	Power on		70	P52	I	RDS clock (V1) (* 2)	SCLK1
12	P90	O	Chip enable for OSD		69	P53	I	Rotary encoder	
13	VSS		GND		68	P54	I	Rotary encoder	
14	XIN		4MHz		67	P55		Serial data port	SOUT2
15	XOUT		4MHz		66	P56		Serial clock port	SCLK2
16	Vcc		+5V		65	P57	I	Protection detect	
17	P46	O	Chip enable for DSP		64	P20	I	Power switch detect	
18	P45	O	Chip enable for Electronic Volume		63	P21	O	SEGMENT 15	FLD1
19	P44	I	NTSC/PAL select for R model		62	P22	O	SEGMENT 14	FLD2
20	P43	O	RDS IC reset		61	P23	O	SEGMENT 13	FLD3
21	P42	I	Remote control signal	INT3	60	P24	O	SEGMENT 12	FLD4
22	P41	I	RDS start trigger	INT1	59	P25	O	SEGMENT 11	FLD5
23	P40	I	NTSC/PAL select for OSD	INT0	58	P26	O	SEGMENT 10	FLD6
24	P87	O	Chip enable for input select 1		57	P27	O	SEGMENT 9	FLD7
25	P86	O	Video control 1		56	P00	O	SEGMENT 8	FLD8
26	P85	O	Video control 2		55	P01	O	SEGMENT 7	FLD9
27	P84	O	Video Rec prohibit		54	P02	O	SEGMENT 6	FLD10
28	VEE		-24V		53	P03	O	SEGMENT 5	FLD11
29	P83	I	Key matrix input 1 (* 1)		52	P04	O	SEGMENT 4	FLD12
30	P82	I	Key matrix input 2 (* 1)		51	P05	O	SEGMENT 3	FLD13
31	P81	I	Key matrix input 3 (* 1)		50	P06	O	SEGMENT 2	FLD14
32	P80	I	Key matrix input 4 (* 1)		49	P07	O	SEGMENT 1	FLD15
33	P37	O	Chip enable for input select 2		48	P10	O	DIGIT 1	FLD16
34	P36	O	Front effect on/off		47	P11	O	DIGIT 2	FLD17
35	P35	O	Full mute		46	P12	O	DIGIT 3	FLD18
36	P34	O	DIGIT 13 (4)	FLD28	45	P13	O	DIGIT 4	FLD19
37	P33	O	DIGIT 12 (3)	FLD27	44	P14	O	DIGIT 5	FLD20
38	P32	O	DIGIT 11 (2)	FLD26	43	P15	O	DIGIT 6	FLD21
39	P31	O	DIGIT 10 (1)	FLD25	42	P16	O	DIGIT 7	FLD22
40	P230	O	DIGIT 9	FLD24	41	P17	O	DIGIT 8	FLD23

* 1 Key Matrix input

	DIGIT 1	DIGIT 2	DIGIT 3	DIGIT 4
Key 1	RDS MODE /FREQ.	EON	A/B/C/D/E	PTY SEEK MODE
Key 2	TUNING Up	TUNING Down	CENTER MODE	
Key 3	PTY SEEK START	FM/AM	TUNING MODE	
Key 4	MEMORY	KEY MODE	PROGRAM	

* 2 Models

	V1	V2	FM	AM
R2	1	O	50k	9k
R1	1	1	100k	10k

IC703 : YSS203B-F

Digital Dolby Pro Logic Decoder

No.	Name	I/O	Function	No.	Name	I/O	Function
1	CD	Its	Serial data of parameter data input	64	WCK	Its	Word clock for parameter data input
2	TSBWD	Ic	LSI test, Normally DVDD	63	BCK	Its	Bit clock for parameter data input
3	TI/O	Ic		62	/CSS	O	Nomally unconnected
4	AVDD	A-	+5V power supply (D/A, A/D)	61	LRS	O	Nomally unconnected
5	RL	AO	RL channel D/A output	60	/TC	Its	Initial clear (Power ON resetting is necessary)
6	FL	AO	FL channel D/A output	59	SYNCO	O	Test for SYNC, nomally DVDD
7	CHL	A-	LINS input, sample/hold Capacitor	58	DVDD	-	+5V power supply (Digital)
8	LINS	AI	L channel A/D input	57	SYNCI	It	Test for SYNC, nomally unconnected
9	RINS	AI	R channel A/D input	56	XI	I	Crystal oscillator
10	CHR	A-	RINS input, sample/hold Capacitor	55	XO	O	Crystal oscillator
11	FR	AO	FR channel D/A output	54	/CE	O	External PS-RAM chip enable
12	RR	AO	RR channel D/A output	53	A10	O	External PS-RAM address
13	CV	AO	A/D, multiplying DAC center Voltage	52	/OE	O	External PS-RAM output enable
14	AGND	A-	Ground (D/A, A/D)	51	A11	O	External PS-RAM address
15	AGND	A-	Ground (Multiplying DAC)	50	A9	O	External PS-RAM address
16	VREF	AI	Multiplying DAC reference Voltage	49	A8	O	External PS-RAM address
17	LINM	AI	L channel Multiplying DAC input	48	A13	O	External PS-RAM address
18	RINM	AI	R channel Multiplying DAC input	47	/WE	O	External PS-RAM write enable
19	VOLM	AO	L channel OP-Amp (-)	46	A14	O	External PS-RAM address
20	VOLP	AO	L channel OP-Amp (+)	45	A12	O	External PS-RAM address
21	VOCM	AO	C channel OP-Amp (-)	44	A7	O	External PS-RAM address
22	VOCP	AO	C channel OP-Amp (+)	43	A6	O	External PS-RAM address
23	VORM	AO	R channel OP-Amp (-)	42	A5	O	External PS-RAM address
24	VORP	AO	R channel OP-Amp (+)	41	DGND	-	Ground (Digital)
25	VVDD	A-	+5V power supply (Multiplying DAC)	40	DGND	-	Ground (Digital)
26	DVDD	-	+5V power supply (Digital)	39	A4	O	External PS-RAM address
27	D7	I/Ot	External PS-RAM data	38	A3	O	External PS-RAM address
28	D6	I/Ot	External PS-RAM data	37	A2	O	External PS-RAM address
29	D5	I/Ot	External PS-RAM data	36	A1	O	External PS-RAM address
30	D4	I/Ot	External PS-RAM data	35	A0	O	External PS-RAM address
31	D3	I/Ot	External PS-RAM data	34	D0	I/Ot	External PS-RAM data
32	D2	I/Ot	External PS-RAM data	33	D1	I/Ot	External PS-RAM data

Note : Letters used in the above I/O column represent as follows.

I: Input terminal O: Output terminal t: TTL level
 C: CMOS level S: Schmidt input A: Analog terminal

■ DISPLAY DATA

● V401 : 13-BT-143GK (VU105900)



● PIN CONNECTION

Pin No.	1	2	3	4	5	6	7	8	9	10	11	12	13	14	15	16	17	18	19	20	21
CONNECTION	F1	F1	NP	NP	P15	P14	P13	P12	P11	P10	P9	P8	P7	P6	P5	P4	P3	P2	P1	NX	NX

Pin No.	22	23	24	25	26	27	28	29	30	31	32	33	34	35	36	37	38	39	40	41
CONNECTION	NX	NX	NX	1G	2G	3G	4G	5G	6G	7G	8G	9G	10G	11G	12G	13G	NP	NP	F2	F2

- NOTE 1) F1, F2 Filament
 2) NP No pin
 3) NX No extend pin
 4) DL Datum Line
 5) 1G~13G Grid
 6) Angle of visual field
 33°min. on upper side.
 25°min. on lower side.

● GRID ASSIGNMENT

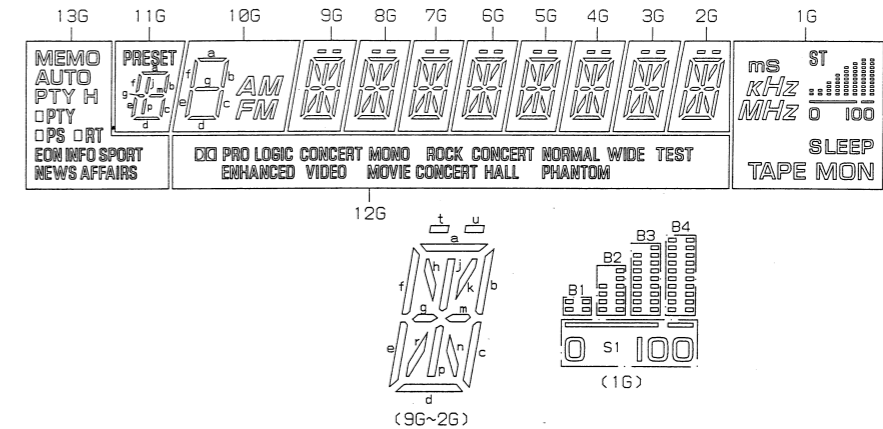

● ANODE CONNECTION

	13G	12G	11G	10G	9G	8G	7G	6G	5G	4G	3G	2G	1G
P1	MEMO	TEST	a	a	a	a	a	a	a	a	a	a	ms
P2	AUTO	WIDE	b,c	b	b	b	b	b	b	b	b	b	KHz
P3	PTY H	NORMAL	d	c	c	c	c	c	c	c	c	c	MHz
P4	PTY	PHANTOM	e,f	d	d	d	d	d	d	d	d	d	ST
P5	(PTY)	CONCERT HALL	g	e	e	e	e	e	e	e	e	e	B1
P6	RT	ROCKT CONCERT	j,p	f	f	f	f	f	f	f	f	f	B2
P7	(RT)	RADIO MOVIE	m	g	g	g	g	g	g	g	g	g	B3
P8	PS	CONCERT VIDEO	PRESET	AM	h	h	h	h	h	h	h	h	B4
P9	(RS)	EXI PRO LOGIC	-	FM	j	j	j	j	j	j	j	j	S1
P10	SPORT	ENHANCED	-	-	k	k	k	k	k	k	k	k	SLEEP
P11	INFO	-	-	-	m	m	m	m	m	m	m	m	TAPE MON
P12	AFFAIRS	-	-	-	n	n	n	n	n	n	n	n	-
P13	NEWS	-	-	-	p	p	p	p	p	p	p	p	-
P14	EON	-	-	-	r	r	r	r	r	r	r	r	-
P15	-	-	-	-	t,u	t,u	t,u	t,u	t,u	t,u	t,u	t,u	-

NO.	Name	Terminal name	Function
1	VSS1	Ground terminal	Connection to GND (Digital system ground terminal)
2	XTAL IN	Crystal oscillation terminal	Terminal to connect the crystal of the crystal oscillator for internal synchronous signal generation and a capacitor or to input an external clock. (2fsc or 4fsc)
3	XTAL OUT	terminal	
4	CTRL1	Crystal oscillation input switching terminal	Switching terminal between the mode to input a clock externally and the mode for crystal oscillation. [L] = Crystal oscillation, [H] = External clock input.
5	BLANK	Blank output terminal	Terminal to output the blank signal (character and bordering OR signal) (MOD0 : complex synchronous signal output at [H]). When resetting (RST terminal = [L]), a crystal oscillation clock is output (but not when resetting by the command).
6	OSC IN	LC oscillation terminal	Terminal to connect the coil of the oscillator character output dot clock generator and capacitor.
7	OSC OUT		
8	CHARA	Character output terminal	Terminal to output a character signal (MOD0 : It becomes an output terminal to judge the external synchronous signal at [H] and outputs the result after judging existence of the external synchronous signal. When a synchronous signal exists, [H] is output.) When resetting (RST terminal = [L]), a dot clock (LC oscillation) is output (but it is not output when reset by the command).
9	/CS	Enable input terminal	Serial data input enable input terminal. The serial data input becomes enable at [L]. A pull-up resistor is built in (hysteresis input).
10	SCLK	Clock input terminal	Input terminal of clock for serial data input. A pull-up resistor is built in (hysteresis input).
11	SIN	Data input terminal	Serial data input terminal. A pull-up resistor is built in (hysteresis input).
12	VDD2	Power supply terminal	Power supply terminal for complex image signal level adjustment (Power supply for analog system)
13	CV OUT	Video signal output terminal	Output terminal for complex image signal.
14	NC		Connected GND or unconnected.
15	CV IN	Video signal input terminal	Input terminal for complex image signal.
16	VDD1	Power supply terminal	Power supply terminal (+5V : power supply for digital system)
17	SYN IN	Synchronous separation circuit input terminal	Video signal input terminal of the built-in synchronous separation circuit (When the built-in synchronous separation circuit is not used, it becomes a horizontal synchronous signal input or a complex synchronous signal input.)
18	SEP C	Synchronous separation circuit bias voltage terminal	Terminal to monitor built-in synchronous separation circuit bias voltage.
19	SEP OUT	Complex synchronous signal output terminal	Terminal to output a complex synchronous signal of built-in synchronous separation circuit [H] when internally synchronized at MOD1 : [H], [L] output when externally synchronized) (When the built-in synchronous separation circuit is not used, SYNIN input signal is output.)
20	SEP IN	Vertical synchronous signal input terminal	Terminal to input a vertical synchronous signal by integrating the output signal of SEPOUT terminal. Connect the integration circuit between SEPOUT terminals. Fix it to VDD1 when not used.
21	CTRL2	NTSC/PAL-M switching input terminal	Pin setting has a priority over switching of NTSC/PAL/PAL-M/PAL-N method. The NTSC method is selected after [L] = reset. NTSC/PAL/PAL-M/PAL-N method setting by a command is effective. [H] = PAL-M method.
22	CTRL3	SEPIN input control terminal	Terminal to control whether or not to input VSYNC signal into SEPIN input terminal. [L] = VSYNC not inputted.
23	/RST	Reset input terminal	System reset input terminal. A pull-up resistor is built in (hysteresis input).
24	VDD1	Power supply terminal (+5V)	Power supply terminal (+5V : power supply for digital system)

■ BLOCK DIAGRAM (1/2)

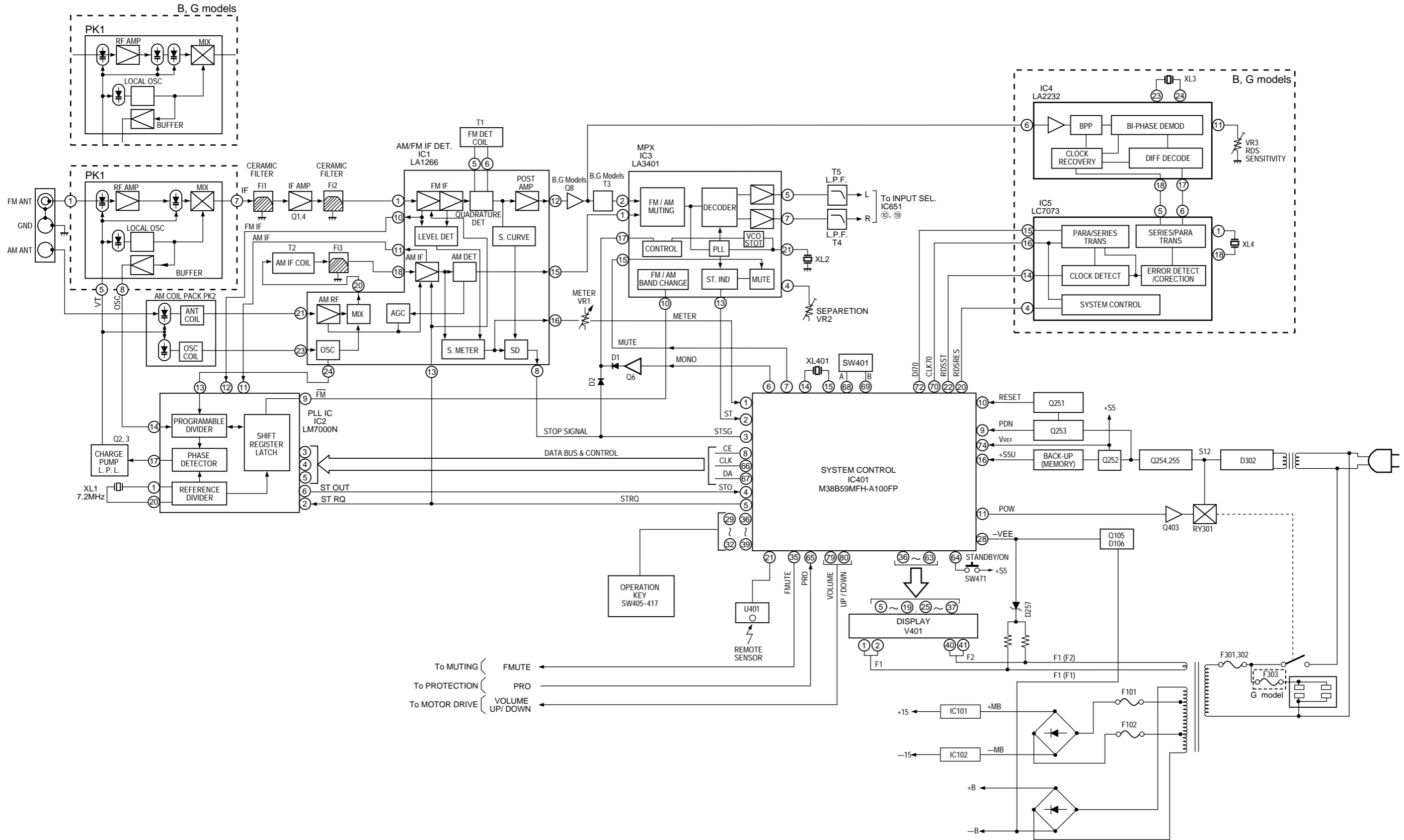

■ BLOCK DIAGRAM (2/2)

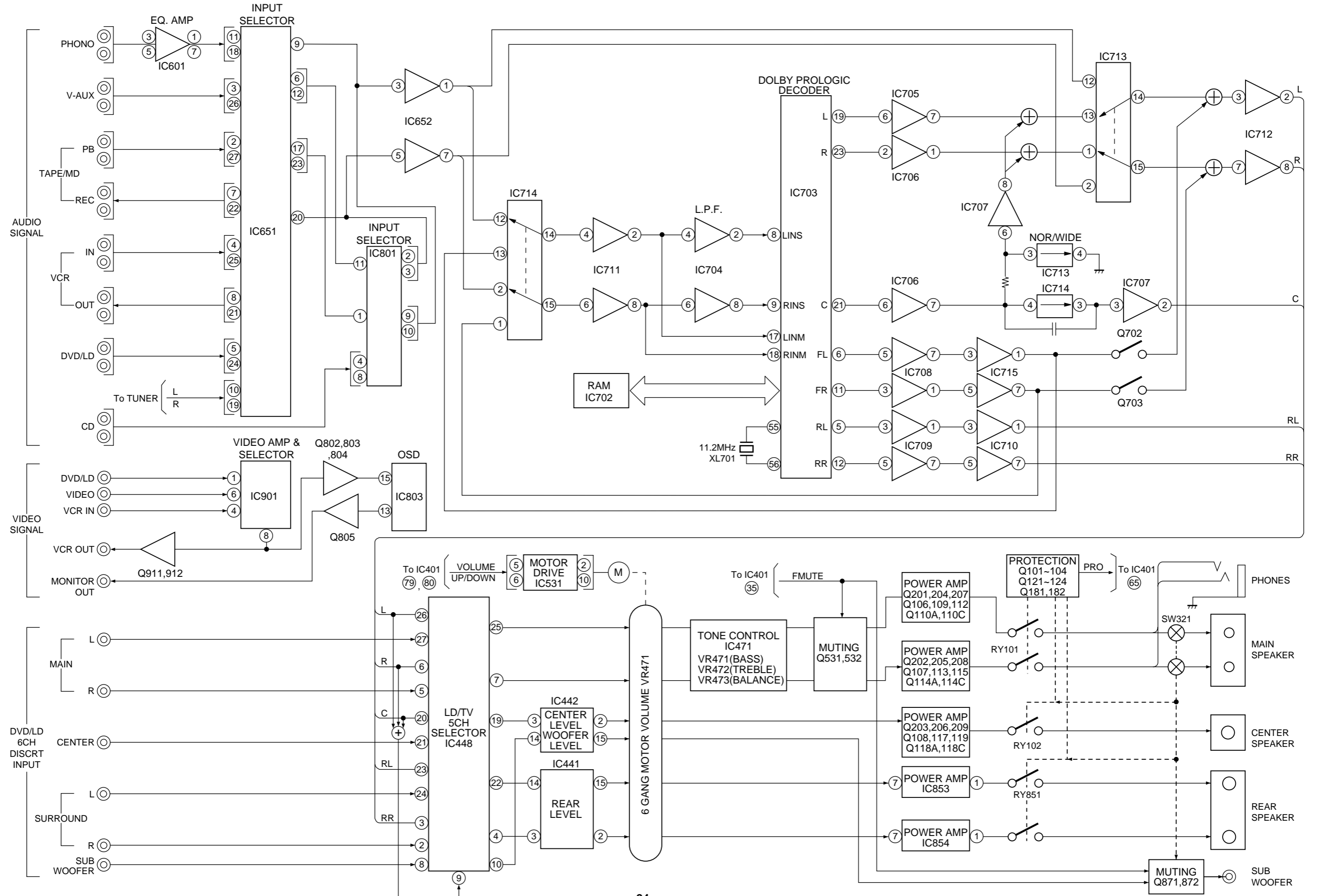

PRINTED CIRCUIT BOARD (Foil side)

① ~ ③ : TEST POINT WAVEFORMS(See page 43)

R model

TUNER P. C. B.

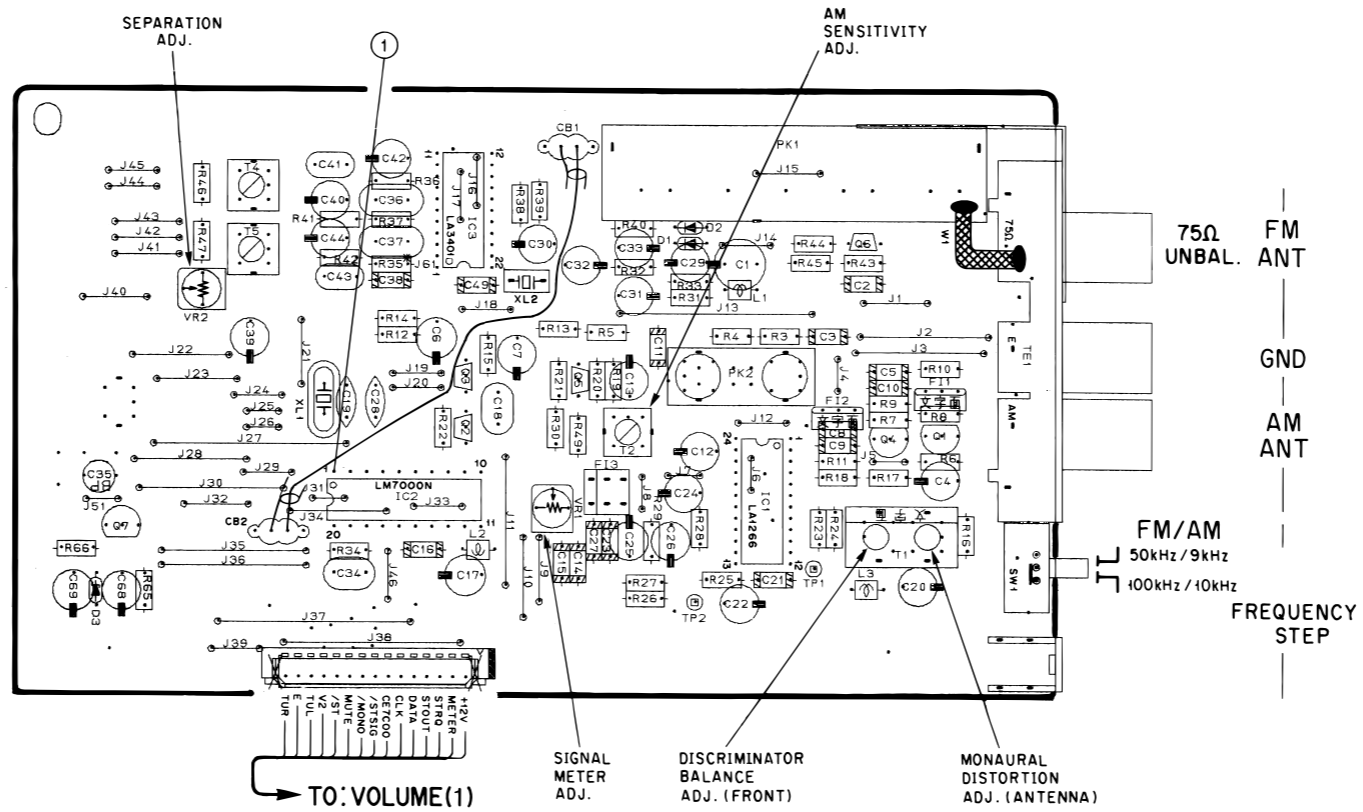

Semiconductor Location
R model
TUNER P.C.B.

Ref. No.	Location
D1	E2
D2	E2
D3	C3
IC1	E2
IC2	D2
IC3	D2
Q1	F2
Q2	D2
Q3	D2
Q4	E2
Q5	E2
Q6	E2
Q7	C3

B,G, models

TUNER P. C. B.

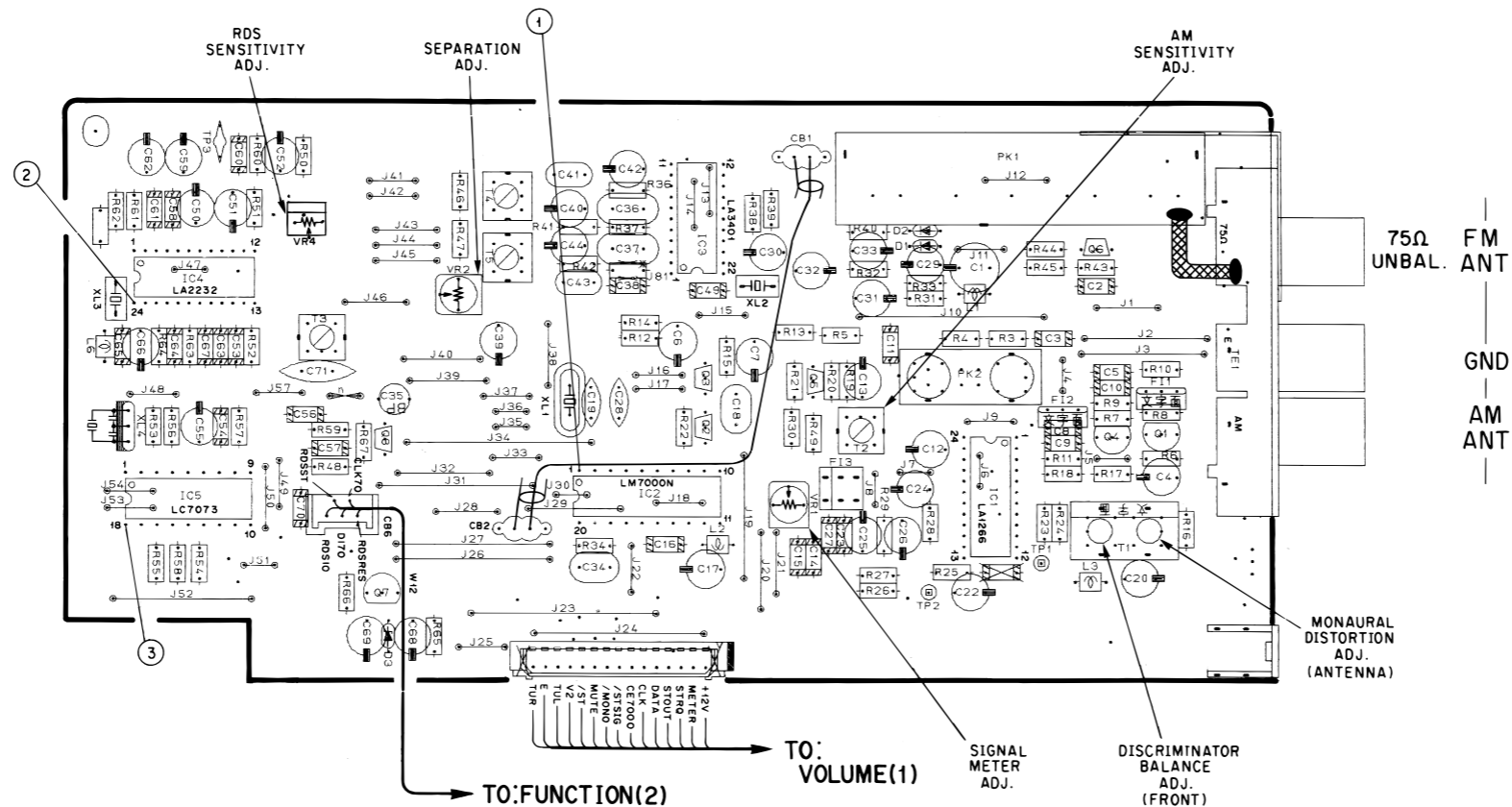

Semiconductor Location
B, G models
TUNER P.C.B.

Ref. No.	Location
D1	E4
D2	E4
D3	C5
IC1	E5
IC2	D5
IC3	D4
IC4	C4
IC5	C5
Q1	F5
Q2	D5
Q3	D5
Q4	E5
Q5	E5
Q6	E4
Q7	C5
Q8	C5

PRINTED CIRCUIT BOARD (Foil side)

● R model

MAIN P. C. B. (3)

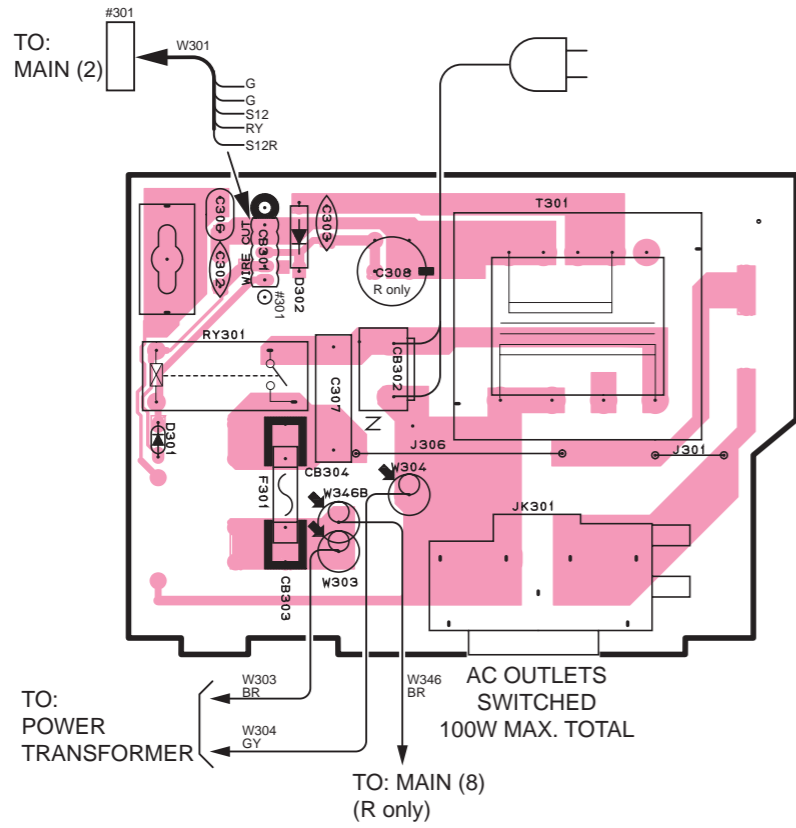

● B, G models

MAIN P. C. B. (3)

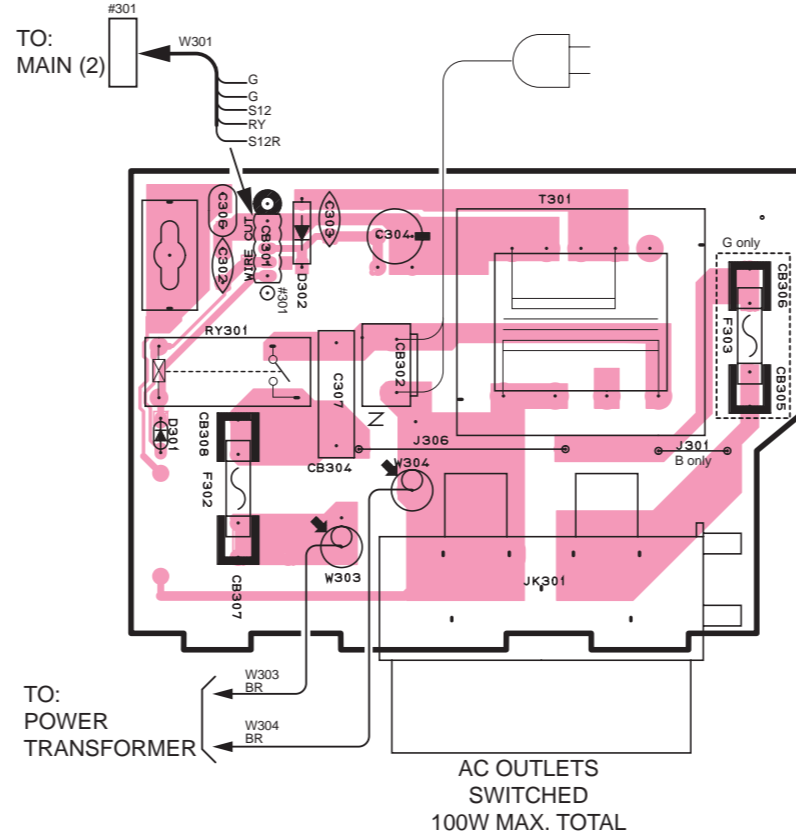

MAIN P. C. B. (5)

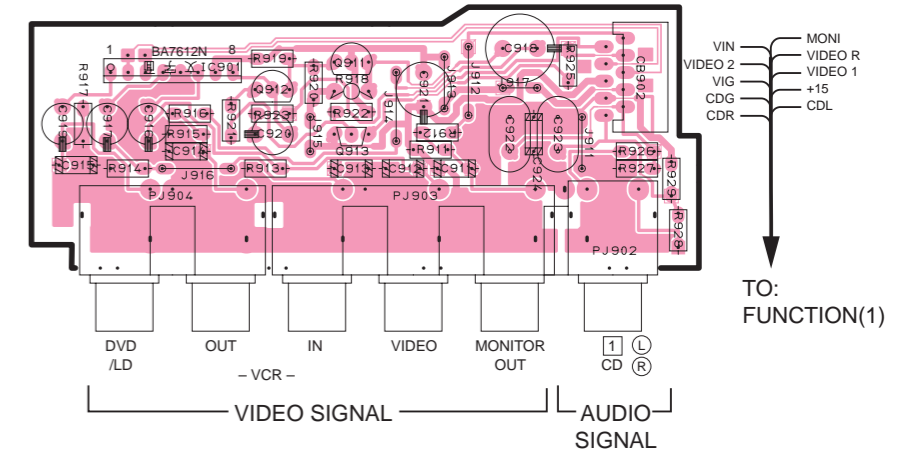

MAIN P. C. B. (7)

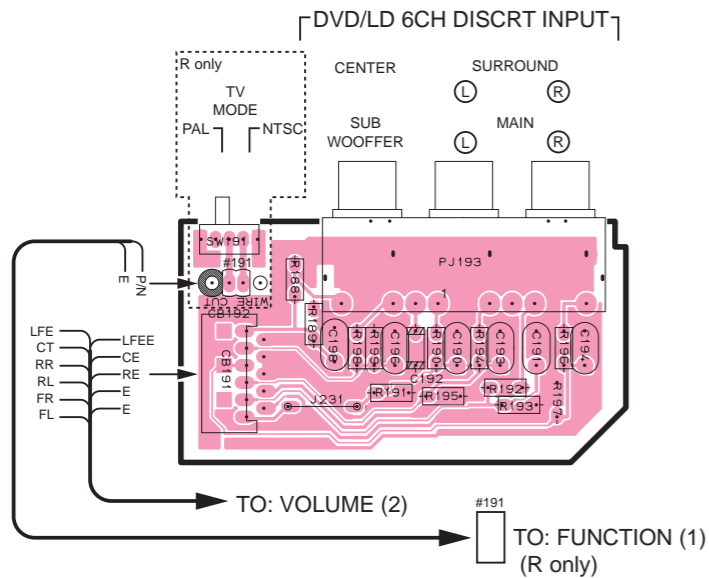

● R model

MAIN P. C. B. (8)

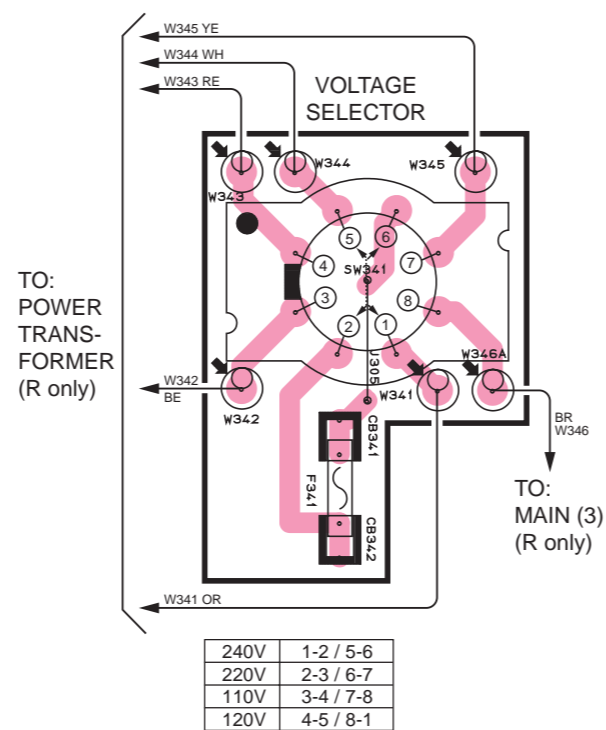

MAIN P. C. B. (9)

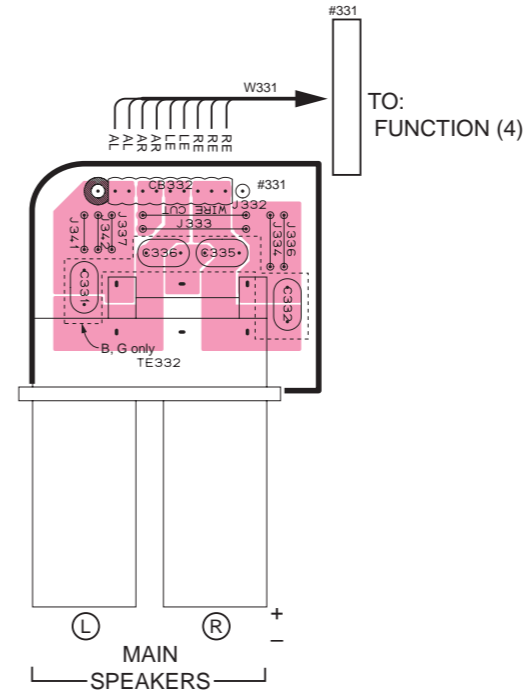

MAIN P. C. B. (10)

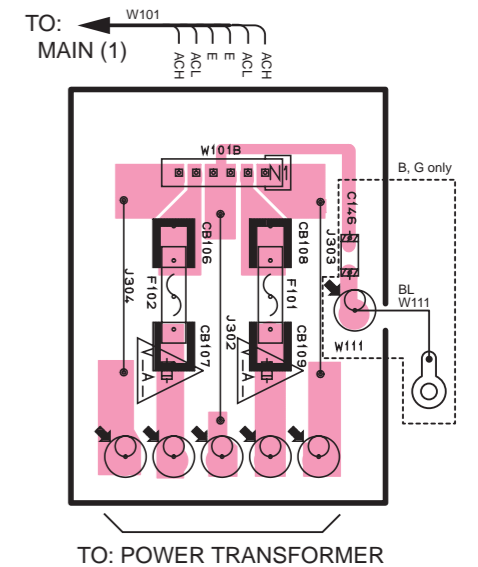

PRINTED CIRCUIT BOARD (Foil side)

● Semiconductor Location

Ref. No.	Location
D101	D4
D102	C4
D103	F2
D104	C4
D106	C4
D107	B3
D108	C3
D109	C2
D110	B2
D111	E2
D112	D3
D113	B2
D201	G4
D251	F5
D253	G5
D254	G5
D255	G5
D256	G5
D257	G4
D258	F5
D851	E5
D852	E5
D853	E5
D854	E5
IC101	B2
IC102	C4
IC853	E5
IC854	E4
Q101	C4
Q102	C4
Q103	C4
Q104	C4
Q105	C4
Q106	D2
Q107	C2
Q108	E2
Q109	D2
Q110A	D2
Q110C	D2
Q111	D2
Q113	C2
Q114A	C2
Q114C	B2
Q115	C2
Q117	E2
Q118A	F2
Q118C	E2
Q119	E2
Q121	E2
Q122	C2
Q123	B2
Q124	E2
Q181	C4
Q182	C4
Q201	G4
Q203	G4
Q204	G4
Q205	H4
Q206	G4
Q207	G5
Q208	H5
Q209	G5
Q251	G5
Q252	G5
Q253	G5
Q254	F5
Q255	F5
Q871	G2
Q872	G2

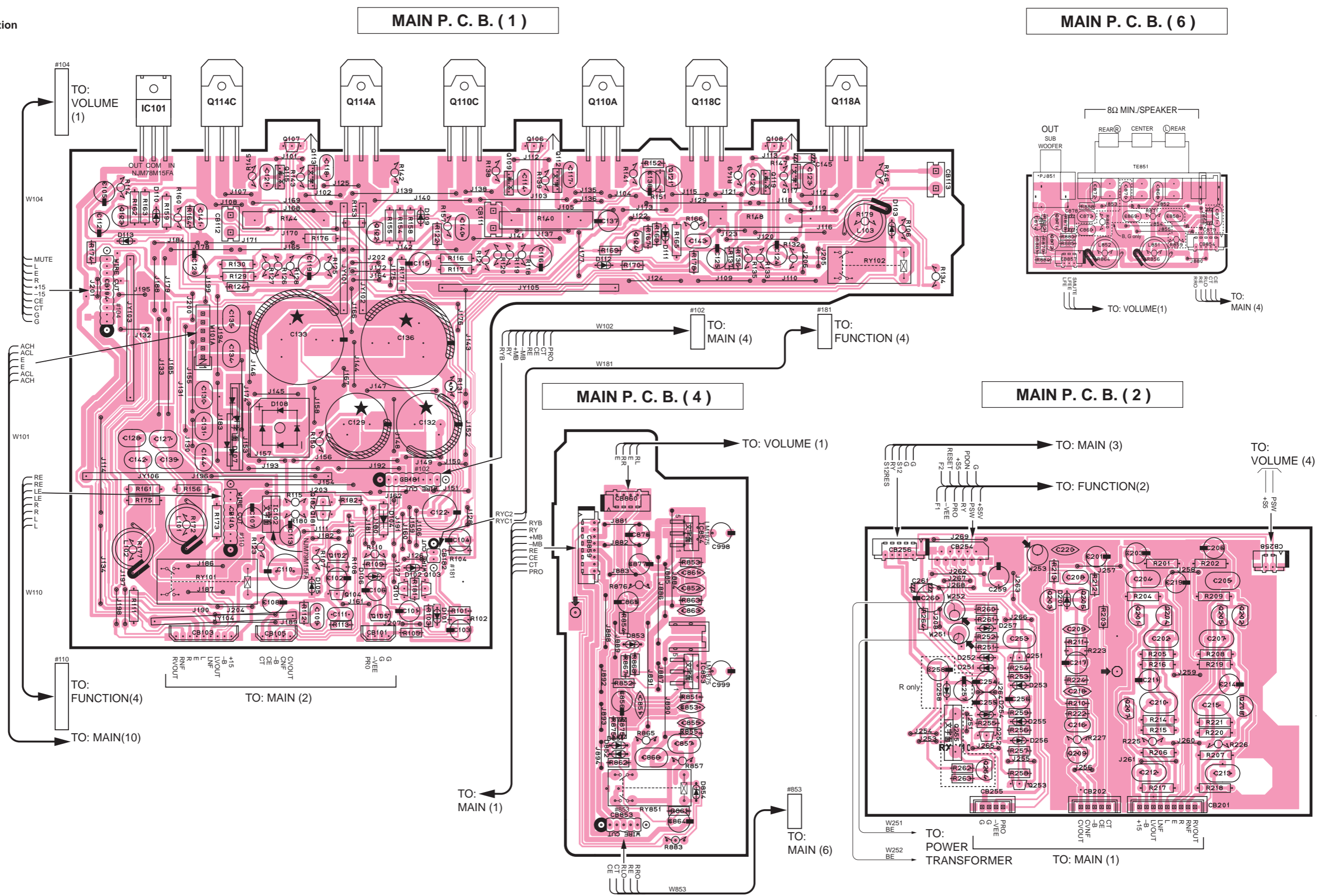

PRINTED CIRCUIT BOARD (Foil side)

FUNCTION P. C. B. (3)

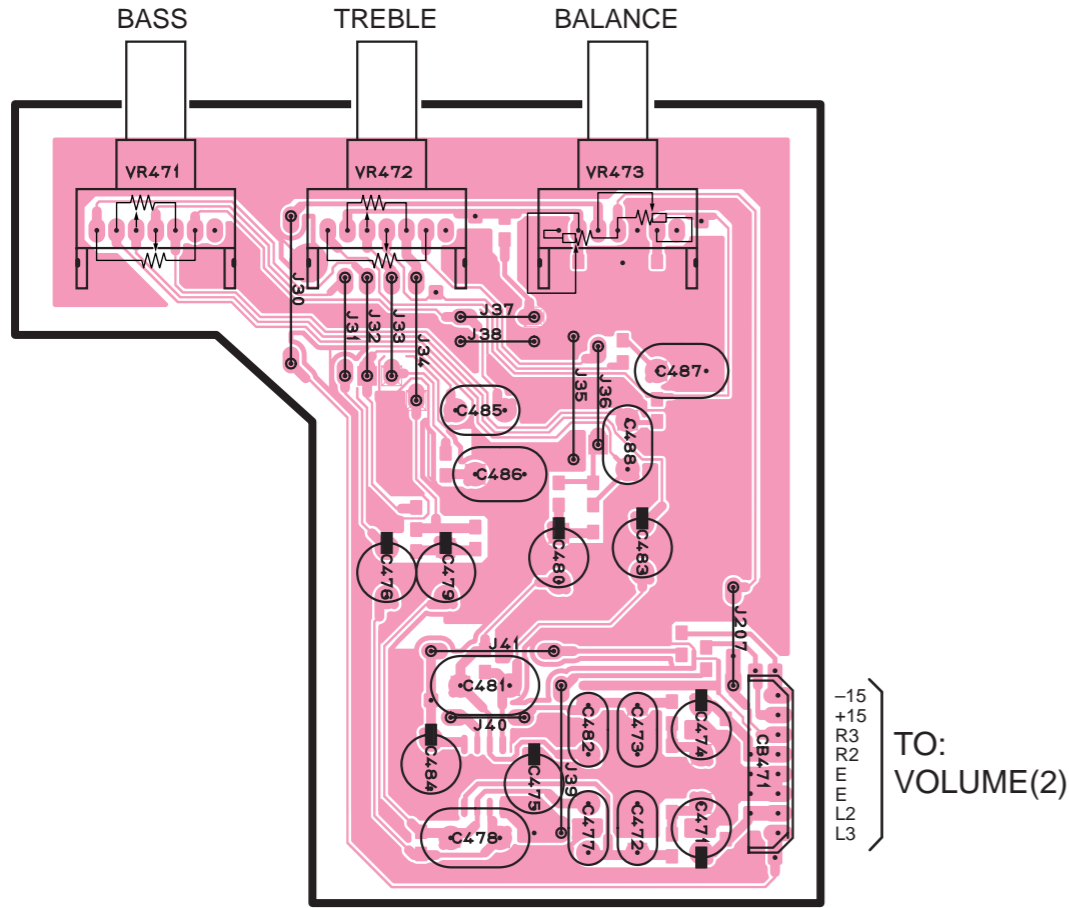

FUNCTION P. C. B. (4)

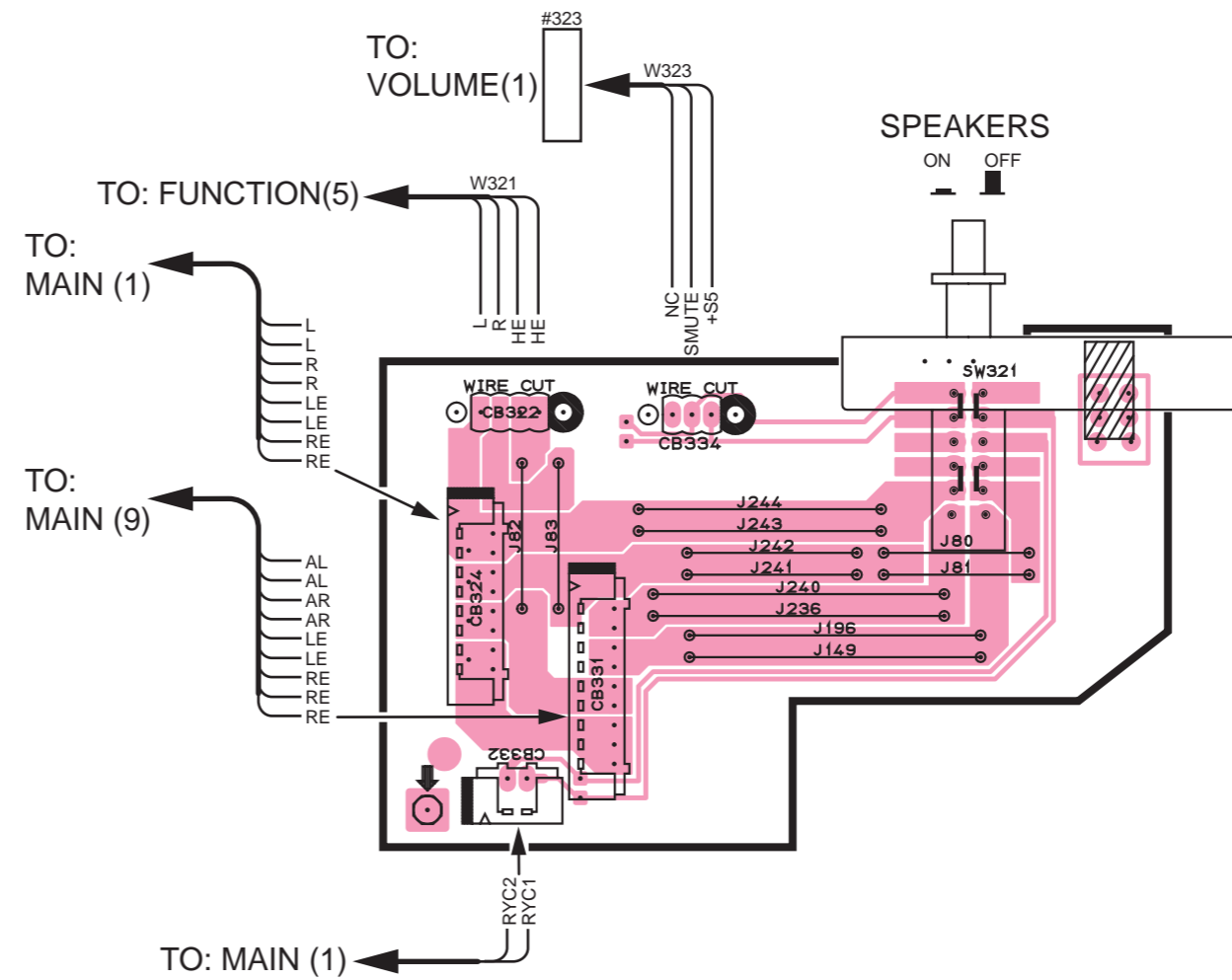

FUNCTION P. C. B. (5)

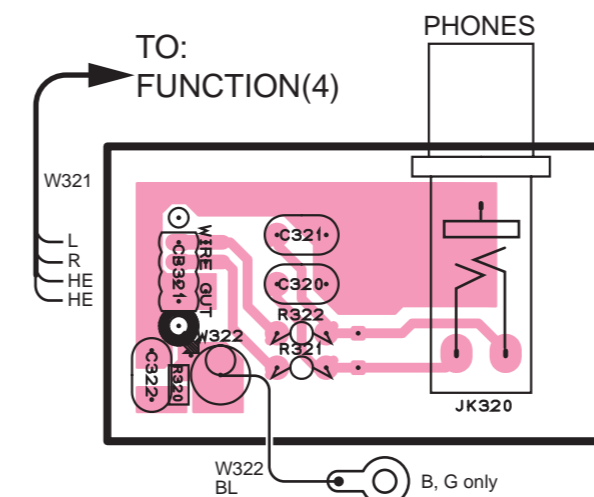

PRINTED CIRCUIT BOARD (Foil side)

⑥ : TEST POINT WAVEFORMS(See page 40)

● Semiconductor Location

Ref. No.	Location
D701	E5
D702	D5
D703	D5
D704	D5
D705	D5
D706	D5
D707	D5
D708	D5
D709	D5
D710	C5
D711	C5
D712	G5
D713	G5
D714	F5
D715	B5
D801	F5
D802	F5
D803	F5
IC651	G3
IC652	F5
IC701	F3
IC702	E4
IC703	E5
IC704	D5
IC705	D5
IC706	E5
IC707	E5
IC708	D5
IC709	D4
IC710	C4
IC711	D5
IC712	C4
IC713	D5
IC714	D5
IC715	C5
IC801	F5
IC802	F2
IC803	G2
Q701	B3
Q702	C2
Q703	C2
Q704	C3
Q705	C3
Q801	F3
Q802	G3
Q803	G3
Q804	F3
Q805	F2

FUNCTION P. C. B. (1)

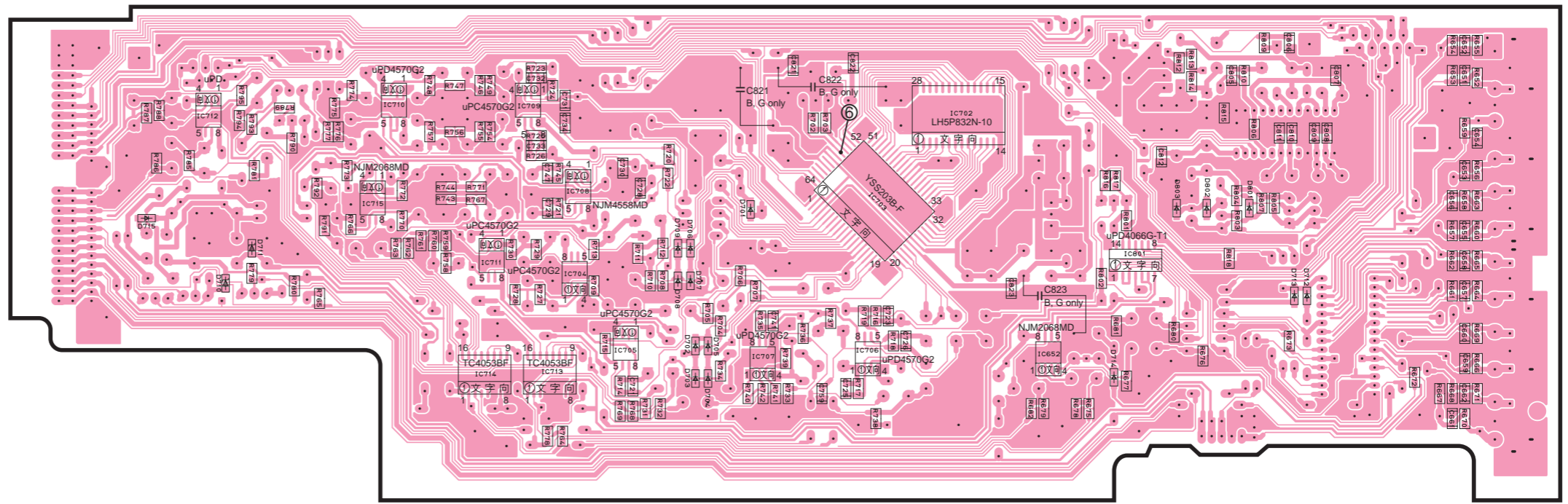
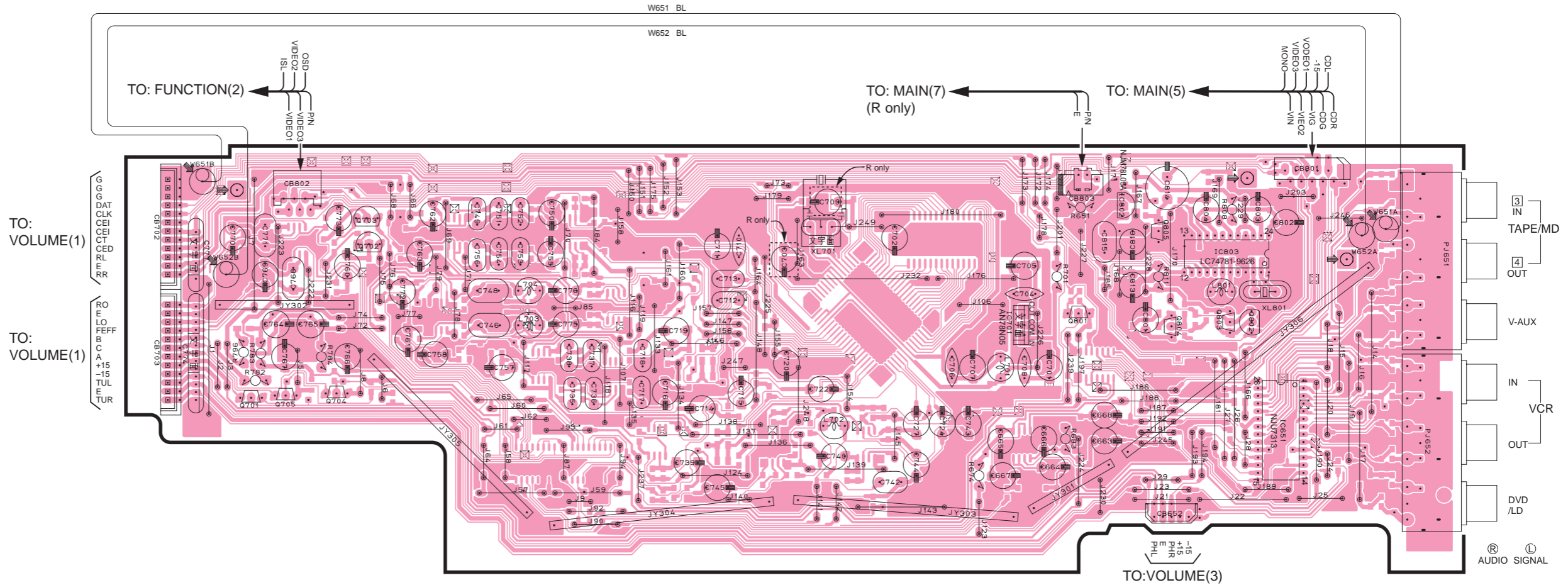

PRINTED CIRCUIT BOARD (Foil side)

④,⑤ : TEST POINT WAVEFORMS(See page 40)

FUNCTION P. C. B. (2)

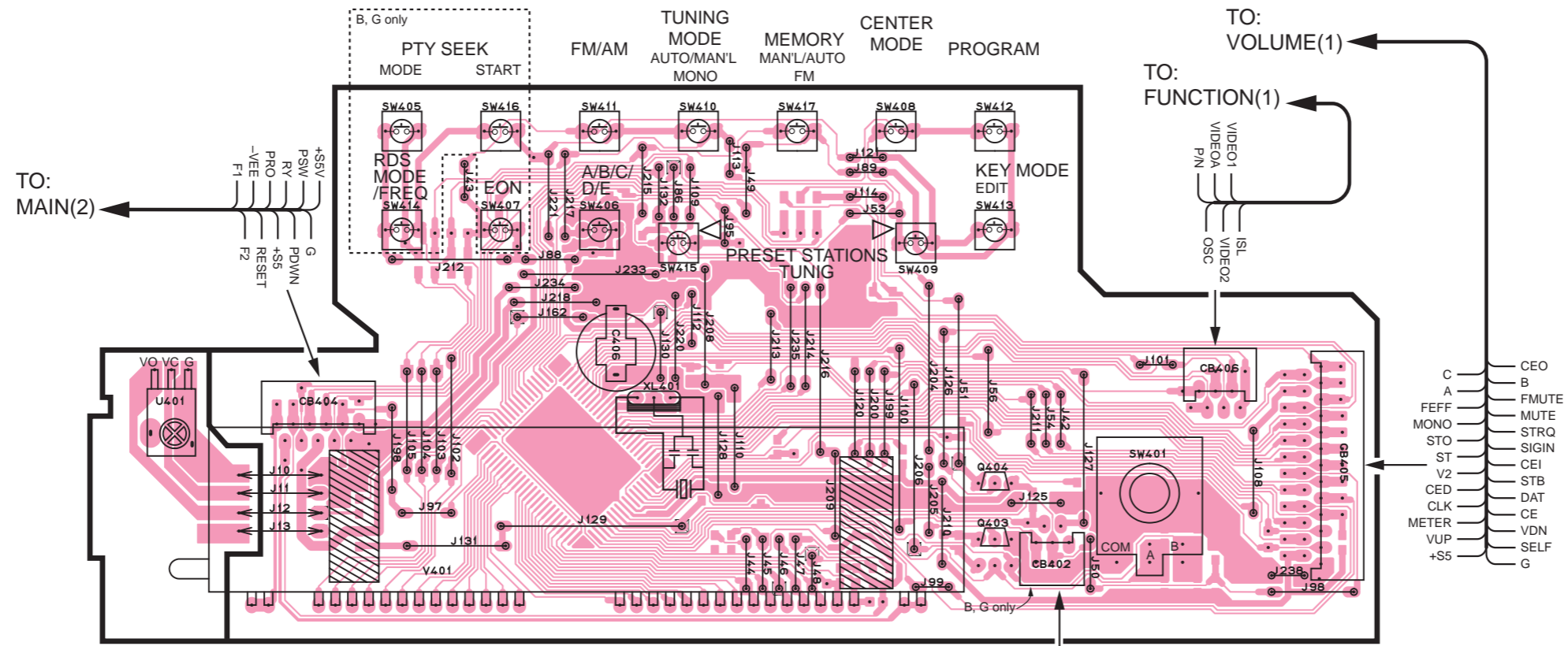

Semiconductor Location

Ref. No.	Location
D402	C5
D403	C5
D404	C5
D405	C5
D406	D4
D407	D4
D408	D4
IC401	D5
Q403	E5
Q404	E3

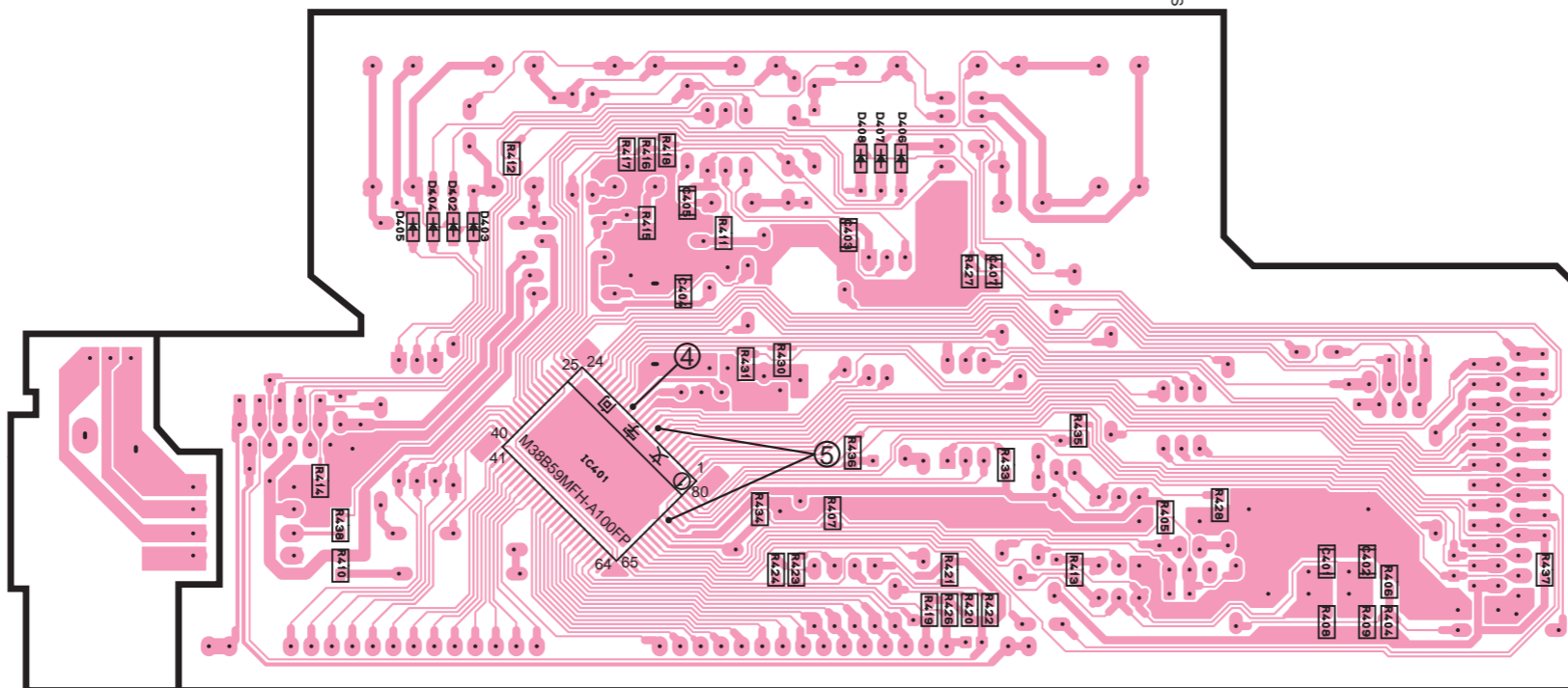

SCHEMATIC DIAGRAM (FUNCTION)

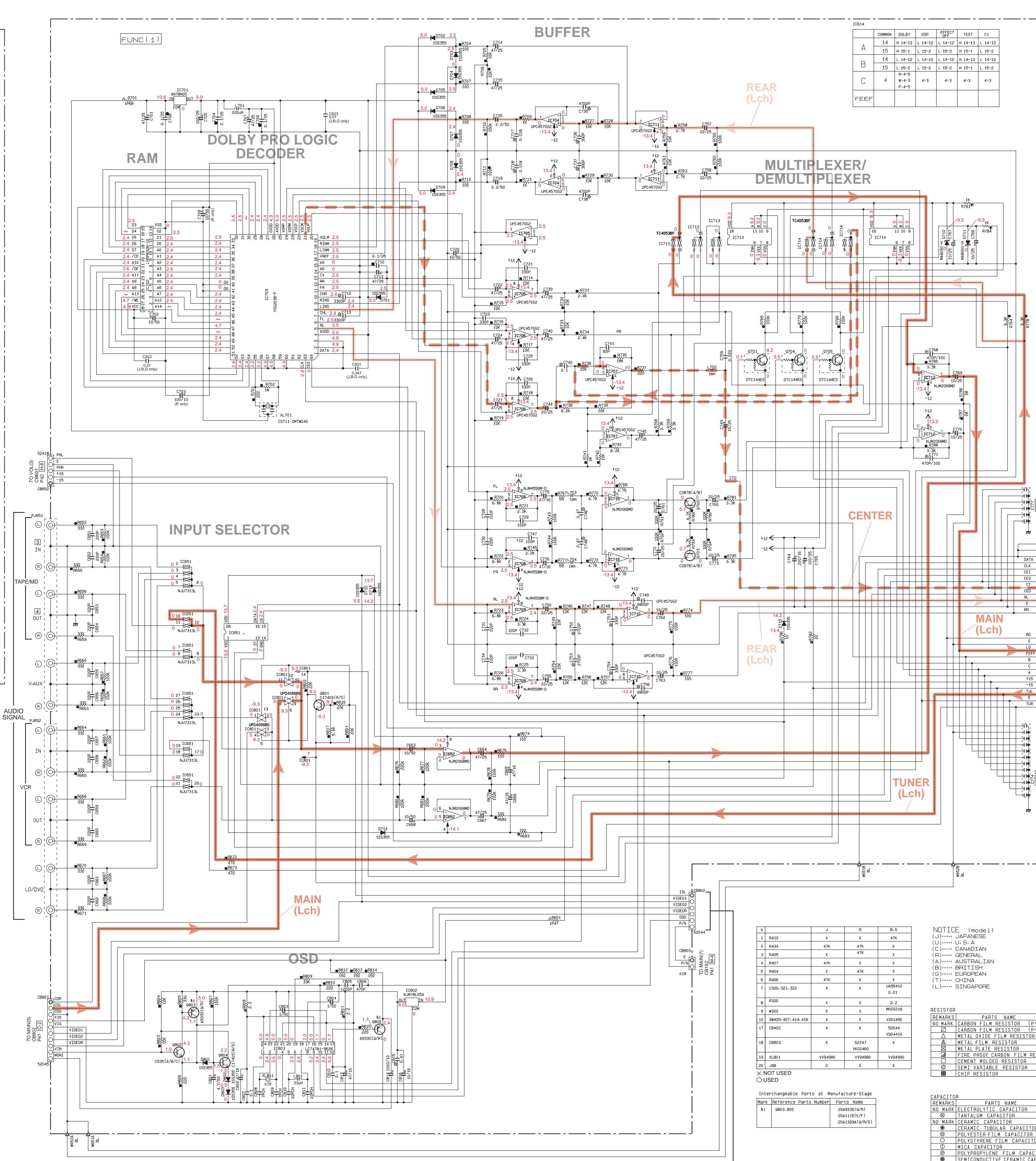
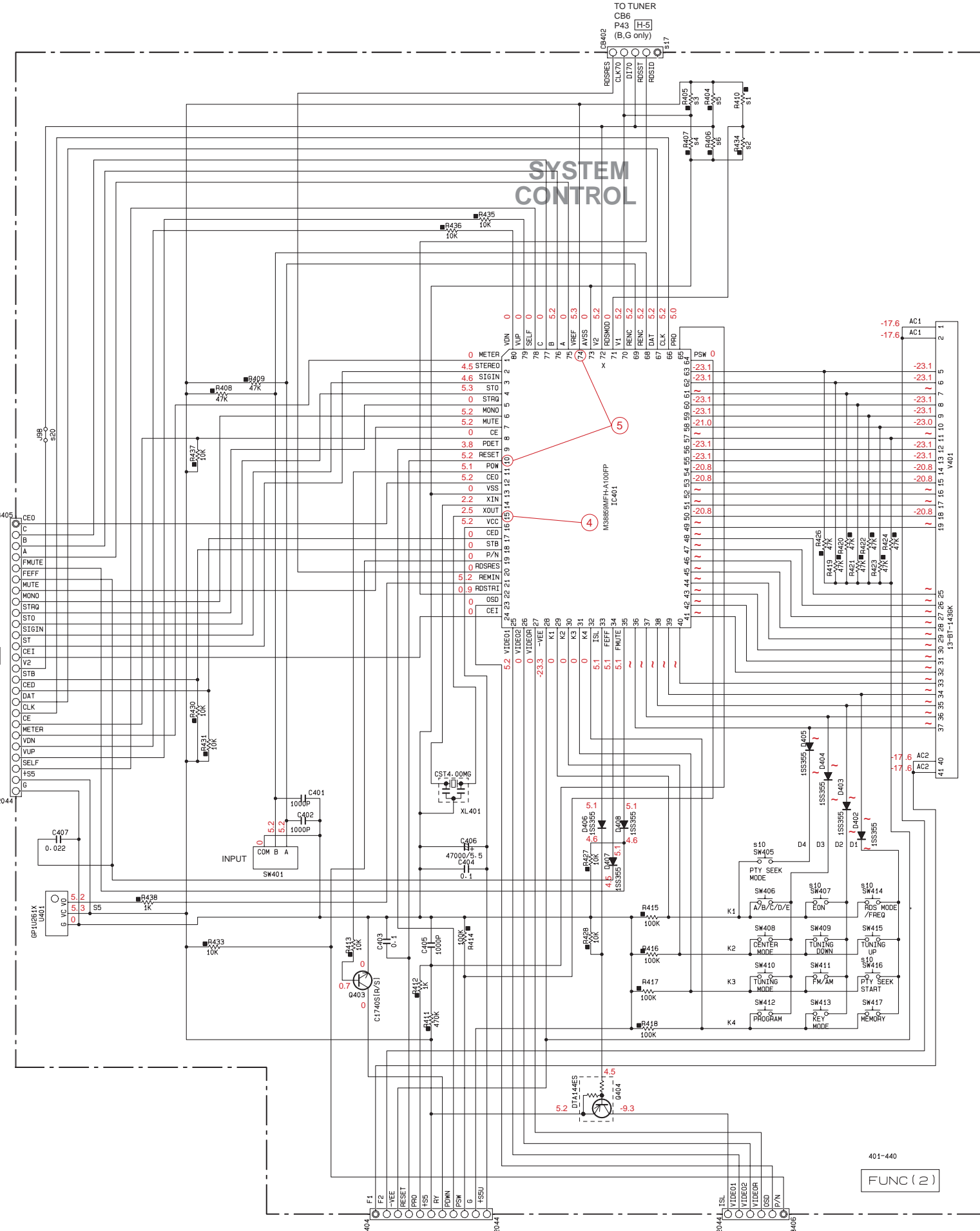

IC BLOCK

IC704-707, 710, 711 : uPC4570G2 Dual OP-Amp

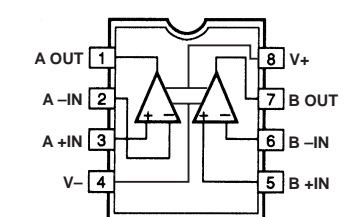

IC471, 652, 712, 715 : NJM2068MD IC708, 709 : NJM4558MD Dual OP-Amp

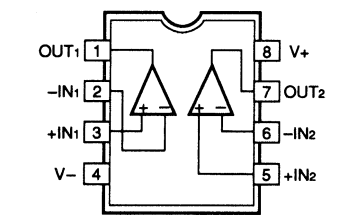

IC651 : NJU7313 Analog Function Switch

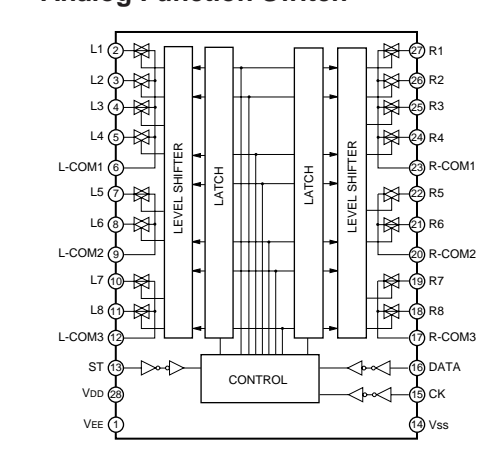

IC713, 714 : TC4053BF Triplet 2-Channel Multiplexer / Demultiplexer

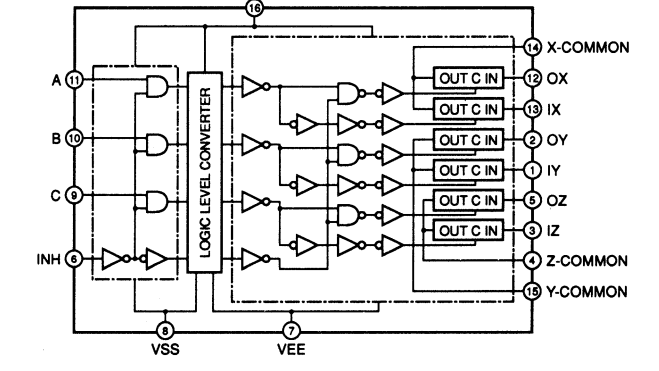

CONTROL INPUTS table with columns for INHIBIT, C, A, and ON CHANNEL, and rows for L, H, and X states.

IC801 : uPD4066G-T1 Quad Bilateral Switch

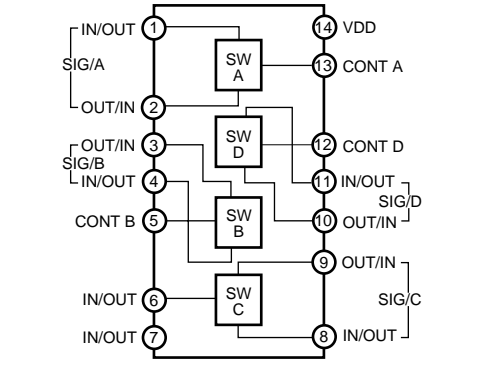

TEST POINT WAVEFORMS

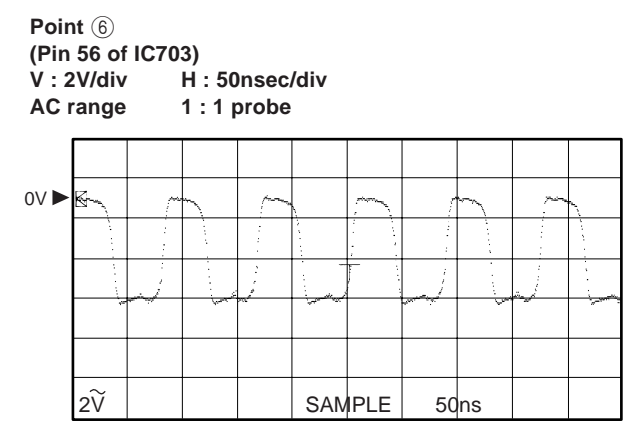
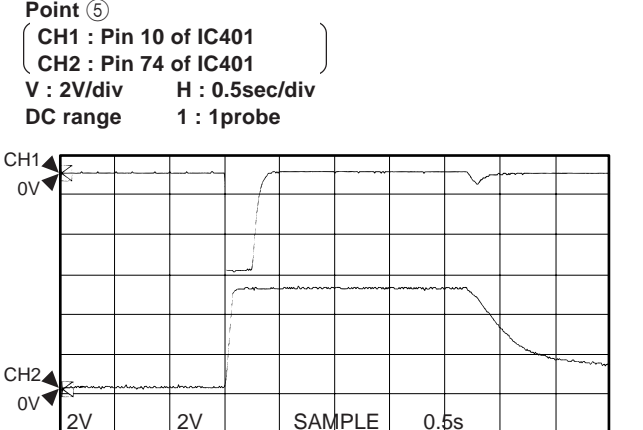
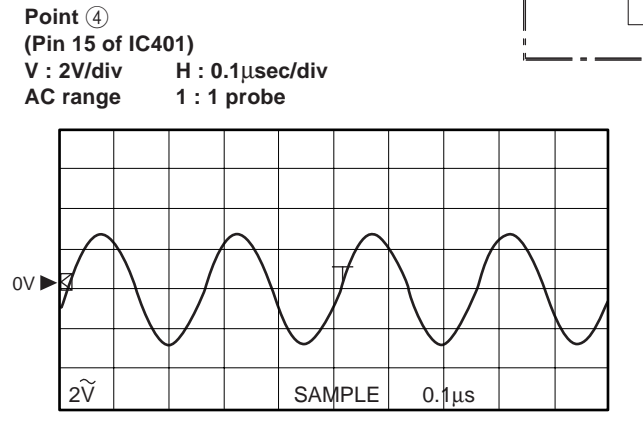

With the POWER switch turned ON, connect the power cord to the AC outlet. Disconnect the power cord from the AC outlet. This waveform is not available by pushing the power switch ON and OFF.

PIN CONNECTION DIAGRAM OF TRANSISTORS, DIODES AND IC'S.

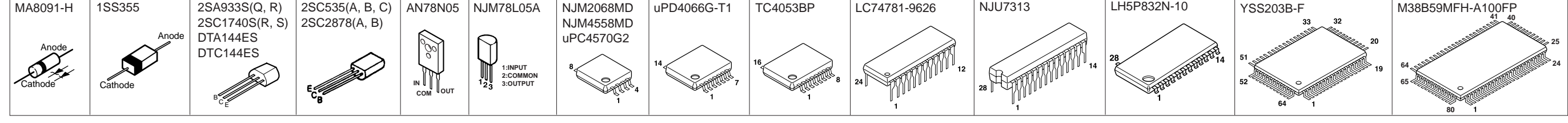

NOTICE (model) table with columns for RESISTOR and CAPACITOR, and rows for various part numbers and values.

All voltages are measured with a 10MΩ/V DC electric volt meter. Components having special characteristics are marked with a triangle symbol and must be replaced with parts having specifications equal to those originally installed. Schematic diagram is subject to change without notice.

SCHEMATIC DIAGRAM (MAIN)

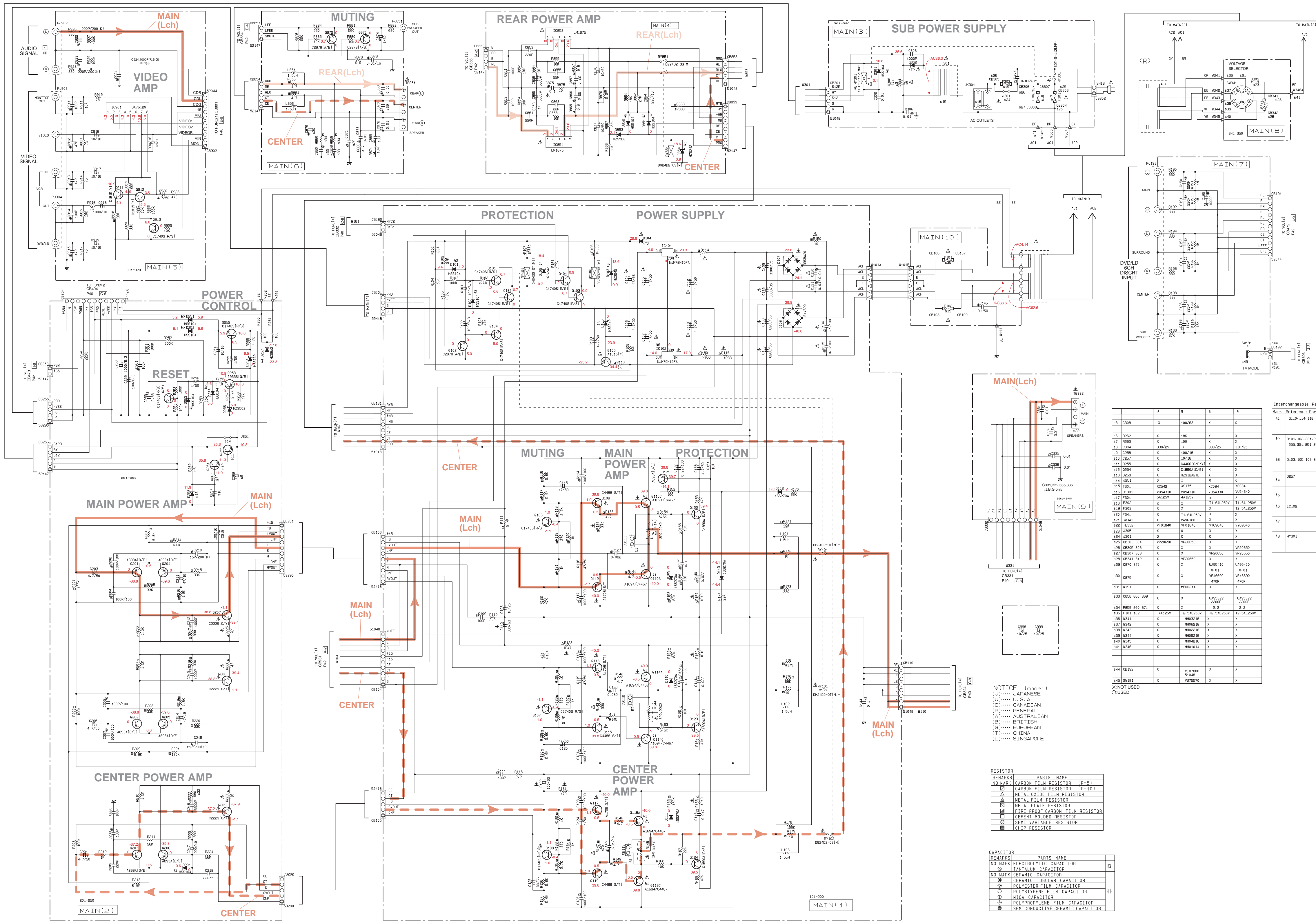

Interchangeable Parts at Manufacture Stage

Mark	Reference Parts Number	Parts Name
41	G10-114-11B	A1894/C467(D/R/V1)
	A1949/C5197(R/V0)	
42	D101-102-201-201-203	H8E104
	205-201-051-050	1S133
		1S176
43	D103-105-106-054	H28242D
		WJ28A-0C
44	D257	H2862
		WJ28A-GA
45	IC102	NJM79M5FA
		AN79M5F
46		
47	RY301	S0179-112LM
		DS018-01M-11
		ALX321

NOTICE (mode1)
 (J)..... JAPANESE
 (U)..... U.S.A
 (C)..... CANADIAN
 (R)..... GENERAL
 (A)..... AUSTRALIAN
 (B)..... BRITISH
 (G)..... EUROPEAN
 (T)..... CHINA
 (L)..... SINGAPORE

RESISTOR

REMARKS	PARTS NAME
NO MARK	CARBON FILM RESISTOR (P=5)
□	CARBON FILM RESISTOR (P=10)
△	METAL OXIDE FILM RESISTOR
○	METAL FILM RESISTOR
■	METAL PLATE RESISTOR
□	FIRE PROOF CARBON FILM RESISTOR
□	CEMENT MOLDED RESISTOR
□	SEMI VARIABLE RESISTOR
□	CHIP RESISTOR

CAPACITOR

REMARKS	PARTS NAME
NO MARK	ELECTROLYTIC CAPACITOR
□	TANTALUM CAPACITOR
○	NO MARK CERAMIC CAPACITOR
●	CERAMIC TUBULAR CAPACITOR
○	POLYESTER FILM CAPACITOR
○	POLYPROPYLENE FILM CAPACITOR
○	MICA CAPACITOR
○	POLYPROPYLENE FILM CAPACITOR
○	SEMICONDUCTIVE CERAMIC CAPACITOR

IC BLOCK

IC853, 854 : LM1875T
 20W Audio Power Amp

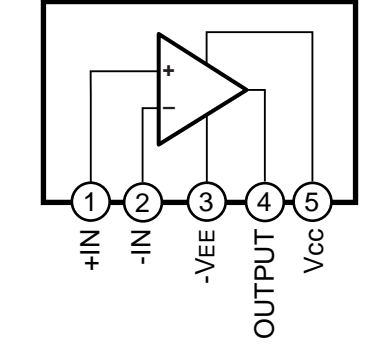

IC901 : BA7612N
 3-Input Video Switch with 6dB Amp

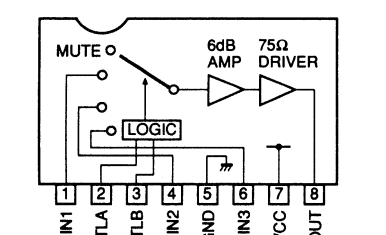

PIN CONNECTION DIAGRAM OF TRANSISTORS, DIODES AND IC's.

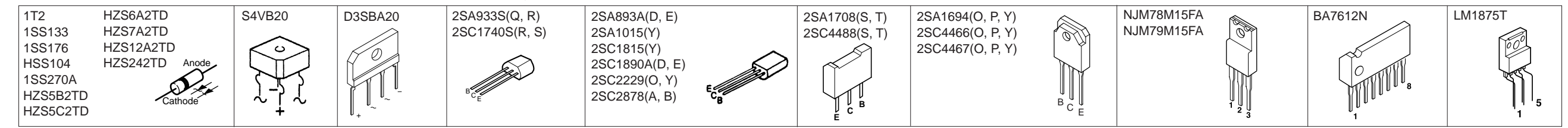

All voltages are measured with a 10MΩ/V DC electric volt meter.
 Components having special characteristics are marked with a triangle and must be replaced with parts having specifications equal to those originally installed.
 Schematic diagram is subject to change without notice.

■ SCHEMATIC DIAGRAM (VOLUME)

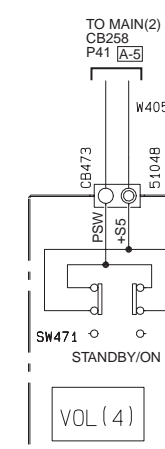
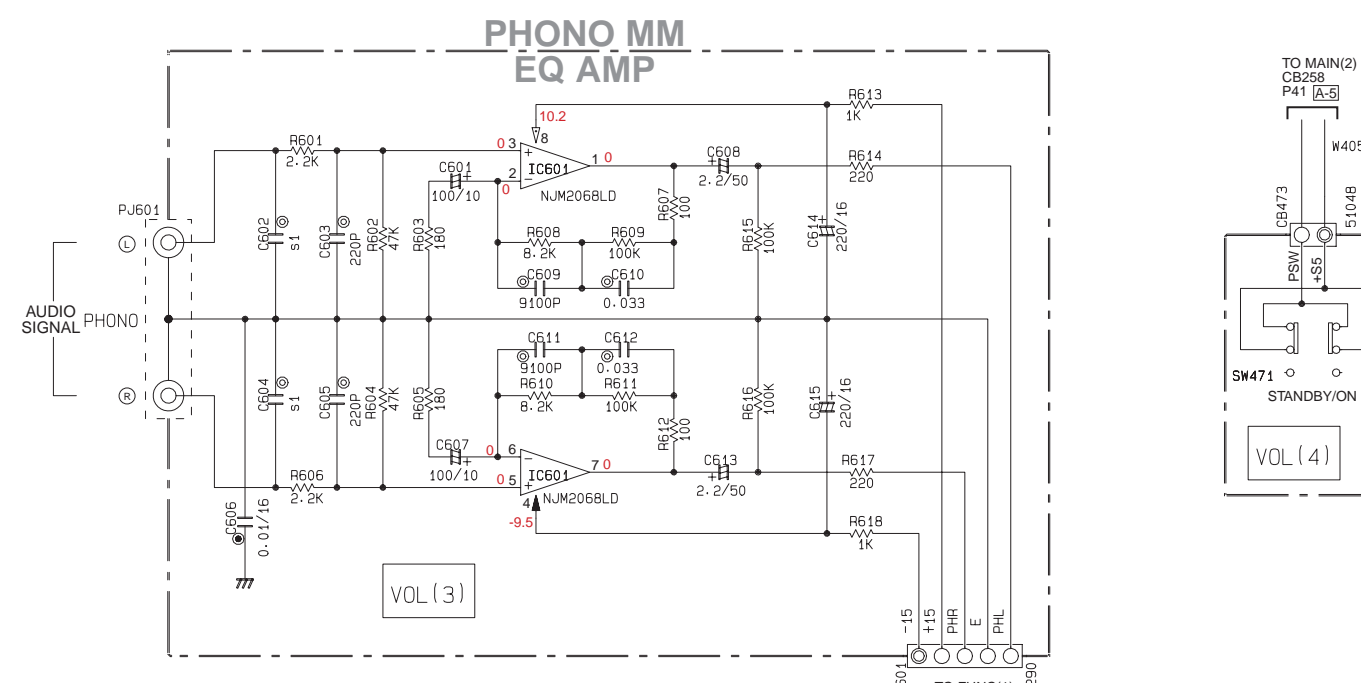
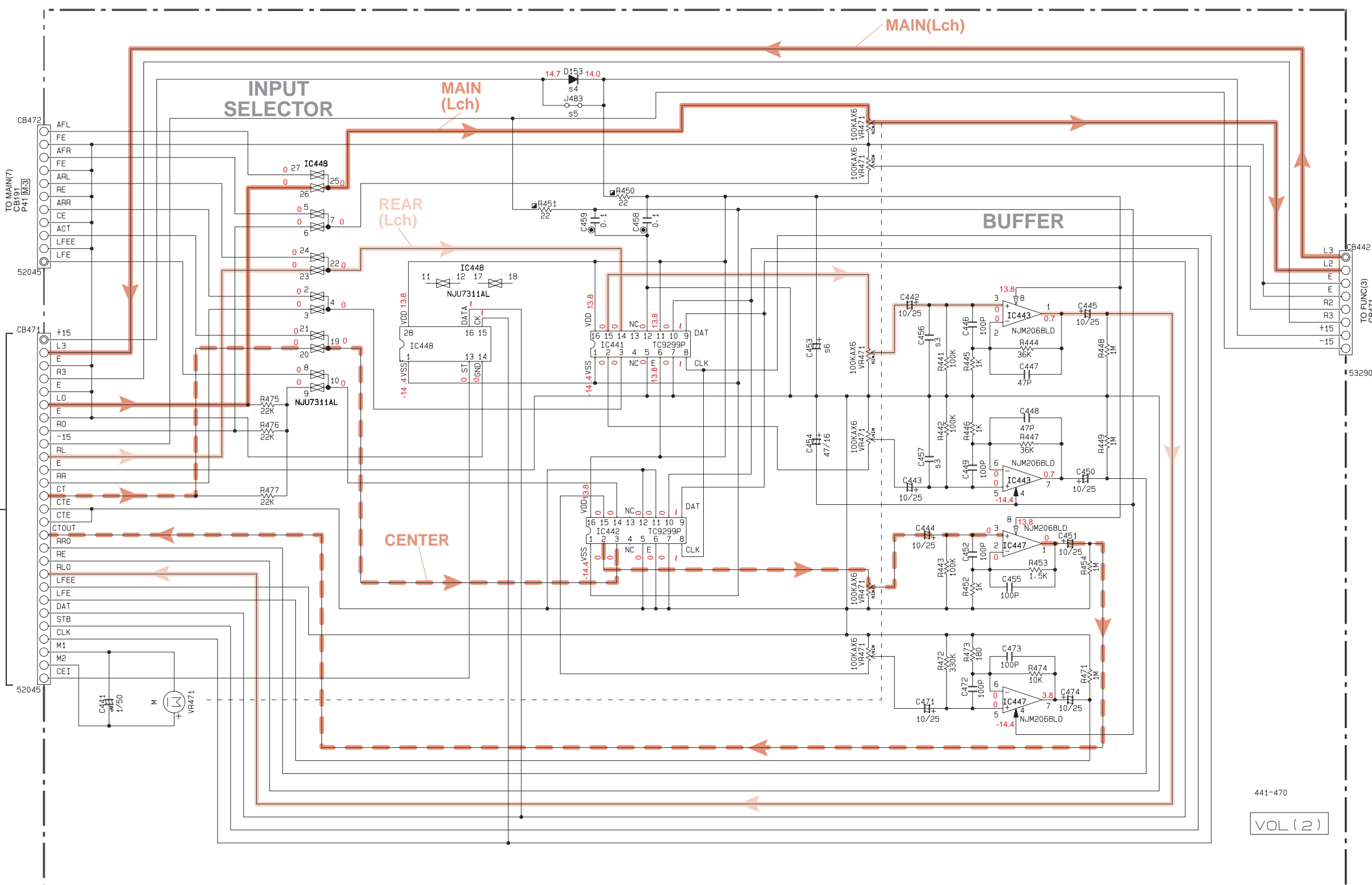
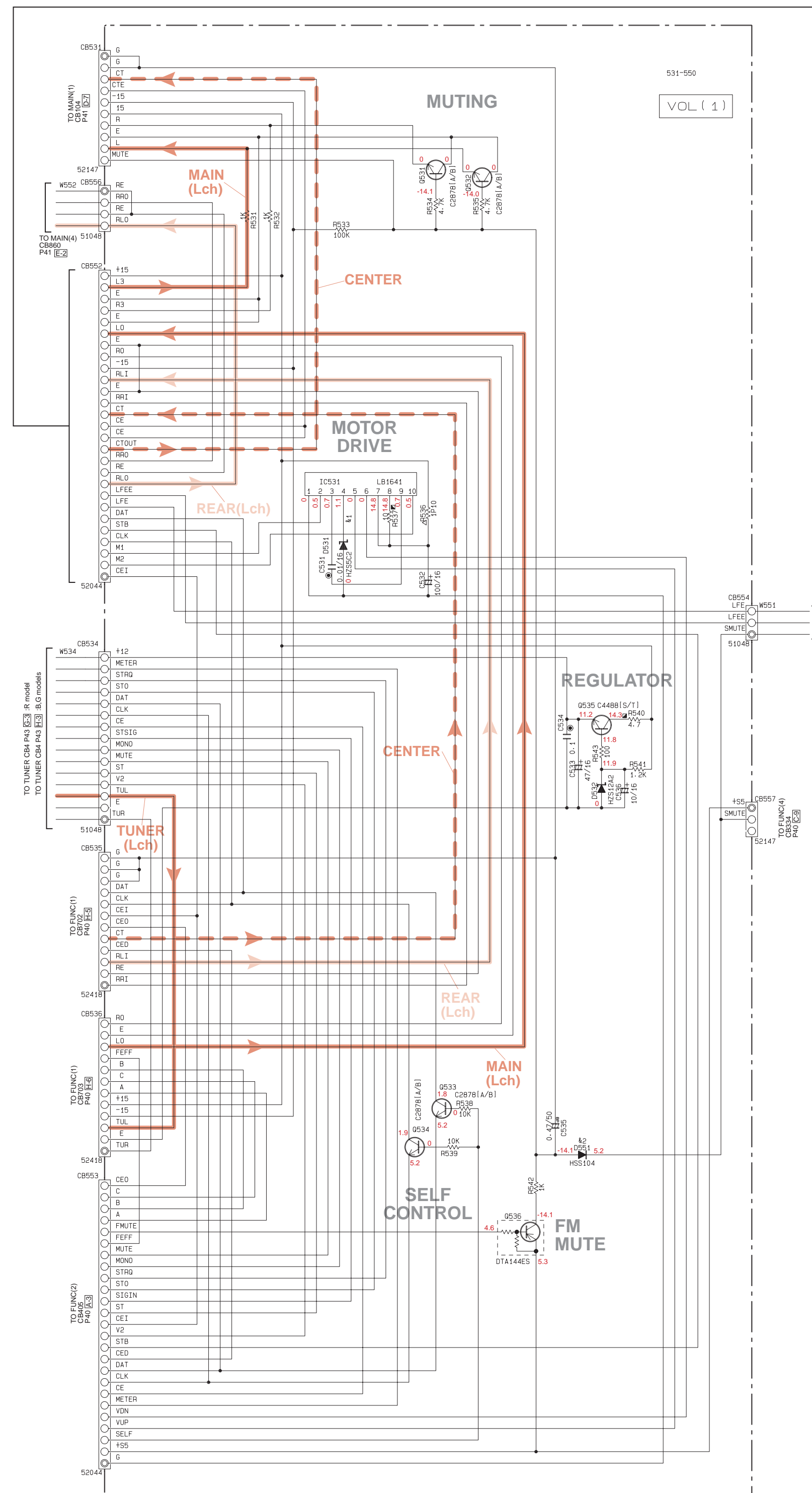

REMARKS	PARTS NAME	UNIT
NO MARK	ELECTROLYTIC CAPACITOR	μF
⊗	TANTALUM CAPACITOR	
NO MARK	CERAMIC CAPACITOR	
⊙	CERAMIC TUBULAR CAPACITOR	
⊖	POLYESTER FILM CAPACITOR	
⊕	POLYSTYRENE FILM CAPACITOR	
⊖	MICA CAPACITOR	
⊕	POLYPROPYLENE FILM CAPACITOR	
⊖	SEMICONDUCTIVE CERAMIC CAPACITOR	

REMARKS	PARTS NAME	UNIT
NO MARK	CARBON FILM RESISTOR [P=5]	
⊕	CARBON FILM RESISTOR [P=10]	
⊖	METAL OXIDE FILM RESISTOR	
⊕	METAL FILM RESISTOR	
⊖	METAL PLATE RESISTOR	
⊕	FIRE PROOF CARBON FILM RESISTOR	
⊖	CEMENT MOLDED RESISTOR	
⊕	SEMI VARIABLE RESISTOR	
⊖	CHIP RESISTOR	

NOTICE (mode1)
 (J)..... JAPANESE
 (U)..... U.S.A
 (C)..... CANADIAN
 (R)..... GENERAL
 (A)..... AUSTRALIAN
 (B)..... BRITISH
 (G)..... EUROPEAN
 (T)..... CHINA
 (L)..... SINGAPORE

■ IC BLOCK

IC443, 447, 601 : NJM2068LD
Dual OP-Amp

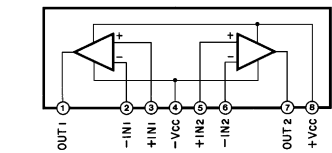

IC441, 442 : TC9299P
Electric Volume

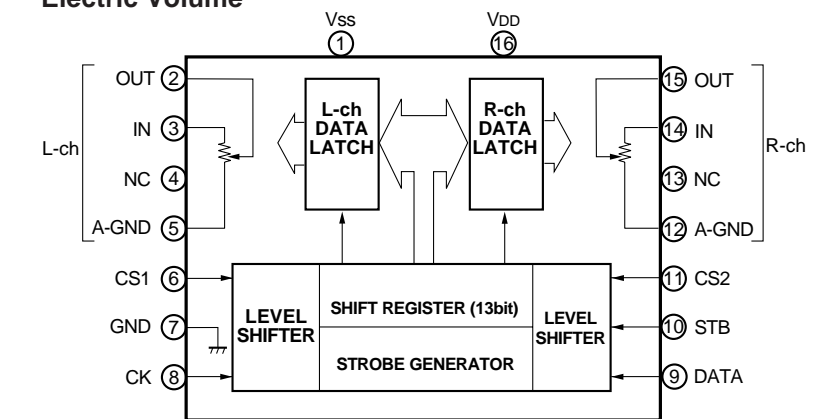

IC448 : NJU7311L
Analog Function Switch

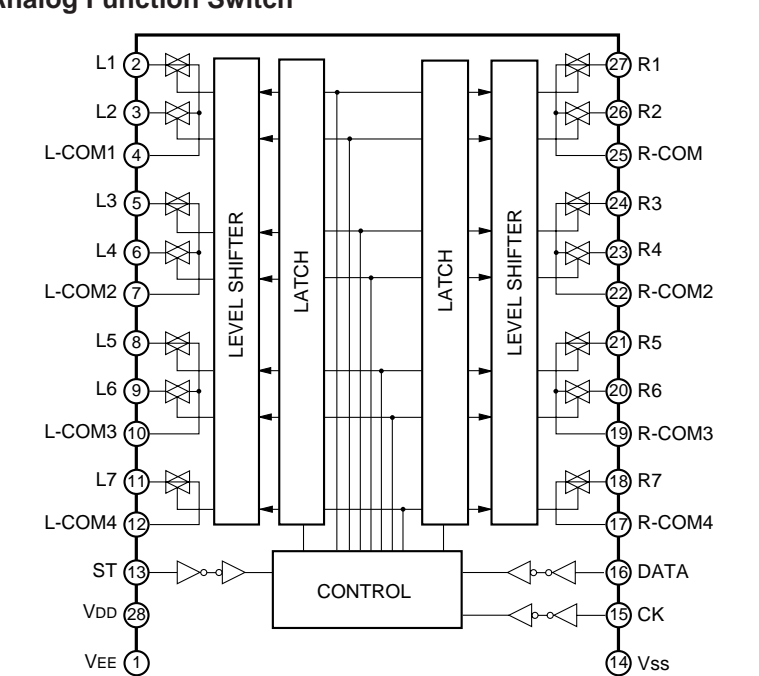

IC531 : LB1641
Motor Drive

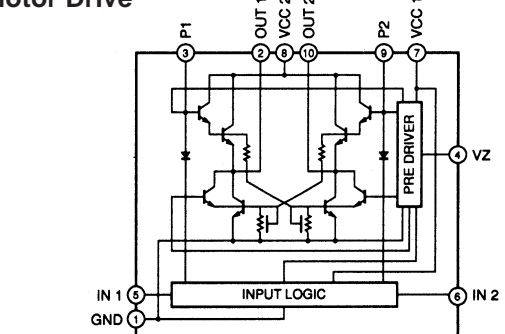

Mark	Reference Parts Number	Parts Name
41	0531	H2562 M72.6-18
42	0551	HSS104 1S5133 1S5176

⊕: NOT USED
 ⊖: USED

Interchangeable Parts at Manufacture-Stage

PIN CONNECTION DIAGRAM OF TRANSISTORS, DIODES AND IC's.

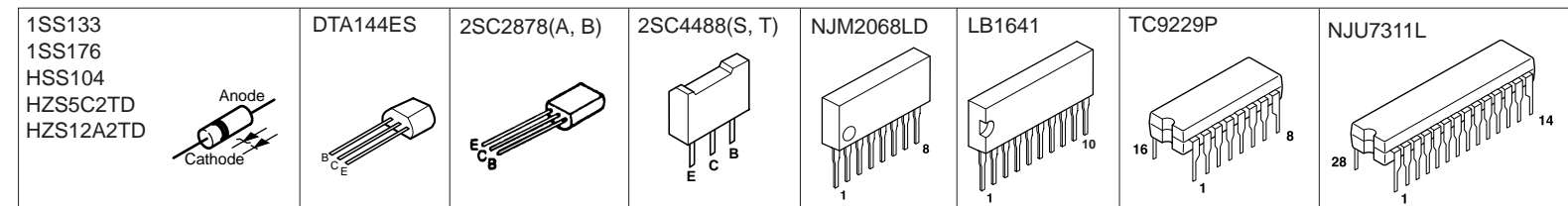

• All voltages are measured with a 10MΩ/V DC electric volt meter.
 • Components having special characteristics are marked ⊕ and must be replaced with parts having specifications equal to those originally installed.
 • Schematic diagram is subject to change without notice.

SCHEMATIC DIAGRAM (TUNER)

The voltages are measured FM (98.1 MHz, STEREO) reception mode. Only the voltages in () are in the AM (1080kHz, MANL) reception mode.

R model

Table with 2 columns: CAPACITOR, PARTS NAME. Lists various capacitor types like TANTALUM, CERAMIC, POLYESTER FILM, etc.

Table with 2 columns: RESISTOR, PARTS NAME. Lists various resistor types like CARBON FILM, METAL OXIDE FILM, etc.

NOTICE (mode 1) (J)..... JAPANESE (U)..... U.S.A (C)..... CANADIAN (R)..... GENERAL (A)..... AUSTRALIAN (B)..... BRITISH (G)..... EUROPEAN (T)..... CHINA (L)..... SINGAPORE

Table with 2 columns: Mark, Reference Parts Number, Parts Name. Lists interchangeable parts like HSS104, HZ56C2, etc.

B, G models

Table with 2 columns: CAPACITOR, PARTS NAME. Lists various capacitor types for B, G models.

Table with 2 columns: RESISTOR, PARTS NAME. Lists various resistor types for B, G models.

NOTICE (mode 1) (J)..... JAPANESE (U)..... U.S.A (C)..... CANADIAN (R)..... GENERAL (A)..... AUSTRALIAN (B)..... BRITISH (G)..... EUROPEAN (T)..... CHINA (L)..... SINGAPORE

Table with 2 columns: Mark, Reference Parts Number, Parts Name. Lists interchangeable parts for B, G models.

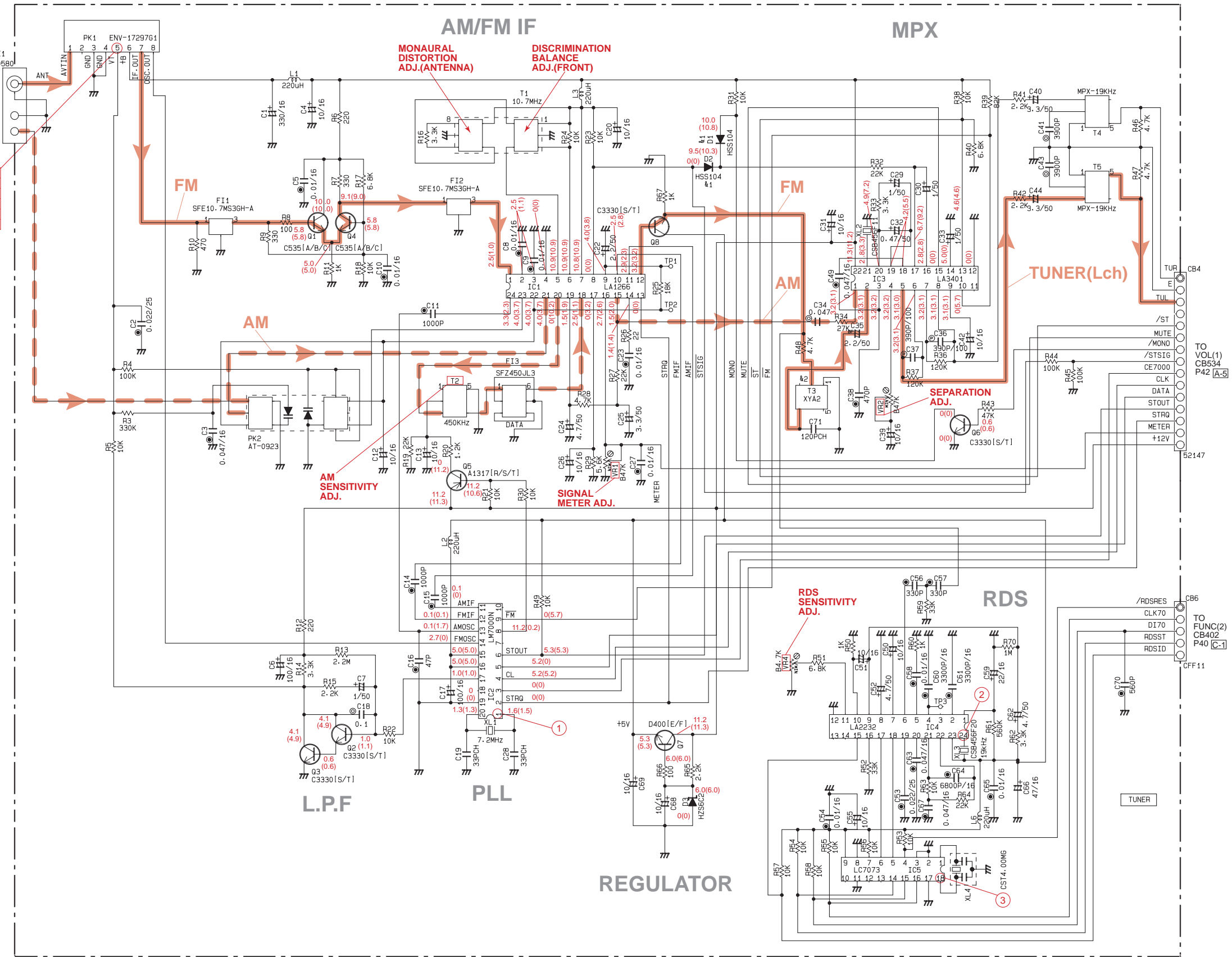
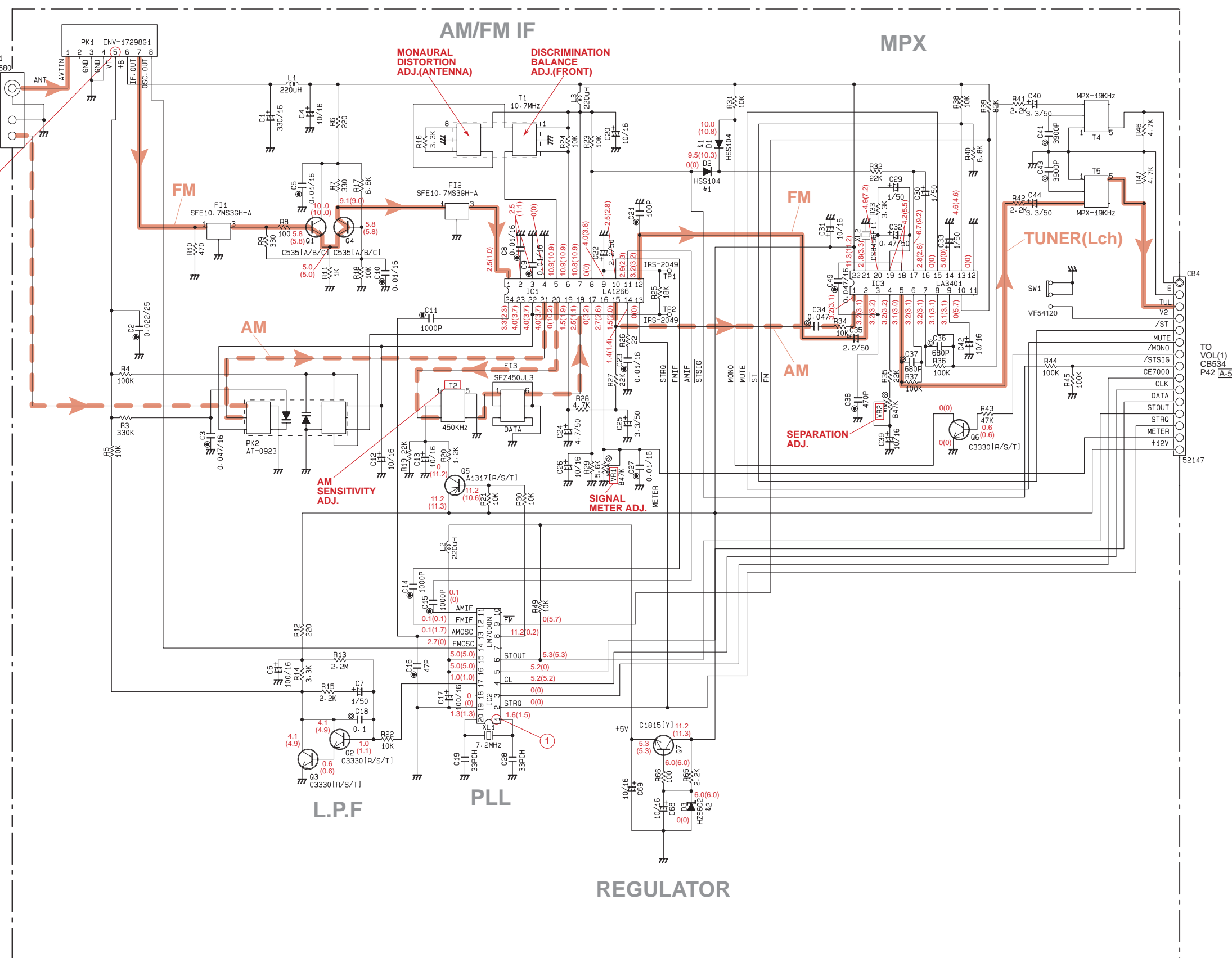

IC BLOCK

IC1 : LA1266 AM / FM IF

IC2 : LM7000N PLL Control

IC3 : LA3401 MPX

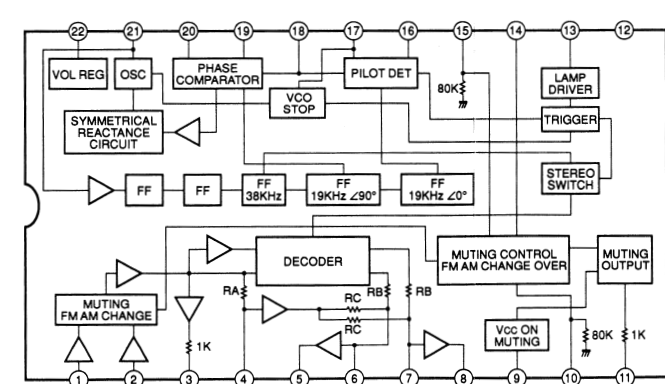
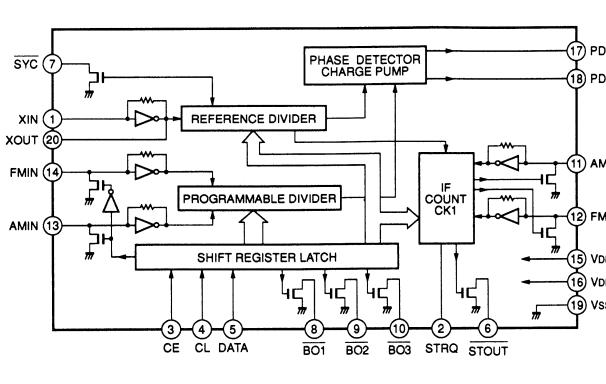
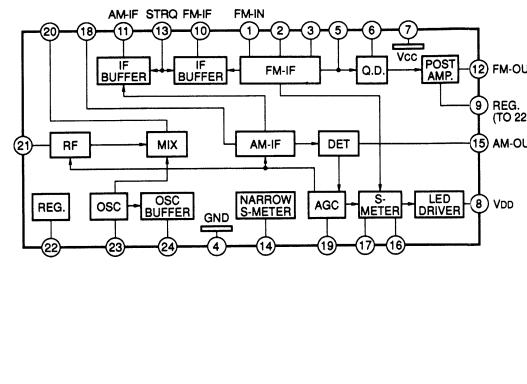

IC4 : LA2232 RDS Detector

IC5 : LC7073 RDS Converter & Controller

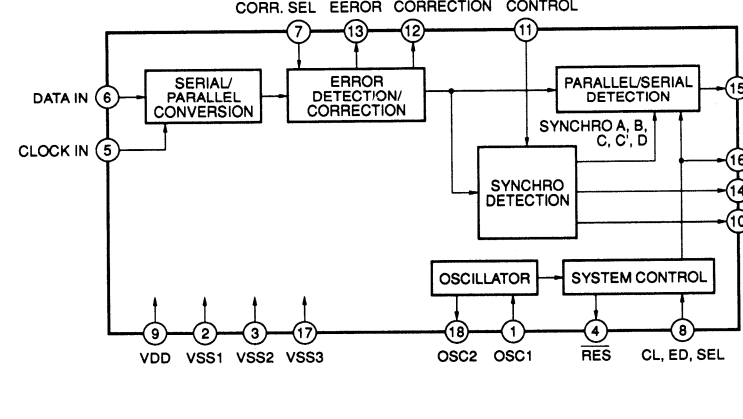
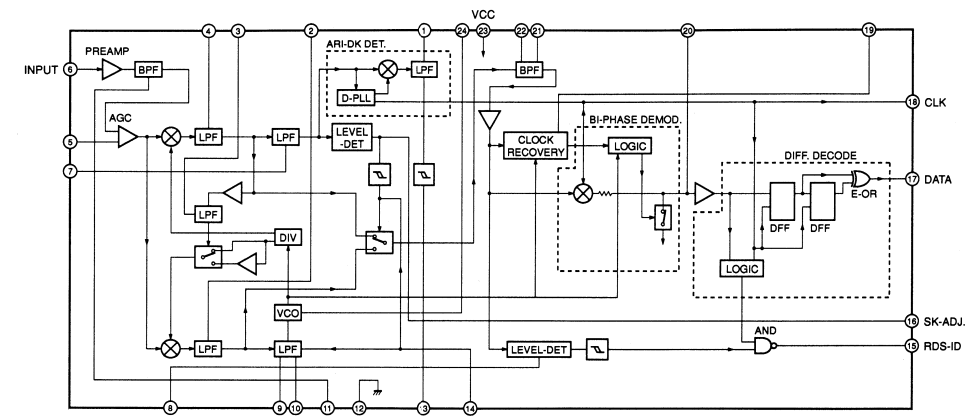

FRONT END PACK

R model PK1 : ENV-17298G1(VR242200)

B, G models PK1 : ENV-17297G1(VQ987600)

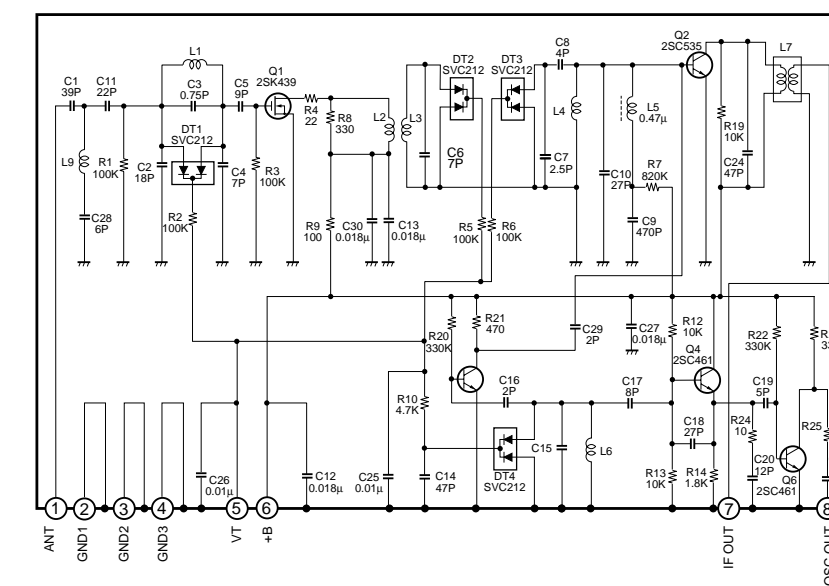
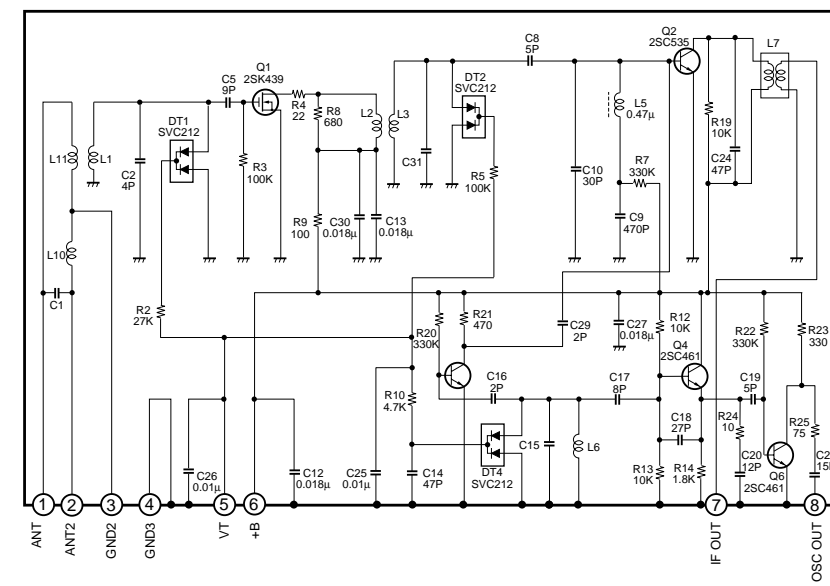

TEST POINT WAVEFORMS

Point ① (Pin 1 of IC2) V : 1V/div H : 0.1μsec/div AC range 1 : 1 probe

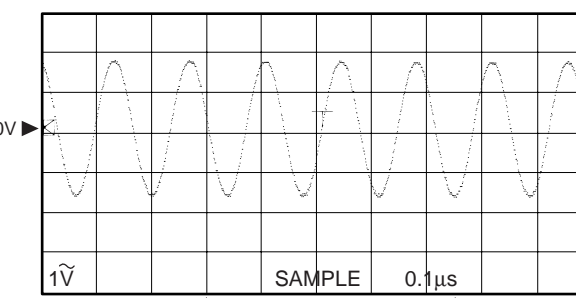

Point ② (Pin 24 of IC4) V : 2V/div H : 1μsec/div AC range 1 : 1 probe

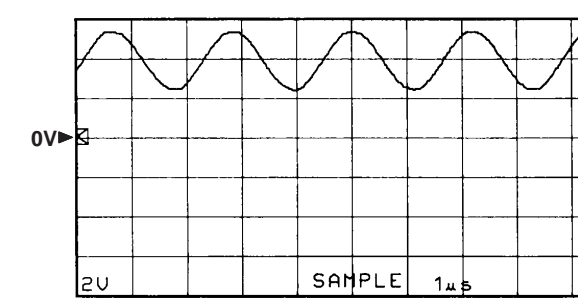

Point ③ (Pin 18 of IC5) V : 2V/div H : 0.1μsec/div AC range 1 : 1 probe

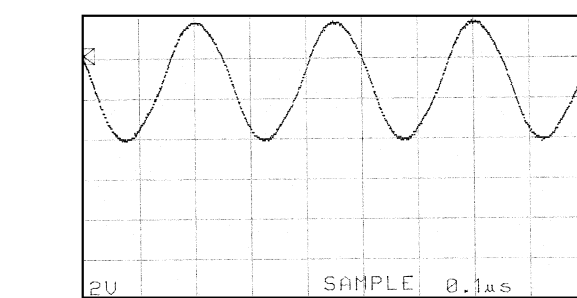

PIN CONNECTION DIAGRAM OF TRANSISTORS, DIODES AND IC's.

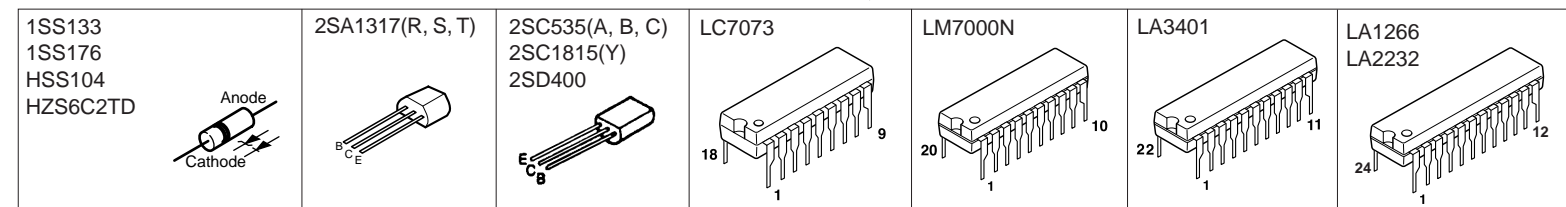

All voltages are measured with a 10MΩ/V DC electric volt meter. Components having special characteristics are marked with a triangle and must be replaced with parts having specifications equal to those originally installed. Schematic diagram is subject to change without notice.

PARTS LIST

■ ELECTRICAL PARTS

■ WARNING

Components having special characteristics are marked \triangle and must be replaced with parts having specifications equal to those originally installed.

- Carbon resistors (1/6W or 1/4W) are not included in the ELECTRICAL PARTS List. For the parts Nos. of the carbon resistores, refer to the last page.

ABBREVIATIONS IN THIS LIST ARE AS FOLLOWS:

C. A. EL. CHP	: CHIP ALUMI. ELECTROLYTIC CAP	L. EMIT	: LIGHT EMITTING MODULE
C. CE	: CERAMIC CAP	LED. DSPLY	: LED DISPLAY
C. CE. ARRAY	: CERAMIC CAP ARRAY	LED. INFRD	: LED, INFRARED
C. CE. CHP	: CHIP CERAMIC CAP	MODUL. RF	: MODULATOR, RF
C. CE. ML	: MULTILAYER CERAMIC CAP	PHOT. CPL	: PHOTO COUPLER
C. CE. M. CHP	: CHIP MULTILAYER CERAMIC CAP	PHOT. INTR	: PHOTO INTERRUPTER
C. CE. SAFTY	: RECOGNIZED CERAMIC CAP	PHOT. RFLCT	: PHOTO REFLECTOR
C. CE. TUBLR	: CERAMIC TUBULAR CAP	PIN. TEST	: PIN, TEST POINT
C. CE. SMI	: SEMI CONDUCTIVE CERAMIC CAP	PLST. RIVET	: PLASTIC RIVET
C. EL	: ELECTROLYTIC CAP	R. ARRAY	: RESISTOR ARRAY
C. MICA	: MICA CAP	R. CAR	: CARBON RESISTOR
C. ML. FLM	: MULTILAYER FILM CAP	R. CAR. CHP	: CHIP RESISTOR
C. MP	: METALLIZED PAPER CAP	R. CAR.FP	: FLAME PROOF CARBON RESISTOR
C. MYLAR	: MYLAR FILM CAP	R. FUS	: FUSABLE RESISTOR
C. MYLAR. ML	: MULTILAYER MYLAR FILM CAP	R. MTL. CHP	: CHIP METAL FILM RESISTOR
C. PAPER	: PAPER CAPACITOR	R. MTL. FILM	: METAL FILM RESISTOR
C. PLS	: POLYSTYRENE FILM CAP	R. MTL. OXD	: METAL OXIDE FILM RESISTOR
C. POL	: POLYESTER FILM CAP	R. MTL. PLAT	: METAL PLATE RESISTOR
C. POLY	: POLYETHYLENE FILM CAP	RSNR. CE	: CERAMIC RESONATOR
C. PP	: POLYPROPYLENE FILM CAP	RSNR. CRYST	: CRYSTAL RESONATOR
C. TNL	: TANTALUM CAP	R. TW. CEM	: TWIN CEMENT FIXED RESISTOR
C. TNT. CHP	: CHIP TANTALUM CAP	R. WW	: WIRE WOUND RESISTOR
C. TRIM	: TRIMMER CAP	SCR. BND. HD	: BIND HEAD B-TITE SCREW
CN	: CONNECTOR	SCR. BW. HD	: BW HEAD TAPPING SCREW
CN. BS. PIN	: CONNECTOR, BASE PIN	SCR. CUP	: CUP TITE SCREW
CN. CANNON	: CONNECTOR, CANNON	SCR. TERM	: SCREW TERMINAL
CN. DIN	: CONNECTOR, DIN	SCR. TR	: SCREW, TRANSISTOR
CN. FLAT	: CONNECTOR, FLAT CABLE	SUPRT. PCB	: SUPPORT, P. C. B.
CN. POST	: CONNECTOR, BASE POST	SURG. PRTCT	: SURGE PROTECTOR
COIL. MX. AM	: COIL, AM MIX	SW. TACT	: TACT SWITCH
COIL. AT. FM	: COIL, FM ANTENNA	SW. LEAF	: LEAF SWITCH
COIL. DT. FM	: COIL, FM DETECT	SW. LEVER	: LEVER SWITCH
COIL. MX. FM	: COIL, FM MIX	SW. MICRO	: MICRO SWITCH
COIL. OUTPT	: OUTPUT COIL	SW. PUSH	: PUSH SWITCH
DIOD. ARRAY	: DIODE ARRAY	SW. RT. ENC	: ROTARY ENCODER
DIODE. BRG	: DIODE BRIDGE	SW. RT. MTR	: ROTARY SWITCH WITH MOTOR
DIODE. CHP	: CHIP DIODE	SW. RT	: ROTARY SWITCH
DIODE. VAR	: VARACTOR DIODE	SW. SLIDE	: SLIDE SWITCH
DIOD. Z. CHP	: CHIP ZENER DIODE	TERM. SP	: SPEAKER TERMINAL
DIODE. ZENR	: ZENER DIODE	TERM. WRAP	: WRAPPING TERMINAL
DSCR. CE	: CERAMIC DISCRIMINATOR	THRMST. CHP	: CHIP THERMISTOR
FER. BEAD	: FERRITE BEADS	TR. CHP	: CHIP TRANSISTOR
FER. CORE	: FERRITE CORE	TR. DGT	: DIGITAL TRANSISTOR
FET. CHP	: CHIP FET	TR. DGT. CHP	: CHIP DIGITAL TRANSISTOR
FL. DSPLY	: FLUORESCENT DISPLAY	TRANS	: TRANSFORMER
FLTR. CE	: CERAMIC FILTER	TRANS. PULS	: PULSE TRANSFRMER
FLTR. COMB	: COMB FILTER MODULE	TRANS. PWR	: POWER TRANSFORMER ASS'y
FLTR. LC. RF	: LC FILTER, EMI	TUNER. AM	: TUNER PACK, AM
GND. MTL	: GROUND PLATE	TUNER. FM	: TUNER PACK, FM
GND. TERM	: GROUND TERMINAL	TUNER. PK	: FRONT-END TUNER PACK
HOLDER. FUS	: FUSE HOLDER	VR	: ROTARY POTENTIOMETER
IC. PRTCT	: IC PROTECTOR	VR. MTR	: POTENTIOMETER WITH MOTOR
JUMPER. CN	: JUMPER CONNECTOR	VR. SW	: POTENTIOMETER WITH ROTARY SW
JUMPER. TST	: JUMPER, TEST POINT	VR. SLIDE	: SLIDE POTENTIOMETER
L. DTCT	: LIGHT DETECTING MODULE	VR. TRIM	: TRIMMER POTENTIOMETER

Note) Those parts marked with "#" are not included in the P. C. B. Ass'y.

TUNER P. C. B.

Schm Ref	PART NO.	Description	
	VT558900	P.C.B.	TUNER(R)
	VV152000	P.C.B.	TUNER(BG)
CB1	VR428700	CN.BS.PIN	2P
CB2	VR428700	CN.BS.PIN	2P
CB4	VF667600	CN.BS.PIN	15P
CB6	VR357600	CN.BS.PIN	5P(BG)
C1	UJ838330	C.EL	330uF 16V
C2	VG280100	C.CE.TUBLR	0.022uF 25V
C3	VJ599000	C.CE.TUBLR	0.047uF 16V
C4	UJ837100	C.EL	10uF 16V
C5	VF467300	C.CE.TUBLR	0.01uF 16V
C6	UJ838100	C.EL	100uF 16V
C7	UJ866100	C.EL	1uF 50V
C8	VF467300	C.CE.TUBLR	0.01uF 16V
C9	VF467300	C.CE.TUBLR	0.01uF 16V
C10	VF467300	C.CE.TUBLR	0.01uF 16V
C11	VF467000	C.CE.TUBLR	1000pF 50V
C12	UJ837100	C.EL	10uF 16V
C13	UJ837100	C.EL	10uF 16V
C14	VF467000	C.CE.TUBLR	1000pF 50V
C15	VF467000	C.CE.TUBLR	1000pF 50V
C16	VF466700	C.CE.TUBLR	47pF 50V
C17	UJ838100	C.EL	100uF 16V
C18	UA655100	C.MYLAR	0.1uF 50V
C19	VA761200	C.CE	33pF 50V
C20	UJ837100	C.EL	10uF 16V
C21	VF466800	C.CE.TUBLR	100pF 50V(R)
C22	UJ866220	C.EL	2.2uF 50V
C23	VF467300	C.CE.TUBLR	0.01uF 16V
C24	UJ866470	C.EL	4.7uF 50V
C25	UJ866330	C.EL	3.3uF 50V
C26	UJ837100	C.EL	10uF 16V
C27	VF467300	C.CE.TUBLR	0.01uF 16V
C28	VA761200	C.CE	33pF 50V
C29	UJ866100	C.EL	1uF 50V
C30	UJ866100	C.EL	1uF 50V
C31	UJ837100	C.EL	10uF 16V
C32	UJ865470	C.EL	0.47uF 50V
C33	UJ866100	C.EL	1uF 50V
C34	UA654470	C.MYLAR	0.047uF 50V
C35	VP890800	C.EL	2.2uF 50V
C36	UA652680	C.MYLAR	680pF 50V(R)
C36	UT652390	C.PP	390pF 100V(BG)
C37	UA652680	C.MYLAR	680pF 50V(R)
C37	UT652390	C.PP	390pF 100V(BG)
C38	VF466900	C.CE.TUBLR	470pF 50V
C39	UJ837100	C.EL	10uF 16V
C40	UJ866330	C.EL	3.3uF 50V
C41	UA653390	C.MYLAR	3900pF 50V
C42	UJ837100	C.EL	10uF 16V
C43	UA653390	C.MYLAR	3900pF 50V
C44	UJ866330	C.EL	3.3uF 50V
C49	VJ599000	C.CE.TUBLR	0.047uF 16V

* New Parts

Schm Ref	PART NO.	Description	
C50	UJ837100	C.EL	10uF 16V(BG)
C51	UJ837100	C.EL	10uF 16V(BG)
C52	UJ866470	C.EL	4.7uF 50V(BG)
C53	VG280100	C.CE.TUBLR	0.022uF 25V(BG)
C54	VF467300	C.CE.TUBLR	0.01uF 16V(BG)
C55	UJ837100	C.EL	10uF 16V(BG)
C56	VG278600	C.CE.TUBLR	330pF 50V(BG)
C57	VG278600	C.CE.TUBLR	330pF 50V(BG)
C58	VF467300	C.CE.TUBLR	0.01uF 16V(BG)
C59	UJ837220	C.EL	22uF 16V(BG)
C60	VG279600	C.CE.TUBLR	3300pF 16V(BG)
C61	VG279600	C.CE.TUBLR	3300pF 16V(BG)
C62	UJ866470	C.EL	4.7uF 50V(BG)
C63	VJ599000	C.CE.TUBLR	0.047uF 16V(BG)
C64	VG279900	C.CE.TUBLR	6800pF 16V(BG)
C65	VF467300	C.CE.TUBLR	0.01uF 16V(BG)
C66	UJ837470	C.EL	47uF 16V(BG)
C67	VJ599000	C.CE.TUBLR	0.047uF 16V(BG)
C68	UJ837100	C.EL	10uF 16V
C69	UJ837100	C.EL	10uF 16V
C70	VG278800	C.CE.TUBLR	560pF 50V(BG)
C71	VA777400	C.CE	120pF 50V(BG)
D1	VD631600	DIODE	1SS133,176,HSS104
D2	VD631600	DIODE	1SS133,176,HSS104
D3	VM974500	DIODE.ZENR	HZS6C2TD 6.0V
Fi1	GG000560	FLTR.CE	SFE10.7MS3GHY-A
Fi2	GG000560	FLTR.CE	SFE10.7MS3GHY-A
Fi3	VC219000	FLTR.CE	SFZ450JL3
IC1	XB760A00	IC	LA1266
IC2	XB818A00	IC	LM7000N
IC3	iG158100	IC	LA3401
IC4	XL801A00	IC	LA2232(BG)
IC5	XL802A00	IC	LC7073(BG)
L1	Vi546100	COIL	220uH
L2	Vi546100	COIL	220uH
L3	Vi546100	COIL	220uH
L6	Vi546100	COIL	220uH(BG)
PK1	VQ987600	TUNER.PK	ENV-17297G1(BG)
PK1	VR242200	TUNER.PK	ENV-17298G1(R)
PK2	Vi027300	COILPAK.AM	
Q1	iC053540	TR	2SC535 A,B,C
Q2	VC218900	TR	2SC3330 R,S,T
Q3	VC218900	TR	2SC3330 R,S,T
Q4	iC053540	TR	2SC535 A,B,C
Q5	VC218700	TR	2SA1317 R,S,T
Q6	VC218900	TR	2SC3330 R,S,T
Q7	iC181510	TR	2SC1815 Y(R)
Q7	iD040040	TR	2SD400(BG)
Q8	VC218900	TR	2SC3330 R,S,T(BG)
SW1	VF541200	SW.SLIDE	SSSF11(R)
T1	VC218600	COIL.DT.FM	10.7MHz
T2	GE100470	COIL.IF.AM	450KHz
T3	VT486800	COIL	XYA2(BG)

* New Parts

TUNER P. C. B. & MAIN P. C. B.

Schm Ref	PART NO.	Description	
T4	VQ138200	FLTR.LC	19KHz
T5	VQ138200	FLTR.LC	19KHz
TE1	LA005800	TERM.ANT	YKD31-0215
TP1	VT969000	PIN.TEST	IRS-2049
TP2	VT969000	PIN.TEST	IRS-2049
TP3	VL448600	JUMPER.TST	(BG)
VR1	VJ694000	VR.TRIM	B47KΩ
VR2	VJ694000	VR.TRIM	B47KΩ
VR4	VA786200	VR.TRIM	B4.7KΩ(BG)
XL1	QU003800	RSNR.CRYS	7.2MHz
XL2	GG000750	RSNR.CE	18.95KHz
XL3	VP602300	RSNR.CE	19KHz(BG)
XL4	VE906000	RSNR.CE	4MHz(BG)
	BB071360	SCR.TERM	8.3x13
	VR282500	PLATE	ANT.
	V2801400	P.C.B.	MAIN(R)
	V2801500	P.C.B.	MAIN(B)
	V2801600	P.C.B.	MAIN(G)
CB101	VQ960700	CN	4P
CB103	VQ961200	CN.BS.PIN	9P
CB104	Vi878800	CN.BS.PIN	10P
CB105	VQ960800	CN.BS.PIN	5P
CB106	VP206500	HOLDER.FUS	EYF-52BC
CB107	VP206500	HOLDER.FUS	EYF-52BC
CB108	VP206500	HOLDER.FUS	EYF-52BC
CB109	VP206500	HOLDER.FUS	EYF-52BC
CB110	Vi878600	CN.BS.PIN	8P
CB111	LA002110	TERM.WRAP	2P
CB112	LA002110	TERM.WRAP	2P
CB113	LA002110	TERM.WRAP	2P
CB181	Vi878600	CN.BS.PIN	8P
CB182	Vi878000	CN.BS.PIN	2P
CB191	VQ044500	CN.BS.PIN	11P
CB192	Vi878000	CN.BS.PIN	2P(R)
CB201	VQ963000	CN.BS.PIN	9P
CB202	VQ962600	CN.BS.PIN	5P
CB254	VM859500	CN.BS.PIN	11P
CB255	VQ962500	CN.BS.PIN	4P
CB256	VK024900	CN.BS.PIN	5P
CB258	VK024600	CN.BS.PIN	2P
CB301	Vi878300	CN.BS.PIN	5P
CB302	VG879900	CN.BS.PIN	2P
CB303	VP206500	HOLDER.FUS	EYF-52BC(R)
CB304	VP206500	HOLDER.FUS	EYF-52BC(R)
CB305	VP206500	HOLDER.FUS	EYF-52BC(G)
CB306	VP206500	HOLDER.FUS	EYF-52BC(G)
CB307	VP206500	HOLDER.FUS	EYF-52BC(BG)
CB308	VP206500	HOLDER.FUS	EYF-52BC(BG)
CB332	Vi878700	CN.BS.PIN	9P
CB341	VP206500	HOLDER.FUS	EYF-52BC(R)
CB342	VP206500	HOLDER.FUS	EYF-52BC(R)
CB853	Vi878300	CN.BS.PIN	5P

* New Parts

Schm Ref	PART NO.	Description	
CB854	VK024900	CN.BS.PIN	5P
CB857	VK024700	CN.BS.PIN	3P
CB859	VK025200	CN.BS.PIN	8P
CB860	VK024800	CN.BS.PIN	4P
CB902	VP113500	CN.BS.PIN	10P
C101	UR818100	C.EL	100uF 6.3V
C102	UR818100	C.EL	100uF 6.3V
C103	UR866470	C.EL	4.7uF 50V
△ C104	UR877330	C.EL	33uF 63V
△ C105	UR866470	C.EL	4.7uF 50V
C106	UR866470	C.EL	4.7uF 50V
△ C107	UR866470	C.EL	4.7uF 50V
C108	UR847100	C.EL	10uF 25V
C109	UA952100	C.MYLAR	100pF 50V
△* C110	UR778330	C.EL	330uF 63V
C111	UA952100	C.MYLAR	100pF 50V
△ C112	UR866470	C.EL	4.7uF 50V
△ C113	UR866470	C.EL	4.7uF 50V
C114	VR325000	C.MYLAR	100pF 100V
C115	UR867470	C.EL	47uF 50V
C116	VG291200	C.EL	47uF 50V
C117	VR325000	C.MYLAR	100pF 100V
C118	VR325000	C.MYLAR	100pF 100V
C119	VG291200	C.EL	47uF 50V
C120	UR867470	C.EL	47uF 50V
C121	VR325000	C.MYLAR	100pF 100V
△ C122	UR878100	C.EL	100uF 63V
C123	VR325000	C.MYLAR	100pF 100V
C124	UR866100	C.EL	1uF 50V
C125	UR867220	C.EL	22uF 50V
C126	VR325000	C.MYLAR	100pF 100V
C127	UA954820	C.MYLAR	0.082uF 50V
C128	UA954820	C.MYLAR	0.082uF 50V
△ C129	VL544800	C.EL	3300uF 35V
△ C130	UA954470	C.MYLAR	0.047uF 50V
△ C131	UA954470	C.MYLAR	0.047uF 50V
△ C132	VL544800	C.EL	3300uF 35V
△ C133	VR670100	C.EL	8200uF 56V
△ C134	VR325400	C.MYLAR	0.1uF 100V
△ C135	VR325400	C.MYLAR	0.1uF 100V
△ C136	VR670100	C.EL	8200uF 56V
* C137	UR895220	C.EL	0.22uF 100V
C138	UR866470	C.EL	4.7uF 50V
C139	UA655100	C.MYLAR	0.1uF 50V
C140	UA954220	C.MYLAR	0.022uF 50V
C141	UA954220	C.MYLAR	0.022uF 50V
C142	UA655100	C.MYLAR	0.1uF 50V
C143	UA954470	C.MYLAR	0.047uF 50V
C144	UA655100	C.MYLAR	0.1uF 50V
C145	VF467300	C.CE.TUBLR	0.01uF 16V
C146	VJ599100	C.CE.TUBLR	0.1uF 50V
C190	UA952220	C.MYLAR	220pF 50V
C191	UA952220	C.MYLAR	220pF 50V

* New Parts

MAIN P.C.B.

Schm Ref	PART NO.	Description		
C192	VF467000	C.CE.TUBLR	1000pF	50V(R)
C192	VF467300	C.CE.TUBLR	0.01uF	16V(BG)
C193	UA952220	C.MYLAR	220pF	50V
C194	UA952220	C.MYLAR	220pF	50V
C196	UA952220	C.MYLAR	220pF	50V
C198	UA952220	C.MYLAR	220pF	50V
C201	UR866470	C.EL	4.7uF	50V
C202	UT652100	C.PP	100pF	100V
C203	UR866470	C.EL	4.7uF	50V
C204	UT652100	C.PP	100pF	100V
C205	UT652100	C.PP	100pF	100V
C206	UR866470	C.EL	4.7uF	50V
C207	UT652100	C.PP	100pF	100V
C208	UA952100	C.MYLAR	100pF	50V
C209	FG612220	C.CE	220pF	50V
C210	VM645500	C.PP	15uF	200V
C211	UR837470	C.EL	47uF	16V
C212	UA953100	C.MYLAR	1000pF	50V
C213	UA953100	C.MYLAR	1000pF	50V
C214	UR837470	C.EL	47uF	16V
C215	VM645500	C.PP	15uF	200V
C216	UA953330	C.MYLAR	3300pF	50V
C217	UR828220	C.EL	220uF	10V
C218	VR412500	C.CE	22pF	500V
C219	UR838100	C.EL	100uF	16V
C220	FG652100	C.CE	100pF	50V(BG)
C253	UA655330	C.MYLAR	0.33uF	50V
C254	UR837100	C.EL	10uF	16V
C255	UR866100	C.EL	1uF	50V
C256	UR866100	C.EL	1uF	50V
C257	UR837100	C.EL	10uF	16V(R)
C258	UR838100	C.EL	100uF	16V(R)
C259	UR818100	C.EL	100uF	6.3V
C260	UR819100	C.EL	1000uF	6.3V
C261	VF466800	C.CE.TUBLR	100pF	50V
C302	FG644100	C.CE	0.01uF	50V
C303	FG613100	C.CE	1000pF	50V
△* C304	UR848330	C.EL	330uF	25V(BG)
C306	UA954100	C.MYLAR	0.01uF	50V
C307	VS741700	C.CE.SAFTY	0.01uF	275V
C308	UR878100	C.EL	100uF	63V(R)
C331	UA954100	C.MYLAR	0.01uF	50V(BG)
C332	UA954100	C.MYLAR	0.01uF	50V(BG)
C335	UA954100	C.MYLAR	0.01uF	50V(BG)
C336	UA954100	C.MYLAR	0.01uF	50V(BG)
C851	FG652100	C.CE	100pF	50V
C852	FG652100	C.CE	100pF	50V
C853	FG612220	C.CE	220pF	50V
C855	FG651220	C.CE	22pF	50V
C856	UR847220	C.EL	22uF	25V
C857	UA655220	C.MYLAR	0.22uF	50V
C858	UA953220	C.MYLAR	2200pF	50V(BG)
C860	UA953220	C.MYLAR	2200pF	50V(BG)

* New Parts

Schm Ref	PART NO.	Description		
C861	FG612220	C.CE	220pF	50V
C863	FG651220	C.CE	22pF	50V
C864	UR828220	C.EL	220uF	10V
C865	UR847220	C.EL	22uF	25V
C866	UA655220	C.MYLAR	0.22uF	50V
C868	UA954100	C.MYLAR	0.01uF	50V
C869	UA953220	C.MYLAR	2200pF	50V(BG)
C870	UA954100	C.MYLAR	0.01uF	50V(BG)
C871	UA954100	C.MYLAR	0.01uF	50V(BG)
C872	UA954100	C.MYLAR	0.01uF	50V
C873	UA954100	C.MYLAR	0.01uF	50V
C874	UN866100	C.EL	1uF	50V
C875	VJ599100	C.CE.TUBLR	0.1uF	50V
C876	UR867100	C.EL	10uF	50V
C877	UR867100	C.EL	10uF	50V
C878	VF467300	C.CE.TUBLR	0.01uF	16V
C879	VF466900	C.CE.TUBLR	470pF	50V(BG)
C911	VF466800	C.CE.TUBLR	100pF	50V
C912	VF466700	C.CE.TUBLR	47pF	50V
C913	VF466700	C.CE.TUBLR	47pF	50V
C914	VF466800	C.CE.TUBLR	100pF	50V
C915	VF466700	C.CE.TUBLR	47pF	50V
C916	UR837100	C.EL	10uF	16V
C917	UR837100	C.EL	10uF	16V
C918	UR829100	C.EL	1000uF	10V
C919	UR837100	C.EL	10uF	16V
C920	UR866470	C.EL	4.7uF	50V
C921	UR838330	C.EL	330uF	16V
C922	VK534000	C.PP	220pF	200V
C923	VK534000	C.PP	220pF	200V
C924	VF467000	C.CE.TUBLR	1000pF	50V(R)
C924	VF467300	C.CE.TUBLR	0.01uF	6V(BG)
C998	UR847100	C.EL	10uF	25V
C999	UR847100	C.EL	10uF	25V
D101	VD631600	DIODE	1SS133,176,HSS104	
D102	VD631600	DIODE	1SS133,176,HSS104	
D103	VM976300	DIODE.ZENR	HZS242TD	24V
△ D104	VS997800	DIODE	1T2	
D105	VM976300	DIODE.ZENR	HZS242TD	24V
D106	VM976300	DIODE.ZENR	HZS242TD	24V
△ D107	VN011300	DIODE.BRG	D3SBA20	4A 200V
△ D108	iH001090	DIODE.BRG	S4VB20	2.6A 200V
D109	VN008700	DIODE	1SS270A	
D110	VN008700	DIODE	1SS270A	
D111	VN008700	DIODE	1SS270A	
D112	VN008700	DIODE	1SS270A	
D113	VN008700	DIODE	1SS270A	
D201	VD631600	DIODE	1SS133,176,HSS104	
D251	VD631600	DIODE	1SS133,176,HSS104	
D252	VD631600	DIODE	1SS133,176,HSS104	
D253	VD631600	DIODE	1SS133,176,HSS104	
D254	VM974600	DIODE.ZENR	HZS7A2TD	7.0V
D255	VD631600	DIODE	1SS133,176,HSS104	

* New Parts

MAIN P.C.B.

Schm Ref	PART NO.	Description	
D256	VM974200	DIODE.ZENR	HZS5C2TD 5.0V
D257	VM974300	DIODE.ZENR	HZS6A2TD 6.0V
D258	VM975500	DIODE.ZENR	HZS12A2TD 12V(R)
D301	VD631600	DIODE	1SS133,176,HSS104
△ D302	VS997800	DIODE	1T2
D851	VD631600	DIODE	1SS133,176,HSS104
D852	VD631600	DIODE	1SS133,176,HSS104
D853	VM974100	DIODE.ZENR	HZS5B2TD 5.0V
D854	VM976300	DIODE.ZENR	HZS242TD 24V
△ F101	KB000690	FUSE	T2.5A 250V
△ F102	KB000690	FUSE	T2.5A 250V
△ F301	VS822900	FUSE	T4.0A 125V(R)
F302	KB001660	FUSE	T1.6A 250V(BG)
F303	KB000690	FUSE	T2.5A 250V(G)
F341	KB001660	FUSE	T1.6A 250V(R)
HS101	VP753100	HEAT.SINK	IC-1625-MML
△# IC101	XJ603A00	IC	NJM78M15FA
△ IC102	XG505A00	IC	NJM79M15FA
△ IC853	XV466A00	IC	LM1875T POWER
△ IC854	XV466A00	IC	LM1875T POWER
IC901	XQ164A00	IC	BA7612N
△ JK301	VU543100	OUTLET.AC	2P(R)
△ JK301	VU543300	OUTLET.AC	1P(B)
△ JK301	VU543400	OUTLET.AC	2P(G)
L101	VU038100	COIL	1.5uH
L102	VU038100	COIL	1.5uH
L103	VU038100	COIL	1.5uH
L851	VU038100	COIL	1.5uH
L852	VU038100	COIL	1.5uH
PJ193	VY834300	JACK.PIN	6P
PJ851	VU827200	JACK.PIN	1P
PJ902	VT848700	JACK.PIN	2P
PJ903	VV852500	JACK.PIN	3P
PJ904	VV325000	JACK.PIN	2P
Q101	iC174020	TR	2SC1740S R,S
Q102	iC287820	TR	2SC2878 A,B
Q103	iC174020	TR	2SC1740S R,S
Q104	iC174020	TR	2SC1740S R,S
△ Q105	iA101510	TR	2SA1015 Y
△ Q106	iC174020	TR	2SC1740S R,S
△ Q107	iC174020	TR	2SC1740S R,S
△ Q108	iC174020	TR	2SC1740S R,S
△ Q109	VP872700	TR	2SC4488 S,T
△# Q110	VT064500	TR.PAIR	2SA1694/C4467 OPY
△ Q112	VP872600	TR	2SA1708 S,T
△ Q113	VP872600	TR	2SA1708 S,T
△# Q114	VT064500	TR.PAIR	2SA1694/C4467 OPY
△ Q115	VP872700	TR	2SC4488 S,T
△ Q117	VP872600	TR	2SA1708 S,T
△# Q118	VT064500	TR.PAIR	2SA1694/C4467 OPY
△ Q119	VP872700	TR	2SC4488 S,T
Q121	VP883000	TR	2SA893A D,E
Q122	VP883100	TR	2SC1890A D,E

* New Parts

Schm Ref	PART NO.	Description	
Q123	VP883100	TR	2SC1890A D,E
Q124	VP883100	TR	2SC1890A D,E
Q181	iC174020	TR	2SC1740S R,S
Q182	iC174020	TR	2SC1740S R,S
Q201	VP883000	TR	2SA893A D,E
Q202	VP883000	TR	2SA893A D,E
Q203	VP883000	TR	2SA893A D,E
Q204	VP883000	TR	2SA893A D,E
Q205	VP883000	TR	2SA893A D,E
Q206	VP883000	TR	2SA893A D,E
△ Q207	VR325600	TR	2SC2229 O,Y
△ Q208	VR325600	TR	2SC2229 O,Y
△ Q209	VR325600	TR	2SC2229 O,Y
Q251	iC174020	TR	2SC1740S R,S
Q252	iC174020	TR	2SC1740S R,S
Q253	iA093320	TR	2SA933S Q,R
Q254	VP883100	TR	2SC1890A D,E(R)
Q255	VP768300	TR	2SC4466 O,P,Y(R)
Q871	iC287820	TR	2SC2878 A,B
Q872	iC287820	TR	2SC2878 A,B
Q911	iC181510	TR	2SC1815 Y
Q912	iC181510	TR	2SC1815 Y
Q913	iC174020	TR	2SC1740S R,S
R106	VP940700	R.MTL.OXD	330Ω 1W
R107	VP941000	R.MTL.OXD	680Ω 1W
R110	HV756100	R.CAR.FP	1KΩ 1/4W
△ R114	HV753100	R.CAR.FP	1Ω 1/4W
△ R115	VP940100	R.MTL.OXD	33Ω 1W
R118	HV756270	R.CAR.FP	2.7KΩ 1/4W
R119	HV755270	R.CAR.FP	270Ω 1/4W
R120	HV756100	R.CAR.FP	1KΩ 1/4W
R121	HV756100	R.CAR.FP	1KΩ 1/4W
△ R123	VP940200	R.MTL.OXD	47Ω 1W
R125	HV756100	R.CAR.FP	1KΩ 1/4W
R126	HV755270	R.CAR.FP	270Ω 1/4W
R127	HV756100	R.CAR.FP	1KΩ 1/4W
R128	HV756270	R.CAR.FP	2.7KΩ 1/4W
△ R131	VK188600	R.FUS	470Ω 1/4W
R132	HV756100	R.CAR.FP	1KΩ 1/4W
R133	HV755270	R.CAR.FP	270Ω 1/4W
R134	HV756100	R.CAR.FP	1KΩ 1/4W
R135	HV756270	R.CAR.FP	2.7KΩ 1/4W
R138	HV753470	R.CAR.FP	4.7Ω 1/4W
△ R139	HV755330	R.CAR.FP	330Ω 1/4W
△ R140	VU981700	R.MTL.PLAT	0.22Ω+0.22 3W
R141	HV753470	R.CAR.FP	4.7Ω 1/4W
R142	HV753470	R.CAR.FP	4.7Ω 1/4W
△ R143	HV755330	R.CAR.FP	330Ω 1/4W
△ R144	VU981700	R.MTL.PLAT	0.22Ω+0.22 3W
R145	HV753470	R.CAR.FP	4.7Ω 1/4W
R146	HV753470	R.CAR.FP	4.7Ω 1/4W
△ R147	HV755470	R.CAR.FP	470Ω 1/4W
△ R148	VU981700	R.MTL.PLAT	0.22Ω+0.22 3W

* New Parts

MAIN P.C.B. & FUNCTION P. C. B.

Schm Ref	PART NO.	Description		
	R149	HV753470	R.CAR.FP	4.7Ω 1/4W
△	R150	HV754100	R.CAR.FP	10Ω 1/4W
△	R157	VP939800	R.MTL.OXD	10Ω 1W
△	R160	VP939800	R.MTL.OXD	10Ω 1W
△	R166	VP939800	R.MTL.OXD	10Ω 1W
	R172	HV754100	R.CAR.FP	10Ω 1/4W
	R177	HV754100	R.CAR.FP	10Ω 1/4W
	R179	HV754100	R.CAR.FP	10Ω 1/4W
△	R180	VP940000	R.MTL.OXD	22Ω 1W
△	R225	HV754470	R.CAR.FP	47Ω 1/4W
△	R226	HV754470	R.CAR.FP	47Ω 1/4W
△	R227	HV754100	R.CAR.FP	10Ω 1/4W
	R856	HV753470	R.CAR.FP	4.7Ω 1/4W
	R857	HV753680	R.CAR.FP	6.8Ω 1/4W
	R859	HV753220	R.CAR.FP	2.2Ω 1/4W(BG)
	R860	HV753220	R.CAR.FP	2.2Ω 1/4W(BG)
	R864	HV753470	R.CAR.FP	4.7Ω 1/4W
	R865	HV753680	R.CAR.FP	6.8Ω 1/4W
	R871	HV753220	R.CAR.FP	2.2Ω 1/4W(BG)
	R876	HV753220	R.CAR.FP	2.2Ω 1/4W
	R883	VP940700	R.MTL.OXD	330Ω 1W
	R918	HV755180	R.CAR.FP	180Ω 1/4W
△	RY101	VK438300	RELAY	DH24D2-OT/M2
△	RY102	VU566700	RELAY	DG24D2-OS/M
△*	RY301	V2712300	RELAY	DC SDT-S-112LMR
	RY851	VU566700	RELAY	DG24D2-OS/M
	SW191	VU755700	SW.SLIDE	SS029-P012BEB(R)
	SW341	VA961800	VOLT.SELCT	ESE-37247-F(R)
△	T301	XC084A00	TRANS.PWR	(BG)
△	T301	XS175A00	TRANS.PWR	(R)
△	TE332	VF018400	TERM.SP	4P(R)
△	TE332	VY696400	TERM.SP	4P(BG)
△	TE851	VU589900	TERM.SP	6P
		VJ828000	PIN	IMSA-6024-03E
		BB071360	SCR.TERM	8.3x13
		VR264300	PLATE.GND	
		VN008600	SCR.TERM	8.3x13
		EP600840	SCR.BND.HD	3x16 FCRM3-BL
		V2801800	P.C.B.	FUNCTION(R)
		V2801900	P.C.B.	FUNCTION(BG)
*	CB321	Vi878200	CN.BS.PIN	4P
*	CB322	Vi878200	CN.BS.PIN	4P
	CB324	VK025200	CN.BS.PIN	8P
	CB331	VK025300	CN.BS.PIN	9P
	CB332	VK024600	CN.BS.PIN	2P
	CB334	Vi878100	CN.BS.PIN	3P
	CB402	VQ044100	CN.BS.PIN	5P(BG)
	CB404	VQ044500	CN.BS.PIN	11P
	CB405	VQ045400	CN.BS.PIN	25P
*	CB406	VQ044200	CN.BS.PIN	6P
	CB471	VQ961100	CN.BS.PIN	8P
	CB652	VQ960800	CN.BS.PIN	5P

* New Parts

Schm Ref	PART NO.	Description		
	CB702	VQ963300	CN.BS.PIN	12P
	CB703	VQ963300	CN.BS.PIN	12P
	CB801	VM688900	CN.BS.PIN	10P
*	CB802	VQ044200	CN.BS.PIN	6P
	CB803	VK024600	CN.BS.PIN	2P(R)
	C320	UA954100	C.MYLAR	0.01uF 50V(BG)
	C321	UA954100	C.MYLAR	0.01uF 50V(BG)
	C322	UA954100	C.MYLAR	0.01uF 50V(BG)
	C401	UB013100	C.CE.M.CHP	1000pF 50V
	C402	UB013100	C.CE.M.CHP	1000pF 50V
	C403	UB045100	C.CE.M.CHP	0.1uF 50V
	C404	UB045100	C.CE.M.CHP	0.1uF 50V
	C405	UB013100	C.CE.M.CHP	1000pF 50V
	C406	VU545000	C.EL	47000uF 5.5V
	C407	UB044220	C.CE.M.CHP	0.022uF 50V
	C471	UR865470	C.EL	0.47uF 50V
	C472	UA952100	C.MYLAR	100pF 50V
	C473	UA952100	C.MYLAR	100pF 50V
	C474	UR865470	C.EL	0.47uF 50V
	C475	UR837470	C.EL	47uF 16V
	C476	UR837220	C.EL	22uF 25V
	C477	UA952100	C.MYLAR	100pF 50V
	C478	VK533800	C.PP	47pF 200V
	C479	UR866220	C.EL	2.2uF 50V
	C480	UR866220	C.EL	2.2uF 50V
	C481	VK533800	C.PP	47pF 200V
	C482	UA952100	C.MYLAR	100pF 50V
	C483	UR837220	C.EL	22uF 25V
	C484	UR837470	C.EL	47uF 16V
	C485	UA655120	C.MYLAR	0.12uF 50V
	C486	UA954330	C.MYLAR	0.033uF 50V
	C487	UA954330	C.MYLAR	0.033uF 50V
	C488	UA655120	C.MYLAR	0.12uF 50V
	C651	UB012220	C.CE.M.CHP	220pF 50V
	C652	UB012220	C.CE.M.CHP	220pF 50V
	C653	UB012220	C.CE.M.CHP	220pF 50V
	C654	UB012220	C.CE.M.CHP	220pF 50V
	C655	UB012220	C.CE.M.CHP	220pF 50V
	C656	UB012220	C.CE.M.CHP	220pF 50V
	C657	UB012220	C.CE.M.CHP	220pF 50V
	C658	UB012220	C.CE.M.CHP	220pF 50V
	C659	UB012220	C.CE.M.CHP	220pF 50V
	C660	UB012220	C.CE.M.CHP	220pF 50V
	C661	UB012220	C.CE.M.CHP	220pF 50V
	C662	UB012220	C.CE.M.CHP	220pF 50V
	C663	VG290900	C.EL	10uF 50V
	C664	UR847470	C.EL	47uF 25V
	C665	UR837470	C.EL	47uF 16V
	C666	UR837470	C.EL	47uF 16V
	C667	UR847470	C.EL	47uF 25V
	C668	VG290900	C.EL	10uF 50V
	C701	UR847470	C.EL	47uF 25V
	C702	UR867100	C.EL	10uF 50V

* New Parts

FUNCTION P.C.B.

Schm Ref	PART NO.	Description		
C703	UR828100	C.EL	100uF	10V
C704	VD930900	C.CE.SMI	0.1uF	25V
C705	UR848100	C.EL	100uF	25V
C706	VD930900	C.CE.SMI	0.1uF	25V
C707	UR847470	C.EL	47uF	25V
C708	VD930900	C.CE.SMI	0.1uF	25V
C709	UR847100	C.EL	10uF	25V
C710	VD930900	C.CE.SMI	0.1uF	25V
C711	UR847470	C.EL	47uF	25V
C712	UA953330	C.MYLAR	3300pF	50V
C713	UA953330	C.MYLAR	3300pF	50V
C714	UR847470	C.EL	47uF	25V
C715	UR847470	C.EL	47uF	25V
C716	UR866220	C.EL	2.2uF	50V
C717	UA954180	C.MYLAR	0.018uF	50V
C718	UA954180	C.MYLAR	0.018uF	50V
C719	UR866220	C.EL	2.2uF	50V
C720	UR867100	C.EL	10uF	50V
C721	UB012330	C.CE.M.CHP	330pF	50V
C722	UR847470	C.EL	47uF	25V
C723	UB012330	C.CE.M.CHP	330pF	50V
C724	UR847470	C.EL	47uF	25V
C725	UB012330	C.CE.M.CHP	330pF	50V
C726	UB012330	C.CE.M.CHP	330pF	50V
C727	UR847470	C.EL	47uF	25V
C728	UB052100	C.CE.M.CHP	100pF	50V
C729	UB052100	C.CE.M.CHP	100pF	50V
C730	UB052100	C.CE.M.CHP	100pF	50V
C731	UB052100	C.CE.M.CHP	100pF	50V
C732	UB052100	C.CE.M.CHP	100pF	50V
C733	UB052100	C.CE.M.CHP	100pF	50V
C734	UB052100	C.CE.M.CHP	100pF	50V
C735	UA953470	C.MYLAR	4700pF	50V
C736	UA952390	C.MYLAR	390pF	50V
C737	UA952390	C.MYLAR	390pF	50V
C738	UA953470	C.MYLAR	4700pF	50V
C739	UR847470	C.EL	47uF	25V
C740	UR847470	C.EL	47uF	25V
C741	UB051820	C.CE.M.CHP	82pF	50V
C742	UA655100	C.MYLAR	0.1uF	50V
C743	UR847100	C.EL	10uF	25V
C744	UR847220	C.EL	22uF	25V
C745	UR847470	C.EL	47uF	25V
C746	UA655470	C.MYLAR	0.47uF	50V
C747	UB052100	C.CE.M.CHP	100pF	50V
C748	UA655470	C.MYLAR	0.47uF	50V
C749	UA953680	C.MYLAR	6800pF	50V
C750	UR847220	C.EL	22uF	25V
C751	UA952330	C.MYLAR	330pF	50V
C752	UA953270	C.MYLAR	2700pF	50V
C753	UA953270	C.MYLAR	2700pF	50V
C754	UA952330	C.MYLAR	330pF	50V
C755	UR847220	C.EL	22uF	25V

* New Parts

Schm Ref	PART NO.	Description		
C756	UA953680	C.MYLAR	6800pF	50V
C757	UR847220	C.EL	22uF	25V
C758	UR847220	C.EL	22uF	25V
C759	UB044220	C.CE.M.CHP	0.022uF	50V
C760	UR847220	C.EL	22uF	25V
C761	UR847220	C.EL	22uF	25V
C762	UR847100	C.EL	10uF	25V
C763	UR847100	C.EL	10uF	25V
C764	UR838220	C.EL	220uF	16V
C765	UR848100	C.EL	100uF	25V
C766	UR847100	C.EL	10uF	25V
C767	UR847100	C.EL	10uF	25V
C768	UT652470	C.PP	470pF	100V
C769	VG288500	C.EL	10uF	50V
C770	VG288500	C.EL	10uF	50V
C771	UT652470	C.PP	470pF	100V
C772	UR847220	C.EL	22uF	25V
C773	UR847220	C.EL	22uF	25V
C774	VP755200	C.CE.ARRAY	100pF	50V
C775	UR837470	C.EL	47uF	16V
C776	UR837470	C.EL	47uF	16V
C777	VH483900	C.CE.ARRAY	100pF	50V
C801	UR866470	C.EL	4.7uF	50V
C802	UR837470	C.EL	47uF	16V
C803	UR866100	C.EL	1uF	50V
C804	UR866100	C.EL	1uF	50V
C805	UB013120	C.CE.M.CHP	1200pF	50V
C806	UB012470	C.CE.M.CHP	470pF	50V
C807	UB045100	C.CE.M.CHP	0.1uF	50V
C808	VJ899200	C.CE.M.CHP	7pF	50V
C809	VJ899200	C.CE.M.CHP	7pF	50V
C810	VJ900300	C.CE.M.CHP	22pF	50V
C811	VJ900300	C.CE.M.CHP	22pF	50V
C812	UB045100	C.CE.M.CHP	0.1uF	50V
C813	UR837470	C.EL	47uF	16V
C814	UR829100	C.EL	1000uF	10V
C815	VR169200	C.MYLAR.ML	ECQ-V1H474JL3	
C816	UR837100	C.EL	10uF	16V
C821	UB044470	C.CE.M.CHP	0.047uF	50V(BG)
C822	UB044100	C.CE.M.CHP	0.01uF	50V(BG)
C823	UB044100	C.CE.M.CHP	0.01uF	50V(BG)
D402	VT332900	DIODE	1SS355	
D403	VT332900	DIODE	1SS355	
D404	VT332900	DIODE	1SS355	
D405	VT332900	DIODE	1SS355	
D406	VT332900	DIODE	1SS355	
D407	VT332900	DIODE	1SS355	
D408	VT332900	DIODE	1SS355	
D701	VT332900	DIODE	1SS355	
D702	VT332900	DIODE	1SS355	
D703	VT332900	DIODE	1SS355	
D704	VT332900	DIODE	1SS355	
D705	VT332900	DIODE	1SS355	

* New Parts

FUNCTION P. C. B. & VOLUME P. C. B.

Schm Ref	PART NO.	Description		Schm Ref	PART NO.	Description	
D706	VT332900	DIODE	1SS355	Q804	iC174020	TR	2SC1740S R,S
D707	VT332900	DIODE	1SS355	Q805	iA093320	TR	2SA933S Q,R
D708	VT332900	DIODE	1SS355	R321	VP940700	R.MTL.OXD	330Ω 1W
D709	VT332900	DIODE	1SS355	R322	VP940700	R.MTL.OXD	330Ω 1W
D710	VU995100	DIODE.ZENR	MA8091-H 9.4V	R651	VP940200	R.MTL.OXD	47Ω 1W
D711	VU995100	DIODE.ZENR	MA8091-H 9.4V	R674	HV755100	R.CAR.FP	100Ω 1/4W
D712	VT332900	DIODE	1SS355	R683	HV755100	R.CAR.FP	100Ω 1/4W
D713	VT332900	DIODE	1SS355	R701	VP940300	R.MTL.OXD	68Ω 1W
D714	VT332900	DIODE	1SS355	R782	HV754220	R.CAR.FP	22Ω 1/4W
D715	VT332900	DIODE	1SS355	R783	HV756100	R.CAR.FP	1KΩ 1/4W
D801	VT332900	DIODE	1SS355	R784	HV756100	R.CAR.FP	1KΩ 1/4W
D802	VT332900	DIODE	1SS355	R796	HV754100	R.CAR.FP	10Ω 1/4W
D803	VT332900	DIODE	1SS355	R808	HV753220	R.CAR.FP	2.2Ω 1/4W
*IC401	XV144A00	IC	M38B59MFH-A100FP	R811	HV753220	R.CAR.FP	2.2Ω 1/4W
IC471	XJ553A00	IC	NJM2068MD	*SW321	V3266600	SW.PUSH	SPUP12 4/2+2/2
IC651	XN588A00	IC	NJU7313	SW401	VT140300	SW.RT.ENC	EC16B12204
IC652	XJ553A00	IC	NJM2068MD	SW405	V2014900	SW.TACT	EVQ21304M(BG)
IC701	XA507A00	IC	AN78N05	SW406	V2014900	SW.TACT	EVQ21304M
IC702	XV743A00	IC	LH5P832N-10 PS-RAM	SW407	V2014900	SW.TACT	EVQ21304M(BG)
IC703	Xi022B00	IC	YSS203B-F	SW408	V2014900	SW.TACT	EVQ21304M
IC704	XF291A00	IC	uPC4570G2	SW409	V2014900	SW.TACT	EVQ21304M
IC705	XF291A00	IC	uPC4570G2	SW410	V2014900	SW.TACT	EVQ21304M
IC706	XF291A00	IC	uPC4570G2	SW411	V2014900	SW.TACT	EVQ21304M
IC707	XF291A00	IC	uPC4570G2	SW412	V2014900	SW.TACT	EVQ21304M
IC708	XV130A00	IC	NJM4558M-D OP AMP	SW413	V2014900	SW.TACT	EVQ21304M
IC709	XV130A00	IC	NJM4558M-D OP AMP	SW414	V2014900	SW.TACT	EVQ21304M(BG)
IC710	XF291A00	IC	uPC4570G2	SW415	V2014900	SW.TACT	EVQ21304M
IC711	XF291A00	IC	uPC4570G2	SW416	V2014900	SW.TACT	EVQ21304M(BG)
*IC712	XJ553A00	IC	NJM2068MD	SW417	V2014900	SW.TACT	EVQ21304M
*IC713	XB738A00	IC	TC4053BF MULTI-PLX	U401	VU674100	L.DTCT	GP1U261X
IC714	XB738A00	IC	TC4053BF MULTI-PLX	V401	VU105900	FL.DSPLY	13-BT-143GK
IC715	XJ553A00	IC	NJM2068MD	VR471	VT743800	VR	B20KΩ
IC801	XF293A00	IC	uPD4066G-T1	VR472	VT743900	VR	B25KΩ
IC802	XJ596A00	IC	NJM78L05A	VR473	VT744100	VR	Z100KΩ
IC803	XS502A00	IC	LC74781-9626	XL401	VE906000	RSNR.CE	4MHz
JK320	VS899700	JACK.PHONE	JY-6317-02-030	XL701	VK175200	RSNR.CE	11.28MHz
L701	VG669500	COIL	220uH	XL801	VV949800	RSNR.CRYS	14.31818MHz(R)
L702	VC362000	COIL	1mH	XL801	VV949900	RSNR.CRYS	17.734475MHz(BG)
L703	VC362000	COIL	1mH		VJ828000	PIN	IMSA-6024-03E
L704	VC362000	COIL	1mH		VR519500	SHEET	
L801	VG668700	COIL	33uH		VR380100	SPACER	FL-T6
PJ651	VJ794600	JACK.PIN	6P				
PJ652	VJ696400	JACK.PIN	6P	*V2802100	P.C.B.	VOLUME	
Q403	iC174020	TR	2SC1740S R,S	CB442	VQ962900	CN.BS.PIN	8P
Q404	VG721700	TR.DGT	DTA144ES	CB471	VQ047800	CN.BS.PIN	27P
Q701	VG722000	TR.DGT	DTC144ES	CB472	VM859500	CN.BS.PIN	11P
Q702	iC287820	TR	2SC2878 A,B	CB473	Vi878000	CN.BS.PIN	2P
Q703	iC287820	TR	2SC2878 A,B	CB531	VF728200	CN.BS.PIN	10P
Q704	VG722000	TR.DGT	DTC144ES	CB534	Vi879300	CN.BS.PIN	15P
Q705	VG722000	TR.DGT	DTC144ES	CB535	VQ961500	CN.BS.PIN	12P
Q801	iC174020	TR	2SC1740S R,S	CB536	VQ961500	CN.BS.PIN	12P
Q802	iC053540	TR	2SC535 A,B,C	CB552	VQ045600	CN.BS.PIN	27P
Q803	iA093320	TR	2SA933S Q,R	CB553	VQ045400	CN.BS.PIN	25P

* New Parts

* New Parts

VOLUME P.C.B.

Schm Ref	PART NO.	Description		
CB554	Vi878100	CN.BS.PIN	3P	
CB556	Vi878200	CN.BS.PIN	4P	
CB557	VK024700	CN.BS.PIN	3P	
CB601	VQ962600	CN.BS.PIN	5P	
C441	UN866100	C.EL	1uF	50V
C442	UR847100	C.EL	10uF	25V
C443	UR847100	C.EL	10uF	25V
C444	UR847100	C.EL	10uF	25V
C445	UR847100	C.EL	10uF	25V
C446	FG652100	C.CE	100pF	50V
C447	FG651470	C.CE	47pF	50V
C448	FG651470	C.CE	47pF	50V
C449	FG652100	C.CE	100pF	50V
C450	UR847100	C.EL	10uF	25V
C451	UR847100	C.EL	10uF	25V
C452	FG652100	C.CE	100pF	50V
C453	UR838330	C.EL	330uF	16V
C454	UR837470	C.EL	47uF	16V
C455	FG652100	C.CE	100pF	50V
C456	FG612220	C.CE	220pF	50V
C457	FG612220	C.CE	220pF	50V
C458	VJ599100	C.CE.TUBLR	0.1uF	50V
C459	VJ599100	C.CE.TUBLR	0.1uF	50V
C471	UR847100	C.EL	10uF	25V
C472	FG652100	C.CE	100pF	50V
C473	FG652100	C.CE	100pF	50V
C474	UR847100	C.EL	10uF	25V
C531	VF467300	C.CE.TUBLR	0.01uF	16V
C532	UR838100	C.EL	100uF	16V
C533	UR837470	C.EL	47uF	16V
C534	VJ599100	C.CE.TUBLR	0.1uF	50V
C535	UN865470	C.EL	0.47uF	50V
C536	UR837100	C.EL	10uF	16V
C601	UR828100	C.EL	100uF	10V
C602	UA952220	C.MYLAR	220pF	50V
C603	UA952220	C.MYLAR	220pF	50V
C604	UA952220	C.MYLAR	220pF	50V
C605	UA952220	C.MYLAR	220pF	50V
C606	VF467300	C.CE.TUBLR	0.01uF	16V
C607	UR828100	C.EL	100uF	10V
C608	UR866220	C.EL	2.2uF	50V
C609	UA653910	C.MYLAR	9100pF	50V
C610	UA954330	C.MYLAR	0.033uF	50V
C611	UA653910	C.MYLAR	9100pF	50V
C612	UA954330	C.MYLAR	0.033uF	50V
C613	UR866220	C.EL	2.2uF	50V
C614	UR838220	C.EL	220uF	16V
C615	UR838220	C.EL	220uF	16V
D153	VD631600	DIODE	1SS133,176,HSS104	
D531	VM974200	DIODE.ZENR	HZS5C2TD 5.0V	
D532	VM975500	DIODE.ZENR	HZS12A2TD 12V	
D551	VD631600	DIODE	1SS133,176,HSS104	
IC441	XR040A00	IC	TC9299P	

* New Parts

Schm Ref	PART NO.	Description		
IC442	XR040A00	IC	TC9299P	
IC443	XM356A00	IC	NJM2068LD	
IC447	XM356A00	IC	NJM2068LD	
IC448	XR838A00	IC	NJU7311L	
IC531	XF494A00	IC	LB1641	
IC601	XM356A00	IC	NJM2068LD	
PJ601	VT848700	JACK.PIN	2P	
Q531	iC287820	TR	2SC2878 A,B	
Q532	iC287820	TR	2SC2878 A,B	
Q533	iC287820	TR	2SC2878 A,B	
Q534	iC287820	TR	2SC2878 A,B	
Q535	VP872700	TR	2SC4488 S,T	
Q536	VG721700	TR.DGT	DTA144ES	
R450	HV754220	R.CAR.FP	22Ω	1/4W
R451	HV754220	R.CAR.FP	22Ω	1/4W
R536	VP939800	R.MTL.OXD	10Ω	1W
R537	HV754100	R.CAR.FP	10Ω	1/4W
R540	HV753470	R.CAR.FP	4.7Ω	1/4W
*SW471	V2573300	SW.PUSH	SPUP12	
*VR471	V2573500	VR.MTR	A100KΩ	
	VJ828000	PIN	IMSA-6024-03E	

■ Chip Resistors

Schm Ref	PART NO.	Description		
	RD253220	R.CAR.CHP	2.2Ω	1/10W
	RD254680	R.CAR.CHP	68Ω	1/10W
	RD255100	R.CAR.CHP	100Ω	1/10W
	RD255150	R.CAR.CHP	150Ω	1/10W
	RD255220	R.CAR.CHP	220Ω	1/10W
	RD255330	R.CAR.CHP	330Ω	1/10W
	RD255390	R.CAR.CHP	390Ω	1/10W
	RD255470	R.CAR.CHP	470Ω	1/10W
	RD256100	R.CAR.CHP	1KΩ	1/10W
	RD256180	R.CAR.CHP	1.8KΩ	1/10W
	RD256220	R.CAR.CHP	2.2KΩ	1/10W
	RD256240	R.CAR.CHP	2.4KΩ	1/10W
	RD256270	R.CAR.CHP	2.7KΩ	1/10W
	RD256330	R.CAR.CHP	3.3KΩ	1/10W
	RD256470	R.CAR.CHP	4.7KΩ	1/10W
	RD256560	R.CAR.CHP	5.6KΩ	1/10W
	RD256680	R.CAR.CHP	6.8KΩ	1/10W
	RD256820	R.CAR.CHP	8.2KΩ	1/10W
	RD257100	R.CAR.CHP	10KΩ	1/10W
	RD257120	R.CAR.CHP	12KΩ	1/10W
	RD257150	R.CAR.CHP	15KΩ	1/10W
	RD257180	R.CAR.CHP	18KΩ	1/10W
	RD257220	R.CAR.CHP	22KΩ	1/10W
	RD257330	R.CAR.CHP	33KΩ	1/10W
	RD257470	R.CAR.CHP	47KΩ	1/10W
	RD258100	R.CAR.CHP	100KΩ	1/10W
	RD258220	R.CAR.CHP	220KΩ	1/10W
	RD258470	R.CAR.CHP	470KΩ	1/10W
	RD259100	R.CAR.CHP	1MΩ	1/10W

* New Parts

MECHANICAL PARTS

Ref. No.	PART NO.	Description	Remarks	Markets
* 1-1-1	V2631600	FRONT PANEL		(R)
* 1-1-1	V2631700	FRONT PANEL		(BG)
1-1-2	VS347800	PANEL, LID		
1-1-3	VV471700	SUB PANEL		
1-1-4	VU845000	WINDOW PANEL, LID		
* 1-1-5	V2632000	PLATE, SP		(R)
* 1-1-5	V2632100	PLATE, SP		(BG)
1-1-6	VQ958500	HINGE, LID		
1-1-7	VT842700	TAPE, GND	FM8100	
1-1-8	VD435300	BIND HEAD P-TITE SCREW	2.6x8 FCRM3-BL	
1- 7	MF106180	FLEXIBLE FLAT CABLE	6P 180mm	
1- 8	MF105350	FLEXIBLE FLAT CABLE	5P 350mm	(BG)
1- 9	MF111200	FLEXIBLE FLAT CABLE	11P 200mm	
1-10	MF125200	FLEXIBLE FLAT CABLE	25P 200mm	
1-11	VT454200	KNOB	D35	
* 1-12	V2724700	KNOB	D31	
1-16	VS757300	KNOB, P	D12	
1-17	VS048400	BUTTON	D7	
1-18	VT184400	BUTTON	D5	
1-21	VU418100	SUPPORT, VR		
1-22	VU975300	SHIELD PLATE		
1-23	VU418000	SUPPORT, FTP		
1-26	VU767000	SHEET, FP		
1-28	VV926300	SHEET	0.5x5x20	
1-31	EP630220	BIND HEAD P-TITE SCREW	3x8 ZMC2-BL	
1-32	EL300690	PW HEAD P-TITE SCREW	3x8-8 FCRM3-BL	
1-33	EP600830	BIND HEAD B-TITE SCREW	3x8 FCRM3-BL	
1-34	EP600520	PAN HEAD P-TITE SCREW	3x8 ZMC2-Y	
△# 3- 5	VT064500	PAIR TRANSISTOR	2SA1694/C4467 OPY	Q110A/C,Q114A/C
△# 3- 5	VT064500	PAIR TRANSISTOR	2SA1694/C4467 OPY	,Q118A/C
△ 3- 6	XJ603A00	IC	NJM78M15FA	IC101
3-10	VU418300	HEAT SINK ASS'Y		
3-11	VV849300	SHEET	19x24	
3-23	VU555400	SUPPORT, HSP		
* 3-24	V2847700	SUPPORT, IC		
3-31	VK173200	SCREW, TRANSISTOR	3x15 SP FCM3	
3-32	EL300650	PW HEAD B-TITE SCREW	3x8-8 FCRM3-BL	
3-33	EP600830	BIND HEAD B-TITE SCREW	3x8 FCRM3-BL	
3-35	VQ368600	PUSH RIVET	P3555-B	
* 5	V2802100	P.C.B. ASS'Y	VOLUME	
6	VT558900	P.C.B. ASS'Y	TUNER	(R)
6	VV152000	P.C.B. ASS'Y	TUNER	(BG)
* 7	V2801800	P.C.B. ASS'Y	FUNCTION	(R)
* 7	V2801900	P.C.B. ASS'Y	FUNCTION	(BG)
* 8	V2801400	P.C.B. ASS'Y	MAIN	(R)
* 8	V2801500	P.C.B. ASS'Y	MAIN	(B)
* 8	V2801600	P.C.B. ASS'Y	MAIN	(G)
△* 11	XV292A00	POWER TRANSFORMER		(R)
△* 11	XV293A00	POWER TRANSFORMER		(BG)
△ 12	VQ508500	POWER CORD ASS'Y		(R)
△ 12	VQ508700	POWER CORD ASS'Y		(G)
△ 12	VV437300	POWER CORD ASS'Y		(B)
* 13	V2438700	CORD STOPPER	#10P1	

* New Parts

Ref. No.	PART NO.	Description	Remarks	Markets
* 14	MF211300	S FLEXIBLE FLAT CABLE	11P 300mm	
* 15	MF127200	FLEXIBLE FLAT CABLE	27P 200mm	(R)
* 15	MF227200	S FLEXIBLE FLAT CABLE	27P 200mm	(BG)
* 16	MF110070	FLEXIBLE FLAT CABLE	10P 70mm	
17	VU590000	BINDING TIE	CBTD001B	
18	VZ625600	BINDING TIE	SE140 L=140	
20	FG612100	CERAMIC CAP	100pF 50V	
* 21	VV948800	CUSHION	10x10x20	(BG)
22	VB933800	FERRITE CORE	BP53RB310190NOA	(BG)
50	VS043700	TOP COVER		
52	VU398700	CHASSIS		
54	VU417700	BOTTOM COVER		
* 56	V2632700	REAR PANEL		(R)
* 56	V2632900	REAR PANEL		(B)
* 56	V2633000	REAR PANEL		(G)
58	VP984800	LEG	D41xH12.5	
60	VU417800	AUPPORT, FBM		
61	VU417900	SUPPORT, RBM		
63	VU418200	SHIELD PLATE		
64	VU555300	SHIELD PLATE		
65	VV080600	SHIELD PLATE		
70	VU890700	SHEET, PWB		
71	VV319800	SHEET, BARRIER		(BG)
73	VT593600	CUSHION	8x10x20	
74	VQ861500	CUSHION	SHEET	
75	VT593700	CUSHION	2x8x25	
76	VS758000	DAMPER, T5		
77	VQ366100	DAMPER, PCB		
80	VU981200	SUPPORT, P.C.B.	No.3596	
81	VL791900	HOLDER, P.C.B.		
98	VQ368500	PUSH RIVET	P3545-B	
99	VQ368600	PUSH RIVET	P3555-B	
100	EP600830	BIND HEAD B-TITE SCREW	3x8 FCRM3-BL	
101	VN413300	BIND HEAD BONDING B-T. SCREW	3x8 MFZN2-BL	
102	VT669300	PW HEAD B-TITE SCREW	3x8-8 MFC2	
104	EP630210	BIND HEAD S-TITE SCREW	3x6 ZMC2-BL	
105	EP600250	BIND HEAD B-TITE SCREW	3x8 ZMC2-Y	
106	EG330030	BIND HEAD SCREW	3x6 FCRM3-BL	
107	VL762900	PW HEAD P-TITE SCREW	3x20-8 FCRM3-BL	(R)
108	VY731200	BONDING HEAD TAPPING SCREW	3x10 MFNI33	
110	VB981200	BIND HEAD S-TITE SCREW	4x8 FCRM3-BL	
112	VH313200	BW HEAD S-TITE SCREW	4x8-10 FNM3-BL	
116	VQ057700	HEXAGONAL CAP NUT	3mm FNM3-3G	
117	03700480	HEXAGONAL CAP NUT	4.0 MFNI33	
* 200	V2685400	ACCESSORIES		
200-1	CX679050	REMOTE CONTROL TRANSMITTER	SBGH20041A	
	VQ147100	LID	74x34BLALPS	
	VR248500	ANTENNA, FM	1P 1.4m	
	VE364900	ANTENNA, AM LOOP	1P 1.0m	
		ANTENNA ADAPTER	PAL 75-300Ω	
		BATTERY, MANGANESE	SUM-3,AA,R06	

* New Parts

REMOTE CONTROL TRANSMITTER

SCHEMATIC DIAGRAM

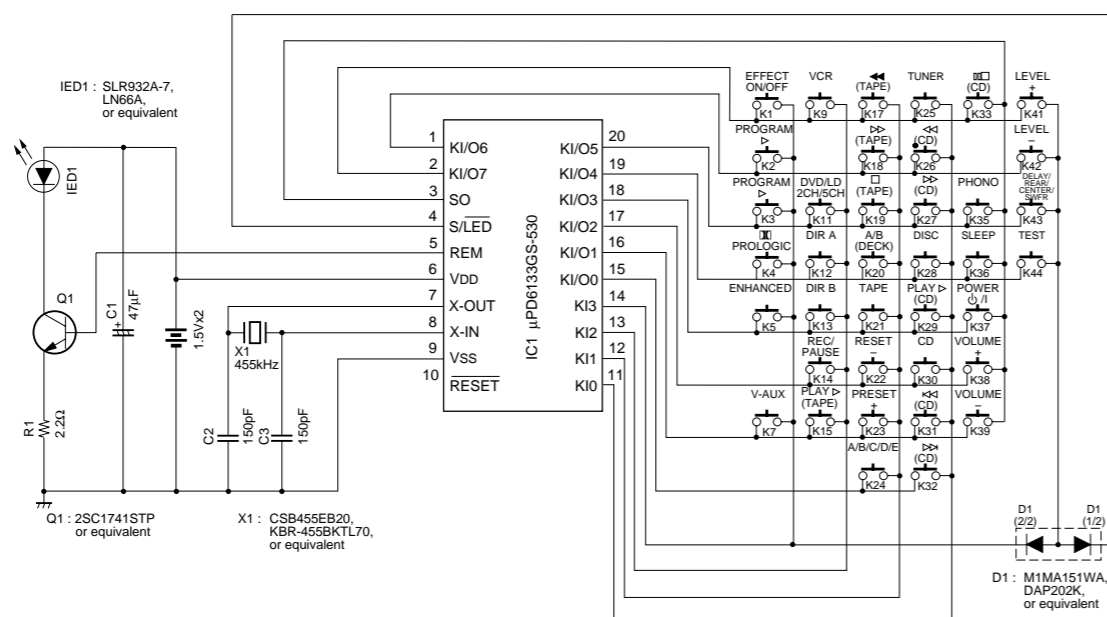
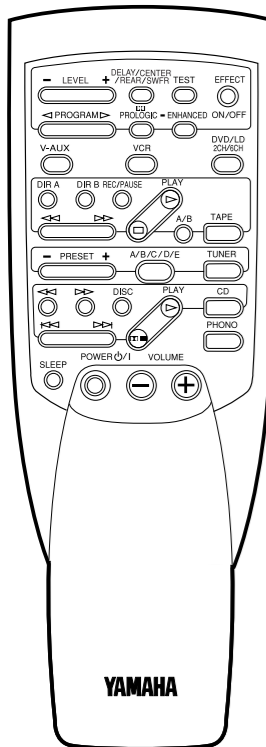

Parts List for Carbon Resistors

Value	1/4W Type Part No.	1/6W Type Part No.	Value	1/4W Type Part No.	1/6W Type Part No.
1.0 Ω	HJ35 3100	HF85 3100	10 kΩ	HF45 7100	HF45 7100
1.8 Ω	HJ35 3180	*	11 kΩ	HF45 7110	HF45 7110
2.2 Ω	HJ35 3220	HF85 3220	12 kΩ	HJ35 7120	HF85 7120
3.3 Ω	HJ35 3330	HF85 3330	13 kΩ	HF45 7130	HF45 7130
4.7 Ω	HJ35 3470	HF85 3470	15 kΩ	HF45 7150	HF45 7150
5.6 Ω	HJ35 3560	HF85 3560	18 kΩ	HF45 7180	HF45 7180
10 Ω	HF45 4100	HF45 4100	22 kΩ	HF45 7220	HF45 7220
15 Ω	HJ35 4150	HF85 4150	24 kΩ	HF45 7240	HF45 7240
22 Ω	HF45 4220	HF45 4220	27 kΩ	HJ35 7270	HF85 7270
27 Ω	HJ35 4270	HF85 4270	30 kΩ	HF45 7300	HF45 7300
33 Ω	HF45 4330	HF45 4330	33 kΩ	HF45 7330	HF45 7330
39 Ω	HJ35 4390	HF85 4390	36 kΩ	HF45 7360	HF45 7360
47 Ω	HF45 4470	HF45 4470	39 kΩ	HF45 7390	HF45 7390
56 Ω	HF45 4560	HF45 4560	47 kΩ	HF45 7470	HF45 7470
68 Ω	HF45 4680	HF45 4680	51 kΩ	HF45 7510	HF45 7510
75 Ω	HF45 4750	HF45 4750	56 kΩ	HF45 7560	HF45 7560
82 Ω	HF45 4820	HF45 4820	62 kΩ	HF45 7620	HF45 7620
91 Ω	HF45 4910	HF45 4910	68 kΩ	HF45 7680	HF45 7680
100 Ω	HF45 5100	HF45 5100	82 kΩ	HF45 7820	HF45 7820
110 Ω	HJ35 5110	HF85 5110	91 kΩ	HF45 7910	HF45 7910
120 Ω	HF45 5120	HF45 5120	100 kΩ	HF45 8100	HF45 8100
150 Ω	HF45 5150	HF45 5150	110 kΩ	HF45 8110	HF45 8110
160 Ω	HJ35 5160	*	120 kΩ	HF45 8120	HF45 8120
180 Ω	HF45 5180	HF45 5180	150 kΩ	HF45 8150	HF45 8150
200 Ω	HF45 5200	HF45 5200	180 kΩ	HF45 8180	HF45 8180
220 Ω	HF45 5220	HF45 5220	220 kΩ	HJ35 8220	HF85 8220
270 Ω	HF45 5270	HF45 5270	270 kΩ	HF45 8270	HF45 8270
330 Ω	HF45 5330	HF45 5330	300 kΩ	HF45 8300	HF45 8300
390 Ω	HF45 5390	HF45 5390	330 kΩ	HF45 8330	HF45 8330
430 Ω	HF45 5430	HF45 5430	390 kΩ	HJ35 8390	HF85 8390
470 Ω	HF45 5470	HF45 5470	470 kΩ	HF45 8470	HF45 8470
510 Ω	HF45 5510	HF45 5510	560 kΩ	HJ35 8560	HF85 8560
560 Ω	HF45 5560	HF45 5560	680 kΩ	HJ35 8680	HF85 8680
680 Ω	HF45 5680	HF45 5680	820 kΩ	HJ35 8820	HF85 8820
820 Ω	HF45 5820	HF45 5820	1.0 MΩ	HF45 9100	HF45 9100
910 Ω	HF45 5910	HF45 5910	1.2 MΩ	HJ35 9120	*
1.0 kΩ	HF45 6100	HF45 6100	1.5 MΩ	HJ35 9150	HF85 9150
1.2 kΩ	HF45 6120	HF45 6120	1.8 MΩ	HJ35 9180	HF85 9180
1.5 kΩ	HF45 6150	HF45 6150	2.2 MΩ	HJ35 9220	HF85 9220
1.8 kΩ	HF45 6180	HF45 6180	3.3 MΩ	HJ35 9330	HF85 9330
2.0 kΩ	HJ35 6200	HF85 6200	3.9 MΩ	HJ35 9390	*
2.2 kΩ	HF45 6220	HF45 6220	4.7 MΩ	HJ35 9470	HF85 9470
2.4 kΩ	HJ35 6240	HF85 6240			
2.7 kΩ	HF45 6270	HF45 6270			
3.0 kΩ	HF45 6300	HF45 6300			
3.3 kΩ	HF45 6330	HF45 6330			
3.6 kΩ	HJ35 6360	HF85 6360			
3.9 kΩ	HF45 6390	HF45 6390			
4.7 kΩ	HF45 6470	HF45 6470			
5.1 kΩ	HF45 6510	HF45 6510			
5.6 kΩ	HF45 6560	HF45 6560			
6.8 kΩ	HF45 6680	HF45 6680			
8.2 kΩ	HF45 6820	HF45 6820			
9.1 kΩ	HF45 6910	HF45 6910			

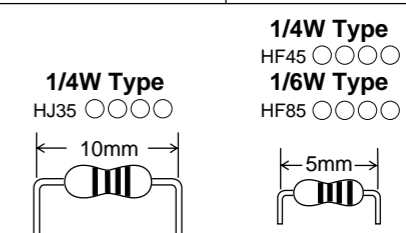

*: Not available