

AV RECEIVER RX-V320

SERVICE MANUAL

For T model

IMPORTANT NOTICE

This manual has been provided for the use of authorized YAMAHA Retailers and their service personnel. It has been assumed that basic service procedures inherent to the industry, and more specifically YAMAHA Products, are already known and understood by the users, and have therefore not been restated.

WARNING: Failure to follow appropriate service and safety procedures when servicing this product may result in personal injury, destruction of expensive components, and failure of the product to perform as specified. For these reasons, we advise all YAMAHA product owners that any service required should be performed by an authorized YAMAHA Retailer or the appointed service representative.

IMPORTANT: The presentation or sale of this manual to any individual of firm does not constitute authorization, certification or recognition of any applicable technical capabilities, or establish a principle-agent relationship of any form.

The data provided is believed to be accurate and applicable to the unit(s) indicated on the cover. The research, engineering, and service departments of YAMAHA are continually striving to improve YAMAHA products. Modifications are, therefore, inevitable and specifications are subject to change without notice or obligation to retrofit. Should any discrepancy appear to exist, please contact the distributor's Service Division.

WARNING: Static discharges can destroy expensive components. Discharge any static electricity your body may have accumulated by grounding yourself to the ground buss in the unit (heavy gauge black wires connect to this buss).

IMPORTANT: Turn the unit OFF during disassembly and part replacement. Recheck all work before you apply power to the unit.

■ CONTENTS

TO SERVICE PERSONNEL	1	AMP ADJUSTMENT	19
REMOTE CONTROL PANEL	1	TUNER ADJUSTMENT	20~23
FRONT PANEL	2	IC DATA	24~32
REAR PANEL	2	DISPLAY DATA	33
SPECIFICATIONS	3~4	BLOCK DIAGRAM	34~37
INTERNAL VIEW	4	PRINTED CIRCUIT BOARD	38~53
DISASSEMBLY PROCEDURES	5	SCHEMATIC DIAGRAM	54~60
SELF DIAGNOSIS FUNCTION	6~17	PARTS LIST	61~74
FACTORY PRESET	18	REMOTE CONTROL TRANSMITTER	75~76



このサービスマニュアルは、エコマーク認定の再生紙を使用しています。
This Service Manual uses recycled paper.



■ TO SERVICE PERSONNEL

1. Critical Components information

Components having special characteristics are marked \triangle and must be replaced with parts having specifications equal to those originally installed.

2. Leakage Current Measurement (For 120V Model only)

When service has been completed, it is imperative that you verify that all exposed conductive surfaces are properly insulated from supply circuits.

- Meter impedance should be equivalent to 1500 ohm shunted by 0.15 μ F.
- Leakage current must not exceed 0.5mA.
- Be sure to test for leakage with the AC plug in both polarities.

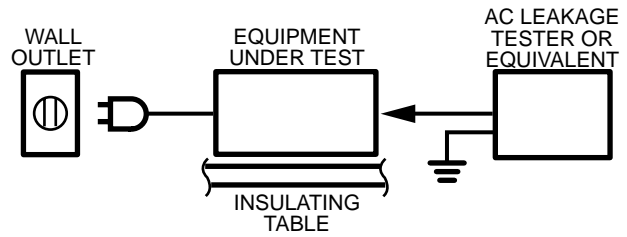

WARNING: CHEMICAL CONTENT NOTICE!

The solder used in the production of this product contains LEAD. In addition, other electrical/electronic and/or plastic (where applicable) components may also contain traces of chemicals found by the California Health and Welfare Agency (and possibly other entities) to cause cancer and/or birth defects or other reproductive harm.

DO NOT PLACE SOLDER, ELECTRICAL/ELECTRONIC OR PLASTIC COMPONENTS IN YOUR MOUTH FOR ANY REASON WHATSOEVER!

Avoid prolonged, unprotected contact between solder and your skin! When soldering, do not inhale solder fumes or expose eyes to solder/flux vapor!

If you come in contact with solder or components located inside the enclosure of this product, wash your hands before handling food.

经DTS公司许可制造，已申请美国专利5,451,942以及其他世界性的专利或待批的专利。“DTS”、“DTS Digital Surround”是DTS公司的商标。DTS公司一九九六年版。版权所有。

经杜比实验室(Dolby Laboratories)授权制造。“Dolby”，“Pro Logic”及双D标志等均为杜比实验室所用商标。机密的未发表著作(Confidential Unpublished Works)。©1992-1997年杜比实验室有限公司。保留版权。

■ REMOTE CONTROL PANEL

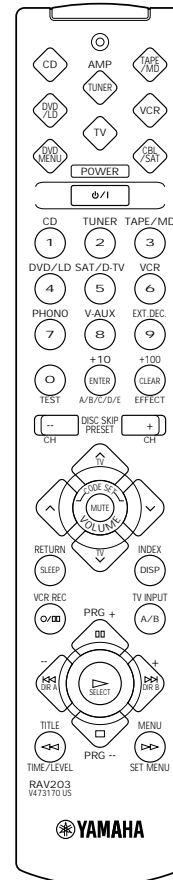

FRONT PANEL

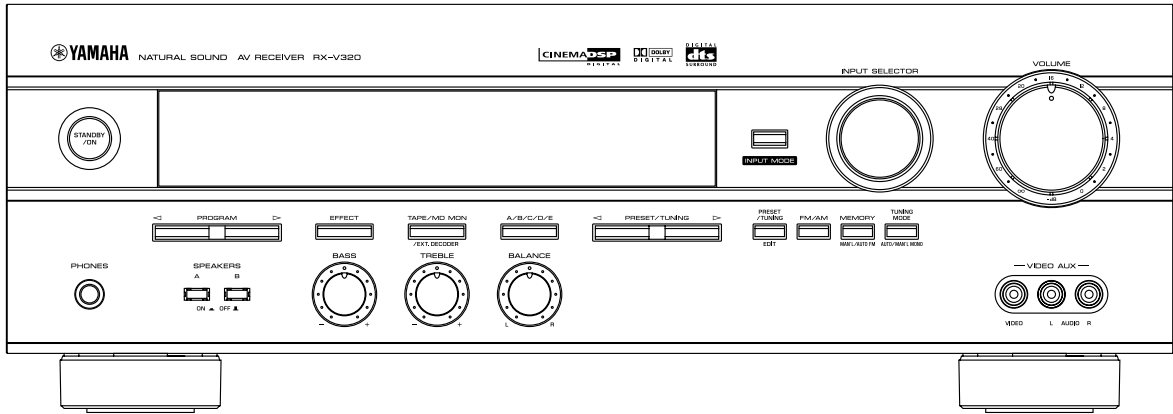

REAR PANEL

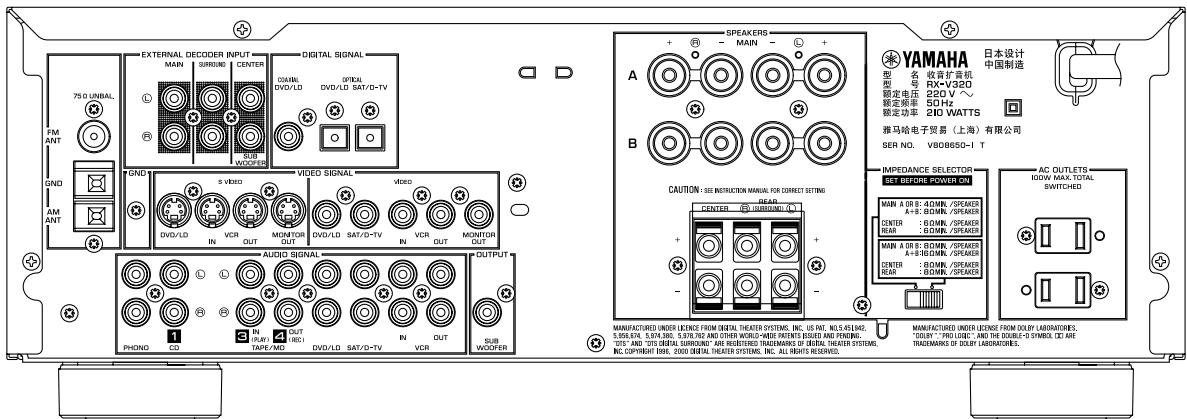

■ SPECIFICATIONS / 规格

■ 音频部分

最小有效输出功率	
20 Hz 至 20 kHz, 0.06% 总谐波失真, 8 欧姆	65 W
主左 / 右, 中置, 后置左 / 右	
1 kHz, 0.09% 总谐波失真, 8 欧姆	70 W
主左 / 右, 中置, 后置左 / 右	
最大输出功率 (EIAJ)	100 W
1 kHz, 10% 总谐波失真, 8 欧姆	
动态功率 (IHF)	90/110/130/150 W
8/6/4/2 欧姆	
阻尼因数	60
20 Hz 至 20 kHz, 8 欧姆	
频率响应	±0.5 dB
CD 等至 MAIN L/R	20 Hz 至 20 kHz, ±0.5 dB
总谐波失真 (20 Hz 至 20 kHz)	0.025 %
CD 等至 MAIN L/R, 35 W, 8 欧姆	
信噪比 (IHF-A 网络仪)	96 dB
CD 等至 MAIN L/R	
(150 mV, 输入短路)	
(250 mV, 输入短路)	100 dB
残留噪音 (IHF-A 网络仪)	150 μ V
MAIN L/R	
输入灵敏度 / 阻抗	150 mV/47 千欧
CD 等	
EXT. DECODER	150 mV/40—47 千欧
输出电平 / 阻抗	150 mV/1.2 千欧
REC OUT	
SUBWOOFER	4.0 V/1.2 千欧
PHONES	0.47 V/390 欧姆
声道分隔度 (音量 -30dB)	60 dB/45 dB
CD 等 (输入 5.1 千欧终接, 1 kHz/10 kHz)	
音调控制特性	
BASS : 提升 / 衰减	±10 dB/50 Hz
TREBLE : 提升 / 衰减	±10 dB/20 Hz

■ 视频部分

视频信号类型	NTSC or PAL
视频信号电平	1 V 峰—峰 / 75 欧姆
S 视频信号电平	
Y	1 V 峰—峰 / 75 欧姆
C	0.286 V 峰—峰 / 75 欧姆
信噪比	50 dB
监视器输出频率响应	5 Hz 至 10 MHz, -3 dB

■ 调频部分

调谐范围	87.50 至 108.00 MHz
信噪比 (单声道 / 立体声)	81 dB/75 dB
IHF	
谐波失真 (1 kHz)	0.1/0.2 %
单声道 / 立体声	
立体声分隔度 (1 kHz)	48 dB
频率响应	20 Hz 至 15 kHz, ±1dB
天线输入	75 欧姆, 不平衡

■ 调幅部分

调谐范围	531 至 1,611 kHz
可用灵敏度	300 μ V/m
信噪比	52 dB
天线	环形天线

■ 一般规格

供电要求	交流 220 V, 50 Hz
功率消耗	210 W (待用模式时 : 5.9 W)
交流输出插座 (最大总功率 100 W)	2 个 (开关输出插座)
尺寸 (宽×高×深)	435 × 151 × 391 mm
重量	10 kg
附件	AM (调幅) 环形天线 × 1 室内 FM (调频) 天线 × 1 遥控器 × 1 电池 (“AAA”, “R03”, “UM-4” 型) × 4

※规格有所变更时, 恕不另行通知。

T China model

● DIMENSIONS

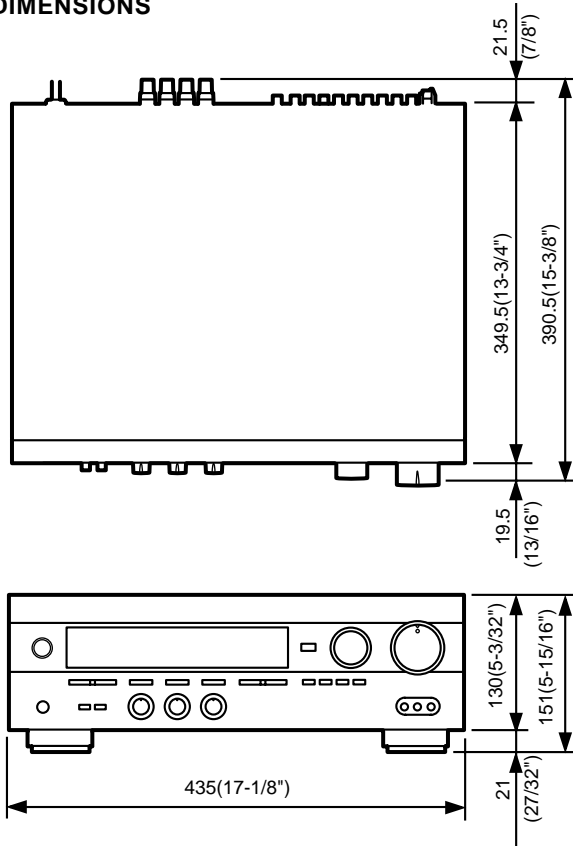

Unit : mm (inch)

警告

当本装置的电源开启时，切勿改变 IMPEDANCE SELECTOR (阻抗选择) 开关的设定，否则可能损坏本装置。

IMPEDANCE SELECTOR (阻抗选择) 开关

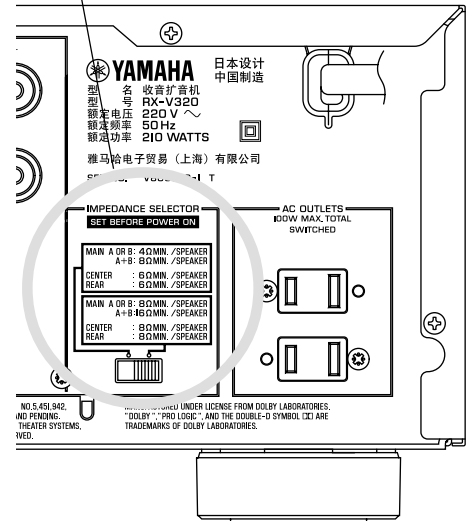

■ INTERNAL VIEW

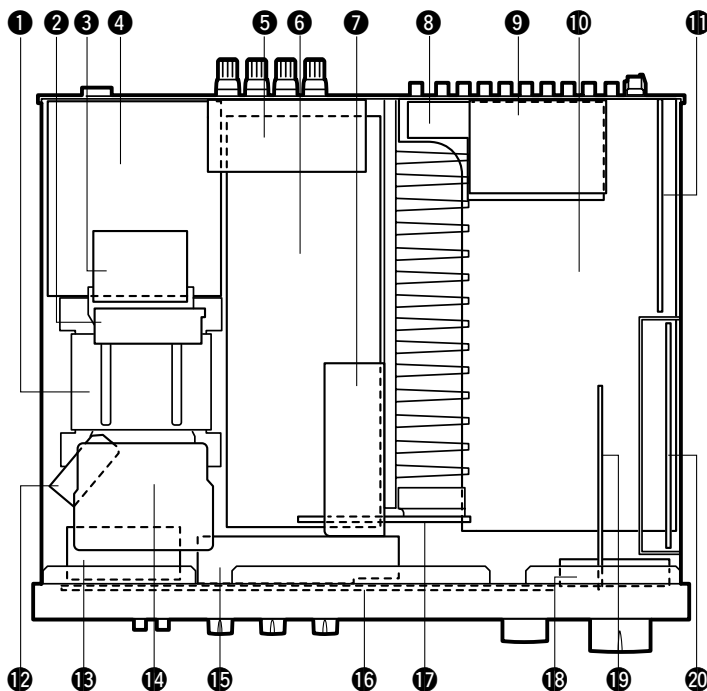

- ① POWER TRANSFORMER
- ② P.C.B. MAIN (6)
- ③ P.C.B. MAIN (5)
- ④ P.C.B. MAIN (2)
- ⑤ P.C.B. MAIN (3)
- ⑥ P.C.B. MAIN (1)
- ⑦ P.C.B. OPERATION (5)
- ⑧ P.C.B. OPERATION (6)
- ⑨ P.C.B. INPUT (3)
- ⑩ P.C.B. INPUT (1)
- ⑪ P.C.B. TUNER
- ⑫ P.C.B. OPERATION (7)
- ⑬ P.C.B. MAIN (4)
- ⑭ P.C.B. INPUT (2)
- ⑮ P.C.B. OPERATION (2)
- ⑯ P.C.B. OPERATION (1)
- ⑰ P.C.B. OPERATION (4)
- ⑱ P.C.B. OPERATION (3)
- ⑲ P.C.B. INPUT (4)
- ⑳ P.C.B. DSP

■ DISASSEMBLY PROCEDURES / 拆卸步骤 (请按照号码顺序进行拆卸。)

1. 顶盖的拆卸方法

将①的4个螺钉和②的4个螺钉卸下。(图1)

2. 前面板的拆卸方法

- a. 将5个旋钮卸下。(图1)
- b. 将③的6个螺钉卸下。(图1)

3. 主放大器修理前的准备

- a. 将固定主扬声器端子的④的2个螺钉卸下。(图2)
- b. 将P.C.B. MAIN(3)往左取出。(图4)
- c. 将固定中心/后扬声器端子和散热器的⑤的3个螺钉卸下。(图2)
- d. 将固定P.C.B. MAIN(1)的配线的通量线卸下。(图3)

注意 装配时, 要注意P.C.B. MAIN(1)的配线, 不要让它发生噪音感应。
- e. 将固定主单元的⑥的2个螺钉卸下。(图3)
- f. 将主单元往前面板侧拉出, 并如图4所示将主单元竖立起来。
- g. 使底盘和P.C.B. MAIN(1)的G201之间短路后, 对其进行接地。

注意 没有接地时, 保护装置将起作用。
- h. 在底盘和P.C.B. MAIN(1)的下面之间插入绝缘片(布、纸等), 以免短路。
- i. 在散热器和前面板的背面之间插入绝缘片(布、纸等), 以免短路。
- j. 用绳子将前面板的螺纹孔和散热器的螺纹孔之间固定起来。(图4)



图2



图3

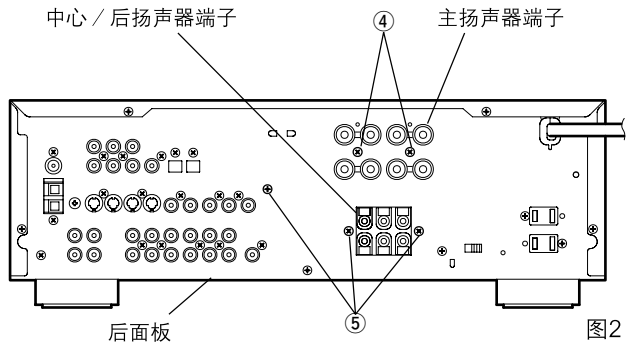

图1

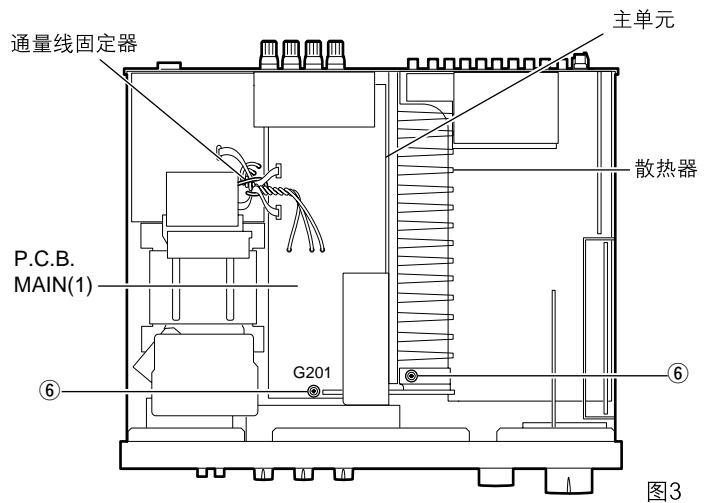

图4

■ SELF DIAGNOSIS FUNCTION / 自我诊断功能

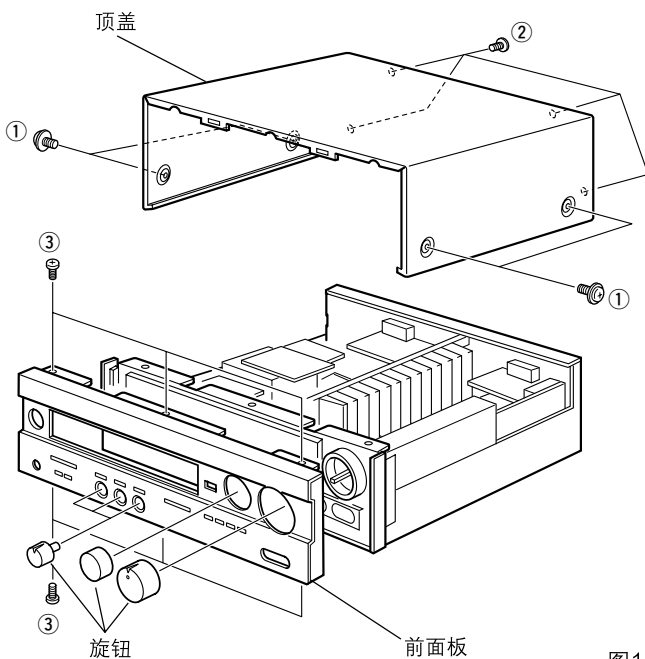
1. 目的和操作

RX-V320 具有自我诊断功能，能通过检查和测量来找出故障部位。

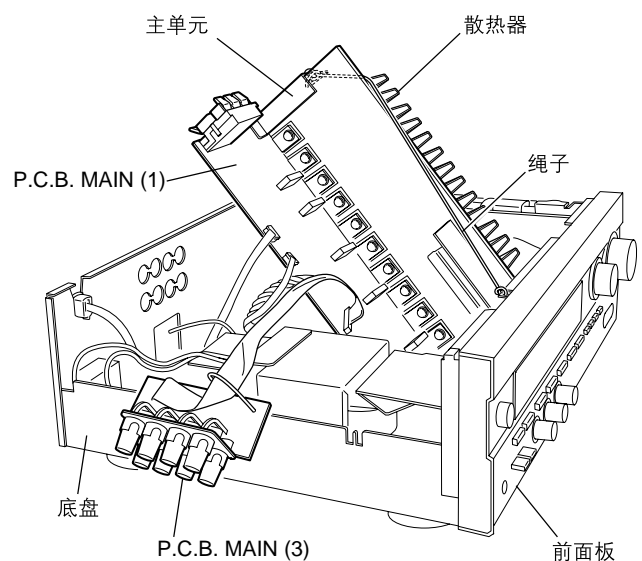
在诊断项目中有 12 个主项目和如下表所列的次项目：

No.	MAIN MENU	SUB-MENU	REMOTE CONTROL CODE (KEY)
1	ANALOG THROUGH	1. MAIN BYPASS 2. DSP 0dB	7A-88 ("1" [DSP mode]) ---
2	DSP THROUGH	1. YSS+SRAM M 2. YSS M 3. DSP FULL BIT	7A-89 ("2" [DSP mode]) --- ---
3	AC-3/DTS THROUGH	1. STATUS (BINARY FORM)	---
4	PRO LOGIC	1. CENTER LARGE 2. EFFECT OFF	7A-8A ("3" [DSP mode]) ---
5	SPEAKERS SET	1. MAIN : SMALL 0dB 2. MAIN : LARGE 0dB 3. MAIN : LARGE -10dB 4. LFE/BASS : MAIN CENTER : NONE 5. LFE/BASS : MAIN 6. LFE/BASS : SUBWOOFER 7. CENTER : NONE 8. CENTER : SMALL REAR : SMALL 9. FRONT MIX	7A-8B ("4" [DSP mode]) 7A-8C ("5" [DSP mode]) 7A-8D ("6" [DSP mode]) 7A-8E ("7" [DSP mode]) 7A-8F ("8" [DSP mode]) 7A-90 ("9" [DSP mode]) 7A-91 ("0" [DSP mode]) --- ---
6	DISPLAY CHECK (EFFECT OFF)	1. (EFFECT OFF) 2. ALL SEGMENTS TURN OFF 3. ALL SEGMENTS TURN ON 4. ALTERNATE SEGMENTS TURN ON 5. SOFTWARE RELEASE DATE	--- --- --- --- ---
7	MANUAL TEST	1. ALL 2. MAIN L 3. CENTER 4. MAIN R 5. REAR R 6. REAR L 7. LFE	--- --- --- --- --- --- ---
8	FACTORY PRESET	1. INHIBIT (Inhibit Memory Initialize) 2. RESERVED (Reserve Memory Initialize)	--- ---
9	AD DATA CHECK	1. --- 2. KEY1, KEY2 3. TUNER SIGNAL LEVEL 4. DC PROTECTION 5. PS PROTECTION	--- --- --- --- ---
10	STATUS INFORMATION FROM DSP	1./2. DSP STATUS (1)/(2) 3./4. CHANNEL STATUS (1)/(2) 5./6. BSI0 (1)/(2) 7./8. BSI1 (1)/(2) 9./10. BSI2 (1)/(2) 11./12. BSI3 (1)/(2) 13./14. BSI4 (1)/(2) 15./16. BSI5 (1)/(2)	--- --- --- --- --- --- --- ---
11	EEPROM WRITING FUNCTION	1. CHECK SUM MODIFICATION DATA EEPROM DATA 2. WRITING CONFIRMATION 3. START WRITING	--- --- ---
12	CHECK SUM/ VERSION/ PORT SETTING/EXIT	1. CHECK SUM 2. VERSION 3. PORT SETTING 4. EXIT	--- --- --- ---

2. 启动和取消

(1) 使功能和显示器启动

启动后，主项目 1 就被选择。

A. 自我诊断程序的启动方法

使用主单元前面板键

将交流电软线的插头插入。在关闭电源的状态下，同时按住 "PRESET/TUNING▷" 和 "A/B/C/D/E" 键（步骤 1），然后按 "STANDBY/ON" 键（步骤 2）。

自我诊断主项目 1 的次项目 1 将会启动。

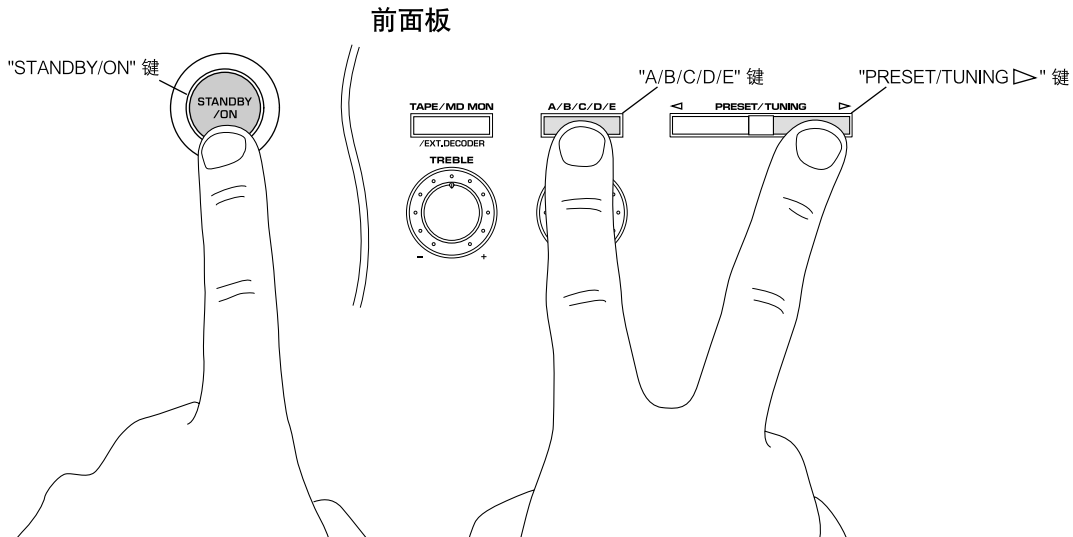

步骤 2 按 "STANDBY/ON" 键。

步骤 1 同时按住 "PRESET/TUNING▷" 和 "A/B/C/D/E" 键。

B. 自我诊断程序的启动设定

启动自我诊断程序时所用的设定如下：

1. EFFECT LEVEL :

CHANNEL	CENTER	R SUR	L SUR	SWFR
LEVEL (dB)	0	0	0	0

- 2. MUTING : OFF
- 3. INPUT (VIDEO) : DVD/LD (DVD/LD)
- 4. CENTER SPEAKER : LARGE
- 5. REAR SPEAKER : LARGE
- 6. MAIN SPEAKER : LARGE
- 7. LFE/BASS OUT : SWFR

C. 启动显示

保护履历信息显示在前面板显示屏上。

● 自我诊断程序启动时的萤光显示

自我诊断程序启动后，主微型计算机的检查总数或保护履历（*1）就显示出来。如果保护功能过去曾经激发过，那么其类型和电压值就显示出来。数秒后，自我诊断项目将会出现。

(*1) 如果检测到过电流、不良电源、放大器直流过补偿等故障、电源将自动关闭。

注意) 关于电源电压和直流保护功能，请参看后述的诊断主项目 9。在诊断主项目 8 中选择 "RESERVED"，而且已经作好 FACTORY PRESET 时，保护履历将被清除。

● 保护履历

下面例子说明保护履历的显示方法：

CHK SUM: XXXX X

当保护功能没有启动时显示。

显示主微型计算机的检查总数（4 位数，十六进制）及其版本（1 个字）。

I PROTECTION

当电流保护功能启动时显示。

在异常状态下，打开电源而功率继电器启动时，保护功能将起作用，并关闭电源。

PS PRT : XX%

当电源保护功能启动时显示。

关于 % 值，这时的电压以 5V/100% 为单位来表示。

在异常状态下打开电源时，电源将于半秒后关闭。

DC PRT : XX%

当功率放大器直流保护功能启动时显示。

关于 % 值，这时的电压以 5V/100% 为单位来表示。

在异常状态下打开电源时，电源将于 2 秒后关闭。

(2) 退出方法

按照下列方法之一进行操作，诊断功能即可退出。解除诊断功能时，注意要进行备用存储器初始化项目（diagnosis No. 8）的设定。

1. 选择诊断主项目 12 的次项目 No. 4 "EXIT"。
2. 按主单元上的 "STANDBY/ON" 键或遥控器上的 "STANDBY" 键，将电源关闭。

3. 启动诊断功能时的操作和显示

(1) 选择诊断项目

诊断项目和次项目可以用前面板键或遥控器来选择。

● 用前面板键来选择

主项目可以用 "PROGRAM </>" 键使其改变，而次项目可以用 "PRESET/TUNING </>" 键使其改变。按 ">" 键将使主项目或次项目的号码增大。

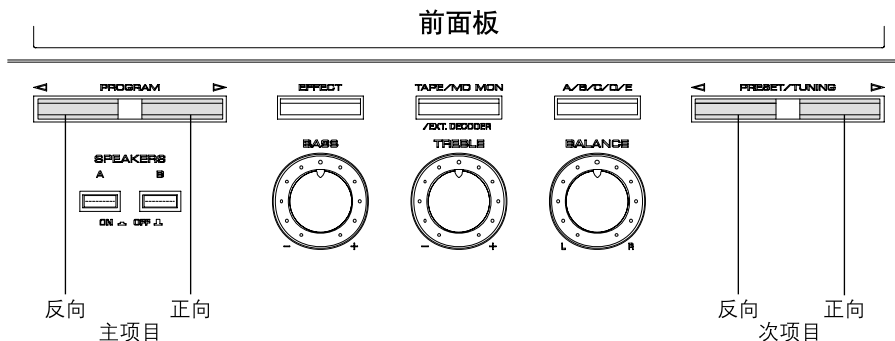

● 用遥控器来选择

项目清单中的遥控码（参看第 6 页上的右栏）对应于 DSP 节目、测试和效果键。参看右图。

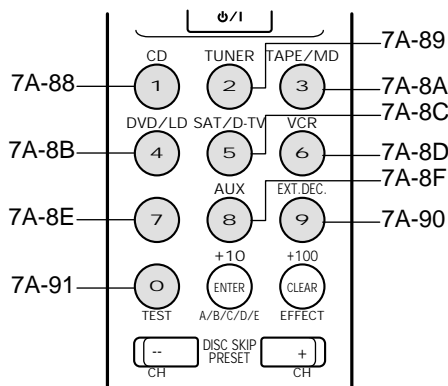

(2) 诊断功能激活时可用的其他功能

下面所列是诊断功能激活时可用的其他功能：

- 输入选择（包括 TAPE MONITOR/EXTERNAL DECODER 在内）
- 效果电平控制（CENTER、REAR、SUBWOOFER）
- 主音量控制
- 静音开 / 关
- 电源开 / 关

(3) 诊断缺省状态

除非另有规定，各项目中的缺省设定和数值如下：

- SPEAKERS : All "LARGE"
- Electronic Volumes : All "0dB"
- DYNAMIC RANGE : MAX
- LFE LEVEL : 0dB (-10dB in AC-3(DOLBY DIGITAL))
- CENTER DELAY : 0ms

4. 诊断功能的内容

本节详细说明自我诊断功能。

No.1 ANALOG THROUGH

输入固定于模拟 (A/D)。有 2 个次项目。

1. MAIN BYPASS **1 MAIN BYPASS**

L/R 信号旁通数字电路，并输出到 MAIN L/R。

不必经过 DSP 处理、传输到 CENTER/SUBWOOFER 和 REAR L/R，L/R 信号即可输出。

(遥控码 7A-88: "1" 键 [DSP mode])

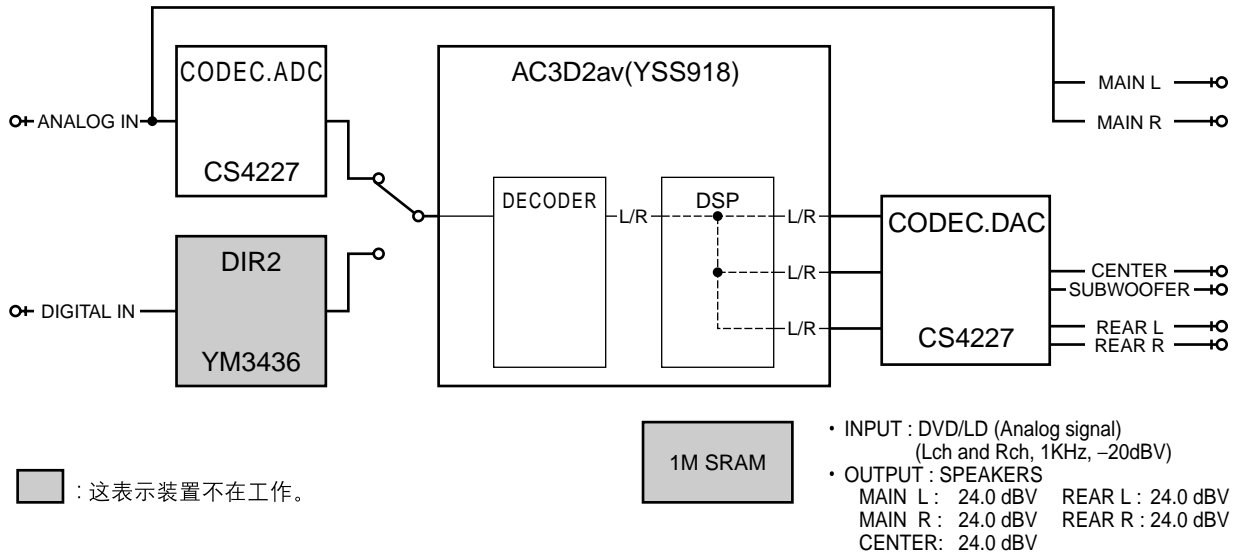

2. DSP 0dB **1 DSP 0DB**

不必经过 DSP 处理、传输到 MAIN L/R、CENTER/SUBWOOFER 和 REAR L/R，L/R 信号即可输出。

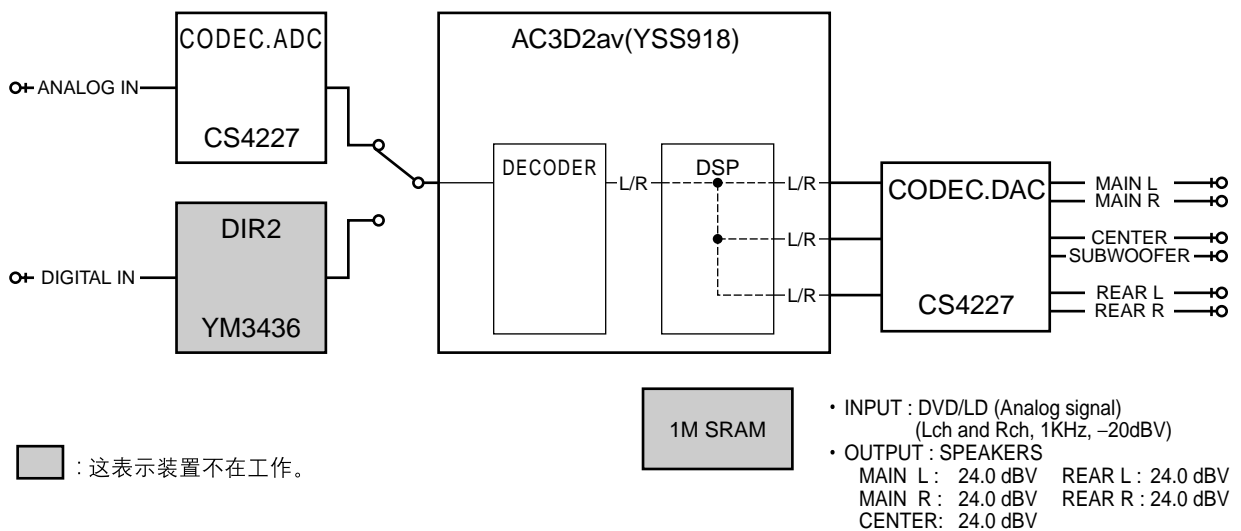

No.2 DSP THROUGH

输入经信号检测自动辨别，并按同轴>光纤>模拟的顺序依次切换。有下列3个次项目。

1. YSS+SRAM **2 YSS+SRAM M**

不必经过 DSP 处理、传输到 MAIN L/R、CENTER/SUBWOOFER，L/R 信号即可输出。

不必经过 DSP 和 SRAM 处理、传输到 REAR L/R，L/R 信号即可输出。

(遥控码 7A-89:"2" 键 [DSP mode])

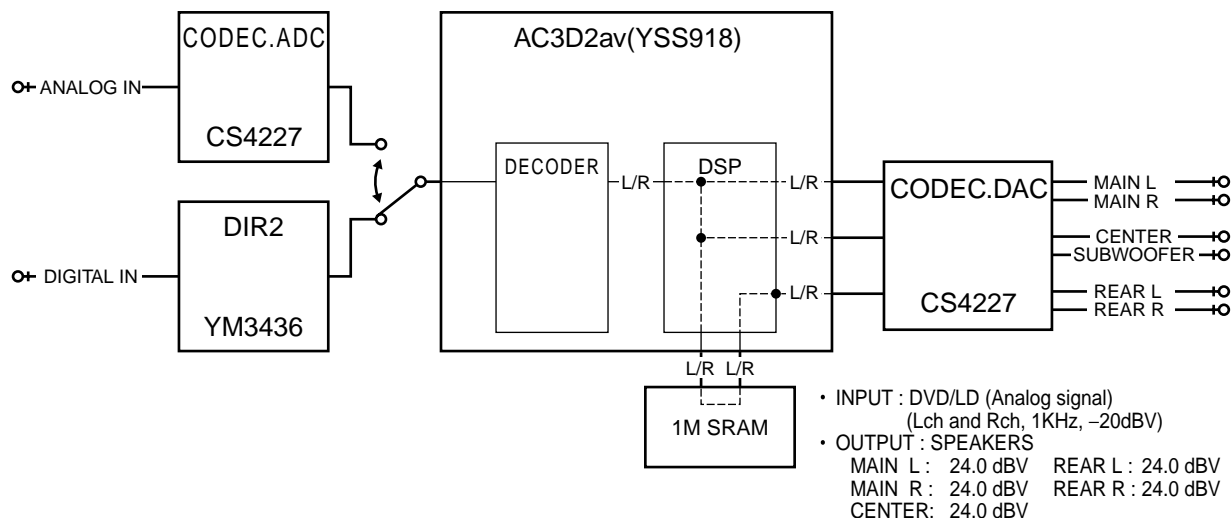

2. YSS M **2 YSS M**

除了输入切换之外，其余均与 "No.1 ANALOG THROUGH" 的 "2. DSP 0dB" 相同。

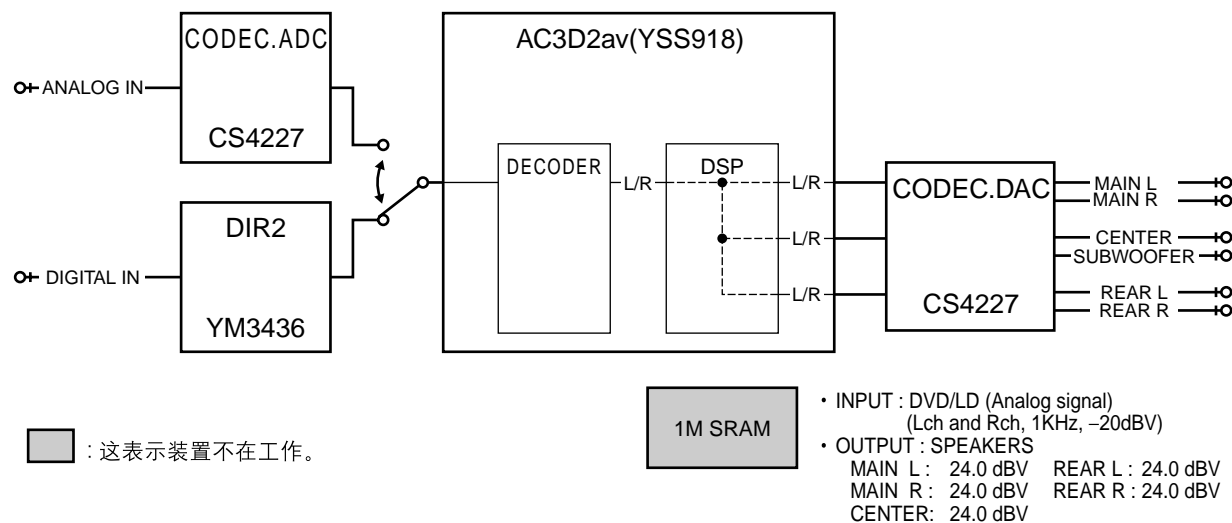

3. DSP FULL BIT **2 DSP FULL BIT**

除了标题余白不能使用，数字数据以全比特从 AC3D2av 输出到 DAC 之外，其余均与上述项目相同。

- INPUT : DVD/LD (Analog signal)
(Lch and Rch, 1KHz, -30dBV)
- OUTPUT : SPEAKERS
MAIN L : 14.0 dBV REAR L : 23.3 dBV
MAIN R : 14.0 dBV REAR R : 23.3 dBV
CENTER: 17.2 dBV

No.3 AC-3/DTS THROUGH

只输入数字信号。根据输入音源执行 AC-3 (DOLBY DIGITAL) 或 DTS 数字环绕声解码工作。

1. STATUS(BINARY FORM) **3 ST:00010000**

AC-3 (DOLBY DIGITAL) 解码信号经由 AC3D2av 输出到各声道。
AC-3 (DOLBY DIGITAL) 信号状态数据将以 2 位数显示于荧光显示屏上。

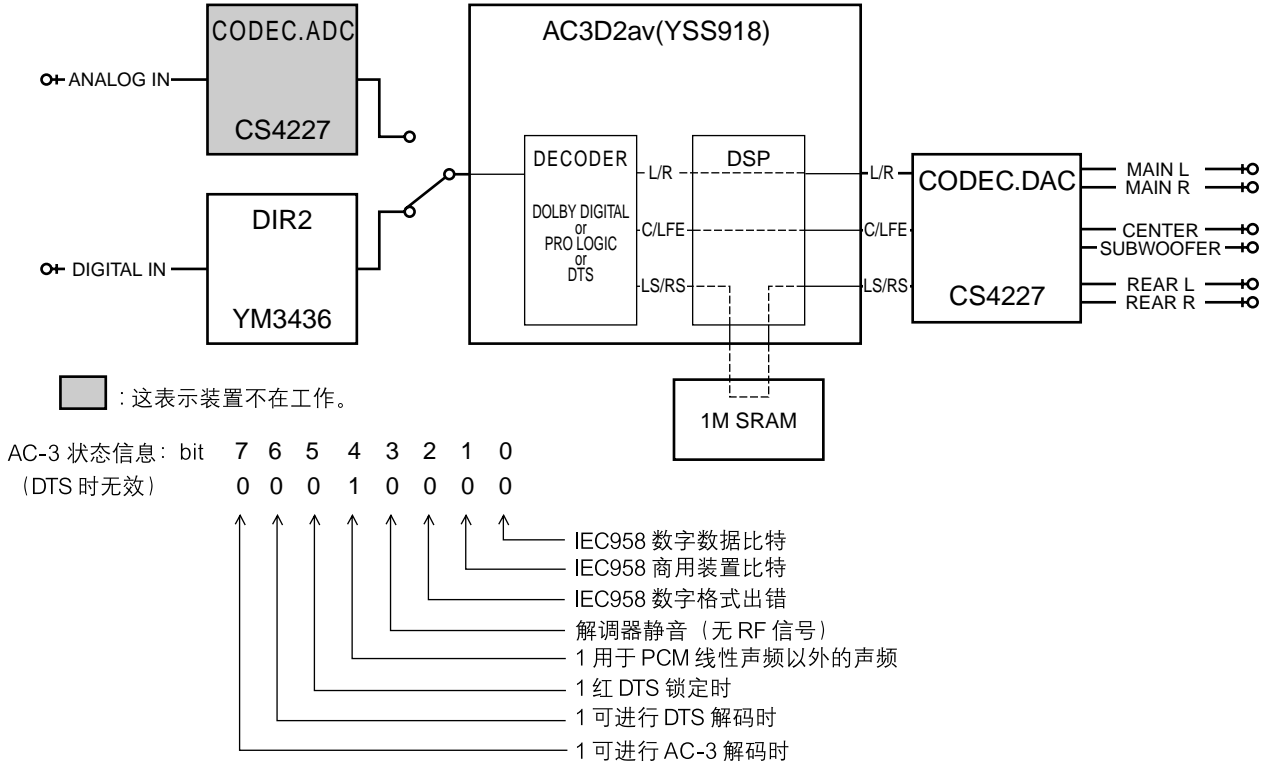

No.4 PRO LOGIC

次项目在 PRO LOGIC (AUTO BALANCE OFF) 和 EFFECT OFF 之间切换。

1. CENTER LARGE **4 PRO CNTR:LRG**

输入经信号检测自动辨别, 并按同轴 > 光纤 > 模拟的顺序依次切换。
DTS 数字环绕声不能使用。输入信号是解码和输出 PRO LOGIC。
(遥控码 7A-8A: "3" 键 [DSP mode])

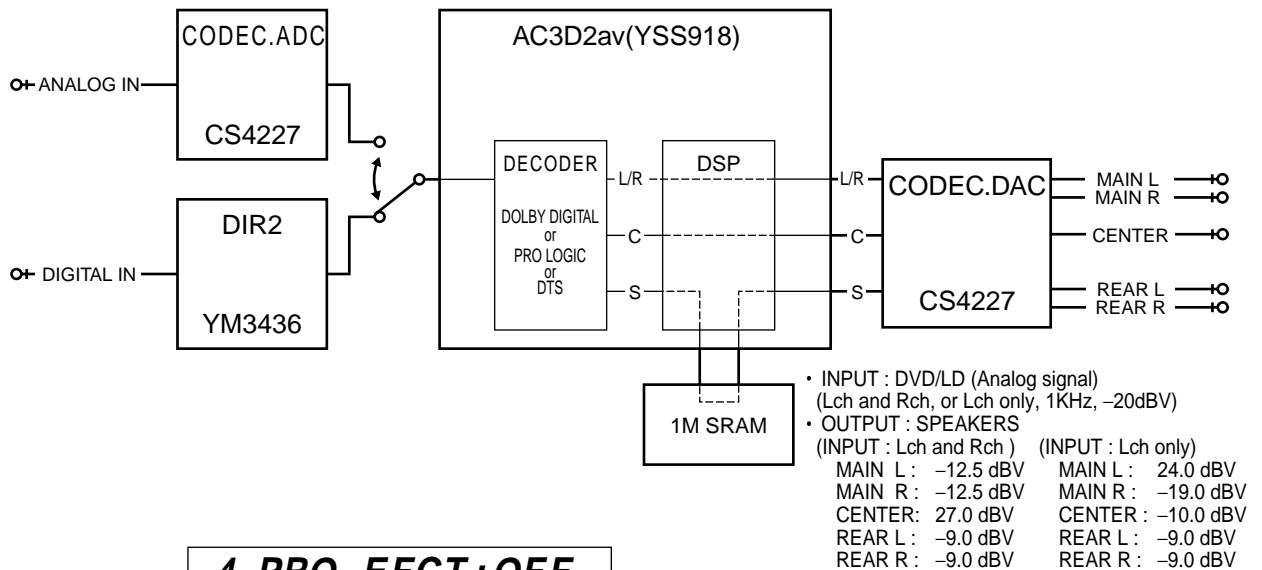

2. EFFECT OFF **4 PRO EFCT:OFF**

只能输入模拟信号。L/R 信号旁通数字电路, 并输出到 MAIN L/R。

No.5 SPEAKERS SET

输入经信号检测自动辨别，并按同轴 > 光纤 > 模拟的顺序依次切换。L/R 信号不经处理即输出到次项目所列的声道。

有如下 9 个次项目。次项目 1-4 的信号路由与 EFFECT OFF 相同。但 MAIN L/R 是经由数字电路的信号。次项目 5-9 的信号路由与 "No. 2 DSP THROUGH" 的 "2. YSS M" 相同。

但在次项目 1-4 中只输出 MAIN L/R。

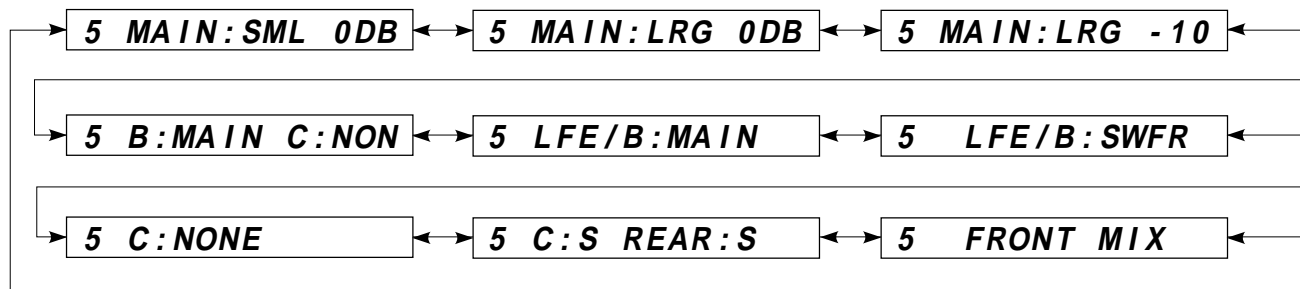

各次项目中的模拟开关设定如下：

	SUB MENU	REMOTE CONTROL CODE	SETTING					OUTPUT					
			CENTER SP	REAR SP	MAIN SP	MAIN LEVEL	LFE/BASS	MAIN L	MAIN R	CENTER	REAR L	REAR R	SUB WOOFER
1	MAIN:SML 0DB	7A-8B	LARGE	LARGE	SMALL	0dB	SWFR	L	R	NONE	NONE	NONE	L+R
2	MAIN:LRG 0DB	7A-8C	LARGE	LARGE	LARGE	0dB	SWFR	L	R	NONE	NONR	NONE	NONE
3	MAIN:LRG -10	7A-8D	LARGE	LARGE	LARGE	-10dB	SWFR	L	R	NONE	NONE	NONE	NONE
4	B:MAIN C:NONE	7A-8E	NONE	LARGE	LARGE	0dB	MAIN	L	R	NONE	NONE	NONE	NONE
5	LFE/B:MAIN	7A-8F	LARGE	LARGE	LARGE	0dB	MAIN	LFE	LFE	C	NONE	NONE	NONE
6	LFE/B:SWFR	7A-90	LARGE	LARGE	LARGE	0dB	SWFR	NONE	NONE	NONE	NONE	NONE	LFE
7	C:NONE	7A-91	NONE	LARGE	LARGE	0dB	SWFR	C+L	C+R	NONE	NONE	NONE	LFE
8	C:S REAR:S	---	SMALL	SMALL	LARGE	0dB	SWFR	FL	FR	C	RL	RR	C+RL+RR+LFE
9	FRONT MIX	7A-12	LARGE	LARGE	LARGE	0dB	SWFR	FL	FR	NONE	NONE	NONE	NONE

LARGE: 使用低音播放功能高的扬声器（大型装置）的模式。声道上的全音域信号都由扬声器输出。

SMALL: 使用低音播放功能低的扬声器（小型装置）的模式。声道上的低音信号（90Hz 以下）混频入经过 LFE/BASS 设定所选择的声道里。

NONE: 不使用中心扬声器的模式。中心声道信号以 3 dB 为单位减少，并混频入 MAIN L/R 里。

LFE/B:MAIN

: 不使用中低音扬声器的模式。LFE 声道信号以 4.5 dB 为单位减少，并混频入 MAIN L/R 里。但由于相差的关系，MAIN L/R 输出不就不是单纯的总和。

次项目的说明如下：

	SUB MENU	说明
1	MAIN:SML 0DB	表示低音改道模式下的高低通滤波器响应及增益。
2	MAIN:LRG 0DB	次项目 1 和 3 的基准。
3	MAIN:LRG -10	表示主电平功能的效果。
4	B:MAIN C:NONE	表示电路效果混频到主声道。
5	LFE/B:MAIN	表示低音混频增益。
6	LFE/B:SWFR	表示 LFE 最大输出。
7	C:NONE	表示中心混频增益。
8	C:S REAR:S	表示低音改道模式下的高低通滤波器响应及增益。
9	FRONT MIX	表示前混频增益。

No.6 DISPLAY CHECK

检查荧光显示屏的程序。显示状态将随着次项目操作改变如下。信号路由与 "No. 4 PRO LOGIC" 的 "2. EFFECT OFF" 相同。

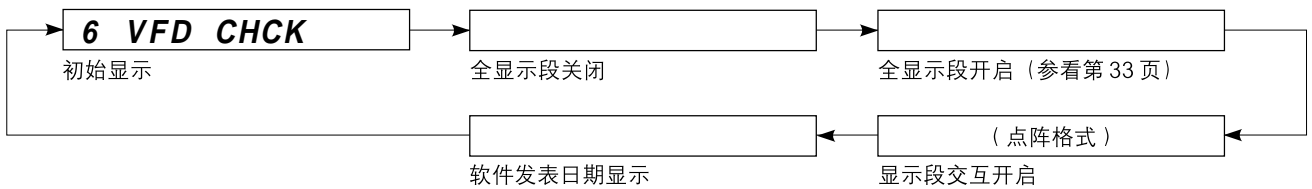

荧光驱动接口和荧光显示段的故障可以用 "全显示段关闭" 和 "全显示段开启" 的方法来检测。
相邻显示段间的短路可以用 "显示段交互开启" (点阵格式) 的方法来检测。

No.7 MANUAL TEST

使用 DSP 内的噪音发生器，可使测试噪音输出到次项目所规定的声道。

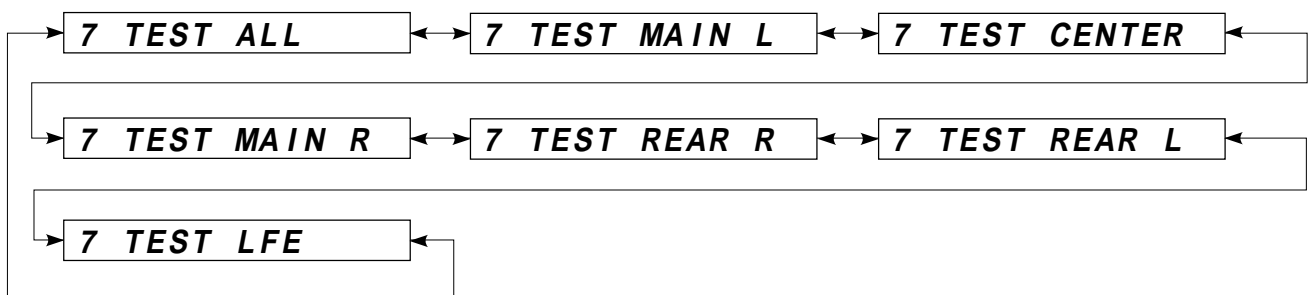

No.8 FACTORY PRESET

含有 DSP 程序、设定项目内容等的备用 RAM 的初期化被保留或被禁止。信号路由与 "No.4 PRO LOGIC" 的 "2. EFFECT OFF" 相同。

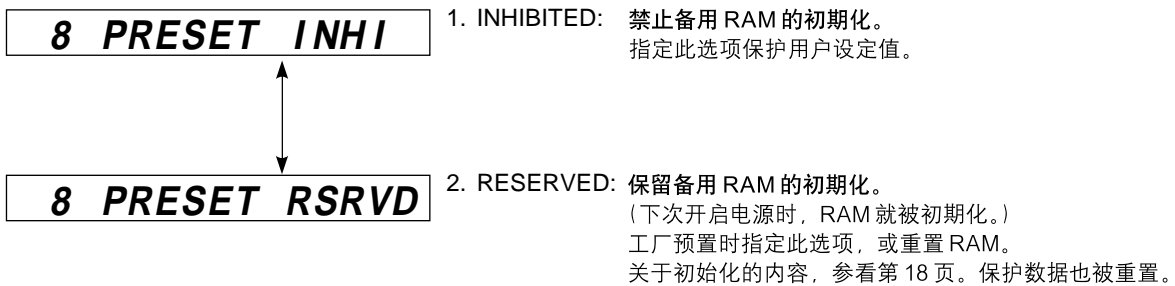

小心： 设定到 PRESET RESERVED 之前，先将下表所列调谐器的现存预置存储器内容记下来。(这是因为设定到 PRESET RESERVED 将会使存储器内容变成工厂设定，亦即用户预置的所有存储将被抹消。)

Page	P1	P2	P3	P4	P5	P6	P7	P8
A								
B								
C								
D								
E								

No.9 AD DATA CHECK

检测键扫描接口、保护检测接口的微型计算机的 A/D 变换值用 % 显示出来 (100% : 5V)。信号路由与 "No. 4 PRO LOGIC" 的 "2. EFFECT OFF" 相同。

主单元上的键不能操作来检测 K1/K2 和 SI 中的所有键的值。

操作 "PRESET/TUNING ◀、▶" 键，转动旋转式编码器 (主单元上的 "INPUT SELECTOR") 就可以切换次项目。



表 1

AD Value	0	14	24	35	45	55	65	75	85
K1	PROGRAM		EFFECT	TAPE/MD MON /EXT DECODER	A/B/C/D/E	—	—	—	
	◀	▶						—	—
K2	PRESET/TUNING		INPUT MODE	PRESET /TUNING EDIT	FM/AM	MEMORY MAN'L/AUTO FM	TUNING MODE AUTO/MAN'L MONO	—	
	◀	▶						—	—

小心:

1. 如果 K1 和 K2 都大于标准值的 ±4%，标准操作将无法进行。
2. 如果 DC 和 PS 超出标准值，保护功能将起作用。电源也将关闭。

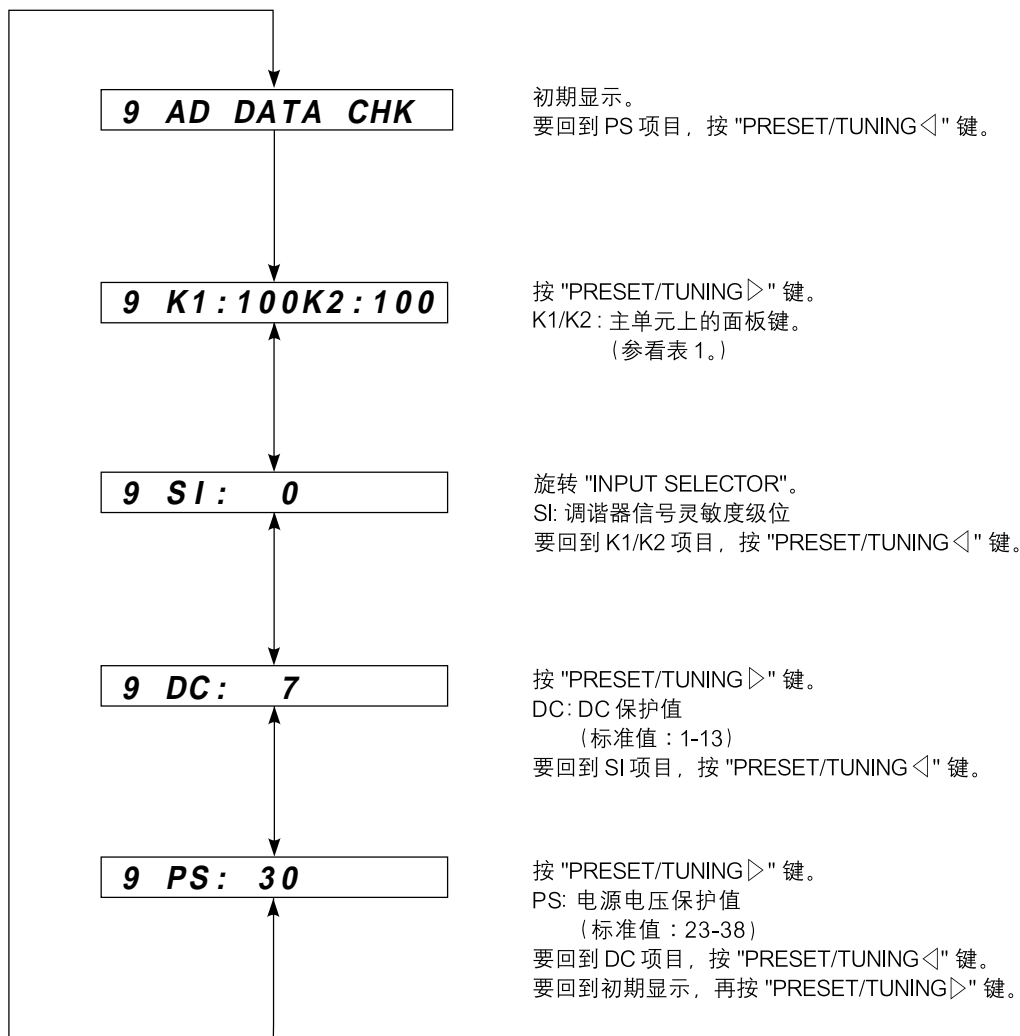
No.10 STATUS INFORMATION FROM DSP

来自 DSP 装置的状态数据以十六进制数字依次显示。
信号路由与 "No. 4 PRO LOGIC" 的 "2. EFFECT OFF" 相同。

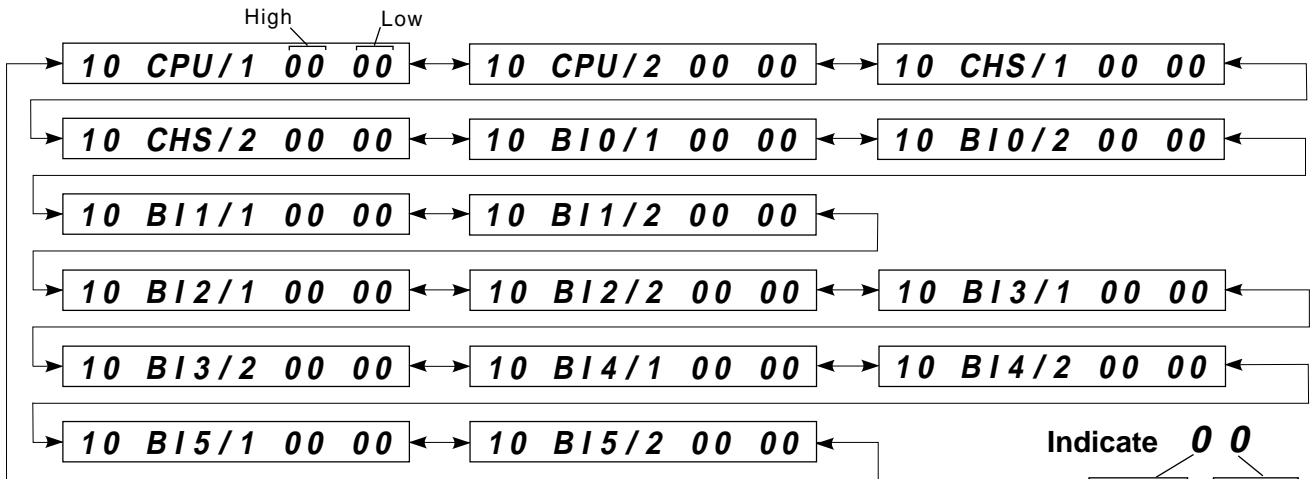

[CPU/1]

<High Byte>

bit7	Mute request	bit3	acmod	
bit6	fs	bit2	0000B:1+1	0001B:1/0
bit5	000B:Analog 001B:32kHz 010B:44.1kHz 011B:48kHz	bit1	0100B:2/1	0101B:3/1
bit4	100B:64kHz 101B:88.2kHz 110B:96kHz 111B:undefined	bit0	0110B:2/2	0111B:3/2
			1000B:7.1	

[Note]

acmod 超过 1000B 时，那就是 DTS 7.1 信号。而 DSP 装置将会静音。
DTS 2/0 的 acmod 如同 0000B:1+1。

<Low Byte>

bit7	AC-3 DECODE OK	bit3	DEM (Demodulator) MUTE (without RF signal)
bit6	DTS DECODE OK	bit2	IEC958 digital format error
bit5	Red DTS record (Flashes and lights)	bit1	IEC958 commercial-use device bit
bit4	1 for audio other than PCM linear audio	bit0	IEC958 digital data bit

[注]

IEC958: 鉴定 PCM 比特流信号的标准。数字格式出错与带不明确的取样频率的数字信号有关（既非 32k、44.1k、48k、64k、88.2k 亦非 96k）。因为 fs 以外的规格时，每一装置的运作无法保证，所以被当作强制模拟模式处理的这种状态（即使可以从检测端子电平进行解码，也会被忽视）和来自模拟输入端子的信号将被选择。“CPU/1”的 bits4-6 将变成 000B（模拟），而微型计算机则与数字开锁时一样工作。

Indicate 00

bit 7 6 5 4 3 2 1 0

Indicate	bit			
	3	2	1	0
0	7	6	5	4
1	0	0	0	1
2	0	0	1	0
3	0	0	1	1
4	0	1	0	0
5	0	1	0	1
6	0	1	1	0
7	0	1	1	1
8	1	0	0	0
9	1	0	0	1
A	1	0	1	0
B	1	0	1	1
C	1	1	0	0
D	1	1	0	1
E	1	1	1	0
F	1	1	1	1

[CPU/2]

<High Byte>

bit7	AC3 KARAOKE	bit3	1
bit6	DIR2 LOCKN	bit2	0
bit5	DIR2 ERR	bit1	DSP is AC3D2 (DTS present)
bit4	AC3D MUTE	bit0	RF DEM (Demodulator) present

<Low Byte> Always "00"

[CHS/1,2] IEC958 声道状态 bits 00-31 适用于 DIR2 以上。

- <CHS/1 High Byte>** bits 00-07
- <CHS/1 Low Byte>** bits 08-15
- <CHS/2 High Byte>** bits 16-23
- <CHS/2 Low Byte>** bits 24-31

[BI0/1,2] 从第一信息组显示含于 AC-3 (DOLBY DIGITAL)/DTS 数字环绕声信号中的比特流信息。

[BI1-5/1,2] 从第一信息组显示含于 AC-3 (DOLBY DIGITAL) 信号中的比特流信息。

No.11 EEPROM WRITING FUNCTION

EEPROM 的检查总数值确认和数据写入。
信号路由与 "No. 4 PRO LOGIC" 的 "2. EFFECT OFF" 相同。

M:XXXX E:XXXX

- M:XXXX: 当微型计算机有 ROM 修正数据时, 显示检查总数值。
当没有数据时, 显示 0000。
- E:XXXX: 当 EEPROM 装上, 并且有 ROM 数据时, 显示检查总数值。
当 EEPROM 没装上, 或者数据异常时, 显示 000。
如果要将微型计算机的 ROM 修正数据写入 EEPROM, 改变到下一次项目。

No.12 CHECK SUM/VERSION/PORT SETTING/EXIT

显示微型计算机的版本、检查总数和接口设定。
信号路由与 "No.4 PRO LOGIC" 的 "2. EFFECT OFF" 相同。
通过次项目操作, 本机退出自我诊断模式, 并回到标准操作模式。

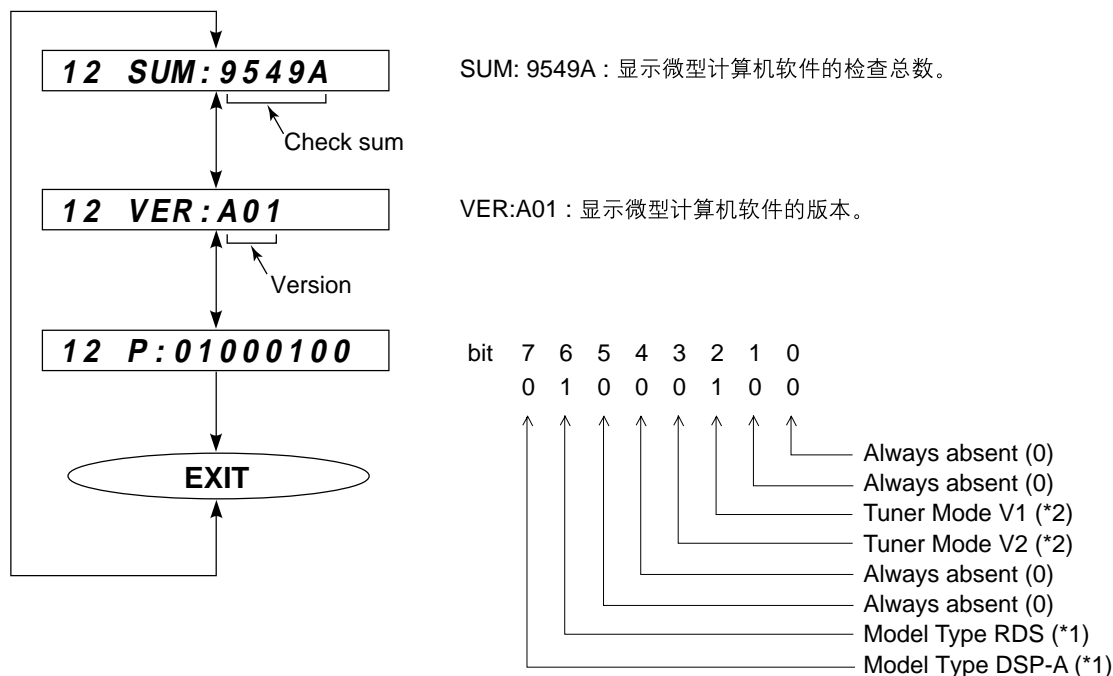

*1 Model type distinction (H=1, L=0)

DSP-A (Pin 3)	0	DSP-A	0	DSP-E	1	RX-V320	1	RDS
RDS (Pin 6)	0		1		0		1	

*2 Destination distinction of Tuner (H=1, L=0)

V1 (Pin 4)	0	J	0	U,C	1	A,B,G	1	R,T
V2 (Pin 5)	0	model	1	models	0	models	1	models

■ FACTORY PRESET

系统设定全都于出厂时初期设定如下：

● INPUT SELECTOR

INPUT		FACTORY PRESET PROGRAM
ROTARY ENCODER	PHONO	CONCERT HALL
	CD	DISCO
	TUNER	ROCK CONCERT
	DVD/LD	SCI-FI
	SAT/D-TV	TV SPORTS
	VCR	DOLBY NORMAL
	V-AUX	DOLBY ENHANCED
MONITOR	TAPE/MD	EFFECT OFF
EXTERNAL	EXT. DECODER	NONE

● EFFECT LEVEL

EFFECT CHANNEL	PRESET VALUE
CENTER	0 dB
RIGHT SURROUND	0 dB
LEFT SURROUND	0 dB
SUBWOOFER	0 dB

● DSP PROGRAM

No.	PROGRAM	SUB-PROGRAM	DELAY PRESET VALUE
1.	DOLBY/DTS SURROUND	NORMAL	PRO LOGIC : 20ms,
		ENHANCED	DOLBY DIGITAL/DTS DIGITAL SUR : 5ms
2.	MOVIE THEATER 1	SPECTACLE	70mm : 23ms, DGTL/DTS : 15ms
		SCI-FI	70mm : 20ms, DGTL/DTS : 16ms
3.	MOVIE THEATER 2	ADVENTURE	70mm : 20ms, DGTL/DTS : 15ms
		GENERAL	
4.	MONO MOVIE	—	49ms
5.	TV SPORTS	—	9ms
6.	DISCO	—	40ms
7.	ROCK CONCERT	—	16ms
8.	CONCERT HALL	—	44ms

● SET MENU

No.	SET MENU	PRESET VALUE
1.	CENTER SP SIZE	CENTER SP : LRG(LARGE)
2.	REAR SP SIZE	REAR SP : LARGE
3.	MAIN SP SIZE	MAIN SP : LARGE
4.	BASS OUT MODE	BASS OUT : BOTH
5.	M. LVL CHOICE	MAIN LVL : NORM (NORMAL)
6.	D. D. LFE OUT LEVEL	D. D. LFE 0 dB
7.	D. RNG CHOICE	D-RANGE : MAX
8.	DTS LFE OUT LEVEL	DTS LFE 0 dB
9.	C. DELAY CHANGE	CENTER DELAY 0ms
10.	MEMORY GUARD	MEM. GUARD : OFF
11.	INPUT MODE SAT/D-TV	SAT INPUT : AUTO

● PRESET STATIONS

STATION		FM FACTORY PRESET DATA (MHz)		STATION		AM FACTORY PRESET DATA (kHz)	
PAGE	NO.	U, C	R, T, A, B, G, L	PAGE	NO.	U, C, R	R, T, A, B, G, L
A/C/E	1	87.5	87.5	B/D	1	630	630
	2	90.1	90.1		2	1080	1080
	3	95.1	95.1		3	1440	1440
	4	98.1	98.1		4	530	531
	5	107.9	108.0		5	1710	1611
	6	88.1	88.1		6	900	900
	7	106.1	106.1		7	1350	1350
	8	107.9	108.0		8	1400	1404

■ AMP ADJUSTMENT

主放大器无效电流的确认

- 电源接通后，立即确认 R239（主左声道）、R245（主右声道）、R262（中置）、R252（后左声道）、R258（后右声道）端子的电压在 0.1mV 和 5.0mV 之间。
- 若超过 5.0mV，打开（截止）R213（主左声道）、R218（主右声道）、R233（中置）、R223（后左声道）、R228（后右声道），并再确认电压。
- 确认 60 分钟之后电压在 0.25mV 和 15.0mV 之间。

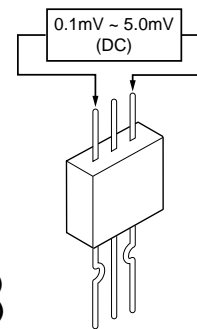
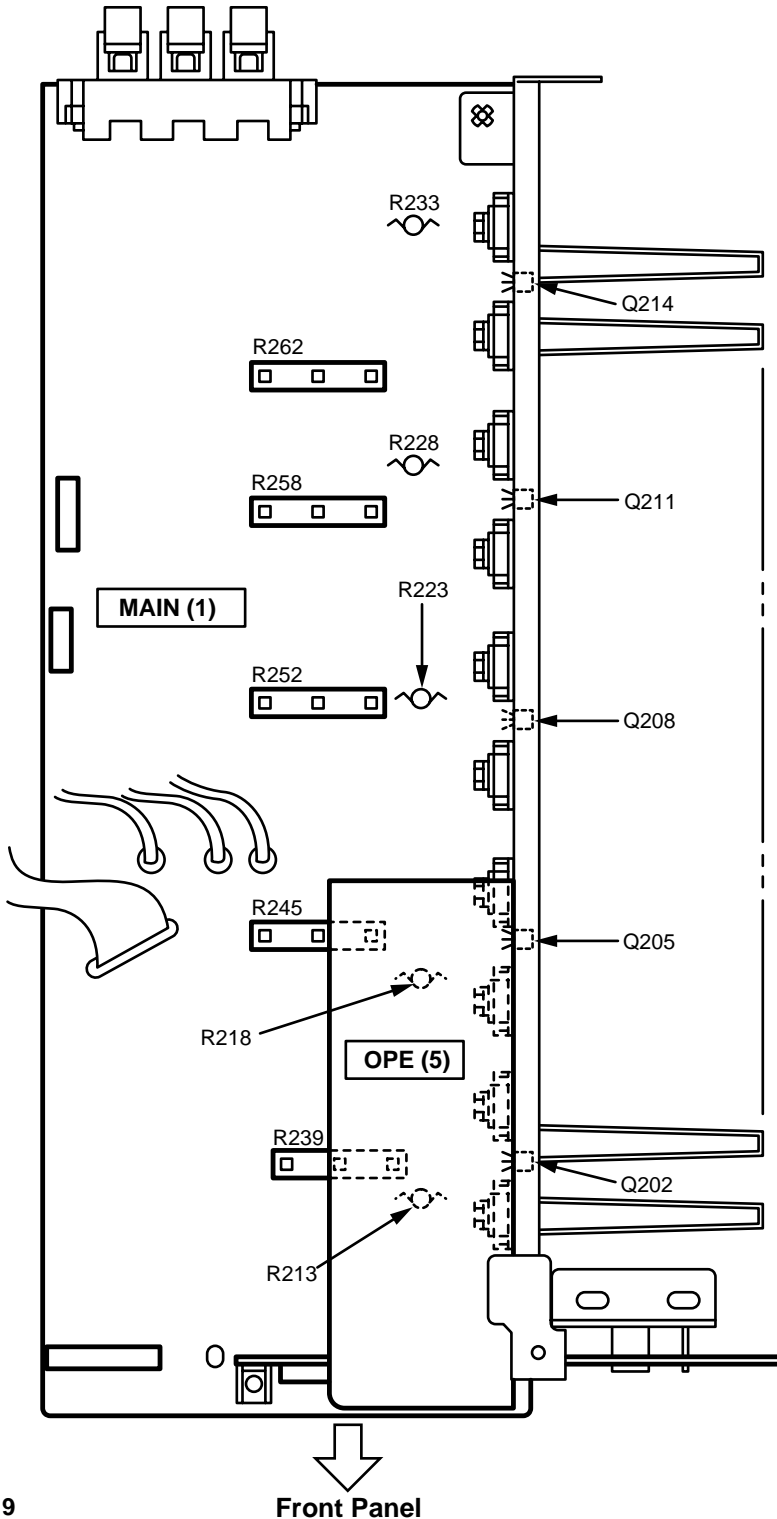

R239(Lch)
R245(Rch)
R262(Cch)
R252(RLch)
R258(RRch)

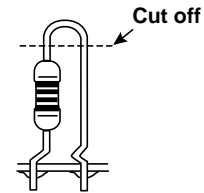

R213(Lch)
R218(Rch)
R233(Cch)
R223(RLch)
R228(RRch)

注)

- 若 R213、R218、R233、R223 和 R228 已经被截止，而且无效电流不流通，再连接 R213、R218、R233、R223 和 R228。
- Q202、Q205、Q208、Q211 和 Q214 是用于温度校正的晶体管。在与散热器的接面涂敷硅滑脂。

■ TUNER ADJUSTMENT

● Measuring Instruments

- 1) FM signal generator (FM SG)
- 2) Stereo signal generator (SSG)
- 3) AM signal generator (AM SG)
- 4) Distortion meter (DIST. M)
- 5) AC Voltmeter (ACVM)
- 6) DC Voltmeter (DCVM)
- 7) Oscilloscope
- 8) Low pass filter (YLF-15, $f_c=15\text{kHz}$)
- 9) Oscillator

● Dummy antenna

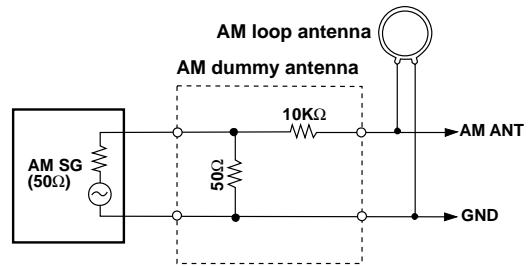
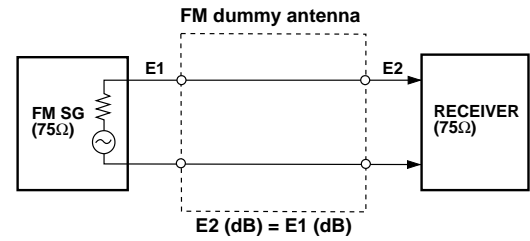
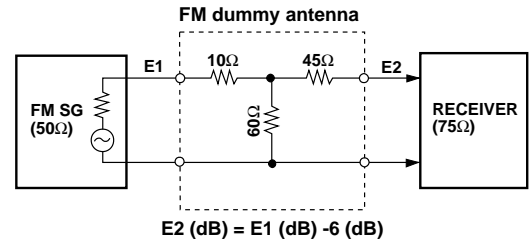

● Test point

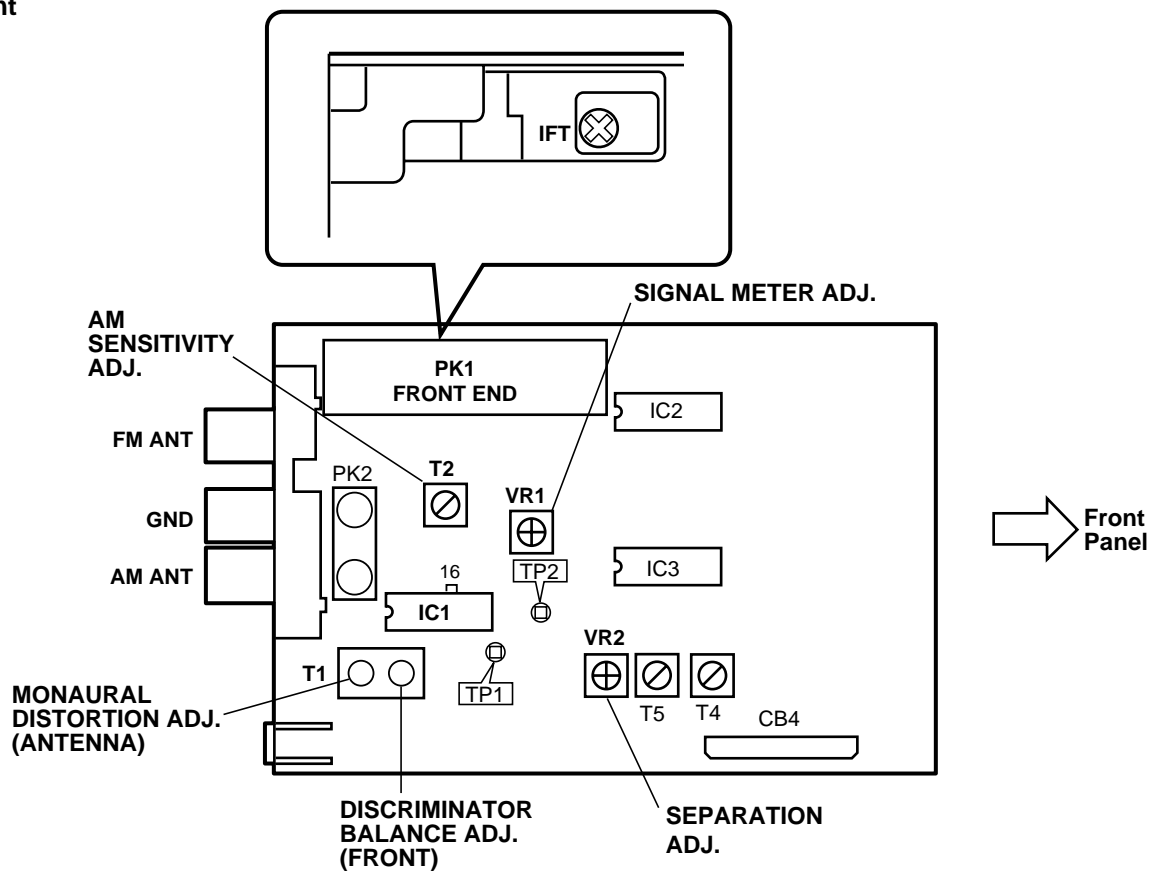

FM 调整

● 调整前

- 1) 对于 dBμ, 1μV=0dBμ。
例如：60dBμ=1mV
- 2) 100% 调制意味着频率偏移为 ± 75kHz。
- 3) 安装匹配变压器，连接 FM SG。

4) 除非另有规定，将各开关设定到如下位置：

INPUT SELECTOR TUNER
TUNING MODE AUTO

● 接线图（测量仪器）

1) 鉴频器平衡调整。

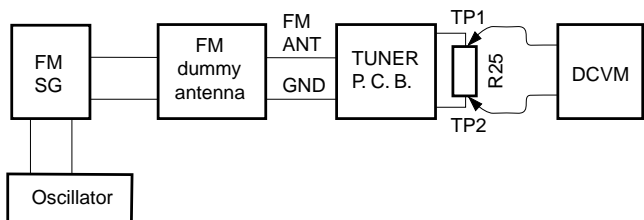

2) 立体声失真调整 / 分离调整。

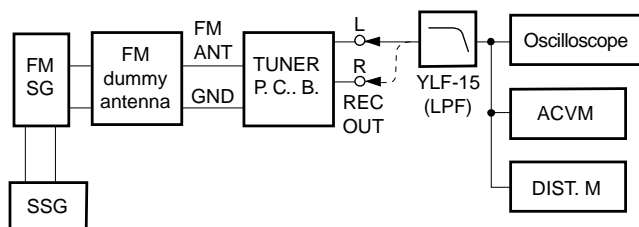

3) 单声道失真调整

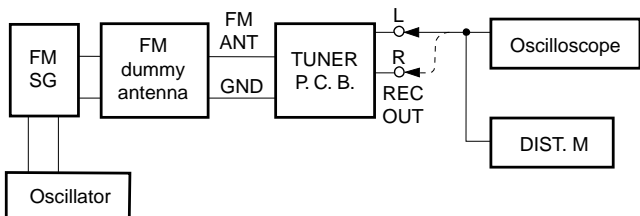

4) 灵敏度验证

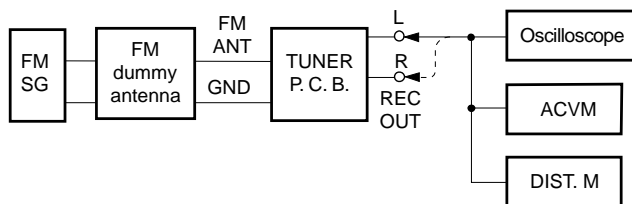

关于 TP 定位和调整点，参看第 20 页。

步骤	调整项目	信号 (ANT IN)	接收频率	调整点	测试点	额定
1	鉴定器平衡的粗调	FM ANT (75Ω) 98.1MHz 70dBμ MONO 100Hz 100% modulation	98.1MHz *(A-4)	T1 (Front side core)	R25 的两端 (TP1 和 TP2 之间)	DC 0V±100mV
2	单声道失真的粗调	与步骤 1 相同。	98.1MHz *(A-4)	T1 (Antenna side core)	REC OUT L, R	使失真减少到最低限度。
3	鉴定器平衡的精调	与步骤 1 相同。	98.1MHz *(A-4)	T1 (Front side core)	R25 的两端 (TP1 和 TP2 之间)	DC 0V±50mV
4	单声道失真的精调	与步骤 1 相同。	98.1MHz *(A-4)	T1 (Antenna side core)	REC OUT L, R	使失真减少到最低限度 (-60dB 或更少)。
5	鉴定器平衡的验证	与步骤 1 相同。	98.1MHz *(A-4)	T1 (Front side core)	R25 的两端 (TP1 和 TP2 之间)	DC 0V±50mV

* 工厂预置的执行 (参看第 18 页) 便于设定用于调整的接收频率。

关于 TP 定位和调整点，参看第 20 页。

步骤	调整项目	信号 (ANT IN)	接收频率	调整点	测试点	额定
6	前端 IFT 的调整	FM ANT (75Ω) 98.1MHz 30dBμ MONO 1kHz 100% modulation	98.1MHz *(A-4)	Front end IFT	Pin 16 of IC1	进行调整，使表达到最大。 小心：IFT 磁心的过调整将会降低灵敏度。(最大 ±90°)
7	单声道失真的验证	FM ANT (75Ω) 98.1MHz 70dBμ MONO 1kHz 100% modulation	98.1MHz *(A-4)		REC OUT L, R	0.1% (-60dB 或更少)
8	立体声失真的验证	FM ANT (75Ω) 98.1MHz 70dBμ Stereo L or R 1kHz, 100% modulation	98.1MHz *(A-4) *Tuning mode should be AUTO.		REC OUT L, R	0.2% (U,C,R,T: -54dB 或更少) ● STEREO 指示灯应点亮。
9	灵敏度的验证	FM ANT (75Ω) 88.1MHz 98.1MHz 106.1MHz MONO 1kHz Modulation off	88.1MHz *(A-6) 98.1MHz *(A-4) 106.1MHz *(A-7)		ANT (75Ω)	1) 将调谐模式设定到 MAN'L MONO。 2) 88.1MHz、98.1 MHz 和 106.1 MHz 各频率的信噪比应为 30dB。 3) 进行检查，确认 ANT 端子处的电压如下： (U,C,R,T: 6dBm 或更少)
10	分离的调整	FM ANT (75Ω) 98.1MHz 70dBμ Stereo L or R 1kHz, 100% modulation	98.1MHz *(A-4)	VR2	REC OUT L, R	在左声道或右声道输出 SSG 的状态下，其它声道的信号漏泄电平应降低到最小。 (48 dB 或更少)
11	信号表的调整	FM ANT (75Ω) 98.1MHz 45dBμ MONO 1kHz, 30% modulation	98.1MHz *(A-4)	VR1		进行调整，使所有信号表都点亮。
		-10dBμ or less				进行检查，确认信号表都关断。
12	自动调谐的验证	FM ANT (75Ω) 98.1MHz 23dBμ Stereo L or R 1kHz, 30% modulation	98.1MHz *(A-4)			● 当调谐键上下移动时，自动接收功能应可使用。 ● 立体声指示灯应点亮。 ● 调谐时，声频静音应启动。

* 工厂预置的执行 (参看第 18 页) 便于设定用于调整的接收频率。

AM 调整 (此项调整应于 FM 调整后进行。)

● 接线图 (测量仪器)

1) 灵敏度的调整。

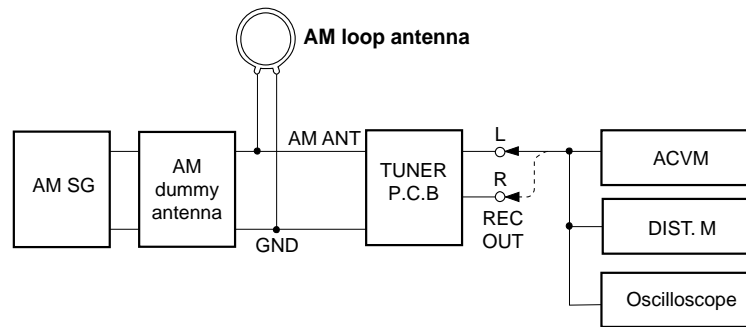

关于 TP 定位和调整点，参看第 20 页。

步骤	调整项目	信号 (ANT IN)	接收频率	调整点	测试点	额定
1	灵敏度的调整 (630kHz)	AM ANT 630kHz 50dB μ 1kHz 30% modulation	630kHz *(B-1)	T2	REC OUT	声频输出应提高到最大限度。重复步骤 1 和步骤 2。
2	灵敏度的验证	AM ANT 630kHz 1080kHz 1440kHz 30% modulation	630kHz *(B-1) 1080kHz *(B-2) 1440kHz *(B-3)		AM ANT	各频道的失真应为 10% 或更少。进行检查，确认 ANT 端子处的电压为 54dB μ 或更少。
3	信号电平显示器的验证	AM ANT 1080kHz 90dB μ MONO 1 kHz 30% modulation	1080kHz *(B-2)			所有信号电平显示器都应点亮。
		-10dB or less				所有信号电平显示器都不应点亮。
4	自动调谐的验证	AM ANT 60dB μ				当调谐键上下移动时，自动接收功能应可使用。 搜索时，声频必须静音。

* 工厂预置的执行 (参看第 18 页。) 便于设定用于调整的接收频率。

IC DATA

IC501 : M30217MA-A205FP

16-bit Microcomputer

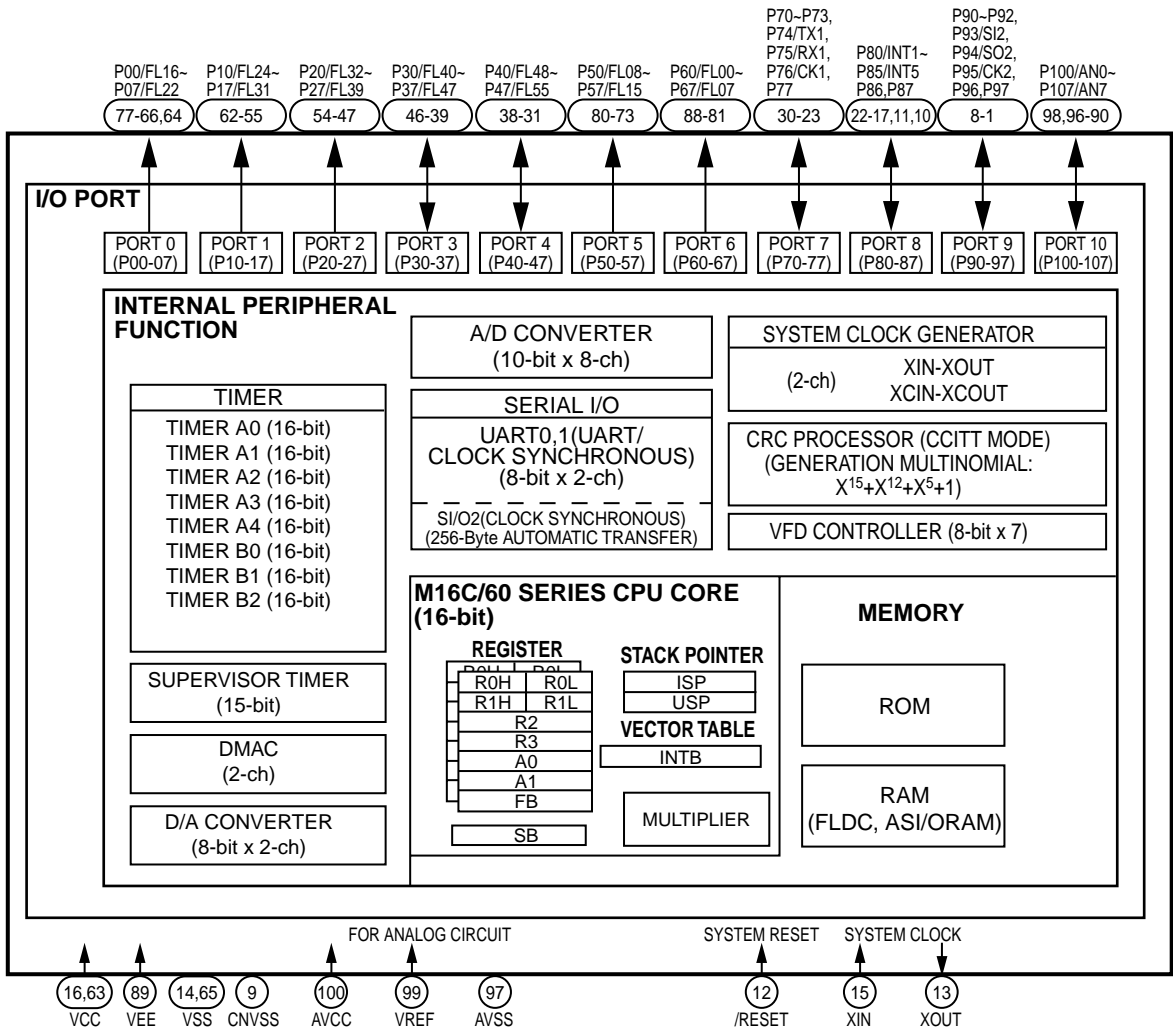
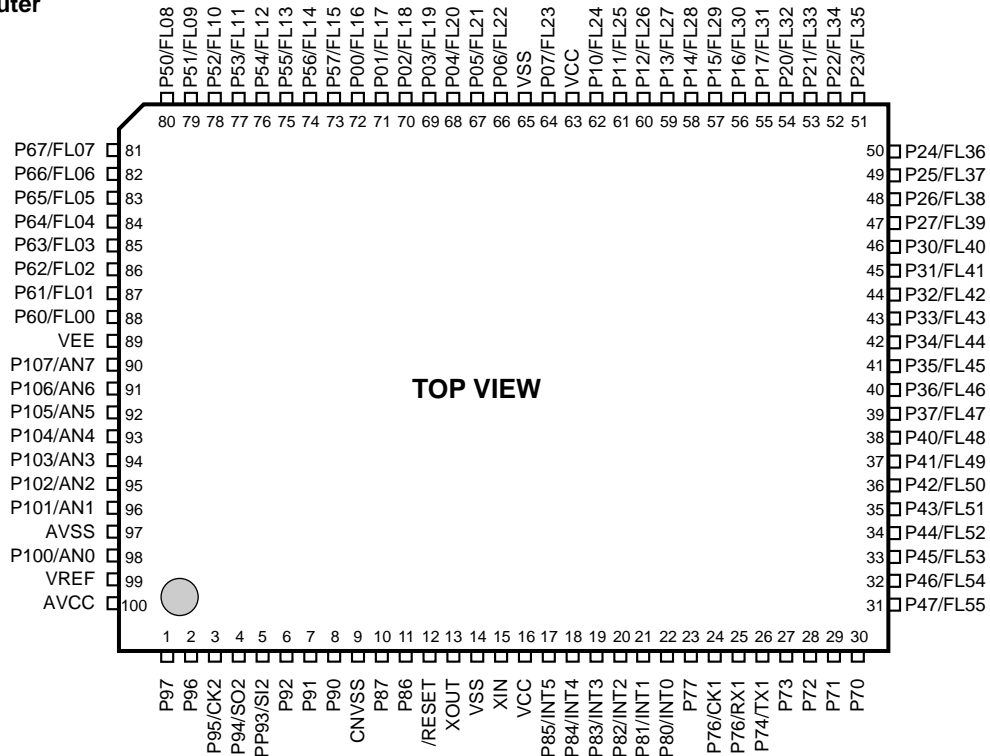

IC501 : M30217MA-A205FP

16-bit Microcomputer

Pin No.	Port	Pin Name	I/O	Function
1	P97	SCK	O	Serial Clock output
2	P96	SDT	O	Serial Data output
3	P95	RCK	O	Clock output for model type distinction (*1)
4	P94	RDT	O	Data output for destination distinction of Tuner (*2)
5	P93	DEST	O	Data input for destination distinction of Tuner (*2)
6	P92	RCE	O	Chip enable output for model type distinction (*1)
7	P91	SCKD	O	Serial Clock output for DIR2
8	P90	SID	O	Serial data output for DIR2
9	CNVSS	CNVSS		For flash μ -COM write connector
10	P87	CKB	O	Clock output for output port expansion IC
11	P86	DTB	O	Data output for output port expansion IC
12	/RESET	/RES		System reset
13	XOUT	XOUT		Crystal oscillator connected (10MHz)
14	VSS	MG		Ground
15	XIN	MU		Crystal oscillator connected (10MHz)
16	VCC	+5BU		+5V Power supply
17	P85/INT5	ERRD	I	Error flag input from DIR2
18	P84/INT4	ERRA	I	Data mute detect input from AC3D2av
19	P83/INT3	REM	I	Remote control input
20	P82/INT2	PDT	I	Power down detect input
21	P81/INT1	PSW	I	Standby switch input
22	P80/INT0	CEAC1	O	Chip enable output 1 for AC3D2av
23	P77	CEAC2	O	Chip enable output 2 for AC3D2av
24	P76/CK1	CLKAC	O	Serial clock output 2 for AC3D2av
25	P75/RX1	RXAC	I	Serial data input from AV3D2av
26	P74/TX1	TXAC	O	Serial data output for AC3D2av
27	P73	CECOD	O	Chip enable output for CODEC ADC/DAC
28	P72	TCE	O	Chip enable output for Tuner
29	P71	CELC	O	Chip enable output for Input Selector
30	P70	CETC	I	Fixed H

Pin No.	Port	Pin Name	I/O	Function
31	P47/FL55	F-CE	O	Chip enable output
32	P46/FL54	F-CK	O	Serial clock output
33	P45/FL53	F-RX	I	Serial data input
34	P44/FL52	F-TX	O	Serial data output
35	P43/FL51	VUP	O	Volume up output
36	P42/FL50	VDN	O	Volume down output
37	P41/FL49	CDO	I	Serial data input from DIR2
38	P40/FL48	DVD-C/O	I	DVD/LD coaxial/optical detect input
39	P37/FL47	DBS-C/O	I	Fixed H
40	P36/FL46	PRI	I	I (Over current) protection detect input
41	P35/FL45	POT-A	I	Rotary encoder input A
42	P34/FL44	POT-B	I	Rotary encoder input B
43	P33/FL43	/ST	I	Stereo input from Tuner
44	P32/FL42	DO	I	Serial data input from Tuner
45	P31/FL41	/ICAC	O	Initial clear output for AC3D2av
46	P30/FL40	PRY	O	Power relay output
47	P27/FL39	SRY	O	Speaker relay output
48	P26/FL38	ERY	O	Effect relay output
49	P25/FL37	G1	O	Grid 1 for FL display
50	P24/FL36	G2	O	Grid 2 for FL display
51	P23/FL35	G3	O	Grid 3 for FL display
52	P22/FL34	G4	O	Grid 4 for FL display
53	P21/FL33	G5	O	Grid 5 for FL display
54	P20/FL32	G6	O	Grid 6 for FL display
55	P17/FL31	G7	O	Grid 7 for FL display
56	P16/FL30	G8	O	Grid 8 for FL display
57	P15/FL29	G9	O	Grid 9 for FL display
58	P14/FL28	G10	O	Grid 10 for FL display
59	P13/FL27	G11	O	Grid 11 for FL display
60	P12/FL26	G12	O	Grid 12 for FL display
61	P11/FL25	G13	O	Grid 13 for FL display
62	P10/FL24	G14	O	Grid 14 for FL display
63	VCC	+5VBU		+5V power supply
64	P07/FL23	G15	O	Grid 15 for FL display
65	VSS	MG		Ground
66	P06/FL22	G16	O	Grid 16 for FL display

*1 Model type distinction (H=1, L=0)

DSP-A (Pin 3)	0	DSP-A	0	DSP-E	1	RX-V320	1	RDS
RDS (Pin 6)	0		1		0		1	

*2 Destination distinction of Tuner (H=1, L=0)

V1 (Pin 4)	0	J model	0	U,C models	1	A,B,G,L models	1	R,T models
V2 (Pin 5)	0		1		0		1	

IC501 : M30217MA-A205FP

16-bit Microcomputer

Pin No.	Port	Pin Name	I/O	Function
67	P05/FL21	P1	O	Segment 1 for FL display
68	P04/FL20	P2	O	Segment 2 for FL display
69	P03/FL19	P3	O	Segment 3 for FL display
70	P02/FL18	P4	O	Segment 4 for FL display
71	P01/FL17	P5	O	Segment 5 for FL display
72	P00/FL16	P6	O	Segment 6 for FL display
73	P57/FL15	P7	O	Segment 7 for FL display
74	P56/FL14	P8	O	Segment 8 for FL display
75	P55/FL13	P9	O	Segment 9 for FL display
76	P54/FL12	P10	O	Segment 10 for FL display
77	P53/FL11	P11	O	Segment 11 for FL display
78	P52/FL10	P12	O	Segment 12 for FL display
79	P51/FL09	P13	O	Segment 13 for FL display
80	P50/FL08	P14	O	Segment 14 for FL display
81	P67/FL07	P15	O	Segment 15 for FL display
82	P66/FL06	P16	O	Segment 16 for FL display
83	P65/FL05	P17	O	Segment 17 for FL display
84	P64/FL04	P18	O	Segment 18 for FL display

Pin No.	Port	Pin Name	I/O	Function
85	P63/FL03	P19	O	Segment 19 for FL display
86	P62/FL02	P20	O	Segment 20 for FL display
87	P61/FL01	P21	O	Segment 21 for FL display
88	P60/FL00	P22	O	Segment 22 for FL display
89	VEE	VP	O	Power supply for FL display
90	P107/AN7	LIMDT	I	Limiter DC detect input
91	P106/AN6	PRV	I	PS (power voltage) protection AD value detect input
92	P105/AN5	PRD	I	DC (power amp voltage) protection AD value detect input
93	P104/AN4	METER	I	Tuner meter AD value input
94	P103/AN3	NC	O	No connection
95	P102/AN2	/FMT	O	Full mute output (L: ON)
96	P101/AN1	KEY2	I	Key 2 AD data value input
97	AVSS	MG		Ground
98	P100/AN0	KEY1	I	Key 1 AD data value input
99	VREF	+5M		Standard power supply for AD input
100	AVCC	+5BU		+5V power supply

IC107 : BU2090

Serial Input/Parallel Output Driver for Output port expansion

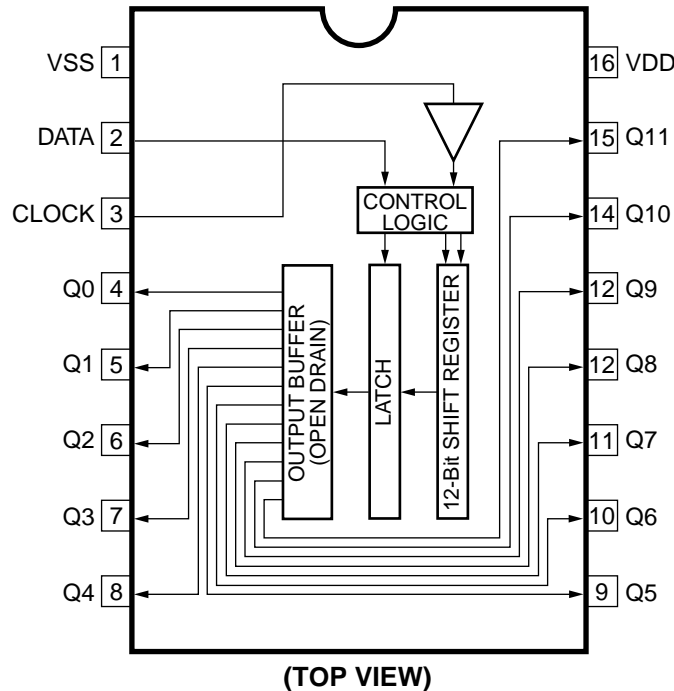

Pin No.	Port	Pin Name	I/O	Function
1	VSS	VSS		Ground
2	DATA	DTB	I	Control data input
3	CLOCK	CKB	I	Control clock input
4	Q0	SW1	O	Video select data
5	Q1	SW2	O	output 1-3(*)
6	Q2	SW3	O	for video input selector
7	Q3	SW4	O	Video select data
8	Q4	SW5	O	output 4,5
9	Q5	/CONT1	O	Limiter control data output 1,2
10	Q6	/CONT2	O	
11	Q7	/-10dB	O	-10dB control data output (L : -10dB)
12	Q8	6ch GAIN	O	6-ch gain control data output (L:6-ch)
13	Q9	/C-MUTE	O	Center mute data output (L:Mute on)
14	Q10	/SW-MUTE	O	Subwoofer mute data output (L:Mute on)
15	Q11	/T-MUTE	O	Tuner mute data output (L : Mute on)
16	VDD	VDD		+5V power supply

* Video input Selector Control (H=High, L=Low)

Video Input	SW1 (Pin4)	SW2 (Pin5)	SW3 (Pin6)
VCR	H	L	H
SAT/D-TV	H	H	L
DVD/LD	L	H	L
V-AUX	L	L	L

IC3 : YM3436DK (DIR2)
Digital Format Interface Receiver

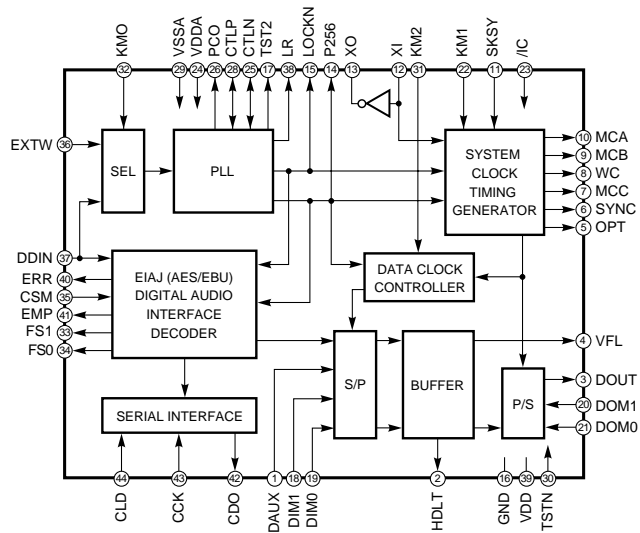
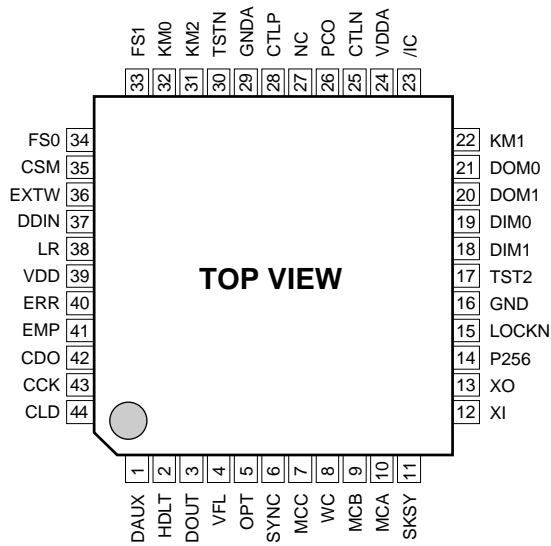

Pin No.	Pin Name	I/O	Function
1	DAUX	I	Audio data input from AC3D2av
2	HDLT	O	Unconnected
3	DOUT	O	Audio data output for AC3D2av
4	VFL	O	Unconnected
5	OPT	O	Unconnected
6	SYNC	O	Unconnected
7	MCC	O	64fs bit clock output for AC3D2av
8	WC	O	1fs word clock output for AC3D2av
9	MCB	O	Unconnected
10	MCA	O	256fs bit clock output for CODEC
11	SKSY	I	Clock synchronization control input (Fixed H)
12	XI	I	Crystal oscillator connection (12.288MHz)
13	XO	O	Crystal oscillator connection (12.288MHz) and external clock output for AC3D2av
14	P256	O	Unconnected
15	LOCKN	O	PLL lock flag output for microcomputer
16	GND		Ground
17	TST2	O	Unconnected
18	DIM1	I	Data input mode selection 0,1
19	DIM0	I	
20	DOM1	I	Data output mode selection 1,0 (Fixed L)
21	DOM0	I	
22	KM1	I	Compulsive analog performance mode input from AC3D2av

Pin No.	Pin Name	I/O	Function
23	/IC	I	Initial clear input from AC3D2av
24	VDDA		Power supply
25	CTLN	I	VCO control negative input
26	PCO	O	PLL phase comparison output
27	NC		Unconnected
28	CTLP	I	VCO control positive input (Fixed L)
29	GNDA		Ground
30	TSTN	I	Unconnected
31	KM2	I	Clock mode switching input 2,0 (Fixed L)
32	KM0	I	
33	FS1	O	Unconnected
34	FS0	O	Unconnected
35	CSM	I	Channel status output method selection(Fixed L)
36	EXTW	I	External synchronous auxiliary input word clock (Fixed L)
37	DIN	I	Digital audio data input
38	LR	O	Unconnected
39	VDD		Power supply
40	ERR	O	Data error flag output for microcomputer
41	EMP	O	Unconnected
42	CDO	O	Serial data output for microcomputer
43	CCK	I	Serial clock input from microcomputer
44	CLD	I	Serial data input from microcomputer

IC4 : YSS918D-F (AC3D2av)

DSP + AC-3(Dolby Digital)/ Pro Logic/ DTS Digital Surround Decoder

No.	Name	I/O	Function
1	VDD1		+5V power supply
2	RAMCEN	O	RAM chip enable output terminal (normally unconnected)
3	RAMA16	O	RAM address output terminal 16, connected to external 1M SRAM address
4	RAMA15	O	RAM address output terminal 15, connected to external 1M SRAM address
5	SDIB0	I	Serial data input B terminal 0 (normally connected to ground)
6	SDIB1	I	Serial data input B terminal 1 (normally connected to ground)
7	SDIB2	I	Serial data input B terminal 2 (normally connected to ground)
8	XI	I	Crystal oscillator connection or external clock input terminal, connected to external DIR2 external clock output
9	XO	O	Crystal oscillator connection (normally unconnected)
10	VSS		Ground
11	AVDD		+3V power supply
12	SDIB3	I	Serial data input B terminal 3 (normally unconnected)
13	TEST		Test terminal (normally unconnected)
14	TEST		Test terminal (normally unconnected)
15	OVFB	O	Overflow detect terminal (normally unconnected)
16	DTSDATA	O	DTS data detect terminal (normally unconnected)
17	AC3DATA	O	AC-3 data detect terminal (normally unconnected)
18	SDOB3	O	Serial data output B terminal 3 (normally unconnected)
19	CPO	O	PLL output terminal (connected to AVSS through external analog filter)
20	AVSS		Ground
21	VDD		+3V power supply
22	SDOA2	O	Serial data output A terminal 2 (normally unconnected)
23	SDOA1	O	Serial data output A terminal 1 (normally unconnected)
24	SDOA0	O	Serial data output A terminal 0 (normally unconnected)
25	RAMA14	O	RAM address terminal 14 output terminal, connected to external 1M SRAM address
26	RAMA13	O	RAM address terminal 13 output terminal, connected to external 1M SRAM address
27	RAMA12	O	RAM address terminal 12 output terminal, connected to external 1M SRAM address
28	RAMA11	O	RAM address terminal 11 output terminal, connected to external 1M SRAM address
29	RAMA10	O	RAM address terminal 10 output terminal, connected to external 1M SRAM address
30	VSS		Ground
31	VDD1		+5V power supply
32	OPORT0	O	Output expansion port terminal 0, digital input selector A output
33	OPORT1	O	Output expansion port terminal 1, digital input selector B output (DIB*)
34	OPORT2	O	Output expansion port terminal 2, connected to external CODEC initial clear input
35	OPORT3	O	Output expansion port terminal 3, connected to external DIR2 compulsive analog performance mode input
36	OPORT4	O	Output expansion port terminal 4, connected to external DIR2 initial clear input
37	OPORT5	O	Output expansion port terminal 5 (normally unconnected)
38	OPORT6	O	Output expansion port terminal 6 (normally unconnected)
39	OPORT7	O	Output expansion port terminal 7 (normally unconnected)
40	VSS		Ground
41	VDD2		+3V power supply
42	RAMA9	O	RAM address output terminal 9 , connected to external 1M SRAM address
43	RAMA8	O	RAM address output terminal 8 , connected to external 1M SRAM address
44	RAMA7	O	RAM address output terminal 7 , connected to external 1M SRAM address
45	SDOB2	O	Serial data output B terminal 2, connected to external CODEC PCM audio data output
46	SDOB1	O	Serial data output B terminal 1, connected to external CODEC PCM audio data output
47	SDOB0	O	Serial data output B terminal 0, connected to external CODEC PCM audio data output
48	SDBCK1	I	Serial data bit clock input terminal 1, connected to external DIR2 64fs bit clock output
49	SDWCK1	I	Serial data word clock input terminal 1, connected to external DIR2 1fs word clock output
50	VSS		Ground

* Digital input
Selector Control
(H=High, L=Low)

Digital Input	DIB(Pin33)
DVD/LD	L
SAT/D-TV	H

IC4 : YSS918D-F (AC3D2av)**DSP + AC-3(Dolby Digital)/ Pro Logic/ DTS Digital Surround Decoder**

No.	Name	I/O	Function
51	VDD2		+3V power supply
52	NONPCM	O	Non-PCM data output terminal (normally unconnected)
53	CRC	O	CRC output terminal (normally unconnected)
54	MUTE	O	Mute output terminal, connected to external microcomputer data mute detect input
55	KARAOKE	O	Karaoke output terminal (normally unconnected)
56	SURENC	O	Surround encoder output terminal (normally unconnected)
57	/SDBCK0	O	Inverted signal of serial data bit clock output terminal 0 (normally unconnected)
58	RAMA6	O	RAM address output terminal 6, connected to external 1M SRAM address
59	RAMA5	O	RAM address output terminal 5, connected to external 1M SRAM address
60	VSS		Ground
61	RAMA4	O	RAM address output terminal 4, connected to external 1M SRAM address
62	/IC	I	Initial clear input terminal, connected to external microcomputer initial clear output
63	TEST		Test terminal (normally unconnected)
64	RAMA3	O	RAM address output terminal 3, connected to external 1M SRAM address
65	/CSB	I	Chip select B input terminal, connected to external microcomputer chip enable output 2
66	/CS	I	Chip select input terminal, connected to external microcomputer chip enable output 1
67	SO	O	Serial data output terminal, connected to external microcomputer serial data input
68	SI	I	Serial data input terminal, connected to external microcomputer serial data output
69	SCK	I	Serial clock input terminal, connected to external microcomputer serial clock output
70	RAMA2	O	RAM address output terminal 2, connected to external 1M SRAM address
71	VDD1		+5V power supply
72	RAMD0	I/O	RAM data bus terminal 0, connected to external 1M SRAM data
73	RAMD1	I/O	RAM data bus terminal 1, connected to external 1M SRAM data
74	RAMD2	I/O	RAM data bus terminal 2, connected to external 1M SRAM data
75	RAMD3	I/O	RAM data bus terminal 3, connected to external 1M SRAM data
76	RAMD4	I/O	RAM data bus terminal 4, connected to external 1M SRAM data
77	RAMD5	I/O	RAM data bus terminal 5, connected to external 1M SRAM data
78	RAMD6	I/O	RAM data bus terminal 6, connected to external 1M SRAM data
79	RAMD7	I/O	RAM data bus terminal 7, connected to external 1M SRAM data
80	VSS		Ground
81	VDD2		+3V power supply
82	SDWCK0	I	Serial data word clock input terminal 0, connected to external DIR2 1fs word clock output
83	SDBCK0	I	Serial data bit clock input terminal 0, connected to external DIR2 64fs bit clock output
84	SDIA0	I	Serial data input A terminal 0, AC-3/DTS bit stream (or PCM) data input, connected to external DIR2 audio data output
85	SDIA1	I	Serial data input A terminal 1 (normally connected to ground)
86	RAMA1	O	RAM address output terminal 1, connected to external 1M SRAM address
87	RAMA0	O	RAM address output terminal 0, connected to external 1M SRAM address
88	RAMWEN	O	RAM write enable output terminal, connected to external 1M SRAM write enable
89	RAMOEN	O	RAM output enable output terminal, connected to external 1M SRAM output enable
90	VSS		Ground
91	VDD		+3V power supply
92	IPORT7	I	Input expansion port terminal 7 (normally connected to ground)
93	IPORT6	I	Input expansion port terminal 6 (normally connected to ground)
94	IPORT5	I	Input expansion port terminal 5 (normally connected to ground)
95	IPORT4	I	Input expansion port terminal 4 (normally connected to ground)
96	IPORT3	I	Input expansion port terminal 3, Front mix select (H:Outside, L:Inside)
97	IPORT2	I	Input expansion port terminal 2, RF select(H:Exist, L:None)
98	IPORT1	I	Input expansion port terminal 1, DTS select (H:DTS (YSS918), L:Non DTS (YSS908))
99	IPORT0	I	Input expansion port terminal 0, SRAM select (H:1M, L:256K)
100	VSS		Ground

IC5 : M5M51288BKJ-20LTE1 (1M SRAM)
131072-word x 8 bit High Speed Static RAM

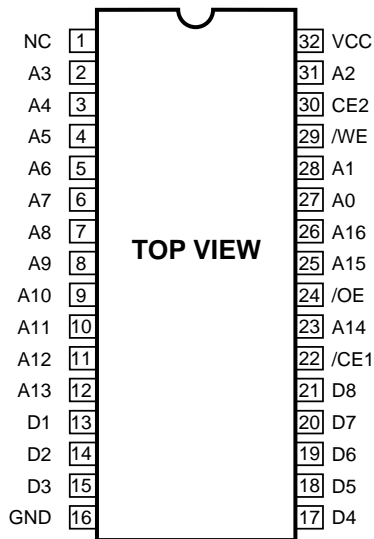

NOTE)
 A0-A16: Address input
 D1-D8: Data input/output
 /CE1,CE2: Chip enable input
 /OE: Output enable input
 /WE: Write enable input

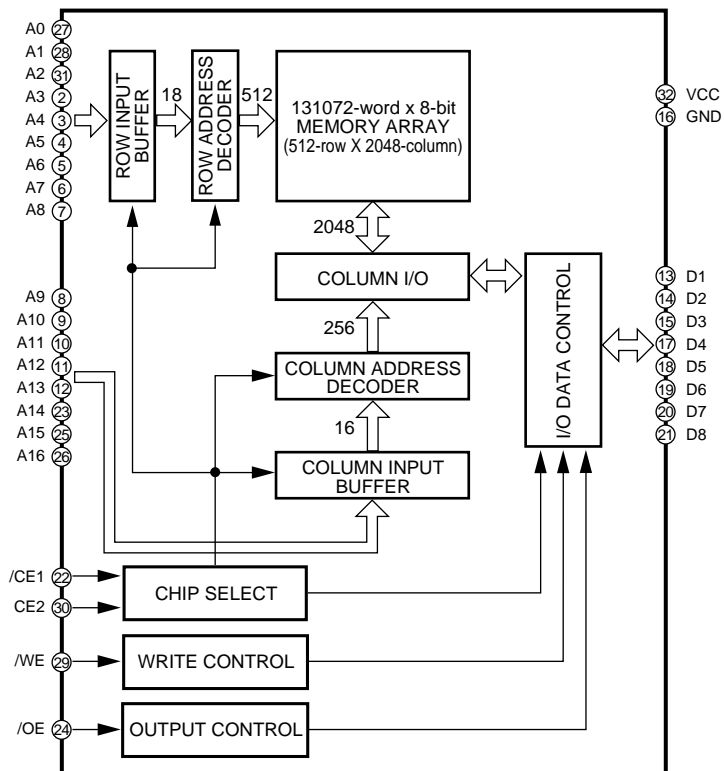

/CE1	CE2	/WE	/OE	Mode	Data I/O	Power
X	L	X	X	Non-selectable	High impedance	On
H	X	X	X	Non-selectable	High impedance	Standby
L	H	L	X	Write mode	Input	On
L	H	H	L	Read mode	Output	On
L	H	H	H		High impedance	On

NOTE) H: High Level L: Low level X: Don't care

IC6: CS4227-KQ CODEC. ADC/DAC)
6-channel 20-bit Codec providing A/D, D/A Converter

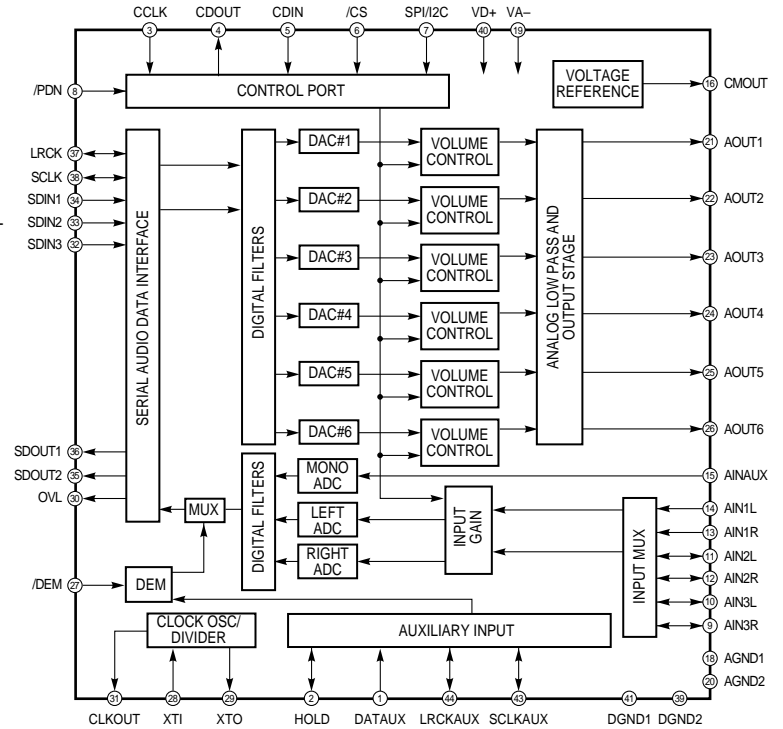
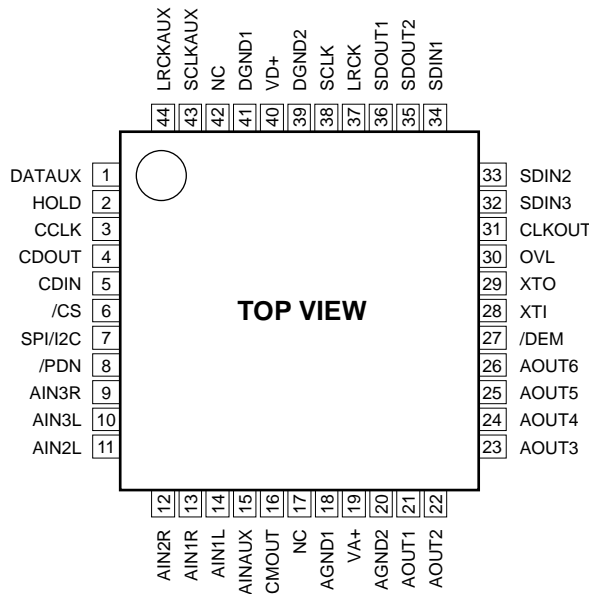

Pin No.	Pin Name	I/O	Function
1	DATAUX	I	DATAUX terminal (Connected to digital ground)
2	HOLD	I/O	HOLD terminal (Connected to digital ground)
3	CCLK	I	Control clock input terminal, serial clock from microcomputer
4	CDOUT	O	CDOUT terminal (Unconnected)
5	CDIN	I	Control data input terminal, serial data from microcomputer
6	/CS	I	Chip select input terminal, codec chip enable from microcomputer
7	SPI/I2C	I	SPI/I2C terminal (Connected to digital ground)
8	/PDN	I	Power down input terminal, initial clear from AC3D2av
9	AIN3R	I/O	AIN3R terminal (Unconnected)
10	AIN3L	I/O	Lch analog input/output terminal 3,2, Lch positive, negative input from input selector
11	AIN2L	I/O	Rch analog input/output terminal 2,1, Rch negative, positive input from input selector
12	AIN2R	I/O	AIN2R terminal (Unconnected)
13	AIN1R	I	AIN1L terminal (Unconnected)
14	AIN1L	I	AIN1L terminal (Unconnected)
15	AINAUX	I	AINAUX terminal (Unconnected)
16	CMOUT	O	Center mute output terminal
17	NC		Non connection terminal
18	AGND1		Analog ground
19	VA+		+5V Analog power supply
20	AGND2		Analog ground
21	AOUT1	O	Analog output terminal 1,2, L,Rch analog output for MAIN
22	AOUT2	O	

Pin No.	Pin Name	I/O	Function
23	AOUT3	O	Analog output terminal 3,4, L,Rch analog output for REAR
24	AOUT4	O	Analog output terminal 5,6, L,Rch analog output for CENTER, LFE
25	AOUT5	O	
26	AOUT6	O	
27	/DEM	I	/DEM terminal (Connected to digital ground)
28	XTI	I	Cryatal input terminal, 256fs bit clock from DIR2
29	XTO	O	XTO terminal (Unconnected)
30	OVL	O	OVL terminal (Unconnected)
31	CLKOUT	O	CLKOUT terminal (Unconnected)
32	SDIN3	I	Serial data input terminal, 3,2,1, PCM audio data from AC3D2av
33	SDIN2	I	
34	SDIN1	I	
35	SDOUT2	O	SDOUT2 terminal (Unconnected)
36	SDOUT1	O	Serial data output terminal1, audio data for DIR2
37	LRCK	I/O	L,Rch clock input/output terminal, 1fs word clock from DIR2
38	SCLK	I/O	Serial clock input/output terminal, 64fs bit clock from DIR2
39	DGND2		Digital ground
40	VD+		+5V digital power supply
41	DGND1		Digital ground
42	NC		Non connection terminal
43	SCLKAUX	I/O	SCLKAUX terminal (Connected to digital ground)
44	LRCKAUX	I/O	LRCKAUX terminal (Connected to digital ground)

DISPLAY DATA

V501 : 16-BT-71GK (V4193300)



PIN CONNECTION

Pin No.	1	2	3	4	5	6	7	8	9	10	11	12	13	14	15	16	17	18	19	20	21	22	23	24	25
CONNECTION	F1	F1	NP	NP	NP	NP	NP	NP	NP	NP	NP	NP	NP	NP	NP	NP	NP	Fd	Fd	NP	NP	P22	P21	P20	P19
Pin No.	26	27	28	29	30	31	32	33	34	35	36	37	38	39	40	41	42	43	44	45	46	47	48	49	50
CONNECTION	P18	P17	P16	P15	P14	P13	P12	P11	P10	P9	P8	P7	P6	P5	P4	P3	P2	P1	NP	NP	16G	15G	14G	13G	12G
Pin No.	51	52	53	54	55	56	57	58	59	60	61	62	63	64	65										
CONNECTION	11G	10G	9G	8G	7G	6G	5G	4G	3G	2G	1G	NP	NP	F2	F2										

NOTE

- 1) F1, F2..... Filament
- 2) NP..... No pin
- 3) P1~P22..... Segment
- 4) 1G~16G..... Grid
- 5) Fd terminals are to be supplied through 51kΩ from Ec.
- 6) Field of vision is a minimum of 23° from the lower side.

GRID ASSIGNMENT

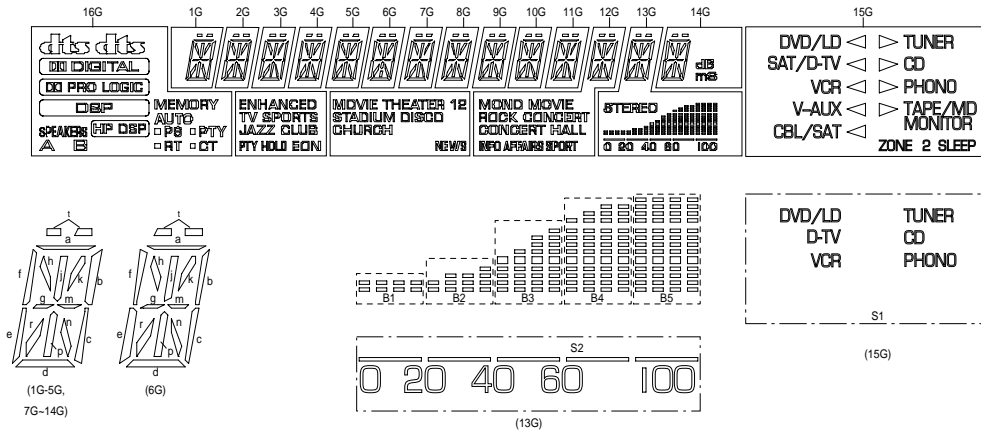

ANODE CONNECTION

	16G	15G	14G	13G	12G	11G	10G	9G	8G	7G	6G	5G	4G	3G	2G	1G
P1	dts (LEFT)	(TUNER)	a	a	a	a	a	a	a	a	a	a	a	a	a	a
P2	(RIGHT) dts	(CD)	b	b	b	b	b	b	b	b	b	b	b	b	b	b
P3	DIGITAL	(PHONO)	c	c	c	c	c	c	c	c	c	c	c	c	c	c
P4	PRO LOGIC	(TAPE/MD)	d	d	d	d	d	d	d	d	d	d	d	d	d	d
P5	DBP	(CBL/SAT)	e	e	e	e	e	e	e	e	e	e	e	e	e	e
P6	HP DSP	(V-AUX)	f	f	f	f	f	f	f	f	f	f	f	f	f	f
P7	SPEAKERS	(VCR)	g	g	g	g	g	g	g	g	g	g	g	g	g	g
P8	A	(SAT/D-TV)	h	h	h	h	h	h	h	h	h	h	h	h	h	h
P9	B	(DVD/LD)	j	j	j	j	j	j	j	j	j	j	j	j	j	j
P10	MEMORY	S1	k	k	k	k	k	k	k	k	k	k	k	k	k	k
P11	AUTO	SAT/	m	m	m	m	m	m	m	m	m	m	m	m	m	m
P12	(PS)	V-AUX	n	n	n	n	n	n	n	n	n	n	n	n	n	n
P13	PS	CBL/SAT	p	p	p	p	p	p	p	p	p	p	p	p	p	p
P14	(PTY)	TAPE/MD	r	r	r	r	r	r	r	r	r	r	r	r	r	r
P15	PTY	MONITOR	t	t	t	t	t	t	t	t	t	t	t	t	t	t
P16	(RT)	ZONE 2	dB	STEREO	MONO MOVIE	MOVIE THEATER	ENHANCED	-	-	-	-	-	-	-	-	-
P17	RT	SLEEP	ms	B1	ROCK CONCERT	1	TV SPORTS	-	-	-	-	-	-	-	-	-
P18	(CT)	-	-	B2	CONCERT HALL	2	JAZZ CLUB	-	-	-	-	-	-	-	-	-
P19	CT	-	-	B3	INFO	STADIUM	PTY HOLD	-	-	-	-	-	-	-	-	-
P20	-	-	-	B4	AFFAIRS	DISCO	EON	-	-	-	-	-	-	-	-	-
P21	-	-	-	B5	SPORT	CHURCH	-	-	-	-	-	-	-	-	-	-
P22	-	-	-	S2	-	NEWS	-	-	-	-	-	-	-	-	-	-

BLOCK DIAGRAM (1/2)

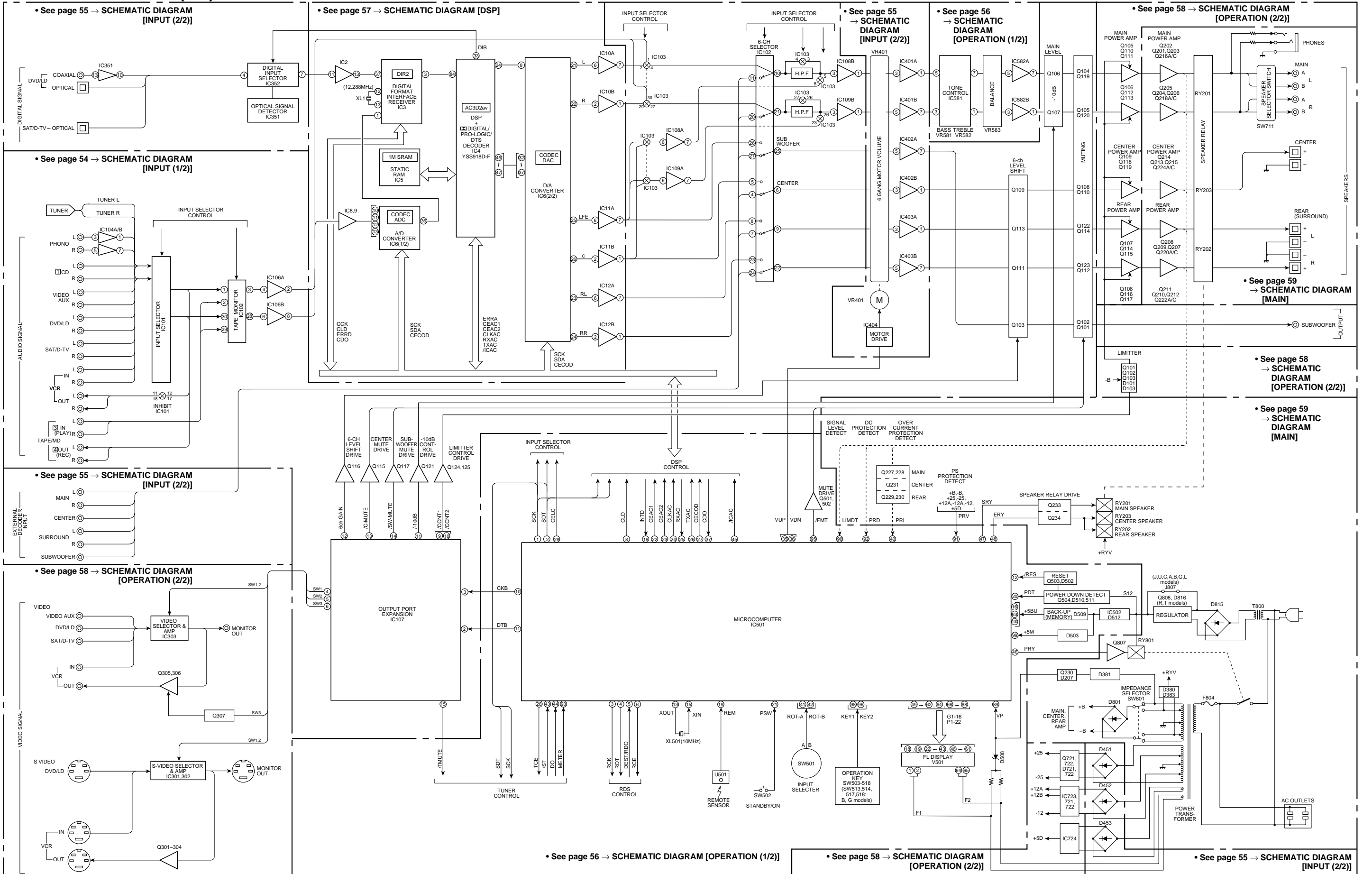

■ BLOCK DIAGRAM (2/2)

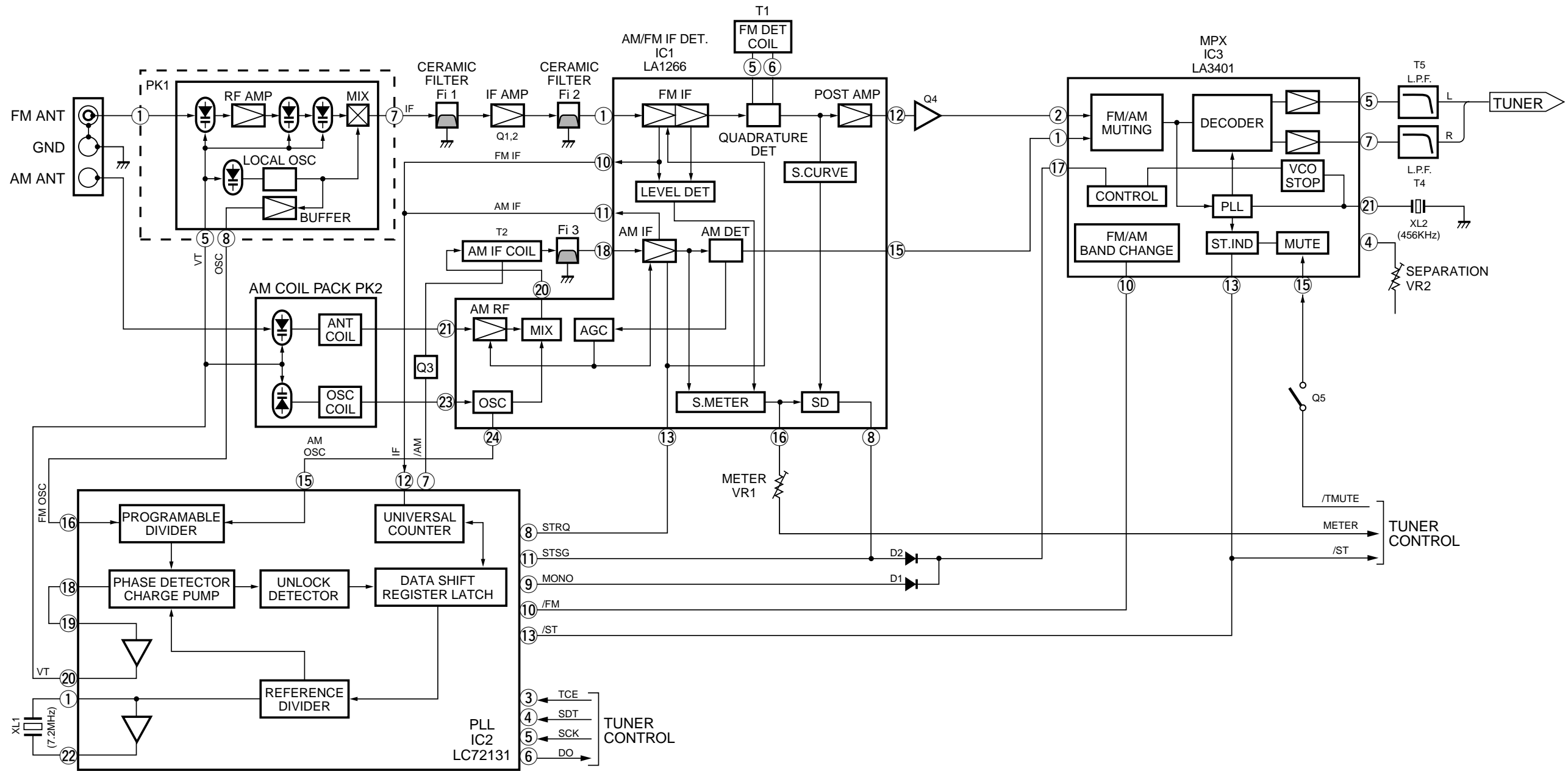

● See page 60→SCHEMATIC DIAGRAM [TUNER]

PRINTED CIRCUIT BOARD (Foil side)

P. C. B. MAIN (2)

P. C. B. TUNER (Lead Type)

Semiconductor Location R,T models

Ref. No.	Location
D801	F3
D814	F4
D815	G5
D816	G5
Q807	F4
Q808	G5

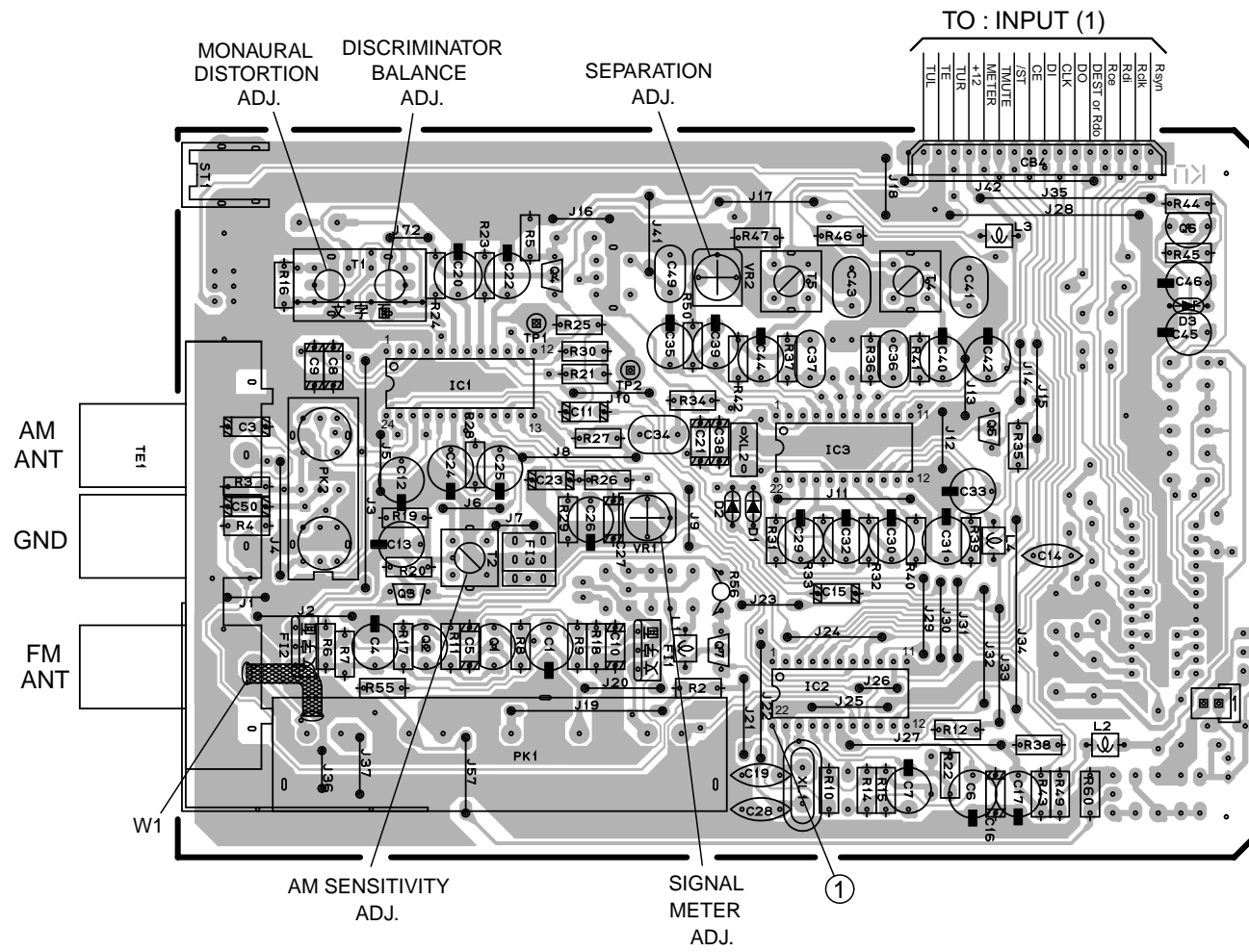

Lead Type Semiconductor Location

Ref. No.	Location
D1	C3
D2	C3
D3	D3
IC1	B3
IC2	C4
IC3	C3
Q1	B4
Q2	B4
Q3	B4
Q4	B3
Q5	C3
Q6	D3
Q7	C4

Point ① (Pin22 of IC2)

V : 2V/div H : 0.1μsec/div DC range 1 : 1 probe

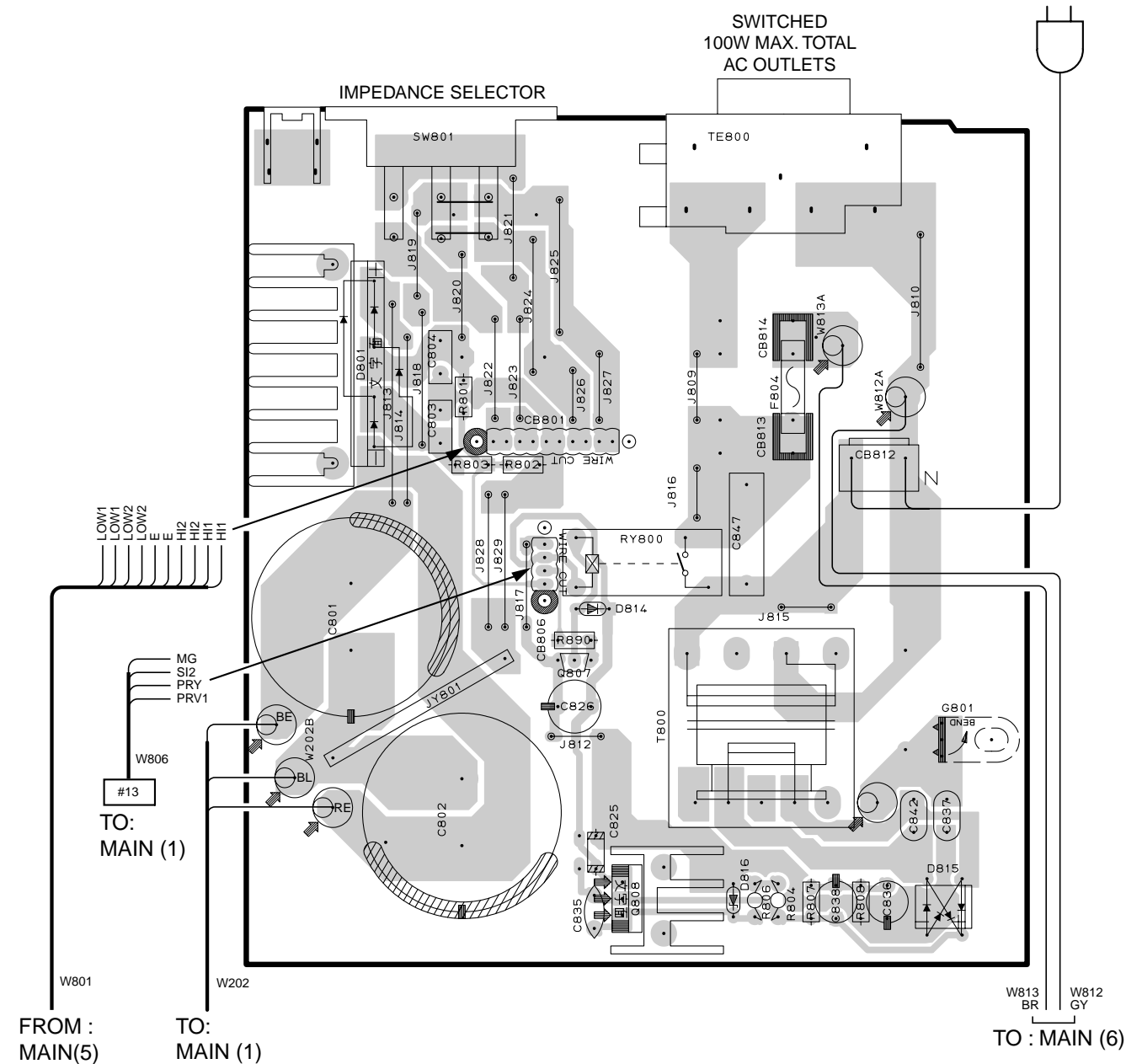
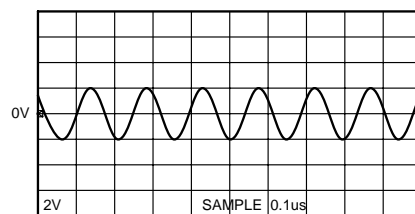

1
2
3
4
5
6

PRINTED CIRCUIT BOARD (Foil side)

P. C. B. MAIN (1)

FROM : OPERATION (4)

3

4

FROM : OPERATION (1)

TO : MAIN (3)

FROM : MAIN (5)

TO : MAIN (5)

TO : MAIN (2)

SPEAKERS
CENTER REAR
(R) (SURROUND) (L)

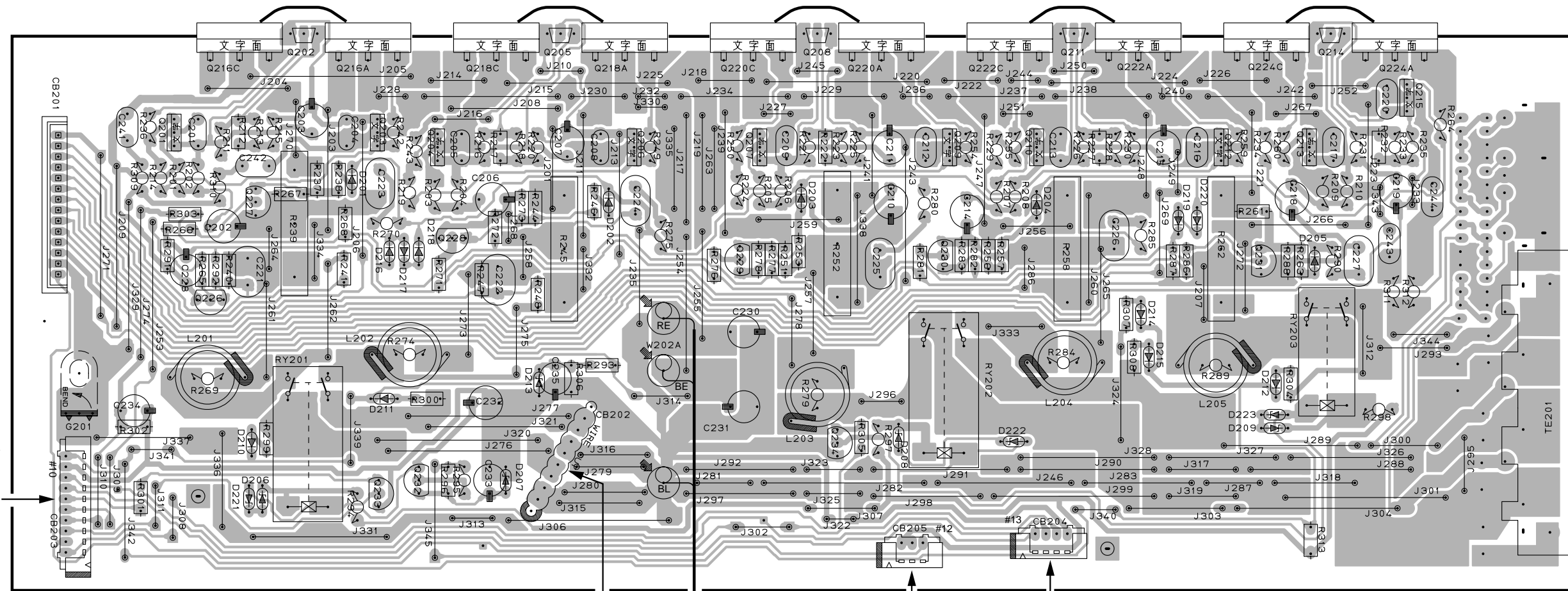

● Semiconductor Location

Ref. No.	Location	Ref. No.	Location	Ref. No.	Location	Ref. No.	Location	Ref. No.	Location
D201	B2	D213	C3	Q201	B2	Q213	F2	Q224C	F2
D202	C2	D214	F3	Q202	B2	Q214	F2	Q226	B3
D203	D2	D215	F3	Q203	C2	Q215	G2	Q227	B2
D204	E2	D216	C2	Q204	C2	Q216A	B2	Q228	C2
D205	F2	D217	C2	Q205	C2	Q216C	B2	Q229	D2
D206	B3	D218	C2	Q206	D2	Q218A	C2	Q230	E2
D207	C3	D219	F2	Q207	D2	Q218C	C2	Q231	F2
D208	E3	D220	F2	Q208	D2	Q220A	E2	Q232	C3
D209	F3	D221	B3	Q209	E2	Q220C	D2	Q233	C3
D210	B3	D222	E3	Q210	E2	Q222A	F2	Q234	D3
D211	C3	D223	F3	Q211	E2	Q222C	E2		
D212	F3			Q212	F2	Q224A	G2		

PRINTED CIRCUIT BOARD (Foil side)

P. C. B. DSP

P. C. B. DSP

TO: INPUT (1)

TO: INPUT (3)

TO: INPUT (1)

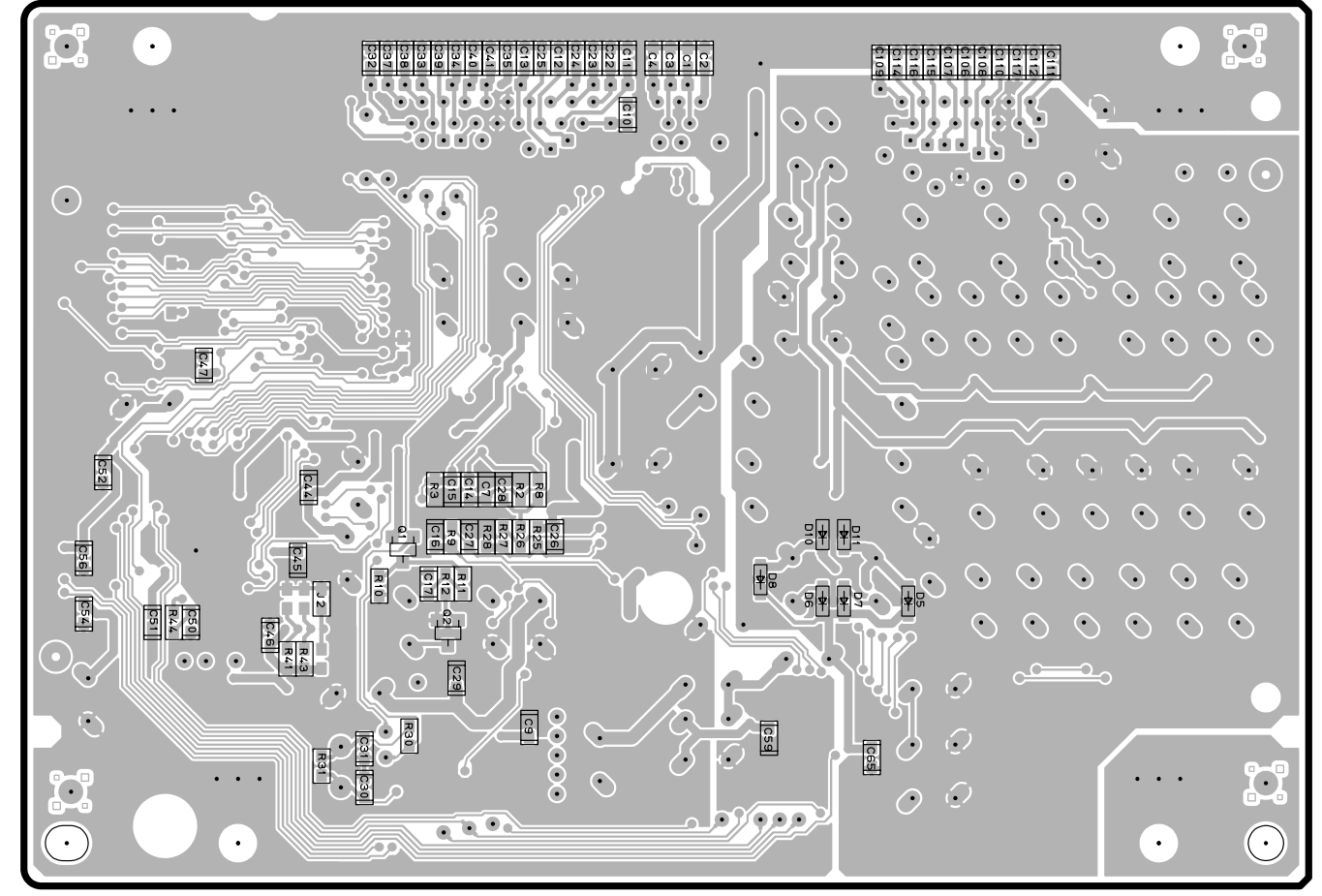
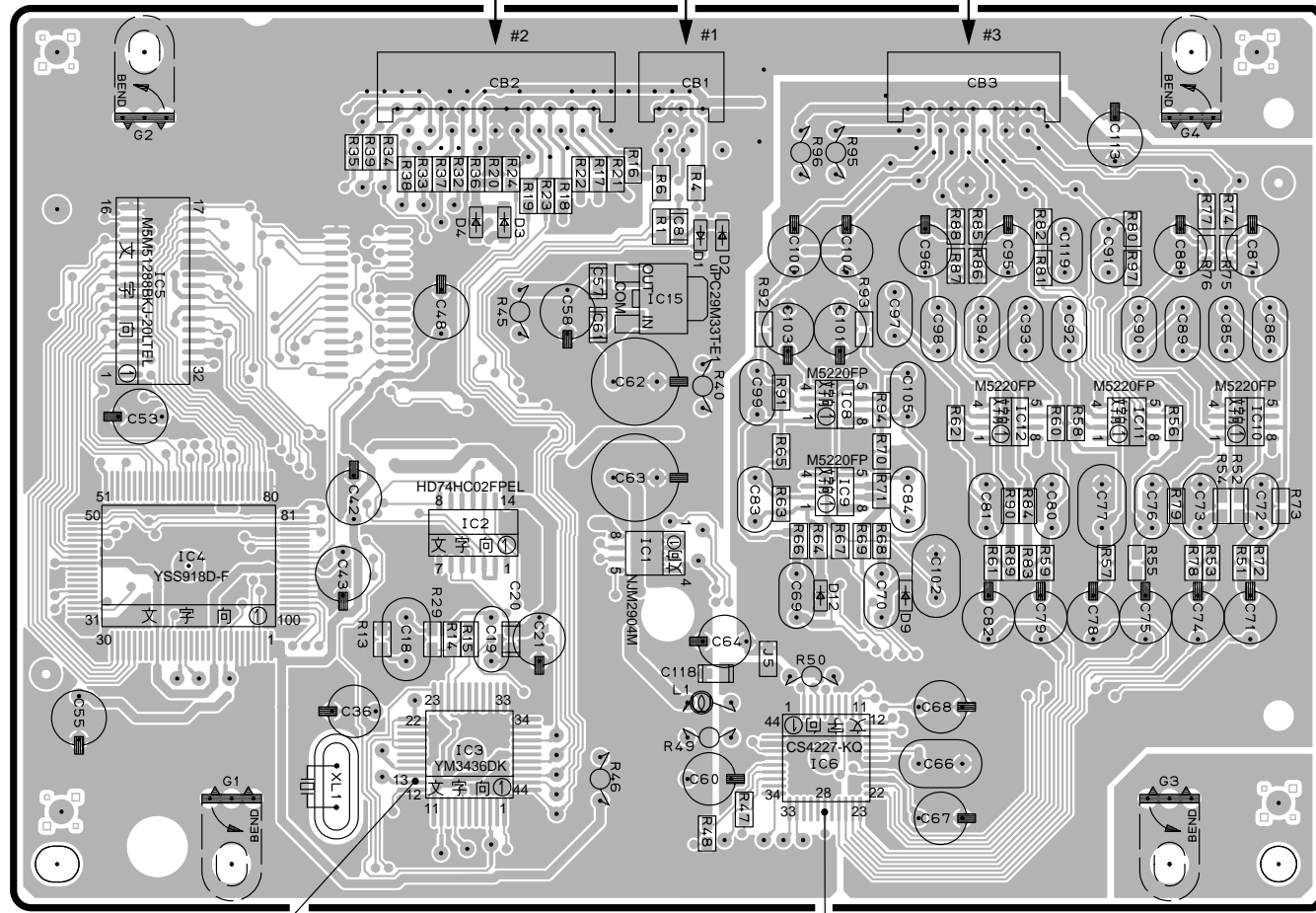

Semiconductor Location

Ref. No.	Location	Ref. No.	Location	Ref. No.	Location
D1	C3	IC1	B3	Q1	F3
D2	C3	IC2	B3	Q2	F4
D3	B3	IC3	B4		
D4	B3	IC4	A3		
D5	G4	IC5	A3		
D6	G4	IC6	C4		
D7	G4	IC8	C3		
D8	G3	IC9	C3		
D9	C4	IC10	D3		
D10	G3	IC11	D3		
D11	G3	IC12	C3		
D12	C4	IC15	B3		

Point ⑤
Pin 13 of IC3
V : 2V/div H : 50nsec/div
DC range 1 : 1 probe

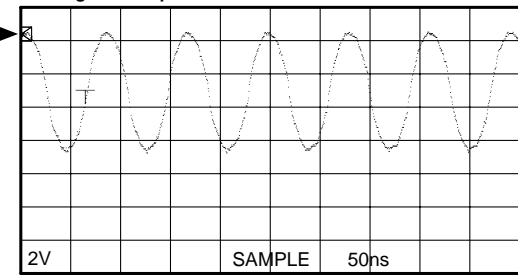

Point ⑥
Pin 28 of IC6
V : 2V/div H : 50nsec/div
DC range 1 : 1 probe

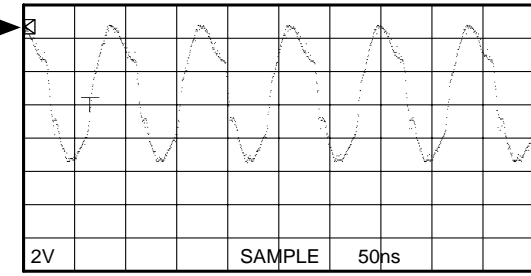

PRINTED CIRCUIT BOARD (Foil side)

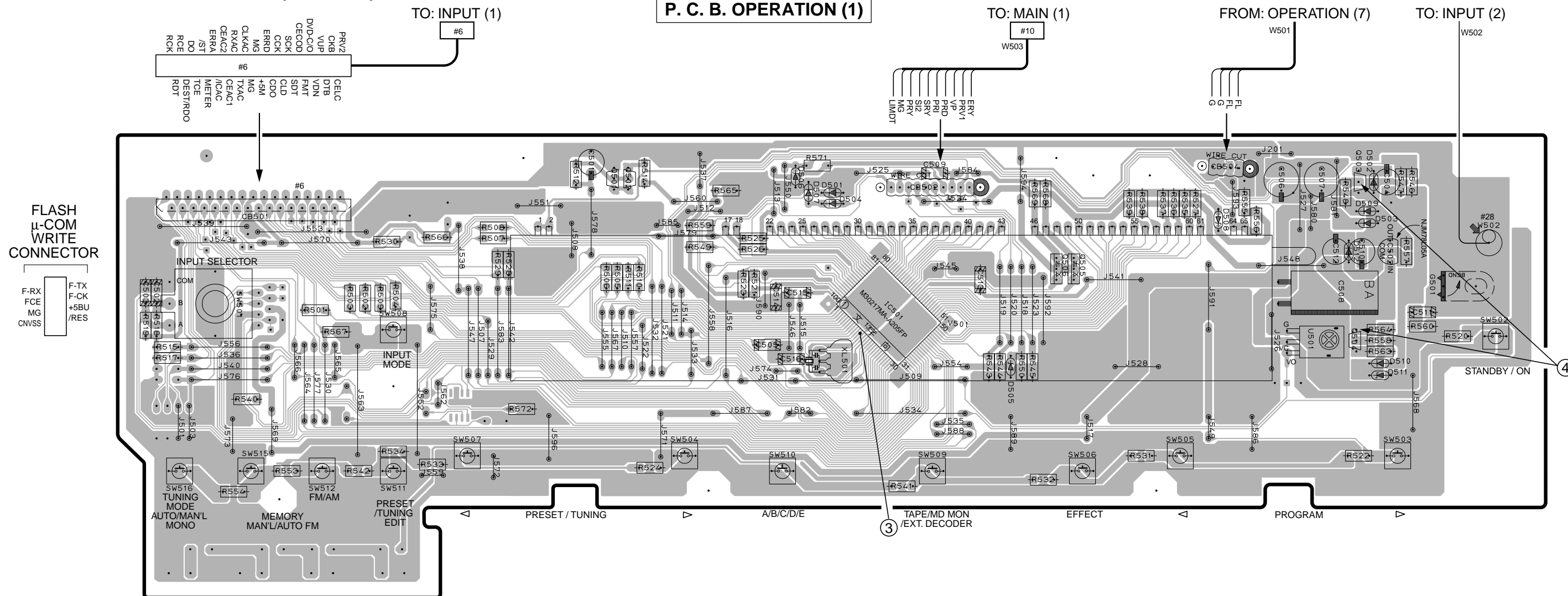

P. C. B. OPERATION (1)

P. C. B. OPERATION (2)

P. C. B. OPERATION (3)

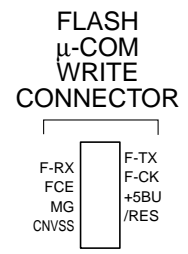

Point ③
(Pin 13 of IC501)
V : 2V/div H : 50nsec/div
DC range 1 : 1 probe

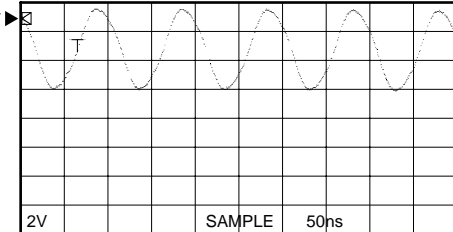

Point ④
(CH1 : Emitter of Q504
CH2 : Collector of Q503)
V : 5V or 2V/div H : 5sec/div
DC range 1 : 1 probe

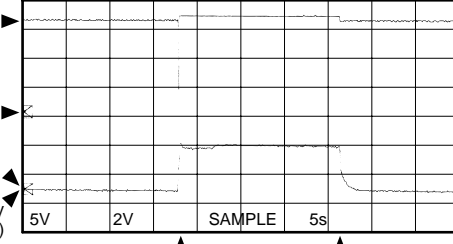

With the POWER switch turned ON, connect the power cord to the AC outlet.
Disconnect the power cord from the AC outlet.
(This waveform is not available by pushing the power switch ON and OFF.)

Semiconductor Location

Ref. No.	Location
D501	E2
D502	G2
D503	G2
D504	E2
D505	F3
D506	E2
D507	E2
D508	G2
D509	G2
D510	G3
D511	G3
D512	G2
IC501	E2
IC502	G2
IC581	D5
IC582	E5
Q501	D2
Q502	D2
Q503	G2
Q504	G3
Q505	F2
Q506	F2

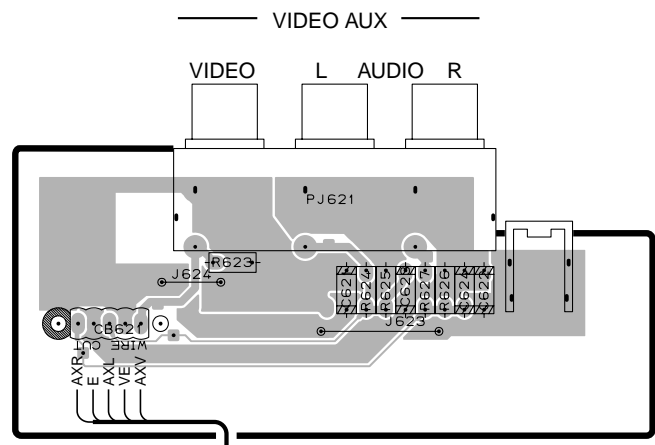
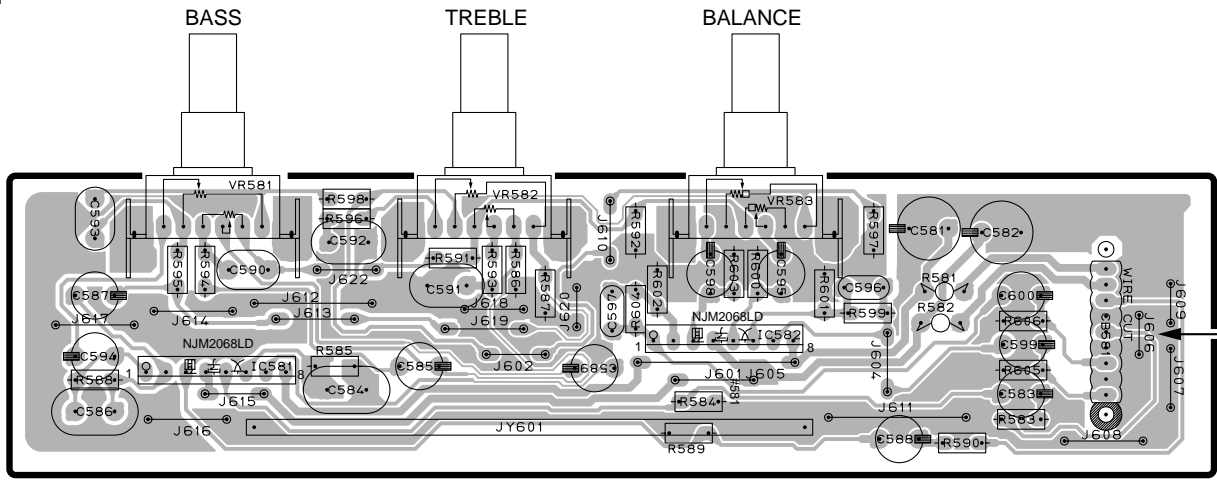

PRINTED CIRCUIT BOARD (Foil side)

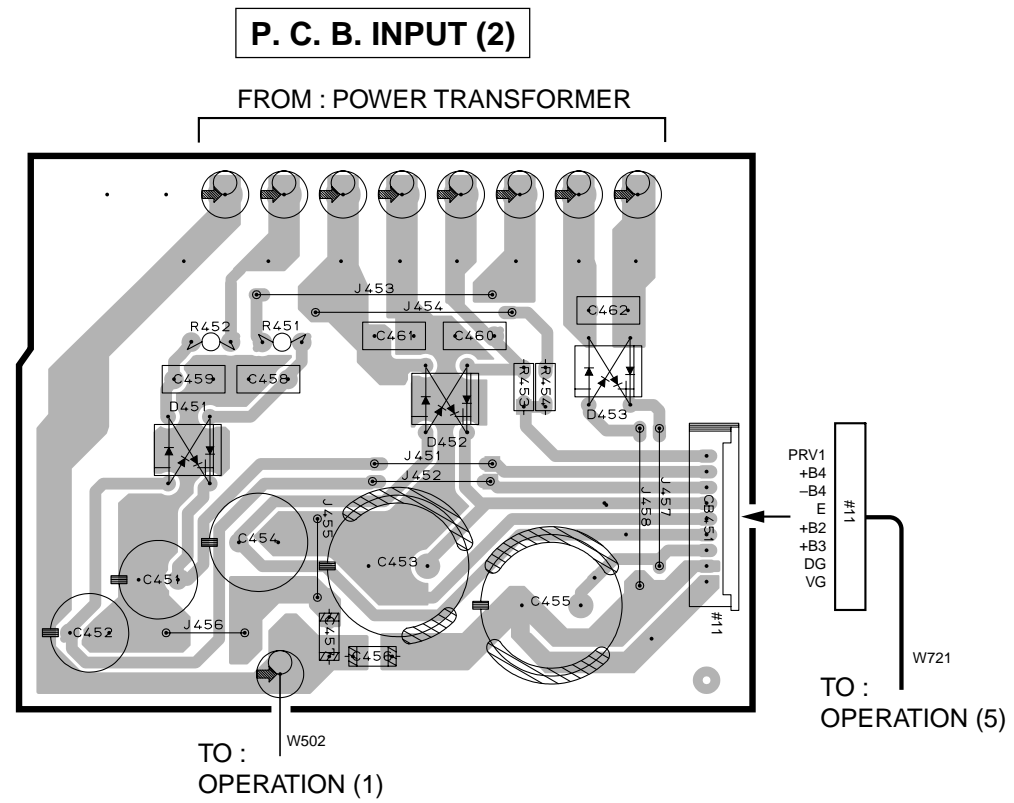
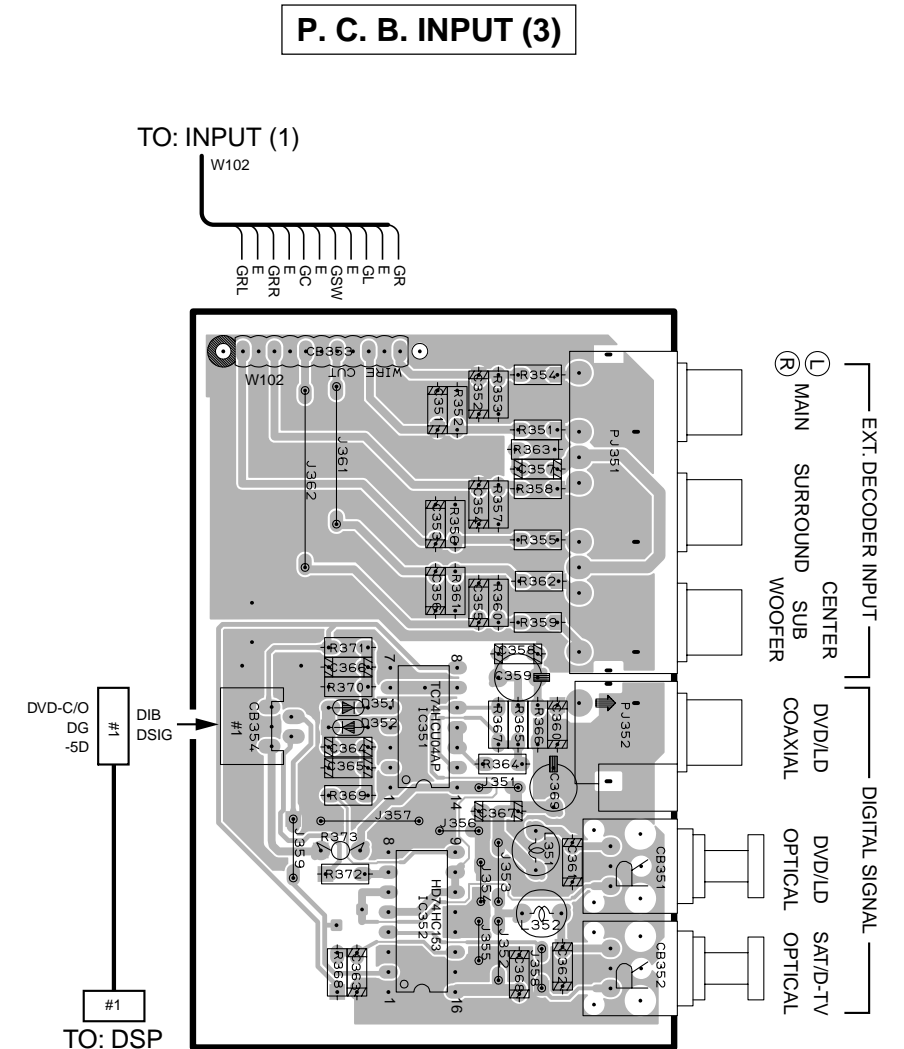
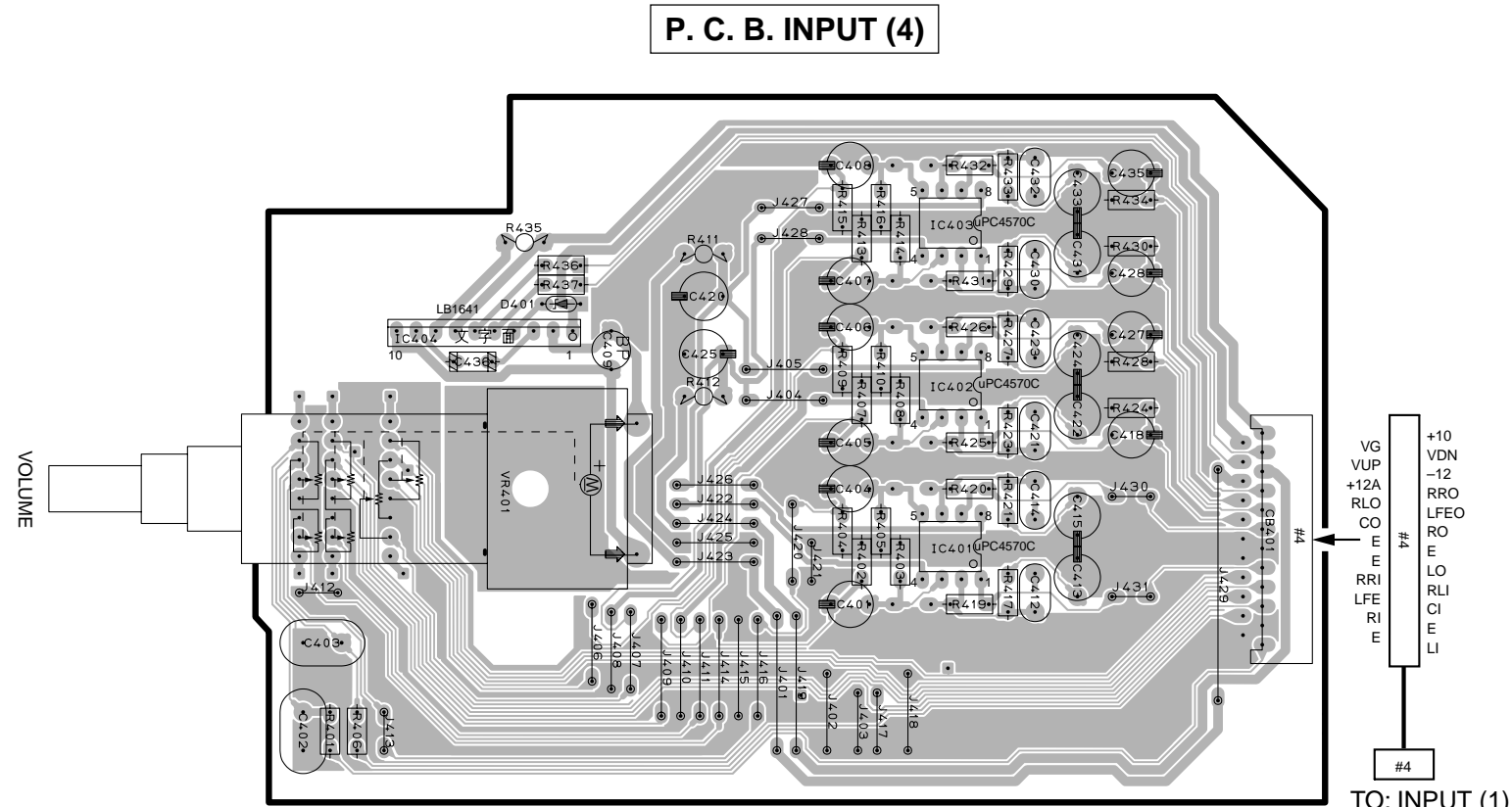

● Semiconductor Location

Ref. No.	Location	Ref. No.	Location
D351	F3	IC351	G3
D352	F3	IC352	G4
D401	C2	IC401	D3
D451	C5	IC402	D2
D452	D5	IC403	D2
D453	D5	IC404	B2

PRINTED CIRCUIT BOARD (Foil side)

P. C. B. INPUT (1)

● Semiconductor Location

Ref. No.	Location	Ref. No.	Location	Ref. No.	Location	Ref. No.	Location
D101	D3	IC101	G4	Q101	F5	Q111	C3
D102	D3	IC102	F4	Q102	G5	Q112	C3
D103	D3	IC103	E4	Q103	F5	Q113	C3
D104	D3	IC104	G2	Q104	D4	Q114	C3
D105	F5	IC105	F2	Q105	C4	Q115	B4
D106	B3	IC106	E3	Q106	D4	Q116	B4
		IC107	B4	Q107	C4	Q117	B4
		IC108	E4	Q108	C3	Q118	D3
		IC109	D4	Q109	C3	Q119	D4
				Q110	C3	Q120	C4
						Q121	B4
						Q122	C3
						Q123	C3
						Q124	B4
						Q125	B4

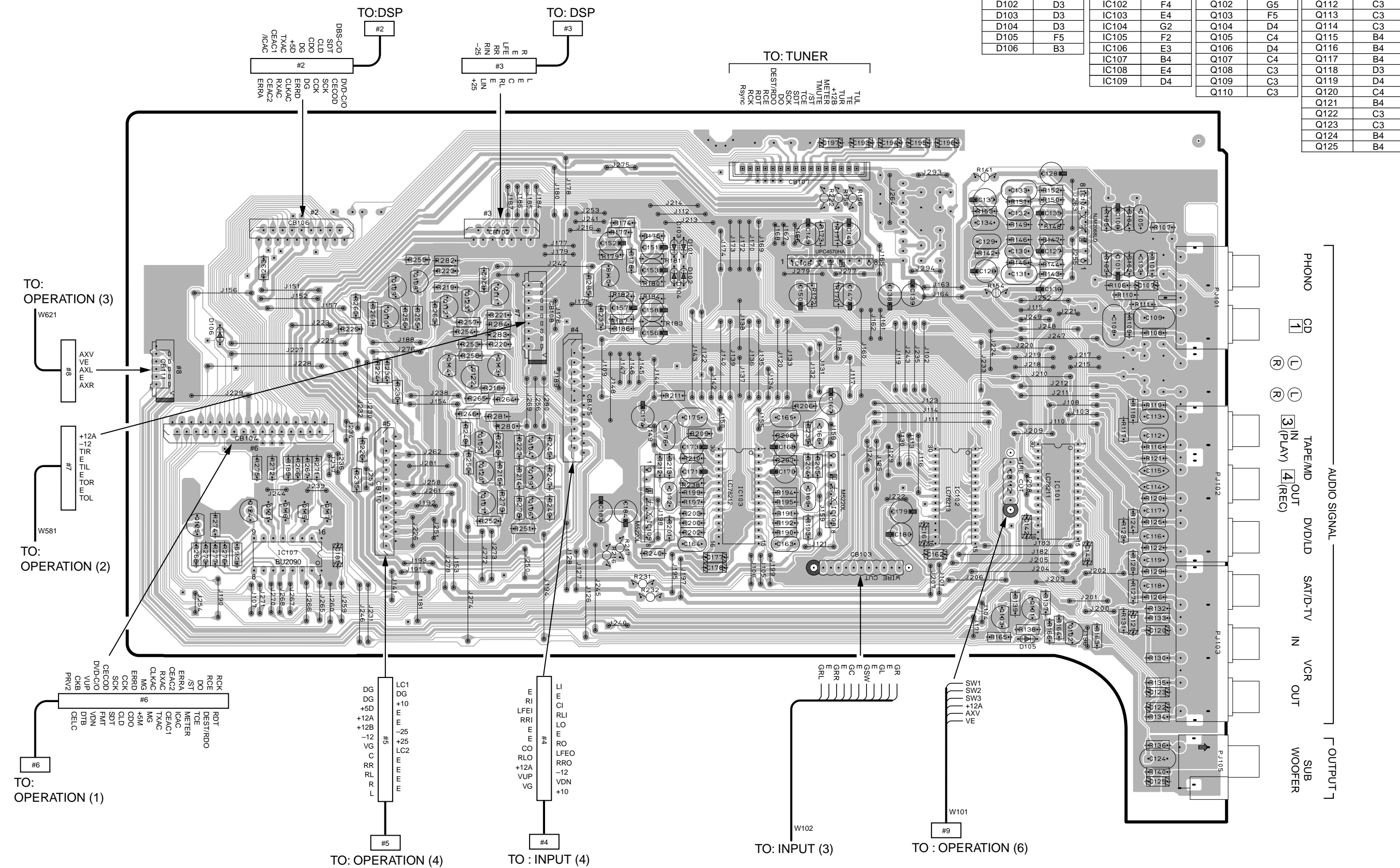

SCHEMATIC DIAGRAM [INPUT (2/2)]

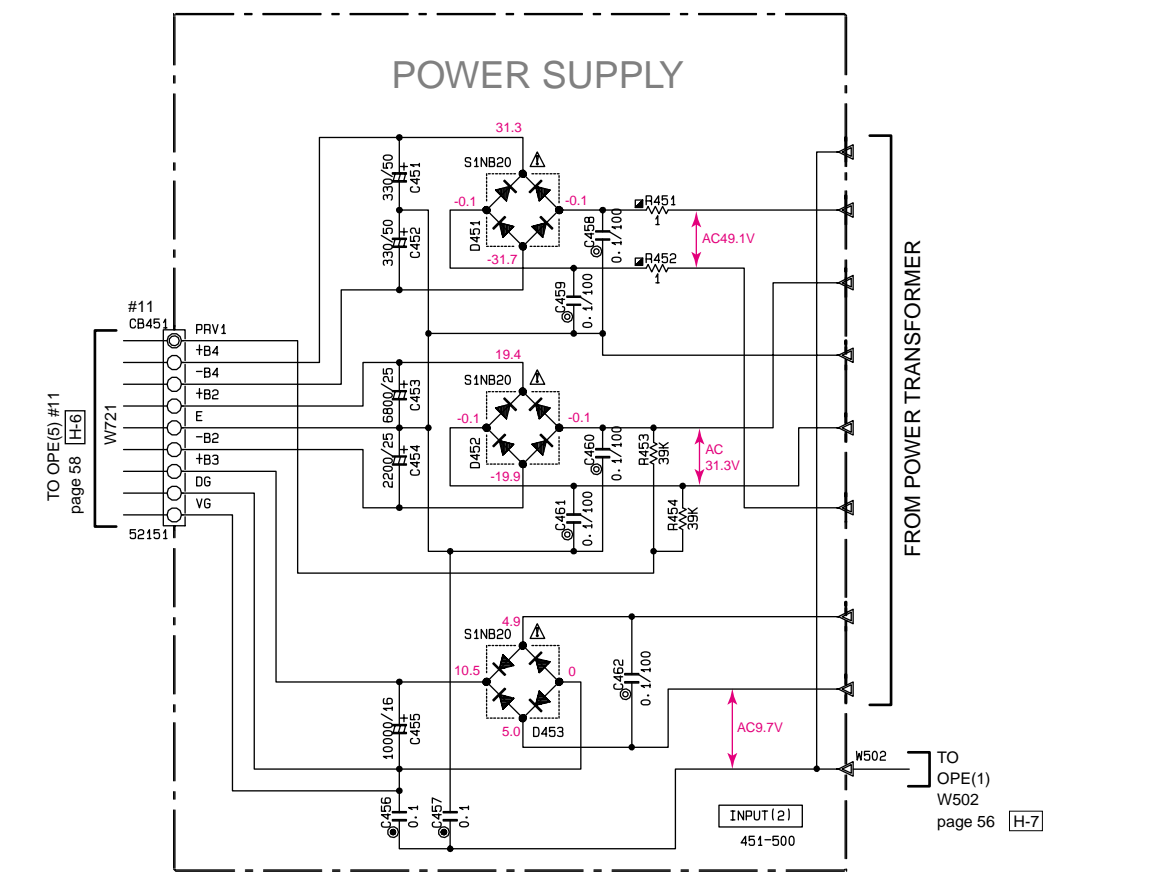
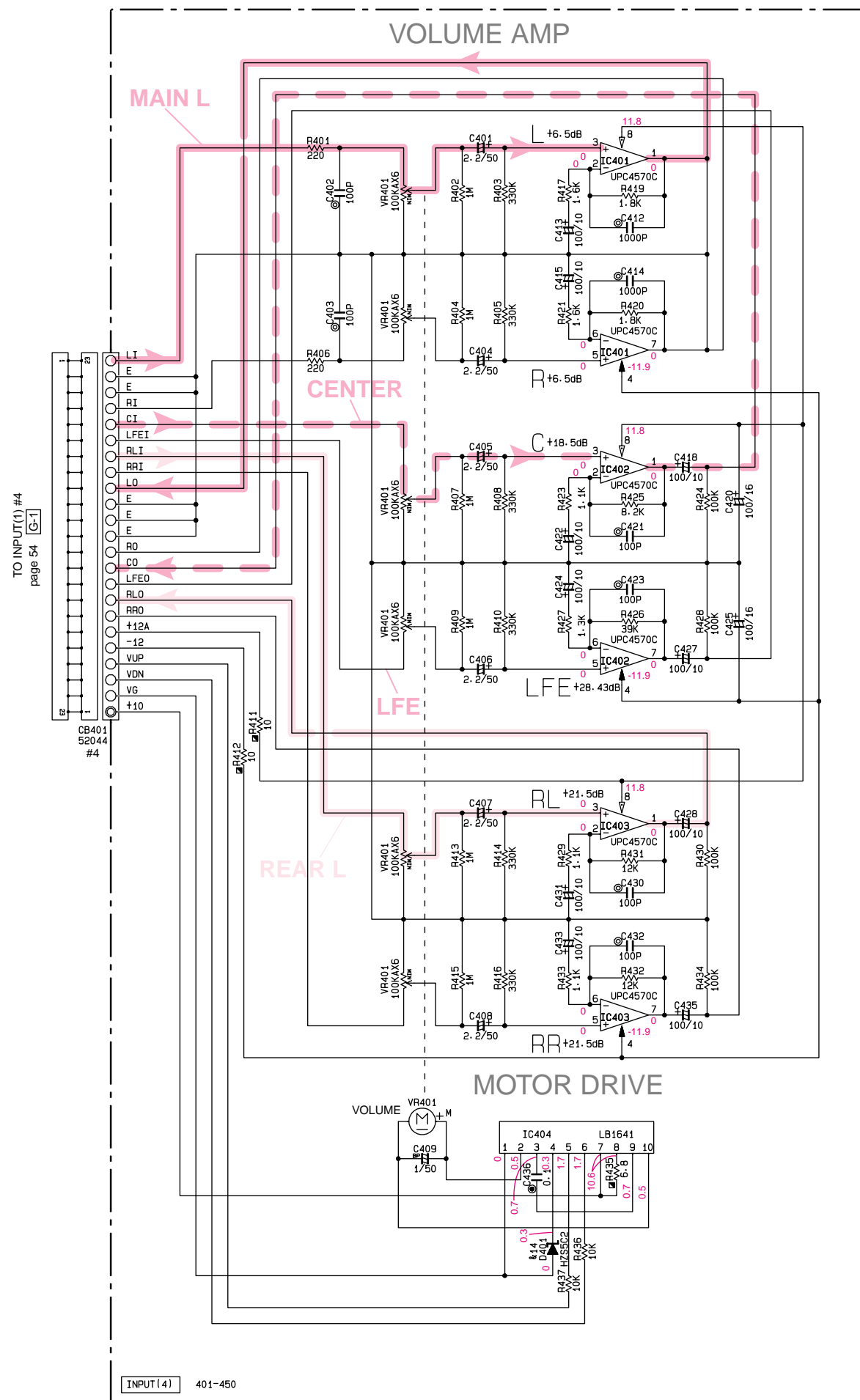
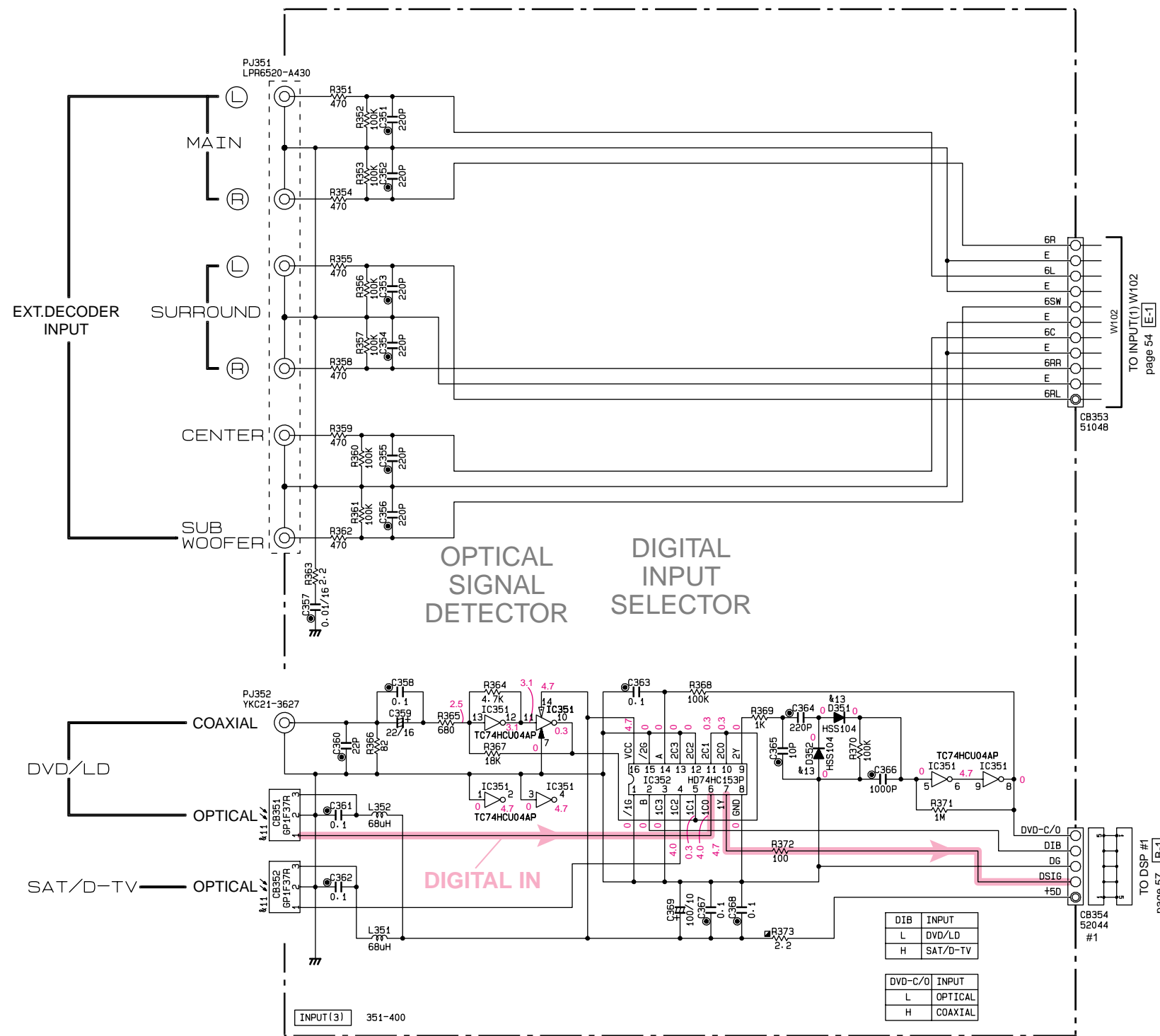

NOTICE (model)
(J)..... JAPANESE
(U)..... U.S.A
(C)..... CANADIAN
(R)..... GENERAL
(A)..... AUSTRALIAN
(B)..... BRITISH
(G)..... EUROPEAN
(T)..... CHINA
(L)..... SINGAPORE

Mark	Reference Parts Number	Parts Name
#11	C8351-352	6P137A TORX176A
#12		
#13	D351-352	HSS104 1SS133 1SS176
#14	D401	H255C2 M72.5-1B
#15		
#16		

REMARKS	PARTS NAME
NO MARK	CARBON FILM RESISTOR (P=5)
Z	CARBON FILM RESISTOR (P=10)
Δ	METAL OXIDE FILM RESISTOR
▲	METAL FILM RESISTOR
⊠	METAL PLATE RESISTOR
⊞	FIRE PROOF CARBON FILM RESISTOR
⊞	CEMENT MOLDED RESISTOR
⊞	SEMI VARIABLE RESISTOR
⊞	CHIP RESISTOR

REMARKS	PARTS NAME
NO MARK	ELECTROLYTIC CAPACITOR
⊞	TANTALUM CAPACITOR
NO MARK	CERAMIC CAPACITOR
⊞	CERAMIC TUBULAR CAPACITOR
⊞	POLYESTER FILM CAPACITOR
⊞	POLYSTYRENE FILM CAPACITOR
⊞	MICA CAPACITOR
⊞	POLYPROPYLENE FILM CAPACITOR
⊞	SEMICONDUCTIVE CERAMIC CAPACITOR
⊞	POLYPHENYLENE SULFIDE FILM CAPACITOR

IC351: TC74HCU04AP
Hex Inverters

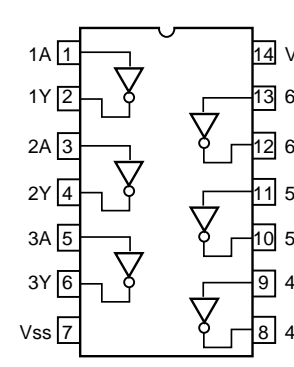

IC352: HD74HC153P
Dual 4 to 1 Data Selectors

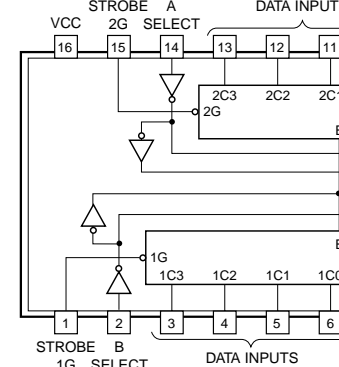

SELECT	STROBE	Y
B	A	G
X	X	H
L	L	L
L	H	L
H	L	L
H	H	L
H	H	C3

H: High Level
L: Low Level
X: Don't care

IC401-403: uPC4570C
Dual OP-Amp

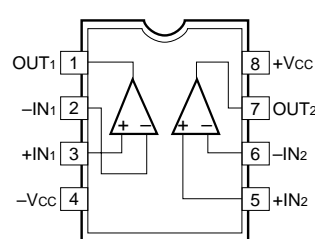

IC404: LB1641
Motor Driver

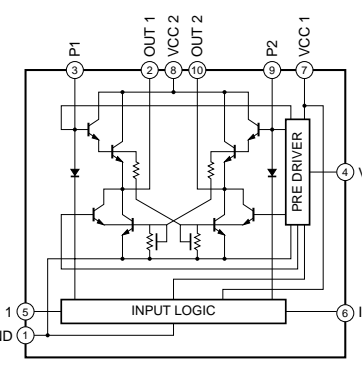

IC104: NJM2068LD
IC108,109: M5220L
Dual OP-Amp

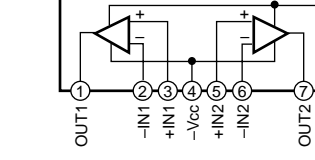

IC105,106: uPC4570HA
Dual OP-Amp

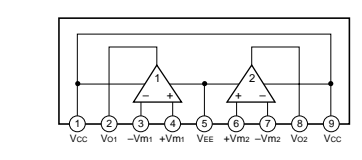

IC101: LC78211
Analog Function Switch

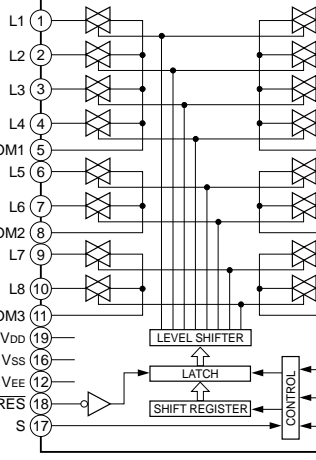

IC102: LC78213
Analog Function Switch

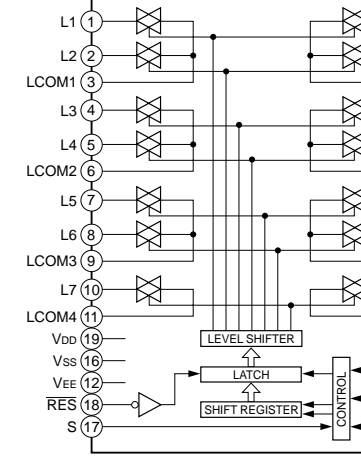

IC103: LC78212
Analog Function Switch

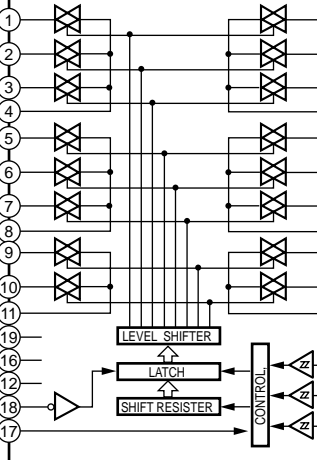

PIN CONNECTION DIAGRAM OF DIODES, TRANSISTORS AND IC'S.

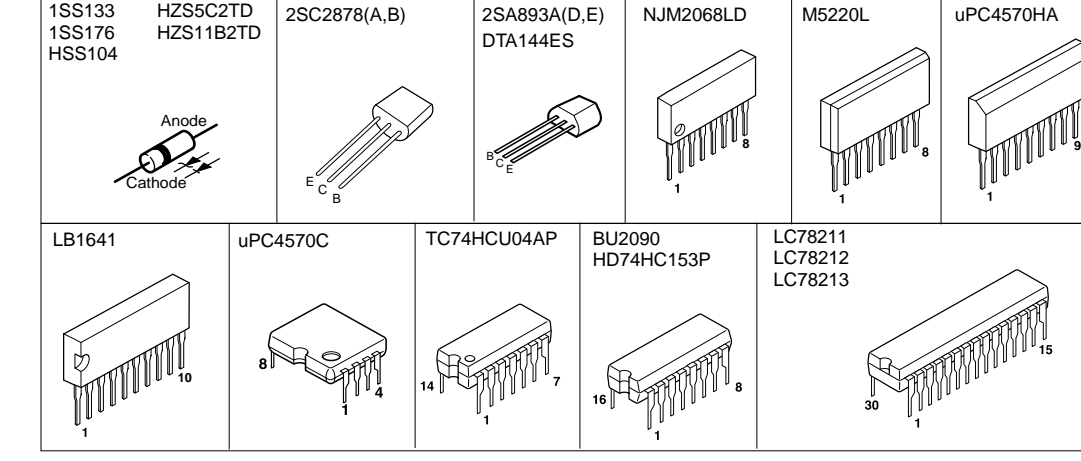

Conditions
• INPUT → CD
• VOLUME → minimum(∞)
• IMPEDANCE → Left
• SELECTOR → Left
• PRO LOGIC → On

• All voltages are measured with a 10MΩ/V DC electric volt meter.
• Components having special characteristics are marked Δ and must be replaced with parts having specifications equal to those originally installed.
• Schematic diagram is subject to change without notice.

SCHEMATIC DIAGRAM (OPERATION [1/2])

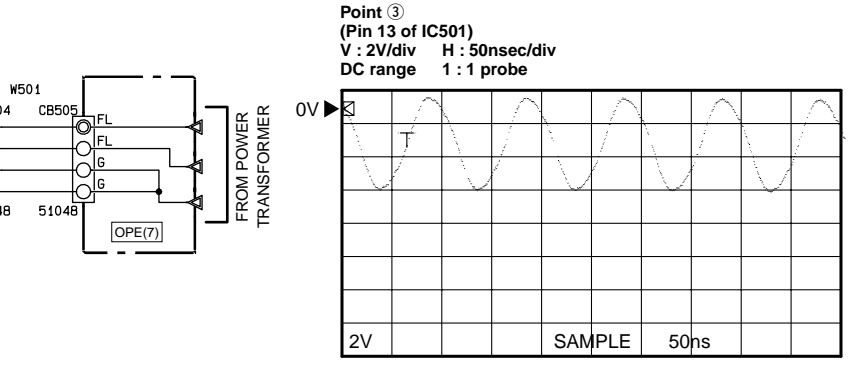
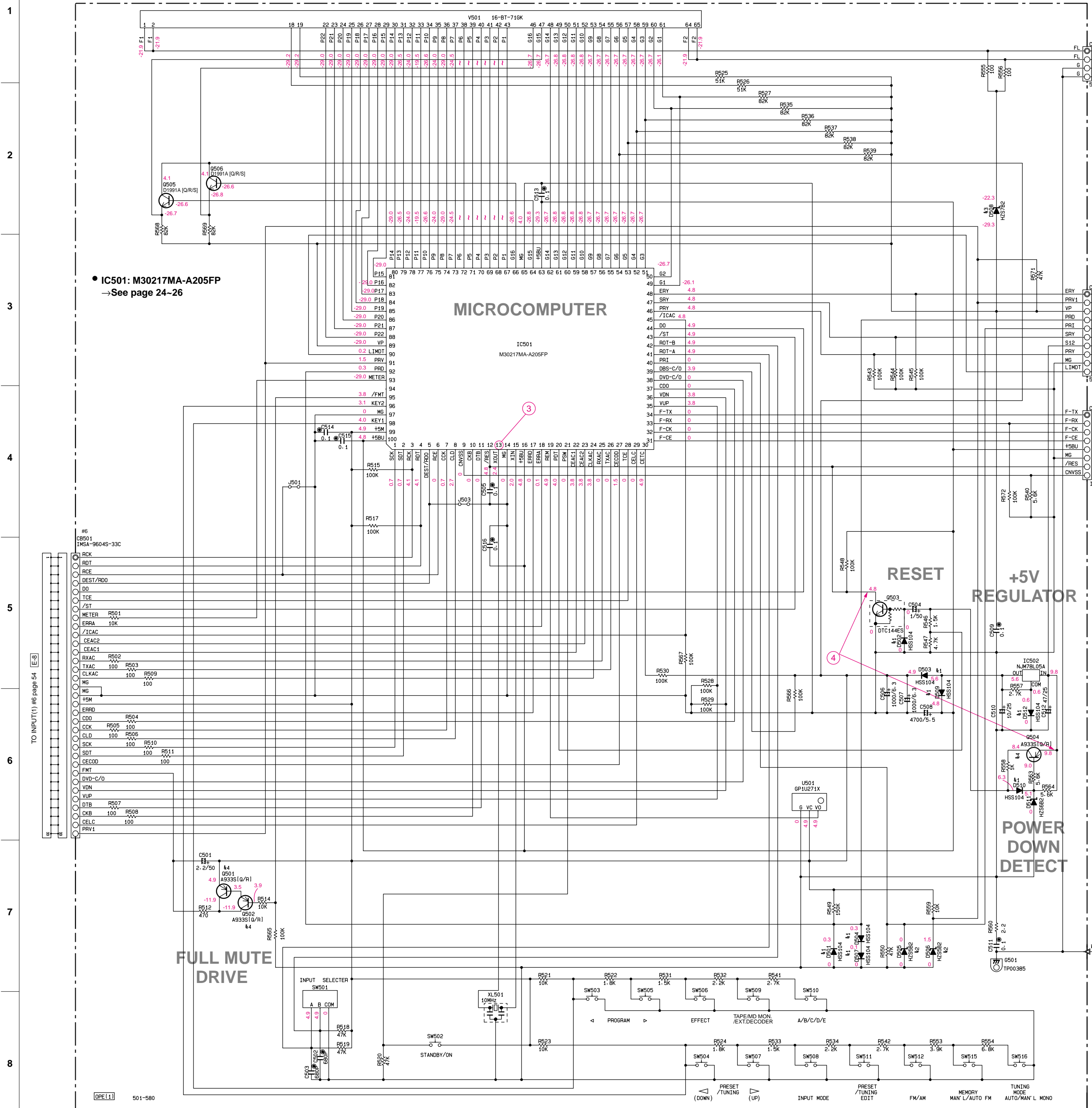

RESISTOR

REMARKS	PARTS NAME
NO MARK	CARBON FILM RESISTOR [P=5]
□	CARBON FILM RESISTOR [P=10]
△	METAL OXIDE FILM RESISTOR
▲	METAL FILM RESISTOR
▢	METAL PLATE FILM RESISTOR
■	FIRE-PROOF CARBON FILM RESISTOR
□	CEMENT MOLDED RESISTOR
○	SEMI-VARIABLE RESISTOR
⊙	CHIP RESISTOR

CAPACITOR

REMARKS	PARTS NAME
NO MARK	ELECTROLYTIC CAPACITOR
⊗	TANTALUM CAPACITOR
○	CERAMIC CAPACITOR
●	CERAMIC TUBULAR CAPACITOR
⊙	POLYESTER FILM CAPACITOR
○	POLYSTYRENE FILM CAPACITOR
○	MICA CAPACITOR
○	POLYPROPYLENE FILM CAPACITOR
●	SEMICONDUCTIVE CERAMIC CAPACITOR
⊙	POLYPHENYLENE SULFIDE FILM CAPACITOR

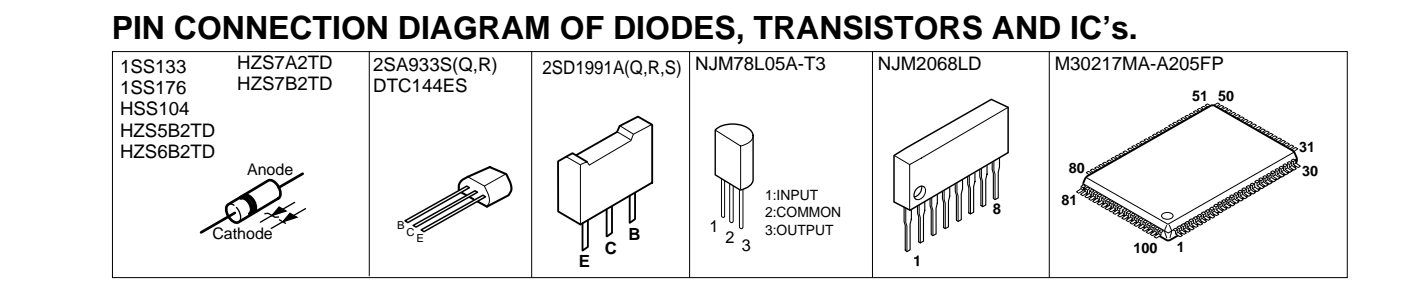
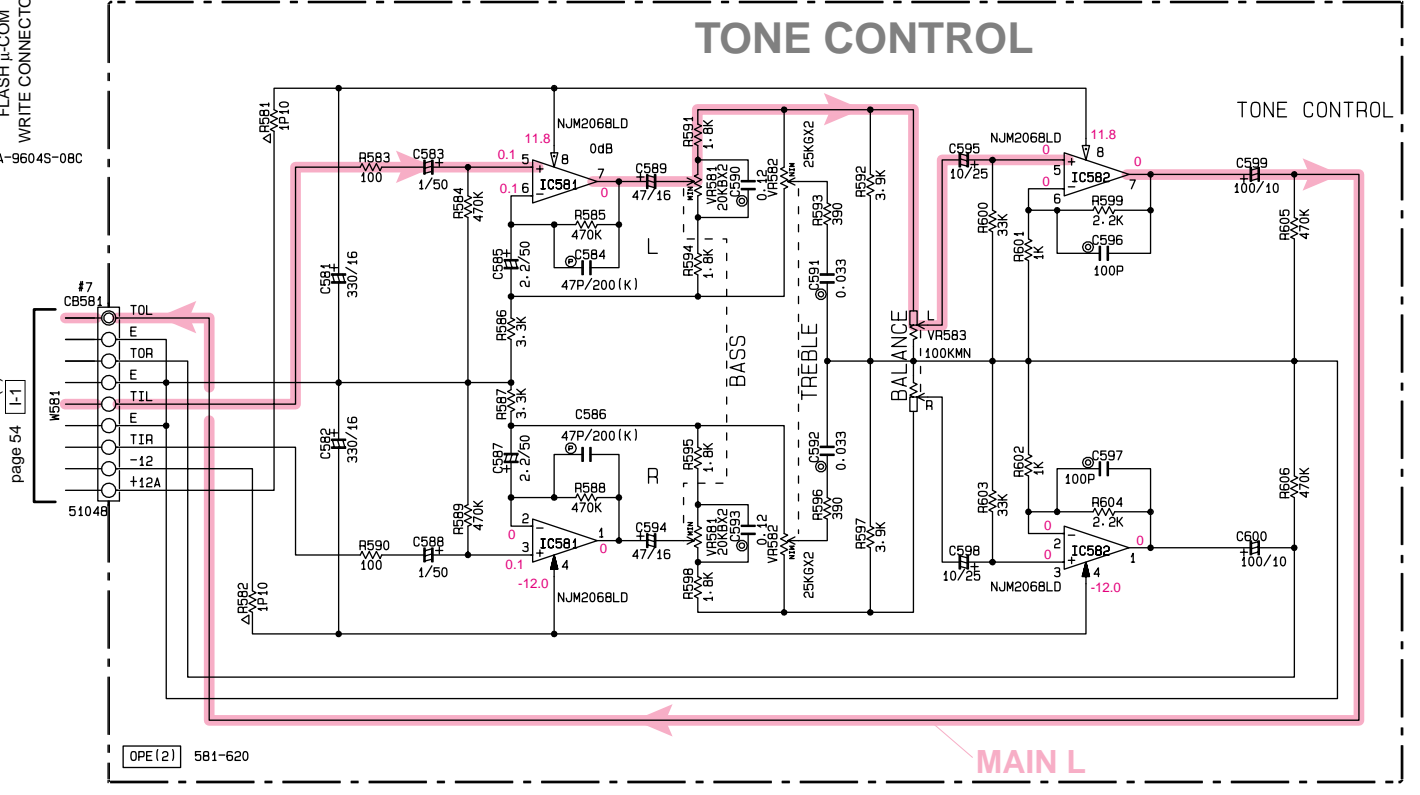
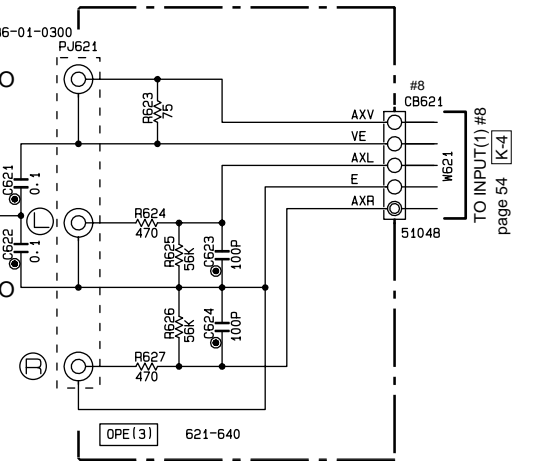
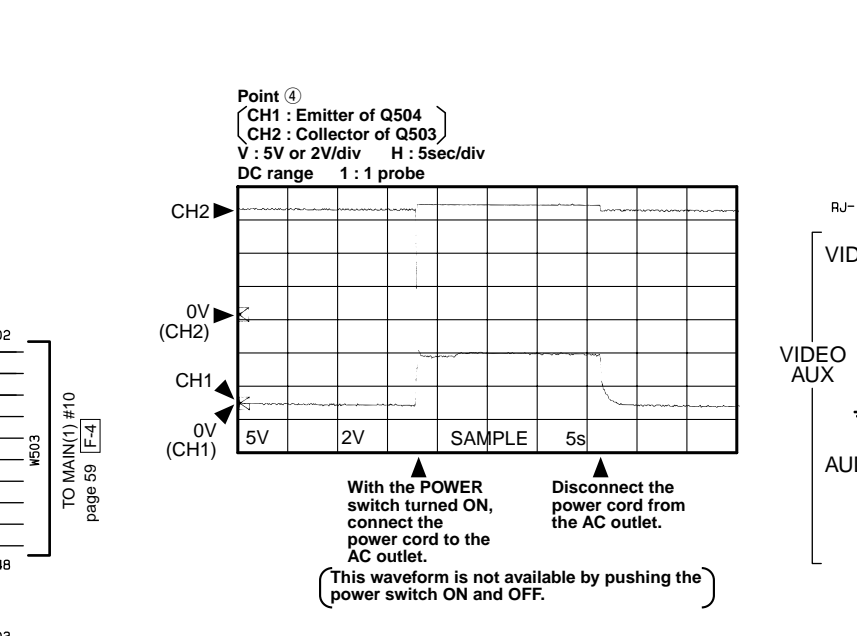

Interchangeable Parts at Manufacture-Stage

Mark	Reference Parts Number	Parts Name
41	D501-502-503-504-507 509-510-512	HSS104 1SS133 1SS176
42	D505-506	HZS582 MT2J4-7C
43	D508	HZS782 MT2J7-5A
44	G501-502-504	2SA933S(Q/R) 2SA1151E(P/R) 2SA1305M(Q/R/S)

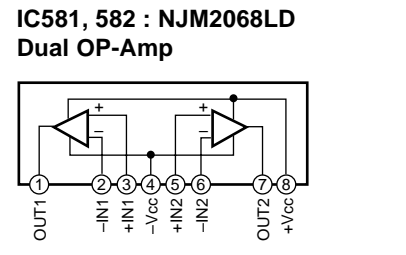

NOTICE (mode1)
(J)..... JAPANESE
(U)..... U. S. A
(C)..... CANADIAN
(R)..... GENERAL
(A)..... AUSTRALIAN
(B)..... BRITISH
(G)..... EUROPEAN
(T)..... CHINA
(L)..... SINGAPORE

- Conditions**
- INPUT → CD
 - VOLUME → minimum(∞)
 - IMPEDANCE SELECTOR → Left
 - PRO LOGIC → On

* All voltages are measured with a 10MΩ/V DC electric volt meter.
* Components having special characteristics are marked △ and must be replaced with parts having specifications equal to those originally installed.
* Schematic diagram is subject to change without notice.

SCHEMATIC DIAGRAM [DSP]

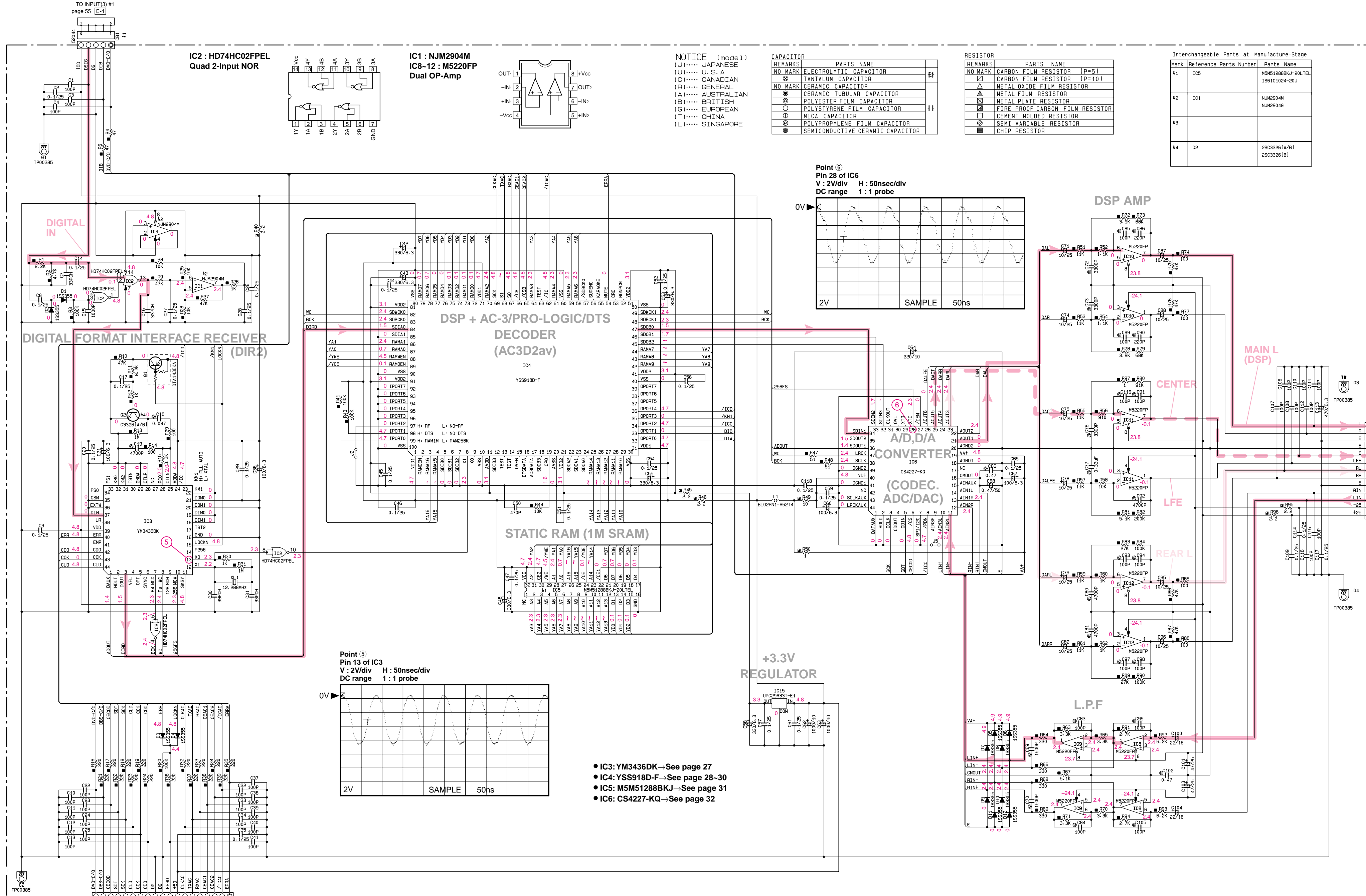

NOTICE (model)

(J)..... JAPANESE
 (U)..... U. S. A
 (C)..... CANADIAN
 (R)..... GENERAL
 (A)..... AUSTRALIAN
 (B)..... BRITISH
 (G)..... EUROPEAN
 (T)..... CHINA
 (L)..... SINGAPORE

REMARKS	PARTS NAME	UNIT
NO MARK	ELECTROLYTIC CAPACITOR	μF
⊗	TANTALUM CAPACITOR	μF
NO MARK	CERAMIC CAPACITOR	
⊙	CERAMIC TUBULAR CAPACITOR	
⊖	POLYESTER FILM CAPACITOR	
○	POLYSTYRENE FILM CAPACITOR	
○	MICA CAPACITOR	
⊖	POLYPROPYLENE FILM CAPACITOR	
●	SEMICONDUCTIVE CERAMIC CAPACITOR	

REMARKS	PARTS NAME	UNIT
NO MARK	CARBON FILM RESISTOR (P=5)	
⊗	CARBON FILM RESISTOR (P=10)	
△	METAL OXIDE FILM RESISTOR	
⊖	METAL FILM RESISTOR	
⊖	METAL PLATE RESISTOR	
⊖	FIRE PROOF CARBON FILM RESISTOR	
⊖	CEMENT MOLDED RESISTOR	
⊖	SEMI VARIABLE RESISTOR	
■	CHIP RESISTOR	

Interchangeable Parts at Manufacture-Stage

Mark	Reference	Parts Number	Parts Name
k1	IC5	M5M51288BKJ-20LTEL	1S61C1024-20J
k2	IC1	NJM2904M	NJM2904M
k3			
k4	Q2	2SC33261A/B1	2SC33261B1

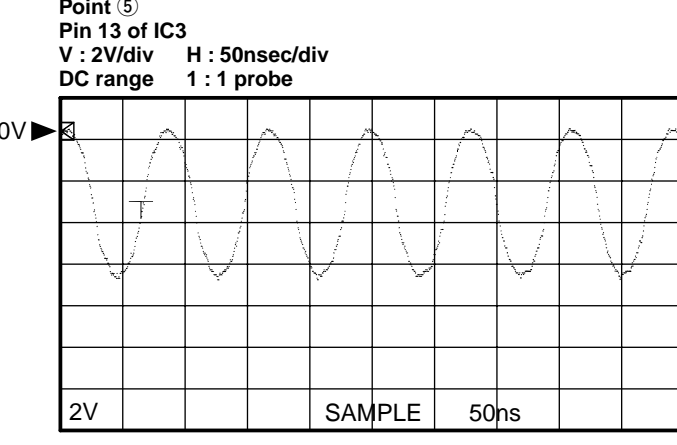
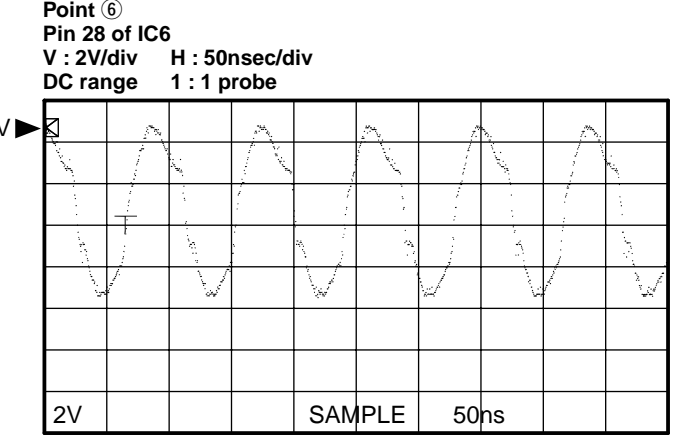

- IC3: YM3436DK → See page 27
- IC4: YSS918D-F → See page 28-30
- IC5: M5M51288BKJ → See page 31
- IC6: CS4227-KQ → See page 32

PIN CONNECTION DIAGRAM OF DIODES, TRANSISTORS AND IC'S.

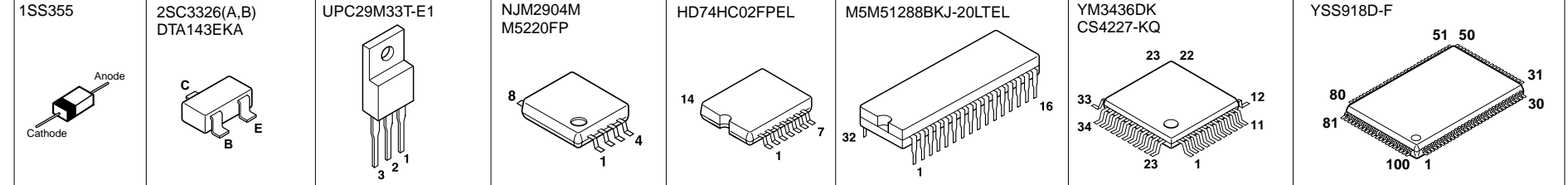

Conditions

- INPUT → CD
- VOLUME → minimum(∞)
- IMPEDANCE SELECTOR → Left
- PRO LOGIC → On

All voltages are measured with a 10MΩ/V DC electric volt meter.
 Components having special characteristics are marked Δ and must be replaced with parts having specifications equal to those originally installed.
 Schematic diagram is subject to change without notice.

■ SCHEMATIC DIAGRAM [OPERATION (2/2)]

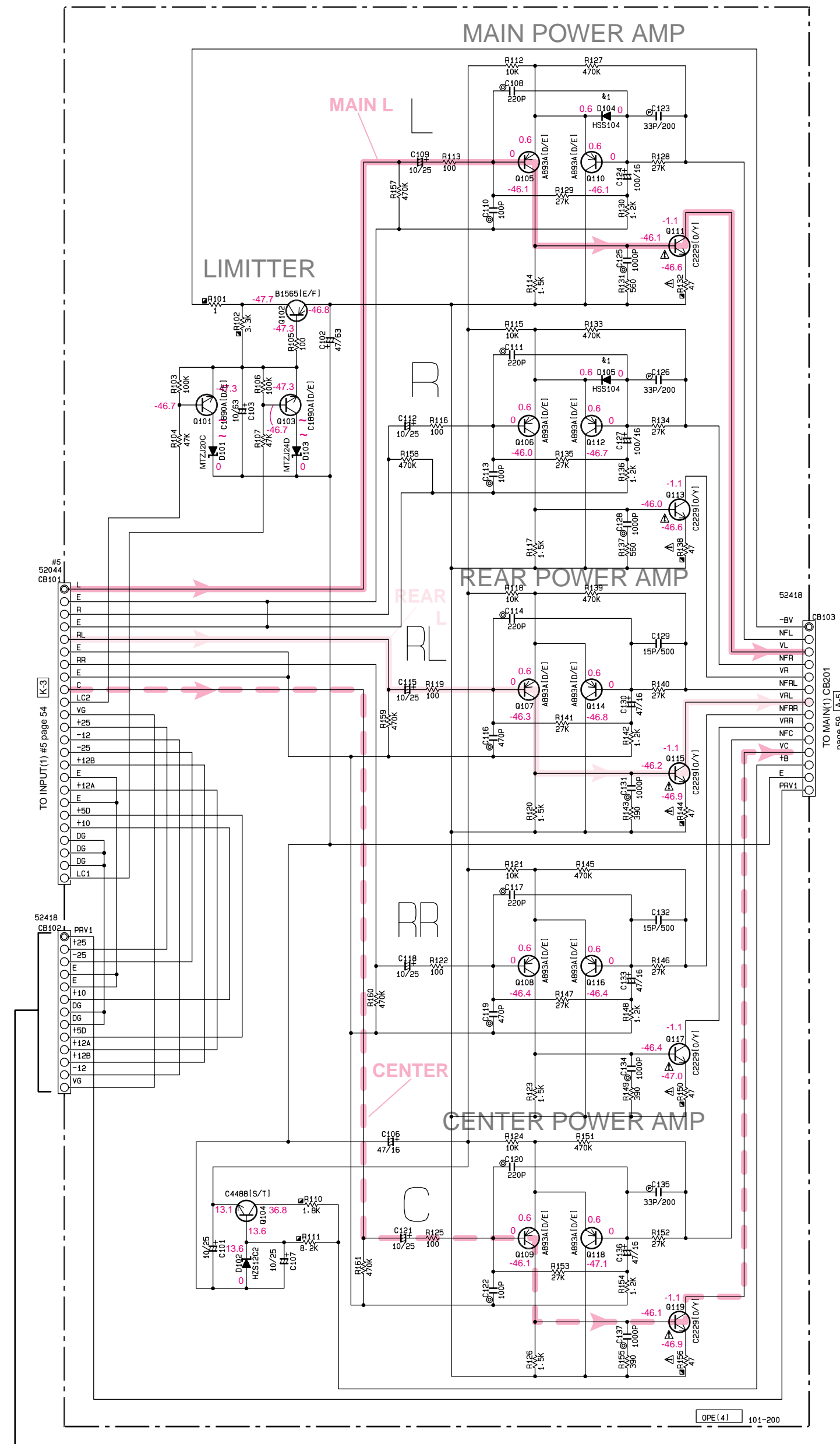

Interchangeable Parts at Manufacture-Stage

Mark	Reference Parts Number	Parts Name
K1	D104-105	HSS104 1SS133 1SS176
K2		
K3		
K4		

NOTICE (model)

(J)..... JAPANESE
 (U)..... U. S. A
 (C)..... CANADIAN
 (R)..... GENERAL
 (A)..... AUSTRALIAN
 (B)..... BRITISH
 (G)..... EUROPEAN
 (T)..... CHINA
 (L)..... SINGAPORE

RESISTOR

REMARKS	PARTS NAME
NO MARK	CARBON FILM RESISTOR (P=5)
□	CARBON FILM RESISTOR (P=10)
△	METAL OXIDE FILM RESISTOR
▭	METAL FILM RESISTOR
▭	METAL PLATE RESISTOR
▭	FIRE PROOF CARBON FILM RESISTOR
▭	CEMENT MOLDED RESISTOR
▭	SEMI VARIABLE RESISTOR
⊙	CHIP RESISTOR

CAPACITOR

REMARKS	PARTS NAME
NO MARK	ELECTROLYTIC CAPACITOR
⊗	TANTALUM CAPACITOR
NO MARK	CERAMIC CAPACITOR
⊙	CERAMIC TUBULAR CAPACITOR
⊙	POLYESTER FILM CAPACITOR
⊙	POLYSTYRENE FILM CAPACITOR
⊙	MICA CAPACITOR
⊙	POLYPROPYLENE FILM CAPACITOR
⊙	SEMICONDUCTIVE CERAMIC CAPACITOR
⊙	POLYPHENYLENE SULFIDE FILM CAPACITOR

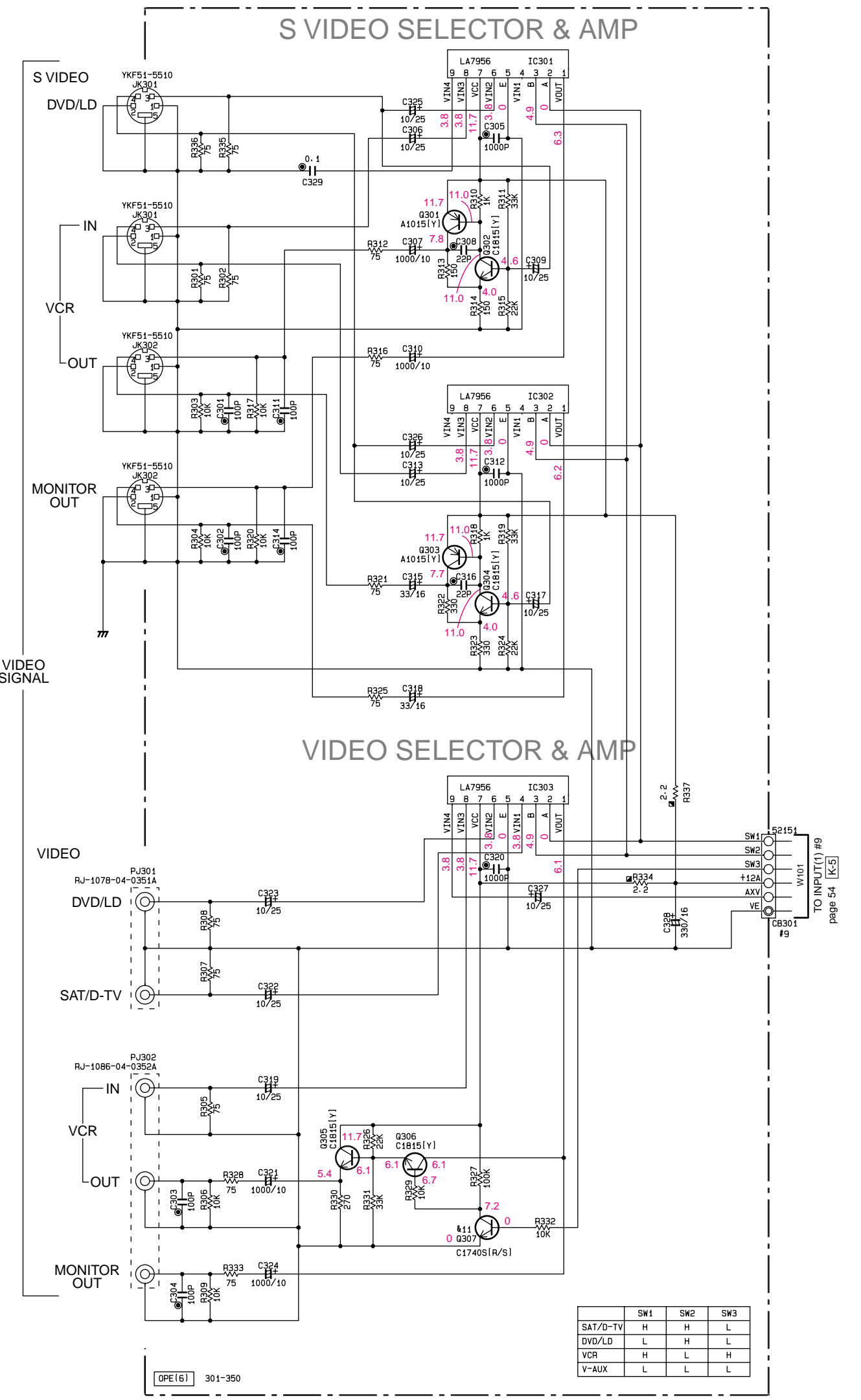
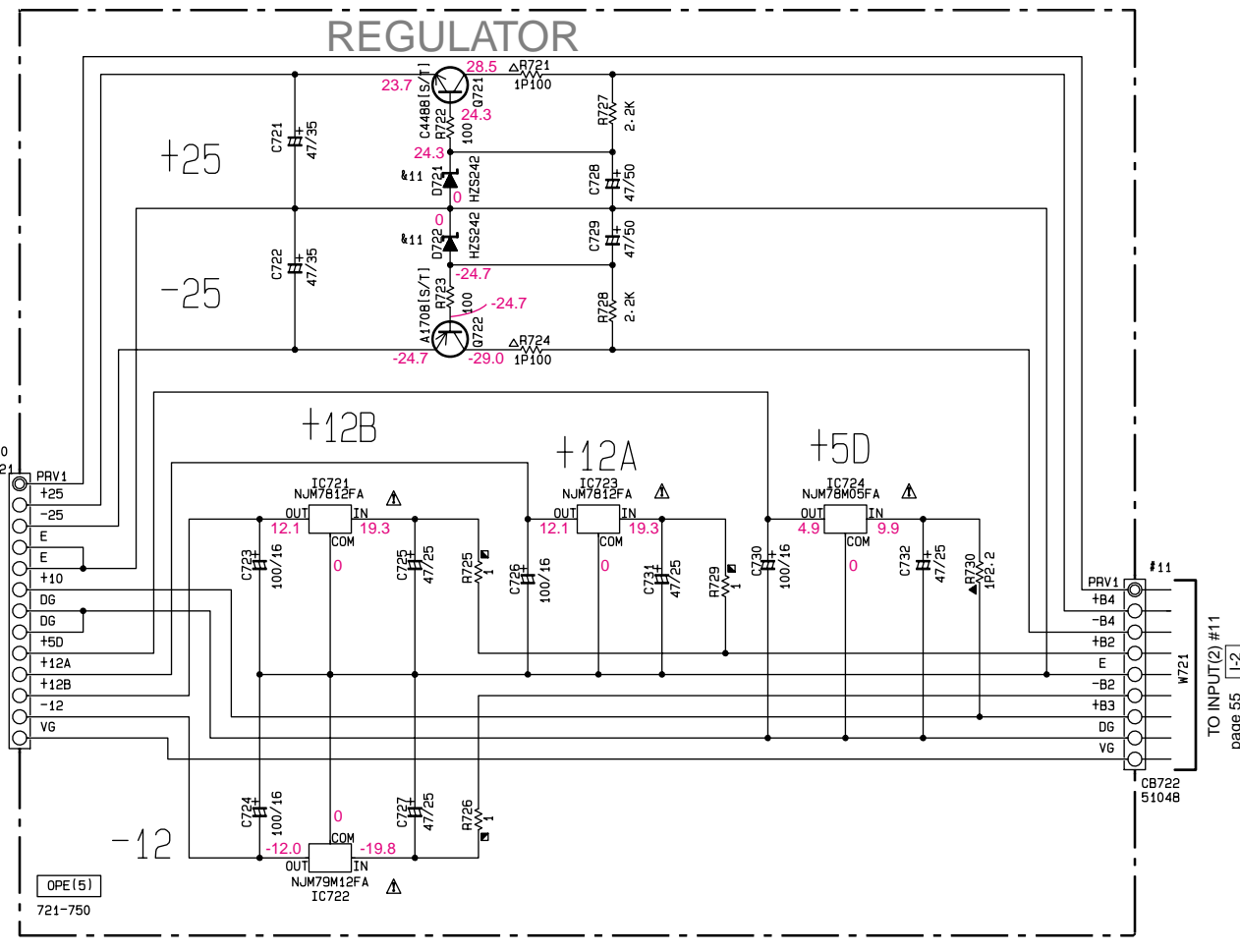

PIN CONNECTION DIAGRAM OF DIODES, TRANSISTORS AND IC'S.

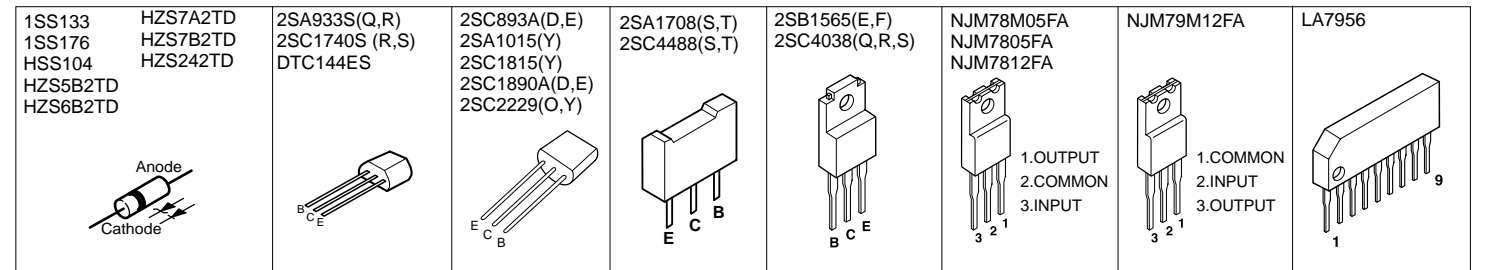

SCHEMATIC DIAGRAM [MAIN]

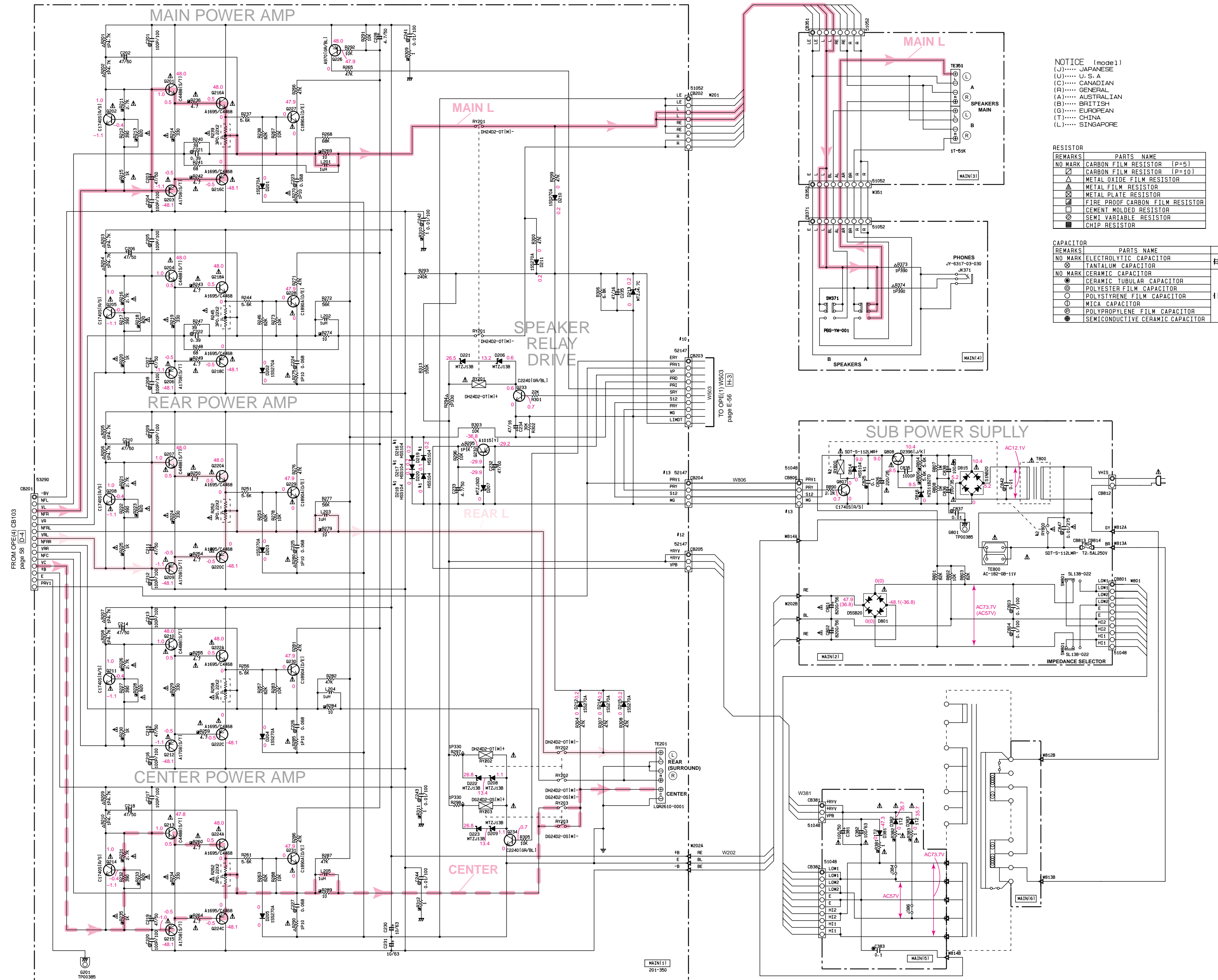

NOTICE (model)
 (J)..... JAPANESE
 (U)..... U. S. A.
 (C)..... CANADIAN
 (R)..... GENERAL
 (A)..... AUSTRALIAN
 (B)..... BRITISH
 (G)..... EUROPEAN
 (T)..... CHINA
 (L)..... SINGAPORE

REMARKS	PARTS NAME
NO MARK	CARBON FILM RESISTOR (P=5)
△	CARBON FILM RESISTOR (P=10)
▲	METAL OXIDE FILM RESISTOR
△	METAL FILM RESISTOR
▣	METAL PLATE RESISTOR
▢	FIRE PROOF CARBON FILM RESISTOR
□	CEMENT MOLDED RESISTOR
⊗	SEMI VARIABLE RESISTOR
■	CHIP RESISTOR

REMARKS	PARTS NAME
NO MARK	ELECTROLYTIC CAPACITOR
⊗	TANTALUM CAPACITOR
NO MARK	CERAMIC CAPACITOR
⊙	CERAMIC TUBULAR CAPACITOR
⊖	POLYESTER FILM CAPACITOR
○	POLYSTYRENE FILM CAPACITOR
⊕	MICA CAPACITOR
⊖	POLYPROPYLENE FILM CAPACITOR
●	SEMICONDUCTIVE CERAMIC CAPACITOR

Interchangeable Parts at Manufacture-Stage

Mark	Reference Parts Number	Parts Name
k1	D216-D220-D814	HSS104 1SS133 1SS176
k2	RY800	SOT-9-112LWR DC1201-01W-11
k3		
k4		

PIN CONNECTION DIAGRAM OF DIODES, TRANSISTORS AND IC'S.

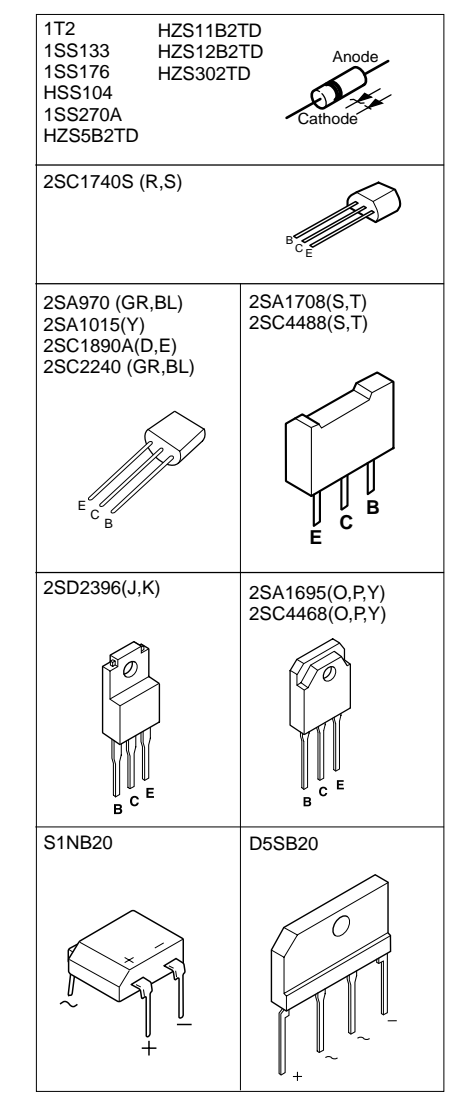

Conditions
 • INPUT → CD
 • VOLUME → minimum(∞)
 • IMPEDANCE SELECTOR → Left
 • PRO LOGIC → On

* All voltages are measured with a 10MΩ/V DC electric volt meter.
 * Components having special characteristics are marked △ and must be replaced with parts having specifications equal to those originally installed.
 * Schematic diagram is subject to change without notice.

SCHEMATIC DIAGRAM [TUNER]

Each voltage given here represents that in the FM (98.1MHz STEREO) reception mode but the one in the parentheses () is that in the AM (1080kHz, MAN'L) reception mode.

REMARKS	PARTS NAME	SYMBOL
NO MARK	ELECTROLYTIC CAPACITOR	⊘
⊗	TANTALUM CAPACITOR	⊗
NO MARK	CERAMIC CAPACITOR	□
⊙	CERAMIC TUBULAR CAPACITOR	⊙
⊖	POLYESTER FILM CAPACITOR	⊖
○	POLYSTYRENE FILM CAPACITOR	○
⊕	MICA CAPACITOR	⊕
⊖	POLYPROPYLENE FILM CAPACITOR	⊖
⊙	SEMICONDUCTIVE CERAMIC CAPACITOR	⊙

REMARKS	PARTS NAME	SYMBOL
NO MARK	CARBON FILM RESISTOR (P=5)	□
⊗	CARBON FILM RESISTOR (P=10)	⊗
△	METAL OXIDE FILM RESISTOR	△
⊠	METAL FILM RESISTOR	⊠
⊡	METAL PLATE RESISTOR	⊡
⊞	FIRE PROOF CARBON FILM RESISTOR	⊞
⊞	CEMENT MOLDED RESISTOR	⊞
⊞	SEMI VARIABLE RESISTOR	⊞
■	CHIP RESISTOR	■

NOTICE (model)
 (J)..... JAPANESE
 (U)..... U. S. A
 (C)..... CANADIAN
 (R)..... GENERAL
 (A)..... AUSTRALIAN
 (B)..... BRITISH
 (G)..... EUROPEAN
 (T)..... CHINA
 (L)..... SINGAPORE

Interchangeable Parts at Manufacture-Stage

Mark	Reference Parts Number	Parts Name
k1	D1-2	HSS104
		1SS133
		1SS176

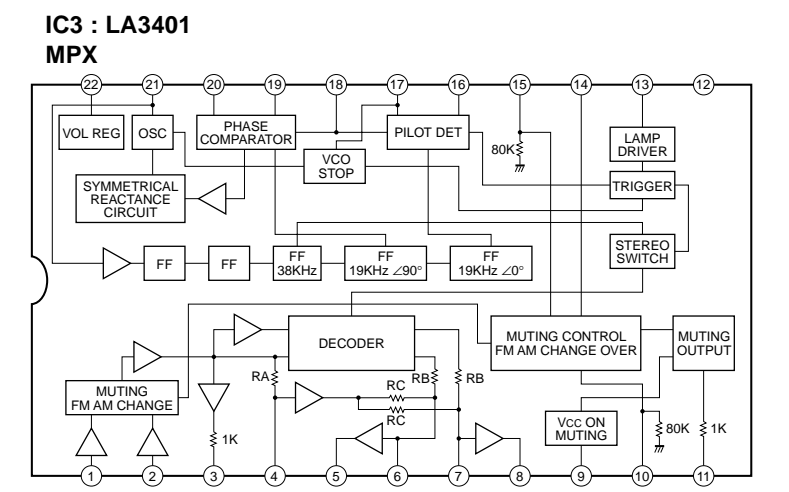
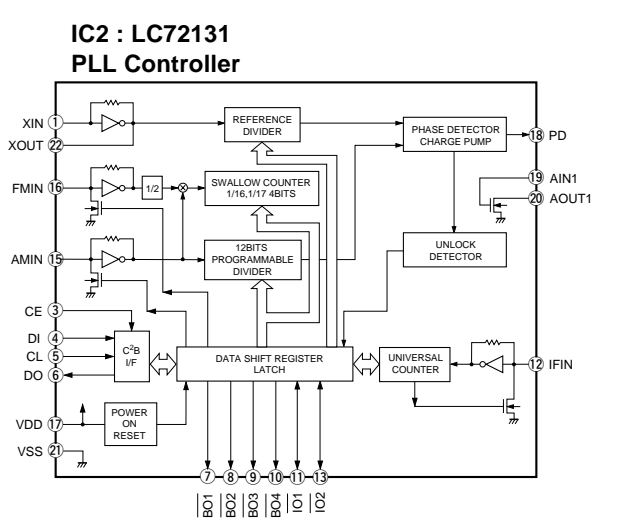
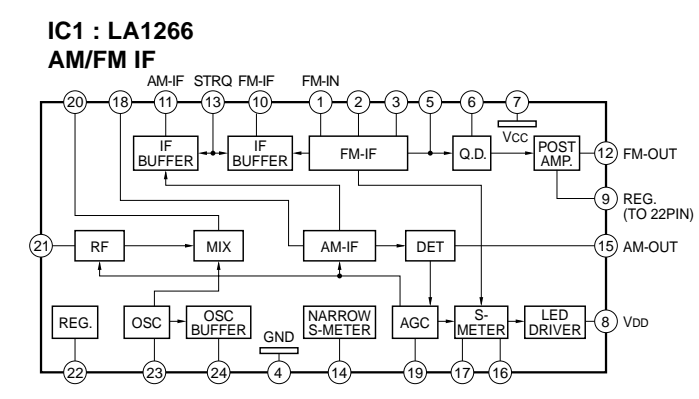

PK1: ENV-172A4G1 (V2716700)

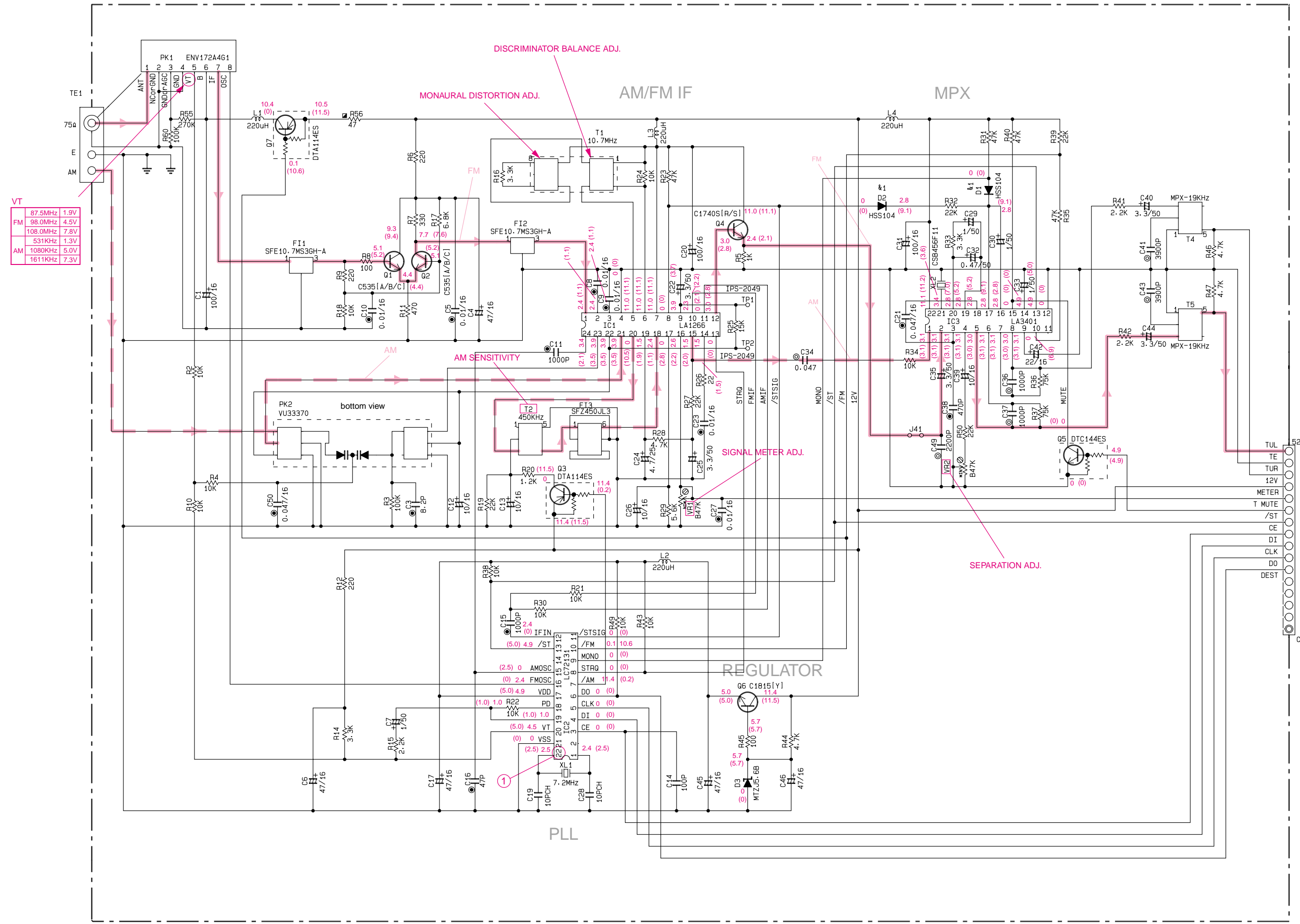
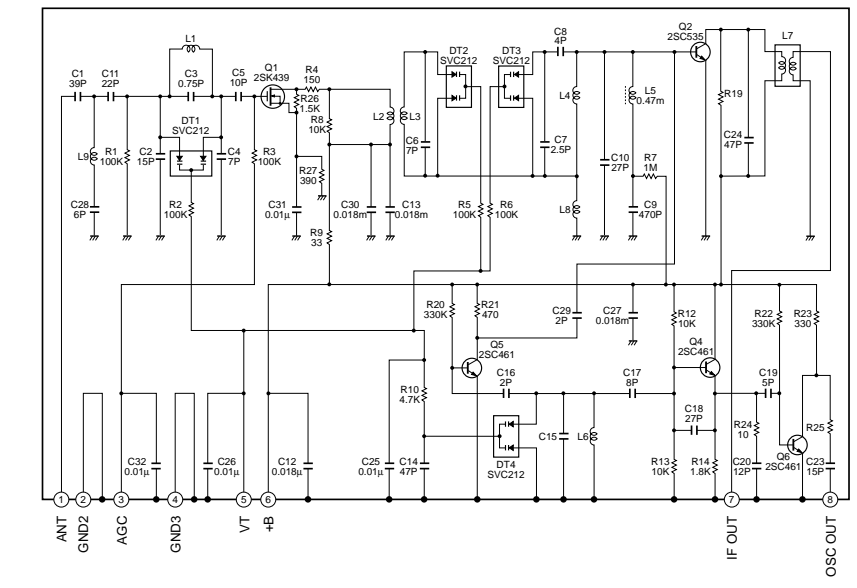

VT

87.5MHz	1.9V
FM 98.0MHz	4.5V
108.0MHz	7.8V
531kHz	1.3V
AM 1080kHz	5.0V
1611kHz	7.3V

Point ① (Pin22 of IC2)

V: 2V/div H: 0.1μsec/div DC range 1:1 probe

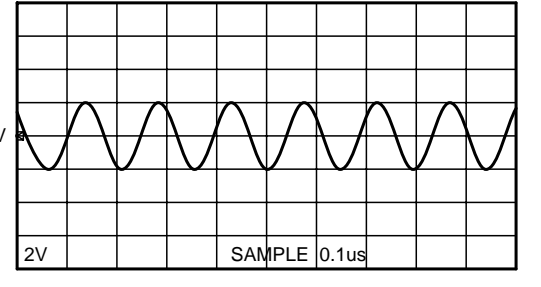

PIN CONNECTION DIAGRAM OF DIODES, TRANSISTORS AND IC's.

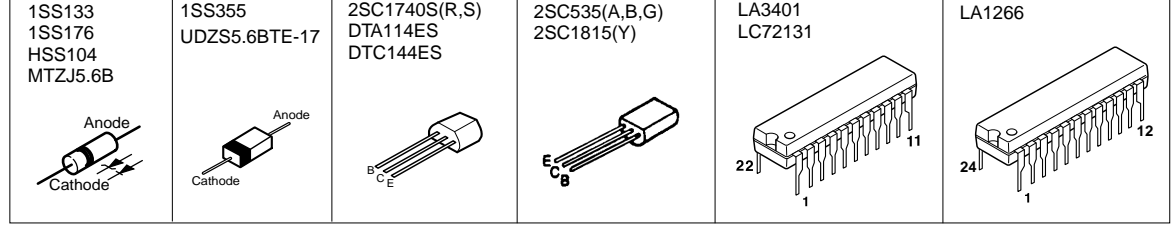

* All voltages are measured with a 10MΩ/V DC electric volt meter.
 * Components having special characteristics are marked Δ and must be replaced with parts having specifications equal to those originally installed.
 * Schematic diagram is subject to change without notice.

PARTS LIST

■ ELECTRICAL PARTS

■ WARNING

Components having special characteristics are marked \triangle and must be replaced with parts having specifications equal to those originally installed.

- Carbon resistors (1/6W or 1/4W) are not included in the ELECTRICAL PARTS List. For the part Nos. of the carbon resistors, refer to last page.
- Chip resistors are listed on page 71.

ABBREVIATIONS IN THIS LIST ARE AS FOLLOWS:

C. A. EL. CHP	: CHIP ALUMI. ELECTROLYTIC CAP	LED. DSPLY	: LED DISPLAY
C. CE	: CERAMIC CAP	LED. INFRD	: LED, INFRARED
C. CE. ARRAY	: CERAMIC CAP ARRAY	MODUL. RF	: MODULATOR, RF
C. CE. CHP	: CHIP CERAMIC CAP	PHOT. CPL	: PHOTO COUPLER
C. CE. ML	: MULTILAYER CERAMIC CAP	PHOT. INTR	: PHOTO INTERRUPTER
C. CE. M. CHP	: CHIP MULTILAYER CERAMIC CAP	PHOT. RFLCT	: PHOTO REFLECTOR
C. CE. SAFTY	: RECOGNIZED CERAMIC CAP	PIN. TEST	: PIN, TEST POINT
C. CE. TUBLR	: CERAMIC TUBULAR CAP	PLST. RIVET	: PLASTIC RIVET
C. CE. SMI	: SEMI CONDUCTIVE CERAMIC CAP	R. ARRAY	: RESISTOR ARRAY
C. EL	: ELECTROLYTIC CAP	R. CAR	: CARBON RESISTOR
C. MICA	: MICA CAP	R. CAR. CHP	: CHIP RESISTOR
C. ML. FLM	: MULTILAYER FILM CAP	R. CAR.FP	: FLAME PROOF CARBON RESISTOR
C. MP	: METALLIZED PAPER CAP	R. FUS	: FUSABLE RESISTOR
C. MYLAR	: MYLAR FILM CAP	R. MTL. CHP	: CHIP METAL FILM RESISTOR
C. MYLAR. ML	: MULTILAYER MYLAR FILM CAP	R. MTL. FILM	: METAL FILM RESISTOR
C. PAPER	: PAPER CAPACITOR	R. MTL. OXD	: METAL OXIDE FILM RESISTOR
C. PLS	: POLYSTYRENE FILM CAP	R. MTL. PLAT	: METAL PLATE RESISTOR
C. POL	: POLYESTER FILM CAP	RSNR. CE	: CERAMIC RESONATOR
C. POLY	: POLYETHYLENE FILM CAP	RSNR. CRYST	: CRYSTAL RESONATOR
C. PP	: POLYPROPYLENE FILM CAP	R. TW. CEM	: TWIN CEMENT FIXED RESISTOR
C. TNTL	: TANTALUM CAP	R. WW	: WIRE WOUND RESISTOR
C. TNT. CHP	: CHIP TANTALUM CAP	SCR. BND. HD	: BIND HEAD B-TITE SCREW
C. TRIM	: TRIMMER CAP	SCR. BW. HD	: BW HEAD TAPPING SCREW
CN	: CONNECTOR	SCR. CUP	: CUP TITE SCREW
CN. BS. PIN	: CONNECTOR, BASE PIN	SCR. TERM	: SCREW TERMINAL
CN. CANNON	: CONNECTOR, CANNON	SCR. TR	: SCREW, TRANSISTOR
CN. DIN	: CONNECTOR, DIN	SUPRT. PCB	: SUPPORT, P. C. B.
CN. FLAT	: CONNECTOR, FLAT CABLE	SURG. PRTCT	: SURGE PROTECTOR
CN. POST	: CONNECTOR, BASE POST	SW. TACT	: TACT SWITCH
COIL. MX. AM	: COIL, AM MIX	SW. LEAF	: LEAF SWITCH
COIL. AT. FM	: COIL, FM ANTENNA	SW. LEVER	: LEVER SWITCH
COIL. DT. FM	: COIL, FM DETECT	SW. MICRO	: MICRO SWITCH
COIL. MX. FM	: COIL, FM MIX	SW. PUSH	: PUSH SWITCH
COIL. OUTPT	: OUTPUT COIL	SW. RT. ENC	: ROTARY ENCODER
DIOD. ARRAY	: DIODE ARRAY	SW. RT. MTR	: ROTARY SWITCH WITH MOTOR
DIODE. BRG	: DIODE BRIDGE	SW. RT	: ROTARY SWITCH
DIODE. CHP	: CHIP DIODE	SW. SLIDE	: SLIDE SWITCH
DIODE. VAR	: VARACTOR DIODE	TERM. SP	: SPEAKER TERMINAL
DIOD. Z. CHP	: CHIP ZENER DIODE	TERM. WRAP	: WRAPPING TERMINAL
DIODE. ZENR	: ZENER DIODE	THRMST. CHP	: CHIP THERMISTOR
DSCR. CE	: CERAMIC DISCRIMINATOR	TR. CHP	: CHIP TRANSISTOR
FER. BEAD	: FERRITE BEADS	TR. DGT	: DIGITAL TRANSISTOR
FER. CORE	: FERRITE CORE	TR. DGT. CHP	: CHIP DIGITAL TRANSISTOR
FET. CHP	: CHIP FET	TRANS	: TRANSFORMER
FL. DSPLY	: FLUORESCENT DISPLAY	TRANS. PULS	: PULSE TRANSFORMER
FLTR. CE	: CERAMIC FILTER	TRANS. PWR	: POWER TRANSFORMER ASS'y
FLTR. COMB	: COMB FILTER MODULE	TUNER. AM	: TUNER PACK, AM
FLTR. LC. RF	: LC FILTER, EMI	TUNER. FM	: TUNER PACK, FM
GND. MTL	: GROUND PLATE	TUNER. PK	: FRONT-END TUNER PACK
GND. TERM	: GROUND TERMINAL	VR	: ROTARY POTENTIOMETER
HOLDER. FUS	: FUSE HOLDER	VR. MTR	: POTENTIOMETER WITH MOTOR
IC. PRTCT	: IC PROTECTOR	VR. SW	: POTENTIOMETER WITH ROTARY SW
JUMPER. CN	: JUMPER CONNECTOR	VR. SLIDE	: SLIDE POTENTIOMETER
JUMPER. TST	: JUMPER, TEST POINT	VR. TRIM	: TRIMMER POTENTIOMETER
L. DTCT	: LIGHT DETECTING MODULE		
L. EMIT	: LIGHT EMITTING MODULE		

Note) Those parts marked with "#" are not included in the P. C. B. Ass'y.

P. C. B. DSP

Schm Ref	PART NO.	Description	
*	V8214500	P. C. B.	DSP
CB1	VQ044100	CN.BS.PIN	5P
CB2	VQ044900	CN.BS.PIN	19P
CB3	VQ044600	CN.BS.PIN	13P
C1	UB052100	C.CE.M.CHP	100pF 50V
C2	UB245100	C.CE.M.CHP	0.1uF 25V
C3	UB052100	C.CE.M.CHP	100pF 50V
C4	UB052100	C.CE.M.CHP	100pF 50V
C7	VJ900700	C.CE.M.CHP	33pF 50V
C8	UB245100	C.CE.M.CHP	0.1uF 25V
C9	UB245100	C.CE.M.CHP	0.1uF 25V
C10	UB052100	C.CE.M.CHP	100pF 50V
C11	UB052100	C.CE.M.CHP	100pF 50V
C12	UB052100	C.CE.M.CHP	100pF 50V
C13	UB052100	C.CE.M.CHP	100pF 50V
C14	UB245100	C.CE.M.CHP	0.1uF 25V
C15	UB013100	C.CE.M.CHP	1000pF 50V
C16	VJ900700	C.CE.M.CHP	33pF 50V
C17	UB245100	C.CE.M.CHP	0.1uF 25V
C18	UA654470	C.MYLAR	0.047uF 50V
C19	UA653470	C.MYLAR	4700pF 50V
C20	UB245100	C.CE.M.CHP	0.1uF 25V
C21	UR818100	C.EL	100uF 6.3V
C22	UB052100	C.CE.M.CHP	100pF 50V
C23	UB052100	C.CE.M.CHP	100pF 50V
C24	UB052100	C.CE.M.CHP	100pF 50V
C25	UB052100	C.CE.M.CHP	100pF 50V
C26	UB245100	C.CE.M.CHP	0.1uF 25V
C27	UB245100	C.CE.M.CHP	0.1uF 25V
C28	UB245100	C.CE.M.CHP	0.1uF 25V
C29	UB245100	C.CE.M.CHP	0.1uF 25V
C30	VJ900300	C.CE.M.CHP	22pF 50V
C31	VJ900300	C.CE.M.CHP	22pF 50V
C32	UB052100	C.CE.M.CHP	100pF 50V
C33	UB052100	C.CE.M.CHP	100pF 50V
C34	UB052100	C.CE.M.CHP	100pF 50V
C35	UB245100	C.CE.M.CHP	0.1uF 25V
C36	UR818100	C.EL	100uF 6.3V
C37	UB052100	C.CE.M.CHP	100pF 50V
C38	UB052100	C.CE.M.CHP	100pF 50V
C39	UB052100	C.CE.M.CHP	100pF 50V
C40	UB052100	C.CE.M.CHP	100pF 50V
C41	UB052100	C.CE.M.CHP	100pF 50V
C42	UR818330	C.EL	330uF 6.3V
C43	UR818330	C.EL	330uF 6.3V
C44	UB245100	C.CE.M.CHP	0.1uF 25V
C45	UB245100	C.CE.M.CHP	0.1uF 25V
C46	UB245100	C.CE.M.CHP	0.1uF 25V
C47	UB245100	C.CE.M.CHP	0.1uF 25V
C48	UR818330	C.EL	330uF 6.3V
C50	UB012470	C.CE.M.CHP	470pF 50V
C51	UB245100	C.CE.M.CHP	0.1uF 25V
C52	UB245100	C.CE.M.CHP	0.1uF 25V

* New Parts

Schm Ref	PART NO.	Description	
C53	UR818330	C.EL	330uF 6.3V
C54	UB245100	C.CE.M.CHP	0.1uF 25V
C55	UR818330	C.EL	330uF 6.3V
C56	UB245100	C.CE.M.CHP	0.1uF 25V
C57	UB245100	C.CE.M.CHP	0.1uF 25V
C58	UR818330	C.EL	330uF 6.3V
C59	UB245100	C.CE.M.CHP	0.1uF 25V
C60	UR818100	C.EL	100uF 6.3V
C61	UB245100	C.CE.M.CHP	0.1uF 25V
C62	UR829100	C.EL	1000uF 10V
C63	UR829100	C.EL	1000uF 10V
C64	UR828220	C.EL	220uF 10V
C65	UB245100	C.CE.M.CHP	0.1uF 25V
C66	VE326800	C.MYLAR.ML	0.47uF 50V
C67	UR818100	C.EL	100uF 6.3V
C68	UR865470	C.EL	0.47uF 50V
C69	UA653150	C.MYLAR	1500pF 50V
C70	UA653150	C.MYLAR	1500pF 50V
C71	UR847100	C.EL	10uF 25V
C72	UA653330	C.MYLAR	3300pF 50V
C73	UA653330	C.MYLAR	3300pF 50V
C74	UR847100	C.EL	10uF 25V
C75	UR847100	C.EL	10uF 25V
C76	UA653330	C.MYLAR	3300pF 50V
C77	UA655330	C.MYLAR	0.33uF 50V
C78	UR847100	C.EL	10uF 25V
C79	UR847100	C.EL	10uF 25V
C80	UA653470	C.MYLAR	4700pF 50V
C81	UA653470	C.MYLAR	4700pF 50V
C82	UR847100	C.EL	10uF 25V
C83	UA652100	C.MYLAR	100pF 50V
C84	UA652100	C.MYLAR	100pF 50V
C85	UA652100	C.MYLAR	100pF 50V
C86	UA652220	C.MYLAR	220pF 50V
C87	UR847100	C.EL	10uF 25V
C88	UR847100	C.EL	10uF 25V
C89	UA652100	C.MYLAR	100pF 50V
C90	UA652220	C.MYLAR	220pF 50V
C91	UA652100	C.MYLAR	100pF 50V
C92	UA653470	C.MYLAR	4700pF 50V
C93	UA652100	C.MYLAR	100pF 50V
C94	UA652100	C.MYLAR	100pF 50V
C95	UR847100	C.EL	10uF 25V
C96	UR847100	C.EL	10uF 25V
C97	UA652100	C.MYLAR	100pF 50V
C98	UA652100	C.MYLAR	100pF 50V
C99	UA652100	C.MYLAR	100pF 50V
C100	UR837220	C.EL	22uF 16V
C101	UR847470	C.EL	47uF 25V
C102	VE326800	C.MYLAR.ML	0.47uF 50V
C103	UR847470	C.EL	47uF 25V
C104	UR837220	C.EL	22uF 16V
C105	UA652100	C.MYLAR	100pF 50V

* New Parts

P. C. B. DSP & P. C. B. INPUT
--

Schm Ref	PART NO.	Description		
C106	UB052100	C.CE.M.CHP	100pF	50V
C107	UB052100	C.CE.M.CHP	100pF	50V
C108	UB052100	C.CE.M.CHP	100pF	50V
C109	UB245100	C.CE.M.CHP	0.1uF	25V
C110	UB052100	C.CE.M.CHP	100pF	50V
C111	UB052100	C.CE.M.CHP	100pF	50V
C112	UB052100	C.CE.M.CHP	100pF	50V
C113	UR818470	C.EL	470uF	6.3V
C114	UB245100	C.CE.M.CHP	0.1uF	25V
C115	UB052100	C.CE.M.CHP	100pF	50V
C116	UB052100	C.CE.M.CHP	100pF	50V
C117	UB245100	C.CE.M.CHP	0.1uF	25V
C118	UB245100	C.CE.M.CHP	0.1uF	25V
C119	UA652100	C.MYLAR	100pF	50V
C120	UB051100	C.CE.M.CHP	10pF	50V
C121	UB051100	C.CE.M.CHP	10pF	50V
D1	VT332900	DIODE	1SS355	
D2	VT332900	DIODE	1SS355	
D3	VT332900	DIODE	1SS355	
D4	VT332900	DIODE	1SS355	
D5	VT332900	DIODE	1SS355	
D6	VT332900	DIODE	1SS355	
D7	VT332900	DIODE	1SS355	
D8	VT332900	DIODE	1SS355	
D9	VT332900	DIODE	1SS355	
D10	VT332900	DIODE	1SS355	
D11	VT332900	DIODE	1SS355	
D12	VT332900	DIODE	1SS355	
G1	VR463400	TERM.GND	D3.5	
G2	VR463400	TERM.GND	D3.5	
G3	VR463400	TERM.GND	D3.5	
G4	VR463400	TERM.GND	D3.5	
IC1	XR038A00	IC	NJM2904M OP AMP	
IC2	XL091A00	IC	HD74HC02FPEL NOR	
IC3	XG948E00	IC	YM3436DK	
IC4	XV304B00	IC	YSS918D-F	
IC5	XV305A00	IC	IS61C1024-20J SRAM	
IC6	XW233A00	IC	CS4227-KQ	
IC8	XV039A00	IC	M5220FP OP AMP	
IC9	XV039A00	IC	M5220FP OP AMP	
IC10	XV039A00	IC	M5220FP OP AMP	
IC11	XV039A00	IC	M5220FP OP AMP	
IC12	XV039A00	IC	M5220FP OP AMP	
IC15	XU965A00	IC	uPC29M33T-E1 3.3V	
L1	GE300610	FER.BEAD	BL02RN1-R62T4	
Q1	VV655200	TR.DGT	DTA143EKA	
Q2	VD303700	TR	2SC3326 A,B	
R40	HV753220	R.CAR.FP	2.2	1/4W
R45	HV753220	R.CAR.FP	2.2	1/4W
R46	HV753220	R.CAR.FP	2.2	1/4W
R49	HV754100	R.CAR.FP	10	1/4W
R50	HV753100	R.CAR.FP	1	1/4W
R95	HV753220	R.CAR.FP	2.2	1/4W

* New Parts

Schm Ref	PART NO.	Description		
R96	HV753220	R.CAR.FP	2.2	1/4W
XL1	Vi552000	RSNR.CRYS	12.288MHz	
*	V8214400	P.C.B.	INPUT	
CB102	VM923600	CN.BS.PIN	13P	
CB103	Vi878900	CN.BS.PIN	11P	
CB104	VQ048200	CN.BS.PIN	33P	
CB105	VM689000	CN.BS.PIN	23P	
CB106	VQ047400	CN.BS.PIN	19P	
CB107	VQ963700	CN.BS.PIN	16P	
CB108	VK025300	CN.BS.PIN	9P	
CB110	VP127700	CN	24P	
CB111	VK024900	CN.BS.PIN	5P	
CB112	Vi878400	CN.BS.PIN	6P	
CB351	V6247600	CN.PHOT.SN	1P	GP1FA552RZ
CB352	V6247600	CN.PHOT.SN	1P	GP1FA552RZ
CB353	Vi878900	CN.BS.PIN	11P	
CB354	VQ044100	CN.BS.PIN	5P	
CB401	VQ045300	CN.BS.PIN	23P	
CB451	VK026800	CN.BS.PIN	9P	
C101	UR866220	C.EL	2.2uF	50V
C103	UA652220	C.MYLAR	220pF	50V
C105	UA652220	C.MYLAR	220pF	50V
C106	UR866220	C.EL	2.2uF	50V
C107	VF467300	C.CE.TUBLR	0.01uF	16V
C108	UA652100	C.MYLAR	100pF	50V
C109	UA652100	C.MYLAR	100pF	50V
C112	UA652100	C.MYLAR	100pF	50V
C113	UA652100	C.MYLAR	100pF	50V
C114	FG651470	C.CE	47pF	50V
C115	FG651470	C.CE	47pF	50V
C116	UA652100	C.MYLAR	100pF	50V
C117	UA652100	C.MYLAR	100pF	50V
C118	UA652100	C.MYLAR	100pF	50V
C119	UA652100	C.MYLAR	100pF	50V
C120	VF466800	C.CE.TUBLR	100pF	50V
C121	VF466800	C.CE.TUBLR	100pF	50V
C122	VF466700	C.CE.TUBLR	47pF	50V
C123	VF466700	C.CE.TUBLR	47pF	50V
C124	UA655220	C.MYLAR	0.22uF	50V
C125	VF467300	C.CE.TUBLR	0.01uF	16V
C126	UR866220	C.EL	2.2uF	50V
C127	UR828220	C.EL	220uF	10V
C128	UR837470	C.EL	47uF	16V
C129	UA653100	C.MYLAR	1000pF	50V
C130	UA653910	C.MYLAR	9100pF	50V
C131	UA654330	C.MYLAR	0.033uF	50V
C132	UA653910	C.MYLAR	9100pF	50V
C133	UA654330	C.MYLAR	0.033uF	50V
C134	UA653100	C.MYLAR	1000pF	50V
C135	UR828220	C.EL	220uF	10V

* New Parts

P. C. B. INPUT

Schm Ref	PART NO.	Description		
C136	UR837470	C. EL	47uF	16V
C137	UR866220	C. EL	2.2uF	50V
C138	UR837470	C. EL	47uF	16V
C139	UR837470	C. EL	47uF	16V
C142	VJ599100	C. CE. TUBLR	0.1uF	50V
C143	VJ599100	C. CE. TUBLR	0.1uF	50V
C147	UR837220	C. EL	22uF	16V
C148	UR847100	C. EL	10uF	25V
C149	UR847100	C. EL	10uF	25V
C150	UR837220	C. EL	22uF	16V
C151	UR847100	C. EL	10uF	25V
C152	UR847100	C. EL	10uF	25V
C153	UR847100	C. EL	10uF	25V
C156	UR847100	C. EL	10uF	25V
C157	UR847100	C. EL	10uF	25V
C158	UR847100	C. EL	10uF	25V
C161	VJ599100	C. CE. TUBLR	0.1uF	50V
C162	VJ599100	C. CE. TUBLR	0.1uF	50V
C163	UA652100	C. MYLAR	100pF	50V
C164	UA652100	C. MYLAR	100pF	50V
C165	UA654270	C. MYLAR	0.027uF	50V
C166	UA654270	C. MYLAR	0.027uF	50V
C167	UR847100	C. EL	10uF	25V
C168	UR847100	C. EL	10uF	25V
C169	UA652100	C. MYLAR	100pF	50V
C170	UR837470	C. EL	47uF	16V
C171	UR837470	C. EL	47uF	16V
C172	UA652100	C. MYLAR	100pF	50V
C173	UR847100	C. EL	10uF	25V
C174	UR847100	C. EL	10uF	25V
C175	UA654270	C. MYLAR	0.027uF	50V
C176	UA654270	C. MYLAR	0.027uF	50V
C177	VJ599100	C. CE. TUBLR	0.1uF	50V
C178	VJ599100	C. CE. TUBLR	0.1uF	50V
C179	UR837470	C. EL	47uF	16V
C180	UR837470	C. EL	47uF	16V
C181	VJ599100	C. CE. TUBLR	0.1uF	50V
C183	UR847470	C. EL	47uF	25V
C184	UR847470	C. EL	47uF	25V
C193	VF466800	C. CE. TUBLR	100pF	50V
C194	VF467000	C. CE. TUBLR	1000pF	50V
C195	VF467300	C. CE. TUBLR	0.01uF	16V
C196	VJ599100	C. CE. TUBLR	0.1uF	50V
C197	VF467000	C. CE. TUBLR	1000pF	50V
C198	VF466800	C. CE. TUBLR	100pF	50V
C199	VF466800	C. CE. TUBLR	100pF	50V
C351	VG278400	C. CE. TUBLR	220pF	50V
C352	VG278400	C. CE. TUBLR	220pF	50V
C353	VG278400	C. CE. TUBLR	220pF	50V
C354	VG278400	C. CE. TUBLR	220pF	50V
C355	VG278400	C. CE. TUBLR	220pF	50V
C356	VG278400	C. CE. TUBLR	220pF	50V
C357	VF467300	C. CE. TUBLR	0.01uF	16V

* New Parts

Schm Ref	PART NO.	Description		
C358	VJ599100	C. CE. TUBLR	0.1uF	50V
C359	UR837220	C. EL	22uF	16V
C360	VG276600	C. CE. TUBLR	22pF	50V
C361	VJ599100	C. CE. TUBLR	0.1uF	50V
C362	VJ599100	C. CE. TUBLR	0.1uF	50V
C363	VJ599100	C. CE. TUBLR	0.1uF	50V
C364	VG278400	C. CE. TUBLR	220pF	50V
C365	VF466600	C. CE. TUBLR	10pF	50V
C366	VF467000	C. CE. TUBLR	1000pF	50V
C367	VJ599100	C. CE. TUBLR	0.1uF	50V
C368	VJ599100	C. CE. TUBLR	0.1uF	50V
C369	UR828100	C. EL	100uF	10V
C370	VJ599100	C. CE. TUBLR	0.1uF	50V
C401	UR866220	C. EL	2.2uF	50V
C402	UA652100	C. MYLAR	100pF	50V
C403	UA652100	C. MYLAR	100pF	50V
C404	UR866220	C. EL	2.2uF	50V
C405	UR866220	C. EL	2.2uF	50V
C406	UR866220	C. EL	2.2uF	50V
C407	UR866220	C. EL	2.2uF	50V
C408	UR866220	C. EL	2.2uF	50V
C409	UN866100	C. EL	1uF	50V
C412	UA653100	C. MYLAR	1000pF	50V
C413	UR828100	C. EL	100uF	10V
C414	UA653100	C. MYLAR	1000pF	50V
C415	UR828100	C. EL	100uF	10V
C418	UR828100	C. EL	100uF	10V
C420	VG287600	C. EL	100uF	25V
C421	UA652100	C. MYLAR	100pF	50V
C422	UR828100	C. EL	100uF	10V
C423	UA652100	C. MYLAR	100pF	50V
C424	UR828100	C. EL	100uF	10V
C425	VG287600	C. EL	100uF	25V
C427	UR828100	C. EL	100uF	10V
C428	UR828100	C. EL	100uF	10V
C430	UA652100	C. MYLAR	100pF	50V
C431	UR828100	C. EL	100uF	10V
C432	UA652100	C. MYLAR	100pF	50V
C433	UR828100	C. EL	100uF	10V
C435	UR828100	C. EL	100uF	10V
C436	VJ599100	C. CE. TUBLR	0.1uF	50V
C451	UR868330	C. EL	330uF	50V
C452	UR868330	C. EL	330uF	50V
C453	UR749680	C. EL	6800uF	25V
C454	UR749220	C. EL	2200uF	25V
C455	UR73A100	C. EL	10000uF	16V
C456	VJ599100	C. CE. TUBLR	0.1uF	50V
C457	VJ599100	C. CE. TUBLR	0.1uF	50V
C458	VS745400	C. POL. MTL	0.1uF	100V
C459	VS745400	C. POL. MTL	0.1uF	100V
C460	VS745400	C. POL. MTL	0.1uF	100V
C461	VS745400	C. POL. MTL	0.1uF	100V
C462	VS745400	C. POL. MTL	0.1uF	100V

* New Parts

P. C. B. INPUT & P. C. B. OPERATION
--

Schm Ref	PART NO.	Description	
D101	VM975300	DIODE .ZENR	HZS11B2TD 11V
D102	VM975300	DIODE .ZENR	HZS11B2TD 11V
D103	VM975300	DIODE .ZENR	HZS11B2TD 11V
D104	VM975300	DIODE .ZENR	HZS11B2TD 11V
D105	VD631600	DIODE	1SS133, 176
D106	VD631600	DIODE	1SS133, 176
D351	VD631600	DIODE	1SS133, 176
D352	VD631600	DIODE	1SS133, 176
D401	VG437400	DIODE .ZENR	MTZJ5.1B 5.1V
△ D451	VR253700	DIODE .BRG	S1NB20 1A 200V
△ D452	VR253700	DIODE .BRG	S1NB20 1A 200V
△ D453	VR253700	DIODE .BRG	S1NB20 1A 200V
IC101	XP894A00	IC	LC78211
IC102	XP896A00	IC	LC78213
IC103	XP895A00	IC	LC78212
IC104	XM356A00	IC	NJM2068LD
IC106	XB247A00	IC	uPC4570HA
IC107	XP265A00	IC	BU2090
IC108	iG092000	IC	M5220L
IC109	iG092000	IC	M5220L
IC351	iG142200	IC	TC74HCU04AP
IC352	XT208A00	IC	HD74HC153P MPX
IC401	XC520A00	IC	uPC4570C
IC402	XC520A00	IC	uPC4570C
IC403	XC520A00	IC	uPC4570C
IC404	XF494A00	IC	LB1641
L351	GE901970	COIL	68uH
L352	GE901970	COIL	68uH
PJ101	VQ260900	JACK .PIN	4P
PJ102	VU857800	JACK .PIN	6P
PJ103	VU857800	JACK .PIN	6P
PJ105	VK437600	JACK .PIN	1P
PJ351	VT003300	JACK .PIN	6P
PJ352	VY667700	JACK .PIN	1P
Q101	iC287820	TR	2SC2878 A, B
Q102	iC287820	TR	2SC2878 A, B
Q103	iC287820	TR	2SC2878 A, B
Q104	iC287820	TR	2SC2878 A, B
Q105	iC287820	TR	2SC2878 A, B
Q106	iC287820	TR	2SC2878 A, B
Q107	iC287820	TR	2SC2878 A, B
Q108	iC287820	TR	2SC2878 A, B
Q109	iC287820	TR	2SC2878 A, B
Q110	iC287820	TR	2SC2878 A, B
Q111	iC287820	TR	2SC2878 A, B
Q112	iC287820	TR	2SC2878 A, B
Q113	iC287820	TR	2SC2878 A, B
Q114	iC287820	TR	2SC2878 A, B
Q115	VG721700	TR .DGT	DTA144ES
Q116	VG721700	TR .DGT	DTA144ES
Q117	VG721700	TR .DGT	DTA144ES
Q118	iC287820	TR	2SC2878 A, B
Q119	iC287820	TR	2SC2878 A, B

* New Parts

Schm Ref	PART NO.	Description	
Q120	iC287820	TR	2SC2878 A, B
Q121	VG721700	TR .DGT	DTA144ES
Q122	iC287820	TR	2SC2878 A, B
Q123	iC287820	TR	2SC2878 A, B
Q124	VP883000	TR	2SA893A D, E
Q125	VP883000	TR	2SA893A D, E
R141	HV755100	R .CAR .FP	100 1/4W
R154	HV755100	R .CAR .FP	100 1/4W
R155	HV753220	R .CAR .FP	2.2 1/4W
R156	HV753220	R .CAR .FP	2.2 1/4W
R216	HV753220	R .CAR .FP	2.2 1/4W
R217	HV753220	R .CAR .FP	2.2 1/4W
R222	HV753220	R .CAR .FP	2.2 1/4W
R231	HV753220	R .CAR .FP	2.2 1/4W
R232	HV753220	R .CAR .FP	2.2 1/4W
R373	HV753220	R .CAR .FP	2.2 1/4W
R411	HV754100	R .CAR .FP	10 1/4W
R412	HV754100	R .CAR .FP	10 1/4W
R435	HV753680	R .CAR .FP	6.8 1/4W
R451	HV753100	R .CAR .FP	1 1/4W
R452	HV753100	R .CAR .FP	1 1/4W
VR401	VV613500	VR	A100K
*	V8214100	P. C. B.	OPERATION
CB101	VP798200	CN .BS .PIN	24P
CB102	VQ961600	CN	13P
CB103	VQ961700	CN .BS .PIN	14P
CB301	VK026500	CN .BS .PIN	6P
CB501	VU273300	CN .BS .PIN	33P
CB502	Vi878800	CN .BS .PIN	10P
CB504	Vi878200	CN .BS .PIN	4P
CB505	Vi878200	CN .BS .PIN	4P
CB581	Vi878700	CN .BS .PIN	9P
CB621	Vi878300	CN .BS .PIN	5P
CB721	VQ963400	CN .BS .PIN	13P
CB722	Vi878700	CN .BS .PIN	9P
C101	UR847100	C .EL	10uF 25V
C102	UR877470	C .EL	47uF 63V
C103	UR877100	C .EL	10uF 63V
C106	UR837470	C .EL	47uF 16V
C107	UR847100	C .EL	10uF 25V
C108	UA652220	C .MYLAR	220pF 50V
C109	UR847100	C .EL	10uF 25V
C110	VQ645600	C .MYLAR	100pF 50V
C111	UA652220	C .MYLAR	220pF 50V
C112	UR847100	C .EL	10uF 25V
C113	VQ645600	C .MYLAR	100pF 50V
C114	UA652220	C .MYLAR	220pF 50V
C115	UR847100	C .EL	10uF 25V
C116	UA652470	C .MYLAR	470pF 50V
C117	UA652220	C .MYLAR	220pF 50V

* New Parts

P. C. B. OPERATION

Schm Ref	PART NO.	Description		
C118	UR847100	C. EL	10uF	25V
C119	UA652470	C. MYLAR	470pF	50V
C120	UA652220	C. MYLAR	220pF	50V
C121	UR847100	C. EL	10uF	25V
C122	UA652100	C. MYLAR	100pF	50V
C123	VQ245400	C. PP	33pF	200V
C124	UR838100	C. EL	100uF	16V
C125	UA653100	C. MYLAR	1000pF	50V
C126	VQ245400	C. PP	33pF	200V
C127	UR838100	C. EL	100uF	16V
C128	UA653100	C. MYLAR	1000pF	50V
C129	VR516400	C. CE	15pF	500V
C130	UR837470	C. EL	47uF	16V
C131	UA653100	C. MYLAR	1000pF	50V
C132	VR516400	C. CE	15pF	500V
C133	UR837470	C. EL	47uF	16V
C134	UA653100	C. MYLAR	1000pF	50V
C135	VQ245400	C. PP	33pF	200V
C136	UR837470	C. EL	47uF	16V
C137	UA653100	C. MYLAR	1000pF	50V
C301	VF466800	C. CE. TUBLR	100pF	50V
C302	VF466800	C. CE. TUBLR	100pF	50V
C303	VF466800	C. CE. TUBLR	100pF	50V
C304	VF466800	C. CE. TUBLR	100pF	50V
C305	VF467000	C. CE. TUBLR	1000pF	50V
C306	UR847100	C. EL	10uF	25V
C307	UR829100	C. EL	1000uF	10V
C308	VG276600	C. CE. TUBLR	22pF	50V
C309	UR847100	C. EL	10uF	25V
C310	UR829100	C. EL	1000uF	10V
C311	VF466800	C. CE. TUBLR	100pF	50V
C312	VF467000	C. CE. TUBLR	1000pF	50V
C313	UR847100	C. EL	10uF	25V
C314	VF466800	C. CE. TUBLR	100pF	50V
C315	UR837330	C. EL	33uF	16V
C316	VG276600	C. CE. TUBLR	22pF	50V
C317	UR847100	C. EL	10uF	25V
C318	UR837330	C. EL	33uF	16V
C319	UR847100	C. EL	10uF	25V
C320	VF467000	C. CE. TUBLR	1000pF	50V
C321	UR829100	C. EL	1000uF	10V
C322	UR847100	C. EL	10uF	25V
C323	UR847100	C. EL	10uF	25V
C324	UR829100	C. EL	1000uF	10V
C325	UR847100	C. EL	10uF	25V
C326	UR847100	C. EL	10uF	25V
C327	UR847100	C. EL	10uF	25V
C328	UR838330	C. EL	330uF	16V
C329	VJ599100	C. CE. TUBLR	0.1uF	50V
C330	UR838100	C. EL	100uF	16V
C501	UR866220	C. EL	2.2uF	50V
C502	VG278900	C. CE. TUBLR	680pF	50V
C503	VG278900	C. CE. TUBLR	680pF	50V

* New Parts

Schm Ref	PART NO.	Description		
C504	UR866100	C. EL	1uF	50V
C505	VJ599100	C. CE. TUBLR	0.1uF	50V
C506	UR819100	C. EL	1000uF	6.3V
C507	UR819100	C. EL	1000uF	6.3V
C508	VS672200	C. EL	4700uF	5.5V
C509	VJ599100	C. CE. TUBLR	0.1uF	50V
C510	UM407100	C. EL	10uF	50V
C511	VJ599100	C. CE. TUBLR	0.1uF	50V
C512	UM397470	C. EL	47uF	16V
C513	VJ599100	C. CE. TUBLR	0.1uF	50V
C514	VJ599100	C. CE. TUBLR	0.1uF	50V
C515	VJ599100	C. CE. TUBLR	0.1uF	50V
C516	VJ599100	C. CE. TUBLR	0.1uF	50V
C581	UR838330	C. EL	330uF	16V
C582	UR838330	C. EL	330uF	16V
C583	UR866100	C. EL	1uF	50V
C584	VK533800	C. PP	47pF	200V
C585	UR866220	C. EL	2.2uF	50V
C586	VK533800	C. PP	47pF	200V
C587	UR866220	C. EL	2.2uF	50V
C588	UR866100	C. EL	1uF	50V
C589	UR837470	C. EL	47uF	16V
C590	UA655120	C. MYLAR	0.12uF	50V
C591	UA654330	C. MYLAR	0.033uF	50V
C592	UA654330	C. MYLAR	0.033uF	50V
C593	UA655120	C. MYLAR	0.12uF	50V
C594	UR837470	C. EL	47uF	16V
C595	UR847100	C. EL	10uF	25V
C596	VQ645600	C. MYLAR	100pF	50V
C597	VQ645600	C. MYLAR	100pF	50V
C598	UR847100	C. EL	10uF	25V
C599	UR828100	C. EL	100uF	10V
C600	UR828100	C. EL	100uF	10V
C621	VJ599100	C. CE. TUBLR	0.1uF	50V
C622	VJ599100	C. CE. TUBLR	0.1uF	50V
C623	VF466800	C. CE. TUBLR	100pF	50V
C624	VF466800	C. CE. TUBLR	100pF	50V
C721	UR857470	C. EL	47uF	35V
C722	UR857470	C. EL	47uF	35V
C723	UR838100	C. EL	100uF	16V
C724	UR838100	C. EL	100uF	16V
C725	UR847470	C. EL	47uF	25V
C726	UR838100	C. EL	100uF	16V
C727	UR847470	C. EL	47uF	25V
C728	UR867470	C. EL	47uF	50V
C729	UR867470	C. EL	47uF	50V
C730	UR838100	C. EL	100uF	16V
C731	UR847470	C. EL	47uF	25V
C732	UR847470	C. EL	47uF	25V
* D101	VG441800	DIODE. ZENR	MTZJ20C	20V
D102	VM975700	DIODE. ZENR	HZS12C2TD	12V
D103	VG442700	DIODE. ZENR	MTZJ24D	24V
D104	VD631600	DIODE	1SS133, 176	

* New Parts

P. C. B. OPERATION

Schm Ref	PART NO.	Description	
D105	VD631600	DIODE	1SS133, 176
D501	VD631600	DIODE	1SS133, 176
D502	VD631600	DIODE	1SS133, 176
D503	VD631600	DIODE	1SS133, 176
D504	VD631600	DIODE	1SS133, 176
D505	VG437200	DIODE .ZENR	MTZJ4.7C 4.7V
D506	VG437200	DIODE .ZENR	MTZJ4.7C 4.7V
D507	VD631600	DIODE	1SS133, 176
D508	VG438500	DIODE .ZENR	MTZJ7.5A 7.5V
D509	VD631600	DIODE	1SS133, 176
D510	VD631600	DIODE	1SS133, 176
D511	VM974400	DIODE .ZENR	HZS6B2TD 6.0V
D512	VD631600	DIODE	1SS133, 176
D721	VG442700	DIODE .ZENR	MTZJ24D 24V
D722	VG442700	DIODE .ZENR	MTZJ24D 24V
G501	VR463400	TERM. GND	D3.5
IC301	XH436A00	IC	LA7956
IC302	XH436A00	IC	LA7956
IC303	XH436A00	IC	LA7956
IC501	XY170B00	IC .CPU	M30217MA-A205FP
IC502	XJ757A00	IC	NJM78L05A-T3
IC581	XM356A00	IC	NJM2068LD
IC582	XM356A00	IC	NJM2068LD
△ IC721	XJ608A00	IC	NJM7812FA
△ IC722	XD343A00	IC	NJM79M12FA
△ IC723	XJ608A00	IC	NJM7812FA
△ IC724	XJ604A00	IC	NJM78M05FA
JK301	VP113600	CN. DIN	2P
JK302	VP113600	CN. DIN	2P
PJ301	VR110100	JACK. PIN	2P
PJ302	VJ695900	JACK. PIN	3P
PJ621	VS549000	JACK. PIN	3P
Q101	VP883100	TR	2SC1890A D, E
Q102	VS883300	TR	2SB1565 E, F
Q103	VP883100	TR	2SC1890A D, E
Q104	VP872700	TR	2SC4488 S, T
Q105	VP883000	TR	2SA893A D, E
Q106	VP883000	TR	2SA893A D, E
Q107	VP883000	TR	2SA893A D, E
Q108	VP883000	TR	2SA893A D, E
Q109	VP883000	TR	2SA893A D, E
Q110	VP883000	TR	2SA893A D, E
△ Q111	VR325600	TR	2SC2229 O, Y
△ Q112	VP883000	TR	2SA893A D, E
△ Q113	VR325600	TR	2SC2229 O, Y
△ Q114	VP883000	TR	2SA893A D, E
△ Q115	VR325600	TR	2SC2229 O, Y
△ Q116	VP883000	TR	2SA893A D, E
△ Q117	VR325600	TR	2SC2229 O, Y
△ Q118	VP883000	TR	2SA893A D, E
△ Q119	VR325600	TR	2SC2229 O, Y
Q301	iA1015I0	TR	2SA1015 Y
Q302	iC1815I0	TR	2SC1815 Y

* New Parts

Schm Ref	PART NO.	Description	
Q303	iA1015I0	TR	2SA1015 Y
Q304	iC1815I0	TR	2SC1815 Y
Q305	iC1815I0	TR	2SC1815 Y
Q306	iC1815I0	TR	2SC1815 Y
Q307	iC174020	TR	2SC1740S R, S
Q501	iA093320	TR	2SA933S Q, R
Q502	iA093320	TR	2SA933S Q, R
Q503	VG722000	TR. DGT	DTC144ES
Q504	iA093320	TR	2SA933S Q, R
Q505	VV900500	TR	2SD1991A Q, R, S
Q506	VV900500	TR	2SD1991A Q, R, S
Q721	VP872700	TR	2SC4488 S, T
Q722	VP872600	TR	2SA1708 S, T
R101	HV753100	R. CAR. FP	1 1/4W
R102	HV756330	R. CAR. FP	3.3K 1/4W
R110	HV756180	R. CAR. FP	1.8K 1/4W
R111	HV756820	R. CAR. FP	8.2K 1/4W
△ R132	HV754470	R. CAR. FP	47 1/4W
△ R138	HV754470	R. CAR. FP	47 1/4W
△ R144	HV754470	R. CAR. FP	47 1/4W
△ R150	HV754470	R. CAR. FP	47 1/4W
△ R156	HV754470	R. CAR. FP	47 1/4W
R334	HV753220	R. CAR. FP	2.2 1/4W
R337	HV753220	R. CAR. FP	2.2 1/4W
R581	VP939800	R. MTL. OXD	10 1W
R582	VP939800	R. MTL. OXD	10 1W
R721	VP940400	R. MTL. OXD	100 1W
R724	VP940400	R. MTL. OXD	100 1W
R725	HV753100	R. CAR. FP	1 1/4W
R726	HV753100	R. CAR. FP	1 1/4W
R729	HV753100	R. CAR. FP	1 1/4W
R730	VP939600	R. MTL. FLM	2.2 1W
ST101	V4040500	SCR. TERM	M3
ST102	V4040500	SCR. TERM	M3
SW501	V4586200	SW. RT. ENC	REB161PVB20F
SW502	VG392900	SW. TACT	SKHVAA
SW503	VG392900	SW. TACT	SKHVAA
SW504	VG392900	SW. TACT	SKHVAA
SW505	VG392900	SW. TACT	SKHVAA
SW506	VG392900	SW. TACT	SKHVAA
SW507	VG392900	SW. TACT	SKHVAA
SW508	VG392900	SW. TACT	SKHVAA
SW509	VG392900	SW. TACT	SKHVAA
SW510	VG392900	SW. TACT	SKHVAA
SW511	VG392900	SW. TACT	SKHVAA
SW512	VG392900	SW. TACT	SKHVAA
SW515	VG392900	SW. TACT	SKHVAA
SW516	VG392900	SW. TACT	SKHVAA
U501	VU591000	L. DTCT	GP1U271X
V501	V4193300	FL. DSPLY	16-BT-71GK
VR581	VP741800	VR	B20K
VR582	VP741900	VR	G25K
VR583	VP742000	VR	MN100K

* New Parts

P. C. B. OPERATION & P. C. B. MAIN

Schm Ref	PART NO.	Description	
* XL501	V4610100	RSNR.CE	10MHz
* V8088300		SHEET	
* V8088500		SPACER	4.6x10x32
* V8214200		P. C. B.	MAIN
CB201	VQ963500	CN.BS.PIN	14P
CB202	VQ585000	CN.BS.PIN	8P
CB203	VF728200	CN.BS.PIN	10P
CB204	VK024800	CN.BS.PIN	4P
CB205	VK024700	CN.BS.PIN	3P
CB351	VQ585000	CN.BS.PIN	8P
CB352	VQ585100	CN.BS.PIN	9P
CB371	VQ585100	CN.BS.PIN	9P
CB381	Vi878100	CN.BS.PIN	3P
CB382	Vi878800	CN.BS.PIN	10P
CB801	Vi878800	CN.BS.PIN	10P
CB806	Vi878200	CN.BS.PIN	4P
CB812	VG879900	CN.BS.PIN	2P
CB813	VP206500	HOLDER.FUS	EYF-52BCT
CB814	VP206500	HOLDER.FUS	EYF-52BCT
C201	VR325000	C.MYLAR	100pF 100V
C202	UR867470	C.EL	47uF 50V
C203	UR867470	C.EL	47uF 50V
C204	VR325000	C.MYLAR	100pF 100V
C205	VR325000	C.MYLAR	100pF 100V
C206	UR867470	C.EL	47uF 50V
C207	UR867470	C.EL	47uF 50V
C208	VR325000	C.MYLAR	100pF 100V
C209	VR325000	C.MYLAR	100pF 100V
C210	UR867470	C.EL	47uF 50V
C211	UR867470	C.EL	47uF 50V
C212	VR325000	C.MYLAR	100pF 100V
C213	VR325000	C.MYLAR	100pF 100V
C214	UR867470	C.EL	47uF 50V
C215	UR867470	C.EL	47uF 50V
C216	VR325000	C.MYLAR	100pF 100V
C217	VR325000	C.MYLAR	100pF 100V
C218	UR867470	C.EL	47uF 50V
C219	UR867470	C.EL	47uF 50V
C220	VR325000	C.MYLAR	100pF 100V
C221	VK399200	C.MYLAR.ML	0.39uF 50V
C222	VK399200	C.MYLAR.ML	0.39uF 50V
C223	UA654680	C.MYLAR	0.068uF 50V
C224	UA654680	C.MYLAR	0.068uF 50V
C225	UA654680	C.MYLAR	0.068uF 50V
C226	UA654680	C.MYLAR	0.068uF 50V
C227	UA654680	C.MYLAR	0.068uF 50V
C228	UR866470	C.EL	4.7uF 50V
C230	UR877100	C.EL	10uF 63V
C231	UR877100	C.EL	10uF 63V
C232	UR867470	C.EL	47uF 50V

* New Parts

Schm Ref	PART NO.	Description	
C233	UR866470	C.EL	4.7uF 50V
C234	UR837470	C.EL	47uF 16V
C235	UR837470	C.EL	47uF 16V
C241	VR325100	C.MYLAR	0.01uF 100V
C242	VR325100	C.MYLAR	0.01uF 100V
C243	VR325100	C.MYLAR	0.01uF 100V
C244	VR325100	C.MYLAR	0.01uF 100V
△ C381	UR868100	C.EL	100uF 50V
△ C382	UR878100	C.EL	100uF 63V
C383	VJ599100	C.CE.TUBLR	0.1uF 50V
△ C801	VV951800	C.EL	8200uF 56V
△ C802	VV951800	C.EL	8200uF 56V
C803	VS745400	C.POL.MTL	0.1uF 100V
C804	VS745400	C.POL.MTL	0.1uF 100V
C825	VJ599100	C.CE.TUBLR	0.1uF 50V
△ C826	UR848220	C.EL	220uF 25V
C835	FG613100	C.CE	1000pF 50V
△ C836	UR858100	C.EL	100uF 35V
C837	Vi716700	C.MYLAR	0.01uF 50V
△ C838	UR858100	C.EL	100uF 35V
C842	UA654100	C.MYLAR	0.01uF 50V
△ C847	VS741700	C.CE.SAFTY	0.01uF 275V
D201	VN008700	DIODE	1SS270A
D202	VN008700	DIODE	1SS270A
D203	VN008700	DIODE	1SS270A
D204	VN008700	DIODE	1SS270A
D205	VN008700	DIODE	1SS270A
D206	VG440500	DIODE.ZENR	MTZJ13B 13V
D207	VG443500	DIODE.ZENR	MTZJ30D 30V
D208	VG440500	DIODE.ZENR	MTZJ13B 13V
D209	VG440500	DIODE.ZENR	MTZJ13B 13V
D210	VN008700	DIODE	1SS270A
D211	VN008700	DIODE	1SS270A
D212	VN008700	DIODE	1SS270A
D213	VG437200	DIODE.ZENR	MTZJ4.7C 4.7V
D214	VN008700	DIODE	1SS270A
D215	VN008700	DIODE	1SS270A
D216	VD631600	DIODE	1SS133,176
D217	VD631600	DIODE	1SS133,176
D218	VD631600	DIODE	1SS133,176
D219	VD631600	DIODE	1SS133,176
D220	VD631600	DIODE	1SS133,176
D221	VG440500	DIODE.ZENR	MTZJ13B 13V
D222	VG440500	DIODE.ZENR	MTZJ13B 13V
D223	VG440500	DIODE.ZENR	MTZJ13B 13V
D381	VS997800	DIODE	1T2
D382	VS997800	DIODE	1T2
D383	VS997800	DIODE	1T2
△ D801	VN011400	DIODE.BRG	D5SB20 5A 200V
D814	VD631600	DIODE	1SS133,176
△ D815	VR253700	DIODE.BRG	S1NB20 1A 200V
D816	VM975300	DIODE.ZENR	HZS11B2TD 11V
△ F804	KB000690	FUSE	T2.5A 250V

* New Parts

P. C. B. MAIN

Schm Ref	PART NO.	Description	
G201	VR463400	TERM.GND	D3.5
G801	VR463400	TERM.GND	D3.5
JK371	VS899700	JACK.PHONE	JY-6317-02-030
L201	V2604200	COIL	1uH
L202	V2604200	COIL	1uH
L203	V2604200	COIL	1uH
L204	V2604200	COIL	1uH
L205	V2604200	COIL	1uH
PN301	V3750200	PIN	L=70
PN302	V3750200	PIN	L=70
PN303	V3750200	PIN	L=70
△ Q201	VP872700	TR	2SC4488 S,T
△ Q202	iC174020	TR	2SC1740S R,S
△ Q203	VP872600	TR	2SA1708 S,T
△ Q204	VP872700	TR	2SC4488 S,T
△ Q205	iC174020	TR	2SC1740S R,S
△ Q206	VP872600	TR	2SA1708 S,T
△ Q207	VP872700	TR	2SC4488 S,T
△ Q208	iC174020	TR	2SC1740S R,S
△ Q209	VP872600	TR	2SA1708 S,T
△ Q210	VP872700	TR	2SC4488 S,T
△ Q211	iC174020	TR	2SC1740S R,S
△ Q212	VP872600	TR	2SA1708 S,T
△ Q213	VP872700	TR	2SC4488 S,T
△ Q214	iC174020	TR	2SC1740S R,S
△ Q215	VP872600	TR	2SA1708 S,T
△ Q216A	iX630850	TR	2SA1695 O,P,Y
△ Q216C	iX630860	TR	2SC4468 O,P,Y
△ Q218A	iX630850	TR	2SA1695 O,P,Y
△ Q218C	iX630860	TR	2SC4468 O,P,Y
△ Q220A	iX630850	TR	2SA1695 O,P,Y
△ Q220C	iX630860	TR	2SC4468 O,P,Y
△ Q222A	iX630850	TR	2SA1695 O,P,Y
△ Q222C	iX630860	TR	2SC4468 O,P,Y
△ Q224A	iX630850	TR	2SA1695 O,P,Y
△ Q224C	iX630860	TR	2SC4468 O,P,Y
△ Q226	iA097030	TR	2SA970 GR,BL
△ Q227	VP883100	TR	2SC1890A D,E
△ Q228	VP883100	TR	2SC1890A D,E
△ Q229	VP883100	TR	2SC1890A D,E
△ Q230	VP883100	TR	2SC1890A D,E
△ Q231	VP883100	TR	2SC1890A D,E
△ Q232	iA101510	TR	2SA1015 Y
△ Q233	iC224030	TR	2SC2240 GR,BL
△ Q234	iC224030	TR	2SC2240 GR,BL
△ Q807	iC174020	TR	2SC1740S R,S
△ Q808	VR510800	TR	2SD2396 J,K
R201	VP941500	R.MTL.OXD	4.7K 1W
R202	VP941500	R.MTL.OXD	4.7K 1W
R203	VP941500	R.MTL.OXD	4.7K 1W
R204	VP941500	R.MTL.OXD	4.7K 1W
R205	VP941500	R.MTL.OXD	4.7K 1W
R206	VP941500	R.MTL.OXD	4.7K 1W

* New Parts

Schm Ref	PART NO.	Description		
R207	VP941500	R.MTL.OXD	4.7K	1W
R208	VP941500	R.MTL.OXD	4.7K	1W
R209	VP941500	R.MTL.OXD	4.7K	1W
R210	VP941500	R.MTL.OXD	4.7K	1W
△ R211	HV756270	R.CAR.FP	2.7K	1/4W
△ R213	HV755820	R.CAR.FP	820	1/4W
△ R214	HV755330	R.CAR.FP	330	1/4W
△ R215	HV756100	R.CAR.FP	1K	1/4W
△ R216	HV756270	R.CAR.FP	2.7K	1/4W
△ R218	HV755820	R.CAR.FP	820	1/4W
△ R219	HV755330	R.CAR.FP	330	1/4W
△ R220	HV756100	R.CAR.FP	1K	1/4W
△ R221	HV756270	R.CAR.FP	2.7K	1/4W
△ R223	HV755820	R.CAR.FP	820	1/4W
△ R224	HV755330	R.CAR.FP	330	1/4W
△ R225	HV756100	R.CAR.FP	1K	1/4W
△ R226	HV756270	R.CAR.FP	2.7K	1/4W
△ R228	HV755820	R.CAR.FP	820	1/4W
△ R229	HV755330	R.CAR.FP	330	1/4W
△ R230	HV756100	R.CAR.FP	1K	1/4W
△ R231	HV756270	R.CAR.FP	2.7K	1/4W
△ R233	HV755820	R.CAR.FP	820	1/4W
△ R234	HV755330	R.CAR.FP	330	1/4W
△ R235	HV756100	R.CAR.FP	1K	1/4W
△ R236	HV753470	R.CAR.FP	4.7	1/4W
△ R239	VU981700	R.MTL.PLAT	0.22	+0.22 3W
△ R242	HV753470	R.CAR.FP	4.7	1/4W
△ R243	HV753470	R.CAR.FP	4.7	1/4W
△ R245	VU981700	R.MTL.PLAT	0.22	+0.22 3W
△ R249	HV753470	R.CAR.FP	4.7	1/4W
△ R250	HV753470	R.CAR.FP	4.7	1/4W
△ R252	VU981700	R.MTL.PLAT	0.22	+0.22 3W
△ R254	HV753470	R.CAR.FP	4.7	1/4W
△ R255	HV753470	R.CAR.FP	4.7	1/4W
△ R258	VU981700	R.MTL.PLAT	0.22	+0.22 3W
△ R259	HV753470	R.CAR.FP	4.7	1/4W
△ R260	HV753470	R.CAR.FP	4.7	1/4W
△ R262	VU981700	R.MTL.PLAT	0.22	+0.22 3W
△ R264	HV753470	R.CAR.FP	4.7	1/4W
R269	HV754100	R.CAR.FP	10	1/4W
△ R270	VP939800	R.MTL.OXD	10	1W
R274	HV754100	R.CAR.FP	10	1/4W
△ R275	VP939800	R.MTL.OXD	10	1W
R279	HV754100	R.CAR.FP	10	1/4W
△ R280	VP939800	R.MTL.OXD	10	1W
R284	HV754100	R.CAR.FP	10	1/4W
△ R285	VP939800	R.MTL.OXD	10	1W
R289	HV754100	R.CAR.FP	10	1/4W
△ R290	VP939800	R.MTL.OXD	10	1W
R294	VP940700	R.MTL.OXD	330	1W
R295	VP941100	R.MTL.OXD	1K	1W
R297	VP940700	R.MTL.OXD	330	1W
R298	VP940700	R.MTL.OXD	330	1W

* New Parts

P. C. B. MAIN & TUNER

Schm Ref	PART NO.	Description		
R309	HV753100	R. CAR. FP	1	1/4W
R310	HV753100	R. CAR. FP	1	1/4W
R311	HV753100	R. CAR. FP	1	1/4W
R312	HV753100	R. CAR. FP	1	1/4W
R373	VP944500	R. MTL. OXD	390	1W
R374	VP944500	R. MTL. OXD	390	1W
△ R381	HV753100	R. CAR. FP	1	1/4W
△ R382	HV753100	R. CAR. FP	1	1/4W
△ R383	HV753100	R. CAR. FP	1	1/4W
R804	HV756560	R. CAR. FP	5.6K	1/4W
R806	HV756560	R. CAR. FP	5.6K	1/4W
△ RY201	VK438300	RELAY	DH24D2-OT/M2	
△ RY202	VK438300	RELAY	DH24D2-OT/M2	
△ RY203	VU566700	RELAY	DG24D2-OS/M	
△ RY800	V2712300	RELAY	DC SDT-S-112LMR	
ST301	V4040500	SCR. TERM	M3	
ST801	V4040500	SCR. TERM	M3	
SW371	VV523900	SW. PUSH	PBS-YM-001	
SW801	V4104200	SW. SLIDE	SL13B-022-AMCS	
△ T800	XW607A00	TRANS. PWR		
TE201	V4470700	TERM. SP	6P	
TE351	VC313700	TERM. SP	8P	
△ TE800	V5867400	OUTLET. AC	2P AC-182-GB-11V	
	EP600140	SCR. BND. HD	3x10	MFZN2BL

* New Parts

Schm Ref	PART NO.	Description		
*	V8214300	P. C. B.	TUNER	
CB4	VQ961900	CN	16P	
C1	VG287600	C. EL	100uF	25V
C3	VG275800	C. CE. TUBLR	8.2pF	50V
C4	UR837470	C. EL	47uF	16V
C5	VF467300	C. CE. TUBLR	0.01uF	16V
C6	UR837470	C. EL	47uF	16V
C7	UM416100	C. EL	1uF	50V
C8	VF467300	C. CE. TUBLR	0.01uF	16V
C9	VF467300	C. CE. TUBLR	0.01uF	16V
C10	VF467300	C. CE. TUBLR	0.01uF	16V
C11	VF467000	C. CE. TUBLR	1000pF	50V
C12	UM397100	C. EL	10uF	16V
C13	UM397100	C. EL	10uF	16V
C14	FG652100	C. CE	100pF	50V
C15	VF467000	C. CE. TUBLR	1000pF	50V
C16	VF466700	C. CE. TUBLR	47pF	50V
C17	UR837470	C. EL	47uF	16V
C19	VA760600	C. CE	10pF	50V
C20	VG287600	C. EL	100uF	25V
C21	VJ599000	C. CE. TUBLR	0.047uF	16V
C22	VG290700	C. EL	3.3uF	50V
C23	VF467300	C. CE. TUBLR	0.01uF	16V
C24	UM406470	C. EL	4.7uF	50V
C25	UM416330	C. EL	3.3uF	50V
C26	UM397100	C. EL	10uF	16V
C27	VF467300	C. CE. TUBLR	0.01uF	16V
C28	VA760600	C. CE	10pF	50V
C29	UM416100	C. EL	1uF	50V
C30	UM416100	C. EL	1uF	50V
C31	VG287600	C. EL	100uF	25V
C32	UM415470	C. EL	0.47uF	50V
C33	UM416100	C. EL	1uF	50V
C34	UA654470	C. MYLAR	0.047uF	50V
C35	VG290700	C. EL	3.3uF	50V
C36	UA653100	C. MYLAR	1000pF	50V
C37	UA653100	C. MYLAR	1000pF	50V
C38	VF466900	C. CE. TUBLR	470pF	50V
C39	VG287200	C. EL	10uF	50V
C40	VG290700	C. EL	3.3uF	50V
C41	UA653390	C. MYLAR	3900pF	50V
C42	UM397220	C. EL	22uF	25V
C43	UA653390	C. MYLAR	3900pF	50V
C44	VG290700	C. EL	3.3uF	50V
C45	UR837470	C. EL	47uF	16V
C46	UR837470	C. EL	47uF	16V
C49	UA653220	C. MYLAR	2200pF	50V
C50	VJ599000	C. CE. TUBLR	0.047uF	16V
D1	VD631600	DIODE	1SS133, 176	
D2	VD631600	DIODE	1SS133, 176	
D3	VG437700	DIODE. ZENR	MTZJ5.6B 5.6V	
Fi1	GG000560	FLTR. CE	SFE10.7MS3GHY-A	
Fi2	GG000560	FLTR. CE	SFE10.7MS3GHY-A	

* New Parts

P. C. B. TUNER

Schm Ref	PART NO.	Description	
Fi3	VC219000	FLTR.CE	SFZ450JL3
IC1	XB760A00	IC	LA1266
IC2	XQ944A00	IC	LC72131
IC3	iG158100	IC	LA3401
L1	Vi546100	COIL	220uH
L2	Vi546100	COIL	220uH
L3	Vi546100	COIL	220uH
L4	Vi546100	COIL	220uH
PK1	V2716700	TUNER.PK	ENV-172A4G1
PK2	VU333700	COIL.RF.AM	940536051A
Q1	iC053540	TR	2SC535 A,B,C
Q2	iC053540	TR	2SC535 A,B,C
Q3	VD678500	TR.DGT	DTA114ES
Q4	iC174020	TR	2SC1740S R,S
Q5	VG722000	TR.DGT	DTC144ES
Q6	iC181510	TR	2SC1815 Y
Q7	VD678500	TR.DGT	DTA114ES
R56	HV754470	R.CAR.FP	47 1/4W
ST1	V4040500	SCR.TERM	M3
T1	VC218600	COIL.DT.FM	10.7MHz
T2	GE100470	COIL.IF.AM	450KHz
T4	VQ138200	FLTR.LC	19KHz
T5	VQ138200	FLTR.LC	19KHz
TE1	VU477800	TERM.ANT	AJ-2038-040
TP1	VT969000	PIN.TEST	IRS-2049
TP2	VT969000	PIN.TEST	IRS-2049
VR1	VJ694000	VR.TRIM	B47K
VR2	VJ694000	VR.TRIM	B47K
XL1	VY734600	RSNR.CRYS	7.2MHz
XL2	GG000750	RSNR.CE	18.95KHz

* New Parts

CHIP RESISTORS

Schm Ref	PART NO.	Description		
	RD250000	R.CAR.CHP	0	1/10W
	RD253100	R.CAR.CHP	1	1/10W
	RD254470	R.CAR.CHP	47	1/10W
	RD254510	R.CAR.CHP	51	1/10W
	RD255100	R.CAR.CHP	100	1/10W
	RD255220	R.CAR.CHP	220	1/10W
	RD255330	R.CAR.CHP	330	1/10W
	RD255470	R.CAR.CHP	470	1/10W
	RD255910	R.CAR.CHP	910	1/10W
	RD256100	R.CAR.CHP	1K	1/10W
	RD256110	R.CAR.CHP	1.1K	1/10W
	RD256220	R.CAR.CHP	2.2K	1/10W
	RD256270	R.CAR.CHP	2.7K	1/10W
	RD256330	R.CAR.CHP	3.3K	1/10W
	RD256390	R.CAR.CHP	3.9K	1/10W
	RD256470	R.CAR.CHP	4.7K	1/10W
	RD256510	R.CAR.CHP	5.1K	1/10W
	RD256620	R.CAR.CHP	6.2K	1/10W
	RD256820	R.CAR.CHP	8.2K	1/10W
	RD257100	R.CAR.CHP	10K	1/10W
	RD257110	R.CAR.CHP	11K	1/10W
	RD257270	R.CAR.CHP	27K	1/10W
	RD257470	R.CAR.CHP	47K	1/10W
	RD257680	R.CAR.CHP	68K	1/10W
	RD257910	R.CAR.CHP	91K	1/10W
	RD258100	R.CAR.CHP	100K	1/10W
	RD258200	R.CAR.CHP	200	1/10W
	RD259100	R.CAR.CHP	1M	1/10W

* New Parts

RX-V320

EXPLODED VIEW

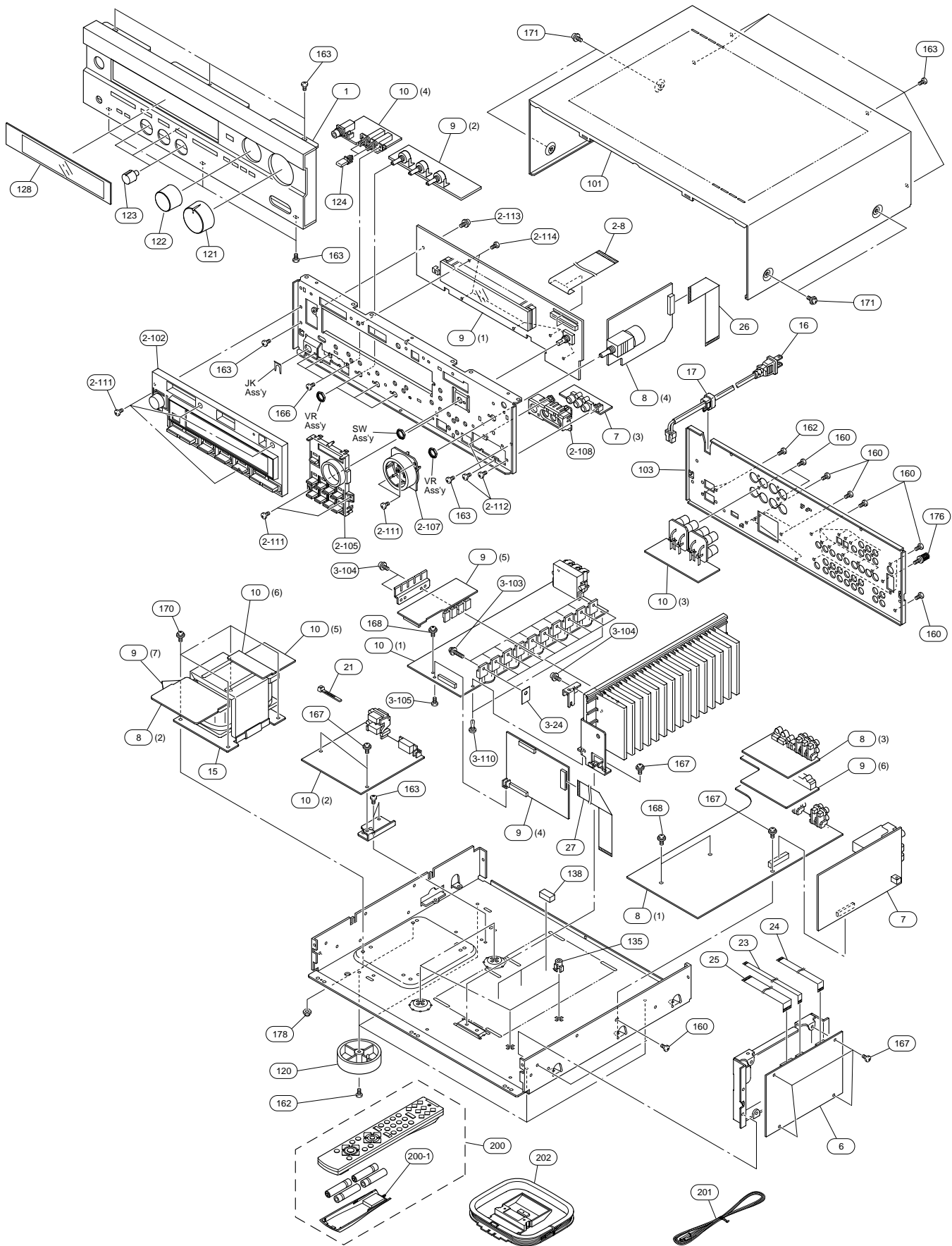

MECHANICAL PARTS

Ref. No.	PART NO.	Description	Remarks
* 1	V8086600	FRONT PANEL	
2-8	MF233200	S FLEXIBLE FLAT CABLE	33P 200mm
* 2-102	V8086700	BUTTON CASE	
* 2-105	V8086800	BUTTON/INPUT320	
* 2-107	V8087000	ESCUTCHEON, VOL	
* 2-108	V8087100	ESCUTCHEON, PJ	
2-111	EP600830	BIND HEAD B-TITE SCREW	3x8 MFC2BL
2-112	VN413300	BIND HEAD BONDING B-T. SCREW	3x8 MFZN2BL
2-113	VT669300	PW HEAD B-TITE SCREW	3x8-8 MFC2
2-114	EP630220	BIND HEAD P-TITE SCREW	3x8 MFZN2BL
3-24	VV849300	SHEET	19x24
3-103	VK173200	SCREW, TRANSISTOR	3x15 SP MFC2
3-104	VT669300	PW HEAD B-TITE SCREW	3x8-8 MFC2
3-105	EG330030	BIND HEAD SCREW	3x6 MFC2BL
3-110	VQ368600	PUSH RIVET	P3555-B
* 6	V8214500	P.C.B. ASS'Y	DSP
* 7	V8214300	P.C.B. ASS'Y	TUNER
* 8	V8214400	P.C.B. ASS'Y	INPUT
* 9	V8214100	P.C.B. ASS'Y	OPERATION
* 10	V8214200	P.C.B. ASS'Y	MAIN
△ 15	XW927A00	POWER TRANSFORMER	
* 16	V8363600	POWER CORD ASS'Y	
17	V2438700	CORD STOPPER	10P1
21	VU590000	BINDING TIE	CBTD001B
23	MF105250	FLEXIBLE FLAT CABLE	5P 250mm
24	MF113140	FLEXIBLE FLAT CABLE	13P 140mm
25	MF219140	S FLEXIBLE FLAT CABLE	19P 140mm
26	MF123140	FLEXIBLE FLAT CABLE	23P 140mm
27	MF124180	FLEXIBLE FLAT CABLE	24P 180mm
* 101	V8085500	TOP COVER	
* 103	V8086500	REAR PANEL	
* 120	V8158400	LEG	
* 121	V8087200	KNOB D40/320	
* 122	V8087300	KNOB D30 ENC 320	
* 123	V8087400	KNOB	
* 124	V8087500	BUTTON, 3/8	
* 128	V8088200	SHEET, WINDOW	
* 135	V8087600	SPACER H8	
* 138	V8088600	SPACER PCB-M	
160	VN413300	BIND HEAD BONDING B-T. SCREW	3x8 MFZN2BL
162	EP600250	BIND HEAD B-TITE SCREW	3x8 MFZN2Y
163	EP600830	BIND HEAD B-TITE SCREW	3x8 MFC2BL
166	EG330030	BIND HEAD SCREW	3x6 MFC2BL
167	VT669300	PW HEAD B-TITE SCREW	3x8-8 MFC2
168	VT669400	PW HEAD B-TITE SCREW	3x15-8 MFC2
170	21991500	PW HEAD S-TITE SCREW	4x8-10 MFC2BL
171	VD069600	PW HEAD S-TITE SCREW	4x8-10 MFNI33
176	VS997700	BIND HEAD S-TITE SCREW	3x10 MFNI33
* 178	V8291900	DAMPER	

* New Parts

Ref. No.	PART NO.	Description		Remarks
200	V4731700	ACCESSORIES REMOTE CONTROL TRANSMITTER	BW0652 RAV203	710650020
200-1	AAX04810	LID		
201	VQ147100	ANTENNA, FM	1.4m 1pc	
202	VQ307400	AM LOOP ANTENNA BATTERY, MANGANESE	81-653-645-110 UM-4NE (2PC)	

* New Parts

REMOTE CONTROL TRANSMITTER

SCHEMATIC DIAGRAM

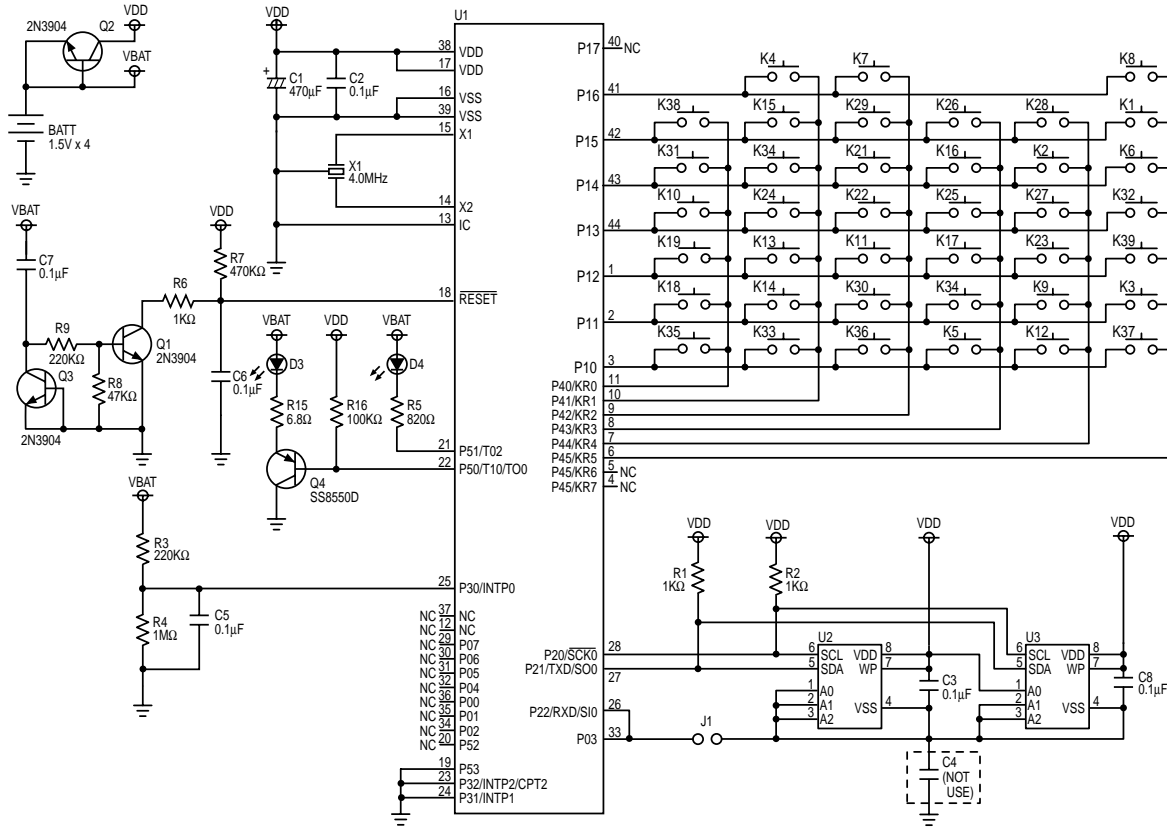

Key Arrangement

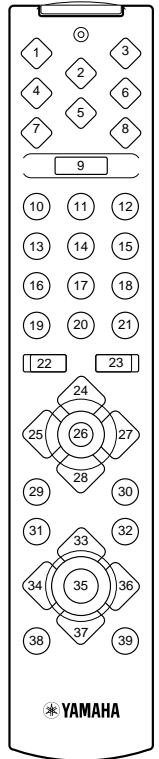

List of the Functional key

Key No.	Key Name	Key Type	TV	CBL/SAT	VCR	DVD MENU	DVD/LD	CD	TAPE/MD	AMP/TUNER
1	CD	Device								
2	AMP/TUNER	Device								
3	TAPE/MD	Device								
4	DVD/LD	Device								
5	TV	Device								
6	VCR	Device								
7	DVD MENU	Device								
8	CBL/SAT	Device								
9	POWER	Primary	TV POWER	CBL/SAT POWER	VCR POWER	DVD/LD POWER	CD POWER	TAPE/MD POWER	AMP POWER	
10	1	Primary	CH1	CH1	CH1	1				CD
11	2	Primary	CH2	CH2	CH2	2				TUNER
12	3	Primary	CH3	CH3	CH3	3				TAPE/MD
13	4	Primary	CH4	CH4	CH4	4				DVD/LD
14	5	Primary	CH5	CH5	CH5	5				SAT/D-TV
15	6	Primary	CH6	CH6	CH6	6				VCR
16	7	Primary	CH7	CH7	CH7	7				PHONO
17	8	Primary	CH8	CH8	CH8	8				V-AUX
18	9	Primary	CH9	CH9	CH9	9				EXT. DEC.
19	0	Primary	CH0	CH0	CH0	0	-	-	-	TEST
20	ENTER	Primary	CH Enter	CH Enter	CH Enter	+10	-	-	-	A/B/C/D/E
21	EFFECT	Primary	AMP EFFECT	+100	AMP EFFECT	CLEAR				AMP EFFECT
22	CH-	Primary	TV CH-	CBL/SAT CH-	VCR CH-	DISC-	DISC-	DISC-	-	PRESET-
23	CH+	Primary	TV CH+	CBL/SAT CH+	VCR CH+	DISC+	DISC+	DISC+	-	PRESET+
24	TV VOL+	Primary								TV VOL+
25	VOL-	Primary								VOL-
26	MUTE	Primary	TV MUTE							AMP MUTE
27	VOL+	Primary								VOL+
28	TV VOL-	Primary								TV VOL-
29	SLEEP	Primary		TV SLEEP		RETURN				SLEEP
30	DISPLAY	Primary	DISPLAY	DISPLAY	DISPLAY	INDEX	DISPLAY	DISPLAY	DISPLAY	-
31	REC	Primary	VCR REC	-	VCR REC	-	-	-	REC/PAUSE	-
32	TV INPUT	Primary							A/B	TV INPUT
33	PAUSE	Primary	VCR PAUSE	Up	VCR PAUSE	Up	PAUSE	PAUSE	PAUSE	PRG+
34	SKIP-	Primary	-	Left	-	Left	SKIP/CHAP-	SKIP-	DIR A/SKIP-	Down
35	PLAY	Primary	VCR PLAY	Menu Select	VCR PLAY	Select	PLAY	PLAY	PLAY	-
36	SKIP+	Primary	-	Right	-	Right	SKIP/CHAP+	SKIP+	DIR B/SKIP+	Up
37	STOP	Primary	VCR STOP	Down	VCR STOP	Down	STOP	STOP	STOP	PRG-
38	REW	Primary	VCR REW	RECALL	VCR REW	TITLE	REW	REW	REW	TIME/LEVEL
39	FF	Primary	VCR FF	MENU	VCR FF	MENU	FF	FF	FF	SET MENU
	Library		TV	CBL/SAT AUX	VCR		DVD (MENU) AUX LD	CD	TAPE MD	X
	Default		0101(PHILIPS)	0006(PIONEER)	0002(ASA)		Yamaha(0008) DVD (MENU)	Yamaha CD(0005)	Yamaha TAPE(0004)	AMP(0003)

-: No Function

List of the Yamaha Code (NEC Format)

Key No.	Key Name	DVD		DVD MENU		LD		CD	
			Yamaha code		Yamaha code		Yamaha code		Yamaha code
9	POWER	DVD POWER	7A-1F(Amp)	DVD POWER	7A-1F(Amp)	LD POWER	7A-1F(Amp)	CD POWER	7A-1F(Amp)
10	1	CD	Punch Through	1	7C-94	CD	Punch Through	CD	Punch Through
11	2	TUNER	Punch Through	2	7C-95	TUNER	Punch Through	TUNER	Punch Through
12	3	TAPE/MD	Punch Through	3	7C-96	TAPE/MD	Punch Through	TAPE/MD	Punch Through
13	4	DVD/LD	Punch Through	4	7C-97	DVD/LD	Punch Through	DVD/LD	Punch Through
14	5	SAT/D-TV	Punch Through	5	7C-98	SAT/D-TV	Punch Through	SAT/D-TV	Punch Through
15	6	VCR	Punch Through	6	7C-99	VCR	Punch Through	VCR	Punch Through
16	7	PHONO	Punch Through	7	7C-9A	PHONO	Punch Through	PHONO	Punch Through
17	8	V-AUX	Punch Through	8	7C-9B	V-AUX	Punch Through	V-AUX	Punch Through
18	9	EXT. DEC.	Punch Through	9	7C-9C	EXT. DEC.	Punch Through	EXT. DEC.	Punch Through
19	0	0	-	0	7C-93	0	-	0	-
20	ENTER	ENTER	-	+10	7C-9D	ENTER	-	ENTER	-
21	EFFECT	EFFECT	Punch Through	CLEAR	7C-9F	EFFECT	Punch Through	EFFECT	Punch Through
22	CH-	DISC-	7C-8A	DISC-	7C-8A	DISC-	-	DISC-	7A-50
23	CH+	DISC+	7C-8B	DISC+	7C-8B	DISC+	-	DISC+	7A-4F
24	TV VOL+	TV VOL+	Punch Through	TV VOL+	Punch Through	TV VOL+	Punch Through	TV VOL+	Punch Through
25	VOL-	VOL-	Punch Through	VOL-	Punch Through	VOL-	Punch Through	VOL-	Punch Through
26	MUTE	AMP MUTE	Punch Through	AMP MUTE	Punch Through	AMP MUTE	Punch Through	AMP MUTE	Punch Through
27	VOL+	VOL+	Punch Through	VOL+	Punch Through	VOL+	Punch Through	VOL+	Punch Through
28	TV VOL-	TV VOL-	Punch Through	TV VOL-	Punch Through	TV VOL-	Punch Through	TV VOL-	Punch Through
29	SLEEP	SLEEP	Punch Through	RETURN	7C-B7	SLEEP	Punch Through	SLEEP	Punch Through
30	DISPLAY	DISPLAY	7C-A6	INDEX	7C-9E	DISPLAY	7C-13	DISPLAY	79-0A
31	REC	REC	-	REC	-	REC	-	REC	-
32	TV INPUT	TV INPUT	Punch Through	TV INPUT	Punch Through	TV INPUT	Punch Through	TV INPUT	Punch Through
33	PAUSE	PAUSE	7C-83	Up	7C-B4	PAUSE	7C-5A	PAUSE	7A-A9
34	SKIP-	SKIP/CHAP-	7C-B9	Left	7C-B5	SIP/CHAP-	7C-02	SKIP-	7A-0B
35	PLAY	PLAY	7C-82	Select	7C-B8	PLAY	7C-05	PLAY	7A-08
36	SKIP+	SKIP/CHAP+	7C-BA	Right	7C-B6	SKIP/CHAP+	7C-03	SKIP+	7A-0A
37	STOP	STOP	7C-85	Down	7C-B3	STOP	7C-5B	STOP	7A-09
38	REW	REW	7C-86	TITLE	7C-B1	REW	7C-06	REW	7A-0D
39	FF	FF	7C-87	MENU	7C-B2	FF	7C-07	FF	7A-0C

- : No Code

Key No.	Key Name	TAPE		MD		AMP/TUNER	
			Yamaha code		Yamaha code		Yamaha code
9	POWER	TAPE/MD POWER	7A-1F(Amp)	7A-1F(Amp)	AMP POWER	7A-1F	
10	1	CD	Punch Through	Punch Through	CD	7A-15	
11	2	TUNER	Punch Through	Punch Through	TUNER	7A-16	
12	3	TAPE/MD	Punch Through	Punch Through	TAPE/MD	7A-18	
13	4	DVD/LD	Punch Through	Punch Through	DVD/LD	7A-17	
14	5	SAT/D-TV	Punch Through	Punch Through	SAT/D-TV	7A-54	
15	6	VCR	Punch Through	Punch Through	VCR	7A-0F	
16	7	PHONO	Punch Through	Punch Through	PHONO	7A-14	
17	8	V-AUX	Punch Through	Punch Through	V-AUX	7A-55	
18	9	EXT. DEC.	Punch Through	Punch Through	EXT. DEC.	7A-87	
19	0	TEST	-	-	TEST	7A-85	
20	ENTER	ENTER	-	-	A/B/C/D/E	7A-12	
21	EFFECT	EFFECT	Punch Through	Punch Through	EFFECT	7A-56	
22	CH-	CH-	-	-	PRESET-	7A-11	
23	CH+	CH+	-	-	PRESET+	7A-10	
24	TV VOL+	TV VOL+	Punch Through	Punch Through	TV VOL+	Punch Through	
25	VOL-	VOL-	Punch Through	Punch Through	VOL-	7A-1B	
26	MUTE	AMP MUTE	Punch Through	Punch Through	AMP MUTE	7A-1C	
27	VOL+	VOL+	Punch Through	Punch Through	VOL+	7A-1A	
28	TV VOL-	TV VOL-	Punch Through	Punch Through	TV VOL-	Punch Through	
29	SLEEP	SLEEP	Punch Through	Punch Through	SLEEP	7A-57	
30	DISPLAY	DISPLAY	-	79-A5	DISPLAY	-	
31	REC	REC/PAUSE	7A-04	79-AF	REC	-	
32	TV INPUT	A/B	7A-06	-	TV INPUT	Punch Through	
33	PAUSE	PAUSE	-	79-A9	PRG+	7A-58	
34	SKIP-	DIR A/SKIP-	7A-07	79-AB	Down	7A-53	
35	PLAY	PLAY	7A-00	79-A8	-	-	
36	SKIP+	DIR B/SKIP+	7A-40	79-AE	Up	7A-52	
37	STOP	STOP	7A-03	79-AA	PRG-	7A-59	
38	REW	REW	7A-01	79-AC	TIME/LEVEL	7A-86	
39	FF	FF	7A-02	79-AD	SET MENU	7A-9C	

- : No Code

Parts List for Carbon Resistors

Value	1/4W Type Part No.	1/6W Type Part No.	Value	1/4W Type Part No.	1/6W Type Part No.
1.0 Ω	HJ35 3100	HF85 3100	10 kΩ	HF45 7100	HF45 7100
1.8 Ω	HJ35 3180	*	11 kΩ	HF45 7110	HF45 7110
2.2 Ω	HJ35 3220	HF85 3220	12 kΩ	HJ35 7120	HF85 7120
3.3 Ω	HJ35 3330	HF85 3330	13 kΩ	HF45 7130	HF45 7130
4.7 Ω	HJ35 3470	HF85 3470	15 kΩ	HF45 7150	HF45 7150
5.6 Ω	HJ35 3560	HF85 3560	18 kΩ	HF45 7180	HF45 7180
10 Ω	HF45 4100	HF45 4100	22 kΩ	HF45 7220	HF45 7220
15 Ω	HJ35 4150	HF85 4150	24 kΩ	HF45 7240	HF45 7240
22 Ω	HF45 4220	HF45 4220	27 kΩ	HJ35 7270	HF85 7270
27 Ω	HJ35 4270	HF85 4270	30 kΩ	HF45 7300	HF45 7300
33 Ω	HF45 4330	HF45 4330	33 kΩ	HF45 7330	HF45 7330
39 Ω	HJ35 4470	HF85 4390	36 kΩ	HF45 7360	HF45 7360
47 Ω	HF45 4470	HF45 4470	39 kΩ	HF45 7390	HF45 7390
56 Ω	HF45 4560	HF45 4560	47 kΩ	HF45 7470	HF45 7470
68 Ω	HF45 4680	HF45 4680	51 kΩ	HF45 7510	HF45 7510
75 Ω	HF45 4750	HF45 4750	56 kΩ	HF45 7560	HF45 7560
82 Ω	HF45 4820	HF45 4820	62 kΩ	HF45 7620	HF45 7620
91 Ω	HF45 4910	HF45 4910	68 kΩ	HF45 7680	HF45 7680
100 Ω	HF45 5100	HF45 5100	82 kΩ	HF45 7820	HF45 7820
110 Ω	HJ35 5110	HF85 5110	91 kΩ	HF45 7910	HF45 7910
120 Ω	HF45 5120	HF45 5120	100 kΩ	HF45 8100	HF45 8100
150 Ω	HF45 5150	HF45 5150	110 kΩ	HF45 8110	HF45 8110
160 Ω	HJ35 5160	*	120 kΩ	HF45 8120	HF45 8120
180 Ω	HF45 5180	HF45 5180	150 kΩ	HF45 8150	HF45 8150
200 Ω	HF45 5200	HF45 5200	180 kΩ	HF45 8180	HF45 8180
220 Ω	HF45 5220	HF45 5220	220 kΩ	HJ35 8220	HF85 8220
270 Ω	HF45 5270	HF45 5270	270 kΩ	HF45 8270	HF45 8270
330 Ω	HF45 5330	HF45 5330	300 kΩ	HF45 8300	HF45 8300
390 Ω	HF45 5390	HF45 5390	330 kΩ	HF45 8330	HF45 8330
430 Ω	HF45 5430	HF45 5430	390 kΩ	HJ35 8390	HF85 8390
470 Ω	HF45 5470	HF45 5470	470 kΩ	HF45 8470	HF45 8470
510 Ω	HF45 5510	HF45 5510	560 kΩ	HJ35 8560	HF85 8560
560 Ω	HF45 5560	HF45 5560	680 kΩ	HJ35 8680	HF85 8680
680 Ω	HF45 5680	HF45 5680	820 kΩ	HJ35 8820	HF85 8820
820 Ω	HF45 5820	HF45 5820	1.0 MΩ	HF45 9100	HF45 9100
910 Ω	HF45 5910	HF45 5910	1.2 MΩ	HJ35 9120	*
1.0 kΩ	HF45 6100	HF45 6100	1.5 MΩ	HJ35 9150	HF85 9150
1.2 kΩ	HF45 6120	HF45 6120	1.8 MΩ	HJ35 9180	HF85 9180
1.5 kΩ	HF45 6150	HF45 6150	2.2 MΩ	HJ35 9220	HF85 9220
1.8 kΩ	HF45 6180	HF45 6180	3.3 MΩ	HJ35 9330	HF85 9330
2.0 kΩ	HJ35 6200	HF85 6200	3.9 MΩ	HJ35 9390	*
2.2 kΩ	HF45 6220	HF45 6220	4.7 MΩ	HJ35 9470	HF85 9470
2.4 kΩ	HJ35 6240	HF85 6240			
2.7 kΩ	HF45 6270	HF45 6270			
3.0 kΩ	HF45 6300	HF45 6300			
3.3 kΩ	HF45 6330	HF45 6330			
3.6 kΩ	HJ35 6360	HF85 6360			
3.9 kΩ	HF45 6390	HF45 6390			
4.7 kΩ	HF45 6470	HF45 6470			
5.1 kΩ	HF45 6510	HF45 6510			
5.6 kΩ	HF45 6560	HF45 6560			
6.8 kΩ	HF45 6680	HF45 6680			
8.2 kΩ	HF45 6820	HF45 6820			
9.1 kΩ	HF45 6910	HF45 6910			

1/4W Type

HJ35 ○○○○

10mm

1/4W Type

HF45 ○○○○

1/6W Type

HF85 ○○○○

5mm

RX-V320

YAMAHA
