

AV RECEIVER

RX-V359/HTR-5930

SERVICE MANUAL

RX-V359/HTR-5930

IMPORTANT NOTICE

This manual has been provided for the use of authorized YAMAHA Retailers and their service personnel. It has been assumed that basic service procedures inherent to the industry, and more specifically YAMAHA Products, are already known and understood by the users, and have therefore not been restated.

WARNING: Failure to follow appropriate service and safety procedures when servicing this product may result in personal injury, destruction of expensive components, and failure of the product to perform as specified. For these reasons, we advise all YAMAHA product owners that any service required should be performed by an authorized YAMAHA Retailer or the appointed service representative.

IMPORTANT: The presentation or sale of this manual to any individual or firm does not constitute authorization, certification or recognition of any applicable technical capabilities, or establish a principle-agent relationship of any form.

The data provided is believed to be accurate and applicable to the unit(s) indicated on the cover. The research, engineering, and service departments of YAMAHA are continually striving to improve YAMAHA products. Modifications are, therefore, inevitable and specifications are subject to change without notice or obligation to retrofit. Should any discrepancy appear to exist, please contact the distributor's Service Division.

WARNING: Static discharges can destroy expensive components. Discharge any static electricity your body may have accumulated by grounding yourself to the ground buss in the unit (heavy gauge black wires connect to this buss).

IMPORTANT: Turn the unit OFF during disassembly and part replacement. Recheck all work before you apply power to the unit.

■ CONTENTS

TO SERVICE PERSONNEL	2~3	DISPLAY DATA	35~36
IMPEDANCE SELECTOR	3	IC DATA	37~43
FRONT PANELS	3~5	PRINTED CIRCUIT BOARD	45~52
REAR PANELS	5~9	PIN CONNECTION DIAGRAM	53~54
REMOTE CONTROL PANELS	10	BLOCK DIAGRAM	55
SPECIFICATIONS	11~12	SCHEMATIC DIAGRAMS	56~60
INTERNAL VIEW	12	REPLACEMENT PARTS LIST	61~69
DISASSEMBLY PROCEDURES	13~15	REMOTE CONTROL	70~71
SELF DIAGNOSIS FUNCTION (DIAG)	16~33	ADVANCED SETUP	72~73
CONFIRMATION OF IDLING CURRENT	34		



このサービスマニュアルは、エコマーク認定の再生紙を使用しています。
This Service Manual uses recycled paper.

100995

© 2006 YAMAHA CORPORATION All rights reserved.
This manual is copyrighted by YAMAHA and may not be copied or
redistributed either in print or electronically without permission.



YAMAHA

YAMAHA CORPORATION
P.O.Box 1, Hamamatsu, Japan

'06.01

■ TO SERVICE PERSONNEL

1. Critical Components Information

Components having special characteristics are marked ⚠ and must be replaced with parts having specifications equal to those originally installed.

2. Leakage Current Measurement (For 120V Models Only)

When service has been completed, it is imperative to verify that all exposed conductive surfaces are properly insulated from supply circuits.

- Meter impedance should be equivalent to 1500 ohms shunted by 0.15µF.

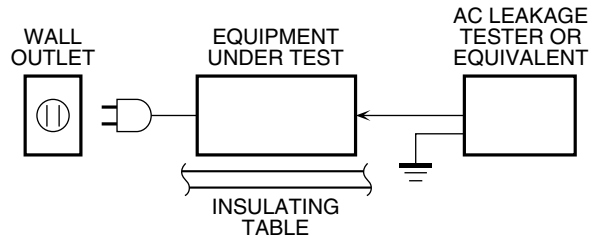

- Leakage current must not exceed 0.5mA.
- Be sure to test for leakage with the AC plug in both polarities.



“CAUTION”

“F371: FOR CONTINUED PROTECTION AGAINST RISK OF FIRE, REPLACE ONLY WITH SAME TYPE 6A, 125V FUSE.”

CAUTION

F371: REPLACE WITH SAME TYPE 6A, 125V FUSE.

ATTENTION

F371: UTILISER UN FUSIBLE DE RECHANGE DE MEME TYPE DE 6A, 125V.

WARNING: CHEMICAL CONTENT NOTICE!

The solder used in the production of this product contains LEAD. In addition, other electrical/electronic and/or plastic (where applicable) components may also contain traces of chemicals found by the California Health and Welfare Agency (and possibly other entities) to cause cancer and/or birth defects or other reproductive harm.

DO NOT PLACE SOLDER, ELECTRICAL/ELECTRONIC OR PLASTIC COMPONENTS IN YOUR MOUTH FOR ANY REASON WHATSOEVER!

Avoid prolonged, unprotected contact between solder and your skin! When soldering, do not inhale solder fumes or expose eyes to solder/flux vapor!

If you come in contact with solder or components located inside the enclosure of this product, wash your hands before handling food.

About Lead Free Solder

The P.C.B.s installed in this unit are soldered using the following solder.

	Side A	Side B
DSP P.C.B.	Lead Free Solder	Lead Free Solder
FUNCTION P.C.B.	—	Lead Free Solder
MAIN P.C.B.	—	Lead Free Solder

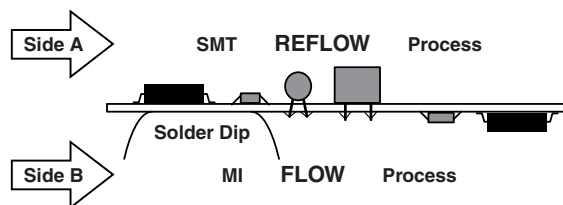

Among some types of lead free solder currently available, it is recommended to use one of the following types for the repair work.

- Sn + Ag + Cu (tin + silver + copper)
- Sn + Cu (tin + copper)
- Sn + Zn + Bi (tin + zinc + bismuth)

Caution:

1. As the melting point temperature of the lead free solder is about 30°C to 40°C (50°F to 70°F) higher than that of the lead solder, be sure to use a soldering iron suitable to each solder.
2. If lead solder must be used, be sure to remove lead free solder from each terminal section of the parts to be replaced and from the area around it completely before soldering, or make sure that the lead free solder and lead solder melt together fully.

■ IMPEDANCE SELECTOR

U, C models

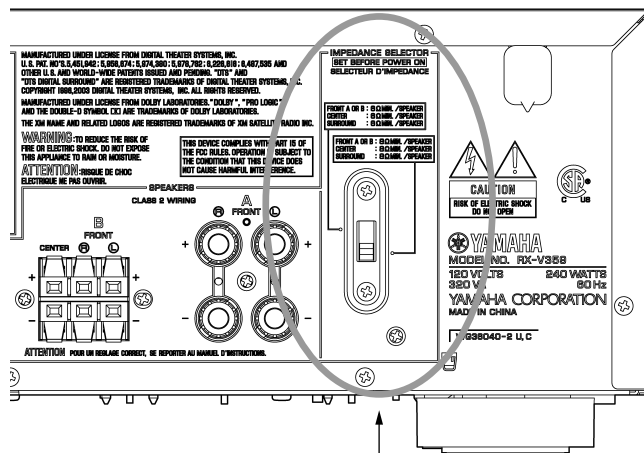

IMPEDANCE SELECTOR

WARNING:
Do not change the IMPEDANCE SELECTOR switch setting while the power to this unit is on, otherwise this unit may be damaged.

■ FRONT PANELS

RX-V359 (C model)

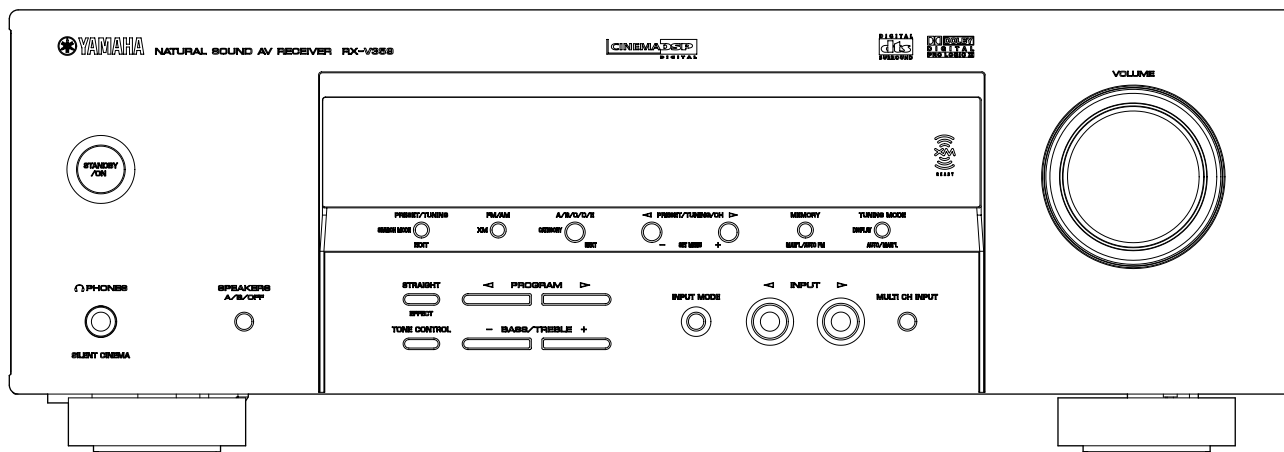

RX-V359/HTR-5930

RX-V359 (R, T, K, A, L models)

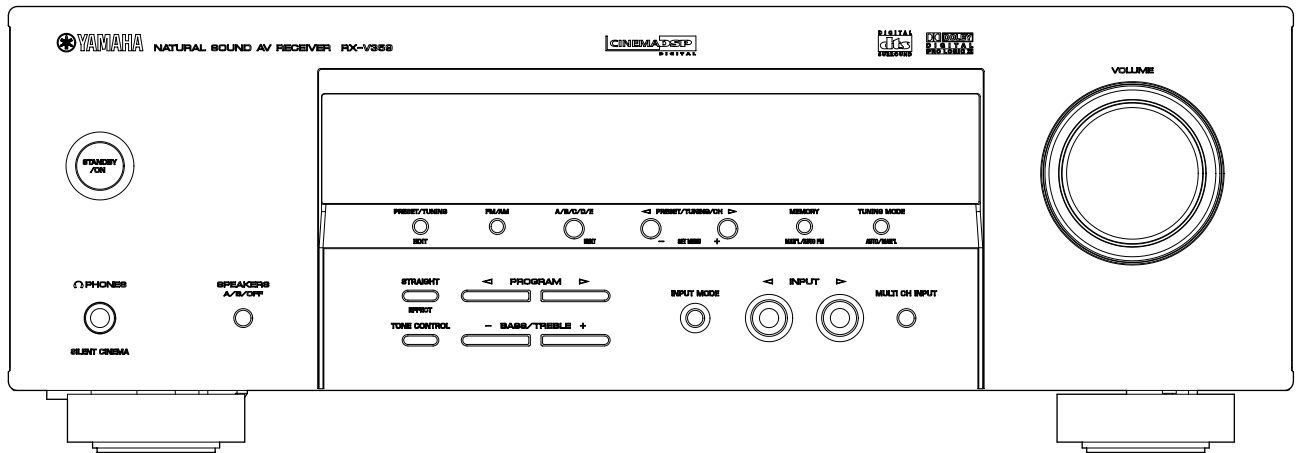

RX-V359 (B, G, E models)

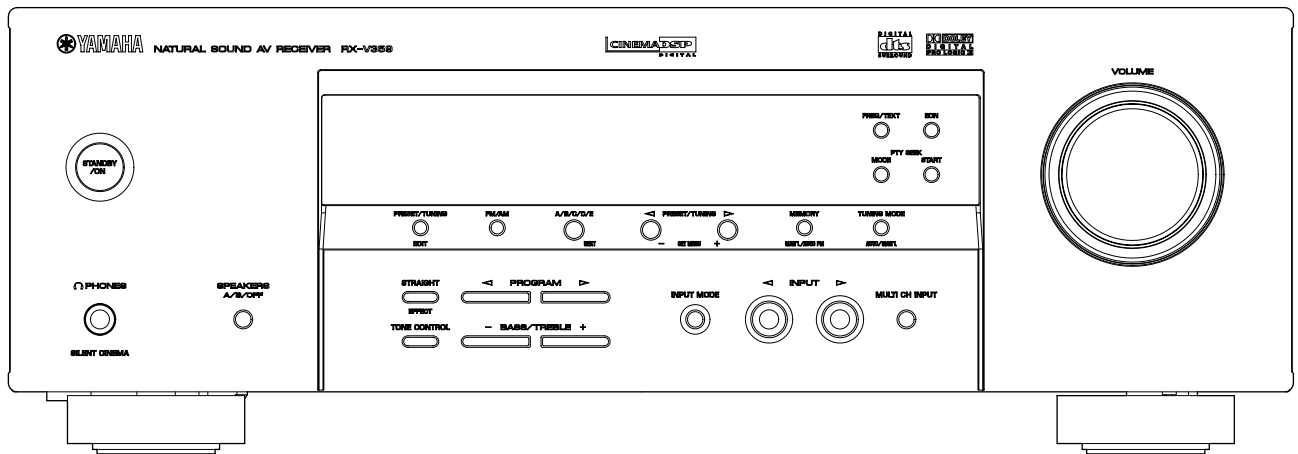

HTR-5930 (U, C models)

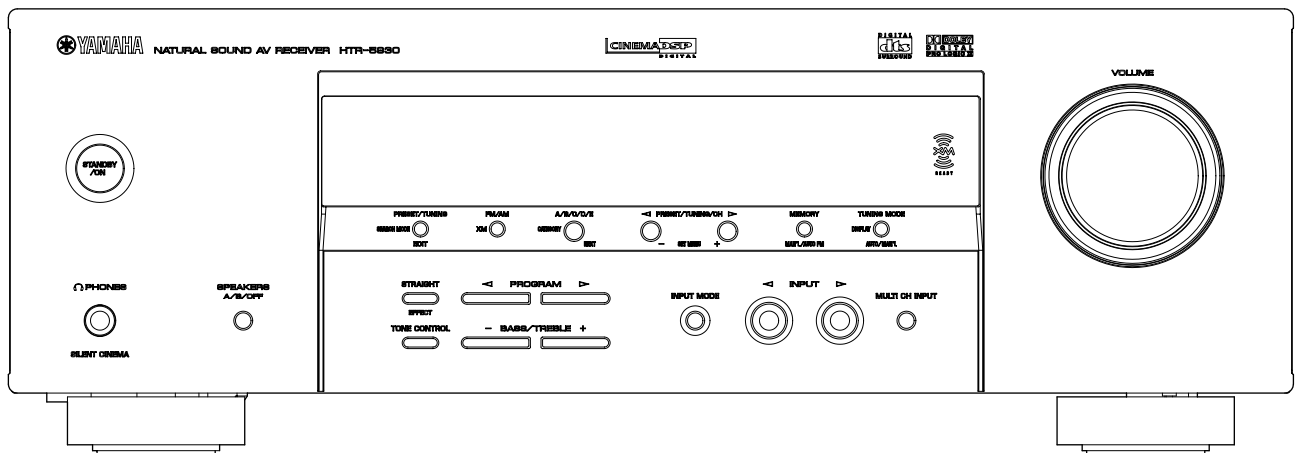

RX-V359/HTR-5930

HTR-5930 (R, T, K, A models)

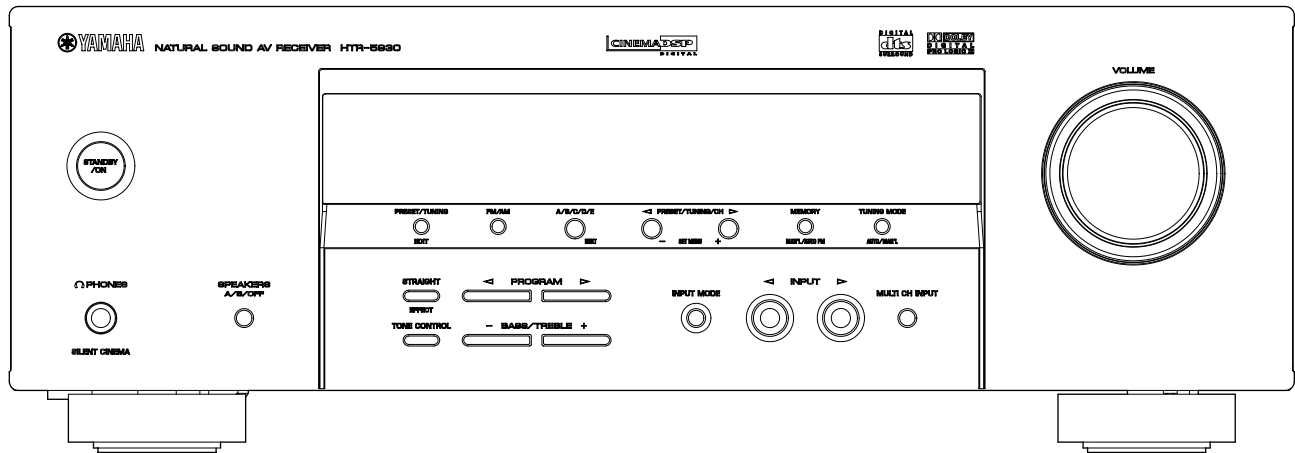

HTR-5930 (B, G, E models)

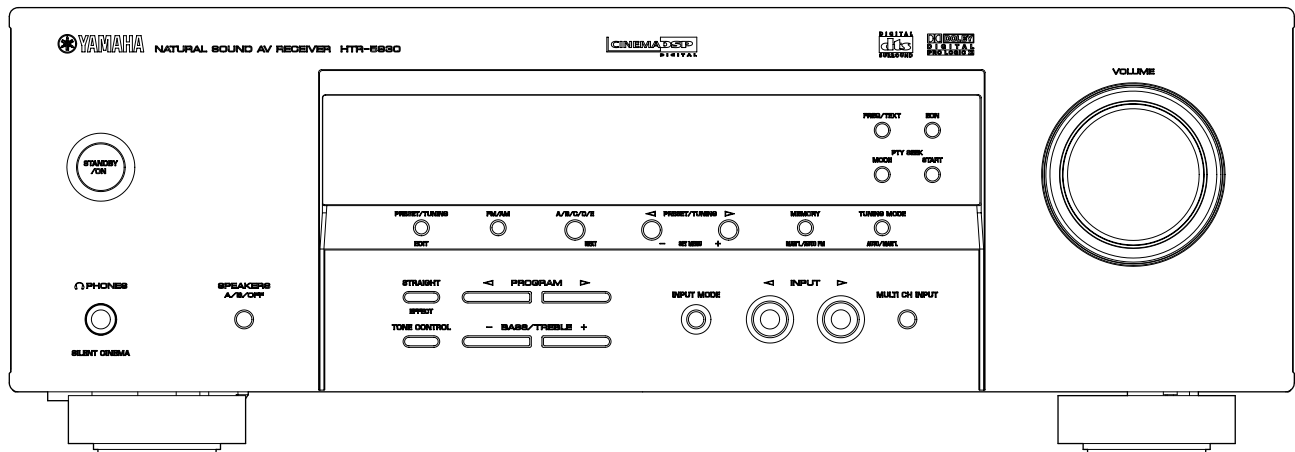

REAR PANELS

RX-V359 (C model)

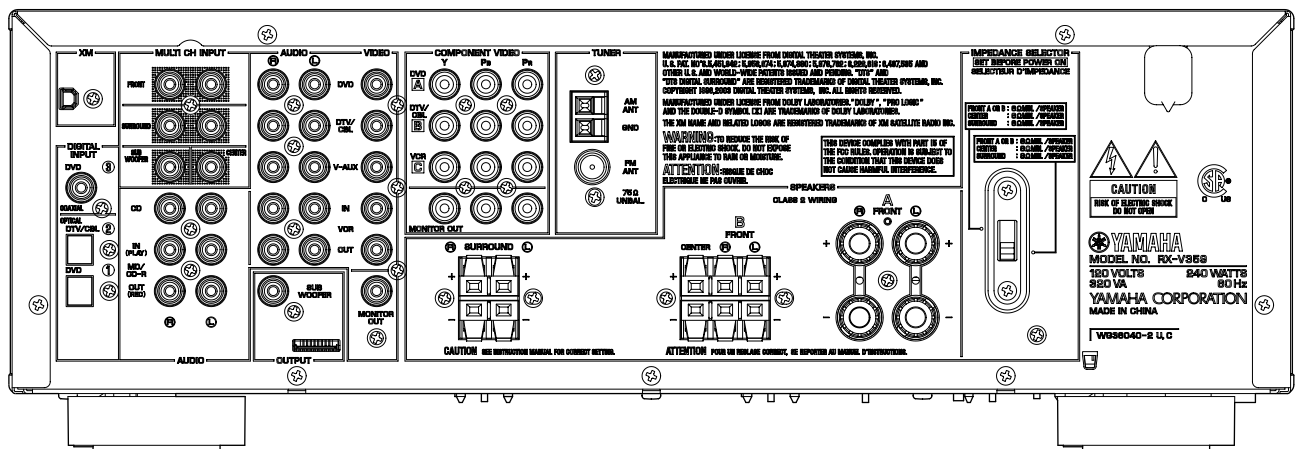

RX-V359/HTR-5930

RX-V359 (R model)

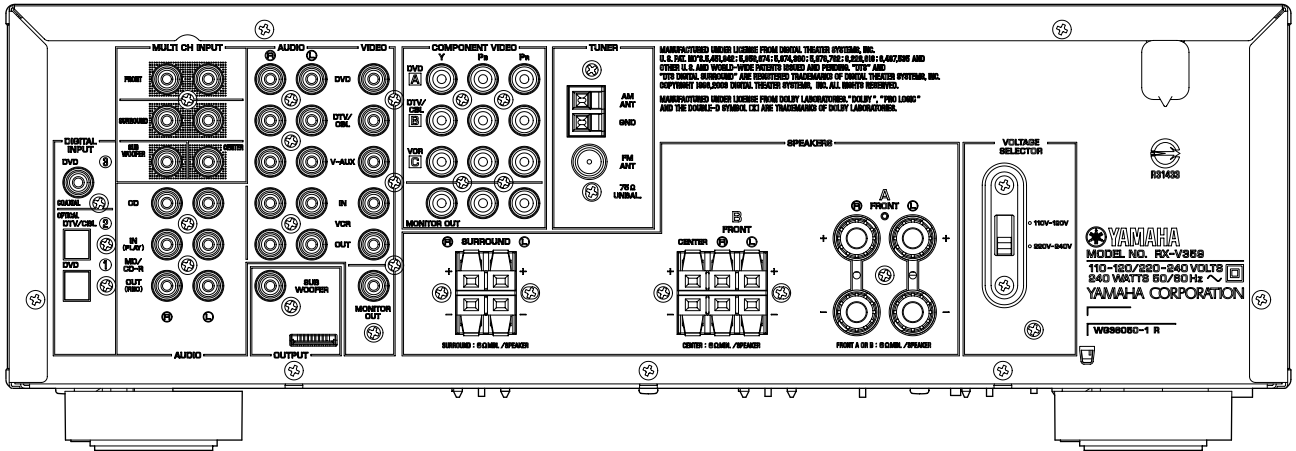

RX-V359 (T model)

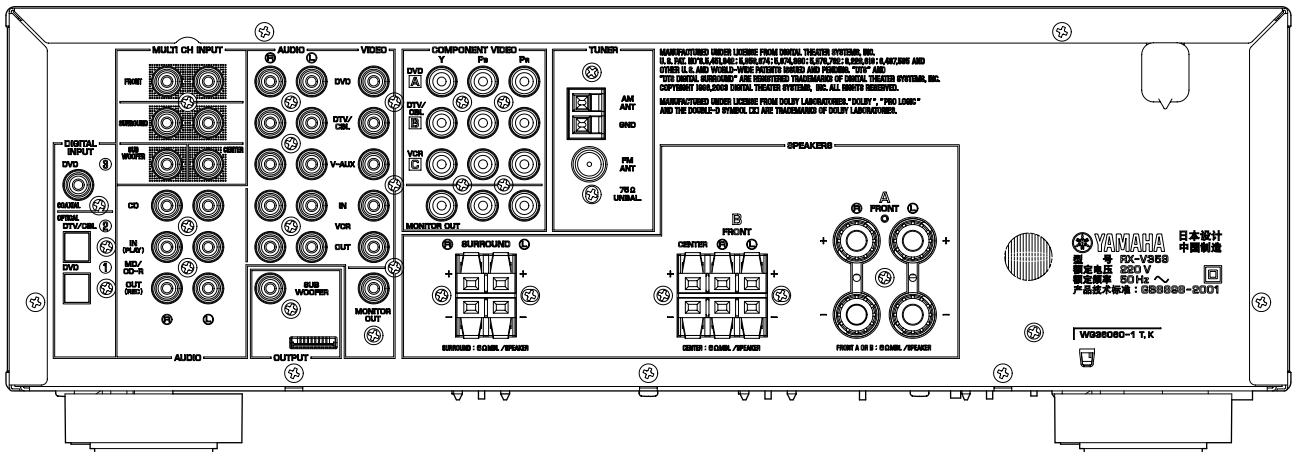

RX-V359 (K model)

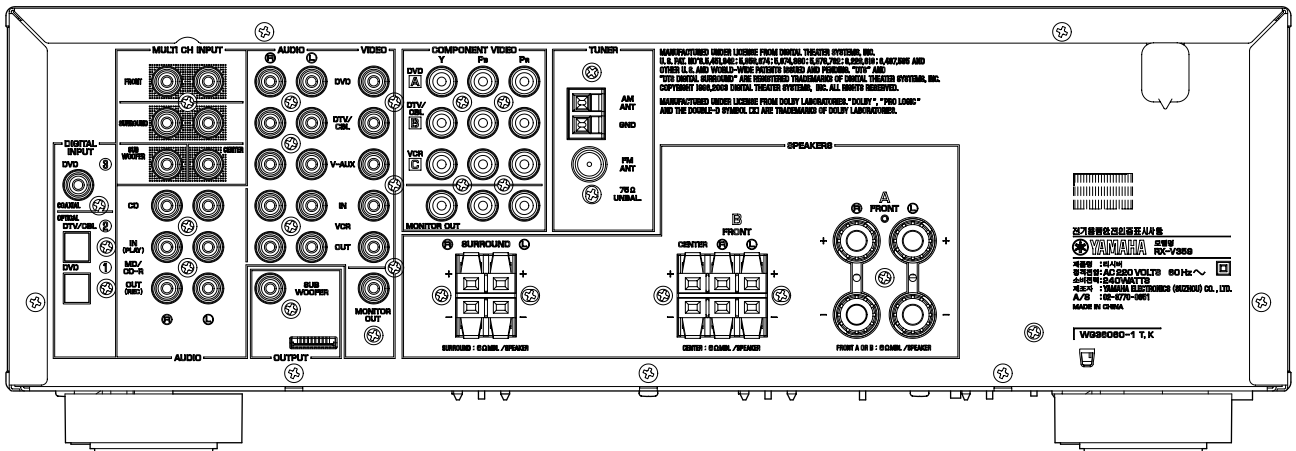

HTR-5930 (U, C models)

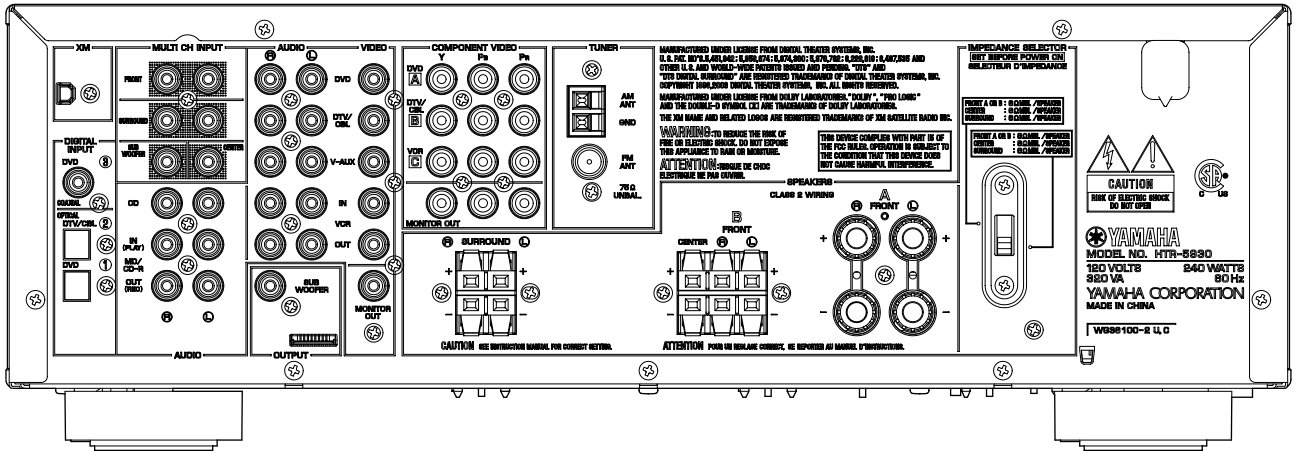

HTR-5930 (R model)

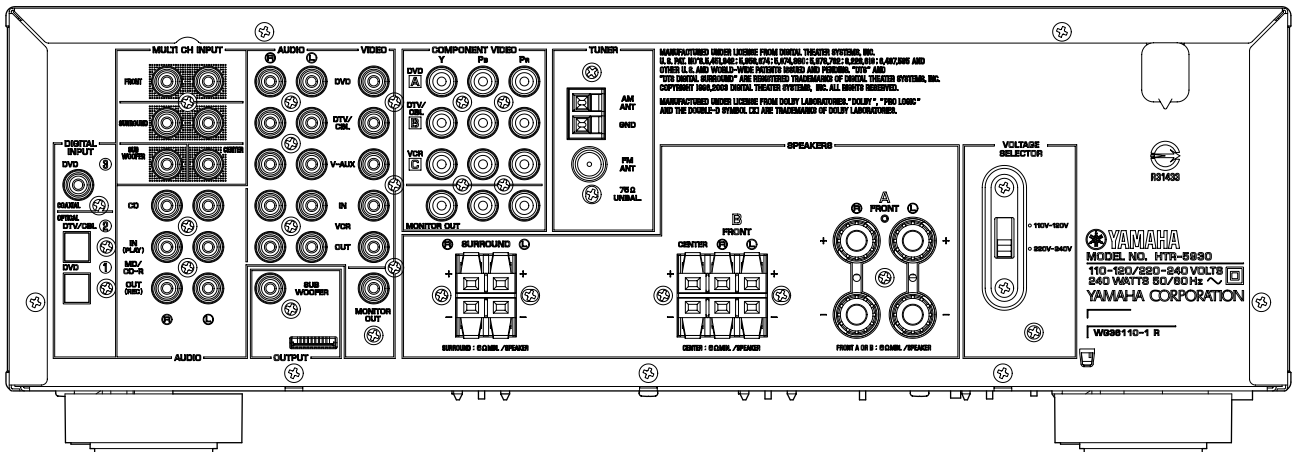

HTR-5930 (T model)

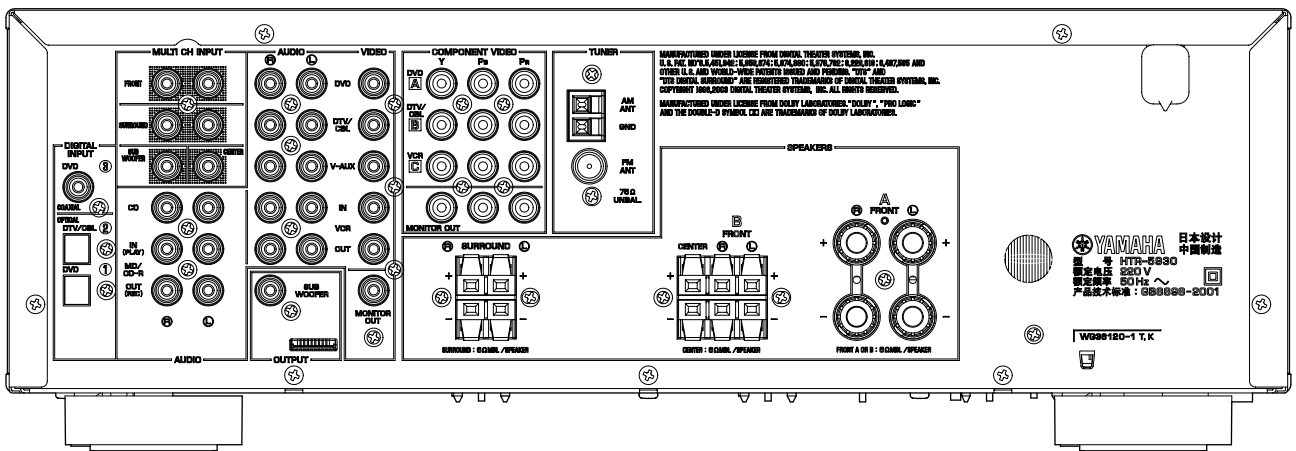

HTR-5930 (K model)

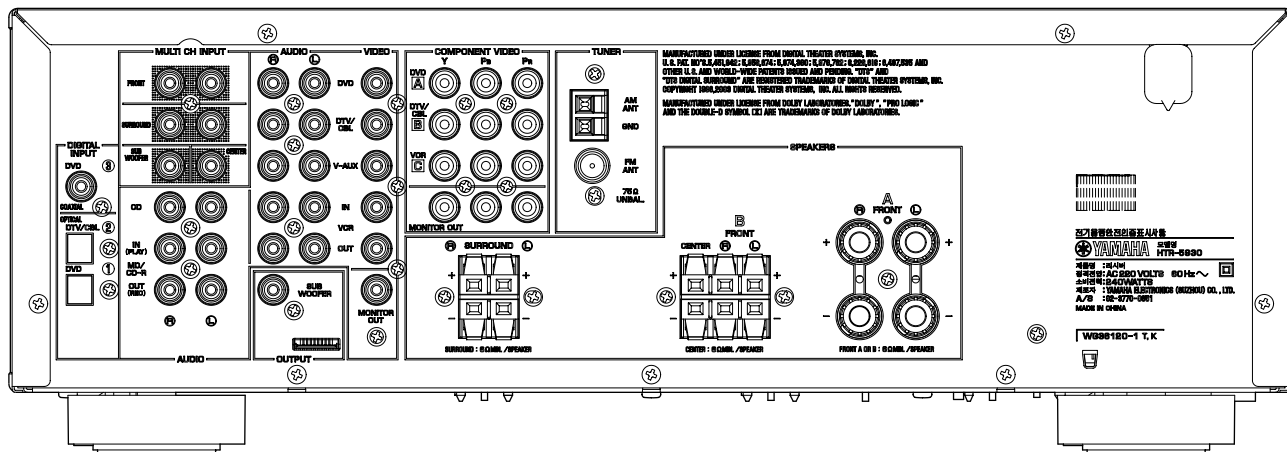

HTR-5930 (A model)

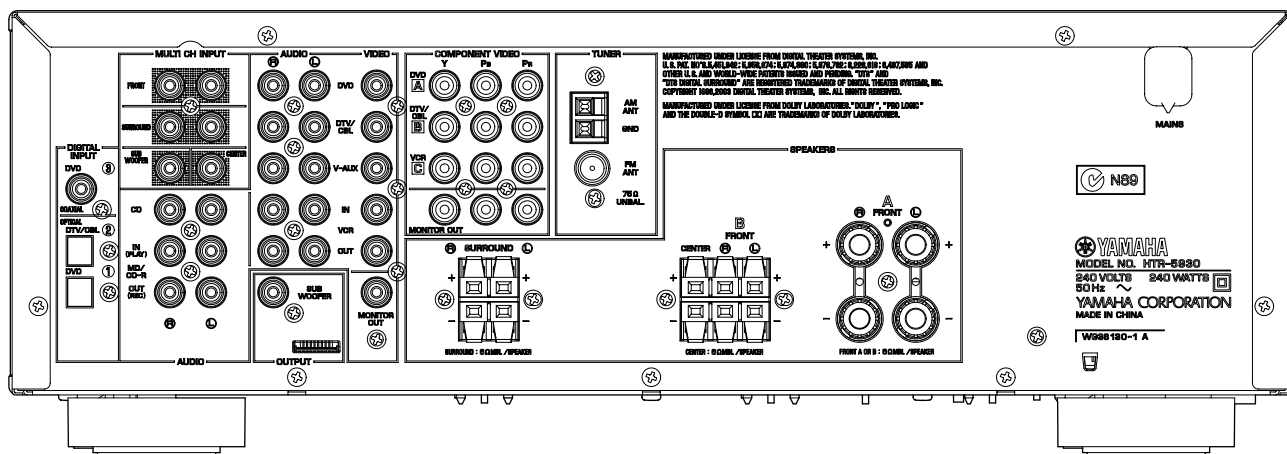

HTR-5930 (B, G, E models)

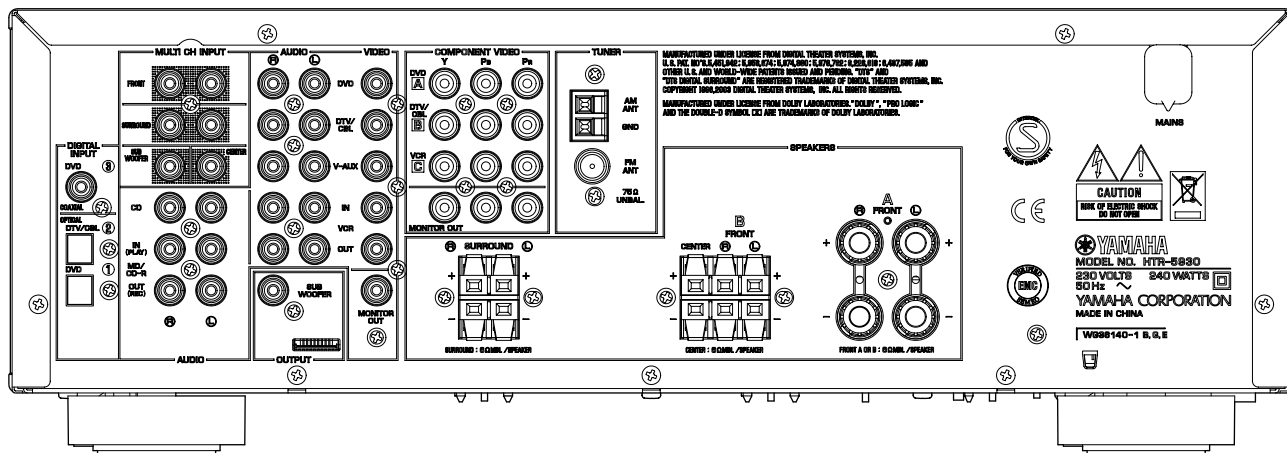

RX-V359/HTR-5930

■ REMOTE CONTROL PANELS

RX-V359 (C, R, T, K, A, L models)
 HTR-5930 (U, C, R, T, K, A models)

RX-V359 (B, G, E models)
 HTR-5930 (B, G, E models)

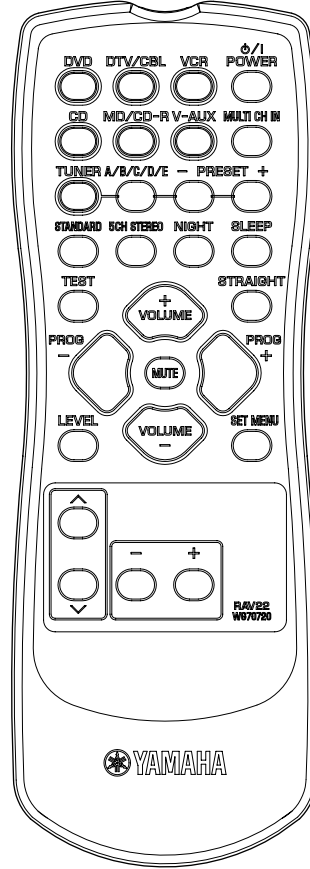
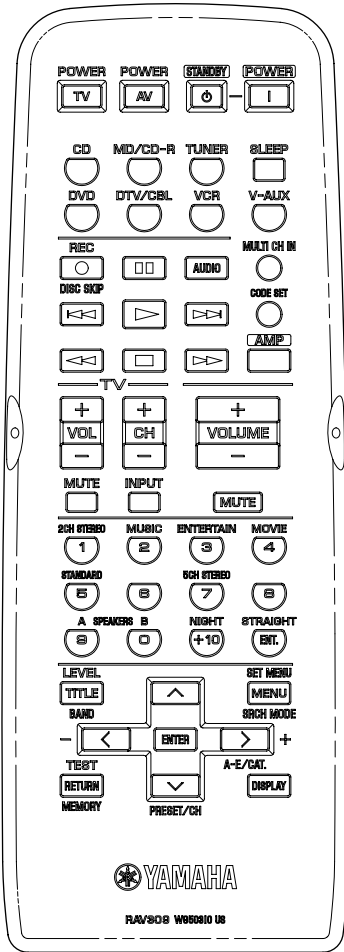

RX-V359/HTR-5930

■ SPECIFICATIONS

■ Audio Section

Minimum RMS Output Power (Power Amp. Section)

(1 kHz, 0.9 % THD, 8 ohms)

FRONT L/R	
U, C models	110 W + 110 W
CENTER	
U, C models	110 W
SURROUND L/R	
U, C models	110 W + 110 W

(1 kHz, 0.9 % THD, 6 ohms)

FRONT L/R	
U, C models	110 W + 110 W
R, T, K, A, B, G, E, L models	100 W + 100 W
CENTER	
U, C models	110 W
R, T, K, A, B, G, E, L models	100 W
SURROUND L/R	
U, C models	110 W + 110 W
R, T, K, A, B, G, E, L models	100 W + 100 W

Maximum Power [R, T, K, L models]

(1 kHz, 10 % THD, 6 ohms)

FRONT L/R	110 W + 110 W
CENTER	110 W
SURROUND L/R	110 W + 110 W

Maximum Output Power Per Channel

[B, G, E, models]

(1 kHz, 0.7 % THD, 4 ohms)

FRONT L/R	105 W + 105 W
CENTER	105 W
SURROUND L/R	105 W + 105 W

IEC Power [B, G, E models]

1 kHz, 0.1 % THD, 6 ohms 90 W + 90 W

Dynamic Power Per Channel (IHF)

U, C models

(8/6/4/2 ohms) 120/140/160/180 W

R, T, K, A, B, G, L, E models

(6/4/2 ohms) 105/135/165 W

Dynamic Headroom [U, C models]

8 ohms 0.38 dB

Input Sensitivity / Input Impedance

CD, etc. 200 mV / 47 k-ohms

EXT. DECODER

FRONT L/R, CENTER, SURROUND L/R,

SUBWOOFER 200 mV / 47 k-ohms

Maximum Input Signal

[U, C, R, T, K, A, B, G, E models]

(1 kHz, 0.5 % THD, Effect on)

CD, etc. 2.0 V or more

Output Level / Output Impedance

REC OUT 200 mV / 1.2 k-ohms

SUBWOOFER (FRONT SP: Small) 4 V / 1.2 k-ohms

Headphone Jack Rated Output / Impedance

CD, etc. (1 kHz, 200 mV, 8 ohms) 0.4 V / 470 ohms

Frequency Response

(10 Hz to 100 kHz)

CD, etc. to FRONT L/R 0 / -3.0 dB

Total Harmonic Distortion

(1 kHz, 50 W, 6 ohms)

CD, etc. (Effect off) to FRONT L/R SP OUT

..... 0.06 % or less

Signal to Noise Ratio (IHF-A Network)

CD, etc. (STEREO) to Input shorted SP OUT

250mV 100 dB or more

Residual Noise (IHF-A Network)

FRONT L/R SP OUT 150 μ V or less

Channel Separation

(Vol -14 dB, STEREO)

CD, etc. (Input 5.1 k-ohms shorted, 1 kHz / 10 kHz)

..... 60 dB or more / 45 dB or more

Tone Control Characteristics

BASS

Boost/Cut \pm 10 dB (100Hz)

TREBLE

Boost/Cut \pm 10 dB (20 kHz)

Filter Characteristics

FRONT, SURROUND L/R

SP Small (H.P.F.) 90 Hz / 12 dB oct.

SUBWOOFER (L.P.F.) 90 Hz / 18 dB oct.

■ Video Section

Video Signal Type

U, C, R, K models NTSC

T, A, B, G, E, L models PAL

Video Signal Level

..... 1 Vp-p / 75 ohms

Component Signal Level

..... 1 Vp-p / 75 ohms

Maximum Input Level

..... 1.5 Vp-p or more

Signal to Noise Ratio

..... 50 dB or more

Monitor Out Frequency Response

Video signal level 5 Hz to 10 MHz, -3 dB

Component signal level 5 Hz to 60 MHz, -3 dB

■ FM Section

Tuning Range

U, C models 87.5 to 107.9 MHz

R, L models 87.5 to 108.0 / 87.50 to 108.00 MHz

T, K, A, B, G, E models 87.50 to 108.00 MHz

50dB Quieting Sensitivity (IHF)

(1 kHz, 100 % Mod.)

Mono 2.8 μ V (20.2 dBf)

Signal to Noise Ratio (IHF)

Mono / Stereo 73 dB / 70 dB

Harmonic Distortion

(1 kHz)

Mono/Stereo 0.5 % / 0.5 %

Antenna Input

..... 75 ohms unbalanced

■ AM Section

Tuning Range

U, C models 530 to 1,710 kHz

R, L models 530 to 1,710 / 531 to 1,611 kHz

T, K, A, B, G, E models 531 to 1,611 kHz

Antenna

..... Loop antenna

■ General

Power Supply

U, C models AC 120 V, 60 Hz

R, L models AC 110-120/220-240 V, 50/60 Hz

T model AC 220 V, 50 Hz

K model AC 220 V, 60 Hz

A model AC 240 V, 50 Hz

B, G, E models AC 230 V, 50 Hz

Power Consumption

U, C models 240 W / 320 VA

R, T, K, A, B, G, E, L models 240 W

Standby Power Consumption (reference data)

U, C models 0.5 W

T, K, A, B, G, E, L models 0.7 W

Maximum Power Consumption [R, L models]

5ch Drive, 10 % THD 510 W

Dimensions (W x H x D)

... 435 x 151 x 317.6 mm (17-1/8" x 5-15/16" x 12-1/2")

Weight

..... 9.0 kg (19 lbs. 13 oz.)

Finish

[RX-V359]

Gold color T, L models

Black color R, A, B, G, E models

Silver color C, R, K, B, G, E models

Titanium color G, L models

[HTR-5930]

Gold color T model

Black color U, C, R models

Silver color U, C, R, T, K, A, G, E models

Accessories

Remote control x 1, Batteries (Manganese dry) x 2,

Indoor FM antenna x 1, AM loop antenna x 1

* Specifications are subject to change without notice due to product improvements.

U U.S.A. model C Canadian model

R General model T Chinese model

K Korean model A Australian model

B British model G European model

E South European model L Singapore model



Manufactured under license from Dolby Laboratories.

"Dolby", "Pro Logic", and the double-D symbol are trademarks of Dolby Laboratories.



"DTS", and "DTS Digital Surround" are registered trademarks of Digital Theater Systems, Inc.

SILENT™
CINEMA

"SILENT CINEMA" is a trademark of YAMAHA CORPORATION.



READY

The XM name and related logos are registered trademarks of XM Satellite Radio Inc.

• DIMENSIONS

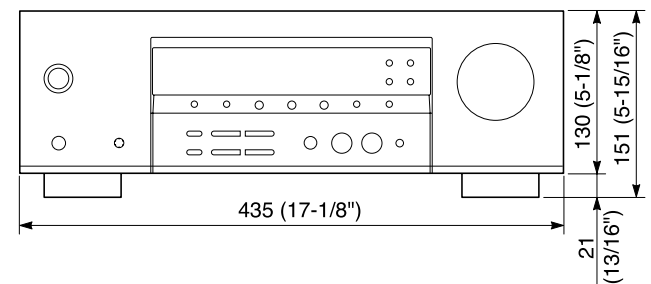
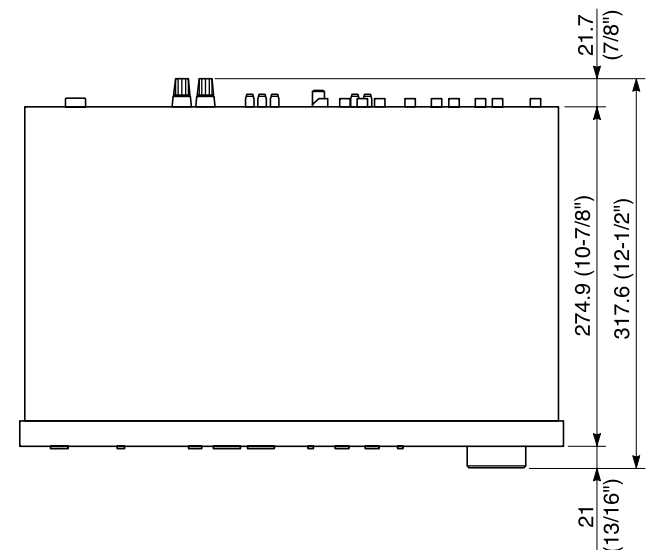

Unit : mm (inch)

• Set Menu Table

The value inside of [] shows initial setting.

Category	No.	MAIN MENU	SUB MENU	VALUE [INITIAL]	
BASIC	1	SETUP	ROOM : S >M L	S/[M]/L	
			SUBWOOFER YES	[YES]/NONE	
			SPEAKERS 5spk	2/3/4/[5]	
			>SET CANCEL	[SET]/CANCEL	
			Check : Test Tone		
			Check OK? Yes	[Yes]/No	
	2	SP LEVEL	FL ----- ----- R	[Center] ±10step	
			C ----- -----	[Center] ±10step	
			SL ----- -----	[Center] ±10step	
			SR ----- -----	[Center] ±10step	
SWFR -----			[0dB] -20step		
SOUND	1	SPEAKER SET	1A CENTER SML	LRG/[SML]/NON	
			1B FRONT LRG	[LRG]/SML	
			1C SURR LR SML	LRG/[SML]/NON	
			1D BASS BOTH	SWFR/FRNT/[BOTH]	
	2	SP DISTANCE	UNIT	meters(m)/feet(ft)	
			FRONT L/R 3.00m	0.3 to 24m [3.00m]/0.1m step	
			CENTER 3.00m	0.3 to 24m [3.00m]/0.1m step (Effective distance difference 1.5m)	
			SURR LR 3.00m	0.3 to 24m [3.00m]/0.1m step	
	3	LFE LEVEL	SP LFE 0	-20dB to [0dB]/1dB step	
			HP LFE 0	-20dB to [0dB]/1dB step	
	4	DYNAMIC RANGE	SP D.R > MAX	MIN/STD/[MAX]	
			HP D.R > MAX	MIN/STD/[MAX]	
	5	TONE BYPASS	> AUTO OFF	[AUTO]/OFF	
	INPUT	1	I/O ASSIGN	1A (A) DVD	VCR, V-AUX, DTV/CBL, [DVD]
				1A (B) DTV/CBL	VCR, V-AUX, [DTV/CBL], DVD
1A (C) VCR				[VCR], V-AUX, DTV/CBL, DVD	
1B (1) DVD				CD, VCR, V-AUX, DTV/CBL, [DVD], MD/CD-R	
1B (2) DTV/CBL				CD, VCR, V-AUX, [DTV/CBL], DVD, MD/CD-R	
1C (3) CD				[CD], VCR, V-AUX, DTV/CBL, DVD, MD/CD-R	
2	INPUT MODE	2 >AUTO LAST	[AUTO]/LAST		
OPTION	1	DISPLAY SET	1 DIMMER 0	-4 to [0]/1 step	
	2	MEMORY GUARD	2 M GUARD OFF	[OFF]/ON	
	3	AUDIO MUTE	3 MUTE: MUTE	[MUTE]/-50dB/-20dB	
	4	XM RADIO SET (U, C models)	4 ANTENNA	NONE/0~100%	
4 SCROLL CONT			[CONT]/ONCE		

■ INTERNAL VIEW

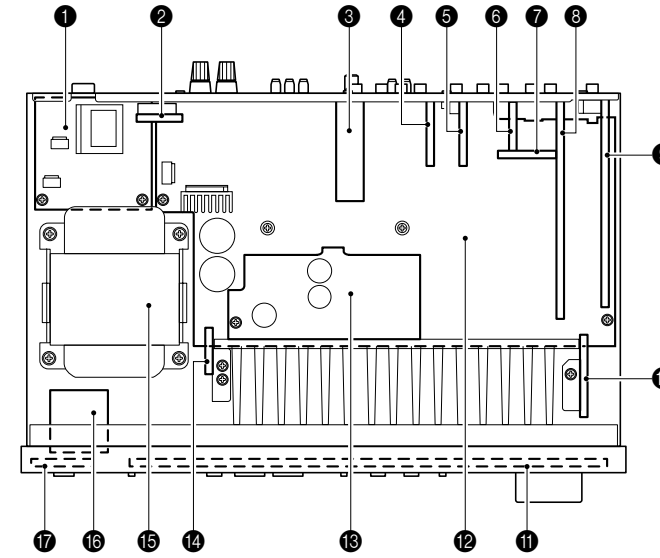

- ① MAIN (2) P.C.B.
- ② MAIN (4) P.C.B. (U, C models)
FUNCTION (7) P.C.B. (R, L models)
- ③ Tuner
- ④ MAIN (5) P.C.B.
- ⑤ MAIN (3) P.C.B.
- ⑥ FUNCTION (3) P.C.B.
- ⑦ FUNCTION (6) P.C.B.
- ⑧ FUNCTION (1) P.C.B.
- ⑨ DSP P.C.B.
- ⑩ FUNCTION (9) P.C.B.
- ⑪ FUNCTION (2) P.C.B.
- ⑫ MAIN (1) P.C.B.
- ⑬ FUNCTION (4) P.C.B.
- ⑭ FUNCTION (8) P.C.B.
- ⑮ Power Transformer
- ⑯ FUNCTION (10) P.C.B.
- ⑰ FUNCTION (5) P.C.B.

• The variable range of the parameter (Min/Max/Step)

		Unit
DSP LEVEL	-6/+3/1	dB
DELAY	1/99/1	ms

5ch Stereo Parameter		Unit
CT LEVEL	0/100/1	%
SL LEVEL	0/100/1	%
SR LEVEL	0/100/1	%

Pro Logic II Music Parameter		Unit
PANORAMA	OFF/ON	
DIMENSIONS	-3/+3/1	
CT WIDTH	0/7/1	

■ DISASSEMBLY PROCEDURES

(Remove parts in the order as numbered.)
Disconnect the power cable from the AC outlet.

1. Removal of Top Cover

- a. Remove 4 screws (①), 4 screws (②) and 1 screw (③). (Fig. 1)
- b. Slide the Top Cover rearward to remove it. (Fig. 1)

2. Removal of Front Panel Unit

- a. Loosen the harness fixture fixing the cable.
- b. Remove CB431, CB653 and CB804. (Fig. 1)
- c. Remove 6 screws (④). (Fig. 1)
- d. Release a hook on the right side of the Front Panel Unit, then remove the Front Panel Unit forward. (Fig. 1)

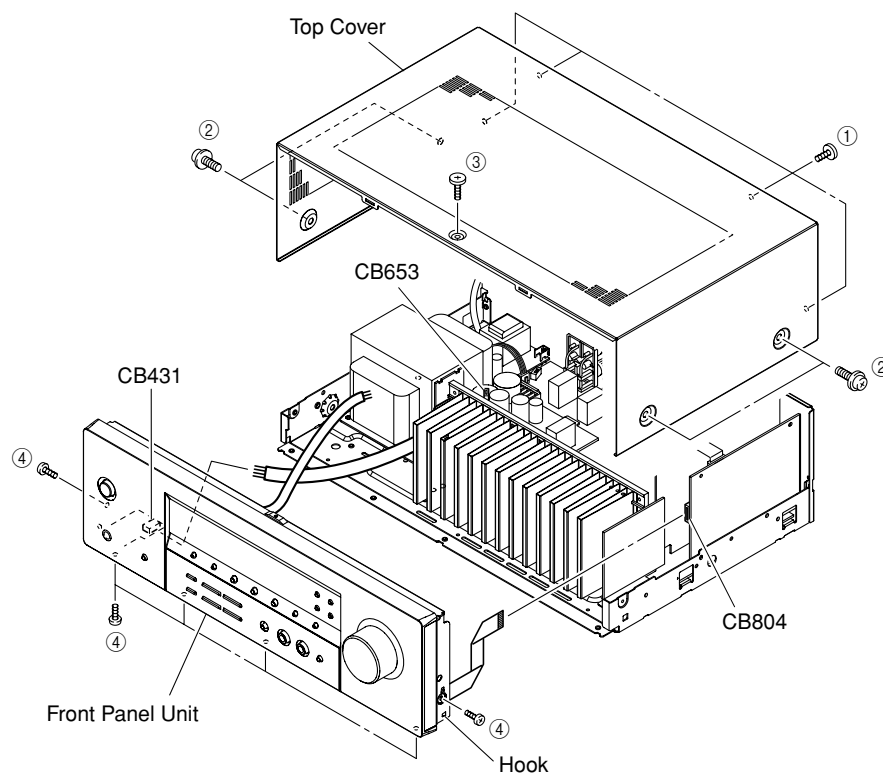

Fig. 1

3. Removal of MAIN (3), MAIN (5), FUNCTION (3), FUNCTION (6) P.C.B.s and Tuner

- a. Remove CB242. (Fig. 2)
- b. Remove 12 screws (5). (Fig. 3)
- c. Remove MAIN (3), MAIN (5) P.C.B.s and the Tuner. (Fig. 2)
- d. Remove 14 (U, C models)/13 (R, T, K, A, B, G, L models) screws (6). (Fig. 3)
- e. Remove 4 screws (7). (Fig. 3)
- f. Remove 2 (U, C, R, L models) screws (8). (Fig. 3)
- g. Remove Cord Stopper. (Fig. 2)
- h. Remove Rear Panel. (Fig. 2)
- i. Remove, FUNCTION (3) and FUNCTION (6) P.C.B.s. (Fig. 2)

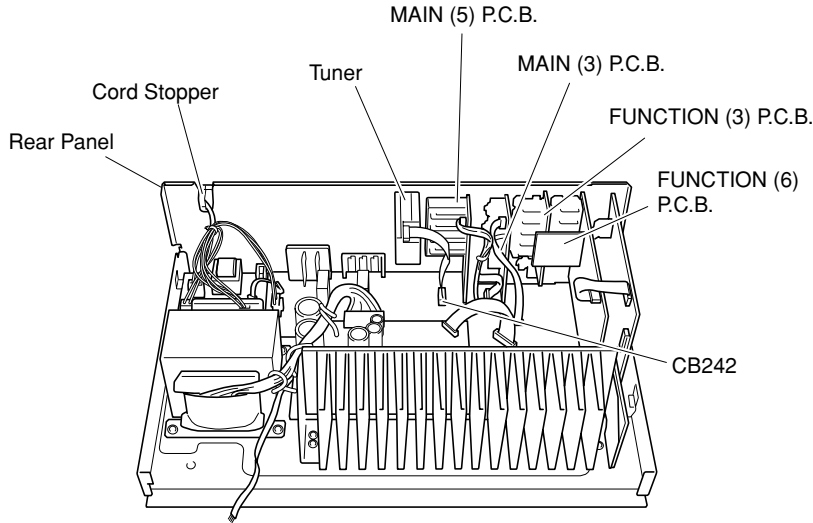

Fig. 2

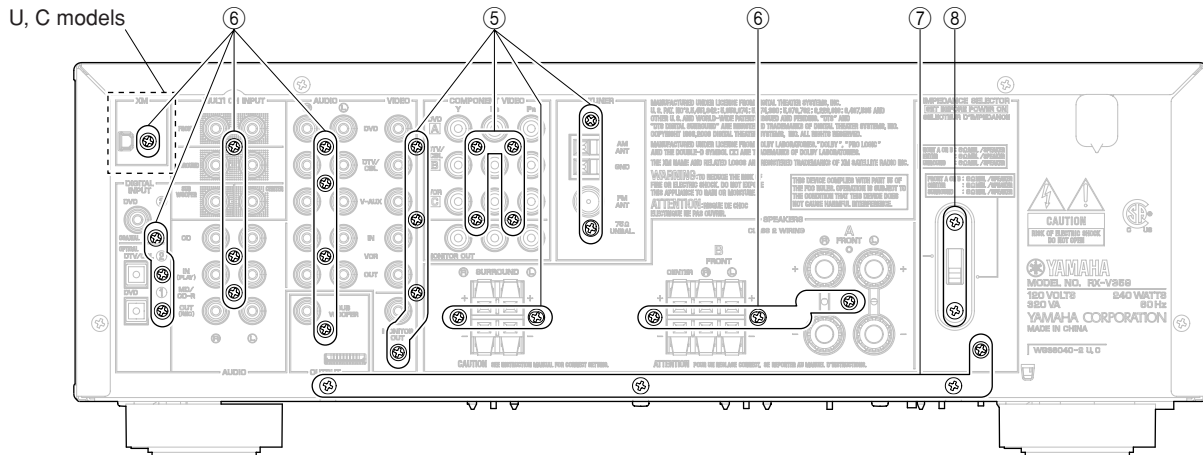
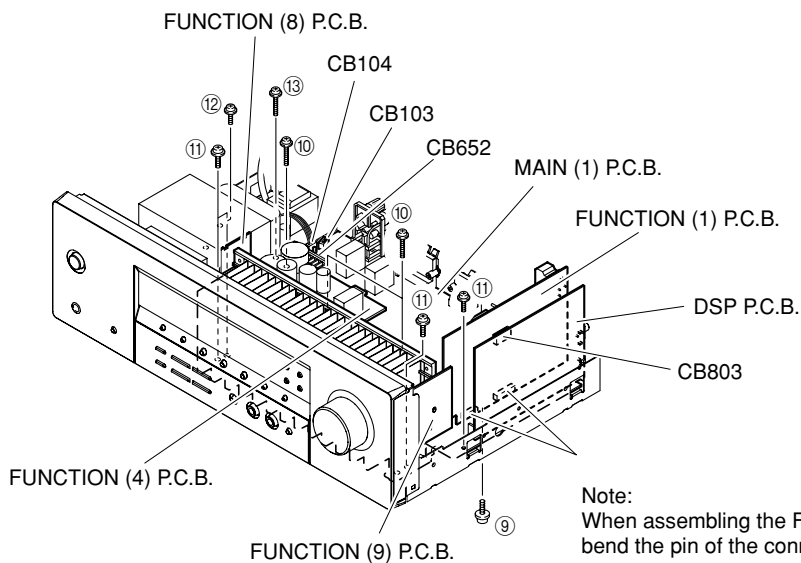

Fig. 3

4. Removal of MAIN (1), DSP, FUNCTION (1), FUNCTION (8) and FUNCTION (9) P.C.B.s

- Remove 1 screw (9). (Fig. 4)
- Remove CB803. (Fig. 4)
- Remove FUNCTION (1) P.C.B. (Fig. 4)
- Remove CB103, CB104 and CB652. (Fig. 4)
- Remove 3 screws (10). (Fig. 4)
- Remove 4 screws (11). (Fig. 4)
- Remove MAIN (1), DSP, FUNCTION (4), FUNCTION (8) and FUNCTION (9) P.C.B.s. (Fig. 4)



Note:
When assembling the FUNCTION (1) P.C.B., be careful not to bend the pin of the connectors (CB101 and CB244).

Fig. 4

When checking the P.C.B.:

- Remove the Top Cover.
- Remove 4 screws (7). (Fig. 3)
- Remove 3 screws (10). (Fig. 4)
- Remove 4 screws (11). (Fig. 4)
- Remove 1 screw (12). (Fig. 4)
- Remove 1 screw (13). (Fig. 4)
- Place the P.C.B. upright. (Fig. A and B)
- Be sure to connect the ground of Rear Panel and MAIN (1) P.C.B. (G103, G104, G241) to the chassis with a ground lead or the like.

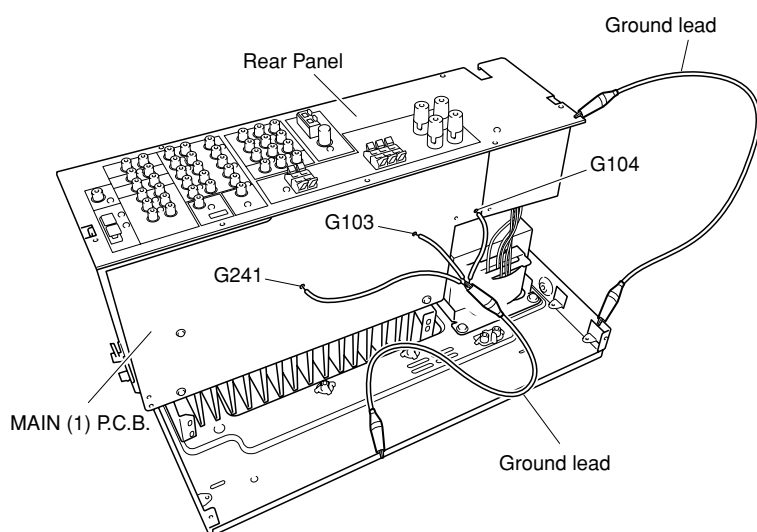

Fig. A

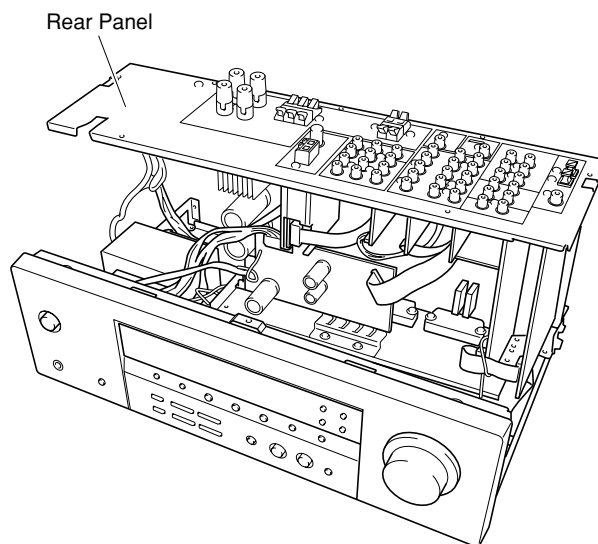

Fig. B

■ SELF DIAGNOSIS FUNCTION (DIAG)

There are 16 DIAG menu items, each of which has sub-menu items.

Listed in the table below are menu items and sub-menu items.

Note that not all menu items listed will apply to the models covered in this service manual.

No	DIAG menu	sub-menu
1	DSP THROUGH 1. ANALOG BYPASS	1. ANALOG BYPASS
		2. DSP BYPASS
		3. YSS Presence 0dB
		4. YSS FULL BIT
		5. YSS FULL BIT P
2	RAM THROUGH 2. RAM FULLBIT	1. RAM FULL BIT
		2. RAM MARGIN
3	DOLBY PRO LOGIC 3. PRO LOGIC I	1. PRO LOGIC I
		2. PRO LOGIC II
		3. Neo:6 (Not applied to these models)
4	SPEAKERS SET 4. FRNT: SML 0dB	1. FRONT: SMALL 0dB
		2. CENTER: NONE (Not applied to these models)
		3. LFE/BASS: FRONT (Not applied to these models)
		4. PRESENCE MIX: 5ch (Not applied to these models)
		5. SURROUND B power (Not applied to these models)
		6. Tone Control Flat
		7. Tone Control +10dB
		8. Tone Control -10dB
5	HP Test 5. FRONT12dB	1. FRONT 12 dB
		2. FRONT 15 dB
6	XCH INPUT 6. XCH INPUT	1. Xch INPUT
		2. LIMIT (Not applied to these models)
7	DISPLAY CHECK 7. VFD CHECK	1. VFD CHECK (Initial display)
		2. VFD DISP OFF (All segments OFF)
		3. VFD DISP ALL (All segments ON 100%)
		4. VFD DIMMER (All segments ON 50%)
		5. CHECKED PATTERN (ON in lattice)
8	MANUAL TEST 8. TEST ALL	1. TEST ALL
		2. TEST FRONT L
		3. TEST CENTER
		4. TEST FRONT R
		5. TEST SURROUND R
		6. TEST SURROUND C (Not applied to these models)
		7. TEST SURROUND L
		8. TEST LFE
9	FACTORY PRESET 9. PRESET INHI	1. PRESET INHIBITED (memory initialization inhibited)
		2. PRESET RESERVED (memory initialized)
10	AD DATA CHECK /FAN TEST DC: 28%PS: 16%	1. DC/PS (protection indication)
		2. THM/Fan
		3. REC-OUT (Not applied to these models)
		4. IMP SW/POWER LIMIT
		5. K0/K1 (panel key)
		6. FAN DRIVE TEST: HIGH (Not applied to these models)
		7. FAN DRIVE TEST: MID (Not applied to these models)
		8. FAN DRIVE TEST: LOW (Not applied to these models)
11	XM STATUS (U, C models) 1k - 1dB/44 x	1. 1k -1dB /44.1k
		2. 1k -61dB /44.1k
		3. Mute /44.1k

No	DIAG menu	sub-menu
		4. XM Tone /44.1k
		5. ISO Tone /44.1k
		6. 1k -1dB /32k
		7. 1k -61dB /32k
		8. Mute /32k
		9. XM Tone /32k
		10. ISO Tone /32k
		11. XM/DT Bus Power: OFF
12	IF STATUS <input type="text" value="IS1:2200020000"/> (Not applied to these models)	1. INSIDE STATUS 1 (5 Byte)
		2. INSIDE STATUS 2 (3 Byte)
		3. CHANNEL STATUS 1 (5 Byte)
		4. CHANNEL STATUS 2 (5 Byte)
		5. CHANNEL STATUS 3 (5 Byte)
		6. CHANNEL STATUS 4 (5 Byte)
		7. CHANNEL STATUS 5 (4 Byte)
		8. BSI (YSS) 1 (5 Byte)
		9. BSI (YSS) 2 (5 Byte)
		10. BSI (YSS) 3 (5 Byte)
		11. BSI (YSS) 4 (4 Byte)
		12. BSI (CS) 1 (5 Byte)
		13. BSI (CS) 2 (5 Byte)
		14. BSI (CS) 3 (5 Byte)
		15. BSI (CS) 4 (5 Byte)
		16. BSI (CS) 5 (1 Byte)
		17. YSS938-1 (5 Byte)
		18. YSS938-2 (5 Byte)
		19. YSS938-3 (4 Byte)
		20. SECOND DECODER (3 Byte)
		21. Mute Trigger (5 Byte)
13	DSP RAM CHECK <input type="text" value="DSP BUS:NoEr"/> (Not applied to these models)	1. DSP BUS CHECK
		2. PLD/SRAM BUS CHECK
14	SD DL CODE <input type="text" value="RDV:XXXXXXXX"/> (Not applied to these models)	1. ROM DATA Version
		2. TOC Area 0
		3. TOC Area 1
		4. TOC Area 2
		5. TOC Area 3
		6. TOC Area 4
		7. TOC Area 5
		8. Sum check Area 0
		9. Sum check Area 1
		10. Sum check Area 2
		11. Sum check Area 3
		12. Sum check Area 4
		13. Sum check Area 5
15	SOFT SWITCH <input type="text" value="15.SW :PCB"/>	1. SW MODE: PCB/SOFT
		2. MODEL SETTING: V357/V357T
		3. TUNER DESTINATION: UC/AKGTE/RL
		4. TUNER: EXIST/NOT
		5. RDS: EXIST/NOT
		6. ZONE 2: EXIST/NOT
		7. VIDEO FORMAT (Not applied to these models)
16	ROM VERSION/CHECK SUM/ PORT <input type="text" value="VER. XXXXX"/>	1. VERSION
		2. CHECK SUM ALL/PROGRAM
		3. PORT
		4. AAC PORT (Not applied to these models)

• **Starting DIAG**

Press the “STANDBY/ON” key while simultaneously pressing those two keys of the main unit as indicated in the figure below.

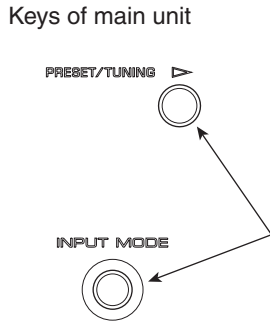

Turn on the power while pressing these keys.

• **Starting DIAG in the protection cancel mode**

If the protection function works and causes hindrance to trouble diagnosis, cancel the protection function as described below, and it will be possible to enter the DIAG mode. (The protection functions other than the excess current detect function will be disabled.)

Press the “STANDBY/ON” key while simultaneously pressing those two keys indicated in the figure above. At this time, keep pressing those two keys for 3 seconds or longer.

In this mode, the “SLEEP” segment of the FL display of the main unit flashes to indicate that the mode is DIAG mode with the protection functions disabled.

CAUTION!

Using this product with the protection function disabled may cause damage to itself. Use special care for this point when using this mode.

• **Canceling DIAG**

[1] Before canceling DIAG, execute setting for PRESET of DIAG menu No.9 (Memory initialization inhibited or Memory initialized).

* In order to keep the user memory stored, be sure to select PRESET INHIBITED (Memory initialization inhibited).

[2] Turn off the power by pressing the “STANDBY/ON” key of the main unit.

• **Display provided when DIAG started**

The FL display of the main unit displays the protection function history data and the version (1 alphabet) and the DIAG menu [sub-menu (ANALOG BYPASS) of DIAG menu No.1 DSP THROUGH] a few seconds later.

When there is no history of protection function:

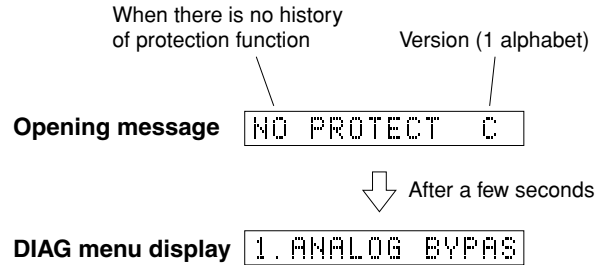

When there is a history of protection function:

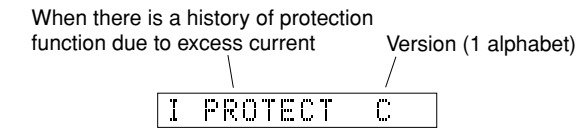

Cause: An excessive current flowed through the power amplifier.

Supplementary information: As the current through the power transistor is detected, the abnormal channel can be identified by checking the current detect transistor.

Turning on the power without correcting the abnormality will cause the protection function to work immediately and the power supply will instantly be shut off.

Note)

- Applying the power to a unit without correcting the abnormality can be dangerous and cause additional circuit damage.
- The output transistors in each amplifier channel should be checked for damage before applying any power.
- The amplifier current should be monitored by measuring across the emitter resistors for each channel.

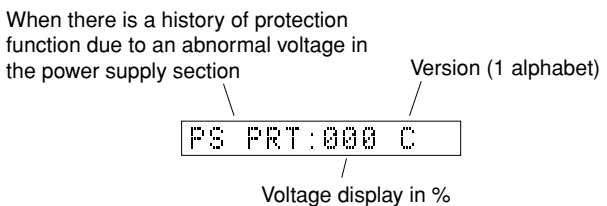

Cause: The voltage in the power supply section is abnormal.

Supplementary information: The abnormal voltage is displayed in % based on 5V as 100%.

Turning on the power without correcting the abnormality will cause the protection function to work 1 second later and the power supply will be shut off.

When there is a history of protection function due to abnormal DC output

DC PRT: C

Version (1 alphabet)

Cause: DC output of the power amplifier is abnormal.

Turning on the power without correcting the abnormality will cause the protection function to work 3 seconds later and the power supply will be shut off.

When there is a history of protection function due to excessive heat sink temperature

TMP PRT: 000 C

Version (1 alphabet)

Voltage display in %

Cause: The temperature of the heat sink is excessive.

Supplementary information: The abnormal voltage is displayed in % based on 5V as 500%.

Turning on the power without correcting the abnormality will cause the protection function to work 1 second later and the power supply will be shut off.

* Additional causes of protection can be due to loose connections, associated components, Microprocessor, etc.

* For the protection voltage value, refer to DIAG menu No.10 described later.

• History of protection function

When the protection function has worked, its history is stored in memory with a backup. Even if no abnormality is noted while servicing the unit, an abnormality which has occurred previously can be defined as long as the backup data has been stored.

The history of the protection function is cleared when DIAG is cancelled by selecting PRESET RESERVED (Memory initialized) of DIAG menu No.9 or when the backup data is erased.

• Display during menu operation

During the DIAG operation, the function at work is indicated on the FL indicator. The contents displayed during the function operation are described in the later section on details of functions.

• Operation procedure of DIAG menu and SUB-MENU

There are 15 MENU items, each of which has some SUB-MENU items.

DIAG menu selection

Main unit: Select the menu using ▷ (Forward) and ◁ (Reverse) PROGRAM keys.

SUB-MENU selection

Main unit: Select the sub-menu using - and + BASS/TREBLE keys.

Keys of main unit

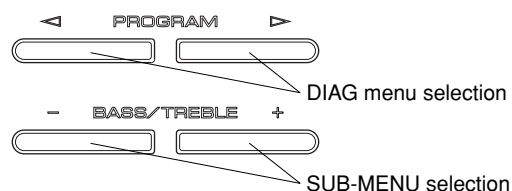

• Functions in DIAG mode

In addition to the DIAG menu items, functions as listed below are available.

- Input selection, MULTI CH input
- Center/Surround/Sub-woofer level adjustment
- Muting
- Power on/off
- Master volume

* Functions related to the tuner and the set menu are not available.

* It is possible to confirm Menu No.11 IF STATUS while keeping the signal process (operation status) of each DIAG menu by using the input mode key of the main unit.

• Initial settings used to start DIAG

The following initial settings are used when starting DIAG. When DIAG is canceled, these settings are restored to those before starting DIAG.

- Master volume: -24dB
- Input: DVD (MULTI CH INPUT OFF)
- Effect level: 0dB
- Audio mute: OFF
- Speaker setting: LARGE / BASS OUT = BOTH
- DIAG menu: DSP THROUGH (1. ANALOG BYPASS)

• Details of DIAG menu

With full-bit output specified in some modes, it is possible to execute 0dBFS output without including the head margin in each channel.

1. DSP THROUGH

Main DSP of YSS938 is selected for Front L/R output.

ANALOG BYPASS

- The signal for L/R is output as it is without passing through the DSP section.

```
1. ANALOG BYPASS
```

Reference data
 INPUT: DVD ANALOG
 SWFR: 50Hz, Others: 1kHz

Input level	Volume	SPEAKER OUTPUT (1kHz)			SUBWOOFER OUTPUT (50Hz)
		FRONT L/R	CENTER	SL/SR	
Both ch, -20 dBm	+6.0 dB	+11.5 dBm	- ∞	- ∞	- ∞

DSP BYPASS

- The signal for L/R is output as it is without passing through the DSP section.

```
1. DSP BYPASS
```

Reference data
 INPUT: DVD ANALOG
 SWFR: 50Hz, Others: 1kHz

Input level	Volume	SPEAKER OUTPUT (1kHz)			SUBWOOFER OUTPUT (50Hz)
		FRONT L/R	CENTER	SL/SR	
Both ch, -20 dBm	+6.0 dB	+11.5 dBm	- ∞	- ∞	- ∞

YSS Presence 0dB

- The Presence CH signal including the head margin is output at the Front CH.
 Head margin:
 FRONT L/R: -6dBFS, Center: 0dBFS,
 SL/SR: 0dBFS, SWFR: Add L/R signal at 0dBFS.

```
1. YSS Presence0dB
```

Reference data
 INPUT: DVD ANALOG
 SWFR: 50Hz, Others: 1kHz

Input level	Volume	SPEAKER OUTPUT (1kHz)			SUBWOOFER OUTPUT (50Hz)
		FRONT L/R	CENTER	SL/SR	
Both ch, -20 dBm	+6.0 dB	- ∞	- ∞	- ∞	- ∞

YSS FULL BIT

- The signal is output in digital full bit without including the head margin. The SWFR signal is output but not in digital full bit.

```
1. YSS FULL BIT
```

Reference data
 INPUT: DVD ANALOG
 SWFR: 50Hz, Others: 1kHz

Input level	Volume	SPEAKER OUTPUT (1kHz)			SUBWOOFER OUTPUT (50Hz)
		FRONT L/R	CENTER	SL/SR	
Both ch, -20 dBm	+6.0 dB	+11.5 dBm	+11.5 dBm	+11.5 dBm	-0.5 dBm

ANALOG BYPASS

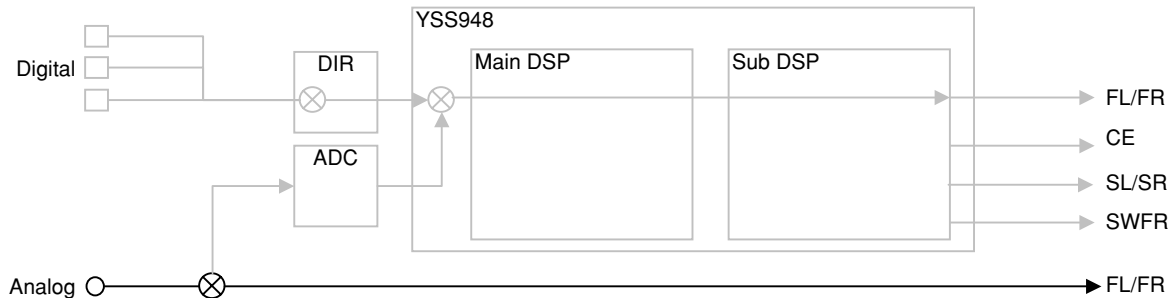

(Shaded items not used in this example)

DSP BYPASS

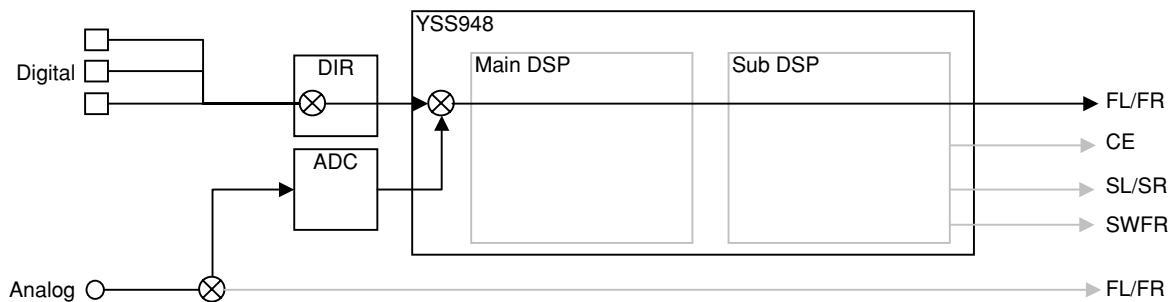

(Shaded items not used in this example)

YSS FULL BIT P

- The Presence CH signal is output in digital full bit at the Front CH.

1. FULL BIT P

Reference data

INPUT: DVD ANALOG

SWFR: 50Hz, Others: 1kHz

Input level	Volume	SPEAKER OUTPUT (1kHz)			SUBWOOFER OUTPUT (50Hz)
		FRONT L/R	CENTER	SL/SR	
Both ch, -20 dBm	+6.0 dB	-∞	-∞	-∞	-∞

YSS FULL BIT (PCM/ANALOG)

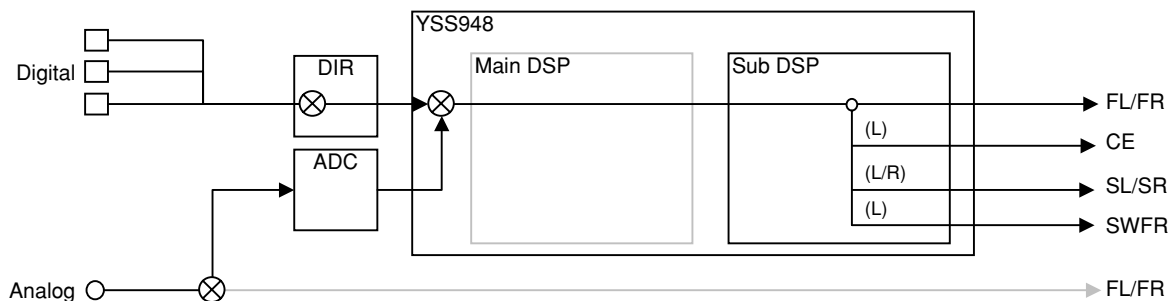

(Shaded items not used in this example)

YSS FULL BIT (DD / DTS)

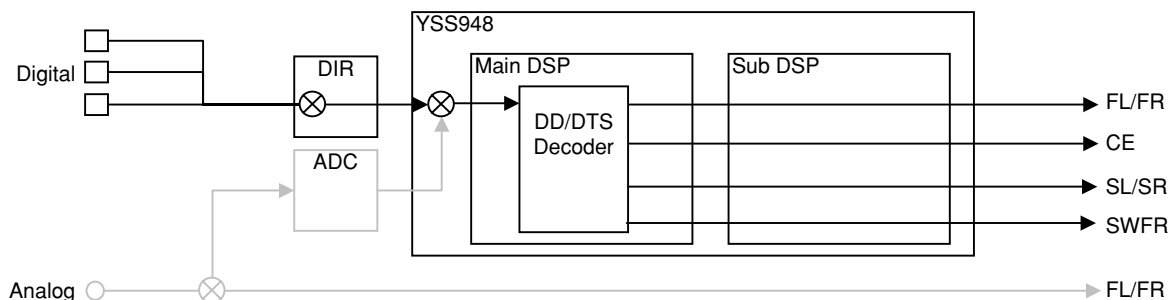

(Shaded items not used in this example)

RX-V359/HTR-5930

2. RAM THROUGH

This function is for YSS948 only.

Only the CT signal is output through the Sub DSP – DRAM.

Reference data

INPUT: DVD ANALOG

SWFR: 50Hz, Others: 1kHz

RAM FULL BIT

Input level	Volume	SPEAKER OUTPUT (1kHz)			SUBWOOFER OUTPUT (50Hz)
		FRONT L/R	CENTER	SL/SR	
Both ch, -20 dBm	+6.0 dB	+11.5 dB	+11.5 dB	+11.5 dB	-0.5 dB

RAM MARGIN

Input level	Volume	SPEAKER OUTPUT (1kHz)			SUBWOOFER OUTPUT (50Hz)
		FRONT L/R	CENTER	SL/SR	
Both ch, -20 dBm	+6.0 dB	+11.5 dB	+11.5 dB	+11.5 dB	-0.5 dB

Input level	Volume	SPEAKER OUTPUT (1kHz)			SUBWOOFER OUTPUT (50Hz)
		FRONT L/R	CENTER	SL/SR	
Both ch, -20 dBm	+6.0 dB	-∞	+5.5 dBm	-∞	-∞

RAM THROUGH (PCM / ANALOG)

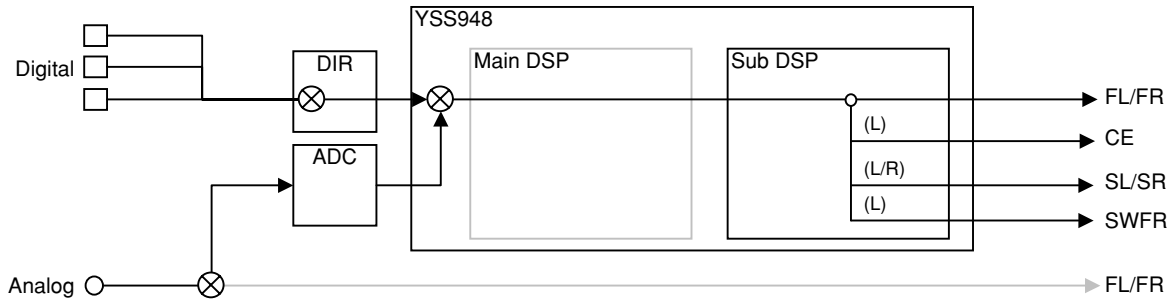

(Shaded items not used in this example)

RAM THROUGH (DD / DTS)

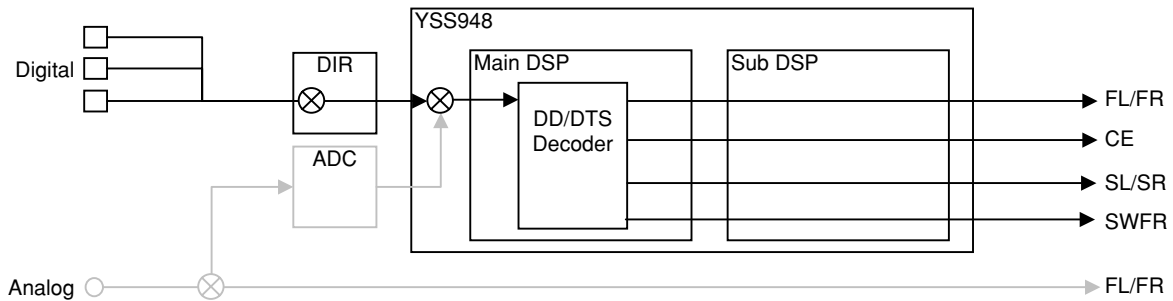

(Shaded items not used in this example)

3. PRO LOGIC

PRO LOGIC I

3. PRO LOGIC I

Reference data

INPUT: DVD ANALOG

SWFR: 50Hz, Others: 1kHz

Input level	Volume	SPEAKER OUTPUT (1kHz)			SUBWOOFER OUTPUT (50Hz)
		FRONT L/R	CENTER	SL/SR	
Each ch, -20 dBm	+6.0 dB	+11.5 dBm	- ∞	- ∞	- ∞
Both ch, -20 dBm	+6.0 dB	- ∞	+14.5 dBm	- ∞	- ∞

PRO LOGIC II

3. PRO LOGIC II

Reference data

INPUT: DVD ANALOG

SWFR: 50Hz, Others: 1kHz

Input level	Volume	SPEAKER OUTPUT (1kHz)			SUBWOOFER OUTPUT (50Hz)
		FRONT L/R	CENTER	SL/SR	
Each ch, -20 dBm	+6.0 dB	+11.5 dBm	- ∞	- ∞	- ∞
Both ch, -20 dBm	+6.0 dB	- ∞	+14.5 dBm	- ∞	- ∞

The L/C/R/SL/SR signals undergo the Pro-Logic processing and C/SL/SR signals are output through Sub DSP-DRAM. The Main DSP is selected for FRONT L/R output.

Using the sub-menu, it is possible to select PRO LOGIC I, II (Movie). The Auto Input Balance function is always off. When the Dolby Digital Multi input is used, the function is the same as in the Dolby Digital Normal mode. The LFE signal is not output when decoding in the PRO LOGIC I, II mode.

PRO LOGIC (PCM / Analog)

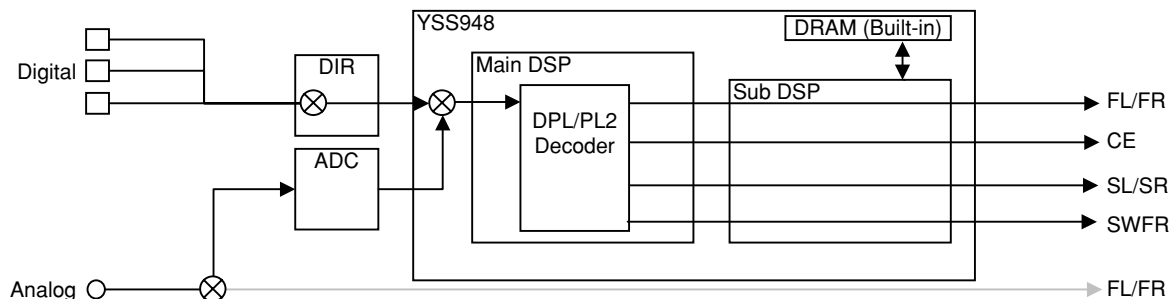

(Shaded items not used in this example)

Neo:6

(Not applied to these models.)

3. Neo:6

4. SPEAKERS SET

The input signal is automatically identified and switched in the priority order of dts → DOLBY DIGITAL → PCM AUDIO → Analog (A/D) according to the signal detection.

The signals output from the DSP block are the same as 1. DSP THROUGH: YSS 0dB.

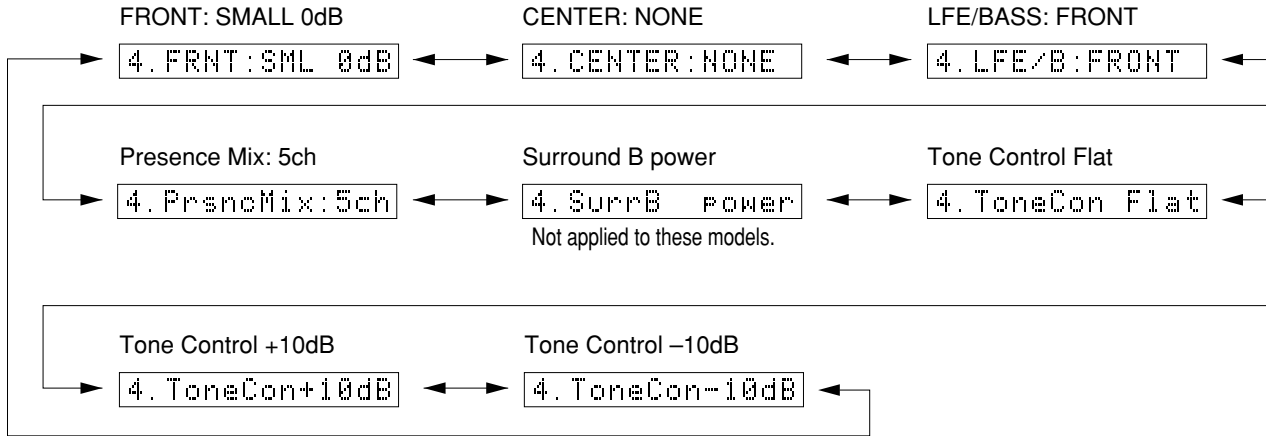

The analog switch settings for each sub-menu are as shown in the table below.

Sub-menu		CENTER SP	SURROUND SP	FRONT SP	FRONT LEVEL	LFE/BASS
1	FRONT: SMALL 0dB	LARGE	LARGE	SMALL	0dB	SWFR
2	CENTER: NONE (Not applied to these models.)	NONE	LARGE	LARGE	0dB	SWFR
3	LFE/BASS: FRONT (Not applied to these models.)	SMALL	SMALL	LARGE	0dB	FRONT
4	Presence Mix: 5CH (Not applied to these models.)	-	-	-	0dB	-

- LARGE:** This mode is used with a speaker having high bass reproduction performance (a large unit). Full bandwidth signals are output.
- SMALL:** This mode is used with a speaker having low bass reproduction performance (a small unit). The signals of 90Hz or less are mixed into the channel specified by LFE/BASS.
- NONE:** This mode is used with no center speaker. The center content is reduced by 3dB and distributed to FRONT L/R.

- FRONT:** LFE of 5.1ch signal or LFE/BASS lower than 90Hz is distributed to FRONT L/R.
- SWFR:** LFE of 5.1ch signal or LFE/BASS lower than 90Hz is output through SUBWOOFER OUT.

Sub-menu		Treble	Bass
6	Tone Control Flat	0 dB	0 dB
7	Tone Control +10dB	+10 dB	+10 dB
8	Tone Control -10dB	-10 dB	-10 dB

Reference data
INPUT: DVD ANALOG (Both ch)

Sub-menu	Input level	Volume	SPEAKER OUTPUT (1kHz)			SUBWOOFER OUTPUT (50Hz)
			FRONT L/R	CENTER	SL/SR	
1 FRONT: SMALL 0dB	1kHz Both ch, -20 dBm	+6.0 dB	+11.5 dBm	- ∞	- ∞	- ∞
2 CENTER: NONE (Not applied to these models.)	1kHz Both ch, -20 dBm	+6.0 dB	+8.9 dBm	- ∞	- ∞	- ∞
3 LFE/BASS: FRONT (Not applied to these models.)	50Hz Both ch, -20 dBm	+6.0 dB	- ∞	- ∞	- ∞	- ∞
4 Presence Mix: 5ch (Not applied to these models.)	1kHz Both ch, -20 dBm	+6.0 dB	+11.5 dBm	- ∞	- ∞	- ∞
5 Surround B Power (Not applied to these models.)	1kHz Both ch, -20 dBm	+6.0 dB	- ∞	- ∞	- ∞	- ∞
6 Tone Control Flat	1kHz Both ch, -20 dBm	+6.0 dB	+11.5 dBm	+11.5 dBm	+11.5 dBm	- ∞
7 Tone Control +10dB	1kHz Both ch, -20 dBm	+6.0 dB	+13.4 dBm	+11.5 dBm	+11.5 dBm	- ∞
8 Tone Control -10dB	1kHz Both ch, -20 dBm	+6.0 dB	+9.6 dBm	+11.5 dBm	+11.5 dBm	- ∞

5. HP Test

The signal is output including the head margin.

FRONT 12dB MARGIN

5. FRONT12dB

Reference data

INPUT: DVD ANALOG

SWFR: 50Hz, Others: 1kHz

Input level	Volume	SPEAKER OUTPUT (1kHz)			SUBWOOFER OUTPUT (50Hz)
		FRONT L/R	CENTER	SL/SR	
Both ch, -20 dBm	+6.0 dB	+23.5 dBm	- ∞	- ∞	- ∞

FRONT 15dB MARGIN

5. FRONT15dB

Reference data

INPUT: DVD ANALOG

SWFR: 50Hz, Others: 1kHz

Input level	Volume	SPEAKER OUTPUT (1kHz)			SUBWOOFER OUTPUT (50Hz)
		FRONT L/R	CENTER	SL/SR	
Both ch, -20 dBm	+6.0 dB	+23.5 dBm	- ∞	- ∞	- ∞

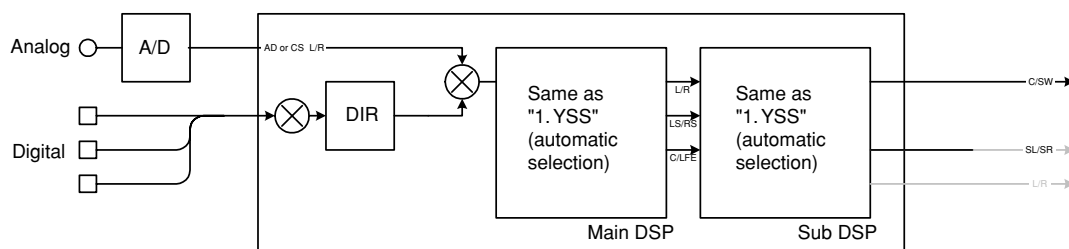

(Shaded items not used in this example)

6. XCH INPUT

The signal input through the MULTI CH INPUT terminals is output.

EXTERNAL DECODER

6. XCH INPUT

Reference data

INPUT: 6CH INPUT

SWFR: 50Hz, Others: 1kHz

Input level	Volume	SPEAKER OUTPUT (1kHz)			SUBWOOFER OUTPUT (50Hz)
		FRONT L/R	CENTER	SL/SR	
Both ch, -20 dBm	+6.0 dB	+11.5 dBm	+11.5 dBm	+11.5 dBm	-10.5 dBm

7. DISPLAY CHECK

This program is used to check the FL display section. The display condition varies as shown below according to the sub-menu operation. The signals are processed using EFFECT OFF (The L/R signal is output using ANALOG FRONT BYPASS.)

Regarding internal/external synchronization selection of the image signals by the microprocessor control, the internal synchronization is selected when the initial display is provided and when all FL's light up and the external synchronization at any other time.

Also, except when the initial display is provided, 128 characters for confirmation of the OSD driver are displayed as the image output.

Segment conditions of the FL driver and the FL tube are checked by turning ON and OFF all segments. Next, the operation of the FL driver is checked by using the dimmer control. Then a short between segments next to each other is checked by turning ON and OFF all segments alternately (in lattice). (In the example below, the segments in the second row from the top are shorted.)

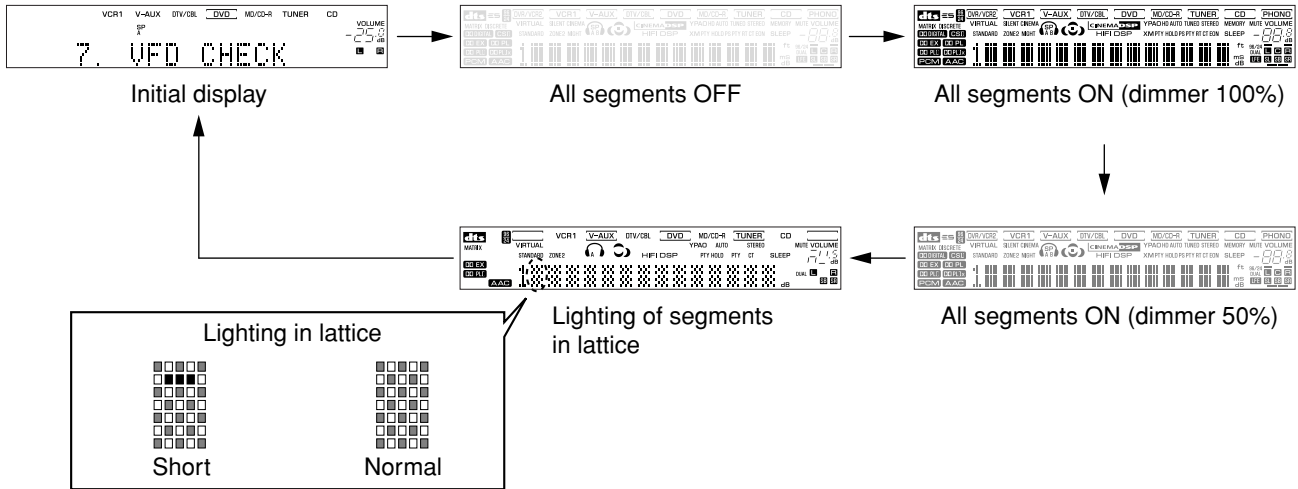

8. MANUAL TEST

The noise generator built into the DSP outputs the test noise through the channels specified by the sub-menu. The noise frequency for LFE is 35 to 250 Hz. Other than that, the center frequency is 800Hz.

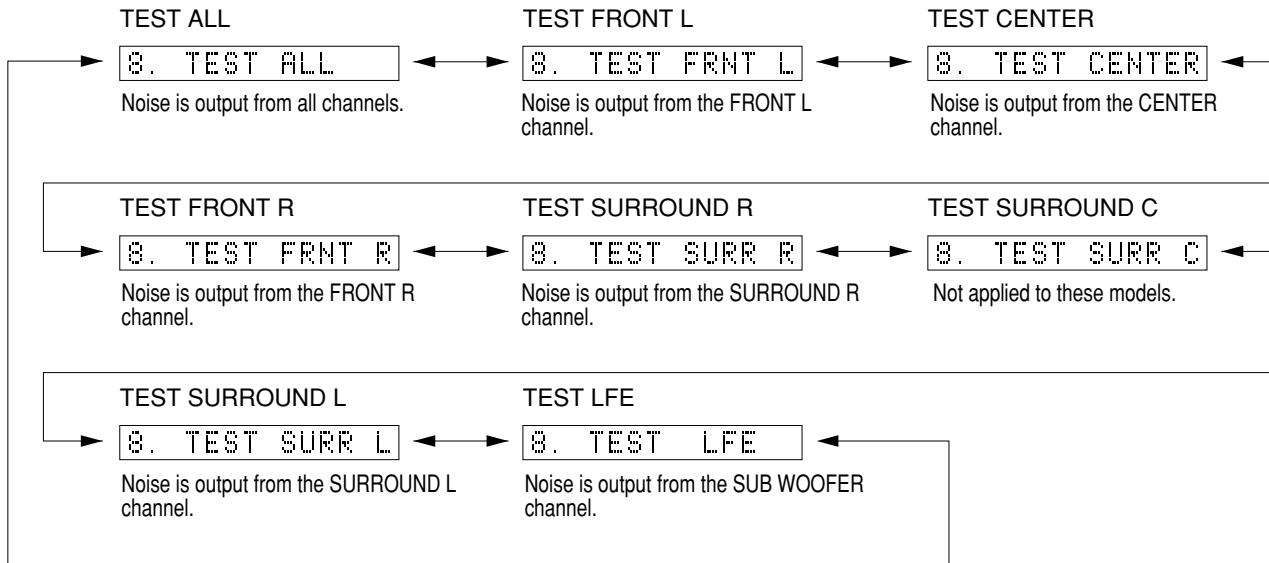

RX-V359/HTR-5930

9. FACTORY PRESET

This menu is used to reserve and inhibit initialization of the back-up RAM. The signals are processed using EFFECT OFF. (The L/R signal is output using ANALOG FRONT BYPASS.)

9. PRESET INHI



9. PRESET RSRV

PRESET INHIBIT (Initialization inhibited)

RAM initialization is not executed. Select this sub-menu to protect the values set by the user. The production history is not erased using this sub-menu.

PRESET RESERVED (Initialization reserved)

Initialization of the back-up RAM is reserved. (Actually, initialization is executed the next time that the power is turned on.) Select this sub-menu to reset to the original factory settings or to reset the RAM. The production history is not erased using this sub-menu.

CAUTION: Before setting to the PRESET RESERVED, write down the existing preset memory content of the Tuner in a table as shown below. (This is because setting to the PRESET RESERVED will cause the user memory content to be erased.)

Preset group	P1	P2	P3	P4	P5	P6	P7	P8
A								
B								
C								
D								
E								

• PRESET STATIONS

STATION		FM FACTORY PRESET DATA (MHz)	
PAGE	NO.	U, C	R, T, K, A, B, G, L, E
A/C/E	1	87.5	87.5
	2	90.1	90.1
	3	95.1	95.1
	4	98.1	98.10
	5	107.9	108.0
	6	88.1	88.1
	7	106.1	106.1
	8	107.9	108.0

STATION		AM FACTORY PRESET DATA (kHz)	
PAGE	NO.	U, C, R	T, K, A, B, G, L, E
B/D	1	630	630
	2	1080	1080
	3	1440	1440
	4	530	531
	5	1710	1611
	6	900	900
	7	1350	1350
	8	1400	1404

RX-V359/HTR-5930

10. AD DATA CHECK/FAN TEST

This menu is used to display the A/D conversion value of the terminals which detects panel keys of the main unit and protection functions in % using the sub-menu. During signal processing, the condition before execution is maintained.

* The figures in the diagram are given as reference only.

DC/PS (protection detection)

DC: DC protection value

Normal value: 17 to 29 (Reference: 5V=100%)

If DC is out of the normal value range, the protection function works to turn off the power.

PS: Power supply voltage protection value

Normal value: 12 to 26 (Reference: 5V=100%)

If PS is out of the normal value range, the protection function works to turn off the power.

DC: 23% PS: 16%

THM/Fan (temperature detection/fan drive level)

THM: Temperature detection value

Normal value: 30 to 147 (Reference: 5V=500%)

If THM is out of the normal value range, the protection function works to turn off the power.

Fan: Current fan drive level on the left and the past fan drive history on the right.

(Not applied to these models.)

THM 43% Fan L/_

REC-OUT

Not applied to these models.

REC-OUT:

IMP SW/POWER LIMIT (Impedance/power limiter detection)

IMP: 8 or 6 ohms impedance switch setting (U, C models)

PL: Power limiter detection value (Reference: 5.0V=255%)

The voltage value of pin No. 91 of IC242 is displayed.

The port (pin No. 4 of IC242) output is controlled by using the input voltage.

value of pin No. 91 of IC242.

When higher than VthH, the port output is changed from H to L.

When lower than VthL, the port output is changed from L to H.

Note:

Vth=Threshold voltage

Detection level

PORT	VthL	VthH	
No. 91	2.41V	2.90V	U, C models (8ohms)
	2.77V	3.25V	U, C models (6ohms)
	2.77V	3.25V	R, T, K, A, B, G, E, L models (6ohms)

Output level

PORT	VthL	VthH	
No. 4	2.22V	4.8V	U, C models (8ohms)
	2.0V	4.8V	U, C models (6ohms)
	2.0V	4.8V	R, T, K, A, B, G, E, L models (6ohms)

IMP: 8 PL: 255%

K0/K1 (Panel key of main unit) (Reference: 5V=100%)

A/D of the key fails to function properly when the standard value is deviated. In this case, check the constant of partial pressure resistor, solder condition, etc. Refer to table 1.

K0: 100% K1: 100%

[Table 1]

U, C, R, T, K, A, L models

Display (%)	K0	K1
0 - 6	MULTI CH INPUT	TUNING MODE
7 - 13	INPUT SELECT RIGHT	MEMORY
14 - 21	INPUT SELECT LEFT	PRESET / TUNING >
22 - 31	INPUT MODE	PRESET / < TUNING
32 - 41	PROGRAM >	A/B/C/D/E
42 - 53	< PROGRAM	FM/AM
54 - 63	BASS / TREBLE +	PRESET / TUNING
64 - 72	BASS / TREBLE -	-
73 - 80	STRAIGHT	-
81 - 88	TONE CONTROL	-
89 - 95	SPEAKERS	-
96-100	KEY OFF	KEY OFF

B, G, E models

Display (%)	K0	K1
0 - 6	MULTI CH INPUT	TUNING MODE
7 - 13	INPUT SELECT RIGHT	MEMORY
14 - 21	INPUT SELECT LEFT	PRESET / TUNING >
22 - 31	INPUT MODE	PRESET / < TUNING
32 - 41	PROGRAM >	A/B/C/D/E
42 - 53	< PROGRAM	FM/AM
54 - 63	BASS / TREBLE +	PRESET / TUNING
64 - 72	BASS / TREBLE -	PTY SEEK MODE
73 - 80	STRAIGHT	PTY SEEK START
81 - 88	TONE CONTROL	EON
89 - 95	SPEAKERS	RDS MODE
96-100	KEY OFF	KEY OFF

When K0/K1 menu is selected, keys become non-operable due to detection of the values of all keys. However, it is possible to advance to the next sub-menu by turning the VOLUME of the main unit. When using this function, note that turning the VOLUME more than 2 clicks will cause the volume value to change.

FAN DRIVE TEST (Not applied to these models.)

HIGH

FAN TEST: HIGH

FAN DRIVE TEST (Not applied to these models.)

MID

FAN TEST: MID

FAN DRIVE TEST (Not applied to these models.)

LOW

FAN TEST: LOW

11. XM STATUS (U, C models)

The output check of XM Radio Antenna is executed.

1k -1dB/44.1k

The test tone (1kHz, -1dB/44.1kHz) is output.

```
1k - 1dB/44 x
```

XM Tone/32k

The XM tone (32kHz) is output.

```
XM Tone/32 x
```

1k -61dB/44.1k

The test tone (1kHz, -61dB/44.1kHz) is output.

```
1k -61dB/44 x
```

ISO Tone/32k

The ISO tone (32kHz) is output.

```
ISO Tone/32 x
```

Mute /44.1k

Nothing is output.

```
Mute /44 x
```

XM/DT Bus Power: OFF

The power of XM module is turned off.

```
Bus Power:OFF
```

XM Tone/44.1k

The XM tone (44.1kHz) is output.

```
XM Tone/44 x
```

ISO Tone/44.1k

The ISO tone (44.1kHz) is output.

```
ISO Tone/44 x
```

1k -1dB/32k

The test tone (1kHz, -1dB/32kHz) is output.

```
1k - 1dB/32 x
```

1k -61dB/32k

The test tone (1kHz, -61dB/32kHz) is output.

```
1k -61dB/32 x
```

Mute /32k

Nothing is output.

```
Mute /32 x
```

12. IF STATUS (Input function status)

(Not applied to these models.)

Using the sub-menu, the status data is displayed one after another in the hexadecimal notation.

During signal processing, the status before execution of this menu is maintained.

* Numeric values in the figure example are for reference.

IS1, 2 (Internal status):

Indicates the status information of the microprocessor.

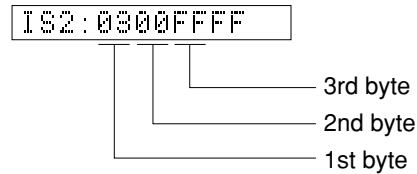
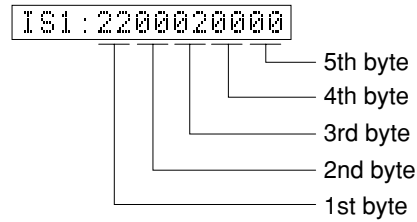

<1st byte> Digital input/output setting value

Upper 4 bits: REC OUT selected /

lower 4 bits: INPUT selected

Value	Choice	Preset name
0	NONE	
1	OPTA	
2	OPTB	DTV/CBL
3	OPTC	DVD
4	OPTD	
6	OPTF	
8	COAXA	CD
9	COAXB	

<2nd byte> Fs information of reproduction signal

Display	00	01	02	03	04	05	06	0A	0B	0C	0D
Fs (kHz)	Analog	32	44.1	48	64	88.2	96	Unknown NRM	Unknown DBL	Unknown QUAD	Not defined

<3rd byte> Audio code mode information of reproduction signal

Display	00	01	02	03	04	05	06	07	08	09	0A	0B	0C	0D
Audio Code	1+1	1/0	2/0	3/0	2/1	3/1	2/2	3/2	2/3	3/3	OVER 6.1	MULTI MONO	MULTI PCE	Unknown

<4th byte> Format information of reproduction signal

*1: Analog processing used for digital reproduction is not possible because of a commercial bit or 4-ch audio reason.

Display	Signal format
00	Analog (Unlock)
01	*1
10	PCM Audio
20	Digital Data
21	IEC1937 Data
22	None PCM
23	Unknown
50	dts
51	Red dts
54	dts-ES MATRIX
58	dts-ES DISCRETE
5C	dts-ES (Both flag)
60	AAC
C0	Dolby Digital
C1	D.D. Karaoke
C4	D.D.6.1 (D.D.EX)

<5th byte> Signal processing status information

*2: With digital signals other than 32kHz, 44.1kHz and 48kHz, through processing method is used for reproducable signals.

bit7	MUTE request	bit3	–
bit6	Red dts flashing	bit2	Through & bypass (*2)
bit5	6.1/EX processing	bit1	–
bit4	FULL MUTE (ON: 1)	bit0	dts analog mute

CS1-5: Indicates channel status information of the input signal (IEC60958).

CS1: FFFFFFFF --- CS5: FFFFFFFF

BY1-4: Indicates information of the bit stream included in the DOLBY DIGITAL signal.

BY1: FFFFFFFF --- BY4: FFFFFFFF

BS1-5: Indicates information of the bit stream included in the dts signal.

BS1: FFFFFFFF --- BS5: 1B

YS1-3: Indicates device status information of YSS938 (IC601).

* The numeric value in the figure is an example for reference.

YS1: A382000069

Byte No.	Function
1	YSS MUTE Reg
2	YSS MODE Reg
3	YSS IPORT BIT 7-0
4	YSS IPORT BIT 14-8
5	YSS OPORT

YS2: 0000000000

Byte No.	Function
1	IEC 1937 Preamble Pc
2	Data Stream Reg
3	Status Reg
4	YSS ZERO Reg
5	MIREG

YS3: 6006603D

Byte No.	Function
1	DIR Status
2	DIR fs
3	DIR fs count
4	YSS ZERO BF

SD: CS49329 unsolicited messages (AUTODETECT_RESPONSE)

SD : FFFFFFFF

MTT: Mute trigger

MTT: 0018001800

Byte No.	Function
1	Mute condition
2	Factor of the last mute
3	Error count of YSS938-FSCNT
4	Mute count by YSS938-FSCNT
5	Error factor of down load of CS49329

13. DSP RAM CHECK

(Not applied to these models.)

This menu is used to self-diagnose whether or not the bus connection for the YSS948 and the external RAM is made properly.

During signal processing, the status before execution of this menu is maintained.

The address bus and the data bus are checked and the connection condition is displayed.

When no error is detected, "NoEr" appears on display.

DSP Bus Check

DSP BUS: NoEr

Display	Description
WAIT	Bus is being checked.
NoEr	No error detected.
DATA	Data bus shorted or open.
RSCS	/RAS or /CAS shorted, or open.
ADDR	Address bus shorted or open.

PLD / SRAM BUS CHECK

SD BUS: None

Display	Description
WAIT	Bus is being checked.
None	No error detected.
EDxx	Data bus shorted or open. (XX: 00-07)
EAXx	Address bus shorted or open. (XX: 00-0E)

14. SD DL CODE

(Not applied to these models.)

This menu is used to display the data version of the FLASH ROM, TOC information and sum calculated value for the second decoder.

RDV

Displays the data version.

```
RDV:XXXXXXXX
```

TA 0-5

Displays the TOC information.

```
TA0:FFFFFFFF
```

SA 0-5

Displays the sum calculated value.

```
SA0:FFFFFFFF
```

15. SOFT SW

This menu is used to switch the function settings on the P.C.B. through the software so as to activate the product. The protection function follows the P.C.B. settings. When connected to AC or in the maker preset state, the unit is initialized to the P.C. B. setting. Display of each function after initialization varies depending on settings on P.C.B. The operation mode can be changed by selecting the sub-menu and then using the EFFECT key. With SOF selected for the SW mode, the settings become effective.

SW MODE: PCB or SOFT can be selected.

```
15. SW : PCB
```

MODEL SETTING: V359 only.

```
15. MODEL: V359
```

TUNER DESTINATION: UC, AKGTE or RL can be selected.

```
15. DEST : UC
```

TUNER: NOT or EXIST can be selected.

```
15. TUNER: EXIST
```

RDS: NOT or EXIST can be selected.

```
15. RDS : NOT
```

ZONE2: NOT or EXIST can be selected.

```
15. ZONE2: NOT
```

VIDEO FORMAT: NTSC or PAL can be selected.
(Not applied to these models.)

```
15. VIDEO: -----
```

16. MICROPROCESSOR INFORMATION

The version, checksum and the port specified by the microprocessor are displayed. The signal is processed using EFFECT OFF. The checksum is obtained by adding the data at every 8 bits for each program area and expressing the result as a 4-figure hexadecimal data.

* Nomic values in the figure example are for reference.

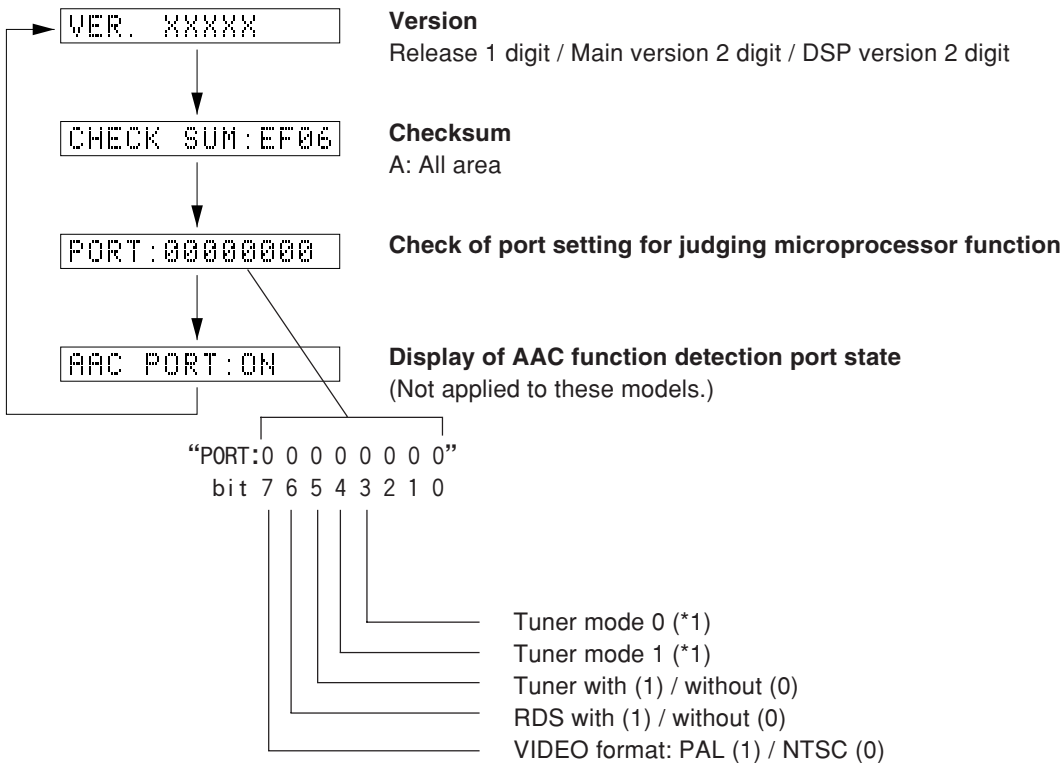

*1

Type	Tuner mode		Port 3 (type 2)	Frequency range	
	1	0		FM	AM
0	0	0	—	76.0-90.0MHz / 100kHz	531-1611kHz / 9kHz
1	1	0	—	87.5-108.0MHz / 50kHz	531-1611kHz / 9kHz
2	0	1	—	87.5-107.9MHz / 200kHz	530-1710kHz / 10kHz
3	1	1	Low	87.5-108.0MHz / 100kHz	530-1710kHz / 10kHz
			High	87.5-108.0MHz / 50kHz	531-1611kHz / 9kHz

RX-V359/HTR-5930

■ CONFIRMATION OF IDLING CURRENT

Confirmation of Idling Current of MAIN (1) P. C. B.

- Right after the power is turned on, confirm that the voltage across the terminals of R157 (FRONT Lch), R158 (FRONT Rch), R148 (CENTER), R156 (SURROUND Lch), R159 (SURROUND Rch) are between 0.1mV and 10.0mV.

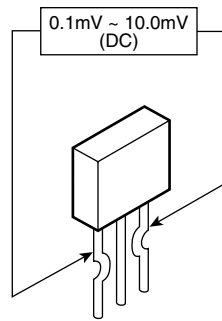

R157 (FRONT Lch)
R158 (FRONT Rch)
R148 (CENTER)
R156 (SURROUND Lch)
R159 (SURROUND Rch)

DISPLAY DATA

● V551 : 17-BT-24GNK (WE289300)

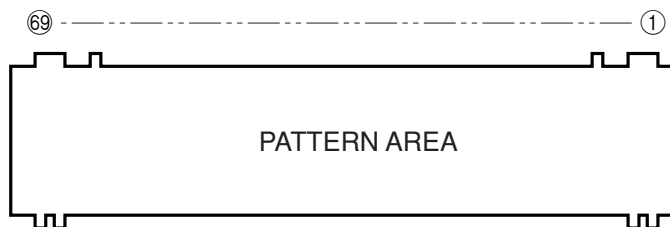

● PIN CONNECTION

Pin No.	69	68	67	66	65	64	63	62	61	60	59	58	57	56	55	54	53	52	51	50	49	48	47	46	45	44	43	42	41	40	39	38	37	36	35
Connection	F2	NX	NP	NP	P1	P2	P3	P4	P5	P6	P7	P8	P9	P10	P11	P12	P13	P14	P15	P16	P17	P18	P19	P20	P21	P22	P23	P24	P25	P26	P27	P28	P29	P30	P31

Pin No.	34	33	32	31	30	29	28	27	26	25	24	23	22	21	20	19	18	17	16	15	14	13	12	11	10	9	8	7	6	5	4	3	2	1
Connection	P32	P33	P34	P35	P36	P37	NX	NX	NX	NX	NX	NX	NX	17G	16G	15G	14G	13G	12G	11G	10G	9G	8G	7G	6G	5G	4G	3G	2G	1G	NP	NP	NX	F1

Note : 1) F1, F2 Filament 2) NP No pin 3) NX No extened pin 4) DL Datum line 5) 1G ~ 16G Grid

● GRID ASSIGNMENT

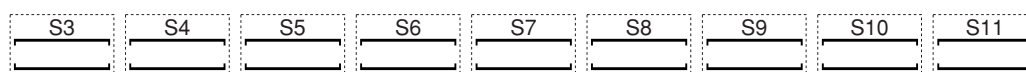
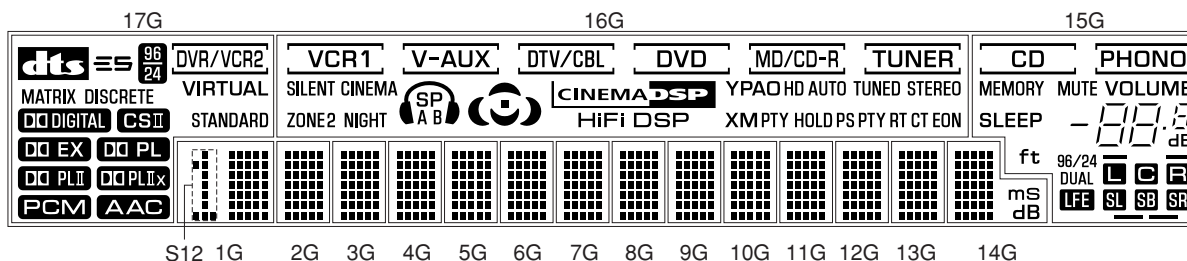

(17G~15G)

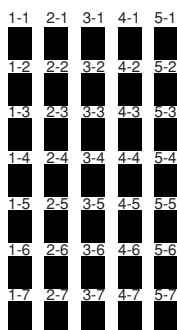

(1G~14G)

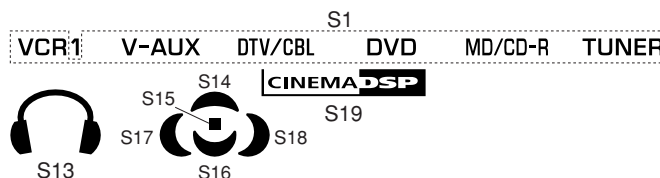

(16G)

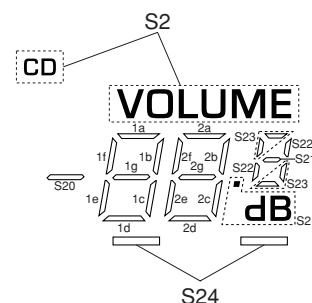

(15G)

RX-V359/HTR-5930

● ANODE CONNECTION

	17G	16G	15G	14G	13G~2G	1G
P1	dtS	EON	SLEEP	1-1	1-1	1-1
P2	ES	CT	MEMORY	2-1	2-1	2-1
P3	MATRIX	RT	MUTE	3-1	3-1	3-1
P4	DISCRETE	PTY	S20	4-1	4-1	4-1
P5	96 24	PS	1a	5-1	5-1	5-1
P6	DD DIGITAL	PTY HOLD	1b	1-2	1-2	1-2
P7	DD EX	XM	1c	2-2	2-2	2-2
P8	DD PL	S14	1d	3-2	3-2	3-2
P9	DD PL II	S15	1e	4-2	4-2	4-2
P10	DD PL IIx	S16	1f	5-2	5-2	5-2
P11	AAC	S17	1g	1-3	1-3	1-3
P12	PCM	S18	2a	2-3	2-3	2-3
P13	STANDARD	SILENT CINEMA	2b	3-3	3-3	3-3
P14	CSI	S13	2c	4-3	4-3	4-3
P15	VIRTUAL	SP	2d	5-3	5-3	5-3
P16	DVR/VCR2	A	2e	1-4	1-4	1-4
P17	S3	B	2f	2-4	2-4	2-4
P18	—	ZONE2	2g	3-4	3-4	3-4
P19	—	NIGHT	S2	4-4	4-4	4-4
P20	—	HiFi DSP	S10	5-4	5-4	5-4
P21	—	S19	S11	1-5	1-5	1-5
P22	—	YPAO	PHONO	2-5	2-5	2-5
P23	—	HD	S21	3-5	3-5	3-5
P24	—	AUTO	S22	4-5	4-5	4-5
P25	—	TUNED	S23	5-5	5-5	5-5
P26	—	STEREO	ft	1-6	1-6	1-6
P27	—	S4	S24	2-6	2-6	2-6
P28	—	S5	96/24	3-6	3-6	3-6
P29	—	S6	DUAL	4-6	4-6	4-6
P30	—	S7	LFE	5-6	5-6	5-6
P31	—	S8	L	1-7	1-7	1-7
P32	—	S9	C	2-7	2-7	2-7
P33	—	⋮	R	3-7	3-7	3-7
P34	—	S1	SL	4-7	4-7	4-7
P35	—	—	SB	5-7	5-7	5-7
P36	—	—	SR	ms	—	S12
P37	—	—	S25	dB	—	—

■ IC DATA

IC242: M30622MWP-A82FP (MAIN P.C.B.)

16-bit Microprocessor

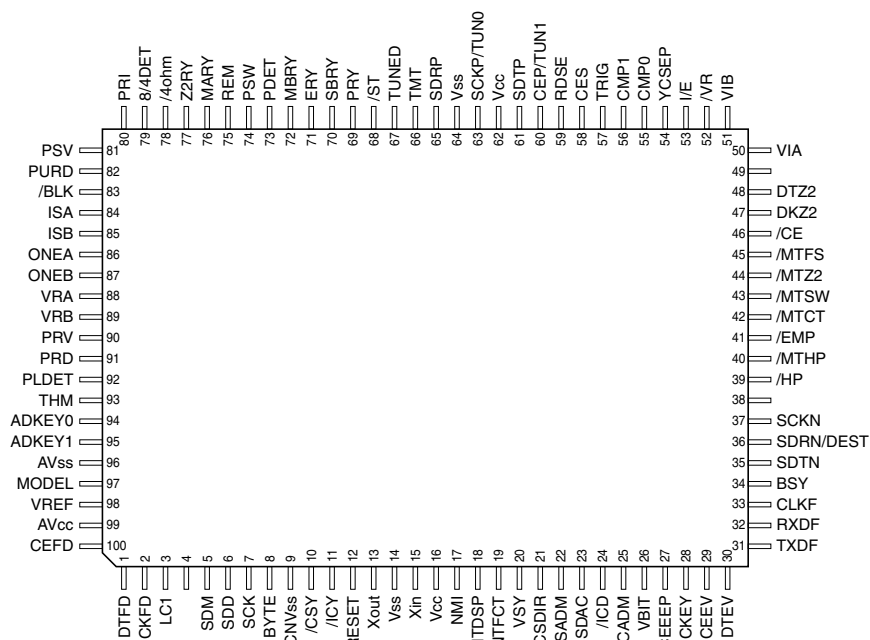

No.	Port Name	Terminal Name	I/O			Function
			PowerOn	Standby	Sleep	
1	P96/ANEX1/SOUT4	DTFD	SO	O	O	FL Driver TxD
2	P95/ANEX0/CLK4	CKFD	SO	O	O	FL Driver CLOCK
3	P94/DA1/TB4in	/BLK	O	O	O	FL Driver turning off
4	P93/DA0/TB3in	LIMA	DA	O	O	Limiter control output
5	P92/TB2in/SOUT3	SDM	SO	O	O	TxD to YSS948/LC89057W, Serial data output
6	P91/TB1in/SIN3	SDD	SI	O	O	RxD from YSS948/LC89057W, Serial data input
7	P90/TB0in/CLK3	SCK	SO	O	O	Clock supply to YSS948/LC89057W, Serial data clock output
8	BYTE	BYTE	MCU	MCU	MCU	Vss : When single chip mode is used
9	CNVss	CNVss	MCU	MCU	MCU	Vss : When single chip mode is used, Vcc : When flash writing is used
10	P87/Xcin	/CSADM	O	O	O	YSS948 chip select CE
11	P86/Xcout	/ICDADM	O	O	O	Initial clear to YSS948
12	/RESET	/RESET	MCU	MCU	MCU	Reset
13	Xout	Xout	MCU	MCU	MCU	Oscillation output (oscillation stopped in Sleep mode)
14	Vss	Vss	MCU	MCU	MCU	Ground for micro-processor
15	Xin	Xin	MCU	MCU	MCU	Oscillation input
16	Vcc1	Vcc	MCU	MCU	MCU	Power supply +5V for micro-processor
17	P85/NMI	NMI	MCU	MCU	MCU	Unused, connected to Vcc
18	P84/INT2	/INTADM	IRQ	O	O	Interruption from YSS948
19	P83/INT1	/INTDIR	IRQ	O	O	Interruption from DIR LC89057W
20	P82/INT0	REM	IRQ	IRQ	O	Interruption from remote control input
21	P81/TA4in/U	/CSDIR	O	O	O	DIR LC89057W chip select
22	P80/TA4out/U	/ICDIR	O	O	O	DIR LC89057W reset
23	P77/TA3in	/HP	I+	O	O	HEAD PHONE detection
24	P76/TA3out	VRA	I+	O	O	Volume Rotaly Encoder A
25	P75/TA2in/W	VRB	I+	O	O	Volume Rotaly Encoder A
26	P74/TA2out/W	-	I	O	O	Unconnected
27	P73/CTS2/RTS2/TA1in/V	/ICCDC	O	O	O	CODEC reset
28	P72/CLK2/TA1out/V	-	O	O	O	Unconnected
29	P71/RXD2/SCL2/TA0in/TB5in	FSCXM	TMR	O	O	XM voice signal fs detection (32 k/44.1 k)
30	P70/TXD2/SDA2/TA0out	-	O	O	O	Unconnected
31	P67/TXD1	TXDF	SO	O	O	Serial light data transmission of Flash ROM TxD
32	P66/RXD1	RXDF	SO	O	O	Serial data reception of Flash ROM RxD

IC242: M30622MWP-A82FP (MAIN P.C.B.)
 16-bit Microprocessor

No.	Port Name	Terminal Name	I/O			Function
			PowerOn	Standby	Sleep	
33	P65/CLK1	CLKF	SO	O	O	Serial clock of Flash ROM clock
34	P64/CTS1/RTS1/CTS0/CLKS1	BSY	O	O	O	BUSY signal output of Flash ROM clock
35	P63/TXD0/SDA0	DTXM	SO	O	O	Serial data transmission for XM IC (UART0)
36	P62/RXD0/SCL0	DRXM	SI	O	O	Serial data reception for XM IC (UART0)
37	P61/CLK0	/ICXM	O	O	O	Chip select for XM IC
38	P60/CTS0/RTS0	/CEEEP	O	O	O	Chip select for EEPROM writing
39	P57/RDY/CLKout	–	O	O	O	Unconnected
40	P56/ALE	–	O	O	O	Unconnected
41	P55/HOLD	/EMP	I	I	I	For FLASH writing (LO)
42	P54/HLDA	–	O	O	O	Unconnected
43	P53/BCLK	BD_DATA	O	O	O	Data output of ROHM volume IC
44	P52/RD	BD_CLK	O	O	O	Clock output of ROHM volume IC
45	P51/WRH/BHE	BD_MUTE	O	O	O	MUTE output of ROHM volume IC
46	IOPORT0	SELXM	O	O	O	Control of logic IC for XM/DIR signal course change (H: XM input/L: DIR input or ADC input)
47	IOPORT1	–	O	O	O	Unconnected
48	–	–	–	–	–	No used
49	–	–	–	–	–	No used
50	–	–	–	–	–	
51	–	–	–	–	–	
52	IOPORT2	–	O	O	O	Unconnected
53	IOPORT3	–	I	O	O	No used
54	IOPORT4	–	I	O	O	No used
55	IOPORT5	DFS	O	O	O	Dual rate change for CODEC/H: Dual rate processing (Dual Rate)
56	P36/A14 / IOPORT6	no connect / SMUTE	O	O	O	Unconnected / MUTE control for CODEC/H: CODEC MUTE ON
57	P35/A13 / IOPORT7	–	O	O	O	Unconnected
58	P34/A12	–	O	O	O	Unconnected
59	P33/A11	–	O	O	O	Unconnected
60	P32/A10	VIA	O	O	O	Control output of VIDEO selector LA7956
61	P31/A9	VIB	O	O	O	Control output of VIDEO selector LA7956
62	Vcc2	Vcc	MCU	MCU	MCU	Power supply +5V for micro-processor
63	P30/A8	XMPWR	O	O	O	Regulator control of power supply reset for XM antenna
64	Vss	Vss	MCU	MCU	MCU	Ground for micro-processor
65	P27/A7	VR1	O	O	O	VIDEO Rec Out Selector
66	P26/A6	–	O	O	O	Unconnected
67	P25/A5	CMP0	O	O	O	Control output of component video switch
68	P24/A4	CMP1	O	O	O	Control output of component video switch
69	P23/A3	SDRR	I	O	O	Serial data reception for RDS IC
70	P22/A2	SCKR	O	O	O	Clock for RDS IC
71	P21/A1	SDTR	O	O	O	Serial data transmission for RDS IC
72	P20/A0	RDSE	O	O	O	RDS Enable
		RDSE	I	O	O	Presence judgment of RDS (H: RDS exists./L: RDS doesn't exist.)
73	P17/D15/INT5	CEP	O	O	O	Chip select of TUNER PLL IC
		TUN1	I	O	O	MODEL distinction 1
74	P16/D14/INT4	PDET	IRQ	IRQ	O	Detection of power down
75	P15/D13/INT3	PSW	IRQ	IRQ	O	Interruption of STANDBY/ON switch
76	P14/D12	SCKP	O	O	O	Clock output of TUNER PLL IC
		TUN0	I	O	O	MODEL distinction 0
77	P13/D11	SDTP	O	O	O	Serial data transmission of TUNER PLL IC
78	P12/D10	SDRP	I+	O	O	Serial data reception of TUNER PLL IC
79	P11/D9	TUNED	I+	O	O	Detection state reception of TUNER
80	P10/D8	/ST	I+	O	O	Stereo state reception of TUNER
81	P07/D7	TMT	O	O	O	MUTE output of TUNER MUTE
82	P06/D6	PRY	O	O	O	Control output of first power relay
83	P05/D5	CSRY	O	O	O	Control output of CENTER/SURROUND channel relay
84	P04/D4	FRRY_B	O	O	O	Control output of FRONT channel/Speaker B
85	P03/D3	FRRY_A	O	O	O	Control output of FRONT channel/Speaker A
86	P02/D2	PRI	I	O	O	Protection over current detection
87	P01/D1	5MSW	O	O	O	Control output of power supply +5V for micro-processor
88	P00/D0	–	O	O	O	Unconnected

IC242: M30622MWP-A82FP (MAIN P.C.B.)

16-bit Microprocessor

No.	Port Name	Terminal Name	I/O			Function
			PowerOn	Standby	Sleep	
89	P107/AN7/KI3	–	O	O	O	No used
90	P106/AN6/KI2	PRD	AD	O	O	AD protection DC detection
91	P105/AN5/KI1	PLDET	AD	O	O	AD power limiter detection
92	P104/AN4/KI0	THM	AD	O	O	AD temperature detection
93	P103/AN3	IMP_6 ohms	I	O	O	Speaker impedance detection (H: 6 ohms/L: 8 ohms)
94	P102/AN2	ADKEY0	AD	O	O	AD Key 0
95	P101/AN1	ADKEY1	AD	O	O	AD Key 1
96	Avss	Avss	MCU	MCU	MCU	Ground for AD
97	P100/AN0	PRD	AD	O	O	AD protection power supply voltage detection
98	Vref	Vref	MCU	MCU	MCU	Reference for AD
99	Avcc	Avcc	MCU	MCU	MCU	Power supply for AD
100	P97/Adtrg/Sin4	CEFD	O	O	O	FL Driver CE

Key Input (A-D) Pull-Up Resistance 10 k-ohms

U, C, R, T, K, A, L models

Ohm	0.0	+1.0k	+1.0k	+1.5k	+2.2k	+3.3k	+4.7k	+6.8k	+10.0k	+22.0k	+47.0k
V	0.0~0.3	~0.65	~1.05	~1.55	~2.05	~2.65	~3.15	~3.6	~4.0	~4.4	~4.75
ADKEY0 (94Pin, AN2)	MULTI CH INPUT	INPUT >	INPUT <	INPUT MODE	PROGRAM >	PROGRAM <	BASS/TREBLE +	BASS/TREBLE –	STEREO/ EFFECT	TONE CONTROL	SPEAKERS A/B/OFF
ADKEY1 (95Pin, AN1)	TUNING MODE	MEMORY	PRESET/TUNING >	PRESET/TUNING <	A/B/C/D/E /NEXT	FM/AM	PRESET/TUNING /EDIT	–	–	–	–

B, G, E models

Ohm	0.0	+1.0k	+1.0k	+1.5k	+2.2k	+3.3k	+4.7k	+6.8k	+10.0k	+22.0k	+47.0k
V	0.0~0.3	~0.65	~1.05	~1.55	~2.05	~2.65	~3.15	~3.6	~4.0	~4.4	~4.75
ADKEY0 (94Pin, AN2)	MULTI CH INPUT	INPUT >	INPUT <	INPUT MODE	PROGRAM >	PROGRAM <	BASS/TREBLE +	BASS/TREBLE –	STEREO/ EFFECT	TONE CONTROL	SPEAKERS A/B/OFF
ADKEY1 (95Pin, AN1)	TUNING MODE	MEMORY	PRESET/TUNING >	PRESET/TUNING <	A/B/C/D/E /NEXT	FM/AM	PRESET/TUNING /EDIT	PTY SEEK MODE	PTY SEEK START	EON	RDS MODE/FREQ

IC811: YSS948-VZ (DSP P.C.B.)

DSP

No.	Pin Name	Classification	Function	I/O	Port Set	Size	Connect
1	AHVSS		PLL section GND	-			DGND
2	AHVSSG		PLL section GND	-			DGND
3	DVSS		PLL section GND	-			DGND
4	DVDD	Power supply	Internal power supply of PLL section (typ1.2V)	-			+1.2VPLL
5	VDD2		Internal power supply (typ1.2V)	-			+1.2V
6	VDD2		Internal power supply (typ1.2V)	-			+1.2V
7	VSS		GND	-			DGND
8	VSS		GND	-			DGND
9	VDD1	Power supply	External power supply (typ3.3V)	-			+3.3V
10	STATUS4	Status port	Inside information output terminal 4	O		2mA	NC
11	STATUS5		Inside information output terminal 5	O		2mA	NC
12	STATUS6		Inside information output terminal 6	O		2mA	NC
13	STATUS7		Inside information output terminal 7	O		2mA	NC
14	VSS		GND	-			DGND
15	VDD2	Power supply	Internal power supply (typ1.2V)	-			+1.2
16	TEST(nPLLSEL)	Test	Terminal for a test / GND terminal	-			DGND
17	TSTSCAN		Terminal for a test / GND terminal	-			DGND
18	XI	Clock	Crystal oscillator connecting terminal / Clock input	I		-	12MA
19	XO		Crystal oscillator connecting terminal	O		-	NC
20	VSS		GND	-			DGND
21	VSS		GND	-			DGND
22	VDD2	Power supply	Internal power supply (typ1.2V)	-			+1.2V
23	VDD2		Internal power supply (typ1.2V)	-			+1.2V
24	TSTIDDQ	Test	Terminal for a test / GND terminal	-			DGND
25	TSTMEMCK		Terminal for a test / GND terminal	-			DGND
26	SDI3	Audio IF	Serial data output 3	I		-	NC
27	SDI2		Serial data output 2	I		-	NC
28	SDI1		Serial data output 1	I		-	ADSDO
29	SDI0		Serial data output 0	I		-	DIRSDO
30	SDIWCK		Input side WORD clock	I		-	RWCK
31	SDIBCK		Input side bit clock	Is		-	RBCK
32	SDIMCK		Input side master clock	Is		-	RMCK
33	VDD1	Power supply	External power supply (typ3.3V)	-			+3.3.V
34	SDOBCK	Audio IF	Output side bit clock	Is/O		4mA	BCKO
35	VSS		GND	-			DGND
36	VDD2	Power supply	Internal power supply (typ1.2V)	-			+1.2V
37	SDOWCK	Audio IF	Output side WORD clock	I/O		4mA	WCKO
38	SDOMCK		Output side master clock	Ot		8mA	MCKO
39	SDO0		Serial data output 0	O		4mA	SDOA0
40	SDO1		Serial data output 1	O		4mA	SDOA1
41	VSS		GND	-			DGND
42	VSS		GND	-			DGND
43	SDO2	Audio IF	Serial data output 2	O		4mA	SDOA2
44	SDO3		Serial data output 3	O		4mA	SDOA3
45	VDD1	Power supply	External power supply (typ3.3V)	-			+3.3V
46	IOPORT0	IO port	General purpose I/O terminal 0	I(+)/O	I	2mA	/MIC
47	IOPORT1		General purpose I/O terminal 1	I(+)/O	O	2mA	MICSEL
48	VSS		GND	-			DGND
49	VSS		GND	-			DGND
50	VDD2	Power supply	Internal power supply (typ1.2V)	-			+1.2V
51	VDD2		Internal power supply (typ1.2V)	-			+1.2V
52	IOPORT2	IO port	General purpose I/O terminal 2	I(+)/O	I	2mA	(CXDTA)
53	IOPORT3		General purpose I/O terminal 3	I(+)/O	O	2mA	4.7k PD or OPEN
54	IOPORT4		General purpose I/O terminal 4	I(+)/O	O	2mA	4.7k PD or OPEN
55	IOPORT5		General purpose I/O terminal 5	I(+)/O	O	2mA	NC
56	IOPORT6		General purpose I/O terminal 6	I(+)/O	O	4mA	NC
57	IOPORT7		General purpose I/O terminal 7	I(+)/O	O	4mA	NC
58	MEMA17	External memory IF	External memory access output terminal 17	O			EXMA17
59	MEMA13		External memory access output terminal 13	O			EXMA13
60	VDD1	Power supply	External power supply (typ3.3V)	-			+3.3V

IC811: YSS948-VZ (DSP P.C.B.)

DSP

No.	Pin Name	Classification	Function	I/O	Port Set	Size	Connect
61	VSS		GND	-			DGND
62	VSS		GND	-			DGND
63	VDD2	Power supply	Internal power supply (typ1.2V)	-			+1.2V
64	VDD2		Internal power supply (typ1.2V)	-			+1.2V
65	MEMA8	External memory IF	External memory access output terminal 8	O		4mA	EXMA8
66	MEMA9		External memory access output terminal 9	O		4mA	EXMA9
67	MEMA11		External memory access output terminal 11	O		4mA	EXMA11
68	nMEMWE		External memory light enable output terminal	O		8mA	/EXMEW
69	VSS		GND	-			DGND
70	VDD2	Power supply	Internal power supply (typ1.2V)	-			+1.2V
71	VDD2		Internal power supply (typ1.2V)	-			+1.2V
72	MEMA15	External memory IF	External memory access output terminal 15	O		4mA	EXMA15
73	MEMA16		External memory access output terminal 16	O		4mA	EXMA16
74	MEMA14		External memory access output terminal 14	O		4mA	EXMA14
75	MEMA12		External memory access output terminal 12	O		4mA	EXMA12
76	MEMA7		External memory access output terminal 7	O		4mA	EXMA7
77	VSS		GND	-			DGND
78	VSS		GND	-			DGND
79	VDD2	Power supply	Internal power supply (typ1.2V)	-			+1.2V
80	VDD2		Internal power supply (typ1.2V)	-			+1.2V
81	MEMA6	External memory IF	External memory access output terminal 6	O		4mA	EXMA6
82	MEMA5		External memory access output terminal 5	O		4mA	EXMA5
83	MEMA4		External memory access output terminal 4	O		4mA	EXMA4
84	MEMA3		External memory access output terminal 3	O		4mA	EXMA3
85	VDD1	Power supply	External power supply (typ3.3V)	-			+3.3V
86	VSS		GND	-			DGND
87	VSS		GND	-			DGND
88	VDD2	Power supply	Internal power supply (typ1.2V)	-			+1.2V
89	VDD2		Internal power supply (typ1.2V)	-			+1.2V
90	MEMA2	External memory IF	External memory access output terminal 2	O		4mA	EXMA2
91	MEMA1		External memory access output terminal 1	O		4mA	EXMA1
92	MEMA0		External memory access output terminal 0	O		4mA	EXMA0
93	VSS		GND	-			DGND
94	VSS		GND	-			DGND
95	VDD2	Power supply	Internal power supply (typ1.2V)	-			+1.2V
96	MEMD0	External memory IF	External memory data I/O terminal 0	I/O		4mA	EXMD0
97	MEMD1		External memory data I/O terminal 1	I/O		4mA	EXMD1
98	MEMD2		External memory data I/O terminal 2	I/O		4mA	EXMD2
99	MEMD3		External memory data I/O terminal 3	I/O		4mA	EXMD3
100	VDD1		External power supply (typ3.3V)	-			+3.3V
101	MEMD4		External memory data I/O terminal 4	I/O		4mA	EXMD4
102	MEMD5		External memory data I/O terminal 5	I/O		4mA	EXMD5
103	MEMD6		External memory data I/O terminal 6	I/O		4mA	EXMD6
104	MEMD7		External memory data I/O terminal 7	I/O		4mA	EXMD7
105	VSS		GND	-			DGND
106	VSS		GND	-			DGND
107	VDD2	Power supply	Internal power supply (typ1.2V)	-			+1.2V
108	VDD2		Internal power supply (typ1.2V)	-			+1.2V
109	nMEMCE	External memory IF	External memory chip select output terminal	O		4mA	/EXMCE
110	MEMA10		External memory access output terminal 10	O		4mA	EXMA10
111	nMEMOE		External memory output enable output terminal	O		4mA	/EXMOE
112	MEMA18		External memory access output terminal 18	O		4mA	EXMA18
113	STATUS0	Status port	Inside information output terminal 0	O		2mA	NC
114	STATUS1		Inside information output terminal 1	O		2mA	NC
115	STATUS2		Inside information output terminal 2	O		2mA	NC
116	STATUS3		Inside information output terminal 3	O		2mA	NC
117	VSS		GND	-			DGND
118	VSS		GND	-			DGND
119	VDD2	Power supply	Internal power supply (typ1.2V)	-			+1.2V
120	VDD2		Internal power supply (typ1.2V)	-			+1.2V

IC811: YSS948-VZ (DSP P.C.B.)

DSP

No.	Pin Name	Classification	Function	I/O	Port Set	Size	Connect
121	VDD1		External power supply (typ3.3V)	-			+3.3V
122	MISO	Microprocessor IF	Data output	Ot		4mA	SDD3
123	VSS		GND	-			DGND
124	MISI	Microprocessor IF	Data input	I		-	SDM3A
125	MISCK		Serial clock	Is		-	SCK3A
126	nMICS		Chip select	Is		-	/CSADM
127	VDD2	Power supply	Internal power supply (typ1.2V)	-			+1.2V
128	VDD2		Internal power supply (typ1.2V)	-			+1.2V
129	VSS		GND	-			DGND
130	VSS		GND	-			DGND
131	nIC	Reset	Hardware/Reset input terminal	Is			/ICADM
132	nTSTREGRST	Test	Terminal for a test / GND terminal	-			DGND
133	ZEROFLG		Terminal for a test / GND terminal	-			DGND
134	nINT	Status port	Interrupt request output terminal	O		2mA	/INTADM
135	nMUTE		MUTE output terminal	O		2mA	NC
136	VDD1	Power supply	External power supply (typ3.3V)	-			+3.3V
137	VDD2		Internal power supply (typ1.2V)	-			+1.2V
138	VDD2		Internal power supply (typ1.2V)	-			+1.2V
139	VSS		GND	-			DGND
140	VSS		GND	-			DGND
141	AVSSR		PLL section GND	-			DGND
142	AVDDR	Power supply	PLL section power supply (typ3.3V)	-			+3.3VPLL
143	AHVDD		PLL section power supply (typ3.3V)	-			+3.3VPLL
144	VHVDDG		PLL section power supply (typ3.3V)	-			+3.3VPLL

I/O Is : Schmidt trigger input terminal
Ot : 3-state digital output terminal
I(+): Input terminal with pull-up resistor
O : Digital output terminal

MEMO

A large empty rectangular box with a double-line border, intended for writing a memo. The box is centered on the page and occupies most of the page area.

RX-V359/HTR-5930

1 ■ PRINTED CIRCUIT BOARD

DSP P.C.B. (Side A)
Lead Free Solder Used

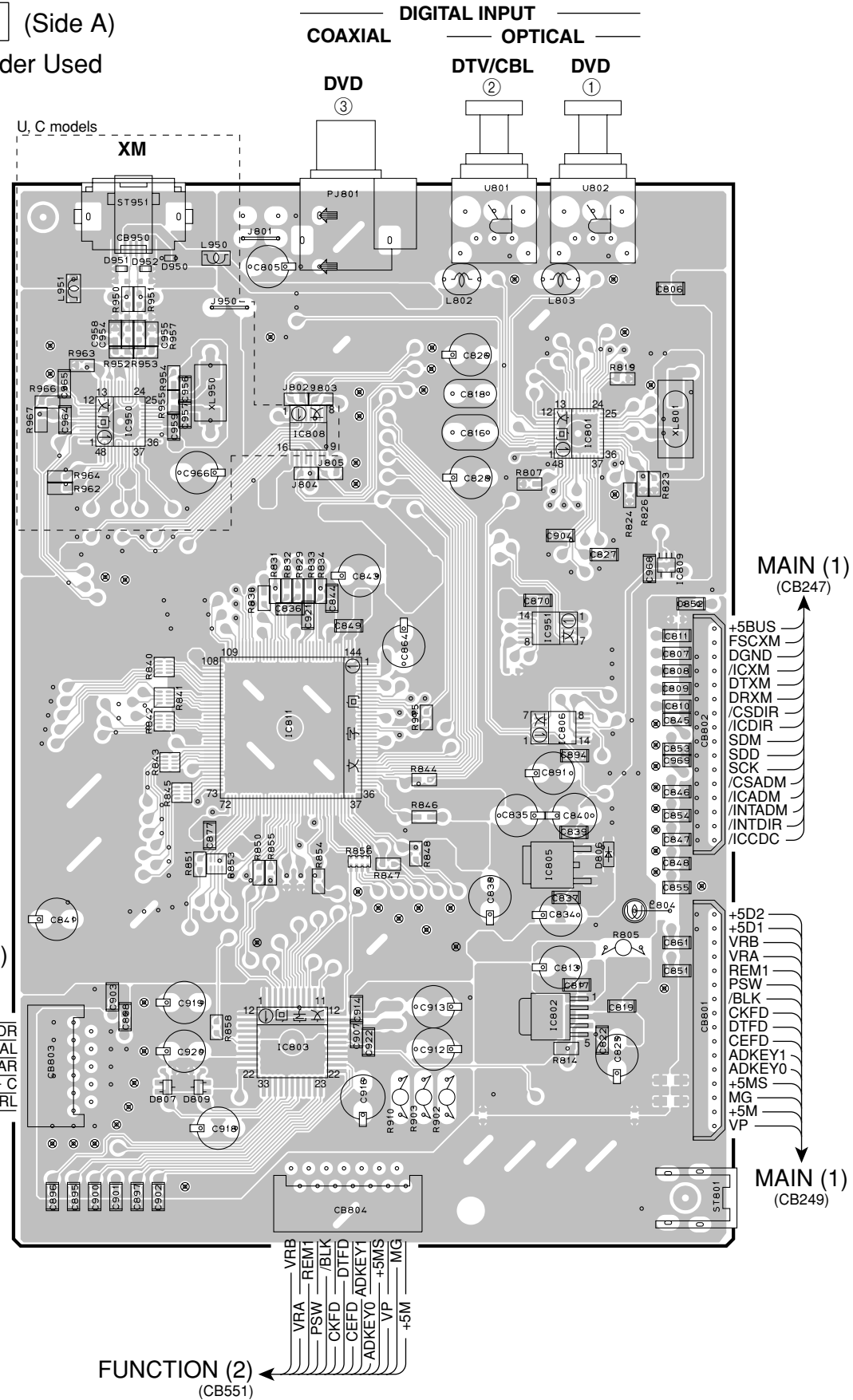

DSP P.C.B. (Side B)
Lead Free Solder Used

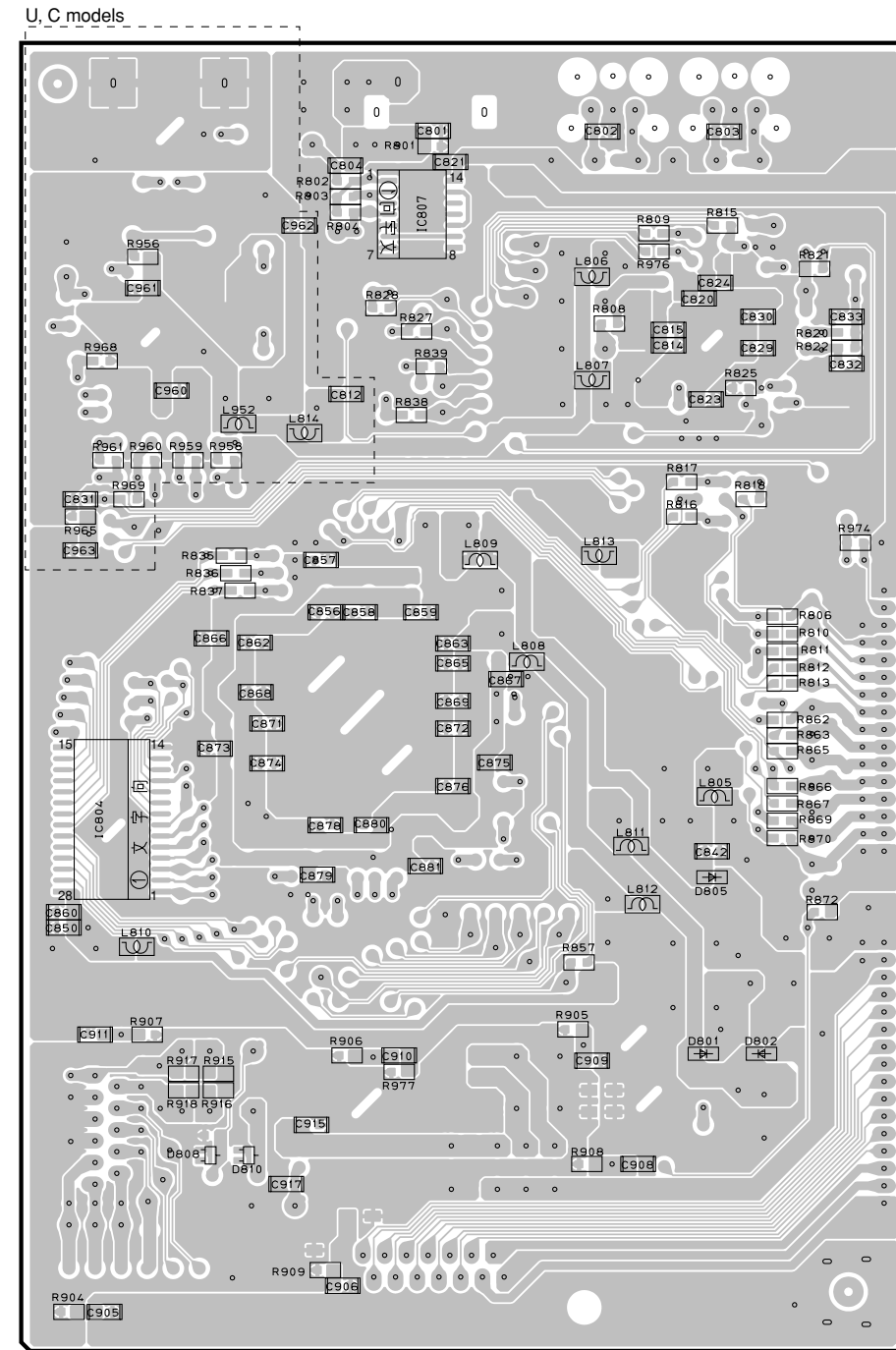

• Semiconductor Location

Ref no.	Location
D801	H6
D802	H6
D805	H5
D806	D5
D807	B6
D808	F6
D809	B6
D810	F6
D950	B2
D951	B2
D952	B2
IC801	D3
IC802	D6
IC803	C6
IC804	F5
IC805	D5
IC806	D4
IC807	G3
IC808	C3
IC809	D4
IC811	C4
IC950	B3
IC951	D4

Circuit No.	U,C	R, T, K, A, B, G, L, E
IC809	O	X
J802- 805	X	O

X: NOT USED
O: USED/APPLICABLE

PRINTED CIRCUIT BOARD

FUNCTION (1) P.C.B. (Side A)

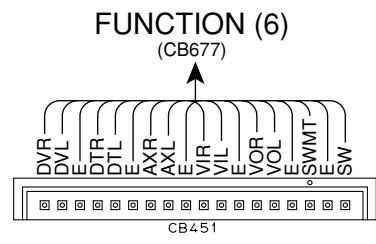
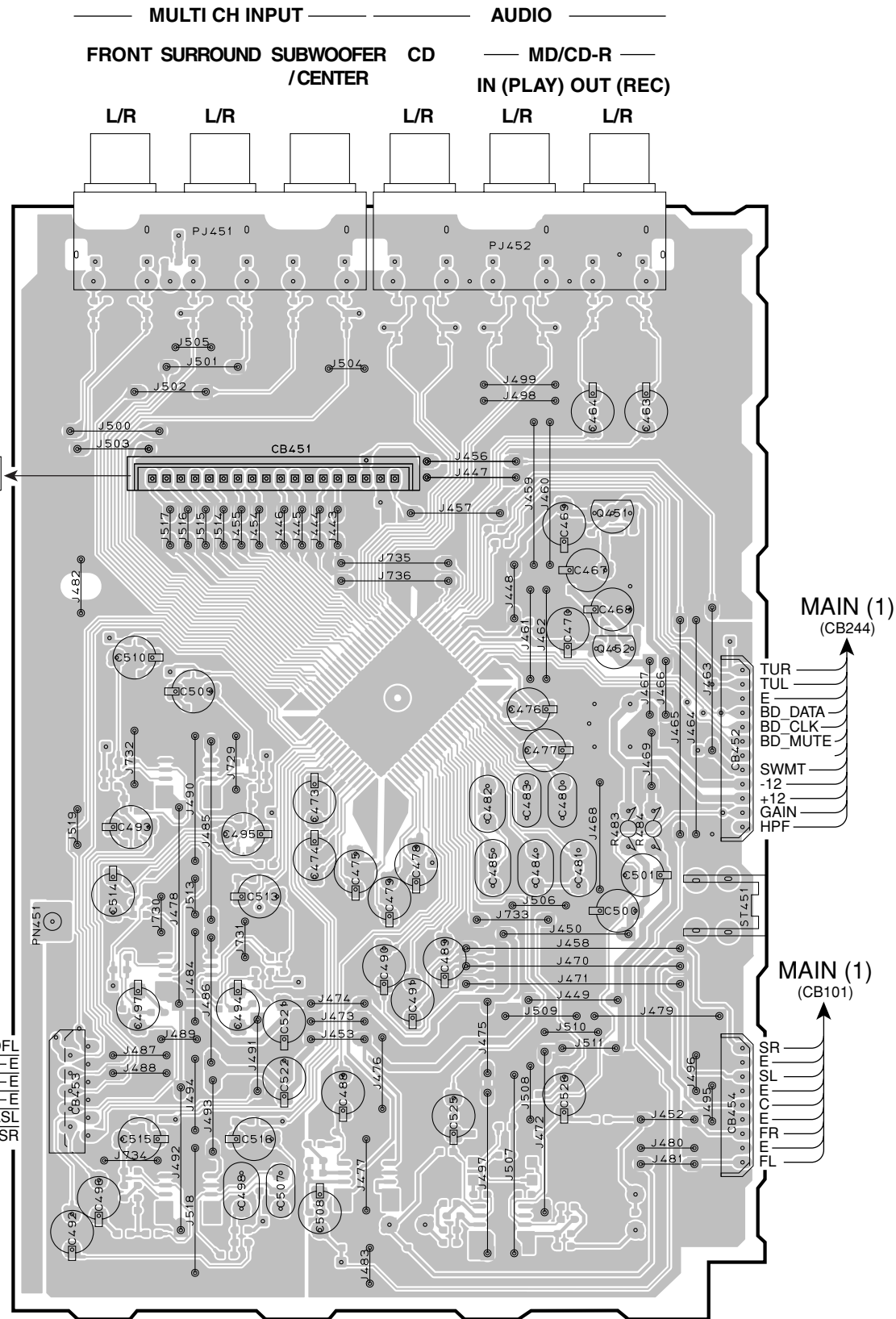

FUNCTION (1) P.C.B. (Side B)

Lead Free Solder Used

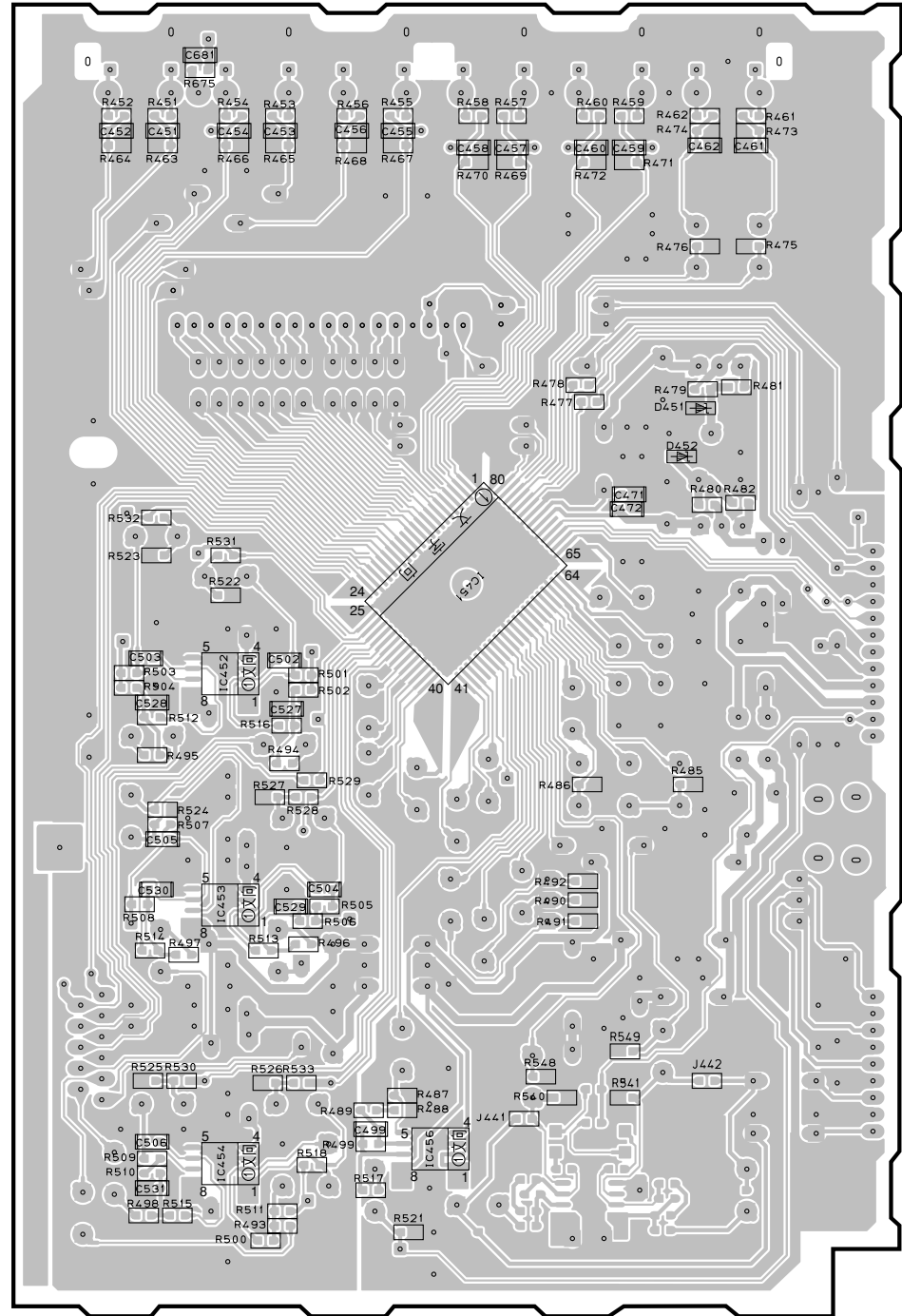

Semiconductor Location

Ref no.	Location
D451	I4
D452	I4
IC451	H4
IC452	G5
IC453	G5
IC454	G6
IC456	H6
Q451	E4
Q452	E4

1 ■ PRINTED CIRCUIT BOARD

FUNCTION (2) P.C.B. (Side A)

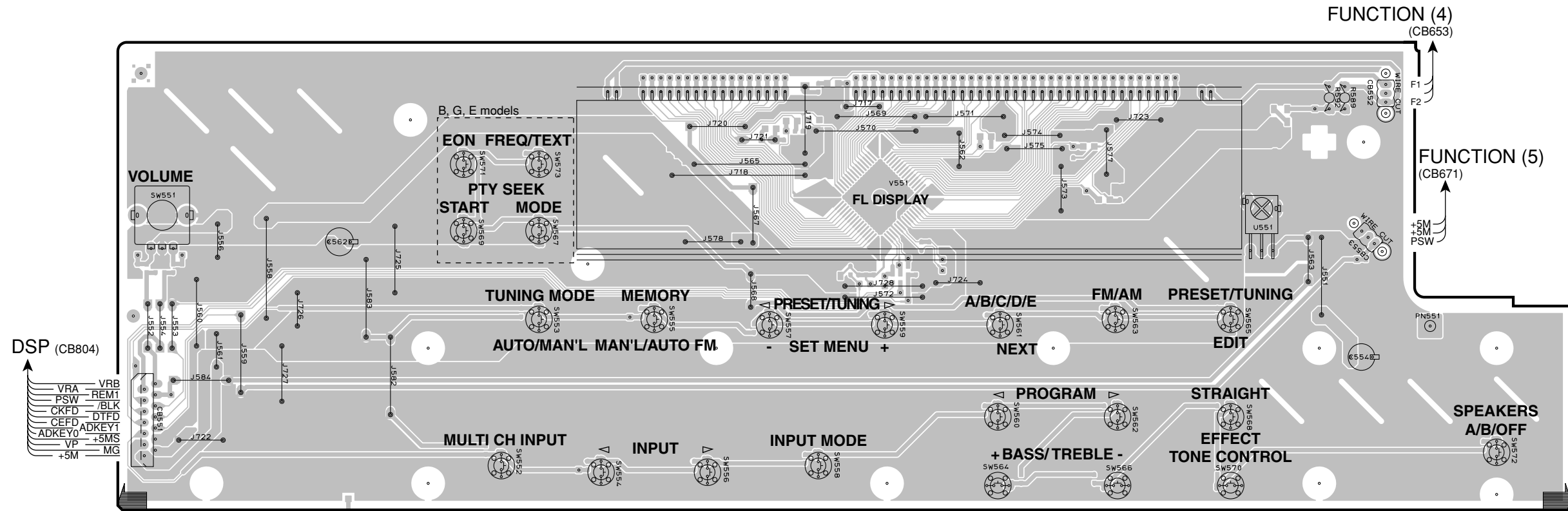

• Semiconductor Location

Ref no.	Location
D551	H5
D552	G5
IC551	E5
Q551	E5
Q552	E5
Q553	G5
Q554	F5
Q555	G5
Q556	E5
Q557	E5

FUNCTION (2) P.C.B. (Side B) Lead Free Solder Used

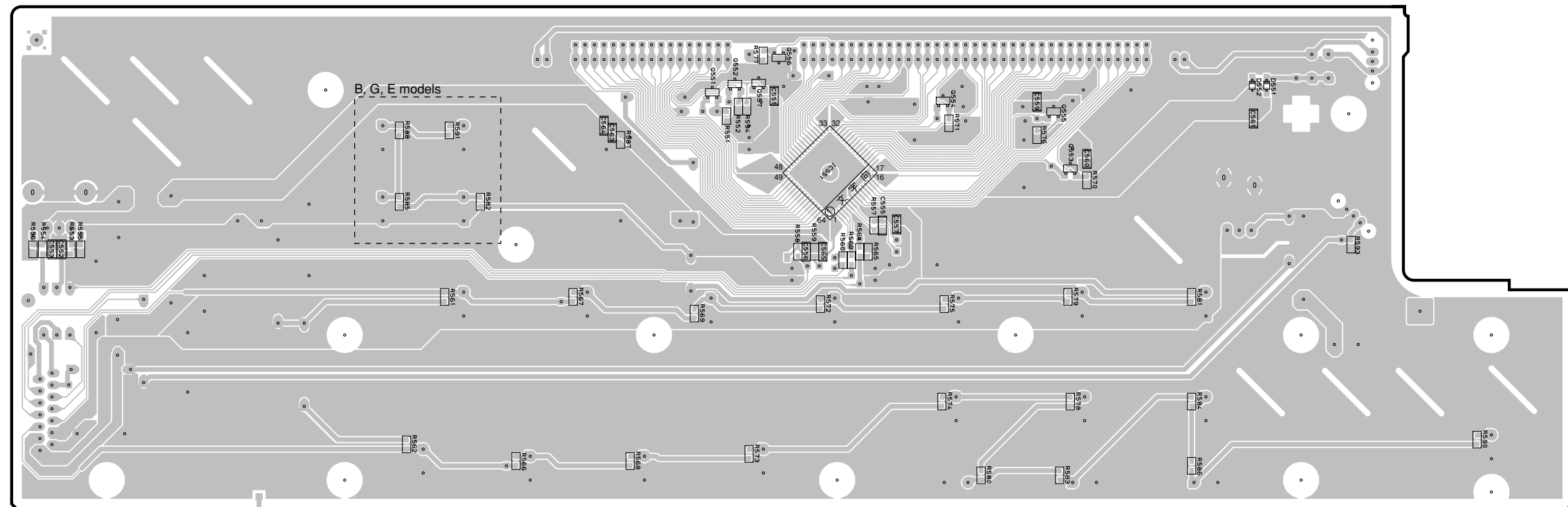

PRINTED CIRCUIT BOARD

FUNCTION (3) P.C.B. (Side A)

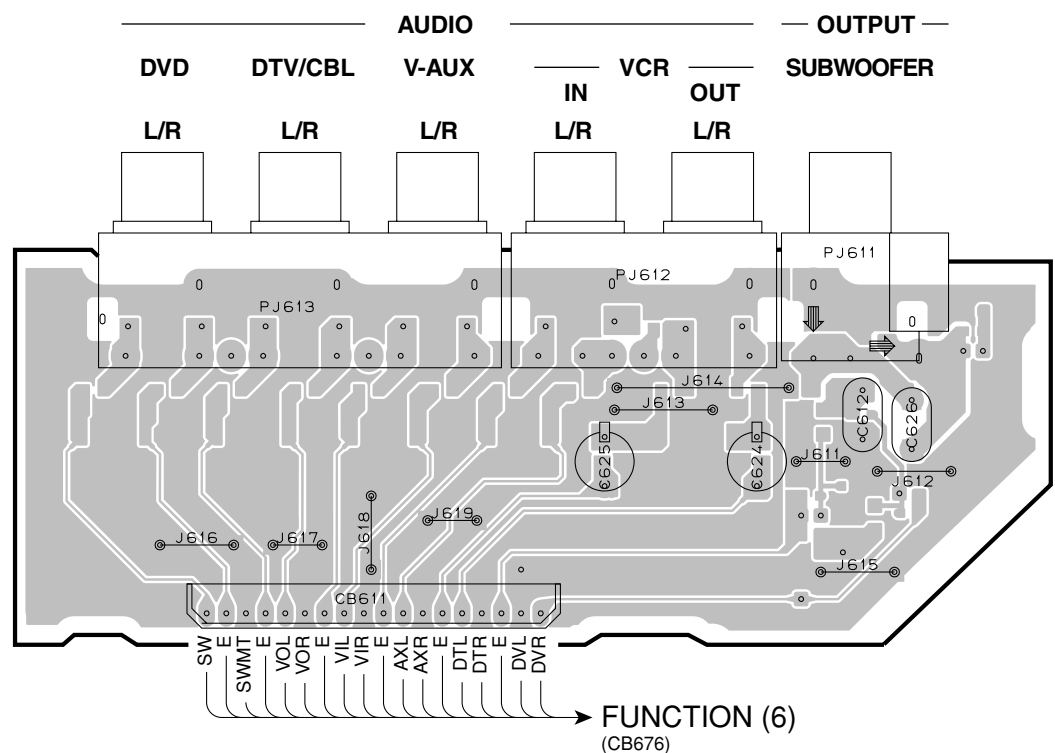

FUNCTION (3) P.C.B. (Side B)

Lead Free Solder Used

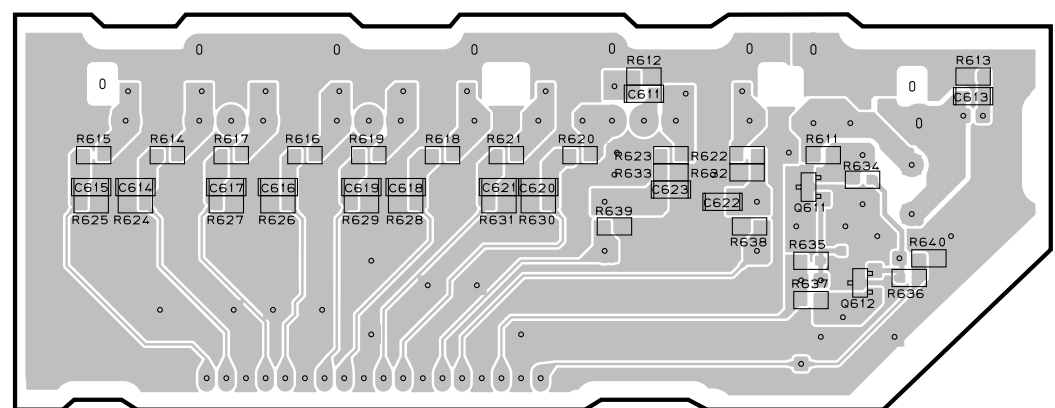

Circuit No.	U, C	R, L	T, K, A, B, G, E
C653	O	X	X
C662	O	X	X
C669	O	X	X
D654	X	O	O
D655	O	X	X
D657	O	X	X
D658	X	O	X
IC655	O	X	X
R653	O	X	X
R674	X	O	X

X: NOT USED
O: USED/APPLICABLE

Semiconductor Location

Ref no.	Location	Ref no.	Location
D652	G6	IC652	G4
D653	H3	IC653	F4
D654	I3	IC654	G4
D655	I3	IC655	F4
D657	F7	Q611	D5
D658	F6	Q612	D6
IC651	G4	Q652	G3

FUNCTION (4) P.C.B. (Side A)

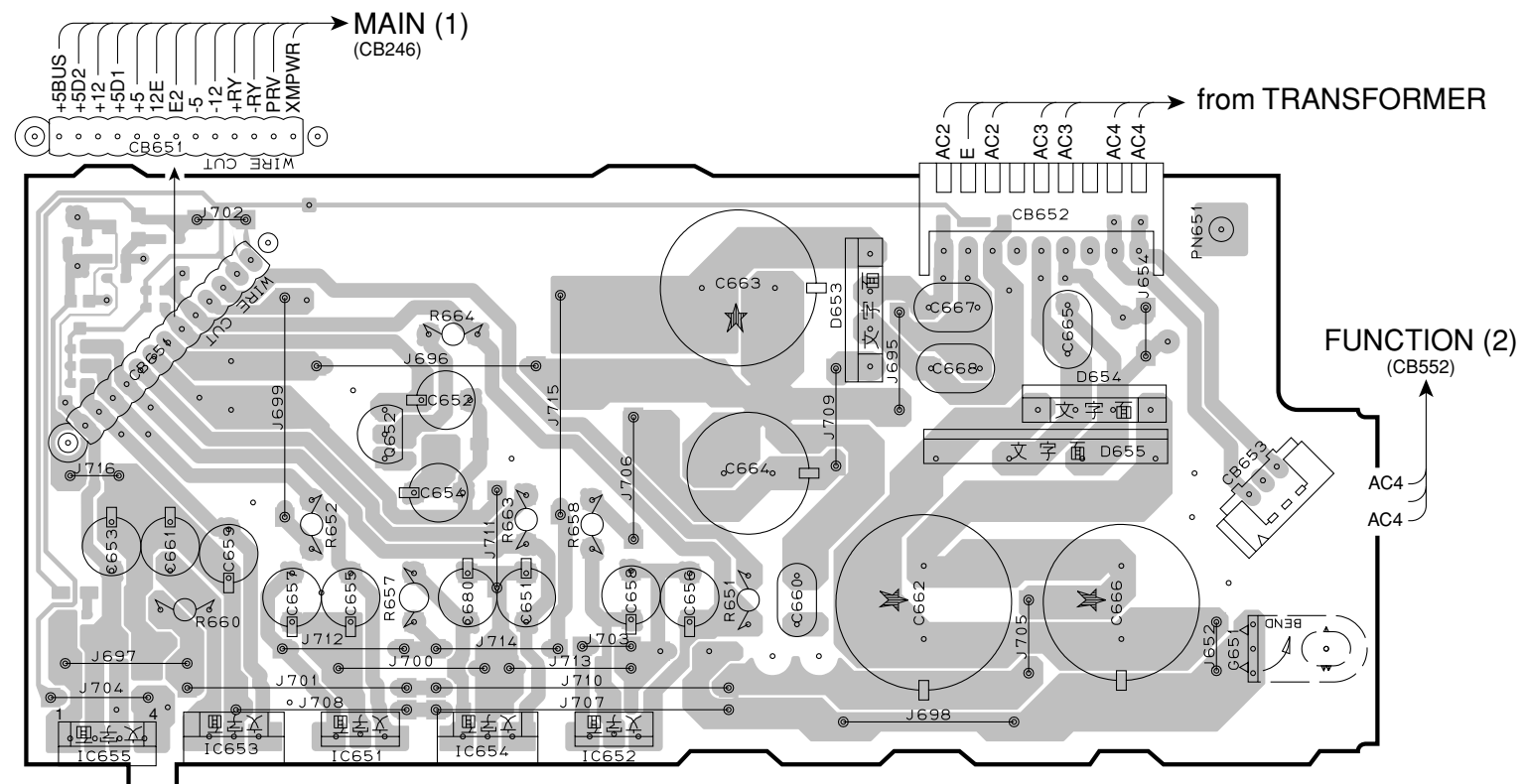

FUNCTION (4) P.C.B. (Side B)

Lead Free Solder Used

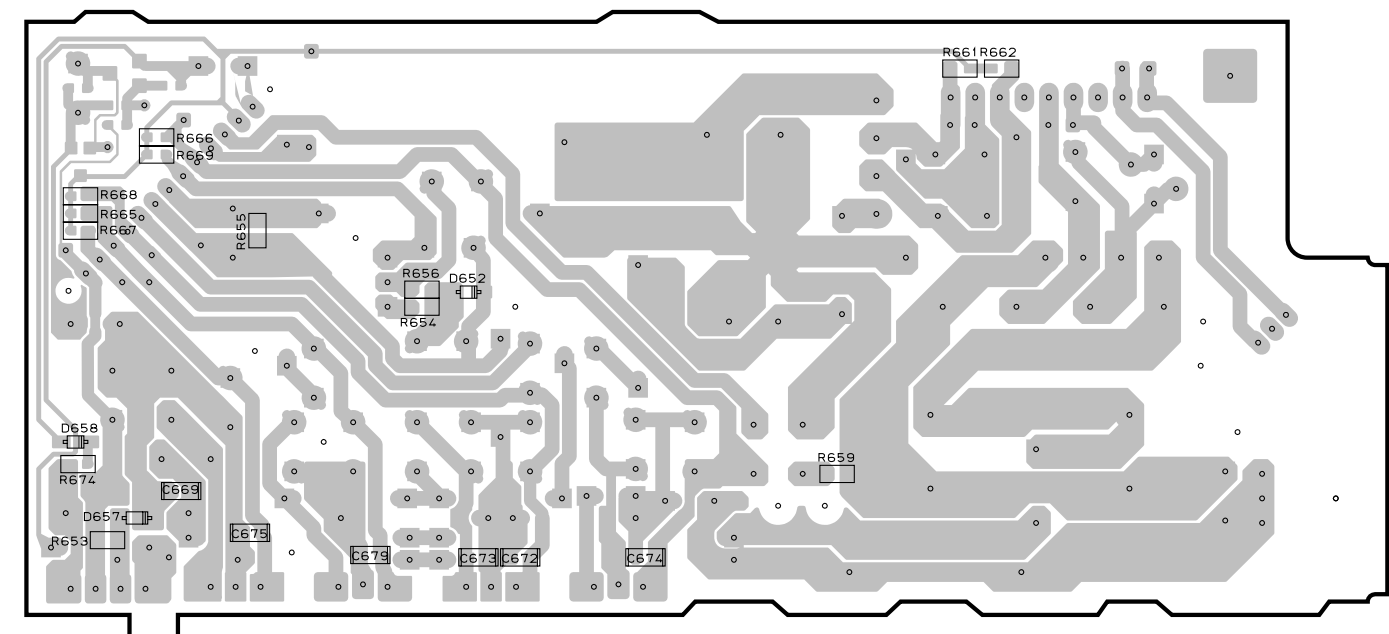

1 ■ PRINTED CIRCUIT BOARD

FUNCTION (5) P.C.B. (Side A)

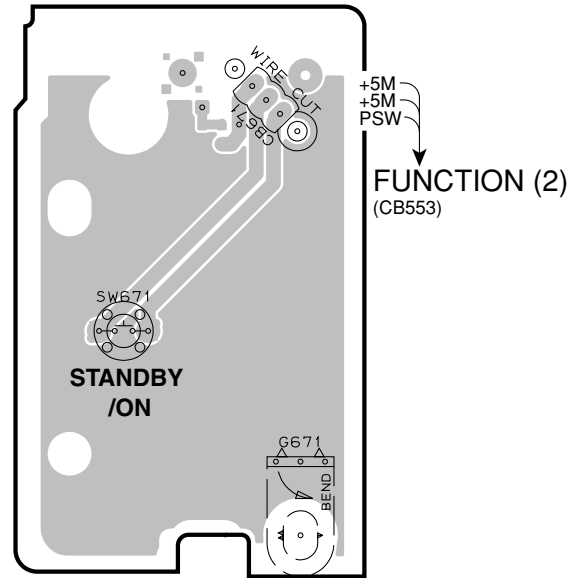

FUNCTION (5) P.C.B. (Side B)

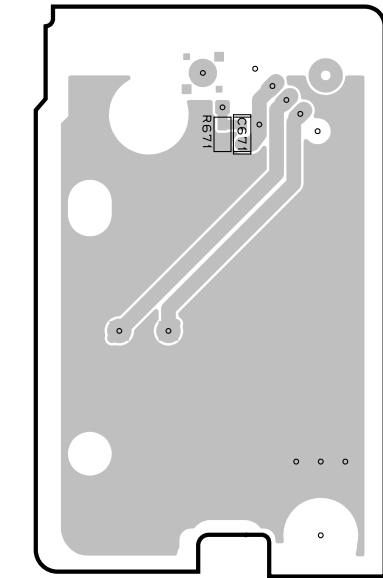

Lead Free Solder Used

FUNCTION (6) P.C.B. (Side A)

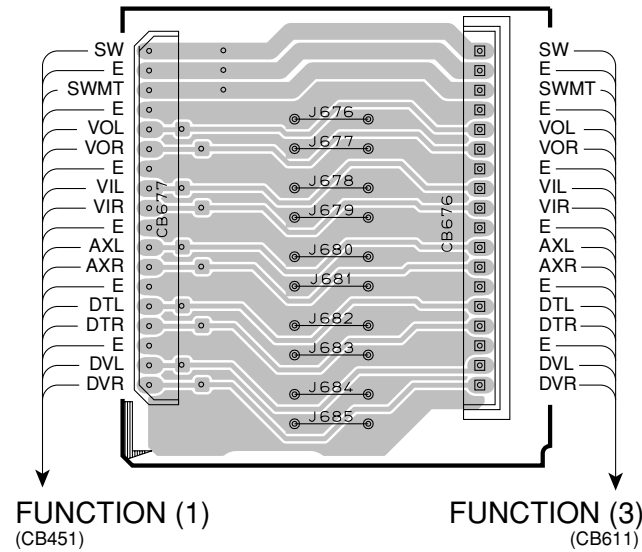

FUNCTION (7) P.C.B. (Side A)

R, L models

from TRANSFORMER

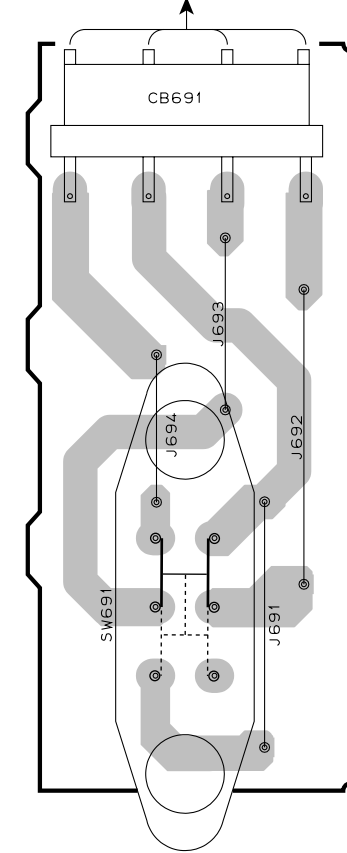

• Semiconductor Location

Ref no.	Location
D431	H5
D432	H6
D433	H6

VOLTAGE SELECTOR

110V-120V
|
220V-240V

FUNCTION (8) P.C.B. (Side A)

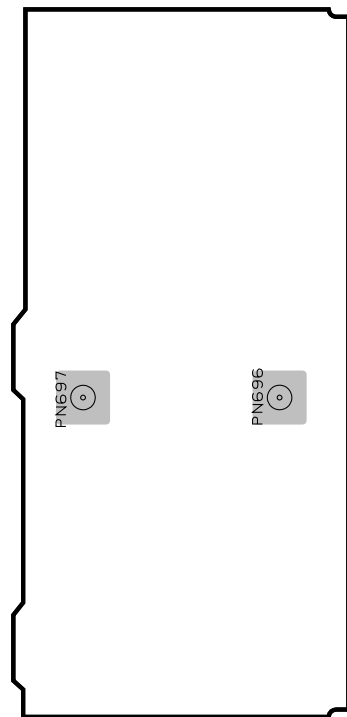

FUNCTION (9) P.C.B. (Side A)

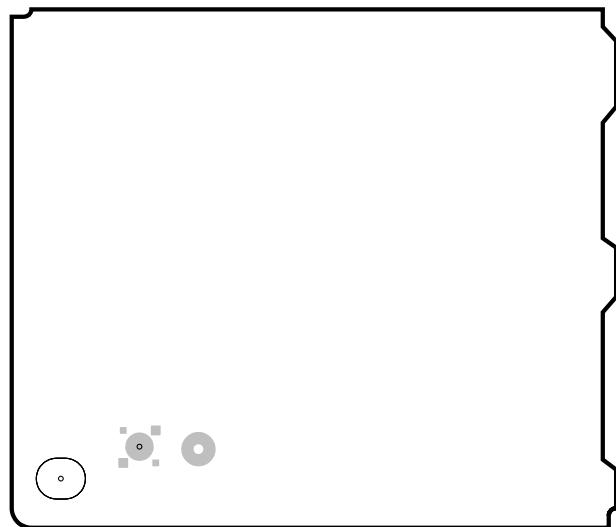

FUNCTION (10) P.C.B. (Side A)

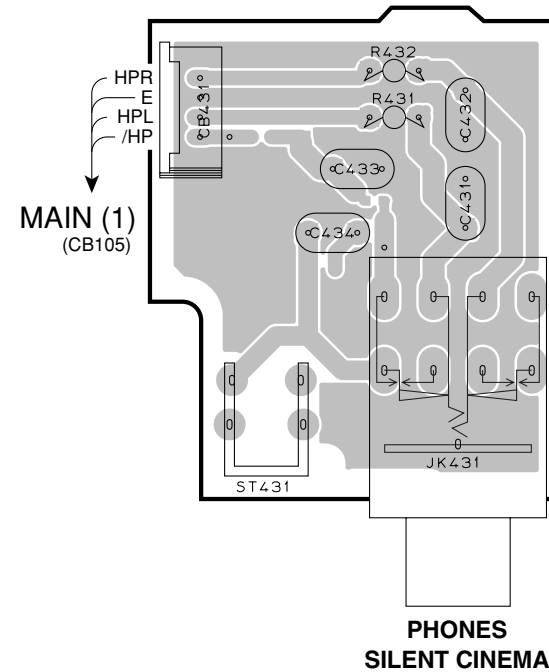

FUNCTION (10) P.C.B. (Side B)

Lead Free Solder Used

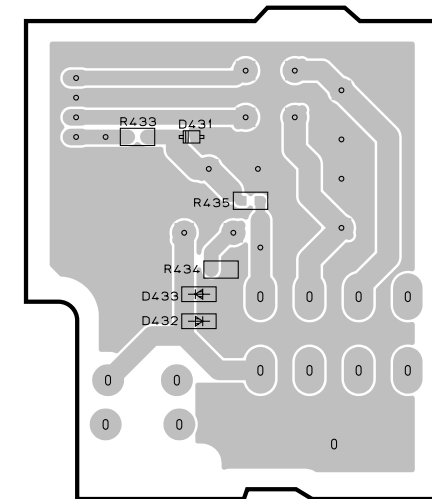

PRINTED CIRCUIT BOARD

MAIN (1) P.C.B. (Side A)

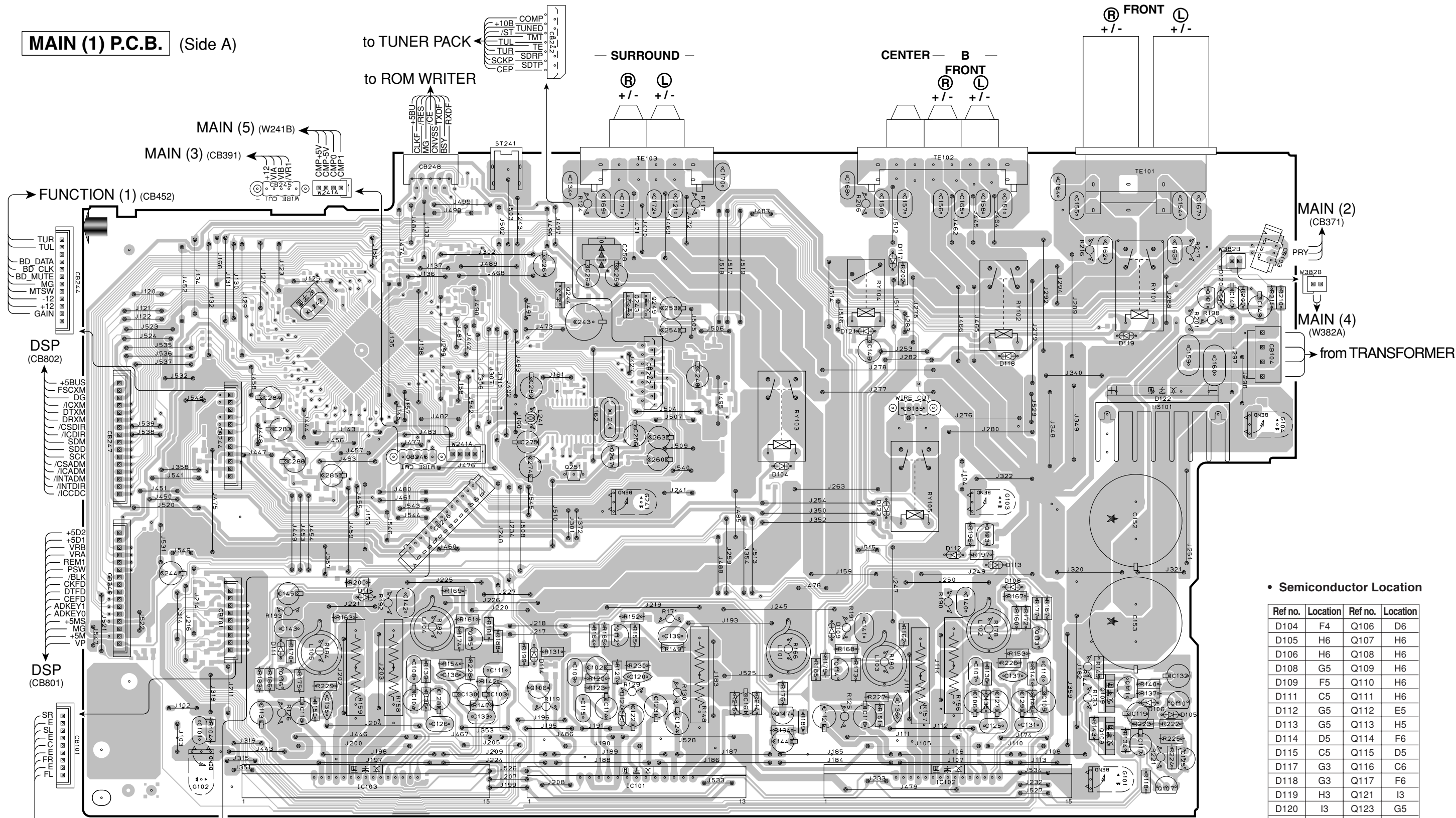

Semiconductor Location

Ref no.	Location	Ref no.	Location
D104	F4	Q106	D6
D105	H6	Q107	H6
D106	H6	Q108	H6
D108	G5	Q109	H6
D109	F5	Q110	H6
D111	C5	Q111	H6
D112	G5	Q112	E5
D113	G5	Q113	H5
D114	D5	Q114	F6
D115	C5	Q115	D5
D117	G3	Q116	C6
D118	G3	Q117	F6
D119	H3	Q121	I3
D120	I3	Q123	G5
D121	F3	Q125	I6
D122	H4	Q243	E3
D123	G4	Q244	D3
D124	E6	Q247	E4
IC101	E6	Q249	E3
IC102	G6	Q251	E4
IC103	C6		

Circuit No.	U, C	R, L	T, K, A	B, G, E	Circuit No.	U, C	R, L	T, K, A	B, G, E
C121, 150, 162, 163, 169	X	O	O	O	Q249	X	O	X	X
C134, 151, 154-158, 164, 165, 167, 168, 170-172	X	O	O	O	Q251	X	X	X	O
C274, 275, 280	X	X	X	O	R117, 124, 206, 216, 217	X	O	O	O
G104	X	O	O	O	XL241	X	X	X	O
L241	X	X	X	O					

X : NOT USED
O : USED / APPLICABLE

PRINTED CIRCUIT BOARD

MAIN (1) P.C.B. (Side B) Lead Free Solder Used

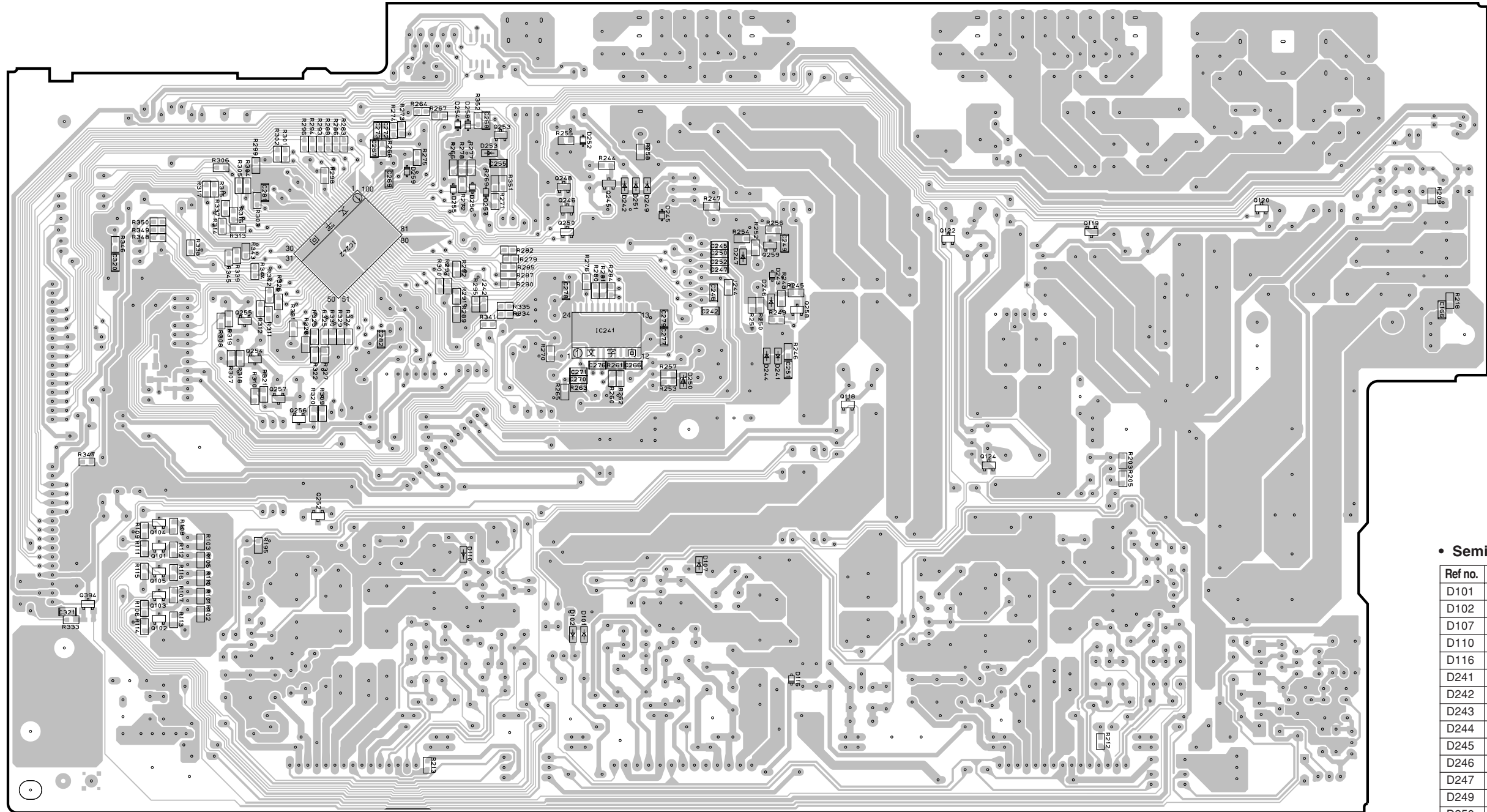

• Semiconductor Location

Ref no.	Location	Ref no.	Location
D101	E5	IC242	C3
D102	E5	Q101	B5
D107	E5	Q102	B5
D110	D5	Q103	B5
D116	F6	Q104	B5
D241	F4	Q105	B5
D242	E3	Q118	F4
D243	F3	Q119	G3
D244	F4	Q120	H3
D245	E3	Q122	G3
D246	F3	Q124	G4
D247	E3	Q245	E3
D249	E3	Q246	E3
D250	E4	Q248	E3
D251	E3	Q250	E3
D252	E3	Q252	C5
D253	D3	Q253	D3
D254	D3	Q254	C4
D255	D3	Q255	C4
D256	D3	Q256	C4
D257	D3	Q257	C4
D258	D3	Q258	F3
D259	D3	Q259	F3
IC241	E4	Q394	B5

Circuit No.	U, C	R, L	T, K, A	B, G, E	Circuit No.	U, C	R, L	T, K, A	B, G, E	Circuit No.	U, C	R, L	T, K, A	B, G, E
C166	X	O	O	O	J242	O	O	O	X	R276, 280	X	X	X	O
C255	O	X	X	X	Q253	O	X	X	X	R281, 284	X	X	X	O
C266, 278	X	X	X	O	R218	X	O	O	O	R289	O	X	X	X
C270, 271	X	X	X	O	R260, 261, 300	X	X	X	O	R291	X	O	O	O
C276	X	X	X	O	R262	X	X	X	O	R295	X	X	O	O
C277, 279	X	X	X	O	R263	X	X	X	O	R297	O	O	X	X
D253	O	X	X	X	R265	X	X	X	O	R351	O	X	X	X
IC241	X	X	X	O	R270	X	X	X	O					

X : NOT USED
O : USED / APPLICABLE

■ PRINTED CIRCUIT BOARD

MAIN (2) P.C.B. (Side A)

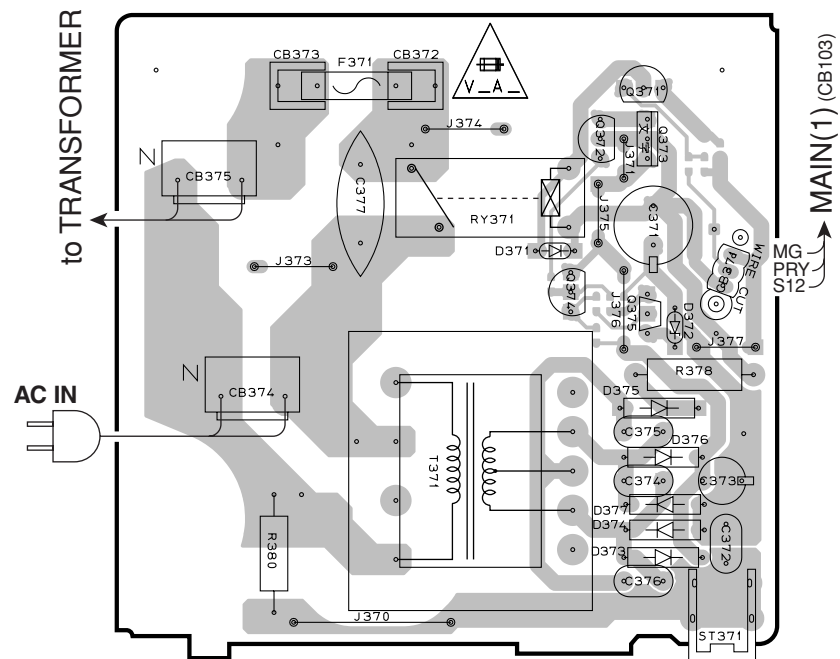

MAIN (2) P.C.B. (Side B)

Lead Free Solder Used

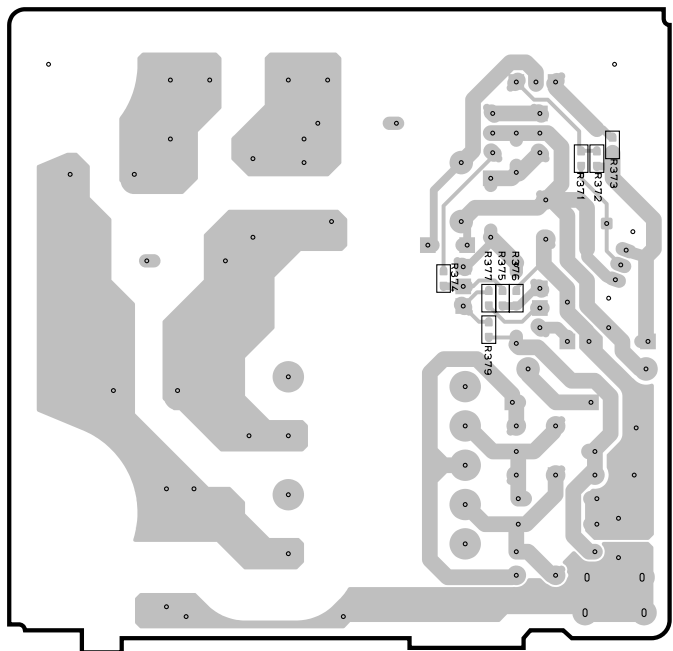

MAIN (3) P.C.B. (Side A)

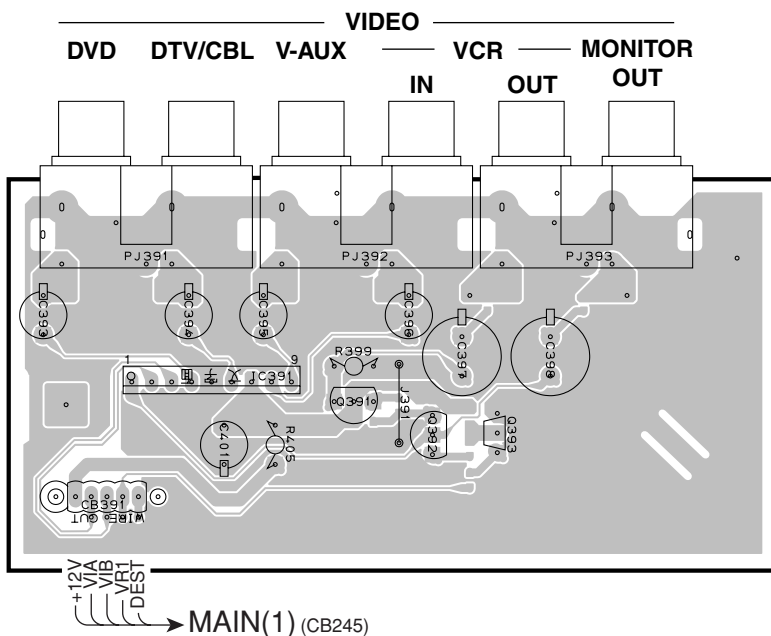

MAIN (3) P.C.B. (Side B)

Lead Free Solder Used

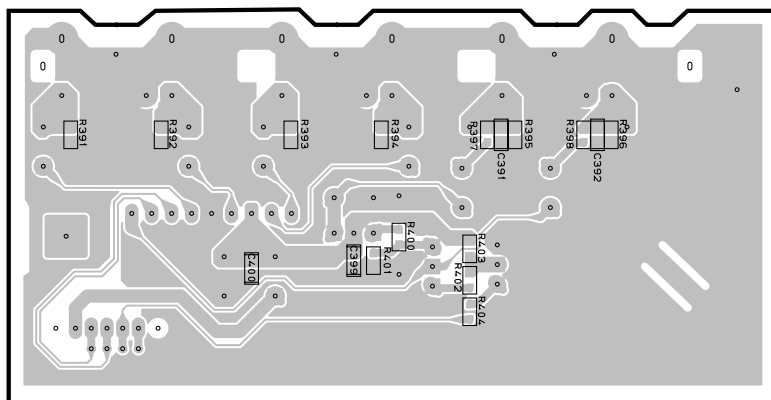

Circuit No.	U, C	R, L	T, K, A, B, G, E	Circuit No.	U, C	R, L	T, K, A, B, G, E
C373	X	O	X	Q375	X	O	X
C375, 376	X	O	X	R374	X	O	X
C374	O	X	O	R375	X	O	X
D372	X	O	X	R376	X	O	X
D375	X	O	X	R377	X	O	X
J371	O	X	O	R378	X	O	X
Q372, 374	X	O	X	R379	X	O	X
Q373	X	O	X	R380	O	X	X

X: NOT USED
O: USED/APPLICABLE

MAIN (4) P.C.B. (Side A)

U, C models

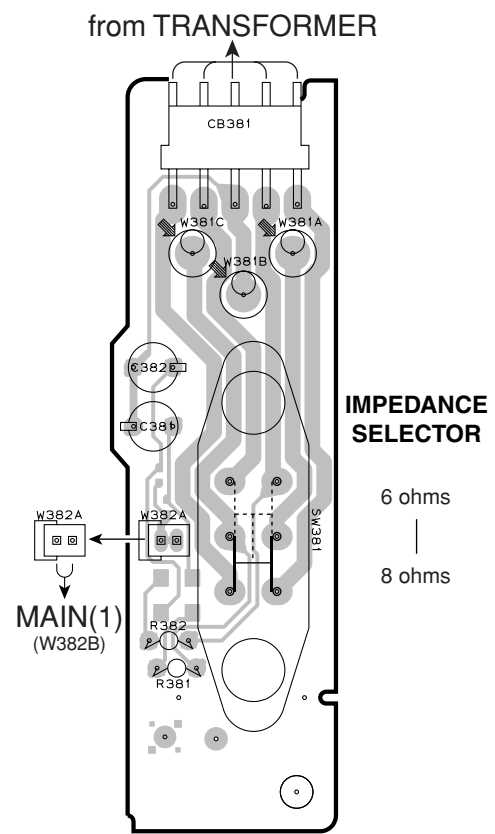

MAIN (4) P.C.B. (Side B)

Lead Free Solder Used
U, C models

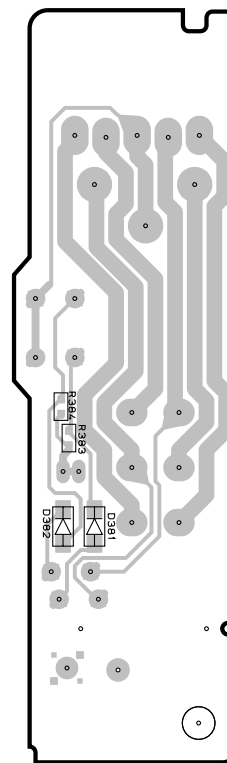

MAIN (5) P.C.B. (Side A)

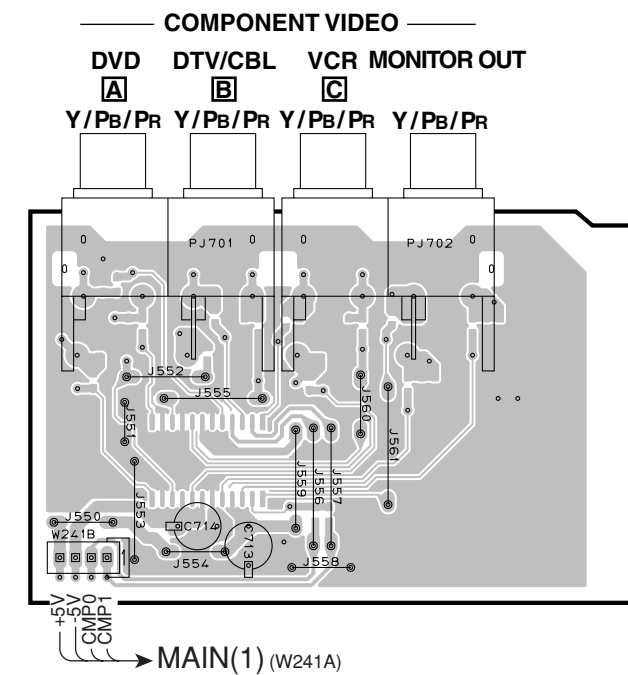

MAIN (5) P.C.B. (Side B)

Lead Free Solder Used

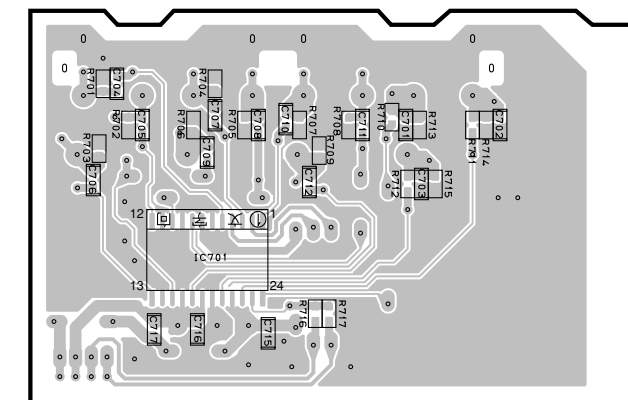



• Semiconductor Location

Ref no.	Location	Ref no.	Location
D371	C3	IC701	I5
D372	C3	Q371	C2
D373	C4	Q372	C2
D374	C4	Q373	C2
D375	C3	Q374	C3
D376	C3	Q375	C3
D377	C3	Q391	E3
D381	G6	Q392	E3
D382	G6	Q393	E3
IC391	D3		

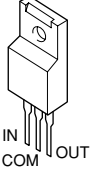
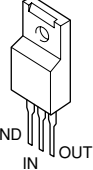
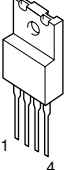
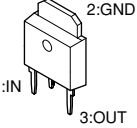
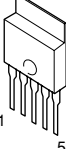

PIN CONNECTION DIAGRAM

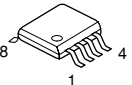
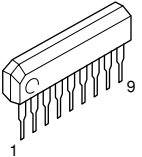
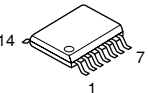
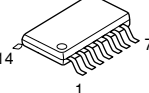
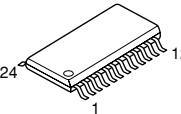
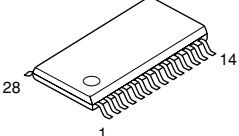
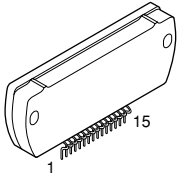
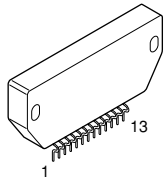
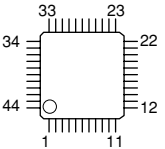
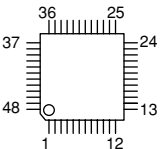
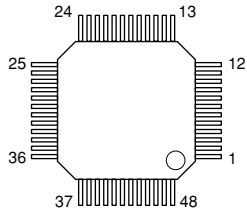
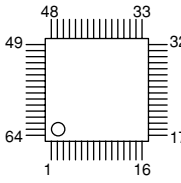
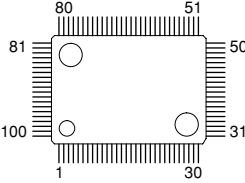
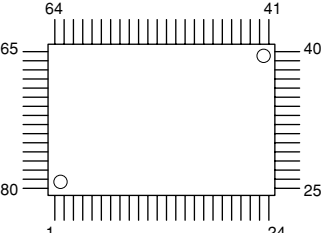
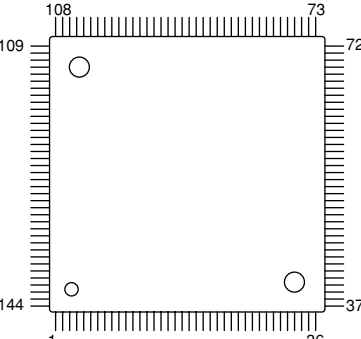
• ICs

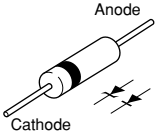
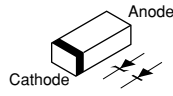
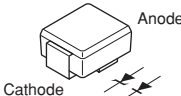
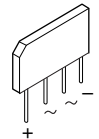
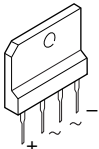

<p>KIA7805API KIA7812API</p> 	<p>KIA7912PI</p> 	<p>NJM2388F05</p> 	<p>NJM2885DL1-33</p> 	<p>PQ012FZ01ZP</p> 	<p>SN74AHCT1G32DCKR</p> 
<p>NJM4565M</p> 	<p>LA7956</p> 	<p>SN74AHC08PWR SN74AHCT08PWR SN74LV157APWR</p> 	<p>MM74HCU04SJX</p> 	<p>LC72722PM NJM2586AM</p> 	
<p>BS62LV256SC-70</p> 	<p>STK433-130-E</p> 	<p>STK404-130Y</p> 	<p>AK4628AVQ</p> 		
<p>F2602E-01</p> 	<p>LC89057W-VF4A-E</p> 	<p>M66003-0131FP</p> 	<p>M30622MWP-A82FP</p> 		
<p>BD3816K1-C</p> 		<p>YSS948-VZ</p> 			

RX-V359/HTR-5930

• Diodes

<p>1SS133,176 1SS270A 1T2</p> <p>MTZJ12C MTZJ30A MTZJ4.7A</p>		<p>1SS355 KDS160-RTK MA8075-H MA8100-H UDZ3.6B UDZ5.1B UDZ6.8B UDZS16B UDZS5.6B UDZS6.2B UDZS9.1B</p>	 <p>RB500V-40 1SS380</p>
<p>1SR154-400</p> 	<p>KPB103G TS4B03G</p> 	<p>TS6P03G</p> 	<p>SB01-05Q</p> 

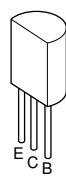
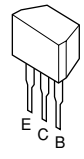
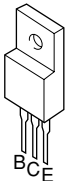
• Transistors

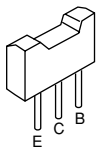
<p>2N5401C-AT 2SA1015 2SA949 2SC1815 2SC2705</p> 	<p>2SC1740S KRC102M-AT</p> 	<p>2SB1274</p> 
<p>2SA1037K 2SC2412K 2SC3326 2SD1938F KRA104S-RTK KRC102S-RTK KRC104S-RTK</p> 	<p>2SA1708 2SC4488</p> 	

RX-V359/HTR-5930

■ BLOCK DIAGRAM

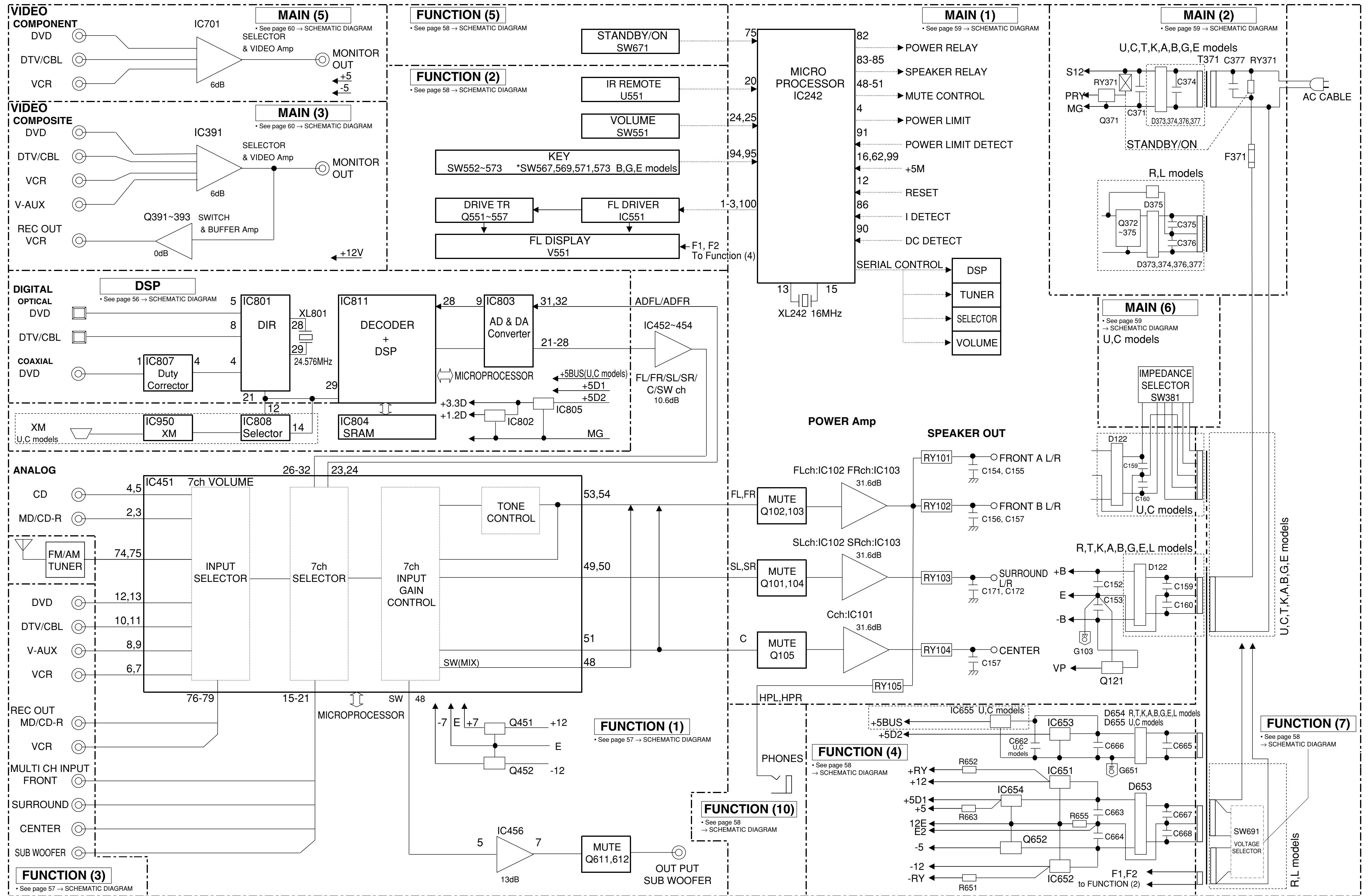

SCHEMATIC DIAGRAM (DSP)

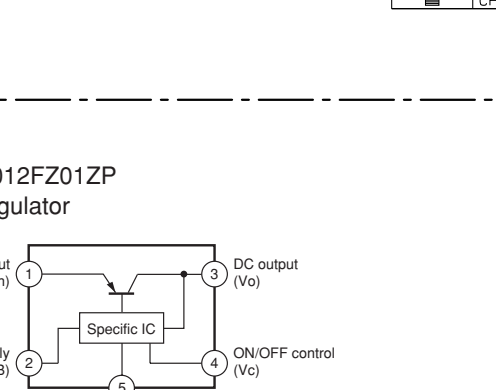
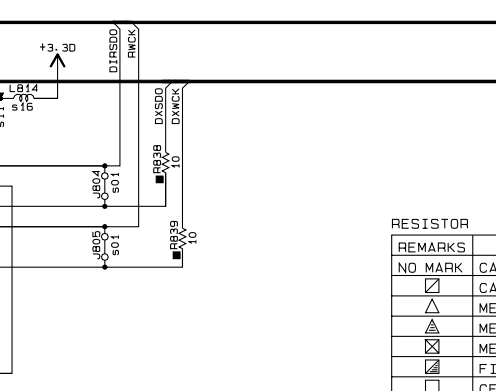
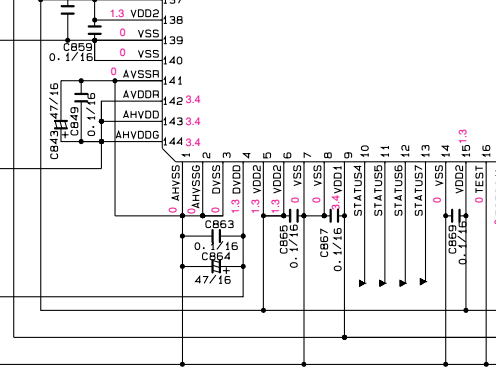
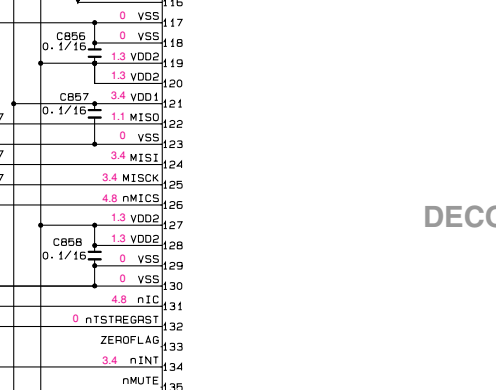
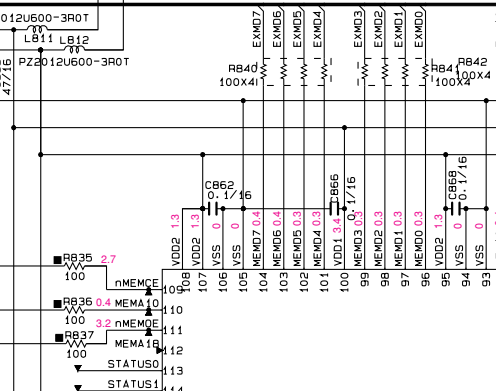
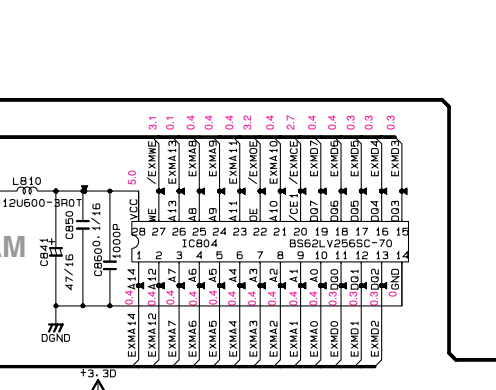
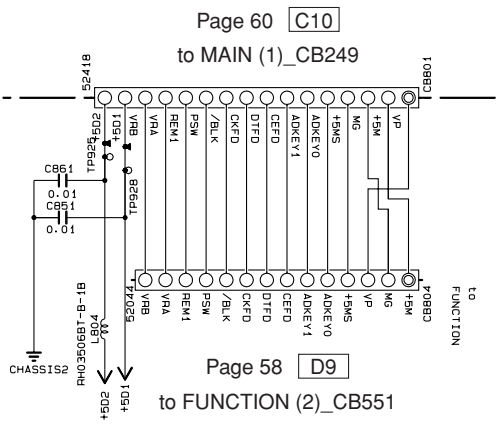
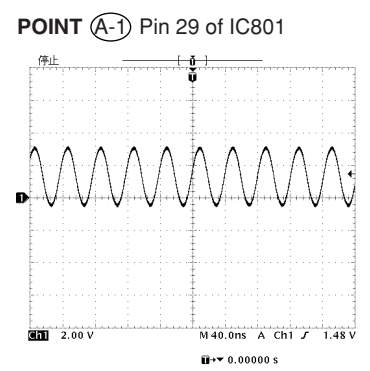
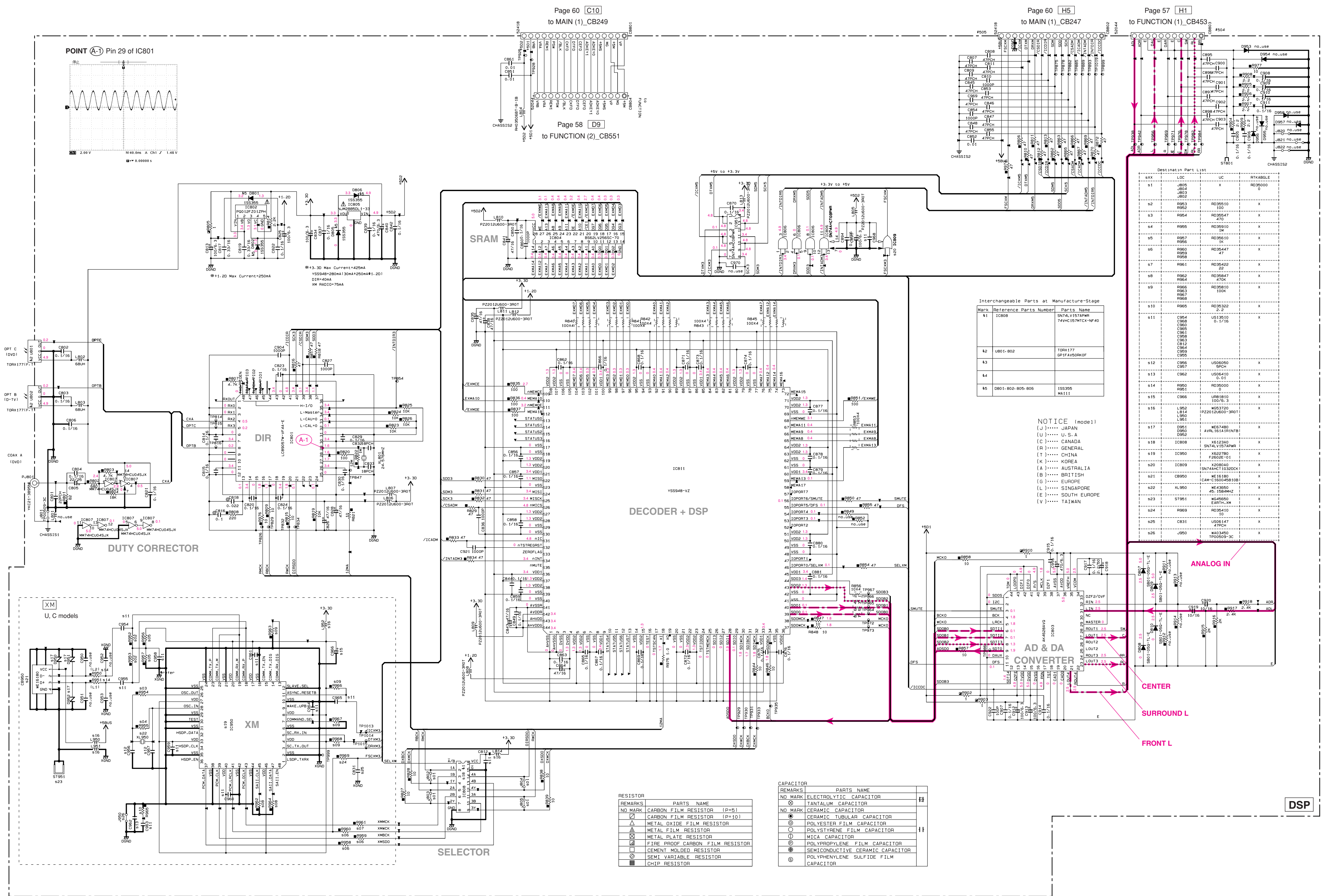

Interchangeable Parts at Manufacture Stage

IC	Reference Parts Number	Parts Name
IC1	IC806	SN74LV157APWR 74VHC157MTCX-MF40
IC2	IC807	MM74HC04SJX
IC3	IC809	SN74AHC1G32DCKR
IC4	IC808	SN74LV157APWR
IC5	IC801	LC89057W-VF4A-E
IC6	IC802	PQ012F201ZP
IC7	IC803	AK4628AVQ
IC8	IC804	BS62LV256SC-70
IC9	IC805	NJM2885DL1-33

RESISTOR

REMARKS	PARTS NAME
NO MARK	CARBON FILM RESISTOR (P+5)
NO MARK	CARBON FILM RESISTOR (P+10)
NO MARK	METAL OXIDE FILM RESISTOR
NO MARK	METAL FILM RESISTOR
NO MARK	METAL PLATE RESISTOR
NO MARK	FIRE PROOF CARBON FILM RESISTOR
NO MARK	CEMENT MOLDED RESISTOR
NO MARK	SEMI VARIABLE RESISTOR
NO MARK	CHIP RESISTOR

CAPACITOR

REMARKS	PARTS NAME
NO MARK	ELECTROLYTIC CAPACITOR
NO MARK	TANTALUM CAPACITOR
NO MARK	DERAMIC CAPACITOR
NO MARK	DERAMIC TUBULAR CAPACITOR
NO MARK	POLYESTER FILM CAPACITOR
NO MARK	POLYSTYRENE FILM CAPACITOR
NO MARK	MICA CAPACITOR
NO MARK	POLYPROPYLENE FILM CAPACITOR
NO MARK	SEMICONDUCTIVE CERAMIC CAPACITOR
NO MARK	POLYPHENYLENE SULFIDE FILM CAPACITOR

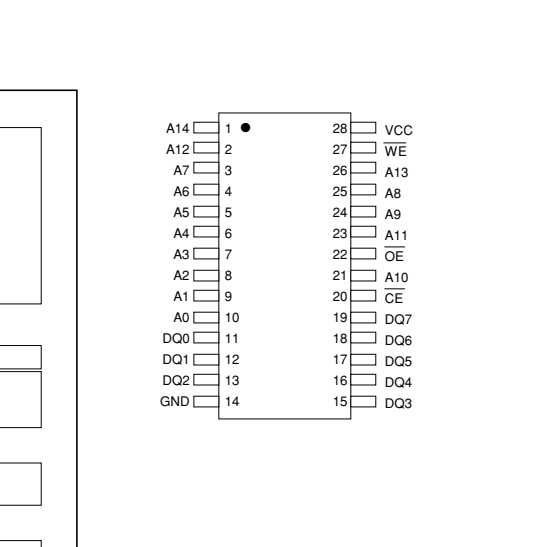
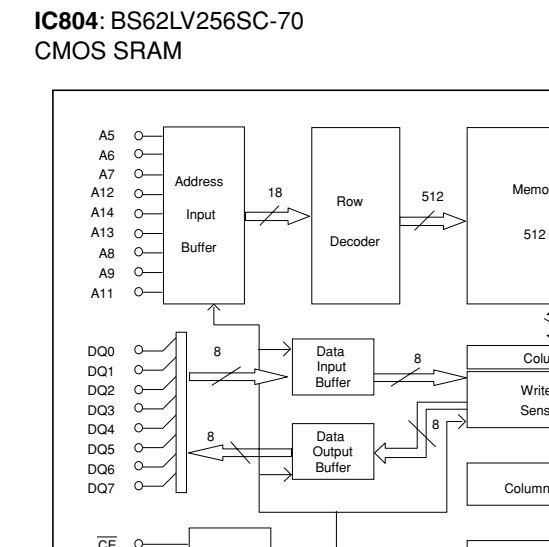
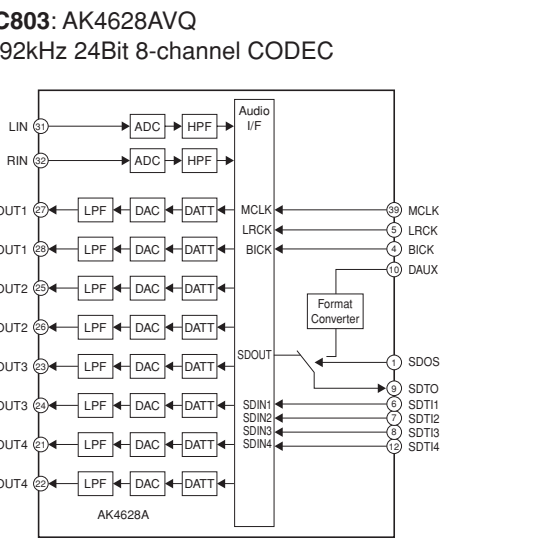
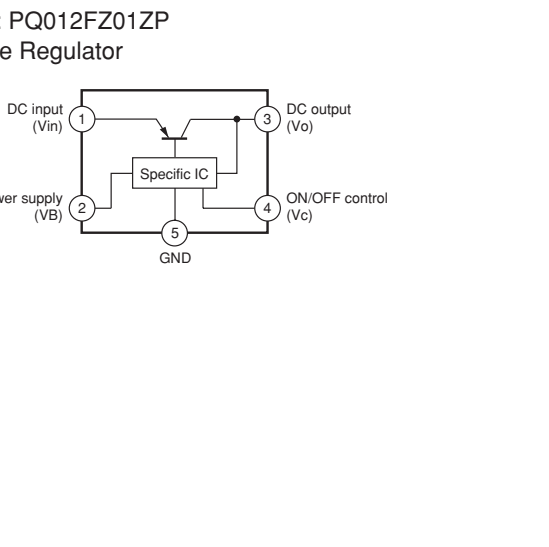
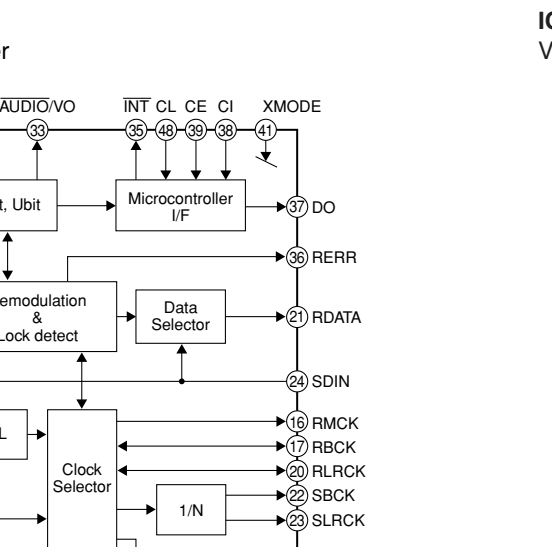
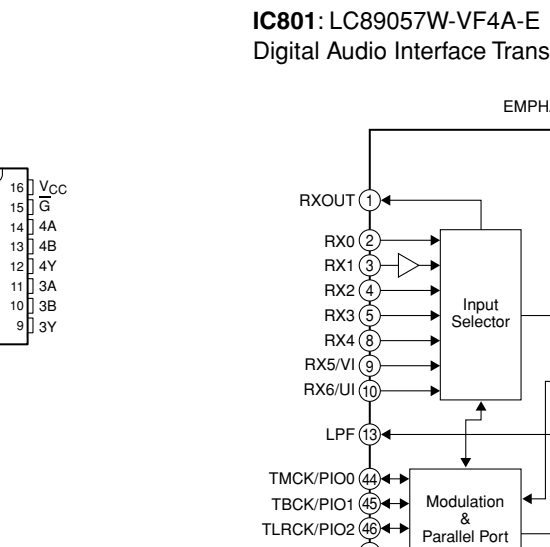
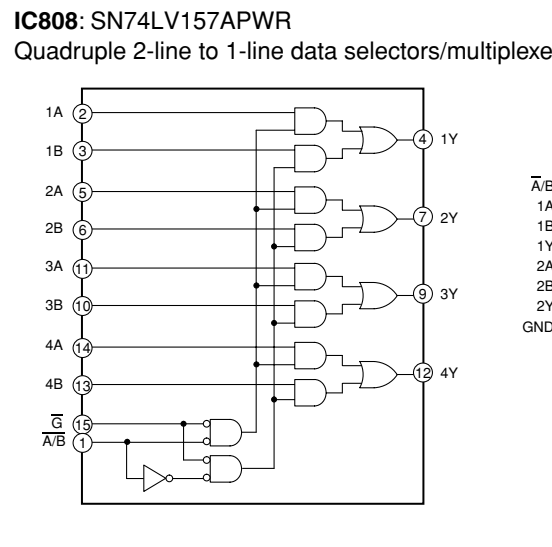

* All voltages are measured with a 10MΩ/V DC electronic volt meter.
 * Components having special characteristics are marked with a triangle and must be replaced with parts having specifications equal to those originally installed.
 * Schematic diagram is subject to change without notice.

SCHEMATIC DIAGRAM (FUNCTION 1/2)

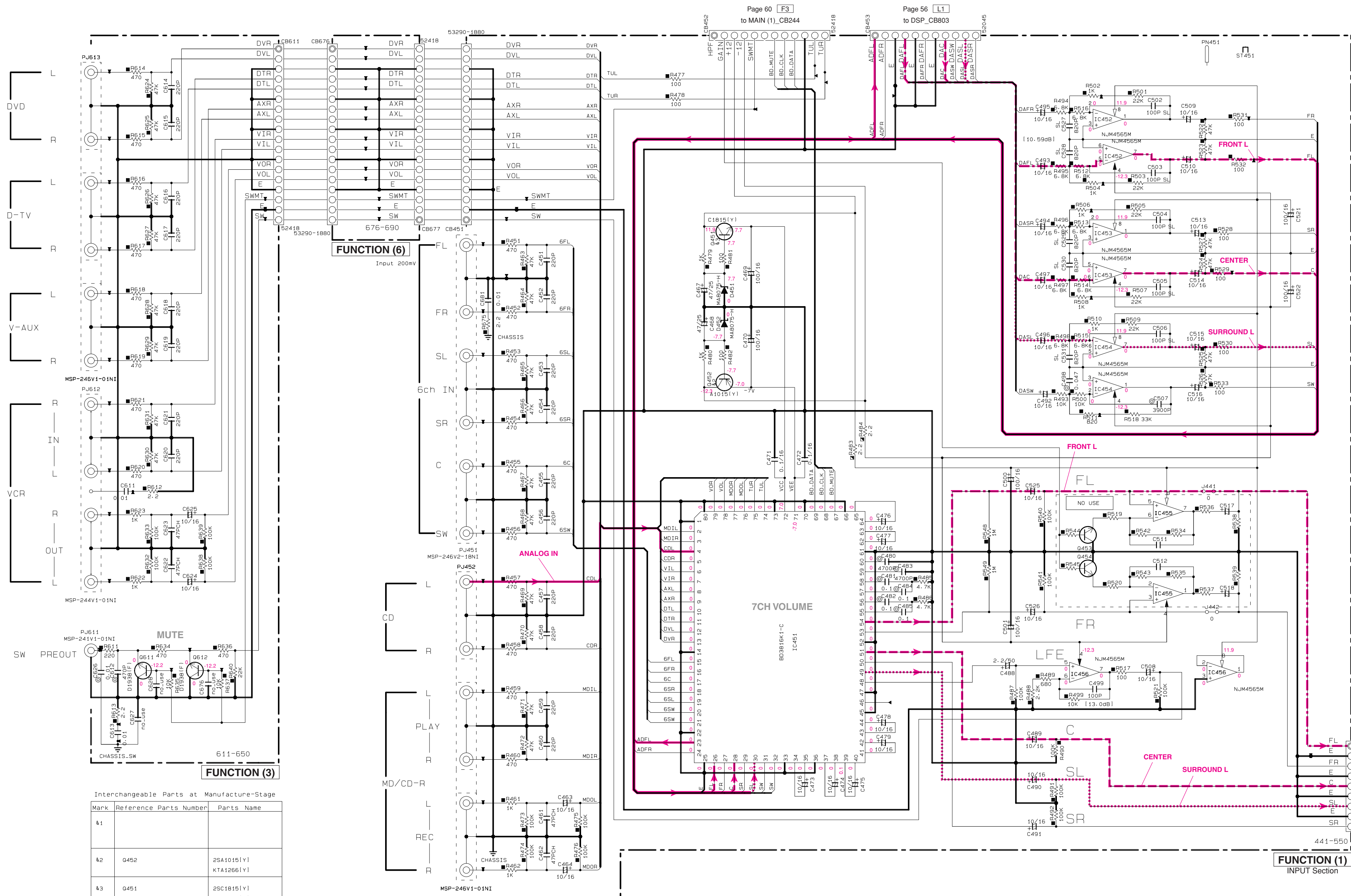

REMARKS	PARTS NAME
NO MARK	CARBON FILM RESISTOR (P=5)
□	CARBON FILM RESISTOR (P=10)
△	METAL OXIDE FILM RESISTOR
▲	METAL FILM RESISTOR
▣	METAL PLATE RESISTOR
⊠	FIRE PROOF CARBON FILM RESISTOR
⊞	CEMENT MOLDED RESISTOR
⊚	SEMI VARIABLE RESISTOR
■	CHIP RESISTOR

REMARKS	PARTS NAME
NO MARK	ELECTROLYTIC CAPACITOR
⊗	TANTALUM CAPACITOR
NO MARK	CAPACITOR
⊙	CERAMIC TUBULAR CAPACITOR
⊖	POLYESTER FILM CAPACITOR
⊕	POLYSTYRENE FILM CAPACITOR
⊖	MICA CAPACITOR
⊕	POLYPROPYLENE FILM CAPACITOR
⊖	SEMICONDUCTIVE CERAMIC CAPACITOR

NOTICE (mode1)
 (J)..... JAPAN
 (U)..... U. S. A
 (C)..... CANADA
 (R)..... GENERAL
 (T)..... CHINA
 (K)..... KOREA
 (A)..... AUSTRALIA
 (B)..... BRITISH
 (G)..... EUROPE
 (L)..... SINGAPORE
 (E)..... SOUTH EUROPE
 (V)..... TAIWAN

Interchangeable Parts at Manufacture-Stage

Mark	Reference Parts Number	Parts Name
⊠1		
⊠2	Q452	2SA1015(Y) KTA1266(Y)
⊠3	Q451	2SC1815(Y) KTC319B(Y)

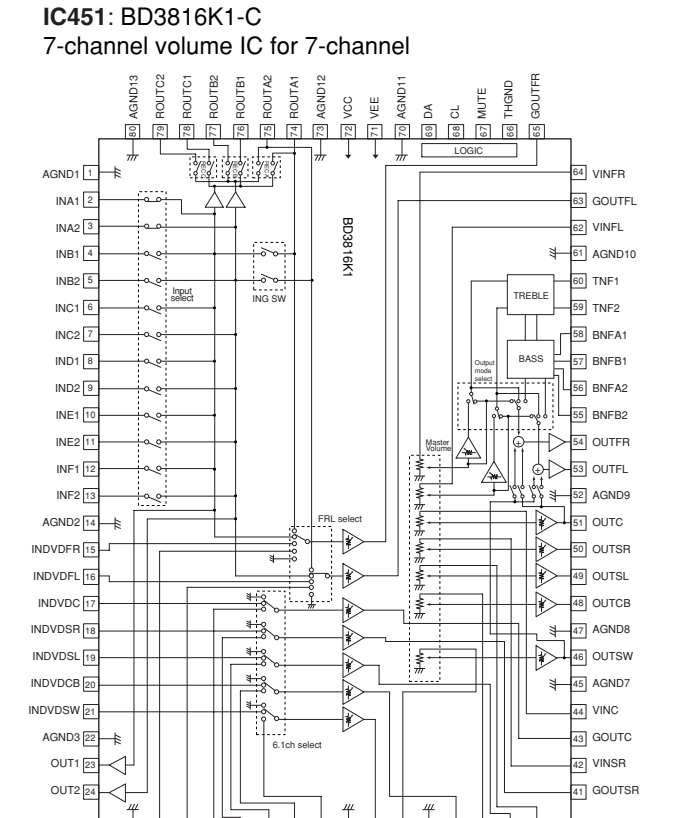
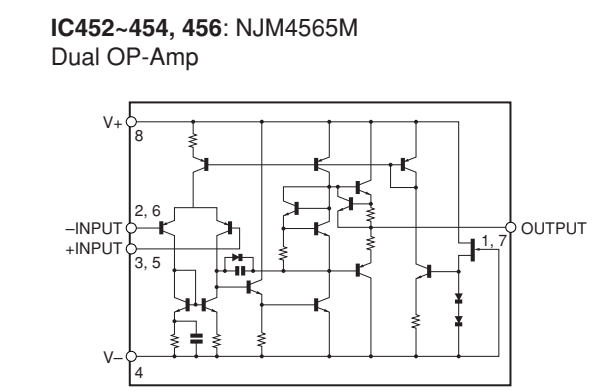

* All voltages are measured with a 10MΩ/V DC electronic volt meter.
 * Components having special characteristics are marked ⊠, and must be replaced with parts having specifications equal to those originally installed.
 * Schematic diagram is subject to change without notice.

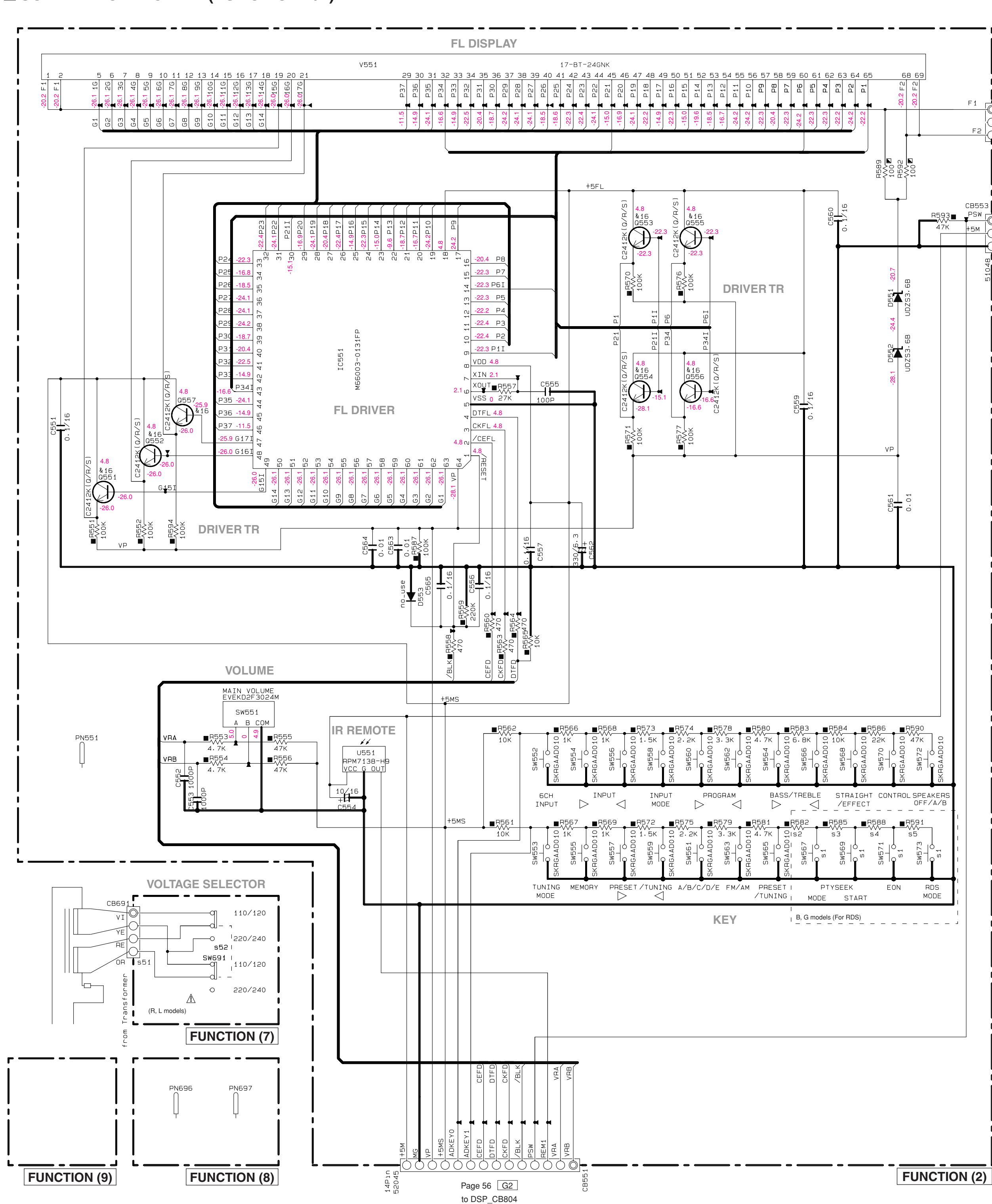

* All voltages are measured with a 10MΩ/V DC electronic volt meter.
 * Components having special characteristics are marked 1, and must be replaced with parts having specifications equal to those originally installed.
 * Schematic diagram is subject to change without notice.

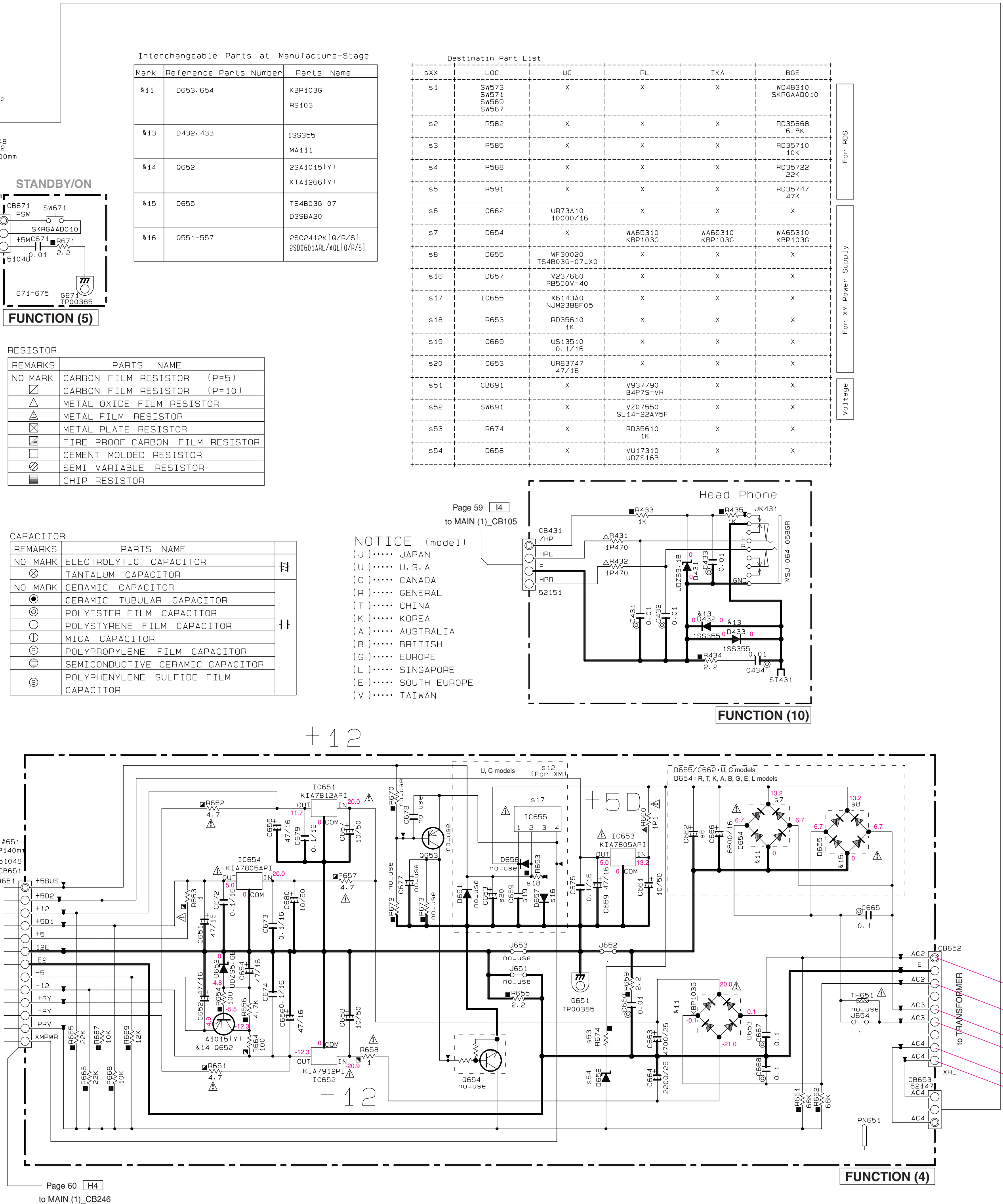

Interchangeable Parts at Manufacture-Stage

Mark	Reference Parts Number	Parts Name
k11	D653-654	KBP103G RS103
k13	D432-433	1SS355 MA111
k14	0652	PSA1015(V) KTA1266(V)
k15	D655	TS4B03G-07 O3SBA20
k16	0551-557	2SC2412K(Q/R/S) 2SD0601AR(L)/Q(L10/R/S)

Destination Part List

sxx	LOC	UC	RL	TKA	BGE
s1	SW673 SW571 SW569 SW567	X	X	X	WD48310 SKRGAD010
s2	R582	X	X	X	RD35608 5-BK
s3	R585	X	X	X	RD35710 10K
s4	R588	X	X	X	RD35722 22K
s5	R591	X	X	X	RD35747 47K
s6	C662	UR73A10 10000/16	X	X	X
s7	D654	X	WA65310 KBP103G	WA65310 KBP103G	WA65310 KBP103G
s8	D655	TS4B03G-07_X0	X	X	X
s16	D657	V237660 RB800V-40	X	X	X
s17	IC655	KS14340 NJM2388F05	X	X	X
s18	R653	RD35610 1K	X	X	X
s19	C659	US13510 0.1/16	X	X	X
s20	C653	UR83747 47/16	X	X	X
s51	CB691	X	V937790 B4P75-VH	X	X
s52	SW691	X	V207950 SL14-22AM5F	X	X
s53	R674	X	RD35610 1K	X	X
s54	D658	X	VU17310 UOZ516B	X	X

RESISTOR

REMARKS	PARTS NAME
NO MARK	CARBON FILM RESISTOR (P=5)
⊠	CARBON FILM RESISTOR (P=10)
⊡	METAL OXIDE FILM RESISTOR
⊢	METAL FILM RESISTOR
⊣	METAL PLATE RESISTOR
⊤	FIRE PROOF CARBON FILM RESISTOR
⊥	CEMENT MOLDED RESISTOR
⊦	SEMI VARIABLE RESISTOR
⊧	CHIP RESISTOR

CAPACITOR

REMARKS	PARTS NAME
NO MARK	ELECTROLYTIC CAPACITOR
⊗	TANTALUM CAPACITOR
NO MARK	CERAMIC CAPACITOR
⊙	CERAMIC TUBULAR CAPACITOR
⊚	POLYESTER FILM CAPACITOR
⊛	POLYSTYRENE FILM CAPACITOR
⊜	MICA CAPACITOR
⊝	POLYPROPYLENE FILM CAPACITOR
⊞	SEMICONDUCTIVE CERAMIC CAPACITOR
⊟	POLYPHENYLENE SULFIDE FILM CAPACITOR

NOTICE (model)
 (J)..... JAPAN
 (U)..... U.S.A
 (C)..... CANADA
 (R)..... GENERAL
 (T)..... CHINA
 (K)..... KOREA
 (A)..... AUSTRALIA
 (B)..... BRITISH
 (G)..... EUROPE
 (L)..... SINGAPORE
 (E)..... SOUTH EUROPE
 (V)..... TAIWAN

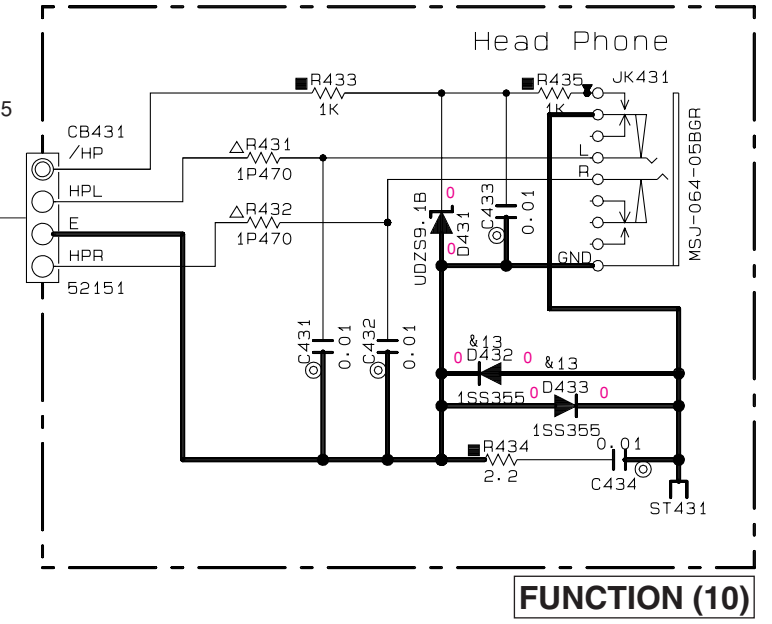

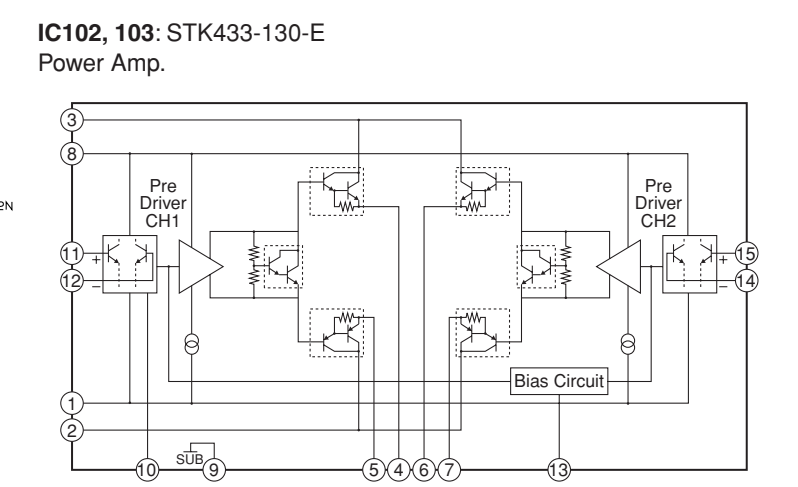
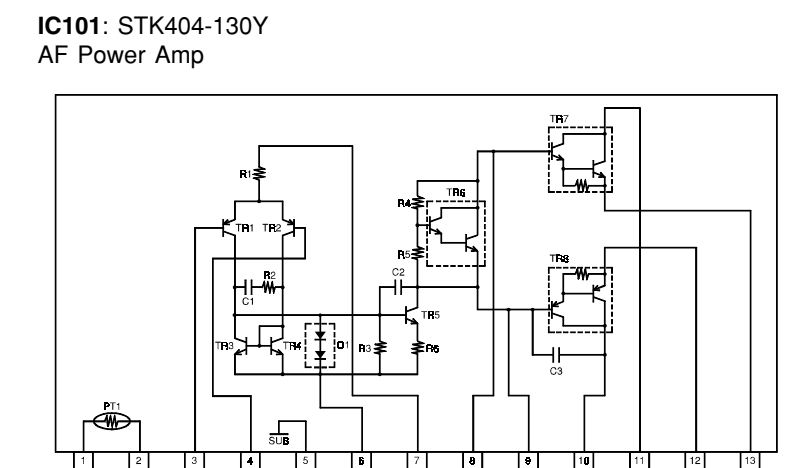
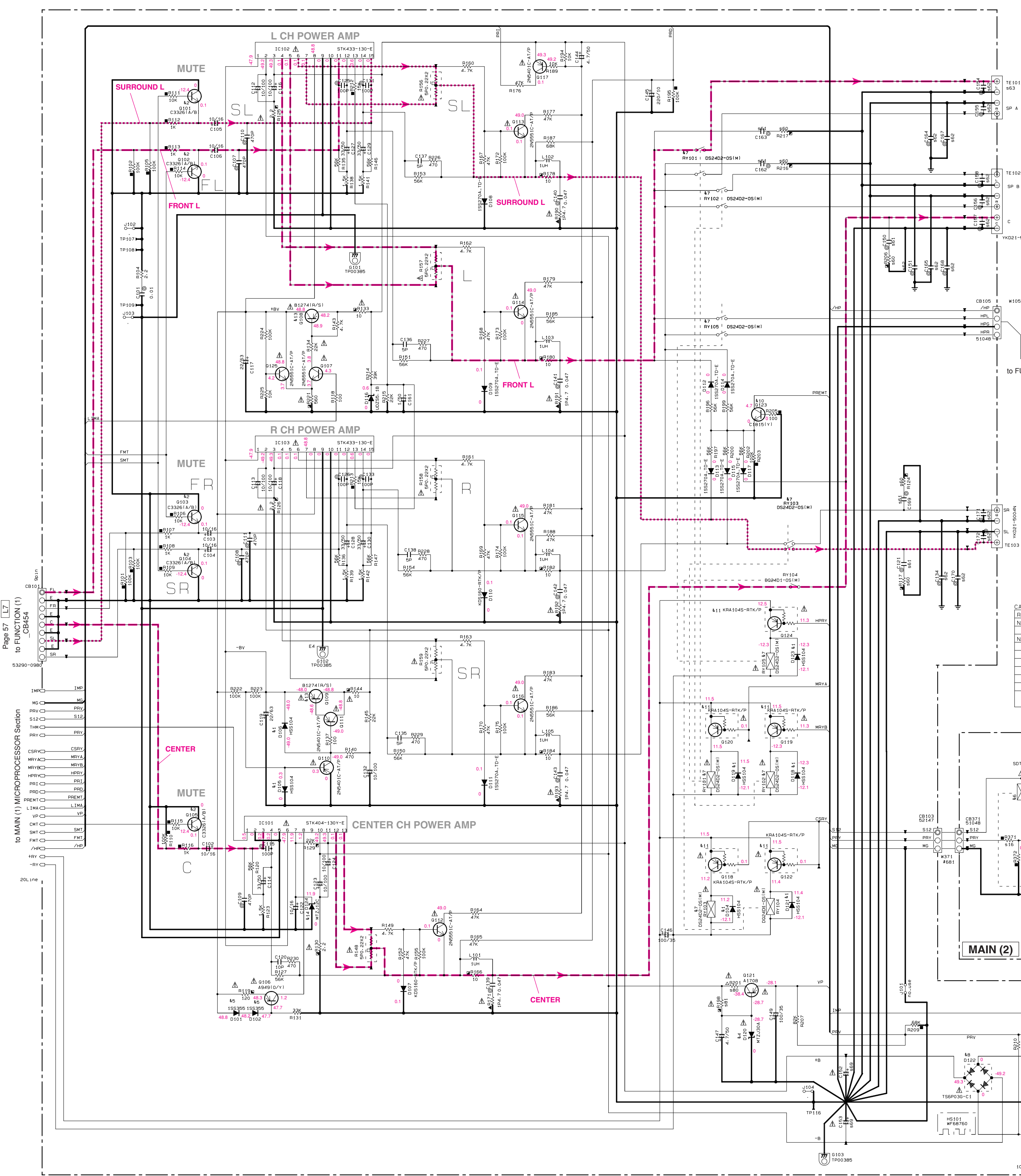

RESISTOR

REMARKS	PARTS NAME
NO MARK	CARBON FILM RESISTOR (P=5)
△	CARBON FILM RESISTOR (P=10)
▲	METAL OXIDE FILM RESISTOR
⊠	METAL FILM RESISTOR
□	METAL PLATE RESISTOR
■	FINE PROOF CARBON FILM RESISTOR
⊚	CEMENT MOLDED RESISTOR
⊙	SEMI VARIABLE RESISTOR
■	CHIP RESISTOR

NOTICE (mode1)
 (J)..... JAPAN
 (U)..... U.S.A.
 (C)..... CANADA
 (K)..... KOREA
 (A)..... AUSTRALIA
 (B)..... BRITISH
 (L)..... EUROPE
 (G)..... SINGAPORE
 (E)..... SOUTH EUROPE
 (V)..... TAIWAN

CAPACITOR

REMARKS	PARTS NAME
NO MARK	ELECTROLYTIC CAPACITOR
⊚	TANTALUM CAPACITOR
⊙	CERAMIC CAPACITOR
●	CERAMIC TUBULAR CAPACITOR
○	POLYESTER FILM CAPACITOR
○	POLYSTYRENE FILM CAPACITOR
○	MICA CAPACITOR
○	POLYPROPYLENE FILM CAPACITOR
○	SEMICONDUCTIVE CERAMIC CAPACITOR
○	POLYPHENYLENE SULFIDE FILM CAPACITOR

Destination Part List

SXK	LOC	R	PA	X	SEC	L
91	L71	VNS0000	X	VNS0000	VNS0000	VNS0000
92	R378	X	VC75790	X	X	VC75790
93	D375	X	Y599780	X	X	Y599780
94	C374	UAG5410	0.01	UAG5410	UAG5410	UAG5410
95	C375	X	UAG5410	0.01	X	UAG5410
96	C376	X	UAG5410	0.01	X	UAG5410
97	D372	X	I410151	X	X	I410151
98	R377	X	RD35747	X	X	RD35747
99	D373	X	RD35747	X	X	RD35747
100	D374	X	RD35747	X	X	RD35747
101	D375	X	RD35747	X	X	RD35747
102	D376	X	RD35747	X	X	RD35747
103	D377	X	RD35747	X	X	RD35747
104	D378	X	RD35747	X	X	RD35747
105	D379	X	RD35747	X	X	RD35747
106	D380	X	RD35747	X	X	RD35747
107	D381	X	RD35747	X	X	RD35747
108	D382	X	RD35747	X	X	RD35747
109	D383	X	RD35747	X	X	RD35747
110	D384	X	RD35747	X	X	RD35747
111	D385	X	RD35747	X	X	RD35747
112	D386	X	RD35747	X	X	RD35747
113	D387	X	RD35747	X	X	RD35747
114	D388	X	RD35747	X	X	RD35747
115	D389	X	RD35747	X	X	RD35747
116	D390	X	RD35747	X	X	RD35747
117	D391	X	RD35747	X	X	RD35747
118	D392	X	RD35747	X	X	RD35747
119	D393	X	RD35747	X	X	RD35747
120	D394	X	RD35747	X	X	RD35747
121	D395	X	RD35747	X	X	RD35747
122	D396	X	RD35747	X	X	RD35747
123	D397	X	RD35747	X	X	RD35747
124	D398	X	RD35747	X	X	RD35747
125	D399	X	RD35747	X	X	RD35747
126	D400	X	RD35747	X	X	RD35747
127	D401	X	RD35747	X	X	RD35747
128	D402	X	RD35747	X	X	RD35747
129	D403	X	RD35747	X	X	RD35747
130	D404	X	RD35747	X	X	RD35747
131	D405	X	RD35747	X	X	RD35747
132	D406	X	RD35747	X	X	RD35747
133	D407	X	RD35747	X	X	RD35747
134	D408	X	RD35747	X	X	RD35747
135	D409	X	RD35747	X	X	RD35747
136	D410	X	RD35747	X	X	RD35747
137	D411	X	RD35747	X	X	RD35747
138	D412	X	RD35747	X	X	RD35747
139	D413	X	RD35747	X	X	RD35747
140	D414	X	RD35747	X	X	RD35747
141	D415	X	RD35747	X	X	RD35747
142	D416	X	RD35747	X	X	RD35747
143	D417	X	RD35747	X	X	RD35747
144	D418	X	RD35747	X	X	RD35747
145	D419	X	RD35747	X	X	RD35747
146	D420	X	RD35747	X	X	RD35747
147	D421	X	RD35747	X	X	RD35747
148	D422	X	RD35747	X	X	RD35747
149	D423	X	RD35747	X	X	RD35747
150	D424	X	RD35747	X	X	RD35747
151	D425	X	RD35747	X	X	RD35747
152	D426	X	RD35747	X	X	RD35747
153	D427	X	RD35747	X	X	RD35747
154	D428	X	RD35747	X	X	RD35747
155	D429	X	RD35747	X	X	RD35747
156	D430	X	RD35747	X	X	RD35747
157	D431	X	RD35747	X	X	RD35747
158	D432	X	RD35747	X	X	RD35747
159	D433	X	RD35747	X	X	RD35747
160	D434	X	RD35747	X	X	RD35747
161	D435	X	RD35747	X	X	RD35747
162	D436	X	RD35747	X	X	RD35747
163	D437	X	RD35747	X	X	RD35747
164	D438	X	RD35747	X	X	RD35747
165	D439	X	RD35747	X	X	RD35747
166	D440	X	RD35747	X	X	RD35747
167	D441	X	RD35747	X	X	RD35747
168	D442	X	RD35747	X	X	RD35747
169	D443	X	RD35747	X	X	RD35747
170	D444	X	RD35747	X	X	RD35747
171	D445	X	RD35747	X	X	RD35747
172	D446	X	RD35747	X	X	RD35747
173	D447	X	RD35747	X	X	RD35747
174	D448	X	RD35747	X	X	RD35747
175	D449	X	RD35747	X	X	RD35747
176	D450	X	RD35747	X	X	RD35747
177	D451	X	RD35747	X	X	RD35747
178	D452	X	RD35747	X	X	RD35747
179	D453	X	RD35747	X	X	RD35747
180	D454	X	RD35747	X	X	RD35747
181	D455	X	RD35747	X	X	RD35747
182	D456	X	RD35747	X	X	RD35747
183	D457	X	RD35747	X	X	RD35747
184	D458	X	RD35747	X	X	RD35747
185	D459	X	RD35747	X	X	RD35747
186	D460	X	RD35747	X	X	RD35747
187	D461	X	RD35747	X	X	RD35747
188	D462	X	RD35747	X	X	RD35747
189	D463	X	RD35747	X	X	RD35747
190	D464	X	RD35747	X	X	RD35747
191	D465	X	RD35747	X	X	RD35747
192	D466	X	RD35747	X	X	RD35747
193	D467	X	RD35747	X	X	RD35747
194	D468	X	RD35747	X	X	RD35747
195	D469	X	RD35747	X	X	RD35747
196	D470	X	RD35747	X	X	RD35747
197	D471	X	RD35747	X	X	RD35747
198	D472	X	RD35747	X	X	RD35747
199	D473	X	RD35747	X	X	RD35747
200	D474	X	RD35747	X	X	RD35747

Interchangeable Parts at Manufacture-Stage

Mark	Reference Number	Parts Name
41	D104-106-118-119-121-123-371	HSS104
42	D101-100	HSS103
43	D372	2SC3381A/B
44	D120	2SC3381B
45	D101-102	2SC3381C
46	Rv371	2SC3381D
47	Rv101-102-103-105	2SC3381E
48	D122	2SC3381F
49	D372-374	2SA10151V1
50	D123	2SA10151V2
51	D118-120-122-124	2SA10151V3
52	D375	2SA10151V4
53	D108-109	2SA10151V5
54	D124	2SA10151V6

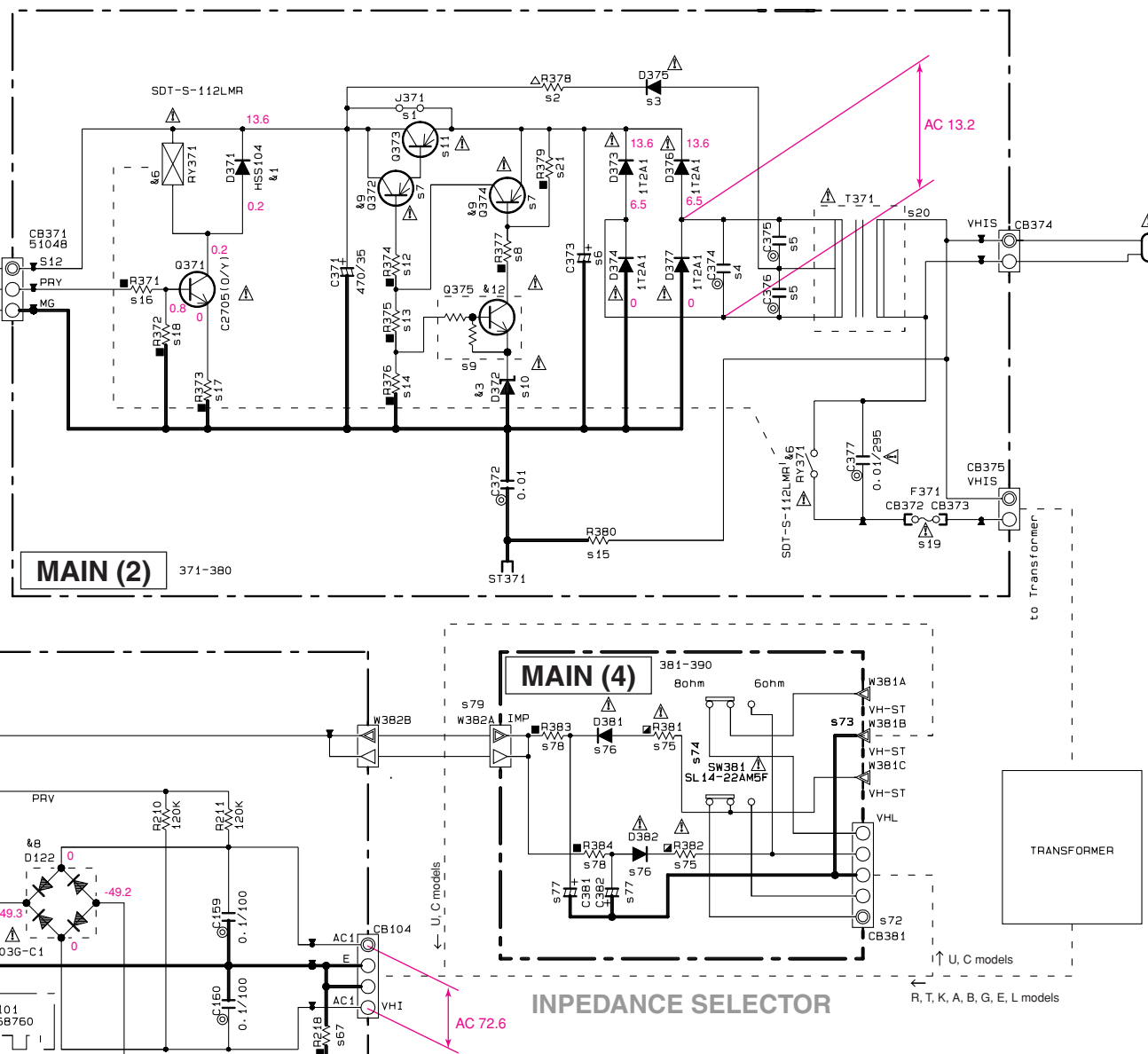

* All voltages are measured with a 10MΩ/V DC electronic volt meter.
 * Components having special characteristics are marked with a triangle and must be replaced with parts having specifications equal to those originally installed.
 * Schematic diagram is subject to change without notice.

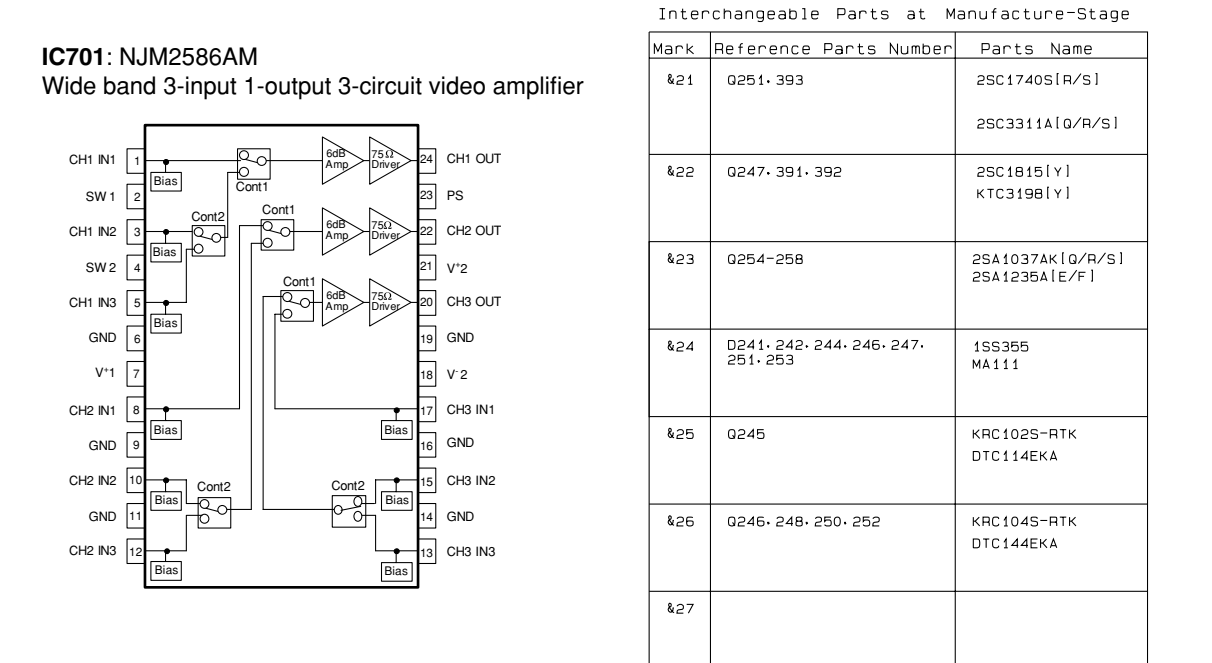
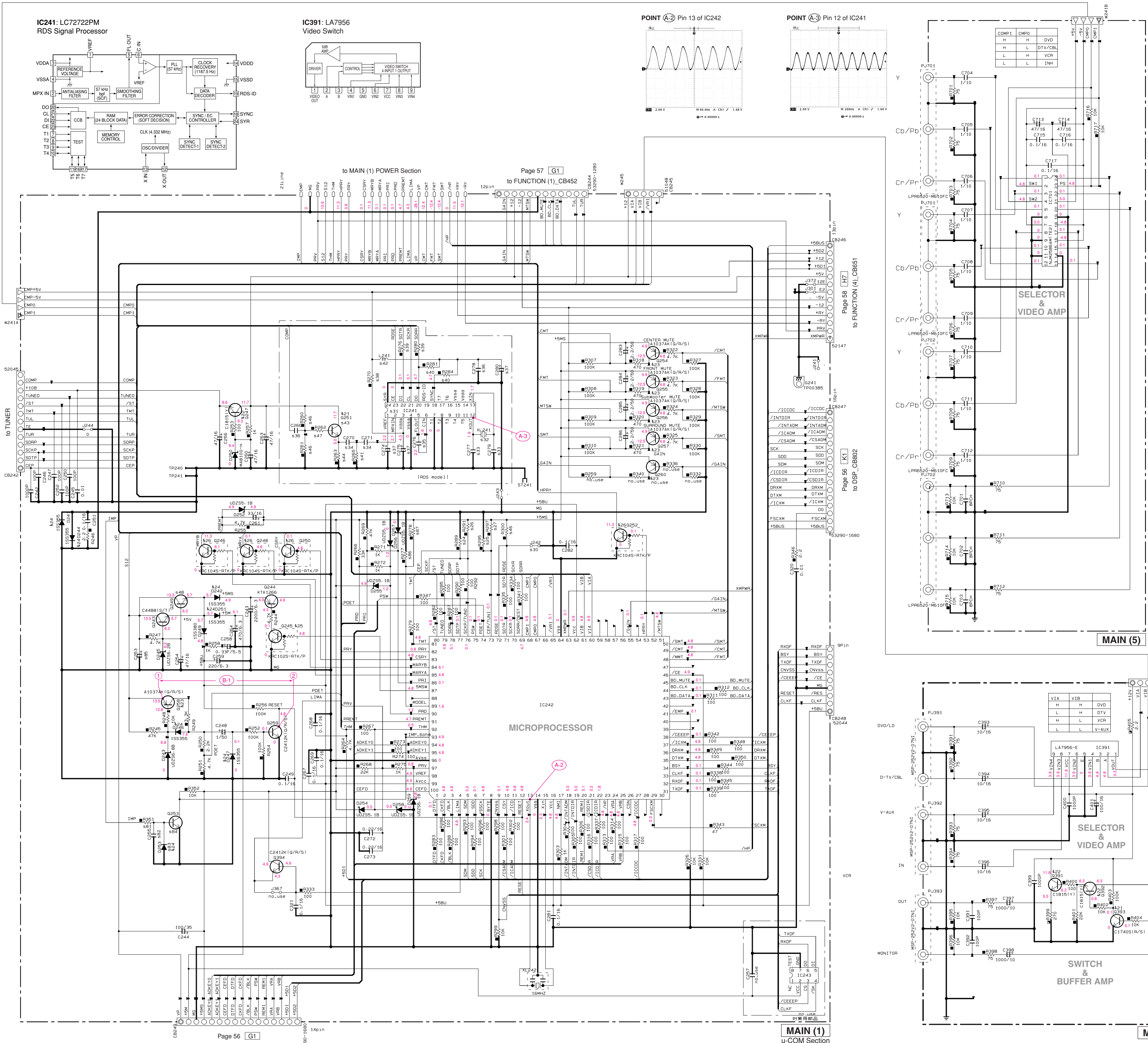

Mark	Reference Parts Number	Parts Name
K21	0251-393	25C174051R/S1
K22	0247-391-392	25C18151Y1 KTC31981Y1
K23	0254-258	25A1037AK(G/R/S1)
K24	0241-242-244-246-247-251-253	15S395 MA111
K25	0245	KRC1025-RTK DTC114EKA
K26	0246-248-250-252	KRC1045-RTK DTC114EKA
K27		

sxx	LDC	UC	R	TA	K	BGE	L
924	R289	RD35810	X	X	X	X	X
925	R299	X	X	RD36810	RD36810	RD36810	X
926	R297	X	RD35810	RD35810	RD35810	RD35810	RD35810
927	R297	RD35810	RD35810	RD35810	X	X	RD35810
930	R242	RD35000	RD35000	RD35000	RD35000	X	RD35000
931	IC241	X	X	X	X	X	LC72722PM-TM-E
932	XL241	X	X	X	X	X	V393090
933	C279	X	X	X	X	X	US56127
934	C271	X	X	X	X	X	US56233
935	C276	X	X	X	X	X	US56356
936	C266	X	X	X	X	X	US13510
937	C278	X	X	X	X	X	US56127
938	C260	X	X	X	X	X	US56127
939	R270	X	X	X	X	X	RD35100
940	R284	X	X	X	X	X	RD35547
941	R265	X	X	X	X	X	RD35722
942	L241	X	X	X	X	X	VB88950
943	Q251	X	X	X	X	X	IC17402
944	R263	X	X	X	X	X	C174051R/S1
945	R260	X	X	X	X	X	RD35810
946	R300	X	X	X	X	X	RD35810
947	R262	X	X	X	X	X	RD35510
948	Q249	X	X	X	X	X	VP87270
949	R261	X	X	X	X	X	C44881S/T1
950	R351	RD35710	X	X	X	X	X
951	C255	US06410	X	X	X	X	X
952	C255	US06410	X	X	X	X	X
953	Q253	VT33290	X	X	X	X	X
954	Q253	VT33290	X	X	X	X	X
955	C253	US06540	X	X	X	X	X
956	R277	RD35810	RD35810	RD35810	RD35810	RD35810	X
957	R278	X	X	X	X	X	RD35810

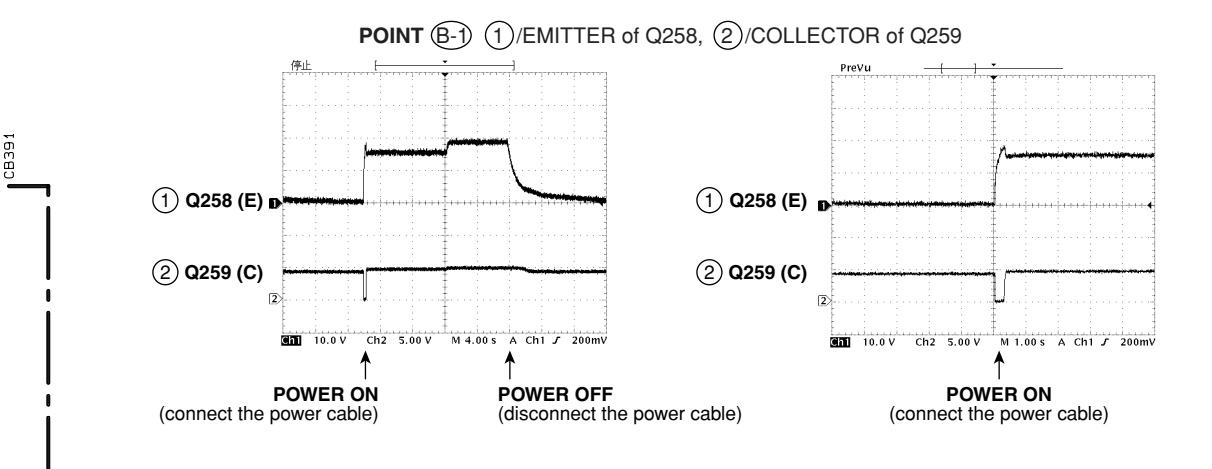

REMARKS	PARTS NAME
NO MARK	ELECTROLYTIC CAPACITOR
⊗	TANTALUM CAPACITOR
NO MARK	CERAMIC CAPACITOR
⊙	CERAMIC TUBULAR CAPACITOR
⊕	POLYESTER FILM CAPACITOR
⊖	POLYSTYRENE FILM CAPACITOR
Ⓜ	MICA CAPACITOR
⊗	POLYPROPYLENE FILM CAPACITOR
⊙	SEMICONDUCTIVE CERAMIC CAPACITOR

REMARKS	PARTS NAME
NO MARK	CARBON FILM RESISTOR (P=5)
⊕	CARBON FILM RESISTOR (P=10)
⊖	METAL OXIDE FILM RESISTOR
⊗	METAL FILM RESISTOR
⊙	METAL PLATE RESISTOR
⊕	FIRE PROOF CARBON FILM RESISTOR
⊖	CEMENT MOLDED RESISTOR
⊗	SEMI VARIABLE RESISTOR
⊙	CHIP RESISTOR

NOTICE (model)
 (J)..... JAPAN
 (U)..... U.S.A
 (C)..... CANADA
 (R)..... GENERAL
 (T)..... CHINA
 (K)..... KOREA
 (A)..... AUSTRALIA
 (B)..... BRITISH
 (G)..... EUROPE
 (L)..... SINGAPORE
 (E)..... SOUTH EUROPE
 (V)..... TAIWAN

* All voltages are measured with a 10MΩ/2V DC electronic volt meter.
 * Components having special characteristics are marked ⊕ and must be replaced with parts having specifications equal to those originally installed.
 * Schematic diagram is subject to change without notice.

■ REPLACEMENT PARTS LIST

• ELECTRICAL REPLACEMENT PARTS LIST

WARNING

Components having special characteristics are marked \triangle and must be replaced with parts having specifications equal to those originally installed.

ABBREVIATIONS IN THIS LIST ARE AS FOLLOWS:

C.A.EL.CHP	: CHIP ALUMI.ELECTROLYTIC CAP	L.EMIT	: LIGHT EMITTING MODULE
C.CE	: CERAMIC CAP	LED.DSPLY	: LED DISPLAY
C.CE.ARRAY	: CERAMIC CAP ARRAY	LED.INFRD	: LED,INFRARED
C.CE.CHP	: CHIP CERAMIC CAP	MODUL.RF	: MODULATOR,RF
C.CE.ML	: MULTILAYER CERAMIC CAP	PHOT.CPL	: PHOTO COUPLER
C.CE.M.CHP	: CHIP MULTILAYER CERAMIC CAP	PHOT.INTR	: PHOTO INTERRUPTER
C.CE.SAFTY	: RECOGNIZED CERAMIC CAP	PHOT.RFLCT	: PHOTO REFLECTOR
C.CE.TUBLR	: CERAMIC TUBULAR CAP	PIN.TEST	: PIN,TEST POINT
C.CE.SMI	: SEMI CONDUCTIVE CERAMIC CAP	PLST.RIVET	: PLASTIC RIVET
C.EL	: ELECTROLYTIC CAP	R.ARRAY	: RESISTOR ARRAY
C.MICA	: MICA CAP	R.CAR.	: CARBON RESISTOR
C.ML.FLM	: MULTILAYER FILM CAP	R.CAR.CHP	: CHIP RESISTOR
C.MP	: METALLIZED PAPER CAP	R.CAR.FP	: FLAME PROOF CARBON RESISTOR
C.MYLAR	: MYLAR FILM CAP	R.FUS	: FUSABLE RESISTOR
C.MYLAR.ML	: MULTILAYER MYLAR FILM CAP	R.MTL.CHP	: CHIP METAL FILM RESISTOR
C.PAPER	: PAPER CAPACITOR	R.MTL.FLM	: METAL FILM RESISTOR
C.PLS	: POLYSTYRENE FILM CAP	R.MTL.OXD	: METAL OXIDE FILM RESISTOR
C.POL	: POLYESTER FILM CAP	R.MTL.PLAT	: METAL PLATE RESISTOR
C.POLY	: POLYETHYLENE FILM CAP	RSNR.CE	: CERAMIC RESONATOR
C.PP	: POLYPROPYLENE FILM CAP	RSNR.CRYS	: CRYSTAL RESONATOR
C.TNTL	: TANTALUM CAP	R.TW.CEM	: TWIN CEMENT FIXED RESISTOR
C.TNTL.CHP	: CHIP TANTALUM CAP	R.CEMENT	: CEMENT RESISTOR
C.TRIM	: TRIMMER CAP	SCR.BND.HD	: BIND HEAD B-TITE SCREW
CN	: CONNECTOR	SCR.BW.HD	: BW HEAD TAPPING SCREW
CN.BS.PIN	: CONNECTOR,BASE PIN	SCR.CUP	: CUP TITE SCREW
CN.CANNON	: CONNECTOR,CANNON	SCR.TERM	: SCREW TERMINAL
CN.DIN	: CONNECTOR,DIN	SCR.TR	: SCREW,TRANSISTOR
CN.FLAT	: CONNECTOR,FLAT CABLE	SUPRT.PCB	: SUPPORT,P.C.B.
CN.POST	: CONNECTOR,BASE POST	SURG.PRTCT	: SURGE PROTECTOR
COIL.MX.AM	: COIL,AM MIX	SW.TACT	: TACT SWITCH
COIL.AT.FM	: COIL,FM ANTENNA	SW.LEAF	: LEAF SWITCH
COIL.DT.FM	: COIL,FM DETECT	SW.LEVER	: LEVER SWITCH
COIL.MX.FM	: COIL,FM MIX	SW.MICRO	: MICRO SWITCH
COIL.OUTPT	: OUTPUT COIL	SW.PUSH	: PUSH SWITCH
DIOD.ARRAY	: DIODE ARRAY	SW.RT.ENC	: ROTARY ENCODER
DIODE.BRG	: DIODE BRIDGE	SW.RT.MTR	: ROTARY SWITCH WITH MOTOR
DIODE.CHP	: CHIP DIODE	SW.RT	: ROTARY SWITCH
DIODE.VAR	: VARACTOR DIODE	SW.SLIDE	: SLIDE SWITCH
DIOD.Z.CHP	: CHIP ZENER DIODE	TERM.SP	: SPEAKER TERMINAL
DIODE.ZENR	: ZENER DIODE	TERM.WRAP	: WRAPPING TERMINAL
DSCR.CE	: CERAMIC DISCRIMINATOR	THRMST.CHP	: CHIP THERMISTOR
FER.BEAD	: FERRITE BEADS	TR.CHP	: CHIP TRANSISTOR
FER.CORE	: FERRITE CORE	TR.DGT	: DIGITAL TRANSISTOR
FET.CHP	: CHIP FET	TR.DGT.CHP	: CHIP DIGITAL TRANSISTOR
FL.DSPLY	: FLUORESCENT DISPLAY	TRANS	: TRANSFORMER
FLTR.CE	: CERAMIC FILTER	TRANS.PULS	: PULSE TRANSFORMER
FLTR.COMB	: COMB FILTER MODULE	TRANS.PWR	: POWER TRANSFORMER ASS'Y
FLTR.LC.RF	: LC FILTER,EMI	TUNER.AM	: TUNER PACK,AM
GND.MTL	: GROUND PLATE	TUNER.FM	: TUNER PACK,FM
GND.TERM	: GROUND TERMINAL	TUNER.PK	: FRONT-ENDTUNER PACK
HOLDER.FUS	: FUSE HOLDER	VR	: ROTARY POTENTIOMETER
IC.PRTCT	: IC PROTECTOR	VR.MTR	: POTENTIOMETER WITH MOTOR
JUMPER.CN	: JUMPER CONNECTOR	VR.SW	: POTENTIOMETER WITH ROTARY SW
JUMPER.TST	: JUMPER,TEST POINT	VR.SLIDE	: SLIDE POTENTIOMETER
L.DTCT	: LIGHT DETECTING MODULE	VR.TRIM	: TRIMMER POTENTIOMETER

P.C.B. DSP

P.C.B. DSP

Ref. No.	Part No.	Description	Markets
	WG674000	P. C. B.	UC
	WG674100	P. C. B.	RTKABGEL
CB801-802	VQ961900	CN	
CB803	VQ044500	CN. BS. PIN	
CB804	VF982200	CN. BS. PIN	
CB950	WE161800	CN. BS. PIN	UC
C801	US061220	C. CE. CHP	22pF 50V B
C802-804	US135100	C. CE. CHP	0.1uF 16V
C805	UR847220	C. EL	22uF 25V
C806	US135100	C. CE. CHP	0.1uF 16V
C807-809	US061470	C. CE. CHP	47pF 50V B
C810	US063100	C. CE. CHP	1000pF 50V B
C811	US061470	C. CE. CHP	47pF 50V B
C812	US135100	C. CE. CHP	0.1uF 16V UC
C813	UR818100	C. EL	100uF 6.3V
C814-815	US135100	C. CE. CHP	0.1uF 16V
C816	VE326000	C. MYLAR	0.1uF 50V
C817	US135330	C. CE. CHP	0.33uF 16V
C818	VE325200	C. MYLAR	0.022uF 50V
C819	US135330	C. CE. CHP	0.33uF 16V
C820-824	US135100	C. CE. CHP	0.1uF 16V
C825	UR818100	C. EL	100uF 6.3V
C826	UR837470	C. EL	47uF 16V
C827	US063100	C. CE. CHP	1000pF 50V B
C828	UR837470	C. EL	47uF 16V
C829-830	US135100	C. CE. CHP	0.1uF 16V
C831	US061470	C. CE. CHP	47pF 50V B UC
C832-833	US061180	C. CE. CHP	18pF 50V B
C834	UR818100	C. EL	100uF 6.3V
C835	UR837470	C. EL	47uF 16V
C836	US063100	C. CE. CHP	1000pF 50V B
C837	US135100	C. CE. CHP	0.1uF 16V
C838	UR837470	C. EL	47uF 16V
C839	US135100	C. CE. CHP	0.1uF 16V
C840	UR818470	C. EL	470uF 6.3V
C841	UR837470	C. EL	47uF 16V
C842	US135100	C. CE. CHP	0.1uF 16V
C843	UR837470	C. EL	47uF 16V
C844	US135100	C. CE. CHP	0.1uF 16V
C845-848	US061470	C. CE. CHP	47pF 50V B
C849-850	US135100	C. CE. CHP	0.1uF 16V
C851-852	US064100	C. CE. CHP	0.01uF 50V B
C853	US061470	C. CE. CHP	47pF 50V B
C854	US063100	C. CE. CHP	1000pF 50V B
C855	US061470	C. CE. CHP	47pF 50V B
C856-859	US135100	C. CE. CHP	0.1uF 16V
C860	US063100	C. CE. CHP	1000pF 50V B
C861	US064100	C. CE. CHP	0.01uF 50V B
C862-863	US135100	C. CE. CHP	0.1uF 16V
C864	UR837470	C. EL	47uF 16V
C865-881	US135100	C. CE. CHP	0.1uF 16V

* New Parts

Ref. No.	Part No.	Description	Markets
C891	UR818100	C. EL	100uF 6.3V
C894	US135100	C. CE. CHP	0.1uF 16V
C895-898	US061470	C. CE. CHP	47pF 50V B
C900-903	US061470	C. CE. CHP	47pF 50V B
C904	US063100	C. CE. CHP	1000pF 50V B
C905-911	US135100	C. CE. CHP	0.1uF 16V
C912-913	UR818100	C. EL	100uF 6.3V
C914-915	US135100	C. CE. CHP	0.1uF 16V
C916	UR818470	C. EL	470uF 6.3V
C917	US135100	C. CE. CHP	0.1uF 16V
C918	UR866220	C. EL	2.2uF 50V
C919-920	UR837100	C. EL	10uF 16V
C921-922	US063100	C. CE. CHP	1000pF 50V B
C954-955	US135100	C. CE. CHP	0.1uF 16V UC
C956-957	US060500	C. CE. CHP	5pF 50V B UC
C958-961	US135100	C. CE. CHP	0.1uF 16V UC
C962	US064100	C. CE. CHP	0.01uF 50V B UC
C963-965	US135100	C. CE. CHP	0.1uF 16V UC
C966	UR818100	C. EL	100uF 6.3V UC
C968	US135100	C. CE. CHP	0.1uF 16V UC
C969	US061470	C. CE. CHP	47pF 50V B
D801-802	VT332900	DIODE	1SS355
D805-806	VT332900	DIODE	1SS355
D807-810	WB081800	DIODE	SB01-05Q
D950-952	WE674800	DIODE	AVRL161A1R1NTB UC
IC801	X6989A00	IC	LC89057W-VF4A-E
IC802	X5945A00	IC	PO012FZ01ZPH
IC803	X6156A00	IC	AK4628AVQ
IC804	X3859A00	IC	BS62LV256SC-70 SRA
IC805	X6869A00	IC	NJM2885DL1-33
IC806	X3824A00	IC	SN74AHCT08PWR
IC807	XY070A00	IC	MM74HCU04SJX INVER
IC808	X6123A00	IC	SN74LV157APWR UC
IC809	X2080A00	IC	SN74AHCT1G32DCKR UC
IC811	X4570A00	IC	YSS948-VZ
IC950	X6227B00	IC	F2602E-01 UC
IC951	X2713A00	IC	SN74AHC08PWR
J802		R. CHP	0Ω 1/16W J RTKABGEL
J803		R. CHP	0Ω 1/16W J RTKABGEL
J804		R. CHP	0Ω 1/16W J RTKABGEL
J805		R. CHP	0Ω 1/16W J RTKABGEL
PJ801	V4483900	JACK. PIN	1P YKC21-3895N
R805	HV753100	R. CAR. FP	1Ω 1/4W
R902-903	HV753100	R. CAR. FP	1Ω 1/4W
R910	HV753100	R. CAR. FP	1Ω 1/4W
R950-951		R. CHP	0Ω 1/16W J UC
R952-953		R. CHP	100Ω 1/16W J UC
R954		R. CHP	470Ω 1/16W J UC
R955		R. CHP	1MΩ 1/16W J UC
R956-957		R. CHP	1KΩ 1/16W J UC
R958-960		R. CHP	47Ω 1/16W J UC

* New Parts

RX-V359/HTR-5930

P.C.B. DSP & P.C.B. FUNCTION

Ref. No.	Part No.	Description	Markets
R961		R. CHP 22Ω 1/16W J	UC
R962		R. CHP 470KΩ 1/16W J	UC
R963		R. CHP 100KΩ 1/16W J	UC
R964		R. CHP 470KΩ 1/16W J	UC
R965		R. CHP 2.2Ω 1/16W J	UC
R966-968		R. CHP 100KΩ 1/16W J	UC
R969		R. CHP 10Ω 1/16W J	UC
ST801	WA789600	SCR. TERM M3	
* U801-802	WE715700	L. DTCT 1P TORX177(F, T)	
* XL801	V3625700	RSNR. CRY5 24.576MHz	
* XL950	WE436500	RSNR. CRY5 45.1584MHz	UC
	WG673600	P. C. B. FUNCTION	UC
	WG673700	P. C. B. FUNCTION	RL
	WG673800	P. C. B. FUNCTION	TKA
	WG673900	P. C. B. FUNCTION	BGE
CB431	VK026300	CN. BS. PIN 4P	
CB451	VQ963900	CN. BS. PIN 18P	
CB452	VQ961500	CN. BS. PIN 12P	
CB453	VM859500	CN. BS. PIN 11P	
CB454	VQ961200	CN. BS. PIN 9P	
CB551	VN394900	CN. BS. PIN 14P	
CB611	VQ962100	CN. BS. PIN 18P	
CB652	LB919090	CN. BS. PIN 9P	
CB653	VK024700	CN. BS. PIN 3P	
CB676	VQ963900	CN. BS. PIN 18P	
CB677	VQ962100	CN. BS. PIN 18P	
* CB691	V9377900	CN. BS. PIN 4P	RL
C431-434	UA654100	C. MYLAR 0.01uF 50V J	
C451-460	US062220	C. CE. CHP 220pF 50V B	
C461-462	US061470	C. CE. CHP 47pF 50V B	
C463-464	UR837100	C. EL 10uF 16V	
C467-468	UR847470	C. EL 47uF 25V	
C469-470	UR838100	C. EL 100uF 16V	
C471-472	US135100	C. CE. CHP 0.1uF 16V	
C473-479	UR837100	C. EL 10uF 16V	
C480	UA653470	C. MYLAR 4700pF 50V J	
C481-482	VE326000	C. MYLAR 0.1uF 50V	
C483	UA653470	C. MYLAR 4700pF 50V J	
C484-485	VE326000	C. MYLAR 0.1uF 50V	
C488	UR866220	C. EL 2.2uF 50V	
C489-497	UR837100	C. EL 10uF 16V	
C498	UA654470	C. MYLAR 0.047uF 50V J	
C499	US062100	C. CE. CHP 100pF 50V B	
C500-501	UR838100	C. EL 100uF 16V	
C502-506	US062100	C. CE. CHP 100pF 50V B	
C507	UA653390	C. MYLAR 3900pF 50V J	
C508-510	UR837100	C. EL 10uF 16V	
C513-516	UR837100	C. EL 10uF 16V	

* New Parts

P.C.B. FUNCTION

Ref. No.	Part No.	Description	Markets
C521-522	UR838100	C. EL 100uF 16V	
C525-526	UR837100	C. EL 10uF 16V	
* C527-531	US162820	C. CE 820pF 50V J	
C551	US135100	C. CE. CHP 0.1uF 16V	
C552-553	US063100	C. CE. CHP 1000pF 50V B	
C554	UR837100	C. EL 10uF 16V	
C555	US062100	C. CE. CHP 100pF 50V B	
C556-557	US135100	C. CE. CHP 0.1uF 16V	
C559-560	US135100	C. CE. CHP 0.1uF 16V	
C561	US064100	C. CE. CHP 0.01uF 50V B	
C562	UR818330	C. EL 330uF 6.3V	
C563-564	US064100	C. CE. CHP 0.01uF 50V B	
C565	US135100	C. CE. CHP 0.1uF 16V	
C611	US064100	C. CE. CHP 0.01uF 50V B	
C612	UA652470	C. MYLAR 470pF 50V J	
C613	US064100	C. CE. CHP 0.01uF 50V B	
C614-621	US062220	C. CE. CHP 220pF 50V B	
C622-623	US061470	C. CE. CHP 47pF 50V B	
C624-625	UR837100	C. EL 10uF 16V	
C626	UA654100	C. MYLAR 0.01uF 50V J	
C651-652	UR837470	C. EL 47uF 16V	UC
C653	UR837470	C. EL 47uF 16V	
C654-656	UR837470	C. EL 47uF 16V	
C657-658	UR867100	C. EL 10uF 50V	
C659	UR837470	C. EL 47uF 16V	
C660	UA654100	C. MYLAR 0.01uF 50V J	
C661	UR867100	C. EL 10uF 50V	
C662	UR73A100	C. EL 10000uF 16V	UC
C663	UR749470	C. EL 4700uF 25V	
C664	UR749220	C. EL 2200uF 25V	
C665	VE326000	C. MYLAR 0.1uF 50V	
C666	UR739680	C. EL 6800uF 16V	
C667-668	VE326000	C. MYLAR 0.1uF 50V	
C669	US135100	C. CE. CHP 0.1uF 16V	UC
C671	US064100	C. CE. CHP 0.01uF 50V B	
C672-675	US135100	C. CE. CHP 0.1uF 16V B	
C679	US135100	C. CE. CHP 0.1uF 16V B	
C680	UR867100	C. EL 10uF 50V	
C681	US064100	C. CE. CHP 0.01uF 50V B	
D431	VU172500	DIODE. ZENR UDZS9.1B	
D432-433	VT332900	DIODE 1SS355	
D451-452	VU994300	DIODE. ZENR MA8075-H 7.7V	
D551-552	VU171500	DIODE. ZENR UDZ 3.6BTE-17 3.6V	
D652	VU172000	DIODE. ZENR UDZS5.6BTE-17 5.6V	
⚠ D653-654	WA653100	DIODE. BRG KBP103G 1.0A 200V	
⚠ D654	WA653100	DIODE. BRG KBP103G 1.0A 200V	RTKABGEL
* ⚠ D655	WF300200	DIODE. BRG TS4B03G C2	UC
D657	V2376600	DIODE. SHOT RB500V-40	UC
* D658	VU173100	DIODE. ZENR UDZS16B TE-17 16V	RL
* IC451	X6299A00	IC BD3816K1-C	
* IC452-454	X7378A00	IC NJM4565M (TE1)	

* New Parts

RX-V359/HTR-5930

P.C.B. FUNCTION

P.C.B. FUNCTION & P.C.B. MAIN

Ref. No.	Part No.	Description	Markets
* IC456	X7378A00	IC NJM4565M(Te1)	
IC551	X6386A00	IC M66003-0131FP	
⚠ IC651	X4153A00	IC KIA7812API	
⚠ IC652	X4154A00	IC KIA7912PI	
⚠ IC653-654	X4928A00	IC KIA7805AP1 5V	
* ⚠ IC655	X6143A00	IC NJM2388F05 5V	UC
JK431	V9408200	JACK. PHONE MSJ-064-05B GR	
PJ451	V7190400	JACK. PIN 6P	
* PJ452	WD195400	JACK. PIN 6P	
* PJ611	WD195600	JACK. PIN 1P	
* PJ612	WD195200	JACK. PIN 4P	
* PJ613	WD195400	JACK. PIN 6P	
PN451	WB213200	PIN L=70 WB21320	
PN551	WB213200	PIN L=70 WB21320	
PN651	WB213200	PIN L=70 WB21320	
PN696-697	WB213200	PIN L=70 WB21320	
Q451	iC181510	TR 2SC1815 Y	
Q452	iA101510	TR 2SA1015 Y	
Q551-557	VV556400	TR 2SC2412K O, R, S	
Q611-612	VZ725900	TR 2SD1938F S, T	
Q652	iA101510	TR 2SA1015 Y	
R431-432	VP940800	R. MTL. OXD 470Ω 1W	
R483-484	HV753220	R. CAR. FP 2.2Ω 1/4W	
R582		R. CHP 6.8KΩ 1/16W J	BGE
R585		R. CHP 10KΩ 1/16W J	BGE
R588		R. CHP 22KΩ 1/16W J	BGE
R589	HV755100	R. CAR. FP 100Ω 1/4W	
R591		R. CHP 47KΩ 1/16W J	BGE
R592	HV755100	R. CAR. FP 100Ω 1/4W	
⚠ R651-652	HV753470	R. CAR. FP 4.7Ω 1/4W	
R653		R. CHP 1KΩ 1/16W J	UC
⚠ R657	HV753470	R. CAR. FP 4.7Ω 1/4W	
⚠ R658	HV753100	R. CAR. FP 1Ω 1/4W	
⚠ R660	VP939500	R. MTL. FLM 1Ω 1W	
⚠ R663	HV753100	R. CAR. FP 1Ω 1/4W	
R664	HV755100	R. CAR. FP 100Ω 1/4W	
R674		R. CHP 1KΩ 1/16W J	RL
* ST431	WA789700	SCR. TERM	
ST451	WA789600	SCR. TERM M3	
SW551	V9281300	SW. RT. ENC EVEKD2F3024B	
SW552-566	WD483100	SW. TACT SKRGAAD010	
SW567	WD483100	SW. TACT SKRGAAD010	BGE
SW568	WD483100	SW. TACT SKRGAAD010	
SW569	WD483100	SW. TACT SKRGAAD010	BGE
SW570	WD483100	SW. TACT SKRGAAD010	
SW571	WD483100	SW. TACT SKRGAAD010	BGE
SW572	WD483100	SW. TACT SKRGAAD010	
SW573	WD483100	SW. TACT SKRGAAD010	BGE
SW671	WD483100	SW. TACT SKRGAAD010	
⚠ SW691	VZ075500	SW. SLIDE SL14-22AM5F	RL
U551	WC746300	L. DTCT RPM7138-H9	

* New Parts

Ref. No.	Part No.	Description	Markets
V551	WE289300	FL. DSPLY 17-BT-24GNK	
	WA790800	SHEET	
	WA790900	SPACER 4.6/10/32	
* ⚠	WG673000	P. C. B.	MAIN UC
* ⚠	WG673100	P. C. B.	MAIN R
* ⚠	WG673200	P. C. B.	MAIN TA
* ⚠	WG673300	P. C. B.	MAIN K
* ⚠	WG673400	P. C. B.	MAIN BGE
* ⚠	WG797800	P. C. B.	MAIN L
CB101	VQ963000	CN. BS. PIN 9P	
CB103	VK024700	CN. BS. PIN 3P	
CB104	LB932040	CN. BS. PIN 4P	
CB242	VM923600	CN. BS. PIN 13P	
CB244	VQ963300	CN. BS. PIN 12P	
CB246	VK025700	CN. BS. PIN 13P	
CB247	VQ963700	CN. BS. PIN 16P	
CB248	VQ044400	CN. BS. PIN 9P	
CB249	VQ963700	CN. BS. PIN 16P	
CB372-373	WC050700	CLIP. FUSE EYF-52BCY	
CB374-375	VG879900	CN. BS. PIN 2P	
CB381	LB933050	CN. BS. PIN 5P	UC
C101	UA654100	C. MYLAR 0.01uF 50V J	
C102-106	UR837100	C. EL 10uF 16V	
C107-111	UA652470	C. MYLAR 470pF 50V J	
C112-113	UR897100	C. EL 10uF 100V	
C114	UR867330	C. EL 33uF 50V	
C115	UA652100	C. MYLAR 100pF 50V J	
C116	UR897100	C. EL 10uF 100V	
C117	UR877220	C. EL 22uF 63V	
C118	UR897100	C. EL 10uF 100V	
C119	UR877220	C. EL 22uF 63V	
C120	FG651100	C. CE 10pF 50V	
C121	UA654220	C. MYLAR 0.022uF 50V J	RTKABGEL
C121	UA654220	C. MYLAR 0.022uF 50V J	
C122	UR837100	C. EL 10uF 16V	
C123-124	UR897100	C. EL 10uF 100V	
C125-126	UA652100	C. MYLAR 100pF 50V J	
C127-130	UR867330	C. EL 33uF 50V	
C131	UA652100	C. MYLAR 100pF 50V J	
C132	UR897100	C. EL 10uF 100V	
C133	UA652100	C. MYLAR 100pF 50V J	
C134	UA654100	C. MYLAR 0.01uF 50V J	
C134	UA654100	C. MYLAR 0.01uF 50V J	RTKABGEL
* C135-138	FG650500	C. CE 5pF 50V	
C139-143	UA654470	C. MYLAR 0.047uF 50V J	
C144	UR866470	C. EL 4.7uF 50V	
C145	UR828220	C. EL 220uF 10V	
C146	UR858100	C. EL 100uF 35V	





* New Parts

RX-V359/HTR-5930



P.C.B. MAIN

P.C.B. MAIN

* 
 * 
 * 
 * 

Ref. No.	Part No.	Description	Markets
C147	UR866470	C. EL 4.7uF 50V	
C149	UR858100	C. EL 100uF 35V	
C150	UA654220	C. MYLAR 0.022uF 50V J	RTKABGEL
C150	UA654220	C. MYLAR 0.022uF 50V J	
C151	UA654100	C. MYLAR 0.01uF 50V J	RTKABGEL
C151	UA654100	C. MYLAR 0.01uF 50V J	
*  C152	WE514200	C. EL 6800uF 63V	UCRTKAL
*  C152	WG674200	C. EL 6800uF 63V	BGE
*  C153	WE514200	C. EL 6800uF 63V	UCRTKAL
*  C153	WG674200	C. EL 6800uF 63V	BGE
C154	UA654100	C. MYLAR 0.01uF 50V J	
C154-155	UA654100	C. MYLAR 0.01uF 50V J	RTKABGEL
C155	UA654100	C. MYLAR 0.01uF 50V J	
C156	UA654100	C. MYLAR 0.01uF 50V J	RTKABGEL
C156	UA654100	C. MYLAR 0.01uF 50V J	
C157	UA654100	C. MYLAR 0.01uF 50V J	RTKABGEL
C157-158	UA654100	C. MYLAR 0.01uF 50V J	
C158	UA654100	C. MYLAR 0.01uF 50V J	RTKABGEL
C159-160	VR324900	C. MYLAR 0.1uF 100V	
C161	UR866100	C. EL 1uF 50V	
C162	UA654220	C. MYLAR 0.022uF 50V J	
C162-163	UA654220	C. MYLAR 0.022uF 50V J	RTKABGEL
C163	UA654220	C. MYLAR 0.022uF 50V J	
C164	UA654100	C. MYLAR 0.01uF 50V J	RTKABGEL
C164	UA654100	C. MYLAR 0.01uF 50V J	
C165	UA654100	C. MYLAR 0.01uF 50V J	RTKABGEL
C165	UA654100	C. MYLAR 0.01uF 50V J	
C166	US064100	C. CE. CHP 0.01uF 50V B	RTKABGEL
C167	UA654100	C. MYLAR 0.01uF 50V J	RTKABGEL
C167	UA654100	C. MYLAR 0.01uF 50V J	
C168	UA654100	C. MYLAR 0.01uF 50V J	RTKABGEL
C168	UA654100	C. MYLAR 0.01uF 50V J	
C169	UA654220	C. MYLAR 0.022uF 50V J	
C169	UA654220	C. MYLAR 0.022uF 50V J	RTKABGEL
C170	UA654100	C. MYLAR 0.01uF 50V J	RTKABGEL
C170	UA654100	C. MYLAR 0.01uF 50V J	
C171	UA654100	C. MYLAR 0.01uF 50V J	RTKABGEL
C171	UA654100	C. MYLAR 0.01uF 50V J	
C172	UA654100	C. MYLAR 0.01uF 50V J	RTKABGEL
C172	UA654100	C. MYLAR 0.01uF 50V J	
C242	US063100	C. CE. CHP 1000pF 50V B	
C243	UR819220	C. EL 2200uF 6.3V	
C244	UR858100	C. EL 100uF 35V	
C245	US064100	C. CE. CHP 0.01uF 50V B	
C246-247	US062100	C. CE. CHP 100pF 50V B	
C248	UR866100	C. EL 1uF 50V	
C249	US135100	C. CE. CHP 0.1uF 16V	
C250	US062100	C. CE. CHP 100pF 50V B	
C251	US135100	C. CE. CHP 0.1uF 16V	
C252	US062100	C. CE. CHP 100pF 50V B	
C253	UR837470	C. EL 47uF 16V	UCTKABGE

* New Parts

Ref. No.	Part No.	Description	Markets
C254	UR877470	C. EL 47uF 63V	RL
C255	US064100	C. CE. CHP 0.01uF 50V B	UC
C256	UR837470	C. EL 47uF 16V	
C258	WB165500	C. EL 0.33F 5.5V	
C259	UR818220	C. EL 220uF 6.3V	
C260	UR837470	C. EL 47uF 16V	
C261	UR837330	C. EL 33uF 16V	
C263	UR837470	C. EL 47uF 16V	
C264	UR818470	C. EL 470uF 6.3V	
C266	US135100	C. CE. CHP 0.1uF 16V	BGE
C267-269	US135100	C. CE. CHP 0.1uF 16V	
C270-271	US062330	C. CE. CHP 330pF 50V B	BGE
C272-273	US135220	C. CE. CHP 0.22uF 16V	
C274-275	UR837470	C. EL 47uF 16V	BGE
C276	US062560	C. CE. CHP 560pF 50V B	BGE
C277	US061270	C. CE. CHP 27pF 50V B	BGE
C278	US135100	C. CE. CHP 0.1uF 16V	BGE
C279	US061270	C. CE. CHP 27pF 50V B	BGE
C280	UR837470	C. EL 47uF 16V	BGE
C281-282	US135100	C. CE. CHP 0.1uF 16V	
C283-286	UR866220	C. EL 2.2uF 50V	
C320	US064100	C. CE. CHP 0.01uF 50V B	
C321	US135100	C. CE. CHP 0.1uF 16V	
C371	UR858470	C. EL 470uF 35V	
C372	UA654100	C. MYLAR 0.01uF 50V J	
C373	UR897100	C. EL 10uF 100V	RL
C374	UA654100	C. MYLAR 0.01uF 50V J	UCTKABGE
C375-376	UA654100	C. MYLAR 0.01uF 50V J	RL
 C377	WB121400	C. CE. SAFTY 0.01uF 295V	
C381-382	UR897100	C. EL 10uF 100V	UC
C391-392	US062100	C. CE. CHP 100pF 50V B	
C393-396	UR837100	C. EL 10uF 16V	
C397-398	UR829100	C. EL 1000uF 10V	
C399	US063100	C. CE. CHP 1000pF 50V B	
C400	US063100	C. CE. CHP 1000pF 50V B	
C401	UR838100	C. EL 100uF 16V	
C701-703	US060800	C. CE. CHP 8pF 50V B	
* C704-712	WE773800	C. CE. M. CHP 1uF 10V B	
C713-714	UR837470	C. EL 47uF 16V	
C715-717	US135100	C. CE. CHP 0.1uF 16V	
D101-102	VT332900	DIODE 1SS355	
D104-106	VD631600	DIODE 1SS133, 176	
D107	WC398800	DIODE KDS160-RTK	
D108-109	VN008700	DIODE 1SS270A	
D110	WC398800	DIODE KDS160-RTK	
D111-115	VN008700	DIODE 1SS270A	
D116	VU171900	DIODE. ZENR UD25.1B 5.1V	
D117	VN008700	DIODE 1SS270A	
D118-119	VD631600	DIODE 1SS133, 176	
 D120	VG443200	DIODE. ZENR MTZJ30A 30V	
D121	VD631600	DIODE 1SS133, 176	

* New Parts

RX-V359/HTR-5930

P.C.B. MAIN

P.C.B. MAIN

Ref. No.	Part No.	Description	Markets
△ D122	WA653200	D1ODE.BRG TS6P03G 6.0A 200V	
D123	VD631600	D1ODE 1SS133, 176	
D124	VG440300	D1ODE.ZENR MTZJ12C 12V	
D241-242	VT332900	D1ODE 1SS355	
D243	VU172200	D1ODE.ZENR UDZ6.8B 6.8V	
D244	VT332900	D1ODE 1SS355	
D245	VU172100	D1ODE.ZENR UDZS6.2B 6.2V	
D246-247	VT332900	D1ODE 1SS355	
D249	VV833200	D1ODE 1SS380	
D250	VU995500	D1ODE.ZENR MA8100-H 10.3V	
D251	VT332900	D1ODE 1SS355	
D252	VU171900	D1ODE.ZENR UDZ5.1B 5.1V	
D253	VT332900	D1ODE 1SS355	UC
D254-259	VU171900	D1ODE.ZENR UDZ5.1B 5.1V	
D371	VD631600	D1ODE 1SS133, 176	
△ D372	VG437000	D1ODE.ZENR MTZJ4.7A 4.7V	RL
△ D373-374	VS997800	D1ODE 1T2	
△ D375	VS997800	D1ODE 1T2	RL
△ D376-377	VS997800	D1ODE 1T2	
△ D381-382	VT532500	D1ODE 1SR154-400	UC
* △ F371	WB221200	FUSE T6A 125V	UCRL
△ F371	VV071700	FUSE 3.15A 250V	TKABGE
* △ IC101	X5064A00	IC STK404-130Y 130W	
* △ IC102-103	X7427A00	IC STK433-130-E	
IC241	X0082A00	IC LC72722PM	BGE
IC242	X7438A00	IC.CPU M30622MWP-A82FP	(MASK ROM)
IC391	XH436A00	IC LA7956	
* IC701	X7362A00	IC NJM2586AM (TE2)	
J242		R. CHP 0Ω 1/16W J	UCRTKAL
PJ391-393	V7190000	JACK. PIN 2P	
PJ701-702	WD442700	JACK. PIN 6P LPR6520-M610FC	
Q101-105	VD303700	TR 2SC3326 A, B	
△ Q106	V3966800	TR 2SA949 O, Y	
△ Q107	WC398400	TR 2N5551C-AT	
△ Q108-109	VC614000	TR 2SB1274 O, R, S	
△ Q110-111	WC397700	TR 2N5401C-AT	
△ Q112-116	WC398400	TR 2N5551C-AT	
△ Q117	WC397700	TR 2N5401C-AT	
△ Q118-120	WC434900	TR. DGT KRA104S-RTK	
△ Q121	VP872600	TR 2SA1708 S, T	
△ Q122	WC434900	TR. DGT KRA104S-RTK	
△ Q123	iC181510	TR 2SC1815 Y	
△ Q124	WC434900	TR. DGT KRA104S-RTK	
△ Q125	WC398400	TR 2N5551C-AT	
Q243	VP872700	TR 2SC4488 S, T	
Q244	iA101510	TR 2SA1015 Y	
Q245	WC435000	TR. DGT KRC102S-RTK	
Q246	WC435100	TR. DGT KRC104S-RTK	
Q247	iC181510	TR 2SC1815 Y	
Q248	WC435100	TR. DGT KRC104S-RTK	
Q249	VP872700	TR 2SC4488 S, T	RL

* New Parts

Ref. No.	Part No.	Description	Markets
Q250	WC435100	TR. DGT KRC104S-RTK	
Q251	iC174020	TR 2SC1740S QRS	BGE
Q252	WC435100	TR. DGT KRC104S-RTK	
Q253	VV556400	TR 2SC2412K Q, R, S	UC
Q254-258	VV556500	TR 2SA1037K Q, R, S	
Q259	VV556400	TR 2SC2412K Q, R, S	
△ Q371	VE198800	TR 2SC2705 O, Y	
△ Q372	iA101510	TR 2SA1015 Y	RL
△ Q373	VP872600	TR 2SA1708 S, T	RL
△ Q374	iA101510	TR 2SA1015 Y	RL
* △ Q375	WC529200	TR. DGT KRC102M-AT	RL
Q391-392	iC181510	TR 2SC1815 Y	
Q393	iC174020	TR 2SC1740S QRS	
Q394	VV556400	TR 2SC2412K Q, R, S	
R117	HV753470	R. CAR. FP 4.7Ω 1/4W	RTKABGEL
△ R119	HV755120	R. CAR. FP 120Ω 1/4W	
R124	HV753470	R. CAR. FP 4.7Ω 1/4W	
R124	HV753470	R. CAR. FP 4.7Ω 1/4W	RTKABGEL
△ R125-126	HV753220	R. CAR. FP 2.2Ω 1/4W	
* R129	HV757220	R. CAR. FP 22KΩ 1/4W	
△ R130	HV753220	R. CAR. FP 2.2Ω 1/4W	
△ R133	HV754100	R. CAR. FP 10Ω 1/4W	
△ R144	HV754100	R. CAR. FP 10Ω 1/4W	
△ R148	WB279900	R. CEMENT RGC55C 0.22+0.22	
△ R156-159	WB279900	R. CEMENT RGC55C 0.22+0.22	
R166	HV754100	R. CAR. FP 10Ω 1/4W	
△ R171	VP939700	R. MTL. FLM 4.7Ω 1W	
R178	HV754100	R. CAR. FP 10Ω 1/4W	
R180	HV754100	R. CAR. FP 10Ω 1/4W	
R182	HV754100	R. CAR. FP 10Ω 1/4W	
R184	HV754100	R. CAR. FP 10Ω 1/4W	
△ R190-193	VP939700	R. MTL. FLM 4.7Ω 1W	
△ R198	HV757220	R. CAR. FP 22KΩ 1/4W	UC
△ R198	HV756470	R. CAR. FP 4.7KΩ 1/4W	RTKABGEL
△ R201	V9199400	R. MTL. OXD 1.2KΩ 1W	UC
* △ R201	VR402600	R. MTL. OXD 820Ω 1W	RTKABGEL
R206	HV753470	R. CAR. FP 4.7Ω 1/4W	
R206	HV753470	R. CAR. FP 4.7Ω 1/4W	RTKABGEL
R216	HV753470	R. CAR. FP 4.7Ω 1/4W	
R216	HV753470	R. CAR. FP 4.7Ω 1/4W	RTKABGEL
R217	HV753470	R. CAR. FP 4.7Ω 1/4W	
R217	HV753470	R. CAR. FP 4.7Ω 1/4W	RTKABGEL
R218		R. CHP 2.2Ω 1/16W J	RTKABGEL
△ R221	HV755560	R. CAR. FP 560Ω 1/4W	
R260-261		R. CHP 100KΩ 1/16W J	BGE
R262		R. CHP 1KΩ 1/16W J	BGE
R263		R. CHP 3.3KΩ 1/16W J	BGE
R265		R. CHP 22KΩ 1/16W J	BGE
R270		R. CHP 100Ω 1/16W J	BGE
R276		R. CHP 470Ω 1/16W J	BGE
R277		R. CHP 100KΩ 1/16W J	UCRTKABGE

* New Parts

RX-V359/HTR-5930

P.C.B. MAIN

Ref. No.	Part No.	Description	Markets
R278		R. CHP 100K Ω 1/16W J	L
R280		R. CHP 470 Ω 1/16W J	BGE
R281		R. CHP 10K Ω 1/16W J	BGE
R284		R. CHP 10K Ω 1/16W J	BGE
R289		R. CHP 100K Ω 1/16W J	UC
R291		R. CHP 100K Ω 1/16W J	RTKABGEL
R295		R. CHP 100K Ω 1/16W J	TKABGE
R297		R. CHP 100K Ω 1/16W J	UCRL
R300		R. CHP 100K Ω 1/16W J	BGE
R351		R. CHP 10K Ω 1/16W J	UC
⚠ R371		R. CHP 4.7K Ω 1/16W J	UCTKABGE
⚠ R371		R. CHP 1.8K Ω 1/16W J	RL
R372		R. CHP 100K Ω 1/16W J	UCTKABGE
R372		R. CHP 560 Ω 1/16W J	R
R373		R. CHP 0 Ω 1/16W J	UCTKABGE
R373		R. CHP 15 Ω 1/16W J	RL
R374		R. CHP 1K Ω 1/16W J	RL
R375		R. CHP 33K Ω 1/16W J	RL
R376		R. CHP 5.6K Ω 1/16W J	RL
R377		R. CHP 47K Ω 1/16W J	RL
R378	VC757900	R. MTL. OXD 47 Ω 2W	RL
R379		R. CHP 100K Ω 1/16W J	RL
R380	V6730000	R. CAR. 2.2M Ω 1/2W	UC
⚠ R381-382	HV753100	R. CAR. FP 1 Ω 1/4W	UC
R383-384		R. CHP 100K Ω 1/16W J	UC
R399	HV755270	R. CAR. FP 270 Ω 1/4W	
R405	HV753220	R. CAR. FP 2.2 Ω 1/4W	
⚠ RY101-103	V5966300	RELAY DS24D2-0S(M)	
⚠ RY104	V5178900	RELAY DC DQ24D1-0S(M)	
⚠ RY105	V5966300	RELAY DS24D2-0S(M)	
⚠ RY371	V2712300	RELAY DC SDT-S-112LMR	
ST241	WA789600	SCR. TERM M3	
ST371	WA789600	SCR. TERM M3	
⚠ SW381	VZ075500	SW. SLIDE SL14-22AM5F	UC
* ⚠ T371	XW606A00	TRANS. PWR	UC
* ⚠ T371	X7426A00	TRANS. PWR	RL
* ⚠ T371	XW608A00	TRANS. PWR	TKABGE
TE101	VY696300	TERM. SP 4P	UCRTA
TE101	VY696400	TERM. SP 4P	KBGEL
TE102	WB054000	TERM. SP YKD21-5002N	
TE103	WB054100	TERM. SP YKD21-5004N	
XL241	V3930900	RSNR. CRY5 4.332MHz	BGE
XL242	WB213000	RSNR. CE 16.0MHz	
	WE774200	SCR. BND. HD 3x10 MFZN2W3	

* New Parts

Chip Resistors

● The chip resistor is not supplied as a replacement part.
 * When a chip resistor is necessary, use the following part.
 AAX60720: CHIP RESISTOR SAMPLE BOOK

Ref. No.	Part No.	Description	Markets
		R. CHP 0 Ω 1/16W J	
		R. CHP 1 Ω 1/16W J	
		R. CHP 2.2 Ω 1/16W J	
		R. CHP 10 Ω 1/16W J	
		R. CHP 15 Ω 1/16W J	
		R. CHP 22 Ω 1/16W J	
		R. CHP 47 Ω 1/16W J	
		R. CHP 75 Ω 1/16W J	
		R. CHP 82 Ω 1/16W J	
		R. CHP 100 Ω 1/16W J	
		R. CHP 220 Ω 1/16W J	
		R. CHP 470 Ω 1/16W J	
		R. CHP 560 Ω 1/16W J	
		R. CHP 680 Ω 1/16W J	
		R. CHP 820 Ω 1/16W J	
		R. CHP 1K Ω 1/16W J	
		R. CHP 1.5K Ω 1/16W J	
		R. CHP 1.8K Ω 1/16W J	
		R. CHP 2K Ω 1/16W J	
		R. CHP 2.2K Ω 1/16W J	
		R. CHP 2.4K Ω 1/16W J	
		R. CHP 3.3K Ω 1/16W J	
		R. CHP 4.7K Ω 1/16W J	
		R. CHP 5.6K Ω 1/16W J	
		R. CHP 6.8K Ω 1/16W J	
		R. CHP 10K Ω 1/16W J	
		R. CHP 12K Ω 1/16W J	
		R. CHP 15K Ω 1/16W J	
		R. CHP 18K Ω 1/16W J	
		R. CHP 22K Ω 1/16W J	
		R. CHP 27K Ω 1/16W J	
		R. CHP 33K Ω 1/16W J	
		R. CHP 47K Ω 1/16W J	
		R. CHP 68K Ω 1/16W J	
		R. CHP 100K Ω 1/16W J	
		R. CHP 220K Ω 1/16W J	
		R. CHP 470K Ω 1/16W J	
		R. CHP 1M Ω 1/16W J	

* New Parts

Replacement Parts List for Carbon Resistors

Value	1/4W Type Part No.	1/6W Type Part No.	Value	1/4W Type Part No.	1/6W Type Part No.
1.0 Ω	HJ35 3100	HF85 3100	10 kΩ	HF45 7100	HF45 7100
1.8 Ω	HJ35 3180	*	11 kΩ	HF45 7110	HF45 7110
2.2 Ω	HJ35 3220	HF85 3220	12 kΩ	HJ35 7120	HF85 7120
3.3 Ω	HJ35 3330	HF85 3330	13 kΩ	HF45 7130	HF45 7130
4.7 Ω	HJ35 3470	HF85 3470	15 kΩ	HF45 7150	HF45 7150
5.6 Ω	HJ35 3560	HF85 3560	18 kΩ	HF45 7180	HF45 7180
10 Ω	HF45 4100	HF45 4100	22 kΩ	HF45 7220	HF45 7220
15 Ω	HJ35 4150	HF85 4150	24 kΩ	HF45 7240	HF45 7240
22 Ω	HF45 4220	HF45 4220	27 kΩ	HJ35 7270	HF85 7270
27 Ω	HJ35 4270	HF85 4270	30 kΩ	HF45 7300	HF45 7300
33 Ω	HF45 4330	HF45 4330	33 kΩ	HF45 7330	HF45 7330
39 Ω	HJ35 4470	HF85 4390	36 kΩ	HF45 7360	HF45 7360
47 Ω	HF45 4470	HF45 4470	39 kΩ	HF45 7390	HF45 7390
56 Ω	HF45 4560	HF45 4560	47 kΩ	HF45 7470	HF45 7470
68 Ω	HF45 4680	HF45 4680	51 kΩ	HF45 7510	HF45 7510
75 Ω	HF45 4750	HF45 4750	56 kΩ	HF45 7560	HF45 7560
82 Ω	HF45 4820	HF45 4820	62 kΩ	HF45 7620	HF45 7620
91 Ω	HF45 4910	HF45 4910	68 kΩ	HF45 7680	HF45 7680
100 Ω	HF45 5100	HF45 5100	82 kΩ	HF45 7820	HF45 7820
110 Ω	HJ35 5110	HF85 5110	91 kΩ	HF45 7910	HF45 7910
120 Ω	HF45 5120	HF45 5120	100 kΩ	HF45 8100	HF45 8100
150 Ω	HF45 5150	HF45 5150	110 kΩ	HF45 8110	HF45 8110
160 Ω	HJ35 5160	*	120 kΩ	HF45 8120	HF45 8120
180 Ω	HF45 5180	HF45 5180	150 kΩ	HF45 8150	HF45 8150
200 Ω	HF45 5200	HF45 5200	180 kΩ	HF45 8180	HF45 8180
220 Ω	HF45 5220	HF45 5220	220 kΩ	HJ35 8220	HF85 8220
270 Ω	HF45 5270	HF45 5270	270 kΩ	HF45 8270	HF45 8270
330 Ω	HF45 5330	HF45 5330	300 kΩ	HF45 8300	HF45 8300
390 Ω	HF45 5390	HF45 5390	330 kΩ	HF45 8330	HF45 8330
430 Ω	HF45 5430	HF45 5430	390 kΩ	HJ35 8390	HF85 8390
470 Ω	HF45 5470	HF45 5470	470 kΩ	HF45 8470	HF45 8470
510 Ω	HF45 5510	HF45 5510	560 kΩ	HJ35 8560	HF85 8560
560 Ω	HF45 5560	HF45 5560	680 kΩ	HJ35 8680	HF85 8680
680 Ω	HF45 5680	HF45 5680	820 kΩ	HJ35 8820	HF85 8820
820 Ω	HF45 5820	HF45 5820	1.0 MΩ	HF45 9100	HF45 9100
910 Ω	HF45 5910	HF45 5910	1.2 MΩ	HJ35 9120	*
1.0 kΩ	HF45 6100	HF45 6100	1.5 MΩ	HJ35 9150	HF85 9150
1.2 kΩ	HF45 6120	HF45 6120	1.8 MΩ	HJ35 9180	HF85 9180
1.5 kΩ	HF45 6150	HF45 6150	2.2 MΩ	HJ35 9220	HF85 9220
1.8 kΩ	HF45 6180	HF45 6180	3.3 MΩ	HJ35 9330	HF85 9330
2.0 kΩ	HJ35 6200	HF85 6200	3.9 MΩ	HJ35 9390	*
2.2 kΩ	HF45 6220	HF45 6220	4.7 MΩ	HJ35 9470	HF85 9470
2.4 kΩ	HJ35 6240	HF85 6240			
2.7 kΩ	HF45 6270	HF45 6270			
3.0 kΩ	HF45 6300	HF45 6300			
3.3 kΩ	HF45 6330	HF45 6330			
3.6 kΩ	HJ35 6360	HF85 6360			
3.9 kΩ	HF45 6390	HF45 6390			
4.7 kΩ	HF45 6470	HF45 6470			
5.1 kΩ	HF45 6510	HF45 6510			
5.6 kΩ	HF45 6560	HF45 6560			
6.8 kΩ	HF45 6680	HF45 6680			
8.2 kΩ	HF45 6820	HF45 6820			
9.1 kΩ	HF45 6910	HF45 6910			

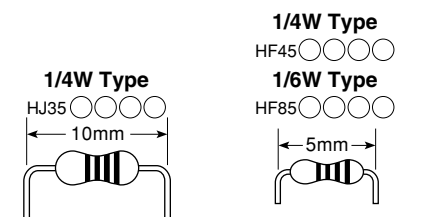

* : Not available

• EXPLODED VIEW

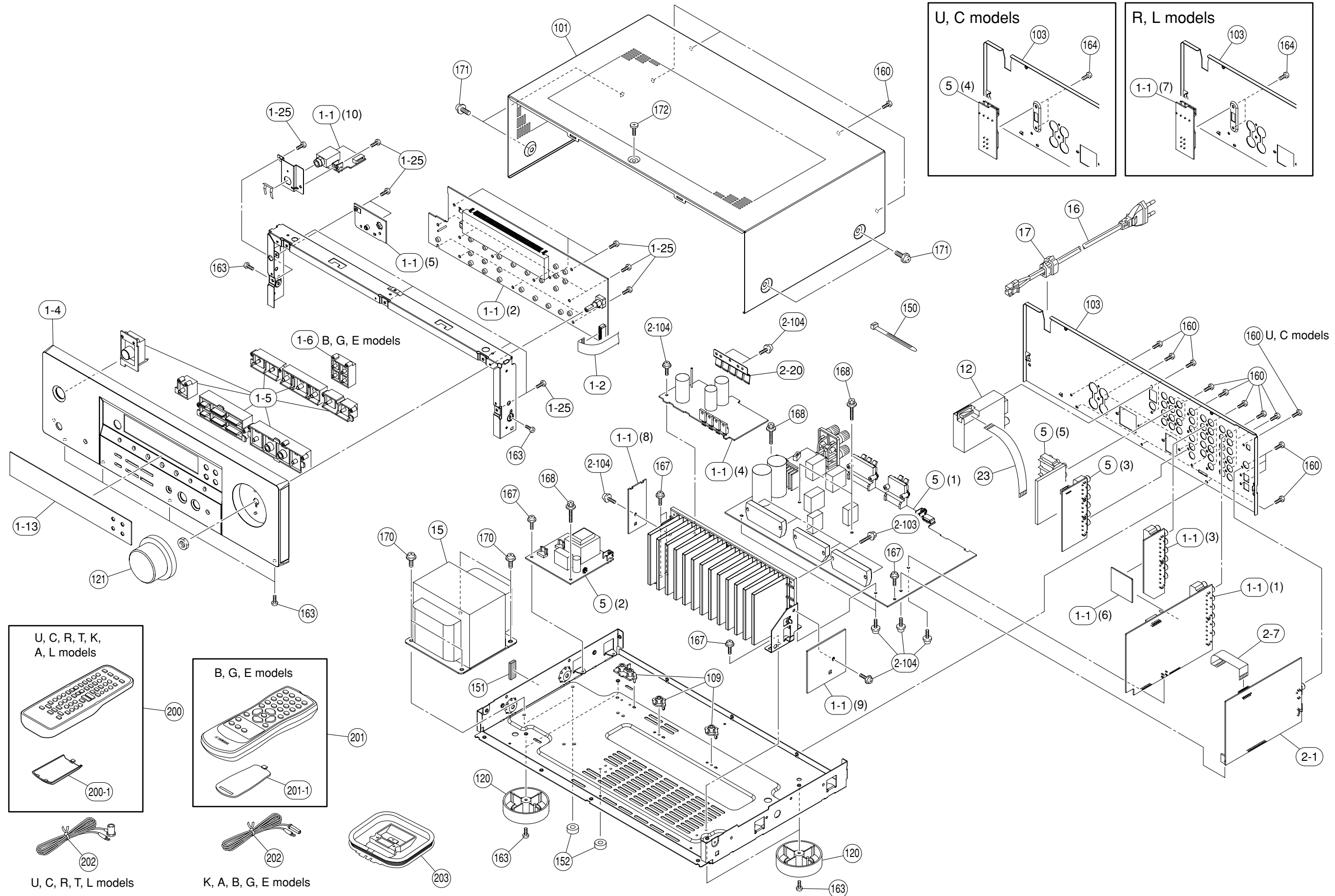

• REPLACEMENT PARTS LIST

Ref. No.	Part No.	Description	Remarks	Markets	
*	1-1	WG673600	P. C. B. ASS'Y	FUNCTION	C
*	1-1	WG673700	P. C. B. ASS'Y	FUNCTION	RL
*	1-1	WG673800	P. C. B. ASS'Y	FUNCTION	TKA
*	1-1	WG673900	P. C. B. ASS'Y	FUNCTION	BGE
*	1-2	MF114180	FLEXIBLE FLAT CABLE	14P 180mm P=1.25	
*	1-4	WG362800	FRONT PANEL	V359GD	
*	1-4	WG362400	FRONT PANEL	V359BL	
*	1-4	WG363100	FRONT PANEL	V359TI	
*	1-4	WG450300	FRONT PANEL	V359SI	C
*	1-4	WG363400	FRONT PANEL	V359SI	RKBGE
*	1-4	WG362900	FRONT PANEL	5930GD	
*	1-4	WG449700	FRONT PANEL	5930BL	UC
*	1-4	WG362700	FRONT PANEL	5930BL	R
*	1-4	WG363500	FRONT PANEL	5930SI	UC
*	1-4	WG363600	FRONT PANEL	5930SI	RTKA
*	1-4	WG363700	FRONT PANEL	5930SI	GE
*	1-5	WC411600	BUTTONCASE 350	GD	
*	1-5	WC411500	BUTTONCASE 350	V359BL	
*	1-5	WC411800	BUTTONCASE 350	5930BL	
*	1-5	WG466200	BUTTONCASE 359	TI	
*	1-5	WC411700	BUTTONCASE 350	SI	
*	1-6	WC411900	BUTTON RDS 350		BGE
*	1-7	MF111070	FLEXIBLE FLAT CABLE	11P 70mm P=1.25	
*	1-13	WG364100	SHEET WINDOW	V359SI, 5930SI	UC
*	1-13	WG364200	SHEET WINDOW	5930BL	UC
*	1-13	WC412800	SHEET WINDOW		RTKAL
*	1-13	WE813800	SHEET WINDOW		BGE
*	1-25	WE774800	BIND HEAD P-TIGHT SCREW	3x8 MFZN2W3	
*	2-1	WG674000	P. C. B. ASS'Y	DSP	C
*	2-1	WG674100	P. C. B. ASS'Y	DSP	RTKABGEL
*	2-7	MF111070	FLEXIBLE FLAT CABLE	11P 70mm P=1.25	
*	2-20	WG451000	SUPPORT TR-5		
*	2-103	WE774600	SCREW IC	3x18 MFZN2W3	
*	2-104	WF002600	PW HEAD B-TIGHT SCREW	3x8 MFZN2W3	
*	5	WG673000	P. C. B. ASS'Y	MAIN	UC
*	5	WG673100	P. C. B. ASS'Y	MAIN	R
*	5	WG673200	P. C. B. ASS'Y	MAIN	TA
*	5	WG673300	P. C. B. ASS'Y	MAIN	K
*	5	WG673400	P. C. B. ASS'Y	MAIN	BGE
*	5	WG797800	P. C. B. ASS'Y	MAIN	L
*	12	WB424000	AM/FM TUNER	ENG067090	UCRL
*	12	WB877300	AM/FM TUNER	FAE381-A07F	T
*	12	WB424100	AM/FM TUNER	ENG077110F	KABGE
*	15	X6311B00	POWER TRANSFORMER		UC
*	15	X5278C00	POWER TRANSFORMER		RL
*	15	X5279C00	POWER TRANSFORMER		TK
*	15	X5280C00	POWER TRANSFORMER		A
*	15	X6312B00	POWER TRANSFORMER		BGE
*	16	WB120500	POWER CABLE	2m	UC
*	16	WC992700	POWER CABLE	2m	R
*	16	WB120600	POWER CABLE	2m	T
*	16	WC753000	POWER CABLE	2m	K

* New Parts

Ref. No.	Part No.	Description	Remarks	Markets		
⚠	16	WC743700	POWER CABLE	2m	A	
⚠	16	WB212200	POWER CABLE	2m	B	
⚠	16	WB212300	POWER CABLE	2m	GEL	
	17	V2438700	CORD STOPPER	10P1		
	23	MF113120	FLEXIBLE FLAT CABLE	13P 120mm P=1.25		
	101	WE065200	TOP COVER		GD	
	101	WE065000	TOP COVER		BL	
	101	WE065100	TOP COVER		TI	
*	101	WG481900	TOP COVER		SI	
*	103	WG360400	REAR PANEL		V359	C
*	103	WG360500	REAR PANEL		V359	R
*	103	WG360600	REAR PANEL		V359	TK
*	103	WG360700	REAR PANEL		V359	A
*	103	WG360800	REAR PANEL		V359	BGE
*	103	WG360900	REAR PANEL		V359	L
*	103	WG361000	REAR PANEL		5930	UC
*	103	WG361100	REAR PANEL		5930	R
*	103	WG361200	REAR PANEL		5930	TK
*	103	WG361300	REAR PANEL		5930	A
*	103	WG361400	REAR PANEL		5930	GE
	109	WA796100	SUPPORT PCB			
	120	WA790600	LEG	D60/H21	GD	
	120	WA790500	LEG	D60/H21	V359BL, TI, SI	
	120	WA790700	LEG	D60/H21	5930BL	
*	121	WG362100	KNOB D48		GD	
*	121	WG362000	KNOB D48		BL	
*	121	WG466100	KNOB D48		TI	
*	121	WG362200	KNOB D48		SI	
	150	WB408000	BINDING TIE	GT-100M		
	151	WB408400	DAMPER SIDE			
	152	WB484700	DAMPER			
	160	WE774100	BIND HEAD BONDING B-T. SCREW	3x8 MFZN2B3		
	163	WE774300	BIND HEAD B-TIGHT SCREW	3x8 MFZN2W3		
	164	WE774000	BIND HEAD SCREW	3x6 MFZN2W3	UCRL	
*	167	WF002600	PW HEAD B-TIGHT SCREW	3x8 MFZN2W3		
	168	WE774600	SCREW IC	3x18 MFZN2W3		
	170	WE774700	BIND HEAD S-TIGHT SCREW	4x10 MFZN2W3		
	171	VD069600	PW HEAD S-TIGHT SCREW	4x8-10 MFN133	GD, TI, SI	
	171	VH313200	PW HEAD S-TIGHT SCREW	4x8-10 MFN13BL	BL	
	172	WE200400	DISH HEAD B-TIGHT SCREW	3x6 MFN133	GD, TI, SI	
	172	WE200500	DISH HEAD B-TIGHT SCREW	3x6 MFN13BL	BL	
			ACCESSORIES			
*	200	WG503100	REMOTE CONTROL	RAV309		UCRTKAL
	200-1	AAX46580	BATTERY COVER		103RRC-244-01G	UCRTKAL
*	201	WG707200	REMOTE CONTROL	RAV22		BGE
	201-1	AAX49660	BATTERY COVER		3139 224 22451	BGE
	202	WB212500	INDOOR FM ANTENNA	1.4m 1pc		UCRTL
	202	WB212400	INDOOR FM ANTENNA	1.4m 1pc		KABGE
*	203	WG950500	AM LOOP ANTENNA	1P 1.2m 1pc		
			BATTERY MANGANESE DRY	R6CP 2pcs		

* New Parts

REMOTE CONTROL RAV309 (U, C, R, T, K, A, L models)

SCHEMATIC DIAGRAM

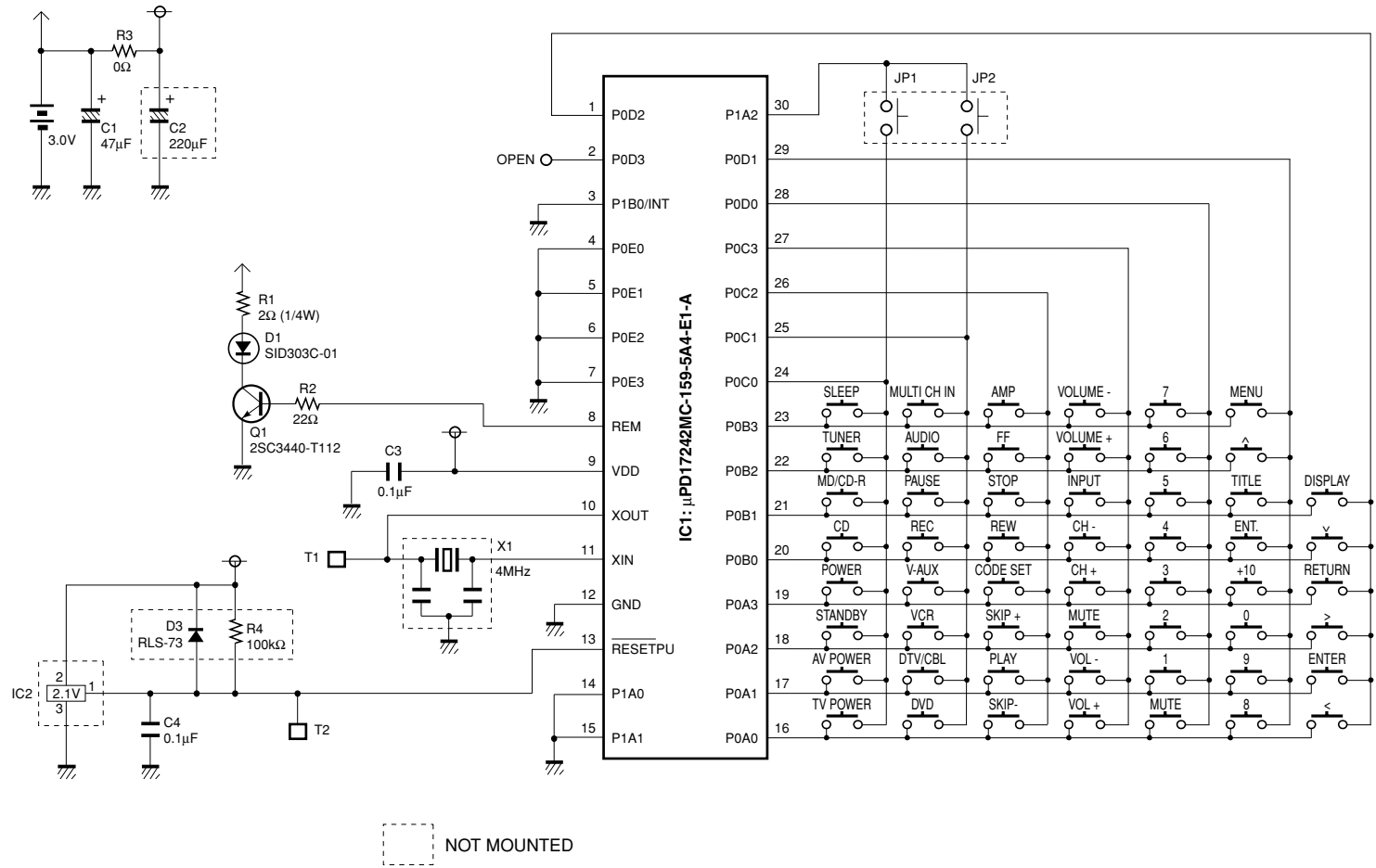

NOT MOUNTED

PANEL

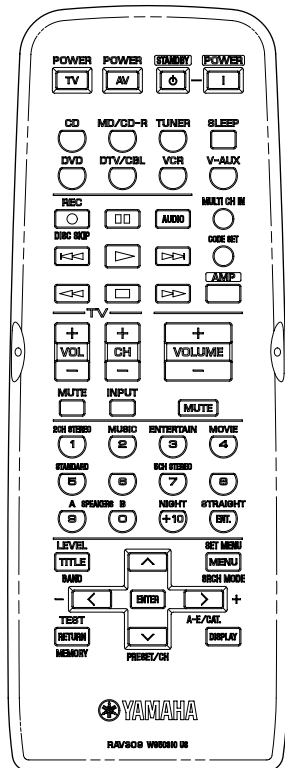

KEY LAYOUT

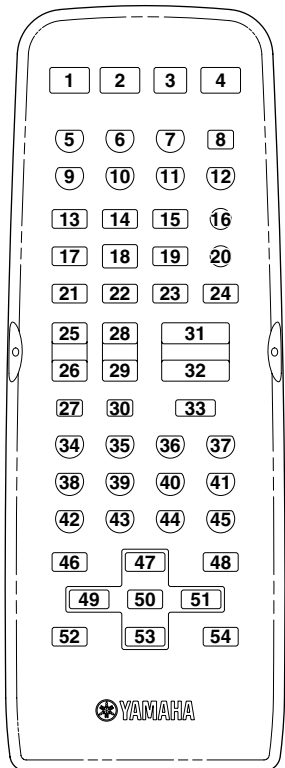

KEY CODE TABLE

Key No.	Function	CODE								
		AMP	CD	MD	CD-R	TUNER	DVD (P)	DVD (Y)	DVD (M)	DVD-R (P)
1	TV POWER	-	-	-	-	-	-	-	-	-
2	AV POWER	-	-	-	7F-80	-	A5-AA	7C-80	3D-8D	A5-AA
3	STANDBY	7A-1E	-	-	-	-	-	-	-	-
4	POWER	7A-1D	-	-	-	-	-	-	-	-
5	CD	7A-15	-	-	-	-	-	-	-	-
6	MD/CD-R	7A-C9	-	-	-	-	-	-	-	-
7	TUNER	7A-16	-	-	-	-	-	-	-	-
8	SLEEP	7A-57	-	-	-	-	-	-	-	-
9	DVD	7A-C1	-	-	-	-	-	-	-	-
10	DTV/CBL	7A-54	-	-	-	-	-	-	-	-
11	VCR	7A-0F	-	-	-	-	-	-	-	-
12	V-AUX	7A-55	-	-	-	-	-	-	-	-
13	REC, DISC SKIP	-	7A-4F	79-AF	-	-	55-56	7C-8B	-	56-5A
14	PAUSE	-	7A-09	79-A9	7F-83	-	AA-5A	7C-83	06-B6	AA-5A
15	AUDIO	-	-	-	-	-	95-A6	7C-AD	33-83	95-A6
16	MULTI CH IN	7A-87	-	-	-	-	-	-	-	-
17	SKIP -	-	7A-0B	79-AB	7F-86	7A-A4	6A-9A	7CB9	49-F9	6A-9A
18	PLAY	-	7A-08	79-A8	7F-82	-	A5-9A	7C-82	0A-BA	A5-9A
19	SKIP +	-	7A-0A	79-AE	7F-87	7A-A5	AA-9A	7C-BA	4A-FA	AA-9A
20	CODE SET	-	-	-	-	-	-	-	-	-
21	REW	-	7A-0D	79-AC	7F-88	7A-A6	69-9A	7C-86	04-B4	69-9A
22	STOP	-	7A-09	79-AA	7F-84	-	6A-5A	7C-85	00-B0	6A-5A
23	FF	-	7A-0C	79-AD	7F-89	7A-A7	A9-9A	7C-87	05-B5	A9-9A
24	AMP	7A-9C	-	-	-	-	-	-	-	-
25	TV VOL +	-	-	-	-	-	-	-	-	-
26	TV VOL -	-	-	-	-	-	-	-	-	-
27	TV MUTE	-	-	-	-	-	-	-	-	-
28	TV CH +	-	-	-	-	-	-	-	-	-
29	TV CH -	-	-	-	-	-	-	-	-	-
30	TV INPUT	-	-	-	-	-	-	-	-	-
31	VOLUME +	7A-1A	-	-	-	-	-	-	-	-
32	VOLUME -	7A-1B	-	-	-	-	-	-	-	-
33	MUTE	7A-1C	-	-	-	-	-	-	-	-
34	1	7A-88	79-11	79-85	7F-91	7A-E5	6A-AA	7C-94	10-A0	6A-AA
35	2	7A-89	79-12	79-86	7F-92	7A-E6	9A-AA	7C-95	11-A1	9A-AA
36	3	7A-8A	79-13	79-87	7F-93	7A-E7	5A-AA	7C-96	12-A2	5A-AA
37	4	7A-8B	79-14	79-88	7F-94	7A-E8	A6-AA	7C-97	13-A3	A6-AA
38	5	7A-8D	79-15	79-89	7F-95	7A-E9	66-AA	7C-98	14-A4	66-AA
39	6	7A-96	79-16	79-8A	7F-96	7A-EA	96-AA	7C-99	15-A5	96-AA
40	7	7A-97	79-17	79-8B	7F-97	7A-EB	56-AA	7C-9A	16-A6	56-AA
41	8	7A-DD	79-18	79-8C	7F-98	7A-EC	A9-AA	7C-9B	17-A7	A9-AA
42	9	7A-9A	79-19	79-8D	7F-99	7A-B1	69-AA	7C-9C	18-A8	69-AA
43	0	7A-9B	79-10	79-8E	7F-90	7A-B2	AA-AA	7C-93	19-A9	AA-AA
44	+10	7A-95	79-1A	79-8F	7F-9A	-	A9-56	7C-9D	89-39	A9-56
45	ENT.	7A-56	79-0B	-	7F-8A	7A-B3	A9-A5	7C-9E	-	A9-A5
46	TITLE	7A-86	-	-	-	7A-AE	6A-56	7C-B1	9B-2B	6A-56
47	^	7A-98	-	-	-	7A-10	A9-66	7C-B4	85-35	A9-66
48	MENU	7A-9C	-	-	-	7A-AB	A6-66	7C-B2	80-30	A6-66
49	<	7A-53	-	-	-	7A-A0	99-66	7C-B5	87-37	99-66
50	ENTER	7A-DE	-	-	-	7A-AD	A5-66	7C-B8	82-32	A5-66
51	>	7A-52	-	-	-	7A-12	59-66	7C-B6	88-38	59-66
52	RETURN	7A-AA	-	-	-	7A-AF	5A-A9	7C-B7	81-31	5A-A9
53	v	7A-99	-	-	-	7A-11	69-66	7C-B3	86-36	69-66
54	DISPLAY	-	79-0A	79-A5	7F-9E	7A-00	55-AA	7C-A6	92-22	55-AA

1 ■ REMOTE CONTROL RAV22 (B, G, E models)

The schematic diagram is not available.

• PANEL

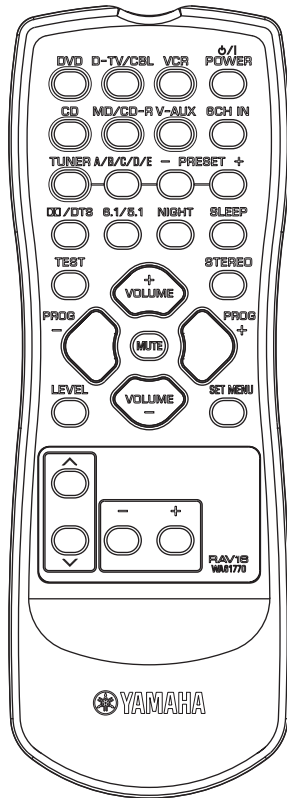

• KEY LAYOUT

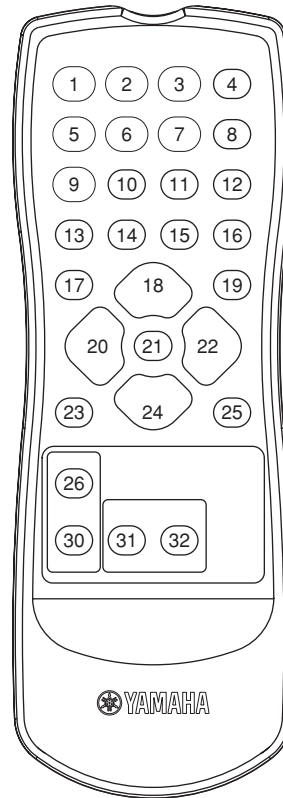

• CUSTOM CODE: 7A

Key No.	Key Name	Data Code
1	DVD	C1
2	D-TV/CBL	54
3	VCR	0F
4	POWER	1F
5	CD	15
6	MD/CD-R	C9
7	V-AUX	55
8	6CH INPUT	87
9	TUNER	16
10	A/B/C/D/E	12
11	PRESET -	11
12	PRESET +	10
13	DD / DTS	90
14	6.1 / 5.1	97
15	NIGHT	95
16	SLEEP	57
17	TEST	85
18	VOLUME +	1A
19	STEREO	56
20	PROG -	59
21	MUTE	1C
22	PROG +	58
23	LEVEL	86
24	VOLUME -	1B
25	SET MENU	9C
26	^	98
27	—	—
28	—	—
29	—	—
30	v	99
31	-	53
32	+	52
33	—	—

ADVANCED SETUP

The advanced setup menu offers additional operations to adjust and customize the way this unit operates. Change the initial settings (indicated in bold under each parameter) to reflect the needs of your listening environment.

Notes

- The settings you make are reflected next time you press **STANDBY/ON** on the front panel (or **POWER** on the remote control) to turn on this unit.
- Only **STANDBY/ON**, **STRAIGHT** and **PROGRAM** </> are effective while you are using the advanced setup menu.
- All the other operations cannot be made while you are using the advanced setup menu.
- During the advanced setup procedure, audio output is muted.
- The advanced setup menu is only available in the front panel display.

(U.S.A. model)

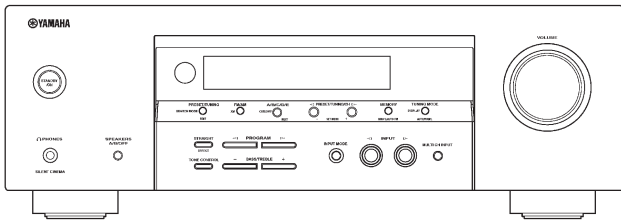

3 (Asia and General models only)
 Press **PROGRAM** </> on the front panel to select the parameter you want to adjust.
 The name of the selected parameter appears in the front panel display.



1 Press STANDBY/ON on the front panel to set this unit to the standby mode.

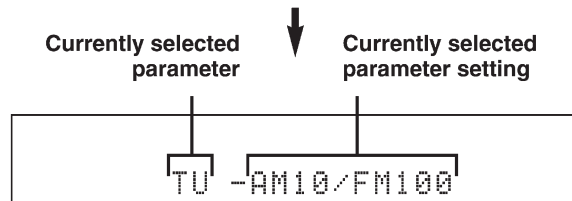

2 Press and hold STRAIGHT on the front panel and then press STANDBY/ON to turn on this unit.
 The advanced setup menu appears in the front panel display.

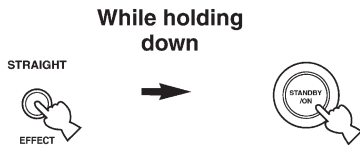

4 Press STRAIGHT on the front panel repeatedly to change the selected parameter setting.



5 Press STANDBY/ON on the front panel to save the new setting and to set this unit to the standby mode.



The settings you made are reflected next time you turn on this unit.

ADVANCED SETUP**■ Factory presets** PRESET

Use this feature to reset all the parameters of this unit to the initial factory settings.

Choices: **CANCEL**, RESET

- Select “CANCEL” not to reset any parameters of this unit.
- Select “RESET” to reset the parameters of this unit.

Notes

- This setting completely resets all the parameters of this unit including the “SET MENU” parameters. However, the advanced setup menu parameters will not be initialized.
- The initial factory settings are activated next time you turn on this unit.

■ Tuner frequency step TU
(Asia and General models only)

Use this feature to set the tuner frequency step according to the frequency spacing in your area.

Choices: **AM10/FM100**, AM9/FM50

- Select “AM10/FM100” for North, Central and South America.
- Select “AM9/FM50” for all other areas.

RX-V359/HTR-5930

