

# DIGITAL HOME THEATER SYSTEM YHT-290/195 AV RECEIVER

# RX-V363/HTR-6130

## SERVICE MANUAL

YHT-290 consists of HTR-6130 and NS-P270D. (C model)

YHT-195 consists of HTR-6130 and NS-P270D. (R, K, A, L models)

NS-P270D consists of NX-E270, NX-C270 and SW-P270.

This service manual is for RX-V363/HTR-6130.

For NX-E270, NX-C270 and SW-P270 service manual, please refer to the following service manual:

NX-P270/NX-P276: 101000

RX-V363/HTR-6130

### IMPORTANT NOTICE

This manual has been provided for the use of authorized YAMAHA Retailers and their service personnel. It has been assumed that basic service procedures inherent to the industry, and more specifically YAMAHA Products, are already known and understood by the users, and have therefore not been restated.

**WARNING:** Failure to follow appropriate service and safety procedures when servicing this product may result in personal injury, destruction of expensive components, and failure of the product to perform as specified. For these reasons, we advise all YAMAHA product owners that any service required should be performed by an authorized YAMAHA Retailer or the appointed service representative.

**IMPORTANT:** The presentation or sale of this manual to any individual or firm does not constitute authorization, certification or recognition of any applicable technical capabilities, or establish a principle-agent relationship of any form.

The data provided is believed to be accurate and applicable to the unit(s) indicated on the cover. The research, engineering, and service departments of YAMAHA are continually striving to improve YAMAHA products. Modifications are, therefore, inevitable and specifications are subject to change without notice or obligation to retrofit. Should any discrepancy appear to exist, please contact the distributor's Service Division.

**WARNING:** Static discharges can destroy expensive components. Discharge any static electricity your body may have accumulated by grounding yourself to the ground buss in the unit (heavy gauge black wires connect to this buss).

**IMPORTANT:** Turn the unit OFF during disassembly and part replacement. Recheck all work before you apply power to the unit.

## CONTENTS

TO SERVICE PERSONNEL .....	2	DISPLAY DATA .....	38-39
FRONT PANELS .....	3-4	IC DATA .....	40-55
REAR PANELS .....	4-9	BLOCK DIAGRAMS .....	56-57
REMOTE CONTROL PANELS .....	9	PRINTED CIRCUIT BOARDS .....	58-71
SPECIFICATIONS .....	10-12	PIN CONNECTION DIAGRAMS .....	72
INTERNAL VIEW .....	13	SCHEMATIC DIAGRAMS .....	73-83
DISASSEMBLY PROCEDURES .....	14-16	REPLACEMENT PARTS LIST .....	85-95
UPDATING FIRMWARE .....	17-19	REMOTE CONTROL .....	96-98
SELF DIAGNOSTIC FUNCTION .....	20-37	Advanced setup .....	99



このサービスマニュアルは、エコマーク認定の再生紙を使用しています。  
This Service Manual uses recycled paper.

101084

© 2008 YAMAHA CORPORATION. All rights reserved.  
This manual is copyrighted by YAMAHA and may not be copied or  
redistributed either in print or electronically without permission.



# YAMAHA

YAMAHA CORPORATION  
P.O.Box 1, Hamamatsu, Japan

'08.02

## ■ TO SERVICE PERSONNEL

### 1. Critical Components Information

Components having special characteristics are marked ⚠ and must be replaced with parts having specifications equal to those originally installed.

### 2. Leakage Current Measurement (For 120V Models Only)

When service has been completed, it is imperative to verify that all exposed conductive surfaces are properly insulated from supply circuits.

- Meter impedance should be equivalent to 1500 ohms shunted by 0.15µF.

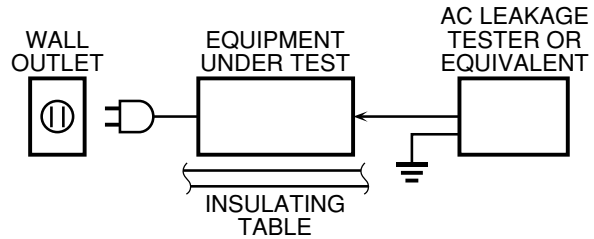

- Leakage current must not exceed 0.5mA.
- Be sure to test for leakage with the AC plug in both polarities.



#### For U model

#### “CAUTION”

“F2251: FOR CONTINUED PROTECTION AGAINST RISK OF FIRE, REPLACE ONLY WITH SAME TYPE 6A, 125V FUSE.”

#### For C model

#### CAUTION

F2251: REPLACE WITH SAME TYPE 6A, 125V FUSE.

#### ATTENTION

F2251: UTILISER UN FUSIBLE DE RECHANGE DE MÊME TYPE DE 6A, 125V.

## WARNING: CHEMICAL CONTENT NOTICE!

This product contains chemicals known to the State of California to cause cancer, or birth defects or other reproductive harm.

DO NOT PLACE SOLDER, ELECTRICAL/ELECTRONIC OR PLASTIC COMPONENTS IN YOUR MOUTH FOR ANY REASON WHAT SO EVER!

Avoid prolonged, unprotected contact between solder and your skin! When soldering, do not inhale solder fumes or expose eyes to solder/flux vapor!

If you come in contact with solder or components located inside the enclosure of this product, wash your hands before handling food.

## About lead free solder

All of the P.C.B.s installed in this unit and solder joints are soldered using the lead free solder.

Among some types of lead free solder currently available, it is recommended to use one of the following types for the repair work.

- Sn + Ag + Cu (tin + silver + copper)
- Sn + Cu (tin + copper)
- Sn + Zn + Bi (tin + zinc + bismuth)

### Caution:

As the melting point temperature of the lead free solder is about 30°C to 40°C (50°F to 70°F) higher than that of the lead solder, be sure to use a soldering iron suitable to each solder.

# FRONT PANELS

RX-V363 (U, C, T models)

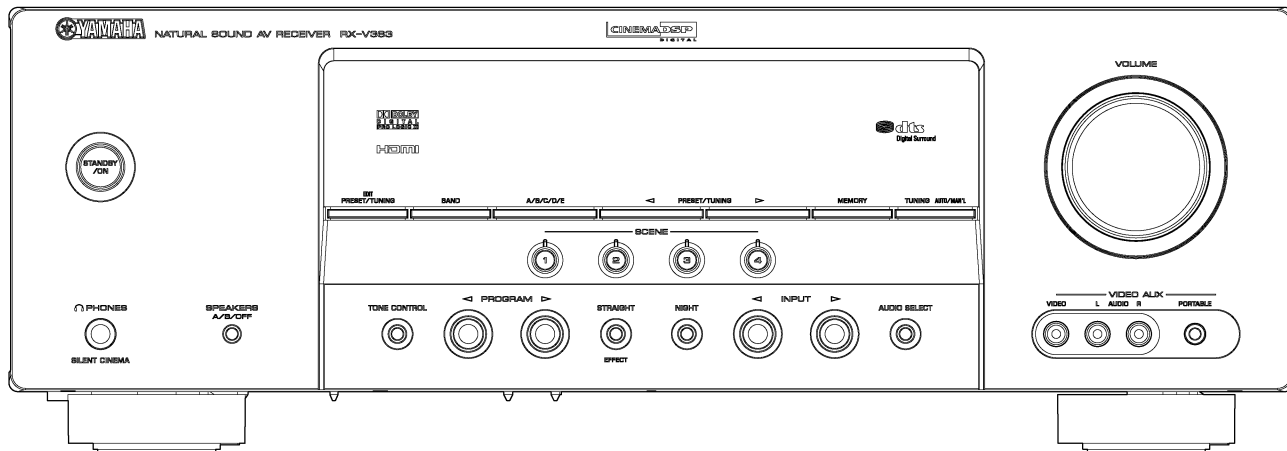

RX-V363 (R, K, A, B, G, E, F, L models)

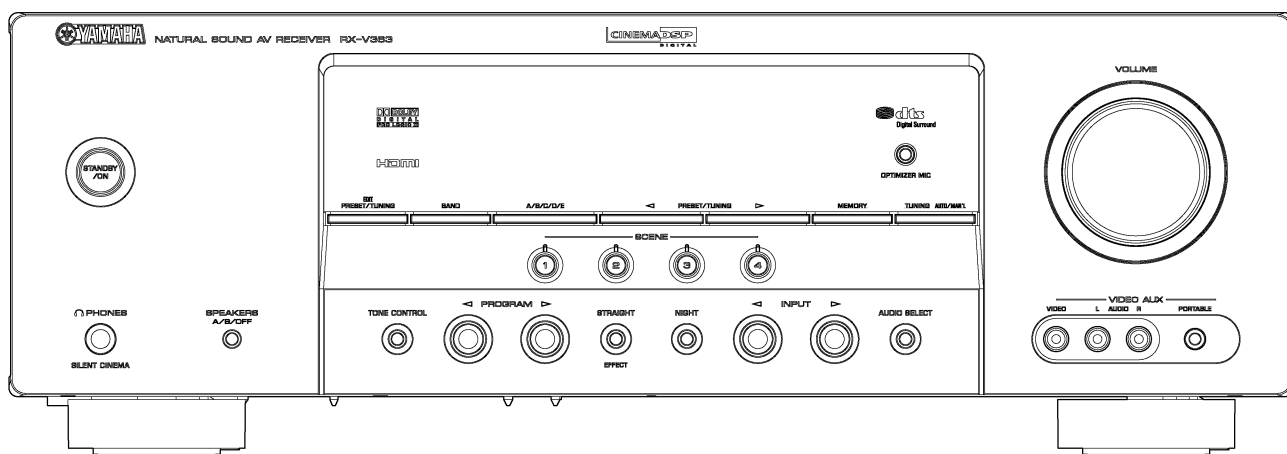

HTR-6130 (U, C, T models)

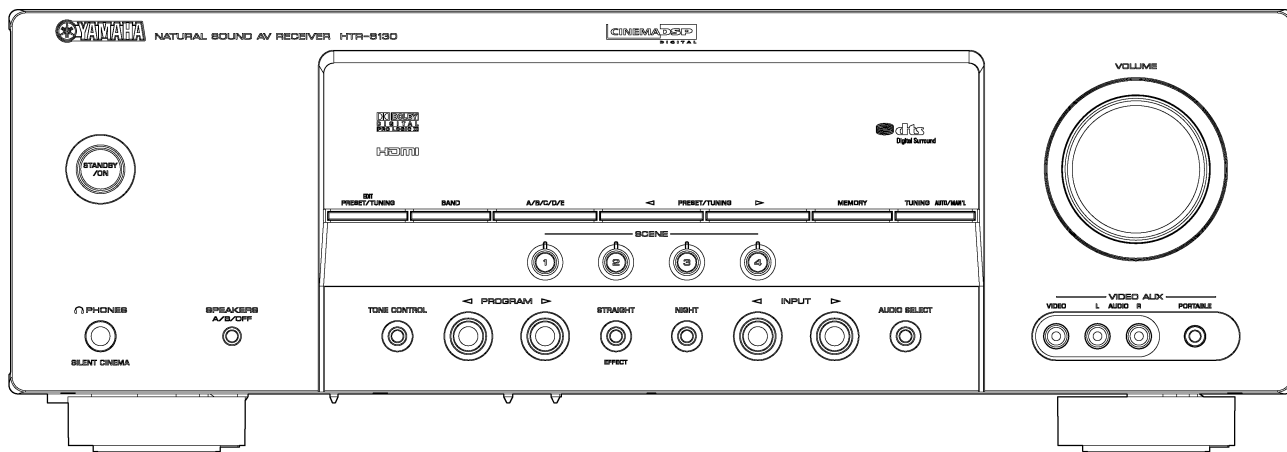

RX-V363/HTR-6130

HTR-6130 (R, K, A, G, E, F, L models)

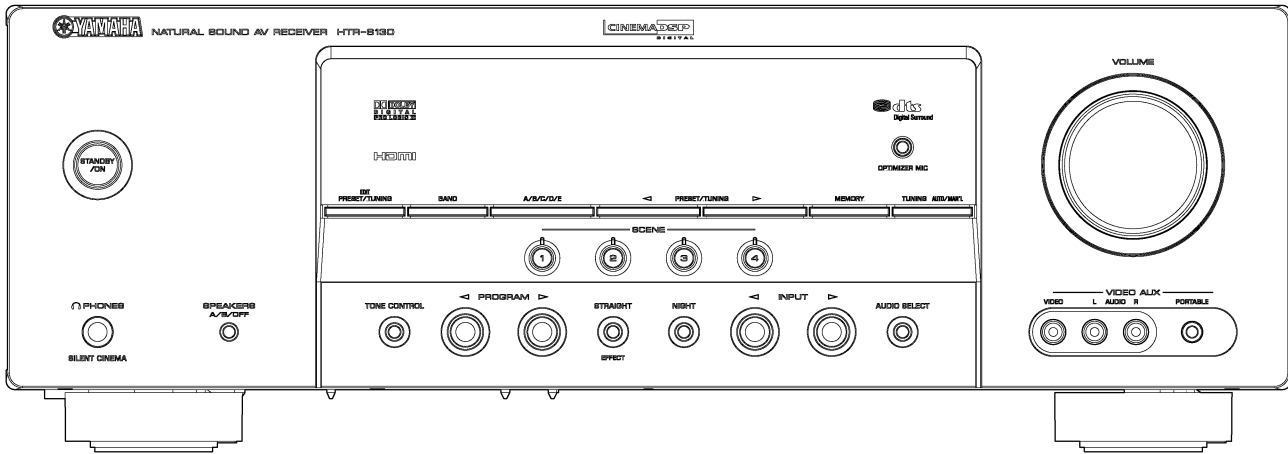

REAR PANELS

RX-V363 (U, C models)

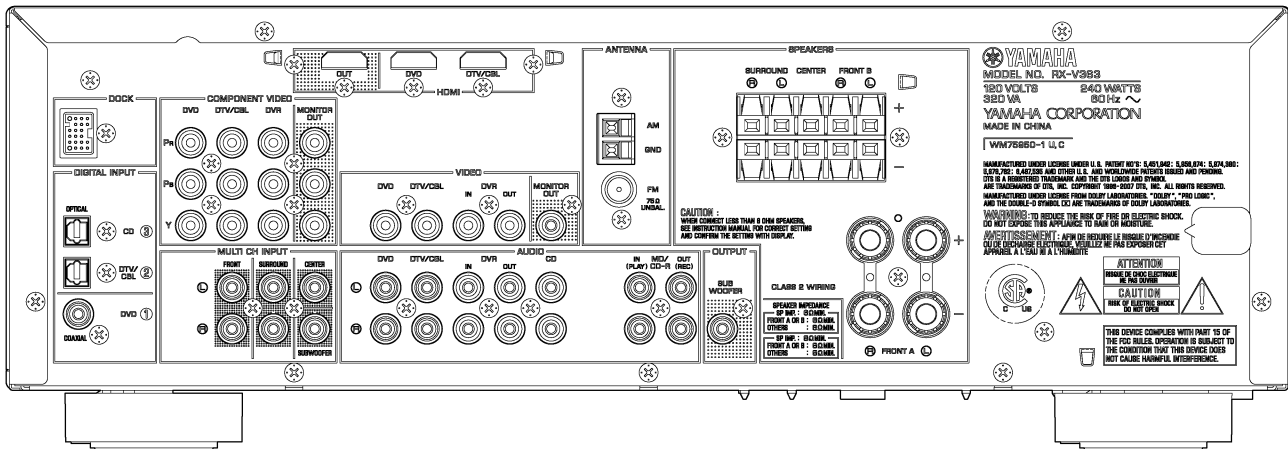

RX-V363 (R model)

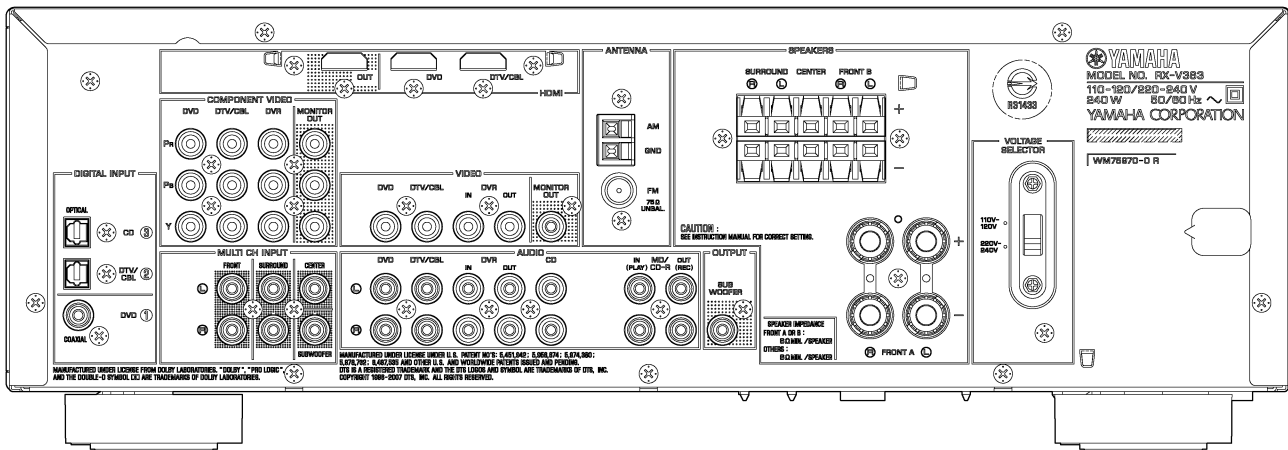

RX-V363/HTR-6130

RX-V363 (T model)

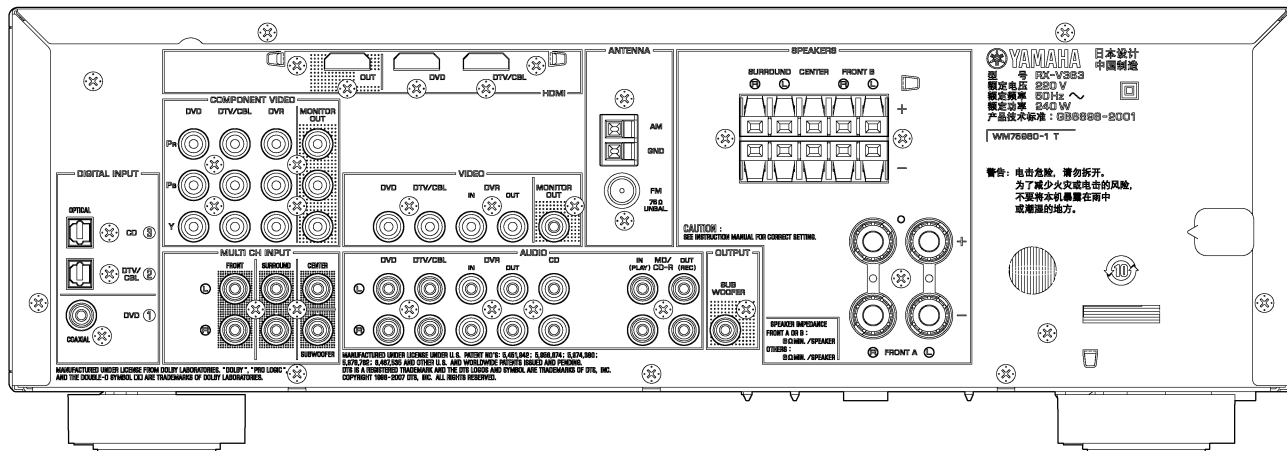

RX-V363 (K model)

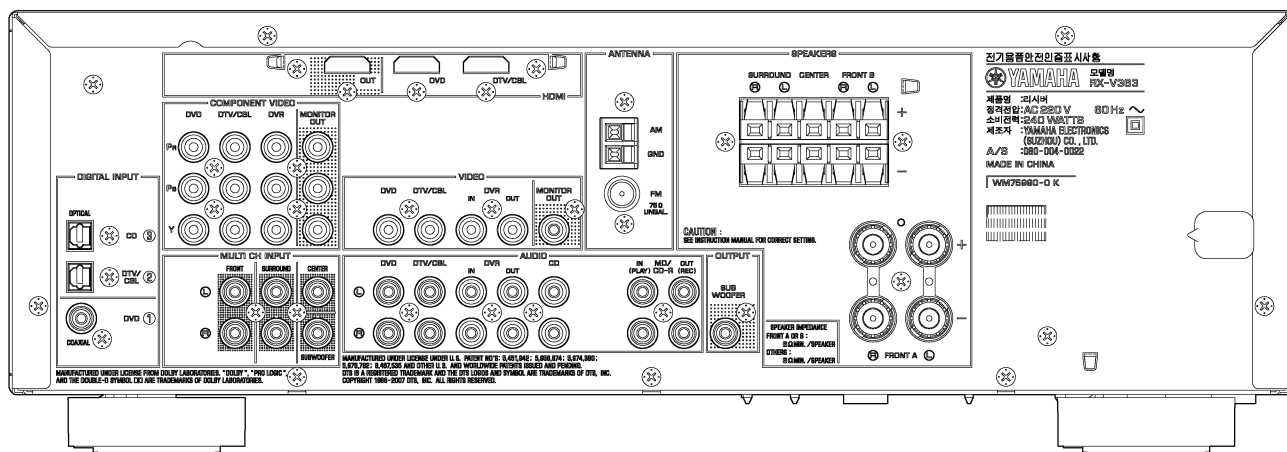

RX-V363 (A model)

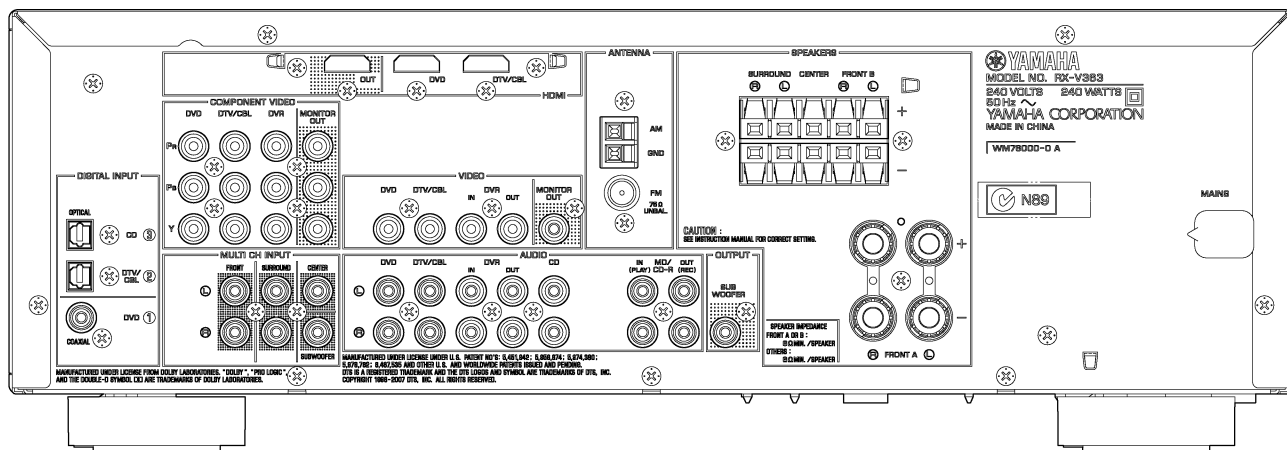

RX-V363/HTR-6130

RX-V363 (B model)

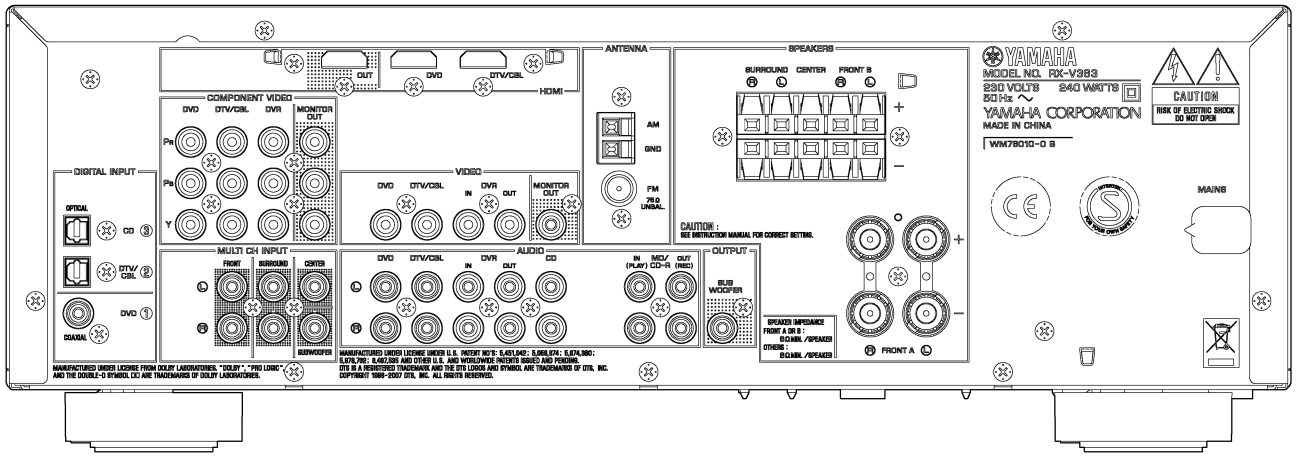

RX-V363 (G, E, F models)

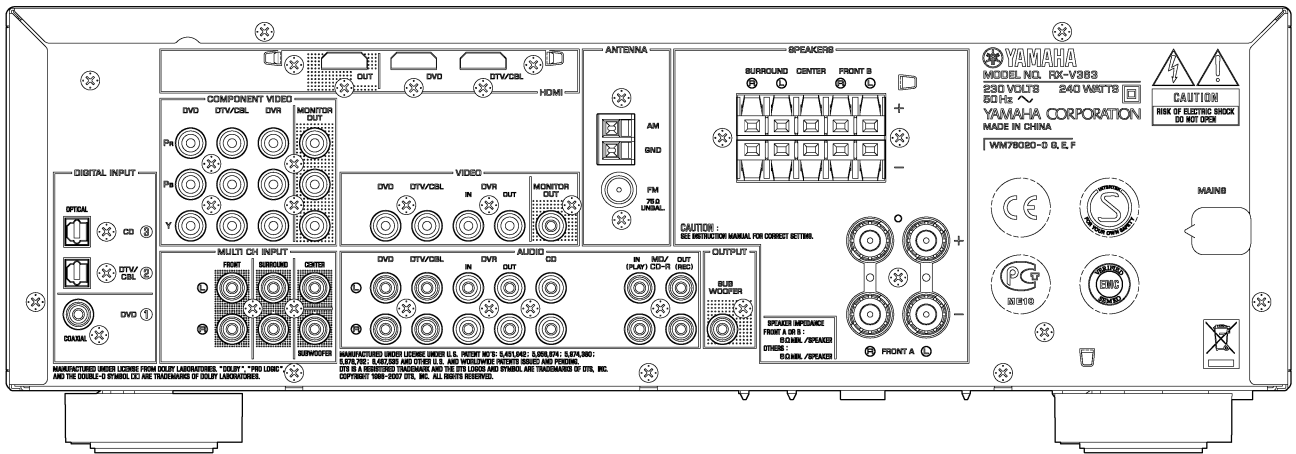

RX-V363 (L model)

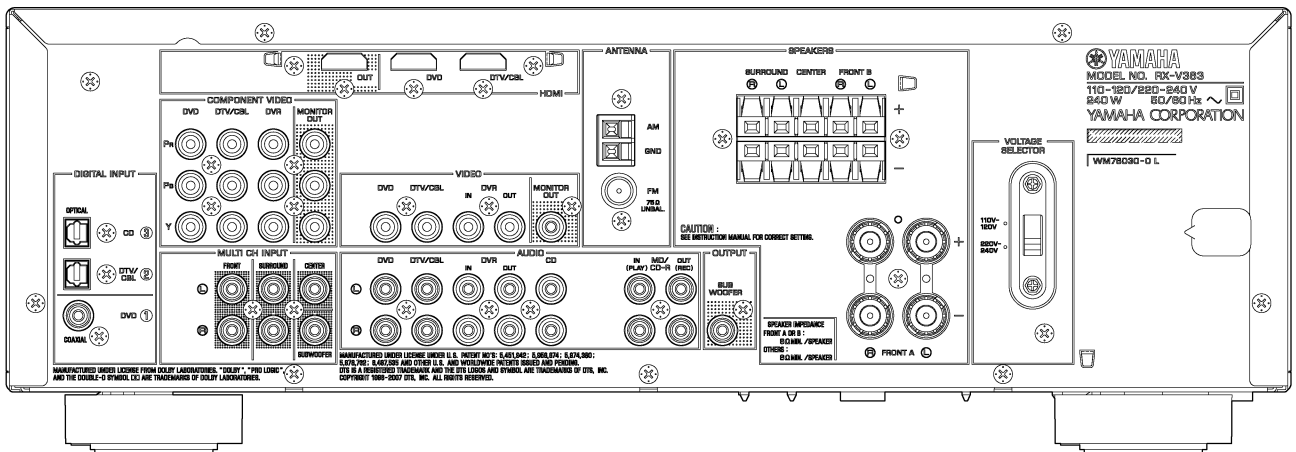

RX-V363/HTR-6130

HTR-6130 (U, C models)

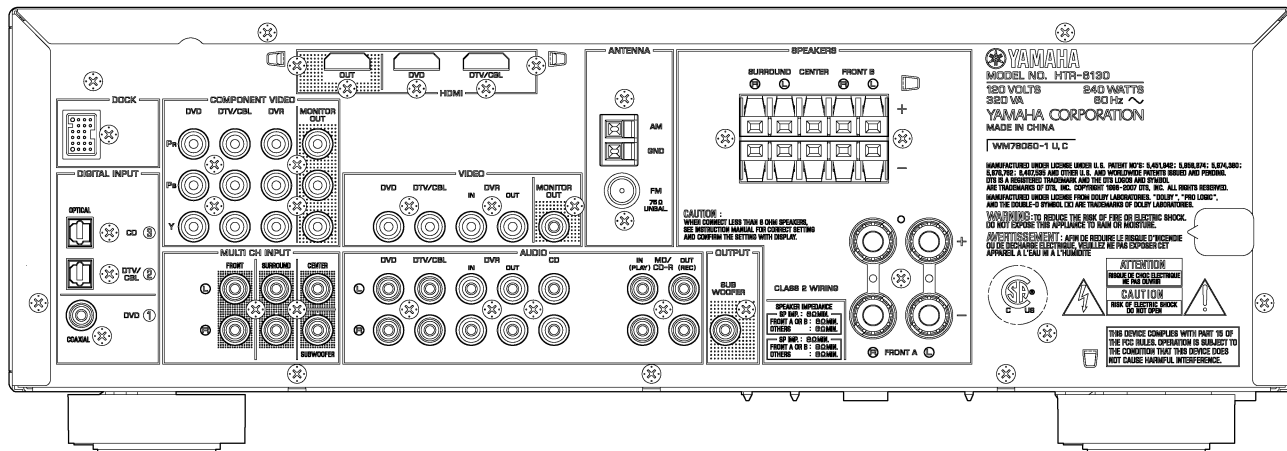

HTR-6130 (R model)

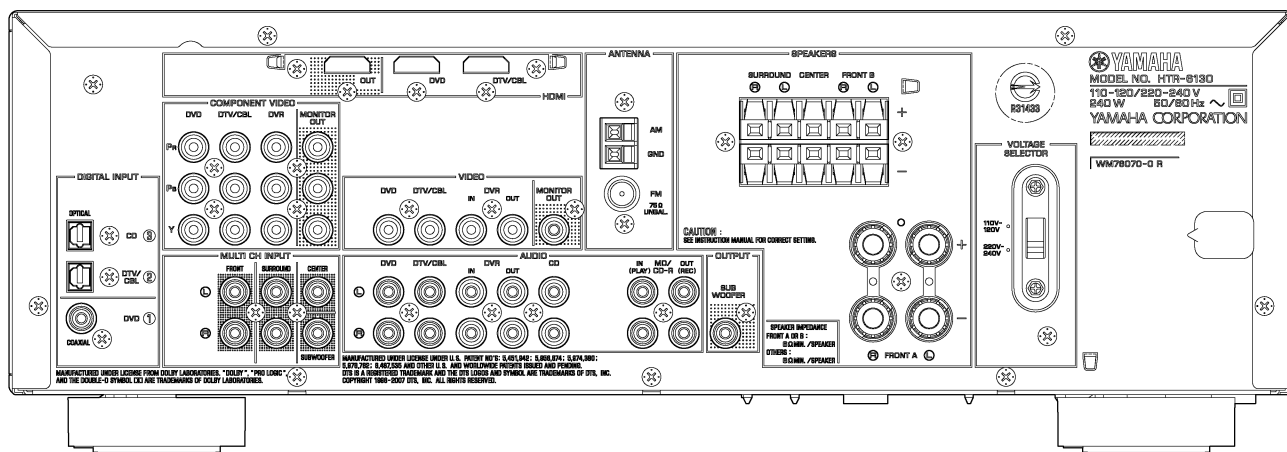

HTR-6130 (T model)

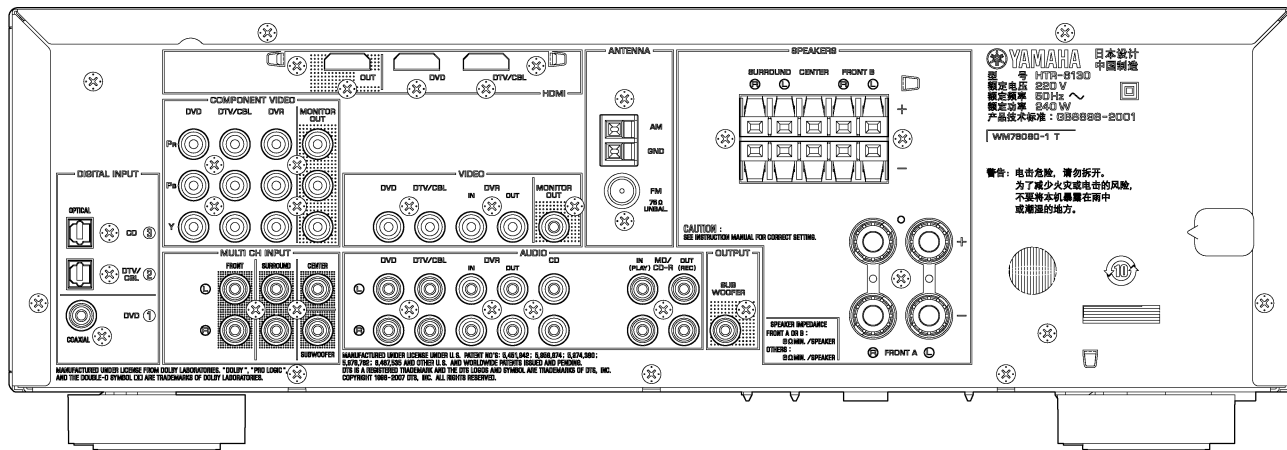

RX-V363/HTR-6130

HTR-6130 (K model)

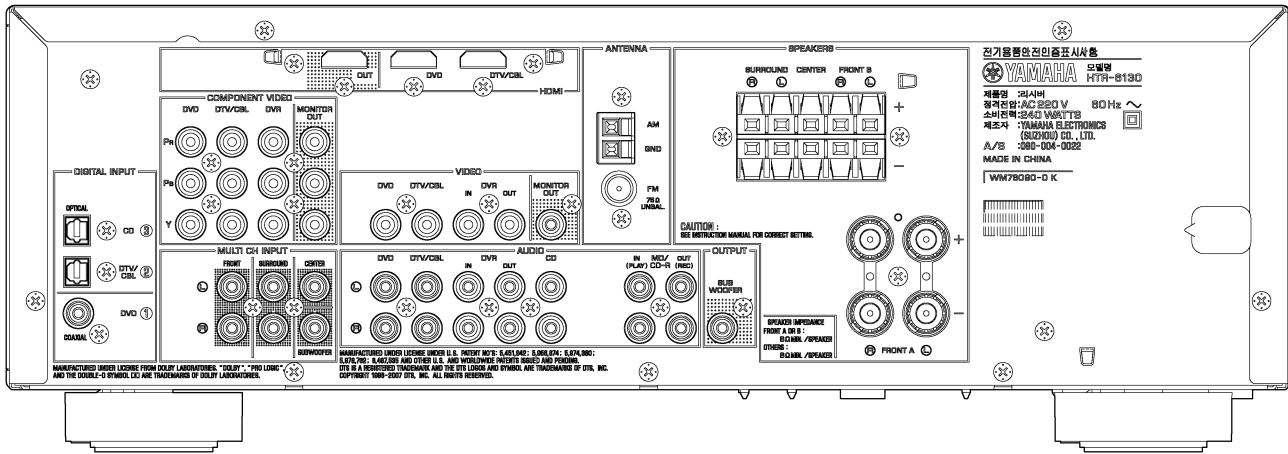

HTR-6130 (A model)

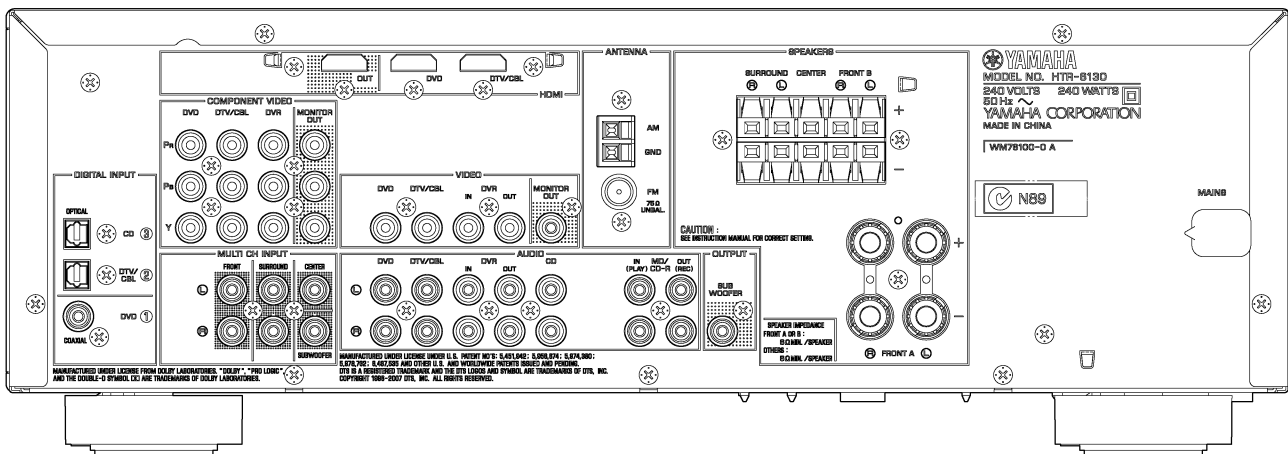

HTR-6130 (G, E, F models)

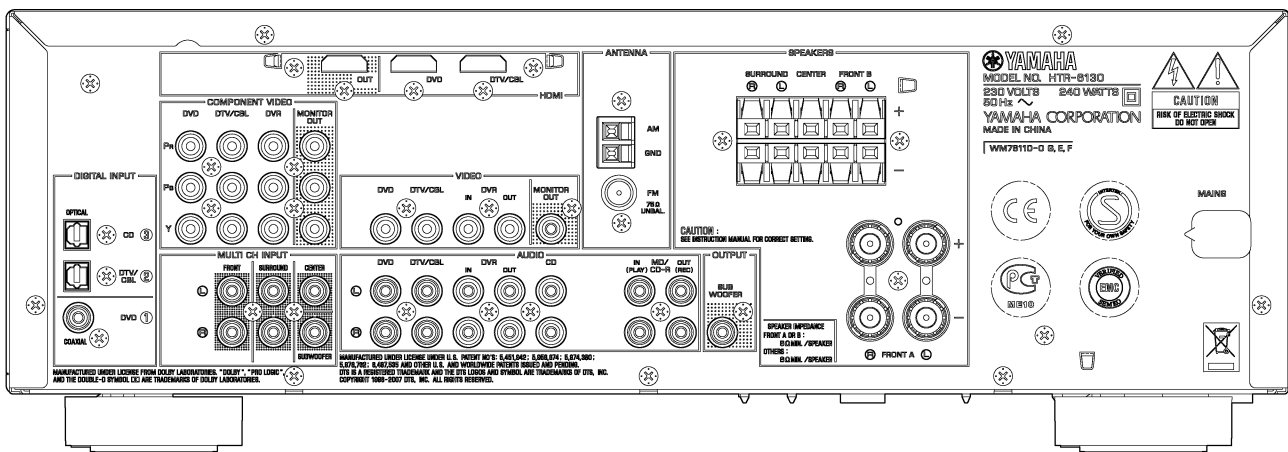



HTR-6130 (L model)

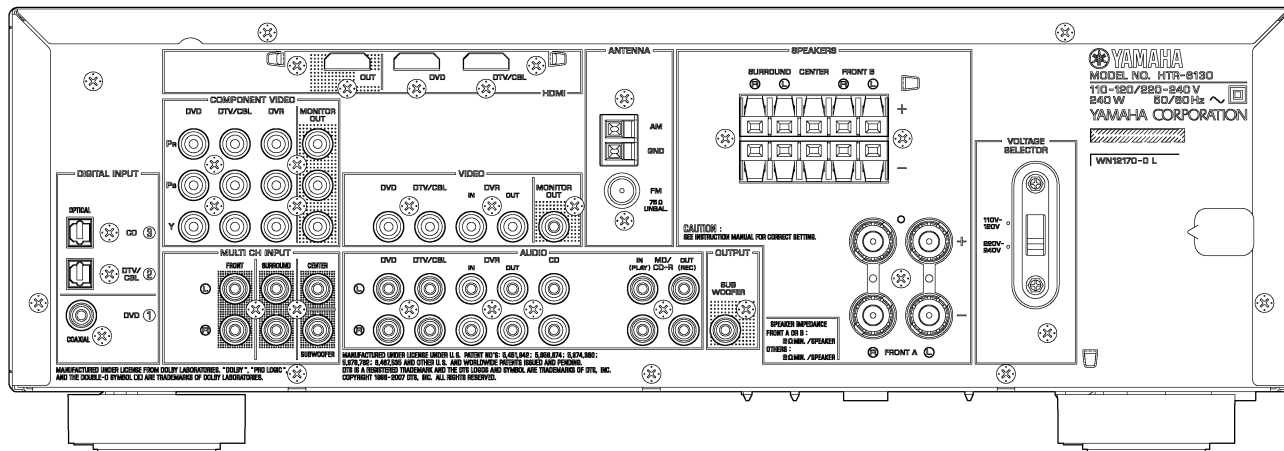

■ REMOTE CONTROL PANELS

- RAV283  
RX-V363 (U, C models)  
HTR-6130 (U, C models)
- RAV284  
RX-V363 (R, T, K, A, L models)  
HTR-6130 (R, T, K, A, L models)
- RAV34  
RX-V363 (B, G, E, F models)  
HTR-6130 (G, E, F models)

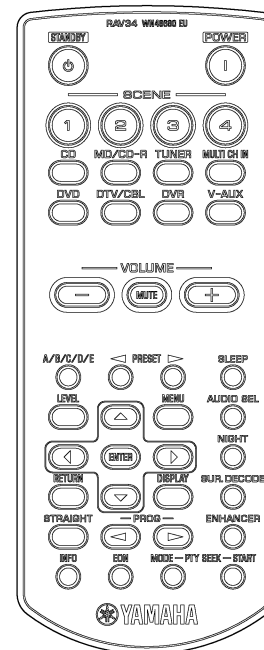
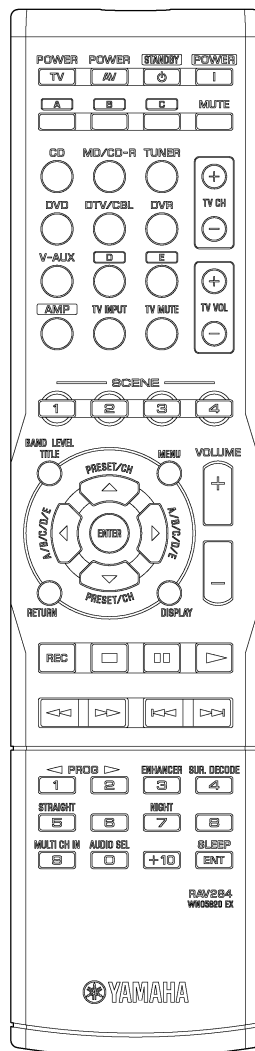
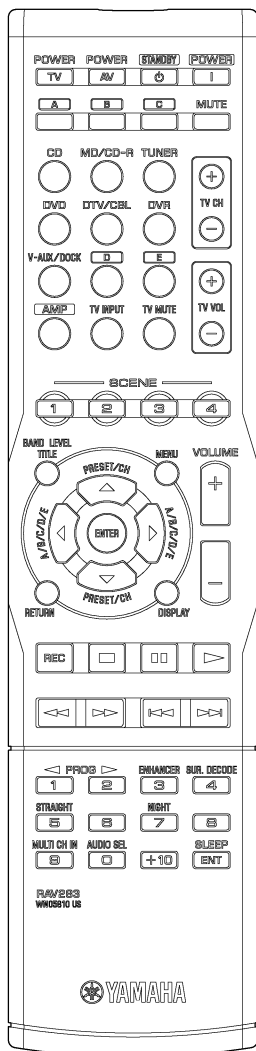

RX-V363/HTR-6130

# ■ SPECIFICATIONS

## ■ Audio Section

### Minimum RMS Output Power (Power Amp. Section)

(1 kHz, 0.9 % THD)  
 FRONT L/R, CENTER, SURROUND L/R  
 U, C models (8 ohms) ..... 100 W/ch  
 R, T, K, A, B, G, E, F, L models (6 ohms) ..... 100 W/ch

### Maximum Power (JEITA) (1 kHz, 10 % THD)

FRONT L/R, CENTER, SURROUND L/R  
 U, C models (8 ohms) ..... 135 W/ch  
 R, T, K, A, L models (6 ohms) ..... 135 W/ch

### Max. Power Per Channel [B, G, E, F models]

(1 kHz, 0.7 % THD, 4 ohms)  
 FRONT L/R, CENTER, SURROUND L/R.... 105 W or more

### IEC Power [B, G, E, F models]

(1 kHz, 0.1 % THD, 6 ohms)  
 MAIN L/R ..... 90 W or more

### Dynamic Power Per Channel (IHF) (FRONT L/R)

U, C models  
 (8/6/4/2 ohms) ..... 110/130/160/180 W  
 R, T, K, A, B, G, E, F, L models  
 (6/4/2 ohms) ..... 105/130/150 W

### Dynamic Headroom

U, C models (8 ohms) ..... 0.41 dB

### Input Sensitivity/Input Impedance

(1 kHz, 100 W / 6 ohms)  
 CD, etc. .... 200 mV / 47 k-ohms  
 MULTI CH INPUT  
 FRONT L/R, CENTER, SURROUND L/R, SUBWOOFER  
 ..... 200 mV / 47 k-ohms

### Maximum Input Signal (1 kHz, 0.5 % THD, Effect on)

CD, etc. .... 2.0 V or more

### Output Level/Output Impedance

REC OUT ..... 200 mV / 1.2 k-ohms  
 SUBWOOFER (2 ch STEREO and FRONT SP: Small)  
 ..... 4 V / 1.2 k-ohms

### Headphone Jack Rated Output/Impedance

CD, etc. (1 kHz, 200 mV, 8 ohms) ..... 400 mV / 470 ohms

### Frequency Response

(10 Hz to 100 kHz)  
 CD, etc. to FRONT L/R ..... 0 / -3.0 dB  
 (10 Hz to 20 kHz)  
 V-AUX to FRONT L/R ..... 0 / -3.0 dB

### Total Harmonic Distortion (1 kHz, 50 W)

CD, etc. (2ch stereo) to FRONT L/R SP OUT  
 U, C models (8 ohms) ..... 0.06 % or less  
 R, T, K, A, B, G, E, F, L models (6 ohms) ..... 0.06 % or less

### Signal to Noise Ratio (IHF-A Network)

CD, etc. (STEREO) to Input shorted SP OUT  
 200 mV ..... 98 dB or more  
 250 mV ..... 100 dB or more

### Residual Noise (IHF-A Network)

FRONT L/R SP OUT ..... 170 μV or less

### Channel Separation

CD, etc. (Input 5.1 k-ohms shorted, 1 kHz / 10 kHz)  
 ..... 60 dB or more / 45 dB or more

### Tone Control Characteristics

BASS  
 Boost/Cut ..... ±10 dB (100 Hz)  
 TREBLE  
 Boost/Cut ..... ±10 dB (20 kHz)

### Filter Characteristics

FRONT, CENTER, SURROUND, SURROUND BACK small (H.P.F.)  
 ..... fc=40/60/80/90/100/110/120/160/200 Hz, 12 dB/oct.  
 SUBWOOFER (L.P.F.)  
 ..... fc=40/60/80/90/100/110/120/160/200 Hz, 24 dB/oct.

## ■ Video Section

### Video Signal Type (Gray back)

U, C, R, K models ..... NTSC  
 T, A, B, G, E, F, L models ..... PAL

### Composite Video Signal Level

..... 1 Vp-p / 75 ohms

### Component Signal Level

Y ..... 1 Vp-p / 75 ohms

### Video Maximum Input Level

..... 1.5 Vp-p or more

### Signal to Noise Ratio (IHF)

..... 50 dB or more

### Monitor Out Frequency Response

Component video signal ..... 5 Hz to 60 MHz, -3 dB

## ■ FM Section

### Tuning Range

U, C models ..... 87.5 to 107.9 MHz  
 R, L models ..... 87.5 to 108.0 / 87.50 to 108.00 MHz  
 T, K, A, B, G, E, F models ..... 87.50 to 108.00 MHz

### 50dB Quieting Sensitivity (IHF) (1 kHz, 100 % Mod.)

Mono ..... 2.8 μV (20.2 dBf)

### Signal to Noise Ratio (IHF)

Mono / Stereo ..... 73 dB / 70 dB

### Harmonic Distortion (1 kHz)

Mono / Stereo ..... 0.5 % / 0.5 %

### Antenna Input ..... 75 ohms unbalanced

## ■ AM Section

### Tuning Range

U, C models ..... 530 to 1,710 kHz  
 R, L models ..... 530 to 1,710 / 531 to 1,611 kHz  
 T, K, A, B, G, E, F models ..... 531 to 1,611 kHz

### Antenna Input ..... Loop antenna

RX-V363/HTR-6130

**General**

**Power Supply**

U, C models ..... AC 120 V, 60 Hz  
 R, L models ..... AC 110-120/220-240 V, 50/60 Hz  
 T model ..... AC 220 V, 50 Hz  
 K model ..... AC 220 V, 60 Hz  
 A model ..... AC 240 V, 50 Hz  
 B, G, E, F models ..... AC 230 V, 50 Hz

**Power Consumption**

U, C models ..... 240 W / 320 VA  
 R, T, K, A, B, G, E, F, L models ..... 240 W

**Standby Power Consumption (reference data)**

U, C, T, K, A, B, G, E, F models ..... 0.8 W

**Maximum Power Consumption (5 ch drive, 10 % THD)**

R, L models ..... 530 W

**Dimensions (W x H x D)**

..... 435 x 151 x 317.6 mm (17-1/8" x 5-15/16" x 12-1/2")

**Weight** ..... 8.0 kg (17 lbs. 10 oz.)

**Finish**

**[RX-V363]**

Gold color ..... T, L models  
 Black color ..... U, C, R, A, B, G, E, F, L models  
 Silver color ..... R, A, G, E, F, L models  
 Titanium color ..... K, B, G, F, L models

**[HTR-6130]**

Gold color ..... T model  
 Black color ..... U, C, R, A, G, F, L models  
 Silver color ..... U, R, K, A, G, E, F, L models

**Accessories** ..... Remote control x 1

Batteries (R03, AAA, UM-4) x 2  
 Indoor FM antenna x 1  
 AM loop antenna x 1  
 Optimizer microphone x 1 (R, K, A, B, G, E, F, L models)

\* Specifications are subject to change without notice due to product improvements.

U ..... U.S.A. model      B ..... British model  
 C ..... Canadian model      G ..... European model  
 R ..... General model      E ..... South European model  
 T ..... Chinese model      F ..... Russian model  
 K ..... Korean model      L ..... Singapore model  
 A ..... Australian model



Manufactured under license from Dolby Laboratories.  
 "Dolby", "Pro Logic", and the double-D symbol are trademarks of Dolby Laboratories.

SILENT™  
 CINEMA

"SILENT CINEMA" is a trademark of Yamaha Corporation.



"HDMI", the "HDMI" logo and "High-Definition Multimedia Interface" are trademarks or registered trademarks of HDMI Licensing LLC.

iPod™

"iPod" is a trademark of Apple Inc., registered in the U.S. and other countries.

Bluetooth®

Bluetooth is a registered trademark of the Bluetooth SIG and is used by Yamaha in accordance with a license agreement.



"DTS" and "DTS Digital Surround" are registered trademarks of DTS, Inc.

**DIMENSIONS**

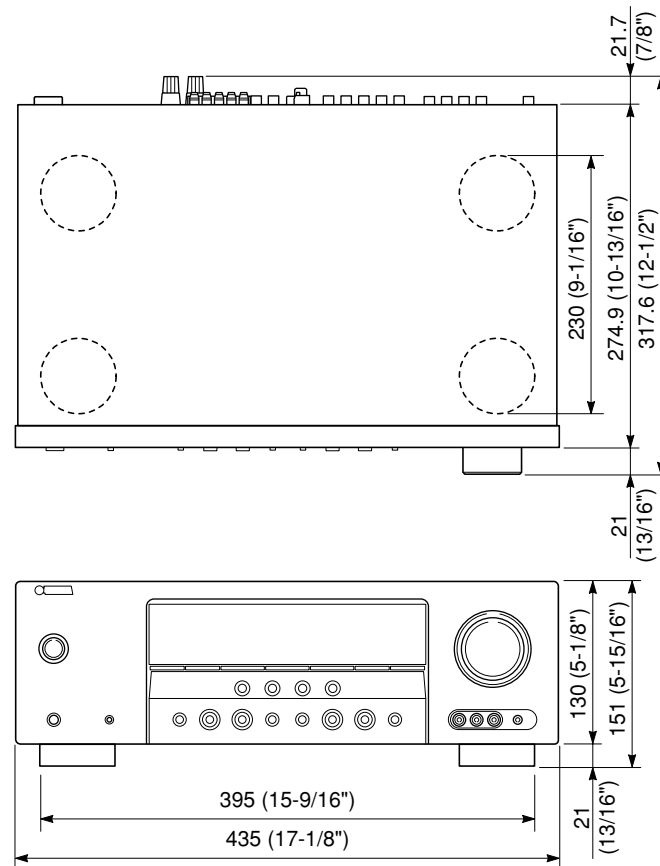

Unit: mm (inch)

**SCENE TEMPLATE**

SCENE name	Contents		Source	Program		NIGHT Mode	Select (Default)	
				Mode	Sub-mode		U, C models	R, T, K, A, B, G, E, F, L models
DVD Viewing	DVD	Movie	DVD	STRAIGHT	–	SYSTEM	O (SCENE 1)	O
DVD Movie Viewing			DVD	MOVIE	Movie Dramatic	SYSTEM	O	O (SCENE 1)
DVD Live Viewing				Music Live	DVD	MUSIC	Pop/Rock	SYSTEM
DVR Viewing	DVR		DVR	MOVIE	Movie Dramatic	SYSTEM	O	O
Music Disc Listening	DVD-Audio / SA-CD / CD	Music Disc	DVD	STEREO	2ch Stereo	SYSTEM	O	O (SCENE 2)
Disc Listening			DVD	STEREO	5ch Stereo	SYSTEM	O (SCENE 2)	O
CD Listening	CD	Music Disc	CD	STEREO	5ch Stereo	SYSTEM	O	O
CD Music Listening			CD	STEREO	2ch Stereo	SYSTEM	O	O
Radio Listening	TUNER/RADIO	FM/AM	FM/AM (TUNER)	MUSIC ENHANCER	Music Enh. 5ch	SYSTEM	O (SCENE 4)	O (SCENE 4)
DOCK Listening	DAP	iPod	DOCK	MUSIC ENHANCER	Music Enh. 5ch	SYSTEM	O	–
		Bluetooth	(V-AUX)					
TV Viewing	TV		DTV/CBL	STRAIGHT	–	SYSTEM	O (SCENE 3)	O (SCENE 3)
TV Sports Viewing			DTV/CBL	ENTERTAINMENT	TV Sports	SYSTEM	O	O
Game Playing	GAME		V-AUX	ENTERTAINMENT	Game	SYSTEM	O	O

**SOUND/SURROUND SELECT MENU**

Sound Field Parameters

		DSP LEVEL	MUSIC ENHANCER
		MIN, [MID], MAX	LOW, [HIGH]
STEREO	2ch Stereo		
	5ch Stereo		
MUSIC	Pop/Rock	O	
	Hall	O	
	Jazz	O	
ENTERTAIN	Game	O	
	TV Sports	O	
MOVIE	Movie Spacious	O	
	Movie Dramatic	O	
ENHANCER	Music Enh. 2ch		O
	Music Enh. 5ch		O

Surround Decoders

DECODING FORMAT		PANORAMA	DIMENSION	CENTER WIDTH
		ON, [OFF]	-3, [STD], +3	0, 1, 2, [3], 4, 5, 6, 7
Dolby Digital				
	DTS			
POST DECODING FORMAT	Dolby Pro Logic			
	Dolby Pro Logic II Music	O	O	O
	Dolby Pro Logic II Movie			
	Dolby Pro Logic II Game			

## • SET MENU TABLE

CATEGORY	MAIN MENU	SUB MENU	SELECT MENU	VALUE [INITIAL]		
BASIC SETUP (U, C, T models)		ROOM	: M	S / [M] / L		
		SUBWOOFER	: YES	[YES] / NONE		
		SPEAKERS	: 5 spk	2 spk / 3 spk / 4 spk / [5 spk]		
		SET / [CANCEL]				
		CHECK	: Test Tone	[YES] / NO		
		CHECK OK?				
		FL	.....  .....			
		FR	.....  .....			
		C	.....  .....			
		SL	.....  .....			
		SR	.....  .....			
		SWFR	.....  .....			
					-10 to +10 dB, [0 dB], 1 dB step	
AUTO SETUP (R, K, A, B, G, E, F, L models)						
Use this feature to automatically adjust speaker and system parameters.						
MANUAL SETUP	1 SOUND MENU	A) SPEAKER SET	FRONT B	: FRONT	[FRONT] / ZONE B	
			FRONT	: LARGE	[LARGE] / SMALL	
			CENTER	: SML	NONE / [SML] / LRG	
			SUR. L/R	: SML	NONE / [SML] / LRG	
			BASS OUT	: BOTH	SWFR / FRNT / [BOTH]	
			CROSSOVER	: 80 Hz	40 / 60 / [80] / 90 / 100 / 110 / 120 / 160 / 200 Hz	
			SWFR PHASE	: NRM	[NRM] / REV	
			FL	.....  .....		
			FR	.....  .....		
			C	.....  .....		
			SL	.....  .....		
			SR	.....  .....		
			SWFR	.....  .....		
						-10 to +10 dB, [0 dB], 1 dB step
						feet (ft) / meters (m)
				feet : 1.0 to 80.0 ft, [10.0 ft], 0.5 ft step		
				feet : 1.0 to 80.0 ft, [8.0 ft], 0.5 ft step		
				feet : 1.0 to 80.0 ft, [10.0 ft], 0.5 ft step		
				meters : 0.30 to 24.00 m, [3.00 m], 0.10 m step		
				meters : 0.30 to 24.00 m, [2.40 m], 0.10 m step		
				meters : 0.30 to 24.00 m, [3.00 m], 0.10 m step		
				[OFF] / ON		
	D) CENTER GEQ			TEST	: > OFF ON	
				100 Hz	--    -- 0 dB	
				300 Hz	--    -- 0 dB	
				1 kHz	--    -- 0 dB	
				3 kHz	--    -- 0 dB	
				10 kHz	--    -- 0 dB	
				SP LFE	: 0 dB	
				HP LFE	: 0 dB	
				SP D. R.	: MAX	
				HP D. R.	: MAX	
	E) LIFE LEVEL			MUTE TYP	: FULL	
			A. DELAY	: 0 ms		
			MAX VOL.	: +16 dB		
			INI. VOL.	: OFF		
			IN (1) [COAXIAL]	: DVD		
			IN (2) [OPTICAL]	: CD		
			IN (3) [OPTICAL]	: DTV/CBL		
F) D. RANGE			UNIT	: feet		
			FRONT L	: 10.0 ft		
			FRONT R	: 10.0 ft		
			CENTER	: 10.0 ft		
			SUR. L	: 10.0 ft		
			SUR. R	: 10.0 ft		
			SWFR	: 10.0 ft		
G) AUDIO SET			SP D. R.	: MAX		
			HP D. R.	: MAX		
			MUTE TYP	: FULL		
			A. DELAY	: 0 ms		
			MAX VOL.	: +16 dB		
			INI. VOL.	: OFF		
			IN (1) [COAXIAL]	: DVD		
			IN (2) [OPTICAL]	: CD		
			IN (3) [OPTICAL]	: DTV/CBL		
2 INPUT MENU		A) INPUT ASSIGN				
B) INPUT RENAME						
C) VOLUME TRIM						
D) DECODER MODE						
3 OPTION MENU						
E) BLUETOOTH (U, C models)						
SIGNAL INFO						

## INTERNAL VIEW

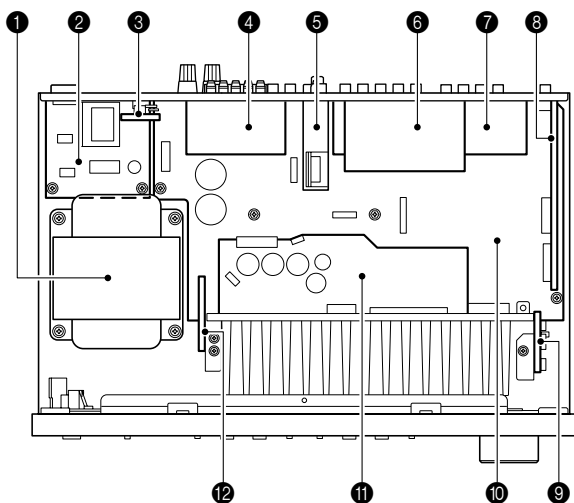

- ❶ Power Transformer
- ❷ OPERATION (3) P.C.B.
- ❸ OPERATION (5) P.C.B. (R, L models)
- ❹ MAIN (3) P.C.B.
- ❺ Tuner
- ❻ HDMI P.C.B.
- ❼ OPERATION (4) P.C.B.
- ❽ DSP P.C.B.
- ❾ MAIN (4) P.C.B.
- ❿ MAIN (1) P.C.B.
- ⓫ OPERATION (2) P.C.B.
- ⓬ OPERATION (11) P.C.B.
- ⓭ OPERATION (6) P.C.B.
- ⓮ OPERATION (10) P.C.B.
- ⓯ OPERATION (1) P.C.B.
- ⓰ OPERATION (7) P.C.B.

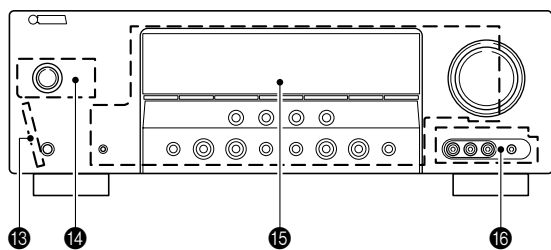

## ■ DISASSEMBLY PROCEDURES

(Remove parts in the order as numbered.)

Disconnect the power cable from the AC outlet.

### 1. Removal of Top Cover

- Remove 4 screws (①), 4 screws (②) and 1 screw (③). (Fig. 1)
- Slide the top cover rearward to remove it. (Fig. 1)

### 2. Removal of Front Panel Unit

- Remove 6 screws (④). (Fig. 1)
- Remove CB192, CB234, CB261 and CB408. (Fig. 1)
- Release hook and then remove the front panel unit. (Fig. 1)

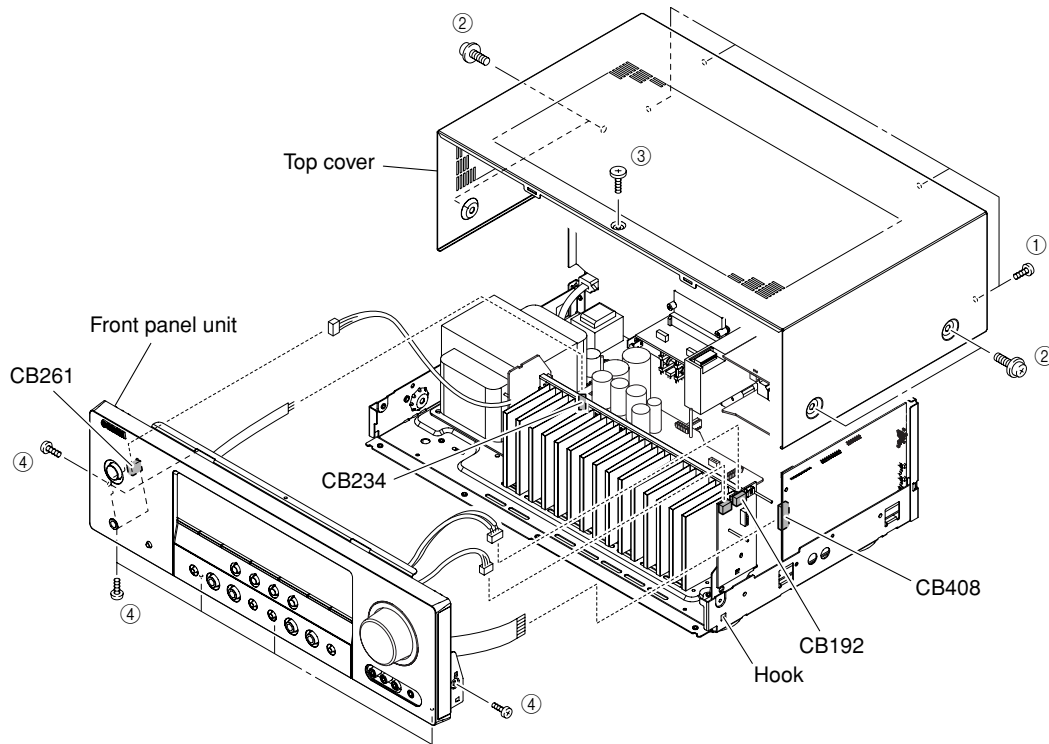

Fig. 1

**3. Removal of HDMI P.C.B.**

- a. Remove CB904 and CB905. (Fig. 2)
- b. Remove 5 screws (⑤). (Fig. 3)
- c. Remove HDMI P.C.B.. (Fig. 2)

**4. Removal of OPERATION (4) P.C.B.**

- a. Remove CB193 and CB182. (Fig. 2)
- b. Remove 7 screws (⑥). (Fig. 3)
- c. Remove OPERATION (4) P.C.B.. (Fig. 2)

**5. Removal of DSP P.C.B.**

- a. Remove 18 screws (⑦), 3 screws (⑧) and 2 screws (⑨) (R, L models). (Fig. 3)
- b. Remove cord stopper. (Fig. 2)
- c. Remove rear panel. (Fig. 2)
- d. Remove screw (⑩). (Fig. 2)
- e. Remove CB512 and CB516. (Fig. 2)
- f. Remove the DSP P.C.B. which is connected directly to the MAIN (1) P.C.B. with board-to-board connectors. (Fig. 2)

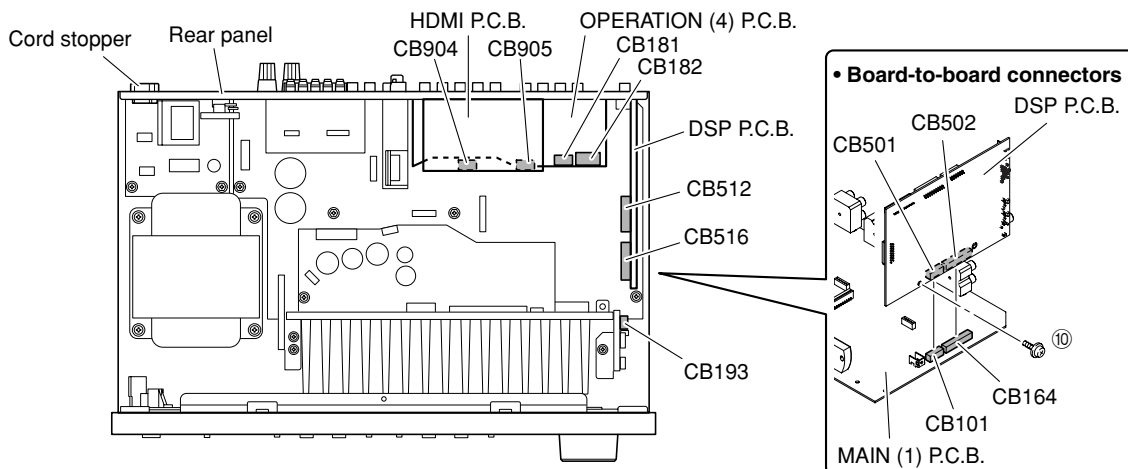

Fig. 2

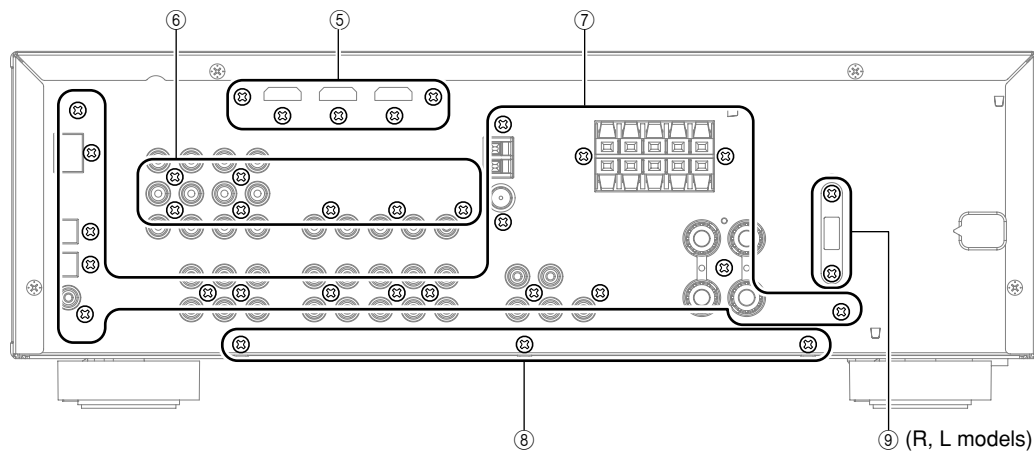

Fig. 3

**When checking the P.C.B.**

- a. Remove the Top cover. (Fig. 1)
  - b. Remove 3 screws (⑧). (Fig. 3)
  - c. Remove 5 screws (⑪) and 4 screws (⑫). (Fig. 4)
  - d. Place the P.C.B.s (with rear panel) upright. (Fig. 5)
  - e. Connect the ground of heat sink, rear panel and MAIN (1) P.C.B. (G103, G104, G105 and ST101) to the chassis with a ground lead or the like. (Fig. 5)
- Use the extension cable for connection for the following connectors. (Fig. 6)  
 DSP P.C.B. CB408 – OPERATION (1) P.C.B. CB202: MF117350 (17P, 300mm)

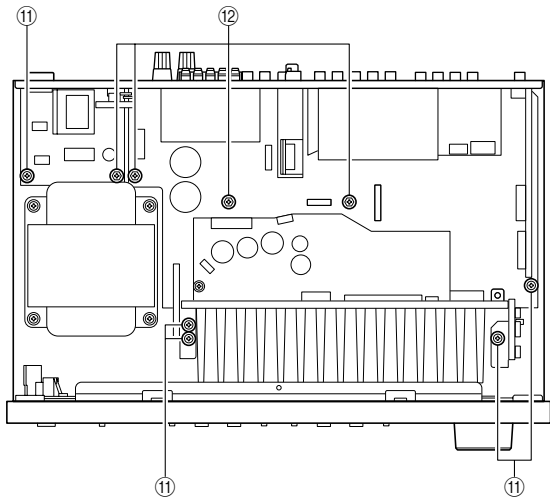

Fig. 4

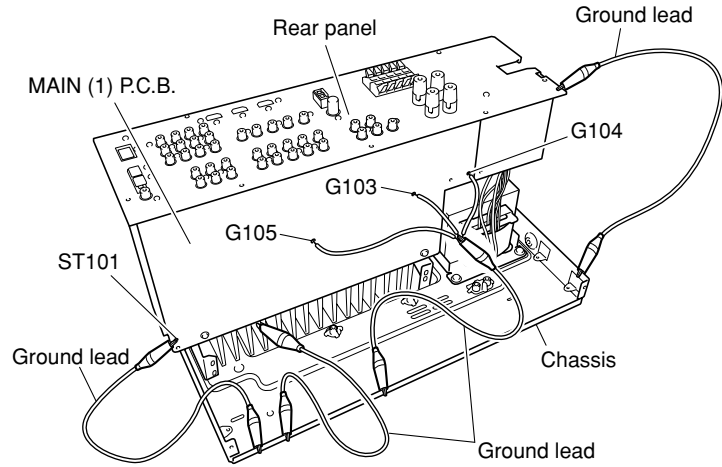

Fig. 5

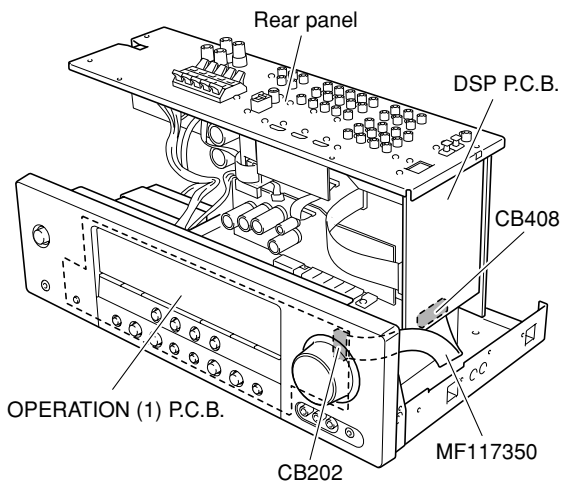

Fig. 6



## ■ UPDATING FIRMWARE

After replacing the following parts, be sure to write the latest firmware.

- DSP P.C.B.
- IC201 (DSP P.C.B.)

### ● Required Tools

- DVD or CD player (with DIGITAL OUTPUT (OPTICAL or COAXIAL) jack)
- Optical cable (when OPTICAL jack is used)
- Digital audio pin cable (when COAXIAL jack is used)
- Firmware CD
  - \* To make the firmware CD, download the latest firmware from the specified download source to PC.

### ● Operation Procedures

1. Connect this unit and DVD/CD player as shown below. (Fig. 1)

#### Example of connection between digital OPTICAL jacks

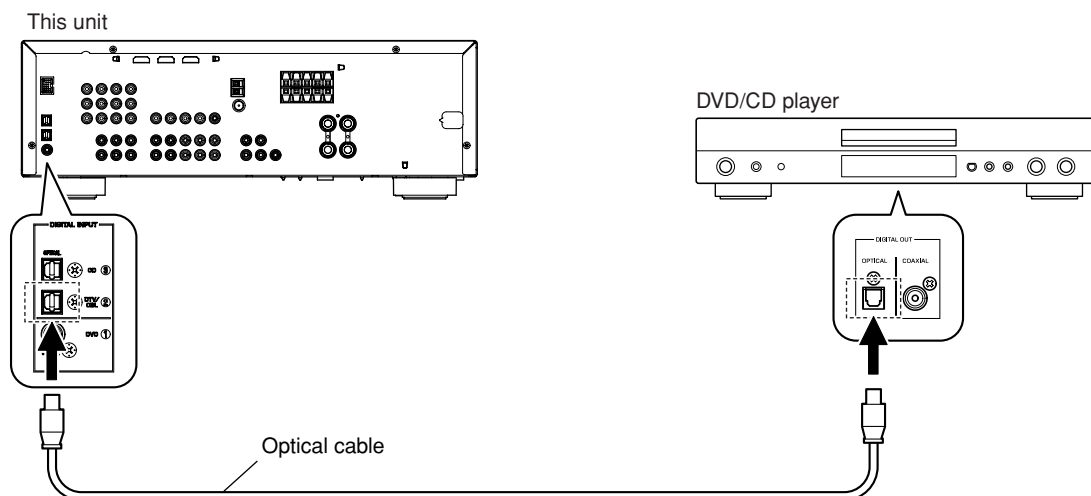

#### Example of connection between digital COAXIAL jacks

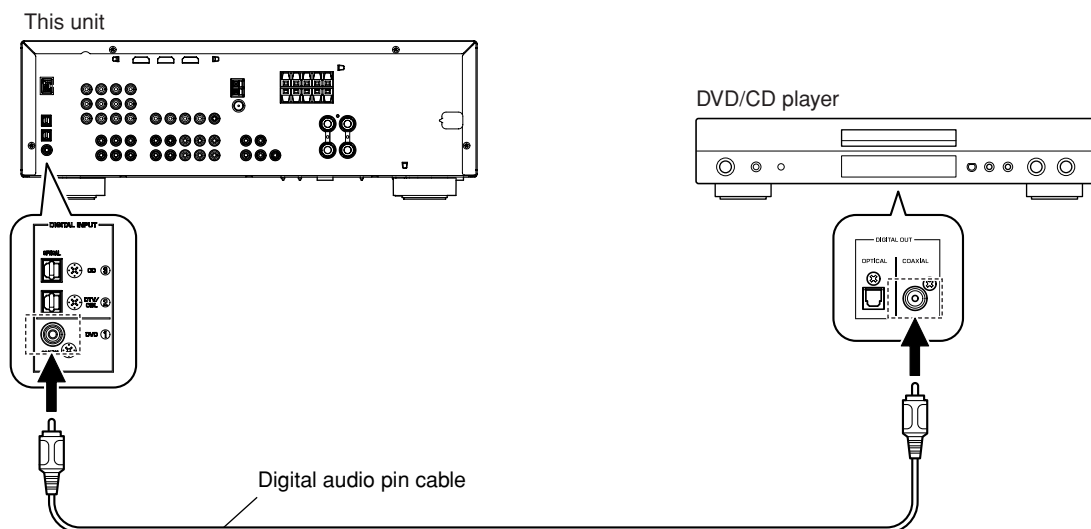

Fig. 1

2. While simultaneously pressing the "STANDBY/ON" and "SPEAKERS A/B/OFF" keys of this unit, connect the power cable of this unit to the AC outlet. (Fig. 2)  
The FIRMWARE UPDATE mode is activated and "SPDIF Upgrade" is displayed. (Fig. 2)

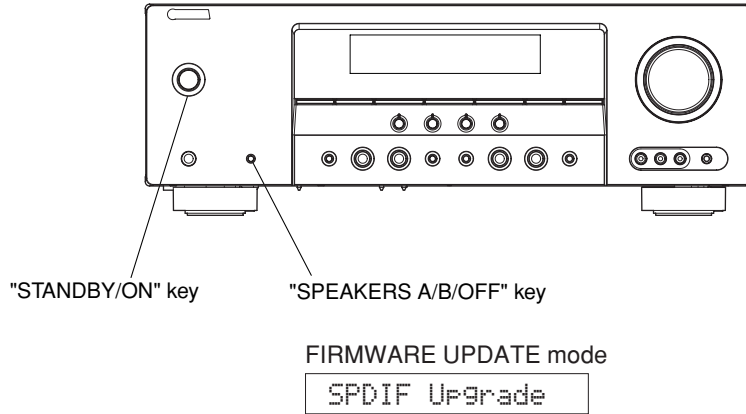

Fig. 2

3. Connect the power cable of DVD/CD player to the AC outlet.
4. Press the "STANDBY/ON" key of the DVD/CD player.
5. Press the "EJECT" key of the DVD/CD player to open the disc tray.
6. Place the firmware CD in the disc tray and close the disc tray.
7. Press the "PLAY" key of the DVD/CD player.  
Then writing of the firmware is started. (Fig. 3)
8. When writing of the firmware is completed, "Upgrade OK", "Please..." and "Turn off!!" are displayed repeatedly. (Fig. 3)



Fig. 3

- \* When the version of the firmware to be written is the same as the one existing in this unit, "Same Version", "Please..." and "Turn off!!" are displayed repeatedly. (Upgrading is not necessary.)

If the display remains unchanged for more than 10 seconds after starting the firmware CD play procedure, perform the firmware CD play procedure again from the beginning.

If "FILE CORRUPTED" is displayed after "Address:XXXXXX", make sure that the firmware CD is not corrupted and perform steps 1 to 8 of "Operation Procedures" again.

If "Upgrade Failed" is displayed, perform Steps 1 to 8 of "Operation Procedures" again.

9. Press the "STOP" key of the DVD/CD player.
10. Press the "EJECT" key of the DVD/CD player to open the disc tray.
11. Remove the firmware CD from the disc tray and close the disc tray.
12. Turn off the power of the DVD/CD player and disconnect the power cable from the AC outlet.
13. Turn off the power by pressing the "STANDBY/ON" key of this unit.

### ● Confirmation of firmware version and checksum

To confirm that the firmware is updated successfully, check the firmware version and checksum value by using the self-diagnostic function menu "14. ROM VER/SUM".

For more information, refer to "SELF DIAGNOSTIC FUNCTION".

- \* When the displayed firmware version and checksum are different from written firmware version and checksum, follow the steps from 1 to 13 of "Operation Procedures" again.

### ● Initializing of this unit

- \* After updating the firmware, be sure to initialize this unit.

1. Connect the power cable of this unit to the AC outlet.
2. Press the "STANDBY/ON" key while simultaneously pressing the "STRAIGHT" and "AUDIO SELECT" keys. (Fig. 5)  
The self-diagnostic function is activated.
3. Select the main menu "13. FACTORY PRESET".
4. Select the "PRESET RSRV".

PRESET INHIBIT (Initialization inhibited)

13.PRESET INHI



PRESET RESERVED (Initialization reserved)

13.PRESET RSRV

5. Turn off the power of this unit and disconnect the power cable from the AC outlet.

## ■ SELF DIAGNOSTIC FUNCTION

This unit has self diagnosis functions that are intended for inspection, measurement and location of faulty point.

There are 14 main menu items, each of which has sub-menu items.

Listed in the table below are menu items and sub-menu items.

Note that not all menu items listed will apply to the models covered in this service manual.

No.	Main menu	Sub-menu
1	BYPASS	ANALOG BYPASS
		DSP BYPASS
2	AUDIO CHECK	AUDIO CHECK
		MUTE ALL
		MUTE SYSTEM IC
		MUTE TRUNSIATOR
3	SPEAKERS SET	FRNT : SML 0dB
		CENTER : NONE
		LFE/B : FRNT
		TONE : MAX
		TONE : MIN
4	6CH-INPUT	6ch INPUT 6-ohm
		6ch INPUT 8-ohm
		LIM : , PLDET : , THM :
5	MIC CHECK	MIC CHECK
6	FL CHECK	VFD CHECK
		VFD DISP OFF
		VFD DISP ALL
		VFD DIMMER
		CHECK PATTERN
7	TEST TONE	TEST ALL
		TEST FRNT L
		TEST CENTER
		TEST FRNT R
		TEST SURR R
		TEST SURR L
		TEST LFE
8	PROTECTION	PRD L : xxx
		PRD H : xxx
		PRV L : xxx
		PRV H : xxx
		THM : xxx
		PLDET8_L : xxx
		PLDET8_H : xxx
		PLDET6_L : xxx
		PLDET6_H : xxx
		PRI : xxx
		PDET : xxx
		9
TH : xxx PL : xxx		
PI : xxx DE : xxx		
K0 : xxx K1 : xxx		

No.	Main menu	Sub-menu
10	PROTECTION HISTORY	History 1 History 2 History 3 History 4
11	iPod	DOCK : xxx DOCK ignore
12	SOFT SW	SW MODE MODEL DESTINATION TUNER DESTINATION VIDEO FORMAT AAC YPAO RDS DOCK (iPod)
13	FACTORY PRESET	PRESET INHI PRESET RSRV
14	ROM VER/SUM	TOTAL VERSION CRC14 ALL program CRC16 apprication & standby (Main program CRC16) CRC16 SPI F/W update code CRC16 S/PDIF/ F/W update code FLASH ROM Read/Write check SDRAM Read/Write check EEPROM Read/Write check

• **Starting Self-diagnostic Function**

Press the “STANDBY/ON” key while simultaneously pressing those two keys of this unit as indicated in the figure below.

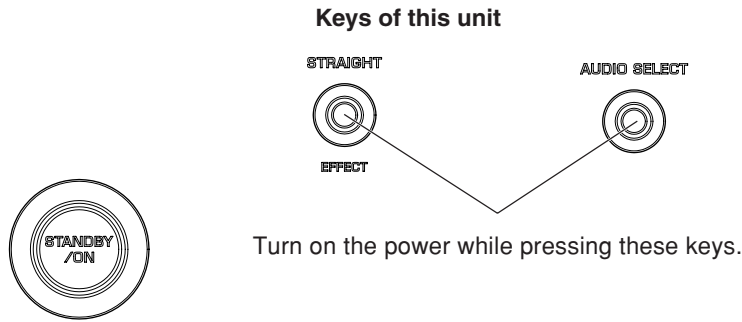

• **Starting Self-diagnostic Function in the protection cancel mode**

If the protection function works and causes hindrance to trouble diagnosis, cancel the protection function as described below, and it will be possible to enter the self-diagnostic function mode. (The protection functions other than the excess current detect function will be disabled.)

Press the “STANDBY/ON” key while simultaneously pressing those two keys indicated in the figure above. At this time, keep pressing those two keys for 3 seconds or longer.

In this mode, the [SLEEP] segment of the FL display of this unit flashes to indicate that the mode is self-diagnostic function mode with the protection functions disabled.

**CAUTION!**  
**Using this product with the protection function disabled may cause damage to this unit. Use special care for this point when using this mode.**

• **Canceling Self-diagnostic Function**

1. Before canceling self-diagnostic function, execute setting for FACTORY PRESET of main menu No.13 (Memory initialization inhibited or Memory initialized).
  - \* In order to keep the user memory stored, be sure to select PRESET INHIBITED (Memory initialization inhibited).
2. Turn off the power by pressing the “STANDBY/ON” key of this unit.

• **Display provided when Self-diagnostic Function started**

On the FL display of this unit, an opening message (including the protection history) appears for a few seconds followed by the self-diagnostic function menu display (1. ANALOG BYPASS).

### When there is no history of protection function:

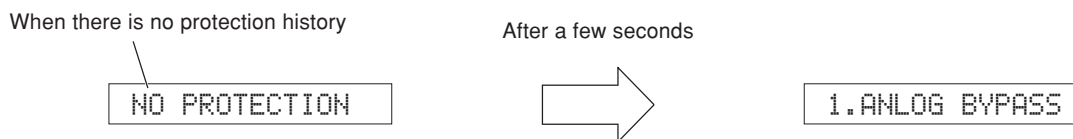

### When there is a history of protection function due to excess current

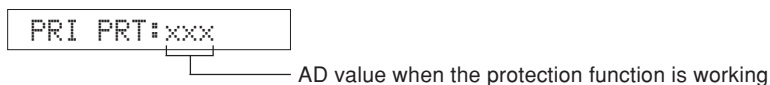

**Cause:** An excessive current flowed through the power amplifier.

**Supplementary information:**

As current of the power amplifier is detected, the abnormal channel can be identified by checking the current detect transistor.

Turning on the power without correcting the abnormality will cause the protection function to work immediately and the power supply will instantly be shut off.

**Note)**

- Applying the power to this unit without correcting the abnormality can be dangerous and cause additional circuit damage. To avoid this, if "PRI" and "PRD" protection function has been activated 3 times continuously, the power will not turn on even when the "STANDBY/ON" key is pressed. In order to turn on the power again, disconnect the power cable of this unit from the AC outlet once and then reconnect it again.
- The output transistors in each amplifier channel should be checked for damage before applying power to this unit.
- Amplifier current should be monitored by measuring DC voltage across the emitter resistors for each channel.

### When there is a history of protection function due to abnormal DC output

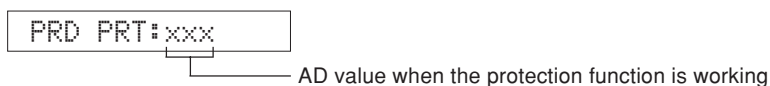

**Cause:** DC output of the power amplifier is abnormal.

**Supplementary information:**

The protection function worked due to a DC voltage appearing at the speaker terminal.

A cause could be a defect in the amplifier.

If the power is turned on with the abnormality unsolved, the protection function works in about 3 seconds to turn off the power.

### When there is a history of protection function due to abnormal voltage in the power supply section

PRV PRT:xxx

AD value when the protection function is working

**Cause:** The voltage in the power supply section is abnormal.

**Supplementary information:**

The protection function worked due to a defect or overload in the power supply.

If the power is turned on with the abnormality unsolved, the protection function works in about 1 second to turn off the power.

### When there is a history of protection function due to excessive heat sink temperature

THM PRT:xxx

AD value when the protection function is working

**Cause:** The temperature of the heat sink is excessive.

**Supplementary information:**

The protection function worked due to the temperature limit being exceeded.

Causes could be poor ventilation or a defect related to the thermal sensor.

If the power is turned on with the abnormality unsolved, the protection function works in about 1 second to turn off the power. For detection of each protection function, refer to main menu described later.

#### History of protection function

When the protection function has worked, its history is stored in memory with a backup.

Even if no abnormality is noted while servicing the unit, an abnormality which has occurred previously can be defined as long as the backup data has been stored.

The history of the protection function is cleared when self-diagnostic function is cancelled by selecting PRESET RESERVED (Memory initialized) of main menu No. 13 or when the backup data is erased.



- **Operation procedure of Main menu and Sub-menu**

There are 14 menu items, each of having sub-menu items.

**Main menu selection:**

Select the menu using “>” (forward) and “<” (reverse) keys of PROGRAM.

**Sub-menu selection:**

Select the sub-menu using “SCENE 2” (forward) and “SCENE 1” (Reverse) keys.

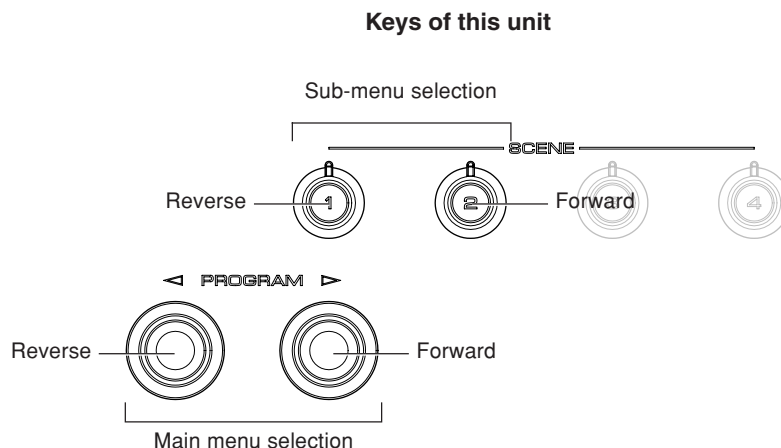

- **Functions in Self-Diagnostic Function mode**

In addition to the self-diagnostic function menu items, functions as listed below are available.

- Power on/off
- Master volume
- Muting
- Speakers A/B/OFF
- Input selection
- Audio select
- Tone control

\* Functions related to the tuner and the set menu are not available.

- **Initial settings used to start Self-Diagnostic Function**

The following initial settings are used when starting self-diagnostic function.

When self-diagnostic function is canceled, these settings are restored to those before starting self-diagnostic function.

- Master volume: -20 dB
- Input: DVD (MULTI CHANNEL INPUT OFF)
- Effect level: 0 dB
- Main menu: 1. ANALOG BYPASS

## • Details of Self-Diagnostic Function menu

### 1. BYPASS

Using the sub-menu, it is possible to select ANALOG BYPASS output or DSP BYPASS output.

#### ANALOG BYPASS

The analog input sound signal is output to FRONT L/R with EFFECT OFF.

1. ANALOG BYPASS

INPUT: DVD ANALOG

SPEAKER OUT: 1 kHz, SUBWOOFER OUTPUT: 50 Hz

Input level	Volume	SPEAKER OUT			SUBWOOFER OUTPUT
		FRONT	CENTER	SURROUND	
Both ch, -20 dBm	+6.0 dB	+11.5 dBm	-∞	-∞	-∞

#### DSP BYPASS

The digital input sound signal is output to FRONT L/R with EFFECT OFF.

1. DSP BYPASS

INPUT: DVD ANALOG

SPEAKER OUT: 1 kHz, SUBWOOFER OUTPUT: 50 Hz

Input level	Volume	SPEAKER OUT			SUBWOOFER OUTPUT
		FRONT	CENTER	SURROUND	
Both ch, -20 dBm	+6.0 dB	+11.5 dBm	-∞	-∞	-∞

### 2. AUDIO CHECK

The input sound signal is output.

\* When the inputted sound signal is 2 ch L/R, it is distributed as follows when output.

**L ch:** FRONT L, CENTER, SURROUND L,  
LFE ( L ch +10 dB)

**R ch:** SURROUND R

2. AUDIO CHECK

INPUT: DVD ANALOG

SPEAKER OUT: 1 kHz, SUBWOOFER OUTPUT: 50 Hz

Input level	Volume	SPEAKER OUT			SUBWOOFER OUTPUT
		FRONT	CENTER	SURROUND	
Both ch, -20 dBm	+6.0 dB	+11.5 dBm	+11.5 dBm	+11.5 dBm	0 dBm

#### MUTE ALL

2. MUTE ALL

#### MUTE SYSTEM IC

2. MUTE SYS IC

#### MUTE TRANSISTOR

2. MUTE TR

### 3. SPEAKER SET

The analog switch settings for each sub-menu are as shown in the table below.

FRONT : SML 0dB	SMALL	LARGE	LARGE	SWFR
CENTER : NONE	LARGE	NONE	LARGE	SWFR
LFE/B : FRNT	LARGE	SMALL	SMALL	FRONT
TONE : MAX	LARGE	LARGE	LARGE	SWFR
TONE : MIN	LARGE	LARGE	LARGE	SWFR

**LARGE:** This mode is used for a speaker with high bass reproduction performance (a large unit). Full bandwidth signals are output.

**SMALL:** This mode is used for a speaker with low bass reproduction performance (a small unit). The signals of 90 Hz or less are mixed into the channel specified by LFE/BASS.

**NONE:** This mode is used for no center speaker. The center content is reduced by 3 dB and distributed to FRONT L/R.

**SWFR:** LFE of 5.1 ch signal or LFE/BASS lower than 90 Hz is output through SUBWOOFER OUT.

**FRONT:** LFE of 5.1 ch signal or LFE/BASS lower than 90 Hz is distributed to FRONT L/R.

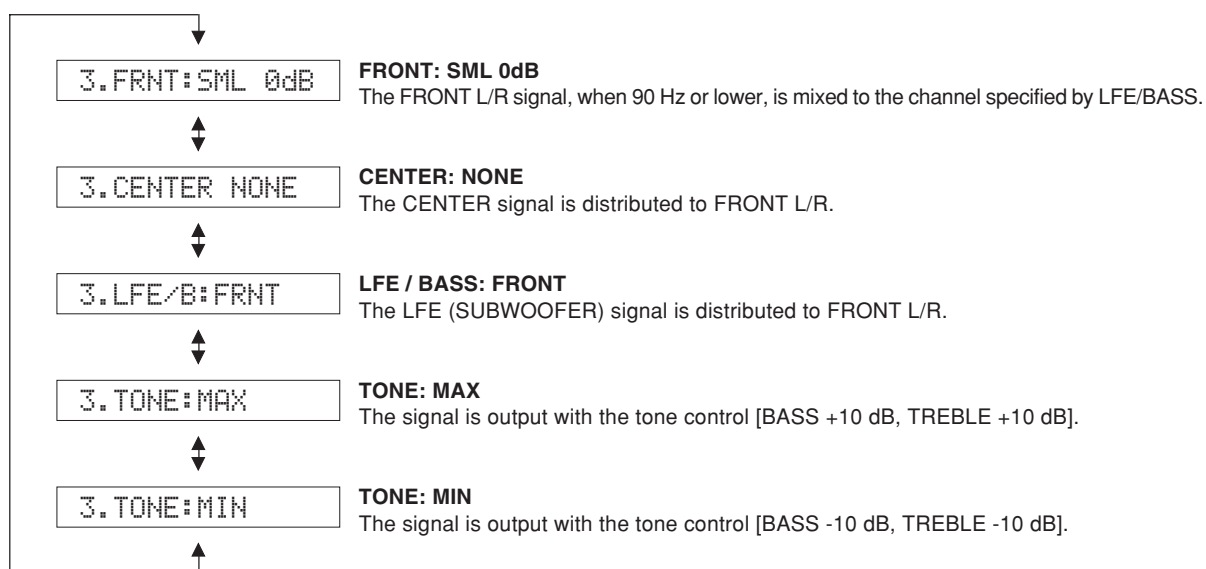

INPUT: DVD ANALOG

SPEAKER OUT: 1 kHz, SUBWOOFER OUTPUT: 50 Hz

Sub-menu	Input level	Volume	SPEAKER OUT			SUBWOOFER OUTPUT
			FRONT	CENTER	SURROUND	
FRONT : SML 0dB	Both ch, -20 dBm	+6.0 dB	+11.5 dBm	-∞	-∞	-3.5 dBm
CENTER : NONE	Both ch, -20 dBm	+6.0 dB	+11.5 dBm	-∞	-∞	-∞
LFE/B : FRNT	Both ch, -20 dBm	+6.0 dB	+11.5 dBm	-∞	-∞	-∞
TONE : MAX	Both ch, -20 dBm	+6.0 dB	+14.5 dBm	-∞	-∞	-∞
TONE : MIN	Both ch, -20 dBm	+6.0 dB	+8.5 dBm	-∞	-∞	-∞

**4. 6CH INPUT**

The input source [MULTI CHANNEL INPUT] is selected.  
It is possible to select the 6-ohm/8-ohm by using the sub-menu.

**6 ch INPUT 6-ohm**

4.6ch INPUT 6Ω

INPUT: MULTI CH INPUT  
SPEAKER OUT: 1 kHz, SUBWOOFER OUTPUT: 50 Hz

Sub-menu	Input level	Volume	SPEAKER OUT			SUBWOOFER OUTPUT
			FRONT	CENTER	SURROUND	
6 ch INPUT 6-ohm	Both ch, -20 dBm	+6.0 dB	+11.5 dBm	+11.5 dBm	+11.5 dBm	-3.5 dBm

**6 ch INPUT 8-ohm**

4.6ch INPUT 8Ω

INPUT: MULTI CH INPUT  
SPEAKER OUT: 1 kHz, SUBWOOFER OUTPUT: 50 Hz

Sub-menu	Input level	Volume	SPEAKER OUT			SUBWOOFER OUTPUT
			FRONT	CENTER	SURROUND	
6 ch INPUT 8-ohm	Both ch, -20 dBm	+6.0 dB	+11.5 dBm	+11.5 dBm	+11.5 dBm	-3.5 dBm

**LIM/PLDET/THM**

**LIM:** Setting value of LIM (Limiter control)

\* Do not change the setting value because this item is only for the use of development staff.

**PLDET:** Power limiter detection  
The A/D conversion value during operation is displayed.

**THM:** Thermo protection detection  
The A/D conversion value during operation is displayed.  
(Reference voltage: 3.3 V=255)

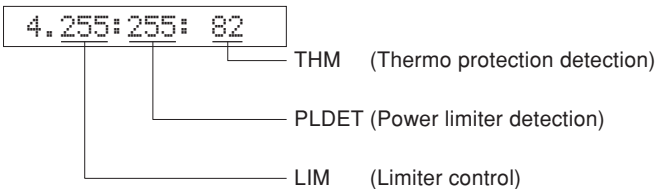

**5. MIC CHECK**

The signals input through the microphone are output of FRONT L/R via A/D and D/A.

5.MIC CHECK

## 6. FL CHECK

Use this program to check the FL display section.  
For audio signal processing, use STRAIGHT.

### Checking FL display section

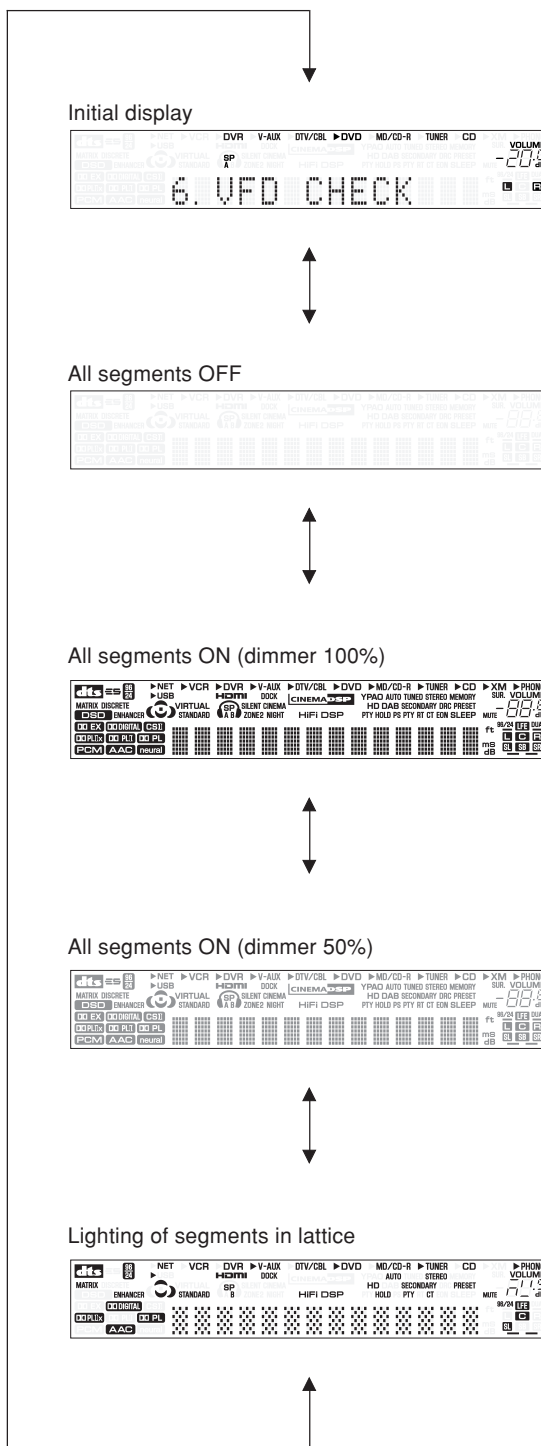

RX-V369/HTR-6130

## 7. TEST TONE

The outputs the noise through the channels specified by the submenu.

The noise frequency for LFE (SUBWOOFER) is 35 to 80 Hz.

Other than that, the noise frequency is 500 to 2 kHz.

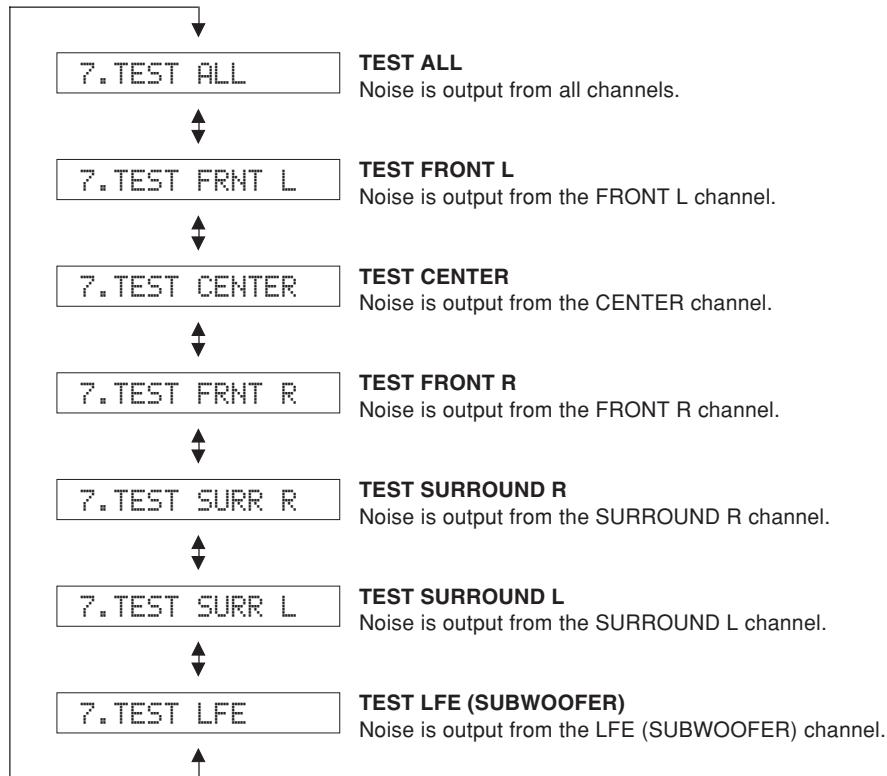

## 8. PROTECTION

The A/D setting value of each protection is displayed.

(Reference voltage: 3.3 V=255)

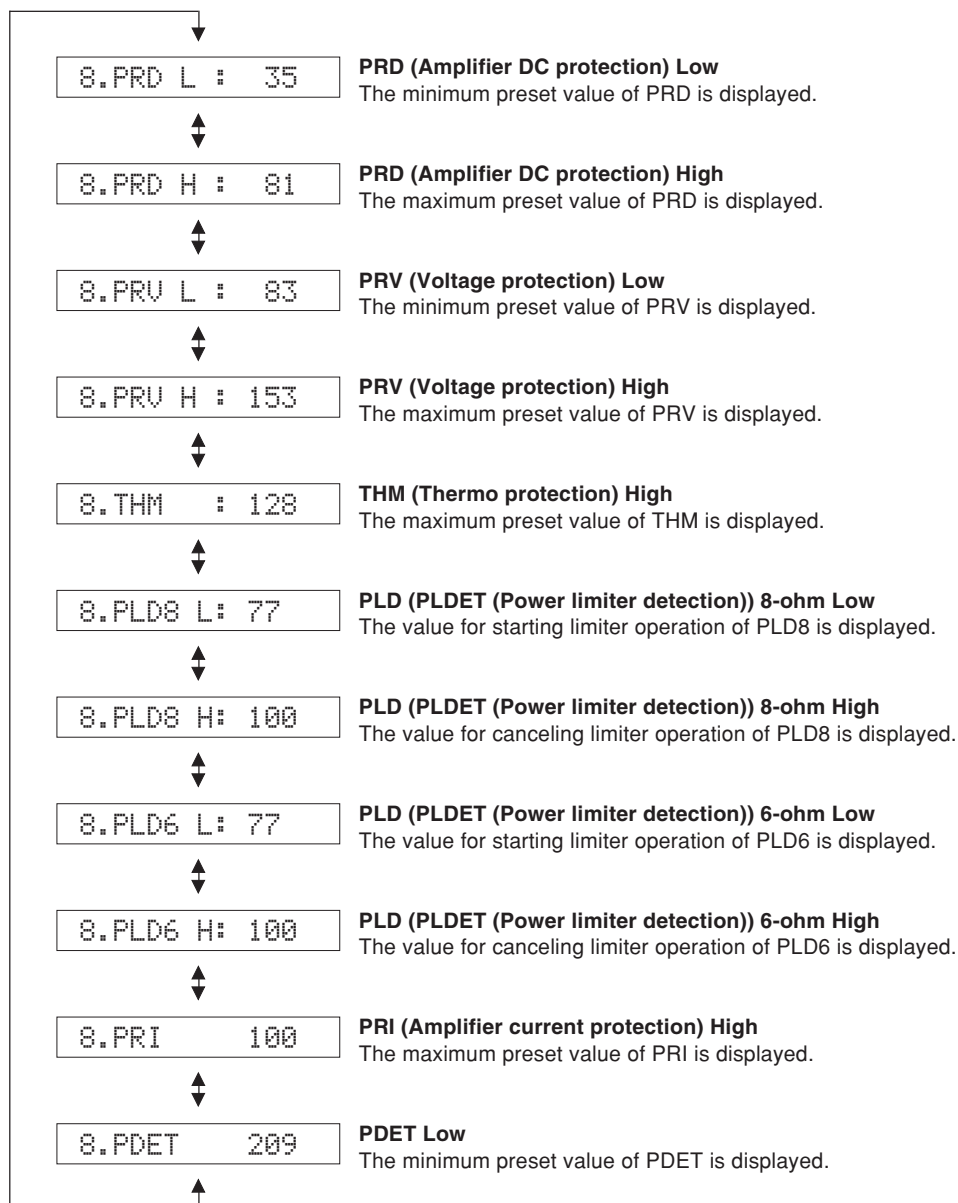

**9. A/D DATA CHECK**

This menu is used to display the A/D conversion value of the microprocessor which detects panel keys of this unit and protection functions in using the sub-menu.

When K0/K1 menu is selected, keys become non-operable due to detection of the values of all keys. However, it is possible to advance to the next sub-menu by turning the VOLUME of this unit. When using this function, note that turning the VOLUME more than 1 click would cause the volume value to change.

Signal processing is maintained in the status before execution.

\* The figures in the diagram are given as reference only.

**PD/PV**

**PD:** PRD (Power amplifier DC protection detection)  
 The output of power amplifier DC (DC voltage) is detected.  
 Normal value: 35 to 81 (Reference voltage: 3.3 V=255)

**PV:** PRV (Voltage protection detection)  
 Voltage detects: ACL, AC2, 10V, S9, +12,  
 -12, +5V and VP  
 Normal value: 84 to 153 (Reference voltage: 3.3 V=255)

\* If PRD and PRV are out of the normal value range, the protection function works to turn off the power.

PD: 57 PV:128

**TH/PL**

**TH:** THM (Thermo protection detection)  
 The temperature of the heat sink is detected.  
 Normal value: 0 to 124 (Reference voltage: 3.3 V=255)

\* If THM is out of the normal value range, the protection function works to turn off the power.

**PL:** PLDET (Power limiter detection)  
 The output voltage of power amplifier is detected.

TH: 77 PL:255

U, C models (Reference voltage: 3.3 V=255)

	During normal operation	Value for starting limiter operation	Value for canceling limiter operation
PLDET	255	77	100
LIM H: 255 / L: 102	H	L	H

(LIM: Limiter control)

R, T, K, A, B, G, E, F, L models (Reference voltage: 3.3 V=255)

	During normal operation	Value for starting limiter operation	Value for canceling limiter operation
PLDET	255	100	131
LIM H: 255 / L: 90	H	L	H

(LIM: Limiter control)

**PI/DE**

**PI:** PRI (Current protection detection)  
 The current of the power amplifier is detected.  
 Normal value: 0 to 100 (Reference voltage: 3.3 V=255)

**DE:** PDET (Sub-trans power detection)  
 Normal value: 209 to 255 (Reference voltage: 3.3 V=255)

\* If PRI and PDET are out of the normal value range, the protection function works to turn off the power.

PI: 12 DE:255



**K0/K1****K0/K1:** KEY0/KEY1 (Panel key of this unit)

The key will fail to function properly if its A/D conversion value deviates more than  $\pm 4$  from reference value. In that case, check the constant of partial pressure resistor, solder condition, etc. with referring to the table below. (Reference voltage: 3.3 V=255)

K0:255 K1:255

Display	KEY0	KEY1
23 $\pm$ 4	SCENE 1	SCENE 3
42 $\pm$ 4	SCENE 2	SCENE 4
66 $\pm$ 4	PROGRAM <	DIRECT
92 $\pm$ 4	PROGRAM >	AUDIO SELECT
120 $\pm$ 4	STRAIGHT	INPUT <
147 $\pm$ 4	TONE CONTROL	INPUT >
165 $\pm$ 4	SEARCH MODE	PRESET/TUNING <
182 $\pm$ 4	FM/AM	PRESET/TUNING >
198 $\pm$ 4	A/B/C/D/E	MEMORY
217 $\pm$ 4	SPEAKERS	TUNING
255	(KEY OFF)	(KEY OFF)

**10. PROTECTION HISTORY**

Four protection histories are displayed.

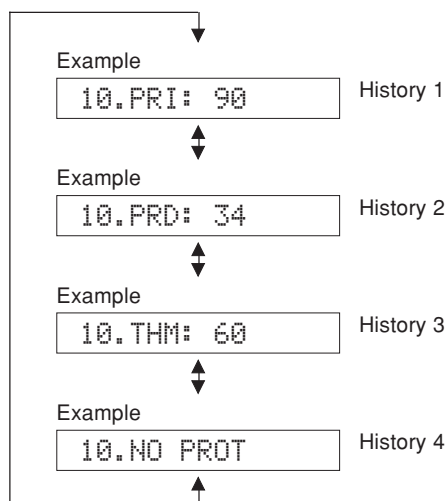

### 11. iPod (U, C models)

This menu is used to test the DOCK connector without the iPod itself. After turning off the power to this unit short between pins No. 14 (TX) and No. 18 (RX), between pins No. 1 (PWR) and No. 17 (ACCPOW) and between pins No. 4 (iPDET) and No. 8 (DGND) of the DOCK connector. (Make sure that the power is turned off when shorting pins.) Start the self-diagnostic function and select this menu.

The check result is displayed according to the following display specifications.

**Note) Be sure to return the shorted pins to their original condition after executing this test.**

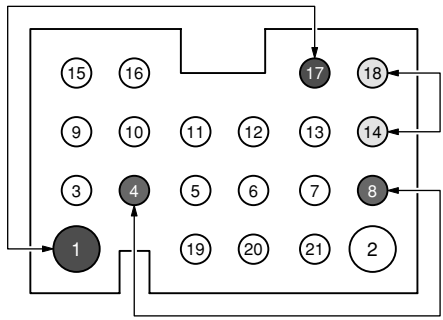

**DOCK CONNECTOR**

11.DOCK=NG NNN  
 All Y = "OK"  
 Others = "NG"

Check item	Result	Display
UART loop back test	OK	Y
	NG	N
iPAP (iPod accessory power) detection	IC402 pin No. 1 High	Y
	Low	N
iPDET (iPod installation to DOCK) detection	IC402 pin No. 12 Low (iPod universal dock)	Y
	High (Bluetooth adapter)	N

#### DOCK ignore

When DOCK and iPod are connected, the input source [DOCK (iPod)] is made ineffective and [V-AUX] is selected.

11.DOCK IGNORE

## 12. SOFT SW

**Note) Do not change the function settings because this menu is only for the use of development staff.**

This menu is used to change the function of this unit by switching the function settings on P.C.B. through the software.

\* Mentioning the details is not allowed because this menu is only for the use of development staff.

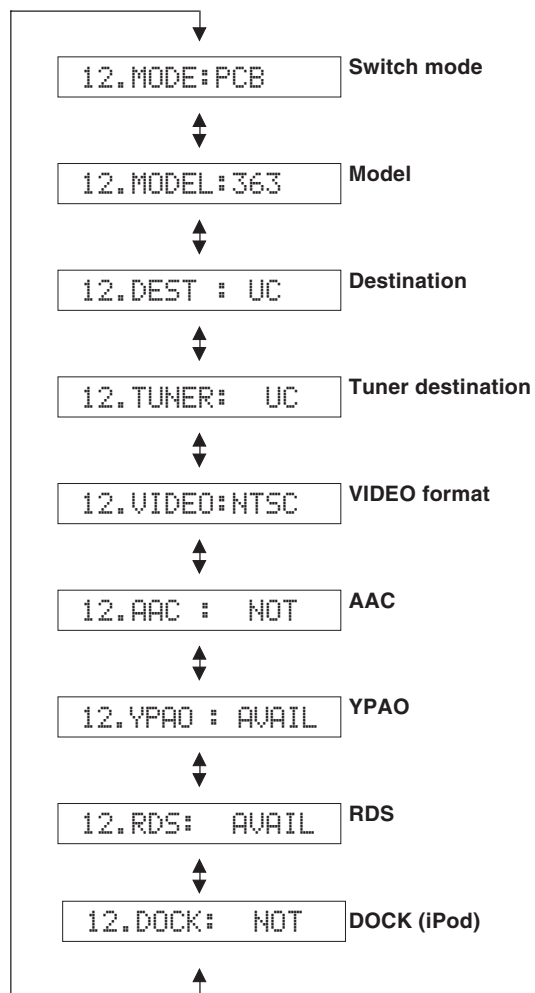

### 13. FACTORY PRESET

This menu is used to reserve and inhibit initialization of the back-up RAM.

The signals are processed using EFFECT OFF (The L/R signal is output using ANALOG BYPASS).

13.PRESET INHI

**PRESET INHIBIT (Initialization inhibited)**

Back-up RAM initialization is not executed. Select this sub-menu to protect the values set by the user.



13.PRESET RSRV

**PRESET RESERVED (Initialization reserved)**

Initialization of the back-up RAM is reserved. (Actually, initialization is executed the next time that the power is turned on.)

Select this sub-menu to reset to the original factory settings or to reset the RAM. Any protection history will be cleared.

**CAUTION:** Before setting to the PRESET RESERVED, write down the existing preset memory content of the tuner in a table as shown below.

(This is because setting to the PRESET RESERVED will cause the user memory content of the tuner to be erased.)

Preset Group	P1	P2	P3	P4	P5	P6	P7	P8
A								
B								
C								
D								
E								



## ■ DISPLAY DATA

### ● V2001 : 17-BT-29GNK (OPERATION P.C.B.)

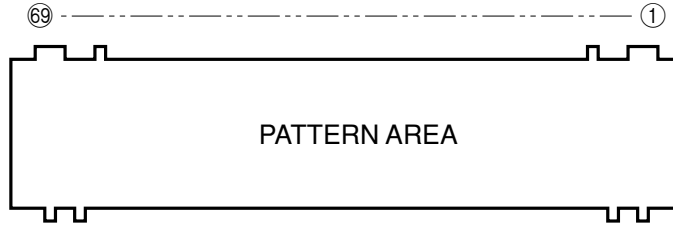

### ● PIN CONNECTION

Pin No.	69	68	67	66	65	64	63	62	61	60	59	58	57	56	55	54	53	52	51	50	49	48	47	46	45	44	43	42	41	40	39	38	37	36	35
Connection	F2	NX	NP	NP	P1	P2	P3	P4	P5	P6	P7	P8	P9	P10	P11	P12	P13	P14	P15	P16	P17	P18	P19	P20	P21	P22	P23	P24	P25	P26	P27	P28	P29	P30	P31

Pin No.	34	33	32	31	30	29	28	27	26	25	24	23	22	21	20	19	18	17	16	15	14	13	12	11	10	9	8	7	6	5	4	3	2	1
Connection	P32	P33	P34	P35	P36	P37	NX	NX	NX	NX	NX	NX	NX	17G	16G	15G	14G	13G	12G	11G	10G	9G	8G	7G	6G	5G	4G	3G	2G	1G	NP	NP	NX	F1

Note : 1) F1, F2 ..... Filament pin 2) NP ..... No pin 3) NX ..... No extend pin 4) 1G-17G ..... Grid pin

### ● GRID ASSIGNMENT

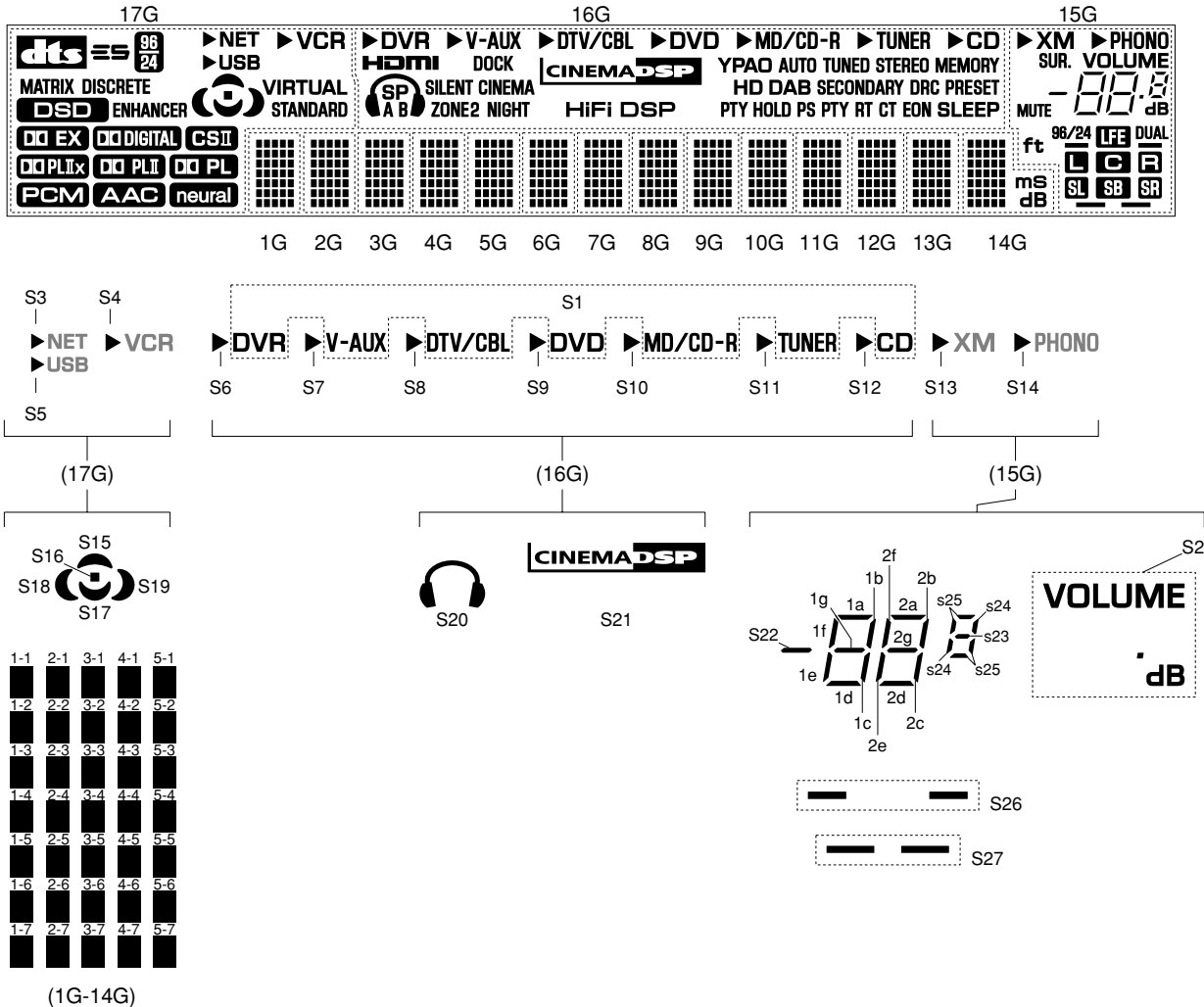

## ● ANODE CONNECTION

	17G	16G	15G	14G	13G-1G
1P	<b>dtc</b>	S1	S2	1-1	1-1
2P	<b>ES</b>	S6	S26	2-1	2-1
3P	MATRIX	S7	S27	3-1	3-1
4P	DISCRETE	S8	S22	4-1	4-1
5P	<b>96 24</b>	S9	1a	5-1	5-1
6P	<b>DSD</b>	S10	1b	1-2	1-2
7P	ENHANCER	S11	1c	2-2	2-2
8P	<b>EX</b>	S12	1d	3-2	3-2
9P	<b>DIGITAL</b>	<b>HDMI</b>	1e	4-2	4-2
10P	<b>CSII</b>	S20	1f	5-2	5-2
11P	<b>PLIX</b>	SP	1g	1-3	1-3
12P	<b>PLII</b>	A	2a	2-3	2-3
13P	<b>PL</b>	B	2b	3-3	3-3
14P	<b>PCM</b>	SILENT CINEMA	2c	4-3	4-3
15P	<b>AAC</b>	ZONE2	2d	5-3	5-3
16P	<b>neural</b>	NIGHT	2e	1-4	1-4
17P	<b>NET</b>	<b>DOCK</b>	2f	2-4	2-4
18P	<b>USB</b>	S21	2g	3-4	3-4
19P	<b>VCR</b>	HiFi DSP	S23	4-4	4-4
20P	S3	YPAO	S24	5-4	5-4
21P	S5	AUTO	S25	1-5	1-5
22P	S4	TUNED	<b>XM</b>	2-5	2-5
23P	S15	STEREO	<b>PHONO</b>	3-5	3-5
24P	S16	MEMORY	S13	4-5	4-5
25P	S17	HD	S14	5-5	5-5
26P	S18	<b>DAB</b>	<b>SUR.</b>	1-6	1-6
27P	S19	<b>SECONDARY</b>	MUTE	2-6	2-6
28P	<b>VIRTUAL</b>	<b>DRC</b>	DUAL	3-6	3-6
29P	STANDARD	<b>PRESET</b>	96/24	4-6	4-6
30P	–	PTY (HOLD)	ft	5-6	5-6
31P	–	HOLD	<b>LFE</b>	1-7	1-7
32P	–	PS	<b>L</b>	2-7	2-7
33P	–	PTY	<b>C</b>	3-7	3-7
34P	–	RT	<b>R</b>	4-7	4-7
35P	–	CT	<b>SL</b>	5-7	5-7
36P	–	EON	<b>SB</b>	ms	–
37P	–	SLEEP	<b>SR</b>	dB	–

# IC DATA

**IC101:** ADSP-BF531 CPU (DSP P.C.B.)  
Microprocessor and DSP

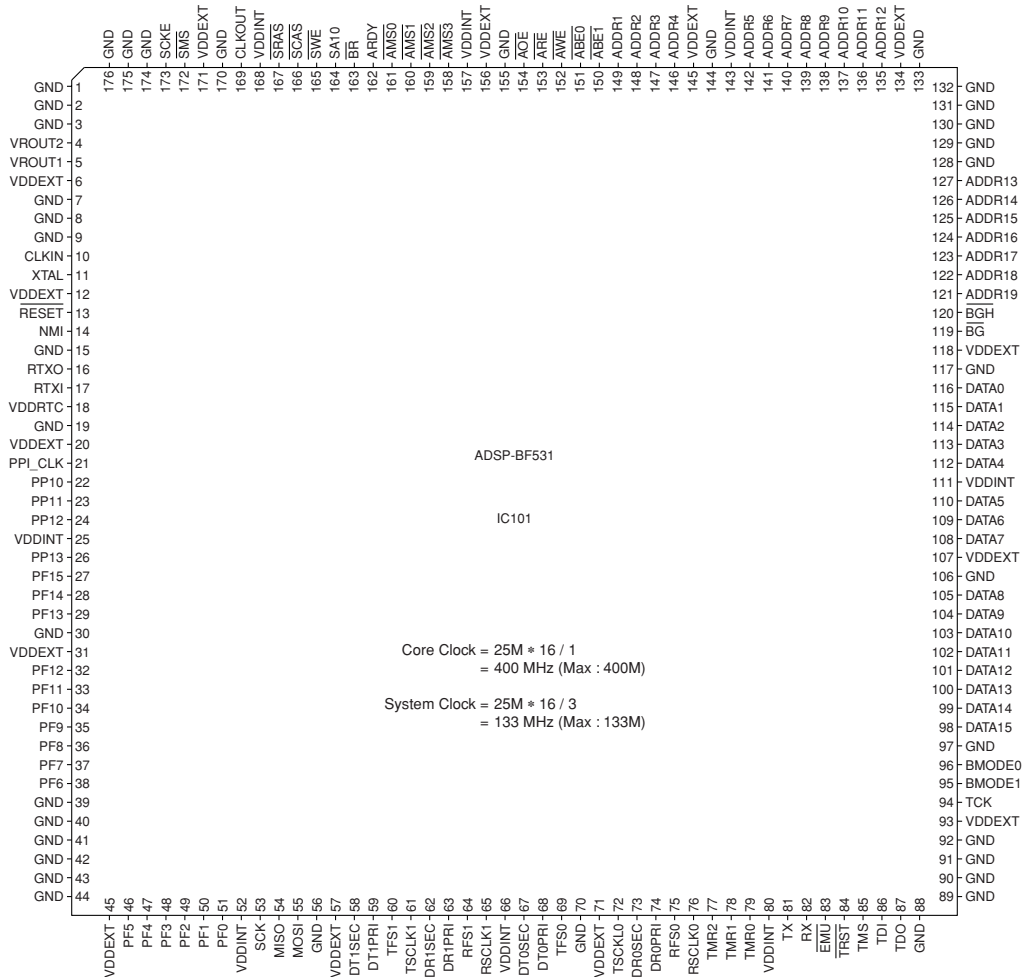
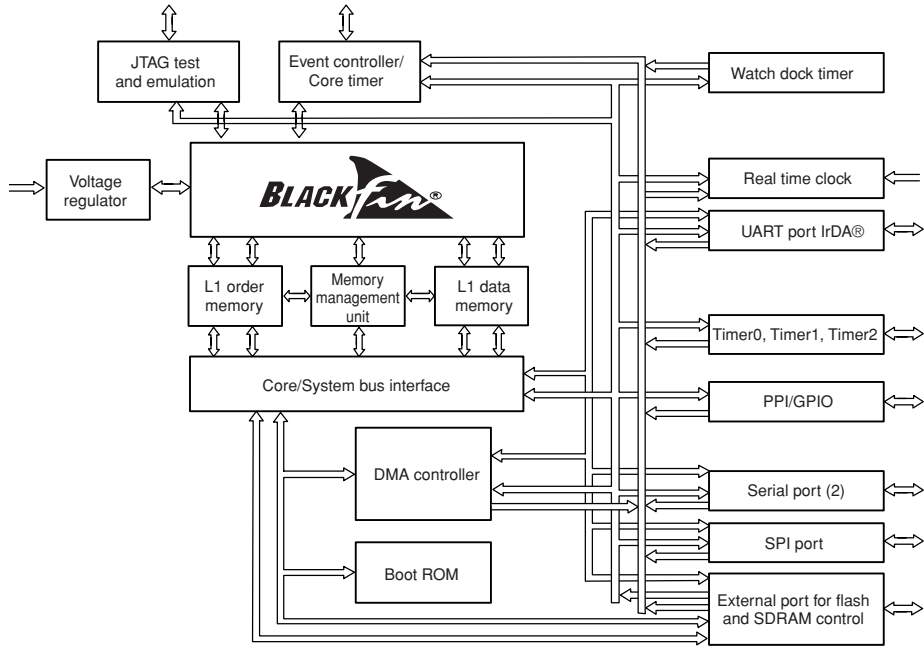

RX-V363/HTR-6130



Pin No.	Port Name	Function Name	I/O	Detail of Function
1	DGND	GND	–	Ground of external
2	DGND	GND	–	Ground of external
3	DGND	GND	–	Ground of external
4	/VINTSW	VROUT2	O	Voltage regulator drive for Q101
5	/VINTSW	VROUT1	O	Voltage regulator drive for Q101
6	VDDEXT	VDDEXT	–	I/O power supply (EX3.3)
7	DGND	GND	–	Ground of external
8	DGND	GND	–	Ground of external
9	DGND	GND	–	Ground of external
10	CLKIN	CLKIN	I	Clock/oscillation input
11	XTAL	XTAL	O	Oscillation output
12	VDDEXT	VDDEXT	–	I/O power supply (EX3.3)
13	/DRESET	/RESET	I	Delayed reset
14	NMI/DGND	NMI	I	(Pull-down)
15	DGND	GND	–	Ground of external
16	–	RTXO	O	
17	RTXI/DGND	RTXI	I	(Pull-down)
18	–	VDDRTC	–	
19	DGND	GND	–	Ground of external
20	VDDEXT	VDDEXT	–	I/O power supply (EX3.3)
21	–	PPI_CLK	I	
22	–	PP10	I/O	
23	–	PP11	I/O	
24	–	PP12	I/O	
25	VDDINT	VDDINT	–	Power supply of microprocessor (BF1.2)
26	–	PP13	I/O	
27	VIB	PF15	O	Video select B
28	VIA	PF14	O	Video select A
29	–	PF13	I	
30	DGND	GND	–	Ground of external
31	VDDEXT	VDDEXT	–	I/O power supply (EX3.3)
32	/ICXM	PF12	O	
33	/XMPWR	PF11	O	
34	INTAK	PF10	I	CODEC IC (IC301) interrupt
35	FSYNC/TFS0	PF9	I	Frame sync detect
36	R2A_DATA	PF8	O	DATA for R2A volume/select IC (IC162)
37	R2A_CLK	PF7	O	CLK for R2A volume/select IC (IC161)
38	VRB	PF6	I	Volume rotary B
39	DGND	GND	–	Ground of external
40	DGND	GND	–	Ground of external
41	DGND	GND	–	Ground of external
42	DGND	GND	–	Ground of external
43	DGND	GND	–	Ground of external
44	DGND	GND	–	Ground of external
45	VDDEXT	VDDEXT	–	I/O power supply (EX3.3)
46	VRA	PF5	I	Volume rotary A
47	REM	PF4	I	IR remote control pulse input
48	PSW	PF3	I	Power switch (STANDBY/ON)
49	/SPISEL2	PF2	O	CS for EEPROM (IC102)
50	/SPISEL1	PF1	O	CS for 4ch ADC (IC401)
51	/EXPE	PF0	O	Extended port enable
52	VDDINT	VDDINT	–	Power supply of microprocessor (BF1.2)
53	SPISCK	SCK	I/O	SPI clock
54	SPIMI	MISO	I/O	Master input/slave output
55	SPIMO	MOSI	I/O	Master output/slave input
56	DGND	GND	–	Ground of external
57	VDDEXT	VDDEXT	–	I/O power supply (EX3.3)
58	DT1SEC	DT1SEC	O	Serial port 1, secondary transmission data
59	DT1PRI	DT1PRI	O	Serial port 1, primary transmission data
60	TFS1	TFS1	I/O	Serial port 1, frame asynchronous transmission

Pin No.	Port Name	Function Name	I/O	Detail of Function
61	TSCLK1	TSCLK1	I/O	Serial port 1, serial transmission clock
62	DR1SEC	DR1SEC	I	Serial port 1, secondary reception data
63	DR1PRI	DR1PRI	I	Serial port 1, primary reception data
64	RFS1	RFS1	I/O	Serial port 1, frame synchronization reception
65	RSCLK1	RSCLK1	I/O	Serial port 1, serial reception clock
66	VDDINT	VDDINT	-	Power supply of microprocessor (BF1.2)
67	DT0SEC	DT0SEC	O	Serial port 0, secondary transmission data
68	DT0PRI	DT0PRI	O	Serial port 0, primary transmission data
69	TFS0	TFS0	I/O	Serial port 0, frame asynchronous transmission
70	DGND	GND	-	Ground of external
71	VDDEXT	VDDEXT	-	I/O power supply (EX3.3)
72	TSCLK0	TSCLK0	I/O	Serial port 0, serial transmission clock
73	DR0SEC	DR0SEC	I	Serial port 0, secondary reception data
74	DR0PRI	DR0PRI	I	Serial port 0, primary reception data
75	RFS0	RFS0	I/O	Serial port 0, frame synchronization reception
76	RSCLK0	RSCLK0	I/O	Serial port 0, serial reception clock
77	-	TMR2	I/O	
78	-	TMR1	I/O	
79	LIMITER	TMR0	O	Limiter control output
80	VDDINT	VDDINT	-	Power supply of microprocessor (BF1.2)
81	DTXM	TX	O	
82	DRXM	RX	I	
83	-	/EMU	O	
84	-	/TRST	I	
85	-	TMS	I	
86	-	TDI	I	
87	-	TDO	O	
88	DGND	GND	-	Ground of external
89	DGND	GND	-	Ground of external
90	DGND	GND	-	Ground of external
91	DGND	GND	-	Ground of external
92	DGND	GND	-	Ground of external
93	VDDEXT	VDDEXT	-	I/O power supply (EX3.3)
94	-	TCK	I	
95	BMODE1	BMODE1	I	(Pull-down)
96	BMODE0	BMODE0	I	(Pull-up)
97	DGND	GND	-	Ground of external
98	D16	DATA15	I/O	SDRAM data bus 16
99	D15	DATA14	I/O	SDRAM data bus 15
100	D14	DATA13	I/O	SDRAM data bus 14
101	D13	DATA12	I/O	SDRAM data bus 13
102	D12	DATA11	I/O	SDRAM data bus 12
103	D11	DATA10	I/O	SDRAM data bus 11
104	D09	DATA9	I/O	SDRAM data bus 09
105	D08	DATA8	I/O	SDRAM data bus 08
106	DGND	GND	-	Ground of external
107	VDDEXT	VDDEXT	-	I/O power supply (EX3.3)
108	D07	DATA7	I/O	SDRAM data bus 07
109	D06	DATA6	I/O	SDRAM data bus 06
110	D05	DATA5	I/O	SDRAM data bus 05
111	VDDINT	VDDINT	-	Power supply of microprocessor (BF1.2)
112	D04	DATA4	I/O	SDRAM data bus 04
113	D03	DATA3	I/O	SDRAM data bus 03
114	D02	DATA2	I/O	SDRAM data bus 02
115	D01	DATA1	I/O	SDRAM data bus 01
116	D00	DATA0	I/O	SDRAM data bus 00
117	DGND	GND	-	Ground of external
118	VDDEXT	VDDEXT	-	I/O power supply (EX3.3)
119	-	/BG	O	
120	-	/BGH	O	

Pin No.	Port Name	Function Name	I/O	Detail of Function
121	A19	ADDR19	O	SDRAM address bus 19
122	A18	ADDR18	O	SDRAM address bus 18
123	A17	ADDR17	O	SDRAM address bus 17
124	A16	ADDR16	O	SDRAM address bus 16
125	A15	ADDR15	O	SDRAM address bus 15
126	A14	ADDR14	O	SDRAM address bus 14
127	A13	ADDR13	O	SDRAM address bus 13
128	DGND	GND	-	Ground of external
129	DGND	GND	-	Ground of external
130	DGND	GND	-	Ground of external
131	DGND	GND	-	Ground of external
132	DGND	GND	-	Ground of external
133	DGND	GND	-	Ground of external
134	VDDEXT	VDDEXT	-	I/O power supply (EX3.3)
135	A12	ADDR12	O	SDRAM address bus 12
136	A11	ADDR11	O	SDRAM address bus 11
137	A10	ADDR10	O	SDRAM address bus 10
138	A09	ADDR9	O	SDRAM address bus 09
139	A08	ADDR8	O	SDRAM address bus 08
140	A07	ADDR7	O	SDRAM address bus 07
141	A06	ADDR6	O	SDRAM address bus 06
142	A05	ADDR5	O	SDRAM address bus 05
143	VDDINT	VDDINT	-	Power supply of microprocessor (BF1.2)
144	DGND	GND	-	Ground of external
145	VDDEXT	VDDEXT	-	I/O power supply (EX3.3)
146	A04	ADDR4	O	SDRAM address bus 04
147	A03	ADDR3	O	SDRAM address bus 03
148	A02	ADDR2	O	SDRAM address bus 02
149	A01	ADDR1	O	SDRAM address bus 01
150	SDQM1	/ABE1	O	SDRAM byte enable/data mask 1
151	SDQM0	/ABE0	O	SDRAM byte enable/data mask 0
152	/AWE	/AWE	O	Write enable (Asynchronous)
153	/ARE	/ARE	O	Read enable
154	/AOE	/AOE	O	Output enable
155	DGND	GND	-	Ground of external
156	VDDEXT	VDDEXT	-	I/O power supply (EX3.3)
157	VDDINT	VDDINT	-	Power supply of microprocessor (BF1.2)
158	/AMS3	/AMS3	O	Bank select 3
159	/AMS2	/AMS2	O	Bank select 2
160	/AMS1	/AMS1	O	Bank select 1
161	/AMS0	/AMS0	O	Bank select 0
162	ARDY	ARDY	I	Hardware ready control
163	/BR	/BR	I	(Pull-up)
164	SA10	SA10	O	A10 pin
165	/SWE	/SWE	O	Write enable (Synchronization)
166	/SCAS	/SCAS	O	Sequence address strobe
167	/SRAS	/SRAS	O	Line address strobe
168	VDDINT	VDDINT	-	Power supply of microprocessor (BF1.2)
169	CLKOUT	CLKOUT	O	Clock output
170	DGND	GND	-	Ground of external
171	VDDEXT	VDDEXT	-	I/O power supply (EX3.3)
172	/SMS	/SMS	O	Bank select
173	SCKE	SCKE	O	Clock enable
174	DGND	GND	-	Ground of external
175	DGND	GND	-	Ground of external
176	DGND	GND	-	Ground of external

• **Microprocessor extended port**

**IC204-IC206:** SN74LV573APWR (DSP P.C.B.)  
Octal 3-state D-latches with 3-state outputs

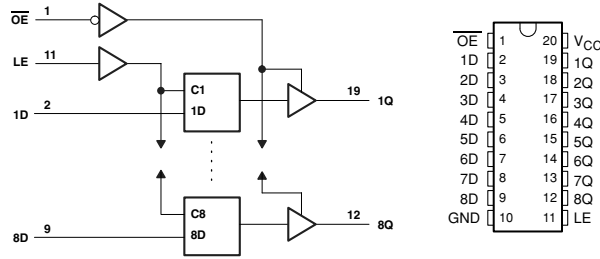

**IC204**

Pin No.	Port Name	Function Name	Detail of Function
1	/OE	/EXPE	Extended port enable
2	1D	D00	Data bus 00
3	2D	D01	Data bus 01
4	3D	D02	Data bus 02
5	4D	D03	Data bus 03
6	5D	D04	Data bus 04
7	6D	D05	Data bus 05
8	7D	D06	Data bus 06
9	8D	D07	Data bus 07
10	GND	DGND	Ground of external
11	LE	LEEX1	Bank select 1
12	8Q	/SPISEL3	CS for CODEC IC (IC301, DSP P.C.B.)
13	7Q	ADSEL2	4ch ADC input select 2
14	6Q	ADSEL1	4ch ADC input select 1
15	5Q	ADSEL0	4ch ADC input select 0
16	4Q	/CCBE	SPI bus switch
17	3Q	/CMT	Center mute
18	2Q	/SMT	Surround mute
19	1Q	/FMT	Front mute
20	VCC	EX3.3	Power supply

**IC205**

Pin No.	Port Name	Function Name	Detail of Function
1	/OE	/EXPE	Extended port enable
2	1D	D08	Data bus 08
3	2D	D09	Data bus 09
4	3D	D10	Data bus 10
5	4D	D11	Data bus 11
6	5D	D12	Data bus 12
7	6D	D13	Data bus 13
8	7D	D14	Data bus 14
9	8D	D15	Data bus 15
10	GND	DGND	Ground of external
11	LE	LEEX1	Bank select 1 (B, G, E, F models)
12	8Q	CLKSEL/RDS_RST	Reset for RDS (B, G, E, F models)
13	7Q	SSEL3	SCENE select LED switch 3
14	6Q	SSEL2	SCENE select LED switch 2
15	5Q	SSEL1	SCENE select LED switch 1
16	4Q	/IC_AK	IC for CODEC IC (IC301, DSP P.C.B.) and VFD (IC201, OPERATION P.C.B.)
17	3Q	/SPISEL4	CS for VFD (IC201, OPERATION P.C.B.)
18	2Q	/3.3SW	+3.3S switch
19	1Q	PRY	Power relay
20	VCC	EX3.3	Power supply

**IC206**

Pin No.	Port Name	Function Name	Detail of Function
1	/OE	/EXPE	Extended port enable
2	1D	D00	Data bus 00
3	2D	D01	Data bus 01
4	3D	D02	Data bus 02
5	4D	D03	Data bus 03
6	5D	D04	Data bus 04
7	6D	D05	Data bus 05
8	7D	D06	Data bus 06
9	8D	D07	Data bus 07
10	GND	DGND	Ground of external
11	LE	LEEX2	Bank select 2
12	8Q	/VR1	Video select R
13	7Q	SPISEL5	CE for tuner
14	6Q	/8ohmSW	AC H/L relay (RY106, MAIN P.C.B.)
15	5Q	HPRY	Headphone relay (RY102, MAIN P.C.B.)
16	4Q	MRYA	Main speakers A relay (RY101, MAIN P.C.B.)
17	3Q	MRYB	Main speakers B relay (RY102, MAIN P.C.B.)
18	2Q	CSRY	Center/surround speakers relay (RY103/R Y105, MAIN P.C.B.)
19	1Q	/SWMT	Subwoofer mute
20	VCC	EX3.3	Power supply

• **Microprocessor ADC select port**

**IC401:** ADC084S021CIMM (DSP P.C.B.)  
4-channel, 200 kSPS, 8-bit A/D converter

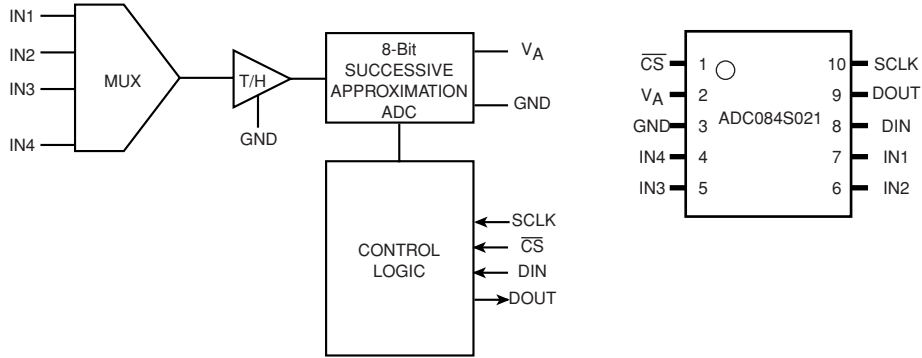

Pin No.	Port Name	Function Name	Detail of Function
1	/CS	/SPISEL1	CS for microprocessor
2	VA	VA	+3.3S
3	GND	DGND	Ground of external
4	IN4	IN4	SPI bus COM (IC402)
5	IN3	IN3	SPI bus COM (IC403)
6	IN2	KEY1	Key input 1
7	IN1	KEY0	Key input 0
8	DIN	SPIMO	Master output/slave input
9	DOUT	SPIMI	Master input/slave output
10	SCLK	SPISCK	SPI clock

Key input (A/D), pull-up resistance 10 k-ohms

Ohm [ohm]	+1.0 k	+1.0 k	+1.5 k	+2.2 k	+3.3 k	+4.7 k	+4.7 k	+6.8 k	+10.0 k	+22.0 k
V [V]	0.3	0.55	0.86	1.2	1.56	1.91	2.14	2.36	2.57	2.81
KEY0 (7 pin)	SCENE 1	SCENE 2	PROGRAM <	PROGRAM >	STRAIGHT	tone CONTROL	SEARCH MODE	FM/AM	A/B/C/D/E	SPEAKERS
KEY1 (6 pin)	SCENE 3	SCENE 4	DIRECT	AUDIO SELECT	INPUT <	INPUT >	PRESET/TUNING <	PRESET/TUNING >	MEMORY	TUNING

**IC402, IC403:** SN74LV4051APWR (DSP P.C.B.)  
8-channel analog multiplexers/demultiplexers

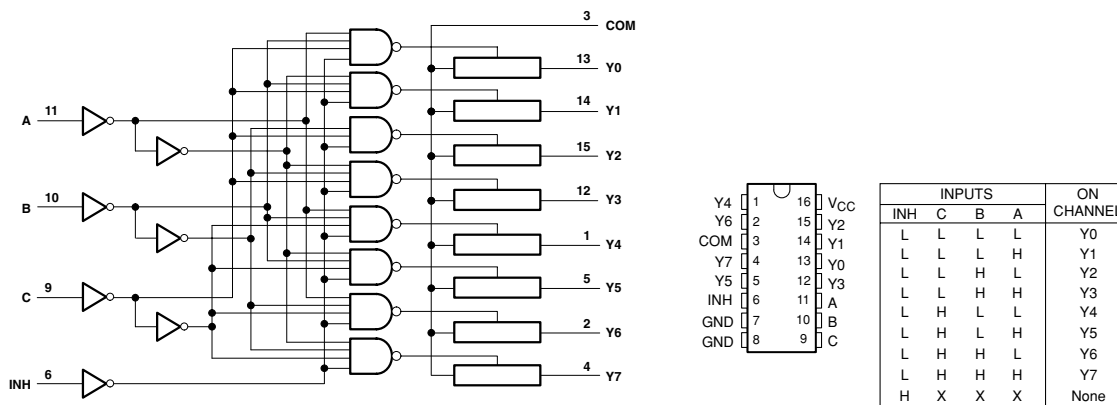

## IC402

Pin No.	Port Name	Function Name	Detail of Function
1	Y4	-	
2	Y6	-	
3	COM	COM	SPI bus IN4 (IC401)
4	Y7	LINKACTIVE	Link detect (U, C models)
5	Y5	XM_MUTE	
6	INH	DGND	(Pull-down)
7	GND	DGND	Ground of external
8	GND	DGND	Ground of external
9	COM	ADSEL2	Input select 2
10	B	ADSEL1	Input select 1
11	A	ADSEL0	Input select 0
12	Y3	-	
13	Y0	-	
14	Y1	/ST	Stereo for tuner
15	Y2	/TUNED	Tuned for tuner
16	Vcc	+3.3S	Power supply

## IC403

Pin No.	Port Name	Function Name	Detail of Function
1	Y4	DEST	Destination 1 *
2	Y6	/PDET	Sub-trans detect
3	COM	COM	SPI bus IN3 (IC401)
4	Y7	/HP	Headphone detect
5	Y5	PRIIN	Current protection
6	INH	DGND	(Pull-down)
7	GND	DGND	Ground of external
8	GND	DGND	Ground of external
9	COM	ADSEL2	Input select 2
10	B	ADSEL1	Input select 1
11	A	ADSEL0	Input select 0
12	Y3	PLDET	Limiter detect
13	Y0	PRDIN	Amplifier DC detect
14	Y1	PRVIN	Voltage protection
15	Y2	THMIN	Thermo protection
16	Vcc	+3.3S	Power supply

\* Destination for A/D port

R406 [ohm]	1.5 k	3.3 k	4.7 k	6.8 k	8.2 k
R407 [ohm]	8.2 k	6.8 k	5.6 k	3.9 k	2.2 k
DEST (1 pin) [V]	2.6-3.0	2.0-2.4	1.6-2.0	1.0-1.4	0.5-0.9
A/D value (3.3 V=255)	206-226	162-182	129-149	83-103	44-64
Destination	U, C	R, L	T	K, A	B, G, E, F

**IC301: AK4588VQ (DSP P.C.B.)**  
2/8-channel audio CODEC with DIR

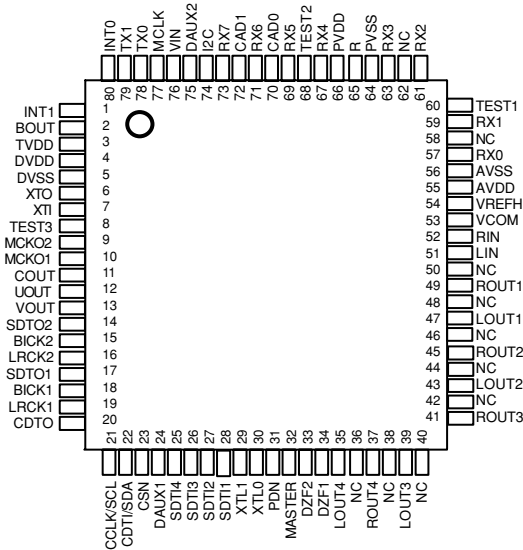
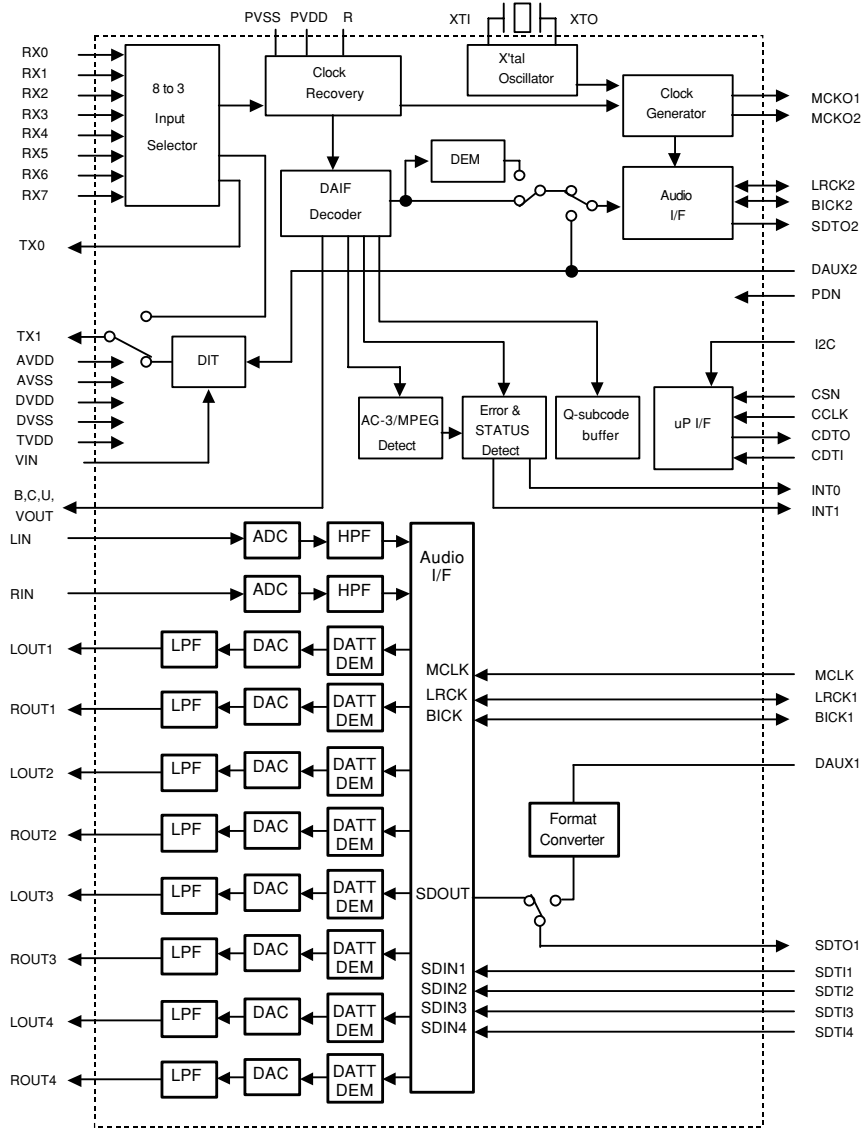



Pin No.	Function Name	I/O	Detail of Function
1	INT1	O	Interrupt 1 pin
2	BOUT	O	Block-start output pin for receiver input "H" during first 40 flames
3	TVDD	–	Output buffer power supply pin, 2.7 V to 5.5 V
4	DVDD	–	Digital power supply pin, 4.5 V to 5.5 V
5	DVSS	–	Digital ground pin
6	XTO	O	X'tal clock output pin
7	XTI	I	X'tal / External clock input pin
8	TEST3	I	Test 3 pin This pin should be connected to DVSS
9	MCKO2	O	Master clock output 2 pin
10	MCKO1	O	Master clock output 1 pin
11	COUT	O	C-bit output pin for receiver input
12	UOUT	O	U-bit output pin for receiver input
13	VOUT	O	V-bit output pin for receiver input
14	SDTO2	O	Audio serial data output pin (DIR/DIT part)
15	BICK2	I/O	Audio serial data clock pin (DIR/DIT part)
16	LRCK2	I/O	Channel clock pin (DIR/DIT part)
17	SDTO1	O	Audio serial data output pin (ADC/DAC part)
18	BICK1	I/O	Audio serial data clock pin (ADC/DAC part)
19	LRCK1	I/O	Input channel clock pin
20	CDTO	O	Control data output pin in serial mode, I2C pin= "L"
21	CCLK	I	Control data clock pin in serial mode, I2C pin= "L"
	SCL	I	Control data clock pin in serial mode, I2C pin= "H"
22	CDTI	I	Control data input pin in serial mode, I2C pin= "L"
	SDA	I/O	Control data pin in serial mode, I2C pin= "H"
23	CSN	I	Chip select pin in serial mode, I2C pin="L"
		I	This pin should be connected to DVSS, I2C pin="H"
24	DAUX1	I	AUX audio serial data input pin (ADC/DAC part)
25	SDTI4	I	DAC4 audio serial data input pin
26	SDTI3	I	DAC3 audio serial data input pin
27	SDTI2	I	DAC2 audio serial data input pin
28	SDTI1	I	DAC1 audio serial data input pin
29	XTL1	I	X'tal frequency select 0 pin
30	XTL0	I	X'tal frequency select 1 pin
31	PDN	I	Power-down mode pin
			When "L", the AK4588 is powered-down, all output pin goes "L", all registers are reset When CAD1-0 pins are changed, the AK4588 should be reset by PDN pin
32	MASTER	I	Master mode select pin "H": Master mode, "L": Slave mode
33	DZF2	O	Zero input detect 2 pin (table 13) When the input data of the group 1 follow total 8192 LRCK cycles with "0" input data, this pin goes to "H" / When RSTN1 bit is "0" or PWDAN bit is "0", this pin goes to "H"
	OVF	O	Analog input overflow detect pin This pin goes to "H" if the analog input of L ch or R ch overflows This pin becomes OVF pin if OVFE bit is set to 1
34	DZF1	O	Zero input detect 1 pin (table 13) When the input data of the group 1 follow total 8192 LRCK cycles with "0" input data, this pin goes to "H" / When RSTN1 bit is "0" or PWDAN bit is "0", this pin goes to "H"
35	LOUT4	O	DAC4 L ch analog output pin
36	NC	–	No connect pin No internal bonding / This pin should be opened
37	ROUT4	O	DAC4 R ch analog output pin
38	NC	–	No connect pin No internal bonding / This pin should be opened
39	LOUT3	O	DAC3 L ch analog output pin
40	NC	–	No connect pin No internal bonding / This pin should be opened

Pin No.	Function Name	I/O	Detail of Function
41	ROUT3	O	DAC3 R ch analog output pin
42	NC	–	No connect pin No internal bonding / This pin should be opened
43	LOUT2	O	DAC2 L ch analog output pin
44	NC	–	No connect pin No internal bonding / This pin should be opened
45	ROUT2	O	DAC2 R ch analog output pin
46	NC	–	No connect pin No internal bonding / This pin should be opened
47	LOUT1	O	DAC1 L ch analog output pin
48	NC	–	No connect pin No internal bonding / This pin should be opened
49	ROUT1	O	DAC1 R ch analog output pin
50	NC	–	No connect pin No internal bonding / This pin should be opened
51	LIN	I	L ch analog input pin
52	RIN	I	R ch analog input pin
53	VCOM	–	Common voltage output pin 2.2 F capacitor should be connected to AVSS externally
54	VREFH	–	Positive voltage reference input pin, AVDD
55	AVDD	–	Analog power supply pin, 4.5 V to 4.5 V
56	AVSS	–	Analog ground pin, 0 V
57	RX0	I	Receiver channel 0 pin (Internal biased pin / Internally biased at PVDD/2)
58	NC	–	No connect pin No internal bonding / This pin should be connected to PVSS
59	RX1	I	Receiver channel 1 pin (Internal biased pin / Internally biased at PVDD/2)
60	TEST1	I	Test 1 pin This pin should be connected to PVSS
61	RX2	I	Receiver channel 2 pin (Internal biased pin / Internally biased at PVDD/2)
62	NC	–	No connect pin No internal bonding / This pin should be connected to PVSS
63	RX3	I	Receiver channel 3 pin (Internal biased pin / Internally biased at PVDD/2)
64	PVSS	–	PLL ground pin
65	R	–	External resistor pin 12 k-ohms +/-1 % resistor should be connected to PVSS externally
66	PVDD	–	PLL power supply pin, 4.5 V to 4.5 V
67	RX4	I	Receiver channel 4 pin (Internal biased pin / Internally biased at PVDD/2)
68	TEST2	I	Test 2 pin This pin should be connected to PVSS
69	RX5	I	Receiver channel 5 pin (Internal biased pin / Internally biased at PVDD/2)
70	CAD0	I	Chip address 0 pin (ADC/DAC part)
71	RX6	I	Receiver channel 6 pin (Internal biased pin / Internally biased at PVDD/2)
72	CAD1	I	Chip address 1 pin (ADC/DAC part)
73	RX7	I	Receiver channel 7 pin (Internal biased pin / Internally biased at PVDD/2)
74	I2C	I	Control mode select pin “L”: 4-wire serial, “H”: I2C bus
75	DAUX2	I	Auxiliary audio data input pin (DIR/DIT part)
76	VIN	I	V-bit input pin for transmitter output
77	MCLK	I	Master clock input pin
78	TX0	O	Transmit channel (through data) output 0 pin
79	TX1	O	Transmit channel output 1 pin When TX bit = “0”, transmit channel (through data) output 1 pin. When TX bit = “1”, transmit channel (DAUX2 data) output pin (default)
80	INT0	O	Interrupt 0 pin

Note: All input pins except internal biased pins and internal pull-down pin should not be left floating.

IC161: R2A15218FP (MAIN P.C.B.)

8-channel electronic volume with 11 input selector and tone control

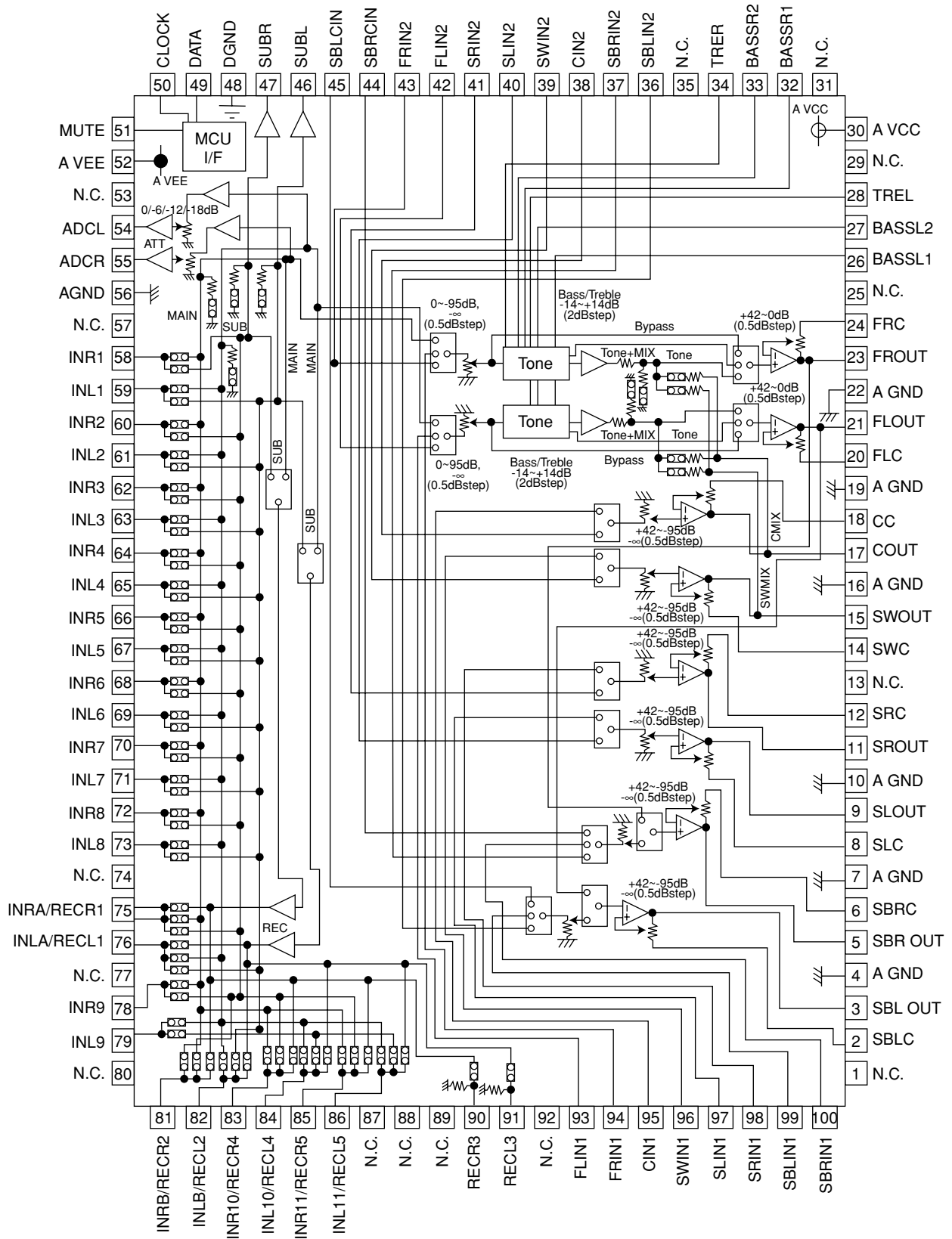

RX-V363/HTR-6130

Pin No.	Function Name	Detail of Function
1	N.C.	No connected
2	SBLC	L/R/C/SW/SL/SR/SBL/SBR ch terminal to connect capacitor to reduce noise from changing the volume
3	SBLOUT	FL/FR/C/SW/SL/SR/SBL/SBR ch output terminal
4	AGND	Analog GND terminal
5	SBROUT	FL/FR/C/SW/SL/SR/SBL/SBR ch output terminal
6	SBRC	L/R/C/SW/SL/SR/SBL/SBR ch terminal to connect capacitor to reduce noise from changing the volume
7	AGND	Analog GND terminal
8	SLC	L/R/C/SW/SL/SR/SBL/SBR ch terminal to connect capacitor to reduce noise from changing the volume
9	SLOUT	FL/FR/C/SW/SL/SR/SBL/SBR ch output terminal
10	AGND	Analog GND terminal
11	SROUT	FL/FR/C/SW/SL/SR/SBL/SBR ch output terminal
12	SRC	L/R/C/SW/SL/SR/SBL/SBR ch terminal to connect capacitor to reduce noise from changing the volume
13	N.C.	No connected
14	SWC	L/R/C/SW/SL/SR/SBL/SBR ch terminal to connect capacitor to reduce noise from changing the volume
15	SWOUT	FL/FR/C/SW/SL/SR/SBL/SBR ch output terminal
16	AGND	Analog GND terminal
17	COUT	FL/FR/C/SW/SL/SR/SBL/SBR ch output terminal
18	CC	L/R/C/SW/SL/SR/SBL/SBR ch terminal to connect capacitor to reduce noise from changing the volume
19	AGND	Analog GND terminal
20	FLC	L/R/C/SW/SL/SR/SBL/SBR ch terminal to connect capacitor to reduce noise from changing the volume
21	FLOUT	FL/FR/C/SW/SL/SR/SBL/SBR ch output terminal
22	AGND	Analog GND terminal
23	FROUT	FL/FR/C/SW/SL/SR/SBL/SBR ch output terminal
24	FRC	L/R/C/SW/SL/SR/SBL/SBR ch terminal to connect capacitor to reduce noise from changing the volume
25	N.C.	No connected
26	BASSL1	L/R ch tone control (Bass) terminal for setting frequency characteristics
27	BASSL2	L/R ch tone control (Bass) terminal for setting frequency characteristics
28	TREL	L/R ch tone control (Treble) terminal for setting frequency characteristics
29	N.C.	No connected
30	AVCC	Positive side power terminal
31	N.C.	No connected
32	BASSR1	L/R ch tone control (Bass) terminal for setting frequency characteristics
33	BASSR2	L/R ch tone control (Bass) terminal for setting frequency characteristics
34	TRER	L/R ch tone control (Treble) terminal for setting frequency characteristics
35	N.C.	No connected
36	SBLIN2	L/R/C/SW/SL/SR/SBL/SBR ch input terminal (multi input 1/2)
37	SBRIN2	L/R/C/SW/SL/SR/SBL/SBR ch input terminal (multi input 1/2)
38	CIN2	L/R/C/SW/SL/SR/SBL/SBR ch input terminal (multi input 1/2)
39	SWIN2	L/R/C/SW/SL/SR/SBL/SBR ch input terminal (multi input 1/2)
40	SLIN2	L/R/C/SW/SL/SR/SBL/SBR ch input terminal (multi input 1/2)
41	SRIN2	L/R/C/SW/SL/SR/SBL/SBR ch input terminal (multi input 1/2)
42	FLIN2	L/R/C/SW/SL/SR/SBL/SBR ch input terminal (multi input 1/2)
43	FRIN2	L/R/C/SW/SL/SR/SBL/SBR ch input terminal (multi input 1/2)
44	SBRCIN	SBL/SBR ch volume input terminal
45	SBLCIN	SBL/SBR ch volume input terminal
46	SUBL	L/R ch SUB output terminal
47	SUBR	L/R ch SUB output terminal
48	DGND	Digital GND terminal
49	DATA	Control data input terminal
50	CLOCK	Control data input terminal
51	MUTE	External Mute Control terminal
52	AVEE	Negative side power terminal
53	N.C.	No connected
54	ADCL	L/R ch ADC output terminal
55	ADCR	L/R ch ADC output terminal

Pin No.	Function Name	Detail of Function
56	AGND	Analog GND terminal
57	N.C.	No connected
58	INR1	L/R ch input terminal (input selector)
59	INL1	L/R ch input terminal (input selector)
60	INR2	L/R ch input terminal (input selector)
61	INL2	L/R ch input terminal (input selector)
62	INR3	L/R ch input terminal (input selector)
63	INL3	L/R ch input terminal (input selector)
64	INR4	L/R ch input terminal (input selector)
65	INL4	L/R ch input terminal (input selector)
66	INR5	L/R ch input terminal (input selector)
67	INL5	L/R ch input terminal (input selector)
68	INR6	L/R ch input terminal (input selector)
69	INL6	L/R ch input terminal (input selector)
70	INR7	L/R ch input terminal (input selector)
71	INL7	L/R ch input terminal (input selector)
72	INR8	L/R ch input terminal (input selector)
73	INL8	L/R ch input terminal (input selector)
74	N.C.	No connected
75	INRA/RECR1	L/R ch input terminal (input selector) / L/R ch REC output terminal
76	INLA/RECL1	L/R ch input terminal (input selector) / L/R ch REC output terminal
77	N.C.	No connected
78	INR9	L/R ch input terminal (input selector)
79	INL9	L/R ch input terminal (input selector)
80	N.C.	No connected
81	INRB/RECR2	L/R ch input terminal (input selector) / L/R ch REC output terminal
82	INLB/RECL2	L/R ch input terminal (input selector) / L/R ch REC output terminal
83	INR10/RECR4	L/R ch input terminal (input selector) / L/R ch REC output terminal
84	INL10/RECL4	L/R ch input terminal (input selector) / L/R ch REC output terminal
85	INR11/RECR5	L/R ch input terminal (input selector) / L/R ch REC output terminal
86	INL11/RECL5	L/R ch input terminal (input selector) / L/R ch REC output terminal
87	N.C.	No connected
88	N.C.	No connected
89	N.C.	No connected
90	RECR3	L/R ch REC output terminal
91	RECL3	L/R ch REC output terminal
92	N.C.	No connected
93	FLIN1	L/R/C/SW/SL/SR/SBL/SBR ch input terminal (multi input 1/2)
94	FRIN1	L/R/C/SW/SL/SR/SBL/SBR ch input terminal (multi input 1/2)
95	CIN1	L/R/C/SW/SL/SR/SBL/SBR ch input terminal (multi input 1/2)
96	SWIN1	L/R/C/SW/SL/SR/SBL/SBR ch input terminal (multi input 1/2)
97	SLIN1	L/R/C/SW/SL/SR/SBL/SBR ch input terminal (multi input 1/2)
98	SRIN1	L/R/C/SW/SL/SR/SBL/SBR ch input terminal (multi input 1/2)
99	SBLIN1	L/R/C/SW/SL/SR/SBL/SBR ch input terminal (multi input 1/2)
100	SBRIN1	L/R/C/SW/SL/SR/SBL/SBR ch input terminal (multi input 1/2)

IC201: M66003-0131FP-R (OPERATION P.C.B.)  
18 digit 5x7 segment VFD controller/driver

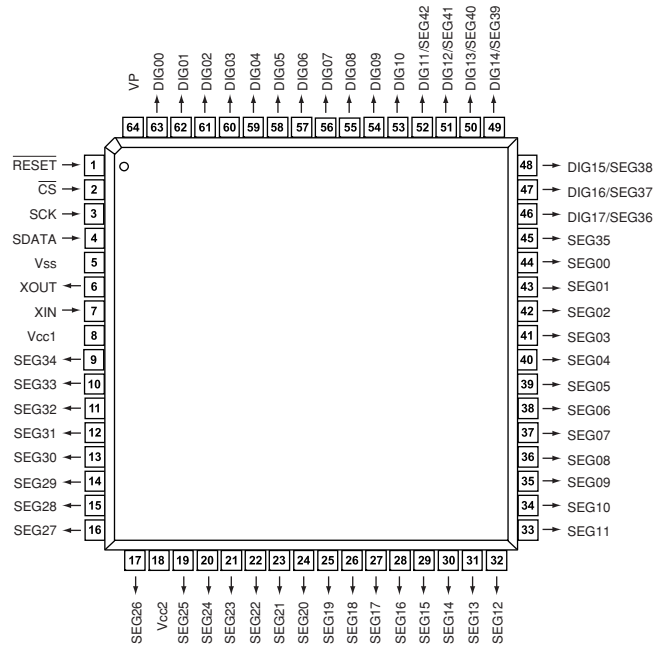
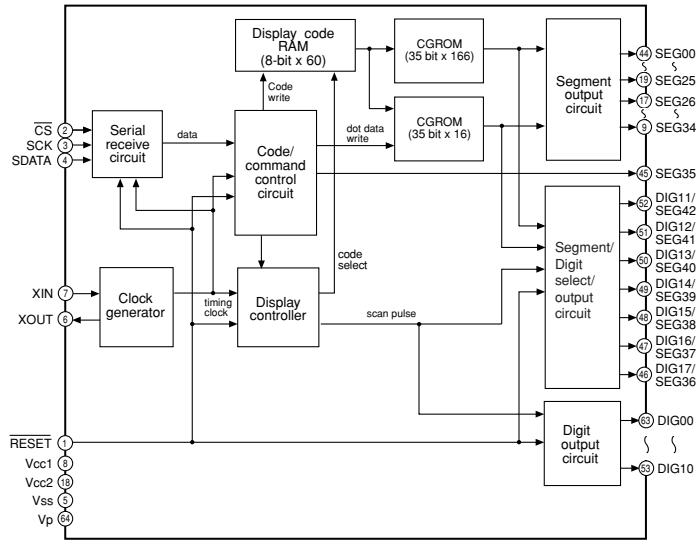

RX-V363/HTR-6130

Pin No.	Port Name	Function Name	I/O	Detail of Function	
1	Reset	/RESET	Reset input	When "L", M66003 is initialized	
2	CS	/CEFL	Chip select input	When "L", communication with the MCU is possible When "H", any instruction from the MCU is neglected	
3	SCK	CKFL	Shift clock input	Serial input data is taken and shifted by the positive edge of SCK	
4	SDATA	DTFL	Serial data input		
5	Vss	VSS		GND (0V)	
6	XOUT	XOUT	Clock output	When use as a CR oscillator, connect external resistor and capacitor / When use an external clock, input external clock to XIN, and XOUT must be opened	
7	XIN	XIN	Clock input		
8	Vcc1	VDD		Positive power supply for internal logic	
9	SEG34	P11	Segment output	Positive power supply for DIG and SEG outputs	
10	SEG33	P2	Segment output		
11	SEG32	P3	Segment output		
12	SEG31	P4	Segment output		
13	SEG30	P5	Segment output		
14	SEG29	P6	Segment output		
15	SEG28	P7	Segment output		
16	SEG27	P8	Segment output		
17	SEG26	P9	Segment output		
18	Vcc2	VDD		Connect to segment (anode) pins of VFD	
19	SEG25	P10	Segment output		
20	SEG24	P11	Segment output		
21	SEG23	P12	Segment output		
22	SEG22	P13	Segment output		
23	SEG21	P14	Segment output		
24	SEG20	P15	Segment output		
25	SEG19	P16	Segment output		
26	SEG18	P17	Segment output		
27	SEG17	P18	Segment output		
28	SEG16	P19	Segment output		
29	SEG15	P20	Segment output		
30	SEG14	P21	Segment output		
31	SEG13	P22	Segment output		
32	SEG12	P23	Segment output		
33	SEG11	P24	Segment output		
34	SEG10	P25	Segment output		
35	SEG09	P26	Segment output		
36	SEG08	P27	Segment output		
37	SEG07	P28	Segment output		
38	SEG06	P29	Segment output		
39	SEG05	P30	Segment output		
40	SEG04	P31	Segment output		
41	SEG03	P32	Segment output		
42	SEG02	P33	Segment output		
43	SEG01	P34	Segment output		
44	SEG00	P35	Segment output		
45	SEG35	P36	Segment output		
46	DIG17/SEG36	P37	Segment output		Connect to digit (grid) pins of VFD
47	DIG16/SEG37	G17I	Digit output		
48	DIG15/SEG38	G16I	Digit output		
49	DIG14/SEG39	G15I	Digit output		
50	DIG13/SEG40	G14	Digit output		
51	DIG12/SEG41	G13	Digit output		
52	DIG11/SEG42	G12	Digit output		
53	DIG10	G11	Digit output		
54	DIG09	G10	Digit output		
55	DIG08	G9	Digit output		
56	DIG07	G8	Digit output		
57	DIG06	G7	Digit output		
58	DIG05	G6	Digit output		
59	DIG04	G5	Digit output		
60	DIG03	G4	Digit output		
61	DIG02	G3	Digit output		
62	DIG01	G2	Digit output		
63	DIG00	G1	Digit output		
64	Vp	VP		Negative power supply to pull down	

# BLOCK DIAGRAMS

## VIDEO, AUDIO and Power Supply Sections

### OPERATION

• See page 79, 80 → SCHEMATIC DIAGRAM

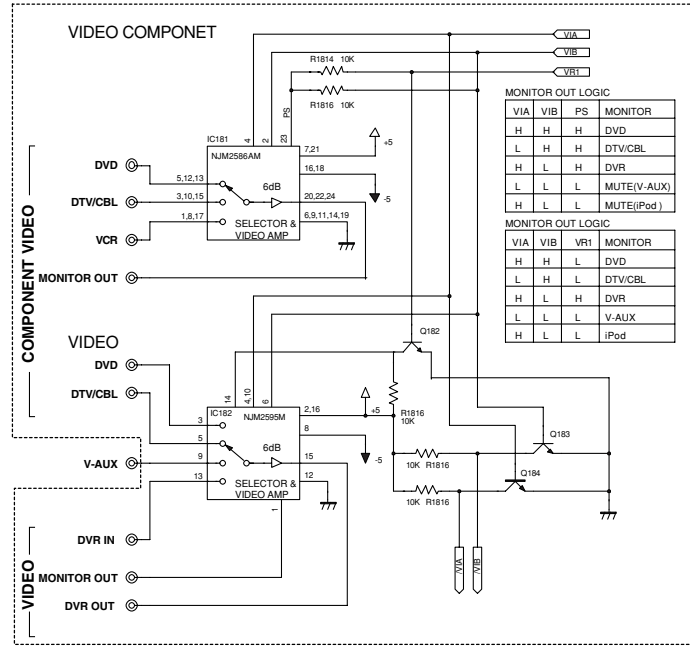

### DSP

• See page 73-78 → SCHEMATIC DIAGRAM

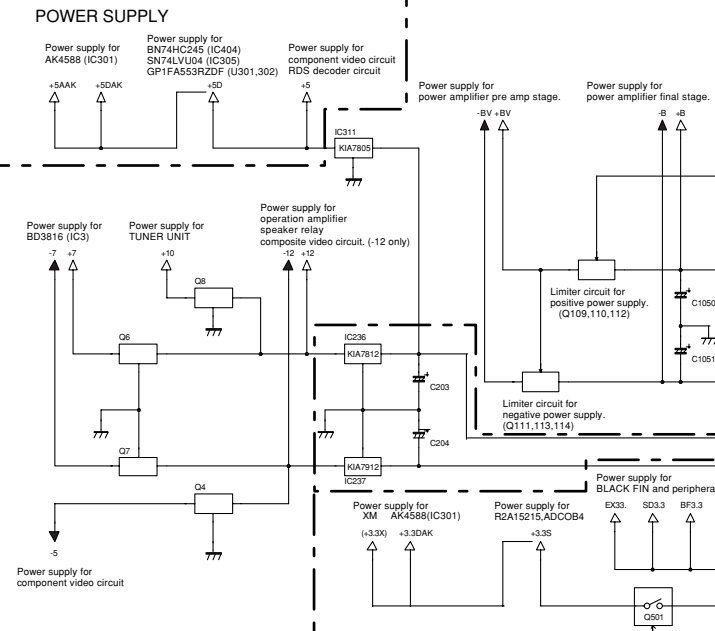

### OPERATION

• See page 79, 80 → SCHEMATIC DIAGRAM

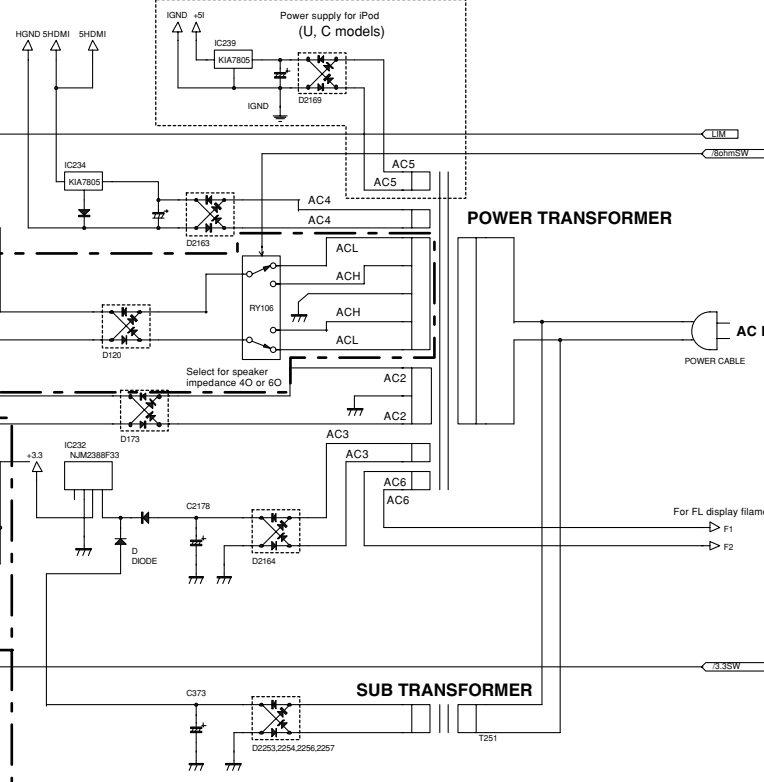

### HDMI

• See page 83 → SCHEMATIC DIAGRAM

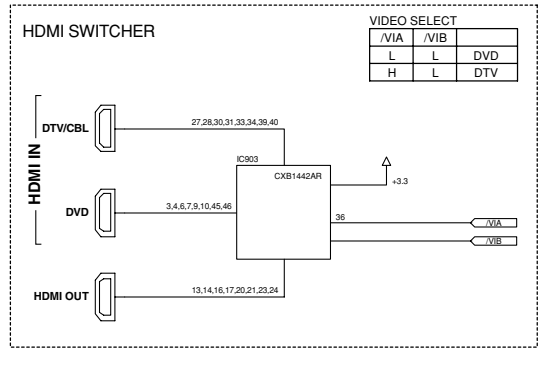

### DSP

• See page 73-78 → SCHEMATIC DIAGRAM

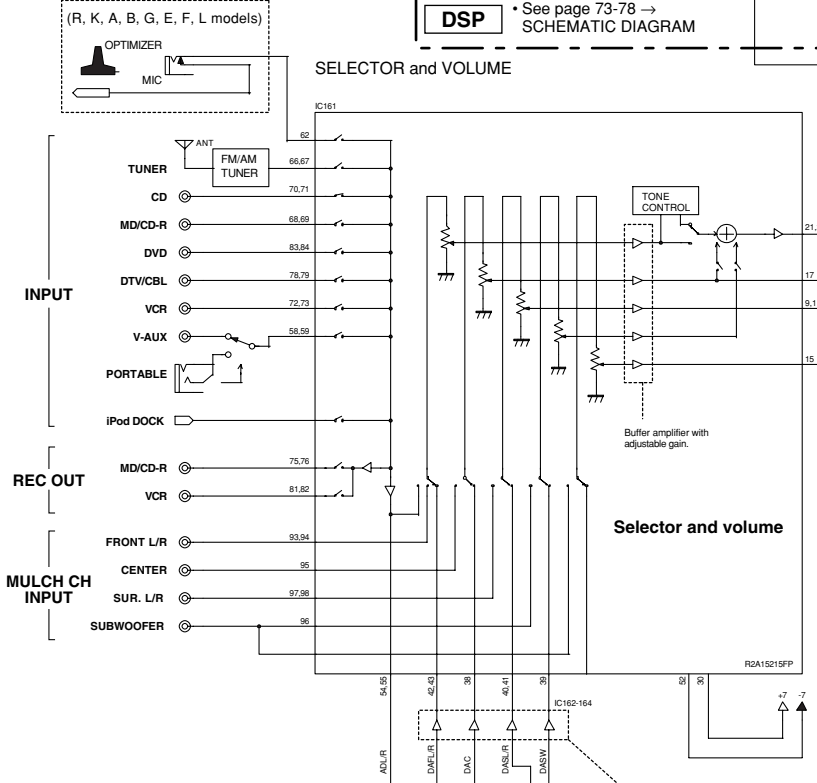

### DSP

• See page 73-78 → SCHEMATIC DIAGRAM

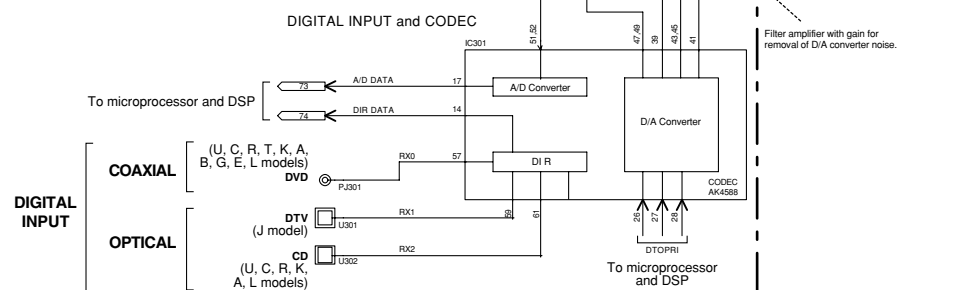

### MAIN

• See page 81, 82 → SCHEMATIC DIAGRAM

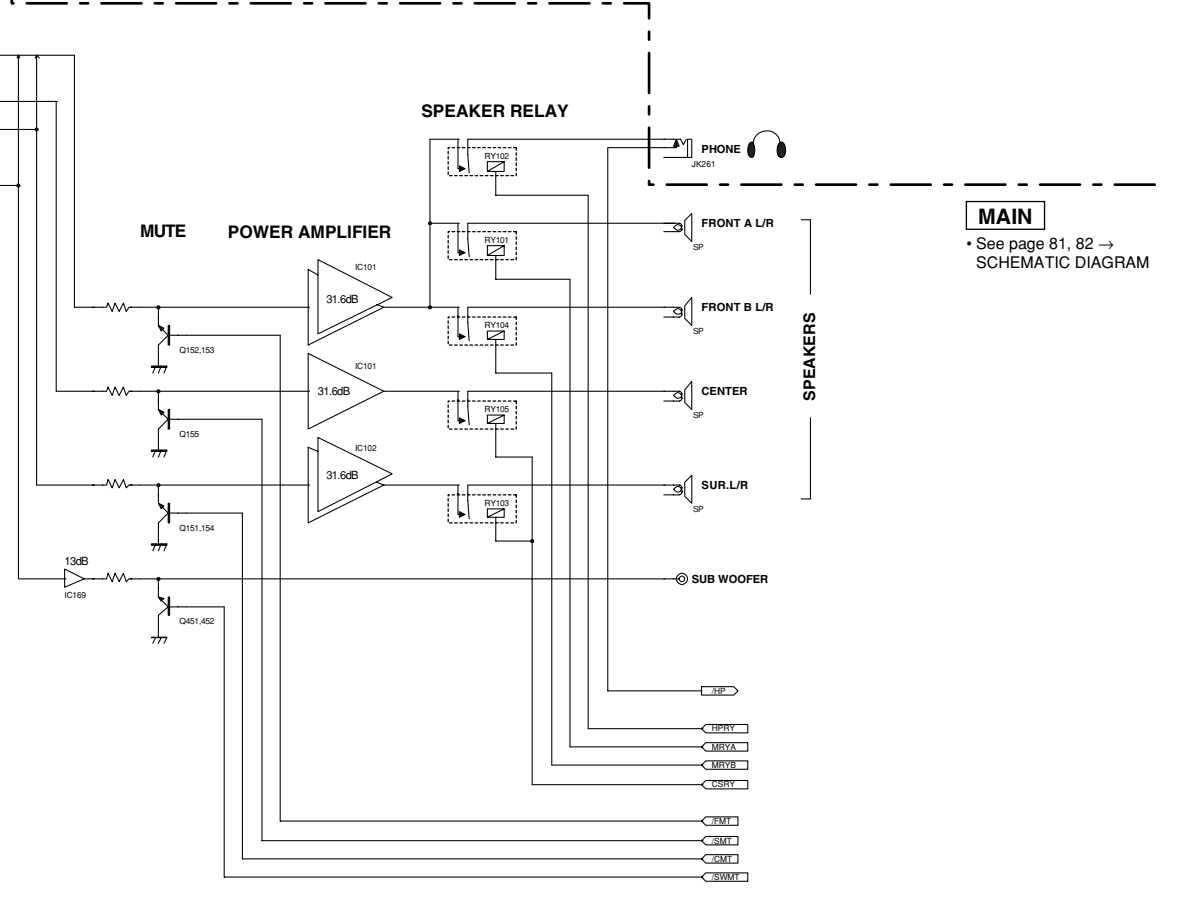



### Control Sections

**OPERATION** • See page 79, 80 → SCHEMATIC DIAGRAM

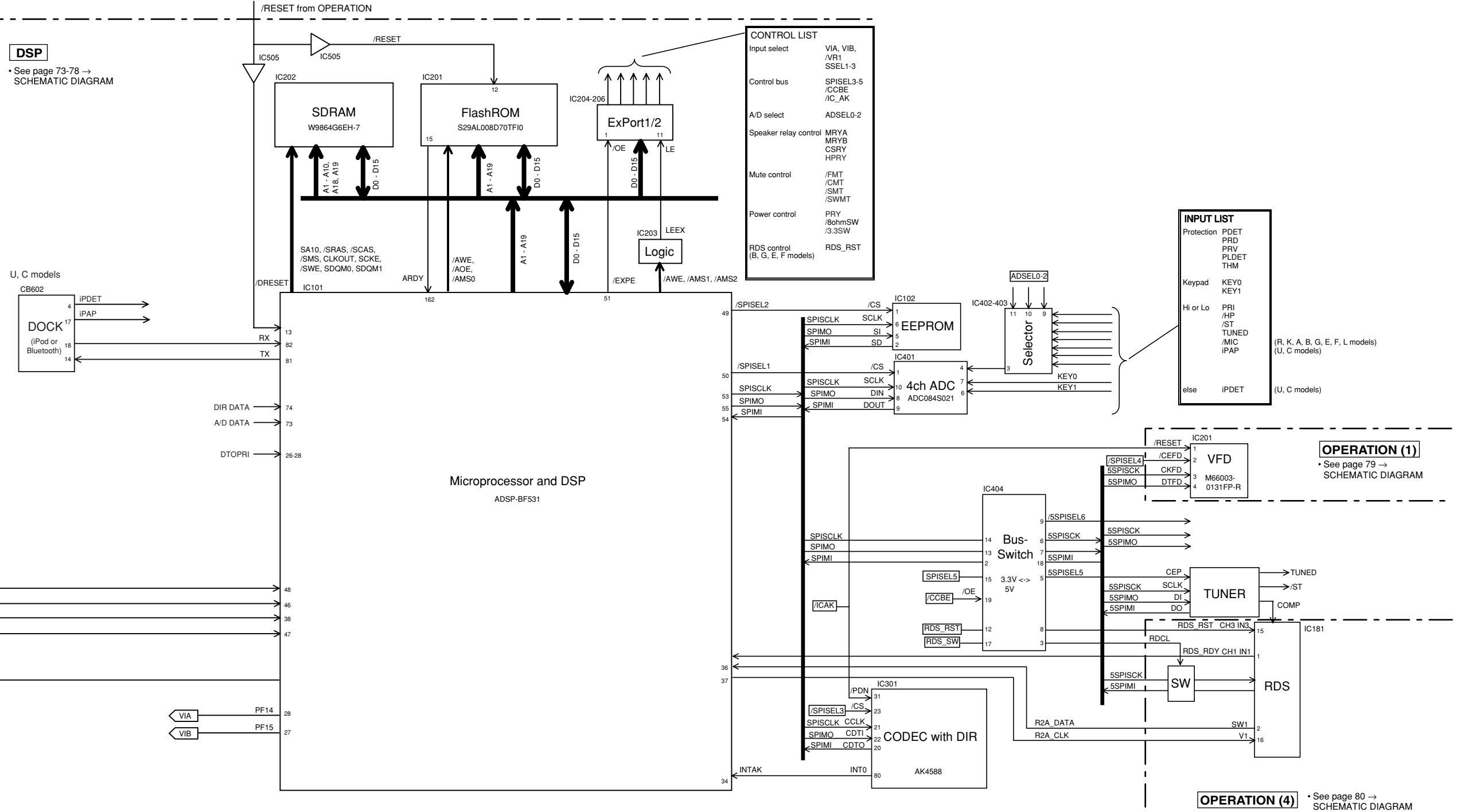

**DSP**  
• See page 73-78 → SCHEMATIC DIAGRAM

U, C models

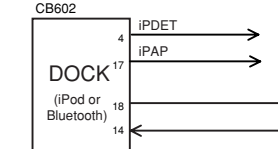

CONTROL LIST	
Input select	VIA, VIB, /VR1, SSEL1-3
Control bus	SPISEL3-5, /CCBE, /IC_AK
A/D select	ADSEL0-2
Speaker relay control	MRYA, MRYB, CSRY, HPRY
Mute control	/FMT, /CMT, /SMT, /SWMT
Power control	PRY, /BohmSW, /3.3SW
RDS control (B, G, E, F models)	RDS_RST

INPUT LIST	
Protection	PDET, PRD, PRV, PLDET, THM
Keypad	KEY0, KEY1
Hi or Lo	PRI, /HP, /ST, TUNED, /MIC, IPAP
else	IPDET

(R, K, A, B, G, E, F, L models)  
(U, C models)

**OPERATION**  
• See page 79, 80 → SCHEMATIC DIAGRAM

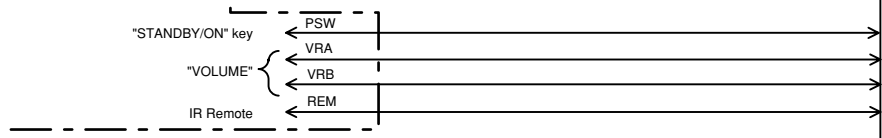

**MAIN**  
• See page 81, 82 → SCHEMATIC DIAGRAM

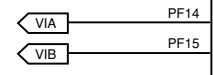

**OPERATION (1)**  
• See page 79 → SCHEMATIC DIAGRAM

**OPERATION (4)** • See page 80 → SCHEMATIC DIAGRAM

PRINTED CIRCUIT BOARDS

DSP P.C.B. (Side A)

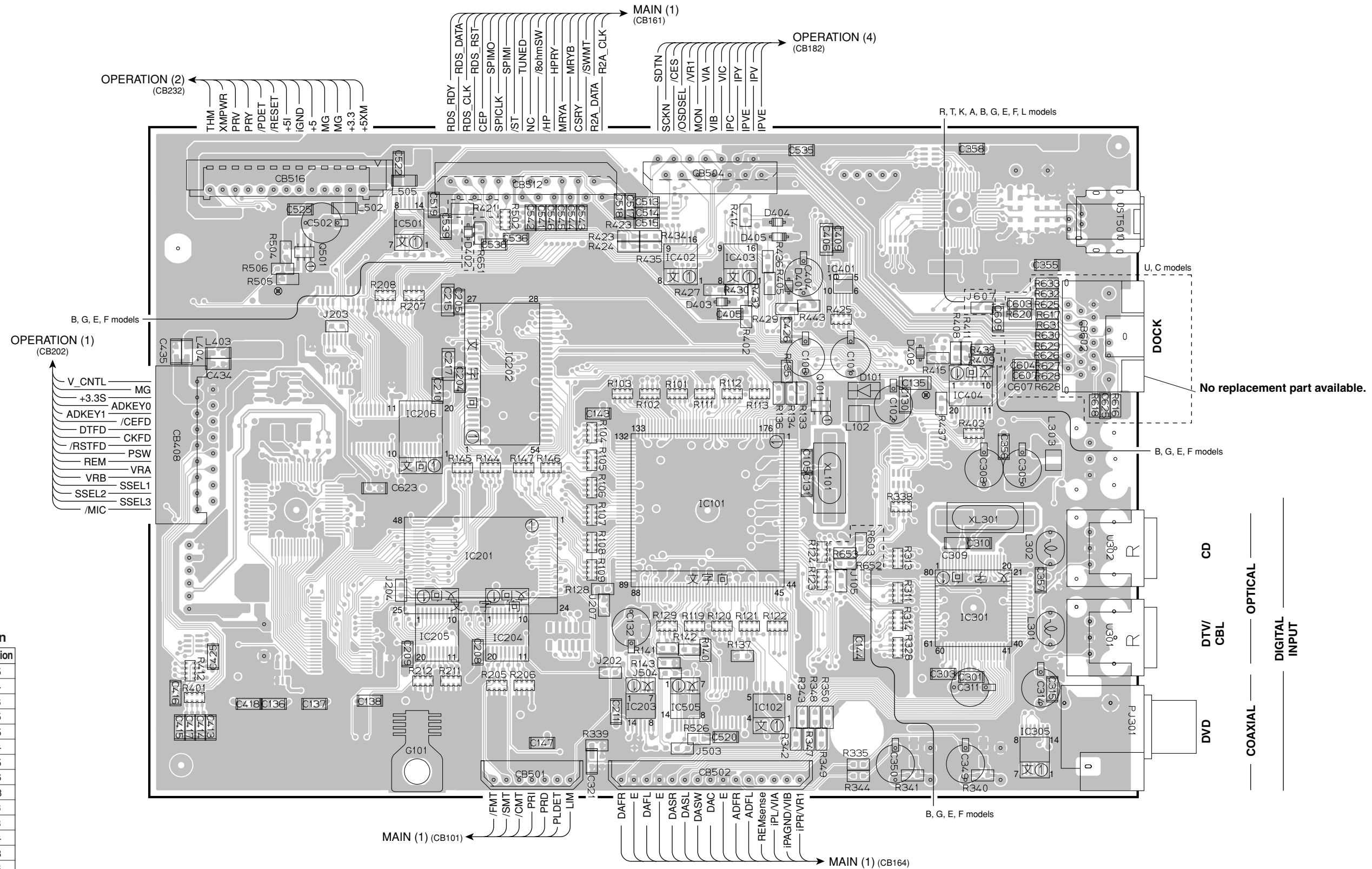

Semiconductor Location

Ref no.	Location	Ref no.	Location
CB408	C4	IC201	E5
CB501	E6	IC202	E4
CB502	F6	IC203	F6
CB504	F3	IC204	E5
CB512	E3	IC205	D5
CB516	D3	IC206	D4
CB602	I4	IC301	H5
D101	G4	IC305	H6
D401	G3	IC401	G3
D402	D3	IC402	F3
D403	F3	IC403	F3
D404	G3	IC404	H4
D405	G3	IC501	D3
D408	G4	IC505	F6
IC101	F5	Q101	G4
IC102	F6	Q501	D3

DSP P.C.B. (Side B)

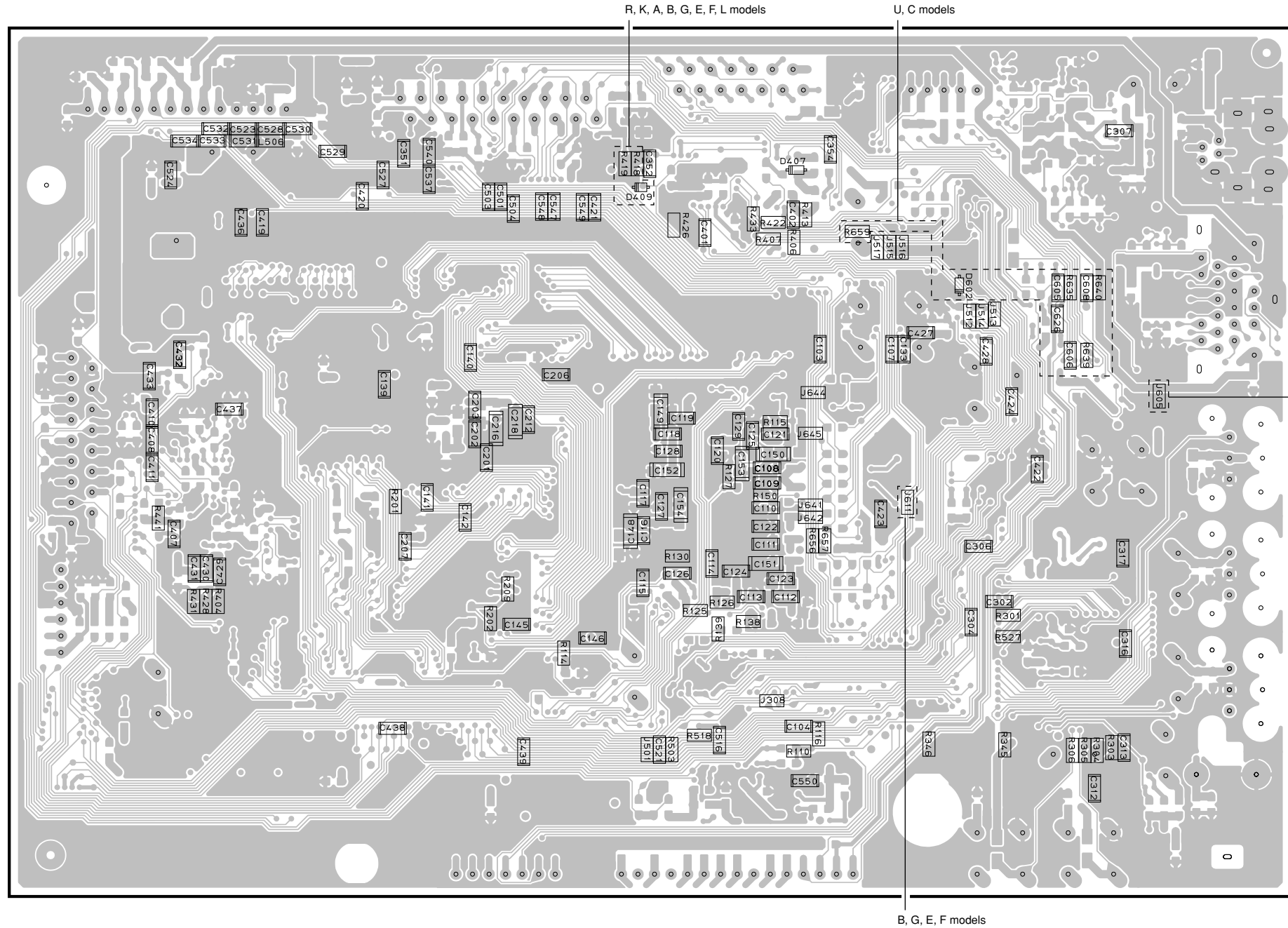

R, T, K, A, B, G, E, F, L models

• Semiconductor Location

Ref no.	Location
D407	F3
D409	F3
D602	G4

**OPERATION (1) P.C.B.** (Side A)

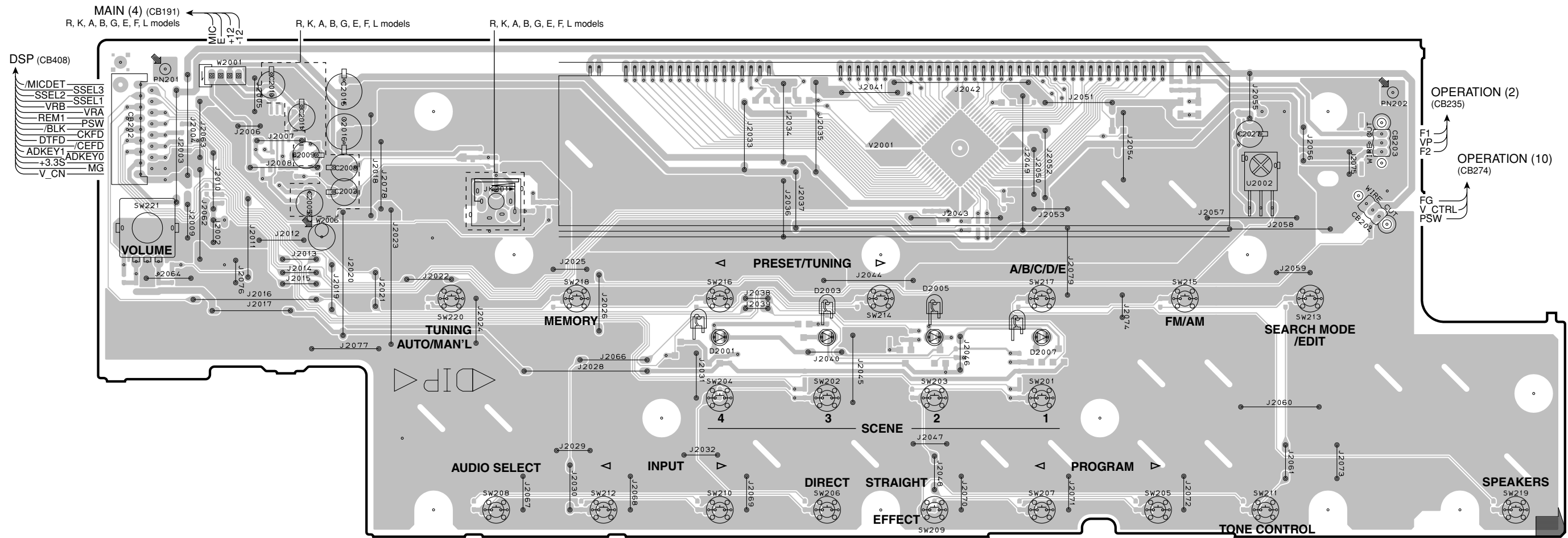

• Semiconductor Location

Ref no.	Location
CB202	B3
CB203	I3
CB204	I4
D2001	E4
D2003	F4
D2005	F4
D2007	G5
D2002	D4

**OPERATION (1) P.C.B.** (Side B)

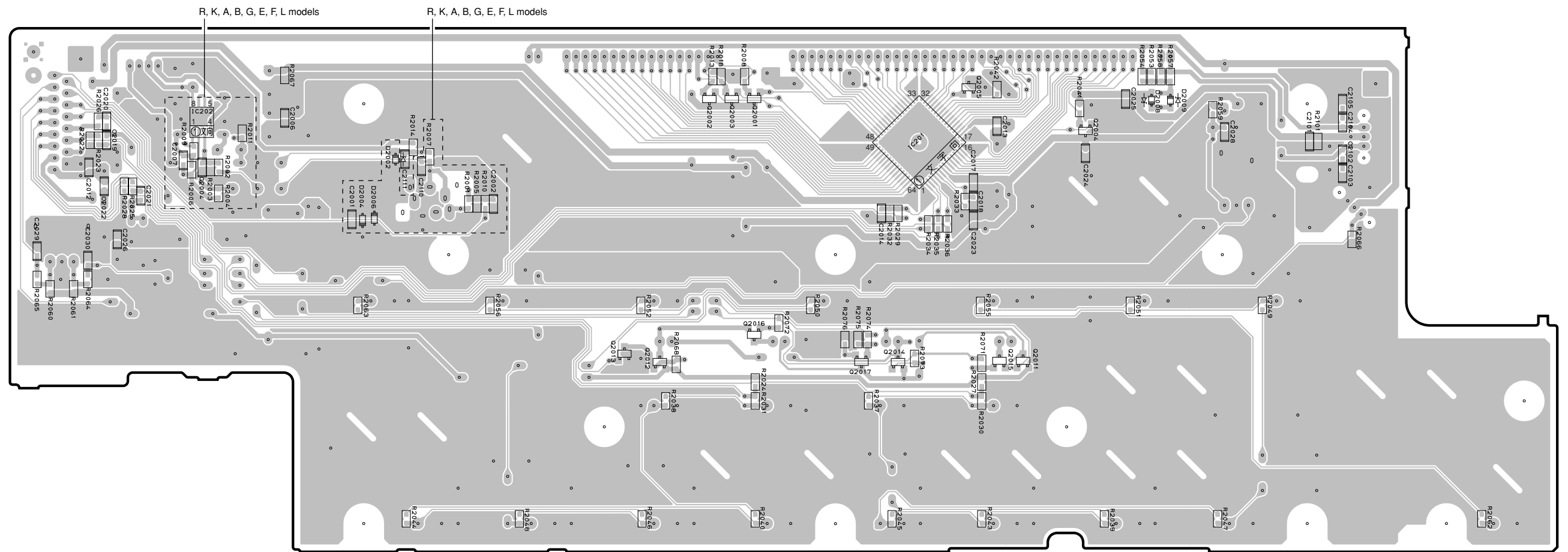

• **Semiconductor Location**

Ref no.	Location	Ref no.	Location
D2002	D4	Q2004	H3
D2004	D4	Q2005	G3
D2006	D4	Q2011	G5
D2008	H3	Q2012	E5
D2009	H3	Q2013	E5
IC201	G3	Q2014	F5
IC202	C3	Q2015	G5
Q2001	F3	Q2016	F5
Q2002	E3	Q2017	F5
Q2003	F3		

**OPERATION (2) P.C.B.** (Side A)

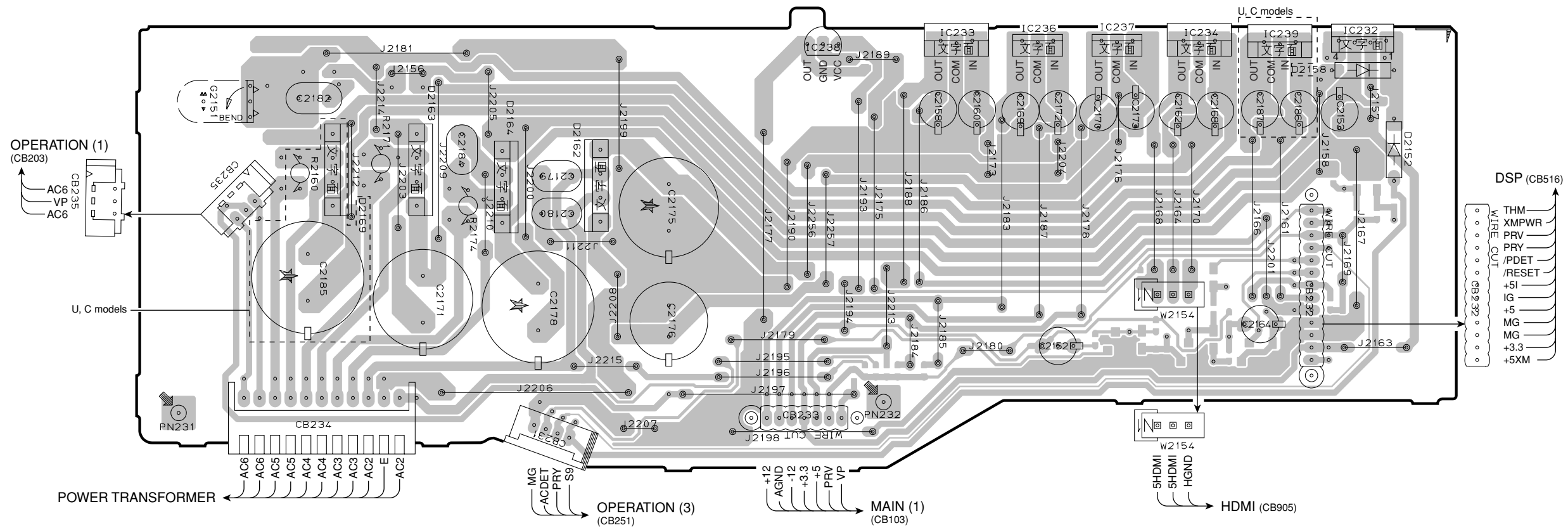

• Semiconductor Location

Ref no.	Location	Ref no.	Location
CB231	D5	D2164	D3
CB232	H4	D2169	C3
CB233	F5	IC232	I3
CB234	C5	IC233	G3
CB235	C4	IC234	H3
D2152	I3	IC236	G3
D2158	I3	IC237	G3
D2162	D3	IC238	F3
D2163	D3	IC239	H3

**OPERATION (2) P.C.B.** (Side B)

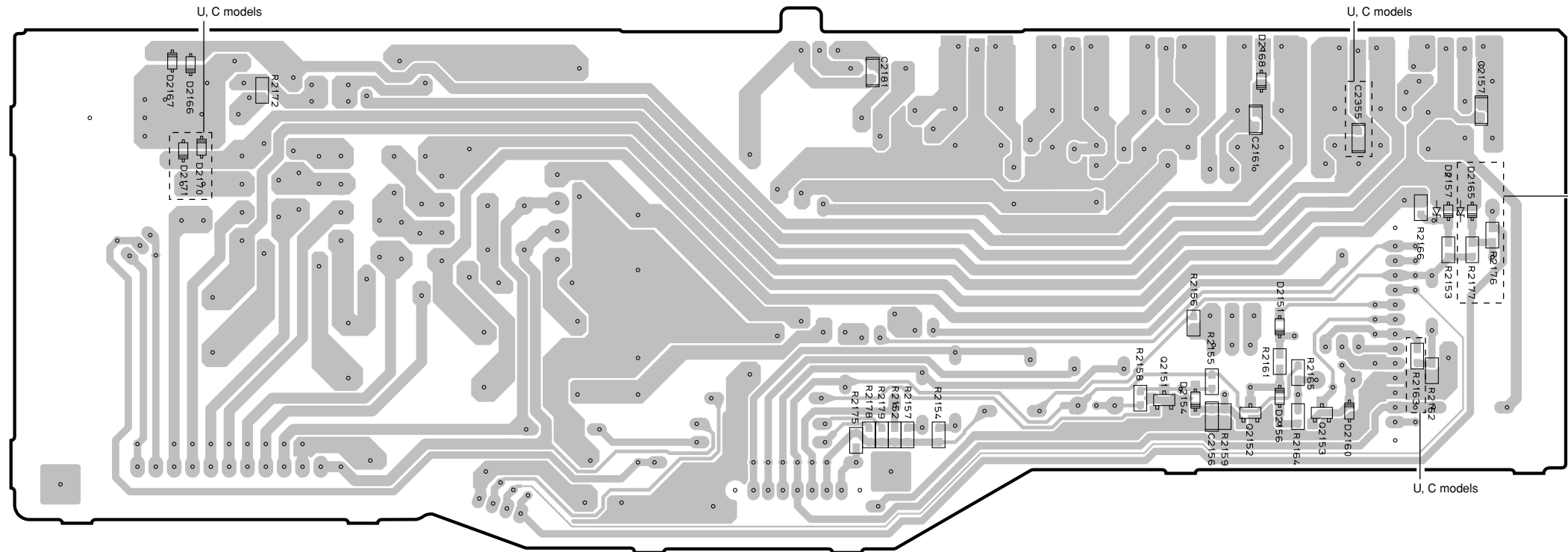

R, T, K, A, B, G, E, F, L models

• **Semiconductor Location**

Ref no.	Location	Ref no.	Location
D2151	H4	D2167	C3
D2154	H4	D2168	H3
D2156	H4	D2170	C3
D2157	I3	D2171	C3
D2160	H4	Q2151	G4
D2165	I3	Q2152	H4
D2166	C3	Q2153	H4

**OPERATION (3) P.C.B.** (Side A)

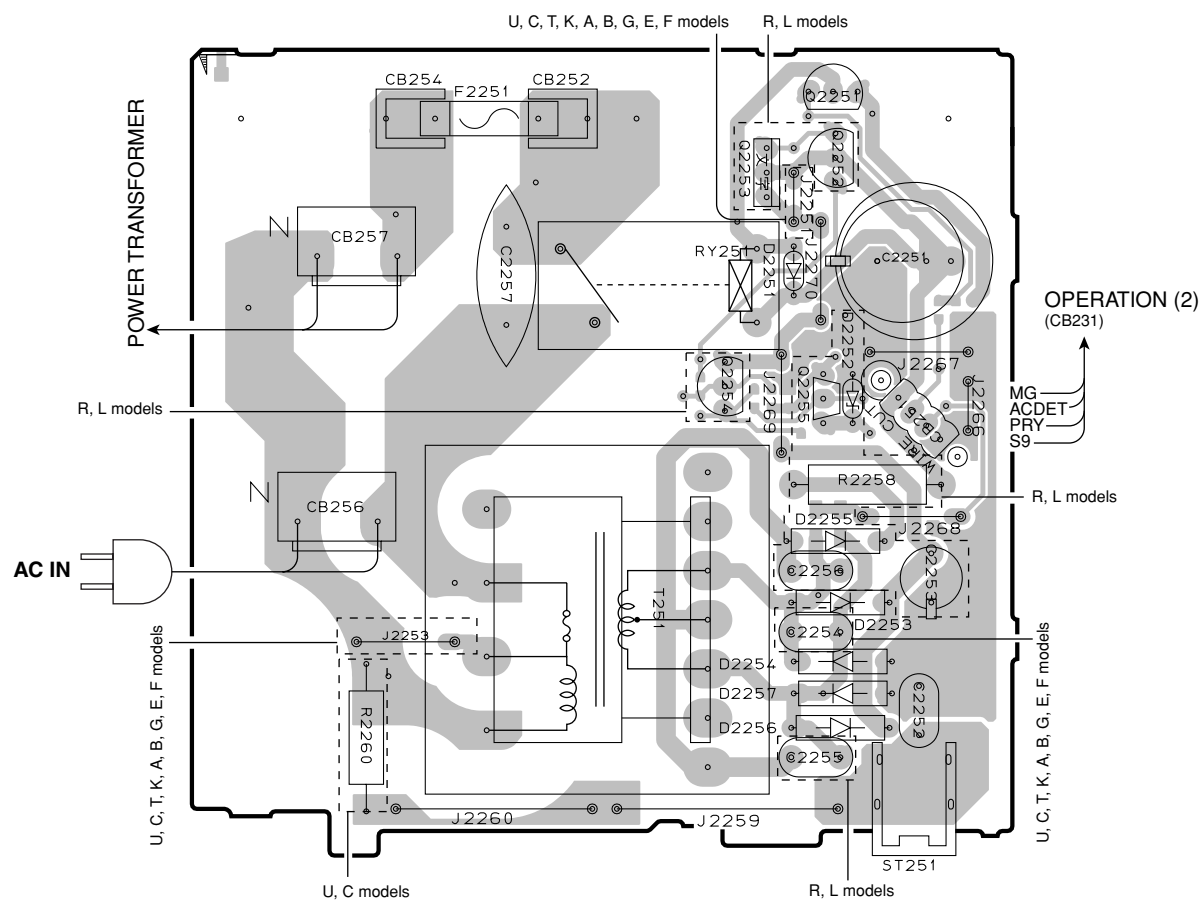

**OPERATION (3) P.C.B.** (Side B)

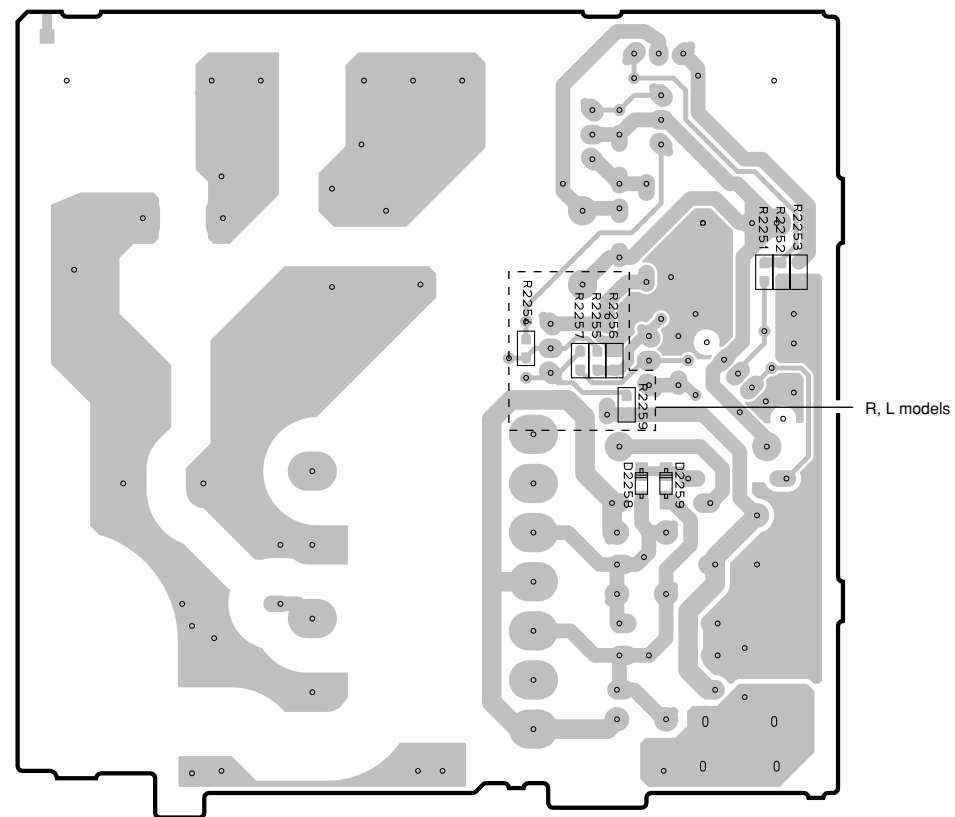

• **Semiconductor Location**

Ref no.	Location	Ref no.	Location
CB251	D4	D2256	D5
CB252	C3	D2257	D5
CB254	C3	Q2251	D3
CB256	B4	Q2252	D3
CB257	B3	Q2253	D3
D2251	D3	Q2254	D4
D2252	D4	Q2255	D4
D2253	D4	D2258	H4
D2254	D5	D2259	I4
D2255	D4		



OPERATION (4) P.C.B. (Side A)

OPERATION (4) P.C.B. (Side B)

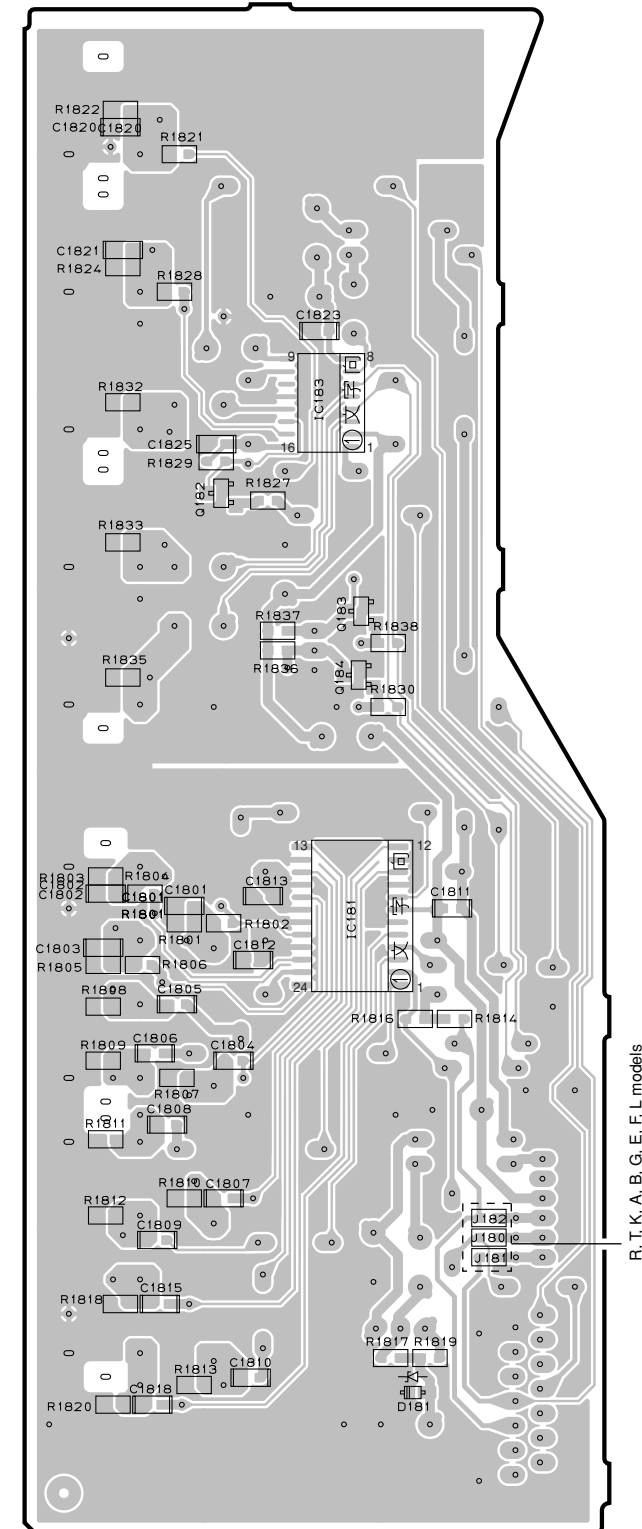
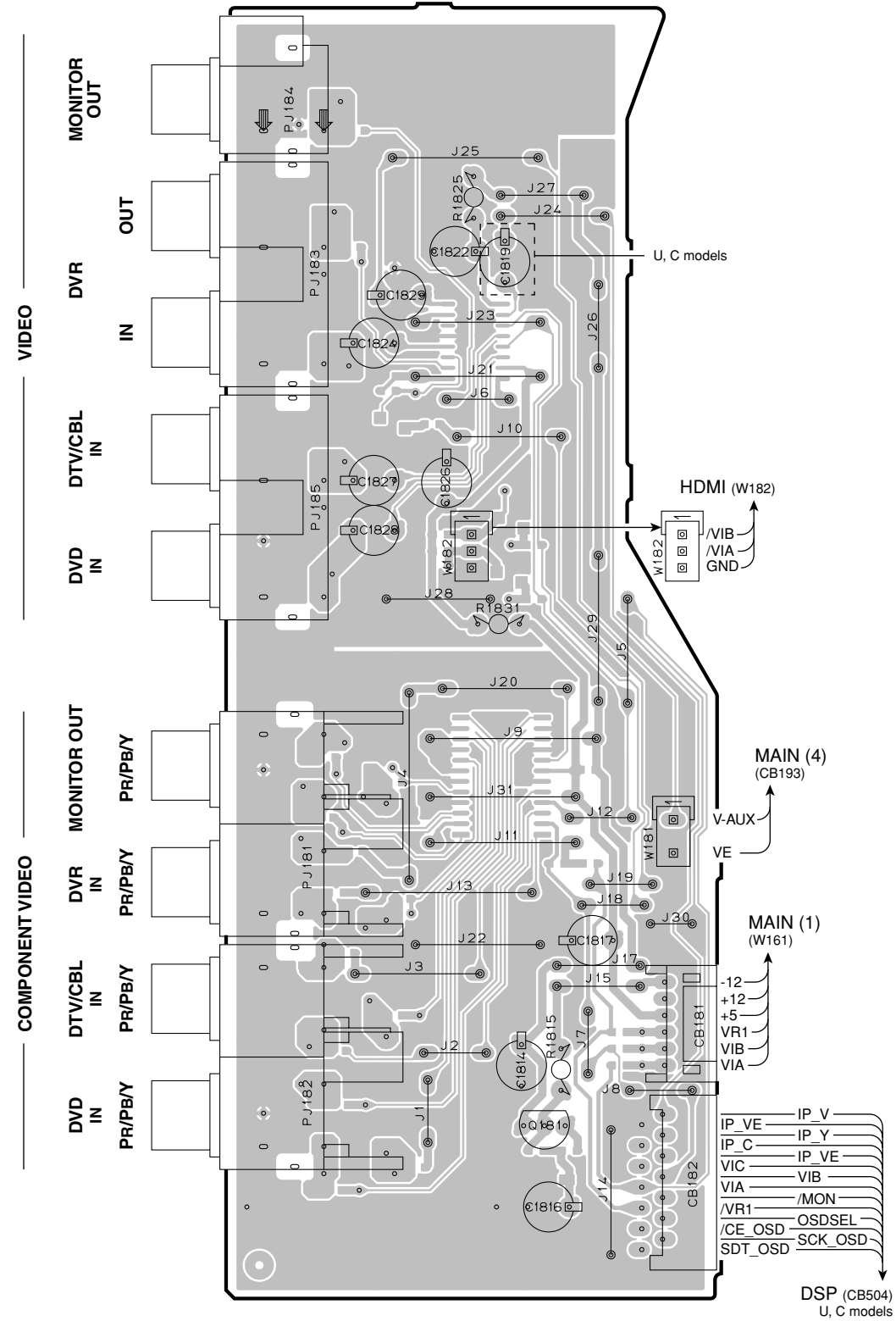

• Semiconductor Location

Ref no.	Location
CB181	D6
CB182	D6
Q181	D6
D181	G6
IC181	G5
IC183	G3
Q182	G3
Q183	G4
Q184	G4

**OPERATION (5) P.C.B.** (Side A)

R, L models

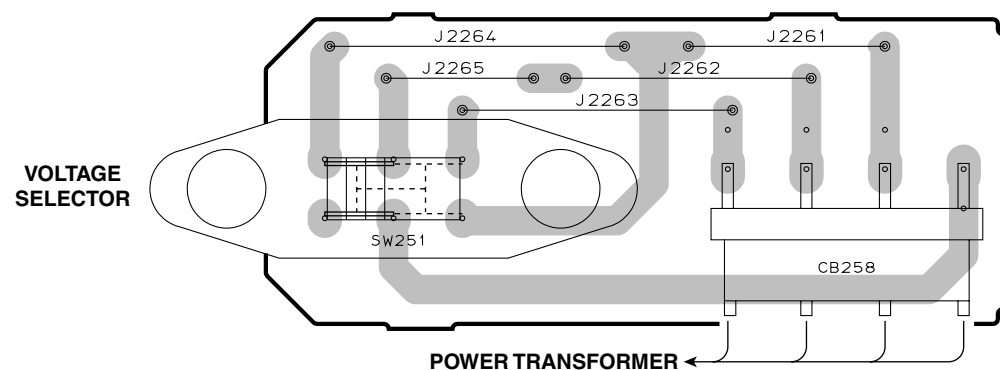

**OPERATION (5) P.C.B.** (Side B)

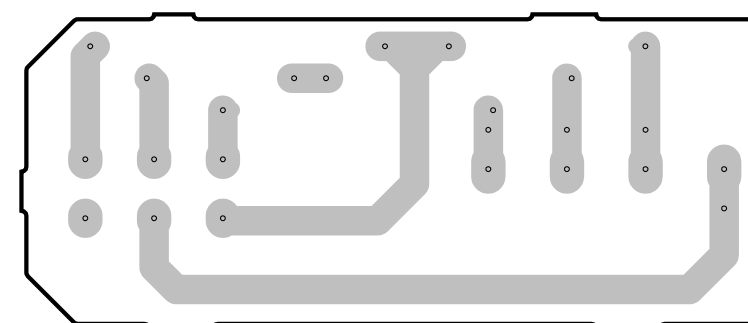

**OPERATION (6) P.C.B.** (Side A)

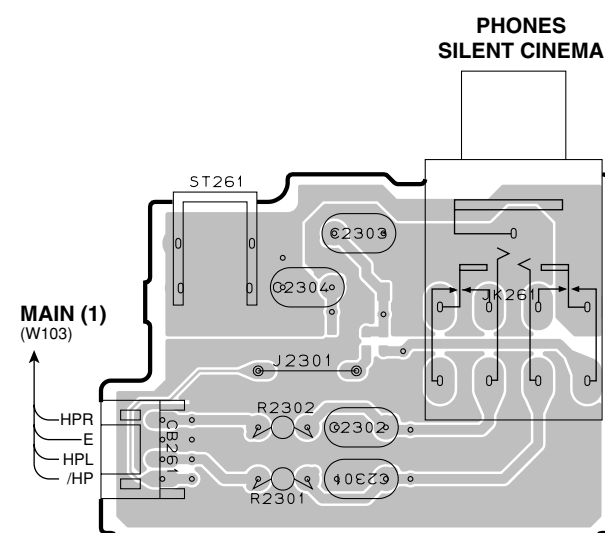

**OPERATION (6) P.C.B.** (Side B)

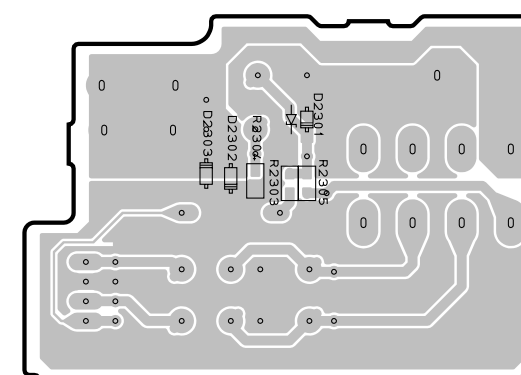

• Semiconductor Location

Ref no.	Location
CB258	D3
CB261	C6
D2301	H5
D2302	H6
D2303	H6

**OPERATION (7) P.C.B.** (Side A)

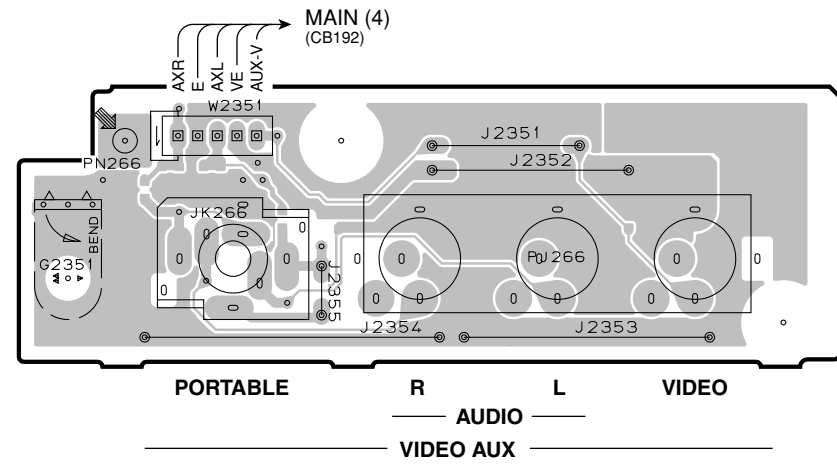

**OPERATION (7) P.C.B.** (Side B)

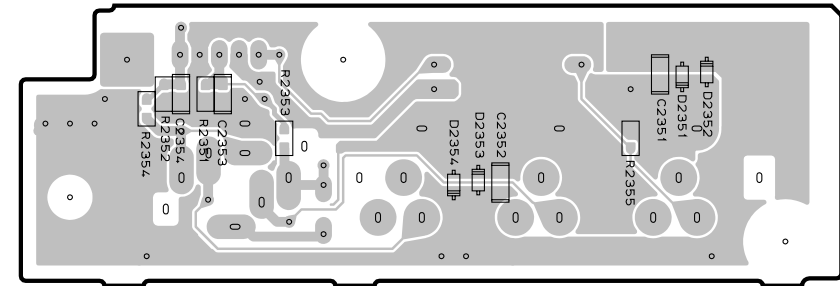

**OPERATION (10) P.C.B.** (Side A)

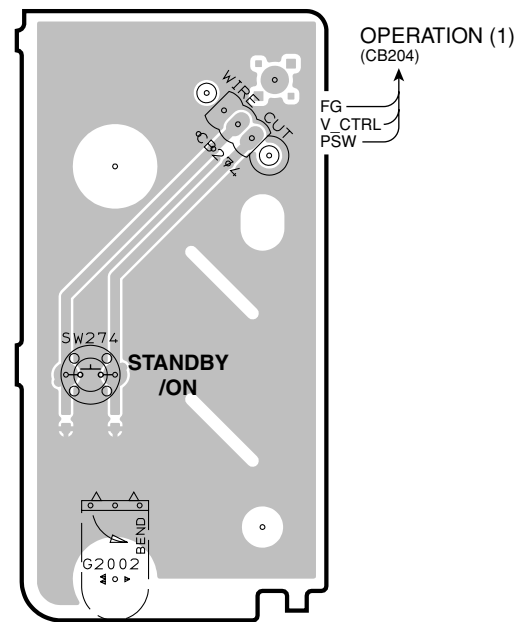

**OPERATION (11) P.C.B.** (Side A)

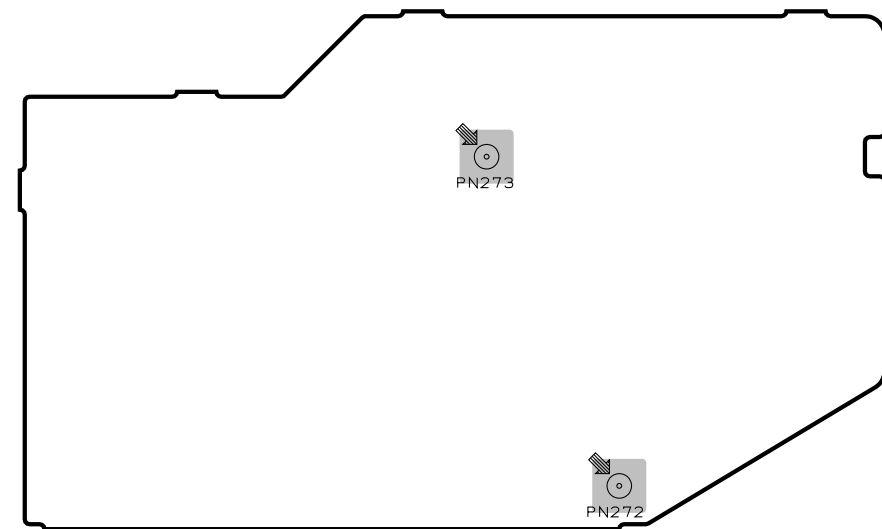

• Semiconductor Location

Ref no.	Location
CB274	C5
D2351	I2
D2352	I2
D2353	H3
D2354	H3

**MAIN (1) P.C.B.** (Side A)

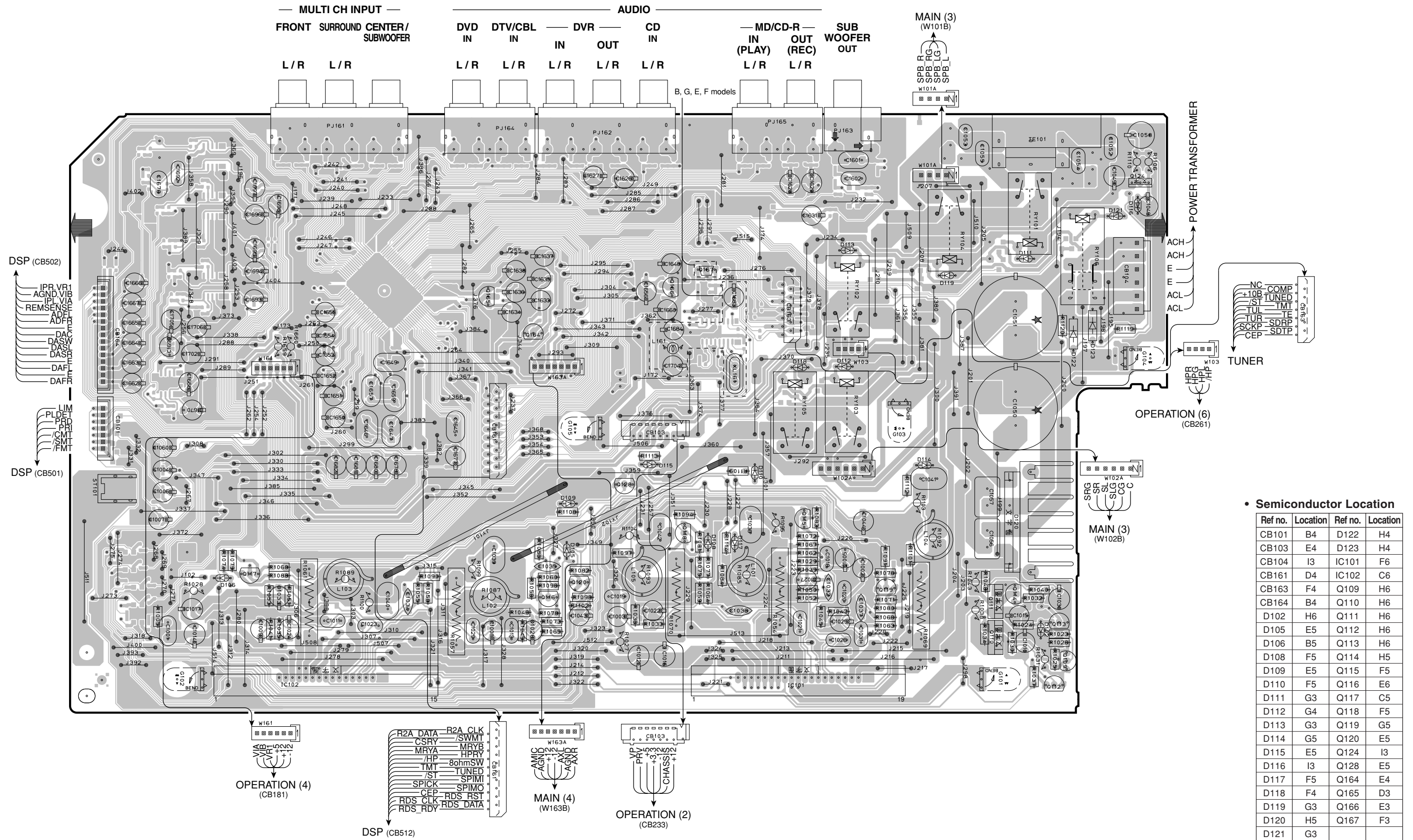

**• Semiconductor Location**

Ref no.	Location	Ref no.	Location
CB101	B4	D122	H4
CB103	E4	D123	H4
CB104	I3	IC101	F6
CB161	D4	IC102	C6
CB163	F4	Q109	H6
CB164	B4	Q110	H6
D102	H6	Q111	H6
D105	E5	Q112	H6
D106	B5	Q113	H6
D108	F5	Q114	H5
D109	E5	Q115	F5
D110	F5	Q116	E6
D111	G3	Q117	C5
D112	G4	Q118	F5
D113	G3	Q119	G5
D114	G5	Q120	E5
D115	E5	Q124	I3
D116	I3	Q128	E5
D117	F5	Q164	E4
D118	F4	Q165	D3
D119	G3	Q166	E3
D120	H5	Q167	F3
D121	G3		

**MAIN (1) P.C.B.** (Side B)

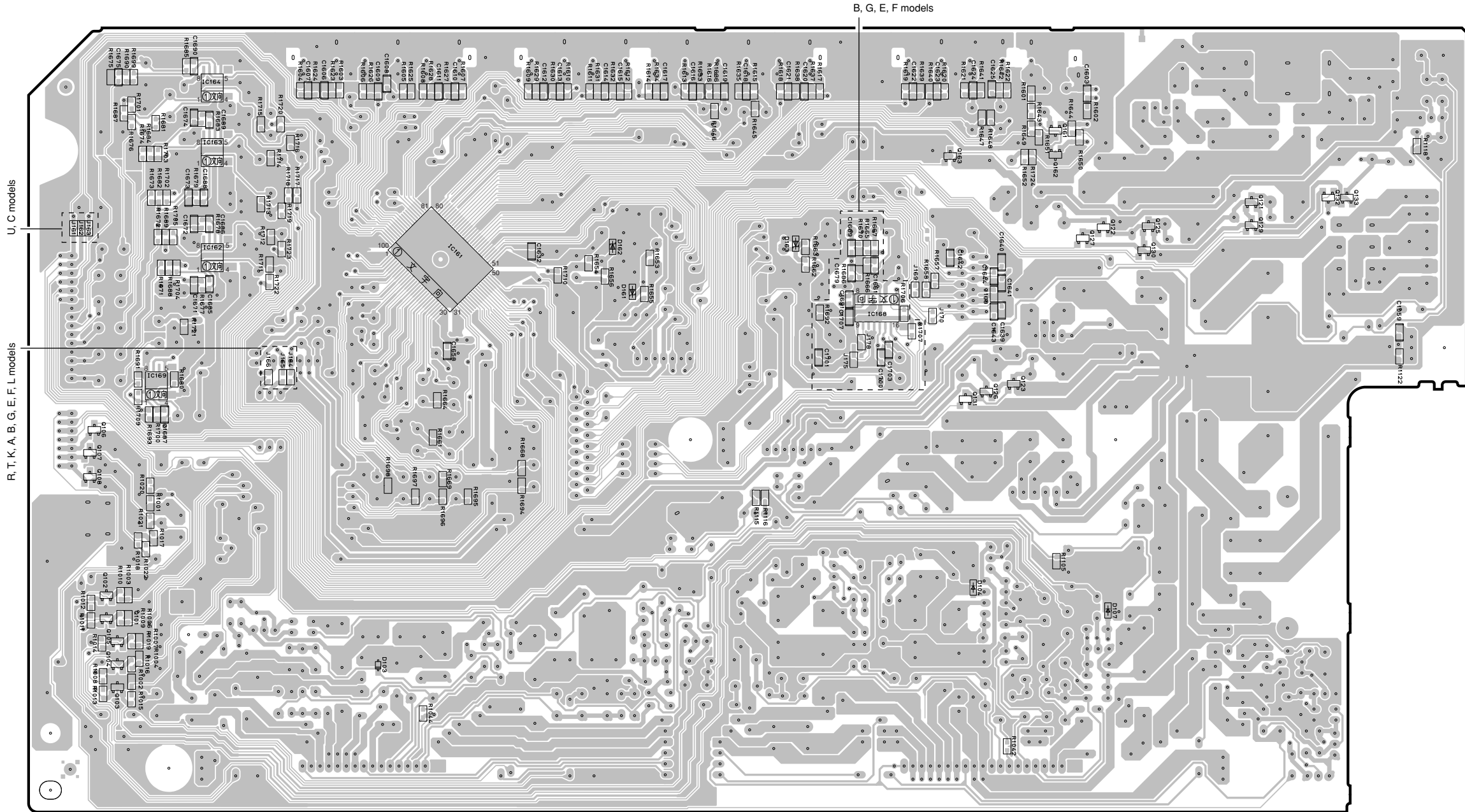

• **Semiconductor Location**

Ref no.	Location	Ref no.	Location
D103	C6	Q106	B4
D104	F5	Q107	B4
D107	G5	Q108	B5
D161	E4	Q121	H3
D162	D3	Q122	G3
D163	E3	Q123	G4
IC161	D3	Q125	G3
IC162	B3	Q126	F4
IC163	B3	Q127	G3
IC164	B3	Q129	H3
IC168	F4	Q130	G3
IC169	B4	Q131	F4
Q101	B5	Q132	H3
Q102	B5	Q133	H3
Q103	B6	Q161	G3
Q104	B6	Q162	G3
Q105	B5	Q163	F3

• Semiconductor Location

Ref no.	Location
CB191	B6
CB192	B6
CB193	C7

**MAIN (3) P.C.B.** (Side A)

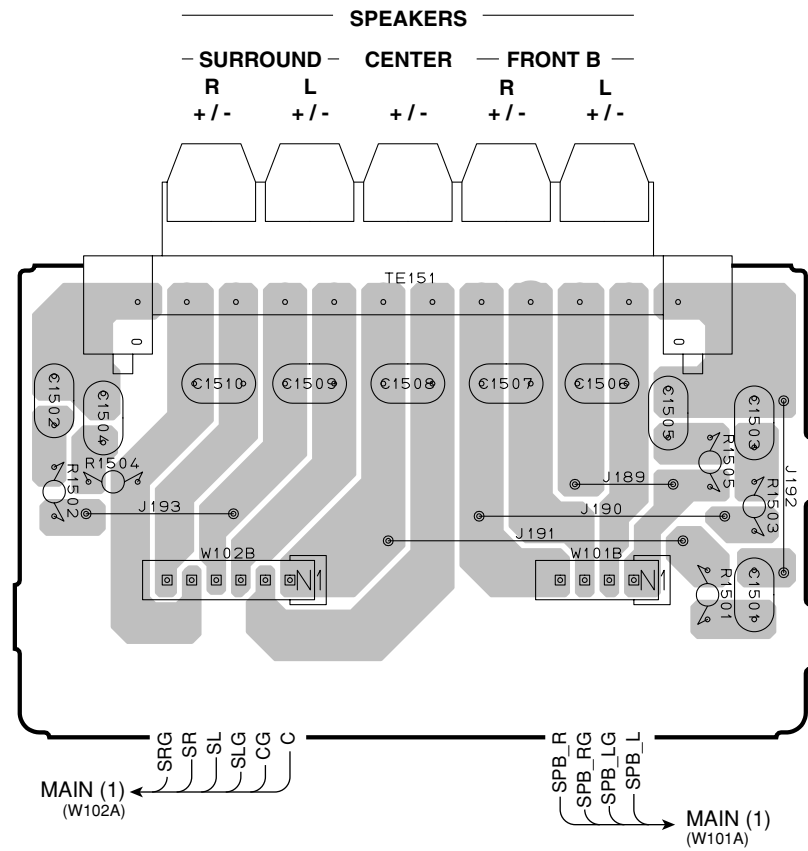

**MAIN (3) P.C.B.** (Side B)

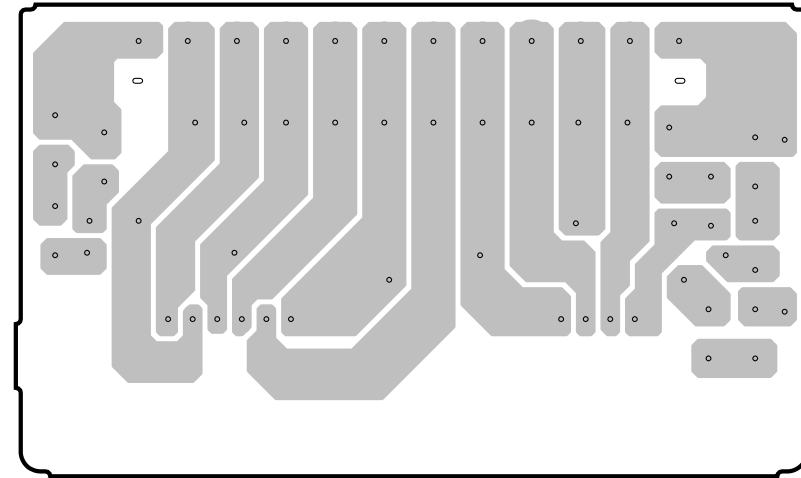

**MAIN (4) P.C.B.** (Side A)

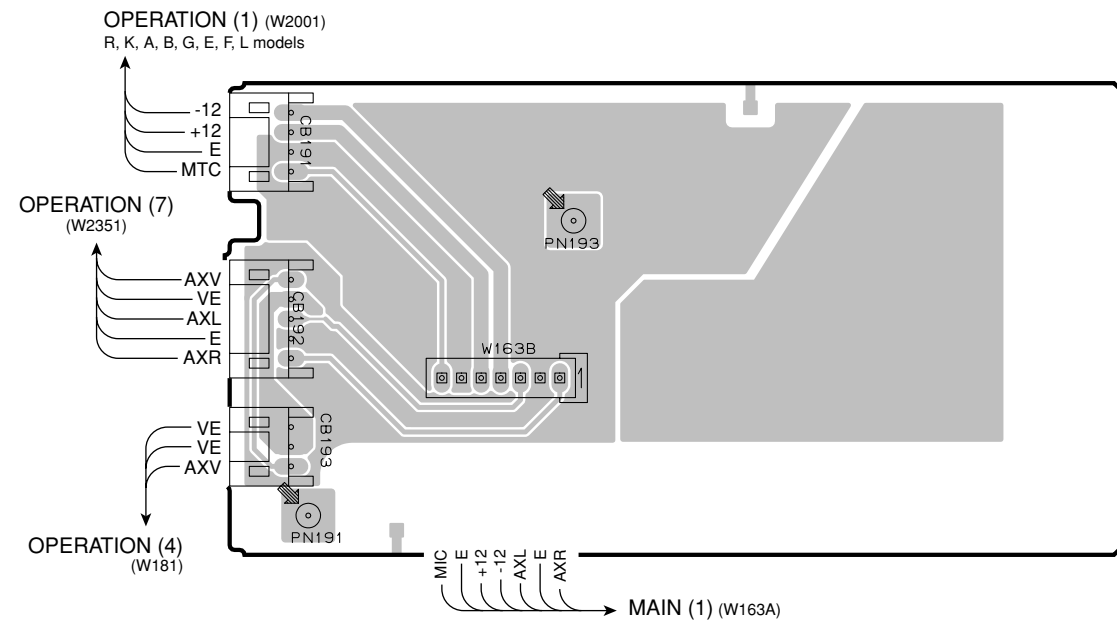

**MAIN (4) P.C.B.** (Side B)

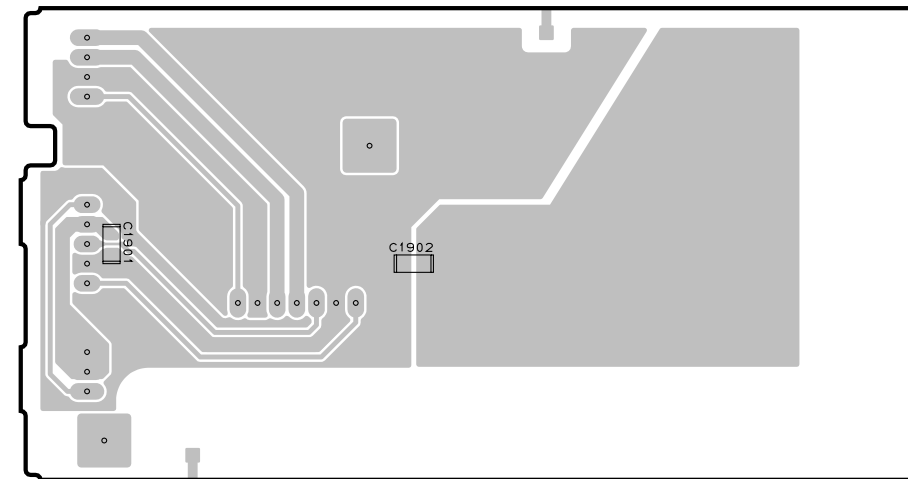

HDMI P.C.B. (Side A)

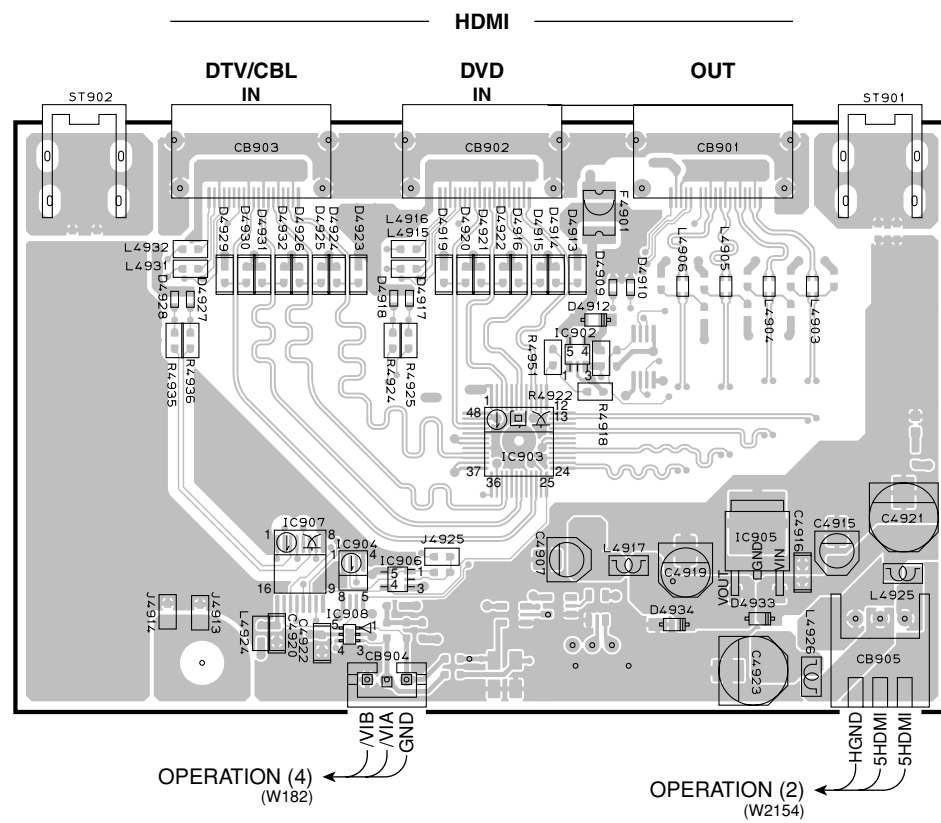

HDMI P.C.B. (Side B)

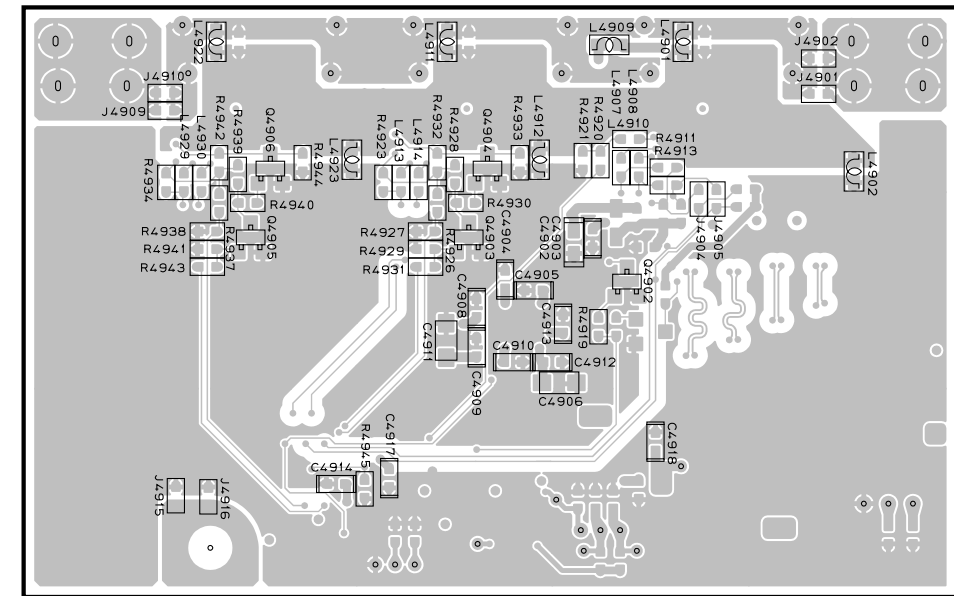

• Semiconductor Location

Ref no.	Location	Ref no.	Location	Ref no.	Location	Ref no.	Location	Ref no.	Location	Ref no.	Location
CB901	D3	D4913	D4	D4921	C4	D4929	B4	IC904	C5	Q4905	G4
CB902	C3	D4914	D4	D4922	C4	D4930	C4	IC905	D5	Q4906	G4
CB903	C3	D4915	C4	D4923	C4	D4931	C4	IC906	C5		
CB904	C5	D4916	C4	D4924	C4	D4932	C4	IC907	C5		
CB905	D5	D4917	C4	D4925	C4	D4933	D5	IC908	C5		
D4909	D4	D4918	C4	D4926	C4	D4934	D5	Q4902	H4		
D4910	D4	D4919	C4	D4927	B4	IC902	D4	Q4903	H4		
D4912	D4	D4920	C4	D4928	B4	IC903	C4	Q4904	H4		

## PIN CONNECTION DIAGRAMS

### ICs

<p>ADC084S021 CIMM</p>	<p>ADSP-BF531 CPU</p>	<p>AK4588VQ</p>	<p>BR25L320F-W EEPROM</p>
<p>CXB1442AR-T4</p>	<p>K4S641632K-UC60000</p>	<p>KIA7805API KIA7812API</p>	<p>KIA79M05PI KIA7912PI</p>
<p>LM61CIZ</p>	<p>LC72725KM NJM2595M (TE1) SN74CB3Q3257PWR</p>	<p>M66003-0131FP-R</p>	<p>NJM2867F3-05</p>
<p>NJM2885DL1-33</p>	<p>NJM2586AM</p>	<p>NJM2388F05 NJM2388F33</p>	<p>NJM4565M</p>
<p>R2A15218FP</p>	<p>SN74AHC02PWR SN74AHC08PWR SN74LV08APWR SN74LVU04APWR</p>	<p>SN74AHCT245PWR SN74LV573APWR</p>	<p>SN74LVC1G08DCKR</p>
<p>SN74LVC2G17DCKR</p>	<p>SN74LVC3G04DCTR</p>	<p>SN74LV157APWR SN74LV4051APWR</p>	<p>STK433-130-E</p>
<p>STK433-330-E</p>			

### Diodes

<p>1SS133, 176 1SS270A 1T2 MTZJ4.7A MTZJ3.3B</p>	<p>RB160L-40 TE25</p>	<p>MA8075-H MA8100-H</p>	<p>KDS160-RTK</p>
<p>KBP103G 1.0A 200V</p>	<p>1SS355 RB500V-40 UDZ3.6BTE-17 UDZ5.1B UDZS3.3BTE-17 UDZS5.6BTE-17 UDZS9.1B</p>	<p>TS6P03G 6.0A 200V</p>	

### Transistors

<p>2SA1015 2N5401C 2N5551C</p>	<p>2SA1037K 2SC2412K 2SC3326 2SD1938F</p>	<p>2SA1708</p>	<p>2SC1740S</p>	<p>2SC1815 2SC2705</p>
<p>KRC102M-AT</p>	<p>KRA102S-RTK/P KRA104S-RTK KRC102S-RTK KRC104S-RTK</p>	<p>KTA1046-Y-U/P</p> <p>1: Base 2: Collector 3: Emitter</p>	<p>RTQ040P02</p> <p>1. Drain 2. Drain 3. Gate 4. Source 5. Drain 6. Drain</p>	



SCHEMATIC DIAGRAMS  
DSP 1/6

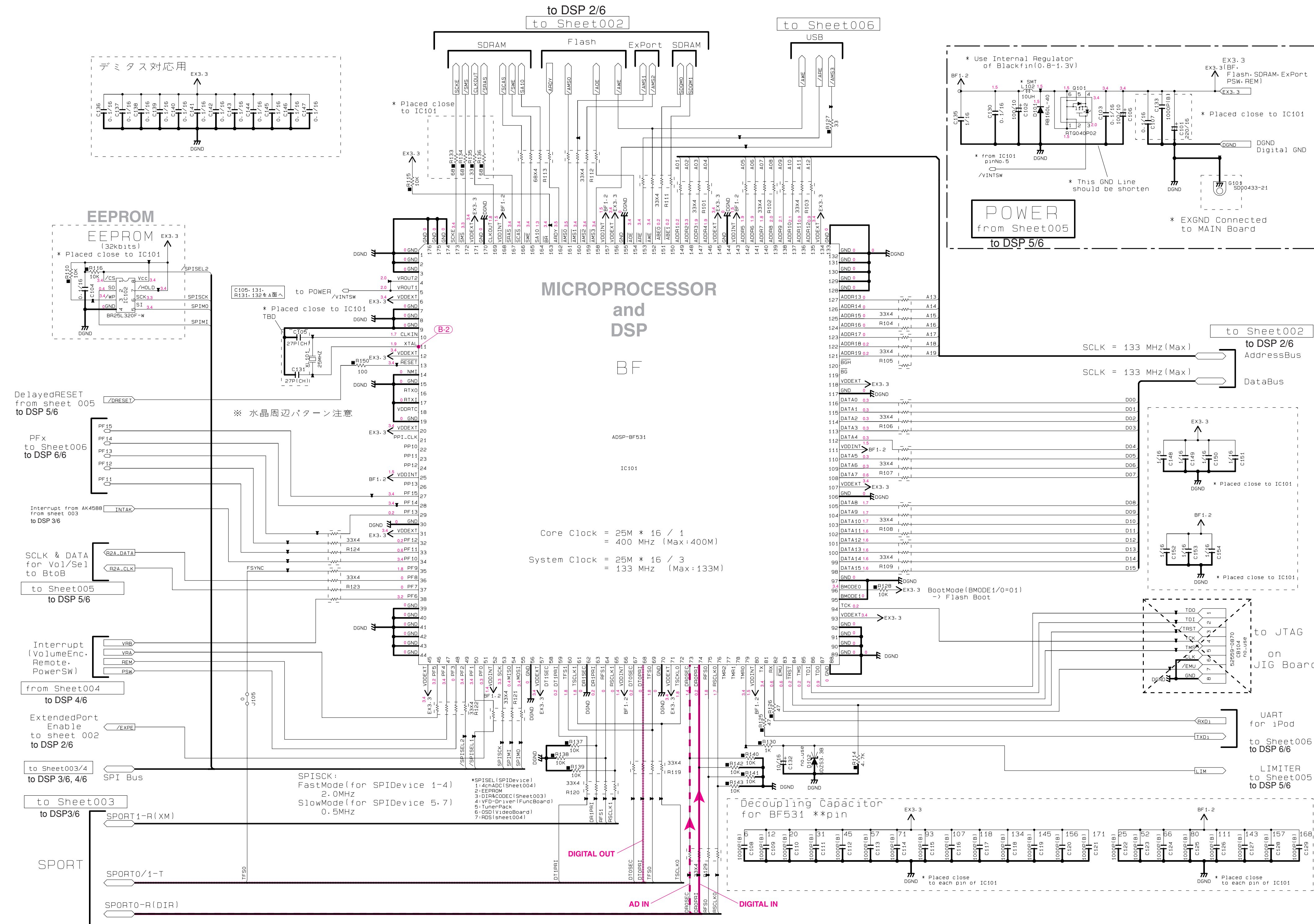

REMARKS	PARTS_NAME
NO MARK	CARBON FILM RESISTOR (P=5)
□	CARBON FILM RESISTOR (P=10)
△	METAL FILM RESISTOR
⊠	METAL PLATE RESISTOR
⊞	FIRE PROOF CARBON FILM RESISTOR
⊞	CEMENT MOLDED RESISTOR
⊞	SEMI VARIABLE RESISTOR
■	CHIP RESISTOR

REMARKS	PARTS_NAME
NO MARK	ELECTROLYTIC CAPACITOR
⊗	TANTALUM CAPACITOR
○	CERAMIC CAPACITOR
●	CERAMIC TUBULAR CAPACITOR
⊙	POLYESTER FILM CAPACITOR
⊚	POLYSTYRENE FILM CAPACITOR
⊛	MICA CAPACITOR
⊜	POLYPROPYLENE FILM CAPACITOR
⊝	SEMICONDUCTIVE CERAMIC CAPACITOR
⊞	POLYPHENYLENE SULFIDE FILM CAPACITOR

NOTICE (mode))  
(J)..... JAPAN  
(U)..... U.S.A  
(C)..... CANADA  
(R)..... GENERAL  
(T)..... CHINA  
(K)..... KOREA  
(A)..... AUSTRALIA  
(B)..... BRITISH  
(G)..... EUROPE  
(L)..... SINGAPORE  
(E)..... SOUTH EUROPE  
(V)..... TAIWAN  
(F)..... RUSSIAN

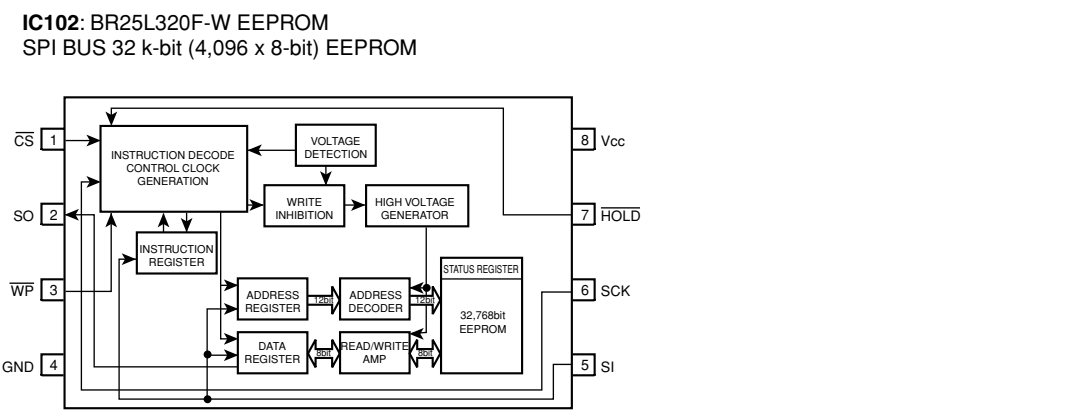
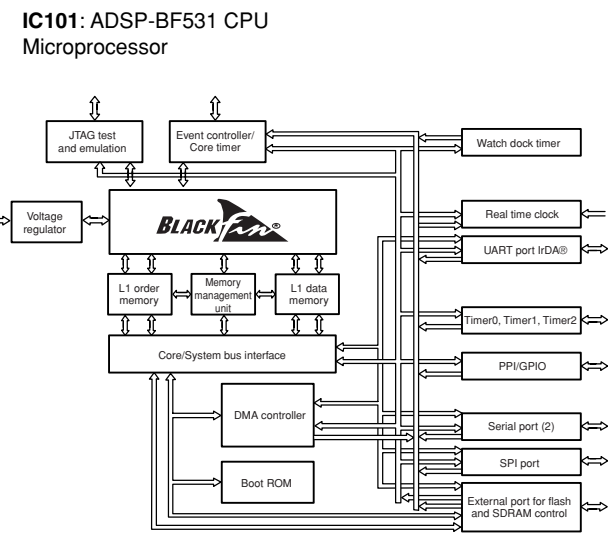
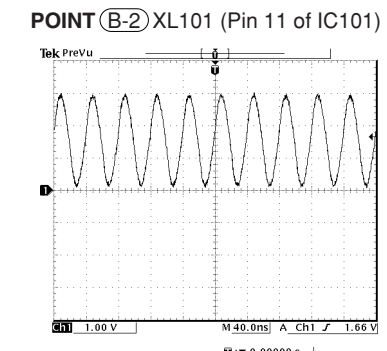

\* All voltages are measured with a 10MQ/V DC electronic voltmeter.  
\* Components having special characteristics are marked .! and must be replaced with parts having specifications equal to those originally installed.  
\* Schematic diagram is subject to change without notice.

DSP 2/6

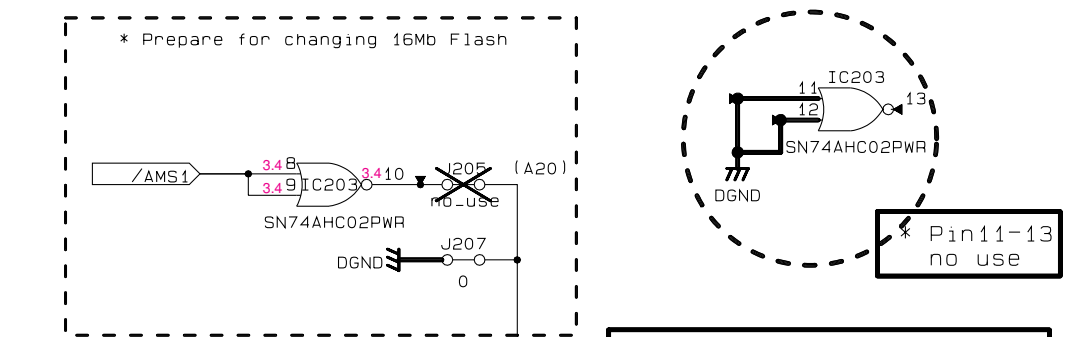
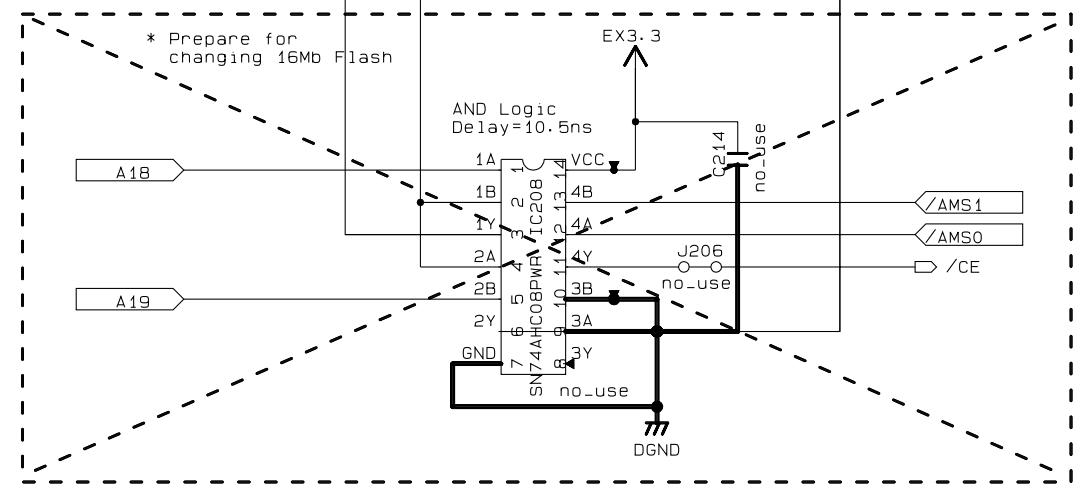
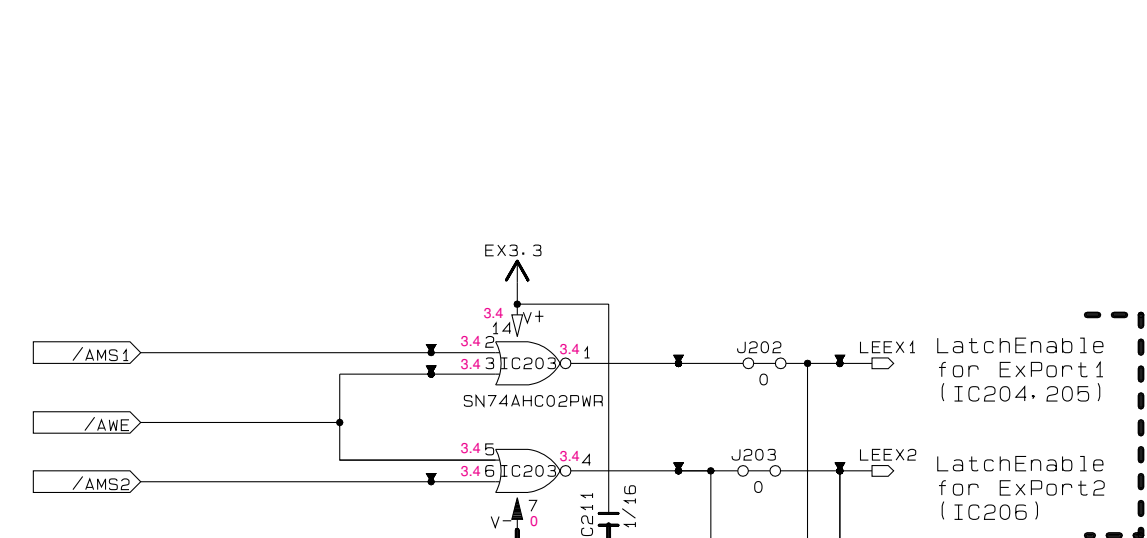

**FlashROM**  
X9590A0  
(F49L160BA-70TG)

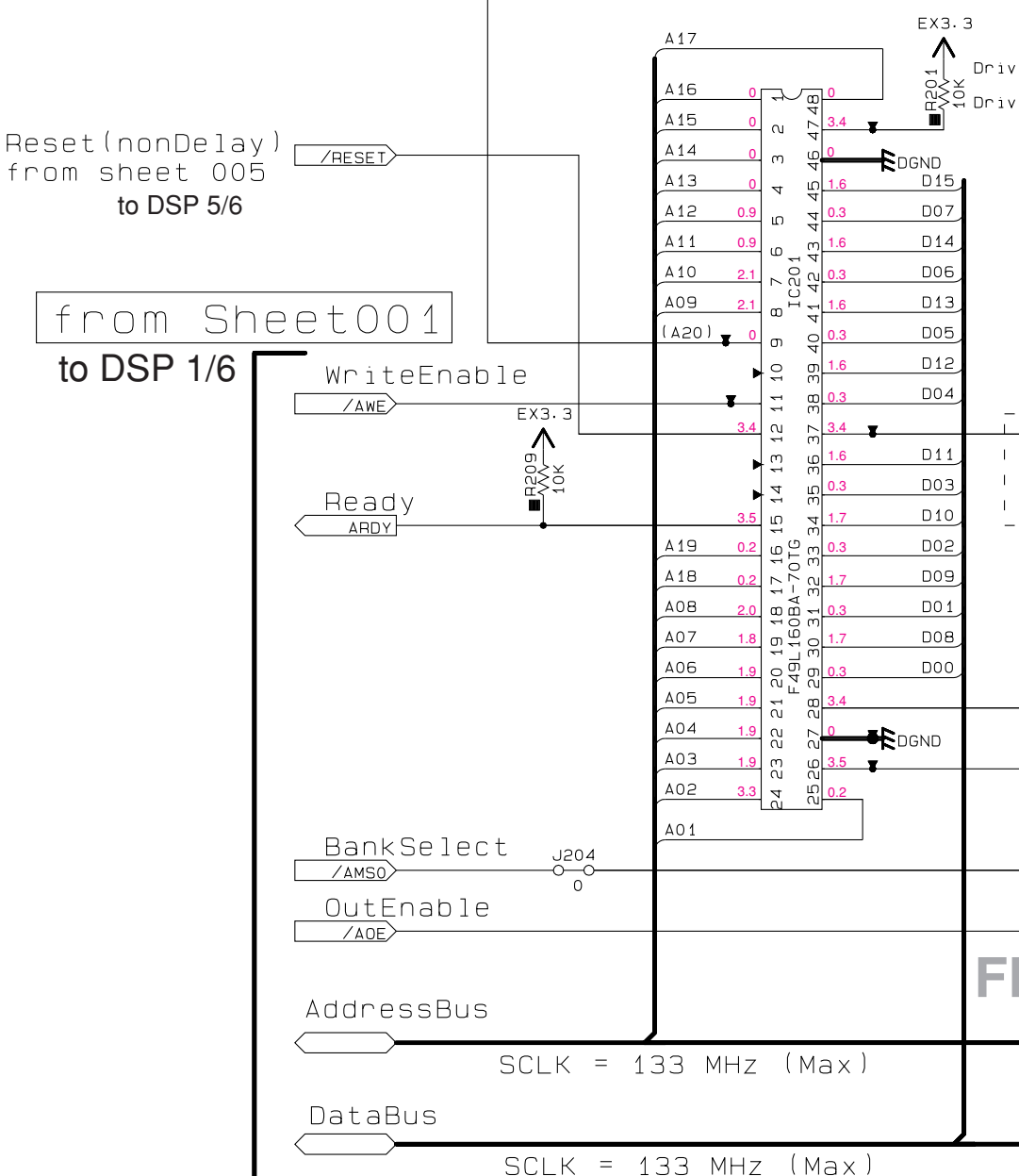

- Asynchronous Memory Bank '0'
- Setup : \*\* Cycle (1-4)
  - Read : \*\* Cycle (1-15)
  - Write : \*\* Cycle (1-15)
  - Hold : \*\* Cycle (0-3)
  - Trans : \*\* Cycle (1-4)

\* If use 16Mb FlashROM  
Setup = 3. Read = Write = 10 for FlashROM  
Setup = 4. Write = 3 for Ex-Port

to DSP 1/6  
from sheet 001

**SDRAM**  
SDRAM

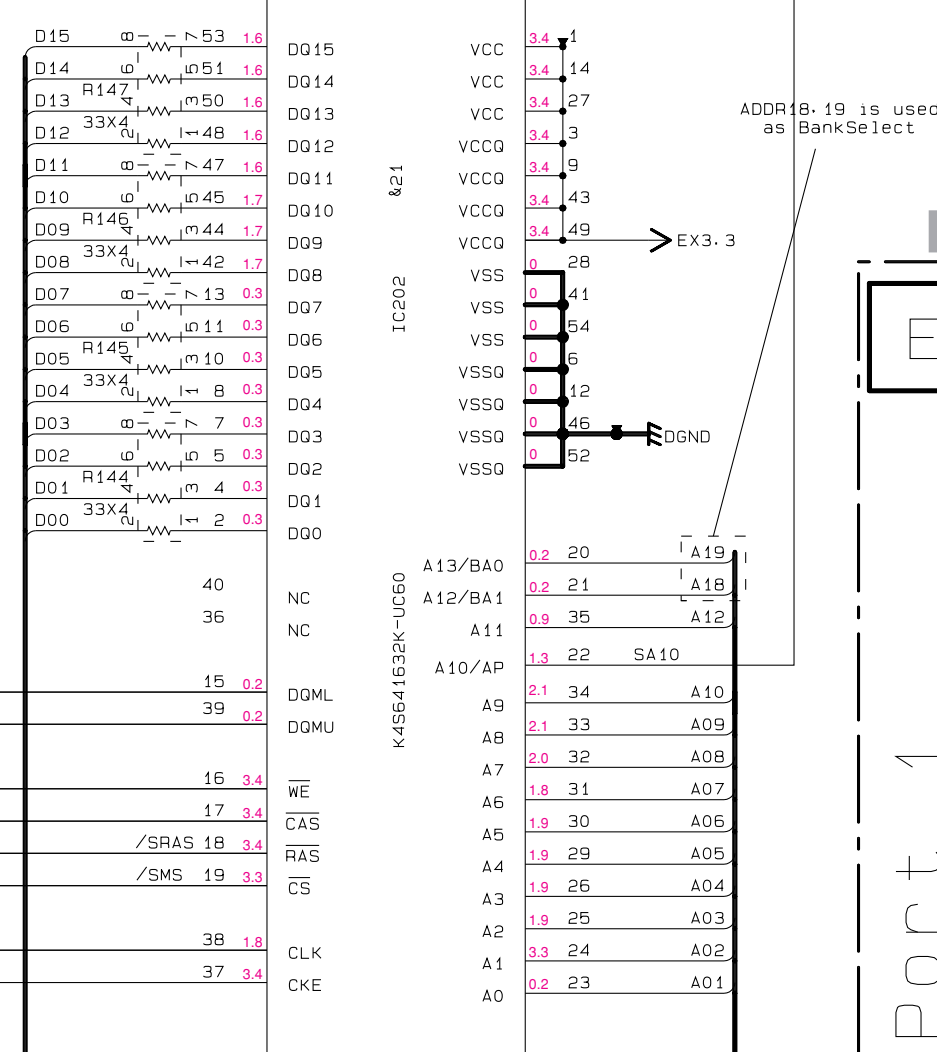

Decoupling Capacitor for SDRAM \*pin

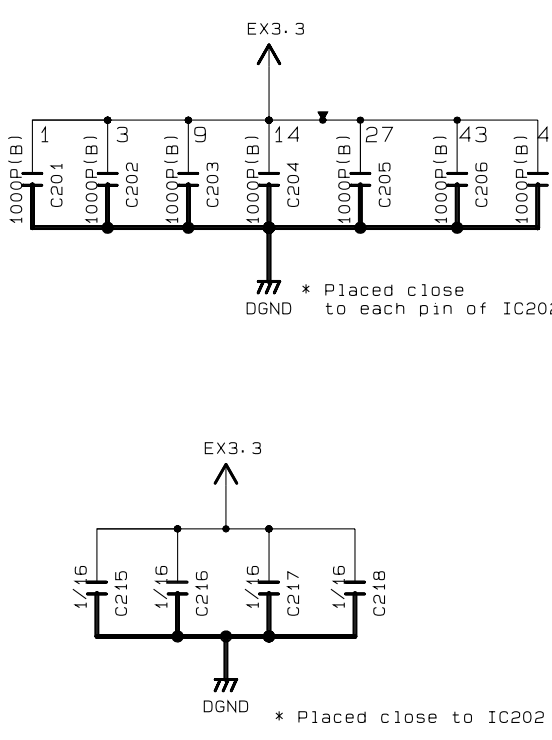

- Asynchronous Memory Bank '2'
- Setup : \*\* Cycle (1-4)
  - Read : \*\* Cycle (1-15)
  - Write : \*\* Cycle (1-15)
  - Hold : \*\* Cycle (0-3)
  - Trans : \*\* Cycle (1-4)

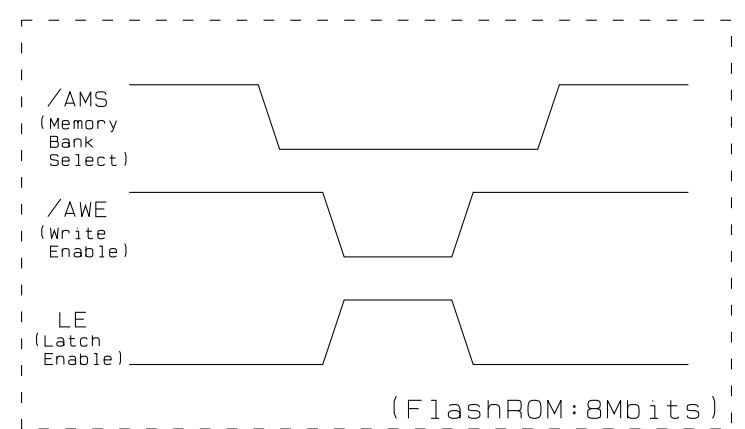

Interchangeable Parts at Manufacture-Stage

Mark	Reference Parts Number	Parts Name
421	IC202	K4S641632K-UC60000 M12L64164A-5TG

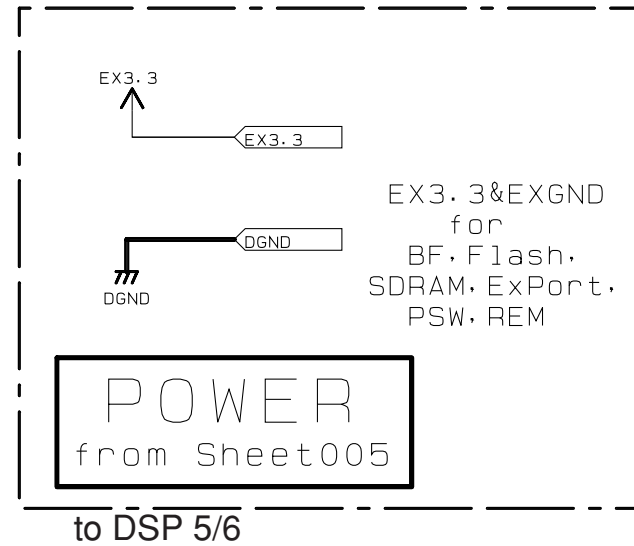

**EXTENDED PORT**  
ExtendedPort

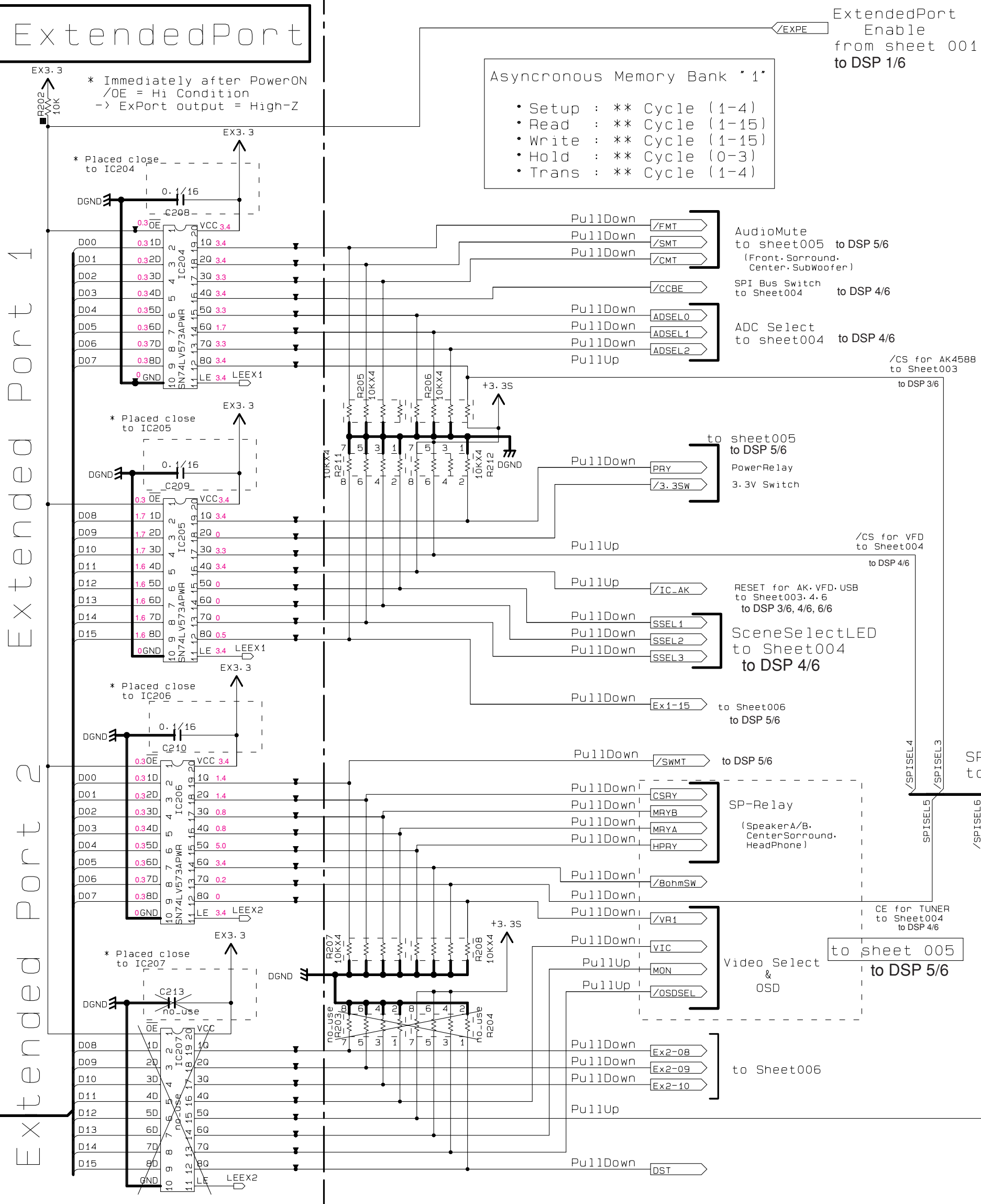

IC202: K4S641632K-UC60000  
64 M synchronous DRAM

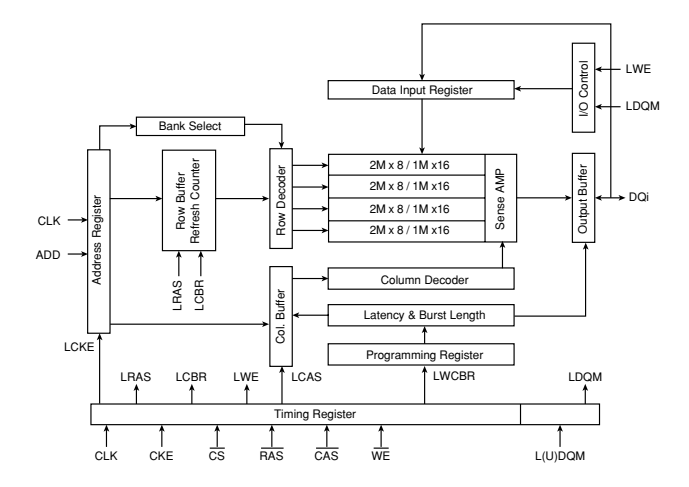

IC203: SN74AHC02PWR  
Quaduple 2-input positive-NOR gates

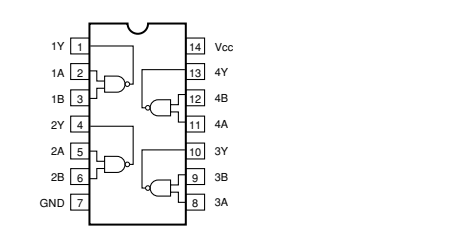

IC204-206: SN74LV573APWR  
Octal transparent D-type latches with 3-state outputs

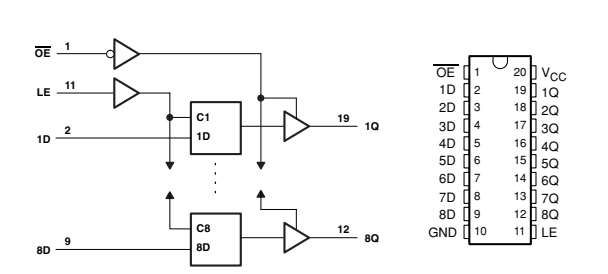

RESISTOR

REMARKS	PARTS NAME
NO MARK	CARBON FILM RESISTOR (P=5)
□	CARBON FILM RESISTOR (P=10)
△	METAL OXIDE FILM RESISTOR
▲	METAL FILM RESISTOR
■	METAL PLATE RESISTOR
⊠	FIRE-PROOF CARBON FILM RESISTOR
⊞	CEMENT MOLDED RESISTOR
⊚	SEMI-VARIABLE RESISTOR
■	CHIP RESISTOR

CAPACITOR

REMARKS	PARTS NAME
NO MARK	ELECTROLYTIC CAPACITOR
⊗	TANTALUM CAPACITOR
NO MARK	CERAMIC CAPACITOR
⊙	CERAMIC TUBULAR CAPACITOR
△	POLYESTER FILM CAPACITOR
○	POLYSTYRENE FILM CAPACITOR
⊖	MICA CAPACITOR
⊕	POLYPROPYLENE FILM CAPACITOR
⊙	SEMICONDUCTIVE CERAMIC CAPACITOR
⊙	POLYPHENYLENE SULFIDE FILM CAPACITOR

NOTICE (mode11)  
(J)..... JAPAN  
(U)..... U.S.A  
(C)..... CANADA  
(R)..... GENERAL  
(T)..... CHINA  
(K)..... KOREA  
(A)..... AUSTRALIA  
(B)..... BRITISH  
(G)..... EUROPE  
(L)..... SINGAPORE  
(E)..... SOUTH EUROPE  
(V)..... TAIWAN  
(F)..... RUSSIAN

\* All voltages are measured with a 10MΩ/V DC electronic voltmeter.  
\* Components having special characteristics are marked with a triangle and must be replaced with parts having specifications equal to those originally installed.  
\* Schematic diagram is subject to change without notice.

Interchangeable Parts at Manufacture-Stage

Mark	Reference Parts Number	Parts Name
422	U301-U302	JSR1165 GP1FAYS1RKF

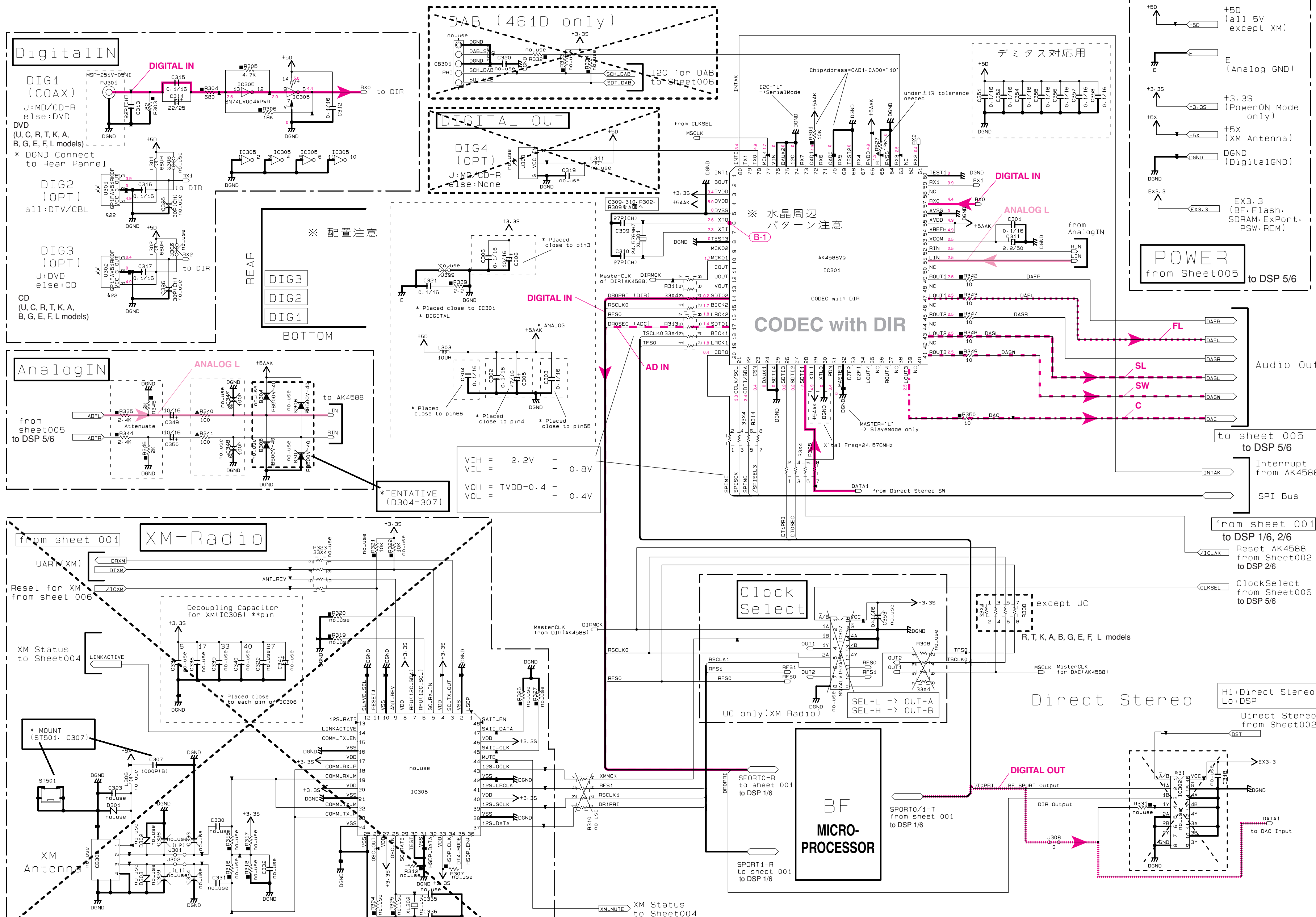



DSP 5/6

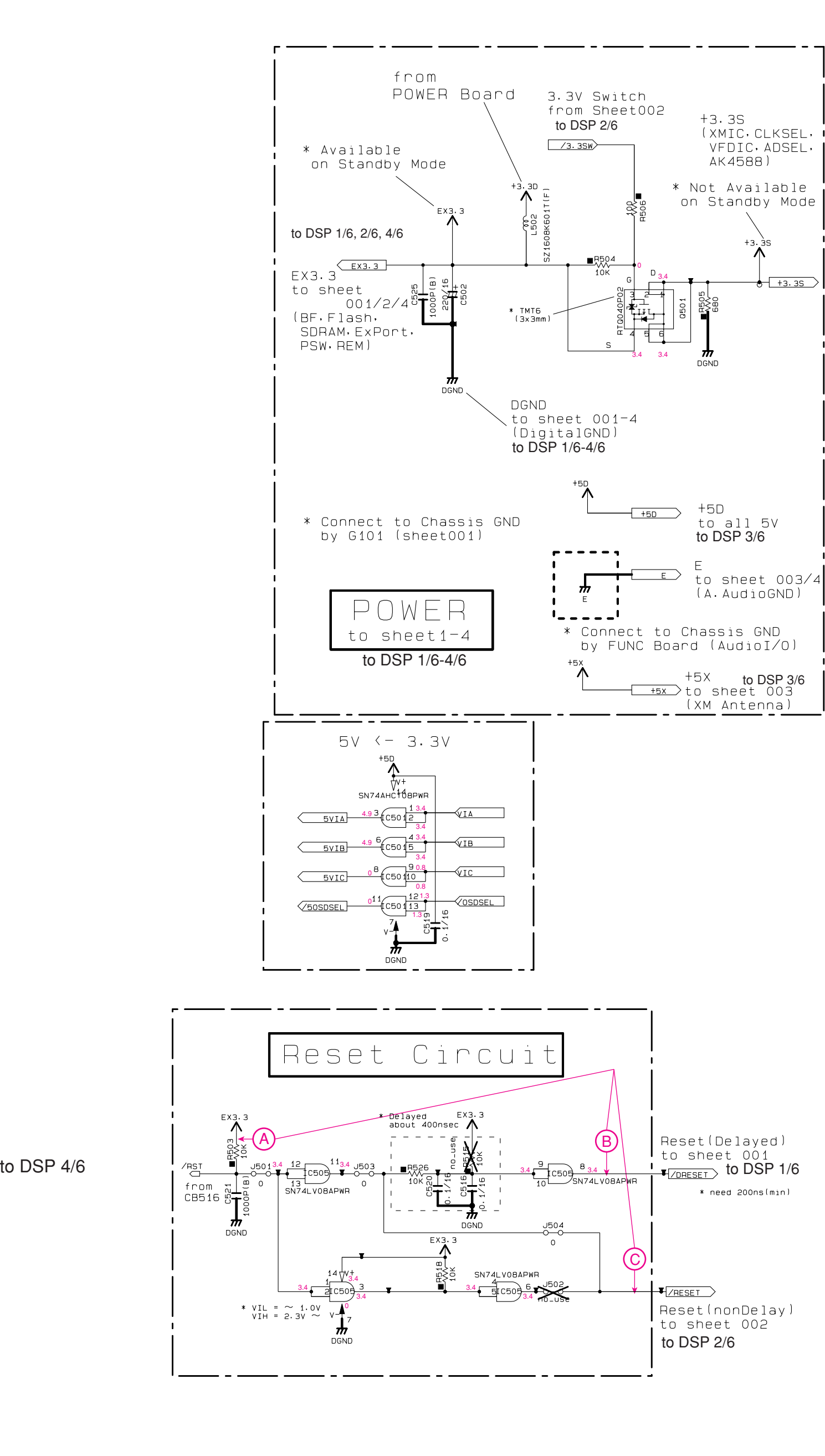
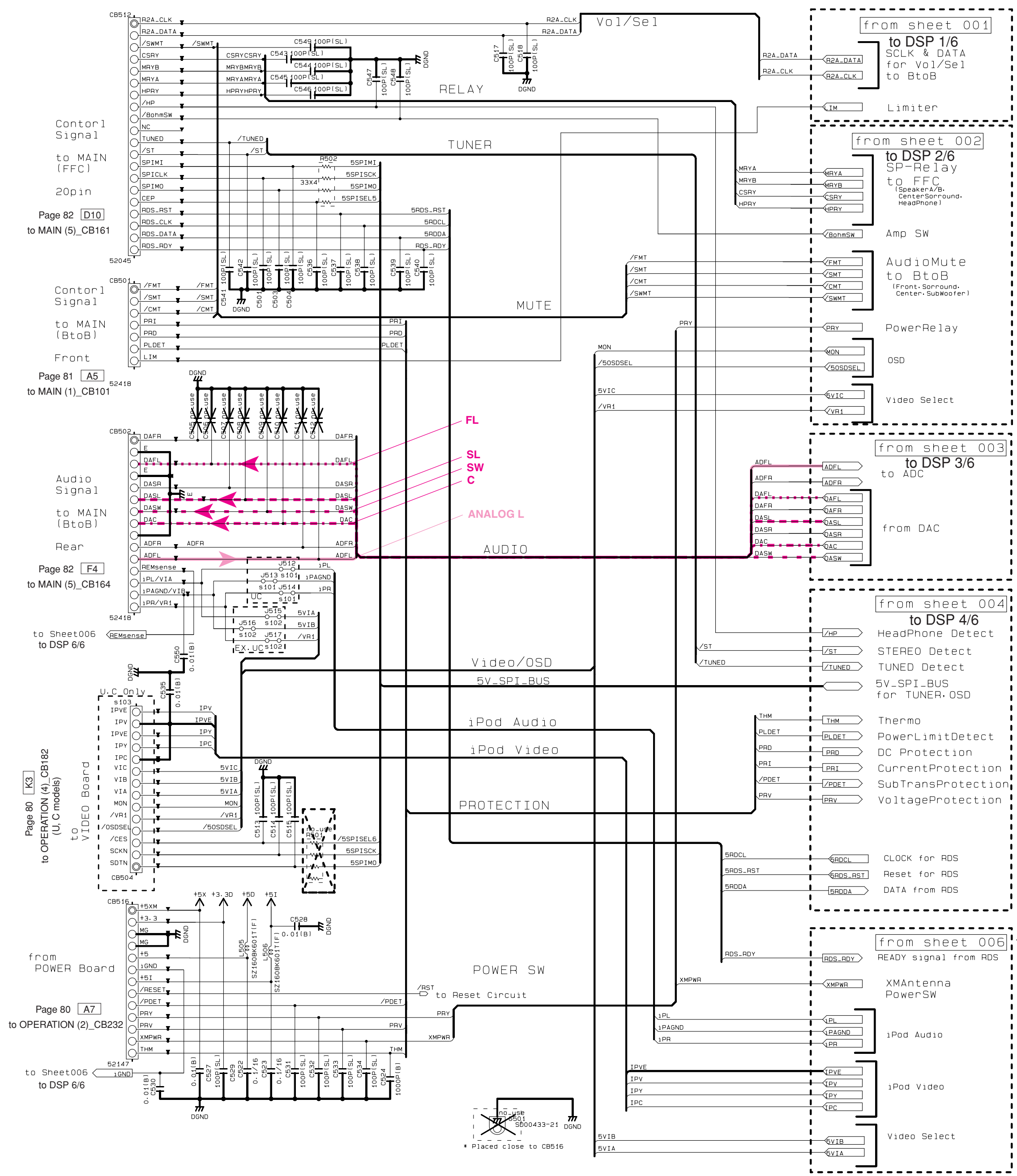

Destination Part List

sxx	LOC	UC	RL	T	KA	BOEF
s101	J514	RD35000	X	X	X	X
	J512	0				
	J513	0				
s102	J517	X	RD35000	0	RD35000	0
	J518	0				
	J519	0				
s103	CB504	VN39450	X	X	X	X
		52045				

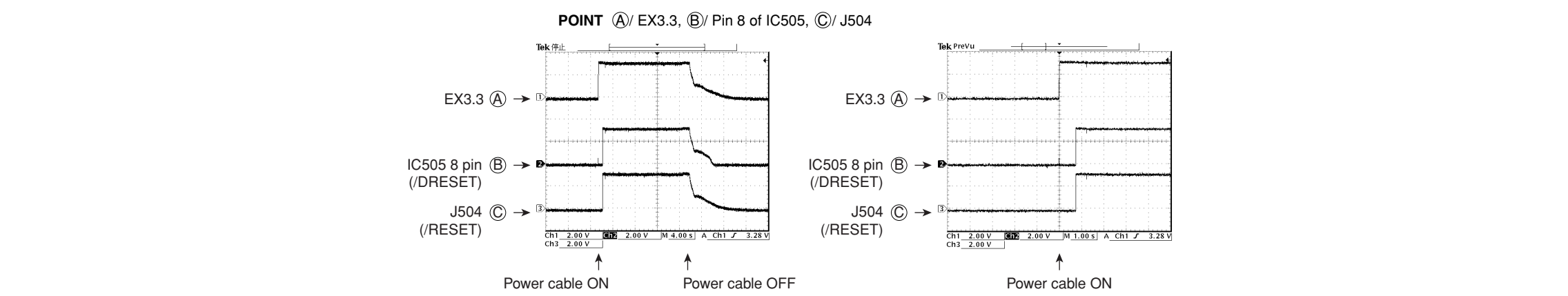

REMARKS	PARTS NAME	REMARKS	PARTS NAME
NO MARK	CARBON FILM RESISTOR (P=5)	NO MARK	ELECTROLYTIC CAPACITOR
□	CARBON FILM RESISTOR (P=10)	⊗	TANTALUM CAPACITOR
△	METAL OXIDE FILM RESISTOR	○	CERAMIC CAPACITOR
▲	METAL FILM RESISTOR	⊙	CERAMIC TUBULAR CAPACITOR
⊠	METAL PLATE RESISTOR	⊕	POLYESTER FILM CAPACITOR
▤	FIRE PROOF CARBON FILM RESISTOR	○	POLYSTYRENE FILM CAPACITOR
▥	CEMENT MOLDED RESISTOR	⊖	MICA CAPACITOR
⊗	SEMI VARIABLE RESISTOR	⊙	POLYPROPYLENE FILM CAPACITOR
■	CHIP RESISTOR	⊕	SEMICONDUCTIVE CERAMIC CAPACITOR
		⊖	POLYPHENYLENE SULFIDE FILM CAPACITOR

NOTICE (model)  
 (J)..... JAPAN  
 (U)..... U.S.A  
 (C)..... CANADA  
 (R)..... GENERAL  
 (T)..... CHINA  
 (K)..... KOREA  
 (A)..... AUSTRALIA  
 (B)..... BRITISH  
 (G)..... EUROPE  
 (L)..... SINGAPORE  
 (E)..... SOUTH EUROPE  
 (V)..... TAIWAN  
 (F)..... RUSSIAN

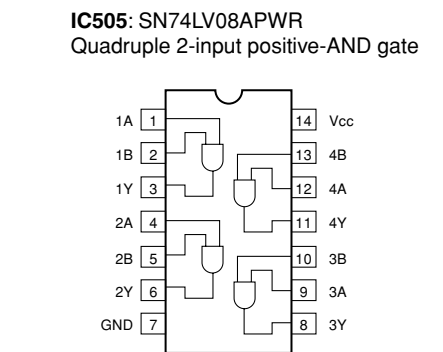
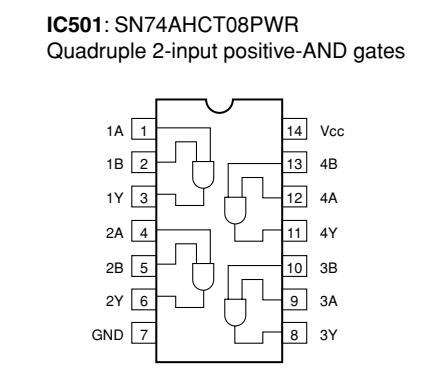

\* All voltages are measured with a 10MΩ/V DC electronic voltmeter.  
 \* Components having special characteristics are marked ! and must be replaced with parts having specifications equal to those originally installed.  
 \* Schematic diagram is subject to change without notice.



OPERATION 1/2

REMARKS	PARTS NAME
NO MARK	CARBON FILM RESISTOR (P=5)
☑	CARBON FILM RESISTOR (P=10)
△	METAL OXIDE FILM RESISTOR
▲	METAL FILM RESISTOR
⊗	METAL PLATE RESISTOR
⊠	FIRE PROOF CARBON FILM RESISTOR
□	CEMENT MOLDED RESISTOR
⊕	SEMI VARIABLE RESISTOR
■	CHIP RESISTOR

REMARKS	PARTS NAME
NO MARK	ELECTROLYTIC CAPACITOR
⊗	TANTALUM CAPACITOR
NO MARK	CERAMIC CAPACITOR
●	CERAMIC TUBULAR CAPACITOR
◎	POLYESTER FILM CAPACITOR
○	POLYSTYRENE FILM CAPACITOR
⊖	MICA CAPACITOR
⊕	POLYPROPYLENE FILM CAPACITOR
⊗	SEMICONDUCTIVE CERAMIC CAPACITOR
⊙	POLYPHENYLENE SULFIDE FILM CAPACITOR

Interchangeable Parts at Manufacture-Stage

Mark	Reference Parts Number	Parts Name
⊗201	02001-2005-2014-2017	25C2412K10/R/S/1 25D0601ARL/ABL10/R/S/1 K1C38755-Y-GR-RTK/P
⊗202	02015-2016	25A1037AK10/R/S/1 KTA1504S-Y-GR-RTK/P
⊗203	02011-2012	DTA114EKA KRA102S-RTK/P
⊗204	Q2013	DTA114EKA KRC102S-RTK/P
⊗205	V2001	17-B1-29GNK HNA-17MM04T
⊗206	Q2004-2006-2302-2303 Q2351-2354	1SS355 MA111

NOTICE (mode1)  
 (J)..... JAPAN  
 (U)..... U.S.A  
 (C)..... CANADA  
 (R)..... GENERAL  
 (T)..... CHINA  
 (K)..... KOREA  
 (A)..... AUSTRALIA  
 (B)..... BRITISH  
 (G)..... EUROPE  
 (L)..... SINGAPORE  
 (E)..... SOUTH EUROPE  
 (V)..... TAIWAN  
 (F)..... RUSSIAN

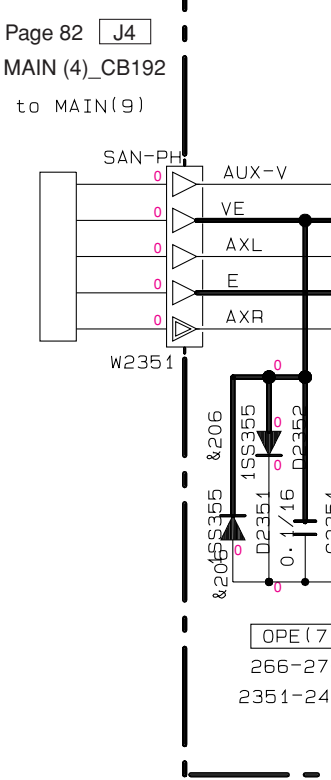
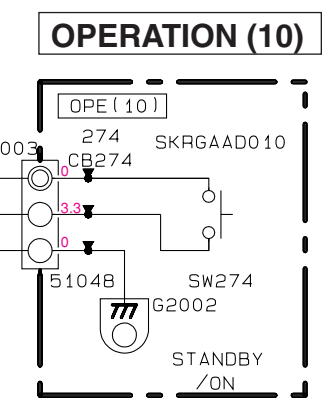
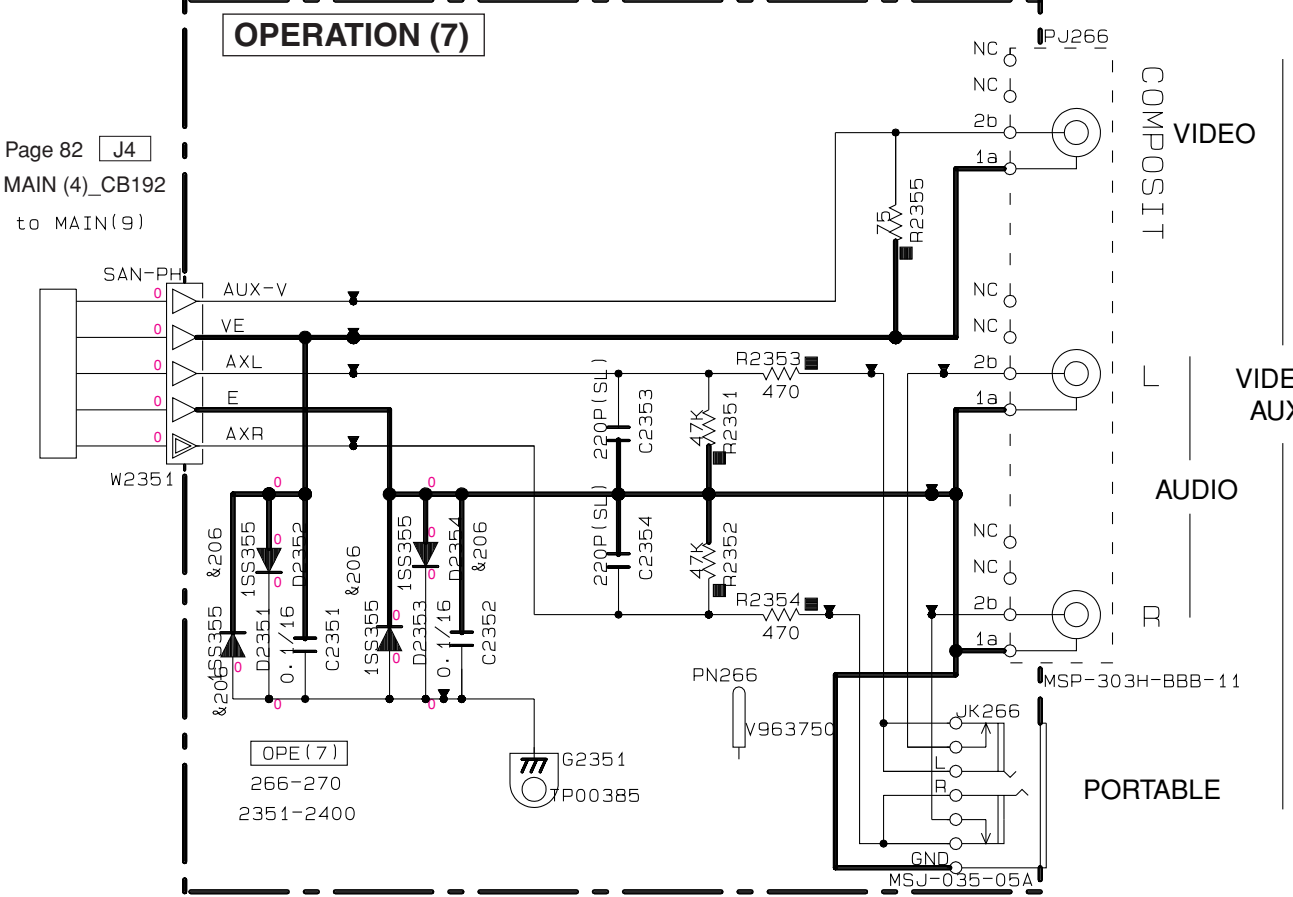
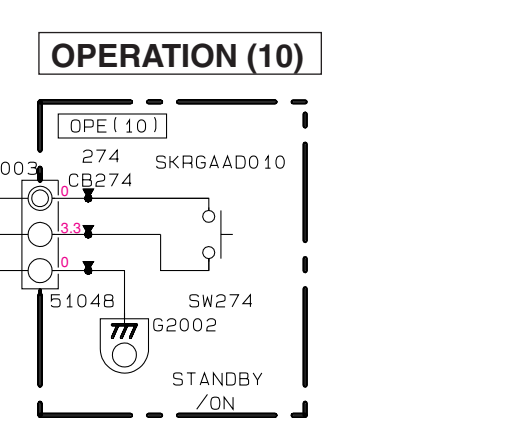
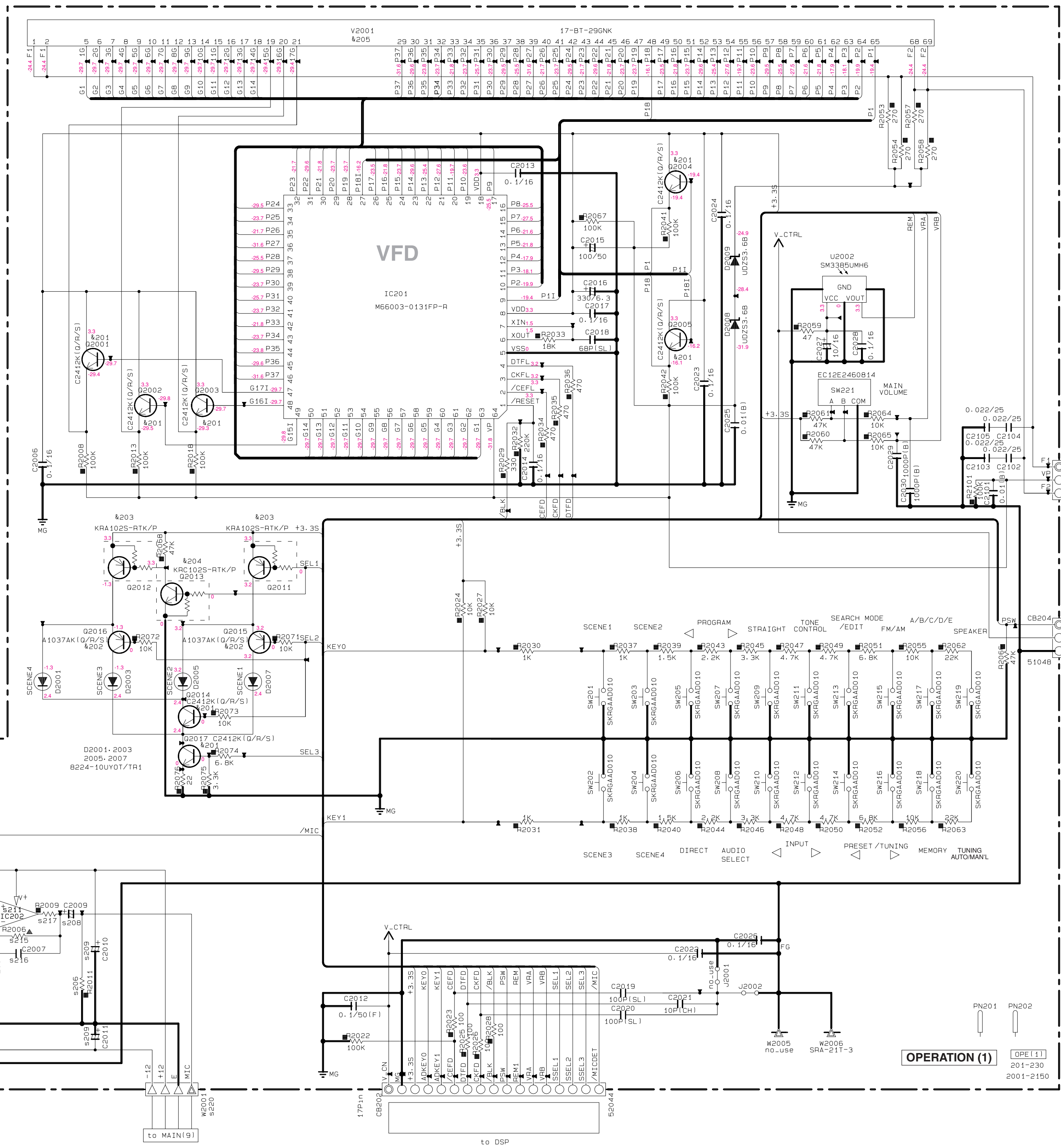

Page 80 [F9]  
to OPERATION (2)\_CB235

Page 82 [J4]  
to MAIN (4)\_CB192  
to MAIN (9)

Page 82 [I4]  
to MAIN (4)\_CB191  
(R, K, A, B, G, E, F, L models)

Page 76 [C7]  
to DSP\_CB408

Page 82 [I4]  
to MAIN (4)\_CB191  
(R, K, A, B, G, E, F, L models)

\* All voltages are measured with a 10MΩ/V DC electronic voltmeter.  
 \* Components having special characteristics are marked with a triangle and must be replaced with parts having specifications equal to those originally installed.  
 \* Schematic diagram is subject to change without notice.

OPERATION 2/2

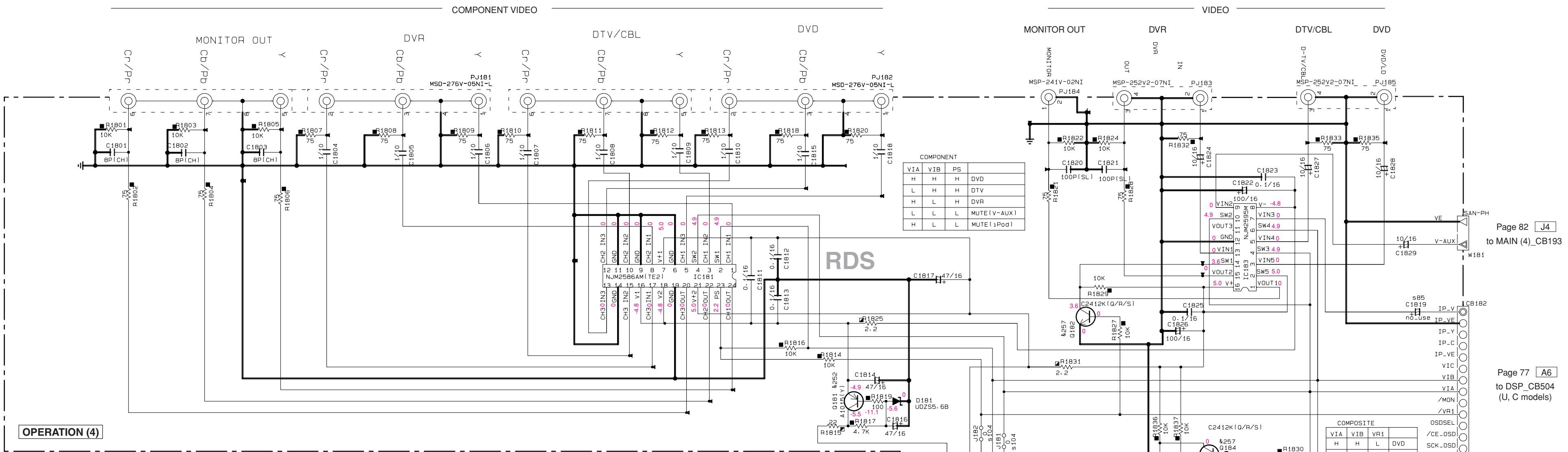

VIA	V1B	PS	DVD
H	H	H	DVD
L	L	L	DTV
L	L	L	DVR
L	L	L	MUTE(Y-AUX)
L	L	L	MUTE(L-Pod)

OPERATION (4)

Page 82 J4  
to MAIN (4) CB193

Page 77 A6  
to DSP CB504  
(U, C models)

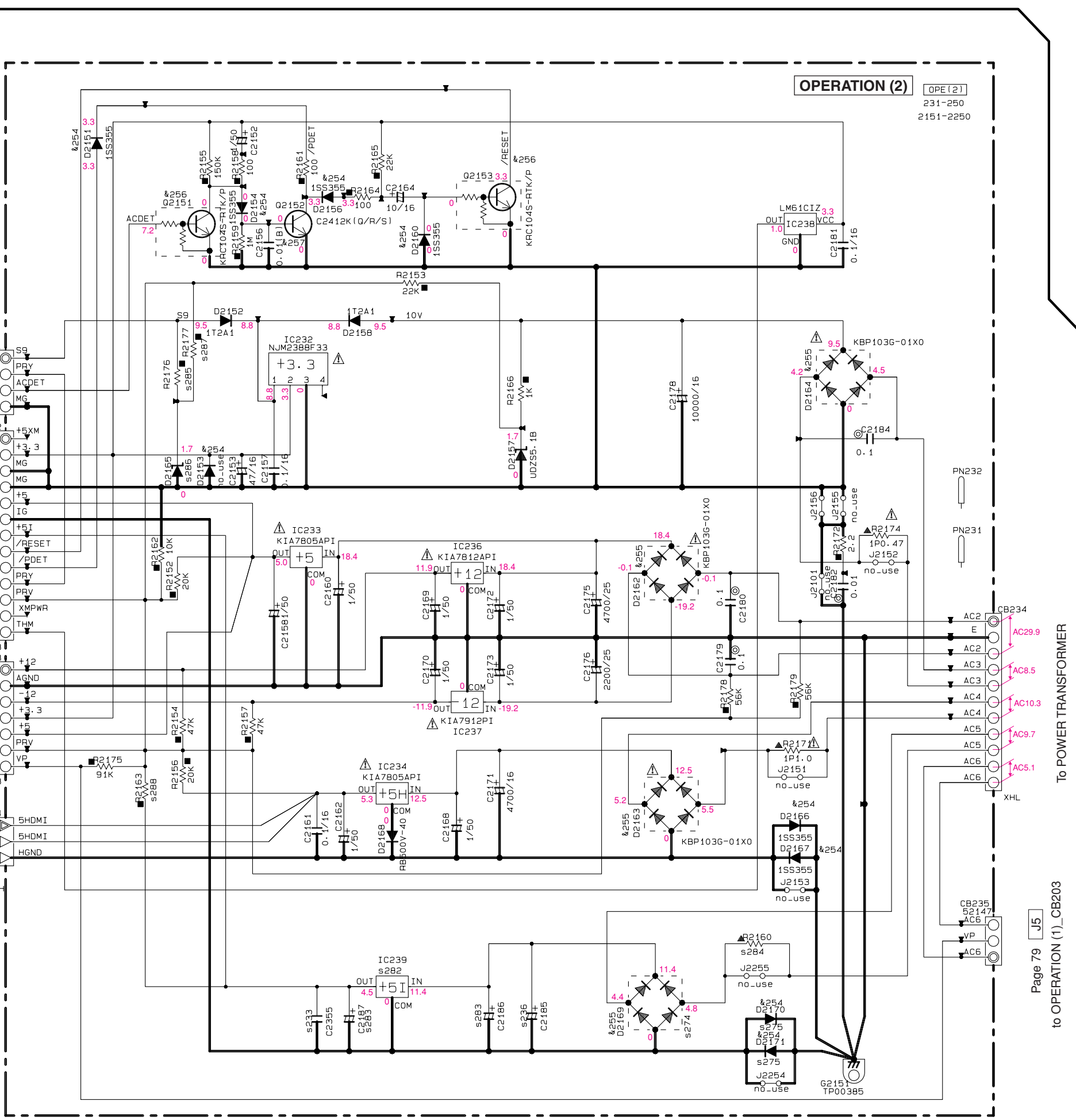

Page 77 B7  
to DSP

Page 81 B6  
to MAIN (1) CB103

Page 83 B6  
to HDMI CB905

OPERATION (2)

Page 21 250  
2151-2550

Page 79 J5  
to OPERATION (1) CB203

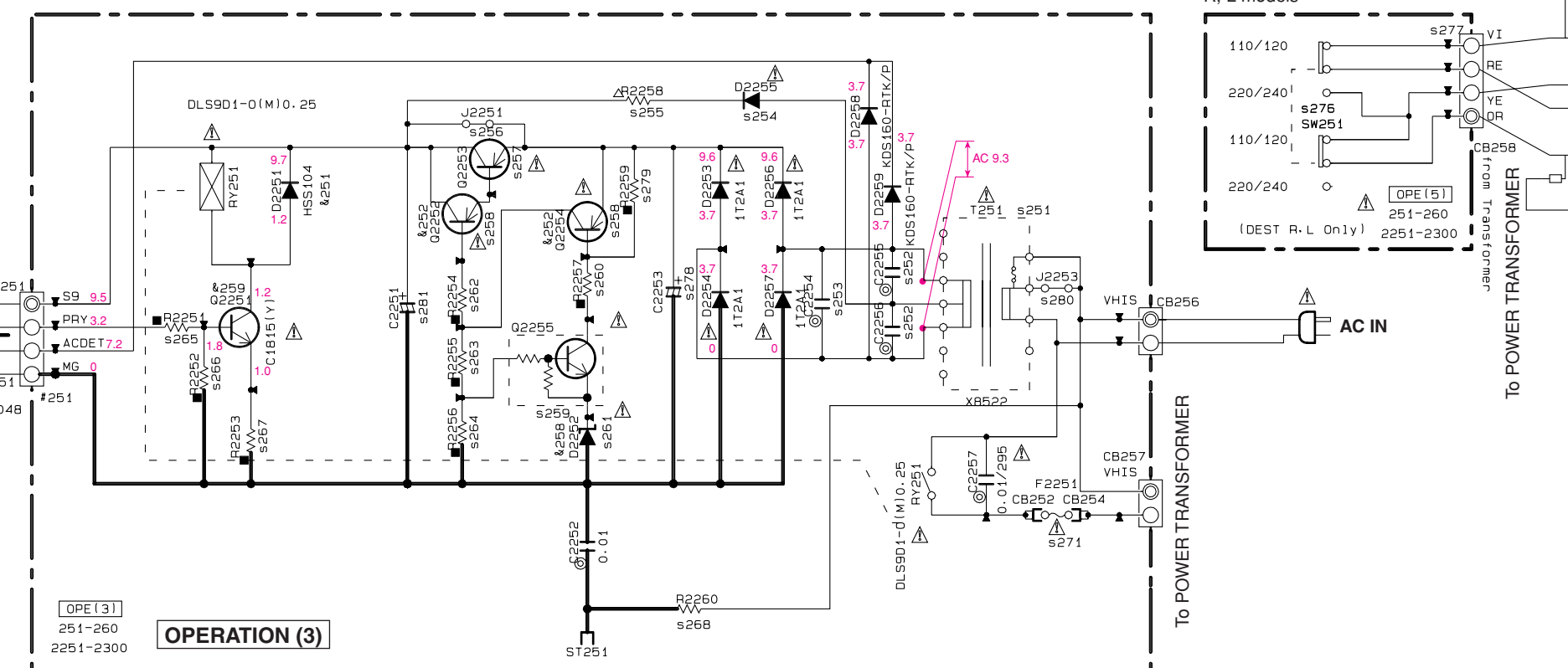

OPERATION (3)

Page 251-290  
2251-2300

Page 82 E3  
to MAIN (5) W161

Page 83 M7  
to HDMI CB904

OPERATION (5)

R, L models

IC183: NJM2595M (TE1)  
5-input 3-output video switch

IC181: NJM2586AM  
Wide band 3-input 1-output 3-circuit video amplifier

IC233, 234, 239: KIA7805API  
Voltage regulator

IC237: KIA7912PI  
Voltage regulator

IC238: LM61C12  
Temperature sensor

REMARKS	PARTS NAME
NO MARK	CARBON FILM RESISTOR (P=5)
□	CARBON FILM RESISTOR (P=10)
△	METAL OXIDE FILM RESISTOR
◇	METAL FILM RESISTOR
⊠	METAL PLATE RESISTOR
⊞	FIRE PROOF CARBON FILM RESISTOR
⊞	CEMENT MOLDED RESISTOR
⊞	SEMI VARIABLE RESISTOR
⊞	CHIP RESISTOR

REMARKS	PARTS NAME
NO MARK	ELECTROLYTIC CAPACITOR
⊞	TANTALUM CAPACITOR
NO MARK	CERAMIC CAPACITOR
⊞	CERAMIC TUBULAR CAPACITOR
⊞	POLYESTER FILM CAPACITOR
⊞	POLYSTYRENE FILM CAPACITOR
⊞	MICA CAPACITOR
⊞	POLYPROPYLENE FILM CAPACITOR
⊞	SEMICONDUCTIVE CERAMIC CAPACITOR

Mark	Reference Parts Number	Parts Name
4251	D2251	HSS104
		ISS133
		ISS176
4252	0181-2252-2254	2S410151V1
		KTA12661V1
		2S410151V
4254	Q2151-2154-2156-2160	ISS356
	2166-2167-2170-2171	MA111
4255	D2162-2164-2169	KBP1036-01X0
		RS103
4256	Q2151-2153	DT144EXA
		KRC1045-RTK/P
4257	0182-184-2152	MT2J4-7A
		GD2J4-7A
4258	D2252	MT2J4-7A
		GD2J4-7A
4259	Q2251	2SC18151V1
		K1C318B
		2SC1815Y

Interchangeable Parts at Manufacture-Stage

NOTICE (model)

(J)..... JAPAN  
(U)..... U.S.A  
(R)..... CANADA  
(G)..... GENERAL  
(T)..... CHINA  
(K)..... KOREA  
(A)..... AUSTRALIA  
(B)..... BRITISH  
(C)..... EUROPE  
(L)..... SINGAPORE  
(E)..... SOUTH EUROPE  
(V)..... TAIWAN  
(F)..... RUSSIAN

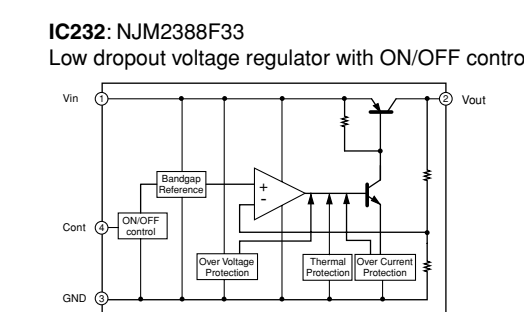
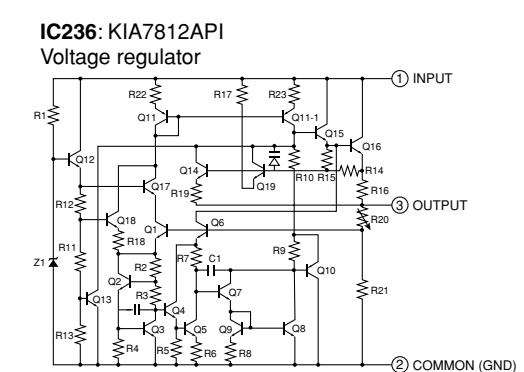
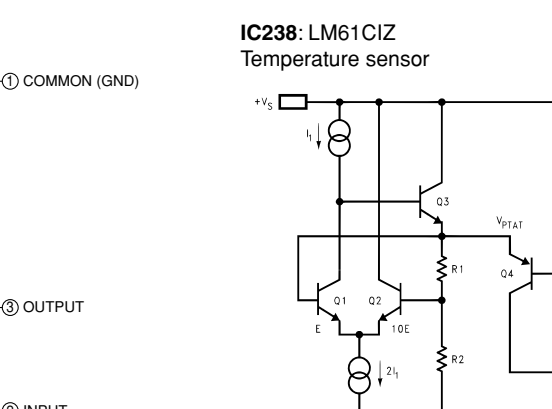
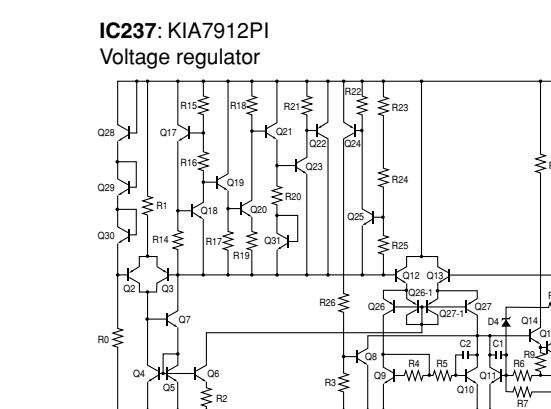
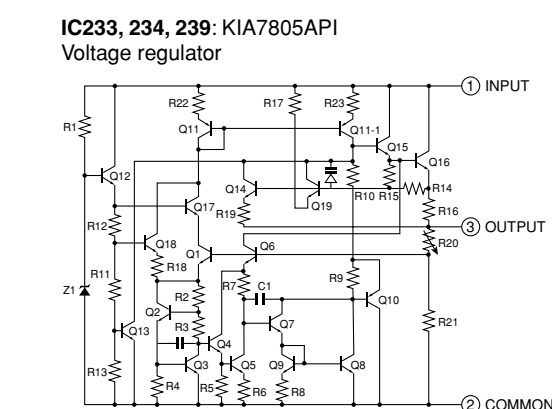
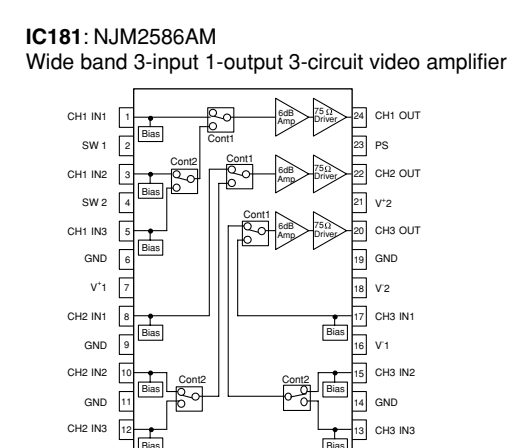
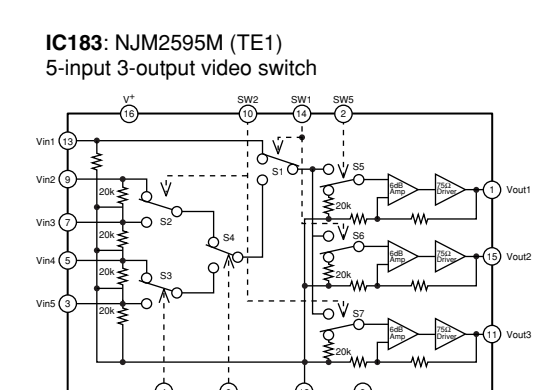

SXX	LOC	UC	RL	T	KABEF
985	C1819	UR83710 10/16	X	X	X
9103	CB182	VF98220 5004	X	X	X
9104	J181	RD35000 0	RD35000 0	RD35000 0	
9201	JK001	X	MSJ-2800C-AG	X	MSJ-2800C-AG
9202	C2002	X	US06310 100P/1B1	X	US06310 100P/1B1
9203	R210	X	RD35610 1K	X	RD35610 1K
9204	R2007	X	RD35647 4.7K	X	RD35647 4.7K
9205	D2006	X	V133290 1S355	X	V133290 1S355
9206	R2005	X	RD35810 100K	X	RD35810 100K
9207	C2001	X	US06410 0.011B1	X	US06410 0.011B1
9208	C2003	X	UM39710 10/16	X	UM39710 10/16
9209	C2008	X	UM39722 22/16	X	UM39722 22/16
9210	R2002	X	RD35522 470	X	RD35522 470
9211	IC202	X	V133290 NLM466M	X	V133290 NLM466M
9212	C2004	X	US06210 100P/1L1	X	US06210 100P/1L1
9213	R2004	X	RF35647 470	X	RF35647 470
9214	C2005	X	UM39747 47/6.3	X	UM39747 47/6.3
9215	R2006	X	RF35712 12K	X	RF35712 12K

SXX	LOC	UC	RL	T	KABEF
9216	C2007	X	US06133 33P/1C1	X	US06133 33P/1C1
9217	R2009	X	RD35682 8.2K	X	RD35682 8.2K
9220	W2001	X	MF40410	X	MF40410
9233	C2355	U513510 0.1/16	X	X	X
9236	C2185	UR73947 4700/16	X	X	X
9251	T251	X852140 X8521	X852340 X8523	X852340 X8523	X852340 X8523
9252	C2256	X	WJ60500 0.01	X	WJ60500 0.01
9253	C2254	WJ60500 0.01	X	WJ60500 0.01	WJ60500 0.01
9254	D2255	X	V999780 11241	X	V999780 11241
9255	R2258	X	V75790 2P47	X	V75790 2P47
9256	J2251	VNS0000	X	VNS0000	VNS0000
9257	D2253	X	U97260 A170815/11	X	U97260 A170815/11
9258	D2252	X	I10151 I10151V1	X	I10151 I10151V1
9259	D2255	X	KRC103M-1/P	X	KRC103M-1/P
9260	R2257	X	RD35747 47K	X	RD35747 47K
9261	D2252	X	V643700 WZ14-7A	X	V643700 WZ14-7A
9262	R2254	X	RD35610 1K	X	RD35610 1K
9263	R2255	X	RD35722 22K	X	RD35722 22K
9264	R2256	X	RD35647 4.7K	X	RD35647 4.7K

SXX	LOC	UC	RL	T	KABEF
9265	R2251	RD35647 4.7K	RD35610 1K	RD35647 4.7K	RD35647 4.7K
9266	R2252	RD35810 100K	RD35647 470	RD35810 100K	RD35810 100K
9267	R2253	RD35433 33	RD35368 6.8	RD35447 47	RD35447 47
9268	R2260	V673000 1/2R2-2M	X	X	X
9271	F2251	W82120 15AL25V	W93310 VV07170 T3.15AL250V	VV07170 T3.15AL250V	VV07170 T3.15AL250V
9274	D2169	W8510	X	X	X
9275	D2171	VT33290 1S355	X	X	X
9276	SK251	X	V207550 SL14-224MF	X	V207550 SL14-224MF
9277	CB258	X	Y93790 84P75-VH	X	Y93790 84P75-VH
9278	C2253	X	UR87110 10/10K	X	UR87110 10/10K
9279	R2259	X	RD35810 100K	X	RD35810 100K
9280	J2253	VNS0000	X	VNS0000	VNS0000
9281	C2251	UR74922 2200/25	UR75922 2200/25	UR74922 2200/25	UR74922 2200/25
9282	IC239	X492840 KIA7805API	X	X	X
9283	C2187	UR86510 1/50	X	X	X
9284	R2160	WJ68240 1P1-0	X	X	X
9285	R2176	X	RD35610 1K	RD35610 1K	RD35610 1K
9286	D2165	X	VU17190 UOZ55-1B	VU17190 UOZ55-1B	VU17190 UOZ55-1B
9287	R2177	X	RD35722 22K	RD35722 22K	RD35722 22K
9288	R2163	RD35720 20K	X	X	X
9289	D2002	X	VU17190 UOZ55-1B	X	VU17190 UOZ55-1B

\* All voltages are measured with a 10MΩ/V DC electronic voltmeter.  
\* Components having special characteristics are marked with a triangle and must be replaced with parts having specifications equal to those originally installed.  
\* Schematic diagram is subject to change without notice.



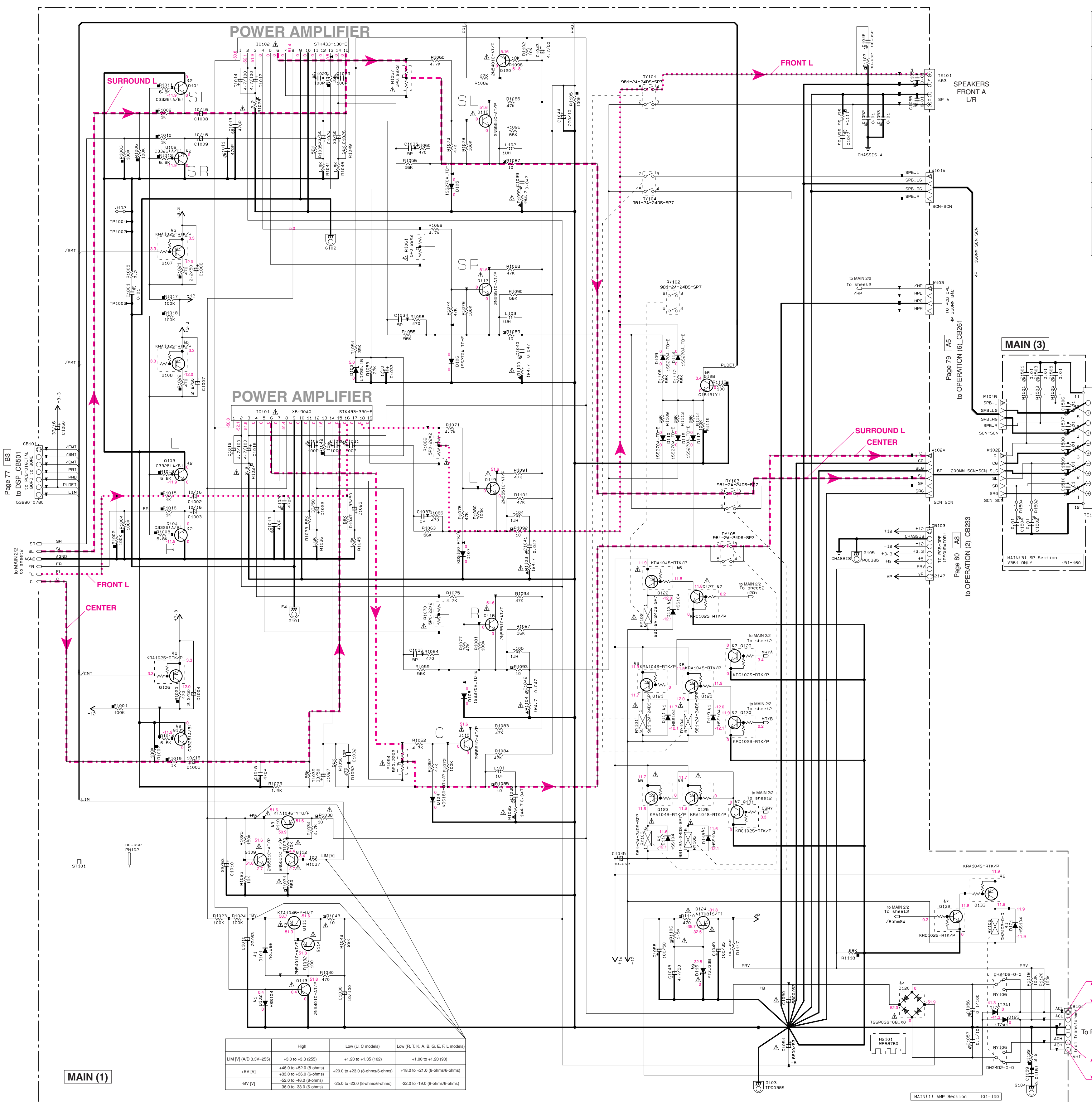

Interchangeable Parts at Manufacture-Stage

Mark	Reference Parts Number	Parts Name
41	D102-111-113 118-119-121	H55104 1S5133 1S5176
42	G101-105	2SC3361A/B1 2SC3361B1 2SC9981A/B1 2SD1938F1S/F1 2SD2794K
43	G10-111	2SB12741R/G1 2SB1661E/F1 KT41046-Y-U/D
44	D120	T56P030-08_X0 R5603M-B-C-J80
45	G106-108	KRA102S-RTK/P DTA114EXA
46	G121-123-125-126-133	KRA104S-RTK/P DTA144EXA
47	G127-129-132	KRC102S-RTK/P DTC114EXA
48	G128	2SC18151-Y1 KTC198B-Y*AT
49	D116	HTZJ33B GDZJ33B

REMARKS

RESISTOR

REMARKS	PARTS NAME
NO MARK	CARBON FILM RESISTOR (P=5)
□	CARBON FILM RESISTOR (P=10)
△	METAL OXIDE FILM RESISTOR
▲	METAL FILM RESISTOR
■	METAL PLATE RESISTOR
⊠	FIRE PROOF CARBON FILM RESISTOR
⊞	CEMENT MOLDED RESISTOR
⊚	SEMI VARIABLE RESISTOR
⊙	CHIP RESISTOR

NOTICE (mode1)

(J)..... JAPAN  
(U)..... U.S.A  
(C)..... CANADA  
(R)..... CHINA  
(T)..... GENERAL  
(K)..... KOREA  
(A)..... AUSTRALIA  
(B)..... BRITISH  
(G)..... EUROPE  
(L)..... SINGAPORE  
(E)..... SOUTH EUROPE  
(V)..... TAIWAN  
(F)..... RUSSIAN

CAPACITOR

REMARKS	PARTS NAME
NO MARK	ELECTROLYTIC CAPACITOR
⊗	TANTALUM CAPACITOR
NO MARK	CERAMIC CAPACITOR
●	POLYESTER FILM CAPACITOR
○	POLYSTYRENE FILM CAPACITOR
○	MICA CAPACITOR
○	POLYPROPYLENE FILM CAPACITOR
○	SEMICONDUCTIVE CERAMIC CAPACITOR
○	POLYPHENYLENE SULFIDE FILM CAPACITOR

MAIN (3)

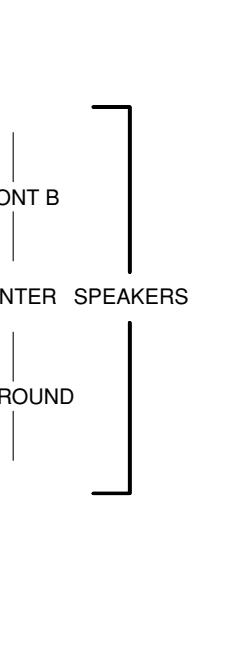

IC101: STK433-330-E

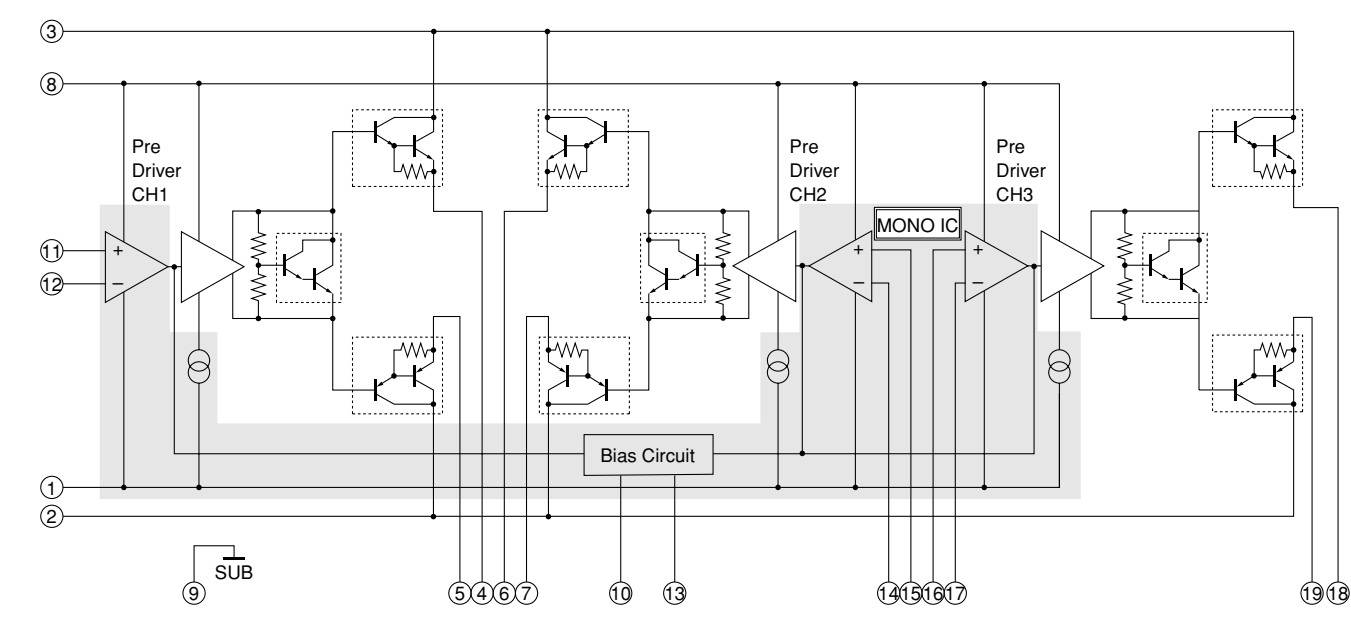

IC102: STK433-130-E

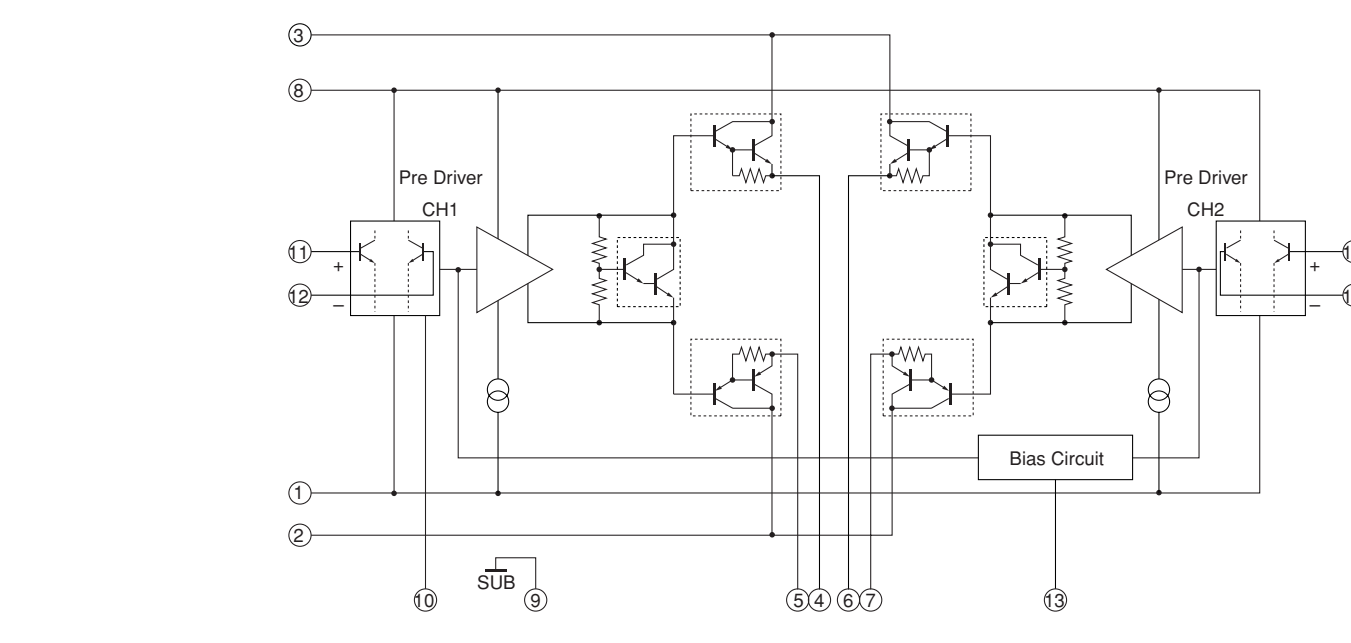

	High	Low (L, C models)	Low (R, T, K, A, B, G, E, F, L models)
LM [V] (A/D 3.3V±25%)	+3.0 to +3.3 (25%)	+1.20 to +1.35 (10%)	+1.00 to +1.20 (9%)
+8V [V]	+46.0 to +52.0 (8-ohms)	+20.0 to +23.0 (8-ohms/6-ohms)	+18.0 to +21.0 (8-ohms/6-ohms)
-8V [V]	+33.0 to +36.0 (8-ohms)	-25.0 to -23.0 (8-ohms/6-ohms)	-22.0 to -19.0 (8-ohms/6-ohms)
-8V [V]	-52.0 to -46.0 (8-ohms)	-25.0 to -23.0 (8-ohms/6-ohms)	-22.0 to -19.0 (8-ohms/6-ohms)

★ All voltages are measured with a 10MQ/V DC electronic voltmeter.  
★ Components having special characteristics are marked !, and must be replaced with parts having specifications equal to those originally installed.  
★ Schematic diagram is subject to change without notice.

MAIN 2/2

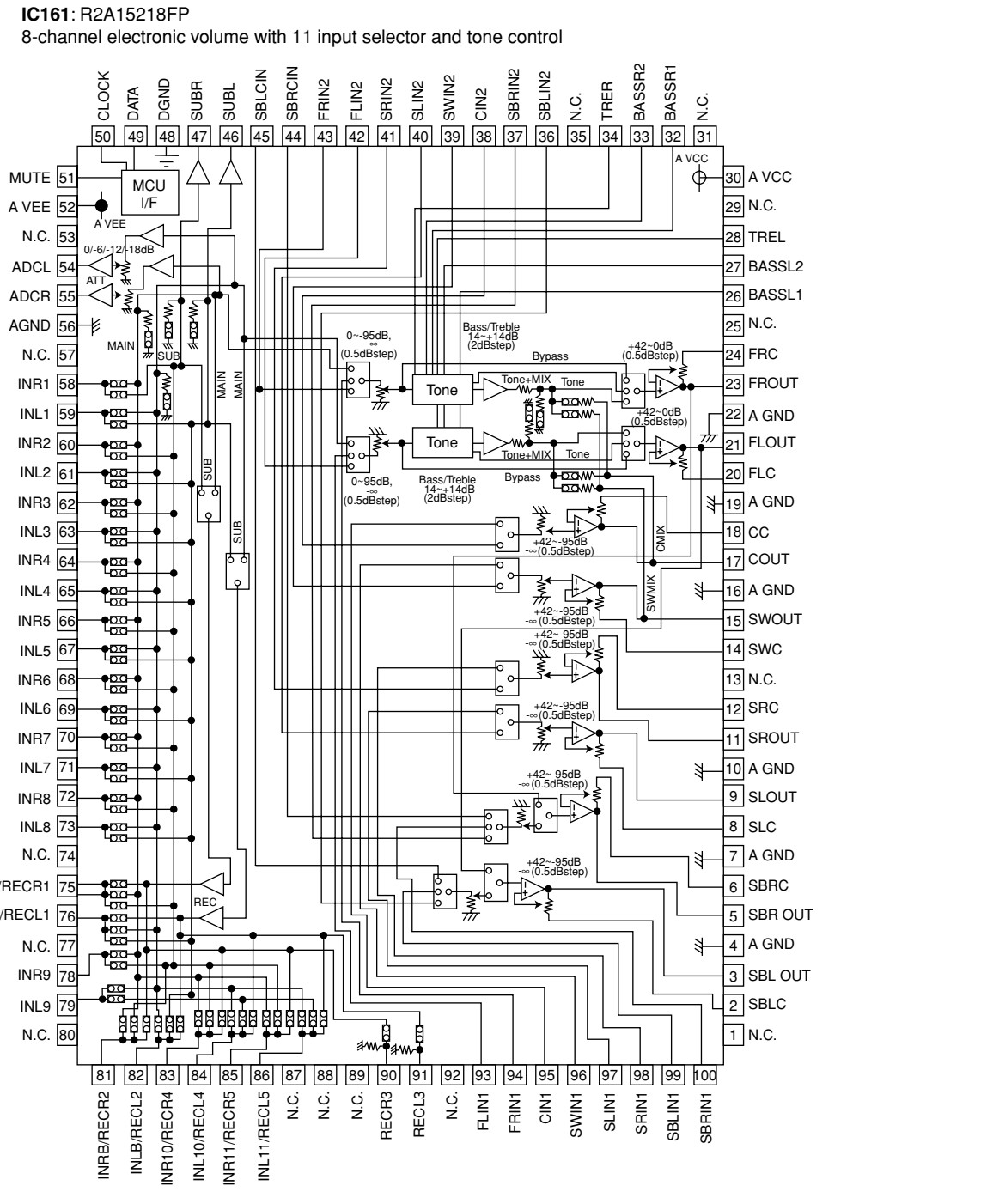
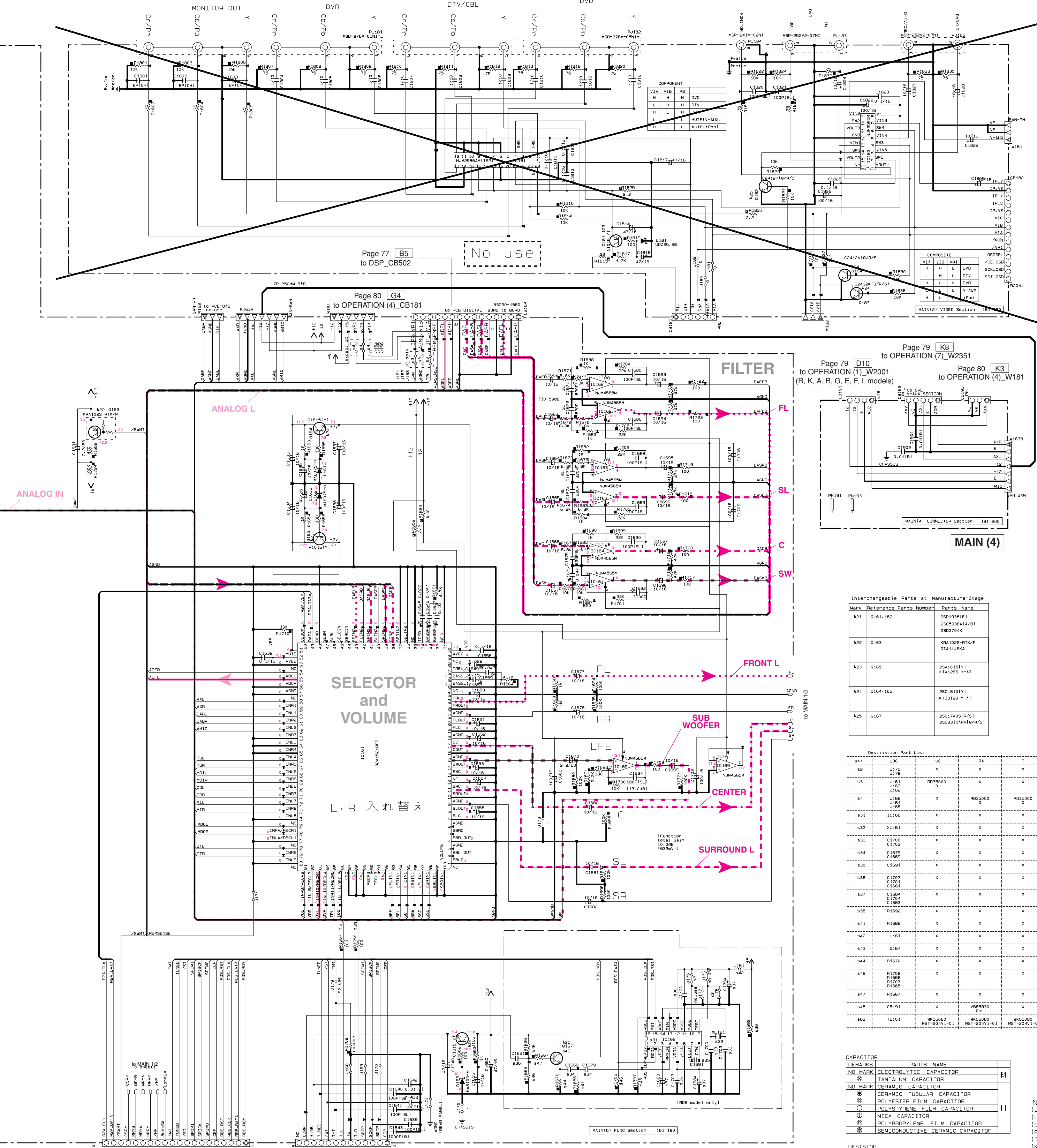
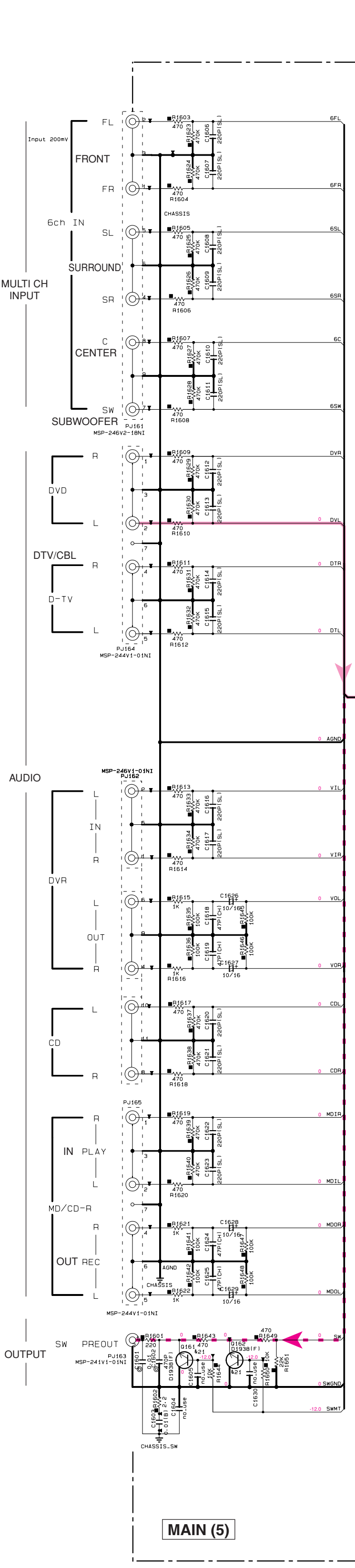

Interchangeable Parts at Manufacture Stage

Mark	Reference Parts Number	Parts Name
421	0161-162	2SD1938(I) 2SC9298(A) (V) 2SD1938
422	0163	MM102P-RTK/P DT114EXA
423	0165	2SA1015(V) 2SA1206 (V-A)
424	0164-166	2SC1815(V) 2SC1398 (V-A)
425	0167	2SC1740(I) (V) 2SC1348(I) (V)

Destination Part List

MARK	LOC	UC	RA	T	NL	REF
42	J75	X	X	X	X	RD9000
43	U161	RD9000	X	X	X	RD9000
44	U162	RD9000	X	X	X	RD9000
45	U163	RD9000	X	X	X	RD9000
46	U164	RD9000	X	X	X	RD9000
47	U165	RD9000	X	X	X	RD9000
48	U166	RD9000	X	X	X	RD9000
49	U167	RD9000	X	X	X	RD9000
50	U168	RD9000	X	X	X	RD9000
51	U169	RD9000	X	X	X	RD9000
52	U170	RD9000	X	X	X	RD9000
53	U171	RD9000	X	X	X	RD9000
54	U172	RD9000	X	X	X	RD9000
55	U173	RD9000	X	X	X	RD9000
56	U174	RD9000	X	X	X	RD9000
57	U175	RD9000	X	X	X	RD9000
58	U176	RD9000	X	X	X	RD9000
59	U177	RD9000	X	X	X	RD9000
60	U178	RD9000	X	X	X	RD9000
61	U179	RD9000	X	X	X	RD9000
62	U180	RD9000	X	X	X	RD9000
63	U181	RD9000	X	X	X	RD9000
64	U182	RD9000	X	X	X	RD9000
65	U183	RD9000	X	X	X	RD9000
66	U184	RD9000	X	X	X	RD9000
67	U185	RD9000	X	X	X	RD9000
68	U186	RD9000	X	X	X	RD9000
69	U187	RD9000	X	X	X	RD9000
70	U188	RD9000	X	X	X	RD9000
71	U189	RD9000	X	X	X	RD9000
72	U190	RD9000	X	X	X	RD9000
73	U191	RD9000	X	X	X	RD9000
74	U192	RD9000	X	X	X	RD9000
75	U193	RD9000	X	X	X	RD9000
76	U194	RD9000	X	X	X	RD9000
77	U195	RD9000	X	X	X	RD9000
78	U196	RD9000	X	X	X	RD9000
79	U197	RD9000	X	X	X	RD9000
80	U198	RD9000	X	X	X	RD9000
81	U199	RD9000	X	X	X	RD9000
82	U200	RD9000	X	X	X	RD9000
83	U201	RD9000	X	X	X	RD9000
84	U202	RD9000	X	X	X	RD9000
85	U203	RD9000	X	X	X	RD9000
86	U204	RD9000	X	X	X	RD9000
87	U205	RD9000	X	X	X	RD9000
88	U206	RD9000	X	X	X	RD9000
89	U207	RD9000	X	X	X	RD9000
90	U208	RD9000	X	X	X	RD9000
91	U209	RD9000	X	X	X	RD9000
92	U210	RD9000	X	X	X	RD9000
93	U211	RD9000	X	X	X	RD9000
94	U212	RD9000	X	X	X	RD9000
95	U213	RD9000	X	X	X	RD9000
96	U214	RD9000	X	X	X	RD9000
97	U215	RD9000	X	X	X	RD9000
98	U216	RD9000	X	X	X	RD9000
99	U217	RD9000	X	X	X	RD9000
100	U218	RD9000	X	X	X	RD9000

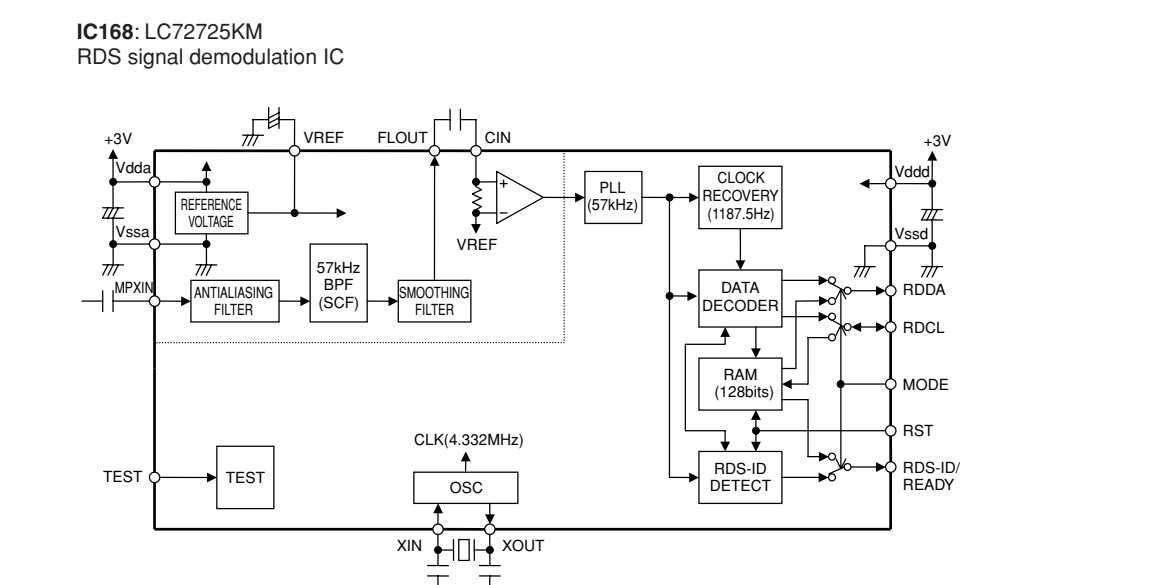
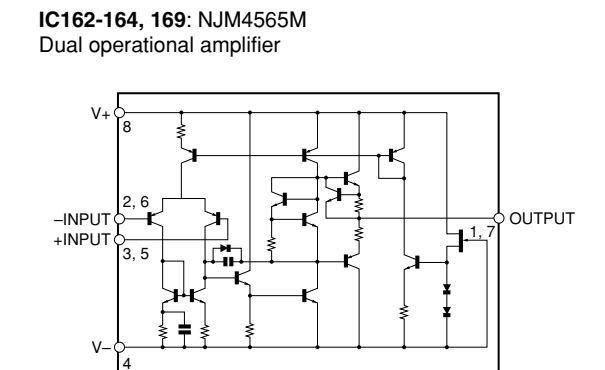

CAPACITOR

REMARKS	PARTS NAME	II
NO MARK	ELECTROLYTIC CAPACITOR	II
NO MARK	TANTALUM CAPACITOR	II
NO MARK	CERAMIC CAPACITOR	II
NO MARK	CERAMIC TUBULAR CAPACITOR	II
NO MARK	POLYESTER FILM CAPACITOR	II
NO MARK	POLYSTYRENE FILM CAPACITOR	II
NO MARK	MICA CAPACITOR	II
NO MARK	POLYPROPYLENE FILM CAPACITOR	II
NO MARK	SEMICONDUCTIVE CERAMIC CAPACITOR	II

RESISTOR

REMARKS	PARTS NAME	II
NO MARK	CARBON FILM RESISTOR (P=5)	II
NO MARK	CARBON FILM RESISTOR (P=10)	II
NO MARK	METAL OXIDE FILM RESISTOR	II
NO MARK	METAL FILM RESISTOR	II
NO MARK	METAL PLATE RESISTOR	II
NO MARK	FINE-PROOF CARBON FILM RESISTOR	II
NO MARK	CEMENT MOLDED RESISTOR	II
NO MARK	SEMI-VARIABLE RESISTOR	II
NO MARK	CHIP RESISTOR	II

NOTICE (mode1)  
(J) JAPAN  
(U) U.S.A  
(C) CANADA  
(R) GENERAL  
(T) CHINA  
(K) KOREA  
(A) AUSTRALIA  
(B) BRITISH  
(G) EUROPE  
(L) SINGAPORE  
(E) SOUTH EUROPE  
(V) TAIWAN  
(F) RUSSIAN

\* All voltages are measured with a 10MΩ/V DC electronic voltmeter.  
\* Components having special characteristics are marked with a triangle and must be replaced with parts having specifications equal to those originally installed.  
\* Schematic diagram is subject to change without notice.

HDMI

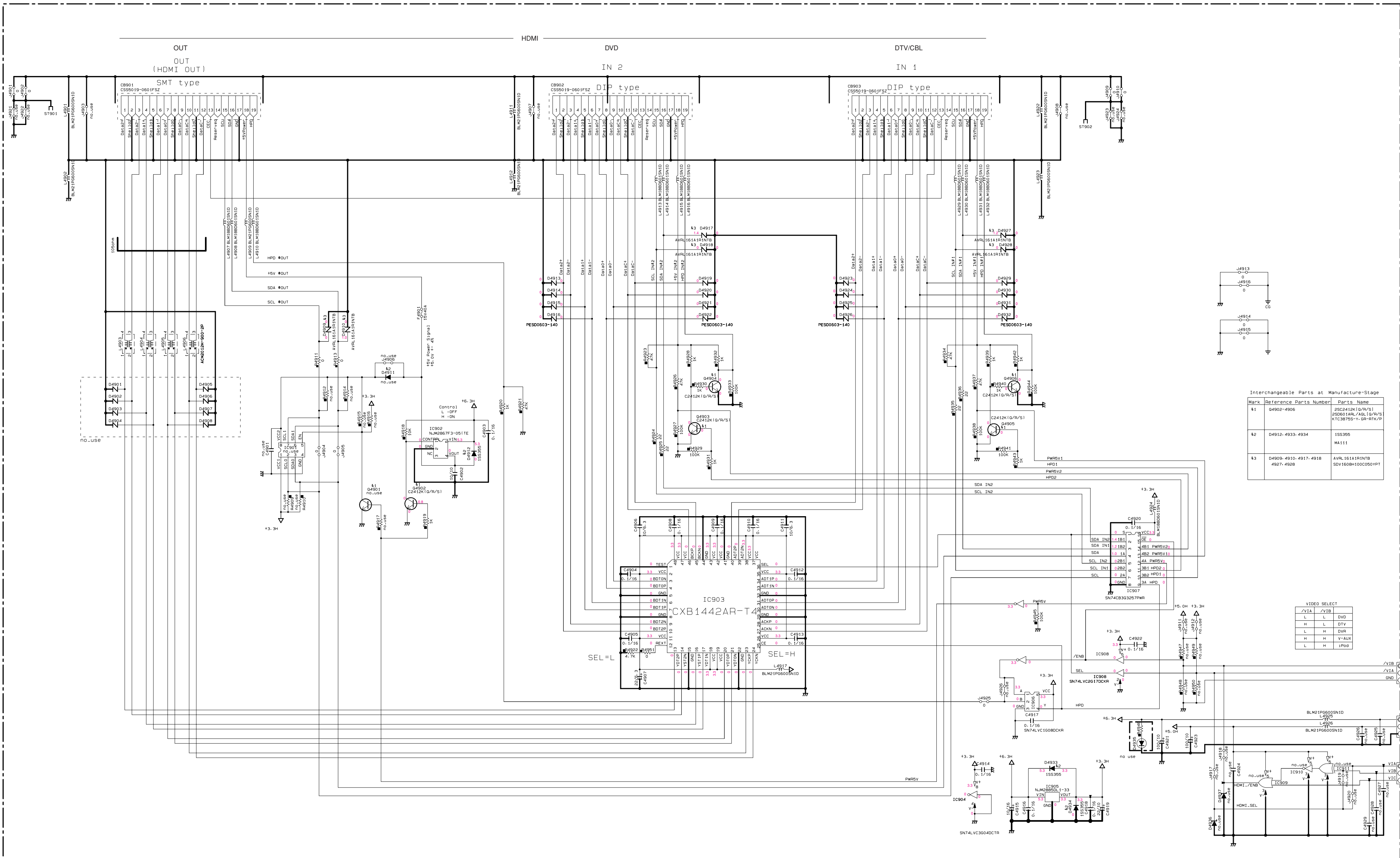

Interchangeable Parts at Manufacture-Stage

Mark	Reference Parts Number	Parts Name
41	04902-4906	ESC6412K1G/R/S1 P20601ARL700,1G/R/S1 KTC30755-V-GR-REV.2P
42	04912-4933-4934	ISS395 MA111
43	04909-4910-4917-4918 4927-4928	AVL16141R1N178 SDV1609M100C050VPT

VIDEO SELECT

VIA	V1B	BVD
L	L	DTV
H	L	DTV
L	H	DVR
H	H	V-AUX
L	H	1P00

Page 80 14  
to OPERATION (4)\_W182

Page 80 1A8  
to OPERATION (2)\_W2154

RESISTOR

REMARKS	PARTS NAME
NO MARK	CARBON FILM RESISTOR (P=5)
⊠	CARBON FILM RESISTOR (P=10)
△	METAL OXIDE FILM RESISTOR
▲	METAL FILM RESISTOR
⊞	METAL PLATE RESISTOR
⊞	FIRE-PROOF CARBON FILM RESISTOR
⊞	CEMENT MOLDED RESISTOR
⊞	SEMI-VARIABLE RESISTOR
⊞	CHIP RESISTOR

CAPACITOR

REMARKS	PARTS NAME
NO MARK	ELECTROLYTIC CAPACITOR
⊞	TANTALUM CAPACITOR
⊞	CERAMIC CAPACITOR
⊞	CERAMIC TUBULAR CAPACITOR
⊞	POLYESTER FILM CAPACITOR
⊞	POLYSTYRENE FILM CAPACITOR
⊞	MICA CAPACITOR
⊞	POLYPROPYLENE FILM CAPACITOR
⊞	SEMICONDUCTIVE CERAMIC CAPACITOR
⊞	POLYPHENYLENE SULFIDE FILM CAPACITOR

NOTICE (mode1)  
 (J)..... JAPAN  
 (U)..... U.S.A  
 (C)..... CANADA  
 (R)..... GENERAL  
 (T)..... CHINA  
 (K)..... KOREA  
 (A)..... AUSTRALIA  
 (B)..... BRITISH  
 (G)..... EUROPE  
 (L)..... SINGAPORE  
 (E)..... SOUTH EUROPE  
 (V)..... TAIWAN  
 (F)..... RUSSIAN

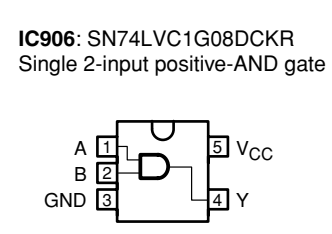
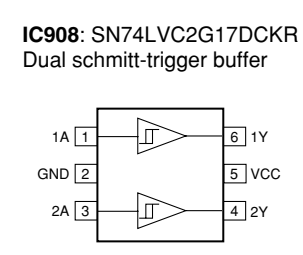
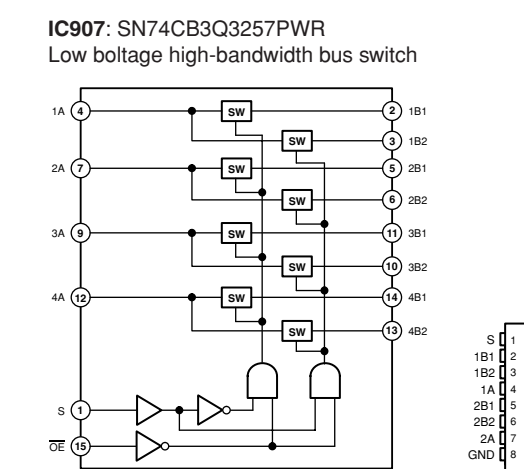
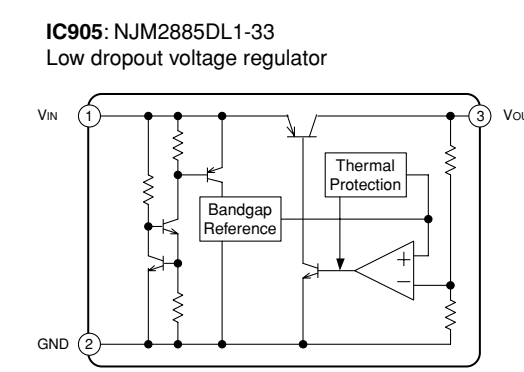
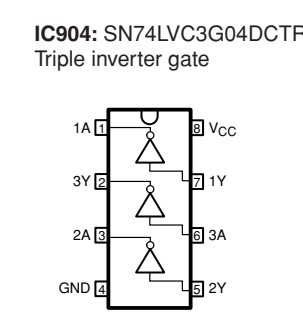
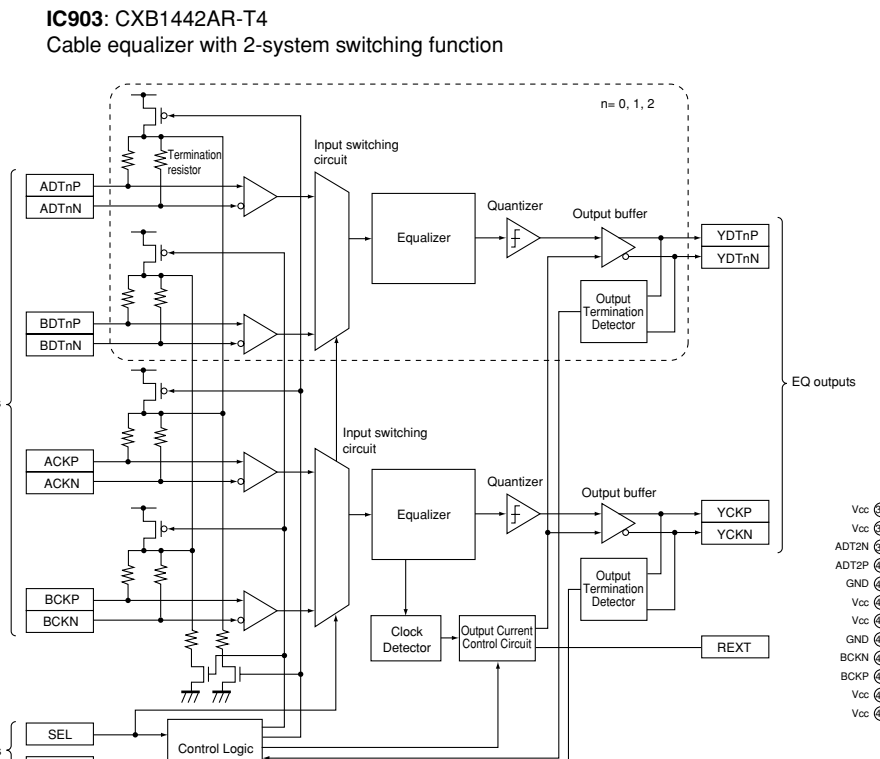
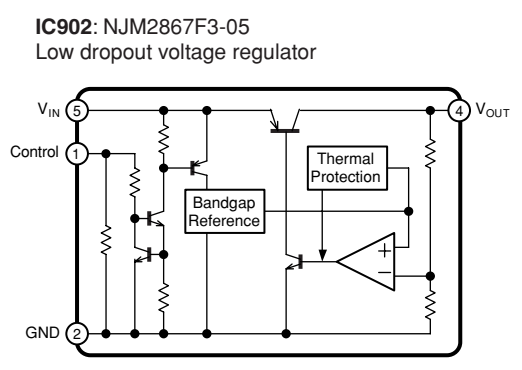

\* All voltages are measured with a 10MΩ/V DC electronic voltmeter.  
 \* Components having special characteristics are marked !, and must be replaced with parts having specifications equal to those originally installed.  
 \* Schematic diagram is subject to change without notice.

## ■ REPLACEMENT PARTS LIST

### • ELECTRICAL COMPONENT PARTS

#### WARNING

- Components having special characteristics are marked  $\triangle$  and must be replaced with parts having specifications equal to those originally installed.
- The chip resistor is not supplied as a replacement part.
  - \* When a chip resistor is necessary, use the following part.  
AAX60720: CHIP RESISTOR SAMPLE BOOK

#### ABBREVIATIONS IN THIS LIST ARE AS FOLLOWS:

C.A.EL.CHP	: CHIP ALUMI.ELECTROLYTIC CAP	L.EMIT	: LIGHT EMITTING MODULE
C.CE	: CERAMIC CAP	LED.DSPLY	: LED DISPLAY
C.CE.ARRAY	: CERAMIC CAP ARRAY	LED.INFRD	: LED,INFRARED
C.CE.CHP	: CHIP CERAMIC CAP	MODUL.RF	: MODULATOR,RF
C.CE.ML	: MULTILAYER CERAMIC CAP	PHOT.CPL	: PHOTO COUPLER
C.CE.M.CHP	: CHIP MULTILAYER CERAMIC CAP	PHOT.INTR	: PHOTO INTERRUPTER
C.CE.SAFTY	: RECOGNIZED CERAMIC CAP	PHOT.RFLCT	: PHOTO REFLECTOR
C.CE.TUBLR	: CERAMIC TUBULAR CAP	PIN.TEST	: PIN,TEST POINT
C.CE.SMI	: SEMI CONDUCTIVE CERAMIC CAP	PLST.RIVET	: PLASTIC RIVET
C.EL	: ELECTROLYTIC CAP	R.ARRAY	: RESISTOR ARRAY
C.MICA	: MICA CAP	R.CAR.	: CARBON RESISTOR
C.ML.FLM	: MULTILAYER FILM CAP	R.CAR.CHP	: CHIP RESISTOR
C.MP	: METALLIZED PAPER CAP	R.CAR.FP	: FLAME PROOF CARBON RESISTOR
C.MYLAR	: MYLAR FILM CAP	R.FUS	: FUSABLE RESISTOR
C.MYLAR.ML	: MULTILAYER MYLAR FILM CAP	R.MTL.CHP	: CHIP METAL FILM RESISTOR
C.PAPER	: PAPER CAPACITOR	R.MTL.FLM	: METAL FILM RESISTOR
C.PLS	: POLYSTYRENE FILM CAP	R.MTL.OXD	: METAL OXIDE FILM RESISTOR
C.POL	: POLYESTER FILM CAP	R.MTL.PLAT	: METAL PLATE RESISTOR
C.POLY	: POLYETHYLENE FILM CAP	RSNR.CE	: CERAMIC RESONATOR
C.PP	: POLYPROPYLENE FILM CAP	RSNR.CRYS	: CRYSTAL RESONATOR
C.TNTL	: TANTALUM CAP	R.TW.CEM	: TWIN CEMENT FIXED RESISTOR
C.TNTL.CHP	: CHIP TANTALUM CAP	R.CEMENT	: CEMENT RESISTOR
C.TRIM	: TRIMMER CAP	SCR.BND.HD	: BIND HEAD B-TIGHT SCREW
CN	: CONNECTOR	SCR.BW.HD	: BW HEAD TAPPING SCREW
CN.BS.PIN	: CONNECTOR,BASE PIN	SCR.CUP	: CUP TIGHT SCREW
CN.CANNON	: CONNECTOR,CANNON	SCR.TERM	: SCREW TERMINAL
CN.DIN	: CONNECTOR,DIN	SCR.TR	: SCREW,TRANSISTOR
CN.FLAT	: CONNECTOR,FLAT CABLE	SUPRT.PCB	: SUPPORT,P.C.B.
CN.POST	: CONNECTOR,BASE POST	SURG.PRTCT	: SURGE PROTECTOR
COIL.MX.AM	: COIL,AM MIX	SW.TACT	: TACT SWITCH
COIL.AT.FM	: COIL,FM ANTENNA	SW.LEAF	: LEAF SWITCH
COIL.DT.FM	: COIL,FM DETECT	SW.LEVER	: LEVER SWITCH
COIL.MX.FM	: COIL,FM MIX	SW.MICRO	: MICRO SWITCH
COIL.OUTPT	: OUTPUT COIL	SW.PUSH	: PUSH SWITCH
DIOD.ARRAY	: DIODE ARRAY	SW.RT.ENC	: ROTARY ENCODER
DIODE.BRG	: DIODE BRIDGE	SW.RT.MTR	: ROTARY SWITCH WITH MOTOR
DIODE.CHP	: CHIP DIODE	SW.RT	: ROTARY SWITCH
DIODE.VAR	: VARACTOR DIODE	SW.SLIDE	: SLIDE SWITCH
DIOD.Z.CHP	: CHIP ZENER DIODE	TERM.SP	: SPEAKER TERMINAL
DIODE.ZENR	: ZENER DIODE	TERM.WRAP	: WRAPPING TERMINAL
DSCR.CE	: CERAMIC DISCRIMINATOR	THRMST.CHP	: CHIP THERMISTOR
FER.BEAD	: FERRITE BEADS	TR.CHP	: CHIP TRANSISTOR
FER.CORE	: FERRITE CORE	TR.DGT	: DIGITAL TRANSISTOR
FET.CHP	: CHIP FET	TR.DGT.CHP	: CHIP DIGITAL TRANSISTOR
FL.DSPLY	: FLUORESCENT DISPLAY	TRANS	: TRANSFORMER
FLTR.CE	: CERAMIC FILTER	TRANS.PULS	: PULSE TRANSFORMER
FLTR.COMB	: COMB FILTER MODULE	TRANS.PWR	: POWER TRANSFORMER ASS'Y
FLTR.LC.RF	: LC FILTER,EMI	TUNER.AM	: TUNER PACK,AM
GND.MTL	: GROUND PLATE	TUNER.FM	: TUNER PACK,FM
GND.TERM	: GROUND TERMINAL	TUNER.PK	: FRONT-ENDTUNER PACK
HOLDER.FUS	: FUSE HOLDER	VR	: ROTARY POTENTIOMETER
IC.PRTCT	: IC PROTECTOR	VR.MTR	: POTENTIOMETER WITH MOTOR
JUMPER.CN	: JUMPER CONNECTOR	VR.SW	: POTENTIOMETER WITH ROTARY SW
JUMPER.TST	: JUMPER,TEST POINT	VR.SLIDE	: SLIDE POTENTIOMETER
L.DTCT	: LIGHT DETECTING MODULE	VR.TRIM	: TRIMMER POTENTIOMETER

**P.C.B. DSP and P.C.B. OPERATION**

\*  
\*  
\*  
\*  
\*  
\*

Ref. No.	Part No.	Description	Markets
	WN242100	P. C. B. DSP	UC
	WN242200	P. C. B. DSP	RL
	WN242300	P. C. B. DSP	T
	WN242400	P. C. B. DSP	KA
	WN242500	P. C. B. DSP	BGEF
CB408	VF982300	CN. BS. PIN 17P	
CB501	VQ961000	CN. BS. PIN 7P	
CB502	VQ961800	CN. BS. PIN 15P	
CB504	VN394900	CN. BS. PIN 14P	UC
CB512	VQ047500	CN. BS. PIN 20P	
CB516	VK025700	CN. BS. PIN 13P	
C101	UR838220	C. EL 220uF 16V	
C102	WH771300	C. EL 100uF 10V	
C103-104	US135100	C. CE. CHP 0.1uF 16V	
C105	US061270	C. CE. CHP 27pF 50V B	
C106	WH771300	C. EL 100uF 10V	
C107	US135100	C. CE. CHP 0.1uF 16V	
C108-129	US063100	C. CE. CHP 1000pF 50V B	
C130	US135100	C. CE. CHP 0.1uF 16V	
C131	US061270	C. CE. CHP 27pF 50V B	
C132	UR837100	C. EL 10uF 16V	
C133	US063100	C. CE. CHP 1000pF 50V B	
C135	UB446100	C. CE. CHP 1uF 16V	
C136-147	US135100	C. CE. CHP 0.1uF 16V	
C148-154	UB446100	C. CE. CHP 1uF 16V	
C201-206	US063100	C. CE. CHP 1000pF 50V B	
C207-211	US135100	C. CE. CHP 0.1uF 16V	
C212	US063100	C. CE. CHP 1000pF 50V B	
C215-218	UB446100	C. CE. CHP 1uF 16V	
C301-304	US135100	C. CE. CHP 0.1uF 16V	
C305	UR837470	C. EL 47uF 16V	
C306	US135100	C. CE. CHP 0.1uF 16V	
C307	US063100	C. CE. CHP 1000pF 50V B	
C308	UR837100	C. EL 10uF 16V	
C309-310	US061270	C. CE. CHP 27pF 50V B	
C311	UR866220	C. EL 2.2uF 50V	
C312	US135100	C. CE. CHP 0.1uF 16V	
C313	US061220	C. CE. CHP 22pF 50V B	
C314	UR847220	C. EL 22uF 25V	
C315-317	US135100	C. CE. CHP 0.1uF 16V	
C321	US135100	C. CE. CHP 0.1uF 16V	
C349-350	UR837100	C. EL 10uF 16V	
C351-352	US135100	C. CE. CHP 0.1uF 16V	
C354-358	US135100	C. CE. CHP 0.1uF 16V	
C401-402	US135100	C. CE. CHP 0.1uF 16V	
C404	UR837470	C. EL 47uF 16V	
C405	US135100	C. CE. CHP 0.1uF 16V	
C406	UB446100	C. CE. CHP 1uF 16V	
C407-408	US062100	C. CE. CHP 100pF 50V B	
C409	US135100	C. CE. CHP 0.1uF 16V	
C410-411	US062100	C. CE. CHP 100pF 50V B	
C413-416	US063100	C. CE. CHP 1000pF 50V B	
C417	US062470	C. CE. CHP 470pF 50V B	
C418-428	US135100	C. CE. CHP 0.1uF 16V	
C429-435	US062100	C. CE. CHP 100pF 50V B	
C436-439	US135100	C. CE. CHP 0.1uF 16V	
C501	US062100	C. CE. CHP 100pF 50V B	
C502	UR838220	C. EL 220uF 16V	
C503-504	US062100	C. CE. CHP 100pF 50V B	
C513-515	US062100	C. CE. CHP 100pF 50V B	

\* New Parts

Ref. No.	Part No.	Description	Markets
C516	US035100	C. CE. CHP 0.1uF 16V B	
C517-518	US062100	C. CE. CHP 100pF 50V B	
C519	US135100	C. CE. CHP 0.1uF 16V	
C520	US035100	C. CE. CHP 0.1uF 16V B	
C521	US063100	C. CE. CHP 1000pF 50V B	
C522-523	US135100	C. CE. CHP 0.1uF 16V	
C524-525	US063100	C. CE. CHP 1000pF 50V B	
C527-528	US064100	C. CE. CHP 0.01uF 50V B	
C529	US062100	C. CE. CHP 100pF 50V B	
C530	US064100	C. CE. CHP 0.01uF 50V B	
C531-534	US062100	C. CE. CHP 100pF 50V B	
C535	US064100	C. CE. CHP 0.01uF 50V B	
C536-549	US062100	C. CE. CHP 100pF 50V B	
C550	US064100	C. CE. CHP 0.01uF 50V B	
C603-608	US062220	C. CE. CHP 220pF 50V B	UC
C609	US135100	C. CE. CHP 0.1uF 16V	UC
C623	US135100	C. CE. CHP 0.1uF 16V	
C625	US063100	C. CE. CHP 1000pF 50V B	UC
C626	US064100	C. CE. CHP 0.01uF 50V B	UC
D101	VS597600	DIODE. CHP RB160L-40 TE25	
D401	VU171400	DIODE. ZENR UDZS3.3BTE-17 3.3V	
D402	VU171400	DIODE. ZENR UDZS3.3BTE-17 3.3V	BGEF
D403-404	VU171400	DIODE. ZENR UDZS3.3BTE-17 3.3V	
D405	VT332900	DIODE 1SS355	
D407	VT332900	DIODE 1SS355	
D408	VU171400	DIODE. ZENR UDZS3.3BTE-17 3.3V	
D409	VU171400	DIODE. ZENR UDZS3.3BTE-17 3.3V	RKABGEFL
D602	VT332900	DIODE 1SS355	UC
G101	WB438000	TERM. GND M4 SD00433-21	
IC101	X7534A00	IC. CPU ADSP-BF531 CPU	
IC102	X8653A00	IC BR25L320F-W EEPROM	
IC201	X9590A00	IC. MEMORY F49L160BA-70TG	(boot only)
IC202	X9626A00	IC. MEMORY K4S641632K-UC60000	
IC203	X4201A00	IC SN74AHC02PWR	
IC204-206	X4285A00	IC SN74LV573APWR	
IC301	X7919A00	IC AK4588VQ	
IC305	X3936A00	IC SN74LVU04APWR	
IC401	X6905A00	IC ADC084S021CIMM	
IC402-403	X5875A00	IC SN74LV4051APWR	
IC404	X2709A00	IC SN74AHCT245PWR	
IC501	X3824A00	IC SN74AHCT08PWR	
IC505	X4463A00	IC SN74LV08APWR	
PJ301	V8795700	JACK. PIN 1P	
Q101	WE736300	FET RT0040P02	
Q501	WE736300	FET RT0040P02	
U301-302	WH169900	CN. PHOTO. R 1P GP1FAV51RK0F	
XL101	VZ540700	RSNR. CRY5 25MHz SMD-49	
XL301	WJ625200	RSNR. CRY5 24.576MHz	
	WN242700	P. C. B. OPERATION	UC
	WN242800	P. C. B. OPERATION	RL
	WN242900	P. C. B. OPERATION	T
	WN243000	P. C. B. OPERATION	KABGEF
CB181	VB858500	CN. BS. PIN 6P	
CB182	VF982200	CN. BS. PIN 14P	UC
CB202	VF982300	CN. BS. PIN 17P	
CB231	VK026300	CN. BS. PIN 4P	
CB234	LB919110	CN. BS. PIN 11P SE	

\* New Parts

RX-V363/HTR-6130

**P.C.B. OPERATION**

Ref. No.	Part No.	Description	Markets
CB235	VK024700	CN. BS. PIN 3P	
CB252	WN077700	CLIP. FUSE CLIP PFC5000-0202F	
CB254	WN077700	CLIP. FUSE CLIP PFC5000-0202F	
CB256-257	VG879900	CN. BS. PIN 2P	
CB258	V9377900	CN. BS. PIN 4P	RL
CB261	VB858300	CN. BS. PIN 4P	
C1801-1803	US060800	C. CE. CHP 8pF 50V B	
C1804-1810	WE773800	C. CE. M. CHP 1uF 10V B	
C1811-1813	US135100	C. CE. CHP 0.1uF 16V	
C1814	UR837470	C. EL 47uF 16V	
C1815	WE773800	C. CE. M. CHP 1uF 10V B	
C1816-1817	UR837470	C. EL 47uF 16V	
C1818	WE773800	C. CE. M. CHP 1uF 10V B	
C1819	UR837100	C. EL 10uF 16V	UC
C1820-1821	US062100	C. CE. CHP 100pF 50V B	
C1822	UR838100	C. EL 100uF 16V	
C1823	US135100	C. CE. CHP 0.1uF 16V	
C1824	UR837100	C. EL 10uF 16V	
C1825	US135100	C. CE. CHP 0.1uF 16V	
C1826	UR838100	C. EL 100uF 16V	
C1827-1829	UR837100	C. EL 10uF 16V	
C2001	US064100	C. CE. CHP 0.01uF 50V B	RKABGEFL
C2002	US063100	C. CE. CHP 1000pF 50V B	RKABGEFL
C2003	UM397100	C. EL 10uF 16V	RKABGEFL
C2004	US062100	C. CE. CHP 100pF 50V B	RKABGEFL
C2005	UM387470	C. EL 47uF 16V	RKABGEFL
C2006	US135100	C. CE. CHP 0.1uF 16V	
C2007	US061330	C. CE. CHP 33pF 50V B	RKABGEFL
C2008	UM397220	C. EL 22uF 25V	RKABGEFL
C2009	UM397100	C. EL 10uF 16V	RKABGEFL
C2010-2011	UM397220	C. EL 22uF 25V	RKABGEFL
C2012	US065100	C. CE. CHP 0.1uF 50V B	
C2013-2014	US135100	C. CE. CHP 0.1uF 16V	
C2015	UR068100	C. EL 100uF 50V	
C2016	UM388330	C. EL 330uF 6.3V	
C2017	US135100	C. CE. CHP 0.1uF 16V	
C2018	US061820	C. CE. CHP 82pF 50V B	
C2019-2020	US062100	C. CE. CHP 100pF 50V B	
C2021	US061100	C. CE. CHP 10pF 50V B	
C2022-2024	US135100	C. CE. CHP 0.1uF 16V	
C2025	US064100	C. CE. CHP 0.01uF 50V B	
C2026	US135100	C. CE. CHP 0.1uF 16V	
C2027	UM397100	C. EL 10uF 16V	
C2028	US135100	C. CE. CHP 0.1uF 16V	
C2029-2030	US063100	C. CE. CHP 1000pF 50V B	
C2101	US064100	C. CE. CHP 0.01uF 50V B	
C2102-2105	US044220	C. CE. CHP 0.022uF 25V B	
C2110-2111	US063100	C. CE. CHP 1000pF 50V B	RKABGEFL
C2152	UR866100	C. EL 1uF 50V	
C2153	UR837470	C. EL 47uF 16V	
C2156	US064100	C. CE. CHP 0.01uF 50V B	
C2157	US135100	C. CE. CHP 0.1uF 16V	
C2158	UR866100	C. EL 1uF 50V	
C2160	UR866100	C. EL 1uF 50V	
C2161	US135100	C. CE. CHP 0.1uF 16V	
C2162	UR866100	C. EL 1uF 50V	
C2164	UR837100	C. EL 10uF 16V	
C2168-2170	UR866100	C. EL 1uF 50V	
C2171	UR739470	C. EL 4700uF 16V	
C2172-2173	UR866100	C. EL 1uF 50V	

\* New Parts

Ref. No.	Part No.	Description	Markets
C2175	UR749470	C. EL 4700uF 25V	
C2176	UR749220	C. EL 2200uF 25V	
C2178	UR73A100	C. EL 10000uF 16V	
C2179-2180	VE326000	C. MYLAR 0.1uF 50V	
C2181	US135100	C. CE. CHP 0.1uF 16V	
C2182	WJ605000	C. MYLAR 0.01uF 50V J	
C2184	VE326000	C. MYLAR 0.1uF 50V	
C2185	UR739470	C. EL 4700uF 16V	UC
C2186-2187	UR866100	C. EL 1uF 50V	UC
C2251	UR749220	C. EL 2200uF 25V	UCKABGEFL
C2251	UR759220	C. EL 2200uF 35V	RL
C2252	WJ605000	C. MYLAR 0.01uF 50V J	
C2253	UR897100	C. EL 10uF 100V	RL
C2254	WJ605000	C. MYLAR 0.01uF 50V J	UCTKABGEFL
C2255-2256	WJ605000	C. MYLAR 0.01uF 50V J	RL
C2257	WB121400	C. CE. SAFTY 0.01uF 295V	
C2301-2304	WJ605000	C. MYLAR 0.01uF 50V J	
C2351-2352	US135100	C. CE. CHP 0.1uF 16V	
C2353-2354	US062220	C. CE. CHP 220pF 50V B	
C2355	US135100	C. CE. CHP 0.1uF 16V	UC
D181	VU172000	DIODE. ZENR UDZS5.6BTE-17 5.6V	
D2001	WJ249600	LED ORANGE	
D2002	VU171900	DIODE. ZENR UDZ5.1B 5.1V	RKABGEFL
D2003	WJ249600	LED ORANGE	
D2004	VT332900	DIODE 1SS355	RKABGEFL
D2005	WJ249600	LED ORANGE	
D2006	VT332900	DIODE 1SS355	RKABGEFL
D2007	WJ249600	LED ORANGE	
D2008-2009	VU171500	DIODE. ZENR UDZ 3.6BTE-17 3.6V	
D2151	VT332900	DIODE 1SS355	
D2152	VS997800	DIODE 1T2	
D2154	VT332900	DIODE 1SS355	
D2156	VT332900	DIODE 1SS355	
D2157	VU171900	DIODE. ZENR UDZ5.1B 5.1V	
D2158	VS997800	DIODE 1T2	
D2160	VT332900	DIODE 1SS355	
D2162-2164	WA653100	DIODE. BRG KBP103G 1A 200V	
D2165	VU171900	DIODE. ZENR UDZ5.1B 5.1V	RTKABGEFL
D2166-2167	VT332900	DIODE 1SS355	
D2168	V2376600	DIODE. SHOT RB500V-40	
D2169	WA653100	DIODE. BRG KBP103G 1A 200V	UC
D2170-2171	VT332900	DIODE 1SS355	UC
D2251	VD631600	DIODE 1SS133, 176	
D2252	VG437000	DIODE. ZENR MTZJ4.7A 4.7V	RL
D2253-2254	VS997800	DIODE 1T2	
D2255	VS997800	DIODE 1T2	RL
D2256-2257	VS997800	DIODE 1T2	
D2258-2259	WC398800	DIODE KDS160-RTK	
D2301	VU172500	DIODE. ZENR UDZS9.1B	
D2302-2303	VT332900	DIODE 1SS355	
D2351-2354	VT332900	DIODE 1SS355	
F2251	WB221200	FUSE T6A 125V	UC
F2251	WM933100	FUSE T5A 250V	RL
F2251	VV071700	FUSE 3.15A 250V	TKABGEFL
IC181	X7362A00	IC NJM2586AM (TE2)	
IC183	X9374A00	IC NJM2595M	
IC201	X6386A00	IC M66003-0131FP	
IC202	X7378A00	IC NJM4565M (TE1)	RKABGEFL
IC232	X6248A00	IC NJM2388F33	
IC233-234	X4928A00	IC KIA7805API 5V	

\* New Parts

RX-V363/HTR-6130

**P.C.B. OPERATION and P.C.B. MAIN**

Ref. No.	Part No.	Description	Markets
△ IC236	X4153A00	IC KIA7812API	
△ IC237	X4154A00	IC KIA7912PI	
IC238	X0515A00	IC LM61CIZ THERMAL	
IC239	X4928A00	IC KIA7805API 5V	UC
JK201	WJ117300	JACK. PHONE PHONES	RKABGEFL
JK261	V9408200	JACK. PHONE MSJ-064-05B GR	
JK266	WJ117400	JACK. MNI OPTIMIZER MIC	
PJ181-182	WG505100	JACK. PIN 6P	
PJ183	V7190000	JACK. PIN 2P	
PJ184	V7189800	JACK. PIN 1P	
PJ185	V7190000	JACK. PIN 2P	
PJ266	WJ117500	JACK. PIN 3P	
PN201-202	V9637500	PIN L=70 #18	
PN231-232	V9637500	PIN L=70 #18	
PN266	V9637500	PIN L=70 #18	
PN272-273	V9637500	PIN L=70 #18	
Q181	iA101510	TR 2SA1015 Y	
Q182-184	VV556400	TR 2SC2412K Q, R, S	
Q2001-2005	VV556400	TR 2SC2412K Q, R, S	
Q2011-2012	WC434800	TR. DGT KRA102S-RTK/P	
Q2013	WC435000	TR. DGT KRC102S-RTK	
Q2014	VV556400	TR 2SC2412K Q, R, S	
Q2015-2016	VV556500	TR 2SA1037K Q, R, S	
Q2017	VV556400	TR 2SC2412K Q, R, S	
Q2151	WC435100	TR. DGT KRC104S-RTK	
Q2152	VV556400	TR 2SC2412K Q, R, S	
Q2153	WC435100	TR. DGT KRC104S-RTK	
Q2251	iC181510	TR 2SC1815 Y	
Q2252	iA101510	TR 2SA1015 Y	RL
△ Q2253	VP872600	TR 2SA1708 S, T	RL
△ Q2254	iA101510	TR 2SA1015 Y	RL
△ Q2255	WC529200	TR. DGT KRC102M-AT	RL
R1815	HV754220	R. CAR. FP 22Ω 1/4W	
R1825	HV753220	R. CAR. FP 2.2Ω 1/4W	
R1831	HV753220	R. CAR. FP 2.2Ω 1/4W	
* R2160	WJ682400	R. MTL. FLM 1Ω 1W J	UC
* R2171	WJ682400	R. MTL. FLM 1Ω 1W J	
* R2174	WJ682000	R. MTL. FLM 0.47Ω 1W J	
R2258	VC757900	R. MTL. OXD 47Ω 2W	RL
R2260	V6730000	R. CAR. 2.2MΩ 1/2W	UC
R2301-2302	WJ685600	R. MTL. FLM 470Ω 1W J	
△ RY251	V9366900	RELAY DLS9D1-0(M)0.25W	
ST251	WA789600	SCR. TERM M3	
ST261	WA789700	SCR. TERM D3.5	
SW201-220	WD483100	SW. TACT SKRGAAD010	
△ SW221	V9597100	SW. RT. ENC EC12E2460802	
△ SW251	VZ075500	SW. SL IDE SL14-22AM5F	RL
SW274	WD483100	SW. TACT SKRGAAD010	
△ T251	X8521A00	TRANS. PWR	UC
△ T251	X8522A00	TRANS. PWR	RL
△ T251	X8523A00	TRANS. PWR	T
△ T251	X8523A00	TRANS. PWR	KABGEF
U2002	WJ645300	L. DTCT SM3385UMH6	
V2001	WJ264400	FL. DSPLY 17-BT-29GNK	
	V6007100	SPACER. FL 4.6/10/32	

\* New Parts

Ref. No.	Part No.	Description	Markets
*	WN241400	P. C. B. MAIN	UC
*	WN241500	P. C. B. MAIN	RA
*	WN241600	P. C. B. MAIN	T
*	WN241700	P. C. B. MAIN	KL
*	WN241800	P. C. B. MAIN	BGEF
CB101	VQ962800	CN. BS. PIN 7P	
CB103	VK025100	CN. BS. PIN 7P	
CB104	LB932060	CN. BS. PIN 6P	
CB161	VQ047500	CN. BS. PIN 20P	
CB163	VM923600	CN. BS. PIN 13P	
CB164	VQ963600	CN. BS. PIN 15P	
CB191	VB858300	CN. BS. PIN 4P	RKABGEFL
CB192	VB858400	CN. BS. PIN 5P	
CB193	VB858200	CN. BS. PIN 3P	
C1001	WJ605000	C. MYLAR 0.01uF 50V J	
C1002-1003	UR837100	C. EL 10uF 16V	
C1004	UR866220	C. EL 2.2uF 50V	
C1005	UR837100	C. EL 10uF 16V	
C1006-1007	UR866220	C. EL 2.2uF 50V	
C1008-1009	UR837100	C. EL 10uF 16V	
C1010	UR877220	C. EL 22uF 63V	
C1011	WJ603300	C. MYLAR 470pF 50V J	
C1012	UR896470	C. EL 4.7uF 100V	
C1013	WJ603300	C. MYLAR 470pF 50V J	
C1014	UR896470	C. EL 4.7uF 100V	
C1015	UR877220	C. EL 22uF 63V	
C1016-1017	UR896470	C. EL 4.7uF 100V	
C1018-1020	WJ603300	C. MYLAR 470pF 50V J	
C1021	WJ602900	C. MYLAR 100pF 50V K	
C1022	UR867330	C. EL 33uF 50V	
C1023	WJ602900	C. MYLAR 100pF 50V K	
C1024-1025	UR867330	C. EL 33uF 50V	
C1026	WJ602900	C. MYLAR 100pF 50V K	
C1027-1028	UR867330	C. EL 33uF 50V	
C1029	WJ602900	C. MYLAR 100pF 50V K	
C1030	UR897100	C. EL 10uF 100V	
C1031	WJ602900	C. MYLAR 100pF 50V K	
C1032	FG651100	C. CE 10pF 50V	
C1033	UR866100	C. EL 1uF 50V	
C1034-1037	FG650500	C. CE 5pF 50V	
C1038-1042	WJ605800	C. MYLAR 0.047uF 50V J	
C1043	UR866470	C. EL 4.7uF 50V	
C1044	UR828220	C. EL 220uF 10V	
C1048	UR866470	C. EL 4.7uF 50V	
C1049	UR858100	C. EL 100uF 35V	
△ C1050-1051	WE514200	C. EL 6800uF 63V	
C1052-1055	WJ605000	C. MYLAR 0.01uF 50V J	
C1056-1057	WJ611400	C. MYLAR 0.1uF 100V J	
C1058	UR868100	C. EL 100uF 50V	
C1059	US064100	C. CE. CHP 0.01uF 50V B	
C1060	UR837330	C. EL 33uF 16V	
C1501-1510	WJ605000	C. MYLAR 0.01uF 50V J	
C1601	WJ605000	C. MYLAR 0.01uF 50V J	
C1602	WJ603300	C. MYLAR 470pF 50V J	
C1603	US064100	C. CE. CHP 0.01uF 50V B	
C1606-1617	US062220	C. CE. CHP 220pF 50V B	
C1618-1619	US061470	C. CE. CHP 47pF 50V B	
C1620-1623	US062220	C. CE. CHP 220pF 50V B	
C1624-1625	US061470	C. CE. CHP 47pF 50V B	
C1626-1629	UR837100	C. EL 10uF 16V	

\* New Parts

RX-V363/HTR-6130

**P.C.B. MAIN**

Ref. No.	Part No.	Description	Markets
C1631	UR866220	C. EL 2.2uF 50V	
C1632	US135100	C. CE. CHP 0.1uF 16V	
C1633-1634	UR837100	C. EL 10uF 16V	
C1635-1636	UR847470	C. EL 47uF 25V	
C1637-1638	UR838100	C. EL 100uF 16V	
C1639-1641	US062100	C. CE. CHP 100pF 50V B	
C1642	US064100	C. CE. CHP 0.01uF 50V B	
C1643	US063100	C. CE. CHP 1000pF 50V B	
C1644	US062100	C. CE. CHP 100pF 50V B	
C1645	WJ605400	C. MYLAR 0.022uF 50V J	
C1646	WJ605800	C. MYLAR 0.047uF 50V J	
C1647	VE326200	C. MYLAR 0.15uF 50V	
C1648	UR837470	C. EL 47uF 16V	
C1649	WJ605400	C. MYLAR 0.022uF 50V J	
C1650-1655	UR837100	C. EL 10uF 16V	
C1656	UR837470	C. EL 47uF 16V	
C1657	VE326200	C. MYLAR 0.15uF 50V	
C1658	US135100	C. CE. CHP 0.1uF 16V	
C1659	WJ605800	C. MYLAR 0.047uF 50V J	
C1660	UR837470	C. EL 47uF 16V	
C1661	US135100	C. CE. CHP 0.1uF 16V	BGEF
C1662-1667	UR837100	C. EL 10uF 16V	
C1668	UR838100	C. EL 100uF 16V	
C1669	US062330	C. CE. CHP 330pF 50V B	BGEF
C1670	UR866220	C. EL 2.2uF 50V	
C1671-1674	US162820	C. CE. CHP 820pF 50V J	
C1675	US062820	C. CE. CHP 820pF 50V B	
C1676	WJ605800	C. MYLAR 0.047uF 50V J	
C1677-1678	UR837100	C. EL 10uF 16V	
C1679	US062330	C. CE. CHP 330pF 50V B	BGEF
C1680-1682	UR837100	C. EL 10uF 16V	
C1683-1684	UR837470	C. EL 47uF 16V	BGEF
C1685-1690	US062100	C. CE. CHP 100pF 50V B	
C1691	US062560	C. CE. CHP 560pF 50V B	BGEF
C1692	WJ604400	C. MYLAR 3900pF 50V J	
C1693-1699	UR837100	C. EL 10uF 16V	
C1700	US061270	C. CE. CHP 27pF 50V B	BGEF
C1701	US135100	C. CE. CHP 0.1uF 16V	BGEF
C1702	UR838100	C. EL 100uF 16V	
C1703	US061270	C. CE. CHP 27pF 50V B	BGEF
C1704	UR837470	C. EL 47uF 16V	BGEF
C1705-1706	UR838100	C. EL 100uF 16V	
C1707	US135100	C. CE. CHP 0.1uF 16V	BGEF
C1901-1902	US064100	C. CE. CHP 0.01uF 50V B	
D102	VD631600	D1ODE 1SS133, 176	
D103	VU171900	D1ODE. ZENR UDZ5.1B 5.1V	
D104	WC398800	D1ODE KDS160-RTK	
D105-106	VNO08700	D1ODE 1SS270A	
D107	WC398800	D1ODE KDS160-RTK	
D108-110	VNO08700	D1ODE 1SS270A	
D111-113	VD631600	D1ODE 1SS133, 176	
D114-115	VNO08700	D1ODE 1SS270A	
D116	VG443700	D1ODE. ZENR MTZJ33B 33V	
D117	VNO08700	D1ODE 1SS270A	
D118-119	VD631600	D1ODE 1SS133, 176	
D120	WA653200	D1ODE. BRG TS6P03G 6A 200V	
D121	VD631600	D1ODE 1SS133, 176	
D122-123	VS997800	D1ODE 1T2	
D161-162	VU994300	D1ODE. ZENR MA8075-H 7.7V	
D163	VU995500	D1ODE. ZENR MA8100-H 10.3V	

\* New Parts

Ref. No.	Part No.	Description	Markets
IC101	X8190A00	IC STK433-330-E	
IC102	X7427A00	IC STK433-130-E	
IC161	X8155B00	IC R2A15218FP	
IC162-164	X7378A00	IC NJM4565M (TE1)	
IC168	X8235A00	IC LC72725KM	BGEF
IC169	X7378A00	IC NJM4565M (TE1)	
PJ161	V7190400	JACK. PIN 6P	
PJ162	V7046800	JACK. PIN 6P MSP-246V1-01N1	
PJ163	V7189700	JACK. PIN 1P	
PJ164-165	V7046700	JACK. PIN 4P MSP-244V1-01N1	
Q101-105	VD303700	TR 2SC3326 A, B	
Q106-108	WC434800	TR. DGT KRA102S-RTK/P	
Q109	WC398400	TR 2N5551C-AT	
Q110-111	WG538600	TR KTA1046-Y-U/P	
Q112	WC398400	TR 2N5551C-AT	
Q113-114	WC397700	TR 2N5401C-AT	
Q115-119	WC398400	TR 2N5551C-AT	
Q120	WC397700	TR 2N5401C-AT	
Q121-123	WC434900	TR. DGT KRA104S-RTK	
Q124	VP872600	TR 2SA1708 S, T	
Q125-126	WC434900	TR. DGT KRA104S-RTK	
Q127	WC435000	TR. DGT KRC102S-RTK	
Q128	iC181510	TR 2SC1815 Y	
Q129-132	WC435000	TR. DGT KRC102S-RTK	
Q133	WC434900	TR. DGT KRA104S-RTK	
Q161-162	VZ725900	TR 2SD1938F S, T	
Q163	WC434800	TR. DGT KRA102S-RTK/P	
Q164	iC181510	TR 2SC1815 Y	
Q165	iA101510	TR 2SA1015 Y	
Q166	iC181510	TR 2SC1815 Y	
Q167	iC174020	TR 2SC1740S QRS	BGEF
R1027-1028	HV753220	R. CAR. FP 2.2Ω 1/4W	
R1031	HV755560	R. CAR. FP 560Ω 1/4W	
R1038	HV754100	R. CAR. FP 10Ω 1/4W	
R1043	HV754100	R. CAR. FP 10Ω 1/4W	
R1054	WB279900	R. CEMENT RGC55C 0.22+0.22	
R1057	WB279900	R. CEMENT RGC55C 0.22+0.22	
R1061	WB279900	R. CEMENT RGC55C 0.22+0.22	
R1069-1070	WB279900	R. CEMENT RGC55C 0.22+0.22	
R1085	HV754100	R. CAR. FP 10Ω 1/4W	
R1087	HV754100	R. CAR. FP 10Ω 1/4W	
R1089	HV754100	R. CAR. FP 10Ω 1/4W	
R1092-1093	HV754100	R. CAR. FP 10Ω 1/4W	
R1095	WB625100	R. MTL. FLM 4.7Ω 1W J	
R1099-1100	WB625100	R. MTL. FLM 4.7Ω 1W J	
R1103-1104	WB625100	R. MTL. FLM 4.7Ω 1W J	
R1106	HV756150	R. CAR. FP 1.5KΩ 1/4W	
R1110	HV755470	R. CAR. FP 470Ω 1/4W	
R1659-1660	HV753220	R. CAR. FP 2.2Ω 1/4W	
RY101-105	WJ122400	RELAY 981-2A-24DS-SP7	
RY106	WE648700	RELAY DC DH24D2-0-Q	
ST101	WA789600	SCR. TERM M3	
TE101	WK560800	TERM. SP 4P MST-204V1-01 NC	UCRTA
TE101	WK560900	TERM. SP 4P MST-204V1-01 WC	KBGEFL
TE151	WJ551900	TERM. SP MSP-120V2-11 (765A)	
XL161	WJ588000	RSNR. CRYST 4.332MHz	BGEF
	WE774200	SCR. BND. HD 3x10 MFZN2W3	

\* New Parts

RX-V363/HTR-6130





**Carbon Resistors**

Value	1/4W Type Part No.	1/6W Type Part No.	Value	1/4W Type Part No.	1/6W Type Part No.
1.0 Ω	HJ35 3100	HF85 3100	10 kΩ	HF45 7100	HF45 7100
1.8 Ω	HJ35 3180	*	11 kΩ	HF45 7110	HF45 7110
2.2 Ω	HJ35 3220	HF85 3220	12 kΩ	HJ35 7120	HF85 7120
3.3 Ω	HJ35 3330	HF85 3330	13 kΩ	HF45 7130	HF45 7130
4.7 Ω	HJ35 3470	HF85 3470	15 kΩ	HF45 7150	HF45 7150
5.6 Ω	HJ35 3560	HF85 3560	18 kΩ	HF45 7180	HF45 7180
10 Ω	HF45 4100	HF45 4100	22 kΩ	HF45 7220	HF45 7220
15 Ω	HJ35 4150	HF85 4150	24 kΩ	HF45 7240	HF45 7240
22 Ω	HF45 4220	HF45 4220	27 kΩ	HJ35 7270	HF85 7270
27 Ω	HJ35 4270	HF85 4270	30 kΩ	HF45 7300	HF45 7300
33 Ω	HF45 4330	HF45 4330	33 kΩ	HF45 7330	HF45 7330
39 Ω	HJ35 4470	HF85 4390	36 kΩ	HF45 7360	HF45 7360
47 Ω	HF45 4470	HF45 4470	39 kΩ	HF45 7390	HF45 7390
56 Ω	HF45 4560	HF45 4560	47 kΩ	HF45 7470	HF45 7470
68 Ω	HF45 4680	HF45 4680	51 kΩ	HF45 7510	HF45 7510
75 Ω	HF45 4750	HF45 4750	56 kΩ	HF45 7560	HF45 7560
82 Ω	HF45 4820	HF45 4820	62 kΩ	HF45 7620	HF45 7620
91 Ω	HF45 4910	HF45 4910	68 kΩ	HF45 7680	HF45 7680
100 Ω	HF45 5100	HF45 5100	82 kΩ	HF45 7820	HF45 7820
110 Ω	HJ35 5110	HF85 5110	91 kΩ	HF45 7910	HF45 7910
120 Ω	HF45 5120	HF45 5120	100 kΩ	HF45 8100	HF45 8100
150 Ω	HF45 5150	HF45 5150	110 kΩ	HF45 8110	HF45 8110
160 Ω	HJ35 5160	*	120 kΩ	HF45 8120	HF45 8120
180 Ω	HF45 5180	HF45 5180	150 kΩ	HF45 8150	HF45 8150
200 Ω	HF45 5200	HF45 5200	180 kΩ	HF45 8180	HF45 8180
220 Ω	HF45 5220	HF45 5220	220 kΩ	HJ35 8220	HF85 8220
270 Ω	HF45 5270	HF45 5270	270 kΩ	HF45 8270	HF45 8270
330 Ω	HF45 5330	HF45 5330	300 kΩ	HF45 8300	HF45 8300
390 Ω	HF45 5390	HF45 5390	330 kΩ	HF45 8330	HF45 8330
430 Ω	HF45 5430	HF45 5430	390 kΩ	HJ35 8390	HF85 8390
470 Ω	HF45 5470	HF45 5470	470 kΩ	HF45 8470	HF45 8470
510 Ω	HF45 5510	HF45 5510	560 kΩ	HJ35 8560	HF85 8560
560 Ω	HF45 5560	HF45 5560	680 kΩ	HJ35 8680	HF85 8680
680 Ω	HF45 5680	HF45 5680	820 kΩ	HJ35 8820	HF85 8820
820 Ω	HF45 5820	HF45 5820	1.0 MΩ	HF45 9100	HF45 9100
910 Ω	HF45 5910	HF45 5910	1.2 MΩ	HJ35 9120	*
1.0 kΩ	HF45 6100	HF45 6100	1.5 MΩ	HJ35 9150	HF85 9150
1.2 kΩ	HF45 6120	HF45 6120	1.8 MΩ	HJ35 9180	HF85 9180
1.5 kΩ	HF45 6150	HF45 6150	2.2 MΩ	HJ35 9220	HF85 9220
1.8 kΩ	HF45 6180	HF45 6180	3.3 MΩ	HJ35 9330	HF85 9330
2.0 kΩ	HJ35 6200	HF85 6200	3.9 MΩ	HJ35 9390	*
2.2 kΩ	HF45 6220	HF45 6220	4.7 MΩ	HJ35 9470	HF85 9470
2.4 kΩ	HJ35 6240	HF85 6240			
2.7 kΩ	HF45 6270	HF45 6270			
3.0 kΩ	HF45 6300	HF45 6300			
3.3 kΩ	HF45 6330	HF45 6330			
3.6 kΩ	HJ35 6360	HF85 6360			
3.9 kΩ	HF45 6390	HF45 6390			
4.7 kΩ	HF45 6470	HF45 6470			
5.1 kΩ	HF45 6510	HF45 6510			
5.6 kΩ	HF45 6560	HF45 6560			
6.8 kΩ	HF45 6680	HF45 6680			
8.2 kΩ	HF45 6820	HF45 6820			
9.1 kΩ	HF45 6910	HF45 6910			

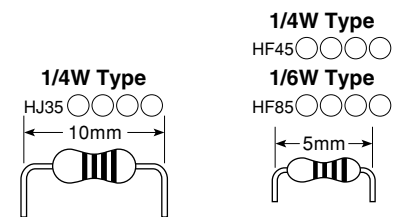

\* : Not available

• OVERALL ASS'Y

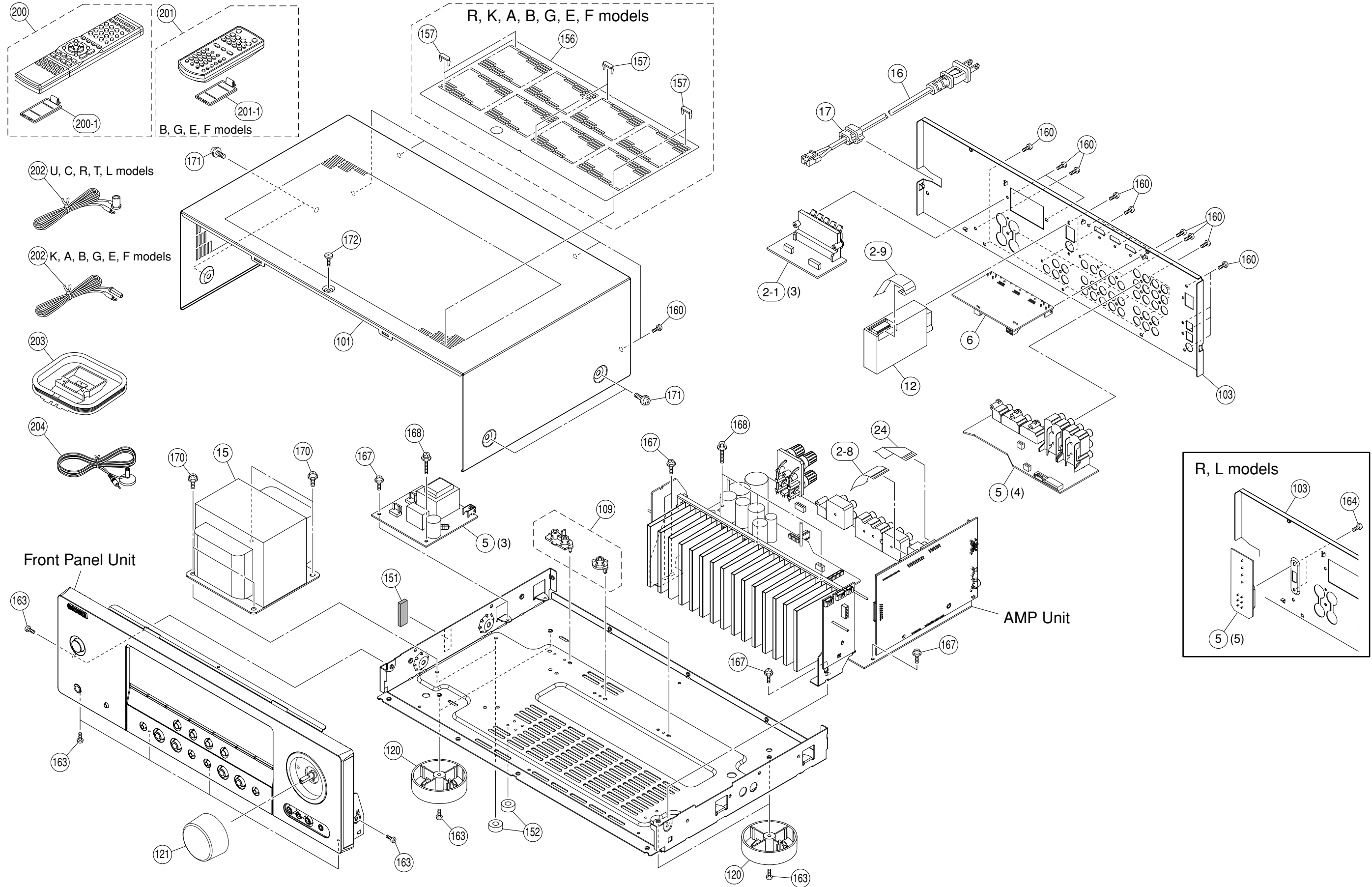

1

2

3

4

5

6

7

Ref. No.	Part No.	Description	Remarks	Markets
2-8	MF120180	FLEXIBLE FLAT CABLE	20P 180mm P=1.25	
2-9	MF113120	FLEXIBLE FLAT CABLE	13P 120mm P=1.25	
* 5	WN242700	P.C.B. ASS'Y	OPERATION	UC
* 5	WN242800	P.C.B. ASS'Y	OPERATION	RL
* 5	WN242900	P.C.B. ASS'Y	OPERATION	T
* 5	WN243000	P.C.B. ASS'Y	OPERATION	KABGEF
* 6	WN243200	P.C.B. ASS'Y	HDMI	
12	WB424000	AM/FM TUNER	ENG06709Q	UCRL
12	WB877300	AM/FM TUNER	FAE381-A07F	T
12	WB424100	AM/FM TUNER	ENG07711Q	KABGEF
* △ 15	X9582A00	POWER TRANSFORMER		UC
* △ 15	X9583A00	POWER TRANSFORMER		RL
* △ 15	X9584A00	POWER TRANSFORMER		TK
* △ 15	X9585A00	POWER TRANSFORMER		A
* △ 15	X9586A00	POWER TRANSFORMER		BGEF
△ 16	WB120500	POWER CABLE	2m	UC
△ 16	WC992700	POWER CABLE	2m	R
△ 16	WB120600	POWER CABLE	2m	T
△ 16	WC753000	POWER CABLE	2m	K
△ 16	WC743700	POWER CABLE	2m	A
△ 16	WB212200	POWER CABLE	2m	B
△ 16	WB212300	POWER CABLE	2m	GEFL
17	V2438700	CORD STOPPER	10P1	
24	MF114100	FLEXIBLE FLAT CABLE	14P 100mm P=1.25	UC
101	WE065200	TOP COVER		GD
101	WE065000	TOP COVER		BL
101	WE065100	TOP COVER		TI
101	WG481900	TOP COVER		SI
* 103	WM759500	REAR PANEL	V363	UC
* 103	WM759700	REAR PANEL	V363	R
* 103	WM759800	REAR PANEL	V363	T
* 103	WM759900	REAR PANEL	V363	K
* 103	WM760000	REAR PANEL	V363	A
* 103	WM760100	REAR PANEL	V363	B
* 103	WM760200	REAR PANEL	V363	GEF
* 103	WM760300	REAR PANEL	V363	L
* 103	WM760500	REAR PANEL	6130	UC
* 103	WM760700	REAR PANEL	6130	R
* 103	WM760800	REAR PANEL	6130	T
* 103	WM760900	REAR PANEL	6130	K
* 103	WM761000	REAR PANEL	6130	A
* 103	WM761100	REAR PANEL	6130	GF
* 103	WN121700	REAR PANEL	6130	L
109	WA796100	SUPPORT P.C.B.		
120	WA790600	LEG	D60/H21 GD	GD
120	WA790500	LEG	D60/H21 HS	BL, TI, SI
* 121	WM749500	KNOB D48		GD
* 121	WM749400	KNOB D48		BL
* 121	WM749600	KNOB D48		TI
* 121	WM749700	KNOB D48		SI
151	WB408400	DAMPER	10x30 t=4	
152	WB484700	DAMPER	SCREW MASK	
156	WJ589800	SHEET TOP		RKABGEF
157	WJ323900	RIVET TOP		RKABGEF
160	WE774100	BIND HEAD BONDING B-T. SCREW	3x8 MFZN2B3	
163	WE774300	BIND HEAD B-TIGHT SCREW	3x8 MFZN2W3	
164	WE774000	BIND HEAD SCREW	3x6 MFZN2W3	RL
167	WF002600	PW HEAD B-TIGHT SCREW	3x8 MFZN2W3	
168	WE774600	SCREW IC	3x18 MFZN2W3	

\* New Parts

Ref. No.	Part No.	Description	Remarks	Markets
170	WE774700	BIND HEAD S-TIGHT SCREW	4x10 MFZN2W3	
171	VD069600	PW HEAD S-TIGHT SCREW	4x8-10 MFN133	GD, TI, SI
171	VH313200	PW HEAD S-TIGHT SCREW	4x8-10 MFN13BL	BL
172	WE200400	DISH HEAD B-TIGHT SCREW	3x6 MFN133	GD, TI, SI
172	WE200500	DISH HEAD B-TIGHT SCREW	3x6 MFN13BL	BL
		ACCESSORIES		
* 200	WN058100	REMOTE CONTROL	RAV283	UC
* 200	WN058200	REMOTE CONTROL	RAV284	RTKAL
200-1	AAX82380	BATTERY COVER		CG-2209
* 201	WN466800	REMOTE CONTROL	RAV34	BGEF
201-1	AAX70730	BATTERY COVER		CG-8912
202	WB212500	INDOOR FM ANTENNA	1.4m 1pc	BGEF
202	WB212400	INDOOR FM ANTENNA	1.4m 1pc	UCRTL
202	WB212600	AM LOOP ANTENNA	1.0m 1pc	KABGEF
* 204	WN649600	OPTIMIZER MICROPHONE BATTERY	6.0m 1pc	EM6022L-HN1700
			RO3, AAA, UM-4 2pcs	RKABGEFL
		SERVICE TOOL		
	MF117350	FLEXIBLE FLAT CABLE	17P 350mm P=1.25	

\* New Parts

• FRONT PANEL UNIT

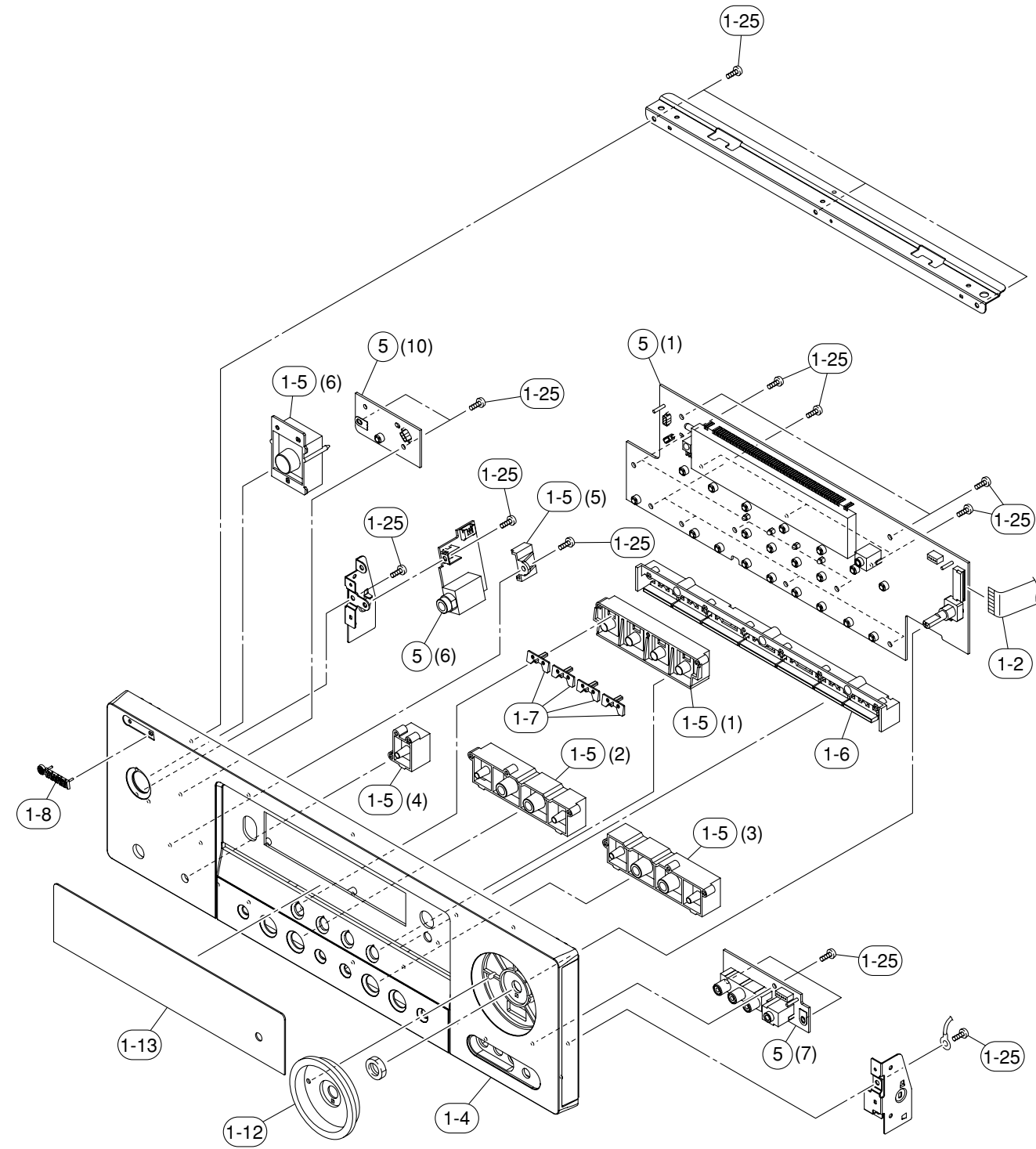

Ref. No.	Part No.	Description	Remarks	Markets
1-2	MF117180	FLEXIBLE FLAT CABLE	17P 180mm P=1.25	
* 1-4	WM753300	FRONT PANEL		V363GD
* 1-4	WM752100	FRONT PANEL		V363BL
* 1-4	WM754100	FRONT PANEL		V363TI
* 1-4	WM754600	FRONT PANEL		V363SI
* 1-4	WM753400	FRONT PANEL		6130GD
* 1-4	WM752200	FRONT PANEL		6130BL
* 1-4	WM755000	FRONT PANEL		6130SI
* 1-4	WM754700	FRONT PANEL		6130SI
1-5	WJ192500	BUTTON CASE		GD
1-5	WJ192300	BUTTON CASE		BL
1-5	WJ192700	BUTTON CASE		TI
1-5	WJ192600	BUTTON CASE		SI
1-6	WJ192800	BUTTON TUNER		
1-7	WJ193200	LENS BUTTON	SCENE	
1-8	WJ193400	EMBLEM GD		GD
1-8	WJ193300	EMBLEM BL		BL, TI, SI
* 1-12	WM750100	ESCUTCHEON VOL		GD
* 1-12	WM750000	ESCUTCHEON VOL		BL
* 1-12	WM750200	ESCUTCHEON VOL		TI
* 1-12	WM750300	ESCUTCHEON VOL		SI
* 1-13	WM995900	SHEET WINDOW		
* 1-13	WM761800	SHEET WINDOW		
1-25	WE774800	BIND HEAD P-TIGHT SCREW	OPTIMIZER MIC 3x8 MFZN2W3	UCT RKABGEFL
5	WN242700	P. C. B. ASS'Y	OPERATION	UC
5	WN242800	P. C. B. ASS'Y	OPERATION	RL
5	WN242900	P. C. B. ASS'Y	OPERATION	T
5	WN243000	P. C. B. ASS'Y	OPERATION	KABGEF

\* New Parts

1 • AMP UNIT

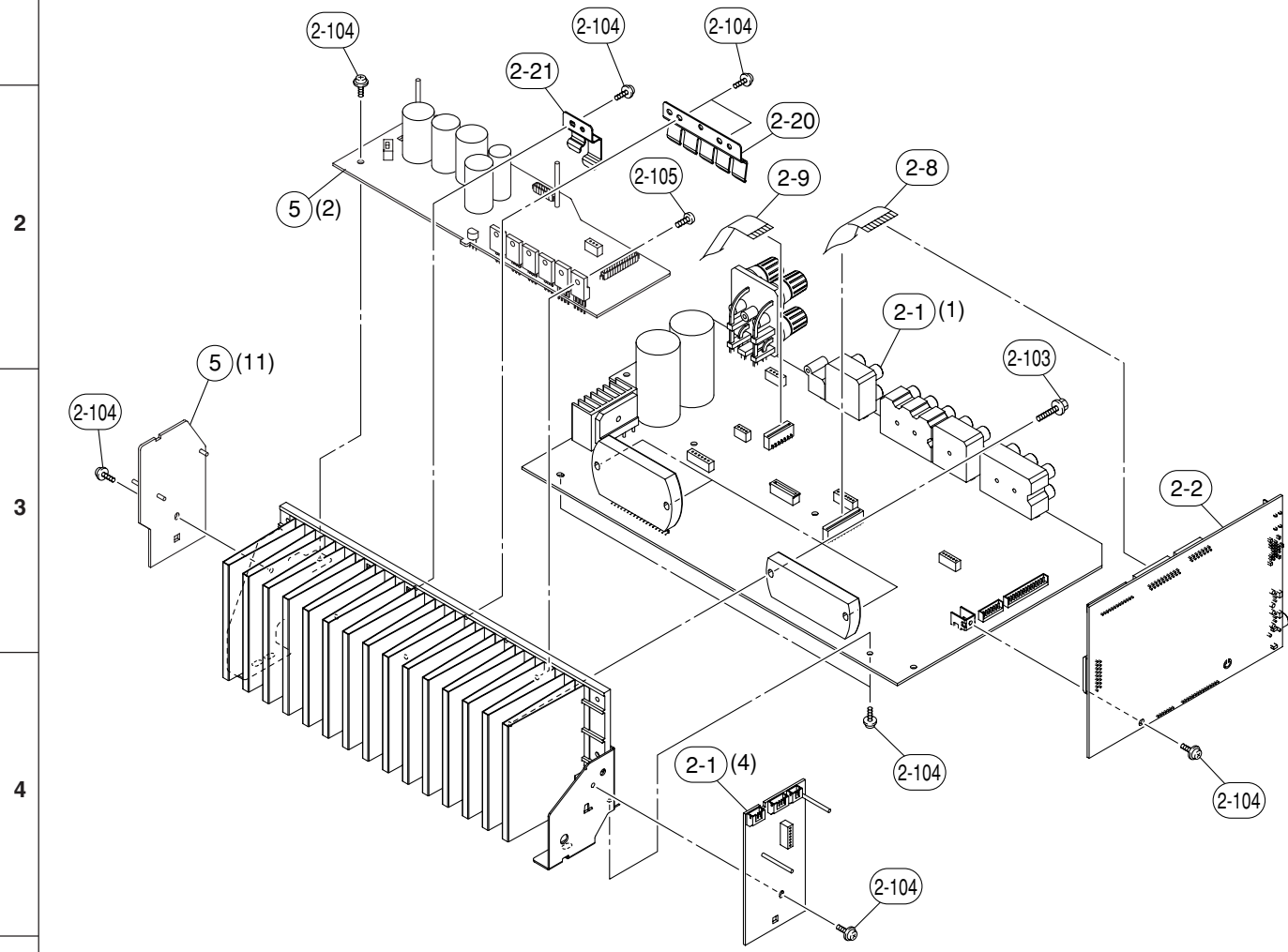

Ref. No.	Part No.	Description	Remarks	Markets	
*	2-1	WN241400	P. C. B. ASS'Y	MAIN	UC
*	2-1	WN241500	P. C. B. ASS'Y	MAIN	RA
*	2-1	WN241600	P. C. B. ASS'Y	MAIN	T
*	2-1	WN241700	P. C. B. ASS'Y	MAIN	KL
*	2-1	WN241800	P. C. B. ASS'Y	MAIN	BGEF
*	2-2	WN242100	P. C. B. ASS'Y	DSP	UC
*	2-2	WN242200	P. C. B. ASS'Y	DSP	RL
*	2-2	WN242300	P. C. B. ASS'Y	DSP	T
*	2-2	WN242400	P. C. B. ASS'Y	DSP	KA
*	2-2	WN242500	P. C. B. ASS'Y	DSP	BGEF
	2-8	MF120180	FLEXIBLE FLAT CABLE	20P 180mm P=1.25	
	2-9	MF113120	FLEXIBLE FLAT CABLE	13P 120mm P=1.25	
	2-20	WG451000	SUPPORT TR-5P		
	2-21	WJ187700	SUPPORT TR-2P		
	2-103	WE774600	SCREW IC	3x18 MFZN2W3	
	2-104	WF002600	PW HEAD B-TIGHT SCREW	3x8 MFZN2W3	
	2-105	WE774300	BIND HEAD B-TIGHT SCREW	3x8 MFZN2W3	
*	5	WN242700	P. C. B. ASS'Y	OPERATION	UC
*	5	WN242800	P. C. B. ASS'Y	OPERATION	RL
*	5	WN242900	P. C. B. ASS'Y	OPERATION	T
*	5	WN243000	P. C. B. ASS'Y	OPERATION	KABGEF

\*: New Parts

## REMOTE CONTROL

- **RAV283** RX-V363 (U, C models), HTR-6130 (U, C models)
- **RAV284** RX-V363 (R, T, K, A, L models), HTR-6130 (R, T, K, A, L models)
- **SCHEMATIC DIAGRAM**

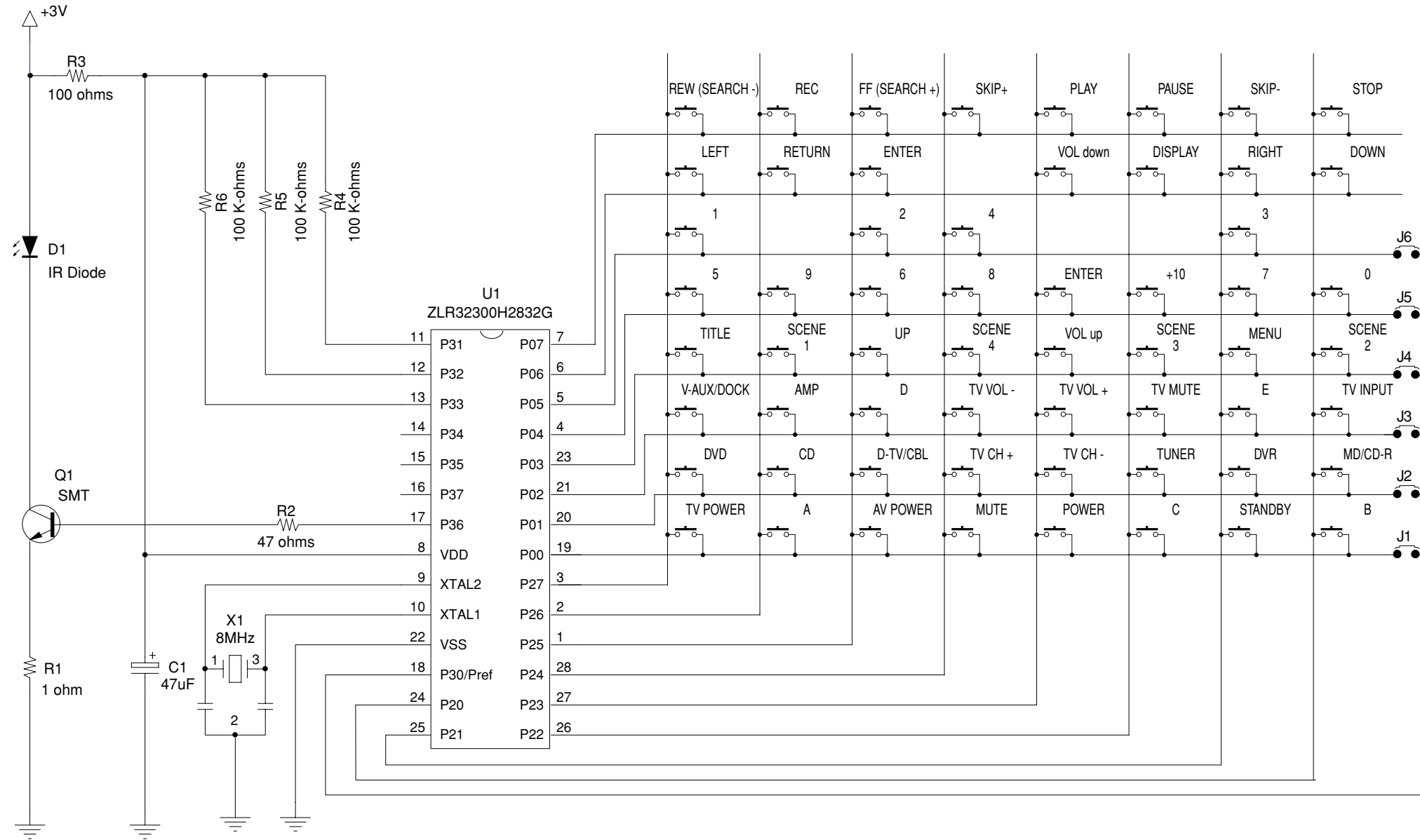

	RAV283	RAV284
J1	X	X
J2	X	X
J3	X	X
J4	O	X
J5	X	O
J6	X	X

## PANELS

### RAV283

RX-V363 (U, C models)  
HTR-6130 (U, C models)

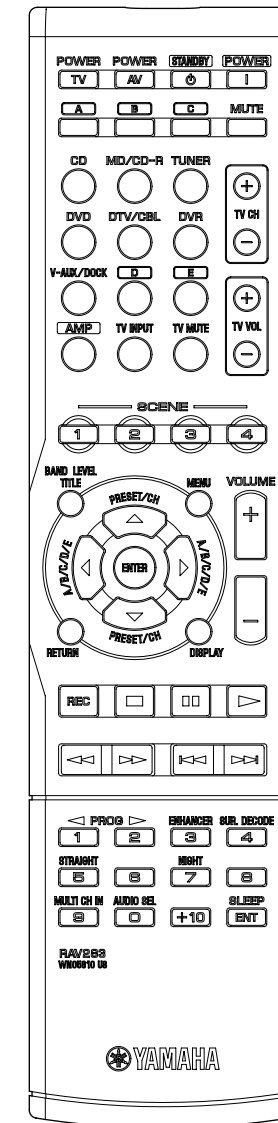

### RAV284

RX-V363 (R, T, K, A, L models)  
HTR-6130 (R, T, K, A, L models)

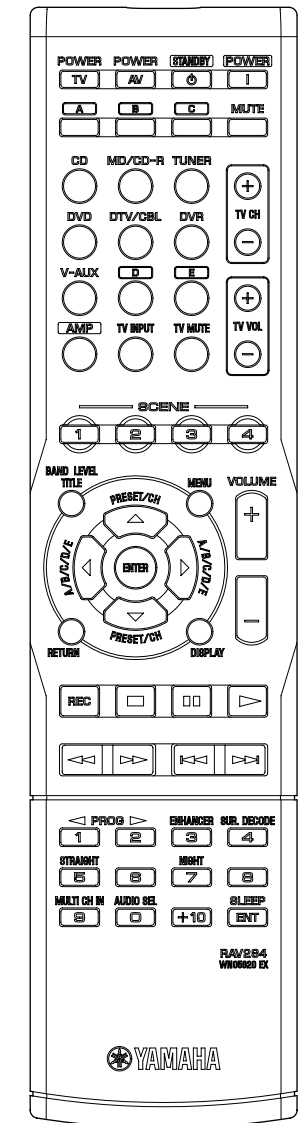

• KEY NO. LAYOUT

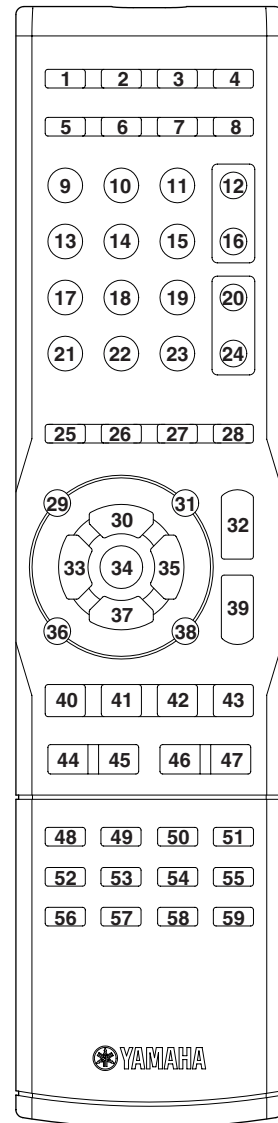

• KEY CODE

Key No.	Label	Command key	AMP										
1	TV POWER	—	(TV POWER)	(TV POWER)	(TV POWER)	(TV POWER)	(TV POWER)	(TV POWER)	(TV POWER)	(TV POWER)	(TV POWER)	(TV POWER)	(TV POWER)
2	AV POWER	—	(device)	79-60	7F-80	D1-1B	7C-80	(DVR POWER)	048.012	7F01-00	—	(DVR POWER)	
3	STANDBY	O	7E-7F	STANDBY									
4	POWER	O	7E-7E	POWER									
5	A	O	7F01-3F	A									
6	B	O	7A-B4	B									
7	C	O	7A-39	C									
8	MUTE	O	7A-1C	MUTE									
9	CD	O	7A-15	CD									
10	MD/CD-R	O	7A-C9	MD/CD-R									
11	TUNER	O	7A-16	TUNER									
12	TV CH +	—	(TV CH +)	(TV CH +)	(TV CH +)	(TV CH +)	(TV CH +)	(TV CH +)	(TV CH +)	(TV CH +)	(TV CH +)	(TV CH +)	(TV CH +)
13	DVD	O	7A-C1	DVD									
14	D-TV/CBL	O	7A-54	DTV/CBL									
15	DVR	O	7A-13	DVR									
16	TV CH -	—	(TV CH -)	(TV CH -)	(TV CH -)	(TV CH -)	(TV CH -)	(TV CH -)	(TV CH -)	(TV CH -)	(TV CH -)	(TV CH -)	(TV CH -)
17	V-AUX/DOCK	O	7A-55	V-AUX (/DOCK)									
18	D	O	7A-0F	VCR									
19	E	O	7A-14	PHONO									
20	TV VOL +	—	(TV VOL +)	(TV VOL +)	(TV VOL +)	(TV VOL +)	(TV VOL +)	(TV VOL +)	(TV VOL +)	(TV VOL +)	(TV VOL +)	(TV VOL +)	(TV VOL +)
21	AMP	O		Enter into AMP mode									
				9	10	11	13	14	15	17	18	19	
				CD	MD/CD-R	TUNER	DVD	DTV/CBL	DVR	V-AUX/DOCK	VCR	PHONO	
22	TV INPUT	—	(TV INPUT)	(TV INPUT)	(TV INPUT)	(TV INPUT)	(TV INPUT)	(TV INPUT)	(TV INPUT)	(TV INPUT)	(TV INPUT)	(TV INPUT)	(TV INPUT)
23	TV MUTE	—	(TV MUTE)	(TV MUTE)	(TV MUTE)	(TV MUTE)	(TV MUTE)	(TV MUTE)	(TV MUTE)	(TV MUTE)	(TV MUTE)	(TV MUTE)	(TV MUTE)
24	TV VOL -	—	(TV VOL -)	(TV VOL -)	(TV VOL -)	(TV VOL -)	(TV VOL -)	(TV VOL -)	(TV VOL -)	(TV VOL -)	(TV VOL -)	(TV VOL -)	(TV VOL -)
25	SCENE 1	O	7A-007F	SCENE SELECT									
26	SCENE 2	O	7A-037C	SCENE SELECT									
27	SCENE 3	O	7A-0679	SCENE SELECT									
28	SCENE 4	O	7A-0976	SCENE SELECT									
29	TITLE	—	7A-86	—	—	7A-AE	7C-B1	—	048.200	7F01-0D	—	—	
30	UP	—	7A-9D	—	—	7A-10	7C-B4	—	048.088	7F01-0E	—	—	
31	MENU	—	7A-84	—	—	7A-AB	7C-B2	—	048.084	7F01-0F	—	—	
32	VOL up	O	7A-1A	VOL UP									
33	LEFT	—	7A-9F	—	—	7A-AC	7C-B5	—	048.090	7F01-10	—	—	
34	ENTER	—	7A-DE	—	—	7A-AD	7C-B8	—	048.092	7F01-11	—	—	
35	RIGHT	—	7A-9E	—	—	7A-12	7C-B6	—	048.091	7F01-12	—	—	
36	RETURN	—	7A-AA	—	—	7A-AF	7C-B7	—	048.131	7F01-13	—	—	
37	DOWN	—	7A-9C	—	—	7A-11	7C-B3	—	048.089	7F01-14	—	—	
38	DISPLAY	—	7A-C2	79-0A	7F-9E	7A-B0	7C-A6	—	048.015	7F01-15	—	—	
39	VOL down	O	7A-1B	VOL DOWN									
40	REC	—	(device)	7A-4F	—	—	7C-8B	(DVR REC)	048.055	7F01-16	—	(DVR REC)	
41	STOP	—	(device)	7A-09	7F-84	—	7C-85	(DVR STOP)	048.049	7F01-1D	—	(DVR STOP)	
42	PAUSE	—	(device)	7A-09	7F-83	—	7C-83	(DVR PAUSE)	048.048	7F01-1A	—	(DVR PAUSE)	
43	PLAY	—	(device)	7A-08	7F-82	—	7C-82	(DVR PLAY)	048.044	7F01-1E	—	(DVR PLAY)	
44	REW (SEARCH -)	—	(device)	7A-0D	7F-88	7A-A4	7C-86	(DVR REW)	048.041	7F01-17	—	(DVR REW)	
45	FF (SEARCH +)	—	(device)	7A-0C	7F-89	7A-A5	7C-87	(DVR FF)	048.040	7F01-18	—	(DVR FF)	
46	SKIP -	—	(device)	7A-0B	7F-86	7A-A6	7C-B9	(DVR SKIP-)	048.033	7F01-1B	—	(DVR SKIP-)	
47	SKIP +	—	(device)	7A-0A	7F-87	7A-A7	7C-BA	(DVR SKIP+)	048.032	7F01-1C	—	(DVR SKIP+)	
48	1	—	7A-59	79-11	7F-91	7A-E5	7C-94	—	048.001	7F01-01	—	—	
49	2	—	7A-58	79-12	7F-92	7A-E6	7C-95	—	048.002	7F01-02	—	—	
50	3	—	7A-94	79-13	7F-93	7A-E7	7C-96	—	048.003	7F01-03	—	—	
51	4	—	7A-8D	79-14	7F-94	7A-E8	7C-97	—	048.004	7F01-04	—	—	
52	5	—	7A-56	79-15	7F-95	7A-E9	7C-98	—	048.005	7F01-05	—	—	
53	6	—	7A-DD	79-16	7F-96	7A-EA	7C-99	—	048.006	7F01-06	—	—	
54	7	—	7A-95	79-17	7F-97	7A-EB	7C-9A	—	048.007	7F01-07	—	—	
55	8	—	7A-C4	79-18	7F-98	7A-EC	7C-9B	—	048.008	7F01-08	—	—	
56	9	—	7A-87	79-19	7F-99	7A-B1	7C-9C	—	048.009	7F01-09	—	—	
57	0	—	7A-C3	79-10	7F-90	7A-B2	7C-93	—	048.000	7F01-0A	—	—	
58	+10	—	—	79-1A	7F-9A	—	7C-9D	—	—	7F01-0B	—	—	
59	ENTER	—	7A-57	79-0B	7F-8A	7A-B3	7C-9E	—	—	7F01-0C	—	—	



● RAV34 RX-V363 (B, G, E, F models), THR-6130 (G, E, F models)

• SCHEMATIC DIAGRAM

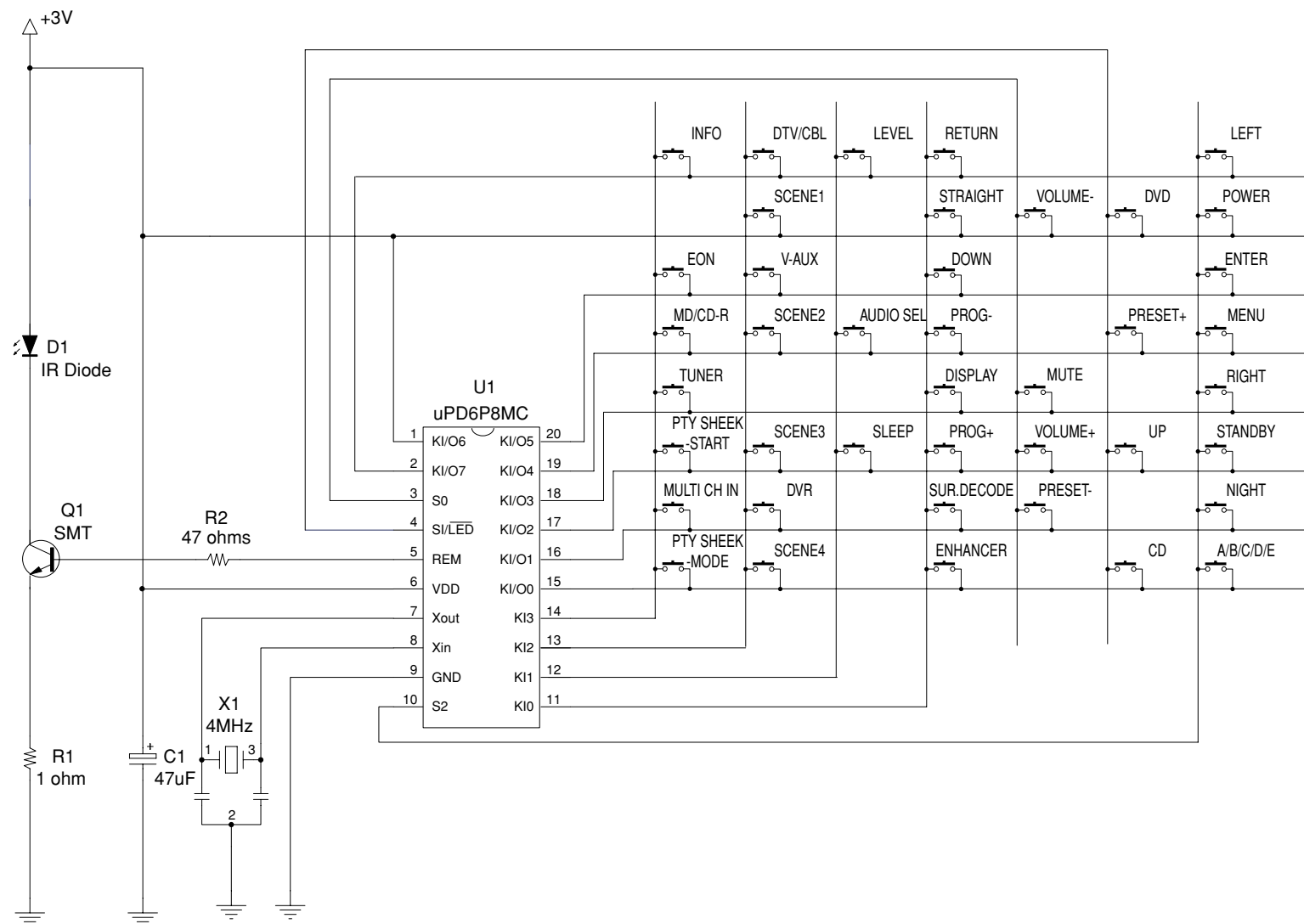

• PANEL

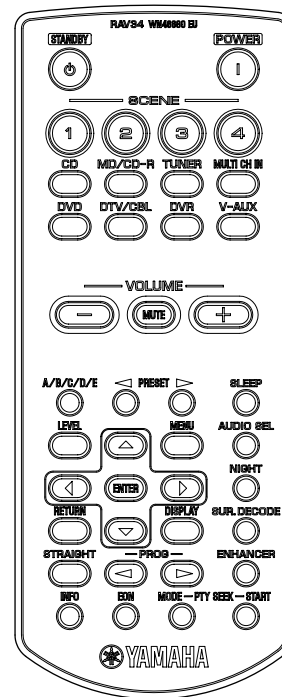

• KEY NO. LAYOUT

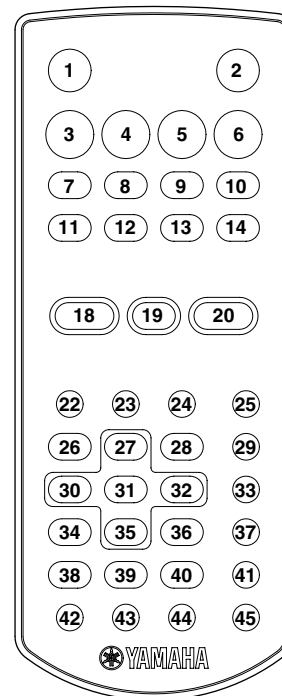

• KEY CODE

Key No.	Key Name	Custom Code	Data Code
1	STANDBY	7E	7F
2	POWER	7E	7E
3	SCENE1	7A	007F
4	SCENE2	7A	037C
5	SCENE3	7A	0679
6	SCENE4	7A	0976
7	CD	7A	15
8	MD/CD-R	7A	C9
9	TUNER	7A	16
10	MULTI CH IN	7A	87
11	DVD	7A	C1
12	DTV/CBL	7A	54
13	DVR	7A	13
14	V-AUX	7A	55
18	VOLUME-	7A	1B
19	MUTE	7A	1C
20	VOLUME+	7A	1A
22	A/B/C/D/E	7A	12
23	PRESET-	7A	11
24	PRESET+	7A	10
25	SLEEP	7A	57
26	LEVEL	7A	86
27	UP	7A	9D
28	MENU	7A	84
29	AUDIO SEL	7A	C3
30	LEFT	7A	9F
31	ENTER	7A	DE
32	RIGHT	7A	9E
33	NIGHT	7A	95
34	RETURN	7A	AA
35	DOWN	7A	9C
36	DISPLAY	7A	C2
37	SUR.DECODE	7A	8D
38	STRAIGHT	7A	56
39	PROG-	7A	59
40	PROG+	7A	58
41	ENHANCER	7A	94
42	INFO	7A	A4
43	EON	7A	A5
44	PTY SHEEK-MODE	7A	A6
45	PTY SHEEK-START	7A	A7

## Advanced setup

This unit has additional menus that are displayed in the front panel display. The advanced setup menu offers additional operations to adjust and customize the way this unit operates. Change the initial settings (indicated in bold under each parameter) to reflect the needs of your listening environment.

### Notes

- Only **STANDBY/ON**, **PROGRAM**  $\triangleleft/\triangleright$  and **STRAIGHT** are effective while you are using the advanced setup menu.
- No other operations can be made while you are using the advanced setup menu.
- The advanced setup menu is only available in the front panel display.

**1 Press **STANDBY/ON** on the front panel to set this unit to the standby mode.**

**2 Press and hold **TONE CONTROL** and then press **STANDBY/ON** to turn on this unit.**

This unit turns on, and the advanced setup menu appears in the front panel display.

**3 Press **PROGRAM**  $\triangleleft/\triangleright$  to select the parameter you want to adjust.**

The name of the selected parameter appears in the front panel display.

**4 Press **STRAIGHT** repeatedly to change the selected parameter setting.**

**5 Press **STANDBY/ON** to confirm your selection and set this unit to the standby mode.**



The settings you made are reflected next time you turn on this unit.

### ■ **Speaker impedance** **SP IMP.** (U.S.A. and Canada models only)

Use this feature to set the speaker impedance of this unit so that it matches that of your speakers.

Choices: **8ΩMIN**, 6ΩMIN

- Select “8ΩMIN” to set the speaker impedance to 8 Ω.
- Select “6ΩMIN” to set the speaker impedance to 6 Ω.

SP IMP.	Speaker	Impedance level
8ΩMIN	Front (A or B)	The impedance of each speaker must be 8 Ω or higher.
	Center	
	Surround	
6ΩMIN	Front (A or B)	The impedance of each speaker must be 6 Ω or higher.
	Center	
	Surround	

### ■ **Tuner frequency step** **TU** (Asia and General models only)

Use this feature to set the tuner frequency step according to the frequency spacing in your area.

Choices: **AM10/FM100**, AM9/FM50

- Select “AM10/FM100” for North, Central and South America.
- Select “AM9/FM50” for all other areas.

### ■ **Initializing** **PRESET**

Use this feature to reset all the parameters of this unit to the initial factory settings.

Choices: **CANCEL**, **RESET**

- Select “CANCEL” not to reset any parameters of this unit.
- Select “RESET” to reset the parameters of this unit.

### Notes

- This setting completely resets all the parameters of this unit including the set menu parameters. However, the advanced setup menu parameters will not be initialized.
- The initial factory settings are activated next time you turn on this unit.

# **RX-V363/HTR-6130**

---

