

STEREO RECEIVER

RX-V390/R-V501/ RX-V390RDS

IMPORTANT NOTICE

This manual has been provided for the use of authorized YAMAHA Retailers and their service personnel. It has been assumed that basic service procedures inherent to the industry, and more specifically YAMAHA Products, are already known and understood by the users, and have therefore not been restated.

WARNING: Failure to follow appropriate service and safety procedures when servicing this product may result in personal injury, destruction of expensive components, and failure of the product to perform as specified. For these reasons, we advise all YAMAHA product owners that any service required should be performed by an authorized YAMAHA Retailer or the appointed service representative.

IMPORTANT: The presentation or sale of this manual to any individual or firm does not constitute authorization, certification or recognition of any applicable technical capabilities, or establish a principle-agent relationship of any form.

The data provided is believed to be accurate and applicable to the unit(s) indicated on the cover. The research, engineering, and service departments of YAMAHA are continually striving to improve YAMAHA products. Modifications are, therefore, inevitable and specifications are subject to change without notice or obligation to retrofit. Should any discrepancy appear to exist, please contact the distributor's Service Division.

WARNING: Static discharges can destroy expensive components. Discharge any static electricity your body may have accumulated by grounding yourself to the ground buss in the unit (heavy gauge black wires connect to this buss).

IMPORTANT: Turn the unit OFF during disassembly and part replacement. Recheck all work before you apply power to the unit.

■ CONTENTS

TO SERVICE PERSONNEL	1
REMOTE CONTROL PANEL	1
FRONT PANELS	2
REAR PANELS	3-4
INTERNAL VIEW	4
SPECIFICATIONS	5-6
DISASSEMBLY PROCEDURES	7
SELF CHECK MODE	8-9
TUNER ADJUSTMENTS	10-13
AMP ADJUSTMENTS	14

IC DATA	15-16
IC BLOCKS	17-18
BLOCK DIAGRAM	19-21
PRINTED CIRCUIT BOARD	22-32
TEST POINT WAVEFORMS	33
DISPLAY DATA	34
PIN CONNECTION DIAGRAM	35
SCHEMATIC DIAGRAM	36-39
PARTS LIST	40-51
REMOTE CONTROL TRANSMITTER	52

■ TO SERVICE PERSONNEL

1. Critical Components Information.
Components having special characteristics are marked and must be replaced with parts having specifications equal to those originally installed.
2. Leakage Current Measurement (For 120V Models Only).
When service has been completed, it is imperative to verify that all exposed conductive surfaces are properly insulated from supply circuits.
 - Meter impedance should be equivalent to 1500 ohm shunted by 0.15 μ F.
 - Leakage current must not exceed 0.5mA.
 - Be sure to test for leakage with the AC plug in both polarities.

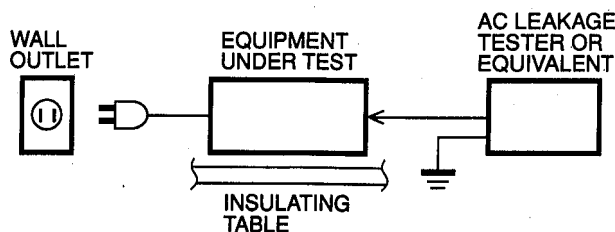

WARNING: CHEMICAL CONTENT NOTICE!

The solder used in the production of this product contains LEAD. In addition, other electrical/electronic and/or plastic (where applicable) components may also contain traces of chemicals found by the California Health and Welfare Agency (and possibly other entities) to cause cancer and/or birth defects or other reproductive harm.

DO NOT PLACE SOLDER, ELECTRICAL/ELECTRONIC OR PLASTIC COMPONENTS IN YOUR MOUTH FOR ANY REASON WHAT SO EVER!

Avoid prolonged, unprotected contact between solder and your skin! When soldering, do not inhale solder fumes or expose eyes to solder/flux vapor!

If you come in contact with solder or components located inside the enclosure of this product, wash your hands before handling food.

■ REMOTE CONTROL PANEL

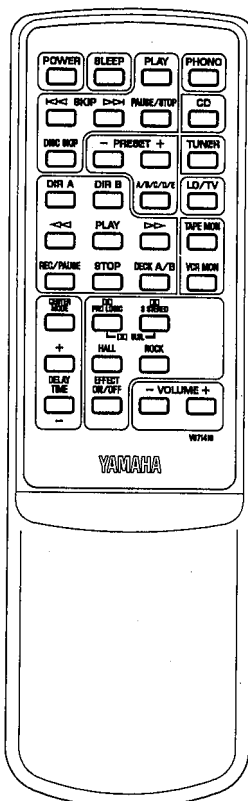

FRONT PANELS

▼ RX-V390

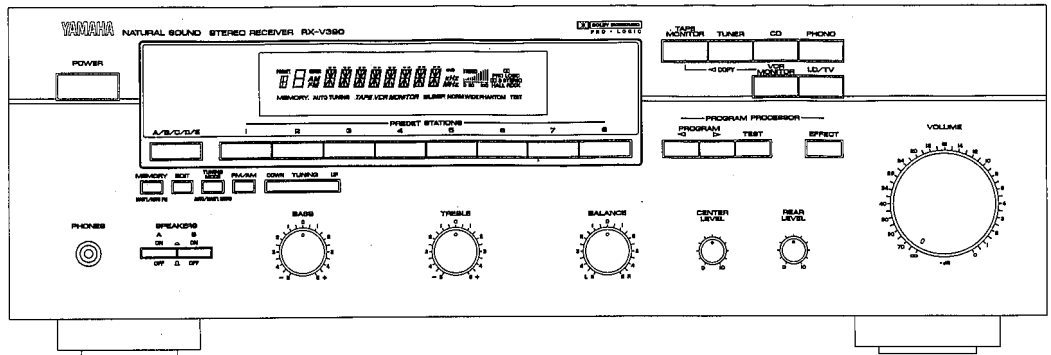

▼ R-V501

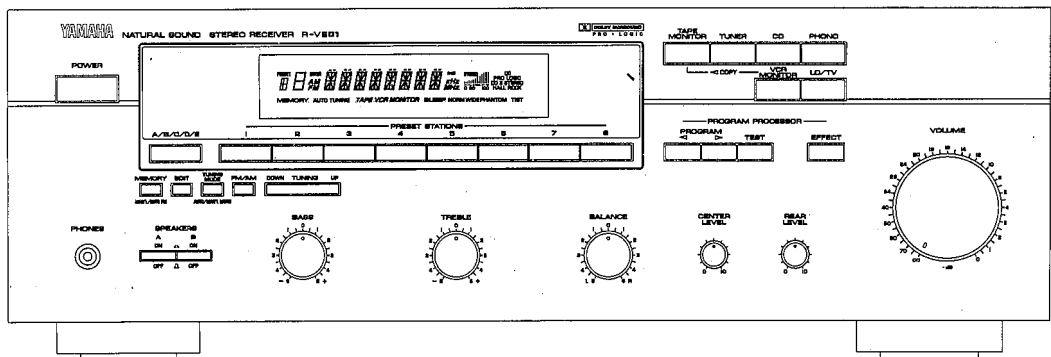

▼ RX-V390RDS

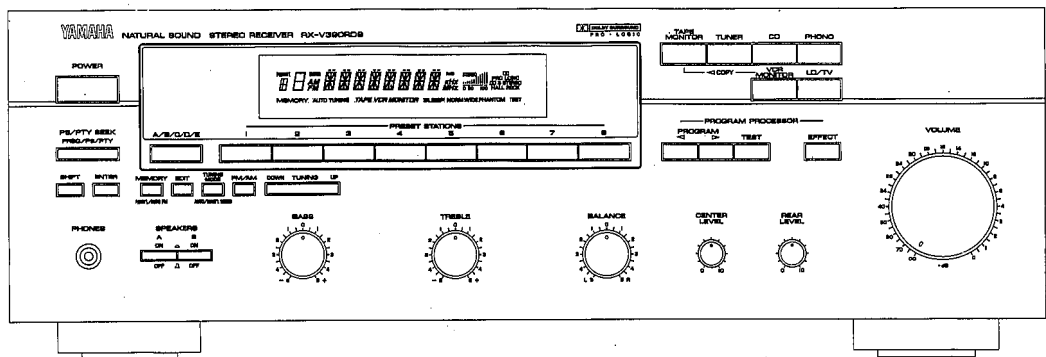

REAR PANELS

▼ RX-V390/R-V501 U model

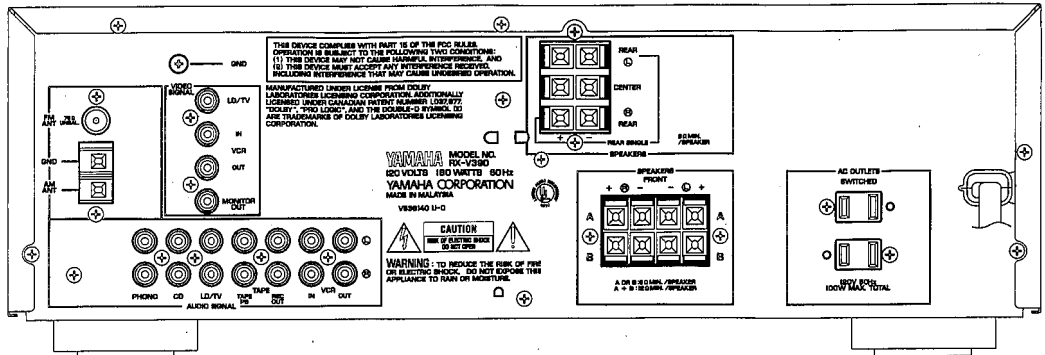

▼ RX-V390/R-V501 C model

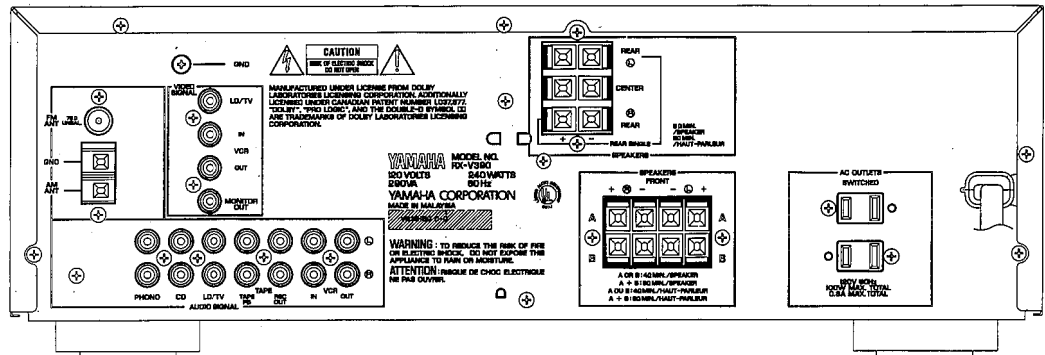

▼ RX-V390 R model

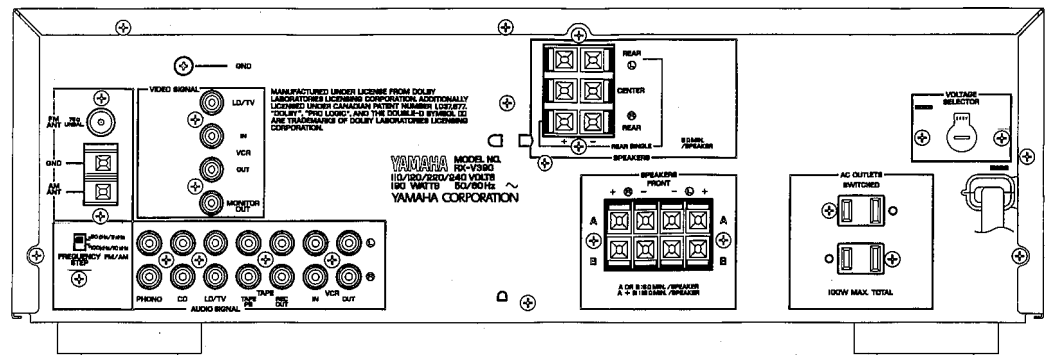

▼ RX-V390 A model

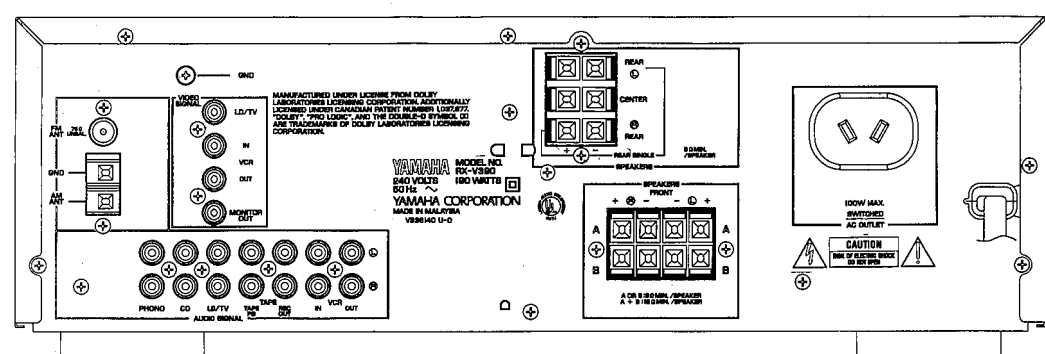

RX-V390/R-V501/RX-V390RDS

▼ RX-V390RDS B model

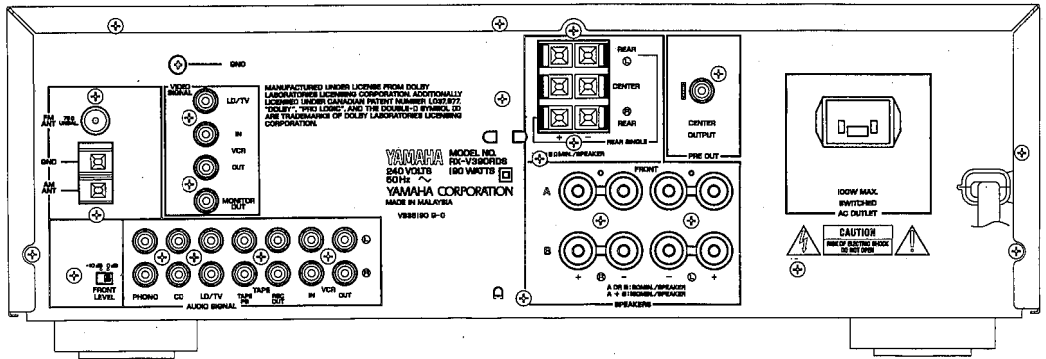

▼ RX-V390RDS G model

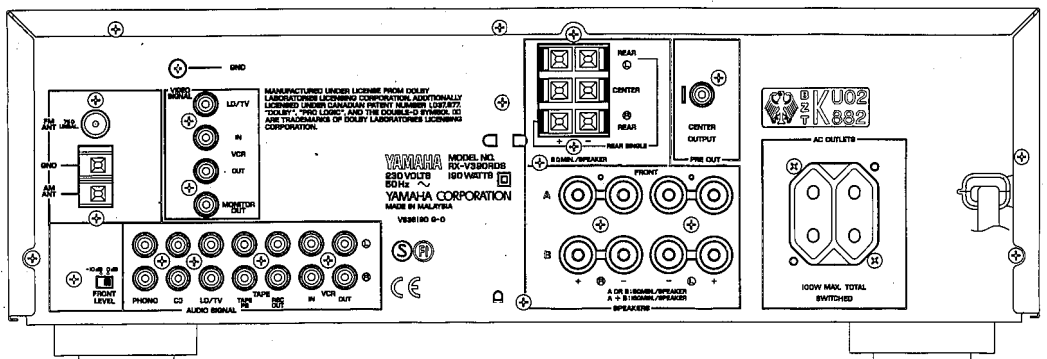

■ INTERNAL VIEW

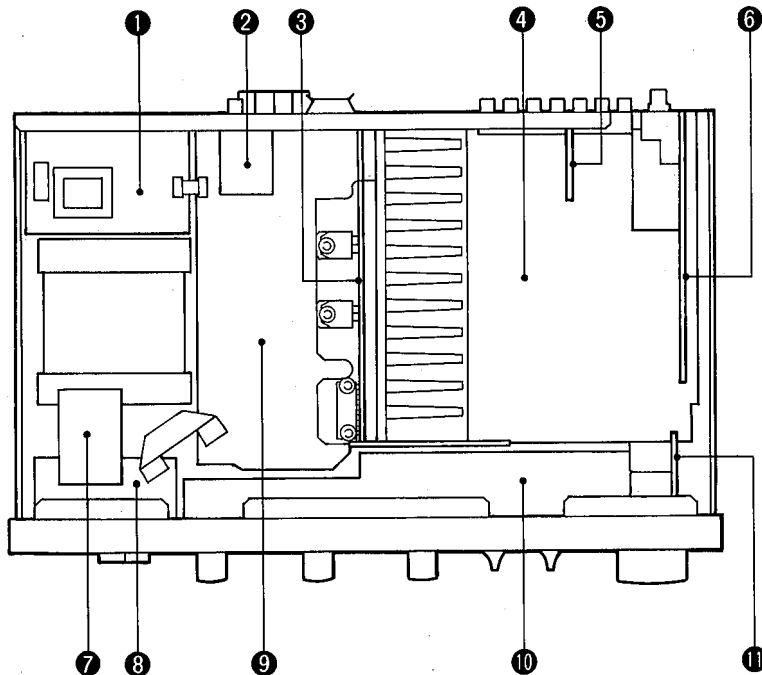

- ① P. C. B. MAIN (2)
- ② P. C. B. INPUT (4)
- ③ P. C. B. INPUT (2)
- ④ P. C. B. INPUT (1)
- ⑤ P. C. B. INPUT (3)
- ⑥ P. C. B. TUNER
- ⑦ P. C. B. INPUT (5)/(6)
- ⑧ P. C. B. MAIN (3)
- ⑨ P. C. B. MAIN (1)
- ⑩ P. C. B. OPERATION (2)
- ⑪ P. C. B. OPERATION (3)

■ SPECIFICATIONS

■ AUDIO SECTION

Minimum RMS Output Power per Channel

RX-V390
 FRONT, 20Hz to 20kHz, 0.04% THD, 8Ω 60W
 CENTER, 1kHz, 0.2% THD, 8Ω 60W
 REAR, 1kHz, 0.7% THD, 8Ω 15W

R-V501
 FRONT, 1kHz, 0.09% THD, 8Ω
 U model 70W
 C model 65W
 CENTER, 1kHz, 0.2% THD, 8Ω
 U model 70W
 C model 65W
 REAR, 1kHz, 0.7% THD, 8Ω 15W

RX-V390RDS
 FRONT, 20Hz to 20kHz, 0.04% THD, 8Ω 60W
 CENTER, 1kHz, 0.2% THD, 8Ω 60W
 REAR, 1kHz, 0.7% THD, 8Ω 15W

Maximum Power per Channel

RX-V390 (R model only)
 FRONT, 1kHz, 10% THD, 8Ω 80W

Dynamic Power per Channel (IHF)

RX-V390
 8/6/4/2Ω*
 U model 80/95/120/140W
 C model 75/95/115/130W

R-V501
 8/6/4/2Ω
 U model 90/105/125/145W
 C model 75/95/115/130W

RX-V390/RX-V390RDS
 8/6/4/2Ω
 R, A, B, G models 80/100/120/135W

DIN Standard Output Power per Channel

RX-V390RDS (G model only)
 1kHz, 0.7% THD, 4Ω 75W

IEC Power

RX-V390RDS (G model only)
 1kHz, 0.1% THD, 8Ω 67W

Power Band Width

0.08% THD, 30W, 8Ω 10Hz to 50kHz

Damping Factor

20Hz to 20kHz, 8Ω 80 or more

Input Sensitivity/Impedance

PHONO MM 2.5mV/47kΩ
 CD etc 150mV/47kΩ

Maximum Input Signal Level

PHONO MM, 1kHz, 0.04% THD 90mV

Headphone Jack Rated Output/Impedance

R-V501
 0.04% THD, RL = 8Ω
 U model 0.56V/330Ω
 C model 0.51V/330Ω

RX-V390/RX-V390RDS
 0.04% THD, RL = 8Ω 0.51V/330Ω

Frequency Response (20Hz to 20kHz)

CD etc, FRONT 0±0.5dB

RIAA Equalization Deviation (20Hz to 20kHz)

PHONO MM 0±0.5dB

Total Harmonic Distortion (20Hz to 20kHz)

PHONO MM to REC OUT (1V) 0.02%

RX-V390/RX-V390RDS

CD etc to FRONT SP OUT (30W/8Ω) 0.02%

R-V501

CD etc to FRONT SP OUT (30W/8Ω) 0.09%

Signal-to-Noise Ratio (IHF-A-Network)

PHONO MM, Input Shorted (5mV) REC OUT 82dB

CD etc, Input Shorted SP OUT(EFFECT OFF) 93dB

Residual Noise (IHF-A-Network)

FRONT, SP OUT 140μV

Channel Separation (Vol. -30dB, EFFECT OFF)

PHONO MM, Input Shorted, 1kHz 60dB

CD etc, Input 5.1kΩ Shorted, 1kHz 60dB

Tone Control Characteristics

BASS : Boost/cut ±10dB (50Hz)
 Turnover Frequency 350Hz

TREBLE : Boost/cut ±10dB (20kHz)
 Turnover Frequency 3.5kHz

Gain Tracking Error (0dB to -60dB) 3dB

Tuner Output Level/Impedance

FM (100% mod., 1kHz)
 Except G, B models 500mV/2.2kΩ
 G, B models (40kHz Dev.) 400mV/2.2kΩ
 AM (30% mod., 1kHz) 150mV/2.2kΩ

■ VIDEO SECTION

Video Signal Level 1.5Vp-p/75Ω

Maximum Input Level 1.5Vp-p

Signal-to-Noise Ratio 50dB

Monitor Output Frequency Response 5Hz~10MHz, -3dB

RX-V390/R-V501/RX-V390RDS

■ FM SECTION

Tuning Range	
U, C models87.5 to 107.9MHz
A, B, G models87.50 to 108.00MHz
R model87.5 to 107.9/87.50 to 108.00MHz
50dB Quieting Sensitivity (IHF, 75 Ω)	
Except G, B models	
Mono1.55μV (15.1dBf)
Stereo21μV (37.7dBf)
Usable Sensitivity (75 Ω)	
(30dB S/N Quieting, 1kHz, 100% mod.)	
Except G, B models	
DIN, Mono (S/N 26dB) G, B models0.9μV
DIN, Stereo (S/N 46dB) G, B models24μV
Image Response Ratio	
Except G, B models45dB
G, B models80dB
IF Response Ratio80dB
Spurious Response Ratio70dB
AM Suppression Ratio55dB
Capture Ratio1.5dB
Alternate Channel Selectivity	
Except G, B models	
Selectivity (two signals, 40kHz Dev.)85dB
G, B models70dB
Signal-to-Noise Ratio	
Mono/Stereo (IHF)	
Except G, B models80/75dB
Mono/Stereo (DIN-weighted, 40kHz Dev.)	
G, B models74/69dB
Harmonic Distortion (1kHz)	
Mono/Stereo	
Except G, B models0.1/0.2%
Mono/Stereo (40kHz Dev.)	
G, B models0.1/0.2%
Frequency Response	
30Hz to 15kHz0 ± 1.5dB
Stereo Separation (1kHz)	
Except G, B models50dB
G, B models (40kHz Dev.)50dB

■ AM SECTION

Tuning Range	
U, C models530 to 1710kHz
A, B, G models531 to 1611kHz
R model531 to 1611/530 to 1710kHz
Usable Sensitivity100μV/m
Selectivity32dB
Signal-to-Noise Ratio50dB
Image Response Ratio40dB
Spurious Response Ratio50dB
Harmonic Distortion (1kHz)0.3%

■ GENERAL

Power Supply	
U, C modelsAC 120V, 60Hz
A, B modelsAC 240V, 50Hz
G modelAC 230V, 50Hz
R modelAC 110/120/220/240V, 50/60Hz
Power Consumption	
RX-V390	
U model180W
C model240W/290VA
R, A models190W
R-V501	
U model200W
C model240W/290VA
RX-V390RDS	
B, G models190W
AC Outlets	
U, C, G, R models, Switched x 2100W max (Total)
A, B models, Switched x 1100W max
Dimensions (W x H x D)435 x 146 x 299mm (17-1/8" x 5-3/4" x 11-3/4")
Weight7.4 kg (16 lbs. 5 oz)
Accessories	
AM loop antenna x 1
Indoor FM antenna x 1
Remote Control Transmitter x 1
Battery (size "AA", "R06") x 2

* Specifications subject to change without notice.

UUSA model	BBritish model
CCanadian model	GEuropean model
AAustralian model	RGeneral model

Manufactured under license from Dolby Laboratories Licensing Corporation. Additionally licensed under Canadian patent number 1,037,877. "Dolby", "Pro Logic", and the double-D symbol  are trademarks of Dolby Laboratories Licensing Corporation.

● DIMENSIONS

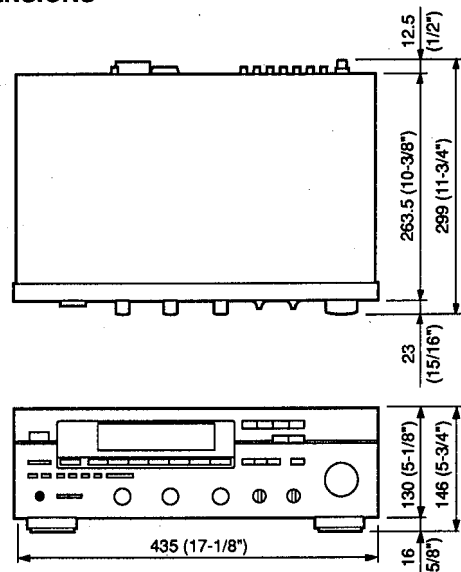

Units : mm (Inch)

RX-V390/R-V501/RX-V390RDS

DISASSEMBLY PROCEDURES (Remove parts in disassembly order as numbered.)

1. Removal of Top Cover

Remove 4 screws (①) and 3 screws (②) in Fig. 1.

2. Removal of Front Panel

- a. Remove 6 knobs.
- b. Remove 6 screws (③) in Fig. 1.

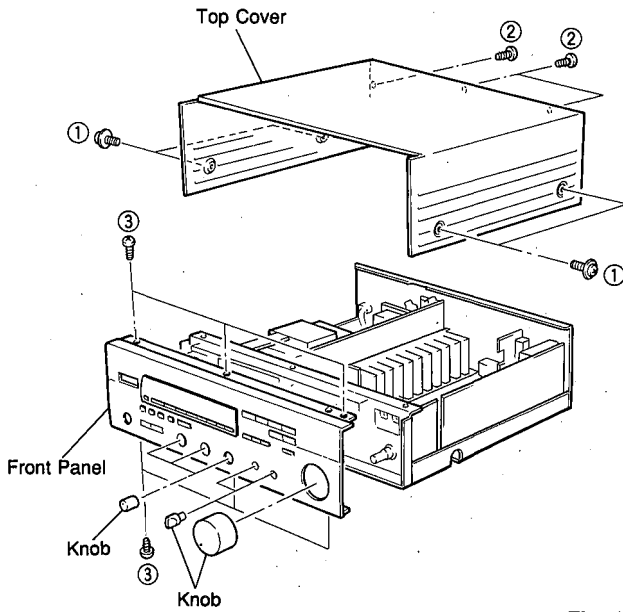

Fig. 1

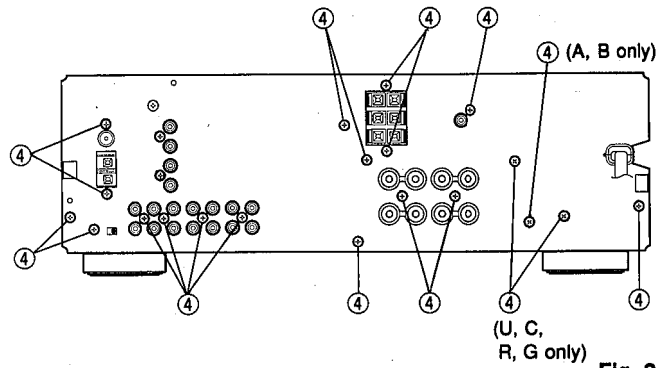

Fig. 2

3. Checking and Parts Replacement of P. C. B. MAIN (1).

- a. Disconnect the power cord from the AC outlet.
- b. Remove 19 screws (④) fixing the Rear Panel in Fig. 2.
- c. Remove 3 screws (⑤) fixing the Main Unit in Fig. 3.
- d. Detach 1 connector terminal (CB104) in Fig. 3.
- e. Operating checks can be taken by shorting between following test points in Fig. 3.

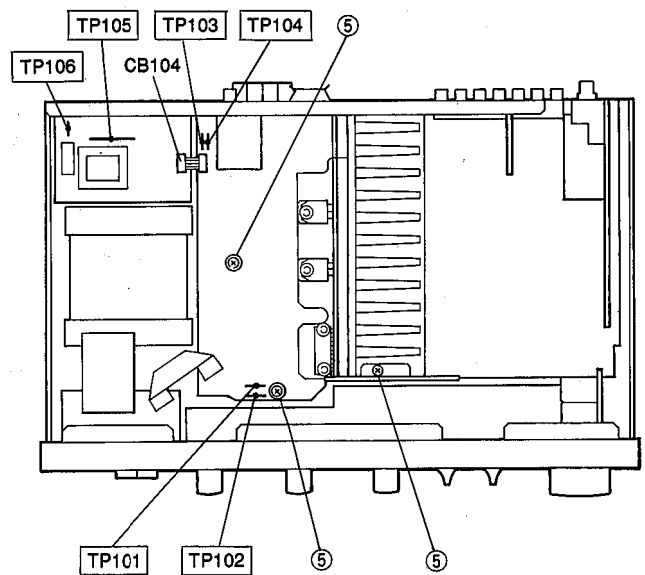

Fig. 3

Short Point
TP101↔TP102
TP103↔TP104
TP105↔TP106

- f. Place the Main Unit on its side as shown in Fig. 4.
- g. Connect the power cord and turn ON the POWER switch.

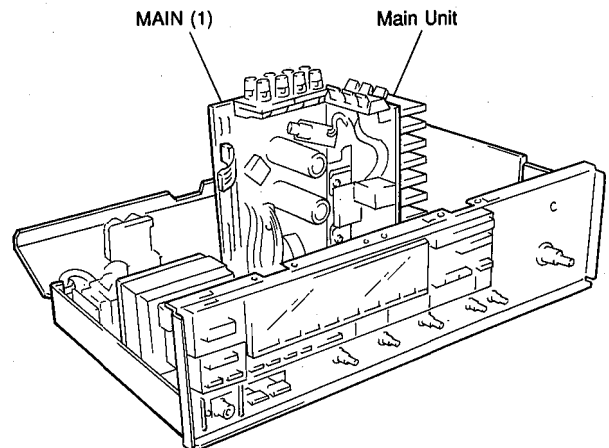

Fig. 4

■ SELF CHECK MODE

This model has a SELF CHECK MODE for facilitating measurement and inspection.

HOW TO START (2 options)

● **SELF CHECK with FACTORY PRESET**

Turn the POWER switch ON while pressing the PRESET STATION NO. 1, 2, 3 keys simultaneously, and then the unit enters the SELF CHECK MODE.

WARNING : FACTORY PRESET is initialized.
All user memory erased.

● **SELF CHECK without FACTORY PRESET**

Turn the POWER switch ON while pressing the PRESET STATION NO. 2, 3, 4 keys simultaneously, and then the unit enters the SELF CHECK MODE.

WARNING : FACTORY PRESET is disabled.

HOW TO EXIT

Turning the POWER switch OFF or pressing the PRESET STATION NO. 8 key cancels the SELF CHECK MODE. (The unit enters normal mode)

● **Factory Preset**

1) **TUNER section**

Preset group	P1	P2	P3	P4	P5	P6	P7	P8
A, C, E	87.5MHz	90.1MHz	95.1MHz	98.1MHz	U, C, R : 107.9MkHz R, A : 108.0MkHz	88.1MHz	106.1MHz	U, C, R : 107.9MkHz R, A : 108.0MHz
B, D	630kHz	1080kHz	1440kHz	U, C, R : 530kHz R, A : 531kHz	U, C, R : 1710kHz R, A : 1611kHz	900kHz	1350kHz	U, C, R : 1400kHz R, A : 1404kHz

All tuning modes are AUTO TUNING and AUTO STEREO.

2) **SURROUND section**

SURROUND MODE : PRO LOGIC
CENTER MODE : NORMAL

3) **SELECTOR section**

INPUT : CD

CAUTION : Before setting to the FACTRY PRESET, write down the existing preset memory content of the Tuner in a table as shown below. (This is because setting to the FACTORY PRESET will cause the user memory content to be erased.)

Preset group	P1	P2	P3	P4	P5	P6	P7	P8
A								
B								
C								
D								
E								

CONTENTS OF SELF CHECK MODE

No.	Menu	Supplement	Select Key
1	MAIN BYPASS	Available input is CD only	PRESET STATION NO.1
2	—	SELF 2 is not programmed in this set.	PRESET STATION NO.2
3	—	SELF 3 is not programmed in this set.	PRESET STATION NO.3
4	DISPLAY CHECK	All segments of FL display will turn on.	PRESET STATION NO.4
5	MANUAL TEST TONE	LEFT/CENTER/RIGHT/REAR	PRESET STATION NO.5
6	PHOTOGRAPH MODE	"NDR 3"	PRESET STATION NO.6
7	ENABLE TO CHANGE INPUT	You can change input after selecting this mode.	PRESET STATION NO.7
(8)	The SELF CHECK MODE is cancelled and returns to the normal operation mode. (MODE EXIT)		PRESET STATION NO.8

DETAILS OF SELF CONTENTS

SELF 1 MAIN BYPASS

- L/R is output through the bypass.
- CENTER level and REAR(Surround) level are (L+R)/2.
- Please connect signal into the CD terminal.
- FL displays "SELF 1"

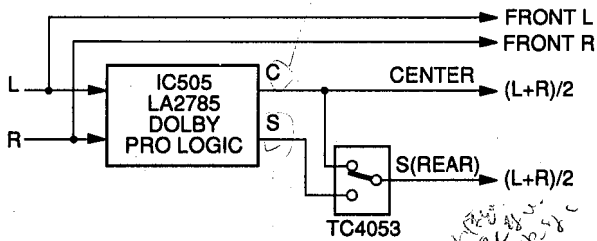

SELF 4 DISPLAY CHECK

- Every FL segment turns ON for 3 seconds.
- FL displays "SELF 4"

SELF 5 MANUAL TEST TONE

- Every time PRESET STATION NO. 5 key is pressed, the TEST TONE shifts in the order of FRONT L, CENTER, FRONT R, REAR and is output.

SELF 6 PHOTOGRAPH MODE

- The FL displays "NDR 3" and the catalogue photographing mode.

SELF 7 CHANGE INPUT MODE

- After selecting this mode, the input selector is enabled. Output signals are the same as in SELF 1.

TUNER ADJUSTMENTS

Measuring Instruments

- FM signal generator (FM SG)
- Stereo signal generator (SSG)
- AM signal generator (AM SG)
- Distortion meter (DIST. M)
- AC voltmeter (ACVM)
- DC voltmeter (DCVM)
- Oscilloscope
- Low pass filter (YLF-15, $f_c=15\text{kHz}$)
- Oscillator

Dummy antenna

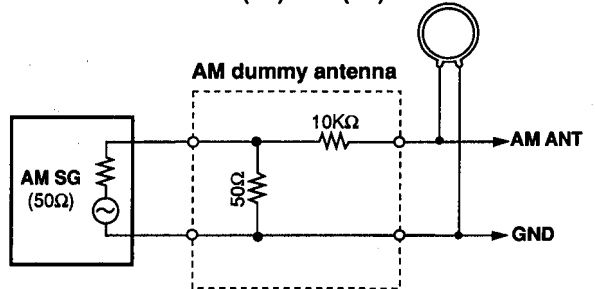
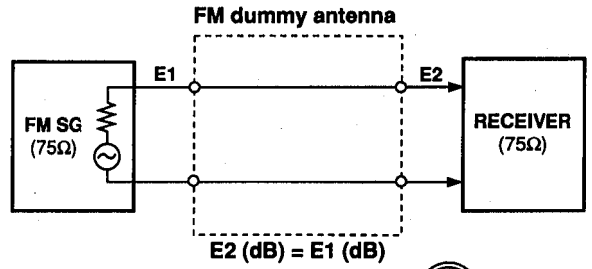
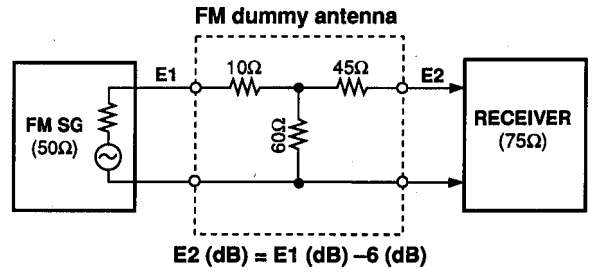

Test point

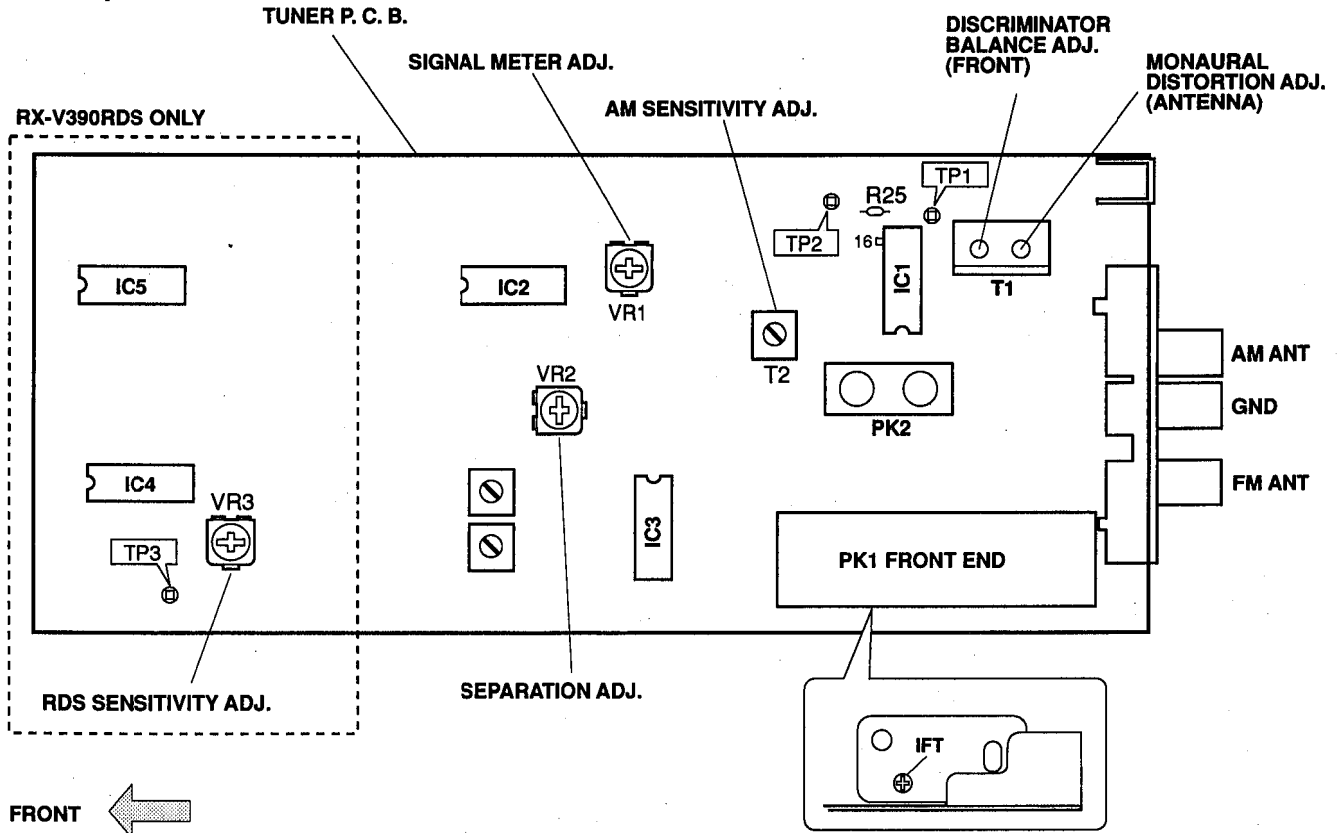

RX-V390/R-V501/
RX-V390RDS

FM Adjustment

● **Before Adjustment**

- 1) For dB, $1\mu V=0dB\mu$ applies.
Example : $60dB\mu=1mV$
- 2) 100% modulation means that the frequency deviation is 75kHz.
- 3) Install the Matching Transformer and connect FM SG.

- 4) Set each switch to the following position unless otherwise specified.

INPUT SELECTOR..... TUNER
TUNING MODE AUTO

● **Connection diagram (Measuring Instruments)**

1) **Discriminator balance adjustment**

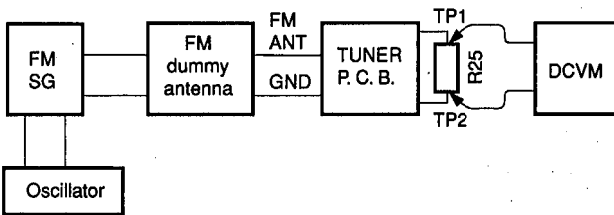

3) **Stereo distortion adjustment/separation adjustment**

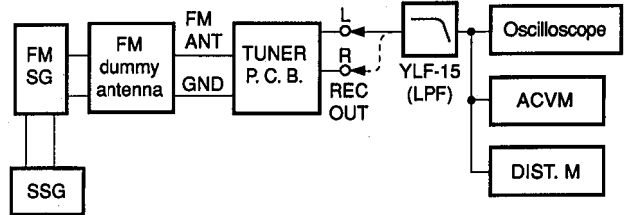

2) **Monaural distortion adjustment**

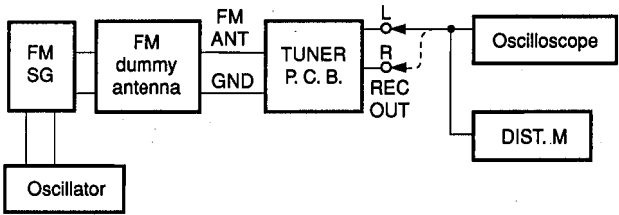

4) **Sensitivity Verification**

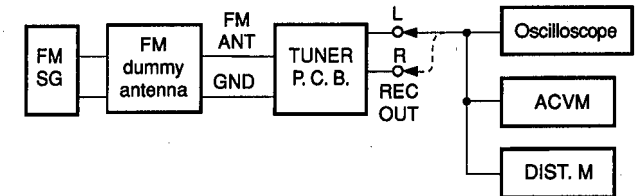

See page 10 for TP locations & adjustment points.

Step	Adjustment Item	Signal (ANT IN)	Reception frequency	Adjustment point	Test point	Rating
1	Rough adjustment of discriminator balance	FM ANT (75Ω) 98.1MHz 70dBμ MONO 1kHz 100% modulation	98.1MHz *(A-4)	T1 (Front side core)	Both ends of R25 (Between TP1 and TP2)	DC 0V±100mV
2	Rough adjustment of monaural distortion	Same as Step 1.	98.1MHz *(A-4)	T1 (Antenna side core)	REC OUT L, R	Minimize the distortion.
3	Fine adjustment of discriminator balance	Same as Step 1.	98.1MHz *(A-4)	T1 (Front side core)	Both ends of R25 (Between TP1 and TP2)	DC 0V±50mV
4	Fine adjustment of monaural distortion	Same as Step 1.	98.1MHz *(A-4)	T1 (Antenna side core)	REC OUT L, R	Minimize the distortion (to 0.25% or less).
5	Verification of discriminator balance	Same as Step 1.	98.1MHz *(A-4)	T1 (Front side core)	Both ends of R25 (Between TP1 and TP2)	DC 0V±50mV

* : Execution of FACTORY PRESET (Refer to page 8.) will facilitate setting reception frequency for adjustment.

Step	Adjustment Item	Signal (ANT IN)	Reception frequency	Adjusted point	Test point	Rating
6	Adjustment of front end IFT	FM ANT (75Ω) 98.1MHz 30dBμ MONO 1kHz, 100% modulation	98.1MHz * (A-4)	Front end IFT	Pin 16 of IC1	Adjust so that the DC voltage is maximum. CAUTION : Over-adjustment of the IFT core will reduce the sensitivity. (Maximum ±90°)
7	Verification of monaural distortion	FM ANT (75Ω) 98.1MHz 70dBμ MONO 1kHz, 100% modulation	98.1MHz * (A-4)		REC OUT L, R	0.4% or less
8	Verification of stereo distortion	FM ANT (75Ω) 98.1MHz 70dBμ Stereo L or R 1kHz, 100% modulation	98.1MHz * (A-4) * Tuning mode should be AUTO.		REC OUT L, R	1% or less • STEREO indicator should light.
9	Verification of sensitivity	FM ANT (75Ω) 88.1MHz 98.1MHz 106.1MHz	88.1MHz * (A-6) 98.1MHz * (A-4) 106.1MHz * (A-7)		ANT (75Ω)	1) Set the tuning mode to MAN'L MONO. 2) S/N should be 30dB at each frequency of 88.1MHz, 98.1MHz, and 106.1MHz. 3) Check to ensure that the voltage at the ANT terminal is 3dBμ (14.25dBf) or less.
10	Adjustment of Separation	FM ANT (75Ω) 98.1MHz 70dBμ Stereo L or R 1kHz, 100% modulation	98.1MHz * (A-4)	VR2	REC OUT L, R	With SSG output at L or R, the signal leakage level at the other channel should be minimized. 36dB or more
11	Adjustment of Signal meter	FM ANT (75Ω) 98.1MHz 45dBμ MONO 1kHz 30% modulation	98.1MHz * (A-4)	VR1		Adjust so that all signal meters light.
		-10dBμ or less				Check to ensure that signal meters turn OFF.
12	Verification of auto tuning	FM ANT (75Ω) 98.1MHz 23dBμ Stereo L or R 1kHz, 30% modulation	98.1MHz			<ul style="list-style-type: none"> • Automatic reception should be available when the tuning key is moved UP and DOWN. • The stereo indicator should light. • Audio muting should be applied during tuning.

* : Execution of FACTORY PRESET (Refer to page 8.) will facilitate setting reception frequency for adjustment.

AM Adjustment (This should be done after FM adjustment.)

● **Connection Diagram (Measuring instruments)**

1) **Adjustment of sensitivity**

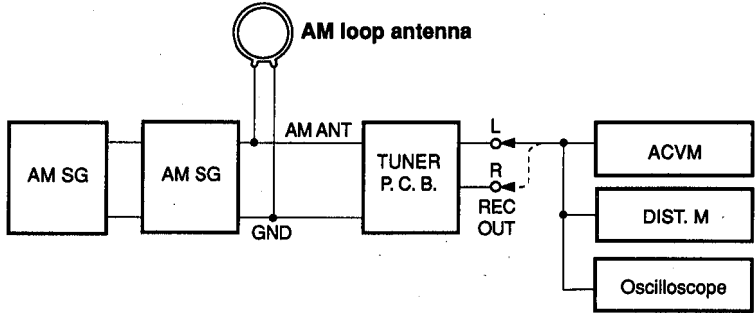

See page 10 for TP locations & adjustment points.

Step	Adjustment Item	Signal (ANT IN)	Reception frequency	Adjustment point	Test point	Rating
1	Adjustment of sensitivity (1440Hz)	AM ANT 1440kHz 50dBμ 1kHz, 30% modulation	1440kHz * (B-3)	T2	REC OUT	Audio output should be maximized.
2	Verification of sensitivity (630kHz)	AM ANT 630kHz 50dBμ 1kHz, 30% modulation	630kHz * (B-1)	T2	REC OUT	Audio output should be maximized. Repeat steps 1 and 2.
3	Verification of sensitivity	AM ANT 630kHz 1080kHz 1440kHz 1kHz, 30% modulation	630kHz * (B-1) 1080kHz * (B-2) 1440kHz * (B-3)		AM ANT	Distortion should be 10% or less at each frequency. Check to ensure that the voltage at the ANT terminal is 54dBμ or less.
4	Verification of auto tuning	AM ANT 60dBμ				Auto reception should be available when the tuning key is moved UP and DOWN.

* : Execution of FACTORY PRESET (Refer to page 8.) will facilitate setting reception frequency for adjustment.

RDS Adjustment (RX-V390RDS ONLY) (This should be done after FM and AM adjustment.)

See page 10 for TP locations & adjustment points.

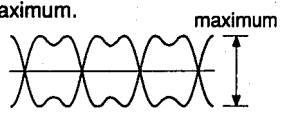
Step	Adjustment Item	Signal (ANT IN)	Reception frequency	Adjustment point	Test point	Rating
1	Adjustment of RDS sensitivity		Receive RDS station.	VR3	Between TP3 and GND.	Adjust so that the AC voltage is maximum. 
2	Verification of auto PS (Program service name)					Confirm that the display automatically tunes to the PS when tuned again.

RX-V390/R-V501/RX-V390RDS

AMP ADJUSTMENTS

Confirmation of Idling Current.

● Front L/R AMP section

After power is turned on, confirm that the voltages at R137(L ch) and R138(R ch) are between 0.05mV~2.0mV(RX-V390/R-V501) or 0.05mV~2.5mV(RX-V390RDS). If they exceeds 2.1mV(RX-V390/R-V501) or 2.6mV(RX-V390RDS), open (cut off) R131(L ch), R132 (R ch) and reconfirm voltage is between 0.05mV~2.0mV(RX-V390/R-V501) or 0.05mV~2.5mV(RX-V390RDS).

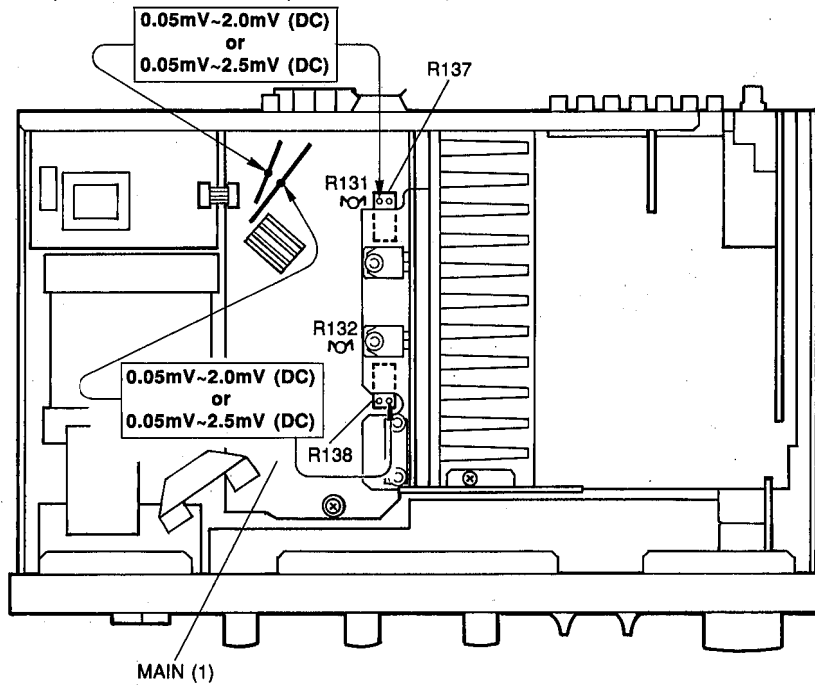

Note)

- If R131(L ch) and R132(R ch) have already been cut off and idling current does not flow, reconnect R131(L ch) and R132(R ch) .
- Q107 and Q108 are transistors for temperature correction. Apply silicone grease to contact surface with the heat sink.

Fig. A

● Center AMP section

In the same way as above, confirm that the voltage across R763 is within 4mV. If it exceeds 4mV, open (cut off) R746 and reconfirm it's within 4mV.

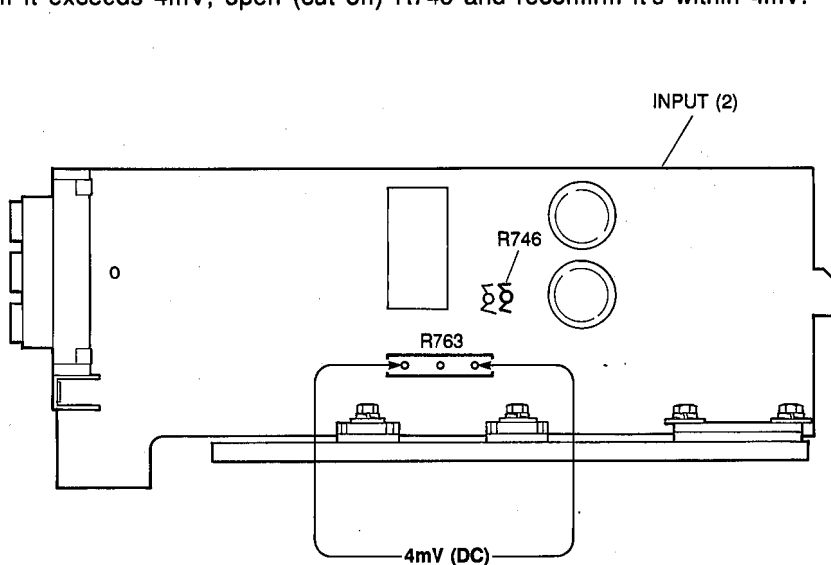

Note)

- If R746(C ch) have already been cut off and idling current does not flow, reconnect R746(C ch) .
- Q712 is the transistor for temperature correction. Apply silicone grease to contact surface with the heat sink.

Fig. B

■ IC DATA

IC301 : M38114M8-104SP
8 bit μ-COM

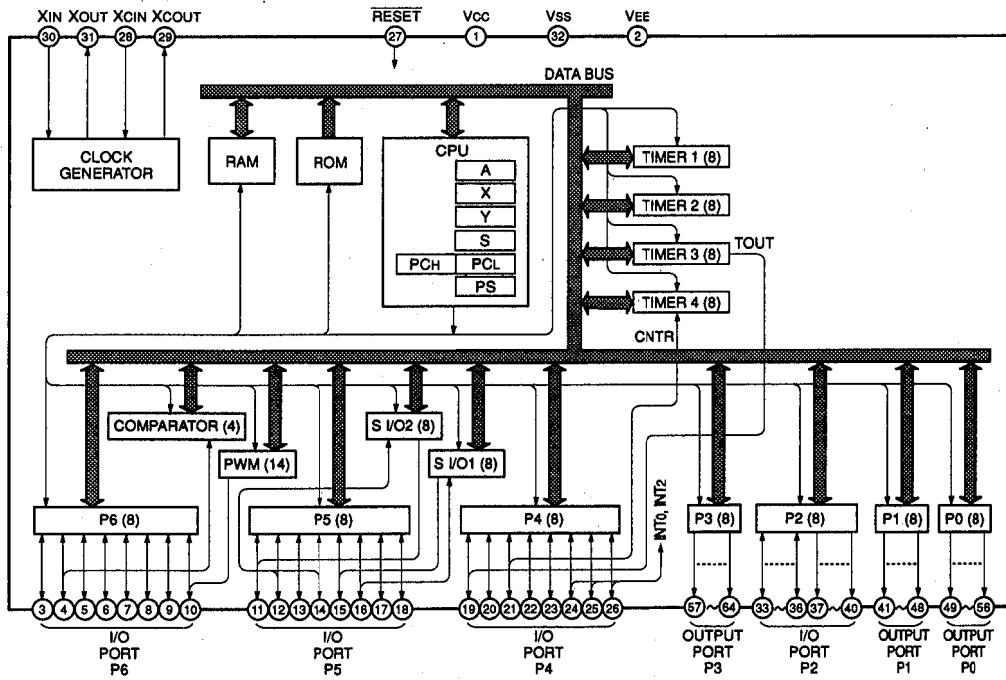
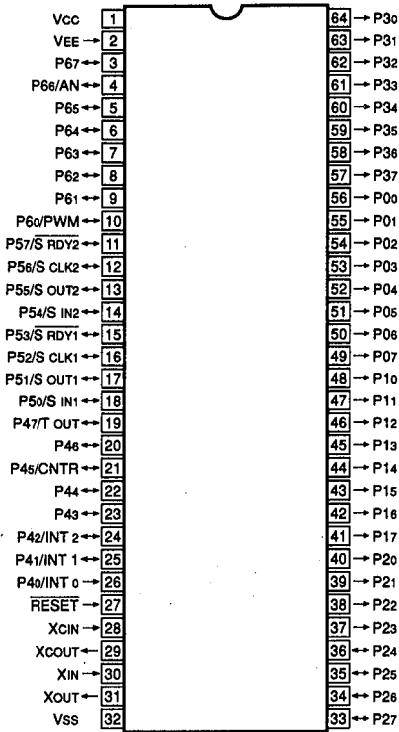

No.	Port	Name	I/O	Function
1	Vcc	VCC	—	+5V
2	Vee	VEE	—	-V(-25V)
3	P67	RDSMOD	I	RDS select (RDS : H)
4	P66	METER	I	Signal meter for tuner (Comparator)
5	P65	DATA2	O	BU2090 Serial data
6	P64	CLK2	O	BU2090 Serial clock
7	P63	PWRLY	O	Power relay
8	P62	PWRSW	I	Power switch

RX-V390/R-V501/RX-V390RDS

No.	Port	Name	I/O	Function
9	P61	FMUTE	O	FULL MUTE
10	P60	CEINP	O	NJU7313 chip enable
11	P57	CEDSP	O	LA2785, LV1010N chip enable
12	P56	CLKOUT1	O	LM7000N, LA2785, LV1010M, NJU7313 serial clock
13	P55	DATA1	O	LM7000N, LA2785, LV1010M, NJU7313 serial data
14	P54	STBY	I/O	*Standby In : H (G model) L : LED ON
15	P53	RDSRES	O	RDS reset
16	P52	V1(RDSCLK)	I	SCLK in from RDS
17	P51	RDSID	I	ID in from RDS
18	P50	V2(RSDAT)	I	SDATA in from RDS
19	P47	STEREO	I	Stereo detect
20	P46	STOUT	I	IF count OK signal
21	P45	SIGIN	I	Station detector
22	P44	CETUN	O	LM7000M chip enable
23	P43	PROTEC	I	Protection detect
24	P42	PDET	I	Power down detect
25	P41	REMIN	I	Remote control signal
26	P40	RDSTRI	I	START in from RDS
27	RESET	RESET	I	Reset
28	XCI		—	GND
29	XCO		—	N. C.
30	XIN	XIN	I	Clock (4MHz)
31	XOUT	XOUT	O	
32	VSS	VSS	—	GND
33	P27	K4	I	Key matrix in
34	P26	K3	I	
35	P25	K2	I	
36	P24	K1	I	
37	P23	D11	O	Fluorescent character display tube anode drive signal
38	P22	D10	O	
39	P21	D09	O	
40	P20	D08	O	
41	P17	D07	O	Fluorescent character display tube anode drive signal & Key scan digit
42	P16	D06	O	
43	P15	D05	O	
44	P14	D04	O	
45	P13	D03	O	
46	P12	D02	O	
47	P11	D01	O	
48	P10	D00	O	
49	P07	SG15	O	Fluorescent character display tube grid drive signal
50	P06	SG14	O	
51	P05	SG13	O	
52	P04	SG12	O	
53	P03	SG11	O	
54	P02	SG10	O	
55	P01	SG09	O	
56	P00	SG08	O	
57	P37	SG07	O	
58	P36	SG06	O	
59	P35	SG05	O	
60	P34	SG04	O	
61	P33	SG03	O	
62	P32	SG02	O	
63	P31	SG01	O	
64	P30	SG00	O	

	K1	K2	K3	K4
D00	PHONO	TUNER	CD	LD/TV
D01	TAPE	VCR	—	—
D02	EFFECT	TEST	DSP UP	DSP DOWN
D03	P1	P2	P3	P4
D04	P5	P6	P7	P8
D05	A/B/C/D/E	TUNING UP	TUNING DOWN	FM/AM
D06	TUNING MODE	EDIT	MEMORY	—
D07	PS/PTY/SEEK	SHIFT	ENTER	—

NOTE) STBY : The standby mode is available if "H" when the microprocessor is reset. The LEDs turn ON at "L" output.

■ IC BLOCKS

IC401~403, 501 : NJM2068L-D
Dual OP-Amp

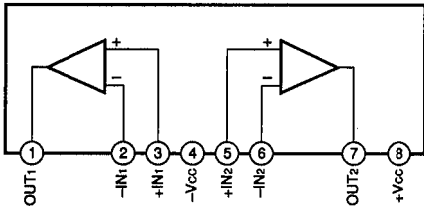

IC503, 507 : NJM2068D-D
Dual OP-Amp

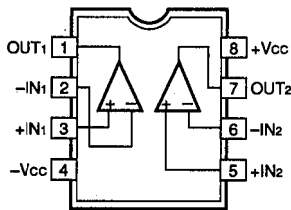

IC701 : BA7612N
3-Input Video Switch with 6dB Amp

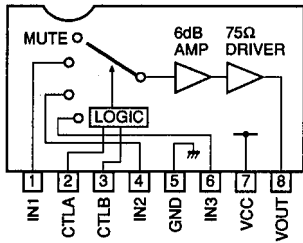

IC702 : μPC1188H
Power Amp

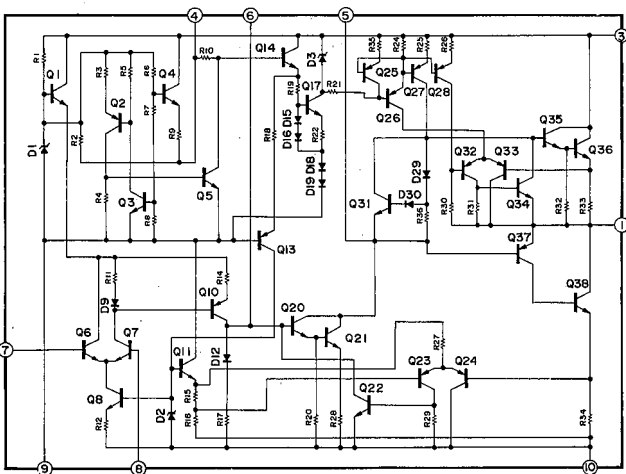

IC502 : NJU7313
Analog Function Switch

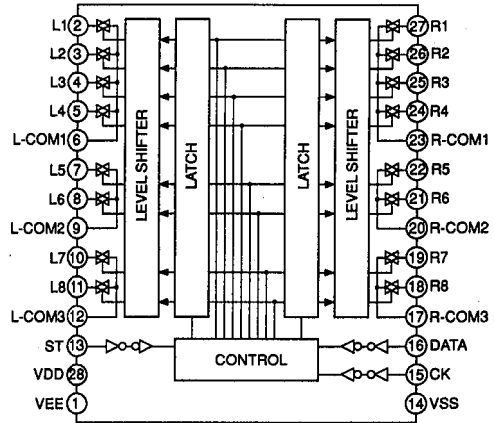

IC504 : TC4053BP
Triple 2-Channel Multiplexer/Demultiplexer

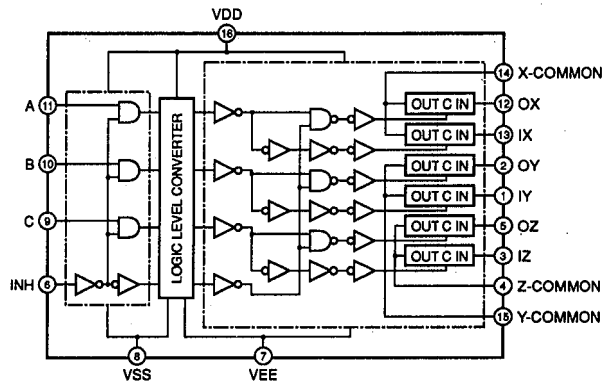

INHIBIT (Pin 6)	CONTROL INPUTS			"ON" CHANNEL
	C (Pin 9)	B (Pin 10)	A (Pin 11)	0X (Pin 12), OY (Pin 2), OZ (Pin 5) 1X (Pin 13), 1Y (Pin 1), 1Z (Pin 3)
L	L	L	L	0X, 0Y, 0Z
L	L	L	H	1X, 0Y, 0Z
L	L	H	L	0X, 1Y, 0Z
L	L	H	H	1X, 1Y, 0Z
L	H	L	L	0X, 0Y, 1Z
L	H	L	H	1X, 0Y, 1Z
L	H	H	L	0X, 1Y, 1Z
L	H	H	H	1X, 1Y, 1Z
H	*	*	*	NOTE

* Don't Care

IC509 : LB1641
Motor Driver

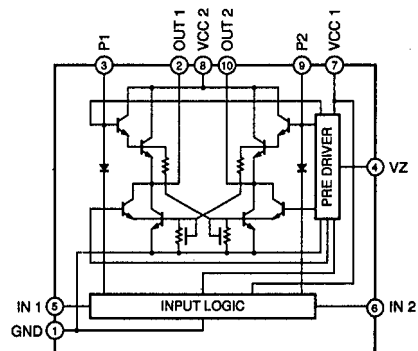

RX-V390/R-V501/RX-V390RDS

IC505 : LA2785
Dolby Pro Logic Surround Matrix Decoder

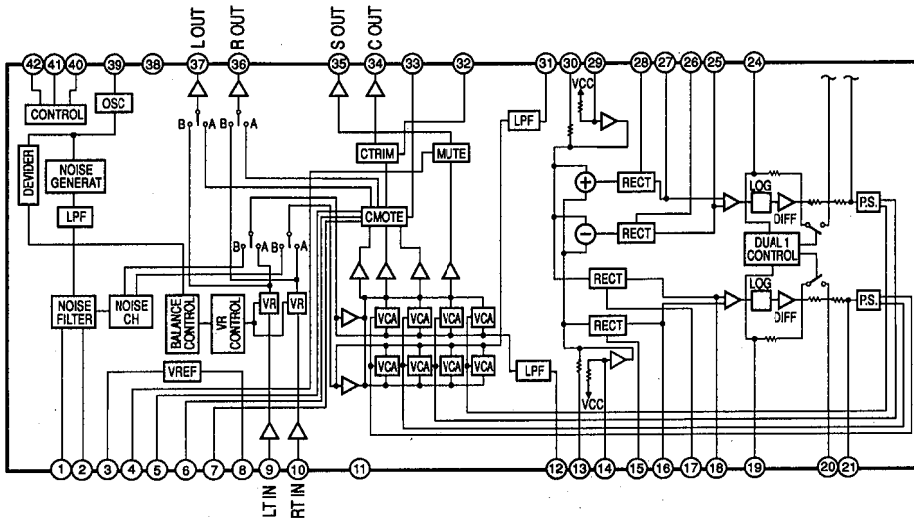

IC506 : LV1010N
Dolby Surround Passive Decoder

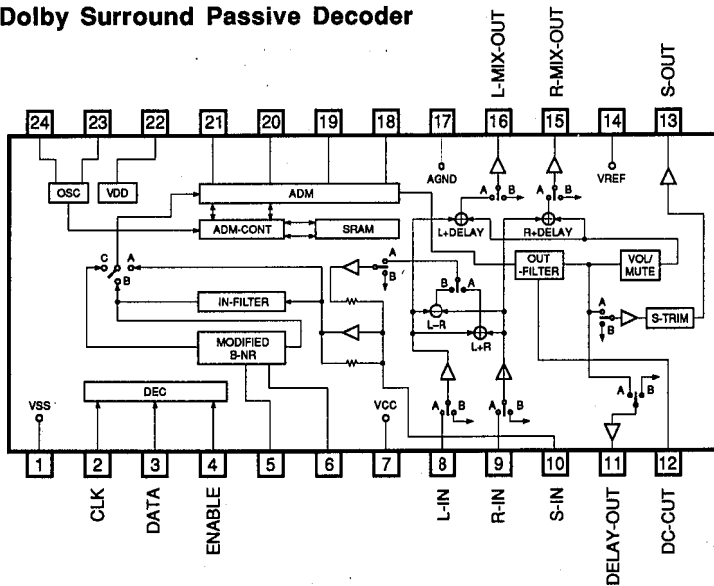

IC508 : BU2090
Serial In/Parallel Out Driver

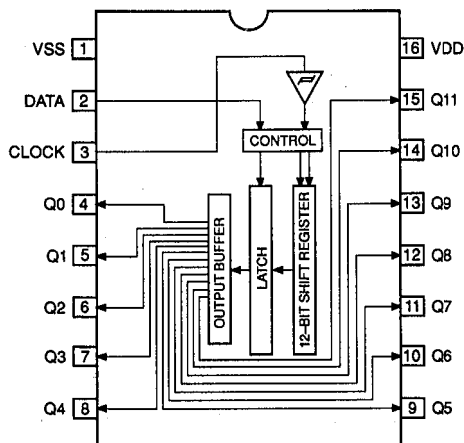

Other IC's

- IC301 : M38114M8-104 → See page 15

RX-V390/R-V501/
 RX-V390RDS

■ BLOCK DIAGRAM

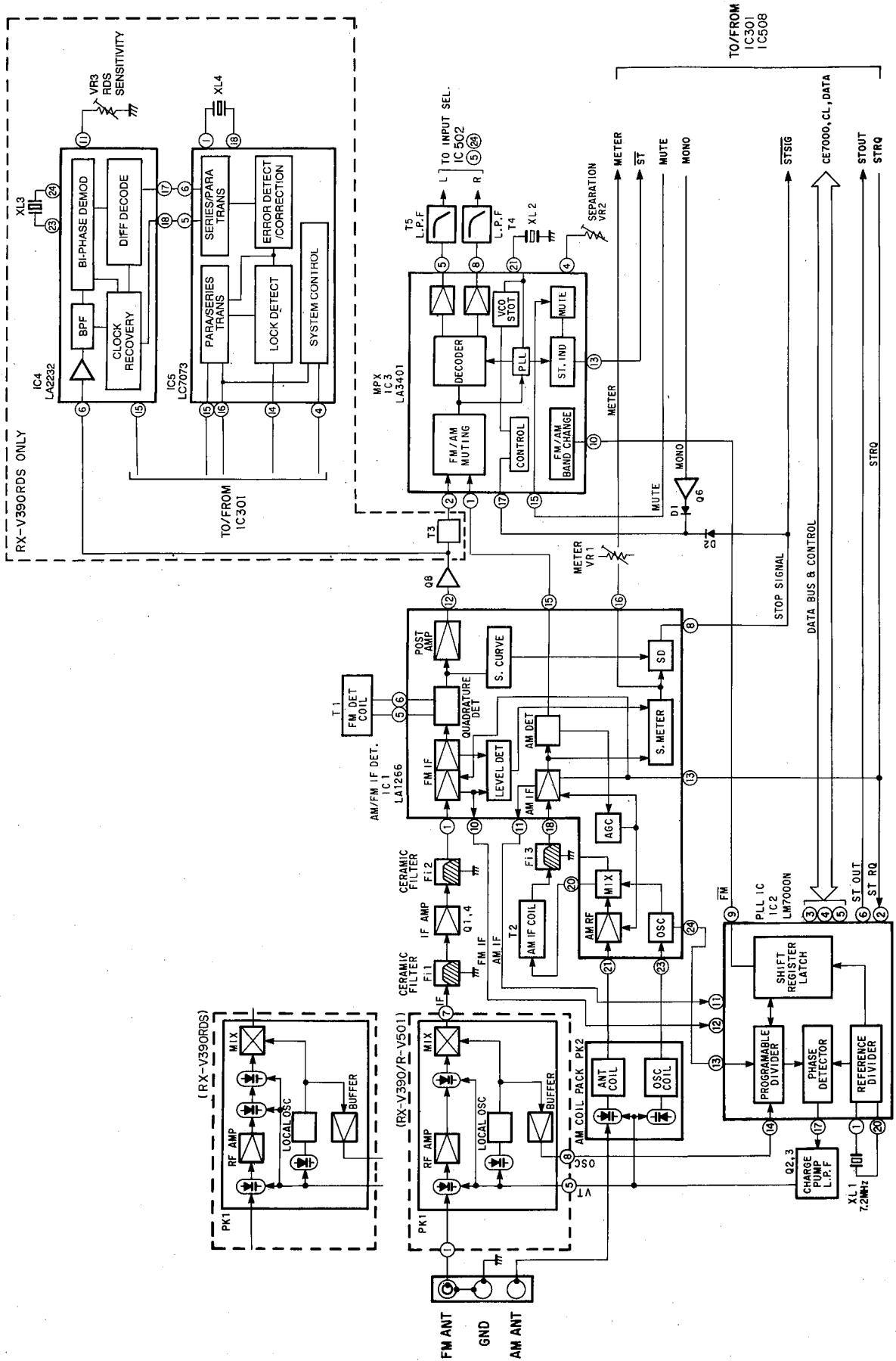

RX-V390/R-V501/
RX-V390RDS

BLOCK DIAGRAM

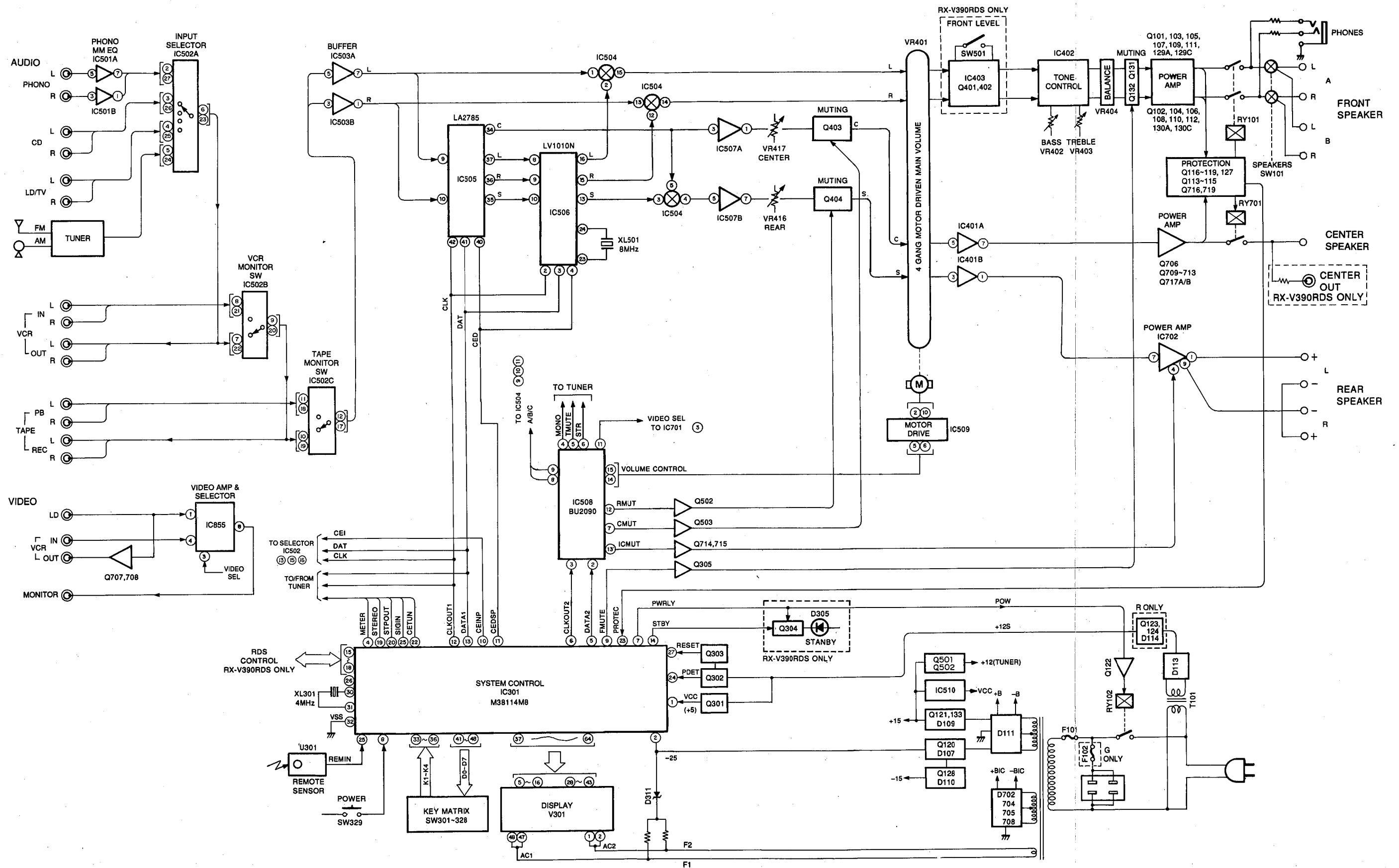

PRINTED CIRCUIT BOARD (Foil side)

⑤ and ⑥ : TEST POINT WAVEFORMS (See page 33)

● RX-V390/R-V501

P.C.B. MAIN (1)

● RX-V390/R-V501

P.C.B. MAIN (3)

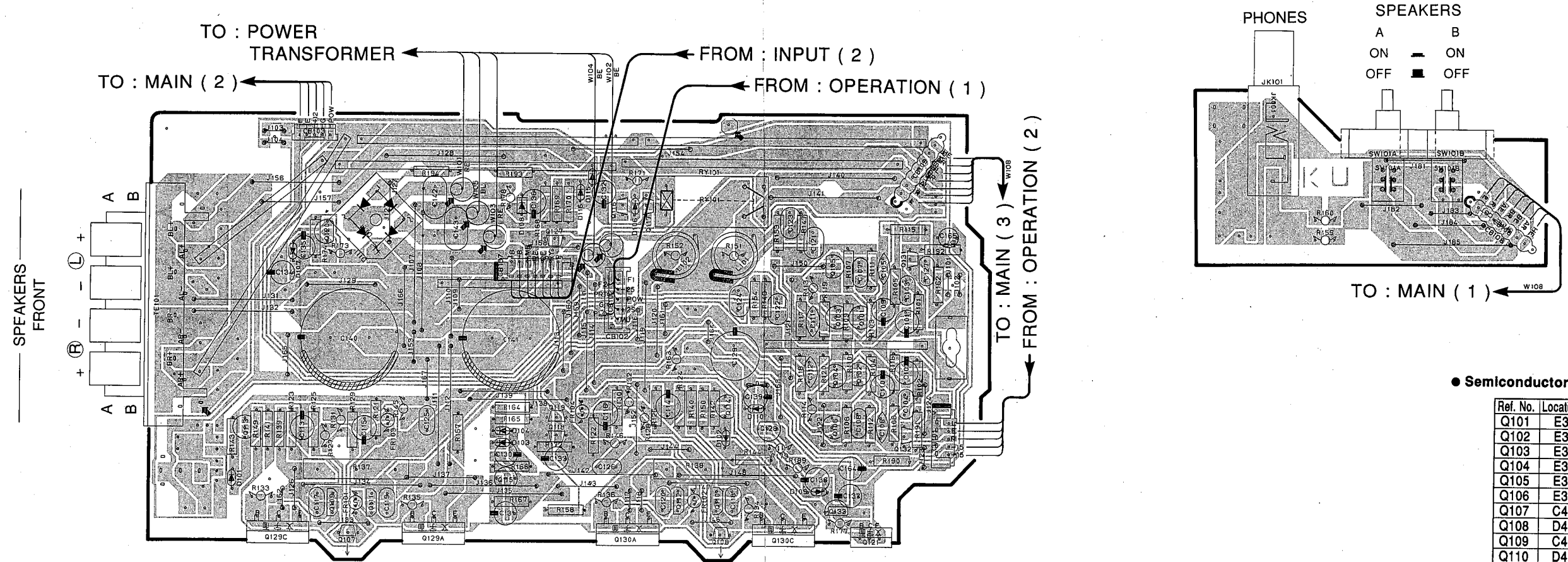

● RX-V390/R-V501

P.C.B. OPERATION (1)

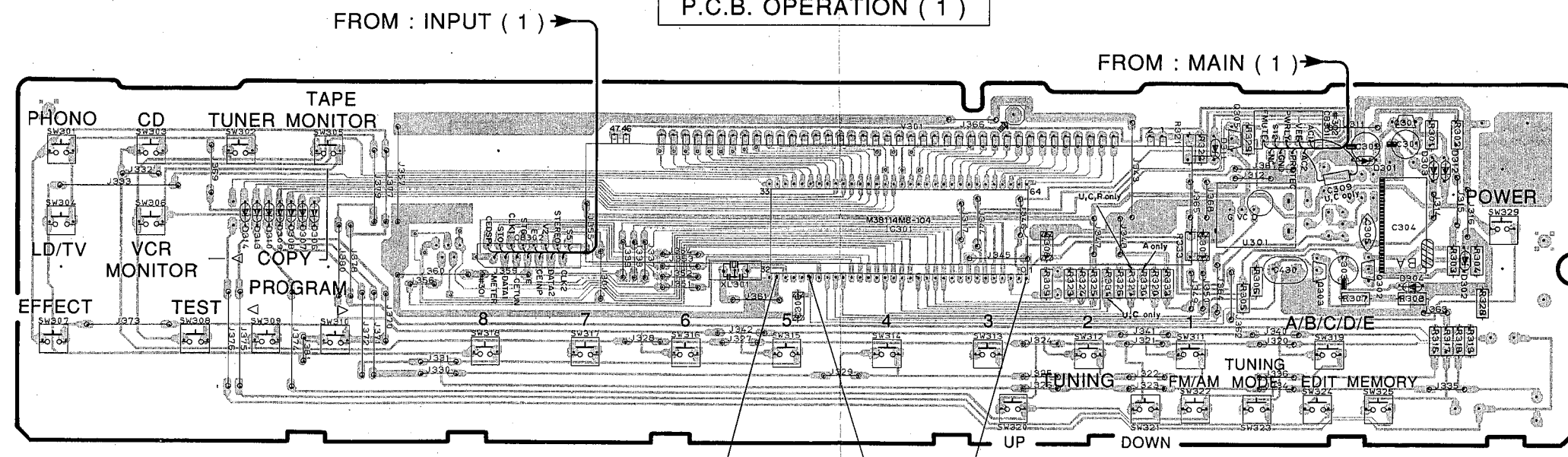

Semiconductor Location

Ref. No.	Location
Q101	E3
Q102	E3
Q103	E3
Q104	E3
Q105	E3
Q106	E3
Q107	C4
Q108	D4
Q109	C4
Q110	D4
Q111	C4
Q112	D4
Q113	B3
Q114	D3
Q115	C3
Q116	D2
Q117	D2
Q118	D3
Q119	D3
Q120	C2
Q121	E4
Q127	D2
Q128	D3
Q129A	C4
Q129C	B4
Q130A	D4
Q130C	D4
Q131	E3
Q132	E3
Q133	E4
Q301	F5
Q302	F5
Q303	F5
Q305	F5
IC301	E5

■ PRINTED CIRCUIT BOARD (Foil side)

⑤ and ⑥ : TEST POINT WAVEFORMS (See page 33)

● RX-V390RDS

P.C.B. MAIN (1)

Note) Mounting of C157, 158 (RX-V390RDS only) shown as below.

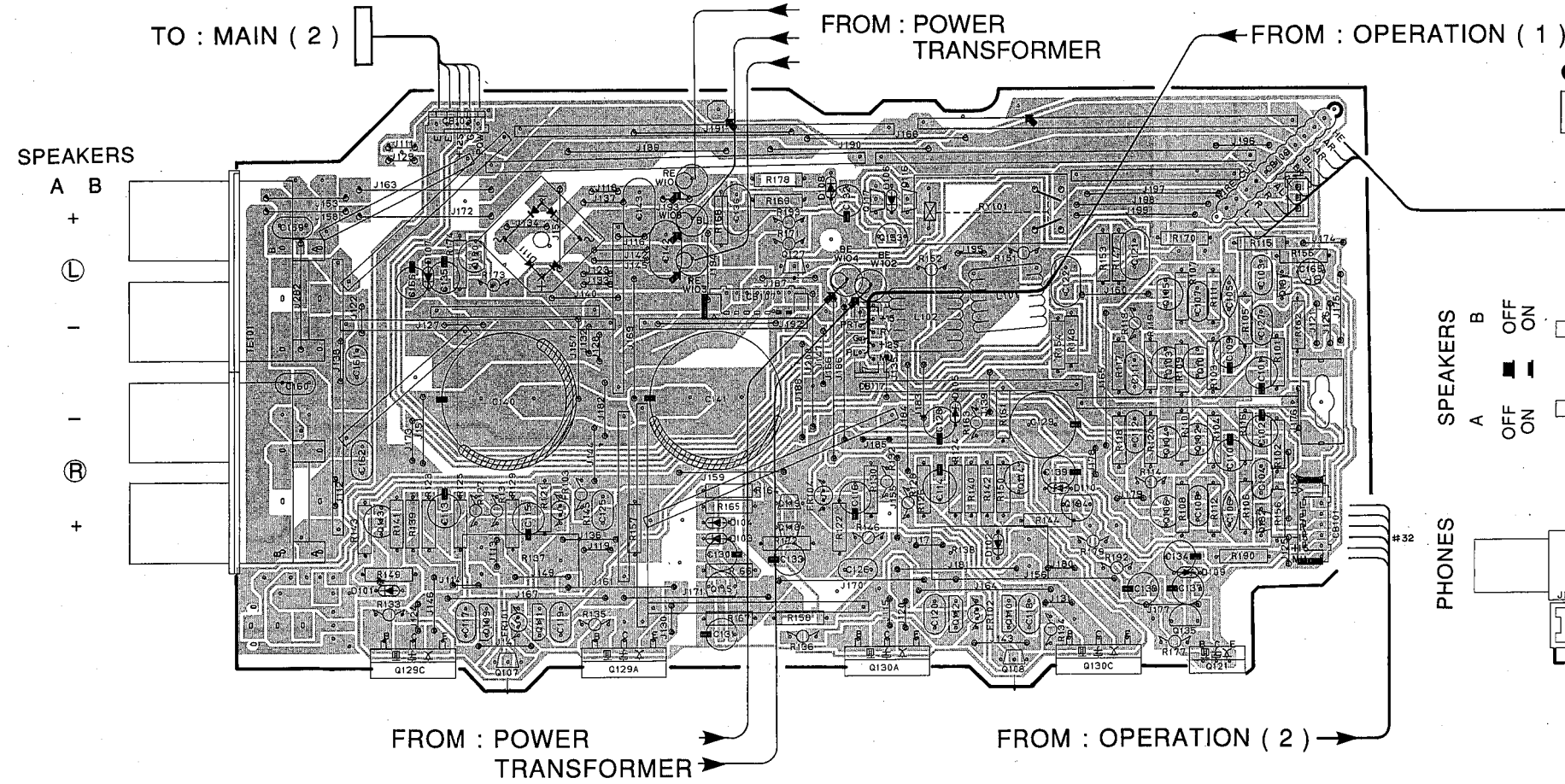

● RX-V390RDS

P.C.B. MAIN (3)

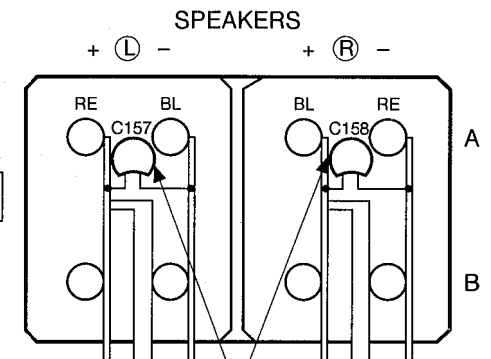

RX-V390RDS only

● Semiconductor Location

Ref. No.	Location
Q101	D2
Q102	D2
Q103	D3
Q104	D3
Q105	D2
Q106	D3
Q107	B3
Q108	D3
Q109	B3
Q110	D3
Q111	B3
Q112	D3
Q113	B3
Q114	D3
Q115	C3
Q116	C2
Q117	C2
Q118	C3
Q119	C3
Q120	B2
Q121	D3
Q127	C2
Q129A	D2
Q129C	B3
Q130A	C3
Q130C	D3
Q131	E2
Q132	E3
Q133	C2
Q134	D3
Q135	D3
Q301	F5
Q302	F5
Q303	F5
Q304	F5
Q305	F5
IC301	D5

● RX-V390RDS

P.C.B. OPERATION (1)

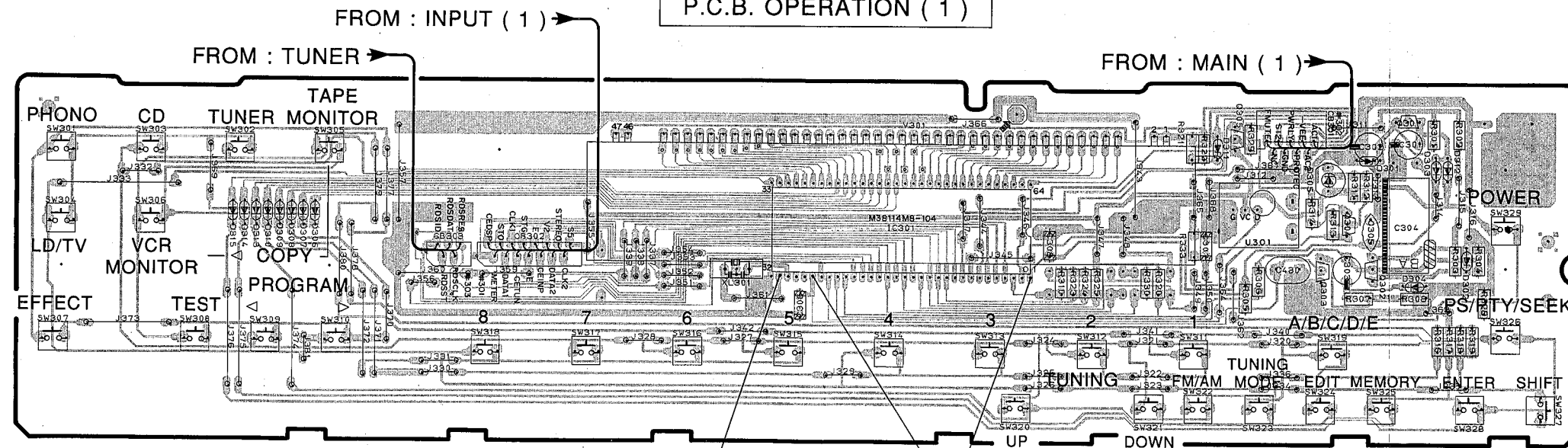

■ PRINTED CIRCUIT BOARD (Foil side)

① to ③ : TEST POINT WAVEFORMS (See page 33)

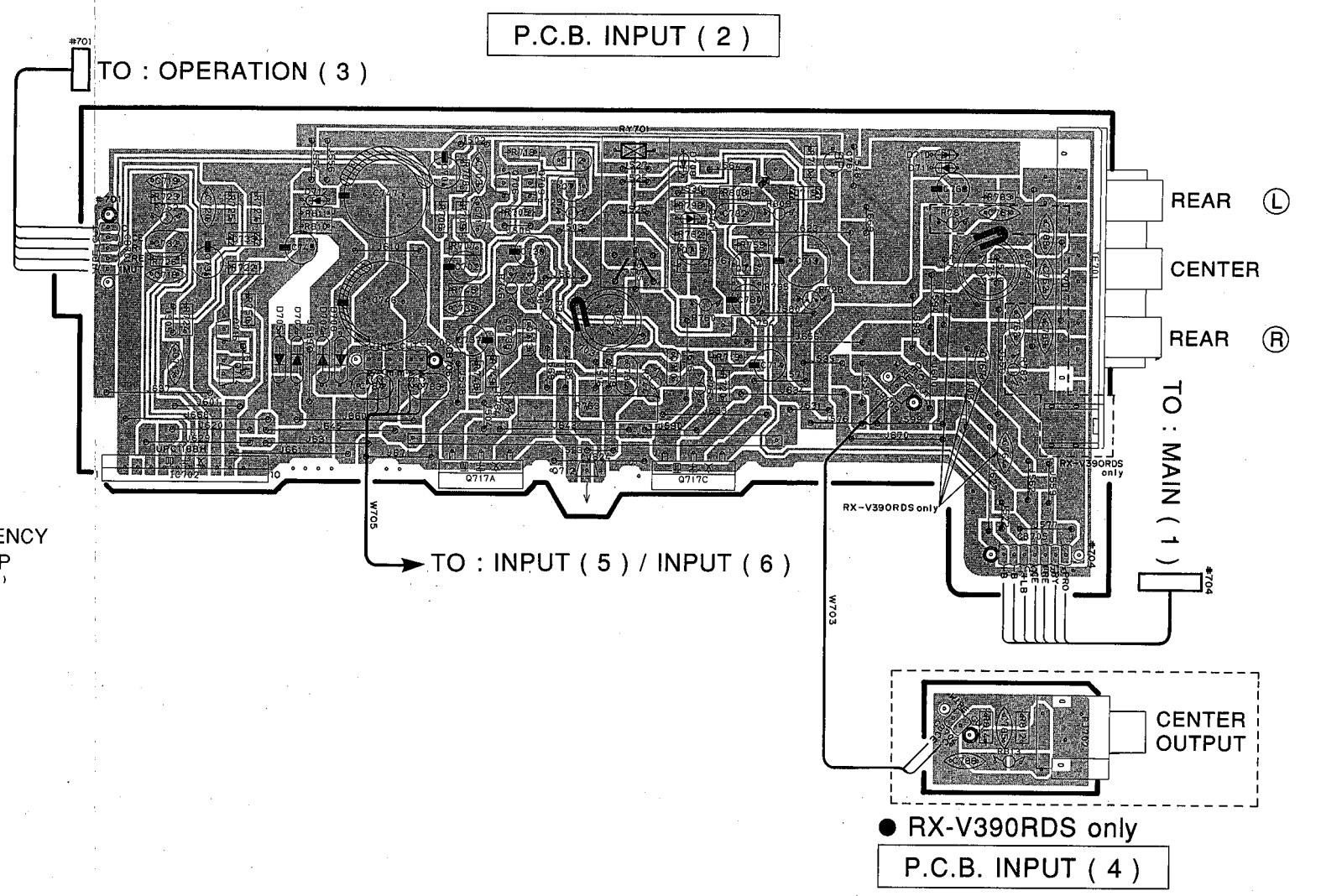
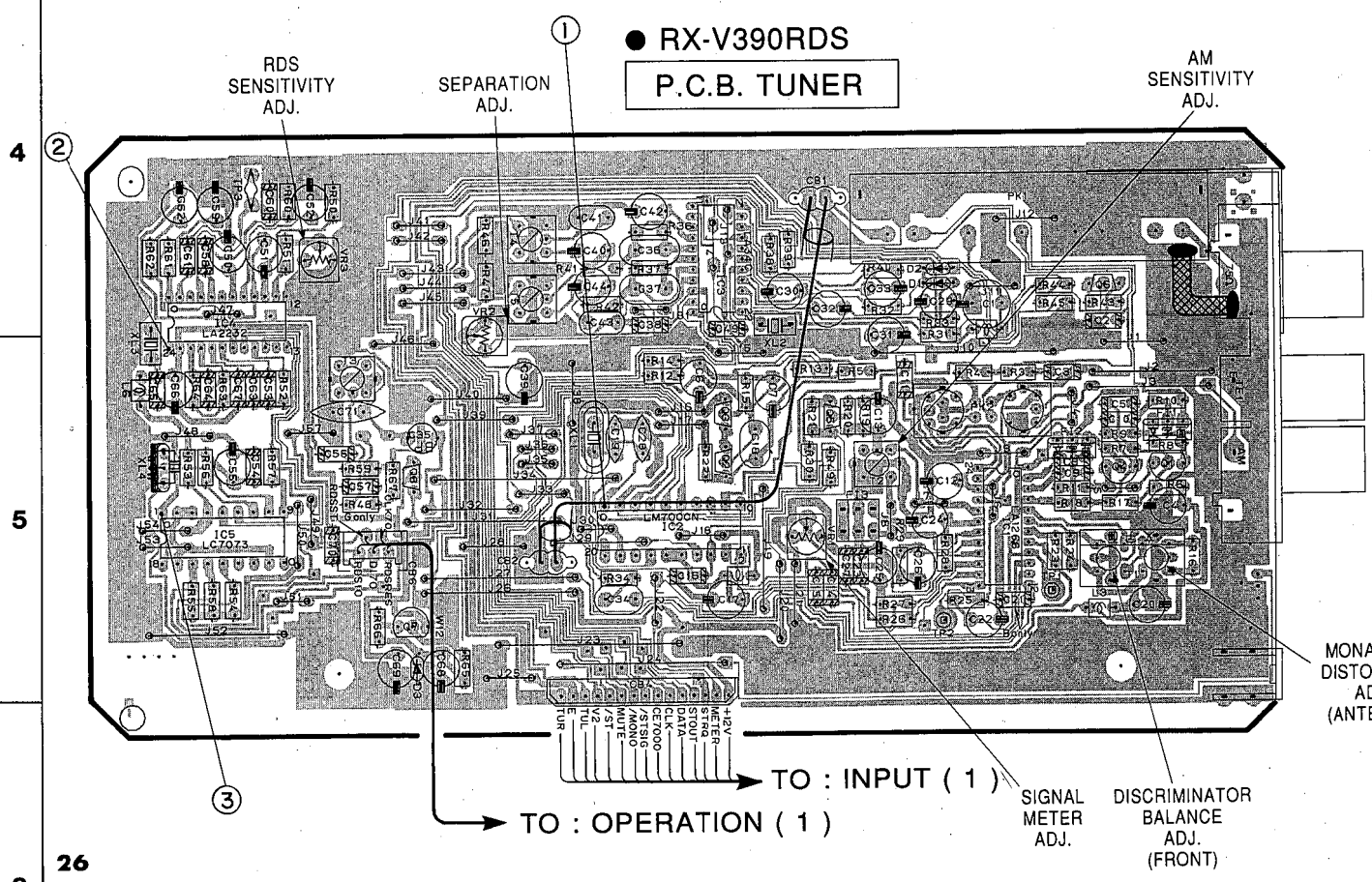
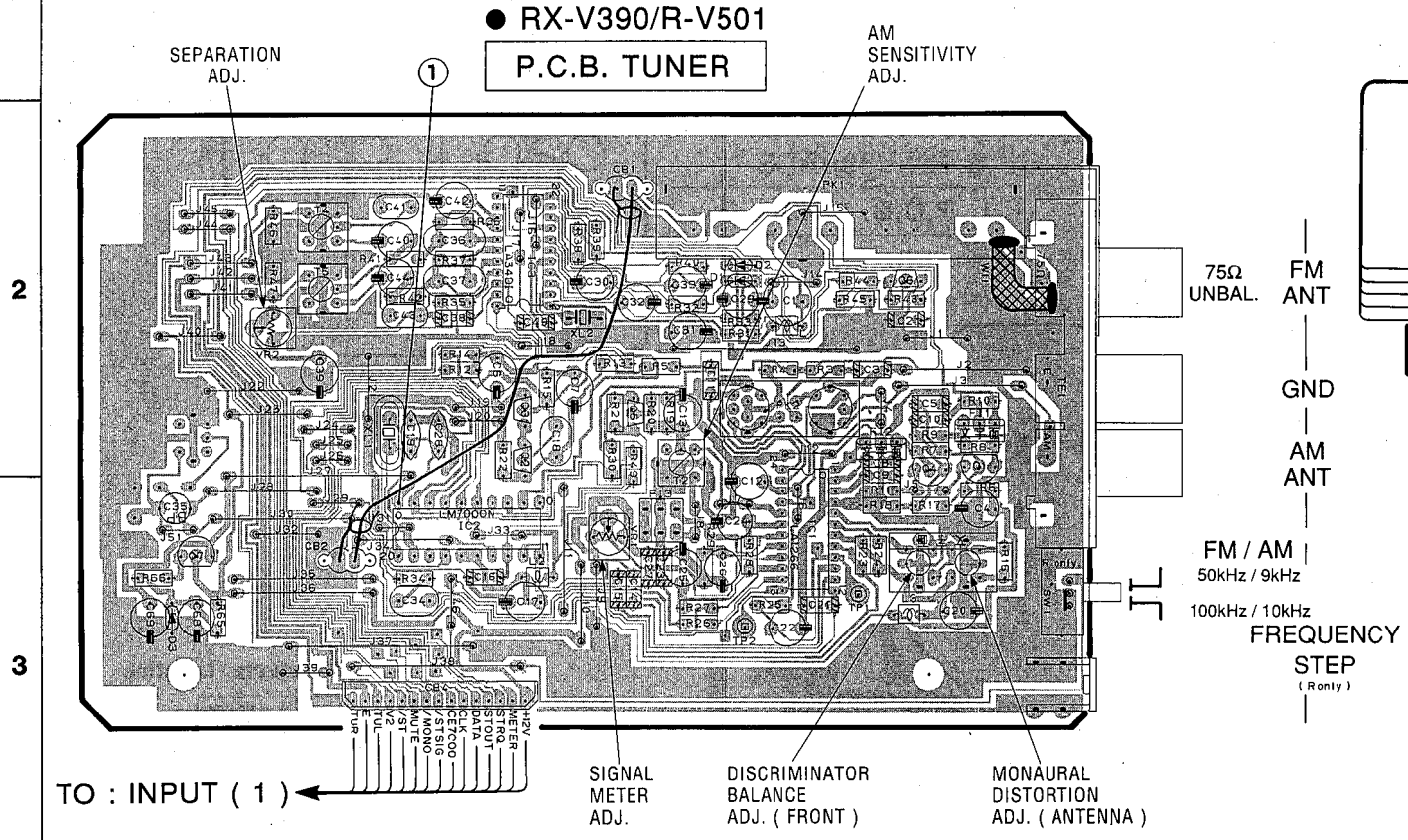

● Semiconductor Location

RX-V390/R-V501 TUNER P.C.B.		RX-V390RDS TUNER P.C.B.		INPUT P.C.B.	
Ref. No.	Location	Ref. No.	Location	Ref. No.	Location
IC1	C3	IC1	C5	IC702	E3
IC2	B3	IC2	B5	Q706	F2
IC3	B2	IC3	B4	Q709	F2
Q1	C2	IC4	A4	Q710	F2
Q2	B2	IC5	A5	Q711	F2
Q3	B2	Q1	D5	Q712	F3
Q4	C2	Q2	C5	Q713	F2
Q5	B2	Q3	C5	Q714	E2
		Q4	D5	Q715	E2
		Q5	C5	Q716	F2
		Q6	D4	Q717A	F3
		Q7	B5	Q717C	F3
		Q8	B5	Q719	F2

■ PRINTED CIRCUIT BOARD (Foil side)

④ : TEST POINT WAVEFORMS (See page 33)

● Semiconductor Location

Ref. No.	Location
IC402	C5
IC403	D5
IC501	E3
IC502	E3
IC503	E2
IC504	F3
IC505	F2
IC506	G2
IC507	G3
IC508	F4
IC509	G3
IC510	G3
IC701	C2
Q401	D5
Q402	D5
Q403	E5
Q404	E5
Q501	F3
Q502	G3
Q503	G3
Q507	C2
Q508	C2

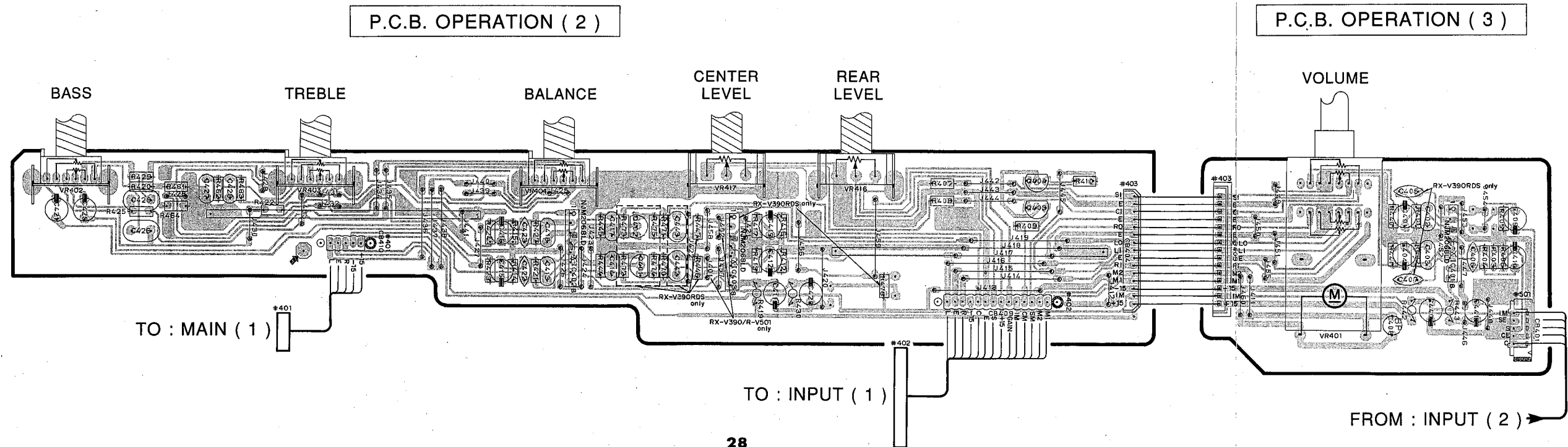
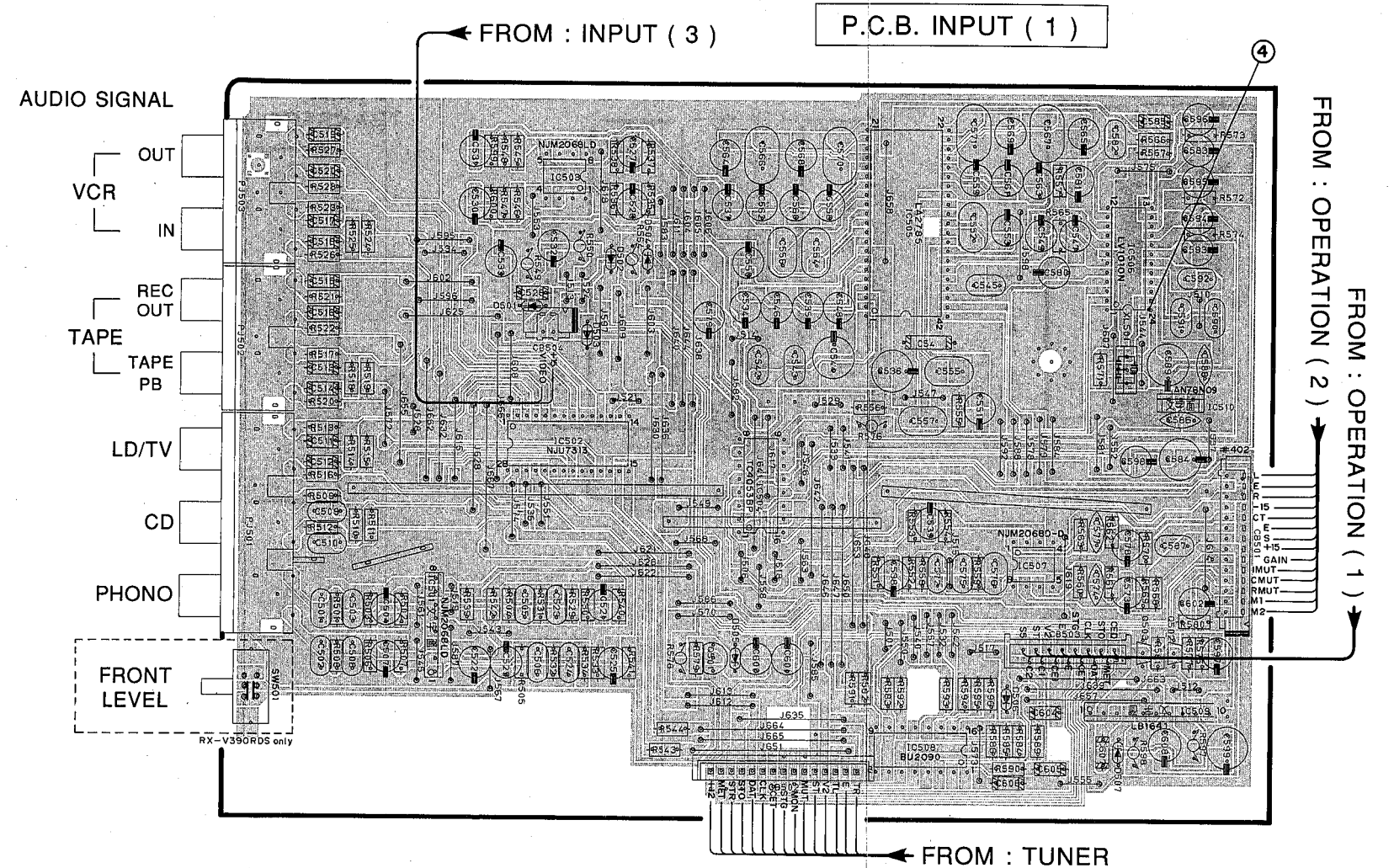
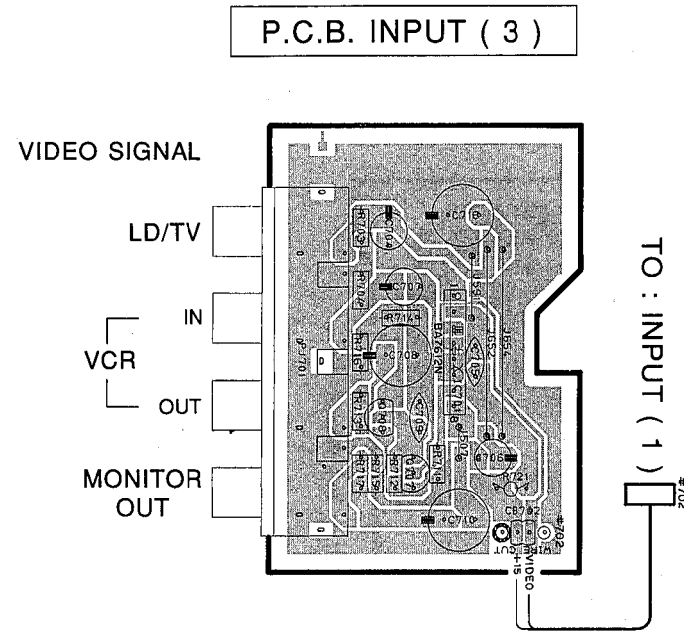

■ PRINTED CIRCUIT BOARD (Foil side)

1
2
3
4
5
6

● U,C models
P.C.B. INPUT (5)

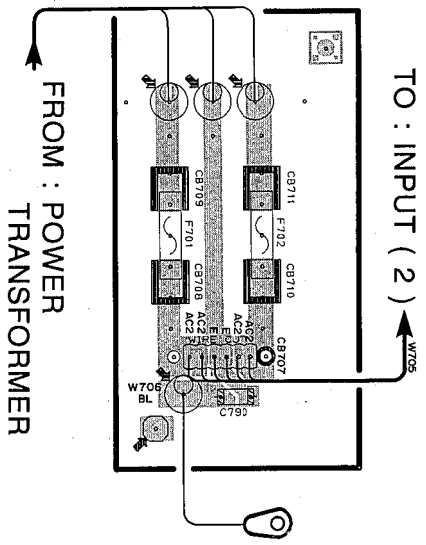

● R,A,B,G models
P.C.B. INPUT (6)

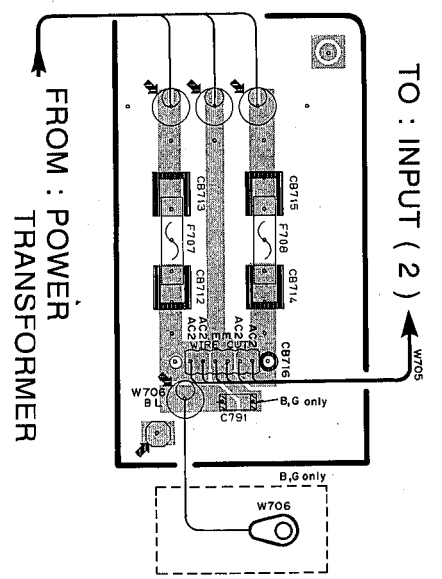

● R model
P.C.B. MAIN (2)

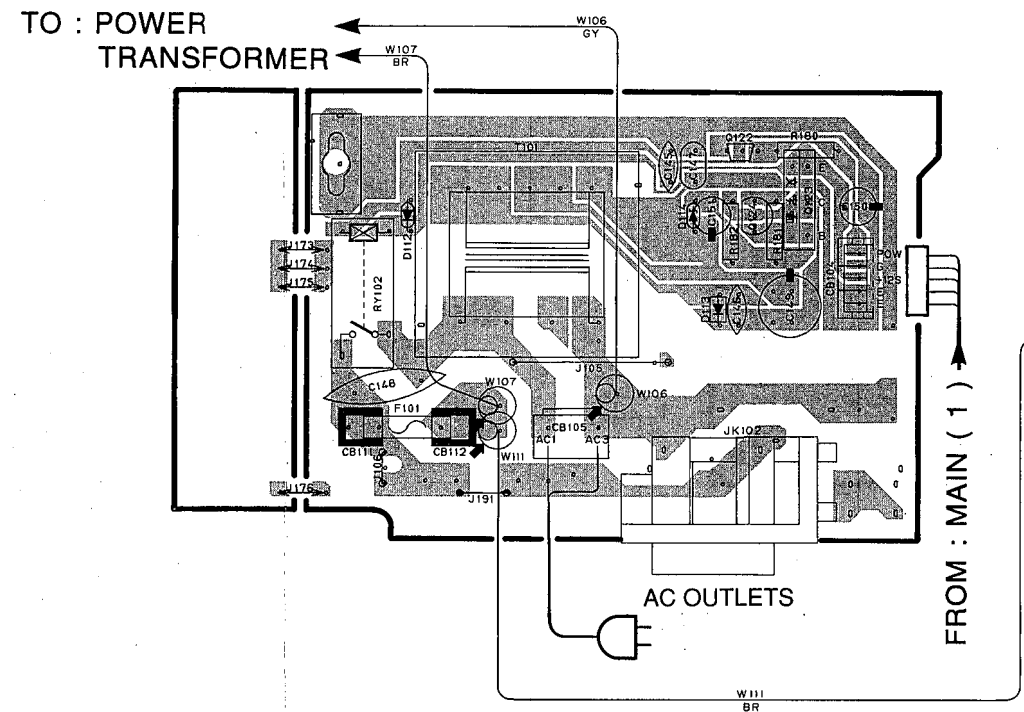

● R model
P.C.B. MAIN (4)

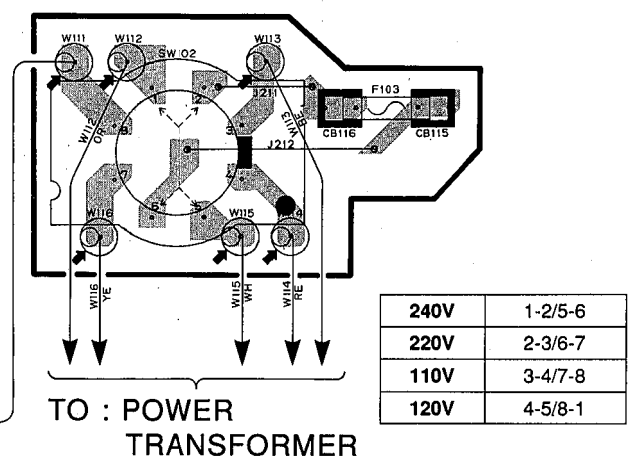

240V	1-2/5-6
220V	2-3/6-7
110V	3-4/7-8
120V	4-5/8-1

● U,C models
P.C.B. MAIN (2)

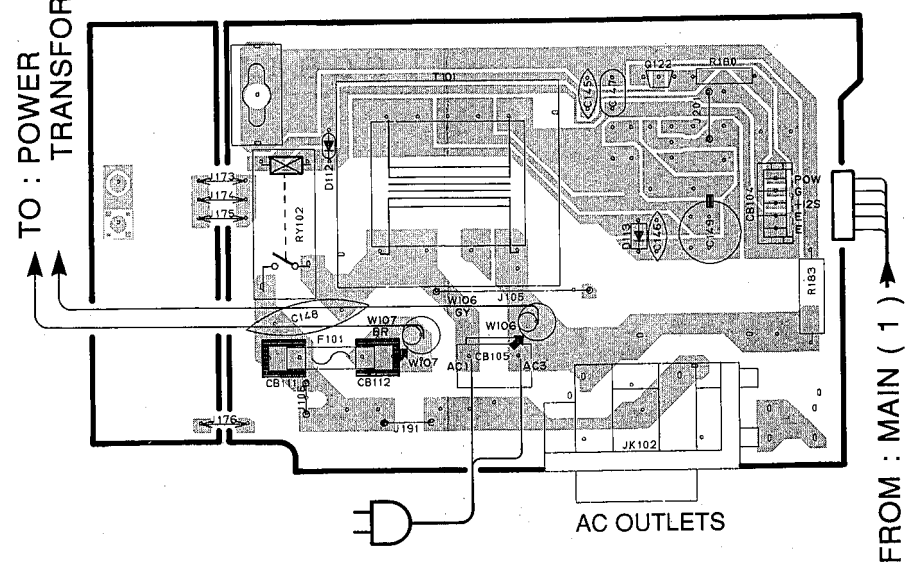

● A model
P.C.B. MAIN (2)

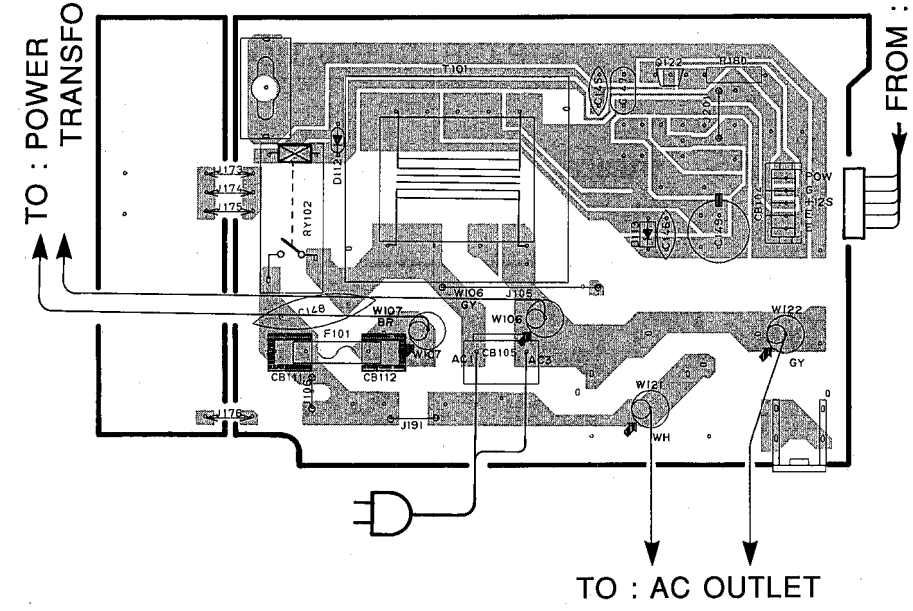

1 ■ PRINTED CIRCUIT BOARD (Foil side)

● B model

P.C.B. MAIN (2)

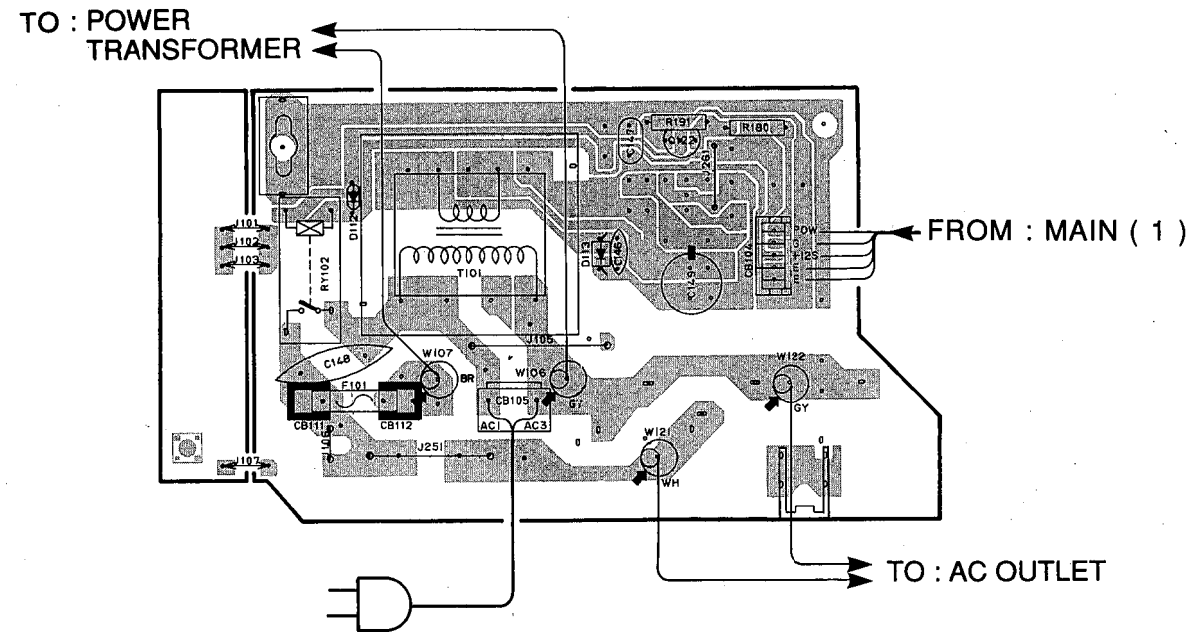

● G model

P.C.B. MAIN (2)

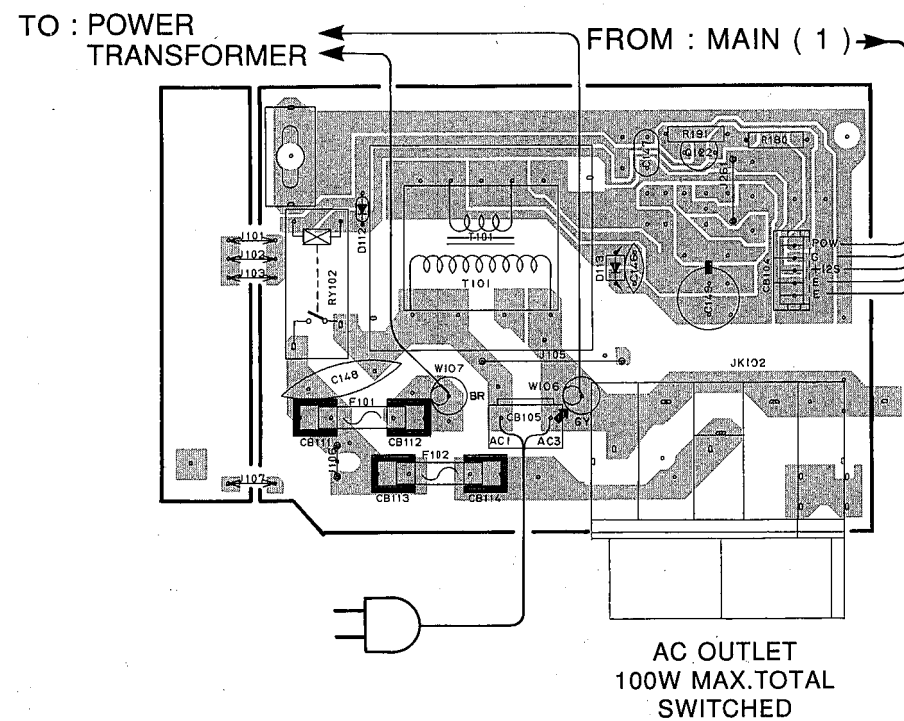

■ TEST POINT WAVEFORMS

Point ①
(Pin 1 of IC2)
V: 2V/div H: 50nsec/div
DC range 1:1 probe

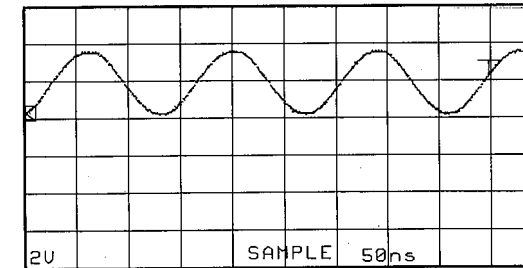

Point ④
(Pin 24 of IC506)
V: 2V/div H: 50nsec/div
DC range 1:1 probe

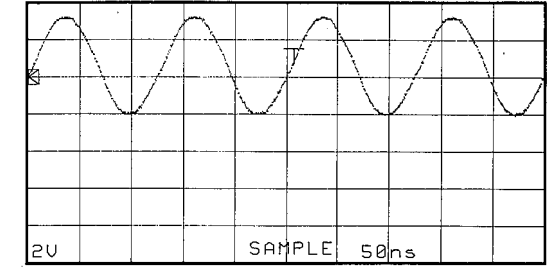

Point ②
(Pin 24 of IC4)
V: 2V/div H: 1μsec/div
DC range 1:1 probe

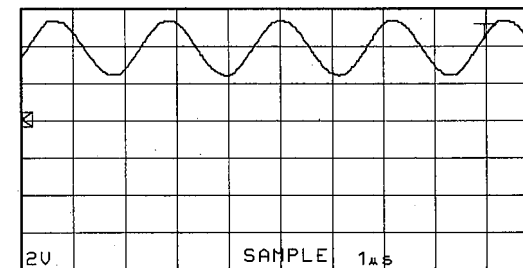

Point ⑤
(Pin 31 of IC301)
V: 2V/div H: 0.1μsec/div
DC range 1:1 probe

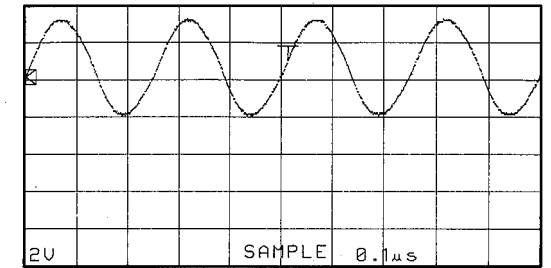

Point ③
(Pin 1 of IC5)
V: 2V/div H: 0.1μsec/div
DC range 1:1 probe

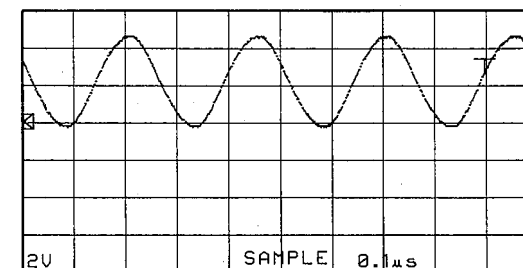

Point ⑥
(CH 1 : Pin 1 of IC301)
(CH 2 : Pin 27 of IC301)
V: 2V/div H: 0.5sec/div
DC range 1:1 probe

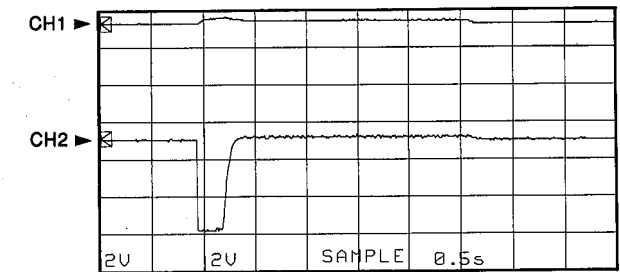

With the POWER switch turned ON, connect the power cord to the AC outlet.

Disconnect the power cord from the AC outlet.

■ DISPLAY DATA (VS576000)

● V301 : 12-BT-64GK

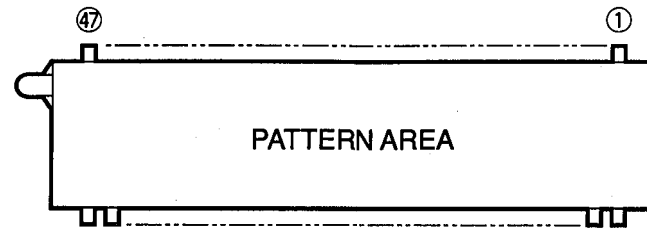

● PIN CONNECTION

PIN NO.	1	2	3	4	5	6	7	8	9	10	11	12	13	14	15	16	17	18	19	20	21
CONNECTION	F1	F1	NP	NP	1G	2G	3G	4G	5G	6G	7G	8G	9G	10G	11G	12G	NC	NC	NC	NC	NC
PIN NO.	22	23	24	25	26	27	28	29	30	31	32	33	34	35	36	37	38	39	40	41	42
CONNECTION	NC	NC	NC	NC	NC	NC	P16	P15	P14	P13	P12	P11	P10	P9	P8	P7	P6	P5	P4	P3	P2
PIN NO.	43	44	45	46	47																
CONNECTION	P1	NP	NP	F2	F2																

NOTE 1) F1, F2..... Filament
 2) NPNo pin
 3) NCNo connection
 4) P1~P16 ... Datum Line
 5) 1G~11G... Grid

● GRID ASSIGNMENT

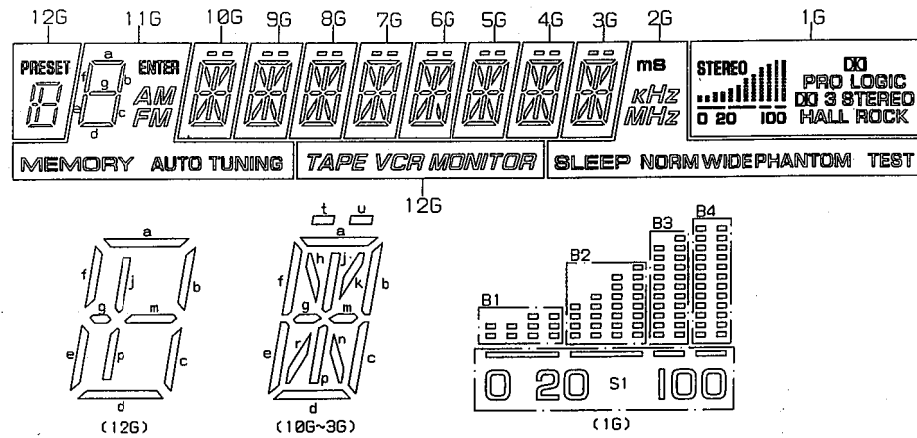

● ANODE CONNECTION

	12G	11G	10G	9G	8G	7G	6G	5G	4G	3G	2G	1G
P1	a	a	a	a	a	a	a	a	a	a	ms	HALL
P2	b, c	b	b	b	b	b	b	b	b	b	SLEEP	ROCK
P3	d	c	c	c	c	c	c	c	c	c	NORM	—
P4	e, f	d	d	d	d	d	d	d	d	d	WIDE	☑ 3 STEREO
P5	g	e	e	e	e	e	e	e	e	e	PHANTOM	—
P6	j, p	f	f	f	f	f	f	f	f	f	—	—
P7	m	g	g	g	g	g	g	g	g	g	TEST	☑ PRO LOGIC
P8	PRESET	ENTER	h	h	h	h	h	h	h	h	—	—
P9	—	AM	j	j	j	j	j	j	j	j	kHz	STEREO
P10	—	FM	k	k	k	k	k	k	k	k	MHz	S1
P11	—	MEMORY	m	m	m	m	m	m	m	m	—	B1
P12	MONITOR	AUTO TUNING	n	n	n	n	n	n	n	n	—	B2
P13	TAPE	—	p	p	p	p	p	p	p	p	—	B3
P14	VCR	—	r	r	r	r	r	r	r	r	—	B4
P15	—	—	t	t	t	t	t	t	t	t	—	—
P16	—	—	u	u	u	u	u	u	u	u	—	—

■ PIN CONNECTION DIAGRAM

● ICs

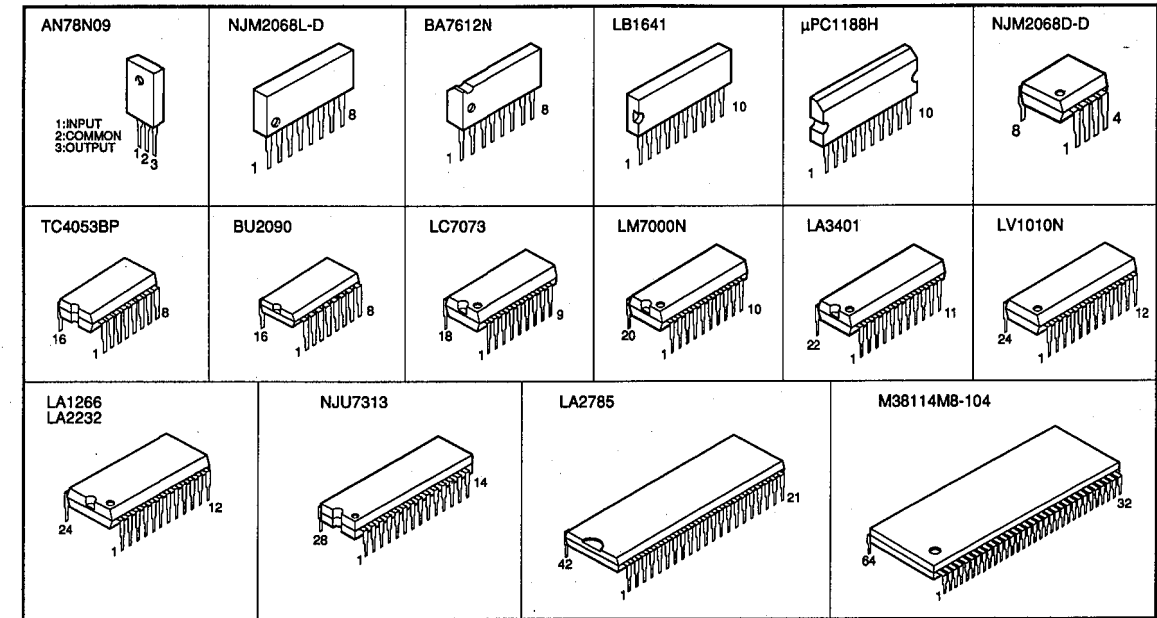

● Diodes

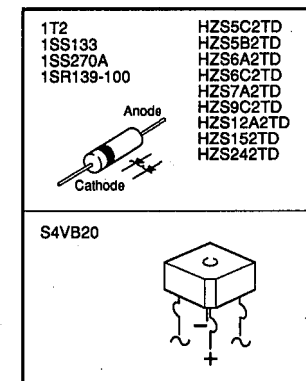

● Transistors

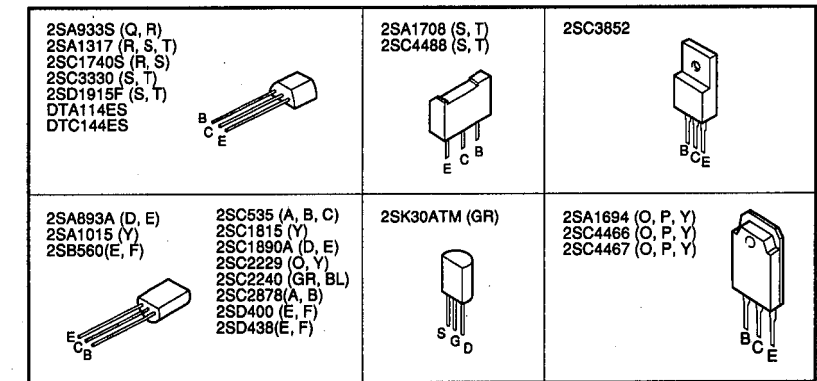

SCHEMATIC DIAGRAM (TUNER)

Each voltage given here represents that in the FM (98.1MHz, STEREO) reception mode but the one in the parentheses () is that in the AM (1080kHz, MAN'L) reception mode.

① to ③ : TEST POINT WAVEFORMS (See page 33)

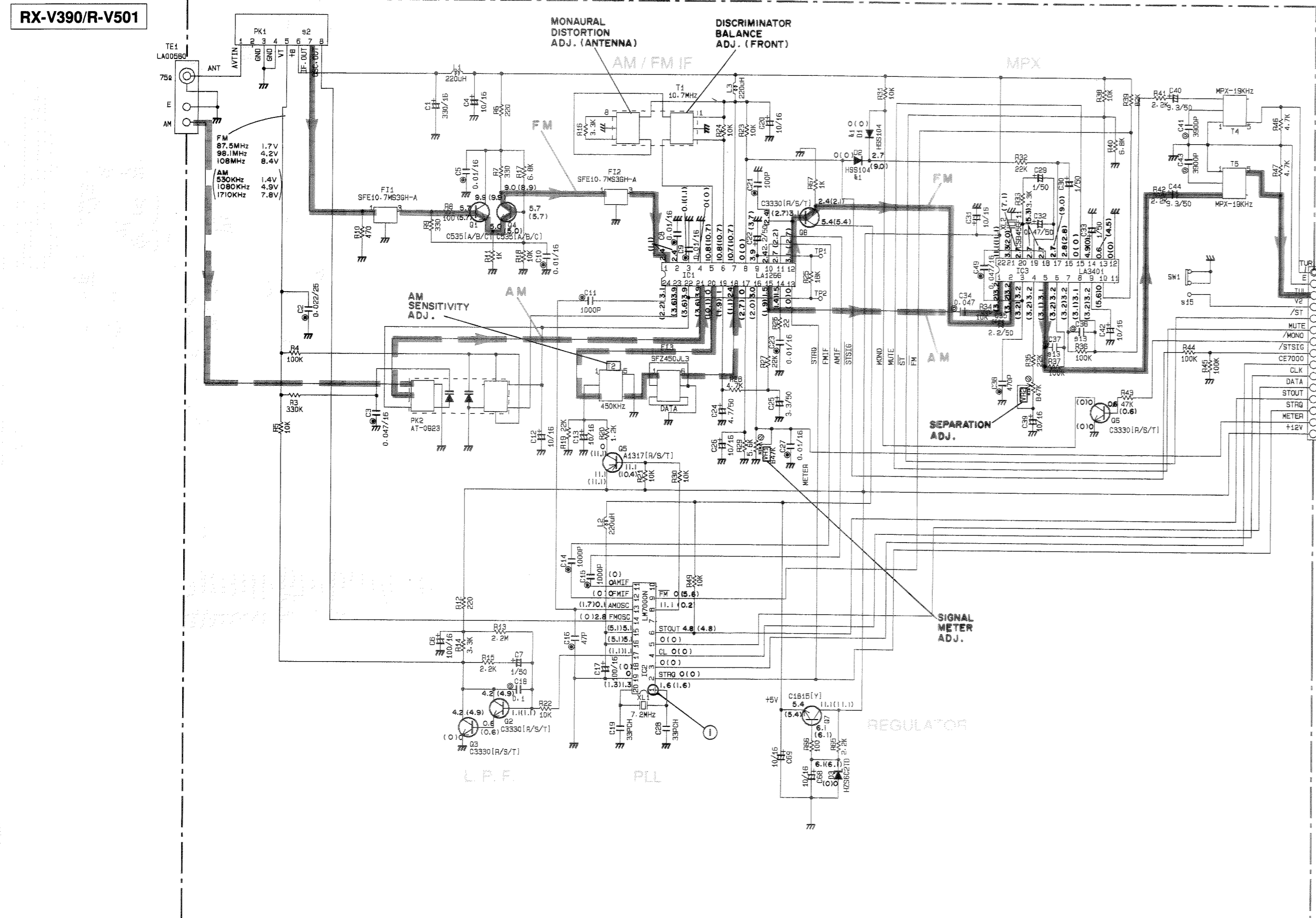

U.C.	R	A
1		
2	PK1	VR2420
3		
4		
5		
6		
7	CE1	100P
8	R34	10K
9	J51	○
10	R4B	○
11	T3	○
12	R55	22K
13	C35-37	800P
14	R35-37	100K
15	BW1	X
16	J51	X

Interchangeable Parts at Manufacture-Stage

Mark	Reference Parts Number	Parts Name
K1	D1-2	H5B104
		18B138
		18B176

CAPACITOR

REMARKS	PARTS NAME	UNIT
NO MARK	ELECTROLYTIC CAPACITOR	μF
◎	TANTALUM CAPACITOR	μF
NO MARK	CERAMIC CAPACITOR	
⊙	CERAMIC TUBULAR CAPACITOR	
○	POLYESTER FILM CAPACITOR	
○	POLYSTYRENE FILM CAPACITOR	
○	MICA CAPACITOR	
⊙	POLYPROPYLENE FILM CAPACITOR	
●	SEMICONDUCTIVE CERAMIC CAPACITOR	

RESISTOR

REMARKS	PARTS NAME	UNIT
NO MARK	CARBON FILM RESISTOR (P=5)	Ω
□	CARBON FILM RESISTOR (P=10)	Ω
△	METAL OXIDE FILM RESISTOR	Ω
▲	METAL FILM RESISTOR	Ω
⊙	METAL PLATE RESISTOR	Ω
■	FIRE PROOF CARBON FILM RESISTOR	Ω
□	CEMENT MOLDED RESISTOR	Ω
⊙	SEMI VARIABLE RESISTOR	Ω
■	CHIP RESISTOR	Ω

NOTICE
 (J)..... Japanese model
 (U)..... U.S.A. model
 (C)..... Canadian model
 (A)..... Australian model
 (G)..... European model
 (B)..... British model
 (R)..... General model
 (P)..... RPP model

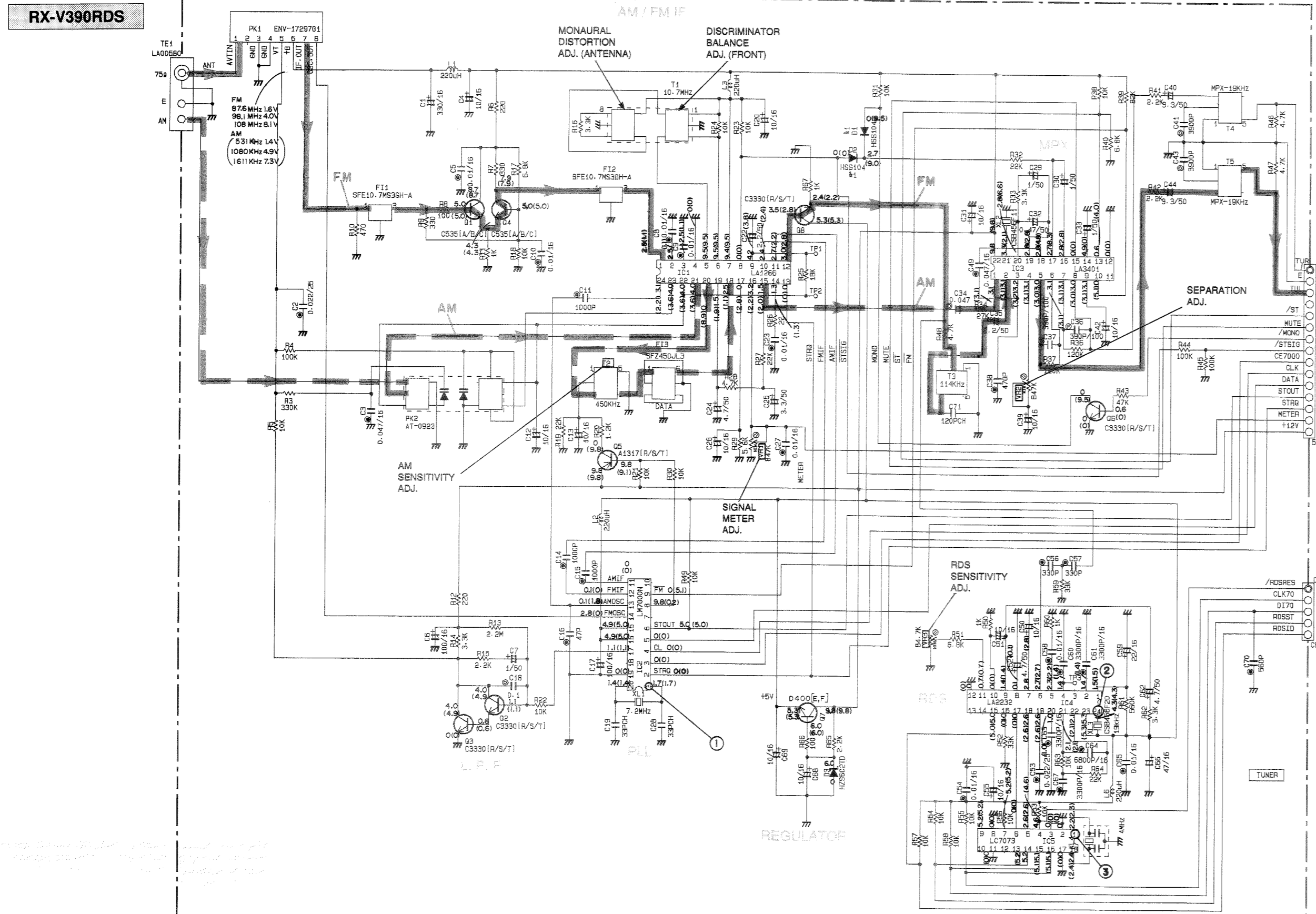

RX-V390/R-V501
 PK1 : ENV-17298GI (VR242200)

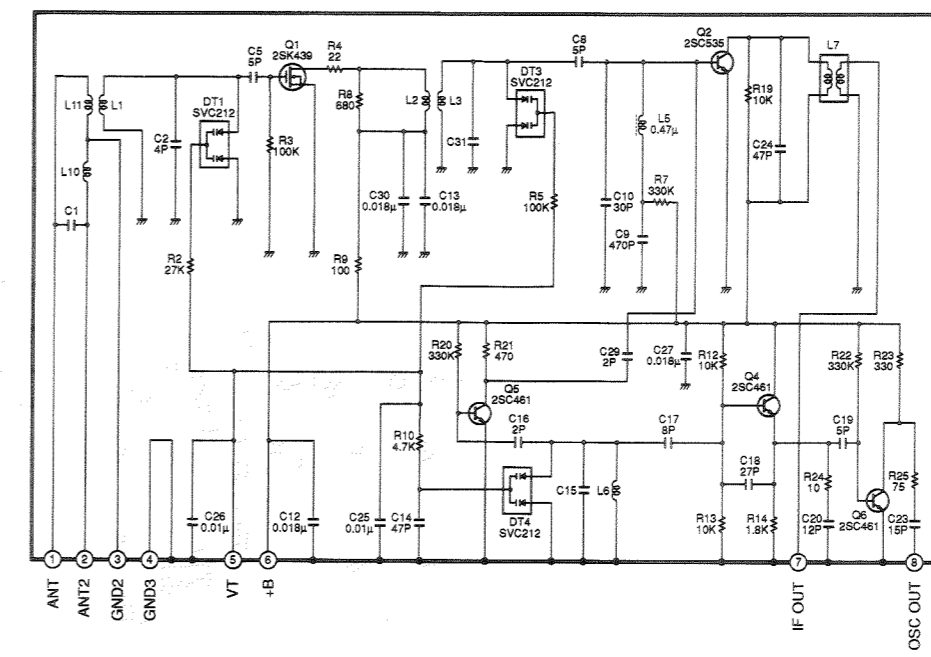

IC1 : LA1266
 AM/FM IF

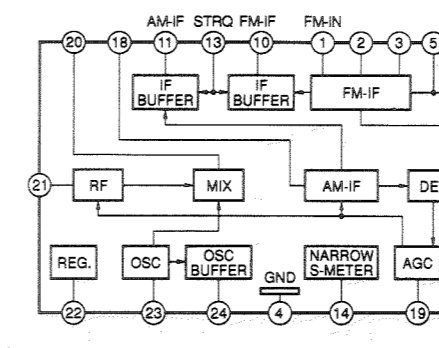

IC3 : LA3401
 MPX

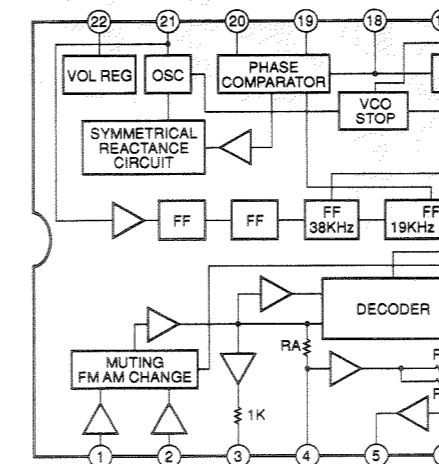

IC4 : LA2232
 RDS Decoder

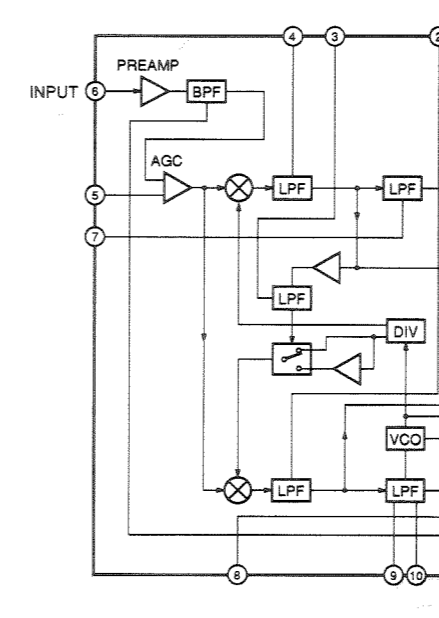

RX-V390RDS
 PK1 : ENV-17297GI (VQ987600)

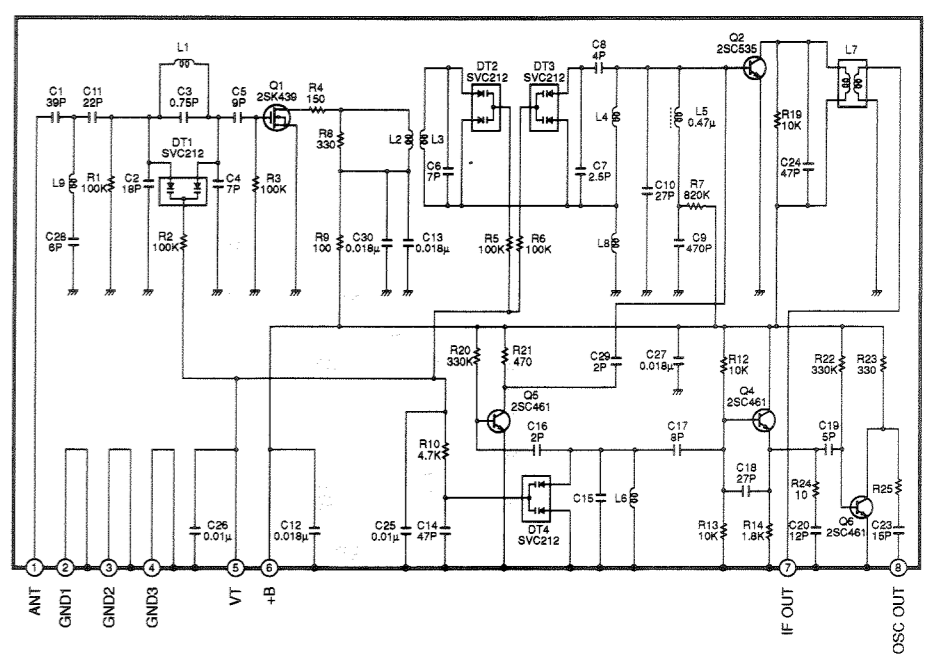

IC2 : LM7000N
 PLL Controller

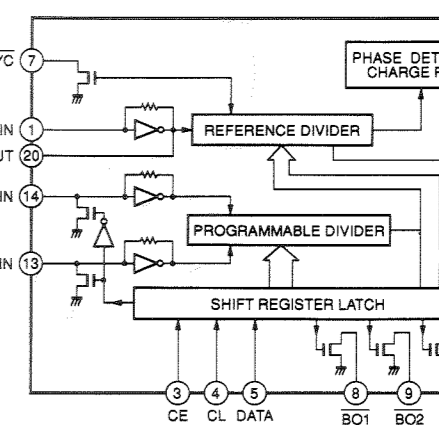

IC5 : LC7073
 RDS Converter & Controller

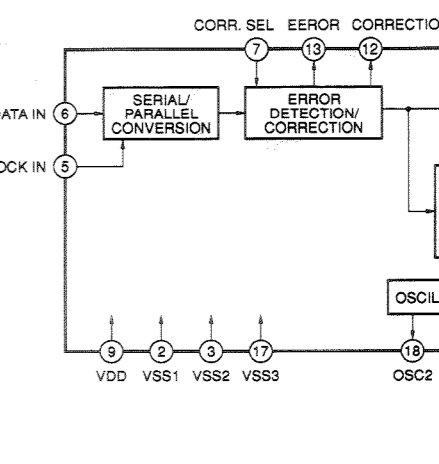

* All voltage are measured with a 10MΩ/DC electric volt meter.
 * Components having special characteristics are marked with a triangle and must be replaced with parts having specifications equal to those originally installed.
 * Schematic diagram is subject to change without notice.

■ SCHEMATIC DIAGRAM (INPUT & EFFECT CONTROL)

④ to ⑥ : TEST POINT WAVEFORMS (See page 33)

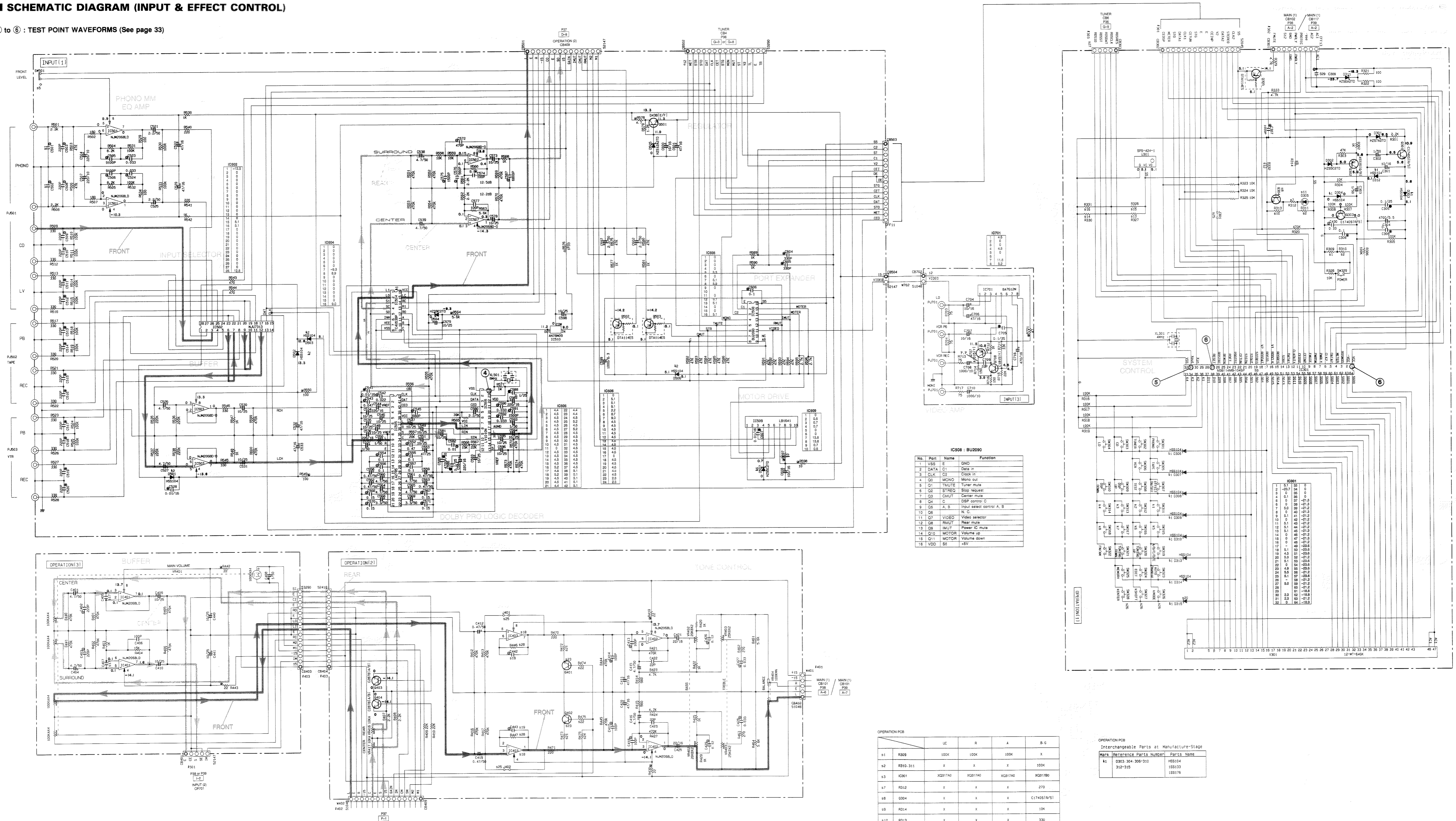

IC508 : BU2090

No.	Part	Name	Function
1	VES	E	GROUND
2	DATA	D1	Data in
3	CLK	CK	Clock in
4	Q0	MEMO	Memory out
5	Q1	TUNUTE	Tuner mute
6	Q2	STRFD	Stop release
7	Q3	CMUT	Center mute
8	Q4	C	DSP control C
9	Q5	A, B	Input select control A, B
10	Q6	IN	IC
11	Q7	VIDEO	Video selector
12	Q8	RMUT	Remote mute
13	Q9	IMUT	Power IC mute
14	Q10	MOTOR	Volume up
15	Q11	MOTOR	Volume down
16	VDD	SE	-5V

INPUT PCB
Interchangeable Parts at Manufacture Stage

Mark	Reference Parts Number	Parts Name
41	10584	IC4053BP UPG4053BP
42	0501-501-506-710-711	HSS104 HSS104 HSS104 HSS104
43		HSS104 HSS104 HSS104 HSS104
44	D709	HSS247D HSS247D HSS247D HSS247D
45	D712	HSS247D HSS247D HSS247D HSS247D
46	0507	HSS247D HSS247D HSS247D HSS247D

INPUT PCB

	U/C	B/A	B/G
1	C761.763	X	X
2	C764.767.768.769	X	X
3	R781.782	X	X
4	C782	X	X
5	0501	X	X
6	C781	X	X
7	R702	X	X
8	C785	X	X
9	C786	X	X
10	R814	X	X
11	R812	X	X
12	R813	X	X
13	C813.704	X	X
14	R718	1K	1K
15	W106	VSS4430	X
16	W103	X	X

CAPACITOR

REMARKS	PARTS NAME
NO MARK	ELECTROLYTIC CAPACITOR
NO MARK	TANTALUM CAPACITOR
NO MARK	CERAMIC CAPACITOR
NO MARK	CERAMIC TUBULAR CAPACITOR
NO MARK	POLYESTER FILM CAPACITOR
NO MARK	POLYPROPYLENE FILM CAPACITOR
NO MARK	MICA CAPACITOR
NO MARK	POLYPROPYLENE FILM CAPACITOR
NO MARK	SEMICONDUCTIVE CERAMIC CAPACITOR

RESISTOR

REMARKS	PARTS NAME
NO MARK	CARBON FILM RESISTOR (D=5)
NO MARK	CARBON FILM RESISTOR (D=10)
NO MARK	METAL GLAZE FILM RESISTOR
NO MARK	METAL FILM RESISTOR
NO MARK	METAL GLAZE RESISTOR
NO MARK	FIRE PROOF CARBON FILM RESISTOR
NO MARK	CEMENT MOLDED RESISTOR
NO MARK	SEMI VARIABLE RESISTOR
NO MARK	CHIP RESISTOR

OPERATION PCB

	UC	B	A	B/G
91	R309	100K	100K	100K
92	R310-311	X	X	X
93	IC301	XQ317AD	XQ317AD	XQ317AD
97	R312	X	X	X
98	Q304	X	X	X
99	R314	X	X	X
100	R313	X	X	X
101	D305	X	X	X
102	R332	10K	10K	10K
103	R337	10K	10K	X
104	R330	X	X	X
105	R328	X	10K	10K
106	R331	10K	X	X
107	C405-407	X	X	X
108	IC403	X	X	X
109	C442-443	X	X	X
120	D315	X	X	X
121	R472-473	X	X	X
122	R474-475	X	X	X
123	D41-402	X	X	X
124	R476	X	X	X
125	J301-401-402	X	X	X
126	W326-327-328	X	X	X
127	CB303	X	X	X
128	R466-471	X	X	X
129	CB309	0.1	X	X

OPERATION PCB
Interchangeable Parts at Manufacture Stage

Mark	Reference Parts Number	Parts Name
41	0903-304-306-310	HSS104 HSS104 HSS104 HSS104
312-315		HSS104 HSS104 HSS104 HSS104

* All voltage are measured with a 10MΩ DC electric volt meter.
* Components having special characteristics are marked Δ and must be replaced with parts having specifications equal to those originally installed.
* Schematic diagram is subject to change without notice.

■ SCHEMATIC DIAGRAM (RX-V390/R-V501 POWER)

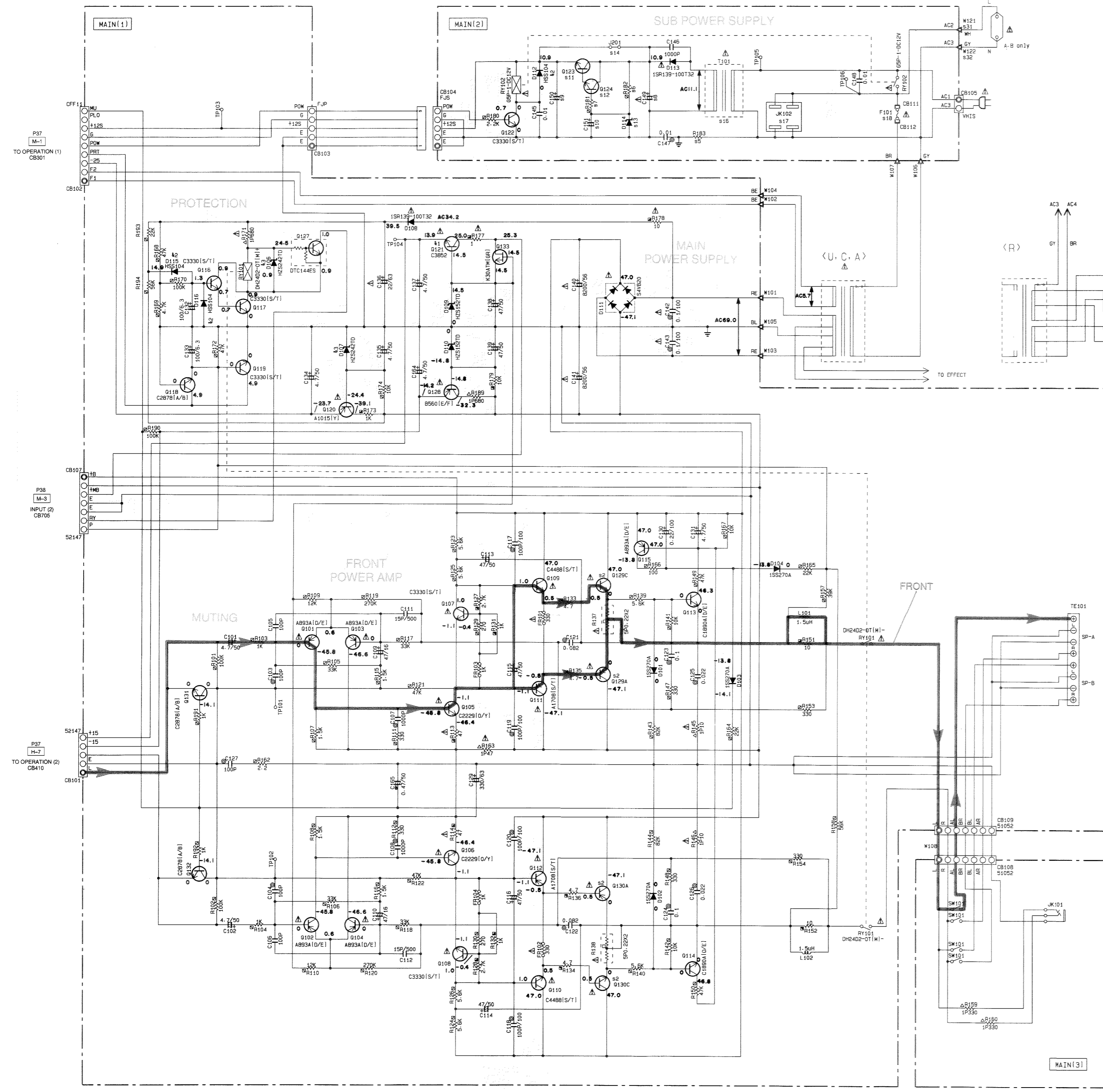

MAIN PCB
Interchangeable Parts at Manufacture-Stage

Mark	Reference Parts Number	Parts Name
41	0121	C4495
42	D112-115-116	HSS104 ISS133 ISS176
43	D106-107	HSS242TD MTJ24-0D

MAIN PCB

	U-C	R	R-V390	R-V501
31				
32	0189-190	A1894(D/P/Y)	A1894(D/P/Y)	A1894(D/P/Y)
33		C4467(D/P/Y)	C4467(D/P/Y)	C4468(D/P/Y)
34	R183	1/2W 2K	X	X
35	R182	X	18K	X
37	R181	X	100	X
38	C149	330/25	330/25	330/25
39	C150	X	100/16	X
40	C151	X	10/16	X
41	D123	X	C4468(D/P/Y)	X
42	D124	X	C1892A(D/E)	X
43	D114	X	HSS1242TD	X
44	J201	0	X	0
45	F103	X	T1-5AL250V	X
46	SW102	X	VAS6180	X
47	C8115-116	X	VP20650	X
48				
49	W111	X	VQ10560	X
50	W112	X	VQ37110	X
51	W113	X	VQ37120	X
52	W114	X	VQ37130	X
53	W115	X	VQ37140	X
54	W116	X	VQ37150	X
55	W121	X	X	VQ10530
56	W122	X	X	VQ10540

CAPACITOR

REMARKS	PARTS NAME
NO MARK	ELECTROLYTIC CAPACITOR
⊖	TANTALUM CAPACITOR
NO MARK	CERAMIC CAPACITOR
⊙	CERAMIC TUBULAR CAPACITOR
⊗	POLYESTER FILM CAPACITOR
○	POLYSTYRENE FILM CAPACITOR
⊕	MICA CAPACITOR
⊗	POLYPROPYLENE FILM CAPACITOR
●	SEMICONDUCTIVE CERAMIC CAPACITOR

RESISTOR

REMARKS	PARTS NAME
NO MARK	CARBON FILM RESISTOR (P=5)
□	CARBON FILM RESISTOR (P=10)
△	METAL OXIDE FILM RESISTOR
▲	METAL FILM RESISTOR
⊖	METAL PLATE RESISTOR
⊕	FIRE PROOF CARBON FILM RESISTOR
⊗	CEMENT MOLDED RESISTOR
⊙	SEMI VARIABLE RESISTOR
■	CHIP RESISTOR

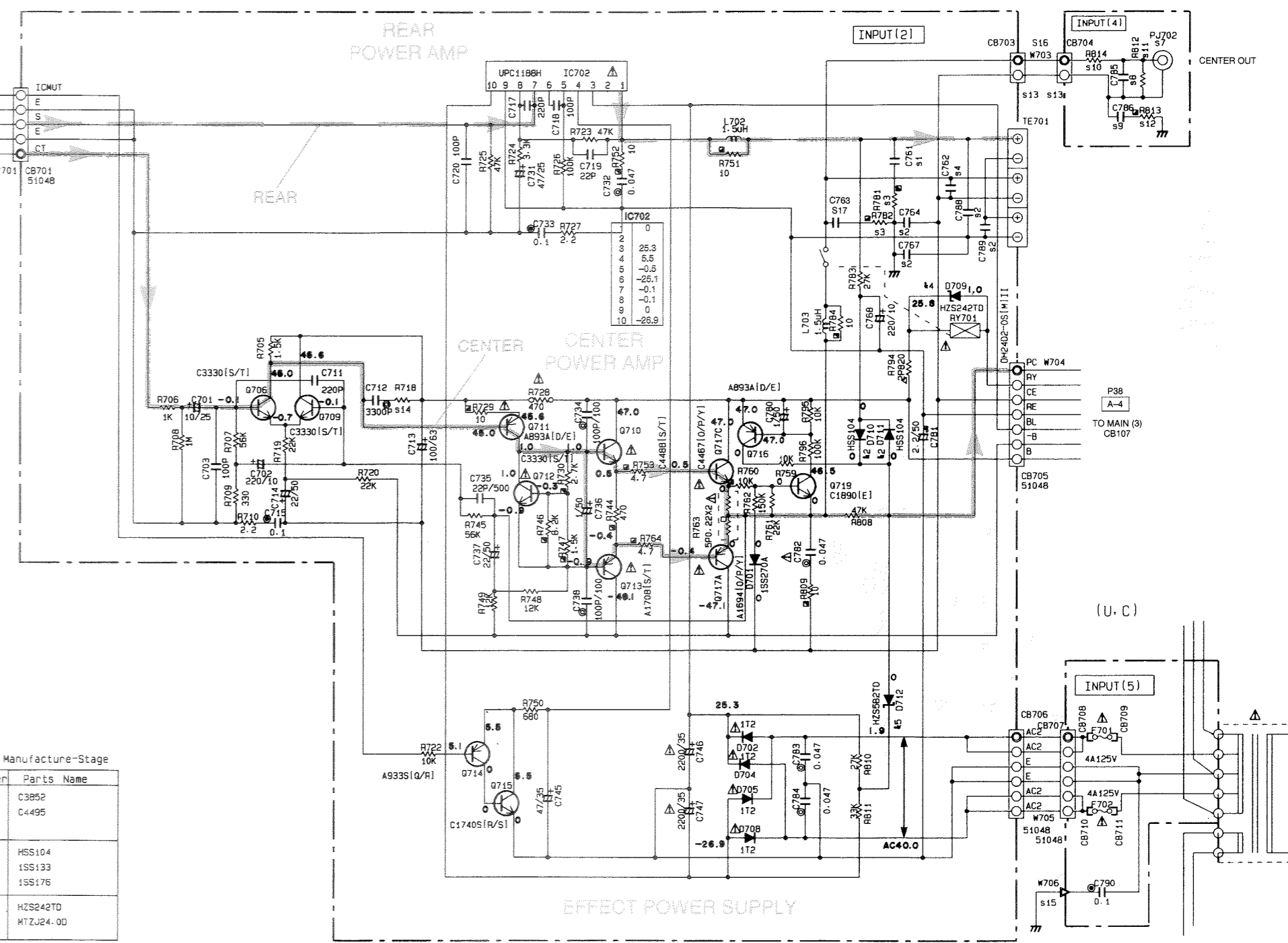

INPUT PCB

	U-C	R-A	R-V	R-G
1	C761-763	X	X	220P
2	C764-767-768-769	X	X	0.01
3	R761-762	X	X	2.2
4	C762	X	X	0.022
5	SW501	X	X	V562050
6	C791	X	X	0.1
7	PJ702	X	X	VK43760
8	C785	X	X	470P
9	C786	X	X	0.1/25
10	R814	X	X	4.7K
11	R812	X	X	470
12	R813	X	X	2.2
13	CB705-704	X	X	V187800
14	R718	1K	1K	680
15	W706	VR84430	X	VR84430
16	W703	X	X	V103780
17	C783	X	X	470P

INPUT PCB
Interchangeable Parts at Manufacture-Stage

Mark	Reference Parts Number	Parts Name
41	1C504	TCA508P UP06058C
42	0501-503-506-710-711	HSS104 ISS133 ISS176
43		
44	D709	HSS242TD MTJ24-0D
45	D712	HSS582TD MTJ24-7C
46	0507	HSS562TD MTJ25-1B

* All voltage are measured with a 10MK/DC electric volt meter.
* Components having special characteristics are marked Δ and must be replaced with parts having specifications equal to those originally installed.
* Schematic diagram is subject to change without notice.

■ SCHEMATIC DIAGRAM (RX-V390RDS POWER)

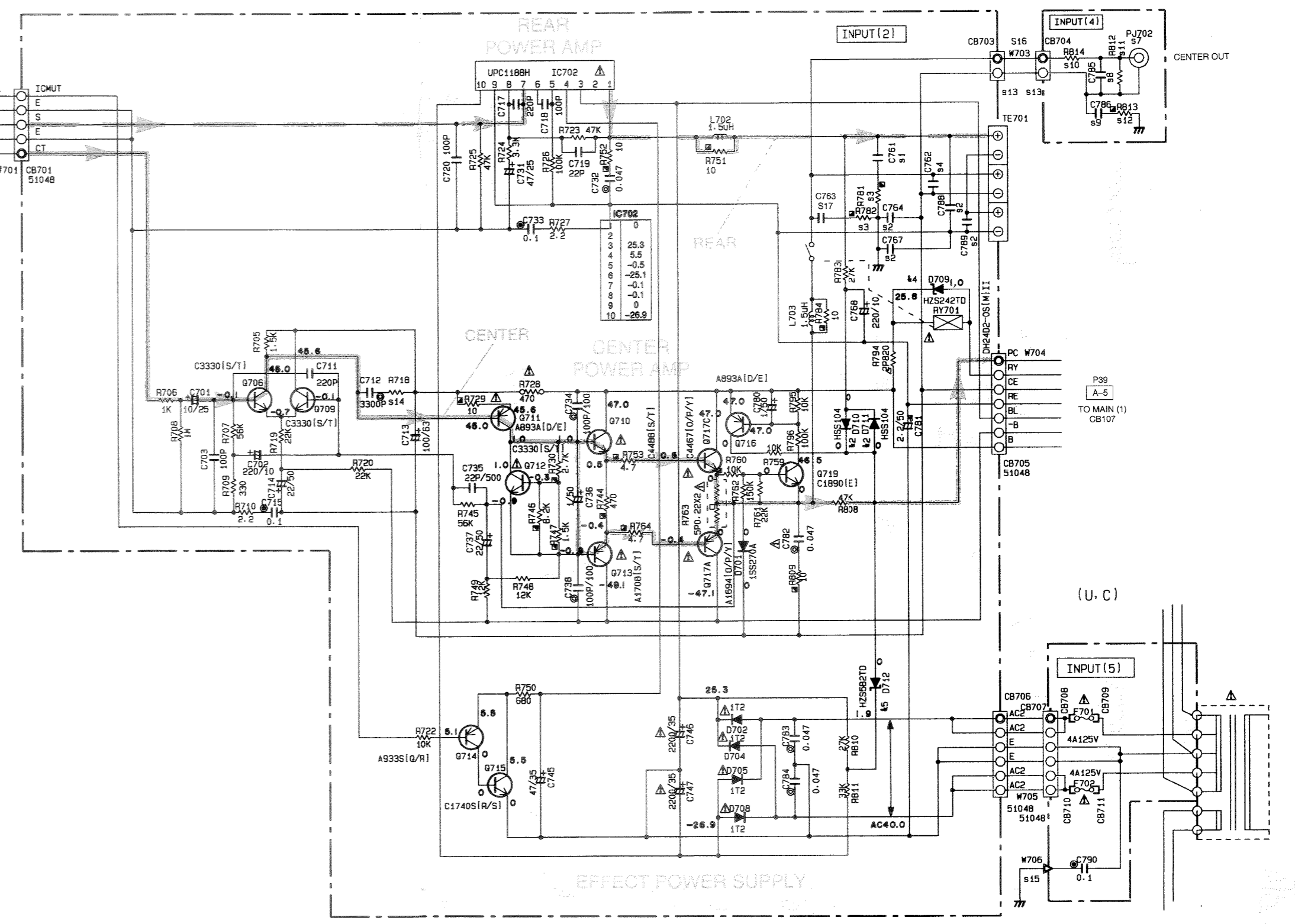
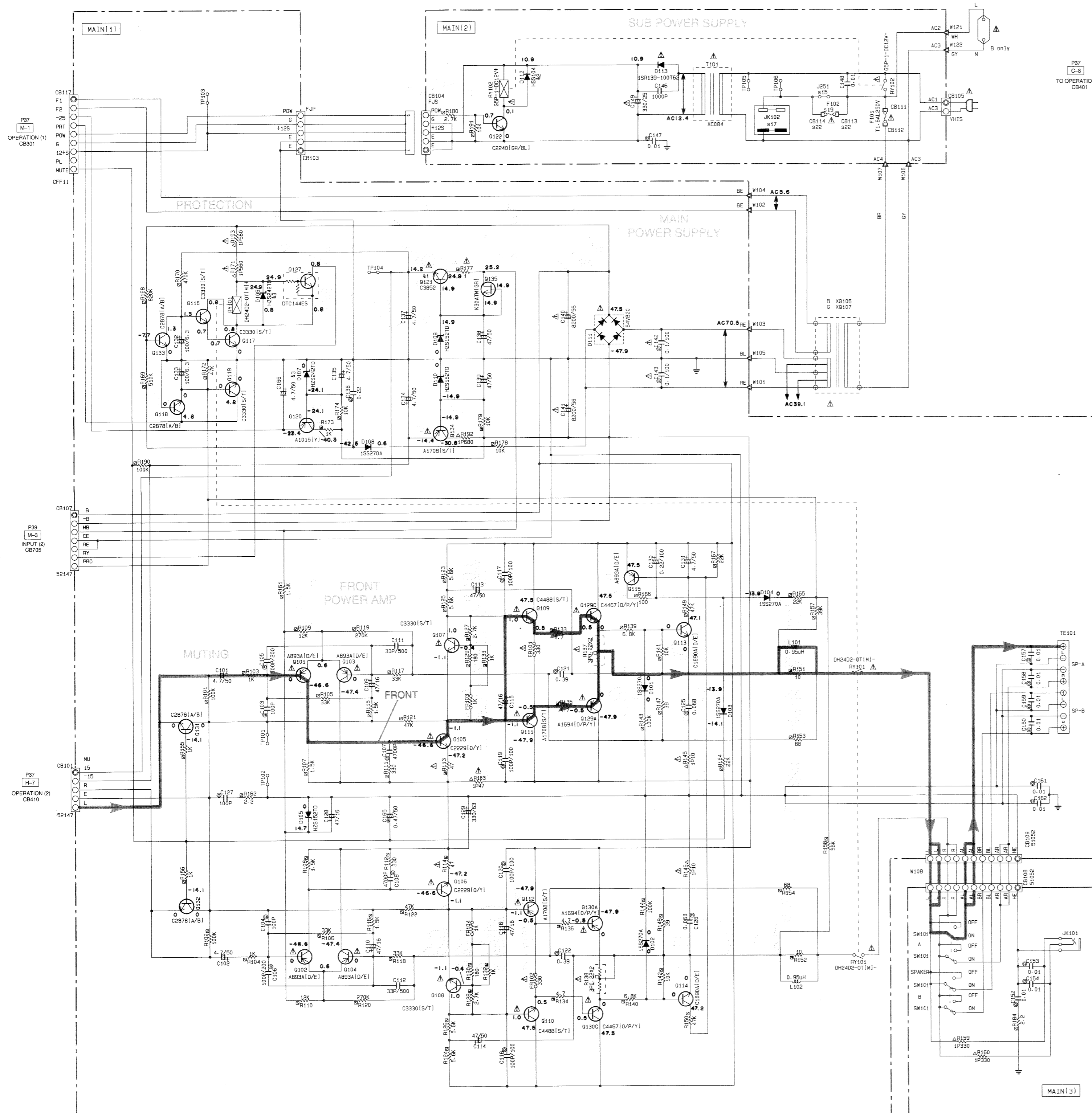

MAIN PCB
Interchangeable Parts at Manufacture-Stage

Mark	Reference	Parts Number	Parts Name
41	G121	29C3952	
42	D112	29C4495	
43	D105-107	H2S2420 M72J24-00	

MAIN PCB

Mark	Reference	Parts Number	Parts Name
S1			
S2			
S4			
S15	J251		X
S17	JK102		VK49070
S19	F102		T2-5A250V KB0030B
S22	CB113-114		VP20650
S24			

INPUT PCB

Mark	Reference	Parts Number	U.C.	R.A.	B.G.
1	C751		X	X	2200P
2	C754-757-788-789		X	X	0-01
3	R781-782		X	X	2-2
4	C762		X	X	0.022
5	SW501		X	X	VS62260
6	C791		X	X	0-1
7	PU702		X	X	VK43750
8	C785		X	X	470P
9	C795		X	X	0.1/25
10	R814		X	X	4.7K
11	R812		X	X	470
12	R813		X	X	2-2
13	CB703-704		X	X	V187800
14	R718		1K	1K	580
15	W706		VRQ4430	X	VRQ4430
16	W705		X	X	V103780
17	C763		X	X	4700P

CAPACITOR

REMARKS	PARTS NAME
NO MARK	ELECTROLYTIC CAPACITOR
⊗	TANTALUM CAPACITOR
NO MARK	CERAMIC CAPACITOR
⊙	CERAMIC TUBULAR CAPACITOR
⊖	POLYESTER FILM CAPACITOR
○	POLYSTYRENE FILM CAPACITOR
Ⓜ	MICA CAPACITOR
⊕	POLYPROPYLENE FILM CAPACITOR
■	SEMICONDUCTIVE CERAMIC CAPACITOR

RESISTOR

REMARKS	PARTS NAME
NO MARK	CARBON FILM RESISTOR (P=5)
⊗	CARBON FILM RESISTOR (P=10)
△	METAL OXIDE FILM RESISTOR
▲	METAL FILM RESISTOR
⊠	METAL PLATE RESISTOR
⊞	FIRE PROOF CARBON FILM RESISTOR
⊚	CEMENT MOLDED RESISTOR
⊙	SEMI-VARIABLE RESISTOR
■	CHIP RESISTOR

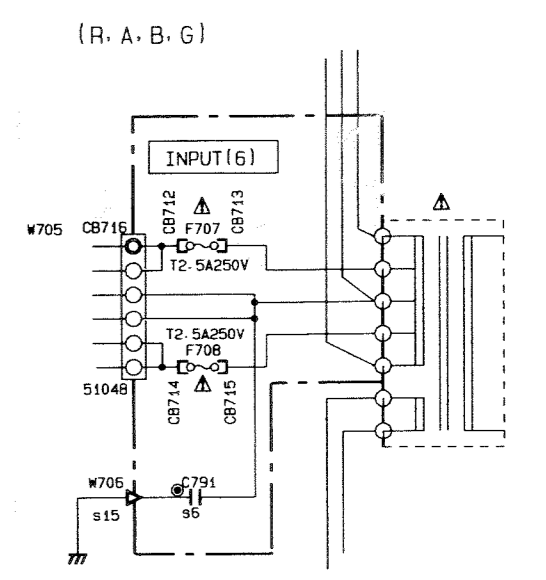

INPUT PCB
Interchangeable Parts at Manufacture-Stage

Mark	Reference	Parts Number	Parts Name
41	IC504		TC4053BP UP04053BC
42	D501-503-506-710-711		HSS104 ISS133 ISS176
43			
44	D705		H2S2420 M72J24-00
45	D712		H2S562TD M72J4-7C
46	D507		H2S5C2TD M72J5-1B

* All voltage are measured with a 10MΩ/DC electric volt meter.
 * Components having special characteristics are marked Δ and must be replaced with parts having specifications equal to those originally installed.
 * Schematic diagram is subject to change without notice.

PARTS LIST

ELECTRICAL PARTS

RX-V390/R-V501/RX-V390RDS

WARNING

Components having special characteristics are marked \triangle and must be replaced with parts having specifications equal to those originally installed.

- Carbon resistors (1/6W or 1/4W) are not included in the ELECTRICAL PARTS List. For the parts No. of the carbon resistors, refer to last page.

ABBREVIATIONS IN THIS LIST ARE AS FOLLOWS :

C.A.EL.CHP	: CHIP ALUMI. ELECTROLYTIC CAP	L.EMIT	: LIGHT EMITTING MODULE
C.CE	: CERAMIC CAP	LED.DSPLY	: LED DISPLAY
C.CE.ARRAY	: CERAMIC CAP ARRAY	LED.INFRD	: LED, INFRARED
C.CE.CHP	: CHIP CERAMIC CAP	MODUL.RF	: MODULATOR, RF
C.CE.ML	: MULTILAYER CERAMIC CAP	PHOT.CPL	: PHOTO COUPLER
C.CE.M.CHP	: CHIP MULTILAYER CERAMIC CAP	PHOT.INTR	: PHOTO INTERRUPTER
C.CE.SAFTY	: RECOGNIZED CERAMIC CAP	PHOT.RFLCT	: PHOTO REFLECTOR
C.CE.TUBLR	: CERAMIC TUBULAR CAP	PIN.TEST	: PIN, TEST POINT
C.CE.SMI	: SEMI CONDUCTIVE CERAMIC CAP	PLST.RIVET	: PLASTIC RIVET
C.EL	: ELECTROLYTIC CAP	R.ARRAY	: RESISTOR ARRAY
C.MICA	: MICA CAP	R.CAR	: CARBON RESISTOR
C.ML.FLM	: MULTILAYER FILM CAP	R.CAR.CHP	: CHIP RESISTOR
C.MP	: METALLIZED PAPER CAP	R.CAR.FP	: FLAME PROOF CARBON RESISTOR
C.MYLAR	: MYLAR FILM CAP	R.FUS	: FUSABLE RESISTOR
C.MYLAR.ML	: MULTILAYER MYLAR FILM CAP	R.MTL.CHP	: CHIP METAL FILM RESISTOR
C.PAPER	: PAPER CAPACITOR	R.MTL.FLM	: METAL FILM RESISTOR
C.PLS	: POLYSTYRENE FILM CAP	R.MTL.OXD	: METAL OXIDE FILM RESISTOR
C.POL	: POLYESTER FILM CAP	R.MTL.PLAT	: METAL PLATE RESISTOR
C.POLY	: POLYETHYLENE FILM CAP	RSNR.CE	: CERAMIC RESONATOR
C.PP	: POLYPROPYLENE FILM CAP	RSNR.CRY	: CRYSTAL RESONATOR
C.TNTL	: TANTALUM CAP	R.TW.CEM	: TWIN CEMENT FIXED RESISTOR
C.TNTL.CHP	: CHIP TANTALUM CAP	R.WW	: WIRE WOUND RESISTOR
C.TRIM	: TRIMMER CAP	SCR.BND.HD	: BIND HEAD B-TITE SCREW
CN	: CONNECTOR	SCR.BW.HD	: BW HEAD TAPPING SCREW
CN.BS.PIN	: CONNECTOR, BASE PIN	SCR.CUP	: CUP TITE SCREW
CN.CANNON	: CONNECTOR, CANNON	SCR.TERM	: SCREW TERMINAL
CN.DIN	: CONNECTOR, DIN	SCR.TR	: SCREW, TRANSISTOR
CN.FLAT	: CONNECTOR, FLAT CABLE	SUPRT.PCB	: SUPPORT, P.C.B.
CN.POST	: CONNECTOR, BASE POST	SURG.PRTCT	: SURGE PROTECTOR
COIL.MX.AM	: COIL, AM MIX	SW.TACT	: TACT SWITCH
COIL.AT.FM	: COIL, FM ANTENNA	SW.LEAF	: LEAF SWITCH
COIL.DT.FM	: COIL, FM DETECT	SW.LEVER	: LEVER SWITCH
COIL.MX.FM	: COIL, FM MIX	SW.MICRO	: MICRO SWITCH
COIL.OUTPT	: OUTPUT COIL	SW.PUSH	: PUSH SWITCH
DIOD.ARRAY	: DIODE ARRAY	SW.RT.ENC	: ROTARY ENCODER
DIODE.BRG	: DIODE BRIDGE	SW.RT.MTR	: ROTARY SWITCH WITH MOTOR
DIODE.CHP	: CHIP DIODE	SW.RT	: ROTARY SWITCH
DIODE.VAR	: VARACTOR DIODE	SW.SLIDE	: SLIDE SWITCH
DIOD.Z.CHP	: CHIP ZENER DIODE	TERM.SP	: SPEAKER TERMINAL
DIODE.ZENR	: ZENER DIODE	TERM.WRAP	: WRAPPING TERMINAL
DSCR.CE	: CERAMIC DISCRIMINATOR	THRMST.CHP	: CHIP THERMISTOR
FER.BEAD	: FERRITE BEADS	TR.CHP	: CHIP TRANSISTOR
FER.CORE	: FERRITE CORE	TR.DGT	: DIGITAL TRANSISTOR
FET.CHP	: CHIP FET	TR.DGT.CHP	: CHIP DIGITAL TRANSISTOR
FL.DSPLY	: FLUORESCENT DISPLAY	TRANS	: TRANSFORMER
FLTR.CE	: CERAMIC FILTER	TRANS.PULS	: PULSE TRANSFORMER
FLTR.COMB	: COMB FILTER MODULE	TRANS.PWR	: POWER TRANSFORMER ASS'y
FLTR.LC.RF	: LC FILTER ,EMI	TUNER.AM	: TUNER PACK, AM
GND.MTL	: GROUND PLATE	TUNER.FM	: TUNER PACK, FM
GND.TERM	: GROUND TERMINAL	TUNER.PK	: FRONT-END TUNER PACK
HOLDER.FUS	: FUSE HOLDER	VR	: ROTARY POTENTIOMETER
IC.PRTCT	: IC PROTECTOR	VR.MTR	: POTENTIOMETER WITH MOTOR
JUMPER.CN	: JUMPER CONNECTOR	VR.SW	: POTENTIOMETER WITH ROTARY SW
JUMPER.TST	: JUMPER, TEST POINT	VR.SLIDE	: SLIDE POTENTIOMETER
L.DTCT	: LIGHT DETECTING MODULE	VR.TRIM	: TRIMMER POTENTIOMETER

Note) Those parts marked with "#" are not included in the P.C.B. ass'y.

P.C.B. TUNER

Schm Ref.	PART NO.	Description		
	VR341800	P. C. B.	TUNER(UC)	
	VR341900	P. C. B.	TUNER(R)	
	VR342000	P. C. B.	TUNER(A)	
	VR384100	P. C. B.	TUNER(BG)	
CB1	VR428700	CN. BS. PIN	2P	
CB2	VR428700	CN. BS. PIN	2P	
* CB4	VQ961800	CN. BS. PIN	15P	
* CB6	VR357600	CN. BS. PIN	5P	
C1	UJ638330	C. EL	330uF	16V
C2	VG280100	C. CE. TUBLR	0.022uF	25V
C3	VJ599000	C. CE. TUBLR	0.047uF	16V
C4	VJ836900	C. EL	10uF	16V
C5	VF467300	C. CE. TUBLR	0.01uF	16V
C6	VF964800	C. EL	100uF	16V
C7	VJ839100	C. EL	1uF	50V
C8	VF467300	C. CE. TUBLR	0.01uF	16V
C9	VF467300	C. CE. TUBLR	0.01uF	16V
C10	VF467300	C. CE. TUBLR	0.01uF	16V
C11	VF467000	C. CE. TUBLR	1000pF	50V
C12	VJ836900	C. EL	10uF	16V
C13	VJ836900	C. EL	10uF	16V
C14	VF467000	C. CE. TUBLR	1000pF	50V
C15	VF467000	C. CE. TUBLR	1000pF	50V
C16	VF466700	C. CE. TUBLR	47pF	50V
C17	VF964800	C. EL	100uF	16V
* C18	UA655100	C. MYLAR	0.1uF	50V
C19	VA761200	C. CE	33pF	50V
C20	VJ836900	C. EL	10uF	16V
C21	VF466800	C. CE. TUBLR	100pF	50V(UCRA)
C22	VJ839200	C. EL	2.2uF	50V
C23	VF467300	C. CE. TUBLR	0.01uF	16V
C24	UM416470	C. EL	4.7uF	50V
C25	UM216330	C. EL	3.3uF	50V
C26	VJ836900	C. EL	10uF	16V
C27	VF467300	C. CE. TUBLR	0.01uF	16V
C28	VA761200	C. CE	33pF	50V
C29	VJ839100	C. EL	1uF	50V
C30	VJ839100	C. EL	1uF	50V
C31	VJ836900	C. EL	10uF	16V
C32	VJ839000	C. EL	0.47uF	50V
C33	VJ839100	C. EL	1uF	50V
* C34	UA654470	C. MYLAR	0.047uF	50V
* C35	VD916400	C. EL	2.2uF	50V
C36	UA652470	C. MYLAR	470pF	50V(A)
C36	UA652680	C. MYLAR	680pF	50V(UCR)
C36	UT452390	C. PP	390pF	100V(G)
C37	UA652470	C. MYLAR	470pF	50V(A)
C37	UA652680	C. MYLAR	680pF	50V(UCR)
C37	UT452390	C. PP	390pF	100V(BG)
C38	VF466900	C. CE. TUBLR	470pF	50V
C39	VJ836900	C. EL	10uF	16V
C40	UM216330	C. EL	3.3uF	50V
C41	UA653390	C. MYLAR	3900pF	50V

* New Parts

Schm Ref.	PART NO.	Description		
C42	VJ836900	C. EL	10uF	16V
C43	UA653390	C. MYLAR	3900pF	50V
C44	UM216330	C. EL	3.3uF	50V
C49	VJ599000	C. CE. TUBLR	0.047uF	16V
C50	VJ836900	C. EL	10uF	16V
C51	VJ836900	C. EL	10uF	16V
C52	UM416470	C. EL	4.7uF	50V
C53	VG280100	C. CE. TUBLR	0.022uF	25V
C54	VF467300	C. CE. TUBLR	0.01uF	16V
C55	VJ836900	C. EL	10uF	16V
C56	VG278600	C. CE. TUBLR	330pF	50V
C57	VG278600	C. CE. TUBLR	330pF	50V
C58	VF467300	C. CE. TUBLR	0.01uF	16V
C59	UM407220	C. EL	22uF	25V
C60	VG279600	C. CE. TUBLR	3300pF	16V
C61	VG279600	C. CE. TUBLR	3300pF	16V
C62	UM416470	C. EL	4.7uF	50V
C63	VJ599000	C. CE. TUBLR	0.047uF	16V
C64	VG279900	C. CE. TUBLR	6800pF	16V
C65	VF467300	C. CE. TUBLR	0.01uF	16V
C66	VJ837200	C. EL	47uF	16V
C67	VJ599000	C. CE. TUBLR	0.047uF	16V
C68	VJ836900	C. EL	10uF	16V
C69	VJ836900	C. EL	10uF	16V
C70	VG278800	C. CE. TUBLR	560pF	50V
C71	VA777400	C. CE	120pF	50V(BG)
D1	VD631600	DIODE	1SS133, 176, HSS104	
D2	VD631600	DIODE	1SS133, 176, HSS104	
D3	VM974500	DIODE. ZENR	HZS6C2TD 6.0V	
Fi1	GG000560	FLTR. CE	SFE10.7MS3GHY-A	
Fi2	GG000560	FLTR. CE	SFE10.7MS3GHY-A	
Fi3	VC219000	FLTR. CE	SFZ450JL3	
IC1	XB760A00	IC	LA1266	
IC2	XB818A00	IC	LM7000N	
IC3	iG158100	IC	LA3401	
IC4	XL801A00	IC	LA2232	
IC5	XL802A00	IC	LC7073	
L1	Vi546100	COIL	220uH	
L2	Vi546100	COIL	220uH	
L3	Vi546100	COIL	220uH	
L6	Vi546100	COIL	220uH	
* PK1	VQ987600	TUNER. PK	EXV-17296G1 (BG)	
* PK1	VR242200	TUNER. PK	EXV-17296G1 (UCRA)	
PK2	Vi027300	COIL. AM		
Q1	iC053540	TR	2SC535 A, B, C	
Q2	VC218900	TR	2SC3330 R, S, T	
Q3	VC218900	TR	2SC3330 R, S, T	
Q4	iC053540	TR	2SC535 A, B, C	
Q5	VC218700	TR	2SA1317 R, S, T	
Q6	VC218900	TR	2SC3330 R, S, T	
Q7	iC1815C0	TR	2SC1815 Y	
Q7	iD040040	TR	2SD400	
Q8	VC218900	TR	2SC3330 R, S, T	

* New Parts

P.C.B. TUNER & MAIN

Schm Ref.	PART NO.	Description	
SW1	VF541200	SW. SLIDE	SSSF11 (R)
T1	VC218600	COIL. DT. FM	10. 7MHz
T2	GE100470	COIL. IF. AM	450KHz
* T3	VQ365700	FLTR. LP	FB-7SG (BG)
* T4	VQ138200	FLTR. LC	19KHz
* T5	VQ138200	FLTR. LC	19KHz
TE1	LA005800	TERM. ANT	YKD31-0215
TP1	LA004120	PIN. TEST	
TP2	LA004120	PIN. TEST	
TP3	VL448600	JUMPER. TST	
VR1	VJ694000	VR. TRIM	B47K Ω
VR2	VJ694000	VR. TRIM	B47K Ω
VR3	VJ693400	VR. TRIM	B4. 7K Ω
XL1	QU003800	RSNR. CRYST	7. 2MHz
XL2	GG000750	RSNR. CE	18. 95MHz
XL3	VP602300	RSNR. CE	19KHz
XL4	VE906000	RSNR. CE	4MHz
*	BB071360	SCR. TERM	8. 3x13
*	VR282500	PLATE	ANT.
*	VS965700	P. C. B.	MAIN (UC) RX-V390
*	VS965800	P. C. B.	MAIN (R)
*	VS965900	P. C. B.	MAIN (A)
*	VS966000	P. C. B.	MAIN (B)
*	VS966100	P. C. B.	MAIN (G)
*	VS996800	P. C. B.	MAIN (UC) R-V501
CB101	VK024900	CN. BS. PIN	5P
* CB102	VR358000	CN. BS. PIN	9P (UCRA)
CB103	VP768100	CN. BS. PIN	5P
CB105	VG879900	CN. BS. PIN	2P
CB107	VK025100	CN. BS. PIN	7P
CB108	VQ584900	CN. BS. PIN	7P (UCRA)
* CB108	VQ585300	CN. BS. PIN	11P (BG)
CB109	VQ584900	CN. BS. PIN	7P (UCRA)
* CB109	VQ585300	CN. BS. PIN	11P (BG)
CB111	VP206500	HOLDER. FUS	EYF-52BC
CB112	VP206500	HOLDER. FUS	EYF-52BC
CB113	VP206500	HOLDER. FUS	EYF-52BC (G)
CB114	VP206500	HOLDER. FUS	EYF-52BC (G)
CB115	VP206500	HOLDER. FUS	EYF-52BC (R)
CB116	VP206500	HOLDER. FUS	EYF-52BC (R)
* CB117	VR358000	CN. BS. PIN	9P (BG)
C101	UM416470	C. EL	4. 7uF 50V (UCRA)
C101	Vi377400	C. EL	4. 7uF 63V (BG)
C102	UM416470	C. EL	4. 7uF 50V (UCRA)
C102	Vi377400	C. EL	4. 7uF 63V (BG)
C103	UA652100	C. MYLAR	100pF 50V
C104	UA652100	C. MYLAR	100pF 50V
C105	FG212100	C. CE	100pF 50V (UCRA)
C105	VK533900	C. PP	100pF 200V (BG)
C106	FG212100	C. CE	100pF 50V (UCRA)

* New Parts

Schm Ref.	PART NO.	Description	
C106	VK533900	C. PP	100pF 200V (BG)
C107	UA653100	C. MYLAR	1000pF 50V (UCRA)
C107	UA653470	C. MYLAR	4700pF 50V (BG)
C108	UA653100	C. MYLAR	1000pF 50V (UCRA)
C108	UA653470	C. MYLAR	4700pF 50V (BG)
C109	VG291200	C. EL	47uF 50V (BG)
C109	VJ837200	C. EL	47uF 16V (UCRA)
C110	VG291200	C. EL	47uF 50V (BG)
C110	VJ837200	C. EL	47uF 16V (UCRA)
* C111	VR516400	C. CE	15p 500V (UCRA)
* C111	VS696700	C. CE	33pF 500V (BG)
* C112	VR516400	C. CE	15p 500V (UCRA)
C112	VS696700	C. CE	33pF 500V (BG)
C113	UJ667470	C. EL	47uF 50V (UCRA)
C113	VG291200	C. EL	47uF 50V (BG)
C114	UJ667470	C. EL	47uF 50V (UCRA)
C114	VG291200	C. EL	47uF 50V (BG)
C115	VE742600	C. EL	47uF 25V (BG)
C115	VG291200	C. EL	47uF 50V (UCRA)
C116	VE742600	C. EL	47uF 25V (BG)
C116	VG291200	C. EL	47uF 50V (UCRA)
* C117	VR325000	C. MYLAR	100pF 100V
* C118	VR325000	C. MYLAR	100pF 100V
* C119	VR325000	C. MYLAR	100pF 100V
* C120	VR325000	C. MYLAR	100pF 100V
C121	UA654820	C. MYLAR	0. 082uF 50V (UCRA)
C121	VK399200	C. MYLAR. ML	0. 39uF 50V (BG)
C122	UA654820	C. MYLAR	0. 082uF 50V (UCRA)
C122	VK399200	C. MYLAR. ML	0. 39uF 50V (BG)
* C123	UA655100	C. MYLAR	0. 1uF 50V
* C124	UA655100	C. MYLAR	0. 1uF 50V
* C125	UA654220	C. MYLAR	0. 022uF 50V (UCRA)
C125	UA654680	C. MYLAR	0. 068uF 50V (BG)
* C126	UA654220	C. MYLAR	0. 022uF 50V (UCRA)
C126	UA654680	C. MYLAR	0. 068uF 50V (BG)
C127	UA652100	C. MYLAR	100pF 50V
C128	VG291200	C. EL	47uF 50V (BG)
* C129	VK182500	C. EL	330uF 63V
C130	UJ895220	C. EL	0. 22uF 100V
C131	UM416470	C. EL	4. 7uF 50V (UCRA)
C131	Vi377400	C. EL	4. 7uF 63V (BG)
C132	VF760000	C. EL	100uF 10V
C133	VF760000	C. EL	100uF 10V
C134	UM416470	C. EL	4. 7uF 50V
C135	UM416470	C. EL	4. 7uF 50V
* C136	UA655220	C. MYLAR	0. 22uF 50V (BG)
* C136	Vi846000	C. EL	22uF 63V (UCRA)
C137	UM416470	C. EL	4. 7uF 50V (UCRA)
C137	Vi377400	C. EL	4. 7uF 63V (BG)
C138	UJ667470	C. EL	47uF 50V (UCRA)
C138	VG291200	C. EL	47uF 50V (BG)
C139	UJ667470	C. EL	47uF 50V (UCRA)
C139	VG291200	C. EL	47uF 50V (BG)

* New Parts

P.C.B. MAIN

Schm Ref.	PART NO.	Description
△ *	C140	VR670100 C. EL 8200uF 56V
△ *	C141	VR670100 C. EL 8200uF 56V
△ *	C142	VR325400 C. MYLAR 0.1uF 100V
△ *	C143	VR325400 C. MYLAR 0.1uF 100V
	C145	FG214100 C. CE 0.01uF 50V
	C146	FG213100 C. CE 1000pF 50V
*	C147	UA654100 C. MYLAR 0.01uF 50V
	C148	Fi514100 C. CE. SAFTY 0.01uF VA-1
△	C149	VG289100 C. EL 330uF 25V(BG)
△ *	C149	VK182500 C. EL 330uF 63V(R)
△	C149	VK457600 C. EL 330uF 25V(UCA)
△	C149	VK457600 C. EL 330uF 25V
	C150	VF964800 C. EL 100uF 16V(R)
	C151	VJ836900 C. EL 10uF 16V(R)
*	C152	UA654100 C. MYLAR 0.01uF 50V(BG)
*	C153	UA654100 C. MYLAR 0.01uF 50V(BG)
*	C154	UA654100 C. MYLAR 0.01uF 50V(BG)
*	C157	UA654100 C. MYLAR 0.01uF 50V(BG)
*	C158	UA654100 C. MYLAR 0.01uF 50V(BG)
*	C159	UA654100 C. MYLAR 0.01uF 50V(BG)
*	C160	UA654100 C. MYLAR 0.01uF 50V(BG)
*	C161	UA654100 C. MYLAR 0.01uF 50V(BG)
*	C162	UA654100 C. MYLAR 0.01uF 50V(BG)
	C164	UM416470 C. EL 4.7uF 50V(UCRA)
*	C165	UK665470 C. EL 0.47uF 50V
	C166	UM416470 C. EL 4.7uF 50V(BG)
	D101	VN008700 DIODE 1SS270A
	D102	VN008700 DIODE 1SS270A
	D103	VN008700 DIODE 1SS270A
	D104	VN008700 DIODE 1SS270A
	D105	VM975800 DIODE. ZENR HZS152TD 15V(BG)
	D106	VM976300 DIODE. ZENR HZS242TD 24V
	D107	VM976300 DIODE. ZENR HZS242TD 24V
△	D108	VH770800 DIODE 1SR139-100(UCRA)
△	D108	VN008700 DIODE 1SS270A(BG)
	D109	VM975800 DIODE. ZENR HZS152TD 15V
	D110	VM975800 DIODE. ZENR HZS152TD 15V
△	D111	iH001090 DIODE. BRG S4VB20 2.6A 200V
	D112	VD631600 DIODE 1SS133, 176, HSS104
△	D113	VH770800 DIODE 1SR139-100(UCRA)
	D113	VH801600 DIODE 1SR139-100(BG)
	D114	VM975500 DIODE. ZENR HZS12A2TD 12V(R)
	D115	VD631600 DIODE 1SS133, 176, (UCRA)
	D116	VD631600 DIODE 1SS133, 176, (UCRA)
△	F101	KB001660 FUSE T1. 60A 250V(ABG)
△ *	F101	VS822900 FUSE T4. 0A 125V(R)
△ *	F101	VS823000 FUSE T5. 0A 125V(UC)
△	F102	KB002980 FUSE T2. 5A 250V(BG)
△	F103	KB001660 FUSE T1. 60A 250V(R)
△	FR101	VK188400 R. FUS 330 Ω 1/4W
△	FR102	VK188400 R. FUS 330 Ω 1/4W
	FR103	VK189000 R. FUS 1K Ω 1/4W
	FR104	VK189000 R. FUS 1K Ω 1/4W

* New Parts

Schm Ref.	PART NO.	Description
	JK101	LB301720 JACK. PHONE
△	JK102	VK480600 OUTLET. AC (UCR)
△	JK102	VK480700 OUTLET. AC (BG)
*	L101	VP575600 COIL 1.5uH(UCRA)
*	L101	VR906600 COIL 0.95uH(BG)
*	L102	VP575600 COIL 1.5uH(UCRA)
*	L102	VR906600 COIL 0.95uH(BG)
△ *	Q101	VP883000 TR 2SA893A D, E
△ *	Q102	VP883000 TR 2SA893A D, E
△ *	Q103	VP883000 TR 2SA893A D, E
△ *	Q104	VP883000 TR 2SA893A D, E
△ *	Q105	VR325600 TR 2SC2229 O, Y
△ *	Q106	VR325600 TR 2SC2229 O, Y
△	Q107	VC218900 TR 2SC3330 R, S, T
△	Q108	VC218900 TR 2SC3330 R, S, T
△ *	Q109	VP872700 TR 2SC4488 S, T
△ *	Q110	VP872700 TR 2SC4488 S, T
△ *	Q111	VP872600 TR 2SA1708 S, T
△ *	Q112	VP872600 TR 2SA1708 S, T
*	Q113	VP883100 TR 2SC1890A D, E
*	Q114	VP883100 TR 2SC1890A D, E
*	Q115	VP883000 TR 2SA893A D, E
	Q116	VC218900 TR 2SC3330 R, S, T
	Q117	VC218900 TR 2SC3330 R, S, T
	Q118	iC287820 TR 2SC2878 A, B
	Q119	VC218900 TR 2SC3330 R, S, T
△	Q120	iA101521 TR 2SA1015 Y
△	Q121	VC938500 TR 2SC3852
	Q122	iC224030 TR 2SC2240 GR, BL (BG)
	Q122	VC218900 TR 2SC3330 R, S(UCRA)
	Q123	VP768300 TR 2SC4466 O, P, Y(R)
*	Q124	VP883100 TR 2SC1890A D, E(R)
	Q127	VG722000 TR. DGT DTC144ES
△	Q128	iB056020 TR 2SB560 E, F(UCRA)
△	Q129A	iX615750 TR 2SA1694:RX-V390/RD
△	Q129C	iX615760 TR 2SC4467:RX-V390/RD
△	Q129A	iX630850 TR 2SA1695:R-V501
△	Q129C	iX630860 TR 2SC4468:R-V501
△	Q130A	iX615750 TR 2SA1694:RX-V390/RD
△	Q130C	iX615760 TR 2SC4467:RX-V390/RD
△	Q130A	iX630850 TR 2SA1695:R-V501
△	Q130C	iX630860 TR 2SC4468:R-V501
	Q131	iC287820 TR 2SC2878 A, B
	Q132	iC287820 TR 2SC2878 A, B
	Q133	iC287820 TR 2SC2878 A, B(BG)
	Q133	iE000020 FET 2SK30ATM GR(UCRA)
△ *	Q134	VP872600 TR 2SA1708 S, T(BG)
	Q135	iE000020 FET 2SK30ATM GR(BG)
△	R113	HV454470 R. CAR. FP 47 Ω 1/4W
△	R114	HV454470 R. CAR. FP 47 Ω 1/4W
	R127	HV456270 R. CAR. FP 2.7K Ω 1/4W
	R128	HV456270 R. CAR. FP 2.7K Ω 1/4W
	R131	HV456100 R. CAR. FP 1K Ω 1/4W

* New Parts

RX-V390/R-V501/RX-V390RDS

P.C.B. MAIN & OPERATION

Schm Ref.	PART NO.	Description		
R132	HV456100	R. CAR. FP	1KΩ	1/4W
R133	HV453470	R. CAR. FP	4.7Ω	1/4W
R134	HV453470	R. CAR. FP	4.7Ω	1/4W
R135	HV453470	R. CAR. FP	4.7Ω	1/4W
R136	HV453470	R. CAR. FP	4.7Ω	1/4W
△*	R137	HZ003780	R. MTL. PLAT	0.22Ω x2 5W(UCRA)
△	R137	VJ695400	R. WW	0.22Ω x2 3W(BG)
△*	R138	HZ003780	R. MTL. PLAT	0.22Ω x2 5W(UCRA)
△	R138	VJ695400	R. WW	0.22Ω x2 3W(BG)
△	R145	HL314100	R. MTL. OXD	10Ω 1W
△	R146	HL314100	R. MTL. OXD	10Ω 1W
	R151	HV454100	R. CAR. FP	10Ω 1/4W
	R152	HV454100	R. CAR. FP	10Ω 1/4W
	R159	HL315330	R. MTL. OXD	330Ω 1W
	R160	HL315330	R. MTL. OXD	330Ω 1W
△	R163	HL314470	R. MTL. OXD	47Ω 1W
△	R171	HL315560	R. MTL. OXD	560Ω 1W(BG)
△	R171	HL315680	R. MTL. OXD	680Ω 1W(UCRA)
	R173	HV456100	R. CAR. FP	1KΩ 1/4W
△	R177	HV453100	R. CAR. FP	1Ω 1/4W
△	R178	HV454100	R. CAR. FP	10Ω 1/4W
	R179	HV457100	R. CAR. FP	10KΩ 1/4W
	R189	HL315680	R. MTL. OXD	680Ω 1W(UCRA)
	R192	HL315680	R. MTL. OXD	680Ω 1W(BG)
△	R193	HL315560	R. MTL. OXD	560Ω 1W(BG)
△	RY101	VK438300	RELAY	DH24D2-OTM-
△	RY102	VH230800	RELAY	G5P-1-DC12V
	SW101	VJ850200	SW. PUSH	PSE021A2KP 2
△	SW102	VA961800	VOLT. SELCT	ESE-37247-F(R)
△	T101	XC082A00	TRANS. PWR	(R)
△	T101	XC083A00	TRANS. PWR	(UC)
△	T101	XC084A00	TRANS. PWR	(AGB)
	TE101	VK506200	TERM. SP	8P(BG)
*	TE101	VS722400	TERM. SP	8P(UCRA)
*	W108	VR759400	CN. FLAT	11P 120mm(BG)
		VJ828000	PIN	IMS A-6024-03E
		BB071360	SCR. TERM	8. 3x13(ABG)
		BB071360	SCR. TERM	8. 3x13
		VJ828000	PIN	IMS A-6024-03E
		VP753100	HEAT. SINK	IC-1625-MML
		BB069510	GND. MTL	No. 6951
		Ei330166	SCR. BND. HD	3x16 FCRM3-BL
*		VS965200	P. C. B.	OPERATION(UC)
*		VS965300	P. C. B.	OPERATION(R)
*		VS965400	P. C. B.	OPERATION(A)
*		VS965600	P. C. B.	OPERATION(BG)
*	CB301	VR361600	CN. BS. PIN	9P
	CB302	VM859600	CN. BS. PIN	15P
	CB303	VQ046900	CN. BS. PIN	5P(BG)
	CB401	VK024900	CN. BS. PIN	5P

* New Parts

Schm Ref.	PART NO.	Description		
*	CB403	VQ963600	CN. BS. PIN	15P
*	CB404	VQ961800	CN. BS. PIN	15P
	CB409	Vi879200	CN. BS. PIN	14P
	CB410	Vi878300	CN. BS. PIN	5P
	C301	VJ836900	C. EL	10uF 16V
	C302	VJ839100	C. EL	1uF 50V
	C303	VJ839100	C. EL	1uF 50V
	C304	VR357400	C. EL	4700uF 5. 5V
	C305	VD930900	C. CE. SMI	0. 1uF 25V
	C306	VH053100	C. CE. TUBLR	0. 1uF 50V
	C307	VF467000	C. CE. TUBLR	1000pF 50V
	C308	VH053100	C. CE. TUBLR	0. 1uF 50V
	C309	VH053100	C. CE. TUBLR	0. 1uF 50V(UC)
	C401	UM416470	C. EL	4. 7uF 50V
	C402	UA652220	C. MYLAR	220pF 50V
	C403	UA652220	C. MYLAR	220pF 50V
	C404	UM416470	C. EL	4. 7uF 50V
	C405	FG212470	C. CE	470pF 50V(BG)
	C406	FG212100	C. CE	100pF 50V
	C407	FG212470	C. CE	470pF 50V(BG)
	C408	VG722100	C. EL	1uF 50V
	C409	UM417100	C. EL	10uF 50V
	C410	UM417100	C. EL	10uF 50V
	C411	VJ837200	C. EL	47uF 16V
	C412	VJ839000	C. EL	0. 47uF 50V
	C413	UA652100	C. MYLAR	100pF 50V
	C414	UA652100	C. MYLAR	100pF 50V
	C415	UM416470	C. EL	4. 7uF 50V
	C416	UM416470	C. EL	4. 7uF 50V
	C417	UA652100	C. MYLAR	100pF 50V
	C418	UA652100	C. MYLAR	100pF 50V
	C419	VJ839000	C. EL	0. 47uF 50V
	C420	VJ837200	C. EL	47uF 16V
	C421	UM407220	C. EL	22uF 25V
	C422	FG251220	C. CE	22pF 50V
	C423	FG251220	C. CE	22pF 50V
	C425	UM407220	C. EL	22uF 25V
*	C426	UA655120	C. MYLAR	0. 12uF 50V
*	C427	UA654330	C. MYLAR	0. 033uF 50V
*	C428	UA654330	C. MYLAR	0. 033uF 50V
*	C429	UA655120	C. MYLAR	0. 12uF 50V
	C430	UA655330	C. MYLAR	0. 33uF 50V
	C440	UM417100	C. EL	10uF 50V
	C441	UM417100	C. EL	10uF 50V
*	C442	UA655100	C. MYLAR	0. 1uF 50V(BG)
*	C443	UA655100	C. MYLAR	0. 1uF 50V(BG)
	D301	VM974600	DIODE. ZENR	HZS7A2TD 7. 0V
	D302	VM974200	DIODE. ZENR	HZS5C2TD 5. 0V
	D303	VD631600	DIODE	1SS133, 176, HSS104
	D304	VD631600	DIODE	1SS133, 176, HSS104
	D305	VP594000	LED(re)	SLR-305VCA47(BG)
	D306	VD631600	DIODE	1SS133, 176, HSS104
	D307	VD631600	DIODE	1SS133, 176, HSS104

* New Parts

RX-V390/R-V501/RX-V390RDS

P.C.B. OPERATION & INPUT

Schm Ref.	PART NO.	Description
D308	VD631600	DIODE 1SS133, 176, HSS104
D309	VD631600	DIODE 1SS133, 176, HSS104
D310	VD631600	DIODE 1SS133, 176, HSS104
D311	VM974300	DIODE. ZENR HZS6A2TD 6.0V
D312	VD631600	DIODE 1SS133, 176, HSS104
D313	VD631600	DIODE 1SS133, 176, HSS104
D314	VD631600	DIODE 1SS133, 176, HSS104
D315	VD631600	DIODE 1SS133, 176, (BG)
IC301	XQ317A00	IC M38114M8-114 (UCRA)
IC301	XQ317B00	IC M38114M8-XXXSP (BG)
IC401	XM356A00	IC NJM2068LD
IC402	XM356A00	IC NJM2068LD
IC403	XM356A00	IC NJM2068LD (BG)
IC403	XM356A00	IC NJM2068LD
Q301	iC174020	TR 2SC1740S R, S
Q302	iA093320	TR 2SA933S Q, R
Q303	iC174020	TR 2SC1740S R, S
Q304	iC174020	TR 2SC1740S R, S (BG)
Q305	VD678500	TR. DGT DTA114ES
Q401	iC287820	TR 2SC2878 A, B (BG)
Q402	iC287820	TR 2SC2878 A, B (BG)
Q403	iC287820	TR 2SC2878 A, B
Q404	iC287820	TR 2SC2878 A, B
R419	HV454220	R. CAR. FP 22Ω 1/4W
R430	HV454220	R. CAR. FP 22Ω 1/4W
R442	HV454220	R. CAR. FP 22Ω 1/4W
R443	HV454220	R. CAR. FP 22Ω 1/4W
SW301	VG392900	SW. TACT SKHVAA
SW302	VG392900	SW. TACT SKHVAA
SW303	VG392900	SW. TACT SKHVAA
SW304	VG392900	SW. TACT SKHVAA
SW305	VG392900	SW. TACT SKHVAA
SW306	VG392900	SW. TACT SKHVAA
SW307	VG392900	SW. TACT SKHVAA
SW308	VG392900	SW. TACT SKHVAA
SW309	VG392900	SW. TACT SKHVAA
SW310	VG392900	SW. TACT SKHVAA
SW311	VG392900	SW. TACT SKHVAA
SW312	VG392900	SW. TACT SKHVAA
SW313	VG392900	SW. TACT SKHVAA
SW314	VG392900	SW. TACT SKHVAA
SW315	VG392900	SW. TACT SKHVAA
SW316	VG392900	SW. TACT SKHVAA
SW317	VG392900	SW. TACT SKHVAA
SW318	VG392900	SW. TACT SKHVAA
SW319	VG392900	SW. TACT SKHVAA
SW320	VG392900	SW. TACT SKHVAA
SW321	VG392900	SW. TACT SKHVAA
SW322	VG392900	SW. TACT SKHVAA
SW323	VG392900	SW. TACT SKHVAA
SW324	VG392900	SW. TACT SKHVAA
SW325	VG392900	SW. TACT SKHVAA
SW326	VG392900	SW. TACT SKHVAA (BG)

* New Parts

Schm Ref.	PART NO.	Description
SW327	VG392900	SW. TACT SKHVAA (BG)
SW328	VG392900	SW. TACT SKHVAA (BG)
SW329	VG392900	SW. TACT SKHVAA
* U301	VR023400	L. DETCT SPS-424-1
* V301	VS576000	FL. DSPLY 12-MT-64GK
* VR401	VS521500	VR. MTR A100KΩ X4
* VR402	VP741800	VR B20KΩ
* VR403	VP741900	VR G25KΩ
* VR404	VP742000	VR MN50KΩ
VR416	VR043900	VR A10KΩ
VR417	VR043900	VR A10KΩ
XL301	VB759100	RSNR. CE 4MHz
	VJ828000	PIN IMSA-6024-03E
	VQ859800	SHEET. FL
* VR380100	VR380100	SPACER FL-T6
* VS966200	VS966200	P. C. B. INPUT (UC)
* VS966300	VS966300	P. C. B. INPUT (R)
* VS966400	VS966400	P. C. B. INPUT (A)
* VS966600	VS966600	P. C. B. INPUT (G)
CB501	VK025800	CN. BS. PIN 14P
* CB502	VQ963600	CN. BS. PIN 15P
* CB503	VR358600	CN. BS. PIN 15P
CB504	VK024600	CN. BS. PIN 2P
CB701	Vi878300	CN. BS. PIN 5P
CB702	Vi878000	CN. BS. PIN 2P
CB703	Vi878000	CN. BS. PIN 2P
CB703	Vi878000	CN. BS. PIN 2P (BG)
CB704	Vi878000	CN. BS. PIN 2P
CB704	Vi878000	CN. BS. PIN 2P (BG)
CB705	Vi878500	CN. BS. PIN 7P
CB706	Vi878400	CN. BS. PIN 6P
CB707	Vi878400	CN. BS. PIN 6P (UC)
CB708	VP206500	HOLDER. FUS EYF-52BC (UC)
CB709	VP206500	HOLDER. FUS EYF-52BC (UC)
CB710	VP206500	HOLDER. FUS EYF-52BC (UC)
CB711	VP206500	HOLDER. FUS EYF-52BC (UC)
CB712	VP206500	HOLDER. FUS EYF-52BC (RABG)
CB713	VP206500	HOLDER. FUS EYF-52BC (RABG)
CB714	VP206500	HOLDER. FUS EYF-52BC (RABG)
CB715	VP206500	HOLDER. FUS EYF-52BC (RABG)
CB716	Vi878400	CN. BS. PIN 6P (RABG)
C503	UA652220	C. MYLAR 220pF 50V
C504	VE117600	C. EL 220uF 10V
C505	UA653910	C. MYLAR 9100pF 50V
C506	UA653910	C. MYLAR 9100pF 50V
C507	VE117600	C. EL 220uF 10V
C508	UA652220	C. MYLAR 220pF 50V
C509	UA652220	C. MYLAR 220pF 50V
C510	UA652220	C. MYLAR 220pF 50V
C511	VG278400	C. CE. TUBLR 220pF 50V

* New Parts

RX-V390/R-V501/RX-V390RDS

P.C.B. INPUT

Schm Ref.	PART NO.	Description		
C512	VG278400	C. CE. TUBLR	220pF	50V
C513	VG278400	C. CE. TUBLR	220pF	50V
C514	VG278400	C. CE. TUBLR	220pF	50V
C515	VG278400	C. CE. TUBLR	220pF	50V
C516	VG278400	C. CE. TUBLR	220pF	50V
C517	VG278400	C. CE. TUBLR	220pF	50V
C518	VG278400	C. CE. TUBLR	220pF	50V
C519	VG278400	C. CE. TUBLR	220pF	50V
C520	VG278400	C. CE. TUBLR	220pF	50V
C521	VJ839200	C. EL	2. 2uF	50V
C522	VJ837200	C. EL	47uF	16V
* C523	UA654330	C. MYLAR	0. 033uF	50V
* C524	UA654330	C. MYLAR	0. 033uF	50V
C525	VJ839200	C. EL	2. 2uF	50V
C526	Vi377400	C. EL	4. 7uF	63V
C527	Vi377400	C. EL	4. 7uF	63V
C528	VF467300	C. CE. TUBLR	0. 01uF	16V
C529	VJ837200	C. EL	47uF	16V
C530	VG290900	C. EL	10uF	50V
C531	VG290900	C. EL	10uF	50V
C532	VJ837200	C. EL	47uF	16V
C533	VJ837200	C. EL	47uF	16V
C534	UM417100	C. EL	10uF	50V
C535	UM417100	C. EL	10uF	50V
C536	UJ648220	C. EL	220uF	25V
C537	VJ839100	C. EL	1uF	50V
C538	UM416470	C. EL	4. 7uF	50V
C539	UM416470	C. EL	4. 7uF	50V
C541	VF467300	C. CE. TUBLR	0. 01uF	16V
* C542	UA654220	C. MYLAR	0. 022uF	50V
* C543	UA654470	C. MYLAR	0. 047uF	50V
C544	UJ648220	C. EL	220uF	25V
C545	UA652680	C. MYLAR	680pF	50V
C546	UM417100	C. EL	10uF	50V
C547	UM417100	C. EL	10uF	50V
C548	UM417100	C. EL	10uF	50V
C549	UM417100	C. EL	10uF	50V
C550	VJ839100	C. EL	1uF	50V
C551	UM417100	C. EL	10uF	50V
C552	UA655470	C. MYLAR	0. 47uF	50V
C553	UJ667470	C. EL	47uF	50V
* C554	UA655100	C. MYLAR	0. 1uF	50V
* C555	UA655100	C. MYLAR	0. 1uF	50V
* C556	UA655100	C. MYLAR	0. 1uF	50V
* C557	UA655100	C. MYLAR	0. 1uF	50V
C558	VJ839000	C. EL	0. 47uF	50V
C559	VJ839000	C. EL	0. 47uF	50V
C560	UM416470	C. EL	4. 7uF	50V
C561	UM416470	C. EL	4. 7uF	50V
C562	VJ839000	C. EL	0. 47uF	50V
C563	VJ839000	C. EL	0. 47uF	50V
C564	UM416470	C. EL	4. 7uF	50V
C565	UM416470	C. EL	4. 7uF	50V

* New Parts

Schm Ref.	PART NO.	Description		
* C566	UA655150	C. MYLAR	0. 15uF	50V
* C567	UA655150	C. MYLAR	0. 15uF	50V
C568	UM216330	C. EL	3. 3uF	50V
C569	UM216330	C. EL	3. 3uF	50V
* C570	UA655150	C. MYLAR	0. 15uF	50V
* C571	UA655150	C. MYLAR	0. 15uF	50V
C572	UA652470	C. MYLAR	470pF	50V
C573	UM417100	C. EL	10uF	50V
C574	FG212100	C. CE	100pF	50V
* C575	UA653150	C. MYLAR	1500pF	50V
C576	UA652560	C. MYLAR	560pF	50V
C577	FG212100	C. CE	100pF	50V
C578	UM417100	C. EL	10uF	50V
C579	UM417100	C. EL	10uF	50V
C580	VJ839200	C. EL	2. 2uF	50V
C581	UM417100	C. EL	10uF	50V
* C582	UA654100	C. MYLAR	0. 01uF	50V
C583	UM417100	C. EL	10uF	50V
C584	UJ648220	C. EL	220uF	25V
C585	VF467100	C. CE. TUBLR	4700pF	16V
C586	VD930900	C. CE. SMI	0. 1uF	25V
* C587	UA653680	C. MYLAR	6800pF	50V
C588	VD930900	C. CE. SMI	0. 1uF	25V
C589	UJ648220	C. EL	220uF	25V
* C590	UA654330	C. MYLAR	0. 033uF	50V
* C591	UA653150	C. MYLAR	1500pF	50V
* C592	UA654330	C. MYLAR	0. 033uF	50V
C593	VJ839100	C. EL	1uF	50V
C594	UM417100	C. EL	10uF	50V
C595	UM417100	C. EL	10uF	50V
C596	UM417100	C. EL	10uF	50V
C597	VJ839200	C. EL	2. 2uF	50V
C598	UM417100	C. EL	10uF	50V
C599	VF637900	C. EL	1000uF	10V
C600	VJ836900	C. EL	10uF	16V
C601	VJ837200	C. EL	47uF	16V
C602	VJ839200	C. EL	2. 2uF	50V
C604	VG278600	C. CE. TUBLR	330pF	50V
C605	VG278600	C. CE. TUBLR	330pF	50V
C606	VH053100	C. CE. TUBLR	0. 1uF	50V
C607	VF467300	C. CE. TUBLR	0. 01uF	16V
C608	VF964800	C. EL	100uF	16V
C701	UM417100	C. EL	10uF	50V
C702	VE117600	C. EL	220uF	10V
C703	FG212100	C. CE	100pF	50V
C704	VJ836900	C. EL	10uF	16V
C705	VD930900	C. CE. SMI	0. 1uF	25V
C706	VJ837200	C. EL	47uF	16V
C707	VJ836900	C. EL	10uF	16V
C708	VF637900	C. EL	1000uF	10V
C709	FG251220	C. CE	22pF	50V
C710	VF637900	C. EL	1000uF	10V
C711	FG212220	C. CE	220pF	50V

* New Parts

P.C.B. INPUT

Schm Ref.	PART NO.	Description
* C712	UA253330	C. MYLAR 3300pF 50V
C713	UH178100	C. EL 100uF 63V
C714	Ui367220	C. EL 22uF 50V
C715	VH053100	C. CE. TUBLR 0.1uF 50V
C716	UJ638470	C. EL 470uF 16V
C717	FG212220	C. CE 220pF 50V
C718	FG212100	C. CE 100pF 50V
C719	FG251220	C. CE 22pF 50V
C720	FG212100	C. CE 100pF 50V
C731	UJ667470	C. EL 47uF 50V
* C732	UA654470	C. MYLAR 0.047uF 50V
C733	VH053100	C. CE. TUBLR 0.1uF 50V
* C734	VR325000	C. MYLAR 100pF 100V
C735	FH611220	C. CE 22pF 500V
C736	VJ839100	C. EL 1uF 50V
C737	Ui367220	C. EL 22uF 50V
* C738	VR325000	C. MYLAR 100pF 100V
C745	UJ667470	C. EL 47uF 50V
△ C746	VG289900	C. EL 2200uF 35V
△ C747	VG289900	C. EL 2200uF 35V
C761	FG413220	C. CE 2200pF 50V (BG)
C762	FG244220	C. CE 0.022uF 50V (BG)
C763	FG213470	C. CE 4700pF 50V (BG)
C764	FG214100	C. CE 0.01uF 50V (BG)
C767	FG214100	C. CE 0.01uF 50V (BG)
C768	VE117600	C. EL 220uF 10V
C780	VJ839100	C. EL 1uF 50V
* C781	VD916400	C. EL 2.2uF 50V
* C782	UA654470	C. MYLAR 0.047uF 50V
* C783	UA654470	C. MYLAR 0.047uF 50V
* C784	UA654470	C. MYLAR 0.047uF 50V
C785	FG212470	C. CE 470pF 50V (BG)
C786	VD930900	C. CE. SMI 0.1uF 25V (BG)
C788	FG214100	C. CE 0.01uF 50V (BG)
C789	FG214100	C. CE 0.01uF 50V (BG)
C790	VH053100	C. CE. TUBLR 0.1uF 50V (UC)
C791	VH053100	C. CE. TUBLR 0.1uF 50V (BG)
D501	VD631600	DIODE 1SS133, 176, HSS104
D502	VD631600	DIODE 1SS133, 176, HSS104
D503	VD631600	DIODE 1SS133, 176, HSS104
D504	VM975100	DIODE. ZENR HZS9C2TD 9.0V
D505	VM975500	DIODE. ZENR HZS12A2TD 12V
D506	VD631600	DIODE 1SS133, 176, HSS104
D507	VM974200	DIODE. ZENR HZS5C2TD 5.0V
△ D701	VN008700	DIODE 1SS270A
△* D702	VS997800	DIODE 1T2
△* D704	VS997800	DIODE 1T2
△* D705	VS997800	DIODE 1T2
△* D708	VS997800	DIODE 1T2
D709	VM976300	DIODE. ZENR HZS242TD 24V
D710	VD631600	DIODE 1SS133, 176, HSS104
D711	VD631600	DIODE 1SS133, 176, HSS104
D712	VM974100	DIODE. ZENR HZS5B2TD 5.0V

* New Parts

Schm Ref.	PART NO.	Description
△* F701	VS822900	FUSE T4.0A 125V (UC)
△* F702	VS822900	FUSE T4.0A 125V (UC)
△ F707	KB000690	FUSE T2.5A 250V (RABG)
△ F708	KB000690	FUSE T2.5A 250V (RABG)
IC501	XM356A00	IC NJM2068LD
* IC502	XN588A00	IC NJU7313
IC503	XA987001	IC NJM2068D
IC504	iG055100	IC TC4053BP
* IC505	XP748A00	IC LA2785
* IC506	XP749A00	IC LV1010
IC507	XA987001	IC NJM2068D
* IC508	XP265A00	IC BU2090
IC509	XF494A00	IC LB1641
* IC510	XQ084A00	IC AN78N09
* IC701	XQ164A00	IC BA7612N
△ IC702	iG102700	IC uPC1188H
* L702	VP575600	COIL 1.5uH
* L703	WP575600	COIL 1.5uH
PJ501	VN308700	JACK. PIN 6P
* PJ502	VT029000	JACK. PIN 4P
* PJ503	VT029000	JACK. PIN 4P
PJ701	VM750500	JACK. PIN 4P
PJ702	VK437600	JACK. PIN 1P (BG)
Q501	iD043820	TR 2SD438 E, F
Q502	VD678500	TR. DGT DTA114ES
Q503	VD678500	TR. DGT DTA114ES
Q706	VC218900	TR 2SC3330 R, S, T
Q707	iA101521	TR 2SA1015 Y
Q708	iC1815C0	TR 2SC1815 Y
Q709	VC218900	TR 2SC3330 R, S, T
△* Q710	VP872700	TR 2SC4488 S, T
△* Q711	VP883000	TR 2SA893A D, E
△ Q712	VC218900	TR 2SC3330 R, S, T
△* Q713	VP872600	TR 2SA1708 S, T
Q714	iA093320	TR 2SA933S Q, R
Q715	iC174020	TR 2SC1740S R, S
* Q716	VP883000	TR 2SA893A D, E
△ Q717A	iX615750	TR 2SA1694 O, P, Y
△ Q717C	iX615760	TR 2SC4467 O, P, Y
* Q719	VP882900	TR 2SC1890 E
R549	HV455100	R. CAR. FP 100 Ω 1/4W
R550	HV455100	R. CAR. FP 100 Ω 1/4W
R564	HV456560	R. CAR. FP 5.6K Ω 1/4W
* R576	HL314330	R. MTL. OXD 33 Ω 1W
R578	HV453470	R. CAR. FP 4.7 Ω 1/4W
R597	HV454100	R. CAR. FP 10 Ω 1/4W
R598	HV454100	R. CAR. FP 10 Ω 1/4W
R721	HV454470	R. CAR. FP 47 Ω 1/4W
△ R728	VK188600	R. FUS 470 Ω 1/4W
R729	HV454100	R. CAR. FP 10 Ω 1/4W
R730	HV456270	R. CAR. FP 2.7K Ω 1/4W
R744	HV455470	R. CAR. FP 470 Ω 1/4W
R746	HV456820	R. CAR. FP 8.2K Ω 1/4W

* New Parts

RX-V390/R-V501/RX-V390RDS

P.C.B. INPUT

Schm Ref.	PART NO.	Description		
R747	HV456150	R. CAR. FP	1.5K Ω	1/4W
R751	HV454100	R. CAR. FP	10 Ω	1/4W
R752	HV454100	R. CAR. FP	10 Ω	1/4W
R753	HV453470	R. CAR. FP	4.7 Ω	1/4W
R760	HV457100	R. CAR. FP	10K Ω	1/4W
Δ *	R763 HZ003780	R. MTL. PLAT	0.22 Ω +0.22	5W
	R764 HV453470	R. CAR. FP	4.7 Ω	1/4W
	R781 HV453220	R. CAR. FP	2.2 Ω	1/4W
	R781 HV453220	R. CAR. FP	2.2 Ω	1/4W
	R782 HV453220	R. CAR. FP	2.2 Ω	1/4W(BG)
	R784 HV454100	R. CAR. FP	10 Ω	1/4W
	R794 HL425820	R. MTL. OXD	820 Ω	2W
	R809 HV454100	R. CAR. FP	10 Ω	1/4W
	R813 HV453220	R. CAR. FP	2.2 Ω	1/4W(BG)
Δ	RY701 VS533600	RELAY	DC DH24D2-OSII	
*	SW501 VS602600	SW. SLIDE	SS070-P022 A(BG)	
*	TE701 VS349400	TERM. SP	6P	
	XL501 VE222400	RSNR. CE	8MHz	
	VJ828000	PIN	IMSA-6024-03E	
*	VR435100	PLATE	W16	
	BB071360	SCR. TERM	8.3x13(BG)	

* New Parts

A

B

C

D

E

RX-V390/R-V501/RX-V390RDS

EXPLODED VIEW

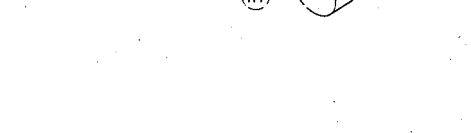
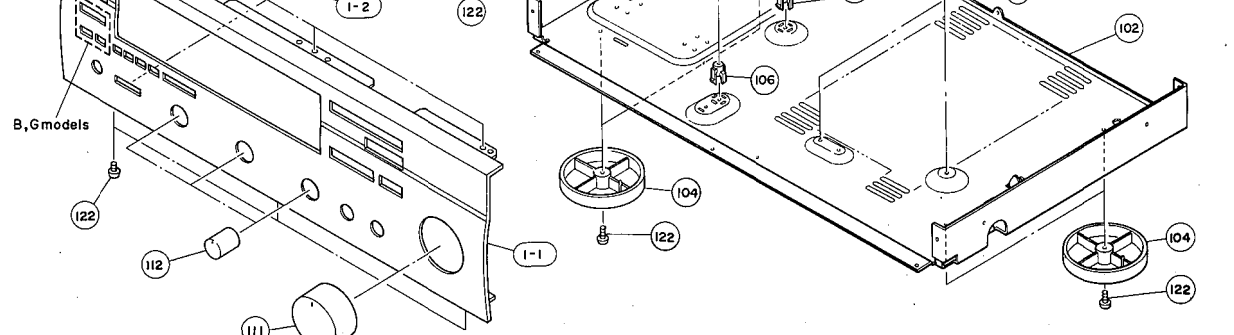
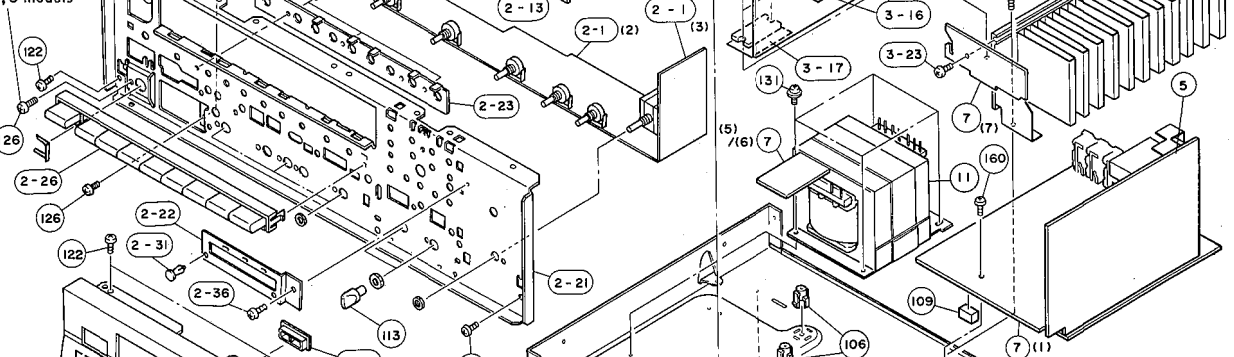
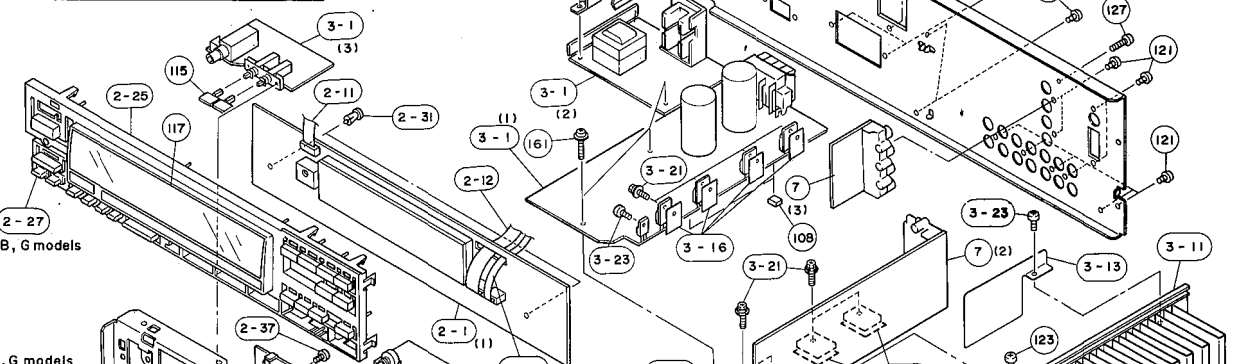
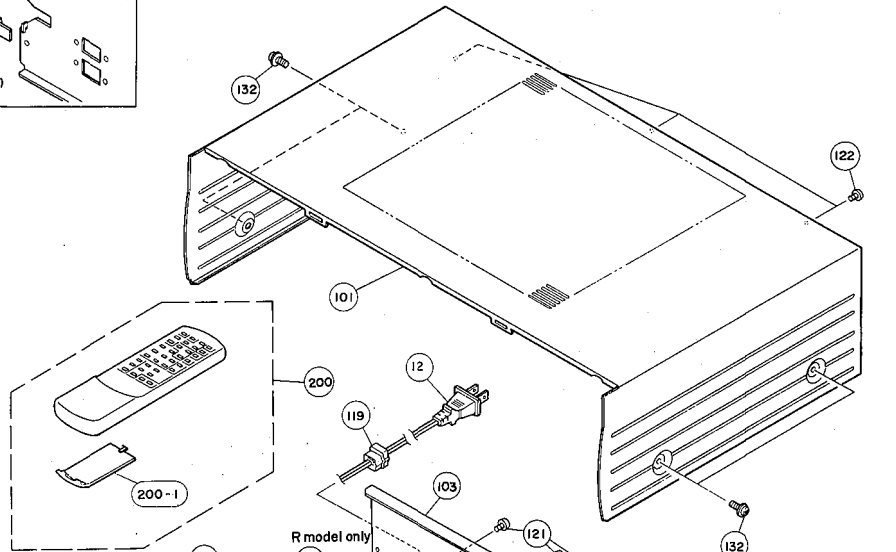
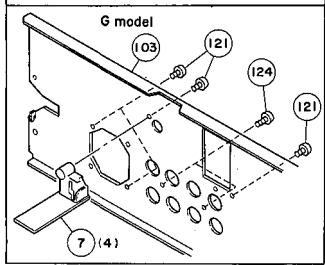
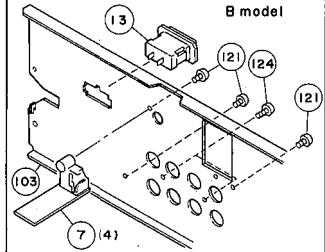
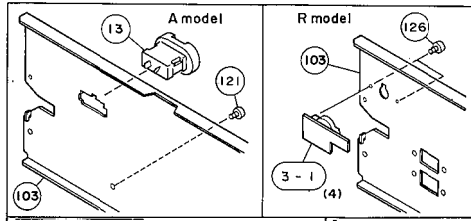

1
2
3
4
5
6
7

MECHANICAL PARTS

Ref. No.	PART NO.	Description	Remarks	Markets
* 1-1	VS789700	FRONT PANEL	RX-V390	(UCRA)
* 1-1	VS789800	FRONT PANEL	RX-V390RDS BL	(BG)
* 1-1	VS789900	FRONT PANEL	RX-V390RDS TI	
* 1-1	VS790000	FRONT PANEL	R-V501	
* 1-2	VQ793400	BUTTON GUIDE	BL	
* 1-2	VQ793500	BUTTON GUIDE	TI	
* 2-1	VS965200	P.C.B. ASS'Y	OPERATION	(UC)
* 2-1	VS965300	P.C.B. ASS'Y	OPERATION	(R)
* 2-1	VS965400	P.C.B. ASS'Y	OPERATION	(A)
* 2-1	VS965600	P.C.B. ASS'Y	OPERATION	(BG)
* 2-11	VR413500	CONNECTOR, FLAT CABLE	9P 200mm	
* 2-12	VT028600	CONNECTOR, FLAT CABLE	15P 300mm	
* 2-13	VT269700	CONNECTOR, FLAT CABLE	5P 260mm	(BG)
* 2-21	VS199600	SUB CHASSIS		
* 2-22	VS906800	HOLDER		
* 2-23	VT305900	SUPPORT, T		
* 2-25	VS864300	BUTTON, CASE	BL	
* 2-25	VS864400	BUTTON, CASE	TI	
* 2-26	VS003500	BUTTON, T	BL	
* 2-26	VS414400	BUTTON, T	TI	
* 2-27	VS196100	BUTTON, R	BL	(BG)
* 2-27	VS196200	BUTTON, R	TI	(G)
* 2-31	VQ368600	PUSH RIVET	P3555-B	
* 2-36	Ei330086	BIND HEAD B-TITE SCREW	3x8 FCRM3-BL	
* 2-37	Ei330066	BIND HEAD B-TITE SCREW	3x6 FCRM3-BL	
* 3-1	VS965700	P.C.B. ASS'Y	MAIN RX-V390	(UC)
* 3-1	VS965800	P.C.B. ASS'Y	MAIN	(R)
* 3-1	VS965900	P.C.B. ASS'Y	MAIN	(A)
* 3-1	VS966000	P.C.B. ASS'Y	MAIN	(B)
* 3-1	VS966100	P.C.B. ASS'Y	MAIN	(G)
* 3-1	VS996800	P.C.B. ASS'Y	MAIN R-V501	(UC)
* 3-11	VS362400	HEAT SINK ASS'Y		
* 3-13	VT037900	BARRIER	EL. CAP	
* 3-16	VK195900	SHEET	19x24	
* 3-17	Vi071200	SHEET, RADIATOR	34x15	
* 3-21	VK173200	SCREW, TRANSISTOR	3x15 SP FCM3	
* 3-23	Ei330086	BIND HEAD B-TITE SCREW	3x8 FCRM3-BL	
* 5	VR341800	P.C.B. ASS'Y	TUNER	(UC)
* 5	VR341900	P.C.B. ASS'Y	TUNER	(R)
* 5	VR342000	P.C.B. ASS'Y	TUNER	(AB)
* 5	VR384100	P.C.B. ASS'Y	TUNER	(G)
* 7	VS966200	P.C.B. ASS'Y	INPUT	(UC)
* 7	VS966300	P.C.B. ASS'Y	INPUT	(R)
* 7	VS966400	P.C.B. ASS'Y	INPUT	(A)
* 7	VS966600	P.C.B. ASS'Y	INPUT	(BG)
Δ* 11	XQ103A00	POWER TRANSFORMER	RX-V390	(U)
Δ* 11	XQ104A00	POWER TRANSFORMER		(C)
Δ* 11	XQ105A00	POWER TRANSFORMER		(R)
Δ* 11	XQ106A00	POWER TRANSFORMER		(AB)
Δ* 11	XQ107A00	POWER TRANSFORMER		(G)
Δ* 11	XQ291A00	POWER TRANSFORMER	R-V501	(U)
Δ* 12	VQ508500	POWER CORD ASS'Y		(R)
Δ* 12	VQ508600	POWER CORD ASS'Y		(A)

* New Parts

Ref. No.	PART NO.	Description	Remarks	Markets
Δ* 12	VS168300	POWER CORD ASS'Y		(UC)
Δ* 12	VS168400	POWER CORD ASS'Y		(G)
Δ 12	VS680700	POWER CORD ASS'Y		(B)
Δ 13	VJ775000	AC OUTLET	2P	(B)
Δ 13	VP418700	AC OUTLET	2P	(A)
* 101	VS362100	TOP COVER	BL	
* 101	VS362200	TOP COVER	TI	
* 102	VQ794000	CHASSIS		
* 103	VS361400	REAR PANEL	RX-V390	(U)
* 103	VS361500	REAR PANEL	RX-V390	(C)
* 103	VS361600	REAR PANEL	RX-V390	(R)
* 103	VS361700	REAR PANEL	RX-V390	(A)
* 103	VS361800	REAR PANEL	RX-V390RDS	(B)
* 103	VS361900	REAR PANEL	RX-V390RDS	(G)
* 103	VS377600	REAR PANEL	R-V501	(U)
* 103	VS377700	REAR PANEL	R-V501	(C)
104	VQ780300	LEG	D60xH16	
104	VQ982800	LEG	D60xH16	
* 106	VR264400	SPACER, H8		
* 108	VQ366100	DAMPER, PCB		
* 109	VQ390100	DAMPER	8x8x15	
* 111	VQ795100	KNOB	D42	BL
* 111	VQ795200	KNOB	D42	TI
* 112	VS409600	KNOB	D18	BL
* 112	VS409800	KNOB	D18	TI
* 113	VR308400	KNOB, VR	D10	BL
* 113	VR308500	KNOB, VR	D10	TI
115	VQ779000	BUTTON	3x14	BL
115	VQ779100	BUTTON	3x14	TI
* 117	VT081800	SHEET, F		(UCRA)
* 117	VT081900	SHEET, F		(BG)
119	VN158600	CORD STOPPER	No. 2104	
121	EN301010	BIND HEAD BONDING TAP. SCREW	3x8 FCRM3-BL	
122	Ei330086	BIND HEAD B-TITE SCREW	3x8 FCRM3-BL	
123	Ei030046	BIND HEAD TAPPING SCREW	3x4 ZMC2-Y	
124	EN335030	BIND HEAD BONDING TAP. SCREW	3x10 FCRM3-BL	(BG)
126	ED330066	BIND HEAD SCREW	3x6 FCRM3-BL	
* 127	VS997700	BIND HEAD S-TITE SCREW	3x10 MFNI33	
131	EK365020	BW HEAD SCREW	4x6 FCRM3-BL	
132	EL300470	BW HEAD S-TITE SCREW	4x8-10 FCRM3-BL	BL
132	EX601150	BW HEAD S-TITE SCREW	4x8-10 FNM3-BL	TI
140	VT635000	HEAT SINK	22x44	(R)
160	VT669300	SCREW+PWH BT	3x8-8 MFC2	
161	VT669400	PW HEAD B-TITE SCREW	3x15-8 MFC2	
		ACCESSORIES		
* 200	VS714100	REMOTE CONTROL TRANSMITTER		
200-1	CX675300	LID	70x31BLSMK	103RRS-028-01MR
* 11	VQ147100	ANTENNA, FM	1P 1.4m	
* 11	VR248500	ANTENNA, AM LOOP	1P 1.0m	
* 11	VE364900	ANTENNA ADAPTER	PAL 75-300Ω	(B)
		BATTERY, MANGANESE	SUM-3, AA, R06	

* New Parts

REMOTE CONTROL TRANSMITTER

SCHEMATIC DIAGRAM

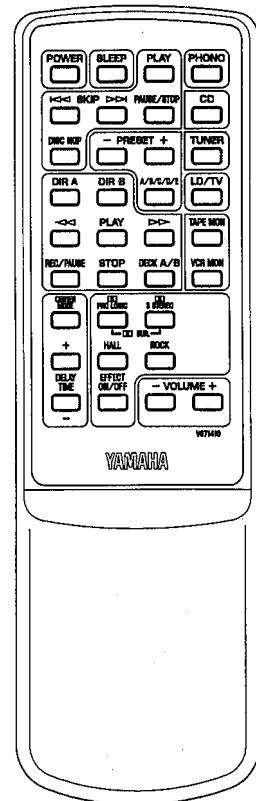
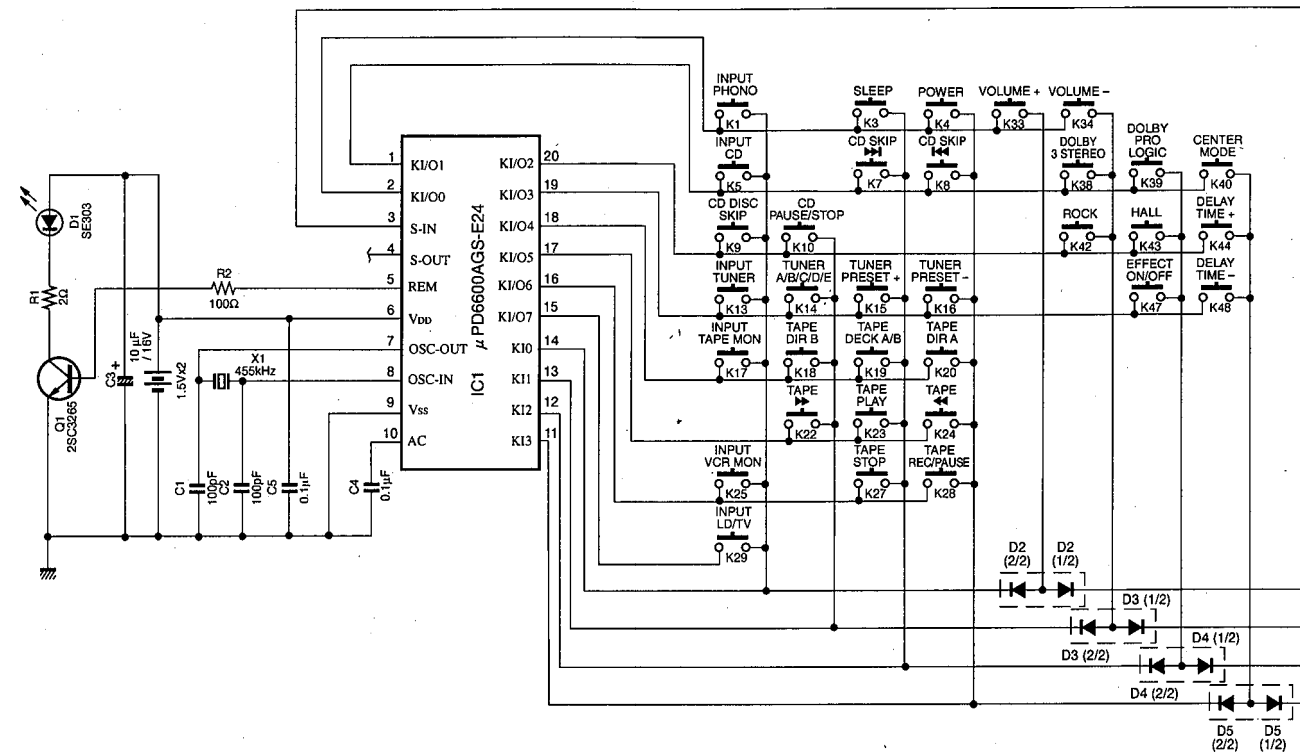

Key No.	Function	HEX	
		CUSTOM	DATA
1	INPUT PHONO	7A	14
3	SLEEP	7A	57
4	POWER	7A	1F
5	INPUT CD	7A	15
7	CD SKIP	7A	0A
8	CD SKIP	7A	0B
9	CD DISC SKIP	7A	4F
10	CD PAUSE/STOP	7A	09
13	INPUT TUNER	7A	16
14	TUNER A/B/C/D/E	7A	12
15	TUNER PRESET +	7A	10
16	TUNER PRESET -	7A	11
17	INPUT TAPE MON	7A	18
18	TAPE DIR B	7A	40
19	TAPE DECK A/B	7A	06
20	TAPE DIR A	7A	07
22	TAPE	7A	01
23	TAPE PLAY	7A	00
24	TAPE	7A	01
25	INPUT VCR MON	7A	0F
27	TAPE STOP	7A	03
28	TAPE REC/PAUSE	7A	04
29	INPUT LD/TV	7A	17
33	VOLUME +	7A	1A
34	VOLUME -	7A	1B
38	DOLBY 3 STEREO	7A	89
39	DOLBY PRO LOGIC	7A	88
40	CENTER MODE	7A	84
42	ROCK	7A	8C
43	HALL	7A	8B
44	DELAY TIME +	7A	52
47	EFFECT ON/OFF	7A	56
48	DELAY TIME -	7A	53

Parts List for Carbon Resistors

Value	1/4W Type Part No.	1/6W Type Part No.	Value	1/4W Type Part No.	1/6W Type Part No.
1.0 Ω	HJ35 3100	HF85 3100	10 kΩ	HF45 7100	HF45 7100
1.8 Ω	HJ35 3180	*	11 kΩ	HF45 7110	HF45 7110
2.2 Ω	HJ35 3220	HF85 3220	12 kΩ	HJ35 7120	HF85 7120
3.3 Ω	HJ35 3330	HF85 3330	13 kΩ	HF45 7130	HF45 7130
4.7 Ω	HJ35 3470	HF85 3470	15 kΩ	HF45 7150	HF45 7150
5.6 Ω	HJ35 3560	HF85 3560	18 kΩ	HF45 7180	HF45 7180
10 Ω	HF45 4100	HF45 4100	22 kΩ	HF45 7220	HF45 7220
15 Ω	HJ35 4150	HF85 4150	24 kΩ	HF45 7240	HF45 7240
22 Ω	HF45 4220	HF45 4220	27 kΩ	HJ35 7270	HF85 7270
27 Ω	HJ35 4270	HF85 4270	30 kΩ	HF45 7300	HF45 7300
33 Ω	HF45 4330	HF45 4330	33 kΩ	HF45 7330	HF45 7330
39 Ω	HJ35 4390	HF85 4390	36 kΩ	HF45 7360	HF45 7360
47 Ω	HF45 4470	HF45 4470	39 kΩ	HF45 7390	HF45 7390
56 Ω	HF45 4560	HF45 4560	47 kΩ	HF45 7470	HF45 7470
68 Ω	HF45 4680	HF45 4680	51 kΩ	HF45 7510	HF45 7510
75 Ω	HF45 4750	HF45 4750	56 kΩ	HF45 7560	HF45 7560
82 Ω	HF45 4820	HF45 4820	62 kΩ	HF45 7620	HF45 7620
91 Ω	HF45 4910	HF45 4910	68 kΩ	HF45 7680	HF45 7680
100 Ω	HF45 5100	HF45 5100	82 kΩ	HF45 7820	HF45 7820
110 Ω	HJ35 5110	HF85 5110	91 kΩ	HF45 7910	HF45 7910
120 Ω	HF45 5120	HF45 5120	100 kΩ	HF45 8100	HF45 8100
150 Ω	HF45 5150	HF45 5150	110 kΩ	HF45 8110	HF45 8110
160 Ω	HJ35 5160	*	120 kΩ	HF45 8120	HF45 8120
180 Ω	HF45 5180	HF45 5180	150 kΩ	HF45 8150	HF45 8150
200 Ω	HF45 5200	HF45 5200	180 kΩ	HF45 8180	HF45 8180
220 Ω	HF45 5220	HF45 5220	220 kΩ	HJ35 8220	HF85 8220
270 Ω	HF45 5270	HF45 5270	270 kΩ	HF45 8270	HF45 8270
330 Ω	HF45 5330	HF45 5330	300 kΩ	HF45 8300	HF45 8300
390 Ω	HF45 5390	HF45 5390	330 kΩ	HF45 8330	HF45 8330
430 Ω	HF45 5430	HF45 5430	390 kΩ	HJ35 8390	HF85 8390
470 Ω	HF45 5470	HF45 5470	470 kΩ	HF45 8470	HF45 8470
510 Ω	HF45 5510	HF45 5510	560 kΩ	HJ35 8560	HF85 8560
560 Ω	HF45 5560	HF45 5560	680 kΩ	HJ35 8680	HF85 8680
680 Ω	HF45 5680	HF45 5680	820 kΩ	HJ35 8820	HF85 8820
820 Ω	HF45 5820	HF45 5820	1.0 MΩ	HF45 9100	HF45 9100
910 Ω	HF45 5910	HF45 5910	1.2 MΩ	HJ35 9120	*
1.0 kΩ	HF45 6100	HF45 6100	1.5 MΩ	HJ35 9150	HF85 9150
1.2 kΩ	HF45 6120	HF45 6120	1.8 MΩ	HJ35 9180	HF85 9180
1.5 kΩ	HF45 6150	HF45 6150	2.2 MΩ	HJ35 9220	HF85 9220
1.8 kΩ	HF45 6180	HF45 6180	3.3 MΩ	HJ35 9330	HF85 9330
2.0 kΩ	HJ35 6200	HF85 6200	3.9 MΩ	HJ35 9390	*
2.2 kΩ	HF45 6220	HF45 6220	4.7 MΩ	HJ35 9470	HF85 9470
2.4 kΩ	HJ35 6240	HF85 6240			
2.7 kΩ	HF45 6270	HF45 6270			
3.0 kΩ	HF45 6300	HF45 6300			
3.3 kΩ	HF45 6330	HF45 6330			
3.6 kΩ	HJ35 6360	HF85 6360			
3.9 kΩ	HF45 6390	HF45 6390			
4.7 kΩ	HF45 6470	HF45 6470			
5.1 kΩ	HF45 6510	HF45 6510			
5.6 kΩ	HF45 6560	HF45 6560			
6.8 kΩ	HF45 6680	HF45 6680			
8.2 kΩ	HF45 6820	HF45 6820			
9.1 kΩ	HF45 6910	HF45 6910			

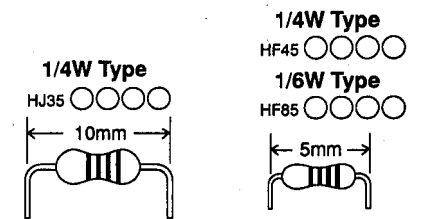

1
2
3
4
5
6
7