

AV RECEIVER

RX-V393RDS

RX-V493RDS

SERVICE MANUAL

IMPORTANT NOTICE

This manual has been provided for the use of authorized YAMAHA Retailers and their service personnel. It has been assumed that basic service procedures inherent to the industry, and more specifically YAMAHA Products, are already known and understood by the users, and have therefore not been restated.

WARNING: Failure to follow appropriate service and safety procedures when servicing this product may result in personal injury, destruction of expensive components, and failure of the product to perform as specified. For these reasons, we advise all YAMAHA product owners that any service required should be performed by an authorized YAMAHA Retailer or the appointed service representative.

IMPORTANT: The presentation or sale of this manual to any individual or firm does not constitute authorization, certification or recognition of any applicable technical capabilities, or establish a principle-agent relationship of any form.

The data provided is believed to be accurate and applicable to the unit(s) indicated on the cover. The research, engineering, and service departments of YAMAHA are continually striving to improve YAMAHA products. Modifications are, therefore, inevitable and specifications are subject to change without notice or obligation to retrofit. Should any discrepancy appear to exist, please contact the distributor's Service Division.

WARNING: Static discharges can destroy expensive components. Discharge any static electricity your body may have accumulated by grounding yourself to the ground buss in the unit (heavy gauge black wires connect to this buss).

IMPORTANT: Turn the unit OFF during disassembly and part replacement. Recheck all work before you apply power to the unit.

RX-V393RDS
RX-V493RDS

■ CONTENTS

<p>TO SERVICE PERSONNEL 1</p> <p>FRONT PANELS 1</p> <p>REAR PANELS 2</p> <p>SPECIFICATIONS 3~4</p> <p>INTERNAL VIEW 5</p> <p>DISASSEMBLY PROCEDURES 5~6</p> <p>SELF CHECK MODE 7~9</p> <p>PROTECTION OPERATION CHECK FUNCTION .. 10</p> <p>AMP ADJUSTMENTS 11</p> <p>TUNER ADJUSTMENTS 12~15</p>	<p>DISPLAY DATA 16</p> <p>IC DATA 17~20</p> <p>RX-V393RDS PRINTED CIRCUIT BOARD 22~31</p> <p>RX-V493RDS PRINTED CIRCUIT BOARD 32~41</p> <p>BLOCK DIAGRAM 42~44</p> <p>PIN CONNECTION DIAGRAM 45</p> <p>RX-V393RDS SCHEMATIC DIAGRAM 46~49</p> <p>RX-V493RDS SCHEMATIC DIAGRAM 50~53</p> <p>PARTS LIST 54~76</p> <p>REMOTE CONTROL TRANSMITTER 77~78</p>
--	---

■ TO SERVICE PERSONNEL

Critical Components Information.
 Components having special characteristics are marked Δ and must be replaced with parts having specifications equal to those originally installed.

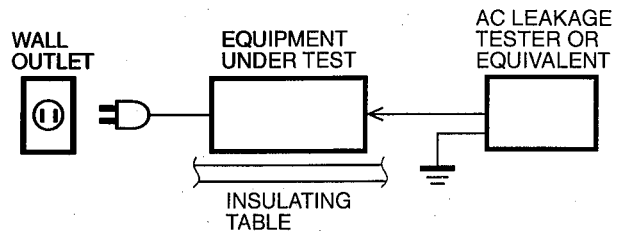

■ FRONT PANELS

▼ RX-V393RDS

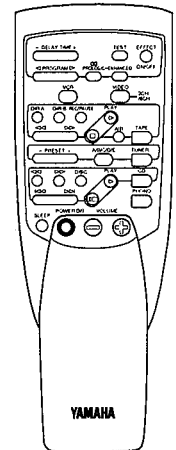
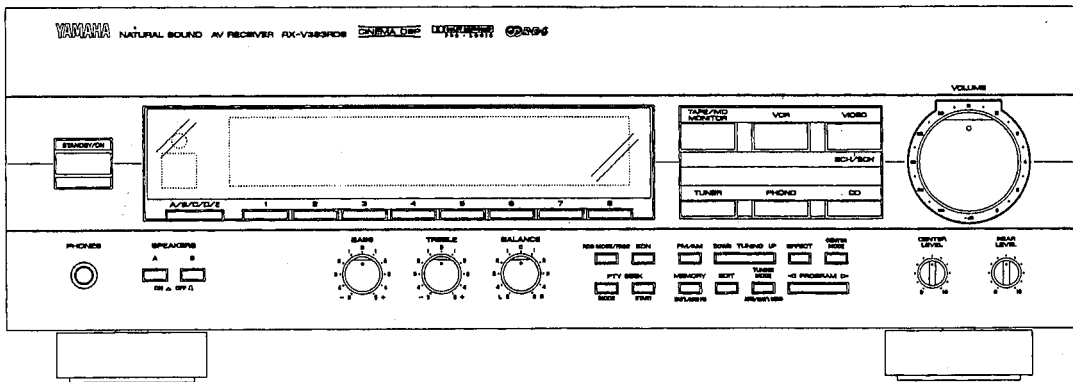

▼ RX-V493RDS

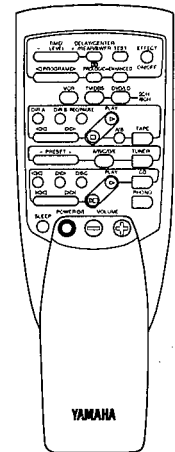
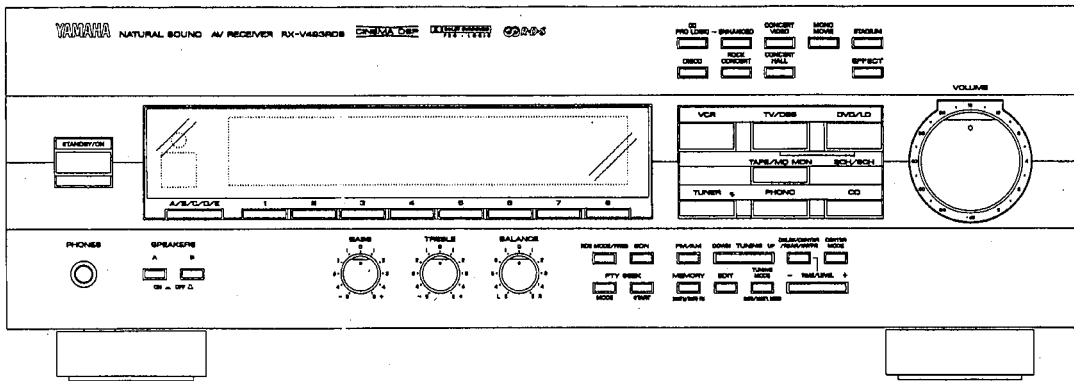

WARNING

Do not change the IMPEDANCE SELECTOR switch setting while the power to this unit is on, otherwise this unit may be damaged.

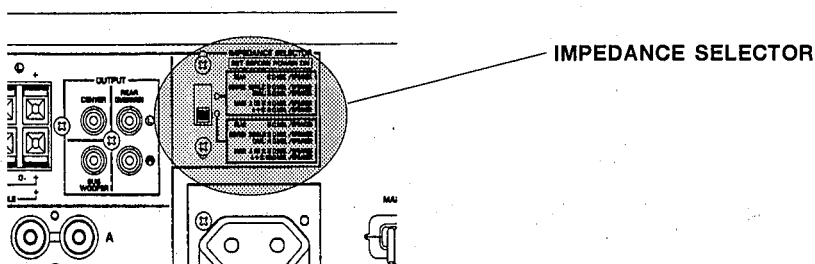

■ REAR PANELS

▼ RX-V393RDS B model

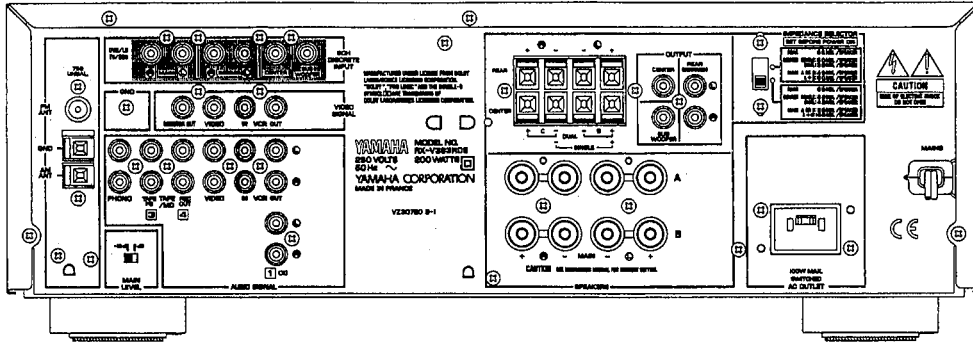

▼ RX-V393RDS G model

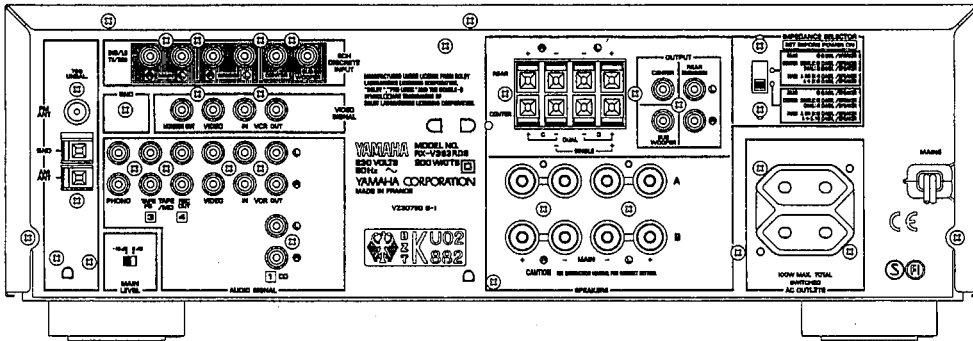

▼ RX-V493RDS B model

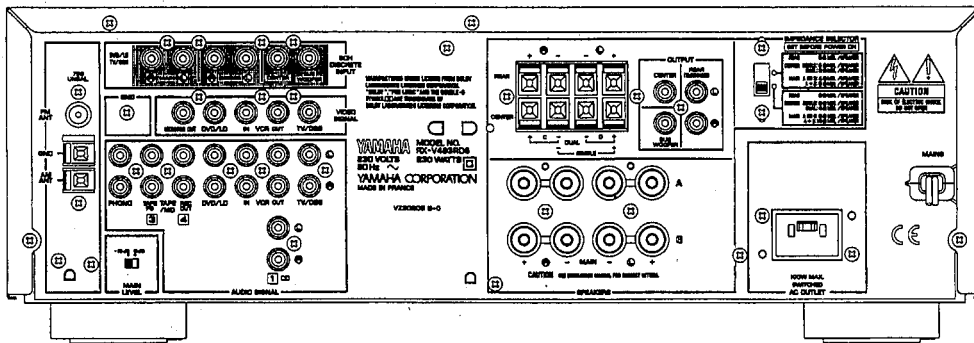

▼ RX-V493RDS G model

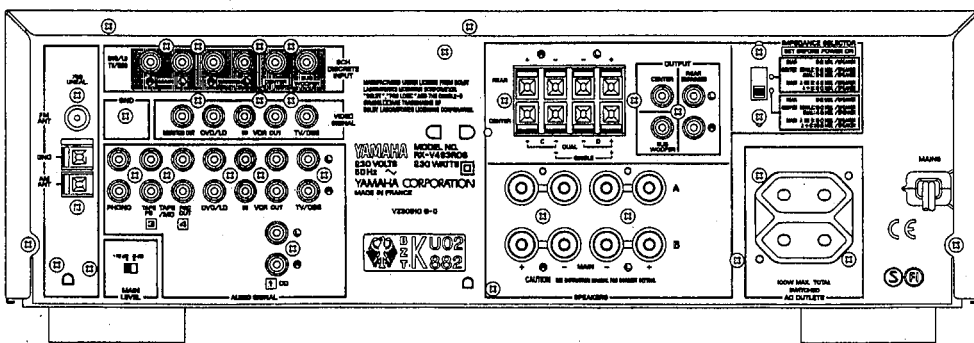

RX-V393RDS
RX-V493RDS

■ SPECIFICATIONS

■ AUDIO SECTION

Minimum RMS Output Power per Channel (Power Amp)	
RX-V393RDS	
MAIN, 20Hz to 20kHz, 0.04% THD, 8Ω	50W + 50W
CENTER, 1kHz, 0.04% THD, 8Ω	50W
REAR, 1kHz, 0.04% THD, 8Ω	20W + 20W
RX-V493RDS	
MAIN, 20Hz to 20kHz, 0.04% THD, 8Ω	65W + 65W
CENTER, 1kHz, 0.04% THD, 8Ω	65W
REAR, 1kHz, 0.04% THD, 8Ω	20W + 20W
Dynamic Power per Channel (IHF)	
RX-V393RDS	
8/6/4/2Ω	80/100/120/135W
RX-V493RDS	
8/6/4/2Ω	95/115/145/165W
DIN Standard Output Power per Channel	
RX-V393RDS	
1kHz, 0.7% THD, 4Ω	75W
RX-V493RDS	
1kHz, 0.7% THD, 4Ω	95W
IEC Power	
RX-V393RDS	
1kHz, 0.1% THD, 8Ω	60W
RX-V493RDS	
1kHz, 0.1% THD, 8Ω	80W
Power Band Width	
RX-V393RDS	
0.1% THD, 25W, 8Ω	10Hz to 50kHz
RX-V493RDS	
0.1% THD, 30W, 8Ω	10Hz to 50kHz
Damping Factor	
20Hz to 20kHz, 8Ω	80 or more
Input Sensitivity/Impedance	
RX-V393RDS	
PHONO MM	2.5mV/47kΩ
6 CH DISCRETE L/R	170mV/56kΩ
6 CH DISCRETE C	170mV/11kΩ
6 CH DISCRETE SW	170mV/40kΩ
6 CH DISCRETE RL/RR	100mV/11kΩ
CD, etc	170mV/47kΩ
RX-V493RDS	
PHONO MM	2.5mV/47kΩ
6 CH DISCRETE L/R	170mV/56kΩ
6 CH DISCRETE C/SW	170mV/40kΩ
6 CH DISCRETE RL/RR	100mV/40kΩ
CD, etc	170mV/47kΩ
Maximum Input Signal Level (1kHz, 0.5% THD)	
PHONO MM	100mV
CD, etc (Effect off)	2.5V
Output Level/Impedance	
REC OUT	170mV/2.5kΩ
CENTER	2V/1.2kΩ
REAR L/R	1.2V/1.2kΩ
SUB WOOFER (Effect off)	4V/1.2kΩ
Headphone Jack Rated Output/Impedance	
0.04% THD, 8Ω	0.45V/330Ω
Frequency Response (20Hz to 20kHz)	
CD, etc	0±0.5dB
RIAA Equalization Deviation (20Hz to 20kHz)	
PHONO MM	0±0.5dB

Total Harmonic Distortion (20Hz to 20kHz)	
PHONO MM to REC OUT (1V)	0.02%
CD, etc to MAIN SP OUT (30W/8Ω)	0.03%
Signal-to-Noise Ratio (IHF-A-Network)	
PHONO MM, Input Shorted (5mV)	80dB
CD, etc, Input Shorted	93dB
Residual Noise (IHF-A-Network)	
MAIN, SP OUT	140μV
Channel Separation (Vol. -30dB, Effect off)	
PHONO MM, Input Shorted, 1kHz	60dB
CD, etc, Input 5.1kΩ Shorted, 1kHz	60dB
Tone Control Characteristics	
BASS : Boost/cut	±10dB (50Hz)
Turnover Frequency	350Hz
TREBLE : Boost/cut	±10dB (20kHz)
Turnover Frequency	3.5kHz
Gain Tracking Error (0dB to -60dB)	
	3dB

■ FM SECTION

Tuning Range	87.50 to 108.00MHz
Usable Sensitivity (75 Ω)	
DIN, Mono (S/N 26dB)	0.9μV
DIN, Stereo (S/N 46dB)	24μV
Selectivity (two signals, 40kHz Dev.)	
	70dB
Signal-to-Noise Ratio	
Mono/Stereo (DIN-weighted, 40kHz Dev.)	75/70dB
Harmonic Distortion	
Mono/Stereo (1kHz)	0.1/0.2%
Frequency Response	
20Hz to 15kHz	0 ± 1.5dB
Stereo Separation	
	50dB
Output Level (40kHz Dev. 1kHz)	
	400mV

■ AM SECTION

Tuning Range	531 to 1611kHz
Usable Sensitivity	100μV/m
Selectivity	32dB
Signal-to-Noise Ratio	50dB
Image Response Ratio	40dB
Spurious Response Ratio	50dB
Harmonic Distortion (1kHz)	0.3%
Output Level (30% mod., 1kHz)	150mV

■ VIDEO SECTION

Video Signal Level	1Vp-p/75Ω
Maximum Input Level	1.5Vp-p
Signal-to-Noise Ratio	50dB
Monitor Output Frequency Response	5Hz~10MHz, -3dB

■ GENERAL

Power Supply	AC 230V, 50Hz
Power Consumption	
RX-V393RDS	200W
RX-V493RDS	230W
AC Outlets	
G models, Switched x 2	100W max (Total)
B model, Switched x 1	100W max
Dimensions (W x H x D)	435 x 151 x 308.5mm (17-1/8" x 5-15/16" x 12-1/8")
Weight	
RX-V393RDS	7.8 kg (17 lbs. 3 oz)
RX-V493RDS	8.7 kg (19 lbs. 3 oz)
Accessories	AM loop antenna x 1 Indoor FM antenna x 1 Remote Control Transmitter x 1 Battery (size "AA", "R06") x 2

* Specifications subject to change without notice.

B British model
G European model

Manufactured under license from Dolby Laboratories Licensing Corporation. "Dolby", "Pro Logic", and the double-D symbol  are trademarks of Dolby Laboratories Licensing Corporation.

● DIMENSIONS

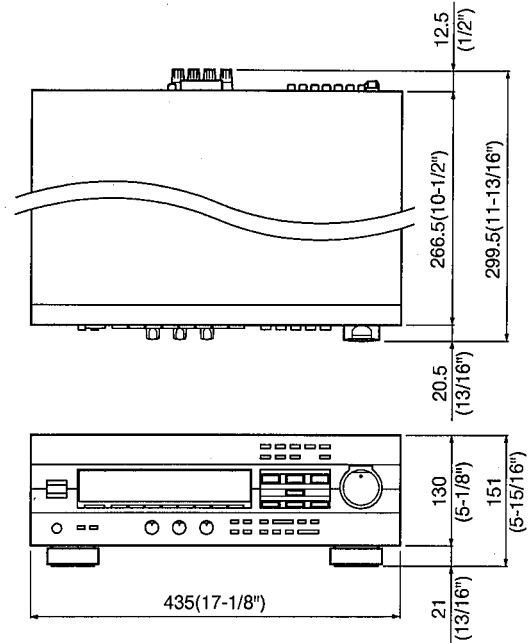

Units : mm (inch)

■ INTERNAL VIEW

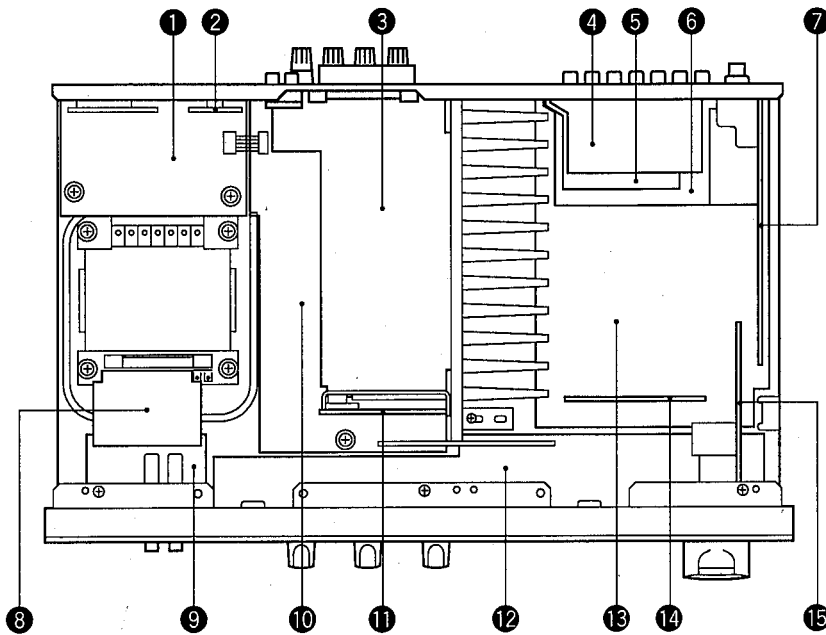

- ① P. C. B. MAIN (2)
- ② P. C. B. MAIN (5)
- ③ P. C. B. INPUT (4)
- ④ P. C. B. OPERATION (4)
- ⑤ P. C. B. OPERATION (3)
- ⑥ P. C. B. INPUT (2)
- ⑦ P. C. B. TUNER
- ⑧ P. C. B. INPUT (6)
- ⑨ P. C. B. MAIN (3)
- ⑩ P. C. B. MAIN (1)
- ⑪ P. C. B. INPUT (5)
- ⑫ P. C. B. OPERATION (2)
- ⑬ P. C. B. INPUT (1)
- ⑭ P. C. B. SELECT
- ⑮ P. C. B. INPUT (3)

■ DISASSEMBLY PROCEDURES (Remove parts in disassembly order as numbered.)

1. Removal of Top Cover

a. Remove 4 screws (①) and 4 screws (②) in Fig. 1.

2. Removal of Front Panel

a. Remove the knobs.

b. Remove 6 screws (③) in Fig. 1.

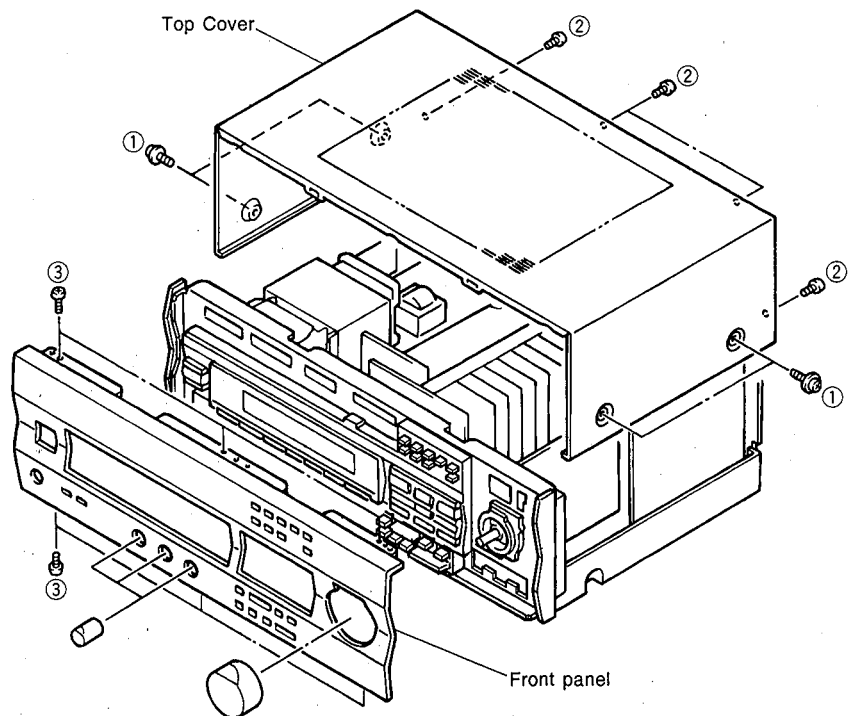

Fig. 1

RX-V393RDS
RX-V493RDS

3. Checking and Parts Replacement of Main Unit

- a. Disconnect the power cord from the AC outlet.
- b. Remove 2 screws (④) and 1 screw (⑤) in Fig. 2.
- c. Detach 1 connector terminal (CB103) in Fig. 2.
- d. Operating checks can be taken by shorting between following test points in Fig. 2.

Short Point
TP101 and TP102
TP103 and TP104
TP105 and TP106

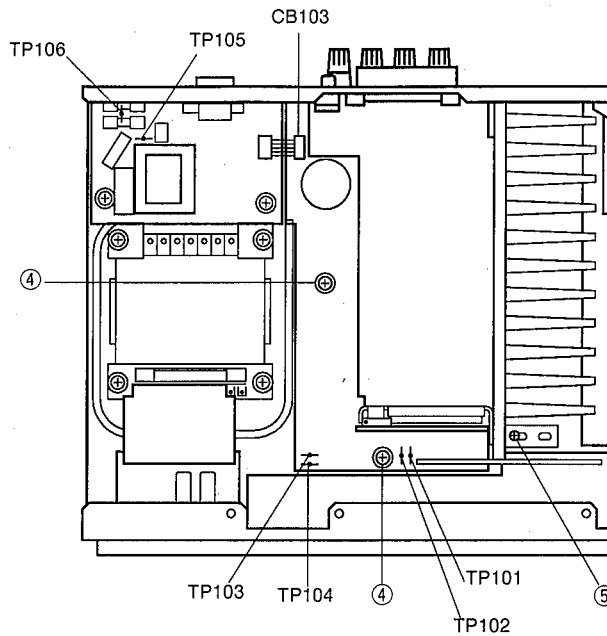

Fig. 2

- e. Remove 11 screws (⑥), 2 screws (⑦) and 2 screws (⑧) in Fig. 3.
- f. Cut 2 binding ties fixing the cable wire.
- g. Place the Main Unit on its side as shown in Fig. 4.
- h. Connect the power cord and turn ON the POWER switch.

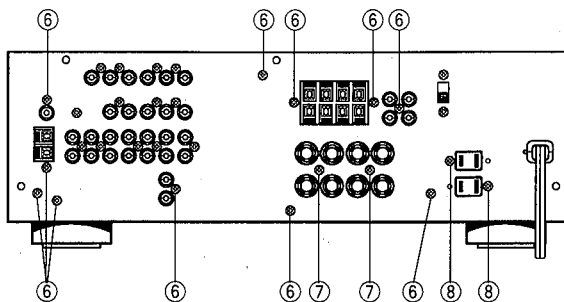

Fig. 3

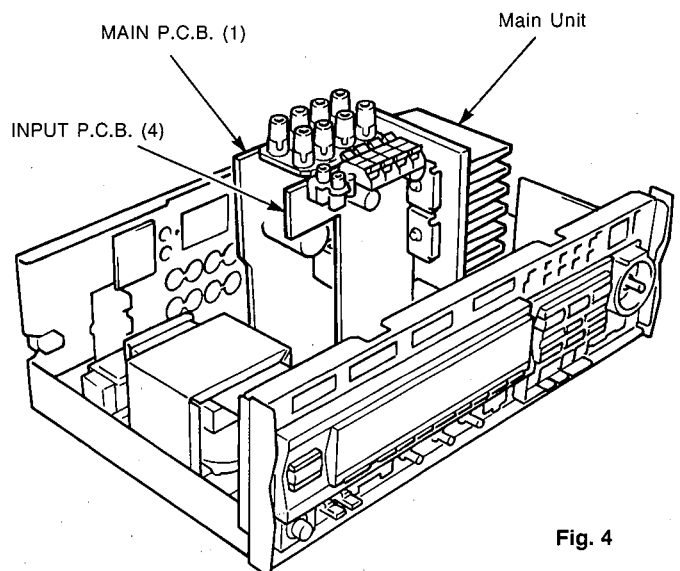

Fig. 4

■ SELF CHECK MODE

This machine has a SELF CHECK MODE (SELF) for facilitating inspection and measurement.

HOW TO START & CANCEL

Turn the POWER switch ON while pressing the VIDEO(V393) DVD/LD(V493) and PRESET STATION No. 8 keys simultaneously, and then the unit enters the SELF CHECK MODE (SELF). FL displays "SELF 1" first.

(The INPUT is CD.)

If the sound field program key of the main unit is pressed, the mode is set to the CHECK mode of that number. It is possible to select the INPUT even during the self check (except for SELF 8). To cancel the SELF CHECK MODE, turn the POWER switch OFF or press the PRESET STATION No. 8 key. (The unit enters the normal mode.)

HOW TO USE SELF CHECK MODE

In order to confirm characteristics (specifications) listed in the table below, use SELF NO. 1, 3 and 4. (For specifications, refer to page 5.)

No.	Items
1	<ul style="list-style-type: none"> • Output Level/Impedance • Frequency Response • Total Harmonic Distortion (Rec Out & MAIN) • S/N
3	<ul style="list-style-type: none"> • Minimum RMS Output Power Per Channel (Center & Rear) • Total Harmonic Distortion (Rear)
4	<ul style="list-style-type: none"> • Minimum RMS Output Power Per Channel (MAIN) • Input Sensitivity/Impedance • Headphone Jack Rated Output/Impedance • Channel Separation • Tone Control Characteristics

CONTENTS OF SELF CHECK MODE

No.	Menu	Select Key
1	RAM THROUGH A	PRESET STATION No. 1
2	RAM THROUGH B	PRESET STATION No. 2
3	RAM THROUGH C	PRESET STATION No. 3
4	EFFECT OFF/DISCO/FL ALL ON	PRESET STATION No. 4
5	MANUAL TEST	PRESET STATION No. 5
6	DOLBY PRO LOGIC	PRESET STATION No. 6
7	MAKER PRESET	PRESET STATION No. 7
8	EXIT	PRESET STATION No. 8

DETAILS OF SELF CONTENT

SELF 1 RAM THROUGH A

- MAIN L/R is output through the bypass.
- CENTER is output with the steering OFF and by (L+R)/2. (WIDE mode)
- RL/RR passes through the PS-RAM and is output through the DSP.
- The electronic volume (for CENTER/REAR) is -10dB.
- FL displays "SELF 1"

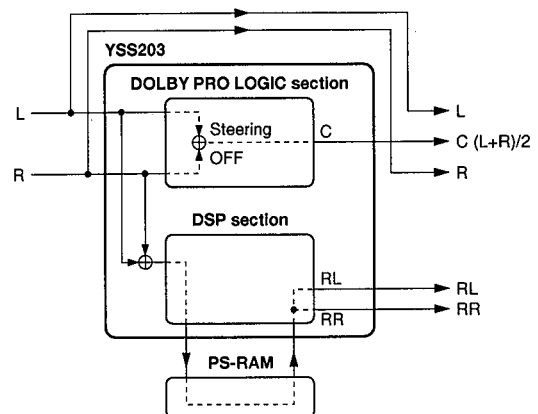

SELF 2 RAM THROUGH B

- L/R and RL/RR pass through the PS-RAM and are output through the DSP.
- CENTER is output with the steering OFF and by (L+R)/2. (WIDE mode)
- The electronic volume (for CENTER/REAR) is -10dB.
- FL displays "SELF 2"

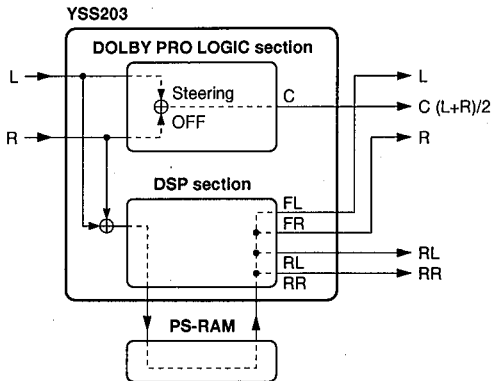

SELF 3 RAM THROUGH C

- L/R is output with the steering OFF.
- CENTER is output with the steering OFF and by (L+R)/2. (WIDE mode)
- RL/RR passes through the PS-RAM and is output through the DSP.
- The electronic volume is +10dB for CENTER and +7dB for REAR.
- FL displays "SELF 3"

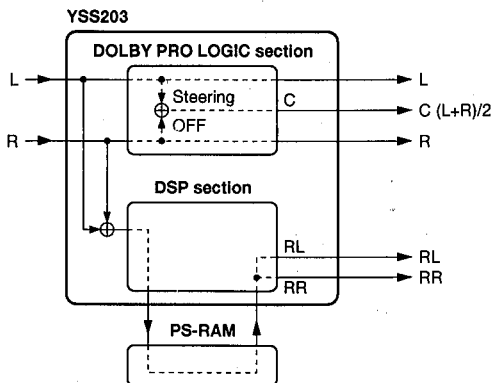

SELF 4 EFFECT OFF/DISCO/FL ALL ON

- Every time the PRESET STATION No. 4 key is pressed, the menu changes.
- 1: EFFECT OFF
 - 2: DISCO (electronic volume is 0dB.)
 - 3: FL displays all ON

SELF 5 MANUAL TEST

- Every time PRESET STATION No. 5 key is pressed, the TEST TONE shifts in the order of L→C→R→S and is output. (The CENTER mode is WIDE)
- The electronic volume (for CENTER/REAR) is 0dB.

SELF 6 DOLBY PRO LOGIC

- The auto input balance which is ON in the normal mode is turned OFF.
- CENTER MODE is changed by pressing the PRESET STATION No. 6 key or the CENTER MODE key.
- The electronic volume (for CENTER/REAR) is 0dB.
- The FL displays "SELF 6" and the center mode.

SELF 7 MAKER PRESET

- Every time the PRESET STATION No. 7 key is pressed, the mode changes between the KEEP DATA and PRESET modes. Turning OFF the power in the "PRESET" mode will restore the FACTORY PRESET mode.

CAUTION : Before setting to the FACTORY PRESET, write down the existing preset memory contents of the Tuner in a table as shown below. (This is because setting to the FACTORY PRESET will cause the memory contents to be as factory set, i.e., all the preset memory by the user will be erased.)

Preset group	P1	P2	P3	P4
A				
B				
C				
D				
E				

Preset group	P5	P6	P7	P8
A				
B				
C				
D				
E				

● **Factory Preset**

1) **SURROUND section**

DELAY TIME	: <input type="checkbox"/> PRO LOGIC	20ms
	: <input type="checkbox"/> ENHANCED	20ms
	: <input type="checkbox"/> CONCERT VIDEO	28ms
	: <input type="checkbox"/> MONO MOVIE	20ms
	: <input type="checkbox"/> STADIUM	45ms
	: <input type="checkbox"/> DISCO	14ms
	: <input type="checkbox"/> ROCK CONCERT	17ms
	: <input type="checkbox"/> CONCERT HALL	30ms
CENTER MODE	: NORMAL	
VOLUME LEVEL	: CENTER	0dB
(RX-V493RDS)	: REAR	0dB

2) **SELECTOR section**

INPUT	: CD
VIDEO (BGV)	: VIDEO(V393) DVD/LD(V493)

3) **TUNER section**

Preset group	P1	P2	P3	P4
A / C / E	87.50MHz	90.10MHz	95.10MHz	98.10MHz
B / D	630kHz	1080kHz	1440kHz	531kHz

Preset group	P5	P6	P7	P8
A / C / E	108.00MHz	88.10MHz	106.10MHz	108.00MHz
B / D	1611kHz	900kHz	1350kHz	1404kHz

For all the above, AUTO TUNING and AUTO STEREO are selected as the TUNING mode.

SELF 8 EXIT

- "MODEL" is displayed first. When the PRESET STATION No. 8 key is pressed again, the unit will exit the SELF CHECK mode.

AMP ADJUSTMENTS

Confirmation of Idling Current

- 1) No signal applied.
- 2) Non-loaded condition.
- 3) Aging is not necessary.

Item	Test Point	Rating (DC)	Note
MAIN L	TP107 (CB120)	0.05mV~2.5mV	If the measured voltage exceeds 2.6mV, cut the lead wire of R131(L ch) or R132(R ch) and then check again if each measured value satisfies the rating.
MAIN R			
CENTER	R415 (Between terminal)	0.01mV~3mV	If the measured voltage exceeds 3.1mV, cut the lead wire of R404(C ch) and then check again if each measured value satisfies the rating.

Note)

- If R131(L ch), R132(R ch) or R404(C ch) have already been cut off and idling current does not flow, reconnect R131(1kΩ), R132(1kΩ) or R404(8.2kΩ).
- Q107, Q108 and Q320 are transistors for temperature correction. Apply silicone grease to the contact surface with the heat sink.

R131 (L ch)
R132 (R ch)
R404 (C ch)

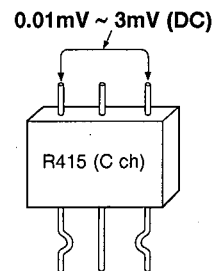
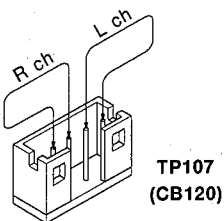
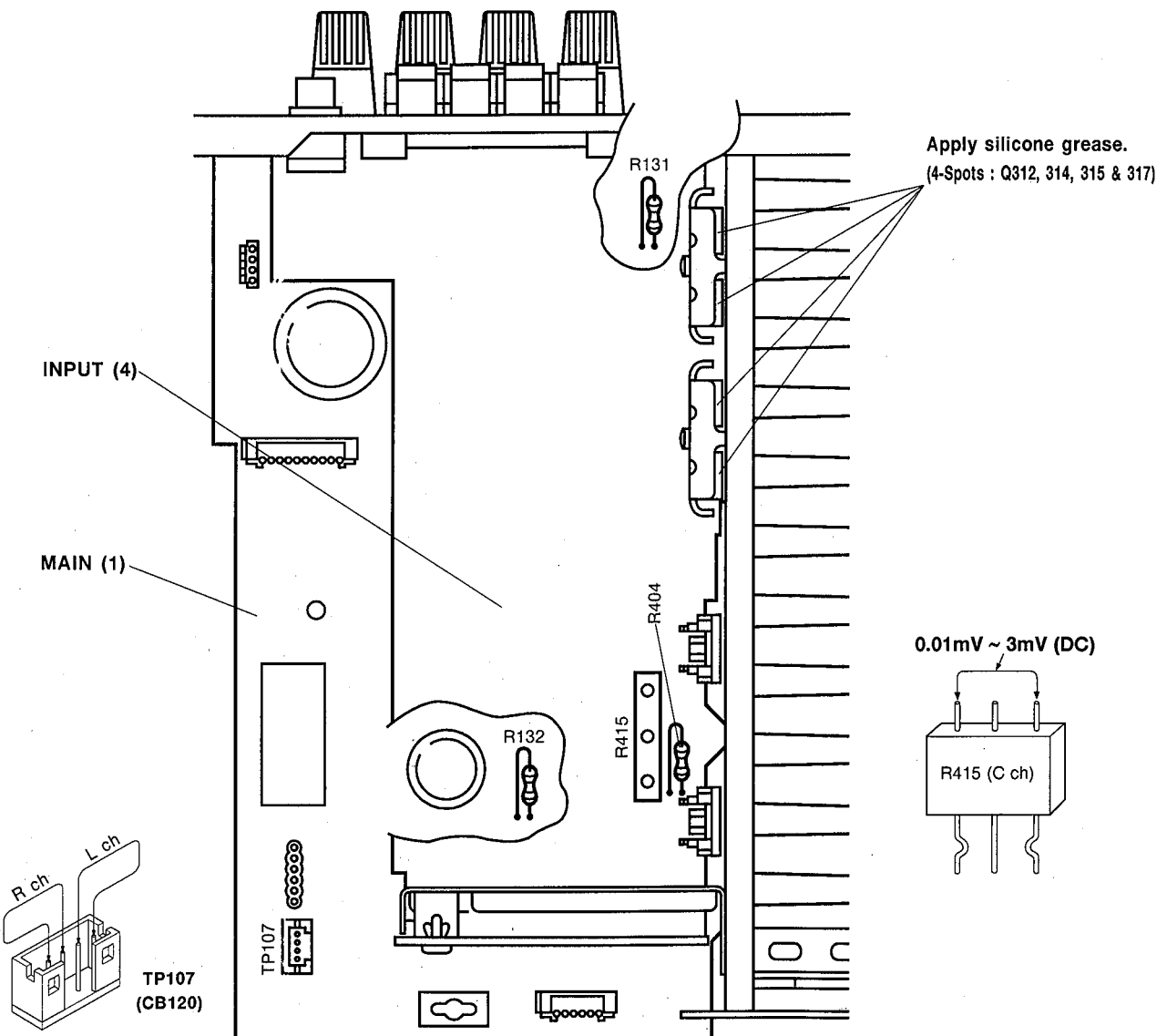
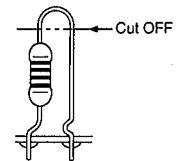

RX-V393RDS
RX-V493RDS

TUNER ADJUSTMENTS

Measuring Instruments

- FM signal generator (FM SG)
- Stereo signal generator (SSG)
- AM signal generator (AM SG)
- Distortion meter (DIST. M)
- AC voltmeter (ACVM)
- DC voltmeter (DCVM)
- Oscilloscope
- Low pass filter (YLF-15, $f_c=15\text{kHz}$)
- Oscillator

Dummy antenna

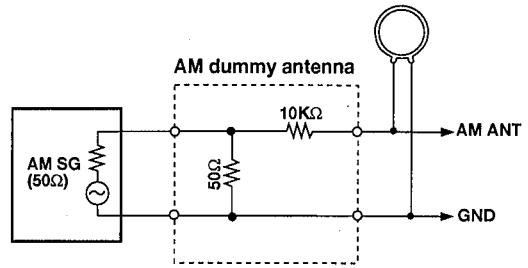
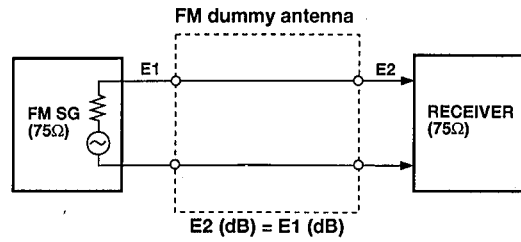
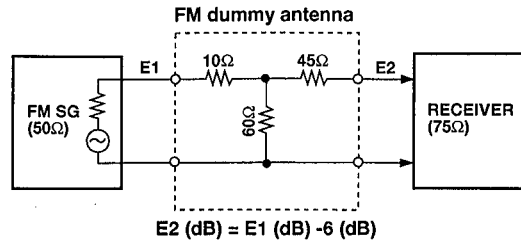

Test point

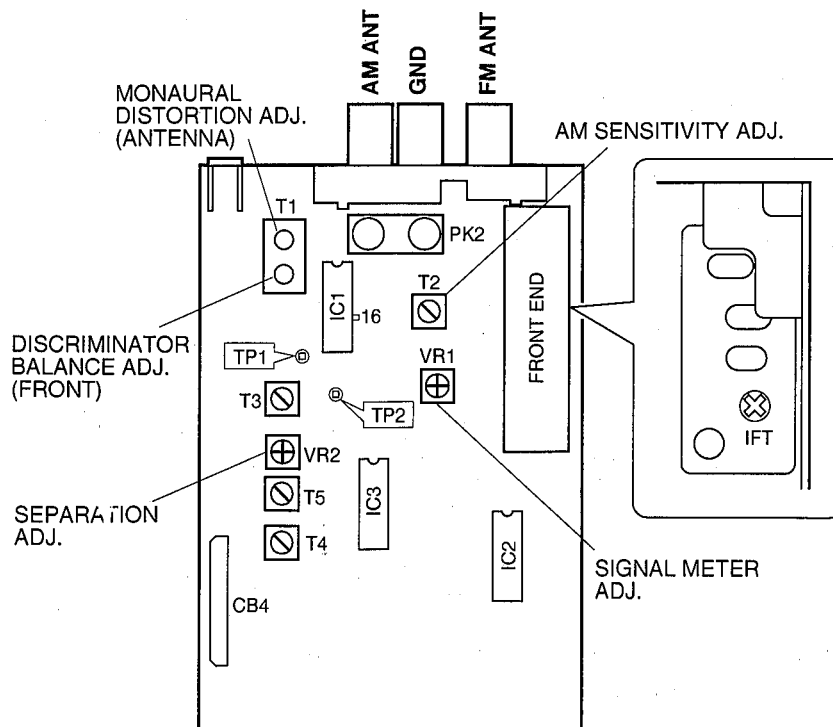

RX-V393RDS
RX-V493RDS

FM Adjustment

● **Before Adjustment**

- 1) For dB, $1\mu V=0dB\mu$
Example : $60dB\mu=1mV$
- 2) 100% modulation means that the frequency deviation is $\pm 75kHz$.

- 3) Install the Matching Transformer and connect FM SG.
- 4) Set each switch to the following position unless otherwise specified.

INPUT SELECTOR..... TUNER
 TUNING MODE AUTO

● **Connection diagram (Measuring instruments)**

1) **Discriminator balance adjustment**

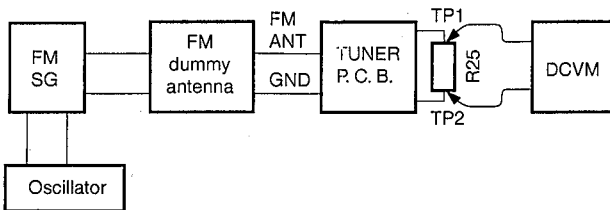

2) **Monaural distortion adjustment**

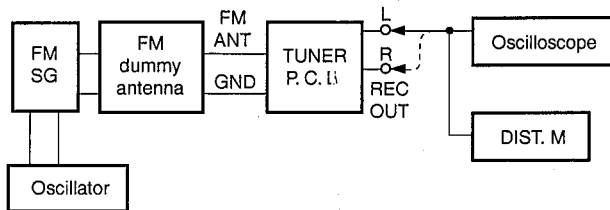

3) **Stereo distortion adjustment/separation adjustment**

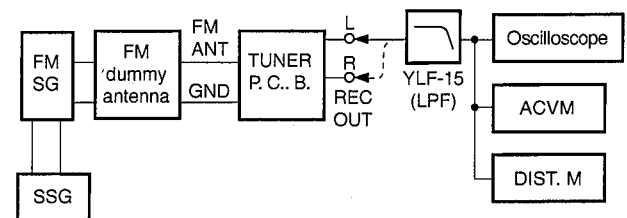

4) **Sensitivity Verification**

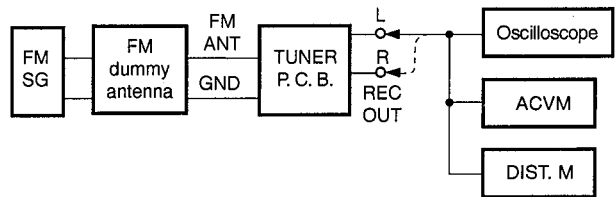

See page 12 for TP locations & adjustment points.

Step	Adjustment item	Signal (ANT IN)	Reception frequency	Adjustment point	Test point	Rating
1	Rough adjustment of discriminator balance	FM ANT (75Ω) 98.1MHz ** 70dBμ MONO 1kHz 100% modulation	98.1MHz * (A-4)	T1 (Front side core)	Both ends of R25 (Between TP1 and TP2)	DC 0V±100mV
2	Rough adjustment of monaural distortion	Same as Step 1.	98.1MHz * (A-4)	T1 (Antenna side core)	REC OUT L, R	Minimize the distortion.
3	Fine adjustment of discriminator balance	Same as Step 1.	98.1MHz * (A-4)	T1 (Front side core)	Both ends of R25 (Between TP1 and TP2)	DC 0V±50mV
4	Fine adjustment of monaural distortion	Same as Step 1.	98.1MHz * (A-4)	T1 (Antenna side core)	REC OUT L, R	Minimize the distortion (to 0.25% or less).
5	Verification of discriminator balance	Same as Step 1.	98.1MHz * (A-4)	T1 (Front side core)	Both ends of R25 (Between TP1 and TP2)	DC 0V±50mV

* : Execution of FACTORY PRESET (Refer to page 9.) will facilitate setting reception frequency for adjustment.

** Must be 98.1MHz ± 5kHz

Step	Adjustment item	Signal (ANT IN)	Reception frequency	Adjusted point	Test point	Rating
6	Adjustment of front end IFT	FM ANT (75Ω) 98.1MHz 30dBμ MONO 1kHz, 100% modulation	98.1MHz * (A-4)	Front end IFT	Pin 16 of IC1	Adjust so that the DC voltage is maximum. CAUTION : Over-adjustment of the IFT core will reduce the sensitivity. Maximum ±90°
7	Verification of monaural distortion	FM ANT (75Ω) 98.1MHz 70dBμ MONO 1kHz, 100% modulation	98.1MHz * (A-4)		REC OUT L, R	0.4% or less
8	Verification of stereo distortion	FM ANT (75Ω) 98.1MHz 70dBμ Stereo L or R 1kHz, 100% modulation	98.1MHz * (A-4) * Tuning mode should be AUTO.		REC OUT L, R	1% or less • STEREO indicator should light.
9	Verification of sensitivity	FM ANT (75Ω) 88.1MHz 98.1MHz 106.1MHz MONO 1kHz Modulation off	88.1MHz * (A-6) 98.1MHz * (A-4) 106.1MHz * (A-7)		ANT (75Ω)	1) Set the tuning mode to MAN'L MONO. (Muting OFF) 2) S/N should be 30dB at each frequency of 88.1MHz, 98.1MHz, and 106.1MHz. 3) Check to ensure that the voltage at the ANT terminal is 6dBμ or less.
10	Adjustment of Separation	FM ANT (75Ω) 98.1MHz 70dBμ Stereo L or R 1kHz, 100% modulation	98.1MHz * (A-4)	VR2	REC OUT L, R	With SSG output at L or R, the signal leakage level at the other channel should be minimized. 36dB or more
11	Adjustment of Signal meter	FM ANT (75Ω) 98.1MHz 45dBμ MONO 1kHz 30% modulation	98.1MHz * (A-4)	VR1		Adjust so that all segments light.
		-10dBμ or less				Check to ensure that signal meters turn OFF.
12	Verification of auto tuning	FM ANT (75Ω) 98.1MHz 23dBμ Stereo L or R 1kHz, 30% modulation	98.1MHz			• Automatic reception should be available when the tuning key is moved UP and DOWN. • The stereo indicator should light. • Audio muting should be applied during tuning.

* : Execution of FACTORY PRESET (Refer to page 9.) will facilitate setting reception frequency for adjustment.

RX-V393RDS
RX-V493RDS

AM Adjustment (This should be done after FM adjustment.)

● **Connection Diagram (Measuring instruments)**

1) **Adjustment of sensitivity**

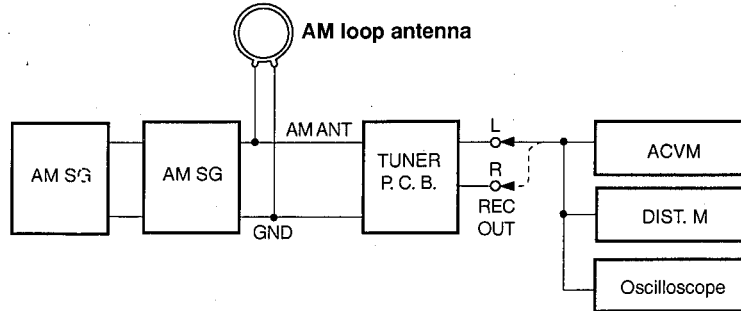

See page 12 for TP locations & adjustment points.

Step	Adjustment item	Signal (ANT IN)	Reception frequency	Adjustment point	Test point	Rating
1	Adjustment of sensitivity (1440Hz)	AM ANT 1440kHz 50dB μ 1kHz 30% modulation	1440kHz * (B-3)	T2	REC OUT	Audio output should be maximized.
2	Verification of sensitivity (630kHz)	AM ANT 630kHz 50dB μ 1kHz 30% modulation	630kHz * (B-1)	T2	REC OUT	Audio output should be maximized. Repeat the Step 1 and 2.
3	Verification of sensitivity	AM ANT 630kHz 1080kHz 1440kHz 30% modulation	630kHz * (B-1) 1080kHz * (B-2) 1440kHz * (B-3)		AM ANT	Distortion should be 10% or less at each frequency. Check to ensure that the voltage at the ANT terminal is 54dB μ or less.
4	Verification of auto tuning	AM ANT 50dB μ				Auto reception should be available when the tuning key is moved UP and DOWN.

* : Execution of FACTORY PRESET (Refer to page 9.) will facilitate setting reception frequency for adjustment.

■ DISPLAY DATA

● V1 : 13-BT-151GK (VV298800)

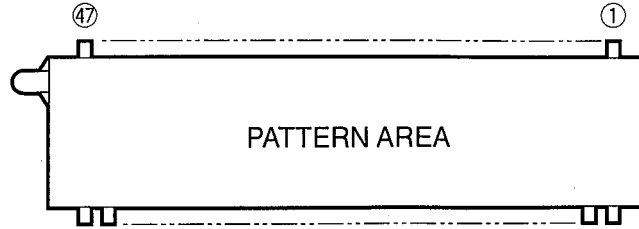

● PIN CONNECTION

PIN NO.	1	2	3	4	5	6	7	8	9	10	11	12	13	14	15	16	17	18	19	20	21
CONNECTION	F1	F1	NP	NP	P1	P2	P3	P4	P5	P6	P7	P8	P9	P10	P11	P12	P13	P14	P15	P16	NC
PIN NO.	22	23	24	25	26	27	28	29	30	31	32	33	34	35	36	37	38	39	40	41	42
CONNECTION	NC	NC	NC	NC	NC	NC	NC	NC	NC	13G	12G	11G	10G	9G	8G	7G	6G	5G	4G	3G	2G
PIN NO.	43	44	45	46	47																
CONNECTION	1G	NP	NP	F2	F2																

NOTE 1) F1, F2 Filament
 2) NP No pin
 3) NC No connection
 4) P1~P16 ... Datum Line
 5) 1G~13G .. Grid

● GRID ASSIGNMENT

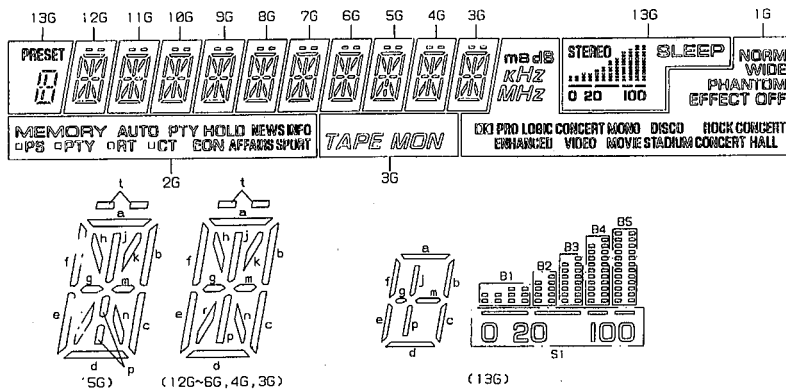

● ANODE CONNECTION

	13G	12G-4G	3G	2G	1G
P1	a	a	a	MEMORY	NORM
P2	b, c	b	b	AUTO	WIDE
P3	d	c	c	PTY HOLD	PHANTOM
P4	e, f	d	d	SPORT	EFFECT OFF
P5	g	e	e	AFFAIRS	ROCK CONCERT
P6	j, p	f	f	INFO	CONCERT HALL
P7	m	g	g	NEWS	DISCO
P8	PRESET	h	h	EDN	STADIUM
P9	STEREO	j	j	CT	MONO MOVIE
P10	B1	k	k	□ (CT)	CONCERT VIDEO
P11	B2	m	m	RT	DIG PRO LOGIC
P12	B3	n	n	□ (RT)	ENHANCED
P13	B4	p	p	PTY	dB
P14	B5	r	r	□ (PTY)	ms
P15	S1	t	t	PS	KHZ
P16	SLEEP	-	TAPE MON	□ (PS)	MHZ

RX-V393RDS
RX-V493RDS

IC DATA

IC4 : M38172M4-192FP
8 bit μ-COM

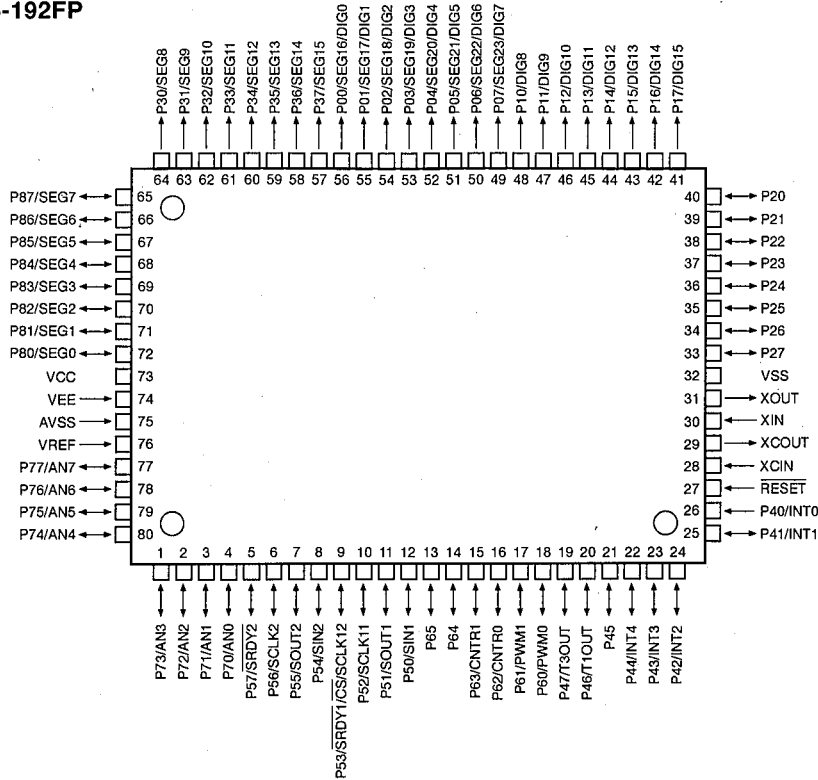

Pin No.	Port	I/O	Function
1	P73	I	KEY AD IN 1 (A-D)
2	P72	I	METER IN (A-D)
3	P71	I	PROTECTION 1 DETECT (not used) (GND)
4	P70	I	PROTECTION 2 DETECT (A-D)
5	P57	I	PROTECTION 3 DETECT
6	P56	O	SCLK 2
7	P55	O	SOUT 2
8	P54	I	DO IN for tuner
9	P53	O	Main mute [L : ON]
10	P52	I	SCLK IN RDS
11	P51	I/O	V2 market / RES OUT RDS
12	P50	I/O	V1 market / SDATA IN RDS
13	P65	I	RDS SELECT IN [H : RDS]
14	P64	I	DSP-A SELECT IN [H : DSPA]
15	P63	I	493 SELECT IN [H : 493]
16	P62	I	V393 SELECT IN [H : V393]
17	P61	O	Center mute [L : ON]
18	P60	O	Rear mute [L : ON]
19	P47	O	CETUN for tuner
20	P46	O	TMUTE for tuner [L : ON]
21	P45	O	Main mute [L : ON]
22	P44	I	/ST for tuner [L : STEREO]
23	P43	I	Power switch in [H : ON]
24	P42	I	Power down detect [L : DOWN]
25	P41	I	REMOTE CONTROL IN (INT1)
26	P40	I	START IN RDS (INT0)
27	RES		RESET

Protection 2 (4 pin)

Detection of an abnormal amplifier DC. Normal when AD value (128 - 255)/256. Detection starts 2 seconds after the power is turned ON.

Protection 3 (5 pin)

Detection of an abnormal amplifier overcurrent. Abnormality detected at H. Detection starts after the power is turned ON.

IC4 : M38172M4-192FP
8 bit μ -COM

Pin No.	Port	I/O	Function
28	XCIN		GND
29	XCOU		OPEN
30	XIN		6.3 MHz IN (CLOCK)
31	XOUT		6.3 MHz OUT (CLOCK)
32	VSS		GND
33	P27	O	VIDEO SELECTOR A (VSEL1)
34	P26	O	VIDEO SELECTOR B (VSEL2)
35	P25	O	NOT VCR SELECT [H : VCR]
36	P24	O	CE VR
37	P23	O	CE SEL
38	P22	O	CE DSP
39	P21	O	VOL UP OUT
40	P20	O	VOL DOWN OUT
41	P17	O	DSP SERIAL SELECT [H : DSP]
42	P16	O	POWER RELAY OUT [H : ON]
43	P15	O	SPEAKER RELAY OUT (MAIN) [H : ON]
44	P14	O	FL DIGIT 1 [H : ON]
45	P13	O	FL DIGIT 2 [H : ON]
46	P12	O	FL DIGIT 3 [H : ON]
47	P11	O	FL DIGIT 4 [H : ON]
48	P10	O	FL DIGIT 5 [H : ON]
49	P07	O	FL DIGIT 6 [H : ON]
50	P06	O	FL DIGIT 7 [H : ON]
51	P05	O	FL DIGIT 8 [H : ON]
52	P04	O	FL DIGIT 9 [H : ON]
53	P03	O	FL DIGIT 10 [H : ON]
54	P02	O	FL DIGIT 11 [H : ON]
55	P01	O	FL DIGIT 12 [H : ON]
56	P00	O	FL DIGIT 13 [H : ON]
57	P37	O	FL SEGMENT 16 [H : ON]
58	P36	O	FL SEGMENT 15 [H : ON]
59	P35	O	FL SEGMENT 14 [H : ON]
60	P34	O	FL SEGMENT 13 [H : ON]
61	P33	O	FL SEGMENT 12 [H : ON]
62	P32	O	FL SEGMENT 11 [H : ON]
63	P31	O	FL SEGMENT 10 [H : ON]
64	P30	O	FL SEGMENT 9 [H : ON]
65	P87	O	FL SEGMENT 8 [H : ON]
66	P86	O	FL SEGMENT 6 [H : ON]
67	P85	O	FL SEGMENT 5 [H : ON]
68	P84	O	FL SEGMENT 4 [H : ON]
69	P83	O	FL SEGMENT 3 [H : ON]
70	P82	O	FL SEGMENT 2 [H : ON]
71	P81	O	FL SEGMENT 1 [H : ON]
72	P80	O	FL SEGMENT 0 [H : ON]
73	VCC		+5V
74	VEE		-21V
75	AVSS		GND
76	VREF		A-D REFERENCE VOLTAGE IN (+5V)
77	P77	I	KEY AD IN 5 (A-D)
78	P76	I	KEY AD IN 4 (A-D)
79	P75	I	KEY AD IN 3 (A-D)
80	P74	I	KEY AD IN 2 (A-D)

IC16 : YSS203B

Digital Dolby Pro Logic Decoder with Auto Input Balance

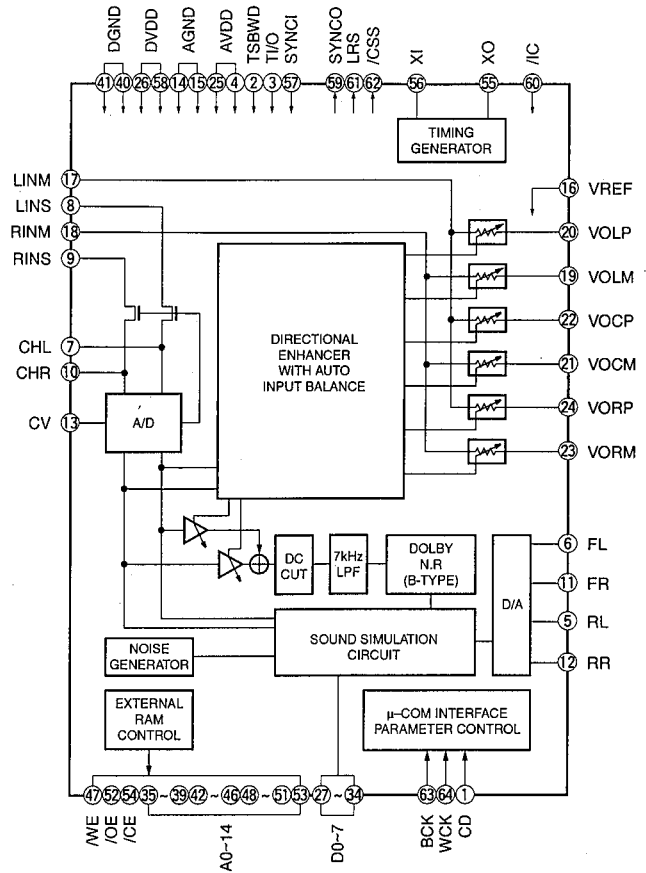
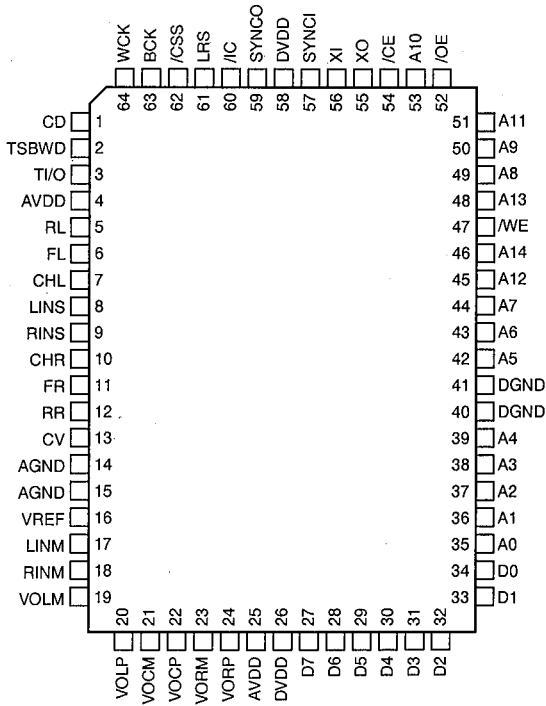

No.	Name	I/O	Function
1	CD	I _S	Serial data of parameter data input
2	TSBWD	I _C	LSI test terminal Normally connected to DVDD terminal
3	TI/O	I _C	LSI test terminal Normally connected to DVDD terminal
4	AVDD	A—	+5V power supply (D/A, A/D section)
5	RL	AO	RL channel D/A output
6	FL	AO	FL channel D/A output
7	CHL	A—	LINS input Sample/hold Capacitor external terminal
8	LINS	AI	L channel A/D input
9	RINS	AI	R channel A/D input
10	CHR	A—	RINS input Sample/hold Capacitor external terminal
11	FR	AO	FR channel D/A output
12	RR	AO	RR channel D/A output
13	CV	AO	A/D, multiplying DAC center voltage
14	AGND	A—	Ground (D/A, A/D section)
15	AGND	A—	Ground (Multiplying DAC section)
16	VREF	AI	Multiplying DAC reference voltage input
17	LINM	AI	L channel Multiplying DAC input
18	RINM	AI	R channel Multiplying DAC input
19	VOLM	AO	L channel operation amplifier, connected to (-) terminal
20	VOLP	AO	L channel operation amplifier, connected to (+) terminal

MEMO

IC16 : YSS203B

Digital Dolby Pro Logic Decoder with Auto Input Balance

No.	Name	I/O	Function
21	VOCM	AO	C channel operation amplifier, connected to (-) terminal
22	VOCP	AO	C channel operation amplifier, connected to (+) terminal
23	VORM	AO	R channel operation amplifier, connected to (-) terminal
24	VORP	AO	R channel operation amplifier, connected to (+) terminal
25	AVDD	A—	+5V power supply (multiplying DAC section)
26	DVDD	—	+5V power supply (digital section)
27	D7	I/Ot	External delay RAM data terminal
28	D6	I/Ot	External delay RAM data terminal
29	D5	I/Ot	External delay RAM data terminal
30	D4	I/Ot	External delay RAM data terminal
31	D3	I/Ot	External delay RAM data terminal
32	D2	I/Ot	External delay RAM data terminal
33	D1	I/Ot	External delay RAM data terminal
34	D0	I/Ot	External delay RAM data terminal
35	A0	O	External data RAM address terminal
36	A1	O	External data RAM address terminal
37	A2	O	External data RAM address terminal
38	A3	O	External data RAM address terminal
39	A4	O	External data RAM address terminal
40	DGND	—	Ground (digital section)
41	DGND	—	Ground (digital section)
42	A5	O	External data RAM address terminal
43	A6	O	External data RAM address terminal
44	A7	O	External data RAM address terminal
45	A12	O	External data RAM address terminal
46	A14	O	External data RAM address terminal
47	/WE	O	External delay RAM write enable terminal
48	A13	O	External delay RAM address terminal
49	A8	O	External delay RAM address terminal
50	A9	O	External delay RAM address terminal
51	A11	O	External delay RAM address terminal
52	/OE	O	External delay RAM output enable terminal
53	A10	O	External delay RAM address terminal
54	/CE	O	External delay RAM chip enable terminal
55	XO	O	Crystal oscillator connecting terminal
56	XI	I	Crystal oscillator connecting terminal
57	SYNCI	It	Test terminal for system synchronization, normally connected to DVDD
58	DVDD	—	+5V power supply (digital section)
59	SYNCO	O	Test terminal for system synchronization, normally unconnected
60	/IC	Ics	Initial clear terminal (Power ON resetting is necessary)
61	LRS	O	External automatic input balance terminal, normally unconnected
62	/CSS	O	External automatic input balance terminal, normally unconnected
63	BCK	I _{ts}	Bit clock for parameter data input
64	WCK	I _{ts}	Word clock for parameter data input

Note : Letters used in the above I/O column represent as follows.

I : Input terminal O : Output terminal t : TTL level
c : CMOS level s : Schmitt input A : Analog terminal

PIN CONNECTION DIAGRAM

● ICs

<p>AN78N05</p> <p>1:INPUT 2:COMMON 3:OUTPUT</p>	<p>M5220L</p>	<p>μPC4570HA</p>	<p>LB1641</p>
<p>NJM79M15FA</p> <p>1:COMMON 2:INPUT 3:OUTPUT</p>	<p>NJM2068L-D NJM4558L-D</p>	<p>LA7956</p>	<p>TC9299P</p>
<p>STK311-020B</p>	<p>LC78213 LC78211</p>		
<p>LA3401 LC72131</p>	<p>YSS203B</p>		
<p>LA1266</p>	<p>M38172M4-192FP</p>		
<p>LH5P832D-10</p>			

● Diodes

<p>1SS133 1SS355 1SS270A 1T2 2A02M</p> <p>Anode Cathode</p>	<p>HZS5C2TD HZS5B2TD HZS6A2TD HZS7A2TD HZS12B2TD HZS12A2TD HZS152TD HZS242TD MA8056-H</p>
<p>S1NB20</p>	
<p>S4VB20</p>	

● Transistors

<p>2SA933S (Q, R) 2SA1740S (R, S) 2SC3330 (S, T) 2SD1915F (S, T) DTA114ES DTC144ES</p> <p>B C E</p>	<p>2SA1708 (S, T) 2SC4488 (S, T)</p> <p>E C B</p>
<p>2SA893A (D, E) 2SA1015 (Y) 2SB647 (C, D)</p> <p>E C B</p>	<p>2SC535 (A, B, C) 2SC1815 (Y) 2SC1890A (D, E) 2SC1890E 2SC2229 (O, Y) 2SC2240 (GR, BL) 2SC2878 (A, B)</p>
<p>2SA1694 (O, P, Y) 2SC4467 (O, P, Y) 2SA1695 (O, P, Y) 2SC4468 (O, P, Y) 2SC4466 (O, P, Y)</p> <p>B C E</p>	<p>2SK30ATM (GR)</p> <p>S G D</p>
	<p>2SD856 (P, Q) 2SC4495</p> <p>B C E</p>

BLOCK DIAGRAM

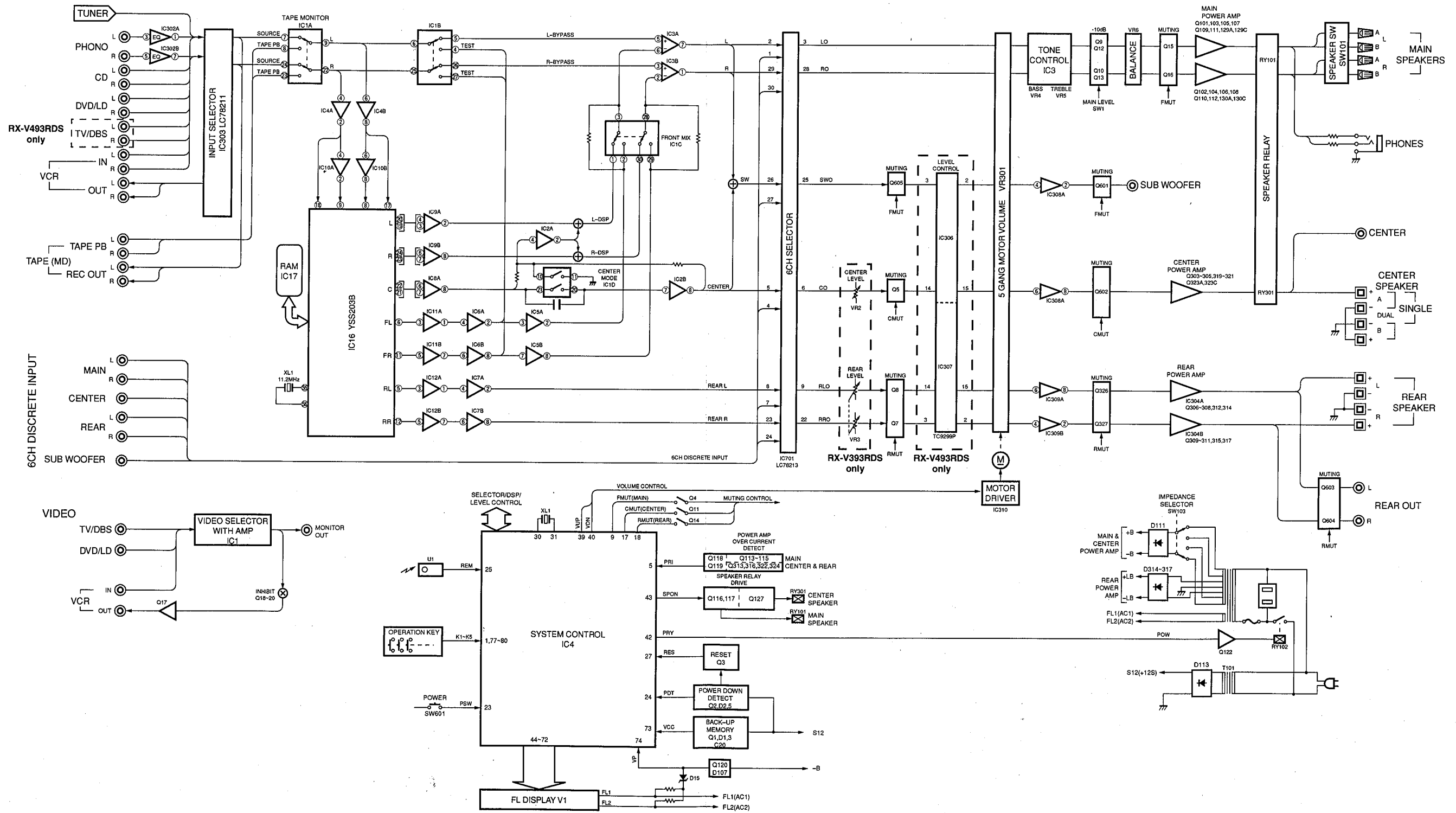

RX-V493RDS SCHEMATIC DIAGRAM (TUNER)

Each voltage given here represents that in the FM (98.1MHz, STEREO) reception mode but the one in the parentheses () is measured in the AM (1080kHz, MAN'L) reception mode.

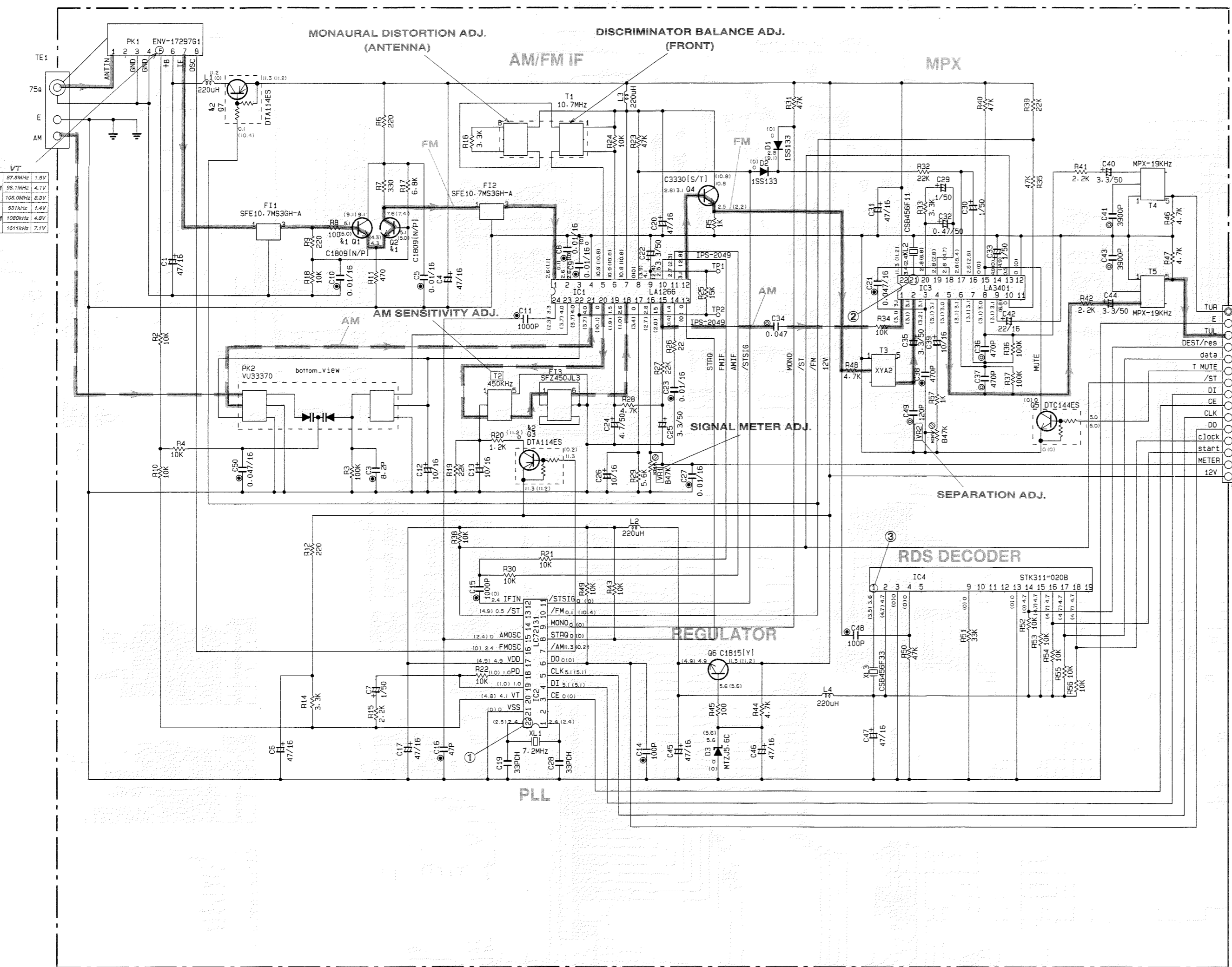

CAPACITOR

REMARKS	PARTS NAME
NO MARK	ELECTROLYTIC CAPACITOR
⊗	TANTALUM CAPACITOR
NO MARK	CERAMIC CAPACITOR
●	CERAMIC TUBULAR CAPACITOR
⊙	POLYESTER FILM CAPACITOR
○	POLYSTYRENE FILM CAPACITOR
⊖	MICA CAPACITOR
⊕	POLYPROPYLENE FILM CAPACITOR
⊗	SEMICONDUCTIVE CERAMIC CAPACITOR

RESISTOR

REMARKS	PARTS NAME
NO MARK	CARBON FILM RESISTOR (P=5)
⊗	CARBON FILM RESISTOR (P=10)
△	METAL OXIDE FILM RESISTOR
⊙	METAL FILM RESISTOR
⊖	METAL PLATE RESISTOR
⊕	FIRE PROOF CARBON FILM RESISTOR
⊗	CEMENT MOLDED RESISTOR
⊖	SEMI VARIABLE RESISTOR
⊕	CHIP RESISTOR

NOTICE (model)
 (J)..... JAPANESE
 (U)..... U. S. A
 (C)..... CANADIAN
 (R)..... GENERAL
 (A)..... AUSTRALIAN
 (B)..... BRITISH
 (G)..... EUROPEAN
 (T)..... CHINA
 (L)..... SINGAPORE

Interchangeable Parts at Manufacture-Stage

Mark	Reference Parts Number	Parts Name
Ⓚ1	01-2	25C1809(N/P) 25C1809S(N/P)
Ⓚ2	03-7	DTA114ES UN4111

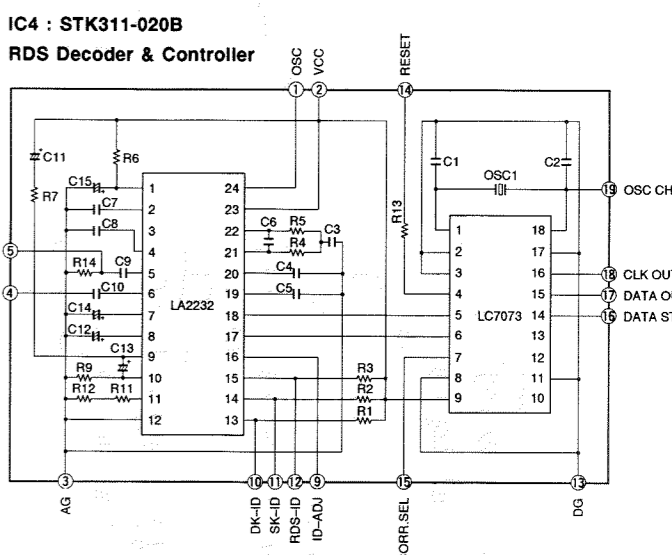
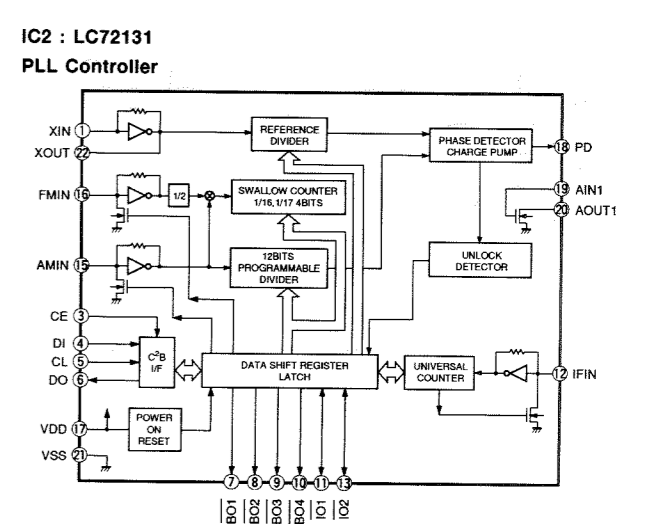
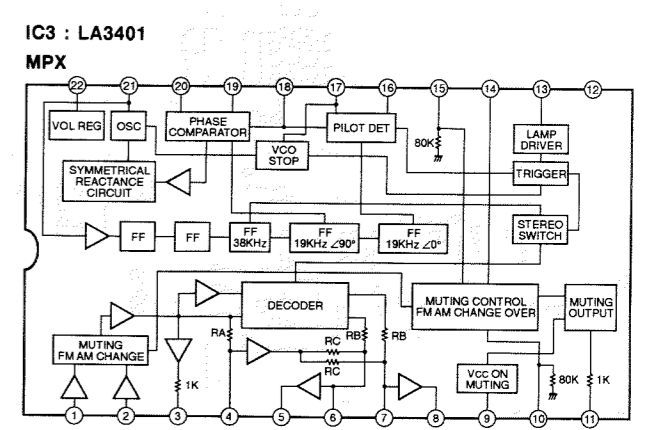
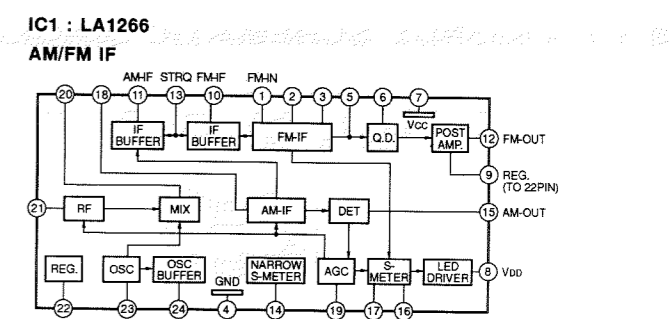

● PK1 : ENV-17297G1 (VQ987600)

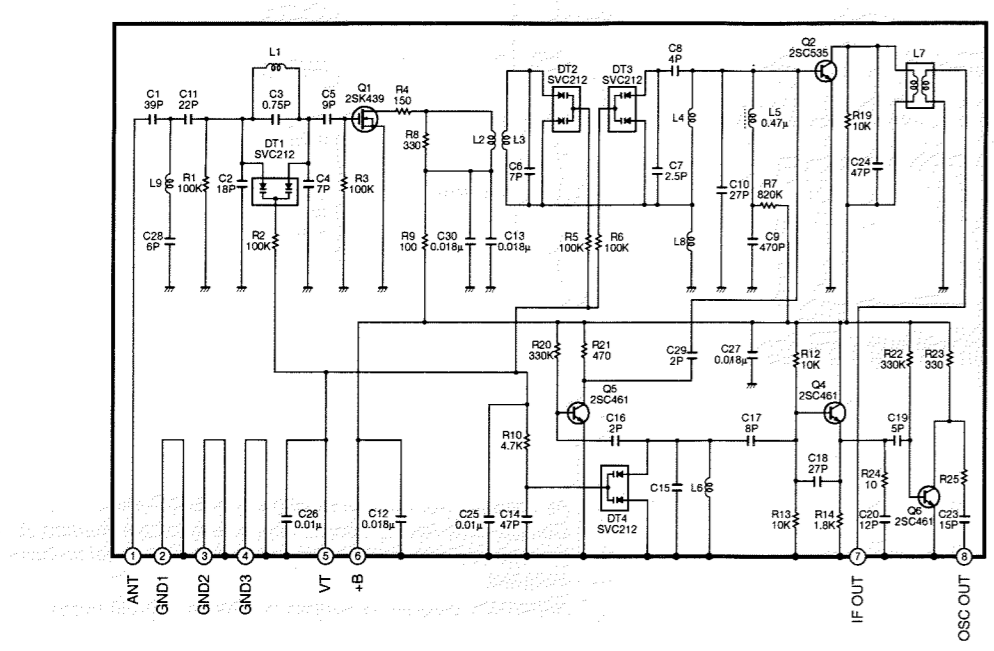

Point ① (Pin22 of IC2) FM reception
 V : 2V/div H : 50nsec/div
 DC range 1 : 1 probe

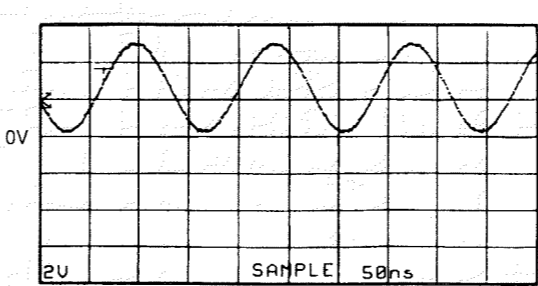

Point ② (Pin21 of IC3)
 V : 2V/div H : 1µsec/div
 DC range 1 : 1 probe

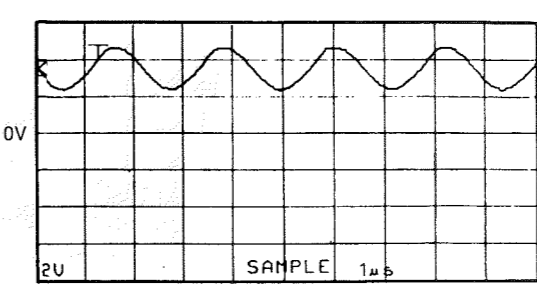

Point ③ (Pin1 of IC4)
 V : 5V/div H : 1µsec/div
 DC range 1 : 1 probe

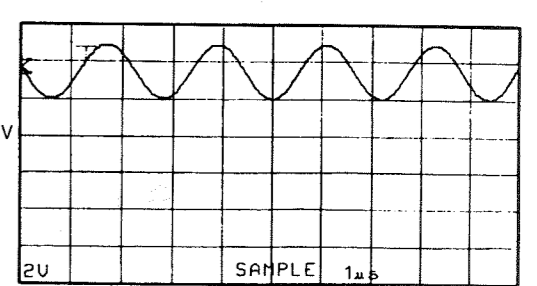

* All voltages are measured with a 10MΩ/DC electric volt meter.
 * Components having special characteristics are marked △ and must be replaced with parts having specifications equal to those originally installed.
 * Schematic diagram is subject to change without notice.

RX-V493RDS SCHEMATIC DIAGRAM (OPERATION & SELECT)

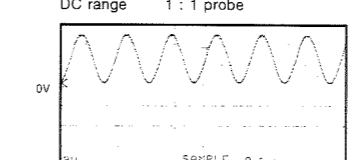
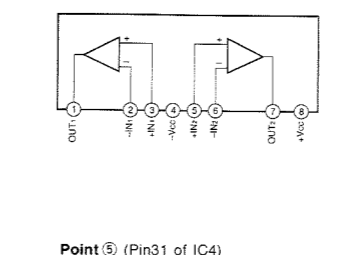
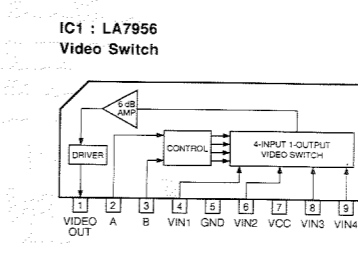
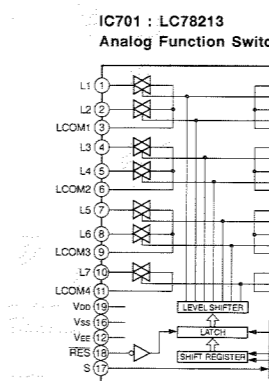
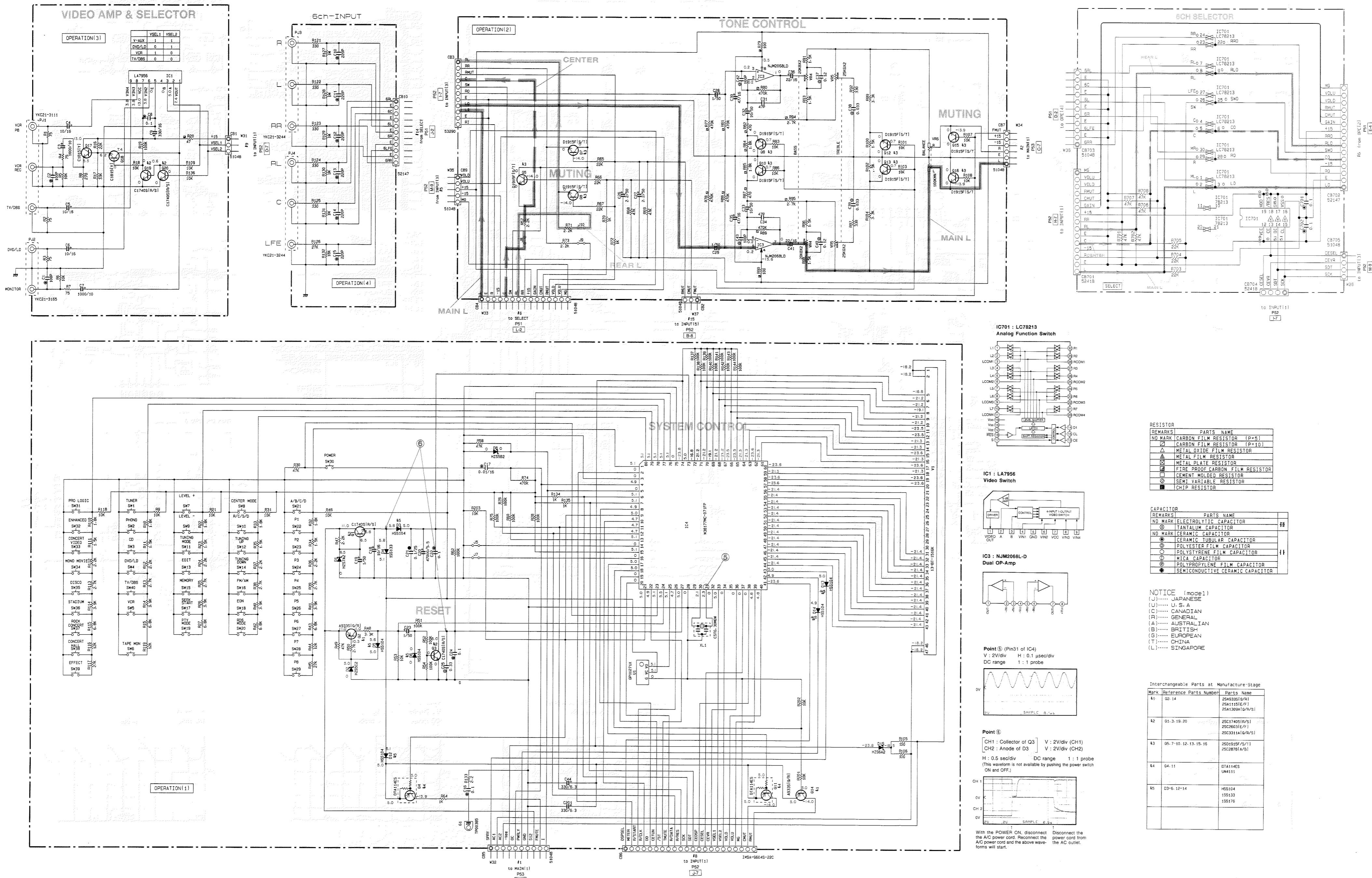

Point ⑤ (Pin3 of IC4)
 V: 2V/div V: 0.1 μsec/div
 DC range 1:1 probe

Point ⑥
 CH1: Collector of Q3 V: 2V/div (CH1)
 CH2: Anode of D3 V: 2V/div (CH2)
 H: 0.5 sec/div DC range 1:1 probe
 (The waveform is not available by passing the power switch ON and OFF.)

With the POWER ON, disconnect the power cord from the AC power cord and the above waveforms will start.

REMARKS	PARTS NAME
NO MARK	CARBON FILM RESISTOR (P=51)
□	CARBON FILM RESISTOR (P=10)
△	METAL OXIDE FILM RESISTOR
⊠	METAL FILM RESISTOR
⊡	METAL PLATE RESISTOR
⊞	FIRE PROOF CARBON FILM RESISTOR
⊟	CEMENT MOLDED RESISTOR
⊞	SEMI VARIABLE RESISTOR
⊞	CHIP RESISTOR

REMARKS	PARTS NAME
NO MARK	ELECTROLYTIC CAPACITOR
NO MARK	TANTALUM CAPACITOR
□	CERAMIC CAPACITOR
○	CERAMIC TUBULAR CAPACITOR
⊙	POLYESTER FILM CAPACITOR
⊙	POLYSTYRENE FILM CAPACITOR
⊙	MICA CAPACITOR
⊙	POLYPROPYLENE FILM CAPACITOR
⊙	SEMICONDUCTIVE CERAMIC CAPACITOR

NOTICE (mode1)
 (J)..... JAPANESE
 (U)..... U.S.A
 (C)..... CANADIAN
 (R)..... GENERAL
 (A)..... AUSTRALIAN
 (B)..... BRITISH
 (G)..... EUROPEAN
 (T)..... CHINA
 (L)..... SINGAPORE

Mark	Reference Parts Number	Parts Name
41	02-14	2S4933S/G/P1 2S4115E/P1 2S4138S1/G/P/S1
42	01-3-19-20	2SC1740S/R/S1 2SC2663E/P1 2SC3314G/P/S1
43	05-7-10-12-13-15-16	2SD1915F/S/1 2SC2878A/S/1
44	04-11	DTA114E5 1M4111
45	03-6-12-14	HE5104 1S5133 1S5176

* All voltages are measured with a 10MΩ/DC electric volt meter.
 * Components having special characteristics are marked △ and must be replaced with parts having specifications equal to those originally installed.
 * Schematic diagram is subject to change without notice.

RX-V493RDS SCHEMATIC DIAGRAM (INPUT)

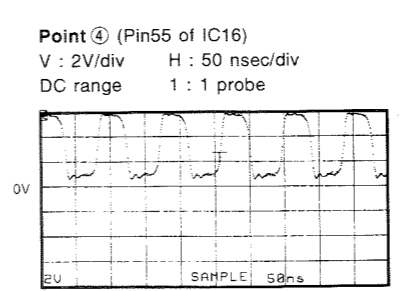
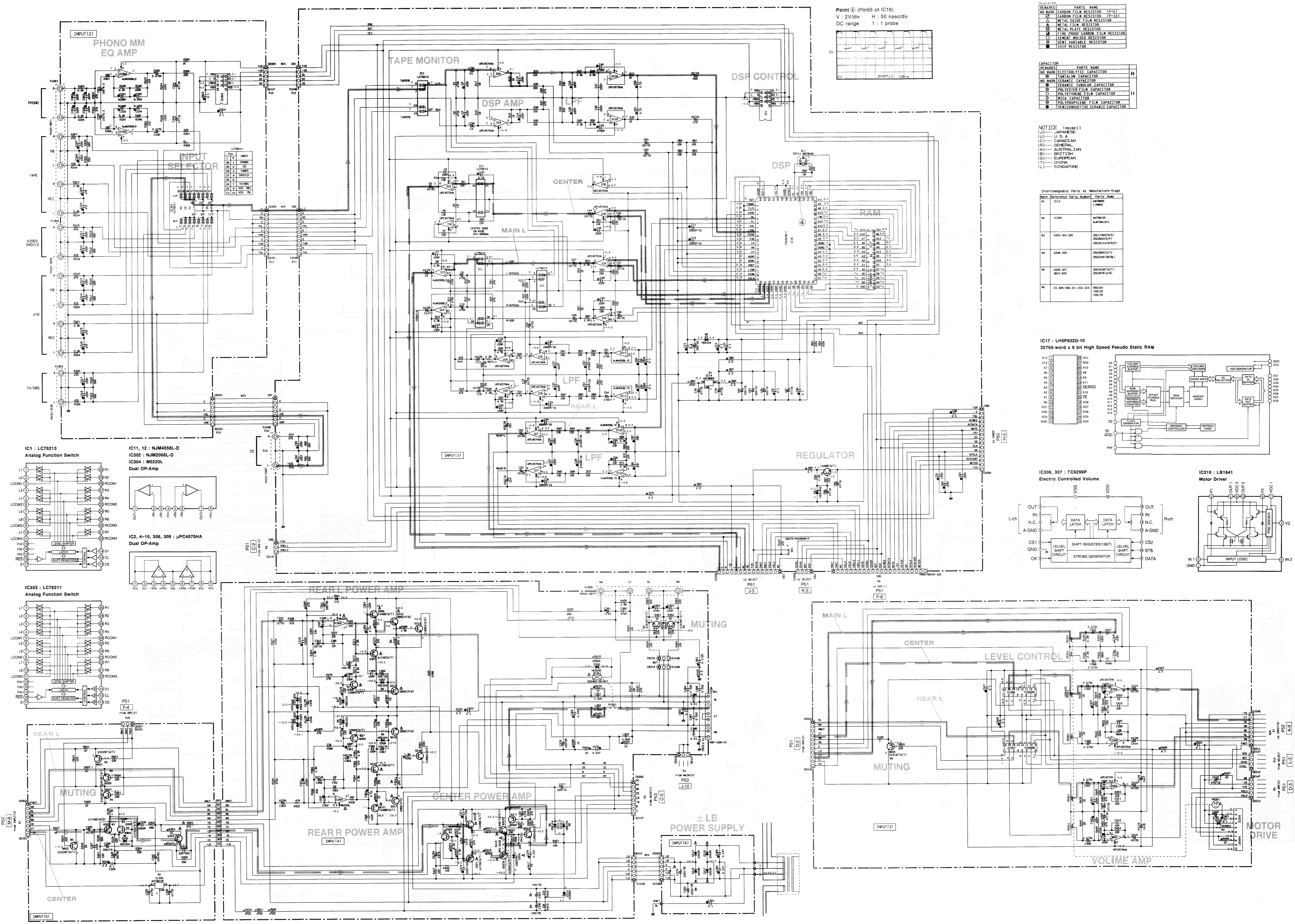

RESISTOR	PARTS NAME
NO MARK	CARBON FILM RESISTOR (F1-F15)
□	CARBON FILM RESISTOR (F1-F15)
△	METAL OXIDE FILM RESISTOR
○	METAL FILM RESISTOR
◇	METAL PLATE RESISTOR
□	THICK FILM CARBON FILM RESISTOR
◇	GENERAL PURPOSE RESISTOR
◇	TRIMMER RESISTOR
◇	TRIMMER RESISTOR
◇	TRIMMER RESISTOR

CAPACITOR	PARTS NAME
NO MARK	ELECTROLYTIC CAPACITOR
□	TANTALUM CAPACITOR
○	CERAMIC DISK CAPACITOR
○	POLYESTER FILM CAPACITOR
○	POLYSTYRENE FILM CAPACITOR
○	POLYPROPYLENE FILM CAPACITOR
○	POLYPROPYLENE FILM CAPACITOR
○	ISOTHERMOPLASTIC CERAMIC CAPACITOR

NOTICE (model)
 (J)..... JAPANESE
 (U)..... U.S.A.
 (C)..... CANADIAN
 (□)..... GENERAL
 (A)..... AUSTRALIAN
 (B)..... BRITISH
 (G)..... EUROPEAN
 (T)..... CHINA
 (L)..... SINGAPORE

Part No.	Reference Part No.	Part Name
41	IC24	ANALOG
42	IC305	ANALOG
43	IC306, 307, 308	REGULATOR
44	IC309, 310	REGULATOR
45	IC311, 312	REGULATOR
46	IC313, 314, 315, 316, 317	REGULATOR

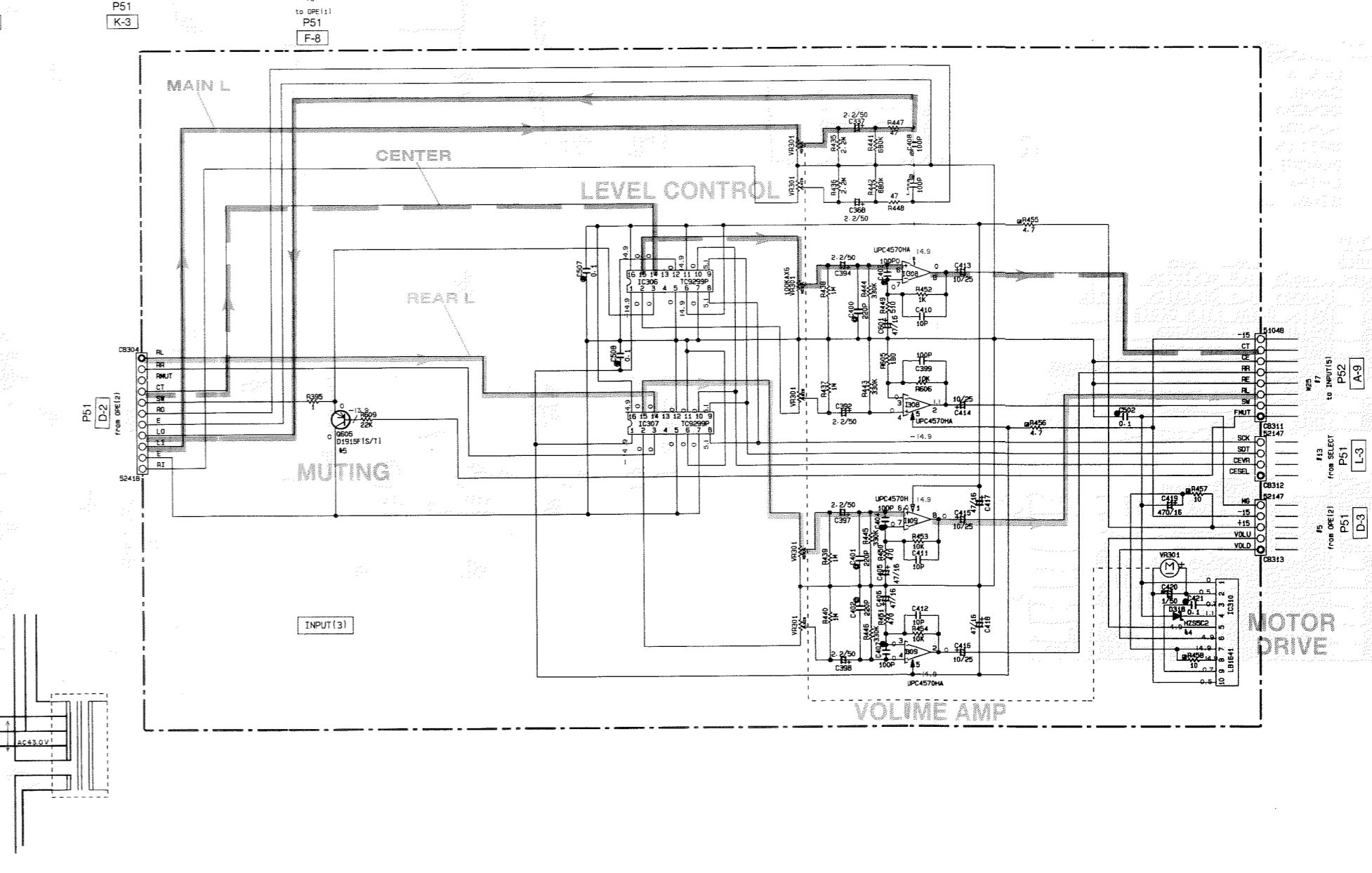
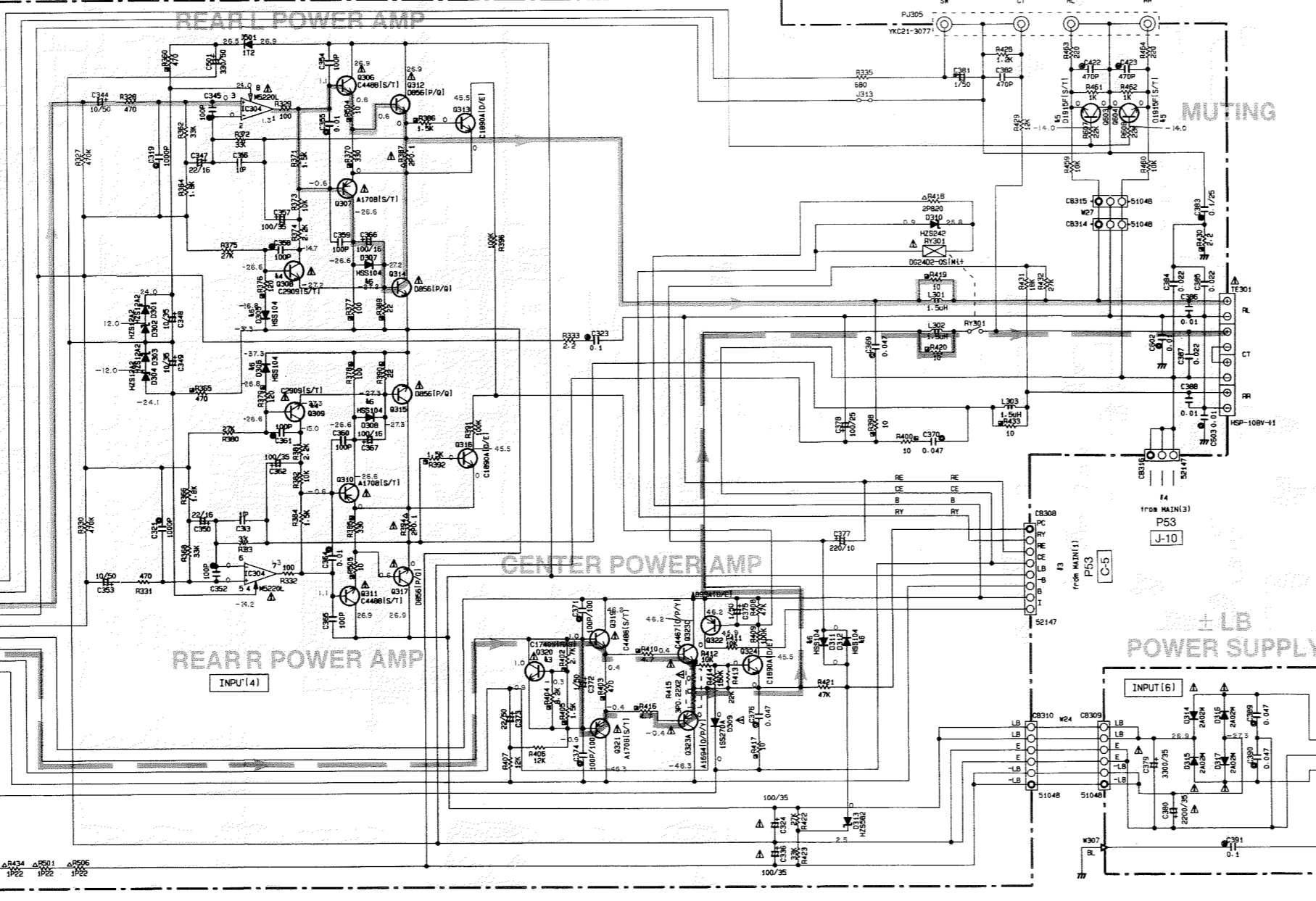
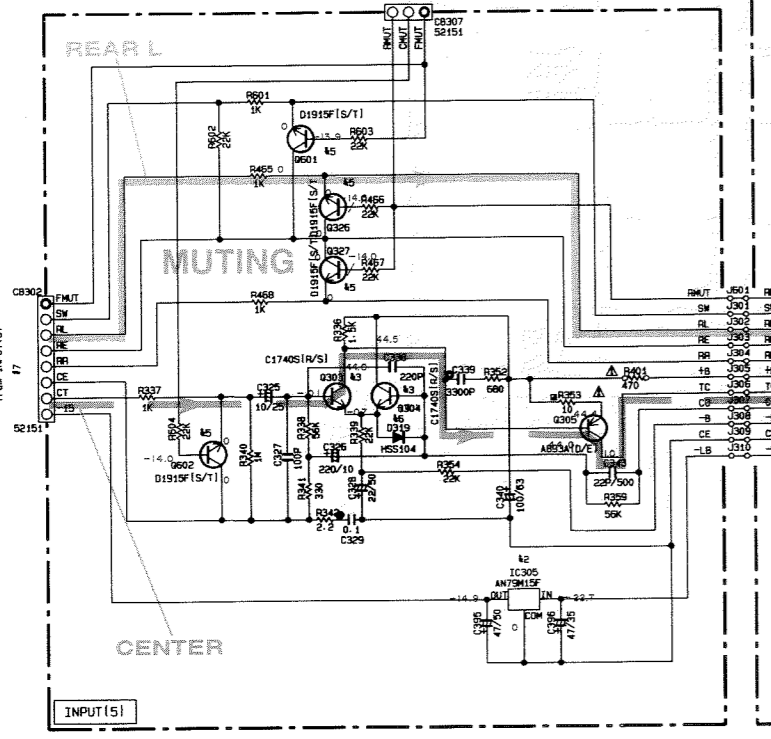
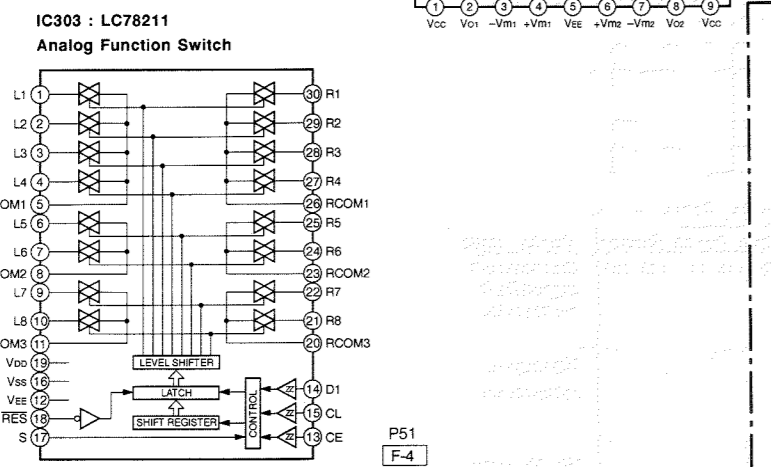
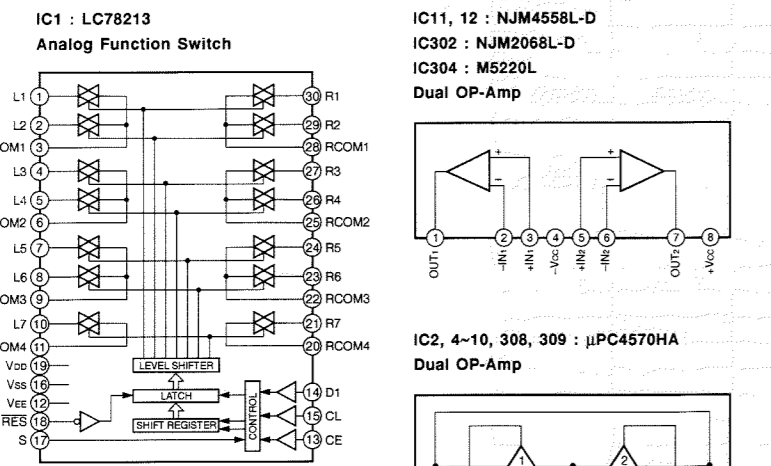
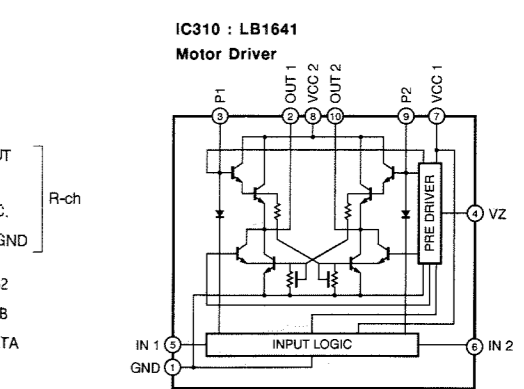
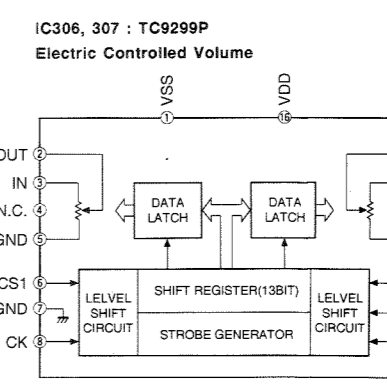
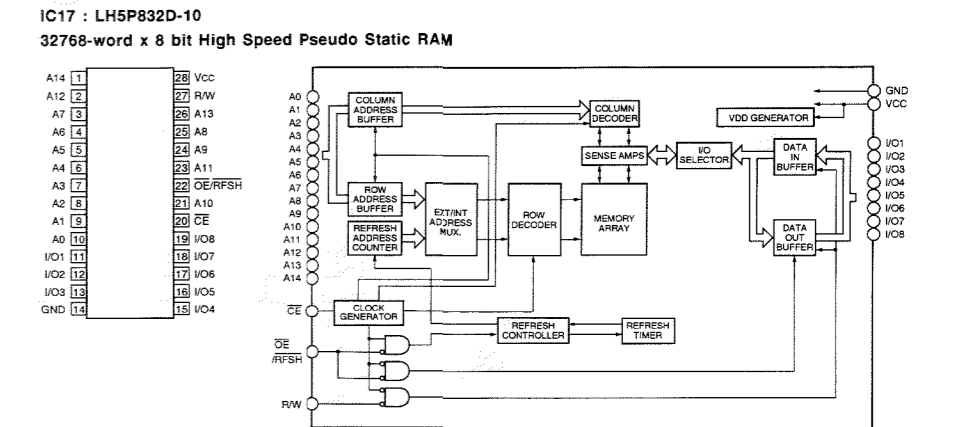

* All voltages are measured with a 10MΩ/DC electric volt meter.
 * Components having special characteristics are marked Δ and must be replaced with parts having specifications equal to those originally installed.
 * Schematic diagram is subject to change without notice.

RX-V493RDS SCHEMATIC DIAGRAM (MAIN)

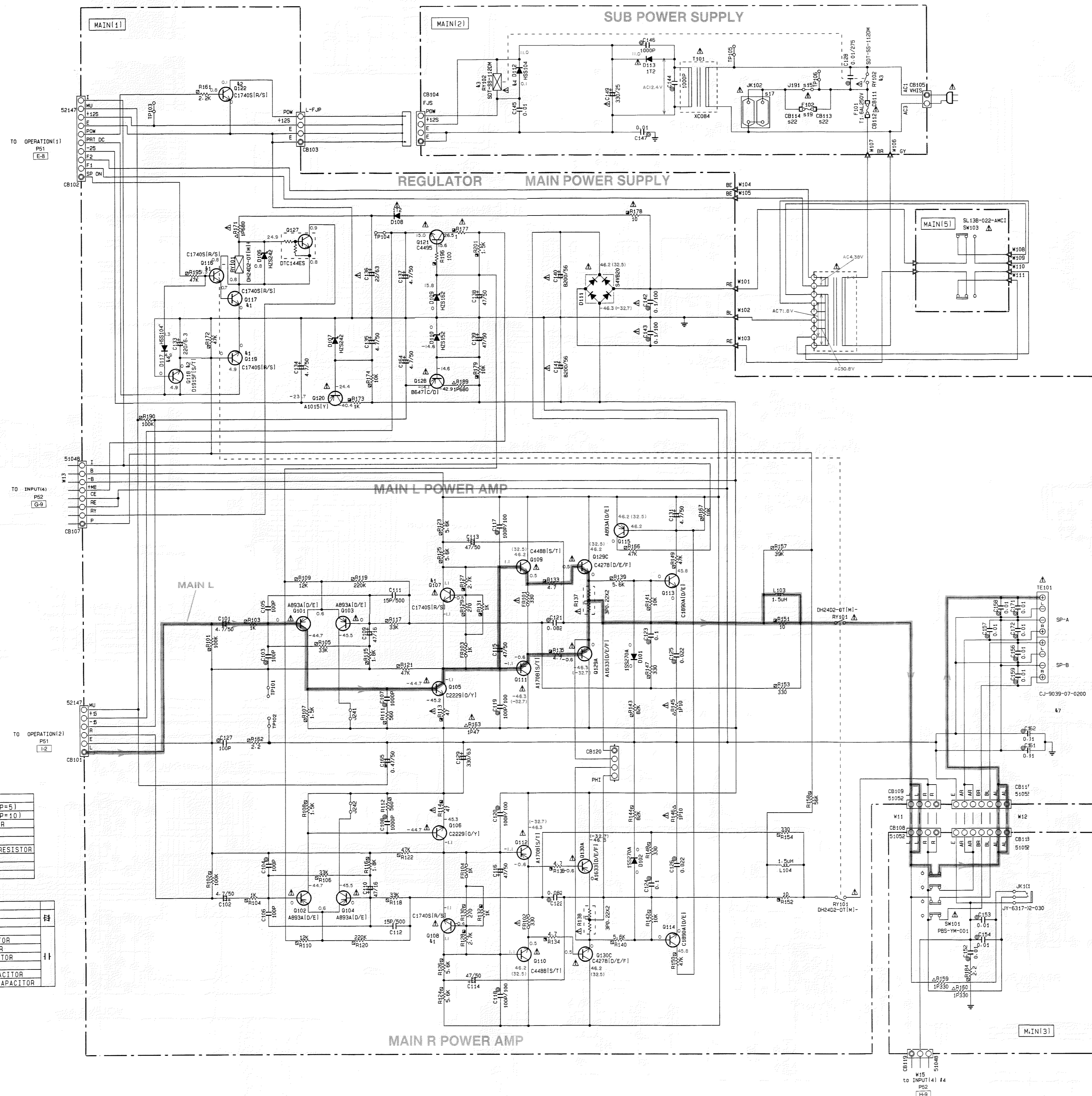

NOTICE (model)
 (J)..... JAPANESE
 (U)..... U.S.A
 (C)..... CANADIAN
 (R)..... GENERAL
 (A)..... AUSTRALIAN
 (B)..... BRITISH
 (G)..... EUROPEAN
 (T)..... CHINA
 (L)..... SINGAPORE

RESISTOR

REMARKS	PARTS NAME
NO MARK	CARBON FILM RESISTOR (P=5)
□	CARBON FILM RESISTOR (P=10)
△	METAL OXIDE FILM RESISTOR
▲	METAL FILM RESISTOR
⊠	METAL PLATE RESISTOR
⊞	FIRE PROOF CARBON FILM RESISTOR
⊡	CEMENT MOLDED RESISTOR
⊚	SEMI VARIABLE RESISTOR
■	CHIP RESISTOR

CAPACITOR

REMARKS	PARTS NAME
NO MARK	ELECTROLYTIC CAPACITOR
⊗	TANTALUM CAPACITOR
NO MARK	CERAMIC CAPACITOR
⊙	CERAMIC TUBULAR CAPACITOR
⊚	POLYESTER FILM CAPACITOR
○	POLYSTYRENE FILM CAPACITOR
⊖	MICA CAPACITOR
⊕	POLYPROPYLENE FILM CAPACITOR
●	SEMICONDUCTIVE CERAMIC CAPACITOR

CIRCUIT CHANGES BY MARKET.

	B	G
S15	J191	0 X
S17	JK102	VU54330 VU54340
S19	F102	X T2-5AL250V
S22	CB113; CB114	X 0

Interchangeable Parts at Manufacture-Stage

Mark	Reference Parts Number	Parts Name
41	0107-108-116-117-119-122	2SC1740S (R/S) 2SC26031S (F1) 2SC3311A (Q/R/S)
42	0118	2SD1915F (S/T1) 2SC2078A (B)
43	RY102	SOT-SS-1120M G5P-1-DC12V
44	D112-117	H5E104 1SS133 1SS176
45		
46		
47	TE101	VU81970 W50620

All voltages are measured with a 10MΩ/DC electric volt meter.
 Components having special characteristics are marked Δ and must be replaced with parts having specifications equal to those originally installed.
 Schematic diagram is subject to change without notice.

1 ■ BLOCK DIAGRAM

1

2

3

4

5

6

7

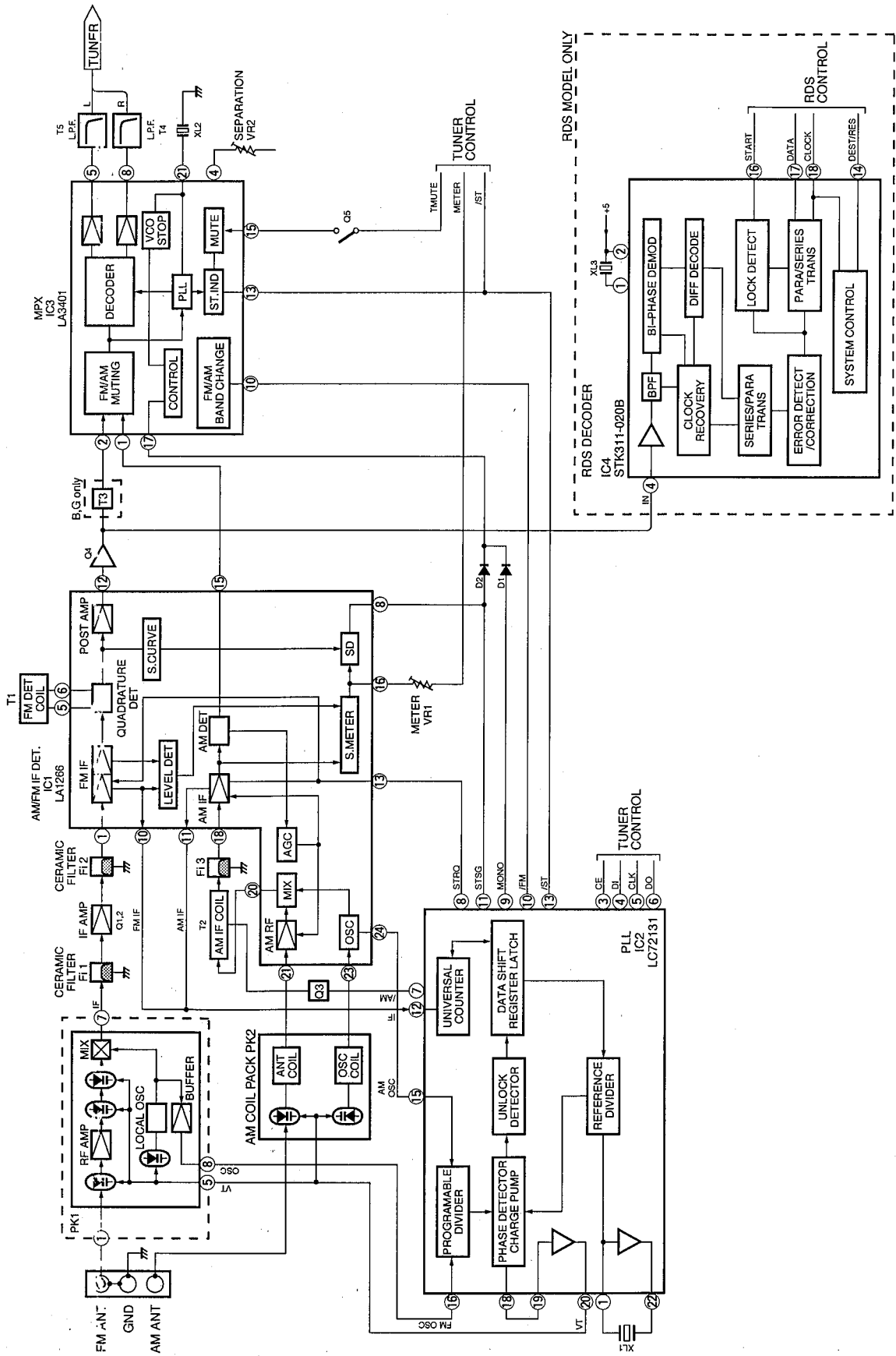

RX-V393RDS SCHEMATIC DIAGRAM (TUNER)

Each voltage given here represents that in the FM (98.1MHz, STEREO) reception mode but the one in the parentheses () is measured in the AM (1080kHz, MAN'L) reception mode.

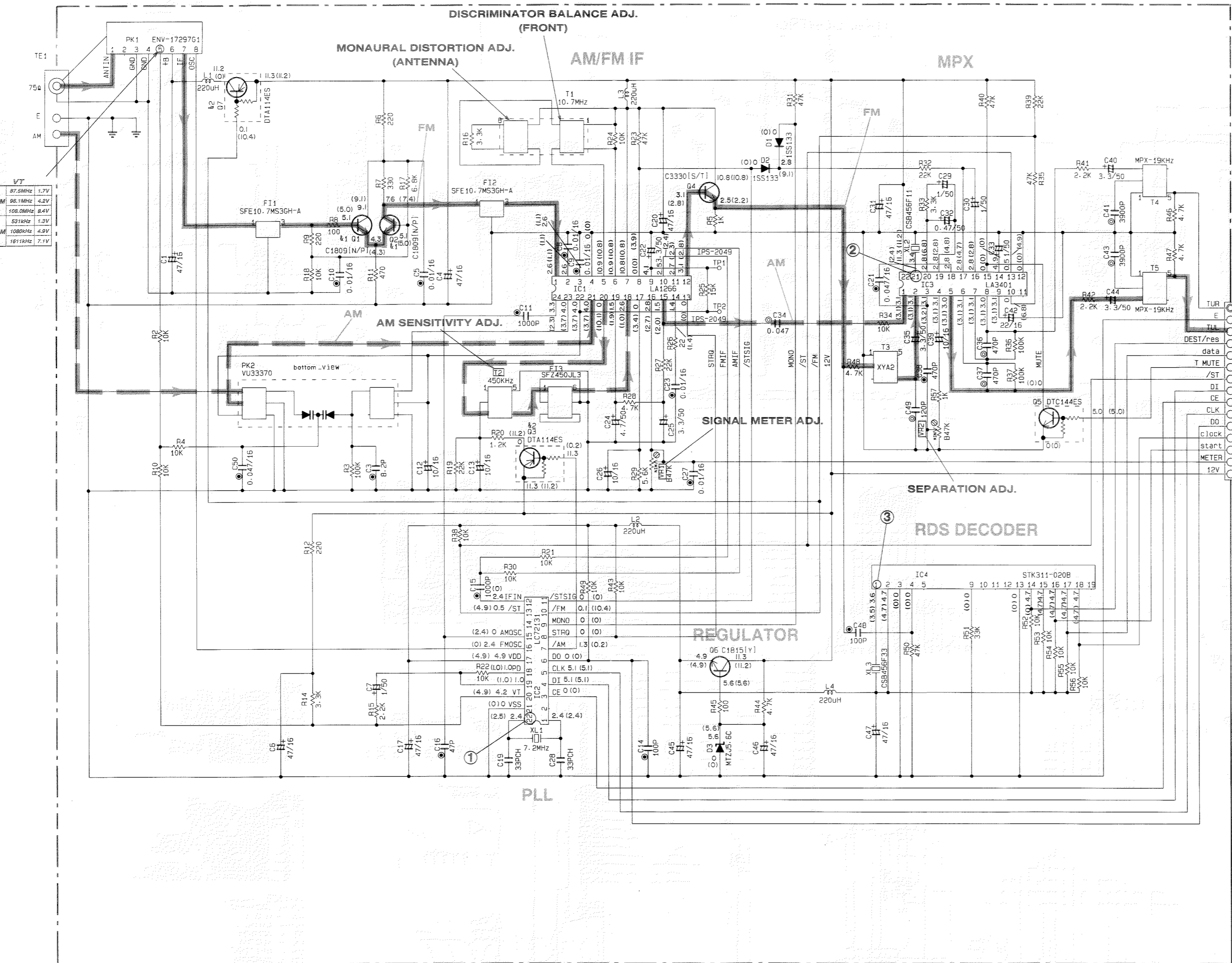

CAPACITOR

REMARKS	PARTS NAME
NO MARK	ELECTROLYTIC CAPACITOR
⊗	TANTALUM CAPACITOR
NO MARK	CERAMIC CAPACITOR
⊙	CERAMIC TUBULAR CAPACITOR
⊖	POLYESTER FILM CAPACITOR
○	POLYSTYRENE FILM CAPACITOR
⊕	MICA CAPACITOR
⊖	POLYPROPYLENE FILM CAPACITOR
⊖	SEMICONDUCTIVE CERAMIC CAPACITOR

RESISTOR

REMARKS	PARTS NAME
NO MARK	CARBON FILM RESISTOR (P=5)
□	CARBON FILM RESISTOR (P=10)
△	METAL OXIDE FILM RESISTOR
⊖	METAL FILM RESISTOR
⊖	METAL PLATE RESISTOR
⊖	FIRE PROOF CARBON FILM RESISTOR
⊖	CEMENT MOLDED RESISTOR
⊖	SEMI VARIABLE RESISTOR
⊖	CHIP RESISTOR

NOTICE (mode1)
 (J)..... JAPANESE
 (U)..... U. S. A
 (C)..... CANADIAN
 (R)..... GENERAL
 (A)..... AUSTRALIAN
 (B)..... BRITISH
 (G)..... EUROPEAN
 (T)..... CHINA
 (L)..... SINGAPORE

Interchangeable Parts at Manufacture-Stage

Mark	Reference Parts Number	Parts Name
k1	01.2	2SC1809IN/P 2SC1809SIN/P1
k2	03.7	DTA114ES UN4111

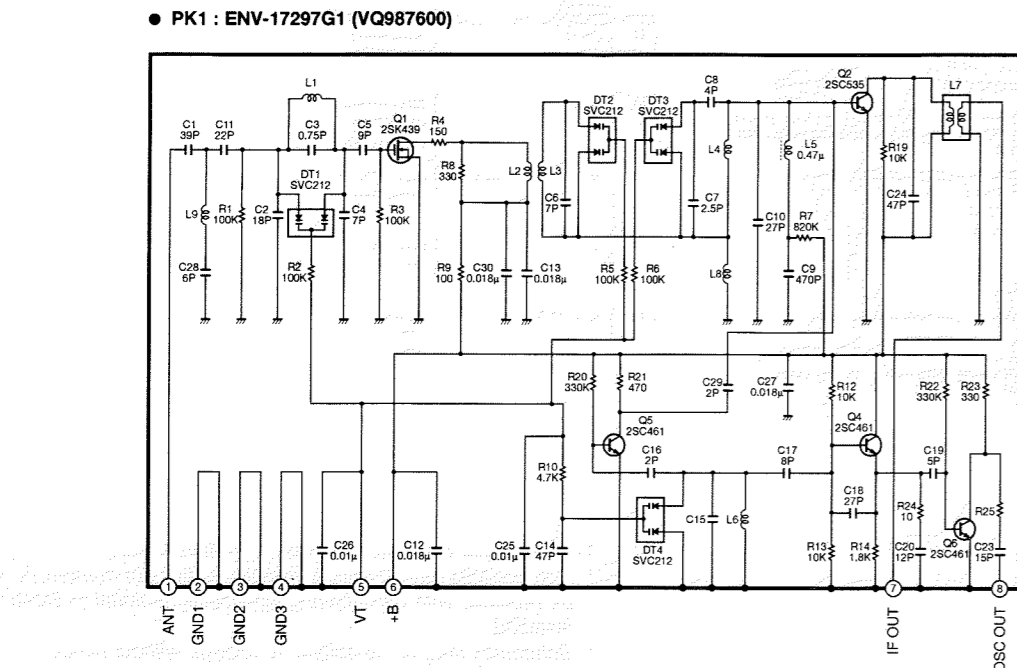
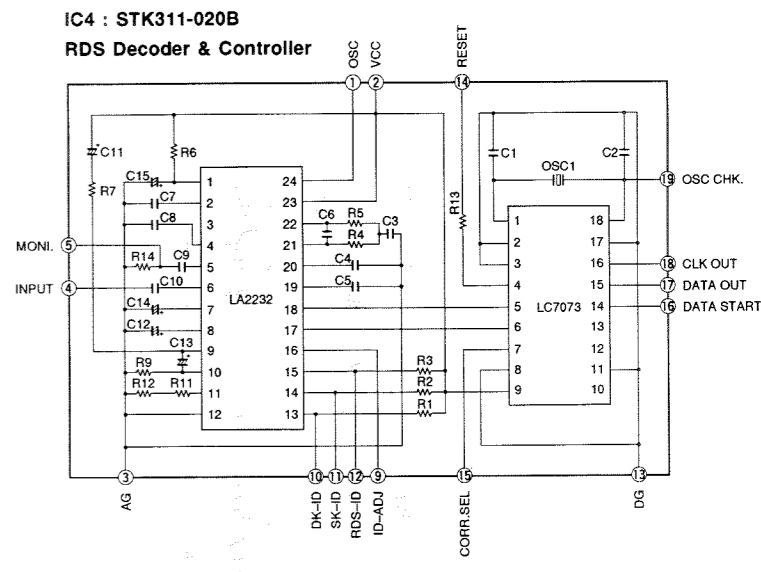
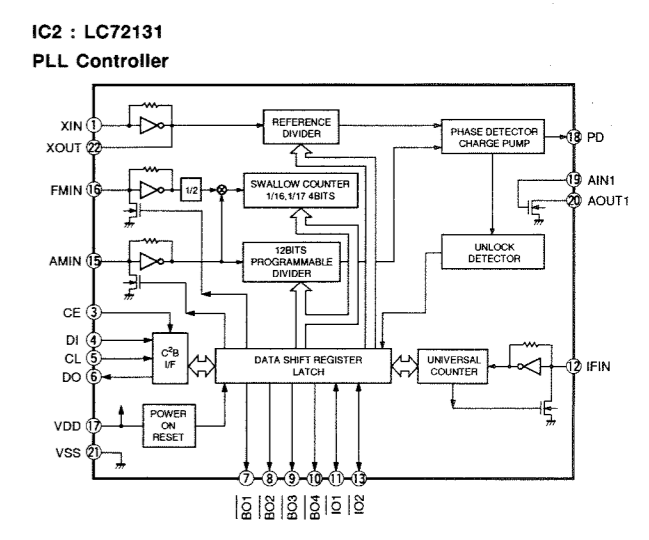
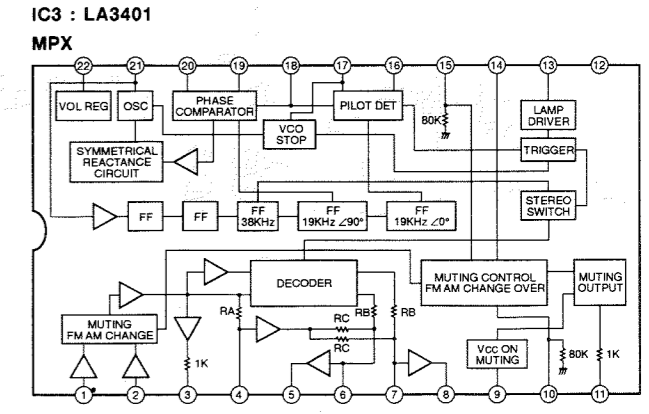
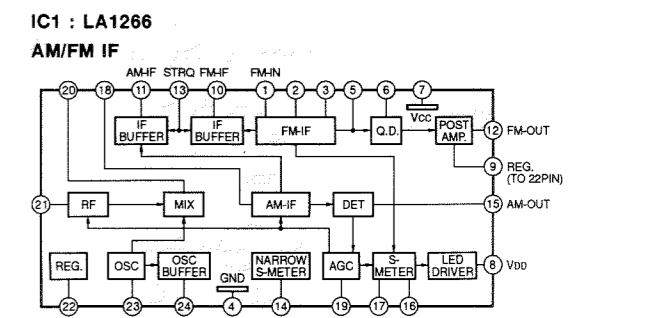

Point ① (Pin22 of IC2) FM reception
 V : 2V/div H : 50nsec/div
 DC range 1 : 1 probe

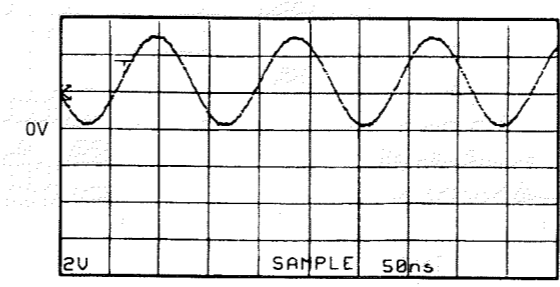

Point ② (Pin21 of IC3)
 V : 2V/div H : 1µsec/div
 DC range 1 : 1 probe

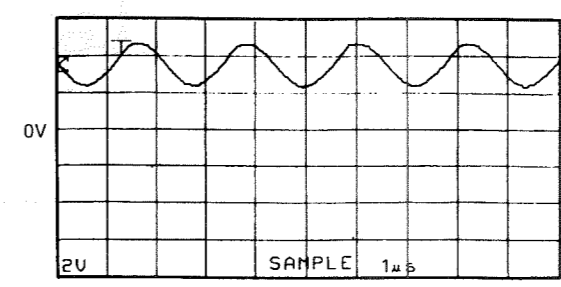

Point ③ (Pin1 of IC4)
 V : 5V/div H : 1µsec/div
 DC range 1 : 1 probe

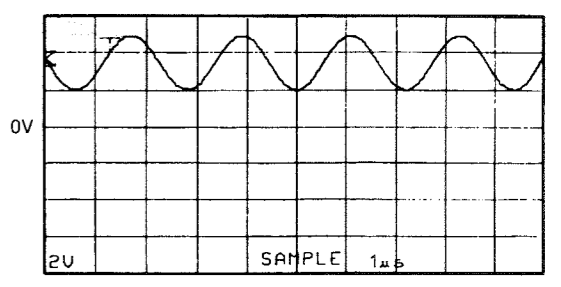

* All voltages are measured with a 10MΩ/DC electric volt meter.
 * Components having special characteristics are marked △ and must be replaced with parts having specifications equal to those originally installed.
 * Schematic diagram is subject to change without notice.

RX-V393RDS SCHEMATIC DIAGRAM (OPERATION & SELECT)

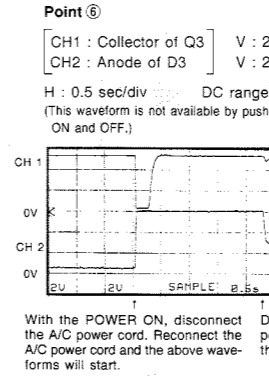
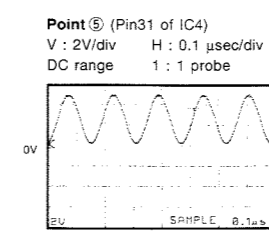
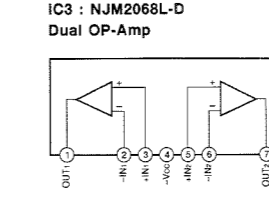
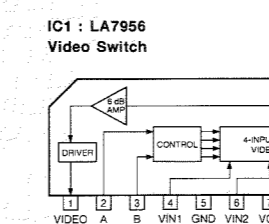
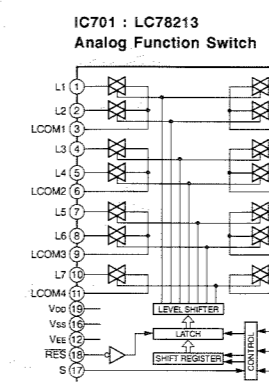
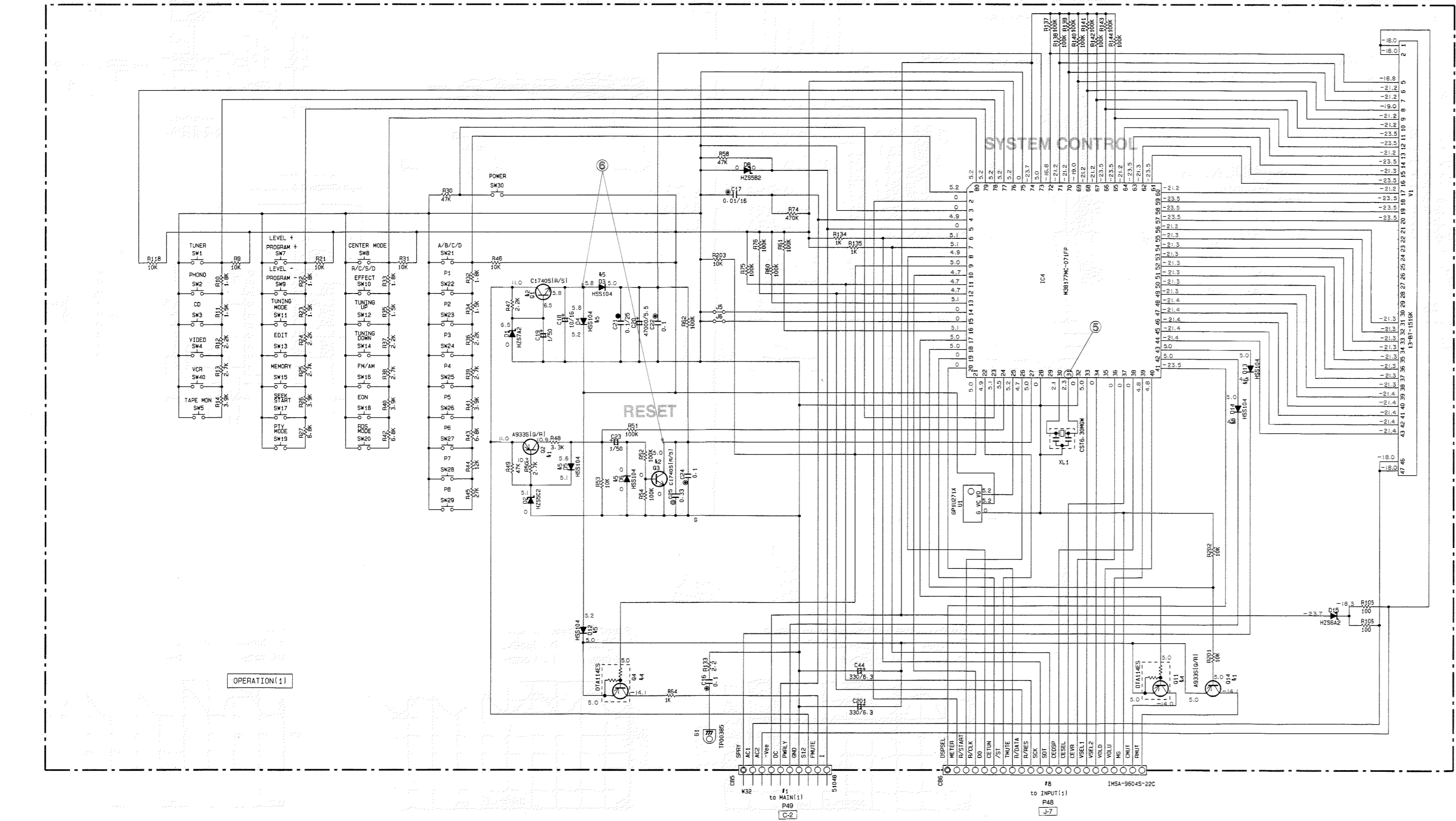
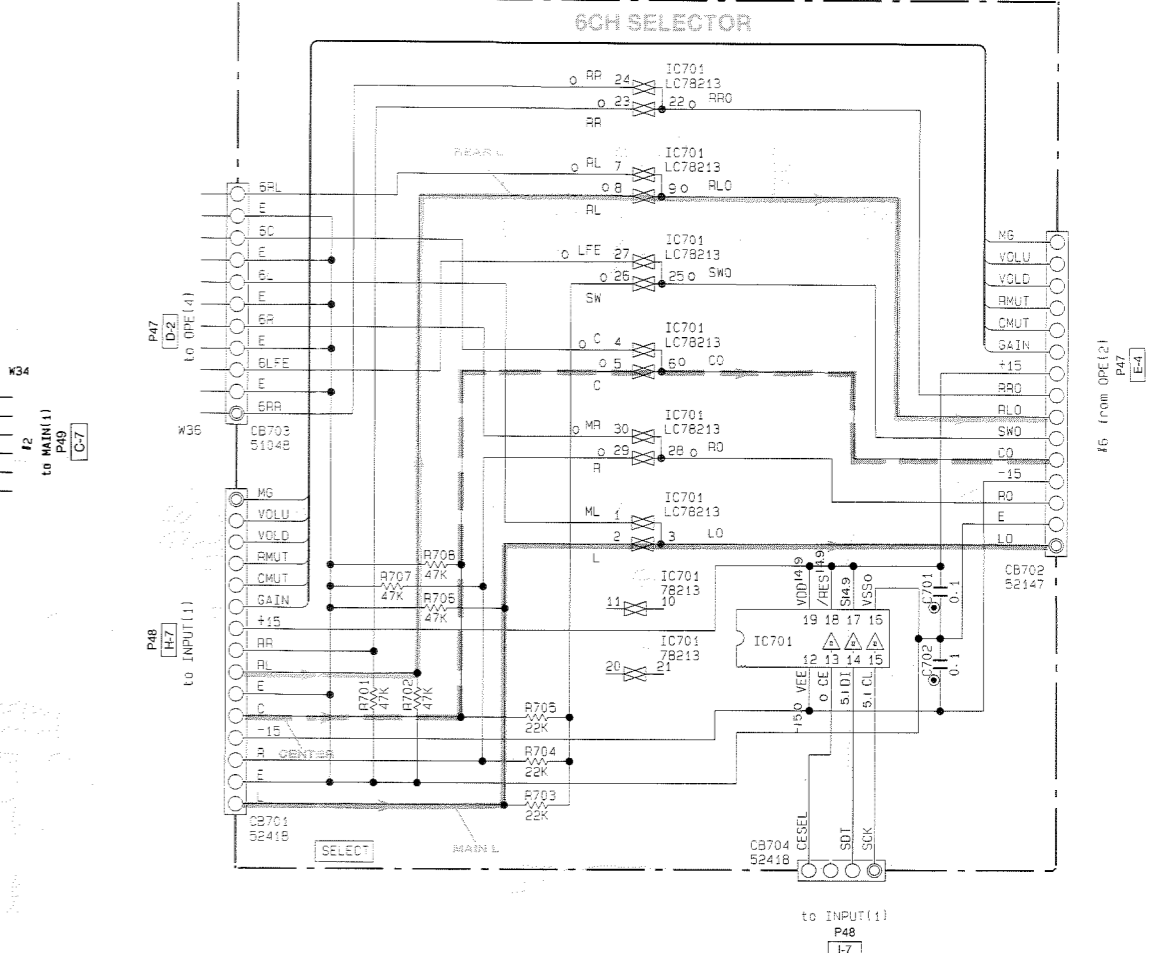
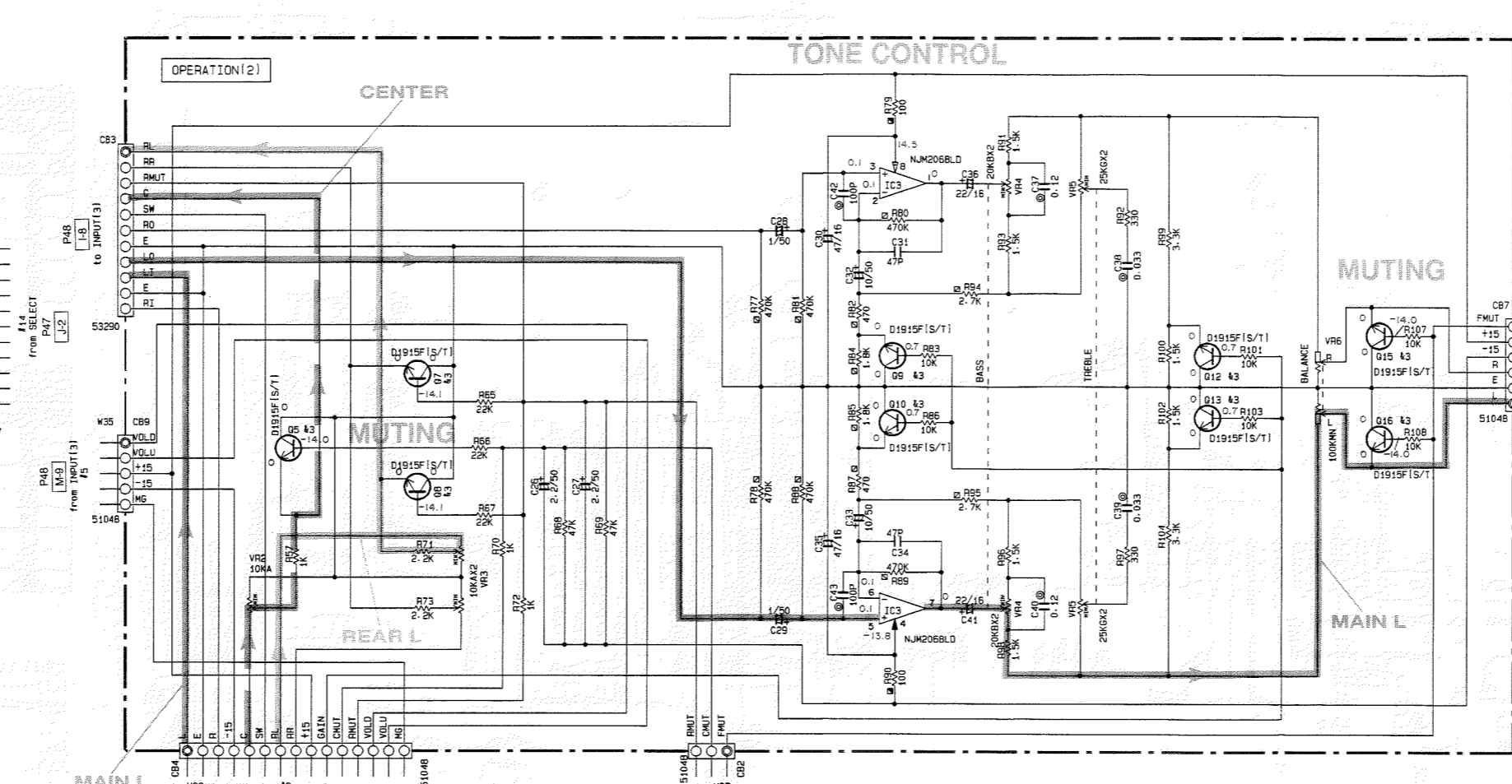
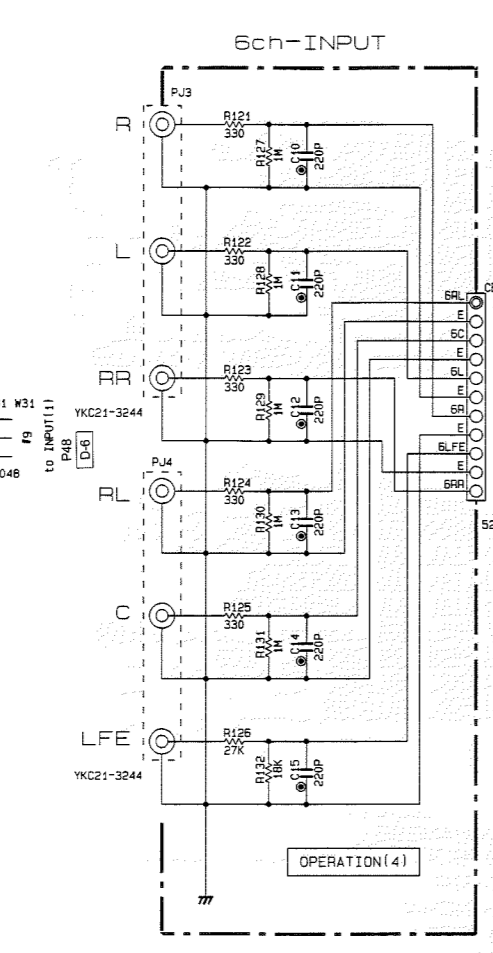
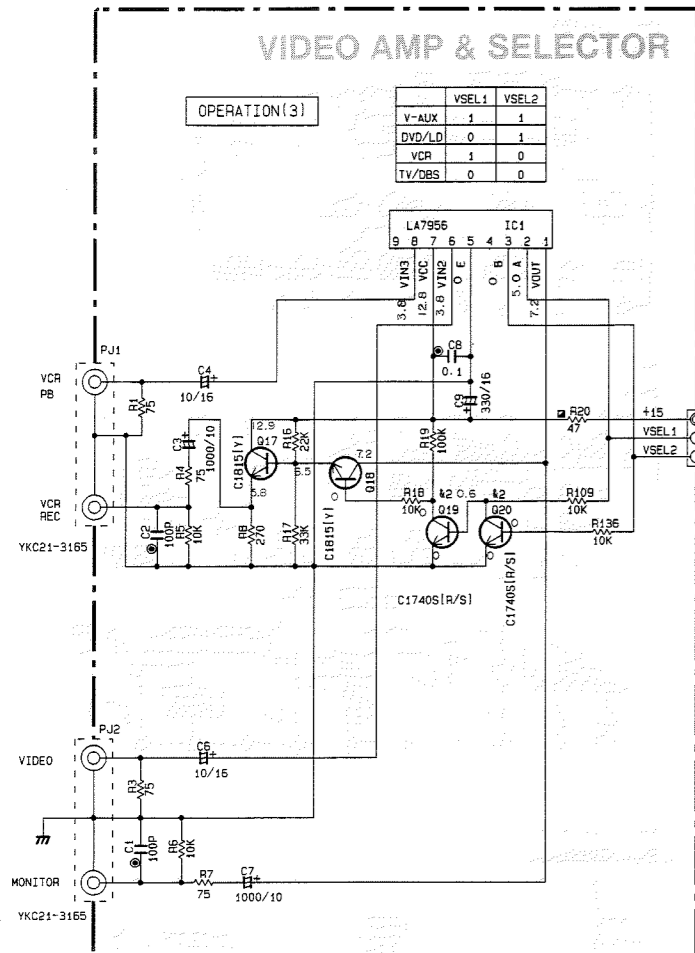

RESISTOR

REMARKS	PARTS NAME
NO MARK	CARBON FILM RESISTOR (P=5)
NO MARK	CARBON FILM RESISTOR (P=10)
△	METAL OXIDE FILM RESISTOR
▲	METAL FILM RESISTOR
□	METAL PATE RESISTOR
■	FIRE PROOF CARBON FILM RESISTOR
⊠	CEMENT MOLDED RESISTOR
⊞	SEMI VARIABLE RESISTOR
⊚	CHIP RESISTOR

CAPACITOR

REMARKS	PARTS NAME
NO MARK	ELECTROLYTIC CAPACITOR
⊗	TANTALUM CAPACITOR
NO MARK	CERAMIC CAPACITOR
○	CERAMIC TUBULAR CAPACITOR
●	POLYESTER FILM CAPACITOR
○	POLYSTYRENE FILM CAPACITOR
⊖	MICA CAPACITOR
⊕	POLYPROPYLENE FILM CAPACITOR
⊙	SEMICONDUCTIVE CERAMIC CAPACITOR

NOTICE (mode)

(J)..... JAPANESE
(U)..... U. S. A.
(C)..... CANADIAN
(R)..... GENERAL
(A)..... AUSTRALIAN
(B)..... BRITISH
(G)..... EUROPEAN
(T)..... CHINA
(L)..... SINGAPORE

Interchangeable Parts at Manufacture-Stage

Mark	Reference Parts Number	Parts Name
R1	02-14	2S40336(G/R) 2S41151(E/F) 2S41309A(G/R/S)
	01-3-19-20	2S51740S(R/S) 2S52803(E/F) 2S53911A(G/R/S)
R3	05-7-10-12-13-15-16	2S01915F15/T1 2S52878(A/B)
	04-11	D1A154E5 U4A111
R5	03-6-12-14	H5S104 1S5133 1S5176

All voltages are measured with a 10MΩ/DC electric volt meter.
Components having special characteristics are marked △, and must be replaced with parts having specifications equal to those originally installed.
Schematic diagram is subject to change without notice.

RX-V393RDS SCHEMATIC DIAGRAM (INPUT)

1
2
3
4
5
6
7
8
9
10

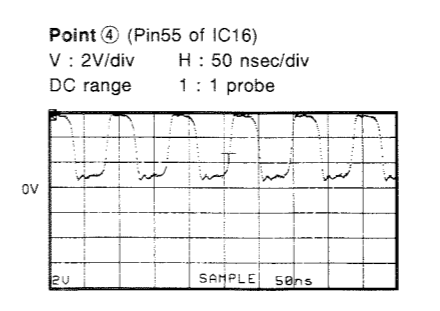
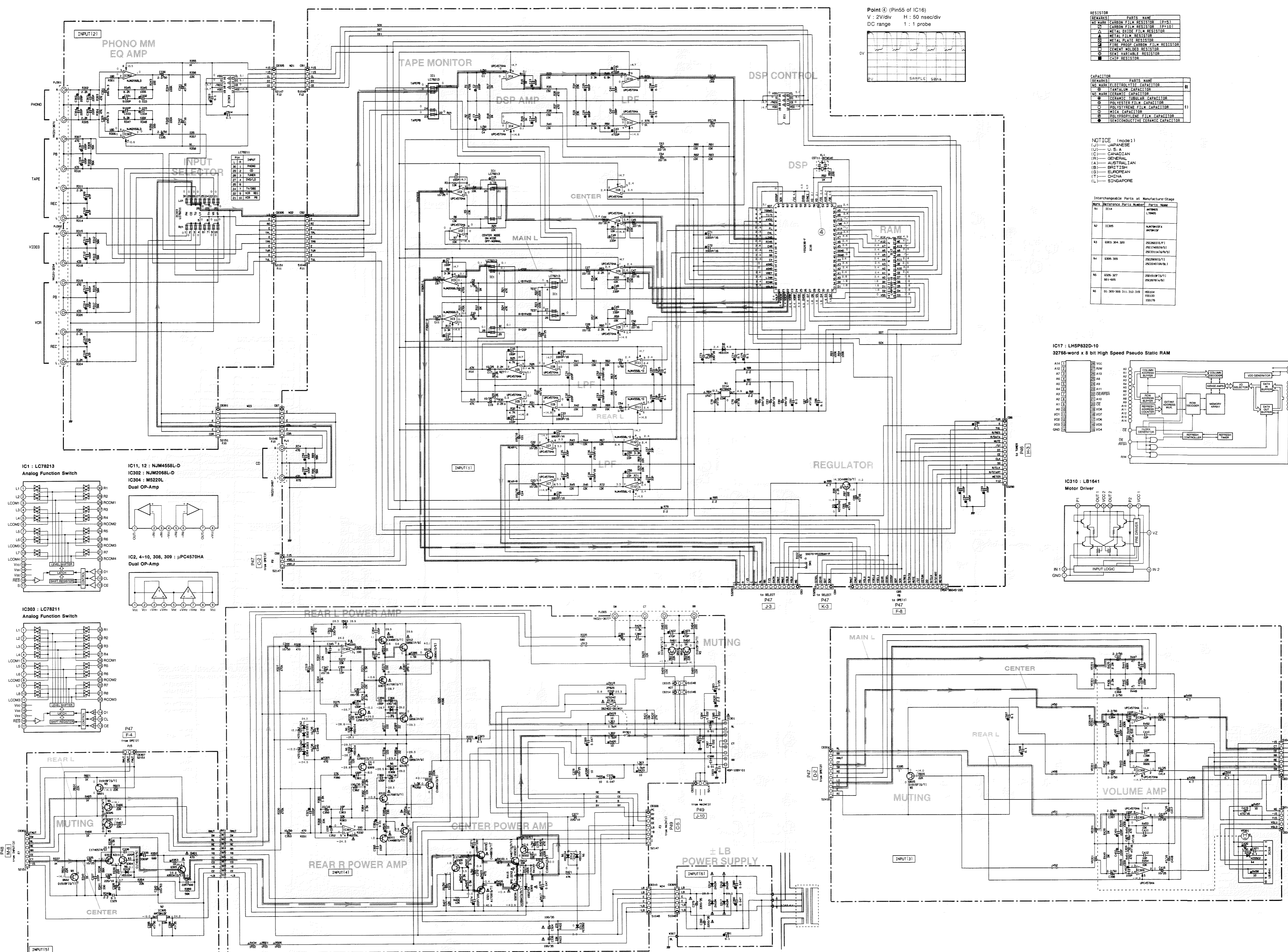

RESISTOR

MARKING	PARTS NAME
□	NO MARK CARBON FILM RESISTOR (RPS1)
○	CARBON FILM RESISTOR (RPI10)
△	METAL FILM RESISTOR
◇	METAL GLAZE RESISTOR
□	FILIP PROSP CARBON FILM RESISTOR
○	CERAMIC WOUND RESISTOR
□	TEFLON FILM RESISTOR
■	CHIP RESISTOR

CAPACITOR

MARKING	PARTS NAME
□	NO MARK ELECTROLYTIC CAPACITOR
□	NO MARK CERAMIC CAPACITOR
○	GENERAL PURPOSE CERAMIC CAPACITOR
◇	POLYESTER FILM CAPACITOR
○	POLYETHYLENE FILM CAPACITOR
○	MICA CAPACITOR
○	POLYPROPYLENE FILM CAPACITOR
○	SEASONALY DYE CERAMIC CAPACITOR

NOTICE (mode 3)
(J)..... JAPANESE
(U)..... U. S. A.
(C)..... CANADIAN
(R)..... GENERAL
(A)..... AUSTRALIAN
(B)..... BRITISH
(S)..... SLOVAKIAN
(T)..... CHINA
(L)..... SINGAPORE

Interchangeable Parts at Manufacture-Stage

Mark	Reference Parts Number	Parts Name
N1	IC14	RAM
N2	ICM5	RAM
N3	6303, 304, 305	OSCILLATOR
N4	6306, 309	OSCILLATOR
N5	6305, 307, 601, 603	OSCILLATOR
N6	D1, 305, 306, 311, 312, 313	REGULATOR

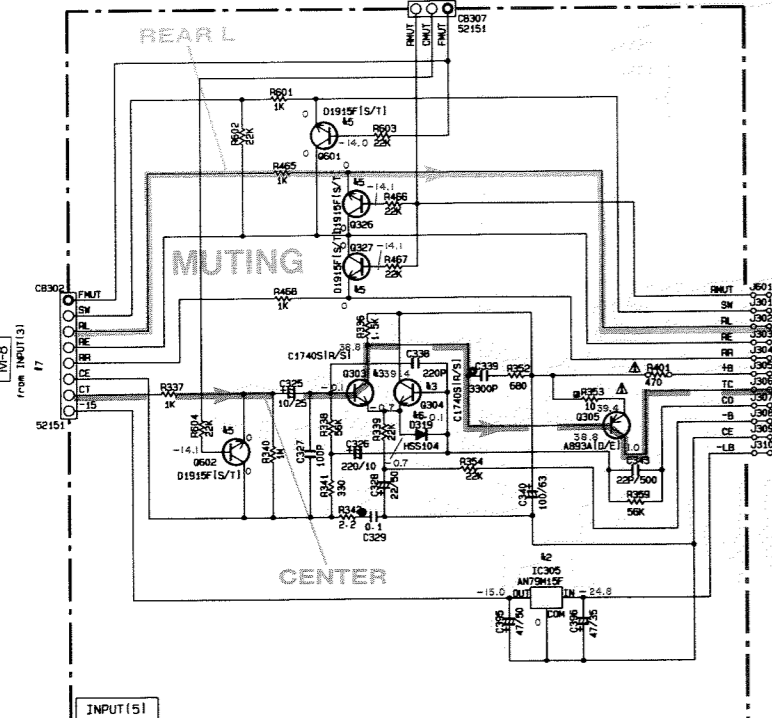
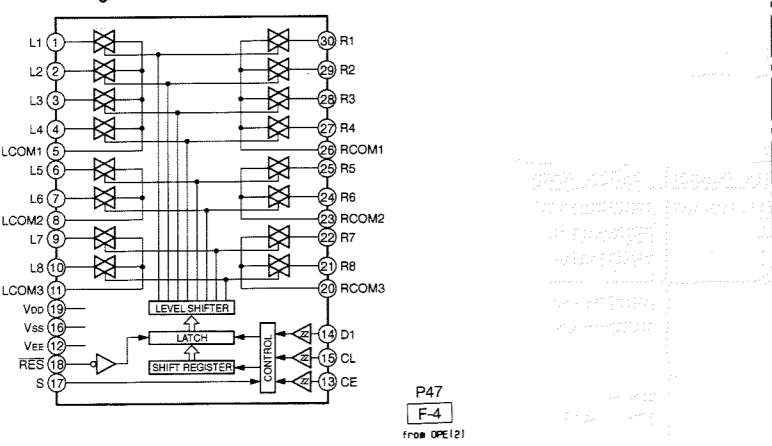
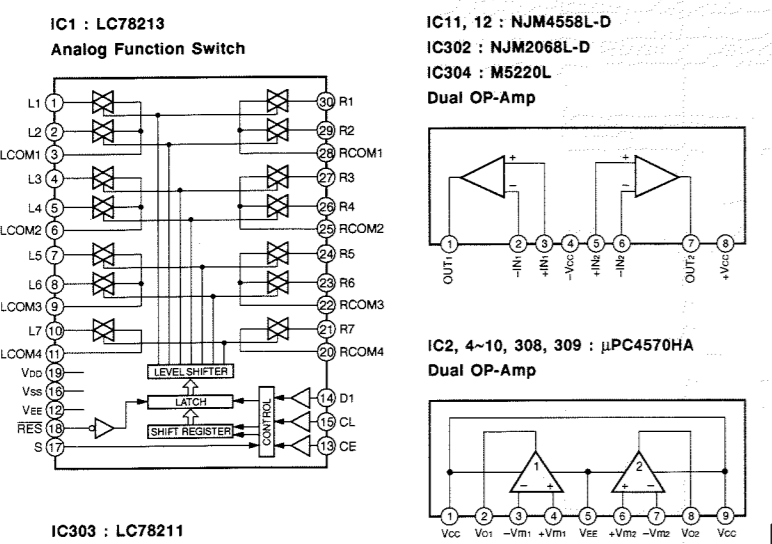
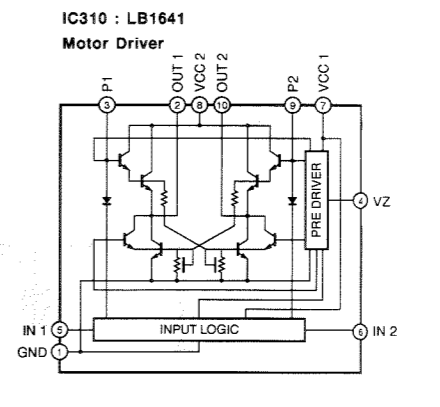
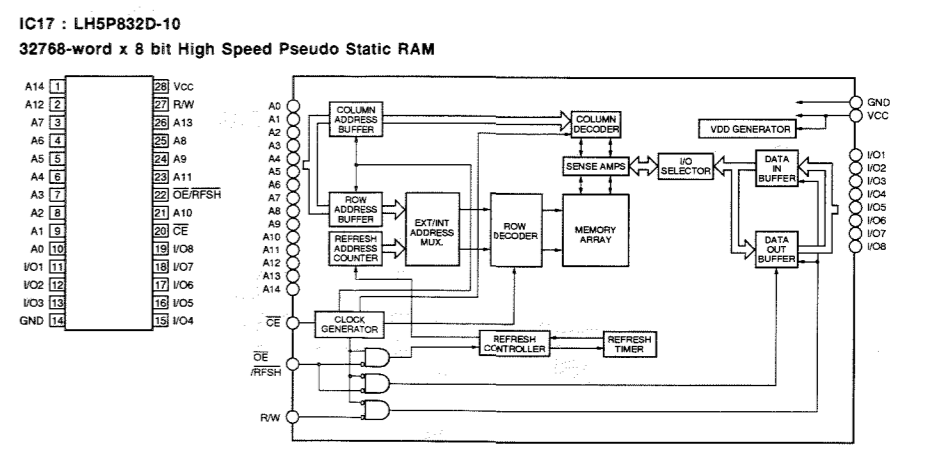

All voltages are measured with a 10MΩ/DC electric volt meter.
Components having special characteristics are marked △, and must be replaced with parts having specifications equal to those originally installed.
Schematic diagram is subject to change without notice.

RX-V393RDS SCHEMATIC DIAGRAM (MAIN)

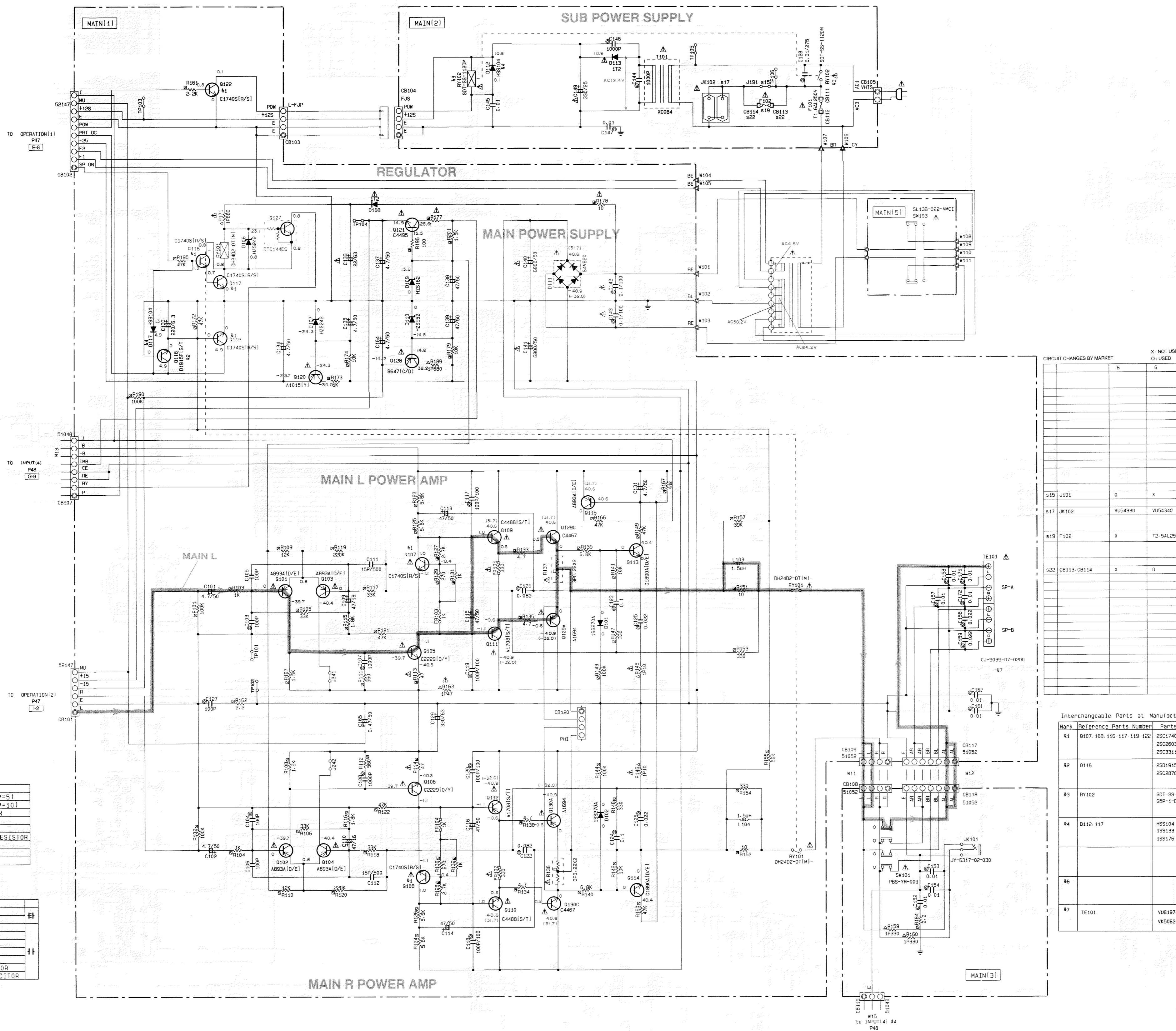

CIRCUIT CHANGES BY MARKET		
	B	G
s15 J191	0	X
s17 JK102	VU54330	VU54340
s19 F102	X	T2-5AL250V
s22 CB113-CB114	X	0

Interchangeable Parts at Manufacture-Stage		
Mark	Reference Parts Number	Parts Name
k1	0107-108-116-117-119-122	25C17405(R/S) 25C2603(E/F) I 25C3311(A/R/S)
k2	0118	25D1915(F/S/T) 25C2876(A/B)
k3	RY102	SOT-SS-1120M 65P-1-DC12V
k4	D112-117	HSS104 ISS133 ISS176
k6		
k7	TE101	VUB1970 VW50620

RESISTOR	
REMARKS	PARTS NAME
NO MARK	CARBON FILM RESISTOR (P=5)
□	CARBON FILM RESISTOR (P=10)
△	METAL OXIDE FILM RESISTOR
⊗	METAL FILM RESISTOR
⊙	METAL PLATE RESISTOR
⊕	FIRE-PROOF CARBON FILM RESISTOR
⊖	CEMENT MOLDED RESISTOR
⊗	SEMI-VARIABLE RESISTOR
⊙	CHIP RESISTOR

CAPACITOR	
REMARKS	PARTS NAME
NO MARK	ELECTROLYTIC CAPACITOR
⊗	TANTALUM CAPACITOR
NO MARK	CERAMIC CAPACITOR
⊙	CERAMIC TUBULAR CAPACITOR
⊕	POLYESTER FILM CAPACITOR
⊖	POLYSTYRENE FILM CAPACITOR
⊗	MICA CAPACITOR
⊙	POLYPROPYLENE FILM CAPACITOR
⊕	SEMICONDUCTIVE CERAMIC CAPACITOR

All voltages are measured with a 10MΩ/DC electric volt meter.
 Components having special characteristics are marked Δ, and must be replaced with parts having specifications equal to those originally installed.
 Schematic diagram is subject to change without notice.

RX-V393RDS PRINTED CIRCUIT BOARD (Foil side)

P. C. B. OPERATION (1)

Point ⑤ (Pin31 of IC4)
 V : 2V/div H : 0.1 μsec/div
 DC range 1 : 1 probe

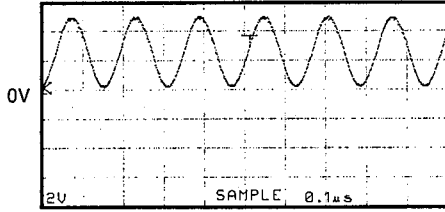

Point ⑥
 CH1 : Collector of Q3 V : 2V/div (CH1)
 CH2 : Anode of D3 V : 2V/div (CH2)

H : 0.5 sec/div DC range 1 : 1 probe
 (This waveform is not available by pushing the power switch ON and OFF.)

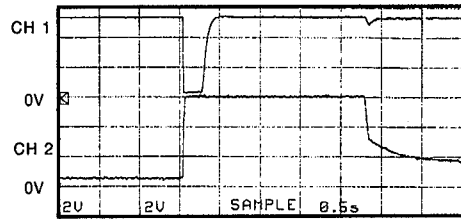

With the POWER ON, disconnect the A/C power cord. Reconnect the A/C power cord and the above waveforms will start.

Disconnect the power cord from the AC outlet.

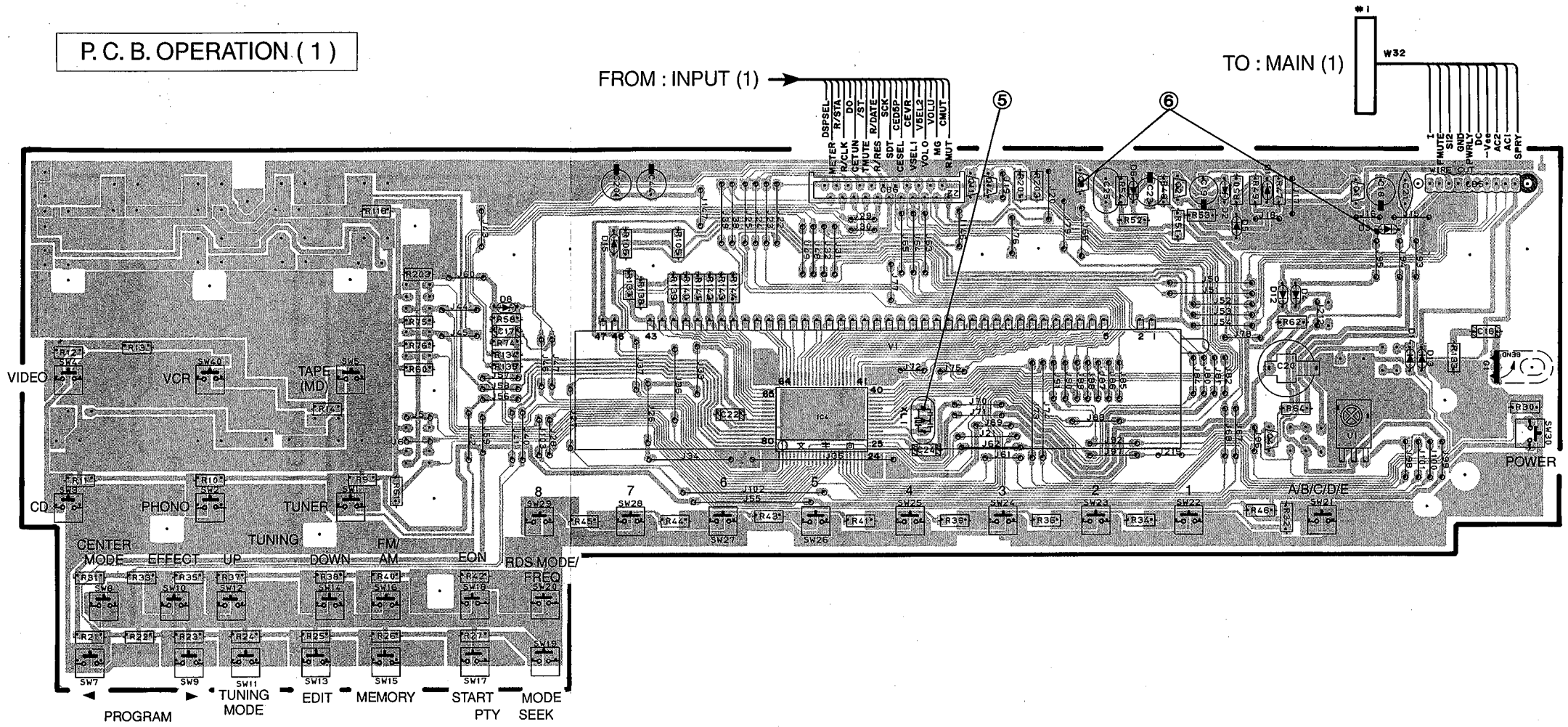

P. C. B. OPERATION (2)

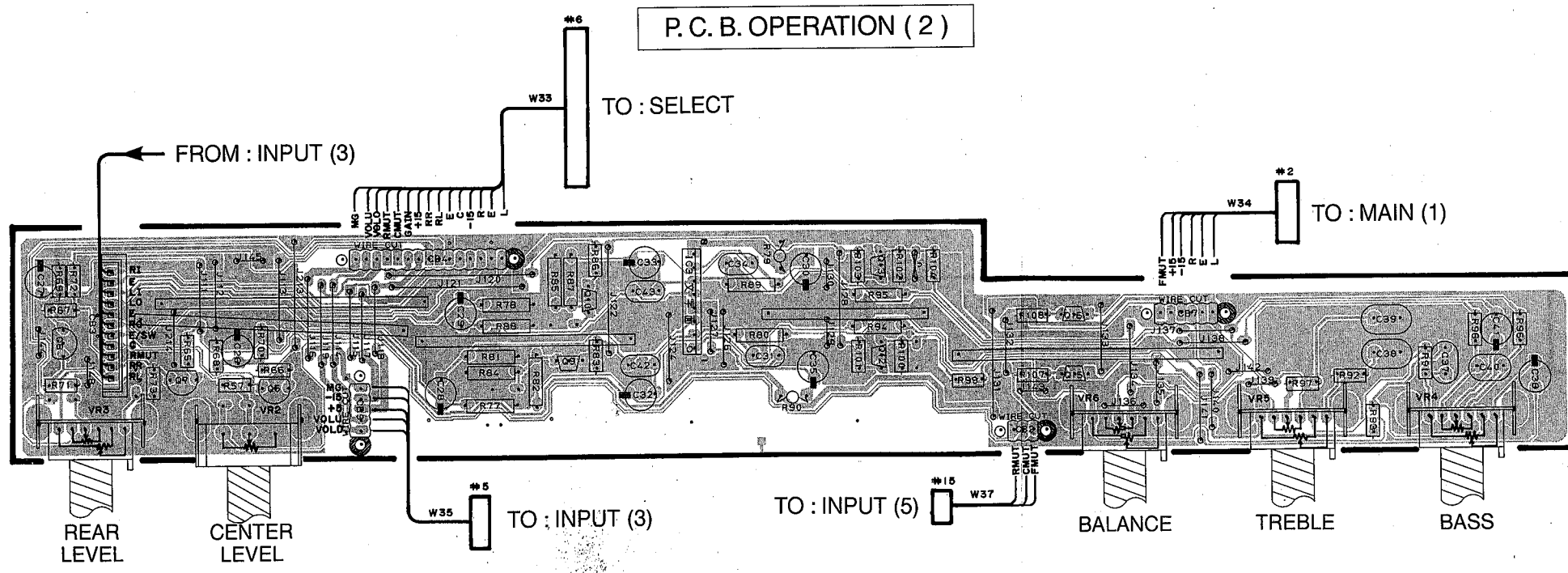

P. C. B. OPERATION (3)

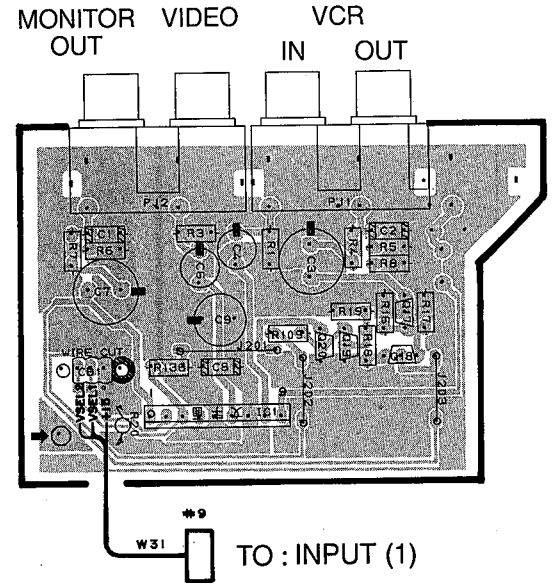

1

2

3

4

5

6

■ RX-V393RDS PRINTED CIRCUIT BOARD (Foil side)

1

P. C. B. OPERATION (4)

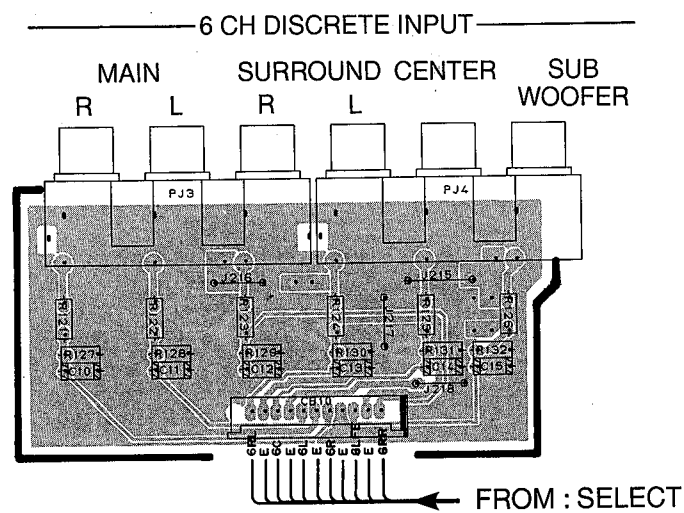

2

3

P. C. B. SELECT

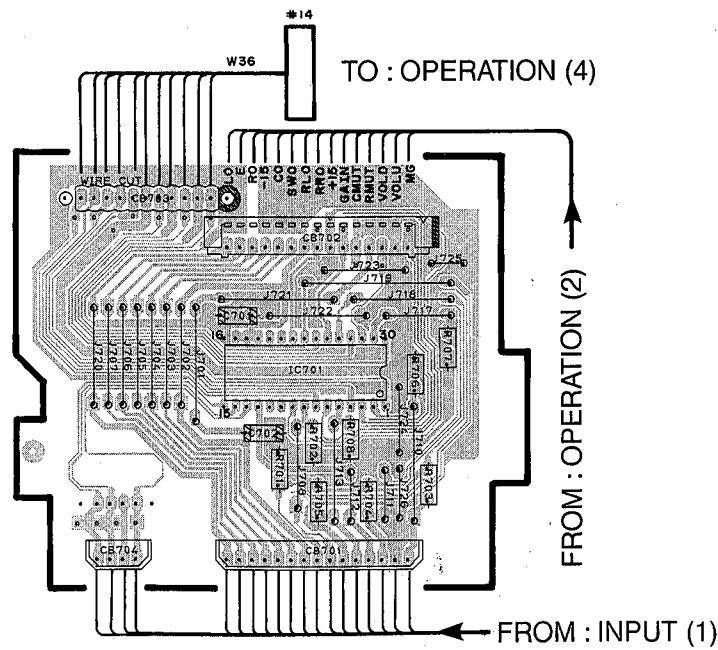

4

5

6

● G model

P. C. B. MAIN (2)

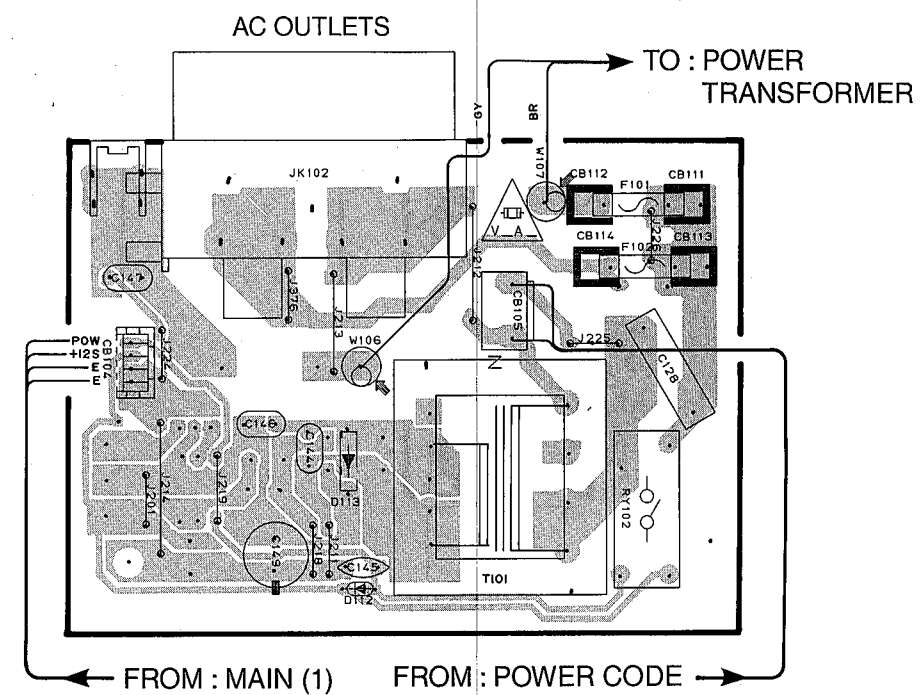

● B model

P. C. B. MAIN (2)

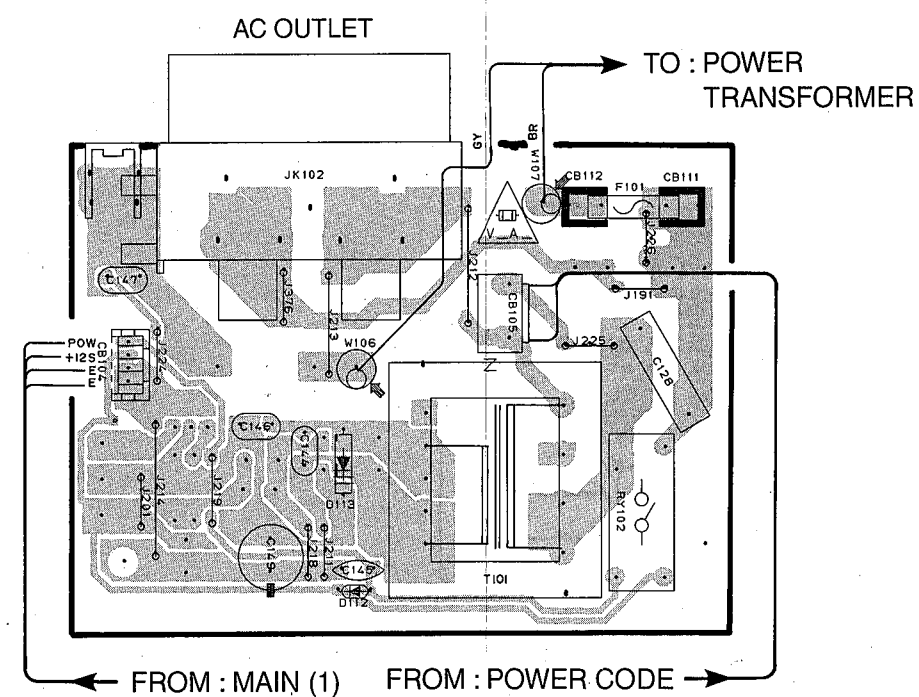

■ RX-V393RDS PRINTED CIRCUIT BOARD (Foil side)

1

P.C.B. MAIN (3)

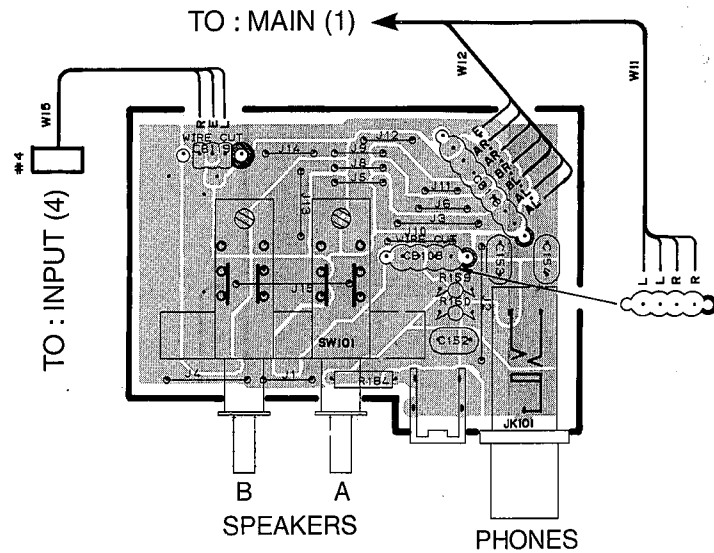

2

3

P.C.B. MAIN (1)

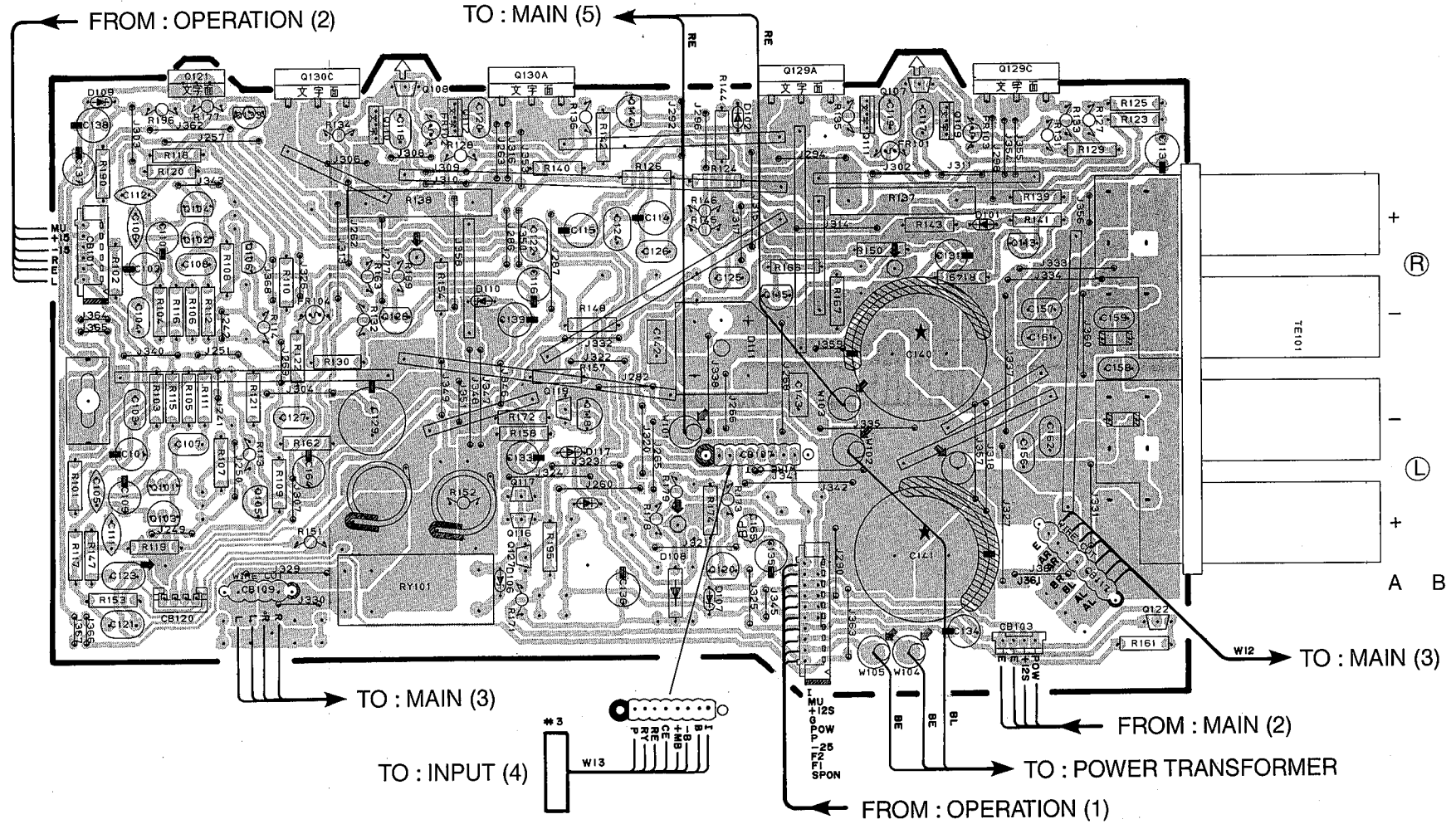

4

P.C.B. MAIN (5)

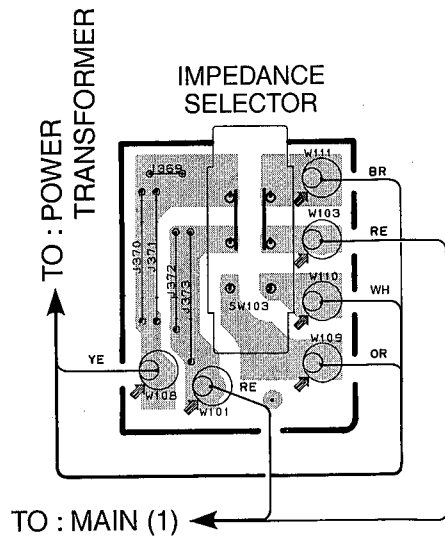

Note) Mounting of C171 and C172 shown as below.

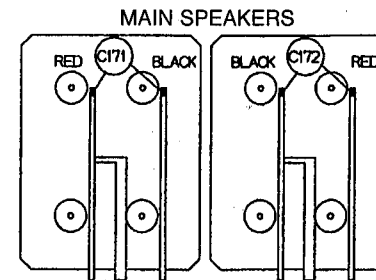

RX-V393RDS PRINTED CIRCUIT BOARD (Foil side)

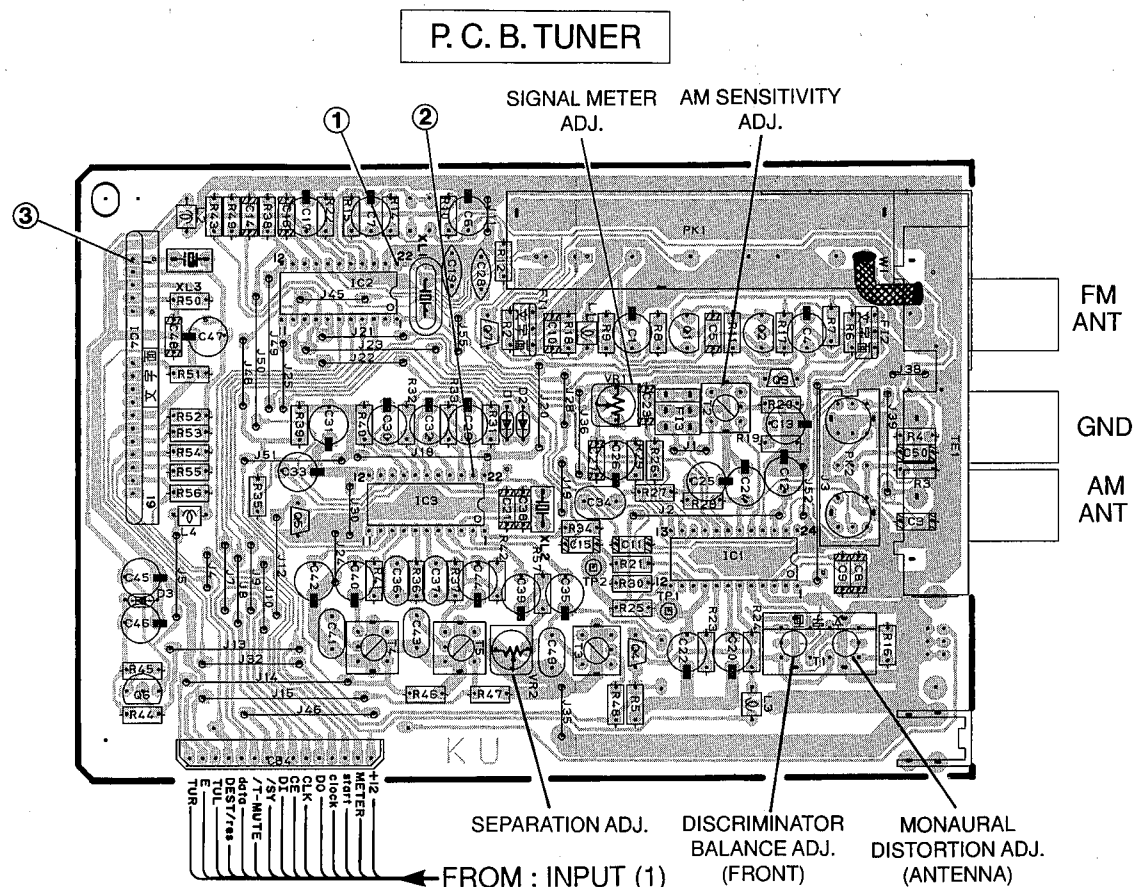

Point ① (Pin22 of IC2) FM reception
 V : 2V/div H : 50 nsec/div
 DC range 1 : 1 probe

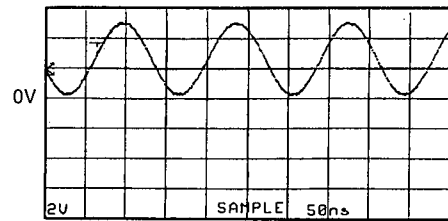

Point ② (Pin21 of IC3)
 V : 2V/div H : 1 μsec/div
 DC range 1 : 1 probe

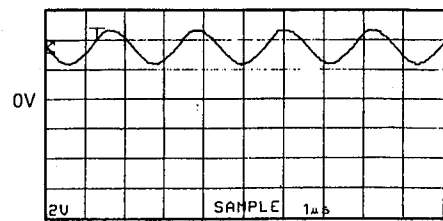

Point ③ (Pin1 of IC4)
 V : 5V/div H : 1 μsec/div
 DC range 1 : 1 probe

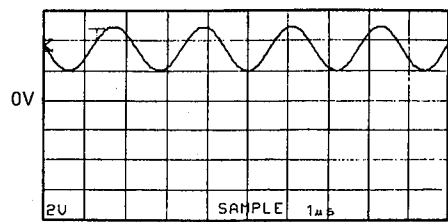

Point ④ (Pin55 of IC16)
 V : 2V/div H : 50 nsec/div
 DC range 1 : 1 probe

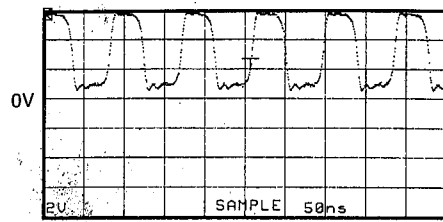

1
2
3
4
5
6

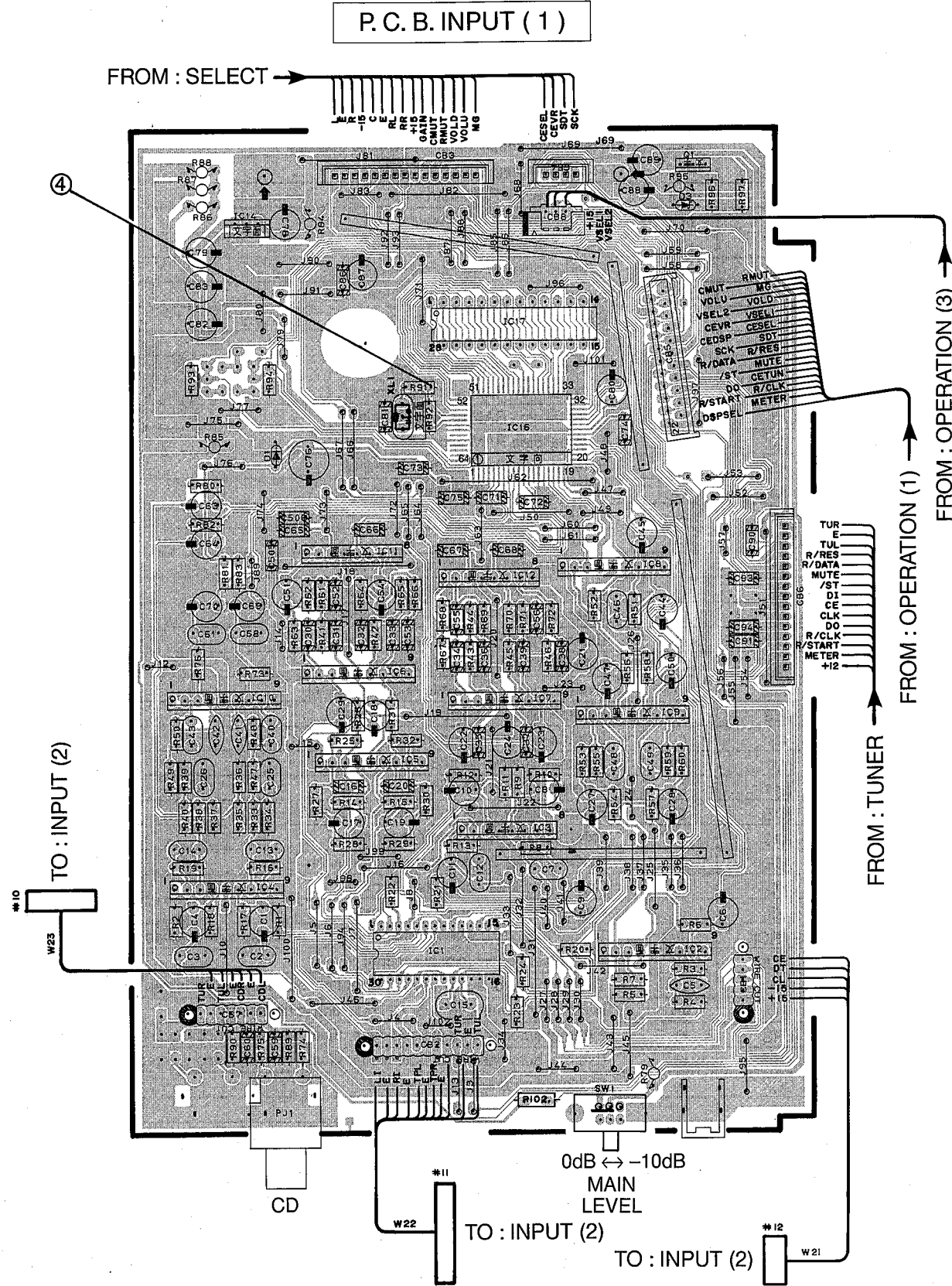

TO: INPUT (2)

0dB ↔ -10dB
 MAIN LEVEL

TO: INPUT (2)

TO: INPUT (2)

■ RX-V393RDS PRINTED CIRCUIT BOARD (Foil side)

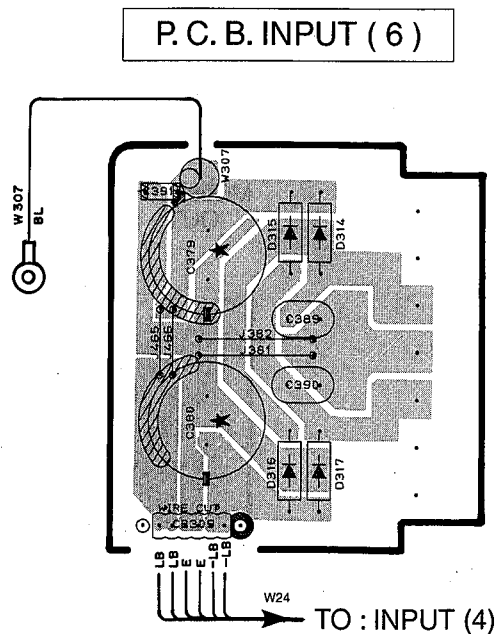
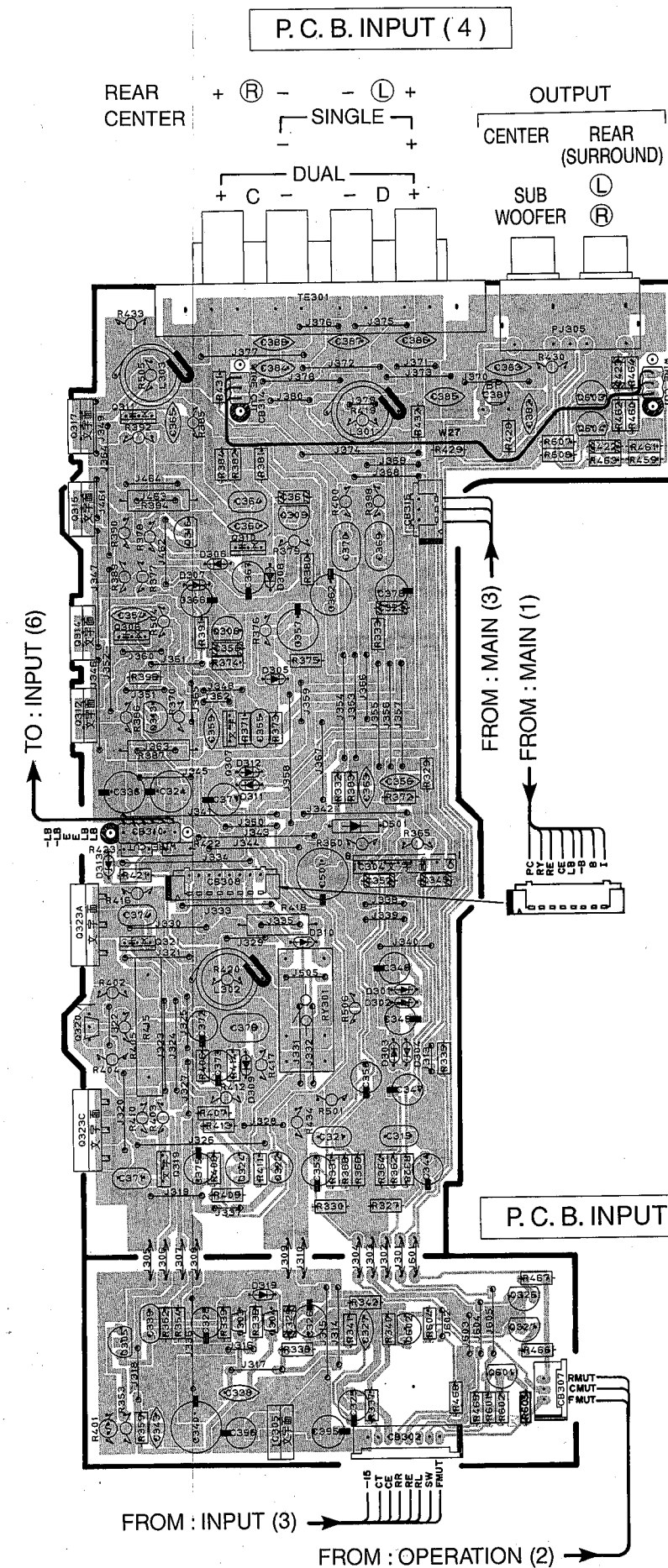
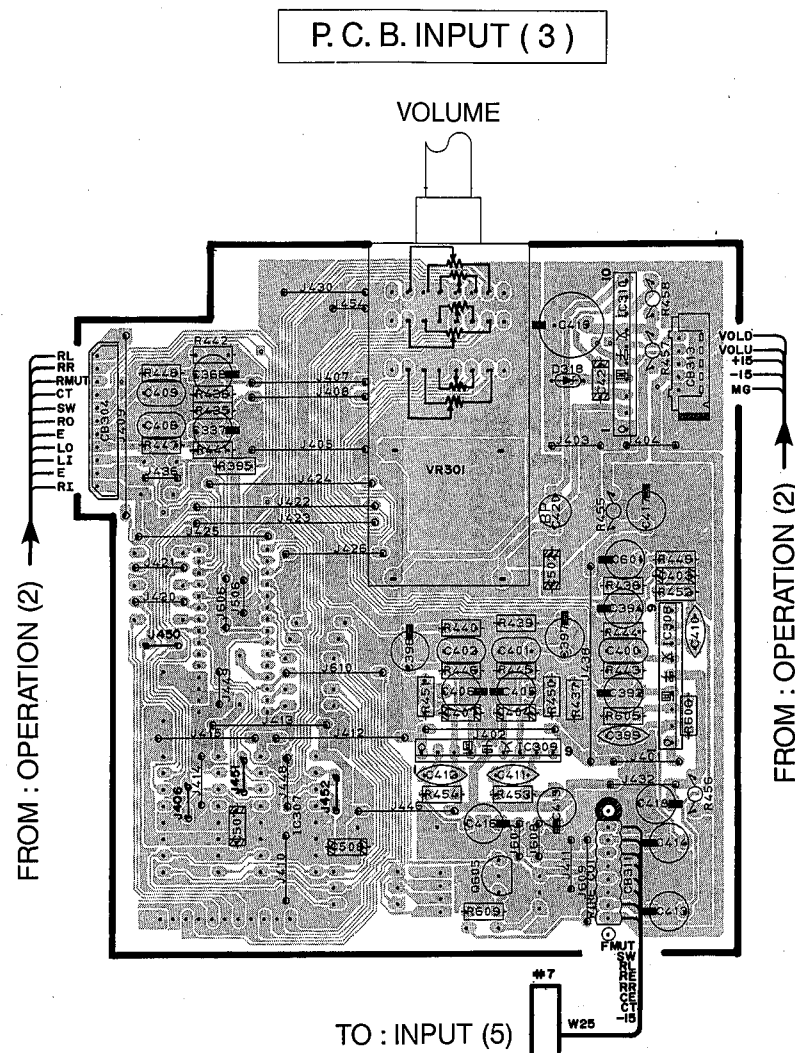
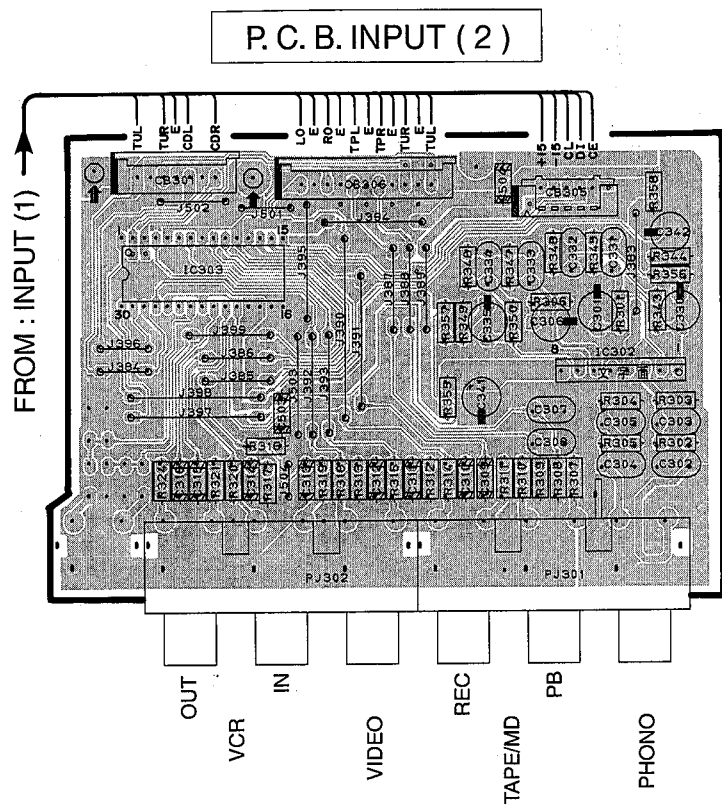

Note) Mounting of C602, C603 and the Earth Plate shown as below.

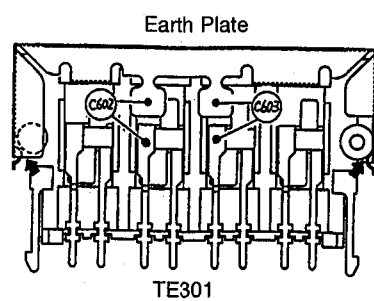

* Insert TE301 in the Earth Plate until → point is caught securely.

1
2
3
4
5
6

PARTS LIST

■ ELECTRICAL PARTS

■ WARNING

Components having special characteristics are marked \triangle and must be replaced with parts having specifications equal to those originally installed.

- Carbon resistors (1/6W or 1/4W) are not included in the ELECTRICAL PARTS List. For the part Nos. of the carbon resistors, refer to the last page.

ABBREVIATIONS IN THIS LIST ARE AS FOLLOWS :

C.A.EL.CHP	: CHIP ALUMI. ELECTROLYTIC CAP	L.EMIT	: LIGHT EMITTING MODULE
C.GE	: CERAMIC CAP	LED.DSPLY	: LED DISPLAY
C.GE.ARRAY	: CERAMIC CAP ARRAY	LED.INFRD	: LED, INFRARED
C.CE.CHP	: CHIP CERAMIC CAP	MODUL.RF	: MODULATOR, RF
C.CE.ML	: MULTILAYER CERAMIC CAP	PHOT.CPL	: PHOTO COUPLER
C.CE.M.CHP	: CHIP MULTILAYER CERAMIC CAP	PHOT.INTR	: PHOTO INTERRUPTER
C.CE.SAFTY	: RECOGNIZED CERAMIC CAP	PHOT.RFLCT	: PHOTO REFLECTOR
C.CE.TUBLR	: CERAMIC TUBULAR CAP	PIN.TEST	: PIN, TEST POINT
C.CE.SMI	: SEMI CONDUCTIVE CERAMIC CAP	PLST.RIVET	: PLASTIC RIVET
C.EL	: ELECTROLYTIC CAP	R.ARRAY	: RESISTOR ARRAY
C.MICA	: MICA CAP	R.CAR	: CARBON RESISTOR
C.ML.FLM	: MULTILAYER FILM CAP	R.CAR.CHP	: CHIP RESISTOR
C.MP	: METALLIZED PAPER CAP	R.CAR.FP	: FLAME PROOF CARBON RESISTOR
C.MYLAR	: MYLAR FILM CAP	R.FUS	: FUSABLE RESISTOR
C.MYLAR.ML	: MULTILAYER MYLAR FILM CAP	R.MTL.CHP	: CHIP METAL FILM RESISTOR
C.PAPER	: PAPER CAPACITOR	R.MTL.FLM	: METAL FILM RESISTOR
C.PLS	: POLYSTYRENE FILM CAP	R.MTL.OXD	: METAL OXIDE FILM RESISTOR
C.POL	: POLYESTER FILM CAP	R.MTL.PLAT	: METAL PLATE RESISTOR
C.POLY	: POLYETHYLENE FILM CAP	RSNR.CE	: CERAMIC RESONATOR
C.PP	: POLYPROPYLENE FILM CAP	RSNR.CRYS	: CRYSTAL RESONATOR
C.TNTL	: TANTALUM CAP	R.TW.CEM	: TWIN CEMENT FIXED RESISTOR
C.TNTL.CHP	: CHIP TANTALUM CAP	R.WW	: WIRE WOUND RESISTOR
C.TRIM	: TRIMMER CAP	SCR.BND.HD	: BIND HEAD B-TITE SCREW
CN	: CONNECTOR	SCR.BW.HD	: BW HEAD TAPPING SCREW
CN.BS.PIN	: CONNECTOR, BASE PIN	SCR.CUP	: CUP TITE SCREW
CN.CANNON	: CONNECTOR, CANNON	SCR.TERM	: SCREW TERMINAL
CN.DIN	: CONNECTOR, DIN	SCR.TR	: SCREW, TRANSISTOR
CN.FLAT	: CONNECTOR, FLAT CABLE	SUPRT.PCB	: SUPPORT, P.C.B.
CN.POST	: CONNECTOR, BASE POST	SURG.PRTCT	: SURGE PROTECTOR
COIL.MX.AM	: COIL, AM MIX	SW.TACT	: TACT SWITCH
COIL.AT.FM	: COIL, FM ANTENNA	SW.LEAF	: LEAF SWITCH
COIL.DT.FM	: COIL, FM DETECT	SW.LEVER	: LEVER SWITCH
COIL.MX.FM	: COIL, FM MIX	SW.MICRO	: MICRO SWITCH
COIL.OUTPT	: OUTPUT COIL	SW.PUSH	: PUSH SWITCH
DIOD.ARRAY	: DIODE ARRAY	SW.RT.ENC	: ROTARY ENCODER
DIODE.BRG	: DIODE BRIDGE	SW.RT.MTR	: ROTARY SWITCH WITH MOTOR
DIODE.CHP	: CHIP DIODE	SW.RT	: ROTARY SWITCH
DIODE.VAR	: VARACTOR DIODE	SW.SLIDE	: SLIDE SWITCH
DIOD.Z.CHP	: CHIP ZENER DIODE	TERM.SP	: SPEAKER TERMINAL
DIODE.ZENR	: ZENER DIODE	TERM.WRAP	: WRAPPING TERMINAL
DSCR.CE	: CERAMIC DISCRIMINATOR	THRMST.CHP	: CHIP THERMISTOR
FER.BEAD	: FERRITE BEADS	TR.CHP	: CHIP TRANSISTOR
FER.CORE	: FERRITE CORE	TR.DGT	: DIGITAL TRANSISTOR
FET.CHP	: CHIP FET	TR.DGT.CHP	: CHIP DIGITAL TRANSISTOR
FL.DSPLY	: FLUORESCENT DISPLAY	TRANS	: TRANSFORMER
FLTR.CE	: CERAMIC FILTER	TRANS.PULS	: PULSE TRANSFORMER
FLTR.COMB	: COMB FILTER MODULE	TRANS.PWR	: POWER TRANSFORMER ASS'y
FLTR.LC.RF	: LC FILTER ,EMI	TUNER.AM	: TUNER PACK, AM
GND.MTL	: GROUND PLATE	TUNER.FM	: TUNER PACK, FM
GND.TERM	: GROUND TERMINAL	TUNER.PK	: FRONT-END TUNER PACK
HOLDER.FUS	: FUSE HOLDER	VR	: ROTARY POTENTIOMETER
IC.PRTCT	: IC PROTECTOR	VR.MTR	: POTENTIOMETER WITH MOTOR
JUMPER.CN	: JUMPER CONNECTOR	VR.SW	: POTENTIOMETER WITH ROTARY SW
JUMPER.TST	: JUMPER, TEST POINT	VR.SLIDE	: SLIDE POTENTIOMETER
L.DTCT	: LIGHT DETECTING MODULE	VR.TRIM	: TRIMMER POTENTIOMETER

Note) Those parts marked with "#" are not included in the P.C.B. ass'y.

RX-V393RDS P.C.B. OPERATION

Schm Ref.	PART NO.	Description		
*	VZ497800	P. C. B.	OPERATION	
CB1	Vi878100	CN. BS. PIN	3P	
CB2	Vi878100	CN. BS. PIN	3P	
CB3	VQ963200	CN. BS. PIN	11P	
CB4	Vi879300	CN. BS. PIN	15P	
CB5	Vi878800	CN. BS. PIN	10P	
CB6	VU272200	CN	22P	
CB7	Vi878400	CN. BS. PIN	6P	
CB9	Vi878300	CN. BS. PIN	5P	
CB10	VK027000	CN. BS. PIN	11P	
C1	VF466800	C. CE. TUBLR	100pF	50V
C2	VF466800	C. CE. TUBLR	100pF	50V
C3	VF637900	C. EL	1000uF	10V
C4	VJ836900	C. EL	10uF	16V
C6	VJ836900	C. EL	10uF	16V
C7	VF637900	C. EL	1000uF	10V
C8	VH053100	C. CE. TUBLR	0. 1uF	50V
C9	UJ638330	C. EL	330uF	16V
C10	VG278400	C. CE. TUBLR	220pF	50V
C11	VG278400	C. CE. TUBLR	220pF	50V
C12	VG278400	C. CE. TUBLR	220pF	50V
C13	VG278400	C. CE. TUBLR	220pF	50V
C14	VG278400	C. CE. TUBLR	220pF	50V
C15	VG278400	C. CE. TUBLR	220pF	50V
C16	VH053100	C. CE. TUBLR	0. 1uF	50V
C17	VF467300	C. CE. TUBLR	0. 01uF	16V
C18	VJ836900	C. EL	10uF	16V
C19	VJ839100	C. EL	1uF	50V
C20	VU545000	C. EL	47000uF	5. 5V
C21	VD930900	C. CE. SMI	0. 1uF	25V
C22	VH053100	C. CE. TUBLR	0. 1uF	50V
C23	VJ839100	C. EL	1uF	50V
C24	VH053100	C. CE. TUBLR	0. 1uF	50V
C25	UA655330	C. MYLAR	0. 33uF	50V
C26	VJ839200	C. EL	2. 2uF	50V
C27	VJ839200	C. EL	2. 2uF	50V
C28	VJ839100	C. EL	1uF	50V
C29	VJ839100	C. EL	1uF	50V
C30	VJ837200	C. EL	47uF	16V
C31	FG211470	C. CE	47pF	50V
C32	UM417100	C. EL	10uF	50V
C33	UM417100	C. EL	10uF	50V
C34	FG211470	C. CE	47pF	50V
C35	VJ837200	C. EL	47uF	16V
C36	UM407220	C. EL	22uF	25V
C37	UA655120	C. MYLAR	0. 12uF	50V
C38	UA654330	C. MYLAR	0. 033uF	50V
C39	UA654330	C. MYLAR	0. 033uF	50V
C40	UA655120	C. MYLAR	0. 12uF	50V
C41	UM407220	C. EL	22uF	25V
C42	UA652100	C. MYLAR	100pF	50V
C43	UA652100	C. MYLAR	100pF	50V
C44	VJ836300	C. EL	330uF	6. 3V

* New Parts

Schm Ref.	PART NO.	Description		
C201	VJ836300	C. EL	330uF	6. 3V
D1	VM974600	DIODE. ZENR	HZS7A2TD	7. 0V
D2	VM974200	DIODE. ZENR	HZS5C2TD	5. 0V
D3	VD631600	DIODE	1SS133, 176, HSS104	
D4	VD631600	DIODE	1SS133, 176, HSS104	
D5	VD631600	DIODE	1SS133, 176, HSS104	
D6	VD631600	DIODE	1SS133, 176, HSS104	
D8	VM974100	DIODE. ZENR	HZS5B2TD	5. 0V
D12	VD631600	DIODE	1SS133, 176, HSS104	
D13	VD631600	DIODE	1SS133, 176, HSS104	
D14	VD631600	DIODE	1SS133, 176, HSS104	
D15	VM974300	DIODE. ZENR	HZS6A2TD	6. 0V
G1	VR463400	TERM. GND	D3. 5	TP00385
IC1	XH436A00	IC	LA7956	
IC3	XM356A00	IC	NJM2068LD	
IC4	XT819A00	IC	M38177MC-071FP	CPU
PJ1	VR110100	JACK. PIN	2P	
PJ2	VR110100	JACK. PIN	2P	
PJ3	VV031700	JACK. PIN	3P	
PJ4	VV031700	JACK. PIN	3P	
Q1	iC174020	TR	2SC1740S	R, S
Q2	iA093320	TR	2SA933S	Q, R
Q3	iC174020	TR	2SC1740S	R, S
Q4	VD678500	TR. DGT	DTA114ES	
Q5	VK432900	TR	2SD1915F	S, T
Q7	VK432900	TR	2SD1915F	S, T
Q8	VK432900	TR	2SD1915F	S, T
Q9	VK432900	TR	2SD1915F	S, T
Q10	VK432900	TR	2SD1915F	S, T
Q11	VD678500	TR. DGT	DTA114ES	
Q12	VK432900	TR	2SD1915F	S, T
Q13	VK432900	TR	2SD1915F	S, T
Q14	iA093320	TR	2SA933S	Q, R
Q15	VK432900	TR	2SD1915F	S, T
Q16	VK432900	TR	2SD1915F	S, T
Q17	iC1815C0	TR	2SC1815	Y
Q18	iC1815C0	TR	2SC1815	Y
Q19	iC174020	TR	2SC1740S	R, S
Q20	iC174020	TR	2SC1740S	R, S
R20	HV454470	R. CAR. FP	47 Ω	1/4W
R79	HV455100	R. CAR. FP	100 Ω	1/4W
R90	HV455100	R. CAR. FP	100 Ω	1/4W
SW1	VG392900	SW. TACT	SKHVAA	
SW2	VG392900	SW. TACT	SKHVAA	
SW3	VG392900	SW. TACT	SKHVAA	
SW4	VG392900	SW. TACT	SKHVAA	
SW5	VG392900	SW. TACT	SKHVAA	
SW7	VG392900	SW. TACT	SKHVAA	
SW8	VG392900	SW. TACT	SKHVAA	
SW9	VG392900	SW. TACT	SKHVAA	
SW10	VG392900	SW. TACT	SKHVAA	
SW11	VG392900	SW. TACT	SKHVAA	
SW12	VG392900	SW. TACT	SKHVAA	

* New Parts

RX-V393RDS
RX-V493RDS

RX-V393RDS P.C.B. OPERATION & MAIN

Schm Ref.	PART NO.	Description	
SW13	VG392900	SW. TACT	SKHVAA
SW14	VG392900	SW. TACT	SKHVAA
SW15	VG392900	SW. TACT	SKHVAA
SW16	VG392900	SW. TACT	SKHVAA
SW17	VG392900	SW. TACT	SKHVAA
SW18	VG392900	SW. TACT	SKHVAA
SW19	VG392900	SW. TACT	SKHVAA
SW20	VG392900	SW. TACT	SKHVAA
SW21	VG392900	SW. TACT	SKHVAA
SW22	VG392900	SW. TACT	SKHVAA
SW23	VG392900	SW. TACT	SKHVAA
SW24	VG392900	SW. TACT	SKHVAA
SW25	VG392900	SW. TACT	SKHVAA
SW26	VG392900	SW. TACT	SKHVAA
SW27	VG392900	SW. TACT	SKHVAA
SW28	VG392900	SW. TACT	SKHVAA
SW29	VG392900	SW. TACT	SKHVAA
SW30	VG392900	SW. TACT	SKHVAA
SW40	VG392900	SW. TACT	SKHVAA
U1	VU591000	L. DTCT	GP1U271X
V1	VV298800	FL. DSPLY	13-BT-151GK
VR2	VR043900	VR	A10KΩ
VR3	VR058000	VR	A10KΩ
VR4	VP741800	VR	B20KΩ
VR5	VP741900	VR	G25KΩ
VR6	VP742000	VR	MN100KΩ
XL1	VR891500	RSNR. CE	6.30MHZ
	VJ828000	PIN	IMS-6024-03E
	VQ859800	SHEET. FL	
	VV499900	SPACER	FL-T7.5

* New Parts

Schm Ref.	PART NO.	Description		
*	VZ417500	P. C. B.	MAIN(B)	
*	VZ417600	P. C. B.	MAIN(G)	
CB101	VF728300	CN	6P	
CB102	VF728200	CN. BS. PIN	10P	
CB103	VS839400	CN. BS. PIN	4P	
CB104	VS839500	CN	4P	
CB105	VG879900	CN. BS. PIN	2P	
CB107	Vi878600	CN. BS. PIN	8P	
CB108	VR428900	CN. BS. PIN	4P	
CB109	VR428900	CN. BS. PIN	4P	
CB111	VP206500	HOLDER. FUS	EYF-52BC	
CB112	VP206500	HOLDER. FUS	EYF-52BC	
CB113	VP206500	HOLDER. FUS	EYF-52BC(G)	
CB114	VP206500	HOLDER. FUS	EYF-52BC(G)	
CB117	VQ584900	CN. BS. PIN	7P	
CB118	VQ584900	CN. BS. PIN	7P	
CB119	Vi878100	CN. BS. PIN	3P	
CB120	VD004700	CN. BS. PIN	4P	
C101	UM416470	C. EL	4.7uF	50V
C102	UM416470	C. EL	4.7uF	50V
C103	UA652100	C. MYLAR	100pF	50V
C104	UA652100	C. MYLAR	100pF	50V
C105	FG212100	C. CE	100pF	50V
C106	FG212100	C. CE	100pF	50V
C107	UA653100	C. MYLAR	1000pF	50V
C108	UA653100	C. MYLAR	1000pF	50V
C109	VJ837200	C. EL	47uF	16V
C110	VJ837200	C. EL	47uF	16V
C111	VR516400	C. CE	15p	500V
C112	VR516400	C. CE	15p	500V
C113	UJ667470	C. EL	47uF	50V
C114	UJ667470	C. EL	47uF	50V
C115	VG291200	C. EL	47uF	50V
C116	VG291200	C. EL	47uF	50V
C117	VR325000	C. MYLAR	100pF	100V
C118	VR325000	C. MYLAR	100pF	100V
C119	VR325000	C. MYLAR	100pF	100V
C120	VR325000	C. MYLAR	100pF	100V
C121	UA654820	C. MYLAR	0.082uF	50V
C122	UA654820	C. MYLAR	0.082uF	50V
C123	UA655100	C. MYLAR	0.1uF	50V
C124	UA655100	C. MYLAR	0.1uF	50V
C125	UA654220	C. MYLAR	0.022uF	50V
C126	UA654220	C. MYLAR	0.022uF	50V
C127	UA652100	C. MYLAR	100pF	50V
C128	VS741700	C. CE. SAFTY	0.01uF	275V
C129	VK182500	C. EL	330uF	63V
C131	UM416470	C. EL	4.7uF	50V
C133	VC815000	C. EL	220uF	6.3V
C134	UM416470	C. EL	4.7uF	50V
C135	UM416470	C. EL	4.7uF	50V
△ C136	Vi846000	C. EL	22uF	63V
C137	UM416470	C. EL	4.7uF	50V

* New Parts

RX-V393RDS
RX-V493RDS

RX-V393RDS P.C.B. MAIN

Schm Ref.	PART NO.	Description
C138	UJ667470	C. EL 47uF 50V
C139	UJ667470	C. EL 47uF 50V
△ C140	VV951700	C. EL 6800uF 50V
△ C141	VV951700	C. EL 6800uF 50V
△ C142	VR325400	C. MYLAR 0.1uF 100V
△ C143	VR325400	C. MYLAR 0.1uF 100V
C144	UA653100	C. MYLAR 1000pF 50V
C145	FG214100	C. CE 0.01uF 50V
C146	UA653100	C. MYLAR 1000pF 50V
C147	UA654100	C. MYLAR 0.01uF 50V
△ C149	VK457600	C. EL 330uF 25V
C152	UA654100	C. MYLAR 0.01uF 50V
C153	UA654100	C. MYLAR 0.01uF 50V
C154	UA654100	C. MYLAR 0.01uF 50V
C156	UA654220	C. MYLAR 0.022uF 50V
C157	UA654100	C. MYLAR 0.01uF 50V
C158	UA654100	C. MYLAR 0.01uF 50V
C159	UA654220	C. MYLAR 0.022uF 50V
C161	UA654100	C. MYLAR 0.01uF 50V
C162	UA654100	C. MYLAR 0.01uF 50V
C164	UM416470	C. EL 4.7uF 50V
C165	UK665470	C. EL 0.47uF 50V
C171	UA654100	C. MYLAR 0.01uF 50V
C172	UA654100	C. MYLAR 0.01uF 50V
D101	VN008700	DIODE 1SS270A
D102	VN008700	DIODE 1SS270A
D106	VM976300	DIODE, ZENR HZS242TD 24V
D107	VM976300	DIODE, ZENR HZS242TD 24V
△ D108	VS997800	DIODE 1T2
D109	VM975900	DIODE, ZENR HZS162TD 16V
D110	VM975800	DIODE, ZENR HZS152TD 15V
△ D111	iH001090	DIODE, BRG S4VB20 2.6A 200V
D112	VD631600	DIODE 1SS133, 176, HSS104
△ D113	VS997800	DIODE 1T2
D117	VD631600	DIODE 1SS133, 176, HSS104
△ F101	KB001660	FUSE T1.60A 250V
△ F102	KB000690	FUSE T2.5A 250V(G)
△ FR101	VK188400	R. FUS 330Ω 1/4W
△ FR102	VK188400	R. FUS 330Ω 1/4W
△ FR103	VK189000	R. FUS 1KΩ 1/4W
△ FR104	VK189000	R. FUS 1KΩ 1/4W
△ JK101	VY687200	JACK, PHONE JY-6317-02-030 NUT
△ JK102	VU543300	OUTLET, AC 1P(B)
△ JK102	VU543400	OUTLET, AC 2P(G)
L103	VP575600	COIL 1.5uH
L104	VP575600	COIL 1.5uH
△ Q101	VP883000	TR 2SA893A D, E
△ Q102	VP883000	TR 2SA893A D, E
△ Q103	VP883000	TR 2SA893A D, E
△ Q104	VP883000	TR 2SA893A D, E
△ Q105	VR325600	TR 2SC2229 O, Y
△ Q106	VR325600	TR 2SC2229 O, Y
△ Q107	iC174020	TR 2SC1740S R, S

* New Parts

Schm Ref.	PART NO.	Description
△ Q108	iC174020	TR 2SC1740S R, S
△ Q109	VP872700	TR 2SC4488 S, T
△ Q110	VP872700	TR 2SC4488 S, T
△ Q111	VP872600	TR 2SA1708 S, T
△ Q112	VP872600	TR 2SA1708 S, T
△ Q113	VP883100	TR 2SC1890A D, E
△ Q114	VP883100	TR 2SC1890A D, E
△ Q115	VP883000	TR 2SA893A D, E
△ Q116	iC174020	TR 2SC1740S R, S
△ Q117	iC174020	TR 2SC1740S R, S
△ Q118	VK432900	TR 2SD1915F S, T
△ Q119	iC174020	TR 2SC1740S R, S
△ Q120	iA101521	TR 2SA1015 Y
△ Q121	VN996900	TR 2SC4495
△ Q122	iC174020	TR 2SC1740S R, S
△ Q127	VG722000	TR, DGT DTC144ES
△ Q128	VR402300	TR 2SB647 C, D
△ Q129A	iX615750	TR 2SA1694 O, P, Y
△ Q129C	iX615760	TR 2SC4467 O, P, Y
△ Q130A	iX615750	TR 2SA1694 O, P, Y
△ Q130C	iX615760	TR 2SC4467 O, P, Y
△ R113	HV454470	R. CAR. FP 47Ω 1/4W
△ R114	HV454470	R. CAR. FP 47Ω 1/4W
△ R127	HV456270	R. CAR. FP 2.7KΩ 1/4W
△ R128	HV456270	R. CAR. FP 2.7KΩ 1/4W
△ R131	HV456100	R. CAR. FP 1KΩ 1/4W
△ R132	HV456100	R. CAR. FP 1KΩ 1/4W
△ R133	HV453470	R. CAR. FP 4.7Ω 1/4W
△ R134	HV453470	R. CAR. FP 4.7Ω 1/4W
△ R135	HV453470	R. CAR. FP 4.7Ω 1/4W
△ R136	HV453470	R. CAR. FP 4.7Ω 1/4W
△ R137	VU981700	R. MIL. PLAT 0.22Ω+0.22 3W
△ R138	VU981700	R. MIL. PLAT 0.22Ω+0.22 3W
△ R145	HL314100	R. MIL. OXD 10Ω 1W
△ R146	HL314100	R. MIL. OXD 10Ω 1W
△ R151	HV454100	R. CAR. FP 10Ω 1/4W
△ R152	HV454100	R. CAR. FP 10Ω 1/4W
△ R159	HL315330	R. MIL. OXD 330Ω 1W
△ R160	HL315330	R. MIL. OXD 330Ω 1W
△ R163	HL314470	R. MIL. OXD 47Ω 1W
△ R171	HL315680	R. MIL. OXD 680Ω 1W
△ R173	HV456100	R. CAR. FP 1KΩ 1/4W
△ R177	HV453100	R. CAR. FP 1Ω 1/4W
△ R178	HV454100	R. CAR. FP 10Ω 1/4W
△ R179	HV457100	R. CAR. FP 10KΩ 1/4W
△ R189	HL315680	R. MIL. OXD 680Ω 1W
△ R196	HV455100	R. CAR. FP 100Ω 1/4W
△ R201	HV456150	R. CAR. FP 1.5KΩ 1/4W
△ RY101	VK438300	RELAY DH24D2-OT/M2
△ RY102	VU349800	RELAY DC SDT-SS-112DM
△ SW101	VV523900	SW. PUSH PBS-YM-001
△ SW103	VZ361100	SW. SLIDE SL13B-022-AMC1
△ T101	XC084A00	TRANS. PWR

* New Parts

RX-V393RDS
RX-V493RDS

RX-V393RDS P.C.B. MAIN & INPUT

Schm Ref.	PART NO.	Description		
△	TE101	VU819700	TERM. SP	8P
		VJ828000	PIN	IMSA-6024-03E
		BB071360	SCR. TERM	8. 3x13
		VR264300	PLATE. GND	
		VP753100	HEAT. SINK	IC-1625-MML
		Ei330166	SCR. BND. HD	3x16 FCRM3-BL
		VY834500	SUPRT	
*	VZ497600	P.C.B.	INPUT	
	CB1	Vi878300	CN. BS. PIN	5P
	CB2	Vi878900	CN. BS. PIN	11P
	CB3	VQ963600	CN. BS. PIN	15P
	CB4	VQ962500	CN. BS. PIN	4P
	CB5	VU272200	CN	22P
	CB6	VQ963600	CN. BS. PIN	15P
	CB7	Vi878500	CN. BS. PIN	7P
	CB8	VK024700	CN. BS. PIN	3P
	CB301	VK026600	CN. BS. PIN	7P
	CB302	VK026700	CN. BS. PIN	8P
	CB304	VQ961400	CN. BS. PIN	11P
	CB305	VK024900	CN. BS. PIN	5P
	CB306	VK027000	CN. BS. PIN	11P
	CB307	VK026200	CN. BS. PIN	3P
	CB308	VK025200	CN. BS. PIN	8P
	CB309	Vi878400	CN. BS. PIN	6P
	CB310	Vi878400	CN. BS. PIN	6P
	CB311	Vi878600	CN. BS. PIN	8P
	CB313	VK024900	CN. BS. PIN	5P
	CB314	Vi878100	CN. BS. PIN	3P
	CB315	Vi878100	CN. BS. PIN	3P
	CB316	VK024700	CN. BS. PIN	3P
	C1	VJ839100	C. EL	1uF 50V
	C2	UA652100	C. MYLAR	100pF 50V
	C3	UA652100	C. MYLAR	100pF 50V
	C4	VJ839100	C. EL	1uF 50V
	C5	FG212100	C. CE	100pF 50V
	C6	UM417100	C. EL	10uF 50V
	C7	UA652100	C. MYLAR	100pF 50V
	C8	VJ839100	C. EL	1uF 50V
	C9	UM417100	C. EL	10uF 50V
	C10	VJ839100	C. EL	1uF 50V
	C11	UM417100	C. EL	10uF 50V
	C12	UA652100	C. MYLAR	100pF 50V
	C13	UA652100	C. MYLAR	100pF 50V
	C14	UA652100	C. MYLAR	100pF 50V
	C15	UA655150	C. MYLAR	0. 15uF 50V
	C16	VF466800	C. CE. TUBLR	100pF 50V
	C17	UM417100	C. EL	10uF 50V
	C18	UM417100	C. EL	10uF 50V
	C19	UM417100	C. EL	10uF 50V
	C20	VF466800	C. CE. TUBLR	100pF 50V

* New Parts

Schm Ref.	PART NO.	Description		
C21	VF964800	C. EL	100uF	16V
C22	UM417100	C. EL	10uF	50V
C23	UM417100	C. EL	10uF	50V
C24	VF964800	C. EL	100uF	16V
C25	UA652680	C. MYLAR	680pF	50V
C26	UA652680	C. MYLAR	680pF	50V
C27	UM407220	C. EL	22uF	25V
C28	UM407220	C. EL	22uF	25V
C29	UM417100	C. EL	10uF	50V
C30	VG279600	C. CE. TUBLR	3300pF	16V
C31	VG278400	C. CE. TUBLR	220pF	50V
C32	VG278400	C. CE. TUBLR	220pF	50V
C33	VG279600	C. CE. TUBLR	3300pF	16V
C34	VG279900	C. CE. TUBLR	6800pF	16V
C35	VG278600	C. CE. TUBLR	330pF	50V
C36	VG279500	C. CE. TUBLR	2700pF	16V
C37	VG278600	C. CE. TUBLR	330pF	50V
C38	VG279500	C. CE. TUBLR	2700pF	16V
C39	VG279900	C. CE. TUBLR	6800pF	16V
C40	UA653470	C. MYLAR	4700pF	50V
C41	FG212330	C. CE	330pF	50V
C42	FG212330	C. CE	330pF	50V
C43	UA653470	C. MYLAR	4700pF	50V
C44	UM407220	C. EL	22uF	25V
C45	UM407220	C. EL	22uF	25V
C46	UA652330	C. MYLAR	330pF	50V
C47	UM407220	C. EL	22uF	25V
C48	UA652330	C. MYLAR	330pF	50V
C49	UA652330	C. MYLAR	330pF	50V
C50	UM407220	C. EL	22uF	25V
C51	VJ839100	C. EL	1uF	50V
C52	VG279500	C. CE. TUBLR	2700pF	16V
C53	VG279500	C. CE. TUBLR	2700pF	16V
C54	VJ839100	C. EL	1uF	50V
C55	VF466600	C. CE. TUBLR	10pF	50V
C56	VF466600	C. CE. TUBLR	10pF	50V
C58	UA654100	C. MYLAR	0. 01uF	50V
C59	VF466800	C. CE. TUBLR	100pF	50V
C60	VF466800	C. CE. TUBLR	100pF	50V
C61	UA654100	C. MYLAR	0. 01uF	50V
C63	UM407220	C. EL	22uF	25V
C64	UM407220	C. EL	22uF	25V
C65	VG277000	C. CE. TUBLR	33pF	50V
C66	VG277000	C. CE. TUBLR	33pF	50V
C67	VG277000	C. CE. TUBLR	33pF	50V
C68	VG277000	C. CE. TUBLR	33pF	50V
C69	UM407220	C. EL	22uF	25V
C70	UM407220	C. EL	22uF	25V
C71	VG279600	C. CE. TUBLR	3300pF	16V
C72	VG279600	C. CE. TUBLR	3300pF	16V
C73	VH053100	C. CE. TUBLR	0. 1uF	50V
C74	VH053100	C. CE. TUBLR	0. 1uF	50V
C75	VH053100	C. CE. TUBLR	0. 1uF	50V

* New Parts

RX-V393RDS
RX-V493RDS

RX-V393RDS P.C.B. INPUT

Schm Ref.	PART NO.	Description		
C76	UJ638330	C. EL	330uF	16V
C78	VJ837200	C. EL	47uF	16V
C79	VJ837200	C. EL	47uF	16V
C80	VF760000	C. EL	100uF	10V
C81	VH053100	C. CE. TUBLR	0. 1uF	50V
C82	VF964800	C. EL	100uF	16V
C83	VE117600	C. EL	220uF	10V
C86	VH053100	C. CE. TUBLR	0. 1uF	50V
C87	VJ837200	C. EL	47uF	16V
C88	VJ837200	C. EL	47uF	16V
C89	VJ837200	C. EL	47uF	16V
C90	VH053100	C. CE. TUBLR	0. 1uF	50V
C91	VF466800	C. CE. TUBLR	100pF	50V
C93	VF466800	C. CE. TUBLR	100pF	50V
C94	VF466800	C. CE. TUBLR	100pF	50V
C301	VF760000	C. EL	100uF	10V
C302	UA652220	C. MYLAR	220pF	50V
C303	UA652220	C. MYLAR	220pF	50V
C304	UA652220	C. MYLAR	220pF	50V
C305	UA652220	C. MYLAR	220pF	50V
C306	VF760000	C. EL	100uF	10V
C307	UA652100	C. MYLAR	100pF	50V
C308	UA652100	C. MYLAR	100pF	50V
C309	VF466700	C. CE. TUBLR	47pF	50V
C310	VF466700	C. CE. TUBLR	47pF	50V
C311	VF466800	C. CE. TUBLR	100pF	50V
C312	VF466800	C. CE. TUBLR	100pF	50V
C313	VF466800	C. CE. TUBLR	100pF	50V
C314	VF466800	C. CE. TUBLR	100pF	50V
C315	VF466700	C. CE. TUBLR	47pF	50V
C316	VF466700	C. CE. TUBLR	47pF	50V
C319	UA653100	C. MYLAR	1000pF	50V
C321	UA653100	C. MYLAR	1000pF	50V
C323	VH053100	C. CE. TUBLR	0. 1uF	50V
C324	UJ668100	C. EL	100uF	50V
C325	UM417100	C. EL	10uF	50V
C326	VE117600	C. EL	220uF	10V
C327	FG212100	C. CE	100pF	50V
C328	Ui367220	C. EL	22uF	50V
C329	VH053100	C. CE. TUBLR	0. 1uF	50V
C330	VJ839200	C. EL	2. 2uF	50V
C331	UA653910	C. MYLAR	9100pF	50V
C332	UA654330	C. MYLAR	0. 033uF	50V
C333	UA653910	C. MYLAR	9100pF	50V
C334	UA654330	C. MYLAR	0. 033uF	50V
C335	VJ839200	C. EL	2. 2uF	50V
C336	UJ668100	C. EL	100uF	50V
C337	VJ839200	C. EL	2. 2uF	50V
C338	FG212220	C. CE	220pF	50V
C339	UA653330	C. MYLAR	3300pF	50V
C340	UH178100	C. EL	100uF	63V
C341	VJ837200	C. EL	47uF	16V
C342	VJ837200	C. EL	47uF	16V

Schm Ref.	PART NO.	Description		
C343	FH611220	C. CE	22pF	500V
C344	UM417100	C. EL	10uF	50V
C345	VF466800	C. CE. TUBLR	100pF	50V
C347	UM407220	C. EL	22uF	25V
C348	UM417100	C. EL	10uF	50V
C349	UM417100	C. EL	10uF	50V
C350	UM407220	C. EL	22uF	25V
C352	VF466800	C. CE. TUBLR	100pF	50V
C353	UM417100	C. EL	10uF	50V
C354	FG212100	C. CE	100pF	50V
C355	UA654100	C. MYLAR	0. 01uF	50V
C356	FG211100	C. CE	10pF	50V
C357	UJ668100	C. EL	100uF	50V
C358	VF466800	C. CE. TUBLR	100pF	50V
C359	FG212100	C. CE	100pF	50V
C360	FG212100	C. CE	100pF	50V
C361	VF466800	C. CE. TUBLR	100pF	50V
C362	UJ668100	C. EL	100uF	50V
C363	FG211100	C. CE	10pF	50V
C364	UA654100	C. MYLAR	0. 01uF	50V
C365	FG212100	C. CE	100pF	50V
C366	VF964800	C. EL	100uF	16V
C367	VF964800	C. EL	100uF	16V
C368	VJ839200	C. EL	2. 2uF	50V
C369	UA654470	C. MYLAR	0. 047uF	50V
C370	UA654470	C. MYLAR	0. 047uF	50V
C371	VR325000	C. MYLAR	100pF	100V
C372	VJ839100	C. EL	1uF	50V
C373	Ui367220	C. EL	22uF	50V
C374	VR325000	C. MYLAR	100pF	100V
C375	VJ839100	C. EL	1uF	50V
C376	UA654470	C. MYLAR	0. 047uF	50V
C377	VE117600	C. EL	220uF	10V
C378	UJ648100	C. EL	100uF	25V
C379	VL544800	C. EL	3300uF	35V
C380	VG289900	C. EL	2200uF	35V
C381	VG722100	C. EL	1uF	50V
C382	FG212470	C. CE	470pF	50V
C383	VD930900	C. CE. SMI	0. 1uF	25V
C384	FG244220	C. CE	0. 022uF	50V
C385	FG244220	C. CE	0. 022uF	50V
C386	FG214100	C. CE	0. 01uF	50V
C387	FG244220	C. CE	0. 022uF	50V
C388	FG214100	C. CE	0. 01uF	50V
C389	UA654470	C. MYLAR	0. 047uF	50V
C390	UA654470	C. MYLAR	0. 047uF	50V
C391	VH053100	C. CE. TUBLR	0. 1uF	50V
C392	VJ839200	C. EL	2. 2uF	50V
C394	VJ839200	C. EL	2. 2uF	50V
C395	UJ667470	C. EL	47uF	50V
C396	VZ410500	C. EL	47uF	35V
C397	VJ839200	C. EL	2. 2uF	50V
C398	VJ839200	C. EL	2. 2uF	50V

* New Parts

* New Parts

RX-V393RDS
RX-V493RDS

△

△

△

RX-V393RDS P.C.B. INPUT

Schm Ref.	PART NO.	Description
C399	FG212100	C. CE 100pF 50V
C400	UA652220	C. MYLAR 220pF 50V
C401	UA652220	C. MYLAR 220pF 50V
C402	UA652220	C. MYLAR 220pF 50V
C403	VF466800	C. CE. TUBLR 100pF 50V
C404	VF466800	C. CE. TUBLR 100pF 50V
C405	VJ837200	C. EL 47uF 16V
C406	VJ837200	C. EL 47uF 16V
C407	VF466800	C. CE. TUBLR 100pF 50V
C408	UA652100	C. MYLAR 100pF 50V
C409	UA652100	C. MYLAR 100pF 50V
C410	FG211100	C. CE 10pF 50V
C411	FG211100	C. CE 10pF 50V
C412	FG211100	C. CE 10pF 50V
C413	UM417100	C. EL 10uF 50V
C414	UM417100	C. EL 10uF 50V
C415	UM417100	C. EL 10uF 50V
C416	UM417100	C. EL 10uF 50V
C417	VJ837200	C. FL 47uF 16V
C418	VJ837200	C. EL 47uF 16V
C419	UJ638470	C. FL 470uF 16V
C420	VG722100	C. EL 1uF 50V
C421	VH053100	C. CE. TUBLR 0.1uF 50V
C422	VF466900	C. CE. TUBLR 470pF 50V
C423	VF466900	C. CE. TUBLR 470pF 50V
C501	UJ638330	C. EL 330uF 16V
C502	VH053100	C. CE. TUBLR 0.1uF 50V
C503	VH053100	C. CE. TUBLR 0.1uF 50V
C504	VH053100	C. CE. TUBLR 0.1uF 50V
C505	VH053100	C. CE. TUBLR 0.1uF 50V
C506	VH053100	C. CE. TUBLR 0.1uF 50V
C507	VH053100	C. CE. TUBLR 0.1uF 50V
C508	VH053100	C. CE. TUBLR 0.1uF 50V
C601	VJ837200	C. EL 47uF 16V
C602	UA654100	C. MYLAR 0.01uF 50V
C603	UA654100	C. MYLAR 0.01uF 50V
D1	VD631600	DIODE 1SS133, 176, HSS104
D3	VM975500	DIODE. ZENR HZS12A2TD 12V
D301	VM975500	DIODE. ZENR HZS12A2TD 12V
D302	VM975500	DIODE. ZENR HZS12A2TD 12V
D303	VM975500	DIODE. ZENR HZS12A2TD 12V
D304	VM975500	DIODE. ZENR HZS12A2TD 12V
D305	VD631600	DIODE 1SS133, 176, HSS104
D306	VD631600	DIODE 1SS133, 176, HSS104
D307	VD631600	DIODE 1SS133, 176, HSS104
D308	VD631600	DIODE 1SS133, 176, HSS104
△ D309	VN008700	DIODE 1SS270A
D310	VM976300	DIODE. ZENR HZS242TD 24V
D311	VD631600	DIODE 1SS133, 176, HSS104
D312	VD631600	DIODE 1SS133, 176, HSS104
D313	VM974100	DIODE. ZENR HZS5B2TD 5.0V
△ D314	VV731400	DIODE 2A02M
△ D315	VV731400	DIODE 2A02M

* New Parts

Schm Ref.	PART NO.	Description
△ D316	VV731400	DIODE 2A02M
△ D317	VV731400	DIODE 2A02M
D318	VM974200	DIODE. ZENR HZS5C2TD 5.0V
D319	VD631600	DIODE 1SS133, 176, HSS104
D501	VS997800	DIODE 1T2
IC1	XP896A00	IC LC78213
IC2	XB247301	IC uPC4570HA
IC3	XM356A00	IC NJM2068LD
IC4	XB247301	IC uPC4570HA
IC5	XB247301	IC uPC4570HA
IC6	XB247301	IC uPC4570HA
IC7	XB247301	IC uPC4570HA
IC8	XB247301	IC uPC4570HA
IC9	XB247301	IC uPC4570HA
IC10	XB247301	IC uPC4570HA
IC11	XQ212A00	IC NJM4558LD
IC12	XQ212A00	IC NJM4558LD
IC14	XA507A00	IC AN78N05
IC16	Xi022B00	IC YSS203B-F
IC17	XS881A00	IC LH5P832D-10 PSRAM
IC302	XM356A00	IC NJM2068LD
IC303	XP894A00	IC LC78211
△ IC304	iG092000	IC M5220L
IC305	XB467001	IC AN79M15F
IC308	XB247301	IC uPC4570HA
IC309	XB247301	IC uPC4570HA
IC310	XF494A00	IC LB1641
L301	VP575600	COIL 1.5uH
L302	VP575600	COIL 1.5uH
L303	VP575600	COIL 1.5uH
PJ1	VR765100	JACK. PIN 2P
PJ301	VZ410600	JACK. PIN 6P
PJ302	VU857800	JACK. PIN 6P
PJ305	VJ249500	JACK. PIN 4P
Q1	VP872700	TR 2SC4488 S, T
Q303	iC174020	TR 2SC1740S R, S
Q304	iC174020	TR 2SC1740S R, S
Q305	VP883000	TR 2SA893A D, E
△ Q306	VP872700	TR 2SC4488 S, T
△ Q307	VP872600	TR 2SA1708 S, T
△ Q308	VC276100	TR 2SC2909 S, T
△ Q309	VC276100	TR 2SC2909 S, T
△ Q310	VP872600	TR 2SA1708 S, T
△ Q311	VP872700	TR 2SC4488 S, T
△ Q312	VV855300	TR 2SD856 Q, P
Q313	VP883100	TR 2SC1890A D, E
Q314	VV855300	TR 2SD856 Q, P
△ Q315	VV855300	TR 2SD856 Q, P
Q316	VP883100	TR 2SC1890A D, E
△ Q317	VV855300	TR 2SD856 Q, P
△ Q319	VP872700	TR 2SC4488 S, T
△ Q320	iC174020	TR 2SC1740S R, S
△ Q321	VP872600	TR 2SA1708 S, T

* New Parts

RX-V393RDS P.C.B. INPUT & SELECT

Schm Ref.	PART NO.	Description
Q322	VP883000	TR 2SA893A D, E
Q323A	iX615750	TR 2SA1694 O, P, Y
Q323C	iX615760	TR 2SC4467 O, P, Y
Q324	VP883100	TR 2SC1890A D, E
Q326	VK432900	TR 2SD1915F S, T
Q327	VK432900	TR 2SD1915F S, T
Q601	VK432900	TR 2SD1915F S, T
Q602	VK432900	TR 2SD1915F S, T
Q603	VK432900	TR 2SD1915F S, T
Q604	VK432900	TR 2SD1915F S, T
Q605	VK432900	TR 2SD1915F S, T
R79	HV453220	R. CAR. FP 2.2Ω 1/4W
R84	HL314470	R. MIL. OXD 47Ω 1W
R85	HV453220	R. CAR. FP 2.2Ω 1/4W
R86	HV453220	R. CAR. FP 2.2Ω 1/4W
R87	HV453220	R. CAR. FP 2.2Ω 1/4W
R88	HV453220	R. CAR. FP 2.2Ω 1/4W
R95	HV453470	R. CAR. FP 4.7Ω 1/4W
R353	HV454100	R. CAR. FP 10Ω 1/4W
R360	HV455470	R. CAR. FP 470Ω 1/4W
R365	HV455470	R. CAR. FP 470Ω 1/4W
R370	HV455330	R. CAR. FP 330Ω 1/4W
R376	HV455120	R. CAR. FP 120Ω 1/4W
R377	HV455100	R. CAR. FP 100Ω 1/4W
R378	HV455100	R. CAR. FP 100Ω 1/4W
R379	HV455120	R. CAR. FP 120Ω 1/4W
R385	HV455330	R. CAR. FP 330Ω 1/4W
R386	HV456150	R. CAR. FP 1.5KΩ 1/4W
R387	VE869300	R. MIL. OXD 0.1Ω 2W
R389	HV454220	R. CAR. FP 22Ω 1/4W
R390	HV454220	R. CAR. FP 22Ω 1/4W
R392	HV456150	R. CAR. FP 1.5KΩ 1/4W
R394	VE869300	R. MIL. OXD 0.1Ω 2W
R398	HV454100	R. CAR. FP 10Ω 1/4W
R400	HV454100	R. CAR. FP 10Ω 1/4W
R401	VK188600	R. FUS 470Ω 1/4W
R402	HV456270	R. CAR. FP 2.7KΩ 1/4W
R403	HV455470	R. CAR. FP 470Ω 1/4W
R404	HV456820	R. CAR. FP 8.2KΩ 1/4W
R405	HV456150	R. CAR. FP 1.5KΩ 1/4W
R410	HV453470	R. CAR. FP 4.7Ω 1/4W
R412	HV457100	R. CAR. FP 10KΩ 1/4W
R415	VU981700	R. MIL. PLAT 0.22Ω+0.22 3W
R416	HV453470	R. CAR. FP 4.7Ω 1/4W
R417	HV454100	R. CAR. FP 10Ω 1/4W
R418	HL425820	R. MIL. OXD 820Ω 2W
R419	HV454100	R. CAR. FP 10Ω 1/4W
R420	HV454100	R. CAR. FP 10Ω 1/4W
R430	HV453220	R. CAR. FP 2.2Ω 1/4W
R433	HV454100	R. CAR. FP 10Ω 1/4W
R434	HL314220	R. MIL. OXD 22Ω 1W
R455	HV453470	R. CAR. FP 4.7Ω 1/4W
R456	HV453470	R. CAR. FP 4.7Ω 1/4W

Schm Ref.	PART NO.	Description
R457	HV454100	R. CAR. FP 10Ω 1/4W
R458	HV454100	R. CAR. FP 10Ω 1/4W
R501	HL314220	R. MIL. OXD 22Ω 1W
R504	HV454100	R. CAR. FP 10Ω 1/4W
R505	HV454100	R. CAR. FP 10Ω 1/4W
R506	HL314220	R. MIL. OXD 22Ω 1W
RY301	VU566700	RELAY DG24D2-OS/M
SW1	VS602600	SW. SLIDE SS070-P022 A
TE301	VS578600	TERM. SP 8P
VR301	VV135100	VR. MTR A100KΩ
XLI	VK175200	RSNR. CE 11.28MHz
	VJ828000	PIN IMSA-6024-03E
	BB071360	SCR. TERM 8.3x13
	V2227700	PLATE. GND REAR SP.
	V2342700	SPACER EFFECT/PCB
	VZ864400	P. C. B. SELECT
CB701	VQ961800	CN. BS. PIN 15P
CB702	VF667600	CN. BS. PIN 15P
CB703	Vi878900	CN. BS. PIN 11P
CB704	VQ960700	CN 4P
C701	VH053100	C. CE. TUBLR 0.1uF 50V
C702	VH053100	C. CE. TUBLR 0.1uF 50V
IC701	XP896A00	IC LC78213

* New Parts

* New Parts

RX-V393RDS P.C.B. TUNER

Schm Ref.	PART NO.	Description
	VV173600	P.C.B. TUNER
CB4	VQ961800	CN. BS. PIN
C1	VG291200	C. EL 47uF 50V
C3	VG275800	C. CE. TUBLR 8.2pF 50V
C4	VG291200	C. EL 47uF 50V
C5	VF467300	C. CE. TUBLR 0.01uF 16V
C6	VG291200	C. EL 47uF 50V
C7	VJ839100	C. EL 1uF 50V
C8	VF467300	C. CE. TUBLR 0.01uF 16V
C9	VF467300	C. CE. TUBLR 0.01uF 16V
C10	VF467300	C. CE. TUBLR 0.01uF 16V
C11	VF467000	C. CE. TUBLR 1000pF 50V
C12	VJ836900	C. EL 10uF 16V
C13	VJ836900	C. EL 10uF 16V
C14	VF466800	C. CE. TUBLR 100pF 50V
C15	VF467000	C. CE. TUBLR 1000pF 50V
C16	VF466700	C. CE. TUBLR 47pF 50V
C17	VG291200	C. EL 47uF 50V
C19	VA761200	C. CE 33pF 50V
C20	VG291200	C. EL 47uF 50V
C21	VJ599000	C. CE. TUBLR 0.047uF 16V
C22	UM216330	C. FL 3.3uF 50V
C23	VF467300	C. CE. TUBLR 0.01uF 16V
C24	UM416470	C. FL 4.7uF 50V
C25	UM216330	C. EL 3.3uF 50V
C26	VJ836900	C. EL 10uF 16V
C27	VF467300	C. CE. TUBLR 0.01uF 16V
C28	VA761200	C. CE 33pF 50V
C29	VJ839100	C. EL 1uF 50V
C30	VJ839100	C. EL 1uF 50V
C31	VG291200	C. EL 47uF 50V
C32	VJ839000	C. EL 0.47uF 50V
C33	VJ839100	C. EL 1uF 50V
C34	UA654470	C. MYLAR 0.047uF 50V
C35	UM216330	C. EL 3.3uF 50V
C36	UA652470	C. MYLAR 470pF 50V
C37	UA652470	C. MYLAR 470pF 50V
C38	VF466900	C. CE. TUBLR 470pF 50V
C39	VJ836900	C. EL 10uF 16V
C40	UM216330	C. EL 3.3uF 50V
C41	UA653390	C. MYLAR 3900pF 50V
C42	UM407220	C. EL 22uF 25V
C43	UA653390	C. MYLAR 3900pF 50V
C44	UM216330	C. EL 3.3uF 50V
C45	VG291200	C. EL 47uF 50V
C46	VG291200	C. EL 47uF 50V
C47	VG291200	C. EL 47uF 50V
C48	VF466800	C. CE. TUBLR 100pF 50V
C49	UA652120	C. MYLAR 120pF 50V
C50	VJ599000	C. CE. TUBLR 0.047uF 16V
D1	iF004600	DIODE 1SS133
D2	iF004600	DIODE 1SS133
D3	VG437800	DIODE. ZENR MTZJ5.6C 5.6V

* New Parts

Schm Ref.	PART NO.	Description
Fi1	GG000560	FLTR. CE SFE10.7MS3GHY-A
Fi2	GG000560	FLTR. CE SFE10.7MS3GHY-A
Fi3	VC219000	FLTR. CE SFZ450JL3
IC1	XB760A00	IC LA1266
IC2	XQ944A00	IC LC72131
IC3	iG158100	IC LA3401
IC4	XQ359A00	IC STK311-020B
L1	Vi546100	COIL 220uH
L2	Vi546100	COIL 220uH
L3	Vi546100	COIL 220uH
L4	Vi546100	COIL 220uH
PK1	VQ987600	TUNER. PK EXV-17296G1
PK2	VU333700	COIL. RF. AM 940536051A
Q1	VB433300	TR 2SC1809 M, N, P
Q2	VB433300	TR 2SC1809 M, N, P
Q3	VD678500	TR. DGT DTA114ES
Q4	VC218900	TR 2SC3330 R, S, T
Q5	VG722000	TR. DGT DTC144ES
Q6	iC1815C0	TR 2SC1815 Y
Q7	VD678500	TR. DGT DTA114ES
T1	VC218600	COIL. DT. FM 10.7MHz
T2	GE100470	COIL. IF. AM 450KHz
T3	VT486800	COIL XYA2
T4	VQ138200	FLTR. LC 19KHz
T5	VQ138200	FLTR. LC 19KHz
TE1	VU477800	TERM. ANT AJ-2038-040
TP1	VT969000	PIN. TEST IRS-2049
TP2	VT969000	PIN. TEST IRS-2049
VR1	VJ694000	VR. TRIM B47K Ω
VR2	VJ694000	VR. TRIM B47K Ω
XL1	VC219100	RSNR. CRY5 7.2MHz
XL2	GG000750	RSNR. CE 18.95KHz
XL3	VS860100	RSNR. CE 19KHz
	BB071360	SCR. TERM 8.3x13
	VR282500	PLATE ANT.
	iX615760	TR 2SC4467 O, P, Y

* New Parts

RX-V493RDS P.C.B. OPERATION

Schm Ref.	PART NO.	Description	
*	VZ497700	P. C. B.	OPERATION
CB1	Vi878100	CN. BS. PIN	3P
CB2	Vi878100	CN. BS. PIN	3P
CB3	VQ963200	CN. BS. PIN	11P
CB4	Vi879300	CN. BS. PIN	15P
CB5	Vi878800	CN. BS. PIN	10P
CB6	VU272200	CN	22P
CB7	Vi878400	CN. BS. PIN	6P
CB9	Vi878300	CN. BS. PIN	5P
CB10	VK027000	CN. BS. PIN	11P
C1	VF466800	C. CE. TUBLR	100pF 50V
C2	VF466800	C. CE. TUBLR	100pF 50V
C3	VF637900	C. EL	1000uF 10V
C4	VJ836900	C. EL	10uF 16V
C5	VJ836900	C. EL	10uF 16V
C6	VJ836900	C. EL	10uF 16V
C7	VF637900	C. EL	1000uF 10V
C8	VH053100	C. CE. TUBLR	0. 1uF 50V
C9	UJ638330	C. EL	330uF 16V
C10	VG278400	C. CE. TUBLR	220pF 50V
C11	VG278400	C. CE. TUBLR	220pF 50V
C12	VG278400	C. CE. TUBLR	220pF 50V
C13	VG278400	C. CE. TUBLR	220pF 50V
C14	VG278400	C. CE. TUBLR	220pF 50V
C15	VG278400	C. CE. TUBLR	220pF 50V
C16	VH053100	C. CE. TUBLR	0. 1uF 50V
C17	VF467300	C. CE. TUBLR	0. 01uF 16V
C18	VJ836900	C. EL	10uF 16V
C19	VJ839100	C. EL	1uF 50V
C20	VU545000	C. EL	47000uF 5. 5V
C21	VD930900	C. CE. SMI	0. 1uF 25V
C22	VH053100	C. CE. TUBLR	0. 1uF 50V
C23	VJ839100	C. EL	1uF 50V
C24	VH053100	C. CE. TUBLR	0. 1uF 50V
C25	UA655330	C. MYLAR	0. 33uF 50V
C26	VJ839200	C. EL	2. 2uF 50V
C27	VJ839200	C. EL	2. 2uF 50V
C28	VJ839100	C. EL	1uF 50V
C29	VJ839100	C. EL	1uF 50V
C30	VJ837200	C. EL	47uF 16V
C31	FG211470	C. CE	47pF 50V
C32	UM417100	C. EL	10uF 50V
C33	UM417100	C. EL	10uF 50V
C34	FG211470	C. CE	47pF 50V
C35	VJ837200	C. EL	47uF 16V
C36	UM407220	C. EL	22uF 25V
C37	UA655120	C. MYLAR	0. 12uF 50V
C38	UA654330	C. MYLAR	0. 033uF 50V
C39	UA654330	C. MYLAR	0. 033uF 50V
C40	UA655120	C. MYLAR	0. 12uF 50V
C41	UM407220	C. EL	22uF 25V
C42	UA652100	C. MYLAR	100pF 50V
C43	UA652100	C. MYLAR	100pF 50V

* New Parts

Schm Ref.	PART NO.	Description	
C44	VJ836300	C. EL	330uF 6. 3V
C201	VJ836300	C. EL	330uF 6. 3V
D1	VM974600	DIODE. ZENR	HZS7A2TD 7. 0V
D2	VM974200	DIODE. ZENR	HZS5C2TD 5. 0V
D3	VD631600	DIODE	1SS133, 176, HSS104
D4	VD631600	DIODE	1SS133, 176, HSS104
D5	VD631600	DIODE	1SS133, 176, HSS104
D6	VD631600	DIODE	1SS133, 176, HSS104
D8	VM974100	DIODE. ZENR	HZS5B2TD 5. 0V
D12	VD631600	DIODE	1SS133, 176, HSS104
D13	VD631600	DIODE	1SS133, 176, HSS104
D14	VD631600	DIODE	1SS133, 176, HSS104
D15	VM974300	DIODE. ZENR	HZS6A2TD 6. 0V
G1	VR463400	TERM. GND	D3. 5 TP00385
IC1	XH436A00	IC	LA7956
IC3	XM356A00	IC	NJM2068LD
IC4	XT819A00	IC	M38177MC-071FP CPU
PJ1	VJ695900	JACK. PIN	3P
PJ2	VR110100	JACK. PIN	2P
PJ3	VV031700	JACK. PIN	3P
PJ4	VV031700	JACK. PIN	3P
Q1	iC174020	TR	2SC1740S R, S
Q2	iA093320	TR	2SA933S Q, R
Q3	iC174020	TR	2SC1740S R, S
Q4	VD678500	TR. DGT	DTA114ES
Q5	VK432900	TR	2SD1915F S, T
Q7	VK432900	TR	2SD1915F S, T
Q8	VK432900	TR	2SD1915F S, T
Q9	VK432900	TR	2SD1915F S, T
Q10	VK432900	TR	2SD1915F S, T
Q11	VD678500	TR. DGT	DTA114ES
Q12	VK432900	TR	2SD1915F S, T
Q13	VK432900	TR	2SD1915F S, T
Q14	iA093320	TR	2SA933S Q, R
Q15	VK432900	TR	2SD1915F S, T
Q16	VK432900	TR	2SD1915F S, T
Q17	iC1815C0	TR	2SC1815 Y
Q18	iC1815C0	TR	2SC1815 Y
Q19	iC174020	TR	2SC1740S R, S
Q20	iC174020	TR	2SC1740S R, S
R20	HV454470	R. CAR. FP	47 Ω 1/4W
R79	HV455100	R. CAR. FP	100 Ω 1/4W
R90	HV455100	R. CAR. FP	100 Ω 1/4W
SW1	VG392900	SW. TACT	SKHVAA
SW2	VG392900	SW. TACT	SKHVAA
SW3	VG392900	SW. TACT	SKHVAA
SW4	VG392900	SW. TACT	SKHVAA
SW5	VG392900	SW. TACT	SKHVAA
SW6	VG392900	SW. TACT	SKHVAA
SW7	VG392900	SW. TACT	SKHVAA
SW8	VG392900	SW. TACT	SKHVAA
SW9	VG392900	SW. TACT	SKHVAA
SW10	VG392900	SW. TACT	SKHVAA

* New Parts

RX-V393RDS
RX-V493RDS

RX-V493RDS P.C.B. OPERATION & MAIN

Schm Ref.	PART NO.	Description	
SW11	VG392900	SW. TACT	SKHVAA
SW12	VG392900	SW. TACT	SKHVAA
SW13	VG392900	SW. TACT	SKHVAA
SW14	VG392900	SW. TACT	SKHVAA
SW15	VG392900	SW. TACT	SKHVAA
SW16	VG392900	SW. TACT	SKHVAA
SW17	VG392900	SW. TACT	SKHVAA
SW18	VG392900	SW. TACT	SKHVAA
SW19	VG392900	SW. TACT	SKHVAA
SW20	VG392900	SW. TACT	SKHVAA
SW21	VG392900	SW. TACT	SKHVAA
SW22	VG392900	SW. TACT	SKHVAA
SW23	VG392900	SW. TACT	SKHVAA
SW24	VG392900	SW. TACT	SKHVAA
SW25	VG392900	SW. TACT	SKHVAA
SW26	VG392900	SW. TACT	SKHVAA
SW27	VG392900	SW. TACT	SKHVAA
SW28	VG392900	SW. TACT	SKHVAA
SW29	VG392900	SW. TACT	SKHVAA
SW30	VG392900	SW. TACT	SKHVAA
SW31	VG392900	SW. TACT	SKHVAA
SW32	VG392900	SW. TACT	SKHVAA
SW33	VG392900	SW. TACT	SKHVAA
SW34	VG392900	SW. TACT	SKHVAA
SW35	VG392900	SW. TACT	SKHVAA
SW36	VG392900	SW. TACT	SKHVAA
SW37	VG392900	SW. TACT	SKHVAA
SW38	VG392900	SW. TACT	SKHVAA
SW39	VG392900	SW. TACT	SKHVAA
SW40	VG392900	SW. TACT	SKHVAA
U1	VU591000	L. DTCT	GP1U271X
V1	VV298800	FL. DSPLY	13-BT-151GK
VR4	VP741800	VR	B20K Ω
VR5	VP741900	VR	G25K Ω
VR6	VP742000	VR	MN100K Ω
XL1	VR891500	RSNR. CE	6. 30MHZ
	VJ828000	PIN	IMSA-6024-03E
	VQ859800	SHEET. FL	
	VV499900	SPACER	FL-T7.5

Schm Ref.	PART NO.	Description	
*	VZ416900	P. C. B.	MAIN(B)
*	VZ417000	P. C. B.	MAIN(G)
CB101	VF728300	CN	6P
CB102	VF728200	CN. BS. PIN	10P
CB103	VS839400	CN. BS. PIN	4P
CB104	VS839500	CN	4P
CB105	VG879900	CN. BS. PIN	2P
CB107	Vi878600	CN. BS. PIN	8P
CB108	VR428900	CN. BS. PIN	4P
CB109	VR428900	CN. BS. PIN	4P
CB111	VP206500	HOLDER. FUS	EYF-52BC
CB112	VP206500	HOLDER. FUS	EYF-52BC
CB113	VP206500	HOLDER. FUS	EYF-52BC(G)
CB114	VP206500	HOLDER. FUS	EYF-52BC(G)
CB117	VQ584900	CN. BS. PIN	7P
CB118	VQ584900	CN. BS. PIN	7P
CB119	Vi878100	CN. BS. PIN	3P
CB120	VD004700	CN. BS. PIN	4P
C101	UM416470	C. EL	4. 7uF 50V
C102	UM416470	C. EL	4. 7uF 50V
C103	UA652100	C. MYLAR	100pF 50V
C104	UA652100	C. MYLAR	100pF 50V
C105	FG212100	C. CE	100pF 50V
C106	FG212100	C. CE	100pF 50V
C107	UA653100	C. MYLAR	1000pF 50V
C108	UA653100	C. MYLAR	1000pF 50V
C109	VJ837200	C. EL	47uF 16V
C110	VJ837200	C. EL	47uF 16V
C111	VR516400	C. CE	15p 500V
C112	VR516400	C. CE	15p 500V
C113	UJ667470	C. EL	47uF 50V
C114	UJ667470	C. EL	47uF 50V
C115	VG291200	C. EL	47uF 50V
C116	VG291200	C. EL	47uF 50V
C117	VR325000	C. MYLAR	100pF 100V
C118	VR325000	C. MYLAR	100pF 100V
C119	VR325000	C. MYLAR	100pF 100V
C120	VR325000	C. MYLAR	100pF 100V
C121	UA654820	C. MYLAR	0. 082uF 50V
C122	UA654820	C. MYLAR	0. 082uF 50V
C123	UA655100	C. MYLAR	0. 1uF 50V
C124	UA655100	C. MYLAR	0. 1uF 50V
C125	UA654220	C. MYLAR	0. 022uF 50V
C126	UA654220	C. MYLAR	0. 022uF 50V
C127	UA652100	C. MYLAR	100pF 50V
C128	VS741700	C. CE. SAFTY	0. 01uF 275V
C129	VK182500	C. EL	330uF 63V
C131	UM416470	C. EL	4. 7uF 50V
C133	VC815000	C. EL	220uF 6. 3V
C134	UM416470	C. EL	4. 7uF 50V
C135	UM416470	C. EL	4. 7uF 50V
△ C136	Vi846000	C. EL	22uF 63V
C137	UM416470	C. EL	4. 7uF 50V

* New Parts

* New Parts

RX-V393RDS
RX-V493RDS

RX-V493RDS P.C.B. MAIN

Schm Ref.	PART NO.	Description
C138	UJ667470	C. EL 47uF 50V
C139	UJ667470	C. EL 47uF 50V
△ C140	VV951800	C. EL 8200uF 56V
△ C141	VV951800	C. EL 8200uF 56V
△ C142	VR325400	C. MYLAR 0.1uF 100V
△ C143	VR325400	C. MYLAR 0.1uF 100V
C144	UA653100	C. MYLAR 1000pF 50V
C145	FG214100	C. CE 0.01uF 50V
C146	UA653100	C. MYLAR 1000pF 50V
C147	UA654100	C. MYLAR 0.01uF 50V
△ C149	VK457600	C. EL 330uF 25V
C152	UA654100	C. MYLAR 0.01uF 50V
C153	UA654100	C. MYLAR 0.01uF 50V
C154	UA654100	C. MYLAR 0.01uF 50V
C156	UA654100	C. MYLAR 0.01uF 50V
C157	UA654100	C. MYLAR 0.01uF 50V
C158	UA654100	C. MYLAR 0.01uF 50V
C159	UA654100	C. MYLAR 0.01uF 50V
C161	UA654100	C. MYLAR 0.01uF 50V
C162	UA654100	C. MYLAR 0.01uF 50V
C164	UM416470	C. EL 4.7uF 50V
C165	UK665470	C. EL 0.47uF 50V
C171	UA654100	C. MYLAR 0.01uF 50V
C172	UA654100	C. MYLAR 0.01uF 50V
D101	VN008700	DIODE 1SS270A
D102	VN008700	DIODE 1SS270A
D106	VM976300	DIODE. ZENR HZS242TD 24V
D107	VM976300	DIODE. ZENR HZS242TD 24V
△ D108	VS997800	DIODE 1T2
D109	VM975900	DIODE. ZENR HZS162TD 16V
D110	VM975800	DIODE. ZENR HZS152TD 15V
△ D111	iH001090	DIODE. BRG S4VB20 2.6A 200V
D112	VD631600	DIODE 1SS133, 176, HSS104
△ D113	VS997800	DIODE 1T2
D117	VD631600	DIODE 1SS133, 176, HSS104
△ F101	KB001660	FUSE T1.60A 250V
△ F102	KB000690	FUSE T2.5A 250V(G)
△ FR101	VK188400	R. FUS 330Ω 1/4W
△ FR102	VK188400	R. FUS 330Ω 1/4W
FR103	VK189000	R. FUS 1KΩ 1/4W
FR104	VK189000	R. FUS 1KΩ 1/4W
JK101	VY687200	JACK. PHONE JY-6317-02-030 NUT
△ JK102	VU543300	OUTLET. AC 1P(B)
△ JK102	VU543400	OUTLET. AC 2P(G)
L103	VP575600	COIL 1.5uH
L104	VP575600	COIL 1.5uH
△ Q101	VP883000	TR 2SA893A D, E
△ Q102	VP883000	TR 2SA893A D, E
△ Q103	VP883000	TR 2SA893A D, E
△ Q104	VP883000	TR 2SA893A D, E
△ Q105	VR325600	TR 2SC2229 O, Y
△ Q106	VR325600	TR 2SC2229 O, Y
△ Q107	iC174020	TR 2SC1740S R, S

* New Parts

Schm Ref.	PART NO.	Description
△ Q108	iC174020	TR 2SC1740S R, S
△ Q109	VP872700	TR 2SC4488 S, T
△ Q110	VP872700	TR 2SC4488 S, T
△ Q111	VP872600	TR 2SA1708 S, T
△ Q112	VP872600	TR 2SA1708 S, T
Q113	VP883100	TR 2SC1890A D, E
Q114	VP883100	TR 2SC1890A D, E
Q115	VP883000	TR 2SA893A D, E
Q116	iC174020	TR 2SC1740S R, S
Q117	iC174020	TR 2SC1740S R, S
Q118	VK432900	TR 2SD1915F S, T
Q119	iC174020	TR 2SC1740S R, S
△ Q120	iA101521	TR 2SA1015 Y
△ Q121	VN996900	TR 2SC4495
Q122	iC174020	TR 2SC1740S R, S
Q127	VG722000	TR. DGT DTC144ES
△ Q128	VR402300	TR 2SB647 C, D
△ Q129A	iX632650	TR 2SA1633 D, E, F
△ Q129C	iX632660	TR 2SC4278 D, E, F
△ Q130A	iX632650	TR 2SA1633 D, E, F
△ Q130C	iX632660	TR 2SC4278 D, E, F
△ R113	HV454470	R. CAR. FP 47Ω 1/4W
△ R114	HV454470	R. CAR. FP 47Ω 1/4W
R127	HV456270	R. CAR. FP 2.7KΩ 1/4W
R128	HV456270	R. CAR. FP 2.7KΩ 1/4W
R131	HV456100	R. CAR. FP 1KΩ 1/4W
R132	HV456100	R. CAR. FP 1KΩ 1/4W
R133	HV453470	R. CAR. FP 4.7Ω 1/4W
R134	HV453470	R. CAR. FP 4.7Ω 1/4W
R135	HV453470	R. CAR. FP 4.7Ω 1/4W
R136	HV453470	R. CAR. FP 4.7Ω 1/4W
△ R137	VU981700	R. MIL. PLAT 0.22Ω+0.22 3W
△ R138	VU981700	R. MIL. PLAT 0.22Ω+0.22 3W
△ R145	HL314100	R. MIL. OXD 10Ω 1W
△ R146	HL314100	R. MIL. OXD 10Ω 1W
R151	HV454100	R. CAR. FP 10Ω 1/4W
R152	HV454100	R. CAR. FP 10Ω 1/4W
R159	HL315330	R. MIL. OXD 330Ω 1W
R160	HL315330	R. MIL. OXD 330Ω 1W
△ R163	HL314470	R. MIL. OXD 47Ω 1W
△ R171	HL315680	R. MIL. OXD 680Ω 1W
R173	HV456100	R. CAR. FP 1KΩ 1/4W
△ R177	HV453100	R. CAR. FP 1Ω 1/4W
△ R178	HV454100	R. CAR. FP 10Ω 1/4W
R179	HV457100	R. CAR. FP 10KΩ 1/4W
R189	HL315680	R. MIL. OXD 680Ω 1W
R196	HV455100	R. CAR. FP 100Ω 1/4W
R201	HV456150	R. CAR. FP 1.5KΩ 1/4W
△ RY101	VK438300	RELAY DH24D2-OT/M2
△ RY102	VU349800	RELAY DC SDT-SS-112DM
△ SW101	VV523900	SW. PUSH PBS-YM-001
△ SW103	VZ361100	SW. SLIDE SL13B-022-AMC1
△ T101	XC084A00	TRANS. PWR

* New Parts

RX-V393RDS
RX-V493RDS

RX-V493RDS P.C.B. MAIN & INPUT

Schm Ref.	PART NO.	Description	
△	TE101	VU819700	TERM. SP 8P
		VJ828000	PIN IMSA-6024-03E
		BB071360	SCR. TERM 8. 3x13
		VR264300	PLATE. GND
		VP753100	HEAT. SINK IC-1625-MML
		Ei330166	SCR. BND. HD 3x16 FCRM3-BL
		VY834500	SUPRT
*	VZ497500	P. C. B.	INPUT
	CB1	Vi878300	CN. BS. PIN 5P
	CB2	Vi878900	CN. BS. PIN 11P
	CB3	VQ963600	CN. BS. PIN 15P
	CB4	VQ962500	CN. BS. PIN 4P
	CB5	VU272200	CN 22P
	CB6	VQ963600	CN. BS. PIN 15P
	CB7	Vi878500	CN. BS. PIN 7P
	CB8	VK024700	CN. BS. PIN 3P
	CB301	VK026600	CN. BS. PIN 7P
	CB302	VK026700	CN. BS. PIN 8P
	CB304	VQ961400	CN. BS. PIN 11P
	CB305	VK024900	CN. BS. PIN 5P
	CB306	VK027000	CN. BS. PIN 11P
	CB307	VK026200	CN. BS. PIN 3P
	CB308	VK025200	CN. BS. PIN 8P
	CB309	Vi878400	CN. BS. PIN 6P
	CB310	Vi878400	CN. BS. PIN 6P
	CB311	Vi878600	CN. BS. PIN 8P
	CB312	VK024800	CN. BS. PIN 4P
	CB313	VK024900	CN. BS. PIN 5P
	CB314	Vi878100	CN. BS. PIN 3P
	CB315	Vi878100	CN. BS. PIN 3P
	CB316	VK024700	CN. BS. PIN 3P
	C1	VJ839100	C. EL 1uF 50V
	C2	UA652100	C. MYLAR 100pF 50V
	C3	UA652100	C. MYLAR 100pF 50V
	C4	VJ839100	C. EL 1uF 50V
	C5	FG212100	C. CE 100pF 50V
	C6	UM417100	C. EL 10uF 50V
	C7	UA652100	C. MYLAR 100pF 50V
	C8	VJ839100	C. EL 1uF 50V
	C9	UM417100	C. EL 10uF 50V
	C10	VJ839100	C. EL 1uF 50V
	C11	UM417100	C. EL 10uF 50V
	C12	UA652100	C. MYLAR 100pF 50V
	C13	UA652100	C. MYLAR 100pF 50V
	C14	UA652100	C. MYLAR 100pF 50V
	C15	UA655150	C. MYLAR 0. 15uF 50V
	C16	VF466800	C. CE. TUBLR 100pF 50V
	C17	UM417100	C. EL 10uF 50V
	C18	UM417100	C. EL 10uF 50V
	C19	UM417100	C. EL 10uF 50V

*New Parts

Schm Ref.	PART NO.	Description	
	C20	VF466800	C. CE. TUBLR 100pF 50V
	C21	VF964800	C. EL 100uF 16V
	C22	UM417100	C. EL 10uF 50V
	C23	UM417100	C. EL 10uF 50V
	C24	VF964800	C. EL 100uF 16V
	C25	UA652680	C. MYLAR 680pF 50V
	C26	UA652680	C. MYLAR 680pF 50V
	C27	UM407220	C. EL 22uF 25V
	C28	UM407220	C. EL 22uF 25V
	C29	UM417100	C. EL 10uF 50V
	C30	VG279600	C. CE. TUBLR 3300pF 16V
	C31	VG278400	C. CE. TUBLR 220pF 50V
	C32	VG278400	C. CE. TUBLR 220pF 50V
	C33	VG279600	C. CE. TUBLR 3300pF 16V
	C34	VG279900	C. CE. TUBLR 6800pF 16V
	C35	VG278600	C. CE. TUBLR 330pF 50V
	C36	VG279500	C. CE. TUBLR 2700pF 16V
	C37	VG278600	C. CE. TUBLR 330pF 50V
	C38	VG279500	C. CE. TUBLR 2700pF 16V
	C39	VG279900	C. CE. TUBLR 6800pF 16V
	C40	UA653470	C. MYLAR 4700pF 50V
	C41	FG212330	C. CE 330pF 50V
	C42	FG212330	C. CE 330pF 50V
	C43	UA653470	C. MYLAR 4700pF 50V
	C44	UM407220	C. EL 22uF 25V
	C45	UM407220	C. EL 22uF 25V
	C46	UA652330	C. MYLAR 330pF 50V
	C47	UM407220	C. EL 22uF 25V
	C48	UA652330	C. MYLAR 330pF 50V
	C49	UA652330	C. MYLAR 330pF 50V
	C50	UM407220	C. EL 22uF 25V
	C51	VJ839100	C. EL 1uF 50V
	C52	VG279500	C. CE. TUBLR 2700pF 16V
	C53	VG279500	C. CE. TUBLR 2700pF 16V
	C54	VJ839100	C. EL 1uF 50V
	C55	VF466600	C. CE. TUBLR 10pF 50V
	C56	VF466600	C. CE. TUBLR 10pF 50V
	C58	UA654100	C. MYLAR 0. 01uF 50V
	C59	VF466800	C. CE. TUBLR 100pF 50V
	C60	VF466800	C. CE. TUBLR 100pF 50V
	C61	UA654100	C. MYLAR 0. 01uF 50V
	C63	UM407220	C. EL 22uF 25V
	C64	UM407220	C. EL 22uF 25V
	C65	VG277000	C. CE. TUBLR 33pF 50V
	C66	VG277000	C. CE. TUBLR 33pF 50V
	C67	VG277000	C. CE. TUBLR 33pF 50V
	C68	VG277000	C. CE. TUBLR 33pF 50V
	C69	UM407220	C. EL 22uF 25V
	C70	UM407220	C. EL 22uF 25V
	C71	VG279600	C. CE. TUBLR 3300pF 16V
	C72	VG279600	C. CE. TUBLR 3300pF 16V
	C73	VH053100	C. CE. TUBLR 0. 1uF 50V
	C74	VH053100	C. CE. TUBLR 0. 1uF 50V

*New Parts

RX-V493RDS P.C.B. INPUT

Schm Ref.	PART NO.	Description		
C75	VH053100	C. CE. TUBLR	0. 1uF	50V
C76	UJ638330	C. EL	330uF	16V
C78	VJ837200	C. EL	47uF	16V
C79	VJ837200	C. EL	47uF	16V
C80	VF760000	C. EL	100uF	10V
C81	VH053100	C. CE. TUBLR	0. 1uF	50V
C82	VF964800	C. EL	100uF	16V
C83	VE117600	C. EL	220uF	10V
C86	VH053100	C. CE. TUBLP	0. 1uF	50V
C87	VJ837200	C. EL	47uF	16V
C88	VJ837200	C. EL	47uF	16V
C89	VJ837200	C. EL	47uF	16V
C90	VH053100	C. CE. TUBLR	0. 1uF	50V
C91	VF466800	C. CE. TUBLR	100pF	50V
C93	VF466800	C. CE. TUBLR	100pF	50V
C94	VF466800	C. CE. TUBLR	100pF	50V
C301	VF760000	C. EL	100uF	10V
C302	UA652220	C. MYLAR	220pF	50V
C303	UA652220	C. MYLAR	220pF	50V
C304	UA652220	C. MYLAR	220pF	50V
C305	UA652220	C. MYLAR	220pF	50V
C306	VF760000	C. EL	100uF	10V
C307	UA652100	C. MYLAR	100pF	50V
C308	UA652100	C. MYLAR	100pF	50V
C309	VF466700	C. CE. TUBLR	47pF	50V
C310	VF466700	C. CE. TUBLR	47pF	50V
C311	VF466800	C. CE. TUBLR	100pF	50V
C312	VF466800	C. CE. TUBLR	100pF	50V
C313	VF466800	C. CE. TUBLR	100pF	50V
C314	VF466800	C. CE. TUBLR	100pF	50V
C315	VF466700	C. CE. TUBLR	47pF	50V
C316	VF466700	C. CE. TUBLR	47pF	50V
C317	VF466800	C. CE. TUBLR	100pF	50V
C318	VF466800	C. CE. TUBLR	100pF	50V
C319	UA653100	C. MYLAR	1000pF	50V
C321	UA653100	C. MYLAR	1000pF	50V
C323	VH053100	C. CE. TUBLR	0. 1uF	50V
△ C324	UJ668100	C. EL	100uF	50V
C325	UM417100	C. EL	10uF	50V
C326	VE117600	C. EL	220uF	10V
C327	FG212100	C. CE	100pF	50V
C328	Ui367220	C. EL	22uF	50V
C329	VH053100	C. CE. TUBLR	0. 1uF	50V
C330	VJ839200	C. EL	2. 2uF	50V
C331	UA653910	C. MYLAR	9100pF	50V
C332	UA654330	C. MYLAR	0. 033uF	50V
C333	UA653910	C. MYLAR	9100pF	50V
C334	UA654330	C. MYLAR	0. 033uF	50V
C335	VJ839200	C. EL	2. 2uF	50V
△ C336	UJ668100	C. EL	100uF	50V
C337	VJ839200	C. EL	2. 2uF	50V
C338	FG212220	C. CE	220pF	50V
C339	UA653330	C. MYLAR	3300pF	50V

* New Parts

Schm Ref.	PART NO.	Description		
C340	UH178100	C. EL	100uF	63V
C341	VJ837200	C. EL	47uF	16V
C342	VJ837200	C. EL	47uF	16V
C343	FH611220	C. CE	22pF	500V
C344	UM417100	C. EL	10uF	50V
C345	VF466800	C. CE. TUBLR	100pF	50V
C347	UM407220	C. EL	22uF	25V
C348	UM417100	C. EL	10uF	50V
C349	UM417100	C. EL	10uF	50V
C350	UM407220	C. EL	22uF	25V
C352	VF466800	C. CE. TUBLR	100pF	50V
C353	UM417100	C. EL	10uF	50V
C354	FG212100	C. CE	100pF	50V
C355	UA654100	C. MYLAR	0. 01uF	50V
C356	FG211100	C. CE	10pF	50V
C357	UJ668100	C. EL	100uF	50V
C358	VF466800	C. CE. TUBLR	100pF	50V
C359	FG212100	C. CE	100pF	50V
C360	FG212100	C. CE	100pF	50V
C361	VF466800	C. CE. TUBLR	100pF	50V
C362	UJ668100	C. EL	100uF	50V
C363	FG211100	C. CE	10pF	50V
C364	UA654100	C. MYLAR	0. 01uF	50V
C365	FG212100	C. CE	100pF	50V
C366	VF964800	C. EL	100uF	16V
C367	VF964800	C. EL	100uF	16V
C368	VJ839200	C. EL	2. 2uF	50V
C369	UA654470	C. MYLAR	0. 047uF	50V
C370	UA654470	C. MYLAR	0. 047uF	50V
C371	VR325000	C. MYLAR	100pF	100V
C372	VJ839100	C. EL	1uF	50V
C373	Ui367220	C. EL	22uF	50V
C374	VR325000	C. MYLAR	100pF	100V
C375	VJ839100	C. EL	1uF	50V
C376	UA654470	C. MYLAR	0. 047uF	50V
C377	VE117600	C. EL	220uF	10V
C378	UJ648100	C. EL	100uF	25V
△ C379	VL544800	C. EL	3300uF	35V
△ C380	VG289900	C. EL	2200uF	35V
C381	VG722100	C. EL	1uF	50V
C382	FG212470	C. CE	470pF	50V
C383	VD930900	C. CE. SMI	0. 1uF	25V
C384	FG244220	C. CE	0. 022uF	50V
C385	FG244220	C. CE	0. 022uF	50V
C386	FG214100	C. CE	0. 01uF	50V
C387	FG244220	C. CE	0. 022uF	50V
C388	FG214100	C. CE	0. 01uF	50V
C389	UA654470	C. MYLAR	0. 047uF	50V
C390	UA654470	C. MYLAR	0. 047uF	50V
C391	VH053100	C. CE. TUBLR	0. 1uF	50V
C392	VJ839200	C. EL	2. 2uF	50V
C394	VJ839200	C. EL	2. 2uF	50V
C395	UJ667470	C. EL	47uF	50V

* New Parts

RX-V393RDS
RX-V493RDS

RX-V493RDS P.C.B. INPUT

Schm Ref.	PART NO.	Description
C396	VZ410500	C. EL. 47uF 35V
C397	VJ839200	C. EL. 2.2uF 50V
C398	VJ839200	C. EL. 2.2uF 50V
C399	FG212100	C. CE. 100pF 50V
C400	UA652220	C. MYLAR 220pF 50V
C401	UA652220	C. MYLAR 220pF 50V
C402	UA652220	C. MYLAR 220pF 50V
C403	VF466800	C. CE. TUBLR 100pF 50V
C404	VF466800	C. CE. TUBLR 100pF 50V
C405	VJ837200	C. EL. 47uF 16V
C406	VJ837200	C. EL. 47uF 16V
C407	VF466800	C. CE. TUBLR 100pF 50V
C408	UA652100	C. MYLAR 100pF 50V
C409	UA652100	C. MYLAR 100pF 50V
C410	FG211100	C. CE. 10pF 50V
C411	FG211100	C. CE. 10pF 50V
C412	FG211100	C. CE. 10pF 50V
C413	UM417100	C. EL. 10uF 50V
C414	UM417100	C. EL. 10uF 50V
C415	UM417100	C. EL. 10uF 50V
C416	UM417100	C. EL. 10uF 50V
C417	VJ837200	C. EL. 47uF 16V
C418	VJ837200	C. EL. 47uF 16V
C419	UJ638470	C. EL. 470uF 16V
C420	VG722100	C. EL. 1uF 50V
C421	VH053100	C. CE. TUBLR 0.1uF 50V
C422	VF466900	C. CE. TUBLR 470pF 50V
C423	VF466900	C. CE. TUBLR 470pF 50V
C501	UJ638330	C. EL. 330uF 16V
C502	VH053100	C. CE. TUBLR 0.1uF 50V
C503	VH053100	C. CE. TUBLR 0.1uF 50V
C504	VH053100	C. CE. TUBLR 0.1uF 50V
C505	VH053100	C. CE. TUBLR 0.1uF 50V
C506	VH053100	C. CE. TUBLR 0.1uF 50V
C507	VH053100	C. CE. TUBLR 0.1uF 50V
C508	VH053100	C. CE. TUBLR 0.1uF 50V
C601	VJ837200	C. EL. 47uF 16V
C602	UA654100	C. MYLAR 0.01uF 50V
C603	UA654100	C. MYLAR 0.01uF 50V
D1	VD631600	DIODE 1SS133, 176, HSS104
D3	VM975500	DIODE. ZENR HZS12A2TD 12V
D301	VM975500	DIODE. ZENR HZS12A2TD 12V
D302	VM975500	DIODE. ZENR HZS12A2TD 12V
D303	VM975500	DIODE. ZENR HZS12A2TD 12V
D304	VM975500	DIODE. ZENR HZS12A2TD 12V
D305	VD631600	DIODE 1SS133, 176, HSS104
D306	VD631600	DIODE 1SS133, 176, HSS104
D307	VD631600	DIODE 1SS133, 176, HSS104
D308	VD631600	DIODE 1SS133, 176, HSS104
D309	VN008700	DIODE 1SS270A
D310	VM976300	DIODE. ZENR HZS242TD 24V
D311	VD631600	DIODE 1SS133, 176, HSS104
D312	VD631600	DIODE 1SS133, 176, HSS104

* New Parts

Schm Ref.	PART NO.	Description
D313	VM974100	DIODE. ZENR HZS5B2TD 5.0V
D314	VV731400	DIODE 2A02M
D315	VV731400	DIODE 2A02M
D316	VV731400	DIODE 2A02M
D317	VV731400	DIODE 2A02M
D318	VM974200	DIODE. ZENR HZS5C2TD 5.0V
D319	VD631600	DIODE 1SS133, 176, HSS104
D501	VS997800	DIODE 1T2
IC1	XP896A00	IC LC78213
IC2	XB247301	IC uPC4570HA
IC3	XM356A00	IC NJM2068LD
IC4	XB247301	IC uPC4570HA
IC5	XB247301	IC uPC4570HA
IC6	XB247301	IC uPC4570HA
IC7	XB247301	IC uPC4570HA
IC8	XB247301	IC uPC4570HA
IC9	XB247301	IC uPC4570HA
IC10	XB247301	IC uPC4570HA
IC11	XQ212A00	IC NJM4558LD
IC12	XQ212A00	IC NJM4558LD
IC14	XA507A00	IC AN78N05
IC16	Xi022B00	IC YSS203B-F
IC17	XS881A00	IC LH5P832D-10 PSRAM
IC302	XM356A00	IC NJM2068LD
IC303	XP894A00	IC LC78211
IC304	iG092000	IC M5220L
IC305	XB467001	IC AN79M15F
IC306	XR040A00	IC TC9299P
IC307	XR040A00	IC TC9299P
IC308	XB247301	IC uPC4570HA
IC309	XB247301	IC uPC4570HA
IC310	XF494A00	IC LB1641
L301	VP575600	COIL 1.5uH
L302	VP575600	COIL 1.5uH
L303	VP575600	COIL 1.5uH
PJ1	VR765100	JACK. PIN 2P
PJ301	VZ410600	JACK. PIN 6P
PJ302	VU857800	JACK. PIN 6P
PJ303	VJ695600	JACK. PIN 2P
PJ305	VJ249500	JACK. PIN 4P
Q1	VP872700	TR 2SC4488 S, T
Q303	iC174020	TR 2SC1740S R, S
Q304	iC174020	TR 2SC1740S R, S
Q305	VP883000	TR 2SA893A D, E
Q306	VP872700	TR 2SC4488 S, T
Q307	VP872600	TR 2SA1708 S, T
Q308	VC276100	TR 2SC2909 S, T
Q309	VC276100	TR 2SC2909 S, T
Q310	VP872600	TR 2SA1708 S, T
Q311	VP872700	TR 2SC4488 S, T
Q312	VV855300	TR 2SD856 Q, P
Q313	VP883100	TR 2SC1890A D, E
Q314	VV855300	TR 2SD856 Q, P

* New Parts

RX-V393RDS
RX-V493RDS

RX-V493RDS P.C.B. INPUT & SELECT

Schm Ref.	PART NO.	Description
△ Q315	VV855300	TR 2SD856 Q, P
Q316	VP883100	TR 2SC1890A D, E
△ Q317	VV855300	TR 2SD856 Q, P
△ Q319	VP872700	TR 2SC4488 S, T
△ Q320	iC174020	TR 2SC1740S R, S
△ Q321	VP872600	TR 2SA1708 S, T
Q322	VP883000	TR 2SA893A D, E
△ Q323A	iX615750	TR 2SA1694 O, P, Y
△ Q323C	iX615760	TR 2SC4467 O, P, Y
Q324	VP883100	TR 2SC1890A D, E
Q326	VK432900	TR 2SD1915F S, T
Q327	VK432900	TR 2SD1915F S, T
Q601	VK432900	TR 2SD1915F S, T
Q602	VK432900	TR 2SD1915F S, T
Q603	VK432900	TR 2SD1915F S, T
Q604	VK432900	TR 2SD1915F S, T
Q605	VK432900	TR 2SD1915F S, T
R79	HV453220	R. CAR. FP 2.2Ω 1/4W
R84	HL314470	R. MTL. OXD 47Ω 1W
R85	HV453220	R. CAR. FP 2.2Ω 1/4W
R86	HV453220	R. CAR. FP 2.2Ω 1/4W
R87	HV453220	R. CAR. FP 2.2Ω 1/4W
R88	HV453220	R. CAR. FP 2.2Ω 1/4W
R95	HV453470	R. CAR. FP 4.7Ω 1/4W
△ R353	HV454100	R. CAR. FP 10Ω 1/4W
R360	HV455470	R. CAR. FP 470Ω 1/4W
R365	HV455470	R. CAR. FP 470Ω 1/4W
R370	HV455330	R. CAR. FP 330Ω 1/4W
R376	HV455120	R. CAR. FP 120Ω 1/4W
R377	HV455100	R. CAR. FP 100Ω 1/4W
R378	HV455100	R. CAR. FP 100Ω 1/4W
R379	HV455120	R. CAR. FP 120Ω 1/4W
R385	HV455330	R. CAR. FP 330Ω 1/4W
R386	HV456150	R. CAR. FP 1.5KΩ 1/4W
△ R387	VE869300	R. MTL. OXD 0.1Ω 2W
R389	HV454220	R. CAR. FP 22Ω 1/4W
R390	HV454220	R. CAR. FP 22Ω 1/4W
R392	HV456150	R. CAR. FP 1.5KΩ 1/4W
△ R394	VE869300	R. MTL. OXD 0.1Ω 2W
R398	HV454100	R. CAR. FP 10Ω 1/4W
R400	HV454100	R. CAR. FP 10Ω 1/4W
△ R401	VK188600	R. FUS 470Ω 1/4W
R402	HV456270	R. CAR. FP 2.7KΩ 1/4W
R403	HV455470	R. CAR. FP 470Ω 1/4W
R404	HV456820	R. CAR. FP 8.2KΩ 1/4W
R405	HV456150	R. CAR. FP 1.5KΩ 1/4W
R410	HV453470	R. CAR. FP 4.7Ω 1/4W
R412	HV457100	R. CAR. FP 10KΩ 1/4W
△ R415	VU981700	R. MTL. PLAT 0.22Ω+0.22 3W
R416	HV453470	R. CAR. FP 4.7Ω 1/4W
R417	HV454100	R. CAR. FP 10Ω 1/4W
R418	HL425820	R. MTL. OXD 820Ω 2W
R419	HV454100	R. CAR. FP 10Ω 1/4W

* New Parts

Schm Ref.	PART NO.	Description
R420	HV454100	R. CAR. FP 10Ω 1/4W
R430	HV453220	R. CAR. FP 2.2Ω 1/4W
R433	HV454100	R. CAR. FP 10Ω 1/4W
R434	HL314220	R. MTL. OXD 22Ω 1W
R455	HV453470	R. CAR. FP 4.7Ω 1/4W
R456	HV453470	R. CAR. FP 4.7Ω 1/4W
R457	HV454100	R. CAR. FP 10Ω 1/4W
R458	HV454100	R. CAR. FP 10Ω 1/4W
R501	HL314220	R. MTL. OXD 22Ω 1W
R504	HV454100	R. CAR. FP 10Ω 1/4W
R505	HV454100	R. CAR. FP 10Ω 1/4W
R506	HL314220	R. MTL. OXD 22Ω 1W
△ RY301	VU566700	RELAY DG24D2-OS/M
SW1	VS602600	SW. SLIDE SS070-P022 A
△ TE301	VS578600	TERM. SP 8P
VR301	VV135100	VR. MTR A100KΩ
XL1	VK175200	RSNR. CE 11.28MHz
	VJ828000	PIN IMSA-6024-03E
	BB071360	SCR. TERM 8.3x13
*	V2227700	PLATE. GND REAR SP.
*	V2342700	SPACER EFFECT/PCB
	VZ864300	P. C. B. SELECT
CB701	VQ961800	CN. BS. PIN 15P
CB702	VF667600	CN. BS. PIN 15P
CB703	Vi878900	CN. BS. PIN 11P
CB704	VQ960700	CN 4P
CB705	Vi878200	CN. BS. PIN 4P
C701	VH053100	C. CE. TUBLR 0.1uF 50V
C702	VH053100	C. CE. TUBLR 0.1uF 50V
IC701	XP896A00	IC LC78213

* New Parts

RX-V393RDS
RX-V493RDS

RX-V493RDS P.C.B. TUNER

Schm Ref.	PART NO.	Description
	VV173600	P.C.B. TUNER
CB4	VQ961800	CN. BS. PIN 15P
C1	VG291200	C. FL 47uF 50V
C3	VG275800	C. CE. TUBLR 8.2pF 50V
C4	VG291200	C. EL 47uF 50V
C5	VF467300	C. CE. TUBLR 0.01uF 16V
C6	VG291200	C. EL 47uF 50V
C7	VJ839100	C. EL 1uF 50V
C8	VF467300	C. CE. TUBLR 0.01uF 16V
C9	VF467300	C. CE. TUBLR 0.01uF 16V
C10	VF467300	C. CE. TUBLR 0.01uF 16V
C11	VF467000	C. CE. TUBLR 1000pF 50V
C12	VJ836900	C. EL 10uF 16V
C13	VJ836900	C. EL 10uF 16V
C14	VF466800	C. CE. TUBLR 100pF 50V
C15	VF467000	C. CE. TUBLR 1000pF 50V
C16	VF466700	C. CE. TUBLR 47pF 50V
C17	VG291200	C. FL 47uF 50V
C19	VA761200	C. CE 33pF 50V
C20	VG291200	C. EL 47uF 50V
C21	VJ599000	C. CE. TUBLR 0.047uF 16V
C22	UM216330	C. EL 3.3uF 50V
C23	VF467300	C. CE. TUBLR 0.01uF 16V
C24	UM416470	C. EL 4.7uF 50V
C25	UM216330	C. EL 3.3uF 50V
C26	VJ836900	C. EL 10uF 16V
C27	VF467300	C. CE. TUBLR 0.01uF 16V
C28	VA761200	C. CE 33pF 50V
C29	VJ839100	C. EL 1uF 50V
C30	VJ839100	C. EL 1uF 50V
C31	VG291200	C. EL 47uF 50V
C32	VJ839000	C. FL 0.47uF 50V
C33	VJ839100	C. EL 1uF 50V
C34	UA654470	C. MYLAR 0.047uF 50V
C35	UM216330	C. EL 3.3uF 50V
C36	UA652470	C. MYLAR 470pF 50V
C37	UA652470	C. MYLAR 470pF 50V
C38	VF466900	C. CE. TUBLR 470pF 50V
C39	VJ836900	C. EL 10uF 16V
C40	UM216330	C. EL 3.3uF 50V
C41	UA653390	C. MYLAR 3900pF 50V
C42	UM407220	C. FL 22uF 25V
C43	UA653390	C. MYLAR 3900pF 50V
C44	UM216330	C. EL 3.3uF 50V
C45	VG291200	C. EL 47uF 50V
C46	VG291200	C. EL 47uF 50V
C47	VG291200	C. EL 47uF 50V
C48	VF466800	C. CE. TUBLR 100pF 50V
C49	UA652120	C. MYLAR 120pF 50V
C50	VJ599000	C. CE. TUBLR 0.047uF 16V
D1	iF004600	DIODE 1SS133
D2	iF004600	DIODE 1SS133
D3	VG437800	DIODE. ZENR MTZJ5.6C 5.6V

* New Parts

Schm Ref.	PART NO.	Description
Fi1	GG000560	FLTR. CE SFE10.7MS3GHY-A
Fi2	GG000560	FLTR. CE SFE10.7MS3GHY-A
Fi3	VC219000	FLTR. CE SFZ450JL3
IC1	XB760A00	IC LA1266
IC2	XQ944A00	IC LC72131
IC3	iG158100	IC LA3401
IC4	XQ359A00	IC STK311-020B
L1	Vi546100	COIL 220uH
L2	Vi546100	COIL 220uH
L3	Vi546100	COIL 220uH
L4	Vi546100	COIL 220uH
PK1	VQ987600	TUNER. PK EXV-17296G1
PK2	VU333700	COIL. RF. AM 940536051A
Q1	VB433300	TR 2SC1809 M, N, P
Q2	VB433300	TR 2SC1809 M, N, P
Q3	VD678500	TR. DGT DTA114ES
Q4	VC218900	TR 2SC3330 R, S, T
Q5	VG722000	TR. DGT DTC144ES
Q6	iC1815C0	TR 2SC1815 Y
Q7	VD678500	TR. DGT DTA114ES
T1	VC218600	COIL. DT. FM 10.7MHz
T2	GE100470	COIL. IF. AM 450KHz
T3	VT486800	COIL XYA2
T4	VQ138200	FLTR. LC 19KHz
T5	VQ138200	FLTR. LC 19KHz
TE1	VU477800	TERM. ANT AJ-2038-040
TP1	VT969000	PIN. TEST IRS-2049
TP2	VT969000	PIN. TEST IRS-2049
VR1	VJ694000	VR. TRIM B47KΩ
VR2	VJ694000	VR. TRIM B47KΩ
XL1	VC219100	RSNR. CRY5 7.2MHz
XL2	GG000750	RSNR. CE 18.95KHz
XL3	VS860100	RSNR. CE 19KHz
	BB071360	SCR. TERM 8.3x13
	VR282500	PLATE ANT.

* New Parts

A

B

C

D

E

RX-V393RDS/RX-V493RDS

1 ■ RX-V393RDS EXPLODED VIEW

1

2

3

4

5

6

7

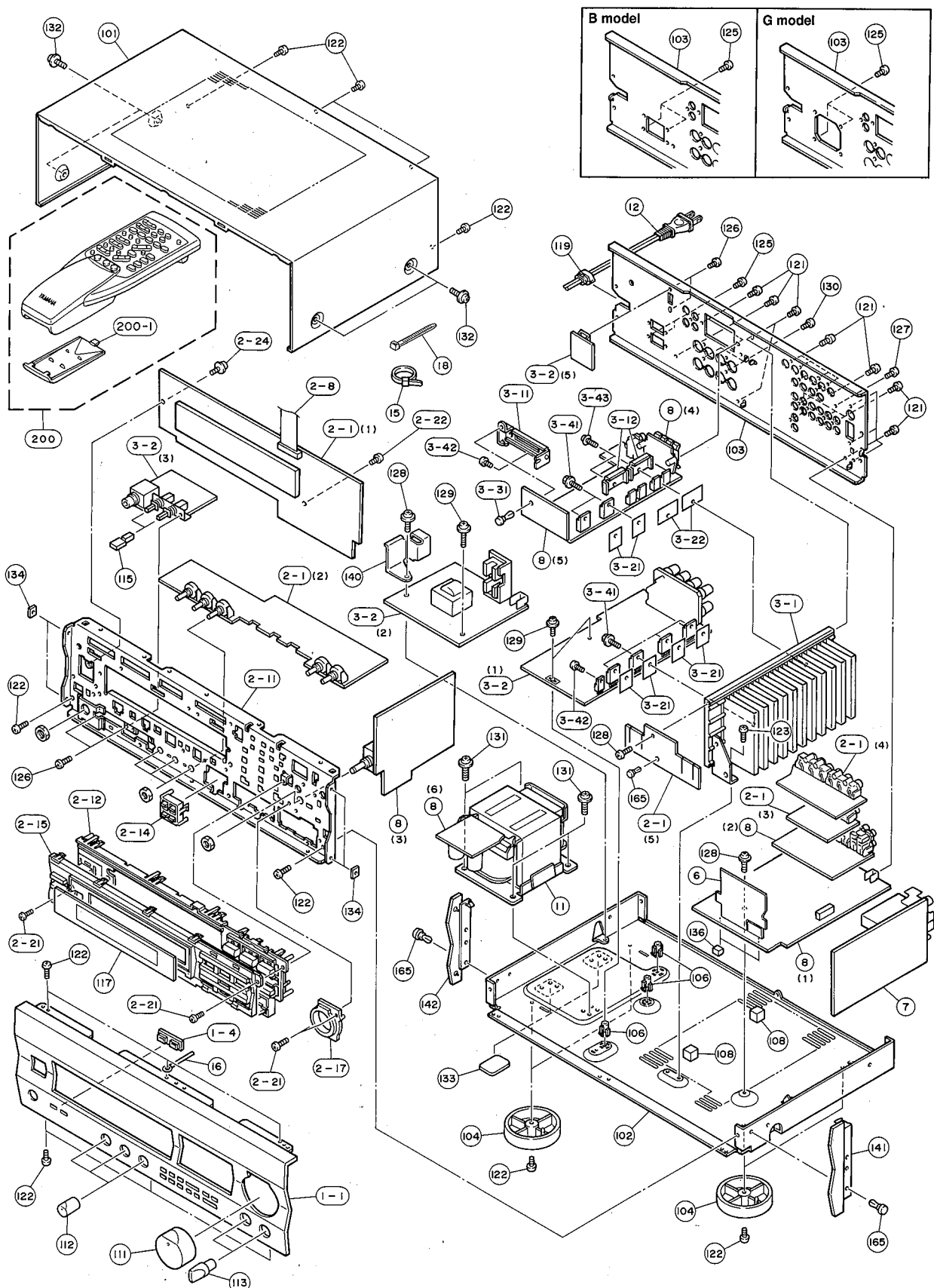

■ RX-V393RDS MECHANICAL PARTS

Ref. No.	PART NO.	Description	Remarks	Markets
* 1-1	VZ305200	FRONT PANEL		BL
* 1-1	VZ305300	FRONT PANEL		TI
1-4	VV123700	ESCUTCHEON, 3/8	2P	BL
1-4	VV123800	ESCUTCHEON, 3/8	2P	TI
* 2-1	VZ497800	P.C.B. ASS'Y	OPERATION	
2-8	MF122400	FLEXIBLE FLAT CABLE C&C	22P 400mm	
2-11	VV140800	SUB CHASSIS	130	
2-12	VV136700	BUTTON CASE		BL
2-12	VV136800	BUTTON CASE		TI
2-14	VV137900	BUTTON, RDS		BL
2-14	VV138000	BUTTON, RDS		TI
* 2-15	VZ309300	CASE, SUB PANEL	6	BL
* 2-15	VZ309400	CASE, SUB PANEL	6	TI
2-17	VV149500	ESCUTCHEON, VOL		BL
2-17	VV149600	ESCUTCHEON, VOL		TI
2-21	Ei330086	BIND HEAD B-TITE SCREW	3x8 FCRM3-BL	
2-22	EP630220	BIND HEAD P-TITE SCREW	3x8 ZMC2-BL	
2-24	VT669300	PW HEAD B-TITE SCREW	3x8-8 MFC2	
3-1	VV899700	HEAT SINK ASS'Y		
* 3-2	VZ417500	P.C.B. ASS'Y	MAIN	(B)
* 3-2	VZ417600	P.C.B. ASS'Y	MAIN	(G)
3-11	VV491300	SUPPORT, PCB		
3-12	VV901900	SUPPORT, TR		
3-21	VK195900	SHEET	19x24	
3-22	VV901800	RADIATION SHEET		
3-31	VQ368500	PUSH RIVET	P3545-B	
3-41	VK173200	SCREW, TRANSISTOR	3x15 SP FCM3	
3-42	Ei330086	BIND HEAD B-TITE SCREW	3x8 FCRM3-BL	
3-43	VT669400	PW HEAD B-TITE SCREW	3x15-8 MFC2	
* 6	VZ864400	P.C.B. ASS'Y	SELECT	
7	VV173600	P.C.B. ASS'Y	TUNER	
* 8	VZ497600	P.C.B. ASS'Y	INPUT	
△ 11	XT087B00	POWER TRANSFORMER		
△ 12	VN363700	POWER CORD ASS'Y		(G)
△ 12	VS680700	POWER CORD ASS'Y		(B)
15	VU590000	BINDING TIE	CBTD001B	
16	CB502030	BINDING TIE	S-75B	
* 18	VZ625600	BINDING TIE	SE140 L=140	
101	VV140400	TOP COVER		BL
101	VV140500	TOP COVER		TI
102	VQ794000	CHASSIS		
* 103	VZ307200	REAR PANEL		(B)
* 103	VZ307300	REAR PANEL		(G)
104	VS025000	LEG	D60xH21	
106	VR264400	SPACER	H8	
108	VQ366100	DAMPER, PCB		
111	VV148800	KNOB	D40	BL
111	VV148900	KNOB	D40	TI
112	VV311000	KNOB	D14	BL
112	VV311400	KNOB	D14	TI
113	VR308400	KNOB, VR	D10	BL
113	VU114800	KNOB, VR	D10	TI
115	VV123500	BUTTON, 3/8		BL

* New Parts

Ref. No.	PART NO.	Description	Remarks	Markets
115	VV123600	BUTTON, 3/8		TI
117	VV139900	SHEET, WINDOW PANEL		
119	VN158600	CORD STOPPER	No.2104	
121	EN301010	BIND HEAD BONDING TAP. SCREW	3x8 FCRM3-BL	
122	Ei330086	BIND HEAD B-TITE SCREW	3x8 FCRM3-BL	
123	EiC30046	BIND HEAD TAPPING SCREW	3x4 ZMC2-Y	
125	EiC30086	BIND HEAD B-TITE SCREW	3x8 ZMC2-Y	
126	ED530066	BIND HEAD SCREW	3x6 FCRM3-BL	
127	VS997700	BIND HEAD S-TITE SCREW	3x10 MFNI33	
128	VT669300	PW HEAD B-TITE SCREW	3x8-8 MFC2	
129	VT669400	PW HEAD B-TITE SCREW	3x15-8 MFC2	
130	VY731200	BONDING HEAD TAPPING SCREW	3x10 MFNI33	
131	EK365090	PW HEAD S-TITE SCREW	4x8-10 FCRM3-BL	
132	EK365090	PW HEAD S-TITE SCREW	4x8-10 FCRM3-BL	BL
132	EX601150	BW HEAD S-TITE SCREW	4x8-10 FNM3-BL	TI
133	VY731400	DAMPER	HOLE	
134	VY989400	DAMPER	SIDE	
* 136	VZ679700	DAMPER	T8/PCB	
140	VZ319700	STOPPER	SCREW	
141	VV124500	PLATE SIDE R	130	BL
141	VV124600	PLATE SIDE R	130	TI
142	VV124300	PLATE SIDE L	130	BL
142	VV124400	PLATE SIDE L	130	TI
165	VQ368600	PUSH RIVET	P3555-B	
		ACCESSORIES		
200	VZ538100	REMOTE CONTROL TRANSMITTER	SBGH20029A RAV8	
200-1	CX679050	LID	74x34BLALPS	
	VQ147100	ANTENNA, FM	1P 1.4m	
	VR248500	ANTENNA, AM LOOP	1P 1.0m	
	VE364900	ANTENNA ADAPTER	PAL 75-300Ω	
		BATTERY, MANGANESE	SUM-3, AA, R06	

* New Parts

■ RX-V493RDS EXPLODED VIEW

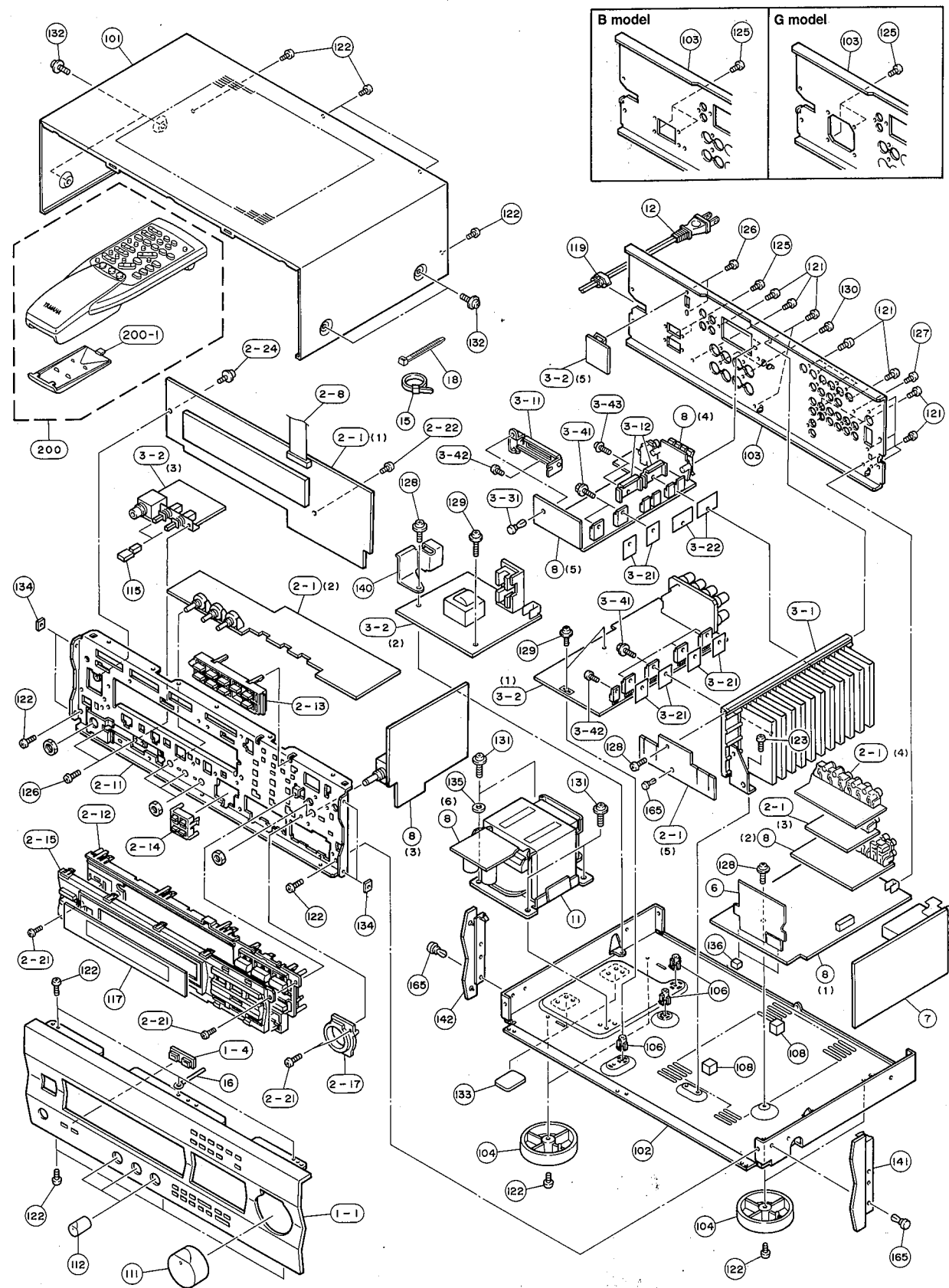

■ RX-V493RDS MECHANICAL PARTS

Ref. No.	PART NO.	Description	Remarks	Markets
* 1-1	VZ304700	FRONT PANEL	BL	
* 1-1	VZ304800	FRONT PANEL	TI	
1-4	VV123700	ESCUTCHEON, 3/8	2P	BL
1-4	VV123800	ESCUTCHEON, 3/8	2P	TI
* 2-1	VZ497700	P.C.B. ASS'Y	OPERATION	
2-8	MF122400	FLEXIBLE FLAT CABLE C&C	22P 400mm	
2-11	VV140700	SUB CHASSIS	130	
2-12	VV136500	BUTTON CASE		BL
2-12	VV136600	BUTTON CASE		TI
2-13	VV137700	BUTTON, DSP		BL
2-13	VV137800	BUTTON, DSP		TI
2-14	VV137900	BUTTON, RDS		BL
2-14	VV138000	BUTTON, RDS		TI
2-15	VZ309000	SUB PANEL CASE	7	BL
2-15	VZ309100	SUB PANEL CASE	7	TI
2-17	VV149500	ESCUTCHEON, VOL		BL
2-17	VV149600	ESCUTCHEON, VOL		TI
2-21	Ei330086	BIND HEAD B-TITE SCREW	3x8	FCRM3-BL
2-22	EP630220	BIND HEAD P-TITE SCREW	3x8	ZMC2-BL
2-24	VT669300	PW HEAD B-TITE SCREW	3x8-8	MFC2
2-31	VZ092400	DAMPER	6x5x10	
3-1	VV143200	HEAT SINK ASS'Y		
* 3-2	VZ416900	P.C.B. ASS'Y	MAIN	(B)
* 3-2	VZ417000	P.C.B. ASS'Y	MAIN	(G)
3-11	VV491300	SUPPORT, PCB		
3-12	VV901900	SUPPORT, TR		
3-21	VK195900	SHEET	19x24	
3-22	VV901800	RADIATION SHEET		
3-31	VQ368500	PUSH RIVET	P3545-B	
3-41	VK173200	SCREW, TRANSISTOR	3x15 SP	FCM3
3-42	Ei330086	BIND HEAD B-TITE SCREW	3x8	FCRM3-BL
3-43	VT669400	PW HEAD B-TITE SCREW	3x15-8	MFC2
* 6	VZ864300	P.C.B. ASS'Y	SELECT	
* 7	VV173600	P.C.B. ASS'Y	TUNER	
* 8	VZ497500	P.C.B. ASS'Y	INPUT	
△ 11	XT073A00	POWER TRANSFORMER		
△ 12	VN363700	POWER CORD ASS'Y		(G)
△ 12	VS680700	POWER CORD ASS'Y		(B)
15	VU590000	BINDING TIE	CBTD001B	
16	CB502030	BINDING TIE	S-75B	
* 18	VZ625600	BINDING TIE	SE140 L=140	
101	VV140400	TOP COVER		BL
101	VV140500	TOP COVER		TI
102	VQ794000	CHASSIS		
* 103	VZ306000	REAR PANEL		(B)
* 103	VZ306100	REAR PANEL		(G)
104	VS025000	LEG	D60xH21	
106	VR264400	SPACER	H8	
108	VQ366100	DAMPER, PCB		
111	VV148800	KNOB	D40	BL
111	VV148900	KNOB	D40	TI
112	VV311400	KNOB	D14	
115	VV123500	BUTTON, 3/8		BL

* New Parts

Ref. No.	PART NO.	Description	Remarks	Markets
115	VV123600	BUTTON, 3/8		TI
117	VV139900	SHEET, WINDOW PANEL		
119	VN158600	CORD STOPPER	No. 2104	
121	EN301010	BIND HEAD BONDING TAP. SCREW	3x8 FCRM3-BL	
122	Ei330086	BIND HEAD B-TITE SCREW	3x8 FCRM3-BL	
123	Ei030046	BIND HEAD TAPPING SCREW	3x4 ZMC2-Y	
125	Ei030086	BIND HEAD B-TITE SCREW	3x8 ZMC2-Y	
126	ED330066	BIND HEAD SCREW	3x6 FCRM3-BL	
127	VS997700	BIND HEAD S-TITE SCREW	3x10 MFNI33	
128	VT669300	PW HEAD B-TITE SCREW	3x8-8 MFC2	
129	VT669400	PW HEAD B-TITE SCREW	3x15-8 MFC2	
130	VY731200	BONDING HEAD TAPPING SCREW	3x10 MFNI33	
131	EK365090	PW HEAD S-TITE SCREW	4x8-10 FCRM3-BL	
132	EK365090	PW HEAD S-TITE SCREW	4x8-10 FCRM3-BL	BL
132	EX601150	BW HEAD S-TITE SCREW	4x8-10 FNM3-BL	TI
133	VY731400	DAMPER	HOLE	
134	VY989400	DAMPER	SIDE	
135	VZ234000	SPACER		
* 136	VZ679700	DAMPER	T8/PCB	
140	VZ319700	STOPPER	SCREW	
141	VV124500	PLATE SIDE R	130	BL
141	VV124600	PLATE SIDE R	130	TI
142	VV124300	PLATE SIDE L	130	BL
142	VV124400	PLATE SIDE L	130	TI
165	VQ368600	PUSH RIVET	P3555-B	
		ACCESSORIES		
200	VZ338200	REMOTE CONTROL TRANSMITTER	SBGH20030A RAV9	
200-1	CX679050	LID	74x34BLALPS	
	VQ147100	ANTENNA, FM	1P 1.4m	
	VR248500	ANTENNA, AM LOOP	1P 1.0m	
	VE364900	ANTENNA ADAPTER	PAL 75-300Ω	
		BATTERY, MANGANESE	SUM-3, AA, R06	

* New Parts

RX-V393RDS
RX-V493RDS

RX-V393RDS/RX-V493RDS

RX-V393RDS REMOTE CONTROL TRANSMITTER

■ SCHEMATIC DIAGRAM

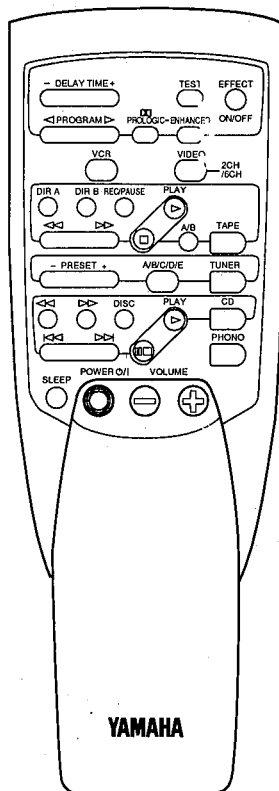
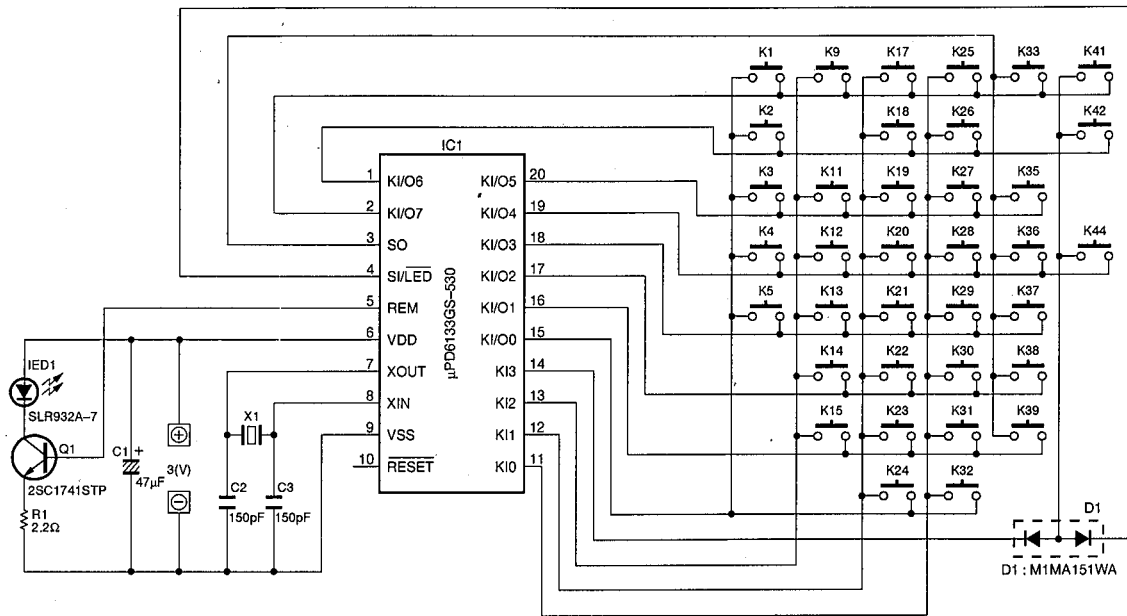

Key No.	FUNCTION	CUSTOM (HEX)	DATA (HEX)
1	EFFECT ON/OFF	7A	56
2	PROGRAM <	7A	59
3	PROGRAM >	7A	58
4	PROLOGIC	7A	88
5	ENHANCED	7A	89
9	VCR	7A	0F
11	VIDEO	7A	17
12	DIR A	7A	07
13	DIR B	7A	40
14	REC/PAUSE	7A	04
15	PLAY (TAPE)	7A	00
17	<<	(TAPE) 7A	01
18	>>	(TAPE) 7A	02
19	□	(TAPE) 7A	03
20	DECK A/B	7A	06
21	TAPE	7A	18
22	PRESET -	7A	11
23	PRESET +	7A	10
24	A/B/C/D/E	7A	12
25	TUNER	7A	16
26	<<	(CD) 7A	0D
27	>>	(CD) 7A	0C
28	DISC	7A	4F
29	PLAY (CD)	7A	08
30	CD	7A	15
31	<<<	(CD) 7A	0B
32	>>>	(CD) 7A	0A
33	□/□	7A	09
35	PHONO	7A	14
36	SLEEP	7A	57
37	POWER	7A	1F
38	VOLUME -	7A	1B
39	VOLUME +	7A	1A
41	DELAY TIME -	7A	53
42	DELAY TIME +	7A	52
44	TEST	7A	85

RX-V493RDS REMOTE CONTROL TRANSMITTER

■ SCHEMATIC DIAGRAM

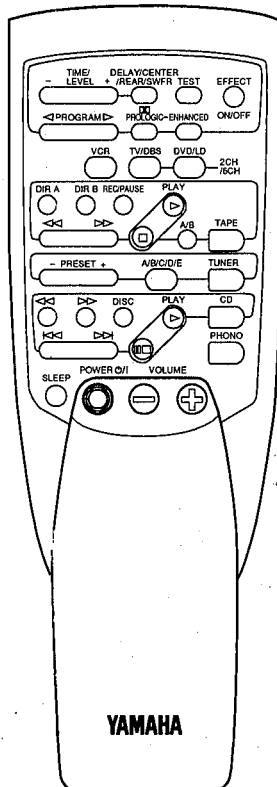
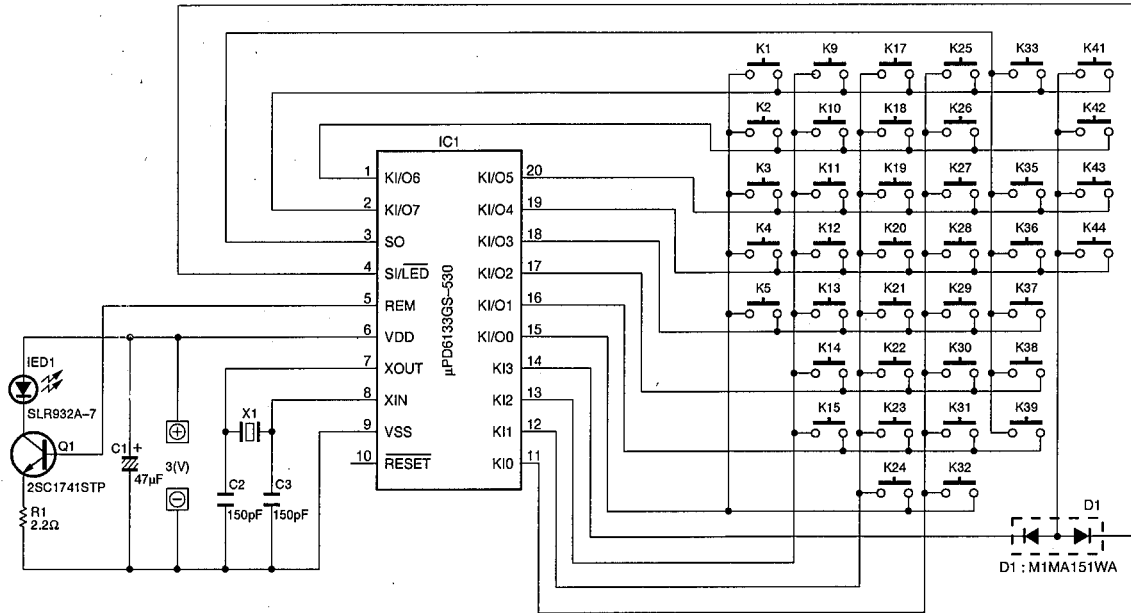

Key No.	FUNCTION	CUSTOM (HEX)	DATA (HEX)
1	EFFECT ON/OFF	7A	56
2	PROGRAM ◀	7A	59
3	PROGRAM ▶	7A	58
4	◻ PROLOGIC	7A	88
5	ENHANCED	7A	89
9	VCR	7A	0F
10	TV/DBS	7A	54
11	DVD/LD	7A	17
12	DIR A	7A	07
13	DIR B	7A	40
14	REC/PAUSE	7A	04
15	PLAY (TAPE)	7A	00
17	◀◀ (TAPE)	7A	01
18	▶▶ (TAPE)	7A	02
19	◻ (TAPE)	7A	03
20	DECK A/B	7A	06
21	TAPE	7A	18
22	PRESET -	7A	11
23	PRESET +	7A	10
24	A/B/C/D/E	7A	12
25	TUNER	7A	16
26	◀◀ (CD)	7A	0D
27	▶▶ (CD)	7A	0C
28	DISC	7A	4F
29	PLAY (CD)	7A	08
30	CD	7A	15
31	◀◀ (CD)	7A	0B
32	▶▶ (CD)	7A	0A
33	◻ (CD)	7A	09
35	PHONO	7A	14
36	SLEEP	7A	57
37	POWER	7A	1F
38	VOLUME -	7A	1B
39	VOLUME +	7A	1A
41	TIME/LEVEL -	7A	53
42	TIME/LEVEL +	7A	52
43	DELAY/CENTER/REAR	7A	86
44	TEST	7A	85

Parts List for Carbon Resistors

Value	1/4W Type Part No.	1/6W Type Part No.	Value	1/4W Type Part No.	1/6W Type Part No.
1.0 Ω	HJ35 3100	HF85 3100	10 kΩ	HF45 7100	HF45 7100
1.8 Ω	HJ35 3180	*	11 kΩ	HF45 7110	HF45 7110
2.2 Ω	HJ35 3220	HF85 3220	12 kΩ	HJ35 7120	HF85 7120
3.3 Ω	HJ35 3330	HF85 3330	13 kΩ	HF45 7130	HF45 7130
4.7 Ω	HJ35 3470	HF85 3470	15 kΩ	HF45 7150	HF45 7150
5.6 Ω	HJ35 3560	HF85 3560	18 kΩ	HF45 7180	HF45 7180
10 Ω	HF45 4100	HF45 4100	22 kΩ	HF45 7220	HF45 7220
15 Ω	HJ35 4150	HF85 4150	24 kΩ	HF45 7240	HF45 7240
22 Ω	HF45 4220	HF45 4220	27 kΩ	HJ35 7270	HF85 7270
27 Ω	HJ35 4270	HF85 4270	30 kΩ	HF45 7300	HF45 7300
33 Ω	HF45 4330	HF45 4330	33 kΩ	HF45 7330	HF45 7330
39 Ω	HJ35 4470	HF85 4390	36 kΩ	HF45 7360	HF45 7360
47 Ω	HF45 4470	HF45 4470	39 kΩ	HF45 7390	HF45 7390
56 Ω	HF45 4560	HF45 4560	47 kΩ	HF45 7470	HF45 7470
68 Ω	HF45 4680	HF45 4680	51 kΩ	HF45 7510	HF45 7510
75 Ω	HF45 4750	HF45 4750	56 kΩ	HF45 7560	HF45 7560
82 Ω	HF45 4820	HF45 4820	62 kΩ	HF45 7620	HF45 7620
91 Ω	HF45 4910	HF45 4910	68 kΩ	HF45 7680	HF45 7680
100 Ω	HF45 5100	HF45 5100	82 kΩ	HF45 7820	HF45 7820
110 Ω	HJ35 5110	HF85 5110	91 kΩ	HF45 7910	HF45 7910
120 Ω	HF45 5120	HF45 5120	100 kΩ	HF45 8100	HF45 8100
150 Ω	HF45 5150	HF45 5150	110 kΩ	HF45 8110	HF45 8110
160 Ω	HJ35 5160	*	120 kΩ	HF45 8120	HF45 8120
180 Ω	HF45 5180	HF45 5180	150 kΩ	HF45 8150	HF45 8150
200 Ω	HF45 5200	HF45 5200	180 kΩ	HF45 8180	HF45 8180
220 Ω	HF45 5220	HF45 5220	220 kΩ	HJ35 8220	HF85 8220
270 Ω	HF45 5270	HF45 5270	270 kΩ	HF45 8270	HF45 8270
330 Ω	HF45 5330	HF45 5330	300 kΩ	HF45 8300	HF45 8300
390 Ω	HF45 5390	HF45 5390	330 kΩ	HF45 8330	HF45 8330
430 Ω	HF45 5430	HF45 5430	390 kΩ	HJ35 8390	HF85 8390
470 Ω	HF45 5470	HF45 5470	470 kΩ	HF45 8470	HF45 8470
510 Ω	HF45 5510	HF45 5510	560 kΩ	HJ35 8560	HF85 8560
560 Ω	HF45 5560	HF45 5560	680 kΩ	HJ35 8680	HF85 8680
680 Ω	HF45 5680	HF45 5680	820 kΩ	HJ35 8820	HF85 8820
820 Ω	HF45 5820	HF45 5820	1.0 MΩ	HF45 9100	HF45 9100
910 Ω	HF45 5910	HF45 5910	1.2 MΩ	HJ35 9120	*
1.0 kΩ	HF45 6100	HF45 6100	1.5 MΩ	HJ35 9150	HF85 9150
1.2 kΩ	HF45 6120	HF45 6120	1.8 MΩ	HJ35 9180	HF85 9180
1.5 kΩ	HF45 6150	HF45 6150	2.2 MΩ	HJ35 9220	HF85 9220
1.8 kΩ	HF45 6180	HF45 6180	3.3 MΩ	HJ35 9330	HF85 9330
2.0 kΩ	HJ35 6200	HF85 6200	3.9 MΩ	HJ35 9390	*
2.2 kΩ	HF45 6220	HF45 6220	4.7 MΩ	HJ35 9470	HF85 9470
2.4 kΩ	HJ35 6240	HF85 6240			
2.7 kΩ	HF45 6270	HF45 6270			
3.0 kΩ	HF45 6300	HF45 6300			
3.3 kΩ	HF45 6330	HF45 6330			
3.6 kΩ	HJ35 6360	HF85 6360			
3.9 kΩ	HF45 6390	HF45 6390			
4.7 kΩ	HF45 6470	HF45 6470			
5.1 kΩ	HF45 6510	HF45 6510			
5.6 kΩ	HF45 6560	HF45 6560			
6.8 kΩ	HF45 6680	HF45 6680			
8.2 kΩ	HF45 6820	HF45 6820			
9.1 kΩ	HF45 6910	HF45 6910			

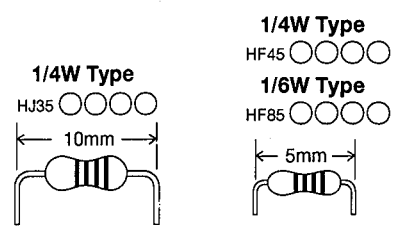

RX-V393RDS
RX-V493RDS