

AV RECEIVER RX-V395/RDS HTR5130/RDS

SERVICE MANUAL

IMPORTANT NOTICE

This manual has been provided for the use of authorized YAMAHA Retailers and their service personnel. It has been assumed that basic service procedures inherent to the industry, and more specifically YAMAHA Products, are already known and understood by the users, and have therefore not been restated.

WARNING: Failure to follow appropriate service and safety procedures when servicing this product may result in personal injury, destruction of expensive components, and failure of the product to perform as specified. For these reasons, we advise all YAMAHA product owners that any service required should be performed by an authorized YAMAHA Retailer or the appointed service representative.

IMPORTANT: The presentation or sale of this manual to any individual or firm does not constitute authorization, certification or recognition of any applicable technical capabilities, or establish a principle-agent relationship of any form.

The data provided is believed to be accurate and applicable to the unit(s) indicated on the cover. The research, engineering, and service departments of YAMAHA are continually striving to improve YAMAHA products. Modifications are, therefore, inevitable and specifications are subject to change without notice or obligation to retrofit. Should any discrepancy appear to exist, please contact the distributor's Service Division.

WARNING: Static discharges can destroy expensive components. Discharge any static electricity your body may have accumulated by grounding yourself to the ground buss in the unit (heavy gauge black wires connect to this buss).

IMPORTANT: Turn the unit OFF during disassembly and part replacement. Recheck all work before you apply power to the unit.

■ CONTENTS

TO SERVICE PERSONNEL	1	TUNER ADJUSTMENTS	13~16
FRONT PANELS	2	DISPLAY DATA	17
REAR PANELS	3~4	IC DATA	18~21
SPECIFICATIONS	5~6	RX-V395/RDS PRINTED CIRCUIT BOARD	22~29
INTERNAL VIEW	7	BLOCK DIAGRAM	30~31
DISASSEMBLY PROCEDURES	7	PIN CONNECTION DIAGRAM	31
SELF CHECK MODE	8~10	RX-V395/RDS SCHEMATIC DIAGRAM	32~36
PROTECTION OPERATION CHECK FUNCTION ..	11	PARTS LIST	37~50
AMP ADJUSTMENTS	12	REMOTE CONTROL TRANSMITTER	51~52



このサービスマニュアルは、エコマーク認定の再生紙を使用しています。
This Service Manual used recycled paper.



■ TO SERVICE PERSONNEL

1. Critical Components Information.
Components having special characteristics are marked  and must be replaced with parts having specifications equal to those originally installed.
2. Leakage Current Measurement (For 120V Models Only).
When service has been completed, it is imperative to verify that all exposed conductive surfaces are properly insulated from supply circuits.
 - Meter impedance should be equivalent to 1500 ohm shunted by 0.15μF.
 - Leakage current must not exceed 0.5mA.
 - Be sure to test for leakage with the AC plug in both polarities.

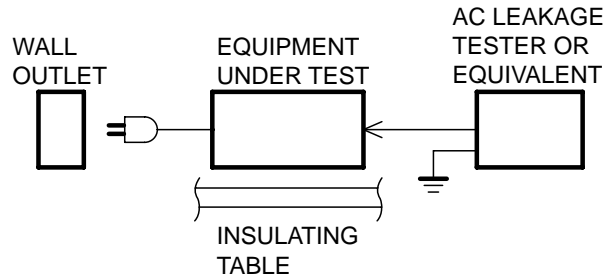

“CAUTION”

“F701 : FOR CONTINUED PROTECTION AGAINST RISK OF FIRE, REPLACE ONLY WITH SAME TYPE 8.0A, 125V FUSE.”

CAUTION

F701 : REPLACE WITH SAME TYPE 8.0A, 125V FUSE.

ATTENTION

F701 : UTILISER UN FUSIBLE DE RECHANGE DE MEME TYPE DE 8.0A, 125V.

WARNING: CHEMICAL CONTENT NOTICE!

The solder used in the production of this product contains LEAD. In addition, other electrical/electronic and/or plastic (where applicable) components may also contain traces of chemicals found by the California Health and Welfare Agency (and possibly other entities) to cause cancer and/or birth defects or other reproductive harm.

DO NOT PLACE SOLDER, ELECTRICAL/ELECTRONIC OR PLASTIC COMPONENTS IN YOUR MOUTH FOR ANY REASON WHATSOEVER!

Avoid prolonged, unprotected contact between solder and your skin! When soldering, do not inhale solder fumes or expose eyes to solder/flux vapor!

If you come in contact with solder or components located inside the enclosure of this product, wash your hands before handling food.

WARNING
Do not change the **IMPEDANCE SELECTOR** switch setting while the power to this unit is on, otherwise this unit may be damaged.

IMPEDANCE SELECTOR

The diagram shows the internal components of the unit. A callout points to the 'IMPEDANCE SELECTOR' switch. Other components shown include speakers (MAIN, CENTER, REAR), AC outlets, and a fuse holder. Text inside the unit includes: 'MANUFACTURED UNDER LICENSE FROM DOLBY LABORATORIES LICENSING CORPORATION', 'THIS DEVICE COMPLIES WITH PART 15 OF THE FCC RULES... SUBJECT TO THE CONDITION THAT THIS DEVICE DOES NOT CAUSE HARMFUL INTERFERENCE', 'WARNING: TO REDUCE THE RISK OF FIRE OR ELECTRIC SHOCK, DO NOT EXPOSE THIS APPLIANCE TO RAIN OR MOISTURE', 'IMPEDANCE SELECTOR (SET BEFORE POWER ON)', 'MAIN A OR B: MAIN SPEAKER', 'CENTER: CENTER SPEAKER', 'REAR: REAR SPEAKER', '120V 60Hz 150W MAX. TOTAL SWITCHED', and 'CAUTION: SEE INSTRUCTIONS MANUAL FOR CORRECT SETTING'.

Manufactured under license from Dolby Laboratories Licensing Corporation. "Dolby", "Pro Logic", and the double-D symbol  are trademarks of Dolby Laboratories Licensing Corporation.

RX-V395/RDS HTR5130/RDS

FRONT PANELS

▼ RX-V395

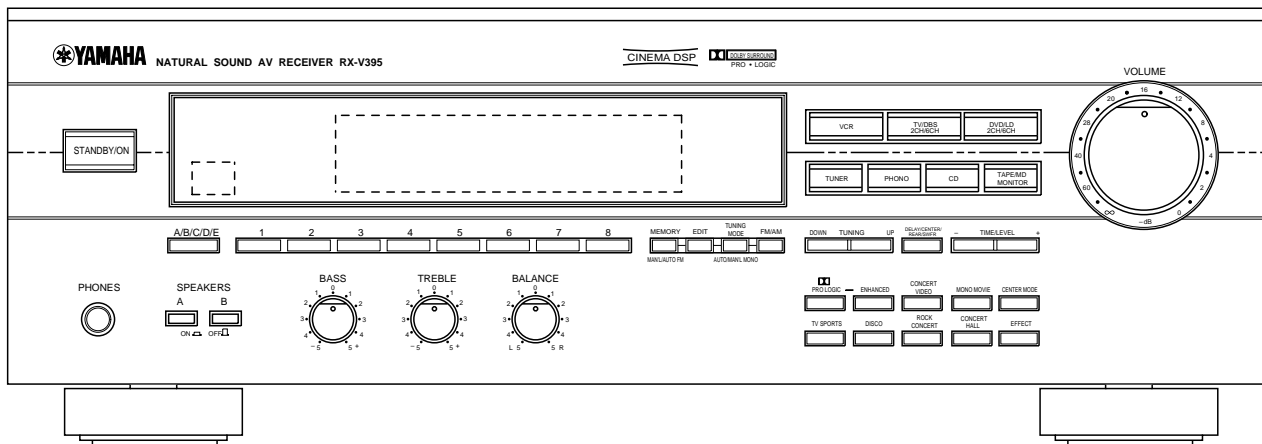

▼ RX-V395RDS

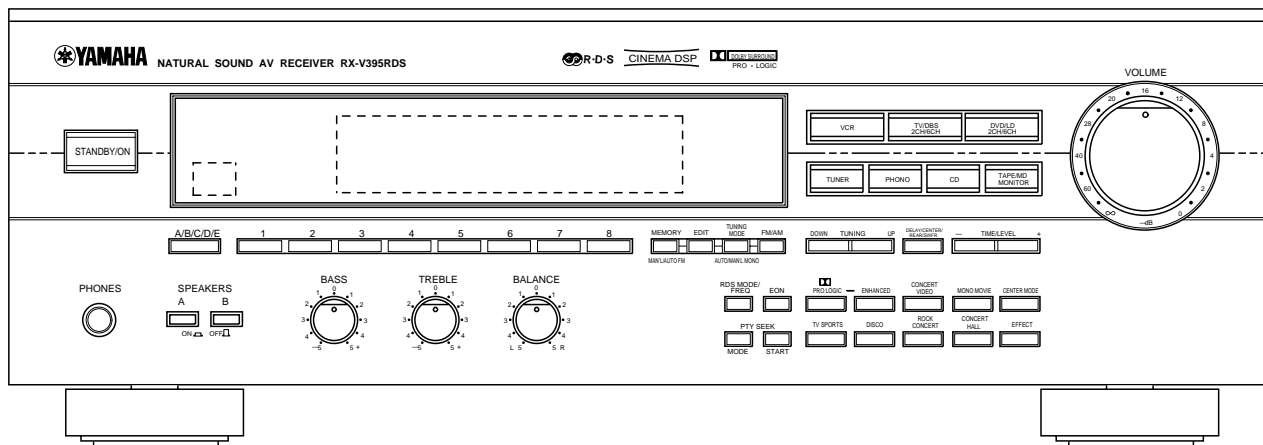

▼ RX-V395 (U, C, R, A, T, L models)

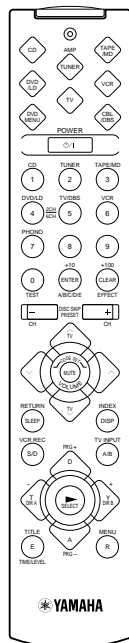

▼ RX-V395/RDS (B, G models)

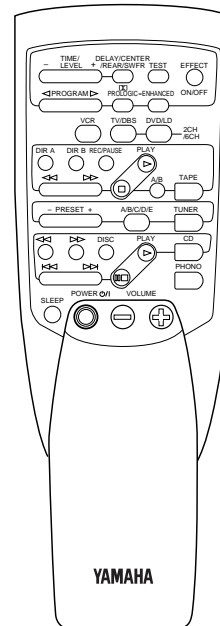

RX-V395/RDS
HTR5130/RDS

REAR PANELS

▼ RX-V395/HTR5130 U model

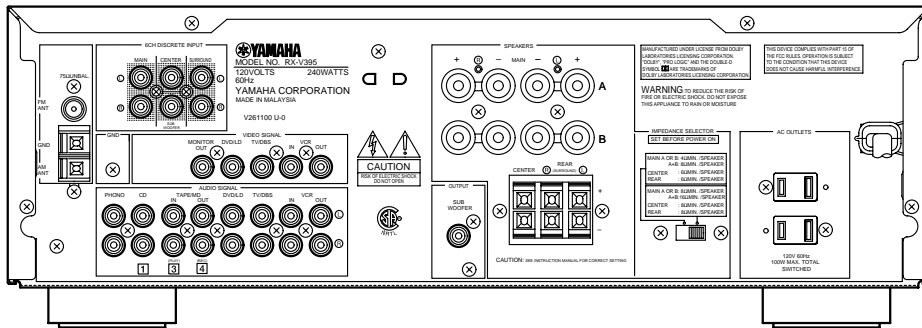

▼ RX-V395/HTR5130 C model

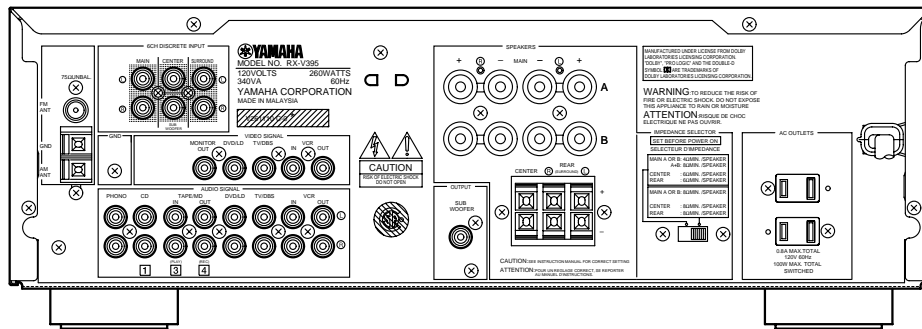

▼ RX-V395/HTR5130 R, T models

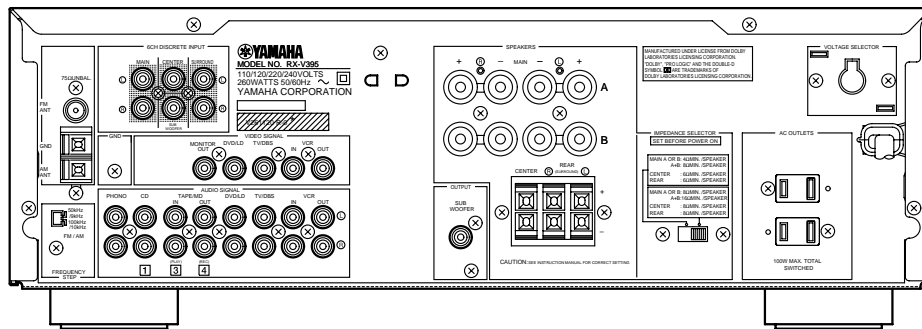

▼ RX-V395/HTR5130 A model

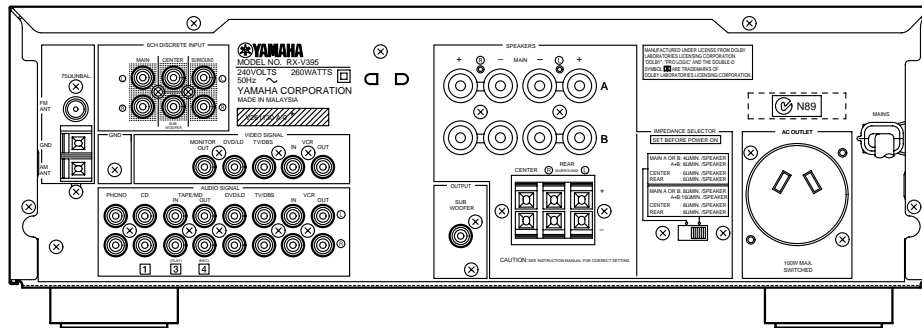

▼ RX-V395/HTR5130 B model

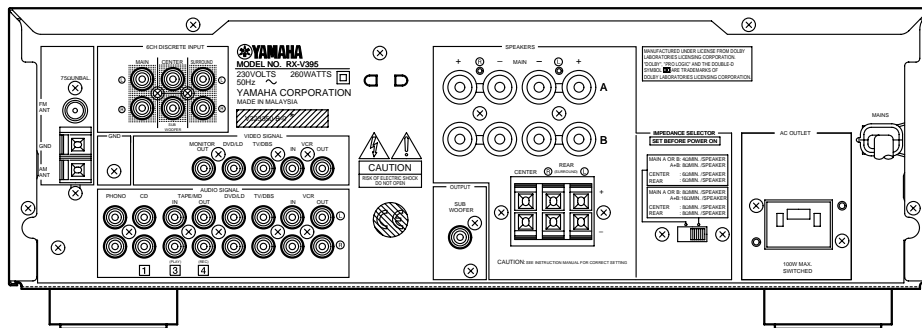

RX-V395/RDS
HTR5130/RDS

▼ RX-V395/HTR5130 G model

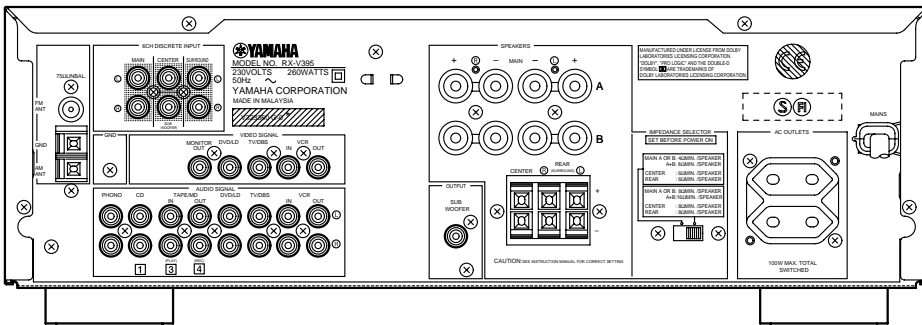

▼ RX-V395RDS/HTR5130RDS B model

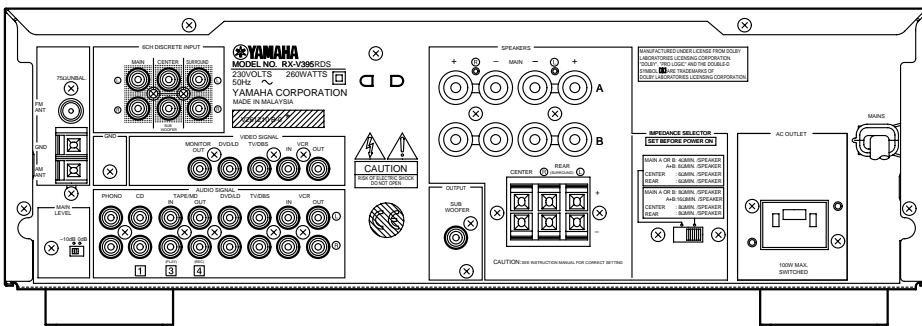

▼ RX-V395RDS/HTR5130RDS G model

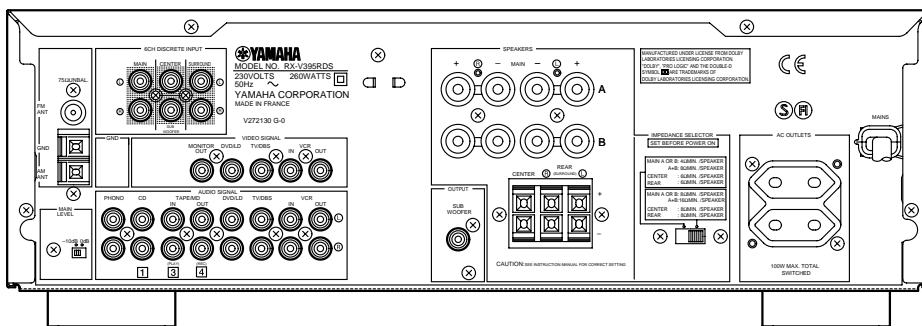

■ SPECIFICATIONS

■ AUDIO SECTION

Minimum RMS Output Power per Channel (Power Amp. Section)
(When both channels are driven)

MAIN L, R	
8 ohms, 20 Hz to 20 kHz, 0.04% THD	60 W + 60 W
CENTER	
8 ohms, 20 Hz to 20 kHz, 0.04% THD	60 W
REAR L, R	
8 ohms, 20 Hz to 20 kHz, 0.04% THD	60 W + 60 W

Minimum RMS Output Power per Channel (Power Amp. Section)
(When both channels are driven)

MAIN L, R	
8 ohms, 1 kHz, 0.07% THD	70 W + 70 W
CENTER	
8 ohms, 1 kHz, 0.07% THD	70 W
REAR L, R	
8 ohms, 1 kHz, 0.07% THD	70 W + 70 W

Maximum Power (EIAJ) [China and General models only]
(When both channels are driven)

MAIN L, R	
8 ohms, 1 kHz, 10% THD	95 W + 95 W
CENTER	
8 ohms, 1 kHz, 10% THD	95 W
REAR L, R	
8 ohms, 1 kHz, 10% THD	95 W + 95 W

Dynamic Power per Channel

(by IHF Dynamic Headroom measuring method)

8 ohms	80 W + 80 W
6 ohms	100 W + 100 W
4 ohms	120 W + 120 W
2 ohms	145 W + 145 W

DIN Standard Output Power per Channel [Europe model only]

MAIN L, R	
4 ohms, 1 kHz, 0.7% THD	100 W + 100 W
CENTER	
4 ohms, 1 kHz, 0.7% THD	100 W
REAR L, R	
4 ohms, 1 kHz, 0.7% THD	100 W + 100 W

Dynamic Headroom [U.S.A and Canada models only]

8 ohms	1.55 dB
--------	---------

IEC Power [Europe model only]

MAIN L, R	
8 ohms, 1 kHz, 0.04% THD	65 W + 65 W

Power Band Width

8 ohms, 30 W, 0.1% THD	10 Hz to 50 kHz
------------------------	-----------------

Damping Factor (SPEAKERS A)

MAIN L, R	
8 ohms, 20 Hz to 20 kHz	60 or more

Input Sensitivity/Impedance

PHONO (MM)	2.5 mV/47 k-ohms
CD/TAPE-MD/DVD-LD/TV-DBS/VCR	150 mV/47 k-ohms
6CH DISCRETE INPUT (EXTERNAL DECODER)	
MAIN L/R	150 mV/47 k-ohms
CENTER	150 mV/40 k-ohms
REAR L/R	150 mV/40 k-ohms
SUBWOOFER	150 mV/40 k-ohms

Maximum Input Signal

PHONO (MM)	
1 kHz, 0.1% THD	100 mV or more
CD/TAPE-MD/DVD-LD/TV-DBS/VCR(EFFECT ON)	
1 kHz, 0.5% THD	2.2 V or more

Output Level/Impedance

REC OUT	150 mV/2.7 k-ohms
SUBWOOFER (EFFECT OFF)	5 V/1.2 k-ohms

Headphone Jack Rated Output Level/Impedance

(1 kHz, 8 ohms, 150 mV)	0.43 V/330 ohms
-------------------------	-----------------

Frequency Response (20 Hz to 20 kHz)

CD/TAPE-MD/DVD-LD/TV-DBS/VCR	0 ± 0.5 dB
------------------------------	------------

RIAA Equalization Deviation

PHONO (MM)	0 ± 0.5 dB
------------	------------

Total Harmonic Distortion (20 Hz to 20 kHz)

PHONO (MM) to REC OUT	
1V	0.02% or less
CD/TAPE-MD/DVD-LD/TV-DBS/VCR (EFFECT OFF) to SP OUT	
30 W/8 ohms	0.025% or less

Signal-to-Noise Ratio (IHF-A Network)

PHONO (MM) to REC OUT (5 mV Input Shorted)	
[U.S.A., Canada, China, and General models]	86 dB or more
[Australia, U.K, and Europe models]	81 dB or more
CD/TAPE-MD/DVD-LD/TV-DBS/VCR to MAIN SP OUT	
(150 mV Input Shorted, EFFECT OFF)	96 dB or more

Residual Noise (IHF-A Network)

MAIN L/R to SP OUT	150 μV or less
--------------------	----------------

Channel Separation (Vol. -30 dB, EFFECT OFF)

PHONO	
(Input Shorted, 1 kHz/10 kHz)	60 dB or more/55 dB or more
CD/TAPE-MD/DVD-LD/TV-DBS/VCR	
(Input 5.1 k-ohms shorted, 1kHz/10 kHz)	60 dB or more/45 dB or more

Tone Control Characteristics

BASS : Boost/cut	± 10 dB, 50 Hz
Turnover Frequency	350 Hz
TREBLE : Boost/cut	± 10 dB, 20 kHz
Turnover Frequency	3.5 kHz

Filter Characteristics

Subwoofer (L.P.F.)	fc = 150 kHz, 6 dB/oct.
--------------------	-------------------------

VIDEO SECTION

Video Signal Level	1 Vp-p/75 ohms
Maximum Input Level	1.5 Vp-p or more
Signal-to-Noise Ratio	50 dB or more
Monitor Output Frequency Response	5 Hz to 10 MHz, -3dB

FM SECTION

Tuning Range	
[U.S.A. and Canada models]	87.5 to 107.9 MHz
[China and General models]	
(frequency step 100 kHz)	87.5 to 108.0 MHz
(frequency step 50 kHz)	87.50 to 108.00 MHz
[Australia, U.K., and Europe models]	87.50 to 108.00 MHz
50 dB Quieting Sensitivity (S/N 50 dB, 1 kHz, 100% Mod.)	
[U.S.A., Canada, China and General models only]	
IHF, Mono	1.6 µV
IHF, Stereo	23 µV
Usable Sensitivity (75 ohms)	
[Australia, U.K. and Europe models only]	
DIN, Mono (S/N 26 dB)	0.9 µV
DIN, Stereo (S/N 46 dB)	28 µV
Alternate Channel Selectivity (± 400 kHz)	
[U.S.A., Canada, China and General models only]	75 dB
Selectivity (two signals, 40 kHz Dev. ± 300 kHz)	
[Australia, U.K. and Europe models only]	55 dB
Signal-to-Noise Ratio (DIN-Weighted, 40 kHz Dev.)	
[Australia, U.K. and Europe models only]	
Mono/Stereo	75 dB/69 dB
Signal-to Noise Ratio (IHF)	
(U.S.A., Canada, General, China models only)	
Mono/stereo	81 dB/75 dB
Harmonic Distortion	
Mono/Stereo (1 kHz)	0.1%/0.2%
Stereo Separation (1 kHz)	48 dB
Frequency Response	
(20 Hz to 15 kHz)	0 ± 1 dB

Output Level	
[Australia, U.K. and Europe models]	
(40 kHz Dev. 1 kHz)	550 mV
[U.S.A., Canada, China and General models]	
(100% mod. 1 kHz)	550 mV
Antenna Input	75 ohms unbalanced

AM SECTION

Tuning Range	
[U.S.A. and Canada models]	530 to 1710 kHz
[China and General models]	
(frequency step 10 kHz)	530 to 1710 kHz
(frequency step 9 kHz)	531 to 1611 kHz
[Australia, U.K. and Europe models]	531 to 1611 kHz
Usable Sensitivity	300 µV/m

Output Level	
(30% mod. 1 kHz)	150 mV
Signal-to-Noise Ratio	52 dB
Antenna Input	Loop antenna

GENERAL

Power Supply	
[U.K. and Europe models]	AC 230 V, 50 Hz
[U.S.A. and Canada models]	AC 120 V, 60 Hz
[Australia model]	AC 240 V, 50 Hz
[China model]	AC 220 V, 50 Hz
[General model]	AC 110/120/220/240 V, 50/60 Hz
Power Consumption	
[U.K., Europe, China, Australia and General models]	260 W
[U.S.A. model]	240 W
[Canada model]	260 W/340 VA
Maximum Power Consumption (10% THD, When 5 channels are driven)	
[General model only]	630 W
AC Outlets	
2 SWITCHED OUTLETS	
[Europe, Canada, U.S.A., China and General models]	100 W max. total
1 SWITCHED OUTLET	
[U.K. and Australia models]	100 W max. total
Dimensions (W x H x D)	435 x 151 x 391 mm (17-1/8" x 5-15/16" x 15-3/8")
Weight	10.5 kg (23 lbs. 2 oz.)
Accessories	AM loop antenna Indoor FM antenna 75-ohm/300-ohm antenna adapter [U.K. model only] Antenna adapter [U.S.A. and Canada models only] Remote Control Transmitter Battery

* Specifications subject to change without notice.

DIMENSIONS

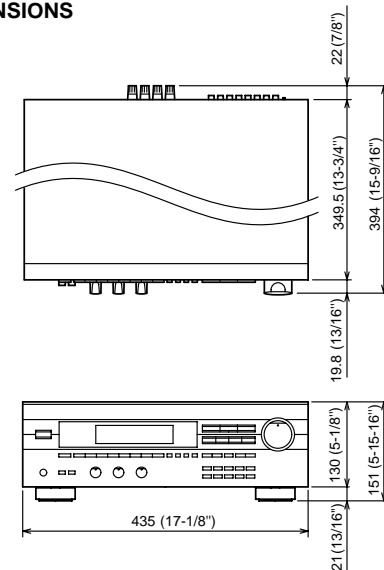

Units : mm (inch)

■ INTERNAL VIEW

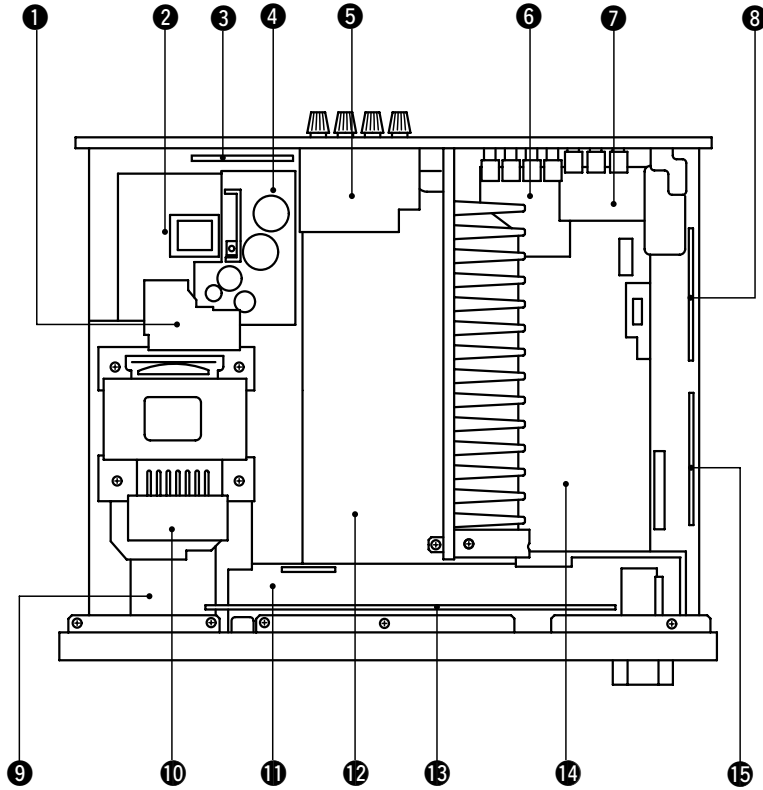

- ① P. C. B. MAIN (6)
- ② P. C. B. INPUT (3)
- ③ P. C. B. MAIN (5)
- ④ P. C. B. MAIN (4)
- ⑤ P. C. B. MAIN (3)
- ⑥ P. C. B. INPUT (2)
- ⑦ P. C. B. INPUT (5)
- ⑧ P. C. B. TUNER
- ⑨ P. C. B. MAIN (2)
- ⑩ P. C. B. INPUT (6)
- ⑪ P. C. B. OPERATION (2)
- ⑫ P. C. B. MAIN (1)
- ⑬ P. C. B. OPERATION (1)
- ⑭ P. C. B. INPUT (1)
- ⑮ P. C. B. INPUT (4)

■ DISASSEMBLY PROCEDURES (Remove parts in disassembly order as numbered.)

1. Removal of Top Cover

a. Remove 4 screws (①) and 4 screws (②) in Fig. 1.

2. Removal of Front Panel

a. Remove the knobs.

b. Remove 6 screws (③) in Fig. 1.

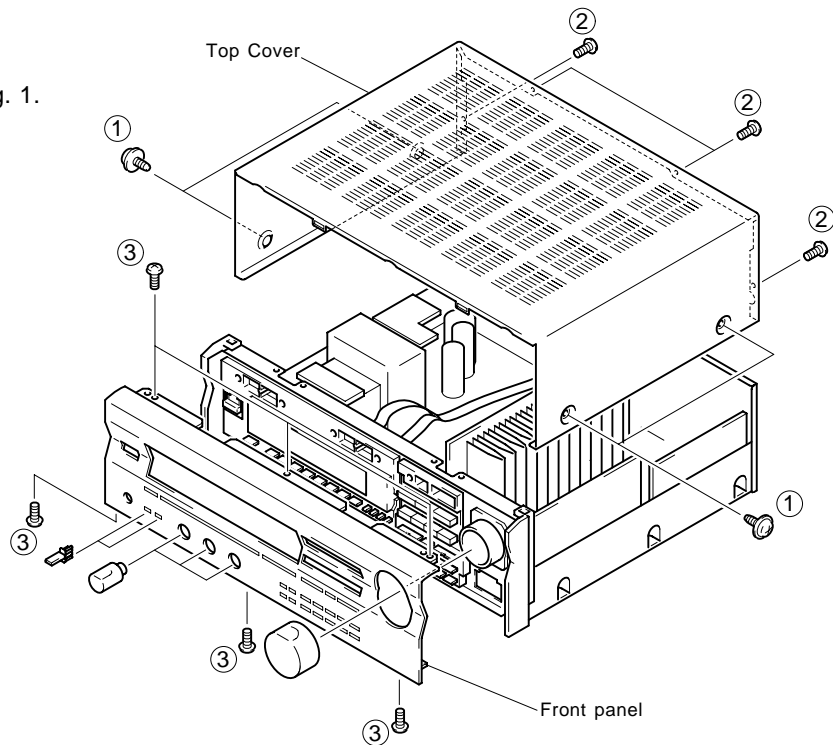

Fig. 1

RX-V395/RDS
HTR5130/RDS

■ SELF CHECK MODE

This machine has a SELF CHECK MODE (SELF) for facilitating inspection and measurement.

HOW TO START & CANCEL

Turn the POWER switch ON while pressing the DVD/LD and PRESET STATION No. 8 keys simultaneously, and then the unit enters the SELF CHECK MODE (SELF). FL displays "SELF 1" first. (The INPUT is CD.)

If the sound field program key of the main unit is pressed, the mode is set to the CHECK mode of that number. It is possible to select the INPUT even during the self check (except for SELF 8). To cancel the SELF CHECK MODE, turn the POWER switch OFF or press the PRESET STATION No. 8 key. (The unit enters the normal mode.)

HOW TO USE SELF CHECK MODE

In order to confirm characteristics (specifications) listed in the table below, use SELF NO. 1, 3 and 4. (For specifications, refer to page 5.)

No.	Items
1	<ul style="list-style-type: none"> • Output Level/Impedance • Frequency Response • Total Harmonic Distortion (Rec Out & MAIN) • S/N
3	<ul style="list-style-type: none"> • Minimum RMS Output Power Per Channel (Center & Rear) • Total Harmonic Distortion (Rear)
4	<ul style="list-style-type: none"> • Minimum RMS Output Power Per Channel (MAIN) • Input Sensitivity/Impedance • Headphone Jack Rated Output/Impedance • Channel Separation • Tone Control Characteristics

CONTENTS OF SELF CHECK MODE

No.	Menu	Select Key
1	RAM THROUGH A	PRESET STATION No. 1
2	RAM THROUGH B	PRESET STATION No. 2
3	RAM THROUGH C	PRESET STATION No. 3
4	EFFECT OFF/DISCO/FL ALL ON	PRESET STATION No. 4
5	MANUAL TEST	PRESET STATION No. 5
6	DOLBY PRO LOGIC	PRESET STATION No. 6
7	MAKER PRESET	PRESET STATION No. 7
8	EXIT	PRESET STATION No. 8

DETAILS OF SELF CONTENT

SELF 1 RAM THROUGH A

- MAIN L/R is output through the bypass.
- CENTER is output with the steering OFF and by (L+R)/2. (WIDE mode)
- RL/RR passes through the PS-RAM and is output through the DSP.
- The electronic volume (for CENTER/REAR) is -10dB.
- FL displays "SELF 1"

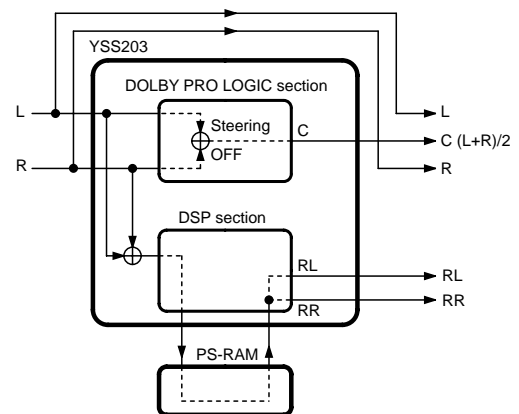

SELF 2 RAM THROUGH B

- L/R and RL/RR pass through the PS-RAM and are output through the DSP.
- CENTER is output with the steering OFF and by (L+R)/2. (WIDE mode)
- The electronic volume (for CENTER/REAR) is -10dB.
- FL displays "SELF 2"

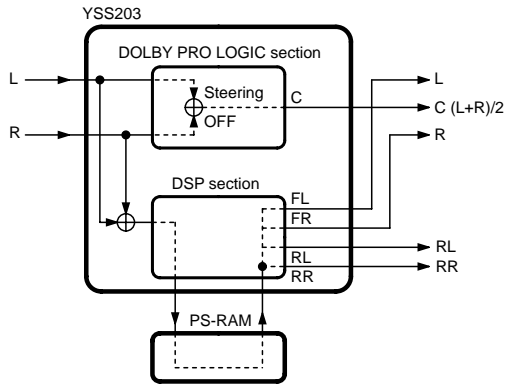

SELF 3 RAM THROUGH C

- L/R is output with the steering OFF.
- CENTER is output with the steering OFF and by (L+R)/2. (WIDE mode)
- RL/RR passes through the PS-RAM and is output through the DSP.
- The electronic volume is +10dB for CENTER and +7dB for REAR.
- FL displays "SELF 3"

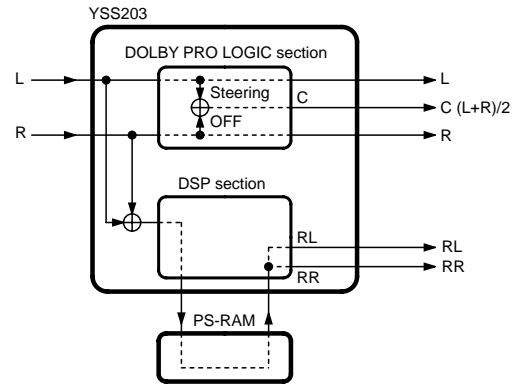

SELF 4 EFFECT OFF/DISCO/FL ALL ON

- Every time the PRESET STATION No. 4 key is pressed, the menu changes.
 - 1: EFFECT OFF
 - 2: DISCO (electronic volume is 0dB.)
 - 3: FL displays all ON

SELF 5 MANUAL TEST

- Every time PRESET STATION No. 5 key is pressed, the TEST TONE shifts in the order of L→C→R→S and is output. (The CENTER mode is WIDE)
- The electronic volume (for CENTER/REAR) is 0dB.

SELF 6 DOLBY PRO LOGIC

- The auto input balance which is ON in the normal mode is turned OFF.
- CENTER MODE is changed by pressing the PRESET STATION No. 6 key or the CENTER MODE key.
- The electronic volume (for CENTER/REAR) is 0dB.
- FL displays "SELF 6" and the center mode.

RX-V395/RDS
HTR5130/RDS

SELF 7 MAKER PRESET

- Every time the PRESET STATION No. 7 key is pressed, the mode changes between the KEEP DATA and PRESET modes. Turning OFF the power in the "PRESET" mode will restore the FACTORY PRESET mode.

CAUTION : Before setting to the FACTORY PRESET, write down the existing preset memory contents of the Tuner in a table as shown below. (This is because setting to the FACTORY PRESET will cause the memory contents to be as factory set, i.e., all the preset memory by the user will be erased.)

Preset group	P1	P2	P3	P4
A				
B				
C				
D				
E				

Preset group	P5	P6	P7	P8
A				
B				
C				
D				
E				

● Factory Preset**1) SURROUND section**

DELAY TIME	:	<input type="checkbox"/> PRO LOGIC	20ms
		ENHANCED	20ms
		CONCERT VIDEO	28ms
		MONO MOVIE	20ms
		STADIUM	45ms
		DISCO	14ms
		ROCK CONCERT	17ms
		CONCERT HALL	30ms
CENTER MODE	:	NORMAL	
VOLUME LEVEL	:	CENTER	0dB
		REAR	0dB

2) SELECTOR section

INPUT	:	CD
VIDEO (BGV)	:	DVD/LD

3) TUNER section

Preset group	P1	P2	P3	P4
A / C / E	87.5MHz	90.1MHz	95.1MHz	98.1MHz
B / D	630kHz	1080kHz	1440kHz	530kHz (U, C, R, T) 531kHz (R, T, A, G)

Preset group	P5	P6	P7	P8
A / C / E	107.9MHz (U, C, R, T) 108.0MHz (R, T, A, G)	88.1MHz	106.1MHz	107.9MHz (U, C, R, T) 108.0MHz (R, T, A, G)
B / D	1710kHz (U, C, R, T) 1611kHz (R, T, A, G)	900kHz	1350kHz	1400kHz (U, C, R, T) 1404kHz (R, T, A, G)

For all the above, AUTO TUNING and AUTO STEREO are selected as the TUNING mode.

SELF 8 EXIT

- "MODEL" is displayed first. When the PRESET STATION No. 8 key is pressed again, the unit will exit the SELF CHECK mode.

■ AMP ADJUSTMENTS

● Confirmation of Idling Current

Right after Power is switched ON, confirm that the voltage across each resistor, R-124, -127, -130, -136, and -143, is between 0.1mV to 5mV. If the voltage exceeds 5.2mV, open (cut off) R-171, -177, -189, -195, -183 and confirm that the voltage becomes 0.1mV to 5mV.

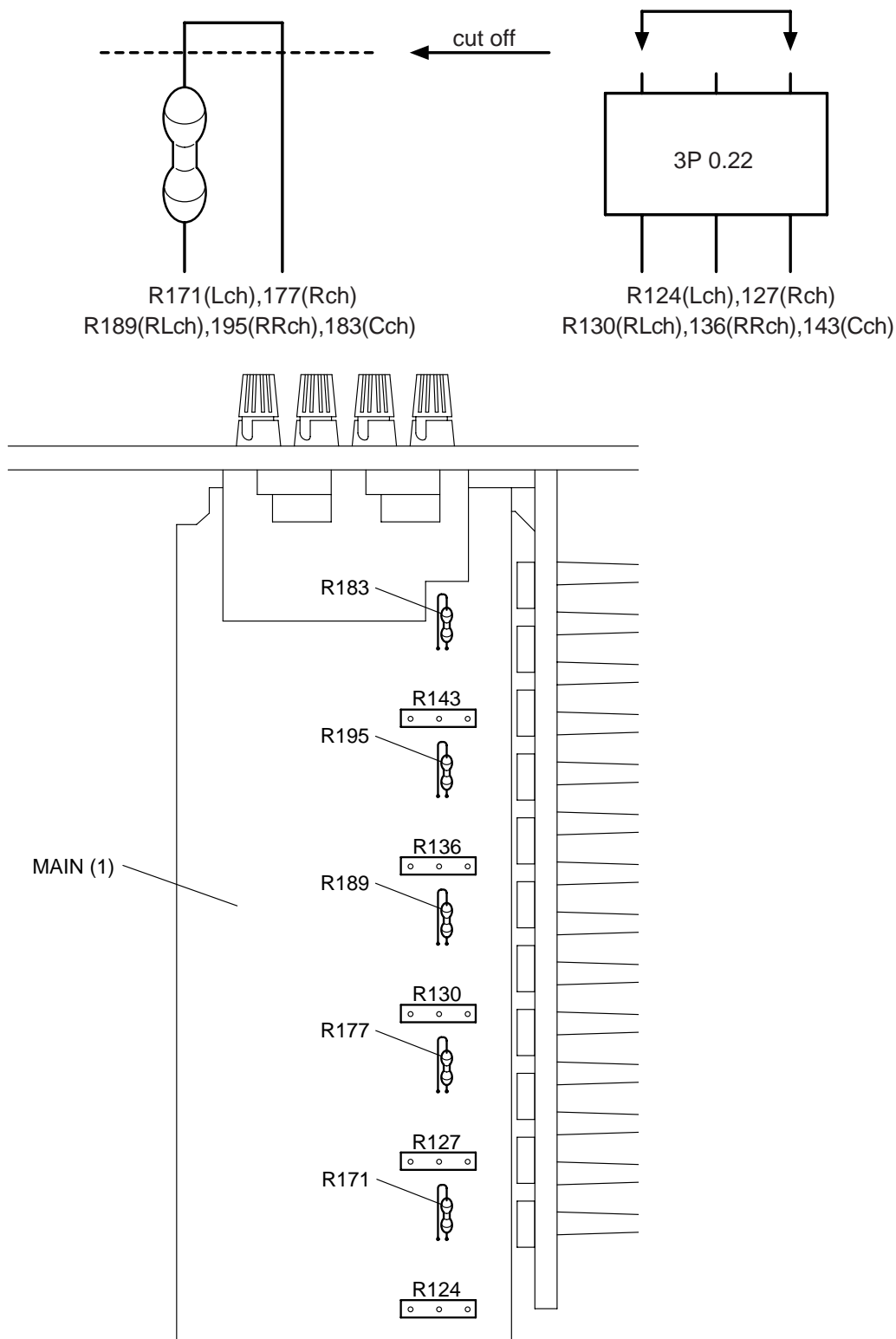

TUNER ADJUSTMENTS

Measuring Instruments

- FM signal generator (FM SG)
- Stereo signal generator (SSG)
- AM signal generator (AM SG)
- Distortion meter (DIST. M)
- AC voltmeter (ACVM)
- DC voltmeter (DCVM)
- Oscilloscope
- Low pass filter (YLF-15, $f_c=15\text{kHz}$)
- Oscillator

Dummy antenna

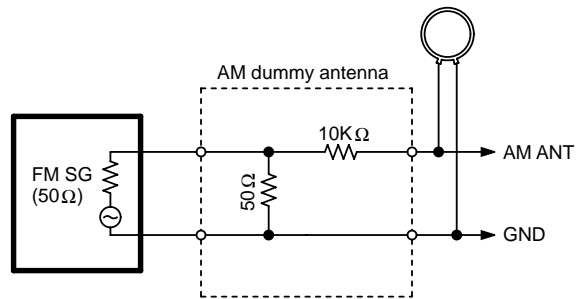
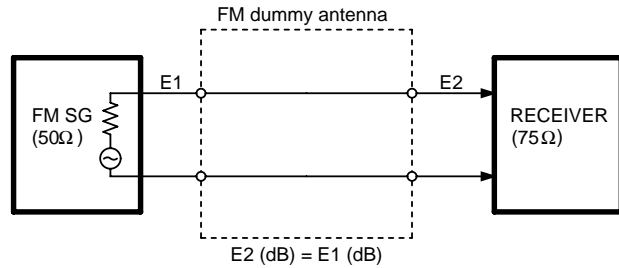
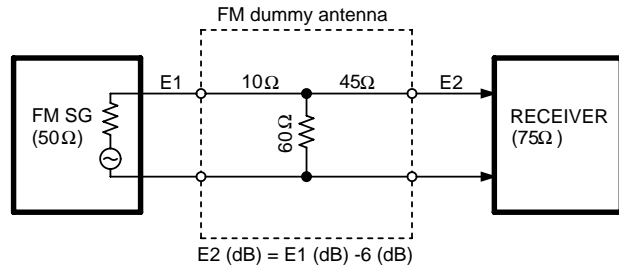

Test point

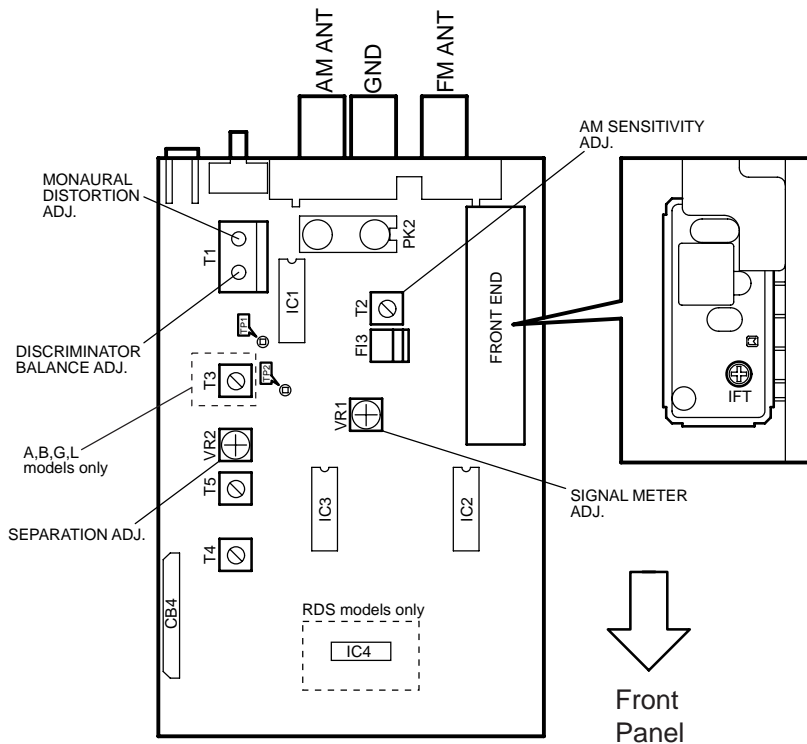

RX-V395/RDS
HTR5130/RDS

FM Adjustment

● Before Adjustment

- 1) For dB, $1\mu V=0dB\mu$
Example : $60dB\mu=1mV$
- 2) 100% modulation means that the frequency deviation is $\pm 75kHz$.

- 3) Install the Matching Transformer and connect FM SG.
- 4) Set each switch to the following position unless otherwise specified.

INPUT SELECTOR TUNER
 TUNING MODE AUTO

● Connection diagram (Measuring instruments)

1) Discriminator balance adjustment

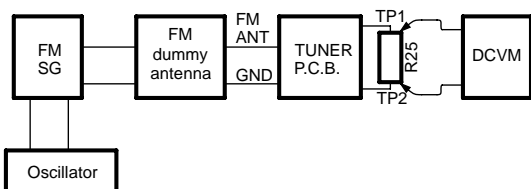

3) Stereo distortion adjustment/separation adjustment

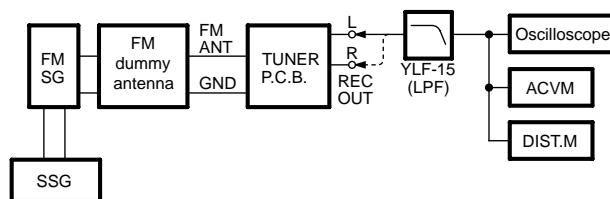

2) Monaural distortion adjustment

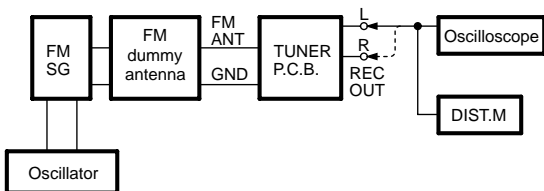

4) Sensitivity Verification

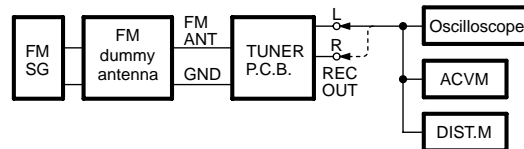

See page 14 for TP locations & adjustment points.

Step	Adjustment item	Signal (ANT IN)	Reception frequency	Adjustment point	Test point	Rating
1	Rough adjustment of discriminator balance	FM ANT (75Ω) 98.1MHz ** 70dBμ MONO 100Hz 100% modulation	98.1MHz * (A-4)	T1 (Front side core)	Both ends of R25 (Between TP1 and TP2)	DC 0V±100mV
2	Rough adjustment of monaural distortion	Same as Step 1.	98.1MHz * (A-4)	T1 (Antenna side core)	REC OUT L, R	Minimize the distortion.
3	Fine adjustment of discriminator balance	Same as Step 1.	98.1MHz * (A-4)	T1 (Front side core)	Both ends of R25 (Between TP1 and TP2)	DC 0V±50mV
4	Fine adjustment of monaural distortion	Same as Step 1.	98.1MHz * (A-4)	T1 (Antenna side core)	REC OUT L, R	Minimize the distortion (-41dB or less).
5	Verification of discriminator balance	Same as Step 1.	98.1MHz * (A-4)	T1 (Front side core)	Both ends of R25 (Between TP1 and TP2)	DC 0V±50mV

* : Execution of FACTORY PRESET (Refer to page 11.) will facilitate setting reception frequency for adjustment.

** Must be 98.1MHz ± 5kHz

Step	Adjustment item	Signal (ANT IN)	Reception frequency	Adjusted point	Test point	Rating
6	Adjustment of front end IFT	FM ANT (75Ω) 98.1MHz ** 30dBμ MONO 1kHz, 100% modulation	98.1MHz * (A-4)	Front end IFT	Pin 16 of IC1	Adjust so that the DC voltage is maximum. CAUTION : Over-adjustment of the IFT core will reduce the sensitivity. Maximum ±90°
7	Verification of monaural distortion	FM ANT (75Ω) 98.1MHz 70dBμ MONO 1kHz, 100% modulation	98.1MHz * (A-4)		REC OUT L, R	0.4%(-41dB) or less
8	Verification of stereo distortion	FM ANT (75Ω) 98.1MHz 70dBμ Stereo L or R 1kHz, 100% modulation	98.1MHz * (A-4) * Tuning mode should be AUTO.		REC OUT L, R	1%(-33dB) or less • STEREO indicator should light.
9	Verification of sensitivity	FM ANT (75Ω) 88.1MHz 98.1MHz 106.1MHz MONO 1kHz 100% modulation	88.1MHz * (A-6) 98.1MHz * (A-4) 106.1MHz * (A-7)		ANT (75Ω)	1) Set the tuning mode to MAN'L MONO. 2) S/N should be 30dB at each frequency of 88.1MHz, 98.1MHz, and 106.1MHz. 3) Check to ensure that the voltage at the ANT terminal is 6dBμ or less. (U,C,R,T : 6dBμ or less) (A,B,G,L : 8dBμ or less)
10	Adjustment of Separation	FM ANT (75Ω) 98.1MHz 70dBμ Stereo L or R 1kHz, 100% modulation	98.1MHz * (A-4)	VR2	REC OUT L, R	With SSG output at L or R, the signal leakage level at the other channel should be minimized. 28dB or more
11	Adjustment of Signal meter	FM ANT (75Ω) 98.1MHz 45dBμ MONO 1kHz 30% modulation	98.1MHz * (A-4)	VR1		Adjust so that all segments light.
		-10dBμ or less				Check to ensure that signal meters turn OFF.
12	Verification of auto tuning	FM ANT (75Ω) 98.1MHz 23dBμ Stereo L or R 1kHz, 30% modulation	98.1MHz * (A-4)			• Automatic reception should be available when the tuning key is moved UP and DOWN. • The stereo indicator should light. • Audio muting should be applied during tuning.

* : Execution of FACTORY PRESET (Refer to page 10.) will facilitate setting reception frequency for adjustment.

** Must be 98.1MHz ± 5kHz

AM Adjustment (This should be done after FM adjustment.)

● **Connection Diagram (Measuring instruments)**

1) Adjustment of sensitivity

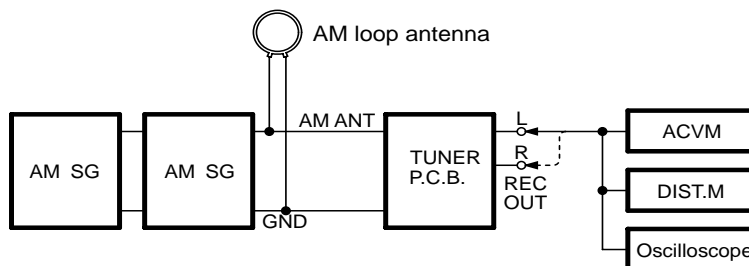

See page 13 for TP locations & adjustment points.

Step	Adjustment item	Signal (ANT IN)	Reception frequency	Adjustment point	Test point	Rating
1	Adjustment of sensitivity (630kHz)	AM ANT 630kHz 50dB μ 1kHz 30% modulation	630kHz * (B-1)	T2	REC OUT	Signal meter should be maximized
2	Verification of sensitivity	AM ANT 630kHz 1080kHz 1440kHz 30% modulation	630kHz * (B-1) 1080kHz * (B-2) 1440kHz * (B-3)		AM ANT	Distortion should be 10% or less at each frequency. Check to ensure that the voltage at the ANT terminal is 54dB μ or less.
3	Verification of signal meter	AM ANT 1080kHz 90dB μ	1080kHz * (B-2)			All signal meters should light.
		-10dB or less				All signal meter should turn OFF.
4	Verification of auto tuning	AM ANT 60dB μ				Auto reception should be available when the tuning key is moved UP and DOWN.

* : Execution of FACTORY PRESET (Refer to page 10.) will facilitate setting reception frequency for adjustment.

■ DISPLAY DATA

● V701 : 13-BT-165GK (V306400)

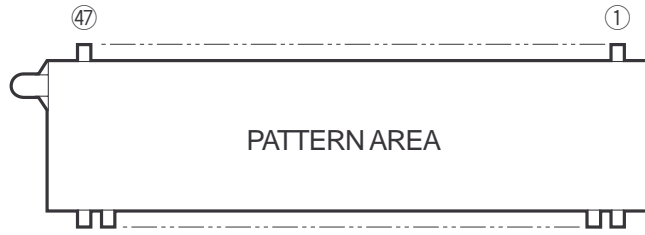

● PIN CONNECTION

PIN NO.	1	2	3	4	5	6	7	8	9	10	11	12	13	14	15	16	17	18	19	20	21
CONNECTION	F1	F1	NP	NP	P1	P2	P3	P4	P5	P6	P7	P8	P9	P10	P11	P12	P13	P14	P15	P16	NC
PIN NO.	22	23	24	25	26	27	28	29	30	31	32	33	34	35	36	37	38	39	40	41	42
CONNECTION	NC	NC	NC	NC	NC	NC	NC	NC	NC	13G	12G	11G	10G	9G	8G	7G	6G	5G	4G	3G	2G
PIN NO.	43	44	45	46	47																
CONNECTION	1G	NP	NP	F2	F2																

NOTE 1) F1, F2 Filament
 2) NP No pin
 3) NC No connection

4) DL Datum Line
 5) 1G~13G .. Grid
 6) Field of vision is a minimum of 25 degrees from the

● GRID ASSIGNMENT

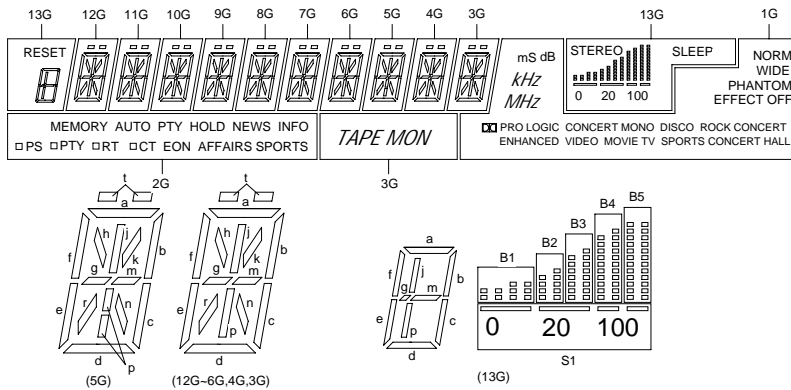

● ANODE CONNECTION

	13G	12G-4G	3G	2G	1G
P1	a	a	a	MEMORY	NORM
P2	b,c	b	b	AUTO	WIDE
P3	d	c	c	PTY HOLD	PHANTOM
P4	e,f	d	d	SPORT	EFFECT OFF
P5	g	e	e	AFFAIRS	ROCK CONCERT
P6	j,p	f	f	INFO	CONCERT HALL
P7	m	g	g	NEWS	DISCO
P8	RESET	h	h	EON	TV SPORTS
P9	STEREO	j	j	CT	MONO MOVIE
P10	B1	k	k	<input type="checkbox"/> [CT]	CONCERT VIDEO
P11	B2	m	m	RT	<input checked="" type="checkbox"/> PRO LOGIC
P12	B3	n	n	<input type="checkbox"/> [RT]	ENHANCED
P13	B4	p	p	RTY	dB
P14	B5	r	r	<input type="checkbox"/> [PTY]	mS
P15	S1	t	t	PS	KHz
P16	SLEEP	-	TAPE MON	<input type="checkbox"/> [PS]	MHz

RX-V395/RDS HTR5130/RDS

IC DATA

IC705 : M38B59EFPF
8 bit μ -COM

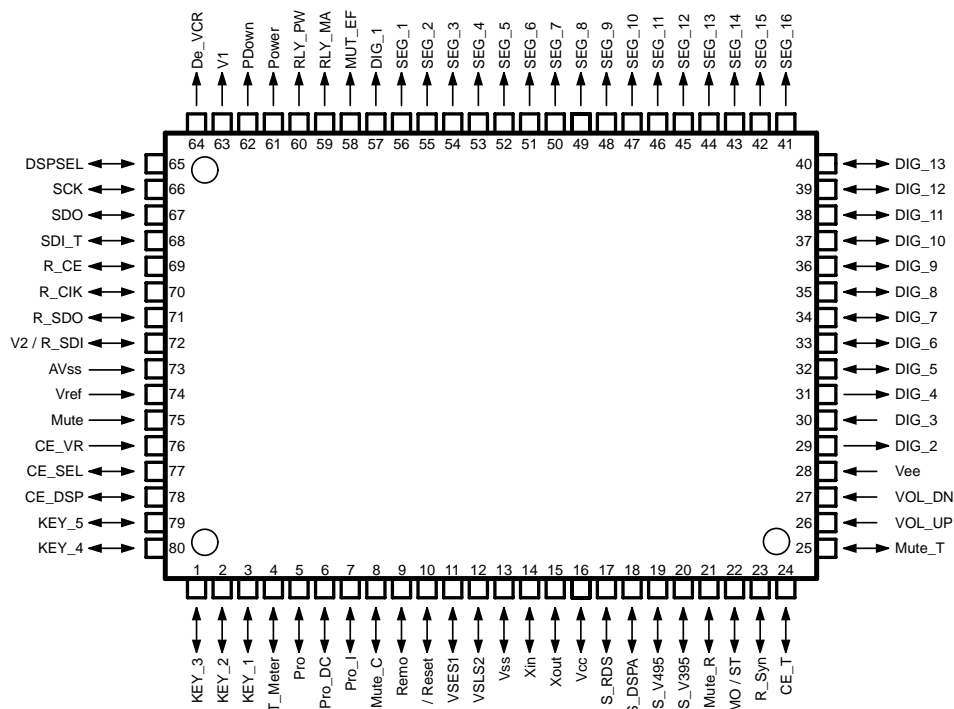

Pin No.	Port	I/O	Function
1	P75	I/O	KEY AD IN 3 (A-D)
2	P74	I/O	KEY AD IN 2 (A-D)
3	P73	I/O	KEY AD IN 1 (A-D)
4	P72	I/O	METER IN (A-D)
5	P71	I/O	PROTECTION 1 DETECT (A-D)
6	P70	I/O	PROTECTION 2 DETECT (A-D)
7	P61	I/O	PROTECTION 3 DETECT
8	P60	I/O	Center mute [L : ON]
9	P47	I	REMOTE CONTROL IN (INT3)
10	/RESET		/RESET
11	P91	I/O	VIDEO SELECTOR A (VSEL1)
12	P90	I/O	VIDEO SELECTOR B (VSEL2)
13	VSS		GND
14	XIN		4 MHz
15	XOUT		4 MHz
16	VCC		+5V
17	P46	I/O	RDS SELECT IN [H : RDS]
18	P45	I/O	DSP-A SELECT IN [H : DSPA]
19	P44	I/O	NC [H : V495]
20	P43	I/O	V395 SELECT IN [H : V395]
21	P42	I/O	Rear mute [L : ON]
22	P41	I/O	/ST for tuner [L : STEREO]
23	P40	I/O	RDS Syn
24	P87	I/O	CETUN for tuner
25	P86	I/O	TMUTE for tuner [L : ON]
26	P85	I/O	VOL UP OUT
27	P84	I/O	VOL DOWN OUT

Protection 2

Detection of an abnormal amplifier DC. Normal when AD value (3 - 35)/256.
Detection starts 3 seconds after the power is turned ON.

Protection 3.

Detection starts immediately after the power is switched ON.

IC705 : M38B59EFPF
8 bit μ -COM

Pin No.	Port	I/O	Function
28	VEE		-25V
29	P83	I/O	DIGIT 2
30	P82	I/O	DIGIT 3
31	P81	I/O	DIGIT 4
32	P80	I/O	DIGIT 5
33	P37	O	DIGIT 6
34	P36	O	DIGIT 7
35	P35	O	DIGIT 8
36	P34	O	DIGIT 9
37	P33	O	DIGIT 10
38	P32	O	DIGIT 11
39	P31	O	DIGIT 12
40	P30	O	DIGIT 13
41	P17	O	SEGMENT 16
42	P16	O	SEGMENT 15
43	P15	O	SEGMENT 14
44	P14	O	SEGMENT 13
45	P13	O	SEGMENT 12
46	P12	O	SEGMENT 11
47	P11	O	SEGMENT 10
48	P10	O	SEGMENT 9
49	P07	I/O	SEGMENT 8
50	P06	I/O	SEGMENT 7
51	P05	I/O	SEGMENT 6
52	P04	I/O	SEGMENT 5
53	P03	I/O	SEGMENT 4
54	P02	I/O	SEGMENT 3
55	P01	I/O	SEGMENT 2
56	P00	I/O	SEGMENT 1
57	P27	I/O	DIGIT 1
58	P26	I/O	Surround SP Relay [H : ON]
59	P25	I/O	Main SP Relay [H : ON]
60	P24	I/O	Power Relay [H : ON]
61	P23	I/O	Power SW IN [H : ON]
62	P22	I/O	Power down detect [L : DOWN]
63	P21	I/O	V1 market
64	P20	I/O	NOT VCR SELECT [H : VCR]
65	P57	I/O	DSP SERIAL SELECT [H : DSP]
66	P56	I/O	SCLK
67	P55	I/O	SOUT
68	P54	I/O	SDI for tuner
69	P53	I/O	RDS CE
70	P52	I/O	RDS CLK
71	P51	I/O	RDS SDO
72	P50	I/O	V2 market / RDS SDI
73	AVSS		GND
74	VREF		+5V
75	P65	I/O	FULL MUTE [L : ON]
76	P64	I/O	CEVR
77	P63	I/O	CESEL
78	P62	I/O	CEDSP
79	P77	I/O	KEY AD IN 5 (A-D)
80	P76	I/O	KEY AD IN 4 (A-D)

V2	V1	market
0	1	G
1	0	U
1	1	R

Set the receiving step for R market by V1=1, V2, 0.1

IC466 : YSS203B-F
Digital Dolby Pro Logic Decoder with Auto Input Balance

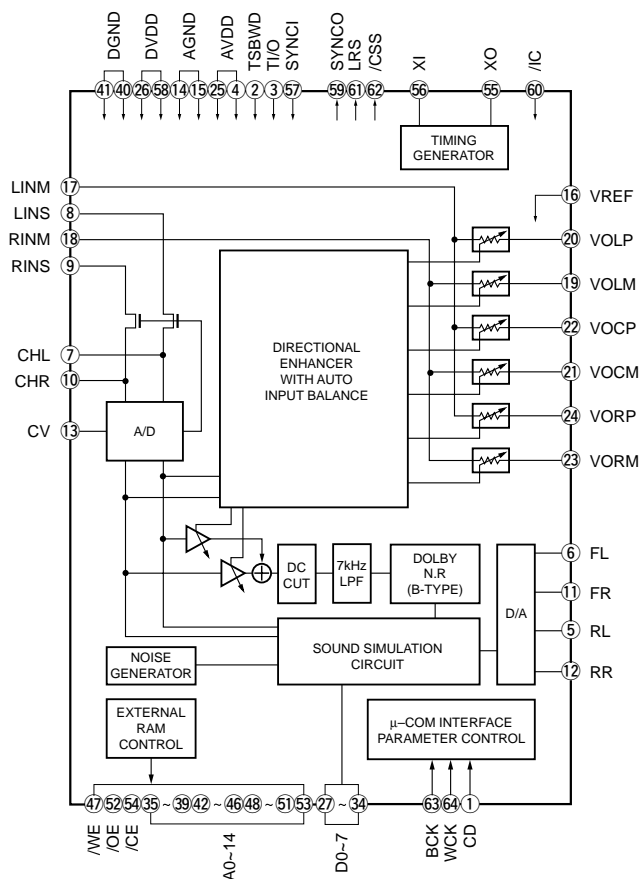
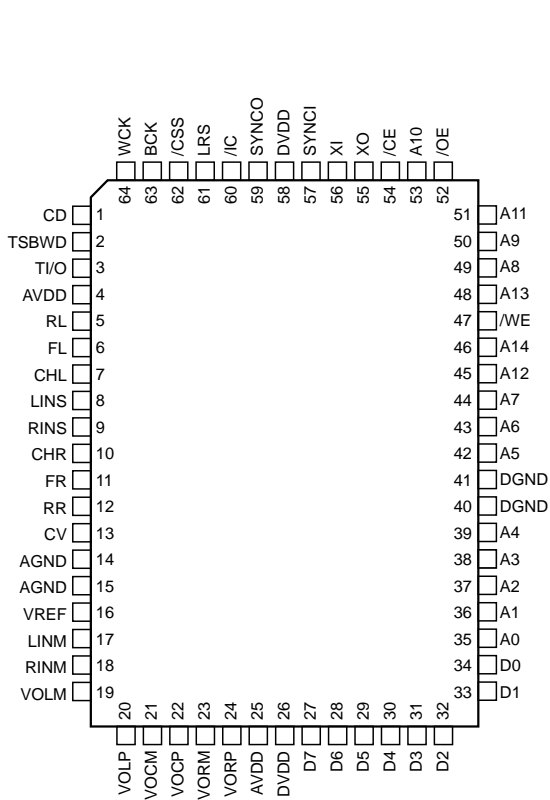

No.	Name	I/O	Function
1	CD	I _S	Serial data of parameter data input
2	TSBWD	I _C	LSI test terminal Normally connected to DVDD terminal
3	Tl/O	I _C	LSI test terminal Normally connected to DVDD terminal
4	AVDD	A—	+5V power supply (D/A, A/D section)
5	RL	AO	RL channel D/A output
6	FL	AO	FL channel D/A output
7	CHL	A—	LINS input Sample/hold Capacitor external terminal
8	LINS	AI	L channel A/D input
9	RINS	AI	R channel A/D input
10	CHR	A—	RINS input Sample/hold Capacitor external terminal
11	FR	AO	FR channel D/A output
12	RR	AO	RR channel D/A output
13	CV	AO	A/D, multiplying DAC center voltage
14	AGND	A—	Ground (D/A, A/D section)
15	AGND	A—	Ground (Multiplying DAC section)
16	VREF	AI	Multiplying DAC reference voltage input
17	LINM	AI	L channel Multiplying DAC input
18	RINM	AI	R channel Multiplying DAC input
19	VOLM	AO	L channel operation amplifier, connected to (-) terminal
20	VOLP	AO	L channel operation amplifier, connected to (+) terminal

IC466 : YSS203B-F

Digital Dolby Pro Logic Decoder with Auto Input Balance

No.	Name	I/O	Function
21	VOCM	AO	C channel operation amplifier, connected to (–) terminal
22	VOCP	AO	C channel operation amplifier, connected to (+) terminal
23	VORM	AO	R channel operation amplifier, connected to (–) terminal
24	VORP	AO	R channel operation amplifier, connected to (+) terminal
25	AVDD	A—	+5V power supply (multiplying DAC section)
26	DVDD	—	+5V power supply (digital section)
27	D7	I/Ot	External delay RAM data terminal
28	D6	I/Ot	External delay RAM data terminal
29	D5	I/Ot	External delay RAM data terminal
30	D4	I/Ot	External delay RAM data terminal
31	D3	I/Ot	External delay RAM data terminal
32	D2	I/Ot	External delay RAM data terminal
33	D1	I/Ot	External delay RAM data terminal
34	D0	I/Ot	External delay RAM data terminal
35	A0	O	External data RAM address terminal
36	A1	O	External data RAM address terminal
37	A2	O	External data RAM address terminal
38	A3	O	External data RAM address terminal
39	A4	O	External data RAM address terminal
40	DGND	—	Ground (digital section)
41	DGND	—	Ground (digital section)
42	A5	O	External data RAM address terminal
43	A6	O	External data RAM address terminal
44	A7	O	External data RAM address terminal
45	A12	O	External data RAM address terminal
46	A14	O	External data RAM address terminal
47	/WE	O	External delay RAM write enable terminal
48	A13	O	External delay RAM address terminal
49	A8	O	External delay RAM address terminal
50	A9	O	External delay RAM address terminal
51	A11	O	External delay RAM address terminal
52	/OE	O	External delay RAM output enable terminal
53	A10	O	External delay RAM address terminal
54	/CE	O	External delay RAM chip enable terminal
55	XO	O	Crystal oscillator connecting terminal
56	XI	I	Crystal oscillator connecting terminal
57	SYNCI	It	Test terminal for system synchronization, normally connected to DVDD
58	DVDD	—	+5V power supply (digital section)
59	SYNCO	O	Test terminal for system synchronization, normally unconnected
60	/IC	Ics	Initial clear terminal (Power ON resetting is necessary)
61	LRS	O	External automatic input balance terminal, (normally unconnected)
62	/CSS	O	External automatic input balance terminal, (normally unconnected)
63	BCK	I _{ts}	Bit clock for parameter data input
64	WCK	I _{ts}	Word clock for parameter data input

Note : Letters used in the above I/O column represent as follows.

I : Input terminal O : Output terminal t : TTL level
c : CMOS level s : Schmidt input A : Analog terminal

RX-V395/RDS PRINTED CIRCUIT BOARD (Foil side)

P.C.B MAIN (1)

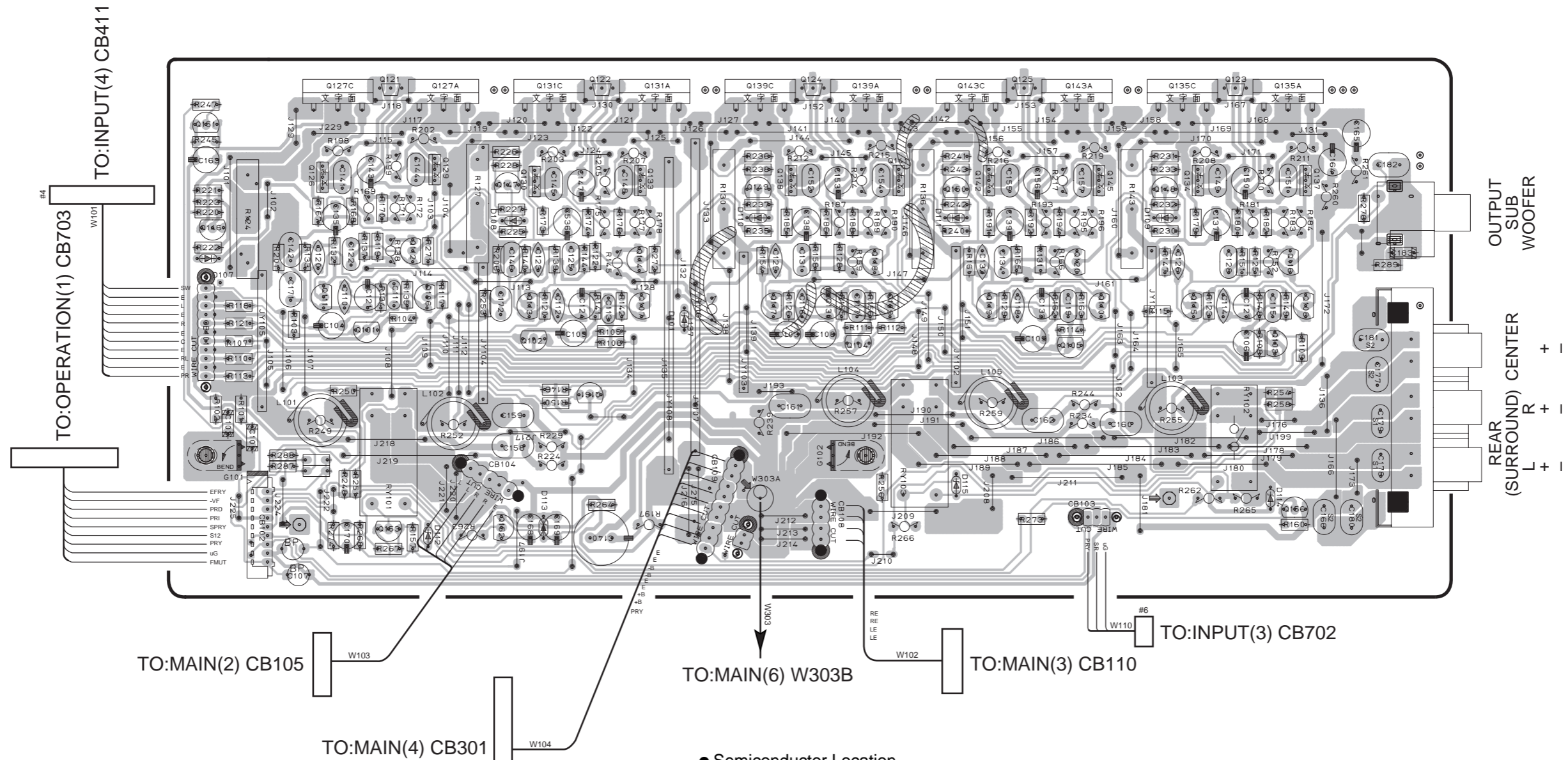

CIRCUIT CHANGES BY MARKET

s	Circuit No.	U. C. R. T. A	B. G
1	C178-179 C188-189-190-191	X	0.01 (UA95410)
2	C177-180-181 C184-185-186-187 C166	X	0.022 (UA95422)

○: USED
X: NOT USED

● Semiconductor Location

Ref. No.	Location
D101	D2
D107	B2
D108	C2
D109	F2
D110	D2
D111	E2
D112	C3
D113	C3
D114	F3
D115	E3
Q101	B3
Q102	C3
Q103	F3
Q104	D3
Q105	E3
Q106	C2
Q107	C2

Ref. No.	Location
Q108	F2
Q109	D2
Q110	E2
Q111	B2
Q112	B2
Q113	C2
Q114	C2
Q115	F2
Q116	F2
Q117	D2
Q118	D2
Q119	E2
Q120	E2
Q121	B1
Q122	C1
Q123	F1
Q124	D1

Ref. No.	Location
Q125	E1
Q126	B2
Q127A	C1
Q127C	B1
Q129	C2
Q130	C2
Q131A	C1
Q131C	C1
Q133	C2
Q134	F2
Q135A	F1
Q135C	F1
Q137	F2
Q138	D2
Q139A	D1
Q139C	D1
Q141	E2

Ref. No.	Location
Q142	E2
Q143A	E1
Q145	E2
Q146	B2
Q147	C2
Q148	F2
Q149	D2
Q151	B2
Q152	C3
Q153	B3
Q156	F3
Q161	C3

● RX-V395/RDS PRINTED CIRCUIT BOARD (Foil side)

P.C.B INPUT (1)

TO:INPUT(4) CB412

TO:INPUT(4) CB409

FROM:TUNNER CB4

● R, T models
P.C.B INPUT (6)

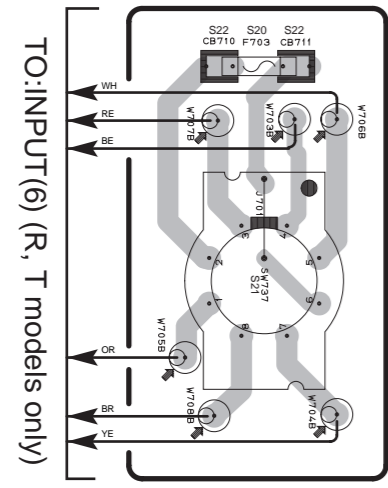

240V	1-2/5-6
220V	2-3/6-7
110V	3-4/7-8
120V	4-5/8-1

TO:OPERATION(1) CB704

FROM:MAIN(4) CB302

● Semiconductor Location

Ref. No.	Location
D401	E3
IC401	F2
IC409	F2
IC415	E2
IC419	E2
IC422	F3
IC431	E3
IC437	E3
IC441	D2
IC445	D2
IC449	D2
IC452	E3
IC457	E3
IC461	D3
IC464	C3
IC465	E3
IC466	D3
IC467	D3
Q402	G4
Q403	G4
Q404	F4
Q405	F4

Point ① (Pin55 of IC466)
V : 2V/div H : 50 nsec/div
DC range 1 : 1 probe

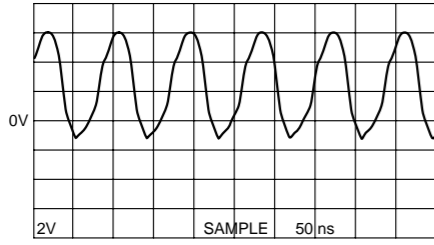

CIRCUIT CHANGES BY MARKET

	U-C	R-T	A	B	G
920	F703	X	T4. 0AL250V KB00079	X	X
921	SW737	X	VA96180	X	X
922	CB710 CB711	X	VP20650	X	X
923	CB705 CB706	X	X	X	VP20650

○ : USED
X : NOT USED

P.C.B INPUT (2)

Up to 18,500
R605 3.3kΩ
R606 3.3kΩ
Solder in the back.

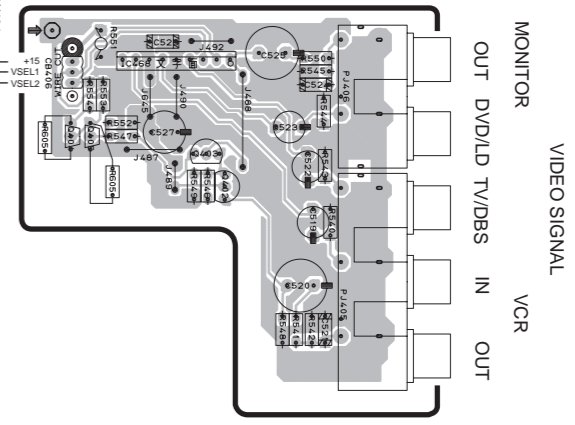

1
2
3
4
5
6

RX-V395/RDS PRINTED CIRCUIT BOARD (Foil side)

CIRCUIT CHANGES BY MARKET

● Semiconductor Location

Ref. No.	Location
D403	F5
D708	B4,C2
D709	C3,C5
D710	C4
D711	C4
IC477	E4
IC478	F4
IC479	E4
IC480	E4
IC483	F4
IC485	F4
Q709	C2,C4
Q710	C4
Q711	C5

	U-C	R-T	A	B	G
S1	RY701	VY73530 V271230 V285040	VY73530 V271230 V285040	VY73530 V271230 V285040	VY73530 V271230 V285040
S2	F701	8-0A125V VS82330	8-0A125V VS82330	T4-0AL250V KB00079	T4-0AL250V KB00079
S3	J711	0	0	0	X
S4	F702	X	X	X	T2-5AH250V VT94290
S5	TE701	VU54310	VU54310	VT91500	VU54330 VU54340
S6	T701	XC083	XT331 XT341	XC084	XC084
S7	R784	1/2P2-2M	X	X	X
S8	D710	X	VR25370	X	X
S9	J708	0	X	0	0
S10	D709	VS99780	X	VS99780	VS99780
S11	C730	330/25	47/63	330/25	330/25
S12	J707	0	X	0	0
S13	R782	X	18K	X	X
S14	D711	X	HZS12A2TD	X	X
S15	Q710	X	C4466[D/P/Y	X	X
S16	Q711	X	C1890A[D/E]	X	X
S17	R783	X	100	X	X
S18	C731	X	10/16	X	X
S19	C728	X	220/16	X	X
S24	W708		MH01040		
S25	W705		MH03040		
S26	W707	X	MH05040	X	X
S27	W703		MH02040		
S28	W706		MH09040		
S29	W704		MH04040		

○ : USED
X : NOT USED

P.C.B INPUT (3)

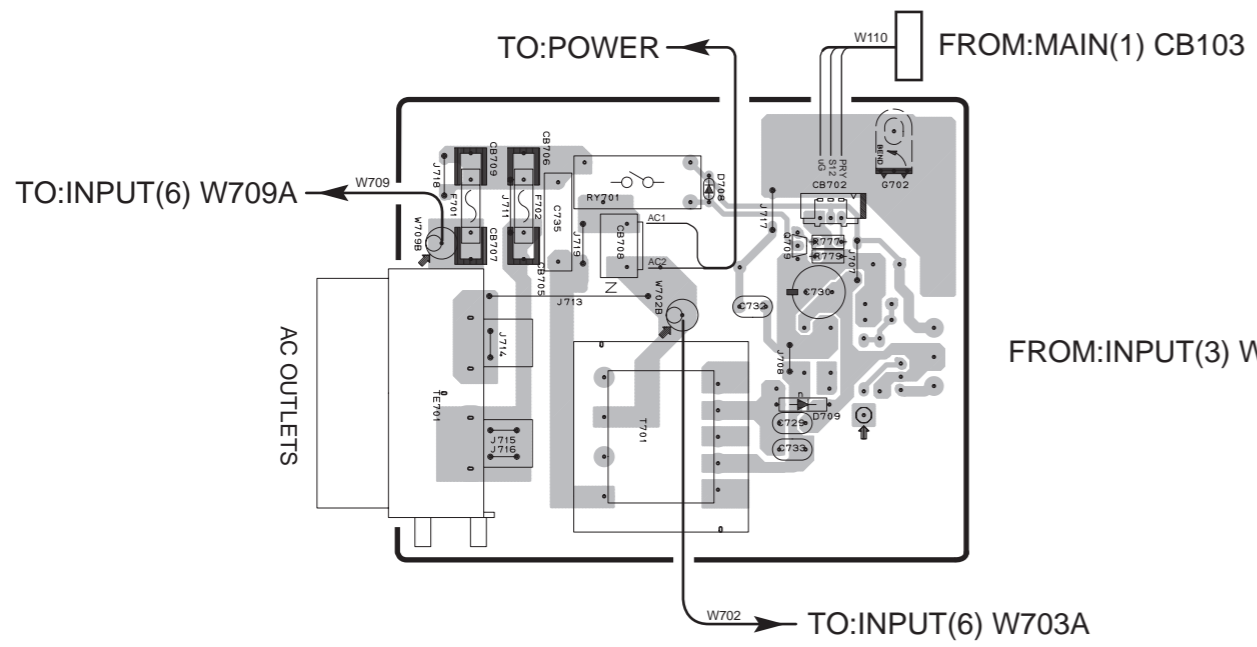

● R,T models
P.C.B INPUT (3)

P.C.B INPUT (7)

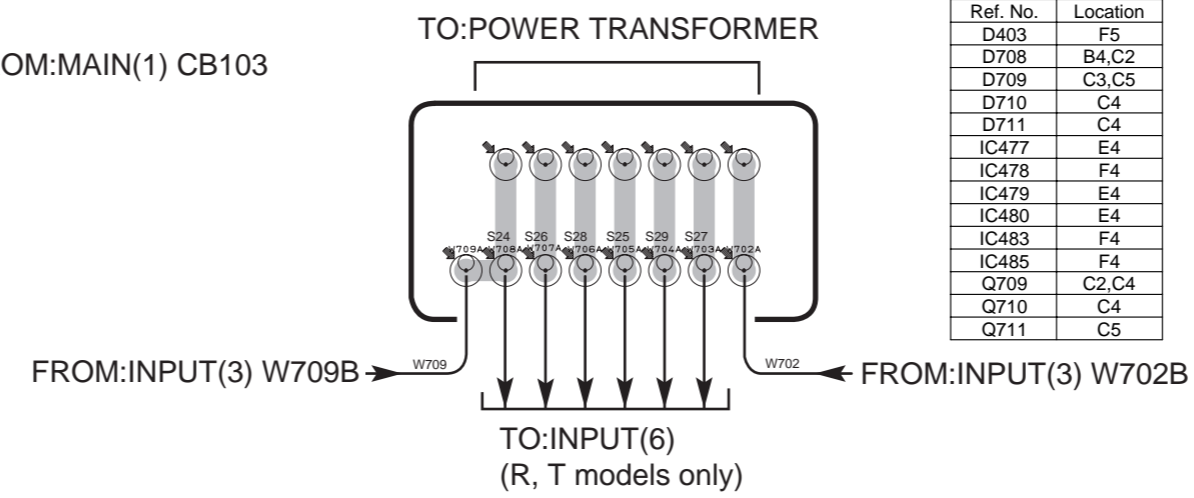

P.C.B INPUT (4)

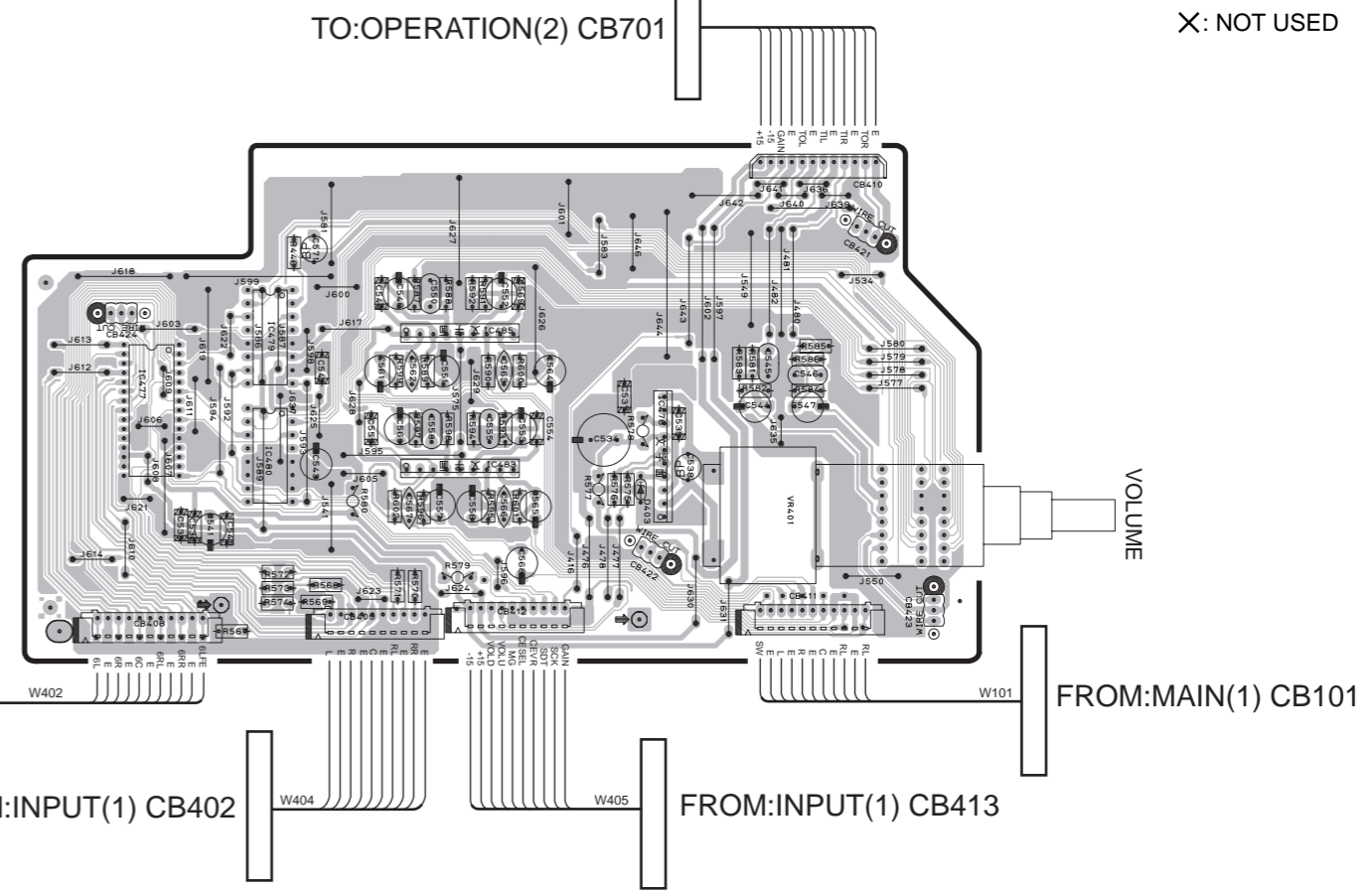

P.C.B INPUT (5)

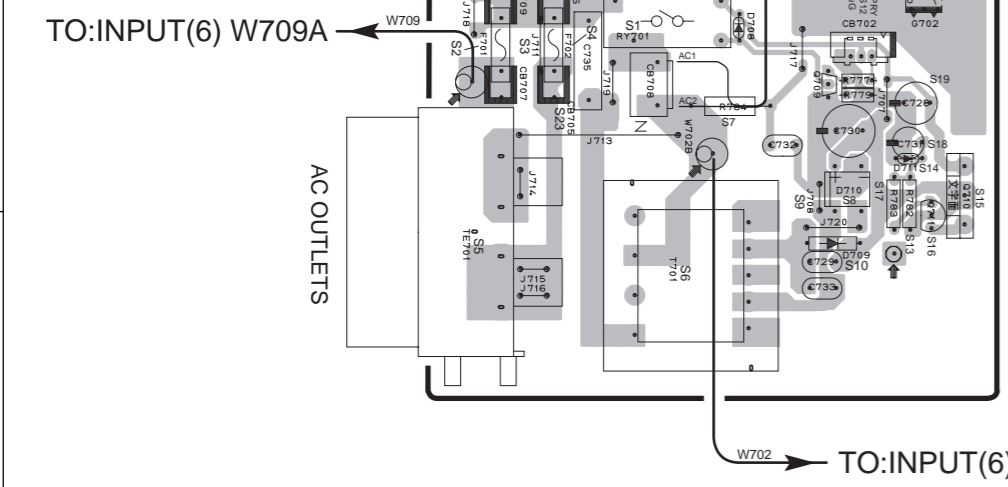
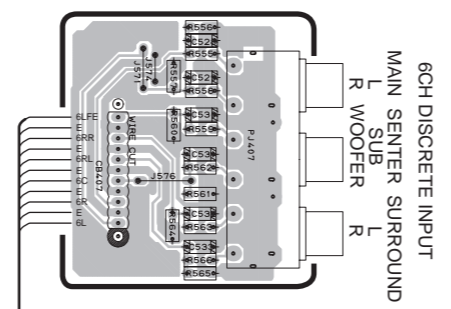

■ RX-V395/RDS PRINTED CIRCUIT BOARD (Foil side)

● U, C, R, T, A, L models

P.C.B TUNER

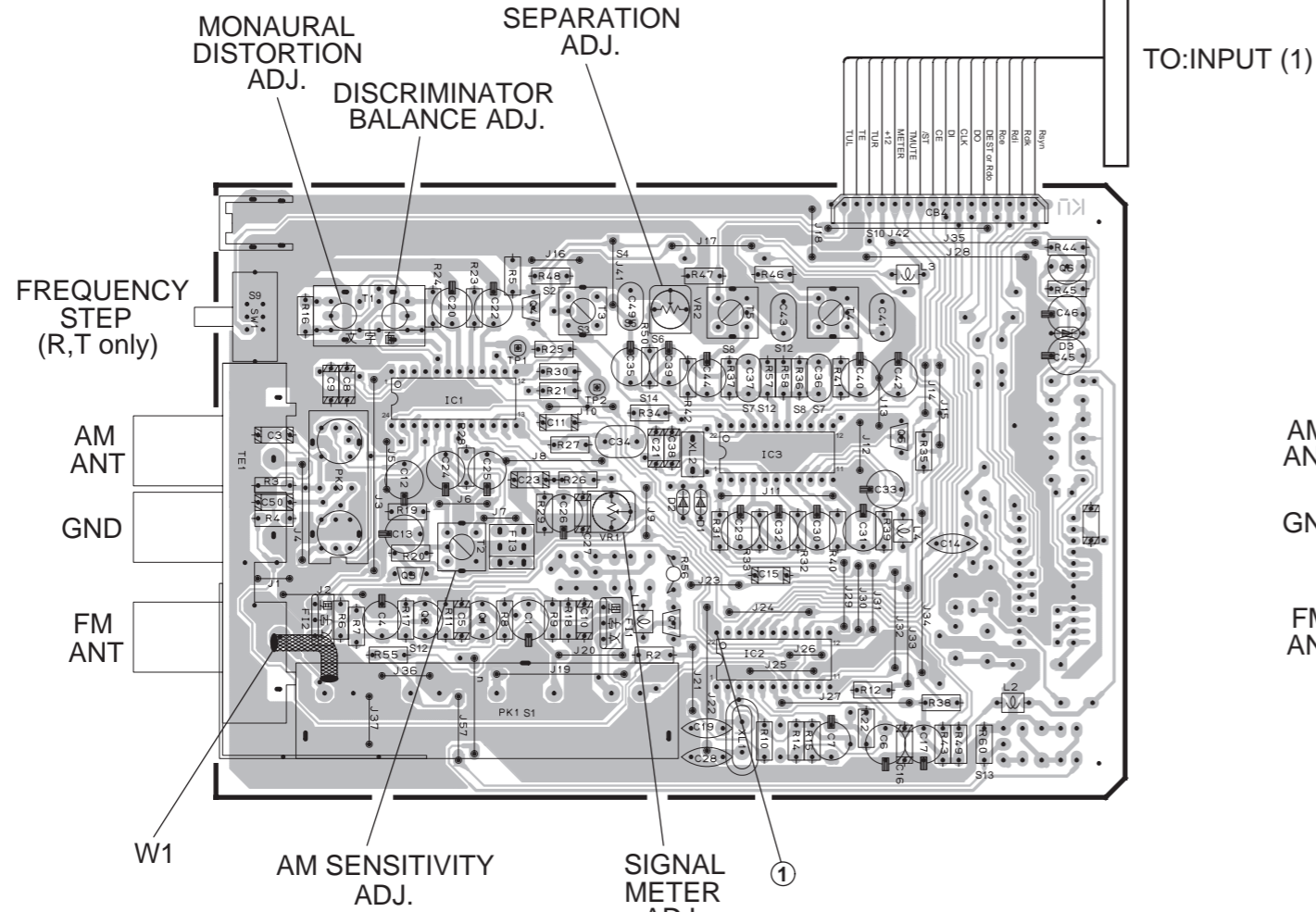

● B, G models

P.C.B TUNER

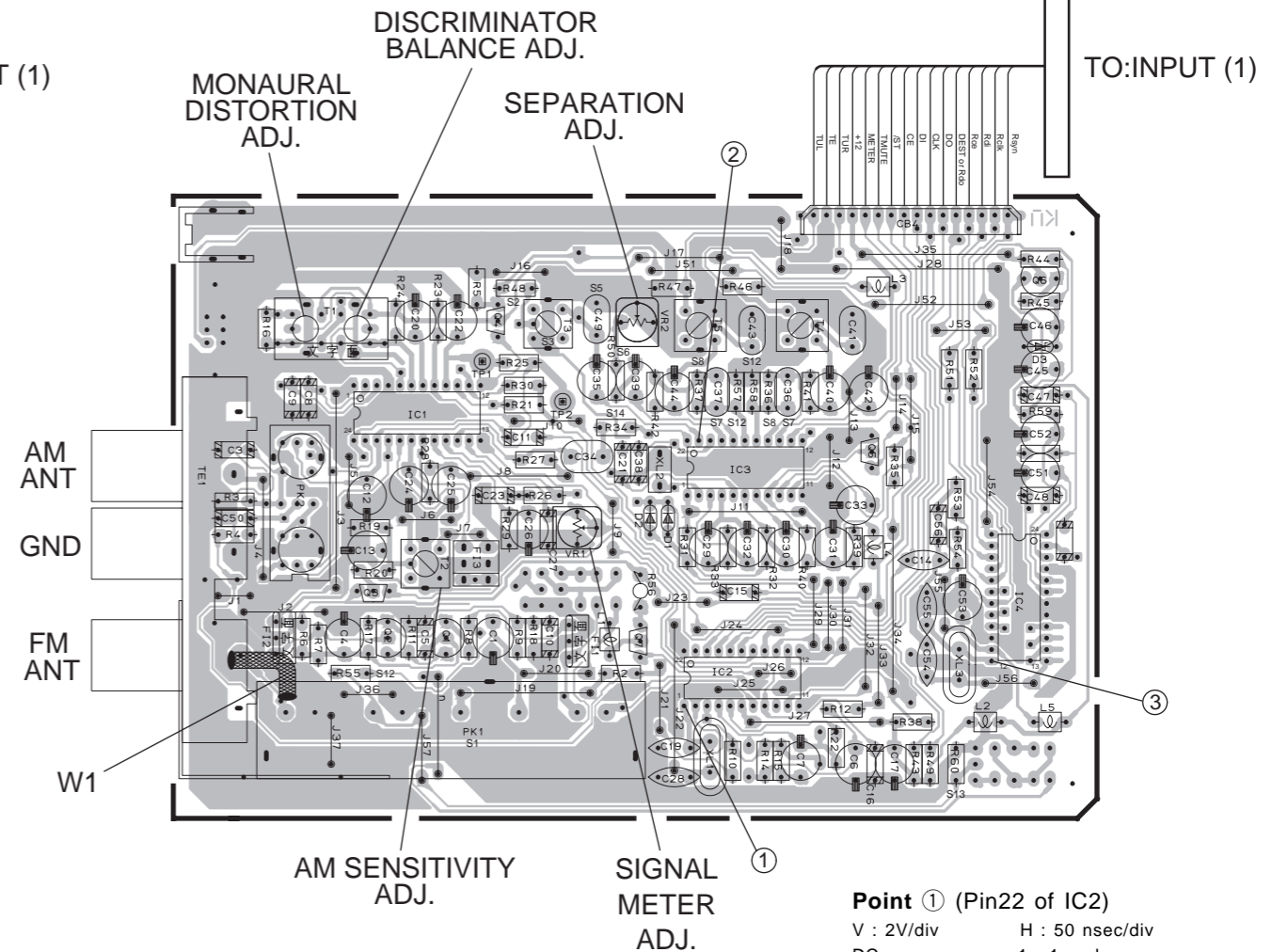

Point ① (Pin22 of IC2)
 V : 2V/div H : 50 nsec/div
 DC range 1 : 1 probe

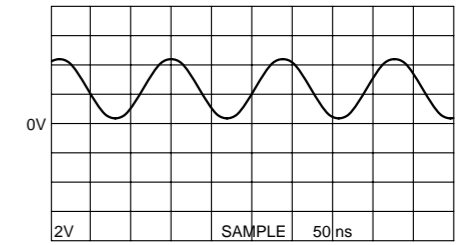

Point ② (Pin21 of IC3)
 V : 2V/div H : 1 μsec/div
 DC range 1 : 1 probe

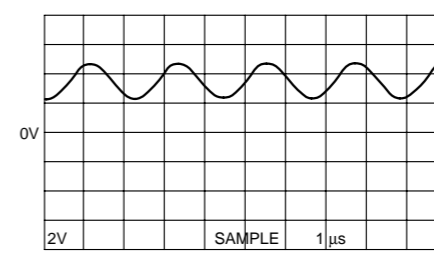

Point ③ (Pin12 of IC4)
 V : 2V/div H : 0.1 μsec/div
 DC range 1 : 1 probe

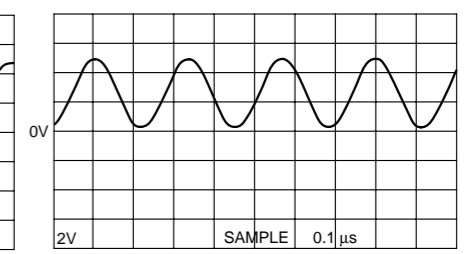

CIRCUIT CHANGES BY MARKET

S	U, C V251860	R, T V251870	A, B, G, L V251880
1	PK1	V290910	V271670
2	R48	X	X 4.7K
3	T3	X	X XYA2 VT48680
4	J41	○	○ X
5	C49	2200P UA95322	2200P UA95322 120P UA95212
6	R50	22K	22K 1K
7	C36-37	1000P UA95310	1000P UA95310 270P UA95227
8	R36-37	75K	75K 180K
9	SW1	X	VS60260 X
10	J42	X	○ X
11			
12	R55-57-58	X	X 270K
13	R60	X	X 180K
14	R34	10K	10K 27K

U, C, R, T, A, L models
 ● Semiconductor Location

Ref. No.	Location
D1	C3
D2	C3
D3	D2
IC1	B2
IC2	C3
IC3	C3
Q1	B3
Q2	B3
Q3	B3
Q4	B2
Q5	C3
Q6	D2
Q7	C3

B, G models
 ● Semiconductor Location

Ref. No.	Location
D1	C3
D2	C3
D3	D3
IC1	B3
IC2	C3
IC3	C3
IC4	D3
Q1	C3
Q2	B3
Q3	B3
Q4	C2
Q5	D3
Q6	D2
Q7	C3

1
2
3
4
5
6

RX-V395/RDS PRINTED CIRCUIT BOARD (Foil side)

● U, C, R, T, A, L models
P.C.B TUNER

● B, G models
P.C.B TUNER

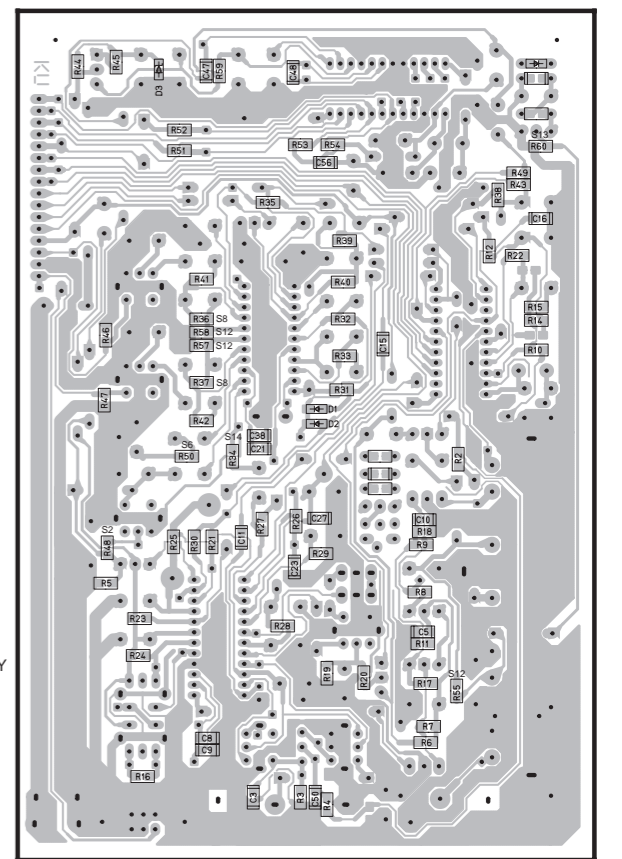
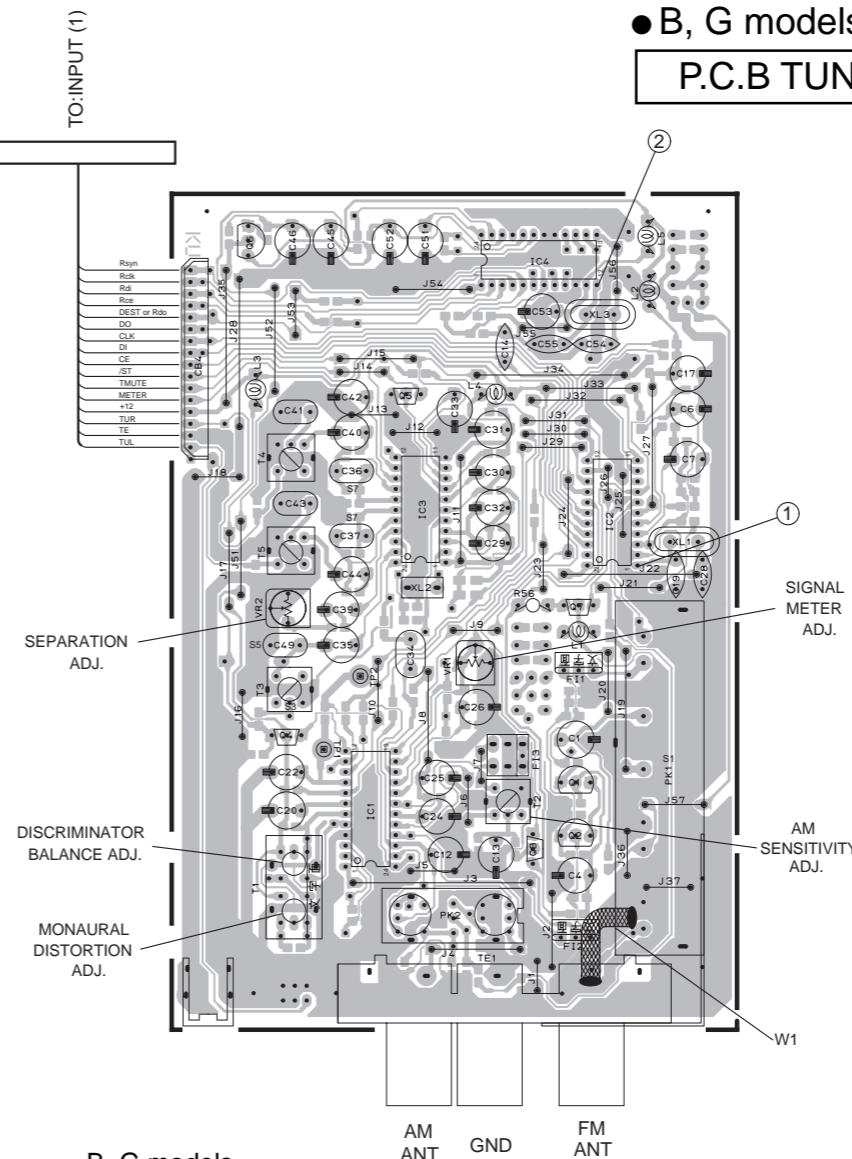
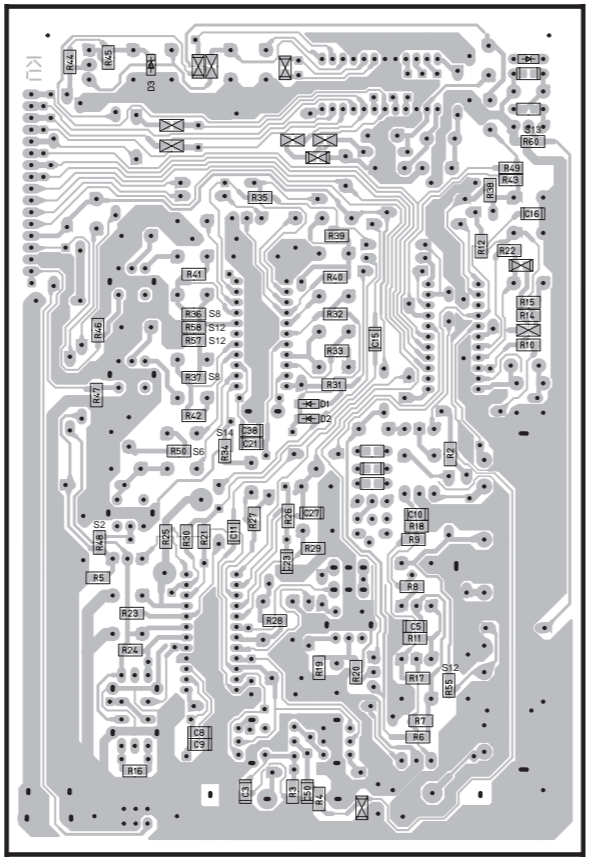
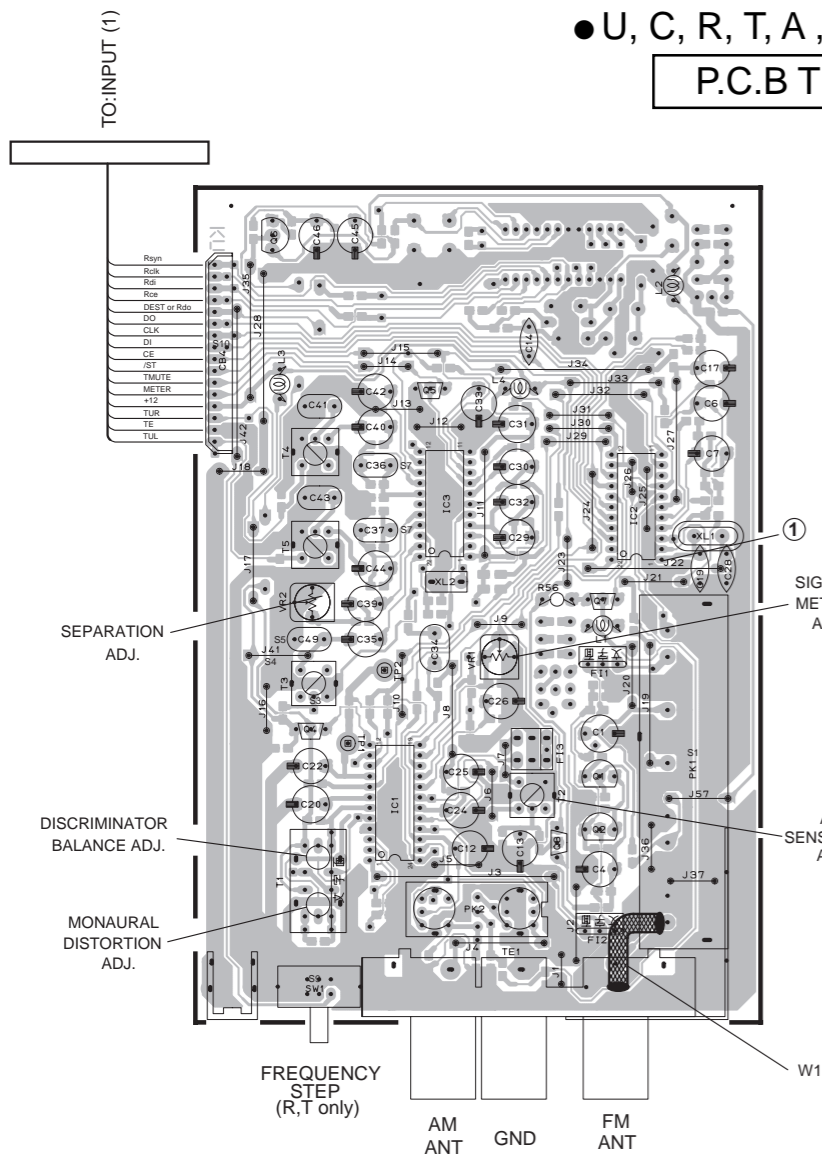

U, C, R, T, A, L models

● Semiconductor Location

Ref. No.	Location
D1	D3
D2	D3
D3	C2
IC1	B3
IC2	B2
IC3	B2
Q1	B3
Q2	B3
Q3	B3
Q4	A3
Q5	B2
Q6	A2
Q7	B3

B, G models

● Semiconductor Location

Ref. No.	Location
D1	H3
D2	H3
D3	G2
IC1	F3
IC2	F2
IC3	F2
IC4	F2
Q1	F3
Q2	F3
Q3	F3
Q4	E3
Q5	F2
Q6	E2
Q7	F3

Point ① (Pin22 of IC2)

V : 2V/div H : 50 nsec/div
 DC range 1 : 1 probe

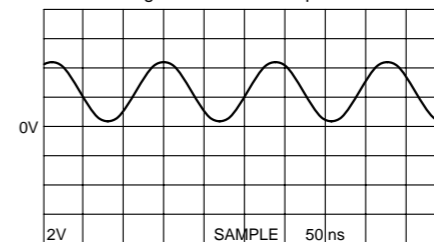

Point ② (Pin12 of IC4)

V : 2V/div H : 0.1 μsec/div
 DC range 1 : 1 probe

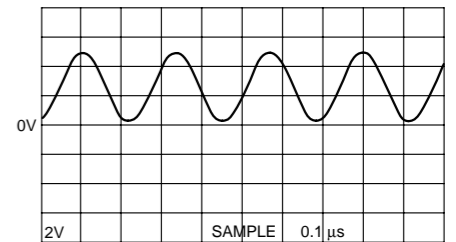

RX-V395/RDS PRINTED CIRCUIT BOARD (Foil side)

P.C.B OPERATION (1)

P.C.B OPERATION (3)

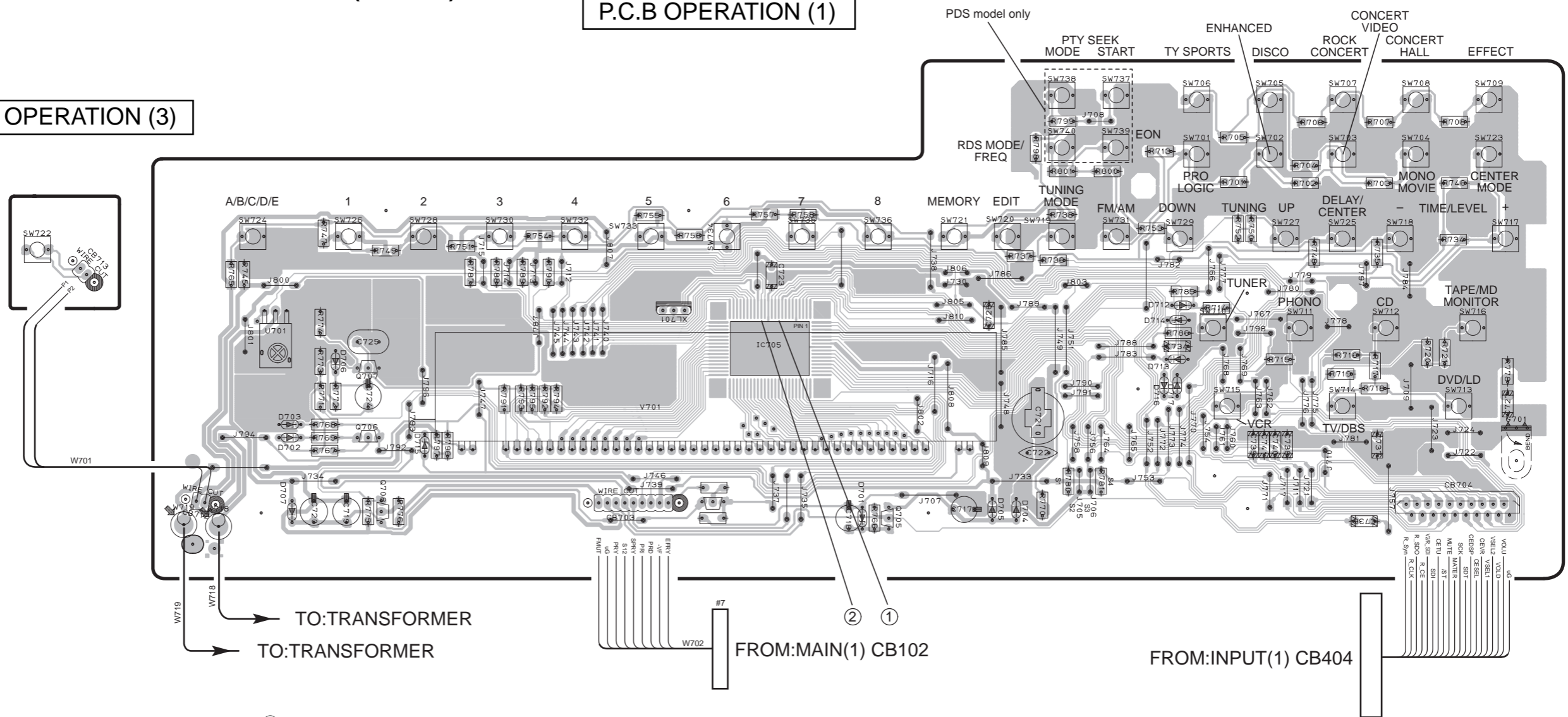

Point ①
 CH1 : Pin 10 of IC705 V : 2V/div CH1
 CH2 : Emitter of Q705 V : 2V/div CH2
 H: 0.5sec/div DC range 1 : 1 probe

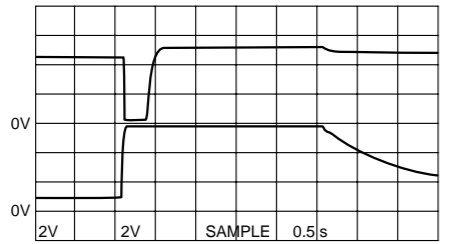

Point ② (Pin15 of IC705)
 V : 2V/div H : 0.1 μsec/div
 DC range 1 : 1 probe

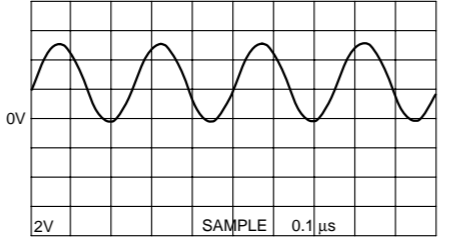

↑ With the power switch turned ON, connect the power cord to the AC outlet

↑ Disconnect the power cord from the AC outlet

[This waveform is not available by pushing the power switch ON and OFF.]

● Semiconductor Location

Ref. No.	Location
D701	D3
D702	B3
D703	B3
D704	E3
D705	E3
D706	B2
D707	B3
D712	E2,F5
D713	E2,F5
D714	E2,F5
D715	B3
D716	E3,F5
D717	E3,F5
D721	F5
D722	F5
D723	F5
IC705	D2
Q705	D3
Q706	B3
Q707	B3
Q708	B3

CIRCUIT CHANGES BY MARKET

		U. C	R. T	A. B. G
s1	R780	X	100K	100K
s2	J705	0	X	X
s3	R781	100K	100K	X
s4	J706	X	X	0

○ : USED
 X : NOT USED

- Up to 18,500
- R801 2.2kΩ
- R802 4.7kΩ
- R803 4.7kΩ
- C801 1000PF 50V
- D721 RB4 410-10
- D722 ISS133
- D723 ISS133

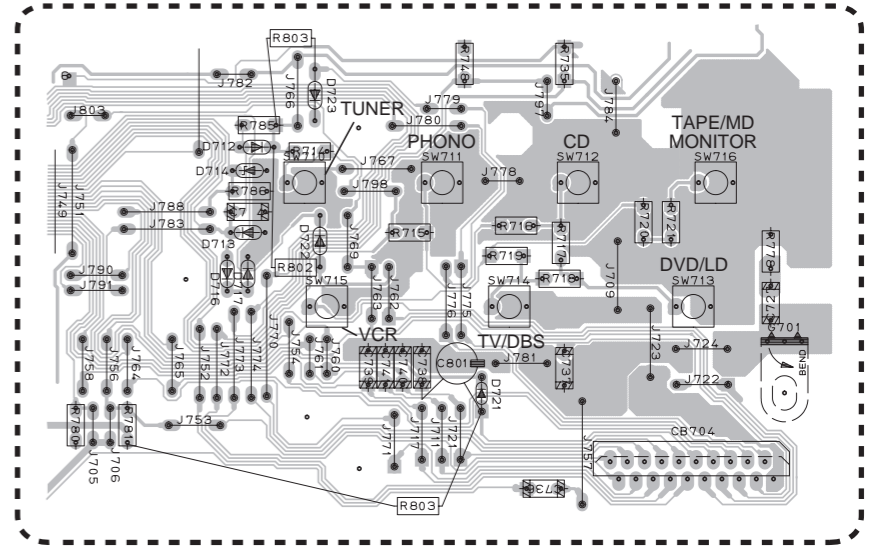

RX-V395/RDS PRINTED CIRCUIT BOARD (Foil side)

P.C.B OPERATION (2)

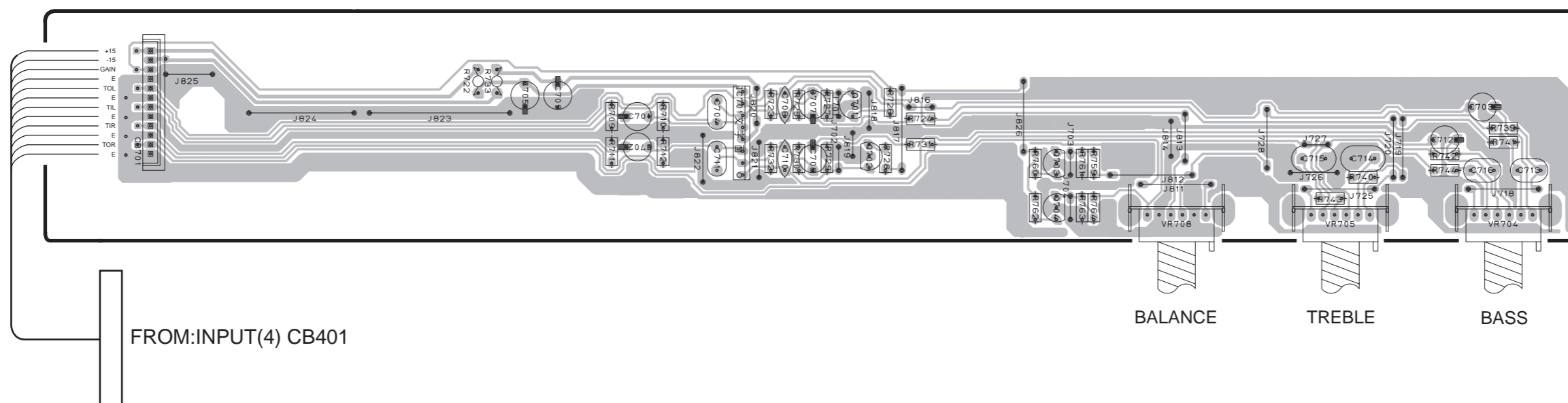

● Semiconductor Location

Ref. No.	Location
IC701	D3
Q701	E3
Q702	E3
Q703	E3
Q704	E3

BLOCK DIAGRAM

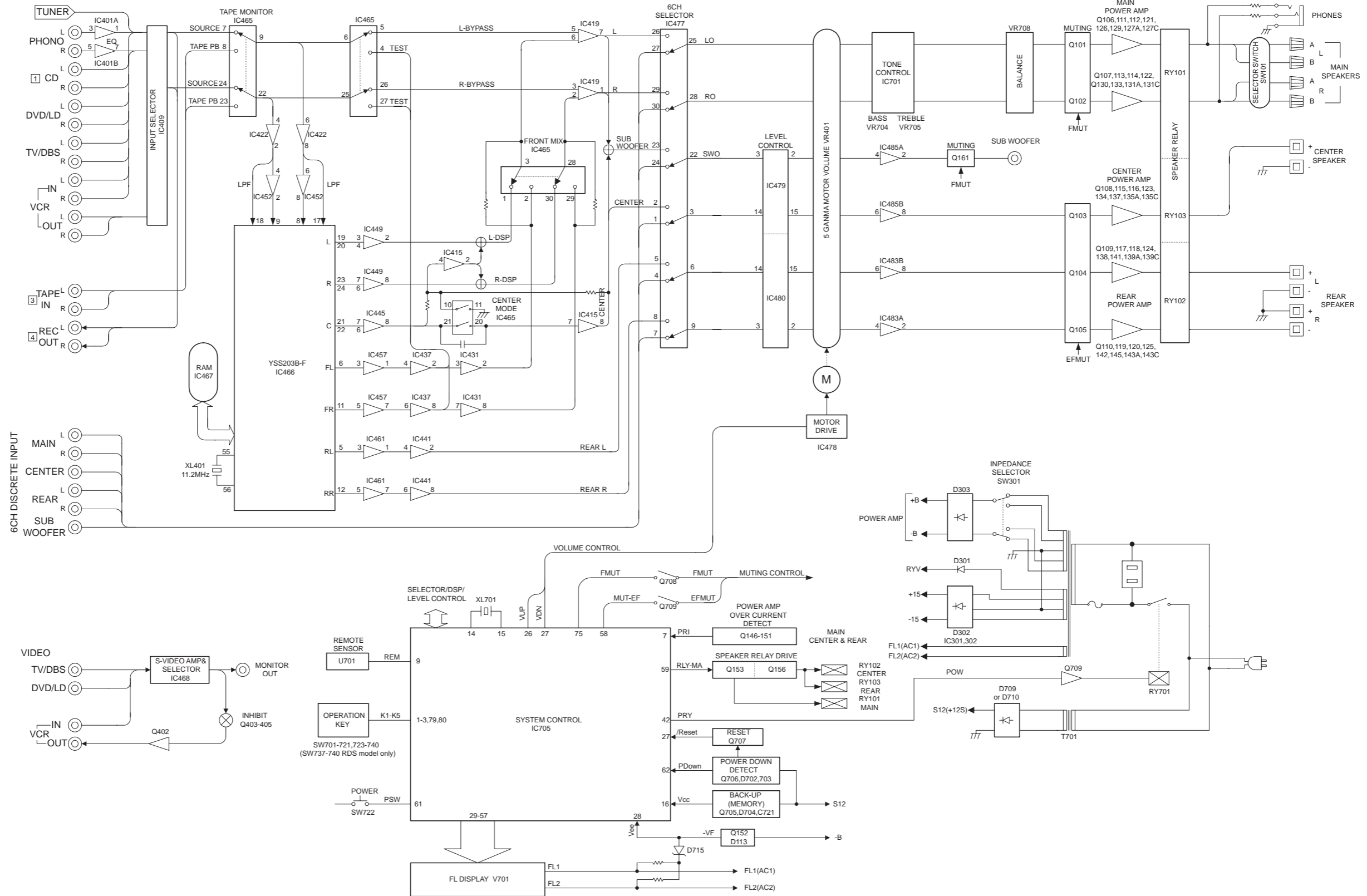

■ BLOCK DIAGRAM

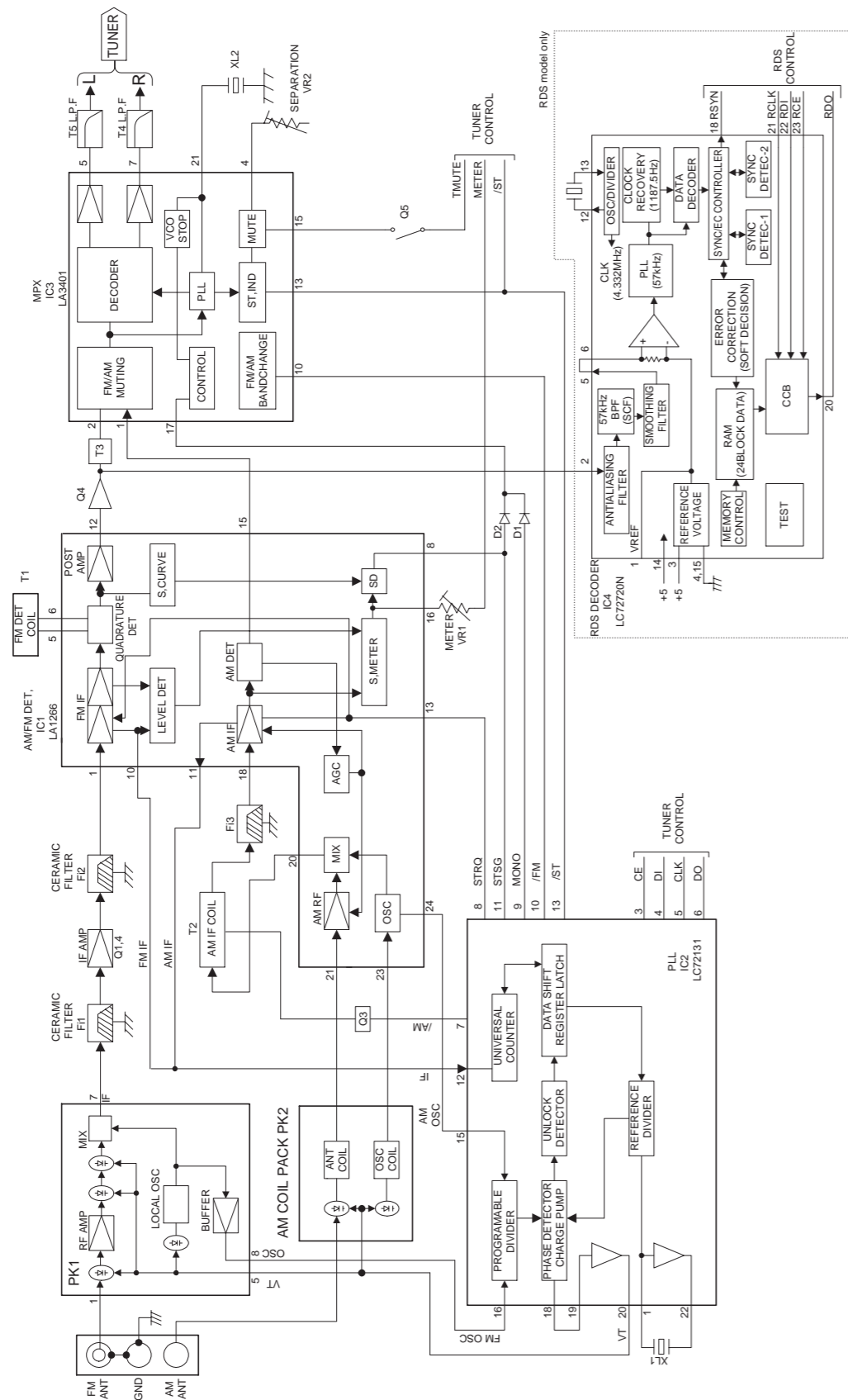

■ PIN CONNECTION DIAGRAM

● ICs

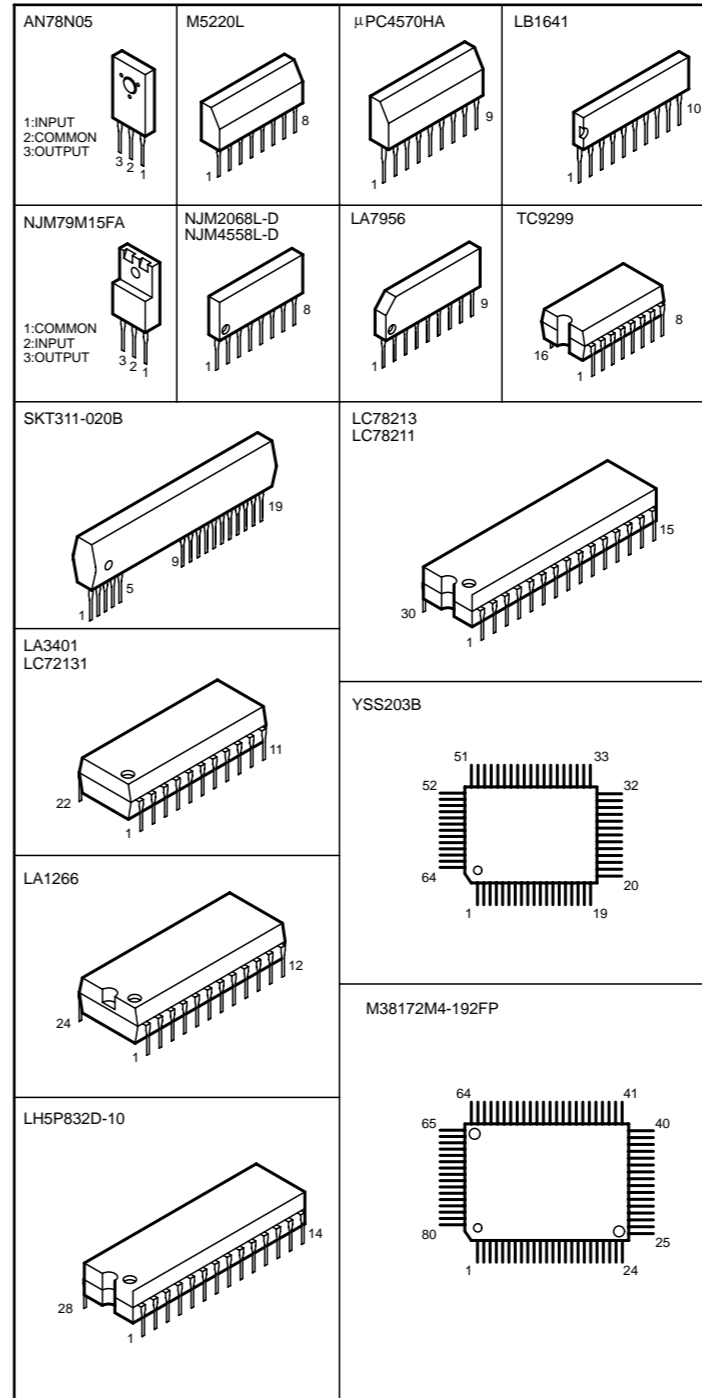

● Diodes

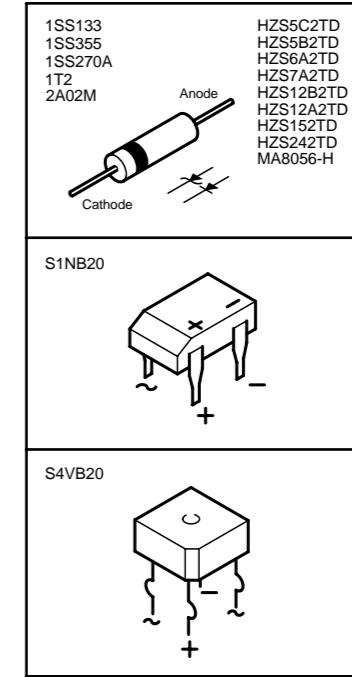

● Transistors

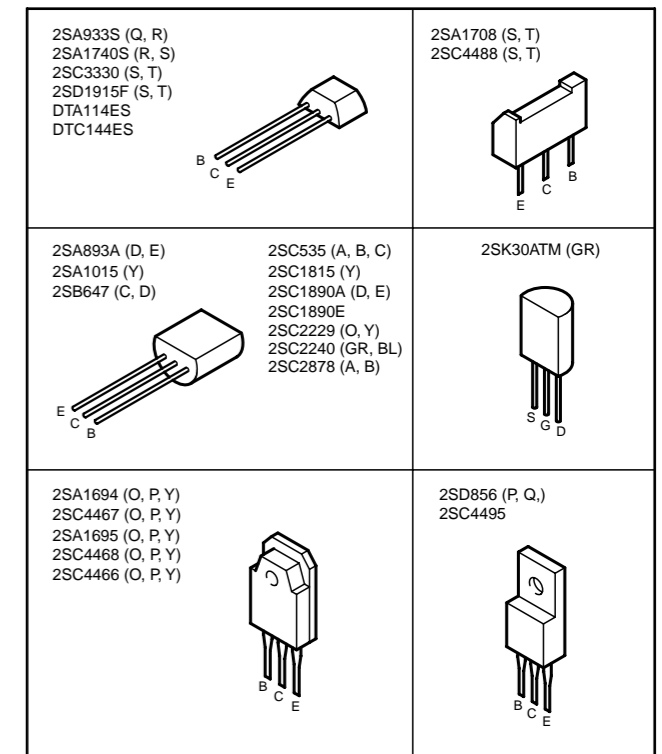

RX-V395/RDS SCHEMATIC DIAGRAM (TUNER)

Each voltage given here represents that in the FM (98.1MHz, STEREO) reception mode but the one in the parentheses () is measured in the AM (1080kHz, MAN'L) reception mode.

VT

87.5MHz	1.7V
98.1MHz	4.1V
108.0MHz	8.3V
531KHz	1.4V
1080KHz	5.1V
1611KHz	7.4V

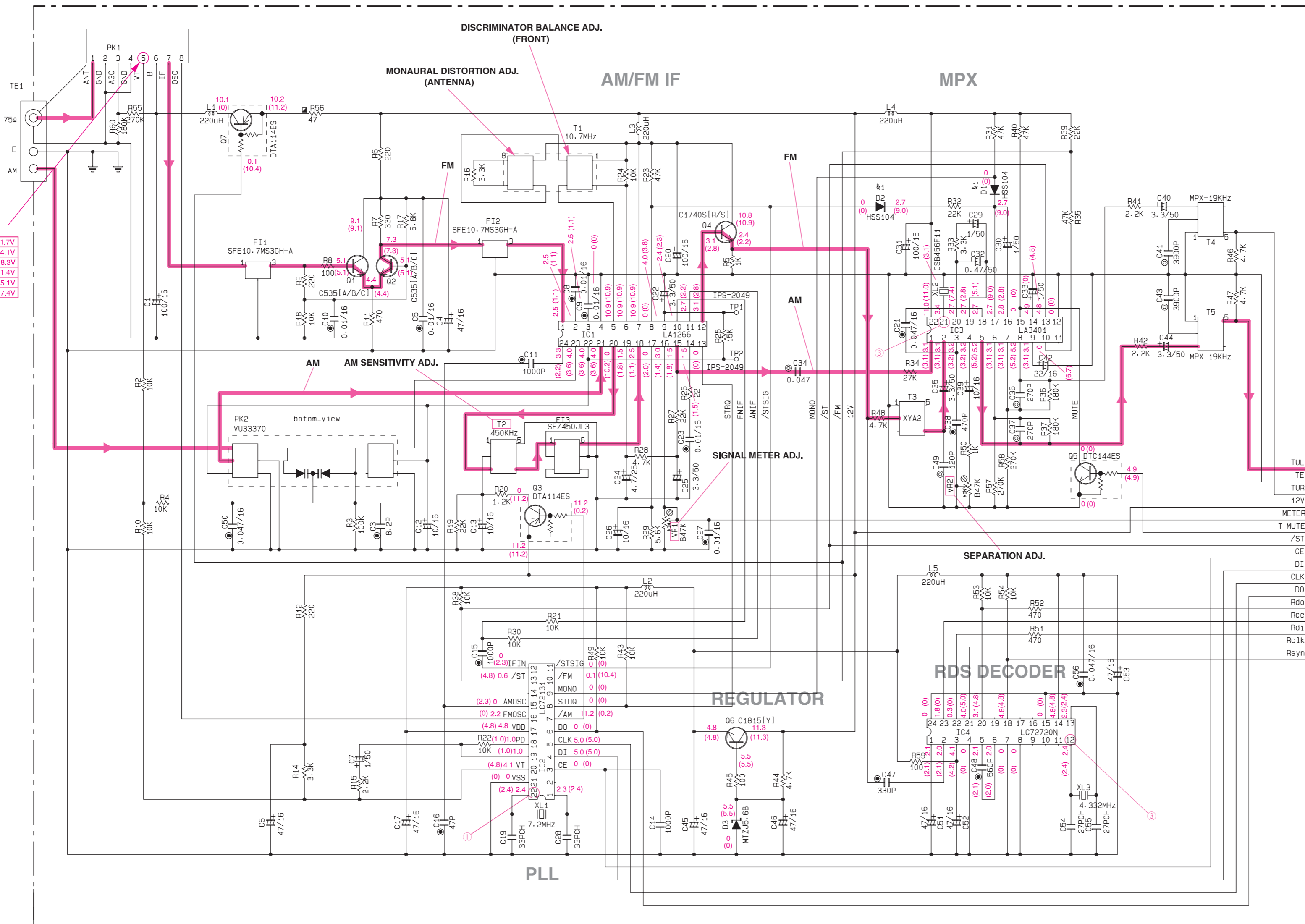

CAPACITOR

REMARKS	PARTS NAME	
NO MARK	ELECTROLYTIC CAPACITOR	ZZ
⊗	TANTALUM CAPACITOR	
NO MARK	CERAMIC CAPACITOR	
⊙	CERAMIC TUBULAR CAPACITOR	
⊖	POLYESTER FILM CAPACITOR	
⊙	POLYSTYRENE FILM CAPACITOR	11
⊖	MICA CAPACITOR	
⊖	POLYPROPYLENE FILM CAPACITOR	
⊖	SEMICONDUCTIVE CERAMIC CAPACITOR	

RESISTOR

REMARKS	PARTS NAME
NO MARK	CARBON FILM RESISTOR (P=5)
□	CARBON FILM RESISTOR (P=10)
△	METAL OXIDE FILM RESISTOR
△	METAL FILM RESISTOR
△	METAL PLATE RESISTOR
⊖	FIRE PROOF CARBON FILM RESISTOR
⊖	CEMENT MOLDED RESISTOR
⊖	SEMI VARIABLE RESISTOR
⊖	CHIP RESISTOR

NOTICE (model)
 (J)..... JAPANESE
 (U)..... U.S.A
 (C)..... CANADIAN
 (R)..... GENERAL
 (A)..... AUSTRALIAN
 (B)..... BRITISH
 (G)..... EUROPEAN
 (T)..... CHINA
 (L)..... SINGAPORE

Interchangeable Parts at Manufacture-Stage

Mark	Reference Parts Number	Parts Name
⋈1	D1.2	HSS104 1SS133 1SS176

• PK1 : ENV-172C8G1R (V2909100) U, C, R, T models

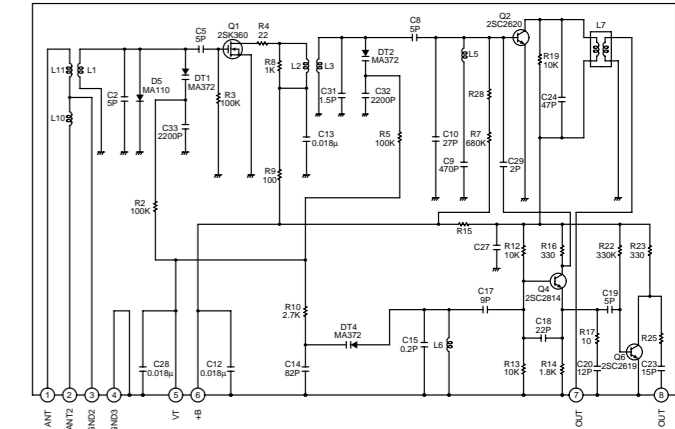

• PK1 : ENV-172A4G1 (V2716700) A, L models

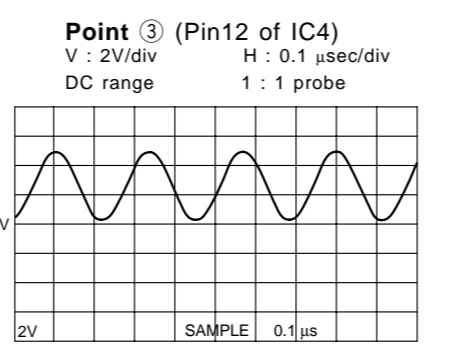
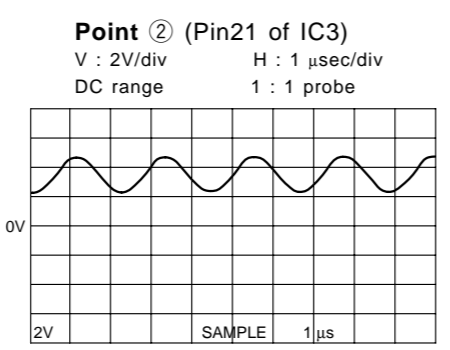
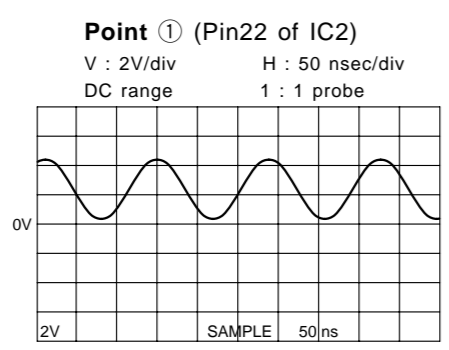
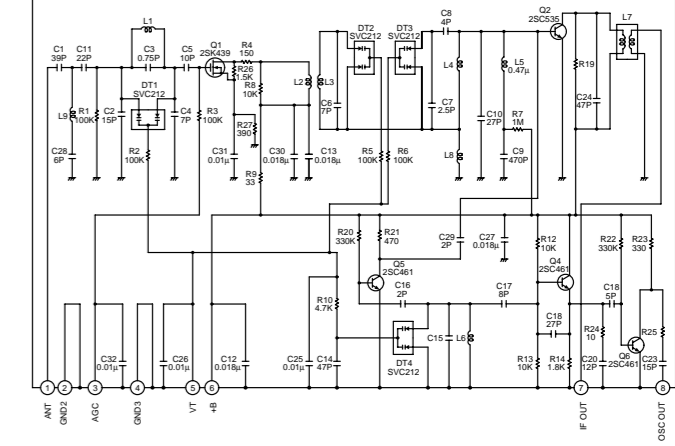

* All voltage are measured with a 10MΩ/DC electric volt meter.
 * Components having special characteristics are marked △ and must be replaced with parts having specifications equal to those originally installed.
 * Schematic diagram is subject to change without notice.

RX-V395/RDS SCHEMATIC DIAGRAM (TUNER)

Each voltage given here represents that in the FM (98.1MHz, STEREO) reception mode but the one in the parentheses () is measured in the AM (1080kHz, MAN'L) reception mode.

CAPACITOR	
REMARKS	PARTS NAME
NO MARK	ELECTROLYTIC CAPACITOR
⊗	TANTALUM CAPACITOR
NO MARK	CERAMIC CAPACITOR
⊙	CERAMIC TUBULAR CAPACITOR
⊖	POLYESTER FILM CAPACITOR
○	POLYSTYRENE FILM CAPACITOR
⊕	MICA CAPACITOR
⊖	POLYPROPYLENE FILM CAPACITOR
⊙	SEMICONDUCTIVE CERAMIC CAPACITOR

RESISTOR	
REMARKS	PARTS NAME
NO MARK	CARBON FILM RESISTOR (P=5)
⊠	CARBON FILM RESISTOR (P=10)
△	METAL OXIDE FILM RESISTOR
⊠	METAL FILM RESISTOR
⊠	METAL PLATE RESISTOR
⊠	FIRE PROOF CARBON FILM RESISTOR
⊠	CEMENT MOLDED RESISTOR
⊠	SEMI VARIABLE RESISTOR
⊠	CHIP RESISTOR

NOTICE (mode1)
 (J)..... JAPANESE
 (U)..... U. S. A
 (C)..... CANADIAN
 (R)..... GENERAL
 (A)..... AUSTRALIAN
 (B)..... BRITISH
 (G)..... EUROPEAN
 (T)..... CHINA
 (L)..... SINGAPORE

Interchangeable Parts at Manufacture-Stage

Mark	Reference Parts Number	Parts Name
⊠	D1.2	HSS104 1SS133 1SS176

S	U-C V251860	R-T V251870	A-B-G-L V251880
1	PK1	V290910	V271670
2	R48	X	X
3	T3	X	X
4	J41	○	○
5	C49	2200P UA95322	120P UA95212
6	R50	22K	22K
7	C36-37	1000P UA95310	1000P UA95310
8	R36-37	75K	75K
9	SW1	X	VS60260
10	J42	X	○
11			
12	R55-57-58	X	X
13	R60	X	X
14	R34	10K	10K

○ : USED
 X : NOT USED

VT	V
FM	87.5MHz 1.9V
FM	98.0MHz 4.5V
FM	108.0MHz 7.8V
AM	531KHz 1.3V
AM	1080KHz 5.0V
AM	1611KHz 7.3V

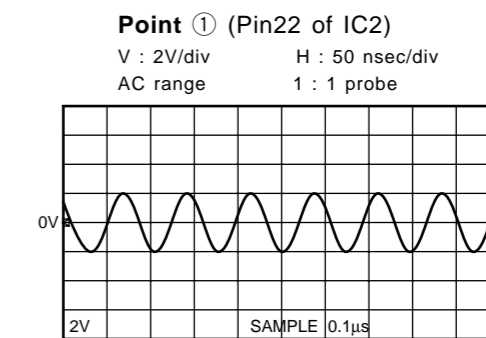
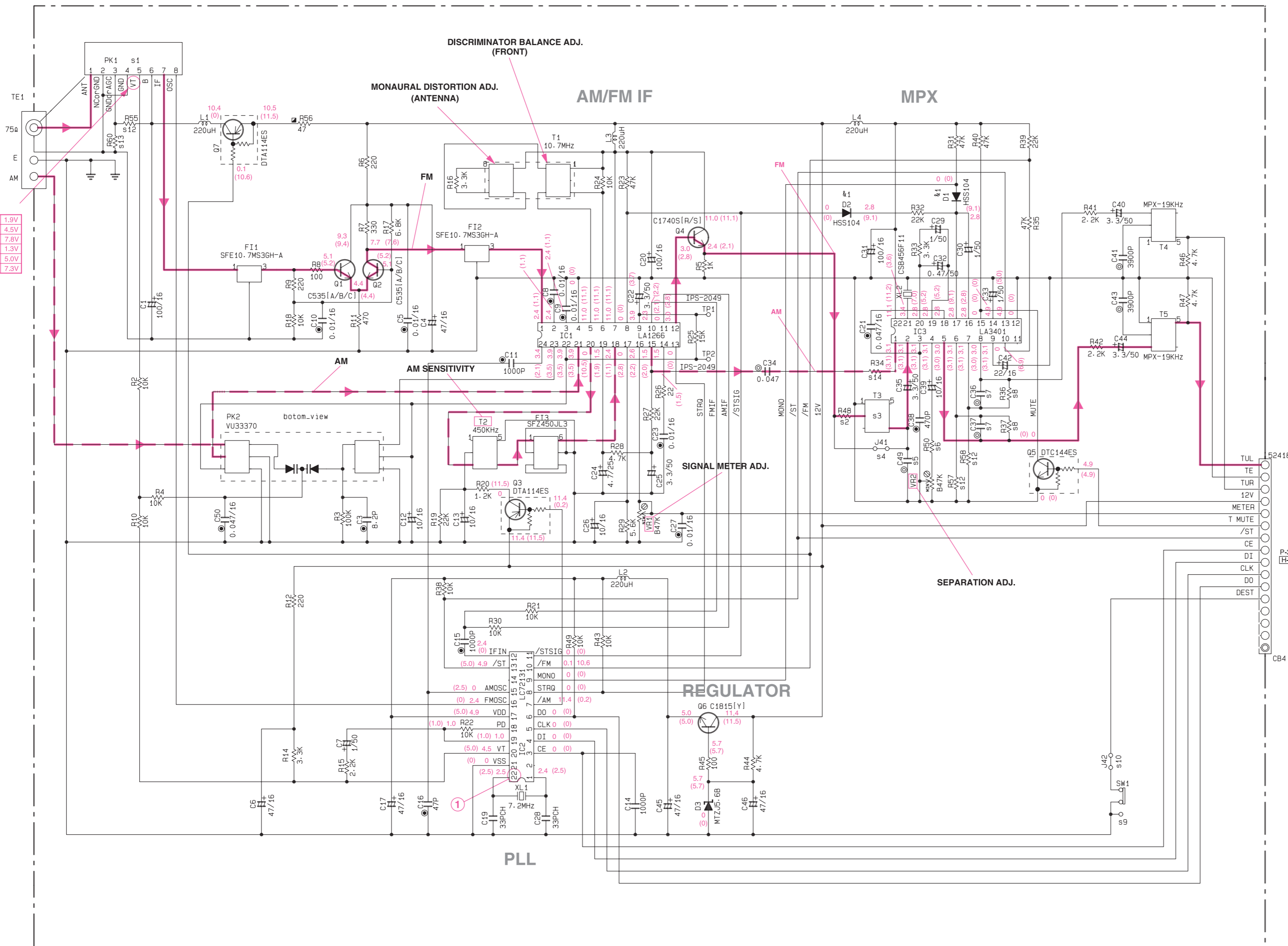

PK1 : ENV-172C8G1R (V2909100) U, C, R, T models

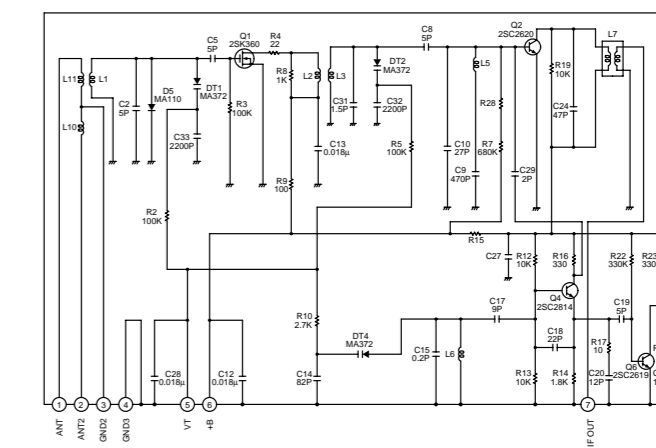

PK1 : ENV-172A4G1 (V2716700) A, L models

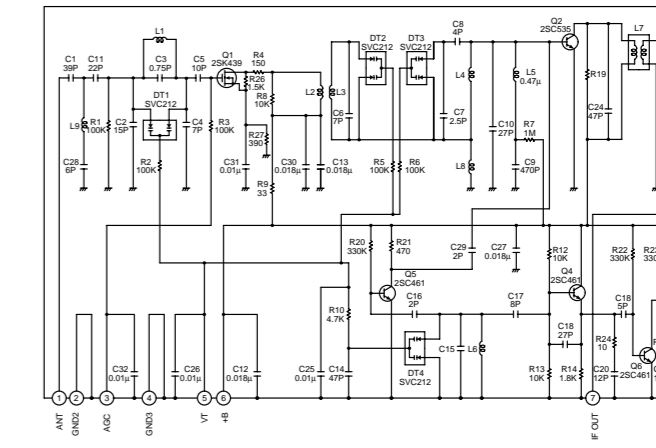

* All voltage are measured with a 10MΩ/DC electric volt meter.
 * Components having special characteristics are marked △ and must be replaced with parts having specifications equal to those originally installed.
 * Schematic diagram is subject to change without notice.

RX-V395/RDS SCHEMATIC DIAGRAM (MAIN)

Each voltage given here represents that in the FM (98.1MHz, STEREO) reception mode but the one in the parentheses () is measured in the AM (1080kHz, MAN'L) reception mode.

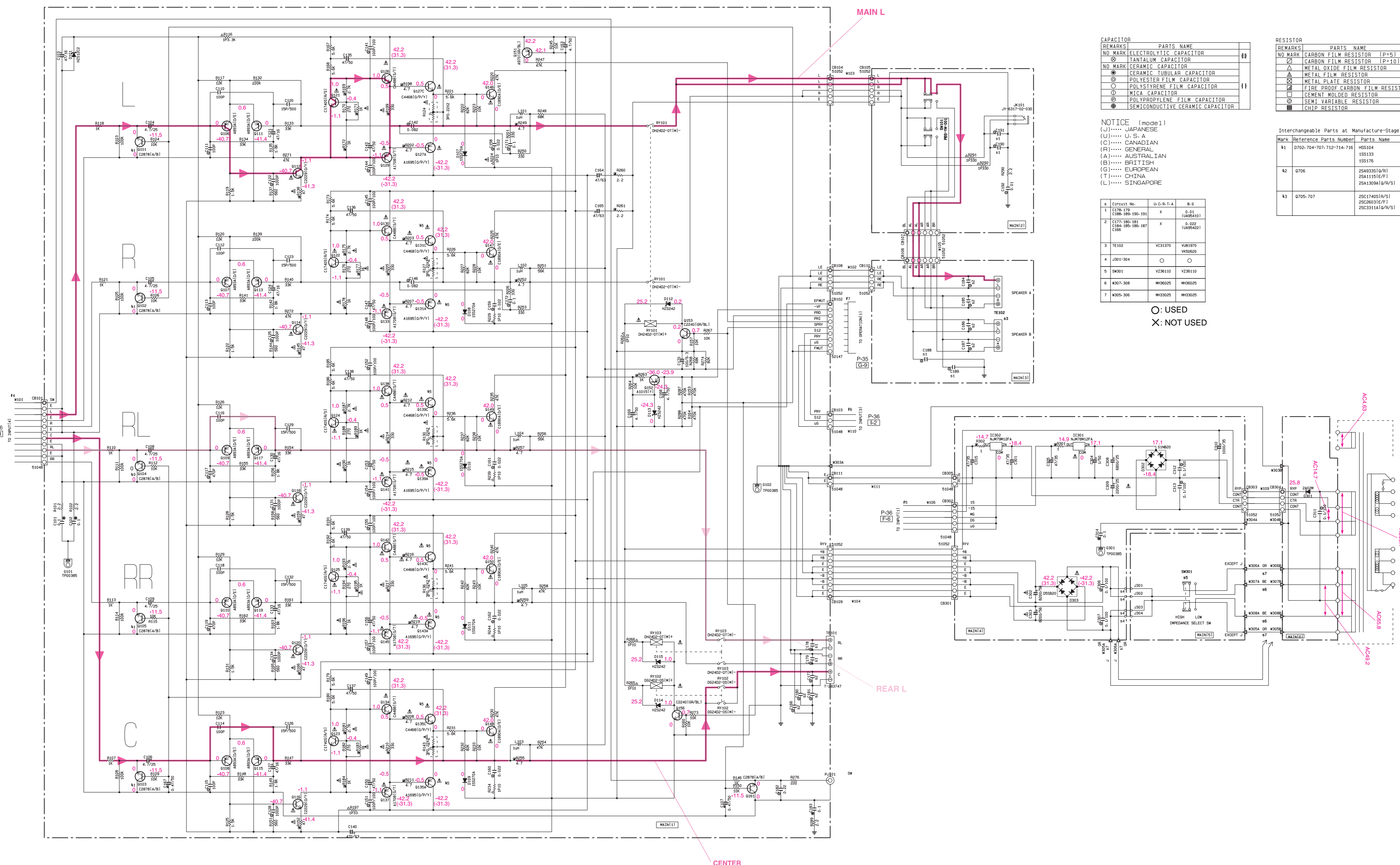

REMARKS	PARTS NAME	UNIT
NO MARK	ELECTROLYTIC CAPACITOR	μF
⊗	TANTALUM CAPACITOR	μF
NO MARK	CERAMIC CAPACITOR	PF
⊙	CERAMIC TUBULAR CAPACITOR	PF
⊖	POLYESTER FILM CAPACITOR	PF
○	POLYSTYRENE FILM CAPACITOR	PF
○	MICA CAPACITOR	PF
⊖	POLYPROPYLENE FILM CAPACITOR	PF
⊖	SEMICONDUCTIVE CERAMIC CAPACITOR	PF

REMARKS	PARTS NAME	UNIT
NO MARK	CARBON FILM RESISTOR (P=5)	Ω
⊗	CARBON FILM RESISTOR (P=10)	Ω
△	METAL OXIDE FILM RESISTOR	Ω
△	METAL PLATE RESISTOR	Ω
⊖	METAL FILM RESISTOR	Ω
⊖	FIRE PROOF CARBON FILM RESISTOR	Ω
⊖	CEMENT WOLDED RESISTOR	Ω
⊖	SEMI VARIABLE RESISTOR	Ω
■	CHIP RESISTOR	Ω

NOTICE (mode1)
 (J)..... JAPANESE
 (U)..... U.S.A
 (C)..... CANADIAN
 (R)..... GENERAL
 (A)..... AUSTRALIAN
 (B)..... BRITISH
 (G)..... EUROPEAN
 (T)..... CHINA
 (L)..... SINGAPORE

8	Circuit No.	U.C.R.T.A	B-G
1	C118-119 C184-189-190-191	X	0.01 (UAS641)
2	C177-180-181 C185-186-187 C188	X	0.02 (UAS642)
3	TE102	VC31370	VR1970 W56620
4	J301-304	○	○
5	SW301	VZ36110	VZ36110
6	M307-308	MH36025	MH36025
7	M305-306	MH33025	MH33025

Mark	Reference Parts Number	Parts Name
41	0702-704-707-712-714-716	HSS104 ISS133 ISS176
42	0706	2SA9336(I/R) 2SA1115(E/P) 2SA1309A(I/R/S)
43	0705-707	2SC17405(I/R/S) 2SC2603(E/P) 2SC3314(I/R/P/S)

○: USED
 X: NOT USED

* All voltage are measured with a 10MΩ/DC electric volt meter.
 * Components having special characteristics are marked △ and must be replaced with parts having specifications equal to those originally installed.
 * Schematic diagram is subject to change without notice.

■ RX-V395/RDS SCHEMATIC DIAGRAM (OPERATION)

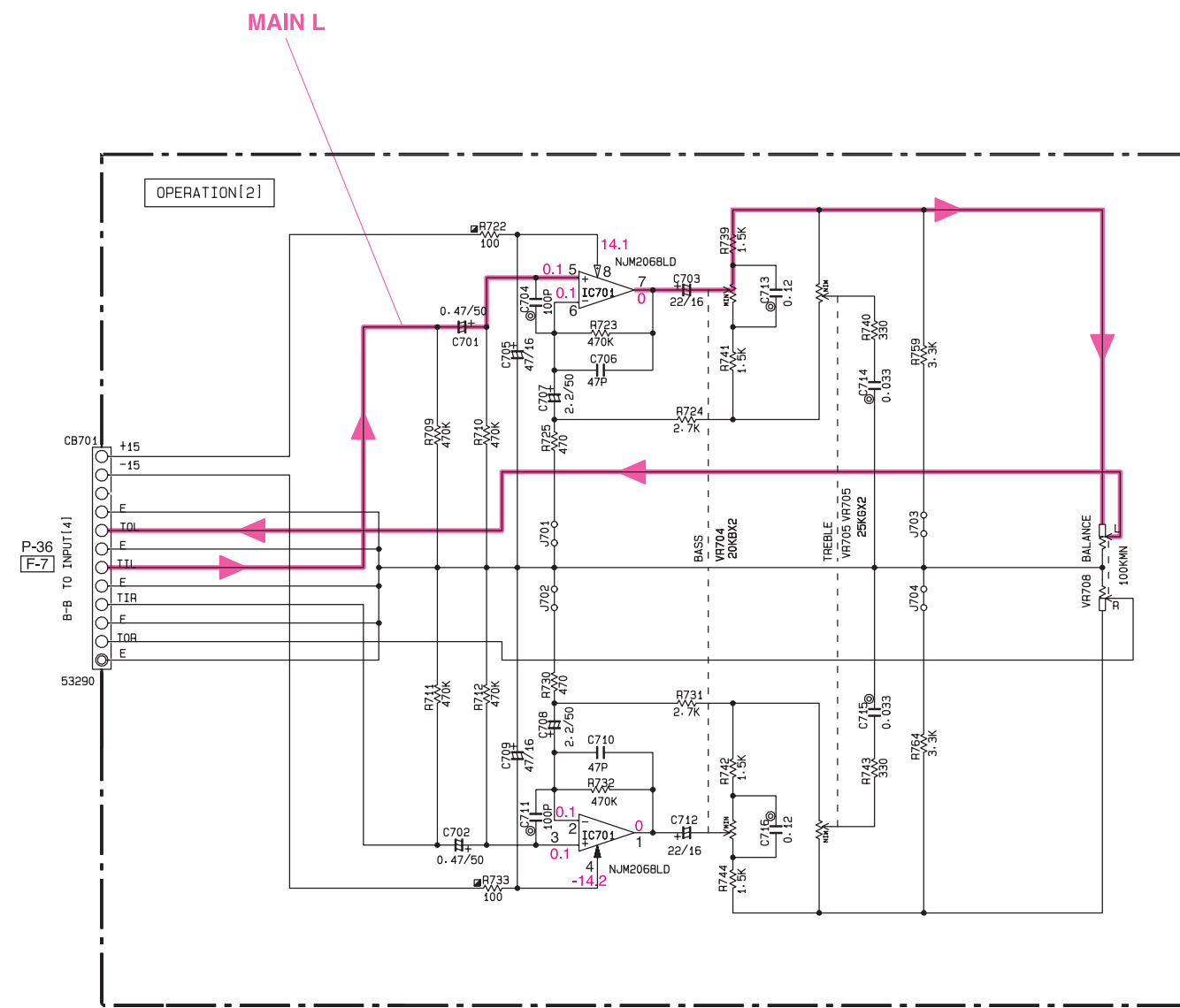

IC701 : NJM2068L-D
Dual OP-Amp

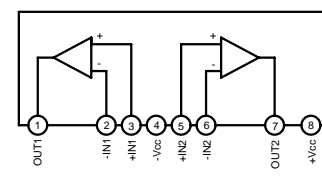

Point ①
[CH1 : Pin 10 of IC705
CH2 : Emitter of Q705]
V : 2V/div CH1
V : 2V/div CH2
H : 0.5sec/div DC range 1 : 1 probe

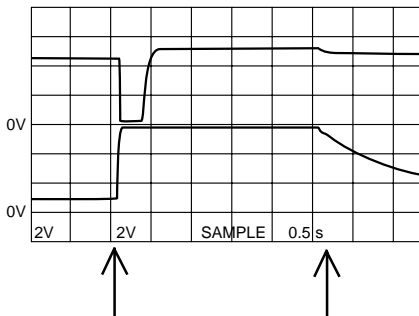

Point ② (Pin15 of IC705)
V : 2V/div H : 0.1µsec/div
DC range 1 : 1 probe

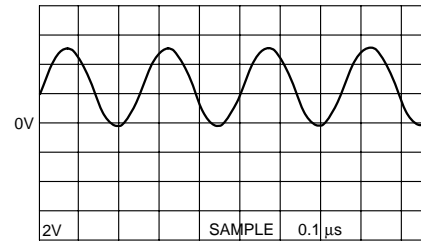

With the power switch turned ON, connect the power cord to the AC outlet

Disconnect the power cord from the AC outlet

[This waveform is not available by pushing the power switch ON and OFF.]

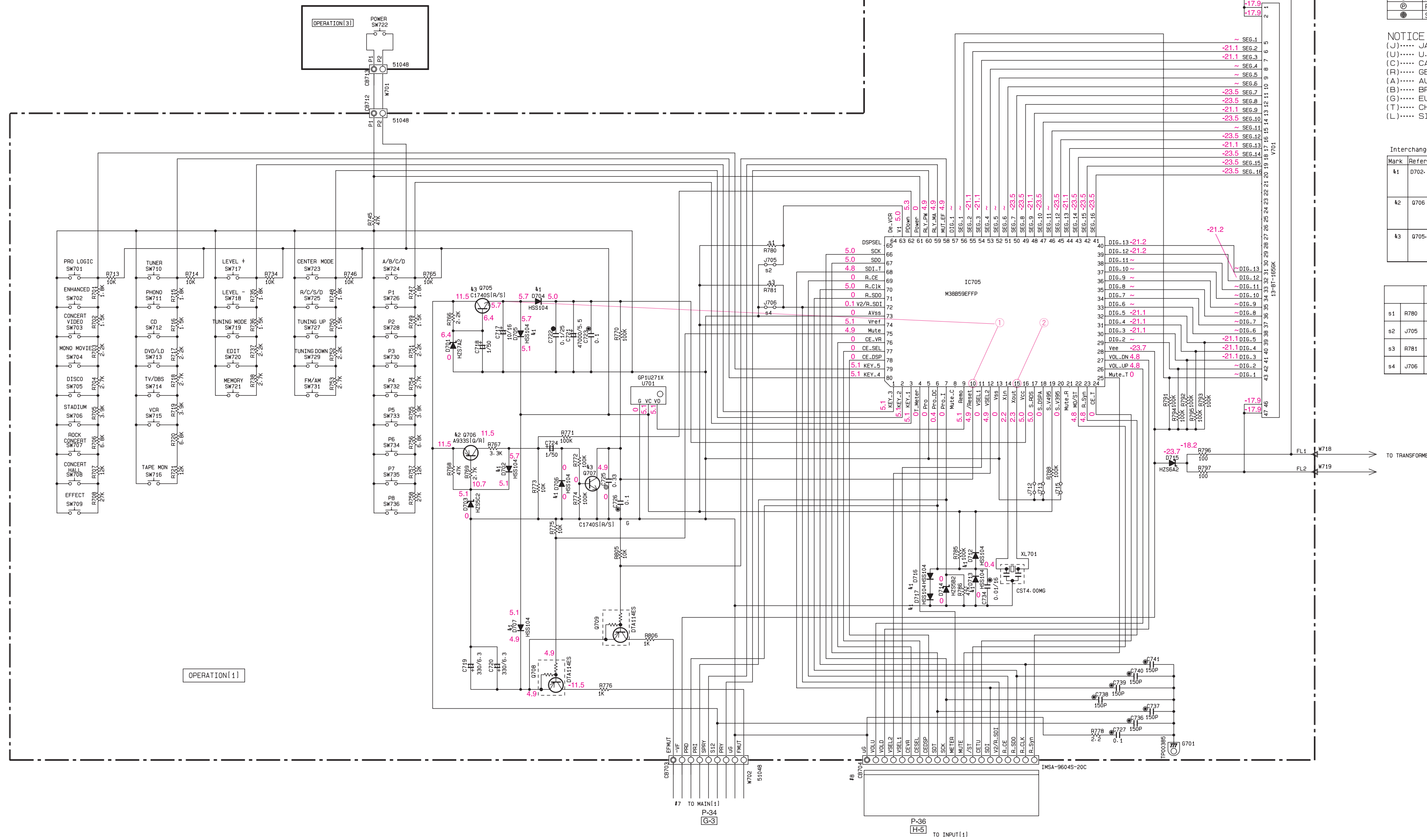

REMARKS	PARTS NAME
NO MARK	CARBON FILM RESISTOR (P=5)
□	CARBON FILM RESISTOR (P=10)
△	METAL OXIDE FILM RESISTOR
▲	METAL FILM RESISTOR
⊠	METAL PLATE RESISTOR
■	FINE PROOF CARBON FILM RESISTOR
⊞	CEMENT MOLDED RESISTOR
⊙	SEMI VARIABLE RESISTOR
■	CHIP RESISTOR

REMARKS	PARTS NAME
NO MARK	ELECTROLYTIC CAPACITOR
⊗	TANTALUM CAPACITOR
NO MARK	CERAMIC CAPACITOR
●	CERAMIC TUBULAR CAPACITOR
⊙	POLYESTER FILM CAPACITOR
○	POLYSTYRENE FILM CAPACITOR
⊖	MICA CAPACITOR
⊕	POLYPROPYLENE FILM CAPACITOR
●	SEMICONDUCTIVE CERAMIC CAPACITOR

NOTICE (mode1)
(J)..... JAPANESE
(U)..... U.S.A
(C)..... CANADIAN
(R)..... GENERAL
(A)..... AUSTRALIAN
(B)..... BRITISH
(G)..... EUROPEAN
(T)..... CHINA
(L)..... SINGAPORE

Mark	Reference Parts Number	Parts Name
41	D700-704-707-710-714-716	H5504 155133 155136
42	9705	2540335D/P1 2541155E/P1 2541909A/D/P/S1
43	9705-707	25C17405I/P/S1 25C26035E/P1 25C33114A/D/P/S1

	U-C	S-T	A-B-D
41	R790	X	100K 100K
42	J705	0	X X X
43	R781	100K	100K X
44	J706	X	X X 0

O : USED
X : NOT USED

* All voltages are measured with a 10MΩ/DC electric volt meter.
* Components having special characteristics are marked Δ, and must be replaced with parts having specifications equal to those originally installed.
* Schematic diagram is subject to change without notice.

RX-V395/RDS SCHEMATIC DIAGRAM (INPUT)

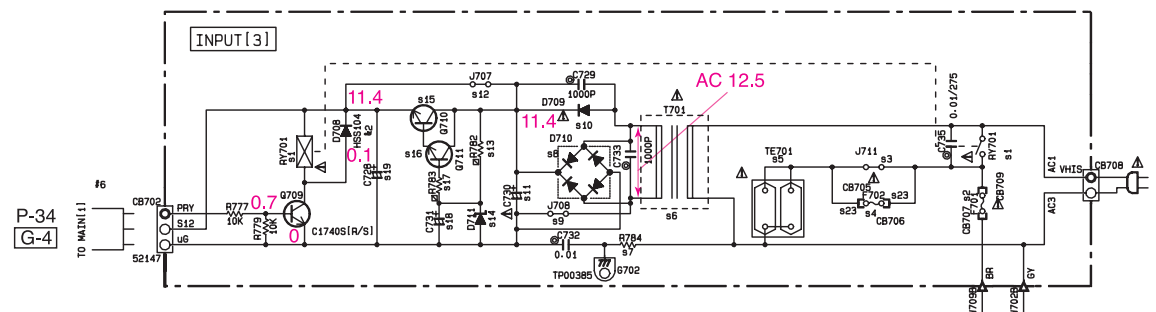
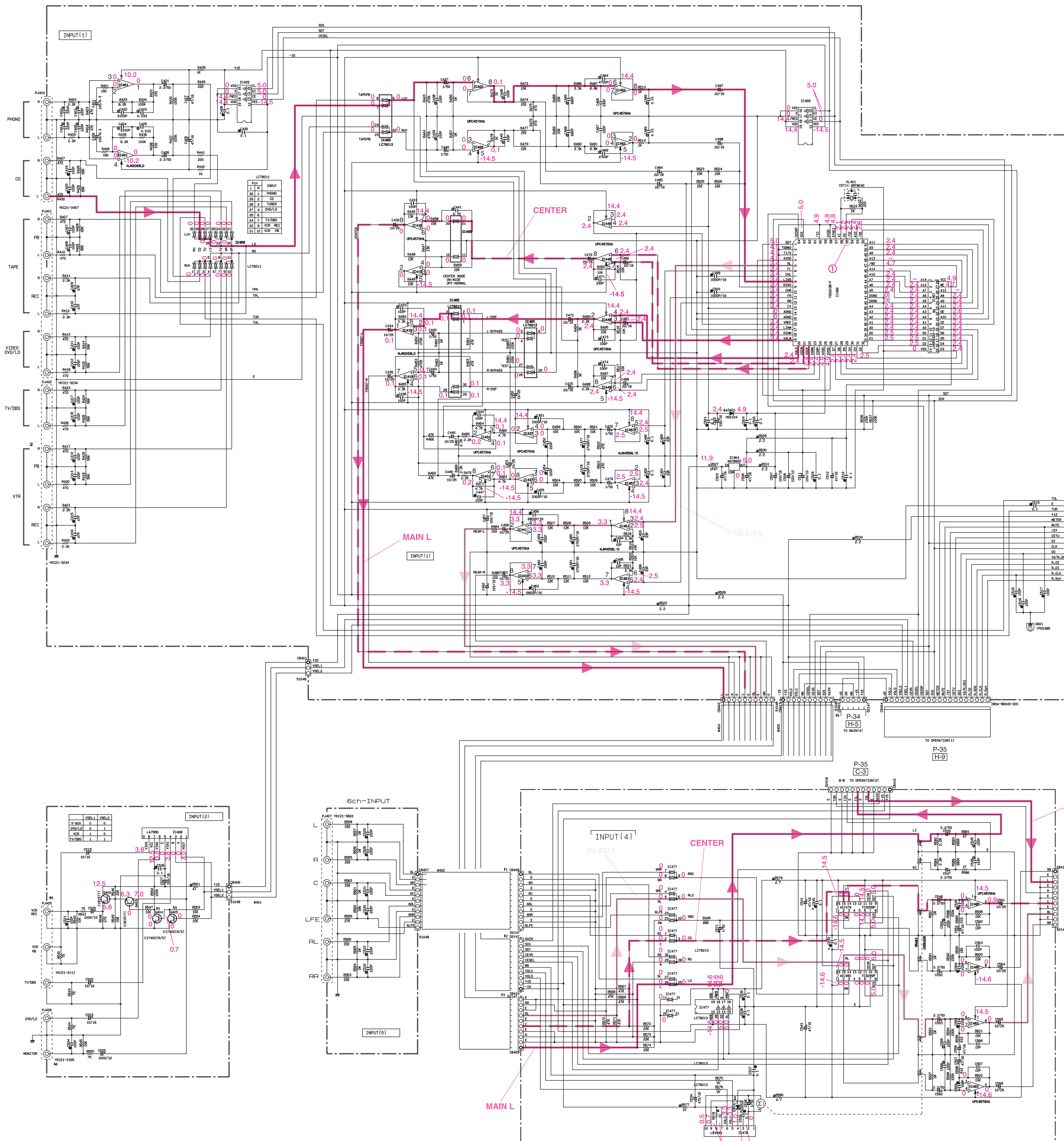

IC401,419 : NJM2068L-D
Dual OP-Amp

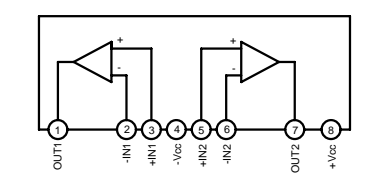

IC468 : LA7956
Video Switch

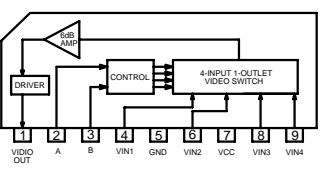

IC415,422,431,437,441,445,449,452,483,485 : μ PC4570HA
Dual OP-Amp

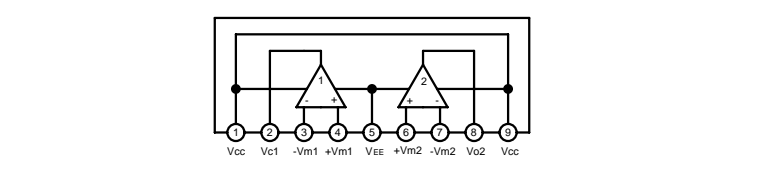

IC479,480 : TC9299P
Electric Controlled Volume

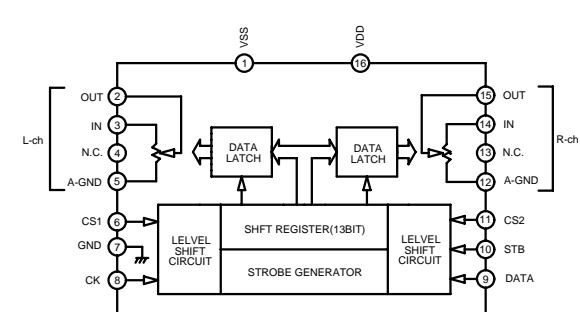

IC467 : LH5P832D-10
32768-word x 8 bit High Speed Pseudo Static RAM

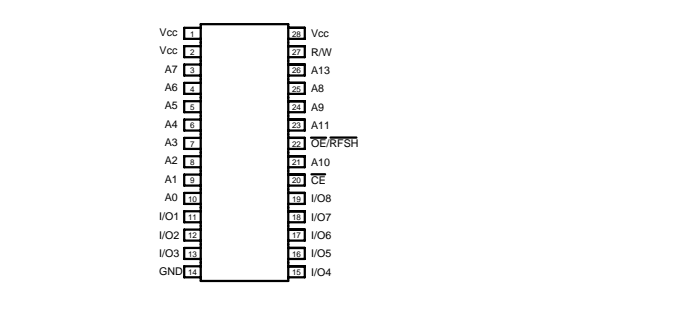

RESISTOR

RESISTOR	PARTS MARK
NO MARK CARBON FILM RESISTOR (P=5)	
NO MARK CARBON FILM RESISTOR (P=10)	
METAL FILM RESISTOR	
METAL OXIDE FILM RESISTOR	
METAL SLIT RESISTOR	
FILM PROOF CARBON FILM RESISTOR	
CENTEL MIXED RESISTOR	
SEMI VARIABLE RESISTOR	
CHIP RESISTOR	

CAPACITOR

CAPACITOR	PARTS NAME
NO MARK ELECTROLYTIC CAPACITOR	
TANTALUM CAPACITOR	
NO MARK CERAMIC CAPACITOR	
CERAMIC DISK CAPACITOR	
POLYESTER FILM CAPACITOR	
POLYPROPYLENE FILM CAPACITOR	
MICA CAPACITOR	
PORCELAIN FILM CAPACITOR	
SEMICONDUCTIVE CERAMIC CAPACITOR	

NOTICE (mode 1)
 (J)..... JAPANESE
 (U)..... U.S.A.
 (C)..... CANADIAN
 (E)..... GENERAL
 (A)..... AUSTRALIAN
 (B)..... BRITISH
 (G)..... EUROPEAN
 (T)..... CHINA
 (L)..... SINGAPORE

IC	U.C	R.1	A	X	S
81	MY70	V77950	V77950	V77950	V77950
82	FR1	V77950	V77950	V77950	V77950
83	J711	0	0	0	X
84	FR2	X	X	X	X
85	TE71	V64300	V79300	V64300	V64345
86	TR1	X091	1731	X094	X094
87	RT4	L7912M	X	X	X
88	DT10	X	V62370	X	X
89	J708	0	X	0	0
90	DT09	V69970	X	V69970	V69970
91	CT90	330/25	47/33	330/25	330/25
92	J707	0	X	0	0
93	RT02	X	10M	X	X
94	DT11	X	V62370	X	X
95	DT10	X	V46610/V471	X	X
96	DT11	X	V62370	X	X
97	RT03	X	100	X	X
98	CT91	X	10/15	X	X
99	CT92	X	10/15	X	X
100	FR103	X	V46610/V471	X	X
101	DT17	X	V69970	X	X
102	DT11	X	W20000	X	X
103	CT90	X	X	X	V69970
104	FR102	X	10/15	X	X
105	FR101	X	10/15	X	X

B	B
83	CT910
83	J711
84	FR2
85	TE71

IC465,477 : LC78213
Analog Function Switch

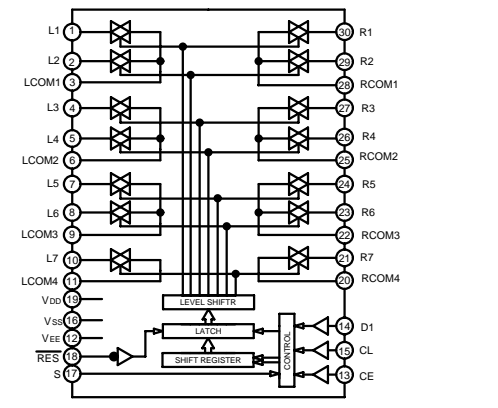

IC478 : LB1641
Motor Driver

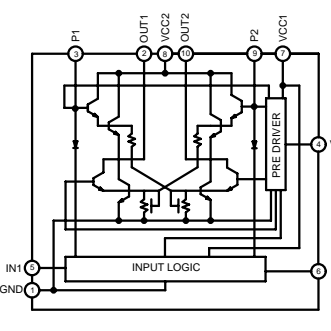

IC457,461 : NJM4558L-D
Dual OP-Amp

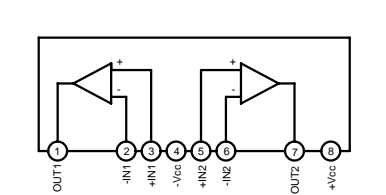

Point ① (Pin55 of IC466)
 V : 2V/div H : 50 nsec/div
 DC range 1 : 1 probe

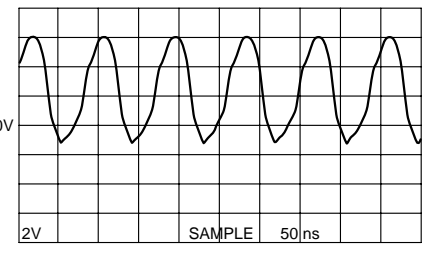

○ : USED
 X : NOT USED

* All voltage are measured with a 10M Ω /DC electric volt meter.
 * Components having special characteristics are marked Δ and must be replaced with parts having specifications equal to those originally installed.
 * Schematic diagram is subject to change without notice.

PARTS LIST

■ WARNING

Components having special characteristics are marked \triangle and must be replaced with parts having specifications equal to those originally installed.

- Carbon resistors (1/6W or 1/4W) are not included in the ELECTRICAL PARTS List. For the part Nos. of the carbon resistors, refer to the last page.

■ ELECTRICAL PARTS

ABBREVIATIONS IN THIS LIST ARE AS FOLLOWS :

C.A.EL.CHP	: CHIP ALUMI. ELECTROLYTIC CAP	L.EMIT	: LIGHT EMITTING MODULE
C.CE	: CERAMIC CAP	LED.DSPLY	: LED DISPLAY
C.CE.ARRAY	: CERAMIC CAP ARRAY	LED.INFRD	: LED, INFRARED
C.CE.CHP	: CHIP CERAMIC CAP	MODUL.RF	: MODULATOR, RF
C.CE.ML	: MULTILAYER CERAMIC CAP	PHOT.CPL	: PHOTO COUPLER
C.CE.M.CHP	: CHIP MULTILAYER CERAMIC CAP	PHOT.INTR	: PHOTO INTERRUPTER
C.CE.SAFTY	: RECOGNIZED CERAMIC CAP	PHOT.RFLCT	: PHOTO REFLECTOR
C.CE.TUBLR	: CERAMIC TUBULAR CAP	PIN.TEST	: PIN, TEST POINT
C.CE.SMI	: SEMI CONDUCTIVE CERAMIC CAP	PLST.RIVET	: PLASTIC RIVET
C.EL	: ELECTROLYTIC CAP	R.ARRAY	: RESISTOR ARRAY
C.MICA	: MICA CAP	R.CAR	: CARBON RESISTOR
C.ML.FLM	: MULTILAYER FILM CAP	R.CAR.CHP	: CHIP RESISTOR
C.MP	: METALLIZED PAPER CAP	R.CAR.FP	: FLAME PROOF CARBON RESISTOR
C.MYLAR	: MYLAR FILM CAP	R.FUS	: FUSABLE RESISTOR
C.MYLAR.ML	: MULTILAYER MYLAR FILM CAP	R.MTL.CHP	: CHIP METAL FILM RESISTOR
C.PAPER	: PAPER CAPACITOR	R.MTL.FLM	: METAL FILM RESISTOR
C.PLS	: POLYSTYRENE FILM CAP	R.MTL.OXD	: METAL OXIDE FILM RESISTOR
C.POL	: POLYESTER FILM CAP	R.MTL.PLAT	: METAL PLATE RESISTOR
C.POLY	: POLYETHYLENE FILM CAP	RSNR.CE	: CERAMIC RESONATOR
C.PP	: POLYPROPYLENE FILM CAP	RSNR.CRYS	: CRYSTAL RESONATOR
C.TNTL	: TANTALUM CAP	R.TW.CEM	: TWIN CEMENT FIXED RESISTOR
C.TNTL.CHP	: CHIP TANTALUM CAP	R.WW	: WIRE WOUND RESISTOR
C.TRIM	: TRIMMER CAP	SCR.BND.HD	: BIND HEAD B-TITE SCREW
CN	: CONNECTOR	SCR.BW.HD	: BW HEAD TAPPING SCREW
CN.BS.PIN	: CONNECTOR, BASE PIN	SCR.CUP	: CUP TITE SCREW
CN.CANNON	: CONNECTOR, CANNON	SCR.TERM	: SCREW TERMINAL
CN.DIN	: CONNECTOR, DIN	SCR.TR	: SCREW, TRANSISTOR
CN.FLAT	: CONNECTOR, FLAT CABLE	SUPRT.PCB	: SUPPORT, P.C.B.
CN.POST	: CONNECTOR, BASE POST	SURG.PRTCT	: SURGE PROTECTOR
COIL.MX.AM	: COIL, AM MIX	SW.TACT	: TACT SWITCH
COIL.AT.FM	: COIL, FM ANTENNA	SW.LEAF	: LEAF SWITCH
COIL.DT.FM	: COIL, FM DETECT	SW.LEVER	: LEVER SWITCH
COIL.MX.FM	: COIL, FM MIX	SW.MICRO	: MICRO SWITCH
COIL.OUTPT	: OUTPUT COIL	SW.PUSH	: PUSH SWITCH
DIOD.ARRAY	: DIODE ARRAY	SW.RT.ENC	: ROTARY ENCODER
DIODE.BRG	: DIODE BRIDGE	SW.RT.MTR	: ROTARY SWITCH WITH MOTOR
DIODE.CHP	: CHIP DIODE	SW.RT	: ROTARY SWITCH
DIODE.VAR	: VARACTOR DIODE	SW.SLIDE	: SLIDE SWITCH
DIOD.Z.CHP	: CHIP ZENER DIODE	TERM.SP	: SPEAKER TERMINAL
DIODE.ZENR	: ZENER DIODE	TERM.WRAP	: WRAPPING TERMINAL
DSCR.CE	: CERAMIC DISCRIMINATOR	THRMST.CHP	: CHIP THERMISTOR
FER.BEAD	: FERRITE BEADS	TR.CHP	: CHIP TRANSISTOR
FER.CORE	: FERRITE CORE	TR.DGT	: DIGITAL TRANSISTOR
FET.CHP	: CHIP FET	TR.DGT.CHP	: CHIP DIGITAL TRANSISTOR
FL.DSPLY	: FLUORESCENT DISPLAY	TRANS	: TRANSFORMER
FLTR.CE	: CERAMIC FILTER	TRANS.PULS	: PULSE TRANSFORMER
FLTR.COMB	: COMB FILTER MODULE	TRANS.PWR	: POWER TRANSFORMER ASS'y
FLTR.LC.RF	: LC FILTER ,EMI	TUNER.AM	: TUNER PACK, AM
GND.MTL	: GROUND PLATE	TUNER.FM	: TUNER PACK, FM
GND.TERM	: GROUND TERMINAL	TUNER.PK	: FRONT-END TUNER PACK
HOLDER.FUS	: FUSE HOLDER	VR	: ROTARY POTENTIOMETER
IC.PRTCT	: IC PROTECTOR	VR.MTR	: POTENTIOMETER WITH MOTOR
JUMPER.CN	: JUMPER CONNECTOR	VR.SW	: POTENTIOMETER WITH ROTARY SW
JUMPER.TST	: JUMPER, TEST POINT	VR.SLIDE	: SLIDE POTENTIOMETER
L.DTCT	: LIGHT DETECTING MODULE	VR.TRIM	: TRIMMER POTENTIOMETER

Note) Those parts marked with “#” are not included in the P.C.B. ass'y.

RX-V395/RX-V395RDS P.C.B. MAIN

Schm Ref.	PART NO.	Description
* *	V3002000	P.C.B. MAIN(UCRAT)
	V3352300	P.C.B. MAIN(BG)
CB101	Vi878900	CN.BS.PIN 11P
CB102	VK025300	CN.BS.PIN 9P
CB103	Vi878100	CN.BS.PIN 3P
CB104	VQ584700	CN.BS.PIN 5P
CB105	VQ584700	CN.BS.PIN 5P
CB106	VQ584800	CN.BS.PIN 6P
CB107	VQ584800	CN.BS.PIN 6P
CB108	VR428900	CN.BS.PIN 4P
CB109	VQ585100	CN.BS.PIN 9P
CB110	VR428900	CN.BS.PIN 4P
CB301	VQ585100	CN.BS.PIN 9P
CB302	Vi878300	CN.BS.PIN 5P
CB303	VR428900	CN.BS.PIN 4P
CB304	VR428900	CN.BS.PIN 4P
CB305	Vi878000	CN.BS.PIN 2P
CB311	Vi878000	CN.BS.PIN 2P
C101	VJ599100	C.CE.TUBLR 0.1uF 50V
C102	VJ599100	C.CE.TUBLR 0.1uF 50V
C103	UR837470	C.EL 47uF 16V
C104	UR846470	C.EL 4.7uF 25V
C105	UR846470	C.EL 4.7uF 25V
C106	UR846470	C.EL 4.7uF 25V
C107	UN865470	C.EL 0.47uF 50V
C108	UR846470	C.EL 4.7uF 25V
C109	UR846470	C.EL 4.7uF 25V
C110	FG652100	C.CE 100pF 50V
C111	VQ645600	C.MYLAR 100pF 50V
C112	FG652100	C.CE 100pF 50V
C113	VQ645600	C.MYLAR 100pF 50V
C114	FG652100	C.CE 100pF 50V
C115	UA952100	C.MYLAR 100pF 50V
C116	FG652100	C.CE 100pF 50V
C117	UA952470	C.MYLAR 470pF 50V
C118	FG652100	C.CE 100pF 50V
C119	UA952470	C.MYLAR 470pF 50V
C120	VR516400	C.CE 15pF 500V
C121	UR837470	C.EL 47uF 16V
C122	UA953100	C.MYLAR 1000pF 50V
C123	VR516400	C.CE 15pF 500V
C124	UR837470	C.EL 47uF 16V
C125	UA953100	C.MYLAR 1000pF 50V
C126	VR516400	C.CE 15pF 500V
C127	UR837470	C.EL 47uF 16V
C128	UA953100	C.MYLAR 1000pF 50V
C129	VR516400	C.CE 15pF 500V
C130	UR837470	C.EL 47uF 16V
C131	UA953100	C.MYLAR 1000pF 50V
C132	VR516400	C.CE 15pF 500V
C133	UR837470	C.EL 47uF 16V
C134	UA953100	C.MYLAR 1000pF 50V
C135	UR867470	C.EL 47uF 50V

* New Parts

Schm Ref.	PART NO.	Description
C136	UR867470	C.EL 47uF 50V
C137	UR867470	C.EL 47uF 50V
C138	UR867470	C.EL 47uF 50V
C139	UR867470	C.EL 47uF 50V
C140	VK347900	C.EL 470uF 63V
C141	VR325000	C.MYLAR 100pF 100V
C142	UA954820	C.MYLAR 0.082uF 50V
C143	UR867470	C.EL 47uF 50V
C144	VR325000	C.MYLAR 100pF 100V
C145	VR325000	C.MYLAR 100pF 100V
C146	UA954820	C.MYLAR 0.082uF 50V
C147	UR867470	C.EL 47uF 50V
C148	VR325000	C.MYLAR 100pF 100V
C149	VR325000	C.MYLAR 100pF 100V
C150	UR867470	C.EL 47uF 50V
C151	VR325000	C.MYLAR 100pF 100V
C152	VR325000	C.MYLAR 100pF 100V
C153	UR867470	C.EL 47uF 50V
C154	VR325000	C.MYLAR 100pF 100V
C155	VR325000	C.MYLAR 100pF 100V
C156	UR867470	C.EL 47uF 50V
C157	VR325000	C.MYLAR 100pF 100V
C158	UA954220	C.MYLAR 0.022uF 50V
C159	UA954220	C.MYLAR 0.022uF 50V
C160	UA954220	C.MYLAR 0.022uF 50V
C161	UA954220	C.MYLAR 0.022uF 50V
C162	UA954220	C.MYLAR 0.022uF 50V
C163	UR866470	C.EL 4.7uF 50V
C164	UR877470	C.EL 47uF 63V
C165	UR877470	C.EL 47uF 63V
C166	UA954220	C.MYLAR 0.022uF 50V(BG)
C167	UN865470	C.EL 0.47uF 50V
C168	UR866470	C.EL 4.7uF 50V
C169	UR866470	C.EL 4.7uF 50V
C170	UR818100	C.EL 100uF 6.3V
C171	UA655100	C.MYLAR 0.1uF 50V
C172	UA655100	C.MYLAR 0.1uF 50V
C177	UA954220	C.MYLAR 0.022uF 50V(BG)
C178	FG644100	C.CE 0.01uF 50V(BG)
C179	FG644100	C.CE 0.01uF 50V(BG)
C180	UA954220	C.MYLAR 0.022uF 50V(BG)
C181	UA954220	C.MYLAR 0.022uF 50V(BG)
C181	UA954220	C.MYLAR 0.022uF 50V
C182	UA655220	C.MYLAR 0.22uF 50V
C183	VJ599100	C.CE.TUBLR 0.1uF 50V
C184	UA954220	C.MYLAR 0.022uF 50V(BG)
C185	UA954220	C.MYLAR 0.022uF 50V(BG)
C186	UA954220	C.MYLAR 0.022uF 50V(BG)
C187	UA954220	C.MYLAR 0.022uF 50V(BG)
C188	UA954100	C.MYLAR 0.01uF 50V(BG)
C189	UA954100	C.MYLAR 0.01uF 50V(BG)
C190	UA954100	C.MYLAR 0.01uF 50V(BG)
C191	UA954100	C.MYLAR 0.01uF 50V(BG)

* New Parts

RX-V395/RDS
HTR5130/RDS

RX-V395/RX-V395RDS P.C.B. MAIN

Schm Ref.	PART NO.	Description		Schm Ref.	PART NO.	Description				
	C192	UA954100	C.MYLAR	0.01uF	50V		Q110	VP883000	TR	2SA893A D,E
	C221	FG644100	C.CE	0.01uF	50V(BG)		Q111	VP883000	TR	2SA893A D,E
	C222	FG644100	C.CE	0.01uF	50V(BG)	△	Q112	VR325600	TR	2SC2229 O,Y
	C301	UR857470	C.EL	47uF	35V		Q113	VP883000	TR	2SA893A D,E
△	C302	VV951800	C.EL	6800uF	56V	△	Q114	VR325600	TR	2SC2229 O,Y
△	C303	VV951800	C.EL	6800uF	56V		Q115	VP883000	TR	2SA893A D,E
	C304	UR866100	C.EL	1uF	50V	△	Q116	VR325600	TR	2SC2229 O,Y
	C305	UR857470	C.EL	47uF	35V		Q117	VP883000	TR	2SA893A D,E
	C306	VS745400	C.POL.MTL	0.1uF	100V	△	Q118	VR325600	TR	2SC2229 O,Y
	C307	VS745400	C.POL.MTL	0.1uF	100V		Q119	VP883000	TR	2SA893A D,E
	C308	UR749680	C.EL	6800uF	25V	△	Q120	VR325600	TR	2SC2229 O,Y
△	C309	UJ749220	C.EL	2200uF	25V	△	Q121	iC174020	TR	2SC1740S R,S
	C310	UR759100	C.EL	1000uF	35V	△	Q122	iC174020	TR	2SC1740S R,S
	C311	VS745400	C.POL.MTL	0.1uF	100V	△	Q123	iC174020	TR	2SC1740S R,S
	C312	VS745400	C.POL.MTL	0.1uF	100V	△	Q124	iC174020	TR	2SC1740S R,S
	C313	VS745400	C.POL.MTL	0.1uF	100V	△	Q125	iC174020	TR	2SC1740S R,S
	C314	VJ599100	C.CE.TUBLR	0.1uF	50V	△	Q126	VP872700	TR	2SC4488 S,T
	C315	UR857470	C.EL	47uF	35V	△	Q127	VR355900	TR.PAIR	2SA1695/C4468 OPY
	D101	VM975700	DIODE.ZENR	HZS12C2TD	12V	△	Q129	VP872600	TR	2SA1708 S,T
	D107	VN008700	DIODE	1SS270A		△	Q130	VP872700	TR	2SC4488 S,T
	D108	VN008700	DIODE	1SS270A		△	Q131	VR355900	TR.PAIR	2SA1695/C4468 OPY
	D109	VN008700	DIODE	1SS270A		△	Q133	VP872600	TR	2SA1708 S,T
	D110	VN008700	DIODE	1SS270A		△	Q134	VP872700	TR	2SC4488 S,T
	D111	VN008700	DIODE	1SS270A		△	Q135	VR355900	TR.PAIR	2SA1695/C4468 OPY
	D112	VM976300	DIODE.ZENR	HZS242TD	24V	△	Q137	VP872600	TR	2SA1708 S,T
	D113	VM976300	DIODE.ZENR	HZS242TD	24V	△	Q138	VP872700	TR	2SC4488 S,T
	D114	VM976300	DIODE.ZENR	HZS242TD	24V	△	Q139	VR355900	TR.PAIR	2SA1695/C4468 OPY
	D115	VM976300	DIODE.ZENR	HZS242TD	24V	△	Q141	VP872600	TR	2SA1708 S,T
	D301	VV731400	DIODE	2A02M		△	Q142	VP872700	TR	2SC4488 S,T
△	D302	VR253700	DIODE.BRG	S1NB20	1.0A 200V	△	Q143	VR355900	TR.PAIR	2SA1695/C4468 OPY
	D303	VN011400	DIODE.BRG	D5SB20	5A 200V	△	Q145	VP872600	TR	2SA1708 S,T
	G101	VR463400	TERM.GND	D3.5	TP00385	△	Q146	VP883100	TR	2SC1890A D,E
	G102	VR463400	TERM.GND	D3.5	TP00385	△	Q147	VP883100	TR	2SC1890A D,E
	G301	VR463400	TERM.GND	D3.5	TP00385	△	Q148	VP883100	TR	2SC1890A D,E
*	HS101	V2989200	HEAT.SINK			△	Q149	VP883100	TR	2SC1890A D,E
△	IC301	XJ602A00	IC	NJM78M12FA		△	Q150	VP883100	TR	2SC1890A D,E
	IC302	XD343A00	IC	NJM79M12FA			Q151	iA097030	TR	2SA970 GR,BL
	JK101	VS899700	JACK.PHONE	JY-6317-02-030			Q152	iA101510	TR	2SA1015 Y
*	L101	V2604200	COIL	1uH			Q153	iC224030	TR	2SC2240 GR,BL
*	L102	V2604200	COIL	1uH			Q156	iC224030	TR	2SC2240 GR,BL
*	L103	V2604200	COIL	1uH			Q161	iC287820	TR	2SC2878 A,B
*	L104	V2604200	COIL	1uH			R116	VP941400	R.MTL.OXD	3.3KΩ 1W
*	L105	V2604200	COIL	1uH		△	R124	VU981700	R.MTL.PLAT	0.22Ω+0.22 3W
	PJ101	VK437600	JACK.PIN	1P		△	R127	VU981700	R.MTL.PLAT	0.22Ω+0.22 3W
	Q101	iC287820	TR	2SC2878 A,B		△	R130	VU981700	R.MTL.PLAT	0.22Ω+0.22 3W
	Q102	iC287820	TR	2SC2878 A,B		△	R136	VU981700	R.MTL.PLAT	0.22Ω+0.22 3W
	Q103	iC287820	TR	2SC2878 A,B		△	R138	HV754470	R.CAR.FP	47Ω 1/4W
	Q104	iC287820	TR	2SC2878 A,B		△	R143	VU981700	R.MTL.PLAT	0.22Ω+0.22 3W
	Q105	iC287820	TR	2SC2878 A,B		△	R145	HV754470	R.CAR.FP	47Ω 1/4W
	Q106	VP883000	TR	2SA893A D,E		△	R152	HV754470	R.CAR.FP	47Ω 1/4W
	Q107	VP883000	TR	2SA893A D,E		△	R159	HV754470	R.CAR.FP	47Ω 1/4W
	Q108	VP883000	TR	2SA893A D,E		△	R166	HV754470	R.CAR.FP	47Ω 1/4W
	Q109	VP883000	TR	2SA893A D,E		△	R169	HV756270	R.CAR.FP	2.7KΩ 1/4W

* New Parts

* New Parts

RX-V395/RX-V395RDS P.C.B. MAIN & INPUT

Schm Ref.	PART NO.	Description		
△	R171	HV756100 R.CAR.FP	1KΩ	1/4W
	R172	HV756100 R.CAR.FP	1KΩ	1/4W
△	R175	HV756270 R.CAR.FP	2.7KΩ	1/4W
△	R177	HV756100 R.CAR.FP	1KΩ	1/4W
△	R178	HV756100 R.CAR.FP	1KΩ	1/4W
△	R181	HV756270 R.CAR.FP	2.7KΩ	1/4W
△	R183	HV756100 R.CAR.FP	1KΩ	1/4W
△	R184	HV756100 R.CAR.FP	1KΩ	1/4W
△	R187	HV756270 R.CAR.FP	2.7KΩ	1/4W
△	R189	HV756100 R.CAR.FP	1KΩ	1/4W
△	R190	HV756100 R.CAR.FP	1KΩ	1/4W
△	R193	HV756270 R.CAR.FP	2.7KΩ	1/4W
△	R195	HV756100 R.CAR.FP	1KΩ	1/4W
△	R196	HV756100 R.CAR.FP	1KΩ	1/4W
	R197	VP940100 R.MTL.OXD	33Ω	1W
	R198	HV753470 R.CAR.FP	4.7Ω	1/4W
△	R199	HV755330 R.CAR.FP	330Ω	1/4W
	R202	HV753470 R.CAR.FP	4.7Ω	1/4W
△	R203	HV753470 R.CAR.FP	4.7Ω	1/4W
△	R205	HV755330 R.CAR.FP	330Ω	1/4W
	R207	HV753470 R.CAR.FP	4.7Ω	1/4W
△	R208	HV753470 R.CAR.FP	4.7Ω	1/4W
△	R210	HV755330 R.CAR.FP	330Ω	1/4W
	R211	HV753470 R.CAR.FP	4.7Ω	1/4W
△	R212	HV753470 R.CAR.FP	4.7Ω	1/4W
△	R214	HV755330 R.CAR.FP	330Ω	1/4W
△	R215	HV753470 R.CAR.FP	4.7Ω	1/4W
△	R216	HV753470 R.CAR.FP	4.7Ω	1/4W
△	R217	HV755330 R.CAR.FP	330Ω	1/4W
△	R219	HV753470 R.CAR.FP	4.7Ω	1/4W
	R224	VP939800 R.MTL.OXD	10Ω	1W
	R229	VP939800 R.MTL.OXD	10Ω	1W
	R234	VP939800 R.MTL.OXD	10Ω	1W
	R239	VP939800 R.MTL.OXD	10Ω	1W
	R244	VP939800 R.MTL.OXD	10Ω	1W
	R249	HV753470 R.CAR.FP	4.7Ω	1/4W
	R252	HV753470 R.CAR.FP	4.7Ω	1/4W
	R255	HV753470 R.CAR.FP	4.7Ω	1/4W
	R257	HV753470 R.CAR.FP	4.7Ω	1/4W
	R259	HV753470 R.CAR.FP	4.7Ω	1/4W
	R260	HV753220 R.CAR.FP	2.2Ω	1/4W
	R261	HV753220 R.CAR.FP	2.2Ω	1/4W
	R262	VP939800 R.MTL.OXD	10Ω	1W
	R263	HV756100 R.CAR.FP	1KΩ	1/4W
	R265	VP939800 R.MTL.OXD	10Ω	1W
	R266	VP939800 R.MTL.OXD	10Ω	1W
	R291	VP940700 R.MTL.OXD	330Ω	1W
	R292	VP940700 R.MTL.OXD	330Ω	1W
	R301	HV753100 R.CAR.FP	1Ω	1/4W
	R302	HV753100 R.CAR.FP	1Ω	1/4W
△	RY101	VK438300 RELAY	DH24D2-OT/M2	
△	RY102	VU566700 RELAY	DG24D2-OS/M	
△	RY103	VK438300 RELAY	DH24D2-OT/M2	

* New Parts

Schm Ref.	PART NO.	Description		
	SW101	VV523900 SW.PUSH	PBS-YM-001	
	SW301	VZ361100 SW.SLIDE	SL13B-022-AMC1	
*	TE101	V2984800 TERM.SP	6P	
	TE102	VC313700 TERM.SP	8P(UCRAT)	
	TE102	VU819700 TERM.SP	8P(BG)	
		VJ828000 PIN	IMSA-6024-03E	
*		V4040500 TERM.SCR	M3	
		EP600830 SCR.BND.HD	3x8 FCRM3-BL	
*		V3001500 P.C.B.	INPUT(UC)	
*		V3002400 P.C.B.	INPUT(RT)	
*		V3002500 P.C.B.	INPUT(A)	
*		V3317700 P.C.B.	INPUT(B)	
*		V3317800 P.C.B.	INPUT(G)	
*		V3457200 P.C.B.	INPUT(B:RDS)	
*		V3457300 P.C.B.	INPUT(G:RDS)	
	CB401	Vi878100 CN.BS.PIN	3P	
	CB402	Vi878800 CN.BS.PIN	10P	
	CB403	VK024900 CN.BS.PIN	5P	
	CB404	VU272000 CN	20P	
	CB405	VQ963700 CN.BS.PIN	16P	
	CB406	Vi878100 CN.BS.PIN	3P	
	CB407	Vi878900 CN.BS.PIN	11P	
	CB408	VK025500 CN.BS.PIN	11P	
	CB409	VF728200 CN.BS.PIN	10P	
	CB410	VQ961500 CN.BS.PIN	12P	
	CB411	VK025500 CN.BS.PIN	11P	
	CB412	VF728200 CN.BS.PIN	10P	
	CB413	Vi878800 CN.BS.PIN	10P	
	CB421	Vi878100 CN.BS.PIN	3P	
	CB422	Vi878100 CN.BS.PIN	3P	
	CB423	Vi878100 CN.BS.PIN	3P	
	CB424	Vi878100 CN.BS.PIN	3P	
	CB702	VK024700 CN.BS.PIN	3P	
	CB705	VP206500 HOLDER.FUS	EYF-52BC(G)	
	CB706	VP206500 HOLDER.FUS	EYF-52BC(G)	
	CB707	VP206500 HOLDER.FUS	EYF-52BC	
	CB708	VG879900 CN.BS.PIN	2P	
	CB709	VP206500 HOLDER.FUS	EYF-52BC	
	CB710	VP206500 HOLDER.FUS	EYF-52BC(RT)	
	CB711	VP206500 HOLDER.FUS	EYF-52BC(RT)	
	C401	UR818100 C.EL	100uF 6.3V	
	C402	UA952220 C.MYLAR	220pF 50V	
	C403	UA952220 C.MYLAR	220pF 50V	
	C404	UA952220 C.MYLAR	220pF 50V	
	C405	UA952220 C.MYLAR	220pF 50V	
	C406	UR818100 C.EL	100uF 6.3V	
	C407	UA952100 C.MYLAR	100pF 50V	
	C408	UA952100 C.MYLAR	100pF 50V	
	C409	VF466700 C.CE.TUBLR	47pF 50V	
	C410	VF466700 C.CE.TUBLR	47pF 50V	

* New Parts

RX-V395/RX-V395RDS P.C.B. INPUT

Schm Ref.	PART NO.	Description		
C411	VF466800	C.CE.TUBLR	100pF	50V
C412	VF466800	C.CE.TUBLR	100pF	50V
C413	VF466800	C.CE.TUBLR	100pF	50V
C414	VF466800	C.CE.TUBLR	100pF	50V
C415	VF466700	C.CE.TUBLR	47pF	50V
C416	VF466700	C.CE.TUBLR	47pF	50V
C417	VF466800	C.CE.TUBLR	100pF	50V
C418	VF466800	C.CE.TUBLR	100pF	50V
C419	VF466800	C.CE.TUBLR	100pF	50V
C420	VF466800	C.CE.TUBLR	100pF	50V
C421	UR866220	C.EL	2.2uF	50V
C422	UA653910	C.MYLAR	9100pF	50V
C423	UA954330	C.MYLAR	0.033uF	50V
C424	UA653910	C.MYLAR	9100pF	50V
C425	UA954330	C.MYLAR	0.033uF	50V
C426	UR866220	C.EL	2.2uF	50V
C427	UR837470	C.EL	47uF	16V
C428	VJ599100	C.CE.TUBLR	0.1uF	50V
C429	UR837470	C.EL	47uF	16V
C430	VJ599100	C.CE.TUBLR	0.1uF	50V
C431	FG652100	C.CE	100pF	50V
C432	UR847100	C.EL	10uF	25V
C433	UA952100	C.MYLAR	100pF	50V
C434	UR847100	C.EL	10uF	25V
C435	UR847100	C.EL	10uF	25V
C436	UA952100	C.MYLAR	100pF	50V
C437	UR866100	C.EL	1uF	50V
C438	UA952100	C.MYLAR	100pF	50V
C439	UA952100	C.MYLAR	100pF	50V
C440	UR866100	C.EL	1uF	50V
C441	UA655150	C.MYLAR	0.15uF	50V
C442	UR866100	C.EL	1uF	50V
C443	UR866100	C.EL	1uF	50V
C444	VF466800	C.CE.TUBLR	100pF	50V
C445	UR847100	C.EL	10uF	25V
C446	UR847100	C.EL	10uF	25V
C447	VF466800	C.CE.TUBLR	100pF	50V
C448	UA952100	C.MYLAR	100pF	50V
C449	UA952100	C.MYLAR	100pF	50V
C450	UR847100	C.EL	10uF	25V
C451	VG279600	C.CE.TUBLR	3300pF	16V
C452	VG278400	C.CE.TUBLR	220pF	50V
C453	UR847100	C.EL	10uF	25V
C454	VG278400	C.CE.TUBLR	220pF	50V
C455	VG279600	C.CE.TUBLR	3300pF	16V
C456	VG279900	C.CE.TUBLR	6800pF	16V
C457	UR838330	C.EL	330uF	16V
C458	UR847100	C.EL	10uF	25V
C459	VG278600	C.CE.TUBLR	330pF	50V
C460	VG278600	C.CE.TUBLR	330pF	50V
C461	UR847100	C.EL	10uF	25V
C462	UR838330	C.EL	330uF	16V
C463	VG279900	C.CE.TUBLR	6800pF	16V

* New Parts

Schm Ref.	PART NO.	Description		
C464	UA953470	C.MYLAR	4700pF	50V
C465	UA952680	C.MYLAR	680pF	50V
C466	FG612330	C.CE	330pF	50V
C467	FG612330	C.CE	330pF	50V
C468	UA952680	C.MYLAR	680pF	50V
C469	UA953470	C.MYLAR	4700pF	50V
C470	UR837220	C.EL	22uF	25V
C471	UA952330	C.MYLAR	330pF	50V
C472	UR837220	C.EL	22uF	25V
C473	UA952330	C.MYLAR	330pF	50V
C474	UA952330	C.MYLAR	330pF	50V
C475	UR837220	C.EL	22uF	25V
C476	UR866100	C.EL	1uF	50V
C477	VG279500	C.CE.TUBLR	2700pF	16V
C478	VG279500	C.CE.TUBLR	2700pF	16V
C479	UR866100	C.EL	1uF	50V
C480	VG279500	C.CE.TUBLR	2700pF	16V
C481	VG279500	C.CE.TUBLR	2700pF	16V
C482	UA954100	C.MYLAR	0.01uF	50V
C483	UA954100	C.MYLAR	0.01uF	50V
C484	UR837220	C.EL	22uF	25V
C485	UR837220	C.EL	22uF	25V
C486	UR837220	C.EL	22uF	25V
C487	UR837220	C.EL	22uF	25V
C488	UR837220	C.EL	22uF	25V
C489	VG277000	C.CE.TUBLR	33pF	50V
C490	VJ599100	C.CE.TUBLR	0.1uF	50V
C491	VG277000	C.CE.TUBLR	33pF	50V
C492	VJ599100	C.CE.TUBLR	0.1uF	50V
C493	VG277000	C.CE.TUBLR	33pF	50V
C494	VF466600	C.CE.TUBLR	10pF	50V
C495	VF466600	C.CE.TUBLR	10pF	50V
C496	VG277000	C.CE.TUBLR	33pF	50V
C497	UR837220	C.EL	22uF	25V
C498	UR837220	C.EL	22uF	25V
C499	VG279600	C.CE.TUBLR	3300pF	16V
C500	VG279600	C.CE.TUBLR	3300pF	16V
C501	VJ599100	C.CE.TUBLR	0.1uF	50V
C502	UR838330	C.EL	330uF	16V
C503	UR837470	C.EL	47uF	16V
C504	VJ599100	C.CE.TUBLR	0.1uF	50V
C505	VJ599100	C.CE.TUBLR	0.1uF	50V
C506	UR837470	C.EL	47uF	16V
C507	UR838100	C.EL	100uF	16V
C508	UR828220	C.EL	220uF	10V
C509	VJ599100	C.CE.TUBLR	0.1uF	50V
C510	VJ599100	C.CE.TUBLR	0.1uF	50V
C511	UR828100	C.EL	100uF	10V
C512	UR837470	C.EL	47uF	16V
C515	VJ599100	C.CE.TUBLR	0.1uF	50V
C516	VF466800	C.CE.TUBLR	100pF	50V
C517	VF466800	C.CE.TUBLR	100pF	50V
C518	VF466800	C.CE.TUBLR	100pF	50V

* New Parts

RX-V395/RX-V395RDS P.C.B. INPUT

Schm Ref.	PART NO.	Description		
C519	UR837100	C.EL	10uF	16V
C520	UR829100	C.EL	1000uF	10V
C521	VF466800	C.CE.TUBLR	100pF	50V
C522	UR837100	C.EL	10uF	16V
C523	UR837100	C.EL	10uF	16V
C524	VF466800	C.CE.TUBLR	100pF	50V
C525	UR829100	C.EL	1000uF	10V
C526	VJ599100	C.CE.TUBLR	0.1uF	50V
C527	UR838330	C.EL	330uF	16V
C528	VG278400	C.CE.TUBLR	220pF	50V
C529	VG278400	C.CE.TUBLR	220pF	50V
C530	VG278400	C.CE.TUBLR	220pF	50V
C531	VG278400	C.CE.TUBLR	220pF	50V
C532	VG278400	C.CE.TUBLR	220pF	50V
C533	VG278400	C.CE.TUBLR	220pF	50V
C534	UR838470	C.EL	470uF	16V
C535	VJ599100	C.CE.TUBLR	0.1uF	50V
C536	VJ599100	C.CE.TUBLR	0.1uF	50V
C537	VJ599100	C.CE.TUBLR	0.1uF	50V
C538	UN866100	C.EL	1uF	50V
C539	VJ599100	C.CE.TUBLR	0.1uF	50V
C540	VJ599100	C.CE.TUBLR	0.1uF	50V
C541	UR838330	C.EL	330uF	16V
C542	VJ599100	C.CE.TUBLR	0.1uF	50V
C543	UR838330	C.EL	330uF	16V
C544	UR866220	C.EL	2.2uF	50V
C545	UA952100	C.MYLAR	100pF	50V
C546	UA952100	C.MYLAR	100pF	50V
C547	UR866220	C.EL	2.2uF	50V
C548	UR866220	C.EL	2.2uF	50V
C549	VF466800	C.CE.TUBLR	100pF	50V
C550	UA952220	C.MYLAR	220pF	50V
C551	UR837470	C.EL	47uF	16V
C552	UR866220	C.EL	2.2uF	50V
C553	UR866220	C.EL	2.2uF	50V
C554	VF466800	C.CE.TUBLR	100pF	50V
C555	UA952220	C.MYLAR	220pF	50V
C556	UR837470	C.EL	47uF	16V
C557	UR837470	C.EL	47uF	16V
C558	UA952220	C.MYLAR	220pF	50V
C559	VF466800	C.CE.TUBLR	100pF	50V
C560	UR866220	C.EL	2.2uF	50V
C561	UR847100	C.EL	10uF	25V
C562	FG651100	C.CE	10pF	50V
C563	FG652100	C.CE	100pF	50V
C564	UR847100	C.EL	10uF	25V
C565	UR847100	C.EL	10uF	25V
C566	FG651100	C.CE	10pF	50V
C567	FG651100	C.CE	10pF	50V
C568	UR847100	C.EL	10uF	25V
C569	VF466800	C.CE.TUBLR	100pF	50V
C571	UA655180	C.MYLAR	0.18uF	50V
C728	UR838220	C.EL	220uF	16V(RT)

* New Parts

Schm Ref.	PART NO.	Description		
C729	UA953100	C.MYLAR	1000pF	50V
C730	UR848470	C.EL	470uF	25V(UCABG)
C730	UR877470	C.EL	47uF	63V(RT)
C731	UR837100	C.EL	10uF	16V(RT)
C732	UA954100	C.MYLAR	0.01uF	50V
C733	UA953100	C.MYLAR	1000pF	50V
C735	VS741700	C.CE.SAFTY	0.01uF	275V
D401	VD631600	DIODE	1SS133,176,HSS104	
D403	VM974200	DIODE.ZENR	HZS5C2TD	5.0V
D708	VD631600	DIODE	1SS133,176,HSS104	
D709	VS997800	DIODE	1T2	
D710	VR253700	DIODE.BRG	S1NB20	1A 200V(RT)
D711	VM975500	DIODE.ZENR	HZS12A2TD	12V(RT)
F701	KB000790	FUSE	T4.0A	250V(ABG)
F701	VS823300	FUSE	T8.0A	125V(UCRT)
F702	VT942900	FUSE	TH2.5A	250V(G)
F703	KB000790	FUSE	T4.0A	250V(RT)
G601	VR463400	TERM.GND	D3.5	TP00385
G702	VR463400	TERM.GND	D3.5	TP00385
IC401	XM356A00	IC	NJM2068LD	
IC409	XP894A00	IC	LC78211	
IC415	XB247A00	IC	uPC4570HA	
IC419	XM356A00	IC	NJM2068LD	
IC422	XB247A00	IC	uPC4570HA	
IC431	XB247A00	IC	uPC4570HA	
IC437	XB247A00	IC	uPC4570HA	
IC441	XB247A00	IC	uPC4570HA	
IC445	XB247A00	IC	uPC4570HA	
IC449	XB247A00	IC	uPC4570HA	
IC452	XB247A00	IC	uPC4570HA	
IC457	XQ212A00	IC	NJM4558LD	
IC461	XQ212A00	IC	NJM4558LD	
IC464	XA507A00	IC	AN78N05	
IC465	XP896A00	IC	LC78213	
IC466	Xi022B00	IC	YSS203B-F	
IC467	XS881A00	IC	LH5P832D-10	PSRAM
IC468	XH436A00	IC	LA7956	
IC477	XP896A00	IC	LC78213	
IC478	XF494A00	IC	LB1641	
IC479	XR040A00	IC	TC9299P	
IC480	XR040A00	IC	TC9299P	
IC483	XB247A00	IC	uPC4570HA	
IC485	XB247A00	IC	uPC4570HA	
PJ401	VU857800	JACK.PIN	6P	
PJ402	VU857800	JACK.PIN	6P	
PJ403	VQ260900	JACK.PIN	4P	
PJ405	VJ695900	JACK.PIN	3P	
PJ406	VR110100	JACK.PIN	2P	
PJ407	V2874800	JACK.PIN	6P	
Q402	iC1815I0	TR	2SC1815 Y	
Q403	iC1815I0	TR	2SC1815 Y	
Q404	iC174020	TR	2SC1740S R,S	
Q405	iC174020	TR	2SC1740S R,S	

* New Parts

RX-V395/RX-V395RDS P.C.B. INPUT & OPERATION

Schm Ref.	PART NO.	Description		
Q709	iC174020	TR	2SC1740S R,S	
Q710	VP768300	TR	2SC4466 O,P,Y(RT)	
Q711	VP883100	TR	2SC1890A D,E(RT)	
R522	HV753220	R.CAR.FP	2.2Ω	1/4W
R527	VP940200	R.MTL.OXD	47Ω	1W
R528	HV753220	R.CAR.FP	2.2Ω	1/4W
R529	HV753220	R.CAR.FP	2.2Ω	1/4W
R530	HV753220	R.CAR.FP	2.2Ω	1/4W
R531	HV753220	R.CAR.FP	2.2Ω	1/4W
R534	HV753220	R.CAR.FP	2.2Ω	1/4W
R551	HV754470	R.CAR.FP	47Ω	1/4W
R577	HV754100	R.CAR.FP	10Ω	1/4W
R578	HV754100	R.CAR.FP	10Ω	1/4W
R579	HV753470	R.CAR.FP	4.7Ω	1/4W
R580	HV753470	R.CAR.FP	4.7Ω	1/4W
△*	RY701	V2712300	RELAY	DC SDTS112(RTABG)
△	RY701	VY735300	RELAY	DC G5P-1(UC)
	SW401	VS602600	SW.SLIDE	SS070-P022 A
△	SW737	VA961800	VOLT.SELCT	ESE-37247-F(RT)
△	T701	XC083A00	TRANS.PWR	(UC)
△	T701	XC084A00	TRANS.PWR	(ABG)
△	T701	XT331A00	TRANS.PWR	(RT)
△	TE701	VT915000	OUTLET.AC	2P(A)
△	TE701	VU543100	OUTLET.AC	2P(UCRT)
△	TE701	VU543300	OUTLET.AC	1P(B)
△	TE701	VU543400	OUTLET.AC	2P(G)
	VR401	VV412800	VR	A100KΩ
	XL401	VK175200	RSNR.CE	11.28MHz
		VJ828000	PIN	IMSA-6024-03E
*		V3000900	P.C.B.	OPERATION(UC)
*		V3001000	P.C.B.	OPERATION(RT)
*		V3001100	P.C.B.	OPERATION(ABG)
*		V3001200	P.C.B.	OPERATION(BG:RDS)
	CB701	VQ963300	CN.BS.PIN	12P
	CB703	Vi878700	CN.BS.PIN	9P
	CB704	VU272000	CN	20P
	CB712	Vi878000	CN.BS.PIN	2P
	CB713	Vi878000	CN.BS.PIN	2P
	C701	UR865470	C.EL	0.47uF 50V
	C702	UR865470	C.EL	0.47uF 50V
	C703	UR837220	C.EL	22uF 25V
	C704	UA952100	C.MYLAR	100pF 50V
	C705	UR837470	C.EL	47uF 16V
	C706	FG651470	C.CE	47pF 50V
	C707	UR866220	C.EL	2.2uF 50V
	C708	UR866220	C.EL	2.2uF 50V
	C709	UR837470	C.EL	47uF 16V
	C710	FG651470	C.CE	47pF 50V
	C711	UA952100	C.MYLAR	100pF 50V
	C712	UR837220	C.EL	22uF 25V

* New Parts

Schm Ref.	PART NO.	Description		
C713	UA655120	C.MYLAR	0.12uF	50V
C714	UA954330	C.MYLAR	0.033uF	50V
C715	UA954330	C.MYLAR	0.033uF	50V
C716	UA655120	C.MYLAR	0.12uF	50V
C717	UR837100	C.EL	10uF	16V
C718	UR866100	C.EL	1uF	50V
C719	UR818330	C.EL	330uF	6.3V
C720	UR818330	C.EL	330uF	6.3V
C721	VU545000	C.EL	47000uF	5.5V
C722	VD930900	C.CE.SMI	0.1uF	25V
C723	VJ599100	C.CE.TUBLR	0.1uF	50V
C724	UR866100	C.EL	1uF	50V
C725	UA655330	C.MYLAR	0.33uF	50V
C726	VJ599100	C.CE.TUBLR	0.1uF	50V
C727	VJ599100	C.CE.TUBLR	0.1uF	50V
C734	VF467300	C.CE.TUBLR	0.01uF	16V
C736	VG278200	C.CE.TUBLR	150pF	50V
C737	VG278200	C.CE.TUBLR	150pF	50V
C738	VG278200	C.CE.TUBLR	150pF	50V
C740	VG278200	C.CE.TUBLR	150pF	50V
C741	VG278200	C.CE.TUBLR	150pF	50V
D701	VM974600	DIODE.ZENR	HZS7A2TD	7.0V
D702	VD631600	DIODE	1SS133,176,HSS104	
D703	VM974600	DIODE.ZENR	HZS7A2TD	7.0V
D704	VD631600	DIODE	1SS133,176,HSS104	
D705	VD631600	DIODE	1SS133,176,HSS104	
D706	VD631600	DIODE	1SS133,176,HSS104	
D707	VD631600	DIODE	1SS133,176,HSS104	
D712	VD631600	DIODE	1SS133,176,HSS104	
D713	VD631600	DIODE	1SS133,176,HSS104	
D714	VM974100	DIODE.ZENR	HZS5B2TD	5.0V
D715	VM974300	DIODE.ZENR	HZS6A2TD	6.0V
D716	VD631600	DIODE	1SS133,176,HSS104	
D717	VD631600	DIODE	1SS133,176,HSS104	
G701	VR463400	TERM.GND	D3.5	TP00385
IC701	XM356A00	IC	NJM2068LD	
* IC705	XV194B00	IC	M38B57M6-126FP	CPU
Q701	iC287820	TR	2SC2878 A,B	
Q702	iC287820	TR	2SC2878 A,B	
Q703	iC287820	TR	2SC2878 A,B	
Q704	iC287820	TR	2SC2878 A,B	
Q705	iC174020	TR	2SC1740S R,S	
Q706	iA093320	TR	2SA933S Q,R	
Q707	iC174020	TR	2SC1740S R,S	
Q708	VD678500	TR.DGT	DTA114ES	
Q709	VD678500	TR.DGT	DTA114ES	
R722	HV755100	R.CAR.FP	100Ω	1/4W
R733	HV755100	R.CAR.FP	100Ω	1/4W
SW701	VG392900	SW.TACT	SKHVAA	
SW702	VG392900	SW.TACT	SKHVAA	
SW703	VG392900	SW.TACT	SKHVAA	
SW704	VG392900	SW.TACT	SKHVAA	
SW705	VG392900	SW.TACT	SKHVAA	

* New Parts

RX-V395/RX-V395RDS P.C.B. OPERATION & TUNER

Schm Ref.	PART NO.	Description		
SW706	VG392900	SW.TACT	SKHVAA	
SW707	VG392900	SW.TACT	SKHVAA	
SW708	VG392900	SW.TACT	SKHVAA	
SW709	VG392900	SW.TACT	SKHVAA	
SW710	VG392900	SW.TACT	SKHVAA	
SW711	VG392900	SW.TACT	SKHVAA	
SW712	VG392900	SW.TACT	SKHVAA	
SW713	VG392900	SW.TACT	SKHVAA	
SW714	VG392900	SW.TACT	SKHVAA	
SW715	VG392900	SW.TACT	SKHVAA	
SW716	VG392900	SW.TACT	SKHVAA	
SW717	VG392900	SW.TACT	SKHVAA	
SW718	VG392900	SW.TACT	SKHVAA	
SW719	VG392900	SW.TACT	SKHVAA	
SW720	VG392900	SW.TACT	SKHVAA	
SW721	VG392900	SW.TACT	SKHVAA	
SW722	VG392900	SW.TACT	SKHVAA	
SW723	VG392900	SW.TACT	SKHVAA	
SW724	VG392900	SW.TACT	SKHVAA	
SW725	VG392900	SW.TACT	SKHVAA	
SW726	VG392900	SW.TACT	SKHVAA	
SW727	VG392900	SW.TACT	SKHVAA	
SW728	VG392900	SW.TACT	SKHVAA	
SW729	VG392900	SW.TACT	SKHVAA	
SW730	VG392900	SW.TACT	SKHVAA	
SW731	VG392900	SW.TACT	SKHVAA	
SW732	VG392900	SW.TACT	SKHVAA	
SW733	VG392900	SW.TACT	SKHVAA	
SW734	VG392900	SW.TACT	SKHVAA	
SW735	VG392900	SW.TACT	SKHVAA	
SW736	VG392900	SW.TACT	SKHVAA	
SW737	VG392900	SW.TACT	SKHVAA	
SW738	VG392900	SW.TACT	SKHVAA	
SW739	VG392900	SW.TACT	SKHVAA	
SW740	VG392900	SW.TACT	SKHVAA	
U701	VU591000	L.DTCT	GP1U271X	
* V701	V3064000	FL.DSPLY	13-BT-165GK	
VR704	VP741800	VR	B20KΩ	
VR705	VP741900	VR	G25KΩ	
VR708	VP742000	VR	MN100KΩ	
* XL701	VE906000	RSNR.CE	4MHz	
* V4098300		SHEET		
* V3422300		SPACER	FL-WIDE	
* V2519300		P.C.B.	TUNER/TU-01(UC)	
* V2519400		P.C.B.	TUNER/TU-01(RT)	
* V2519500		P.C.B.	TUNER/TU-01(ABGL)	
* V2519600		P.C.B.	TUNER/TU-01RDS(BG)	
C1	VG287600	C.EL	100uF	25V
C3	UB050800	C.CE.M.CHP	8pF	50V
C4	UR837470	C.EL	47uF	16V

* New Parts

Schm Ref.	PART NO.	Description		
C5	UB044100	C.CE.M.CHP	0.01uF	50V
C6	UR837470	C.EL	47uF	16V
C7	UM416100	C.EL	1uF	50V
C8	UB044100	C.CE.M.CHP	0.01uF	50V
C9	UB044100	C.CE.M.CHP	0.01uF	50V
C10	UB044100	C.CE.M.CHP	0.01uF	50V
C11	UB013100	C.CE.M.CHP	1000pF	50V
C12	UM397100	C.EL	10uF	16V
C13	UM397100	C.EL	10uF	16V
C14	FG652100	C.CE	100pF	50V
C15	UB013100	C.CE.M.CHP	1000pF	50V
C16	UB051470	C.CE.M.CHP	47pF	50V
C17	UR837470	C.EL	47uF	16V
C19	V4006100	C.CE	10pF	50V
C20	VG287600	C.EL	100uF	25V
C21	UB044470	C.CE.M.CHP	0.047uF	50V
C22	VG290700	C.EL	3.3uF	50V
C23	UB044100	C.CE.M.CHP	0.01uF	50V
C24	UM406470	C.EL	4.7uF	50V
C25	UM416330	C.EL	3.3uF	50V
C26	UM397100	C.EL	10uF	16V
C27	UB044100	C.CE.M.CHP	0.01uF	50V
C28	VA760600	C.CE	10pF	50V
C29	UM416100	C.EL	1uF	50V
C30	UM416100	C.EL	1uF	50V
C31	VG287600	C.EL	100uF	25V
C32	UM415470	C.EL	0.47uF	50V
C33	UM416100	C.EL	1uF	50V
C34	UA954470	C.MYLAR	0.047uF	50V
C35	VG290700	C.EL	3.3uF	50V
C36	UA952270	C.MYLAR	270pF	50V(ABGL)
C36	UA953100	C.MYLAR	1000pF	50V(UCRT)
C37	UA952270	C.MYLAR	270pF	50V(ABGL)
C37	UA953100	C.MYLAR	1000pF	50V(UCRT)
C38	UB012470	C.CE.M.CHP	470pF	50V
C39	VG287200	C.EL	10uF	50V
C40	VG290700	C.EL	3.3uF	50V
C41	UA953390	C.MYLAR	3900pF	50V
C42	UM397220	C.EL	22uF	25V
C43	UA953390	C.MYLAR	3900pF	50V
C44	VG290700	C.EL	3.3uF	50V
C45	UR837470	C.EL	47uF	16V
C46	UR837470	C.EL	47uF	16V
C47	UB012330	C.CE.M.CHP	330pF	50V
C48	UB012560	C.CE.M.CHP	560pF	50V
C49	UA952120	C.MYLAR	120pF	50V(ABGL)
C49	UA953220	C.MYLAR	2200pF	50V(UCRT)
C50	UB044470	C.CE.M.CHP	0.047uF	50V
C51	UR837470	C.EL	47uF	16V
C52	UR837470	C.EL	47uF	16V
C53	UR837470	C.EL	47uF	16V
C54	VA761100	C.CE	27pF	50V
C55	VA761100	C.CE	27pF	50V

* New Parts

RX-V395/RX-V395RDS P.C.B. TUNER

Schm Ref.	PART NO.	Description		
C56	UB044470	C.CE.M.CHP	0.047uF	50V
C57	UB012330	C.CE.M.CHP	330pF	50V
CB4	VQ961900	CN	16P	
D1	VT332900	DIODE	1SS355	
D2	VT332900	DIODE	1SS355	
D3	VU172000	DIODE.ZENR	UDZS5.6BTE-17	5.6V
Fi1	GG000560	FLTR.CE	SFE10.7MS3GHY-A	
Fi2	GG000560	FLTR.CE	SFE10.7MS3GHY-A	
Fi3	VC219000	FLTR.CE	SFZ450JL3	
IC1	XB760A00	IC	LA1266	
IC2	XQ944A00	IC	LC72131	
IC3	iG158100	IC	LA3401	
IC4	XU664A00	IC	LC72720N(BG)	
L1	VU889500	COIL	220uH	
L2	VU889500	COIL	220uH	
L3	VU889500	COIL	220uH	
L4	VU889500	COIL	220uH	
L5	VU889500	COIL	220uH	
PK1	V2716700	TUNER.PK	ENV-172A4G1(ABGL)	
PK1	V2909100	TUNER.PK	ENV-172C8G1R(UCRT)	
PK2	VU333700	COIL.RF.AM	940536051A	
Q1	iC053540	TR	2SC535 A,B,C	
Q2	iC053540	TR	2SC535 A,B,C	
Q3	VD678500	TR.DGT	DTA114ES	
Q4	iC174020	TR	2SC1740S R,S	
Q5	VG722000	TR.DGT	DTC144ES	
Q6	iC181510	TR	2SC1815 Y	
Q7	VD678500	TR.DGT	DTA114ES	
R56	HV754470	R.CAR.FP	47Ω	1/4W
SW1	VS602600	SW.SLIDE	SS070-P022 A(RT)	
T1	VC218600	COIL.DT.FM	10.7MHz	
T2	VR895700	COIL.IF	450KHz	
T3	VT486800	COIL	XYA2(ABGL)	
T4	VQ138200	FLTR.LC	19KHz	
T5	VQ138200	FLTR.LC	19KHz	
TE1	VU477800	TERM.ANT	AJ-2038-040	
TP1	VT969000	PIN.TEST	IRS-2049	
TP2	VT969000	PIN.TEST	IRS-2049	
VR1	VJ694000	VR.TRIM	B47KΩ	
VR2	VJ694000	VR.TRIM	B47KΩ	
XL1	VY734600	RSNR.CRYS	7.2MHz	
XL2	GG000750	RSNR.CE	18.95KHz	
XL3	V3930900	RSNR.CRYS	4.332MHz	
	BB071360	SCR.TERM	8.3x13	
	VR282500	PLATE	ANT.	
*	V2519300	P.C.B.CHP	TUNER/TU-01(UC)	
*	V2519400	P.C.B.CHP	TUNER/TU-01(RT)	
*	V2519500	P.C.B.CHP	TUNER/TU-01(ABGL)	
*	V2519600	P.C.B.CHP	TUNER/TU-01RDS(BG)	
C1	VG287600	C.EL	100uF	25V

* New Parts

Schm Ref.	PART NO.	Description		
C3	UB050800	C.CE.M.CHP	8pF	50V
C4	UR837470	C.EL	47uF	16V
C5	UB044100	C.CE.M.CHP	0.01uF	50V
C6	UR837470	C.EL	47uF	16V
C7	UM416100	C.EL	1uF	50V
C8	UB044100	C.CE.M.CHP	0.01uF	50V
C9	UB044100	C.CE.M.CHP	0.01uF	50V
C10	UB044100	C.CE.M.CHP	0.01uF	50V
C11	UB013100	C.CE.M.CHP	1000pF	50V
C12	UM397100	C.EL	10uF	16V
C13	UM397100	C.EL	10uF	16V
C14	FG652100	C.CE	100pF	50V
C15	UB013100	C.CE.M.CHP	1000pF	50V
C16	UB051470	C.CE.M.CHP	47pF	50V
C17	UR837470	C.EL	47uF	16V
C19	V4006100	C.CE	10pF	50V
C20	VG287600	C.EL	100uF	25V
C21	UB044470	C.CE.M.CHP	0.047uF	50V
C22	VG290700	C.EL	3.3uF	50V
C23	UB044100	C.CE.M.CHP	0.01uF	50V
C24	UM406470	C.EL	4.7uF	50V
C25	UM416330	C.EL	3.3uF	50V
C26	UM397100	C.EL	10uF	16V
C27	UB044100	C.CE.M.CHP	0.01uF	50V
C28	VA760600	C.CE	10pF	50V
C29	UM416100	C.EL	1uF	50V
C30	UM416100	C.EL	1uF	50V
C31	VG287600	C.EL	100uF	25V
C32	UM415470	C.EL	0.47uF	50V
C33	UM416100	C.EL	1uF	50V
C34	UA954470	C.MYLAR	0.047uF	50V
C35	VG290700	C.EL	3.3uF	50V
C36	UA952270	C.MYLAR	270pF	50V(ABGL)
C36	UA953100	C.MYLAR	1000pF	50V(UCRT)
C37	UA952270	C.MYLAR	270pF	50V(ABGL)
C37	UA953100	C.MYLAR	1000pF	50V(UCRT)
C38	UB012470	C.CE.M.CHP	470pF	50V
C39	VG287200	C.EL	10uF	50V
C40	VG290700	C.EL	3.3uF	50V
C41	UA953390	C.MYLAR	3900pF	50V
C42	UM397220	C.EL	22uF	25V
C43	UA953390	C.MYLAR	3900pF	50V
C44	VG290700	C.EL	3.3uF	50V
C45	UR837470	C.EL	47uF	16V
C46	UR837470	C.EL	47uF	16V
C47	UB012330	C.CE.M.CHP	330pF	50V
C48	UB012560	C.CE.M.CHP	560pF	50V
C49	UA952120	C.MYLAR	120pF	50V(ABGL)
C49	UA953220	C.MYLAR	2200pF	50V(UCRT)
C50	UB044470	C.CE.M.CHP	0.047uF	50V
C51	UR837470	C.EL	47uF	16V
C52	UR837470	C.EL	47uF	16V
C53	UR837470	C.EL	47uF	16V

* New Parts

■ RX-V395/RX-V395RDS MECHANICAL PARTS

Ref. No.	PART NO.	Description	Remarks	Markets
* 1	V2591700	FRONT PANEL	RX-V395 BL	
* 1	V2591800	FRONT PANEL	HTR-5130	
* 1-1	V2591300	FRONT PANEL	RX-V395RDS BL	
* 1-1	V2591400	FRONT PANEL	RX-V395RDS BL	
* 1-1	V3147200	FRONT PANEL	RX-V395 TI	
* 1-1	V3230700	FRONT PANEL	HTR-5130RDS	
* 1-4	V2468600	ESCUTCHOEN	3/8	
* 2-1	V3000900	P.C.B.ASS'Y	OPERATION	(UC)
* 2-1	V3001000	P.C.B.ASS'Y	OPERATION	(RT)
* 2-1	V3001100	P.C.B.ASS'Y	OPERATION	(ABG)
* 2-1	V3001200	P.C.B.ASS'Y	OPERATION	RDS (BG)
* 2-2	V3001500	P.C.B.ASS'Y	INPUT	(UC)
* 2-2	V3002400	P.C.B.ASS'Y	INPUT	(RT)
* 2-2	V3002500	P.C.B.ASS'Y	INPUT	(A)
* 2-2	V3317700	P.C.B.ASS'Y	INPUT	(B)
* 2-2	V3317800	P.C.B.ASS'Y	INPUT	(G)
* 2-2	V3457200	P.C.B.ASS'Y	INPUT	RDS (B)
* 2-2	V3457300	P.C.B.ASS'Y	INPUT	RDS (G)
2-8	MF120180	FLEXIBLE FLAT CABLE	20P 180mm	
* 2-11	V2599000	SUB CHASSIS		
* 2-12	V2465500	BUTTON CASE	RX-V395RDS BL	
* 2-12	V2465600	BUTTON CASE	RX-V395 TI	
* 2-12	V2592100	BUTTON CASE	RX-V395 BL	
* 2-12	V2592200	BUTTON CASE	HTR-5130 GP	
* 2-12	V2633800	BUTTON CASE	HTR-5130RDS GP	
* 2-13	V2467000	BUTTON,RDS	BL	
* 2-13	V2467100	BUTTON,RDS	TI	
* 2-14	V3524600	SUPPORT,BUTTON		
* 2-15	V2592700	BUTTON,INPUT	RX-V395/RDS BL	
* 2-15	V2592800	BUTTON,INPUT	RX-V395/RDS TI	
* 2-15	V2989400	BUTTON,INPUT	HTR-5130 GP	
* 2-17	V2467900	ESCUTCHEON,VOL	RX-V395/RDS BL	
* 2-17	V2468000	ESCUTCHEON,VOL	RX-V395/RDS TI	
* 2-17	V2468100	ESCUTCHEON,VOL	HTR-5130 GD	(T)
* 2-17	V2468200	ESCUTCHEON,VOL	HTR-5130 GP	(UCA)
* 2-18	V2599200	SUPPORT,PCB		
2-21	EP600830	BIND HEAD B-TITE SCREW	3x8 FCRM3-BL	
2-23	VT669300	PW HEAD B-TITE SCREW	3x8-8 MFC2	
2-24	EP630220	BIND HEAD P-TITE SCREW	3x8 ZMC2-BL	
2-31	VQ368500	PUSH RIVET	P3545-B	
* 3-1	V2989100	HEAT SINK ASS'Y		
* 3-2	V3002000	P.C.B.ASS'Y	MAIN	(UCRAT)
* 3-2	V3352300	P.C.B.ASS'Y	MAIN	(BG)
3-3	VV849300	SHEET	19x24	
3-12	VQ368500	PUSH RIVET	P3545-B	
3-13	VK173200	SCREW,TRANSISTOR	3x15 SP FCM3	
3-20	VQ368600	PUSH RIVET	P3555-B	
* 7	V2518600	P.C.B.ASS'Y	TUNER/TU-01	(UC)
* 7	V2518700	P.C.B.ASS'Y	TUNER/TU-01	(RT)
* 7	V2518800	P.C.B.ASS'Y	TUNER/TU-01	(ABG)
* 7	V2518900	P.C.B.ASS'Y	TUNER/TU-01RDS	(BG)
15	XV766A00	POWER TRANSFORMER		(U)
15	XV767A00	POWER TRANSFORMER		(RT)

* New Parts

RX-V395/RDS
HTR5130/RDS

Ref. No.	PART NO.	Description	Remarks	Markets
	15	XV768A00	POWER TRANSFORMER	(A)
	15	XV769A00	POWER TRANSFORMER	(BG)
	15	XV775B00	POWER TRANSFORMER	(C)
△	16	V2296800	POWER CORD ASS'Y	(A)
△	16	V2363800	POWER CORD ASS'Y	(UC)
△	16	VN363700	POWER CORD ASS'Y	(G)
△	16	VV437300	POWER CORD ASS'Y	(B)
△	16	VZ542500	POWER CORD ASS'Y	(RT)
*	17	V2438700	CORD STOPPER	10P1
	21	VU590000	BINDING TIE	CBTD001B
*	101	V2609600	TOP COVER	BL
*	101	V2609700	TOP COVER	TI
*	102	V3155400	CHASSIS	
*	103	V2611000	REAR PANEL	RX-V395 (U)
*	103	V2611100	REAR PANEL	RX-V395 (C)
*	103	V2611200	REAR PANEL	RX-V395 (RT)
*	103	V2611300	REAR PANEL	RX-V395 (A)
*	103	V2611600	REAR PANEL	RX-V395RDS (G)
*	103	V2611700	REAR PANEL	HTR-5130 (U)
*	103	V2611800	REAR PANEL	HTR-5130 (C)
*	103	V2611900	REAR PANEL	HTR-5130 (T)
*	103	V2612000	REAR PANEL	HTR-5130 (A)
*	103	V2612100	REAR PANEL	RX-V395RDS (B)
*	103	V3230800	REAR PANEL	HTR-5130RDS (G)
*	103	V3231600	REAR PANEL	HTR-5130RDS (B)
*	103	V3233500	REAR PANEL	RX-V395 (B)
*	103	V3233600	REAR PANEL	RX-V395 (G)
*	112	V2919000	FRAME	
	120	VS025000	LEG	D60xH21
	120	V0042500	LEG	D60xH21
	120	VV544300	LEG	D60xH21
	120	VV544300	LEG	D60xH21
	121	VV148800	KNOB	D40
	121	VV148900	KNOB	D40
	123	VV311000	KNOB	D14
	123	VV311400	KNOB	D14
*	124	V2918800	BUTTON	3x8
*	124	V2918900	BUTTON	3x8
*	128	V2605600	SHEET,WINDOW	
*	131	V2468800	PLATE SIDE L	130
*	131	V2468900	PLATE SIDE L	130
*	132	V2469100	PLATE SIDE R	130
*	132	V2469200	PLATE SIDE R	130
	135	VR264400	SPACER	H8
*	136	V4548600	DAMPER	RX-V395 (BG)
*	138	V2879500	SPACER PCB-M	
*	139	V3198100	DAMPER	GUARD
	155	VQ368600	PUSH RIVET	P3555-B
	160	VN413300	BIND HEAD BONDING B-T.SCREW	3x8 MFZN2-BL
	161	VY731200	BONDING HEAD TAPPING SCREW	3x10 MFNI33
	162	EP600830	BIND HEAD B-TITE SCREW	3x8 FCRM3-BL
	163	EP600250	BIND HEAD B-TITE SCREW	3x8 ZMC2-Y
	166	EG330030	BIND HEAD SCREW	3x6 FCRM3-BL

* New Parts

Ref. No.	PART NO.	Description	Remarks	Markets
167	VT669300	PW HEAD B-TITE SCREW	3x8-8 MFC2	
168	VT669400	PW HEAD B-TITE SCREW	3x15-8 MFC2	
169	VS997700	BIND HEAD S-TITE SCREW	3x10 MFNI33	
170	21991500	PW HEAD S-TITE SCREW	4x8-10 FCRM3-BL	
171	21991500	PW HEAD S-TITE SCREW	4x8-10 FCRM3-BL	BL
171	VH313200	BW HEAD S-TITE SCREW	4x8-10 FNM3-BL	TI
178	03700480	HEXAGONAL CAP NUT	4.0 MFNI33	
		ACCESSORIES		
* 200	V3426000	REMOTE CONTROL TRANSMITTER	RAV202	(UCRAT)
* 200-1	AAX04810	LID (Limited supply part)	113x31	(UCRAT)
200	VZ338200	REMOTE CONTROL TRANSMITTER	SBGH20030A RAV9	(BG)
200-1	CX679050	LID		(BG)
	VQ147100	ANTENNA,FM	1.4m	
	VR248500	ANTENNA,AM LOOP	1.0m	
	VE364900	ANTENNA ADAPTER	PAL 75-300Ω	(B)
	VT948000	ANTENNA ADAPTER		(UC)
		BATTERY,MANGANESE	SUM-4,AAA,R03	(UCRAT)
		BATTERY,MANGANESE	SUM-3,AA,R06	(BG)

* New Parts

RX-V395/RDS
HTR5130/RDS

1 RX-V395/RDS (B,G Models) REMOTE CONTROL TRANSMITTER

2 ■ SCHEMATIC DIAGRAM

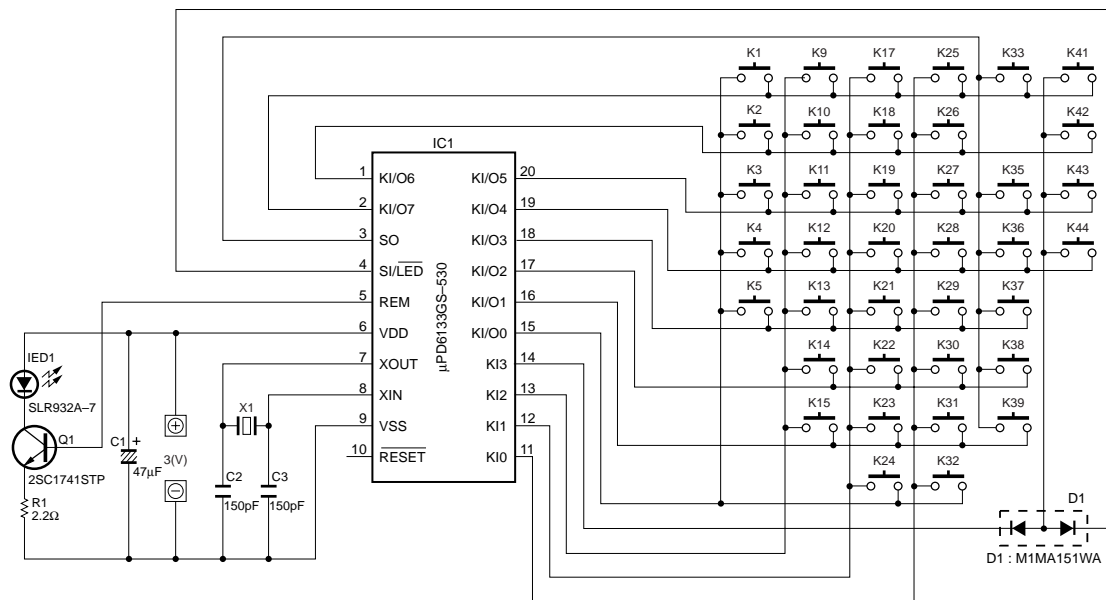

3

4

5

6

7

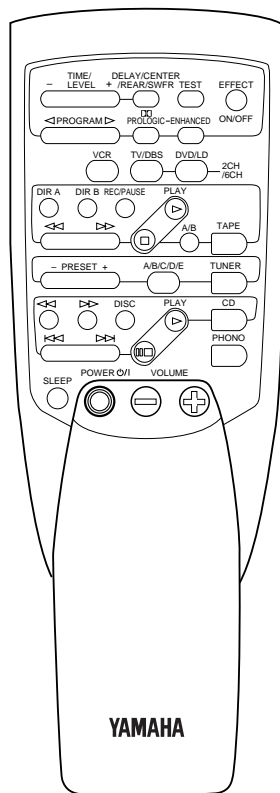

Key No.	FUNCTION	CUSTOM (HEX)	DATA (HEX)
1	EFFECT ON/OFF	7A	56
2	PROGRAM q	7A	59
3	PROGRAM w	7A	58
4	V PROLOGIC	7A	88
5	ENHANCED	7A	89
9	VCR	7A	0F
10	TV/DBS	7A	54
11	DVD/LD	7A	17
12	DIR A	7A	07
13	DIR B	7A	40
14	REC/PAUSE	7A	04
15	PLAY (TAPE)	7A	00
17	e (TAPE)	7A	01
18	r (TAPE)	7A	02
19	a (TAPE)	7A	03
20	DECK A/B	7A	06
21	TAPE	7A	18
22	PRESET -	7A	11
23	PRESET +	7A	10
24	A/B/C/D/E	7A	12
25	TUNER	7A	16
26	e (CD)	7A	0D
27	r (CD)	7A	0C
28	DISC	7A	4F
29	PLAY (CD)	7A	08
30	CD	7A	15
31	t (CD)	7A	0B
32	y (CD)	7A	0A
33	j	7A	09
35	PHONO	7A	14
36	SLEEP	7A	57
37	POWER	7A	1F
38	VOLUME -	7A	1B
39	VOLUME +	7A	1A
41	TIME/LEVEL -	7A	53
42	TIME/LEVEL +	7A	52
43	DELAY/CENTER/REAR	7A	86
44	TEST	7A	85

RX-V395/RDS (U,C,R,A,T,L Models) REMOTE CONTROL TRANSMITTER

SCHEMATIC DIAGRAM

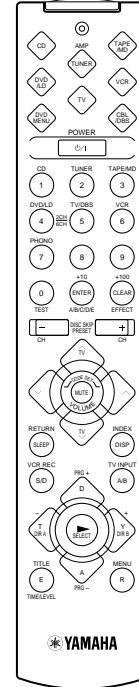
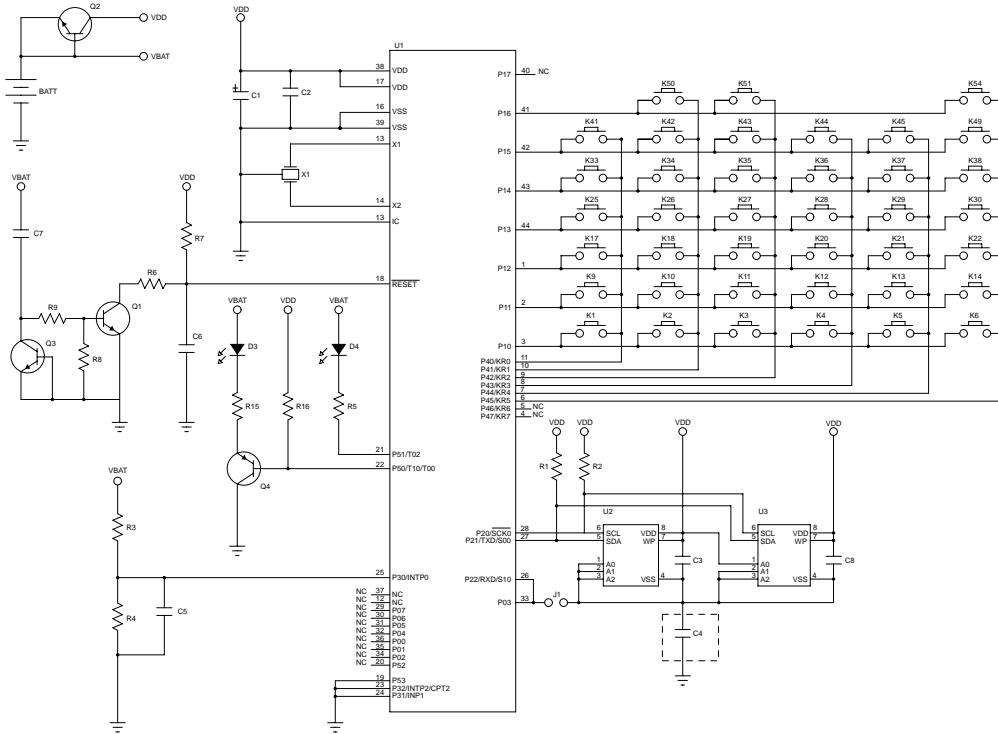

NO	Key Label	Key Type	TV	CABLE/DBS	VCR	DVD/MENU	DVD/LD	CD	TAPE/MD	AMP/TUNER
1	CD	Device								
2	AMP/TUNER	Device								
3	TAPE/MD	Device								
4	DVD/LD	Device								
5	TV	Device								
6	VCR	Device								
7	DVD MENU	Device								
8	CABLE/DBS	Device								
9	POWER	Primary	TV POWER	CBL/DBS POWER	VCR POWER	DVD/LD POWER	CD POWER	TAPE/MD POWER	AMP POWER	
10	1	Primary	CH1	CH1	CH1	1				CD
11	2	Primary	CH2	CH2	CH2	2				TUNER
12	3	Primary	CH3	CH3	CH3	3				TAPE/MD
13	4	Primary	CH4	CH4	CH4	4				DVD/LD
14	5	Primary	CH5	CH5	CH5	5				TV/DBS
15	6	Primary	CH6	CH6	CH6	6				VCR
16	7	Primary	CH7	CH7	CH7	7				PHONO
17	8	Primary	CH8	CH8	CH8	8				V-AUX
18	9	Primary	CH9	CH9	CH9	9				EXT. DECODER
19	0	Primary	CH0	CH0	CH0	0				TEST
20	ENTER	Primary	CH Enter	CH Enter	CH Enter	+10				A/B/C/D/E
21	EFFECT	Primary	AMP EFFECT	+100	AMP EFFECT	CLEAR				AMP EFFECT
22	CH-	Primary	TV CH-	CBL/DBS CH-	VCR CH-	DISC-	DISC-	DISC-		PRESET-
23	CH+	Primary	TV CH+	CBL/DBS CH+	VCR CH+	DISC+	DISC+	DISC+		PRESET+
24	TV VOL+	Primary								TV VOL+
25	VOL-	Primary								TV VOL-
26	MUTE	Primary	TV MUTE							AMP MUTE
27	VOL+	Primary								TV VOL+
28	TV VOL-	Primary								TV VOL-
29	SLEEP	Primary								TV SLEEP
30	DISPLAY	Primary	DISPLAY	DISPLAY	DISPLAY	INDEX	DISPLAY	DISPLAY	DISPLAY	
31	REC	Primary	VCR REC		VCR REC				REC/PAUSE	
32	TV INPUT	Primary								TV INPUT
33	PAUSE	Primary	VCR PAUSE	Up	VCR PAUSE	Up	PAUSE	PAUSE	PAUSE	PRG+
34	SKIP-	Primary		Left		Left	SKIP/CHAP-	SKIP-	DIR A/SKIP-	Down
35	PLAY	Primary	VCR PLAY	Menu Select	VCR PLAY	Select	PLAY	PLAY	PLAY	
36	SKIP+	Primary		Right		Right	SKIP/CHAP+	SKIP+	DIR B/SKIP+	Up
37	STOP	Primary	VCR STOP	Down	VCR STOP	Down	STOP	STOP	STOP	PRG-
38	REW	Primary	VCR REW	RECALL	VCR REW	TITLE	REW	REW	REW	TIME/LEVEL
39	FF	Primary	VCR FF	MENU	VCR FF	MENU	FF	FF	FF	SET MENU
	Library		TV	CABLE DBS (SAT)	VCR	DVD (MENU)	CD	TAPE MD		x
				MENU		AUX LD				
	Default		0101 (PHILIPS)	0006 (PIONEER)	0002 (ASA)	Yamaha (0008) DVD (MENU)	Yamaha CD (0005)	Yamaha TAPE (0004)		AMP (0003)

Parts List for Carbon Resistors

Value	1/4W Type Part No.	1/6W Type Part No.	Value	1/4W Type Part No.	1/6W Type Part No.
1.0 Ω	HJ35 3100	HF85 3100	10 kΩ	HF45 7100	HF45 7100
1.8 Ω	HJ35 3180	*	11 kΩ	HF45 7110	HF45 7110
2.2 Ω	HJ35 3220	HF85 3220	12 kΩ	HJ35 7120	HF85 7120
3.3 Ω	HJ35 3330	HF85 3330	13 kΩ	HF45 7130	HF45 7130
4.7 Ω	HJ35 3470	HF85 3470	15 kΩ	HF45 7150	HF45 7150
5.6 Ω	HJ35 3560	HF85 3560	18 kΩ	HF45 7180	HF45 7180
10 Ω	HF45 4100	HF45 4100	22 kΩ	HF45 7220	HF45 7220
15 Ω	HJ35 4150	HF85 4150	24 kΩ	HF45 7240	HF45 7240
22 Ω	HF45 4220	HF45 4220	27 kΩ	HJ35 7270	HF85 7270
27 Ω	HJ35 4270	HF85 4270	30 kΩ	HF45 7300	HF45 7300
33 Ω	HF45 4330	HF45 4330	33 kΩ	HF45 7330	HF45 7330
39 Ω	HJ35 4470	HF85 4390	36 kΩ	HF45 7360	HF45 7360
47 Ω	HF45 4470	HF45 4470	39 kΩ	HF45 7390	HF45 7390
56 Ω	HF45 4560	HF45 4560	47 kΩ	HF45 7470	HF45 7470
68 Ω	HF45 4680	HF45 4680	51 kΩ	HF45 7510	HF45 7510
75 Ω	HF45 4750	HF45 4750	56 kΩ	HF45 7560	HF45 7560
82 Ω	HF45 4820	HF45 4820	62 kΩ	HF45 7620	HF45 7620
91 Ω	HF45 4910	HF45 4910	68 kΩ	HF45 7680	HF45 7680
100 Ω	HF45 5100	HF45 5100	82 kΩ	HF45 7820	HF45 7820
110 Ω	HJ35 5110	HF85 5110	91 kΩ	HF45 7910	HF45 7910
120 Ω	HF45 5120	HF45 5120	100 kΩ	HF45 8100	HF45 8100
150 Ω	HF45 5150	HF45 5150	110 kΩ	HF45 8110	HF45 8110
160 Ω	HJ35 5160	*	120 kΩ	HF45 8120	HF45 8120
180 Ω	HF45 5180	HF45 5180	150 kΩ	HF45 8150	HF45 8150
200 Ω	HF45 5200	HF45 5200	180 kΩ	HF45 8180	HF45 8180
220 Ω	HF45 5220	HF45 5220	220 kΩ	HJ35 8220	HF85 8220
270 Ω	HF45 5270	HF45 5270	270 kΩ	HF45 8270	HF45 8270
330 Ω	HF45 5330	HF45 5330	300 kΩ	HF45 8300	HF45 8300
390 Ω	HF45 5390	HF45 5390	330 kΩ	HF45 8330	HF45 8330
430 Ω	HF45 5430	HF45 5430	390 kΩ	HJ35 8390	HF85 8390
470 Ω	HF45 5470	HF45 5470	470 kΩ	HF45 8470	HF45 8470
510 Ω	HF45 5510	HF45 5510	560 kΩ	HJ35 8560	HF85 8560
560 Ω	HF45 5560	HF45 5560	680 kΩ	HJ35 8680	HF85 8680
680 Ω	HF45 5680	HF45 5680	820 kΩ	HJ35 8820	HF85 8820
820 Ω	HF45 5820	HF45 5820	1.0 MΩ	HF45 9100	HF45 9100
910 Ω	HF45 5910	HF45 5910	1.2 MΩ	HJ35 9120	*
1.0 kΩ	HF45 6100	HF45 6100	1.5 MΩ	HJ35 9150	HF85 9150
1.2 kΩ	HF45 6120	HF45 6120	1.8 MΩ	HJ35 9180	HF85 9180
1.5 kΩ	HF45 6150	HF45 6150	2.2 MΩ	HJ35 9220	HF85 9220
1.8 kΩ	HF45 6180	HF45 6180	3.3 MΩ	HJ35 9330	HF85 9330
2.0 kΩ	HJ35 6200	HF85 6200	3.9 MΩ	HJ35 9390	*
2.2 kΩ	HF45 6220	HF45 6220	4.7 MΩ	HJ35 9470	HF85 9470
2.4 kΩ	HJ35 6240	HF85 6240			
2.7 kΩ	HF45 6270	HF45 6270			
3.0 kΩ	HF45 6300	HF45 6300			
3.3 kΩ	HF45 6330	HF45 6330			
3.6 kΩ	HJ35 6360	HF85 6360			
3.9 kΩ	HF45 6390	HF45 6390			
4.7 kΩ	HF45 6470	HF45 6470			
5.1 kΩ	HF45 6510	HF45 6510			
5.6 kΩ	HF45 6560	HF45 6560			
6.8 kΩ	HF45 6680	HF45 6680			
8.2 kΩ	HF45 6820	HF45 6820			
9.1 kΩ	HF45 6910	HF45 6910			

1/4W Type

HJ35 ○○○○

10mm

1/6W Type

HF45 ○○○○

HF85 ○○○○

5mm

RX-V395/RDS HTR5130/RDS

YAMAHA