

AV RECEIVER RX-V396/RX-V396RDS HTR-5230/HTR-5230RDS SERVICE MANUAL

IMPORTANT NOTICE

This manual has been provided for the use of authorized YAMAHA Retailers and their service personnel. It has been assumed that basic service procedures inherent to the industry, and more specifically YAMAHA Products, are already known and understood by the users, and have therefore not been restated.

WARNING: Failure to follow appropriate service and safety procedures when servicing this product may result in personal injury, destruction of expensive components, and failure of the product to perform as specified. For these reasons, we advise all YAMAHA product owners that any service required should be performed by an authorized YAMAHA Retailer or the appointed service representative.

IMPORTANT: The presentation or sale of this manual to any individual of firm does not constitute authorization, certification or recognition of any applicable technical capabilities, or establish a principle-agent relationship of any form.

The data provided is believed to be accurate and applicable to the unit(s) indicated on the cover. The research, engineering, and service departments of YAMAHA are continually striving to improve YAMAHA products. Modifications are, therefore, inevitable and specifications are subject to change without notice or obligation to retrofit. Should any discrepancy appear to exist, please contact the distributor's Service Division.

WARNING: Static discharges can destroy expensive components. Discharge any static electricity your body may have accumulated by grounding yourself to the ground buss in the unit (heavy gauge black wires connect to this buss).

IMPORTANT: Turn the unit OFF during disassembly and part replacement. Recheck all work before you apply power to the unit.

■ CONTENTS

TO SERVICE PERSONNEL	1	AMP ADJUSTMENT	21
REMOTE CONTROL PANELS	1	TUNER ADJUSTMENT	22~25
FRONT PANELS	2	IC DATA	26~34
REAR PANELS	3~4	DISPLAY DATA	35
SPECIFICATIONS	5~6	BLOCK DIAGRAM	36~39
INTERNAL VIEW	7	PRINTED CIRCUIT BOARD	40~59
DISASSEMBLY PROCEDURES	7	SCHEMATIC DIAGRAM	60~67
SELF DIAGNOSIS FUNCTION	8~19	PARTS LIST	68~85
FACTORY PRESET	20	REMOTE CONTROL TRANSMITTER	86~88



このサービスマニュアルは、エコマーク認定の再生紙を使用しています。
This Service Manual uses recycled paper.



■ TO SERVICE PERSONNEL

1. Critical Components information
Components having special characteristics are marked \triangle and must be replaced with parts having specifications equal to those originally installed.
2. Leakage Current Measurement (For 120V Model only)
When service has been completed, it is imperative that you verify that all exposed conductive surfaces are properly insulated from supply circuits.
 - Meter impedance should be equivalent to 1500 ohm shunted by 0.15 μ F.
 - Leakage current must not exceed 0.5mA.
 - Be sure to test for leakage with the AC plug in both polarities.

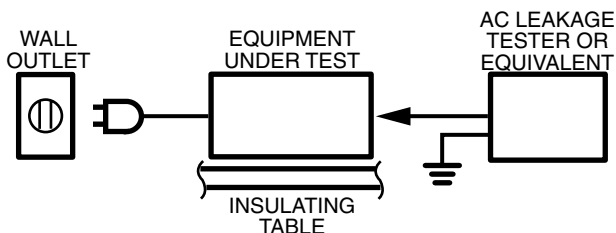

"CAUTION"

"F804: FOR CONTINUED PROTECTION AGAINST RISK OF FIRE, REPLACE ONLY WITH SAME TYPE 6.0A, 125V FUSE."

ATTENTION

F804: UTILISER UN FUSIBLE DE RECHANGE DE MEME TYPE DE 6.0A, 125V FUSE

WARNING: CHEMICAL CONTENT NOTICE!

The solder used in the production of this product contains LEAD. In addition, other electrical/electronic and/or plastic (where applicable) components may also contain traces of chemicals found by the California Health and Welfare Agency (and possibly other entities) to cause cancer and/or birth defects or other reproductive harm.

DO NOT PLACE SOLDER, ELECTRICAL/ELECTRONIC OR PLASTIC COMPONENTS IN YOUR MOUTH FOR ANY REASON WHATSOEVER!

Avoid prolonged, unprotected contact between solder and your skin! When soldering, do not inhale solder fumes or expose eyes to solder/flux vapor!

If you come in contact with solder or components located inside the enclosure of this product, wash your hands before handling food.

■ REMOTE CONTROL PANELS

▼ U,C,R,T and A models

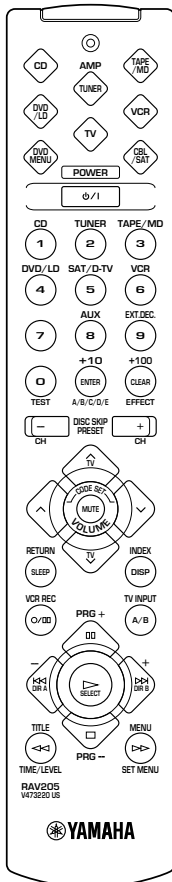

▼ B and G models

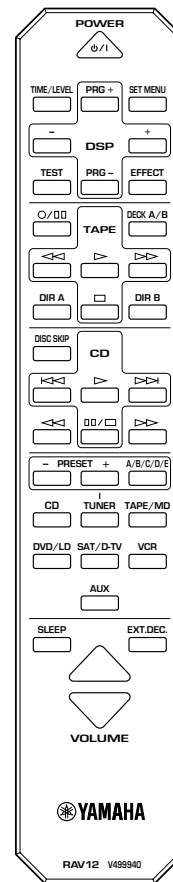

FRONT PANELS

- ▼ RX-V396 • U, C, A, B and G models→BL (Black model)
 • R and T models→BL (Black model) and GD (Gold model)

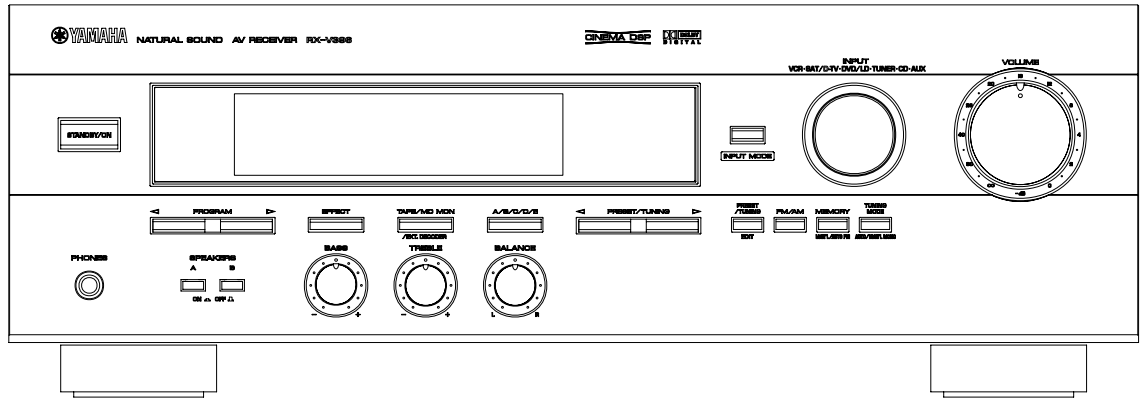

- ▼ RX-V396RDS • B and G models→BL (Black model)

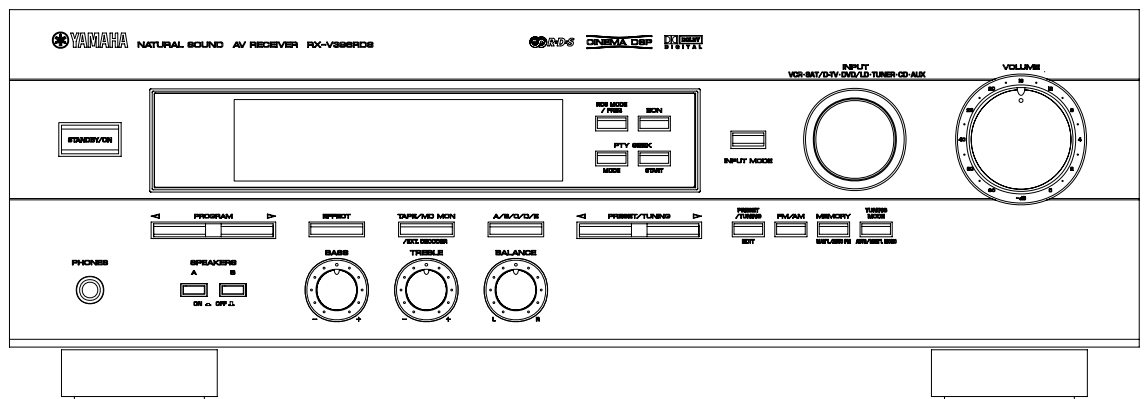

- ▼ HTR-5230 • U, C and A models→BL (Black model)
 • T models→BL (Black model) and GD (Gold model)

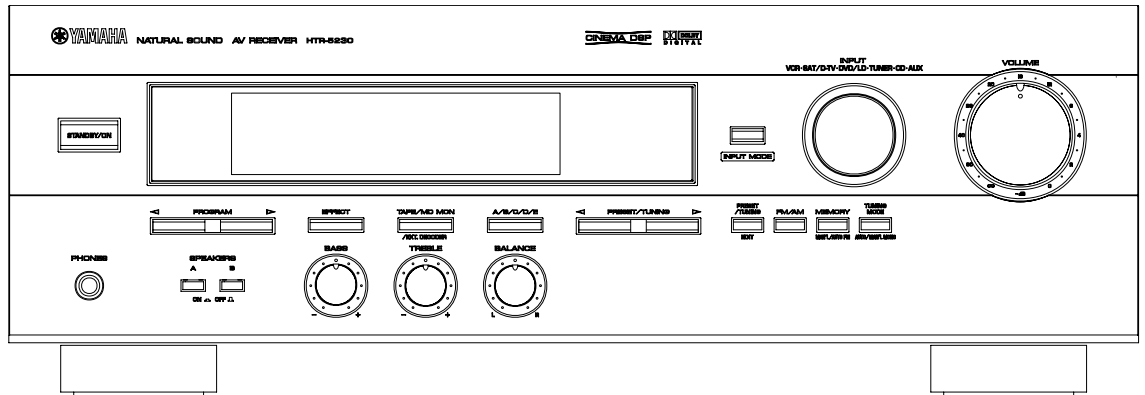

- ▼ HTR-5230RDS • B and G models→BL (Black model)

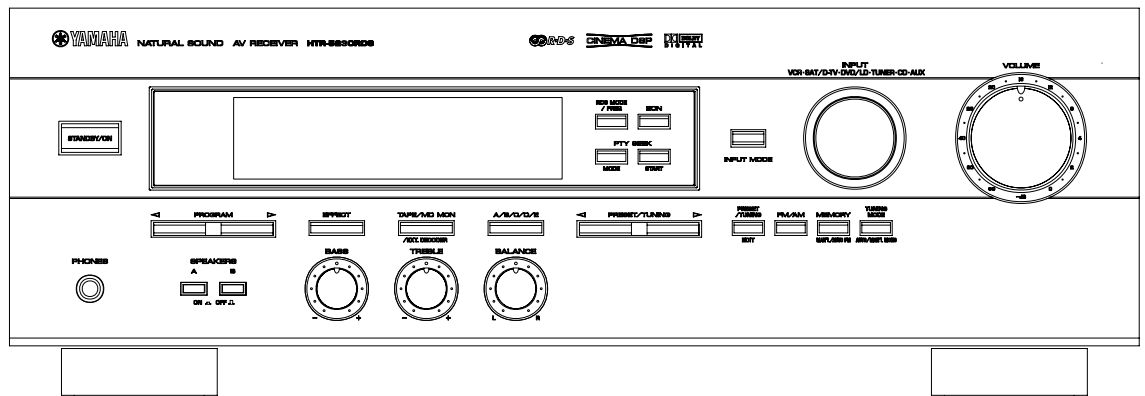

REAR PANELS

▼ RX-V396/HTR-5230 U model

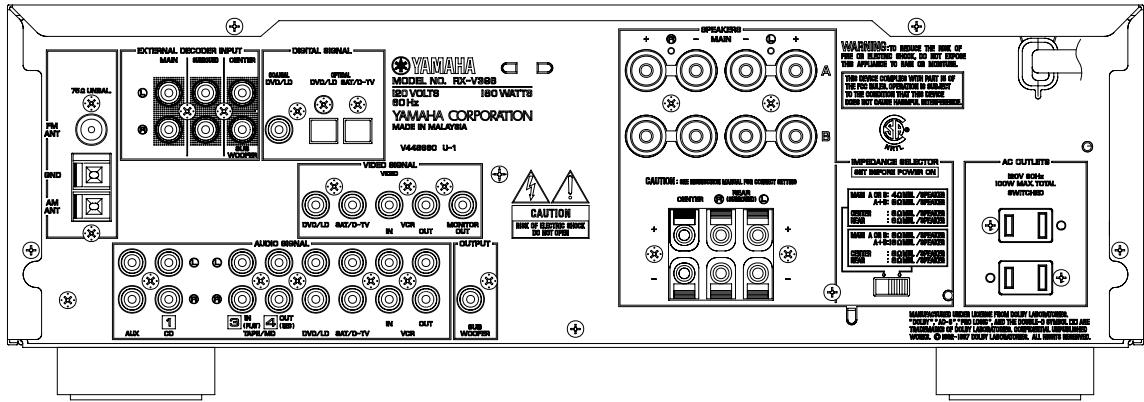

▼ RX-V396/HTR-5230 C model

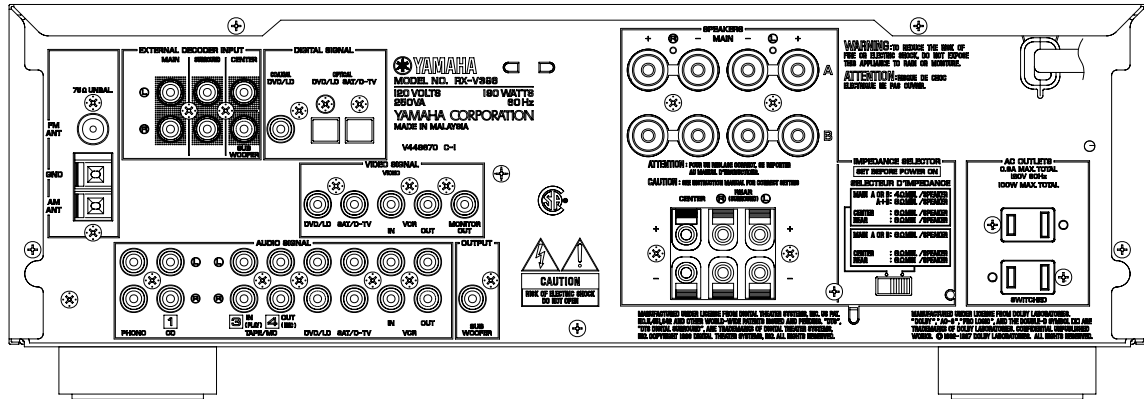

▼ RX-V396 R model

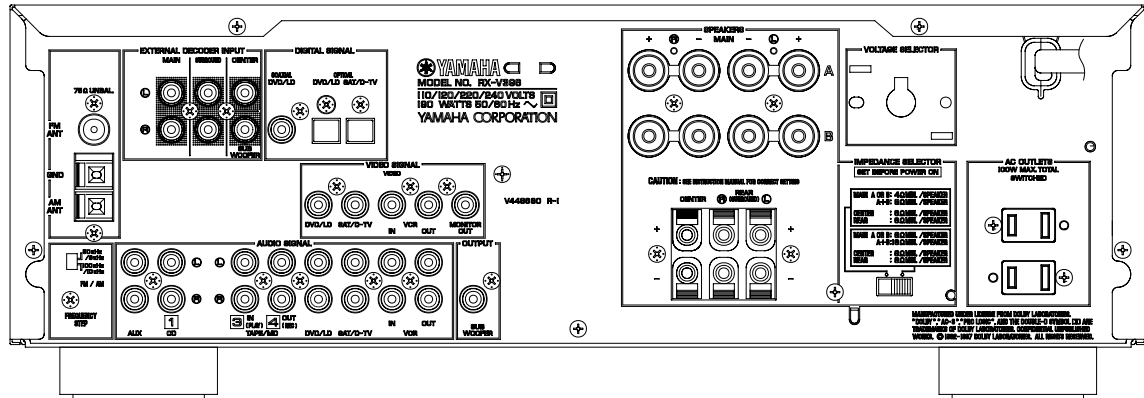

▼ RX-V396/HTR-5230 T model

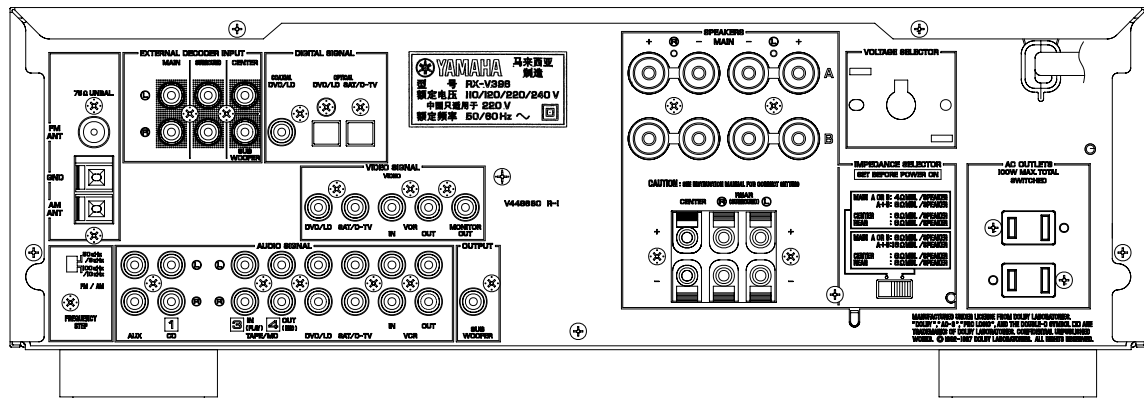

▼ RX-V396/HTR-5230 A model

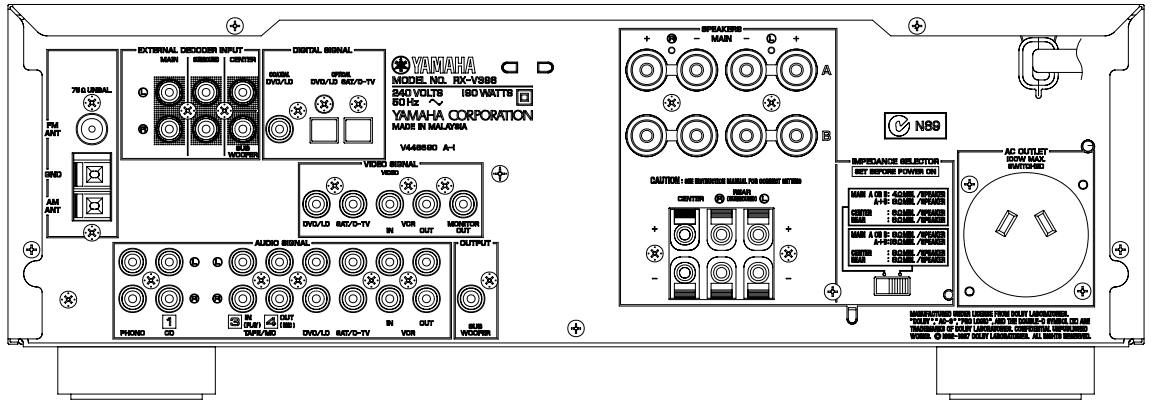

▼ RX-V396/RX-V396RDS/HTR-5230RDS B model

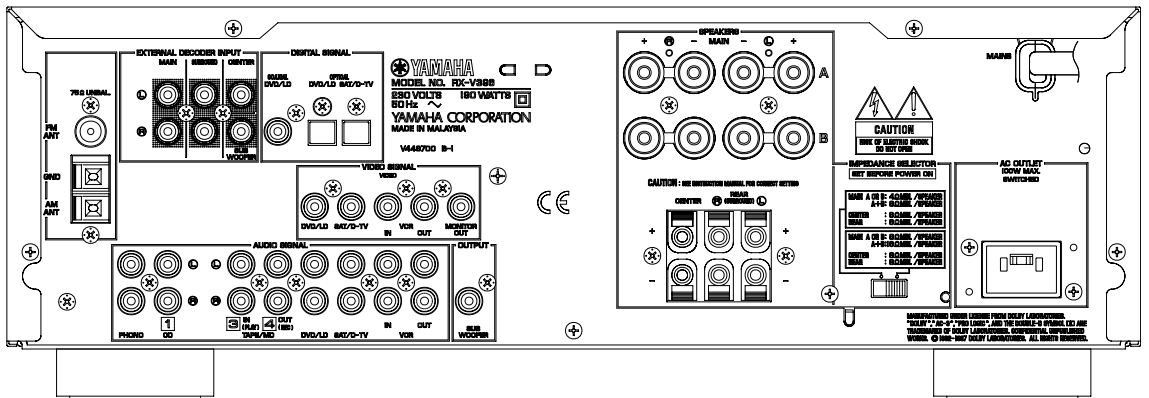

▼ RX-V396/RX-V396RDS/HTR-5230RDS G model

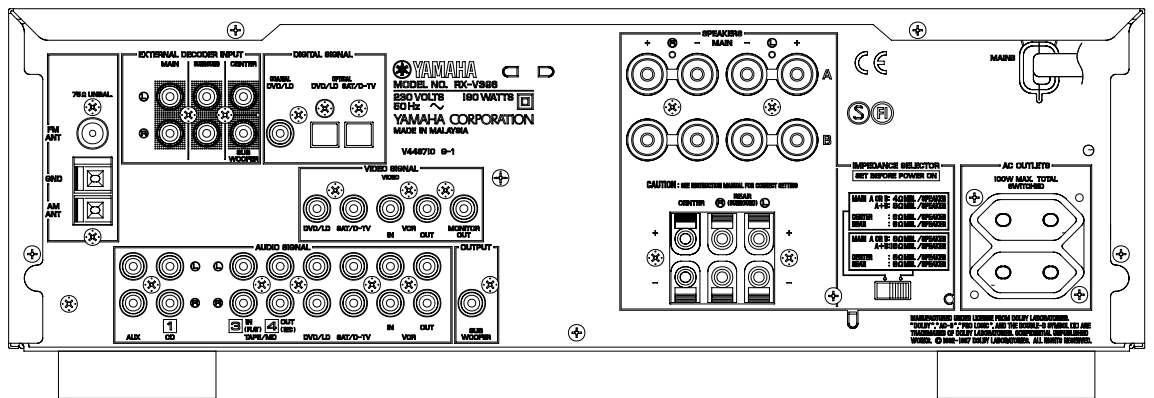

■ SPECIFICATIONS

■AUDIO SECTION

Minimum RMS Output Power Per Channel (Power Amp. Section)

U, C models		
MAIN L/R, REAR L/R		
20Hz to 20kHz, 0.06% THD, 8Ω	60W+60W	
1kHz, 0.09% THD, 8Ω	70W+70W	
CENTER		
20Hz to 20kHz, 0.06% THD, 8Ω	60W	
1kHz, 0.09% THD, 8Ω	70W	
R,T,A,B,G,L models		
MAIN L/R, REAR L/R		
20Hz to 20kHz, 0.06% THD, 8Ω	60W+60W	
1kHz, 0.09% THD, 8Ω	65W+65W	
CENTER		
20Hz to 20kHz, 0.06% THD, 8Ω	60W	
1kHz, 0.09% THD, 8Ω	65W	

Maximum Power (EIAJ)

R, T models only		
MAIN L/R, REAR L/R		
1kHz, 10% THD, 8Ω	95W+95W	
CENTER, 1kHz, 10% THD, 8Ω	95W	

Dynamic Power Per Channel (IHF)

MAIN L/R		
U, C models		
8/6/4/2Ω		
90W+90W/110W+110W/130W+130W/150W+150W		
R, T models		
8/6/4/2Ω		
85W+85W/105W+105W/125W+125W/145W+145W		

DIN Standard Output Power Per Channel

G model only		
MAIN L/R, 1kHz, 0.7% THD, 4Ω	90W+90W	

Dynamic Headroom(8Ω)

U, C models only	1.76dB	
------------------	--------	--

IEC Power

G model only		
MAIN L/R, 1kHz, 0.06% THD, 8Ω	65W+65W	

Damping Factor (SPEAKER A)

MAIN L/R, 20Hz to 20kHz, 8Ω	60	
-----------------------------	----	--

Input Sensitivity/Input Impedance

CD etc.	150mV/47kΩ	
MAIN L/R (EXTERNAL DECODER)	150mV/47kΩ	
CENTER	150mV/40kΩ	
SURROUND L/R	150mV/40kΩ	
SUB WOOFER	150mV/40kΩ	

Maximum Input Signal Level (1kHz)

CD etc. (EFFECT ON), 0.5% THD	2.2V	
-------------------------------	------	--

Output Level/Output Impedance

REC OUT	150mV/1.2kΩ	
SUB WOOFER (MAIN SP : SMALL)	4V/1.2kΩ	

Headphone Jack Rated Output/Impedance

CD etc., Input=1kHz, 150mV, RL=8Ω	0.47V/390Ω	
-----------------------------------	------------	--

Frequency Response(20Hz to 20kHz)

CD etc., MAIN	0±0.5dB	
---------------	---------	--

Total Harmonic Distortion(20Hz to 20kHz)

CD etc.(EFFECT OFF) to MAIN SP OUT(30W/8Ω)	0.025%	
--	--------	--

Signal-to-Noise Ratio(IHF-A Network)

CD etc.(EFFECT OFF), Input shorted, SP OUT	96dB	
--	------	--

Residual Noise(IHF-A Network)

MAIN L/R, SP OUT	150μV	
------------------	-------	--

Channel Separation(Vol. -30dB, EFFECT OFF)

CD etc, Input 5.1kΩ terminated, 1kHz/10kHz	60dB/45dB	
--	-----------	--

Tone Control Characteristics

BASS : Boost/Cut	±10dB(50Hz)	
: Turnover Frequency	350Hz	
TREBLE : Boost/Cut	±10dB(20kHz)	
: Turnover Frequency	3.5kHz	

Filter Characteristics

MAIN, CENTER, REAR SP SMALL : H.P.F.	
	fc=90Hz, 12dB/oct.
SUB WOOFER : L.P.F.	
	fc=90Hz, 18dB/oct.

■FM SECTION

Tuning Range

U, C models	87.5 to 107.9MHz
R, T models (Frequency Step: 100kHz)	87.5 to 108.0MHz
(Frequency Step: 50kHz)	87.50 to 108.00MHz
A, B, G models	87.50 to 108.00MHz

50dB Quieting Sensitivity (IHF)

U, C, R, T models only	
Mono, 1kHz, 100% mod	1.6μV(15.3dBf)
Stereo, 1kHz, 100% mod	23μV(38.5dBf)

Usable Sensitivity (DIN)

A, B, G models only	
DIN, Mono(S/N 26dB)	0.9μV
DIN, Stereo(S/N 46dB)	28μV

Alternate Channel Selectivity

U, C, R, T models (±400kHz)	75dB
A, B, G models (±300kHz)	
Selectivity(two signals, 40kHz Dev.)	55dB

Signal-to-Noise Ratio

U, C, R models (IHF)	
Mono/Stereo	81dB/75dB
A, B, G models (DIN-Weighted, 40kHz Dev.)	
Mono/Stereo	75dB/69dB

Harmonic Distortion (1kHz)

Mono/Stereo	0.1%/0.2%
-------------	-----------

Stereo Separation (1kHz)

	48dB
--	------

Frequency Response (20Hz to 15kHz)

	0±1dB
--	-------

Output Level (1kHz)

U, C, R, T models (100% mod.)	550mV
A, B, G models (40kHz Dev.)	550mV

Antenna Input

	75Ω unbalanced
--	----------------

■AM SECTION

Tuning Range

U, C models	530 to 1710kHz
R, T models (Frequency Step : 10kHz)	530 to 1710kHz
(Frequency Step : 9kHz)	531 to 1611kHz
A, B, G models	531 to 1611kHz

Usable Sensitivity

	300μV/m
--	---------

Signal-to-Noise Ratio

	52dB
--	------

Output Level (1kHz, 30% mod.)

	150mV
--	-------

Antenna

	Loop antenna
--	--------------

VIDEO SECTION

Video Signal Type	
U, C models	NTSC
R model	NTSC/PAL
T, A, B, G models	PAL
Video Signal Level	
1Vp-p/75Ω	
Maximum Input Level	
1.5Vp-p	
Signal-to-Noise Ratio	
50dB	
Monitor Output Frequency Response(-3dB)	
5Hz~10MHz	

GENERAL

Power Supply	
U, C models	AC120V, 60Hz
R model	AC110/120/220/240V, 50/60Hz
T models	AC220V, 50Hz
A model	AC240V, 50Hz
B, G models	AC230V, 50Hz
Power Consumption	
U model	180W
R, T, A, B, G models	190W
C model	190W/250VA
Standby Power Consumption	
U, C, models	0.90W
A, B, G models	0.96W
Maximum Power Consumption	
R model only	
5CH Simultaneous output, 10% THD	480W
AC Outlet	
U, C, R, T, G models, Switched x 2	100W max(Total)
A, B models, Switched x 1	100W max
Dimensions(W x H x D)	
435 x 151 x 390.5mm	
(17-1/8" x 5-15/16" x 15-3/8")	
Weight	
10kg(23lbs.)	
Accessories	
Remote Control Transmitter x 1	
Indoor FM antenna x 1	
AM loop antenna x 1	
Battery	
U, C, R, T, A models	
(size "AAA", "R03") x 4	
B, G models	
(size "AA", "R06") x 2	

Power Consumption	
U model	180W
R, T, A, B, G models	190W
C model	190W/250VA
Standby Power Consumption	
U, C, models	0.90W
A, B, G models	0.96W
Maximum Power Consumption	
R model only	
5CH Simultaneous output, 10% THD	480W
AC Outlet	
U, C, R, T, G models, Switched x 2	100W max(Total)
A, B models, Switched x 1	100W max
Dimensions(W x H x D)	
435 x 151 x 390.5mm	
(17-1/8" x 5-15/16" x 15-3/8")	
Weight	
10kg(23lbs.)	
Accessories	
Remote Control Transmitter x 1	
Indoor FM antenna x 1	
AM loop antenna x 1	
Battery	
U, C, R, T, A models	
(size "AAA", "R03") x 4	
B, G models	
(size "AA", "R06") x 2	

Standby Power Consumption	
U, C, models	0.90W
A, B, G models	0.96W
Maximum Power Consumption	
R model only	
5CH Simultaneous output, 10% THD	480W
AC Outlet	
U, C, R, T, G models, Switched x 2	100W max(Total)
A, B models, Switched x 1	100W max
Dimensions(W x H x D)	
435 x 151 x 390.5mm	
(17-1/8" x 5-15/16" x 15-3/8")	
Weight	
10kg(23lbs.)	
Accessories	
Remote Control Transmitter x 1	
Indoor FM antenna x 1	
AM loop antenna x 1	
Battery	
U, C, R, T, A models	
(size "AAA", "R03") x 4	
B, G models	
(size "AA", "R06") x 2	

Maximum Power Consumption	
R model only	
5CH Simultaneous output, 10% THD	480W
AC Outlet	
U, C, R, T, G models, Switched x 2	100W max(Total)
A, B models, Switched x 1	100W max
Dimensions(W x H x D)	
435 x 151 x 390.5mm	
(17-1/8" x 5-15/16" x 15-3/8")	
Weight	
10kg(23lbs.)	
Accessories	
Remote Control Transmitter x 1	
Indoor FM antenna x 1	
AM loop antenna x 1	
Battery	
U, C, R, T, A models	
(size "AAA", "R03") x 4	
B, G models	
(size "AA", "R06") x 2	

AC Outlet	
U, C, R, T, G models, Switched x 2	100W max(Total)
A, B models, Switched x 1	100W max
Dimensions(W x H x D)	
435 x 151 x 390.5mm	
(17-1/8" x 5-15/16" x 15-3/8")	
Weight	
10kg(23lbs.)	
Accessories	
Remote Control Transmitter x 1	
Indoor FM antenna x 1	
AM loop antenna x 1	
Battery	
U, C, R, T, A models	
(size "AAA", "R03") x 4	
B, G models	
(size "AA", "R06") x 2	

Dimensions(W x H x D)	
435 x 151 x 390.5mm	
(17-1/8" x 5-15/16" x 15-3/8")	
Weight	
10kg(23lbs.)	
Accessories	
Remote Control Transmitter x 1	
Indoor FM antenna x 1	
AM loop antenna x 1	
Battery	
U, C, R, T, A models	
(size "AAA", "R03") x 4	
B, G models	
(size "AA", "R06") x 2	

Weight	
10kg(23lbs.)	
Accessories	
Remote Control Transmitter x 1	
Indoor FM antenna x 1	
AM loop antenna x 1	
Battery	
U, C, R, T, A models	
(size "AAA", "R03") x 4	
B, G models	
(size "AA", "R06") x 2	

Accessories	
Remote Control Transmitter x 1	
Indoor FM antenna x 1	
AM loop antenna x 1	
Battery	
U, C, R, T, A models	
(size "AAA", "R03") x 4	
B, G models	
(size "AA", "R06") x 2	

* Specifications subject to change without notice.
U U. S. A. model **A** Australian model
C Canadian model **B** British model
R General model **G** European model
T China model

BL.....Black model **GD**.....Gold model
TI.....Titan model

Manufactured under license from Dolby Laboratories.
 "DOLBY", "AC-3", "PRO LOGIC", and the double-D symbol  are trademarks of Dolby Laboratories.
 Confidential unpublished works.
 ©1992-1997 Dolby Laboratories. All rights reserved.

DIMENSIONS

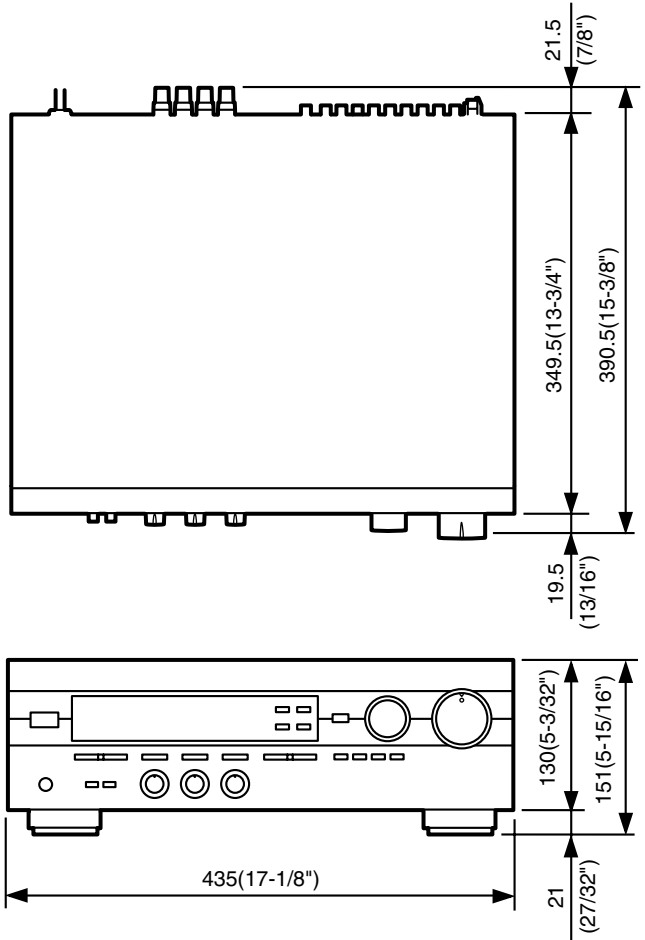

Units: mm (inch)

WARNING
 Do not change the **IMPEDANCE SELECTOR** switch setting while the power to this unit is on, otherwise this unit may be damaged.

IMPEDANCE SELECTOR

The diagram shows the internal mechanism of the impedance selector switch. It includes labels for 'VOLUME MOTOR', 'IMPEDANCE SELECTOR (SET BEFORE POWER ON)', and 'AC OUTLETS (DO NOT MANUALLY SWITCH)'. The switch is shown in three positions: A, B, and C. Position A is for 'IMPEDANCE SELECTOR (SET BEFORE POWER ON)'. Position B is for 'IMPEDANCE SELECTOR (SET BEFORE POWER ON)'. Position C is for 'IMPEDANCE SELECTOR (SET BEFORE POWER ON)'. The diagram also shows the 'AC OUTLETS (DO NOT MANUALLY SWITCH)' and the 'VOLUME MOTOR'.

INTERNAL VIEW

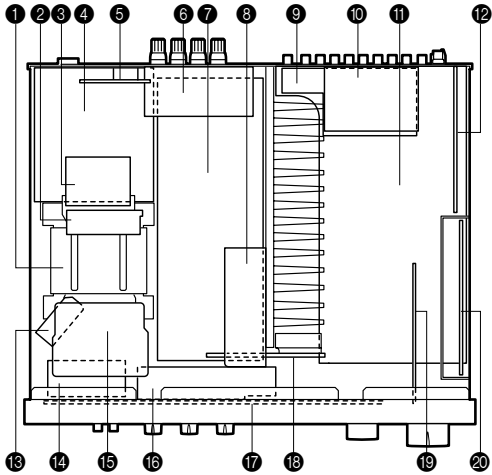

- | | |
|------------------------|-------------------------|
| 1 POWER TRANSFORMER | 11 P.C.B. INPUT (1) |
| 2 P.C.B. MAIN (6) | 12 P.C.B. TUNER |
| 3 P.C.B. MAIN (5) | 13 P.C.B. OPERATION (7) |
| 4 P.C.B. MAIN (2) | 14 P.C.B. MAIN (4) |
| 5 P.C.B. MAIN (7) | 15 P.C.B. INPUT (2) |
| (R, T models only) | 16 P.C.B. OPERATION (2) |
| 6 P.C.B. MAIN (3) | 17 P.C.B. OPERATION (1) |
| 7 P.C.B. MAIN (1) | 18 P.C.B. OPERATION (4) |
| 8 P.C.B. OPERATION (5) | 19 P.C.B. INPUT (4) |
| 9 P.C.B. OPERATION (6) | 20 P.C.B. DSP |
| 10 P.C.B. INPUT (3) | |

DISASSEMBLY PROCEDURES

(Remove parts in disassembly order as numbered.)

1. Removal of Top Cover

Remove 4 screws (1) and 4 screws (2) in Fig. 1.

2. Removal of Front Panel

- Remove 5 knobs.
- Remove 6 screws (3) in Fig. 1.

3. Before Checking and Parts Replacement of Main Amplifier [P.C.B. MAIN (1)]

- Remove 2 screws (4) fixing the Main Speaker terminal in Fig. 2.
- Take out the P.C.B. MAIN (3) to Left side in Fig. 4.
- Remove 3 screws (5) fixing the Center/Rear Speaker terminal and the Heat Sink in Fig. 2.
- Remove the Binding Tie fixing P.C.B. MAIN (1)'s wiring in Fig. 3.

Note) When the assembling, P.C.B. MAIN (1)'s wiring regardfully for ungenerated noise induction.

- Remove 2 screws (6) fixing the Main Unit in Fig. 3.
 - While pull out the Main Unit to the Front Panel side, place the Main Unit on its side as shown in Fig. 4.
 - Connect to ground by shorting G201 on P.C.B. MAIN (1) and the chassis.
- Note)** When unconnected to ground, the protection function is active.
- Insert the insulator seet (Cloth, Paper or equivalent) so that unshorted the between bottom side of P.C.B. MAIN (1) and the chassis.
 - Insert the insulator seet (Cloth, Paper or equivalent) so that unshorted the between back side of Front Panel and the Heat Sink.
 - Using a string, fix the between screw-hole of the Heat Sink and screw-hole of the Front Panel in Fig. 4.

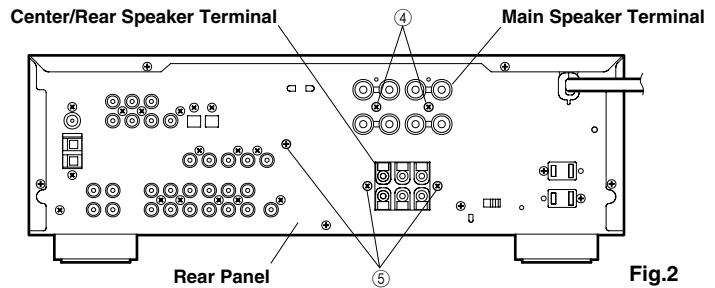

Fig.2

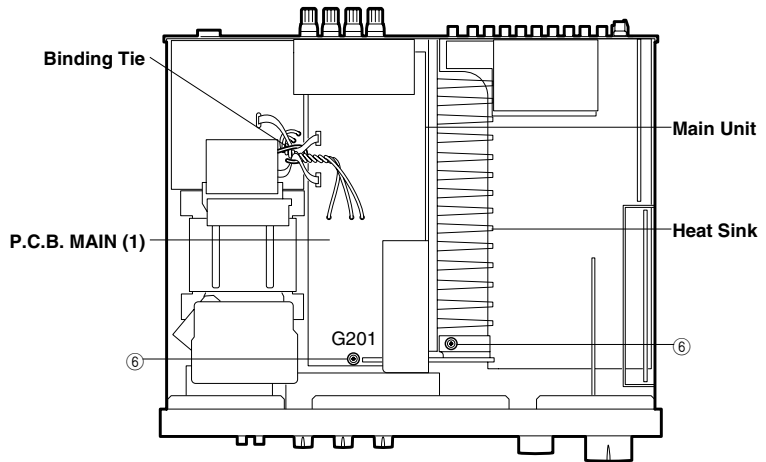

Fig.3

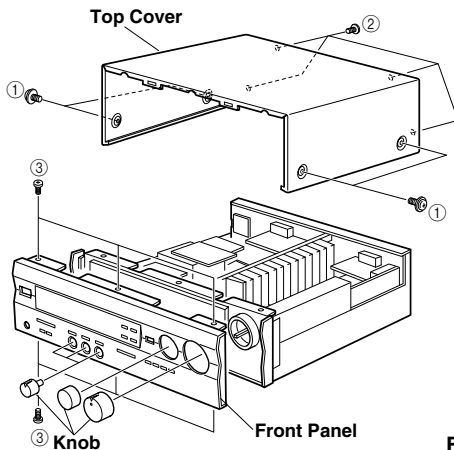

Fig.1

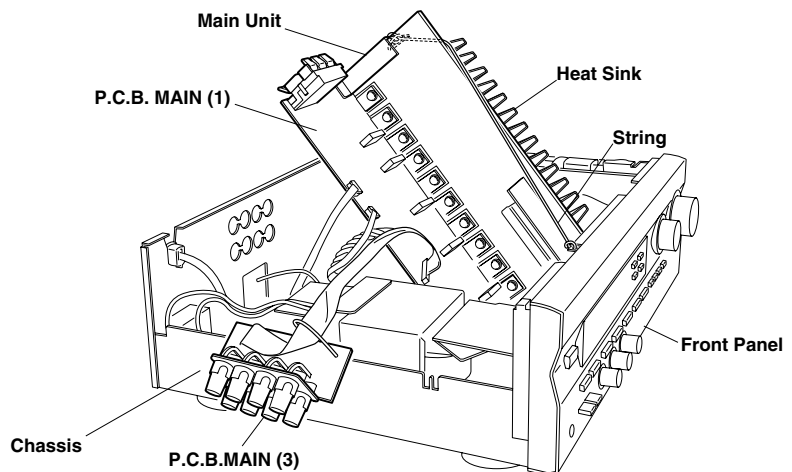

Fig.4

■ SELF DIAGNOSIS FUNCTION

1. PURPOSE AND OPERATION

The RX-V396/RX-V396RDS/HTR-5230/HTR 5230RDS has a Self Diagnosis Function to locate a faulty part, if any, by inspecting and taking measurements.

There are 12 main items in the diagnostic menu and sub-menu items as listed below.

No.	MAIN MENU	SUB-MENU	REMOTE CONTROL CODE (KEY)
1	ANALOG THROUGH	1. MAIN BYPASS 2. DSP 0dB	7A-88 ("1" [DSP mode]) ---
2	DSP THROUGH	1. YSS+SRAM M 2. YSS M 3. DSP FULL BIT	7A-89 ("2" [DSP mode]) --- ---
3	AC-3 THROUGH	1. STATUS (BINARY FORM)	---
4	PRO LOGIC	1. CENTER LARGE 2. EFFECT OFF	7A-8A ("3" [DSP mode]) ---
5	SPEAKERS SET	1. MAIN : SMALL 0dB 2. MAIN : LARGE 0dB 3. MAIN : LARGE -10dB 4. LFE/BASS : MAIN CENTER : NONE 5. LFE/BASS : MAIN 6. LFE/BASS : SUBWOOFER 7. CENTER : NONE 8. CENTER : SMALL REAR : SMALL 9. FRONT MIX	7A-8B ("4" [DSP mode]) 7A-8C ("5" [DSP mode]) 7A-8D ("6" [DSP mode]) 7A-8E ("7") 7A-8F ("8" [DSP mode]) 7A-90 ("9" [DSP mode]) 7A-91 ("0" [DSP mode]) --- ---
6	DISPLAY CHECK (EFFECT OFF)	1. (EFFECT OFF) 2. ALL SEGMENTS TURN OFF 3. ALL SEGMENTS TURN ON 4. ALTERNATE SEGMENTS TURN ON 5. SOFTWARE RELEASE DATE	--- --- --- --- ---
7	MANUAL TEST	1. ALL 2. MAIN L 3. CENTER 4. MAIN R 5. REAR R 6. REAR L 7. LFE	--- --- --- --- --- --- ---
8	FACTORY PRESET	1. INHIBIT (Inhibit Memory Initialize) 2. RESERVED (Reserve Memory Initialize)	--- ---
9	AD DATA CHECK	1. --- 2. KEY1, KEY2 3. TUNER SIGNAL LEVEL 4. DC PROTECTION 5. PS PROTECTION	--- --- --- --- ---
10	STATUS INFORMATION FROM DSP	1./2. DSP STATUS (1)/(2) 3./4. CHANNEL STATUS (1)/(2) 5./6. BSI0 (1)/(2) 7./8. BSI1 (1)/(2) 9./10. BSI2 (1)/(2) 11./12. BSI3 (1)/(2) 13./14. BSI4 (1)/(2) 15./16. BSI5 (1)/(2)	--- --- --- --- --- --- ---
11	EEPROM WRITING FUNCTION	1. CHECK SUM MODIFICATION DATA EEPROM DATA 2. WRITING CONFIRMATION 3. START WRITING	--- --- ---
12	CHECK SUM/ VERSION/ PORT SETTING/EXIT	1. CHECK SUM 2. VERSION 3. PORT SETTING 4. EXIT	--- --- --- ---

2. BEGINNING AND CANCELLATION

(1) Starting up the function and the display

After starting up, main menu No.1 is selected.

A. How to start diagnostic program

Using the front panel keys of the main unit

Plug in the AC power cord. With the Power OFF, hold down the "PRESET/TUNING ▷" and "A/B/C/D/E" keys simultaneously (Step 1), then press the "STANDBY/ON" key (Step 2).

Sub menu No. 1 of the diagnosis main menu No. 1 will start.

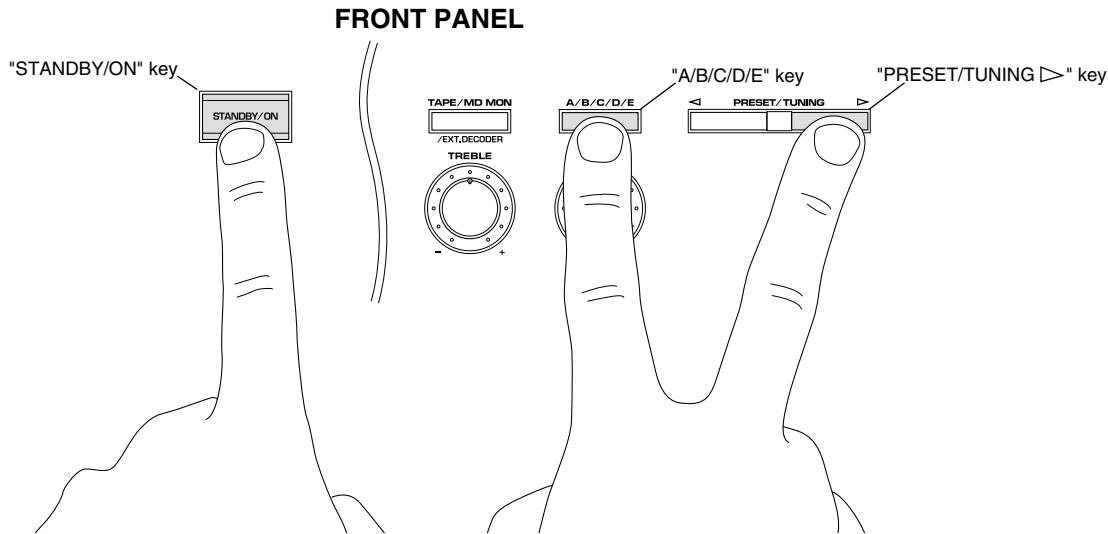

Step2. Press the "STANDBY/ON" key.

Step1. Hold down the "PRESET/TUNING ▷" and "A/B/C/D/E" key simultaneously.

B. Settings for start-up of diagnostic program

The settings used when starting the diagnostic program are as follows.

1. EFFECT LEVEL :

CHANNEL	CENTER	R SUR	L SUR	SWFR
LEVEL (dB)	0	0	0	0

- 2. MUTING : OFF
- 3. INPUT (VIDEO) : DVD/LD (DVD/LD)
- 4. CENTER SPEAKER : LARGE
- 5. REAR SPEAKER : LARGE
- 6. MAIN SPEAKER : LARGE
- 7. LFE/BASS OUT : SWFR

C. Start-up display

The protection history information appears on the front panel display.

● FL display at start-up of diagnostic program

When the diagnostic program has started, the check sum of the main microcomputer or the protection history (*1) is displayed. If the protection function has been activated in the past, the type and voltage value are displayed. After a few seconds the diagnosis function menu will appear.

(*1) If a faulty condition is detected such as excessive current, a bad power supply or excessive amplifier DC offset, the Power will be switched OFF automatically.

Note) For the voltages of the power and DC protection functions, see the diagnosis main menu No. 9, which will be described later. The protection history will be cleared when "RESERVED" is selected in the diagnosis main menu No. 8 and FACTORY PRESET is engaged.

● Protection history

The following examples show how the protection history is displayed:

CHK SUM : XXXX X

Appears when the protection function has not been activated. Displayed the check sum (4-digit, hexadecimal) and the version (one letter) of the main microcomputer.

I PROTECTION

Appears when the current protection function has been activated. When power is turned on in an abnormal condition, the power relay will come on, protection will operate immediately, and power will turn off.

PS PRT : XX%

Appears when the power protection function has been activated. For the % value, the voltage at that point is shown by 5V/100%. When power is turned on in an abnormal condition, power will turn off after half a second.

DC PRT : XX%

Appears when the power amp DC protection function has been activated. For the % value, the voltage at that point is shown by 5V/100%. When power is turned on in an abnormal condition, power will turn off after two seconds.

(2) Exiting method

The diagnosis function can be exited by any of the following procedures. Take care with the setting of backup memory initialization menu (diagnosis No. 8) when releasing the diagnosis function.

1. Select sub-menu No. 4 "EXIT" of the diagnosis main menu No. 12.
2. Press the "STANDBY/ON" key on the main unit or "STANDBY" key on the remote control to turn Power OFF.

3. OPERATION AND DISPLAY WHEN STARTING DIAGNOSIS FUNCTION

(1) Selection of diagnostic menu

The diagnostic menu and the sub-menu can be selected by using the front panel keys of the main unit or the remote control unit.

● Selection by using the front panel keys of the main unit

The main menu can be changed cyclically by using the "PROGRAM </>" keys, and the sub-menu, by using the "PRESET/TUNING </>" keys. The ">" key will increase the main or sub-menu number.

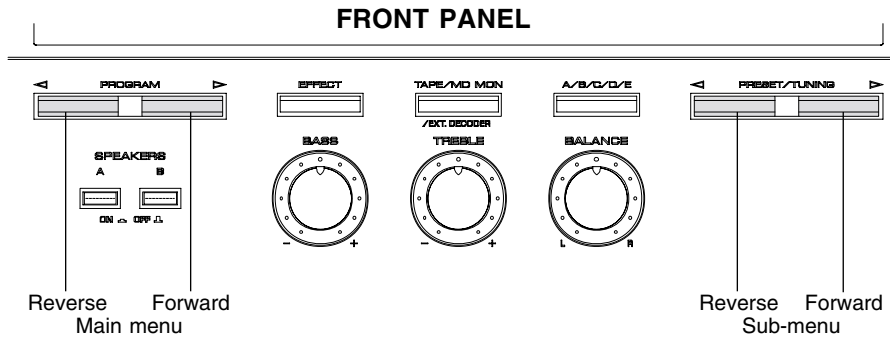

● Selection by using the remote control unit

The remote control codes in the menu list (see right column on page 8) correspond to the DSP program, test and effect keys. See the figure on the right.

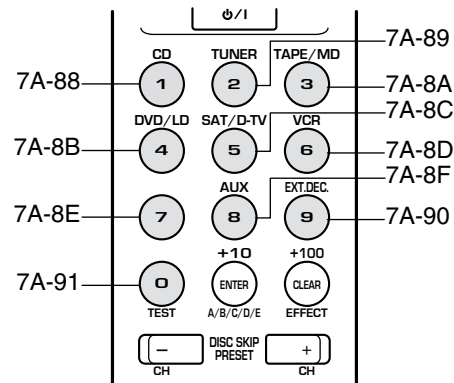

(2) Other functions available while diagnosis function is active

Listed below are the other functions available while the diagnosis function is active.

- Selection of the input (include TAPE MONITOR/EXTERNAL DECODER)
- Effect level control (CENTER, REAR, SUBWOOFER)
- Master volume control
- Muting on/off
- Power on/off

(3) Diagnosis default status

When not otherwise specified, default settings and values in each menu are as follows:

- SPEAKERS : All "LARGE"
- Electronic Volumes : All "0dB"
- DYNAMIC RANGE : MAX
- LFE LEVEL : 0dB (-10dB in AC-3(DOLBY DIGITAL))
- CENTER DELAY : 0ms

4. CONTENTS OF DIAGNOSIS FUNCTION

This section describes the contents of the Self Diagnosis Function in detail.

No.1 ANALOG THROUGH

The input is fixed to analog (A/D). There are two sub-menus.

1. MAIN BYPASS **1 MAIN BYPASS**

The L/R signals bypass the digital circuit, and are output to the MAIN L/R.

The L/R signals are output without being processed to the CENTER/SUBWOOFER and REAR L/R through the DSP. (Remote control code 7A-88: "1" key [DSP mode])

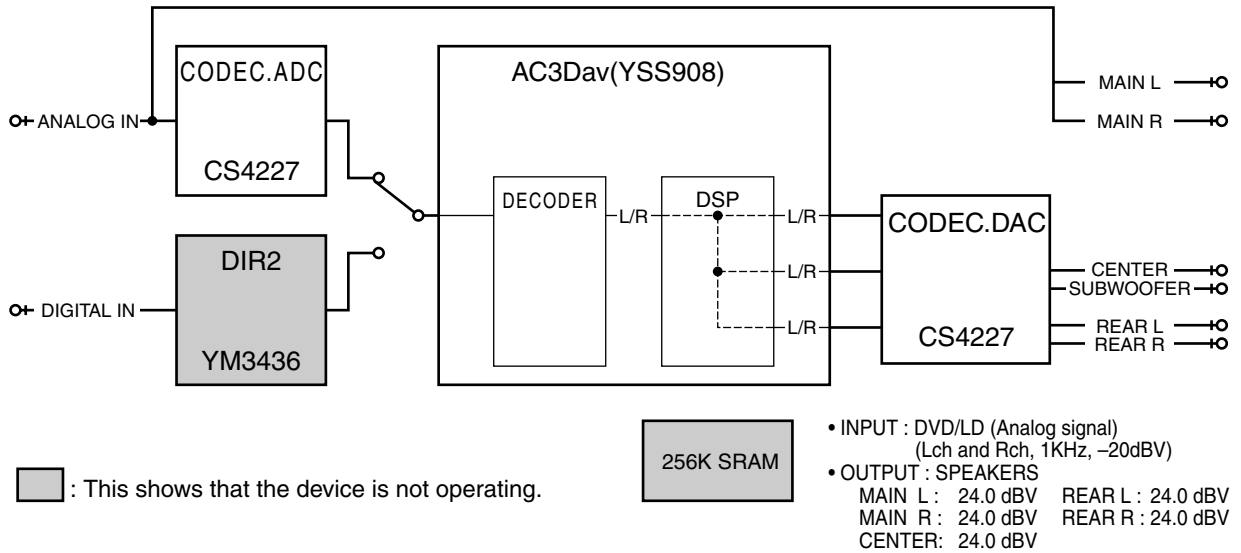

2. DSP 0dB **1 DSP 0dB**

The L/R signals are output without being processed to the MAIN L/R, CENTER/SUBWOOFER and REAR L/R through the DSP.

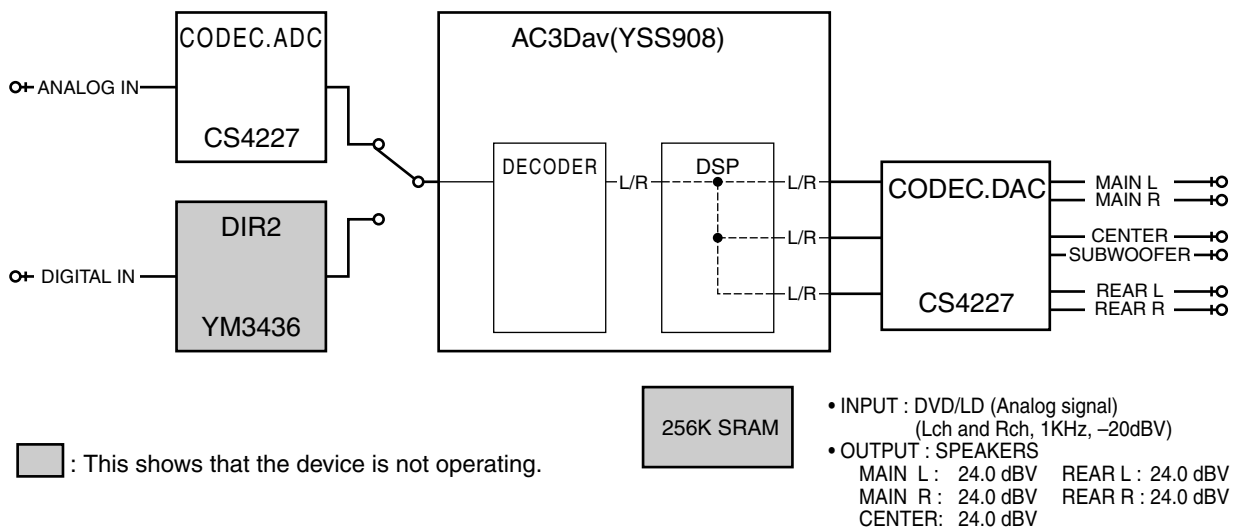

No.2 DSP THROUGH

The input is automatically discriminated by signal detection and switched with priorities Coaxial>Optical>Analog.
There are the following three sub-menus.

1. YSS+SRAM **2 YSS+SRAM M**

The L/R signals are output without being processed to the MAIN L/R, CENTER/SUBWOOFER through the DSP.
The L/R signals are output without being processed to the REAR L/R through the DSP and the SRAM.
(Remote control code 7A-89:"2" key [DSP mode])

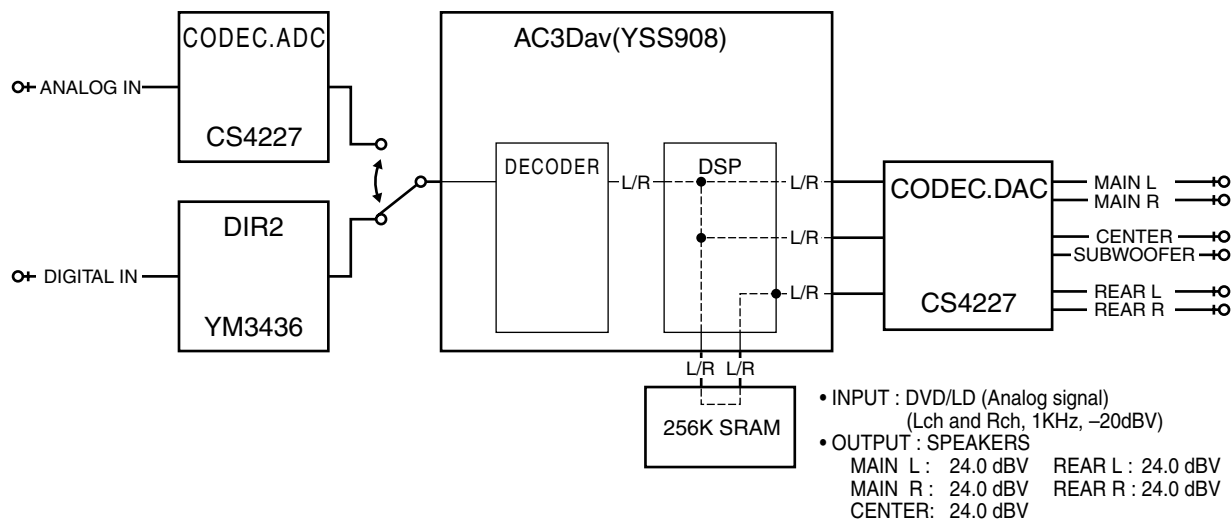

2. YSS M **2 YSS M**

Same as "2. DSP 0dB" of "No.1 ANALOG THROUGH", except for the input switching.

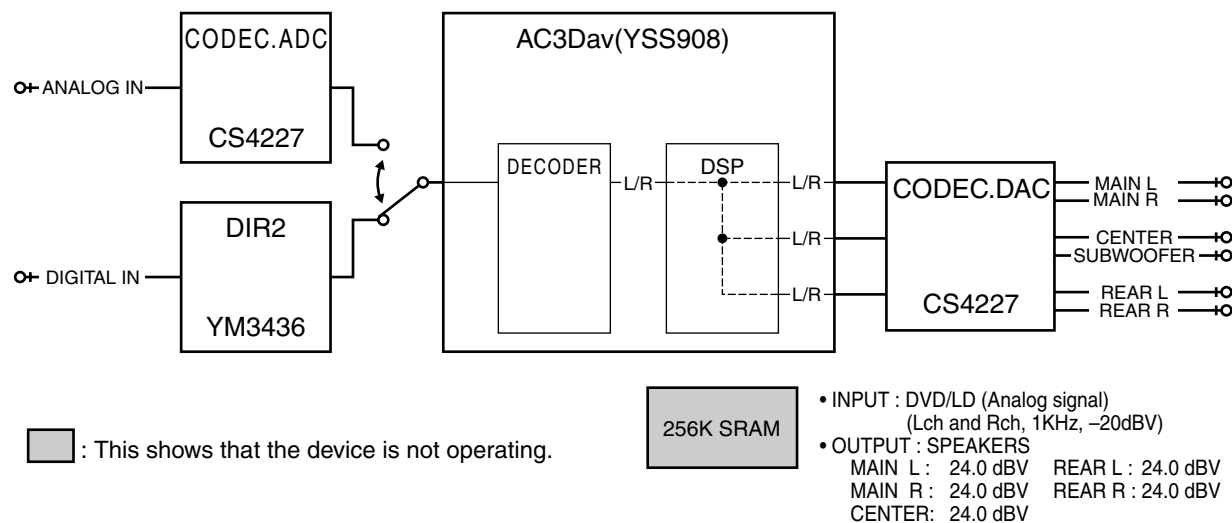

3. DSP FULL BIT **2 DSP FULL BIT**

Same as the above menu, except that the head margin is disabled, and the digital data is output with full bits from AC3Dav to DAC.

- INPUT : DVD/LD (Analog signal)
(Lch and Rch, 1KHz, -30dBV)
- OUTPUT : SPEAKERS
MAIN L : 14.0 dBV REAR L : 23.3 dBV
MAIN R : 14.0 dBV REAR R : 23.3 dBV
CENTER: 17.2 dBV

No.3 AC-3 THROUGH

The input is digital signal only. AC-3 (DOLBY DIGITAL) decoding operation is executed, according to the input source.

1. STATUS(BINARY FORM)

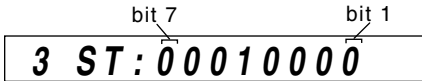

AC-3 (DOLBY DIGITAL) decoded signals are output to each channel via AC3Dav. The AC-3 (DOLBY DIGITAL) signal status data will be displayed in the FL display using a binary number.

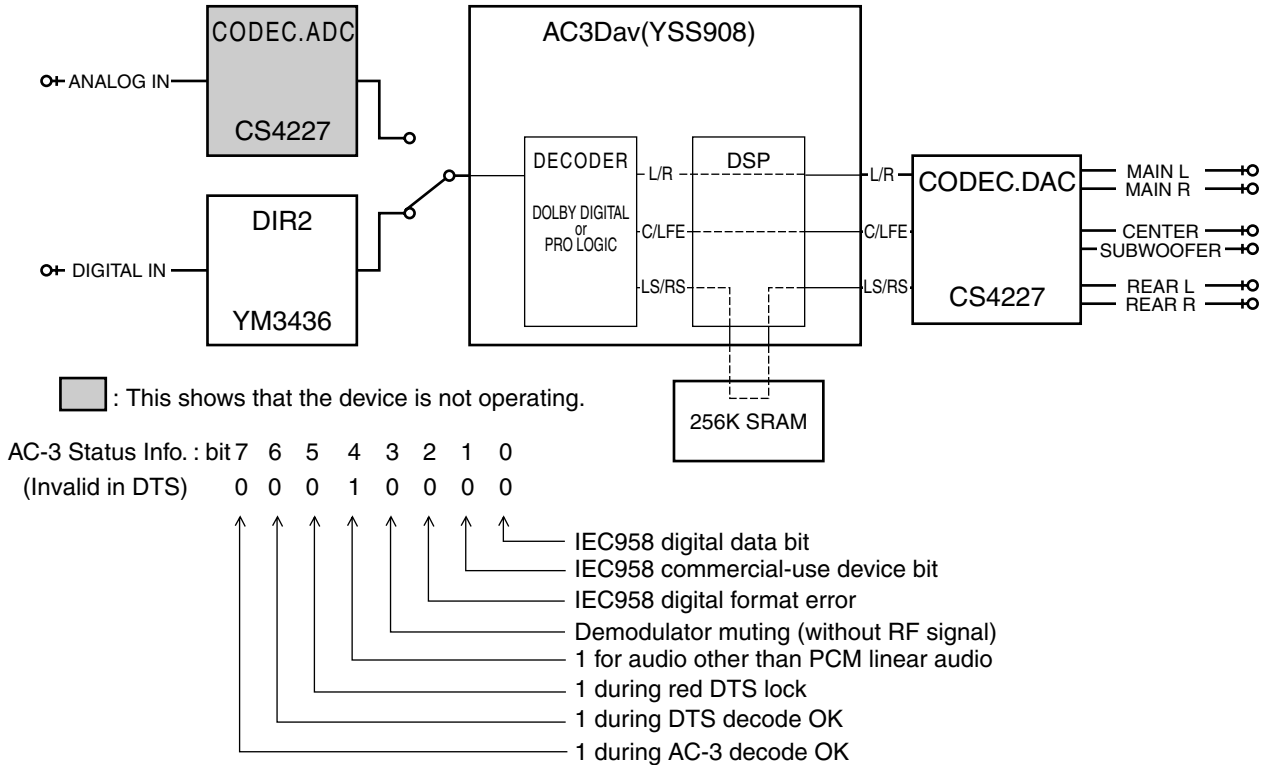

No.4 PRO LOGIC

The submenu is switched between PRO LOGIC (AUTO BALANCE OFF) and EFFECT OFF.

1. CENTER LARGE 4 PRO CNTR:LRG

The input is automatically discriminated by signal detection and switched with priorities Coaxial>Optical>Analog. AC-3 (DOLBY DIGITAL) is disabled. The input signals are PRO LOGIC decoded and output. (Remote control code 7A-8A: "3" key [DSP mode])

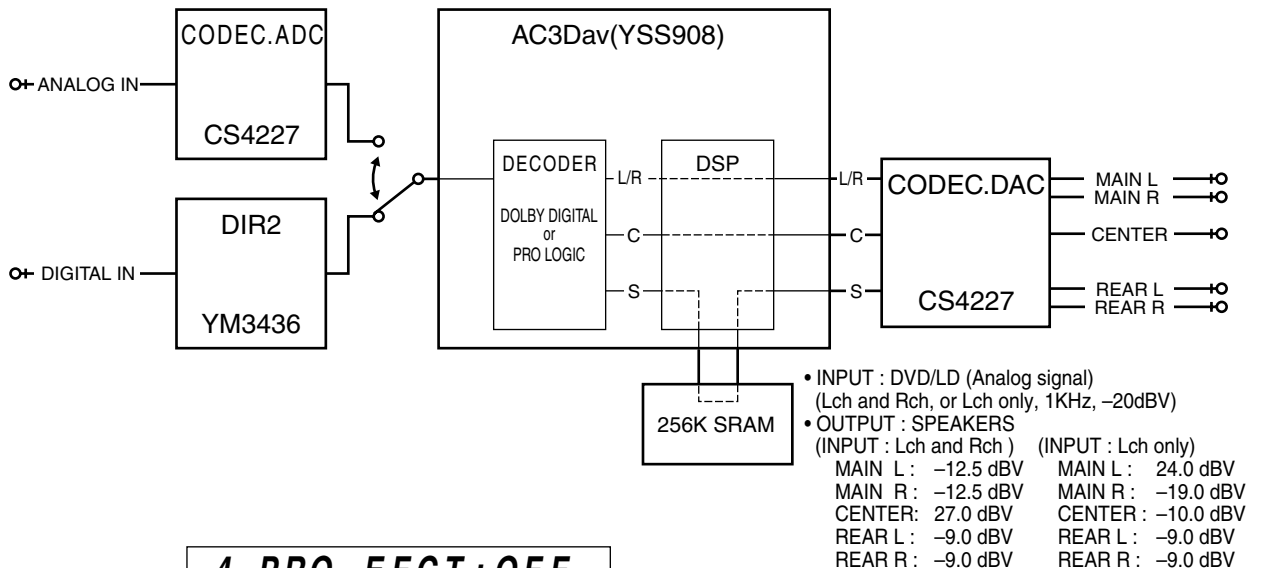

2. EFFECT OFF 4 PRO EFCT:OFF

The input is only for analog signal. The L/R signals bypass the digital circuit and are output to the MAIN L/R.

No.5 SPEAKERS SET

The input is automatically discriminated by signal detection and switched with priorities Coaxial>Optical>Analog. The L/R signals are output to channels specified by the sub-menu without being processed.

There are the following nine sub-menus items. Signal routes of the sub-menu 1-4 are the same as EFFECT OFF. But MAIN L/R are signals through the digital circuit.

Signal routes of the sub-menu 5-9 are the same as "2. YSS M" of "No. 2 DSP THROUGH".

However, only MAIN L/R are output in the sub-menu 1-4.

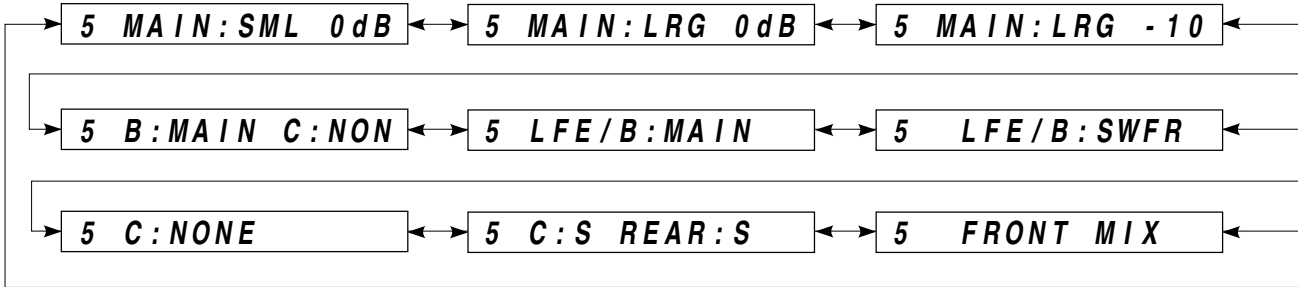

The analog switches in each sub-menu are set as follows:

	SUB MENU	REMOTE CONTROL CODE	SETTING					OUTPUT					
			CENTER SP	REAR SP	MAIN SP	MAIN LEVEL	LFE/BASS	MAIN L	MAIN R	CENTER	REAR L	REAR R	SUB WOOFER
1	MAIN:SML 0DB	7A-8B	LARGE	LARGE	SMALL	0dB	SWFR	L	R	NONE	NONE	NONE	L+R
2	MAIN:LRG 0DB	7A-8C	LARGE	LARGE	LARGE	0dB	SWFR	L	R	NONE	NONR	NONE	NONE
3	MAIN:LRG -10	7A-8D	LARGE	LARGE	LARGE	-10dB	SWFR	L	R	NONE	NONE	NONE	NONE
4	B:MAIN C:NONE	7A-8E	NONE	LARGE	LARGE	0dB	MAIN	L	R	NONE	NONE	NONE	NONE
5	LFE/B:MAIN	7A-8F	LARGE	LARGE	LARGE	0dB	MAIN	LFE	LFE	C	NONE	NONE	NONE
6	LFE/B:SWFR	7A-90	LARGE	LARGE	LARGE	0dB	SWFR	NONE	NONE	NONE	NONE	NONE	LFE
7	C:NONE	7A-91	NONE	LARGE	LARGE	0dB	SWFR	C+L	C+R	NONE	NONE	NONE	LFE
8	C:S REAR:S	---	SMALL	SMALL	LARGE	0dB	SWFR	FL	FR	C	RL	RR	C+RL+RR+LFE
9	FRONT MIX	7A-12	LARGE	LARGE	LARGE	0dB	SWFR	FL	FR	NONE	NONE	NONE	NONE

LARGE: Mode in which speakers with high bass-sound playback capability (large unit) are used. Full-range signals present on the channel are output from the speaker.

SMALL: Mode in which speakers with low bass-sound playback capability (small unit) are used. Low bass signals (below 90Hz) on the channel are mixed into the channel selected by the LFE/BASS setting.

NONE: Mode in which center speaker is not used. The center channel signal is reduced by 3 dB and mixed into MAIN L/R.

LFE/B:MAIN

: Mode in which subwoofer speaker is not used. The LFE channel signal is reduced by 4.5 dB and mixed into MAIN L/R. But because of the phase difference, the MAIN L/R output is not simply summed.

Description of the submenu as follows:

	SUB MENU	DESCRIPTION
1	MAIN:SML 0DB	Verification of the High and low pass filter response and gain in the bass redirection mode.
2	MAIN:LRG 0DB	Reference of the sub menu No. 1 and 3.
3	MAIN:LRG -10	Verification of the effect in the main level function.
4	B:MAIN C:NONE	Verification of the mixing circuit effect to the main channel.
5	LFE/B:MAIN	Verification of the bass mix gain.
6	LFE/B:SWFR	Verification of the LFE maximum output.
7	C:NONE	Verification of the center mix gain.
8	C:S REAR:S	Verification of the high and low pass filter response and gain in the bass redirection mode.
9	FRONT MIX	Verification of the front mix gain.

No.6 DISPLAY CHECK

Check program for FL display. The display status will change as follows with sub-menu operation. signal route is the same as "2. EFFECT OFF" of "No. 4 PRO LOGIC".

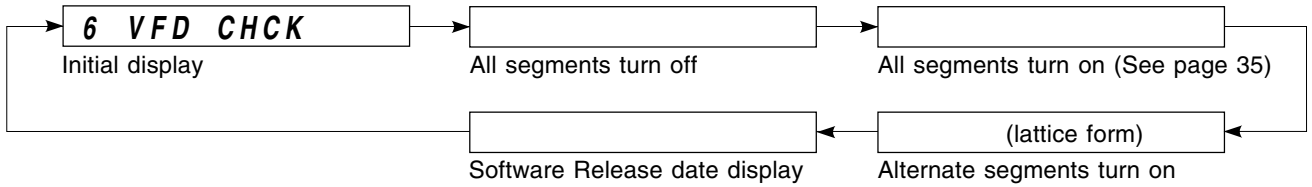

A defect of the FL drive port and FL display segments can be detected by using "All segments turn off" and "All segments turn on".

A short-circuit between adjacent segments can be detected by using "Alternate segments turn on" (lattice form).

No.7 MANUAL TEST

By using the noise generator built into the DSP, a test noise outputs to the channel specified by the sub-menu.

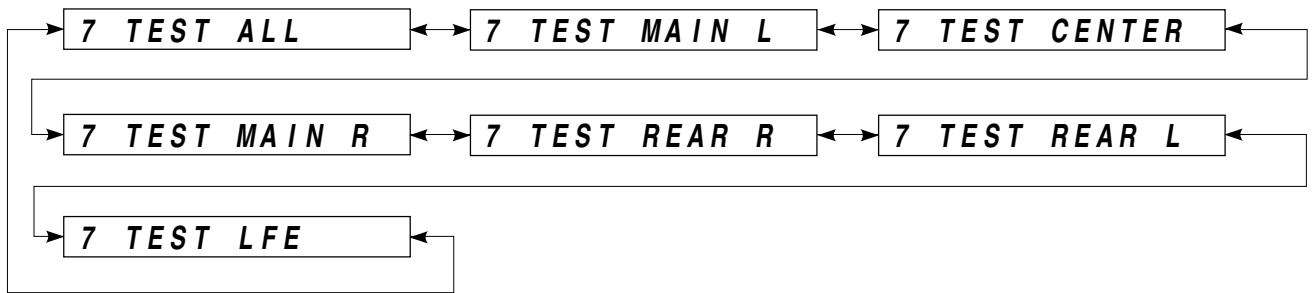

No.8 FACTORY PRESET

The initialization of the back-up RAM, which contains, the DSP program, set menu contents, etc. is reserved or inhibited. Signal route is the same as "2. EFFECT OFF" of "No.4 PRO LOGIC".

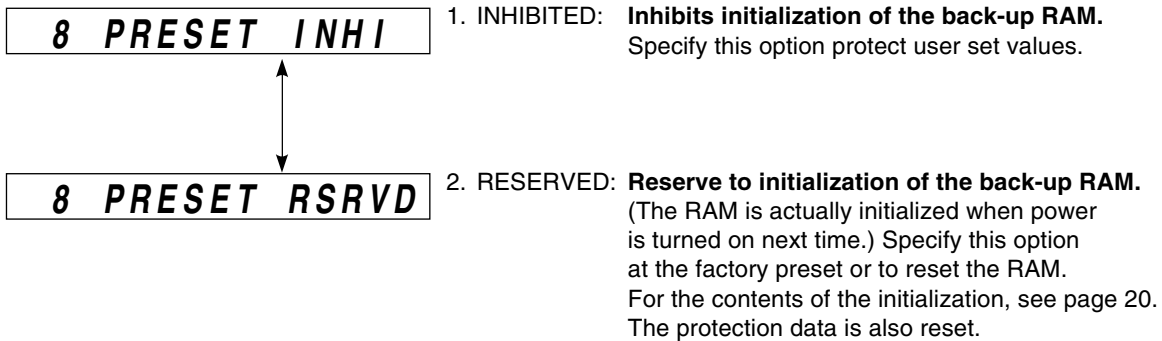

Caution : Before setting to the PRESET RESERVED, write down the existing preset memory contents of the Tuner in a table as shown below. (This is because setting to the PRESET RESERVED will cause the memory contents to be as factory set, i.e., all the preset memory by the user will be erased.)

Page	P1	P2	P3	P4	P5	P6	P7	P8
A								
B								
C								
D								
E								

No.9 AD DATA CHECK

The A/D conversion values of the microcomputer which detects key scan port, protection detection port, etc. are displayed in % (100%:5V). Signal route is the same as "2. EFFECT OFF" of "No. 4 PRO LOGIC".

The keys on the main unit cannot be operated to detect the values of all keys in the K1/K2 and SI.

Operating the "PRESET/TUNING ◀, ▶" key and turning the rotary encoder ("INPUT SELECTOR" on the main unit) will switch the sub-menu.

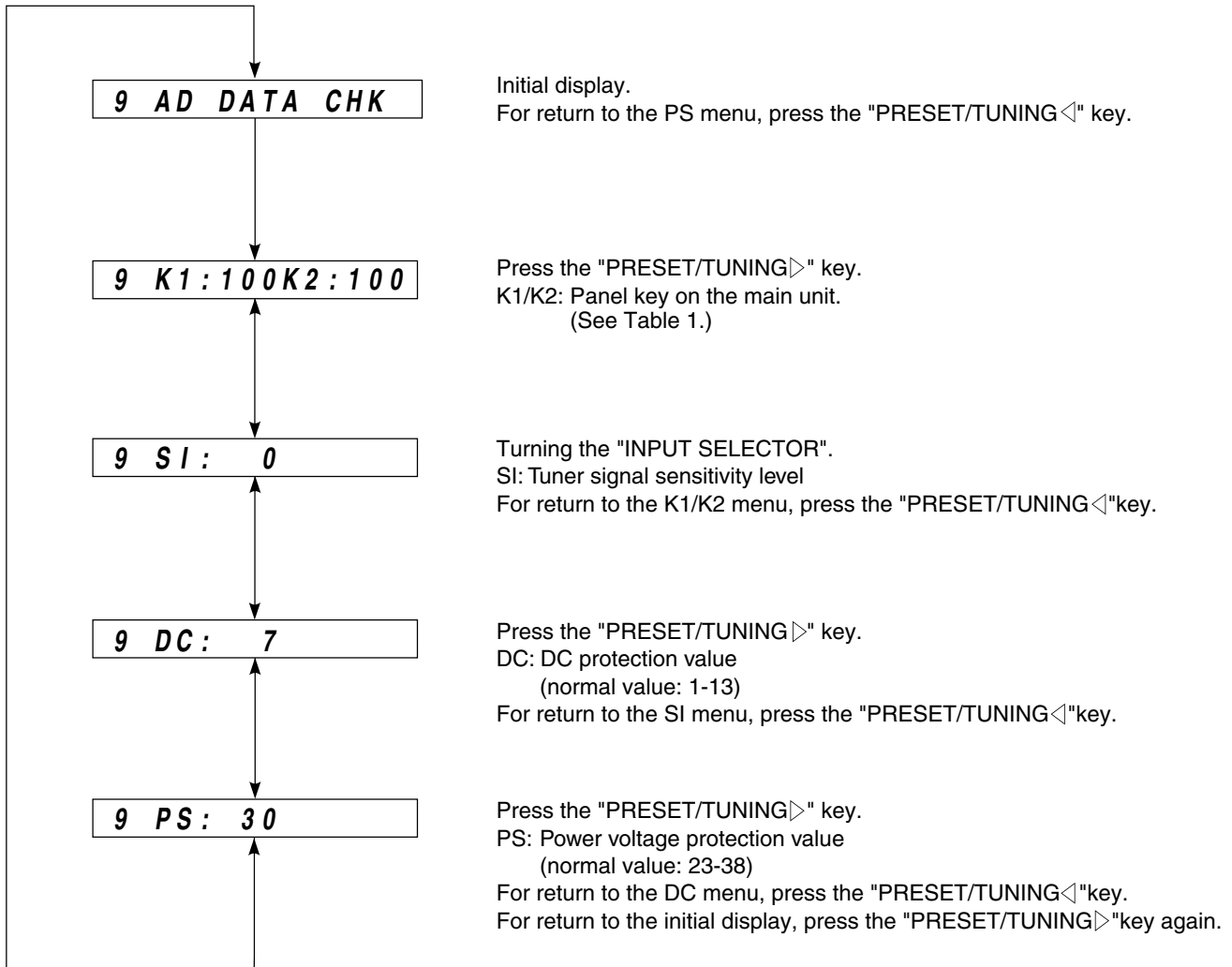

Table 1

AD Value	0	14	24	35	45	55	65	75	85
K1	PROGRAM		EFFECT	TAPE/MD MON /EXT DECODER	EFFECT	RDS MODE /FREQ	EON	PTY SEEK	
	◀	▶						MODE	START
K2	PRESET/TUNING		INPUT MODE	PRESET /TUNING EDIT	FM/AM	MEMORY MAN'L/AUTO FM	TUNING MODE AUTO/MAN'L MONO	—	—
	◀	▶							

Cautions:

1. If K1 and K2 are more than ±4% from the reference values, normal operation will not be executed.
2. If DC and PS are outside the normal values, the protection function will operate and power will turn off.

No.10 STATUS INFORMATION FROM DSP

The status data from the DSP block is sequentially displayed in a hexadecimal number.
Signal route is the same as "2. EFFECT OFF" of "No. 4 PRO LOGIC".

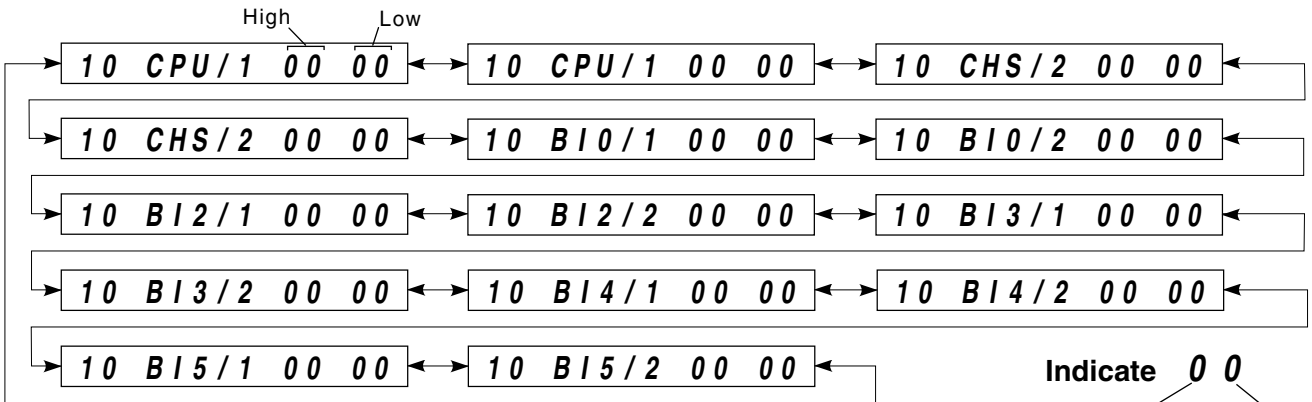

[CPU/1]

<High Byte>

bit7	Mute request	bit3	acmod
bit6	fs	bit2	0000B:1+1 0001B:1/0 0010B:2/0 0011B:3/0
bit5	000B:Analog 001B:32kHz 010B:44.1kHz 011B:48kHz	bit1	0100B:2/1 0101B:3/1 0110B:2/2 0111B:3/2
bit4	100B:64kHz 101B:88.2kHz 110B:96kHz 111B:undefined	bit0	1000B:7.1

[Note]

When acmod is beyond 1000B, it is DTS 7.1 signal. And the DSP block will be muted.
The acmod of DTS 2/0 is as 0000B:1+1.

<Low Byte>

bit7	AC-3 DECODE OK	bit3	DEM (Demodulator) MUTE (without RF signal)
bit6	DTS DECODE OK	bit2	IEC958 digital format error
bit5	Red DTS record (Flashes and lights)	bit1	IEC958 commercial-use device bit
bit4	1 for audio other than PCM linear audio	bit0	IEC958 digital data bit

[Note]

IEC958: Standard to identify the PCM bit stream signal. Digital format error refers to a digital signal with the sampling frequency undefined (neither 32k,44.1k,48k,64k,88.2k nor 96k). Since the operation of each device cannot be assured at fs outside specifications, this status handled as the forced analog mode (ignored even if decoding is OK from the detection terminal level), and the signals from the analog input terminal will be selected. Bits 4-6 of "CPU/1" will be 000B (Analog), and the microcomputer operates in the same way as with digital unlocking.

Indicate 00
bit 7 6 5 4 3 2 1 0

Indicate	bit			
	3	2	1	0
0	7	6	5	4
1	0	0	0	1
2	0	0	1	0
3	0	0	1	1
4	0	1	0	0
5	0	1	0	1
6	0	1	1	0
7	0	1	1	1
8	1	0	0	0
9	1	0	0	1
A	1	0	1	0
B	1	0	1	1
C	1	1	0	0
D	1	1	0	1
E	1	1	1	0
F	1	1	1	1

[CPU/2]

<High Byte>

bit7	AC3 KARAOKE	bit3	1
bit6	DIR2 LOCKN	bit2	0
bit5	DIR2 ERR	bit1	DSP is AC3D2 (DTS present)
bit4	AC3D MUTE	bit0	RF DEM (Demodulator) present

<Low Byte> Always "00"

[CHS/1,2] IEC958 channel status bits 00-31 available from DIR2.

- <CHS/1 High Byte> bits 00-07
- <CHS/1 Low Byte> bits 08-15
- <CHS/2 High Byte> bits 16-23
- <CHS/2 Low Byte> bits 24-31

[BI0/1,2] Displays the bit stream information contained in AC-3(DOLBY DIGITAL)/DTS Digital Surround signal from the first byte.

[BI1-5/1,2] Displays the bit stream information contained in AC-3(DOLBY DIGITAL) signal from the first byte.

No.11 EEPROM WRITING FUNCTION

The check sum value confirmation of EEPROM and data writing.
Signal route is the same as "2. EFFECT OFF" of "No. 4 PRO LOGIC".

M:XXXX E:XXXX

M:XXXX: The check sum value is displayed when the microcomputer has ROM modification data.
0000 is displayed when there is no data.
E:XXXX: The check sum value is displayed when the EEPROM is installed on and it has the ROM data .
000 is displayed when EEPROM is not mounted on or data is unusual.
If you want to write ROM modification data of the microcomputer into the EEPROM, change to the next sub-menu.

No.12 CHECK SUM/VERSION/PORT SETTING/EXIT

The version, the check sum, and the port setting of the microcomputer are displayed.
Signal route is the same as "2. EFFECT OFF" of "No.4 PRO LOGIC".
By the sub-menu operation, the set exits the self-diagnosis mode and returns to the normal operation mode.

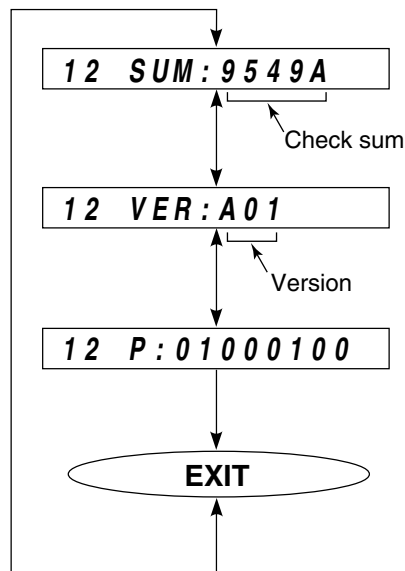

SUM: 9549A : The check sum of the microcomputer software is displayed.

VER:A01 : The version of the microcomputer software is displayed.

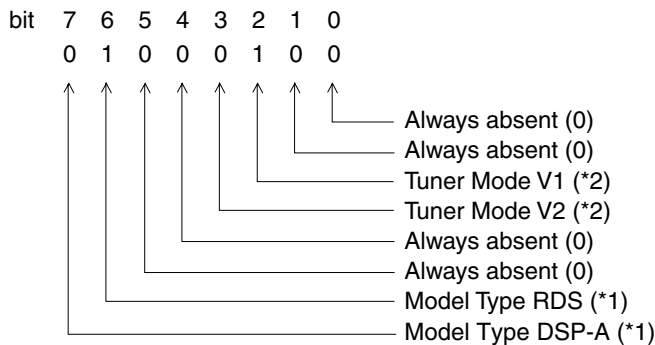

*1 Model type distinction (H=1, L=0)

DSP-A (Pin 3)	0	DSP-A	0	DSP-E	1	RX-V396	1	RX-V396RDS
RDS (Pin 6)	0		1		0	HTR-5230	1	HTR 5230RDS
						DSP-R396		

*2 Destination distinction of Tuner (H=1, L=0)

V1 (Pin 4)	0	J	0	U,C	1	A,B,G	1	R,T
V2 (Pin 5)	0	model	1	models	0	models	1	models

■ FACTORY PRESET

All of the system settings are initially set from the factory as follows.

● INPUT SELECTOR

INPUT		FACTORY PRESET PROGRAM
ROTARY ENCODER	AUX	DOLBY ENHANCED
	CD	DISCO
	TUNER	ROCK CONCERT
	DVD/LD	SCI-FI
	SAT/D-TV	TV SPORTS
	VCR	DOLBY NORMAL
MONITOR	TAPE/MD	EFFECT OFF
EXTERNAL	EXT. DECODER	NONE

● EFFECT LEVEL

EFFECT CHANNEL	PRESET VALUE
CENTER	0 dB
RIGHT SURROUND	0 dB
LEFT SURROUND	0 dB
SUBWOOFER	0 dB

● DSP PROGRAM

No.	PROGRAM	SUB-PROGRAM	DELAY PRESET VALUE
1.	DOLBY/DTS SURROUND	NORMAL	PRO LOGIC : 20ms,
		ENHANCED	DOLBY DIGITAL : 5ms
2.	MOVIE THEATER 1	SPECTACLE	70mm : 23ms, DGTL : 15ms
		SCI-FI	70mm : 20ms, DGTL : 16ms
3.	MOVIE THEATER 2	ADVENTURE	70mm : 20ms, DGTL : 15ms
		GENERAL	
4.	MONO MOVIE	-	49ms
5.	TV SPORTS	-	9ms
6.	DISCO	-	40ms
7.	ROCK CONCERT	-	16ms
8.	CONCERT HALL	-	44ms

● SET MENU

No.	SET MENU	PRESET VALUE
1.	CENTER SP SIZE	CENTER SP : LRG(LARGE)
2.	REAR SP SIZE	REAR SP : LARGE
3.	MAIN SP SIZE	MAIN SP : LARGE
4.	BASS OUT MODE	BASS OUT : BOTH
5.	M. LVL CHOICE	MAIN LVL : NRML (NORMAL)
6.	D. D. LFE OUT LEVEL	D. D. LFE 0 dB
7.	D. RNG CHOICE	D-RANGE : MAX
8.	C. DELAY CHANGE	CENTER DELAY 0ms
9.	MEMORY GUARD	MEM. GUARD : OFF
10.	INPUT MODE SAT/D-TV	SAT INPUT : AUTO

● PRESET STATIONS

STATION		FM FACTORY PRESET DATA (MHz)		STATION		AM FACTORY PRESET DATA (kHz)	
PAGE	NO.	U, C	R, T, A, B, G, L	PAGE	NO.	U, C, R	R, T, A, B, G, L
A/C/E	1	87.5	87.5	B/D	1	630	630
	2	90.1	90.1		2	1080	1080
	3	95.1	95.1		3	1440	1440
	4	98.1	98.1		4	530	531
	5	107.9	108.0		5	1710	1611
	6	88.1	88.1		6	900	900
	7	106.1	106.1		7	1350	1350
	8	107.9	108.0		8	1400	1404

■ AMP ADJUSTMENT

Confirmation of Idling Current of Main Amplifier

- Right after power is turned on, confirm that the voltage across the terminals of R239(Main Lch), R245(Main Rch), R262(Center), R252(Rear Lch), R258(Rear Rch) are between 0.1mV and 5.0mV.
- If it exceeds 5.0mV, open (cut off) R213 (Main Lch), R218 (Main Rch), R233 (Center), R223 (Rear Lch), R228 (Rear Rch) and reconfirm the voltage.
- Confirm that the voltage is 0.25mV ~ 15.0mV after 60 minutes.

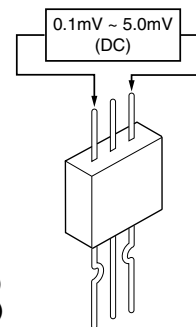
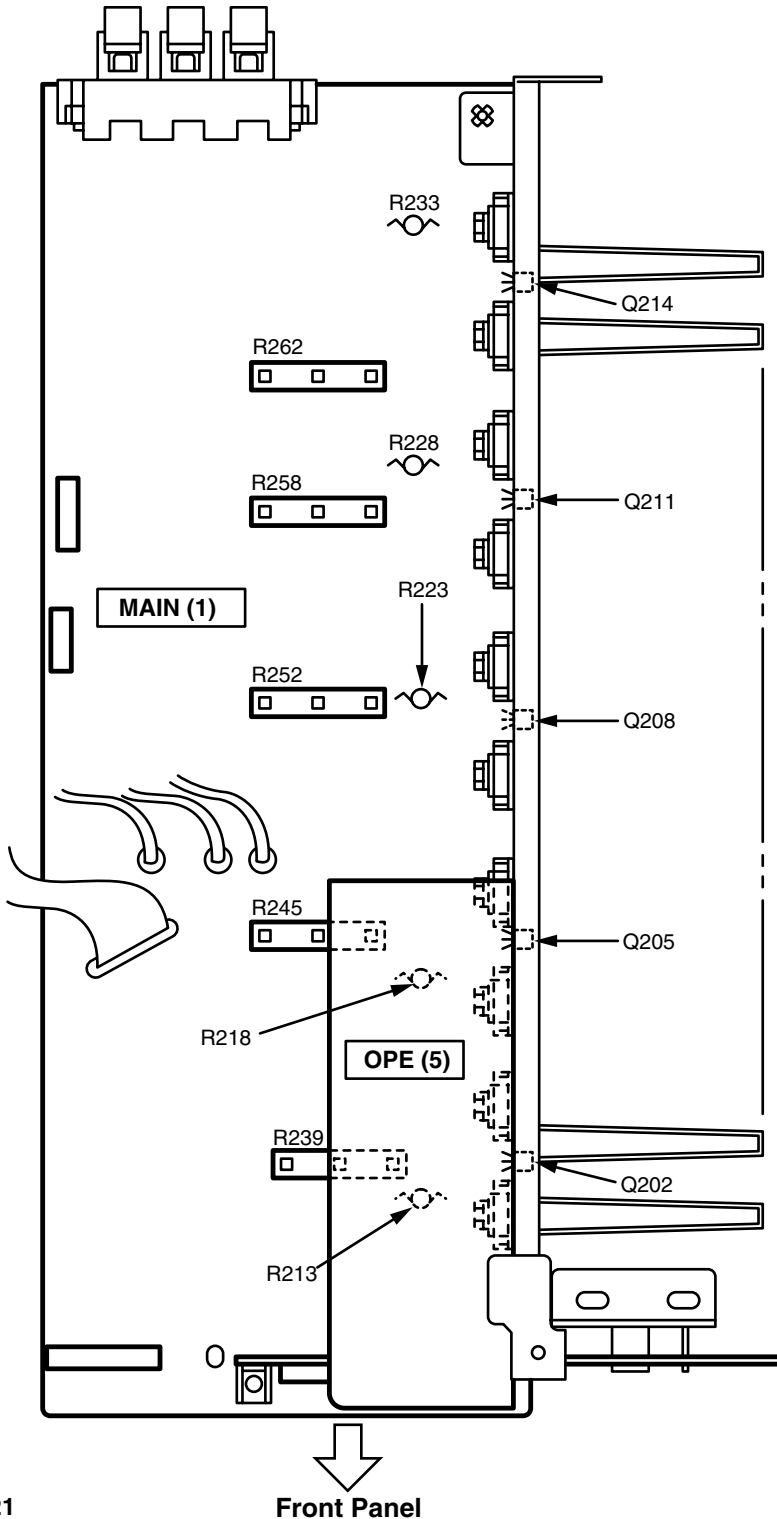

R239(Lch)
R245(Rch)
R262(Cch)
R252(RLch)
R258(RRch)

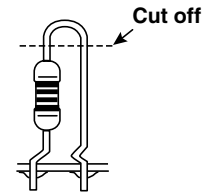

R213(Lch)
R218(Rch)
R233(Cch)
R223(RLch)
R228(RRch)

Note)

- If R213, R218, R233, R223 and R228 have already been cut off and idling current does not flow, reconnect R213, R218, R233, R223 and R228.
- Q202, Q205, Q208, Q211 and Q214 are transistors for temperature correction. Apply silicone grease to contact surface with the heat sink.

■ TUNER ADJUSTMENT

● Measuring Instruments

- 1) FM signal generator (FM SG)
- 2) Stereo signal generator (SSG)
- 3) AM signal generator (AM SG)
- 4) Distortion meter (DIST. M)
- 5) AC Voltmeter (ACVM)
- 6) DC Voltmeter (DCVM)
- 7) Oscilloscope
- 8) Low pass filter (YLF-15, $f_c=15\text{kHz}$)
- 9) Oscillator

● Dummy antenna

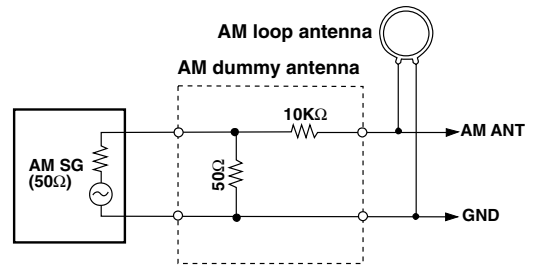
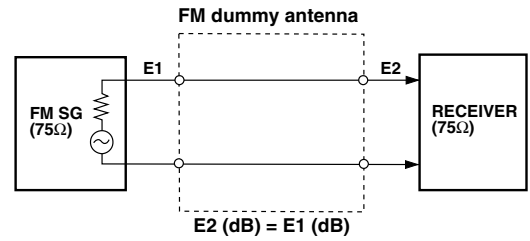
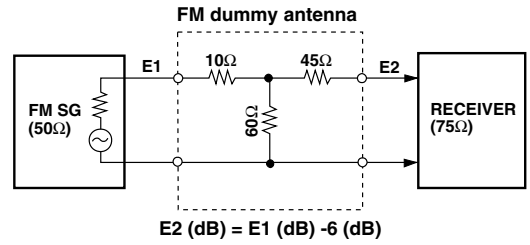

● Test point

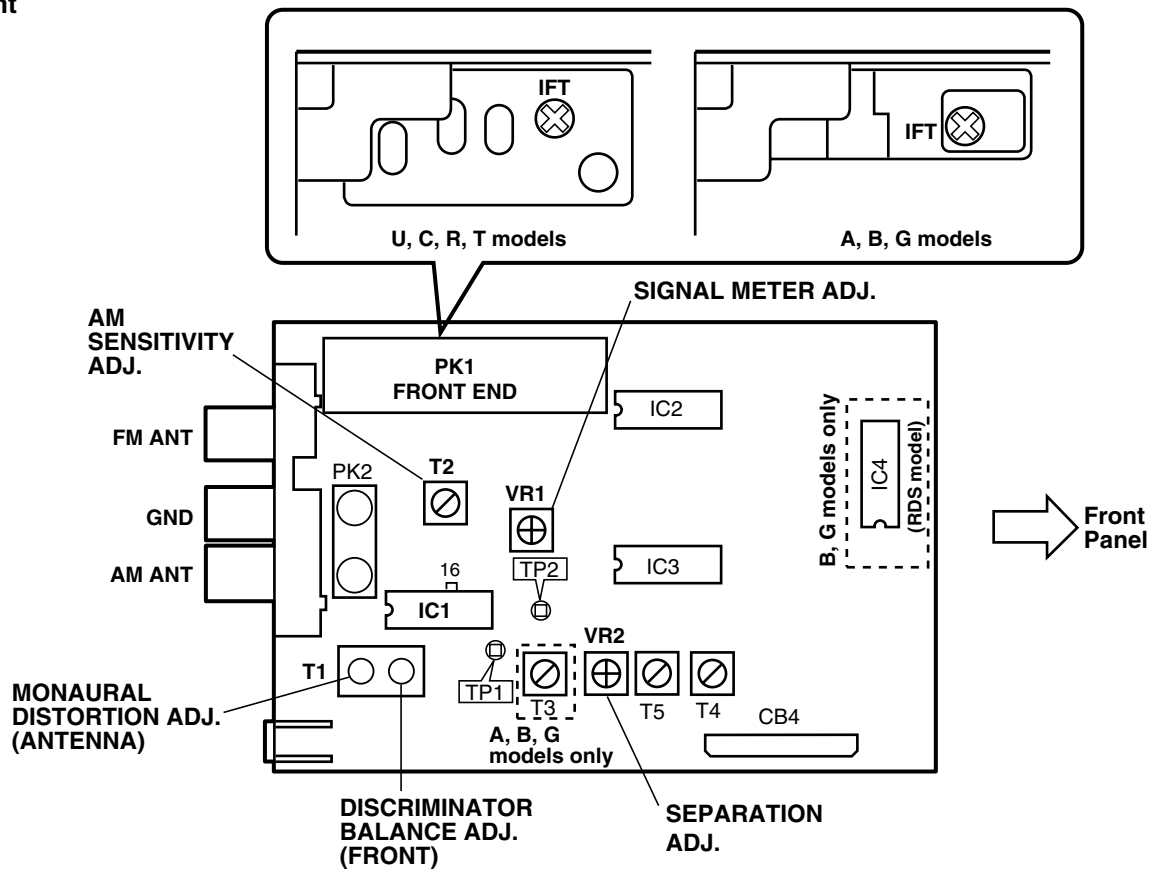

FM Adjustment

● Before Adjustment

- 1) For dB μ , 1 μ V=0dB μ applies.
Example : 60dB μ =1mV
- 2) 100% modulation means that the frequency deviation is \pm 75kHz.
- 3) Install the Matching Transformer and connect FM SG.

- 4) Set each switch to the following position unless otherwise specified.

INPUT SELECTOR TUNER
TUNING MODE AUTO

● Connection diagram (Measuring instruments)

- 1) Discriminator balance adjustment.

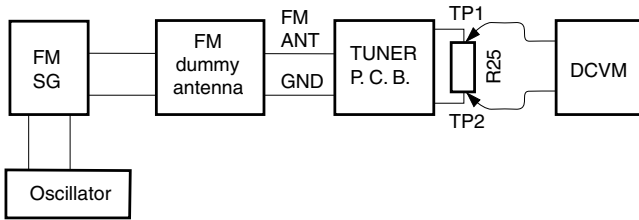

- 2) Stereo distortion adjustment/separation adjustment.

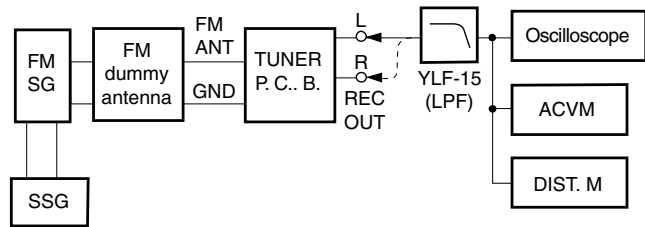

- 3) Monaural distortion adjustment

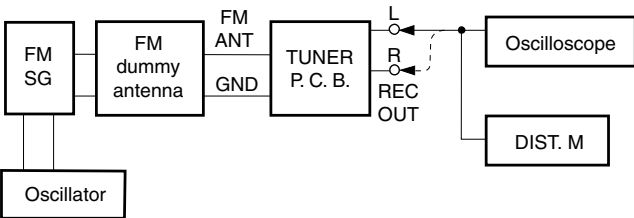

- 4) Sensitivity Verification

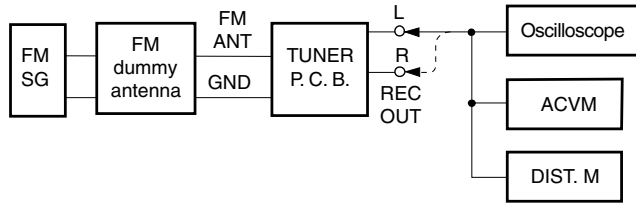

See page 22 for TP locations & adjustment points.

Step	Adjustment item	Signal (ANT IN)	Reception frequency	Adjustment point	Test point	Rating
1	Rough adjustment of discriminator balance	FM ANT (75 Ω) 98.1MHz 70dB μ MONO 100Hz 100% modulation	98.1MHz *(A-4)	T1 (Front side core)	Both ends of R25 (Between TP1 and TP2)	DC 0V \pm 100mV
2	Rough adjustment of monaural distortion	Same as Step 1.	98.1MHz *(A-4)	T1 (Antenna side core)	REC OUT L, R	Minimize the distortion.
3	Fine adjustment of discriminator balance	Same as Step 1.	98.1MHz *(A-4)	T1 (Front side core)	Both ends of R25 (Between TP1 and TP2)	DC 0V \pm 50mV
4	Fine adjustment of monaural distortion	Same as Step 1.	98.1MHz *(A-4)	T1 (Antenna side core)	REC OUT L, R	Minimize the distortion (-60dB or less).
5	Verification of discriminator balance	Same as Step 1.	98.1MHz *(A-4)	T1 (Front side core)	Both ends of R25 (Between TP1 and TP2)	DC 0V \pm 50mV

* Execution of FACTORY PRESET (Refer to page 20) will facilitate setting reception frequency for adjustment.

See page 22 for TP locations & adjustment points.

Step	Adjustment item	Signal (ANT IN)	Reception frequency	Adjustment point	Test point	Rating
6	Adjustment of front end IFT	FM ANT (75Ω) 98.1MHz 30dBμ MONO 1kHz 100% modulation	98.1MHz *(A-4)	Front end IFT	Pin 16 of IC1	Adjust so that the meter is maximum. CAUTION: Over-adjustment of the IFT core will reduce the sensitivity. (Maximum±90°)
7	Verification of monaural distortion	FM ANT (75Ω) 98.1MHz 70dBμ MONO 1kHz 100% modulation	98.1MHz *(A-4)		REC OUT L, R	0.1% (-60dB or less)
8	Verification of stereo distortion	FM ANT (75Ω) 98.1MHz 70dBμ Stereo L or R 1kHz, 100% modulation	98.1MHz *(A-4) *Tuning mode should be AUTO.		REC OUT L, R	0.2% (U,C,R,T: -54dB or less) (A,B,G: -28dB or less) ● STEREO indicator should light.
9	Verification of sensitivity	FM ANT (75Ω) 88.1MHz 98.1MHz 106.1MHz MONO 1kHz Modulation off	88.1MHz *(A-6) 98.1MHz *(A-4) 106.1MHz *(A-7)		ANT (75Ω)	1) Set the tuning mode to MAN'L MONO. 2) S/N should be 30dB at each frequency of 88.1MHz, 98.1MHz, and 106.1MHz. 3) Check to ensure that the voltage at the ANT terminal is as follows. (U,C,R,T: 6dBμ or less) (A,B,G: 8dBμ or less)
10	Adjustment of separation	FM ANT (75Ω) 98.1MHz 70dBμ Stereo L or R 1kHz, 100% modulation	98.1MHz *(A-4)	VR2	REC OUT L, R	With SSG output at L or R, the signal leakage level at the other channel should be minimized. (48 dB or less)
11	Adjustment of signal meter	FM ANT (75Ω) 98.1MHz 45dBμ MONO 1kHz, 30% modulation -10dBμ or less	98.1MHz *(A-4)	VR1		Adjust so that all signal meters light. Check to ensure that signal meters turn OFF.
12	Verification of auto tuning	FM ANT (75Ω) 98.1MHz 23dBμ Stereo L or R 1kHz, 30% modulation	98.1MHz *(A-4)			● Automatic reception should be available when the tuning key is moved UP and DOWN. ● The stereo indicator should light. ● Audio muting should be applied during tuning.

* Execution of FACTORY PRESET (Refer to page 20.) will facilitate setting reception frequency for adjustment.

AM Adjustment (This should be done after FM adjustment.)

● **Connection diagram (Measuring instruments)**

1) Adjustment of sensitivity.

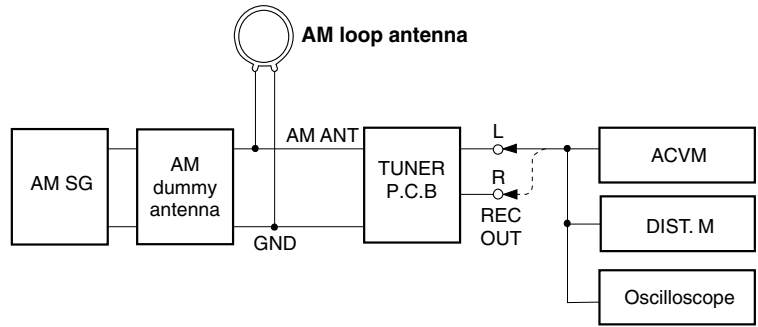

See page 22 for TP locations & adjustment points.

Step	Adjustment item	Signal (ANT IN)	Reception frequency	Adjustment point	Test point	Rating
1	Adjustment of sensitivity (630kHz)	AM ANT 630kHz 50dB μ 1kHz 30% modulation	630kHz *(B-1)	T2	REC OUT	Audio output should be maximized. Repeat steps 1 and 2.
2	Verification of sensitivity	AM ANT 630kHz 1080kHz 1440kHz 30% modulation	630kHz *(B-1) 1080kHz *(B-2) 1440kHz *(B-3)		AM ANT	Distortion should be 10% or less at each frequency. Check to ensure that the voltage at the ANT terminal is 54dB μ or less.
3	Verification of signal meter	AM ANT 1080kHz 90dB MONO 1 kHz 30% modulation —10dB or less	1080kHz *(B-2)			All signal meters should light. All signal meters should turn OFF.
4	Verification of auto tuning	AM ANT 60dB μ				Auto reception should be available when the tuning key is moved UP and DOWN. Audio must be muted during search.

* Execution of FACTORY PRESET (Refer to page 20.) will facilitate setting reception frequency for adjustment.

IC DATA

IC501 : M30217MA-A203FP

16-bit Microcomputer

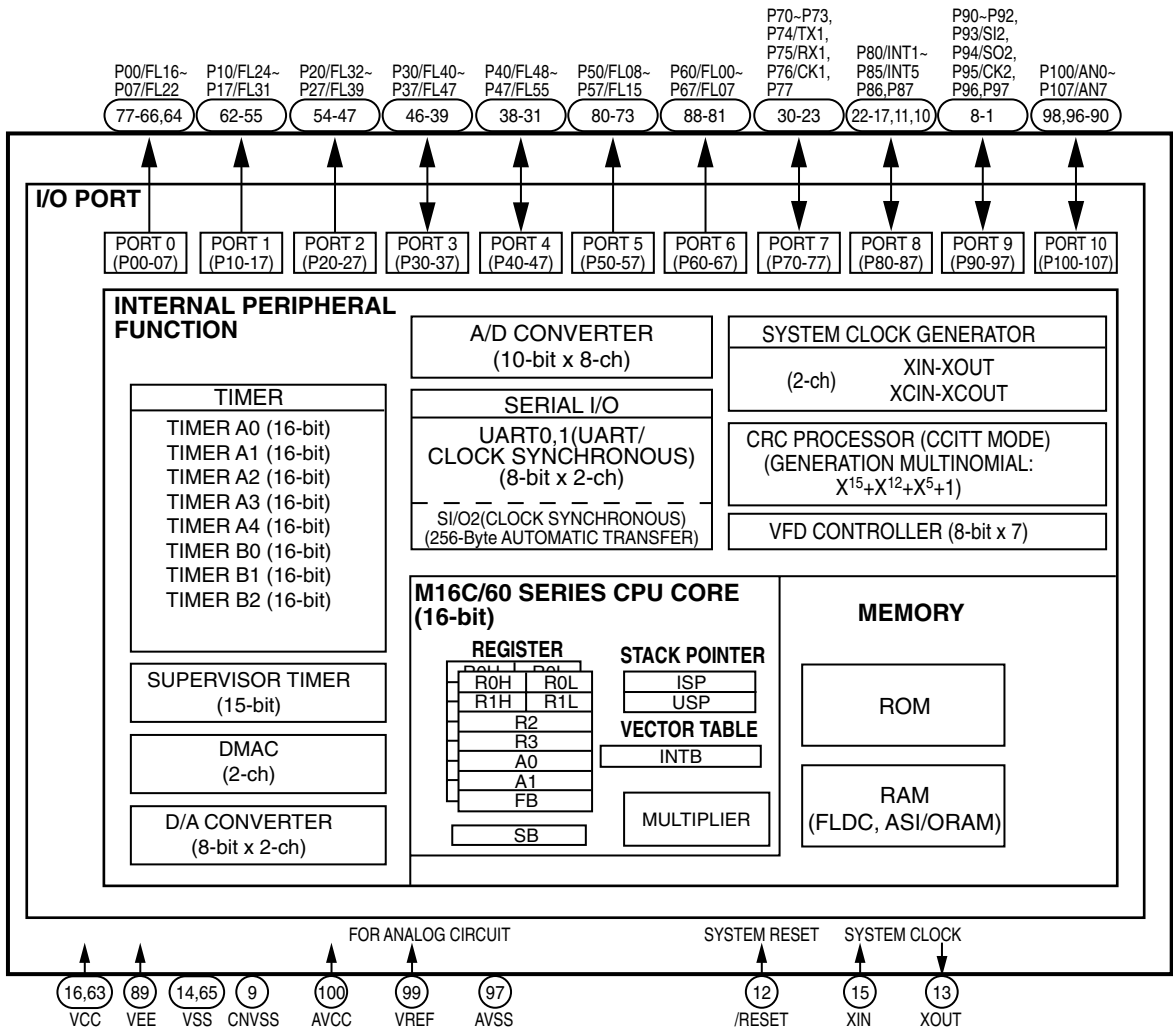
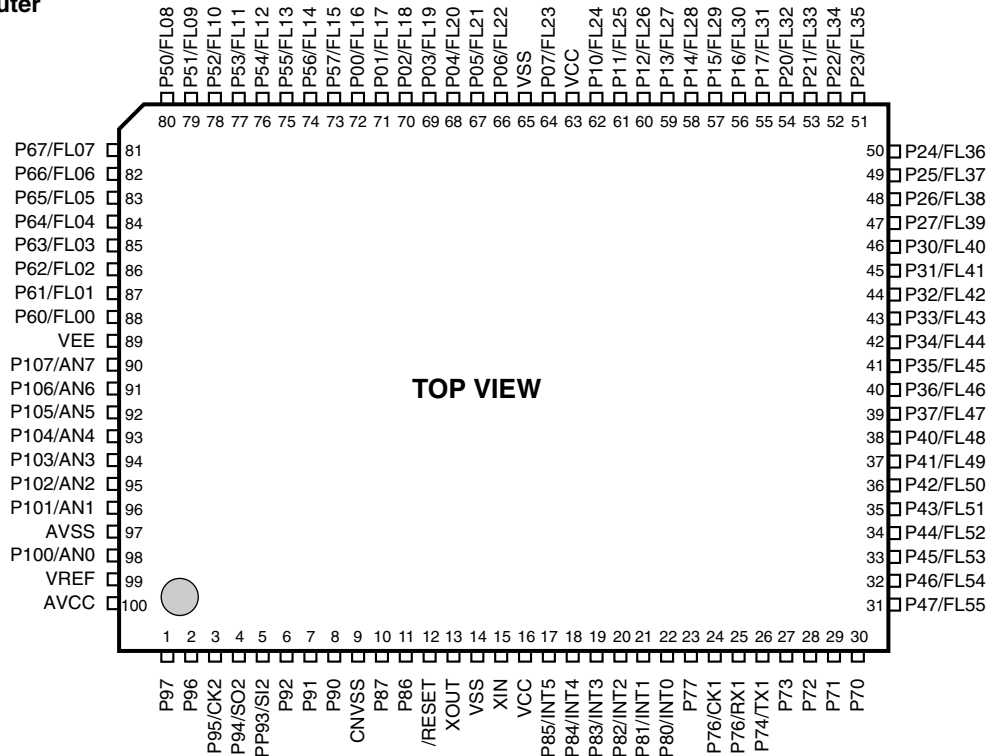

IC501 : M30217MA-A202FP

16-bit Microcomputer

Pin No.	Port	Pin Name	I/O	Function
1	P97	SCK	O	Serial Clock output
2	P96	SDT	O	Serial Data output
3	P95	RCK	O	Clock output for model type distinction (*1)
4	P94	RDT	O	Data output for destination distinction of Tuner (*2)
5	P93	DEST	O	Data input for destination distinction of Tuner (*2)
6	P92	RCE	O	Chip enable output for model type distinction (*1)
7	P91	SCKD	O	Serial Clock output for DIR2
8	P90	SID	O	Serial data output for DIR2
9	CNVSS	CNVSS		For flash μ-COM write connector
10	P87	CKB	O	Clock output for output port expansion IC
11	P86	DTB	O	Data output for output port expansion IC
12	/RESET	/RES		System reset
13	XOUT	XOUT		Crystal oscillator connected (10MHz)
14	VSS	MG		Ground
15	XIN	MU		Crystal oscillator connected (10MHz)
16	VCC	+5BU		+5V Power supply
17	P85/INT5	ERRD	I	Error flag input from DIR2
18	P84/INT4	ERRA	I	Data mute detect input from AC3Dav
19	P83/INT3	REM	I	Remote control input
20	P82/INT2	PDT	I	Power down detect input
21	P81/INT1	PSW	I	Standby switch input
22	P80/INT0	CEAC1	O	Chip enable output 1 for AC3Dav
23	P77	CEAC2	O	Chip enable output 2 for AC3Dav
24	P76/CK1	CLKAC	O	Serial clock output 2 for AC3Dav
25	P75/RX1	RXAC	I	Serial data input from AV3Dav
26	P74/TX1	TXAC	O	Serial data output for AC3Dav
27	P73	CECOD	O	Chip enable output for CODEC ADC/DAC
28	P72	TCE	O	Chip enable output for Tuner
29	P71	CELC	O	Chip enable output for Input Selector
30	P70	CETC	I	Fixed H

Pin No.	Port	Pin Name	I/O	Function
31	P47/FL55	F-CE	O	Chip enable output
32	P46/FL54	F-CK	O	Serial clock output
33	P45/FL53	F-RX	I	Serial data input
34	P44/FL52	F-TX	O	Serial data output
35	P43/FL51	VUP	O	Volume up output
36	P42/FL50	VDN	O	Volume down output
37	P41/FL49	CDO	I	Serial data input from DIR2
38	P40/FL48	DVD-C/O	I	DVD/LD coaxial/optical detect input
39	P37/FL47	DBS-C/O	I	Fixed H
40	P36/FL46	PRI	I	I (Over current) protection detect input
41	P35/FL45	POT-A	I	Rotary encoder input A
42	P34/FL44	POT-B	I	Rotary encoder input B
43	P33/FL43	/ST	I	Stereo input from Tuner
44	P32/FL42	DO	I	Serial data input from Tuner
45	P31/FL41	/ICAC	O	Initial clear output for AC3Dav
46	P30/FL40	PRY	O	Power relay output
47	P27/FL39	SRY	O	Speaker relay output
48	P26/FL38	ERY	O	Effect relay output
49	P25/FL37	G1	O	Grid 1 for FL display
50	P24/FL36	G2	O	Grid 2 for FL display
51	P23/FL35	G3	O	Grid 3 for FL display
52	P22/FL34	G4	O	Grid 4 for FL display
53	P21/FL33	G5	O	Grid 5 for FL display
54	P20/FL32	G6	O	Grid 6 for FL display
55	P17/FL31	G7	O	Grid 7 for FL display
56	P16/FL30	G8	O	Grid 8 for FL display
57	P15/FL29	G9	O	Grid 9 for FL display
58	P14/FL28	G10	O	Grid 10 for FL display
59	P13/FL27	G11	O	Grid 11 for FL display
60	P12/FL26	G12	O	Grid 12 for FL display
61	P11/FL25	G13	O	Grid 13 for FL display
62	P10/FL24	G14	O	Grid 14 for FL display
63	VCC	+5VBU		+5V power supply
64	P07/FL23	G15	O	Grid 15 for FL display
65	VSS	MG		Ground
66	P06/FL22	G16	O	Grid 16 for FL display

*1 Model type distinction (H=1, L=0)

DSP-A (Pin 3)	0	DSP-A	0	DSP-E	1	RX-V396 HTR-5230 DSP-R396	1	RX-V396RDS HTR 5230RDS
RDS (Pin 6)	0		1		0		1	

*2 Destination distinction of Tuner (H=1, L=0)

V1 (Pin 4)	0	J	0	U,C	1	A,B,G	1	R,T
V2 (Pin 5)	0	model	1	models	0	models	1	models

IC501 : M30217MA-A202FP

16-bit Microcomputer

Pin No.	Port	Pin Name	I/O	Function
67	P05/FL21	P1	O	Segment 1 for FL display
68	P04/FL20	P2	O	Segment 2 for FL display
69	P03/FL19	P3	O	Segment 3 for FL display
70	P02/FL18	P4	O	Segment 4 for FL display
71	P01/FL17	P5	O	Segment 5 for FL display
72	P00/FL16	P6	O	Segment 6 for FL display
73	P57/FL15	P7	O	Segment 7 for FL display
74	P56/FL14	P8	O	Segment 8 for FL display
75	P55/FL13	P9	O	Segment 9 for FL display
76	P54/FL12	P10	O	Segment 10 for FL display
77	P53/FL11	P11	O	Segment 11 for FL display
78	P52/FL10	P12	O	Segment 12 for FL display
79	P51/FL09	P13	O	Segment 13 for FL display
80	P50/FL08	P14	O	Segment 14 for FL display
81	P67/FL07	P15	O	Segment 15 for FL display
82	P66/FL06	P16	O	Segment 16 for FL display
83	P65/FL05	P17	O	Segment 17 for FL display
84	P64/FL04	P18	O	Segment 18 for FL display

Pin No.	Port	Pin Name	I/O	Function
85	P63/FL03	P19	O	Segment 19 for FL display
86	P62/FL02	P20	O	Segment 20 for FL display
87	P61/FL01	P21	O	Segment 21 for FL display
88	P60/FL00	P22	O	Segment 22 for FL display
89	VEE	VP	O	Power supply for FL display
90	P107/AN7	LIMDT	I	Limiter DC detect input
91	P106/AN6	PRV	I	PS (power voltage) protection AD value detect input
92	P105/AN5	PRD	I	DC (power amp voltage) protection AD value detect input
93	P104/AN4	METER	I	Tuner meter AD value input
94	P103/AN3	NC	O	No connection
95	P102/AN2	/FMT	O	Full mute output (L: ON)
96	P101/AN1	KEY2	I	Key 2 AD data value input
97	AVSS	MG		Ground
98	P100/AN0	KEY1	I	Key 1 AD data value input
99	VREF	+5M		Standard power supply for AD input
100	AVCC	+5BU		+5V power supply

IC107 : BU2090

Serial Input/Parallel Output Driver for Output port expansion

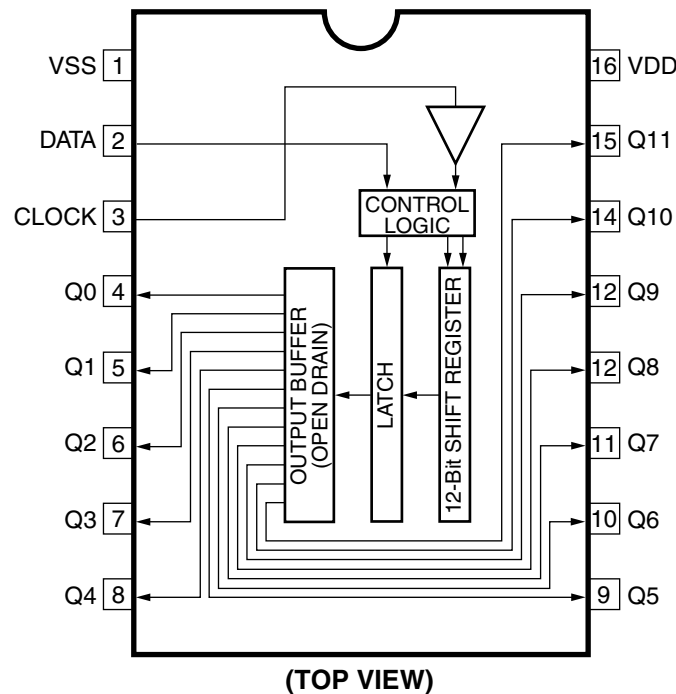

Pin No.	Port	Pin Name	I/O	Function
1	VSS	VSS		Ground
2	DATA	DTB	I	Control data input
3	CLOCK	CKB	I	Control clock input
4	Q0	SW1	O	Video select data output 1-3(*)
5	Q1	SW2	O	
6	Q2	SW3	O	
7	Q3	SW4	O	Video select data
8	Q4	SW5	O	output 4,5
9	Q5	/CONT1	O	Limiter control data output 1,2
10	Q6	/CONT2	O	
11	Q7	/-10dB	O	-10dB control data output (L : -10dB)
12	Q8	6ch GAIN	O	6-ch gain control data output (L:6-ch)
13	Q9	/C-MUTE	O	Center mute data output (L:Mute on)
14	Q10	/SW-MUTE	O	Subwoofer mute data output (L:Mute on)
15	Q11	/T-MUTE	O	Tuner mute data output (L : Mute on)
16	VDD	VDD		+5V power supply

* Video input Selector Control (H=High, L=Low)

Video Input	SW1 (Pin4)	SW2 (Pin5)	SW3 (Pin6)
VCR	H	L	H
SAT/D-TV	H	H	L
DVD/LD	L	H	L

IC3 : YM3436DK (DIR2)

Digital Format Interface Receiver

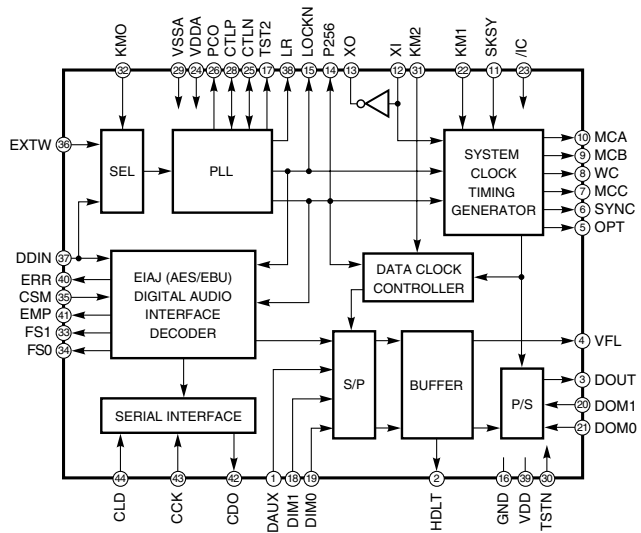
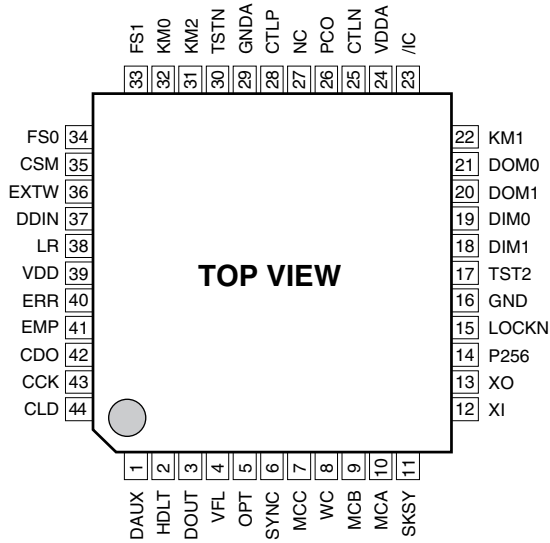

Pin No.	Pin Name	I/O	Function
1	DAUX	I	Audio data input from AC3Dav
2	HDLT	O	Unconnected
3	DOUT	O	Audio data output for AC3Dav
4	VFL	O	Unconnected
5	OPT	O	Unconnected
6	SYNC	O	Unconnected
7	MCC	O	64fs bit clock output for AC3Dav
8	WC	O	1fs word clock output for AC3Dav
9	MCB	O	Unconnected
10	MCA	O	256fs bit clock output for CODEC
11	SKSY	I	Clock synchronization control input (Fixed H)
12	XI	I	Crystal oscillator connection (12.288MHz)
13	XO	O	Crystal oscillator connection (12.288MHz) and external clock output for AC3Dav
14	P256	O	Unconnected
15	LOCKN	O	PLL lock flag output for microcomputer
16	GND		Ground
17	TST2	O	Unconnected
18	DIM1	I	Data input mode selection 0,1
19	DIM0	I	
20	DOM1	I	Data output mode selection 1,0 (Fixed L)
21	DOM0	I	
22	KM1	I	Compulsive analog performance mode input from AC3Dav

Pin No.	Pin Name	I/O	Function
23	/IC	I	Initial clear input from AC3Dav
24	VDDA		Power supply
25	CTLN	I	VCO control negative input
26	PCO	O	PLL phase comparison output
27	NC		Unconnected
28	CTLP	I	VCO control positive input (Fixed L)
29	GNDA		Ground
30	TSTN	I	Unconnected
31	KM2	I	Clock mode switching input 2,0 (Fixed L)
32	KM0	I	
33	FS1	O	Unconnected
34	FS0	O	Unconnected
35	CSM	I	Channel status output method selection(Fixed L)
36	EXTW	I	External synchronous auxiliary input word clock (Fixed L)
37	DIN	I	Digital audio data input
38	LR	O	Unconnected
39	VDD		Power supply
40	ERR	O	Data error flag output for microcomputer
41	EMP	O	Unconnected
42	CDO	O	Serial data output for microcomputer
43	CCK	I	Serial clock input from microcomputer
44	CLD	I	Serial data input from microcomputer

IC4 : YSS908-F (AC3Dav)
DSP + AC-3(Dolby Digital)/ Pro Logic Decoder

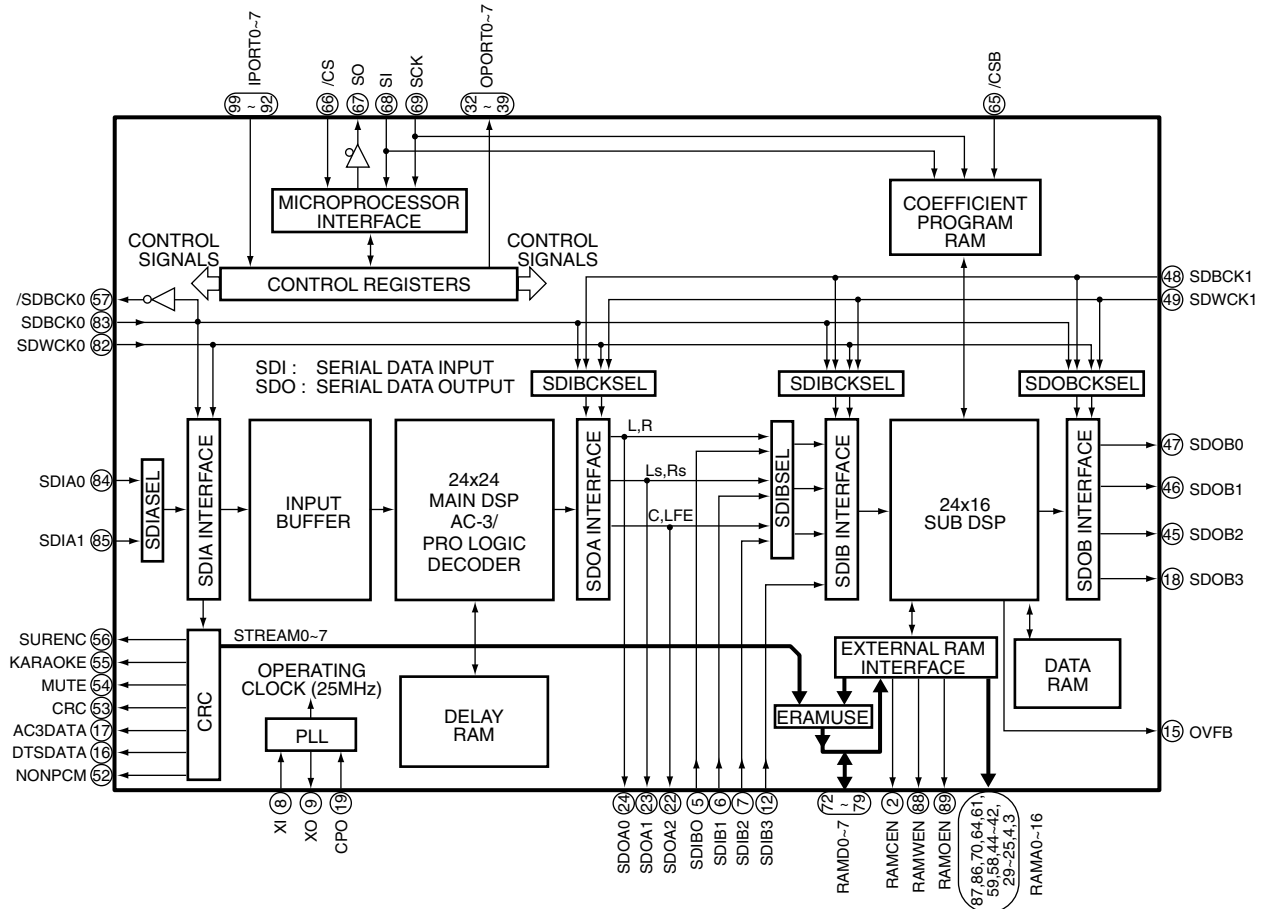
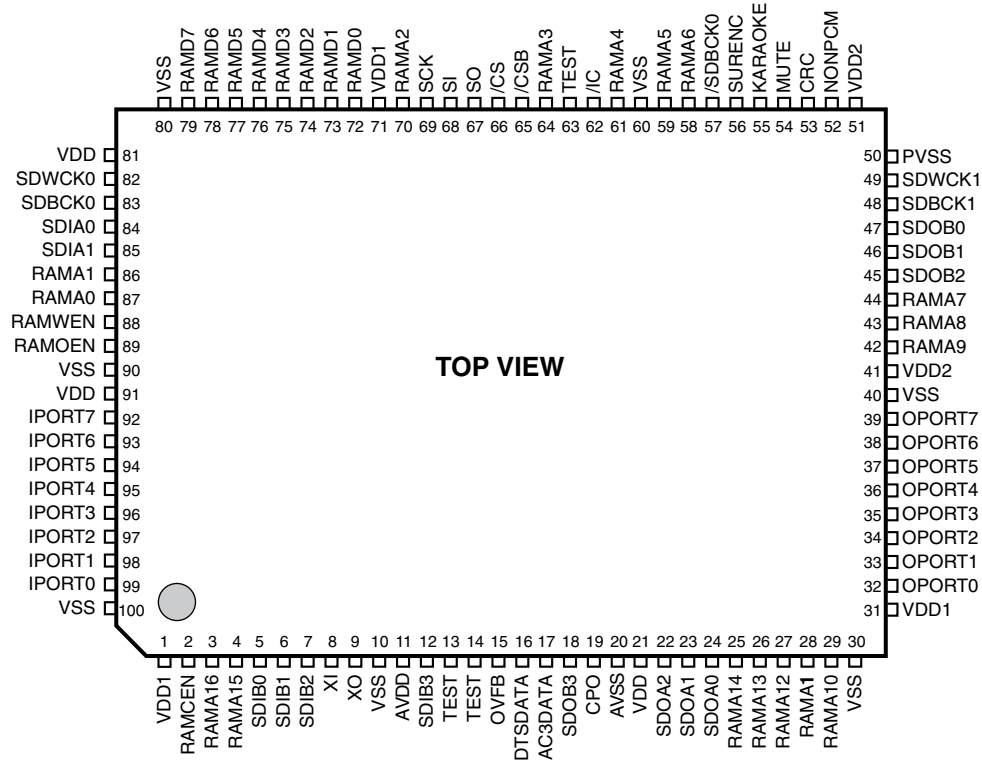

IC4 : YSS908-F (AC3Dav)

DSP + AC-3(Dolby Digital)/ Pro Logic Decoder

No.	Name	I/O	Function
1	VDD1		+5V power supply
2	RAMCEN	O	RAM chip enable output terminal (normally unconnected)
3	RAMA16	O	RAM address output terminal 16, connected to external 256K SRAM address
4	RAMA15	O	RAM address output terminal 15, connected to external 256K SRAM address
5	SDIB0	I	Serial data input B terminal 0 (normally connected to ground)
6	SDIB1	I	Serial data input B terminal 1 (normally connected to ground)
7	SDIB2	I	Serial data input B terminal 2 (normally connected to ground)
8	XI	I	Crystal oscillator connection or external clock input terminal, connected to external DIR2 external clock output
9	XO	O	Crystal oscillator connection (normally unconnected)
10	VSS		Ground
11	AVDD		+3V power supply
12	SDIB3	I	Serial data input B terminal 3 (normally unconnected)
13	TEST		Test terminal (normally unconnected)
14	TEST		Test terminal (normally unconnected)
15	OVFB	O	Overflow detect terminal (normally unconnected)
16	DTSDATA	O	DTS data detect terminal (normally unconnected)
17	AC3DATA	O	AC-3 data detect terminal (normally unconnected)
18	SDOB3	O	Serial data output B terminal 3 (normally unconnected)
19	CPO	O	PLL output terminal (connected to AVSS through external analog filter)
20	AVSS		Ground
21	VDD		+3V power supply
22	SDOA2	O	Serial data output A terminal 2 (normally unconnected)
23	SDOA1	O	Serial data output A terminal 1 (normally unconnected)
24	SDOA0	O	Serial data output A terminal 0 (normally unconnected)
25	RAMA14	O	RAM address terminal 14 output terminal, connected to external 256K SRAM address
26	RAMA13	O	RAM address terminal 13 output terminal, connected to external 256K SRAM address
27	RAMA12	O	RAM address terminal 12 output terminal, connected to external 256K SRAM address
28	RAMA11	O	RAM address terminal 11 output terminal, connected to external 256K SRAM address
29	RAMA10	O	RAM address terminal 10 output terminal, connected to external 256K SRAM address
30	VSS		Ground
31	VDD1		+5V power supply
32	OPORT0	O	Output expansion port terminal 0, digital input selector A output
33	OPORT1	O	Output expansion port terminal 1, digital input selector B output (DIB*)
34	OPORT2	O	Output expansion port terminal 2, connected to external CODEC initial clear input
35	OPORT3	O	Output expansion port terminal 3, connected to external DIR2 compulsive analog performance mode input
36	OPORT4	O	Output expansion port terminal 4, connected to external DIR2 initial clear input
37	OPORT5	O	Output expansion port terminal 5 (normally unconnected)
38	OPORT6	O	Output expansion port terminal 6 (normally unconnected)
39	OPORT7	O	Output expansion port terminal 7 (normally unconnected)
40	VSS		Ground
41	VDD2		+3V power supply
42	RAMA9	O	RAM address output terminal 9 , connected to external 256K SRAM address
43	RAMA8	O	RAM address output terminal 8 , connected to external 256K SRAM address
44	RAMA7	O	RAM address output terminal 7 , connected to external 256K SRAM address
45	SDOB2	O	Serial data output B terminal 2, connected to external CODEC PCM audio data output
46	SDOB1	O	Serial data output B terminal 1, connected to external CODEC PCM audio data output
47	SDOB0	O	Serial data output B terminal 0, connected to external CODEC PCM audio data output
48	SDBCK1	I	Serial data bit clock input terminal 1, connected to external DIR2 64fs bit clock output
49	SDWCK1	I	Serial data word clock input terminal 1, connected to external DIR2 1fs word clock output
50	VSS		Ground

* Digital input
Selector Control
(H=High, L=Low)

Digital Input	DIB(Pin33)
DVD/LD	L
SAT/D-TV	H

IC4 : YSS908-F (AC3Dav)

DSP + AC-3(Dolby Digital)/ Pro Logic Decoder

No.	Name	I/O	Function
51	VDD2		+3V power supply
52	NONPCM	O	Non-PCM data output terminal (normally unconnected)
53	CRC	O	CRC output terminal (normally unconnected)
54	MUTE	O	Mute output terminal, connected to external microcomputer data mute detect input
55	KARAOKE	O	Karaoke output terminal (normally unconnected)
56	SURENC	O	Surround encoder output terminal (normally unconnected)
57	/SDBCK0	O	Inverted signal of serial data bit clock output terminal 0 (normally unconnected)
58	RAMA6	O	RAM address output terminal 6, connected to external 256K SRAM address
59	RAMA5	O	RAM address output terminal 5, connected to external 256K SRAM address
60	VSS		Ground
61	RAMA4	O	RAM address output terminal 4, connected to external 256K SRAM address
62	/IC	I	Initial clear input terminal, connected to external microcomputer initial clear output
63	TEST		Test terminal (normally unconnected)
64	RAMA3	O	RAM address output terminal 3, connected to external 256K SRAM address
65	/CSB	I	Chip select B input terminal, connected to external microcomputer chip enable output 2
66	/CS	I	Chip select input terminal, connected to external microcomputer chip enable output 1
67	SO	O	Serial data output terminal, connected to external microcomputer serial data input
68	SI	I	Serial data input terminal, connected to external microcomputer serial data output
69	SCK	I	Serial clock input terminal, connected to external microcomputer serial clock output
70	RAMA2	O	RAM address output terminal 2, connected to external 256K SRAM address
71	VDD1		+5V power supply
72	RAMD0	I/O	RAM data bus terminal 0, connected to external 256K SRAM data
73	RAMD1	I/O	RAM data bus terminal 1, connected to external 256K SRAM data
74	RAMD2	I/O	RAM data bus terminal 2, connected to external 256K SRAM data
75	RAMD3	I/O	RAM data bus terminal 3, connected to external 256K SRAM data
76	RAMD4	I/O	RAM data bus terminal 4, connected to external 256K SRAM data
77	RAMD5	I/O	RAM data bus terminal 5, connected to external 256K SRAM data
78	RAMD6	I/O	RAM data bus terminal 6, connected to external 256K SRAM data
79	RAMD7	I/O	RAM data bus terminal 7, connected to external 256K SRAM data
80	VSS		Ground
81	VDD2		+3V power supply
82	SDWCK0	I	Serial data word clock input terminal 0, connected to external DIR2 1fs word clock output
83	SDBCK0	I	Serial data bit clock input terminal 0, connected to external DIR2 64fs bit clock output
84	SDIA0	I	Serial data input A terminal 0, AC-3/DTS bit stream (or PCM) data input, connected to external DIR2 audio data output
85	SDIA1	I	Serial data input A terminal 1 (normally connected to ground)
86	RAMA1	O	RAM address output terminal 1, connected to external 256K SRAM address
87	RAMA0	O	RAM address output terminal 0, connected to external 256K SRAM address
88	RAMWEN	O	RAM write enable output terminal, connected to external 256K SRAM write enable
89	RAMOEN	O	RAM output enable output terminal, connected to external 256K SRAM output enable
90	VSS		Ground
91	VDD		+3V power supply
92	IPORT7	I	Input expansion port terminal 7 (normally connected to ground)
93	IPORT6	I	Input expansion port terminal 6 (normally connected to ground)
94	IPORT5	I	Input expansion port terminal 5 (normally connected to ground)
95	IPORT4	I	Input expansion port terminal 4 (normally connected to ground)
96	IPORT3	I	Input expansion port terminal 3, Front mix select (H:Outside, L:Inside)
97	IPORT2	I	Input expansion port terminal 2, RF select(H:Exist, L:None)
98	IPORT1	I	Input expansion port terminal 1, DTS select (H:DTS (YSS918), L:Non DTS (YSS908))
99	IPORT0	I	Input expansion port terminal 0, SRAM select (H:1M, L:256K)
100	VSS		Ground

IC7 : LP61256GS-8Q (256K SRAM)

32768-word x 8-bit High Speed Static RAM

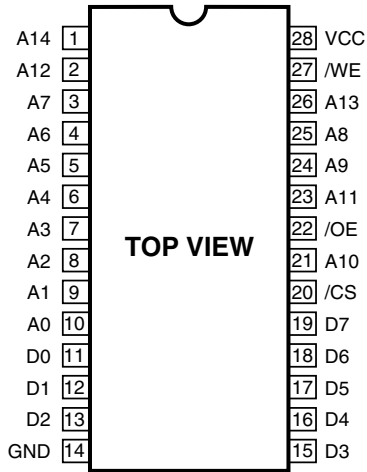

NOTE)

- A0-A14: Address input
- D0-D7: Data input/output
- /CS: Chip select input
- /OE: Output enable input
- /WE: Write enable input

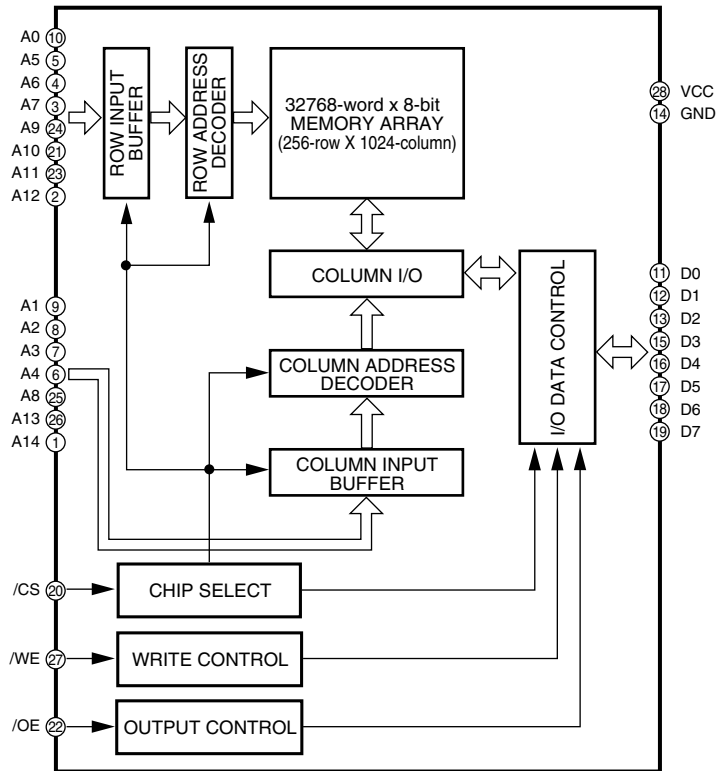

IC6: CS4227-KQ CODEC. ADC/DAC)
6-channel 20-bit Codec providing A/D, D/A Converter

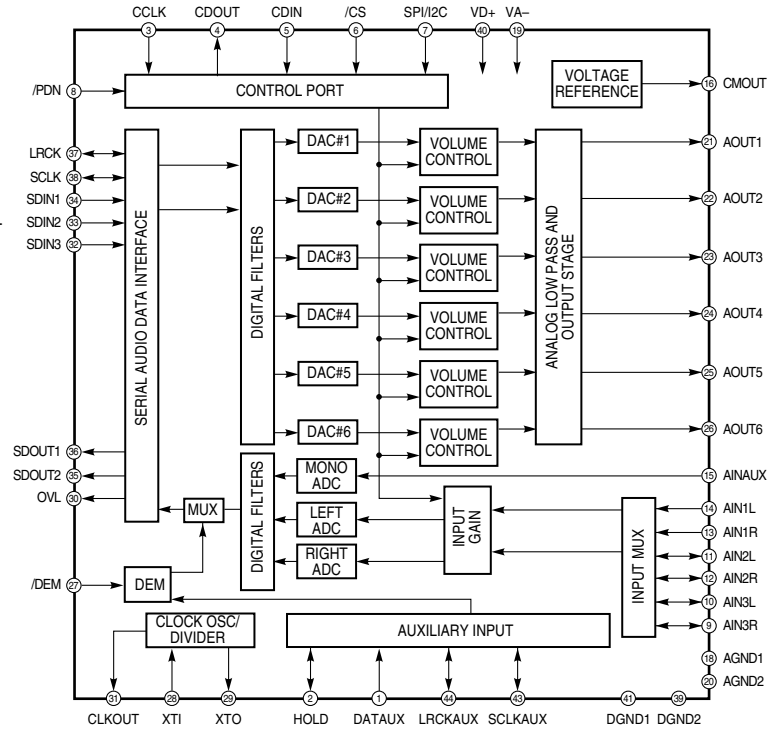
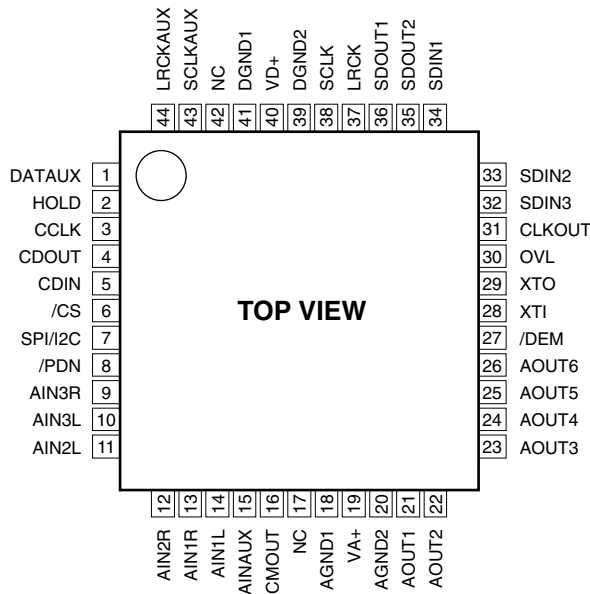

Pin No.	Pin Name	I/O	Function
1	DATAUX	I	DATAUX terminal (Connected to digital ground)
2	HOLD	I/O	HOLD terminal (Connected to digital ground)
3	CCLK	I	Control clock input terminal, serial clock from microcomputer
4	CDOUT	O	CDOUT terminal (Unconnected)
5	CDIN	I	Control data input terminal, serial data from microcomputer
6	/CS	I	Chip select input terminal, codec chip enable from microcomputer
7	SPI/I2C	I	SPI/I2C terminal (Connected to digital ground)
8	/PDN	I	Power down input terminal, initial clear from AC3D2av
9	AIN3R	I/O	AIN3R terminal (Unconnected)
10	AIN3L	I/O	Lch analog input/output terminal 3,2, Lch positive, negative input from input selector
11	AIN2L	I/O	Rch analog input/output terminal 2,1, Rch negative, positive input from input selector
12	AIN2R	I/O	AIN2R terminal (Unconnected)
13	AIN1R	I	AIN1R terminal (Unconnected)
14	AIN1L	I	AIN1L terminal (Unconnected)
15	AINAUX	I	AINAUX terminal (Unconnected)
16	CMOUT	O	Center mute output terminal
17	NC		Non connection terminal
18	AGND1		Analog ground
19	VA+		+5V Analog power supply
20	AGND2		Analog ground
21	AOUT1	O	Analog output terminal 1,2, L,Rch analog output for MAIN
22	AOUT2	O	

Pin No.	Pin Name	I/O	Function
23	AOUT3	O	Analog output terminal 3,4, L,Rch analog output for REAR
24	AOUT4	O	
25	AOUT5	O	Analog output terminal 5,6, L,Rch analog output for CENTER, LFE
26	AOUT6	O	
27	/DEM	I	/DEM terminal (Connected to digital ground)
28	XTI	I	Cryatal input terminal, 256fs bit clock from DIR2
29	XTO	O	XTO terminal (Unconnected)
30	OVL	O	OVL terminal (Unconnected)
31	CLKOUT	O	CLKOUT terminal (Unconnected)
32	SDIN3	I	Serial data input terminal, 3,2,1, PCM audio data from AC3Dav
33	SDIN2	I	
34	SDIN1	I	
35	SDOUT2	O	SDOUT2 terminal (Unconnected)
36	SDOUT1	O	Serial data output terminal1, audio data for DIR2
37	LRCK	I/O	L,Rch clock input/output terminal, 1fs word clock from DIR2
38	SCLK	I/O	Serial clock input/output terminal, 64fs bit clock from DIR2
39	DGND2		Digital ground
40	VD+		+5V digital power supply
41	DGND1		Digital ground
42	NC		Non connection terminal
43	SCLKAUX	I/O	SCLKAUX terminal (Connected to digital ground)
44	LRCKAUX	I/O	LRCKAUX terminal (Connected to digital ground)

■ DISPLAY DATA

● V501 : 15-BT-67GNK (V4420300)

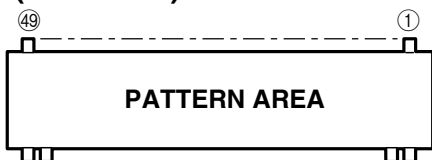

• PIN CONNECTION

Pin No.	1	2	3	4	5	6	7	8	9	10	11	12	13	14	15	16	17	18	19	20	21	22	23	24	25
CONNECTION	F1	F1	NP	NP	P22	P21	P20	P19	P18	P17	P16	P15	P14	P13	P12	P11	P10	P9	P8	P7	P6	P5	P4	P3	P2
Pin No.	26	27	28	29	30	31	32	33	34	35	36	37	38	39	40	41	42	43	44	45	46	47	48	49	
CONNECTION	P1	NX	NX	NX	NX	15G	14G	13G	12G	11G	10G	9G	8G	7G	6G	5G	4G	3G	2G	1G	NP	NP	F2	F2	

NOTE 1) F1, F2.....Filament
 2) NP.....No pin
 3) NX.....No extend pin
 4) P1~P22.....Segment
 5) 1G~15G.....Grid

• GRID ASSIGNMENT

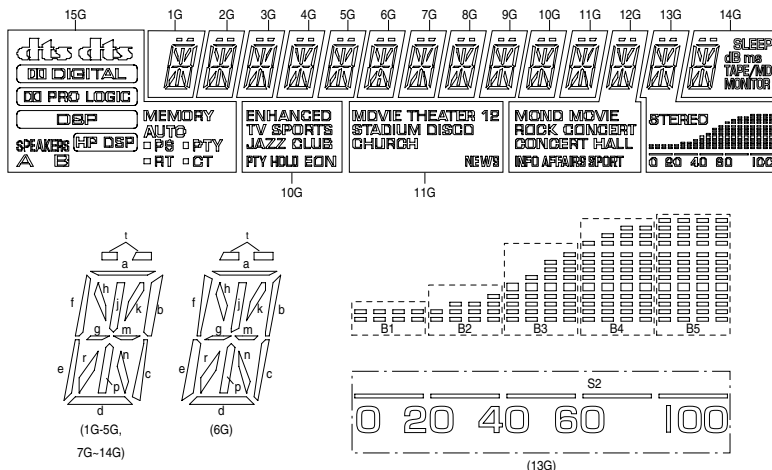

• ANODE CONNECTION

	15G	14G	13G	12G	11G	10G	9G	8G	7G	6G	5G	4G	3G	2G	1G
P1	(LEFT)	a	a	a	a	a	a	a	a	a	a	a	a	a	a
P2	(RIGHT)	b	b	b	b	b	b	b	b	b	b	b	b	b	b
P3		c	c	c	c	c	c	c	c	c	c	c	c	c	c
P4		d	d	d	d	d	d	d	d	d	d	d	d	d	d
P5		e	e	e	e	e	e	e	e	e	e	e	e	e	e
P6		f	f	f	f	f	f	f	f	f	f	f	f	f	f
P7		g	g	g	g	g	g	g	g	g	g	g	g	g	g
P8		h	h	h	h	h	h	h	h	h	h	h	h	h	h
P9		j	j	j	j	j	j	j	j	j	j	j	j	j	j
P10		k	k	k	k	k	k	k	k	k	k	k	k	k	k
P11		m	m	m	m	m	m	m	m	m	m	m	m	m	m
P12	<input type="checkbox"/> (PS)	n	n	n	n	n	n	n	n	n	n	n	n	n	n
P13		p	p	p	p	p	p	p	p	p	p	p	p	p	p
P14	<input type="checkbox"/> (PTY)	r	r	r	r	r	r	r	r	r	r	r	r	r	r
P15		t	t	t	t	t	t	t	t	t	t	t	t	t	t
P16	<input type="checkbox"/> (RT)	dB	STEREO	MONO MOVIE	MOVIE THEATER	ENHANCED	-	-	-	-	-	-	-	-	-
P17		ms	B1	ROCK CONCERT	1	TV SPORTS	-	-	-	-	-	-	-	-	-
P18	<input type="checkbox"/> (CT)	SLEEP	B2	CONCERT HALL	2	JAZZ CLUB	-	-	-	-	-	-	-	-	-
P19		TAPE/MD MONITOR	B3	INFO	STADIUM	PTY HOLD	-	-	-	-	-	-	-	-	-
P20	-	-	B4	AFFAIRS	DISCO	EON	-	-	-	-	-	-	-	-	-
P21	-	-	B5	SPORT	CHURCH	-	-	-	-	-	-	-	-	-	-
P22	-	-	S1	-	NEWS	-	-	-	-	-	-	-	-	-	-

BLOCK DIAGRAM (1/2)

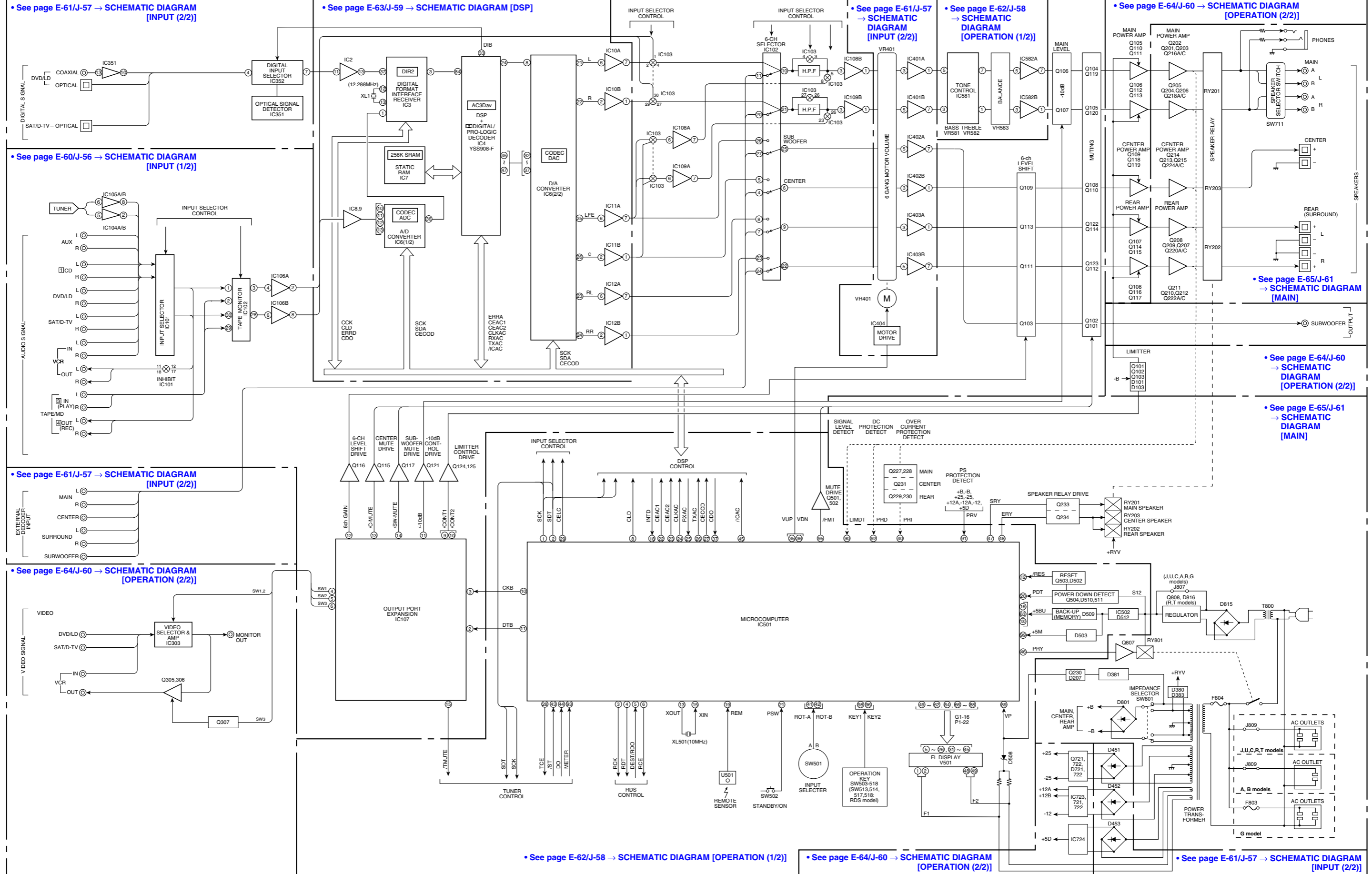

■ BLOCK DIAGRAM (2/2)

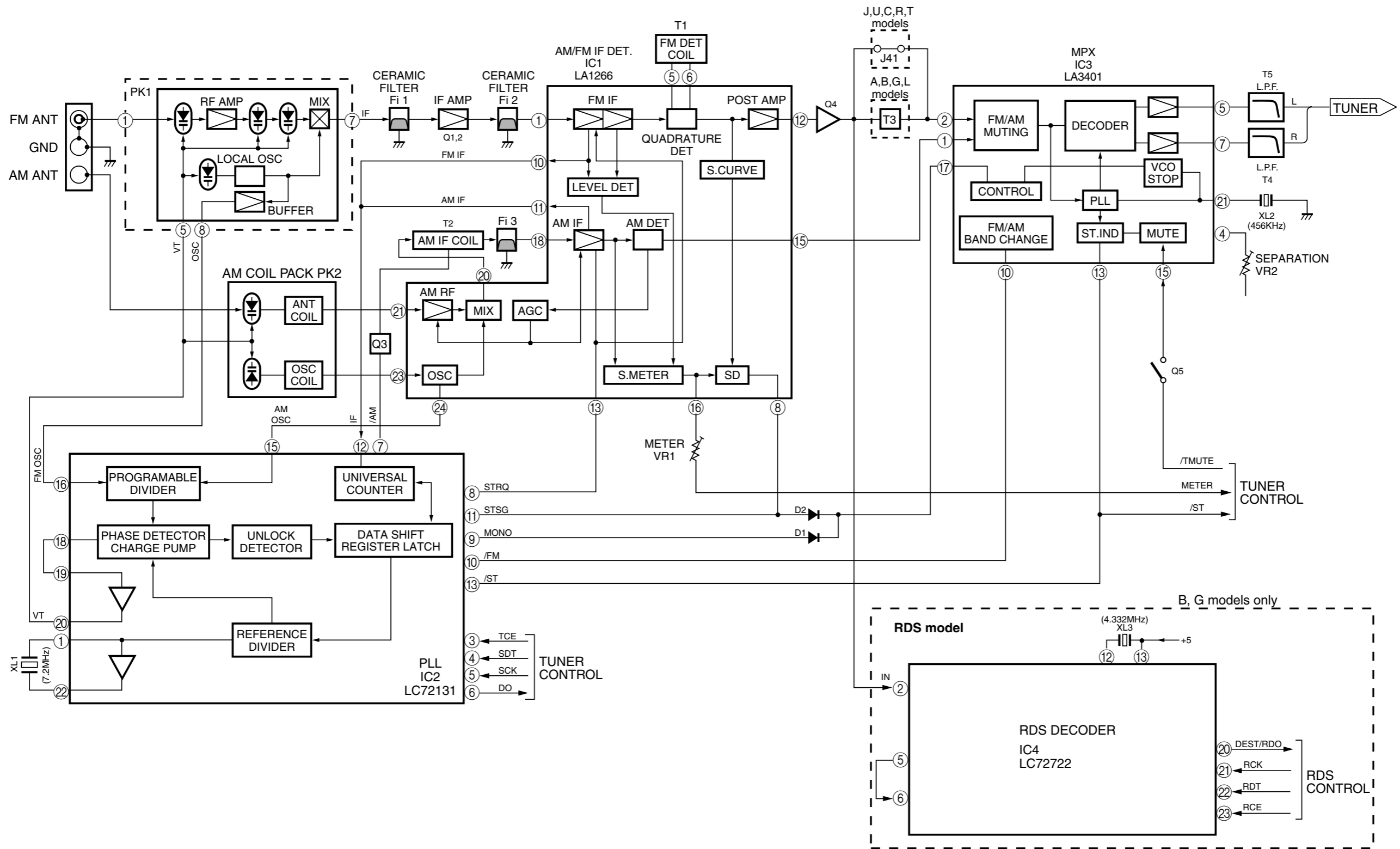

- See page E-66/J-62 → SCHEMATIC DIAGRAM [TUNER] J, U, C, R, T, A, B and G models
- See page E-67/J-63 → SCHEMATIC DIAGRAM [TUNER] B and G models (RDS model)

PRINTED CIRCUIT BOARD (Foil side)

There are two types of Tuner P. C. B. assemblies for this model: One has only lead-type device and the other has lead-type and surface-mount (SMD) devices. These two P. C. B. assemblies are interchangeable.

P. C. B. ASS'Y TUNER LIST

Model	Markets	Lead Type	Lead & SMD
RX-V396RDS/ HTR-5230RDS	B, G	V2518900	V2519600

B and G models (RDS model) P. C. B. TUNER (Lead Type)

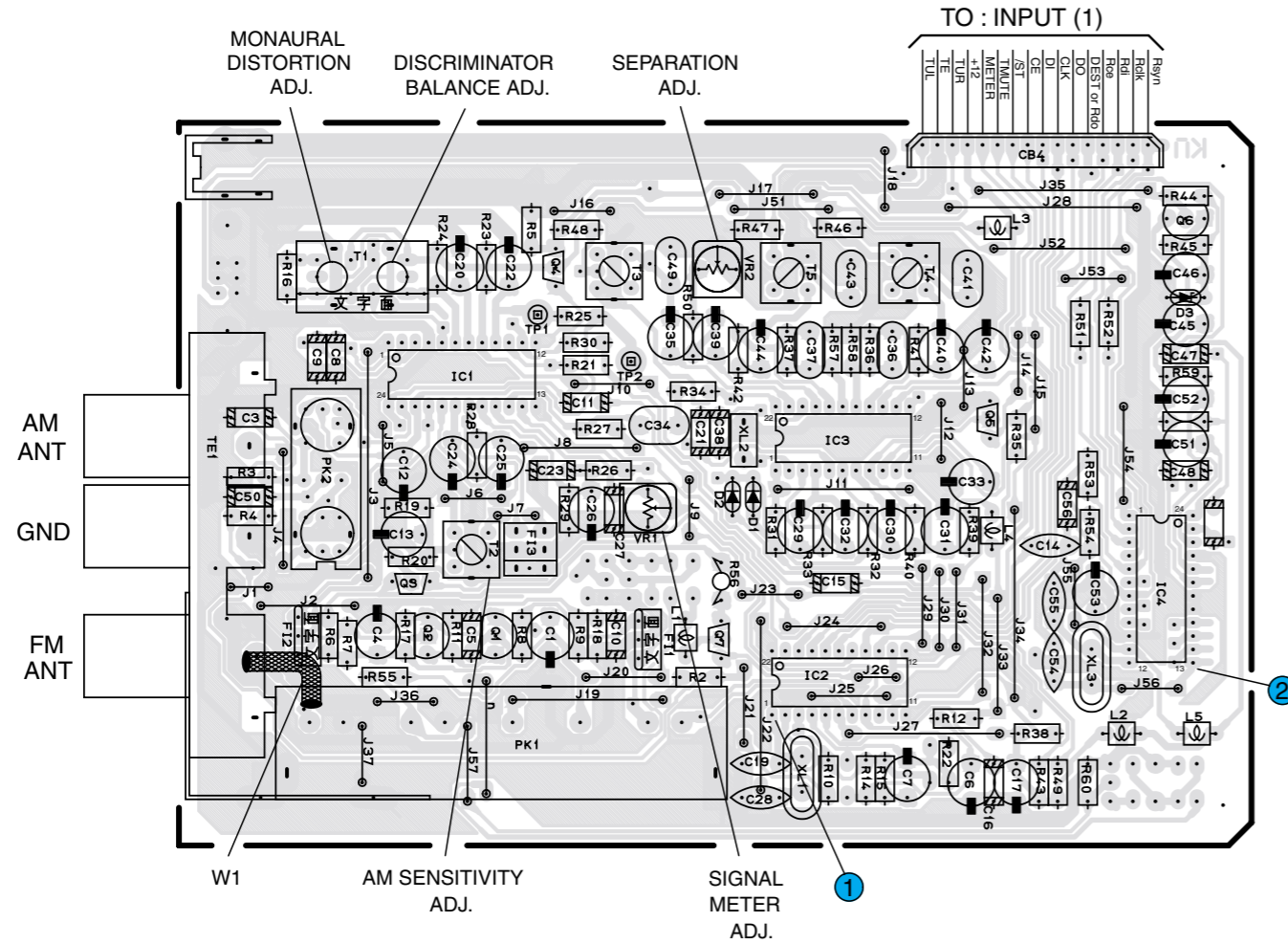

Lead Type

● Semiconductor Location

Ref. No.	Location
D1	C3
D2	C3
D3	D3
IC1	B3
IC2	C4
IC3	C3
IC4	D3
Q1	B4
Q2	B4
Q3	B3
Q4	B3
Q5	C3
Q6	D2
Q7	C4

Point ① (Pin22 of IC2)

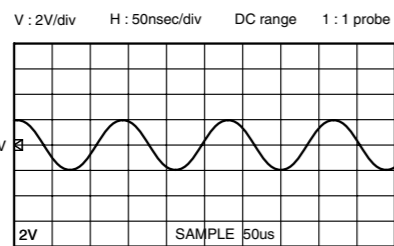

Point ② (Pin12 of IC4)

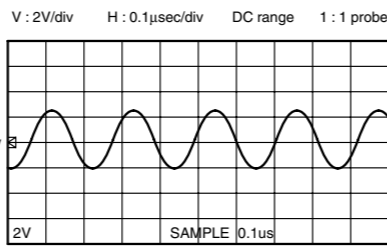

Lead Type & SMD

● Semiconductor Location

Ref. No.	Location
D1	G5
D2	G5
D3	H4
IC1	F2
IC2	G3
IC3	G2
IC4	H3
Q1	F3
Q2	F3
Q3	F3
Q4	F2
Q5	G2
Q6	H2
Q7	G3

B and G models (RDS model) P. C. B. TUNER (Lead Type & SMD)

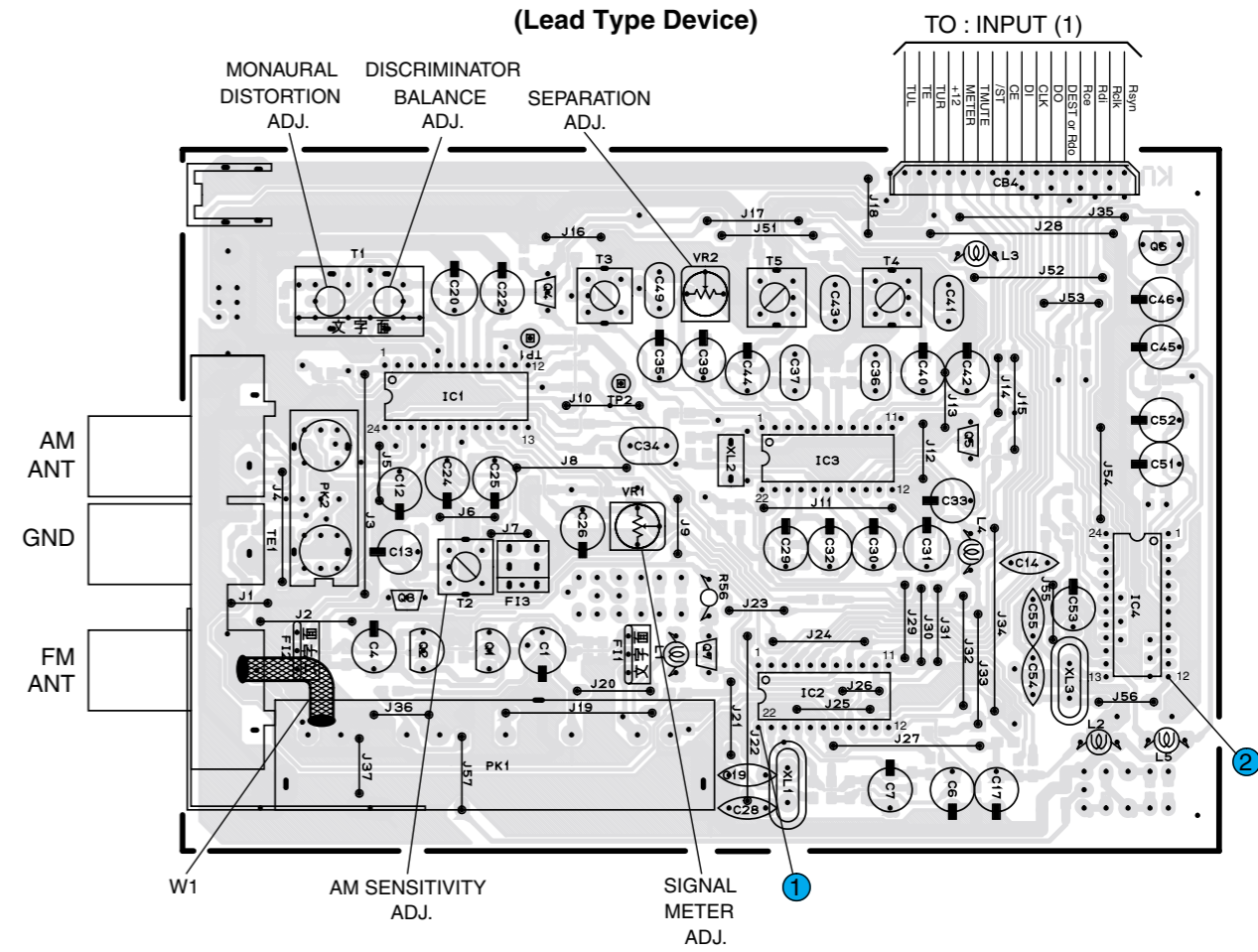

(Surface Mount Device)

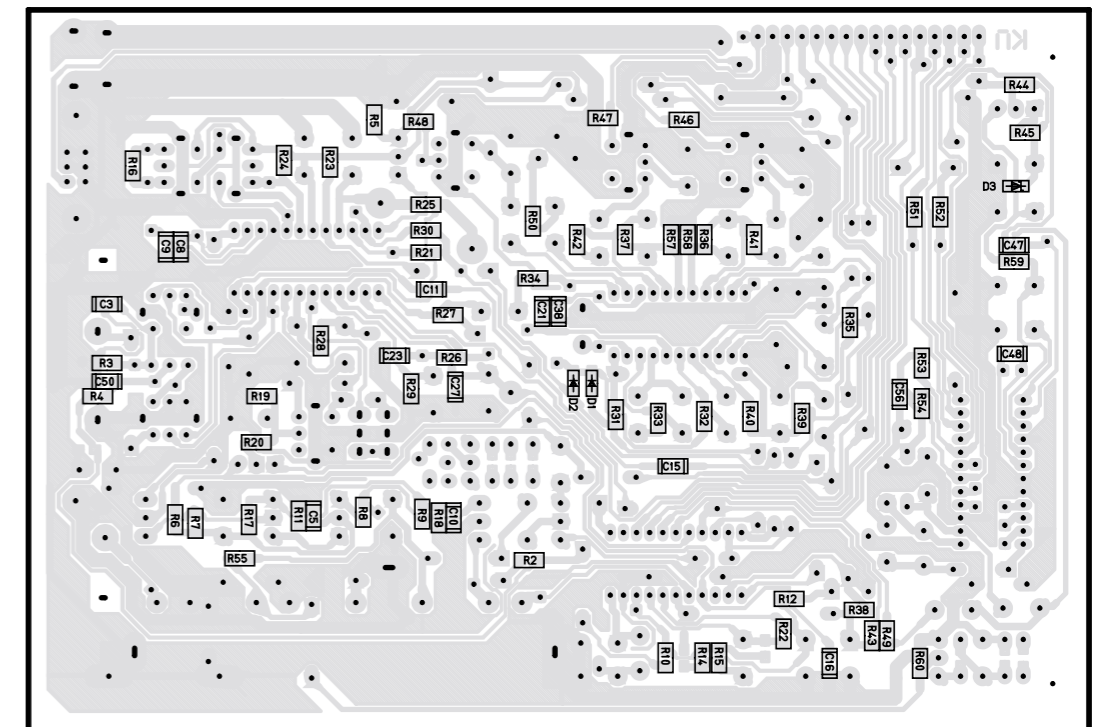

PRINTED CIRCUIT BOARD (Foil side)

There are two types of Tuner P. C. B. assemblies for this model: One has only lead-type device and the other has lead-type and surface-mount (SMD) devices. These two P. C. B. assemblies are interchangeable.

P. C. B. ASS'Y TUNER LIST

Model	Markets	Lead Type	Lead & SMD
DSP-R396	J	V2518500	V2519200
RX-V396/HTR-5230	U, C	V2518600	V2519300
RX-V396/HTR-5230	R, T/T	V2518700	V2519400
RX-V396/HTR-5230	A, B, G/A	V2518800	V2519500

● J, U, C, R, T, A, B and G models
P. C. B. TUNER (Lead Type)

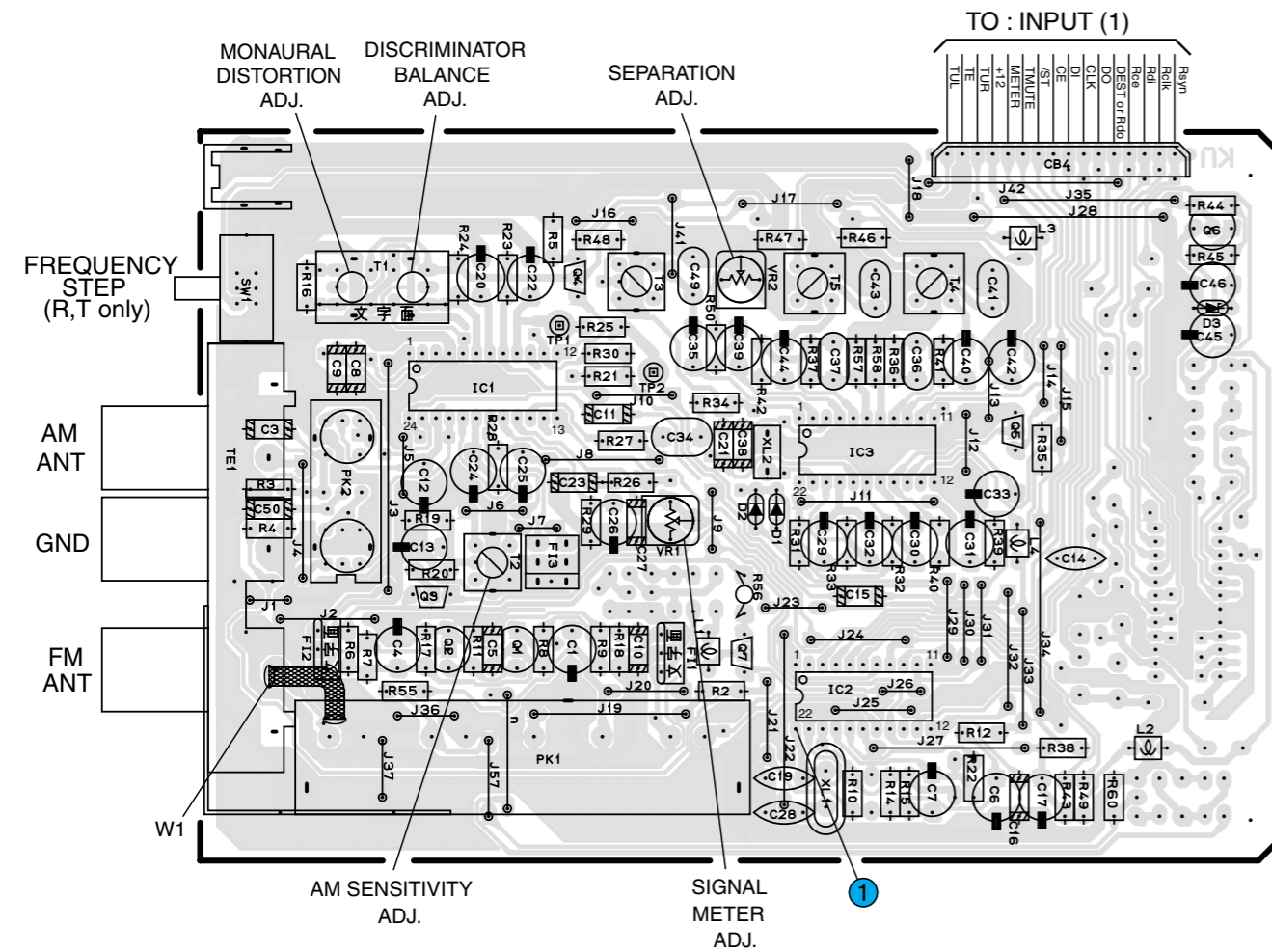

Lead Type
● Semiconductor Location

Ref. No.	Location
D1	C3
D2	C3
D3	D3
IC1	B3
IC2	C4
IC3	C3
Q1	B4
Q2	B4
Q3	B4
Q4	B3
Q5	C3
Q6	D3
Q7	C4

CIRCUIT CHANGES BY MARKET.

	J	U,C	R,T	A,B,G,L
R48	X	X	X	○
T3	X	X	X	○
J41	○	○	○	X
SW1	X	X	○	X
J42	X	X	○	X
R55	X	X	X	○
R57	X	X	X	○
R58	X	X	X	○
R60	X	X	X	○

○:USED X:NOT USED

Point ① (Pin22 of IC2)

V : 2V/div H : 0.1µsec/div DC range 1 : 1 probe

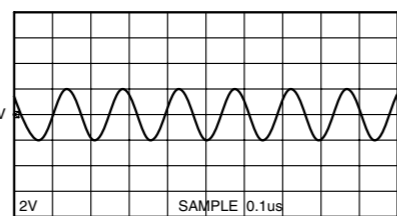

Lead Type & SMD
● Semiconductor Location

Ref. No.	Location
D1	G5
D2	G5
D3	H4
IC1	F2
IC2	G3
IC3	G2
Q1	F3
Q2	F3
Q3	F3
Q4	F2
Q5	G2
Q6	H2
Q7	G3

● J, U, C, R, T, A, B and G models
P. C. B. TUNER (Lead Type & SMD)
(Lead Type Device)

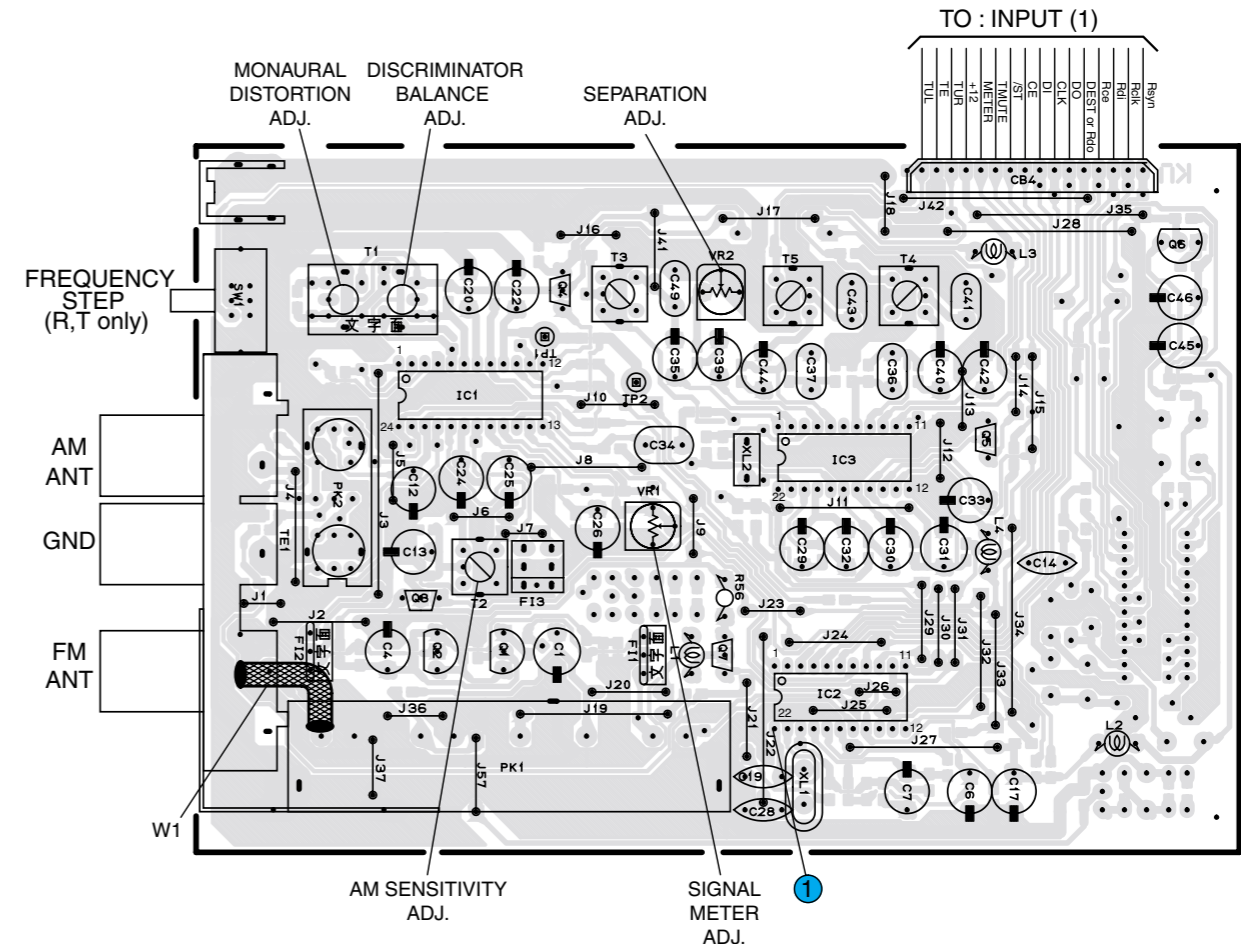

(Surface Mount Device)

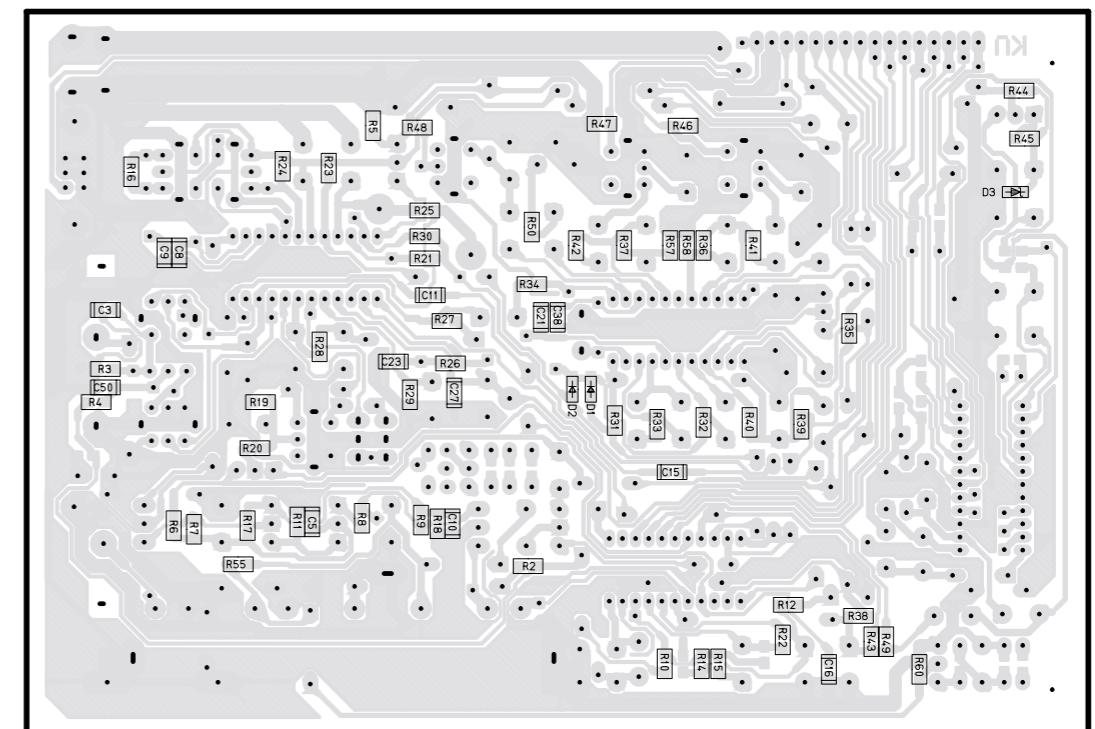

PRINTED CIRCUIT BOARD (Foil side)

J, U, C, A, B and G models

P. C. B. MAIN (2)

Semiconductor Location J,U,C,A,B,G models

Ref. No.	Location
D801	B3
D814	C4
D815	D5
Q807	B4

SWITCHED
100W MAX. TOTAL
AC OUTLETS
J,U,C
models

SWITCHED
100W MAX. (A,B models)
100W MAX. TOTAL (G,L models)
AC OUTLETS
A,B,G
models

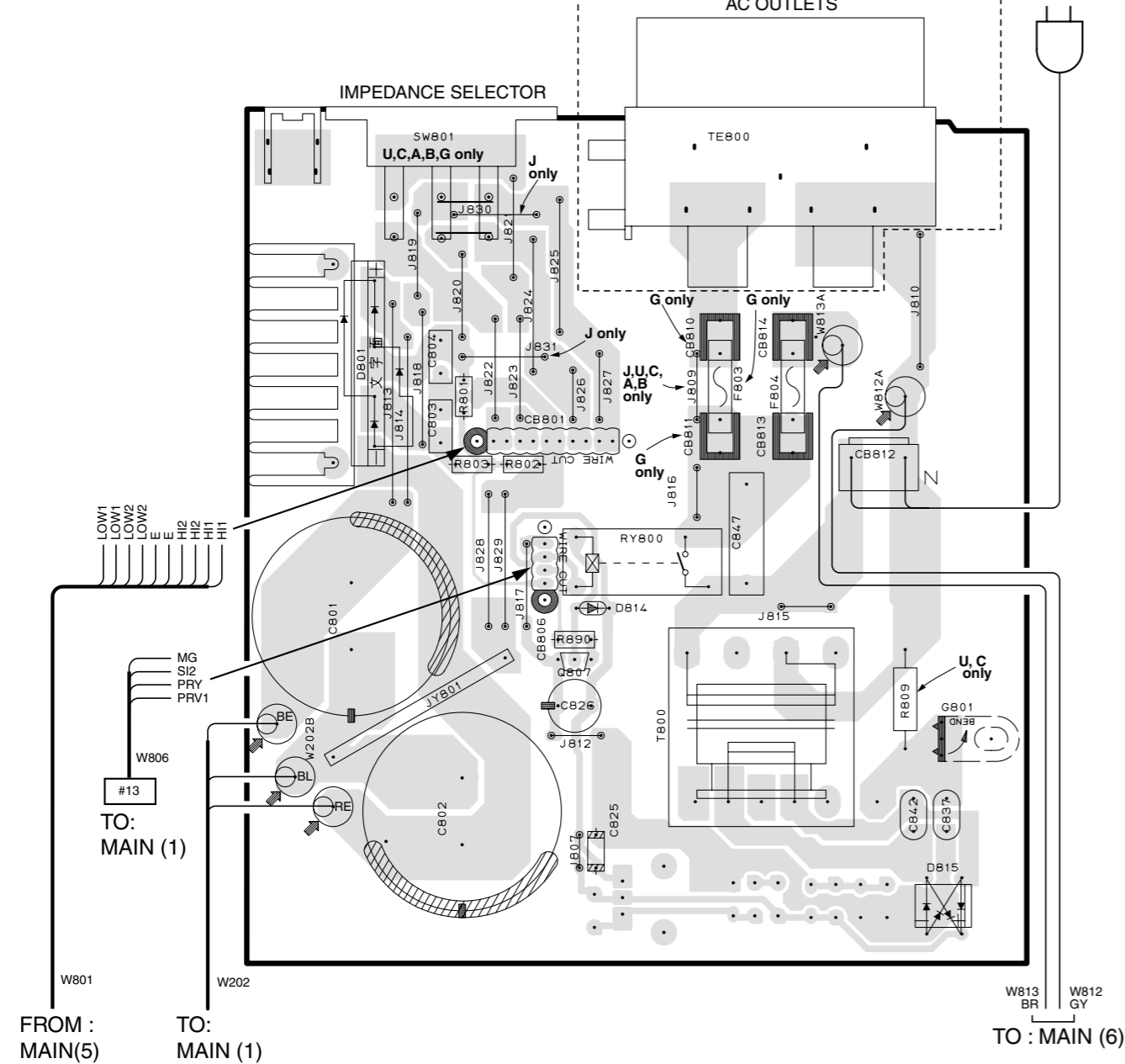

R and T models only

P. C. B. MAIN (2)

Semiconductor Location R,T models

Ref. No.	Location
D801	F3
D814	F4
D815	G5
D816	G5
Q807	F4
Q808	G5

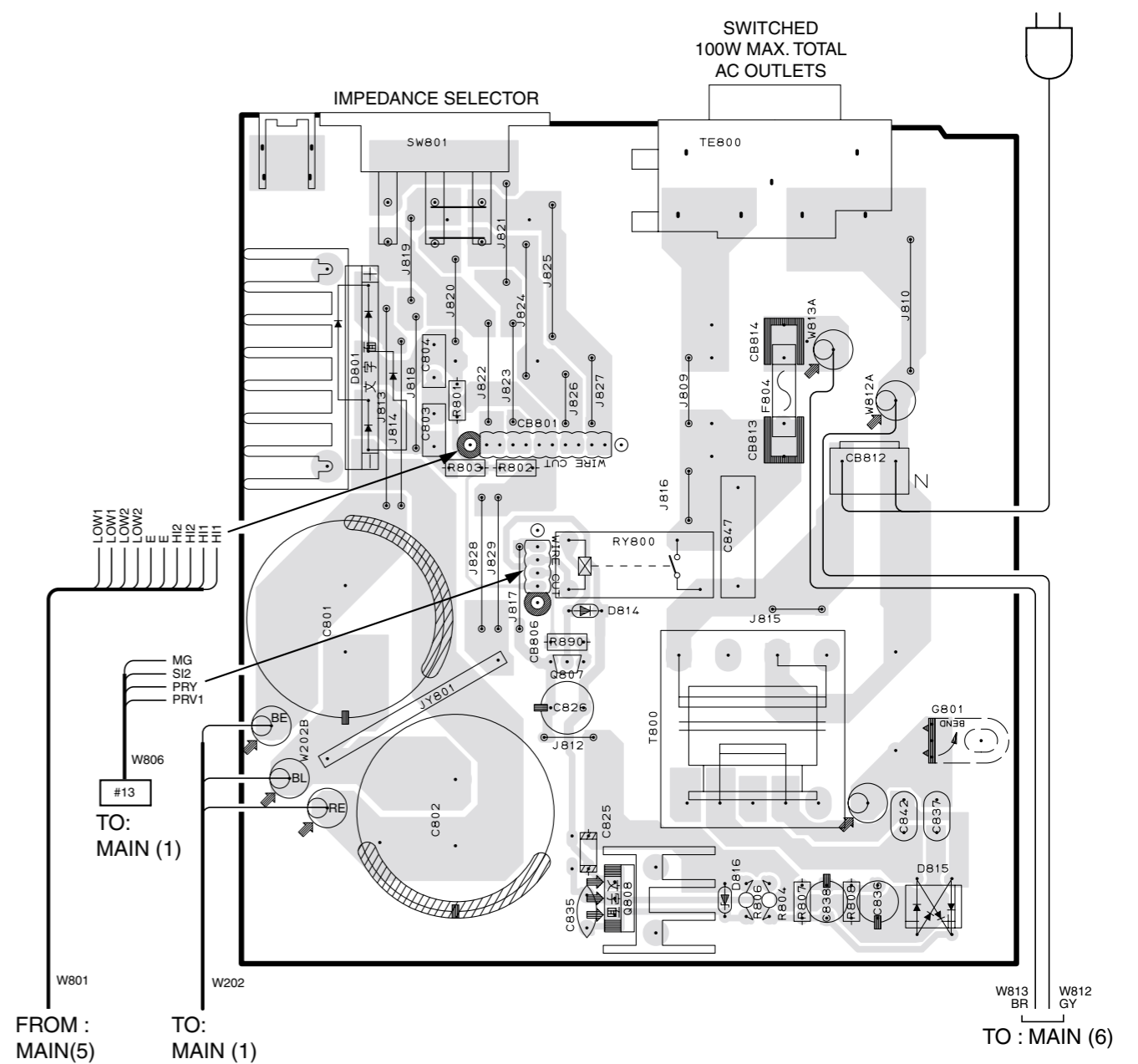

PRINTED CIRCUIT BOARD (Foil side)

P. C. B. MAIN (6)

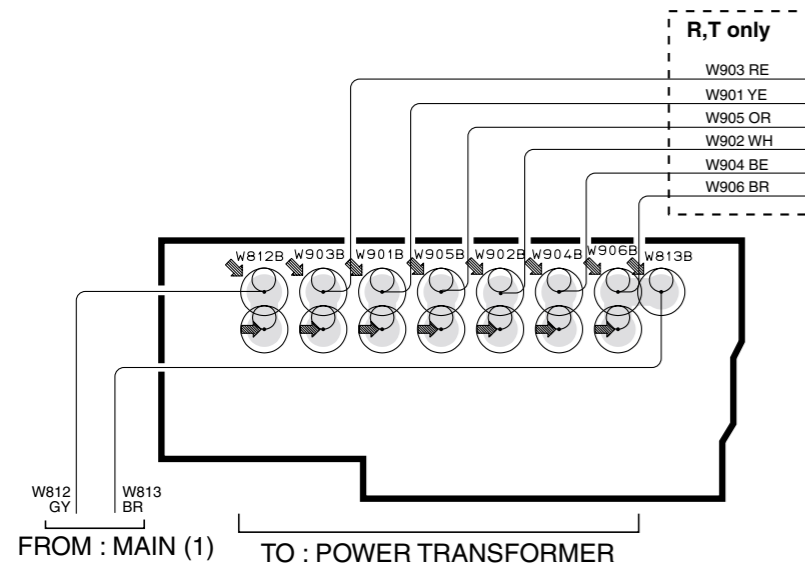

R,T only
 W903 RE
 W901 YE
 W905 OR
 W902 WH
 W904 BE
 W906 BR

R and T models only
 P. C. B. MAIN (7)

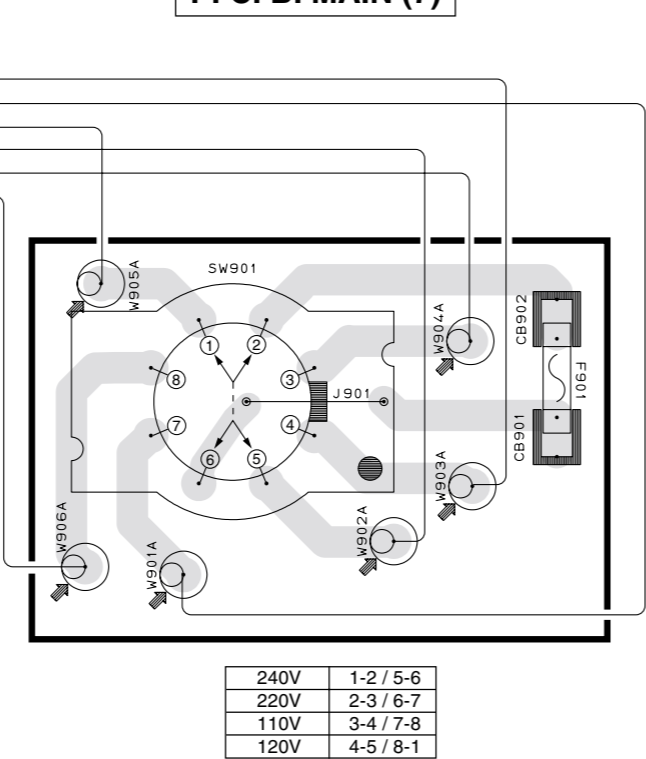

P. C. B. MAIN (3)

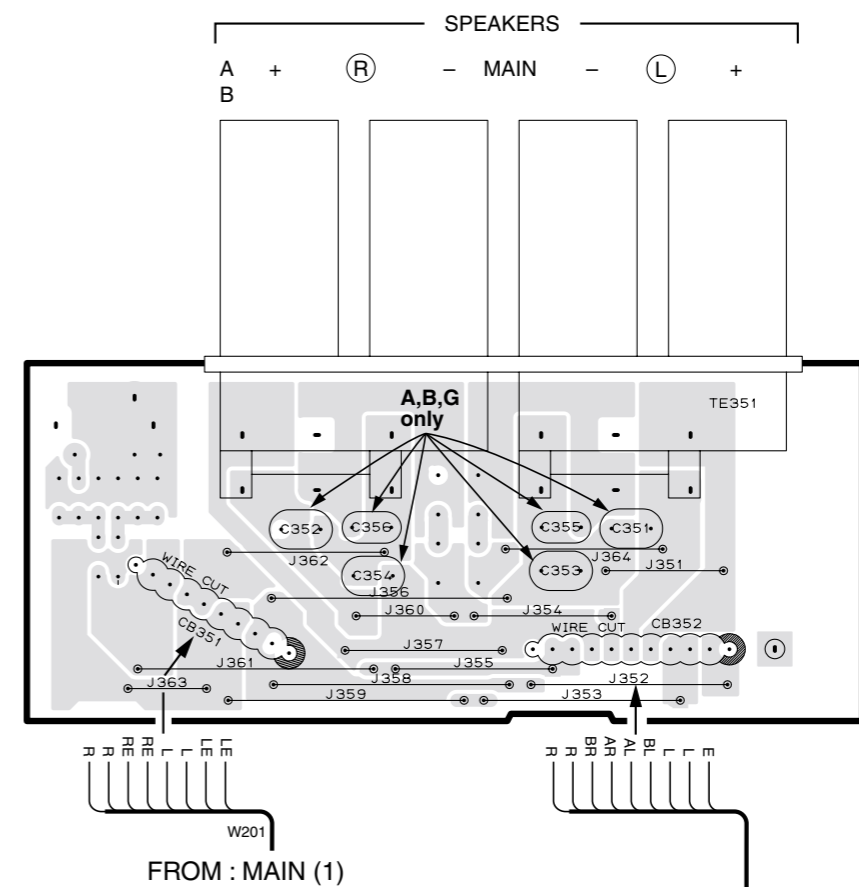

P. C. B. MAIN (5)

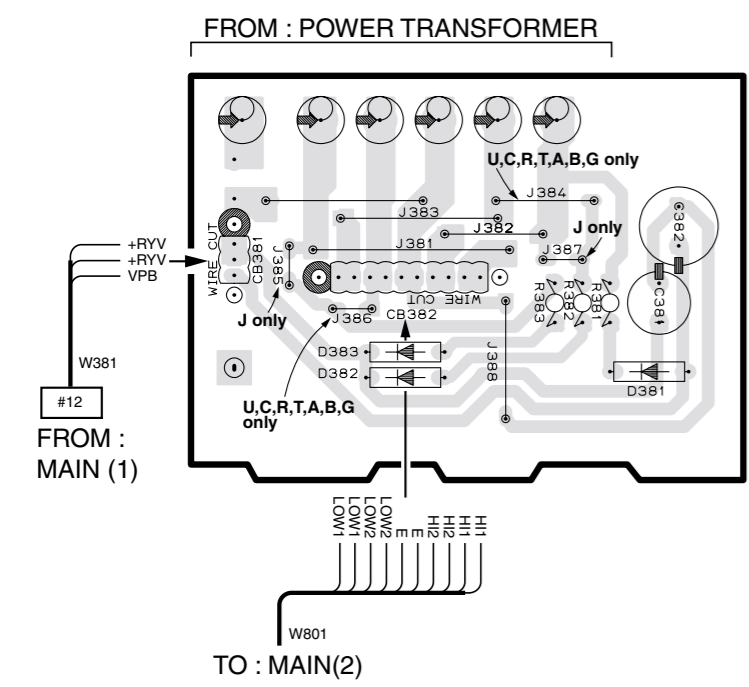

Semiconductor Location

Ref. No.	Location
D381	B5
D382	B5
D383	B5

P. C. B. MAIN (4)

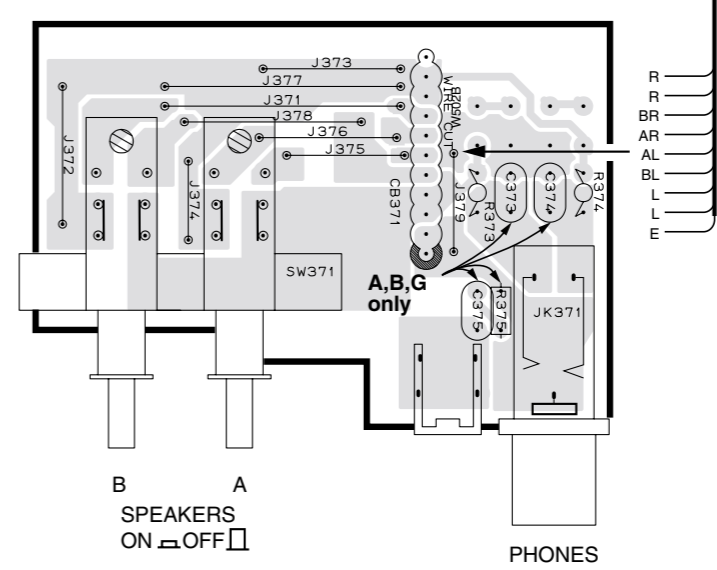

PRINTED CIRCUIT BOARD (Foil side)

P. C. B. MAIN (1)

FROM : OPERATION (4)

3

4

5

6

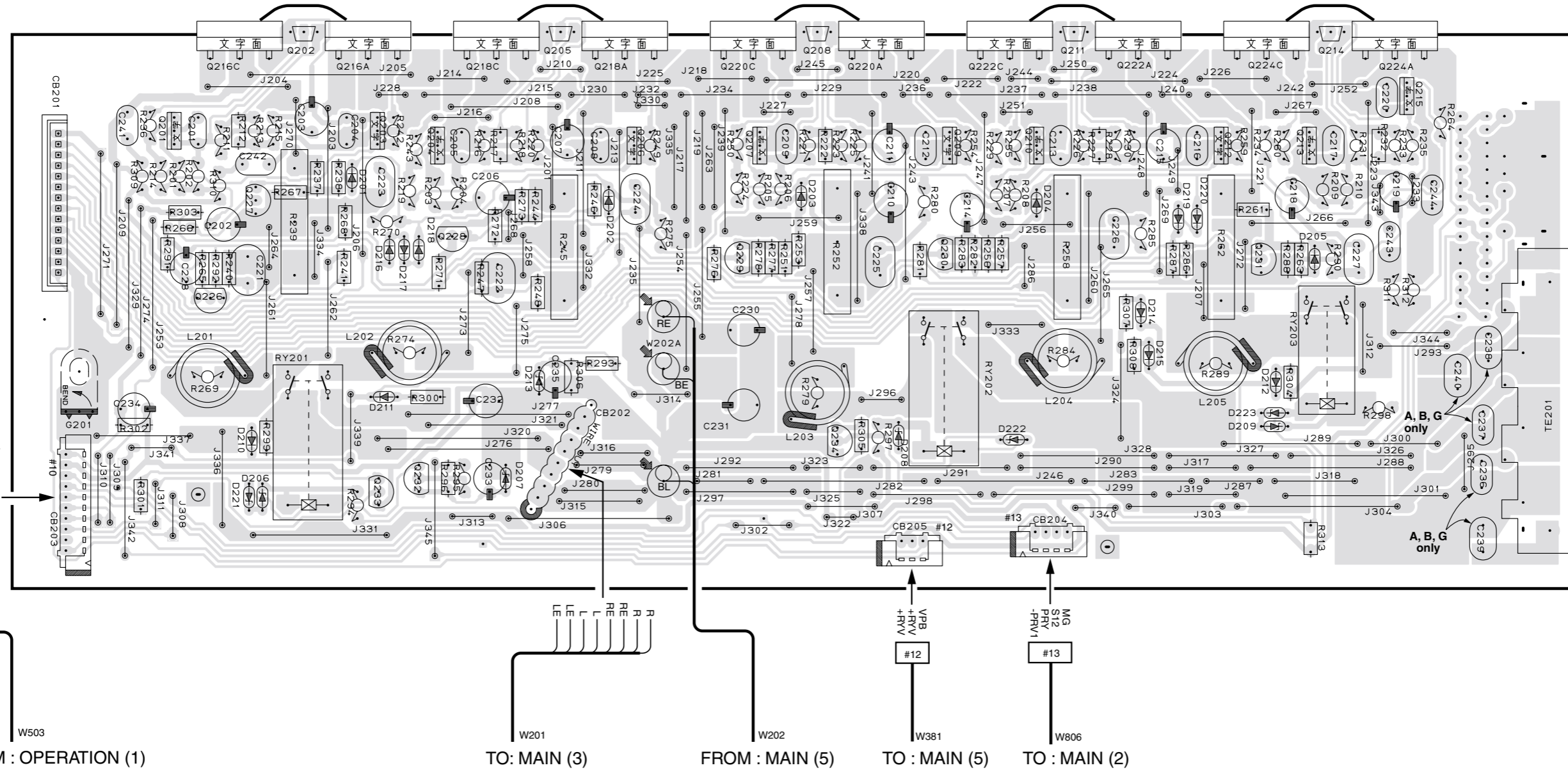

FROM : OPERATION (1)

TO : MAIN (3)

FROM : MAIN (5)

TO : MAIN (5)

TO : MAIN (2)

● Semiconductor Location

Ref. No.	Location	Ref. No.	Location	Ref. No.	Location	Ref. No.	Location	Ref. No.	Location
D201	B2	D213	C3	Q201	B2	Q213	F2	Q224C	F2
D202	C2	D214	F3	Q202	B2	Q214	F2	Q226	B3
D203	D2	D215	F3	Q203	C2	Q215	G2	Q227	B2
D204	E2	D216	C2	Q204	C2	Q216A	B2	Q228	C2
D205	F2	D217	C2	Q205	C2	Q216C	B2	Q229	D2
D206	B3	D218	C2	Q206	D2	Q218A	C2	Q230	E2
D207	C3	D219	F2	Q207	D2	Q218C	C2	Q231	F2
D208	E3	D220	F2	Q208	D2	Q220A	E2	Q232	C3
D209	F3	D221	B3	Q209	E2	Q220C	D2	Q233	C3
D210	B3	D222	E3	Q210	E2	Q222A	F2	Q234	D3
D211	C3	D223	F3	Q211	E2	Q222C	E2		
D212	F3			Q212	F2	Q224A	G2		

PRINTED CIRCUIT BOARD (Foil side)

P. C. B. OPERATION (4)

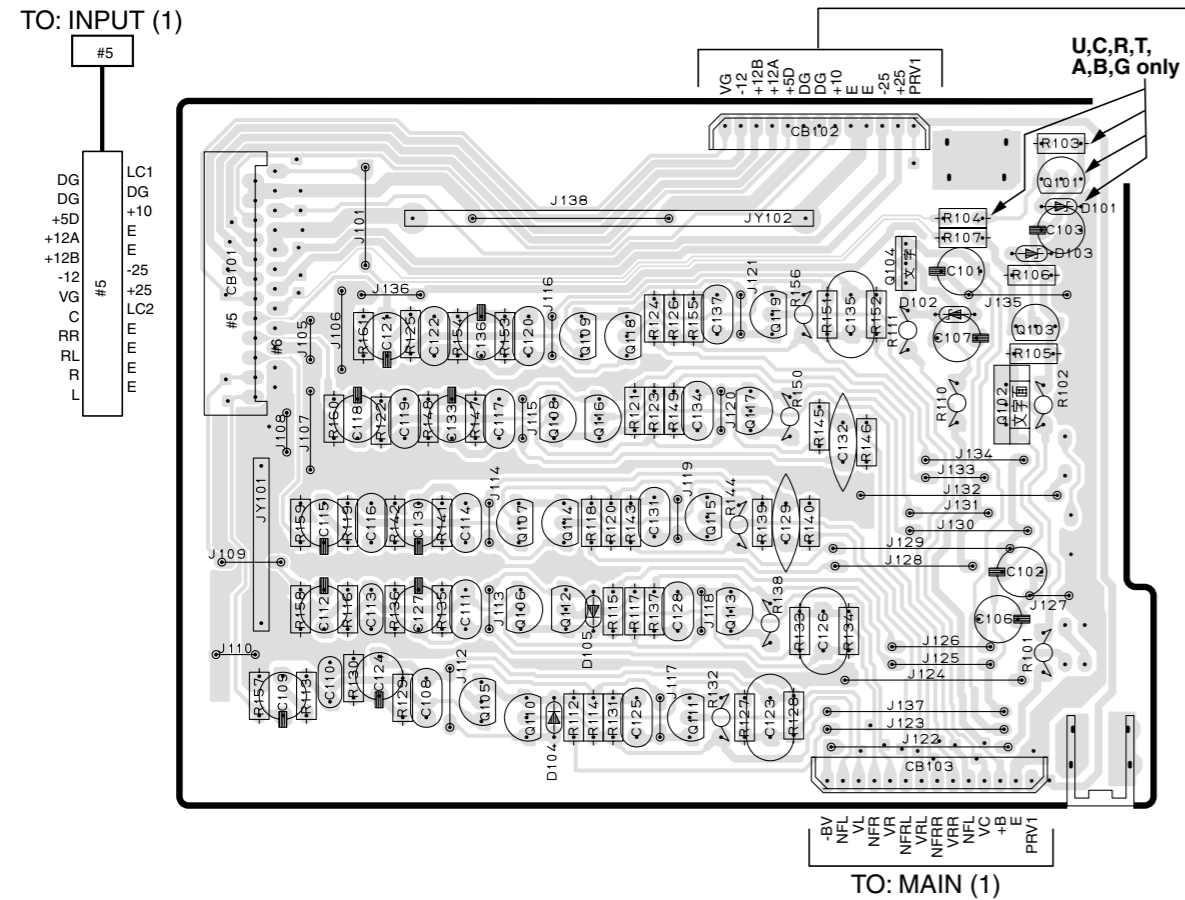

P. C. B. OPERATION (5)

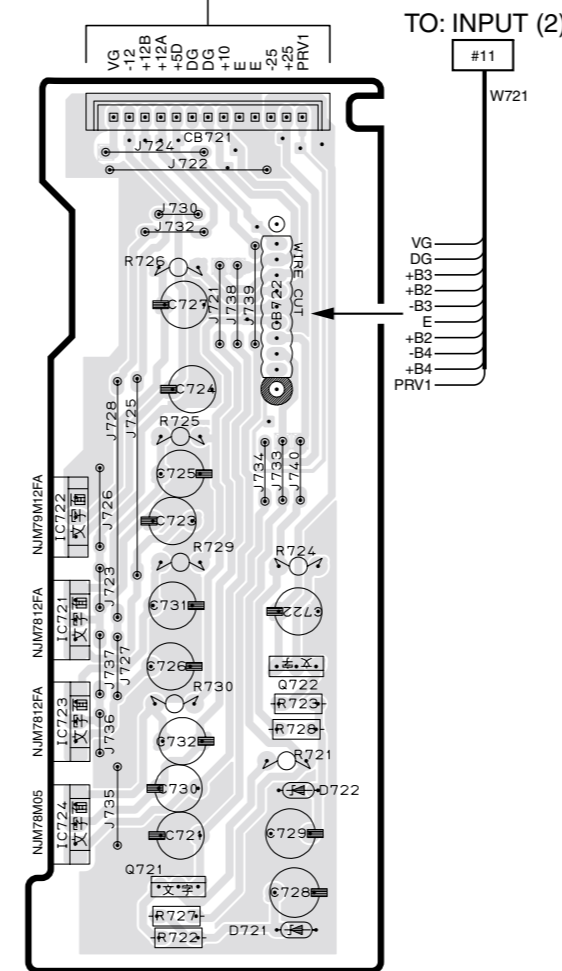

P. C. B. OPERATION (6)

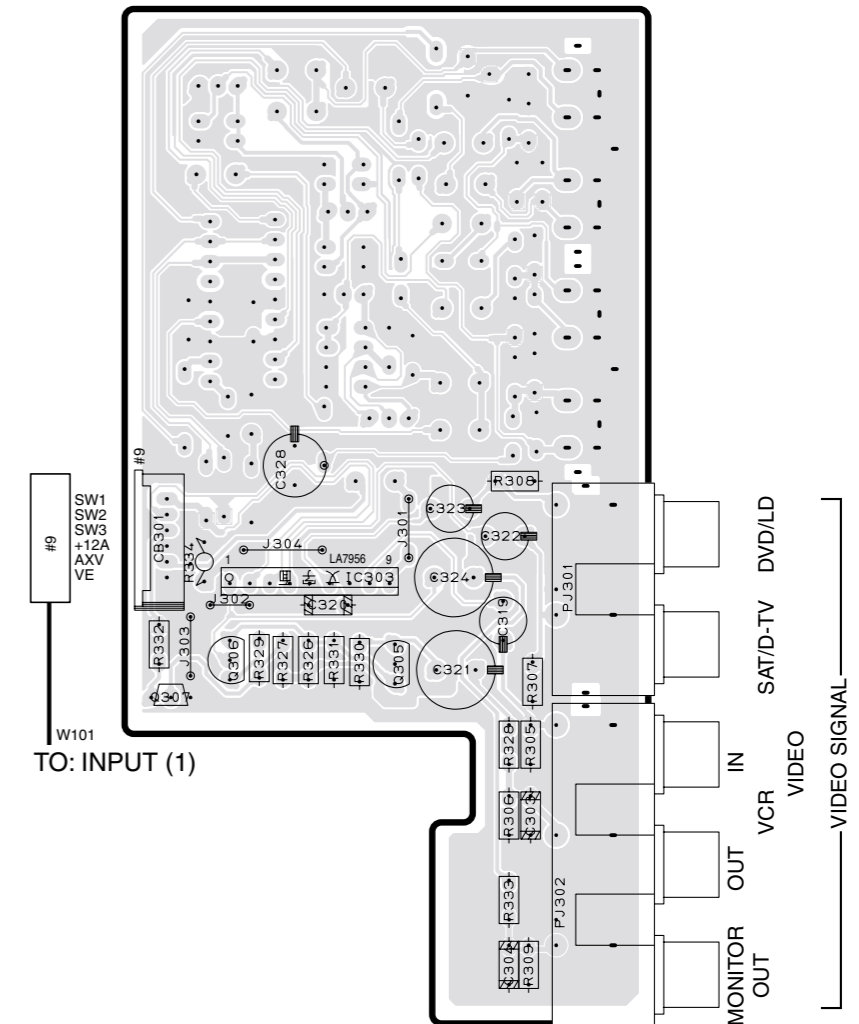

● Semiconductor Location

Ref. No.	Location	Ref. No.	Location	Ref. No.	Location
D101	C2	Q101	C2	Q113	C3
D102	C2	Q102	C2	Q114	B3
D103	C2	Q103	C2	Q115	C3
D104	B3	Q104	C2	Q116	B2
D105	B3	Q105	B3	Q117	C2
D721	E4	Q106	B3	Q118	B2
D722	E3	Q107	B3	Q119	C2
IC303	G3	Q108	B2	Q305	G3
IC721	E3	Q109	B2	Q306	F3
IC722	E3	Q110	B3	Q307	F3
IC723	E3	Q111	B3	Q721	E4
IC724	E3	Q112	B3	Q722	E3

P. C. B. OPERATION (7)

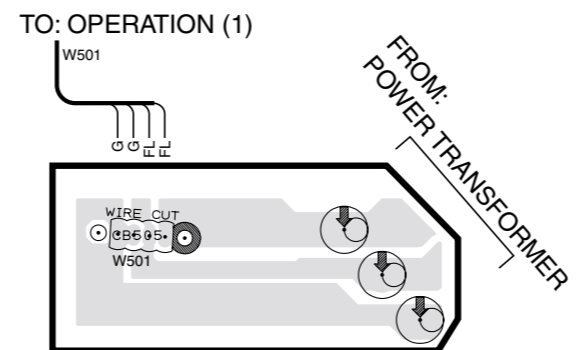

PRINTED CIRCUIT BOARD (Foil side)

P. C. B. DSP

P. C. B. DSP

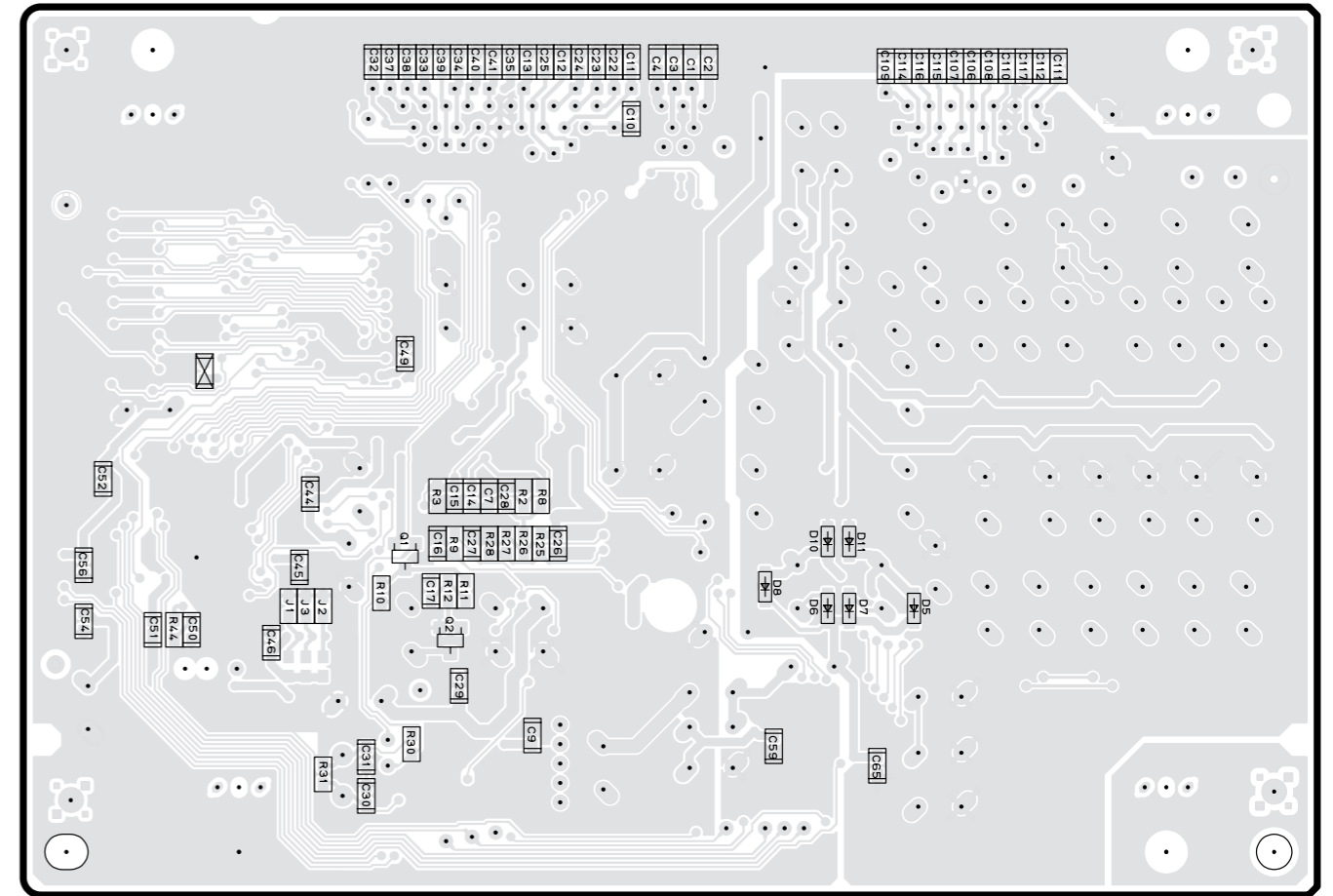
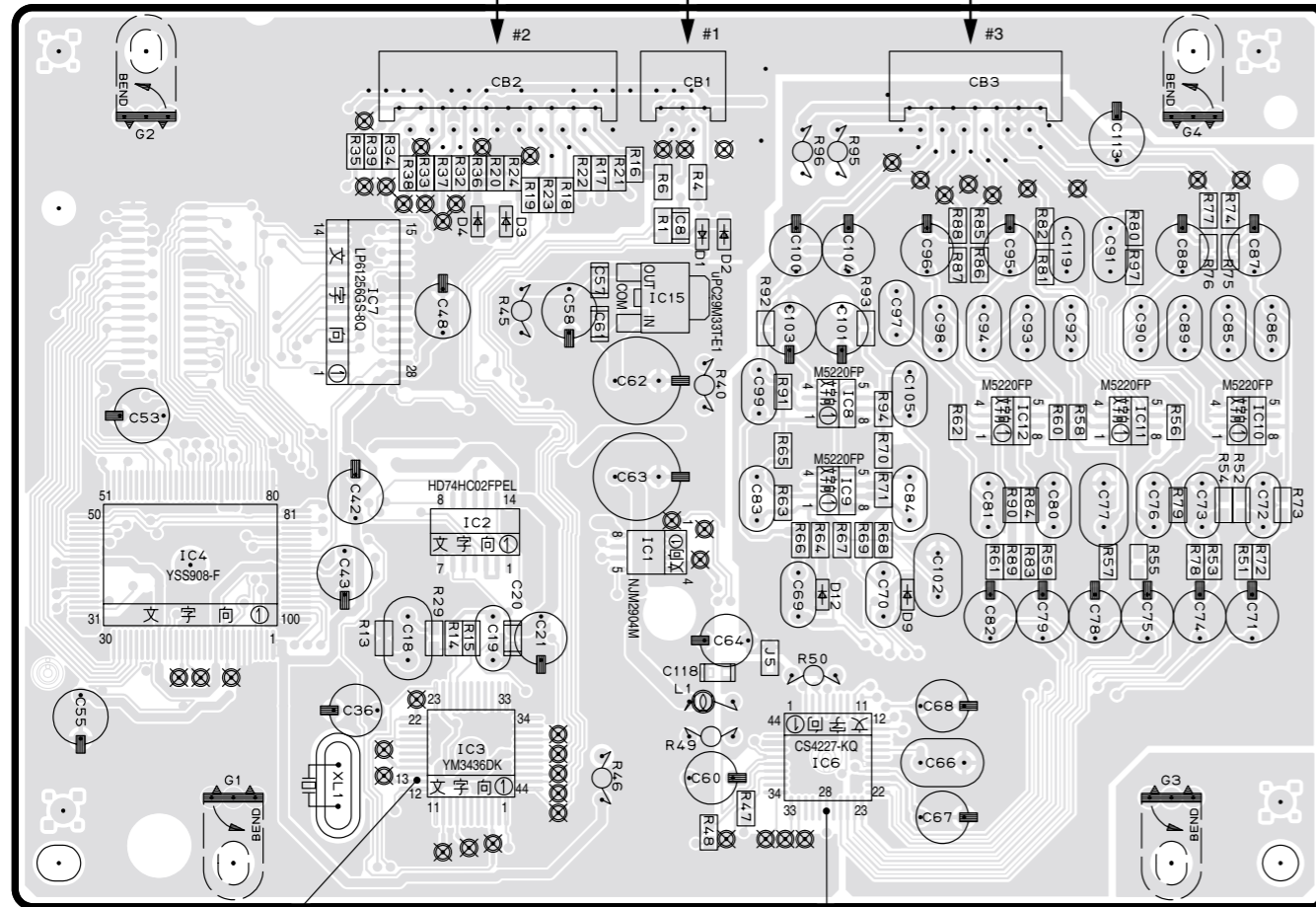
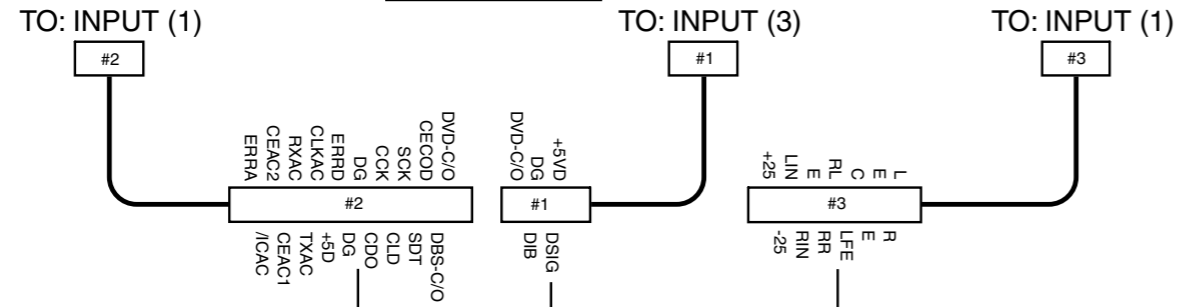

Semiconductor Location

Ref. No.	Location	Ref. No.	Location	Ref. No.	Location
D1	C3	IC1	B3	Q1	F3
D2	C3	IC2	B3	Q2	F4
D3	B3	IC3	B4		
D4	B3	IC4	A3		
D5	G4	IC5	A3		
D6	G4	IC6	C4		
D7	G4	IC8	C3		
D8	G3	IC9	C3		
D9	C4	IC10	D3		
D10	G3	IC11	D3		
D11	G3	IC12	C3		
D12	C4	IC15	B3		

Point ⑤
Pin 13 of IC3
V : 2V/div H : 50nsec/div
DC range 1 : 1 probe

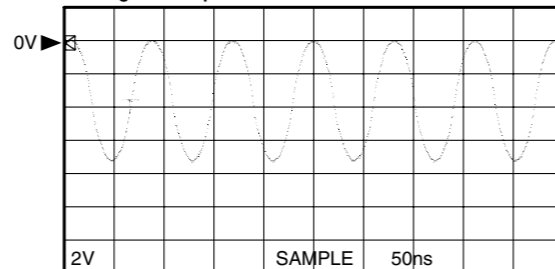

Point ⑥
Pin 28 of IC6
V : 2V/div H : 50nsec/div
DC range 1 : 1 probe

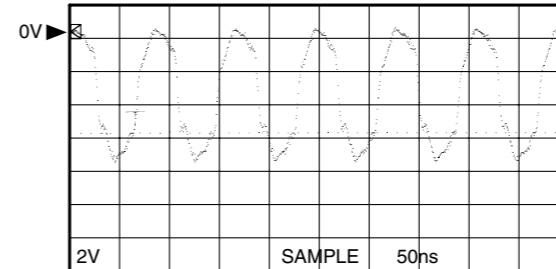

PRINTED CIRCUIT BOARD (Foil side)

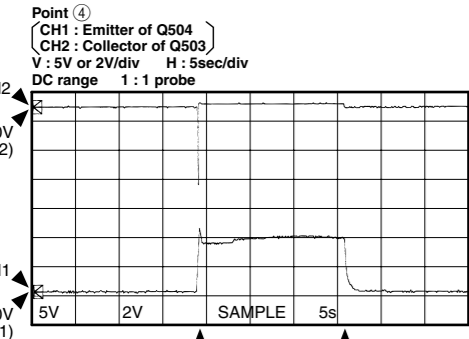
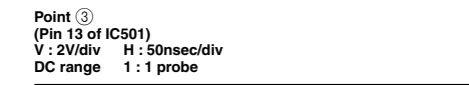
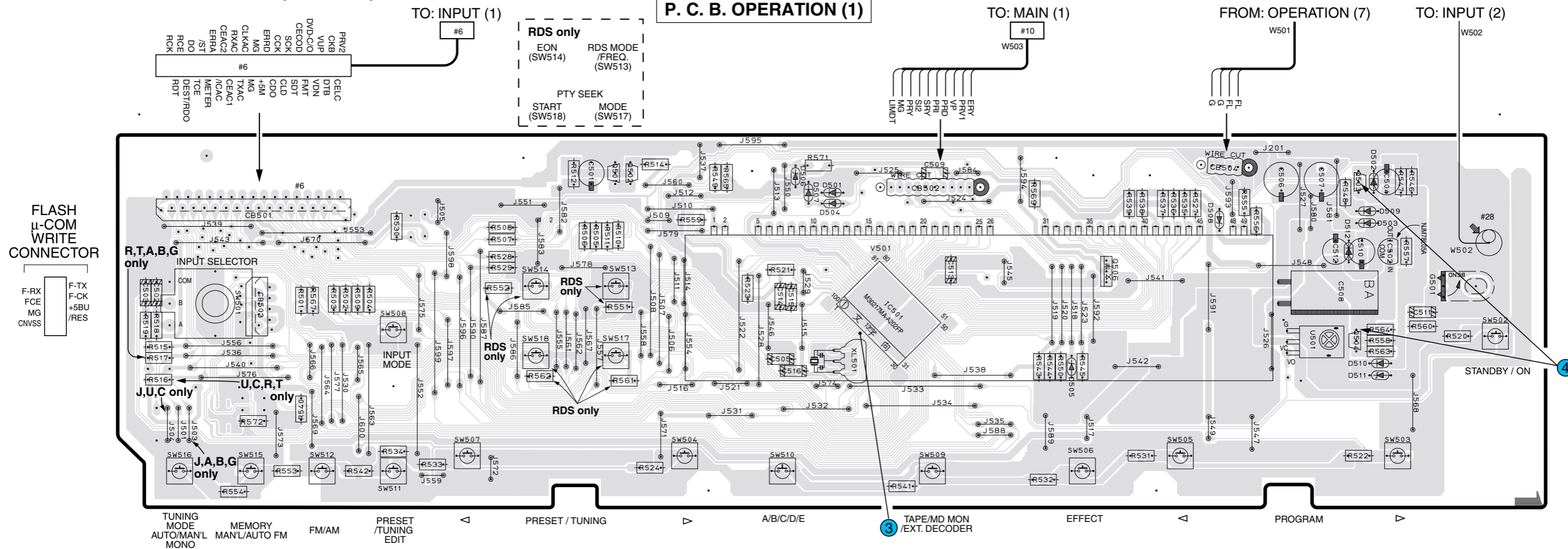

Semiconductor Location

Ref. No.	Location
D501	E2
D502	G2
D503	G2
D504	E2
D505	F3
D506	E2
D507	E2
D508	G2
D509	G2
D510	G3
D511	G3
D512	G2
IC501	E2
IC502	G2
IC581	D5
IC582	E5
Q501	D2
Q502	D2
Q503	G2
Q504	G3
Q506	F2

P. C. B. OPERATION (2)

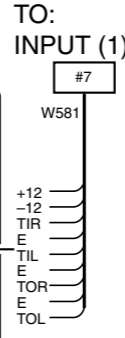
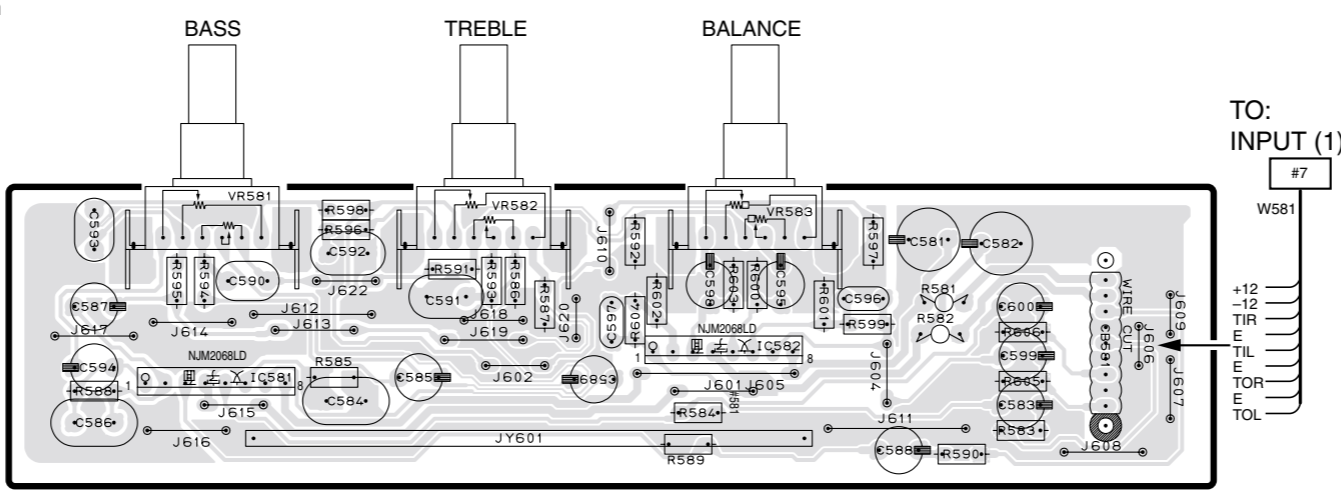

With the POWER switch turned ON, connect the power cord to the AC outlet.
Disconnect the power cord from the AC outlet.

(This waveform is not available by pushing the power switch ON and OFF.)

PRINTED CIRCUIT BOARD (Foil side)

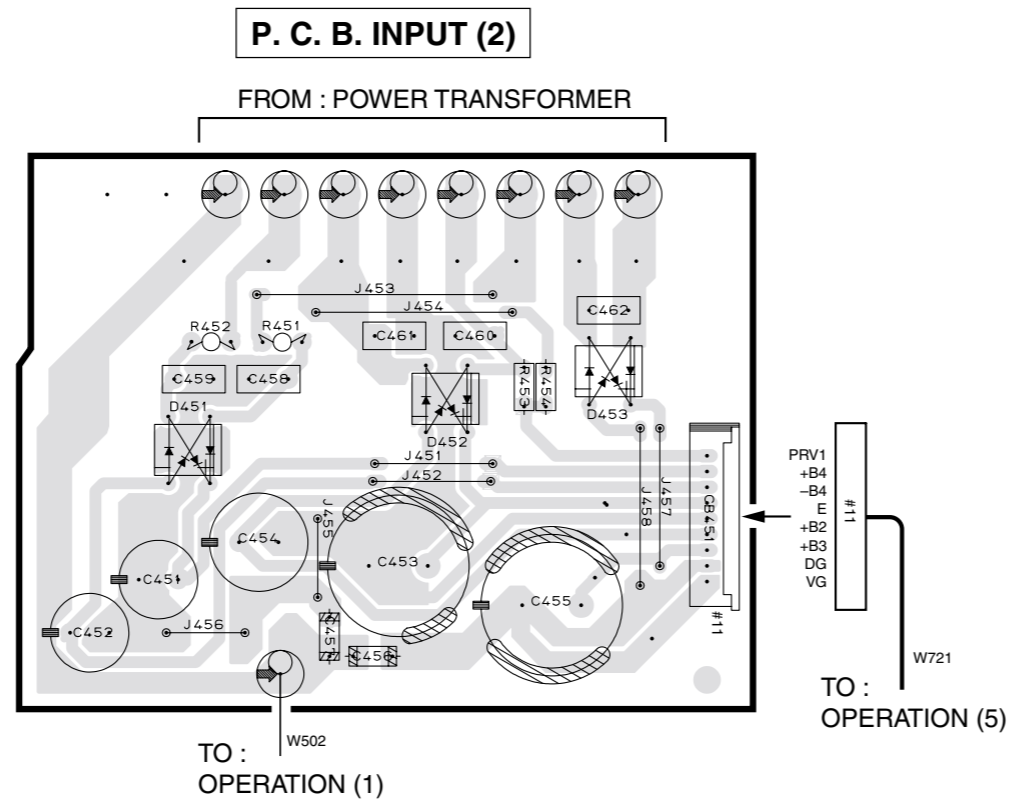
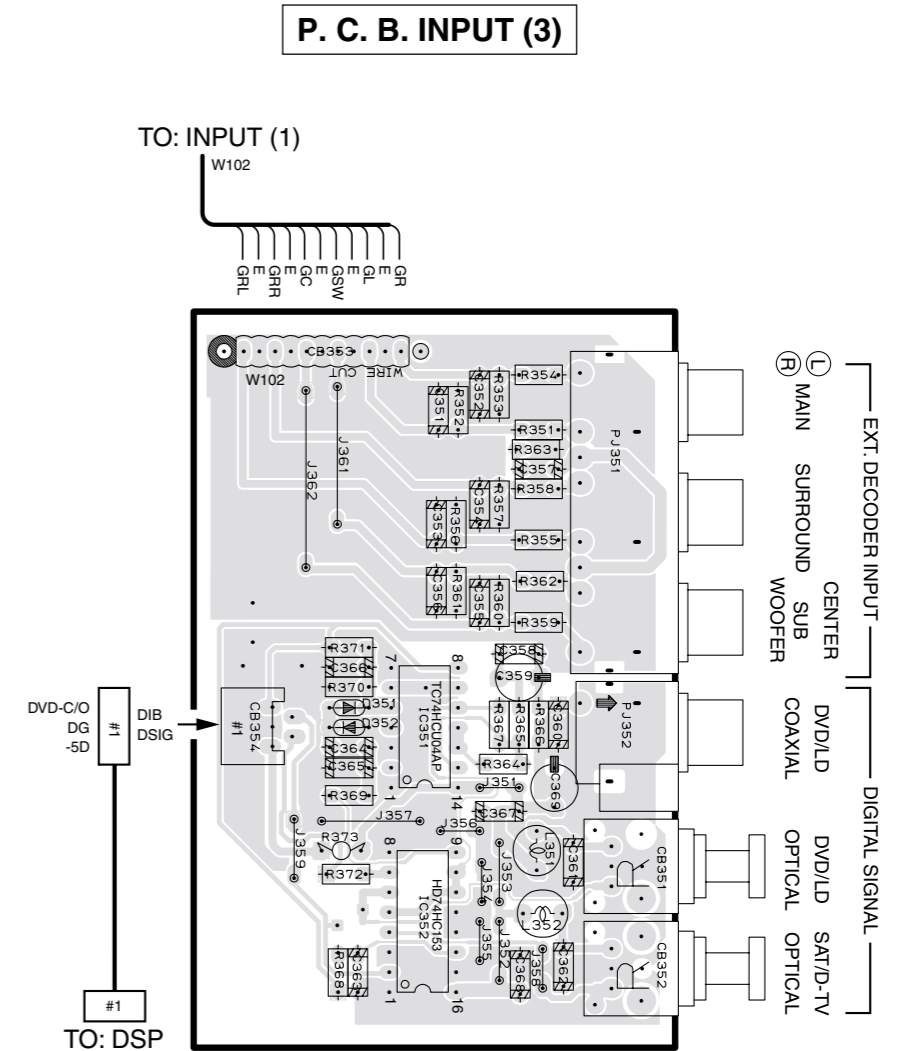
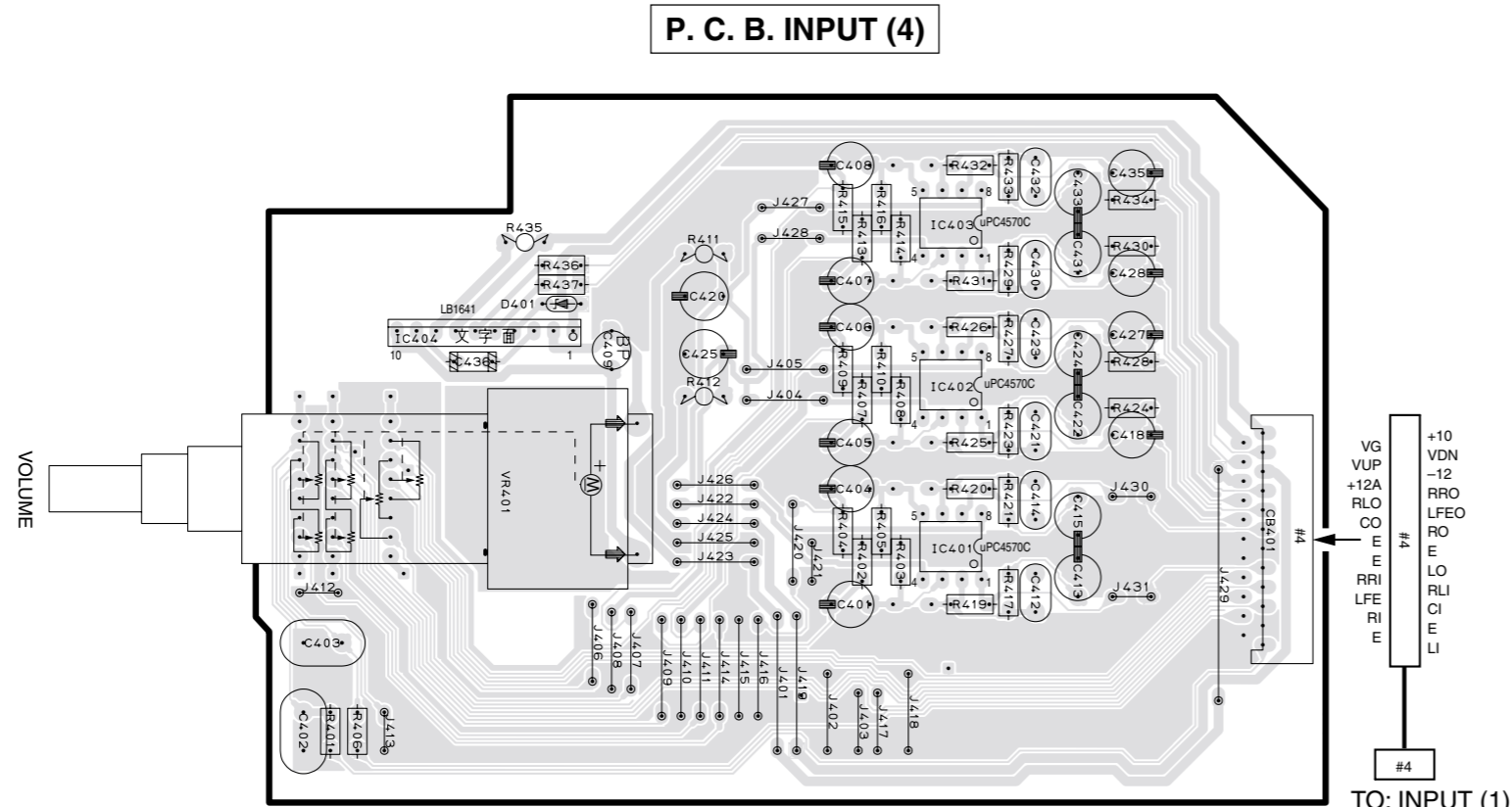

● Semiconductor Location

Ref. No.	Location	Ref. No.	Location
D351	F3	IC351	G3
D352	F3	IC352	G4
D401	C2	IC401	D3
D451	C5	IC402	D2
D452	D5	IC403	D2
D453	D5	IC404	B2

PRINTED CIRCUIT BOARD (Foil side)

P. C. B. INPUT (1)

● Semiconductor Location

Ref. No.	Location	Ref. No.	Location	Ref. No.	Location	Ref. No.	Location
D101	D3	IC101	G4	Q101	F5	Q111	C3
D102	D3	IC102	F4	Q102	G5	Q112	C3
D103	D3	IC103	E4	Q103	F5	Q113	C3
D104	D3	IC105	F2	Q104	D4	Q114	C3
D105	F5	IC106	E3	Q105	C4	Q115	B4
D106	B3	IC107	B4	Q106	D4	Q116	B4
		IC108	E4	Q107	C4	Q117	B4
		IC109	D4	Q108	C3	Q118	D3
				Q109	C3	Q119	D4
				Q110	C3	Q120	C4
						Q121	B4
						Q122	C3
						Q123	C3
						Q124	B4
						Q125	B4

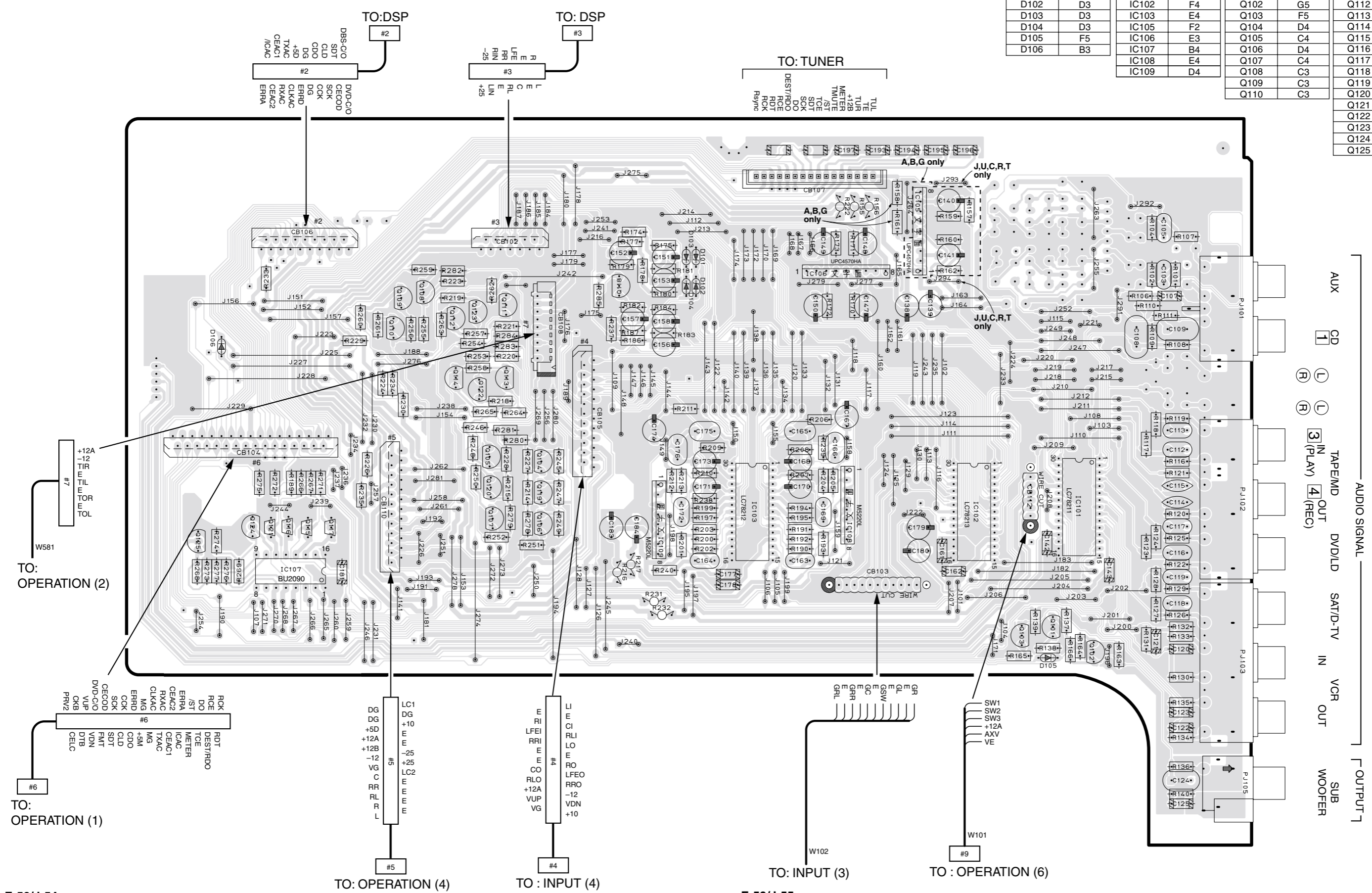

■ SCHEMATIC DIAGRAM [INPUT (1/2)]

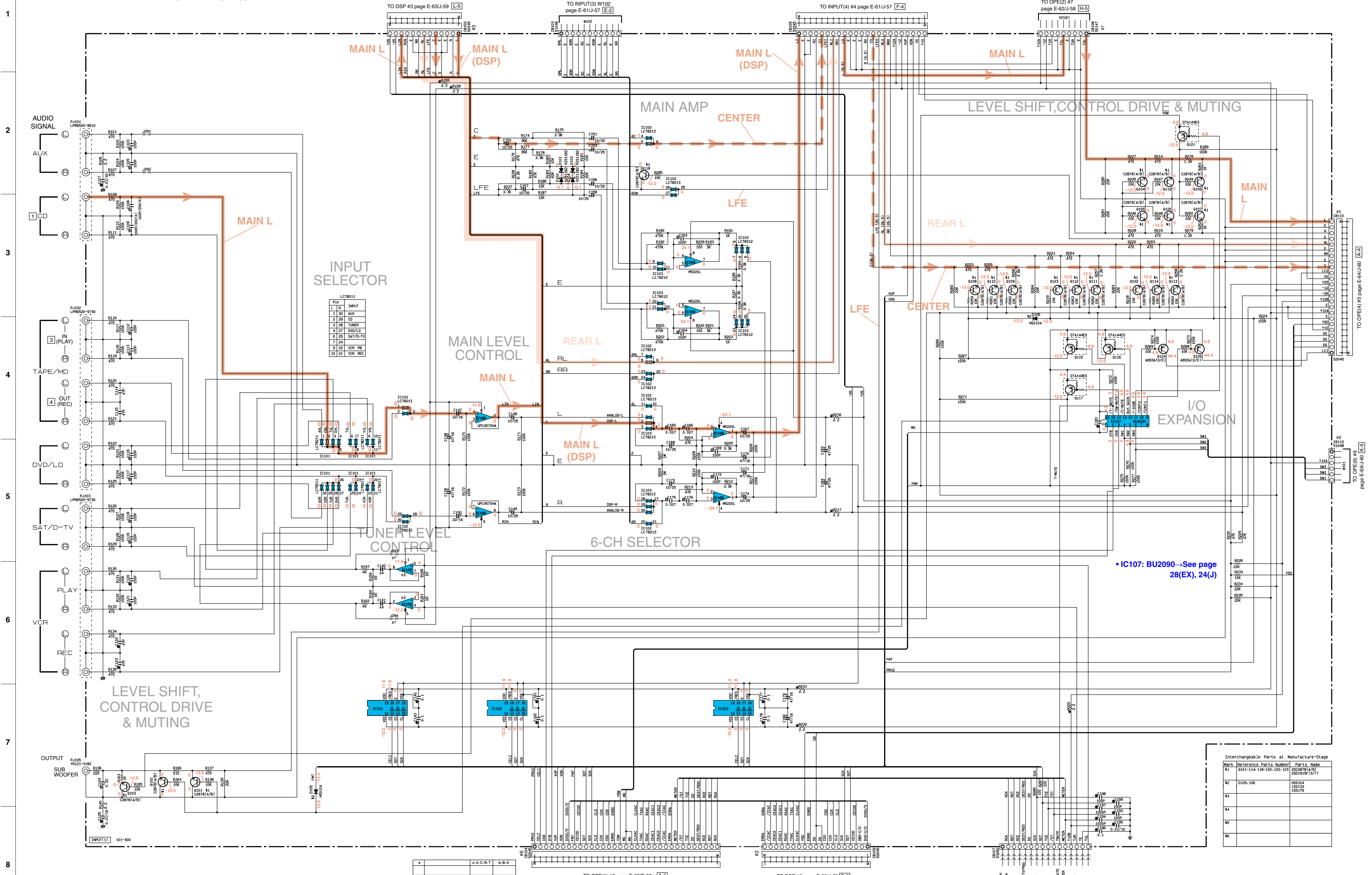

LC78211

Pin	INPUT
1	30 AUX
2	29 CD
3	28 TUNER
4	27 DVD/LD
5	25 SAT/D-TV
6	24 VCR
7	22 VCR PB
8	21 VCR REC

• IC107: BU2090 → See page 28(EX), 24(J)

IC BLOCK → See page E-61/J-57
PIN CONNECTION DIAGRAM → See page E-61/J-57

Interchangeable Parts at Manufacture-Stage

Mark	Reference Parts Number	Parts Name
41	0101-114-118-120-123	2SC2878(A/B) 2SC3184(A/B)
42	D105-106	MS554 15S33 15S176
43		
44		
45		
46		

NOTICE (mode1)

REMARKS	PARTS NAME
(J)..... JAPANESE	
(U)..... U. S. A.	
(C)..... CANADIAN	
(R)..... GENERAL	
(A)..... AUSTRALIAN	
(B)..... BRITISH	
(G)..... EUROPEAN	
(T)..... CHINA	
(L)..... SINGAPORE	

REMARKS	PARTS NAME
NO MARK	CARBON FILM RESISTOR (P=5)
□	CARBON FILM RESISTOR (P=10)
△	METAL OXIDE FILM RESISTOR
●	METAL FILM RESISTOR
⊠	METAL PLATE RESISTOR
⊞	FIRE PROOF CARBON FILM RESISTOR
⊞	CEMENT MOLDED RESISTOR
⊞	SEMI VARIABLE RESISTOR
■	CHIP RESISTOR

REMARKS	PARTS NAME
NO MARK	ELECTROLYTIC CAPACITOR
⊖	TANTALUM CAPACITOR
NO MARK	CERAMIC CAPACITOR
●	CERAMIC TUBULAR CAPACITOR
⊖	POLYESTER FILM CAPACITOR
○	POLYSTYRENE FILM CAPACITOR
⊖	MICA CAPACITOR
⊖	POLYPROPYLENE FILM CAPACITOR
●	SEMICONDUCTIVE CERAMIC CAPACITOR

J. U. C. R. T.	A. B. G.
3	IC105
4	C140-141
5	R158-161
6	R157-162
7	J293-294

Conditions (RX-V396RDS)
 • INPUT → CD
 • VOLUME → minimum(∞)
 • IMPEDANCE SELECTOR → Left
 • PRO LOGIC → On

* All voltages are measured with a 10MΩ/V DC electric volt meter.
 * Components having special characteristics are marked with a triangle and must be replaced with parts having specifications equal to those originally installed.
 * Schematic diagram is subject to change without notice.

SCHEMATIC DIAGRAM [INPUT (2/2)]

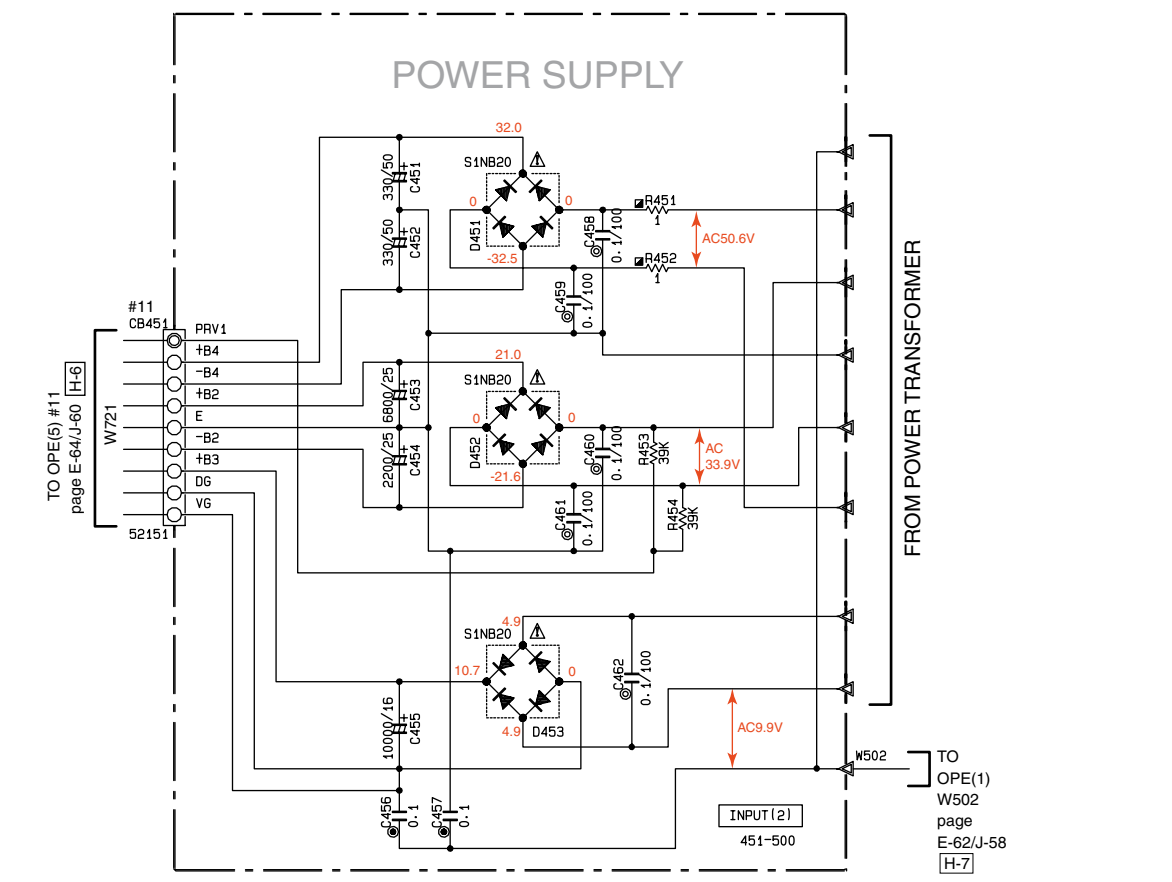
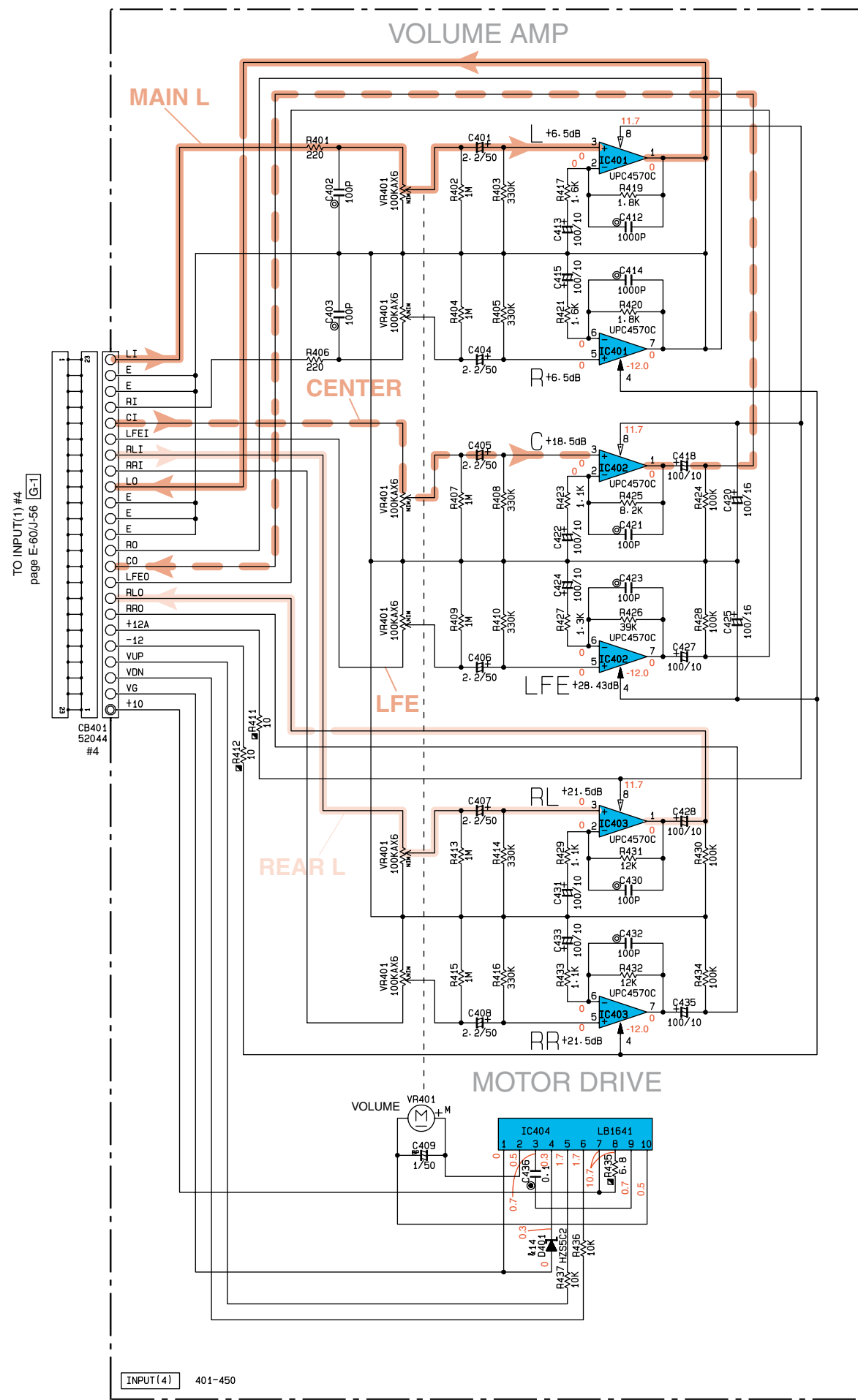
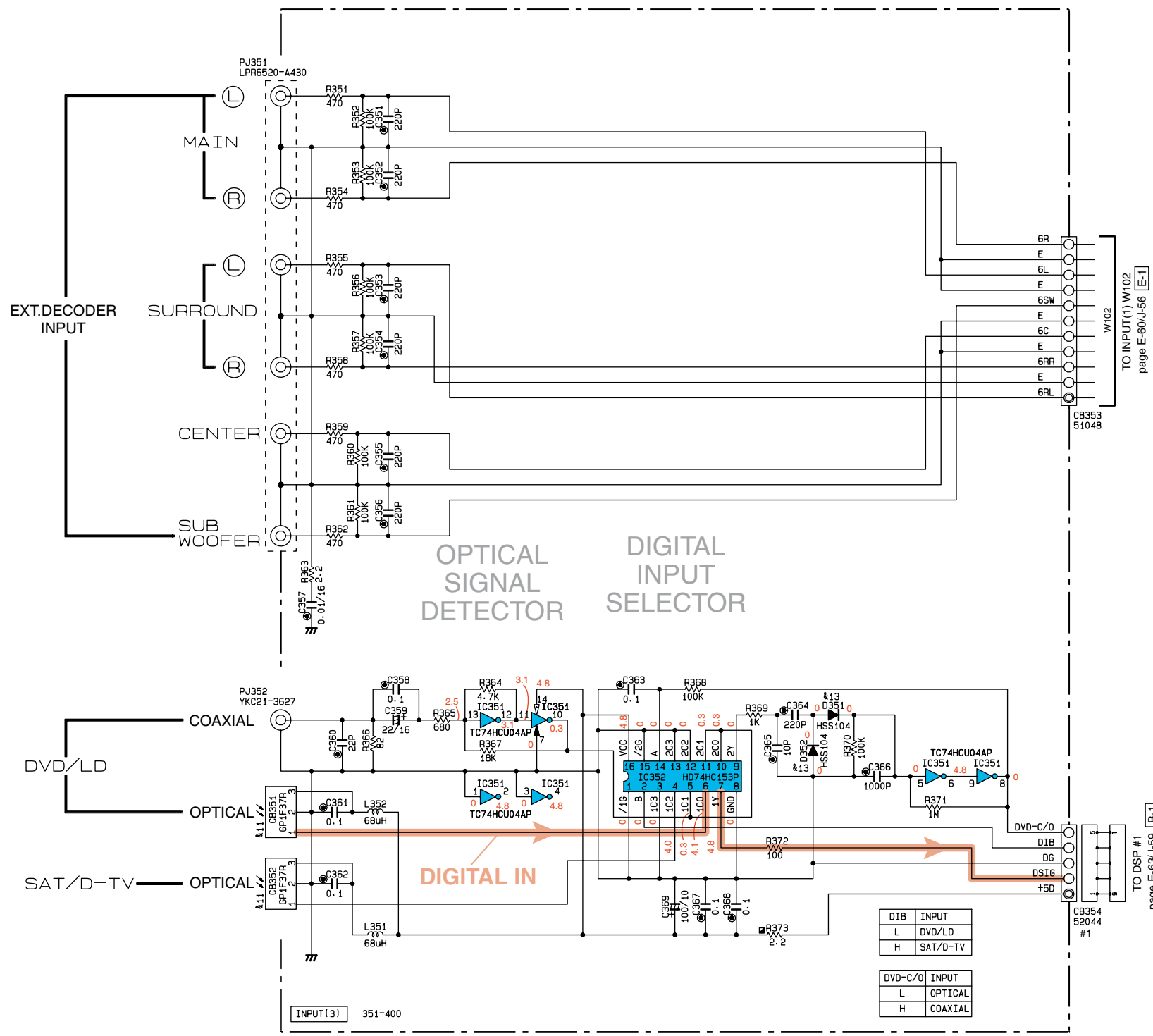

NOTICE (model)
 (J)..... JAPANESE
 (U)..... U.S.A.
 (C)..... CANADIAN
 (R)..... GENERAL
 (A)..... AUSTRALIAN
 (B)..... BRITISH
 (G)..... EUROPEAN
 (T)..... CHINA
 (L)..... SINGAPORE

Interchangeable Parts at Manufacture-Stage

Mark	Reference Parts Number	Parts Name
#11	CB351-352	6P1F37R 10R176A
#12		
#13	D351-352	HSS104 1SS133 1SS176
#14	D401	HZ55C2 MT2.5-1B
#15		
#16		

RESISTOR

REMARKS	PARTS NAME
NO MARK	CARBON FILM RESISTOR (P=5)
□	CARBON FILM RESISTOR (P=10)
△	METAL OXIDE FILM RESISTOR
▲	METAL FILM RESISTOR
⊠	METAL PLATE RESISTOR
⊞	FIRE PROOF CARBON FILM RESISTOR
⊞	CEMENT MOLDED RESISTOR
⊞	SEMI VARIABLE RESISTOR
■	CHIP RESISTOR

CAPACITOR

REMARKS	PARTS NAME
NO MARK	ELECTROLYTIC CAPACITOR
⊗	TANTALUM CAPACITOR
NO MARK	CERAMIC CAPACITOR
⊙	CERAMIC TUBULAR CAPACITOR
⊙	POLYESTER FILM CAPACITOR
○	POLYSTYRENE FILM CAPACITOR
⊖	MICA CAPACITOR
⊖	POLYPROPYLENE FILM CAPACITOR
⊖	SEMICONDUCTIVE CERAMIC CAPACITOR
⊖	POLYPHENYLENE SULFIDE FILM CAPACITOR

IC351: TC74HC04AP Hex Inverters

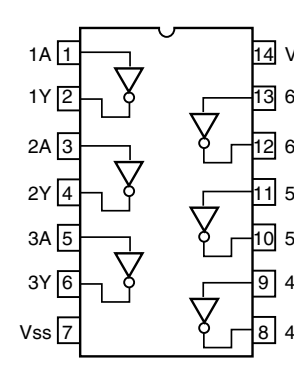

IC352: HD74HC153P Dual 4 to 1 Data Selectors

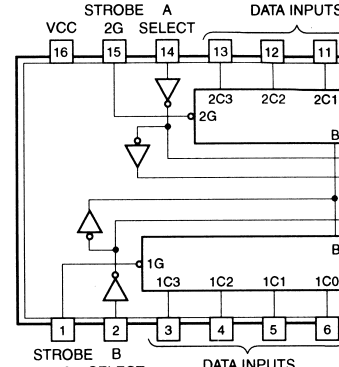

SELECT	STROBE	Y
B A	G	Y
X X	H	L
L L	L	C0
L H	L	C1
H L	L	C2
H H	L	C3

H: High Level
 L: Low Level
 X: Don't care

IC401-403: uPC4570C Dual OP-Amp

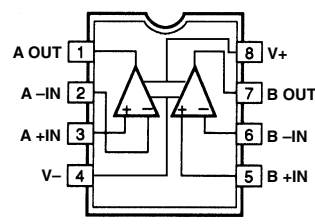

IC404: LB1641 Motor Driver

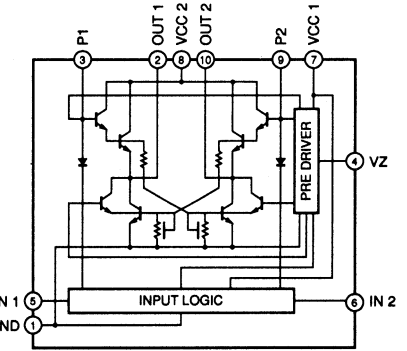

IC108,109: M5220L Dual OP-Amp

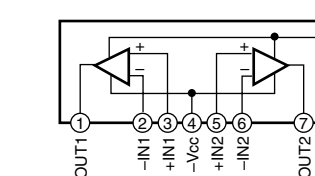

IC105,106: uPC4570HA Dual OP-Amp

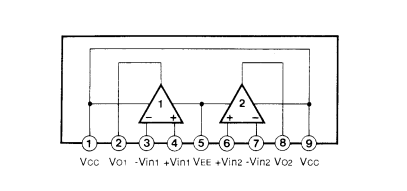

PIN CONNECTION DIAGRAM OF DIODES, TRANSISTORS AND IC's.

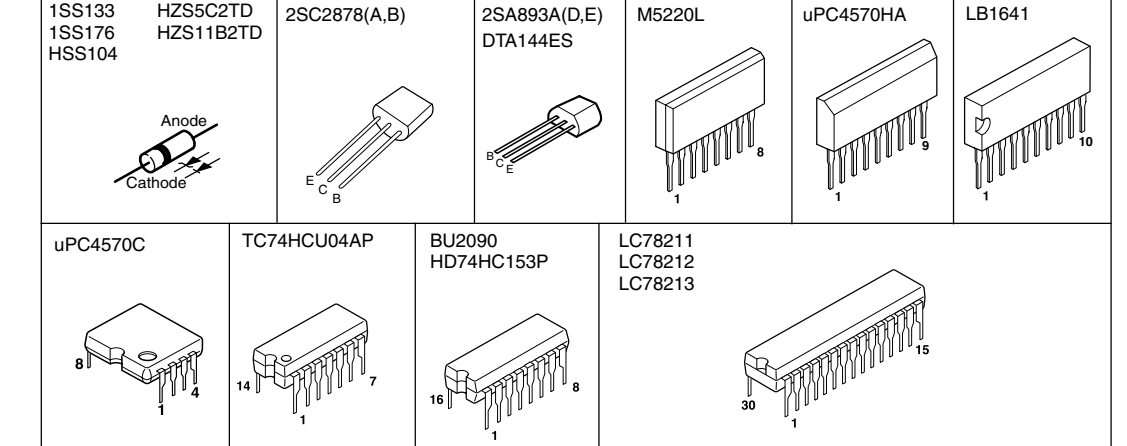

Conditions (RX-V396RDS)
 • INPUT → CD
 • VOLUME → minimum(∞)
 • IMPEDANCE
 • SELECTOR → Left
 • PRO LOGIC → On

• All voltages are measured with a 10MΩ/V DC electric volt meter.
 • Components having special characteristics are marked Δ and must be replaced with parts having specifications equal to those originally installed.
 • Schematic diagram is subject to change without notice.

SCHEMATIC DIAGRAM [OPERATION (1/2)]

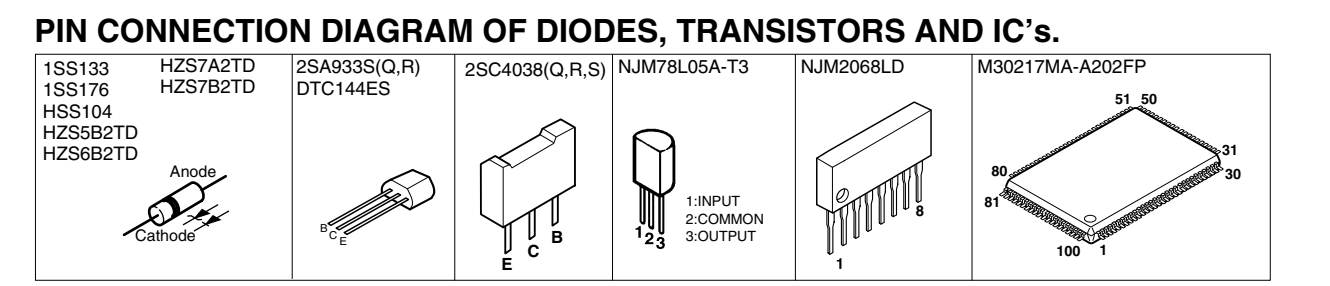
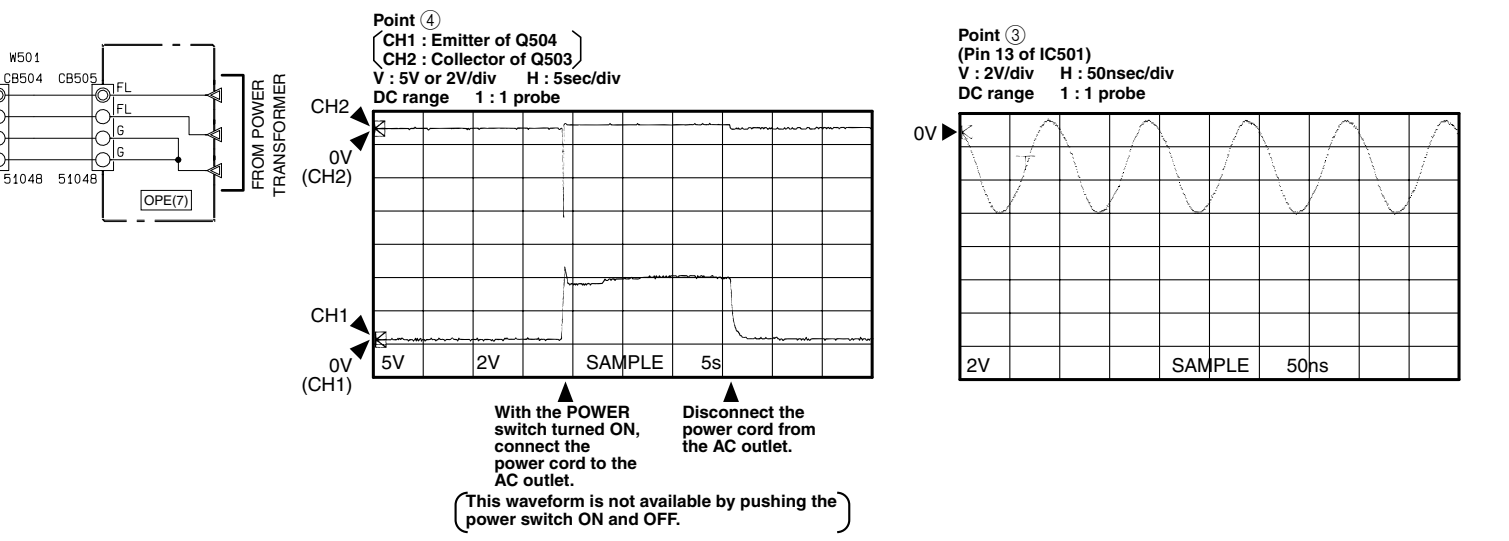
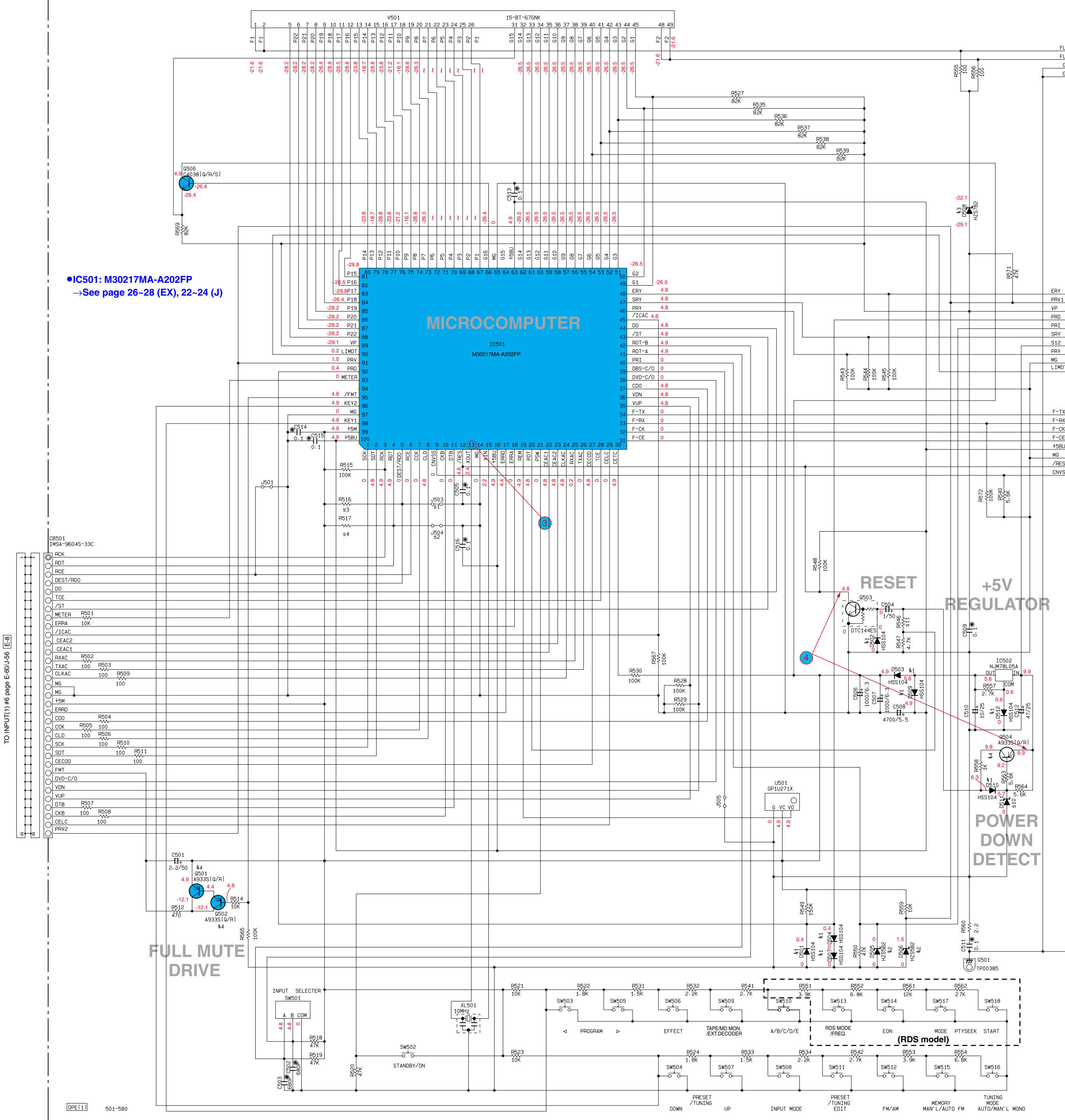

REMARKS	PARTS NAME	REMARKS	PARTS NAME
NO MARK	CARBON FILM RESISTOR (P=5)	NO MARK	ELECTROLYTIC CAPACITOR
□	CARBON FILM RESISTOR (P=10)	⊗	TANTALUM CAPACITOR
△	METAL FILM RESISTOR	NO MARK	CERAMIC CAPACITOR
◇	METAL FILM RESISTOR	⊙	CERAMIC TUBULAR CAPACITOR
⊙	METAL PLATE RESISTOR	⊖	POLYESTER FILM CAPACITOR
⊖	FIRE PROOF CARBON FILM RESISTOR	⊕	POLYSTYRENE FILM CAPACITOR
⊕	CEMENT MOLDED RESISTOR	⊗	MICA CAPACITOR
⊗	SEMI VARIABLE RESISTOR	⊖	POLYPROPYLENE FILM CAPACITOR
⊖	CHIP RESISTOR	⊕	SEMICONDUCTIVE CERAMIC CAPACITOR
		⊗	POLYPHENYLENE SULFIDE FILM CAPACITOR

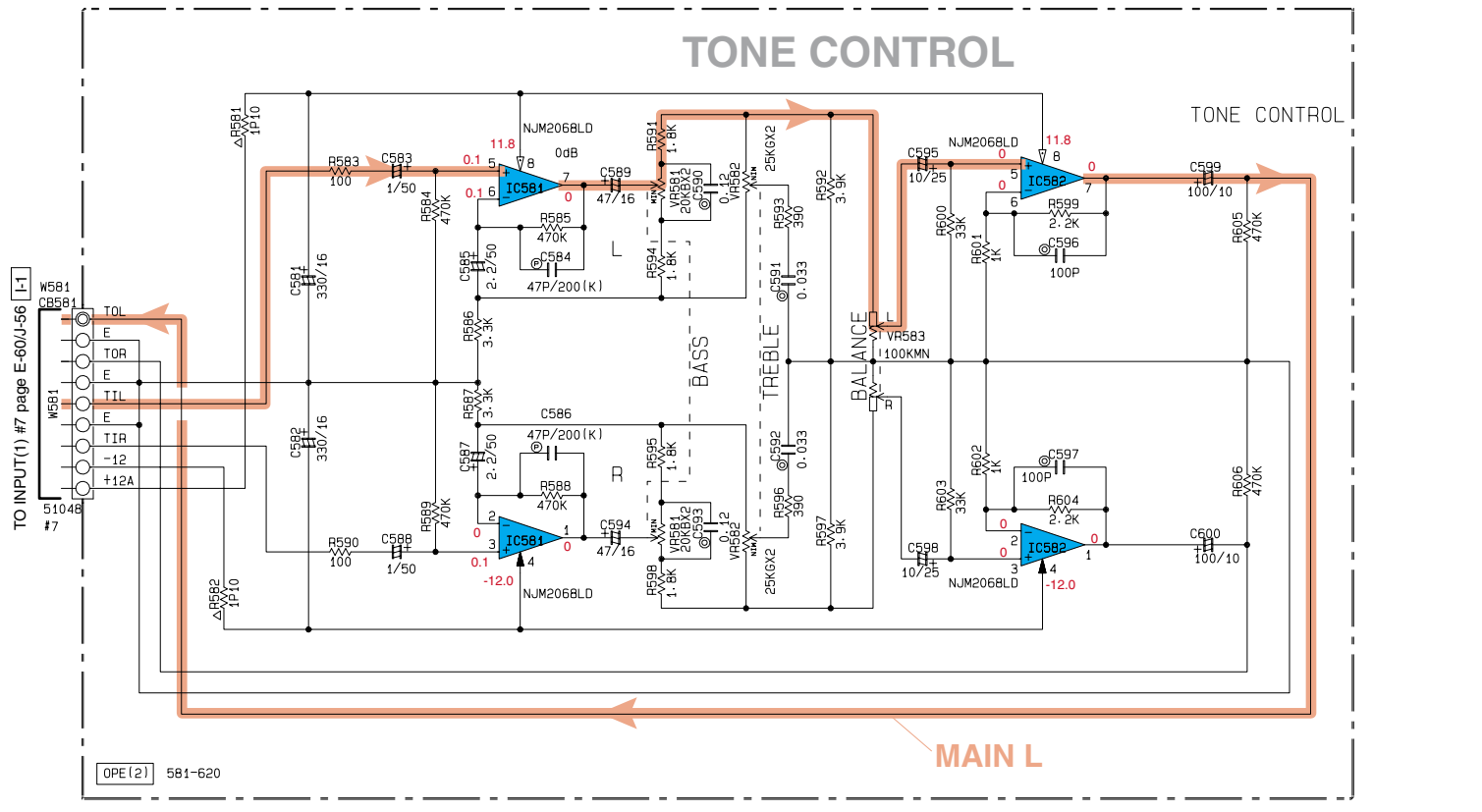

Mark	Reference	Parts Number	Parts Name
k1	D501-502-503-504-507	509-510-512	HSS104 1SS133 1SS176
k2	D505-506		HZS5B2 MTZJ4.7C
k3	D508		HZS7B2 MTZJ7.5A
k4	D501-502-504		2SA933S(Q/R) 2SA1115(E/F) 2SA1305A(Q/R/S)

Mark	Reference	Parts Number	Parts Name	
J				
U-C				
R-T				
A-B-G				
D511	HZS7A2	HZS7A2	HZS6B2	HZS7A2
D512	VW97460	VW97460	VW97460	VW97460
D513	2.2K	2.2K	1.5K	2.2K
D514	HF45622	HF45622	HF45615	HF45622

Interchangeable Parts at Manufacture-Stage

NOTICE (model)
 (J)..... JAPANESE
 (U)..... U. S. A
 (C)..... CANADIAN
 (R)..... GENERAL
 (A)..... AUSTRALIAN
 (B)..... BRITISH
 (E)..... EUROPEAN
 (T)..... CHINA
 (L)..... SINGAPORE

- Conditions (RX-V396RDS)
 • INPUT → CD
 • VOLUME → minimum(∞)
 • IMPEDANCE → 100Ω
 • SELECTOR → Left
 • PRO LOGIC → On

* All voltages are measured with a 10MΩ/V DC electric volt meter.
 * Components having special characteristics are marked Δ and must be replaced with parts having specifications equal to those originally installed.
 * Schematic diagram is subject to change without notice. E-62/J-58

SCHEMATIC DIAGRAM [DSP]

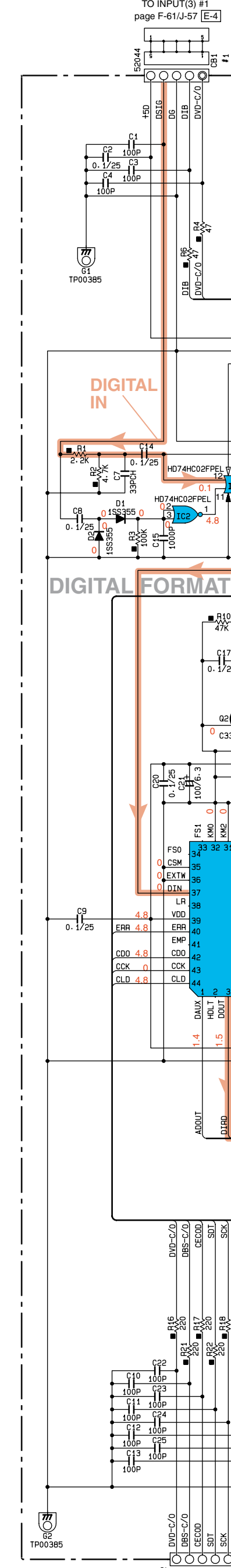
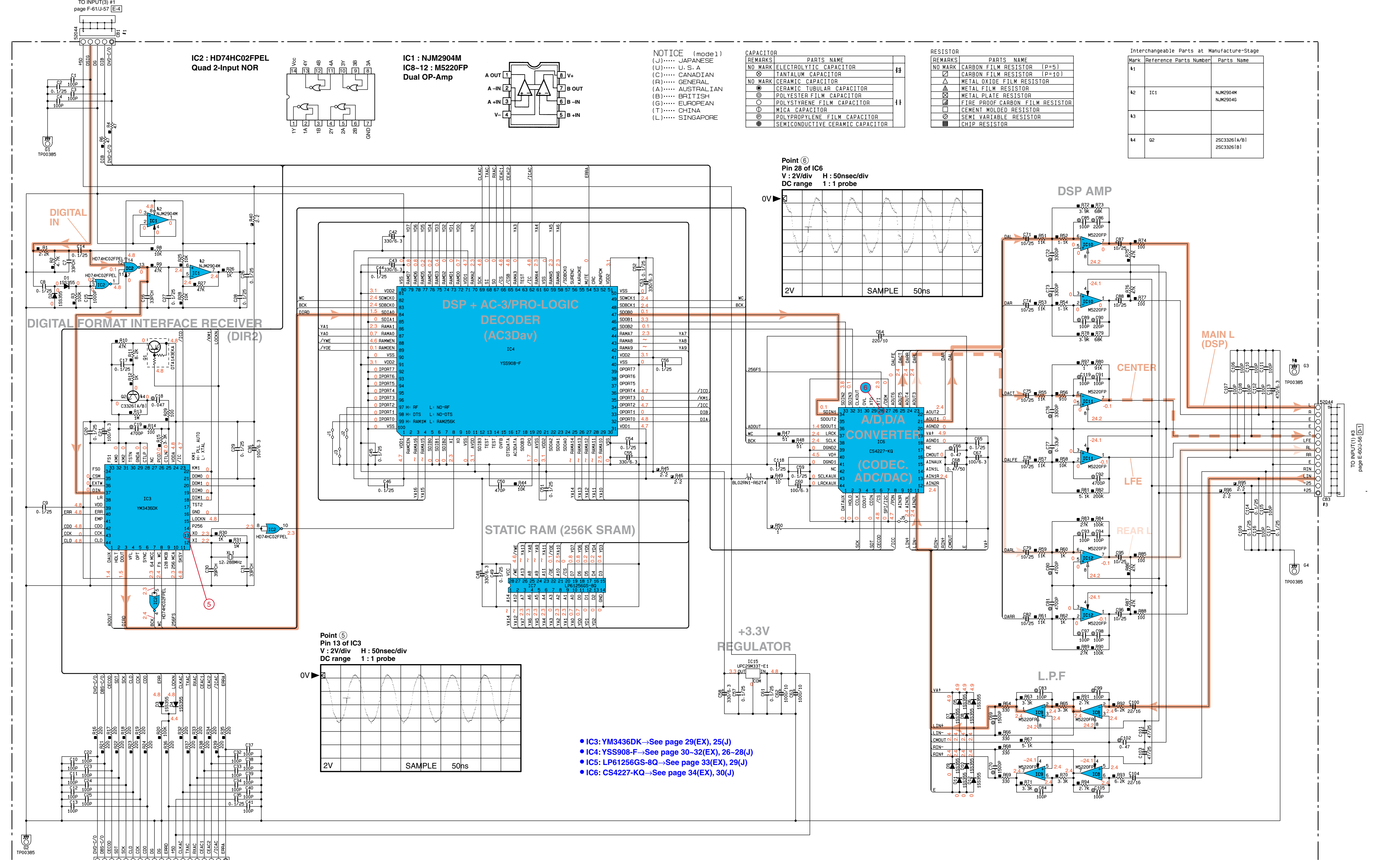

IC2 : HD74HC02FPEL
Quad 2-Input NOR

IC1 : NJM2904M
IC8-12 : M5220FP
Dual OP-Amp

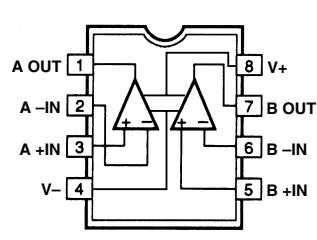

NOTICE (model)
(J)..... JAPANESE
(U)..... U. S. A
(C)..... CANADIAN
(R)..... GENERAL
(A)..... AUSTRALIAN
(B)..... BRITISH
(G)..... EUROPEAN
(T)..... CHINA
(L)..... SINGAPORE

REMARKS	PARTS NAME
NO MARK	ELECTROLYTIC CAPACITOR
⊗	TANTALUM CAPACITOR
NO MARK	CERAMIC CAPACITOR
⊙	CERAMIC TUBULAR CAPACITOR
⊖	POLYESTER FILM CAPACITOR
○	POLYSTYRENE FILM CAPACITOR
⊕	MICA CAPACITOR
⊖	POLYPROPYLENE FILM CAPACITOR
⊙	SEMICONDUCTIVE CERAMIC CAPACITOR

REMARKS	PARTS NAME
NO MARK	CARBON FILM RESISTOR (P=5)
⊗	CARBON FILM RESISTOR (P=10)
△	METAL OXIDE FILM RESISTOR
⊖	METAL FILM RESISTOR
⊕	METAL PLATE RESISTOR
⊖	FIBRE PROOF CARBON FILM RESISTOR
⊕	CEMENT MOLDED RESISTOR
⊖	SEMI VARIABLE RESISTOR
⊕	CHP RESISTOR

Mark	Reference Parts Number	Parts Name
k1		
k2	IC1	NJM2904M NJM2904G
k3		
k4	Q2	2SC3326(A/B) 2SC3326(B)

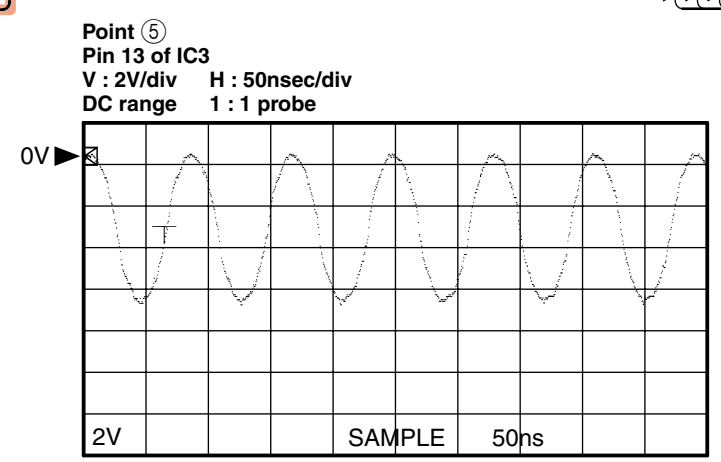
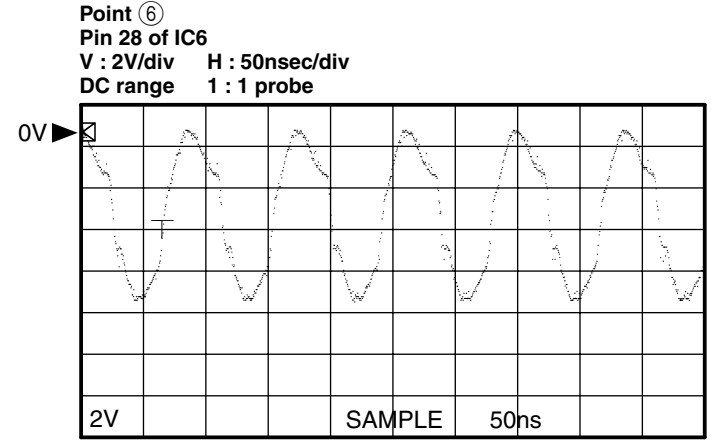

- IC3: YM3436DK → See page 29(EX), 25(J)
- IC4: YSS908-F → See page 30-32(EX), 26-28(J)
- IC5: LP61256GS-8Q → See page 33(EX), 29(J)
- IC6: CS4227-KQ → See page 34(EX), 30(J)

PIN CONNECTION DIAGRAM OF DIODES, TRANSISTORS AND IC'S.

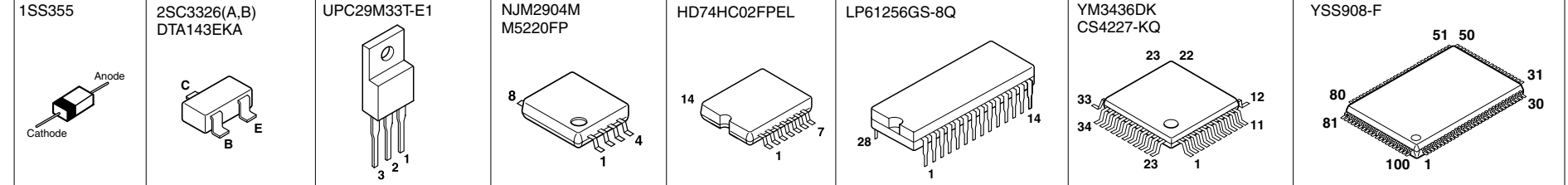

Conditions (RX-V396RDS)
• INPUT → CD
• VOLUME → minimum(∞)
• IMPEDANCE SELECTOR → Left
• PRO LOGIC → On

• All voltages are measured with a 10MΩ/V DC electric volt meter.
• Components having special characteristics are marked Δ and must be replaced with parts having specifications equal to those originally installed.
• Schematic diagram is subject to change without notice.

■ SCHEMATIC DIAGRAM [OPERATION (2/2)]

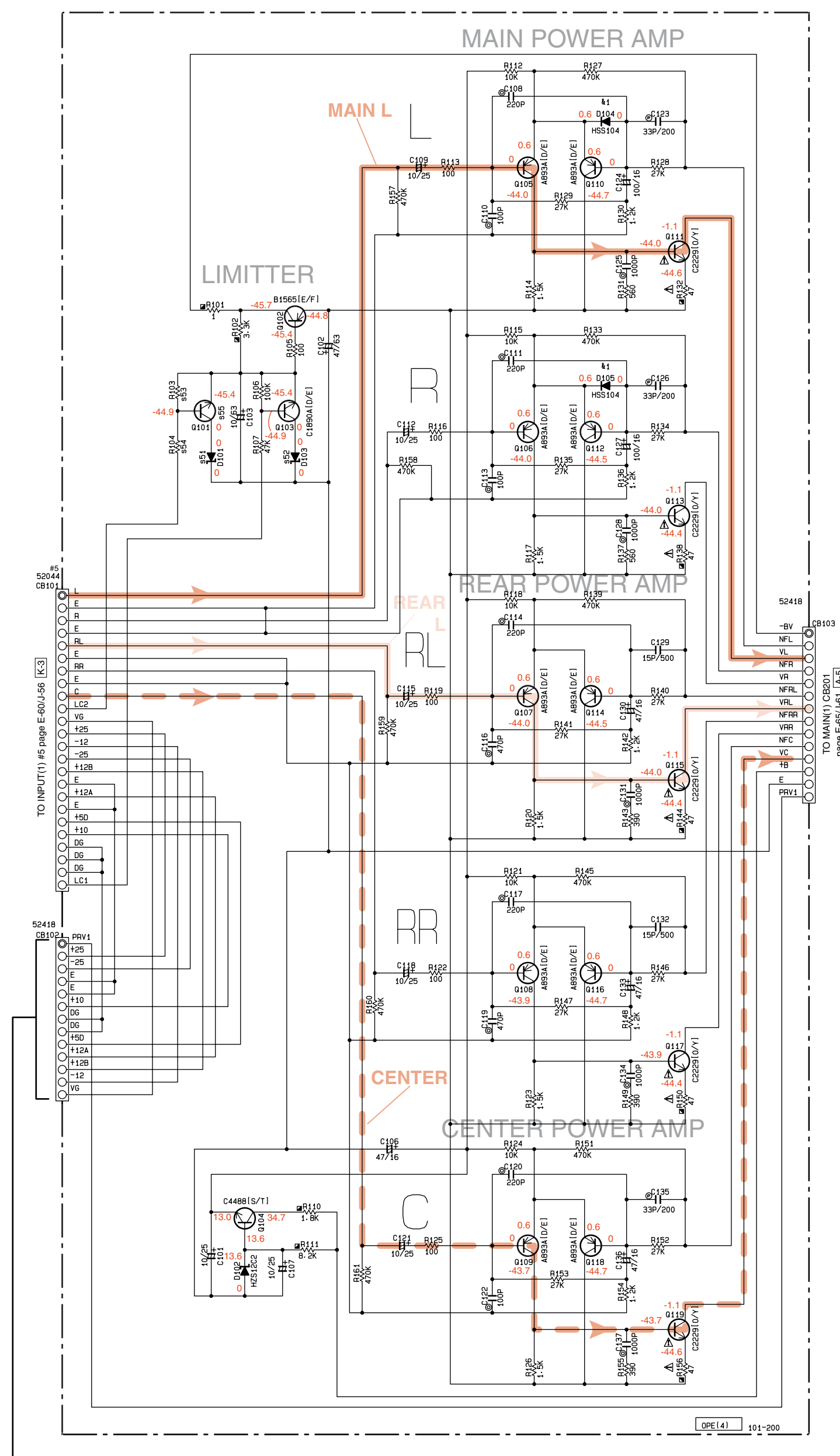

Interchangeable Parts at Manufacture-Stage

Mark	Reference Parts Number	Parts Name
K1	D104-105	HSS104 ISS133 ISS176
K2		
K3		
K4		

	J	U-C	R-T	A-B-G
#51	D101	X	HZS182 VM97600	HZS182 VM97600
#52	D103	X	HZS202 VM97610	HZS202 VM97620
#53	R103	X	100K HF45810	100K HF45810
#54	R104	X	47K HF45747	47K HF45747
#55	Q101	X	C1890A(D,E) VP88310	C1890A(D,E) VP88310

X: NOT USED

NOTICE (model)

- (J)..... JAPANESE
- (U)..... U. S. A
- (C)..... CANADIAN
- (R)..... GENERAL
- (A)..... AUSTRALIAN
- (B)..... BRITISH
- (G)..... EUROPEAN
- (T)..... CHINA
- (L)..... SINGAPORE

RESISTOR

REMARKS	PARTS NAME
NO MARK	CARBON FILM RESISTOR (P=5)
□	CARBON FILM RESISTOR (P=10)
△	METAL OXIDE FILM RESISTOR
○	METAL FILM RESISTOR
□	METAL PLATE RESISTOR
□	FIRE PROOF CARBON FILM RESISTOR
□	CEMENT MOLDED RESISTOR
□	SEMI VARIABLE RESISTOR
□	CHIP RESISTOR

CAPACITOR

REMARKS	PARTS NAME
NO MARK	ELECTROLYTIC CAPACITOR
⊗	TANTALUM CAPACITOR
NO MARK	CERAMIC CAPACITOR
○	CERAMIC TUBULAR CAPACITOR
○	POLYESTER FILM CAPACITOR
○	POLYSTYRENE FILM CAPACITOR
○	MICA CAPACITOR
○	POLYPROPYLENE FILM CAPACITOR
○	SEMICONDUCTIVE CERAMIC CAPACITOR
○	POLYPHENYLENE SULFIDE FILM CAPACITOR

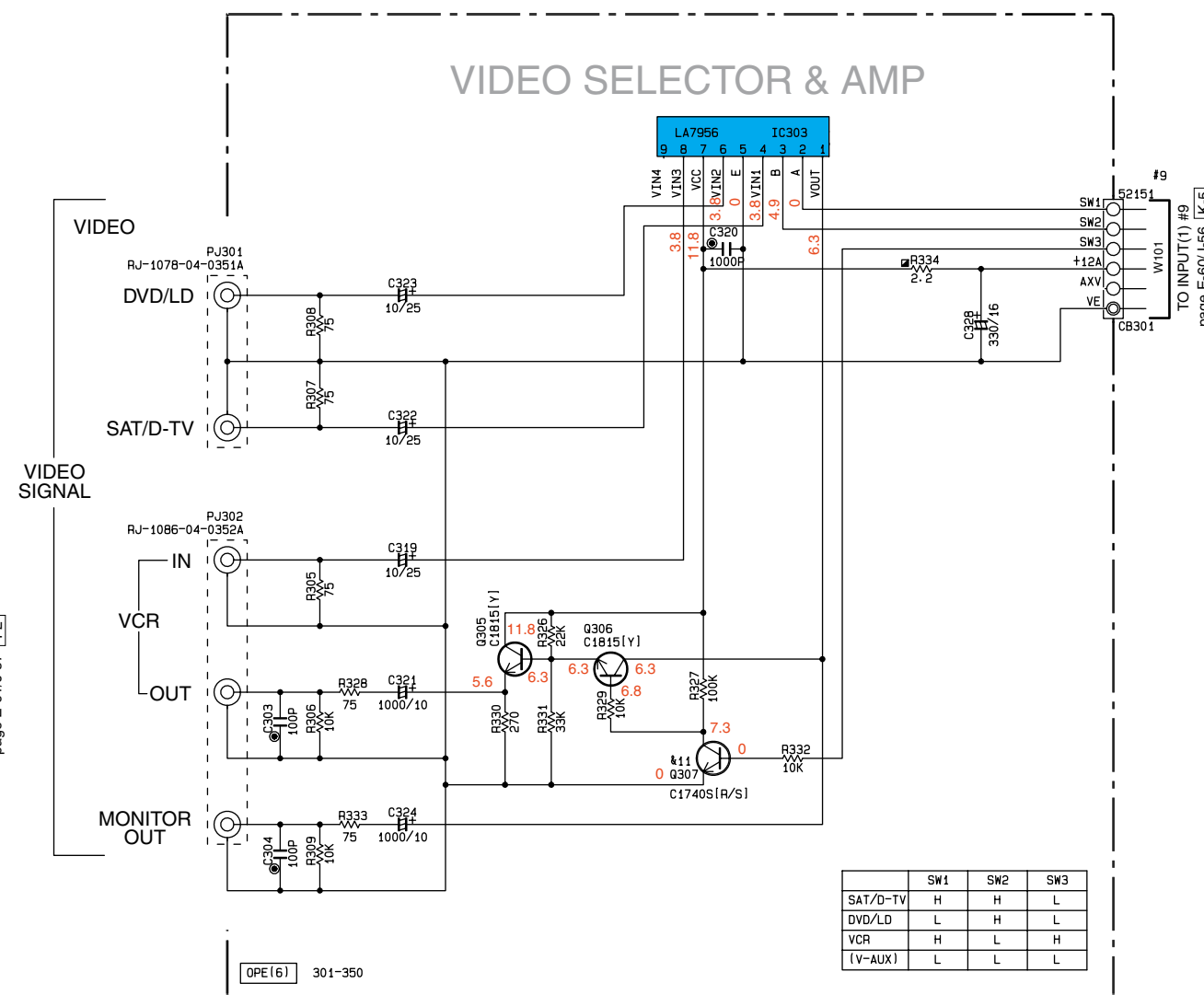
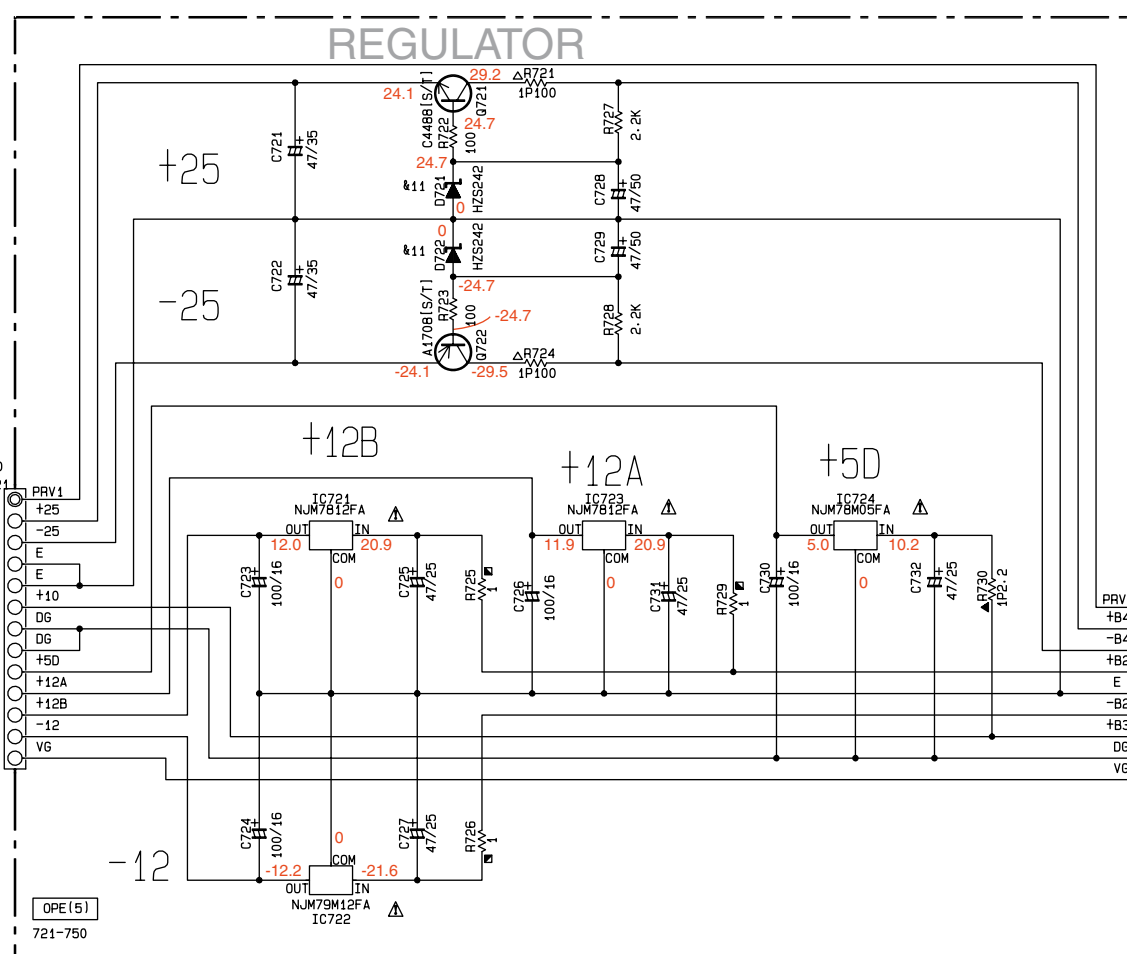

PIN CONNECTION DIAGRAM OF DIODES, TRANSISTORS AND IC's.

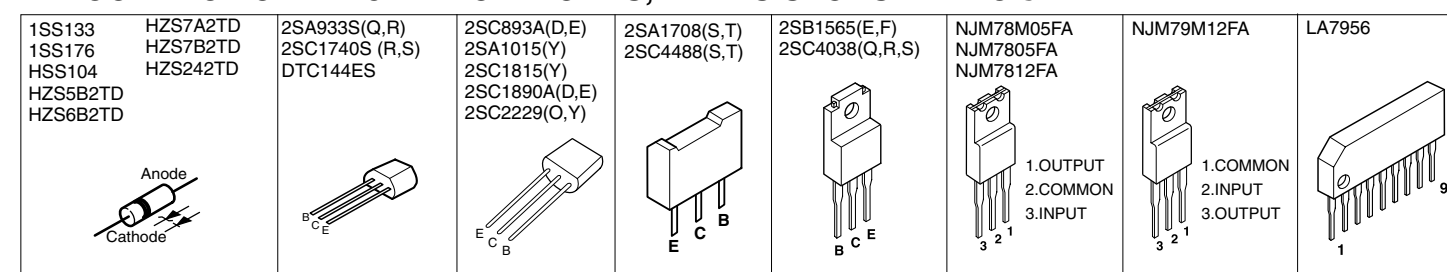

IC303 : LA7956
Video Switch

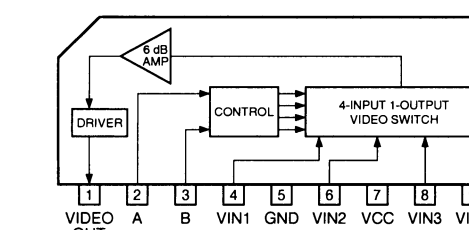

Conditions (RX-V396RDS)

- INPUT → CD
- VOLUME → minimum(←→)
- IMPEDANCE
- SELECTOR → Left
- PRO LOGIC → On

- * All voltages are measured with a 10MΩ/V DC electric volt meter.
- * Components having special characteristics are marked △ and must be replaced with parts having specifications equal to those originally installed.
- * Schematic diagram is subject to change without notice.

SCHEMATIC DIAGRAM [MAIN]

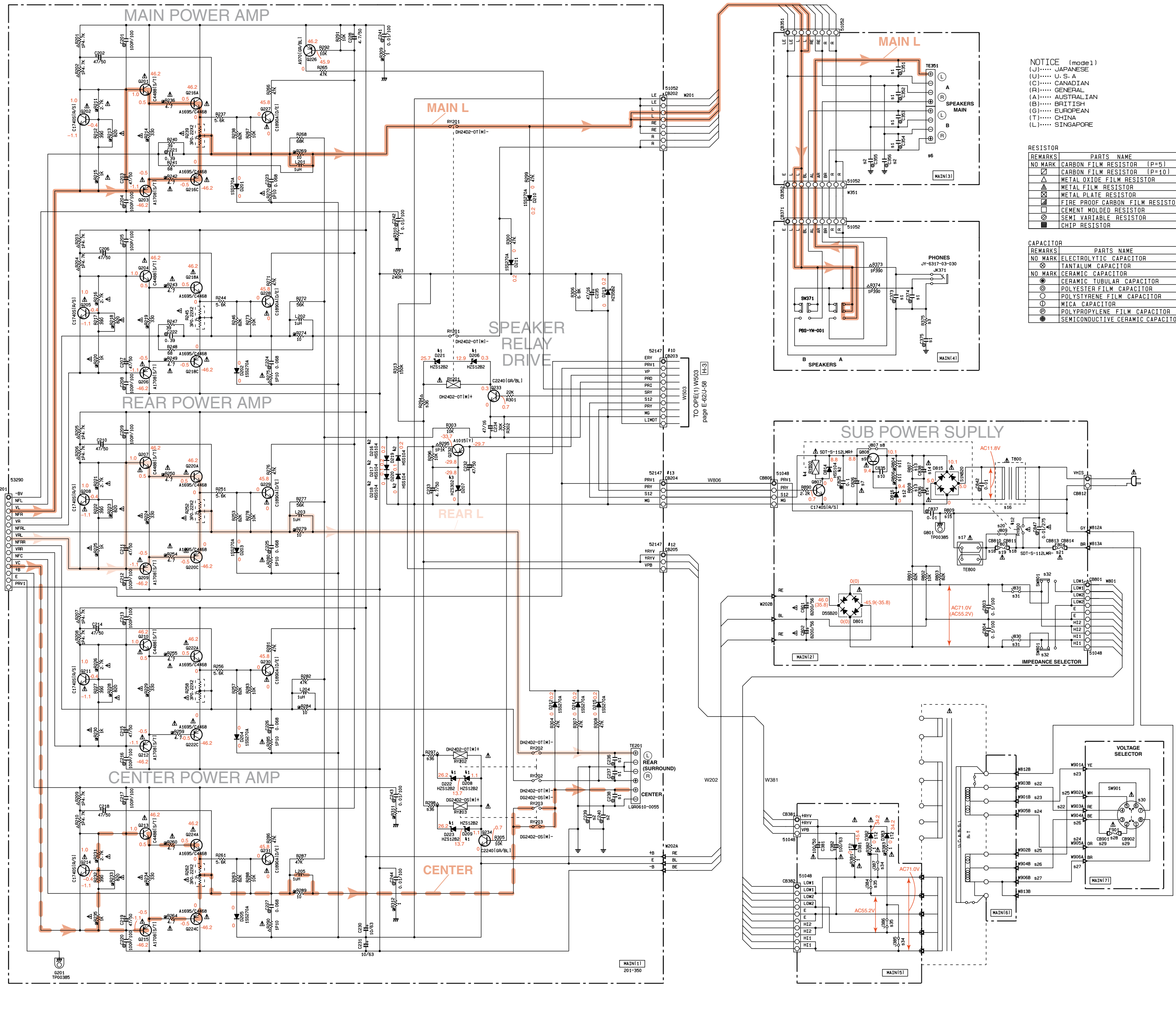

NOTICE (model1)
 (J)..... JAPANESE
 (U)..... U.S.A.
 (C)..... CANADIAN
 (R)..... GENERAL
 (A)..... AUSTRALIAN
 (B)..... BRITISH
 (G)..... EUROPEAN
 (T)..... CHINA
 (L)..... SINGAPORE

RESISTOR

REMARKS	PARTS NAME
NO MARK	CARBON FILM RESISTOR (P=5)
△	CARBON FILM RESISTOR (P=10)
▲	METAL OXIDE FILM RESISTOR
▴	METAL FILM RESISTOR
▾	METAL PLATE RESISTOR
■	FIRE PROOF CARBON FILM RESISTOR
□	CEMENT MOLDED RESISTOR
▨	SEMI VARIABLE RESISTOR
●	CHIP RESISTOR

CAPACITOR

REMARKS	PARTS NAME
NO MARK	ELECTROLYTIC CAPACITOR
⊗	TANTALUM CAPACITOR
NO MARK	CERAMIC CAPACITOR
⊙	CERAMIC TUBULAR CAPACITOR
⊚	POLYESTER FILM CAPACITOR
○	POLYSTYRENE FILM CAPACITOR
○	MICA CAPACITOR
○	POLYPROPYLENE FILM CAPACITOR
●	SEMICONDUCTIVE CERAMIC CAPACITOR

Circuit No.	MODEL No.					
	J	U-C	R-T	A	S	
1	C296-297-298 C314-352-353-354 C373-374-375	X	X	X	0.01 U4954101	0.01 U4954101
2	C239-240-255-266	X	X	X	0.022 U4954221	0.022 U4954221
3	R375	X	X	X	2.2 W453221	2.2 W453221
4						
5						
6	TE351	VC31370	VC31370	VC31370	VC31370	V481140 V481140
7	CR26	470/25 UR84347	470/25 UR84347	220/25 UR84822	470/25 UR84347	470/25 UR84347
8	RB07	0	0	0	0	0
9	R008	X	X	X	D23961JX1 W61292	X
10	CR09	X	X	X	1000P F061310	X
11	RB04-806	X	X	X	5-9K W67555	X
12	DR16	X	X	X	H251827D W67530	X
13	RB07-808	X	X	X	1M W45910	X
14	CR36-838	X	X	X	100/35 UR85810	X
15	RB09	X	X	X	1/250-2M W33252	X
16	T800	XW605	XW605	XW607	XW608	XW608
17	TE800	VU54310	VU54310	V474640	VY15000	VU54330 VU54340
18	CB810-811	X	X	X	X	X
19	R803	X	X	X	X	X
20	RB09	0	0	0	0	0
21	R804	6A125V W82310	6A125V W82310	6A125V W82310	T2-5AL250V W82059	T2-5AL250V W82059
22	W903	X	X	X	X	X
23	W901	X	X	X	X	X
24	W905	X	X	X	X	X
25	W902	X	X	X	X	X
26	W904	X	X	X	X	X
27	W906	X	X	X	X	X
28	F901	X	X	X	X	X
29	CB901-902	X	X	X	X	X
30	SW901	X	X	X	X	X
31	LB30-831	0	X	X	X	X
32	SW801	X	X	X	X	X
34	LJ385-387	0	X	X	X	X
35	LJ384-386	X	0	0	0	0
36	R294-297-298	VP94090 IP950	VP94070 IP930	VP94070 IP930	VP94070 IP930	VP94070 IP930
37	TE201	V447070 LR2610-000	V447070 LR2610-000	V447070 LR2610-000	V447070 LR2610-000	V447090 LR2610-000

X:NOT USED ○:USED

Interchangeable Parts at Manufacture-Stage

Mark	Reference Parts Number	Parts Name
K1	D206-208-209- D221-222-223	HZ51282 WTJ1338
K2	D216-D220-D814	HSS104 1SS133 1SS176
K3	D207	HZ5302 WTJ3300
K4	RV800	OC307-S-112LMR OC305101-S11-11 OCAL4S231

PIN CONNECTION DIAGRAM OF DIODES, TRANSISTORS AND IC'S.

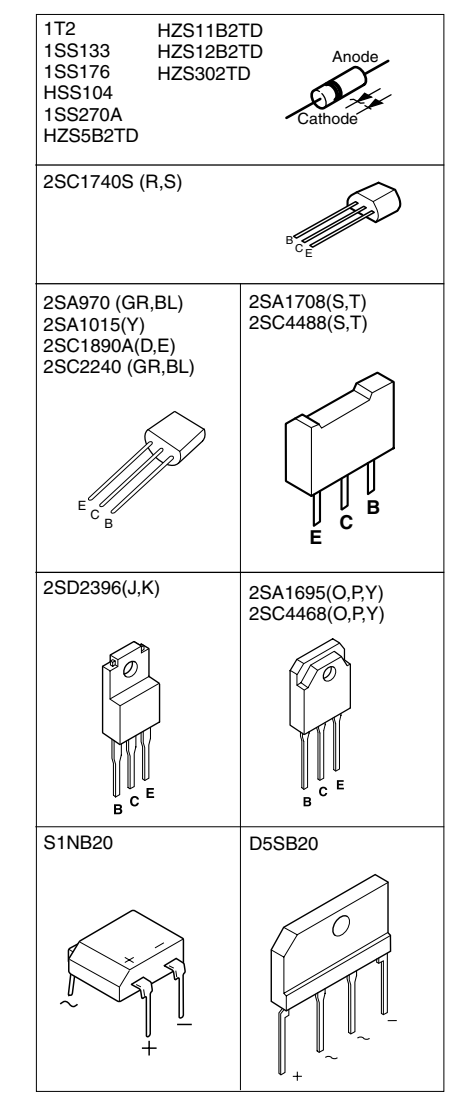

Conditions (RX-V396RDS)
 • INPUT → CD
 • VOLUME → minimum(∞)
 • IMPEDANCE SELECTOR → Left
 • PRO LOGIC → On

• All voltages are measured with a 10MΩ/V DC electric voltmeter.
 • Components having special characteristics are marked Δ and must be replaced with parts having specifications equal to those originally installed.
 • Schematic diagram is subject to change without notice.

SCHEMATIC DIAGRAM [TUNER] J, U, C, R, T, B and G models

Each voltage given here represents that in the FM (83MHz: J model or 98.1MHz: EX model STEREO) reception mode but the one in the parentheses () is that in the AM (1080kHz, MAN'L) reception mode.

REMARKS	PARTS NAME	SYMBOL
NO MARK	ELECTROLYTIC CAPACITOR	⊘
⊗	TANTALUM CAPACITOR	⊗
NO MARK	CERAMIC CAPACITOR	□
⊙	CERAMIC TUBULAR CAPACITOR	⊙
○	POLYESTER FILM CAPACITOR	○
○	POLYSTYRENE FILM CAPACITOR	○
○	MICA CAPACITOR	○
○	POLYPROPYLENE FILM CAPACITOR	○
⊙	SEMICONDUCTIVE CERAMIC CAPACITOR	⊙

REMARKS	PARTS NAME	SYMBOL
NO MARK	CARBON FILM RESISTOR (P=5)	□
□	CARBON FILM RESISTOR (P=10)	□
△	METAL OXIDE FILM RESISTOR	△
△	METAL FILM RESISTOR	△
□	METAL PLATE RESISTOR	□
□	FIRE PROOF CARBON FILM RESISTOR	□
□	CEMENT MOLDED RESISTOR	□
□	SEMI VARIABLE RESISTOR	□
□	CHIP RESISTOR	□

NOTICE (mode1)
 (J)..... JAPANESE
 (U)..... U. S. A
 (C)..... CANADIAN
 (R)..... GENERAL
 (A)..... AUSTRALIAN
 (B)..... BRITISH
 (G)..... EUROPEAN
 (T)..... CHINA
 (L)..... SINGAPORE

IC1 : LA1266 AM/FM IF

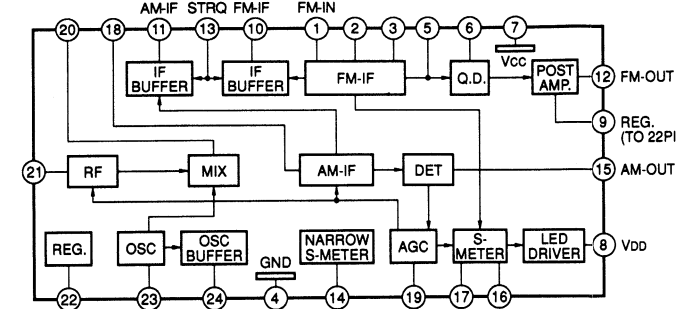

IC2 : LC72131 PLL Controller

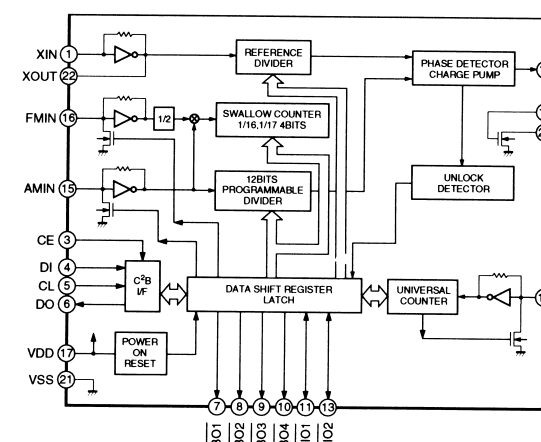

IC3 : LA3401 MPX

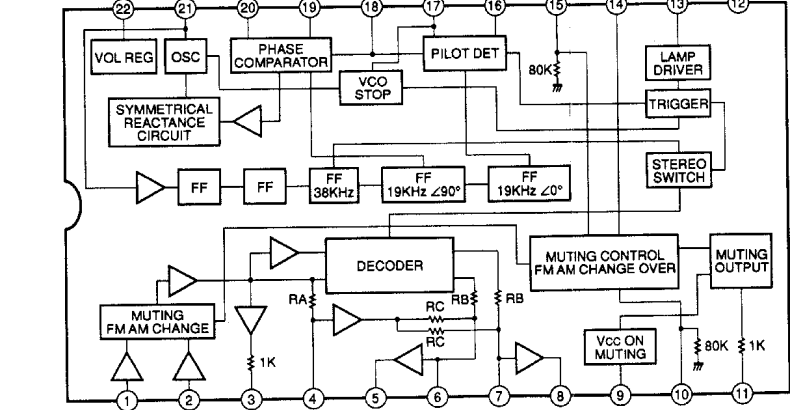

PK1 : ENV-142C2G1R (V290900) J model

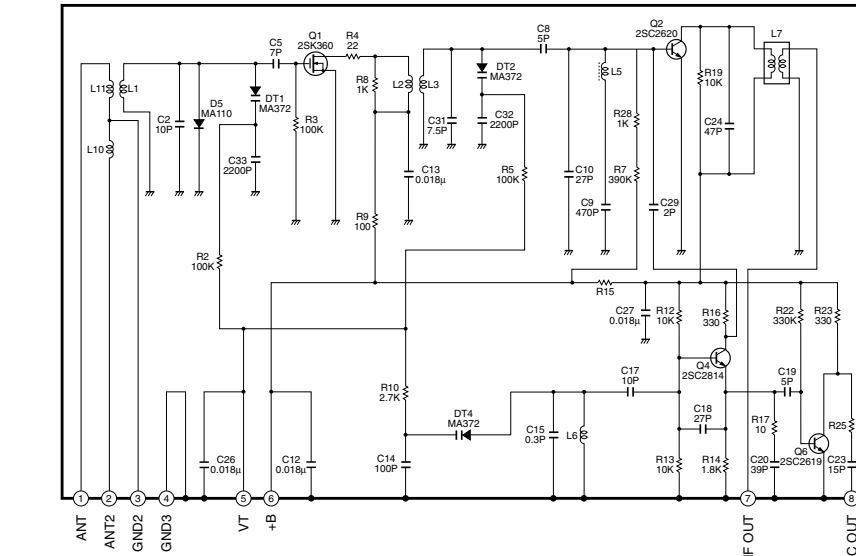

PK1 : ENV-172C8G1R (V290910) U, C, R, T models

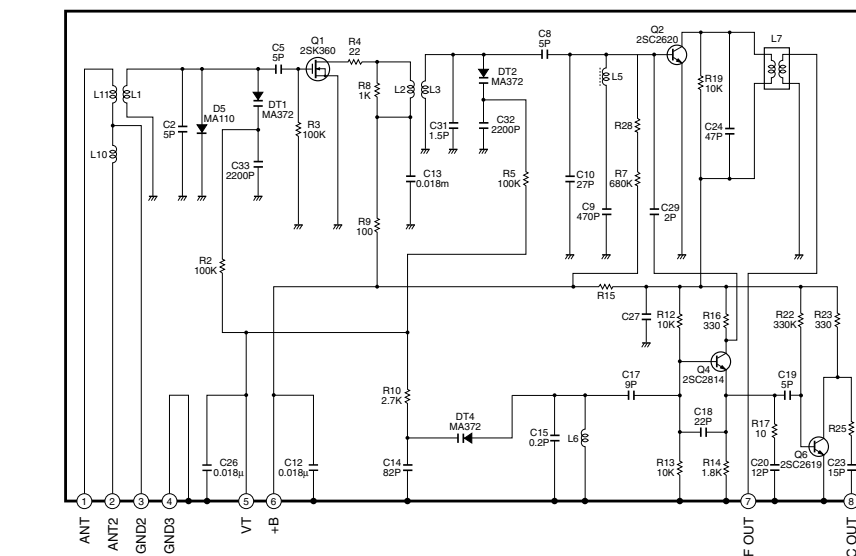

PK1 : ENV-172A4G1 (V271670) A, B, G, L models

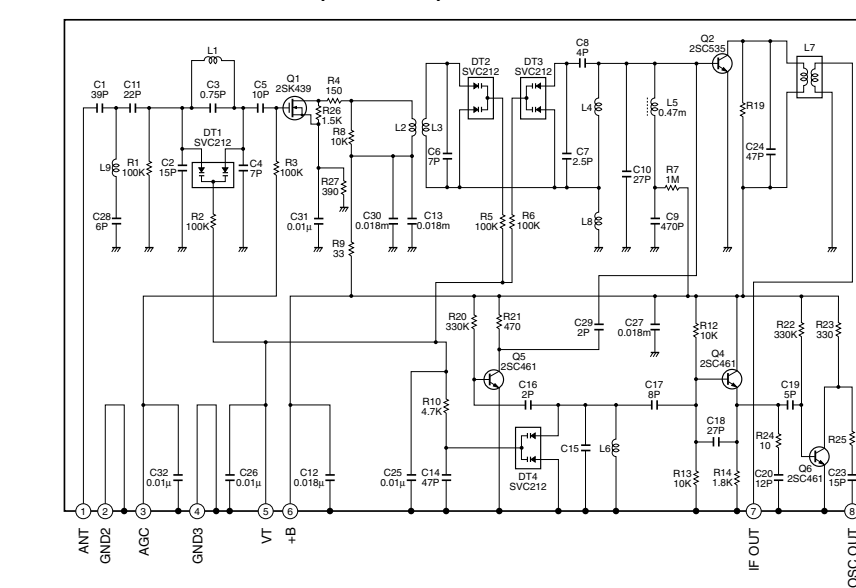

	J	U-C	R-T	A-B-G-L
1 PK1	V290900	V290910	V271670	V271670
2 R48				R22547
3 T3				XYA2 VT48680
4 J41				
5 C49	2200P UA95322	2200P UA95322	2200P UA95322	120P UA95212
6 R50	22K RD25722	22K RD25722	22K RD25722	1K RD25810
7 C36-37	680P UA95268	1000P UA95310	1000P UA95310	270P UA95227
8 R36-37	75K RD25775	75K RD25775	75K RD25775	180K RD25818
9 SM1				VS60260
10 J42				
11 R55		270K RD25827	270K RD25827	
12 R57-58				270K RD25827
13 R60		100K RD25810	100K RD25810	
14 R34	10K RD25710	10K RD25710	10K RD25710	27K RD25827
15 F12	6500056	6500056	6500056	V454520

○ USED
 □ NOT USED

TO INPUT(1)
 page E-60/J-56
 [8]

	Lead Type	Lead Type & SMD
21 D1, 2	1SS133, 1SS176, HSS104 VD631600	1SS355 VT33290
22 D3	MTZJ5.6B VG43770	UDZS5.6BTE-17 VU17200
23 L1,2,3,4	V654610	VU88950
24 C3	8.2P/50 VG27580	8P/50 UB05080
25 C5,8,9,10,23,27	0.01/16 VF46730	0.01/50 UB04410
26 C11,15	1000P/50 VF46700	1000P/130 UB01310
27 C16	47P/50 VA46670	47P/50 UB05147
28		
29 C21,50	0.047/16 VJ59900	0.047/50 UB04447
30 C38	470P/50 VF46690	470P/50 UB01247

Point ① (Pin22 of IC2)

V : 2V/div H : 0.1μsec/div DC range 1 : 1 probe

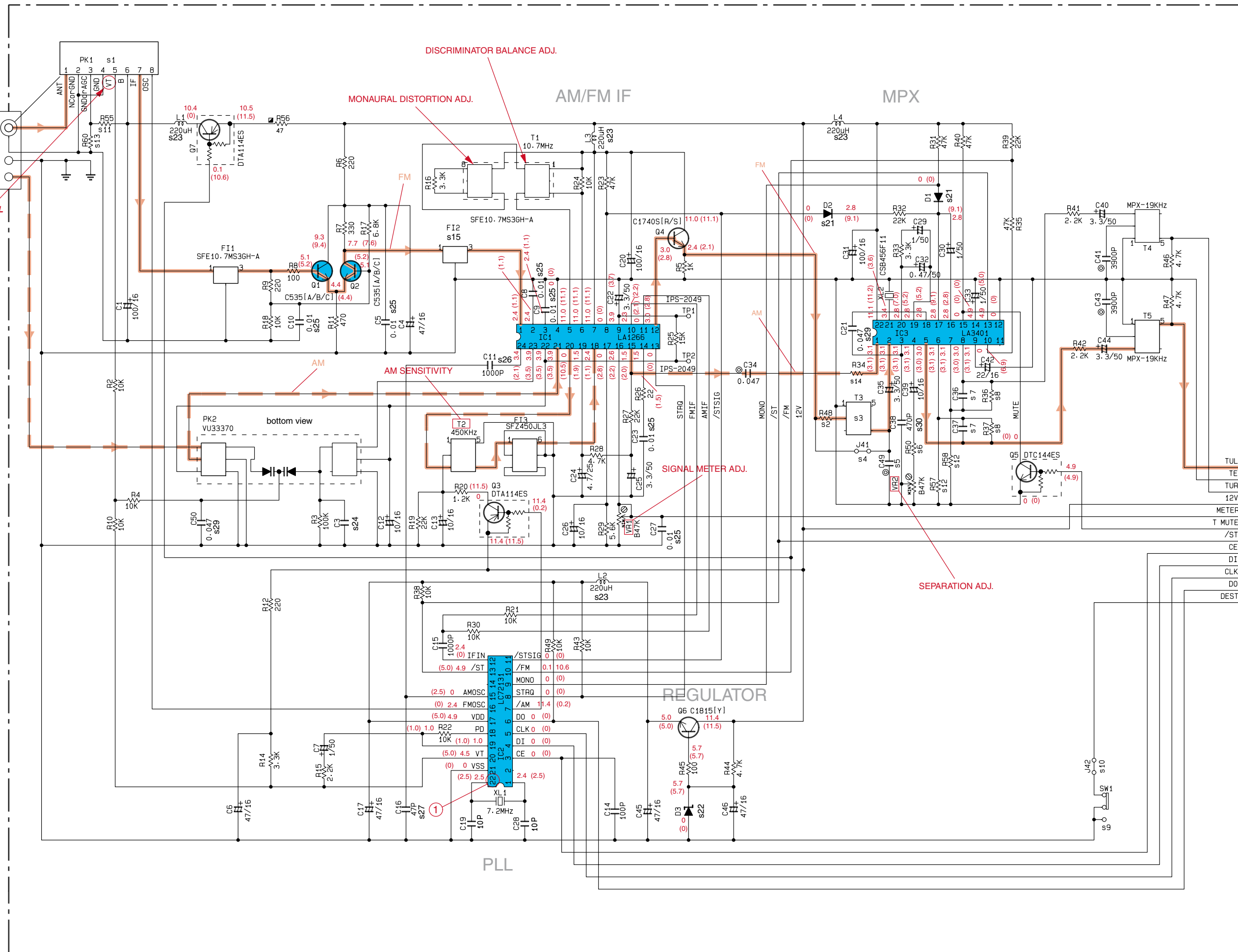
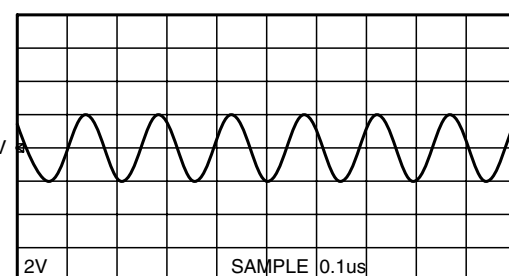

PIN CONNECTION DIAGRAM OF DIODES, TRANSISTORS AND IC's.

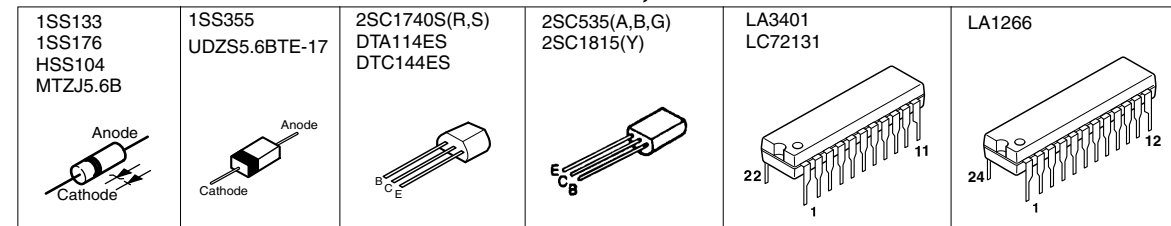

* All voltages are measured with a 10MΩ/V DC electric volt meter.
 * Components having special characteristics are marked with a triangle and must be replaced with parts having specifications equal to those originally installed.
 * Schematic diagram is subject to change without notice.

SCHEMATIC DIAGRAM [TUNER] B, G models (RDS model)

Each voltage given here represents that in the FM (98.1MHz STEREO) reception mode but the one in the parentheses () is that in the AM (1080kHz, MAN'L) reception mode.

CAPACITOR	
REMARKS	PARTS NAME
NO MARK	ELECTROLYTIC CAPACITOR
⊗	TANTALUM CAPACITOR
NO MARK	CERAMIC CAPACITOR
⊙	CERAMIC TUBULAR CAPACITOR
⊖	POLYESTER FILM CAPACITOR
○	POLYSTYRENE FILM CAPACITOR
⊕	MICA CAPACITOR
⊖	POLYPROPYLENE FILM CAPACITOR
⊙	SEMICONDUCTIVE CERAMIC CAPACITOR

RESISTOR	
REMARKS	PARTS NAME
NO MARK	CARBON FILM RESISTOR (P=5)
⊗	CARBON FILM RESISTOR (P=10)
△	METAL OXIDE FILM RESISTOR
⊖	METAL FILM RESISTOR
⊕	METAL PLATE RESISTOR
⊖	FIRE PROOF CARBON FILM RESISTOR
⊕	CEMENT MOLDED RESISTOR
⊖	SEMI VARIABLE RESISTOR
⊙	CHIP RESISTOR

NOTICE (mode1)
 (J)..... JAPANESE
 (U)..... U.S.A
 (C)..... CANADIAN
 (R)..... GENERAL
 (A)..... AUSTRALIAN
 (B)..... BRITISH
 (G)..... EUROPEAN
 (T)..... CHINA
 (L)..... SINGAPORE

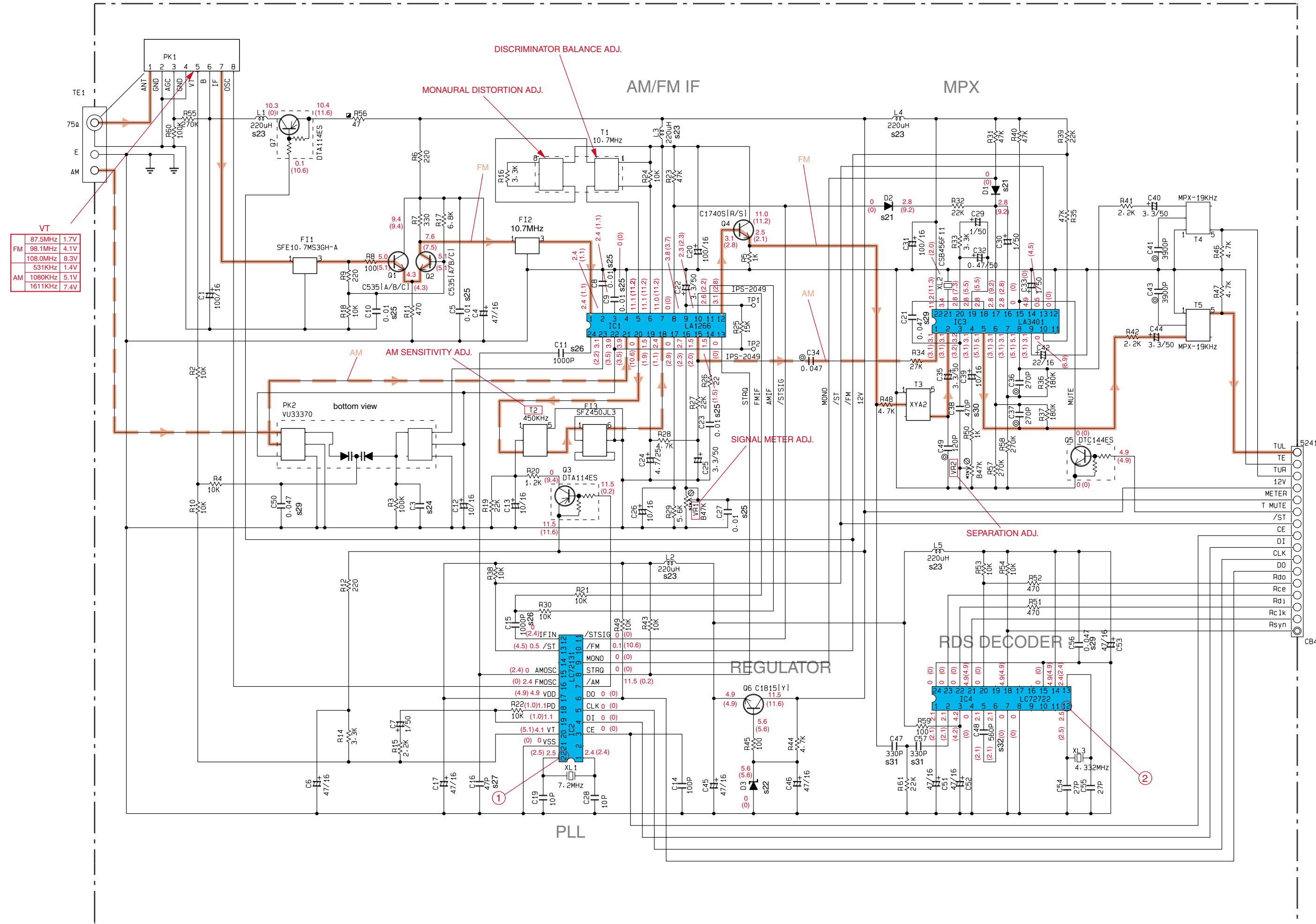

VT

87.5MHz	1.7V
FM 98.1MHz	4.1V
108.0MHz	8.3V
531kHz	1.4V
AM 1080kHz	5.1V
1611kHz	7.4V

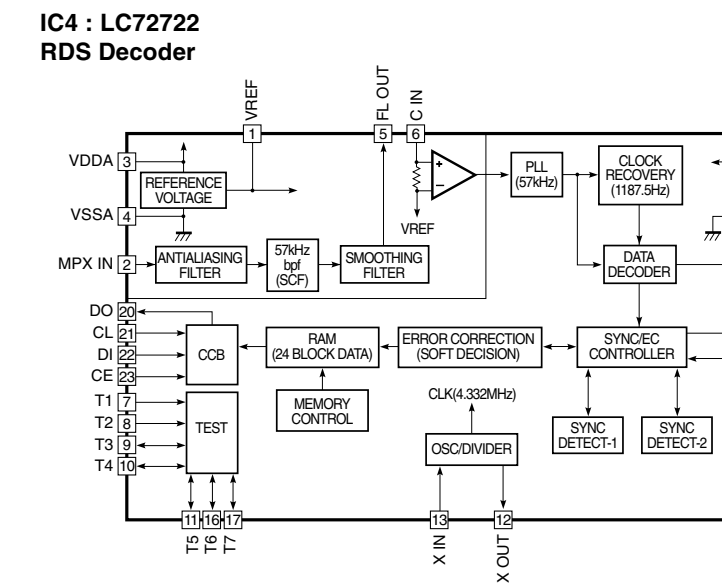
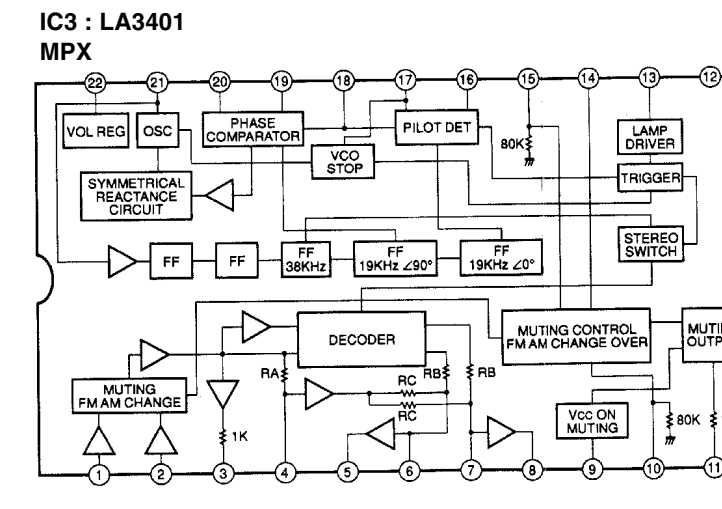
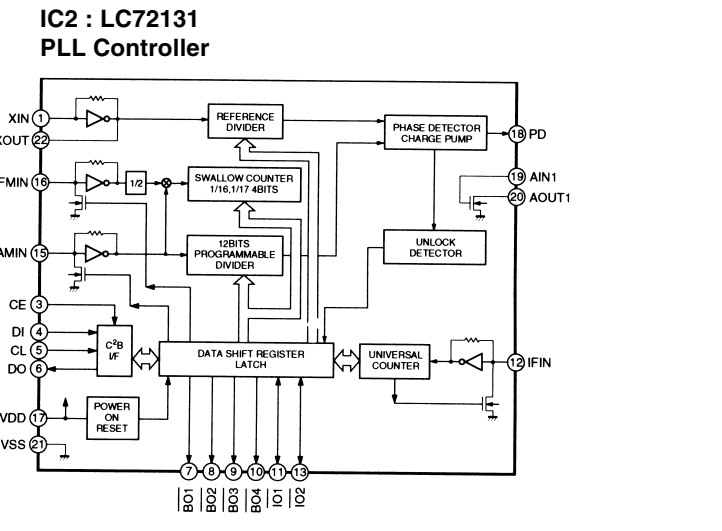
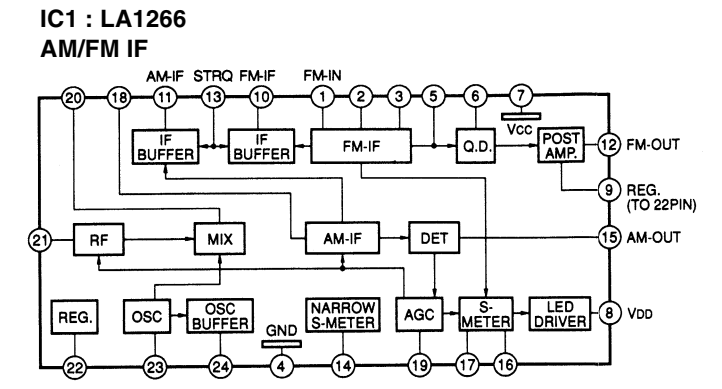

TO INPUT(1)
CB107
page E-60J-56

s	Lead Type	Lead Type & SMD
21	D1, 2	1SS133, 1SS176, HSS104, VD631600
22	D3	MTZJ5.6B
23	L1,2,3,4,5	VS4610
24	C3	8.2P/50, 8P/50, VG27580
25	C5,8,9,10,23,27	0.01/16, 0.01/50, VF46730
26	C11,15	1000P/50, 1000P/50, VF46700
27	C16	47P/50, 47P/50, VA46670
28		
29	C21,50,56	0.047/16, VJ59900
30	C38	470P/50, VF46690
31	C47,57	330P/50, VG27860
32	C48	560P/50, VG27880

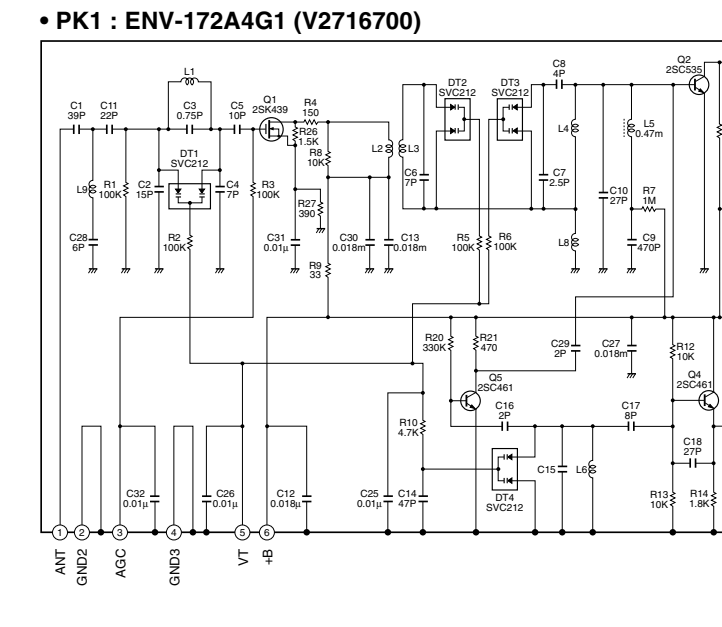

PIN CONNECTION DIAGRAM OF DIODES, TRANSISTORS AND IC's.

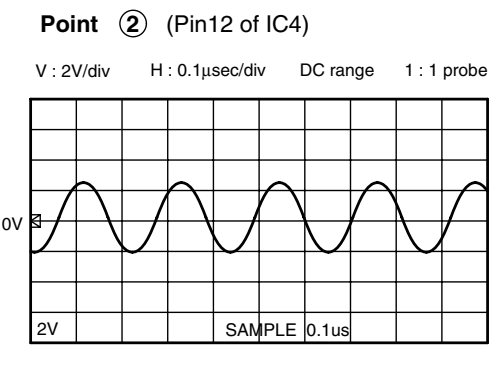
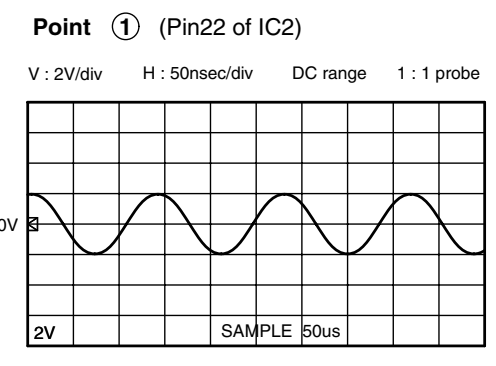
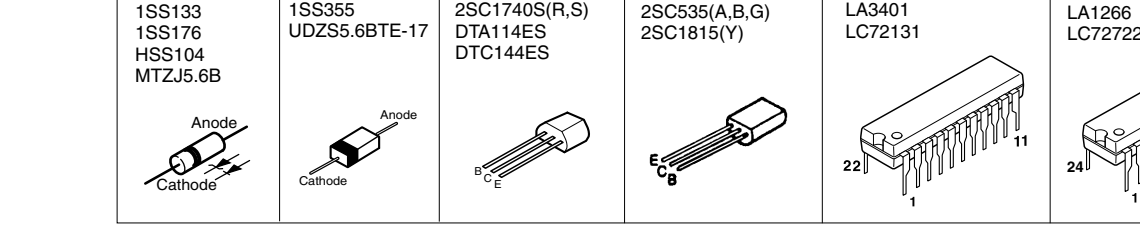

* All voltages are measured with a 10MΩ/V DC electric volt meter.
 * Components having special characteristics are marked Δ and must be replaced with parts having specifications equal to those originally installed.
 * Schematic diagram is subject to change without notice.

PARTS LIST

■ ELECTRICAL PARTS

■ WARNING

Components having special characteristics are marked \triangle and must be replaced with parts having specifications equal to those originally installed.

- Carbon resistors (1/6W or 1/4W) are not included in the ELECTRICAL PARTS List. For the part Nos. of the carbon resistors, refer to page 81.
- Chip resistors are listed on page 80.

ABBREVIATIONS IN THIS LIST ARE AS FOLLOWS:

C. A. EL. CHP	: CHIP ALUMI. ELECTROLYTIC CAP	LED. DSPLY	: LED DISPLAY
C. CE	: CERAMIC CAP	LED. INFRD	: LED, INFRARED
C. CE. ARRAY	: CERAMIC CAP ARRAY	MODUL. RF	: MODULATOR, RF
C. CE. CHP	: CHIP CERAMIC CAP	PHOT. CPL	: PHOTO COUPLER
C. CE. ML	: MULTILAYER CERAMIC CAP	PHOT. INTR	: PHOTO INTERRUPTER
C. CE. M. CHP	: CHIP MULTILAYER CERAMIC CAP	PHOT. RFLCT	: PHOTO REFLECTOR
C. CE. SAFTY	: RECOGNIZED CERAMIC CAP	PIN. TEST	: PIN, TEST POINT
C. CE. TUBLR	: CERAMIC TUBULAR CAP	PLST. RIVET	: PLASTIC RIVET
C. CE. SMI	: SEMI CONDUCTIVE CERAMIC CAP	R. ARRAY	: RESISTOR ARRAY
C. EL	: ELECTROLYTIC CAP	R. CAR	: CARBON RESISTOR
C. MICA	: MICA CAP	R. CAR. CHP	: CHIP RESISTOR
C. ML. FLM	: MULTILAYER FILM CAP	R. CAR.FP	: FLAME PROOF CARBON RESISTOR
C. MP	: METALLIZED PAPER CAP	R. FUS	: FUSABLE RESISTOR
C. MYLAR	: MYLAR FILM CAP	R. MTL. CHP	: CHIP METAL FILM RESISTOR
C. MYLAR. ML	: MULTILAYER MYLAR FILM CAP	R. MTL. FILM	: METAL FILM RESISTOR
C. PAPER	: PAPER CAPACITOR	R. MTL. OXD	: METAL OXIDE FILM RESISTOR
C. PLS	: POLYSTYRENE FILM CAP	R. MTL. PLAT	: METAL PLATE RESISTOR
C. POL	: POLYESTER FILM CAP	RSNR. CE	: CERAMIC RESONATOR
C. POLY	: POLYETHYLENE FILM CAP	RSNR. CRYST	: CRYSTAL RESONATOR
C. PP	: POLYPROPYLENE FILM CAP	R. TW. CEM	: TWIN CEMENT FIXED RESISTOR
C. TNTL	: TANTALUM CAP	R. WW	: WIRE WOUND RESISTOR
C. TNT. CHP	: CHIP TANTALUM CAP	SCR. BND. HD	: BIND HEAD B-TITE SCREW
C. TRIM	: TRIMMER CAP	SCR. BW. HD	: BW HEAD TAPPING SCREW
CN	: CONNECTOR	SCR. CUP	: CUP TITE SCREW
CN. BS. PIN	: CONNECTOR, BASE PIN	SCR. TERM	: SCREW TERMINAL
CN. CANNON	: CONNECTOR, CANNON	SCR. TR	: SCREW, TRANSISTOR
CN. DIN	: CONNECTOR, DIN	SUPRT. PCB	: SUPPORT, P. C. B.
CN. FLAT	: CONNECTOR, FLAT CABLE	SURG. PRTCT	: SURGE PROTECTOR
CN. POST	: CONNECTOR, BASE POST	SW. TACT	: TACT SWITCH
COIL. MX. AM	: COIL, AM MIX	SW. LEAF	: LEAF SWITCH
COIL. AT. FM	: COIL, FM ANTENNA	SW. LEVER	: LEVER SWITCH
COIL. DT. FM	: COIL, FM DETECT	SW. MICRO	: MICRO SWITCH
COIL. MX. FM	: COIL, FM MIX	SW. PUSH	: PUSH SWITCH
COIL. OUTPT	: OUTPUT COIL	SW. RT. ENC	: ROTARY ENCODER
DIOD. ARRAY	: DIODE ARRAY	SW. RT. MTR	: ROTARY SWITCH WITH MOTOR
DIODE. BRG	: DIODE BRIDGE	SW. RT	: ROTARY SWITCH
DIODE. CHP	: CHIP DIODE	SW. SLIDE	: SLIDE SWITCH
DIODE. VAR	: VARACTOR DIODE	TERM. SP	: SPEAKER TERMINAL
DIOD. Z. CHP	: CHIP ZENER DIODE	TERM. WRAP	: WRAPPING TERMINAL
DIODE. ZENR	: ZENER DIODE	THRMST. CHP	: CHIP THERMISTOR
DSCR. CE	: CERAMIC DISCRIMINATOR	TR. CHP	: CHIP TRANSISTOR
FER. BEAD	: FERRITE BEADS	TR. DGT	: DIGITAL TRANSISTOR
FER. CORE	: FERRITE CORE	TR. DGT. CHP	: CHIP DIGITAL TRANSISTOR
FET. CHP	: CHIP FET	TRANS	: TRANSFORMER
FL. DSPLY	: FLUORESCENT DISPLAY	TRANS. PULS	: PULSE TRANSFORMER
FLTR. CE	: CERAMIC FILTER	TRANS. PWR	: POWER TRANSFORMER ASS'y
FLTR. COMB	: COMB FILTER MODULE	TUNER. AM	: TUNER PACK, AM
FLTR. LC. RF	: LC FILTER, EMI	TUNER. FM	: TUNER PACK, FM
GND. MTL	: GROUND PLATE	TUNER. PK	: FRONT-END TUNER PACK
GND. TERM	: GROUND TERMINAL	VR	: ROTARY POTENTIOMETER
HOLDER. FUS	: FUSE HOLDER	VR. MTR	: POTENTIOMETER WITH MOTOR
IC. PRTCT	: IC PROTECTOR	VR. SW	: POTENTIOMETER WITH ROTARY SW
JUMPER. CN	: JUMPER CONNECTOR	VR. SLIDE	: SLIDE POTENTIOMETER
JUMPER. TST	: JUMPER, TEST POINT	VR. TRIM	: TRIMMER POTENTIOMETER
L. DTCT	: LIGHT DETECTING MODULE		
L. EMIT	: LIGHT EMITTING MODULE		

Note) Those parts marked with "#" are not included in the P. C. B. Ass'y.

P. C. B. DSP

Schm Ref	PART NO.	Description	
*	V4810600	P.C.B.	DSP
CB1	VQ044100	CN.BS.PIN	5P
CB2	VQ044900	CN.BS.PIN	19P
CB3	VQ044600	CN.BS.PIN	13P
C1	UB052100	C.CE.M.CHP	100pF 50V
C2	UB245100	C.CE.M.CHP	0.1uF 25V
C3	UB052100	C.CE.M.CHP	100pF 50V
C4	UB052100	C.CE.M.CHP	100pF 50V
C7	VJ900700	C.CE.M.CHP	33pF 50V
C8	UB245100	C.CE.M.CHP	0.1uF 25V
C9	UB245100	C.CE.M.CHP	0.1uF 25V
C10	UB052100	C.CE.M.CHP	100pF 50V
C11	UB052100	C.CE.M.CHP	100pF 50V
C12	UB052100	C.CE.M.CHP	100pF 50V
C13	UB052100	C.CE.M.CHP	100pF 50V
C14	UB245100	C.CE.M.CHP	0.1uF 25V
C15	UB013100	C.CE.M.CHP	1000pF 50V
C16	VJ900700	C.CE.M.CHP	33pF 50V
C17	UB245100	C.CE.M.CHP	0.1uF 25V
C18	UA954470	C.MYLAR	0.047uF 50V
C19	UA953470	C.MYLAR	4700pF 50V
C20	UB245100	C.CE.M.CHP	0.1uF 25V
C21	UR818100	C.EL	100uF 6.3V
C22	UB052100	C.CE.M.CHP	100pF 50V
C23	UB052100	C.CE.M.CHP	100pF 50V
C24	UB052100	C.CE.M.CHP	100pF 50V
C25	UB052100	C.CE.M.CHP	100pF 50V
C26	UB245100	C.CE.M.CHP	0.1uF 25V
C27	UB245100	C.CE.M.CHP	0.1uF 25V
C28	UB245100	C.CE.M.CHP	0.1uF 25V
C29	UB245100	C.CE.M.CHP	0.1uF 25V
C30	VJ900900	C.CE.M.CHP	39pF 50V
C31	VJ900700	C.CE.M.CHP	33pF 50V
C32	UB052100	C.CE.M.CHP	100pF 50V
C33	UB052100	C.CE.M.CHP	100pF 50V
C34	UB052100	C.CE.M.CHP	100pF 50V
C35	UB245100	C.CE.M.CHP	0.1uF 25V
C36	UR818100	C.EL	100uF 6.3V
C37	UB052100	C.CE.M.CHP	100pF 50V
C38	UB052100	C.CE.M.CHP	100pF 50V
C39	UB052100	C.CE.M.CHP	100pF 50V
C40	UB052100	C.CE.M.CHP	100pF 50V
C41	UB052100	C.CE.M.CHP	100pF 50V
C42	UR818330	C.EL	330uF 6.3V
C43	UR818330	C.EL	330uF 6.3V
C44	UB245100	C.CE.M.CHP	0.1uF 25V
C45	UB245100	C.CE.M.CHP	0.1uF 25V
C46	UB245100	C.CE.M.CHP	0.1uF 25V
C48	UR818330	C.EL	330uF 6.3V
C49	UB245100	C.CE.M.CHP	0.1uF 25V
C50	UB012470	C.CE.M.CHP	470pF 50V
C51	UB245100	C.CE.M.CHP	0.1uF 25V
C52	UB245100	C.CE.M.CHP	0.1uF 25V

* New Parts

Schm Ref	PART NO.	Description	
C53	UR818330	C.EL	330uF 6.3V
C54	UB245100	C.CE.M.CHP	0.1uF 25V
C55	UR818330	C.EL	330uF 6.3V
C56	UB245100	C.CE.M.CHP	0.1uF 25V
C57	UB245100	C.CE.M.CHP	0.1uF 25V
C58	UR818330	C.EL	330uF 6.3V
C59	UB245100	C.CE.M.CHP	0.1uF 25V
C60	UR818100	C.EL	100uF 6.3V
C61	UB245100	C.CE.M.CHP	0.1uF 25V
C62	UR829100	C.EL	1000uF 10V
C63	UR829100	C.EL	1000uF 10V
C64	UR828220	C.EL	220uF 10V
C65	UB245100	C.CE.M.CHP	0.1uF 25V
* C66	VE326800	C.MYLAR.ML	0.47uF 50V
C67	UR818100	C.EL	100uF 6.3V
C68	UR865470	C.EL	0.47uF 50V
C69	UA953150	C.MYLAR	1500pF 50V
C70	UA953150	C.MYLAR	1500pF 50V
C71	UR847100	C.EL	10uF 25V
C72	UA953330	C.MYLAR	3300pF 50V
C73	UA953330	C.MYLAR	3300pF 50V
C74	UR847100	C.EL	10uF 25V
C75	UR847100	C.EL	10uF 25V
C76	UA953330	C.MYLAR	3300pF 50V
C77	UA655330	C.MYLAR	0.33uF 50V
C78	UR847100	C.EL	10uF 25V
C79	UR847100	C.EL	10uF 25V
C80	UA953470	C.MYLAR	4700pF 50V
C81	UA953470	C.MYLAR	4700pF 50V
C82	UR847100	C.EL	10uF 25V
C83	UA952100	C.MYLAR	100pF 50V
C84	UA952100	C.MYLAR	100pF 50V
C85	UA952100	C.MYLAR	100pF 50V
C86	UA952220	C.MYLAR	220pF 50V
C87	UR847100	C.EL	10uF 25V
C88	UR847100	C.EL	10uF 25V
C89	UA952100	C.MYLAR	100pF 50V
C90	UA952220	C.MYLAR	220pF 50V
C91	UA952100	C.MYLAR	100pF 50V
C92	UA653470	C.MYLAR	4700pF 50V
C93	UA952100	C.MYLAR	100pF 50V
C94	UA952100	C.MYLAR	100pF 50V
C95	UR847100	C.EL	10uF 25V
C96	UR847100	C.EL	10uF 25V
C97	UA952100	C.MYLAR	100pF 50V
C98	UA952100	C.MYLAR	100pF 50V
C99	UA952100	C.MYLAR	100pF 50V
C100	UR837220	C.EL	22uF 25V
C101	UR847470	C.EL	47uF 25V
* C102	VE326800	C.MYLAR.ML	0.47uF 50V
C103	UR847470	C.EL	47uF 25V
C104	UR837220	C.EL	22uF 25V
C105	UA952100	C.MYLAR	100pF 50V

* New Parts

P. C. B. DSP & P. C. B. INPUT
--

Schm Ref	PART NO.	Description	
C106	UB052100	C.CE.M.CHP	100pF 50V
C107	UB052100	C.CE.M.CHP	100pF 50V
C108	UB052100	C.CE.M.CHP	100pF 50V
C109	UB245100	C.CE.M.CHP	0.1uF 25V
C110	UB052100	C.CE.M.CHP	100pF 50V
C111	UB052100	C.CE.M.CHP	100pF 50V
C112	UB052100	C.CE.M.CHP	100pF 50V
C113	UR818470	C.EL	470uF 6.3V
C114	UB245100	C.CE.M.CHP	0.1uF 25V
C115	UB052100	C.CE.M.CHP	100pF 50V
C116	UB052100	C.CE.M.CHP	100pF 50V
C117	UB245100	C.CE.M.CHP	0.1uF 25V
C118	UB245100	C.CE.M.CHP	0.1uF 25V
C119	UA952100	C.MYLAR	100pF 50V
D1	VT332900	DIODE	1SS355
D2	VT332900	DIODE	1SS355
D3	VT332900	DIODE	1SS355
D4	VT332900	DIODE	1SS355
D5	VT332900	DIODE	1SS355
D6	VT332900	DIODE	1SS355
D7	VT332900	DIODE	1SS355
D8	VT332900	DIODE	1SS355
D9	VT332900	DIODE	1SS355
D10	VT332900	DIODE	1SS355
D11	VT332900	DIODE	1SS355
D12	VT332900	DIODE	1SS355
G1	VR463400	TERM.GND	D3.5 TP00385
G2	VR463400	TERM.GND	D3.5 TP00385
G3	VR463400	TERM.GND	D3.5 TP00385
G4	VR463400	TERM.GND	D3.5 TP00385
IC1	XR038A00	IC	NJM2904M OP AMP
IC2	XL091A00	IC	HD74HC02FEL NOR
IC3	XG948E00	IC	YM3436DK
IC4	XU728A00	IC	YSS908-F
* IC6	XW233A00	IC	CS4227-KQ
* IC7	XW728A00	IC	LP61256GS-8Q SRAM
IC8	XV039A00	IC	M5220FP OP AMP
IC9	XV039A00	IC	M5220FP OP AMP
IC10	XV039A00	IC	M5220FP OP AMP
IC11	XV039A00	IC	M5220FP OP AMP
IC12	XV039A00	IC	M5220FP OP AMP
IC15	XU965A00	IC	uPC29M33T-E1 3.3V
L1	GE300610	FER.BEAD	BL02RN1-R62T4
* Q1	VV655200	TR.DGT	DTA143EKA
Q2	VD303700	TR	2SC3326 A,B
R40	HV753220	R.CAR.FP	2.2Ω 1/4W
R45	HV753220	R.CAR.FP	2.2Ω 1/4W
R46	HV753220	R.CAR.FP	2.2Ω 1/4W
R49	HV754100	R.CAR.FP	10Ω 1/4W
R50	HV753100	R.CAR.FP	1Ω 1/4W
R95	HV753220	R.CAR.FP	2.2Ω 1/4W
R96	HV753220	R.CAR.FP	2.2Ω 1/4W
XL1	Vi552000	RSNR.CRYS	12.288MHz

* New Parts

Schm Ref	PART NO.	Description	
*	V5100100	P.C.B.	INPUT(UCRT)
*	V5100200	P.C.B.	INPUT(ABG)
CB102	VM923600	CN.BS.PIN	13P
CB103	Vi878900	CN.BS.PIN	11P
* CB104	VQ048200	CN.BS.PIN	33P
CB105	VM689000	CN.BS.PIN	23P
CB106	VQ047400	CN.BS.PIN	19P
CB107	VQ963700	CN.BS.PIN	16P
CB108	VK025300	CN.BS.PIN	9P
* CB110	VP127700	CN	24P
CB112	Vi878400	CN.BS.PIN	6P
CB351	V2508700	CN.PHOT.SN	1P GP1F37R
CB352	V2508700	CN.PHOT.SN	1P GP1F37R
CB353	Vi878900	CN.BS.PIN	11P
CB354	VQ044100	CN.BS.PIN	5P
CB401	VQ045300	CN.BS.PIN	23P
CB451	VK026800	CN.BS.PIN	9P
C103	UA952100	C.MYLAR	100pF 50V
C105	UA952100	C.MYLAR	100pF 50V
C107	VF467300	C.CE.TUBLR	0.01uF 16V
C108	VK533900	C.PP	100pF 200V
C109	VK533900	C.PP	100pF 200V
C112	UA952100	C.MYLAR	100pF 50V
C113	UA952100	C.MYLAR	100pF 50V
C114	FG651470	C.CE	47pF 50V
C115	FG651470	C.CE	47pF 50V
C116	UA952100	C.MYLAR	100pF 50V
C117	UA952100	C.MYLAR	100pF 50V
C118	UA952100	C.MYLAR	100pF 50V
C119	UA952100	C.MYLAR	100pF 50V
C120	VF466800	C.CE.TUBLR	100pF 50V
C121	VF466800	C.CE.TUBLR	100pF 50V
C122	VF466700	C.CE.TUBLR	47pF 50V
C123	VF466700	C.CE.TUBLR	47pF 50V
C124	UA655220	C.MYLAR	0.22uF 50V
C125	VF467300	C.CE.TUBLR	0.01uF 16V
C138	UR837470	C.EL	47uF 16V
C139	UR837470	C.EL	47uF 16V
C140	UR847100	C.EL	10uF 25V(ABG)
C141	UR847100	C.EL	10uF 25V(ABG)
C142	VJ599100	C.CE.TUBLR	0.1uF 50V
C143	VJ599100	C.CE.TUBLR	0.1uF 50V
C147	UR837220	C.EL	22uF 25V
C148	UR847100	C.EL	10uF 25V
C149	UR847100	C.EL	10uF 25V
C150	UR837220	C.EL	22uF 25V
C151	UR847100	C.EL	10uF 25V
C152	UR847100	C.EL	10uF 25V
C153	UR847100	C.EL	10uF 25V
C156	UR847100	C.EL	10uF 25V

* New Parts

P. C. B. INPUT

Schm Ref	PART NO.	Description		
C157	UR847100	C.EL	10uF	25V
C158	UR847100	C.EL	10uF	25V
C161	VJ599100	C.CE.TUBLR	0.1uF	50V
C162	VJ599100	C.CE.TUBLR	0.1uF	50V
C163	UA952100	C.MYLAR	100pF	50V
C164	UA952100	C.MYLAR	100pF	50V
C165	UA954270	C.MYLAR	0.027uF	50V
C166	UA954270	C.MYLAR	0.027uF	50V
C167	UR847100	C.EL	10uF	25V
C168	UR847100	C.EL	10uF	25V
C169	UA952100	C.MYLAR	100pF	50V
C170	UR837470	C.EL	47uF	16V
C171	UR837470	C.EL	47uF	16V
C172	UA952100	C.MYLAR	100pF	50V
C173	UR847100	C.EL	10uF	25V
C174	UR847100	C.EL	10uF	25V
C175	UA954270	C.MYLAR	0.027uF	50V
C176	UA954270	C.MYLAR	0.027uF	50V
C177	VJ599100	C.CE.TUBLR	0.1uF	50V
C178	VJ599100	C.CE.TUBLR	0.1uF	50V
C179	UR837470	C.EL	47uF	16V
C180	UR837470	C.EL	47uF	16V
C181	VJ599100	C.CE.TUBLR	0.1uF	50V
C183	UR847470	C.EL	47uF	25V
C184	UR847470	C.EL	47uF	25V
C193	VF466800	C.CE.TUBLR	100pF	50V
C194	VF467000	C.CE.TUBLR	1000pF	50V
C195	VF467300	C.CE.TUBLR	0.01uF	16V
C196	VJ599100	C.CE.TUBLR	0.1uF	50V
C197	VF467000	C.CE.TUBLR	1000pF	50V
C198	VF466800	C.CE.TUBLR	100pF	50V
C199	VF466800	C.CE.TUBLR	100pF	50V
C351	VG278400	C.CE.TUBLR	220pF	50V
C352	VG278400	C.CE.TUBLR	220pF	50V
C353	VG278400	C.CE.TUBLR	220pF	50V
C354	VG278400	C.CE.TUBLR	220pF	50V
C355	VG278400	C.CE.TUBLR	220pF	50V
C356	VG278400	C.CE.TUBLR	220pF	50V
C357	VF467300	C.CE.TUBLR	0.01uF	16V
C358	VJ599100	C.CE.TUBLR	0.1uF	50V
C359	UR837220	C.EL	22uF	25V
C360	VG276600	C.CE.TUBLR	22pF	50V
C361	VJ599100	C.CE.TUBLR	0.1uF	50V
C362	VJ599100	C.CE.TUBLR	0.1uF	50V
C363	VJ599100	C.CE.TUBLR	0.1uF	50V
C364	VG278400	C.CE.TUBLR	220pF	50V
C365	VF466600	C.CE.TUBLR	10pF	50V
C366	VF467000	C.CE.TUBLR	1000pF	50V
C367	VJ599100	C.CE.TUBLR	0.1uF	50V
C368	VJ599100	C.CE.TUBLR	0.1uF	50V
C369	UR828100	C.EL	100uF	10V
C401	UR866220	C.EL	2.2uF	50V
C402	UA952100	C.MYLAR	100pF	50V

* New Parts

Schm Ref	PART NO.	Description		
C403	UA952100	C.MYLAR	100pF	50V
C404	UR866220	C.EL	2.2uF	50V
C405	UR866220	C.EL	2.2uF	50V
C406	UR866220	C.EL	2.2uF	50V
C407	UR866220	C.EL	2.2uF	50V
C408	UR866220	C.EL	2.2uF	50V
C409	UN866100	C.EL	1uF	50V
C412	UA953100	C.MYLAR	1000pF	50V
C413	UR828100	C.EL	100uF	10V
C414	UA953100	C.MYLAR	1000pF	50V
C415	UR828100	C.EL	100uF	10V
C418	UR828100	C.EL	100uF	10V
C420	VG287600	C.EL	100uF	25V
C421	UA952100	C.MYLAR	100pF	50V
C422	UR828100	C.EL	100uF	10V
C423	UA952100	C.MYLAR	100pF	50V
C424	UR828100	C.EL	100uF	10V
C425	VG287600	C.EL	100uF	25V
C427	UR828100	C.EL	100uF	10V
C428	UR828100	C.EL	100uF	10V
C430	UA952100	C.MYLAR	100pF	50V
C431	UR828100	C.EL	100uF	10V
C432	UA952100	C.MYLAR	100pF	50V
C433	UR828100	C.EL	100uF	10V
C435	UR828100	C.EL	100uF	10V
C436	VJ599100	C.CE.TUBLR	0.1uF	50V
C451	UR868330	C.EL	330uF	50V
C452	UR868330	C.EL	330uF	50V
C453	UR749680	C.EL	6800uF	25V
C454	UR749220	C.EL	2200uF	25V
C455	UR73A100	C.EL	10000uF	16V
C456	VJ599100	C.CE.TUBLR	0.1uF	50V
C457	VJ599100	C.CE.TUBLR	0.1uF	50V
C458	VS745400	C.POL.MTL	0.1uF	100V
C459	VS745400	C.POL.MTL	0.1uF	100V
C460	VS745400	C.POL.MTL	0.1uF	100V
C461	VS745400	C.POL.MTL	0.1uF	100V
C462	VS745400	C.POL.MTL	0.1uF	100V
D101	VM975300	DIODE.ZENR	HZS11B2TD	11V
D102	VM975300	DIODE.ZENR	HZS11B2TD	11V
D103	VM975300	DIODE.ZENR	HZS11B2TD	11V
D104	VM975300	DIODE.ZENR	HZS11B2TD	11V
D105	VD631600	DIODE	1SS133,176,HSS104	
D106	VD631600	DIODE	1SS133,176,HSS104	
D351	VD631600	DIODE	1SS133,176,HSS104	
D352	VD631600	DIODE	1SS133,176,HSS104	
D401	VM974200	DIODE.ZENR	HZS5C2TD	5.0V
△ D451	VR253700	DIODE.BRG	S1NB20	1.0A 200V
△ D452	VR253700	DIODE.BRG	S1NB20	1.0A 200V
△ D453	VR253700	DIODE.BRG	S1NB20	1.0A 200V
IC101	XP894A00	IC	LC78211	
IC102	XP896A00	IC	LC78213	
IC103	XP895A00	IC	LC78212	

* New Parts

P. C. B. INPUT & P. C. B. OPERATION
--

Schm Ref	PART NO.	Description	
IC105	XB247A00	IC	uPC4570HA(ABG)
IC106	XB247A00	IC	uPC4570HA
IC107	XP265A00	IC	BU2090
IC108	iG092000	IC	M5220L
IC109	iG092000	IC	M5220L
IC351	iG142200	IC	TC74HCU04AP
IC352	XT208A00	IC	HD74HC153P MPX
IC401	XC520A00	IC	uPC4570C
IC402	XC520A00	IC	uPC4570C
IC403	XC520A00	IC	uPC4570C
IC404	XF494A00	IC	LB1641
L351	GE901970	COIL	68uH
L352	GE901970	COIL	68uH
PJ101	VJ696300	JACK.PIN	4P
PJ102	VU857800	JACK.PIN	6P
PJ103	VU857800	JACK.PIN	6P
PJ105	VK437600	JACK.PIN	1P
PJ351	VT003300	JACK.PIN	6P
PJ352	VY667700	JACK.PIN	1P
Q101	iC287820	TR	2SC2878 A,B
Q102	iC287820	TR	2SC2878 A,B
Q103	iC287820	TR	2SC2878 A,B
Q104	iC287820	TR	2SC2878 A,B
Q105	iC287820	TR	2SC2878 A,B
Q106	iC287820	TR	2SC2878 A,B
Q107	iC287820	TR	2SC2878 A,B
Q108	iC287820	TR	2SC2878 A,B
Q109	iC287820	TR	2SC2878 A,B
Q110	iC287820	TR	2SC2878 A,B
Q111	iC287820	TR	2SC2878 A,B
Q112	iC287820	TR	2SC2878 A,B
Q113	iC287820	TR	2SC2878 A,B
Q114	iC287820	TR	2SC2878 A,B
Q115	VG721700	TR.DGT	DTA144ES
Q116	VG721700	TR.DGT	DTA144ES
Q117	VG721700	TR.DGT	DTA144ES
Q118	iC287820	TR	2SC2878 A,B
Q119	iC287820	TR	2SC2878 A,B
Q120	iC287820	TR	2SC2878 A,B
Q121	VG721700	TR.DGT	DTA144ES
Q122	iC287820	TR	2SC2878 A,B
Q123	iC287820	TR	2SC2878 A,B
Q124	VP883000	TR	2SA893A D,E
Q125	VP883000	TR	2SA893A D,E
R155	HV753220	R.CAR.FP	2.2Ω 1/4W
R156	HV753220	R.CAR.FP	2.2Ω 1/4W
R216	HV753220	R.CAR.FP	2.2Ω 1/4W
R217	HV753220	R.CAR.FP	2.2Ω 1/4W
R222	HV753220	R.CAR.FP	2.2Ω 1/4W
R231	HV753220	R.CAR.FP	2.2Ω 1/4W
R232	HV753220	R.CAR.FP	2.2Ω 1/4W
R373	HV753220	R.CAR.FP	2.2Ω 1/4W
R411	HV754100	R.CAR.FP	10Ω 1/4W

* New Parts

Schm Ref	PART NO.	Description	
R412	HV754100	R.CAR.FP	10Ω 1/4W
R435	HV753680	R.CAR.FP	6.8Ω 1/4W
R451	HV753100	R.CAR.FP	1Ω 1/4W
R452	HV753100	R.CAR.FP	1Ω 1/4W
VR401	VV613500	VR	A100KΩ
*	V5102200	P.C.B.	OPERATION(UC)
*	V5102300	P.C.B.	OPERATION(RT)
*	V5102400	P.C.B.	OPERATION(ABG)
*	V5102500	P.C.B.	OPERATION(BG)
CB101	VP798200	CN.BS.PIN	24P
CB102	VQ961600	CN	13P
CB103	VQ961700	CN.BS.PIN	14P
CB301	VK026500	CN.BS.PIN	6P
CB501	VU273300	CN.BS.PIN	33P
CB502	Vi878800	CN.BS.PIN	10P
CB504	Vi878200	CN.BS.PIN	4P
CB505	Vi878200	CN.BS.PIN	4P
CB581	Vi878700	CN.BS.PIN	9P
CB721	VQ963400	CN.BS.PIN	13P
CB722	Vi878700	CN.BS.PIN	9P
C101	UR847100	C.EL	10uF 25V
C102	UR877470	C.EL	47uF 63V
C103	UR877100	C.EL	10uF 63V
C106	UR837470	C.EL	47uF 16V
C107	UR847100	C.EL	10uF 25V
C108	UA952220	C.MYLAR	220pF 50V
C109	UR847100	C.EL	10uF 25V
C110	VQ645600	C.MYLAR	100pF 50V
C111	UA952220	C.MYLAR	220pF 50V
C112	UR847100	C.EL	10uF 25V
C113	VQ645600	C.MYLAR	100pF 50V
C114	UA952220	C.MYLAR	220pF 50V
C115	UR847100	C.EL	10uF 25V
C116	UA952470	C.MYLAR	470pF 50V
C117	UA952220	C.MYLAR	220pF 50V
C118	UR847100	C.EL	10uF 25V
C119	UA952470	C.MYLAR	470pF 50V
C120	UA952220	C.MYLAR	220pF 50V
C121	UR847100	C.EL	10uF 25V
C122	UA952100	C.MYLAR	100pF 50V
C123	VQ245400	C.PP	33pF 200V
C124	UR838100	C.EL	100uF 16V
C125	UA953100	C.MYLAR	1000pF 50V
C126	VQ245400	C.PP	33pF 200V
C127	UR838100	C.EL	100uF 16V
C128	UA953100	C.MYLAR	1000pF 50V
C129	VR516400	C.CE	15pF 500V
C130	UR837470	C.EL	47uF 16V
C131	UA953100	C.MYLAR	1000pF 50V
C132	VR516400	C.CE	15pF 500V

* New Parts

P. C. B. OPERATION

Schm Ref	PART NO.	Description		
C133	UR837470	C.EL	47uF	16V
C134	UA953100	C.MYLAR	1000pF	50V
C135	VQ245400	C.PP	33pF	200V
C136	UR837470	C.EL	47uF	16V
C137	UA953100	C.MYLAR	1000pF	50V
C303	VF466800	C.CE.TUBLR	100pF	50V
C304	VF466800	C.CE.TUBLR	100pF	50V
C319	UR847100	C.EL	10uF	25V
C320	VF467000	C.CE.TUBLR	1000pF	50V
C321	UR829100	C.EL	1000uF	10V
C322	UR847100	C.EL	10uF	25V
C323	UR847100	C.EL	10uF	25V
C324	UR829100	C.EL	1000uF	10V
C328	UR838330	C.EL	330uF	16V
C501	UR866220	C.EL	2.2uF	50V
C502	VG278900	C.CE.TUBLR	680pF	50V
C503	VG278900	C.CE.TUBLR	680pF	50V
C504	UR866100	C.EL	1uF	50V
C505	VJ599100	C.CE.TUBLR	0.1uF	50V
C506	UR819100	C.EL	1000uF	6.3V
C507	UR819100	C.EL	1000uF	6.3V
C508	VS672200	C.EL	4700uF	5.5V
C509	VJ599100	C.CE.TUBLR	0.1uF	50V
C510	UR847100	C.EL	10uF	25V
C511	VJ599100	C.CE.TUBLR	0.1uF	50V
C512	UR847470	C.EL	47uF	25V
C513	VJ599100	C.CE.TUBLR	0.1uF	50V
C514	VJ599100	C.CE.TUBLR	0.1uF	50V
C515	VJ599100	C.CE.TUBLR	0.1uF	50V
C516	VJ599100	C.CE.TUBLR	0.1uF	50V
C581	UR838330	C.EL	330uF	16V
C582	UR838330	C.EL	330uF	16V
C583	UR866100	C.EL	1uF	50V
C584	VK533800	C.PP	47pF	200V
C585	UR866220	C.EL	2.2uF	50V
C586	VK533800	C.PP	47pF	200V
C587	UR866220	C.EL	2.2uF	50V
C588	UR866100	C.EL	1uF	50V
C589	UR837470	C.EL	47uF	16V
C590	UA655120	C.MYLAR	0.12uF	50V
C591	UA954330	C.MYLAR	0.033uF	50V
C592	UA954330	C.MYLAR	0.033uF	50V
C593	UA655120	C.MYLAR	0.12uF	50V
C594	UR837470	C.EL	47uF	16V
C595	UR847100	C.EL	10uF	25V
C596	VQ645600	C.MYLAR	100pF	50V
C597	VQ645600	C.MYLAR	100pF	50V
C598	UR847100	C.EL	10uF	25V
C599	UR828100	C.EL	100uF	10V
C600	UR828100	C.EL	100uF	10V
C721	UR857470	C.EL	47uF	35V
C722	UR857470	C.EL	47uF	35V
C723	UR838100	C.EL	100uF	16V

* New Parts

Schm Ref	PART NO.	Description		
C724	UR838100	C.EL	100uF	16V
C725	UR847470	C.EL	47uF	25V
C726	UR838100	C.EL	100uF	16V
C727	UR847470	C.EL	47uF	25V
C728	UR867470	C.EL	47uF	50V
C729	UR867470	C.EL	47uF	50V
C730	UR838100	C.EL	100uF	16V
C731	UR847470	C.EL	47uF	25V
C732	UR847470	C.EL	47uF	25V
* D101	VM976000	DIODE.ZENR	HZS182TD	18V
D102	VM975700	DIODE.ZENR	HZS12C2TD	12V
D103	VM976200	DIODE.ZENR	HZS222TD	22V
D104	VD631600	DIODE	1SS133,176,HSS104	
D105	VD631600	DIODE	1SS133,176,HSS104	
D501	VD631600	DIODE	1SS133,176,HSS104	
D502	VD631600	DIODE	1SS133,176,HSS104	
D503	VD631600	DIODE	1SS133,176,HSS104	
D504	VD631600	DIODE	1SS133,176,HSS104	
D505	VM974100	DIODE.ZENR	HZS5B2TD	5.0V
D506	VM974100	DIODE.ZENR	HZS5B2TD	5.0V
D507	VD631600	DIODE	1SS133,176,HSS104	
D508	VM974700	DIODE.ZENR	HZS7B2TD	7.0V
D509	VD631600	DIODE	1SS133,176,HSS104	
D510	VD631600	DIODE	1SS133,176,HSS104	
D511	VM974400	DIODE.ZENR	HZS6B2TD	6.0V(RT)
D511	VM974600	DIODE.ZENR	HZS7A2TD	7V(UCABG)
D512	VD631600	DIODE	1SS133,176,HSS104	
D721	VM976300	DIODE.ZENR	HZS242TD	24V
D722	VM976300	DIODE.ZENR	HZS242TD	24V
G501	VR463400	TERM.GND	D3.5	TP00385
IC303	XH436A00	IC	LA7956	
IC501	XY170B00	IC.CPU	M30217MA-A202FP	
IC502	XJ757A00	IC	NJM78L05A-T3	
IC581	XM356A00	IC	NJM2068LD	
IC582	XM356A00	IC	NJM2068LD	
△ IC721	XJ608A00	IC	NJM7812FA	
△ IC722	XD343A00	IC	NJM79M12FA	
△ IC723	XJ608A00	IC	NJM7812FA	
△ IC724	XJ604A00	IC	NJM78M05FA	
PJ301	VR110100	JACK.PIN	2P	
PJ302	VJ695900	JACK.PIN	3P	
Q101	VP883100	TR	2SC1890A	D,E
Q102	VS883300	TR	2SB1565	E,F
Q103	VP883100	TR	2SC1890A	D,E
Q104	VP872700	TR	2SC4488	S,T
Q105	VP883000	TR	2SA893A	D,E
Q106	VP883000	TR	2SA893A	D,E
Q107	VP883000	TR	2SA893A	D,E
Q108	VP883000	TR	2SA893A	D,E
Q109	VP883000	TR	2SA893A	D,E
Q110	VP883000	TR	2SA893A	D,E
△ Q111	VR325600	TR	2SC2229	O,Y
Q112	VP883000	TR	2SA893A	D,E

* New Parts

P. C. B. OPERATION & P. C. B. MAIN

Schm Ref	PART NO.	Description	
△	Q113	VR325600	TR 2SC2229 O,Y
	Q114	VP883000	TR 2SA893A D,E
△	Q115	VR325600	TR 2SC2229 O,Y
	Q116	VP883000	TR 2SA893A D,E
△	Q117	VR325600	TR 2SC2229 O,Y
	Q118	VP883000	TR 2SA893A D,E
△	Q119	VR325600	TR 2SC2229 O,Y
	Q305	iC181510	TR 2SC1815 Y
	Q306	iC181510	TR 2SC1815 Y
	Q307	iC174020	TR 2SC1740S R,S
	Q501	iA093320	TR 2SA933S Q,R
	Q502	iA093320	TR 2SA933S Q,R
	Q503	VG722000	TR.DGT DTC144ES
	Q504	iA093320	TR 2SA933S Q,R
	Q506	VR948600	TR 2SC4038 Q,R,S
	Q721	VP872700	TR 2SC4488 S,T
	Q722	VP872600	TR 2SA1708 S,T
	R101	HV753100	R.CAR.FP 1Ω 1/4W
	R102	HV756330	R.CAR.FP 3.3KΩ 1/4W
*	R110	HV756180	R.CAR.FP 1.8KΩ 1/4W
	R111	HV756820	R.CAR.FP 8.2KΩ 1/4W
△	R132	HV754470	R.CAR.FP 47Ω 1/4W
△	R138	HV754470	R.CAR.FP 47Ω 1/4W
△	R144	HV754470	R.CAR.FP 47Ω 1/4W
△	R150	HV754470	R.CAR.FP 47Ω 1/4W
△	R156	HV754470	R.CAR.FP 47Ω 1/4W
	R334	HV753220	R.CAR.FP 2.2Ω 1/4W
	R581	VP939800	R.MTL.OXD 10Ω 1W
	R582	VP939800	R.MTL.OXD 10Ω 1W
	R721	VP940400	R.MTL.OXD 100Ω 1W
	R724	VP940400	R.MTL.OXD 100Ω 1W
	R725	HV753100	R.CAR.FP 1Ω 1/4W
	R726	HV753100	R.CAR.FP 1Ω 1/4W
	R729	HV753100	R.CAR.FP 1Ω 1/4W
	R730	VP939600	R.MTL.FLM 2.2Ω 1W
*	SW501	V4586200	SW.RT.ENC REB161PVB20F
	SW502	VG392900	SW.TACT SKHVAA
	SW503	VG392900	SW.TACT SKHVAA
	SW504	VG392900	SW.TACT SKHVAA
	SW505	VG392900	SW.TACT SKHVAA
	SW506	VG392900	SW.TACT SKHVAA
	SW507	VG392900	SW.TACT SKHVAA
	SW508	VG392900	SW.TACT SKHVAA
	SW509	VG392900	SW.TACT SKHVAA
	SW510	VG392900	SW.TACT SKHVAA
	SW511	VG392900	SW.TACT SKHVAA
	SW512	VG392900	SW.TACT SKHVAA
	SW513	VG392900	SW.TACT SKHVAA
	SW514	VG392900	SW.TACT SKHVAA
	SW515	VG392900	SW.TACT SKHVAA
	SW516	VG392900	SW.TACT SKHVAA
	SW517	VG392900	SW.TACT SKHVAA
	SW518	VG392900	SW.TACT SKHVAA

* New Parts

Schm Ref	PART NO.	Description	
	U501	VU591000	L.DTCT GP1U271X
*	V501	V4420300	FL.DSPLY 15-BT-67GNK
	VR581	VP741800	VR B20KΩ
	VR582	VP741900	VR G25KΩ
	VR583	VP742000	VR MN100KΩ
*	XL501	V4610100	RSNR.CE 10MHz
		V5289500	SHEET
*		V4186900	SPACER FL-WIDE
		V4040500	SCR.TERM M3
*		V5104200	P.C.B. MAIN(UC)
*		V5104300	P.C.B. MAIN(RT)
*		V5104400	P.C.B. MAIN(A)
*		V5104500	P.C.B. MAIN(B)
*		V5104600	P.C.B. MAIN(G)
	CB201	VQ963500	CN.BS.PIN 14P
	CB202	VQ585000	CN.BS.PIN 8P
	CB203	VF728200	CN.BS.PIN 10P
	CB204	VK024800	CN.BS.PIN 4P
	CB205	VK024700	CN.BS.PIN 3P
	CB351	VQ585000	CN.BS.PIN 8P
	CB352	VQ585100	CN.BS.PIN 9P
	CB371	VQ585100	CN.BS.PIN 9P
	CB381	Vi878100	CN.BS.PIN 3P
	CB382	Vi878800	CN.BS.PIN 10P
	CB801	Vi878800	CN.BS.PIN 10P
	CB806	Vi878200	CN.BS.PIN 4P
	CB810	VP206500	HOLDER.FUS EYF-52BC (G)
	CB811	VP206500	HOLDER.FUS EYF-52BC (G)
	CB812	VG879900	CN.BS.PIN 2P
	CB813	VP206500	HOLDER.FUS EYF-52BC
	CB814	VP206500	HOLDER.FUS EYF-52BC
	CB901	VP206500	HOLDER.FUS EYF-52BC (RT)
	CB902	VP206500	HOLDER.FUS EYF-52BC (RT)
	C201	VR325000	C.MYLAR 100pF 100V
	C202	UR867470	C.EL 47uF 50V
	C203	UR867470	C.EL 47uF 50V
	C204	VR325000	C.MYLAR 100pF 100V
	C205	VR325000	C.MYLAR 100pF 100V
	C206	UR867470	C.EL 47uF 50V
	C207	UR867470	C.EL 47uF 50V
	C208	VR325000	C.MYLAR 100pF 100V
	C209	VR325000	C.MYLAR 100pF 100V
	C210	UR867470	C.EL 47uF 50V
	C211	UR867470	C.EL 47uF 50V
	C212	VR325000	C.MYLAR 100pF 100V
	C213	VR325000	C.MYLAR 100pF 100V
	C214	UR867470	C.EL 47uF 50V
	C215	UR867470	C.EL 47uF 50V
	C216	VR325000	C.MYLAR 100pF 100V
	C217	VR325000	C.MYLAR 100pF 100V

* New Parts

P. C. B. MAIN

Schm Ref	PART NO.	Description		
C218	UR867470	C.EL	47uF	50V
C219	UR867470	C.EL	47uF	50V
C220	VR325000	C.MYLAR	100pF	100V
C221	VK399200	C.MYLAR.ML	0.39uF	50V
C222	VK399200	C.MYLAR.ML	0.39uF	50V
C223	UA954680	C.MYLAR	0.068uF	50V
C224	UA954680	C.MYLAR	0.068uF	50V
C225	UA954680	C.MYLAR	0.068uF	50V
C226	UA954680	C.MYLAR	0.068uF	50V
C227	UA954680	C.MYLAR	0.068uF	50V
C228	UR866470	C.EL	4.7uF	50V
C230	UR877100	C.EL	10uF	63V
C231	UR877100	C.EL	10uF	63V
C232	UR867470	C.EL	47uF	50V
C233	UR866470	C.EL	4.7uF	50V
C234	UR837470	C.EL	47uF	16V
C235	UR837470	C.EL	47uF	16V
C236	UA954100	C.MYLAR	0.01uF	50V(ABG)
C237	UA954100	C.MYLAR	0.01uF	50V(ABG)
C238	UA954100	C.MYLAR	0.01uF	50V(ABG)
C239	UA954220	C.MYLAR	0.022uF	50V(ABG)
C240	UA954220	C.MYLAR	0.022uF	50V(ABG)
C241	VR325100	C.MYLAR	0.01uF	100V
C242	VR325100	C.MYLAR	0.01uF	100V
C243	VR325100	C.MYLAR	0.01uF	100V
C244	VR325100	C.MYLAR	0.01uF	100V
C351	UA954100	C.MYLAR	0.01uF	50V(ABG)
C352	UA954100	C.MYLAR	0.01uF	50V(ABG)
C353	UA954100	C.MYLAR	0.01uF	50V(ABG)
C354	UA954100	C.MYLAR	0.01uF	50V(ABG)
C355	UA954220	C.MYLAR	0.022uF	50V(ABG)
C356	UA954220	C.MYLAR	0.022uF	50V(ABG)
C373	UA954100	C.MYLAR	0.01uF	50V(ABG)
C374	UA954100	C.MYLAR	0.01uF	50V(ABG)
C375	UA954100	C.MYLAR	0.01uF	50V(ABG)
△ C381	UR868100	C.EL	100uF	50V
△ C382	UR878100	C.EL	100uF	63V
△ C801	VV951800	C.EL	6800uF	56V
△ C802	VV951800	C.EL	6800uF	56V
C803	VS745400	C.POL.MTL	0.1uF	100V
C804	VS745400	C.POL.MTL	0.1uF	100V
C825	VJ599100	C.CE.TUBLR	0.1uF	50V
C826	UR848220	C.EL	220uF	25V(RT)
△ C826	UR848470	C.EL	470uF	25V(UCABG)
C835	FG613100	C.CE	1000pF	50V(RT)
△ C836	UR858100	C.EL	100uF	35V(RT)
C837	Vi716700	C.MYLAR	0.01uF	50V
△ C838	UR858100	C.EL	100uF	35V(RT)
C842	UA954100	C.MYLAR	0.01uF	50V
△ C847	VS741700	C.CE.SAFTY	0.01uF	275V
D201	VN008700	DIODE	1SS270A	
D202	VN008700	DIODE	1SS270A	
D203	VN008700	DIODE	1SS270A	

* New Parts

Schm Ref	PART NO.	Description	
D204	VN008700	DIODE	1SS270A
D205	VN008700	DIODE	1SS270A
D206	VM975600	DIODE.ZENR	HZS12B2TD 12V
D207	VM976500	DIODE.ZENR	HZS302TD 30V
D208	VM975600	DIODE.ZENR	HZS12B2TD 12V
D209	VM975600	DIODE.ZENR	HZS12B2TD 12V
D210	VN008700	DIODE	1SS270A
D211	VN008700	DIODE	1SS270A
D212	VN008700	DIODE	1SS270A
D213	VM974100	DIODE.ZENR	HZS5B2TD 5.0V
D214	VN008700	DIODE	1SS270A
D215	VN008700	DIODE	1SS270A
D216	VD631600	DIODE	1SS133,176,HSS104
D217	VD631600	DIODE	1SS133,176,HSS104
D218	VD631600	DIODE	1SS133,176,HSS104
D219	VD631600	DIODE	1SS133,176,HSS104
D220	VD631600	DIODE	1SS133,176,HSS104
D221	VM975600	DIODE.ZENR	HZS12B2TD 12V
D222	VM975600	DIODE.ZENR	HZS12B2TD 12V
D223	VM975600	DIODE.ZENR	HZS12B2TD 12V
D381	VS997800	DIODE	1T2
D382	VS997800	DIODE	1T2
D383	VS997800	DIODE	1T2
△ D801	VN011400	DIODE.BRG	D5SB20 5A 200V
D814	VD631600	DIODE	1SS133,176,HSS104
△ D815	VR253700	DIODE.BRG	S1NB20 1.0A 200V
D816	VM975300	DIODE.ZENR	HZS11B2TD 11V(RT)
△ F803	VT942900	FUSE	TH2.5A 250V(G)
△ F804	KB000690	FUSE	T2.5A 250V(ABG)
△ F804	VS823100	FUSE	6.0A 125V(UCRT)
△ F901	KB000690	FUSE	T2.5A 250V(RT)
G201	VR463400	TERM.GND	D3.5 TP00385
G801	VR463400	TERM.GND	D3.5 TP00385
HS801	V2692300	HEAT.SINK	BPUE36-30
HS802	V2984900	HEAT.SINK	PUH16-25(RT)
JK371	VS899700	JACK.PHONE	JY-6317-02-030
L201	V2604200	COIL	1uH
L202	V2604200	COIL	1uH
L203	V2604200	COIL	1uH
L204	V2604200	COIL	1uH
L205	V2604200	COIL	1uH
△ Q201	VP872700	TR	2SC4488 S,T
△ Q202	iC174020	TR	2SC1740S R,S
△ Q203	VP872600	TR	2SA1708 S,T
△ Q204	VP872700	TR	2SC4488 S,T
△ Q205	iC174020	TR	2SC1740S R,S
△ Q206	VP872600	TR	2SA1708 S,T
△ Q207	VP872700	TR	2SC4488 S,T
△ Q208	iC174020	TR	2SC1740S R,S
△ Q209	VP872600	TR	2SA1708 S,T
△ Q210	VP872700	TR	2SC4488 S,T
△ Q211	iC174020	TR	2SC1740S R,S
△ Q212	VP872600	TR	2SA1708 S,T

* New Parts

P. C. B. MAIN

Schm Ref	PART NO.	Description		Schm Ref	PART NO.	Description					
△	Q213	VP872700	TR	2SC4488 S,T	△	R245	VU981700	R.MTL.PLAT	0.22Ω+0.22Ω	3W	
△	Q214	iC174020	TR	2SC1740S R,S	△	R249	HV753470	R.CAR.FP	4.7Ω	1/4W	
△	Q215	VP872600	TR	2SA1708 S,T	△	R250	HV753470	R.CAR.FP	4.7Ω	1/4W	
△	Q216	VR355900	TR.PAIR	2SA1695/C4468 OPY	△	R252	VU981700	R.MTL.PLAT	0.22Ω+0.22Ω	3W	
△	Q218	VR355900	TR.PAIR	2SA1695/C4468 OPY	△	R254	HV753470	R.CAR.FP	4.7Ω	1/4W	
△	Q220	VR355900	TR.PAIR	2SA1695/C4468 OPY	△	R255	HV753470	R.CAR.FP	4.7Ω	1/4W	
△	Q222	VR355900	TR.PAIR	2SA1695/C4468 OPY	△	R258	VU981700	R.MTL.PLAT	0.22Ω+0.22Ω	3W	
△	Q224	VR355900	TR.PAIR	2SA1695/C4468 OPY	△	R259	HV753470	R.CAR.FP	4.7Ω	1/4W	
	Q226	iA097030	TR	2SA970 GR,BL	△	R260	HV753470	R.CAR.FP	4.7Ω	1/4W	
△	Q227	VP883100	TR	2SC1890A D,E	△	R262	VU981700	R.MTL.PLAT	0.22Ω+0.22Ω	3W	
△	Q228	VP883100	TR	2SC1890A D,E	△	R264	HV753470	R.CAR.FP	4.7Ω	1/4W	
△	Q229	VP883100	TR	2SC1890A D,E		R269	HV754100	R.CAR.FP	10Ω	1/4W	
△	Q230	VP883100	TR	2SC1890A D,E	△	R270	VP939800	R.MTL.OXD	10Ω	1W	
△	Q231	VP883100	TR	2SC1890A D,E		R274	HV754100	R.CAR.FP	10Ω	1/4W	
	Q232	iA101510	TR	2SA1015 Y	△	R275	VP939800	R.MTL.OXD	10Ω	1W	
	Q233	iC224030	TR	2SC2240 GR,BL		R279	HV754100	R.CAR.FP	10Ω	1/4W	
	Q234	iC224030	TR	2SC2240 GR,BL	△	R280	VP939800	R.MTL.OXD	10Ω	1W	
	Q807	iC174020	TR	2SC1740S R,S		R284	HV754100	R.CAR.FP	10Ω	1/4W	
△	Q808	VR510800	TR	2SD2396 J,K(RT)	△	R285	VP939800	R.MTL.OXD	10Ω	1W	
	R201	VP941500	R.MTL.OXD	4.7KΩ	1W	R289	HV754100	R.CAR.FP	10Ω	1/4W	
	R202	VP941500	R.MTL.OXD	4.7KΩ	1W	△	R290	VP939800	R.MTL.OXD	10Ω	1W
	R203	VP941500	R.MTL.OXD	4.7KΩ	1W		R294	VP940700	R.MTL.OXD	330Ω	1W
	R204	VP941500	R.MTL.OXD	4.7KΩ	1W		R295	VP941100	R.MTL.OXD	1KΩ	1W
	R205	VP941500	R.MTL.OXD	4.7KΩ	1W		R297	VP940700	R.MTL.OXD	330Ω	1W
	R206	VP941500	R.MTL.OXD	4.7KΩ	1W		R298	VP940700	R.MTL.OXD	330Ω	1W
	R207	VP941500	R.MTL.OXD	4.7KΩ	1W		R309	HV753100	R.CAR.FP	1Ω	1/4W
	R208	VP941500	R.MTL.OXD	4.7KΩ	1W		R310	HV753100	R.CAR.FP	1Ω	1/4W
	R209	VP941500	R.MTL.OXD	4.7KΩ	1W		R311	HV753100	R.CAR.FP	1Ω	1/4W
	R210	VP941500	R.MTL.OXD	4.7KΩ	1W		R312	HV753100	R.CAR.FP	1Ω	1/4W
△	R211	HV756270	R.CAR.FP	2.7KΩ	1/4W		R373	VP944500	R.MTL.OXD	390Ω	1W
△	R213	HV755820	R.CAR.FP	820Ω	1/4W		R374	VP944500	R.MTL.OXD	390Ω	1W
△	R214	HV755330	R.CAR.FP	330Ω	1/4W		R381	HV753100	R.CAR.FP	1Ω	1/4W
△	R215	HV756100	R.CAR.FP	1KΩ	1/4W		R382	HV753100	R.CAR.FP	1Ω	1/4W
△	R216	HV756270	R.CAR.FP	2.7KΩ	1/4W		R383	HV753100	R.CAR.FP	1Ω	1/4W
△	R218	HV755820	R.CAR.FP	820Ω	1/4W		R804	HV756560	R.CAR.FP	5.6KΩ	1/4W(RT)
△	R219	HV755330	R.CAR.FP	330Ω	1/4W		R806	HV756560	R.CAR.FP	5.6KΩ	1/4W(RT)
△	R220	HV756100	R.CAR.FP	1KΩ	1/4W	△	RY201	VK438300	RELAY	DH24D2-OT/M2	
△	R221	HV756270	R.CAR.FP	2.7KΩ	1/4W	△	RY202	VK438300	RELAY	DH24D2-OT/M2	
△	R223	HV755820	R.CAR.FP	820Ω	1/4W	△	RY203	VU566700	RELAY	DG24D2-OS/M	
△	R224	HV755330	R.CAR.FP	330Ω	1/4W	△	RY800	V2712300	RELAY	DC SDT-S-112LMR	
△	R225	HV756100	R.CAR.FP	1KΩ	1/4W		SW371	VV523900	SW.PUSH	PBS-YM-001	
△	R226	HV756270	R.CAR.FP	2.7KΩ	1/4W	*	SW801	V4104200	SW.SLIDE	SL13B-022-AMCS	
△	R228	HV755820	R.CAR.FP	820Ω	1/4W		SW901	VA961800	VOLT.SELCT	ESE-37247-F(RT)	
△	R229	HV755330	R.CAR.FP	330Ω	1/4W	△*	T800	XW606A00	TRANS.PWR	(UC)	
△	R230	HV756100	R.CAR.FP	1KΩ	1/4W	△*	T800	XW607A00	TRANS.PWR	(RT)	
△	R231	HV756270	R.CAR.FP	2.7KΩ	1/4W	△*	T800	XW608A00	TRANS.PWR	(ABG)	
△	R233	HV755820	R.CAR.FP	820Ω	1/4W	*	TE201	V4470700		6P(UCRTA)	
△	R234	HV755330	R.CAR.FP	330Ω	1/4W	*	TE201	V4470900		6P(BG)	
△	R235	HV756100	R.CAR.FP	1KΩ	1/4W	*	TE351	V4811400	TERM.SP	8P(BG)	
△	R236	HV753470	R.CAR.FP	4.7Ω	1/4W		TE351	VC313700	TERM.SP	8P(UCRTA)	
△	R239	VU981700	R.MTL.PLAT	0.22Ω+0.22Ω	3W	△	TE800	V4746400	OUTLET.AC	S2-764T-214C(RT)	
△	R242	HV753470	R.CAR.FP	4.7Ω	1/4W	△	TE800	VT915000	OUTLET.AC	2P(A)	
△	R243	HV753470	R.CAR.FP	4.7Ω	1/4W	△	TE800	VU543100	OUTLET.AC	2P(UC)	

* New Parts

* New Parts

P. C. B. MAIN & P. C. B. TUNER

Schm Ref	PART NO.	Description	
△ TE800	VU543300	OUTLET.AC	1P(B)
△ TE800	VU543400	OUTLET.AC	2P(G)
	V3750200	PIN	L=70
	V4040500	SCR.TERM	M3
	EP600140	SCR.BND.HD	3x10 MFZN2-BL

• Lead Type

Schm Ref	PART NO.	Description	
	V2518600	P.C.B.	TUNER/TU-01NC(UC)
	V2518700	P.C.B.	TUNER/TU-01NC(RT)
	V2518800	P.C.B.	TUNERTU-01NC(ABGL)
	V2518900	P.C.B.	TUNERTU01RDSNC(BG)
CB4	VQ961900	CN	16P
C1	VG287600	C.EL	100uF 25V
C3	VG275800	C.CE.TUBLR	8.2pF 50V
C4	UR837470	C.EL	47uF 16V
C5	VF467300	C.CE.TUBLR	0.01uF 16V
C6	UR837470	C.EL	47uF 16V
C7	UM416100	C.EL	1uF 50V
C8	VF467300	C.CE.TUBLR	0.01uF 16V
C9	VF467300	C.CE.TUBLR	0.01uF 16V
C10	VF467300	C.CE.TUBLR	0.01uF 16V
C11	VF467000	C.CE.TUBLR	1000pF 50V
C12	UM397100	C.EL	10uF 16V
C13	UM397100	C.EL	10uF 16V
C14	FG652100	C.CE	100pF 50V
C15	VF467000	C.CE.TUBLR	1000pF 50V
C16	VF466700	C.CE.TUBLR	47pF 50V
C17	UR837470	C.EL	47uF 16V
C19	VA760600	C.CE	10pF 50V
C20	VG287600	C.EL	100uF 25V
C21	VJ599000	C.CE.TUBLR	0.047uF 16V
C22	VG290700	C.EL	3.3uF 50V
C23	VF467300	C.CE.TUBLR	0.01uF 16V
C24	UM406470	C.EL	4.7uF 50V
C25	UM416330	C.EL	3.3uF 50V
C26	UM397100	C.EL	10uF 16V
C27	VF467300	C.CE.TUBLR	0.01uF 16V
C28	VA760600	C.CE	10pF 50V
C29	UM416100	C.EL	1uF 50V
C30	UM416100	C.EL	1uF 50V
C31	VG287600	C.EL	100uF 25V
C32	UM415470	C.EL	0.47uF 50V
C33	UM416100	C.EL	1uF 50V
C34	UA954470	C.MYLAR	0.047uF 50V
C35	VG290700	C.EL	3.3uF 50V
C36	UA952270	C.MYLAR	270pF 50V(ABGL)
C36	UA953100	C.MYLAR	1000pF 50V(UCRT)
C36	V3451700	C.PP	270pF 100V(RDS BG)
C37	UA952270	C.MYLAR	270pF 50V(ABGL)
C37	UA953100	C.MYLAR	1000pF 50V(UCRT)
C37	V3451700	C.PP	270pF 100V(RDS BG)
C38	VF466900	C.CE.TUBLR	470pF 50V
C39	VG287200	C.EL	10uF 50V
C39	VQ082700	C.EL	10uF 16V(RDS BG)
C40	VE020000	C.EL	3.3uF 50V(RDS BG)
C40	VG290700	C.EL	3.3uF 50V
C41	UA953390	C.MYLAR	3900pF 50V
C41	VL884100	C.PP	3900pF 100V(RDS BG)
C42	UM397220	C.EL	22uF 25V
C43	UA953390	C.MYLAR	3900pF 50V

* New Parts

* New Parts

P. C. B. TUNER

Schm Ref	PART NO.	Description	
C43	VL884100	C.PP	3900pF 100V(RDS BG)
C44	VE020000	C.EL	3.3uF 50V(RDS BG)
C44	VG290700	C.EL	3.3uF 50V
C45	UR837470	C.EL	47uF 16V
C46	UR837470	C.EL	47uF 16V
C47	VG278600	C.CE.TUBLR	330pF 50V
C48	VG278800	C.CE.TUBLR	560pF 50V
C49	UA952120	C.MYLAR	120pF 50V(ABGL)
C49	UA953220	C.MYLAR	2200pF 50V(UCRT)
C49	V3451600	C.PP	120pF 100V(RDS BG)
C50	VJ599000	C.CE.TUBLR	0.047uF 16V
C51	UR837470	C.EL	47uF 16V
C52	UR837470	C.EL	47uF 16V
C53	UR837470	C.EL	47uF 16V
C54	VA761100	C.CE	27pF 50V
C55	VA761100	C.CE	27pF 50V
C56	VJ599000	C.CE.TUBLR	0.047uF 16V
C57	VG278600	C.CE.TUBLR	330pF 50V
C59	VF467300	C.CE.TUBLR	0.01uF 16V(UC)
D1	VD631600	DIODE	1SS133,176,HSS104
D2	VD631600	DIODE	1SS133,176,HSS104
D3	VG437700	DIODE.ZENR	MTZJ5.6B 5.6V
Fi1	GG000560	FLTR.CE	SFE10.7MS3GHY-A
Fi2	GG000560	FLTR.CE	SFE10.7MS3GHY(UCRT)
Fi2	V4545200	FLTR.CE	SFE10.7MJA1(ABGL)
Fi3	VC219000	FLTR.CE	SFZ450JL3
IC1	XB760A00	IC	LA1266
IC2	XQ944A00	IC	LC72131
IC3	iG158100	IC	LA3401
IC4	XY534A00	IC	LC72722(RDS BG)
L1	Vi546100	COIL	220uH
L2	Vi546100	COIL	220uH
L3	Vi546100	COIL	220uH
L4	Vi546100	COIL	220uH
L5	Vi546100	COIL	220uH
PK1	V2716700	TUNER.PK	ENV172A4G1(ABGL)
PK1	V2909100	TUNER.PK	ENV-172C8G1R(UCRT)
PK2	VU333700	COIL.RF.AM	940536051A
Q1	iC053540	TR	2SC535 A,B,C
Q2	iC053540	TR	2SC535 A,B,C
Q3	VD678500	TR.DGT	DTA114ES
Q4	iC174020	TR	2SC1740S R,S
Q5	VG722000	TR.DGT	DTC144ES
Q6	iC181510	TR	2SC1815 Y
Q7	VD678500	TR.DGT	DTA114ES
R56	HV754470	R.CAR.FP	47Ω 1/4W(ABGL)
R56	HV755100	R.CAR.FP	100Ω 1/4W(UCRT)
SW1	VS602600	SW.SLIDE	SS070-P022 A(RT)
T1	V3725400	COIL.DT	10.7MHZ 104A
T2	VR895700	COIL.IF	450KHz
T3	VT486800	COIL	XYA2(ABGL)
T4	VQ138200	FLTR.LC	19KHz
T5	VQ138200	FLTR.LC	19KHz

* New Parts

Schm Ref	PART NO.	Description	
TE1	VU477800	TERM.ANT	AJ-2038-040
TP1	VT969000	PIN.TEST	IRS-2049
TP2	VT969000	PIN.TEST	IRS-2049
VR1	VJ694000	VR.TRIM	B47KΩ
VR2	VJ694000	VR.TRIM	B47KΩ
XL1	VY734600	RSNR.CRYS	7.2MHz
XL2	GG000750	RSNR.CE	456KHz
XL3	V3930900	RSNR.CRYS	4.332MHz
	BB071360	SCR.TERM	8.3x13
	VR282500	PLATE	ANT.

* New Parts

• Lead Type & SMD

Schm Ref	PART NO.	Description	
	V2519300	P.C.B.	TUNER/TU-01CP(UC)
	V2519400	P.C.B.	TUNER/TU-01CP(RT)
	V2519500	P.C.B.	TUNER/TU-01CP(ABGL)
	V2519600	P.C.B.	TUNERTU01RDSCP(BG)
CB4	VQ961900	CN	16P
C1	VG287600	C.EL	100uF 25V
C3	UB050800	C.CE.M.CHP	8pF 50V
C4	UR837470	C.EL	47uF 16V
C5	UB044100	C.CE.M.CHP	0.01uF 50V
C6	UR837470	C.EL	47uF 16V
C7	UM416100	C.EL	1uF 50V
C8	UB044100	C.CE.M.CHP	0.01uF 50V
C9	UB044100	C.CE.M.CHP	0.01uF 50V
C10	UB044100	C.CE.M.CHP	0.01uF 50V
C11	UB013100	C.CE.M.CHP	1000pF 50V
C12	UM397100	C.EL	10uF 16V
C13	UM397100	C.EL	10uF 16V
C14	FG652100	C.CE	100pF 50V
C15	UB013100	C.CE.M.CHP	1000pF 50V
C16	UB051470	C.CE.M.CHP	47pF 50V
C17	UR837470	C.EL	47uF 16V
C19	VA760600	C.CE	10pF 50V
C20	VG287600	C.EL	100uF 25V
C21	UB044470	C.CE.M.CHP	0.047uF 50V
C22	VG290700	C.EL	3.3uF 50V
C23	UB044100	C.CE.M.CHP	0.01uF 50V
C24	UM406470	C.EL	4.7uF 50V
C25	UM416330	C.EL	3.3uF 50V
C26	UM397100	C.EL	10uF 16V
C27	UB044100	C.CE.M.CHP	0.01uF 50V
C28	VA760600	C.CE	10pF 50V
C29	UM416100	C.EL	1uF 50V
C30	UM416100	C.EL	1uF 50V

* New Parts

P. C. B. TUNER

Schm Ref	PART NO.	Description		
C31	VG287600	C.EL	100uF	25V
C32	UM415470	C.EL	0.47uF	50V
C33	UM416100	C.EL	1uF	50V
C34	UA954470	C.MYLAR	0.047uF	50V
C35	VG290700	C.EL	3.3uF	50V
C36	UA952270	C.MYLAR	270pF	50V(ABGL)
C36	UA953100	C.MYLAR	1000pF	50V(UCRT)
C36	V3451700	C.PP	270pF	100V(RDS BG)
C37	UA952270	C.MYLAR	270pF	50V(ABGL)
C37	UA953100	C.MYLAR	1000pF	50V(UCRT)
C37	V3451700	C.PP	270pF	100V(RDS BG)
C38	UB012470	C.CE.M.CHP	470pF	50V
C39	VG287200	C.EL	10uF	50V
C39	VQ082700	C.EL	10uF	16V(RDS BG)
C40	VE020000	C.EL	3.3uF	50V(RDS BG)
C40	VG290700	C.EL	3.3uF	50V
C41	UA953390	C.MYLAR	3900pF	50V
C41	VL884100	C.PP	3900pF	100V(RDS BG)
C42	UM397220	C.EL	22uF	25V
C43	UA953390	C.MYLAR	3900pF	50V
C43	VL884100	C.PP	3900pF	100V(RDS BG)
C44	VE020000	C.EL	3.3uF	50V(RDS BG)
C44	VG290700	C.EL	3.3uF	50V
C45	UR837470	C.EL	47uF	16V
C46	UR837470	C.EL	47uF	16V
C47	UB012330	C.CE.M.CHP	330pF	50V
C48	UB012560	C.CE.M.CHP	560pF	50V
C49	UA952120	C.MYLAR	120pF	50V(ABGL)
C49	UA953220	C.MYLAR	2200pF	50V(UCRT)
C49	V3451600	C.PP	120pF	100V(RDS BG)
C50	UB044470	C.CE.M.CHP	0.047uF	50V
C51	UR837470	C.EL	47uF	16V
C52	UR837470	C.EL	47uF	16V
C53	UR837470	C.EL	47uF	16V
C54	VA761100	C.CE	27pF	50V
C55	VA761100	C.CE	27pF	50V
C56	UB044470	C.CE.M.CHP	0.047uF	50V
C57	UB012330	C.CE.M.CHP	330pF	50V
C59	VF467300	C.CE.TUBLR	0.01uF	16V(UC)
D1	VT332900	DIODE	1SS355	
D2	VT332900	DIODE	1SS355	
D3	VU172000	DIODE.ZENR	UDZS5.6BTE-17	5.6V
Fi1	GG000560	FLTR.CE	SFE10.7MS3GHY-A	
Fi2	GG000560	FLTR.CE	SFE10.7MS3GHY(UCRT)	
Fi2	V4545200	FLTR.CE	SFE10.7MJA1(ABGL)	
Fi3	VC219000	FLTR.CE	SFZ450JL3	
IC1	XB760A00	IC	LA1266	
IC2	XQ944A00	IC	LC72131	
IC3	iG158100	IC	LA3401	
IC4	XY534A00	IC	LC72722(RDS BG)	
L1	VU889500	COIL	220uH	
L2	VU889500	COIL	220uH	
L3	VU889500	COIL	220uH	

* New Parts

Schm Ref	PART NO.	Description	
L4	VU889500	COIL	220uH
L5	VU889500	COIL	220uH
PK1	V2716700	TUNER.PK	ENV-172A4G1(ABGL)
PK1	V2909100	TUNER.PK	ENV-172C8G1R(UCRT)
PK2	VU333700	COIL.RF.AM	940536051A
Q1	iC053540	TR	2SC535 A,B,C
Q2	iC053540	TR	2SC535 A,B,C
Q3	VD678500	TR.DGT	DTA114ES
Q4	iC174020	TR	2SC1740S R,S
Q5	VG722000	TR.DGT	DTC144ES
Q6	iC181510	TR	2SC1815 Y
Q7	VD678500	TR.DGT	DTA114ES
R56	HV754470	R.CAR.FP	47Ω 1/4W(ABGL)
R56	HV755100	R.CAR.FP	100Ω 1/4W(UCRT)
SW1	VS602600	SW.SLIDE	SS070-P022 A(RT)
T1	V3725400	COIL.DT	10.7MHZ 104A
T2	VR895700	COIL.IF	450KHz
T3	VT486800	COIL	XYA2
T4	VQ138200	FLTR.LC	19KHz
T5	VQ138200	FLTR.LC	19KHz
TE1	VU477800	TERM.ANT	AJ-2038-040
TP1	VT969000	PIN.TEST	IRS-2049
TP2	VT969000	PIN.TEST	IRS-2049
VR1	VJ694000	VR.TRIM	B47KΩ
VR2	VJ694000	VR.TRIM	B47KΩ
XL1	VY734600	RSNR.CRY5	7.2MHz
XL2	GG000750	RSNR.CE	456KHz
XL3	V3930900	RSNR.CRY5	4.332MHz
	BB071360	SCR.TERM	8.3x13
	VR282500	PLATE	ANT.

* New Parts

Parts List for Carbon Resistors

■ Chip Resistors

Schm Ref	PART NO.	Description
	RD250000	R.CAR.CHP 0Ω 1/10W
	RD253100	R.CAR.CHP 1Ω 1/10W
	RD254470	R.CAR.CHP 47Ω 1/10W
	RD254510	R.CAR.CHP 51Ω 1/10W
	RD255100	R.CAR.CHP 100Ω 1/10W
	RD255220	R.CAR.CHP 220Ω 1/10W
	RD255330	R.CAR.CHP 330Ω 1/10W
	RD255910	R.CAR.CHP 910Ω 1/10W
	RD256100	R.CAR.CHP 1KΩ 1/10W
	RD256110	R.CAR.CHP 1.1KΩ 1/10W
	RD256220	R.CAR.CHP 2.2KΩ 1/10W
	RD256270	R.CAR.CHP 2.7KΩ 1/10W
	RD256330	R.CAR.CHP 3.3KΩ 1/10W
	RD256390	R.CAR.CHP 3.9KΩ 1/10W
	RD256470	R.CAR.CHP 4.7KΩ 1/10W
	RD256510	R.CAR.CHP 5.1KΩ 1/10W
	RD256620	R.CAR.CHP 6.2KΩ 1/10W
	RD256820	R.CAR.CHP 8.2KΩ 1/10W
	RD257100	R.CAR.CHP 10KΩ 1/10W
	RD257110	R.CAR.CHP 11KΩ 1/10W
	RD257270	R.CAR.CHP 27KΩ 1/10W
	RD257470	R.CAR.CHP 47KΩ 1/10W
	RD257680	R.CAR.CHP 68KΩ 1/10W
	RD257910	R.CAR.CHP 91KΩ 1/10W
	RD258100	R.CAR.CHP 100KΩ 1/10W
	RD258200	R.CAR.CHP 200Ω 1/10W
	RD259100	R.CAR.CHP 1MΩ 1/10W

* New Parts

Value	1/4W Type Part No.	1/6W Type Part No.	Value	1/4W Type Part No.	1/6W Type Part No.
1.0 Ω	HJ35 3100	HF85 3100	10 kΩ	HF45 7100	HF45 7100
1.8 Ω	HJ35 3180	*	11 kΩ	HF45 7110	HF45 7110
2.2 Ω	HJ35 3220	HF85 3220	12 kΩ	HJ35 7120	HF85 7120
3.3 Ω	HJ35 3330	HF85 3330	13 kΩ	HF45 7130	HF45 7130
4.7 Ω	HJ35 3470	HF85 3470	15 kΩ	HF45 7150	HF45 7150
5.6 Ω	HJ35 3560	HF85 3560	18 kΩ	HF45 7180	HF45 7180
10 Ω	HF45 4100	HF45 4100	22 kΩ	HF45 7220	HF45 7220
15 Ω	HJ35 4150	HF85 4150	24 kΩ	HF45 7240	HF45 7240
22 Ω	HF45 4220	HF45 4220	27 kΩ	HJ35 7270	HF85 7270
27 Ω	HJ35 4270	HF85 4270	30 kΩ	HF45 7300	HF45 7300
33 Ω	HF45 4330	HF45 4330	33 kΩ	HF45 7330	HF45 7330
39 Ω	HJ35 4390	HF85 4390	36 kΩ	HF45 7360	HF45 7360
47 Ω	HF45 4470	HF45 4470	39 kΩ	HF45 7390	HF45 7390
56 Ω	HF45 4560	HF45 4560	47 kΩ	HF45 7470	HF45 7470
68 Ω	HF45 4680	HF45 4680	51 kΩ	HF45 7510	HF45 7510
75 Ω	HF45 4750	HF45 4750	56 kΩ	HF45 7560	HF45 7560
82 Ω	HF45 4820	HF45 4820	62 kΩ	HF45 7620	HF45 7620
91 Ω	HF45 4910	HF45 4910	68 kΩ	HF45 7680	HF45 7680
100 Ω	HF45 5100	HF45 5100	82 kΩ	HF45 7820	HF45 7820
110 Ω	HJ35 5110	HF85 5110	91 kΩ	HF45 7910	HF45 7910
120 Ω	HF45 5120	HF45 5120	100 kΩ	HF45 8100	HF45 8100
150 Ω	HF45 5150	HF45 5150	110 kΩ	HF45 8110	HF45 8110
160 Ω	HJ35 5160	*	120 kΩ	HF45 8120	HF45 8120
180 Ω	HF45 5180	HF45 5180	150 kΩ	HF45 8150	HF45 8150
200 Ω	HF45 5200	HF45 5200	180 kΩ	HF45 8180	HF45 8180
220 Ω	HF45 5220	HF45 5220	220 kΩ	HJ35 8220	HF85 8220
270 Ω	HF45 5270	HF45 5270	270 kΩ	HF45 8270	HF45 8270
330 Ω	HF45 5330	HF45 5330	300 kΩ	HF45 8300	HF45 8300
390 Ω	HF45 5390	HF45 5390	330 kΩ	HF45 8330	HF45 8330
430 Ω	HF45 5430	HF45 5430	390 kΩ	HJ35 8390	HF85 8390
470 Ω	HF45 5470	HF45 5470	470 kΩ	HF45 8470	HF45 8470
510 Ω	HF45 5510	HF45 5510	560 kΩ	HJ35 8560	HF85 8560
560 Ω	HF45 5560	HF45 5560	680 kΩ	HJ35 8680	HF85 8680
680 Ω	HF45 5680	HF45 5680	820 kΩ	HJ35 8820	HF85 8820
820 Ω	HF45 5820	HF45 5820	1.0 MΩ	HF45 9100	HF45 9100
910 Ω	HF45 5910	HF45 5910	1.2 MΩ	HJ35 9120	*
1.0 kΩ	HF45 6100	HF45 6100	1.5 MΩ	HJ35 9150	HF85 9150
1.2 kΩ	HF45 6120	HF45 6120	1.8 MΩ	HJ35 9180	HF85 9180
1.5 kΩ	HF45 6150	HF45 6150	2.2 MΩ	HJ35 9220	HF85 9220
1.8 kΩ	HF45 6180	HF45 6180	3.3 MΩ	HJ35 9330	HF85 9330
2.0 kΩ	HJ35 6200	HF85 6200	3.9 MΩ	HJ35 9390	*
2.2 kΩ	HF45 6220	HF45 6220	4.7 MΩ	HJ35 9470	HF85 9470
2.4 kΩ	HJ35 6240	HF85 6240			
2.7 kΩ	HF45 6270	HF45 6270			
3.0 kΩ	HF45 6300	HF45 6300			
3.3 kΩ	HF45 6330	HF45 6330			
3.6 kΩ	HJ35 6360	HF85 6360			
3.9 kΩ	HF45 6390	HF45 6390			
4.7 kΩ	HF45 6470	HF45 6470			
5.1 kΩ	HF45 6510	HF45 6510			
5.6 kΩ	HF45 6560	HF45 6560			
6.8 kΩ	HF45 6680	HF45 6680			
8.2 kΩ	HF45 6820	HF45 6820			
9.1 kΩ	HF45 6910	HF45 6910			

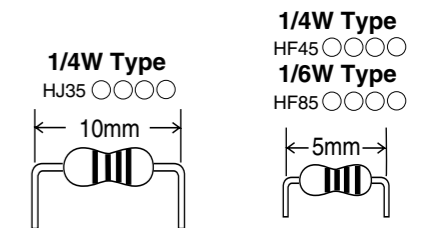

*: Not available

EXPLODED VIEW

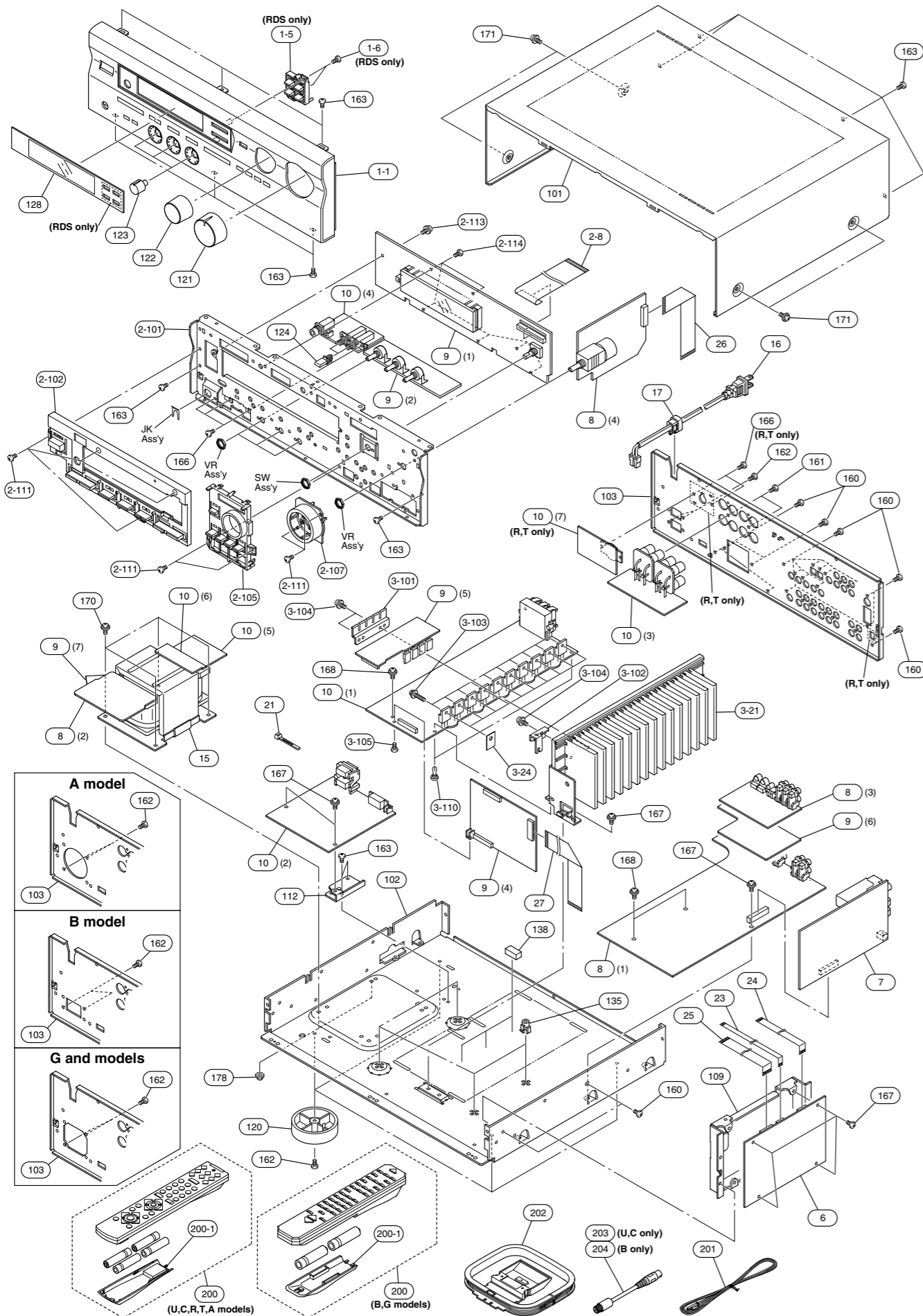

MECHANICAL PARTS

Ref. No.	PART NO.	Description	Remarks	Markets
* 1-1	V4485300	FRONT PANEL		RX-V396 BL
* 1-1	V4485400	FRONT PANEL		RX-V396 GD
* 1-1	V4485700	FRONT PANEL		HTR-5230 BL
* 1-1	V4485800	FRONT PANEL		RX-V396RDSML BL
* 1-1	V4485900	FRONT PANEL		HTR-5230RDSMLBL
* 1-1	V6134100	FRONT PANEL		HTR-5230 GD
1-5	V4490300	BUTTON		BL
1-6	EP630220	BIND HEAD P-TITE SCREW	3x8 ZMC2-BL	
* 2-8	MF233200	S FLEXIBLE FLAT CABLE	33P 200mm	
* 2-101	V4168800	SUB CHASSIS		RX-V396/RDS BL
* 2-102	V4489200	BUTTON CASE		RX-V396 GD
* 2-102	V4489300	BUTTON CASE		HTR-5230/RDS BL
* 2-102	V4489400	BUTTON CASE		HTR-5230 GD
* 2-105	V4171300	BUTTON INPUT		BL
* 2-105	V4171800	BUTTON INPUT		GD
2-105	V5624200	BUTTON INPUT		HTR-5230 GD
2-107	V2467900	ESCUTCHEON, VOL		BL
2-107	V2468000	ESCUTCHEON, VOL		HTR-5230 GD
2-107	V2468100	ESCUTCHEON, VOL		GD
2-107	V2468200	ESCUTCHEON, VOL		HTR-5230/RDS GP
2-111	EP600830	BIND HEAD B-TITE SCREW	3x8 FCRM3-BL	
2-113	VT669300	PW HEAD B-TITE SCREW	3x8-8 MFC2	
2-114	EP630220	BIND HEAD P-TITE SCREW	3x8 ZMC2-BL	
* 3-21	V4489500	HEAT SINK ASS'Y		
3-24	VV849300	SHEET	19x24	
3-101	V2461000	SUPPORT, TR		
* 3-102	V4490200	SUPPORT, PCB		RX-V496
3-103	VK173200	SCREW, TRANSISTOR	3x15 SP FCM3	
3-104	VT669300	PW HEAD B-TITE SCREW	3x8-8 MFC2	
3-105	EG330030	BIND HEAD SCREW	3x6 FCRM3-BL	
3-110	VQ368600	PUSH RIVET	P3555-B	
* 6	V4810600	P.C.B. ASS'Y	DSP	(UC)
7	V2518600	P.C.B. ASS'Y	TUNER/TU-01NC	(RT)
7	V2518700	P.C.B. ASS'Y	TUNER/TU-01NC	(ABG)
7	V2518800	P.C.B. ASS'Y	TUNER/TU-01NC	(BG)
7	V2518900	P.C.B. ASS'Y	TUNER/TU-01RDS NC	(BG)
* 8	V5100100	P.C.B. ASS'Y	INPUT	(UCRT)
* 8	V5100200	P.C.B. ASS'Y	INPUT	(ABG)
* 9	V5102200	P.C.B. ASS'Y	OPERATION	(UC)
* 9	V5102300	P.C.B. ASS'Y	OPERATION	(RT)
* 9	V5102400	P.C.B. ASS'Y	OPERATION	(ABG)
* 9	V5102500	P.C.B. ASS'Y	OPERATION	RDS (BG)
* 10	V5104200	P.C.B. ASS'Y	MAIN	(UC)
* 10	V5104300	P.C.B. ASS'Y	MAIN	(RT)
* 10	V5104400	P.C.B. ASS'Y	MAIN	(A)
* 10	V5104500	P.C.B. ASS'Y	MAIN	(B)
* 10	V5104600	P.C.B. ASS'Y	MAIN	(G)
△* 15	XW917A00	POWER TRANSFORMER		(U)
△* 15	XW918A00	POWER TRANSFORMER		(C)
△* 15	XW919A00	POWER TRANSFORMER		(RT)
△* 15	XW920A00	POWER TRANSFORMER		(A)
△* 15	XW921A00	POWER TRANSFORMER		(BG)

* New Parts

Ref. No.	PART NO.	Description	Remarks	Markets	
△	16	V2296800	POWER CORD ASS'Y		(A)
△	16	V2363800	POWER CORD ASS'Y		(UC)
△	16	VN363700	POWER CORD ASS'Y		(G)
△	16	VV437300	POWER CORD ASS'Y		(B)
△	16	VZ542500	POWER CORD ASS'Y	(RT)	
	17	V2438700	CORD STOPPER	'10P1	
	21	VU590000	BINDING TIE	CBTD001B	
	23	MF105250	FLEXIBLE FLAT CABLE	5P 250mm	
	24	MF113140	FLEXIBLE FLAT CABLE	13P 140mm	
*	25	MF219140	S FLEXIBLE FLAT CABLE	19P 140mm	
	26	MF123140	FLEXIBLE FLAT CABLE	23P 140mm	
*	27	MF124180	FLEXIBLE FLAT CABLE	24P 180mm	
	101	V2609600	TOP COVER		BL
	101	VZ884500	TOP COVER		GD
	102	V3155400	CHASSIS		
*	103	V4486600	REAR PANEL		RX-V396 (U)
*	103	V4486700	REAR PANEL		RX-V396 (C)
*	103	V4486800	REAR PANEL		RX-V396 (RT)
*	103	V4486900	REAR PANEL		RX-V396 (A)
*	103	V4487000	REAR PANEL		RX-V396 (B)
*	103	V4487100	REAR PANEL		RX-V396 (G)
*	103	V4488500	REAR PANEL		HTR-5230 (U)
*	103	V4488600	REAR PANEL		HTR-5230 (C)
*	103	V4488700	REAR PANEL		HTR-5230 (A)
*	103	V4488800	REAR PANEL		HTR-5230 (T)
	103	V4487700	REAR PANEL		RX-V396RDS (B)
	103	V4487800	REAR PANEL		RX-V396RDS (G)
	103	V4489000	REAR PANEL		HTR-5230RDS (B)
	103	V4489100	REAR PANEL		HTR-5230RDS (G)
	109	V2461100	SHIELD CASE		
*	112	V4168900	FRAME/PCB		
	120	V0042500	LEG	D60xH21	RX-V396 GD
	120	VS025000	LEG	D60xH21	RX-V396/RDS BL
	120	VV544300	LEG	D60xH21	HTR-5230/RDS
*	121	V4172900	KNOB D40		BL
*	121	V4173100	KNOB D40		GD
*	122	V4172600	KNOB D30 ENC		BL
*	122	V4172800	KNOB D30 ENC		GD
*	123	V4172000	KNOB		BL
*	123	V4172200	KNOB		GD
	124	V2918800	BUTTON	3x8	BL
	124	V2918900	BUTTON	3x8	HTR-5230 GD
*	124	V4562700	BUTTON	3x8	GD
*	128	V4490000	SHEET, WINDOW		RX-V396/HTR-5230
	128	V4490100	SHEET, WINDOW		RX-V396RDS
*	128	V4807800	SHEET, WINDOW		HTR-5230RDS
	135	VR264400	SPACER	H8	
	138	V2879500	SPACER PCB-M		
	160	VN413300	BIND HEAD BONDING B-T. SCREW	3x8 MFZN2-BL	
	161	VY731200	BONDING HEAD TAPPING SCREW	3x10 MFNI33	
	162	EP600250	BIND HEAD B-TITE SCREW	3x8 ZMC2-Y	
	163	EP600830	BIND HEAD B-TITE SCREW	3x8 FCRM3-BL	
	166	EG330030	BIND HEAD SCREW	3x6 FCRM3-BL	

* New Parts

Ref. No.	PART NO.	Description	Remarks	Markets
167	VT669300	PW HEAD B-TITE SCREW	3x8-8 MFC2	
168	VT669400	PW HEAD B-TITE SCREW	3x15-8 MFC2	
170	21991500	PW HEAD S-TITE SCREW	4x8-10 FCRM3-BL	
171	21991500	PW HEAD S-TITE SCREW	4x8-10 FCRM3-BL	BL
171	VD069600	PW HEAD S-TITE SCREW	4x8-10 MFNI-33	GD
178	03700480	HEXAGONAL CAP NUT	4.0 MFNI33	
		ACCESSORIES		
* 200	V4732200	REMOTE CONTROL TRANSMITTER	RAV205	(UCRTA)
* 200	V4999400	REMOTE CONTROL TRANSMITTER	RAV12	(BG)
200-1	AAX04810	LID	710650020	(UCRTA)
* 200-1	AAX13340	LID	BLJYE 60050001	(BG)
201	VQ147100	ANTENNA, FM	1.4m	
202	VR248500	ANTENNA, AM LOOP	1.0m	
203	VT948000	ANTENNA ADAPTER		(UC)
204	VE364900	ANTENNA ADAPTER	PAL 75-300Ω	(B)
		BATTERY, MANGANESE	SUM-4,AAA,R03	(UCRTA)
		BATTERY, MANGANESE	SUM-3,AA,R06	(BG)

* New Parts

REMOTE CONTROL TRANSMITTER

SCHEMATIC DIAGRAM

• J,U,C,R,T and A models → RAV205

Key Arrangement

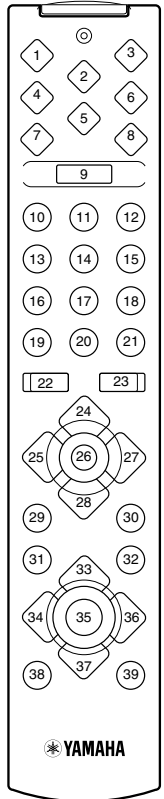
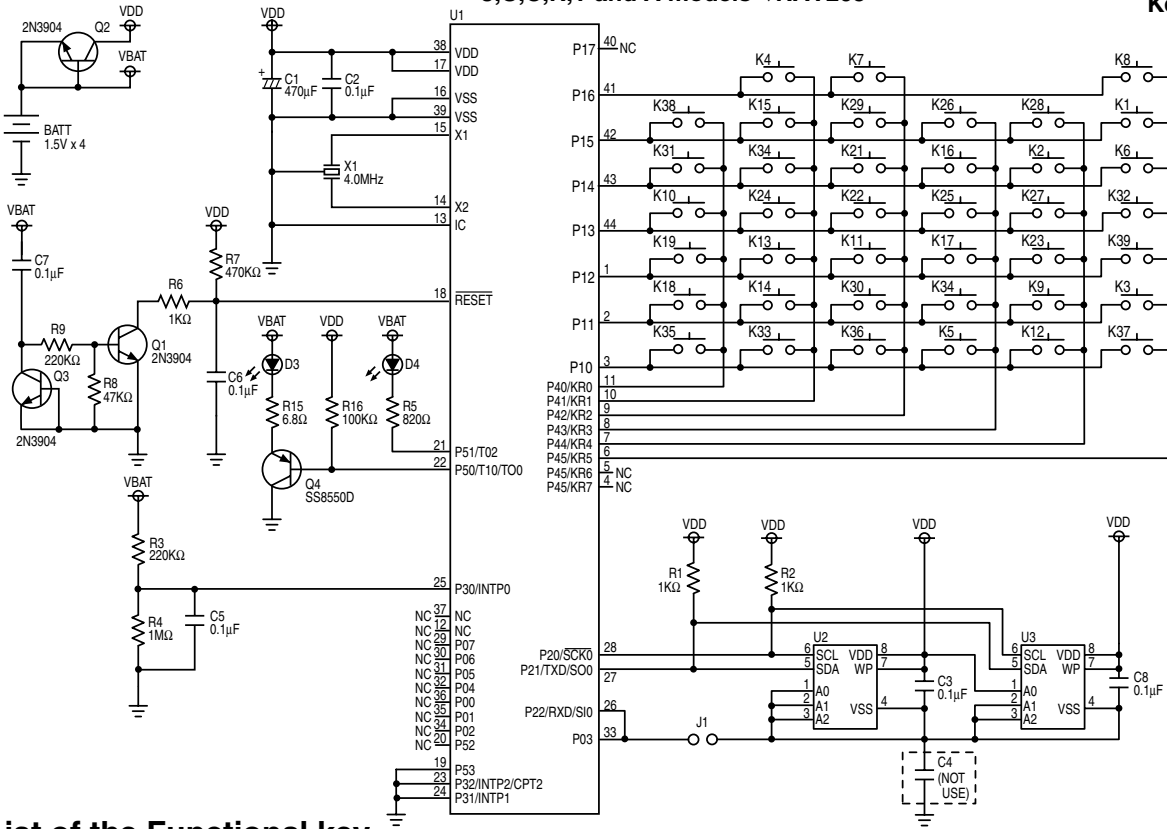

List of the Functional key

Key No.	Key Name	Key Type	TV	CBL/SAT	VCR	DVD MENU	DVD/LD	CD	TAPE/MD	AMP/TUNER	
1	CD	Device									
2	AMP/TUNER	Device									
3	TAPE/MD	Device									
4	DVD/LD	Device									
5	TV	Device									
6	VCR	Device									
7	DVD MENU	Device									
8	CBL/SAT	Device									
9	POWER	Primary	TV POWER	CBL/SAT POWER	VCR POWER	DVD/LD POWER		CD POWER	TAPE/MD POWER	AMP POWER	
10	1	Primary	CH1	CH1	CH1	1			CD		
11	2	Primary	CH2	CH2	CH2	2			TUNER		
12	3	Primary	CH3	CH3	CH3	3			TAPE/MD		
13	4	Primary	CH4	CH4	CH4	4			DVD/LD		
14	5	Primary	CH5	CH5	CH5	5			SAT/D-TV		
15	6	Primary	CH6	CH6	CH6	6			VCR		
16	7	Primary	CH7	CH7	CH7	7			-		
17	8	Primary	CH8	CH8	CH8	8			AUX		
18	9	Primary	CH9	CH9	CH9	9			EXT. DEC.		
19	0	Primary	CH0	CH0	CH0	0	-	-	-	TEST	
20	ENTER	Primary	CH Enter	CH Enter	CH Enter	+10	-	-	-	A/B/C/D/E	
21	EFFECT	Primary	AMP EFFECT	+100	AMP EFFECT	CLEAR			AMP EFFECT		
22	CH-	Primary	TV CH-	CBL/SAT CH-	VCR CH-	DISC-	DISC-	DISC-	-	PRESET-	
23	CH+	Primary	TV CH+	CBL/SAT CH+	VCR CH+	DISC+	DISC+	DISC+	-	PRESET+	
24	TV VOL+	Primary				TV VOL+					
25	VOL-	Primary				VOL-					
26	MUTE	Primary	TV MUTE			AMP MUTE					
27	VOL+	Primary				VOL+					
28	TV VOL-	Primary				TV VOL-					
29	SLEEP	Primary	TV SLEEP			RETURN	SLEEP				
30	DISPLAY	Primary	DISPLAY	DISPLAY	DISPLAY	INDEX	DISPLAY	DISPLAY	DISPLAY	-	
31	REC	Primary	VCR REC	-	VCR REC	-	-	-	REC/PAUSE	-	
32	TV INPUT	Primary	TV INPUT							A/B	TV INPUT
33	PAUSE	Primary	VCR PAUSE	Up	VCR PAUSE	Up	PAUSE	PAUSE	PAUSE	PRG+	
34	SKIP-	Primary	-	Left	-	Left	SKIP/CHAP-	SKIP-	DIR A/SKIP-	Down	
35	PLAY	Primary	VCR PLAY	Menu Select	VCR PLAY	Select	PLAY	PLAY	PLAY	-	
36	SKIP+	Primary	-	Right	-	Right	SKIP/CHAP+	SKIP+	DIR B/SKIP+	Up	
37	STOP	Primary	VCR STOP	Down	VCR STOP	Down	STOP	STOP	STOP	PRG-	
38	REW	Primary	VCR REW	RECALL	VCR REW	TITLE	REW	REW	REW	TIME/LEVEL	
39	FF	Primary	VCR FF	MENU	VCR FF	MENU	FF	FF	FF	SET MENU	
	Library		TV	CBL SAT	VCR	DVD (MENU)		CD	TAPE MD	X	
				AUX		AUX	LD				
	Default		0101(PHILIPS)	0006(PIONEER)	0002(ASA)	Yamaha(0008) DVD (MENU)		Yamaha CD(0005)	Yamaha TAPE(0004)	AMP(0003)	

-: No Function

List of the Yamaha Code (NEC Format)

Key No.	Key Name	DVD		DVD MENU		LD		CD	
		Yamaha code	Punch Through	Yamaha code	Punch Through	Yamaha code	Punch Through	Yamaha code	Punch Through
9	POWER	DVD POWER	7A-1F(Amp)	DVD POWER	7A-1F(Amp)	LD POWER	7A-1F(Amp)	CD POWER	7A-1F(Amp)
10	1	CD	Punch Through	1	7C-94	CD	Punch Through	CD	Punch Through
11	2	TUNER	Punch Through	2	7C-95	TUNER	Punch Through	TUNER	Punch Through
12	3	TAPE/MD	Punch Through	3	7C-96	TAPE/MD	Punch Through	TAPE/MD	Punch Through
13	4	DVD/LD	Punch Through	4	7C-97	DVD/LD	Punch Through	DVD/LD	Punch Through
14	5	SAT/D-TV	Punch Through	5	7C-98	SAT/D-TV	Punch Through	SAT/D-TV	Punch Through
15	6	VCR	Punch Through	6	7C-99	VCR	Punch Through	VCR	Punch Through
16	7	7	-	7	7C-9A	7	-	7	-
17	8	AUX	Punch Through	8	7C-9B	AUX	Punch Through	AUX	Punch Through
18	9	EXT. DEC.	Punch Through	9	7C-9C	EXT. DEC.	Punch Through	EXT. DEC.	Punch Through
19	0	0	-	0	7C-93	0	-	0	-
20	ENTER	ENTER	-	+10	7C-9D	ENTER	-	ENTER	-
21	EFFECT	EFFECT	Punch Through	CLEAR	7C-9F	EFFECT	Punch Through	EFFECT	Punch Through
22	CH-	DISC-	7C-8A	DISC-	7C-8A	DISC-	-	DISC-	7A-50
23	CH+	DISC+	7C-8B	DISC+	7C-8B	DISC+	-	DISC+	7A-4F
24	TV VOL+	TV VOL+	Punch Through	TV VOL+	Punch Through	TV VOL+	Punch Through	TV VOL+	Punch Through
25	VOL-	VOL-	Punch Through	VOL-	Punch Through	VOL-	Punch Through	VOL-	Punch Through
26	MUTE	AMP MUTE	Punch Through	AMP MUTE	Punch Through	AMP MUTE	Punch Through	AMP MUTE	Punch Through
27	VOL+	VOL+	Punch Through	VOL+	Punch Through	VOL+	Punch Through	VOL+	Punch Through
28	TV VOL-	TV VOL-	Punch Through	TV VOL-	Punch Through	TV VOL-	Punch Through	TV VOL-	Punch Through
29	SLEEP	SLEEP	Punch Through	RETURN	7C-B7	SLEEP	Punch Through	SLEEP	Punch Through
30	DISPLAY	DISPLAY	7C-A6	INDEX	7C-9E	DISPLAY	7C-13	DISPLAY	79-0A
31	REC	REC	-	REC	-	REC	-	REC	-
32	TV INPUT	TV INPUT	Punch Through	TV INPUT	Punch Through	TV INPUT	Punch Through	TV INPUT	Punch Through
33	PAUSE	PAUSE	7C-83	Up	7C-B4	PAUSE	7C-5A	PAUSE	7A-A9
34	SKIP-	SKIP/CHAP-	7C-B9	Left	7C-B5	SIP/CHAP-	7C-02	SKIP-	7A-0B
35	PLAY	PLAY	7C-82	Select	7C-B8	PLAY	7C-05	PLAY	7A-08
36	SKIP+	SKIP/CHAP+	7C-BA	Right	7C-B6	SKIP/CHAP+	7C-03	SKIP+	7A-0A
37	STOP	STOP	7C-85	Down	7C-B3	STOP	7C-5B	STOP	7A-09
38	REW	REW	7C-86	TITLE	7C-B1	REW	7C-06	REW	7A-0D
39	FF	FF	7C-87	MENU	7C-B2	FF	7C-07	FF	7A-0C

- : No Code

Key No.	Key Name	TAPE		MD		AMP/TUNER	
		Yamaha code	Punch Through	Yamaha code	Punch Through	Yamaha code	Punch Through
9	POWER	TAPE/MD POWER	7A-1F(Amp)	7A-1F(Amp)	AMP POWER	7A-1F	
10	1	CD	Punch Through	Punch Through	CD	7A-15	
11	2	TUNER	Punch Through	Punch Through	TUNER	7A-16	
12	3	TAPE/MD	Punch Through	Punch Through	TAPE/MD	7A-18	
13	4	DVD/LD	Punch Through	Punch Through	DVD/LD	7A-17	
14	5	SAT/D-TV	Punch Through	Punch Through	SAT/D-TV	7A-54	
15	6	VCR	Punch Through	Punch Through	VCR	7A-0F	
16	7	7	-	-	7	-	
17	8	AUX	Punch Through	Punch Through	AUX	7A-55	
18	9	EXT. DEC.	Punch Through	Punch Through	EXT. DEC.	7A-87	
19	0	TEST	-	-	TEST	7A-85	
20	ENTER	ENTER	-	-	A/B/C/D/E	7A-12	
21	EFFECT	EFFECT	Punch Through	Punch Through	EFFECT	7A-56	
22	CH-	CH-	-	-	PRESET-	7A-11	
23	CH+	CH+	-	-	PRESET+	7A-10	
24	TV VOL+	TV VOL+	Punch Through	Punch Through	TV VOL+	Punch Through	
25	VOL-	VOL-	Punch Through	Punch Through	VOL-	7A-1B	
26	MUTE	AMP MUTE	Punch Through	Punch Through	AMP MUTE	7A-1C	
27	VOL+	VOL+	Punch Through	Punch Through	VOL+	7A-1A	
28	TV VOL-	TV VOL-	Punch Through	Punch Through	TV VOL-	Punch Through	
29	SLEEP	SLEEP	Punch Through	Punch Through	SLEEP	7A-57	
30	DISPLAY	DISPLAY	-	79-A5	DISPLAY	-	
31	REC	REC/PAUSE	7A-04	79-AF	REC	-	
32	TV INPUT	A/B	7A-06	-	TV INPUT	Punch Through	
33	PAUSE	PAUSE	-	79-A9	PRG+	7A-58	
34	SKIP-	DIR A/SKIP-	7A-07	79-AB	Down	7A-53	
35	PLAY	PLAY	7A-00	79-A8	-	-	
36	SKIP+	DIR B/SKIP+	7A-40	79-AE	Up	7A-52	
37	STOP	STOP	7A-03	79-AA	PRG-	7A-59	
38	REW	REW	7A-01	79-AC	TIME/LEVEL	7A-86	
39	FF	FF	7A-02	79-AD	SET MENU	7A-9C	

- : No Code

SCHEMATIC DIAGRAM

• B and G models → RAV12

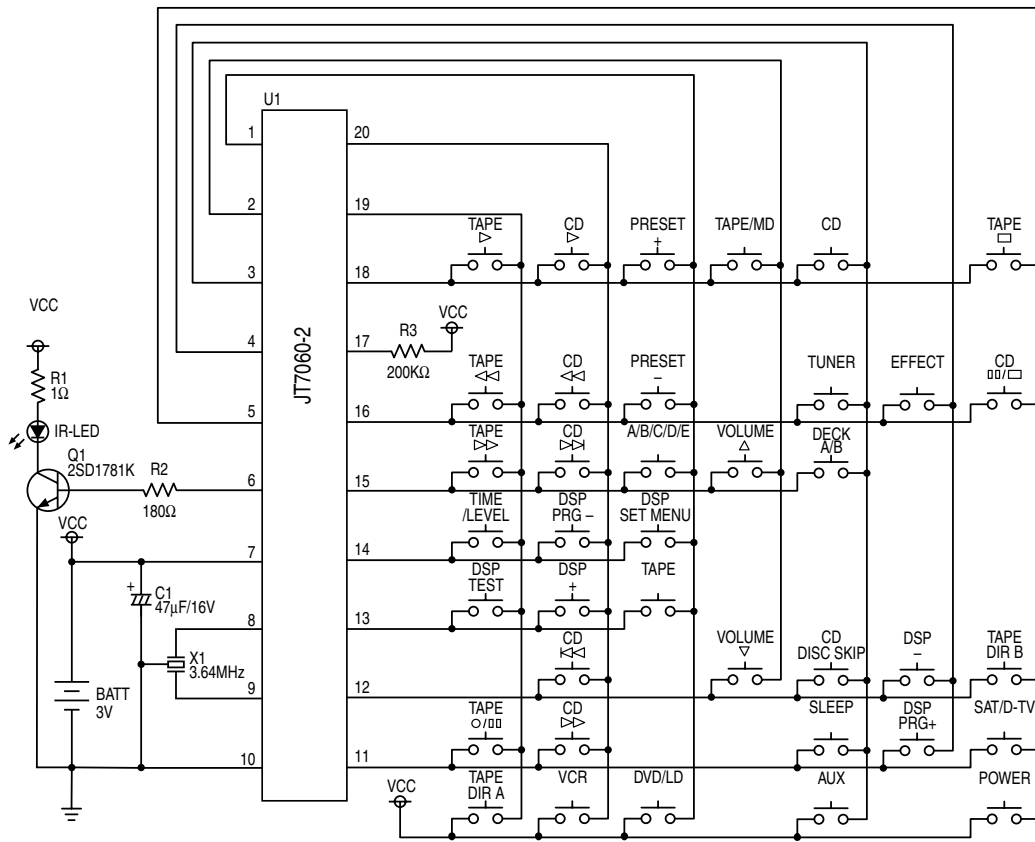

Key Arrangement

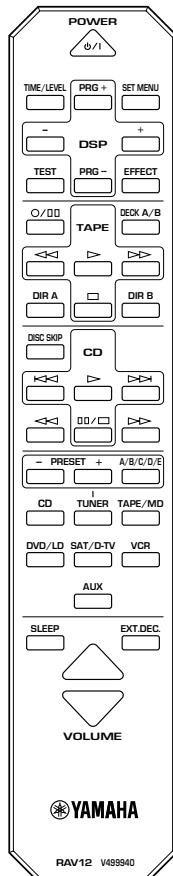

Code of the Functional key

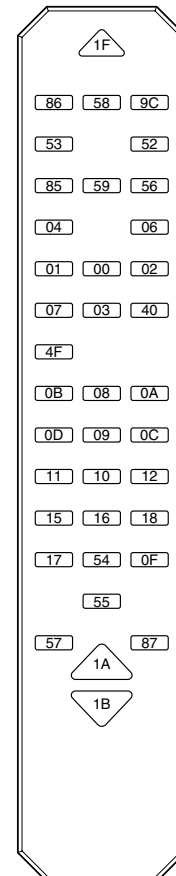

**RX-V396/RX-V396RDS/
HTR-5230/HTR-5230RDS**

YAMAHA
