

SUBWOOFER SYSTEM YST-SW015

SERVICE MANUAL

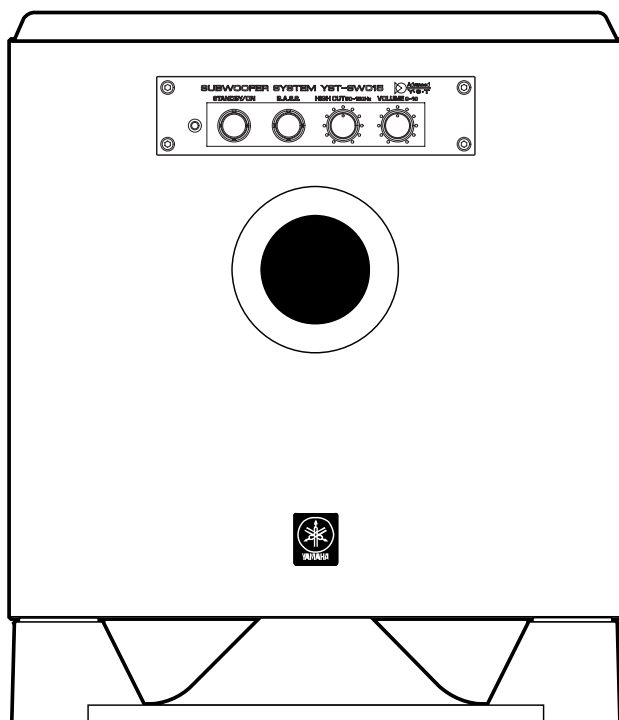

IMPORTANT NOTICE

This manual has been provided for the use of authorized YAMAHA Retailers and their service personnel.

It has been assumed that basic service procedures inherent to the industry, and more specifically YAMAHA Products, are already known and understood by the users, and have therefore not been restated.

WARNING: Failure to follow appropriate service and safety procedures when servicing this product may result in personal injury, destruction of expensive components, and failure of the product to perform as specified. For these reasons, we advise all YAMAHA product owners that any service required should be performed by an authorized YAMAHA Retailer or the appointed service representative.

IMPORTANT: The presentation or sale of this manual to any individual or firm does not constitute authorization, certification or recognition of any applicable technical capabilities, or establish a principle-agent relationship of any form.

The data provided is believed to be accurate and applicable to the unit(s) indicated on the cover. The research, engineering, and service departments of YAMAHA are continually striving to improve YAMAHA products. Modifications are, therefore, inevitable and specifications are subject to change without notice or obligation to retrofit. Should any discrepancy appear to exist, please contact the distributor's Service Division.

WARNING: Static discharges can destroy expensive components. Discharge any static electricity your body may have accumulated by grounding yourself to the ground buss in the unit (heavy gauge black wires connect to this buss).

IMPORTANT: Turn the unit OFF during disassembly and part replacement. Recheck all work before you apply power to the unit.

CONTENTS

TO SERVICE PERSONNEL	2
SPECIFICATIONS / 参考仕様	2
INTERNAL VIEW	3
REAR PANELS	3~4
DISASSEMBLY PROCEDURES / 分解手順	5~6
CONFIRMATION OF AUTO STANDBY OPERATION / AUTO STANDBY動作確認	7

BLOCK DIAGRAM	8
PRINTED CIRCUIT BOARD	9~10
SCHEMATIC DIAGRAM	11
PARTS LIST	13~19
Parts List for Carbon Resistors	20



このサービスマニュアルは、エコマーク認定の再生紙を使用しています。
This Service Manual uses recycled paper.



■ TO SERVICE PERSONNEL

- Critical Components Information
Components having special characteristics are marked  and must be replaced with parts having specifications equal to those originally installed.
- Leakage Current Measurement (For 120V Models Only)
When service has been completed, it is imperative to verify that all exposed conductive surfaces are properly insulated from supply circuits.
 - Meter impedance should be equivalent to 1500 ohm shunted by 0.15μF.



“CAUTION”

“F1: FOR CONTINUED PROTECTION AGAINST RISK OF FIRE, REPLACE ONLY WITH SAME TYPE 2A, 125V FUSE.”

CAUTION

F1: REPLACE WITH SAME TYPE 2A, 125V FUSE.

ATTENTION

F1: UTILISER UN FUSIBLE DE RECHANGE DE MEME TYPE DE 2A, 125V.

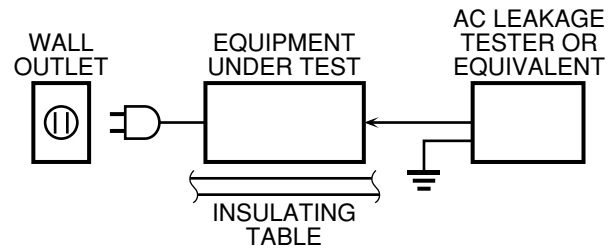

- Leakage current must not exceed 0.5mA.
- Be sure to test for leakage with the AC plug in both polarities.

WARNING: CHEMICAL CONTENT NOTICE!

The solder used in the production of this product contains LEAD. In addition, other electrical/electronic and /or plastic (where applicable) components may also contain traces of chemicals found by the California Health and Welfare Agency (and possibly other entities) to cause cancer and/or birth defects or other reproductive harm.

DO NOT PLACE SOLDER, ELECTRICAL/ELECTRONIC OR PLASTIC COMPONENTS IN YOUR MOUTH FOR ANY REASON WHATSOEVER!

Avoid prolonged, unprotected contact between solder and your skin! When soldering, do not inhale solder fumes or expose eyes to solder/flux vapor!

If you come in contact with solder or components located inside the enclosure of this product, wash your hands before handling food.

■ SPECIFICATIONS / 参考仕様

Type / 型式 Advanced Yamaha Active Servo Technology

Output Power / 出力 70 W (100 Hz, 5 Ω, 10% T.H.D.)

Input Sensitivity / 入力感度
INPUT (PJ) 30 mV (100 Hz, 70 W / 5 Ω, L + R)

Input Impedance / 入力インピーダンス
INPUT (PJ) 12 kΩ

Frequency Response / 再生周波数帯域 30 Hz to 200 Hz

Driver / スピーカーユニット 6.5" cone, Magnetic Shielding Type

Input Section / 入力部
INPUT RCA Pin Jack

Operation Section / 操作部
Front Panel STANDBY/ON Switch, B.A.S.S. Switch, VOLUME Control, HIGH CUT Control, LED Indicator
Rear Panel Power Switch, Auto Standby Switch (HIGH / LOW / OFF), Phase Switch (NORM / REV), Voltage Selector (R, T, K models)

Power Supply / 電源
U, C models AC 120 V, 60 Hz
A model AC 240 V, 50 Hz
B, G models AC 230 V, 50 Hz
R, T, K models AC 110-120 / 220-240 V, 50/60 Hz
J model AC 100 V, 50/60 Hz

Power Consumption / 消費電力
U, C, A, B, G, R, T, K models 70 W
J model 38 W

Standby Power Consumption / 待機時消費電力 0.8 W

Dimension / 外形寸法 (W x H x D) 280 x 325 x 320 mm
(11" x 12-13/16" x 12-5/8")

Weight / 質量 9.2 kg (20 lbs. 5 oz.)

Finish

Cherry Color All models
Black Color All models
Silver Color All models

Accessories / 付属品

Subwoofer Cable (3 m) x 1 pc (J model),
Non-skid Pad x 4 pcs

* Specifications are subject to change without notice due to product improvements.

※ 参考仕様および外観は予告なく変更されることがあります。

U U.S.A. model	C Canadian model
A Australian model	B British model
G European model	R General model
T Chinese model	K Korean model
J Japanese model	

• DIMENSIONS / 寸法図

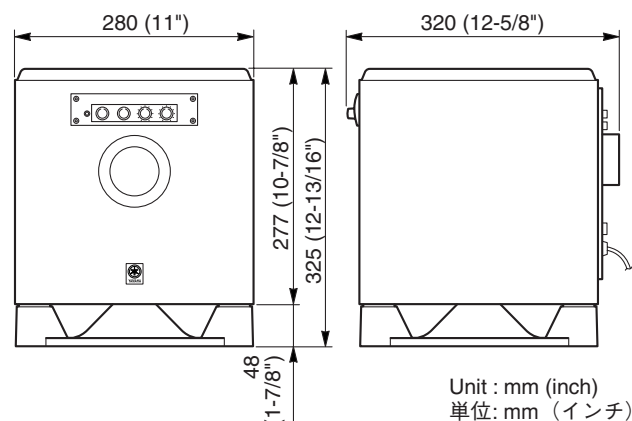

INTERNAL VIEW

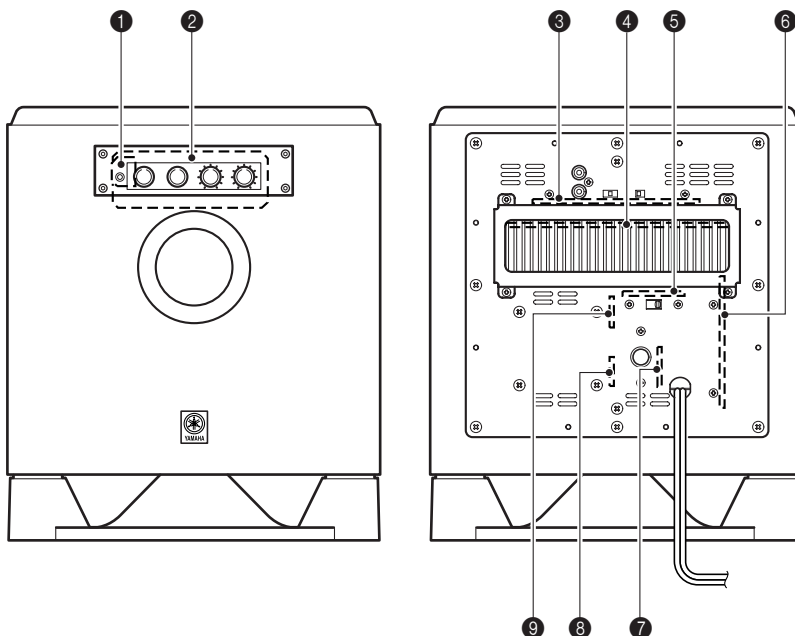

- ① MAIN (8) P.C.B.
- ② MAIN (4) P.C.B.
- ③ MAIN (3) P.C.B.
- ④ MAIN (1) P.C.B.
- ⑤ MAIN (9) P.C.B. (R, T, K models)
- ⑥ MAIN (2) P.C.B.
- ⑦ MAIN (5) P.C.B.
- ⑧ MAIN (7) P.C.B. (U, C, A, B, G, J models)
MAIN (10) P.C.B. (R, T, K models)
- ⑨ MAIN (6) P.C.B.

REAR PANELS

U, C models

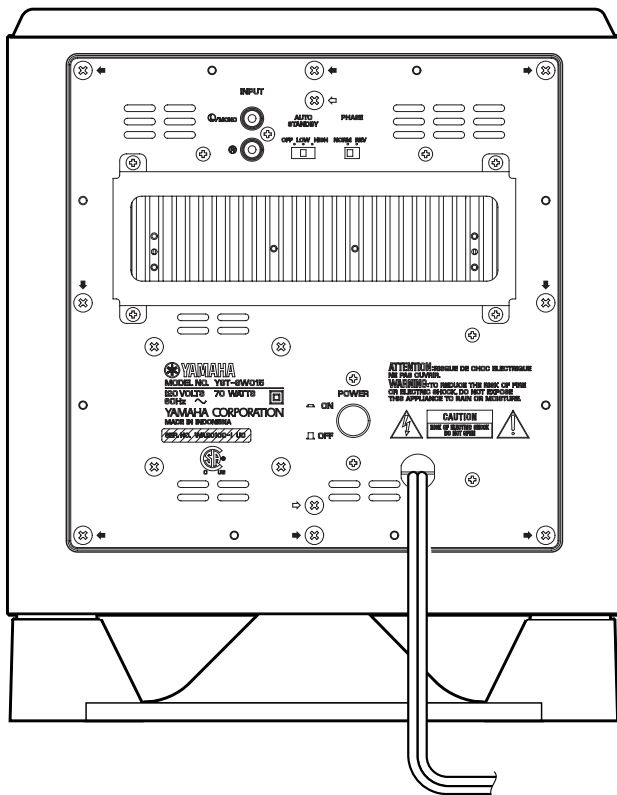

A model

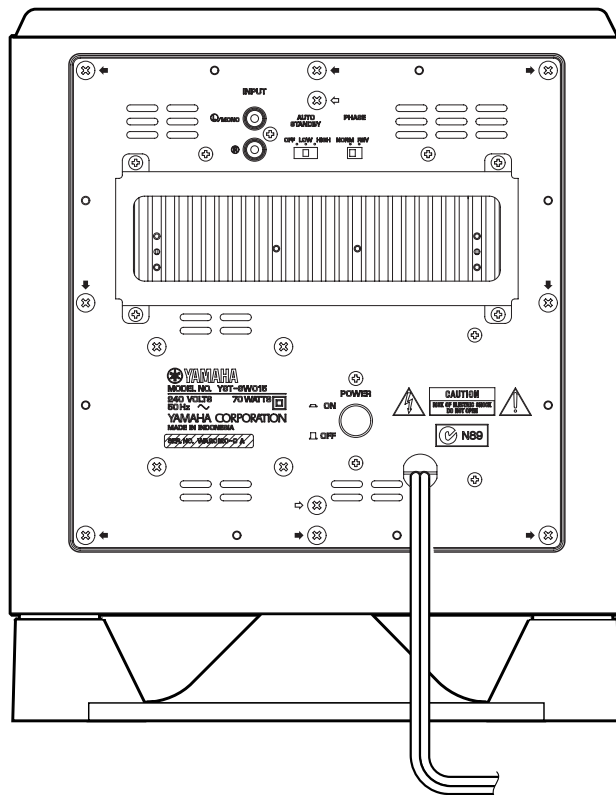

B, G models

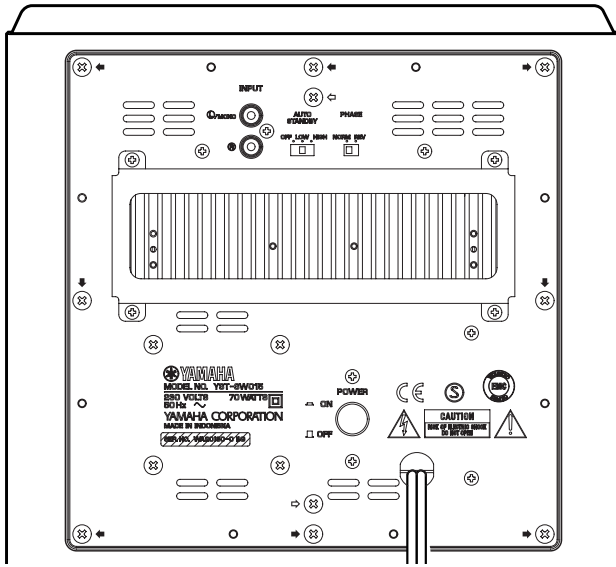

R model

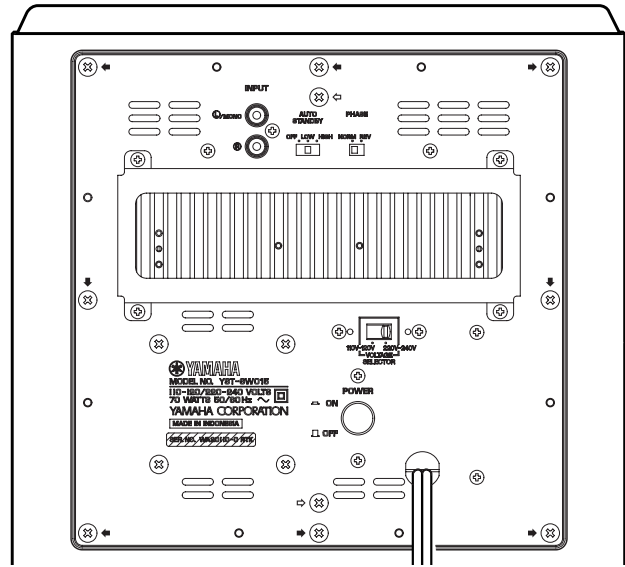

T model

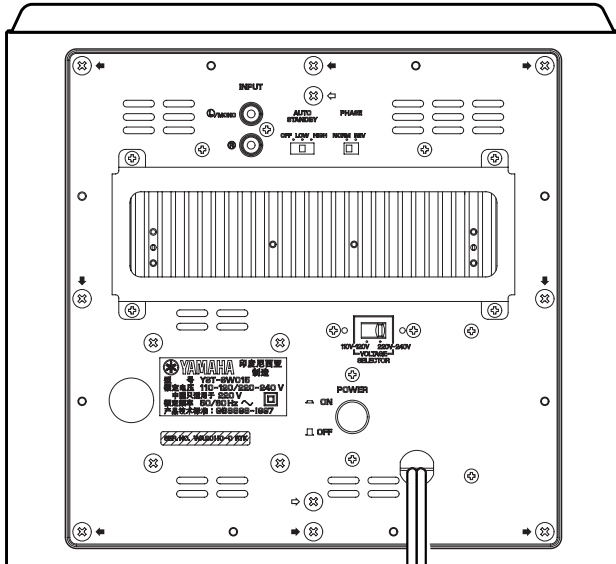

K model

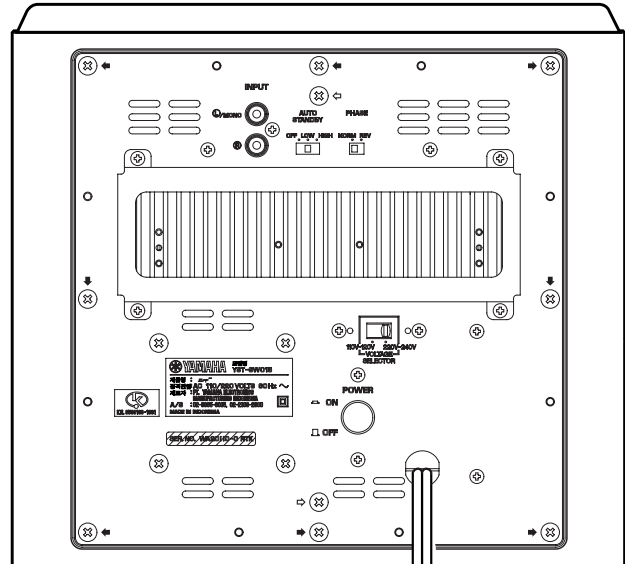

J model

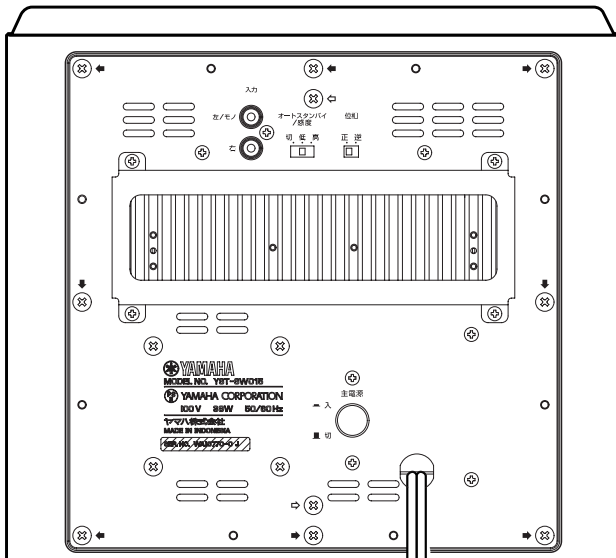

YST-SW015

■ DISASSEMBLY PROCEDURE / 分解手順

(Remove parts in the order as numbered.)
Disconnect the power cable from the AC outlet.

(番号順に部品を取り外してください。)
AC電源コンセントから、電源コードを抜いてください。

1. Removal of Driver

- Remove 4 screws (①) and then remove the Base. (Fig. 1)
- Remove 4 screws (②) and then remove the Driver. (Fig. 1)
- Disconnect the connector connected to the terminal of the Driver. (Fig. 1)

1. スピーカーユニットの外し方

- ①のネジ4本を外し、ベースを取り外します。(Fig. 1)
- ②のネジ4本を外し、スピーカーユニットを取り外します。(Fig. 1)
- スピーカーユニットの端子に接続されているコネクタを外します。(Fig. 1)

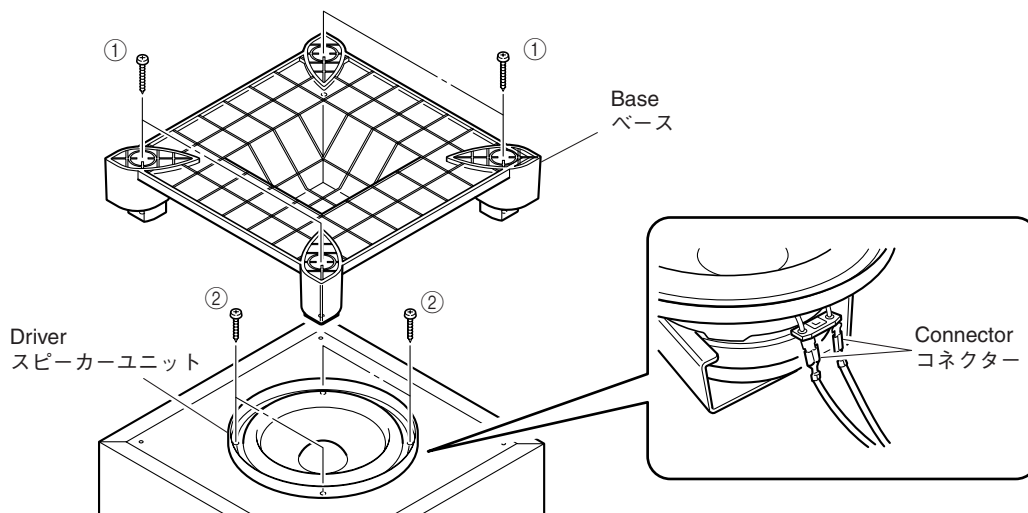

Fig. 1

2. Removal of Front Panel Ass'y

- Remove 4 screws (③). (Fig. 2)
* Use an Allen wrench (2.5mm) to unscrew the Front Panel Ass'y.
- Pull out the front panel ass'y and remove CB4. (Fig. 2)

2. フロントパネルAss'yの外し方

- ③のネジ4本を外します。(Fig. 2)
※ 取り外しには六角レンチ(2.5mm)を使用します。
- フロントパネルAss'yを引き出し、CB4を外します。(Fig. 2)

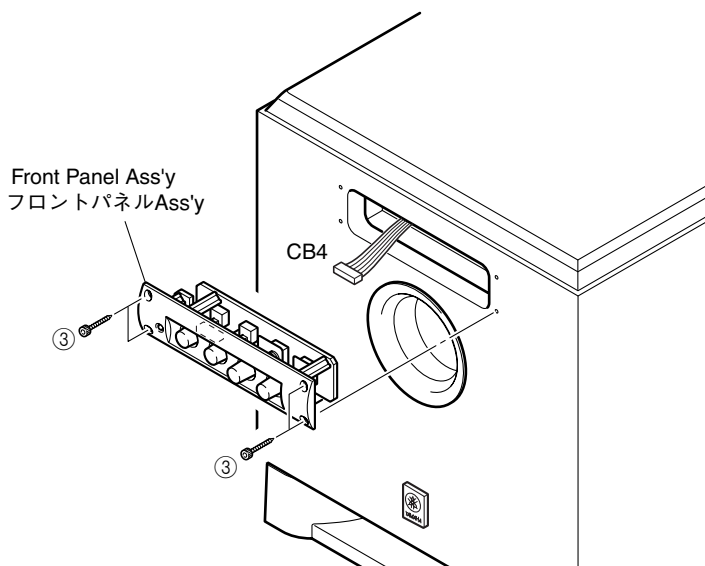

Fig. 2

3. Removal of Rear Panel Ass'y

- a. Remove 8 screws (④). (Fig. 3)
 - * Screws (④) are identified with arrow marks (◄).
- b. Pull out the rear panel ass'y. (Fig. 3)
- a. Remove 2 screws (⑤). (Fig. 3)
 - * Screws (⑤) are identified with arrow marks (◄).
- b. Remove the cover. (Fig. 3)

3. リアパネルAss'yの外し方

- a. ④のネジ8本を外します。(Fig. 3)
 - ※ 取り外す④のネジには矢印(◄)が印刷されています。
- b. リアパネルAss'yを引き出します。(Fig. 3)
- c. ⑤のネジ2本を外します。(Fig. 3)
 - ※ 取り外す⑤のネジには矢印(◄)が印刷されています。
- d. カバーを外します。(Fig. 3)

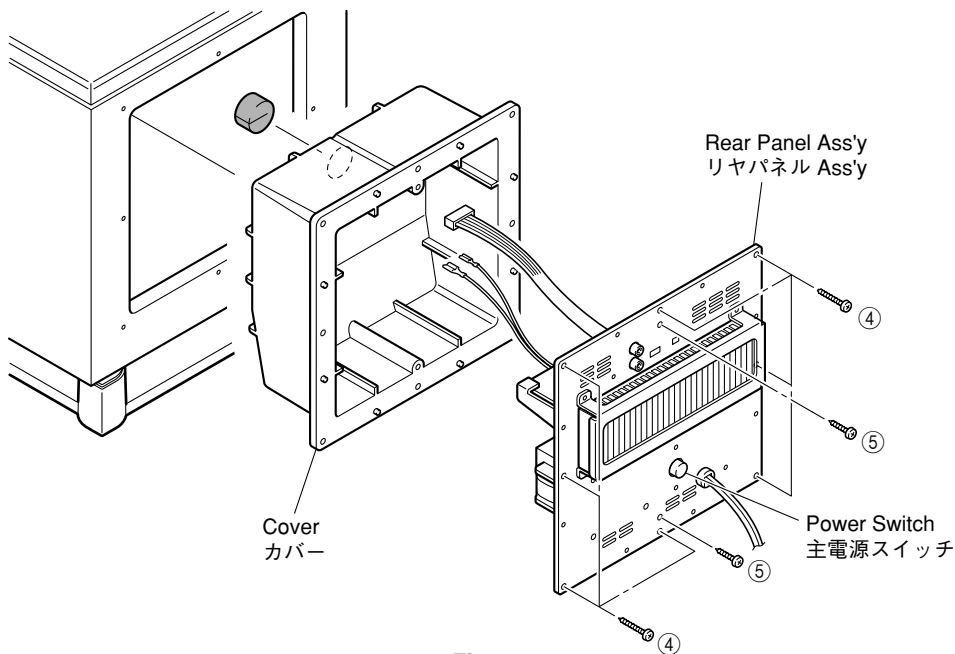

Fig. 3

When Checking the P.C.B.:

- Connect all the connectors removed during disassembly back to the original positions.
- Spread cloth first and place the rear panel ass'y on it. (Fig. 4)

P.C.B.チェックをする場合には

- 分解の際に外したコネクタをすべて元通りに接続します。
- ゴムシートと布を敷き、その上にリアパネルAss'yを置いてチェックします。(Fig. 4)

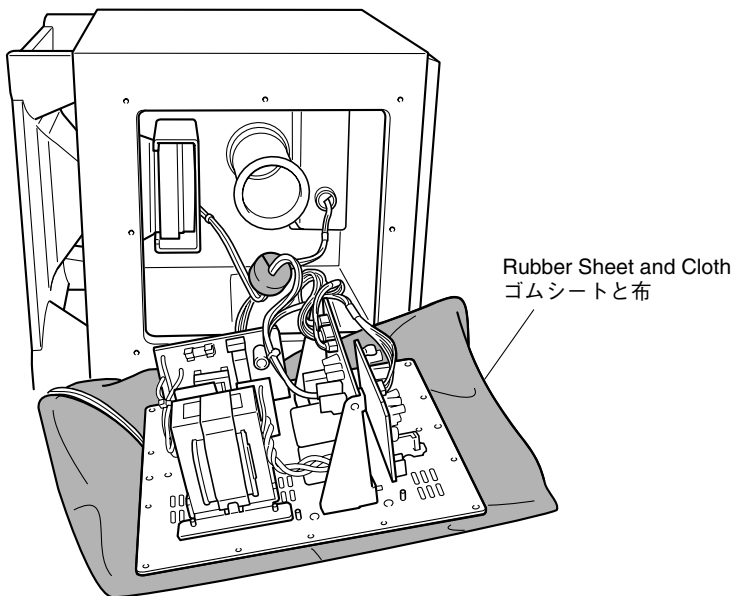

Fig. 4

■ CONFIRMATION OF AUTO STANDBY OPERATION / AUTO STANDBY動作確認

Setting

- 1) Turn off the power switch located on the rear panel.
- 2) In order to shorten the time required for operation check; connect a 10kΩ resistor at both ends of R60 on the MAIN P.C.B. (3).
- 3) Connect the output signal from the signal generator to the INPUT of the unit.
- 4) Set the signal generator for the sine wave of 100Hz, 8mV.
- 5) Turn on the power switch located on the rear panel.

Confirmation

- 1) Set the AUTO STANDBY switch to the LOW position.

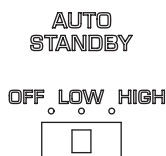

- 2) Turn on the STANDBY/ON switch.
The display LED lights up (green) and its color changes to red after 5 to 10 seconds.
- 3) Turn off the STANDBY/ON switch.
The display LED goes off.
- 4) Set the AUTO STANDBY switch to the HIGH position.

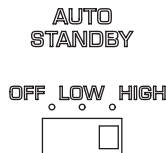

- 5) Turn on the STANDBY/ON switch.
The display LED lights up (green) and its color remains unchanged even after time have elapsed.
- 6) Turn off the STANDBY/ON switch.
The display LED goes off.

After Confirmation

- 1) Turn off the power switch located on the rear panel.
- 2) Disconnect the 10kΩ resistor connected to both ends of R60.

● 設定

- 1) リアパネルにある主電源スイッチをOFFにします。
- 2) 動作確認時間を短縮するため、MAIN P.C.B. (3)にあるR60の両端に10kΩの抵抗を取り付けます。
- 3) 信号発生器の出力信号を本機の入力端子に接続します。
- 4) 信号発生器を正弦波、100Hz、8mVに設定します。
- 5) リアパネルにある主電源スイッチをONにします。

● 確認

- 1) オートスタンバイ/感度スイッチを「低」に合わせます。

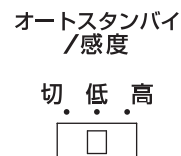

- 2) STANDBY/ONスイッチをONにします。
表示LEDが点灯(緑色)します。5～10秒後、表示LEDが赤色に変わります。
- 3) STANDBY/ONスイッチをOFFにします。
表示LEDが消灯します。
- 4) オートスタンバイ/感度スイッチを「高」に合わせます。

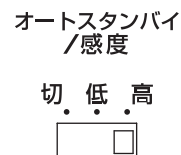

- 5) STANDBY/ONスイッチをONにします。
表示LEDが点灯(緑色)します。時間が経過しても表示LEDの色は変化しません。
- 6) STANDBY/ONスイッチをOFFにします。
表示LEDが消灯します。

● 確認終了後

- 1) リアパネルにある主電源スイッチをOFFにします。
- 2) R60両端に取り付けた抵抗を外します。

■ BLOCK DIAGRAM

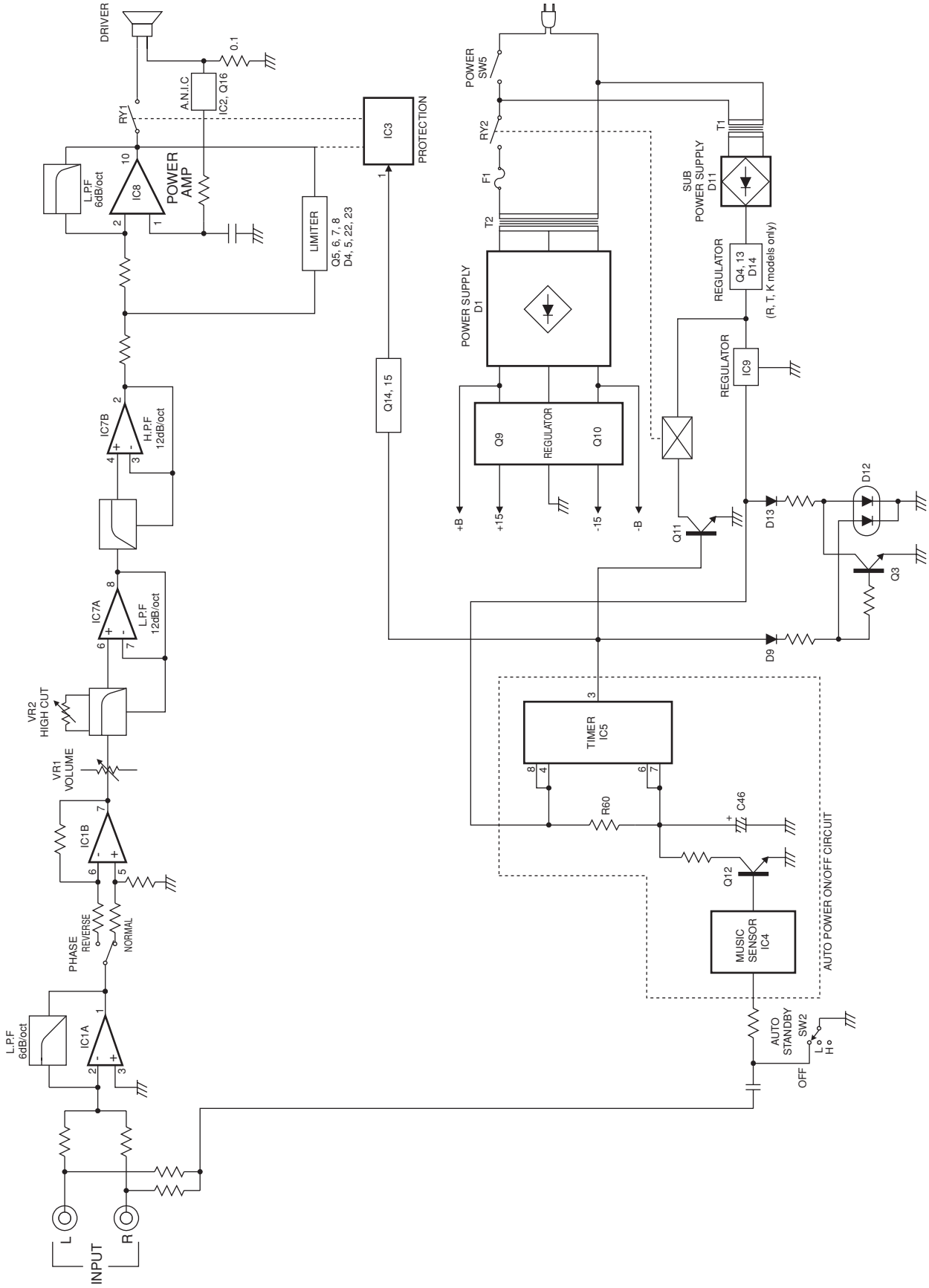

YST-SW015

• Semiconductor Location

Ref. No.	Location
D1	E3
D2	E4
D3	E4
D4	A3
D5	B3
D6	C2
D7	B3
D9	C4
D10	G4
D11	H4
D14	H4
D19	C3
D20	C3
D22	A3
D23	B3
IC1	C6
IC2	C3
IC3	D4
IC5	E7
IC8	C2
IC9	G4
Q1	B3
Q2	B3
Q4	G4
Q5	A3
Q6	B3
Q7	A3
Q8	B3
Q9	E4
Q10	E4
Q11	G4
Q12	E6
Q13	G4
Q14	C4
Q15	C4
Q16	B3

■ PRINTED CIRCUIT BOARD (Foil side)

MAIN (1) P. C. B. (Lead Type Device)

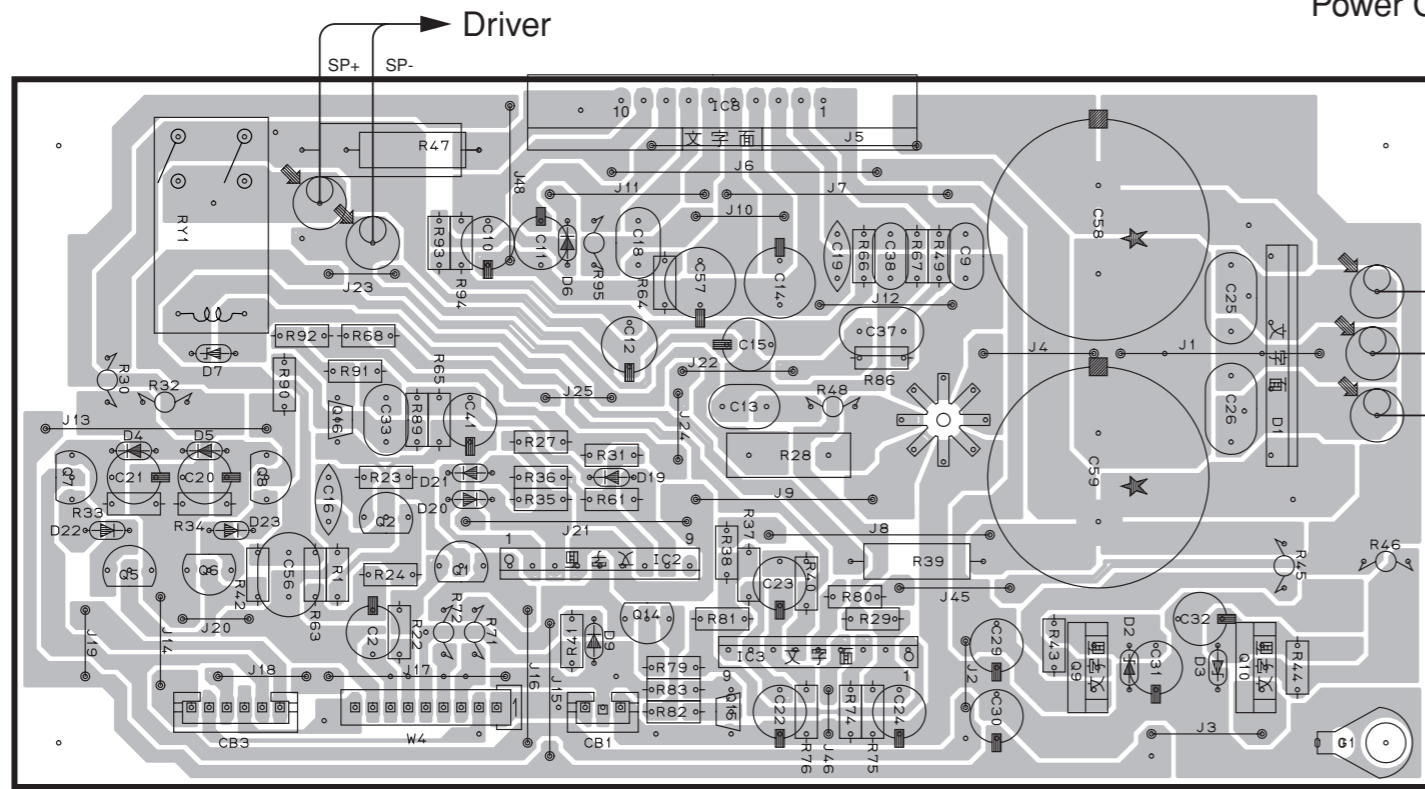

MAIN (2) P. C. B. (Lead Type Device)

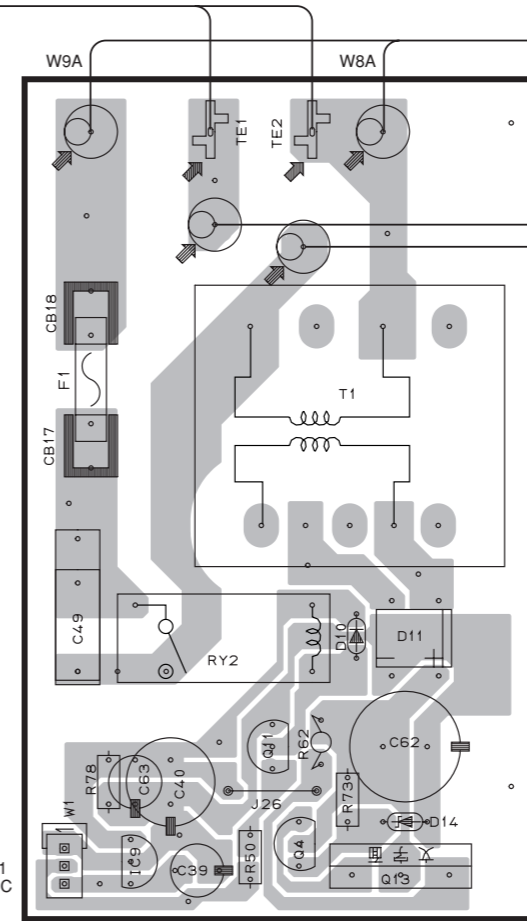

MAIN (3) P. C. B. (Lead Type Device)

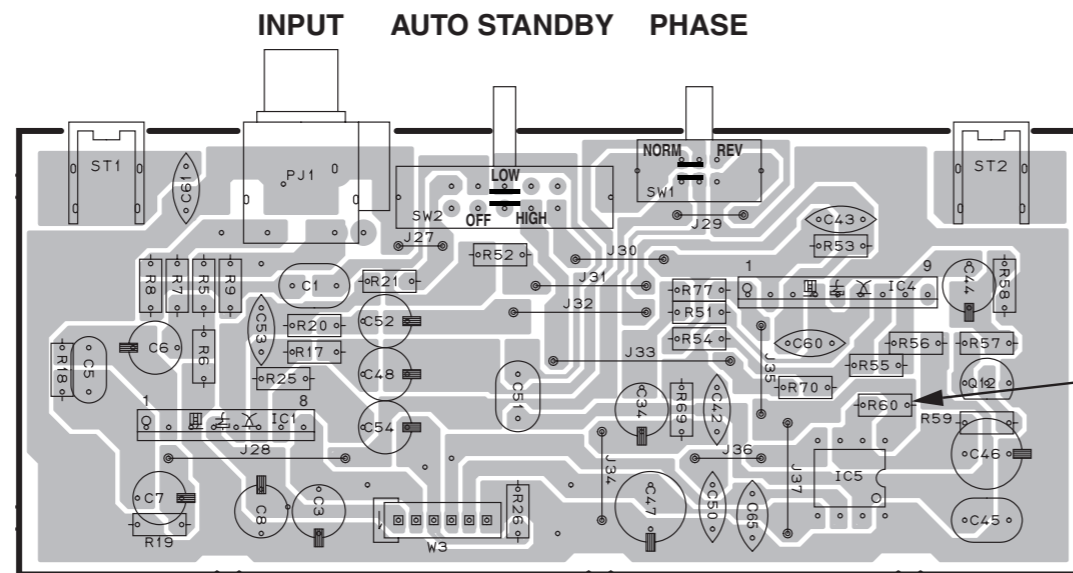

Circuit No.	J	U, C	R, T, K	A	B, G
C40	0	0	X	0	0
C53	X	X	X	X	0
C62, 63	X	X	0	X	X
CB7, 8	X	X	0	X	X
D14	X	X	0	X	X
F2	X	X	0	X	X
Q4, 13	X	X	0	X	X
R62	0	0	X	0	0
R73	X	X	0	X	X
SW6	X	X	0	X	X
W13-16	X	X	0	X	X

X: NOT USED
O: USED / APPLICABLE

PRINTED CIRCUIT BOARD (Foil side)

Semiconductor Location

Ref. No.	Location
D12	H2
D13	D2
IC7	C2
Q3	D2

MAIN (4) P. C. B. (Lead Type Device)

MAIN (5) P. C. B.
(Lead Type Device)

MAIN (8) P. C. B.
(Lead Type Device)

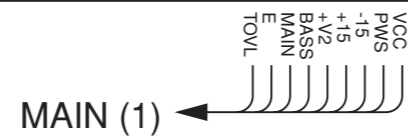
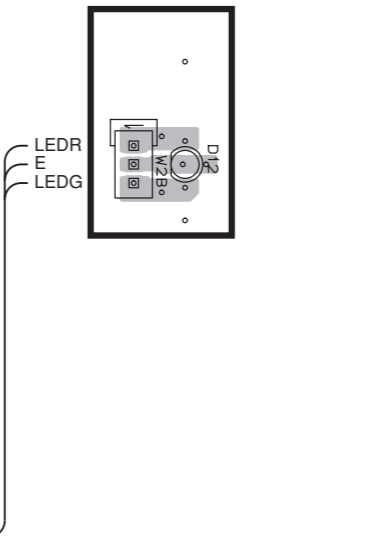
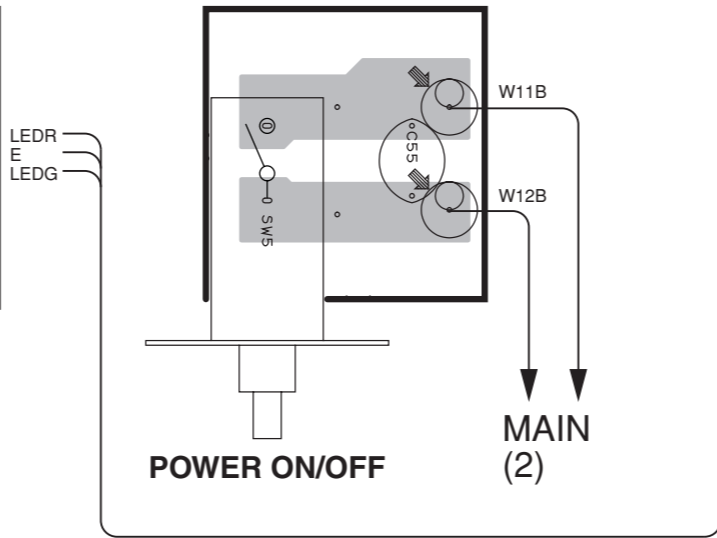
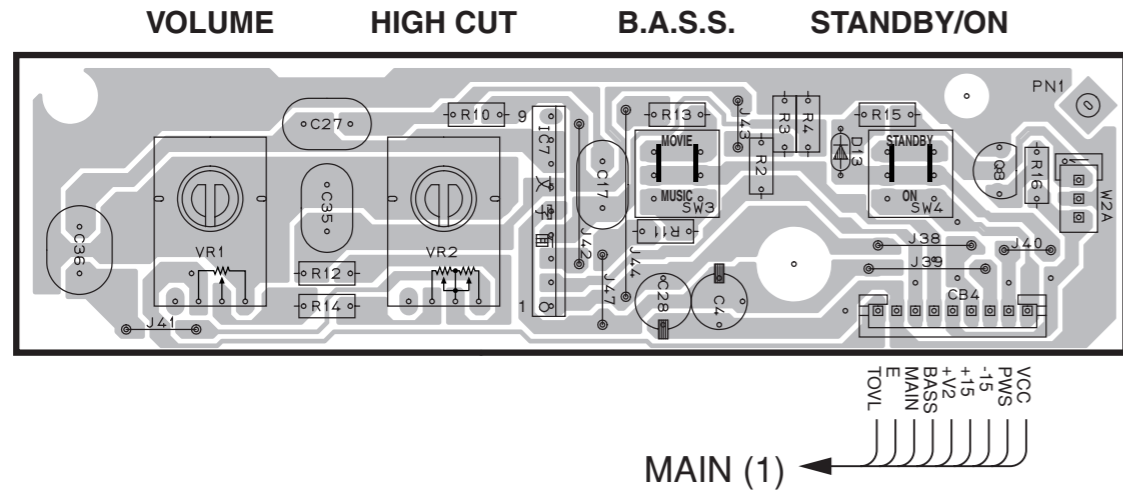

U, C, A, B, G, J models

R, T, K models

MAIN (6) P. C. B.
(Lead Type Device)

MAIN (6) P. C. B.
(Lead Type Device)

MAIN (9) P. C. B.
(Lead Type Device)

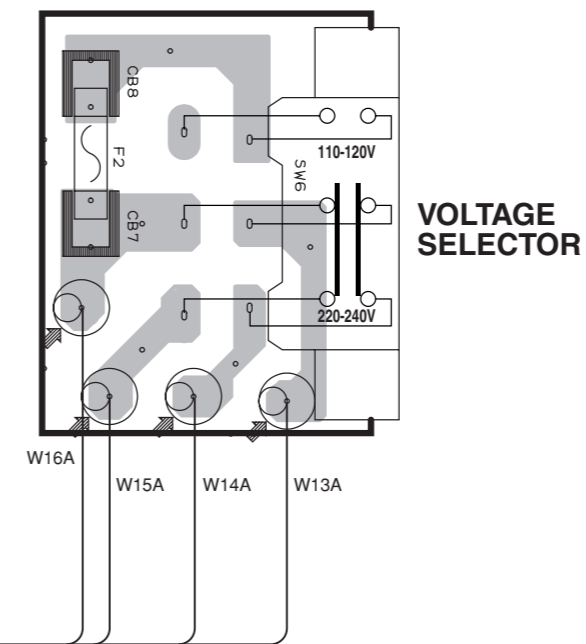
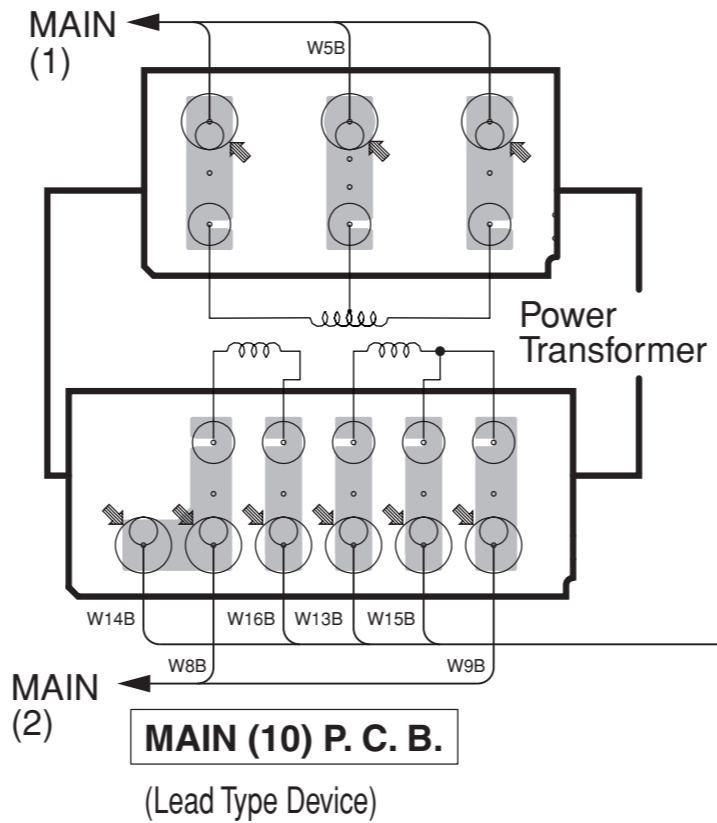
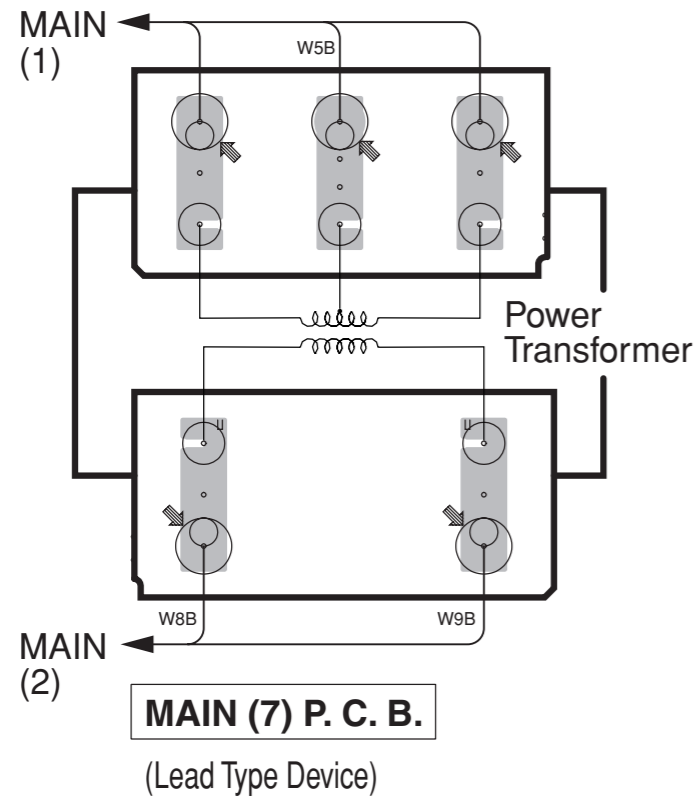

Circuit No.	J	U, C	R, T, K	A	B, G
C40	O	O	X	O	O
C53	X	X	X	X	O
CB2, 63	X	X	O	X	X
CB7, 8	X	X	O	X	X
D14	X	X	O	X	X
F2	X	X	O	X	X
Q4, 13	X	X	O	X	X
R62	O	O	X	O	O
R73	X	X	O	X	X
SW6	X	X	O	X	X
W13-16	X	X	O	X	X

X: NOT USED
O: USED / APPLICABLE

SCHEMATIC DIAGRAM

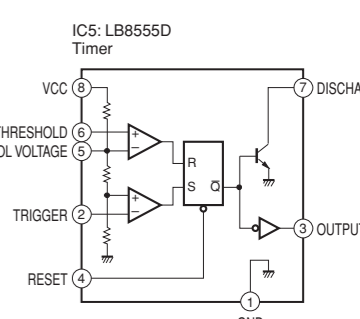
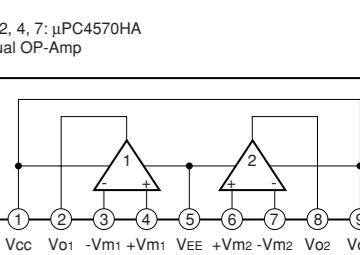
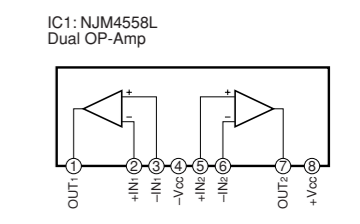
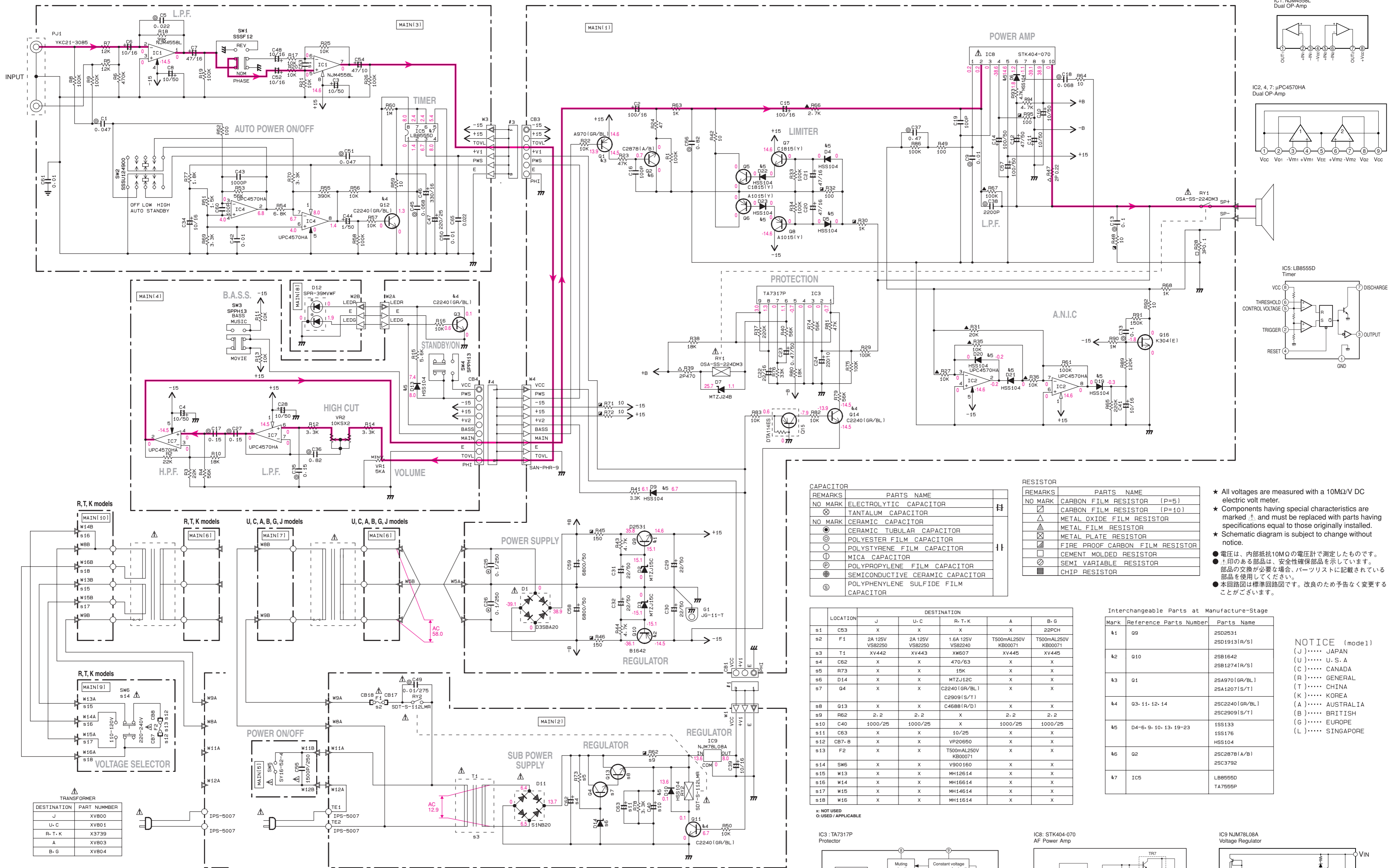

CAPACITOR

REMARKS	PARTS NAME
⊗	ELECTROLYTIC CAPACITOR
⊗	TANTALUM CAPACITOR
NO MARK	CERAMIC CAPACITOR
⊙	CERAMIC TUBULAR CAPACITOR
⊙	POLYESTER FILM CAPACITOR
⊙	POLYSTYRENE FILM CAPACITOR
⊙	MICA CAPACITOR
⊙	POLYPROPYLENE FILM CAPACITOR
⊙	SEMICONDUCTIVE CERAMIC CAPACITOR
⊙	POLYPHENYLENE SULFIDE FILM CAPACITOR

RESISTOR

REMARKS	PARTS NAME
⊗	CARBON FILM RESISTOR (P=5)
⊗	CARBON FILM RESISTOR (P=10)
⊙	METAL OXIDE FILM RESISTOR
⊙	METAL FILM RESISTOR
⊙	METAL PLATE RESISTOR
⊙	FIRE PROOF CARBON FILM RESISTOR
⊙	CEMENT MOLDED RESISTOR
⊙	SEMI VARIABLE RESISTOR
⊙	CHIP RESISTOR

★ All voltages are measured with a 10MΩ/V DC electric volt meter.
 ★ Components having special characteristics are marked ⊗ and must be replaced with parts having specifications equal to those originally installed.
 ★ Schematic diagram is subject to change without notice.
 ● 電圧は、内部抵抗10MΩの電圧計で測定したものです。
 ● ⊗印のある部品は、安全性確保部品を示しています。部品の交換が必要な場合、パーツリストに記載されている部品を使用してください。
 ● 本回路図は標準回路図です。改良のため予告なく変更することがございます。

Interchangeable Parts at Manufacture-Stage

Mark	Reference Parts Number	Parts Name
Ⓚ1	09	2SD2531 2SD1913(R/S)
Ⓚ2	010	2SB1642 2SB1274(R/S)
Ⓚ3	01	2SA970(GR/BL) 2SA1207(S/T)
Ⓚ4	03-11-12-14	2SC2240(GR/BL) 2SC2909(S/T)
Ⓚ5	D4-6-9-10-13-19-23	1SS133 1SS176 HSS104
Ⓚ6	02	2SC2878(A/B) 2SC3792
Ⓚ7	IC5	LB8555D TA7555P

NOTICE (mode1)
 (J)..... JAPAN
 (U)..... U. S. A
 (C)..... CANADA
 (R)..... GENERAL
 (T)..... CHINA
 (K)..... KOREA
 (A)..... AUSTRALIA
 (B)..... BRITISH
 (G)..... EUROPE
 (L)..... SINGAPORE

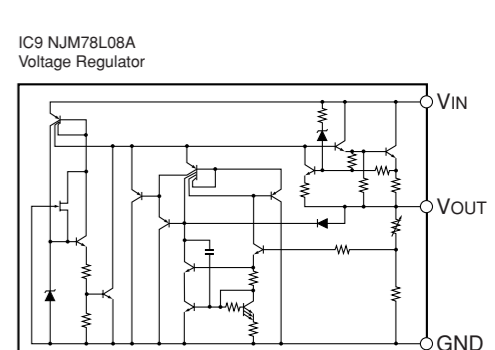
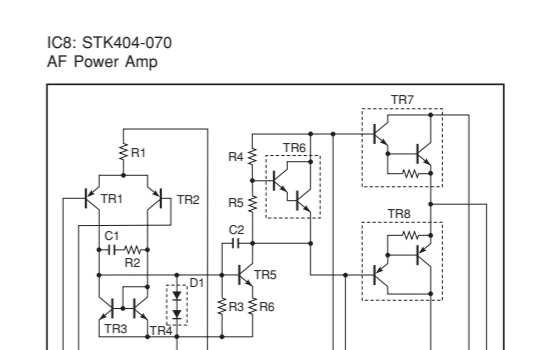
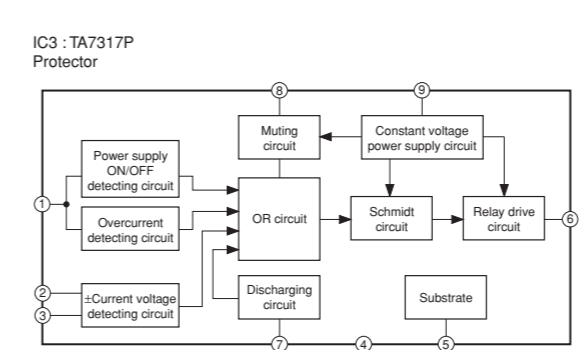
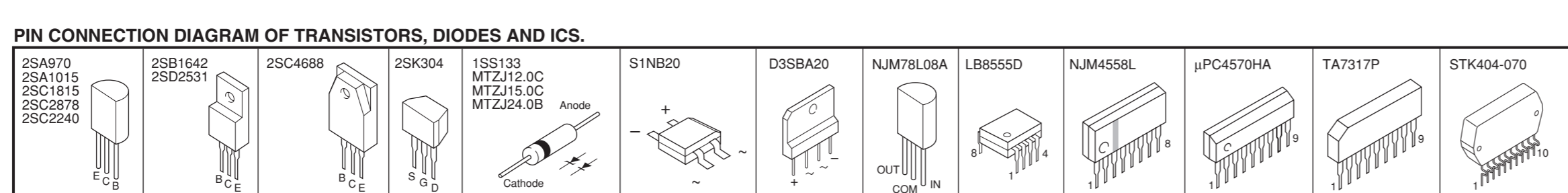

PARTS LIST

■ ELECTRICAL PARTS

■ WARNING

- Components having special characteristics are marked \triangle and must be replaced with parts having specifications equal to those originally installed.
- Carbon resistors (1/6W or 1/4W) are not included in the ELECTRICAL PARTS List. For the parts No. of the carbon resistors, refer to last page.
- \triangle 印のある部分は、安全確保部品を示しています。部品の交換が必要な場合、パーツリストに記載されている部品を使用してください。
- 本機に使用しているカーボン抵抗は1/6Wまたは1/4Wです。このパーツリストには、記載しておりませんので、部品番号がHF45○○○○タイプまたは同等品を使用してください。
- 部品価格ランクは、予告なく変更することがあります。

ABBREVIATIONS IN THIS LIST ARE AS FOLLOWS:

C.A.EL.CHP	: CHIP ALUMI.ELECTROLYTIC CAP	L.EMIT	: LIGHT EMITTING MODULE
C.CE	: CERAMIC CAP	LED.DSPLY	: LED DISPLAY
C.CE.ARRAY	: CERAMIC CAP ARRAY	LED.INFRD	: LED,INFRARED
C.CE.CHP	: CHIP CERAMIC CAP	MODUL.RF	: MODULATOR,RF
C.CE.ML	: MULTILAYER CERAMIC CAP	PHOT.CPL	: PHOTO COUPLER
C.CE.M.CHP	: CHIP MULTILAYER CERAMIC CAP	PHOT.INTR	: PHOTO INTERRUPTER
C.CE.SAFY	: RECOGNIZED CERAMIC CAP	PHOT.RFLCT	: PHOTO REFLECTOR
C.CE.TUBLR	: CERAMIC TUBULAR CAP	PIN.TEST	: PIN,TEST POINT
C.CE.SMI	: SEMI CONDUCTIVE CERAMIC CAP	PLST.RIVET	: PLASTIC RIVET
C.EL	: ELECTROLYTIC CAP	R.ARRAY	: RESISTOR ARRAY
C.MICA	: MICA CAP	R.CAR.	: CARBON RESISTOR
C.ML.FLM	: MULTILAYER FILM CAP	R.CAR.CHP	: CHIP RESISTOR
C.MP	: METALLIZED PAPER CAP	R.CAR.FP	: FLAME PROOF CARBON RESISTOR
C.MYLAR	: MYLAR FILM CAP	R.FUS	: FUSABLE RESISTOR
C.MYLAR.ML	: MULTILAYER MYLAR FILM CAP	R.MTL.CHP	: CHIP METAL FILM RESISTOR
C.PAPER	: PAPER CAPACITOR	R.MTL.FLM	: METAL FILM RESISTOR
C.PLS	: POLYSTYRENE FILM CAP	R.MTL.OXD	: METAL OXIDE FILM RESISTOR
C.POL	: POLYESTER FILM CAP	R.MTL.PLAT	: METAL PLATE RESISTOR
C.POLY	: POLYETHYLENE FILM CAP	RSNR.CE	: CERAMIC RESONATOR
C.PP	: POLYPROPYLENE FILM CAP	RSNR.CRYS	: CRYSTAL RESONATOR
C.TNTL	: TANTALUM CAP	R.TW.CEM	: TWIN CEMENT FIXED RESISTOR
C.TNTL.CHP	: CHIP TANTALUM CAP	R.WW	: WIRE WOUND RESISTOR
C.TRIM	: TRIMMER CAP	SCR.BND.HD	: BIND HEAD B-TITE SCREW
CN	: CONNECTOR	SCR.BW.HD	: BW HEAD TAPPING SCREW
CN.BS.PIN	: CONNECTOR,BASE PIN	SCR.CUP	: CUP TITE SCREW
CN.CANNON	: CONNECTOR,CANNON	SCR.TERM	: SCREW TERMINAL
CN.DIN	: CONNECTOR,DIN	SCR.TR	: SCREW,TRANSISTOR
CN.FLAT	: CONNECTOR,FLAT CABLE	SUPRT.PCB	: SUPPORT,P.C.B.
CN.POST	: CONNECTOR,BASE POST	SURG.PRTCT	: SURGE PROTECTOR
COIL.MX.AM	: COIL,AM MIX	SW.TACT	: TACT SWITCH
COIL.AT.FM	: COIL,FM ANTENNA	SW.LEAF	: LEAF SWITCH
COIL.DT.FM	: COIL,FM DETECT	SW.LEVER	: LEVER SWITCH
COIL.MX.FM	: COIL,FM MIX	SW.MICRO	: MICRO SWITCH
COIL.OUTPT	: OUTPUT COIL	SW.PUSH	: PUSH SWITCH
DIOD.ARRAY	: DIODE ARRAY	SW.RT.ENC	: ROTARY ENCODER
DIODE.BRG	: DIODE BRIDGE	SW.RT.MTR	: ROTARY SWITCH WITH MOTOR
DIODE.CHP	: CHIP DIODE	SW.RT	: ROTARY SWITCH
DIODE.VAR	: VARACTOR DIODE	SW.SLIDE	: SLIDE SWITCH
DIOD.Z.CHP	: CHIP ZENER DIODE	TERM.SP	: SPEAKER TERMINAL
DIODE.ZENR	: ZENER DIODE	TERM.WRAP	: WRAPPING TERMINAL
DSCR.CE	: CERAMIC DISCRIMINATOR	THRMST.CHP	: CHIP THERMISTOR
FER.BEAD	: FERRITE BEADS	TR.CHP	: CHIP TRANSISTOR
FER.CORE	: FERRITE CORE	TR.DGT	: DIGITAL TRANSISTOR
FET.CHP	: CHIP FET	TR.DGT.CHP	: CHIP DIGITAL TRANSISTOR
FL.DSPLY	: FLUORESCENT DISPLAY	TRANS	: TRANSFORMER
FLTR.CE	: CERAMIC FILTER	TRANS.PULS	: PULSE TRANSFORMER
FLTR.COMB	: COMB FILTER MODULE	TRANS.PWR	: POWER TRANSFORMER ASS'Y
FLTR.LC.RF	: LC FILTER,EMI	TUNER.AM	: TUNER PACK,AM
GND.MTL	: GROUND PLATE	TUNER.FM	: TUNER PACK,FM
GND.TERM	: GROUND TERMINAL	TUNER.PK	: FRONT-ENDTUNER PACK
HOLDER.FUS	: FUSE HOLDER	VR	: ROTARY POTENTIOMETER
IC.PRTCT	: IC PROTECTOR	VR.MTR	: POTENTIOMETER WITH MOTOR
JUMPER.CN	: JUMPER CONNECTOR	VR.SW	: POTENTIOMETER WITH ROTARY SW
JUMPER.TST	: JUMPER,TEST POINT	VR.SLIDE	: SLIDE POTENTIOMETER
L.DTCT	: LIGHT DETECTING MODULE	VR.TRIM	: TRIMMER POTENTIOMETER

Note) Those parts marked with “#” are not included in the P.C.B. ass'y.

P.C.B. MAIN

Schm Ref.	PART NO.	Description	Remarks	Markets	部 品 名	Rank
	WA113100	P. C. B.	MAIN	J	P C B M A I N	
	WA113200	P. C. B.	MAIN	UC	P C B M A I N	
	WA113300	P. C. B.	MAIN	RTK	P C B M A I N	
	WA113400	P. C. B.	MAIN	A	P C B M A I N	
	WA113500	P. C. B.	MAIN	BG	P C B M A I N	
CB1	VB389900	CN. BS. PIN	3P		ベースピン	01
CB3	VB390200	CN. BS. PIN	6P		コネクタベースポスト	01
CB4	VB390500	CN. BS. PIN	9P		コネクタベースポスト	03
CB7	VP206500	HOLDER. FUS	EYF-52BCT	RTK	ヒューズホルダー	01
CB8	VP206500	HOLDER. FUS	EYF-52BCT	RTK	ヒューズホルダー	01
CB17	VP206500	HOLDER. FUS	EYF-52BCT		ヒューズホルダー	01
CB18	VP206500	HOLDER. FUS	EYF-52BCT		ヒューズホルダー	01
C1	UA654470	C. MYLAR	0.047uF 50V		マイラーコン	01
C2	UR838100	C. EL	100uF 16V		ケミコン	01
C3	UR867100	C. EL	10uF 50V		ケミコン	01
C4	UR867100	C. EL	10uF 50V		ケミコン	01
C5	UA654220	C. MYLAR	0.022uF 50V		マイラーコン	01
C6	UR837100	C. EL	10uF 16V		ケミコン	01
C7	UR837470	C. EL	47uF 16V		ケミコン	01
C8	UR867100	C. EL	10uF 50V		ケミコン	01
C9	UA654100	C. MYLAR	0.01uF 50V		マイラーコン	01
C10	UR867100	C. EL	10uF 50V		ケミコン	01
C11	UR867100	C. EL	10uF 50V		ケミコン	01
C12	UR867470	C. EL	47uF 50V		ケミコン	01
C13	UA655100	C. MYLAR	0.1uF 50V		マイラーコン	01
C14	UR868100	C. EL	100uF 50V		ケミコン	01
C15	UR838100	C. EL	100uF 16V		ケミコン	01
C16	FG652100	C. CE	100pF 50V		セラコン	01
C17	UA655150	C. MYLAR	0.15uF 50V		マイラーコン	01
C18	UA654680	C. MYLAR	0.068uF 50V		マイラーコン	02
C19	FG652100	C. CE	100pF 50V		セラコン	01
C20	UR837470	C. EL	47uF 16V		ケミコン	01
C21	UR837470	C. EL	47uF 16V		ケミコン	01
C22	UR837220	C. EL	22uF 16V		ケミコン	01
C23	UR865470	C. EL	0.47uF 50V		ケミコン	01
C24	UR828220	C. EL	220uF 10V		ケミコン	01
C25	V6887300	C. MYLAR	0.1uF 250V		コンデンサ	
C26	V6887300	C. MYLAR	0.1uF 250V		コンデンサ	
C27	UA655150	C. MYLAR	0.15uF 50V		マイラーコン	01
C28	UR867100	C. EL	10uF 50V		ケミコン	01
C29	UR867220	C. EL	22uF 50V		ケミコン	01
C30	UR867220	C. EL	22uF 50V		ケミコン	01
C31	UR867220	C. EL	22uF 50V		ケミコン	01
C32	UR867220	C. EL	22uF 50V		ケミコン	01
C33	UA655100	C. MYLAR	0.1uF 50V		マイラーコン	01
C34	UR837100	C. EL	10uF 16V		ケミコン	01
C35	UA655150	C. MYLAR	0.15uF 50V		マイラーコン	01
C36	UA655820	C. MYLAR	0.82uF 50V		マイラーコン	01
C37	UA655470	C. MYLAR	0.47uF 50V		マイラーコン	01
C38	UA653220	C. MYLAR	2200pF 50V		マイラーコン	01
C39	UR837100	C. EL	10uF 16V		ケミコン	01
C40	UR749100	C. EL	1000uF 25V	JUCABG	ケミコン	01
C41	UR837100	C. EL	10uF 16V		ケミコン	01

* New Parts * 新規部品(マーク#の部品は、基板に含まれません)

P.C.B. MAIN

Schm Ref.	PART NO.	Description	Remarks	Markets	部 品 名	Rank
C42	FG644100	C. CE	0.01uF 50V		セラコン	01
C43	FG613100	C. CE	1000pF 50V		セラコン	01
C44	UR866100	C. EL	1uF 50V		ケミコン	01
C45	UA654680	C. MYLAR	0.068uF 50V		マイラーコン	02
C46	UR838330	C. EL	330uF 16V		ケミコン	01
C47	UR848220	C. EL	220uF 25V		ケミコン	01
C48	UR837100	C. EL	10uF 16V		ケミコン	01
△ C49	V6185300	C. CE. SAFTY	0.01uF 275V		規格認定コン	
C50	FG644100	C. CE	0.01uF 50V		セラコン	01
C51	UA654470	C. MYLAR	0.047uF 50V		マイラーコン	01
C52	UR837100	C. EL	10uF 16V		ケミコン	01
C53	VA761000	C. CE	22pF 50V	BG	セラコン	01
C54	UR827470	C. EL	47uF 10V		ケミコン	01
* △ C55	V7682500	C. CE. SAFTY	1500pF 250V		規格認定コン K H	01
C56	UA655820	C. MYLAR	0.82uF 50V		マイラーコン	01
C57	UR868100	C. EL	100uF 50V		ケミコン	01
* C58	V3757300	C. EL	6800uF 50V		ケミコン	06
* C59	V3757300	C. EL	6800uF 50V		ケミコン	06
C60	FG652100	C. CE	100pF 50V		セラコン	01
C61	FG644100	C. CE	0.01uF 50V		セラコン	01
* C62	UR778470	C. EL	470uF 63V	RTK	ケミコン	
C63	UR847100	C. EL	10uF 25V	RTK	ケミコン	01
C64	UR868100	C. EL	100uF 50V		ケミコン	01
C65	FG644220	C. CE	0.022uF 50V		セラコン	01
△ D1	VN011300	D10DE. BRG	D3SBA20 4A 200V		ダイオード	03
D2	VG440900	D10DE. ZENR	MTZJ15C 15V		ツェナーダイオード	01
D3	VG440900	D10DE. ZENR	MTZJ15C 15V		ツェナーダイオード	01
D4	VD631600	D10DE	1SS133, 176		ダイオード	01
D5	VD631600	D10DE	1SS133, 176		ダイオード	01
D6	VD631600	D10DE	1SS133, 176		ダイオード	01
D7	VG442500	D10DE. ZENR	MTZJ24B 24V		ツェナーダイオード	01
D9	VD631600	D10DE	1SS133, 176		ダイオード	01
D10	VD631600	D10DE	1SS133, 176		ダイオード	01
△ D11	VR253700	D10DE. BRG	S1NB20 1A 200V		D Iブリッジ X 4	02
D12	VS079300	LED	SPR-39MVW		2色 LED	01
D13	VD631600	D10DE	1SS133, 176		ダイオード	01
D14	VG440300	D10DE. ZENR	MTZJ12C 12V	RTK	ツェナーダイオード	01
D19	VD631600	D10DE	1SS133, 176		ダイオード	01
D20	VD631600	D10DE	1SS133, 176		ダイオード	01
D21	VD631600	D10DE	1SS133, 176		ダイオード	01
D22	VD631600	D10DE	1SS133, 176		ダイオード	01
D23	VD631600	D10DE	1SS133, 176		ダイオード	01
△ F1	VS822500	FUSE	2A 125V	JUC	ヒューズ	02
△ F1	VS822400	FUSE	1.6A 125V	RTK	ヒューズ	02
△ F1	KB000710	FUSE	T500mA 250V	ABG	ヒューズ	02
△ F2	KB000710	FUSE	T500mA 250V	RTK	ヒューズ	02
G1	V7235100	CN. GND	JG-11-T		接地端子	
IC1	XM922A00	IC	NJM4558L	SINGLE IN LINE	IC	01
IC2	XB247A00	IC	uPC4570HA		IC	02
IC3	X3369A00	IC	TA7317P		IC	
IC4	XB247A00	IC	uPC4570HA		IC	02
* IC5	X2020A00	IC	LB8555D		アンプ IC S I L	
IC7	XB247A00	IC	uPC4570HA		IC	02

* New Parts * 新規部品(マーク#の部品は、基板に含まれません)

P.C.B. MAIN

Schm Ref.	PART NO.	Description	Remarks	Markets	部 品 名	Rank	
* ⚠	IC8	X3587A00	IC	STK404-070 60W		パワー IC	
	IC9	iG160100	IC	NJM78L08A 8V		電源 IC	02
	PJ1	VT666100	JACK. PIN	2P		ピンジャック	03
	Q1	iA097030	TR	2SA970 GR, BL		トランジスタ	01
	Q2	iC287820	TR	2SC2878 A, B		トランジスタ	01
	Q3	iC224030	TR	2SC2240 GR, BL		トランジスタ	01
	Q4	iC224030	TR	2SC2240 GR, BL	RTK	トランジスタ	01
	Q5	iC181510	TR	2SC1815 Y		トランジスタ	01
	Q6	iA101510	TR	2SA1015 Y		トランジスタ	01
	Q7	iC181510	TR	2SC1815 Y		トランジスタ	01
	Q8	iA101510	TR	2SA1015 Y		トランジスタ	01
	Q9	V6896700	TR	2SD2531		トランジスタ	
	Q10	V6896500	TR	2SB1642		トランジスタ	
	Q11	iC224030	TR	2SC2240 GR, BL		トランジスタ	01
	Q12	iC224030	TR	2SC2240 GR, BL		トランジスタ	01
	Q13	VK801200	TR	2SC4688 R, 0	RTK	トランジスタ	04
	Q14	iC224030	TR	2SC2240 GR, BL		トランジスタ	01
	Q15	VD678500	TR	DTA114ES TR		トランジスタ	01
	Q16	V3028000	FET	2SK304 E		F E T	01
	R27	HB027100	R. MTL. FLM	10K Ω 1/4W		金属被膜抵抗	
	R28	V6022600	R. WW	0.1 Ω 3W		セメント抵抗	
	R30	HV756100	R. CAR. FP	1K Ω 1/4W		不燃化カーボン抵抗	01
	R31	HB027200	R. MTL. FLM	20K Ω 1/4W		金属被膜抵抗	
	R32	HV755100	R. CAR. FP	100 Ω 1/4W		不燃化カーボン抵抗	01
	R35	HB027100	R. MTL. FLM	10K Ω 1/4W		金属被膜抵抗	
	R36	HB027100	R. MTL. FLM	10K Ω 1/4W		金属被膜抵抗	
*	R39	VC760500	R. MTL. OXD	470 Ω 2W		酸化金属被膜抵抗	01
	R45	HV755150	R. CAR. FP	150 Ω 1/4W		不燃化カーボン抵抗	01
	R46	HV755150	R. CAR. FP	150 Ω 1/4W		不燃化カーボン抵抗	01
	R47	VC751900	R. MTL. OXD	0.22 Ω 2W		酸化金属被膜抵抗	02
	R48	HV754100	R. CAR. FP	10 Ω 1/4W		不燃化カーボン抵抗	01
	R62	HV753220	R. CAR. FP	2.2 Ω 1/4W	JUCABG	不燃化カーボン抵抗	01
*	R66	HB026270	R. MTL. FLM	2.7K Ω 1/4W		金属被膜抵抗	01
	R67	HB028100	R. MTL. FLM	100K Ω 1/4W		金属被膜抵抗	
	R71	HV754100	R. CAR. FP	10 Ω 1/4W		不燃化カーボン抵抗	01
	R72	HV754100	R. CAR. FP	10 Ω 1/4W		不燃化カーボン抵抗	01
	R95	HV755100	R. CAR. FP	100 Ω 1/4W		不燃化カーボン抵抗	01
⚠	RY1	VU161600	RELAY	DC OSA-SS-224DM3		リレー 24V	05
⚠	RY2	V2712300	RELAY	DC SDT-S-112LMR		リレー 12V	05
	ST1	V4040500	SCR. TERM	M3		スクリュー/ターミナル	01
	ST2	V4040500	SCR. TERM	M3		スクリュー/ターミナル	01
	SW1	VL012000	SW. SLIDE	SSSF12	PHASE	スライドSW	02
	SW2	VD179500	SW. SLIDE	SSSU12	AUTO STANDBY	スライドSW	04
	SW3	VS066500	SW. PUSH	SPPH13-W	B. A. S. S.	プッシュスイッチ	03
	SW4	VS066500	SW. PUSH	SPPH13-W	STANDBY/ON	プッシュスイッチ	03
⚠	SW5	V8377400	SW. POWER	SY16-52-4	POWER	パワースイッチ	
* ⚠	SW6	V9001600	SW. SLIDE	ESD26606A	VOLTAGE SELECTOR	スライドSW	
⚠	T1	XV442A00	TRANS. PWR		J	電源トランス	05
* ⚠	T1	XV443A00	TRANS. PWR		UC	電源トランス	
⚠	T1	XW607A00	TRANS. PWR		RTK	電源トランス	05
* ⚠	T1	XV445A00	TRANS. PWR		ABG	電源トランス	
	TE1	VT658100	TERM. WRAP	352-TX119		ラッピング端子	01
	TE2	VT658100	TERM. WRAP	352-TX119		ラッピング端子	01

* New Parts * 新規部品(マーク#の部品は、基板に含まれません)

P.C.B. MAIN

Schm Ref.	PART NO.	Description	Remarks	Markets	部 品 名	Rank
* * VR1	WA113000	VR	A 5K Ω	VOLUME	ロータリーVR	
VR2	WA112800	VR	SC 10K Ω	HIGH CUT	ロータリーVR	
	V5995800	PLATE. GND			アースプレート	
	V7572400	HOLDER. LED	LE56209-0		LEDホルダー	

* New Parts * 新規部品(マーク#の部品は、基板に含まれません)

YST-SW015

EXPLODED VIEW

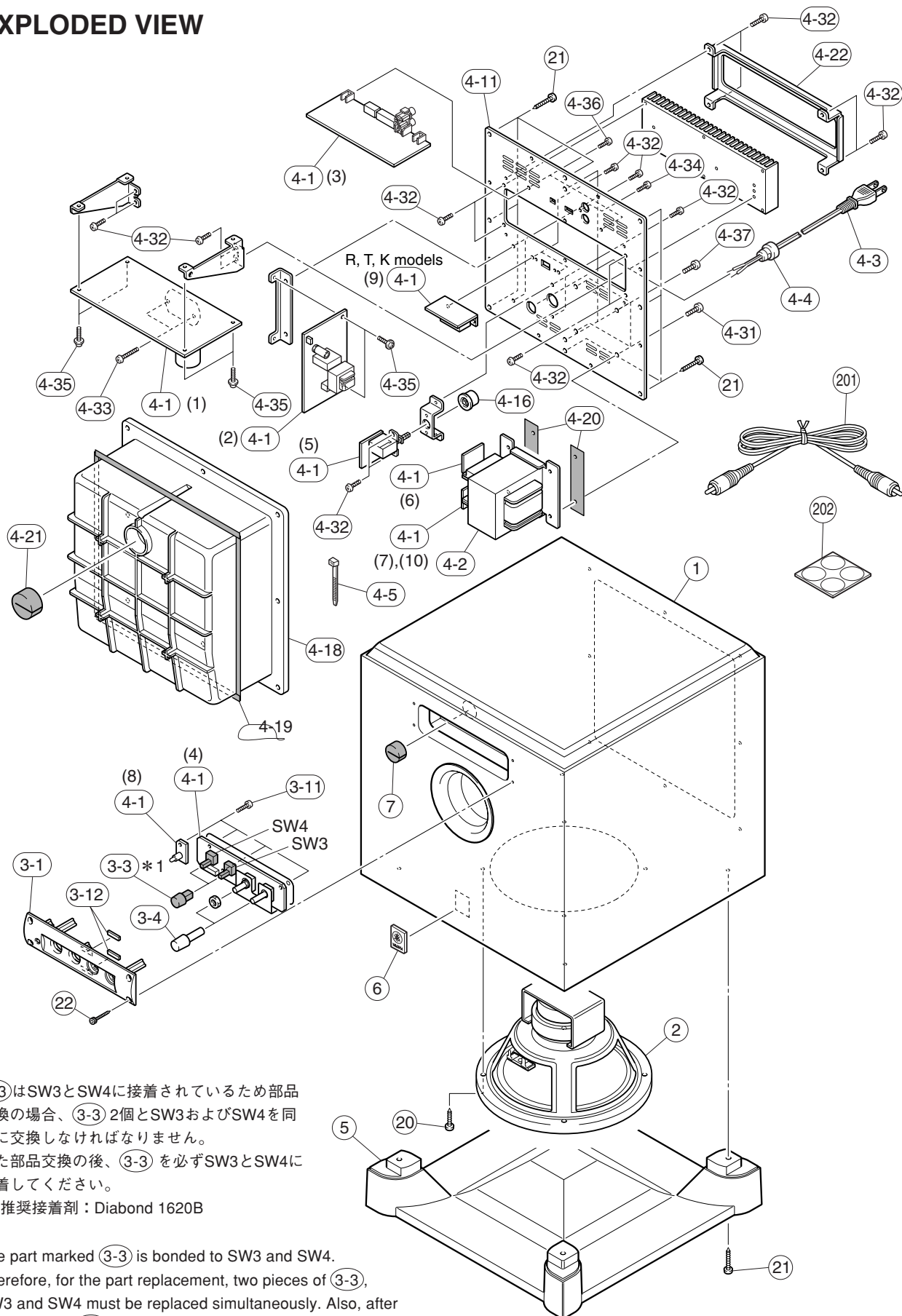

*1 (3-3)はSW3とSW4に接着されているため部品交換の場合、(3-3) 2個とSW3およびSW4を同時に交換しなければなりません。また部品交換の後、(3-3)を必ずSW3とSW4に接着してください。

推奨接着剤：Diabond 1620B

*1 The part marked (3-3) is bonded to SW3 and SW4. Therefore, for the part replacement, two pieces of (3-3), SW3 and SW4 must be replaced simultaneously. Also, after replacement, (3-3) must be bonded to SW3 and SW4.

Recommended adhesive: Diabond 1620B

MECHANICAL PARTS

Schm Ref.	PART NO.	Description	Remarks	Markets	部品名	Rank
*	1	WA192600	CABINET ASS'Y	CH	キャビネットASSY	
*	1	WA192700	CABINET ASS'Y	BL	キャビネットASSY	
*	1	WA192800	CABINET ASS'Y	SI	キャビネットASSY	
	2	X2323A00	DRIVER, WOOFER	16cm 6Ω 25W	スピーカーユニット	10
*	3-1	WA085100	FRONT PANEL		フロントパネル	
*	3-3	WA085200	SWITCH KNOB		スイッチノブ	
*	3-4	WA085300	VOLUME KNOB		ボリュームノブ	
	3-11	EP600280	BIND HEAD P-TITE SCREW	3x8 MFZN2Y	バインドPタイトネジ	01
*	3-12	WA971100	PACKING 97110		パッキン97110	
*	4-1	WA113100	P.C.B ASS'Y	MAIN	J PCB MAIN	
*	4-1	WA113200	P.C.B ASS'Y	MAIN	UC PCB MAIN	
*	4-1	WA113300	P.C.B ASS'Y	MAIN	RTK PCB MAIN	
*	4-1	WA113400	P.C.B ASS'Y	MAIN	A PCB MAIN	
*	4-1	WA113500	P.C.B ASS'Y	MAIN	BG PCB MAIN	
⚠	4-2	XV800A00	POWER TRANSFORMER		J 電源トランス	09
⚠	4-2	XV801A00	POWER TRANSFORMER		UC 電源トランス	09
* ⚠	4-2	X3739A00	POWER TRANSFORMER		RTK 電源トランス	
⚠	4-2	XV803A00	POWER TRANSFORMER		A 電源トランス	09
⚠	4-2	XV804A00	POWER TRANSFORMER		BG 電源トランス	09
⚠	4-3	V6893000	POWER CABLE	2m	J 電源コード	06
⚠	4-3	V2689600	POWER CABLE	2m	UC 電源コード	05
* ⚠	4-3	WA507100	POWER CABLE	2m	R 電源コード	
⚠	4-3	VZ555600	POWER CABLE	2m	T 電源コード	05
* ⚠	4-3	V8012900	POWER CABLE	2m	K 電源コード	
* ⚠	4-3	V6792800	POWER CABLE	2m	A 電源コード	
* ⚠	4-3	V6977100	POWER CABLE	2m	B 電源コード	
* ⚠	4-3	V6893100	POWER CABLE	2m	G 電源コード	
	4-4	CB072750	CORD STOPPER	SR-4N-4	コードストッパー	01
	4-5	CB069250	BINDING TIE	BK-1	束線止め	01
*	4-11	WA107700	REAR PANEL		J リアパネル	
*	4-11	WA201000	REAR PANEL		UC リアパネル	
*	4-11	WA201100	REAR PANEL		RTK リアパネル	
*	4-11	WA201200	REAR PANEL		A リアパネル	
*	4-11	WA201300	REAR PANEL		BG リアパネル	
*	4-16	WA217100	POWER KNOB		パワーノブ	
*	4-18	WA084900	COVER		カバー	
*	4-19	WA201400	PACKING 20140		パッキン 20140	
*	4-20	V7799400	PACKING E		パッキン E	
	4-21	V7324600	BUSH		ブッシュ	
*	4-22	WA110800	REAR COVER		リアカバー	
	4-31	V6655200	BIND HEAD S-TITE SCREW	4x8 MFZN2BL	＋バインドSタイト	
	4-32	EP600190	BIND HEAD B-TITE SCREW	3x8 MFZN2BL	バインドBタイトネジ	01
	4-33	EP600380	BIND HEAD B-TITE SCREW	3x16 MFZN2BL	バインドBタイトネジ	01
	4-34	EP630660	BIND HEAD P-TITE SCREW	3x10 MFZN2BL	バインドPタイトネジ	01
	4-35	VT669300	PW HEAD B-TITE SCREW	3x8-8 MFC2	PWヘッドBタイトネジ	01
	4-36	VC082800	BIND HEAD BONDING SCREW	3x6 MFC2BL	ボンディング小ネジ	01
	4-37	VA847600	BIND HEAD P-TITE SCREW	4x12 MFZN2BL	バインドPタイトネジ	01
*	5	WA085400	BASE		ベース	
	6	V9467400	EMBLEM		エンブレム	
	7	V5984900	BUSH, B		ブッシュ B	01
	20	EP040070	BIND HEAD TAPPING SCREW	4x20 MFZN2BL	バインドTPネジ	01
	21	VF573000	BIND HEAD TAPPING SCREW	4x25 MFZN2BL	バインドTPネジ	01
*	22	WA200300	HEXAGON SOCKET TAPPING SCREW	3x20 MFN133	六角穴付TP #1	

* New Parts * 新規部品(マーク#の部品は、基板に含まれません)

Schm Ref.	PART NO.	Description	Remarks	Markets	部品名	Rank
	201	V3262500	ACCESSORIES			
	202	V5982400	SUBWOOFER CABLE	1P 3m 1pc	J	付属品
			NON SKID PAD	M25 t2 4pcs/set		サブウーハーケーブル
						滑止パッド
						04
						03

* New Parts * 新規部品(マーク#の部品は、基板に含まれません)

Parts List for Carbon Resistors

Value	1/4W Type Part No.	1/6W Type Part No.	Value	1/4W Type Part No.	1/6W Type Part No.
1.0 Ω	HJ35 3100	HF85 3100	10 kΩ	HF45 7100	HF45 7100
1.8 Ω	HJ35 3180	*	11 kΩ	HF45 7110	HF45 7110
2.2 Ω	HJ35 3220	HF85 3220	12 kΩ	HJ35 7120	HF85 7120
3.3 Ω	HJ35 3330	HF85 3330	13 kΩ	HF45 7130	HF45 7130
4.7 Ω	HJ35 3470	HF85 3470	15 kΩ	HF45 7150	HF45 7150
5.6 Ω	HJ35 3560	HF85 3560	18 kΩ	HF45 7180	HF45 7180
10 Ω	HF45 4100	HF45 4100	22 kΩ	HF45 7220	HF45 7220
15 Ω	HJ35 4150	HF85 4150	24 kΩ	HF45 7240	HF45 7240
22 Ω	HF45 4220	HF45 4220	27 kΩ	HJ35 7270	HF85 7270
27 Ω	HJ35 4270	HF85 4270	30 kΩ	HF45 7300	HF45 7300
33 Ω	HF45 4330	HF45 4330	33 kΩ	HF45 7330	HF45 7330
39 Ω	HJ35 4470	HF85 4390	36 kΩ	HF45 7360	HF45 7360
47 Ω	HF45 4470	HF45 4470	39 kΩ	HF45 7390	HF45 7390
56 Ω	HF45 4560	HF45 4560	47 kΩ	HF45 7470	HF45 7470
68 Ω	HF45 4680	HF45 4680	51 kΩ	HF45 7510	HF45 7510
75 Ω	HF45 4750	HF45 4750	56 kΩ	HF45 7560	HF45 7560
82 Ω	HF45 4820	HF45 4820	62 kΩ	HF45 7620	HF45 7620
91 Ω	HF45 4910	HF45 4910	68 kΩ	HF45 7680	HF45 7680
100 Ω	HF45 5100	HF45 5100	82 kΩ	HF45 7820	HF45 7820
110 Ω	HJ35 5110	HF85 5110	91 kΩ	HF45 7910	HF45 7910
120 Ω	HF45 5120	HF45 5120	100 kΩ	HF45 8100	HF45 8100
150 Ω	HF45 5150	HF45 5150	110 kΩ	HF45 8110	HF45 8110
160 Ω	HJ35 5160	*	120 kΩ	HF45 8120	HF45 8120
180 Ω	HF45 5180	HF45 5180	150 kΩ	HF45 8150	HF45 8150
200 Ω	HF45 5200	HF45 5200	180 kΩ	HF45 8180	HF45 8180
220 Ω	HF45 5220	HF45 5220	220 kΩ	HJ35 8220	HF85 8220
270 Ω	HF45 5270	HF45 5270	270 kΩ	HF45 8270	HF45 8270
330 Ω	HF45 5330	HF45 5330	300 kΩ	HF45 8300	HF45 8300
390 Ω	HF45 5390	HF45 5390	330 kΩ	HF45 8330	HF45 8330
430 Ω	HF45 5430	HF45 5430	390 kΩ	HJ35 8390	HF85 8390
470 Ω	HF45 5470	HF45 5470	470 kΩ	HF45 8470	HF45 8470
510 Ω	HF45 5510	HF45 5510	560 kΩ	HJ35 8560	HF85 8560
560 Ω	HF45 5560	HF45 5560	680 kΩ	HJ35 8680	HF85 8680
680 Ω	HF45 5680	HF45 5680	820 kΩ	HJ35 8820	HF85 8820
820 Ω	HF45 5820	HF45 5820	1.0 MΩ	HF45 9100	HF45 9100
910 Ω	HF45 5910	HF45 5910	1.2 MΩ	HJ35 9120	*
1.0 kΩ	HF45 6100	HF45 6100	1.5 MΩ	HJ35 9150	HF85 9150
1.2 kΩ	HF45 6120	HF45 6120	1.8 MΩ	HJ35 9180	HF85 9180
1.5 kΩ	HF45 6150	HF45 6150	2.2 MΩ	HJ35 9220	HF85 9220
1.8 kΩ	HF45 6180	HF45 6180	3.3 MΩ	HJ35 9330	HF85 9330
2.0 kΩ	HJ35 6200	HF85 6200	3.9 MΩ	HJ35 9390	*
2.2 kΩ	HF45 6220	HF45 6220	4.7 MΩ	HJ35 9470	HF85 9470
2.4 kΩ	HJ35 6240	HF85 6240			
2.7 kΩ	HF45 6270	HF45 6270			
3.0 kΩ	HF45 6300	HF45 6300			
3.3 kΩ	HF45 6330	HF45 6330			
3.6 kΩ	HJ35 6360	HF85 6360			
3.9 kΩ	HF45 6390	HF45 6390			
4.7 kΩ	HF45 6470	HF45 6470			
5.1 kΩ	HF45 6510	HF45 6510			
5.6 kΩ	HF45 6560	HF45 6560			
6.8 kΩ	HF45 6680	HF45 6680			
8.2 kΩ	HF45 6820	HF45 6820			
9.1 kΩ	HF45 6910	HF45 6910			

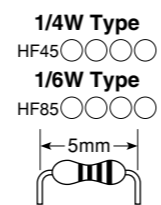
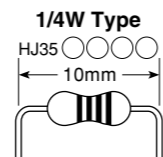

YST-SW015

