

# SUBWOOFER SYSTEM YST-SW030/YST-SW010

## SERVICE MANUAL

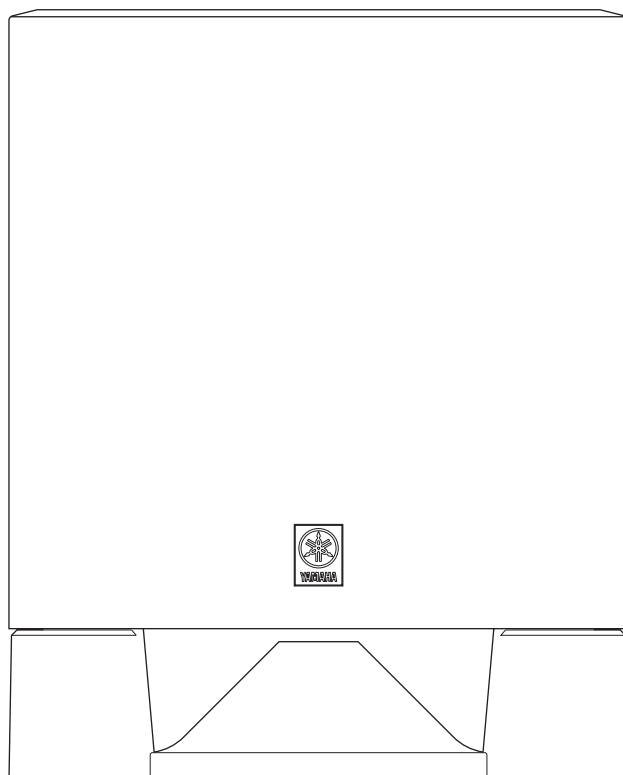

### IMPORTANT NOTICE

This manual has been provided for the use of authorized YAMAHA Retailers and their service personnel.

It has been assumed that basic service procedures inherent to the industry, and more specifically YAMAHA Products, are already known and understood by the users, and have therefore not been restated.

**WARNING:** Failure to follow appropriate service and safety procedures when servicing this product may result in personal injury, destruction of expensive components, and failure of the product to perform as specified. For these reasons, we advise all YAMAHA product owners that any service required should be performed by an authorized YAMAHA Retailer or the appointed service representative.

**IMPORTANT:** The presentation or sale of this manual to any individual or firm does not constitute authorization, certification or recognition of any applicable technical capabilities, or establish a principle-agent relationship of any form.

The data provided is believed to be accurate and applicable to the unit(s) indicated on the cover. The research, engineering, and service departments of YAMAHA are continually striving to improve YAMAHA products. Modifications are, therefore, inevitable and specifications are subject to change without notice or obligation to retrofit. Should any discrepancy appear to exist, please contact the distributor's Service Division.

**WARNING:** Static discharges can destroy expensive components. Discharge any static electricity your body may have accumulated by grounding yourself to the ground buss in the unit (heavy gauge black wires connect to this buss).

**IMPORTANT:** Turn the unit OFF during disassembly and part replacement. Recheck all work before you apply power to the unit.

## ■ CONTENTS

TO SERVICE PERSONNEL .....	2
SPECIFICATIONS / 参考仕様 .....	3~4
INTERNAL VIEW .....	4
REAR PANELS .....	5~8
DISASSEMBLY PROCEDURES / 分解手順 .....	9~10

BLOCK DIAGRAM .....	10
PRINTED CIRCUIT BOARD .....	11~12
SCHEMATIC DIAGRAM .....	13~14
PARTS LIST .....	15~25



このサービスマニュアルは、エコマーク認定の再生紙を使用しています。  
This Service Manual uses recycled paper.

100886



**YAMAHA**  
YAMAHA CORPORATION  
P.O.Box 1, Hamamatsu, Japan

YST-SW030/  
YST-SW010

## ■ TO SERVICE PERSONNEL

### 1. Critical Components Information

Components having special characteristics are marked  and must be replaced with parts having specifications equal to those originally installed.

### 2. Leakage Current Measurement (For 120V Models Only)

When service has been completed, it is imperative to verify that all exposed conductive surfaces are properly insulated from supply circuits.

- Meter impedance should be equivalent to 1500 ohm shunted by 0.15μF.

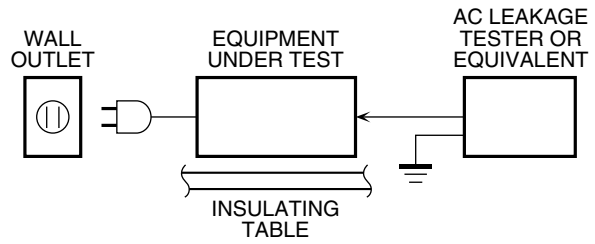

- Leakage current must not exceed 0.5mA.
- Be sure to test for leakage with the AC plug in both polarities.



### “CAUTION”

“F1: FOR CONTINUED PROTECTION AGAINST RISK OF FIRE, REPLACE ONLY WITH SAME TYPE 2A (YST-SW030) / 1.6A (YST-SW010), 125V FUSE.”

### CAUTION

F1: REPLACE WITH SAME TYPE 2A (YST-SW030) / 1.6A (YST-SW010), 125V FUSE.

### ATTENTION

F1: UTILISER UN FUSIBLE DE RECHANGE DE MEME TYPE DE 2A (YST-SW030) / 1.6A (YST-SW010), 125V.

## WARNING: CHEMICAL CONTENT NOTICE!

The solder used in the production of this product contains LEAD. In addition, other electrical/electronic and /or plastic (where applicable) components may also contain traces of chemicals found by the California Health and Welfare Agency (and possibly other entities) to cause cancer and/or birth defects or other reproductive harm.

DO NOT PLACE SOLDER, ELECTRICAL/ELECTRONIC OR PLASTIC COMPONENTS IN YOUR MOUTH FOR ANY REASON WHATSOEVER!

Avoid prolonged, unprotected contact between solder and your skin! When soldering, do not inhale solder fumes or expose eyes to solder/flux vapor!

If you come in contact with solder or components located inside the enclosure of this product, wash your hands before handling food.

## About Lead Free Solder / 無鉛ハンダについて

The foil side of MAIN P.C.B. used for this product are soldered with lead free soldering material which is an alloy of Sn+Ag+Cu (tin + silver + copper).

Among some types of lead free solder currently available, it is recommended to use one of the following types for the repair work.

- Sn + Ag + Cu (tin + silver + copper)
- Sn + Cu (tin + copper)
- Sn + Zn + Bi (tin + zinc + bismuth)

### Caution:

1. As the melting point temperature of the lead free solder is about 30°C to 40°C (50°F to 70°F) higher than that of the lead solder, be sure to use a soldering iron suitable to each solder.
2. If lead solder must be used, be sure to remove lead free solder from each terminal section of the parts to be replaced and from the area around it completely before soldering, or make sure that the lead free solder and lead solder melt together fully.

この製品に使用されているMAIN P.C.B.のハンダ面のハンダ付けには、Sn+Ag+Cu(錫+銀+銅)の合金である無鉛ハンダが使用されています。

無鉛ハンダにはいくつかの種類がありますが、修理時には下記のような無鉛ハンダの使用を推奨します。

- ・ Sn+Ag+Cu(錫+銀+銅)
- ・ Sn+Cu(錫+銅)
- ・ Sn+Zn+Bi(錫+亜鉛+ビスマス)

### 注意：

- ① 無鉛ハンダの融点温度は通常の鉛入りハンダに比べ30～40℃程度高くなっていますので、それぞれのハンダに合ったハンダごてをご使用ください。
- ② 鉛入りハンダを使わざるを得ない場合は、あらかじめ交換する部品端子部やその周辺部の無鉛ハンダをすべて取り除くか、あるいは無鉛ハンダと鉛入りハンダが十分に溶けた状態となるようにハンダ付けしてください。

## ■ SPECIFICATIONS / 参考仕様

Type / 型式 ..... Advanced Yamaha Active Servo Technology

Output Power / 出力 (100 Hz, 5 ohms, 10% T.H.D.)

[YST-SW030] ..... 75 W

[YST-SW010] ..... 50 W

Input Sensitivity / 入力感度 (50 Hz, 5 ohms)

INPUT (PJ)

[YST-SW030] ..... 70 mV (75 W)

[YST-SW010] ..... 50 mV (50 W)

Dynamic Power / ダイナミックパワー (5 ohms)

[YST-SW030] ..... 130 W

[YST-SW010] ..... 100 W

Input Impedance / 入力インピーダンス

INPUT (PJ) ..... 12 k-ohms

Frequency Response / 再生周波数帯域

[YST-SW030] ..... 28 Hz to 200 Hz

[YST-SW010] ..... 30 Hz to 200 Hz

Driver / スピーカーユニット (Magnetic Shielding Type)

[YST-SW030] ..... 8" (20 cm) cone

[YST-SW010] ..... 6.5" (16 cm) cone

Input Section / 入力部

INPUT ..... RCA Pin Jack

Operation Section / 操作部

Rear Panel .... Power Switch, Volume Control, LED Indicator,  
Voltage Selector (L, R, T, K models)

Power Supply / 電源

U, C models ..... AC 120 V, 60 Hz

A model ..... AC 240 V, 50 Hz

B, G models ..... AC 230 V, 50 Hz

L, R, T models ..... AC 110-120 / 220-240 V, 50 / 60 Hz

K model ..... AC 110 / 220 V, 60 Hz

J model ..... AC 100 V, 50 / 60 Hz

Power Consumption / 消費電力

[YST-SW030]

U, C, A, B, G, L, R, T, K models ..... 70 W

J model ..... 40 W

[YST-SW010]

U, C, A, B, G, L, R, T, K models ..... 45 W

J model ..... 30 W

Dimensions / 外形寸法 (W x H x D)

[YST-SW030] ..... 290 x 361 x 311 mm

(11-7/16" x 14-3/16" x 12-1/4")

[YST-SW010] ..... 280 x 325 x 293 mm

(11-1/16" x 12-13/16" x 11-9/16")

Weight / 質量

[YST-SW030] ..... 10.0 kg (22 lbs. 1 oz.)

[YST-SW010] ..... 8.5 kg (18 lbs. 12 oz.)

Finish

Cherry Color ..... A, B, G, L, R, T, K, J models

Black Color ..... U, C, A, B, G, L, R, T, J models

Silver Color ..... U, C, A, B, G, L, R, T, K, J models

Accessories / 付属品

Subwoofer Cable (5 m) x 1, Non-skid Pad x 4

\* Specifications are subject to change without notice due to product improvements.

※ 参考仕様および外観は予告なく変更されることがあります。

U ..... U.S.A. model

C ..... Canadian model

A ..... Australian model

B ..... British model

G ..... European model

L ..... Singapore model

R ..... General model

T ..... Chinese model

K ..... Korean model

J ..... Japanese model

### • DIMENSIONS / 寸法図

[YST-SW030]

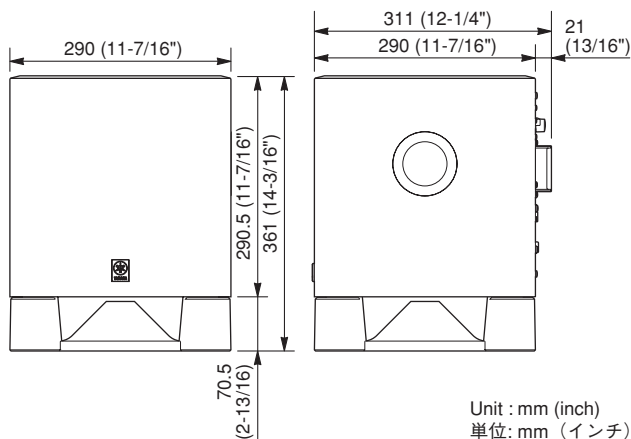

[YST-SW010]

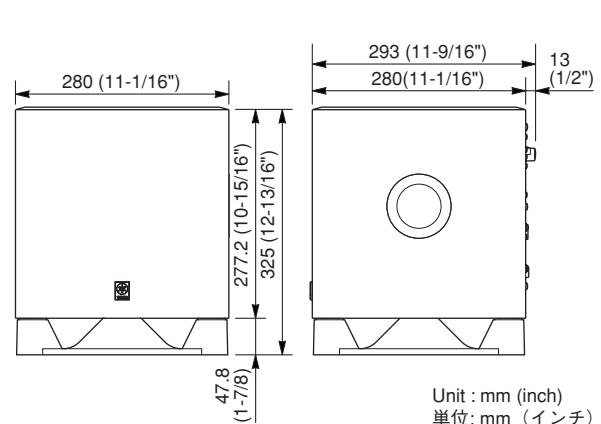



**Advanced YST**

Advanced Yamaha Active Servo Technology is a unique system to let the speaker unit have a perfectly linear motion by the speaker and amplifier combination.

**アドバンスドヤマハアクティブサーボテクノロジー**

アドバンスドヤマハアクティブサーボテクノロジーは、スピーカーとアンプの組み合わせにより振動板を効率よくスムーズに動かし最大音圧時のリニアリティを大幅に改善したユニークなシステムです。



**QD-Bass Technology**

QD-Bass (Quatre Dispersion Bass) technology is a Yamaha unique technology to radiate the sound efficiently in four horizontal direction.

**QD ベーステクノロジー**

QD(キューディー)ベーステクノロジーは、低音エネルギーを4水平方向に効率よく放射するヤマハ独自のテクノロジーです。

**INTERNAL VIEW**

YST-SW030

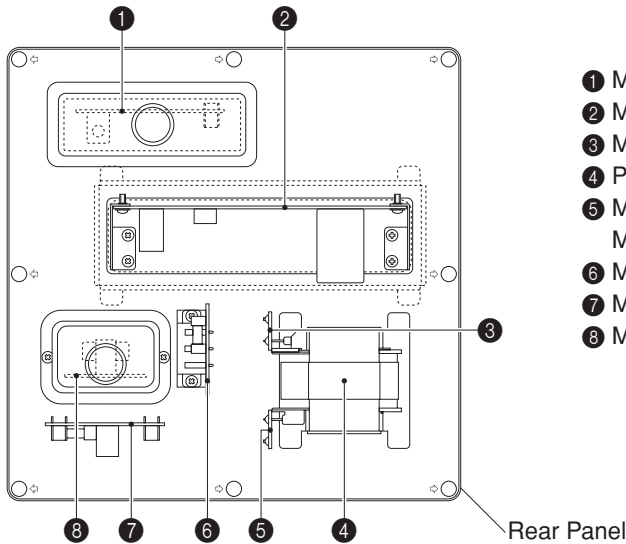

- ① MAIN (3) P.C.B.
- ② MAIN (1) P.C.B.
- ③ MAIN (6) P.C.B.
- ④ Power Transformer
- ⑤ MAIN (7) P.C.B. (U, C, A, B, G, J models)  
MAIN (10) P.C.B. (L, R, T, K models)
- ⑥ MAIN (9) P.C.B. (L, R, T, K models only)
- ⑦ MAIN (2) P.C.B.
- ⑧ MAIN (4) P.C.B.

YST-SW010

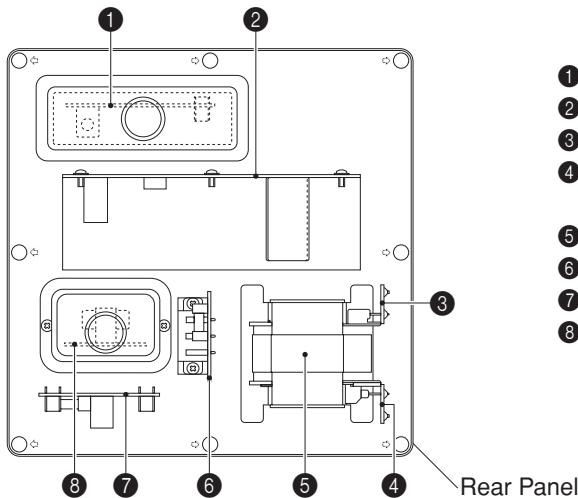

- ① MAIN (3) P.C.B.
- ② MAIN (1) P.C.B.
- ③ MAIN (6) P.C.B.
- ④ MAIN (7) P.C.B. (U, C, A, B, G, J models)  
MAIN (10) P.C.B. (L, R, T, K models)
- ⑤ Power Transformer
- ⑥ MAIN (9) P.C.B. (L, R, T, K models only)
- ⑦ MAIN (2) P.C.B.
- ⑧ MAIN (4) P.C.B.

YST-SW030/  
YST-SW010

# REAR PANELS

YST-SW030 (U, C models)

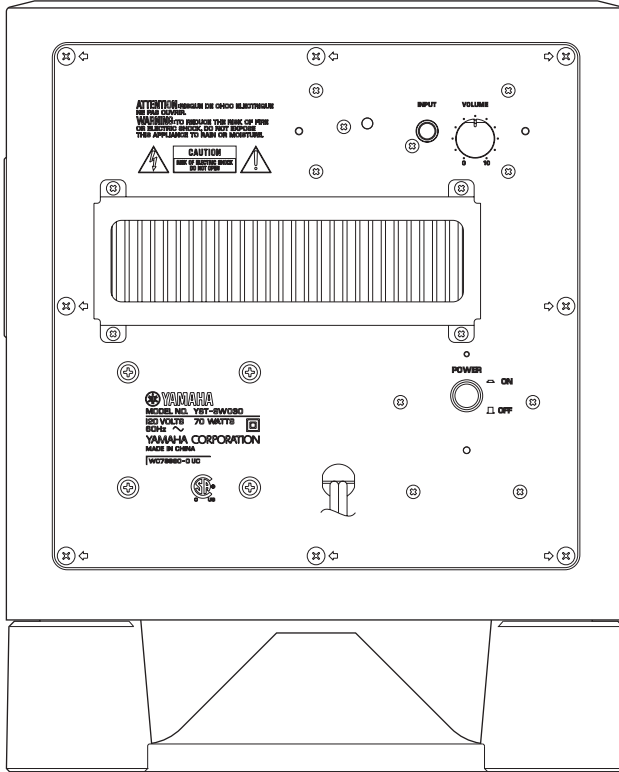

YST-SW030 (A model)

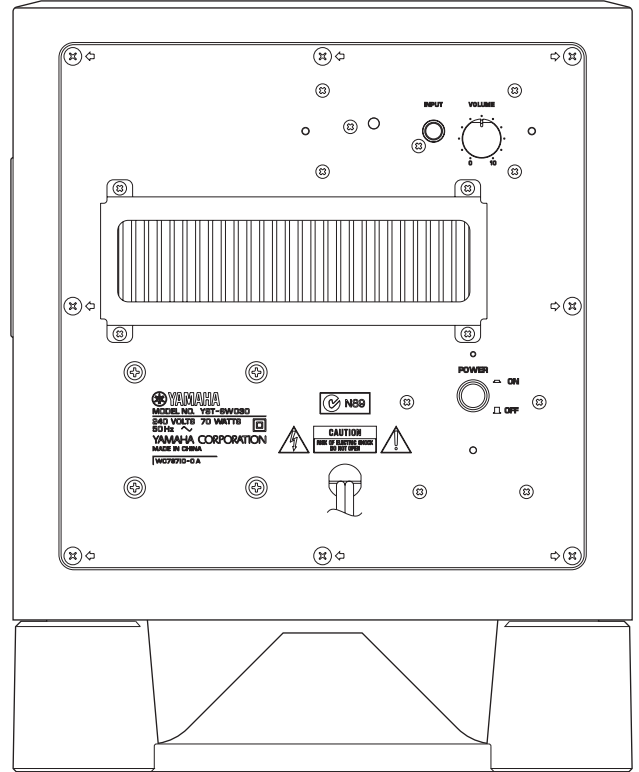

YST-SW030 (B, G models)

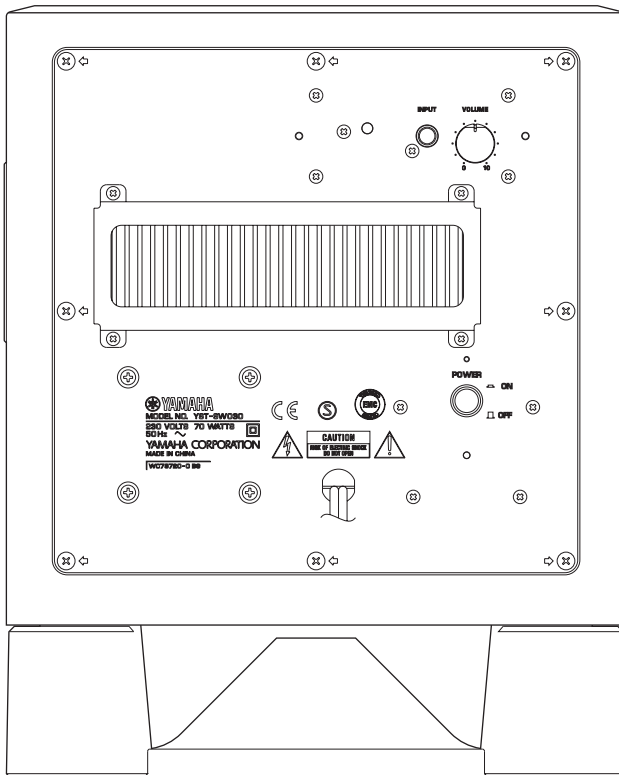

YST-SW030 (L model)

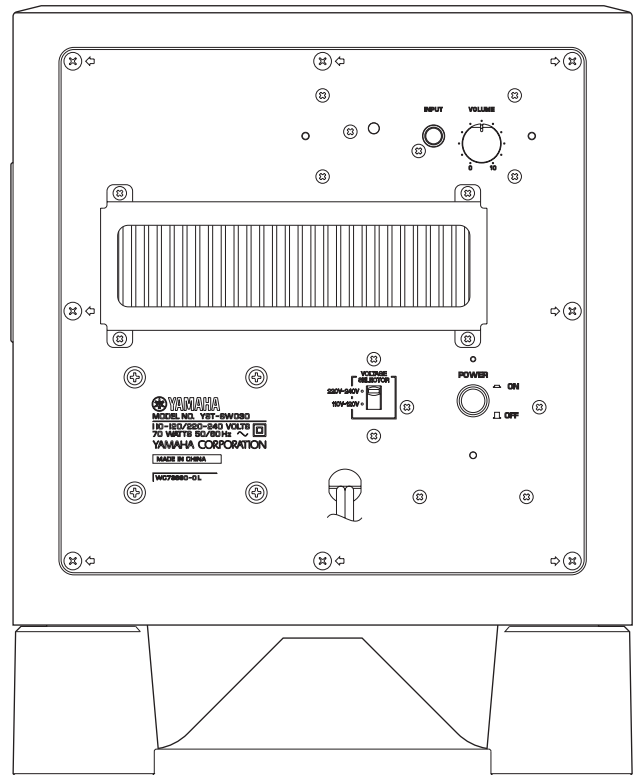

YST-SW030/  
YST-SW010

YST-SW030 (R model)

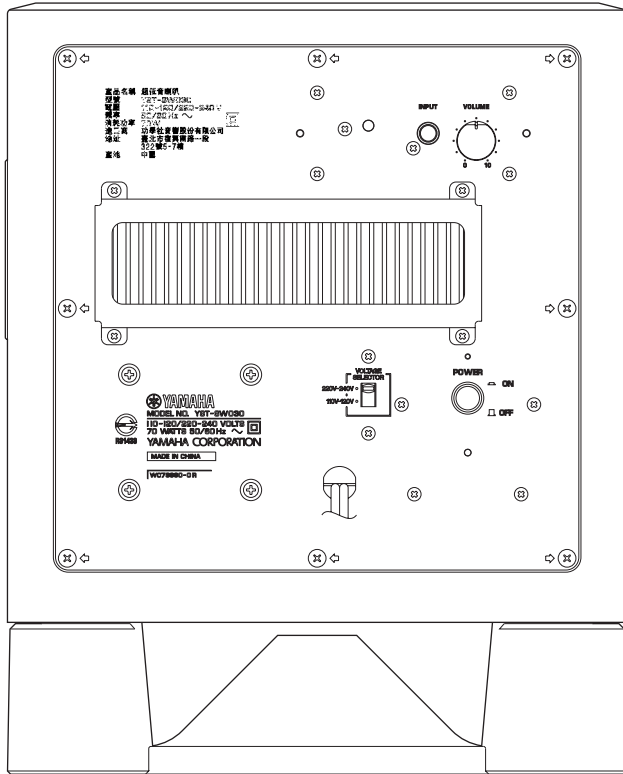

YST-SW030 (T model)

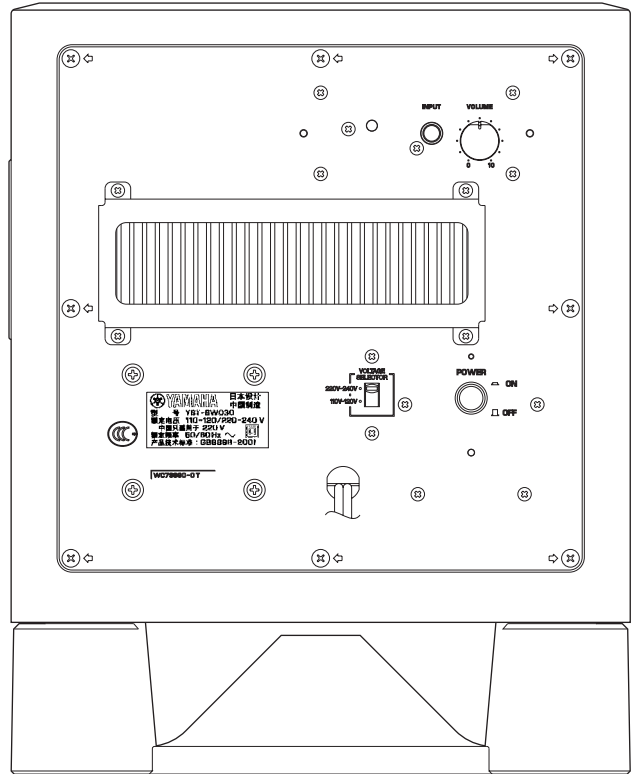

YST-SW030 (K model)

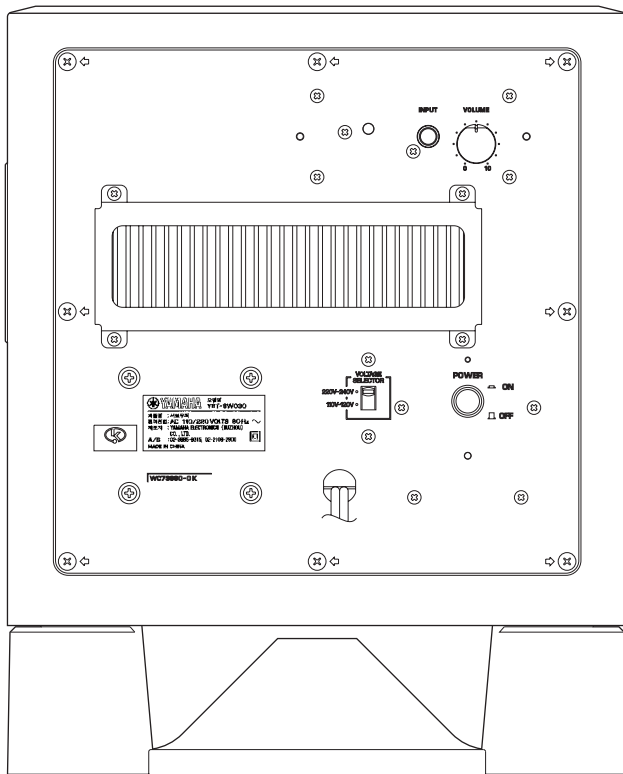

YST-SW030 (J model)

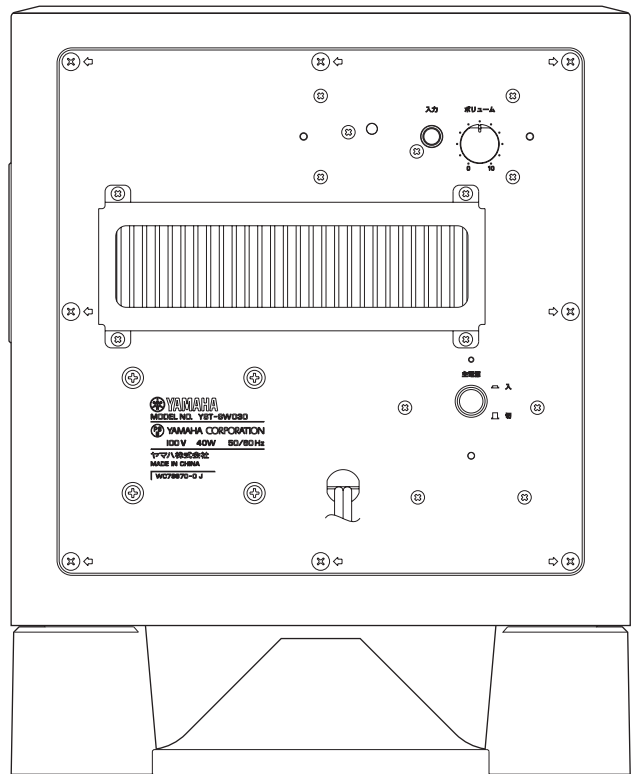

YST-SW030/  
YST-SW010

YST-SW010 (U, C models)

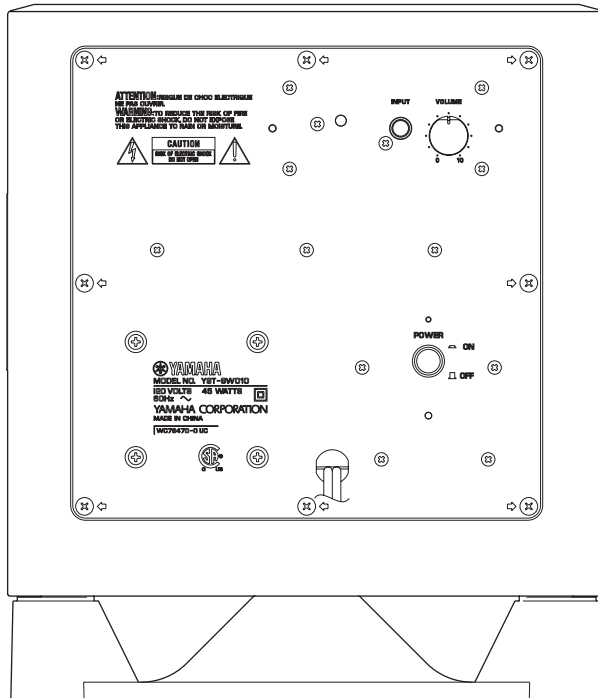

YST-SW010 (A model)

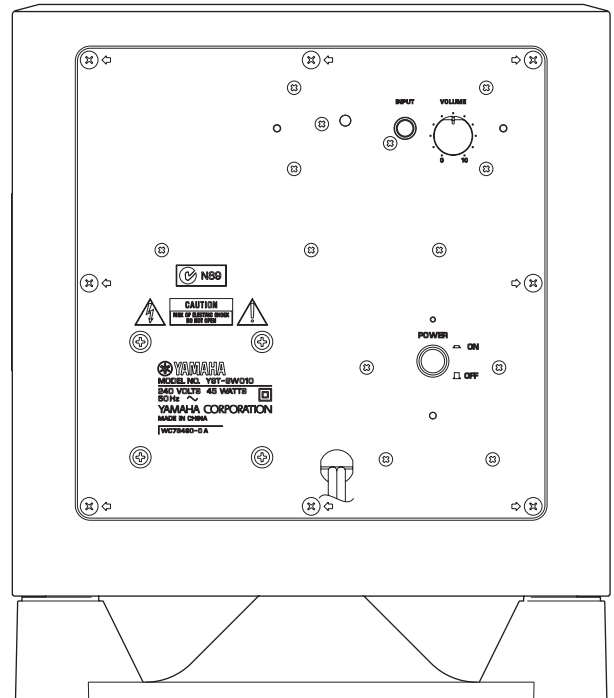

YST-SW010 (B, G models)

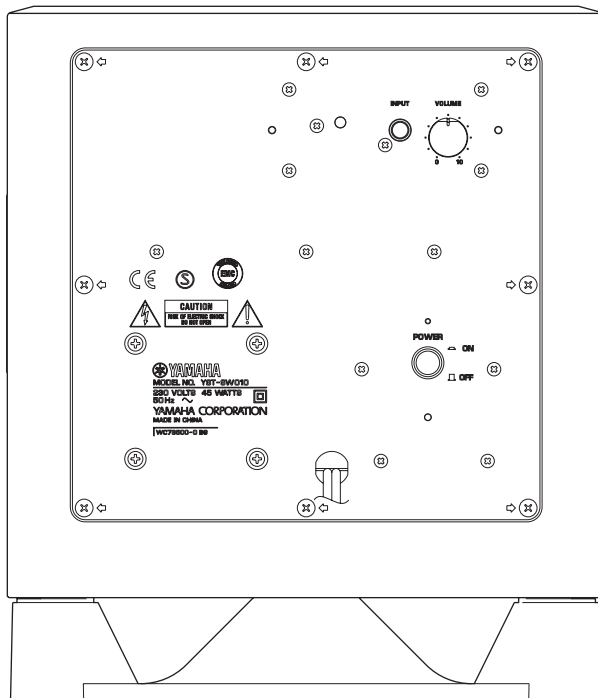

YST-SW010 (L model)

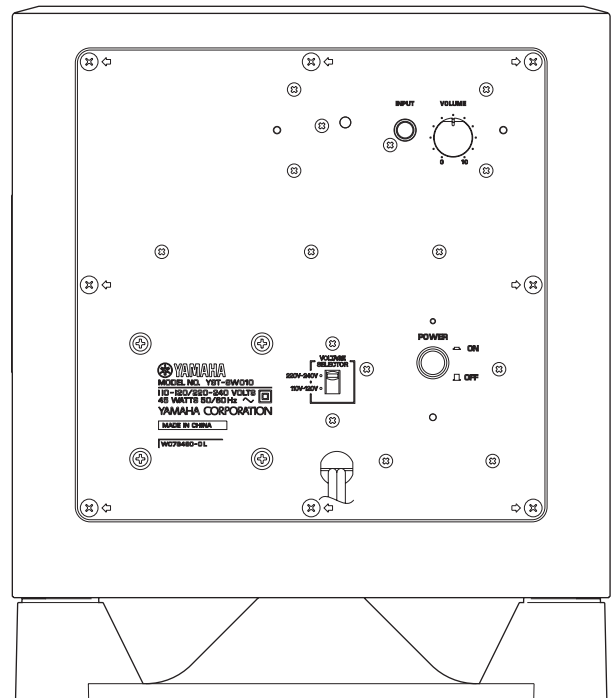

YST-SW030/  
YST-SW010

YST-SW010 (R model)

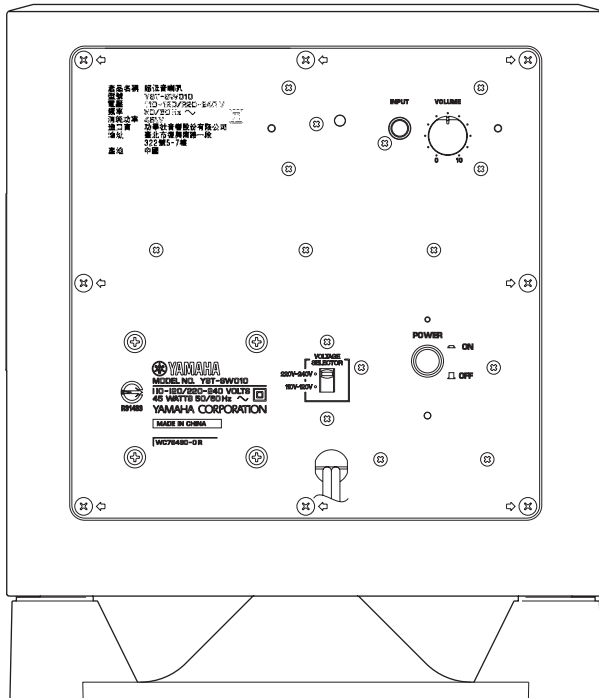

YST-SW010 (T model)

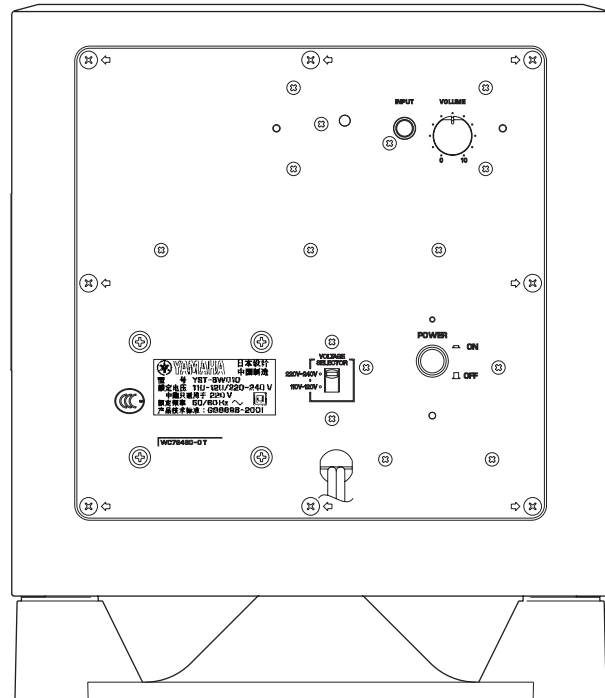

YST-SW010 (K model)

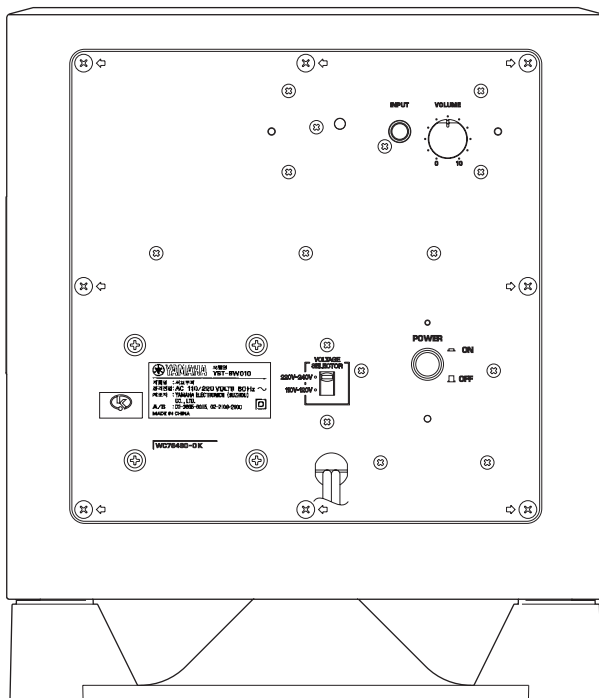

YST-SW010 (J model)

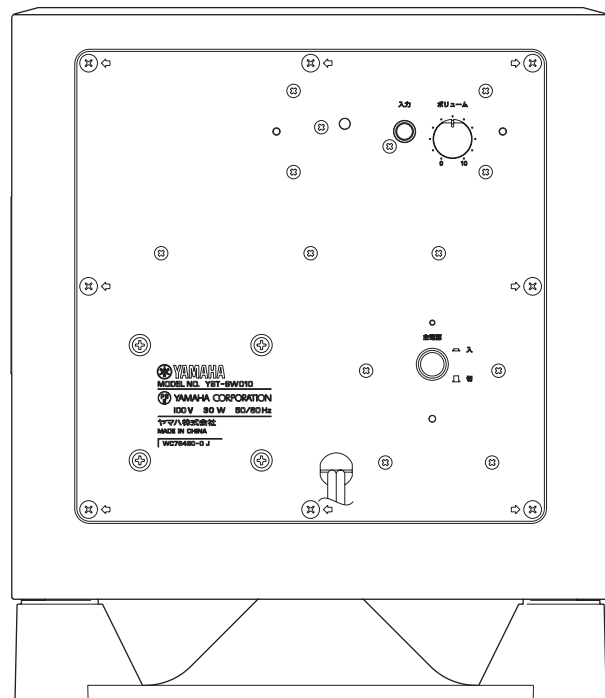

YST-SW030/  
YST-SW010



## DISASSEMBLY PROCEDURES / 分解手順

\* The description below uses YST-SW030 as a representative model.

※ 本項目では、代表としてYST-SW030について記述します。

(Remove parts in the order as numbered.)

(番号順に部品を取り外してください。)

Disconnect the power cable from the AC outlet.

AC電源コンセントから、電源コードを抜いてください。

### 1. Removal of Driver

- Remove 4 screws (①) and then remove the Base. (Fig. 1)
- Remove 4 screws (②) and then remove the Driver. (Fig. 1)
- Disconnect the connector connected to the terminal of the Driver. (Fig. 1)

### 1. スピーカーユニットの外し方

- ①のネジ4本を外し、ベースを取り外します。(Fig. 1)
- ②のネジ4本を外し、スピーカーユニットを取り外します。(Fig. 1)
- スピーカーユニットの端子に接続されているコネクタを外します。(Fig. 1)

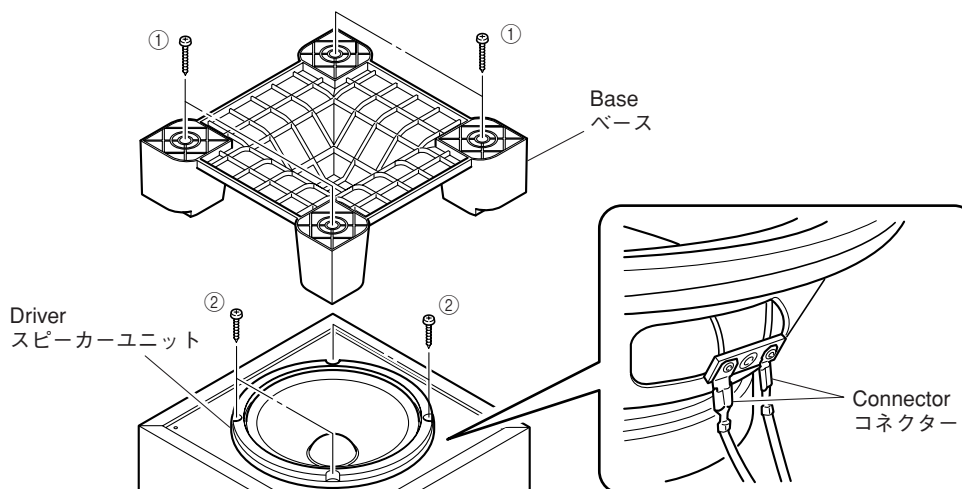

Fig. 1

### 2. Removal of Rear Panel Ass'y

- Remove 8 screws (③). (Fig. 2)  
\* Screws (③) are identified with arrow marks (◀).
- Pull out the rear panel ass'y. (Fig. 2)

### 2. リアパネルAss'yの外し方

- ③のネジ8本を外します。(Fig. 2)  
※ 取り外す③のネジには矢印(◀)が印刷されています。
- リアパネルAss'yを引き出します。(Fig. 2)

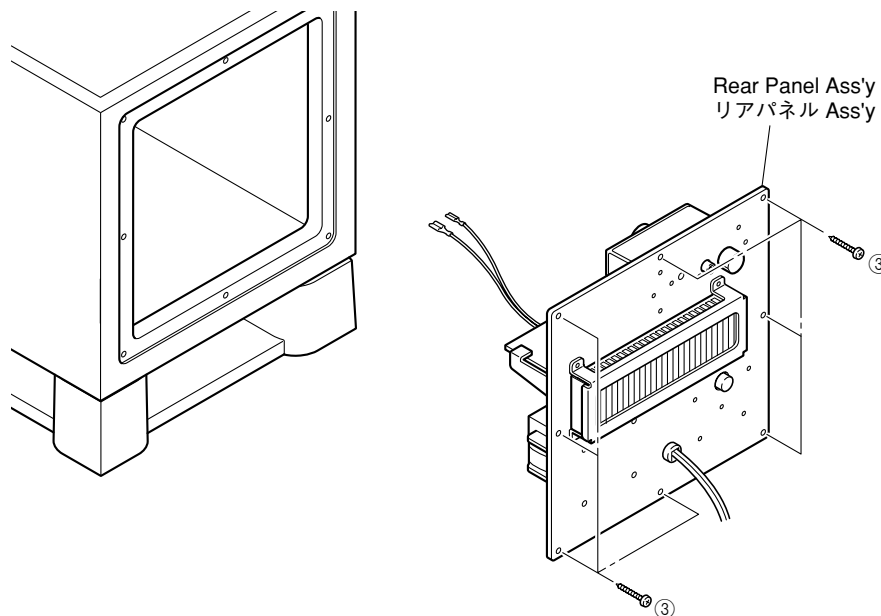

Fig. 2

**When Checking the P.C.B.:**

- Connect all the connectors removed during disassembly back to the original positions.
- Spread the Rubber sheet and cloth for insulation purpose and place the rear panel ass'y on it. (Fig. 3)

**P.C.B.チェックをする場合には**

- 分解の際に外したコネクタをすべて元通りに接続します。
- 絶縁のためにゴムシートと布を敷き、その上にリアパネル Ass'yを置いてチェックします。(Fig. 3)

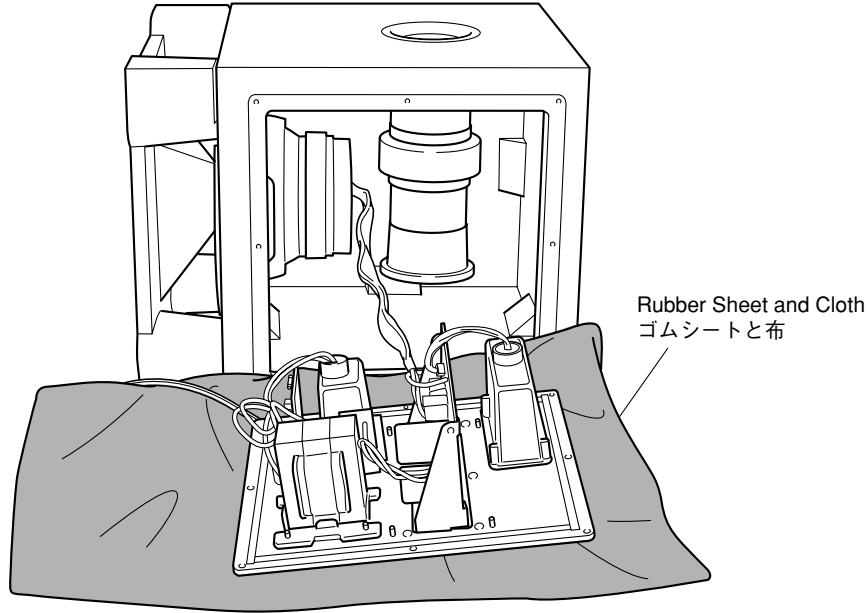
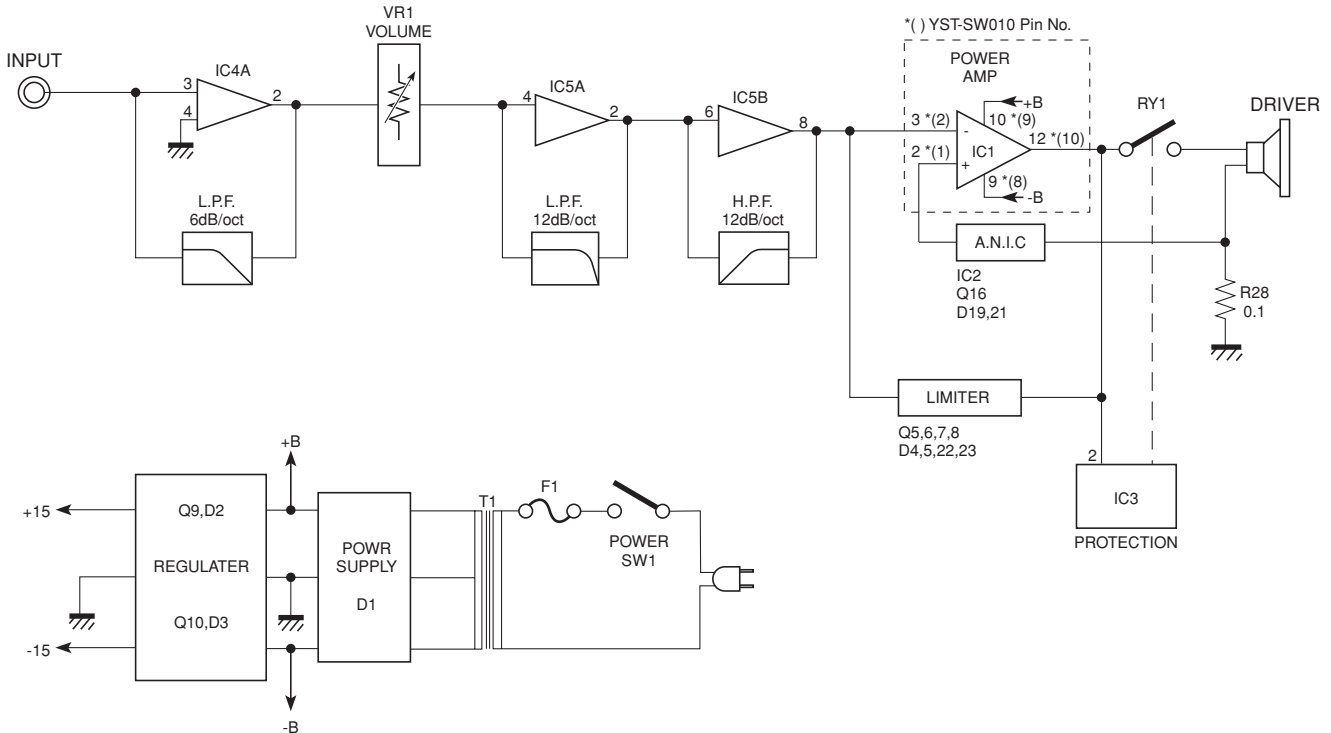

Fig. 3

**■ BLOCK DIAGRAM**



1 ■ PRINTED CIRCUIT BOARD (Foil side)

YST-SW030

MAN (1) P. C. B. (Lead Type Device)

MAN (3) P. C. B. (Lead Type Device)

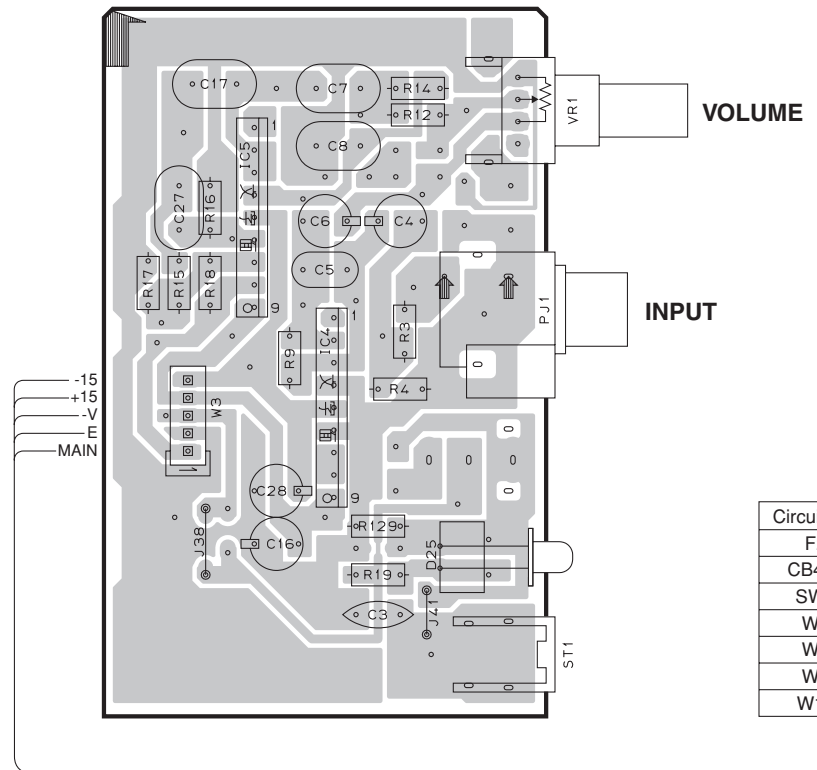

DRIVER

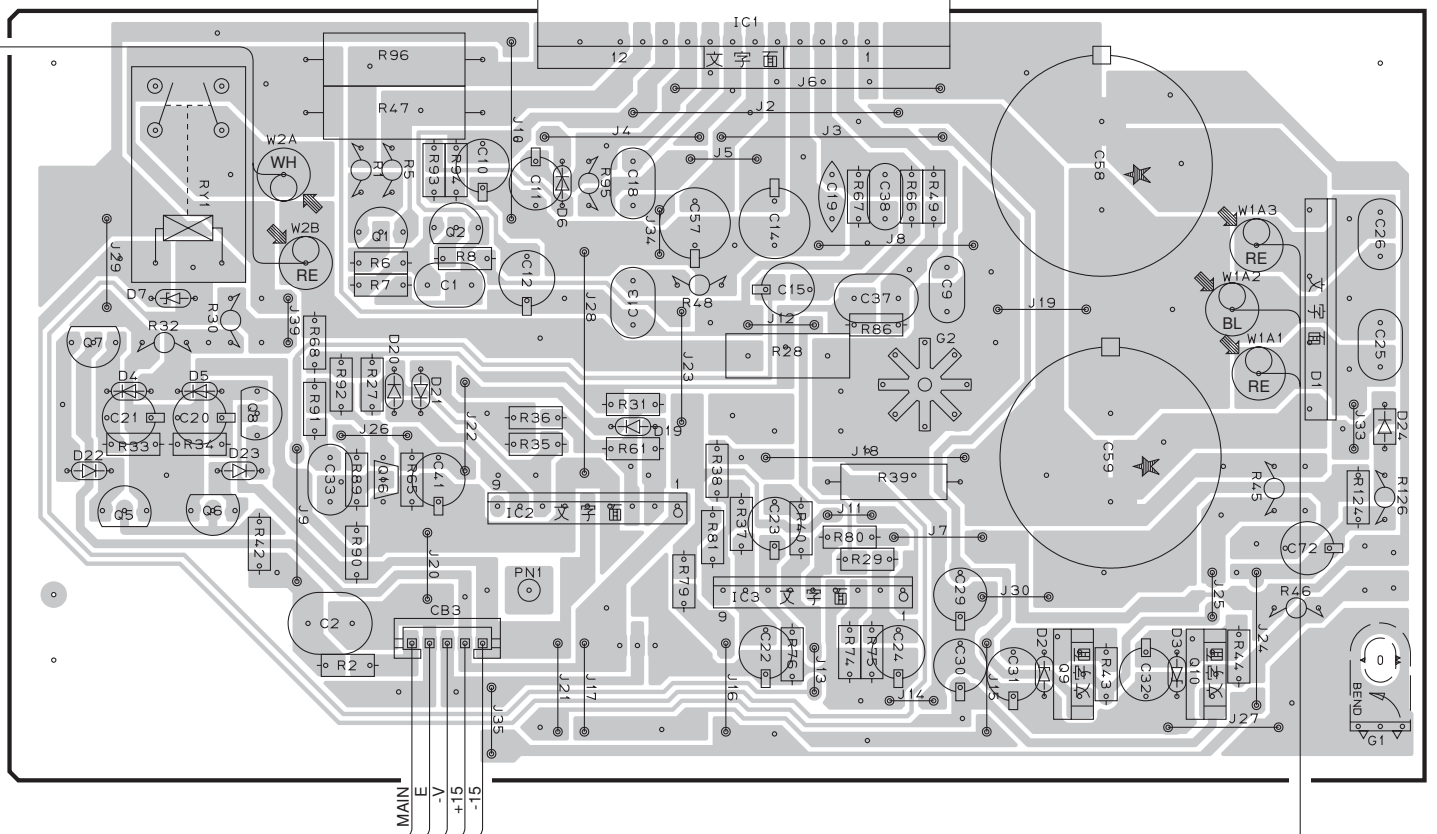

Circuit No.	U, C, A, B, G, J	L, R, T, K
F2	X	O
CB4, 5	X	O
SW2	X	O
W7	X	O
W8	X	O
W9	X	O
W10	X	O

4

MAN (2) P. C. B. (Lead Type Device)

MAN (7) P. C. B. (Lead Type Device)

MAN (6) P. C. B. (Lead Type Device)

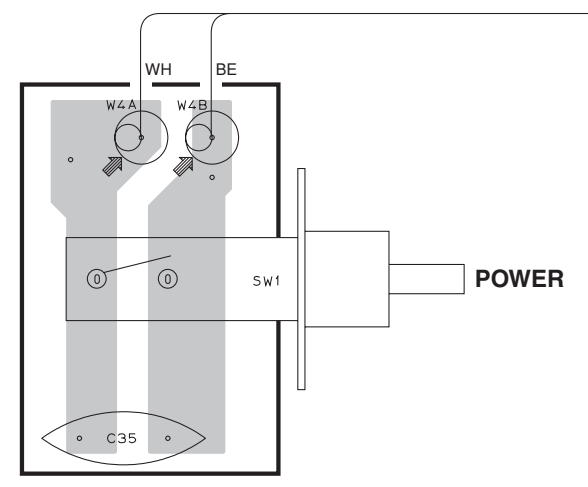

MAN (4) P. C. B. (Lead Type Device)

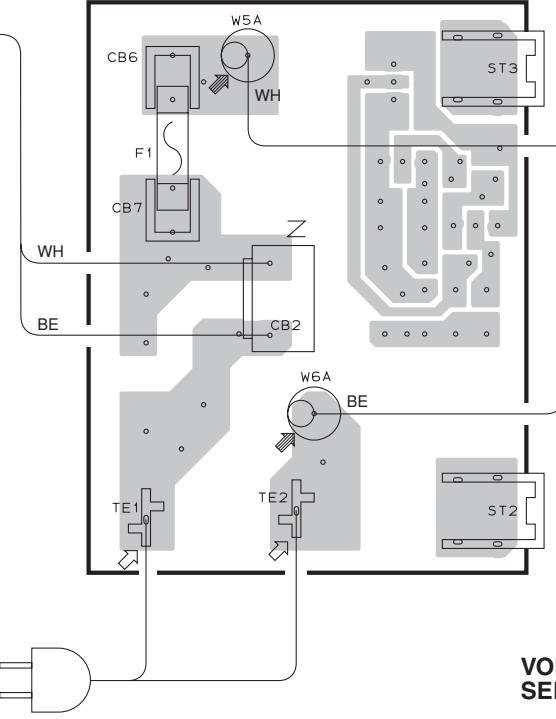

VOLTAGE SELECTOR

U, C, A, B, G, J models only

L, R, T, K models

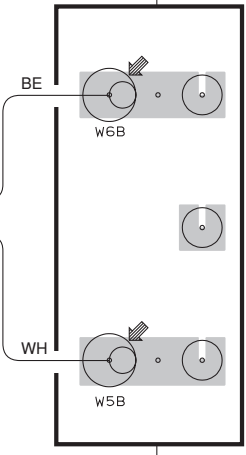

Power Transformer

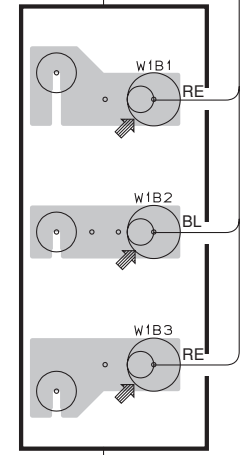

Power Transformer

6

• Semiconductor Location

Ref. no.	Location	Ref. no.	Location	Ref. no.	Location	Ref. no.	Location
D1	I2	D19	G3	IC2	G3	Q6	F3
D2	H3	D20	F2	IC3	H3	Q7	E2
D3	I3	D21	F2	IC4	B3	Q8	F3
D4	E2	D22	E3	IC5	B2	Q9	H3
D5	F2	D23	F3	Q1	F2	Q10	I3
D6	G2	D24	J3	Q2	F2		
D7	E2	IC1	G1	Q5	E3		

7

MAN (9) P. C. B. (Lead Type Device)

MAN (10) P. C. B. (Lead Type Device)

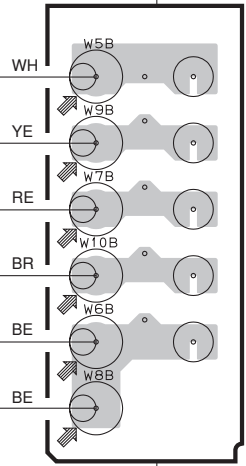
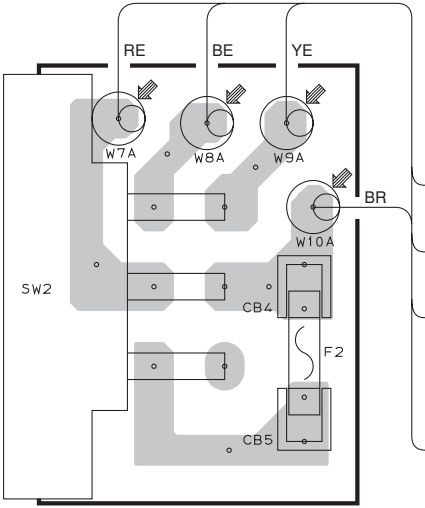

PRINTED CIRCUIT BOARD (Foil side)

YST-SW010

MAIN (3) P. C. B. (Lead Type Device)

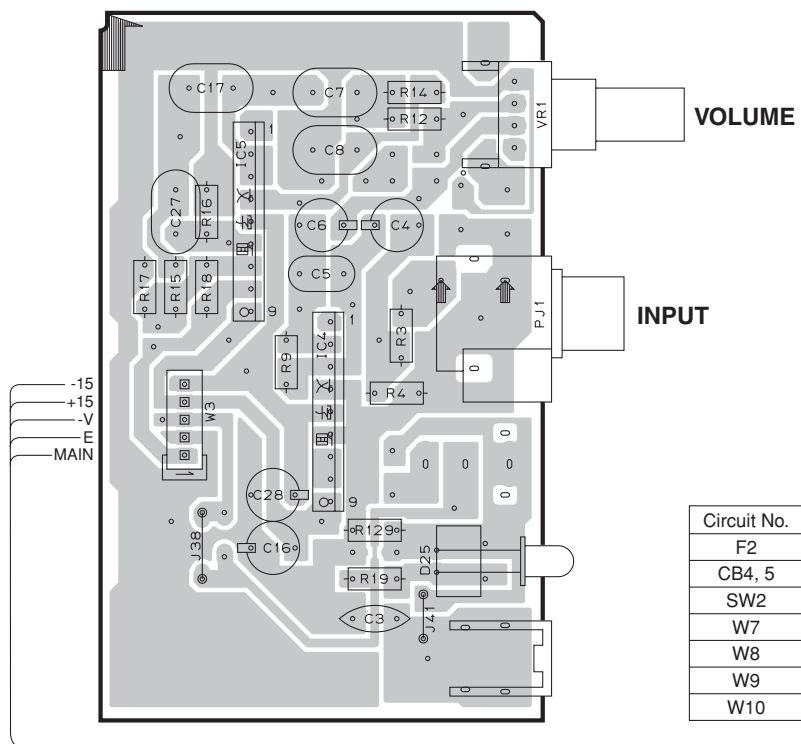

Circuit No.	U, C, A, B, G, J	L, R, T, K
F2	X	O
CB4, 5	X	O
SW2	X	O
W7	X	O
W8	X	O
W9	X	O
W10	X	O

MAIN (1) P. C. B. (Lead Type Device)

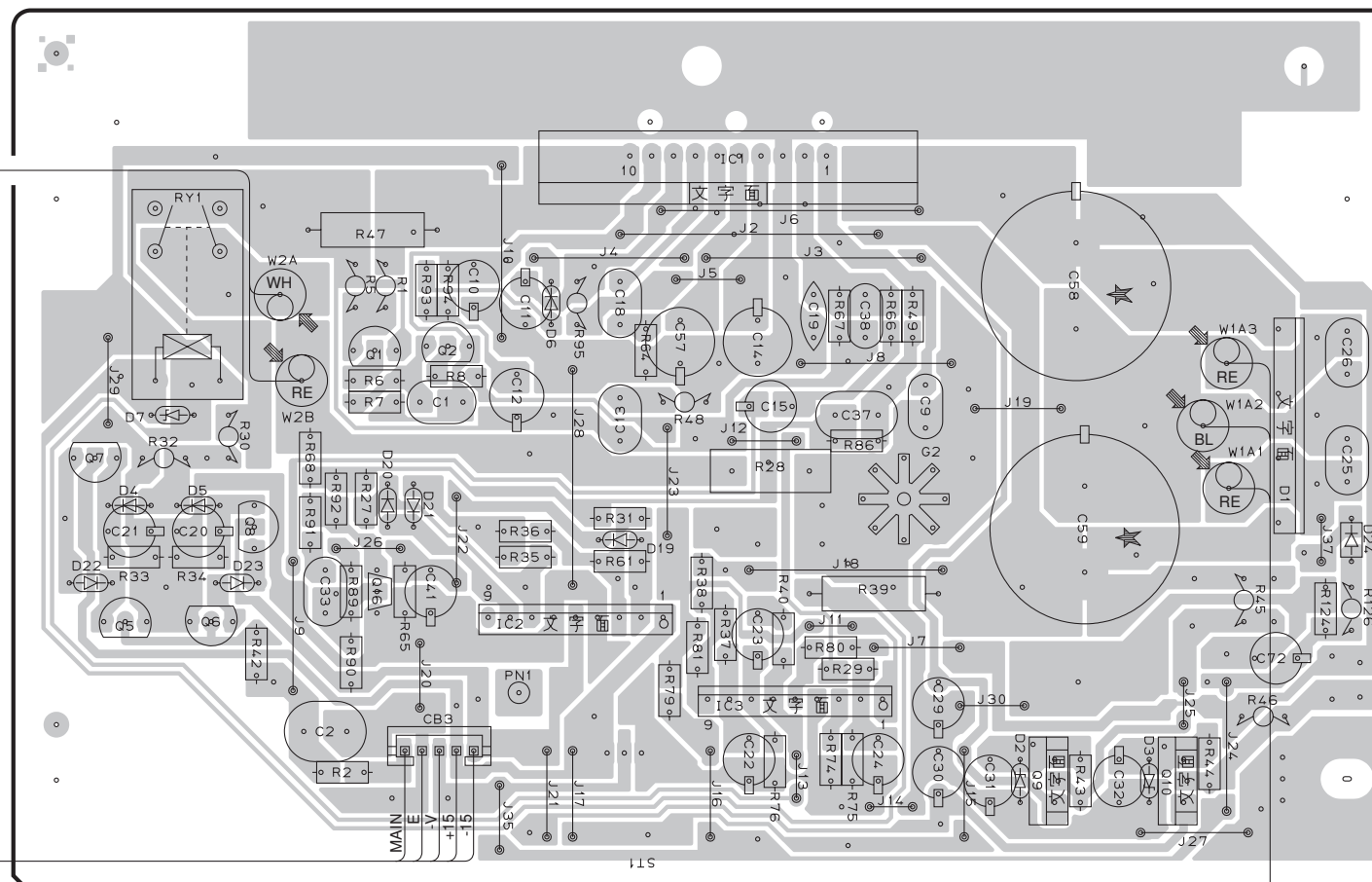

Semiconductor Location

Ref. no.	Location	Ref. no.	Location	Ref. no.	Location	Ref. no.	Location
D1	I2	D19	G3	IC2	G3	Q6	F3
D2	H4	D20	F3	IC3	H3	Q7	E3
D3	I4	D21	F3	IC4	B3	Q8	F3
D4	E3	D22	E3	IC5	B2	Q9	I4
D5	F3	D23	F3	Q1	F2	Q10	I4
D6	G2	D24	J3	Q2	G2		
D7	F2	IC1	G1	Q5	E3		

MAIN (2) P. C. B. (Lead Type Device)

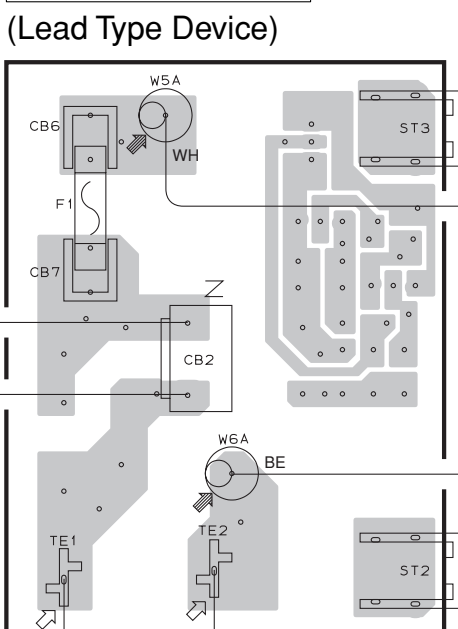

MAIN (7) P. C. B. (Lead Type Device)

U, C, A, B, G, J models only

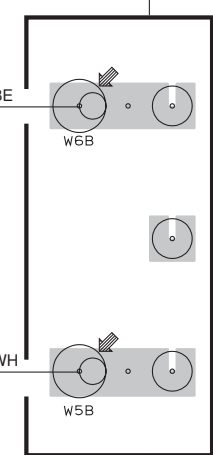

MAIN (6) P. C. B. (Lead Type Device)

(Lead Type Device)

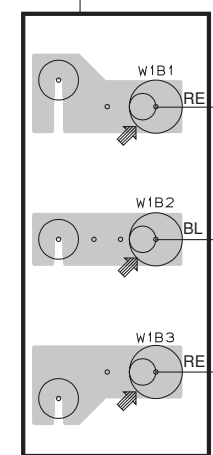

MAIN (4) P. C. B. (Lead Type Device)

(Lead Type Device)

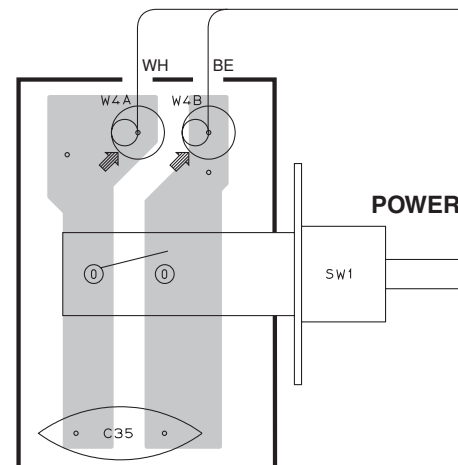

VOLTAGE SELECTOR

L, R, T, K models only

MAIN (9) P. C. B. (Lead Type Device)

(Lead Type Device)

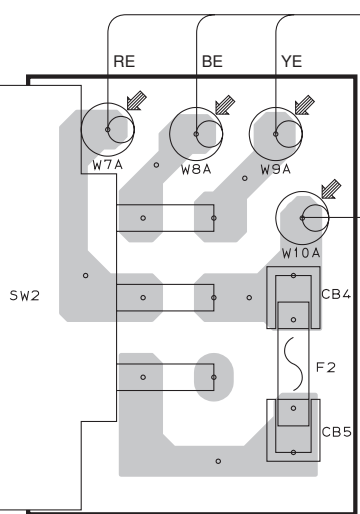

L, R, T, K models only

MAIN (10) P. C. B. (Lead Type Device)

(Lead Type Device)

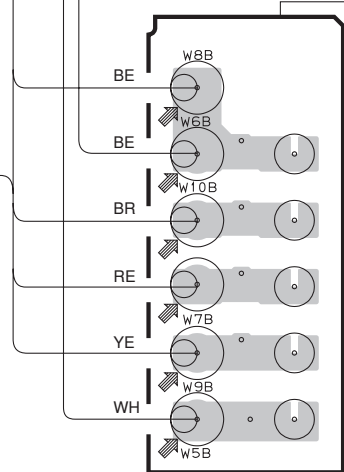

Power Transformer

Power Transformer

SCHEMATIC DIAGRAM

YST-SW030

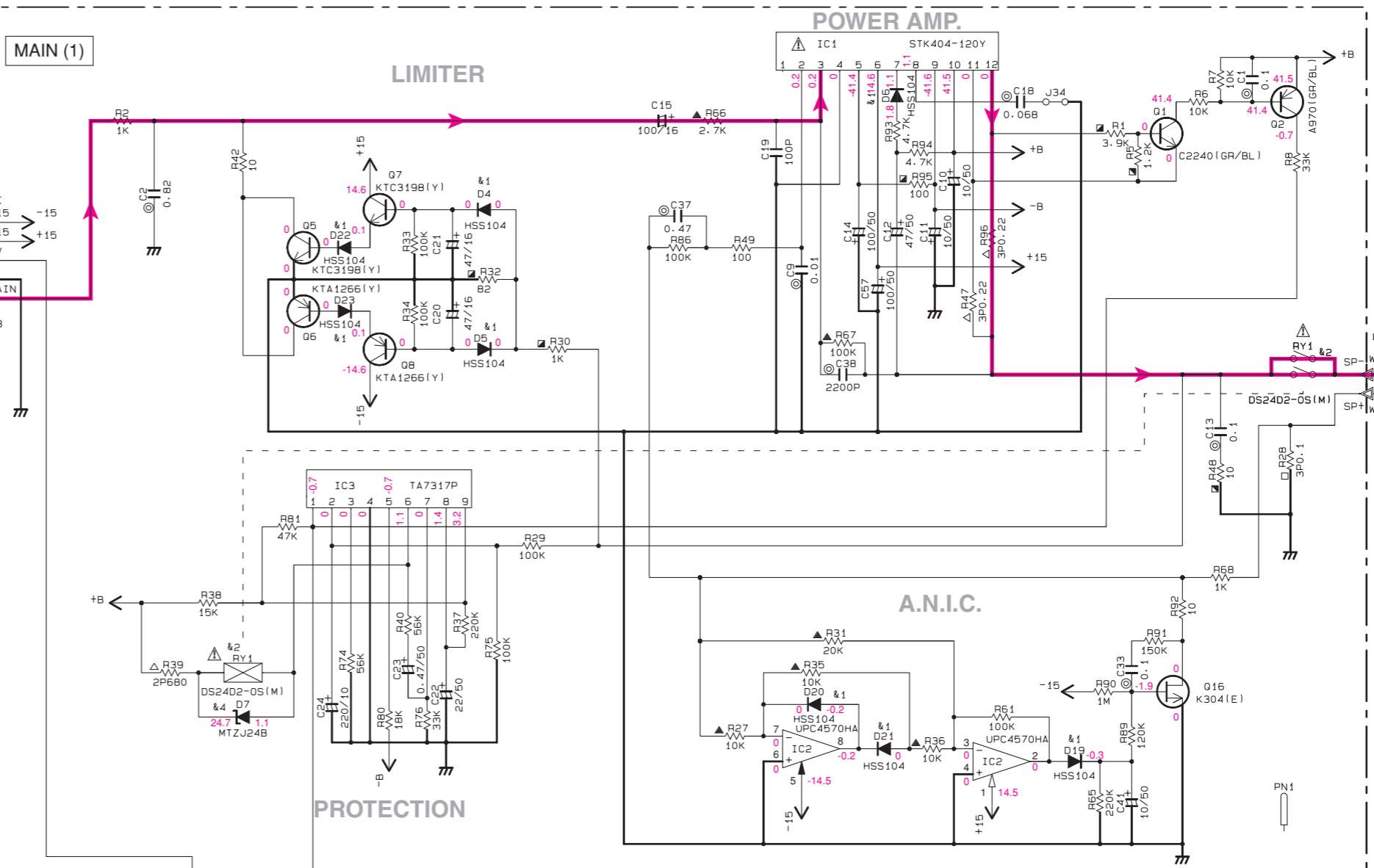
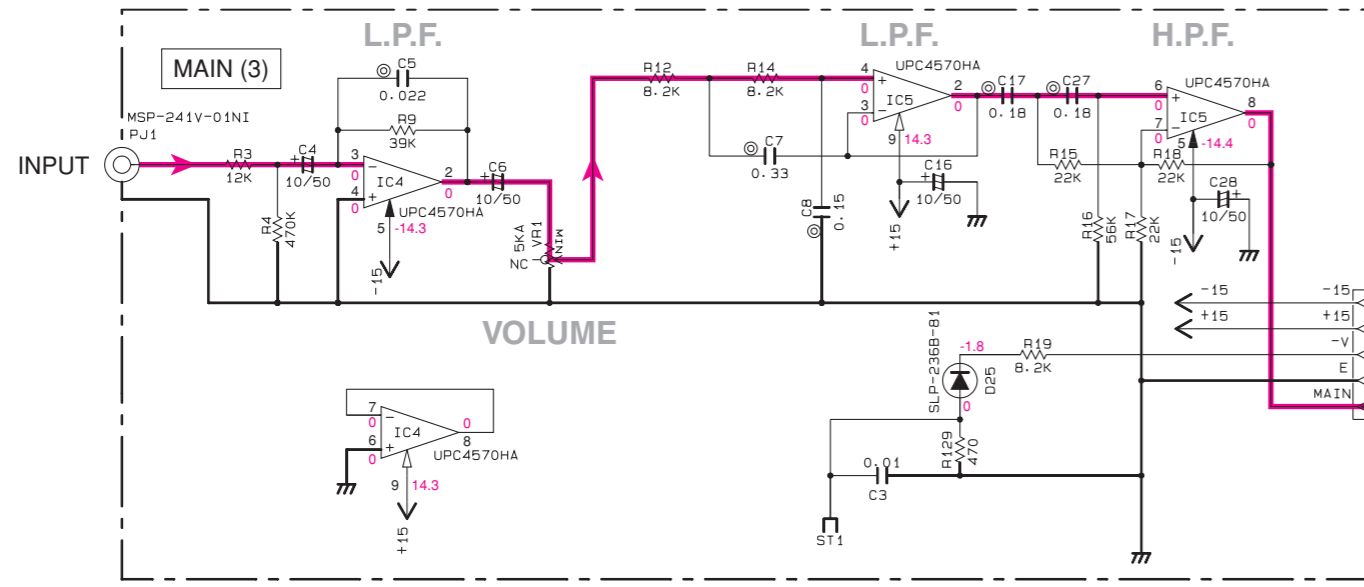

NOTICE (model)  
 (J)..... JAPAN  
 (U)..... U. S. A  
 (C)..... CANADA  
 (R)..... GENERAL  
 (T)..... CHINA  
 (K)..... KOREA  
 (A)..... AUSTRALIA  
 (B)..... BRITISH  
 (G)..... EUROPE  
 (L)..... SINGAPORE

TRANSFORMER

DESTINATION	PART NUMBER
J	X5307
U. C	X5308
R. T. K. L	X5309
A	X5310
B. G	X5311

CAPACITOR

REMARKS	PARTS NAME	Symbol
NO MARK	ELECTROLYTIC CAPACITOR	⊘
⊗	TANTALUM CAPACITOR	⊗
NO MARK	CERAMIC CAPACITOR	□
○	CERAMIC TUBULAR CAPACITOR	○
⊙	POLYESTER FILM CAPACITOR	⊙
⊚	POLYSTYRENE FILM CAPACITOR	⊚
Ⓜ	MICA CAPACITOR	Ⓜ
Ⓟ	POLYPROPYLENE FILM CAPACITOR	Ⓟ
Ⓢ	SEMICONDUCTIVE CERAMIC CAPACITOR	Ⓢ
Ⓣ	POLYPHENYLENE SULFIDE FILM CAPACITOR	Ⓣ

RESISTOR

REMARKS	PARTS NAME	Symbol
NO MARK	CARBON FILM RESISTOR (P=5)	□
□	CARBON FILM RESISTOR (P=10)	□
△	METAL OXIDE FILM RESISTOR	△
⊠	METAL FILM RESISTOR	⊠
⊞	METAL PLATE RESISTOR	⊞
⊞	FIRE PROOF CARBON FILM RESISTOR	⊞
□	CEMENT MOLDED RESISTOR	□
Ⓢ	SEMI VARIABLE RESISTOR	Ⓢ
Ⓣ	CHIP RESISTOR	Ⓣ

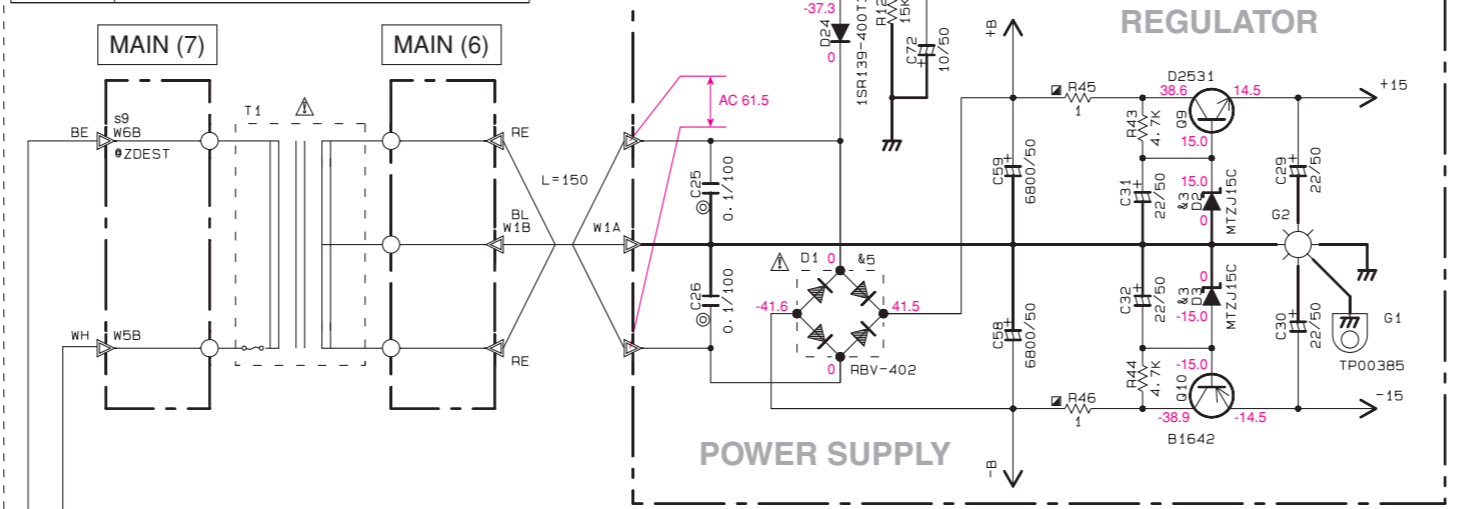
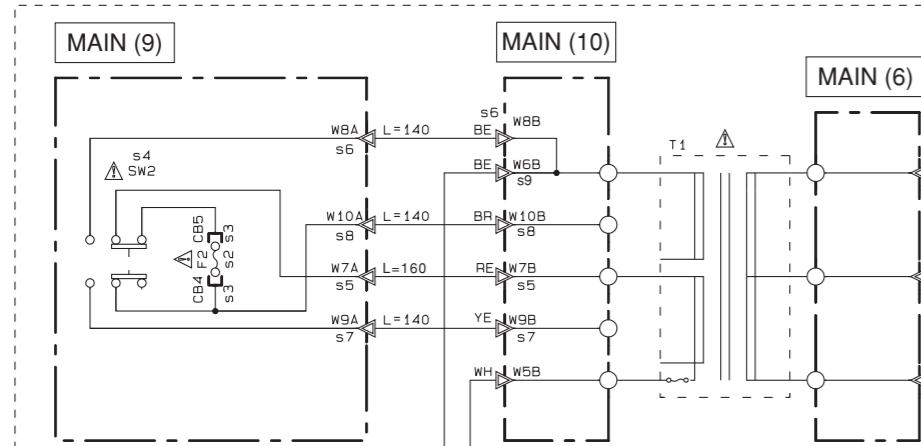

Interchangeable Parts at Manufacture-Stage

LOCATION	DESTINATION	J. U. C			R. T. K. L			A. B. G		
		F1	F2	CB4-5	SW2	W7	WB	W9	W10	WB
S1	F1	2A125V	2A125V	T630MAL250V	X	X	X	X	X	X
S2	F2	X	X	T630MAL250V	X	X	X	X	X	X
S3	CB4-5	X	X	WC05070	X	X	X	X	X	X
S4	SW2	X	X	WC90670	X	X	X	X	X	X
S5	W7	X	X	WC05070	X	X	X	X	X	X
S6	WB	X	X	WC90670	X	X	X	X	X	X
S7	W9	X	X	WC05070	X	X	X	X	X	X
S8	W10	X	X	WC90670	X	X	X	X	X	X
S9	WB	X	X	WC90670	X	X	X	X	X	X

Mark	Reference Parts Number	Parts Name
Ⓢ1	D4-6-19-23	ISS133 ISS176 HSS104
Ⓢ2	RY1	DG2402-051M1 GSPA-2B
Ⓢ3	D2-3	MTZJ15C GDZJ15C
Ⓢ4	D7	MTZJ24B GDZJ24B
Ⓢ5	D1	RBV-402 D35BA20

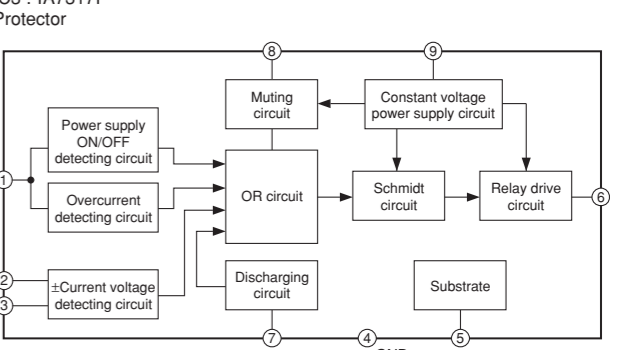
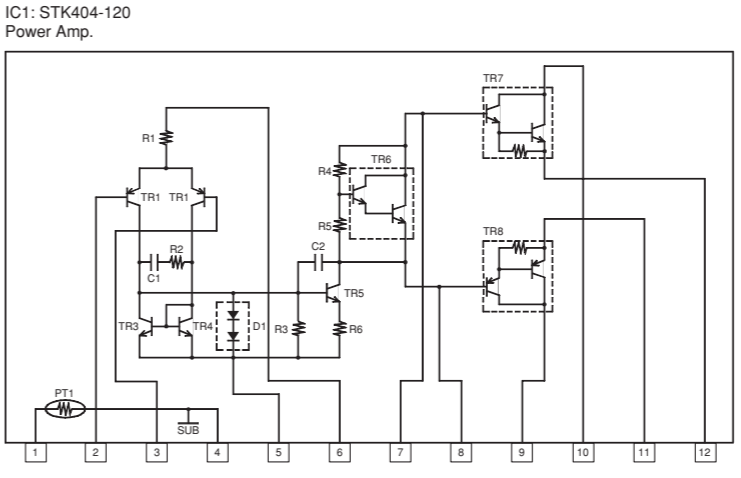
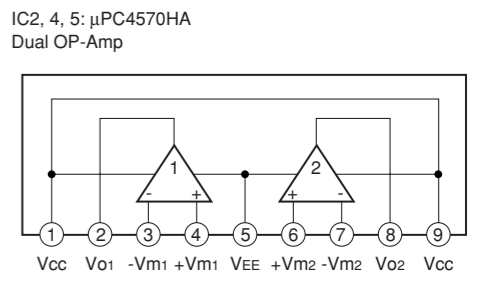

L, R, T, K models

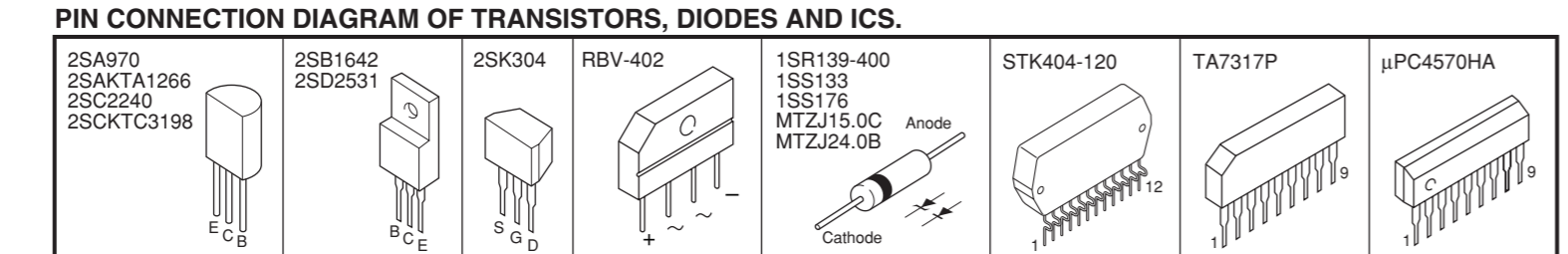

★ All voltages are measured with a 10MΩV DC electronic volt meter.  
 ★ Components having special characteristics are marked with a triangle (▲) and must be replaced with parts having specifications equal to those originally installed.  
 ★ Schematic diagram is subject to change without notice.

★ 電圧は、内部抵抗10MΩの電圧計で測定したものです。  
 ★ ▲印のある部品は、安全性確保部品を示しています。部品の交換が必要な場合、パーツリストに記載されている部品を使用してください。  
 ★ 本回路図は標準回路図です。改良のため予告なく変更することがございます。

SCHEMATIC DIAGRAM

YST-SW010

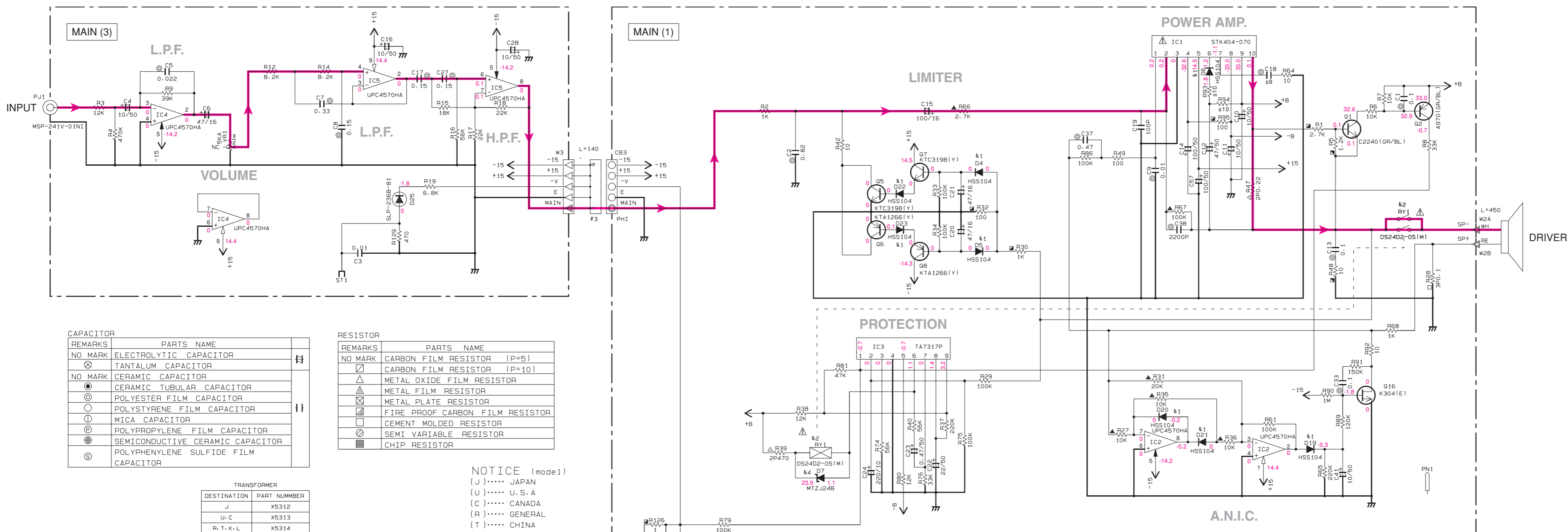

REMARKS	PARTS NAME	MARK
NO MARK	ELECTROLYTIC CAPACITOR	⊖
⊗	TANTALUM CAPACITOR	⊗
NO MARK	CERAMIC CAPACITOR	○
●	CERAMIC TUBULAR CAPACITOR	●
○	POLYESTER FILM CAPACITOR	○
○	POLYSTYRENE FILM CAPACITOR	○
Ⓜ	MICA CAPACITOR	Ⓜ
Ⓢ	POLYPROPYLENE FILM CAPACITOR	Ⓢ
Ⓢ	SEMICONDUCTIVE CERAMIC CAPACITOR	Ⓢ
Ⓢ	POLYPHENYLENE SULFIDE FILM CAPACITOR	Ⓢ

REMARKS	PARTS NAME	MARK
NO MARK	CARBON FILM RESISTOR (P=5)	□
□	CARBON FILM RESISTOR (P=10)	□
△	METAL OXIDE FILM RESISTOR	△
△	METAL FILM RESISTOR	△
□	METAL PLATE RESISTOR	□
□	FIRE PROOF CARBON FILM RESISTOR	□
□	CEMENT MOLDED RESISTOR	□
□	SEMI VARIABLE RESISTOR	□
□	CHIP RESISTOR	□

TRANSFORMER	
DESTINATION	PART NUMBER
J	X5312
U. C	X5313
R. T. K. L	X5314
A	X5315
B. G	X5316

NOTICE (model)

(J)..... JAPAN  
 (U)..... U. S. A  
 (C)..... CANADA  
 (R)..... GENERAL  
 (T)..... CHINA  
 (K)..... KOREA  
 (A)..... AUSTRALIA  
 (B)..... BRITISH  
 (G)..... EUROPE  
 (L)..... SINGAPORE

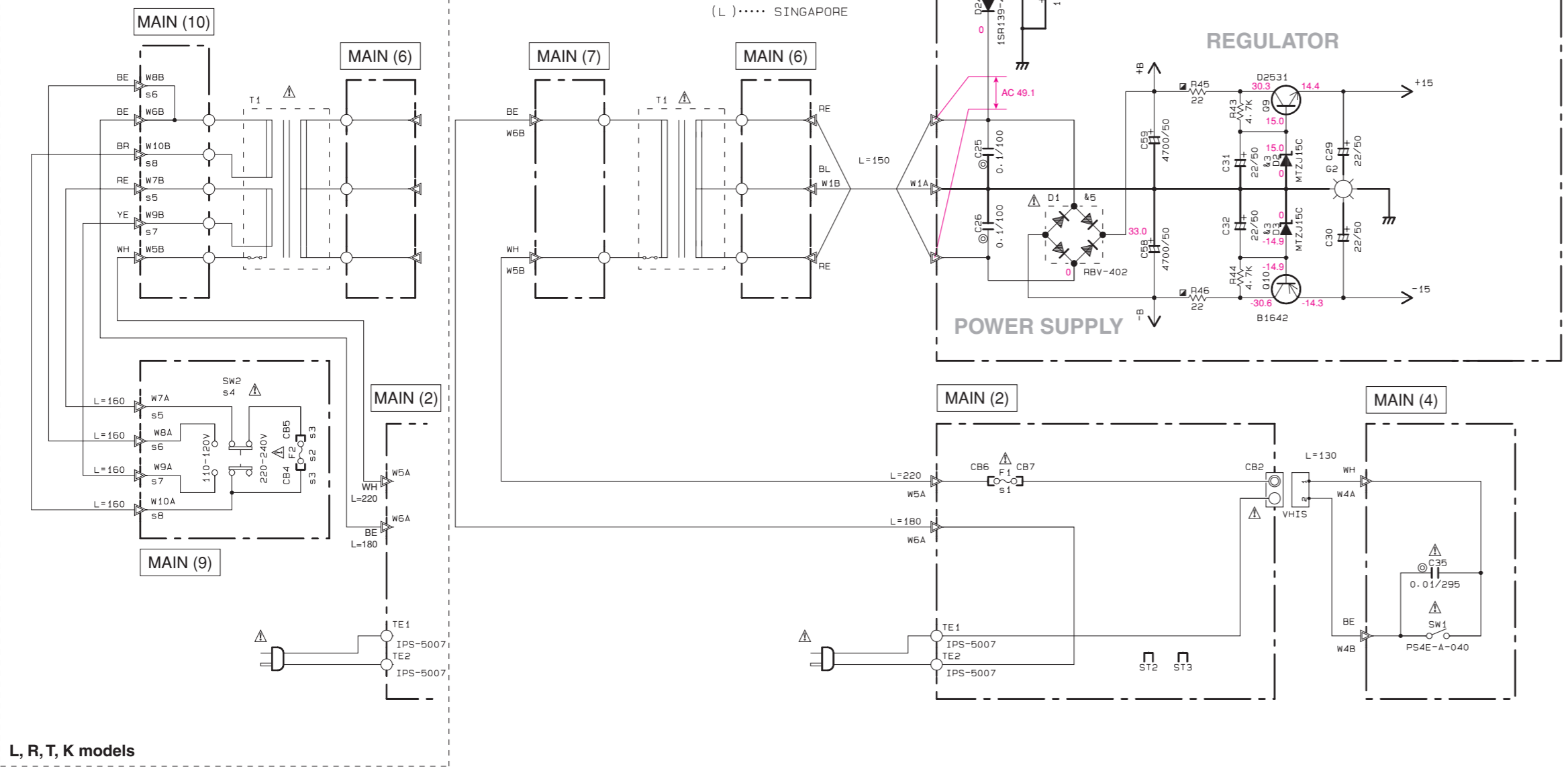

LOCATION	DESTINATION		
	J. U. C	R. T. K. L	A. B. G
s1	F1	1-6A125V	1-6A125V T400MAL250V
s2	F2	X	T400MAL250V X
s3	CB4, 5	X	WC05070 X
s4	SW2	X	WC90670 X
s5	W7	X	MH12616 X
s6	WB	X	MH16616 X
s7	WS	X	MH14616 X
s8	W10	X	MH11616 X
s9	C18	0.068/50	0.033/50 0.068/50
s10	R93, 94	4.7k	10.0k 4.7k

Interchangeable Parts at Manufacture-Stage		
Mark	Reference Parts Number	Parts Name
s1	D4-6, 19-23	1S5133 1S5176 HSS104
s2	Ry1	DG2402-0S1M1 05PA-2B
s3	D2, 3	MTZJ15C GDZJ15C
s4	D7	MTZJ24B GDZJ24B
s5	D1	RBV-402 D3SBA20

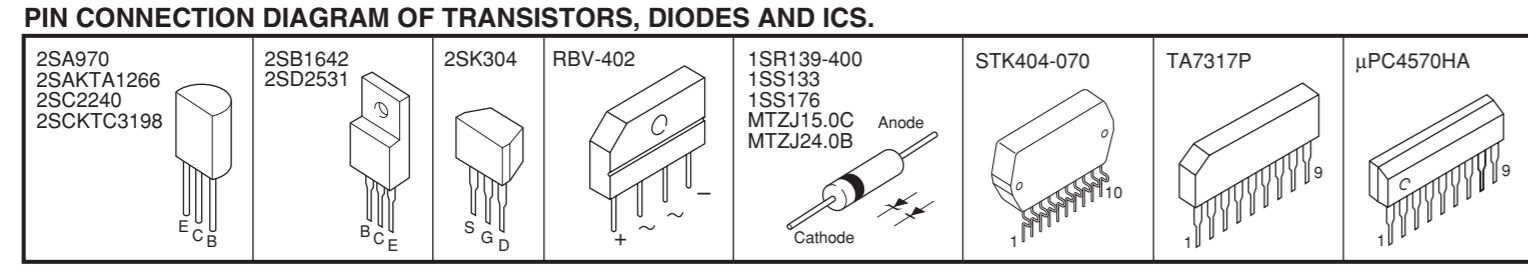
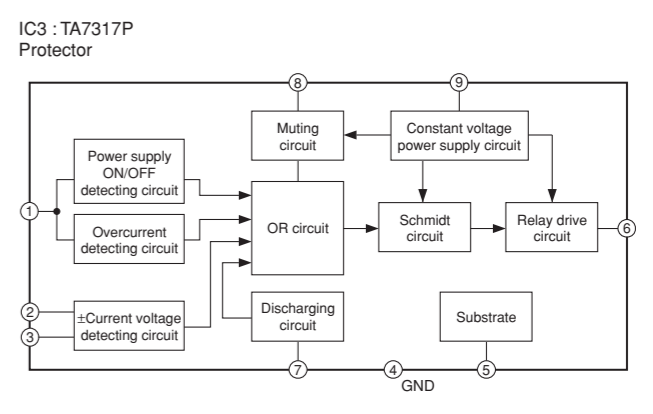
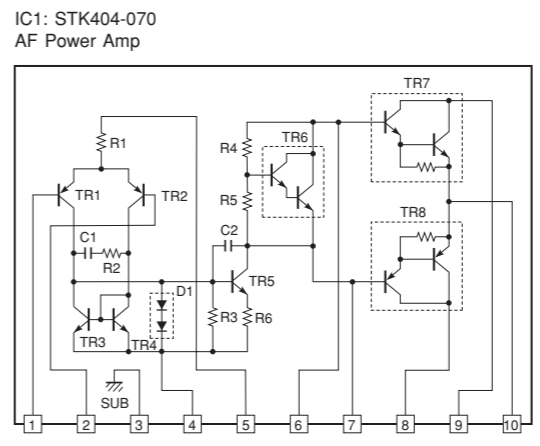
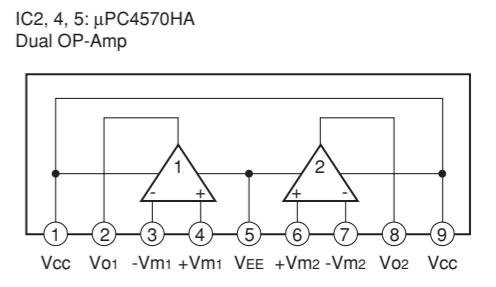



★ All voltages are measured with a 10M $\Omega$  DC electronic volt meter.  
 ★ Components having special characteristics are marked  $\Delta$ , and must be replaced with parts having specifications equal to those originally installed.  
 ★ Schematic diagram is subject to change without notice.

★ 電圧は、内部抵抗10M $\Omega$ の電圧計で測定したものです。  
 ★  $\Delta$ 印のある部品は、安全性確保部品を示しています。部品の交換が必要な場合、パーツリストに記載されている部品を使用してください。  
 ★ 本回路図は標準回路図です。改良のため予告なく変更することがございます。

# PARTS LIST

## ■ ELECTRICAL PARTS

### ■ WARNING

- Components having special characteristics are marked  and must be replaced with parts having specifications equal to those originally installed.
- Carbon resistors (1/6W or 1/4W) are not included in the ELECTRICAL PARTS List. For the parts No. of the carbon resistors, refer to last page.
- 印のある部分は、安全確保部品を示しています。部品の交換が必要な場合、パーツリストに記載されている部品を使用してください。
- 本機に使用しているカーボン抵抗は1/6Wまたは1/4Wです。このパーツリストには、記載しておりませんので、部品番号がHF450000タイプまたは同等品を使用してください。
- 部品価格ランクは、予告なく変更することがあります。

### ABBREVIATIONS IN THIS LIST ARE AS FOLLOWS:

C.A.EL.CHP	: CHIP ALUMI.ELECTROLYTIC CAP	L.EMIT	: LIGHT EMITTING MODULE
C.CE	: CERAMIC CAP	LED.DSPLY	: LED DISPLAY
C.CE.ARRAY	: CERAMIC CAP ARRAY	LED.INFRD	: LED,INFRARED
C.CE.CHP	: CHIP CERAMIC CAP	MODUL.RF	: MODULATOR,RF
C.CE.ML	: MULTILAYER CERAMIC CAP	PHOT.CPL	: PHOTO COUPLER
C.CE.M.CHP	: CHIP MULTILAYER CERAMIC CAP	PHOT.INTR	: PHOTO INTERRUPTER
C.CE.SAFTY	: RECOGNIZED CERAMIC CAP	PHOT.RFLCT	: PHOTO REFLECTOR
C.CE.TUBLR	: CERAMIC TUBULAR CAP	PIN.TEST	: PIN,TEST POINT
C.CE.SMI	: SEMI CONDUCTIVE CERAMIC CAP	PLST.RIVET	: PLASTIC RIVET
C.EL	: ELECTROLYTIC CAP	R.ARRAY	: RESISTOR ARRAY
C.MICA	: MICA CAP	R.CAR.	: CARBON RESISTOR
C.ML.FLM	: MULTILAYER FILM CAP	R.CAR.CHP	: CHIP RESISTOR
C.MP	: METALLIZED PAPER CAP	R.CAR.FP	: FLAME PROOF CARBON RESISTOR
C.MYLAR	: MYLAR FILM CAP	R.FUS	: FUSABLE RESISTOR
C.MYLAR.ML	: MULTILAYER MYLAR FILM CAP	R.MTL.CHP	: CHIP METAL FILM RESISTOR
C.PAPER	: PAPER CAPACITOR	R.MTL.FLM	: METAL FILM RESISTOR
C.PLS	: POLYSTYRENE FILM CAP	R.MTL.OXD	: METAL OXIDE FILM RESISTOR
C.POL	: POLYESTER FILM CAP	R.MTL.PLAT	: METAL PLATE RESISTOR
C.POLY	: POLYETHYLENE FILM CAP	RSNR.CE	: CERAMIC RESONATOR
C.PP	: POLYPROPYLENE FILM CAP	RSNR.CRYS	: CRYSTAL RESONATOR
C.TNTL	: TANTALUM CAP	R.TW.CEM	: TWIN CEMENT FIXED RESISTOR
C.TNTL.CHP	: CHIP TANTALUM CAP	R.WW	: WIRE WOUND RESISTOR
C.TRIM	: TRIMMER CAP	SCR.BND.HD	: BIND HEAD B-TITE SCREW
CN	: CONNECTOR	SCR.BW.HD	: BW HEAD TAPPING SCREW
CN.BS.PIN	: CONNECTOR,BASE PIN	SCR.CUP	: CUP TITE SCREW
CN.CANNON	: CONNECTOR,CANNON	SCR.TERM	: SCREW TERMINAL
CN.DIN	: CONNECTOR,DIN	SCR.TR	: SCREW,TRANSISTOR
CN.FLAT	: CONNECTOR,FLAT CABLE	SUPRT.PCB	: SUPPORT,P.C.B.
CN.POST	: CONNECTOR,BASE POST	SURG.PRTCT	: SURGE PROTECTOR
COIL.MX.AM	: COIL,AM MIX	SW.TACT	: TACT SWITCH
COIL.AT.FM	: COIL,FM ANTENNA	SW.LEAF	: LEAF SWITCH
COIL.DT.FM	: COIL,FM DETECT	SW.LEVER	: LEVER SWITCH
COIL.MX.FM	: COIL,FM MIX	SW.MICRO	: MICRO SWITCH
COIL.OUTPT	: OUTPUT COIL	SW.PUSH	: PUSH SWITCH
DIOD.ARRAY	: DIODE ARRAY	SW.RT.ENC	: ROTARY ENCODER
DIODE.BRG	: DIODE BRIDGE	SW.RT.MTR	: ROTARY SWITCH WITH MOTOR
DIODE.CHP	: CHIP DIODE	SW.RT	: ROTARY SWITCH
DIODE.VAR	: VARACTOR DIODE	SW.SLIDE	: SLIDE SWITCH
DIOD.Z.CHP	: CHIP ZENER DIODE	TERM.SP	: SPEAKER TERMINAL
DIODE.ZENR	: ZENER DIODE	TERM.WRAP	: WRAPPING TERMINAL
DSCR.CE	: CERAMIC DISCRIMINATOR	THRMST.CHP	: CHIP THERMISTOR
FER.BEAD	: FERRITE BEADS	TR.CHP	: CHIP TRANSISTOR
FER.CORE	: FERRITE CORE	TR.DGT	: DIGITAL TRANSISTOR
FET.CHP	: CHIP FET	TR.DGT.CHP	: CHIP DIGITAL TRANSISTOR
FL.DSPLY	: FLUORESCENT DISPLAY	TRANS	: TRANSFORMER
FLTR.GE	: CERAMIC FILTER	TRANS.PULS	: PULSE TRANSFORMER
FLTR.COMB	: COMB FILTER MODULE	TRANS.PWR	: POWER TRANSFORMER ASS'Y
FLTR.LC.RF	: LC FILTER,EMI	TUNER.AM	: TUNER PACK,AM
GND.MTL	: GROUND PLATE	TUNER.FM	: TUNER PACK,FM
GND.TERM	: GROUND TERMINAL	TUNER.PK	: FRONT-ENDTUNER PACK
HOLDER.FUS	: FUSE HOLDER	VR	: ROTARY POTENTIOMETER
IC.PRTCT	: IC PROTECTOR	VR.MTR	: POTENTIOMETER WITH MOTOR
JUMPER.CN	: JUMPER CONNECTOR	VR.SW	: POTENTIOMETER WITH ROTARY SW
JUMPER.TST	: JUMPER,TEST POINT	VR.SLIDE	: SLIDE POTENTIOMETER
L.DTCT	: LIGHT DETECTING MODULE	VR.TRIM	: TRIMMER POTENTIOMETER

**Note)** Those parts marked with “#” are not included in the P.C.B. ass'y.

**YST-SW030**  
**P.C.B. MAIN**

Schm Ref.	PART NO.	Description	Remarks	Markets	部 品 名	Rank	
	WC740200	P. C. B.	MAIN		JUC	P C B メイン	
	WC740300	P. C. B.	MAIN		RTKL	P C B メイン	
	WC740400	P. C. B.	MAIN		ABG	P C B メイン	
△	CB2	VG879900	CN. BS. PIN	2P		ベースピン	01
	CB3	VB390100	CN. BS. PIN	5P		ベースピン	01
	CB4	WC050700	HOLDER. FUS	EYF52BCY	RTKL	ヒューズホルダー	01
	CB5	WC050700	HOLDER. FUS	EYF52BCY	RTKL	ヒューズホルダー	01
	CB6	WC050700	HOLDER. FUS	EYF52BCY		ヒューズホルダー	01
	CB7	WC050700	HOLDER. FUS	EYF52BCY		ヒューズホルダー	01
	C1	VE326000	C. MYLAR. ML	0.1uF 50V		積層マイラーコン	01
	C2	VE327100	C. MYLAR. ML	0.82uF 50V		積層マイラーコン	02
	C3	FG644100	C. CE	0.01uF 50V		セラコン	01
	C4	UR867100	C. EL	10uF 50V		ケミコン	01
	C5	UA654220	C. MYLAR	0.022uF 50V		マイラーコン	01
	C6	UR867100	C. EL	10uF 50V		ケミコン	01
	C7	VE326600	C. MYLAR. ML	0.33uF 50V		積層マイラーコン	01
	C8	VE326200	C. MYLAR. ML	0.15uF 50V		積層マイラーコン	
	C9	UA654100	C. MYLAR	0.01uF 50V		マイラーコン	01
	C10	UR867100	C. EL	10uF 50V		ケミコン	01
	C11	UR867100	C. EL	10uF 50V		ケミコン	01
	C12	UR867470	C. EL	47uF 50V		ケミコン	01
	C13	VE326000	C. MYLAR. ML	0.1uF 50V		積層マイラーコン	01
	C14	UR868100	C. EL	100uF 50V		ケミコン	01
	C15	UR838100	C. EL	100uF 16V		ケミコン	01
	C16	UR867100	C. EL	10uF 50V		ケミコン	01
	C17	VE326300	C. MYLAR. ML	0.18uF 50V		積層マイラーコン	01
	C18	UA654680	C. MYLAR	0.068uF 50V		マイラーコン	01
	C19	FG652100	C. CE	100pF 50V		セラコン	01
	C20	UR837470	C. EL	47uF 16V		ケミコン	01
	C21	UR837470	C. EL	47uF 16V		ケミコン	01
	C22	UR867220	C. EL	22uF 50V		ケミコン	01
	C23	UR865470	C. EL	0.47uF 50V		ケミコン	01
	C24	UR828220	C. EL	220uF 10V		ケミコン	01
	C25	VT898000	C. MYLAR	0.1uF 100V		マイラーコン	01
	C26	VT898000	C. MYLAR	0.1uF 100V		マイラーコン	01
	C27	VE326300	C. MYLAR. ML	0.18uF 50V		積層マイラーコン	01
	C28	UR867100	C. EL	10uF 50V		ケミコン	01
	C29	UR867220	C. EL	22uF 50V		ケミコン	01
	C30	UR867220	C. EL	22uF 50V		ケミコン	01
	C31	UR867220	C. EL	22uF 50V		ケミコン	01
	C32	UR867220	C. EL	22uF 50V		ケミコン	01
	C33	VE326000	C. MYLAR. ML	0.1uF 50V		積層マイラーコン	01
△	C35	WB121400	C. CE. SAFTY	0.01uF 295V		規格認定コン	
	C37	VE326800	C. MYLAR. ML	0.47uF 50V		積層マイラーコン	01
	C38	UA653220	C. MYLAR	2200pF 50V		マイラーコン	01
	C41	UR867100	C. EL	10uF 50V		ケミコン	
	C57	UR868100	C. EL	100uF 50V		ケミコン	01
	C58	V3757300	C. EL	6800uF 50V		ケミコン	06
	C59	V3757300	C. EL	6800uF 50V		ケミコン	06
	C72	UR867100	C. EL	10uF 50V		ケミコン	01
△	D1	VC971500	D10DE. BRG	RBV-402 4A 200V		ダイオード	03
	D2	VG440900	D10DE. ZENR	MTZJ15C 15V		ツェナーダイオード	01
	D3	VG440900	D10DE. ZENR	MTZJ15C 15V		ツェナーダイオード	01

\* New Parts \* 新規部品(マーク#の部品は、基板に含まれません)

YST-SW030/  
YST-SW010



## YST-SW030

## P.C.B. MAIN

Schm Ref.	PART NO.	Description	Remarks	Markets	部 品 名	Rank
D4	VD631600	D10DE	1SS133, 176		ダイオード	01
D5	VD631600	D10DE	1SS133, 176		ダイオード	01
D6	VD631600	D10DE	1SS133, 176		ダイオード	01
D7	VG442500	D10DE. ZENR	MTZJ24B 24V		ツェナーダイオード	01
D19	VD631600	D10DE	1SS133, 176		ダイオード	01
D20	VD631600	D10DE	1SS133, 176		ダイオード	01
D21	VD631600	D10DE	1SS133, 176		ダイオード	01
D22	VD631600	D10DE	1SS133, 176		ダイオード	01
D23	VD631600	D10DE	1SS133, 176		ダイオード	01
D24	VU264100	D10DE	1SR139-400		ダイオード	01
* D25	WB884500	LED	SLP-236B-81		L E D	
* △ F1	WC804700	FUSE	2A 125V	JUCRKL	ヒューズ1 2 5 V	
* △ F1	VV335300	FUSE	0.63A 250V	ABG	ヒューズ2 5 0 V	
* F2	VV335300	FUSE	0.63A 250V	RTKL	ヒューズ2 5 0 V	
G2	V5995800	PLATE. GND			アースプレート	
△ IC1	X3830A00	IC	STK404-120 120W		アンプ I C S I P	
IC2	XB247A00	IC	uPC4570HA		I C	02
IC3	X3369A00	IC	TA7317P		I C	04
IC4	XB247A00	IC	uPC4570HA		I C	02
IC5	XB247A00	IC	uPC4570HA		I C	02
* PJ1	WC871000	JACK. PIN	MSP-241V-01N1		ピンジャック 1 P	
PN1	WB213200	PIN	L=70 WB21320		スタイルピン	
Q1	iC224030	TR	2SC2240 GR, BL		トランジスタ	01
Q2	iA097030	TR	2SA970 GR, BL		トランジスタ	01
* Q5	WB228800	TR	2SCKTC3198 Y-AT		トランジスタ	
* Q6	WB228700	TR	2SAKTA1266 Y-AT		トランジスタ	
* Q7	WB228800	TR	2SCKTC3198 Y-AT		トランジスタ	
* Q8	WB228700	TR	2SAKTA1266 Y-AT		トランジスタ	
Q9	V6896700	TR	2SD2531		トランジスタ	03
Q10	V6896500	TR	2SB1642		トランジスタ	04
Q16	V3028000	FET	2SK304 E		F E T	01
R1	HV756390	R. CAR. FP	3.9K Ω 1/4W		不燃化カーボン抵抗	01
R5	HV756120	R. CAR. FP	1.2K Ω 1/4W		不燃化カーボン抵抗	01
* R27	WC798300	R. MTL. FLM	10K Ω 1/4W		金属被膜抵抗	
R28	V6022600	R. WW	0.1 Ω 3W		セメント抵抗	
R30	HV756100	R. CAR. FP	1K Ω 1/4W		不燃化カーボン抵抗	01
* R31	WC799000	R. MTL. FLM	20K Ω 1/4W		金属被膜抵抗	
R32	HV754820	R. CAR. FP	82 Ω 1/4W		不燃化カーボン抵抗	01
* R35	WC798300	R. MTL. FLM	10K Ω 1/4W		金属被膜抵抗	
* R36	WC798300	R. MTL. FLM	10K Ω 1/4W		金属被膜抵抗	
R39	VC761000	R. MTL. OXD	680 Ω 2W		酸化金属被膜抵抗	01
R45	HV753100	R. CAR. FP	1 Ω 1/4W		不燃化カーボン抵抗	01
R46	HV753100	R. CAR. FP	1 Ω 1/4W		不燃化カーボン抵抗	01
R47	VD952400	R. MTL. OXD	0.22 Ω 3W		酸化金属被膜抵抗	01
R48	HV754100	R. CAR. FP	10 Ω 1/4W		不燃化カーボン抵抗	01
* R66	WC796900	R. MTL. FLM	2.7K Ω 1/4W		金属被膜抵抗	
* R67	WC800700	R. MTL. FLM	100K Ω 1/4W		金属被膜抵抗	
R95	HV755100	R. CAR. FP	100 Ω 1/4W		不燃化カーボン抵抗	01
R96	VD952400	R. MTL. OXD	0.22 Ω 3W		酸化金属被膜抵抗	01
R126	HV753100	R. CAR. FP	1 Ω 1/4W		不燃化カーボン抵抗	01
△ RY1	V5966300	RELAY	DS24D2-0S(M)		リレー 2 4 V	05
ST1	WA789600	SCR. TERM	M3		スクリューターミナル	
ST2	WA789600	SCR. TERM	M3		スクリューターミナル	

\* New Parts \* 新規部品(マーク#の部品は、基板に含まれません)

YST-SW030

YST-SW010

P.C.B. MAIN

Schm Ref.	PART NO.	Description	Remarks	Markets	部 品 名	Rank	
* △	ST3	WA789600	SCR. TERM	M3		スクリューターミナル	
* △	SW1	WD018300	SW. PUSH	PS4E-A-040 U. C. S		プッシュSW	
* △	SW2	WC906700	SW. SLIDE	SDKPA40300	RTKL	スライドSW	
	TE1	VT658100	TERM. WRAP	352-TX119		ラッピング端子	01
	TE2	VT658100	TERM. WRAP	352-TX119		ラッピング端子	01
*	VR1	WC595500	VR	A 5KΩ		ロータリーVR	
*		WD192100	CUSHION			クッション	
*		WC785400	P. C. B.	MAIN	JUC	P C B メイン	
*		WC785500	P. C. B.	MAIN	RTKL	P C B メイン	
*		WC785600	P. C. B.	MAIN	ABG	P C B メイン	
△	CB2	VG879900	CN. BS. PIN	2P		ベースピン	01
	CB3	VB390100	CN. BS. PIN	5P		ベースピン	01
	CB4	WC050700	HOLDER. FUS	EYF52BCY	RTKL	ヒューズホルダー	01
	CB5	WC050700	HOLDER. FUS	EYF52BCY	RTKL	ヒューズホルダー	01
	CB6	WC050700	HOLDER. FUS	EYF52BCY		ヒューズホルダー	01
	CB7	WC050700	HOLDER. FUS	EYF52BCY		ヒューズホルダー	01
	C1	VE326000	C. MYLAR. ML	0.1uF 50V		積層マイラーコン	01
	C2	VE327100	C. MYLAR. ML	0.82uF 50V		積層マイラーコン	02
	C3	FG644100	C. CE	0.01uF 50V		セラコン	01
	C4	UR867100	C. EL	10uF 50V		ケミコン	01
	C5	UA654220	C. MYLAR	0.022uF 50V		マイラーコン	01
	C6	UR837470	C. EL	47uF 16V		ケミコン	01
	C7	VE326600	C. MYLAR. ML	0.33uF 50V		積層マイラーコン	01
	C8	VE326200	C. MYLAR. ML	0.15uF 50V		積層マイラーコン	
	C9	UA654100	C. MYLAR	0.01uF 50V		マイラーコン	01
	C10	UR867100	C. EL	10uF 50V		ケミコン	01
	C11	UR867100	C. EL	10uF 50V		ケミコン	01
	C12	UR867470	C. EL	47uF 50V		ケミコン	01
	C13	VE326000	C. MYLAR. ML	0.1uF 50V		積層マイラーコン	01
	C14	UR868100	C. EL	100uF 50V		ケミコン	01
	C15	UR838100	C. EL	100uF 16V		ケミコン	01
	C16	UR867100	C. EL	10uF 50V		ケミコン	01
	C17	VE326200	C. MYLAR. ML	0.15uF 50V		積層マイラーコン	
	C18	UA654680	C. MYLAR	0.068uF 50V	JUCABG	マイラーコン	02
	C18	UA654330	C. MYLAR	0.033uF 50V	RTKL	マイラーコン	01
	C19	FG652100	C. CE	100pF 50V		セラコン	01
	C20	UR837470	C. EL	47uF 16V		ケミコン	01
	C21	UR837470	C. EL	47uF 16V		ケミコン	01
	C22	UR867220	C. EL	22uF 50V		ケミコン	01
	C23	UR865470	C. EL	0.47uF 50V		ケミコン	01
	C24	UR828220	C. EL	220uF 10V		ケミコン	01
	C25	VT898000	C. MYLAR	0.1uF 100V		マイラーコン	01
	C26	VT898000	C. MYLAR	0.1uF 100V		マイラーコン	01
	C27	VE326200	C. MYLAR. ML	0.15uF 50V		積層マイラーコン	
	C28	UR867100	C. EL	10uF 50V		ケミコン	01
	C29	UR867220	C. EL	22uF 50V		ケミコン	01
	C30	UR867220	C. EL	22uF 50V		ケミコン	01
	C31	UR867220	C. EL	22uF 50V		ケミコン	01
	C32	UR867220	C. EL	22uF 50V		ケミコン	01
	C33	VE326000	C. MYLAR. ML	0.1uF 50V		積層マイラーコン	01

\* New Parts \* 新規部品(マーク#の部品は、基板に含まれません)

## YST-SW010

## P.C.B. MAIN

Schm Ref.	PART NO.	Description	Remarks	Markets	部 品 名	Rank
△ C35	WB121400	C. CE. SAFTY	0.01uF 295V		規格認定コン	
C37	VE326800	C. MYLAR. ML	0.47uF 50V		積層マイラーコン	01
C38	UA653220	C. MYLAR	2200pF 50V		マイラーコン	01
C41	UR867100	C. EL	10uF 50V		ケミコン	01
C57	UR868100	C. EL	100uF 50V		ケミコン	01
C58	V6476700	C. EL	4700uF 50V		ケミコン	
C59	V6476700	C. EL	4700uF 50V		ケミコン	
C72	UR867100	C. EL	10uF 50V		ケミコン	01
△ D1	VC971500	D10DE. BRG	RBV-402 4A 200V		ダイオード	03
D2	VG440900	D10DE. ZENR	MTZJ15C 15V		ツェナーダイオード	01
D3	VG440900	D10DE. ZENR	MTZJ15C 15V		ツェナーダイオード	01
D4	VD631600	D10DE	1SS133, 176		ダイオード	01
D5	VD631600	D10DE	1SS133, 176		ダイオード	01
D6	VD631600	D10DE	1SS133, 176		ダイオード	01
D7	VG442500	D10DE. ZENR	MTZJ24B 24V		ツェナーダイオード	01
D19	VD631600	D10DE	1SS133, 176		ダイオード	01
D20	VD631600	D10DE	1SS133, 176		ダイオード	01
D21	VD631600	D10DE	1SS133, 176		ダイオード	01
D22	VD631600	D10DE	1SS133, 176		ダイオード	01
D23	VD631600	D10DE	1SS133, 176		ダイオード	01
D24	VU264100	D10DE	1SR139-400		ダイオード	
* D25	WB884500	LED	SLP-236B-81		L E D	
* △ F1	WC804600	FUSE	1.6A 125V	JUCRTKL	ヒューズ125V	
* △ F1	VV335000	FUSE	0.4A 250V	ABG	ヒューズ250V	
* △ F2	VV335000	FUSE	0.4A 250V	RTKL	ヒューズ250V	
G2	V5995800	PLATE. GND			アースプレート	
△ IC1	X3587A00	IC	STK404-070 60W		パワー IC	09
IC2	XB247A00	IC	uPC4570HA		IC	02
IC3	X3369A00	IC	TA7317P		IC	04
IC4	XB247A00	IC	uPC4570HA		IC	02
IC5	XB247A00	IC	uPC4570HA		IC	02
* PJ1	WC871000	JACK. PIN	MSP-241V-01N1		ピンジャック 1P	
PN1	WB213200	PIN	L=70 WB21320		スタイルピン	
Q1	iC224030	TR	2SC2240 GR, BL		トランジスタ	01
Q2	iA097030	TR	2SA970 GR, BL		トランジスタ	01
* Q5	WB228800	TR	2SCKTC3198 Y-AT		トランジスタ	
* Q6	WB228700	TR	2SAKTA1266 Y-AT		トランジスタ	
* Q7	WB228800	TR	2SCKTC3198 Y-AT		トランジスタ	
* Q8	WB228700	TR	2SAKTA1266 Y-AT		トランジスタ	
Q9	V6896700	TR	2SD2531		トランジスタ	03
Q10	V6896500	TR	2SB1642		トランジスタ	04
Q16	V3028000	FET	2SK304 E		F E T	01
R1	HV756270	R. CAR. FP	2.7KΩ 1/4W		不燃化カーボン抵抗	01
R5	HV756120	R. CAR. FP	1.2KΩ 1/4W		不燃化カーボン抵抗	01
* R27	WC798300	R. MTL. FLM	10KΩ 1/4W		金属被膜抵抗	
R28	V6022600	R. WW	0.1Ω 3W		セメント抵抗	
R30	HV756100	R. CAR. FP	1KΩ 1/4W		不燃化カーボン抵抗	01
* R31	WC799000	R. MTL. FLM	20KΩ 1/4W		金属被膜抵抗	
R32	HV755100	R. CAR. FP	100Ω 1/4W		不燃化カーボン抵抗	01
* R35	WC798300	R. MTL. FLM	10KΩ 1/4W		金属被膜抵抗	
* R36	WC798300	R. MTL. FLM	10KΩ 1/4W		金属被膜抵抗	
R39	VC760500	R. MTL. OXD	470Ω 2W		酸化金属被膜抵抗	01
R45	HV754220	R. CAR. FP	22Ω 1/4W		不燃化カーボン抵抗	01

\* New Parts \* 新規部品(マーク#の部品は、基板に含まれません)

## YST-SW010

## P.C.B. MAIN

Schm Ref.	PART NO.	Description	Remarks	Markets	部 品 名	Rank
R46	HV754220	R. CAR. FP	22Ω 1/4W		不燃化カーボン抵抗	01
R47	VC751900	R. MTL. OXD	0.22Ω 2W		酸化金属被膜抵抗	01
R48	HV754100	R. CAR. FP	10Ω 1/4W		不燃化カーボン抵抗	01
* R66	WC796900	R. MTL. FLM	2.7KΩ 1/4W		金属被膜抵抗	
* R67	WC800700	R. MTL. FLM	100KΩ 1/4W		金属被膜抵抗	
R95	HV755100	R. CAR. FP	100Ω 1/4W		不燃化カーボン抵抗	01
R126	HV753100	R. CAR. FP	1Ω 1/4W		不燃化カーボン抵抗	01
△ RY1	V5966300	RELAY	DS24D2-0S(M)		リレー 24V	05
ST1	WA789600	SCR. TERM	M3		スクリューターミナル	
ST2	WA789600	SCR. TERM	M3		スクリューターミナル	
ST3	WA789600	SCR. TERM	M3		スクリューターミナル	
* △ SW1	WD018300	SW. PUSH	PS4E-A-040 U.C.S		プッシュSW	
* △ SW2	WC906700	SW. SLIDE	SDKPA40300	RTKL	スライドSW	
TE1	VT658100	TERM. WRAP	352-TX119		ラッピング端子	01
TE2	VT658100	TERM. WRAP	352-TX119		ラッピング端子	01
* VR1	WC595500	VR	A 5KΩ		ロータリーVR	
* WD192100	WD192100	CUSHION			クッション	

\* New Parts \* 新規部品(マーク#の部品は、基板に含まれません)

# Parts List for Carbon Resistors

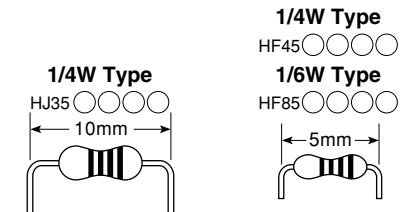
Value	1/4W Type Part No.	1/6W Type Part No.	Value	1/4W Type Part No.	1/6W Type Part No.
1.0 Ω	HJ35 3100	HF85 3100	10 kΩ	HF45 7100	HF45 7100
1.8 Ω	HJ35 3180	*	11 kΩ	HF45 7110	HF45 7110
2.2 Ω	HJ35 3220	HF85 3220	12 kΩ	HJ35 7120	HF85 7120
3.3 Ω	HJ35 3330	HF85 3330	13 kΩ	HF45 7130	HF45 7130
4.7 Ω	HJ35 3470	HF85 3470	15 kΩ	HF45 7150	HF45 7150
5.6 Ω	HJ35 3560	HF85 3560	18 kΩ	HF45 7180	HF45 7180
10 Ω	HF45 4100	HF45 4100	22 kΩ	HF45 7220	HF45 7220
15 Ω	HJ35 4150	HF85 4150	24 kΩ	HF45 7240	HF45 7240
22 Ω	HF45 4220	HF45 4220	27 kΩ	HJ35 7270	HF85 7270
27 Ω	HJ35 4270	HF85 4270	30 kΩ	HF45 7300	HF45 7300
33 Ω	HF45 4330	HF45 4330	33 kΩ	HF45 7330	HF45 7330
39 Ω	HJ35 4470	HF85 4390	36 kΩ	HF45 7360	HF45 7360
47 Ω	HF45 4470	HF45 4470	39 kΩ	HF45 7390	HF45 7390
56 Ω	HF45 4560	HF45 4560	47 kΩ	HF45 7470	HF45 7470
68 Ω	HF45 4680	HF45 4680	51 kΩ	HF45 7510	HF45 7510
75 Ω	HF45 4750	HF45 4750	56 kΩ	HF45 7560	HF45 7560
82 Ω	HF45 4820	HF45 4820	62 kΩ	HF45 7620	HF45 7620
91 Ω	HF45 4910	HF45 4910	68 kΩ	HF45 7680	HF45 7680
100 Ω	HF45 5100	HF45 5100	82 kΩ	HF45 7820	HF45 7820
110 Ω	HJ35 5110	HF85 5110	91 kΩ	HF45 7910	HF45 7910
120 Ω	HF45 5120	HF45 5120	100 kΩ	HF45 8100	HF45 8100
150 Ω	HF45 5150	HF45 5150	110 kΩ	HF45 8110	HF45 8110
160 Ω	HJ35 5160	*	120 kΩ	HF45 8120	HF45 8120
180 Ω	HF45 5180	HF45 5180	150 kΩ	HF45 8150	HF45 8150
200 Ω	HF45 5200	HF45 5200	180 kΩ	HF45 8180	HF45 8180
220 Ω	HF45 5220	HF45 5220	220 kΩ	HJ35 8220	HF85 8220
270 Ω	HF45 5270	HF45 5270	270 kΩ	HF45 8270	HF45 8270
330 Ω	HF45 5330	HF45 5330	300 kΩ	HF45 8300	HF45 8300
390 Ω	HF45 5390	HF45 5390	330 kΩ	HF45 8330	HF45 8330
430 Ω	HF45 5430	HF45 5430	390 kΩ	HJ35 8390	HF85 8390
470 Ω	HF45 5470	HF45 5470	470 kΩ	HF45 8470	HF45 8470
510 Ω	HF45 5510	HF45 5510	560 kΩ	HJ35 8560	HF85 8560
560 Ω	HF45 5560	HF45 5560	680 kΩ	HJ35 8680	HF85 8680
680 Ω	HF45 5680	HF45 5680	820 kΩ	HJ35 8820	HF85 8820
820 Ω	HF45 5820	HF45 5820	1.0 MΩ	HF45 9100	HF45 9100
910 Ω	HF45 5910	HF45 5910	1.2 MΩ	HJ35 9120	*
1.0 kΩ	HF45 6100	HF45 6100	1.5 MΩ	HJ35 9150	HF85 9150
1.2 kΩ	HF45 6120	HF45 6120	1.8 MΩ	HJ35 9180	HF85 9180
1.5 kΩ	HF45 6150	HF45 6150	2.2 MΩ	HJ35 9220	HF85 9220
1.8 kΩ	HF45 6180	HF45 6180	3.3 MΩ	HJ35 9330	HF85 9330
2.0 kΩ	HJ35 6200	HF85 6200	3.9 MΩ	HJ35 9390	*
2.2 kΩ	HF45 6220	HF45 6220	4.7 MΩ	HJ35 9470	HF85 9470
2.4 kΩ	HJ35 6240	HF85 6240			
2.7 kΩ	HF45 6270	HF45 6270			
3.0 kΩ	HF45 6300	HF45 6300			
3.3 kΩ	HF45 6330	HF45 6330			
3.6 kΩ	HJ35 6360	HF85 6360			
3.9 kΩ	HF45 6390	HF45 6390			
4.7 kΩ	HF45 6470	HF45 6470			
5.1 kΩ	HF45 6510	HF45 6510			
5.6 kΩ	HF45 6560	HF45 6560			
6.8 kΩ	HF45 6680	HF45 6680			
8.2 kΩ	HF45 6820	HF45 6820			
9.1 kΩ	HF45 6910	HF45 6910			
					

\* : Not available

YST-SW030/YST-SW010

# EXPLODED VIEW

## YST-SW030

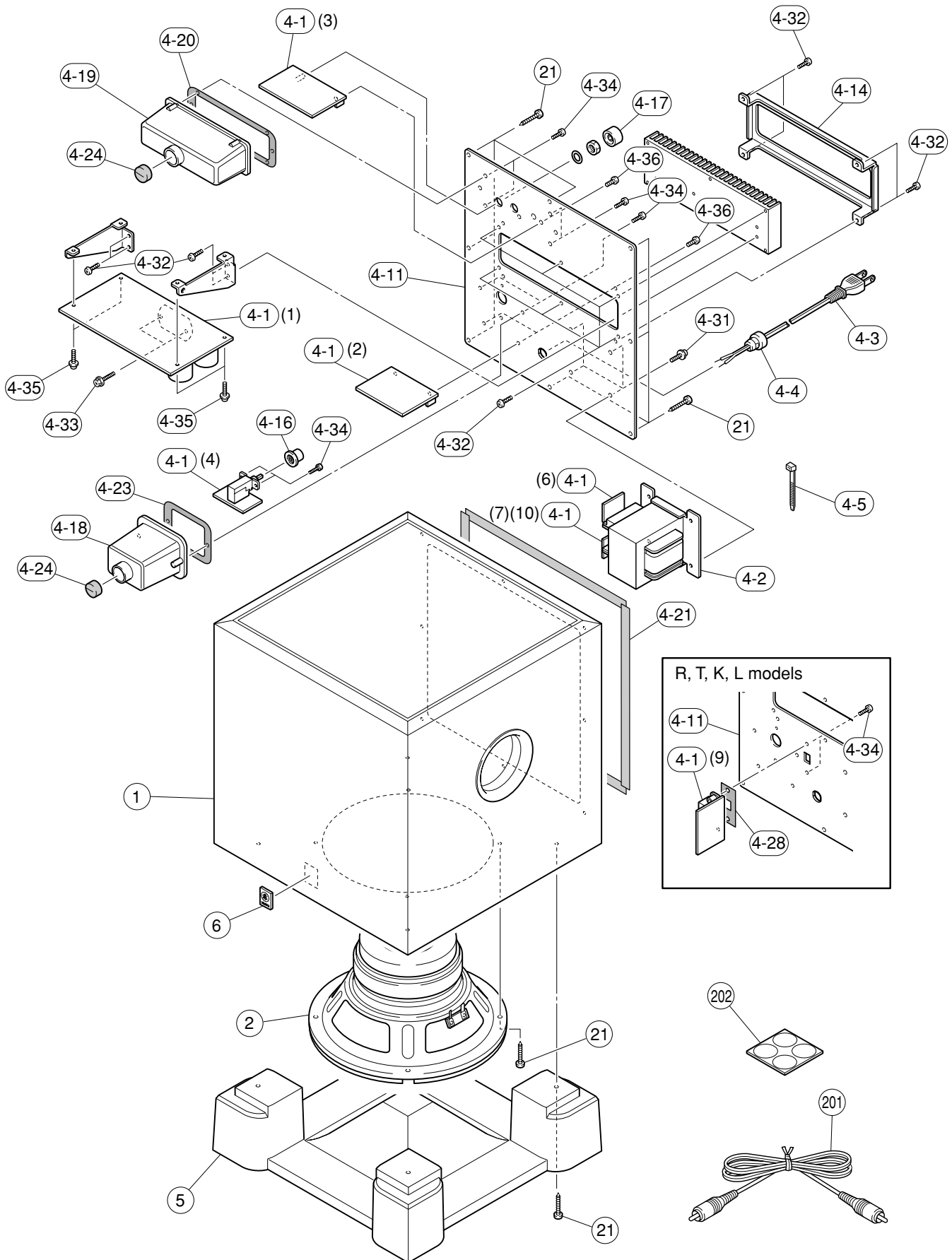

## MECHANICAL PARTS

Schm	Ref.	PART NO.	Description	Remarks	Markets	部 品 名	Rank	
*	1	WC727900	CABINET ASS'Y		CH	キャビネットASSY		
*	1	WC727800	CABINET ASS'Y		BL	キャビネットASSY		
*	1	WC727700	CABINET ASS'Y		SI	キャビネットASSY		
*	2	X5399A00	DRIVER, WOOFER	20cm 6Ω	JA2025	スピーカーユニット		
*	4-1	WC740200	P.C.B. ASS'Y	MAIN		P C B メイン		
*	4-1	WC740300	P.C.B. ASS'Y	MAIN		P C B メイン		
*	4-1	WC740400	P.C.B. ASS'Y	MAIN		P C B メイン		
*	△	4-2	X5307B00	POWER TRANSFORMER		J	電源トランス	
*	△	4-2	X5308A00	POWER TRANSFORMER		UC	電源トランス	
*	△	4-2	X5309B00	POWER TRANSFORMER		RTKL	電源トランス	
*	△	4-2	X5310B00	POWER TRANSFORMER		A	電源トランス	
*	△	4-2	X5311B00	POWER TRANSFORMER		BG	電源トランス	
*	△	4-3	WC906000	POWER CABLE	2m	J	電源コード	
*	△	4-3	WC906100	POWER CABLE	2m	UC	電源コード	
*	△	4-3	WD042000	POWER CABLE	2m	R	電源コード	
*	△	4-3	WC906200	POWER CABLE	2m	T	電源コード	
*	△	4-3	WC906300	POWER CABLE	2m	K	電源コード	
*	△	4-3	WC906400	POWER CABLE	2m	A	電源コード	
*	△	4-3	WC906500	POWER CABLE	2m	B	電源コード	
*	△	4-3	WC906600	POWER CABLE	2m	GL	電源コード	
*	4-4	CB072750	CORD STOPPER	SR-4N-4			コードストッパー	01
*	4-5	WB408000	BINDING TIE	GT-100M HUA WEI			インシュロックタイ	
*	4-11	WC736700	REAR PANEL			J	リアパネル	
*	4-11	WC736800	REAR PANEL			UC	リアパネル	
*	4-11	WC736900	REAR PANEL			RTKL	リアパネル	
*	4-11	WC737100	REAR PANEL			A	リアパネル	
*	4-11	WC737200	REAR PANEL			BG	リアパネル	
*	4-14	WC739100	REAR COVER				リアカバー	
*	4-16	WC738200	POWER KNOB				パワーノブ	
*	4-17	WC757900	VOLUME KNOB				ボリュームノブ	
*	4-18	WC738400	COVER/P. SW				カバー/P. SW	
*	4-19	WC738100	COVER/46X114				カバー/46X114	
*	4-20	WC738800	PACKING 738800				パッキン 738800	
*	4-21	WC738500	PACKING				パッキン	
*	4-23	WC758000	PACKING 75800				パッキン 758000	
*	4-24	WC739000	BUSH				ブッシュ	
*	4-28	WC869800	GASKET			RTKL	ガスケット	
*	4-31	21991500	PW HEAD S-TIGHT SCREW	4x8-10 MFC2BL			PWヘッドSタイトネジ	01
*	4-32	EP600190	BIND HEAD B-TIGHT SCREW	3x8 MFZN2BL			バインドBタイトネジ	01
*	4-33	VK865300	HEX. HEAD TAP. SCREW WITH WS	3x18 MFC2BL			座金付六角タッピングネジ	01
*	4-34	EP630660	BIND HEAD P-TIGHT SCREW	3x10 MFZN2BL			バインドPタイトネジ	01
*	4-35	VT669300	PW HEAD B-TIGHT SCREW	3x8-8 MFC2			PWヘッドBタイトネジ	01
*	4-36	VA295800	BIND HEAD SCREW	3x8 MFZN2BL			バインド小ネジ	01
*	5	WC735400	BASE				ベース	
*	6	WC788700	EMBLEM				エンブレム	
*	21	VF573000	BIND HEAD TAPPING SCREW	4x25 MFZN2BL			バインドTPネジ	01
*	201	WC947800	ACCESSORIES SUBWOOFER CABLE	1P 5m 1pc			付属品 サブウーハーケーブル	
*	202	WC731500	NON SKID PAD	M32 t2 4pcs/set			滑止パッド	

\* New Parts \* 新規部品(マーク#の部品は、基板に含まれません)

YST-SW030/YST-SW010

# EXPLODED VIEW

## YST-SW010

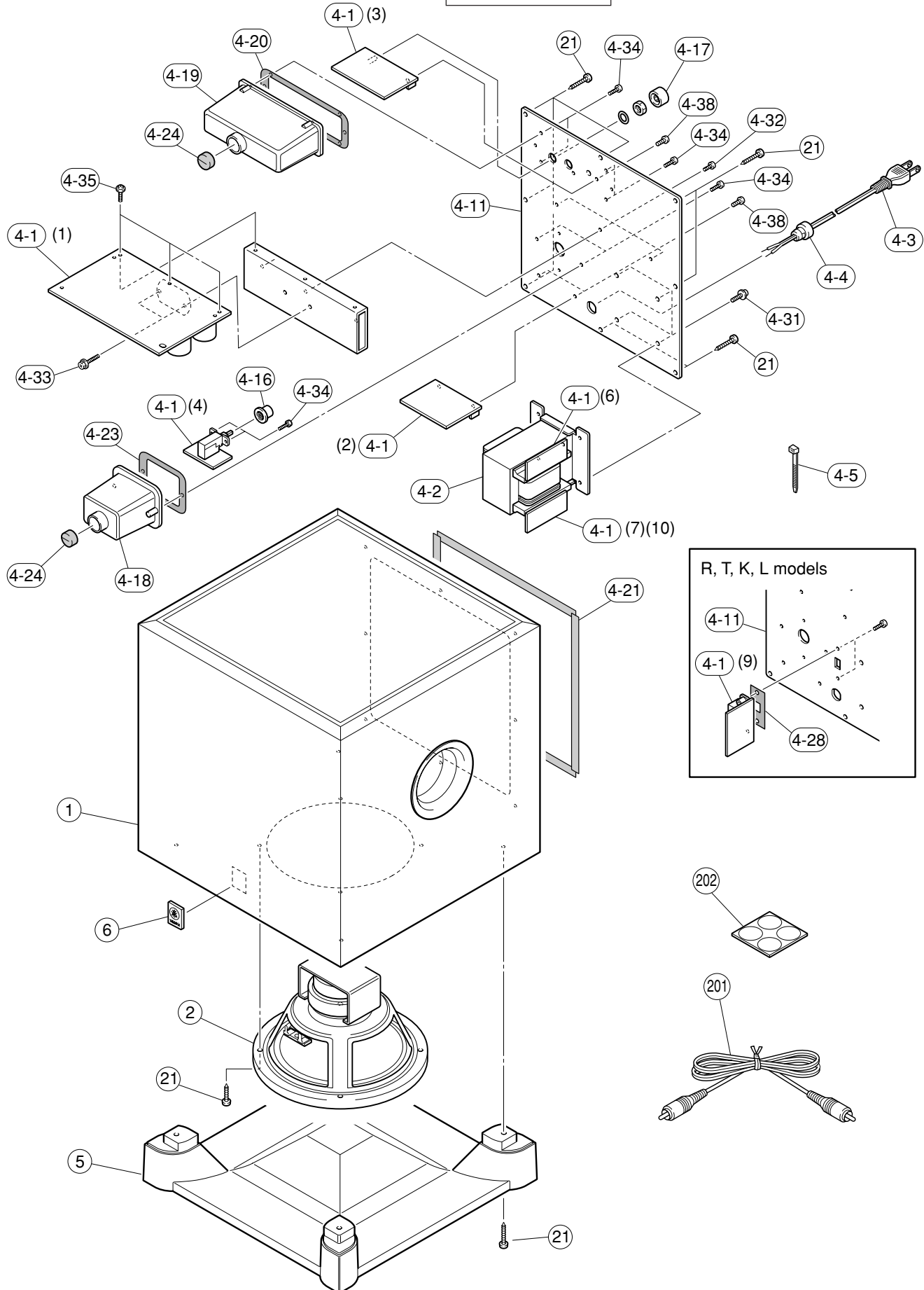



## MECHANICAL PARTS

Schm	Ref.	PART NO.	Description	Remarks	Markets	部 品 名	Rank
*	1	WC781500	CABINET ASS'Y	CH		キャビネットASSY	
*	1	WC781400	CABINET ASS'Y	BL		キャビネットASSY	
*	1	WC781300	CABINET ASS'Y	SI		キャビネットASSY	
*	2	X5400A00	DRIVER, WOOFER	JA1690		スピーカーユニット	
*	4-1	WC785400	P.C.B. ASS'Y	MAIN	JUC	PCB メイン	
*	4-1	WC785500	P.C.B. ASS'Y	MAIN	RTKL	PCB メイン	
*	4-1	WC785600	P.C.B. ASS'Y	MAIN	ABG	PCB メイン	
*	△	4-2	X5312A00	POWER TRANSFORMER	J	電源トランス	
*	△	4-2	X5313A00	POWER TRANSFORMER	UC	電源トランス	
*	△	4-2	X5314A00	POWER TRANSFORMER	RTKL	電源トランス	
*	△	4-2	X5315A00	POWER TRANSFORMER	A	電源トランス	
*	△	4-2	X5316A00	POWER TRANSFORMER	BG	電源トランス	
*	△	4-3	WC906000	POWER CABLE	J	電源コード	
*	△	4-3	WC906100	POWER CABLE	UC	電源コード	
*	△	4-3	WD042000	POWER CABLE	R	電源コード	
*	△	4-3	WC906200	POWER CABLE	T	電源コード	
*	△	4-3	WC906300	POWER CABLE	K	電源コード	
*	△	4-3	WC906400	POWER CABLE	A	電源コード	
*	△	4-3	WC906500	POWER CABLE	B	電源コード	
*	△	4-3	WC906600	POWER CABLE	GL	電源コード	
*	4-4	CB072750	CORD STOPPER	SR-4N-4		コードストッパー	01
*	4-5	WB408000	BINDING TIE	GT-100M HUA WEI		インシュロックタイ	
*	4-11	WC784600	REAR PANEL		J	リアパネル	
*	4-11	WC784700	REAR PANEL		UC	リアパネル	
*	4-11	WC784800	REAR PANEL		RTKL	リアパネル	
*	4-11	WC784900	REAR PANEL		A	リアパネル	
*	4-11	WC785000	REAR PANEL		BG	リアパネル	
*	4-16	WC738200	POWER KNOB			パワーノブ	
*	4-17	WC757900	VOLUME KNOB			ボリュームノブ	
*	4-18	WC738400	COVER/P. SW			カバー/P. SW	
*	4-19	WC738100	COVER/46X114			カバー/46X114	
*	4-20	WC738800	PACKING 738800			パッキン 738800	
*	4-21	WC785200	PACKING			パッキン	
*	4-23	WC758000	PACKING 75800			パッキン 75800	
*	4-24	WC739000	BUSH			ブッシュ	
*	4-28	WC869800	GASKET		RTKL	ガスケット	
*	4-31	21991500	PW HEAD S-TIGHT SCREW	4x8-10 MFC2BL		PWヘッドSタイトネジ	01
*	4-32	EP600190	BIND HEAD B-TIGHT SCREW	3x8 MFZN2BL		バインドBタイトネジ	01
*	4-33	VK865300	HEX. HEAD TAP. SCREW WITH WS	3x18 MFC2BL		座金付六角タッピングネジ	01
*	4-34	EP630660	BIND HEAD P-TIGHT SCREW	3x10 MFZN2BL		バインドPタイトネジ	01
*	4-35	VT669300	PW HEAD B-TIGHT SCREW	3x8-8 MFC2		PWヘッドBタイトネジ	01
*	4-38	VA295800	BIND HEAD SCREW	3x8 MFZN2BL		バインド小ネジ	01
*	5	WC784200	BASE			ベース	
*	6	WC788700	EMBLEM			エンブレム	
*	21	VF573000	BIND HEAD TAPPING SCREW	4x25 MFZN2BL		バインドTPネジ	01
*	201	WC947800	ACCESSORIES SUBWOOFER CABLE	1P 5m 1pc		付属品 サブウーハーケーブル	
*	202	WC783900	NON SKID PAD	M25 t2 4pcs/set		滑止パッド	

\* New Parts \* 新規部品(マーク#の部品は、基板に含まれません)

# YST-SW030/YST-SW010

---

