



600W into 4 or 2 ohms per channel



AP2020

PROFESSIONAL SERIES

TYPE: AP2020

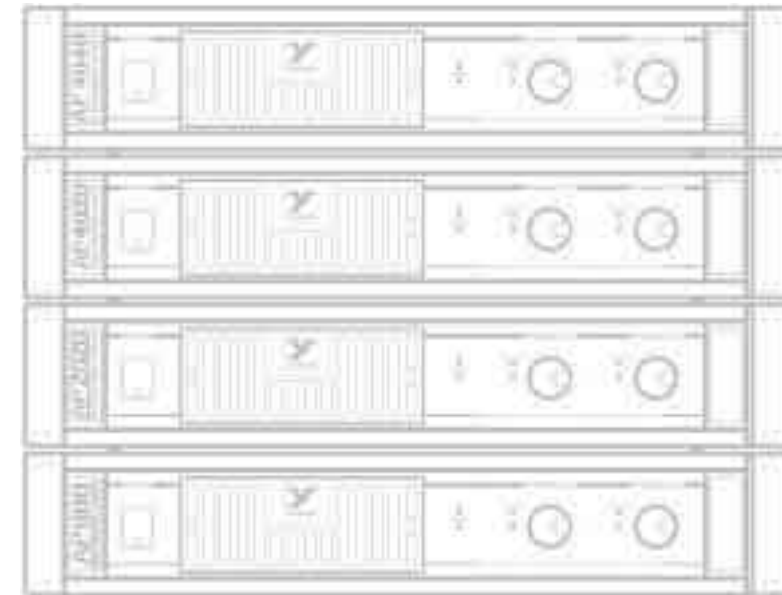

WEB ACCESS: <http://www.yorkville.com>

WORLD HEADQUARTERS CANADA

Yorkville Sound
550 Granite Court
Pickering, Ontario
L1W-3Y8 CANADA

Voice: (905) 837-8481
Fax: (905) 837-8746

U.S.A.

Yorkville Sound Inc.
4625 Witmer Industrial Estate
Niagara Falls, New York
14305 USA

Voice: (716) 297-2920
Fax: (716) 297-3689

M 1129 (input board)
• Schematic
• PCB Layout

M 1130 (power amp module)
• Schematic
• PCB Layout

M 1132 (pot board)
• Schematic
• PCB Layout

M 1131 (power supply board)
• Schematic
• PCB Layout



Quality and Innovation Since 1963
Printed in Canada

SERVICE MANUAL

IMPORTANT SAFETY INSTRUCTIONS



INSTRUCTIONS PERTAINING TO A RISK OF FIRE, ELECTRIC SHOCK, OR INJURY TO PERSONS.

INSTRUCTIONS RELATIVES AU RISQUE DE FEU, CHOC ÉLECTRIQUE, OU BLESSURES AUX PERSONNES.

CAUTION:

TO REDUCE THE RISK OF ELECTRIC SHOCK, DO NOT REMOVE COVER (OR BACK). NO USER SERVICEABLE PARTS INSIDE.

REFER SERVICING TO QUALIFIED SERVICE PERSONNEL.

AVIS:

N'ENLEVEZ PAS LE COUVERT (OU LE PANNEAU ARRIERE). NE CONTIENT AUCUNE PIECE REPARABLE PAR L'UTILISATEUR.

CONSULTEZ UN TECHNICIEN QUALIFIE POUR L'ENTRETIEN.

Read Instructions:

The **Owner's Manual** should be read and understood before operation of your unit. Please, save these instructions for future reference.

Packaging:

Keep the box and packaging materials, in case the unit needs to be returned for service.

Warning:

When using electric products, basic precautions should always be followed, including the following:

Power Sources:

Your unit should be connected to a power source only of the voltage specified in the owners manual or as marked on the unit. This unit has a polarized plug. Do not use with an extension cord or receptacle unless the plug can be fully inserted. Precautions should be taken so that the grounding scheme on the unit is not defeated.

Hazards:

Do not place this product on an unstable cart, stand, tripod, bracket or table. The product may fall, causing serious personal injury and serious damage to the product. Use only with cart, stand, tripod, bracket, or table recommended by the manufacturer or sold with the product. Follow the manufacturer's instructions when installing the product and use mounting accessories recommended by the manufacturer.

The apparatus should not be exposed to dripping or splashing water; no objects filled with liquids should be placed on the apparatus.

Terminals marked with the "lightning bolt" are hazardous live; the external wiring connected to these terminals require installation by an instructed person or the use of ready made leads or cords.

No naked flame sources, such as lighted candles, should be placed on the apparatus.

Power Cord:

The AC supply cord should be routed so that it is unlikely that it will be damaged. If the AC supply cord is damaged **DO NOT OPERATE THE UNIT.**

Service:

The unit should be serviced only by qualified service personnel.

Veillez lire le manuel:

Il contient des informations qui devraient étre comprises avant l'opération de votre appareil. Conservez S.V.P. ces instructions pour consultations ultérieures

Emballage:

Conservez la boite au cas ou l'appareil devait étre retourner pour réparation.

Warning:

Attention: Lors de l'utilisation de produits électrique, assurez-vous d'adhérer à des précautions de bases incluant celle qui suivent:

Alimentation:

L'appareil ne doit étre branché qu'à une source d'alimentation correspondant au voltage spécifié dans le manuel ou tel qu'indiqué sur l'appareil. Cet appareil est équipé d'une prise d'alimentation polarisée. Ne pas utiliser cet appareil avec un cordon de raccordement à moins qu'il soit possible d'insérer complètement les trois lames. Des précautions doivent étre prises afin d'éviter que le système de mise à la terre de l'appareil ne soit désengagé.

Hazard:

Ne pas placer cet appareil sur un chariot, un support, un trépied ou une table instables. L'appareil pourrait tomber et blesser quelqu'un ou subir des dommages importants. Utiliser seulement un chariot, un support, un trépied ou une table recommandés par le fabricant ou vendus avec le produit. Suivre les instructions du fabricant pour installer l'appareil et utiliser les accessoires recommandés par le fabricant.

Il convient de ne pas placer sur l'appareil de sources de flammes nues, telles que des bougies allumées.

L'appel ne doit pas étre exposé à des égouttements d'eau ou des éclaboussures et qu'aucun objet rempli de liquide tel que des vases ne doit étre placé sur l'appareil.

Les dispositifs marqués d'une symbole "d'éclair" sont des parties dangereuses au toucher et que les câblages extérieurs connectés à ces dispositifs de connexion extérieure doivent étre effectués par un opérateur formé ou en utilisant des cordons déjà préparés.

Cordon d'alimentation:

Évitez d'endommager le cordon d'alimentation. **N'UTILISEZ PAS L'APPAREIL** si le cordon d'alimentation est endommagé.

Service:

Consultez un technicien qualifié pour l'entretien de votre appareil.

AP2020 Parts List 5/29/00

YS #	Description	Qty.	YS #	Description	Qty.	YS #	Description	Qty.
3570	14 PIN SCKT CLOSED FRAME DIP ONLY	1	3415	RED ON RIGHT DUAL BINDING POST TPP5	1	4762	1/4W 9K760 0.1%*** T&R RES	8
5906	RED 3MM LED 1V9 20MA .4SPCR T&R	3	3918	1/4" JCK PCB MT HORZ SLIM W/SCREW	2	4629	1/2W 10K 5% T&R RES	4
6405	RED 3MM LED 1V7 5MA BRT	4	6956	SPKON 4C PCB MT HORZ GRY #4	2	4800	1/4W 10K0 1% T&R RES	3
5908	GRN 3MM LED 1V9 20MA .4SPCR T&R	3	3657	XLR FEML PCB MT HORZ NO SHELL	2	4829	1/4W 10K 5% T&R RES	2
6408	GRN 3MM LED 1V9 5MA FROSTED	3	3451	EYELET SMALL 0.089 OD PLATED	63	4983	1/4W 10K 5%MINI T&R RES	3
6419	BRIDGE 35A 400V WIRE LEAD G13504	2	3860	FAN 80MM X 80MM 40CFM 12VDC	1	6116	1/4W 10K0 1%MINI MF T&R RES	8
6425	BAV21 200V 0A25 DIODE T&R	8	8434	AP SERIES PLASTIC HANDLE PAIR	1	5008	1/4W 14K7 1% T&R RES	4
6825	1N4148 75V 0A45 DIODE T&R	63	3896	HEATSINK WAKEFIELD 274-3AB	4	4830	1/4W 15K 5% T&R RES	4
6438	1N4004 400V 1A0 DIODE T&R	6	8433	AP SERIES PLASTIC KNOB	2	4979	1/4W 15K 5%MINI T&R RES	10
6934	MR854 400V 3A0 DIODE FASREC	12	8661	BUTTON KNOB FLAT GREY	3	4876	1/4W 16K 5% T&R RES	1
6439	1N5225B 3V0 0W5 ZENER 5% T&R	2	8437	FAN FILTER LABEL	1	4771	1/4W 17K8 1% T&R RES	6
6440	1N750ARL 4V7 0W5 ZENER 5% T&R	1	3468	8' 3/16 SJT AC LINE CORD STRIP 17"	1	4885	1/4W 20K 5% T&R RES	3
6459	1N4732A 4V7 1W0 ZENER 5% T&R	2	3821	HEYCO #1200 STRAIN RELIEF	1	6123	1/4W 20K0 1%MINI MF T&R RES	2
6436	1N753ARL 6V2 0W5 ZENER 5% T&R	2	8261	GE VELVET LEXAN .007" X 12" X 24"	0.304	5003	1/4W 30K1 1% T&R RES	4
6461	1N5240BRL 10V0 0W5 ZENER 5% T&R	2	8262	GE VELVET LEXAN .015" X 12" X 24"	0.002	4840	1/4W 33K 5% T&R RES	5
6486	1N5244B 14V0 0W5 ZENER 5% T&R	4	3661	.6 CIR WAFER WLCK RA 0.1" GOLD	2	6122	1/4W 33K 5%MINI T&R RES	1
6822	1N4745A 16V0 1W0 ZENER 5% T&R	8	3662	.6 CIR WAFER WLCK VT 0.1" GOLD	1	5002	1/4W 42K2 1% T&R RES	2
6432	1N5248B 18V0 0W5 ZENER 5% T&R	4	3672	6 CIR CABLE HOLDER .098	3	4834	1/4W 47K 5% T&R RES	2
6460	1N5260B 43V0 0W5 ZENER 5% T&R	3	8701	4-40 KEPS NUT ZINC	16	6119	1/4W 47K 5%MINI T&R RES	2
5101	BC550C TO92 NPN TRAN T&R TB	21	8793	4-40 HEX NUT ZINC	3	4835	1/4W 56K 5% T&R RES	4
5102	BC560C TO92 PNP TRAN T&R TB	18	8760	6-32 KEPS NUT TIN PLATED	32	4761	1/4W 60K4 1% T&R RES	4
5103	MPSA06 TO92 NPN TRAN T&R TA	3	8800	6-32 KEPS NUT ZINC	5	4848	1/4W 62K 5% T&R RES	1
5107	2N5551 TO92 NPN TRAN T&R TA	2	8720	#8 SPRING NUT	2	4838	1/4W 100K 5% T&R RES	3
5108	2N5401 TO92 PNP TRAN T&R TA	4	8712	5/16-24 JAM NUT JS500	1	4851	1/4W 120K 5% T&R RES	2
5113	MPSA42 TO92 NPN TRAN T&R TA	4	3797	TO-247 THERMO CONDUCTIVE PAD	4	6137	1/4W 200K 5%MINI T&R RES	2
5105	MPSA13 TO92 NPN DARL T&R TA	2	3815	TO3 PREGREASED MICA 56-03-2AP	16	4841	1/4W 220K 5% T&R RES	2
6814	MJF6668 T221D PNP TRAN DARL TJ	1	3823	TO-220 THERMO PAD SMALL HOLE	4	6126	1/4W 220K 5%MINI T&R RES	6
6815	MJF6388 T221D NPN TRAN DARL TJ	2	3846	TO220 THERMO PAD LARGE HOLE 56359B	4	4843	1/4W 470K 5% T&R RES	2
6873	MJE340 TO126 NPN TRAN TG	6	4597	22AWG STRAN TC WIR JMP	29	6127	1/4W 470K 5%MINI T&R RES	2
6874	MJE350 TO126 PNP TRAN TG	6	4599	22AWG SOLID SC WIR T&R JMP	79	4951	1/4W 4M7 5% 2"U T&R RES	2
6752	MTP10N15L TO220 NCH MFET TN	2	5299	24AWG SOLID SC WIR RAD JMP	52	6132	1/4W 8M2 5%MINI T&R RES	2
6933	MTP23P06 TO220 PCH MFET TN	2	4745	5.0W 0R1 5% BLK RES	8	3709	.7" 6C-26AWG RIB 1 WLCK HDR 098	1
6900	YS6900 (22) TO3 NPN TRAN TH	8	4682	1/2W 1R 5%PHILIPS SMAL T&R RES	6	3710	17" 6C-26AWG RIB 1 WLCK HDR 098	2
6989	MJL1302A TO3P PNP TRAN TK	2	4877	1/4W 1R 5%FLAME PROOF T&R RES	10	3622	14" 14C-28AWG DIP HDR CABLE .05"	1
6990	MJL3281A TO3P NPN TRAN TK	2	4911	1/4W 2R2 5% T&R RES	8	3696	RELAY 1C 02AMP DC24 006MA PC-S	2
6927	YS6927 (23) TO3 PNP TRAN TH	8	4748	2.0W 3R9 5% T&R	4	8870	#4 X 1/4 PAN PH TYPE A ZINC	2
6840	MC33078P IC DUAL OP AMP	6	4733	5.0W 5R6 5% BLK RES	2	8865	4-40 X 5/16 PAN PH MS JS500	4
6889	TLO74CN IC QUAD O/A T.J ONLY	1	4605	1/8W 10R 5% T&R RES	1	8729	#4 X 3/8 FLAT QUAD TYPE A JS500 BLK	6
5190	MBS4992 TO92 8V5 DIAC	2	4610	1/4W 10R 2%FLAME PROOF T&R RES	6	8742	4-40 X 3/8 PAN PH TAPTITE JS500	4
6444	MAC224-4 TO220 40A TRIAC 200V	2	4875	1/4W 10R 5% T&R RES	4	8861	4-40 X 3/8 PAN PH MS JS500	3
6859	NSL-28AA OPTO-COUPLER	2	4930	1/4W 10R 5% 2"U T&R RES	1	8741	4-40 X 1/2 PAN PH MS JS500	8
6478	AS35FN-TO92 TEMPERATURE SENSOR	2	4591	1/8W 22R1 1%FLAME PROOF T&R RES	2	8871	4-40 X 5/8 PAN PH MS JS500	8
5200	10P 200V 5%CAP T&R RAD CER.2"NPO	4	4607	1/8W 39R 2%FLAME PROOF T&R RES	14	8799	#6 X 1/4 PAN PH TYPE B JS500	2
5817	15P 100V 2%CAP T&R RAD CER.2"NPO	2	4899	1/4W 39R 5% T&R RES	2	8832	6-32 X 1/4 PAN PH TAPTITE JS500	4
5405	27P 200V 5%CAP T&R RAD CER.2"NPO	2	4817	1/4W 47R 5% T&R RES	2	8801	6-32 X 3/8 PAN PH TAPTITE JS500	3
5411	150P 100V 10%CAP T&R BEAD NPO	2	4811	1/4W 68R 5% T&R RES	6	8829	6-32 X 3/8 FLAT PH TAPTITE BO#4 HEA	18
5412	220P 100V 10%CAP T&R BEAD NPO	12	4608	1/8W 75R 2%FLAME PROOF T&R RES	8	8761	6-32 X 1/2 PAN PHIL MS ZINC CLEAR	32
5417	330P 50V 10%CAP T&R BEAD NPO	2	4852	1/4W 100R 5% T&R RES	1	8823	6-32 X 1 PAN PH TAPTITE JS500	1
5206	1N 400V 5%CAP T&R RAD .2"FLM	2	4859	1/4W 150R 5% T&R RES	4	8763	8-32 X 1/2 PAN PH MS JS500 BLACK	4
5422	1N 50V 10%CAP T&R BEAD NPO	4	4645	1/8W 220R0 1%FLAME PROOF T&R RES	2	8869	8-18 X 1/2 THRD CUTTING FOR PLASTIC	4
5273	1N5 200V 5%CAP T&R RAD CER.2"NPO	4	4857	1/4W 220R 5% T&R RES	2	8999	8-32 X 5/8 PAN PH TAPTITE JS500	11
5274	2N2 200V 5%CAP T&R RAD CER.2"NPO	4	4977	1/4W 220R 5%MINI T&R RES	2	8719	8-32 X 3/4 FILLISTER PHIL MS JS500	2
5209	4N7 250V 5%CAP T&R RAD .2"FLM	4	4606	1/8W 249R 2%FLAME PROOF T&R RES	10	8809	10-32 X 1/4 PAN PH TAPTITE JS500	6
6451	4N7 250V 20%CAP BLK 'Y' 10MM AC	1	4770	1/4W 249R 1% T&R RES	10	8731	10-16 X 5/8 TYPE B HEX W/SLOT JS500	12
5204	10N 100V 10%CAP T&R RAD .2"FLM	2	4821	1/4W 470R 5% T&R RES	14	8711	5/16-24 X 3 GRD 5 HEX BOLT JS500	1
5834	10N 250V 20%CAP BLK RAD POLY FLM	2	4980	1/4W 470R 5%MINI T&R RES	2	8663	11/64 NYLON SPACER (MICRO PLASTIC)	32
5210	22N 100V 10%CAP T&R RAD .2"FLM	4	4609	1/8W 1K 2%FLAME PROOF T&R RES	4	8629	10-32 X 1/4 SPACER PHENOLIC	8
6435	22N 275V 20%CAP BLK 'X2' 15MM AC	2	4623	1/2W 1K 5% T&R RES	2	3744	SNAP IN .375 SPACER RICHCO	5
5308	47N 50V 10%CAP T&R BEAD X7R	2	4823	1/4W 1K 5% T&R RES	4	3739	CUSTOM 4 LED SPACER	6
5226	68N 100V 5%CAP T&R RAD .2"FLM	4	4981	1/4W 1K 5%MINI T&R RES	10	3858	3/4 PLASTIC HEX SPACER #4	4
5228	100N 100V 5%CAP T&R RAD .2"FLM	14	4998	5.0W 1K2 5% BLK RES	4	8657	6-32 X 3/8" HEX SPACER ALUMINUM	1
5314	100N 50V 10%CAP T&R BEAD X7R	3	4624	1/2W 1K5 5% T&R RES	2	3429	SPDT ROKR SW QUIK 180' AC PWR BL/BL	1
5229	150N 63V 10%CAP T&R RAD .2"FLM	4	4988	1/4W 1K5 5%MINI T&R RES	4	3436	DPDT PUSH SW PCMT H BREAK B4 MAKE	3
5231	220N 63V 10%CAP T&R RAD .2"FLM	2	4791	1/4W 1K54 1% T&T RES	4	3587	DPDT ROKR SW QUIK 250'AC/PWR ON-OFF	1
5882	220N 250V 10%CAP BLK RAD POLY FLM	4	5005	2.0W 1K8 5% BLK RES	4	3705	4P3T SLID SW PCMT H	1
5257	2U2 63V 20%CAP T&R RAD .2"EL	2	4808	1/4W 2K 5% T&R RES	1	3417	PC SCREW TERMINAL PC MOUNT	1
5259	4U7 63V 20%CAP T&R RAD .2"EL	3	6113	1/4W 2K 5%MINI T&R RES	5	7584	SQUARE-CUT O RING FOR AP AIR FILTER	1
5281	10U 16V 20%CAP T&R RAD .2"NP	2	5006	1.0W 2K7 5% T&R RES	4	8432	AP SERIES AIR GRILL	1
5629	10U 160V 20%CAP BLK 10X13MM EL	4	6206	1/4W 3K01 1% T&R RES	2	8432P	LOGO HOT STAMPED ON AP800 GRILL	1
5260	22U 50V 20%CAP T&R RAD .2"EL	14	4826	1/4W 3K3 5% T&R RES	2	1198	AP2020 120VAC 60HZ TRD	1
5961	33U 16V 20%CAP T&R RAD .2"NP	8	6136	1/4W 3K3 5%MINI T&R RES	4	Z122P	BLACK ANODIZE APH/SINK	6
5267	100U 25V 20%CAP T&R RAD .2"EL	6	6205	1/4W 3K40 1% T&R RES	2	*M15.3X	M1131 X 3 AP2020 PCB	0.333
5897	330U 16V 20%CAP BLK 08X11MM EL	6	4850	1/4W 3K9 5% T&R RES	1	*M18X9	M1130 X 2 AP2020 PWR. BD ZOZ C	1
5618	470U 25V 20%CAP BLK 10X15MM EL	1	4827	1/4W 4K7 5% T&R RES	2	M13.85	M1128 X 6 AP4200 POT BOARD	0.167
5617	3300U 63V 20%CAP BLK 25X31MM ELS	4	4982	1/4W 4K7 5%MINI T&R RES	18	M14.75	M1129 X 4 AP4200 INPUT BOARD	0.25
5895	6800U 63V 20%CAP BLK 25X50MM ELS	8	6141	1/4W 5K6 5%MINI T&R RES	4			
4390	10K AUD 16MM DETENT P22	2	4862	1/4W 5K6 5% T&R RES	4			
4524	4K7 TRIM POT V	2	5001	1/4W 6K04 1% T&R RES	2			
3606	12.0 AMP CIRCUIT BREAKER	1	4926	1/4W 7K5 5% 2"U T&R RES	2			
3759	4UH COIL 14AWG ZOBEL VERTICAL	2	4663	1/2W 8K2 5% T&R RES	2			
3410	RED ON LEFT DUAL BINDING POST TPP5	1	4990	1/4W 8K2 5%MINI T&R RES	1			

BALANCED INPUT

FILTER

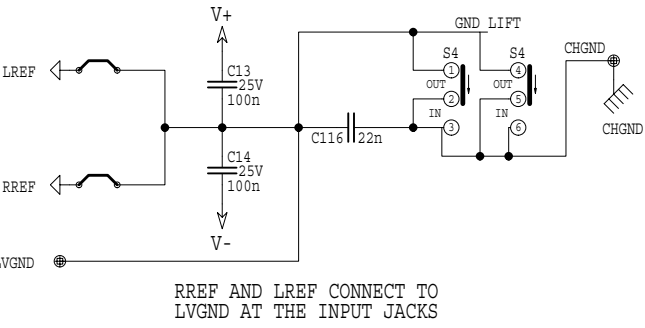
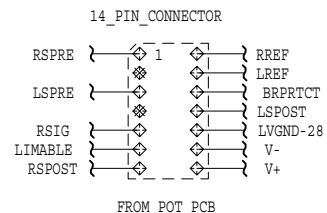
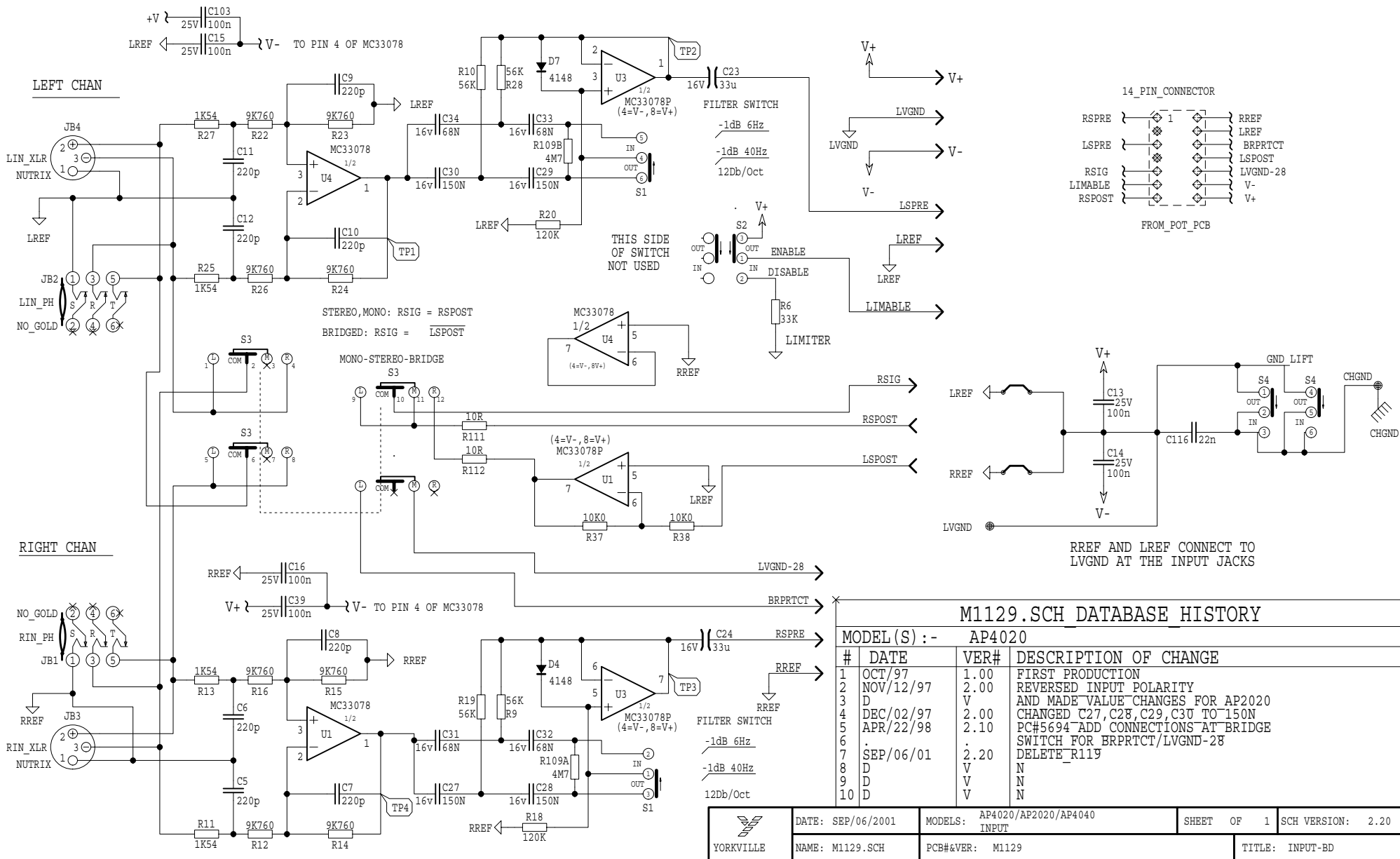

RREF AND LREF CONNECT TO LVGND AT THE INPUT JACKS

M1129.SCH DATABASE HISTORY

MODEL(S) :- AP4020			
#	DATE	VER#	DESCRIPTION OF CHANGE
1	OCT/97	1.00	FIRST PRODUCTION
2	NOV/12/97	2.00	REVERSED INPUT POLARITY
3	D	V	AND MADE VALUE CHANGES FOR AP2020
4	DEC/02/97	2.00	CHANGED C27, C28, C29, C30 TO 150N
5	APR/22/98	2.10	PC#5694 ADD CONNECTIONS AT BRIDGE
6	.	.	SWITCH FOR BRPRTCT/LVGND-28
7	SEP/06/01	2.20	DELETE_R119
8	D	V	N
9	D	V	N
10	D	V	N

YORKVILLE	DATE: SEP/06/2001	MODELS: AP4020/AP2020/AP4040 INPUT	SHEET OF 1	SCH VERSION: 2.20
	NAME: M1129.SCH	PCB#&VER: M1129	TITLE: INPUT-BD	

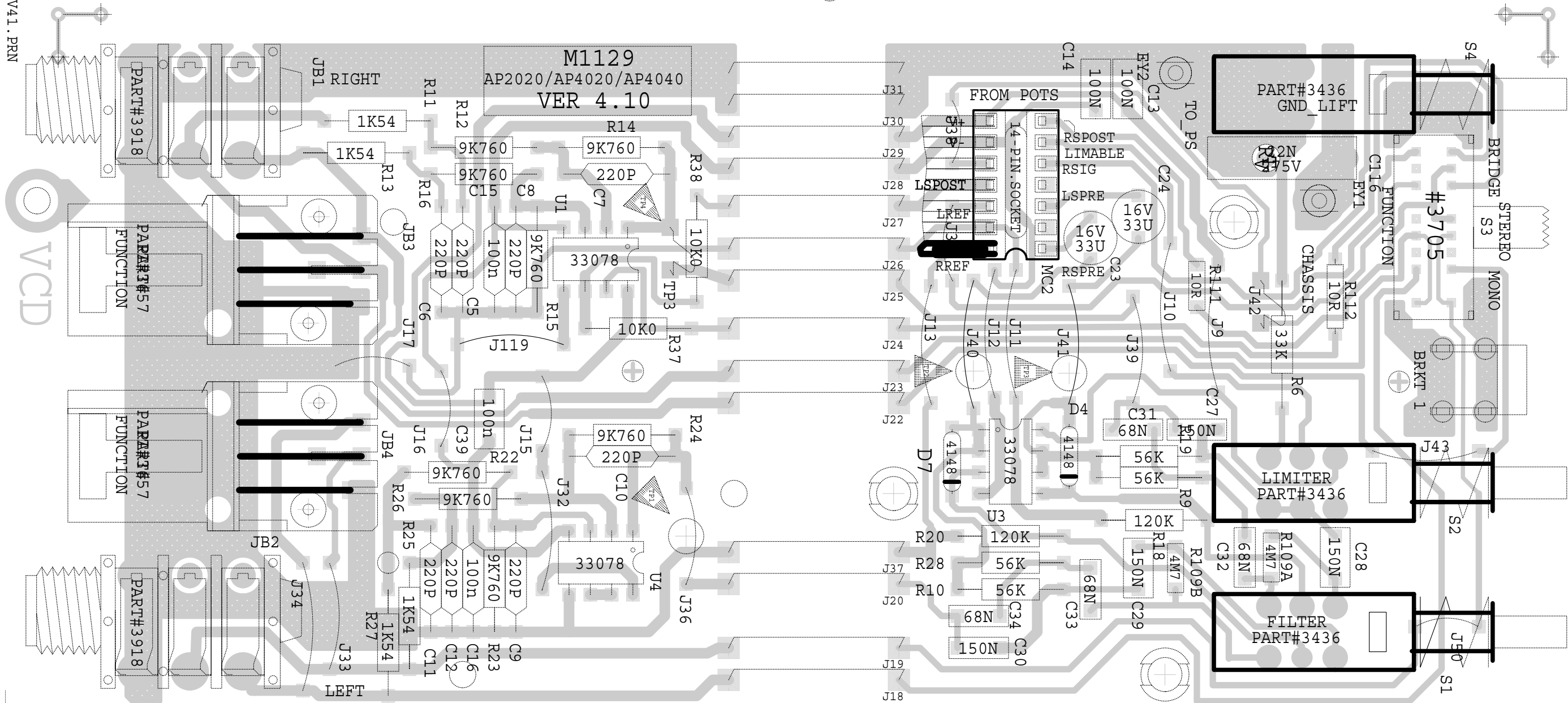

PRODUCTION NOTES

- 1 FOR XLR #3657 USE SCREW PT#8829 UP THROUGH THE BOTTOM
- 2 FOR M1129B VX1200/2400/J/2402 DO NOT STUFF J40 AND J41 ADD WIRES IN BOARD ASSEMBLY

M1129.PCB DATABASE HISTORY

MODEL(S) :- AP4020/4040/2020/VX1200/2400/2402

#	DATE	VER#	DESCRIPTION OF CHANGE
1	OCT/97	1.00	FIRST PRODUCTION
2	NOV/97	2.00	SWITCH RREF WITH LREF AND
3	D	V	RSPRE WITH LSPRE AT 14PIN CONNECTOR
4	D	V	SWAP INPUTS TO BE NONINVERTING
5	DEC/02/97	2.00	CHANGE C27 C28 C29 C30 TO 150N
6	APR/16/98	3.00	PC#5694 PINS 10-12 OF MC2 CONNECTED TO BRIDGE SWITCH
7	.	.	.
8	JUL/01/98	4.00	ISOLATE PIN OF SWITCH S3
9	SEP/06/01	4.10	PC#6436 REPLACE R119 10K0->JUMPER
10	D	V	N
11	D	V	N

U:\M1130V15.PRN

M1130.SCH DATABASE HISTORY			M1130.SCH DATABASE HISTORY				
#	DATE	VER#	DESCRIPTION OF CHANGE	#	DATE	VER#	DESCRIPTION OF CHANGE
MODEL(S) :- AP2200			MODEL(S) :- AP2020				
1	DEC/16/97	1.10	PC# R21,R36 20K->15K R31,82K->47K D43 20V->18V R3 20K->30K1 R52, R61 16K9->14K7 R53, R57 64K9->50K4 R34,R55 24K9->17K8 R79,R114 220R->249R C35, C38 22N->4N7 C1768UP->1N5 C25 470P->1N ADD D46, R118, R119, C43 PC# D9 4148->4004 C30, C32 4P7->->10P/200V	1	SEP/06/01	1.40	PC#6434 ADD C44, C45, R120, R121
2				2	JUN/17/02	1.50	PC#6538 R120, 121 100R->470R
3				3			
4				4			C44, 45 1N->220P D41, 42 14V->16V
5				5			C27 10H->33N Q18, 20, 22, 24 #6900->MJ21196_Q30, 32, 34, 36 #6927->MJ21195
6				6			
7				7			
8				8			
9	FEB/23/98	1.20	CORRECTION ATT Q7	9			
10	MAR/10/98	1.30	PC#5641_ADD_LD1	10			

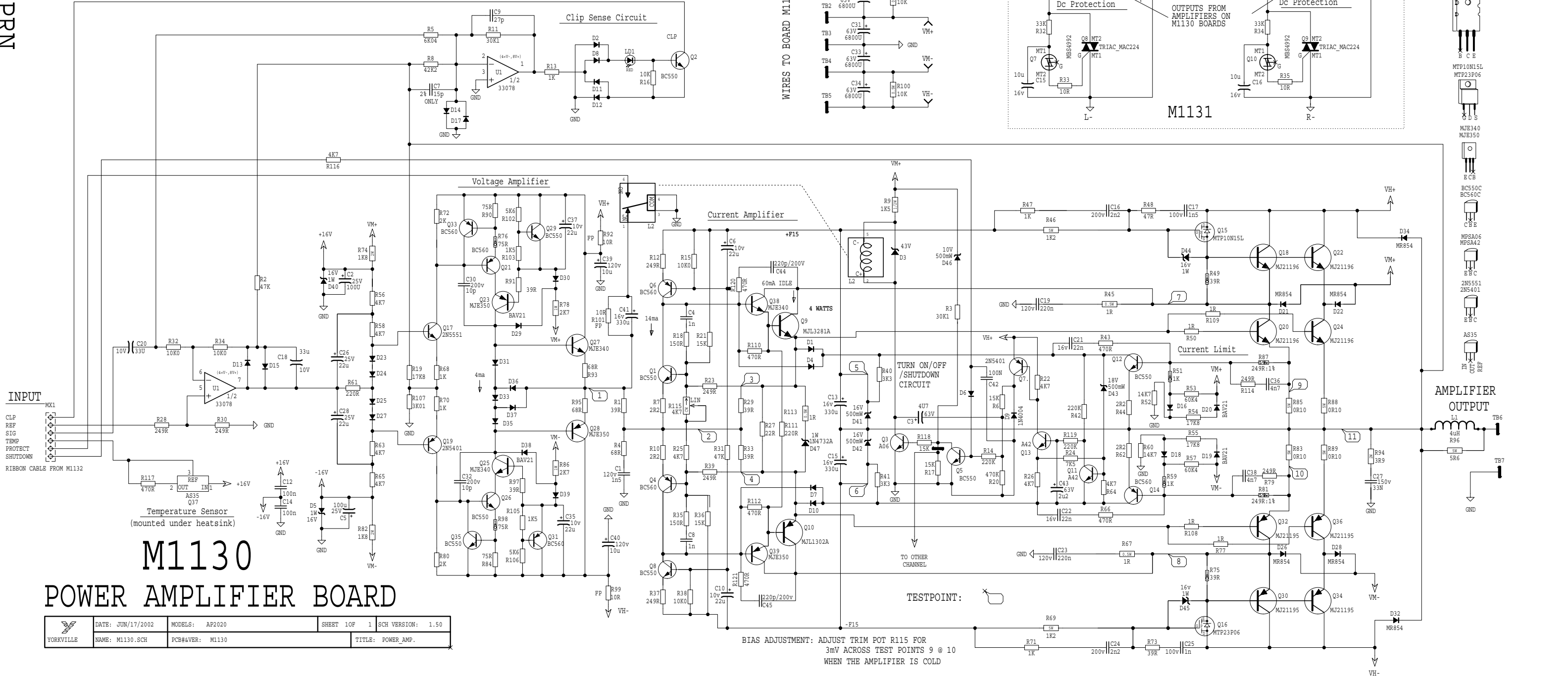

WIRES TO BOARD M1131

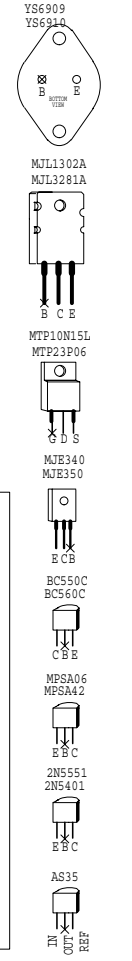
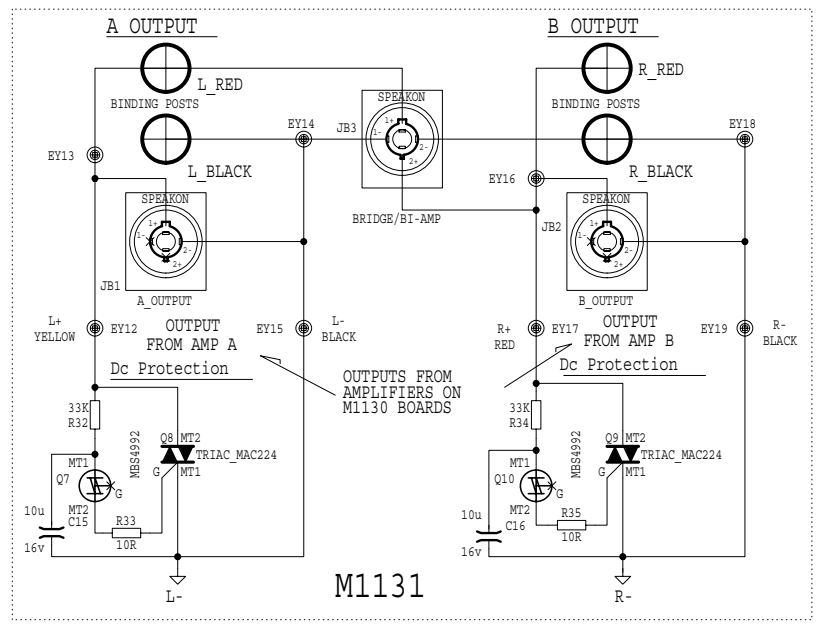
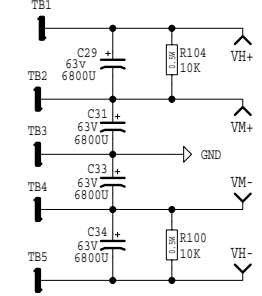

M1130 POWER AMPLIFIER BOARD

YORKVILLE	DATE: JUN/17/2002	MODELS: AP2020	SHEET 1 OF 1	SCH VERSION: 1.50
	NAME: M1130.SCH	PC#&VER: M1130	TITLE: POWER_AMP.	

BIAS ADJUSTMENT: ADJUST TRIM POT R115 FOR 3mv ACROSS TEST POINTS 9 @ 10 WHEN THE AMPLIFIER IS COLD

PRODUCTION NOTES
MOUNTING DETAILS FOR 5W

REF: 9609

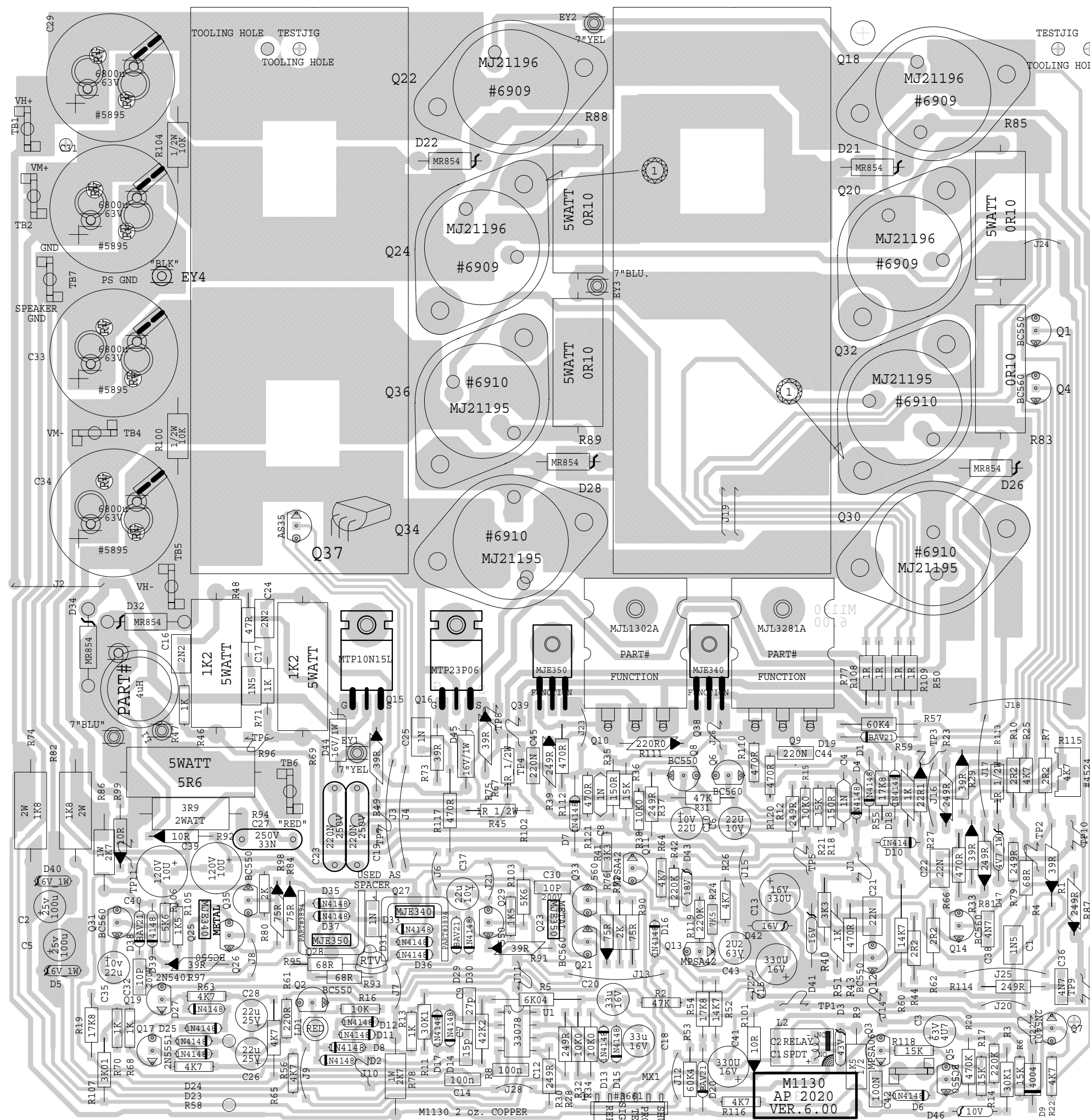

SOS COPPER

Q1 Q4 ARE HAND INSERTED

ADD #8629 SPACERS ONLY ON
5 WATT RESISTORS
R46, R69

MOUNTING HARDWARE FOR Q9, Q10

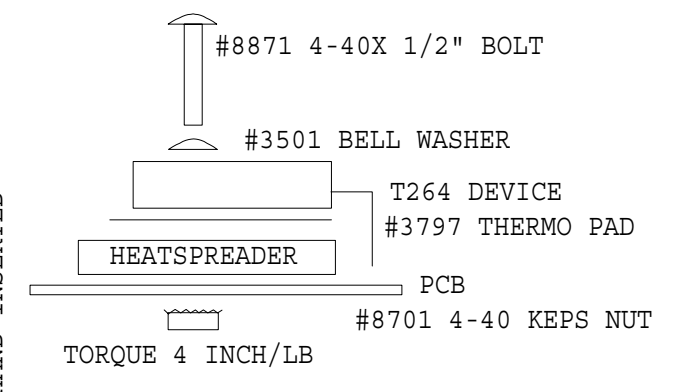

MOUNTING HARDWARE FOR Q38, Q39

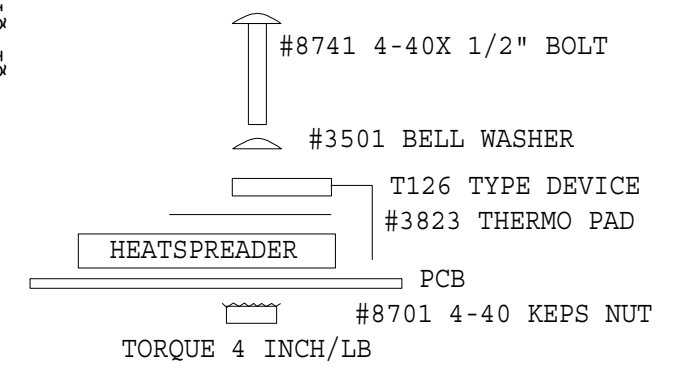

MOUNTING HARDWARE FOR Q15, Q16

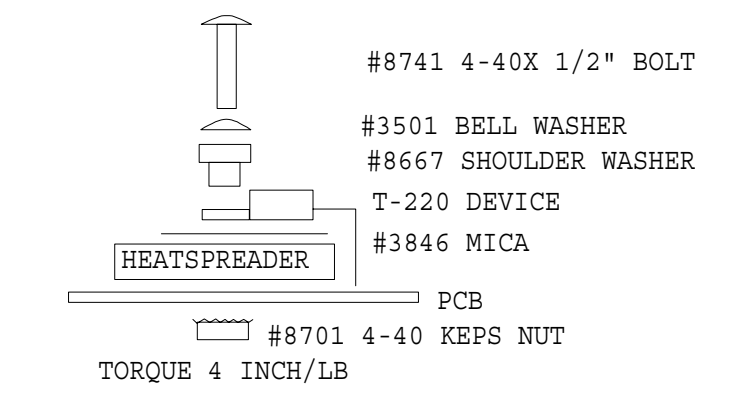

MOUNTING HARDWARE FOR TO3 OUTPUTS

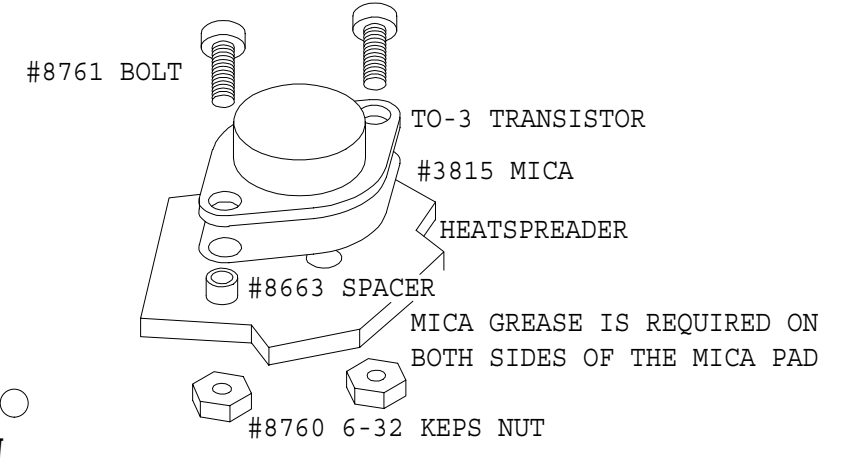

INITIAL TORQUE FOR TO-3'S IS 8 INCH/LB
FINAL TORQUE AFTER HEATSINK HAS
COOLED FROM WAVE SOLDER IS 6 INCH/LB

MOUNTING FOR Q28, Q37
#8701 4-40 HEX NUT

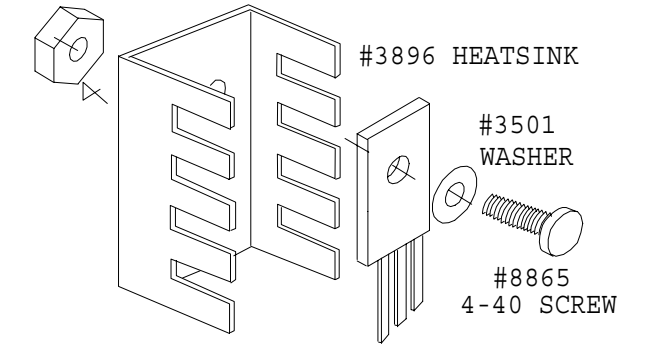

ASSEMBLY M1130-6.00

PCB MECH M1130-6.00

M1130.PCB DATABASE HISTORY			
MODEL(S)	DATE	VER#	DESCRIPTION OF CHANGE
AP-2020	DEC/97	1.00	FIRST PRODUCTION
	DEC/16/97	2.00	PC# R21,R36 20K->15K R31 82K->47K D43 20V->18V R3 20K->30KI R52 R61 16K9->14K7 R53,R57 64K9->60K4 R54,R55 24K9->17K8 R79,R114 220R->249R C36,C38 22N->4N7 C17 680P->1N5 C25 470P->1N ADD R118,R119,C43,D46 ADD TAB TO CONNECT 1 AMP->OTHER AMP PC# R109,50,108,70 FLAMPREF->REG D9 4I48->4004 C30,C32 4P7->10P/200V PC#5641 ADD LD1 DO PC5634->5642
	JUL/17/98	4.00	PC#5799 TAB3 TO EYELET EY4
	SEP/06/01	5.00	PC#6434 ADD C45,C121 AT Q39_ADD_C44 R120 AT Q38
	DEC/17/01	5.10	PC#6051 Q27,Q28 HTSNK #3896->#3894 PC#6493 R120/R121 150R->100R
	JUN/17/02	5.20	PC#6538 Q18,20,22,24 #6900->6909 Q30,32,34,36 #6927->#6910 R120,121 100R->470R C44,C45 1N->220P D41,42 14V->16V C27 10N->33N PC#6547_ADD_TEST-JIG_HOLE
	JUL/04/02	6.00	

TAB WIRE COLOURS

TAB 1	RED	16AWG
TAB 2	YEL	16AWG
TAB 4	BLK	16AWG
TAB 4	WHT	16AWG
TAB 5	BLU	16AWG
TAB 6	OUTPUT +	
TAB 7	OUTPUT -	

USE #XXXX SMALL BODY 1R 1W FOR R33,R49

Q37 IS HAND INSERTED AND BENT OVER WITH FLAT SIDE UP AS SHOWN

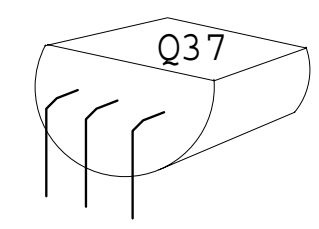

SERVICE WARNING: POTENTIALS CLOSE TO 200 VDC, USE CAUTION.

POWER SUPPLY

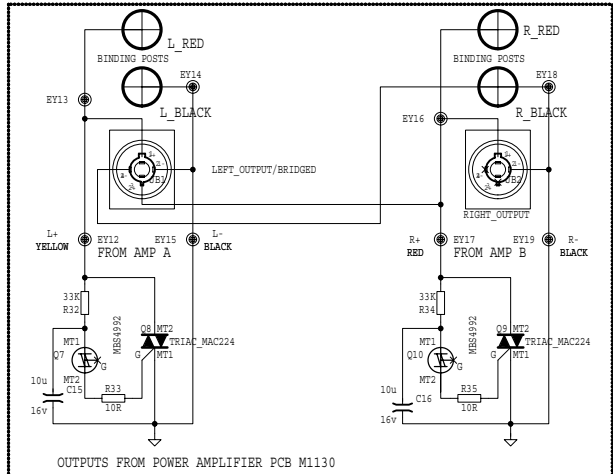
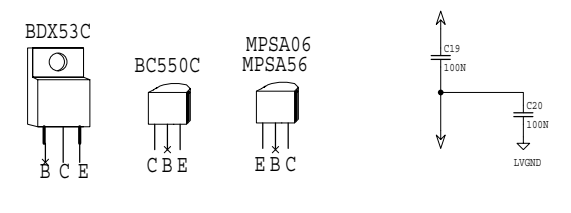
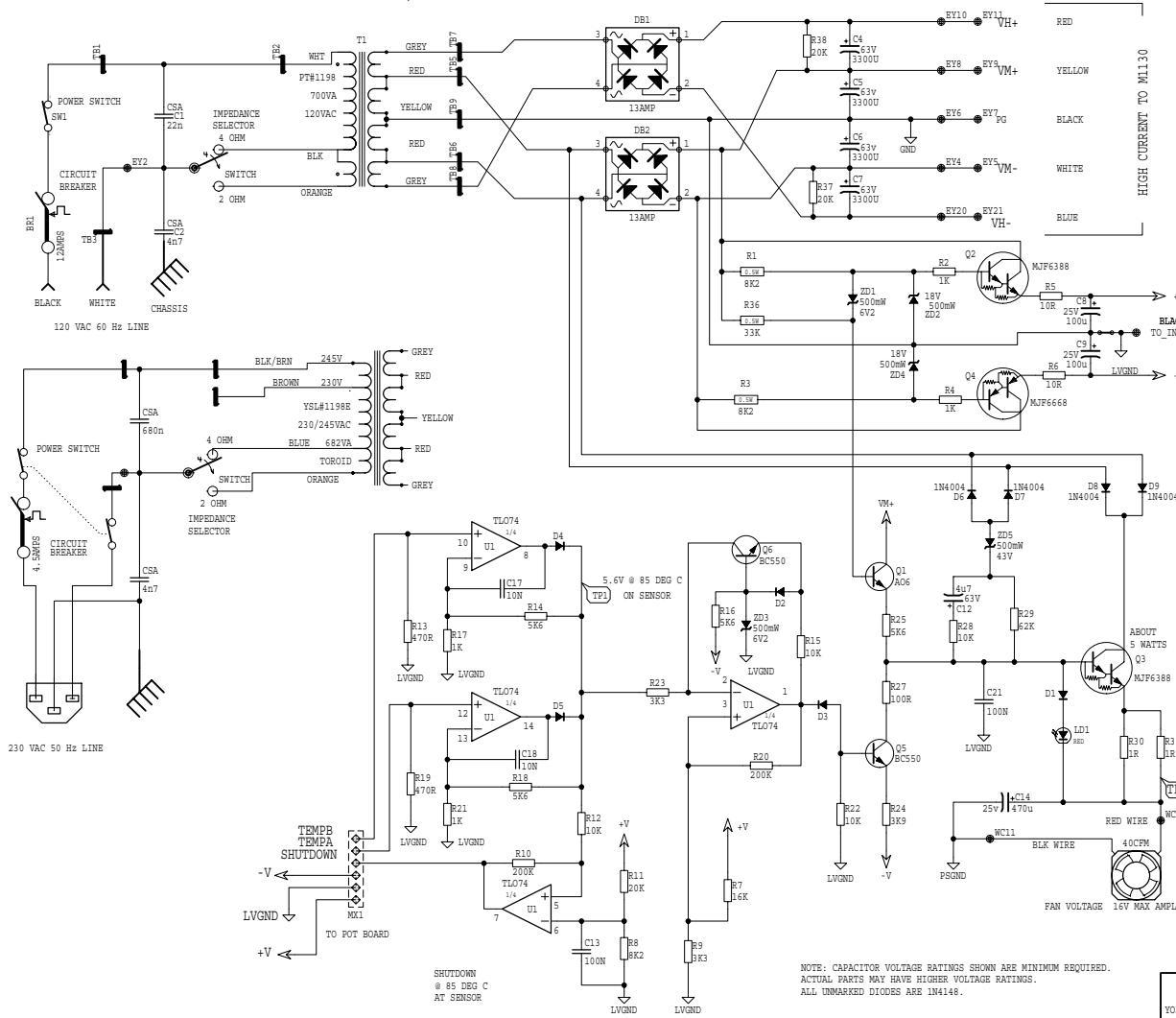

M1131.SCH DATABASE HISTORY

MODEL(S) :- AP2020			
#	DATE	VER#	DESCRIPTION OF CHANGE
1	NOV/97	1.00	FIRST PRODUCTION
2	MAY/27/98	1.10	ADD CE POWER SUPPLY
3	JUL/16/98	1.20	XPMR WIRE COLORS TO CSA/CE STANDARD
4	OCT/14/99	1.30	DELETE ONE SPEAKER JACK
5	MAY/08/00	1.40	PCB#5654_ZDI-4V7->6V2
6	D	V	N
7	D	V	N
8	D	V	N
9	D	V	N
10	D	V	N

ASSEMBLY M1131-3.00
 PCB MECH M1131-3.00

BLANK SIZE=15.000" X 10.000"



2 OZ COPPER

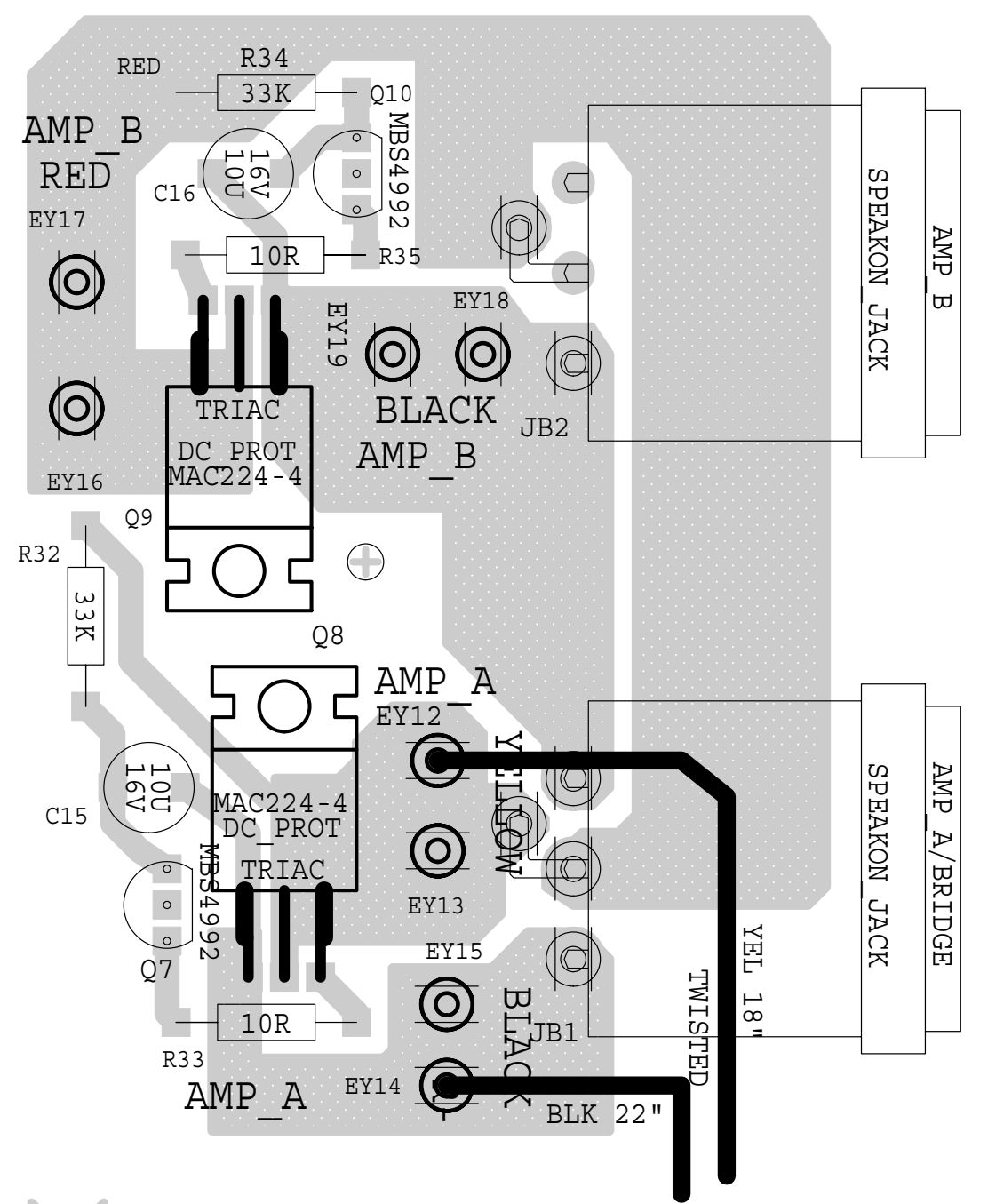
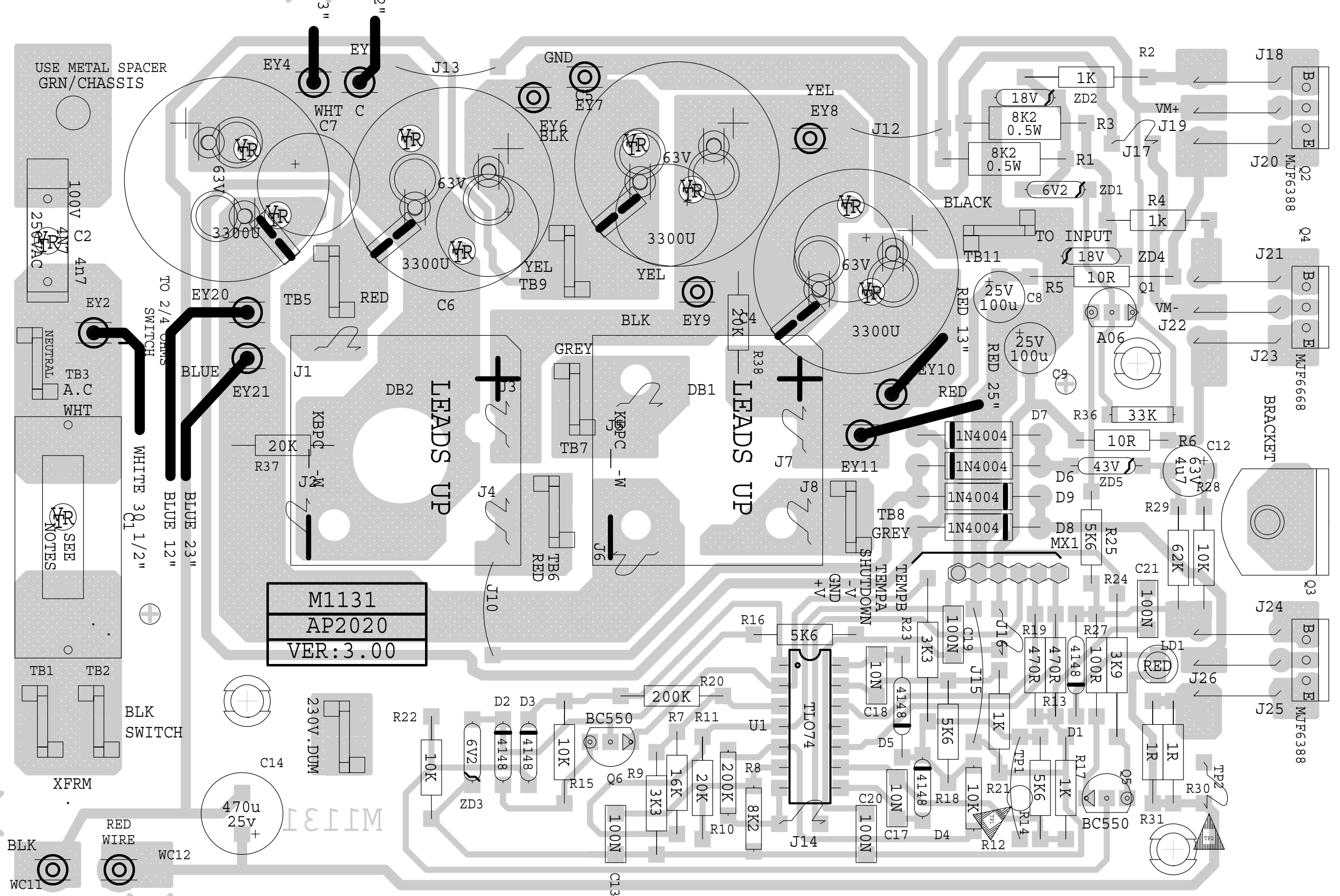

VCD

00.3-1311M EPT29D1102

M1131
 AP2020
 VER:3.00

M1131.PCB DATABASE HISTORY

MODEL(S) :- AP2020			
#	DATE	VER#	DESCRIPTION OF CHANGE
1	MAR/12/98	2.00	PC#5654 ZD1 4V7->6V2 MOVE SHEARS TO CLEAR HEATSPREADER 1 EYELET->TAB
2	.	.	.
3	AUG/24/99	3.00	PC#5943,#6064 PARTS MOVED FOR CLEARANCE IN AUTOINS C2_#6458->6451
4	.	.	PC#6009 SPKON REMOVED
5	.	.	PC#6064_MOVE_ZD4_TAB11
6	SEP/17/99	.	.
7	D	V	N
8	D	V	N
9	D	V	N
10	D	V	N
11	D	V	N

PRODUCTION NOTES

- DO NOT CUT CENTER LEAD OF THE TRIACS BEND THE LEAD (UNCUT) ALONG THE TRACE AND SOLDER
- SEE PETER BEFORE MOUNTING L BRACKET
- FOR C1 USE 22N FOR NORTH AMERICAN AND 680N FOR EURO/CE
- Q8,Q9 USE #8799 SELF TAPPING SCREW
- Q2,Q3,Q4 BEND THE LEADS (UNCUT) ALONG THE TRACE

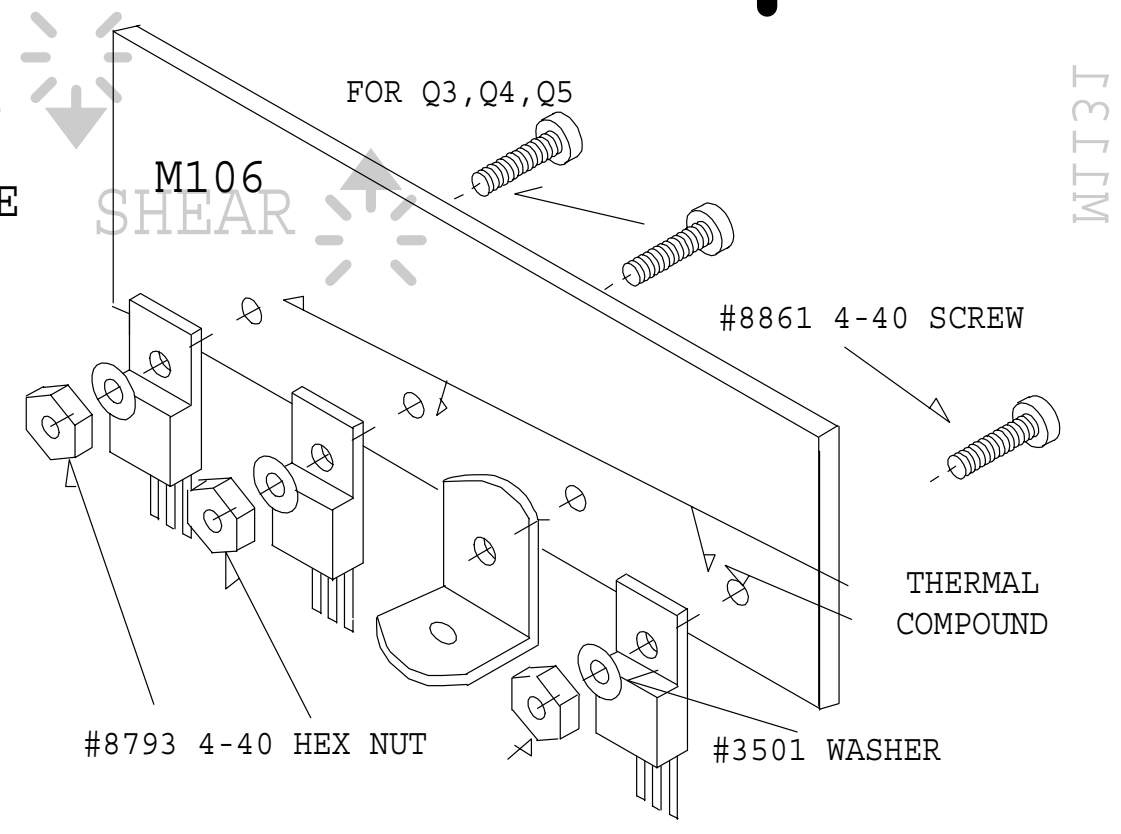

1311M

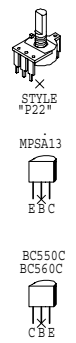
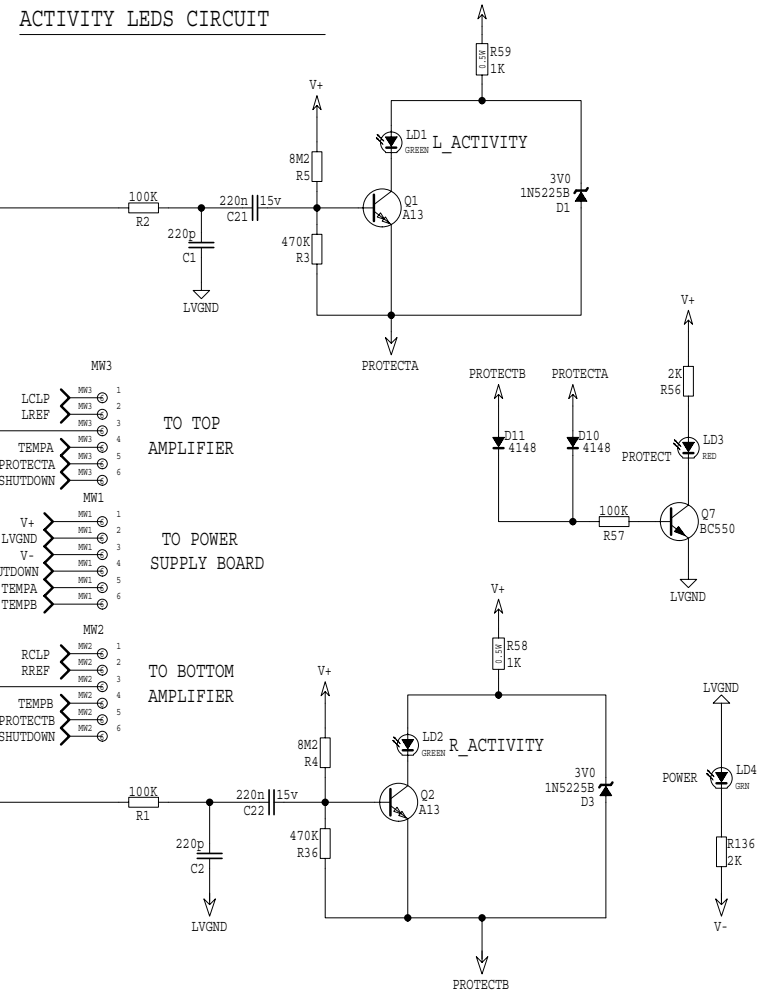
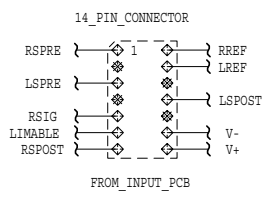
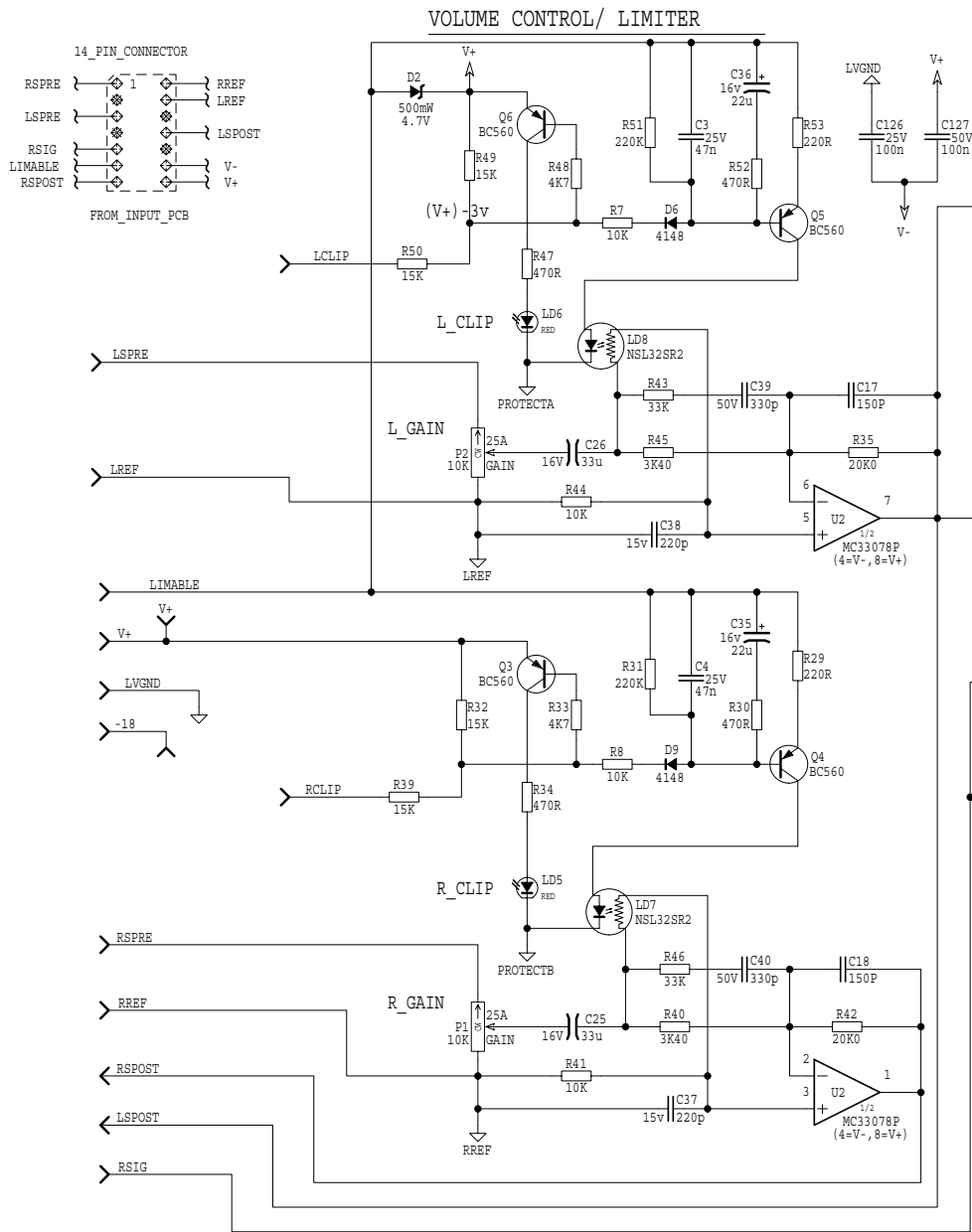

M1132.SCH DATABASE HISTORY

MODEL(S) :- AP2020			
#	DATE	VER#	DESCRIPTION OF CHANGE
1	APR/03/98	1.10	C17/C18 100P->150P
2	NOV/20/01	1.20	PC#6466_LD7, LD8_NSL28AA->NSL32SR2
3	D	V	N
4	D	V	N
5	D	V	N
6	D	V	N
7	D	V	N
8	D	V	N
9	D	V	N
10	D	V	N

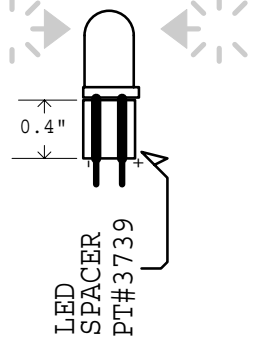
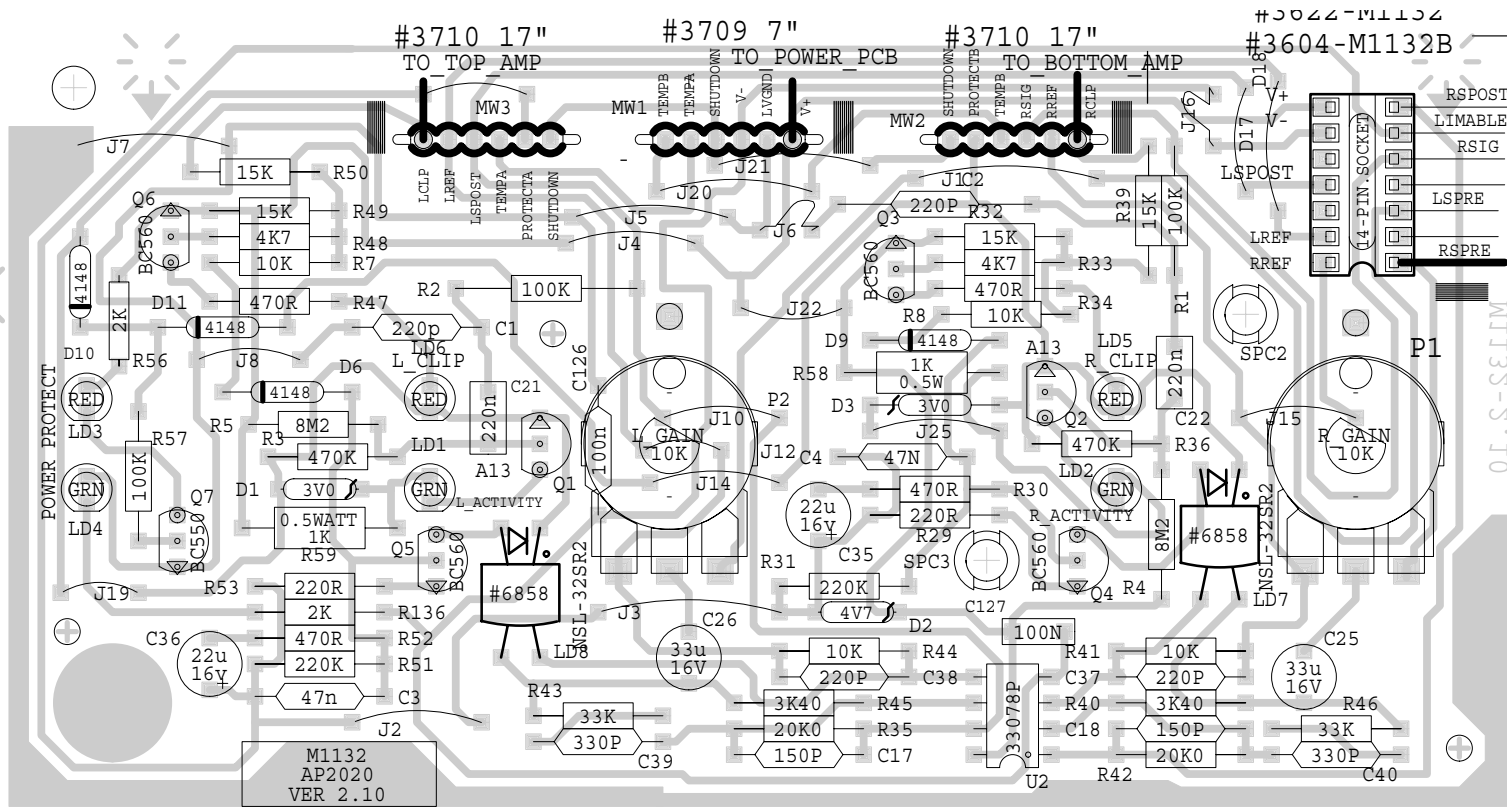

M1132.PCB DATABASE HISTORY

MODEL(S) :- AP2020/VX1200

#	DATE	VER#	DESCRIPTION OF CHANGE
1	DEC/09/98	2.00	PC#5688 SPACING FOR C38,C37 CHANGED
2	.	.	R58,R59 SPACING TO .76" FOR I/2W
3	.	.	POT SUPPORT SCREW HOLES ADDED
4	NOV/20/01	2.10	PC#6466_LD7,LD8_NSL-28AA->NSL32SR2
5	D	V	N
6	D	V	N
7	D	V	N
8	D	V	N
9	D	V	N
10	D	V	N
11	D	V	N

NOTES

- 1 ADD A STICKER OVER THE AP-2020 LEGEND "M1132B" TO AID IN IDENTIFYING VX1200 BOARDS
- 2 FOR M1132 USE #3622 CABLE FOR M1132B USE #3604 CABLE

