



**WORLD HEADQUARTERS
CANADA**

Yorkville Sound
550 Granite Court
Pickering, Ontario
L1W-3Y8 CANADA

Voice: (905) 837-8481
Fax: (905) 837-8746

U.S.A.

Yorkville Sound Inc.
4625 Witmer Industrial Estate
Niagara Falls, New York
14305 USA

Voice: (716) 297-2920
Fax: (716) 297-3689



Quality and Innovation Since 1963
Printed in Canada



AP508/512

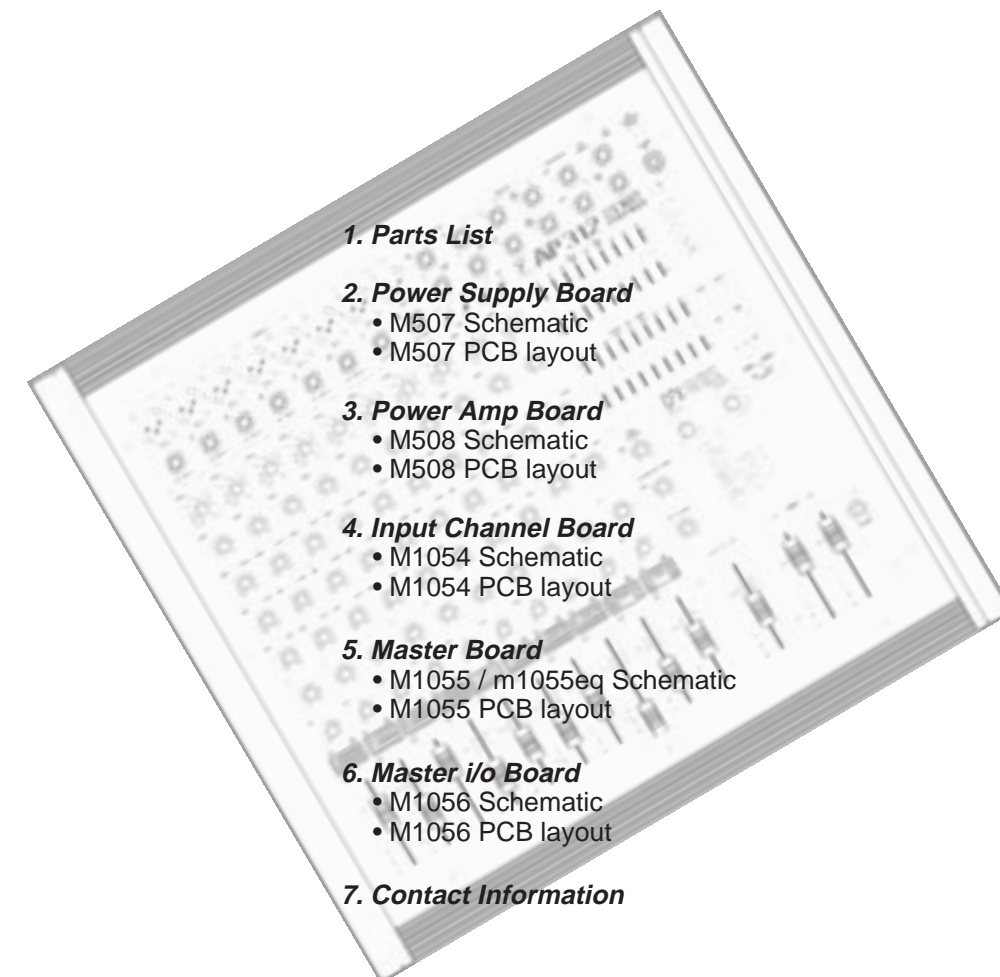

SERVICE MANUAL

IMPORTANT SAFETY INSTRUCTIONS



**INSTRUCTIONS PERTAINING TO A
RISK OF FIRE, ELECTRIC SHOCK, OR
INJURY TO PERSONS.**

**INSTRUCTIONS RELATIVES AU
RISQUE DE FEU, CHOC ÉLECTRIQUE,
OU BLESSURES AUX PERSONNES.**

CAUTION:

**DO NOT REMOVE COVER (OR BACK).
NO USER SERVICEABLE PARTS INSIDE.**

**REFER SERVICING TO QUALIFIED
SERVICE PERSONNEL.**

**AFIN DE RÉDUIRE LES RISQUE DE CHOC
ÉLECTRIQUE, N'ENLEVEZ PAS LE COUVERT (OU
NE CONTIENT AUCUNE
PIÈCE RÉPARABLE PAR L'UTILISATEUR.**

**CONSULTEZ UN TECHNICIEN
QUALIFIÉ POUR L'ENTRETIEN.**

Read Instructions:

The *Owner's Manual* should be read and understood before operation of your unit. Please, save these instructions for future reference.

Packaging:

Keep the box and packaging materials, in case the unit needs to be returned for service.

Warning:

When using electric products, basic precautions should always be followed, including the following:

Power Sources:

Your unit should be connected to a power source only of the voltage specified in the owners manual or as marked on the unit. This unit has a polarized plug. Do not use with an extension cord or receptacle unless all three blades can be fully inserted to prevent blade exposure. Precautions should be taken so that the grounding scheme on the unit is not defeated.

Power Cord:

The AC supply cord should be routed so that it is unlikely that it will be damaged. If the AC supply cord is damaged **DO NOT OPERATE THE UNIT.**

Service:

The unit should be serviced only by qualified service personnel.

Veillez lire le manuel:

Il contient des informations qui devraient être comprises avant l'opération de votre appareil. Conservez S.V.P. ces instructions pour consultations ultérieures

Emballage:

Conservez la boîte au cas où l'appareil devait être retourner pour réparation.

Warning:

Attention: Lors de l'utilisation de produits électrique, assurez-vous d'adhérer à des précautions de bases incluant celle qui suivent:

Alimentation:

L'appareil ne doit être branché qu'à une source d'alimentation correspondant au voltage spécifié dans le manuel ou tel qu'indiqué sur l'appareil. Cet appareil est équipé d'une prise d'alimentation polarisée. Ne pas utiliser cet appareil avec un cordon de raccordement à moins qu'il soit possible d'insérer complètement les trois lames. Des précautions doivent être prises afin d'éviter que le système de mise à la terre de l'appareil ne soit désengagé.

Cordon d'alimentation:

Évitez d'endommager le cordon d'alimentation. **N'UTILISEZ PAS L'APPAREIL** si le cordon d'alimentation est endommagé.

Service:

Consultez un technicien qualifié pour l'entretien de votre appareil.

AP5xxParts List 11/4/98

YS #	Description	Qty.	YS #	Description	Qty.	YS #	Description	Qty.
5990	GREEN 3MM LED 1V7 20MA RAD W/STOPER	20	5318	220N 50V 10%CAP T&R BEAD X7R	1	3468	87 3/16 SUT AC LINE CORD STRIP 17"	1
5991	RED 3MM LED 1V9 20MA RAD W/STOPER	9	5233	330N 63V 5%CAP T&R RADIAL.2"FILM	7	3821	HEYCO #1200 STRAIN RELIEF	1
5996	RED 1.5 LED 0V0 00MA 7SEG DISPLAY	1	5240	680N 63V 10%CAP T&R RADIAL.2"FILM	3	3520	24 PIN BREAKAWAY .156	0.375
6403	ORANGE3MM LED 1V7 5MA	16	5254	1U 63V 20%CAP T&R RAD EL.2"4X7M	2	3521	SIDE ENTRY PCB CONN .156 8POS	1
6420	RED 5MM LED 1V7 20MA BRGT SAR5734	2	5256	1U 63V 5%CAP T&R RADIAL.2"FILM	3	3538	24 PIN BREAKAWAY LOCK .156	0.5
6419	BRIDGE 35A 400V WIRE LEAD GI3504	2	5258	4U7 63V 20%CAP T&R RAD EL.2"8X7M	9	3548	SIDE ENTRY PCB CONN .156 4POS	1
6425	BAV21 200V 0A25 DIODE T&R	8	5259	4U7 63V 20%CAP T&R RADIAL ELE.2"	5	3596	36PIN BREAKAWAY .15GOLD .100	1.326
6438	1N4004 400V 1A0 DIODE T&R	24	5281	10U 16V 20%CAP NONPOLAR T&R .2"	2	3597	12 CIR HDR BOT ENTRY 0.1" GOLD	3
6825	1N4148 75V 0A45 DIODE T&R	96	5885	10U 100V 20%CAP T&R AXIAL ELECTRO	2	3598	16 PIN 25SQ 100 DIL VOIDA1	1
6479	MUR415 150V 4A0 DIODE FAST RECOV	12	5260	22U 50V 20%CAP T&R RADIAL ELE.2"	23	3599	16 SKT 25SQ 100 DIL DUAL-ENTRY	1
5121	MZ4615RL 2V0 W25 ZENER 5% T&R	2	5631	22U 50V 20%CAP T&R RAD 7MM EL.2"	10	3631	PCB CONN 9 CIR BOTTOM .156	1
6440	1N750ARL 4V7 0W5 ZENER 5% T&R	4	5961	33U 16V 20%CAP NONPOLAR T&R RAD	55	3637	16 PIN DUAL 90 BREAKAWAY .100	1
6436	1N753ARL 6V2 0W5 ZENER 5% T&R	3	5265	68U 25V 20%CAP T&R RADIAL ELE.2"	5	3638	12 CIR CABLE HOLDER .098	6
6461	1N5240BRL 10V0 0W5 ZENER 5% T&R	6	5879	100U 16V 20%CAP T&R RAD EL.2"8X7M	8	3674	9 CIR CABLE HOLDER .098	1
6450	1N5242B 12V0 0W5 ZENER 5% T&R	2	5914	100U 63V 20%CAP RADIAL ELECT BULK	4	5992	9 PIN SINGLE-IN-LINE IC SOCKET	2
6465	1N5250B 20V0 0W5 ZENER 5% T&R	1	5883	220U 100V 5%CAP RADIAL ELECT BULK	2	8701	4-40 KEPS NUT ZINC	8
6463	1N5251BRL 22V0 0W5 ZENER 5% T&R	4	5623	330U 16V 20%CAP AXIAL ELECTR BULK	1	8793	4-40 HEX NUT ZINC	3
6460	1N5260B 43V0 0W5 ZENER 5% T&R	1	5621	470U 63V 20%CAP RADIAL ELECT BULK	5	8800	6-32 KEPS NUT ZINC	10
6855	NJM7805FA TO220 POS 5V0 REG IS	1	5859	4700U 50V 20%CAP RADIAL ELECT BULK	2	8844	6-32 PEMNUT	9
6856	NJM7815FA TO220 POS 15V0 REG IS	1	5868	4700U 16V 10%CAP RADIAL ELECT BULK	1	8787	8-32 KEPS NUT ZINC	5
6857	NJM7915FA TO220 NEG 15V0 REG IS	1	5890	5600U 100V 20%CAP RAD ELECT 35X50MM	2	8880	3/16 PUSHNUT SPAENAUER #177078	6
5101	BC550C TO92 NPN TRANS. T&R	24	4402	10K 3B-LIN-DETENT STYLE"P11"16MM	24	8797	5/16-18 KEPS NUT SJ500	2
5102	BC560C TO92 PNP TRANS. T&R	23	4561	10K 1B-LINEAR STYLE"P11"16MM	34	3846	TO220 MICA THERMAL CONDUCTOR 56359B	1
5103	MPSA06 TO92 NPN TRANS. T&R	3	4574	10K SLD 1B S V 60M WHT SFT	8	4597	22AWG STRAN TC WIR	106
5104	MPSA56 TO92 PNP TRANS. T&R	1	3995	20K SLD ST WHT KB V 30M DT	9	4599	22AWG SOLID SC WIR T&R	134
5109	MPSA43 TO92 NPN TRANS.	11	3996	20K SLD MON WHT KB V 30M DT	9	5299	24AWG SOLID SC WIR RAD	26
5110	MPSA93 TO92 PNP TRANS.	14	4559	20K 5C-REV/AUDIO STYLE"P12"16MM	8	4745	5.0W 0R1 5% BLK RES	4
5111	MPSA17 TO92 NPN TRANS. T&R	4	4564	20K STEREO1B-LINEAR STYLE"P17"18MM	4	4688	1/2W 2R2 5% T&R RES	4
5105	MPSA13 TO92 NPN DARLINGTON&R	14	4563	50K 1B-LINEAR STYLE"P12"16MM	4	4748	2.0W 3R9 5% BLK RES	2
5106	MPSA63 TO92 PNP DARLINGTON&R	1	4401	50K 1B-LINEAR STYLE"P11"16MM	8	4605	1/8W 10R 5% T&R RES	8
5116	BC264D TO92 N CHAN J FETT&R	2	4582	50K SLD V 60M MONO	5	4675	1/2W 10R 5% T&R RES	2
5119	2N5638 TO92 N CHAN J FETT&R	4	4581	ROTARY ENCODER 4-BIT VER PCB DSHAFT	1	4875	1/4W 10R 5% T&R RES	1
6788	BD238 TO126 PNP TRANS	1	2460	8.00 AMP SWITCH BREAKER BLUE	1	4930	1/4W 10R 5% .2"U T&R RES	2
6811	MJF15031 221D- PNP TRANS	1	3819	5UH COIL 18AWG R000 AIR CORE	2	4812	1/4W 18R 5% T&R RES	1
6912	BDX53C TO220 NPN DARLINGTON	1	3464	WIRE TO BOARD CRIMP 18-24 AWGT/LEAD	14	4591	1/8W 22R1 1%FLAME PROOF T&R RES	2
6928	IRFP250 TO247 N CHAN MOSFET	6	3490	CLIP 250X032 14-16AWG DISCO/INSL	7	4817	1/4W 47R 5% T&R RES	1
6991	MJL21193 TO3P PNP TRANS PWR	2	3601	RING TERMINAL 16AWG WIRE & #8 SCREW	1	4590	1/8W 100R0 1%FLAME PROOF T&R RES	2
6798	MC4741CP IC QUAD OP AMP	2	3602	RING TERMINAL 18AWG WIRE & #8 SCREW	3	4852	1/4W 100R 5% T&R RES	23
6840	MC33078P IC DUAL OP AMP	17	3682	250 MALE PCB TAB BULK ON CATRIGE	2	4921	1/4W 100R 5% .2"U T&R RES	31
6882	TL072CP IC FET DUAL OP AMP	21	3432	NARROW PC MNT JK SKT M203-2	4	4859	1/4W 150R 5% T&R RES	9
6884	NE5532N IC DUAL OP AMP	1	3498	M203-02 PLAIN PC MNT JK SKT	18	4909	1/4W 200R 5% T&R RES	2
6889	TL074CN IC QUAD O/A TEXASI ONLY	1	3523	M203-02A GOLD TIP PC MNT JK SKT	9	4932	1/4W 200R 5% .2"U T&R RES	8
6894	LM3916 IC LED DISPLAY DRIVER	2	3528	M203-02C GOLD TIP/RING PC MNT JK	3	4857	1/4W 220R 5% T&R RES	2
6745	LM13600N IC XCONDUCTANCE AMP	1	3460	MOULDED DUAL RCA SOCKET GOLD PLATED	2	4944	1/4W 220R 5% .2"U T&R RES	17
6959	4052 IC DUAL 1/4 CMOS SWITC	1	3611	TELEPHONE JACK 8 CIR 90 LP	1	4606	1/8W 249R 2%FLAME PROOF T&R RES	15
6960	4017 IC DECADE CNT/DIVIDE	2	3613	TELEPHONE JACK 8 CIR TOP ENT	1	4770	1/4W 249R 1% T&R RES	16
6945	745188 PROM IC PREPROG. FOR AP/MXR	1	3660	FEMALE PC MOUNT XLR NTRX.NC3FPR-H-O	8	4867	1/4W 270R 5% T&R RES	2
5190	MBS4992 TO92 8V5 DIAC T&R	2	3414	INTERNATIONAL PC MOUNT FUSEHOLDER	10	4945	1/4W 270R 5% .2"U T&R RES	16
6446	MAC15A4FP TO220 15A TRIAC 200V	2	2449	1.0 AMP SLO-BLO .25X1.25 FUSE	1	4780	1/8W 274R 1%FLAME PROOF T&R RES	4
6472	4K7 3% 0W0 THERMISTOR	3	2414	8.0 AMP SLO-BLO .25X1.25 FUSE	2	4798	1/4W 300R 5% T&R RES	1
6473	68K 3% 0W0 THERMISTOR	6	2405	10.0 AMP SLO-BLO .25X1.25 FUSE	2	4698	1/8W 475R 1%FLAME PROOF T&R RES	4
6474	10R 3% 0W0 PTC THERMISTOR	8	3630	FAN GUARD METAL 80MM CHROME	1	4821	1/4W 470R 5% T&R RES	16
6477	100K 5% 1/4W THERMISTOR T&R 0.2	1	3860	FAN 80MM X 80MM 40CFM 12VDC	1	4933	1/4W 470R 5% .2"U T&R RES	6
5405	.27P 200V 5%CAP T&R RAD CER.2"NPO	2	8559	AUDIOPRO GABLE "SET" ABS PLASTIC	1	4799	1/4W 562R 1% T&R RES	16
5203	.47P 100V 2%CAP T&R RAD CER.2"NPO	3	3692	HEATSINK THERMALLOY 6079-PB	1	4891	1/4W 620R 5% T&R RES	4
5199	100P 100V 2%CAP T&R RAD CER.2"NPO	9	3501	B52200F006 COMP WASH #4 SMALL	6	4922	1/4W 620R 5% .2"U T&R RES	8
5196	150P 100V 2%CAP T&R RAD CER.2"NPO	1	3556	XSISTOR HOLD SPRING-BAR (PLATED)	4	4781	1/8W 681R 1%FLAME PROOF T&R RES	2
5201	470P 100V 5%CAP T&R RAD CER.2"NPO	27	3800	BELLY BUTTON #BB1 CORDS CANADA	8	4873	1/4W 680R 5% T&R RES	2
5420	680P 50V 10%CAP T&R BEAD NPO	1	3862	SIL PAD 400 1.5X6.75	2	4923	1/4W 680R 5% .2"U T&R RES	9
5816	680P 100V 5%CAP T&R RAD CER.2"NPO	4	8682	#4 TEFLON WASHER .125ID .281OD .031	11	4924	1/4W 750R 5% .2"U T&R RES	3
5206	1N 400V 5%CAP T&R RADIAL.2"FILM	4	3857	VELCRO HOOK	0.5	4925	1/4W 820R 5% .2"U T&R RES	3
5422	1N 50V 10%CAP T&R BEAD NPO	2	8499	6-32X1 STEEL PEM STUD	2	4758	1/4W 953R 1% T&R RES	8
5423	1N2 50V 10%CAP T&R BEAD X7R	16	8500	6-32X3/4 STEEL PEM STUD	2	4823	1/4W 1K 5% T&R RES	1
5273	1N5 200V 5%CAP T&R RAD CER.2"NPO	8	3448	REAN JACK NUT WHITE	3	4934	1/4W 1K 5% .2"U T&R RES	19
5208	2N2 400V 5%CAP T&R RADIAL.2"FILM	5	3449	REAN JACK NUT RED	3	4854	1/4W 1K2 5% T&R RES	16
5275	3N3 100V 5%CAP T&R RADIAL.2"FILM	6	3518	CLEAR PVC TUBING .500" DIA. 105?C	1	4935	1/4W 1K5 5% .2"U T&R RES	8
5209	4N7 250V 5%CAP T&R RADIAL.2"FILM	9	3552	NYLON SPRING CLAMP	2	4825	1/4W 1K8 5% T&R RES	2
6451	4N7 250V 20%CAP AC Y ONLY RAD10MM	1	3795	#8 GROUND LUG ZIERICK 505-169	2	4946	1/4W 2K 5% .2"U T&R RES	48
5204	10N 100V 10%CAP T&R RADIAL.2"FILM	10	3798	8" NYLON CABLE TIE	2	4936	1/4W 2K7 5% .2"U T&R RES	10
5207	18N 100V 5%CAP T&R RADIAL.2"FILM	3	3799	ROUND BUMPER BUTTON BLACK	18	4826	1/4W 3K3 5% T&R RES	3
5210	22N 100V 10%CAP T&R RADIAL.2"FILM	15	3810	4" NYLON CABLE TIE	13	4827	1/4W 4K7 5% T&R RES	21
6435	22N 275V 20%CAP AC X2 RAD BLK15MM	1	3852	STICK ON CABLE WRAP ANCHOR	1	4943	1/4W 4K7 5% .2"U T&R RES	15
5222	33N 100V 10%CAP T&R RADIAL.2"FILM	6	8470	CUPWASHER FOR #1230 XFORMER	2	4639	1/4W 4K99 1% T&R RES	60
5224	47N 100V 10%CAP T&R RADIAL.2"FILM	3	8591	SLIDE POT KNOB-RED	2	4939	1/4W 5K1 5% .2"U T&R RES	2
5226	68N 100V 5%CAP T&R RADIAL.2"FILM	3	8638	AP MIXER SERIES PUSH SW BUTTON GREY	7	4685	1.0W 5K6 5% T&R RES	2
5227	82N 100V 5%CAP T&R RADIAL.2"FILM	3	8690	BLACK FADER KNOB - MICROMIX	13	4862	1/4W 5K6 5% T&R RES	8
5228	100N 100V 5%CAP T&R RADIAL.2"FILM	38	8702	GREEN KNOB FOR "NEW" M.MIX/A.PRO	20	4801	1/4W 6K98 1% T&R RES	16
5314	100N 50V 10%CAP T&R BEAD X7R	14	8703	BLUE KNOB FOR "NEW" M.MIX/A.PRO	26	4887	1/4W 7K5 5% T&R RES	6
5230	180N 63V 5%CAP T&R RADIAL.2"FILM	3	8704	RED KNOB FOR "NEW" M.MIX/A.PRO	19	4926	1/4W 7K5 5% .2"U T&R RES	24
5231	220N 63V 10%CAP T&R RADIAL.2"FILM	7	8705	GREY KNOB FOR "NEW" M.MIX/A.PRO	18	4863	1/4W 8K2 5% T&R RES	16

AP5xx Parts List 11/4/98

YS No.	Description	Qty.	YS No.	Description	Qty.
4955	1/4W 8K2 5% .2"U T&R RES	16	3437	DPDT PUSH SW PCMT V MINI UGT 3522	5
4762	1/4W 9K760 0.1% *** T&R RES	8	3439	SP SERIES VERTICAL MOM PCB SWITCH	2
4800	1/4W 10K0 1% T&R RES	18	8454	3M #396 1" ADHESIVE TAPE	1.67
4829	1/4W 10K 5% T&R RES	35	8887	1/2" 2 SIDED TAPE A.E.BLAKE# 969	1
4940	1/4W 10K 5% .2"U T&R RES	52	3409	THERMO SW N/CLOSED OP/184F CL/144F	1
4856	1/4W 12K 5% T&R RES	3	3422	THERMO/BRKR:N/CLOSED OPEN@60C	1
4953	1/4W 12K 5% .2"U T&R RES	1	1295	AP-508/512 T?RD	1
4775	1/4W 14K0 1% T&R RES	38		AP-1212 MASTER SECTION BOARD	1
4630	1/2W 15K 5% T&R RES	2		ALESIS DIG RVB BOARD	1
4830	1/4W 15K 5% T&R RES	21	0.25	M1053 X 25 AP-1212 JACK PCB:	0.32
4831	1/4W 18K 5% T&R RES	11		M1062 X 20 ALESIS BUFFER BRD	0.05
4954	1/4W 18K 5% .2"U T&R RES	1		M1015 X 18 AP-1212 LED GUIDE	0.112
4832	1/4W 22K 5% T&R RES	3	0.4	M1054 X 2 AP-1212 MIXER PCB	1
4902	1/4W 24K 5% T&R RES	3		M1081X3, M1056X3, PCB	0.33
4833	1/4W 27K 5% T&R RES	4			
4956	1/4W 27K 5% .2"U T&R RES	4			
4890	1/4W 30K 5% T&R RES	1			
4941	1/4W 30K 5% .2"U T&R RES	10			
4917	1/4W 31K6 1% T&R RES	6			
4840	1/4W 33K 5% T&R RES	2			
4947	1/4W 33K 5% .2"U T&R RES	22			
6122	1/4W 33K 5%MINI T&R RES	8			
4878	1/4W 43K 5% T&R RES	2			
4834	1/4W 47K 5% T&R RES	3			
4927	1/4W 47K 5% .2"U T&R RES	19			
4835	1/4W 56K 5% T&R RES	5			
4928	1/4W 56K 5% .2"U T&R RES	9			
4837	1/4W 82K 5% T&R RES	8			
4929	1/4W 82K 5% .2"U T&R RES	12			
4838	1/4W 100K 5% T&R RES	7			
4942	1/4W 100K 5% .2"U T&R RES	2			
6120	1/4W 100K 5%MINI T&R RES	4			
4849	1/4W 180K 5% T&R RES	4			
4949	1/4W 180K 5% .2"U T&R RES	2			
4841	1/4W 220K 5% T&R RES	7			
4843	1/4W 470K 5% T&R RES	2			
4880	1/4W 680K 5% T&R RES	3			
4844	1/4W 1M 5% T&R RES	12			
4948	1/4W 1M 5% .2"U T&R RES	4			
4888	1/4W 4M7 5% T&R RES	5			
4951	1/4W 4M7 5% .2"U T&R RES	8			
3612	23" 9C-24AWG RIBBON HEAVY DUT.100"	1			
3614	16" 8C-24AWG TELEPHONE CABLE .050"	1			
3625	4.5" 5C-26AWG RIBBON CABLE .100"	1			
3626	12" 16C-28AWG RIBBON CABLE SOCKETS	1			
3639	1.7"12C-26AWG RIBBON CABLE 0.25" S&R	2			
3678	14" 4C-26AWG RIBBON CABLE .100"	1			
3679	6" 12C-28AWG RIBBON CABLE .100"	2			
8865	4-40 X 5/16 PAN PH MS SJ500	21			
8742	4-40 X 3/8 PAN PH TAPTITE JS500	35			
8861	4-40 X 3/8 PAN PH MS SJ500	2			
8741	4-40 X 1/2 PAN PH MS JS500	1			
8871	4-40 X 5/8 PAN PH MS SJ500	6			
8799	#6 X 1/4 PAN PH TYPE B JS500	1			
8832	6-32 X 1/4 PAN PH TAPTITE SJ500	5			
8807	6-32 X 5/16 PAN PH MS SJ500	8			
8829	6-32 X 3/8 FLAT PH TAPTITE BO#4 HEA	8			
8823	6-32 X 1 PAN PH TAPTITE SJ500	2			
8838	6-32 X 1 HEX ND MS ZINC	4			
8802	8-32 X 3/8 PAN QUAD TPTTE SJ500 #6H	7			
8803	8-32 X 3/8 PAN QUAD TAPTITE SJ500	4			
8815	8-32 X 3/4 PAN PH TAPTITE SJ500	6			
8809	10-32 X 1/4 PAN PH TAPTITE SJ500	3			
8749	10-32 X 1/2 QDX PH TAPTITE JS500	12			
8783	10-32 X 1 PAN QUAD TT JS500 BLACK	4			
8740	5/16-18 X 3 GRD 5 HEX BOLT JS500	1			
8656	.171 X 1/4 NYLON SPACER #SP42	4			
3833	8 X 3/8 (250 OD,.171 ID)NY SPACER	2			
3739	CUSTOM .4 LED SPACER	16			
3851	1/2 PCB PLASTIC SPACER	7			
3859	1/2 PLASTIC HEX SPACER #4	4			
3858	3/4 PLASTIC HEX SPACER #4	11			
8657	6-32 X 3/8" HEX SPACER ALUMINUM	4			
8667	SHOULDER WASHER SWS-229 LENGTH 1/8	1			
3517	NYLON WASHER #8 0.062	6			
3511	#6 FLAT WASHER NYLON	8			
8485	#6 SPLIT WASHER ZINC	6			
8491	#10 SPLIT LOCK WASHER BO	4			
8820	#8 FLAT WASHER SJ500	4			
8850	#10 INT TOOTH LOCKWASHER BO	2			

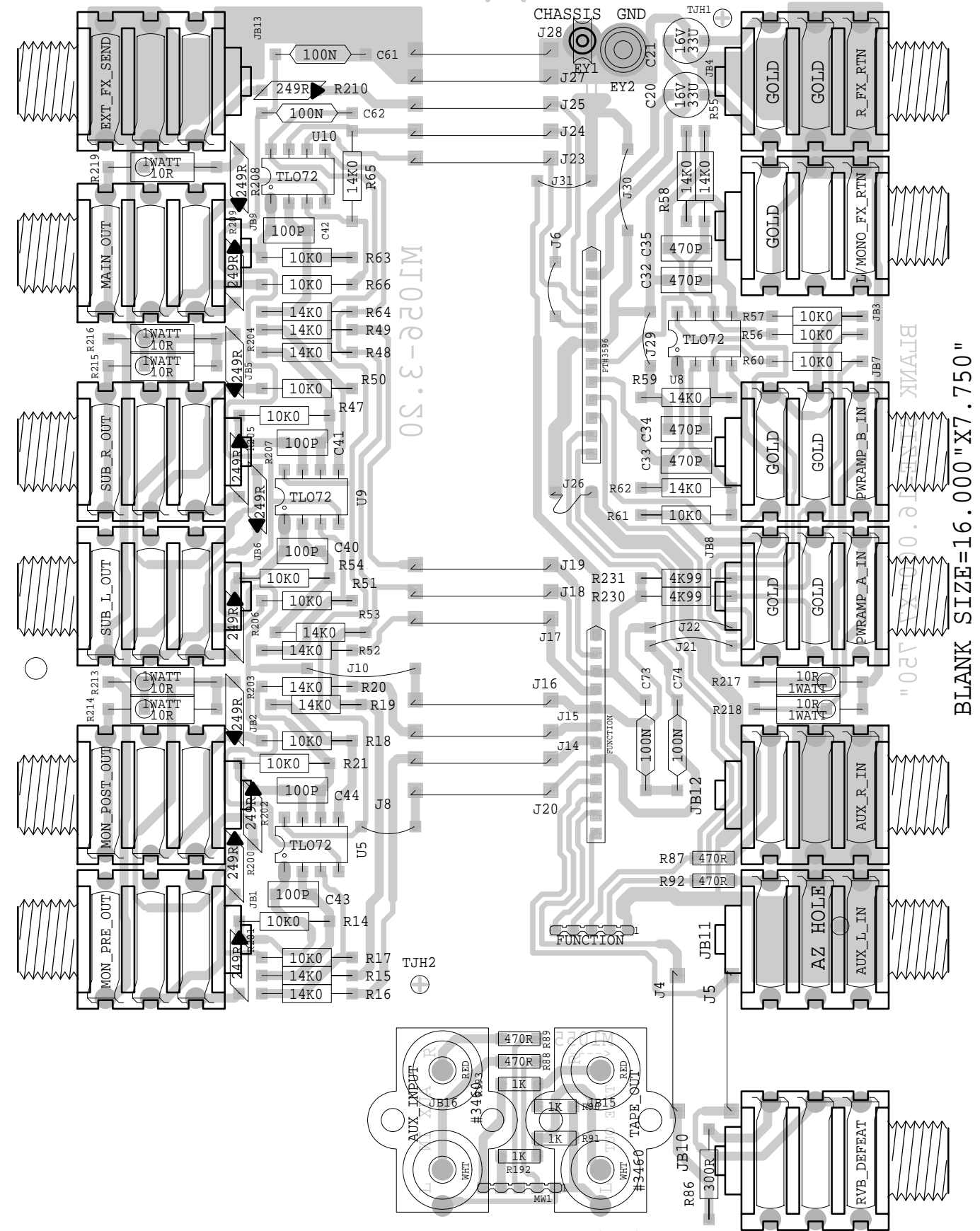

SOLDSIDE M1056-3.20
SHEAR

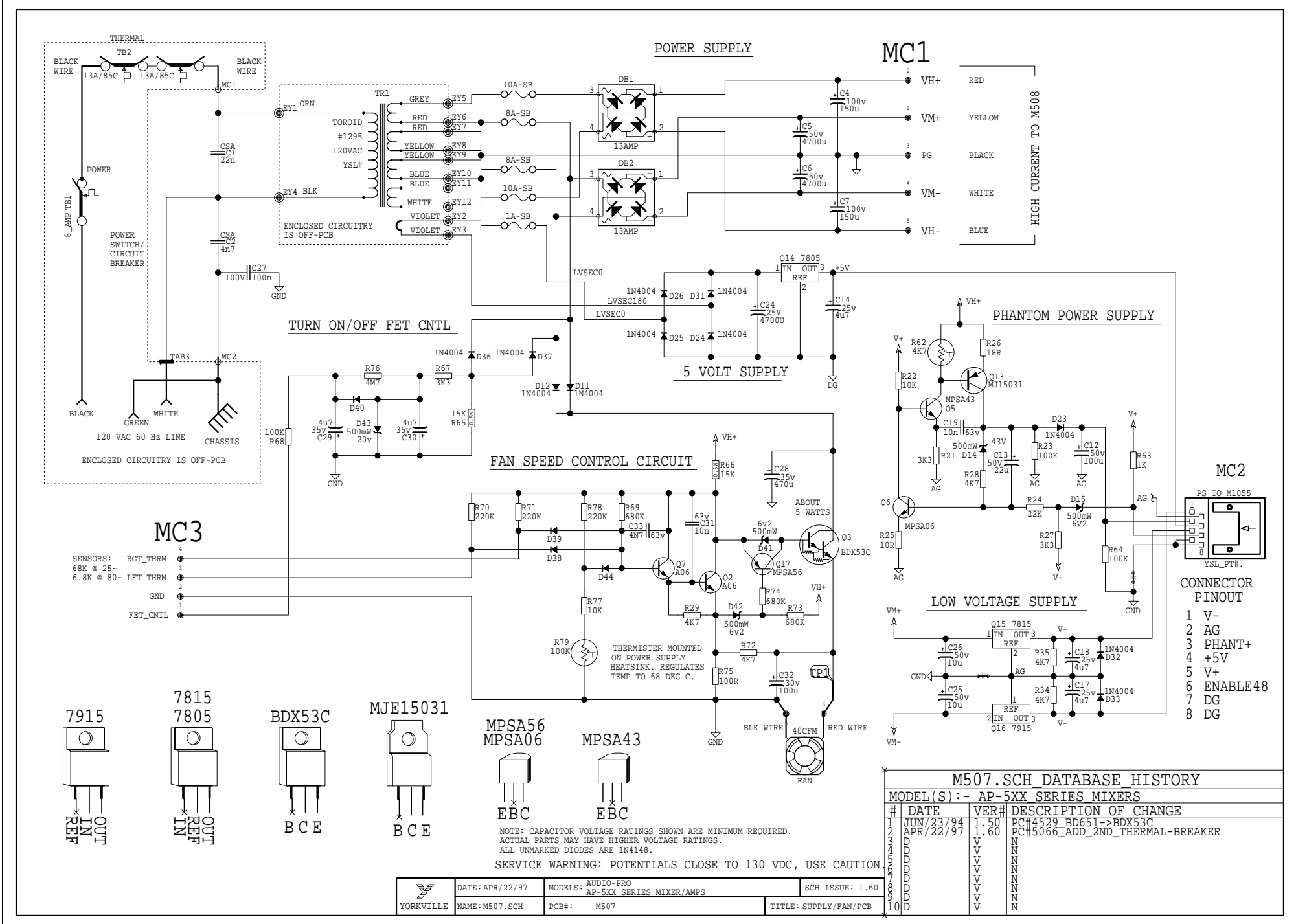

"002" EX "02S" S.F=ES12
 BLANK SIZE=12.250" X9.

SHEAR

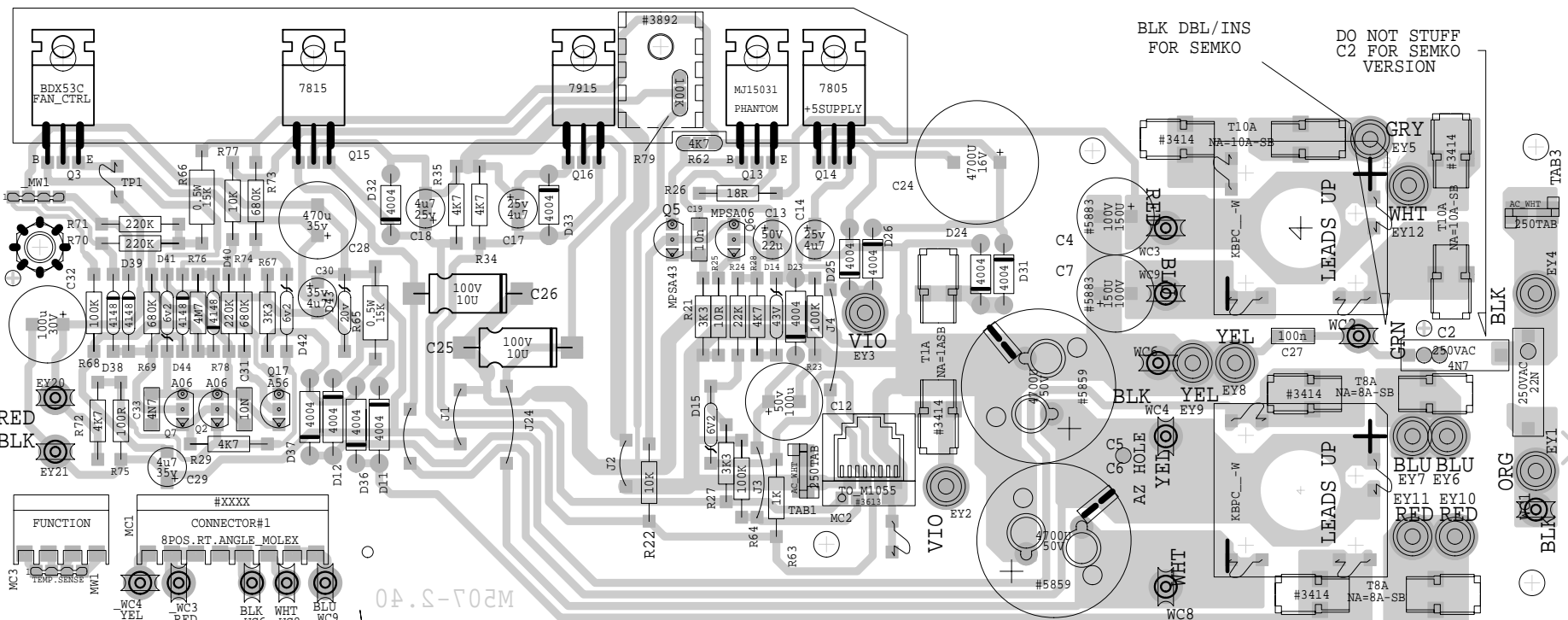

VCD SHEAR

ETCH GUIDE

SHEAR

SHEAR

ETCH GUIDE

A

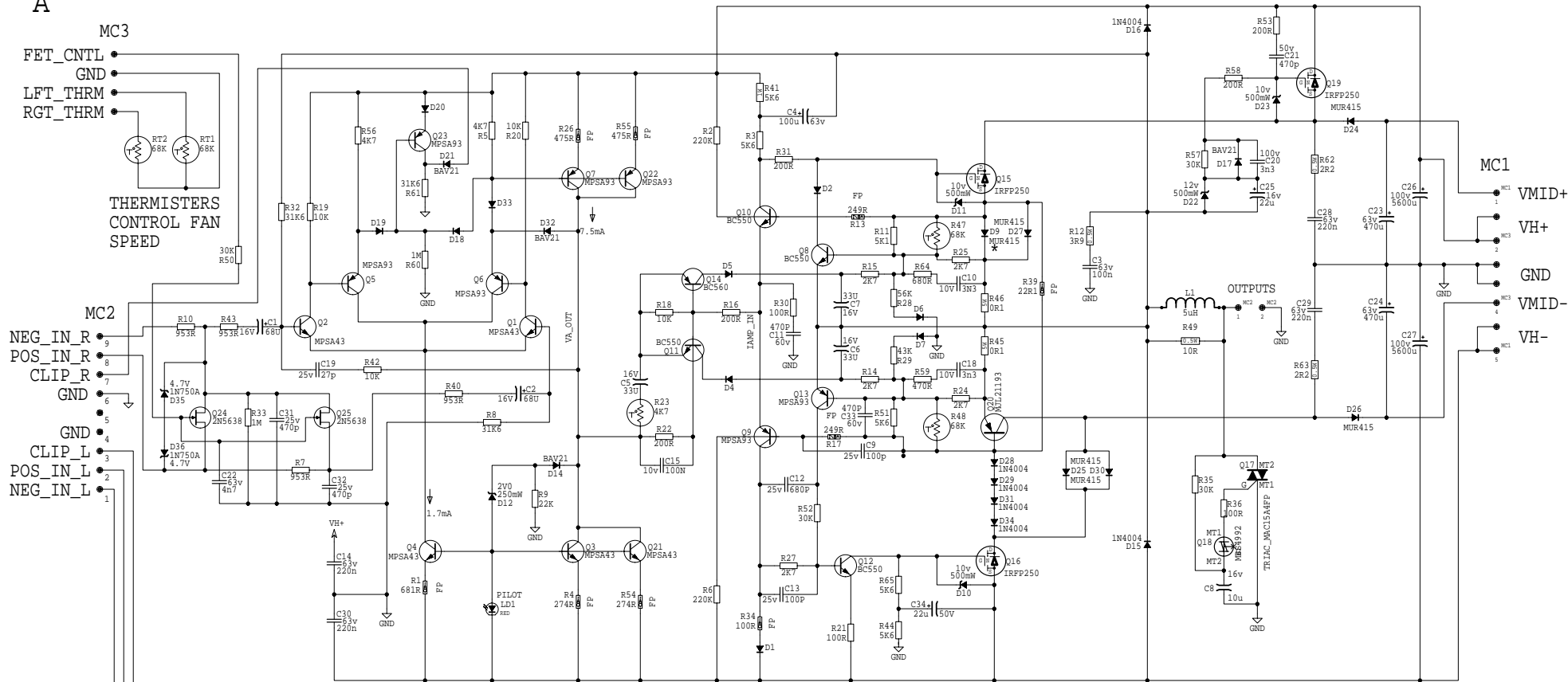

SERVICE WARNING: POTENTIALS GREATER THAN 130VDC PRESENT.

USE EXTREME CAUTION.

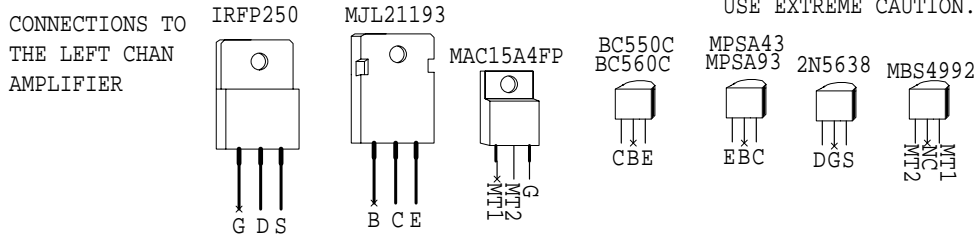

CONNECTIONS TO THE LEFT CHAN AMPLIFIER

CLIP_L
POS_IN_L
NEG_IN_L

YORKVILLE	DATE: JUNE/15/94	MODEL: AUDIOPRO_5XX_SERIES MIXERS	SCH ISSUE: 2.80
	NAME: M508.SCH	PCB#&VER: M508-3.10	TITLE: PWR_AMP

A

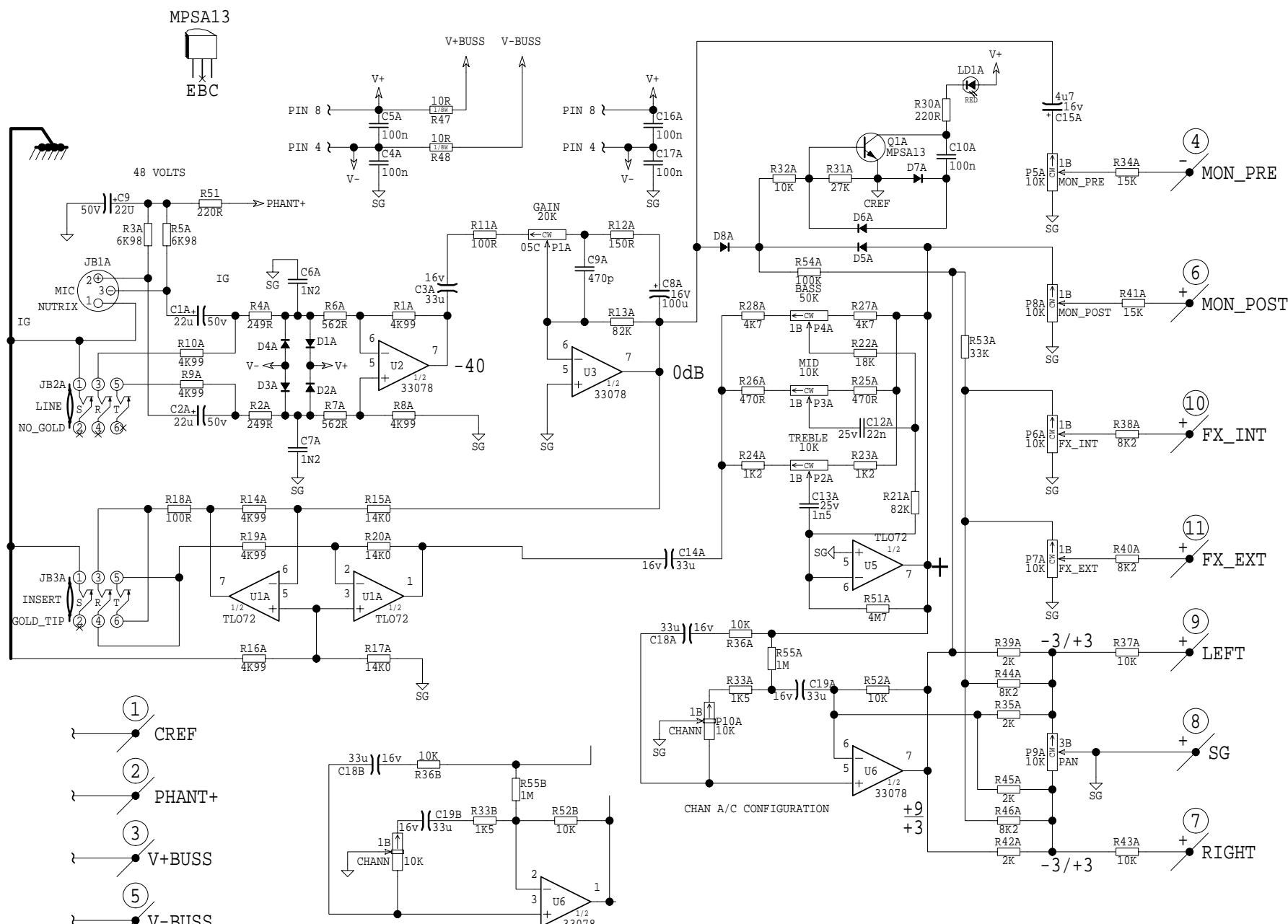

- ① CREF
- ② PHANT+
- ③ V+BUSS
- ⑤ V-BUSS
- ⑧ BUSS PIN NUMBER

YORKVILLE SOUND LTD	FOR MODEL(S): 1200_SERIES_MIXERS	PCB #: M1054
CAD FILE NAME: C:\PCAD\EXE\M1054.SCH	DESIGN BY: PFI & GA	DRAWN BY: PFI
PCB VER: M1054-3.10	SCH ISSUE: 2.00	DATE: MAR/25/97
		TITLE: CHANNEL_STRIP

