



SERVICE MANUAL

M8 TYPE: YS1024

WEB ACCESS: <http://www.yorkville.com>

WORLD HEADQUARTERS CANADA

Yorkville Sound
550 Granite Court
Pickering, Ontario
L1W-3Y8 CANADA

Voice: (905) 837-8481
Fax: (905) 837-8746

U.S.A.

Yorkville Sound Inc.
4625 Witmer Industrial Estate
Niagara Falls, New York
14305 USA

Voice: (716) 297-2920
Fax: (716) 297-3689



Quality and Innovation Since 1963
Printed in Canada

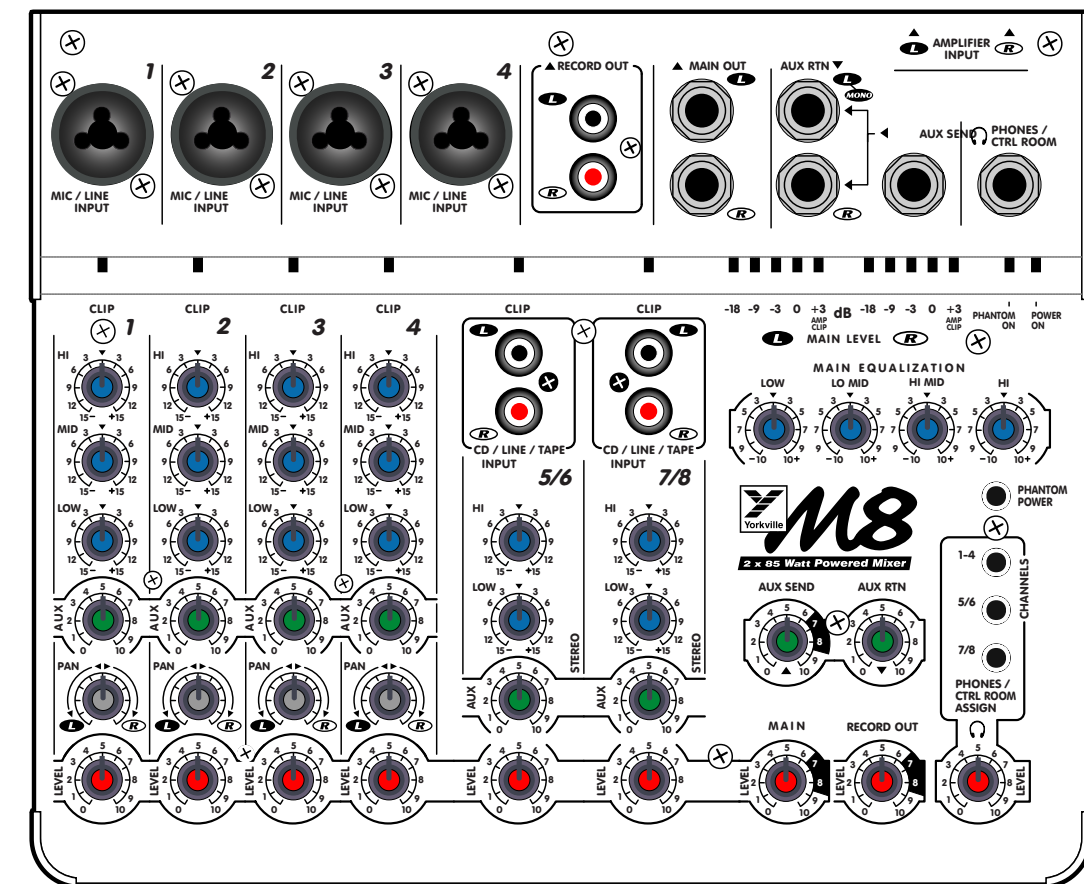

IMPORTANT SAFETY INSTRUCTIONS



INSTRUCTIONS PERTAINING TO A RISK OF FIRE, ELECTRIC SHOCK, OR INJURY TO PERSONS.

CAUTION:

TO REDUCE THE RISK OF ELECTRIC SHOCK, DO NOT REMOVE COVER (OR BACK). NO USER SERVICEABLE PARTS INSIDE.

REFER SERVICING TO QUALIFIED SERVICE PERSONNEL.

Read Instructions:

The **Owner's Manual** should be read and understood before operation of your unit. Please, save these instructions for future reference.

Packaging:

Keep the box and packaging materials, in case the unit needs to be returned for service.

Warning:

When using electric products, basic precautions should always be followed, including the following:

Power Sources:

Your unit should be connected to a power source only of the voltage specified in the owners manual or as marked on the unit. This unit has a polarized plug. Do not use with an extension cord or receptacle unless the plug can be fully inserted. Precautions should be taken so that the grounding scheme on the unit is not defeated.

Hazards:

Do not place this product on an unstable cart, stand, tripod, bracket or table. The product may fall, causing serious personal injury and serious damage to the product. Use only with cart, stand, tripod, bracket, or table recommended by the manufacturer or sold with the product. Follow the manufacturer's instructions when installing the product and use mounting accessories recommended by the manufacturer.

The apparatus should not be exposed to dripping or splashing water; no objects filled with liquids should be placed on the apparatus.

Terminals marked with the "lightning bolt" are hazardous live; the external wiring connected to these terminals require installation by an instructed person or the use of ready made leads or cords.

No naked flame sources, such as lighted candles, should be placed on the apparatus.

Power Cord:

The AC supply cord should be routed so that it is unlikely that it will be damaged. If the AC supply cord is damaged **DO NOT OPERATE THE UNIT.**

Service:

The unit should be serviced only by qualified service personnel.

INSTRUCTIONS RELATIVES AU RISQUE DE FEU, CHOC ÉLECTRIQUE, OU BLESSURES AUX PERSONNES.

AVIS:

AFIN DE REDUIRE LES RISQUE DE CHOC ELECTRIQUE, N'ENLEVEZ PAS LE COUVERT (OU LE PANNEAU ARRIERE). NE CONTIENT AUCUNE PIECE REPARABLE PAR L'UTILISATEUR.

CONSULTEZ UN TECHNICIEN QUALIFIE POUR L' ENTRETIEN.

Veillez lire le manuel:

Il contient des informations qui devraient étre comprises avant l'opération de votre appareil. Conservez S.V.P. ces instructions pour consultations ultérieures

Emballage:

Conservez la boîte au cas ou l'appareil devait étre retourner pour réparation.

Attention:

Lors de l'utilisation de produits électrique, assurez-vous d'adhérer à des précautions de bases incluant celle qui suivent:

Alimentation:

L'appareil ne doit étre branché qu'à une source d'alimentation correspondant au voltage spécifié dans le manuel ou tel qu'indiqué sur l'appareil. Cet appareil est équipé d'une prise d'alimentation polarisée. Ne pas utiliser cet appareil avec un cordon de raccordement à moins qu'il soit possible d'insérer complètement les trois lames. Des précautions doivent étre prises afin d'éviter que le système de mise à la terre de l'appareil ne soit désengagé.

Risque:

Ne pas placer cet appareil sur un chariot, un support, un trépied ou une table instables. L'appareil pourrait tomber et blesser quelqu'un ou subir des dommages importants. Utiliser seulement un chariot, un support, un trépied ou une table recommandés par le fabricant ou vendus avec le produit. Suivre les instructions du fabricant pour installer l'appareil et utiliser les accessoires recommandés par le fabricant.

Il convient de ne pas placer sur l'appareil de sources de flammes nues, telles que des bougies allumées.

L'appareil ne doit pas étre exposé à des égouttements d'eau ou des éclaboussures et qu'aucun objet rempli de liquide tel que des vases ne doit étre placé sur l'appareil.

Les dispositifs marqués d'une symbole "d'éclair" sont des parties dangereuses au toucher et que les câblages extérieurs connectés à ces dispositifs de connection extérieure doivent étre effectués par un opérateur formé ou en utilisant des cordons déjà préparés.

Cordon d'alimentation:

Évitez d'endommager le cordon d'alimentation. **N'UTILISEZ PAS L'APPAREIL** si le cordon d'alimentation est endommagé.

Service:

Consultez un technicien qualifié pour l'entretien de votre appareil.

SPECIFICATIONS

Number of Channels	8
Mono Channel EQ	Low, Mid, High
Stereo Channel EQ	Low, High
Inputs - XLR (balanced)	4
Inputs - 1/4-inch	4
Inputs - RCA (unbalanced)	2 Pairs
Clip /Mute LED	All Channels
Phantom Power	24V + LED Indicator
Auxiliary Sends	Yes
Record Outputs	Stereo RCA Pair
Max Gain to Line Out -Mic Input (dB)	+88db
Max Gain to Line Out -Line Input (dB)	+73db
Master EQ -1 (type /Channels /Range - dB)	Graphic / Stereo / 4 Band 100 Hz - 12,000 Hz
Main Outputs (Line Level)	2 x 1/4 inch (TRS)
Main Amp Inputs (Line Level)	2 x 1/4 inch (TRS)
Outputs - Amp A - 1/4-inch Jacks	1
Outputs - Amp B - 1/4-inch Jacks	1
Mixer - Signal to Noise Ratio (dB)	101 / 105
Mixer - Frequency Response (Tone and EQ Flat,+/-2dB)	20 HZ - 20,000 Hz
Mixer - Input Referred Noise to line out, @ 150 ohms (dBV)	-123
Mixer THD (Main out w/ -10dB input)	less than 0.01%
Amp A - Power Output @ 4 ohms	85W
Amp B - Power Output @ 4 ohms	85W
THD - 1kHz (dB)	less than 0.01%
THD - 20Hz-20kHz (dB)	less than 0.01%
Hum and Noise (un / A weight -dB)	0.942857143
Typical crosstalk -1 kHz (dB)	better than -60db
CMRR @ 60Hz (min/typ)	-37db / -60db
Max Voltage Gain (dB)	22db
Power Consumption (typ/max)	250VA
Dimensions (DWH, inches)	8.25 x 10 x 3.75
Dimensions (DWH, cm)	21 x 25 x 10
Weight (lbs/kg)	5.45 / 2.5

Yorkville **m8**
powered mixer

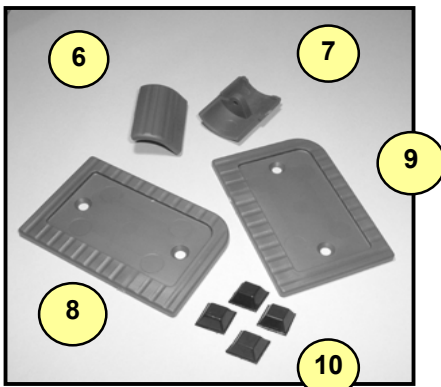
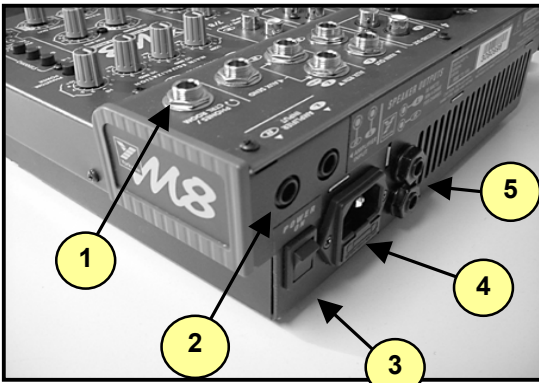

#	Part#	Description
Labeled Components		
1	3921	1/4" JCK PCB MT VERT STER RT SWT
2	3918	1/4" JCK PCB MT HORZ SLIM W/SCREW
3	3702	DPST ROKR SW 187" AC PWR SEMKO
4	3438	230 AC RECEPTACLE FUSE & 250 TABS
5	3918	1/4" JCK PCB MT HORZ SLIM W/SCREW
6	8428L	M8 LEFT CORNER
7	8428R	M8 RIGHT CORNER
8	8429R	M8 RIGHT EAR
9	8429L	M8 LEFT EAR
10	3827	SQUARE BUMPER BUTTON BLACK
11	8300B	BLUE RUBBER FEEL GRAY RIB BODY KNOB
12	8300G	GREEN RUBER FEEL GRAY RIB BODY KNOB
13	8300	GRAY RUBBER FEEL GRAY RIB BODY KNOB
14	8300R	RED RUBBER FEEL GRAY RIB BODY KNOB
15	3416	1/4"&XLR PCB MT VERT COMBO
16	3460	RCA DUAL PCB MT VERT GOLD .475"
17	3466	RCA DUAL PCB MT VERT GOLD 24MM
18	8633	ROUND PUSH BUTTON 1/4" BLACK
19	z614	M8 REAR & GABLE DECALS
20	2475	T3,15A GDC BUSSMANN 5X20MM FUSE
21	3428	8' 3/18 SJT AC LINE CORD REMOVABLE



- 19 Lexan Label Set
- 20 fuse
- 21 ac line cord

**Real Gear.
Real People.**

M8 Parts List 1/29/2004

YS #	Description	Qty.	YS #	Description	Qty.	YS #	Description	Qty.
7704	RED LED 2V2 20MA 1206 SMT	8	4434	.10K B LIN 9MM DETENT P32	8	4791	1/4W 1K54 1% T&T RES	10
7705	YEL LED 2V2 20MA 1206 SMT	3	4438	.10K B LIN 12MM STEREO DETENTP34	2	6104	1/4W 2K2 5%MINI T&R RES	3
7706	GRN LED 2V2 20MA 1206 SMT	7	4426	.20K 4B LIN 9MM P32	4	6114	1/4W 2K49 1%MINI MF T&R RES	16
6775	BRIDGE 10A 600V WIRE LEAD SIP	1	4440	.20K B LIN 12MM STEREO DETENTP34	4	6148	1/4W 2K05 1%MINI MF T&R RES	1
6825	1N4148 75V 0A45 DIODE T&R	36	4433	.50K B LIN 9MM P32	1	6156	1/4W 3K01 1%MINI MF T&R RES	1
6826	STTA806D 600V 8A DIODE ULTRAFAST	2	4435	.50K B LIN 9MM DETENT P32	4	4788	1/4W 3K160 0.1% *** T&R RES	1
6892	UF4004 200V 1A0 DIODE ULTRAFAST	2	4437	.50K B LIN 12MM STEREO P34	2	4992	1/4W 3K16 1% T&R RES	4
6438	1N4007 400V 1A0 DIODE T&R	1	4439	.50K B LIN 12MM STEREO DETENTP34	2	6205	1/4W 3K40 1% T&R RES	1
6471	MBR160 60V 1A0 DIODE SCHTKY	1	4441	.50K 4B LIN 12MM STEREO P34	2	5028	1/4W 3K74 1% T&R RES	5
6461	1N5240BRL 10V0 0W5 ZENER 5% T&R	1	4430	100K 4B LIN 12MM STEREO P34	1	4850	1/4W 3K9 5% T&R RES	2
6818	1N5245B 15V0 0W5 ZENER 5% T&R	1	6492	1300UH COIL COMMON MODE 4AMP	1	4774	1/4W 4K12 1% T&R RES	1
6824	1N5246B 16V0 0W5 ZENER 5% T&R	2	3478	CLIP 205/187X032 18-22AWG DISCO/INS	7	4982	1/4W 4K7 5%MINI T&R RES	1
6463	1N5251BRL 22V0 0W5 ZENER 5% T&R	1	3489	CLIP 250X032 18-22AWG DISCO/INS	1	4639	1/4W 4K99 1% T&R RES	21
6426	1N5254B 27V0 0W5 ZENER 5% T&R	2	3544	12 CIR HDR TOP ENTRY 1.25 FFC ZIF	1	6128	1/4W 4K99 1%MINI MF T&R RES	47
5123	NJM431L TO92 S 2V0 REG T&R V4	1	3601	RING TERMINAL 16AWG WIRE & #8 SCREW	1	4717	1/4W 6K19 1%MINI T&R RES	2
5101	BC550C TO92 NPN TRAN T&R TB	3	3682	250 MALE PCB TAB REEL	1	6121	1/4W 6K98 1%MINI MF T&R RES	1
5102	BC560C TO92 PNP TRAN T&R TB	1	3918	1/4" JCK PCB MT HORZ SLIM W/SCREW	4	7751	1/8W 7K32 1% 0805 SMT RES	1
5103	MPSA06 TO92 NPN TRAN T&R TA	3	3921	1/4" JCK PCB MT VERT STER RT SWT	2	5027	1/4W 9K09 1% T&R RES	6
5104	MPSA56 TO92 PNP TRAN T&R TA	4	3460	RCA DUAL PCB MT VERT GOLD .475"	6	6112	1/4W 9K09 1%MINI MF T&R RES	10
5105	MPSA13 TO92 NPN DARL T&R TA	2	3466	RCA DUAL PCB MT VERT GOLD 24MM	1	4810	1/4W 9K1 5% T&R RES	1
5112	MPSA29 100V TO92 NPN DARL T&R TA	1	3417	6-32 SCREW TERMINAL PC MNT STRAIGHT	1	4800	1/4W 10K0 1% T&R RES	1
6607	TIP111 TO220 NPN TRAN TE	1	3416	1/4"&XLR PCB MT VERT COMBO	4	4829	1/4W 10K 5% T&R RES	1
6612	TIP116 TO220 PNP TRAN TE	1	3656	FAN 40MM X 40MM 6CFM 24VDC 50MA	1	4940	1/4W 10K 5% .2"U T&R RES	9
6891	TIP50 TO220 NPN TRAN TE	1	2475	T3.15A GDC BUSSMANN 5X20MM FUSE	1	4960	1/4W 10K0 1% .2"U T&R RES	7
6947	SPW17N80C3 TO247 NCH MFT	1	3909	XTR CLIP 1.2X0.5" TO220	2	4983	1/4W 10K 5%MINI T&R RES	9
6759	NJM4580L DUAL OPAMP SIL8 IC	1	3910	XTR SPRING 0.4" V TO220	6	6116	1/4W 10K0 1%MINI MF T&R RES	34
6757	LM3886 IC 85 WATT POWER AMP	2	8887	RUBBER GROMMET ID .125/OD .35 BLK	1	4901	1/4W 13K 5% T&R RES	4
6804	MC33079P IC QUAD OP AMP	11	3438	230 AC RECEPTACLE FUSE & 250 TABS	1	4775	1/4W 14K0 5% T&R RES	1
6840	MC33078P IC DUAL OP AMP	3	3827	SQUARE BUMPER BUTTON BLACK	6	4771	1/4W 17K8 1% T&R RES	4
6882	TL072CP IC FET DUAL OP AMP	1	8300	GRY SOFT GRAY RIB KNOB 90DEGR	4	6123	1/4W 20K0 1%MINI MF T&R RES	17
6639	L6561 IC POWER FACTOR	1	8633	ROUND PUSH BUTTON 1/4" BLACK	4	4777	1/4W 21K5 1% T&R RES	2
6745	LM13600N IC XCONDUCTANCE AMP	1	8300B	BLU SOFT GRAY RIB KNOB 90DEGR-R	20	4632	1/2W 22K 5% T&R RES	2
6881	H11A817C IC OPTO-COUPLER CSA	1	8300G	GRN SOFT GRAY RIB KNOB 90DEGR-R	8	6118	1/4W 22K 5%MINI T&R RES	1
6467	10K 10% THERMISTOR NTC TO-92	1	8300R	RED SOFT GRAY RIB KNOB 90DEGR-R	9	4633	1/2W 27K 5% T&R RES	1
4590	VARISTOR 23J 385V MOV 7MM	1	3531	14PIN STACKER VERTICAL .100	1	6129	1/4W 27K 5%MINI T&R RES	1
5817	.15P 100V 2%CAP T&R RAD CER.2"NPO	2	3538	24 PIN BREAKAWAY LOCK .156	1	5003	1/4W 30K1 1% T&R RES	1
5203	.47P 100V 2%CAP T&R RAD CER.2"NPO	9	3549	TRIFURCON TERM .156	4	4853	1/4W 39K 5% T&R RES	1
5199	100P 100V 2%CAP T&R RAD CER.2"NPO	2	3558	TERM HOUSING 4 CIR .156/RAMP	1	6117	1/4W 39K 5%MINI T&R RES	24
5196	150P 100V 2%CAP T&R RAD CER.2"NPO	4	3566	12 CIR HDR BOT ENTRY 1.25 FFC	1	6154	1/4W 39K2 1%MINI MF T&R RES	4
5211	330P 100V 5%CAP T&R RAD CER.2"NPO	8	3662	.6 CIR WAFER W/LCK VT 0.1" GOLD	2	5009	1/4W 40K2 1% T&R RES	2
5194	470P 1000V 10%CAP T&R RAD CER.2"Y5P	1	3672	6 CIR CABLE HOLDER .098	2	4908	1/4W 45K3 1% T&R RES	2
5201	470P 100V 5%CAP T&R RAD CER.2"NPO	2	8701	4-40 KEPS NUT ZINC	11	4634	1/2W 47K 5% T&R RES	2
5816	680P 100V 5%CAP T&R RAD CER.2"NPO	4	8800	6-32 KEPS NUT ZINC	4	4927	1/4W 47K 5% .2"U T&R RES	3
5206	.1N 400V 5%CAP T&R RAD .2"FLM	10	3929	ELASTOMER PAD 15GTR 1.75 X 1.25	1	6119	1/4W 47K 5%MINI T&R RES	3
5422	.1N 50V 10%CAP T&R BEAD NPO	1	3959	TO220 THERMO PAD STICK-ON	4	6149	1/4W 47K5 1%MINI MF T&R RES	4
5424	.1N5 50V 10%CAP T&R BEAD Y5P	1	3907	LITEPIPE CLEAR PLASTIC M8/	18	4761	1/4W 60K4 1% T&R RES	1
5606	1N5 50V 5%CAP T&R RAD CER.2" X7R	11	8428L	M8 LEFT CORNER	1	4942	1/4W 100K 5% .2"U T&R RES	3
5852	.10U 35V 20%CAP BLK 05X05MM EL	14	8428R	M8 RIGHT CORNER	1	6120	1/4W 100K 5%MINI T&R RES	13
5208	.2N2 400V 5%CAP T&R RAD .2"FLM	1	8429L	M8 LEFT EAR	1	4976	1/4W 120K 5% MINI T&R RES	2
5275	.3N3 100V 5%CAP T&R RAD .2"FLM	4	8429R	M8 RIGHT EAR	1	6155	1/4W 143K 1%MINI MF T&R RES	2
6451	.4N7 250V 20%CAP BLK 'Y' 10MM AC	5	3818	EMI SUPPRESSION FERRITE BEAD T&R	7	4839	1/4W 150K 5% T&R RES	2
5204	.10N 100V 10%CAP T&R RAD .2"FLM	6	4959	5.0W 0R068 1% BLK RES	2	6137	1/4W 200K 5%MINI T&R RES	2
5523	.10N 250V 20%CAP BLK RAD 'Y2' AC	2	2007	1/4W 1R 5%FLAME PROOF T&R RES	2	6135	1/4W 270K 5%MINI T&R RES	2
5226	.68N 100V 5%CAP T&R RAD .2"FLM	4	4703	2.0W 2R 5% T&R RES	2	6127	1/4W 470K 5%MINI T&R RES	8
5227	.82N 100V 5%CAP T&R RAD .2"FLM	1	4649	2.0W 2R7 5%10MM BODY T&R RES	2	4844	1/4W 1M 5% T&R RES	2
5212	100N 63V 5%CAP T&R RAD .2"FLM	26	2037	1/4W 10R FUSIBLE T&R RES	3	4888	1/4W 4M7 5% T&R RES	4
5228	100N 100V 5%CAP T&R RAD .2"FLM	13	2012	1/8W 15R 2%FLAME PROOF T&R RES	1	4951	1/4W 4M7 5% .2"U T&R RES	2
5314	100N 50V 10%CAP T&R BEAD X7R	6	2039	1/4W 22R0 FUSIBLE T&R RES	1	3525	3" 6C-26AWG RIB 1 W/LCK HDR 098	2
5865	100N 250V 10%CAP BLK RAD POLY FLM	3	2017	1/4W 47R5 1%FLAME PROOF T&R RES	2	3642	10 D12C-FFC CABLE 7.5MMBACKING-PINS	1
5231	220N 63V 10%CAP T&R RAD .2"FLM	7	4658	1/2W 82R 5% T&R RES	1	8742	4-40 X 3/8 PAN PH TAPTITE J5500	11
5318	220N 50V 10%CAP T&R BEAD X7R	2	4602	1/8W 100R 5% T&R RES	4	8789	4-40 X 1/4 PAN PH MS ZINC	1
5234	470N 63V 10%CAP T&R RAD .2"FLM	2	4909	1/4W 200R 5% T&R RES	1	8826	4-40 X 3/16 FL UC PH MS TAPTITE B0	4
5240	680N 63V 10%CAP T&R RAD .2"FLM	4	4958	2.0W 220R 10% T&R RES	2	8864	4-40 X 1/2 PAN PH TAPTITE J5500 BLK	8
5266	680N 250V 20%CAP BLK 'X2' 30MM AC	1	6152	1/4W 221R 1%MINI MF T&R RES	4	8871	4-40 X 5/8 PAN PH MS J5500	3
5256	.1U 63V 5%CAP T&R RAD .2"FLM	1	2024	1/8W 249R 2%FLAME PROOF T&R RES	1	8842	#4 X 5/16 PAN QUAD TYPE A J5500 BLK	11
5262	.1U 275V 20%CAP BLK 'X2'26.0MM AC	1	4770	1/4W 249R 1% T&R RES	24	8801	6-32 X 3/8 PAN PH TAPTITE J5500	6
5263	.1U5 500V 20%CAP BLK	1	4655	1/2W 330R 5% T&R RES	1	8805	4-40 X 1/4 PAN PH TAPTITE B0	27
5259	.4U7 63V 20%CAP T&R RAD .2"EL	2	2028	1/8W 475R 1%FLAME PROOF T&R RES	8	8829	6-32 X 3/8 FLAT PH TAPTITE BO#4 HEA	2
5281	.10U 16V 20%CAP T&R RAD .2"NP	4	4980	1/4W 470R 5%MINI T&R RES	1	8823	6-32 X 1 PAN PH TAPTITE J5500	4
5260	.22U 50V 20%CAP T&R RAD .2"EL	7	4799	1/4W 562R 1% T&R RES	12	8607	3/16 NYLON SPACER OD 1/8 X ID .063	8
5631	.22U 50V 20%CAP T&R 6X7MM .2"EL	4	5019	1/4W 620R 5%MINI T&R RES	1	3209	3/16 SPACER ID .110/OD .250 NYLON	5
5961	.33U 16V 20%CAP T&R RAD .2"NP	21	6151	1/4W 619R 1%MINI MF T&R RES	8	3210	1/4 PLASTIC HEX SPACER #4	3
5267	100U 25V 20%CAP T&R RAD .2"EL	3	4873	1/4W 680R 5% T&R RES	2	3859	1/2 PLASTIC HEX SPACER #4	5
5879	100U 16V 20%CAP T&R 8X7MM .2"EL	16	4924	1/4W 750R 5% .2"U T&R RES	2	8658	3/16 SPACER ID .110/OD .25 ALUM	2
5880	100U 35V 20%CAP BULK .1"EL	1	5017	2.0W 910R 5% T&R RES	1	8505	4-40 X 1/2" HEX SPACER ALUMINUM	1
5621	470U 63V 20%CAP BLK 12X25MM EL	2	4758	1/4W 953R 1% T&R RES	1	8472	#4 FLAT WASHER NYLON	5
5616	3300U 50V 20%CAP BLK 18X35MM EL	4	4934	1/4W 1K 5% .2"U T&R RES	3	3511	#6 FLAT WASHER NYLON	5
4428	.10K 3B LIN 9MM DETENT P32	4	6110	1/4W 1K0 1%MINI MF T&R RES	6	3522	DPDT MINI PC VERT SNP ALT	4
4431	.10K 5C R/A 12MM STEREO P34	1	4802	1/4W 1K21 1% T&R RES	2	3702	DPST ROKR SW 187" AC PWR SEMKO	1
4432	.10K B LIN 9MM P32	6	4988	1/4W 1K5 5%MINI T&R RES	4	1247	M8 PC MOUNT SWITCHING XFMR	1

M8 BOARD CONNECTION DIAGRAM

JANUARY 28, 2004

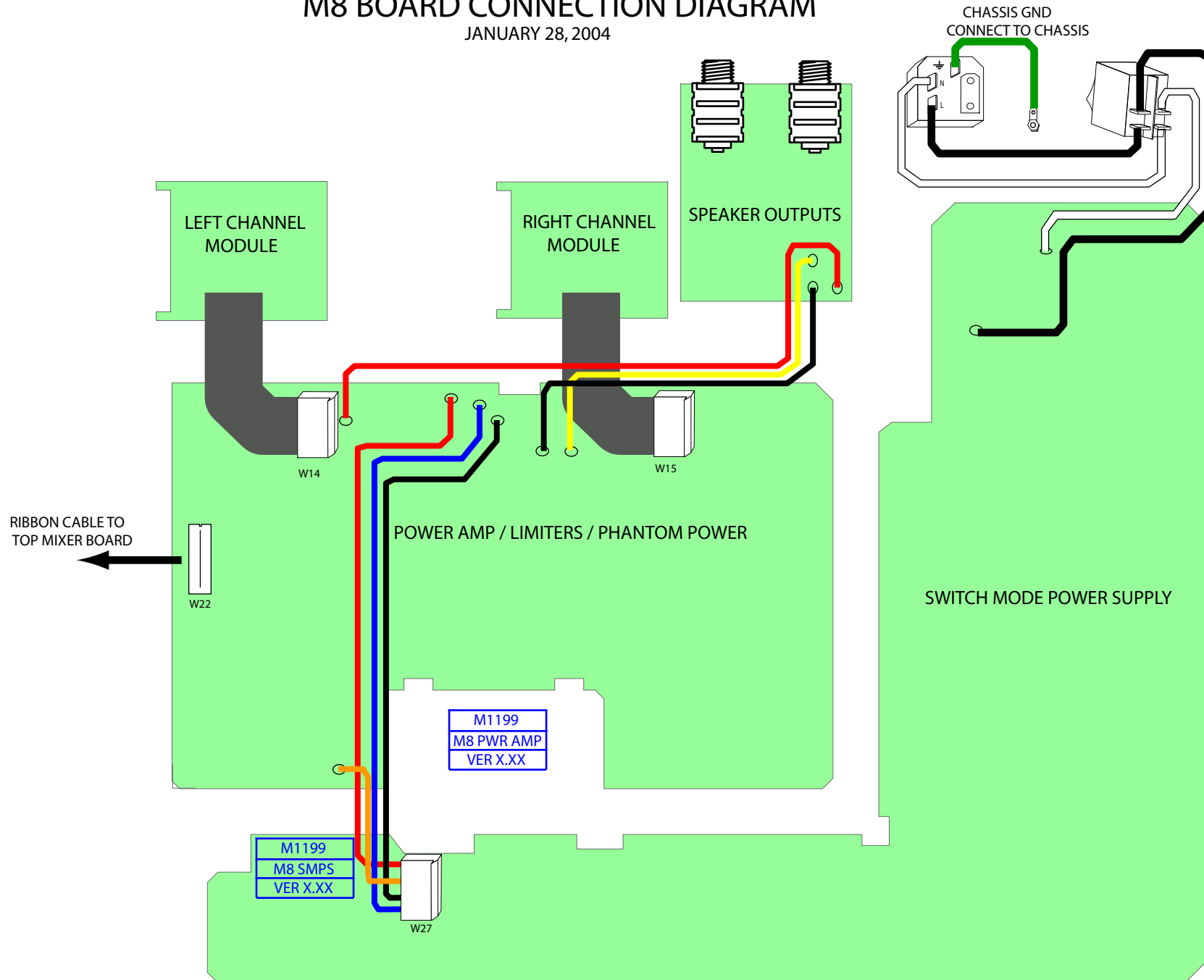

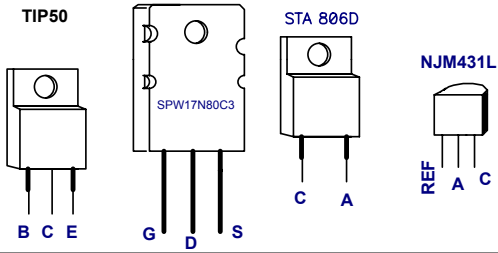
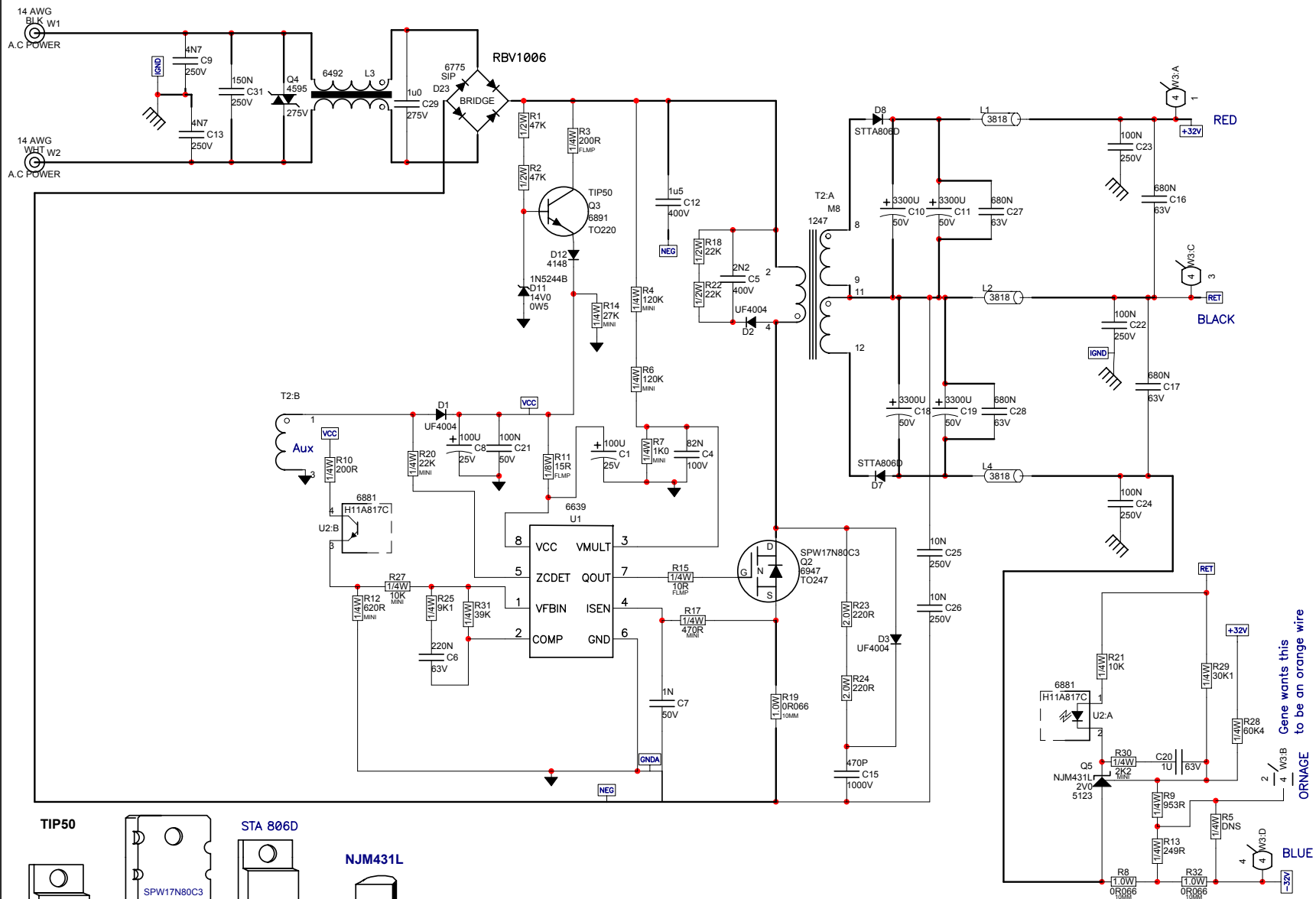

Yorkville

Product **M8**

UNIVERSAL SMPS	PCB# M1196	Sheet 1 of 2
Date: Fri Jun 27, 2003	Rev: {Revision}	
Filename: M1196 V1.SCH2002		

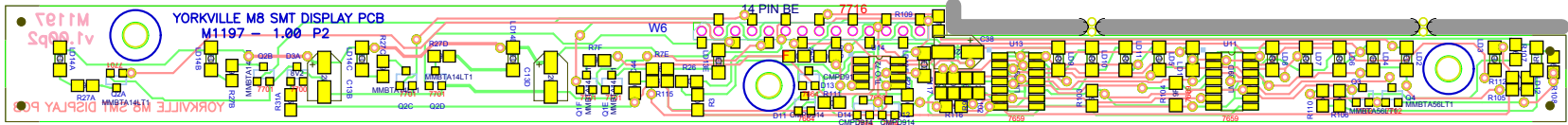

● 7011M
Sq00.vv
M1197

YORKVILLE M8 SMT DISPLAY PCB
M1197 - 1.00 P2

3 200 8 000

7011M
Sq00.vv
M1197
Bottom M1197.005

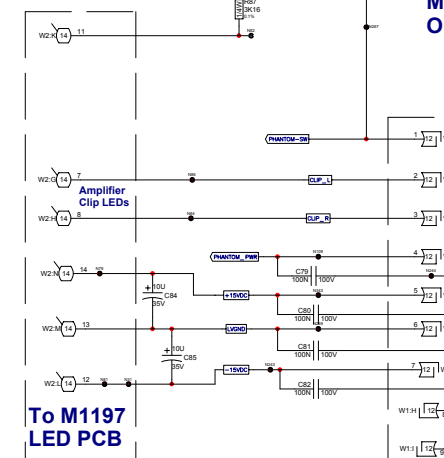
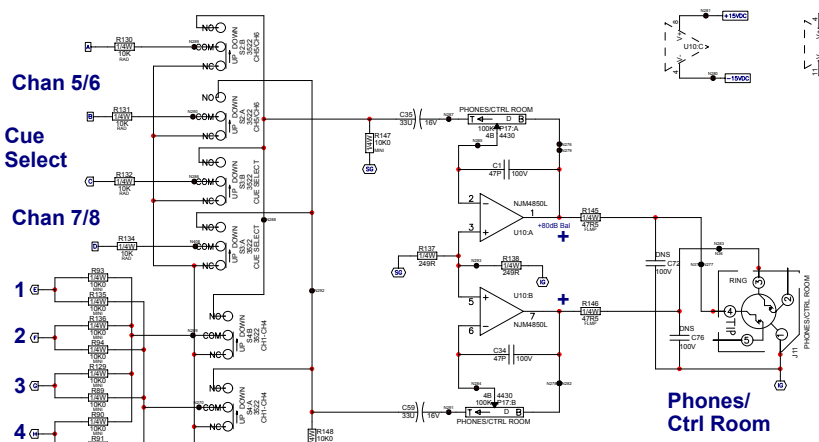
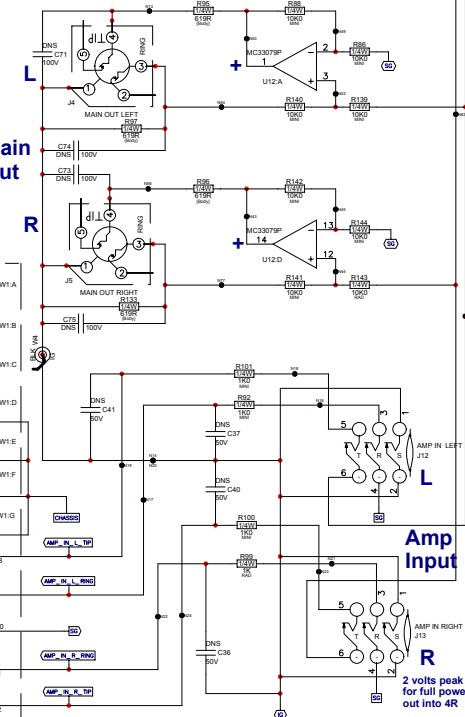
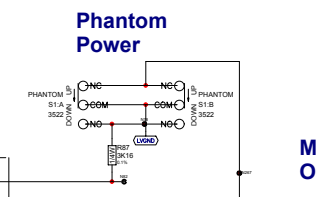
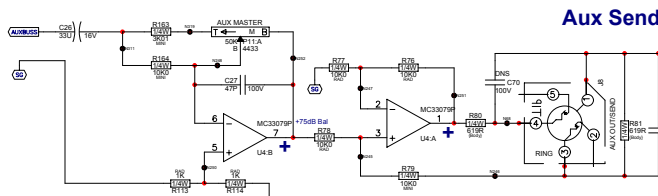
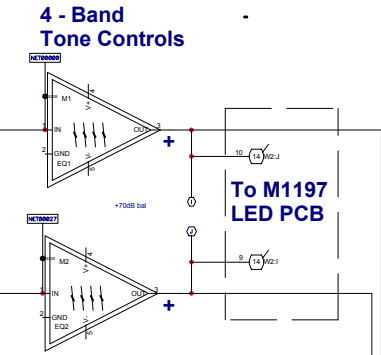
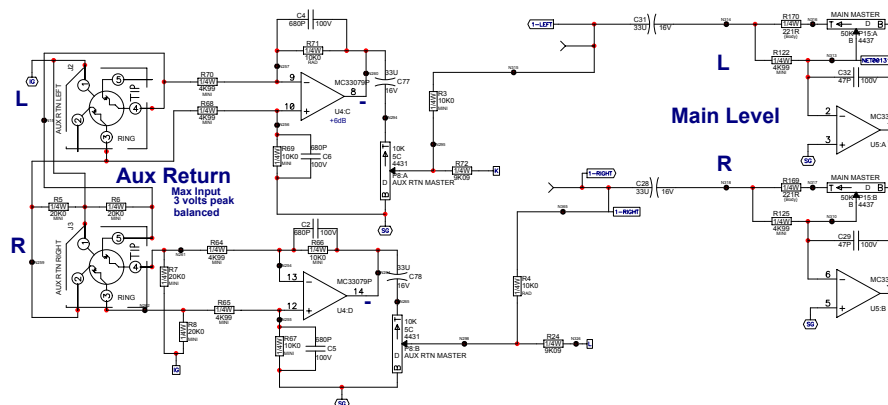
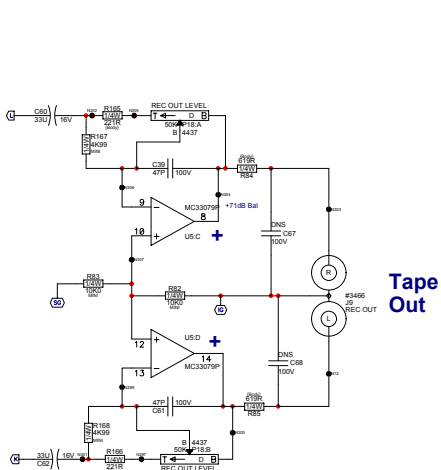

M1198.PCB_DATABASE_HISTORY			
MODEL(S):-	M8	#	DATE
		V	24
		V	25
		V	26
1	JULY 25 03	P2	28
	JULY 25 03	P2	29
	JULY 25 03	P2	30
	JULY 25 03	P2	31
	JULY 25 03	V1.00	32
	Aug 21, 2003	V1.00	33
	SEPT 22 03	V2.00	34
	SEPT 30 03	V2.00	35
	26-NOV-2003	V2.00	36
		V	37
		V	38
		V	39
		V	40
		V	41
		V	42
		V	43
		V	44
		V	45
		V	46
		V	47
		V	48
		V	49
		V	50

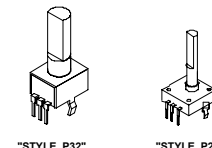

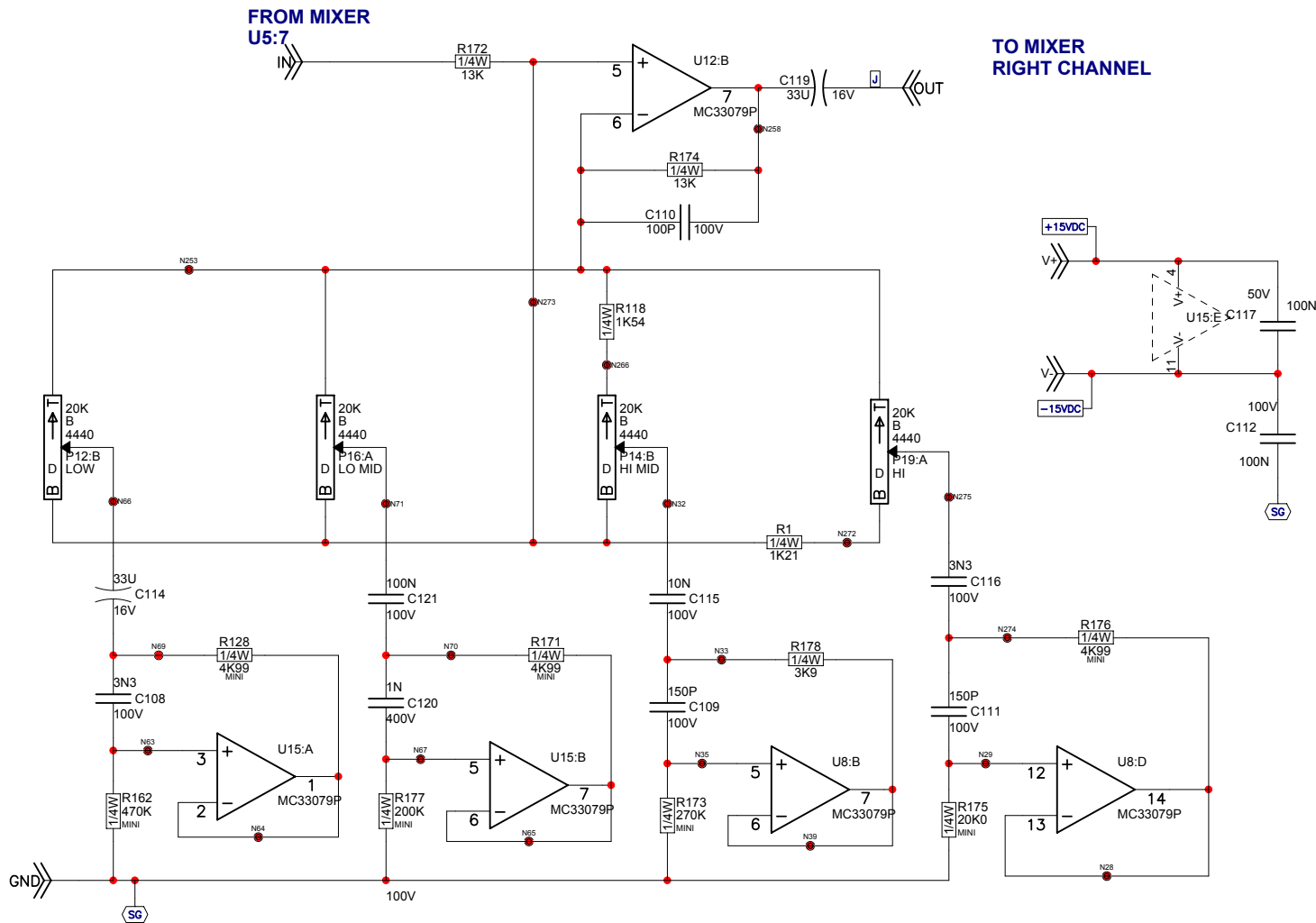

FROM MIXER
U5:7

TO MIXER
RIGHT CHANNEL

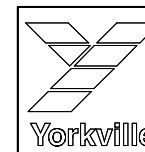

Product **M8**

EQ2

PCB# M1198

Sheet 6 of 6

Date: Wed Jan 14, 2004

Rev: 2V00

Filename: M1198 V2.00 sch.SCH2002

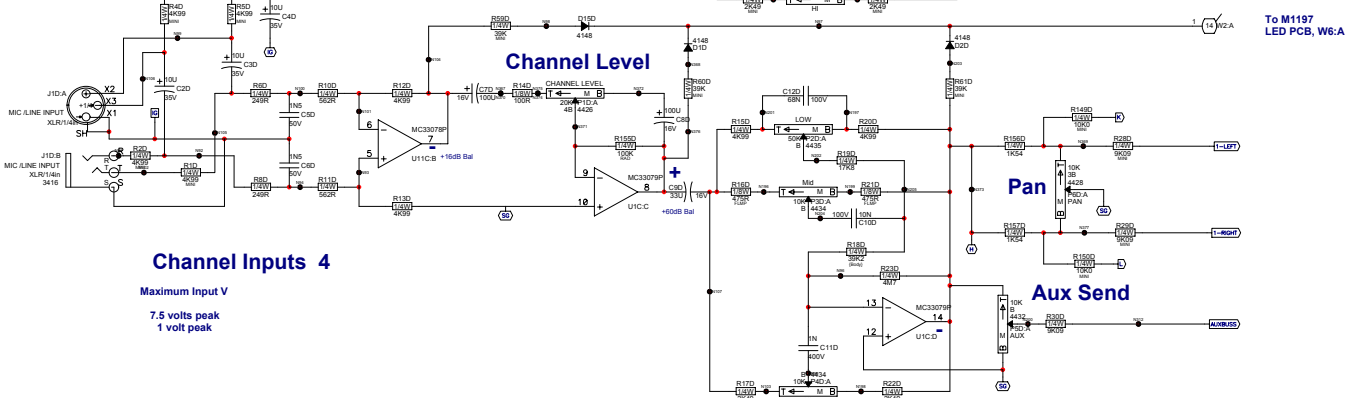
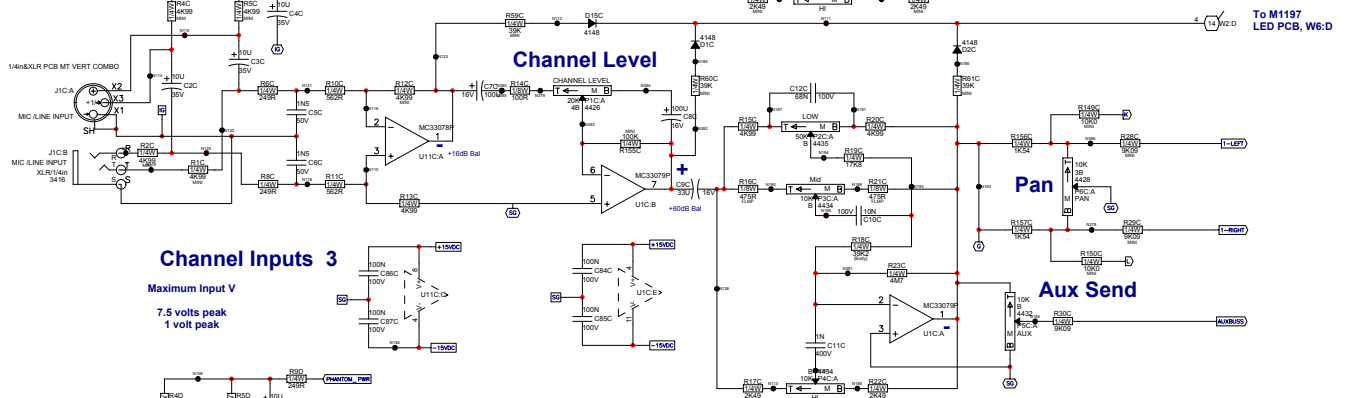
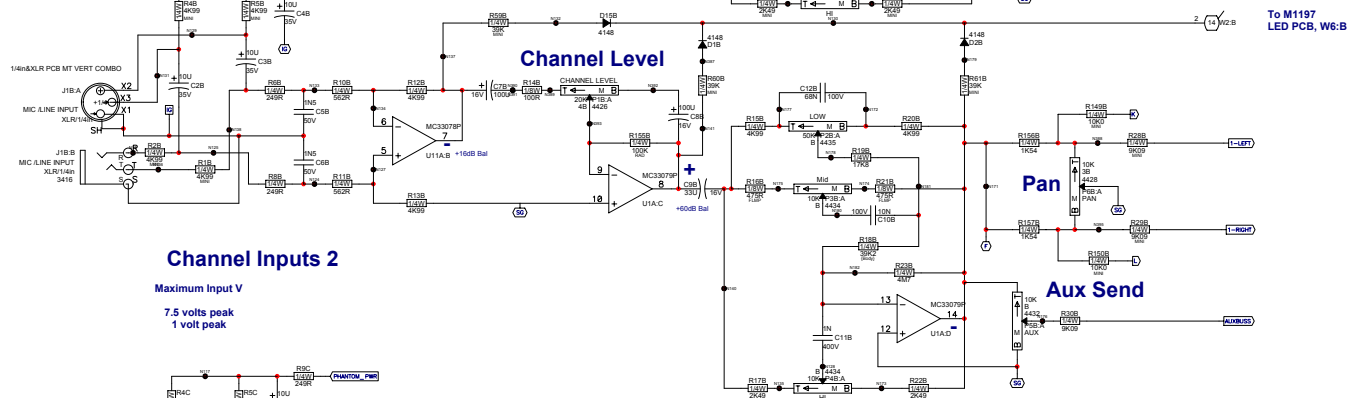
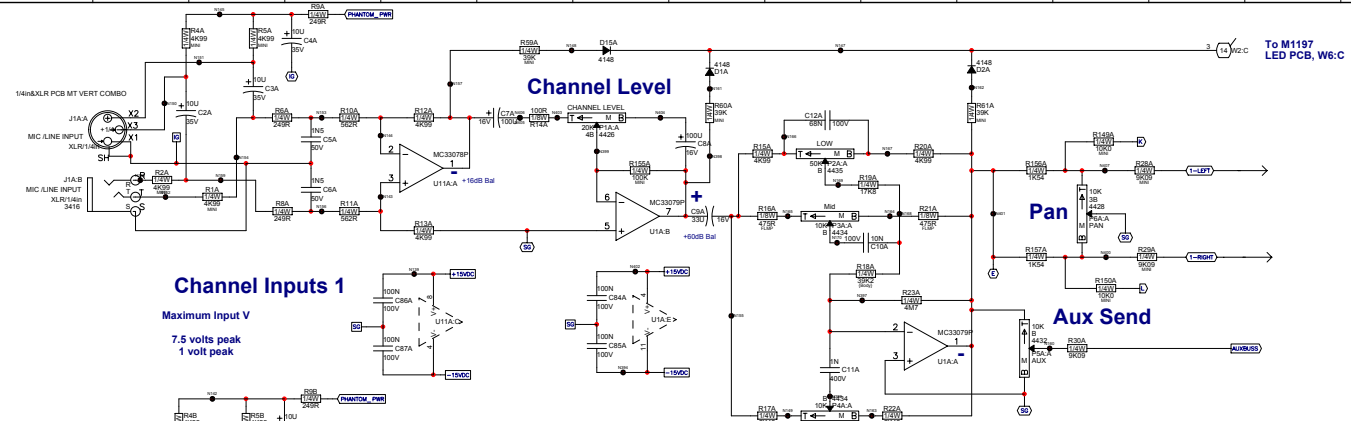

To M1197 LED PCB

Channel Inputs 5/6

Maximum Input V
14 volts peak

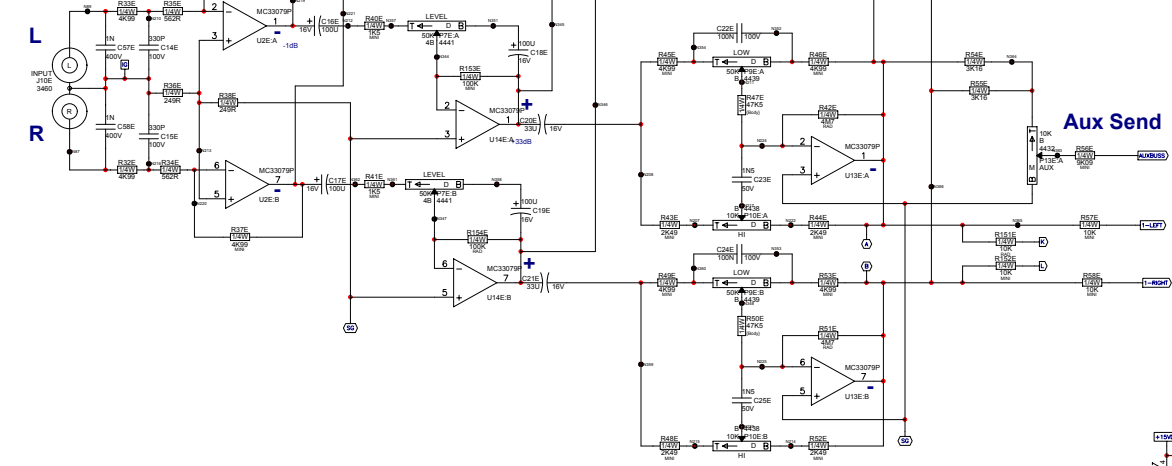

To M1197 LED PCB

Channel Inputs 7/8

Maximum Input V
14 volts peak

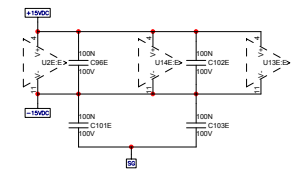
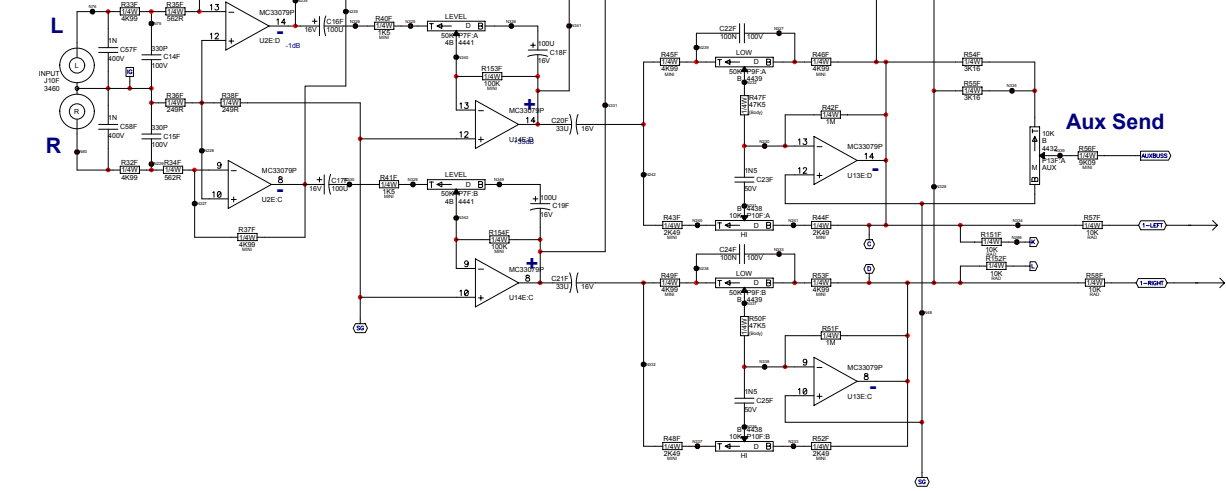

Note 1

- M1198
 Mixer Board
 connection missing from pin 10 of U1c to gnd through the snap in lead of P6D
 P10E: don't make a connection through the snap in lead
 R143 should be 10K0
 C1, C34 from 100p to 47p
 Plated hole missing for the IG wire and the chassis screw to the metal spacer
 3 ground loops to cut
 R17 A,B,C,D, R22 A,B,C,D 1K21 to 2K49
 R43E,F,R48E,F,R44E,F,R52E,F 1K21 to 2K49
 cut back frame of tape out RCA jacks to accommodate mounting of the LED board. 2nd run: move RCA jacks
 Chan 2,4 move trace to reduce bleedthrough
 remove jumper from IG to SG
 1. Remove the jumper wire between IG and SG nets
 2. Reduce gain in Aux send circuit by 5 dB R163 becomes 3K01 1% and R164 becomes 10K0 1%
 3. Change R76, R77, and R78 to 10K0 1% mini
 4. Change C63, C64, C65 and C66 to 20K0 1% mini
 5. Add 680pF capacitors across R66, R67, R69, and R71
 6. Move trace from R3--C31 away from U5 pin 1.

MODEL(S):-		M8
#	PC#	PENDING CHANGE
1	6661	R76 TOO CLOSE TO C85; R4B TOO CLOSE TO C4A&C4B
2	PC	X
3	PC	X
4	PC	X
5	PC	X
6	PC	X
7	PC	X
8	PC	X
9	PC	X
10	PC	X
11	PC	X
12	PC	X
13	PC	X

*PLACE IMPLEMENTED CHANGES INTO BOARD HISTORY

M1198 .PCB_DATABASE_HISTORY			#	DATE	VER#	DESCRIPTION OF CHANGE
MODEL(S):-	M8					
1			24	D	V	Z
2			25	D	V	Z
3			26	D	V	Z
4			27	D	V	Z
5			28	D	V	Z
6			29	D	V	Z
7			30	D	V	Z
8			31	D	V	Z
9			32	D	V	Z
10			33	D	V	Z
11			34	D	V	Z
12			35	D	V	Z
13			36	D	V	Z
14			37	D	V	Z
15			38	D	V	Z
16			39	D	V	Z
17			40	D	V	Z
18			41	D	V	Z
19			42	D	V	Z
20			43	D	V	Z
21			44	D	V	Z
22			45	D	V	Z
23			46	D	V	Z
24			47	D	V	Z
25			48	D	V	Z
26			49	D	V	Z
27			50	D	V	Z

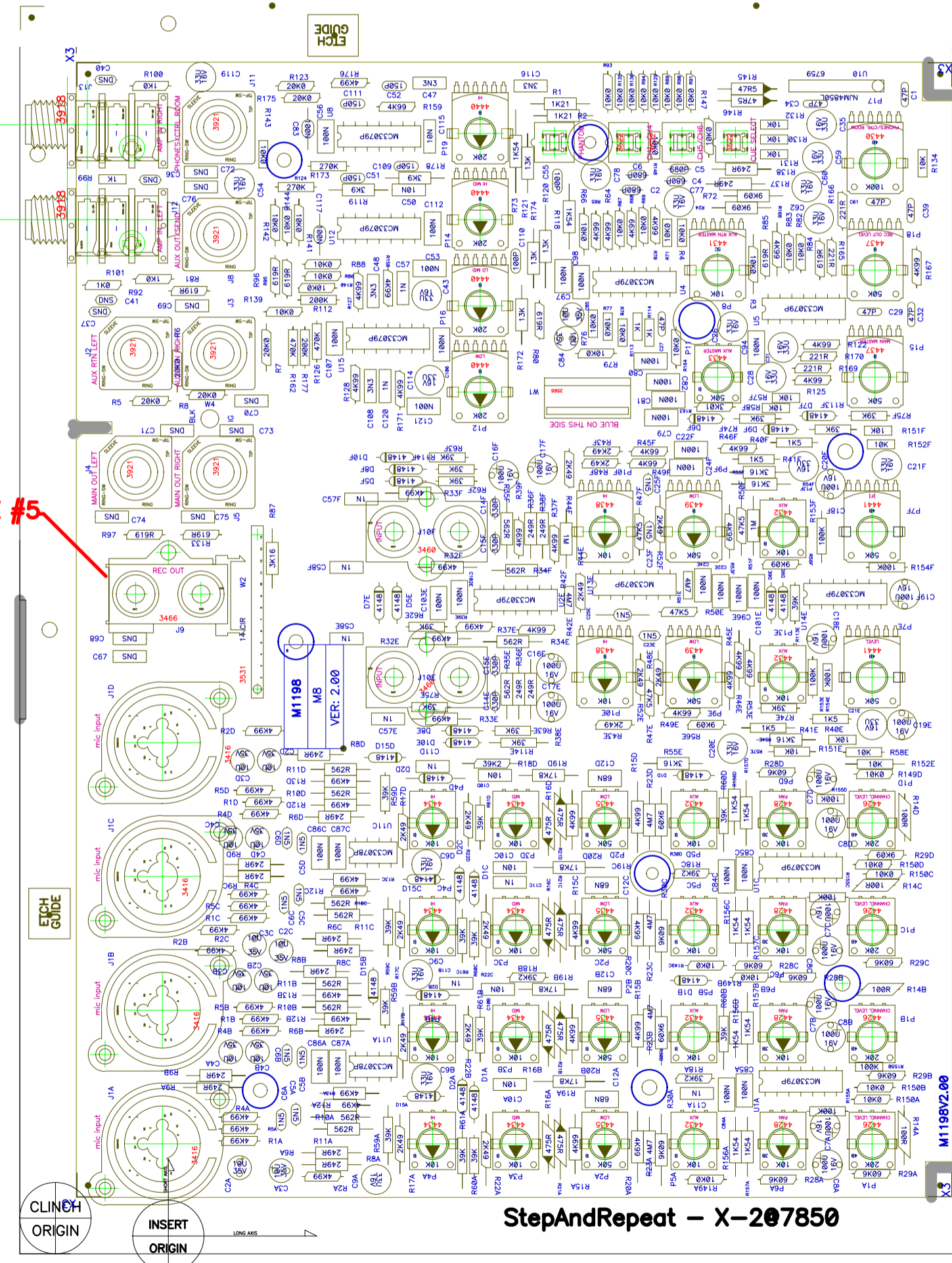

StepAndRepeat - X-207850

PRODUCTION NOTES:

- (1) ADD #3511 UNDER RCA JACKS * J10E & J10F *
- (2) DO NOT USE ANY HARDWARE WITH J12 & J13
- (3) PUSH CAPS FLAT DOWN BEFORE WAVE SOLDER C2A,B,C,D C3A,B,C,D C4A,B,C,D
- (4) ADD PEELABLE MASK(PINK GOOP) UNDER W1 Prevents any Flux from getting into W1.
- (5) REMOVE SNUB ON END OF #3466 JACK

M1198 TOP PCB					
MODEL(S):-		M8			
REF	FUNCTION	PART#	KNOB	{NEW}	
P4A, B,C,D	HI	4434	BLUE	BLUE	
P3A, B,C,D	MID	4434	BLUE	BLUE	
P2A,B,C,D,E,F	LOW	4435	BLUE	BLUE	
P5A,B,C,D,E,F	AUX	4432	GRN	GRN	
P6A,B,C,D,E,F	PAN	4428	GRAY	GRAY	
P1A, B,C,D	LEVEL	4426	RED	RED	
P11	AUX SEND	4433	GRN	GRN	
P12,16,14,19	MAIN EQ	4440	BLUE	BLUE	
P17	HEADPHONES	4430	RED	RED	
P15	MAIN	4437	RED	RED	
P18	RECORD OUT	4437	RED	RED	
P8	AUX RTN	4431	GRN	GRN	

EYELET LEGEND

- SOCKET
- SOCKET UPSIDE DOWN
- NORMAL
- NORMAL LARGE
- SOCKET WITH DIRECTION
- TAB

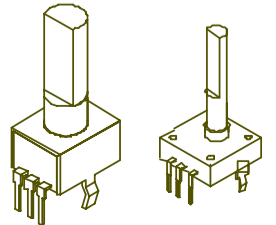

STYLE_P32 *STYLE_P20*

Note 1

- M1198
 Mixer Board
 connection missing from pin 10 of U1c to gnd through the snap in lead of P6D
 P10E: don't make a connection through the snap in lead
 R143 should be 10K0
 C1, C34 from 100p to 47p
 Plated hole missing for the IG wire and the chassis screw to the metal spacer
 3 ground loops to cut
 R17 A,B,C,D, R22 A,B,C,D 1K21 to 2K49
 R43E,F, R48E,F, R44E,F, R52E,F 1K21 to 2K49
 cut back frame of tape out RCA jacks to accommodate mounting of the LED board. 2nd run: move RCA jacks
 Chan 2,4 move trace to reduce bleedthrough
 remove jumper from IG to SC
1. Remove the jumper wire between IG and SG nets
 2. Reduce gain in Aux send circuit by 5 dB R163 becomes 3K01 1x and R164 becomes 10K0 1x
 3. Change R76, R77, and R78 to 10K0 1x mini
 4. Change C63, C64, C65 and C66 to 20K0 1x mini
 5. Add 680pF capacitors across R66, R67, R69, and R71
 6. Move trace from R3--C31 away from U5 pin 1.

MODEL(S):-		M8
#	PC#	PENDING CHANGE
1	6661	R76 TOO CLOSE TO C85; R4B TOO CLOSE TO C4A&C4B
2	PC	X
3	PC	X
4	PC	X
5	PC	X
6	PC	X
7	PC	X
8	PC	X
9	PC	X
10	PC	X
11	PC	X
12	PC	X
13	PC	X

*PLACE IMPLEMENTED CHANGES INTO BOARD HISTORY

M1198 .PCB_DATABASE_HISTORY				#	DATE	VER#	DESCRIPTION OF CHANGE
MODEL(S):-		M8					
#	DATE	VER#	DESCRIPTION OF CHANGE				
1	JUN/25/03	P2	CHANGE C1,C34 FROM 100P TO 47P	24	D	V	N
2	JUN/25/03	P2	CHANGE R17A,B,C,D R22A,B,C,D FROM 1K21 TO 2K49	25	D	V	N
3	JUN/25/03	P2	CHANGE R43E,R43F,R48E,R48F FROM 1K21 TO 2K49	26	D	V	N
4	JULY 25 03	P2	DNS---->C67,68,69,70,71,72,73,74,75,76,36,37,40,41	27	D	V	N
5	JULY 25 03	V1.00	PILOT RUN	28	D	V	N
6	Aug 21, 2003	V1.00	Renumber marconi nodes. Changed XC3.8 to testjig holes	29	D	V	N
7	SEPT 22 03	V2.00	PILOT RUN CHANGES& MOVE TO VER:2.00	30	D	V	N
8	SEPT 30 03	V2.00	SEE NOTE 1	31	D	V	N
9	26-NOV-2003	V2.00	Replacements: 4442-->4441, 5267-->5879	32	D	V	N
10	D	V		33	D	V	N
11	D	V		34	D	V	N
12	D	V		35	D	V	N
13	D	V		36	D	V	N
14	D	V		37	D	V	N
15	D	V		38	D	V	N
16	D	V		39	D	V	N
17	D	V		40	D	V	N
18	D	V		41	D	V	N
19	D	V		42	D	V	N
20	D	V		43	D	V	N
21	D	V		44	D	V	N
22	D	V		45	D	V	N
23	D	V		46	D	V	N
24	D	V		47	D	V	N
25	D	V		48	D	V	N
26	D	V		49	D	V	N
27	D	V		50	D	V	N

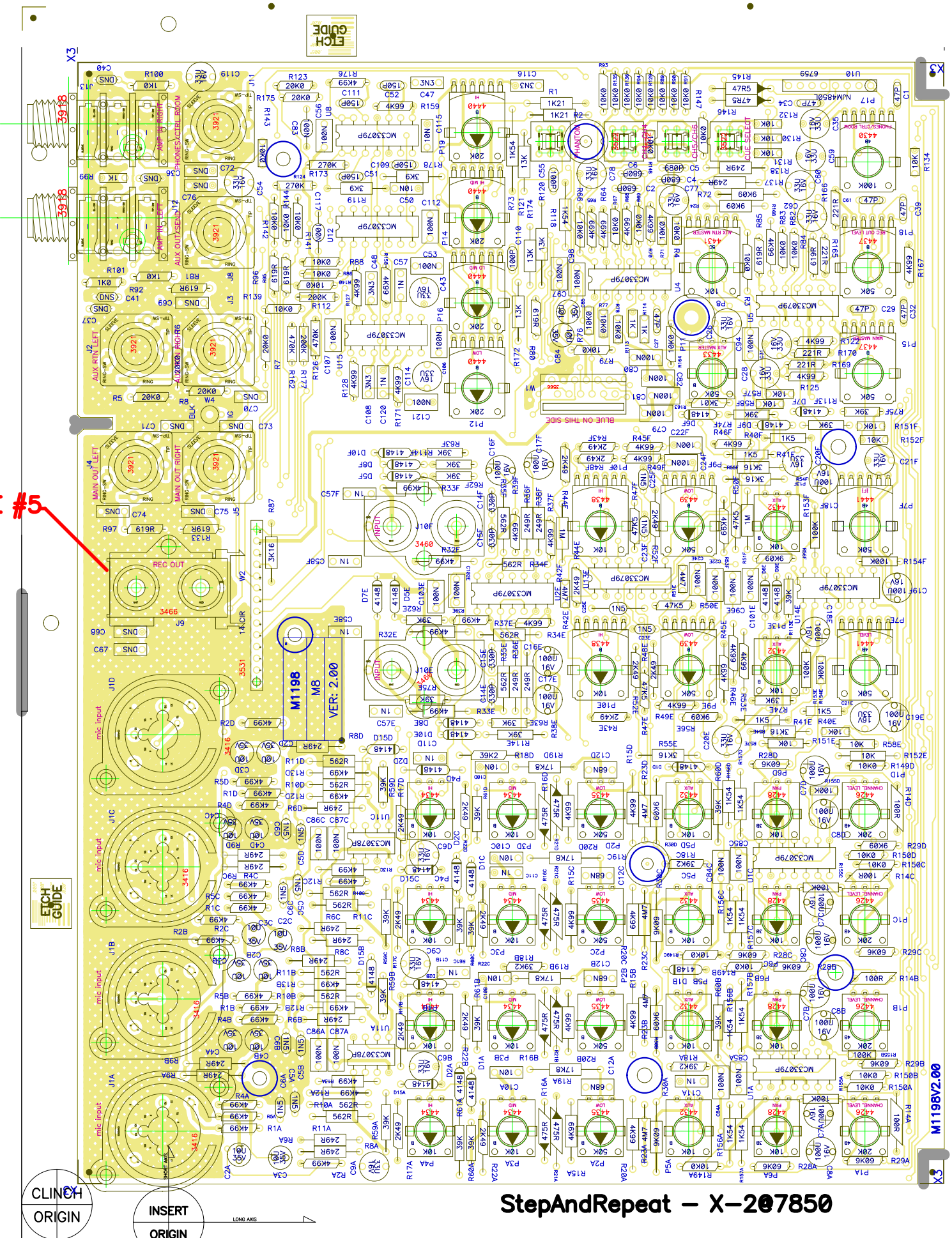

StepAndRepeat - X-207850

PRODUCTION NOTES:

- (1) ADD #3511 UNDER RCA JACKS * J10E & J10F *
- (2) DO NOT USE ANY HARDWARE WITH J12 & J13
- (3) PUSH CAPS FLAT DOWN BEFORE WAVE SOLDER C2A,B,C,D C3A,B,C,D C4A,B,C,D
- (4) ADD PEELABLE MASK(PINK GOOP) UNDER W1 Prevents any Flux from getting into W1.
- (5) REMOVE SNUB ON END OF #3466 JACK

M1198 TOP PCB				
MODEL(S):-		M8		
REF	FUNCTION	PART#	KNOB	{NEW}
P4A, B,C,D	HI	4434	BLUE	BLUE
P3A, B,C,D	MID	4434	BLUE	BLUE
P2A,B,C,D,E,F	LOW	4435	BLUE	BLUE
P5A,B,C,D,E,F	AUX	4432	GRN	GRN
P6A,B,C,D,E,F	PAN	4428	GRAY	GRAY
P1A, B,C,D	LEVEL	4426	RED	RED
P11	AUX SEND	4433	GRN	GRN
P12,16,14,19	MAIN EQ	4440	BLUE	BLUE
P17	HEADPHONES	4430	RED	RED
P15	RECORD	4437	RED	RED
P18	RECORD OUT	4437	RED	RED

EYELET LEGEND

- SOCKET
- SOCKET UPSIDE DOWN
- NORMAL
- NORMAL LARGE
- SOCKET WITH DIRECTION
- TAB

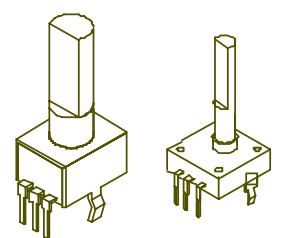

*STYLE_P32 *STYLE_P20

Note 1

- M1198 Mixer Board
 connection missing from pin 10 of U1c to gnd through the snap in lead of P6D
 P10E: don't make a connection through the snap in lead
 R143 should be 10K0
 C1, C34 from 100p to 47p
 Plated hole missing for the IG wire and the chassis screw to the metal spacer
 3 ground loops to cut
 R17 A,B,C,D, R22 A,B,C,D 1K21 to 2K49
 R43E,F, R48E,F, R44E,F, R52E,F 1K21 to 2K49
 cut back frame of tape out RCA jacks to accommodate mounting of the LED board. 2nd run: move RCA jacks
 Chan 2,4 move trace to reduce bleedthrough
 remove jumper from IG to SG
 1. Remove the jumper wire between IG and SG nets
 2. Reduce gain in Aux send circuit by 5 dB R163 becomes 3K01 1% and R164 becomes 10K0 1%
 3. Change R76, R77, and R78 to 10K0 1% mini
 4. Change C63, C64, C65 and C66 to 20K0 1% mini
 5. Add 680pF capacitors across R66, R67, R69, and R71
 6. Move trace from R3-C31 away from U5 pin 1.

MODEL(S):-		M8
#	PC#	PENDING CHANGE
1	6661	R76 TOO CLOSE TO C85; R4B TOO CLOSE TO C4A&C4B
2	PC	X
3	PC	X
4	PC	X
5	PC	X
6	PC	X
7	PC	X
8	PC	X
9	PC	X
10	PC	X
11	PC	X
12	PC	X
13	PC	X

*PLACE IMPLEMENTED CHANGES INTO BOARD HISTORY

M1198 .PCB_DATABASE_HISTORY				#	DATE	VER#	DESCRIPTION OF CHANGE
MODEL(S):-	M8	VER#	DESCRIPTION OF CHANGE				
				24	D	V	Z
				25	D	V	Z
				26	D	V	Z
				27	D	V	Z
				28	D	V	Z
				29	D	V	Z
				30	D	V	Z
				31	D	V	Z
				32	D	V	Z
				33	D	V	Z
				34	D	V	Z
				35	D	V	Z
				36	D	V	Z
				37	D	V	Z
				38	D	V	Z
				39	D	V	Z
				40	D	V	Z
				41	D	V	Z
				42	D	V	Z
				43	D	V	Z
				44	D	V	Z
				45	D	V	Z
				46	D	V	Z
				47	D	V	Z
				48	D	V	Z
				49	D	V	Z
				50	D	V	Z

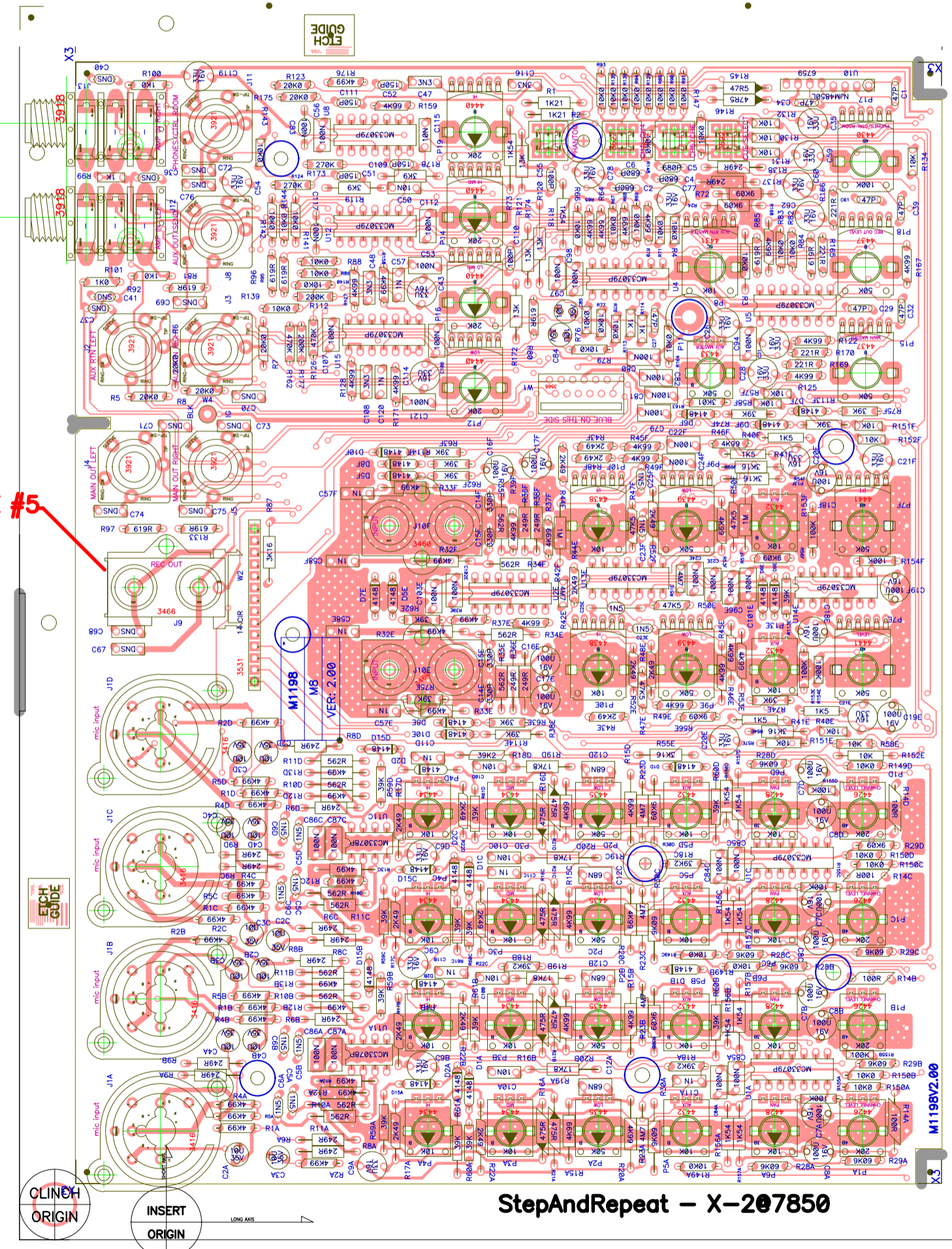

PRODUCTION NOTES:

- (1) ADD #3511 UNDER RCA JACKS * J10E & J10F *
- (2) DO NOT USE ANY HARDWARE WITH J12 & J13
- (3) PUSH CAPS FLAT DOWN BEFORE WAVE SOLDER C2A,B,C,D C3A,B,C,D C4A,B,C,D
- (4) ADD PEELABLE MASK(PINK GOOP) UNDER W1 Prevents any Flux from getting into W1.
- (5) REMOVE SNUB ON END OF #3466 JACK

M1198 TOP PCB

MODEL(S):-		M8		
REF	FUNCTION	PART#	KNOB	{NEW}
P4A, B,C,D	HI	4434	BLUE	BLUE
P3A, B,C,D	MID	4434	BLUE	BLUE
P2A,B,C,D,E,F	LOW	4435	BLUE	BLUE
P5A,B,C,D,E,F	AUX	4432	GRN	GRN
P6A,B,C,D,E,F	PAN	4428	GRAY	GRAY
P1A, B,C,D	LEVEL	4426	RED	RED
P11	AUX SEND	4433	GRN	GRN
P12,16,14,19	MAIN EQ	4440	BLUE	BLUE
P17	HEADPHONES	4430	RED	RED
P15	MAIN	4437	RED	RED
P18	RECORD OUT	4437	RED	RED
PB	AUX RTN	4431	GRN	GRN

EYELET LEGEND

- SOCKET
- SOCKET UPSIDE DOWN
- NORMAL
- NORMAL LARGE
- SOCKET WITH DIRECTION
- TAB

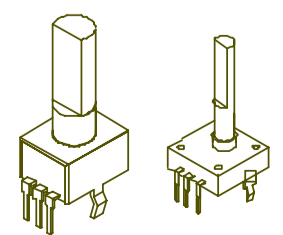

STYLE_P32

STYLE_P20

LEFT CHANNEL

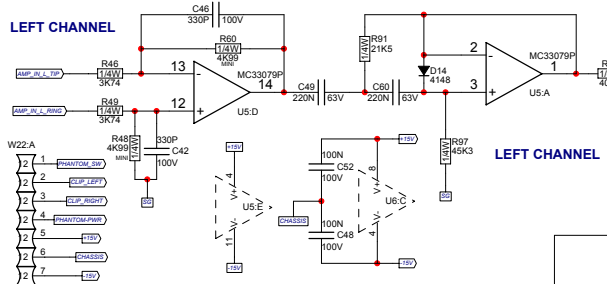

LEFT CHANNEL

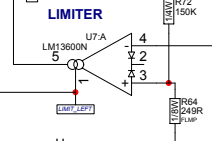

LIMITER

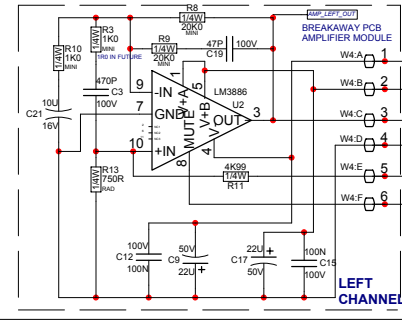

LEFT CHANNEL

BREAKAWAY PCB SPEAKER OUTPUT JACKS

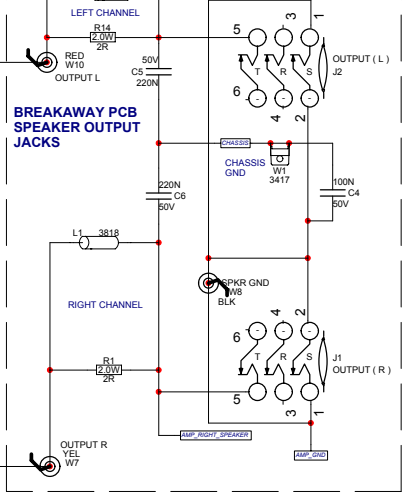

RIGHT CHANNEL

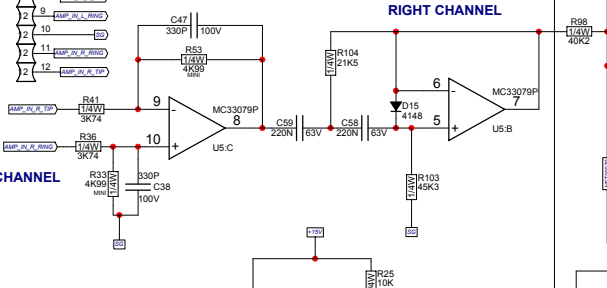

RIGHT CHANNEL

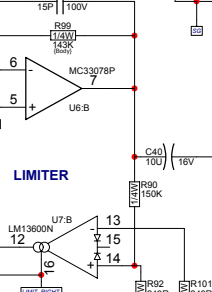

LIMITER

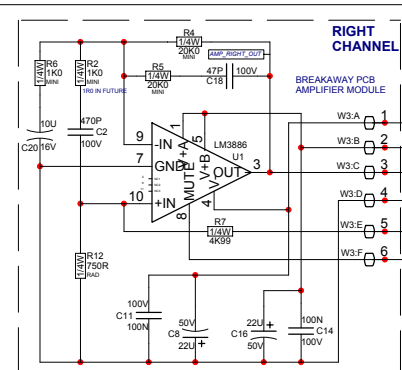

RIGHT CHANNEL

RIGHT CHANNEL

PHANTOM POWER

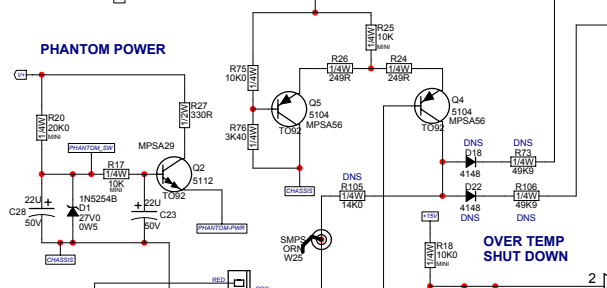

OVER TEMP SHUT DOWN

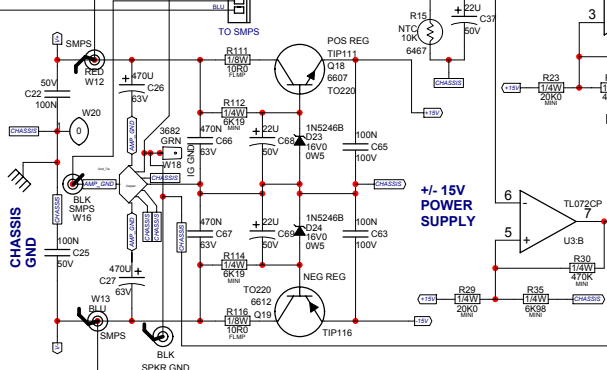

+/- 15V POWER SUPPLY

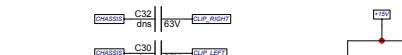

CLIP / LIMIT PROTECT

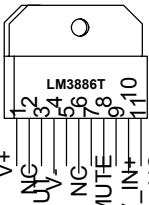

MPSA56 BC550C
MPSA13 BC560C

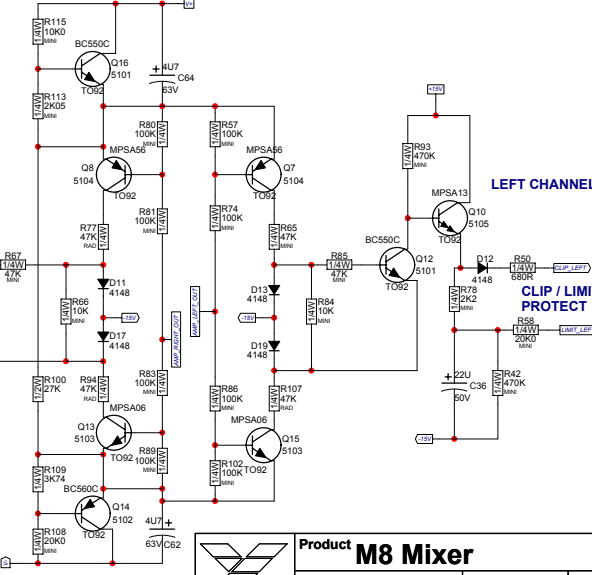

CLIP / LIMIT PROTECT



Product M8 Mixer		
Power Amp	PCB# M1199	Sheet 1 of 3
Date: Wed Jan 14, 2004	Rev: 2.10	
Filename: M1199V2.10 sch.SCH2002		

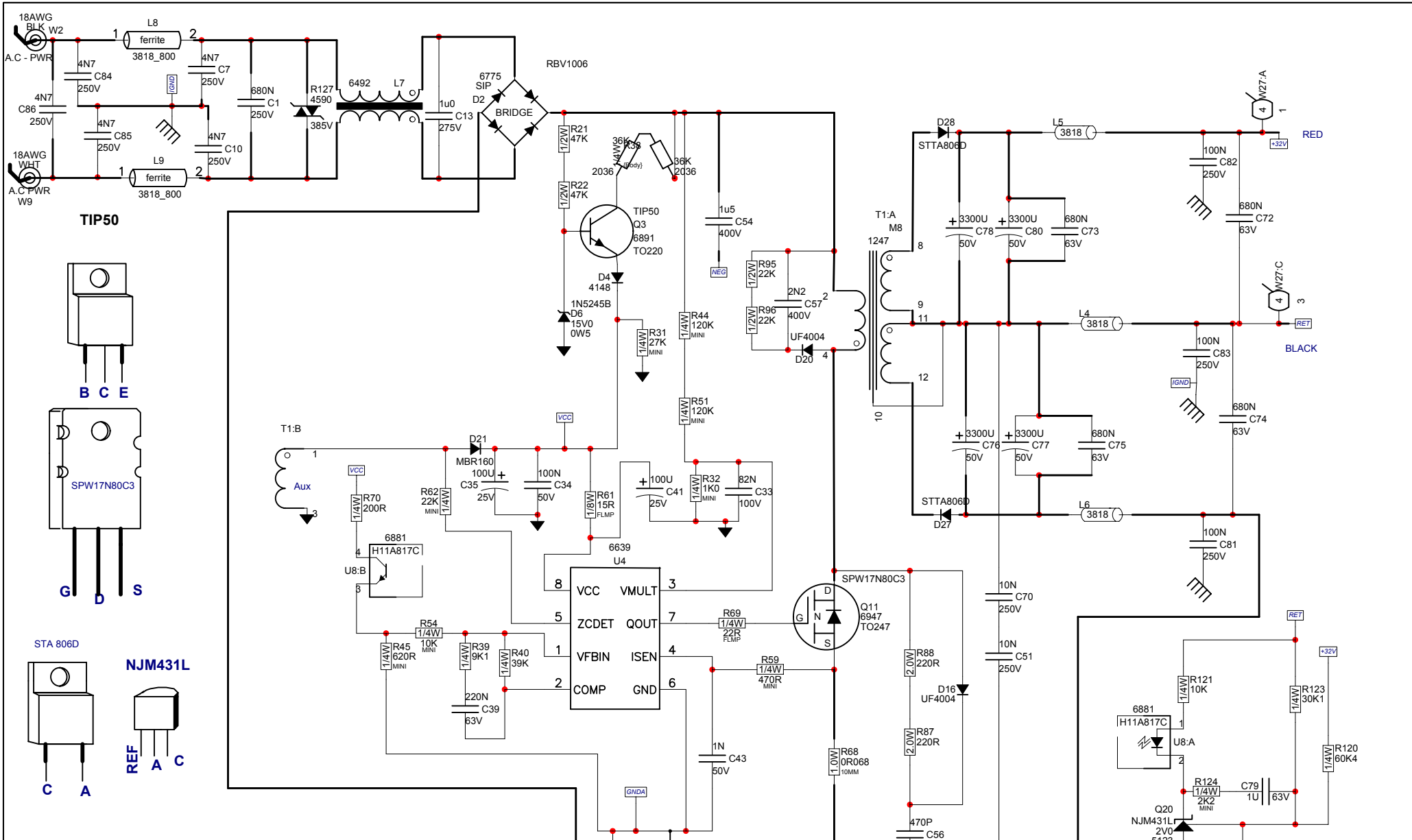

M8 2 X 85W PWR MIXER WITH UNIVERSAL SMPs

MODEL(S):-	M8		
#	DATE	VER#	DESCRIPTION OF CHANGE
1	OCT 27 03	V2.00	MERGE M1196&M1196 WITH PILOT RUN CHANGES
2	OCT 27 03	V2.00	DNS ---->D10,D19,R95,R87
3	OCT 27 03	V2.00	Pilot run changes ...See note 1
4	NOV 27 03	V2.00	Fixed position of right side VCD, corrected version, moved bot-left corner route to stop vampire tooth.
5	D	V	
6	DEC 2 03	V2.00	Changed W11&W26 from .125 to .156
7	JAN 6 04	V2.10	PC#6665: R127(275V->385V), R38(200R->2 x 36k), D6(1N5244->1N5245), D21(UF4004->MBR160)
8	D	V	
9	JAN 6 04	V2.10	PC#6666: R69(10R->22R)
10	D	V	
11	D	V	
12	D	V	
13	D	V	

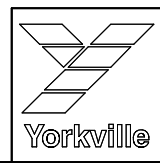
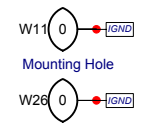

Product M8 Mixer

Power Supply	PCB# M1199	Sheet 2 of 3
Date: Wed Jan 14, 2004	Rev:2.10	
Filename: M1199V2.10 sch.SCH2002		

M8 2 X 85W PWR MIXER WITH UNIVERSAL SMPS			
MODEL(S):- M8			
#	DATE	VER#	DESCRIPTION OF CHANGE
1	OCT 27 03	V2.00	MERGE M1196&M1196 WITH PILOTRUN CHANGES
2	OCT 27 03	V2.00	DNS ---->D10,D19,R95,R87
3	OCT 27 03	V2.00	Pilot run changes ... See note 1
4	NOV 27 03	V2.00	Fixed position of right side VCD, corrected version, moved bot-left corner route to stop vampire tooth.
5	DEC 2 03	V2.00	Changed W11&W26 from .125 to .156
6	JAN 6 04	V2.10	PC#6665: R127(275V->385V), R38(200R->2 x 36k), D6(1N5244->1N5245), D21(1N4004->MFR160)
7	JAN 6 04	V2.10	PC#6666: R69(10R->22R)
8			
9			
10			
11			
12			
13			

PRODUCTION NOTES:

- (1) ADD #8647 STANDOFF FOR D2 AND Q11
- (2) J1 & J2 MUST BE FLAT ON PCB BEFORE WAVE SOLDER TRIM WIRES ON PCB AFTER WAVE SOLDER
- (3) HAND INSERT R2,R3,R15, R87 & R88 - BEND R87&R88 AS SHOWN



- (4) HAND WIRE TWO 2036 RESISTORS TO FORM R38 AS SHOWN:



- (5) HAND WIRE +VE TERM OF C9 TO PIN 7 OF U2, C12 TO C15 ON RESISTOR SIDE AND C11 TO C14 ON RESISTOR SIDE

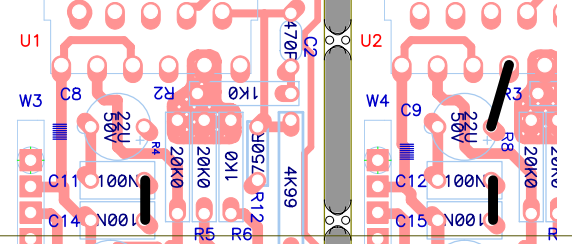

M1199 PENDING CHANGES

MODEL(S):- M8		
#	PC#	PENDING CHANGE
1	6662	C8 TOO CLOSE TO C11; C9 TOO CLOSE TO C12; Q15 TOO CLOSE TO C64
2	PC	X
3	6668	PC#6668: R2,R3(6110->2007)
4	6667	REPOUR COPPER AROUND U1&U2 TO CON. C9,C11,C15
5	PC	X
6	PC	X
7	PC	X
8	PC	X
9	PC	X
10	PC	X
11	PC	X
12	PC	X
13	PC	X

PLACE IMPLEMENTED CHANGES INTO BOARD HISTO

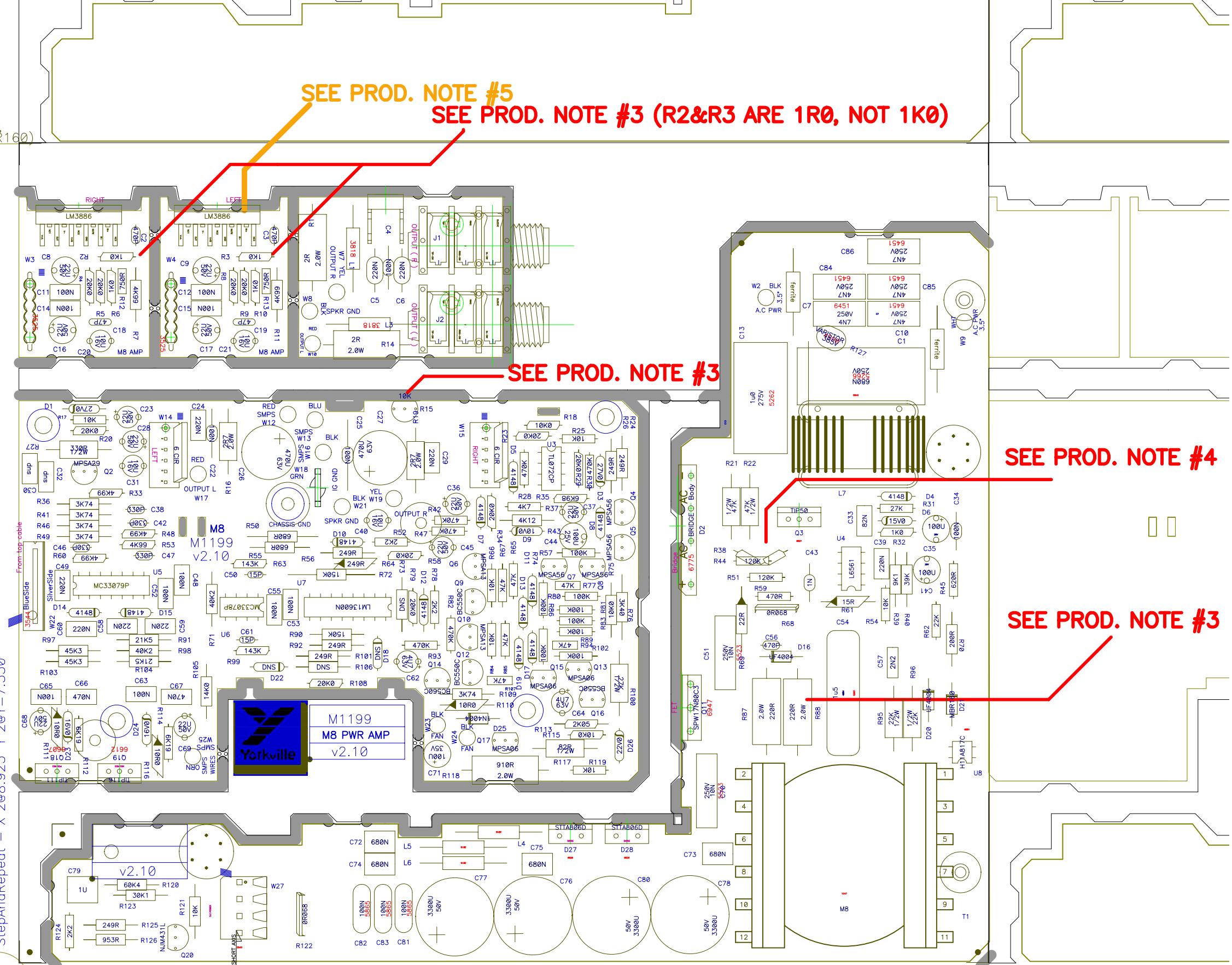
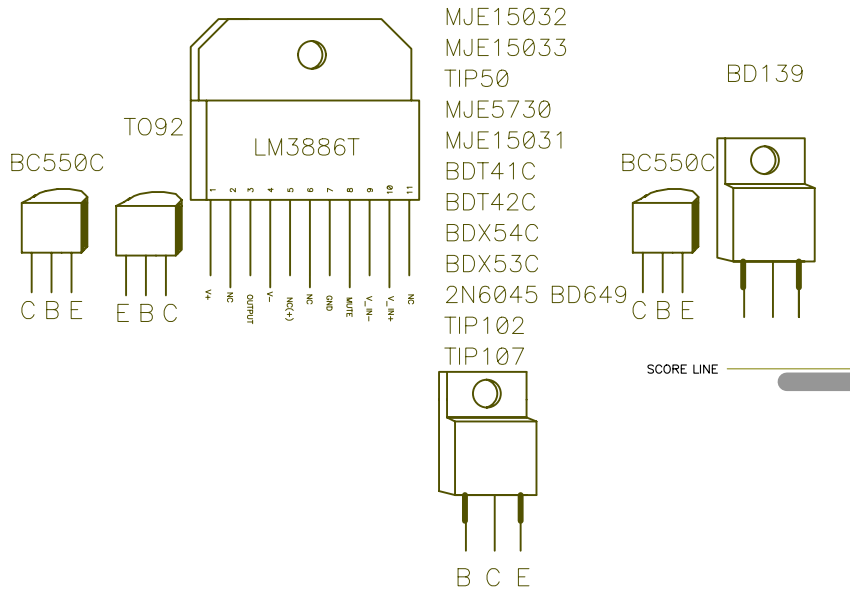

SEE PROD. NOTE #5

SEE PROD. NOTE #3 (R2&R3 ARE 1R0, NOT 1K0)

SEE PROD. NOTE #3

SEE PROD. NOTE #4

SEE PROD. NOTE #3

BLANK=18.850" X 16.1000"
StepAndRepeat - X @08.925" Y 2@Y=7.550"

CLINCH ORIGIN
BLANK=18.850" X 16.1000"

INSERT ORIGIN

Pcb MechM1199v2.10
Top AssyM1199v2.10

ETCH GUIDE

M8 2 X 85W PWR MIXER WITH UNIVERSAL SMPS			
MODEL(S):- M8			
#	DATE	VER#	DESCRIPTION OF CHANGE
1	OCT 27 03	V2.00	MERGE M1196&M1196 WITH PILOTRUN CHANGES
2	OCT 27 03	V2.00	DNS ---->D10,D19,R95,R87
3	OCT 27 03	V2.00	Pilot run changes ... See note 1
4	NOV 27 03	V2.00	Fixed position of right side VCD, corrected version, moved bot-left corner route to stop vampire tooth.
5	DEC 2 03	V2.00	Changed W11&W26 from .125 to .156
6	JAN 6 04	V2.10	PC#6665: R127(275V->385V), R38(200R->2 x 36k), D6(1N5244->1N5245), D21(1N4004->MFR160)
7	JAN 6 04	V2.10	PC#6666: R69(10R->22R)
8			
9			
10			
11			
12			
13			

PRODUCTION NOTES:

- (1) ADD #8647 STANDOFF FOR D2 AND Q11
- (2) J1 & J2 MUST BE FLAT ON PCB BEFORE WAVE SOLDER TRIM WIRES ON PCB AFTER WAVE SOLDER
- (3) HAND INSERT R2,R3,R15, R87 & R88 - BEND R87&R88 AS SHOWN



- (4) HAND WIRE TWO 2036 RESISTORS TO FORM R38 AS SHOWN:



- (5) HAND WIRE +VE TERM OF C9 TO PIN 7 OF U2, C12 TO C15 ON RESISTOR SIDE AND C11 TO C14 ON RESISTOR SIDE

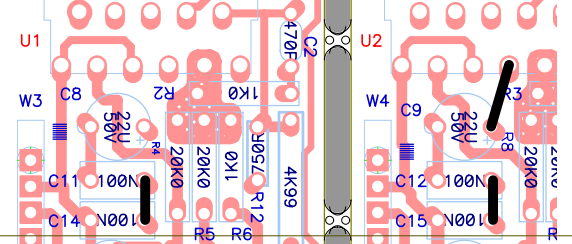

M1199 PENDING CHANGES

MODEL(S):- M8		
#	PC#	PENDING CHANGE
1	6662	C8 TOO CLOSE TO C11; C9 TOO CLOSE TO C12; Q15 TOO CLOSE TO C64
2	PC	X
3	6668	PC#6668: R2,R3(6110->2007)
4	6667	REPOUR COPPER AROUND U1&U2 TO CON. C9,C11,C15
5	PC	X
6	PC	X
7	PC	X
8	PC	X
9	PC	X
10	PC	X
11	PC	X
12	PC	X
13	PC	X

PLACE IMPLEMENTED CHANGES INTO BOARD HISTOF

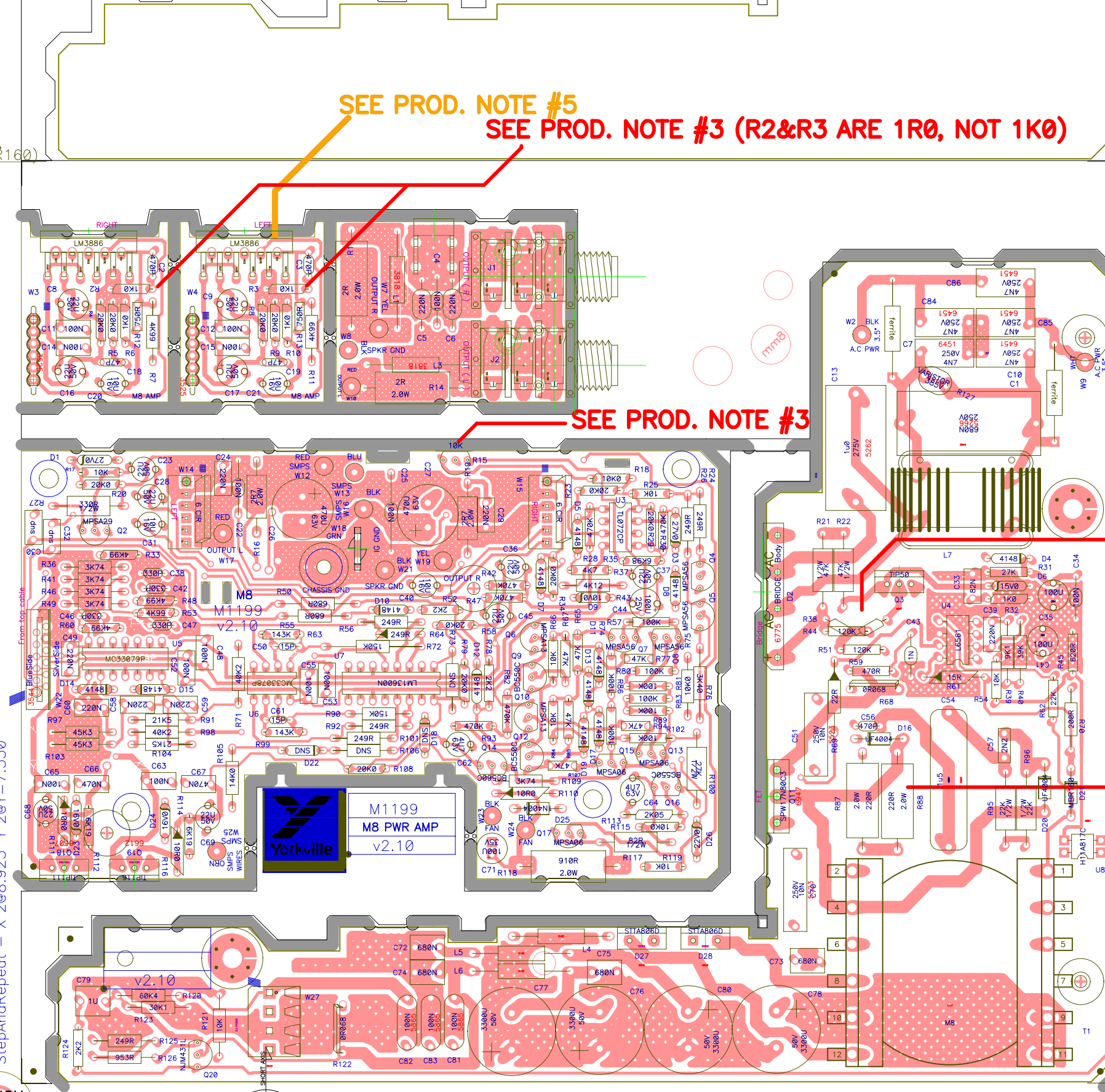
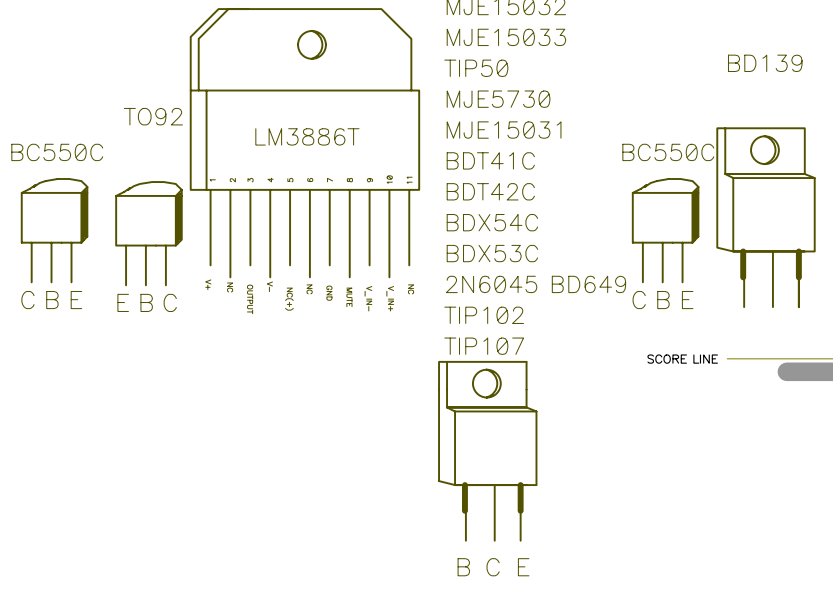

SEE PROD. NOTE #5
SEE PROD. NOTE #3 (R2&R3 ARE 1R0, NOT 1K0)

SEE PROD. NOTE #3

SEE PROD. NOTE #4

SEE PROD. NOTE #3

BLANK=18.850" X 16.1000"
StepAndRepeat - X @08.925" Y 2@Y=7.550"

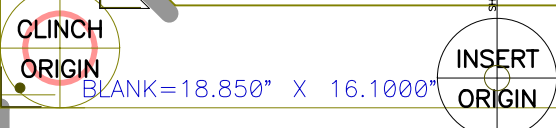

Pcb MechM1199v2.10
Top AssyM1199v2.10



M8 2 X 85W PWR MIXER WITH UNIVERSAL SMPS			
MODEL(S):- M8			
#	DATE	VER#	DESCRIPTION OF CHANGE
1	OCT 27 03	V2.00	MERGE M1196&M1196 WITH PILOTRUN CHANGES
2	OCT 27 03	V2.00	DNS ---->D10,D19,R95,R87
3	OCT 27 03	V2.00	Pilot run changes ... See note 1
4	NOV 27 03	V2.00	Fixed position of right side VCD, corrected version, moved bot-left corner route to stop vampire tooth.
5	DEC 2 03	V2.00	Changed W11&W26 from .125 to .156
6	JAN 6 04	V2.10	PC#6665: R127(275V->385V), R38(200R->2 x 36k), D6(1N5244->1N5245), D21(1N4004->MFR160)
7	JAN 6 04	V2.10	PC#6666: R69(10R->22R)
8			
9			
10			
11			
12			
13			

PRODUCTION NOTES:

- (1) ADD #8647 STANDOFF FOR D2 AND Q11
- (2) J1 & J2 MUST BE FLAT ON PCB BEFORE WAVE SOLDER TRIM WIRES ON PCB AFTER WAVE SOLDER
- (3) HAND INSERT R2,R3,R15, R87 & R88 - BEND R87&R88 AS SHOWN



- (4) HAND WIRE TWO 2036 RESISTORS TO FORM R38 AS SHOWN:



- (5) HAND WIRE +VE TERM OF C9 TO PIN 7 OF U2, C12 TO C15 ON RESISTOR SIDE AND C11 TO C14 ON RESISTOR SIDE

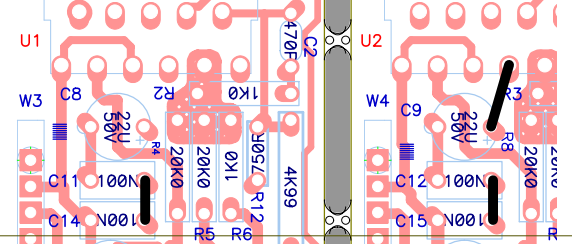

M1199 PENDING CHANGES

MODEL(S):- M8		
#	PC#	PENDING CHANGE
1	6662	C8 TOO CLOSE TO C11; C9 TOO CLOSE TO C12; Q15 TOO CLOSE TO C64
2	PC	X
3	6668	PC#6668: R2,R3(6110->2007)
4	6667	REPOUR COPPER AROUND U1&U2 TO CON. C9,C11,C15
5	PC	X
6	PC	X
7	PC	X
8	PC	X
9	PC	X
10	PC	X
11	PC	X
12	PC	X
13	PC	X

PLACE IMPLEMENTED CHANGES INTO BOARD HISTOF

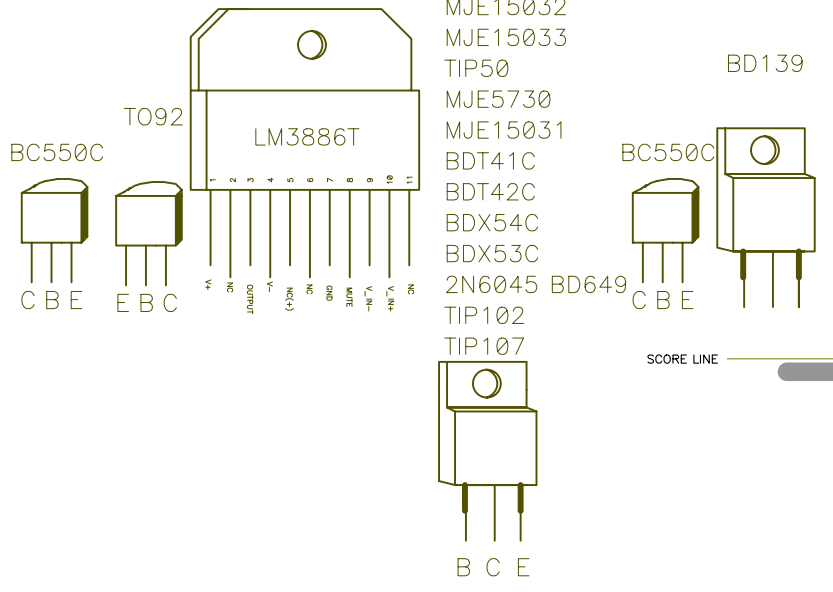

BLANK=18.850" X 16.1000"
StepAndRepeat - X @08.925" Y 2@Y=7.550"

CLINCH ORIGIN

BLANK=18.850" X 16.1000"

INSERT ORIGIN

LONG AXIS

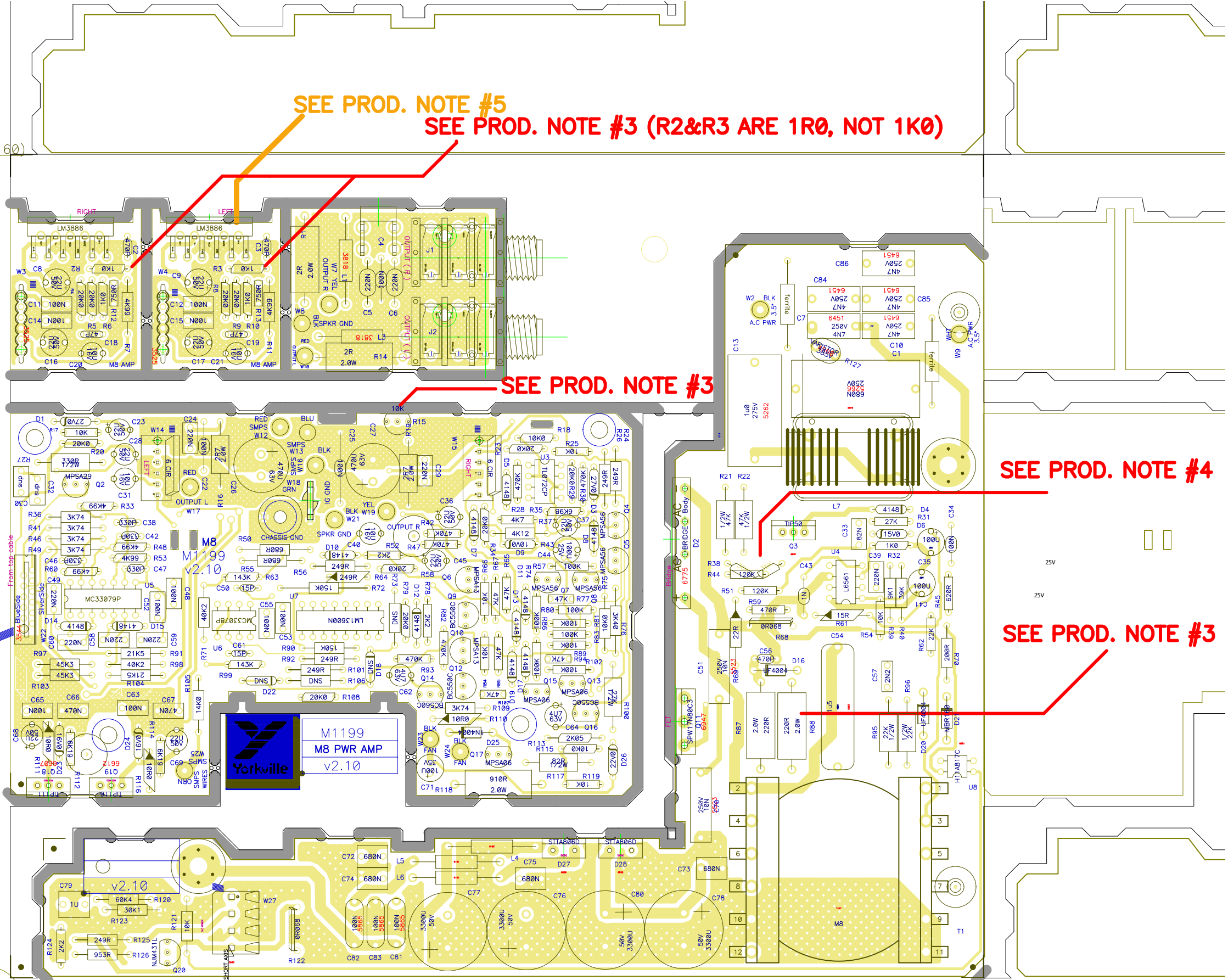

SEE PROD. NOTE #5

SEE PROD. NOTE #3 (R2&R3 ARE 1R0, NOT 1K0)

SEE PROD. NOTE #3

SEE PROD. NOTE #4

SEE PROD. NOTE #3

01.5veer1TM

qoT

Pcb MechM1199v2.10
Top AssyM1199v2.10

