



SERVICE MANUAL

MODEL TYPE: YS1037
NX750P

WEB ACCESS: <http://www.yorkville.com>

WORLD HEADQUARTERS CANADA

Yorkville Sound
550 Granite Court
Pickering, Ontario
L1W-3Y8 CANADA

Voice: (905) 837-8481
Fax: (905) 837-8746

U.S.A.

Yorkville Sound Inc.
4625 Witmer Industrial Estate
Niagara Falls, New York
14305 USA

Voice: (716) 297-2920
Fax: (716) 297-3689



Quality and Innovation Since 1963
Printed in Canada



IMPORTANT SAFETY INSTRUCTIONS



This lightning flash with arrowhead symbol, within an equilateral triangle, is intended to alert the user to the presence of uninsulated "dangerous voltage" within the product's enclosure that may be of sufficient magnitude to constitute a risk of electric shock to persons.

Ce symbole d'éclair avec tête de flèche dans un triangle équilatéral est prévu pour alerter l'utilisateur de la présence d'un « voltage dangereux » non-isolé à proximité de l'enceinte du produit qui pourrait être d'ampleur suffisante pour présenter un risque de choc électrique.



CAUTION AVIS

**RISK OF ELECTRIC SHOCK
DO NOT OPEN**

**RISQUE DE CHOC ELECTRIQUE
NE PAS OUVRIR**



The exclamation point within an equilateral triangle is intended to alert the user to the presence of important operating and maintenance (servicing) instructions in the literature accompanying the appliance.

Le point d'exclamation à l'intérieur d'un triangle équilatéral est prévu pour alerter l'utilisateur de la présence d'instructions importantes dans la littérature accompagnant l'appareil en ce qui concerne l'opération et la maintenance de cet appareil.

FOLLOW ALL INSTRUCTIONS

**Instructions pertaining to a risk of fire,
electric shock, or injury to a person**

**CAUTION: TO REDUCE THE RISK OF ELECTRIC
SHOCK, DO NOT REMOVE COVER (OR BACK).**

NO USER SERVICEABLE PARTS INSIDE.

**REFER SERVICING TO QUALIFIED
SERVICE PERSONNEL.**

SUIVEZ TOUTES LES INSTRUCTIONS

**Instructions relatives au risque de feu,
choc électrique, ou blessures aux personnes**

**AVIS: AFIN DE REDUIRE LES RISQUE DE CHOC
ELECTRIQUE, N'ENLEVEZ PAS LE COUVERT (OU LE
PANNEAU ARRIERE) NE CONTIENT AUCUNE PIECE**

REPARABLE PAR L'UTILISATEUR.

**CONSULTEZ UN TECHNICIEN QUALIFIE
POUR L'ENTRETIEN**

Read Instructions: The Owner's Manual should be read and understood before operation of your unit. Please, save these instructions for future reference and heed all warnings.

Clean only with dry cloth.

Packaging: Keep the box and packaging materials, in case the unit needs to be returned for service.

Warning: To reduce the risk of fire or electric shock, do not expose this apparatus to rain or moisture. *Do not use this apparatus near water!*

Warning: When using electric products, basic precautions should always be followed, including the following:

Power Sources

Your unit should be connected to a power source only of the voltage specified in the owners manual or as marked on the unit. This unit has a polarized plug. Do not use with an extension cord or receptacle unless the plug can be fully inserted. Precautions should be taken so that the grounding scheme on the unit is not defeated. An apparatus with CLASS I construction shall be connected to a Mains socket outlet with a protective earthing ground. Where the MAINS plug or an appliance coupler is used as the disconnect device, the disconnect device shall remain readily operable.

Hazards

Do not place this product on an unstable cart, stand, tripod, bracket or table. The product may fall, causing serious personal injury and serious damage to the product. Use only with cart, stand, tripod, bracket, or table recommended by the manufacturer or sold with the product. Follow the manufacturer's instructions when installing the product and use mounting accessories recommended by the manufacturer. Only use attachments/accessories specified by the manufacturer

Note: Prolonged use of headphones at a high volume may cause health damage on your ears.

The apparatus should not be exposed to dripping or splashing water; no objects filled with liquids should be placed on the apparatus.

Terminals marked with the "lightning bolt" are hazardous live; the external wiring connected to these terminals require installation by an instructed person or the use of ready made leads or cords.

Ensure that proper ventilation is provided around the appliance. Do not install near any heat sources such as radiators, heat registers, stoves, or other apparatus (including amplifiers) that produce heat.

No naked flame sources, such as lighted candles, should be placed on the apparatus.

Power Cord

Do not defeat the safety purpose of the polarized or grounding-type plug. A polarized plug has two blades with one wider than the other. A grounding type plug has two blades and a third grounding prong. The wide blade or the third prong are provided for your safety. If the provided plug does not fit into your outlet, consult an electrician for replacement of the obsolete outlet. The AC supply cord should be routed so that it is unlikely that it will be damaged. Protect the power cord from being walked on or pinched particularly at plugs. If the AC supply cord is damaged DO NOT OPERATE THE UNIT. To completely disconnect this apparatus from the AC Mains, disconnect the power supply cord plug from the AC receptacle. The mains plug of the power supply cord shall remain readily operable.

Unplug this apparatus during lightning storms or when unused for long periods of time.

Service

The unit should be serviced only by qualified service personnel. Servicing is required when the apparatus has been damaged in any way, such as power-supply cord or plug is damaged, liquid has been spilled or objects have fallen into the apparatus, the apparatus has been exposed to rain or moisture, does not operate normally, or has been dropped.

Veillez Lire le Manuel: Il contient des informations qui devraient être comprises avant l'opération de votre appareil. Conservez. Gardez S.V.P. ces instructions pour consultations ultérieures et observez tous les avertissements.

Nettoyez seulement avec le tissu sec.

Emballage: Conservez la boîte au cas où l'appareil devait être retourner pour réparation.

Avertissement: Pour réduire le risque de feu ou la décharge électrique, n'exposez pas cet appareil à la pluie ou à l'humidité. *N'utilisez pas cet appareil près de l'eau!*

Attention: Lors de l'utilisation de produits électrique, assurez-vous d'adhérer à des précautions de bases incluant celle qui suivent:

Alimentation

L'appareil ne doit être branché qu'à une source d'alimentation correspondant au voltage spécifié dans le manuel ou tel qu'indiqué sur l'appareil. Cet appareil est équipé d'une prise d'alimentation polarisée. Ne pas utiliser cet appareil avec un cordon de raccordement à moins qu'il soit possible d'insérer complètement les trois lames. Des précautions doivent être prises afin d'éviter que le système de mise à la terre de l'appareil ne soit désengagé. Un appareil construit selon les normes de CLASS I devrait être raccordé à une prise murale d'alimentation avec connexion intacte de mise à la masse. Lorsqu'une prise de branchement ou un coupleur d'appareils est utilisée comme dispositif de débranchement, ce dispositif de débranchement devra demeurer pleinement fonctionnel avec raccordement à la masse.

Risque

Ne pas placer cet appareil sur un chariot, un support, un trépied ou une table instables. L'appareil pourrait tomber et blesser quelqu'un ou subir des dommages importants. Utiliser seulement un chariot, un support, un trépied ou une table recommandés par le fabricant ou vendus avec le produit. Suivre les instructions du fabricant pour installer l'appareil et utiliser les accessoires recommandés par le fabricant. Utilisez seulement les attachments/accessoires indiqués par le fabricant

Note: L'utilisation prolongée des écouteurs à un volume élevé peut avoir des conséquences néfastes sur la santé sur vos oreilles. .

Il convient de ne pas placer sur l'appareil de sources de flammes nues, telles que des bougies allumées.

L'appareil ne doit pas être exposé à des égouttements d'eau ou des éclaboussures et qu'aucun objet rempli de liquide tel que des vases ne doit être placé sur l'appareil.

Assurez que l'appareil est fourni de la propre ventilation. Ne procédez pas à l'installation près de source de chaleur tels que radiateurs, registre de chaleur, fours ou autres appareils (incluant les amplificateurs) qui produisent de la chaleur.

Les dispositifs marqués d'une symbole "d'éclair" sont des parties dangereuses au toucher et que les câblages extérieurs connectés à ces dispositifs de connexion extérieure doivent être effectués par un opérateur formé ou en utilisant des cordons déjà préparés.

Cordon d'Alimentation

Ne pas enlever le dispositif de sécurité sur la prise polarisée ou la prise avec tige de mise à la masse du cordon d'alimentation. Une prise polarisée dispose de deux lames dont une plus large que l'autre. Une prise avec tige de mise à la masse dispose de deux lames en plus d'une troisième tige qui connecte à la masse. La lame plus large ou la tige de mise à la masse est prévu pour votre sécurité. La prise murale est désuète si elle n'est pas conçue pour accepter ce type de prise avec dispositif de sécurité. Dans ce cas, contactez un électricien pour faire remplacer la prise murale. Évitez d'endommager le cordon d'alimentation. Protégez le cordon d'alimentation. Assurez-vous qu'on ne marche pas dessus et qu'on ne le pince pas en particulier aux prises. **N'UTILISEZ PAS L'APPAREIL** si le cordon d'alimentation est endommagé. Pour débrancher complètement cet appareil de l'alimentation CA principale, déconnectez le cordon d'alimentation de la prise d'alimentation murale. Le cordon d'alimentation du bloc d'alimentation de l'appareil doit demeurer pleinement fonctionnel.

Débranchez cet appareil durant les orages ou si inutilisé pendant de longues périodes.

Service

Consultez un technicien qualifié pour l'entretien de votre appareil. L'entretien est nécessaire quand l'appareil a été endommagé de quelque façon que se soit. Par exemple si le cordon d'alimentation ou la prise du cordon sont endommagés, si il y a eu du liquide qui a été renversé à l'intérieur ou des objets sont tombés dans l'appareil, si l'appareil a été exposé à la pluie ou à l'humidité, si il ne fonctionne pas normalement, ou a été échappé.

NX750P Parts List 11/12/2009

YS #	Description	Qty.	YS #	Description	Qty.	YS #	Description	Qty.	YS #	Description	Qty.
5906	RED 3MM LED 1V9 20MA.4SPCER T&R	1	5258	4U7 63V 20%CAP T&R 8X7MM .2"EL	4	2024	1/8W 249R 2%FLAME PROOF T&R RES	3	8801	6-32 X 3/8 PAN PH TAPTITE JS500	13
5907	YEL 3MM LED 1V9 20MA.4SPCER T&R	1	5266	680N 250V 20%CAP BLK 'X2' 30MM AC	1	4945	1/4W 270R 5% 2"U T&R RES	1	8829	6-32 X 3/8 FLAT PH TAPTITE B0AC HEA	4
5908	GRN 3MM LED 1V9 20MA.4SPCER T&R	1	5949	.3U3 140AC10%CAP BLK RAD POLYP FLM	3	6150	1/4W 301R 1%MINI MF T&R RES	1	8796	6-32 X 5/8 PAN PH TAPTITE ZINC	11
6421	MR752 200V 6A0 DIODE	4	5951	.3U3 250DC10%CAP BLK MPOLYP FLM	1	4789	1/4W 324R0 0.1% *** T&R RES	1	8803	8-32 X 3/8 PAN PH TAPTITE JS500	7
6438	1N4007 1000V 1A0 DIODE T&R	2	5280	22U 50V 20%CAP T&R RAD .2"EL	1	2026	1/4W 332R0 1%FLAME PROOF T&R RES	1	8804	8-32X1.25 PAN PH MS ZINC CLEAR	4
6733	BAT85 30V 0A2 DIODE SCHT T&R	6	5282	.10U 16V 20%CAP T&R 5X7MM .2"NP	2	4690	1/2W 442R 1% T&R RES	1	8843	10-32 X 1 1/8 FLAT QUAD MS JS500	4
6825	1N4148 75V 0A45 DIODE T&R	19	5631	.22U 50V 20%CAP T&R 6X7MM .2"EL	3	4933	1/4W 470R 5% 2"U T&R RES	3	8786	10-32 X 1 1/4 PAN QD MS JS500 BLACK	38
6827	1N5402 200V 3A0 DIODE	8	5945	.10U 63V 20%CAP T&R RAD .2"EL	3	4980	1/4W 470R 5%MINI T&R RES	1	8751	10-32 X 2 PAN QUAD MS JS500	3
6892	UF4004 200V 1A0 DIODE ULTRAFAS	1	5961	.33U 16V 20%CAP T&R RAD .2"NP	5	5029	1/4W 499R 1% T&R RES	1	8935	1/4-20 X 23MM JOINT CON. BOLT □B/O	4
6934	MR854 400V 3A0 DIODE FASREC	2	5265	.68U 25V 20%CAP T&R RAD .2"EL	1	2028	1/8W 475R 1%FLAME PROOF T&R RES	3	8847	1/4-20 X 1 1/4 FLAT PH MS JS500	4
6426	1N5254B 27V0 0W5 ZENER 5% T&R	1	5862	3300U 180V 20%CAP RAD 40X50MM 5PIN	2	5014	1/4W 562R0 0.1% *** T&R RES	4	8926	5/16-18X3 CARRIAGE BOLT ZINC	1
6432	1N5248B 18V0 0W5 ZENER 5% T&R	2	5887	2200U 50V 20%CAP BLK 18X27MM EL	2	2030	1/8W 681R 1%FLAME PROOF T&R RES	3	8879	M5 X 10 DIN 7985 QUAD ZINC SCREW	2
6436	1N753ARL 6V2 0W5 ZENER 5% T&R	1	5912	2200U 63V 20%CAP RADIAL ELECT BULK	2	4743	1/4W 681R0 0.1% *** T&R RES	2	8995	3/8" STEEL FLAT WASHER, BLACK	5
6440	1N750ARL 4V7 0W5 ZENER 5% T&R	3	4432	.10K B LIN 9MM P32	2	4923	1/4W 680R 5% 2"U T&R RES	1	3751	SNAP IN 5/16 SPACER RICHCO	7
6450	1N5242B 12V0 0W5 ZENER 5% T&R	3	4434	.10K B LIN 9MM DETENT P32	2	2031	1/8W 820R 5%FLAME PROOF T&R RES	1	3851	1/2 PCB PLASTIC SPACER	6
6461	1N5240BRL 10V0 0W5 ZENER 5% T&R	1	4435	.50K B LIN 9MM DETENT P32	1	4934	1/4W 1K 5% 2"U T&R RES	2	3859	1/2 PLASTIC HEX SPACER #4	2
6463	1N5251BRL 22V0 0W5 ZENER 5% T&R	1	706	1/2"X48"X250" DURABUBBLE	42	6110	1/4W 1K0 1%MINI MF T&R RES	16	7410	15" 8R 600WPGM SPKR NEO 15-286-8	1
6465	1N5250B 20V0 0W5 ZENER 5% T&R	1	713	25 X 20 X 50 2 MIL PLASTIC BAG	1	4996	1/4W 1K070 0.1% *** T&R RES	1	8908	#10 SAE FLAT WASHER .25ID .565" OD	18
6728	MC78L05ACP TO92 P .5V0 REG TR V4	1	3976	SNAP ON 0.843" INSULATING BUSHING	1	4585	1/4W 1K2 5%MINI T&R RES	3	8921	#3MM ID3.2MM ODT .0MM THICK 5MM	4
6824	1N5246B 16V0 0W5 ZENER 5% T&R	2	6492	1300UH COIL COMMUNOD 4AMP	1	4611	0.6W 18K7 1% MF T&R RES	2	8667	SHOULDER WASHER SWS-229 LENGTH 1/8	4
6871	MC7915CT TO220 N 15V0 REG V2	1	8483	ADAPTOR, SPEAKER STAND METAL BLACK	1	4769	1/4W 1K4 1% T&R RES	5	8482	3/8 ID FLAT WASHER	4
6872	MC7815CT TO220 P 15V0 REG V1	1	8538	RUBBER BUMPER W/ WASHER 1.375X1.375	3	2034	1/8W 1K5 5%FLAME PROOF T&R RES	2	8489	1/4-20 SPLIT WASHER BLACK OXIDE	20
5101	BC550C TO92 NPN TRAN T&R TB	1	3485	CLIP 250X032 18-22AWG RIGHT ANGL	4	4935	1/4W 1K5 5% 2"U T&R RES	4	8492	7/16" SPLIT LOCK WASHER CLEAR ZINC	5
5102	BC560C TO92 PNP TRAN T&R TB	2	3489	CLIP 250X032 18-22AWG DISCO/INSL	9	4683	1.0W 1K8 5% T&R RES	1	3522	DPDT MCR PC VERT SNP ALT	2
5103	MPSA06 TO92 NPN TRAN T&R TA	1	3490	CLIP 250X032 14-16AWG DISCO/INSL	7	6105	1/4W 1K8 5%MINI T&R RES	3	3585	DPDT ROKR SW QUIK 250° AC/PWR IEC85	1
5105	MPSA13 TO92 NPN DARL T&R TA	1	3921	1/4" JACK PCB MT VERT STER RT SWT	4	4946	1/4W 2K 5% 2"U T&R RES	2	3392	250 MALE TAB 2IN T&R	17
5107	2N5551 TO92 NPN TRAN T&R TA	2	3453	XLR MALE PCB MT VERT	1	6113	1/4W 2K 5%MINI T&R RES	3	3395	THERMO/BRKR/N/CLOSED OPEN@82C	1
5108	2N5401 TO92 PNP TRAN T&R TA	4	4010	XLR FEMALE PCB MT VERT 24MM AA-SERIES	2	4705	2.0W 2K2 5% BLK RES	2	CH1337	NX750P POWER TRFMR TRD	1
5114	MPSA92 TO92 PNP TRAN T&R TA	2	3482	LOWPROFILE FUSEHOLDER 1/4" BUSSMANN	1	6104	1/4W 2K2 5%MINI T&R RES	6			
5119	2N5638 TO92 NCH JFET T&R TC	2	2465	7.0 AMP FAST-BLO .25X1.25 FUSE	1	2035	1/4W 2K21 1%FLAME PROOF T&R RES	2			
6873	MJE340 TO126 NPN TRAN TG	1	2487	7.0 AMP SLO-BLO T&R FUSE	2	6114	1/4W 2K49 1%MINI MF T&R RES	2			
6911	BDX54C TO220 PNP TRAN DARL TE	1	7393	.8R 30W 1.00" DRIVER BMS	1	4764	1/4W 2K740 0.1% *** T&R RES	1			
6912	BDX53C TO220 NPN TRAN DARL TE	1	3501	B5220F006 COMP WASH #4 SMALL	9	6124	1/4W 3K 5%MINI T&R RES	2			
6931	IRFP140N TO247 NCH MFET TM	1	8933	1/4-20 INSIDE 7/16-20 UNF FLATALLEN	5	4938	1/4W 3K3 5% 2"U T&R RES	1			
6932	IRFP9140N TO247 PCH MFET TM	1	8938	1/4-20 X 10MM INSERT NUT, TYPE D	8	5022	1/4W 3K57 1% T&R RES	1			
6967	IRFP23N50L TO247 NCH MFET TM	2	3645	AC SOCKET RECEPTACLE WITH 0.250 TAB	1	4850	1/4W 3K9 5% T&R RES	1			
6603	74HC14N IC HEX INV SCHMID	2	3810	4" NYLON CABLE TIE	12	4756	1/4W 4K120 0.1% *** T&R RES	2			
6605	74HC86N IC QUAD 2INP XOR	1	3841	5.5" NYLON CABLE TIE	2	4943	1/4W 4K7 5% 2"U T&R RES	7			
6640	LM311 IC VOLTAGE COMPARATOR	3	3852	STICK ON CABLE WRAP ANCHOR	1	4982	1/4W 4K7 5%MINI T&R RES	2			
6804	MC33079P IC QUAD OP AMP	1	3558	TERM HOUSING 4 CIR .156/RAMP	1	6128	1/4W 4K99 1%MINI MF T&R RES	1			
6840	MC33078P IC DUAL OP AMP	1	3559	TERM HOUSING 8 CIR .156/RAMP	1	5001	1/4W 6K04 1% T&R RES	1			
6884	NE5532N IC DUAL OP AMP	16	3674	9 CIR CABLE HOLDER .098	1	4978	1/4W 6K8 5%MINI T&R RES	5			
6887	IR2110 IC HILO FET DRIVER	1	4004	.9 CIR WAFER WLCK VT 0.1"	1	4768	5.0W 12K 5% BLK RES	5			
6964	74HC74N IC DUAL FLIPFLOP	1	3538	24 PIN BREAKAWAY LOCK .156	0.46	4940	1/4W 10K 5% 2"U T&R RES	10			
5190	MBS4992 TO92 8V5 DIAC T&R	1	3549	TRIFURCON TERM .156	12	6116	1/4W 10K0 1%MINI MF T&R RES	10			
6517	STM-BTB-600BRG TO220 ??A TRIAC 600V	1	8632	KNOB ROUND PUSHBUTTON 1/4" GREY	2	4979	1/4W 15K 5%MINI T&R RES	3			
6858	NLS-32SR2 OPTO-COUPLER LDR	2	9915	KNOB 0-DEG RED SOFT GRAY RIB	2	4954	1/4W 18K 5% 2"U T&R RES	3			
5401	.10P 500V 5%CAP T&R RAD CER.2"NPO	1	9916	KNOB 0-DEG GRD SOFT GRAY RIB	1	6123	1/4W 20K0 1%MINI MF T&R RES	2			
5406	.33P 50V 10%CAP BLK BEAD NPO	2	9917	KNOB 0-DEG GRN SOFT GRAY RIB	2	6118	1/4W 22K 5%MINI T&R RES	3			
5817	.15P 100V 2%CAP T&R RAD CER.2"NPO	1	3426	8' 3/16 STJ AC LINE CORD REMOV-B-CSA	1	4956	1/4W 27K 5% 2"U T&R RES	3			
5199	100P 100V 2%CAP T&R RAD CER.2"NPO	1	3826	STRAIN RELIEF HEYCO #1150	1	4941	1/4W 30K 5% 2"U T&R RES	1			
5203	.47P 100V 2%CAP T&R RAD CER.2"NPO	1	8240D	LOGO YORKVILLE SMALL BLUE DOMED	1	4947	1/4W 33K 5% 2"U T&R RES	2			
5410	100P 100V 10%CAP T&R BEAD NPO	1	3792	288UH CHOKE 89T20AWG/77091MAGNNTKS	1	4686	1/4W 37K4 1% METAL FILM T&R RES	3			
5412	220P 100V 10%CAP T&R BEAD NPO	2	3792CORE	77091-AT KOOL-MU TOROID CORE	1	4927	1/4W 47K 5% 2"U T&R RES	4			
5201	.470P 100V 5%CAP T&R RAD CER.2"NPO	6	8701	4-40 KEPS NUT ZINC	9	6119	1/4W 47K 5%MINI T&R RES	4			
5208	.2N2 400V 5%CAP T&R RAD .2"FLM	2	8939	10-32 X 10MM INSERT NUT, TYPE D	45	4835	1/4W 56K 5% T&R RES	1			
5275	.3N3 100V 5%CAP T&R RAD .2"FLM	3	8800	8-32 KEPS NUT ZINC	2	4848	1/4W 62K 5% T&R RES	1			
5422	.1N 50V 10%CAP T&R BEAD NPO	2	8787	8-32 KEPS NUT ZINC	3	4929	1/4W 82K 5% 2"U T&R RES	1			
5816	680P 100V 5%CAP T&R RAD CER.2"NPO	4	8934	7/16-20 UNF HEX NUT GRD 5 CLEAR ZNC	5	4942	1/4W 100K 5% 2"U T&R RES	1			
5204	.10N 100V 10%CAP T&R RAD .2"FLM	2	8797	5/16-18 KEPS NUT JS500	1	4638	1/2W 150K 5% T&R RES	1			
5207	.18N 100V 5%CAP T&R RAD .2"FLM	1	3884	SARCON THERMAL GASKET 4.55"X1.00"	1	4796	1/4W 180K 5%MINI T&R RES	1			
5209	.4N7 250V 5%CAP T&R RAD .2"FLM	1	NX15PCABINET	15"NX SET W/POWER BACK BLACK PLASTIC	1	4949	1/4W 180K 5% 2"U T&R RES	2			
5210	.22N 100V 10%CAP T&R RAD .2"FLM	1	4599	22AWG SOLID SC WIR T&R JMP	6	6135	1/4W 270K 5%MINI T&R RES	1			
5215	.27N 100V 5%CAP T&R RAD .2"FLM	3	5299	24AWG SOLID SC WIR RAD JMP	1	6127	1/4W 470K 5%MINI T&R RES	1			
5222	.33N 100V 10%CAP T&R RAD .2"FLM	1	4660	5.0W 0R047 5% BLK RES	2	4948	1/4W 1M 5% 2"U T&R RES	7			
5224	.47N 100V 10%CAP T&R RAD .2"FLM	2	2005	1.0W 0R47 5%FLAME PROOF T&R RES	4	3535	10.0° 9C-26AWG RIB 1 WLCK HDR 098"	1			
5271	.5N6 100V 5%CAP T&R RAD .2"FLM	1	4682	1/2W 1R 5%PHILIPS SMAL T&R RES	1	3696	RELAY 1 C 02AMP DC24 006MA PC-S	1			
6451	.4N7 250V 20%CAP BLK 'Y' 10MM AC	1	4911	1/4W 2R2 5% T&R RES	1	3790	EMI FILTER FOR RIBBON CABLE	1			
5212	100N 63V 5%CAP T&R RAD .2"FLM	43	4813	1/4W 6R2 5% T&R RES	2	9041	.093" HOLE 156" STAG 16GA 36"X120"	4			
5226	68N 100V 5%CAP T&R RAD .2"FLM	6	2010	1/8W 10R0 2%FLAME PROOF T&R RES	4	9070	18GA ELECTRO GALV STEEL 4'X8' SHEET	2.78			
5228	100N 100V 5%CAP T&R RAD .2"FLM	1	4930	1/4W 10R 5% 2"U T&R RES	1	9140	.125" 48X96 UTILITY ALUM SPV 1 SIDE	0.26			
5229	150N 63V 10%CAP T&R RAD .2"FLM	1	2038	1/4W 11R FUSIBLE T&R RES	2	9141	.125" 48X96 UTILITY ALUMINIUM	1.33			
5231	220N 63V 10%CAP T&R RAD .2"FLM	1	6134	1/4W 47R 5%MINI T&R RES	1	9250	.040" 48X96 5052H32 ALUM VINYL LAMI	0.4			
5233	330N 63V 5%CAP T&R RAD .2"FLM	3	2018	1/8W 75R 2%FLAME PROOF T&R RES	3	9549	.187" 48X96 UTILITY ALUMINIUM	0.616			
5234	470N 63V 10%CAP T&R RAD .2"FLM	3	2019	1/8W 100R0 1%FLAME PROOF T&R RES	3	9640	.025" FISHPAPER (FLAT 48" SHEETS)	0.13			
5242	100N 250V 20%CAP BLK 'X2' 15MM AC	1	4921	1/4W 100R 5% 2"U T&R RES	1	8842	#4 X 5/16 PAN QUAD TYPE A JS500 BLK	6			
5314	100N 50V 10%CAP T&R BEAD X7R	2	4984	1/4W 150R 5%MINI T&R RES	1	8865	4-40 X 5/16 PAN PH MS JS500	4			
5254	.1U 63V 20%CAP T&R 4X7MM .2"EL	1	4819	1/4W 180R 5% T&R RES	2	8871	4-40 X 5/8 PAN PH MS JS500	9			
5255	.1U 63V 20%CAP T&R RAD .2"EL	2	4944	1/4W 220R 5% 2							

nx750p

750 WATT POWERED LOUDSPEAKER ENCLOSURE

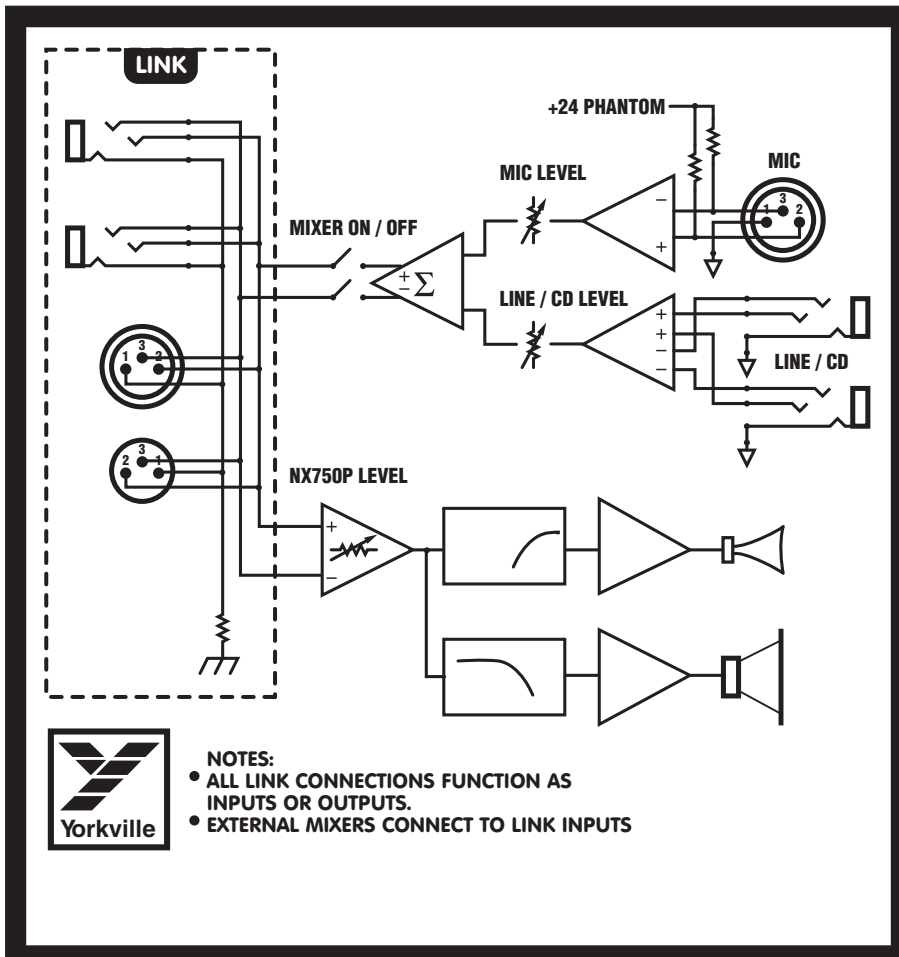

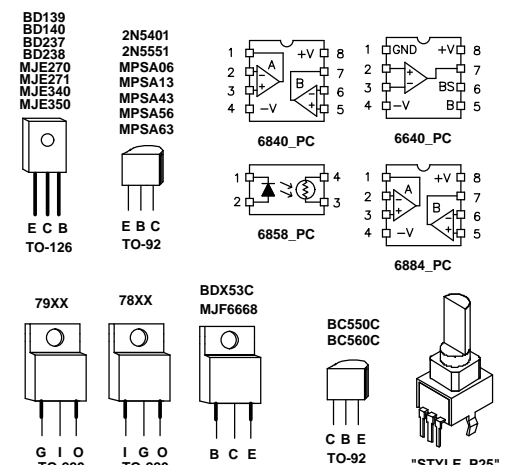
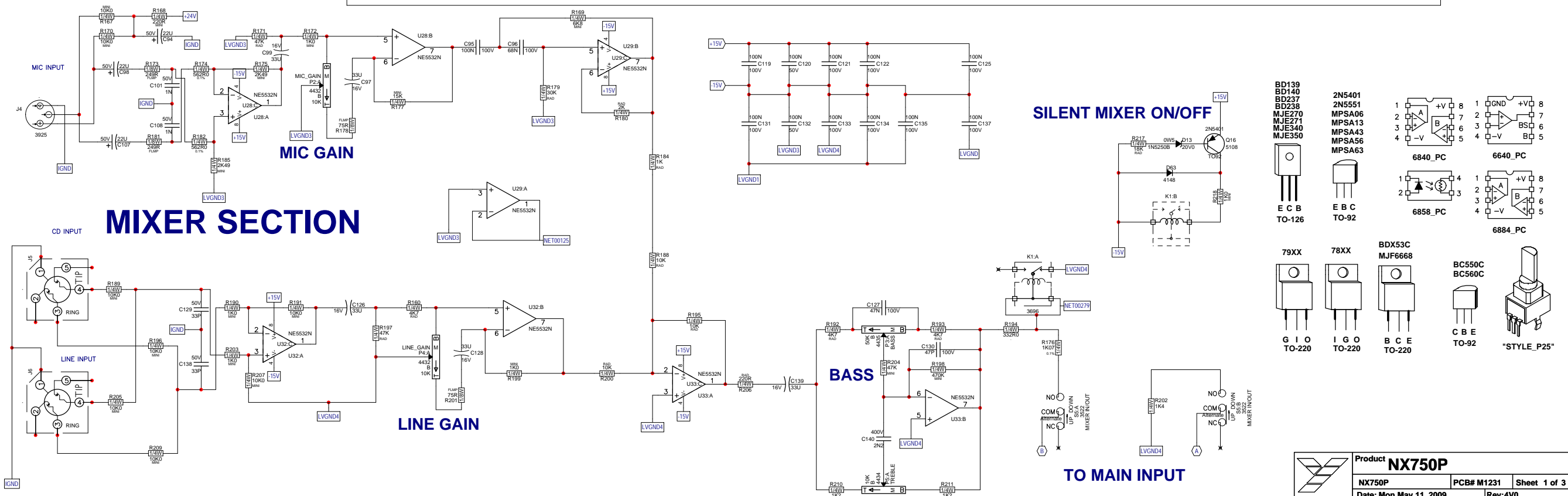
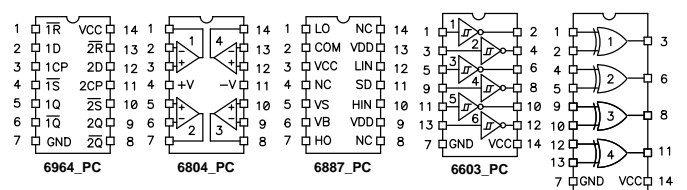
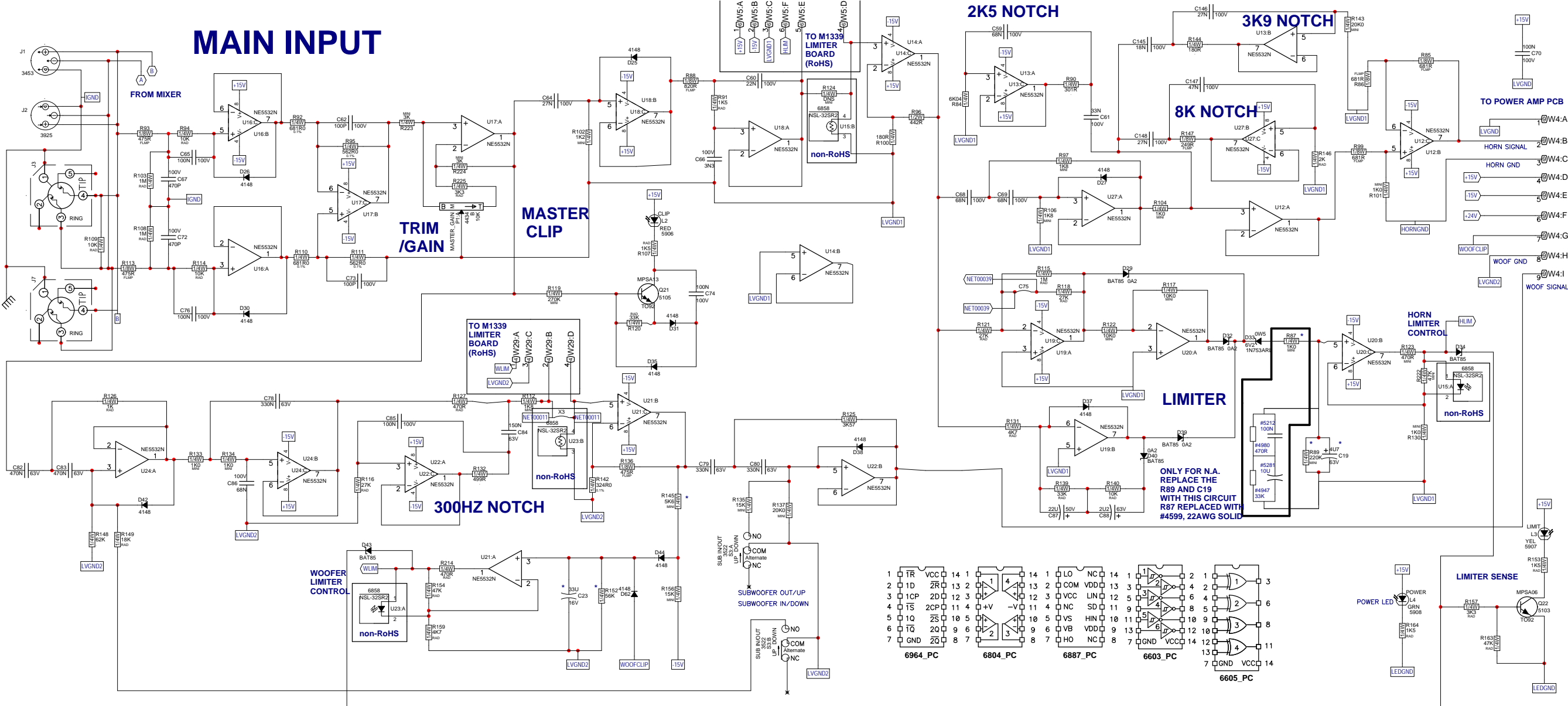

HORN AMP

PHANTOM SUPPLY

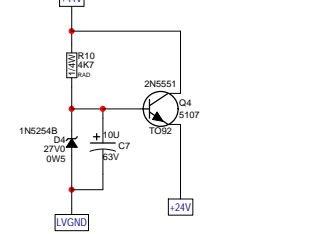

FROM INPUT PCB

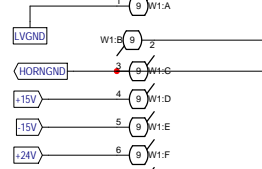

SILENT ON/OFF

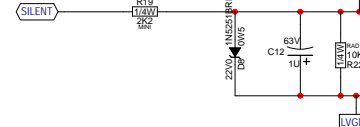

WOOFER AMP

+/-15V_C

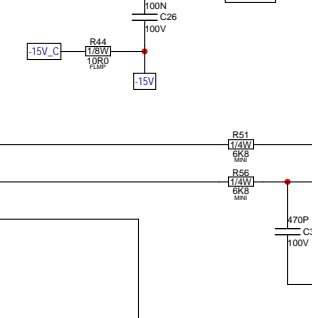

+/-15V_MOD

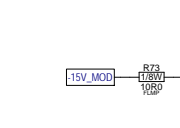

+5V_MOD

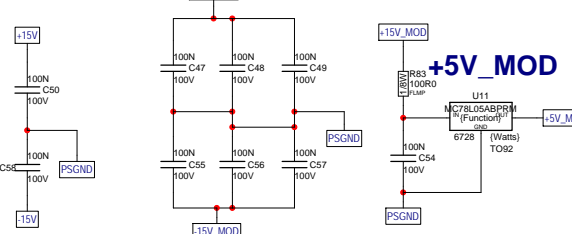

SILENT ON/OFF

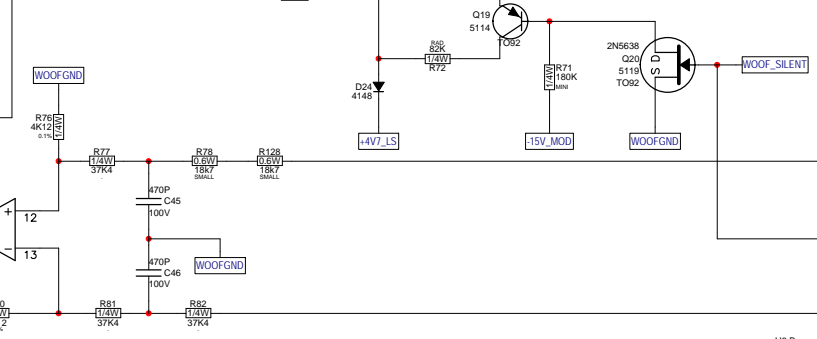

Product **NX750P**
 NX750P PCB# M1231 Sheet 2 of 3
 Date: Mon May 11, 2009 Rev:4V0
 Filename: M1231V400sch.sch2002

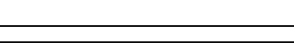
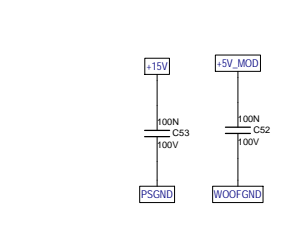
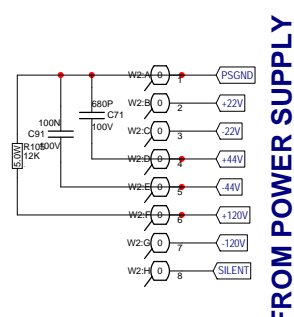
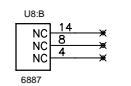

M1231.PCB_DATABASE_HISTORY		
MODEL(S):-	VER#	DESCRIPTION OF CHANGE
#	DATE	VER#
1	AUGUST 2004	V1.00
2	NOV-26-2004	V1.00
3	MAY30th 2005	V2.00
4	.	.
5	.	.
6	SEP-21-2005	.
7	OCT-31-2005	.
8	DEC-13-2005	.
9	AUG-16-2006	V2.01
10	.	.
11	OCT 16 2006	V3.00
12	FEB 07 2007	V3.01

M1231.PCB_DATABASE_HISTORY		
MODEL(S):-	VER#	DESCRIPTION OF CHANGE
#	DATE	VER#
1	.	.
2	.	.
3	.	.
4	22-AUG-2007	V3.02
5	.	.
6	.	.
7	01-FEB-2008	V3.03
8	.	.
9	.	.
10	.	.
11	11-MAY-2009	V4.00
12	.	.
13	.	.

POT LIST				
NX750P				
REF	FUNCTION	PART#	KNOB	(NEW)
P1	MAIN GAIN	#4434	GREY	#9916
P2	MIC GAIN	#4432	RED	#9915
P3	BASS CONTROL	#4435	GREEN	#9917
P4	CD/LINE GAIN	#4432	RED	#9915
P5	TREBLE CONTROL	#4434	GREEN	#9917
F	F	P	K	N
F	F	P	K	N
F	F	P	K	N
F	F	P	K	N
F	F	P	K	N
F	F	P	K	N
F	F	P	K	N

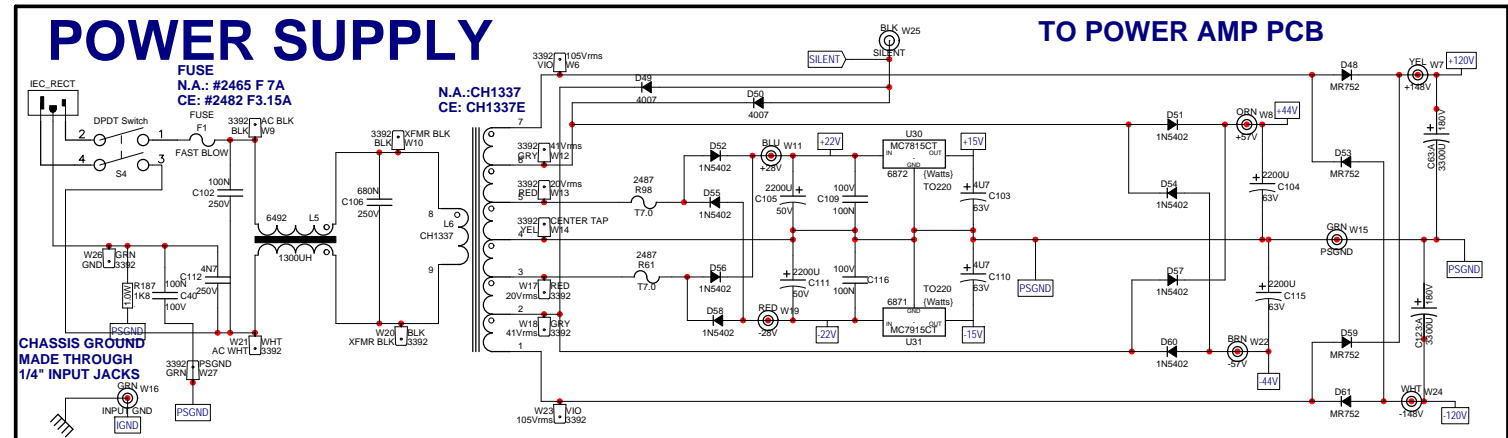

	WITHOUT CROWBAR		WITH CROWBAR	
	N.A.	CE	N.A.	CE
TRANSFORMER	CH1337	CH1337E	CH1337	CH1337E
FUSE F1	#2465 F 7A	#2482 F3.15A	#2465 F 7A	#2479 F 5A

	Product NX750P		
	NX750P	PCB# M1231	Sheet 3 of 3
	Date: Mon May 11, 2009	Rev:4V0	
	Filename: M1231V400sch.sch2002		



SEE LAYOUT DIAGRAM



PRODUCTION NOTES

- NOTE THAT THERE ARE SEVERAL LINES ON THE DSBOTMASK LAYER. THESE MAY BE USED FOR MARCONI TEST POINTS SO HAVE THIS LAYER ON IF DOING ANY MODIFICATIONS.
- MAKE SURE TO RTV ALL LARGE CAPACITORS TO SOMETHING CLOSE



- SLIDE EMI FILTER OVER RIBBON BEFORE INSERTING INTO P.C.B.

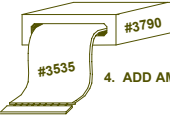

*****IMPORTANT*****

- ADD AMPLE RTV UNDER ENTIRE BASE OF OUTPUT COIL L1

- LEADS FOR 5 WATT RESISTORS MUST BE BENT ON THE MACHINE LEAD LOOP MUST NOT BE ABOVE TOP OF RESISTOR



- FIT #8921 FLAT WASHER BETWEEN #3501 BELL WASHER AND #8667 SHOULDER WASHER FOR Q2, Q10 U30 AND U31

- AUTO INSERT DO NOT STUFF R21 BOARD ASSEMBLY, PUT #6125 18K 1/4W

- PC7453, RESTORE HORN LIMITTER, CHECK THE PRODUCTION NOTES ON NEXT PAGE, PAGE 3. THIS IS ONLY FOR NORTH AMERICA UNITS.

- PC7398, ADD CROWBAR CIRCUIT AND CHANGE THE FUSE VALUE AT THE SAME TIME.

	WITHOUT CROWBAR		WITH CROWBAR	
	N.A.	CE	N.A.	CE
XFRM	CH1337	CH1337E	CH1337	CH1337E
FUSE F1	#2465 F 7A	#2482 F3.15A	#2465 F 7A	#2479 F 5A

10. M1231, PARTS REPLACEMENT TABLE

	M1231A CE	M1231B N. AMERICA
C23	#5961, 33U 16V 20%	#6281, 10U 50V 20%
C19	#6258, 4U7 63V 20%	DNS, SEE NOTE ON PAGE 3, PC7453
D34	#6733, 30V 0A2 DIODE	#6825, 75V 0A45 DIODE
D43	#6733, 30V 0A2 DIODE	#6825, 75V 0A45 DIODE
R87	#6110, 1K 1/4W 5% MINI	#4599, 22AWG SOLID
R89	#6126, 220K 1/4W 5% MINI	DNS, SEE NOTE ON PAGE 3, PC7453
R124	DNS	#6113, 2K 1/4W 5% MINI
R145	#6141, 5K6 1/4W 5%	#6128, 4K99 1/4W 1% MINI
R157	#4938, 3K3 1/4W 5%	#4940, 10K 1/4W 5%
U15	DNS	#6858 OPTO-COUPLER
U23	DNS	#6858 OPTO-COUPLER
W5	#3709, 7in 6C-26AWG RIB 1 W/LCK HDR	DNS
W29	#4036, 8in 4C-26AWG RIB 1 W/LCK HDR	DNS
X3	DNS	#4599, 22AWG SOLID

- M1231B, U15 AND U23 ARE HAND INSERTED AFTER WAVE SOLDERING. PUT OPTOCOUPLERS AS SHOWN IN THE PHOTOS.

PHOTO 1 U15

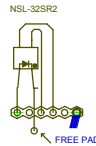
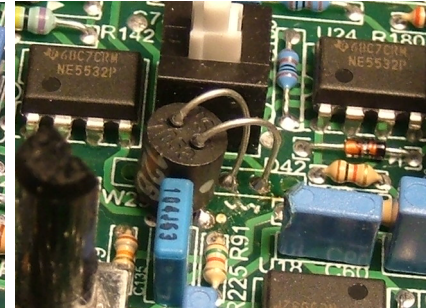
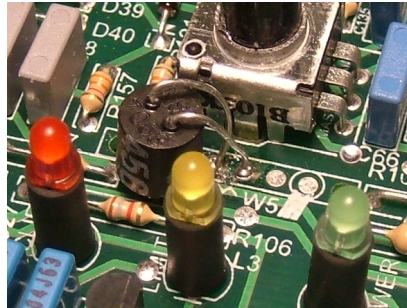
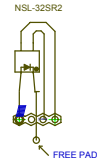

PHOTO 2 U23





SEE LAYOUT DIAGRAM



M1231.PCB_DATABASE_HISTORY			
MODEL(S):- NX750P			
#	DATE	VER#	DESCRIPTION OF CHANGE
1	AUGUST 2004	V1.00	MADE FROM M1158-V.200
2	NOV-26-2004	.	PC#6772: REV. WIRE COLORS ON WOOFER & HORN (GT)
3	MAY30th 2005	V2.00	CHANGED POWER SUPPLY CAPACITORS TO NEW
4	.	.	FIVE LEG #5862 3300U & FORCE UPDATED BOARD (M.R)
5	.	.	C102 FROM 22N #6435 TO 100N #5242
6	SEP-21-2005	.	PC#6979:GT:R6&R23 #4815 12R->#2038 11R FUSIBLE
7	OCT-31-2005	.	PC7003:GT:R9 #4979 15K->#6104 2K2, ADD 8921 WASHER
8	DEC-13-2005	.	PC#7052:GT:Q14&Q15 6914 IRFP350->6967 IRFP23N50LPBF
9	JUN-29-2006	V2.01	AH, PC#7136, REPLACE R77, R81 AND R82 WITH #4686
10	.	.	37K4 1% 1/4W. REPLACE R78 WITH #4611
11	OCT 16 2006	V3.00	PC#7178, Updated limiter for RoHS compliance
12	.	.	PC#7167, ENLARGE HOLE SIZE FOR #3522
13	FEB 07 2007	V3.01	AH, PC#7205, C37 100N #5212 TO 470P #5201

M1231.PCB_DATABASE_HISTORY			
MODEL(S):- NX750P			
#	DATE	VER#	DESCRIPTION OF CHANGE
1	.	.	R177 4K7 #4982 TO 15K #4979
2	.	.	ONLY M1231A CE VER. R157 10K #4940 TO 3K3 #4938
3	.	.	D34 AND D43 1N4148 #6825 TO BAT 85 #6733
4	22-AUG-2007	V3.02	PC#7261, N.A. VERSION CHANGE R152 150K #4839 TO
5	.	.	56K #4835, R89 1K #4981 TO 56K #5018, C23 22U #563 TO
6	.	.	10U #5281 C19 1U #5254 TO 4U7 #5258
7	01-FEB-2008	V3.03	PC#7453, ONLY FOR NA. REMOVE C19 AND R89 FROM AI.
8	.	.	BA WILL PUT 33K,470R,100N AND 10U AS SHOWN
9	.	.	PC#7398, ADD CROWBAR CIRCUIT AND CHANGE FUSE
10	.	.	AT THE SAME TIME SEE PRODUCTION NOTE
11	11-MAY-2009	V4.00	PC#7356, 7701, AND 7757 - PAD UPDATE, XLR MTG HOLE
12	D	V	ADDED. X1 REF REMOVED IN LAYOUT
13	D	V	N

POT LIST				
MODEL(S):- NX750P				
REF	FUNCTION	PART#	KNOB	{NEW}
P1	MAIN GAIN	#4434	GREY	#9916
P2	MIC GAIN	#4432	RED	#9915
P3	BASS CONTROL	#4435	GREEN	#9917
P4	CD/LINE GAIN	#4432	RED	#9915
P5	TREBLE CONTROL	#4434	GREEN	#9917
R	F	P	K	N
R	F	P	K	N
R	F	P	K	N
R	F	P	K	N
R	F	P	K	N
R	F	P	K	N

PIN CONFIGURATION

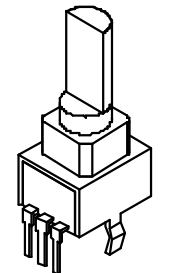
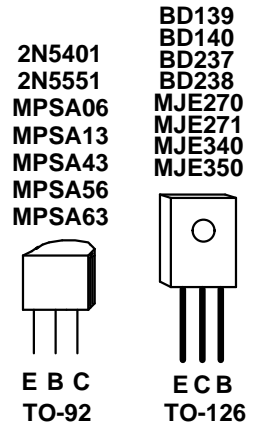
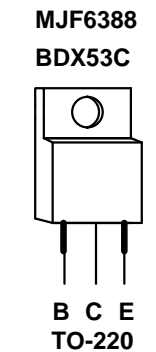
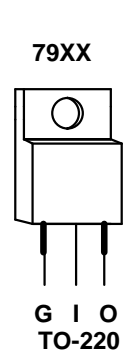
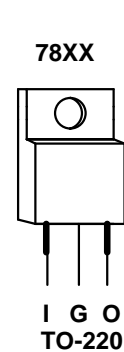
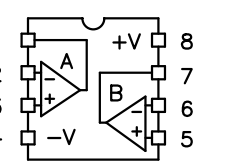
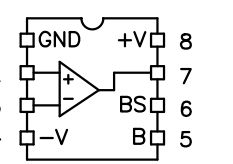
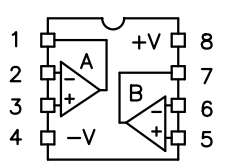
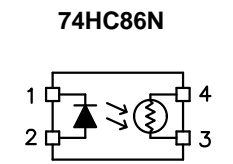
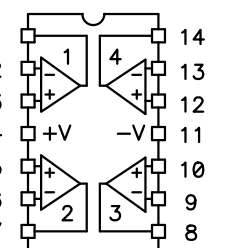
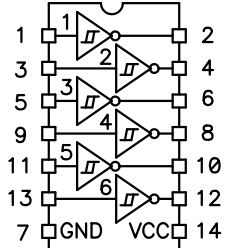
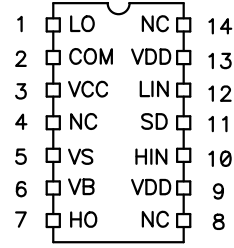
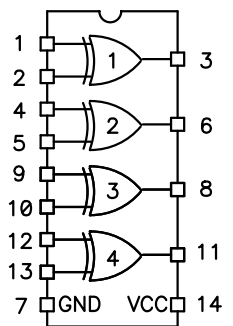

"STYLE_P32"

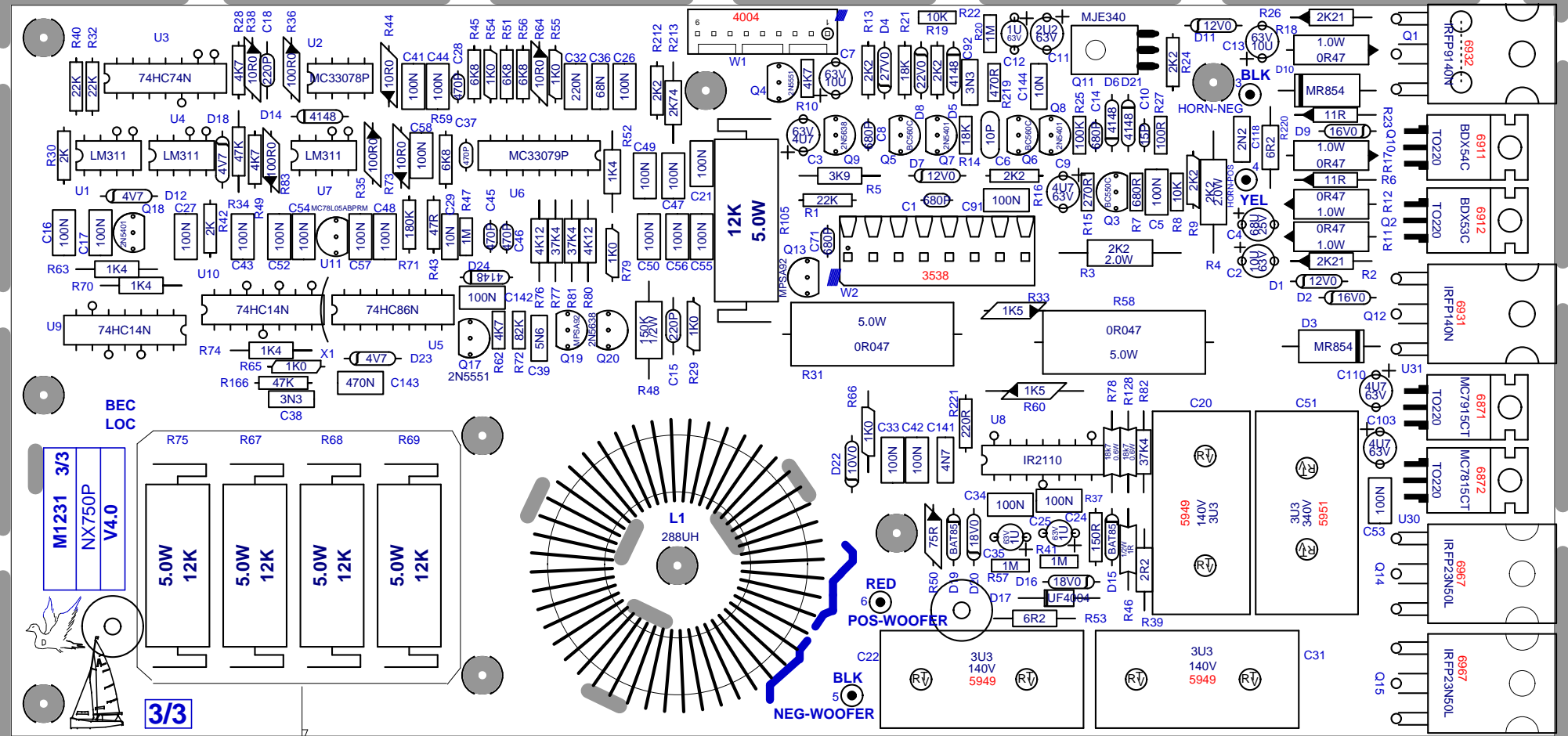
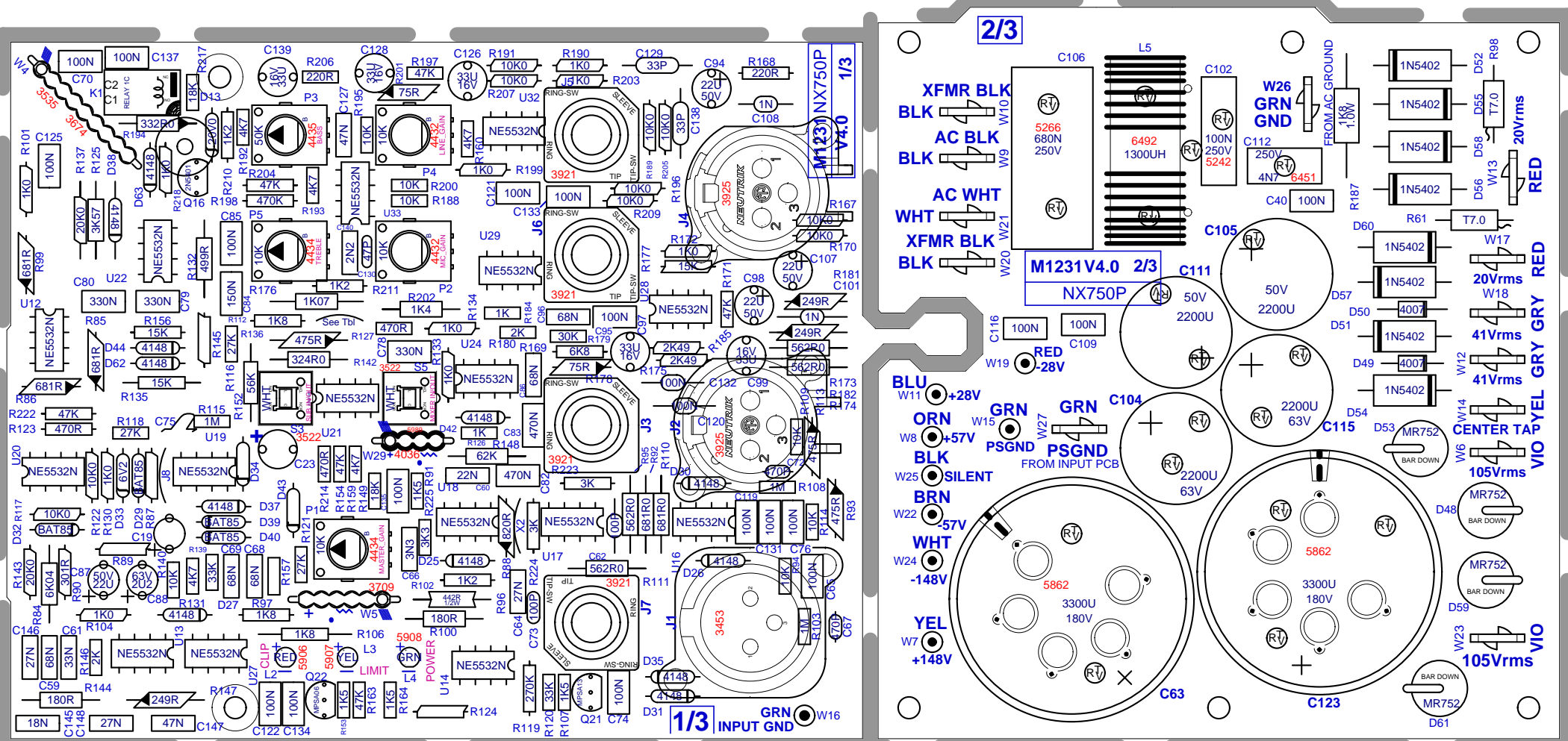

TRANSFORMER SECONDARY'S CH1337

X65 M1231A CE
X64 M1231B N. AME.

SEE NOTE 5
BlankSize - 11000x10000 Pcb Mech M1231 V4.0

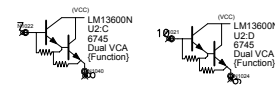
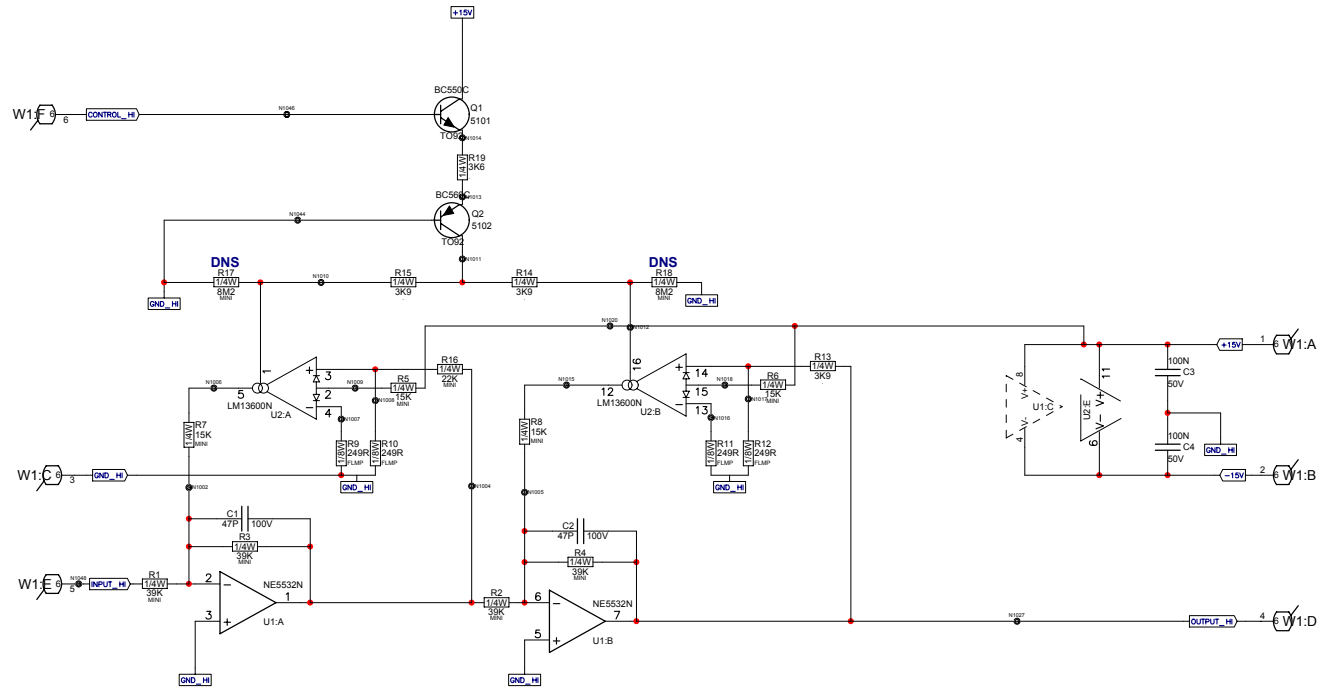

Product RoHS Limiter		
Limit_HI	PCB# M1339	Sheet 1 of 3
Date: Wed Mar 28, 2007	Rev: 1V10	YsType: YsType
Filename: M1339-1V10 sch.sch2002		

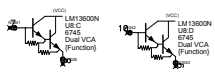
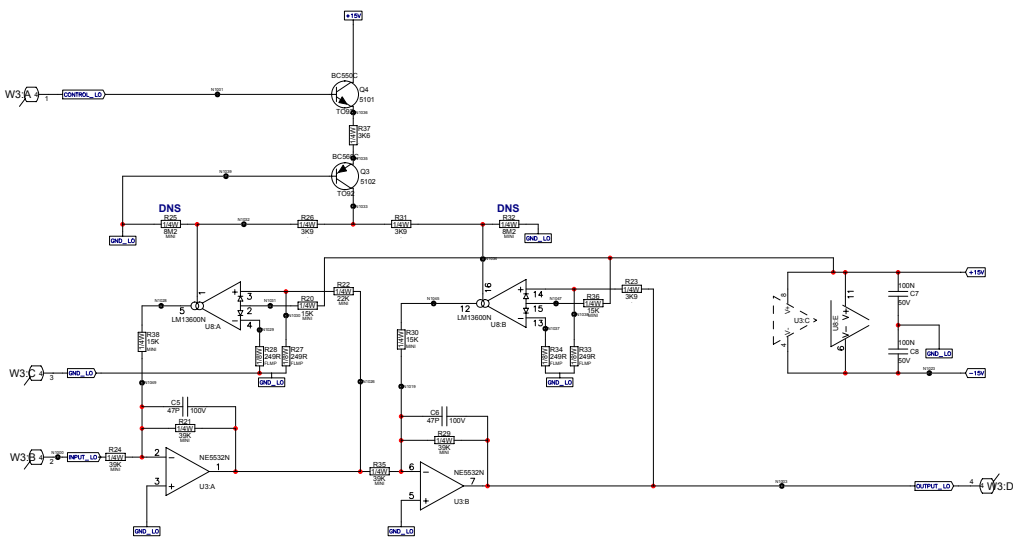



Limiter M1339 1V10

M1339 1A10

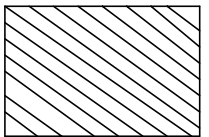
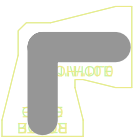
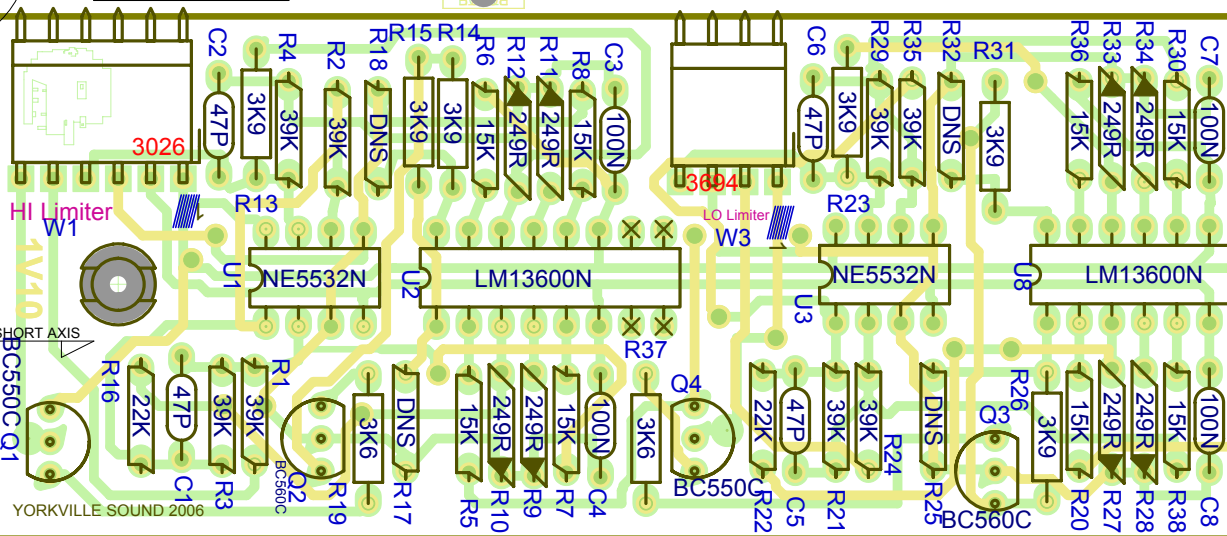

CLINCH
ORIGIN

INSERT
ORIGIN

HI Limiter
W1

LO Limiter
W3

SHORT AXIS

YORKVILLE SOUND 2006

LONG AXIS

M____PCB_DATABASE_HISTORY			
MODEL(S):-		MODEL	
#	DATE	VER#	DESCRIPTION OF CHANGE
1	19SEP2006	1V00	FIRST PROTO
2	20OCT2006	1V10	ADDED BEC LOC
3	24JAN2008		PC 7447, CHANGE W1, #3661 TO #3026
4	D	V	N
5	D	V	N
6	D	V	N
7	D	V	N
8	D	V	N
9	D	V	N
10	D	V	N
11	D	V	N
12	D	V	N
13	D	V	N
1	D	V	N
2	D	V	N
3	D	V	N
4	D	V	N
5	D	V	N
6	D	V	N
7	D	V	N
8	D	V	N
9	D	V	N
10	D	V	N
11	D	V	N
12	D	V	N
13	D	V	N
1	D	V	N
2	D	V	N
3	D	V	N
4	D	V	N
5	D	V	N
6	D	V	N
7	D	V	N
8	D	V	N
9	D	V	N
10	D	V	N
11	D	V	N
12	D	V	N
13	D	V	N



SEE LAYOUT DIAGRAM



PRODUCTION NOTES

1. Do not stuff parts R17,18,25,32

M____PCB_DATABASE_HISTORY				
MODEL(S):-		MODEL		
#	DATE	VER#	DESCRIPTION OF CHANGE	
1	D	V	N	
2	D	V	N	
3	D	V	N	
4	D	V	N	
5	D	V	N	
6	D	V	N	
M____PENDING CHANGES				
MODEL(S):-		MODEL		
#	PC#	PENDING CHANGE		
1	PC	X		
2	PC	X		
3	PC	X		
4	PC	X		
5	PC	X		
6	PC	X		
*PLACE IMPLEMENTED CHANGES INTO BOARD HISTORY				
{TITLE}				
MODEL(S):- {MODEL}				
REF	FUNCTION	PART#	NOB	{NEW}
R	F	P	K	N
R	F	P	K	N
R	F	P	K	N
R	F	P	K	N
R	F	P	K	N
R	F	P	K	N
R	F	P	K	N
R	F	P	K	N
R	F	P	K	N
R	F	P	K	N
R	F	P	K	N

LEAD/PIN REFERENCE

MPSA56 BC560C
MPSA06 BC550C



E B C
TO-92

C B E
TO-92

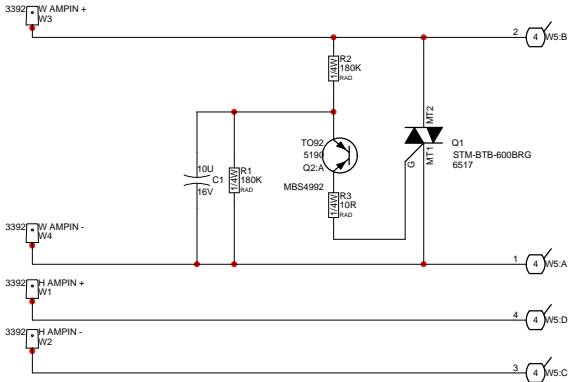

M1369 PCB_DATABASE_HISTORY			
MODEL(S):-		CROW BAR	
#	DATE	VER#	DESCRIPTION OF CHANGE
1	28-NOV-2007	1.00	FIRST DESIGN
2	02-JUN-2008	2.00	UPDATE TABS
3	D	V	N
4	D	V	N
5	D	V	N
6	D	V	N
7	D	V	N
8	D	V	N
9	D	V	N
10	D	V	N
11	D	V	N
12	D	V	N
13	D	V	N



Product CROW BAR		
Sheet1	PCB# M1369	Sheet 1 of 1
Date: Mon Jun 02, 2008	Rev:2.00	YsType:YsType
Filename: M1369V200sch.sch2002		

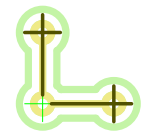
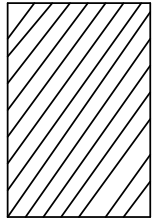
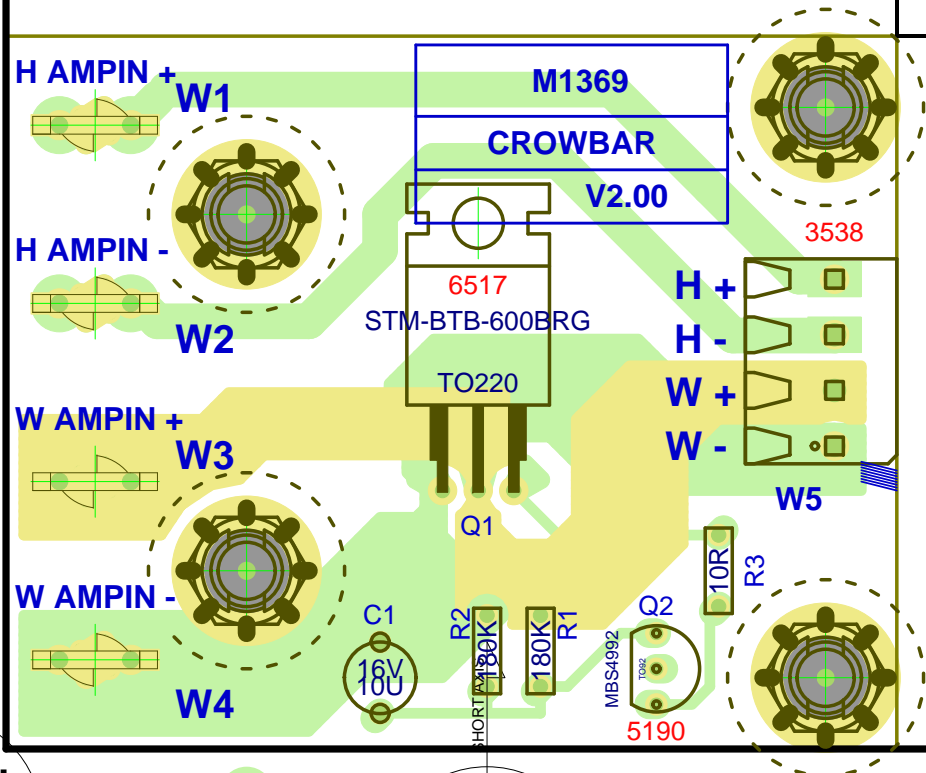

VCD

LONG AXIS



2ozCopper



SEE LAYOUT DIAGRAM



PRODUCTION NOTES

1. USE #8799, #6 1/4 PAN SCREW FOR TRIAC Q1

M1369 PCB_DATABASE_HISTORY			
MODEL(S):-		CROW BAR	
#	DATE	VER#	DESCRIPTION OF CHANGE
1	28-NOV-2007	1.00	FIRST DESIGN
2	02-JUN-2008	2.00	UPDATE TABS
3	D	V	N
4	D	V	N
5	D	V	N
6	D	V	N
7	D	V	N
8	D	V	N
9	D	V	N
10	D	V	N
11	D	V	N
12	D	V	N
13	D	V	N

LEAD/PIN REFERENCE

0.128" NPT HOLES MUST NOT BE SECOND DRILLED

STM-BTB-600BRG



MT1 G MT2
TO-220

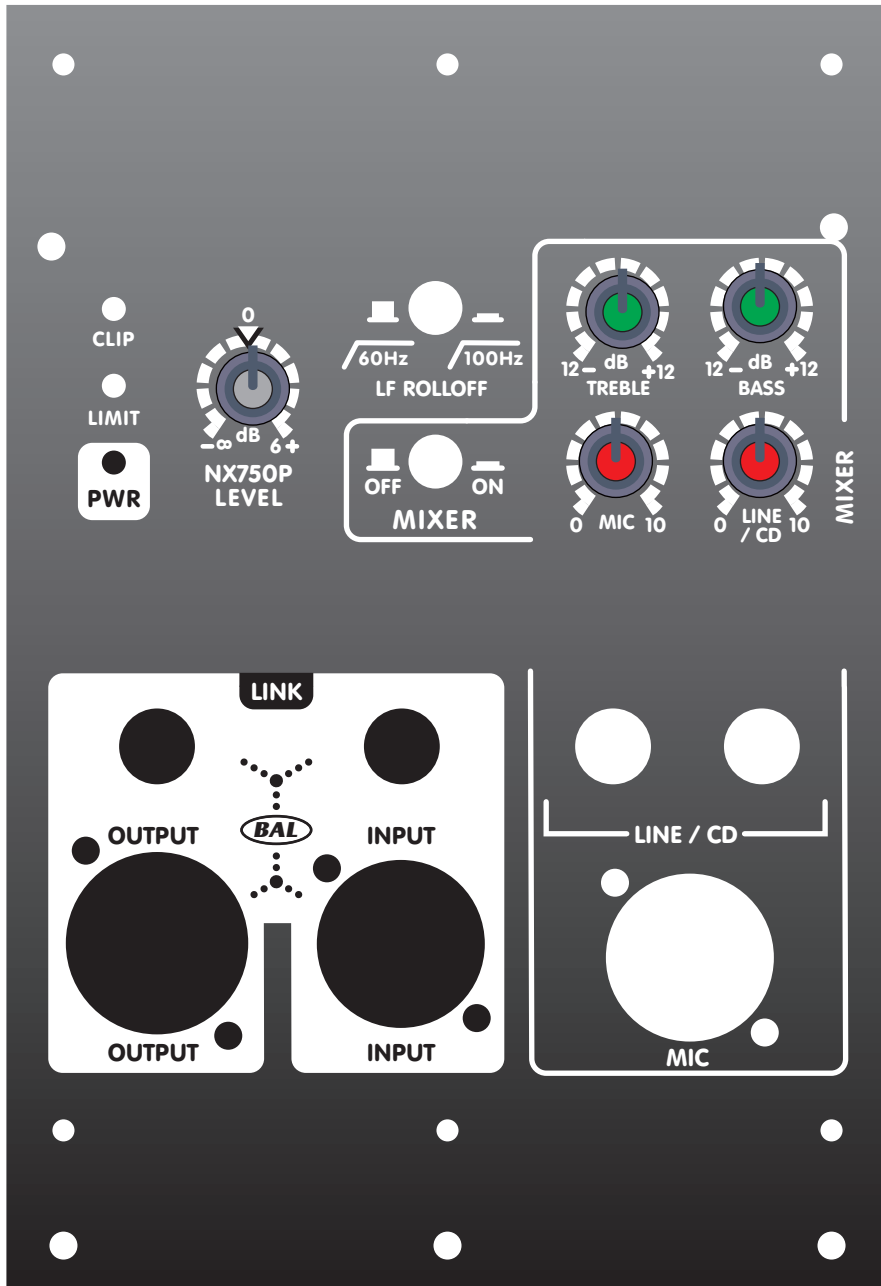

YS#9916 Gray Knob (qty: 1)



YS#9917 Green Knob (qty: 2)



YS#89915 Red Knob (qty: 2)